

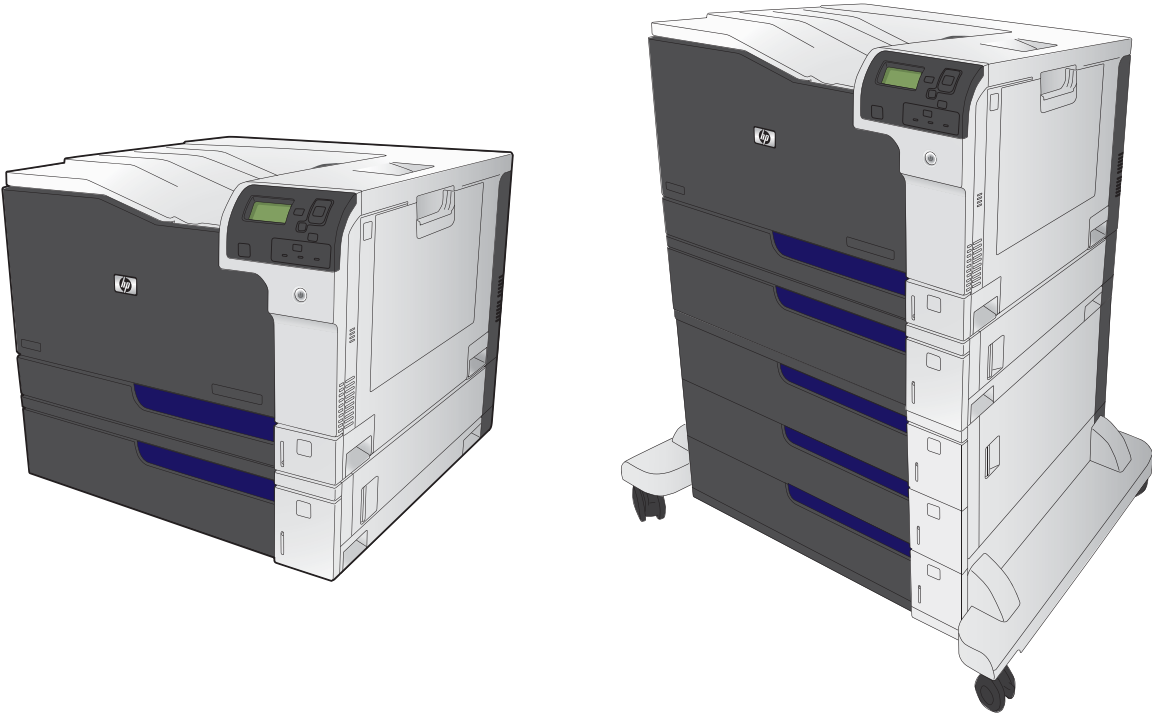

HP COLOR LASERJET ENTERPRISE CP5520

PRINTER SERIES

Service Manual





HP Color LaserJet Enterprise CP5520 Printer Series

Service Manual

Copyright and License

© 2010 Copyright Hewlett-Packard Development Company, L.P.

Reproduction, adaptation, or translation without prior written permission is prohibited, except as allowed under the copyright laws.

The information contained herein is subject to change without notice.

The only warranties for HP products and services are set forth in the express warranty statements accompanying such products and services. Nothing herein should be construed as constituting an additional warranty. HP shall not be liable for technical or editorial errors or omissions contained herein.

Part number: CE707-90935

Edition 1, 11/2010

Trademark Credits

Adobe®, Acrobat®, and PostScript® are trademarks of Adobe Systems Incorporated.

Corel® is a trademark or registered trademark of Corel Corporation or Corel Corporation Limited.

Microsoft®, Windows®, Windows® XP, and Windows Vista® are U.S. registered trademarks of Microsoft Corporation.

UNIX® is a registered trademark of The Open Group.

ENERGY STAR® and the ENERGY STAR® mark are registered U.S. marks.

Conventions used in this guide

 **TIP:** Tips provide helpful hints or shortcuts.

 **NOTE:** Notes provide important information to explain a concept or to complete a task.

 **CAUTION:** Cautions indicate procedures that you should follow to avoid losing data or damaging the product.

 **WARNING!** Warnings alert you to specific procedures that you should follow to avoid personal injury, catastrophic loss of data, or extensive damage to the product.

Table of contents

1 Theory of operation	1
Basic operation	2
Major product systems	2
Product block diagram	2
Sequence of operation	3
Normal sequence of operation	3
Formatter-control system	5
Sleep mode	5
Input/output	6
CPU	6
Memory	6
Firmware	6
Nonvolatile memory	6
P/L overview	6
PML	7
Control panel	7
Engine-control system	8
DC controller	9
Motors	12
Fans	14
Fuser-control circuit	15
Fuser temperature control	16
Fuser protective function	17
Fuser failure detection	18
Low-voltage power supply	19
Overcurrent/overvoltage protection	21
High-voltage power supply	22
Laser scanner system	24
Laser failure detection	25
Image-formation system	26
Electrophotographic process	26
Image formation process	28

Latent-image formation block	29
Pre-exposure	29
Primary charging	29
Laser beam exposure	30
Developing block	31
Transfer block	32
Primary transfer	32
Secondary transfer	32
Separation	33
Fusing block	33
ITB cleaning block	34
Drum cleaning block	34
Print cartridges	35
Memory tag	36
Cartridge presence detection	36
Toner level detection	36
Cartridge life detection	36
Developing unit engagement and disengagement control	36
ITB unit	38
Primary transfer roller engagement and disengagement control	39
ITB unit presence detection	40
ITB cleaning mechanism	40
Calibration	41
Color-misregistration control	42
Environment change control	43
Image stabilization control	43
Image density control (DMAX)	43
Image halftone control (DHALF)	43
Pickup, feed, and delivery system	44
Photo sensors	46
Motors and solenoids	47
Pickup and feed block	47
Tray 2 cassette pickup	48
Tray 2 cassette multiple-feed prevention	49
Tray 2 cassette media-size detection and Tray 2 cassette-presence detection ...	50
Tray 2 cassette lift-up operation	51
Cassette media-presence detection	53
Tray 1 (MP tray) paper pickup	53
Tray 1 (MP tray) last-paper detection	54
Paper feed	55
Skew-feed prevention	57

Media detection	58
Feed-speed control	59
Fusing and delivery block	59
Loop control	59
Pressure roller pressurization and depressurization control	61
Output bin full detection	62
Duplex block (duplex models only)	63
Duplex reverse and duplex feed control	63
Duplex operation	64
Jam detection	66
Paper feeder	68
Paper-feeder motors	69
Paper-feeder paper pickup and feed	70
Cassette media-size detection and cassette-presence detection	70
Paper-feeder cassette lift operation	71
Paper-feeder jam detection	72
Optional 3X500-sheet paper deck	73
Motor control	76
Pickup-and-feed operation	77
Cassette media-size detection and cassette-presence detection	78
Cassette lift-up operation	79
Jam detection	81
2 Removal and replacement	83
Introduction	84
Removal and replacement strategy	84
Electrostatic discharge	84
Required tools	85
Service approach	86
Before performing service	86
After performing service	86
Post-service test	86
Print-quality test	86
Removal and replacement procedures	87
Print cartridges	87
Toner-collection unit	91
Fuser	93
Reset the New Fuser Kit setting at the control panel	93
Pickup roller (Tray 1)	94
Separation pad (Tray 1)	95
Separation roller assembly (Tray 2)	97

Pickup roller (Tray 2)	98
Pickup roller, separation roller, and feed roller (1 x 500-sheet and 3 x 500-sheet paper feeders)	99
Secondary transfer roller	101
Intermediate transfer belt (ITB)	102
Reset the New Transfer Kit setting at the control panel	104
Formatter PCA	105
Hard Drive	107
Remove the encrypted HDD	108
Remove the solid-state hard drive	109
Covers	111
Identification and location	111
Right-front cover and control-panel assembly	113
Left cover	115
Rear cover	116
Remove the rear cover	116
Toner collection unit access door	117
Right-rear cover	119
Reinstall the right-rear cover	120
Top cover	121
Remove the top cover	121
Front-door assembly	123
Right-door assembly	126
Main assemblies	130
Formatter case	130
Remove the formatter case	130
Laser/scanner assembly	132
Remove the laser/scanner assembly	132
Paper pickup assembly	135
Remove the paper pickup assembly	135
Reinstall the paper pickup assembly	138
Registration sensor assembly	142
Remove the registration sensor assembly	142
Lifter-drive assembly	145
Remove the lifter-drive assembly	145
ITB front guide assembly	148
ITB rear guide assembly	151
Residual toner full sensor	152
Remove the residual toner full sensor	152
Main drive assembly	157
Remove the main drive assembly	157

Install the main drive assembly	167
Fuser drive assembly	172
Remove the fuser drive assembly	172
Install a replacement fuser drive assembly	174
Fuser gear assembly	176
Remove the fuser gear assembly	176
Install a replacement fuser gear assembly	182
Paper delivery assembly	184
Remove the delivery assembly	184
Reinstall the paper delivery assembly	185
Duplex drive assembly (duplex models)	187
Remove the duplex-drive assembly	187
Delivery drive assembly (simplex models)	189
Remove the delivery drive assembly	189
Residual-toner-feed assembly	190
Remove the residual-toner-feed assembly	190
ITB motor (M1)	192
Remove the ITB motor	192
Drum motor (M2)	194
Remove the drum motor	194
Developing motor (M3)	195
Remove the developing motor	195
Fuser motor (M4)	196
Remove the fuser motor	196
Developing-disengagement motor (M6)	197
Remove the developing-disengagement motor	197
Power-supply fan (FM1)	198
Remove the power-supply fan	198
Fuser fan (FM2)	201
Remove the fuser fan	201
Formatter fan (FM3) and ICB PCA	204
Remove the formatter fan and ICB PCA	204
DC controller PCA	207
Remove the DC controller PCA	207
Low-voltage power supply	209
Remove the low-voltage power supply	209
Imaging (developing) high-voltage power supply	213
Remove the imaging (developing) high-voltage power supply	213
First transfer high-voltage power supply	214
Remove the first transfer high-voltage power supply	214
Second transfer high-voltage power supply	216

Remove the second transfer high-voltage power supply	216
Driver PCA	218
Remove the driver PCA	218
Power switch PCA	220
Remove the power switch PCA	220
Environmental sensor	221
Remove the environmental sensor	221
1 x 500-sheet paper feeder assembly	222
1 x 500 rear cover	222
1 x 500 left cover	223
1 x 500 right-front cover	225
1 x 500 front-upper cover	226
1 x 500 right door	227
1 x 500 right-lower cover	229
1 x 500 pickup assembly	230
1 x 500 lifter-drive assembly	233
1 x 500 pickup motor	234
1 x 500 driver PCA	235
3 x 500-sheet paper feeder (optional accessory)	236
3 x 500 rear cover	236
3 x 500 right and left cassette rails	237
3 x 500 paper deck controller PCAs	238
3 x 500 paper deck lifter-drive assembly	239
3 x 500 paper deck pickup motor	240
3 x 500 front-lower cover	241
3 x 500 left cover	242
3 x 500 right-corner cover	243
3 x 500 front-upper cover	244
3 x 500 right-door assembly	245
3 x 500 right-lower cover 1	247
3 x 500 right-lower cover 2	248
3 x 500 left-lower cover	249
3 x 500 rear-lower cover	250
Remove the 3 x 500 rear-lower cover	250
3 x 500 paper deck pickup assembly	251
Remove the 3 x 500 paper deck pickup assembly	251

3 Solve problems 253

Solve problems checklist	254
Menu map	256
Current settings pages	256

Control panel menus	257
Sign In menu	257
Retrieve Job From USB menu	257
Retrieve Job From Device Memory menu	257
Supplies menu	258
Trays menu	260
Administration menu	261
Reports menu	261
General Settings menu	261
Retrieve From USB Settings menu	266
Print Settings menu	266
Print Options menu	267
Display Settings menu	269
Manage Supplies menu	270
Manage Trays menu	271
Network Settings menu	272
Troubleshooting menu	275
Device Maintenance menu	276
Backup/Restore menu	276
Calibration/Cleaning menu	277
USB Firmware Upgrade menu	277
Service menu	278
Troubleshooting process	279
Determine the problem source	279
Pre-troubleshooting checklist	279
Troubleshooting flowchart	280
Power subsystem	282
Power-on checks	282
Power-on troubleshooting overview	282
Tools for troubleshooting	284
Component diagnostics	284
LED diagnostics	284
Understand lights on the formatter	284
Engine diagnostics	285
Defeating interlocks	286
Disable cartridge check	287
Engine test button	288
Paper-path test	288
Manual sensor test	289
Front-door opening/closing switch (PS14)	291
Right-door opening/closing sensor (PS15)	292

TOP (top-of-page) sensor (PS5)	294
Fuser loop sensors 1 and 2 (PS7 and PS8)	295
Fuser pressure-release sensor (PS9)	296
Fuser output sensor (PS6)	297
Developer alienation sensor (PS11)	298
ITB alienation switch (SW5)	299
Tray/Bin manual sensor test	300
Tray 1 paper sensor (PS2)	302
Tray 2 paper present sensor (PS1)	303
Tray 2 paper surface sensor (PS4)	304
Tray 2 paper size switches (SW7 and SW8)	305
Tray 3 paper sensor (SR3)	306
Tray 3 paper surface sensor (SR2)	307
Tray 3 paper size sensors (SW2 and SW3)	308
Tray 3 feed sensor (SR1)	309
Tray 3 door opening/closing sensor (SW1)	310
Tray 4 paper sensor (SR3)	311
Tray 4 paper surface sensor (SR2)	311
Tray 4 paper size sensors (SW2 and SW3)	311
Tray 4 feed sensor (SR1)	311
Tray 4 door opening/closing door sensor (SW1)	311
Tray 5 paper sensor (SR83)	312
Tray 5 paper surface sensor (SR82)	312
Tray 5 paper size sensors (SW82 and SW83)	312
Tray 5 feed sensor (SR81)	312
Tray 5 door opening/closing sensor (SW1)	312
Tray 6 paper sensor (SR93)	312
Tray 6 paper surface sensor (SR92)	312
Tray 6 paper size sensors (SW92 and SW93)	312
Tray 6 feed sensor (SR91)	312
Tray 6 door opening/closing sensor (SW1)	312
Output-bin-full sensor (PS10)	313
Paper-path sensors test	313
Print/stop test	314
Component tests	314
Component test (special-mode test)	314
Additional component tests	317
Diagrams	319
Block diagrams	319
Plug/jack locations	321
Location of connectors	322

DC controller connections	322
Product connections	324
Locations of major components	331
General timing charts	338
General circuit diagram	340
Internal print-quality test pages	344
Print-quality-troubleshooting pages	344
Diagnostics page	347
Clean the paper path	349
Set up an auto cleaning page	349
Configuration page	350
Configuration page	350
HP embedded Jetdirect page	352
Finding important information on the configuration pages	353
Color-band test	354
Print quality troubleshooting tools	355
Repetitive image-defect ruler	355
Calibrate the product	356
Control panel menus	356
Sign In menu	357
Retrieve Job From USB menu	358
Retrieve Job From Device Memory menu	359
Supplies menu	360
Trays menu	363
Administration menu	365
Reports menu	365
General Settings menu	367
Retrieve From USB Settings menu	380
Print Settings menu	380
Print Options menu	382
Display Settings menu	384
Manage Supplies menu	385
Manage Trays menu	388
Network Settings menu	391
Troubleshooting menu	401
Device Maintenance menu	406
Backup/Restore menu	406
Calibration/Cleaning menu	407
USB Firmware Upgrade menu	408
Service menu	409
Interpret control-panel messages, status-alert messages, and event code errors	411

10.0X.Y0 Supply memory error	411
10.22.50	412
10.22.51	412
10.22.52	412
10.23.50	412
10.23.51	413
10.23.52	413
10.23.70 Printing past very low	413
10.XX.34 Used supply in use	414
10.XX.40 Genuine HP supplies installed	414
10.XX.41 Unsupported supply in use	415
10.XX.70 Printing past very low	415
10.YY.15 Install <supply>	416
10.YY.25 Wrong cartridge in <color> slot	416
10.YY.35 Incompatible <supply>	417
11.00.YY Internal clock error	418
13.00.00	418
13.A3.FF	418
13.D3.DZ	418
13.WX.EE	419
13.WX.FF	419
13.WX.YZ Fuser area jam	420
13.WX.YZ Fuser wrap jam	421
13.WX.YZ Jam below control panel	422
13.WX.YZ Jam in lower right door	422
13.WX.YZ Jam in middle right door	423
13.WX.YZ Jam in right door	423
13.WX.YZ Jam in Tray 1	424
13.WX.YZ Jam in Tray <X>	424
20.00.00 Insufficient memory To continue, press OK	425
21.00.00 Page too complex	425
32.1C.XX	425
32.21.00	430
40.00.01 USB I/O buffer overflow To continue, press OK	430
40.00.02 Embedded I/O buffer overflow To continue, press OK	430
40.00.03 EIO buffer overflow To continue, press OK	430
40.00.04 Unsupported USB accessory detected To continue, press OK	430
40.00.05 Embedded I/O bad transmission To continue, press OK	431
41.02.00 Error	431
41.03.YZ Unexpected size in tray <X>	431
41.05.YZ Unexpected type in tray <X>	432

41.07.YZ Error To continue, press OK	434
42.XX.YY	436
47.00.XX	436
47.01.XX	436
47.02.XX	436
47.03.XX	437
47.04.XX	437
47.05.00	437
47.06.XX	437
47.WX.YZ Printer calibration error To continue, press OK	437
50.WX.YZ Fuser error To continue, turn off then on	439
51.00.YY Error	442
52.XX.00 Error To continue, turn off then on	442
54.XX.YY Error	443
55.00.YY DC controller error To continue, turn off then on	445
55.0X.YY DC controller error To continue, turn off then on	446
56.00.YY Error To continue, turn off then on	446
57.00.0Y Error To continue, turn off then on	446
59.00.YY Error To continue, turn off then on	447
59.0X.50 Error To continue, turn off then on	448
59.0X.60 Error To continue, turn off then on	449
59.0X.70 Error To continue, turn off then on	449
59.0X.80 Error To continue, turn off then on	449
60.00.0Y Tray <Y> lifting error	450
61.00.01	451
62.00.00 No system To continue, turn off then on	452
70.00.00 Error To continue, turn off then on	452
80.0X.YY Embedded JetDirect error	452
98.00.01 Corrupt data in firmware volume	454
98.00.02 Corrupt data in solutions volume	454
98.00.03 Corrupt data in configuration volume	454
98.00.04 Corrupt data in job data volume	454
99.00.01 Upgrade not performed file is corrupt	455
99.00.02 Upgrade not performed timeout during receive	455
99.00.03 Upgrade not performed error writing to disk	455
99.00.04 Upgrade not performed timeout during receive	455
99.00.05 Upgrade not performed timeout during receive	456
99.00.06 Upgrade not performed error reading upgrade	456
99.00.07 Upgrade not performed error reading upgrade	456
99.00.08 Upgrade not performed error reading upgrade	456
99.00.09 Upgrade canceled by user	457

99.00.10 Upgrade canceled by user	457
99.00.11 Upgrade canceled by user	457
99.00.12 Upgrade not performed the file is invalid	457
99.00.13 Upgrade not performed the file is invalid	458
99.00.14 Upgrade not performed the file is invalid	458
99.00.2X	458
99.09.60 Unsupported disk	459
99.09.61 Unsupported disk	459
99.09.62 Unknown disk	459
99.09.63 Incorrect disk	460
99.09.64 Disk malfunction	460
99.09.65 Disk data error	460
99.09.66 No disk data installed	460
99.09.67 Disk is not bootable please download firmware	460
99.XX.YY	461
<Binname> Full Remove all paper from bin	461
<Supply> almost full	461
<Supply> low OR Supplies low	461
<Supply>very low OR Supplies very low	462
<Tray X> lifting	463
[File System] device failure To clear, press OK	464
[File System] file operation failed To clear, press OK	464
[File System] file system is full To clear, press OK	464
[File System] is not initialized	464
[File System] is write protected	464
Accept bad signature	464
Bad optional tray connection	465
Calibration reset pending	465
Canceling	465
Canceling... <jobname>	465
Checking engine	466
Checking paper path	466
Chosen personality not available To continue, press OK	466
Cleaning do not grab paper	466
Cleaning... ..	466
Clearing event log	467
Clearing paper path	467
Close front door	467
Close lower right door	467
Close middle right door	468
Close right door	468

Close upper right door For help press ?	468
Cooling device	468
Creating cleaning page	469
Data received To print last page, press OK	469
EIO <X> disk initializing	469
EIO <X> disk not functional	469
EIO <X> disk spinning up	470
Event log is empty	470
Expected drive missing	470
HP Secure Hard Drive disabled	470
Incompatible <supply>	471
Incompatible supplies	471
Initializing...	471
Install <supply>	472
Install <supply> Close rear door	472
Install Fuser Unit	472
Install supplies	473
Install Transfer Unit	473
Internal disk not functional	473
Internal disk spinning up	474
Load Tray <X>: [Type], [Size]	474
Load Tray <X>: [Type], [Size] To use another tray, press OK	475
Loading program <XX> Do not power off	475
Manually feed output stack Then press OK to print second sides	475
Manually feed: [Type], [Size]	475
Manually feed: [Type], [Size] To use another tray, press OK	476
Moving solenoid	476
Moving solenoid and motor	476
No job to cancel	476
Paused	477
Performing Color Band Test...	477
Performing Paper Path Test...	477
Please wait...	477
Printing CMYK samples...	477
Printing Color Usage Log...	478
Printing Configuration...	478
Printing Demo Page...	478
Printing Diagnostics Page...	478
Printing Engine Test...	478
Printing Event Log...	478
Printing File Directory...	479

Printing Font List...	479
Printing Fuser Test Page...	479
Printing Help Page...	479
Printing Menu Map...	479
Printing PQ Troubleshooting...	480
Printing Registration Page...	480
Printing RGB Samples...	480
Printing stopped	480
Printing Supplies Status Page...	480
Printing Usage Page...	480
Processing duplex job Do not grab paper until job completes	481
Processing job from tray <X>... Do not grab paper until job completes	481
Processing... <filename>	481
Processing... copy <X> of <Y>	481
Ready	482
Ready <IP Address>	482
Remove all print cartridges	482
Remove at least one print cartridge	482
Remove shipping lock from Tray 2	482
Replace <supply>	483
Replace supplies	484
Restore Factory Settings	484
Restricted from printing in color	485
Rotating <color> motor	485
Rotating motor	485
Size mismatch in Tray <X>	485
Sleep mode on	486
Supplies in wrong positions	486
Tray <X> empty: [Type], [Size]	486
Tray <X> open	487
Tray <X> overfilled	488
Troubleshooting	488
Type mismatch Tray <X>	488
Unsupported drive installed To continue, press OK	489
Unsupported supply in use OR Unsupported supply installed To continue, press OK	489
Unsupported tray configuration	490
Unsupported USB accessory detected Remove USB accessory	490
USB accessory needs too much power Remove USB and turn off then on	490
USB accessory not functional	490
Used supply installed To continue, press OK OR Used supply in use	491

Wrong cartridge in <color> slot	491
Event-log messages	492
Print an event log	493
View an event log	493
Clear an event log	494
Clear jams	495
Common causes of jams	495
Jam locations	496
Clear jams in the upper-right door	501
Clear jams in the lower-right door	503
Clear jams in Tray 1	504
Clear jams from Tray 2, Tray 3, or an optional tray	506
Clear jams in the output bin area	507
Jam causes and solutions	508
Jams in the output bin	508
Jams in the fuser and transfer area	508
Jams in the duplex area (duplex models only)	509
Jams in Tray 1, Tray 2 and internal paper path	510
Jams in Tray 3, 4, 5, and 6	513
Change jam recovery	515
Solve paper-handling problems	516
Product feeds multiple sheets	516
Product feeds incorrect page size	516
Product pulls from incorrect tray	517
Paper does not feed automatically	517
Paper does not feed from Tray 2, 3, 4, 5, or 6	517
Transparencies or glossy paper will not feed	518
Envelopes jam or will not feed in the product	519
Output is curled or wrinkled	519
Product will not duplex or duplexes incorrectly	520
Use manual print modes	521
Solve image-quality problems	524
Print quality examples	524
Clean the product	531
Clean the paper path	531
Set up an auto cleaning page	531
Solve performance problems	532
Solve connectivity problems	533
Solve direct-connect problems	533
Solve network problems	533
Service mode functions	534

Service menu	534
Product resets	536
Restore factory-set defaults	536
Clean Disk and Partial Clean functions	537
Active and repository firmware locations	537
Partial Clean	537
Execute a Partial Clean	538
Clean Disk	538
Execute a Clean Disk	539
Preboot menu options	540
Product updates	547
Determine the installed revision of firmware	547
Perform a firmware upgrade	547
Embedded Web Server	547
USB storage device (Preboot menu)	548
USB storage device (control-panel menu)	549
4 Parts and diagrams	551
Order parts by authorized service providers	552
Order parts, accessories, and supplies	552
Related documentation and software	552
Supplies part numbers	553
Customer self repair parts	553
Service replacement parts	555
Accessories part numbers	557
How to use the parts lists and diagrams	558
Assembly locations	559
External covers, panels, and doors	560
Right door assembly	562
Internal components (1 of 9)	564
Internal components (2 of 9)	566
Internal components (3 of 9)	568
Internal components (4 of 9)	570
Internal components (5 of 9)	572
Internal components (6 of 9)	574
Internal components (7 of 9)	576
Internal components (8 of 9)	578
Internal components (9 of 9)	580
1x250 cassette	582
Paper pick-up assembly	584
Paper delivery assembly	586

Printed circuit assemblies	588
1x500 paper feeder	590
1x500PF external components	590
1x500PF internal components	592
1x500PF PCA	594
3x500 paper feeder	596
3x500PF external components	596
3x500PF internal components	598
3x500PF cassette	600
3x500PF PCAs	602
Alphabetical parts list	604
Numerical parts list	617

Appendix A Service and support 631

Hewlett-Packard limited warranty statement	632
HP's Premium Protection Warranty: LaserJet print cartridge limited warranty statement	633
Color LaserJet Fuser Kit, Transfer Kit, and Toner Collection Unit Limited Warranty Statement	634
Data stored on the print cartridge	635
End User License Agreement	636
Customer self-repair warranty service	638
Customer support	639

Appendix B Product specifications 641

Physical specifications	642
Power consumption, electrical specifications, and acoustic emissions	642
Environmental specifications	642

Appendix C Regulatory information 643

FCC regulations	644
Environmental product stewardship program	645
Protecting the environment	645
Ozone production	645
Power consumption	645
Paper use	645
Plastics	645
HP LaserJet print supplies	645
Return and recycling instructions	646
United States and Puerto Rico	646
Multiple returns (more than one cartridge)	646
Single returns	646

Shipping	646
Non-U.S. returns	646
Paper	647
Material restrictions	647
Disposal of waste equipment by users in private households in the European Union	647
Chemical substances	648
Material Safety Data Sheet (MSDS)	648
For more information	648
Declaration of Conformity	649
Certificate of Volatility	651
Types of memory	651
Volatile memory	651
Non-volatile memory	651
Hard-disk-drive memory	651
Safety statements	652
Laser safety	652
Canadian DOC regulations	652
VCCI statement (Japan)	652
Power cord instructions	652
Power cord statement (Japan)	652
EMC statement (China)	653
EMC statement (Korea)	653
EMI statement (Taiwan)	653
Laser statement for Finland	653
GS statement (Germany)	654
Substances Table (China)	654
Restriction on Hazardous Substances statement (Turkey)	654
Index	655

1 Theory of operation

- [Basic operation](#)
- [Formatter-control system](#)
- [Engine-control system](#)
- [Image-formation system](#)
- [Pickup, feed, and delivery system](#)
- [Paper feeder](#)
- [Optional 3X500-sheet paper deck](#)

Basic operation

Major product systems

The product contains the following five systems:

- Engine-control system
- Laser scanner system
- Image-formation system
- Media feed system
- Optional paper feeder system

Product block diagram

Figure 1-1 Product block diagram

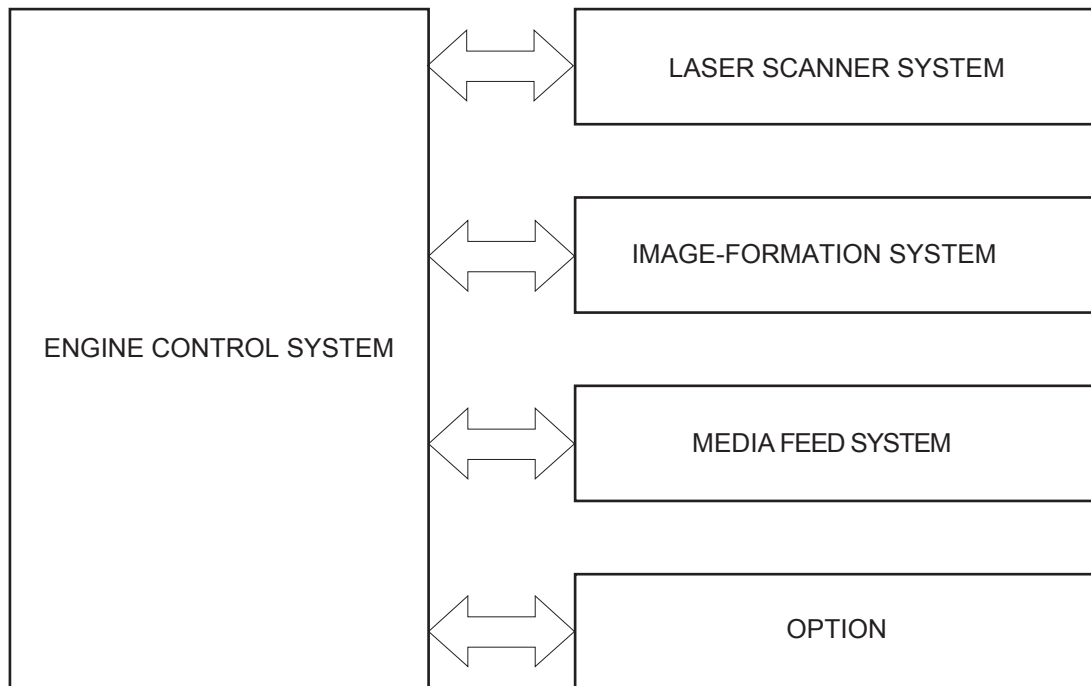

Sequence of operation

The DC controller in the engine-control system controls the operational sequences of the product. The following table describes durations and operations for each period of a print operation from the time the product is turned on until the motor stops rotating.

Normal sequence of operation

Table 1-1 Sequence of operation

Name	Timing	Purpose
WAIT	From the time the power switch is turned on, the door is closed, or the product exits Sleep mode, until the product is ready for a print operation.	Brings the product to printable condition: <ul style="list-style-type: none">• Detects and heats the fuser• Detects the print cartridge and any cartridge changes• Detects the ITB, and moves the ITB and the developing unit to the home position• Cleans residual toner from the intermediate transfer belt (ITB) and the secondary transfer roller
STBY (standby)	From the end of the WAIT or LSTR period until either a print command is sent or the power switch is turned off.	Maintains the product in printable condition: <ul style="list-style-type: none">• Enters Sleep mode if the sleep command is received• Performs a calibration if the calibration command is received
INTR (initial rotation)	From the time the print command is received until the product picks up a piece of paper.	Prepares for the print job <ul style="list-style-type: none">• Activates the high-voltage power supply• Activates the laser scanner• Opens the laser shutter• Cleans the protective laser glass• Engages the print cartridges• Warms the fuser

Table 1-1 Sequence of operation (continued)

Name	Timing	Purpose
PRINT	From the end of the INTR period until the last sheet completes the fusing operation.	<p>Prints</p> <ul style="list-style-type: none">• Forms the image on the photosensitive drum• Transfers the toner image to the paper• Fuses the toner image to the paper
LSTR (last rotation)	From the end of the PRINT period until the main motor stops rotating.	<p>Moves the last printed sheet to the output bin.</p> <ul style="list-style-type: none">• Stops the high-voltage power supply• Stops the laser scanner• Closes the laser shutter• Cleans the protective laser glass• Disengages the print cartridges• Stops the fuser <p>The product enters the INTR period as the LSTR period is completed, if the formatter sends another print command.</p>

Formatter-control system

The formatter is responsible for the following procedures:

- Controlling sleep mode
- Receiving and processing print data from the various product interfaces
- Monitoring control-panel functions and relaying product-status information (through the control panel and the network or bidirectional interface)
- Developing and coordinating data placement and timing with the DC controller PCA
- Storing font information
- Communicating with the host computer through the network or the bidirectional interface

The formatter receives a print job from the network or bidirectional interface and separates it into image information and instructions that control the printing process. The DC controller PCA synchronizes the image-formation system with the paper-input and -output systems, and then signals the formatter to send the print-image data.

The formatter also provides the electrical interface and mounting locations for an additional DIMM.

Sleep mode

 **NOTE:** In the **Display Settings** menu (a sub menu of the **Administration** menu), this item is termed **Sleep Mode**.

This feature conserves power after the product has been idle for an adjustable period of time. When the product is in **Sleep Mode**, the control-panel backlight is turned off, but the product retains all settings, downloaded fonts, and macros. The default setting is for **Sleep Mode** to be enabled, and the product enters **Sleep Mode** after a 15-minute idle time.

The product exits **Sleep Mode** and enters the warm-up cycle when any of the following events occur:

- A print job, valid data, or a PML or PJJL command is received
- A control-panel button is pressed
- A cover is opened
- A paper tray is opened
- The engine-test switch is pressed

 **NOTE:** Product error messages override the Sleep message. The product enters **Sleep Mode** at the appropriate time, but the error message continues to appear.

Input/output

The product has three I/O interfaces:

- USB 2.0 port for connecting directly to a computer
- Internal 10/100Base-T network port
- Walk-up USB port

CPU

The formatter incorporates a 800 MHz Vermillion processor.

Memory

The random access memory (RAM) on the formatter printed circuit assembly (PCA) contains the page, I/O buffers, and the font storage area. It stores printing and font information received from the host system, and can also serve to temporarily store a full page of print-image data before the data is sent to the print engine.

 **NOTE:** If the product encounters a problem when managing available memory, a clearable warning message appears on the control-panel display.

Firmware

The firmware is contained in the internal solid state drive (SSD) or hard disk (HD). A remote firmware upgrade process is used to overwrite and upgrade the firmware on the SSD or HD.

Nonvolatile memory

The product uses nonvolatile memory (NVRAM) to store device and user configuration settings. The contents of NVRAM are retained when the product is turned off or disconnected.

PJL overview

The printer job language (PJL) is an integral part of configuration, in addition to the standard printer command language (PCL). With standard cabling, the product can use PJL to perform a variety of functions.

- Two-way communication with the host computer through a network connection or a USB connection. The product can inform the host about the control-panel settings which can be changed from the host.
- Dynamic I/O switching. The product uses this switching to be configured with a host on each I/O. The product can receive data from more than one I/O simultaneously, until the I/O buffer is full. This can occur even when the product is offline.

- Context-sensitive switching. The product can automatically recognize the personality (PS or PCL) of each job and configure itself to serve that personality.
- Isolation of print environment settings from one print job to the next. For example, if a print job is sent to the product in landscape mode, the subsequent print jobs print in landscape mode only if they are formatted for landscape printing.

PML

The printer management language (PML) allows remote configuration and status read-back through the I/O ports.

Control panel

The formatter sends and receives product status and command data to and from the control-panel PCA.

Engine-control system

The engine-control system coordinates all product functions, according to commands that the formatter sends. The engine-control system drives the laser/scanner system, the image formation system, and the pickup/feed/delivery system.

The engine control system contains the following major components:

- DC controller
- Low-voltage power supply
- High-voltage power supply

Figure 1-2 Engine-control system

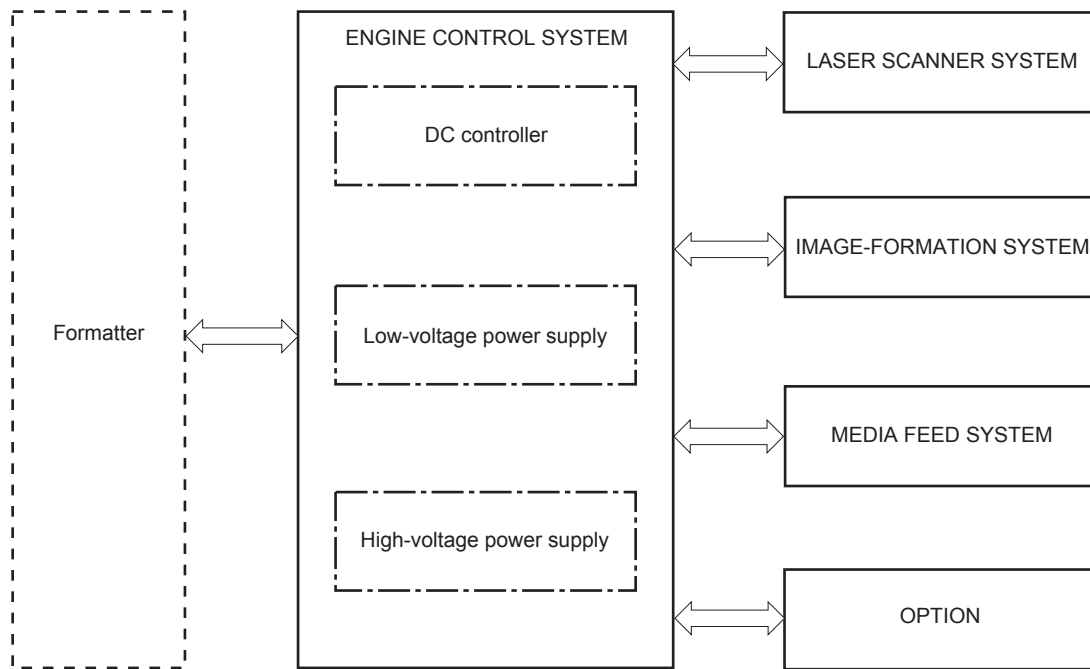

DC controller

The DC controller controls the operational sequence of the product.

Figure 1-3 DC controller diagram

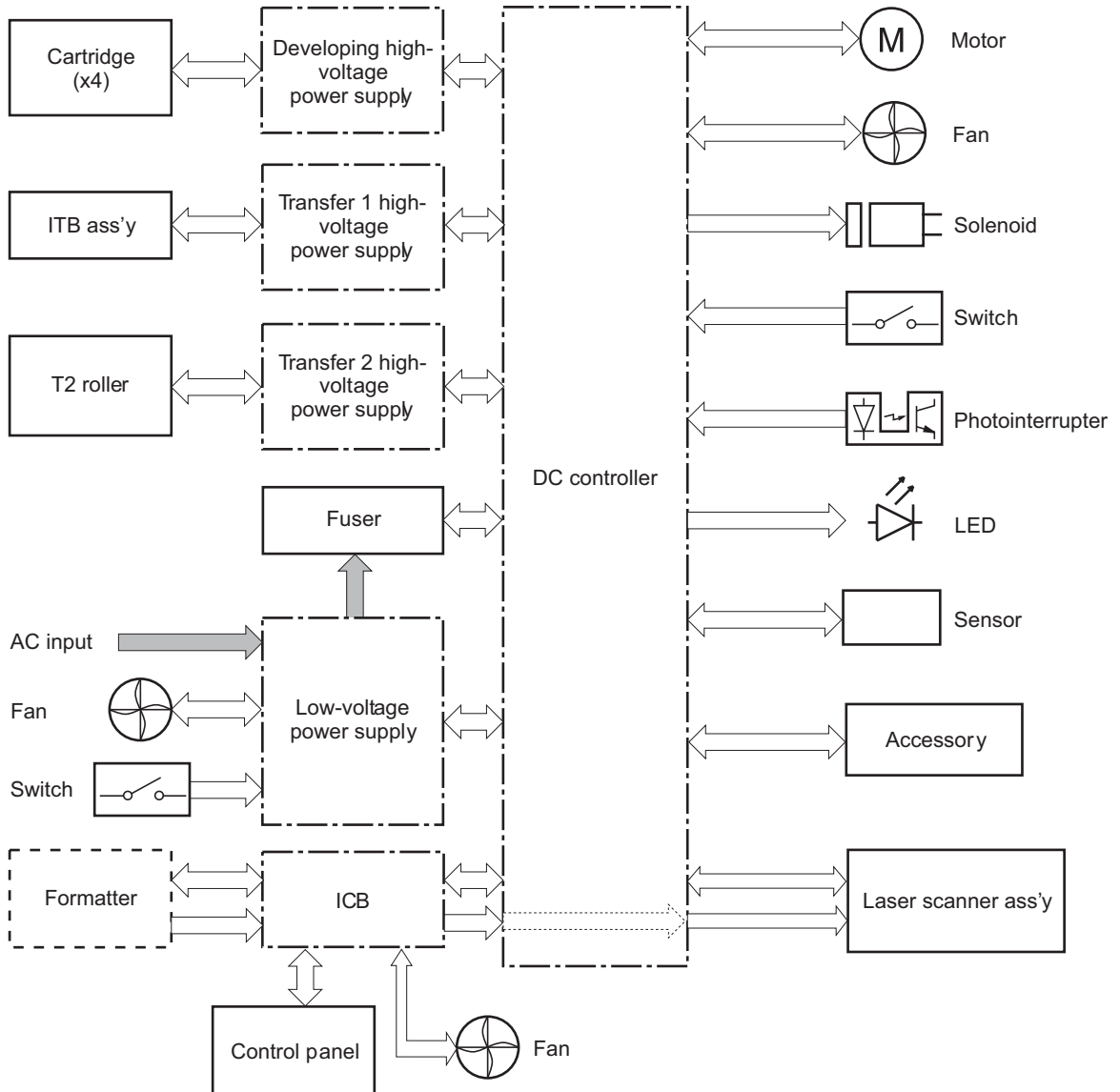

The DC controller controls the product's electrical components, listed in the following table.

Table 1-2 Electrical components

Component type	Abbreviation	Name
Switch	SW1	Power switch
	SW2	24V interlock switch
	SW3	5V interlock switch 1
	SW4	5V interlock switch 2
	SW5	Primary transfer disengagement switch
	SW6	Toner collection unit switch
	SW7	Tray 2 cassette media end guide position switch
	SW8	Tray 2 cassette media width guide position switch
Solenoid	SL1	Tray 2 cassette pickup solenoid
	SL2	Tray 1 pickup solenoid
	SL3	Duplex reverse solenoid 1 (duplex models only)
	SL5	Primary transfer disengagement solenoid
	SL7	Duplex reverse solenoid 2 (duplex models only)
Fan	FM1	Power supply fan
	FM2	Fuser fan
	FM3	Formatter fan
Photointerrupter (sensor)	PS1	Tray 2 cassette paper-presence sensor
	PS2	Tray 1 paper-presence sensor
	PS3	Last-paper sensor
	PS4	Tray 2 cassette paper-stack surface sensor
	PS5	Top-of-page (TOP) sensor
	PS6	Fuser delivery sensor
	PS7	Loop sensor 1
	PS8	Loop sensor 2
	PS9	Fuser pressure-release sensor
	PS10	Output bin full sensor
	PS11	Developing disengagement sensor
	PS12	Black drum home-position sensor
	PS13	YMC drum home-position sensor
	PS14	Front door sensor
	PS15	Right door sensor

Table 1-2 Electrical components (continued)

Component type	Abbreviation	Name
Motor	M1	ITB Motor
	M2	Drum motor
	M3	Developing motor
	M4	Fuser motor
	M5	Pickup motor
	M6	Developing disengagement motor
	M7	Duplex reverse motor (duplex model only)
	M8	Duplex feed motor (duplex model only)
M9	Tray 2 cassette lifter motor	
M10	Scanner motor	

Motors

The product has ten motors for paper feed and image formation. The DC controller determines there is a motor failure if a motor does not reach a specified speed within a specified period after motor startup, or if the rotational speed is outside a specified range for a specified period.

Figure 1-4 Motors

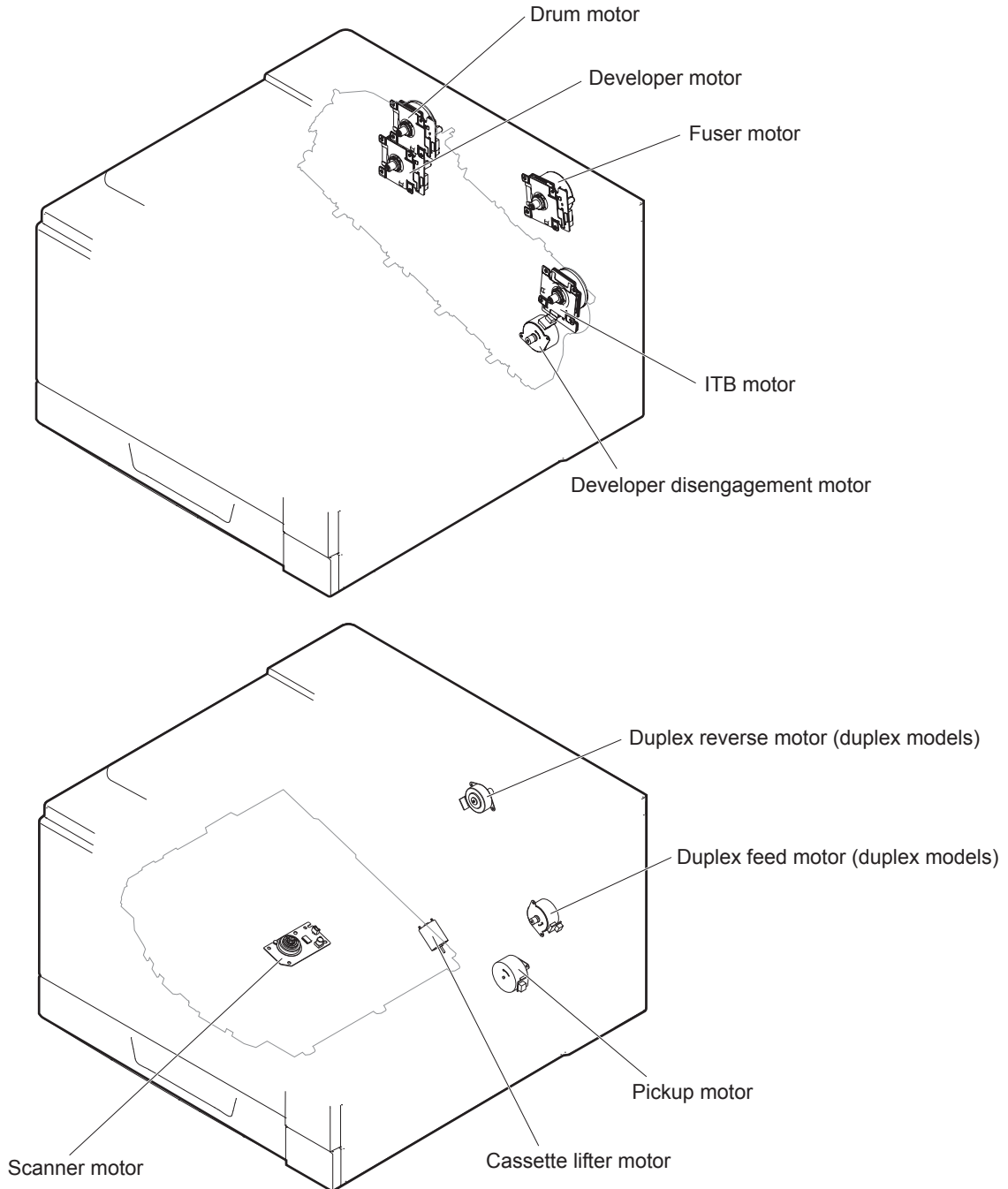

Table 1-3 Motors

Description	Components driven	Failure detection
ITB motor (M1)	ITB Black photosensitive drum Black developing roller	Yes
Drum motor (M2)	Yellow, magenta, and cyan photosensitive drums	Yes
Developing motor (M3)	Yellow, magenta, and cyan developing rollers	Yes
Fuser motor (M4)	Fuser pressure and delivery rollers Pressurizes and depressurizes the pressure roller Engages and disengages the primary transfer roller	Yes
Pickup motor (M5)	Tray 1 pickup roller Tray 2 cassette pickup roller Feed roller	No
Developing disengagement motor (M6)	Engages and disengages the developing unit	No
Duplex reverse motor (M7; duplex models only)	Duplex reverse roller	No
Duplex feed motor (M8; duplex models only)	Duplex feed roller	No
Tray 2 cassette lifter motor (M9)	Lifter for the Tray 2 cassette	No
Scanner motor (M10)	Scanner mirror	No

Fans

The product uses three fans to maintain the correct internal temperature. The DC controller determines a fan failure when a fan locks for a specified period after it starts driving.

Figure 1-5 Fans

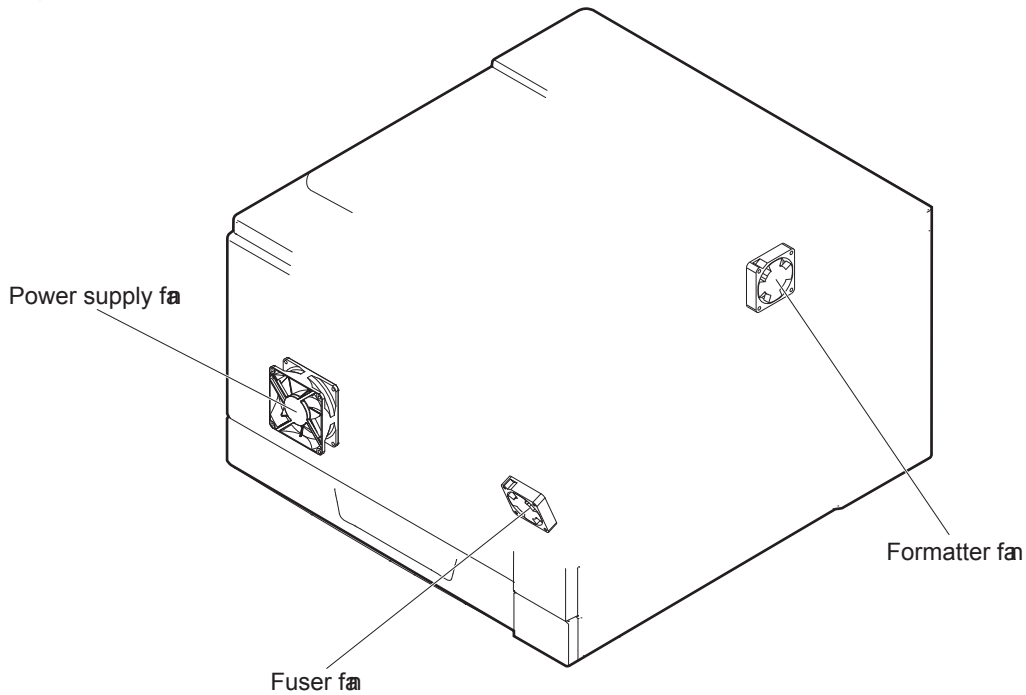

Table 1-4 Fans

Description	Area cooled	Type	Speed
Power supply fan (FM1)	Low-voltage power supply Output bin Delivery unit Laser scanner unit	Intake	Full/Half
Fuser (FM2)	Duplex feed unit ITB area	Intake	Full
Formatter (FM3)	Formatter area	Intake	Controlled by the formatter

Fuser-control circuit

The fuser-control circuit monitors and controls the temperature in the fuser. The product uses on-demand fusing. The fuser-control circuit consists of the following major components:

- Fuser main heater (H1): Heats the center of the fuser sleeve
- Fuser sub heater (H2): Heats the ends of the fuser sleeve
- Thermistors; detect the fuser temperature (contact type)
 - Sleeve thermistor (TH1): Detects the temperature at the center of the fuser sleeve
 - Main thermistor (TH2): Detects the temperature at the center of the fuser heater
 - Sub thermistor 1 (TH3): Detects the temperature at the end of the fuser heater nearest the front of the product
 - Sub thermistor 2 (TH4): Detects the temperature at the end of the fuser heater nearest the rear of the product
- Thermal fuse (FU1): Prevents abnormal temperature rise in the fuser heater (non-contact type)

Figure 1-6 Fuser-control circuit

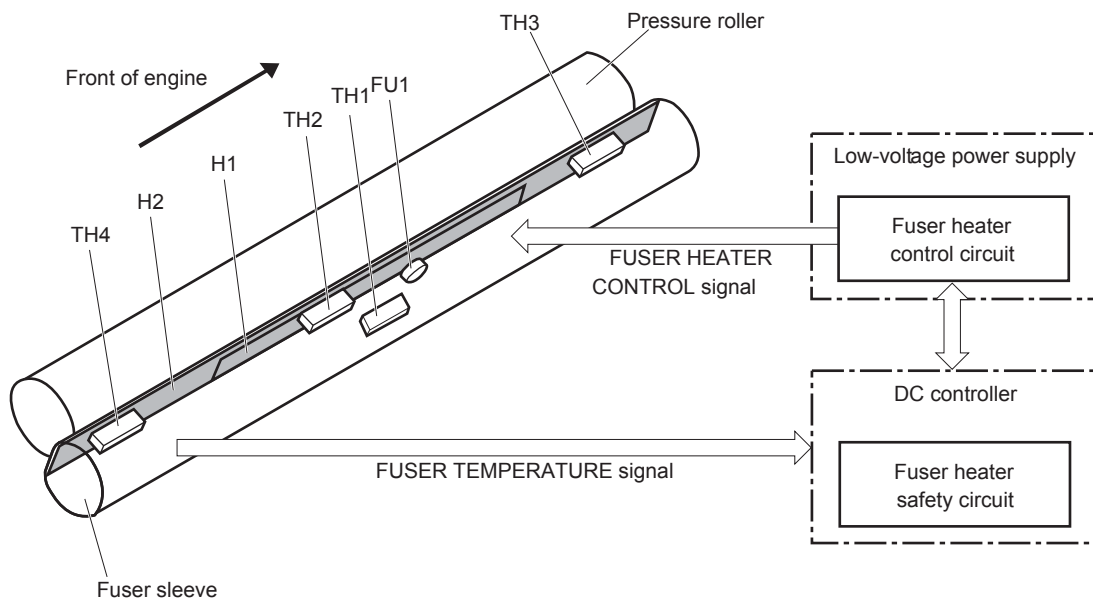

Fuser temperature control

The fuser temperature control maintains the fuser heater at its targeted temperature.

The fuser main heater and sub heater control the temperature of the fuser sleeve.

The DC controller monitors the main thermistor and the sleeve thermistor. The DC controller controls the FUSER MAIN HEATER CONTROL (FSRD1) and the FUSER SUB-HEATER CONTROL (FSRD2) signals according to the detected temperature. The fuser-heater control circuit controls the fuser heater depending on the signal so that the heater remains at the targeted temperature.

Figure 1-7 Fuser-heater control circuit

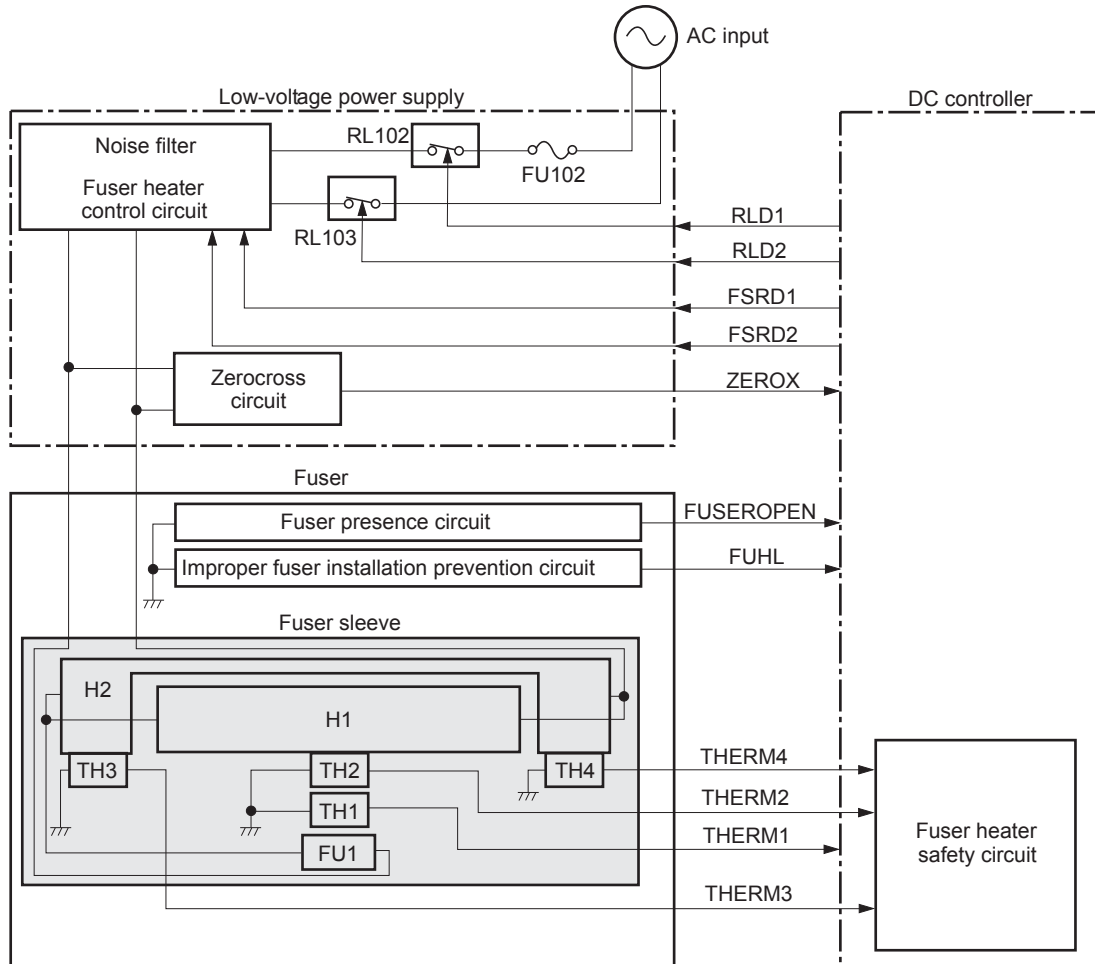

Fuser protective function

The protective function detects an abnormal temperature rise of the fuser unit and interrupts power supply to the fuser heater.

The following three protective components prevent an abnormal temperature rise of the fuser heater:

- DC controller
 - The DC controller interrupts power supply to the fuser heater when it detects an abnormal temperature of the fuser heater.
- Fuser-heater safety circuit
 - The fuser heater safety circuit interrupts power supply to the fuser heater when the detected temperature of the main and sub thermistors is abnormal.
- Thermal fuse
 - The thermal fuse is broken to interrupt power supply to the fuser heater when the thermostitch detects an abnormal temperature of the fuser heater.
 - The current detection circuit detects the current value flowing in the fuser heater control circuit. The DC controller deactivates the FUSER HEATER CONTROL signal and releases the relay to interrupt power supply to the fuser heater when it detects a specified current value or higher by the CURRENT DETECTION (FUR_CURRMS) signal.

Fuser failure detection

The DC controller determines a fuser unit failure, deactivates the FUSER HEATER CONTROL signal, releases the relay to interrupt power supply to the fuser heater, and then notifies the formatter of a failure state when it encounters the following conditions:

- Abnormal temperature rise: The sleeve thermistor does not rise at a specified temperature within a specified period after the fuser heater control starts.
- Abnormally low temperature: The thermistors are at a specified temperature or lower during a print operation or other fuser heating cycle.
- Abnormally high temperature: The thermistors are at a specified temperature or higher, regardless of the fuser control status.
- Drive circuit abnormality: The frequency in the zerocross circuit is out of a specified range when the product is turned on or is in the standby period.

Low-voltage power supply

The low-voltage power supply (LVPS) converts AC input voltage to DC voltage.

Figure 1-8 Low-voltage power supply

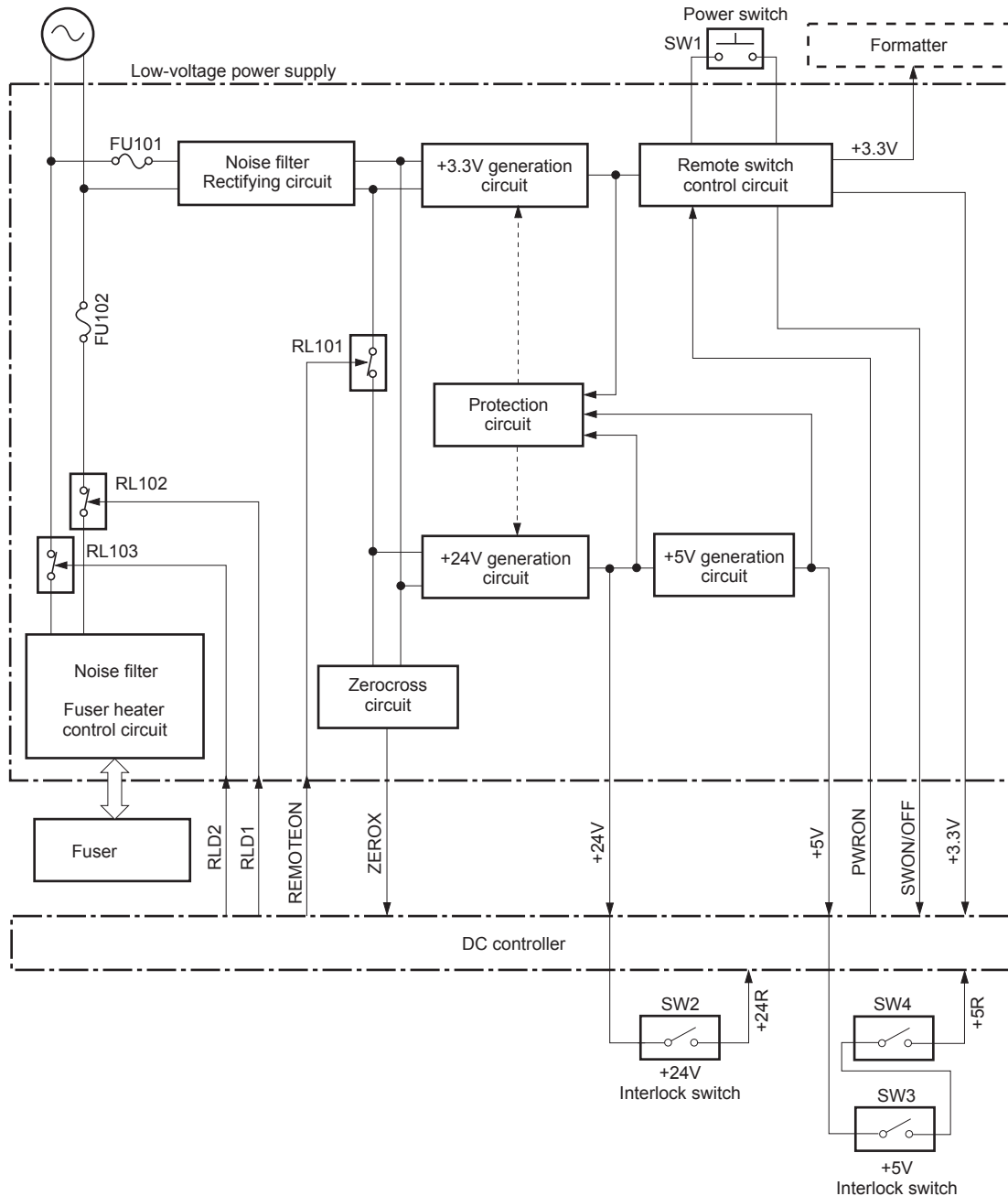

The product uses three DC voltages: 24V, 5V, and 3.3V. The voltages are subdivided as follows:

+24V	Supplied constantly
	Stopped during Sleep mode
+24R	Interrupted when the front or right door is opened

+5V	Supplied constantly Stopped during Sleep mode
+5R	Interrupted when the front or right door is opened
+3.3V	Supplied constantly

Overcurrent/overvoltage protection

The low-voltage power supply has a protective circuit against overcurrent and overvoltage to prevent failures in the power supply circuit. The low-voltage power supply automatically stops supplying the DC voltage whenever excessive current flows or voltage abnormally increases.

If the dc voltage is not being supplied from the low-voltage power supply, the protective function may be running. In this case, turn off the power switch and unplug the power cord. Do not turn the power switch on until the root cause is found.

The LVPS has two fuses on the PCA. The LVPS 24V output is interrupted to the fuser and the high-voltage power supply if the either of the interlock switches (SW3 and SW4) is in the off position (door open).

⚠ **WARNING!** The product power switch only interrupts dc voltage from the LVPS. The AC voltage is present in the product when the power cord is plugged into a power receptacle and the power switch is in the off position. You must unplug the product power cord before servicing the product.

WARNING! If you believe the overcurrent or overvoltage protection circuits have been activated, do not plug in the product power cord or turn on the product power until the cause of the failure is found and corrected.

In addition, fuses in the low-voltage power supply protect against overcurrent. If overcurrent flows into the AC line, the fuses melt and cut off the power distribution.

High-voltage power supply

The DC controller controls the high-voltage power supply to generate biases.

Figure 1-9 High-voltage power supply

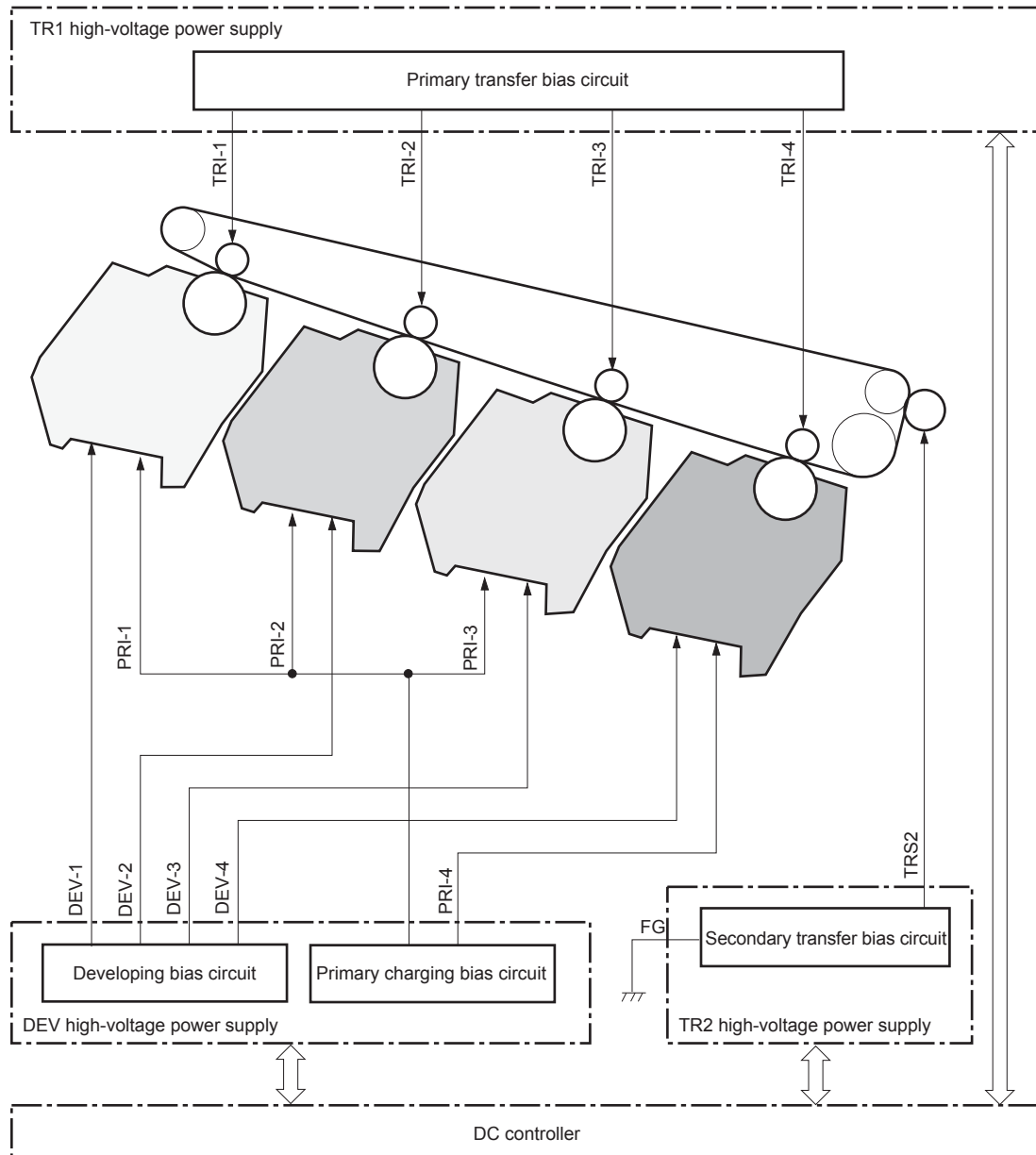

The high-voltage power supply (HVPS) applies biases to the following components:

- Primary charging roller: The primary charging bias is applied to the surface of the photosensitive drum to charge it uniformly negative as a preparation for the image formation.
- Developing roller: The developing bias is used to adhere toner to an electrostatic latent image formed on the photosensitive drum.

- Primary transfer roller: The primary transfer bias is used to transfer the toner from each photosensitive drum onto the ITB.
- Secondary transfer roller: The secondary transfer bias is used to transfer the toner image from the ITB onto the paper. The reversed bias is applied to transfer residual toner on the secondary transfer roller back to the ITB. The residual toner on the ITB is deposited in the toner collection unit.

Laser scanner system

The laser scanner system forms latent images on the photosensitive drums according to the VIDEO signals sent from the formatter.

The main components of the laser/scanner are the laser unit and the scanner motor unit. The DC controller sends signals to the laser/scanner to control the functions of these components.

Figure 1-10 Laser/scanner system

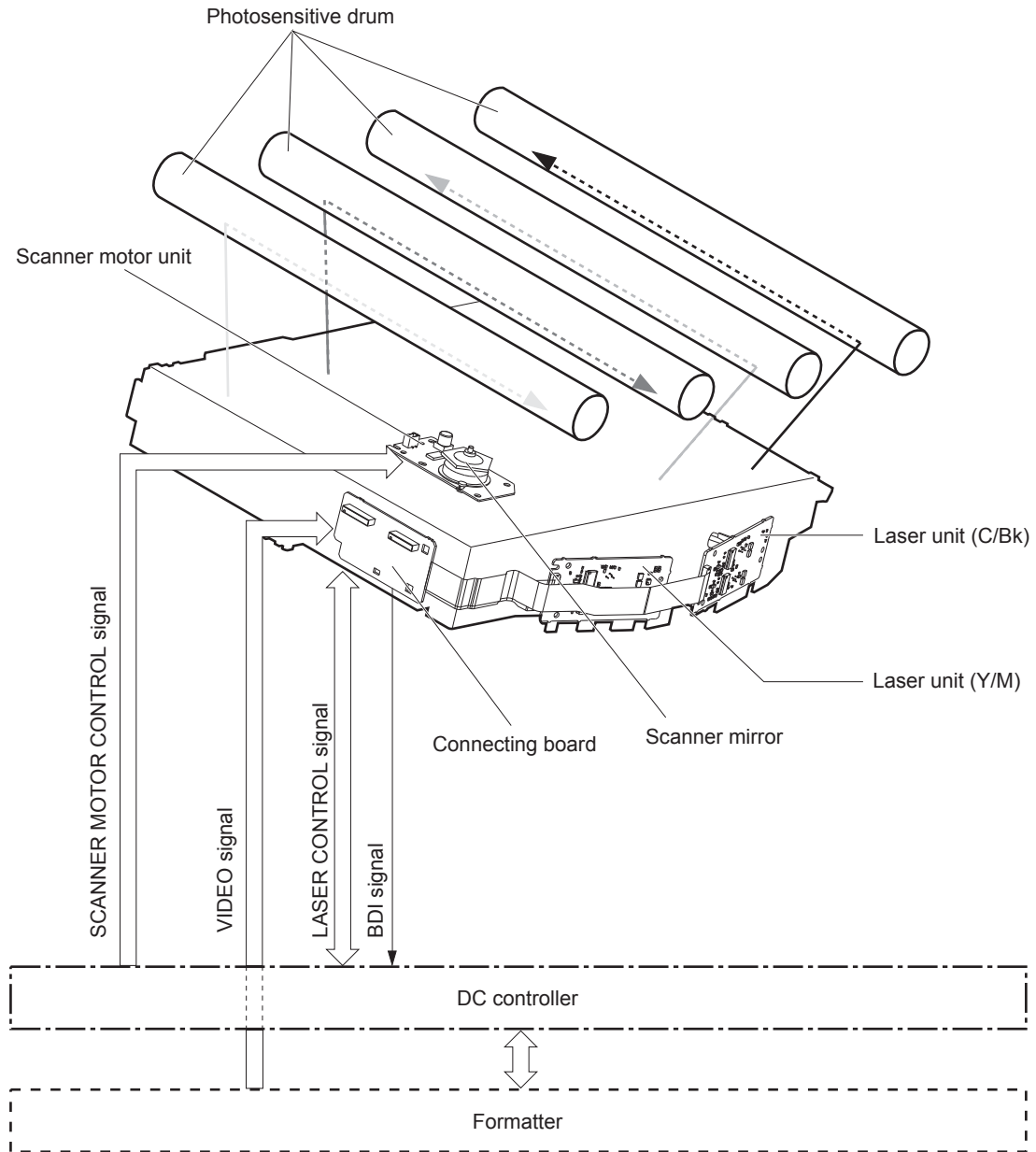

Laser failure detection

The DC controller determines an optical unit failure and notifies the formatter, if the laser/scanner encounters the following conditions:

- The scanner motor does not reach a specified rotation frequency within a specified period of the scanner motor start up.
- The beam detect (BD) interval is out of a specified value during a print operation.

Image-formation system

Electrophotographic process

The electrophotographic process forms an image on the paper. Following are the major components used in the process:

- Print cartridges
- Intermediate transfer belt (ITB)
- Secondary transfer roller
- Fuser
- Laser scanner

The DC controller uses the laser scanner and HVPS to form the toner image on the photosensitive drum. The image is transferred to the print media and then fused onto the paper.

Figure 1-11 Electrophotographic process block diagram

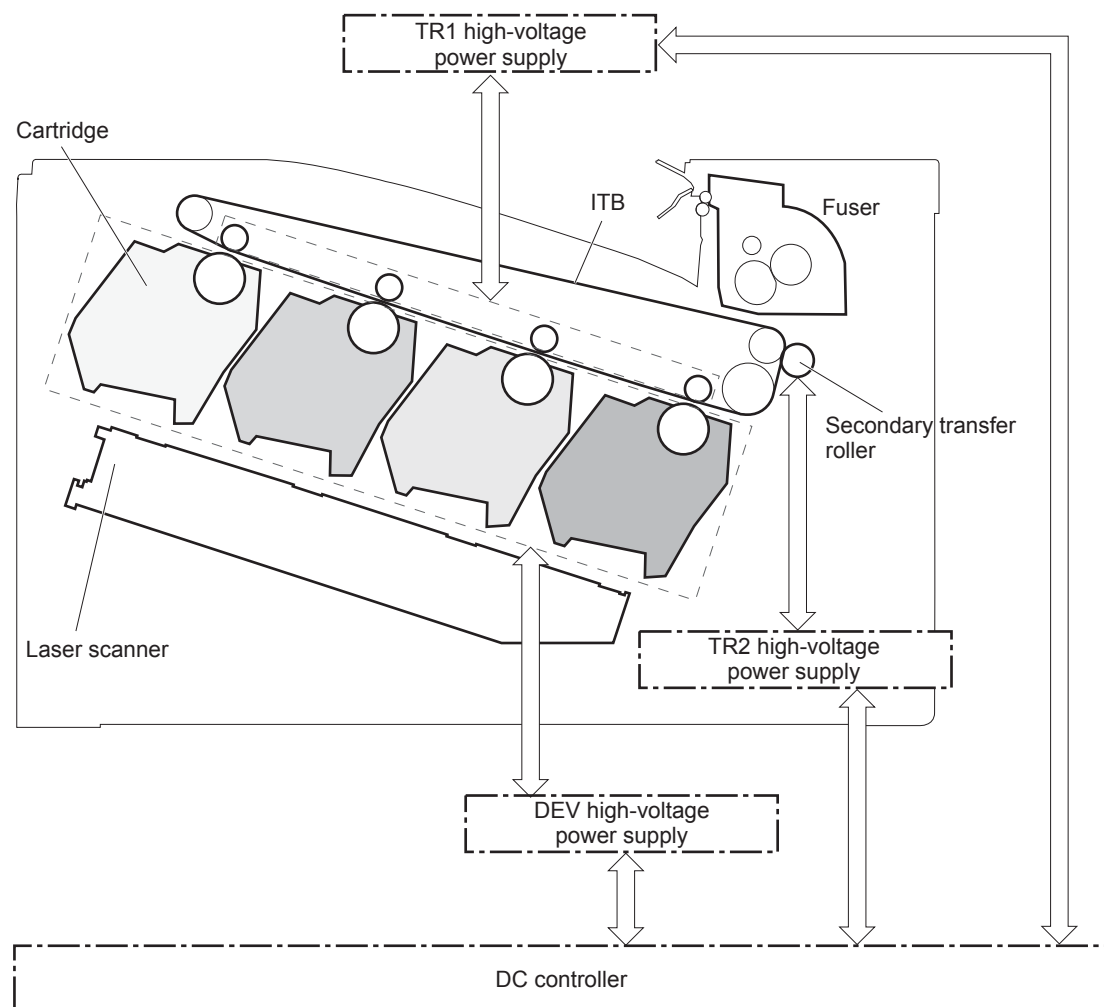

Figure 1-12 Electrophotographic process drive system

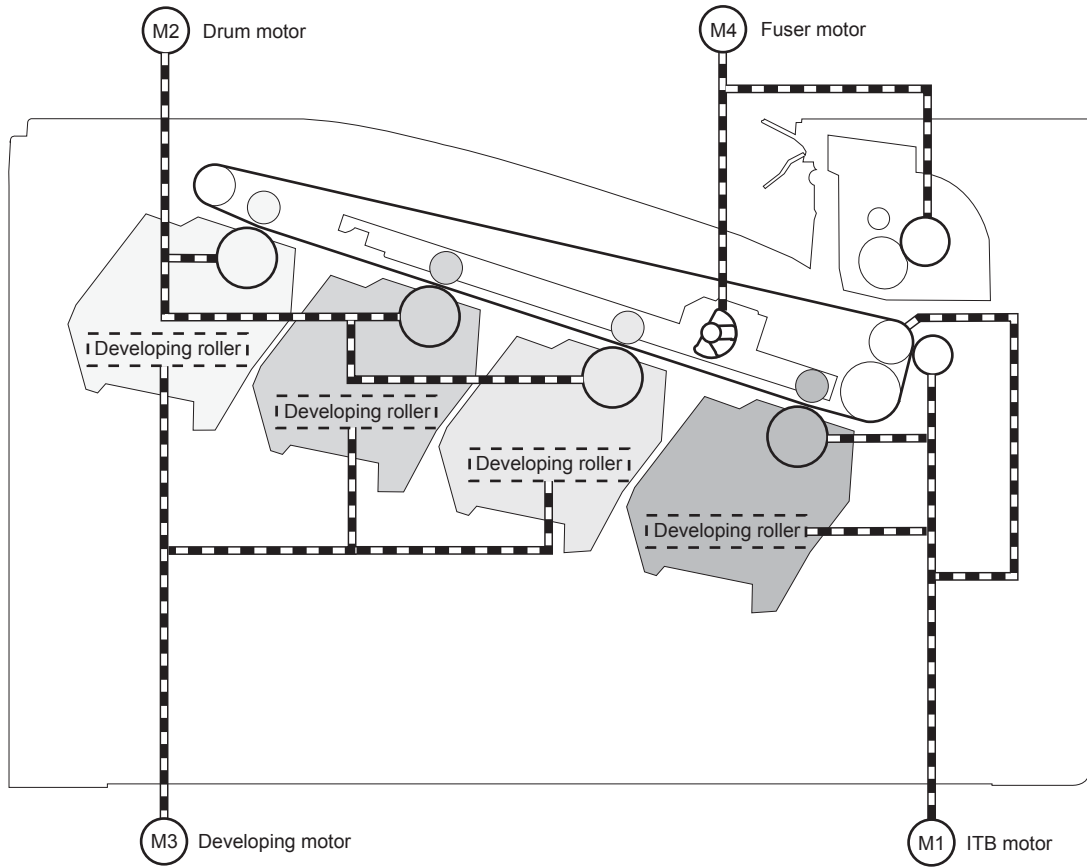
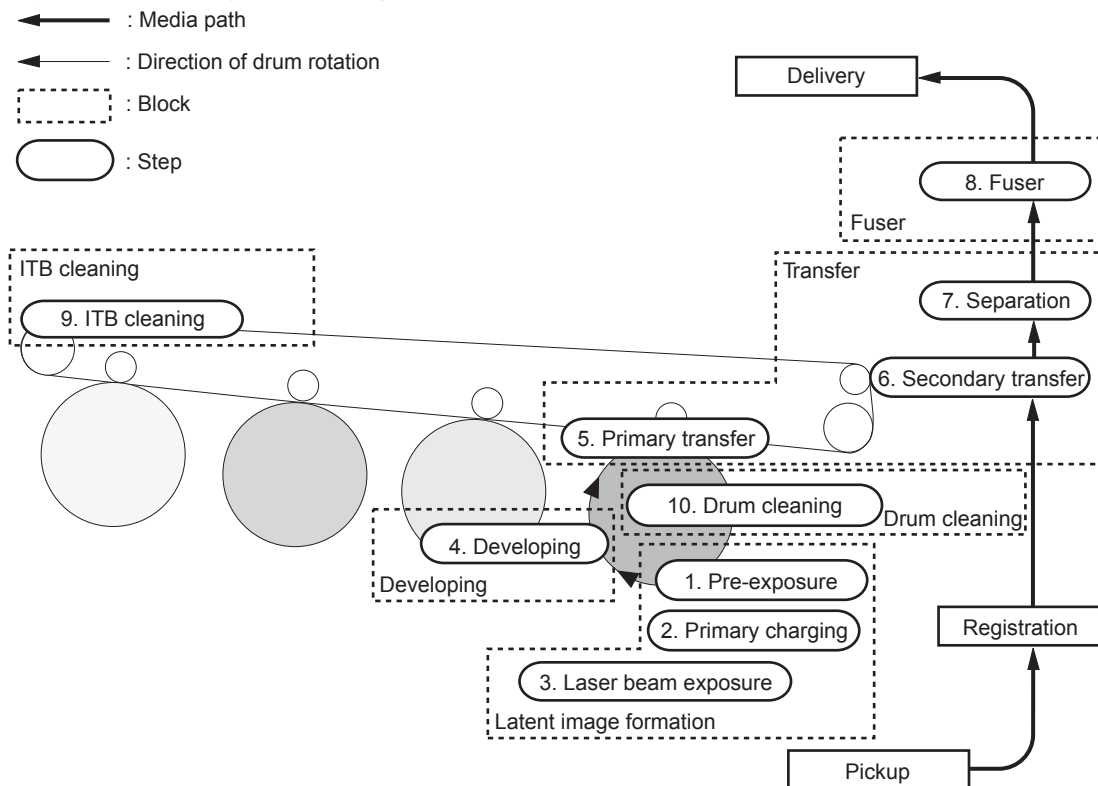

Image formation process

Each of the following processes functions independently and must be coordinated with the other product processes. Image formation consists of the following processes:

Latent-image formation block	Step 1: pre-exposure Step 2: primary charging Step 3: laser-beam exposure
Developing block	Step 4: developing
Transfer block	Step 5: primary transfer Step 6: secondary transfer Step 7: separation
Fusing block	Step 8: fusing
ITB cleaning block	Step 9: ITB cleaning
Drum cleaning block	Step 10: Drum cleaning

Figure 1-13 Image formation process



Latent-image formation block

During the latent-image formation stage, the laser scanner forms invisible images on the photosensitive drums in the print cartridges.

Pre-exposure

Step 1: Light from the pre-exposure LED strikes the photosensitive drum surface. This eliminates the residual electrical charges on the drum surface.

Figure 1-14 Pre-exposure

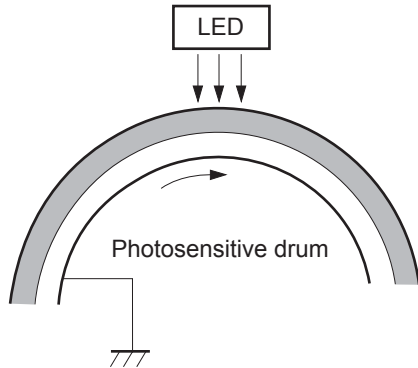

Primary charging

Step 2: DC and AC biases are applied to the primary charging roller, which transfers a uniform negative potential to the photosensitive drum.

Figure 1-15 Primary charging

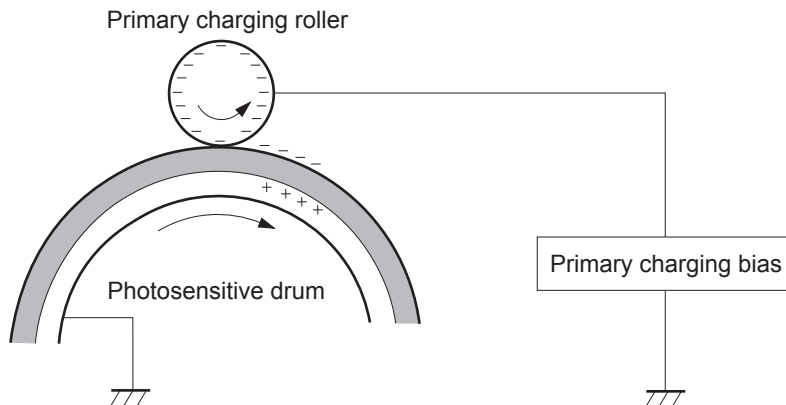

Laser beam exposure

Step 3: The laser beam scans the photosensitive drum to neutralize negative charges on parts of the drum surface. An electrostatic latent image is formed on the drum where negative charges were neutralized.

Figure 1-16 Laser beam exposure

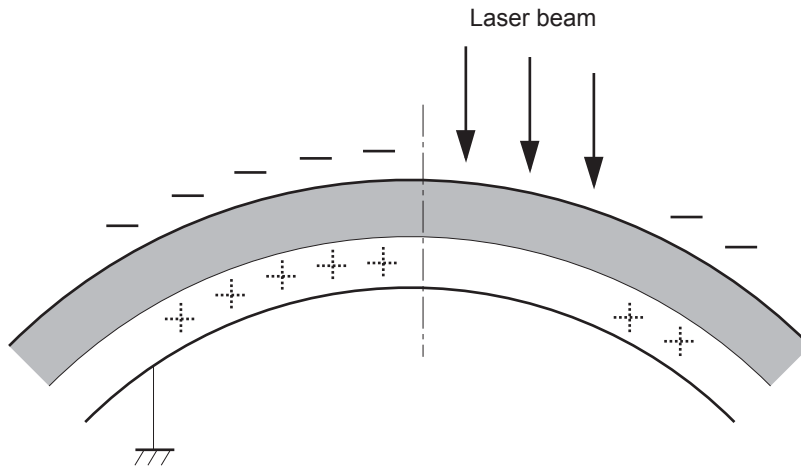

Developing block

Step 4: In the print cartridge, toner acquires a negative charge from the friction that occurs when the developing roller rotates against the developing blade. The developing bias is applied to the developing roller to create a difference in the electric potential of the drum. When the negatively charged toner comes in contact with the photosensitive drum, it adheres to the latent image because the drum surface has a higher potential.

Figure 1-17 Developing

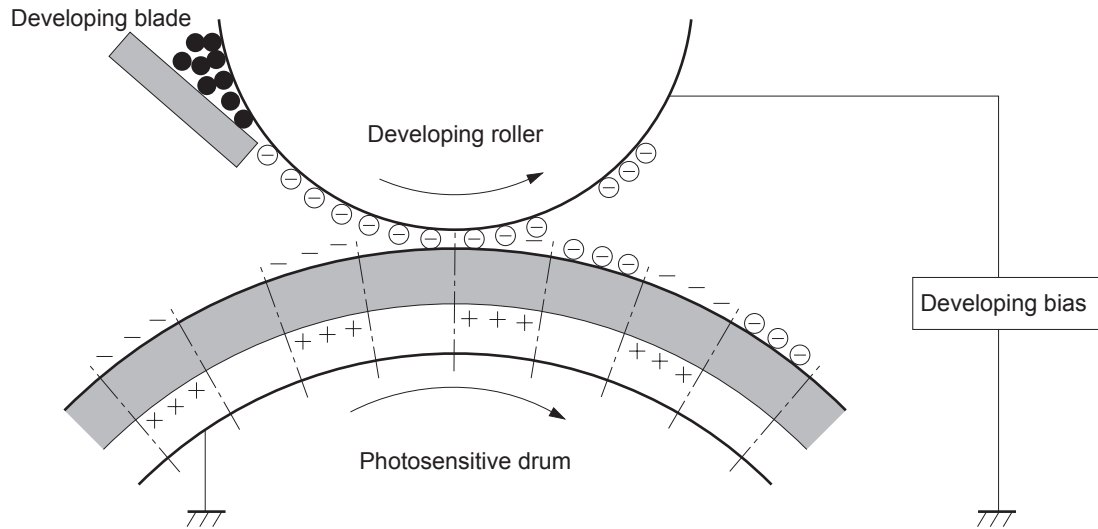

Transfer block

Primary transfer

Step 5: The toner on the photosensitive drum is transferred to the intermediate transfer belt (ITB). The ITB is given a positive charge by the bias of the primary transfer roller. The negatively charged toner on the drum surface is transferred onto the ITB. All four color planes are transferred onto the ITB in this step.

Figure 1-18 Primary transfer

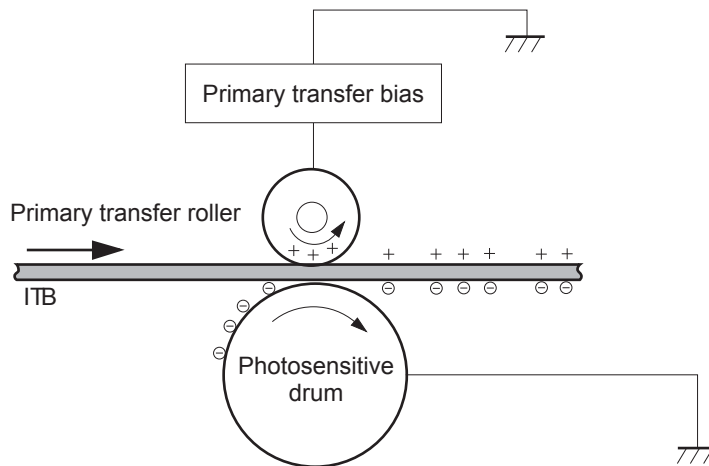

Secondary transfer

Step 6: The toner image on the ITB is transferred to the paper. The secondary transfer bias is applied to the secondary transfer roller to charge the paper positive. As the paper passes between the secondary transfer roller and the ITB, the complete toner image on the ITB is transferred onto the paper.

Figure 1-19 Secondary transfer

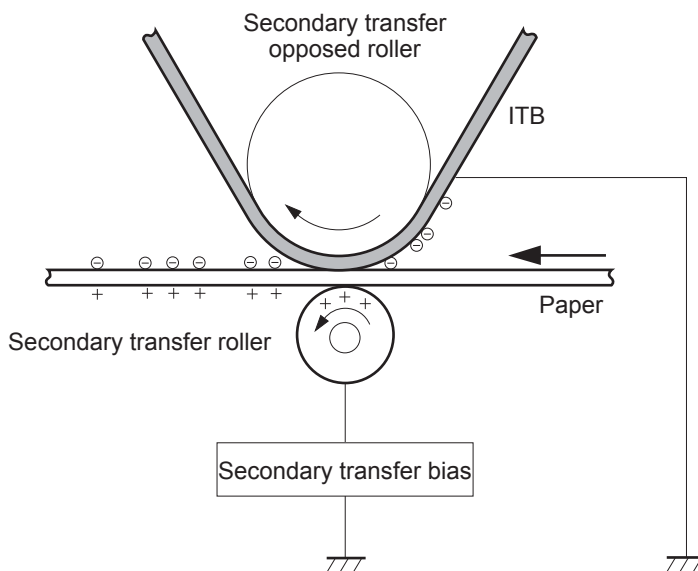

Separation

Step 7: The elasticity of the paper and the curvature of the secondary transfer opposed roller cause the paper to separate from the ITB. The static charge eliminator reduces back side static charge of the paper and controls excess discharge after the transfer process for stable media feed and image quality.

Figure 1-20 Separation

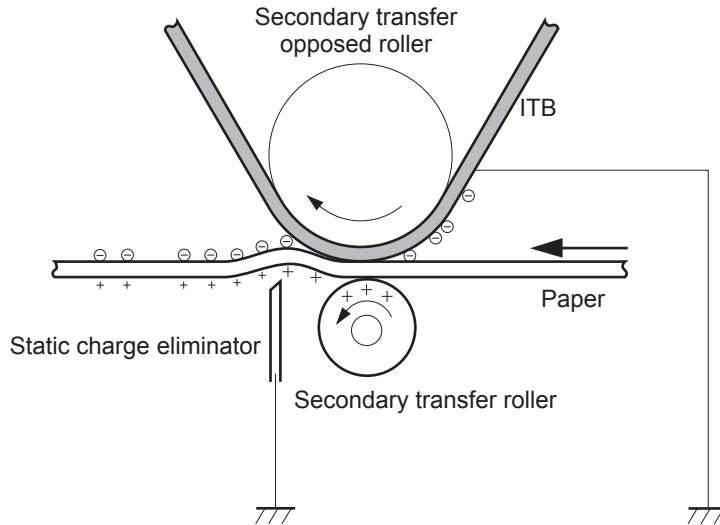

Fusing block

Step 8: The product uses an on-demand fuser. The toner image is permanently affixed to the printing paper by heat and pressure.

Figure 1-21 Fusing

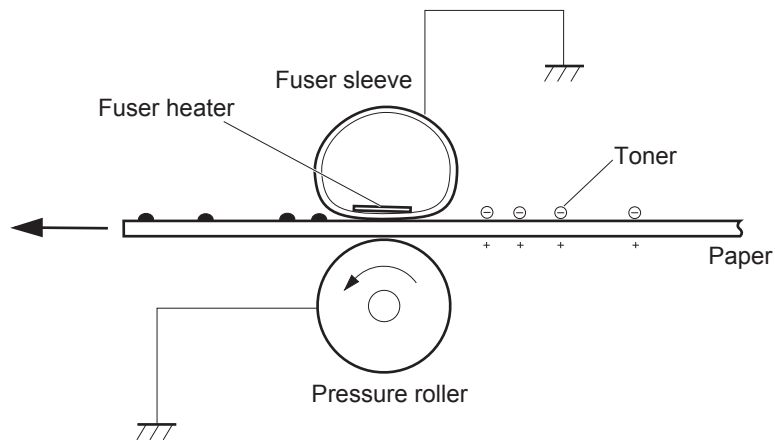

ITB cleaning block

Step 9: The cleaning blade scrapes the residual toner off the surface of the ITB. The residual toner feed screw deposits residual toner in the toner collection unit.

Figure 1-22 ITB cleaning

Residual toner feed screw

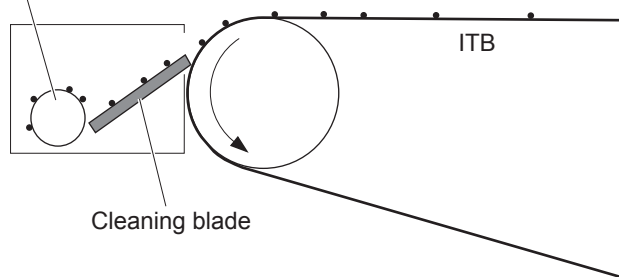

Drum cleaning block

Step 10: The cleaning blade scrapes the residual toner off the surface of the photosensitive drum, and toner is deposited in the waste section inside the print cartridge.

Figure 1-23 Drum cleaning

Cleaning blade

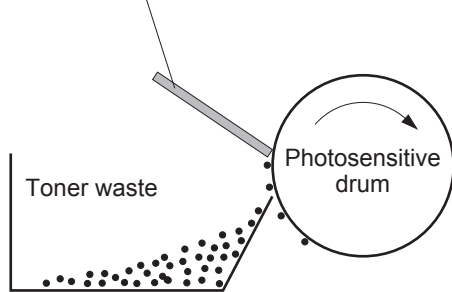

Print cartridges

The product has four print cartridges, one for each color: yellow, magenta, cyan, and black. Each of them has the same structure. The cartridges are filled with toner and consist of the following components:

- Photosensitive drum
- Developing unit
- Primary charging roller

The DC controller rotates the motors to drive the photosensitive drum, developing unit, and primary charging roller.

Figure 1-24 Print cartridge block diagram

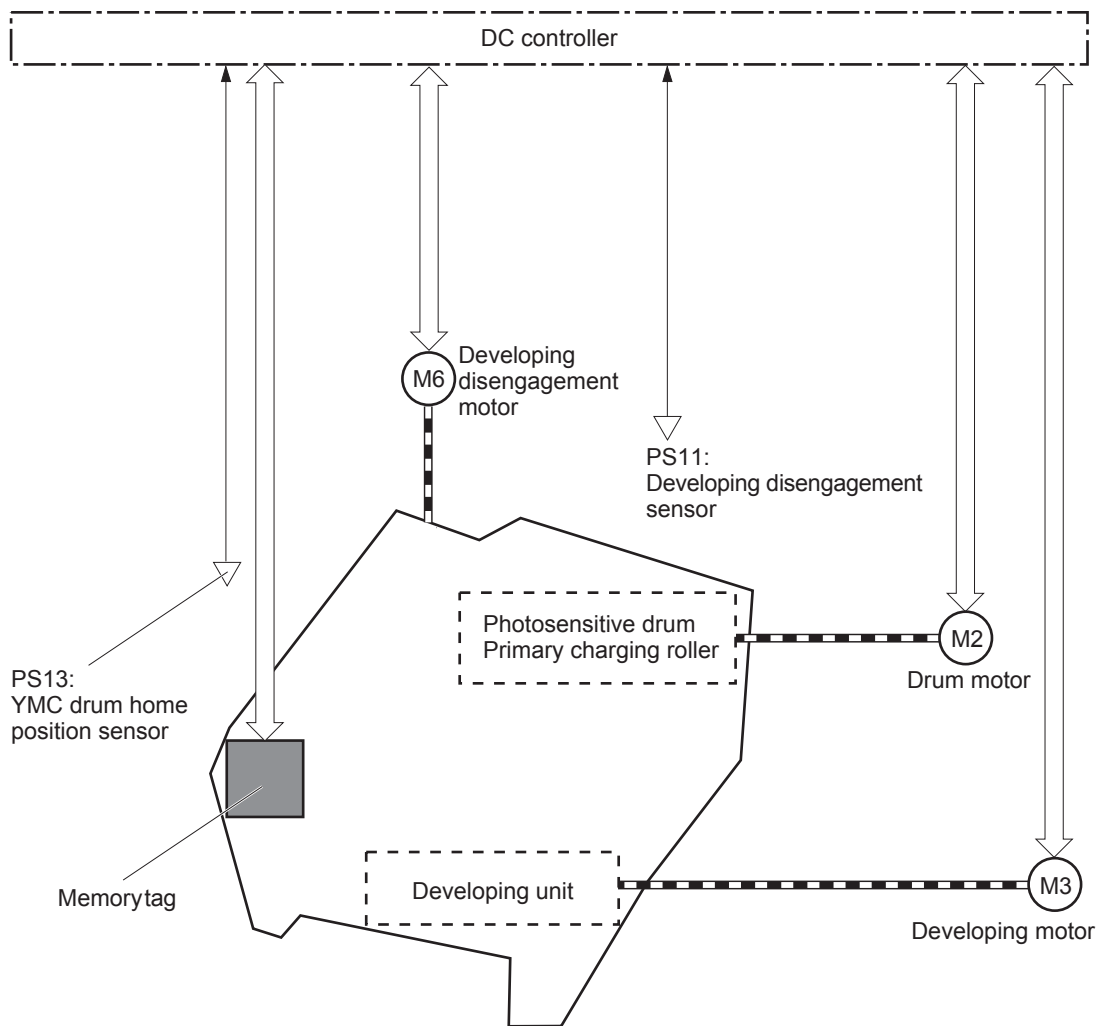

Memory tag

The memory tag is a non-volatile memory chip in the cartridge that stores information about usage for the cartridge. The product reads and writes the data in the memory tag. The DC controller determines a memory tag error and notifies the formatter when it fails to either read from or write to the memory tag.

Cartridge presence detection

The DC controller detects the presence of the cartridges by monitoring the cartridge e-label and ground circuit. When the DC controller determines a cartridge absence, it notifies the formatter.

Toner level detection

The DC controller detects the remaining toner level in a cartridge by the optical detection method. The DC controller notifies the formatter of the remaining toner level.

Cartridge life detection

The DC controller detects the cartridge life by monitoring the total operational wear limit or remaining toner level of the cartridge. The DC controller determines a cartridge end of life and notifies the formatter when the operational wear limit of the cartridge reaches a specified amount or the cartridge runs out of toner.

Developing unit engagement and disengagement control

The developing unit engagement and disengagement control engages the developing unit with the photosensitive drum or disengages the developing unit from the drum depending on the print mode: full-color mode or black-only mode. The developing unit is engaged only when required, preventing a deterioration of the drums and maximizing their life.

The developing disengagement motor rotates the developing disengagement cam. As the cam rotates, the developing unit engages with or separates from the photosensitive drum.

When the product is turned on and when each print job is completed, all four of the developing units disengage from the photosensitive drums. When the print mode is in full-color mode, all of the developing units engage with the drums. When the print mode is in black-only mode, only black developing unit engages with the drum.

The DC controller determines a developing disengagement motor abnormality and notifies the formatter when it does not detect a specified signal from the developing disengagement sensor during the developing roller engagement and disengagement operation.

Figure 1-25 Developing unit engagement and disengagement control

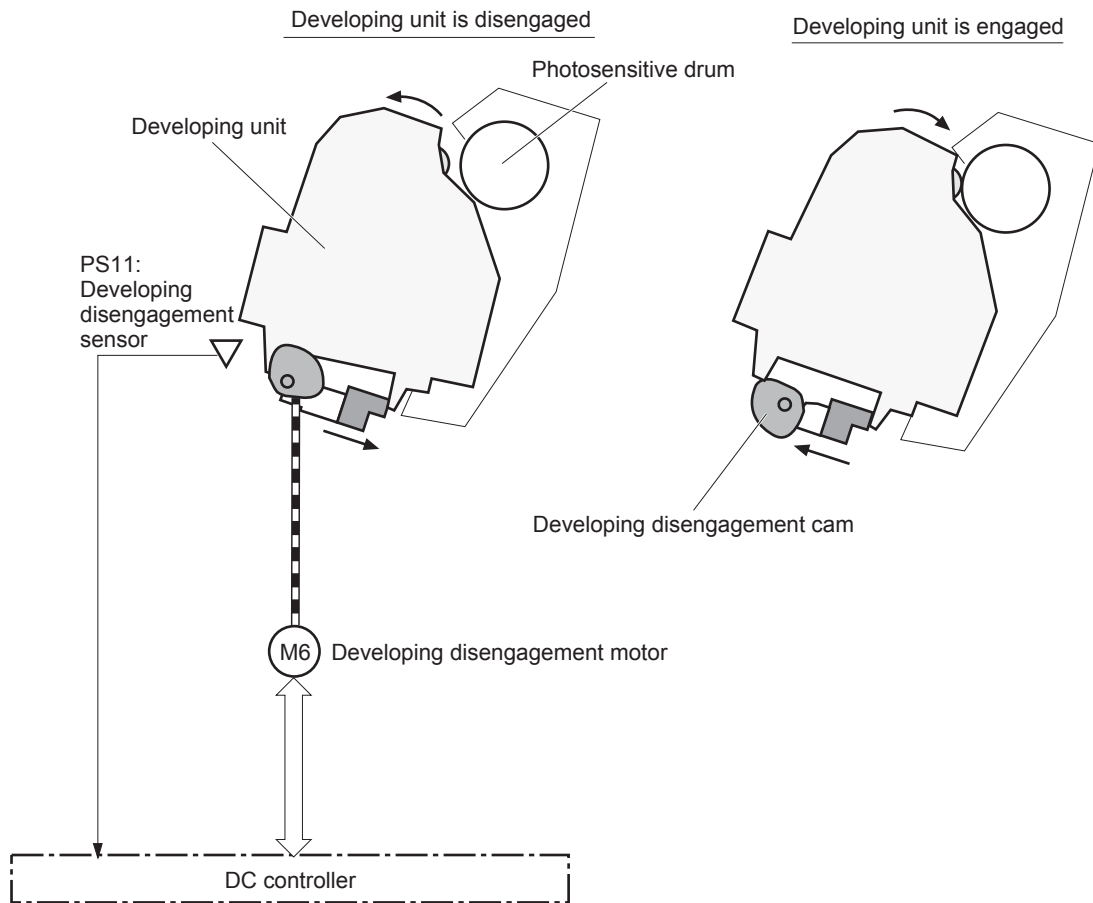

ITB unit

The ITB unit receives the toner image from the photosensitive drums and transfers the complete toner image to the print media. The ITB unit consists of the following components:

- ITB
- ITB drive roller
- Primary transfer rollers
- ITB cleaner

The ITB motor drives the ITB drive roller which rotates the ITB. The rotation of the ITB causes the primary transfer rollers to rotate. The ITB cleaner cleans the ITB surface.

Figure 1-26 ITB unit block diagram

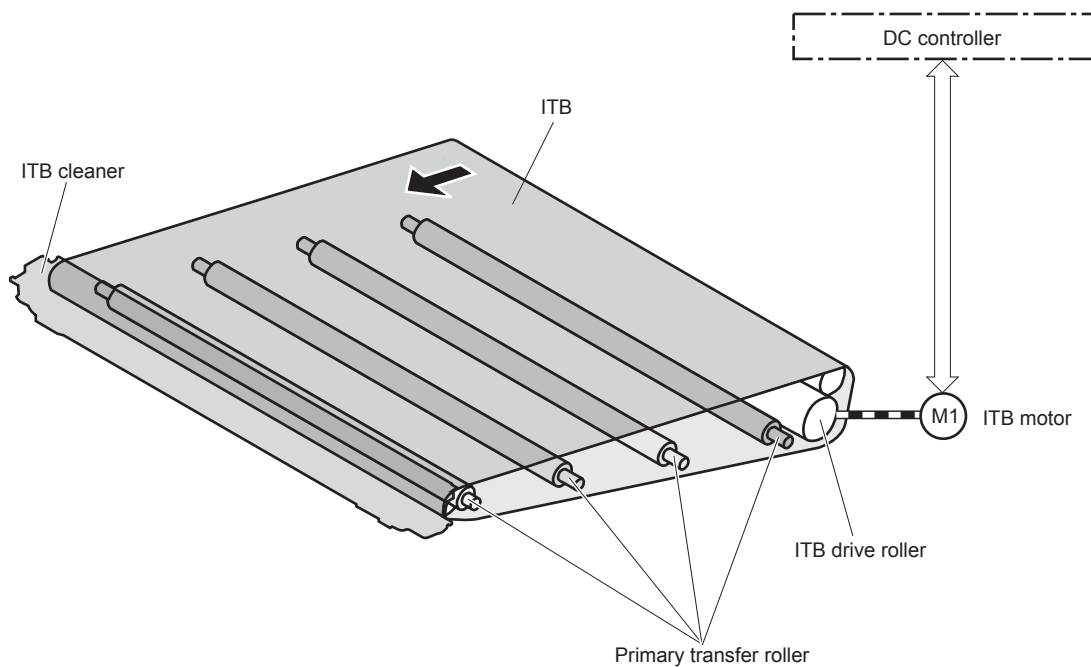

Primary transfer roller engagement and disengagement control

Figure 1-27 Primary transfer roller engagement and disengagement control

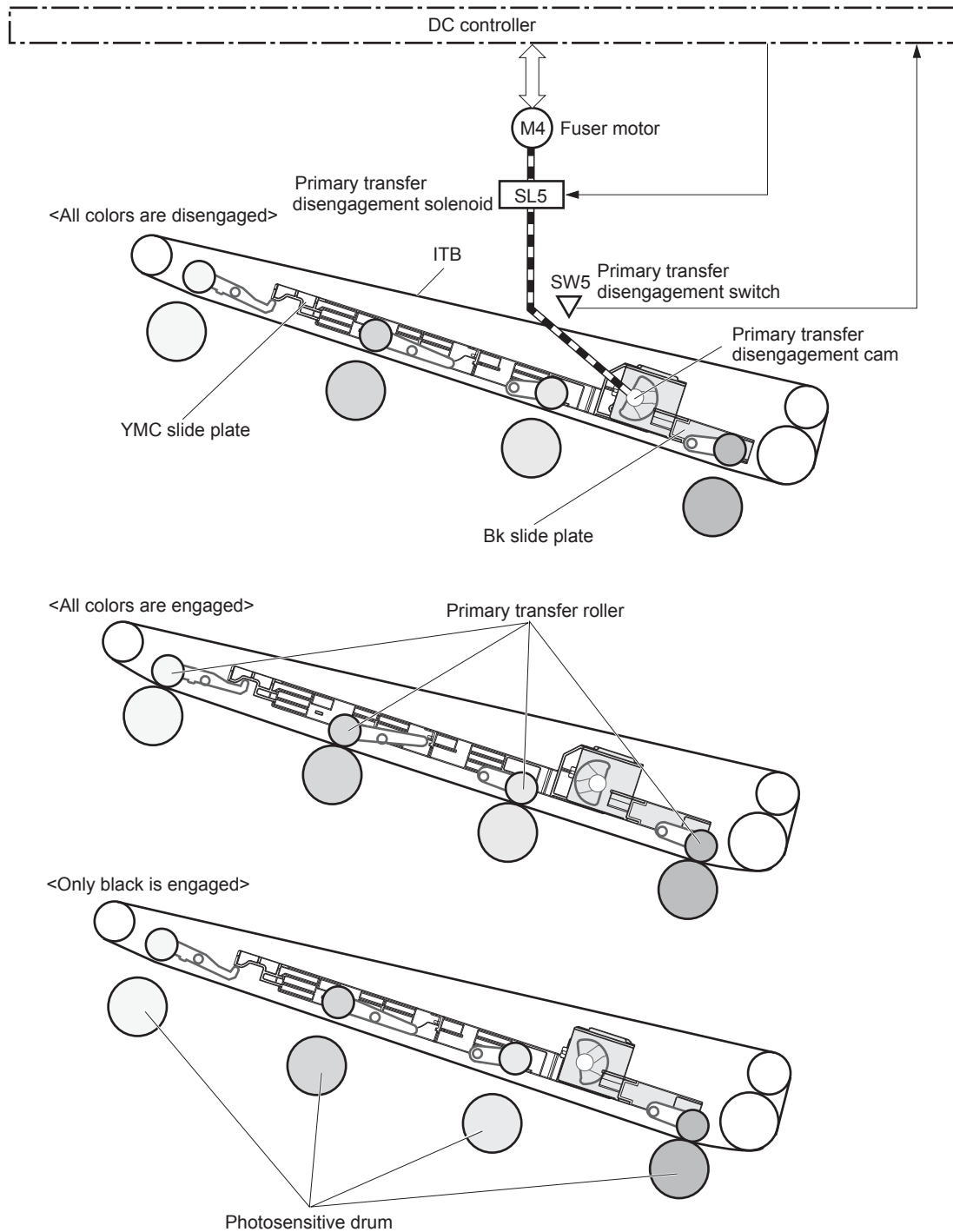

The primary transfer roller engagement and disengagement control engages the ITB with the photosensitive drum, or disengages the ITB from the drum, depending on the requirements of the print job.

- **All rollers disengaged:** The ITB disengages from all four photosensitive drums. This is the state during a standby period, and also is the home position for the primary transfer rollers.
- **All rollers engaged:** The ITB engages with all the four photosensitive drums. This is the state for full-color jobs.
- **Only black roller engaged:** The ITB engages with only the black photosensitive drum. This is the state for the black-only print jobs.

The operational sequence of the primary transfer roller engagement and disengagement control is as follows:

1. The fuser motor drives the primary transfer disengagement solenoid to rotate the primary transfer disengagement cam.
2. As the cam rotates, the YMC slide plate or the Bk slide plate moves to right or left. This causes the primary transfer roller to move up or down.
3. The ITB engages with or disengages from the photosensitive drum depending on the movement of the primary transfer rollers.

The DC controller determines that an abnormal primary transfer roller disengagement error has occurred and notifies the formatter. This error happens when the DC controller does not detect a specified signal from the primary transfer disengagement switch, even though the primary transfer disengagement solenoid is driven.

ITB unit presence detection

The DC controller detects the ITB unit presence by monitoring the primary transfer disengagement switch. The DC controller drives the primary transfer disengagement solenoid for specified times during the initial rotation period of the following:

- The product is turned on
- The product exits Sleep mode
- The door is closed

The DC controller determines an ITB unit absence and notifies the formatter when it does not detect a specified signal from the primary transfer disengagement switch.

ITB cleaning mechanism

The cleaning blade in the ITB cleaner scrapes the residual toner off the ITB surface. The ITB motor drives the residual toner feed screw and the screw deposits the residual toner in the toner collection unit.

The DC controller detects whether the toner collection unit is full by monitoring the ITB residual toner full sensor. When the DC controller determines the toner collection unit is full, it notifies the formatter. The

DC controller also detects the presence of the toner collection unit by monitoring the toner collection unit switch.

Figure 1-28 ITB cleaning mechanism

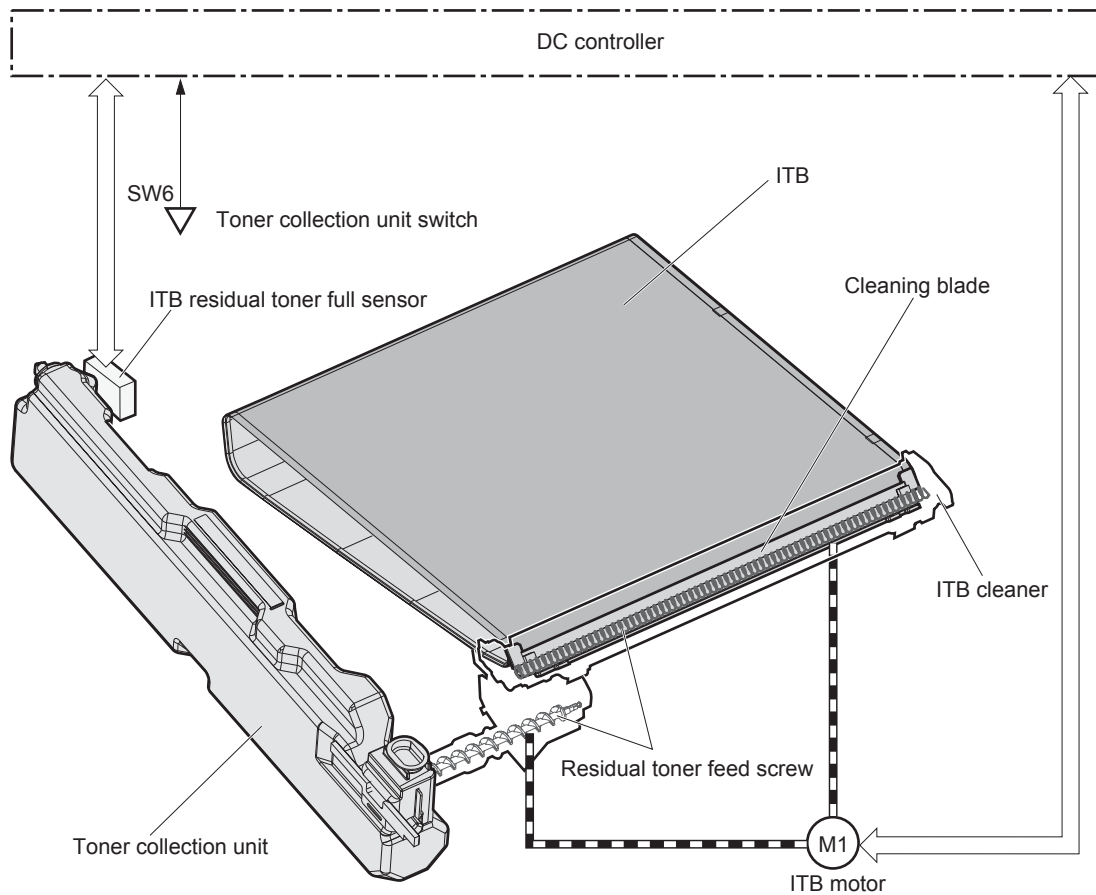

Calibration

The product calibrates itself to print a high-quality image. The calibration corrects a color-misregistration and color-density variation caused by environment changes or variation inherent in the product. The product performs the following calibrations:

- Color-misregistration control
- Environment change control
- Image stabilization control

Color-misregistration control

The color-misregistration control corrects the misaligned color planes caused by the variation inherent in the laser scanner units or cartridges. The color-misregistration control corrects the following:

- Horizontal scanning start position
- Horizontal scanning magnification
- Vertical scanning start position

The DC controller forms a pattern of toner on the surface of the ITB, and measures a misaligned length with the registration density sensor and the registration density belt-perimeter sensor. Accordingly, the formatter calibrates the color-misregistration.

Figure 1-29 Color-misregistration control

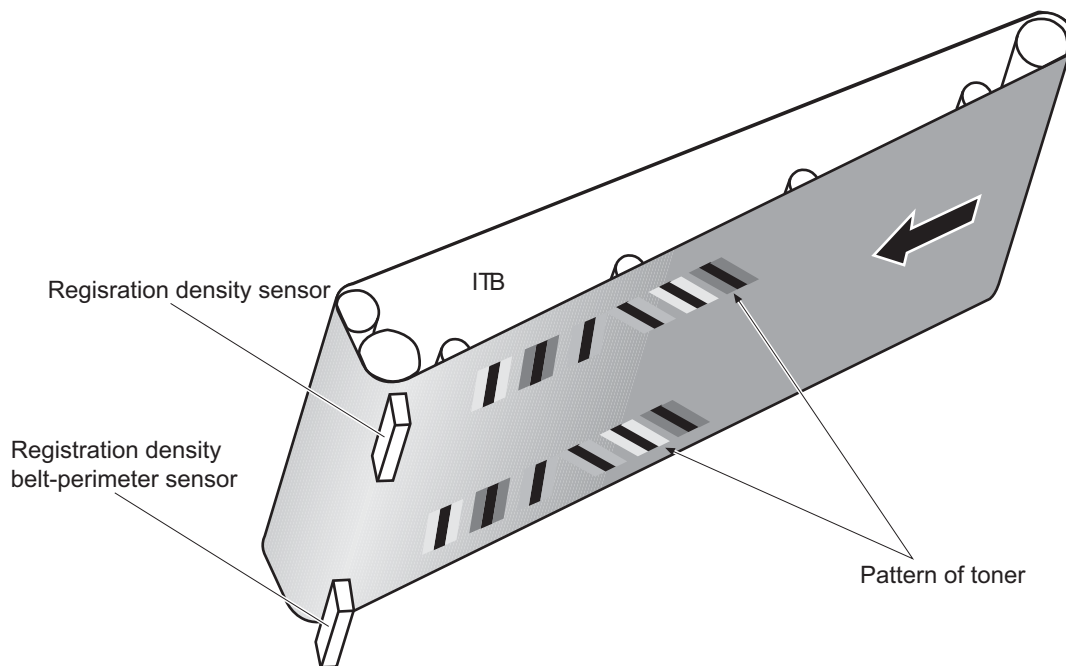

The DC controller commands the formatter to perform the color-misregistration control whenever one of the following occurs:

- The product is turned on or the door is closed, after replacing any one of the cartridges
- The product is turned on or the door is closed, after replacing the ITB unit or the laser scanner unit
- A specified number of pages have been printed
- Continuous printing for a specified period of time
- Cold starting of the fuser when the product is turned on

If data from the registration density or registration density belt-perimeter sensor is out of a specified range during the cartridge-presence detection or when starting the color-misregistration control, the DC controller determines an abnormal sensor and notifies the formatter.

Environment change control

The environment change control calibrates each high-voltage bias to obtain an appropriate image according to the environment changes. The DC controller determines the environment, where the product is installed, based on the surrounding temperature and humidity data from the environment sensor. It adjusts the high-voltage biases to accommodate environmental changes.

The DC controller determines an environment sensor abnormality and notifies the formatter when it detects out of specified range data from the environment sensor.

Image stabilization control

The image stabilization control reduces the fluctuations in image density caused by environmental changes or deterioration of the photosensitive drums or toner. The two kinds of image stabilization controls are image density control (DMAX) and image halftone control (DHALF).

Image density control (DMAX)

The image density control calibrates each high-voltage bias to stabilize the image density variation caused by the deterioration of the photosensitive drum or toner. The DC controller commands the formatter to control the image density under the following conditions:

- The detected temperature of the fuser is a specified degree or lower when the product is turned on
- The product is turned on, or the door is closed, and also whenever a specified number of pages have been printed after replacing any one of the cartridges
- The product is turned, on or the door is closed, after replacing the ITB unit or the laser scanner unit
- A specified number of pages have been printed
- After a specified period of time from the previous image density control
- The environment is changed for a specified condition after the previous image density control

Image halftone control (DHALF)

The image halftone control is performed by the formatter to calibrate the halftone. The DC controller measures the halftone pattern according to a command from the formatter. Accordingly, the formatter calibrates the halftone. The DC controller controls the image halftone under the following conditions:

- The image density control is completed
- The formatter sends a command

Pickup, feed, and delivery system

The pickup/feed/delivery system consists of several types of feed rollers and sensors. The duplex model has a mechanism that reverses and refeeds the print media to print two sides automatically.

Figure 1-30 Pickup, feed, and delivery system

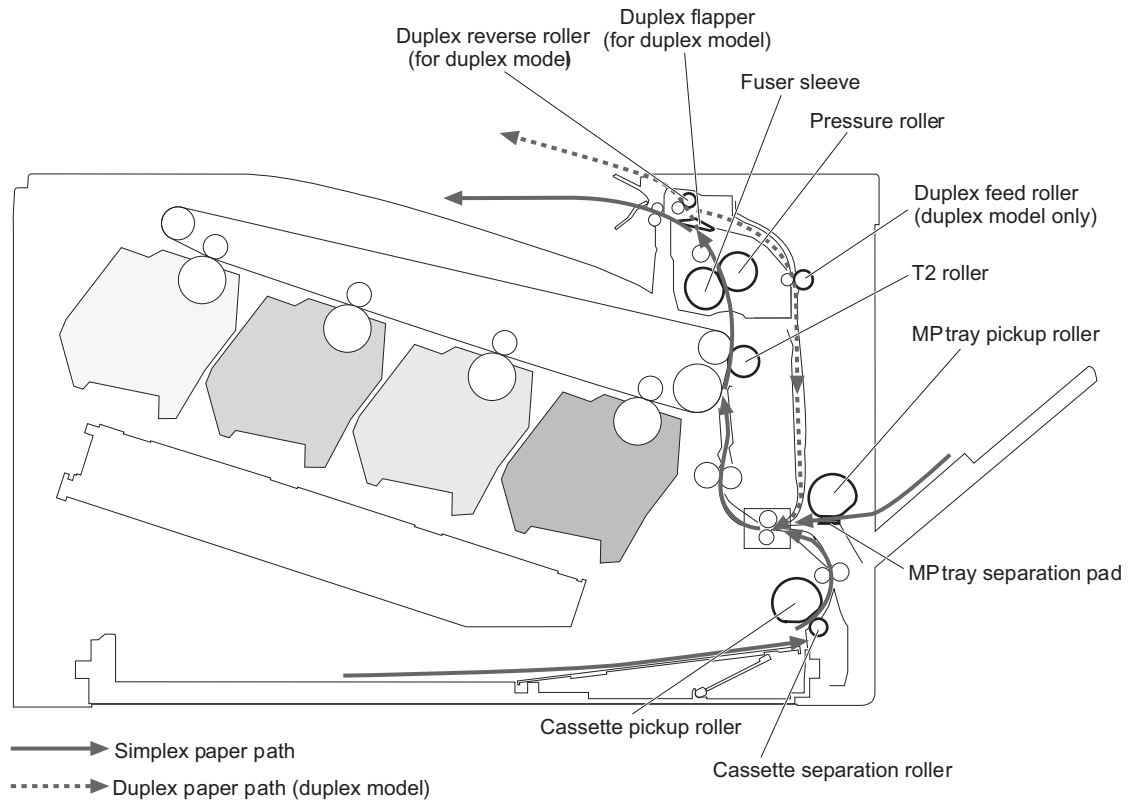

The pickup/feed/delivery system can be divided into the following three blocks:

- **Pickup-and-feed block:** From each input source to the fuser inlet
- **Fuser-and-delivery block:** From the fuser to the output bin
- **Duplex block:** From the duplex reverse unit to the duplex re-pickup unit (duplex models only)

Figure 1-31 Pickup, feed, and delivery system blocks

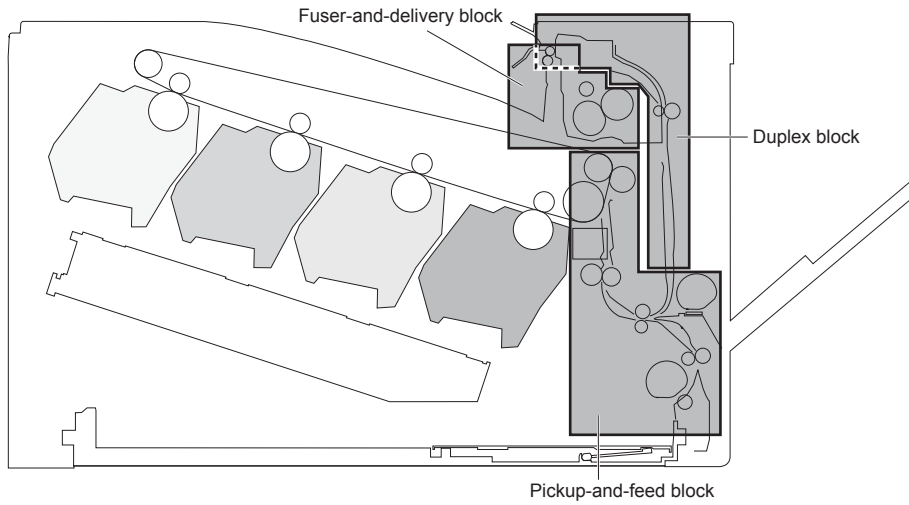

Photo sensors

Figure 1-32 Photo sensors (paper path)

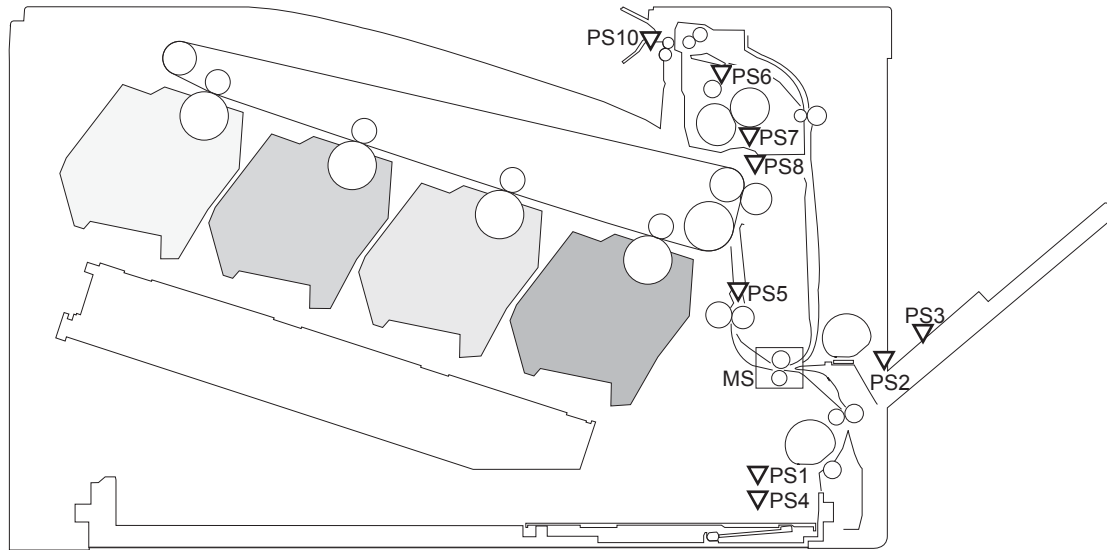

Table 1-5 Photo sensors and switches (product)

Item	Description	Item	Description
PS1	Tray 2 cassette paper-presence sensor	PS6	Fuser delivery sensor
PS2	Tray 1 (MP tray) paper-presence sensor	PS7	Loop sensor 1
PS3	Last-paper sensor	PS8	Loop sensor 1
PS4	Tray 2 cassette paper-stack surface sensor	PS10	Output bin media-full sensor
PS5	Top-of-Page (TOP) sensor		

Motors and solenoids

Figure 1-33 Motors and solenoids (paper path)

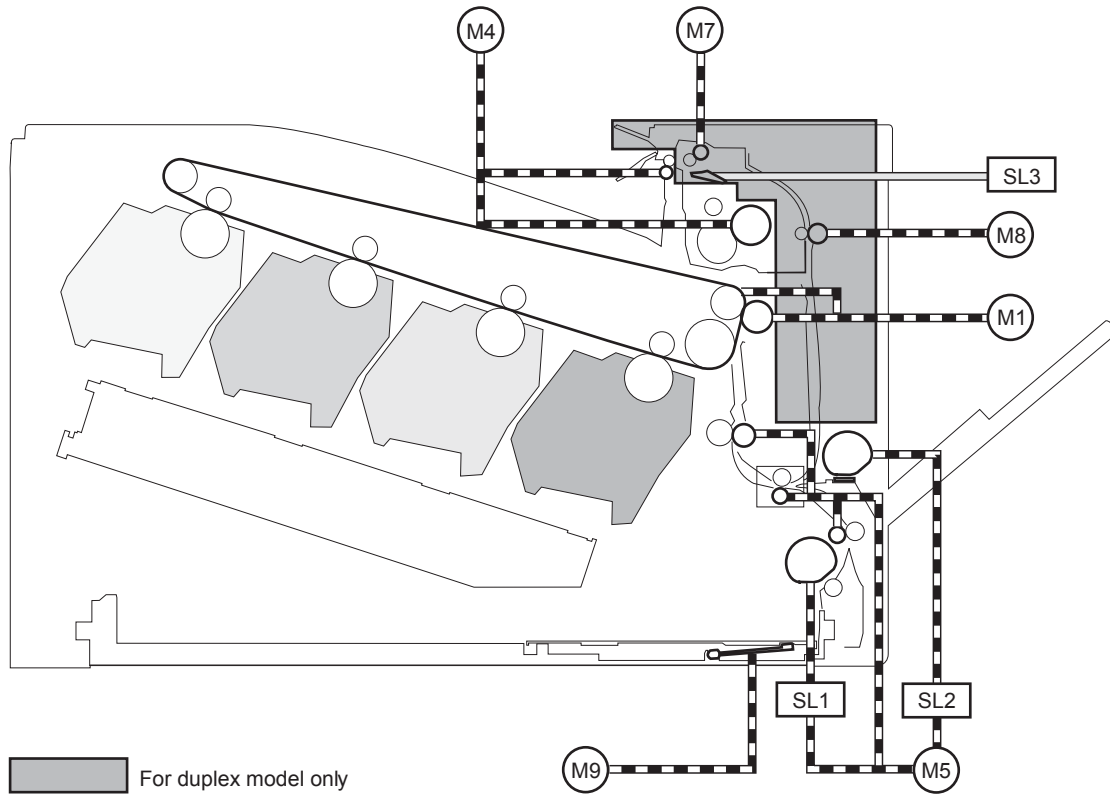

Table 1-6 Motors and solenoids (paper path)

Item	Description	Item	Description
M1	ITB motor	M9	Tray 2 cassette lifter motor
M4	Fuser motor	SL1	Tray 2 cassette pickup solenoid
M5	Pickup motor	SL2	Tray 1 (MP tray) pickup solenoid
M7	Duplex reverse motor (duplex models only)	SL3	Duplex reverse solenoid 1 (duplex models only)
M8	Duplex feed motor (duplex models only)		

Pickup and feed block

The pickup-and-feed block picks one sheet of paper from the Tray 2 cassette or the MP tray and feeds it into the fuser.

Tray 2 cassette pickup

The operational sequence of the Tray 2 cassette pickup is as follows:

1. The product is turned on or the Tray 2 cassette is inserted.
2. The lift-up operation and the lifting plate spring move up the lifting plate to the position where the paper can be picked up.
3. The DC controller rotates the pickup motor when it receives a print command from the formatter.
4. The Tray 2 cassette (CST) feed roller rotates.
5. The Tray 2 cassette (CST) pickup solenoid is driven at a specified timing.
6. The Tray 2 cassette (CST) pickup roller rotates and picks up the paper.
7. The Tray 2 cassette (CST) separation roller removes any multiple-fed sheets.
8. One sheet of paper is fed into the product.

 **NOTE:** The lift-up operation pushes up the lifting plate to keep the stack surface of paper at the pickup position.

Figure 1-34 Tray 2 cassette pickup operation



Tray 2 cassette multiple-feed prevention

The product uses a separation roller method to prevent multiple sheets of print media from entering the paper path. The Tray 2 cassette separation roller does not have its own driving force. Therefore the Tray 2 cassette separation roller follows the rotation of the Tray 2 cassette pickup roller.

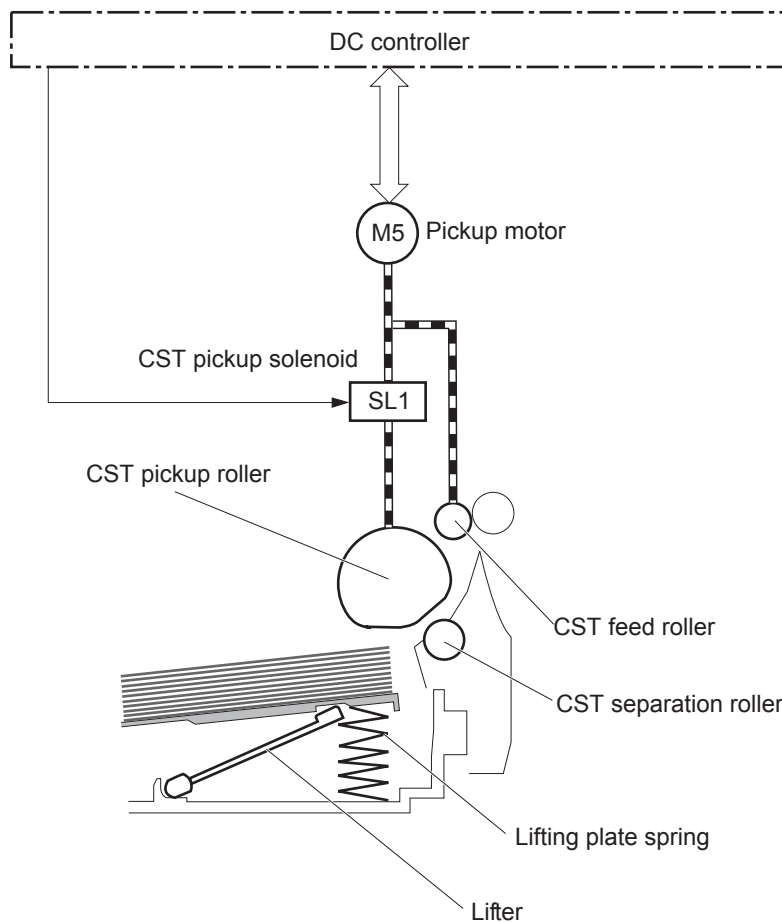
During normal feed, when the product picks up one piece of paper, the Tray 2 cassette separation roller is driven by the Tray 2 cassette pickup roller through one sheet of paper. Thus the separation roller rotates in the paper feed direction.

During multiple-feed, when the product picks up more than one piece of paper, the low friction force between the sheets weakens the driving force from the Tray 2 cassette pickup roller. In addition, some braking force is always applied to the Tray 2 cassette separation roller, so the weak rotational force of the pickup roller is not enough to rotate the separation roller. Therefore, the separation roller holds back any multiple-fed sheets, and one sheet of paper is fed into the product.

Figure 1-35 Tray 2 cassette multiple-feed prevention

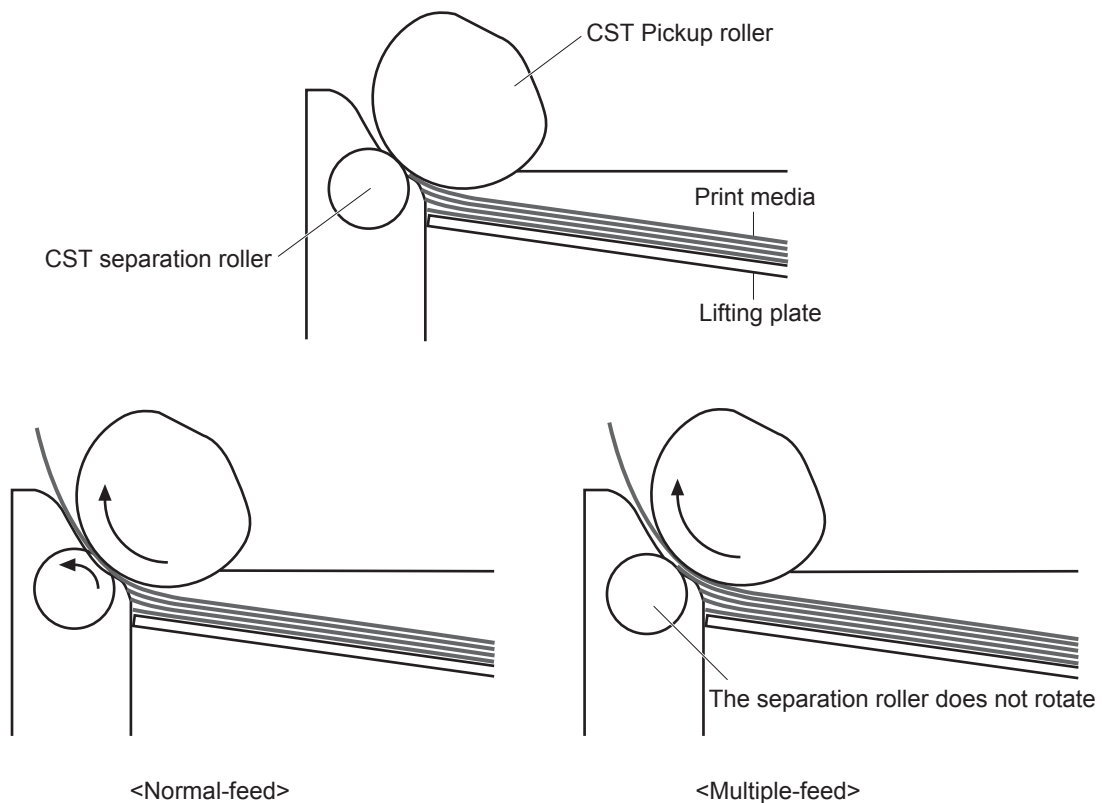

Tray 2 cassette media-size detection and Tray 2 cassette-presence detection

The DC controller detects the size of paper loaded in the Tray 2 cassette by using the Tray 2 cassette-media-end switch and Tray 2 cassette media width switch.

The DC controller also detects the presence of the cassette by using the Tray 2 cassette media end switch. The DC controller notifies the formatter if the Tray 2 cassette is absent.

Table 1-7 Tray 2 cassette media-size detection and Tray 2 cassette-presence detection (product base)

Paper size	Cassette media width sensor			Cassette media end switch		
	Top switch	Center switch	Bottom switch	Top switch ¹	Center switch	Bottom switch
A4	On	On	On	See footnote	Off	Off
Letter	On	On	Off		Off	Off
B5	On	Off	Off		Off	Off
Executive	Off	Off	Off		Off	Off
A5-R	Off	On	On		Off	Off
B5-R	Off	Off	On		Off	Off
Letter-R	On	Off	On		Off	Off
A4-R	On	Off	On		Off	On
A3	On	On	On		On	On
11 X 17	On	On	Off		On	On
B4	On	Off	Off		On	On
Legal	On	Off	On		On	On

¹ The top Tray 2 cassette-media-end switch detects the presence of the Tray 2 cassette. It turns off when the Tray 2 cassette is present and turns on when the Tray 2 cassette is absent.

Tray 2 cassette lift-up operation

The cassette lift-up operation keeps the surface of the paper stack surface at the correct pickup position whenever the following conditions occur:

- Product power is turned on
- Tray 2 cassette is installed

The list below describes the sequence of the Tray 2 cassette lift-up operation.

- The Tray 2 cassette lifter motor rotates to move the lifter rack toward the Tray 2 cassette-media-stack surface sensor.
- As the lifter rack moves, the lifter moves up.
- The Tray 2 cassette lifter motor stops when the Tray 2 cassette-media-stack surface sensor detects the lifter rack.

The DC controller determines a Tray 2 cassette lifter motor failure and notifies the formatter if the Tray 2 cassette-media-stack surface sensor does not detect the lifter rack within a specified period after the Tray 2 cassette lifter motor starts rotating.

Figure 1-36 Tray 2 cassette lift-up operation

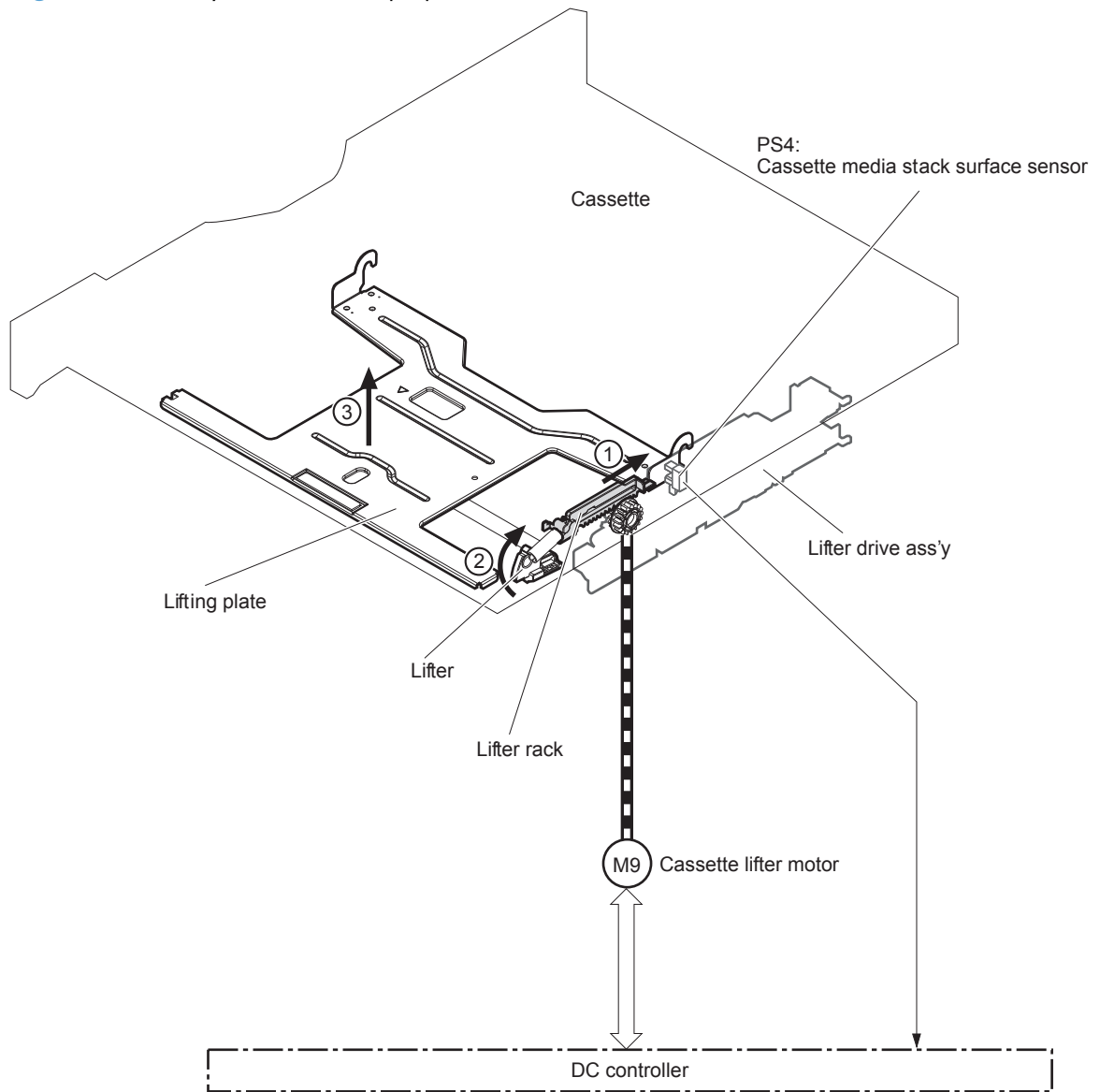

Cassette media-presence detection

The Tray 2 cassette-media-out sensor detects the presence of paper in the Tray 2 cassette.

The DC controller notifies the formatter when the Tray 2 cassette-media-out sensor detects the media is absent.

Figure 1-37 Tray 2 cassette media-presence detection

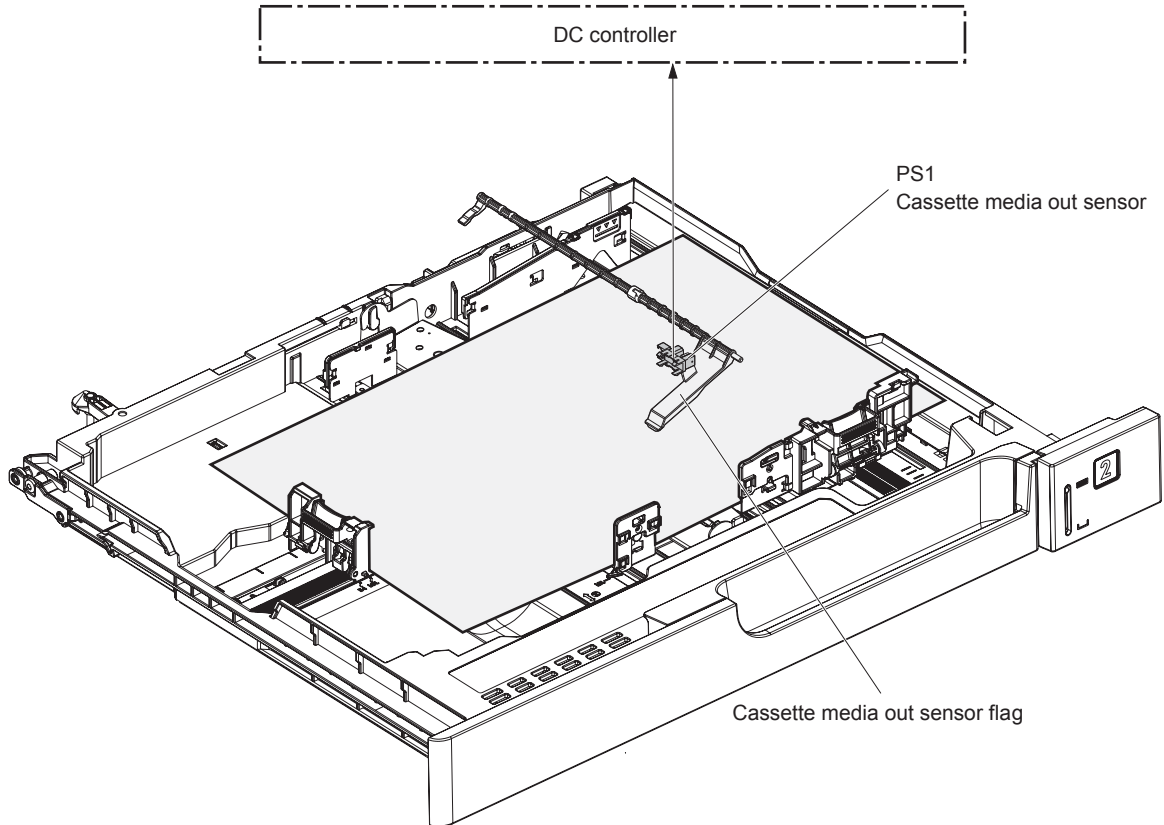

Tray 1 (MP tray) paper pickup

The operational sequence of the MP tray pickup is as follows:

1. The DC controller rotates the pickup motor when it receives a print command from the formatter.
2. As the MP tray pickup solenoid is driven, the MP tray pickup roller rotates and the lifting plate moves up.
3. The MP tray pickup roller picks up the paper.
4. The MP tray separation pad removes any multiple-fed sheets and one sheet of paper is fed into the product.

The MP tray media presence sensor detects the presence of print media on the MP tray.

Figure 1-38 Tray 1 (MP tray) paper pickup

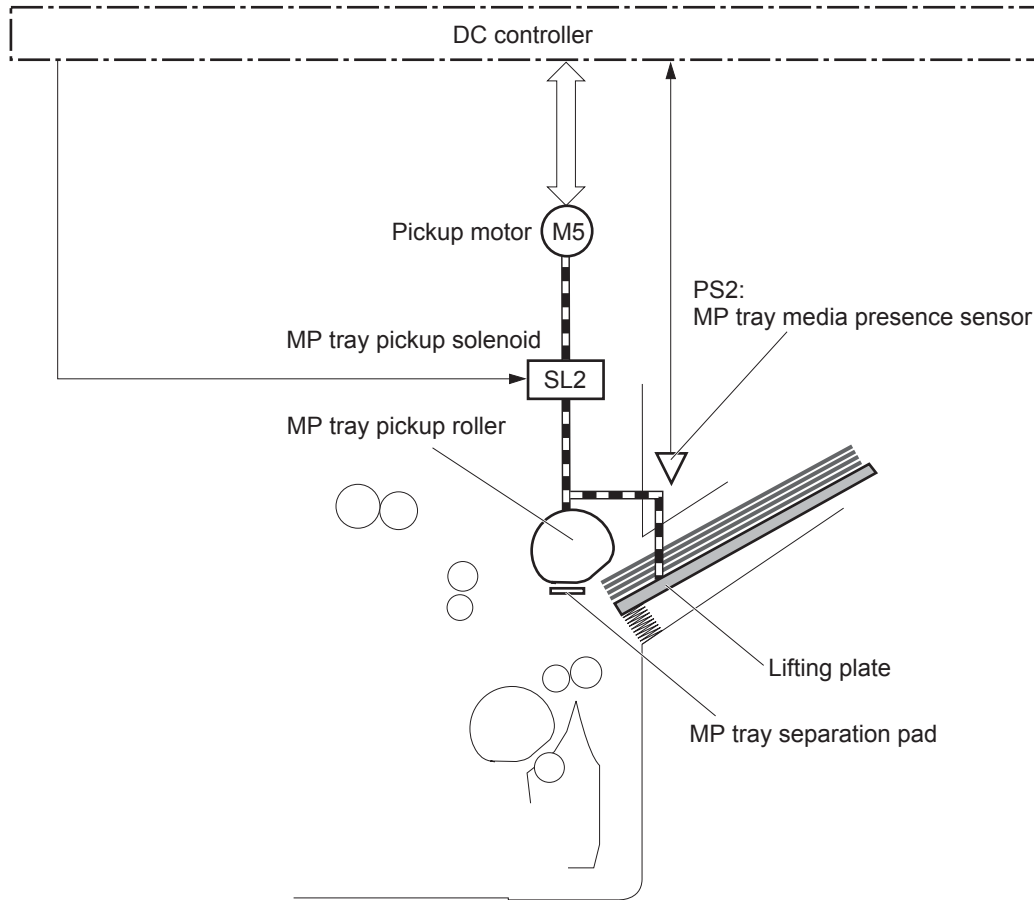

Tray 1 (MP tray) last-paper detection

The product detects whether the print media on the MP tray is the last sheet during continuous printing to prevent toner contamination on the photosensitive drums and the ITB.

The product attempts to form the next image before the DC controller detects a media absence because the paper path between the MP tray media-presence sensor and the registration roller is short. To prevent the photosensitive drums and the ITB from being contaminated with toner, the last-paper sensor detects the last-paper. The MP tray last-paper detection roller rotates when the last-paper is picked up.

The DC controller notifies the formatter of a media absence when it detects the last-paper by the last-paper sensor.

Figure 1-39 Tray 1 (MP tray) last-paper detection

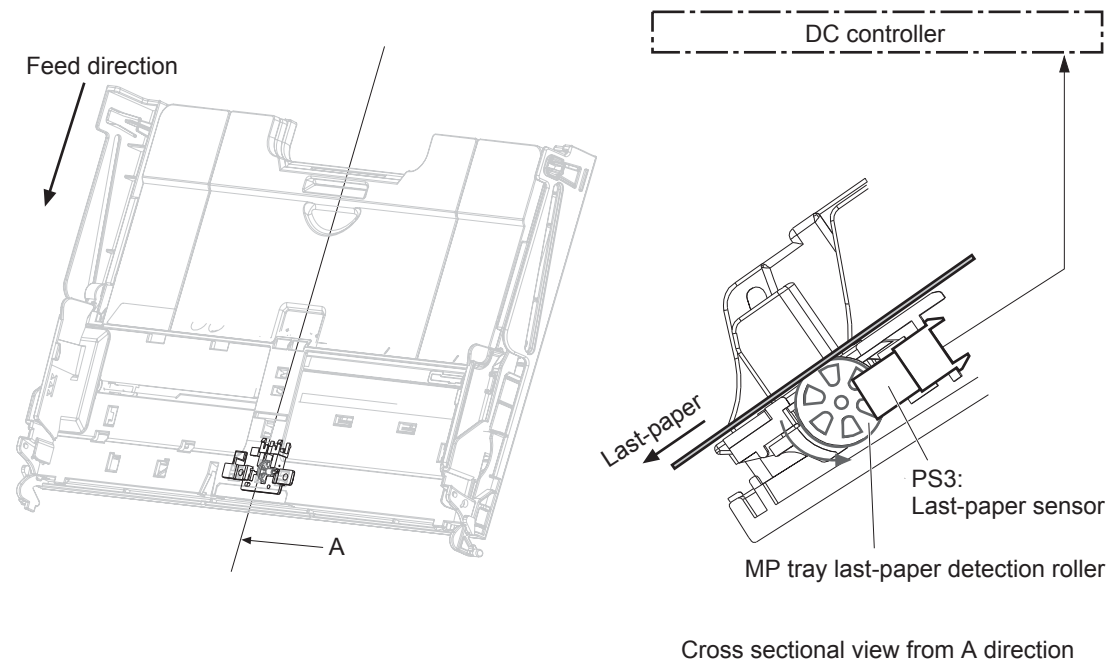

Paper feed

After the paper pickup operation, the paper picked up from either the Tray 2 cassette or MP tray is then fed to the fixing-and-delivery block.

1. The registration shutter corrects the skew-feeding of the paper that is picked up from the Tray 2 cassette or MP tray.
2. When the TOP sensor detects the leading edge of paper, the DC controller controls the rotational speed of the pickup motor to align with the leading edge of toner image on the ITB.
3. The toner image on the ITB is transferred onto the paper, and the paper is fed to the fusing-and-delivery block.

The DC controller notifies the formatter of a paper size mismatch error when the paper length detected by the TOP sensor does not match the paper size specified by the formatter.

Figure 1-40 Paper feed

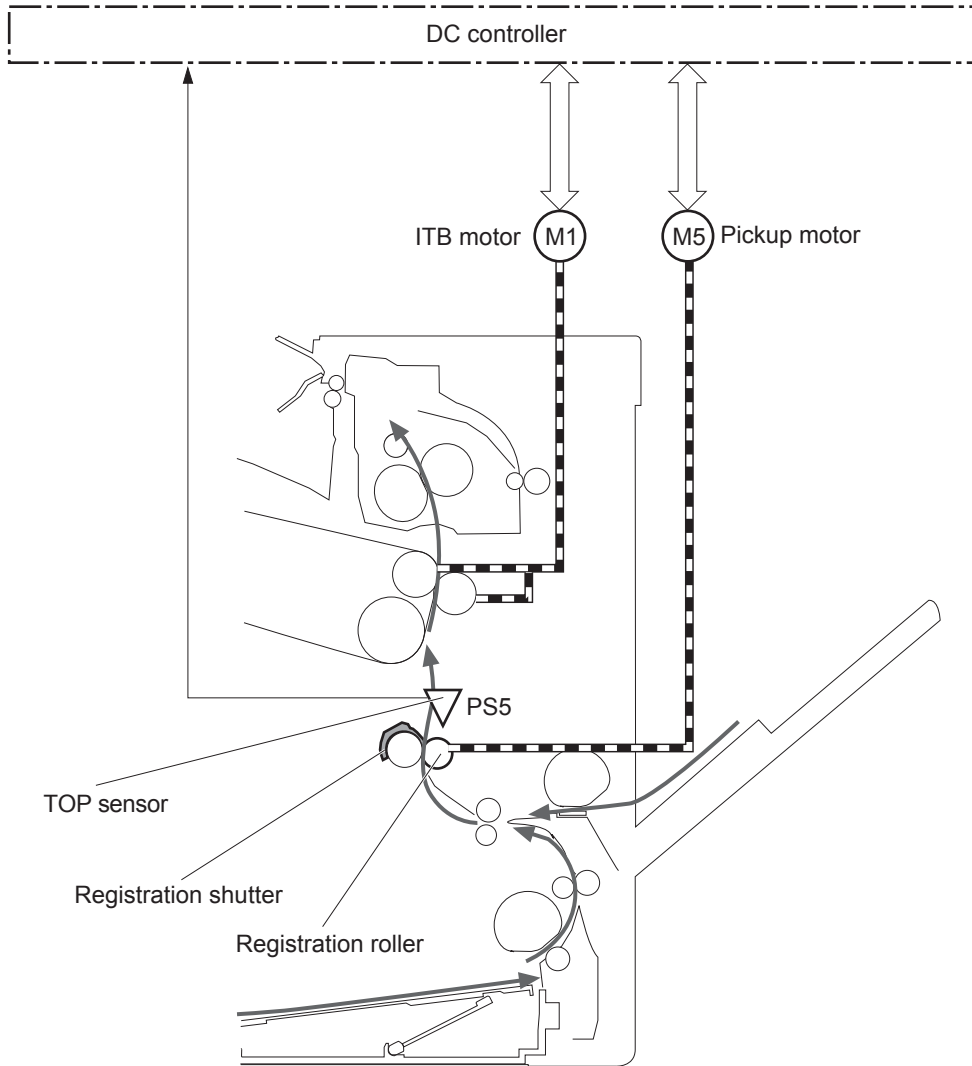

Skew-feed prevention

The printer corrects the skew feed without decreasing the throughput.

1. The leading edge of paper strikes the registration shutter and aligns.
2. As the feed rollers keep pushing the paper, the paper gets warped against the registration shutter.
3. The stiffness of paper pushes up the registration shutter and the realigned paper passes through straightened.

Figure 1-41 Skew-feed prevention

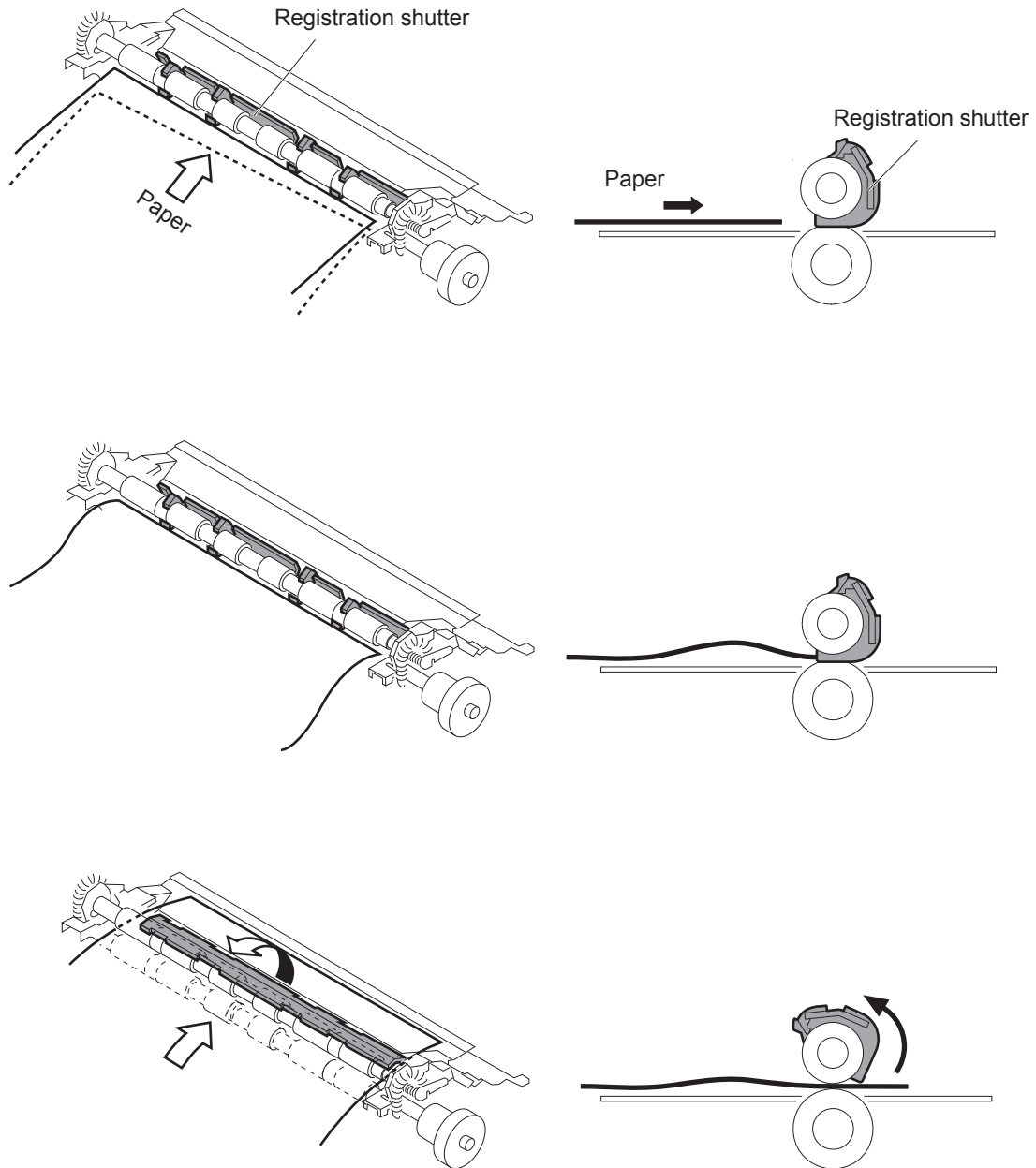

Media detection

The product automatically selects an optimal print mode for a print-media by monitoring the media sensors on the paper path.

Media detection sensor types

- Reflected light type (detects the glossiness of paper)
- Transmitted light type (detects the thickness of paper)

The DC controller detects the type of print-media by the reflected light and the transmitted light, and switches the print modes accordingly. The DC controller identifies the following paper type:

- Plain paper
- Light paper
- Heavy paper
- Glossy paper
- Glossy film
- Overhead transparency (OHT)

The DC controller determines a media mismatch error and notifies the formatter under the following conditions:

- Simplex printing
 - The specified print mode is OHT, but the media sensor detects media other than an overhead transparency.
 - The specified print mode is something other than OHT, but the media sensor detects an overhead transparency.
- Duplex printing
 - The specified print mode is for duplex-printable-print mode, but the media sensor detects an overhead transparency. For more information about duplex-printable mode, see [Duplex block \(duplex models only\) on page 63](#).

The DC controller flashes the media sensor during the initial rotation period under the following conditions:

- Product power is turned on
- The door is closed

The DC controller determines a media sensor abnormality and notifies the formatter when the light intensity is out of a specified range.

Feed-speed control

The product adjusts the feed speed to obtain the best print quality depending on the type of print media. The product prints at the speed corresponding to the print mode specified by the formatter.

Auto Sense mode	Print mode	Print speed	Media sensor detection
Normal mode	Normal	1/1	Yes
Light mode	Light media 1	1/1	Yes
Heavy Mode	Heavy media 1	2/3	Yes
Cardstock Mode	Heavy media 3	1/3	No
Transparency Mode	OHT	1/3	Yes
Transparency2 Mode	OHT + higher fuser temp	1/3	Yes
Envelope Mode	Envelope	2/3	No
Label Mode	Label	1/3	No
Tough Mode	Glossy film	1/3	Yes
Extra Heavy Mode	Heavy media 2	1/3	Yes
Heavy Glossy Mode	Glossy media 1	2/3	Yes
X-hvyglossymode	Glossy media 2	1/3	Yes
Rough Mode	Rough	2/3	No
Card Glossy Mode	Glossy media 3	1/3	Yes
4mm trns Mode	OHT + lower fuser temp	1/3	Yes
Light Rough Mode	Light media 1 + fuser temp adjustments	1/1	Yes

Fusing and delivery block

The fusing-and-delivery block fuses the toner image onto the print media and delivers the printed page to the output bin.

Loop control

The product controls the loop (slackness) of print media to prevent the defects of print quality and media feed.

- If the fuser sleeve rotates slower than the ITB, the paper loop increases and an image defect or paper crease occurs.
- If the fuser sleeve rotates faster than the ITB, the paper loop decreases and an image is stretched because the toner image is not transferred to the paper correctly

Two loop sensors located between the fuser sleeve and the ITB detect the paper loop. Accordingly the DC controller controls the rotational speed of the fuser motor to keep the loop amount properly.

- Loop sensor 1: Detects the paper loop for heavy media
- Loop sensor 2: Detects the paper loop for plain media other than heavy media

Figure 1-42 Loop control

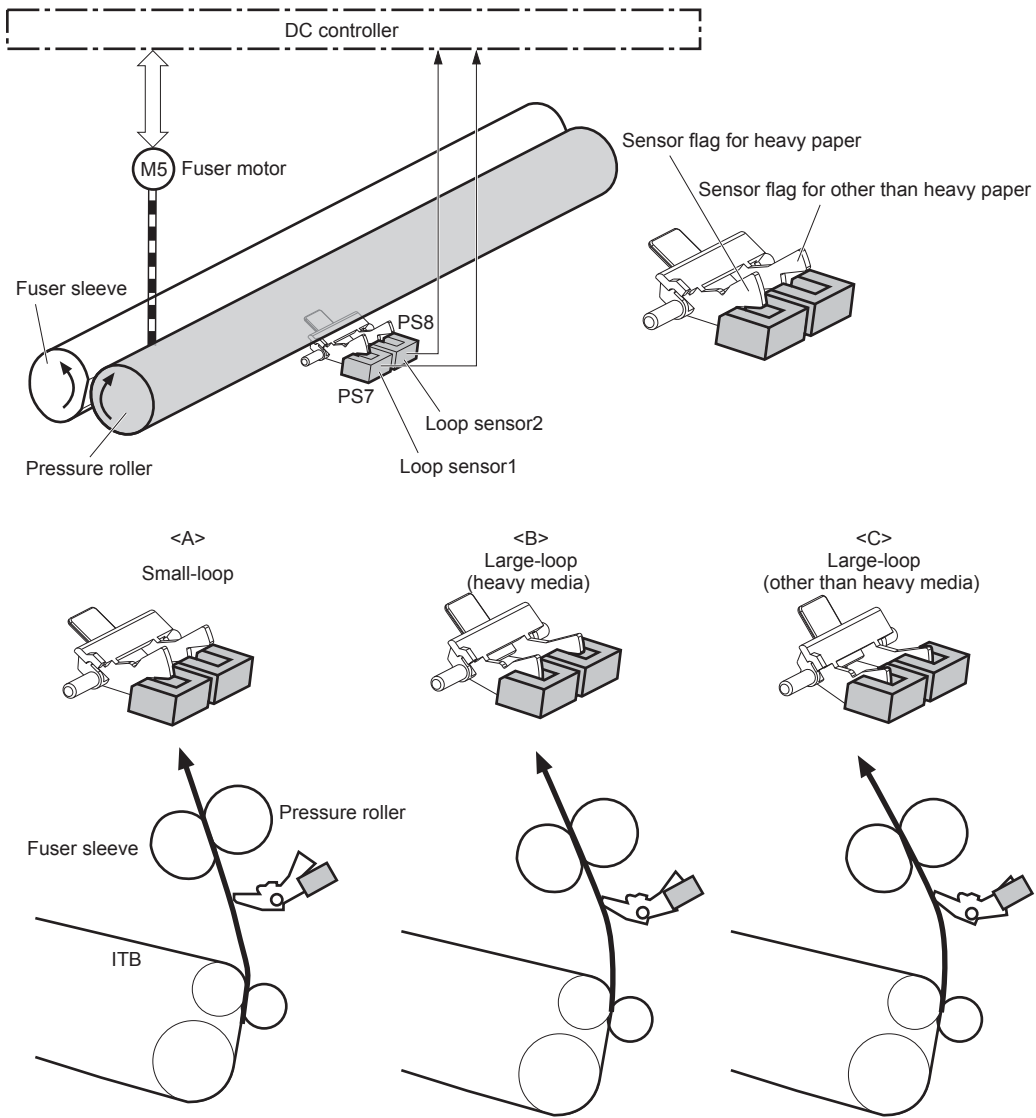

Loop sensor1	Loop sensor2	Speed of fuser motor	Illus.
OFF	OFF	Speed down	A
ON	OFF	Heavy media: Speed up Other media: Speed down	B
ON	ON	Speed up	C

Pressure roller pressurization and depressurization control

The product releases the pressure roller from the fuser sleeve, except during printing, to prevent deforming the fuser sleeve and the pressure roller and to facilitate the jam-clearing procedure.

1. The DC controller reverses the fuser motor to rotate the fuser pressure release cam.
2. The pressure roller is pressurized or depressurized depending on the position of the cam.

The DC controller determines a fuser pressure-release mechanism abnormality and notifies the formatter when it does not sense the fuser pressure-release sensor for a specified period from when it reverses the fuser motor.

Figure 1-43 Pressure roller pressurization and depressurization control

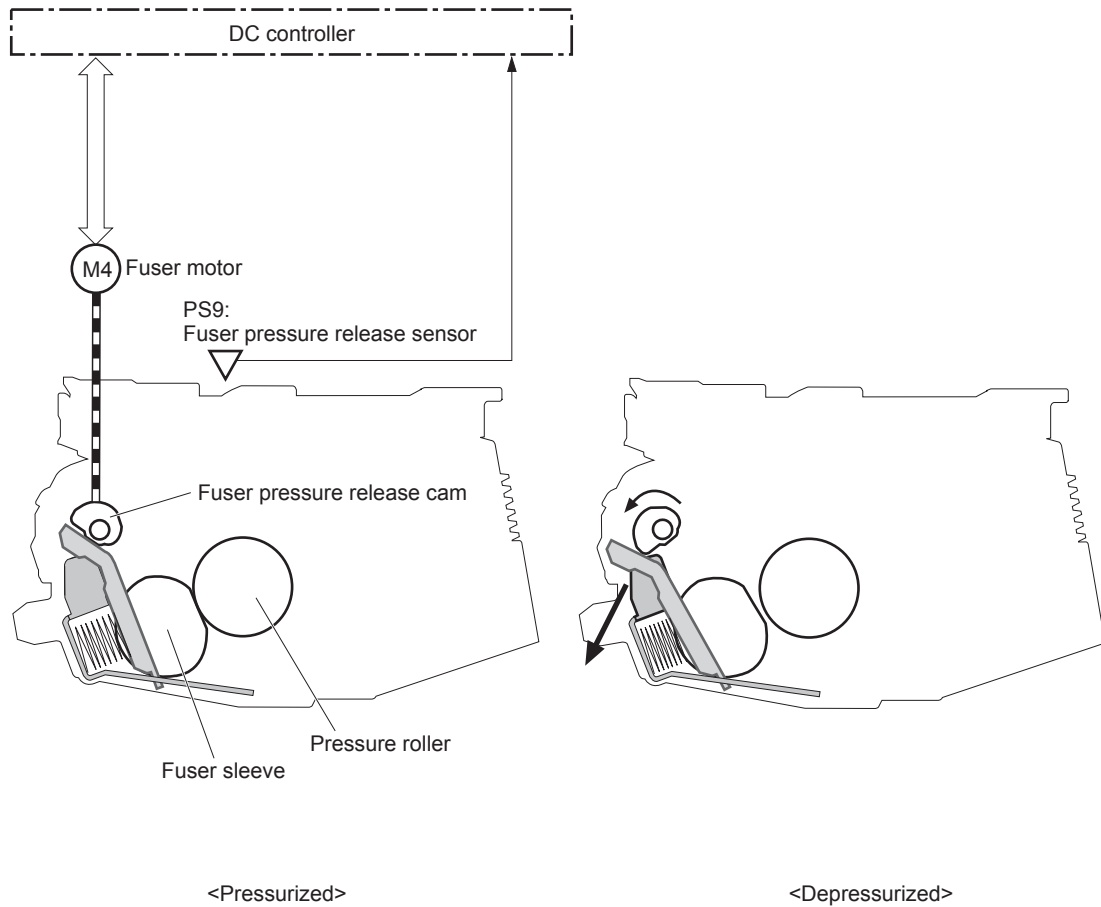

Output bin full detection

The output bin media-full sensor detects whether the output bin is full of printed pages. The DC controller determines the output bin is full and notifies the formatter when it senses the output bin media-full sensor is on for a specified period during standby or printing.

Figure 1-44 Output bin full detection

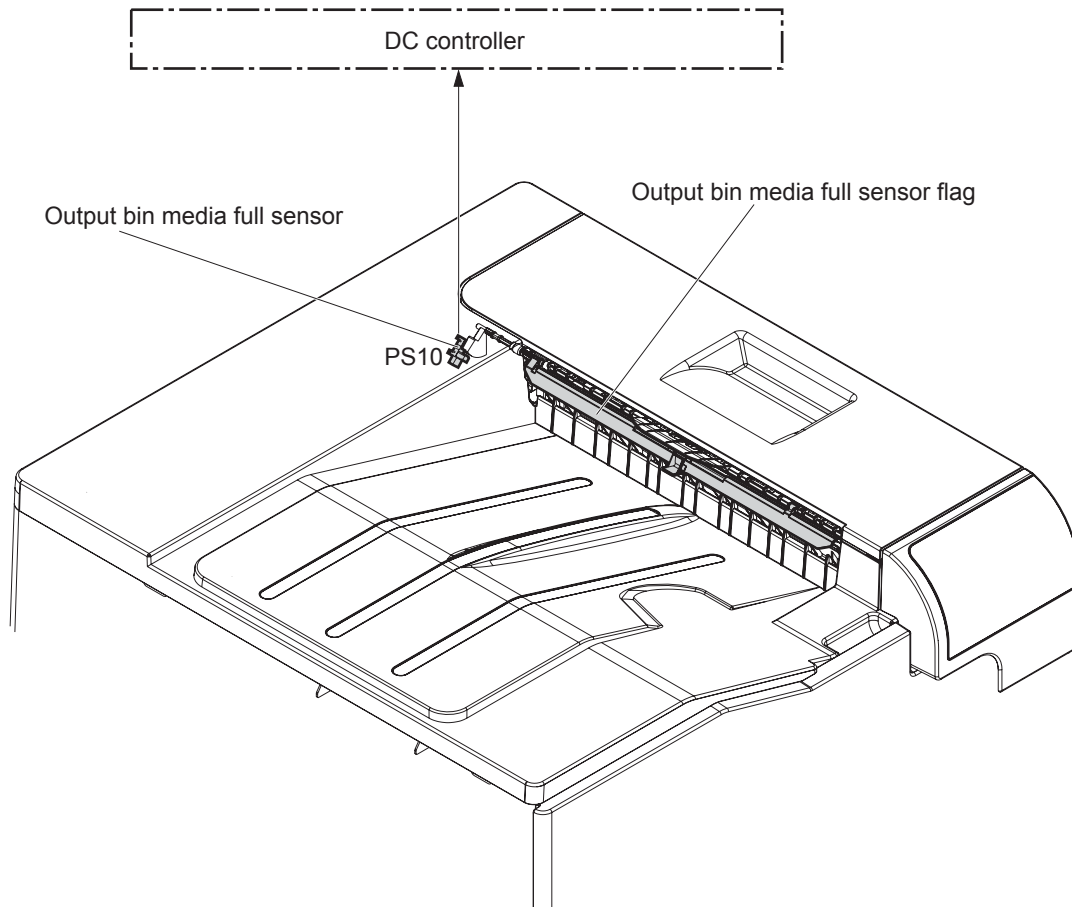

Duplex block (duplex models only)

The duplex block reverses and feeds the paper.

Figure 1-45 Duplex block

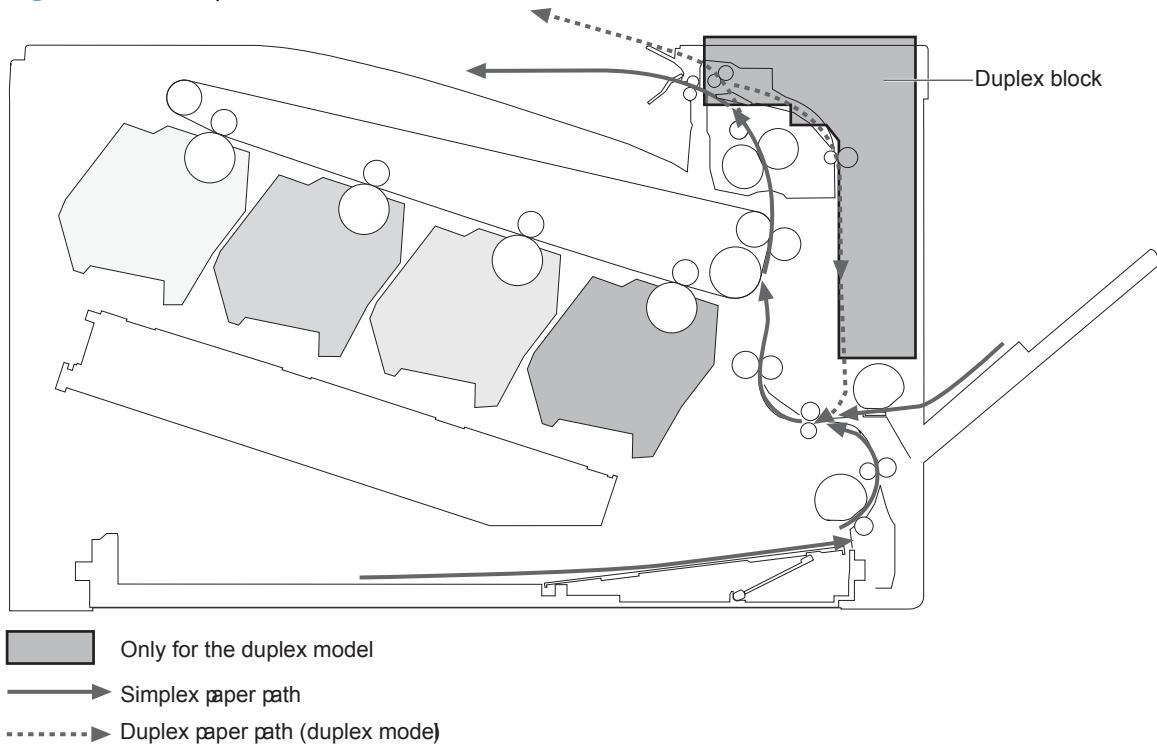

Duplex reverse and duplex feed control

The duplex reverse control reverses the paper after the first side is printed. The duplex feed control feeds the paper to the duplex block to print the second side of the page.

The operational sequence of the duplex reverse and duplex feed control is as follows:

1. The DC controller rotates the duplex reverse motor and drives the duplex reverse solenoid at a specified timing after the first side of page is printed.
2. The duplex flapper moves and the paper is fed by the duplex reverse roller.
3. The duplex reverse motor is reversed.
4. The duplex reverse roller is reversed accordingly the paper is switched back.

5. The duplex feed motor rotates.
6. The duplex feed roller feeds the paper.

Figure 1-46 Duplex operation

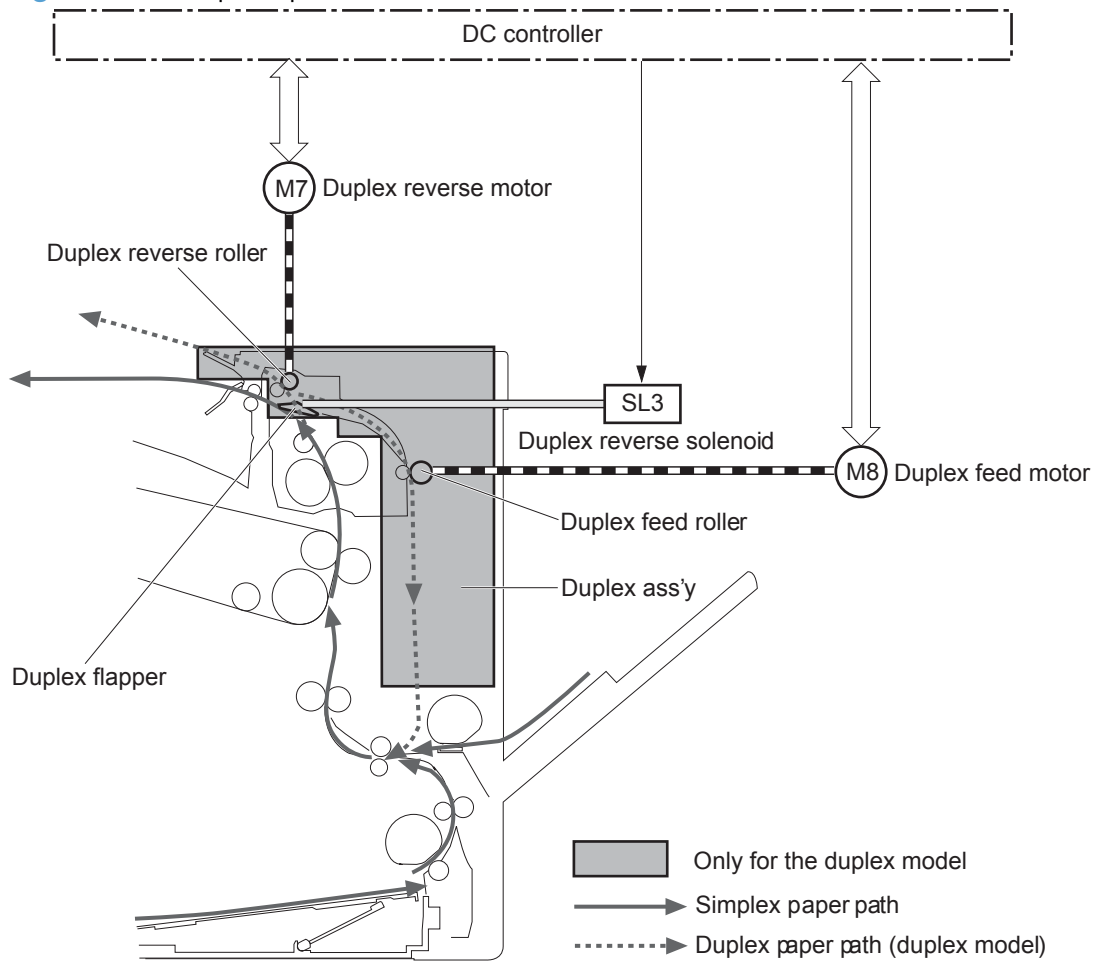

Duplex operation

The product prints two sides of paper with the following operation depending on the paper size.

- One-sheet operation: Feeds one sheet of two-sided page in a duplex print operation
- Two-sheet operation: Feeds two sheets of two-sided page in a duplex print operation

The duplex print operation is specified by the formatter.

The duplex print is performed only with the duplex printable paper size and specified print mode. See [Table 1-8 Paper sizes, duplex operation on page 65](#) and [Table 1-9 Print modes, duplex operation on page 65](#).

Table 1-8 Paper sizes, duplex operation

Paper size	Duplexing media feed mode
A4-R	One-sheet operation
A3	
Letter-R	
B4	
B5-R	
Ledger	
Legal	
A4	
B5	Two-sheet operation
Letter	
A5-R	
Executive	

Table 1-9 Print modes, duplex operation

Print mode	Duplex print ¹	Print mode	Duplex print ¹
AUTO	Yes	X-hvyglossy	Yes
Normal	Yes	Card glossy	No
Light	Yes	Rough	Yes
Light rough	Yes	Transparency	No
Heavy	Yes	4mm transparency	No
Extra heavy	No	Tough	Yes
Cardstock	No	Label	No
heavy glossy	Yes	Envelop	No

¹ This table shows whether the automatic duplex operation is available for each print mode, but it does not mean that the print-quality of the automatic duplex print operation will be acceptable.

Jam detection

The product uses the following sensors to detect the presence of print-media and to check whether the print-media is being fed correctly or has jammed:

- TOP sensor (PS5)
- Fuser delivery sensor (PS6)
- Loop sensor 1 (PS7)
- Loop sensor 2 (PS8)
- Output bin media full sensor (PS10)

Figure 1-47 Sensors for jam detection

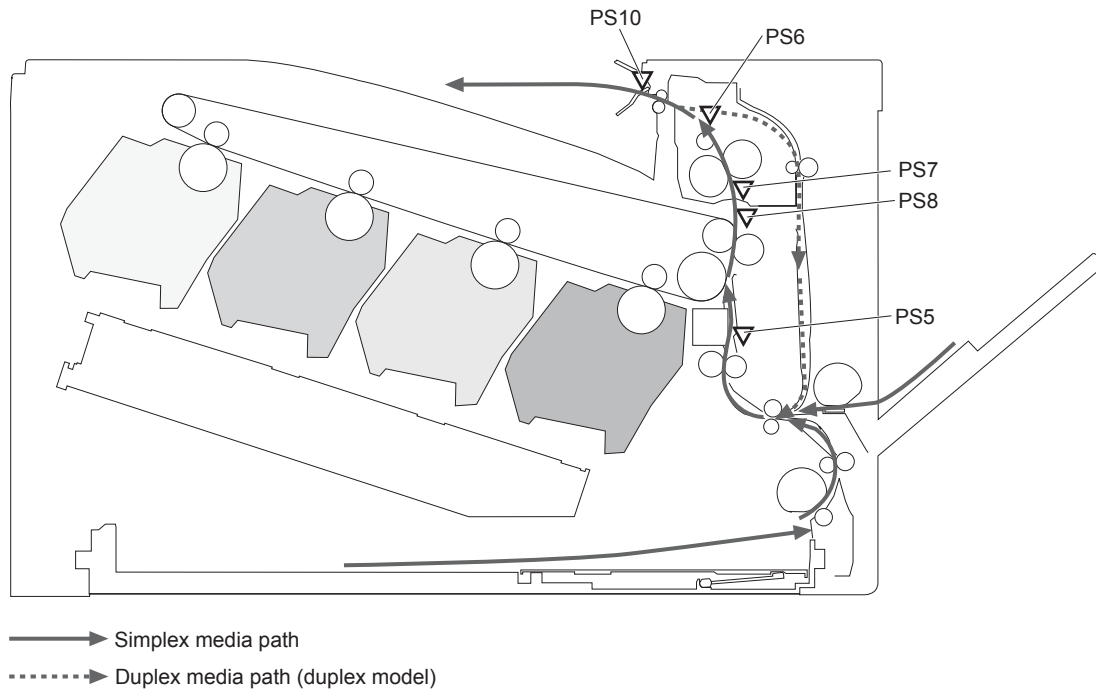

The product detects the following jams:

Pickup delay jam	<p>Tray 1 (MP tray): The TOP sensor does not detect the leading edge of paper within a specified period, including a retry, after the MP tray pickup solenoid is turned on.</p> <p>Tray 2 cassette: The TOP sensor does not detect the leading edge of paper within a specified period, including a retry, after the Tray 2 cassette pickup solenoid is turned on.</p> <p>Paper feeder: The TOP sensor does not detect the leading edge of paper within a specified period after the paper-feeder (PF) feed sensor detects the leading edge.</p>
Pickup stationary jam	The TOP sensor does not detect the trailing edge of paper within a specified period after the leading edge of paper reaches the secondary transfer roller unit.
Fuser delivery delay jam	The fuser delivery sensor does not detect the leading edge of paper within a specified period after the leading edge of paper reaches the secondary transfer roller unit.

Fuser delivery stationary jam	<p>The fuser delivery sensor does not detect the trailing edge of paper within a specified period after the TOP sensor detects the trailing edge.</p> <p>The output bin media full sensor does not detect the leading edge of paper within a specified period after the fuser delivery sensor detects the leading edge.</p>
Wrapping jam	The fuser delivery sensor detects a paper absence yet it does not detect the trailing edge of paper after it detects the leading edge.
Residual paper jam	<p>One of the following sensors detects a presence of paper when the printer is turned on or when the door is closed.</p> <ul style="list-style-type: none"> • TOP sensor • Fuser delivery sensor • Loop sensor 1 • Loop sensor 2 <p>NOTE: The product automatically clears all paper from the paper path if the TOP sensor detects residual paper when the product is turned on or a door is closed.</p>
Door open jam	The door open is detected during a paper feed operation.
Duplex re-pickup jam (duplex model only)	The TOP sensor does not detect the leading edge of paper within a specified period after the paper is reversed during a duplex print operation.

Paper feeder

This product supports a 500-sheet tray (Tray 3). The operational sequence of the paper feeder is controlled by the paper feeder controller PCA.

Figure 1-48 Paper-feeder paper path

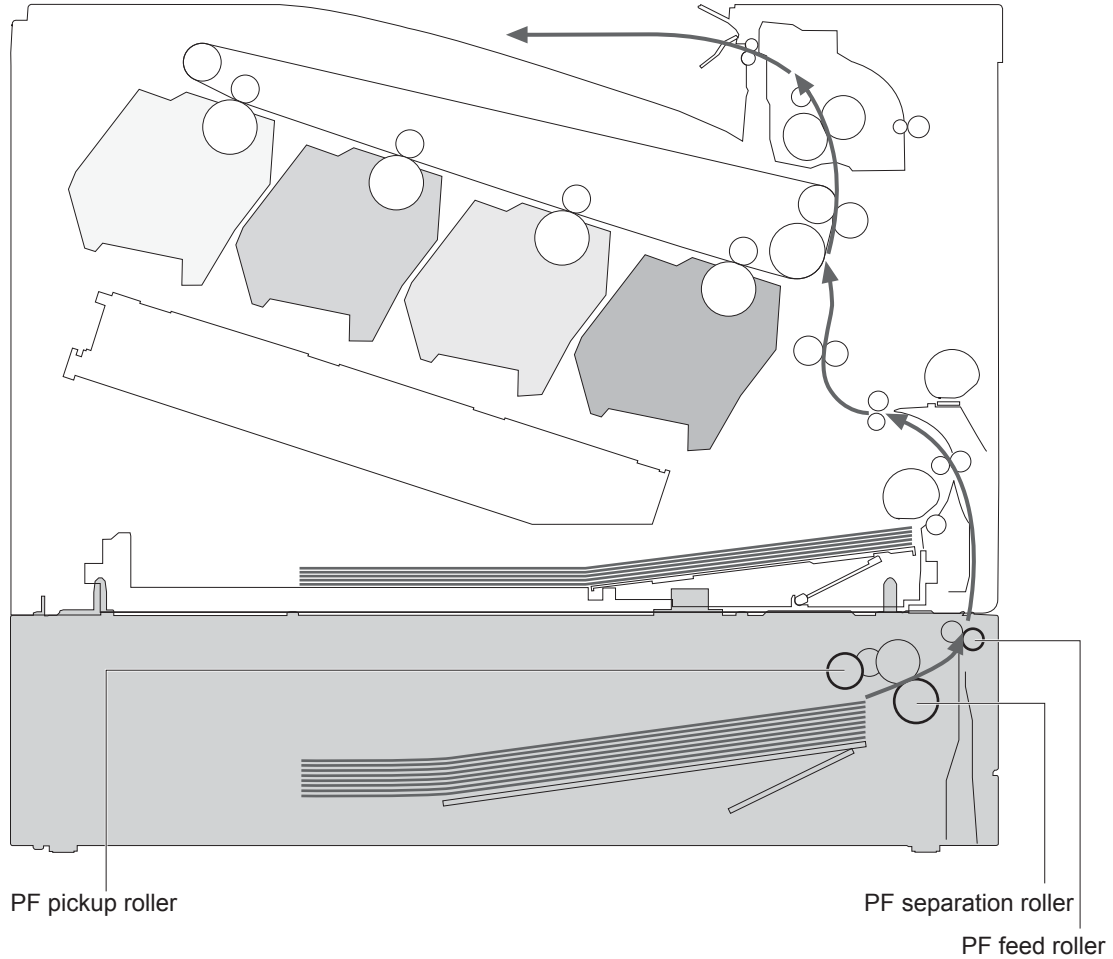
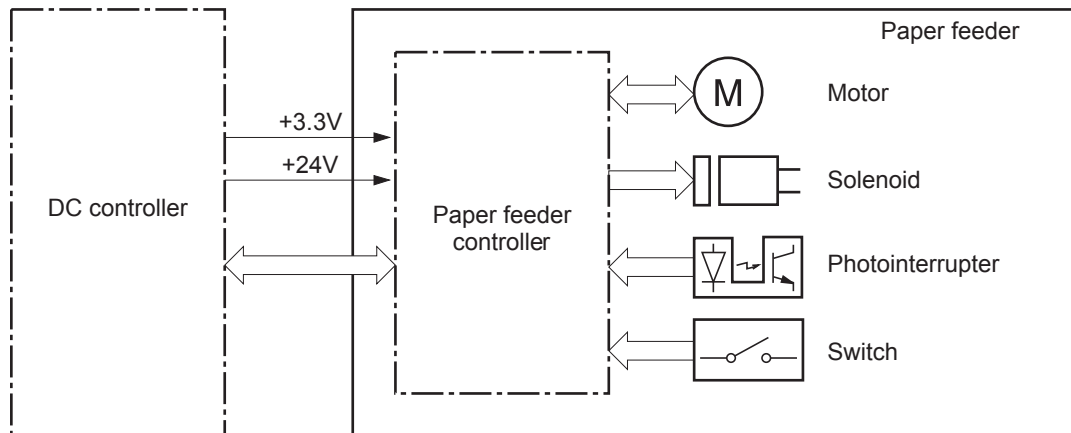

Figure 1-49 Paper-feeder block diagram



Paper-feeder motors

The paper feeder has two motors for paper feed and cassette lift-up operation.

Figure 1-50 Paper-feeder motors

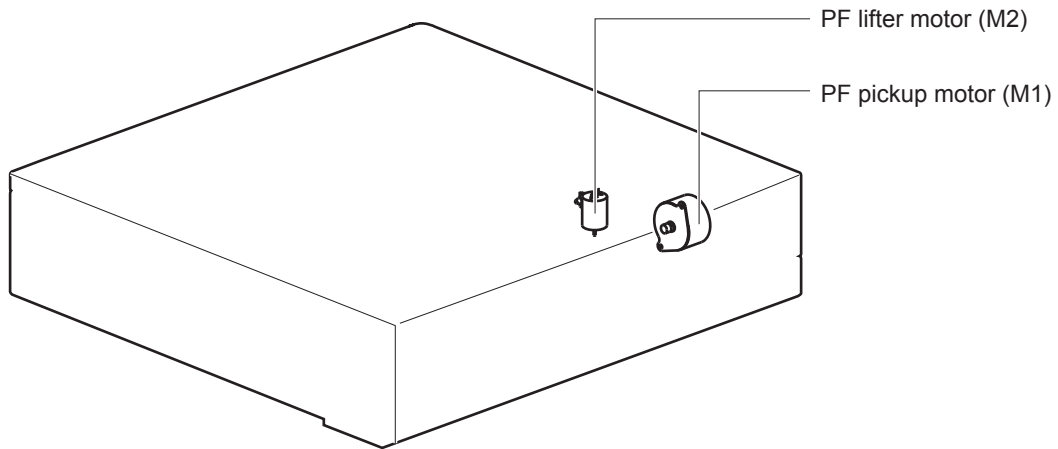

Table 1-10 Paper-feeder motors

Motor	Driving part	Failure detection
PF pickup motor (M1)	PF pickup roller PF separation roller PF feed roller	No
PF lifter motor (M2)	Lifter for the PF cassette	No

Paper-feeder paper pickup and feed

The pickup-and-feed operation picks up one sheet of print media in the paper-feeder cassette and feeds it to the product.

Figure 1-51 Paper-feeder electrical components

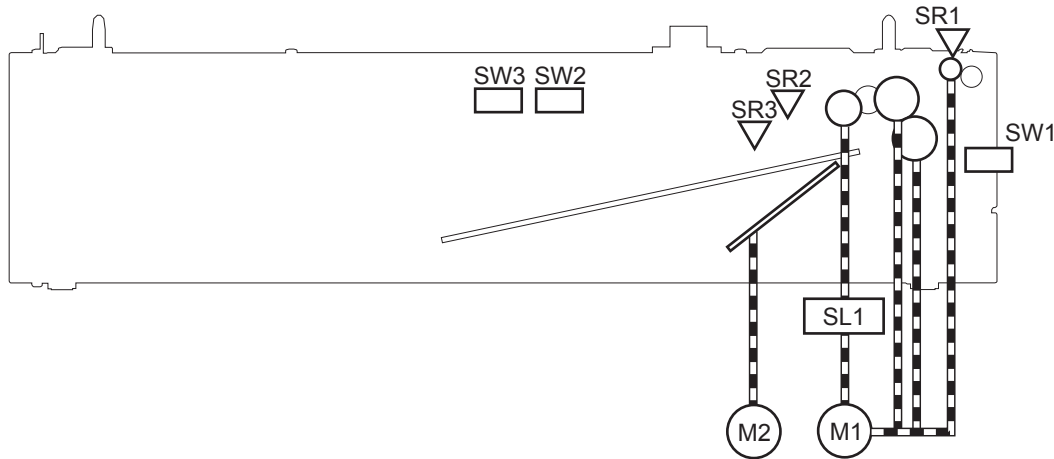

Table 1-11 Paper-feeder electrical components

Component type	Abbreviation	Description
Motor	M1	PF pickup motor
	M2	PF lifter motor
Solenoid	SL01	PF pickup solenoid
Photointerruptor (sensor)	SR1	PF paper-feed sensor
	SR2	PF paper-stack surface sensor
	SR3	PF cassette paper-presence sensor
Switch	SW1	PF door-open switch
	SW2	PF cassette paper end-plate position switch
	SW3	PF cassette paper-width switch

Cassette media-size detection and cassette-presence detection

The paper feeder detects the size of the paper loaded in the paper feeder cassette by monitoring the paper feeder cassette media end switch and the paper feeder cassette media width switch. It also detects the presence of cassette by monitoring the switches. The paper feeder controller notifies the formatter through the DC controller when it determines a cassette is absent.

Table 1-12 Cassette media-size detection and cassette-presence detection (Tray 3)

Paper size	Paper feeder			Paper feeder		
	Cassette media-width sensor			Cassette media-end switch		
	Top switch	Center switch	Bottom switch	Top switch	Center switch	Bottom switch
Executive	Off	On	On	On	On	On
Letter	Off	Off	On	On	On	On
A5	On	On	Off	On	On	On
B5	Off	On	Off	On	On	On
A4	Off	Off	Off	On	On	On
Ledger	Off	Off	On	Off	Off	On
Legal	On	On	Off	Off	Off	On
B4	Off	On	Off	Off	Off	On
A3	Off	Off	Off	Off	Off	On
A4-R Letter-R	NOTE: The product cannot detect the paper size of A4-R and Letter-R. If A4-R or Letter-R sized paper is loaded to the cassette, A5 size is notified to the formatter.					
Universal	On	On	Off	Off	On	On
Cassette absent	Off	Off	Off	Off	Off	Off

Paper-feeder cassette lift operation

The cassette lift-up operation keeps the surface of the paper stack at the pickup position whenever the following occurs:

- Product power is turned on
- Cassette is installed
- Stack surface in the cassette lowers

The operational sequence of the cassette lift-up is as follows:

1. The PF lifter motor rotates to raise the lifter.
2. When the PF paper-stack surface sensor detects the surface of the paper stack, the PF lifter motor stops.
3. The lifter motor rotates again when the PF paper-stack surface detects that the paper surface is lowered during a print operation.

The paper feeder controller PCA determines a PF lifter motor failure and notifies the formatter through the DC controller when the PF paper-stack surface sensor does not detect the stack surface within a specified period after the PF lifter motor starts rotating.

Figure 1-52 Paper-feeder cassette lift operation

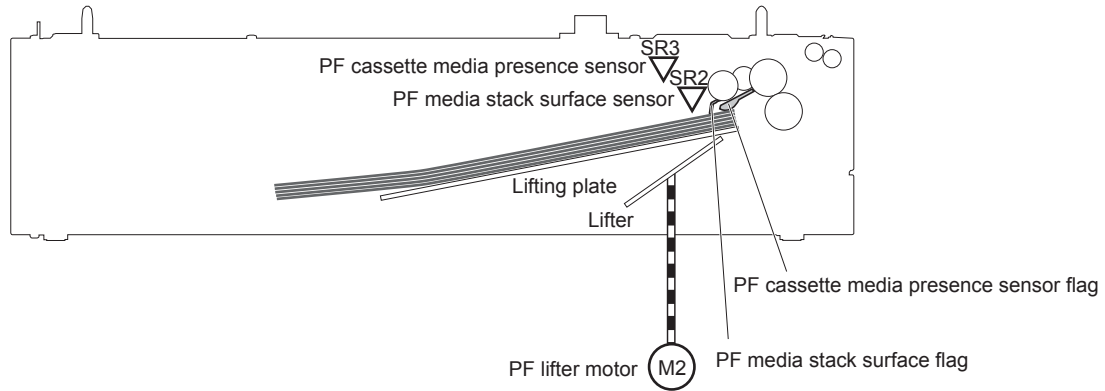

Paper-feeder jam detection

The paper feeder uses the PF paper-feed sensor (SR1) to detect the presence of print-media and to check whether print-media is being fed correctly or has jammed.

Figure 1-53 Paper-feeder jam detection

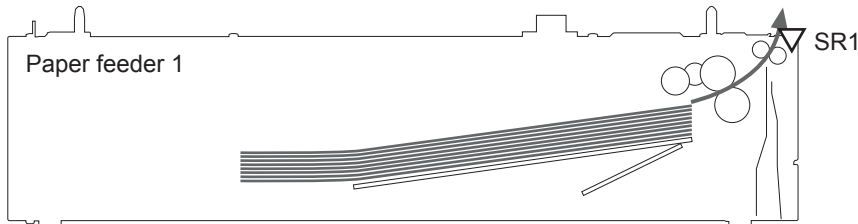

The paper feeder detects the following jams:

PF pickup delay jam	The PF paper-feed sensor does not detect the leading edge of paper within a specified period, including a retry, after the PF pickup solenoid is turned on.
PF residual paper jam	The PF paper-feed sensor detects a presence of paper when the printer is turned on, when the door is closed or when the automatic delivery is performed.
PF door open jam	A door open is detected during paper-feed operation.

Optional 3X500-sheet paper deck

The 3x500-sheet paper deck is installed at bottom of the product. It picks up the paper and feeds it to the printer. The paper deck controller controls the operational sequence of the paper deck.

Figure 1-54 3X500-sheet paper deck

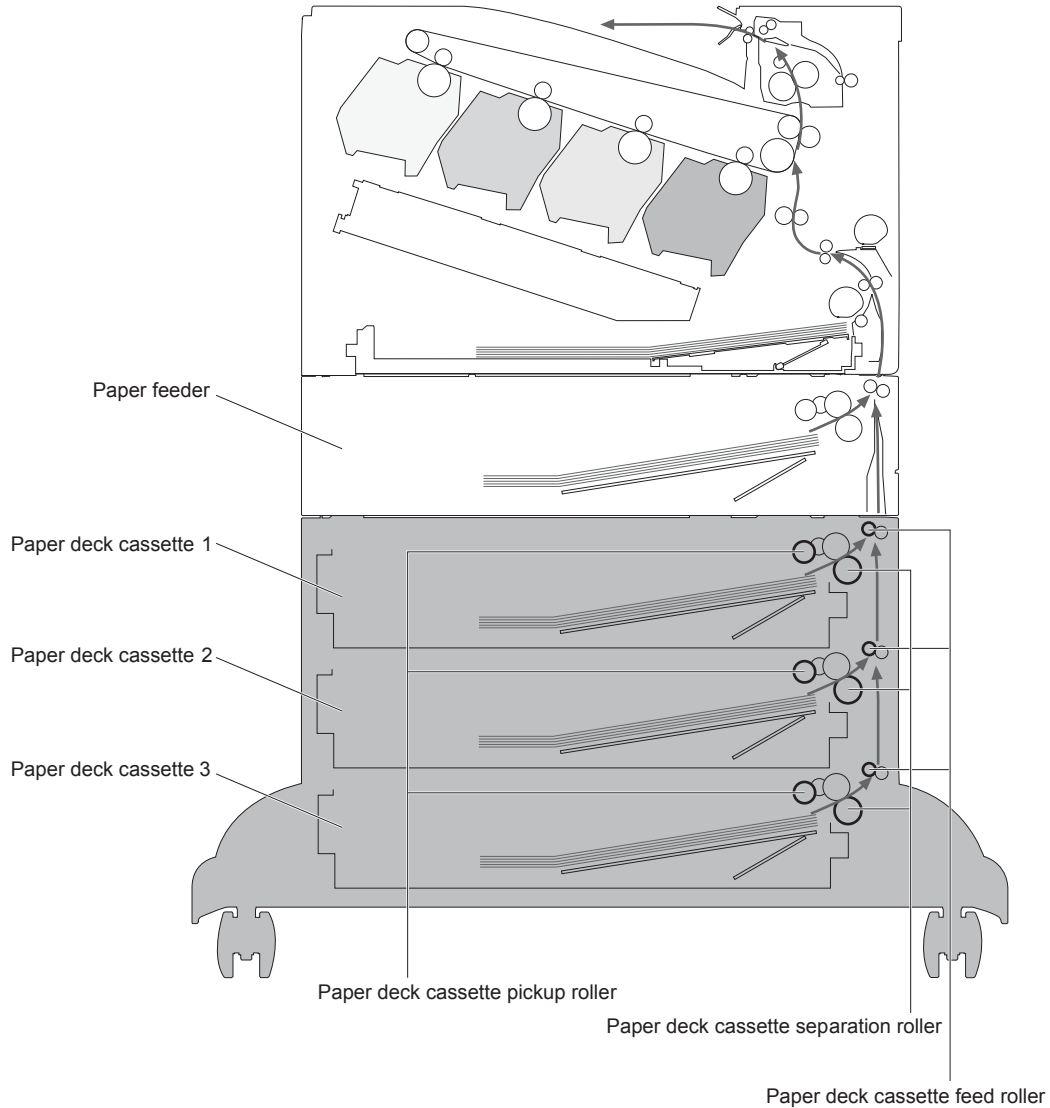

The signal flow of the paper deck controller is shown below.

Figure 1-55 3X500-sheet paper deck block diagram

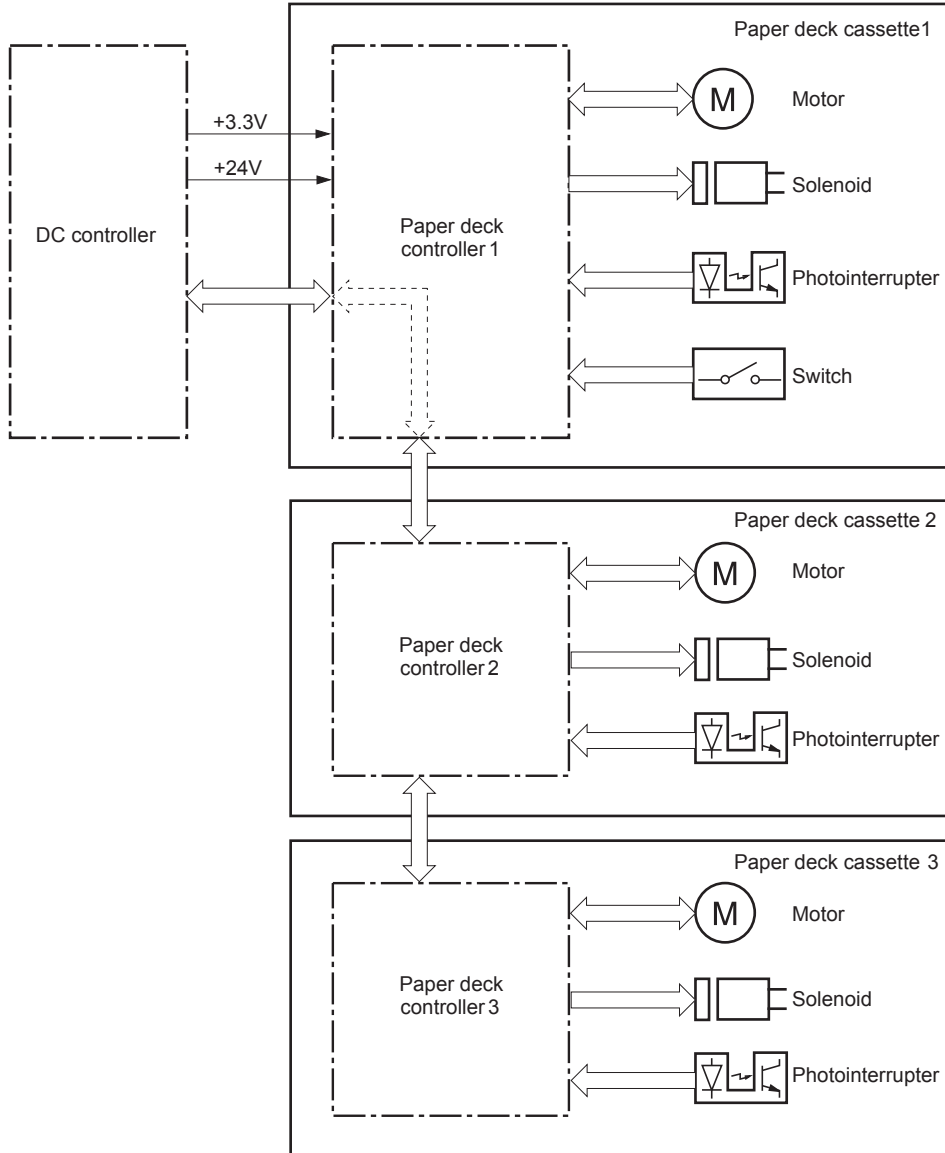

Table 1-13 3X500-sheet paper deck

Component		Description
Motor	M1	Paper deck cassette 1 pickup motor
	M2	Paper deck cassette 1 lifter motor
	M81	Paper deck cassette 2 pickup motor
	M82	Paper deck cassette 2 lifter motor
	M91	Paper deck cassette 3 pickup motor
	M92	Paper deck cassette 3 lifter motor

Table 1-13 3X500-sheet paper deck (continued)

Component		Description
Solenoid	SL1	Paper deck cassette 1 pickup solenoid
	SL82	Paper deck cassette 2 pickup solenoid
	SL92	Paper deck cassette 3 pickup solenoid
Photointerrupter	SR1	Paper deck cassette 1 media feed sensor
	SR2	Paper deck cassette 1 stack surface sensor
	SR3	Paper deck cassette 1 cassette media out sensor
	SR81	Paper deck cassette 2 media feed sensor
	SR82	Paper deck cassette 2 stack surface sensor
	SR83	Paper deck cassette 2 cassette media out sensor
	SR91	Paper deck cassette 3 media feed sensor
	SR92	Paper deck cassette 3 stack surface sensor
	SR93	Paper deck cassette 3 cassette media out sensor
Switch	SW1	Paper deck door-open-detection switch
	SW2	Paper deck cassette 1 cassette media end switch
	SW3	Paper deck cassette 1 cassette media width switch
	SW82	Paper deck cassette 2 cassette media end switch
	SW83	Paper deck cassette 2 cassette media width switch
	SW92	Paper deck cassette 3 cassette media end switch
	SW93	Paper deck cassette 3 cassette media width switch

Motor control

Each of the paper deck cassettes uses two motors for paper-feed and cassette lift-up operation.

Figure 1-56 Paper deck motors

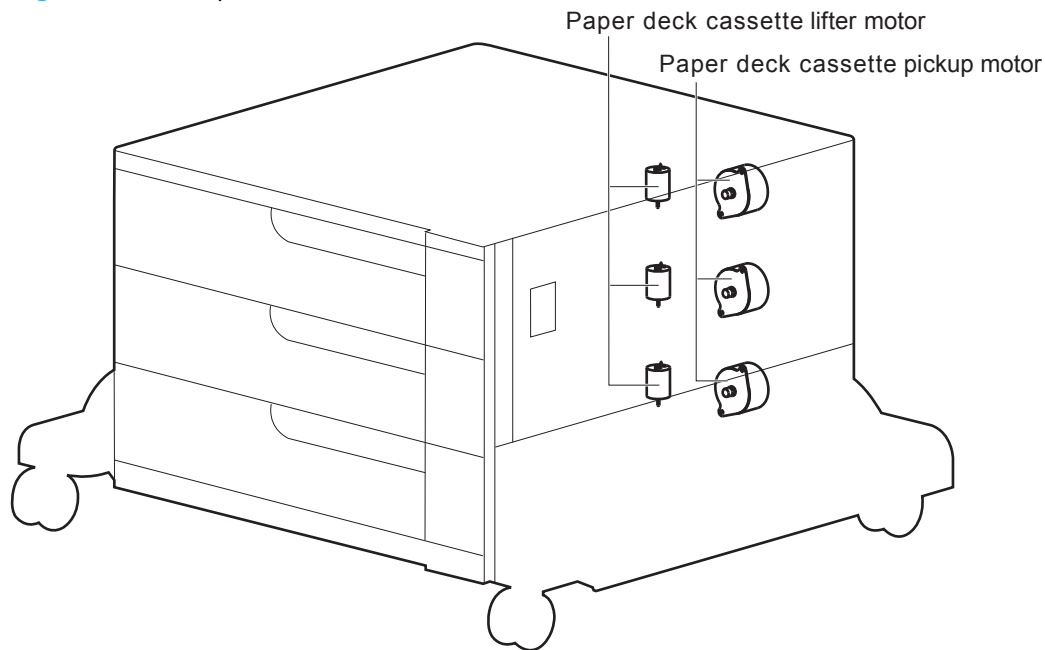

Table 1-14 Paper deck motors

Component		Component driven	Failure detection
Paper deck cassette 1 pickup motor	M1	Paper deck cassette 1 pickup roller, paper deck cassette 1 separation roller, and paper deck cassette 1 feed roller	No
Paper deck cassette 1 lifter motor	M2	Lifter for the paper deck cassette 1	No
Paper deck cassette 2 pickup motor	M81	Paper deck cassette 2 pickup roller, paper deck cassette 2 separation roller, and paper deck cassette 2 feed roller	No
Paper deck cassette 2 lifter motor	M82	Lifter for the paper deck cassette 2	No
Paper deck cassette 3 pickup motor	M91	Paper deck cassette 3 pickup roller, paper deck cassette 3 separation roller, and paper deck cassette 3 feed roller	No
Paper deck cassette 3 lifter motor	M92	Lifter for the paper deck cassette 3	No

Pickup-and-feed operation

The pickup-and-feed operation picks up one sheet of paper in the paper deck cassette and feeds it to the product. The paper deck has three cassettes but each cassette performs the same operation. Paper deck cassette 3 is used to describe the pickup-and-feed operation in this section.

Figure 1-57 Pickup-and-feed operation

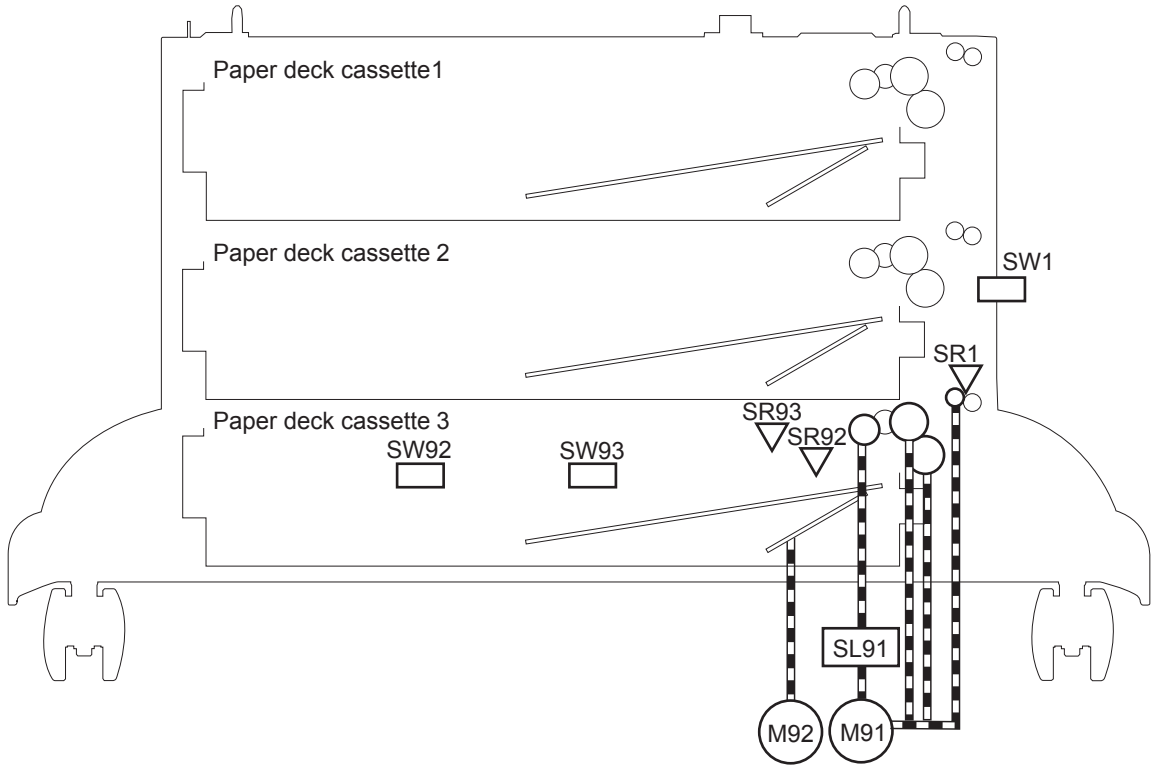

Table 1-15 Pickup-and-feed operation

Component		Signal
Paper deck cassette 1 pickup motor	M1	PAPER DECK CASSETTE 1 PICKUP MOTOR CONTROL signal
Paper deck cassette 1 lifter motor	M2	PAPER DECK CASSETTE 1 LIFTER MOTOR CONTROL signal
Paper deck cassette 1 pickup solenoid	SL01	PAPER DECK CASSETTE 1 SOLENOID signal
Paper deck cassette 1 media feed sensor	SR1	PAPER DECK CASSETTE 1 MEDIA FEED signal
Paper deck cassette 1 media stack surface sensor	SR2	PAPER DECK CASSETTE 1 MEDIA STACK SURFACE signal
Paper deck cassette 1 media out sensor	SR3	PAPER DECK CASSETTE 1 MEDIA OUT signal
Paper deck door-open-detection switch	SW1	PAPER DECK DOOR OPEN DETECTION signal
Paper deck cassette 1 media end switch	SW2	PAPER DECK CASSETTE 1 MEDIA END signal
Paper deck cassette 1 media width switch	SW3	PAPER DECK CASSETTE 1 MEDIA WIDTH signal
Paper deck cassette 2 pickup motor	M81	PAPER DECK CASSETTE 2 PICKUP MOTOR CONTROL signal

Table 1-15 Pickup-and-feed operation (continued)

Component		Signal
Paper deck cassette 2 lifter motor	M82	PAPER DECK CASSETTE 2 LIFTER MOTOR CONTROL signal
Paper deck cassette 2 pickup solenoid	SL82	PAPER DECK CASSETTE 2 SOLENOID signal
Paper deck cassette 2 media feed sensor	SR81	PAPER DECK CASSETTE 2 MEDIA FEED signal
Paper deck cassette 2 media stack surface sensor	SR82	PAPER DECK CASSETTE 2 MEDIA STACK SURFACE signal
Paper deck cassette 2 media out sensor	SR83	PAPER DECK CASSETTE 2 MEDIA OUT signal
Paper deck cassette 2 media end switch	SW82	PAPER DECK CASSETTE 2 MEDIA END signal
Paper deck cassette 2 media width switch	SW83	PAPER DECK CASSETTE 2 MEDIA WIDTH signal
Paper deck cassette 3 pickup motor	M91	PAPER DECK CASSETTE 3 PICKUP MOTOR CONTROL signal
Paper deck cassette 3 lifter motor	M92	PAPER DECK CASSETTE 3 LIFTER MOTOR CONTROL signal
Paper deck cassette 3 pickup solenoid	SL91	PAPER DECK CASSETTE 3 SOLENOID signal
Paper deck cassette 3 media feed sensor	SR91	PAPER DECK CASSETTE 3 MEDIA FEED signal
Paper deck cassette 3 media stack surface sensor	SR92	PAPER DECK CASSETTE 3 MEDIA STACK SURFACE signal
Paper deck cassette 3 media out sensor	SR93	PAPER DECK CASSETTE 3 MEDIA OUT signal
Paper deck cassette 3 media end switch	SW92	PAPER DECK CASSETTE 3 MEDIA END signal
Paper deck cassette 3 media width switch	SW93	PAPER DECK CASSETTE 3 MEDIA WIDTH signal

Cassette media-size detection and cassette-presence detection

The paper deck detects the size of the paper loaded in the paper deck cassette by monitoring the paper deck cassette media end switch and the paper deck cassette media width switch. It also detects the presence of cassette by monitoring the switches. The paper deck controller notifies the formatter through the DC controller when it determines a cassette is absent.

Table 1-16 Cassette media-size detection and cassette-presence detection (3X500-sheet paper deck)

Paper size	3X500-sheet paper deck			3X500-sheet paper deck		
	Cassette media width sensor			Cassette media end switch		
	Top switch	Center switch	Bottom switch	Top switch	Center switch	Bottom switch
Executive	Off	On	On	On	On	On
Letter	Off	Off	On	On	On	On
A5	On	On	Off	On	On	On

Table 1-16 Cassette media-size detection and cassette-presence detection (3X500-sheet paper deck) (continued)

B5	Off	On	Off	On	On	On
A4	Off	Off	Off	On	On	On
Ledger	Off	Off	On	Off	Off	On
Legal	On	On	Off	Off	Off	On
B4	Off	On	Off	Off	Off	On
A3	Off	Off	Off	Off	Off	On
A4-R Letter-R	NOTE: The product cannot detect the paper size of A4-R and Letter-R. If A4-R or Letter-R sized paper is loaded to the cassette, A5 size is notified to the formatter.					
Universal	On	On	Off	Off	On	On
Cassette absent	Off	Off	Off	Off	Off	Off

Cassette lift-up operation

The cassette lift-up operation keeps the surface of the paper stack at the pickup position whenever the following occurs:

- Product power is turned on
- Cassette is installed
- Stack surface in the cassette lowers

The paper deck cassette media-out sensor detects the presence of paper in the paper deck cassette. Paper deck cassette 3 is used to describe the Cassette lift-up operation in this section.

Figure 1-58 Cassette lift-up operation

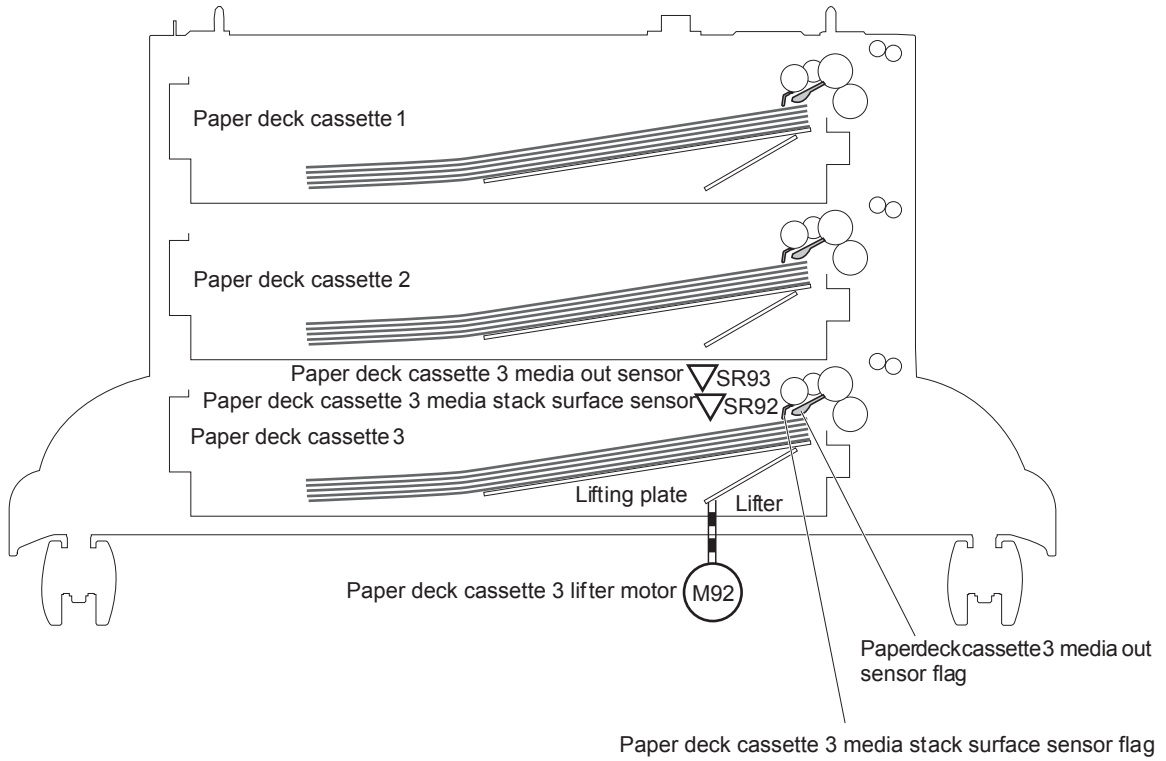

Jam detection

The paper deck uses the following sensors to detect the presence of paper and to check whether paper is being fed correctly or has jammed.

- Paper deck cassette 1 media feed sensor (SR1)
- Paper deck cassette 2 media feed sensor (SR81)
- Paper deck cassette 3 media feed sensor (SR91)

Figure 1-59 Jam detection

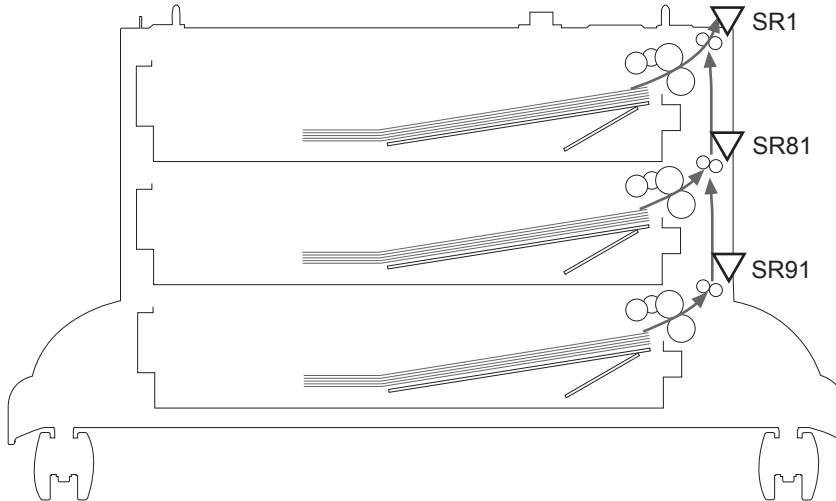

The paper deck detects the following jams.

- Paper deck no pick jam 1

The paper deck cassette 1 media feed sensor does not detect the leading edge of paper within a specified period after the paper deck cassette 2 media feed sensor detects the leading edge. The paper deck cassette 2 media feed sensor does not detect the leading edge of paper within a specified period after the paper deck cassette 3 media feed sensor detects the leading edge.

- Paper deck no pick jam 2

The paper deck cassette 1 media feed sensor does not detect the leading edge of paper within a specified period, including a retry, after the paper deck cassette 1 pickup solenoid has turned on. The paper deck cassette 2 media feed sensor does not detect the leading edge of paper within a specified period, including a retry, after the paper deck cassette 2 pickup solenoid has turned on. The paper deck cassette 3 media feed sensor does not detect the leading edge of paper within a specified period, including a retry, after the paper deck cassette 3 pickup solenoid has turned on.

- Paper deck residual paper jam

Any one of the following sensors detects a presence of paper after the automatic delivery is performed when the printer is turned on or when the door is closed.

- Paper deck cassette 1 media feed sensor
- Paper deck cassette 2 media feed sensor
- Paper deck cassette 3 media feed sensor
- Paper deck door open jam

A paper deck door open is detected during a paper-feed operation.

- Automatic Delivery

The paper deck automatically clears the paper if any one of the following sensors detects the residual paper during the initial sequence after the printer is turned on or after the door is closed.

- Paper deck cassette 1 media feed sensor
- Paper deck cassette 2 media feed sensor
- Paper deck cassette 3 media feed sensor

2 Removal and replacement

- [Introduction](#)
- [Removal and replacement strategy](#)
- [Electrostatic discharge](#)
- [Required tools](#)
- [Service approach](#)
- [Removal and replacement procedures](#)

Introduction

This chapter describes the removal and replacement of field-replaceable units (FRUs) only.

Replacing FRUs is generally the reverse of removal. Occasionally, notes and tips are included to provide directions for difficult or critical replacement procedures.

HP does *not* support repairing individual subassemblies or troubleshooting to the component level.

Note the length, diameter, color, type, and location of each screw. Be sure to return each screw to its original location during reassembly.

Incorrectly routed or loose wire harnesses can interfere with other internal components and can become damaged or broken. Frayed or pinched harness wires can be difficult to find. When replacing wire harnesses, always use the provided wire loops, lance points, or wire-harness guides and retainers.

Removal and replacement strategy

⚠ **WARNING!** Turn the product off, wait 5 seconds, and then remove the power cord before attempting to service the product. If this warning is not followed, severe injury can result, in addition to damage to the product. The power must be on for certain functional checks during troubleshooting. However, disconnect the power supply during parts removal.

Never operate or service the product with the protective cover removed from the laser/scanner assembly. The reflected beam, although invisible, can damage your eyes.

The sheet-metal parts can have sharp edges. Be careful when handling sheet-metal parts.

⚠ **CAUTION:** Do not bend or fold the flat flexible cables (FFCs) during removal or installation. Also, do not straighten pre-folds in the FFCs. You *must* fully seat all FFCs in their connectors. Failure to fully seat an FFC into a connector can cause a short circuit in a PCA.

🔧 **NOTE:** To install a self-tapping screw, first turn it counterclockwise to align it with the existing thread pattern, and then carefully turn it clockwise to tighten. Do not overtighten. If a self-tapping screw-hole becomes stripped, repair the screw-hole or replace the affected assembly.

💡 **TIP:** For clarity, some photos in this chapter show components removed that would not be removed to service the product. If necessary, remove the components listed at the beginning of a procedure before proceeding to service the product.

Electrostatic discharge

⚠ **CAUTION:**  Some parts are sensitive to electrostatic discharge (ESD). Look for the ESD reminder when removing product parts. Always perform service work at an ESD-protected workstation or mat, or use an ESD strap. If an ESD workstation, mat, or strap is not available, ground yourself by touching the sheet-metal chassis *before* touching an ESD-sensitive part.

Protect the ESD-sensitive parts by placing them in ESD pouches when they are out of the product.

Required tools

- #2 Phillips screwdriver with a magnetic tip and a 152-mm (6-inch) shaft length
- Small flat blade screwdriver
- Needle-nose pliers
- ESD mat or ESD strap (if one is available)
- Portable USB storage device (USB thumbdrive); for firmware upgrade
- Penlight (optional)

△ **CAUTION:** Always use a Phillips screwdriver (callout 1). Do not use a pozidrive screwdriver (callout 2) or any motorized screwdriver. These can damage screws or screw threads.

Figure 2-1 Phillips and pozidrive screwdriver comparison

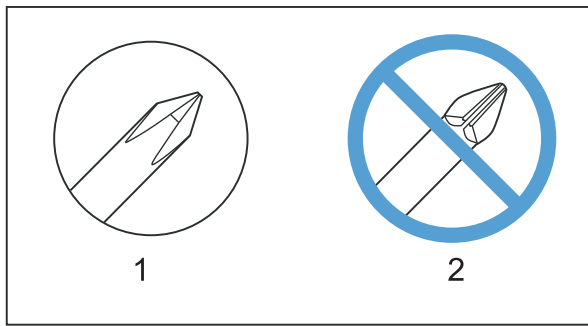

Service approach

Before performing service

- Remove all media from the product.
- Turn off the power using the power switch.
- Unplug the power cable and interface cable or cables.
- Place the product on an ESD workstation or mat, or use an ESD strap (if one is available). If an ESD workstation, mat, or strap is not available, ground yourself by touching the sheet-metal chassis *before* touching an ESD-sensitive part.
- Remove the print cartridges. See [Print cartridges on page 87](#).
- Remove the tray cassette or cassettes.

After performing service

- Plug in the power cable.
- Reinstall the print cartridges.
- Reinstall the tray cassette or cassettes.
- If the 1 x 500-sheet paper feeder or optional 3 x 500-sheet paper feeder was removed for service, place the product on the feeder or feeders. Engage the feeder tray locks to secure the feeder or feeders to the product.

Post-service test

Perform the following test to verify that the repair or replacement was successful.

Print-quality test

1. Verify that you have completed the necessary reassembly steps.
2. Make sure that the tray contains clean, unmarked paper.
3. Attach the power cord and interface cable or interface cables, and then turn on the product.
4. Verify that the expected startup sounds occur.
5. Print a configuration page, and then verify that the expected printing sounds occur.
6. Print a demo page, and then verify that the print quality is as expected.
7. Send a print job from the host computer, and then verify that the output meets expectations.
8. If necessary, restore any customer-specified settings.
9. Clean the outside of the product with a damp cloth.

Removal and replacement procedures

 **NOTE:** The following assemblies are Customer Self Repair (CSR) components. Go to [Covers on page 111](#) or [Main assemblies on page 130](#) for information about removing service assemblies.

Print cartridges

When a print cartridge approaches the end of its estimated useful life, the control panel displays a message recommending that you order a replacement. The product can continue to print using the current print cartridge until the control panel displays a message instructing you to replace the cartridge, unless you have selected the option to override the message by using the **Supply Settings** menu.

 **NOTE:** Cartridge life remaining is used to determine if a supply is near or at estimated end of life. Cartridge life remaining is approximate only, and varies depending on types of documents printed and other factors.

The product uses four colors and has a different print cartridge for each color: black (K), magenta (M), cyan (C), and yellow (Y).

You can replace a print cartridge when the print quality is no longer acceptable. The control-panel message also indicates the color of the cartridge that has reached the end of its estimated useful life. Replacement instructions are provided on the label on the print cartridge.

 **CAUTION:** If toner gets on clothing, wipe it off with a dry cloth and wash the clothes in cold water. Hot water sets toner into fabric.

 **NOTE:** Information about recycling used print cartridges is contained in the print-cartridge box.

Replace print cartridges

1. Open the front door. Make sure that the door is completely open.

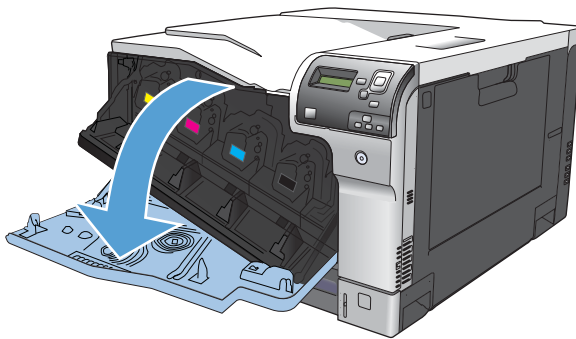

2. Grasp the handle of the used print cartridge and pull out to remove.

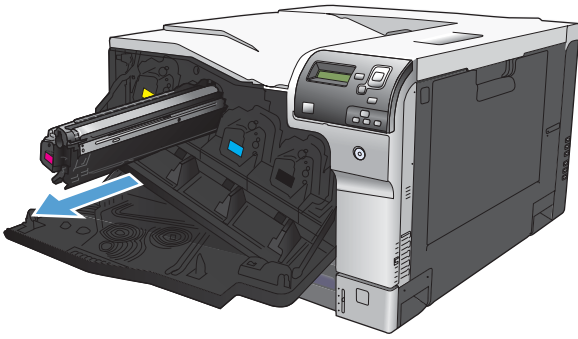

3. Remove the new print cartridge from its protective bag.

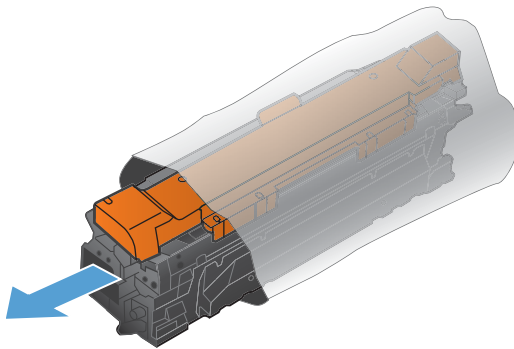

 **NOTE:** Be careful not to damage the memory tag on the print cartridge.

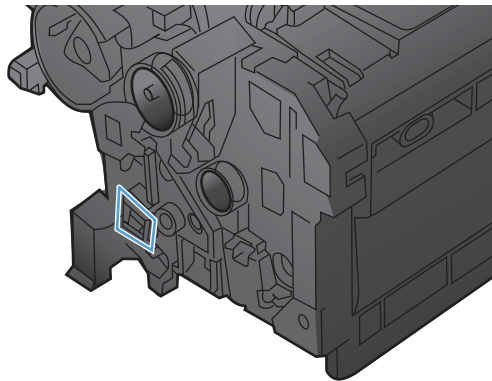

4. Grasp both sides of the print cartridge and distribute the toner by gently rocking the print cartridge.

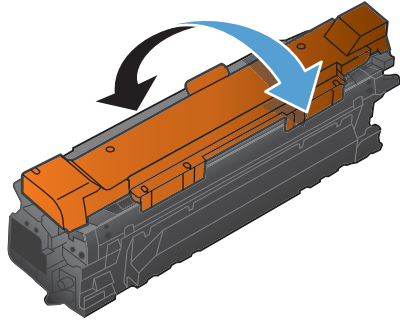

5. Remove the orange protective cover from the print cartridge. Place the protective cover on the used print cartridge to protect it during shipping.

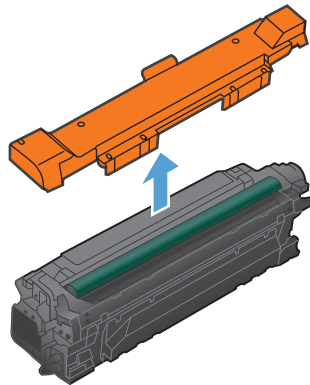

△ **CAUTION:** Avoid prolonged exposure to light.

Do not touch the green roller. Doing so can damage the cartridge.

📄 **NOTE:** Store the used print cartridge in the protective bag removed from the replacement cartridge. Information about recycling used print cartridges is contained in the print-cartridge box.

6. Align the print cartridge with its slot and insert the print cartridge until it clicks into place.

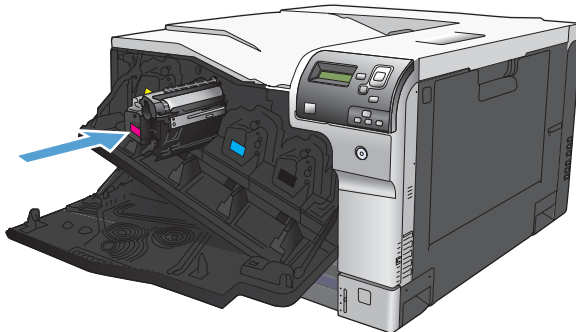

7. Close the front door.

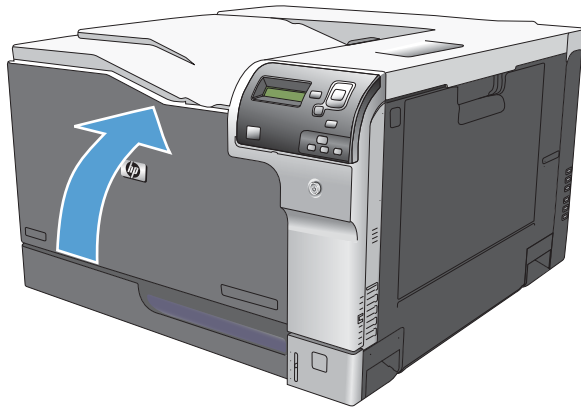

Toner-collection unit

 **NOTE:** The toner-collection unit (TCU) is designed for a single use. Do not try to empty the toner-collection unit and reuse it. To recycle a discarded toner-collection unit, follow the instructions that come with a replacement toner-collection unit.

1. Open the TCU access door (callout 1) on the product back side.
2. Grasp the top of the TCU (callout 2), and then remove it from the product.

Figure 2-2 Remove the toner-collection unit (1 of 3)

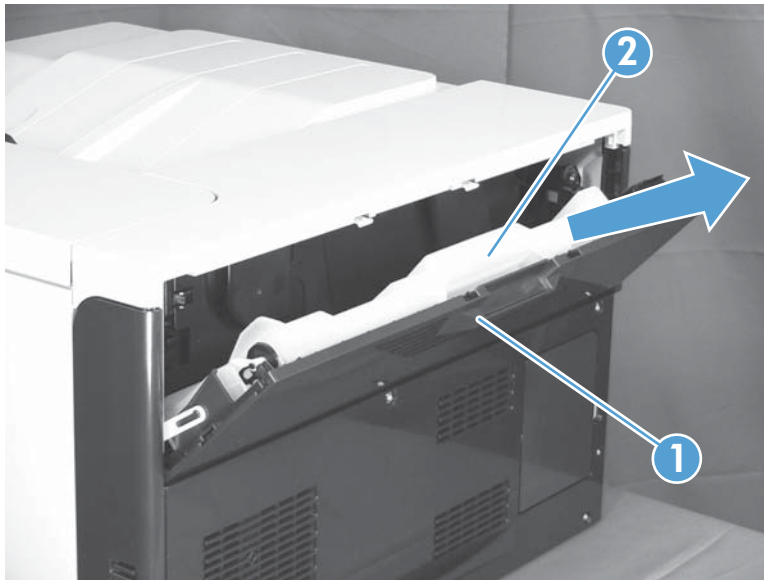

3. Remove the plug from the discarded TCU.

Figure 2-3 Remove the toner-collection unit (2 of 3)



4. Install the plug onto the discarded TCU before putting it into the box and mailing it for recycling.

Figure 2-4 Remove the toner-collection unit (3 of 3)



Fuser

△ **CAUTION:** The fuser might be hot. Allow enough time after turning off the product power for the fuser to cool.

1. Open the right-door assembly.
2. Grasp the handles and squeeze the blue release levers (callout 1).

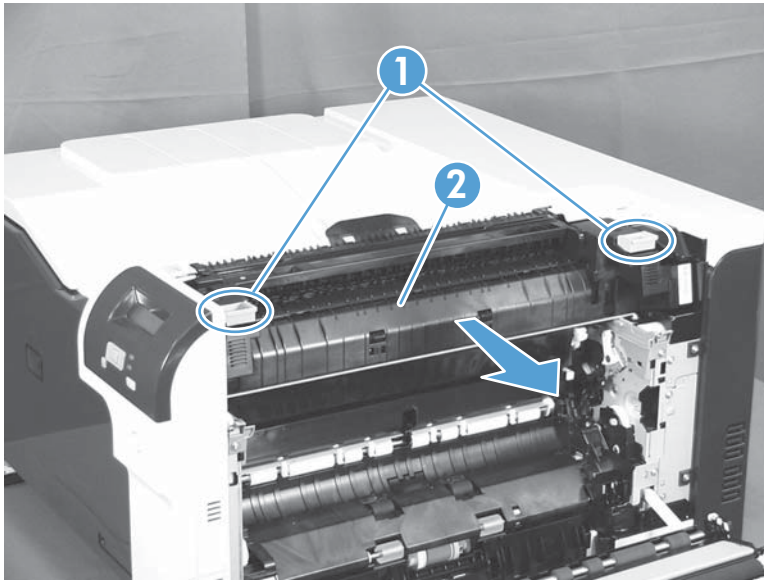

Figure 2-5 Remove the fuser



3. Pull the fuser (callout 2) straight out of the product to remove it.

Reset the New Fuser Kit setting at the control panel

📄 **NOTE:** Use this procedure to reset the internal page count if a replacement fuser is installed.

1. At the control panel, press the Home button .
2. Open the following menus:
 - **Administration**
 - **Manage Supplies**
 - **Reset Supplies**
 - **New Fuser Kit**
3. Use the **Down** arrow button  to highlight the **Yes** item, and then press **OK** to select it.

Pickup roller (Tray 1)

△ **CAUTION:** Do not touch the spongy roller surface unless you are replacing the roller. Skin oils on the roller can cause paper pickup problems.

1. Open Tray 1 (callout 1), and then remove the pickup roller cover (callout 2).

Figure 2-6 Remove the pickup roller (Tray 1) (1 of 2)

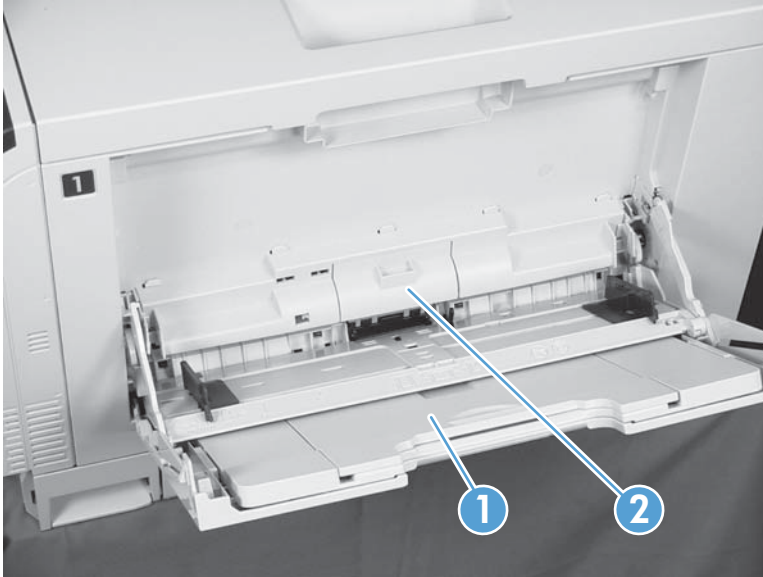

2. Spread out the pickup roller retainers (callout 1) until both sides unlatch, and then remove the pickup roller (callout 2).

💡 **Reinstallation tip** When you reinstall the roller, make sure that the roller snaps into place

Figure 2-7 Remove the pickup roller (Tray 1) (2 of 2)

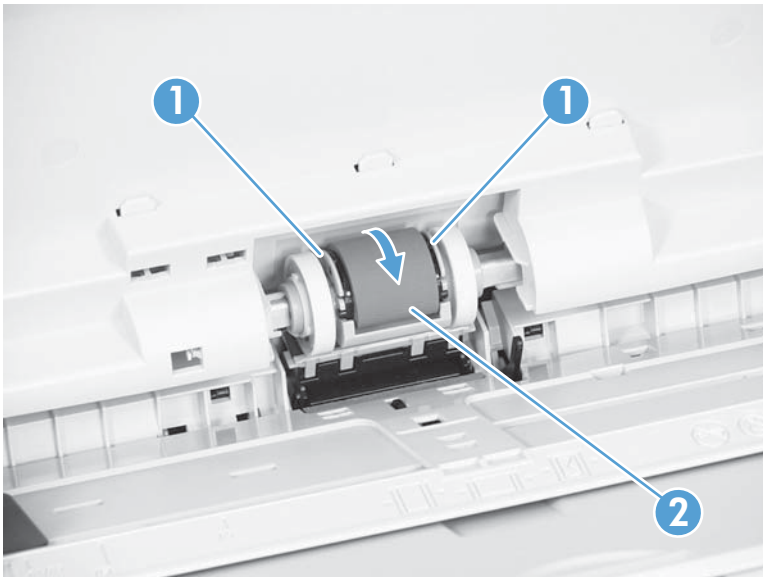

Separation pad (Tray 1)

△ **CAUTION:** Do not touch the spongy roller surface unless you are replacing the roller. Skin oils on the roller can cause paper pickup problems.

1. Open Tray 1 (callout 1), and then remove the pickup roller cover (callout 2).

Figure 2-8 Remove the separation pad (Tray 1) (1 of 4)

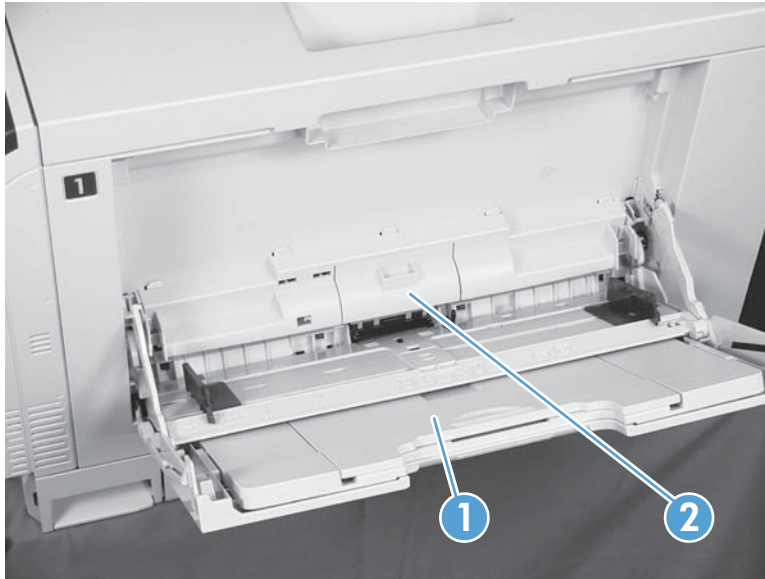

2. Take out the tool (callout 2) supplied with a new separation pad (callout 1).

Figure 2-9 Remove the separation pad (Tray 1) (2 of 4)

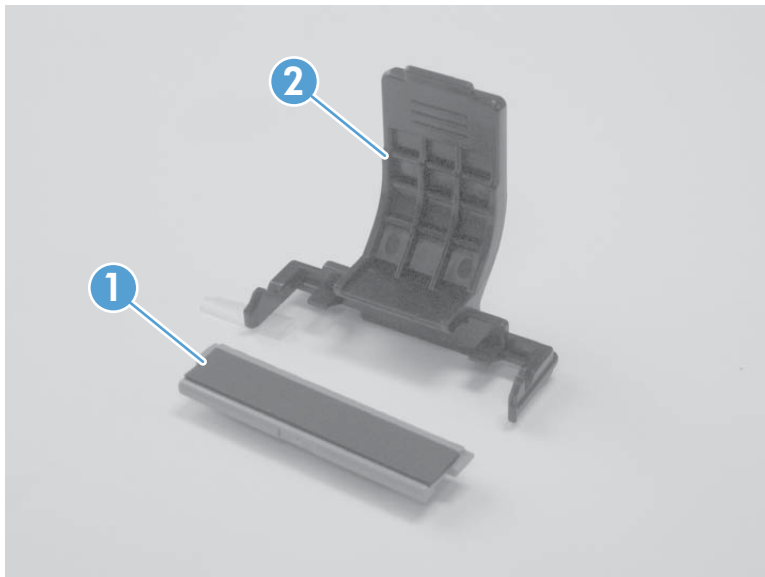

3. Insert the tool under the separation pad.

Figure 2-10 Remove the separation pad (Tray 1) (3 of 4)

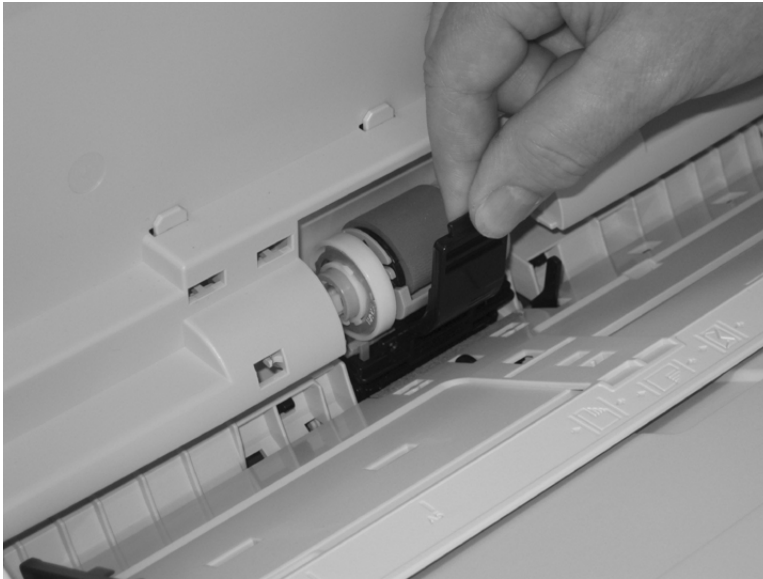

4. Rotate the top of the tool away from the product to release the separation pad, and then remove the tool and the separation pad together.

Figure 2-11 Remove the separation pad (Tray 1) (4 of 4)



 **Reinstallation tip** You do not need to use the tool to install the new separation pad. Press the new pad with your hand until it snaps into place and engages with the engine.

Separation roller assembly (Tray 2)

△ **CAUTION:** Do not touch the spongy roller surface unless you are replacing the roller. Skin oils on the roller can cause paper pickup problems.

1. Remove Tray 2 from the product.
2. Open the right-door assembly.
3. On the separation roller assembly, slide the lever (callout 1) toward the unlocked icon  until it clicks into the unlocked position.

Figure 2-12 Remove the separation roller assembly (Tray 2) (1 of 2)



4. Pull the separation roller assembly up and remove it from the product.

💡 **Reinstallation tip** When you install the separation roller assembly, make sure that it snaps into the locked position.

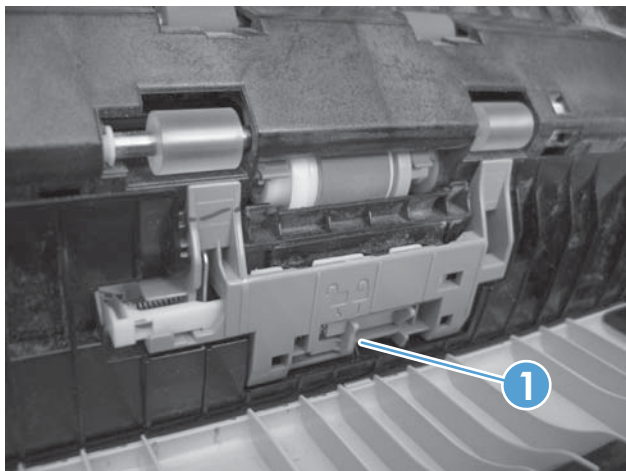
Figure 2-13 Remove the separation roller assembly (Tray 2) (2 of 2)

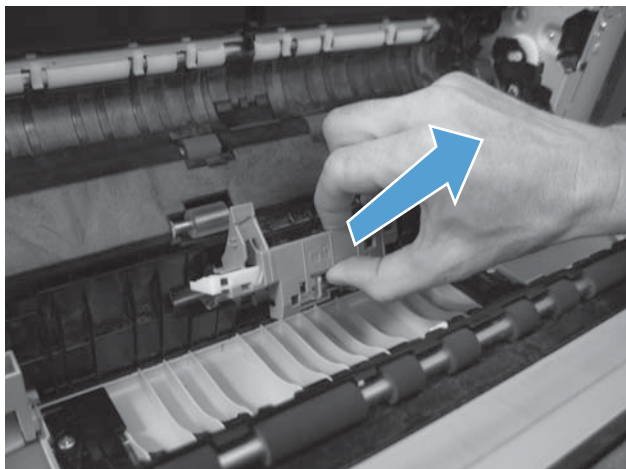

Pickup roller (Tray 2)

△ **CAUTION:** Do not touch the spongy roller surface unless you are replacing the roller. Skin oils on the roller can cause paper pickup problems.

1. Open Tray 2.
2. Open the right-door assembly.
3. Remove the separation roller assembly (see [Separation roller assembly \(Tray 2\) on page 97](#))
4. Lift one of the two levers (callout 1) on either side of the pickup roller, and then push the right side of the roller in the direction of the arrow.

Figure 2-14 Remove the pickup roller (Tray 2)

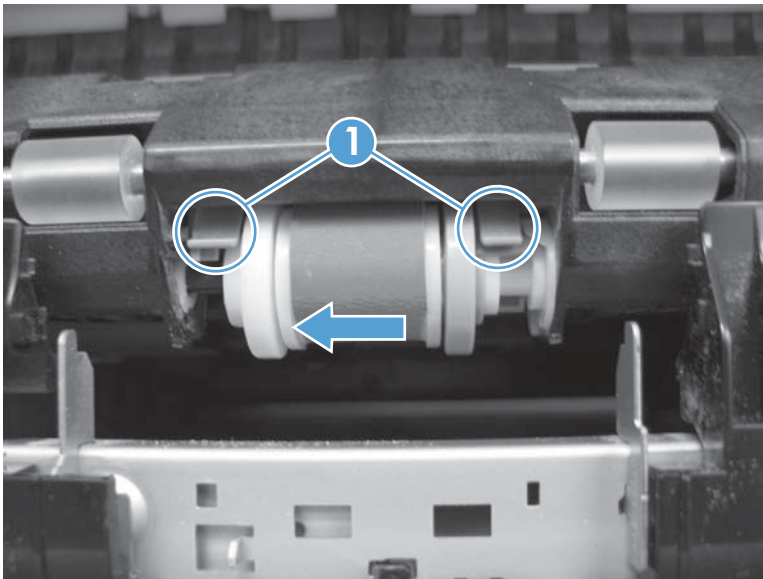

5. Remove the pickup roller.

💡 **Reinstallation tip** Insert the left side of the roller into the product first. Make sure that the replacement roller snaps into place.

Pickup roller, separation roller, and feed roller (1 x 500-sheet and 3 x 500-sheet paper feeders)

△ **CAUTION:** Do not touch the spongy roller surface unless you are replacing the roller. Skin oils on the roller can cause paper pickup problems.

💡 **TIP:** You do not have to separate the product from the feeder to remove these rollers.

1. Remove the Tray 3 or Tray 4/5/6 cassette from the product, and then locate the rollers on the right-hand side of the tray cavity.

Figure 2-15 Remove the 1 x 500 or 3 x 500 rollers (1 of 2)

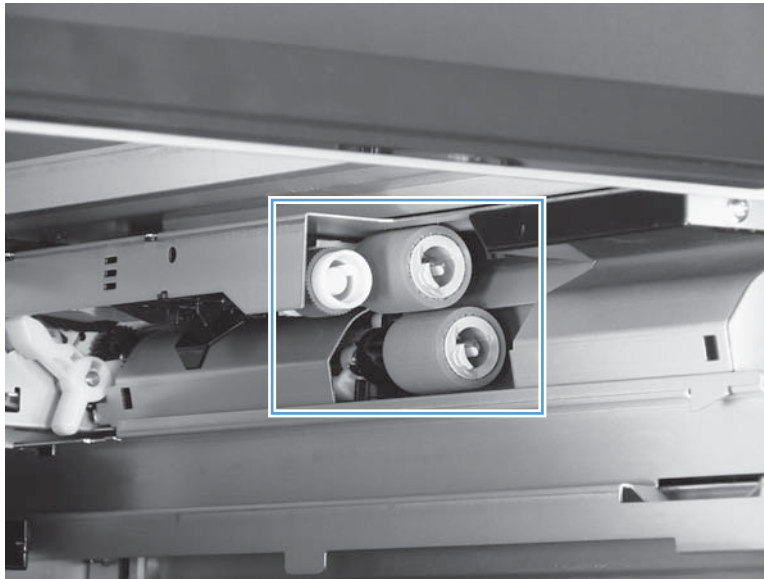

2. Release three tabs, and then pull the rollers in the direction of the arrow.

Figure 2-16 Remove the 1 x 500 or 3 x 500 rollers (2 of 2)

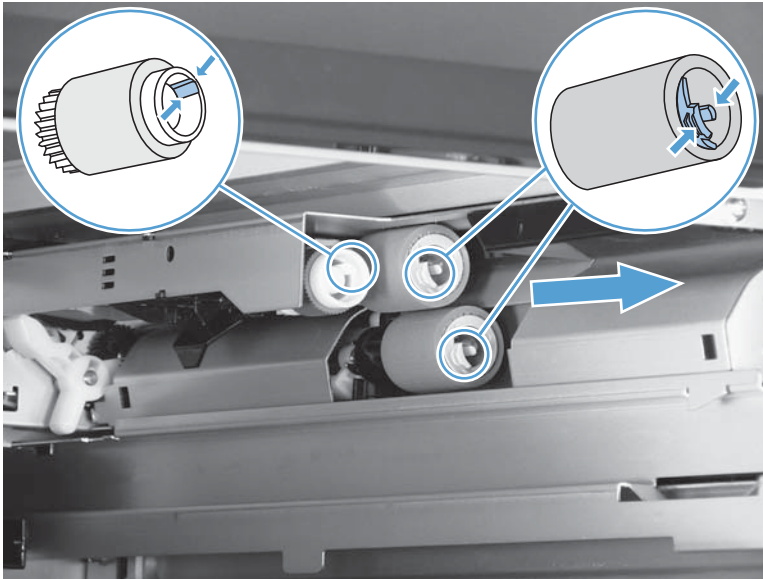

 **Reinstallation tip** When you reinstall the rollers, make sure that the rollers snap into place.

Secondary transfer roller

△ **CAUTION:** Do not touch the spongy roller surface unless you are replacing the roller. Skin oils on the roller can cause image quality problems.

📝 **NOTE:** If the secondary transfer roller is replaced, HP recommends that the ITB be replaced also. If both components are replaced at the same time, you must use the control-panel menus to reset the **Transfer Kit** menu item. See [Reset the **New Transfer Kit** setting at the control panel on page 104.](#)

1. Open the right-door assembly.
2. Grasp one of the blue round features (callout 1) on either end of the transfer roller, and then lift the transfer roller (callout 2) off of the product.

Figure 2-17 Remove the transfer roller

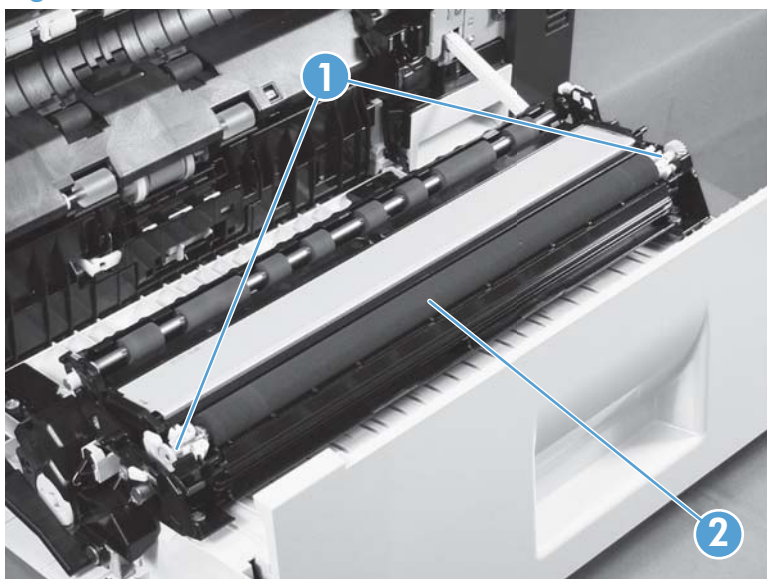

💡 **TIP:** Place the new roller assembly in place with the roller gear (callout 1) on the right side, and then press down to ensure that the roller shaft snaps securely in the roller clasps.

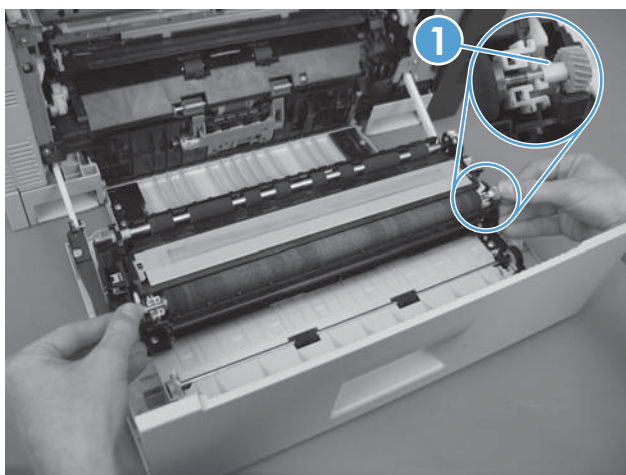

Intermediate transfer belt (ITB)

△ **CAUTION:** Do not touch the black-plastic belt. Skin oils and fingerprints on the belt can cause print-quality problems. Always place the ITB on a flat surface in a safe and protected location.

📖 **NOTE:** If the ITB assembly is replaced, HP recommends that the secondary transfer roller be replaced also. If both components are replaced at the same time, you must use the control-panel menus to reset the **Transfer Kit** menu item. See [Reset the **New Transfer Kit** setting at the control panel on page 104](#).

1. Open the right-door assembly.
2. Use both hands to grasp the blue levers (callout 1), apply slight downward pressure, and pull the ITB toward you at a downward angle.

Figure 2-18 Remove the intermediate transfer belt (1 of 3)

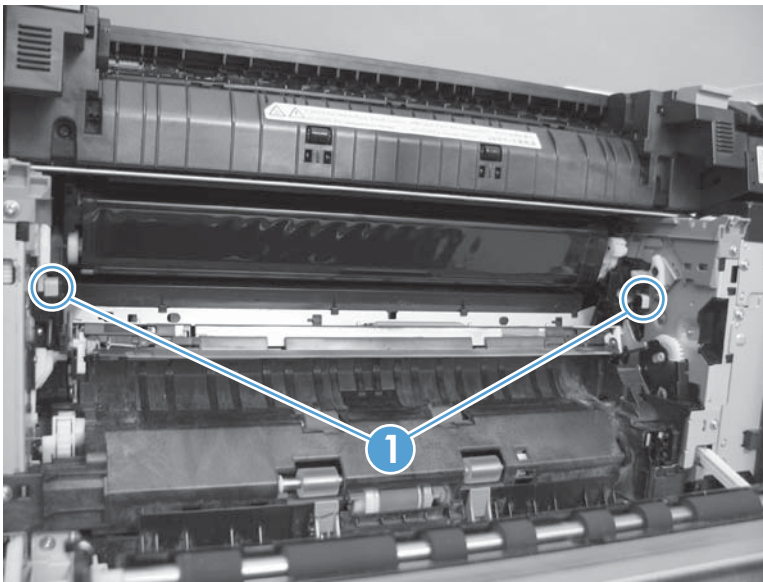

3. Pull the ITB out of the product until two large handles expand along the right and left side of the ITB.

Figure 2-19 Remove the intermediate transfer belt (2 of 3)

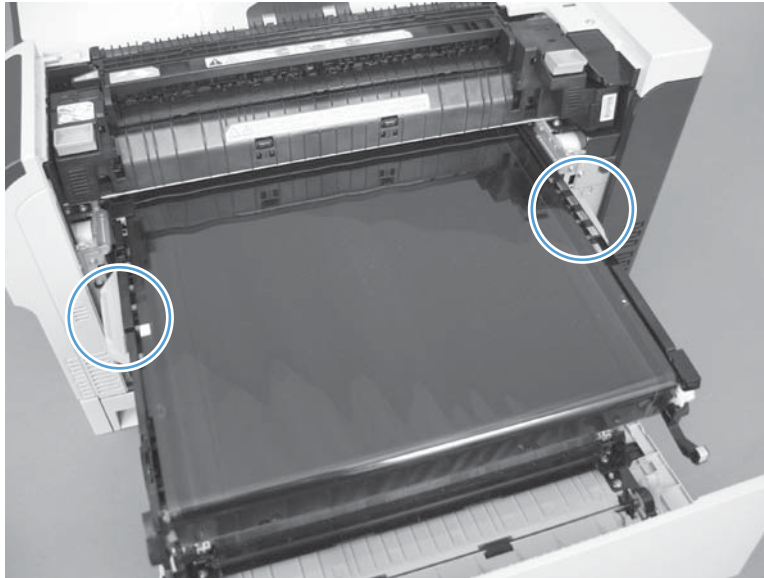

4. Grasp the large handles on the ITB, pull it straight out of the product until it stops, and then pull up to remove it from the product.

△ **CAUTION:** The ITB is a sensitive component. Be careful when handling the ITB so that it is not damaged. Always place the ITB in a safe and protected location.



Figure 2-20 Remove the intermediate transfer belt (3 of 3)



💡 **Reinstallation tip** If you are installing a replacement ITB, make sure that you remove all of the packing tape and the protective cover sheet.

Reset the New Transfer Kit setting at the control panel

 **NOTE:** Use this procedure to reset the internal page count if a replacement ITB and secondary transfer roller are installed.

1. At the control panel, press the Home button .
2. Open the following menus:
 - **Administration**
 - **Manage Supplies**
 - **Reset Supplies**
 - **New Transfer Kit**
3. Use the **Down** arrow button  to highlight the **Yes** item, and then press **OK** to select it.

Formatter PCA

△ **CAUTION:**  ESD sensitive component.

Do not replace the laser scanner and the formatter PCA at the same time. The settings for the laser scanner are stored in the formatter RAM. When you install a new laser scanner, it reads the settings from the formatter.

Do not replace the DC controller PCA and the formatter PCA at the same time. The settings for the DC Controller PCA are stored in the formatter RAM. When you install a new DC Controller PCA, it reads the settings from the formatter.

 **NOTE:** If possible, print a configuration page before replacing the formatter. You might need to transfer the serial number and the page count information to the new formatter.

1. Disconnect communication cables (if installed).

△ **CAUTION:** Make sure that the product power is off and that the power cord is unplugged.

Figure 2-21 Remove the formatter (1 of 2)

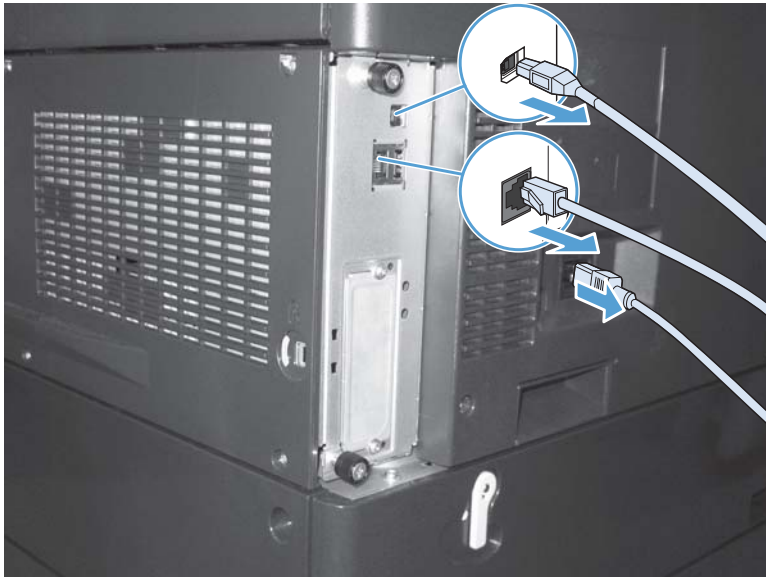

2. Loosen two thumb screws, and then pull the formatter straight out and away from the product to remove it.

Figure 2-22 Remove the formatter (2 of 2)

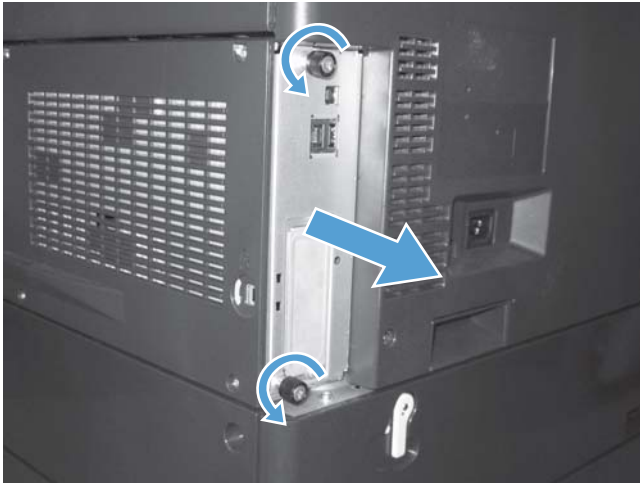

3. Firmly pull the formatter from the product. Place the formatter on a clean, flat, grounded surface.

 **Reinstallation tip** If the formatter PCA was replaced, print a configuration page and make sure that the serial number and page count information were transferred to the formatter PCA. If they were not, use the **Service** menu to reset these values.

Hard Drive

Before proceeding, remove the following components:

- Formatter PCA. See [Formatter PCA on page 105](#).

Identify the hard drive type

- Encrypted hard-disk drive (callout 1)

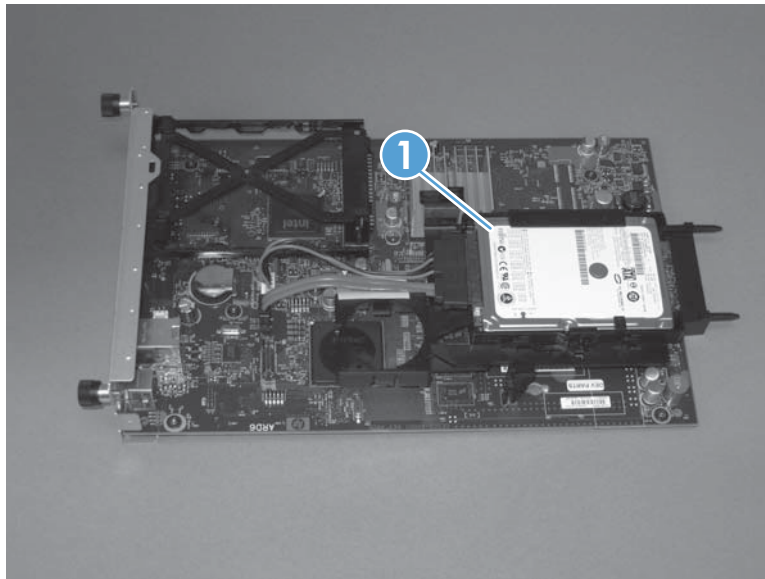

- Solid-state hard drive (callout 1)

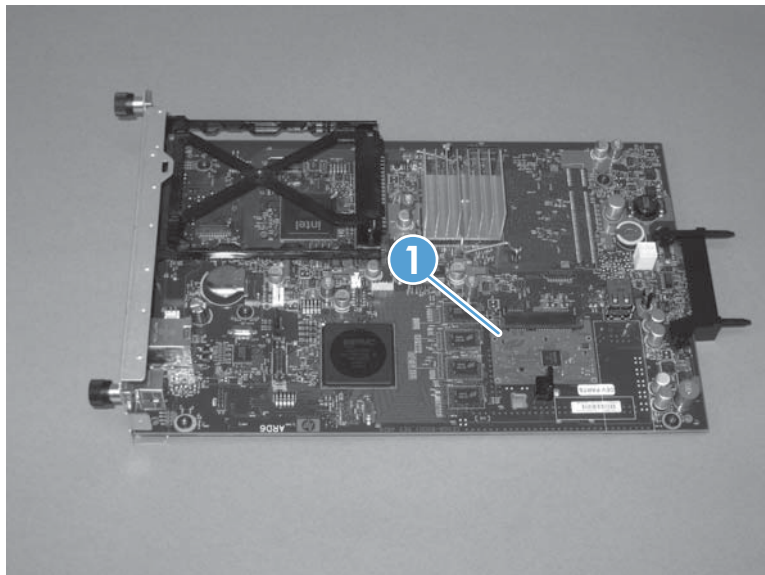

Remove the encrypted HDD

NOTE: If you are installing a replacement hard drive, you must reinstall the product firmware. See [Product updates on page 547](#).

1. Disconnect two connectors (callout 1).

Figure 2-23 Remove the encrypted HDD (1 of 3)

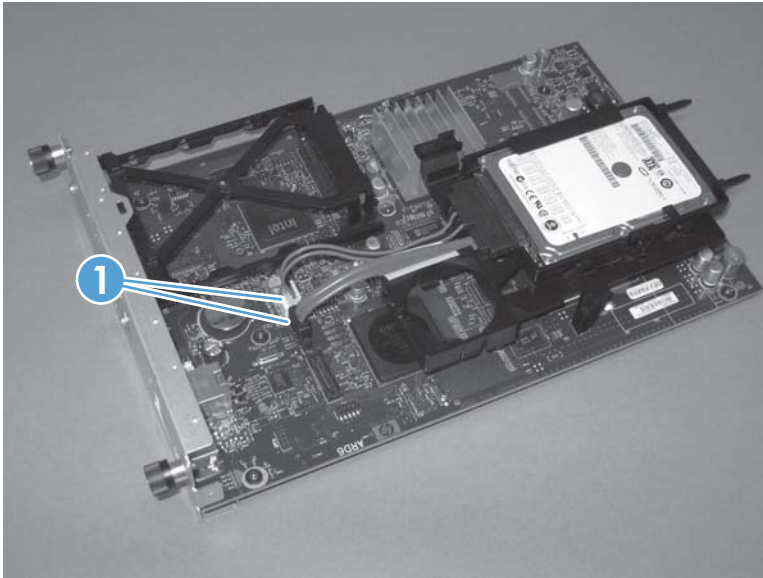

2. Release one tab (callout 1), and then slightly separate the HDD support arm from the PCA.

Figure 2-24 Remove the encrypted HDD (2 of 3)

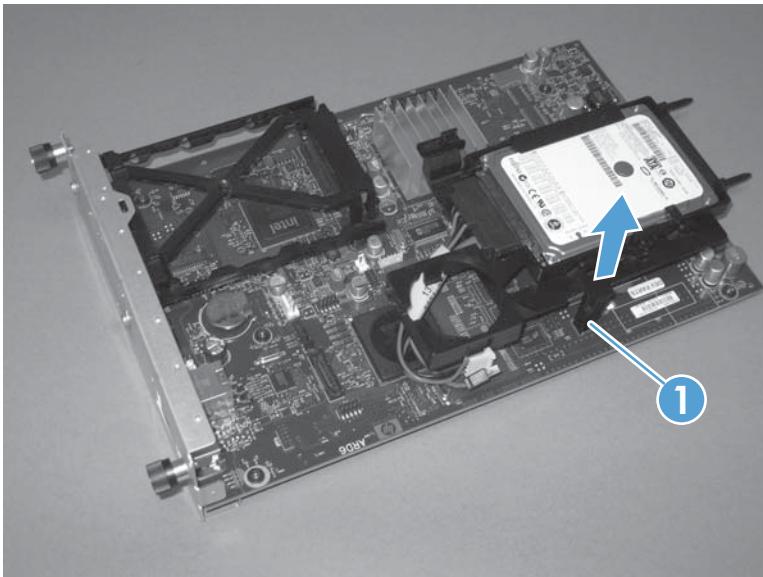

3. Rotate the HDD up and away from the PCA, and then slide it as shown below to remove it.

Figure 2-25 Remove the encrypted HDD (3 of 3)

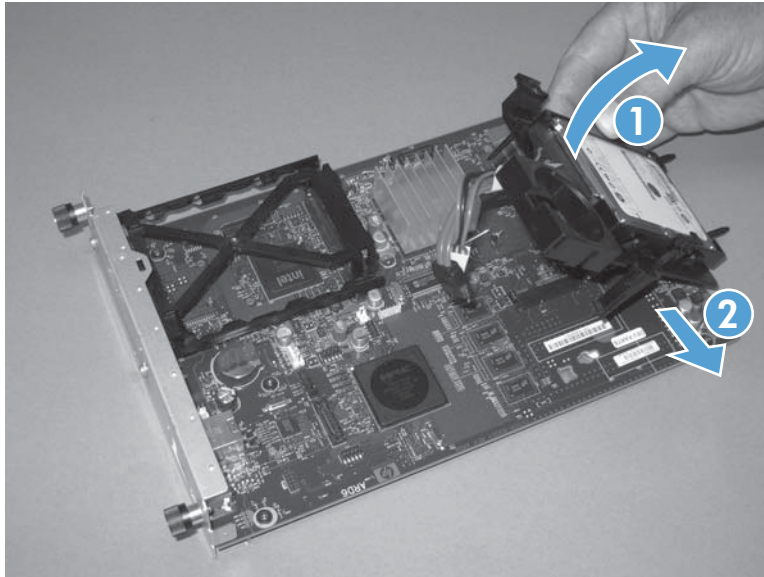

Remove the solid-state hard drive

 **NOTE:** If you are installing a replacement hard drive, you must reinstall the product firmware. See [Product updates on page 547](#).

1. Release the hard drive lock.

Figure 2-26 Remove the solid-state hard drive (1 of 3)

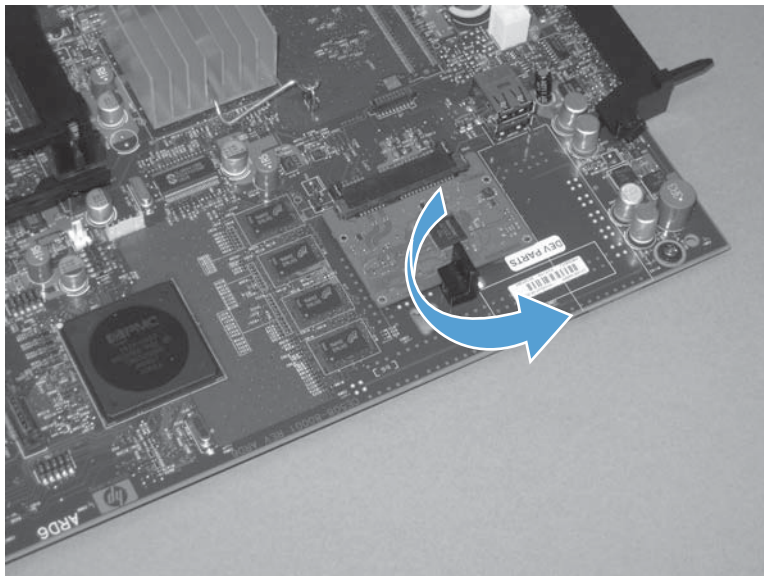

2. Remove the lock from the PCA.

Figure 2-27 Remove the solid-state hard drive (2 of 3)

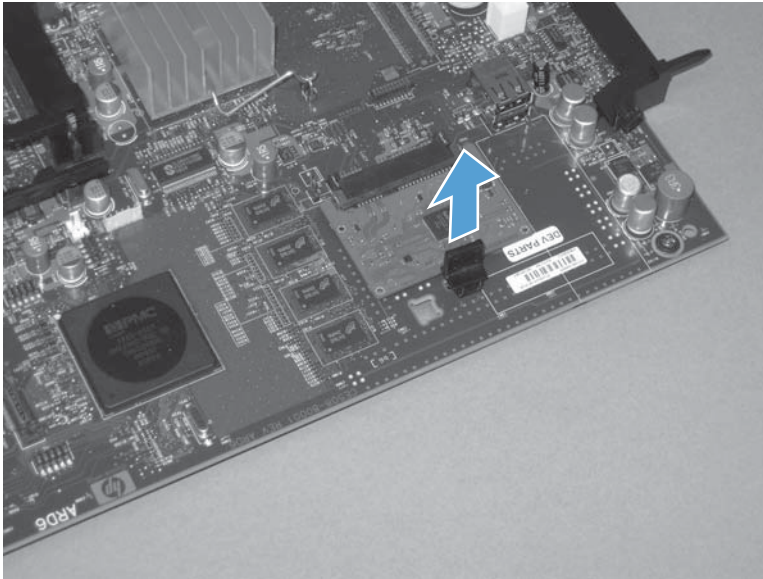

3. Disconnect the solid-state PCA from the formatter PCA, and then remove it.

Figure 2-28 Remove the solid-state hard drive (3 of 3)

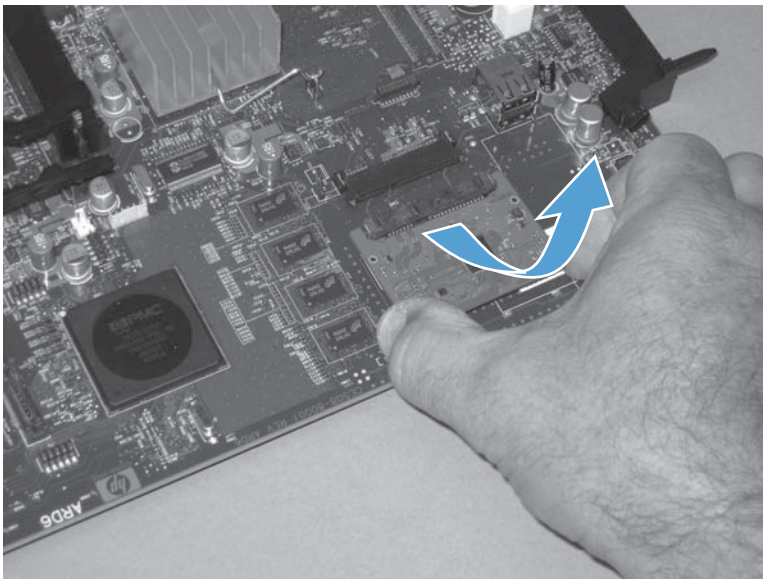

Covers

Identification and location

Figure 2-29 External panels, covers, and doors

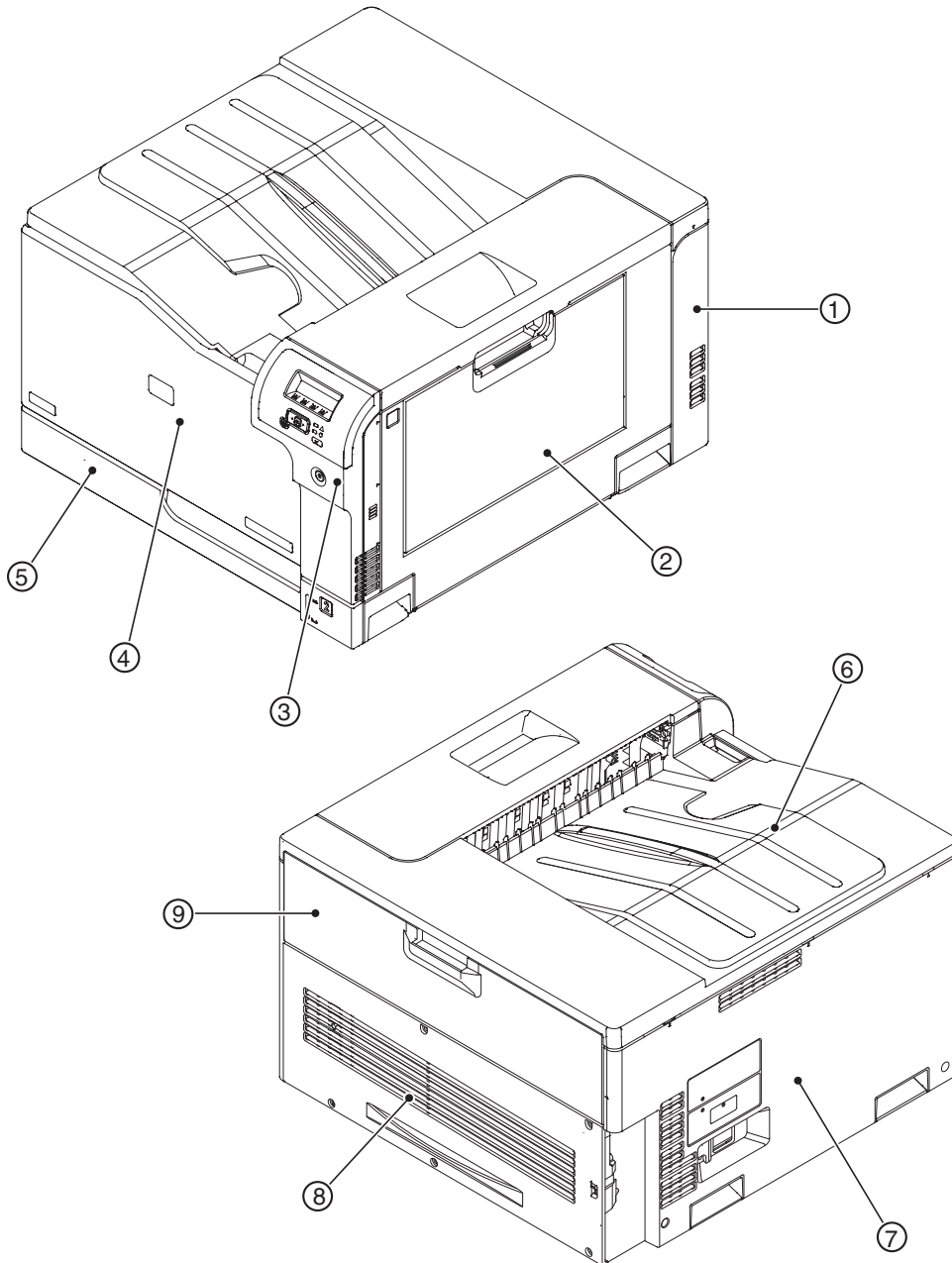

Table 2-1 External panels, covers, and doors

Item	Description	Item	Description
1	Rear-right cover (see Right-rear cover on page 119)	6	Top cover (see Top cover on page 121)

Table 2-1 External panels, covers, and doors (continued)

Item	Description	Item	Description
2	Right-door assembly (see Right-door assembly on page 126)	7	Left cover (see Left cover on page 115)
3	Right-front cover and control-panel assembly (see Right-front cover and control-panel assembly on page 113)	8	Rear cover (see Rear cover on page 116)
4	Front-door assembly (see Front-door assembly on page 123)	9	Toner collection unit access door (see Toner collection unit access door on page 117)
5	Tray 2 cassette		

Right-front cover and control-panel assembly

1. Open the front door and the right door.
2. Remove two screws (callout 1).

Figure 2-30 Remove the right-front cover and control-panel assembly (1 of 3)

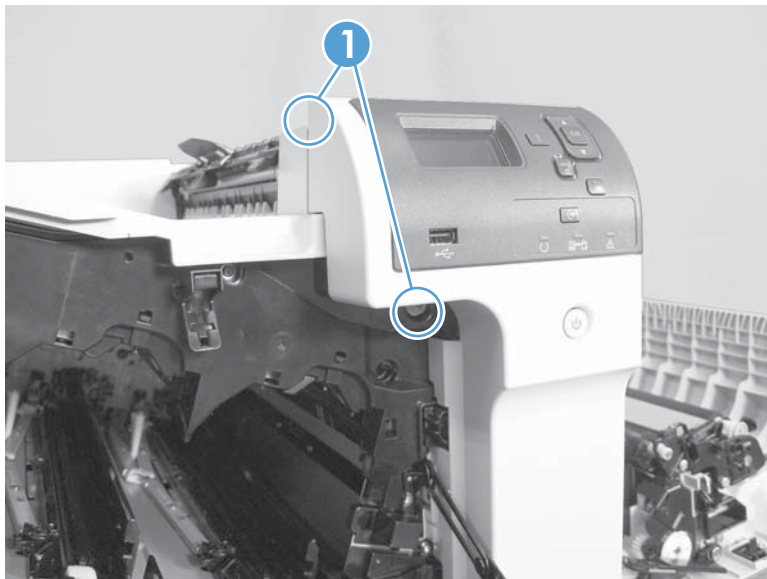

3. Release 3 tabs (callout 1) on the right side of the assembly.

Figure 2-31 Remove the right-front cover and control-panel assembly (2 of 3)

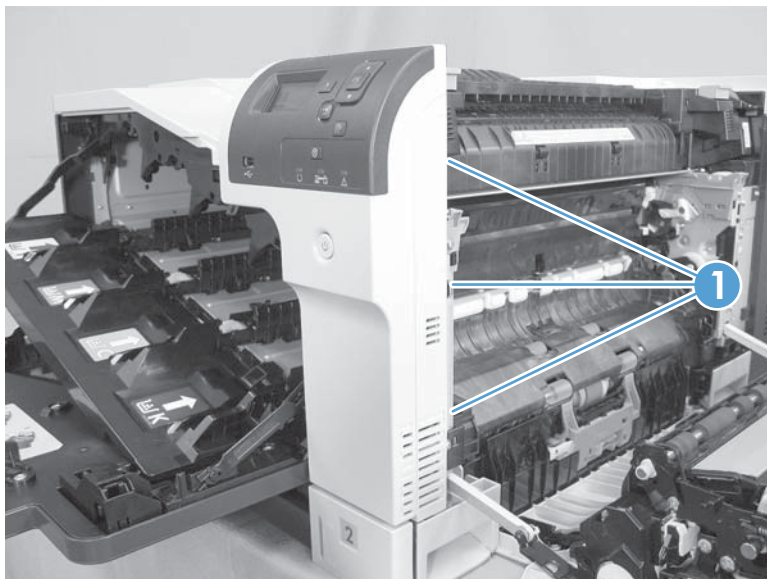

4. Support the assembly, release one cable retainer (callout 1), and then disconnect two connectors (callout 2). Remove the assembly.

Figure 2-32 Remove the right-front cover and control-panel assembly (3 of 3)

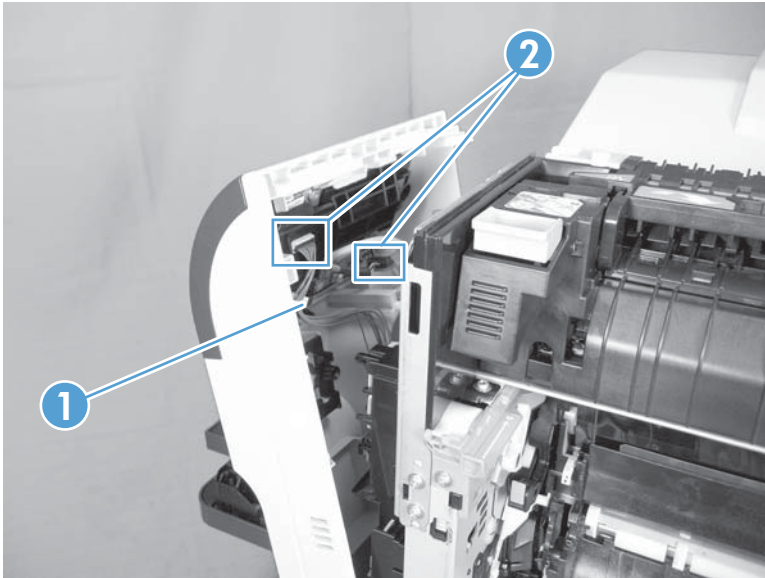



Left cover

1. Remove Tray 2 from the product.
2. Open the front door.
3. Remove three screws (callout 1). Starting from the left side of the cover, release six tabs (callout 2), and then remove the cover from the product.

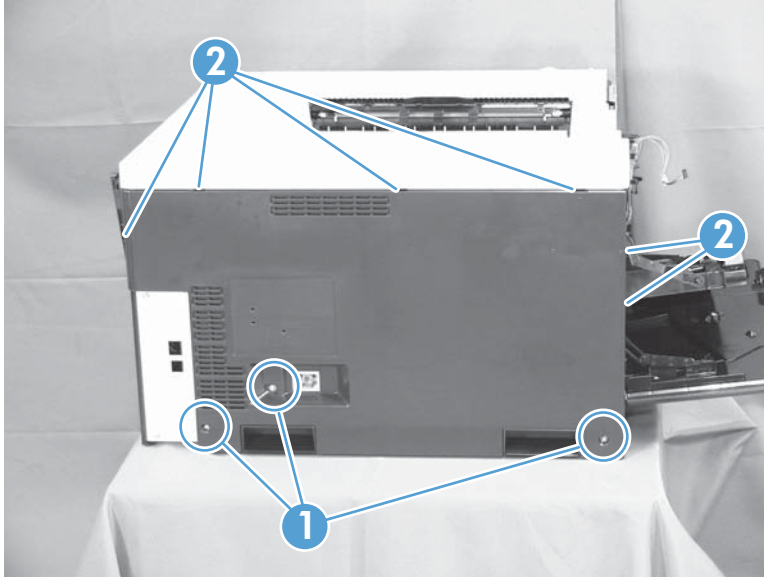
Figure 2-33 Remove the left cover



 **TIP:** Opening the toner-collection door might make it easier to release the tabs on the left side of the cover.

 **Reinstallation tip** If the front door will not close after the left cover has been reinstalled, verify that the two tabs on the right side of the cover have been aligned correctly with the product chassis.

Rear cover

Remove the rear cover

- ▲ Remove five screws (callout 1), and then remove the cover (callout 2) from the product.

Figure 2-34 Remove the rear cover

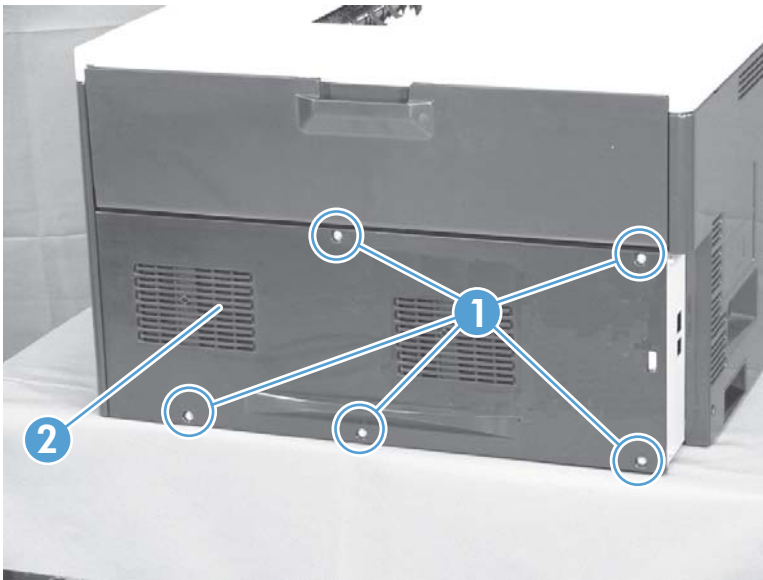

Toner collection unit access door

1. Open the toner collection unit access door (callout 1), remove the toner collection unit, and then release the link arm (callout 2) on the left side of the door.

Figure 2-35 Remove the toner collection unit access door (1 of 3)

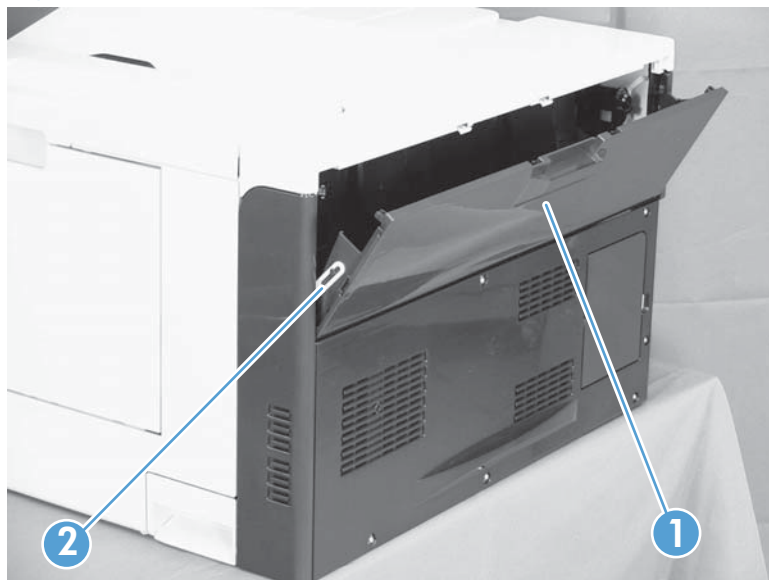

2. Partially close the door so that the right link arm (callout 1) can clear the stop (callout 2) on the door, and then disengage the link arm from the door.

△ **CAUTION:** Do not disconnect the right-hand link arm when the door is completely open. Doing so can disconnect the link arm spring.

Figure 2-36 Remove the toner collection unit access door (2 of 3)

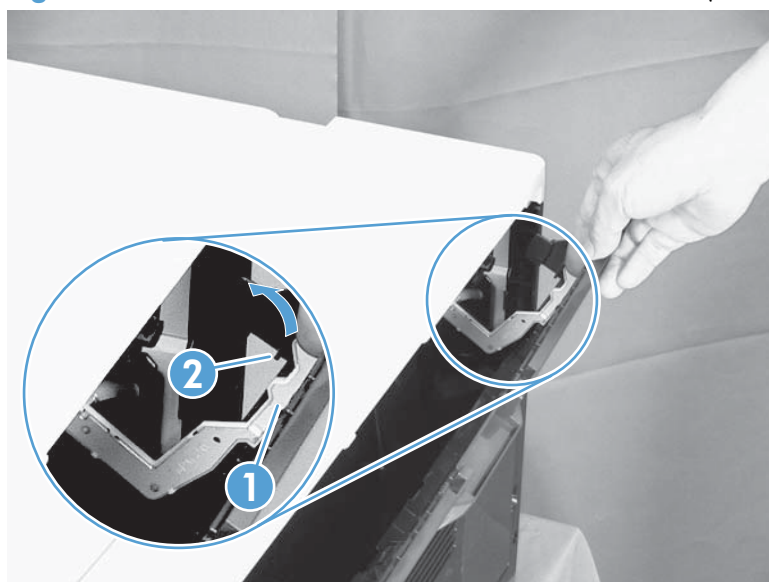

3. Rotate the access door down 90 degrees (callout 1), and then pull on the right side of the door (callout 2) to remove the access door.

Figure 2-37 Remove the toner collection unit access door (3 of 3)

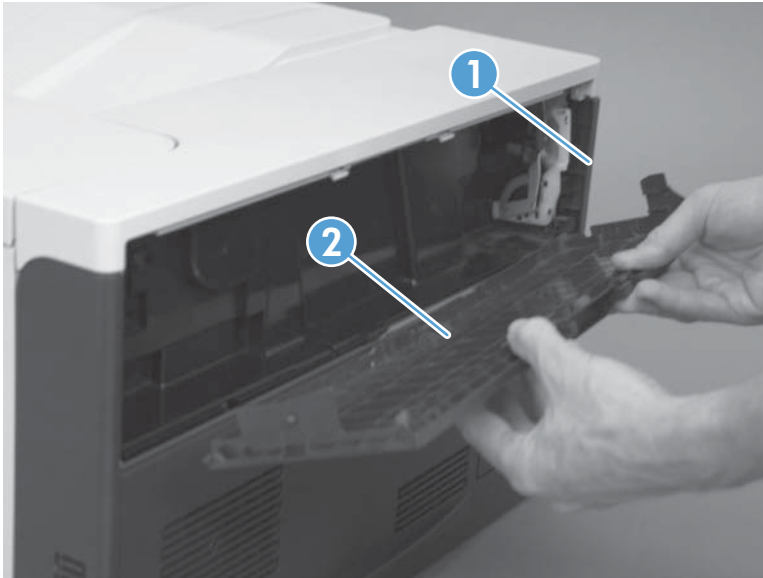

Right-rear cover

1. Remove the rear cover. See [Rear cover on page 116](#).
2. Open the right-door assembly.
3. Remove two screws (callout 1), release one tab (callout 2), and then remove the cover.

△ **CAUTION:** The ground spring on the back of the cover can easily be dislodged. Be careful not to lose it. See [Reinstall the right-rear cover on page 120](#).

Figure 2-38 Remove the right-rear cover

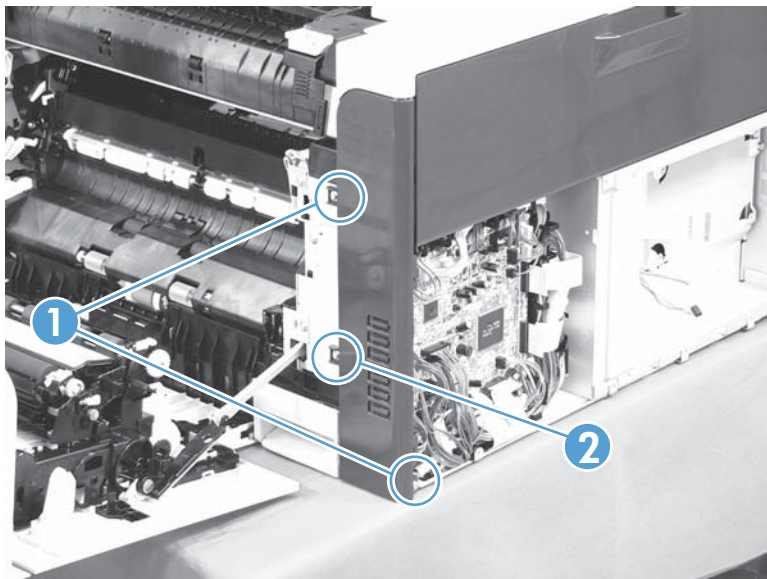

Reinstall the right-rear cover

- ▲ Make sure that the ground spring (callout 1) is correctly installed before you reinstall the right-rear cover.

Figure 2-39 Right-rear cover ground spring

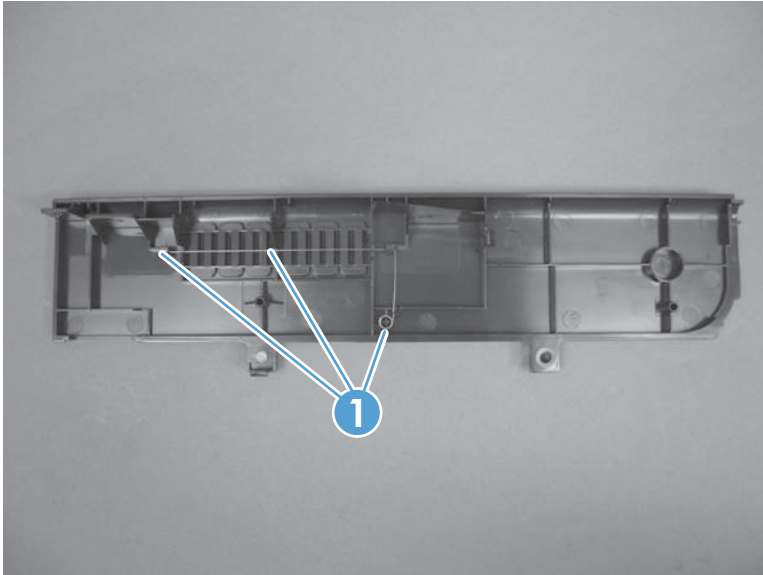

Top cover

Before proceeding, remove the following components:

- Right-front cover and control-panel assembly. See [Right-front cover and control-panel assembly on page 113](#).
- Left cover. See [Left cover on page 115](#).
- Remove the rear cover. See [Rear cover on page 116](#).
- Right-rear cover. See [Right-rear cover on page 119](#).

Remove the top cover

1. Open the right-door assembly, and then remove four screws (callout 1).

Figure 2-40 Remove the top cover (1 of 2)

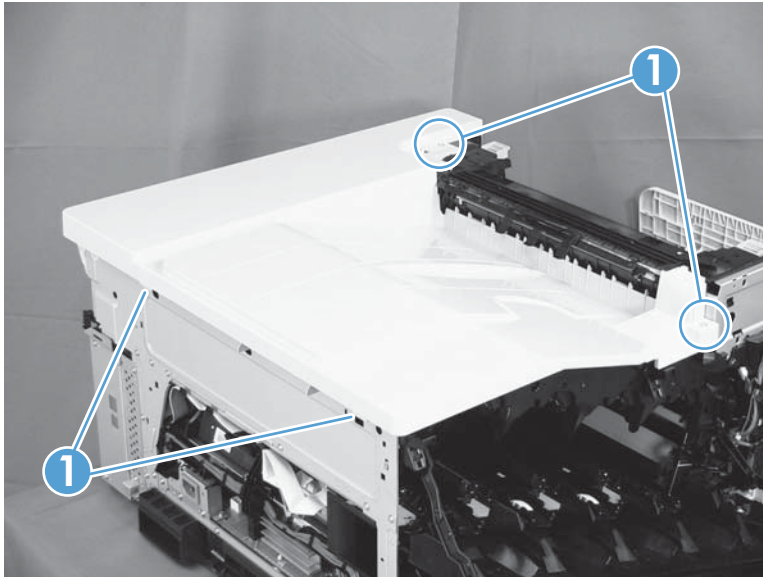

2. Open the toner-collection door.

3. Release two tabs (callout 1), and then remove the cover (callout 2).

Figure 2-41 Remove the top cover (2 of 2)

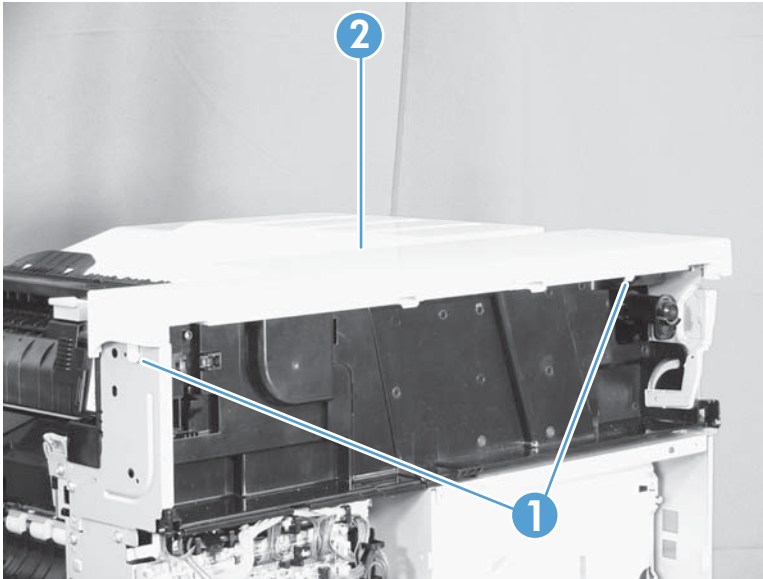

Front-door assembly

1. Remove the control panel. See [Right-front cover and control-panel assembly on page 113](#).
2. Open the front door.
3. Remove one screw (callout 1) and the inner cover rail mount (callout 2).

△ **CAUTION:** As shown in [Figure 2-43 Remove the front-door assembly \(2 of 4\) on page 123](#), when removing the inner cover rail mount (callout 3), hold down the inner cover (callout 4) with one hand to prevent it from springing back at the product.

Figure 2-42 Remove the front-door assembly (1 of 4)

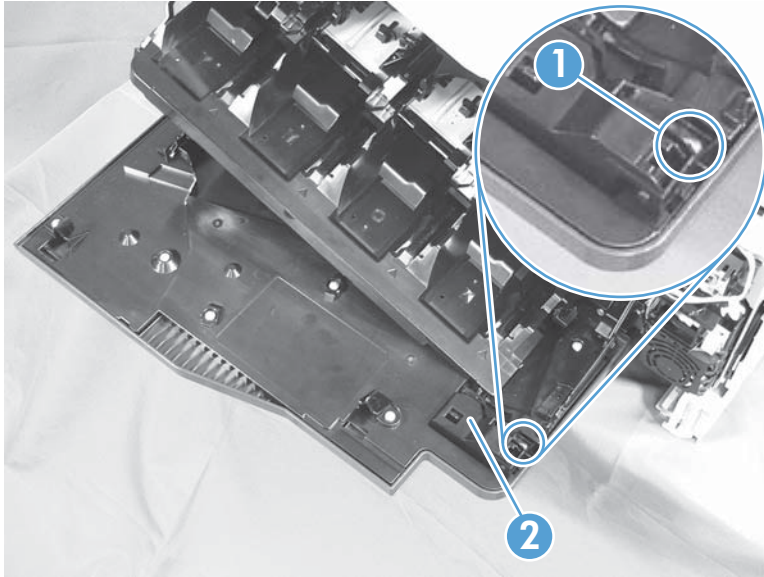
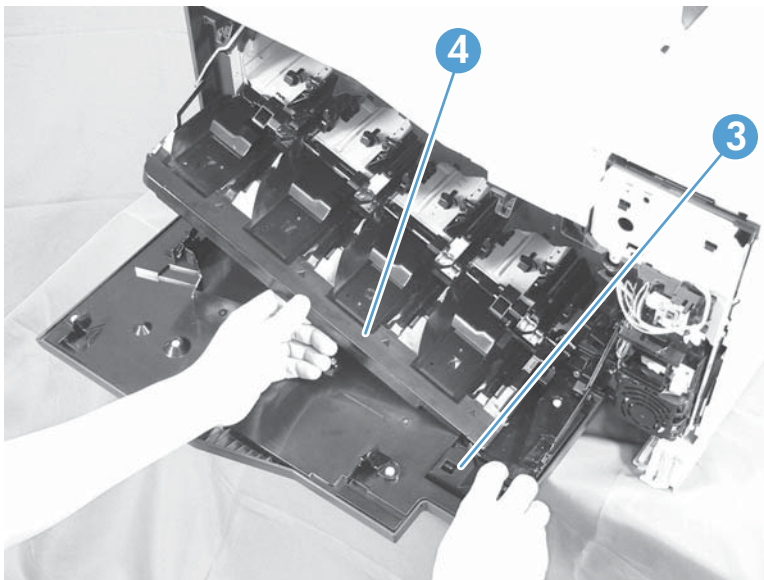
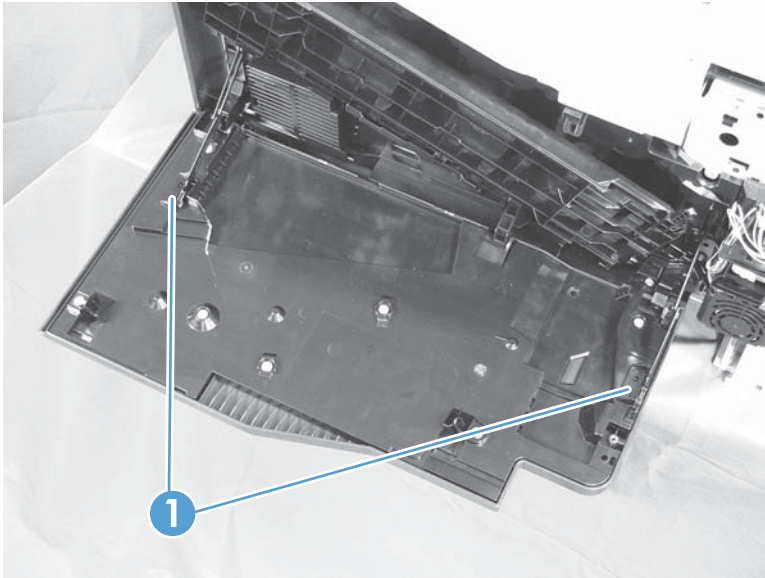



Figure 2-43 Remove the front-door assembly (2 of 4)



4. Close the inner cover, and then release two tabs on each stopper (callout 1) with a small flat-blade screwdriver (callout 2).

Figure 2-44 Remove the front-door assembly (3 of 4)



 **NOTE:** Each tab is at the end of the stopper that is closest to the product.

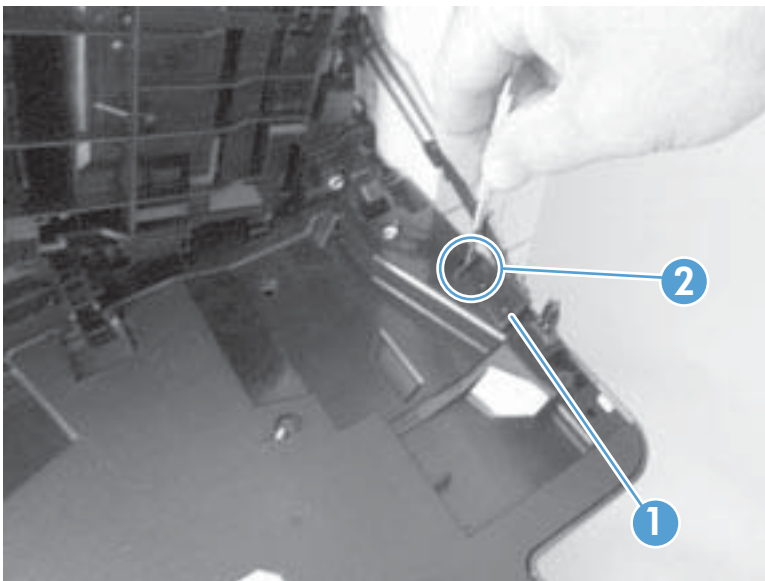

5. Position the door as shown below (callout 1), and then slide the front-door assembly in the direction that the arrow indicates to remove it from the product.

Figure 2-45 Remove the front-door assembly (4 of 4)

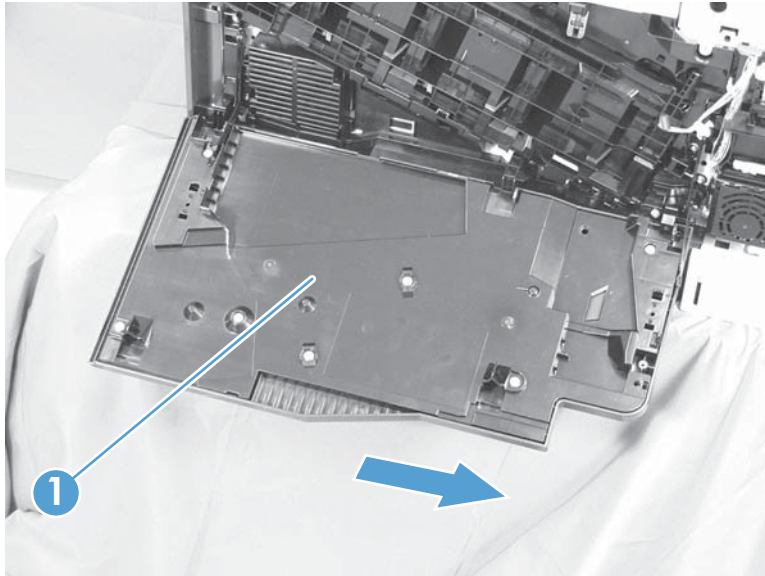

Right-door assembly

Remove the following components:

- Rear cover (see [Rear cover on page 116](#))
 - Right rear cover (see [Right-rear cover on page 119](#))
1. Open the right-door assembly
 2. Remove one screw (callout 1), release the link arm (callout 2), and then disconnect two connectors (callout 3).

 **NOTE:** The link arm is spring loaded and retracts into the product.

Figure 2-46 Remove the right-door assembly (1 of 6)

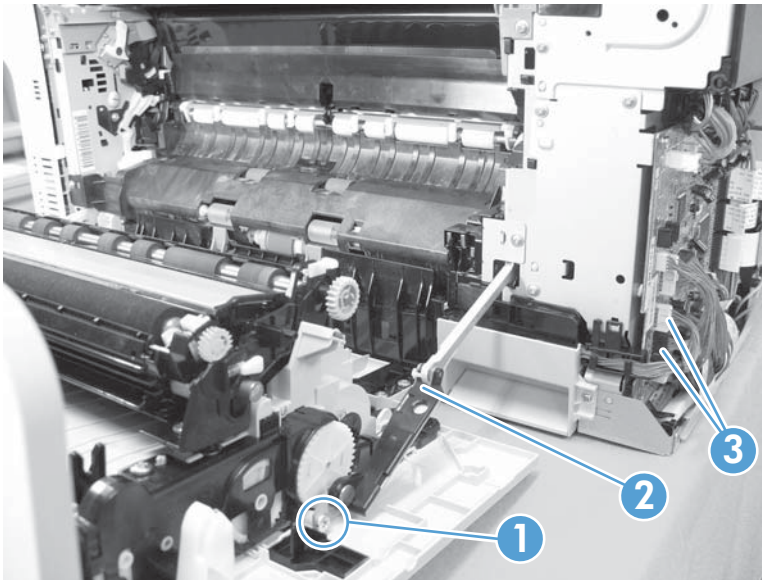

3. Carefully release one tab (callout 1), and then remove the cable cover (callout 2).

Figure 2-47 Remove the right-door assembly (2 of 6)

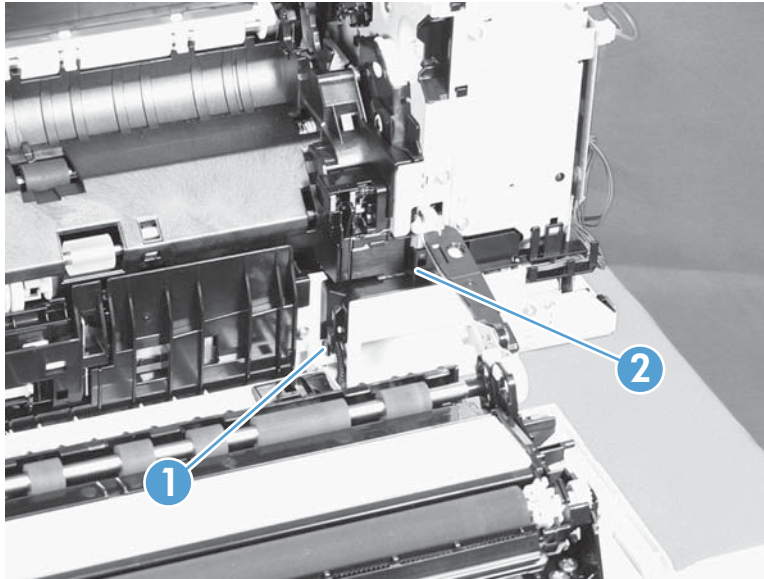

4. Release one tab (callout 1), and then remove the guide (callout 2).

 **TIP:** Release the wire harnesses from the guide as you remove it.

Figure 2-48 Remove the right-door assembly (3 of 6)



5. Disconnect two connectors (callout 1).

Figure 2-49 Remove the right-door assembly (4 of 6)

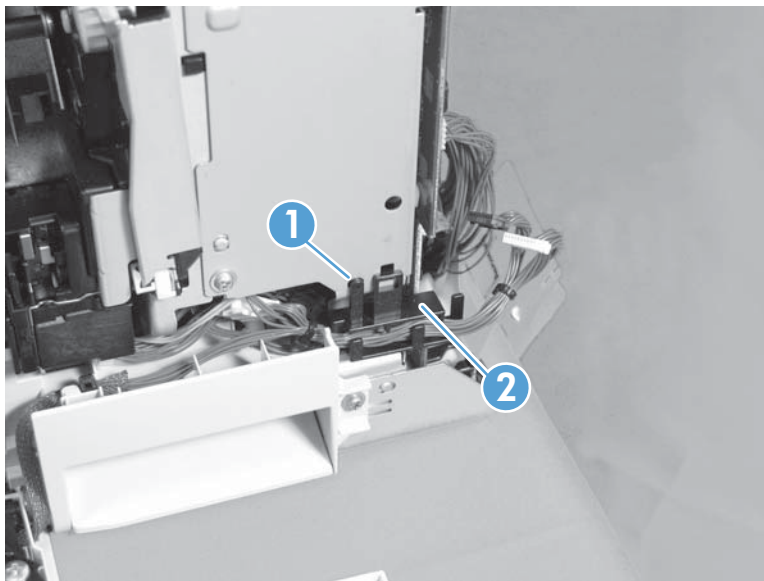
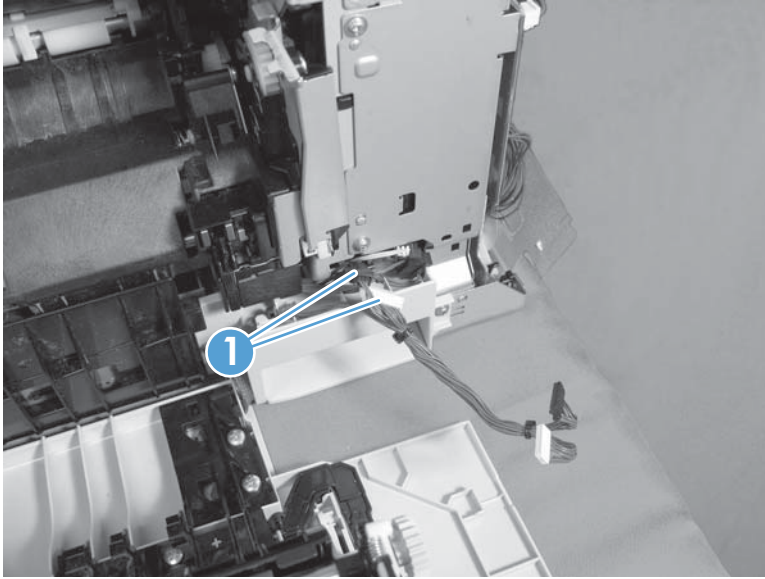

6. Remove one screw (callout 1), and then release the link arm (callout 2).

Figure 2-50 Remove the right-door assembly (5 of 6)

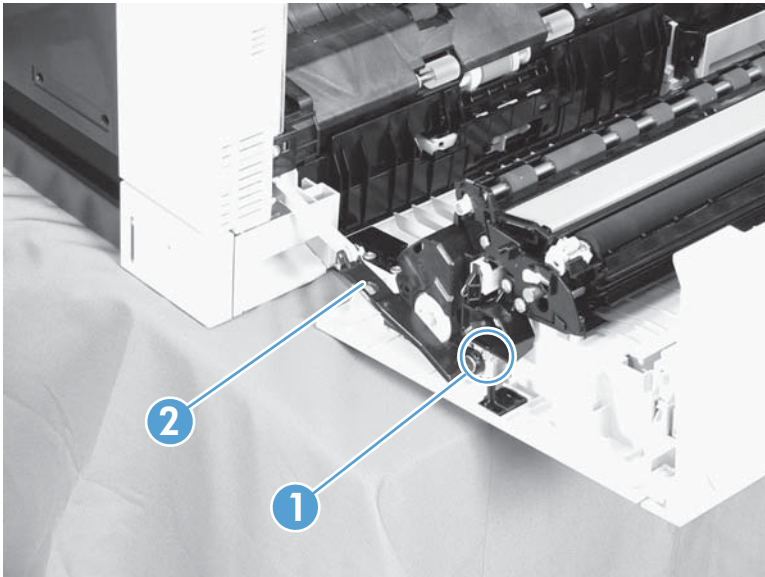

7. Remove two screws (callout 1), remove the hinge (callout 2), and then slide the right-door assembly (callout 3) to the left to remove it.

Figure 2-51 Remove the right-door assembly (6 of 6)

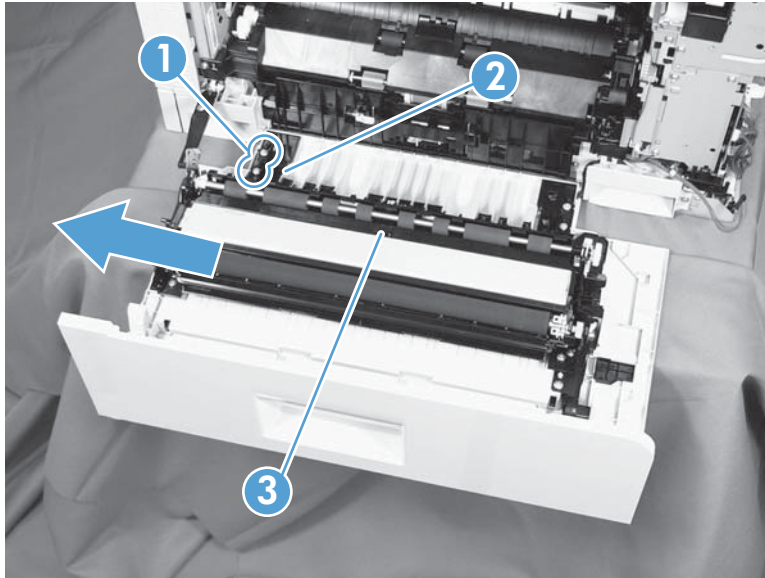

Main assemblies

TIP: For clarity, some photos in this chapter show components removed that would not be removed to service the product. If necessary, remove the components listed at the beginning of a procedure before proceeding to service the product.

Formatter case

Before proceeding, remove the following components:

- Formatter PCA. See [Formatter PCA on page 105](#).
- Left cover. See [Left cover on page 115](#).
- Rear cover. See [Rear cover on page 116](#).

Remove the formatter case

1. Remove two screws (callout 1).

Figure 2-52 Remove the formatter case assembly (1 of 2)

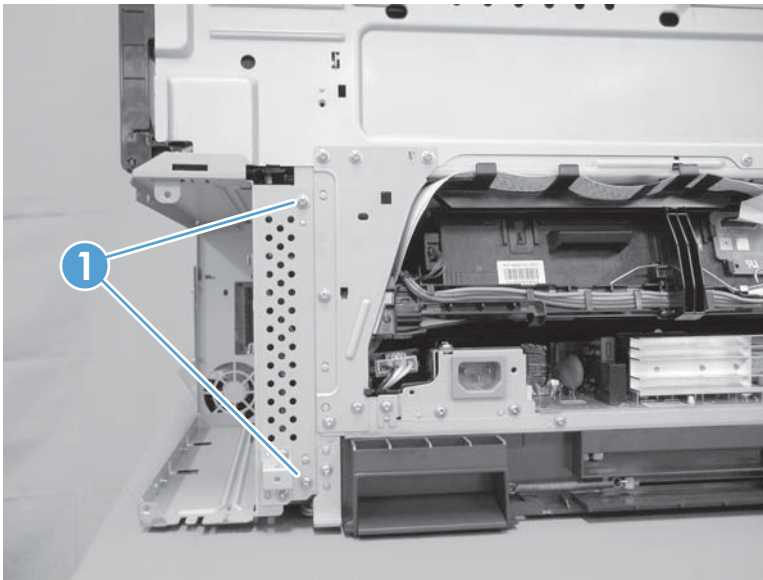

2. Remove nine screws (callout 1), and then slide the formatter case unit (callout 2) away from the DC controller to remove it.

Figure 2-53 Remove the formatter case assembly (2 of 2)

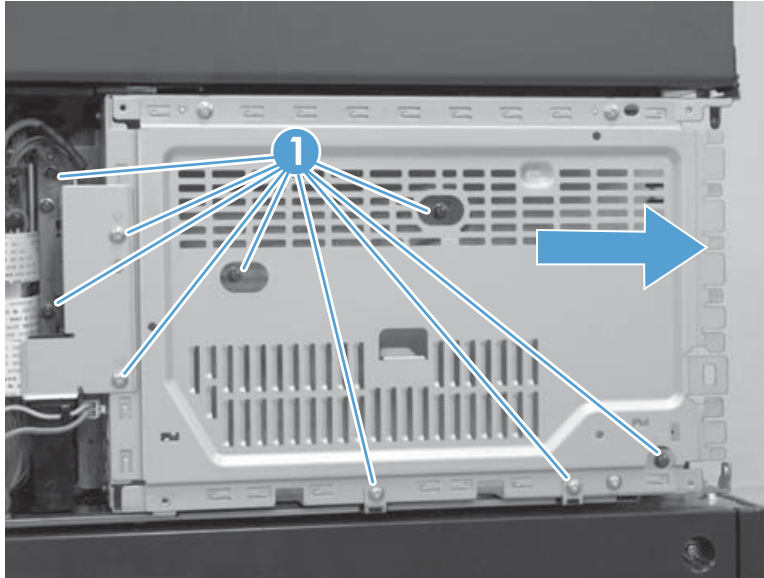

Laser/scanner assembly

- △ **CAUTION:** Do not replace the laser scanner and the formatter PCA at the same time. The settings for the laser scanner are stored in the formatter RAM. When you install a new laser scanner, it reads the settings from the formatter.

Before proceeding, remove the following components:

- Tray 2
- Left cover. See [Left cover on page 115](#).

Remove the laser/scanner assembly

1. Open the front door.
2. On the left side of the product, pinch and remove the fan duct (callout 1), and then disconnect the two flat cables (callout 2).

Figure 2-54 Remove the laser/scanner assembly (1 of 4)

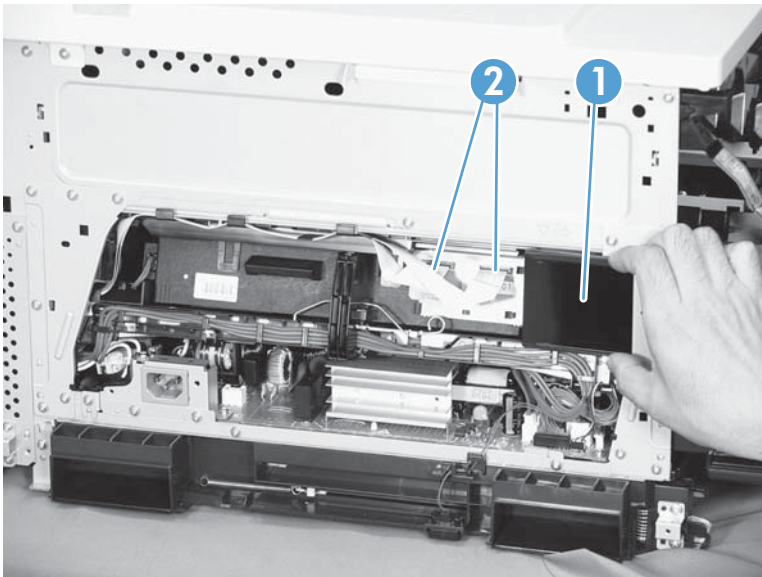

3. Release one tab (callout 1), remove the stopper (callout 2), and then disconnect one connector (callout 3).

Figure 2-55 Remove the laser/scanner assembly (2 of 4)

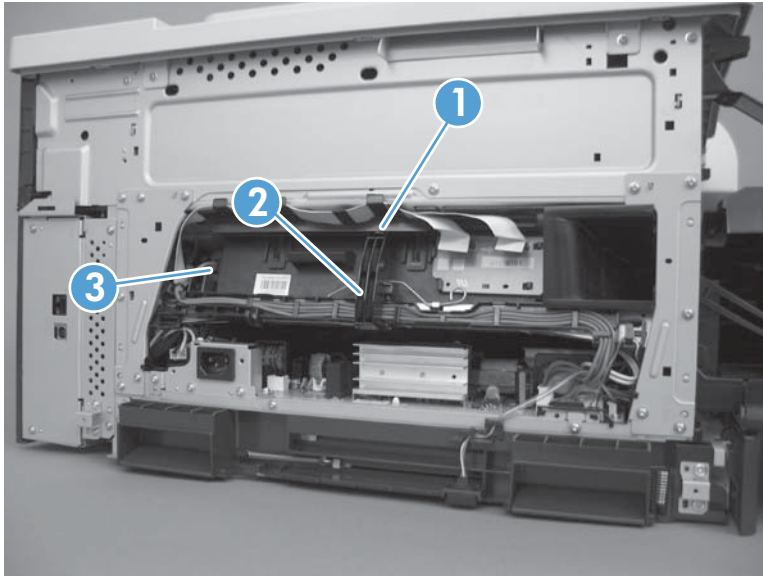

4. Release one tab (callout 1), and then slide the cable guide (callout 2) in the direction that the arrow indicates.
5. Remove the cable guide (callout 2) and the flat cables (callout 3) together, and then remove one spring (callout 4).

Figure 2-56 Remove the laser/scanner assembly (3 of 4)

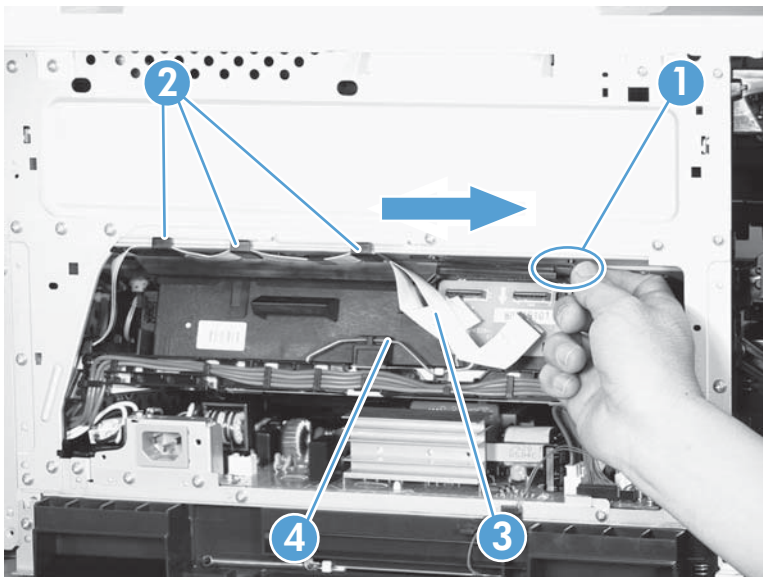

6. While holding up the handle (callout 1), pull the laser/scanner (callout 2) up slightly and then out of the product.

△ **CAUTION:** Do not touch the protective glass strip on top of the assembly.

Figure 2-57 Remove the laser/scanner assembly (4 of 4)

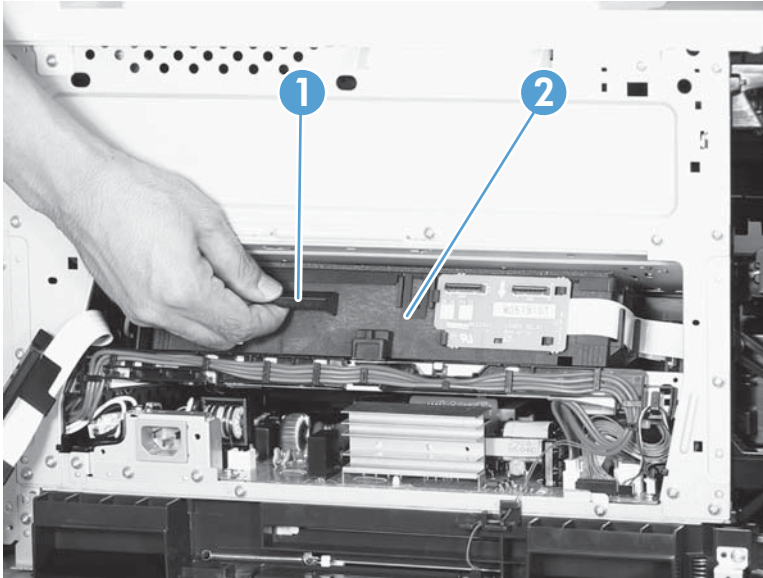

💡 **Reinstallation tip** Align the assembly with the guides on the left side of the opening when reinstalling the assembly.

Align the pin on the bottom of the assembly with the hole in the product when reinstalling the assembly. After pushing the assembly into the product, you might have to pull the assembly slightly forward to seat the pin in the hole.

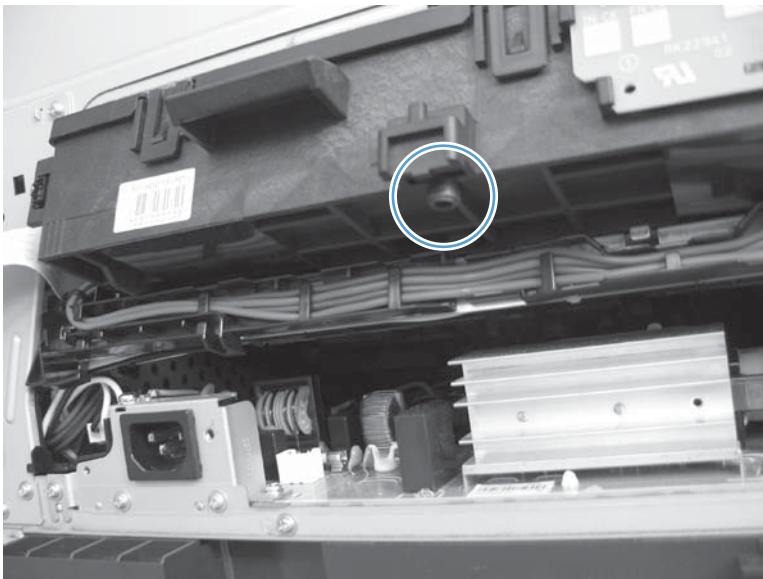

Paper pickup assembly

Before proceeding, remove the following components:

- Tray 2 cassette.
- Tray 2 separation roller assembly. See [Separation roller assembly \(Tray 2\) on page 97](#).
- ITB. See [Intermediate transfer belt \(ITB\) on page 102](#).

Remove the paper pickup assembly

1. Open the right door, pull out one tab (callout 1), pull the bottom of the cable cover out, and then pull up to remove the cable cover (callout 2).

Figure 2-58 Remove the paper pickup assembly (1 of 3)

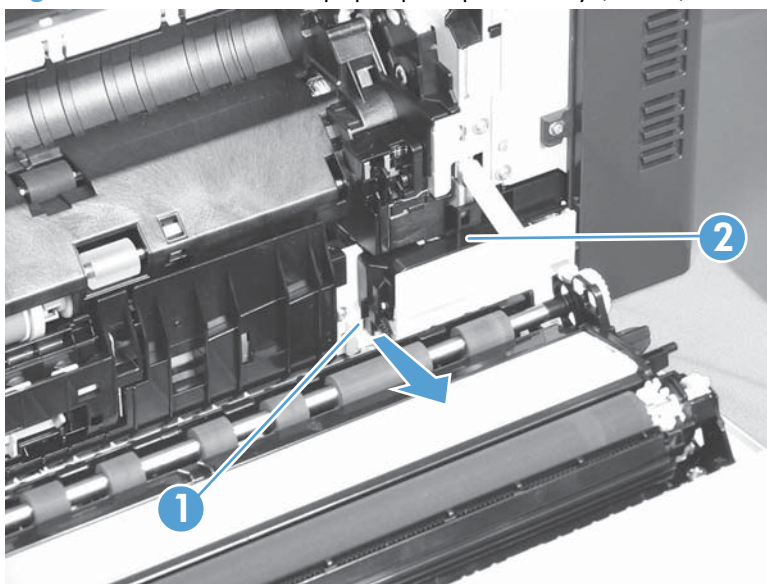

2. Disconnect four connectors (callout 1).

 **NOTE:** The connectors might be hidden behind the assembly.

Figure 2-59 Remove the paper pickup assembly (2 of 3)



3. Pull out one tab (callout 1), and then slide the guide (callout 2) to the right to remove it.

Figure 2-60 Remove the paper pickup assembly (3 of 3)

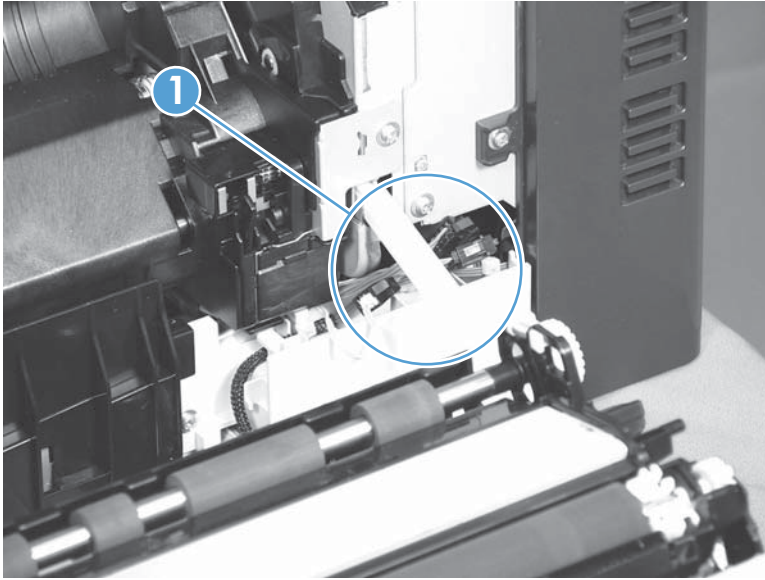
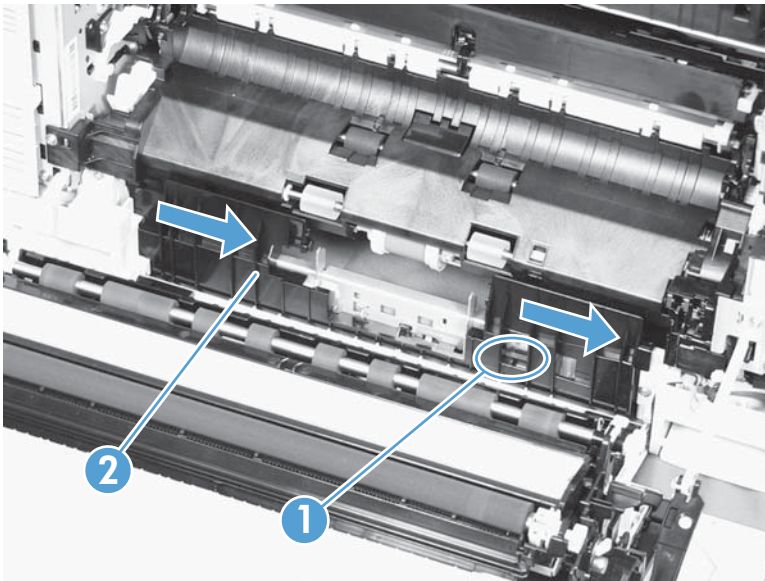

4. Remove two screws (callout 1), move the registration sensor flag (callout 2) to the up position, and then pull the paper pickup assembly (callout 3) toward you to remove it.

Figure 2-61 Remove the paper pickup assembly (4 of 4)

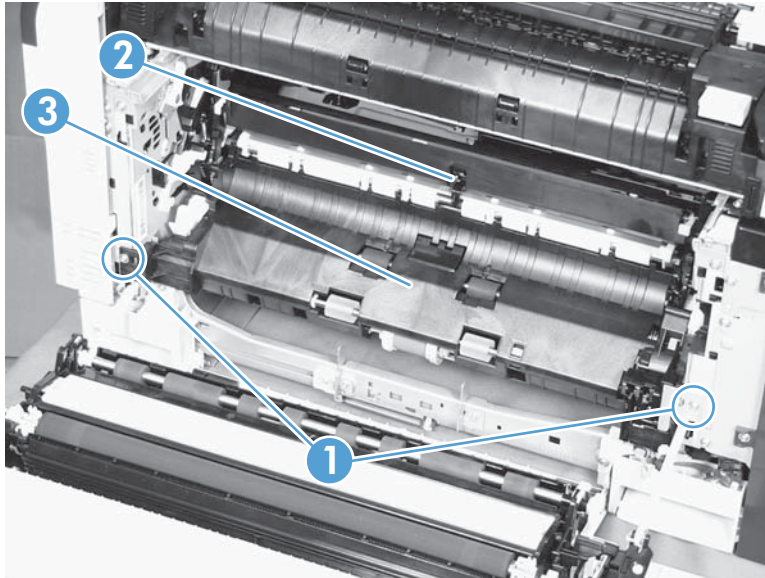

Reinstall the paper pickup assembly

Use the steps below to reinstall the paper pickup assembly. If you are installing a replacement assembly, also see [Installing a replacement paper pickup assembly on page 140](#) after completing these steps.

1. When reassembling the paper pickup assembly (callout 1), the sensor flag (callout 2) is in the way. Be sure to hold up the sensor flag when reassembling.

Figure 2-62 Reinstall the paper pickup assembly

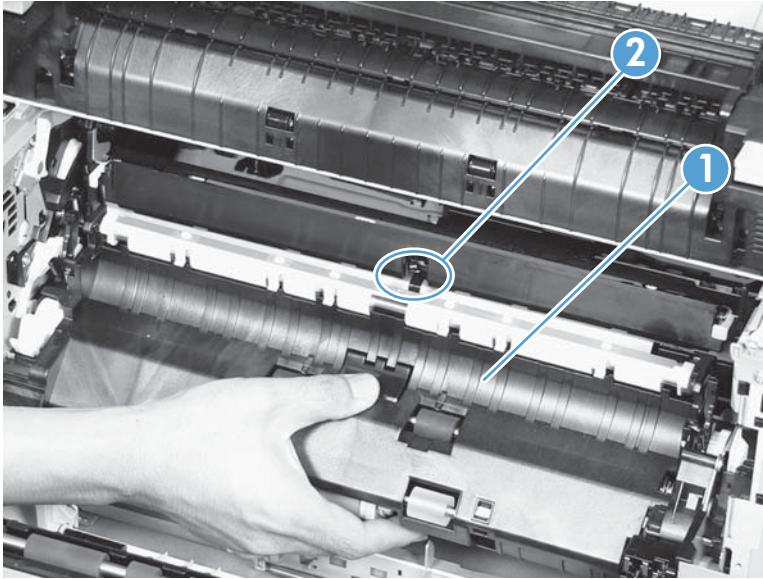

2. Make sure that the sensor flag is correctly installed, and that the flag moves properly after reassembling the paper pickup assembly.

Figure 2-63 Paper pickup assembly sensor flag correctly installed

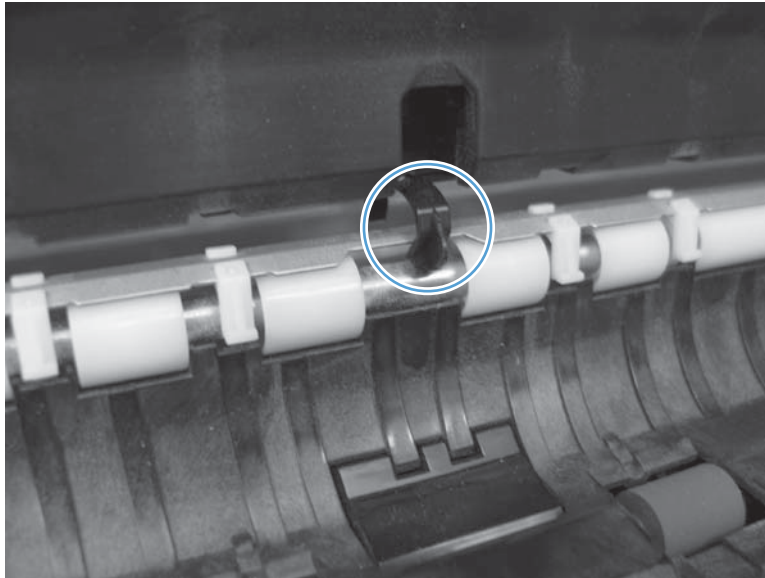
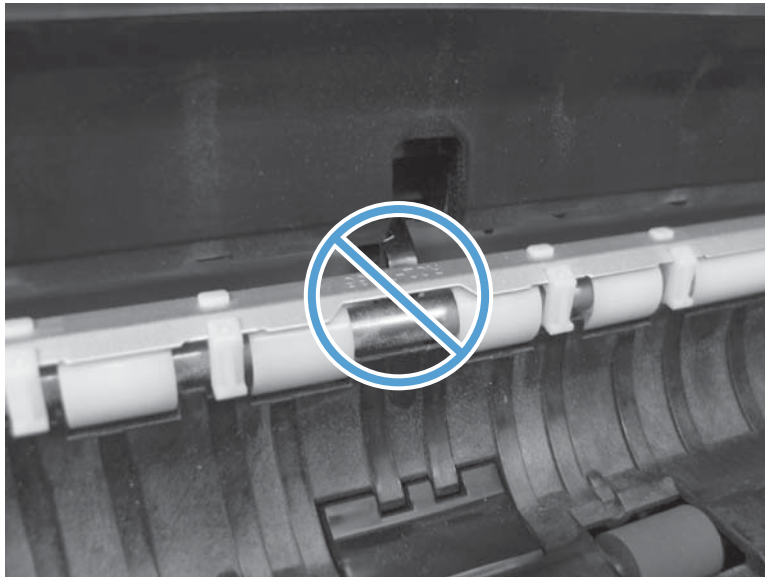





Figure 2-64 Paper pickup assembly sensor flag incorrectly installed



Installing a replacement paper pickup assembly

- ▲ Use the **Service** menu to reset the **New Registration Roller** menu item and enter the **Media Sensor Value** from the replacement paper pickup assembly.

Reset the New Registration Roller menu item

- a. Press the Home button .
- b. Open the following menus:
 - **Device Maintenance**
 - **Service**
 - **Service Access Code**
- c. Use the arrow buttons to enter the access code, and then press the **OK** button.
- d. Press the **Down** arrow button  to highlight the **New Registration Roller** menu, and then press the **OK** button.
- e. Press the **Down** arrow button  to highlight the **Yes** item, and then press the **OK** button.

Reset the Media Sensor Value

- a. Press the Home button .
- b. Open the following menus:
 - **Device Maintenance**
 - **Service**
 - **Service Access Code**
- c. Use the arrow buttons to enter the access code, and then press the **OK** button.

- d. Press the **Down** arrow button ▼ to highlight the **Media Sensor Value** menu, and then press the **OK** button.

Figure 2-65 Media sensor value label



- e. Use the arrow buttons to enter the media sensor value found on the replacement assembly.
- f. Press the **OK** button to save to save the value.

Registration sensor assembly

Before proceeding, remove the following components:

- Tray 2 cassette.
- Cassette separation roller assembly. See [Separation roller assembly \(Tray 2\) on page 97](#).
- Intermediate transfer belt (ITB). See [Intermediate transfer belt \(ITB\) on page 102](#).
- Cassette pickup drive assembly. See [Paper pickup assembly on page 135](#).

Remove the registration sensor assembly

1. Push the tab (callout 1) down, and then pull the top of the cover (callout 2). You might need a small flat-blade screwdriver to press down the tab.

Figure 2-66 Remove the registration sensor assembly (1 of 4)

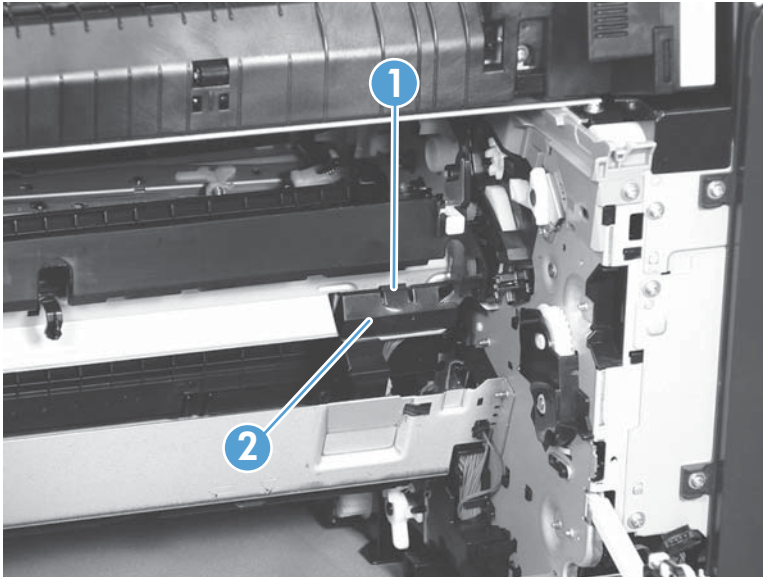

2. Disconnect one connector (callout 1), and then detach the bottom part of the spring (callout 2) at the right end. If necessary, use a pick or needle-nose pliers to detach the spring.

Figure 2-67 Remove the registration sensor assembly (2 of 4)

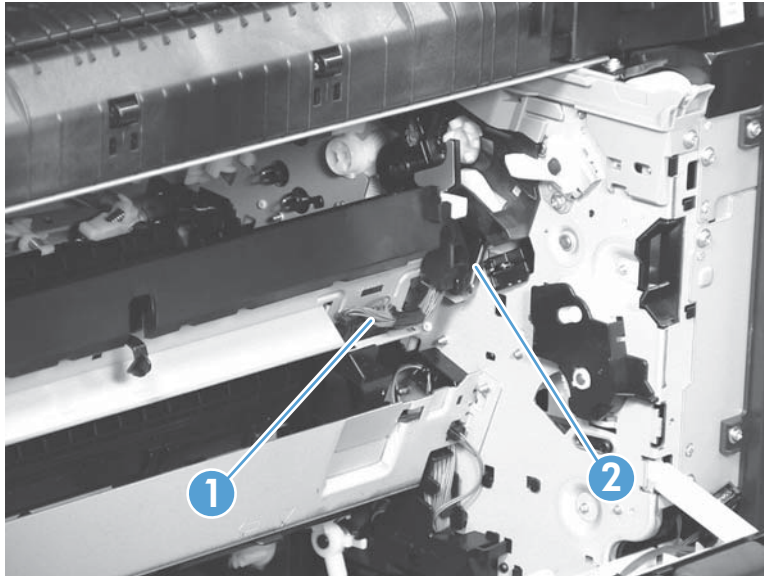

3. Detach the bottom of one spring (callout 1) at the left end.

Figure 2-68 Remove the registration sensor assembly (3 of 4)

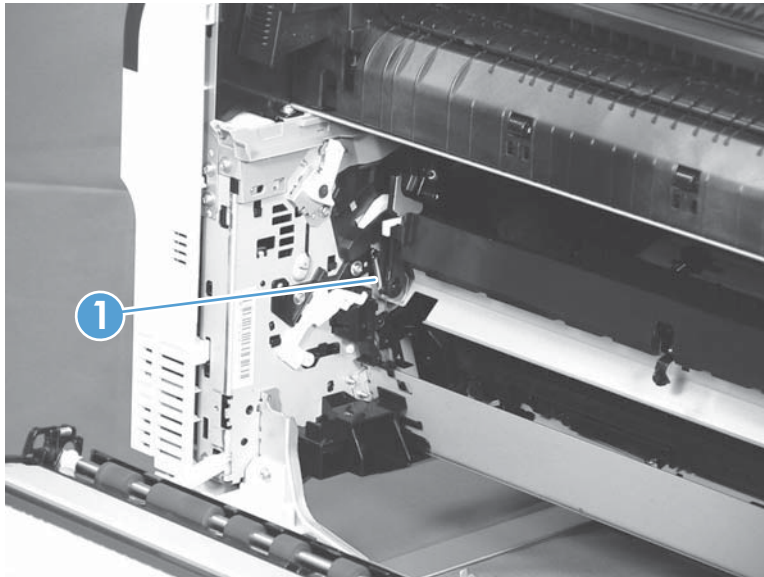

4. Release one of the registration sensor unit pivot hinges from the shafts (callout 1), pull out that end of the assembly (callout 2), and then repeat the procedure on the other pivot hinge.

Figure 2-69 Remove the registration sensor assembly (4 of 4)

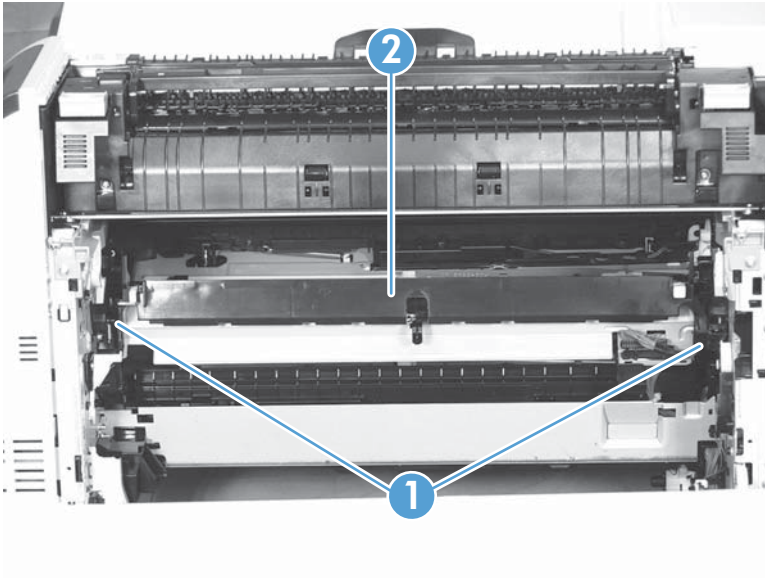

Lifter-drive assembly

Before proceeding, remove the following components:

- Tray 2 cassette.
- Fuser. See [Fuser on page 93](#).
- ITB. See [Intermediate transfer belt \(ITB\) on page 102](#).
- 1 x 500-paper feeder. See [1 x 500-sheet paper feeder assembly on page 222](#).
- 3 x 500-paper feeder (optional accessory). See [3 x 500-sheet paper feeder \(optional accessory\) on page 236](#).

Remove the lifter-drive assembly

1. Verify that the right door is closed, and then turn the product so that the front side faces up.

Figure 2-70 Remove the lifter-drive assembly (1 of 3)



2. Release the tab (callout 1), and then pull up to remove the cover (callout 2).

Figure 2-71 Remove the lifter-drive assembly (2 of 3)

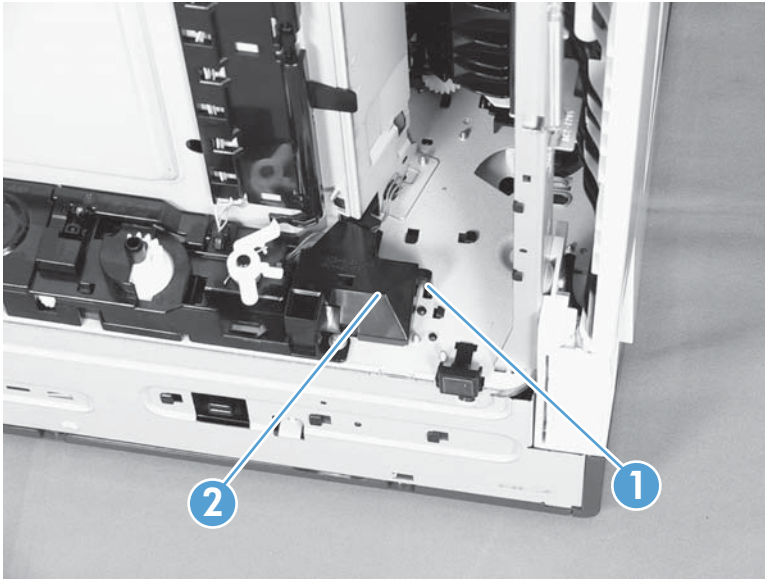

3. Disconnect two connectors (callout 1), remove one screw (callout 2), and then remove the lifter drive unit (callout 3).

Figure 2-72 Remove the lifter-drive assembly (3 of 3)

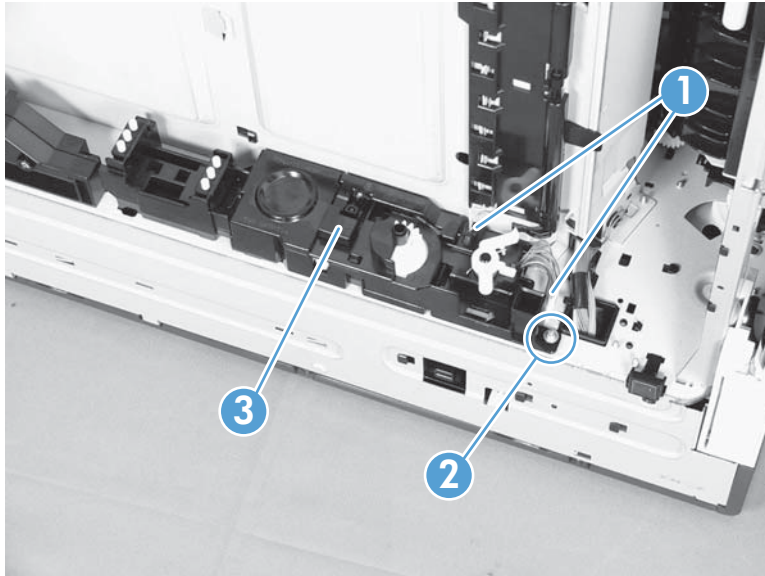

 **Reinstallation tip** Make sure that the tabs align correctly when reinstalling the lifter-drive assembly.

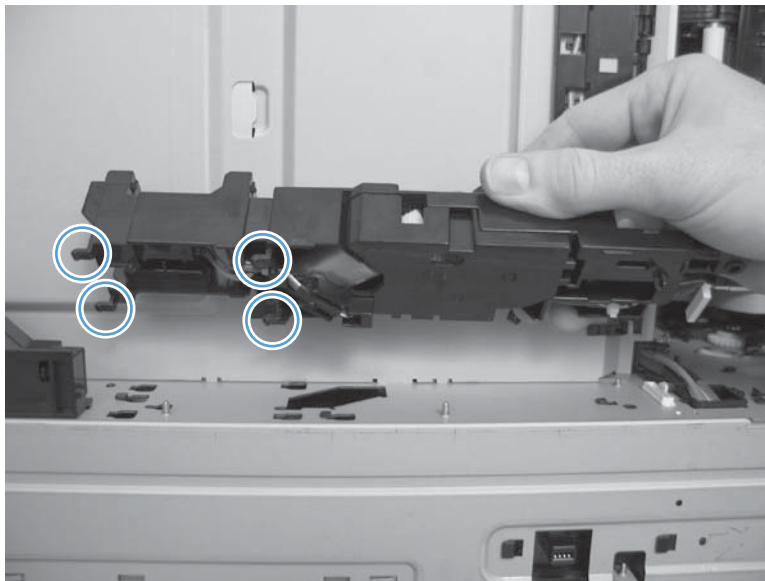

ITB front guide assembly

Before proceeding, remove the following components:

- ITB. See [Intermediate transfer belt \(ITB\) on page 102](#).
 - Right-front cover and control-panel assembly. See [Right-front cover and control-panel assembly on page 113](#).
 - Left cover. See [Left cover on page 115](#).
 - Rear cover. See [Rear cover on page 116](#).
 - Right-rear cover. See [Right-rear cover on page 119](#).
 - Top cover. See [Top cover on page 121](#).
1. Open the front door (callout 1) halfway, and then push up the upper part of the link arm (callout 2) to detach it from the product chassis.

Figure 2-73 Remove the ITB front guide assembly (1 of 4)

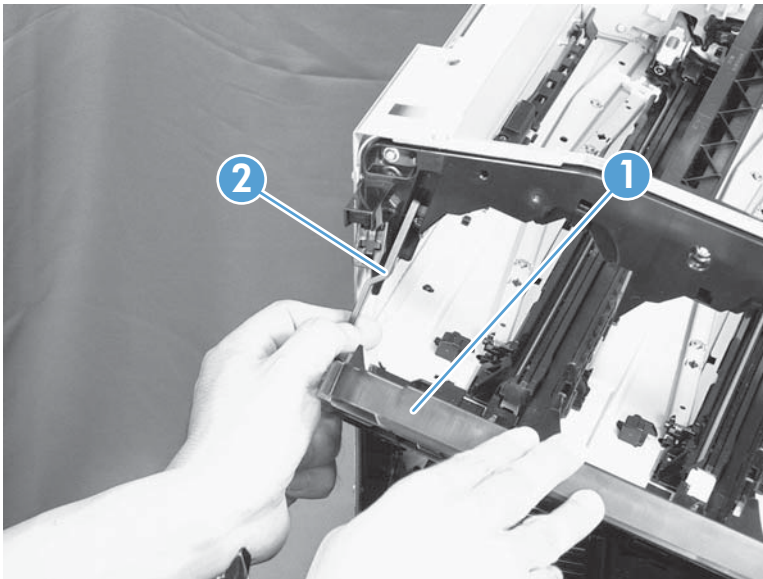

2. Remove three screws (callout 1), release four tabs (callout 2), and then remove the cartridge upper guide unit (callout 3).

Figure 2-74 Remove the ITB front guide assembly (2 of 4)

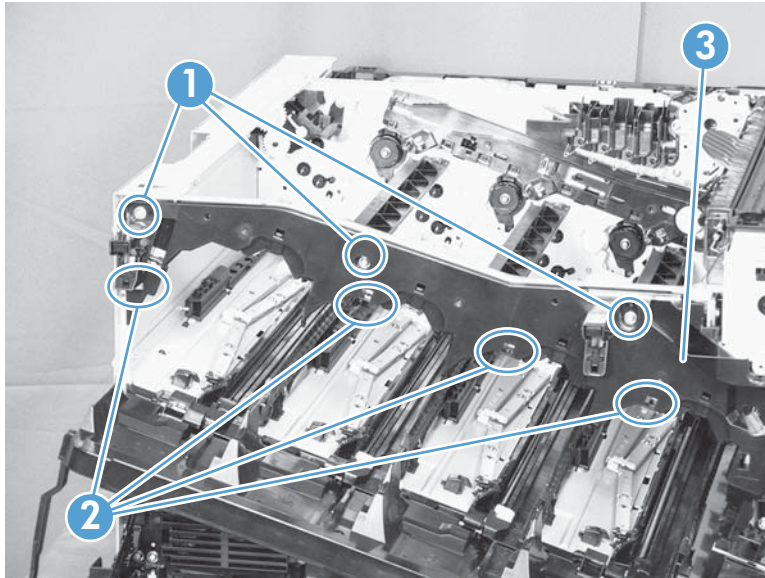

3. Disconnect one connector (callout 1), and then release the cables (callout 3) from the cable clamp (callout 2).

Figure 2-75 Remove the ITB front guide assembly (3 of 4)

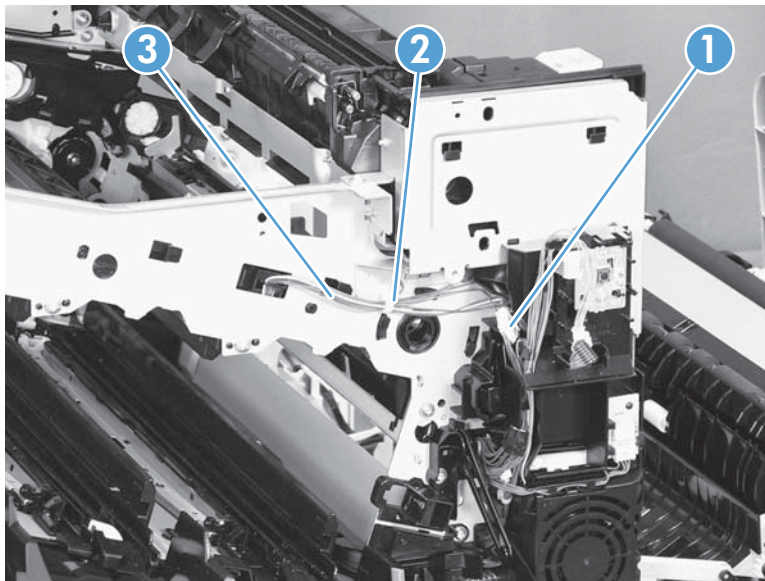

4. Release one tab (callout 1), and then slide the ITB front guide assembly (callout 2) in the direction that the arrow indicates to remove it.

Figure 2-76 Remove the ITB front guide assembly (4 of 4)

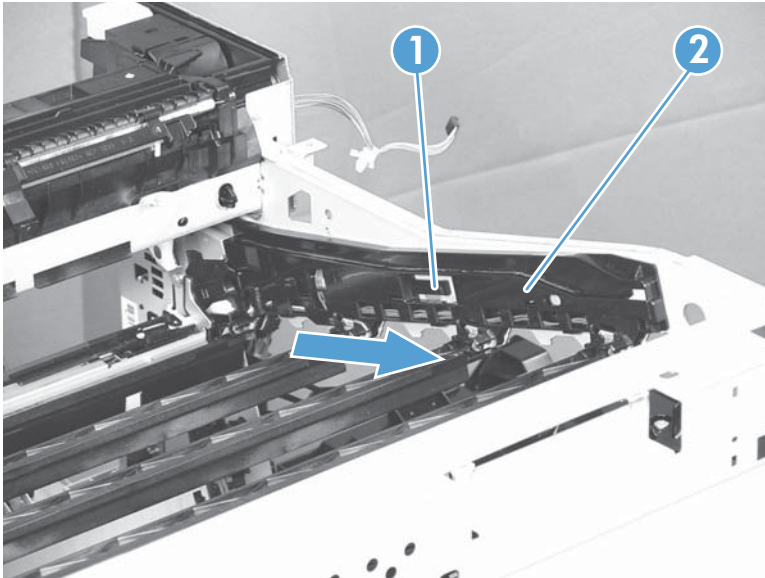

ITB rear guide assembly

Before proceeding, remove the following components:

- ITB. See [Intermediate transfer belt \(ITB\) on page 102](#).
 - Right-front cover and control-panel assembly. See [Right-front cover and control-panel assembly on page 113](#).
 - Left cover. See [Left cover on page 115](#).
 - Rear cover. See [Rear cover on page 116](#).
 - Right-rear cover. See [Right-rear cover on page 119](#).
 - Top cover. See [Top cover on page 121](#).
- ▲ Disconnect one connector (callout 1), release one tab (callout 2), and then slide the ITB rear guide unit (callout 3) in the direction that the arrow indicates to remove it.

Figure 2-77 Remove the ITB rear guide assembly

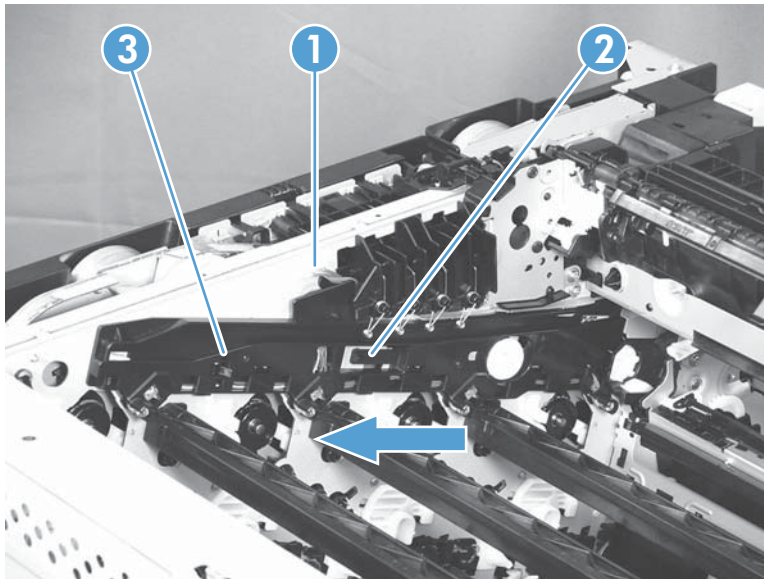

Residual toner full sensor

Before proceeding, remove the following components:

- Toner-collection unit. See [Toner-collection unit on page 91](#).
- Right-front cover and control-panel assembly. See [Right-front cover and control-panel assembly on page 113](#).
- Left cover. See [Left cover on page 115](#).
- Rear cover. See [Rear cover on page 116](#).
- Toner collection unit access door. See [Toner collection unit access door on page 117](#).
- Right-rear cover. See [Right-rear cover on page 119](#).
- Top cover. See [Top cover on page 121](#).

Remove the residual toner full sensor

1. Release one tab (callout 1), and then remove the cover (callout 2).

Figure 2-78 Remove the residual toner full sensor (1 of 4)

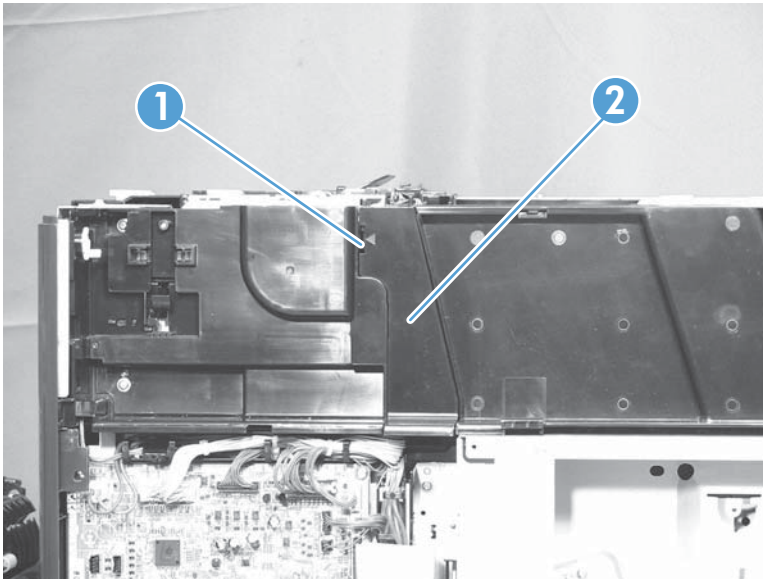

2. Remove two M4-screws (callout 1) and one M3-screw (callout 2). Then remove the toner cover (callout 3).

Figure 2-79 Remove the residual toner full sensor (2 of 4)

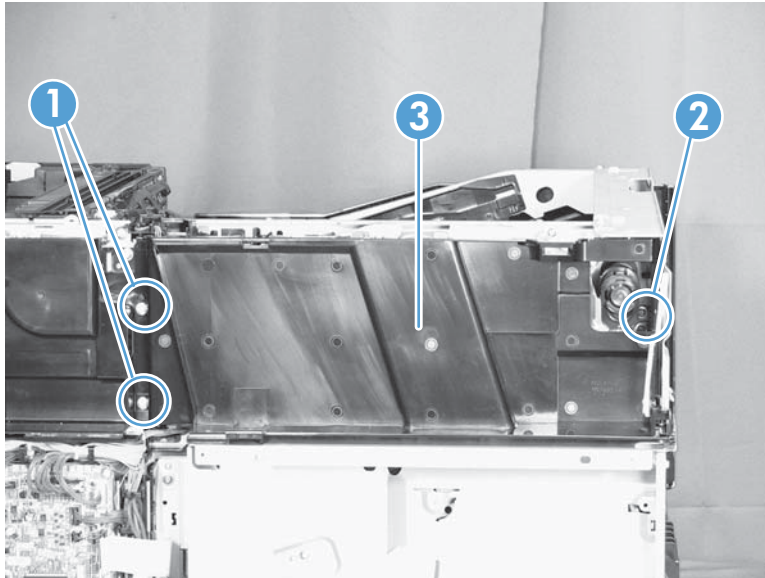

3. Disconnect one connector (callout 1), remove three screws (callout 2), and then remove the residual toner full sensor assembly (callout 3).

△ **CAUTION:** During the removal process, make sure that the white gear (callout 4) does not fall out of the assembly. The white gear might stay on the product, and not come off with the assembly.

Figure 2-80 Remove the residual toner full sensor (3 of 4)

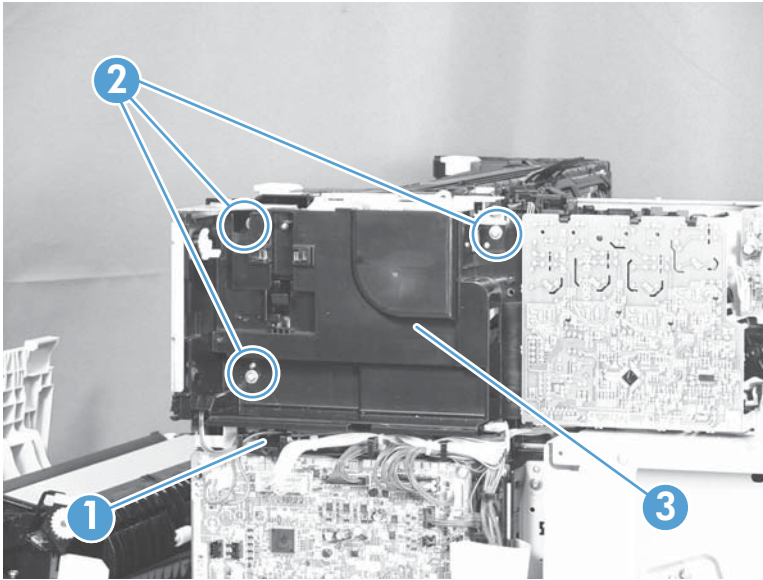
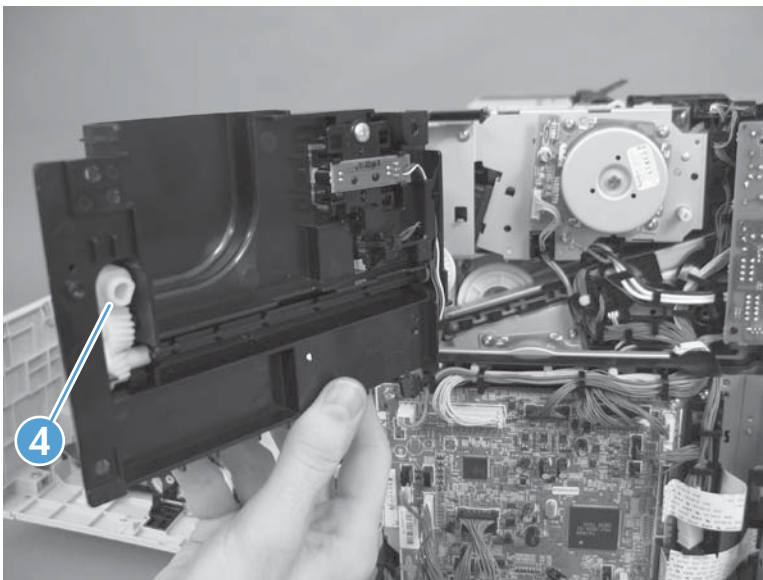

Figure 2-81 Remove the residual toner full sensor (4 of 4)



Reinstall the residual toner full sensor

1. If the white gear (callout 1) was removed with the residual toner full sensor assembly, carefully remove it from the assembly.

Figure 2-82 Reinstall the residual toner full sensor (1 of 3)

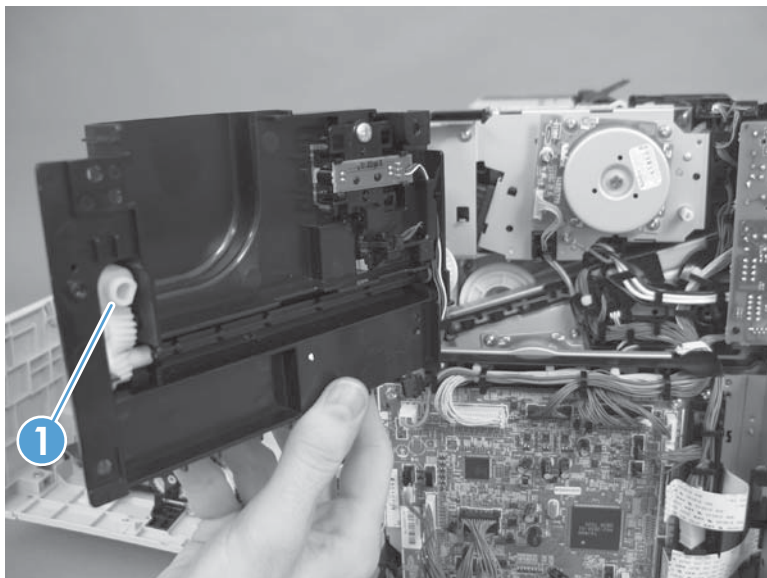

2. Align the flat portion of the gear with the corresponding flat portion of the drive shaft.

Figure 2-83 Reinstall the residual toner full sensor (2 of 3)

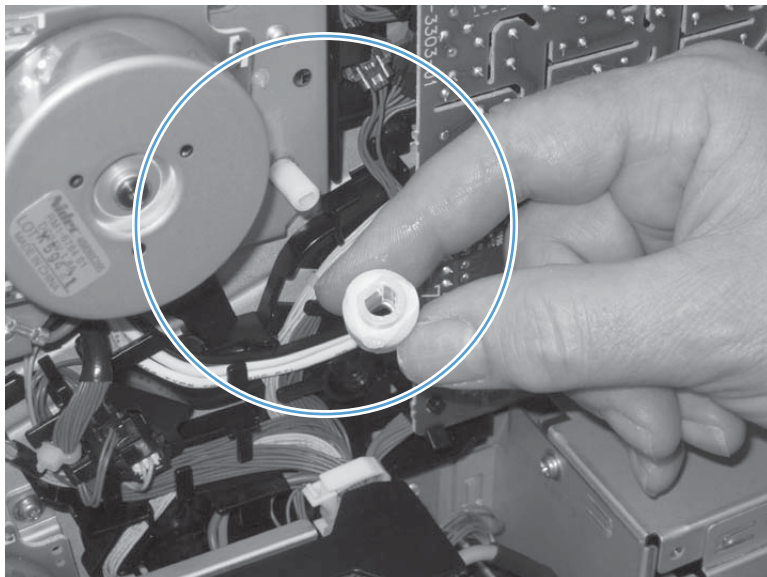

3. Install the gear on the shaft before you install the residual toner full sensor assembly.

Figure 2-84 Reinstall the residual toner full sensor (3 of 3)

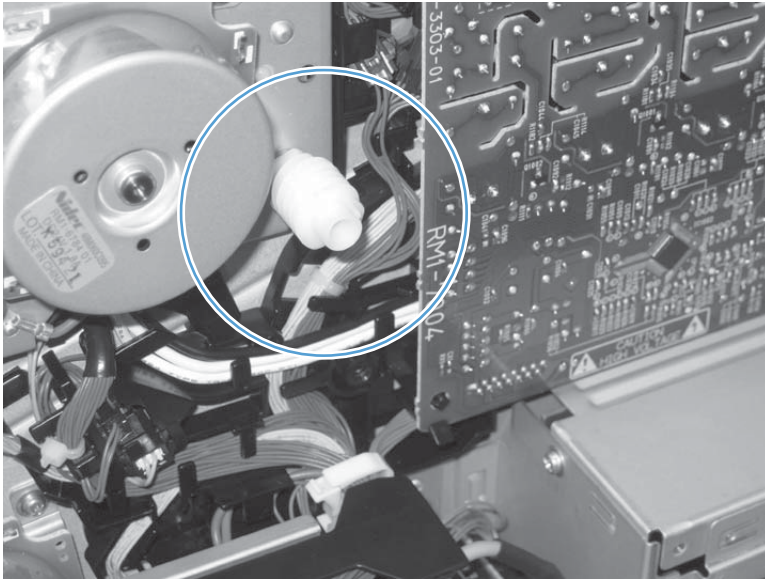

Main drive assembly

Before proceeding, remove the following components:

- Toner-collection unit. See [Toner-collection unit on page 91](#).
- Formatter PCA. See [Formatter PCA on page 105](#).
- Formatter case. See [Formatter case on page 130](#).
- Right-front cover and control-panel assembly. See [Right-front cover and control-panel assembly on page 113](#).
- Left cover. See [Left cover on page 115](#).
- Rear cover. See [Rear cover on page 116](#).
- Toner collection unit access door. See [Toner collection unit access door on page 117](#).
- Right-rear cover. See [Right-rear cover on page 119](#).
- Top cover. See [Top cover on page 121](#).
- Residual-toner full sensor. See [Residual toner full sensor on page 152](#).

Remove the main drive assembly

1. Disconnect three connectors (callout 1) and one FFC (callout 2).

Figure 2-85 Remove the main drive assembly (1 of 17)

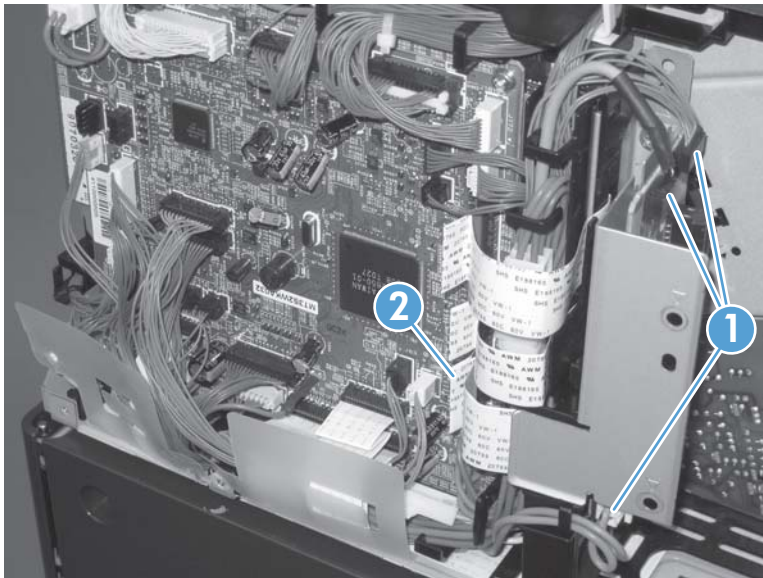

2. Remove one screw (callout 1), and then remove the sheet-metal plate (callout 2).

Figure 2-86 Remove the main drive assembly (2 of 17)

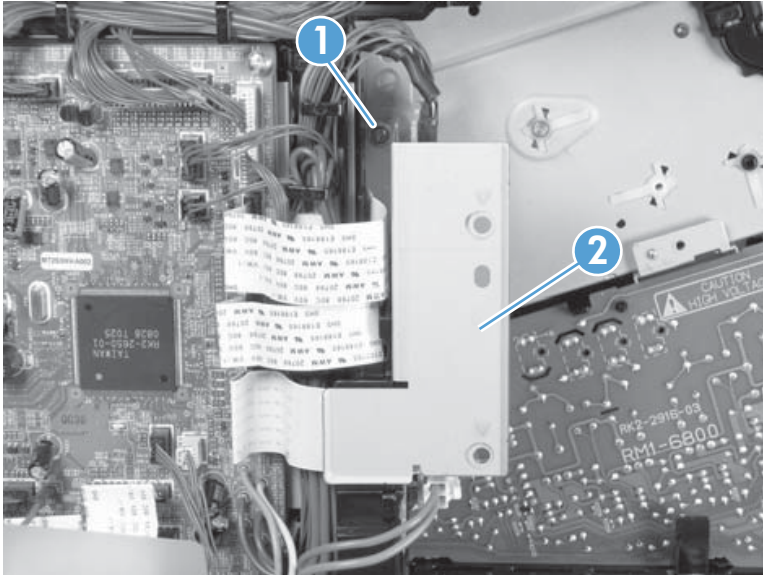

3. Disconnect twenty-two connectors and six FFCs on the DC controller PCA (callout 1).

 **TIP:** Three connectors (callout 2) should be empty when the DC controller is reinstalled.

Figure 2-87 Remove the main drive assembly (3 of 17)



4. Disconnect three intermediate connectors (callout 1), and then release the wire harnesses (callout 3) from the guides (callout 2).

Figure 2-88 Remove the main drive assembly (4 of 17)

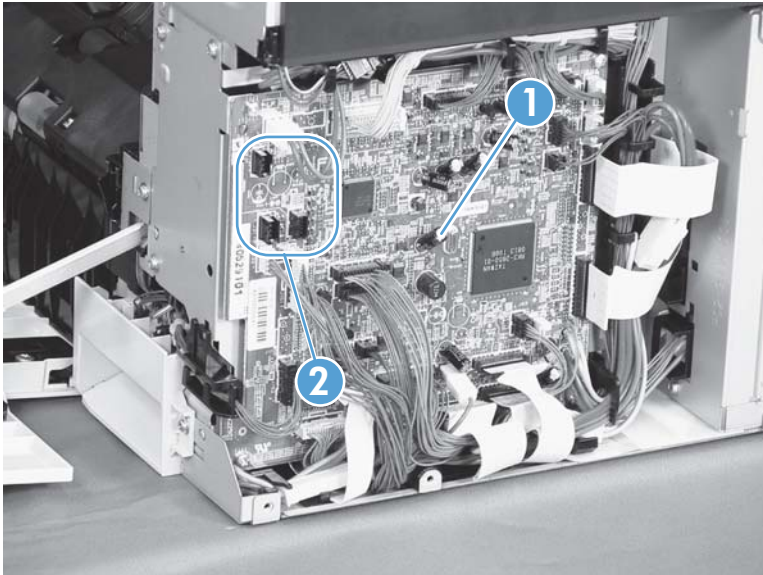
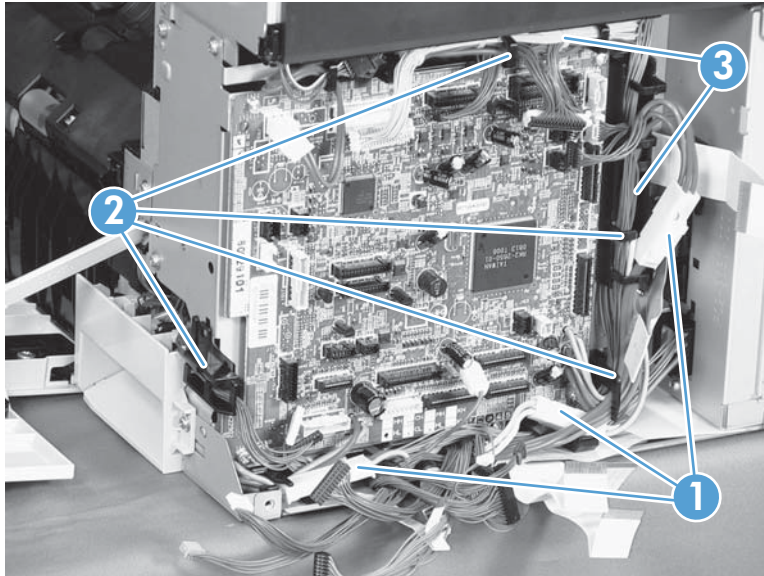

5. Release one tab (callout 1), and then remove the guide (callout 2).

 **TIP:** Release the wire harnesses from the guide as you remove it.

Figure 2-89 Remove the main drive assembly (5 of 17)



6. Remove five screws (callout 1), and then remove the DC controller and the two sheet-metal support plates.

△ **CAUTION:** Carefully unthread the FFCs from the plate to avoid damaging them when you remove the DC controller and the two sheet-metal support plates.

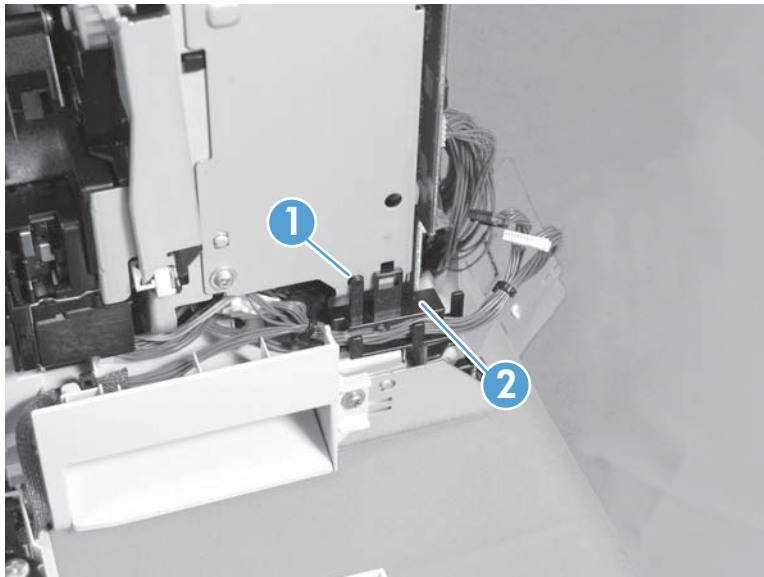
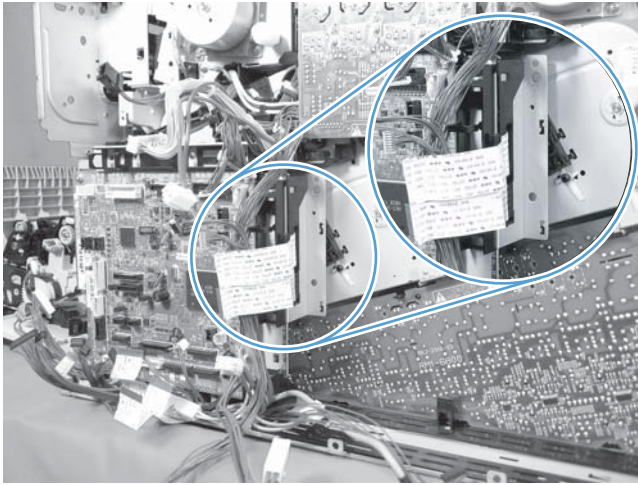
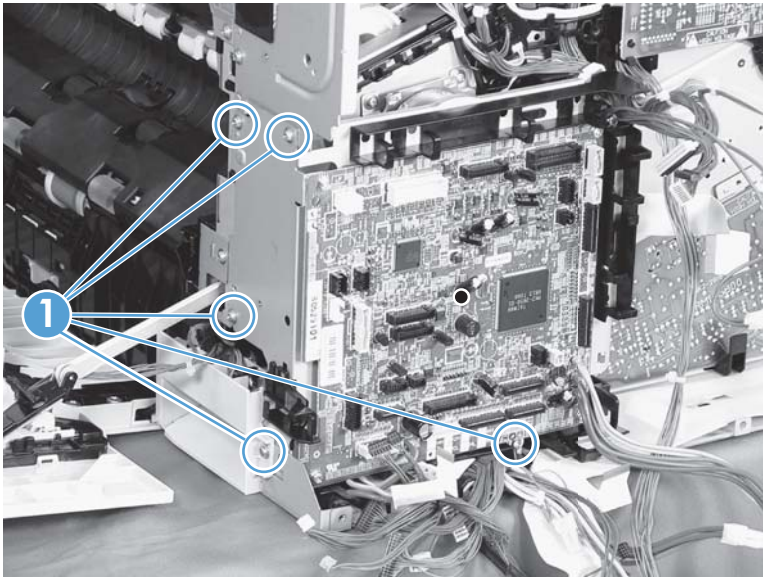
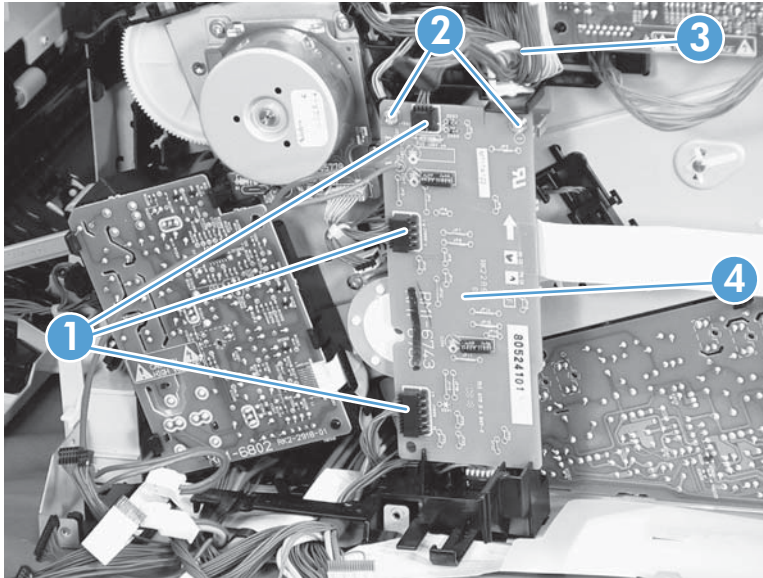

Figure 2-90 Remove the main drive assembly (6 of 17)



7. Disconnect three connectors (callout 1), remove two screws (callout 2), release one wire retainer (callout 3), and then remove the driver PCA (callout 4).

Figure 2-91 Remove the main drive assembly (7 of 17)



8. Remove one screw (callout 1), and then remove the second transfer high-voltage power supply (callout 2) and the PCA holder (callout 3) assembly.

Figure 2-92 Remove the main drive assembly (8 of 17)

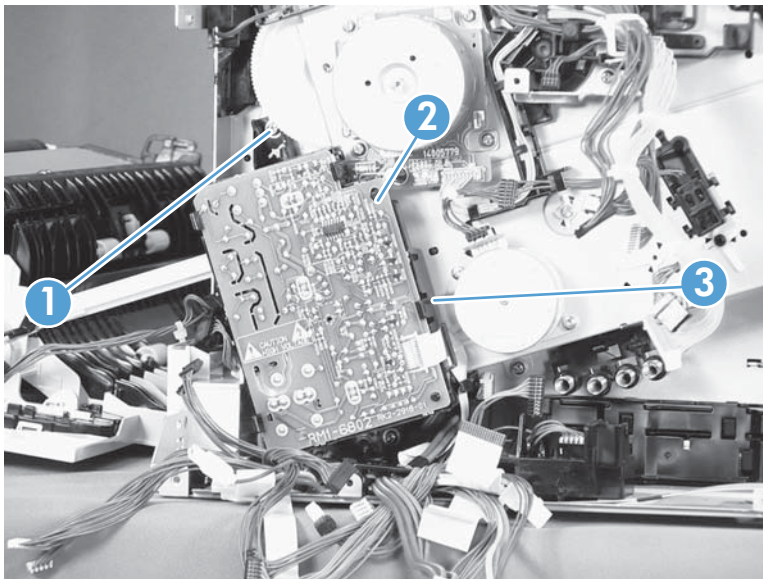

9. Release one tab (callout 1), and then remove the cover (callout 2).

Figure 2-93 Remove the main drive assembly (9 of 17)

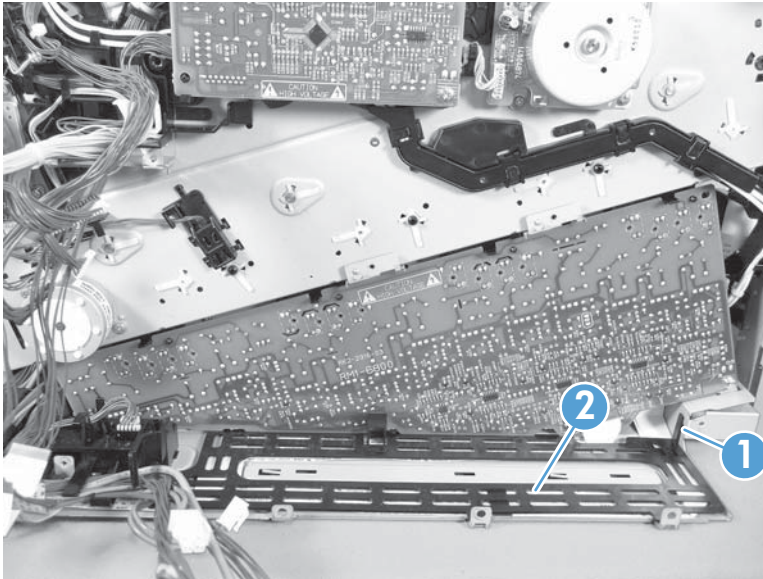

10. Remove one screw (callout 1), release four tabs (callout 2), and then remove the developing high-voltage power supply (callout 3).

 **Reinstallation tip** When you reinstall the power supply PCA, look through the holes on the PCA (callout 4) and make sure that the contact springs are correctly positioned against the back side of the PCA.

Figure 2-94 Remove the main drive assembly (10 of 17)



11. Remove one screw (callout 1), release four tabs (callout 2), and then separate the first transfer high-voltage power supply (callout 3) from the product.

△ **CAUTION:** The PCA is still connected to the product. Disconnect one connector (callout 4) on the back side of the PCA to remove it.

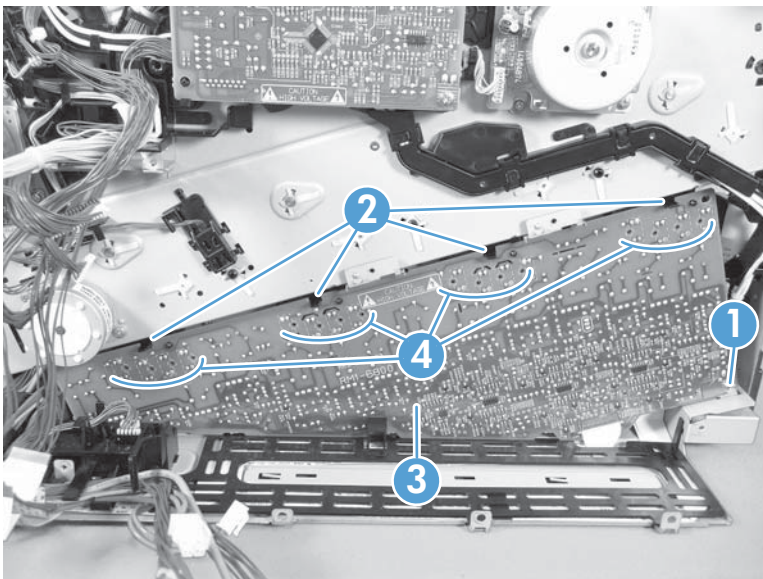
💡 **Reinstallation tip** When you reinstall the power supply PCA, look through the holes on the PCA (callout 5) and make sure that the contact springs are correctly positioned against the back side of the PCA.

Figure 2-95 Remove the main drive assembly (11 of 17)

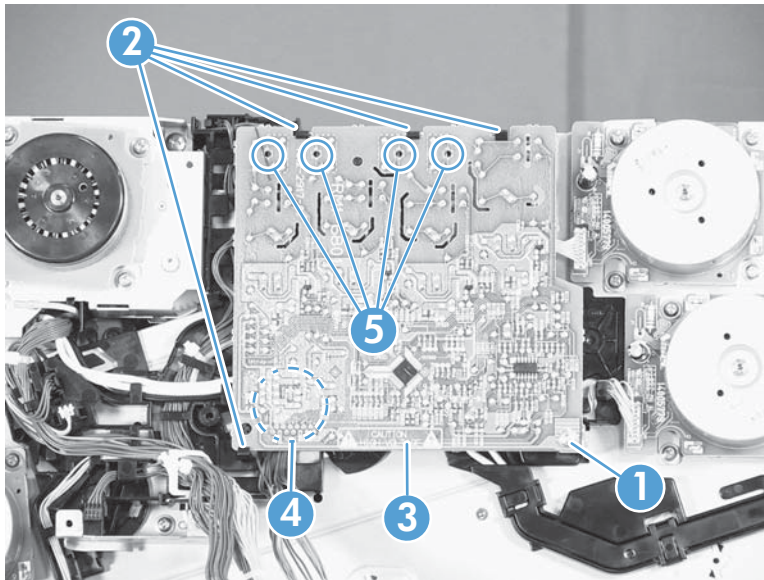

12. Remove two screws (callout 1), and then remove the sheet-metal support brackets (callout 2).

Figure 2-96 Remove the main drive assembly (12 of 17)

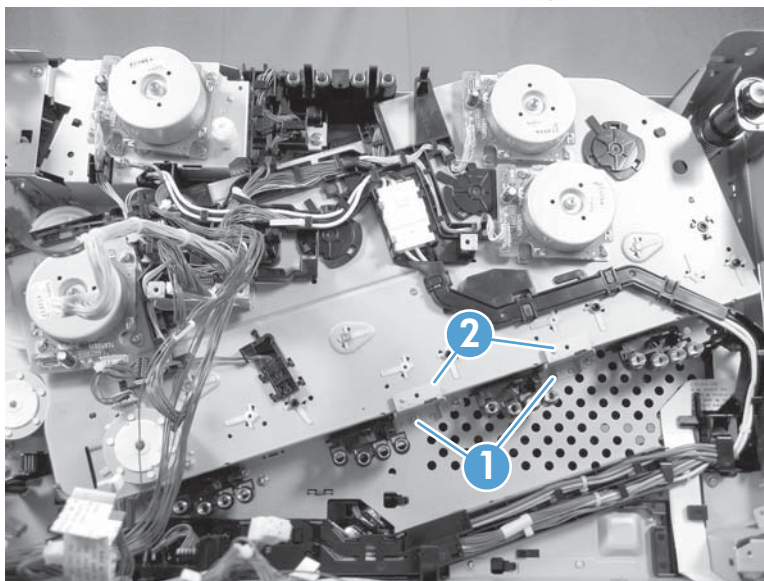

13. Disconnect one connector (callout 1), release one tab (callout 2), slide the cable guide (callout 3) to the left to release the it, and then move the guide to the side, out of the way.

 **TIP:** It might be easier to disconnect the connector if you release it from the holder.

Figure 2-97 Remove the main drive assembly (13 of 17)



14. Use a small flat blade screwdriver to release one tab (callout 1), and then remove the sensor holder (callout 2).

Figure 2-98 Remove the main drive assembly (14 of 17)

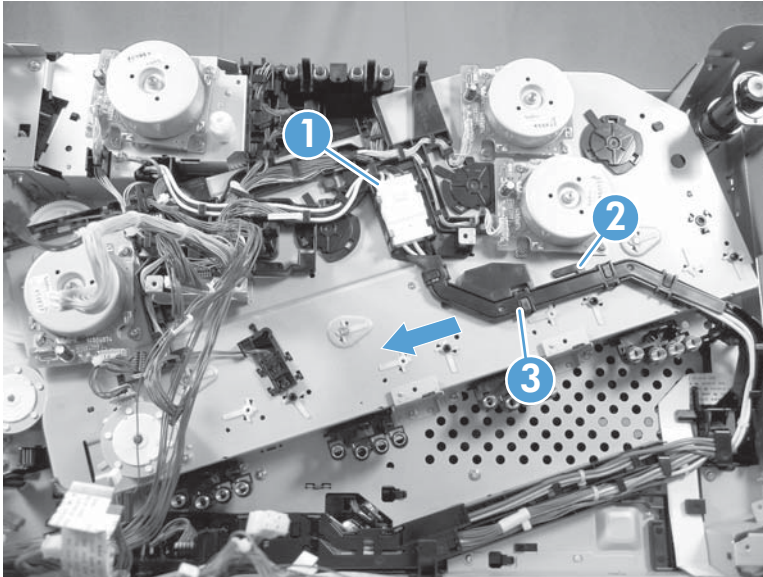
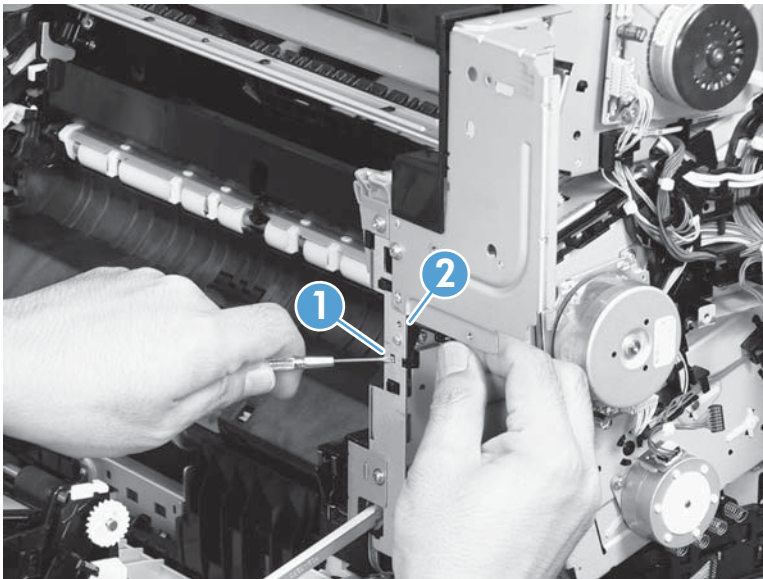

15. Disconnect one connector (callout 1), and then remove the sensor assembly.

Figure 2-99 Remove the main drive assembly (15 of 17)

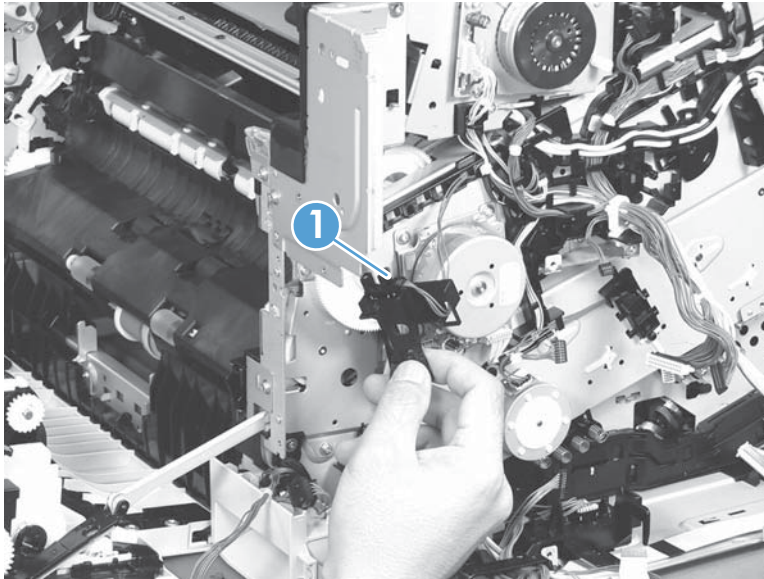

16. Disconnect six connectors (callout 1), and then release the wire harnesses from the guides (callout 2).

Figure 2-100 Remove the main drive assembly (16 of 17)

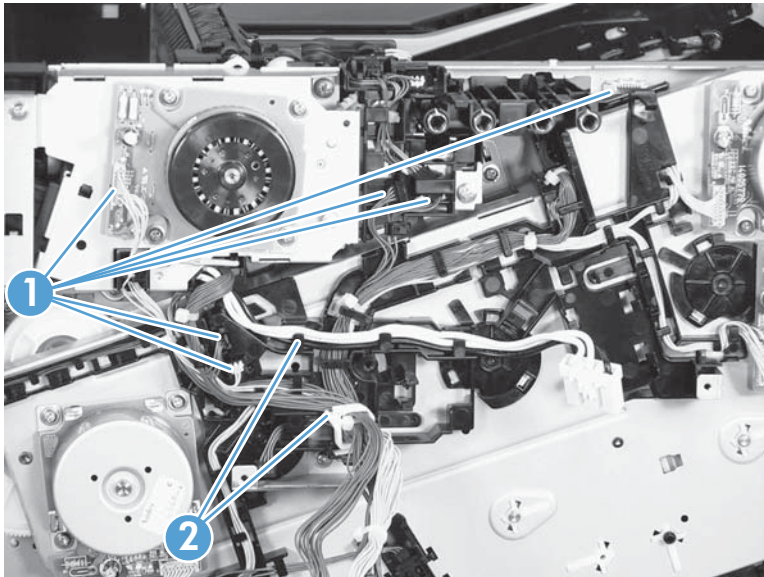

17. Remove six screws (callout 1), and then remove the main drive assembly (callout 2).

 **NOTE:** Make sure that the right door is closed.

Figure 2-101 Remove the main drive assembly (17 of 17)



Install the main drive assembly

 **NOTE:** **Installing a replacement assembly:** follow the instructions in this section.

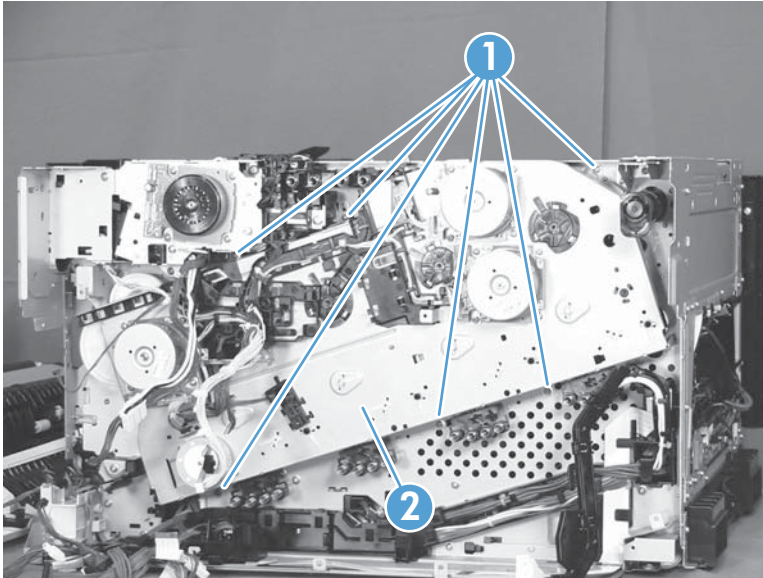
Reinstalling the original assembly: some of these instructions in this section do not apply (for example, removing the shipping spacers). **Do not** rotate the gears when handling the assembly. If the gears are rotated—and become out of phase—it will be difficult to install the assembly on the product.

1. Do not remove the orange spacers and spacer shipping tape (callout 1) installed on the replacement main drive assembly. Remove the remaining shipping tape (callout 2).

△ **CAUTION:** A gear (callout 3) on the back of the assembly is not captive when the shipping tape is removed. Do not lose the gear when handling the assembly with the shipping tape removed.

When removing tape, make sure that the entire strip is removed. Check the back of the assembly to verify that the entire strip of tape is removed.

Figure 2-102 Install the main drive assembly (1 of 8)

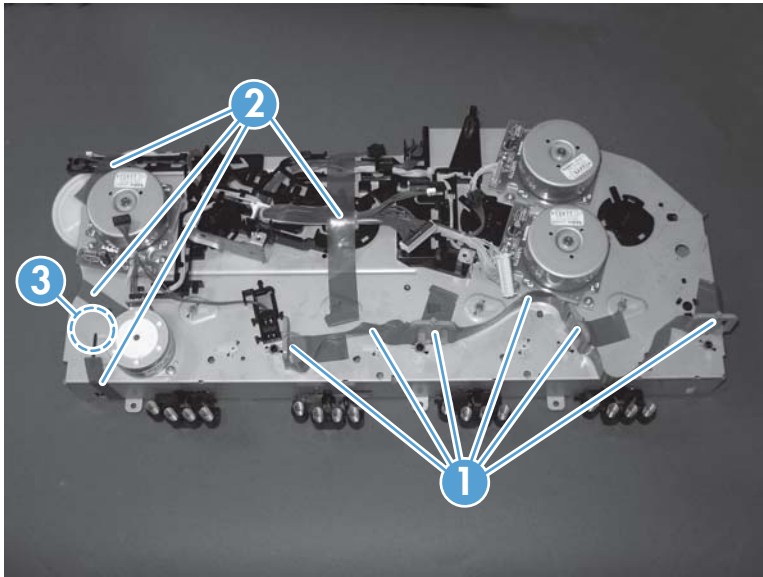

2. With the right door closed, position the drive assembly near the product, and then rotate it up and onto the chassis.

 **NOTE:** Make sure that the right-door link arm shaft (callout 1) aligns with and is positioned in the hole (callout 2) on the arm on the drive assembly, and that the pins on the assembly (callout 3) are positioned in the holes in the link arms on the chassis (callout 4).

Figure 2-103 Install the main drive assembly (2 of 8)



3. Install one screw (callout 1).

 **NOTE:** Do not fully tighten this screw.

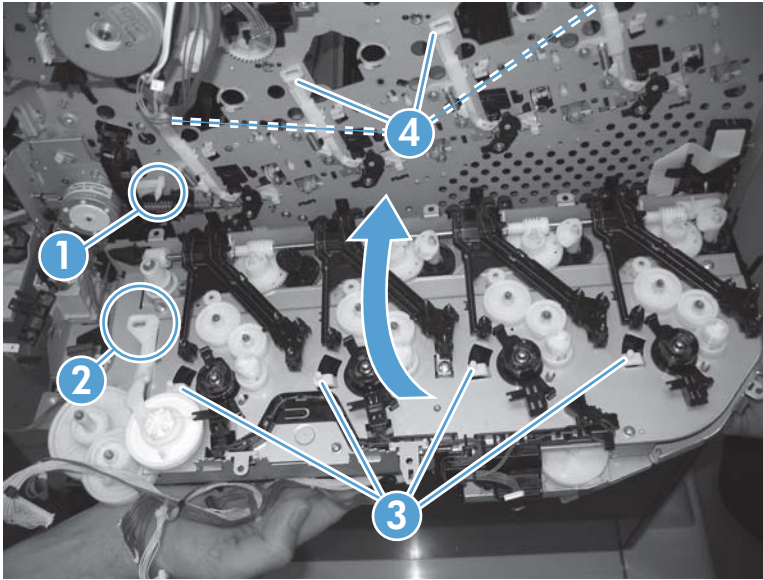
Figure 2-104 Install the main drive assembly (3 of 8)



4. From the top of the product, look at each shutter arm. Make sure that they are in the closed position (callout 1). If they are in the open position (callout 2), carefully push on the shutters to close them.

Figure 2-105 Install the main drive assembly (4 of 8)

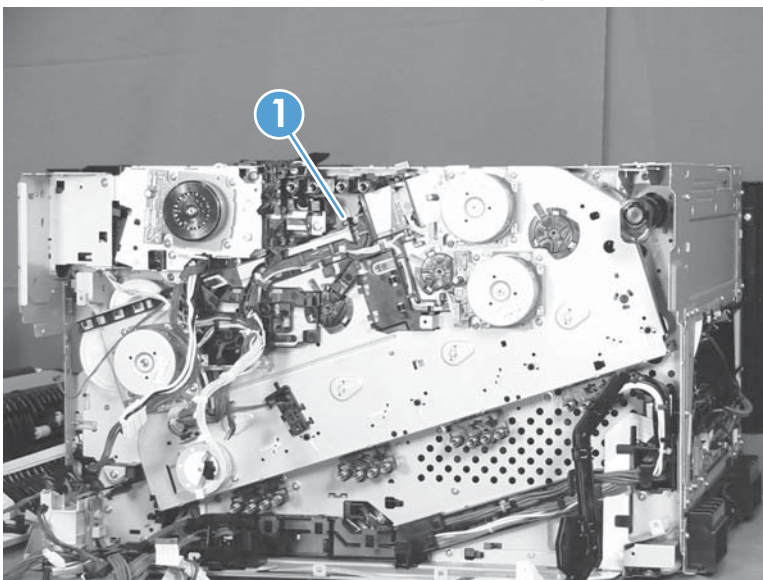
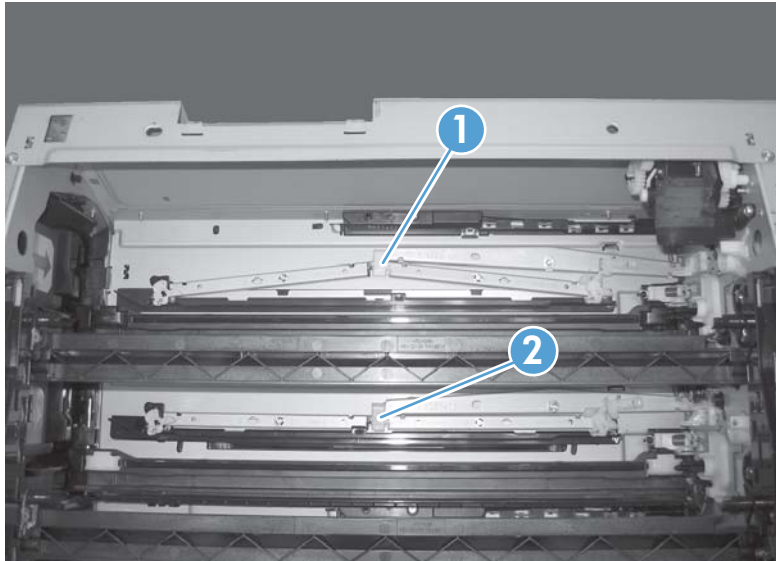

5. Make sure that the six sheet-metal screw tabs (callout 1) on the drive assembly are flat against the product chassis.

 **NOTE:** If the tabs are not flat against the chassis, the developer-disengagement drive gears and cams—on the back side of the drive assembly—are not properly aligned with, and seated in, the corresponding holes on the product. Remove the drive assembly, realign it, and then reinstall it. See [Figure 2-103 Install the main drive assembly \(2 of 8\) on page 168](#).

Figure 2-106 Install the main drive assembly (5 of 8)



6. With the drive assembly correctly installed, verify the following:
 - Open and close the front door. The OPC drum drive gears (callout 1; two shown, four total) must move in and out when viewed from inside the product.
 - Open and close the right door. The ITB drive gear (callout 2) must move in and out when viewed from inside the product.

Figure 2-107 Install the main drive assembly (6 of 8)

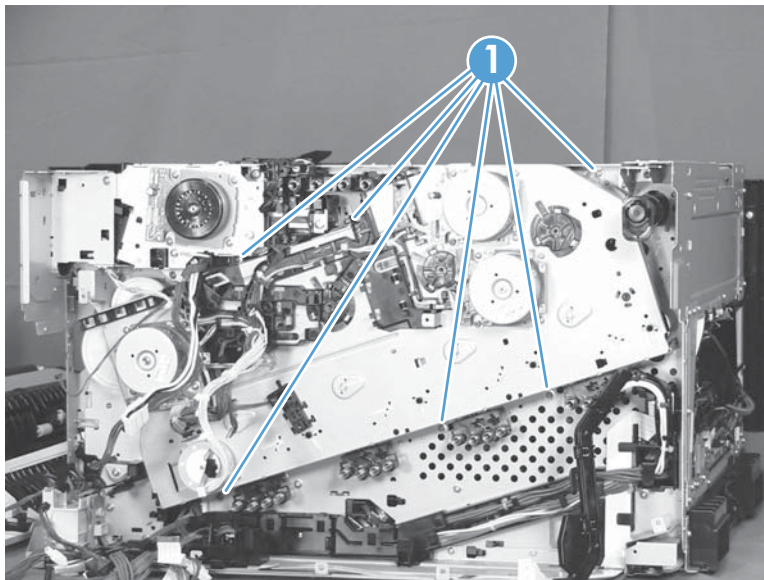
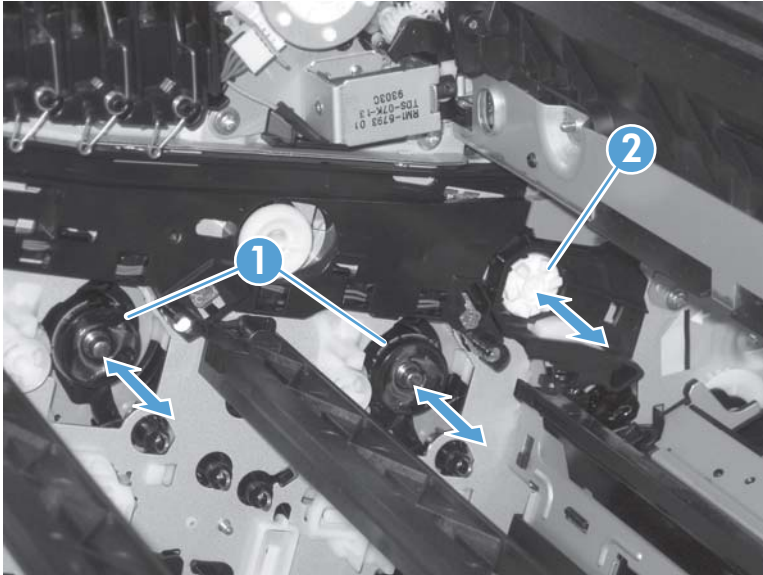

7. Install the remaining five mounting screws, tighten all six screws (callout 1), and then remove the orange spacers and spacer shipping tape.

Figure 2-108 Install the main drive assembly (7 of 8)

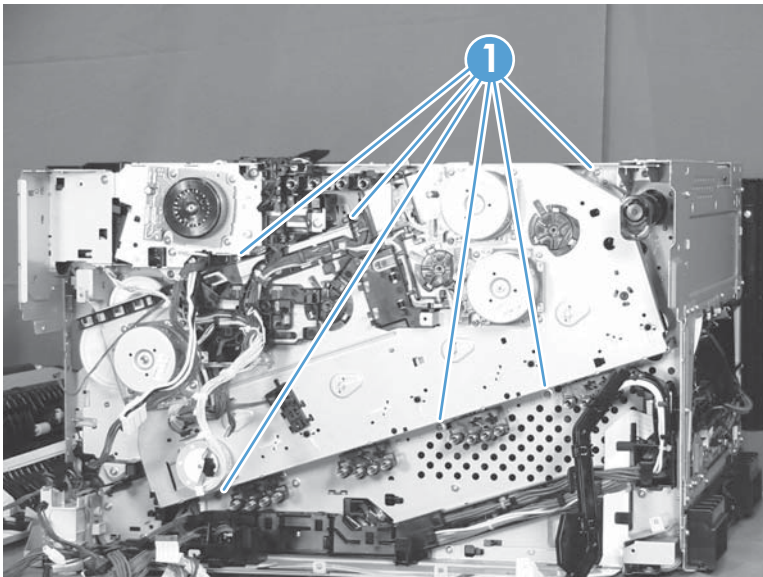

8. Reinstall the two small sheet-metal brackets.

 **NOTE:** The tab on the sheet-metal brackets must be inserted in the hole in the drive assembly chassis as shown below.

Figure 2-109 Install the main drive assembly (8 of 8)



Fuser drive assembly

Before proceeding, remove the following components:

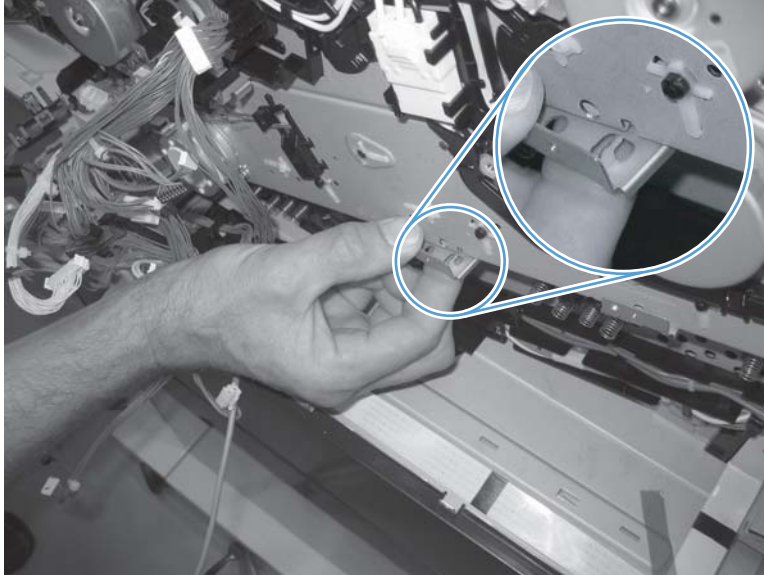
- Toner-collection unit. See [Toner-collection unit on page 91](#).
- Fuser. See [Fuser on page 93](#).
- Formatter PCA. See [Formatter PCA on page 105](#).
- Formatter case. See [Formatter case on page 130](#)
- Right-front cover and control-panel assembly. See [Right-front cover and control-panel assembly on page 113](#).
- Left cover. See [Left cover on page 115](#).
- Rear cover. See [Rear cover on page 116](#).
- Toner collection unit access door. See [Toner collection unit access door on page 117](#).
- Right-rear cover. See [Right-rear cover on page 119](#).
- Top cover. See [Top cover on page 121](#).
- Residual-toner full sensor. See [Residual toner full sensor on page 152](#).
- Main drive assembly. See [Main drive assembly on page 157](#).

Remove the fuser drive assembly

1. Remove one screw (callout 1) and the cover (callout 2).

Figure 2-110 Remove the fuser drive assembly (1 of 3)

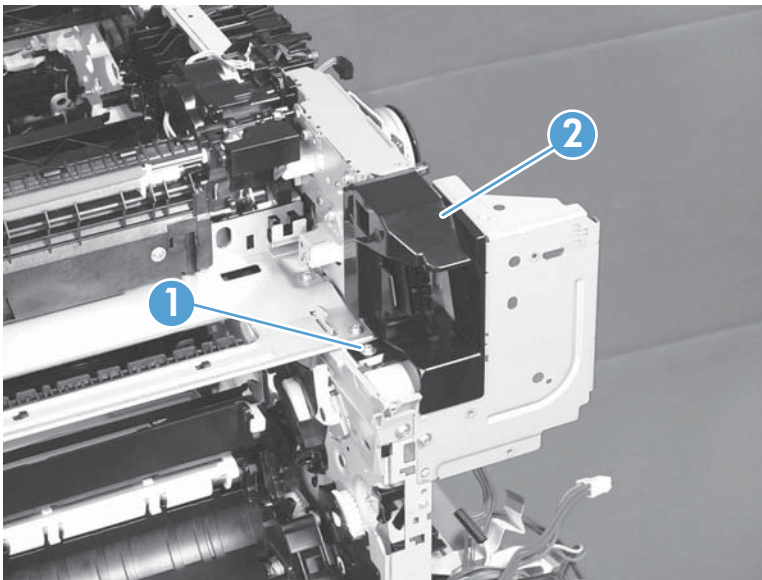

2. Disconnect two connectors (callout 1).

Figure 2-111 Remove the fuser drive assembly (2 of 3)

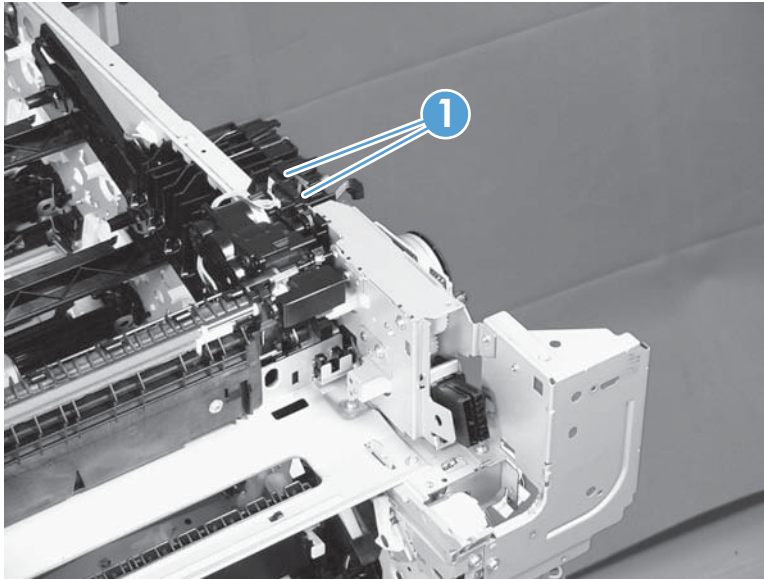

3. Remove four screws (callout 1), and then remove the fuser drive assembly.

Figure 2-112 Remove the fuser drive assembly (3 of 3)

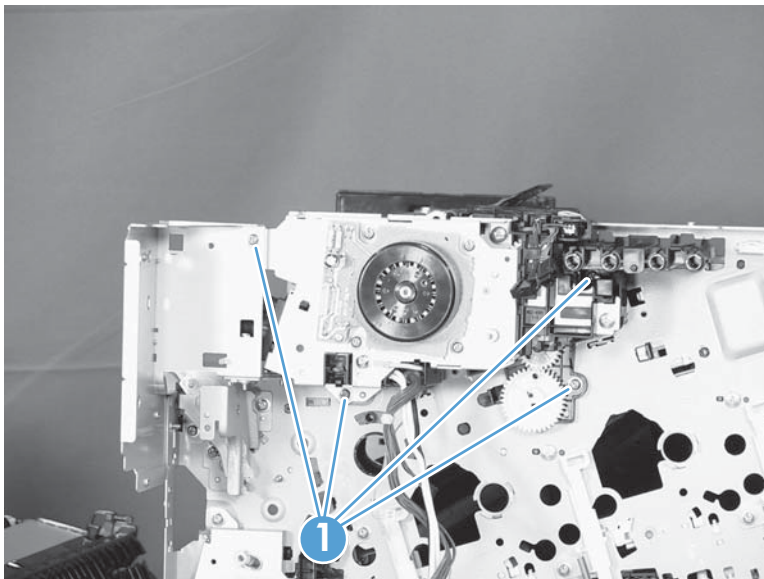

Install a replacement fuser drive assembly

Use the following procedure to install a replacement fuser drive assembly or reinstall the original fuser drive assembly.

- 1. Replacement fuser drive assembly:** Before beginning, take note of the spacer (callout 1) on the replacement fuser drive assembly.

Original fuser drive assembly: Proceed to the next step.

 **NOTE:** The fuser drive motor is shown removed in the following figure. However, you do not need to remove the fuser motor to install the fuser drive assembly.

Figure 2-113 Install a replacement fuser drive assembly (1 of 3)



- 2. Replacement fuser drive assembly:** Fasten the replacement fuser gear assembly to the product with four screws. Install the screws in the order shown below (callouts 1 to 4).

Original fuser drive assembly: Install, but do not fully tighten four screws (callouts 1 to 4). Carefully push the drive assembly to the left (toward the right-door side of the product) until it slightly shifts forward. Apply steady pressure to hold the assembly in place, and then tighten the screws.

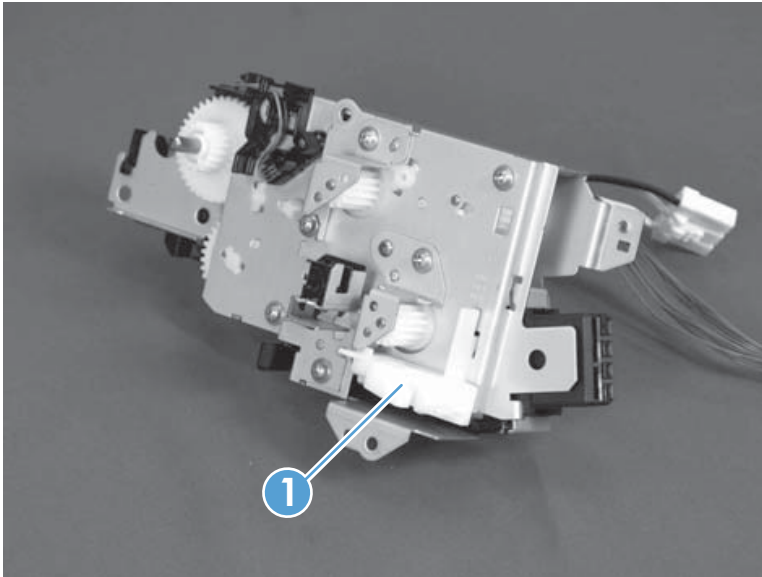
Figure 2-114 Install a replacement fuser drive assembly (2 of 3)

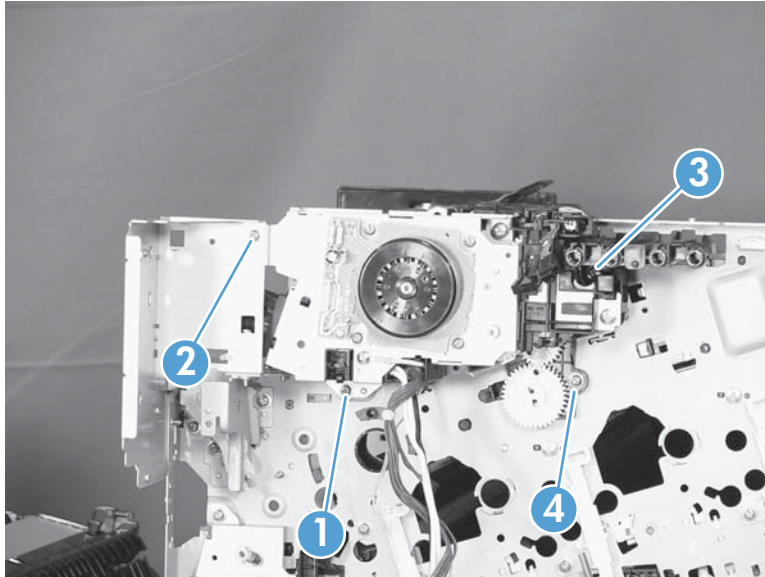

- 3. Replacement fuser drive assembly:** Release two tabs in the order shown below (callouts 1 and 2), and then remove the spacer (callout 3).

Original fuser drive assembly: Installation complete—this step is not required.

Figure 2-115 Install a replacement fuser drive assembly (3 of 3)

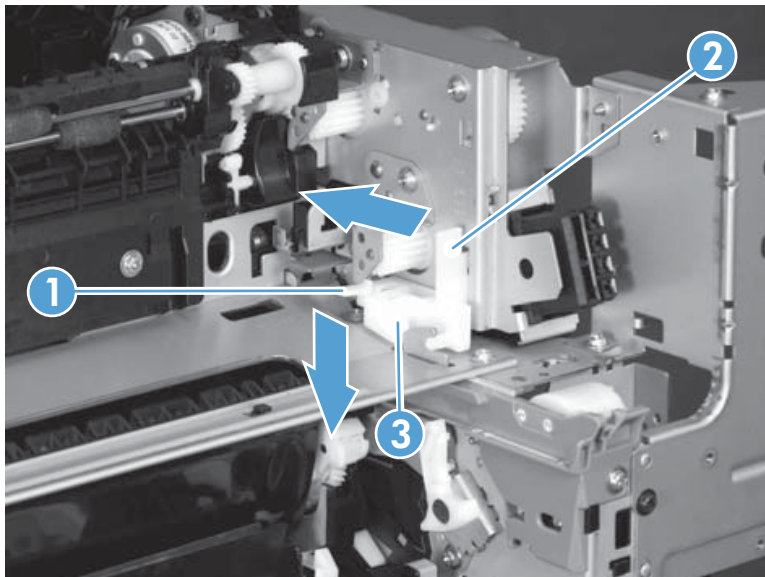

Fuser gear assembly

Before proceeding, remove the following components:

- Toner-collection unit. See [Toner-collection unit on page 91](#).
- Fuser. See [Fuser on page 93](#).
- Right-front cover and control-panel assembly. See [Right-front cover and control-panel assembly on page 113](#).
- Left cover. See [Left cover on page 115](#).
- Toner collection unit access door. See [Toner collection unit access door on page 117](#).
- Rear cover. See [Rear cover on page 116](#).
- Right-rear cover. See [Right-rear cover on page 119](#).
- Top cover. See [Top cover on page 121](#).
- Residual toner full sensor. See [Residual toner full sensor on page 152](#).

Remove the fuser gear assembly

1. Remove one screw (callout 1) and the cover (callout 2).

Figure 2-116 Remove the fuser gear assembly (1 of 9)

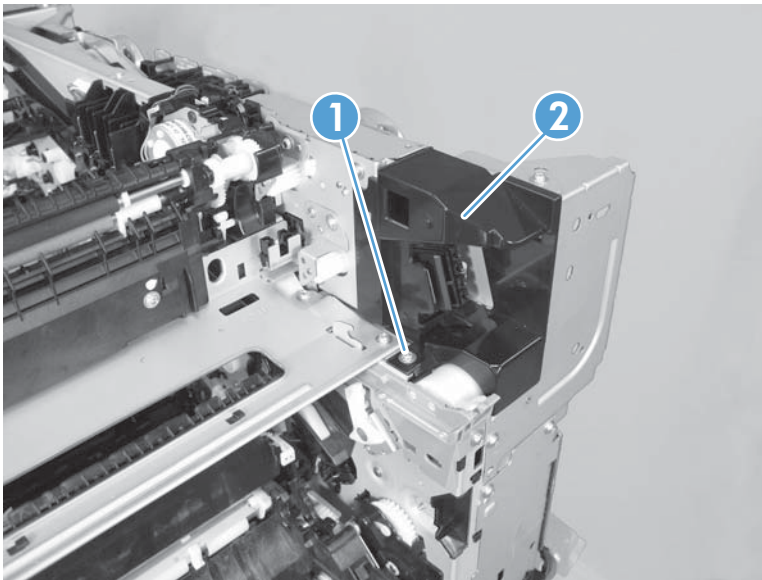

2. Remove one screw (callout 1), release four tabs (callout 2), and then separate the first transfer high-voltage power supply (callout 3) from the product.

△ **CAUTION:** The PCA is still connected to the product.

💡 **Reinstallation tip** When you reinstall the power supply PCA, look through the holes on the PCA (callout 5) and make sure that the contact springs are correctly positioned against the back side of the PCA.

Figure 2-117 Remove the fuser gear assembly (2 of 9)

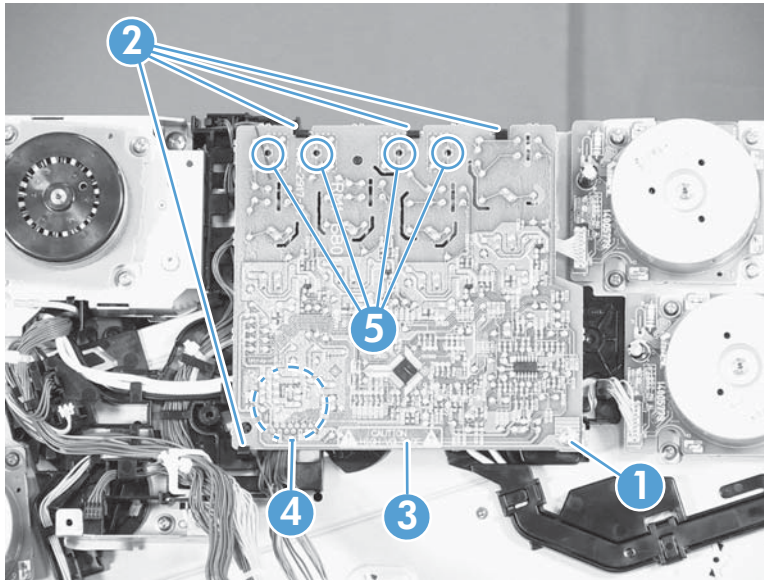

3. Disconnect one connector (callout 1) and then remove the first transfer high-voltage power supply (callout 2).

Figure 2-118 Remove the fuser gear assembly (3 of 9)

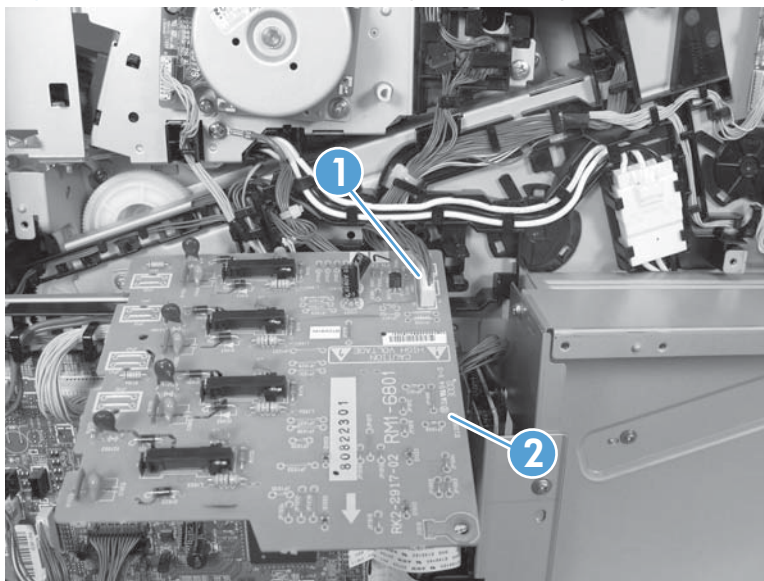

4. Disconnect one connector (callout 1), remove four screws (callout 2), and then remove the fuser motor (callout 3).

Figure 2-119 Remove the fuser gear assembly (4 of 9)

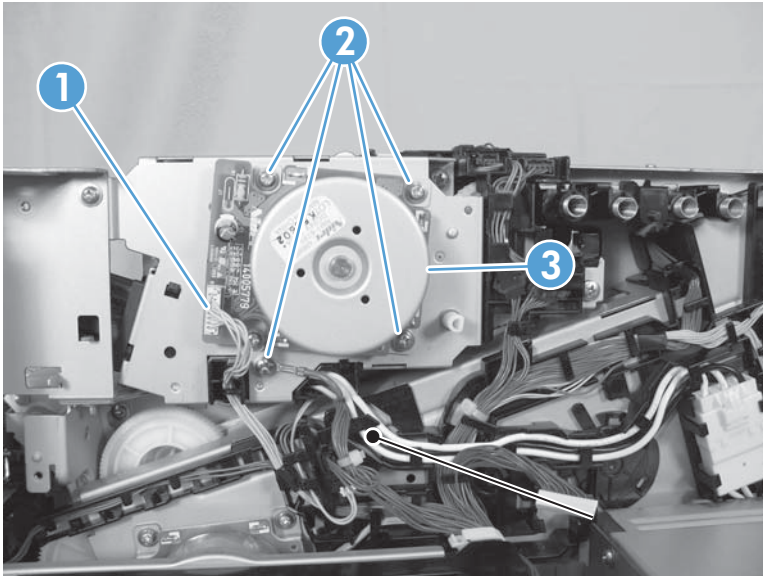

5. Disconnect three connectors (callout 1), and then release the wire harnesses from the guide (callout 2).

Figure 2-120 Remove the fuser gear assembly (5 of 9)

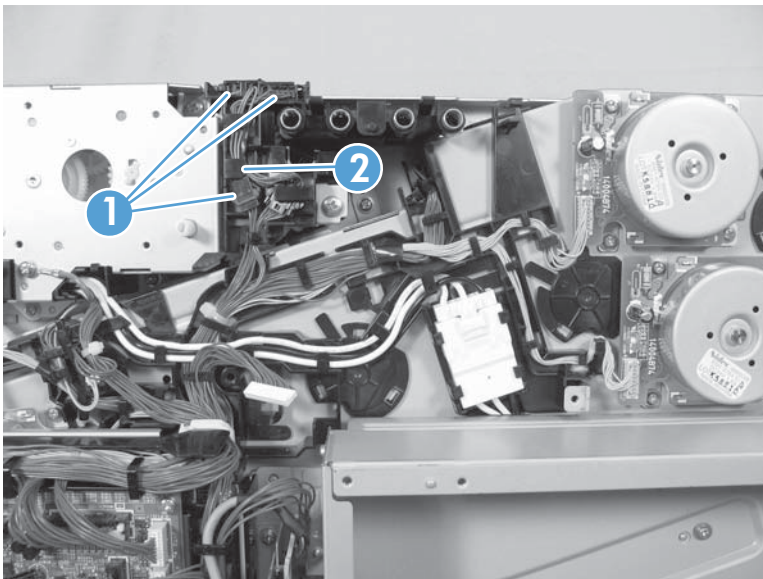

6. Disconnect one connector (callout 1), and then release the wire harness from the guide (callout 2).

 **TIP:** It might be easier to disconnect the connector, if you release it from the black-plastic holder.

Figure 2-121 Remove the fuser gear assembly (6 of 9)

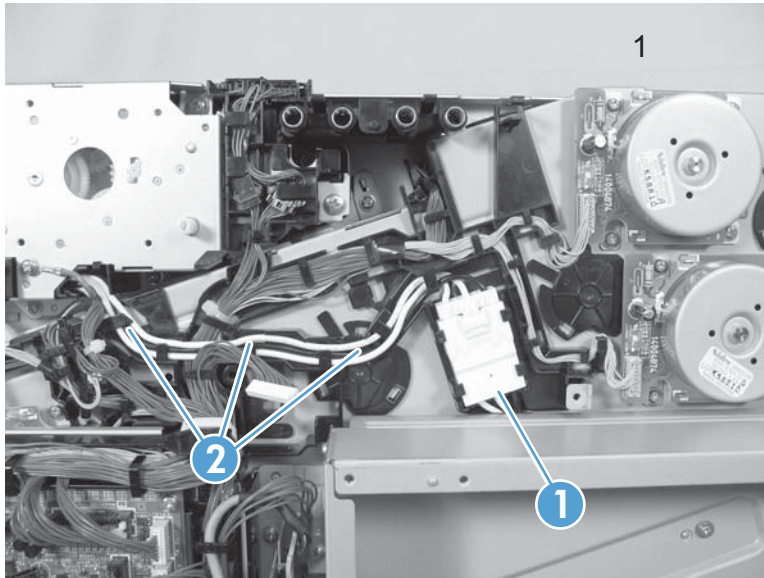

7. Disconnect two connectors (callout 1), and then release the wire harness from the retainer and guide (callout 2).

Figure 2-122 Remove the fuser gear assembly (7 of 9)

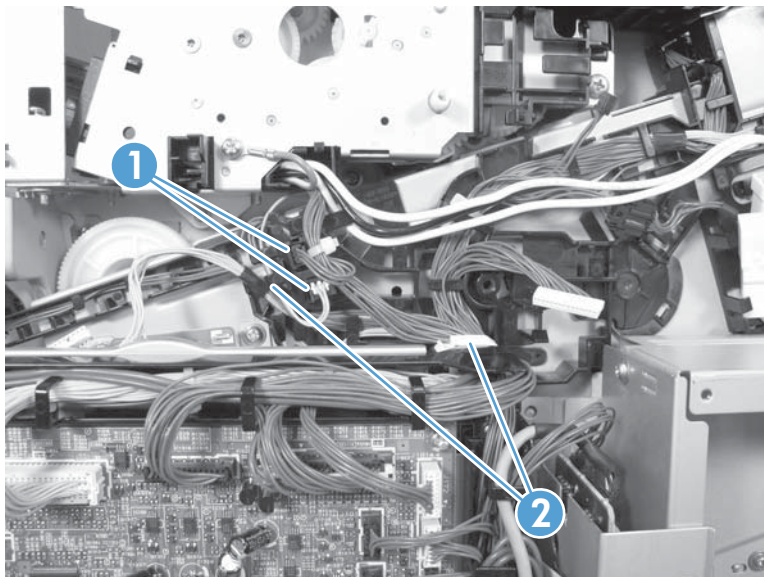

8. Disconnect one connector (callout 1), and then release the wire harness from the guide (callout 2).

Figure 2-123 Remove the fuser gear assembly (8 of 9)

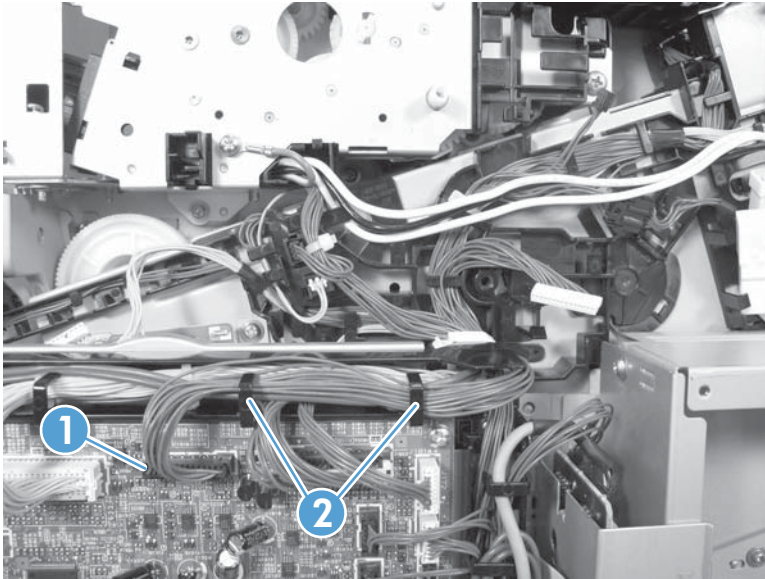

9. Remove four screws (callout 1), and then remove the fuser gear assembly (callout 2).

△ **CAUTION:** Do not remove the gear or solenoid located behind the fuser gear assembly. The gear and solenoid are installed in specific alignment with the other components behind the assembly. If the gear or solenoid are removed, the product will not properly function.

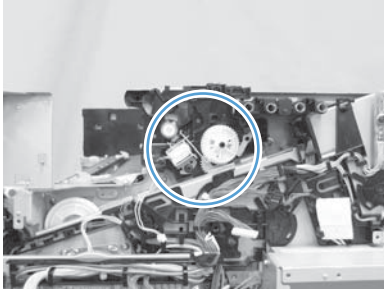
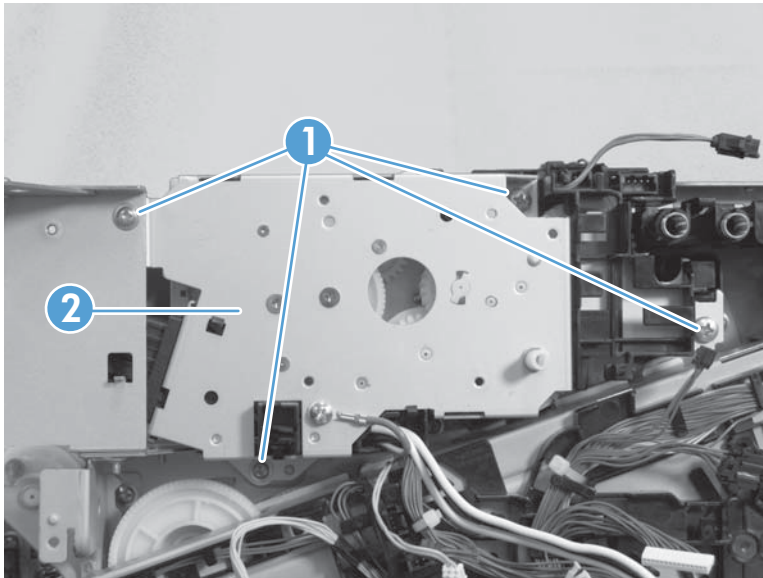

Figure 2-124 Remove the fuser gear assembly (9 of 9)



Install a replacement fuser gear assembly

Use the following procedure to install a replacement fuser drive assembly or reinstall the original fuser gear assembly.

- 1. Replacement fuser gear assembly:** Before beginning, take note of the spacer (callout 1) on the replacement fuser drive assembly.

Original fuser gear assembly: Proceed to the next step.

 **NOTE:** The fuser drive motor is shown removed in the following figure. However, you do not need to remove the fuser motor to install the fuser gear assembly.

Figure 2-125 Install a replacement fuser gear assembly (1 of 3)



- 2. Replacement fuser drive assembly:** Fasten the replacement fuser gear assembly to the product with four screws. Install the screws in the order shown below (callouts 1 to 4).

Original fuser drive assembly: Install, but do not fully tighten four screws (callouts 1 to 4). Carefully push the drive assembly to the left (toward the right-door side of the product) until it slightly shifts forward. Apply steady pressure to hold the assembly in place, and then tighten the screws.

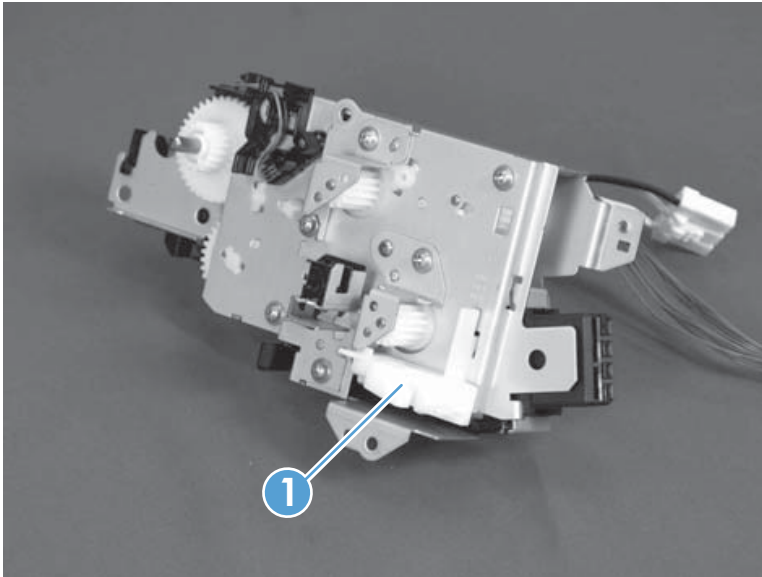
Figure 2-126 Install a replacement fuser gear assembly (2 of 3)

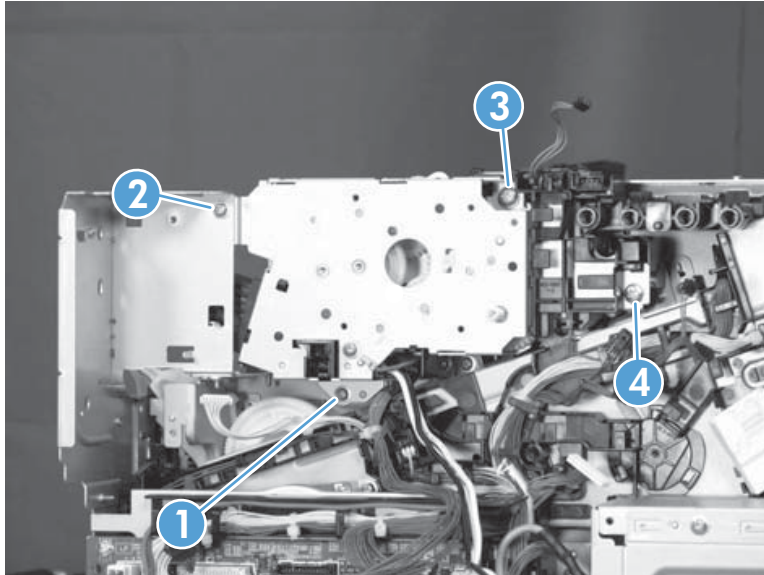

- 3. Replacement fuser drive assembly:** Release two tabs in the order shown below (callouts 1 and 2), and then remove the spacer (callout 3).

Original fuser drive assembly: Installation complete—this step is not required.

Figure 2-127 Install a replacement fuser gear assembly (3 of 3)

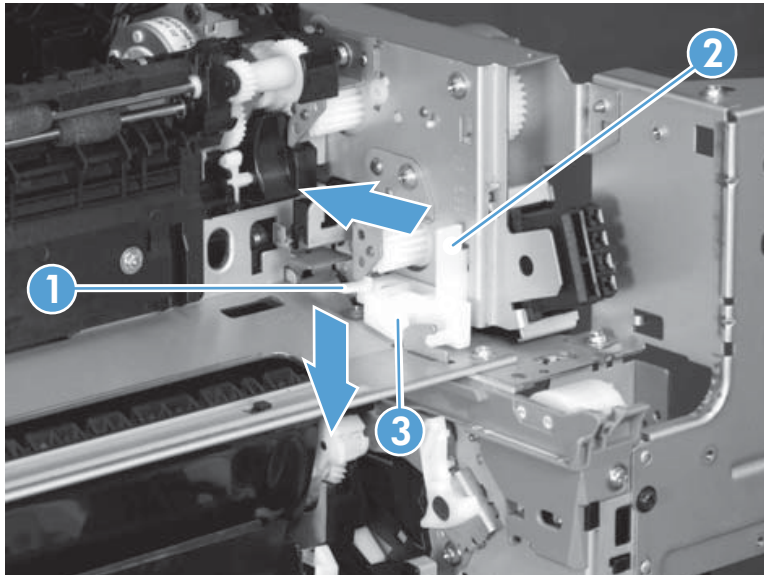

Paper delivery assembly

Before proceeding, remove the following components:

- Fuser. See [Fuser on page 93](#).
- Intermediate transfer belt (ITB). See [Intermediate transfer belt \(ITB\) on page 102](#).
- Right-front cover and control-panel assembly. See [Right-front cover and control-panel assembly on page 113](#).
- Left cover. See [Left cover on page 115](#).
- Right-rear cover. See [Right-rear cover on page 119](#).
- Top cover. See [Top cover on page 121](#).

Remove the delivery assembly

1. Remove two screws (callout 1), remove the cover (callout 2), and then remove two screws (callout 3).

Figure 2-128 Remove the paper delivery assembly (1 of 2)

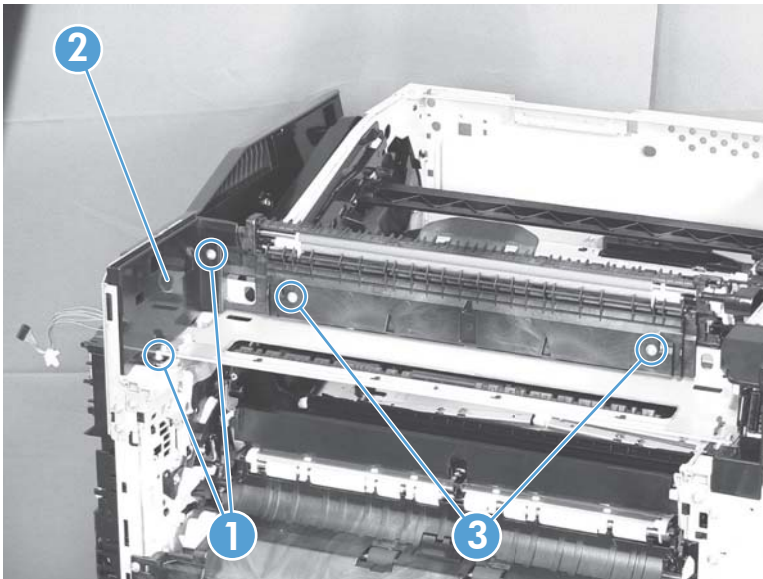

2. Pull the left side of the unit away from the engine, and then slide the delivery unit (callout 1) in the direction that the arrow indicates to remove it.

Figure 2-129 Remove the paper delivery assembly (2 of 2)

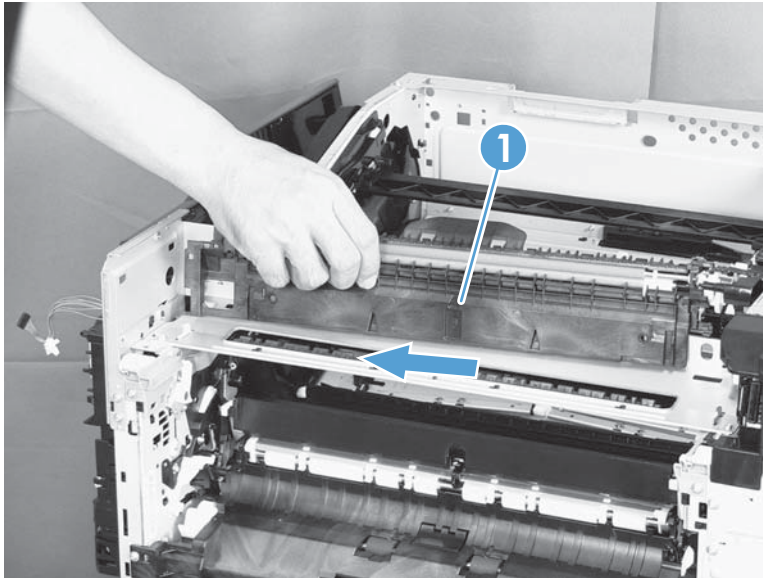

Reinstall the paper delivery assembly

1. Make sure that the delivery assembly (callout 1) two mounting holes (callout 2) align with the shafts (callout 3) on the product.

Figure 2-130 Reinstall the paper delivery assembly (1 of 3)

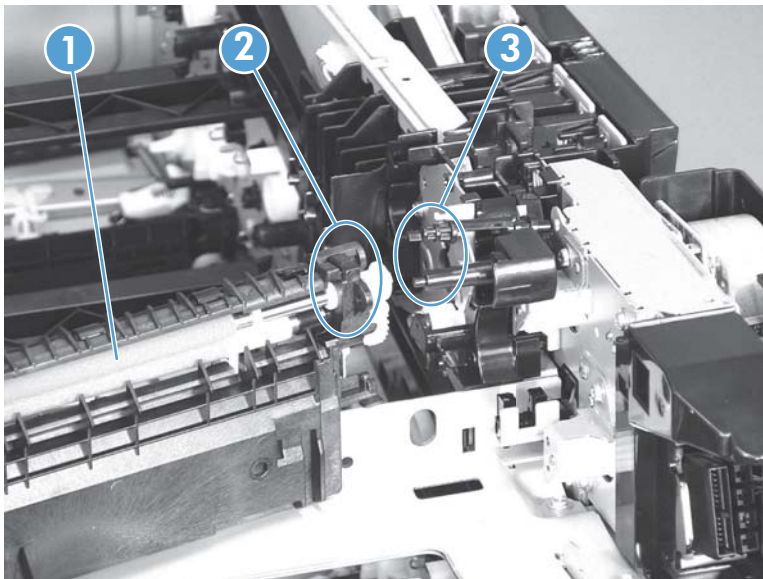

2. During reassembly, the white gear (callout 1) can become dislodged. Make sure that it is correctly installed on the assembly.

Figure 2-131 Reinstall the paper delivery assembly (2 of 3)

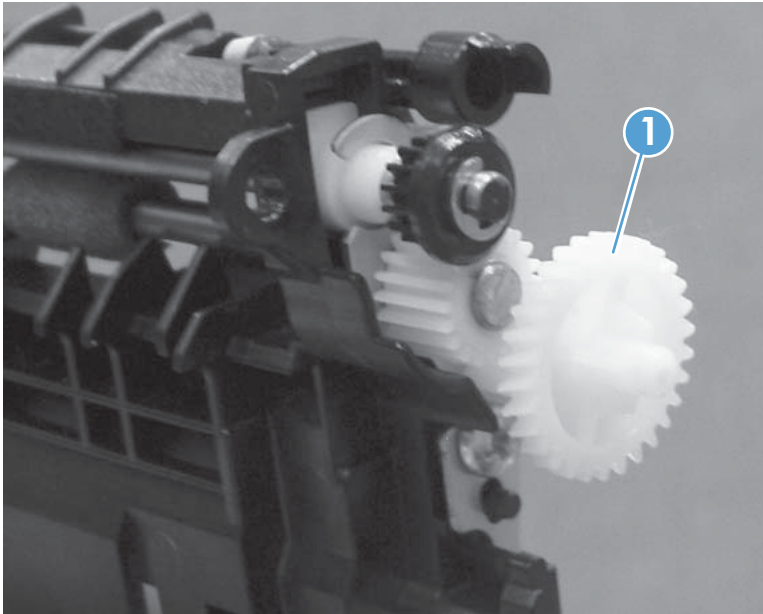

3. After reinstalling the delivery assembly, verify that the sensor flag (callout 1) moves smoothly.

Figure 2-132 Reinstall the paper delivery assembly (3 of 3)

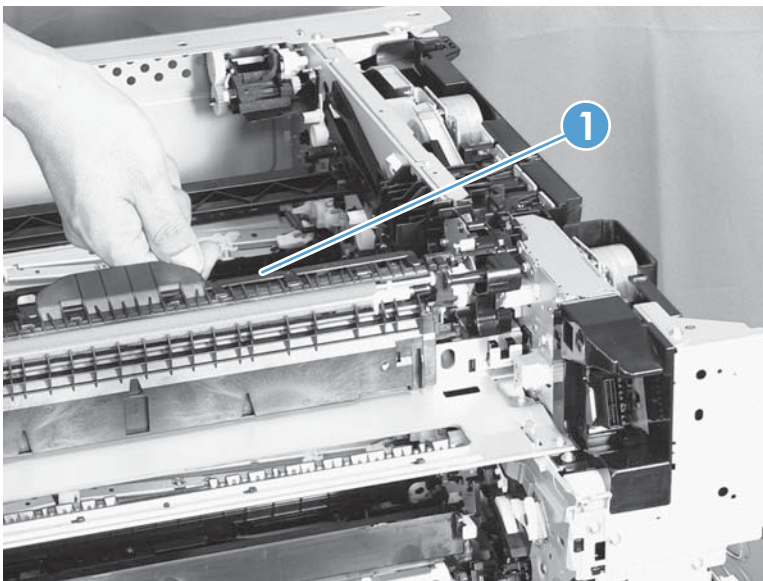

Duplex drive assembly (duplex models)

Before proceeding, remove the following components:

- Fuser. See [Fuser on page 93](#).
- Intermediate transfer belt (ITB). See [Intermediate transfer belt \(ITB\) on page 102](#).
- Right-front cover and control-panel assembly. See [Right-front cover and control-panel assembly on page 113](#).
- Left cover. See [Left cover on page 115](#).
- Rear cover. See [Rear cover on page 116](#).
- Right-rear cover. See [Right-rear cover on page 119](#).
- Top cover. See [Top cover on page 121](#).
- Delivery assembly. See [Paper delivery assembly on page 184](#).

Remove the duplex-drive assembly

1. Disconnect two connectors (callout 1).

Figure 2-133 Remove the duplex-drive assembly (1 of 3)

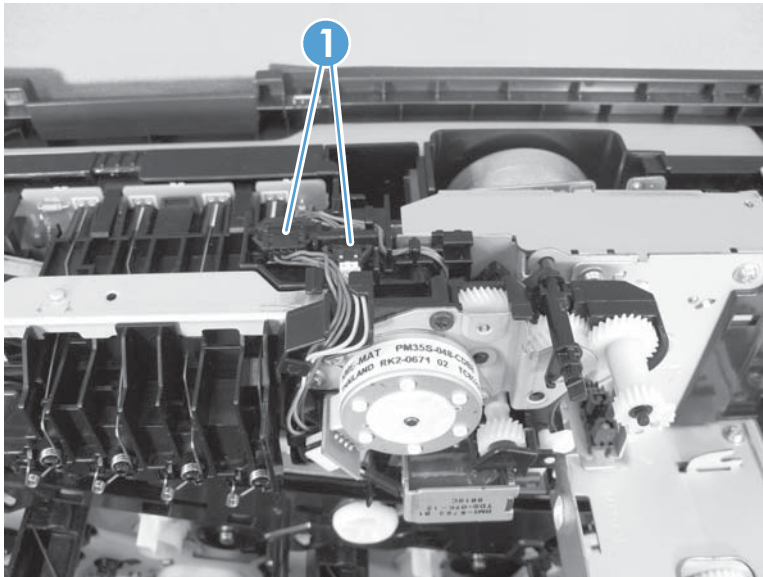

2. Remove three screws (callout 1).

Figure 2-134 Remove the duplex-drive assembly (2 of 3)

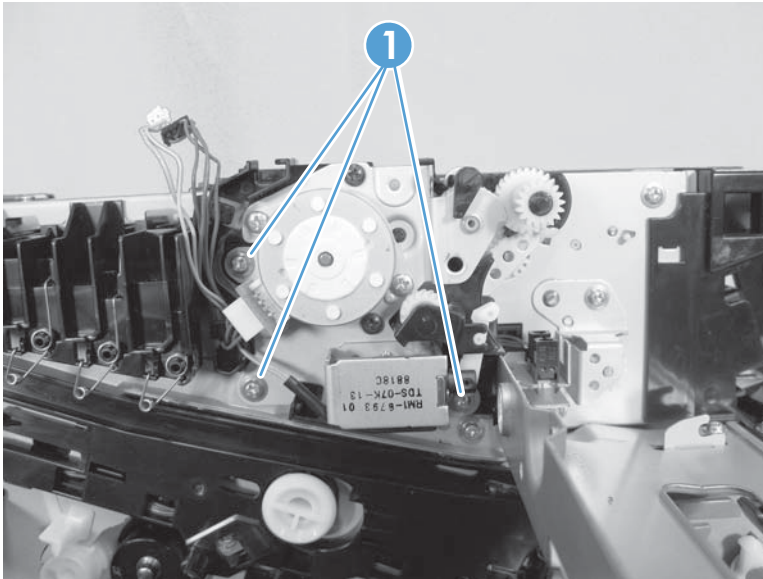

3. Release one tab (callout 1), and then remove the assembly (callout 2).

Figure 2-135 Remove the duplex-drive assembly (3 of 3)

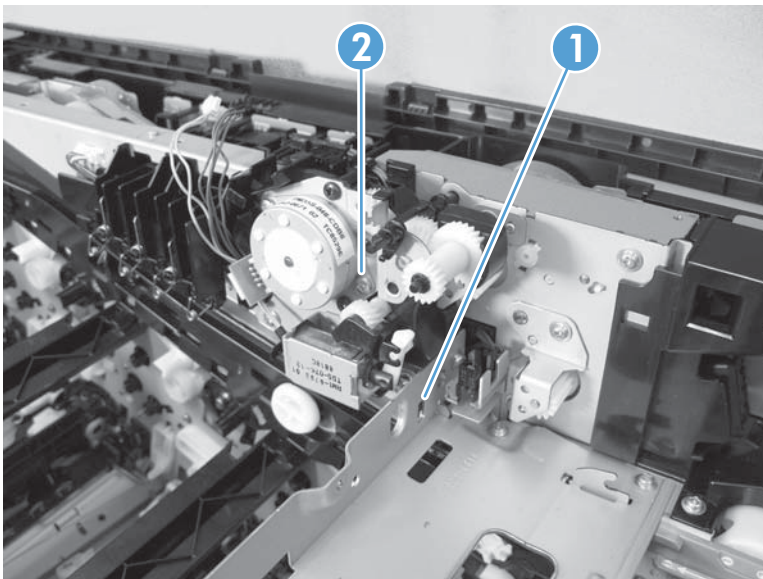

Delivery drive assembly (simplex models)

Before proceeding, remove the following components:

- Fuser. See [Fuser on page 93](#).
- Intermediate transfer belt (ITB). See [Intermediate transfer belt \(ITB\) on page 102](#).
- Right-front cover and control-panel assembly. See [Right-front cover and control-panel assembly on page 113](#).
- Left cover. See [Left cover on page 115](#).
- Rear cover. See [Rear cover on page 116](#).
- Right-rear cover. See [Right-rear cover on page 119](#).
- Top cover. See [Top cover on page 121](#).
- Delivery assembly. See [Paper delivery assembly on page 184](#).

Remove the delivery drive assembly

- ▲ Remove three screws (callout 1), release one tab (callout 2), and then remove the delivery drive assembly (callout 3).

Figure 2-136 Remove the delivery drive assembly

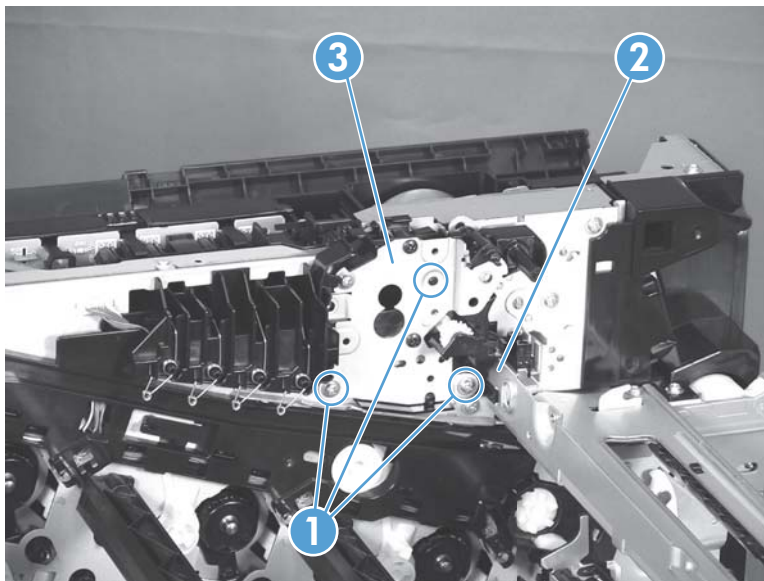

Residual-toner-feed assembly

Before proceeding, remove the following components:

- Intermediate transfer belt (ITB). See [Intermediate transfer belt \(ITB\) on page 102](#).
- Left cover. See [Left cover on page 115](#).
- Rear cover. See [Rear cover on page 116](#).
- Toner collection unit access door. See [Toner collection unit access door on page 117](#).
- Right-rear cover. See [Right-rear cover on page 119](#).
- Top cover. See [Top cover on page 121](#).
- Toner cover. See the first step of [Residual toner full sensor on page 152](#).

Remove the residual-toner-feed assembly

1. Release one tab (callout 1) by pulling the tab up. If necessary, use a small, flat-blade screwdriver to pull the tab up. Remove the shutter (callout 2), and then pull the spring (callout 3) off the assembly.

 **NOTE:** There might be a piece of transparent tape over the tab (callout 1). Remove the tape to release the tab.

Figure 2-137 Remove the residual-toner-feed assembly (1 of 2)



2. Remove two screws (callout 1), and then remove the residual-toner-feed assembly (callout 2).

 **NOTE:** When removing the residual-toner-feed assembly (callout 2), make sure that the assembly does not separate from the toner auger. This can spill toner in the product. To reduce the risk of such an incident, pull the assembly in the direction indicated by the arrow.

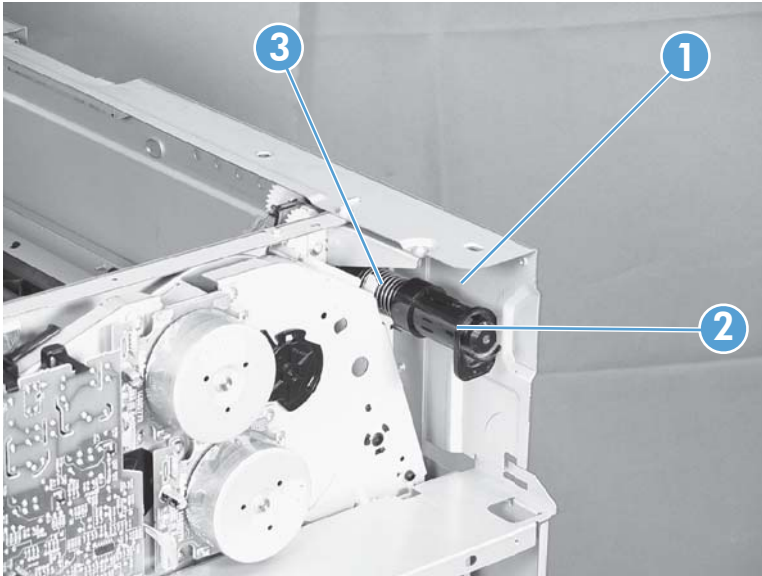
Figure 2-138 Remove the residual-toner-feed assembly (2 of 2)



ITB motor (M1)

Before proceeding, remove the following components:

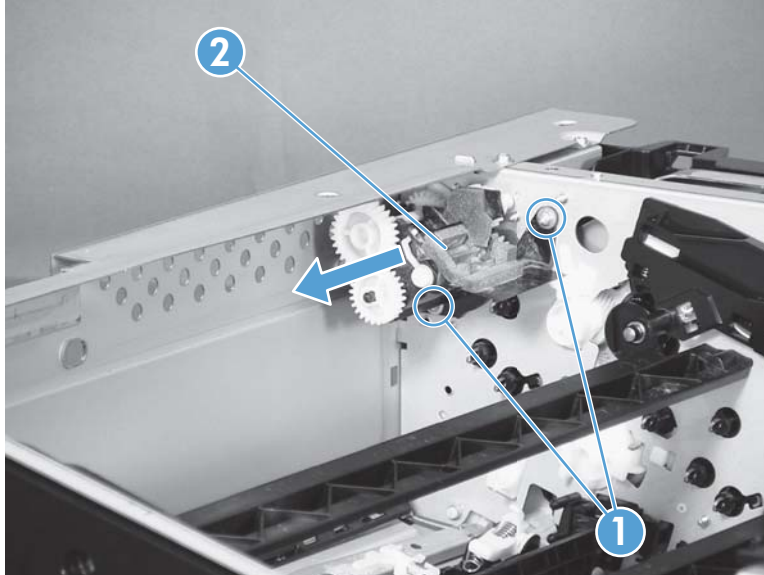
- Toner-collection unit. See [Toner-collection unit on page 91](#).
- Toner collection unit access door. See [Toner collection unit access door on page 117](#).
- Rear cover. See [Rear cover on page 116](#).
- Right-rear cover. See [Right-rear cover on page 119](#).

Remove the ITB motor

1. Disconnect all of the cables and FFCs from the DC controller (release the cables from the guides), remove six screws (callout 1), and then remove the DC controller and the DC controller support.

Figure 2-139 Remove the ITB motor (1 of 2)

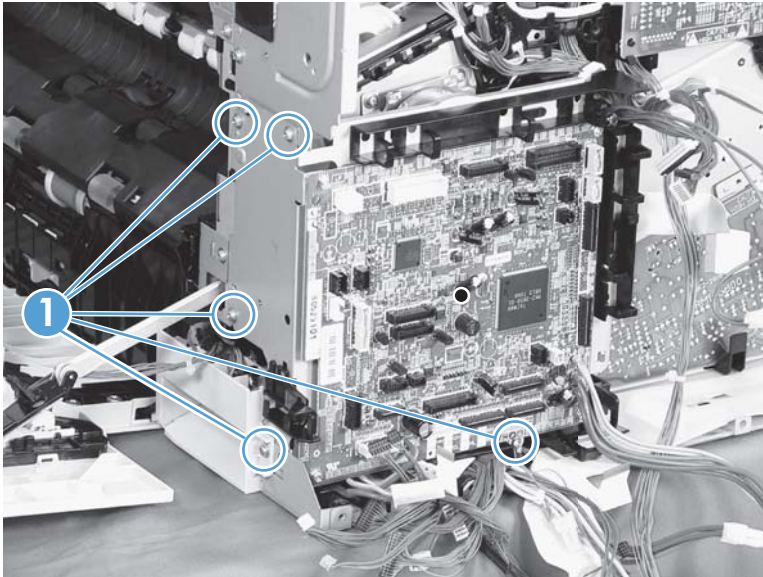

2. Disconnect one connector (callout 1), remove four screws (callout 2), and then remove the motor (callout 3).

Figure 2-140 Remove the ITB motor (2 of 2)

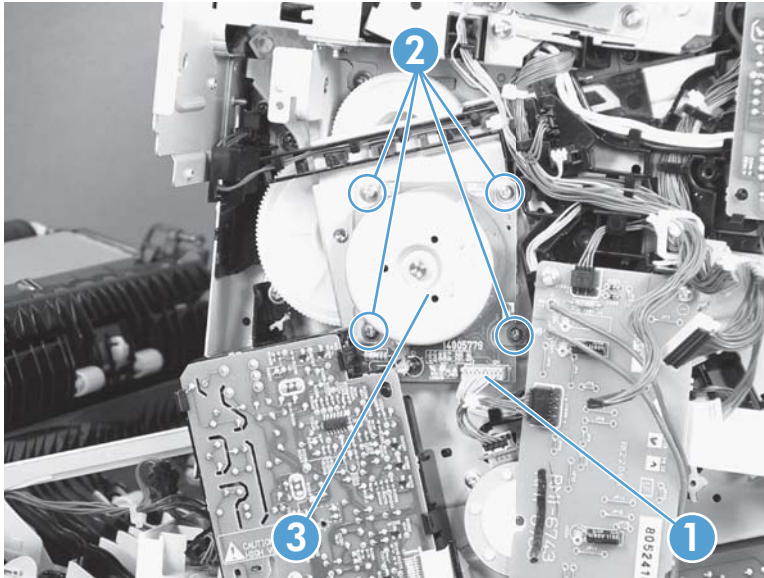

Drum motor (M2)

Before proceeding, remove the following components:

- Toner collection unit. See [Toner-collection unit on page 91](#).
- Right-front cover and control-panel assembly. See [Right-front cover and control-panel assembly on page 113](#).
- Left cover. See [Left cover on page 115](#).
- Rear cover. See [Rear cover on page 116](#).
- Toner collection unit access door. See [Toner collection unit access door on page 117](#).
- Right-rear cover. See [Right-rear cover on page 119](#).
- Top cover. See [Top cover on page 121](#).
- Toner cover. See the first and second steps of [Residual toner full sensor on page 152](#).

Remove the drum motor

Disconnect one connector (callout 1), remove four screws (callout 2), and then remove the motor (callout 3).

Figure 2-141 Remove the drum motor

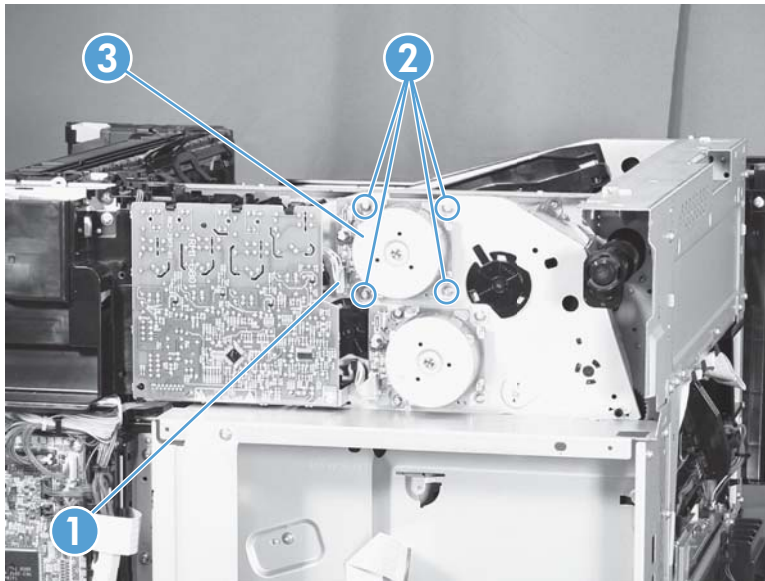

Developing motor (M3)

Before proceeding, remove the following components:

- Toner collection unit. See [Toner-collection unit on page 91](#).
- Right-front cover and control-panel assembly. See [Right-front cover and control-panel assembly on page 113](#).
- Left cover. See [Left cover on page 115](#).
- Rear cover. See [Rear cover on page 116](#).
- Toner collection unit access door. See [Toner collection unit access door on page 117](#).
- Right-rear cover. See [Right-rear cover on page 119](#).
- Top cover. See [Top cover on page 121](#).
- Toner cover. See the first and second steps of [Residual toner full sensor on page 152](#).

Remove the developing motor

Disconnect one connector (callout 1), remove four screws (callout 2), and then remove the motor (callout 3).

Figure 2-142 Remove the developing motor

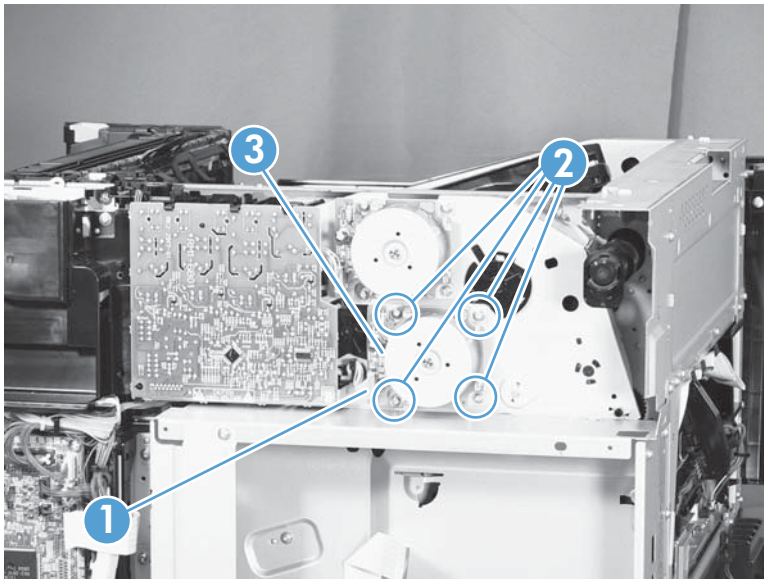

Fuser motor (M4)

Before proceeding, remove the following components:

- Toner collection unit. See [Toner-collection unit on page 91](#).
- Right-front cover and control-panel assembly. See [Right-front cover and control-panel assembly on page 113](#).
- Left cover. See [Left cover on page 115](#).
- Rear cover. See [Rear cover on page 116](#).
- Toner collection unit access door. See [Toner collection unit access door on page 117](#).
- Right-rear cover. See [Right-rear cover on page 119](#).
- Top cover. See [Top cover on page 121](#).
- Residual toner full sensor. See [Residual toner full sensor on page 152](#).

Remove the fuser motor

Disconnect one connector (callout 1), remove four screws (callout 2), and then remove the motor (callout 3).

Figure 2-143 Remove the fuser motor

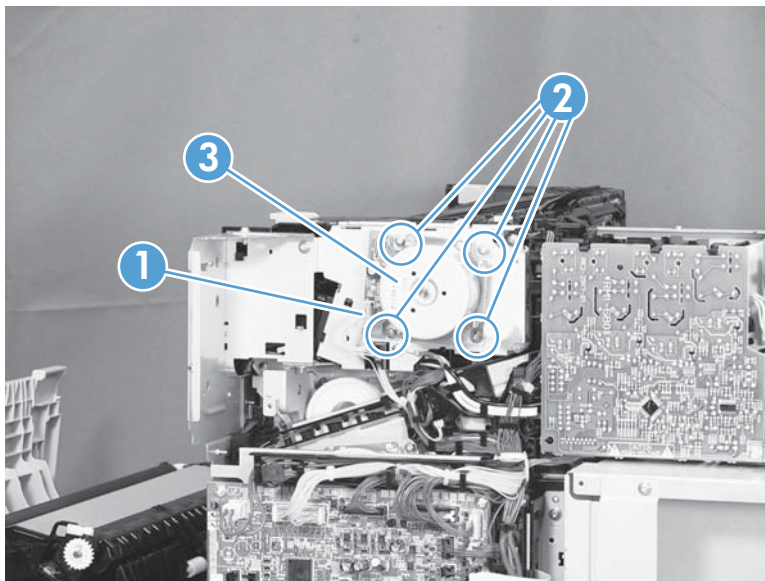

Developing-disengagement motor (M6)

Before proceeding, remove the following components:

- Rear cover. See [Rear cover on page 116](#).
- Right-rear cover. See [Right-rear cover on page 119](#).
- Driver PCA. See [Driver PCA on page 218](#).

Remove the developing-disengagement motor

Disconnect one connector (callout 1), remove two screws (callout 2), and then remove the motor (callout 3).

Figure 2-144 Remove the developing-disengagement motor

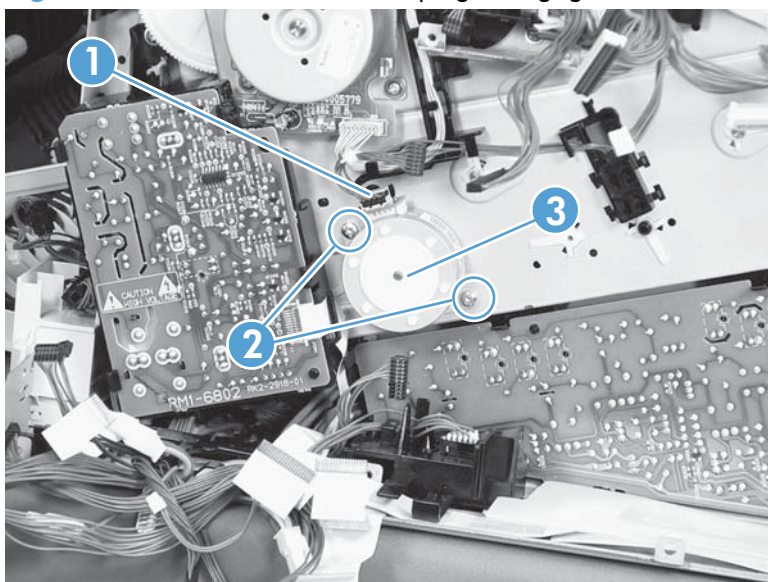

Power-supply fan (FM1)

Before proceeding, remove the following components:

- Right-front cover and control-panel assembly. See [Right-front cover and control-panel assembly on page 113](#).
- Left cover. See [Left cover on page 115](#).
- Front-door assembly (steps 1 and 2 only). See [Front-door assembly on page 123](#).

Remove the power-supply fan

1. Disconnect one connector (callout 1), and then release the cables (callout 3) from the guide (callout 2).

Figure 2-145 Remove the power-supply fan (1 of 3)

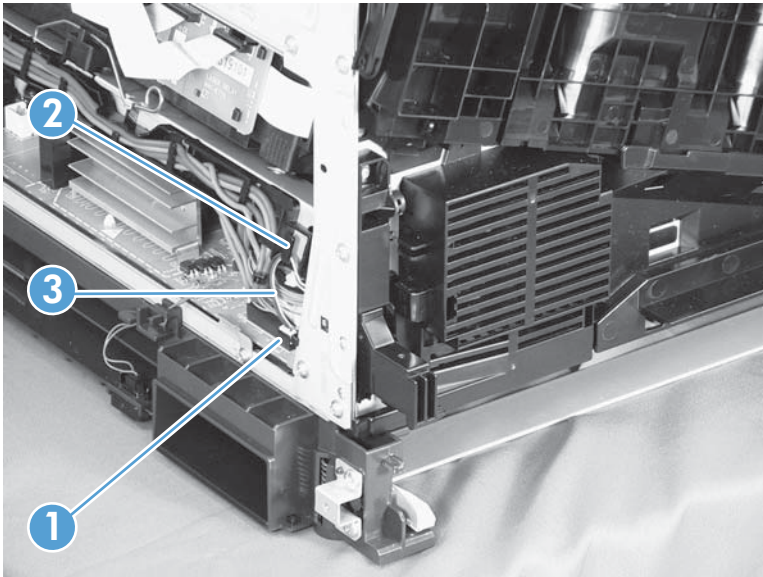

2. Release two tabs (callout 1), and then remove the fan (callout 2) and the fan holder (callout 3) together.

Figure 2-146 Remove the power-supply fan (2 of 3)

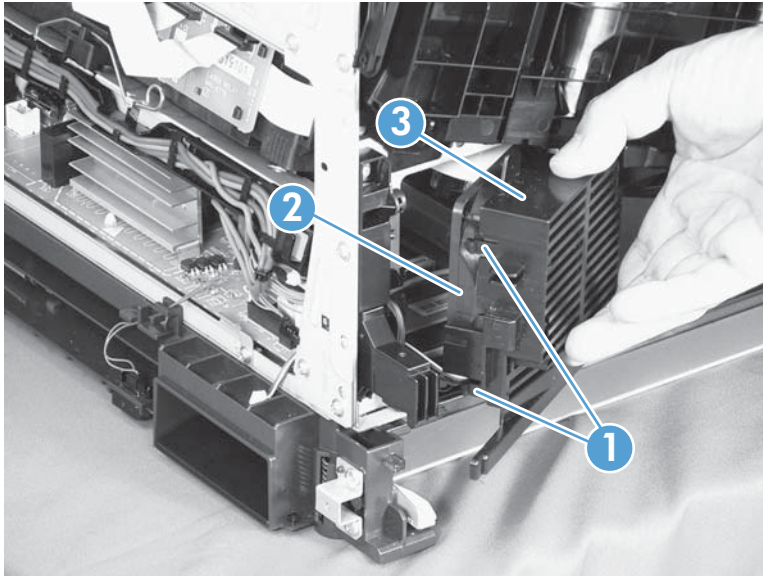

3. Pull on the sides of the fan holder to remove the fan from the holder.

Figure 2-147 Remove the power-supply fan (3 of 3)

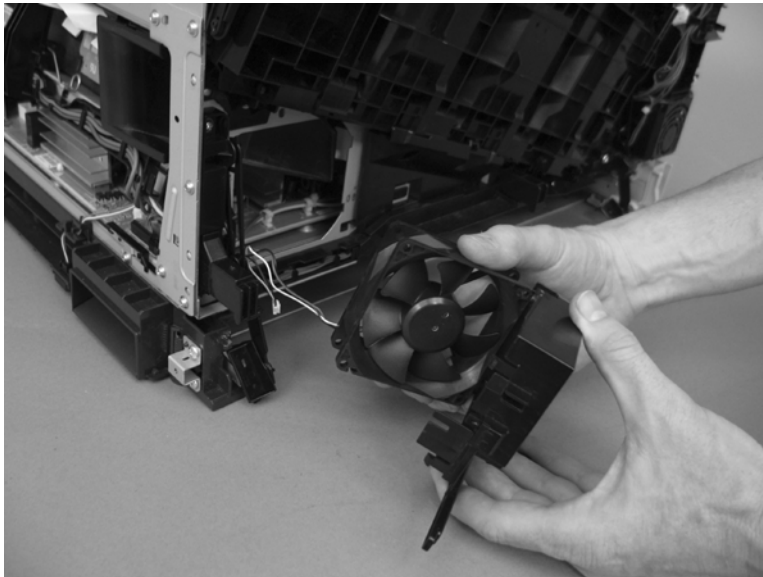

 **Reinstallation tip** When reinstalling the fan, verify that the fan cables (callout 1) are positioned as shown and that the label (callout 2) on the fan is facing toward the inside of the product.

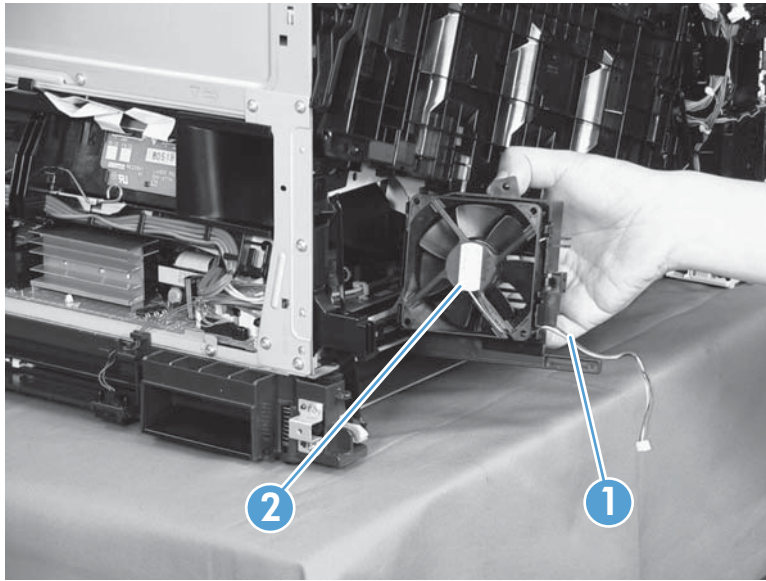

Fuser fan (FM2)

Before proceeding, remove the following components:

- Right-front cover and control-panel assembly. See [Right-front cover and control-panel assembly on page 113](#).

Remove the fuser fan

1. Disconnect one connector (callout 1), release one tab (callout 2), and then slide the guide (callout 3) down to remove it.

Figure 2-148 Remove the fuser fan (1 of 4)

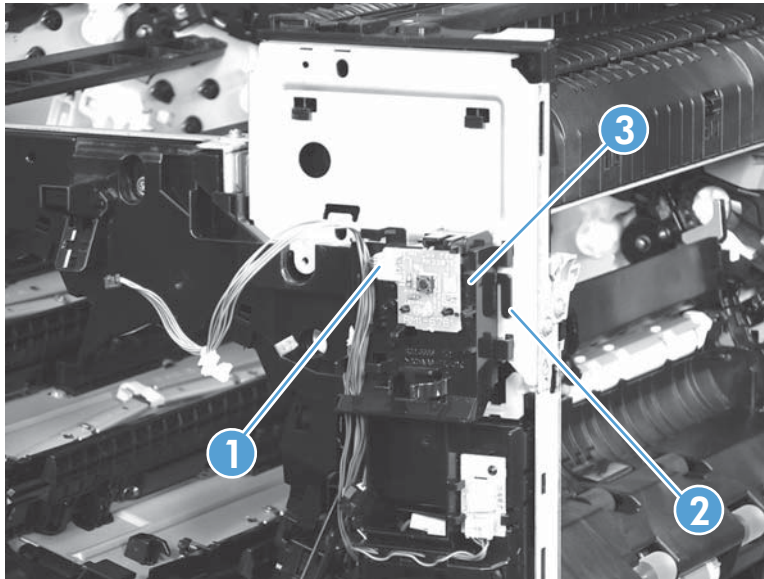

2. Disconnect three connectors (callout 1), and then release the cables (callout 3) from the cable guides (callout 2).

Figure 2-149 Remove the fuser fan (2 of 4)

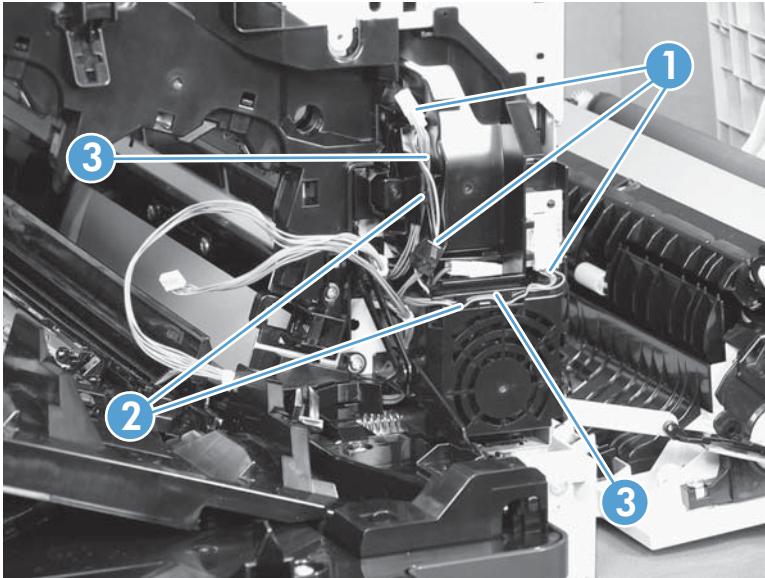

3. Release four tabs (callout 1), and then remove the fan (callout 2) and the fan holder (callout 3) together.

Figure 2-150 Remove the fuser fan (3 of 4)

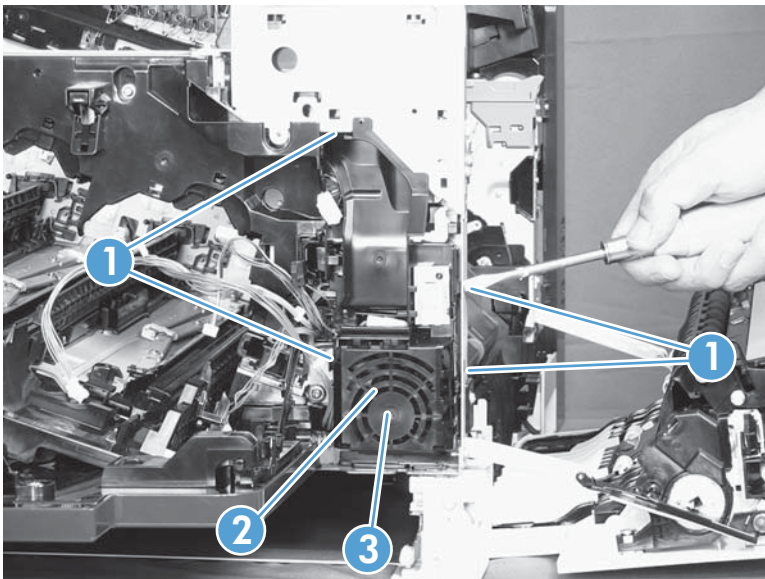

4. Turn the fan holder over, and then pull the fan out of the holder.

Figure 2-151 Remove the fuser fan (4 of 4)

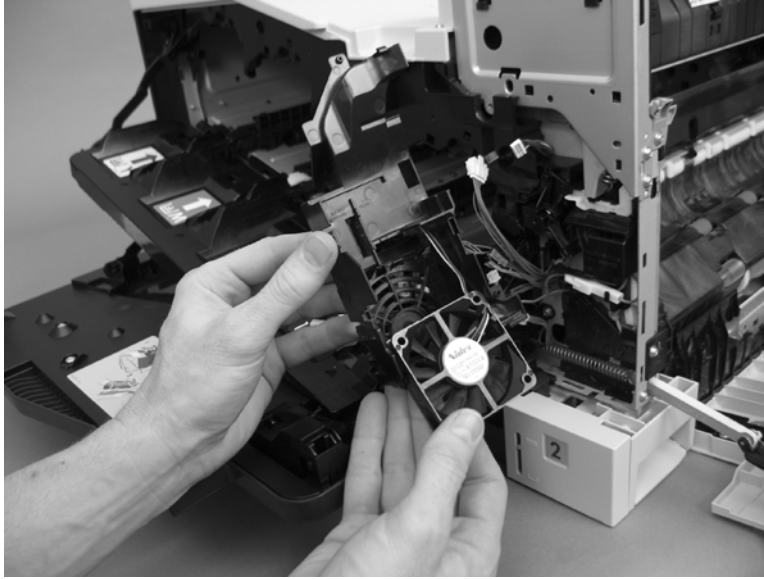

 **Reinstallation tip** Note the wiring path and label orientation for reinstallation.

Formatter fan (FM3) and ICB PCA

Before proceeding, remove the following components:

- Left cover. See [Left cover on page 115](#).
- Rear cover. See [Rear cover on page 116](#).
- Formatter PCA. See [Formatter PCA on page 105](#).
- Formatter case. See [Formatter case on page 130](#).

Remove the formatter fan and ICB PCA

1. Disconnect three connectors (callout 1) and one FFC (callout 2).

Figure 2-152 Remove the formatter fan (1 of 5)

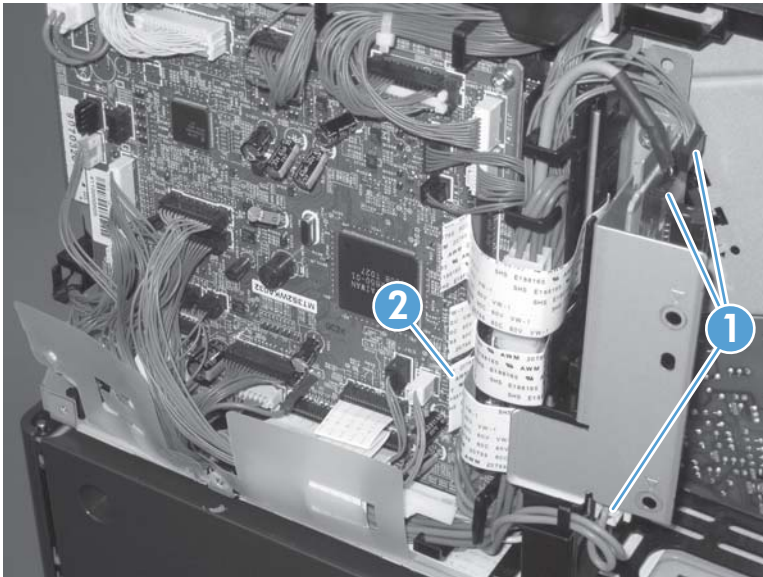

2. Remove one screw (callout 1) and then remove the sheet-metal plate (callout 2).

Figure 2-153 Remove the formatter fan (2 of 5)

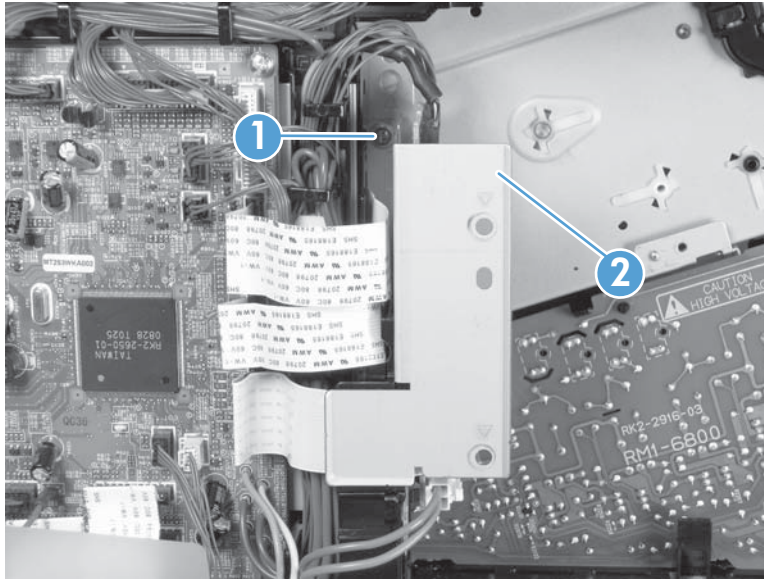

3. Disconnect one connector (callout 1), remove two screws (callout 2), and then remove the interconnect board (IBC) PCA (callout 3) from the assembly.

Figure 2-154 Remove the formatter fan (3 of 5)

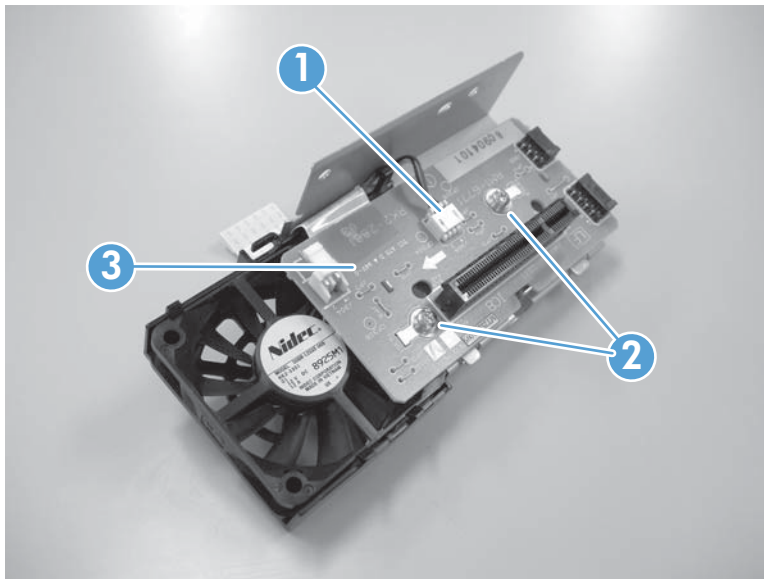

4. Release one tab (callout 1) and slide the formatter fan away from the sheet-metal plate to remove it.

Figure 2-155 Remove the formatter fan (4 of 5)

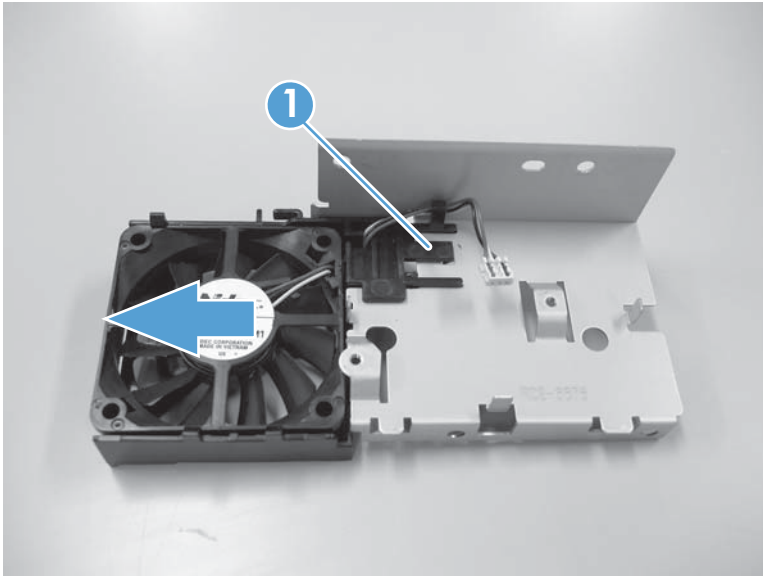

5. Release three tabs (callout 1) and remove the fan (callout 2) from the holder (callout 3).

Figure 2-156 Remove the formatter fan (5 of 5)

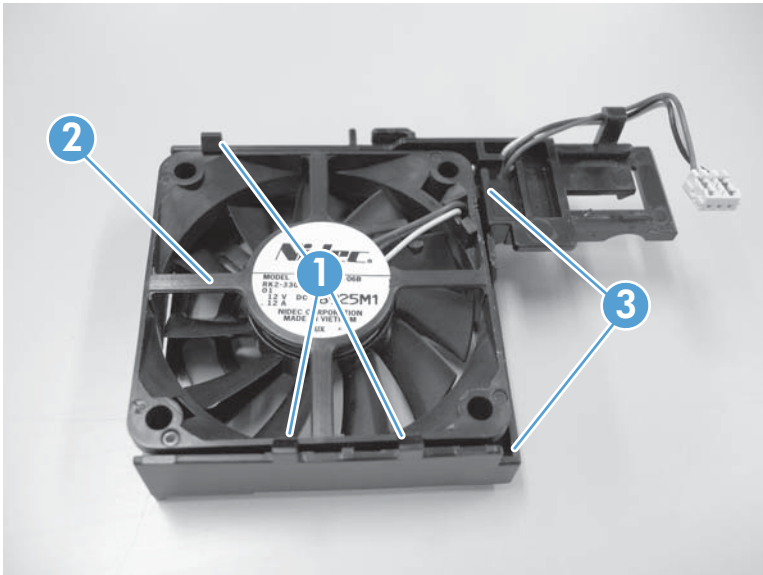

DC controller PCA

- △ **CAUTION:** Do not replace the DC controller PCA and the formatter PCA at the same time. The settings for the DC Controller PCA are stored in the formatter RAM. When you install a new DC Controller PCA, it reads the settings from the formatter.

Before proceeding, remove the following components:

- Rear cover. See [Rear cover on page 116](#).
- Right-rear cover. See [Right-rear cover on page 119](#).

Remove the DC controller PCA

- △ **CAUTION:**  ESD-sensitive part.

1. Disconnect 22 connectors and six flat cables on the DC controller PCA (callout 1).

-  **Reinstallation tip** Two connectors (callout 2) should be empty when the DC controller is reinstalled.

Figure 2-157 Remove the DC controller PCA (1 of 3)



2. Disconnect three intermediate connectors (callout 1), and then release the cables (callout 3) from the cable guides (callout 2) on the top and right sides of the DC controller PCA.

Figure 2-158 Remove the DC controller PCA (2 of 3)

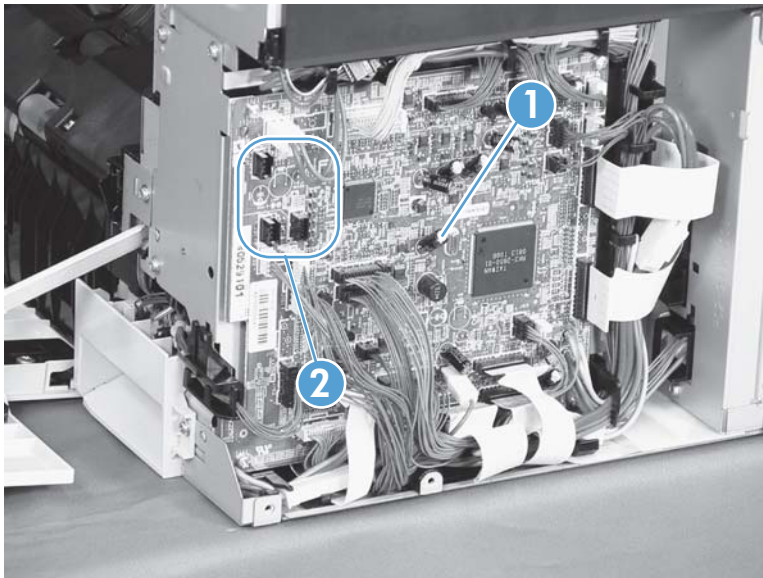
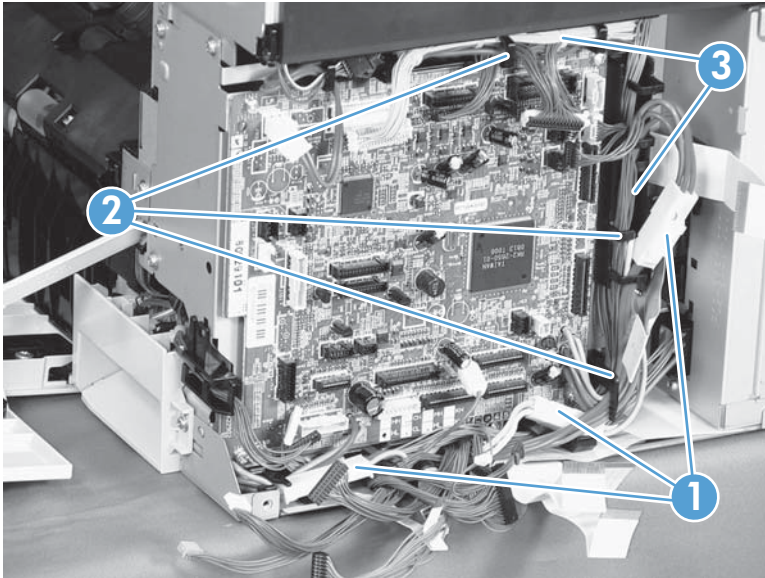

3. Remove four screws (callout 1), and then remove the DC controller PCA (callout 2).

Figure 2-159 Remove the DC controller PCA (3 of 3)

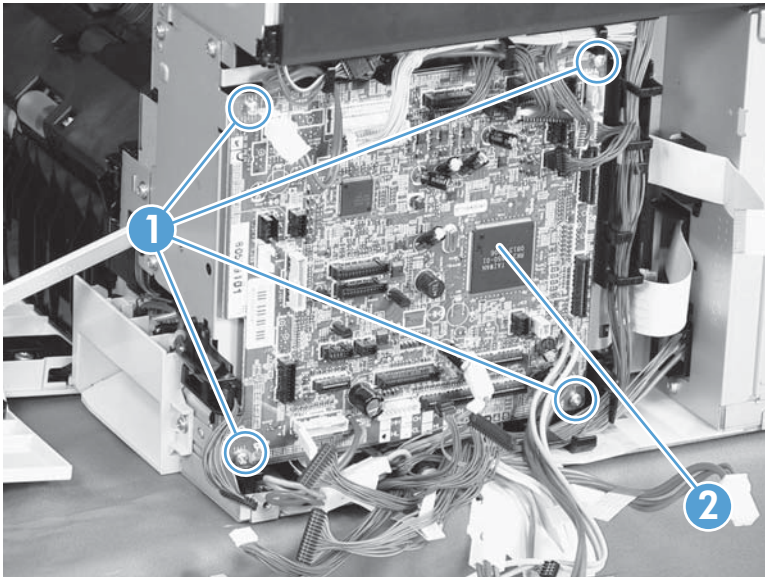

Low-voltage power supply

Before proceeding, remove the following components:

- Tray 2 cassette.
- Left cover. See [Left cover on page 115](#).

Remove the low-voltage power supply

⚠ **WARNING!** When removing the low-voltage power supply unit (callout 1), do not touch the electric element (callout 2) as shown. Be sure to hold the bottom side of the low-voltage power supply unit.

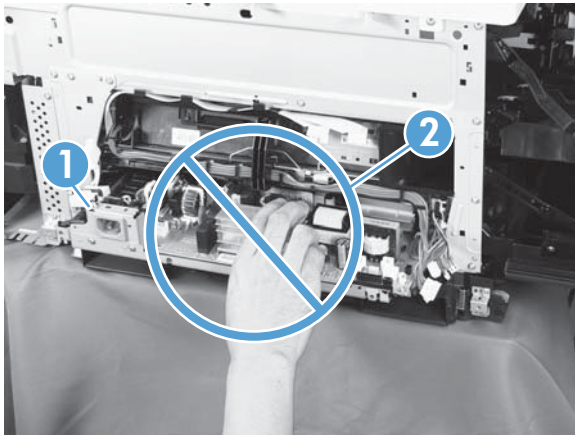

△ **CAUTION:**  ESD-sensitive part.

Unplug the power cord from the product before proceeding.

1. Open the front door, disconnect two connectors (callout 1), and then remove three screws (callout 2) that have a triangular icon next to them.

Figure 2-160 Remove the low-voltage power supply (1 of 3)

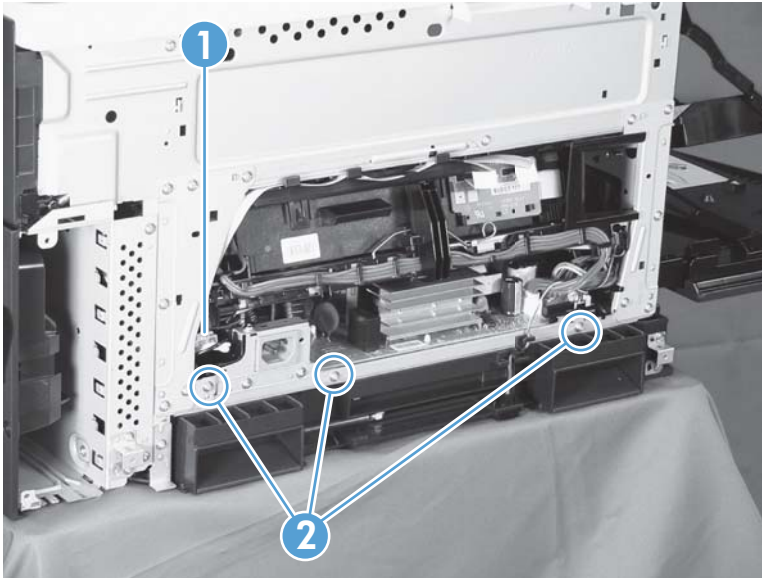

2. Slightly lift up on the low-voltage power supply (callout 1), slide it slightly forward, disconnect eight connectors (callout 2), and then release the cables from the front cable clamp.

⚠ WARNING! Do not use the power supply electric element (callout 3) as a handle to pull out the power supply.

💡 TIP: One of the connectors (callout 2) is located far back inside the product.

Figure 2-161 Remove the low-voltage power supply (2 of 3)

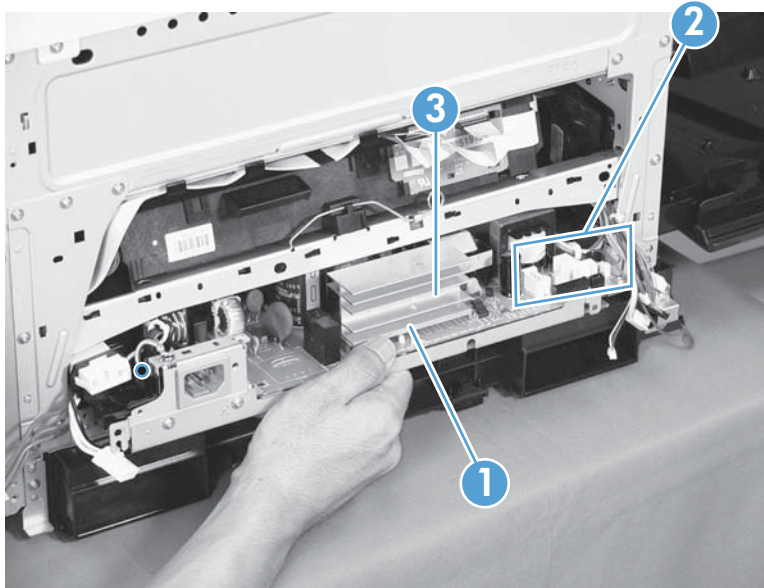

3. Release the cables (callout 2) from the rear cable clamp (callout 1), disconnect one rear connector (callout 3), and then remove the low-voltage power supply unit (callout 4).

Figure 2-162 Remove the low-voltage power supply (3 of 3)

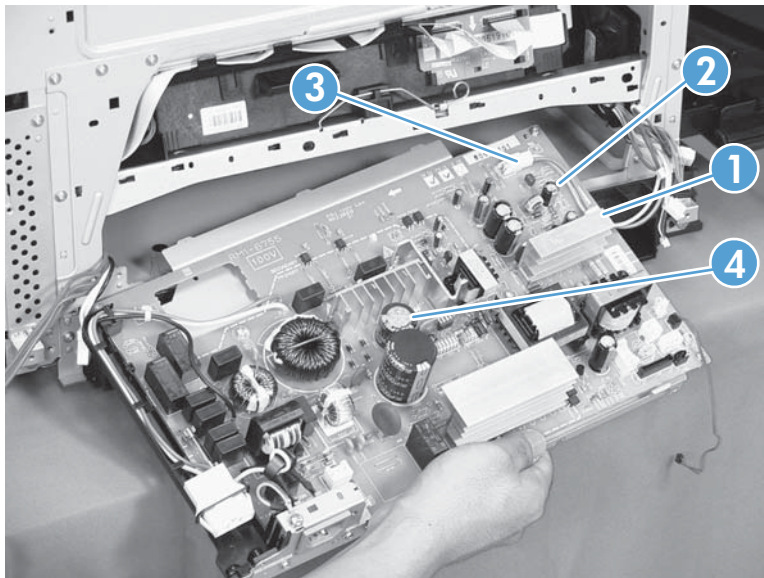

 **Reinstallation tip** When reinstalling the low-voltage power supply unit (callout 1), be careful not to catch the AC cables (callout 2) in the low-voltage power supply unit.

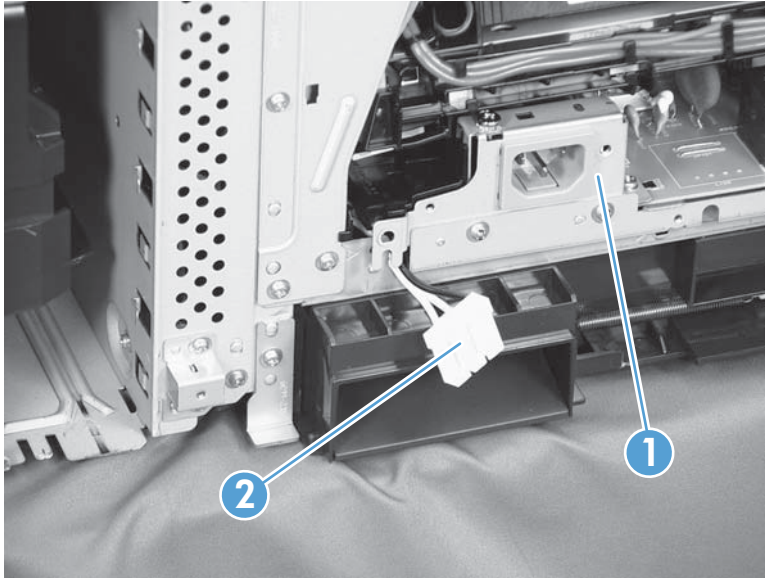

Imaging (developing) high-voltage power supply

Before proceeding, remove the following components:

- Rear cover. See [Rear cover on page 116](#).
- Right-rear cover. See [Right-rear cover on page 119](#).
- Formatter case. See [Formatter case on page 130](#).

Remove the imaging (developing) high-voltage power supply

△ **CAUTION:**  ESD-sensitive part.

Remove one screw (callout 1), release four tabs (callout 2), remove the cable routing plate (callout 3), and then remove the imaging (developing) high-voltage power supply PCA.

💡 **Reinstallation tip** Reinsert the power supply by angling the smaller left end behind the DC controller and driver PCA. Ensure that the power supply sits behind the black tab (callout 4). Carefully press the power supply to engage all four tabs.

When you reinstall the power supply PCA, look through the holes on the PCA (callout 5) and make sure that the contact springs are correctly positioned against the back side of the PCA.

Figure 2-163 Remove the imaging (developing) high-voltage power supply

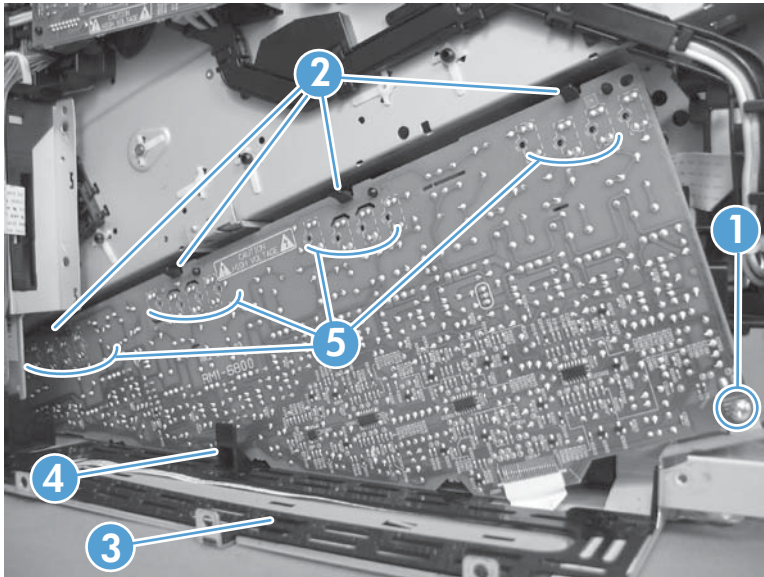

First transfer high-voltage power supply

Before proceeding, remove the following components:

- Toner collection unit. See [Toner-collection unit on page 91](#).
- Right-front cover and control-panel assembly. See [Right-front cover and control-panel assembly on page 113](#).
- Left cover. See [Left cover on page 115](#).
- Rear cover. See [Rear cover on page 116](#).
- Toner collection unit access door. See [Toner collection unit access door on page 117](#).
- Right-rear cover. See [Right-rear cover on page 119](#).
- Top cover. See [Top cover on page 121](#).
- Toner cover. See the first and second steps of [Residual toner full sensor on page 152](#).

Remove the first transfer high-voltage power supply

△ **CAUTION:**  ESD-sensitive part.

1. Remove one screw (callout 1), release three tabs (callout 2), and then slide the power supply off the alignment post (callout 3).

Figure 2-164 Remove the first transfer high-voltage power supply (1 of 2)

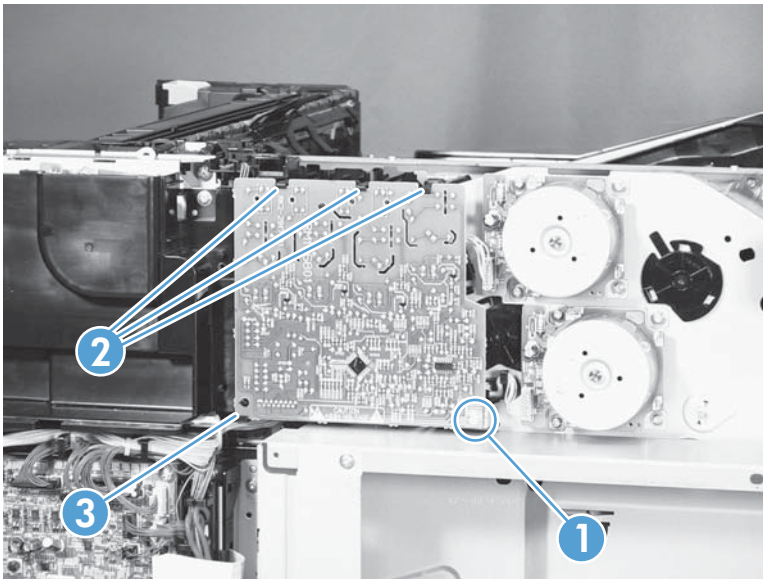

2. Disconnect one connector (callout 2), and then remove the first transfer high-voltage power supply PCA (callout 1).

Figure 2-165 Remove the first transfer high-voltage power supply (2 of 2)

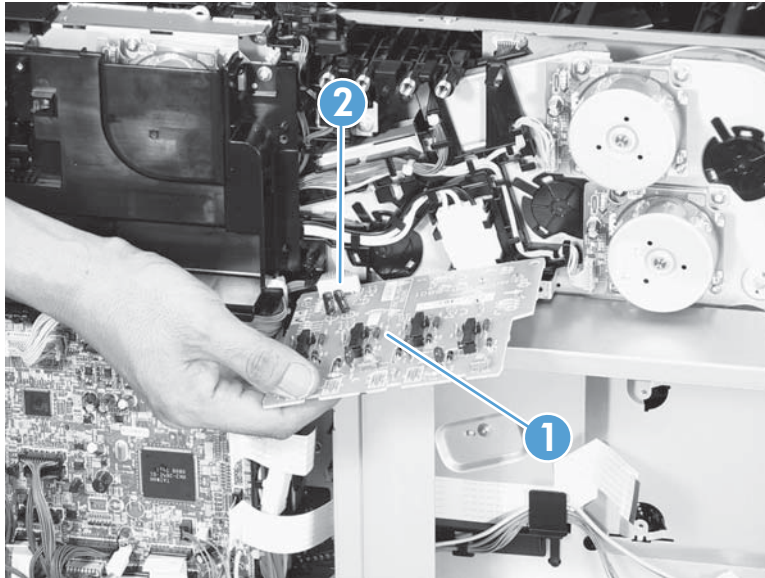

Reinstallation tip When you reinstall the power supply PCA, look through the holes on the PCA (callout 1) and make sure that the contact springs are correctly positioned against the back side of the PCA.

Figure 2-166 Reinstall the first transfer high-voltage power supply

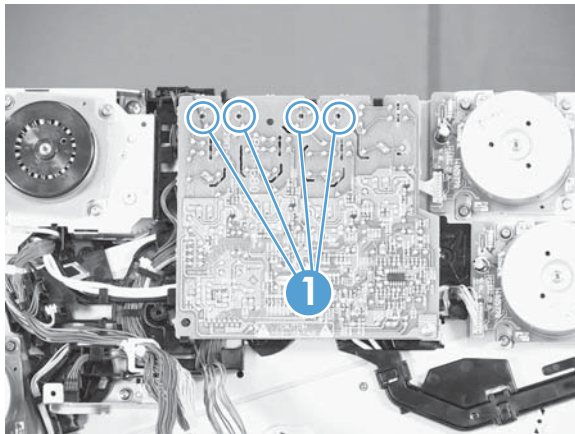

Second transfer high-voltage power supply

Before proceeding, remove the following components:

- Rear cover. See [Rear cover on page 116](#).
- Right-rear cover. See [Right-rear cover on page 119](#).

Remove the second transfer high-voltage power supply

△ **CAUTION:**  ESD-sensitive part.

1. Disconnect all of the cables and FFCs from the DC controller (release the cables from the guides), remove five screws (callout 1), and then remove the DC controller and the DC controller support.

Figure 2-167 Remove the second transfer high-voltage power supply (1 of 2)

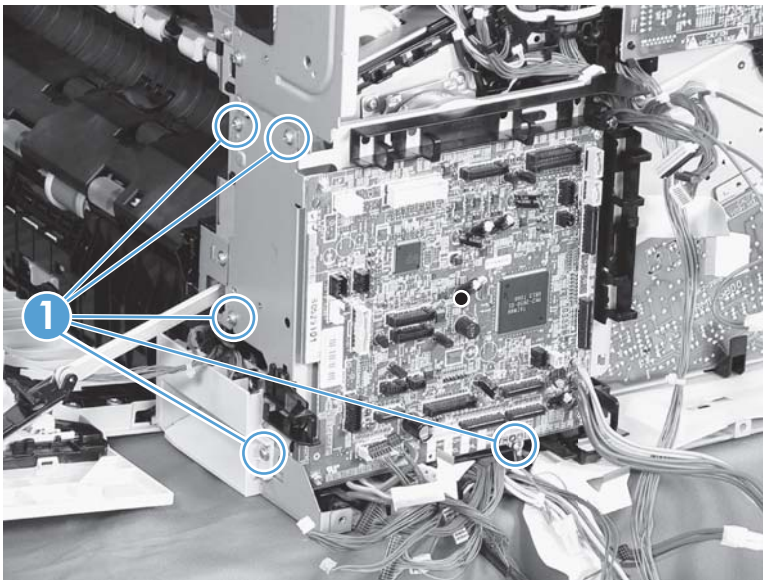

2. Release four tabs (callout 1), and then unrout the cable (callout 2) as you remove the second transfer high-voltage power supply (callout 3).

Figure 2-168 Remove the second transfer high-voltage power supply (2 of 2)

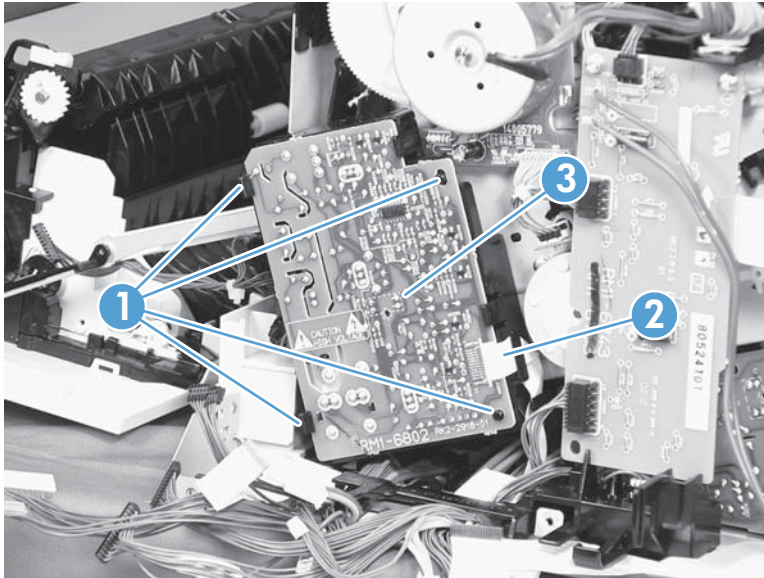

Driver PCA

Before proceeding, remove the following components:

- Rear cover. See [Rear cover on page 116](#).
- Right-rear cover. See [Right-rear cover on page 119](#).

Remove the driver PCA

△ **CAUTION:**  ESD-sensitive part.

1. Disconnect all of the cables and FFCs from the DC controller (release the cables from the guides), remove six screws (callout 1), and then remove the DC controller and the DC controller support.

Figure 2-169 Remove the driver PCA (1 of 2)

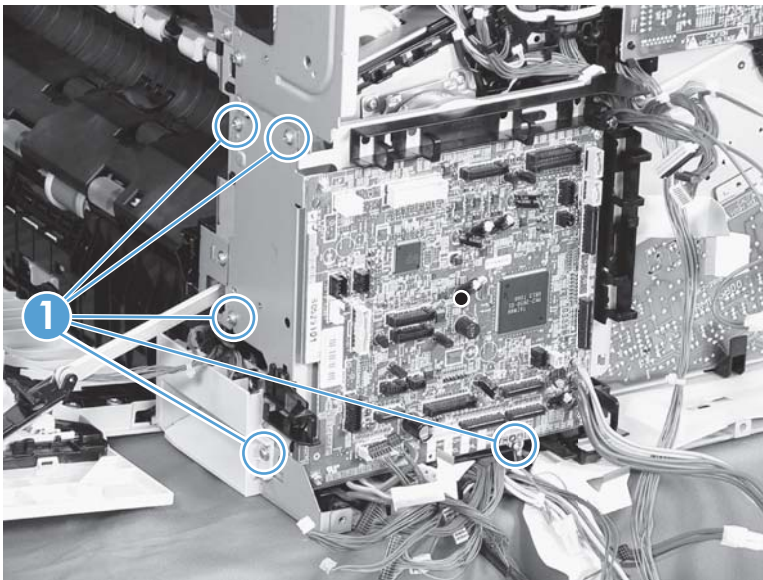

2. Disconnect three connectors (callout 1), remove two screws (callout 2), and then unroute the cable (callout 3) as you remove the driver PCA (callout 4).

Figure 2-170 Remove the driver PCA (2 of 2)

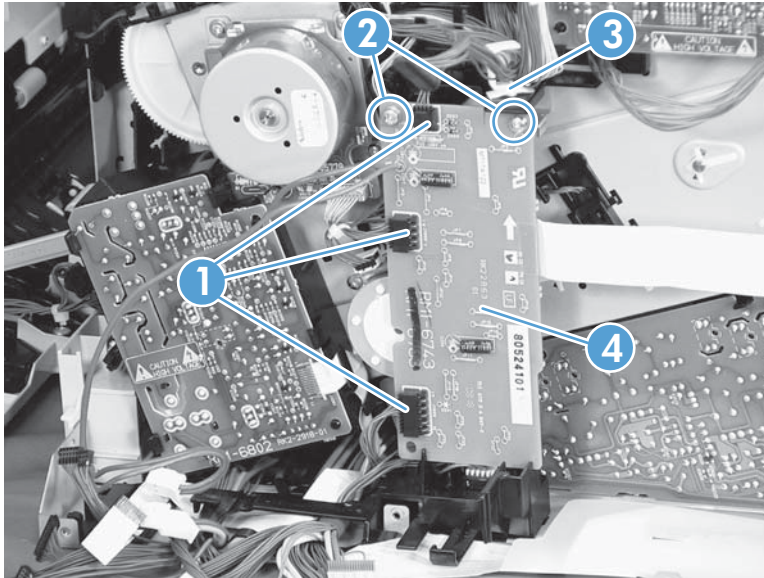

Power switch PCA

Before proceeding, remove the following components:

- Right-front cover and control-panel assembly. See [Right-front cover and control-panel assembly on page 113](#).

Remove the power switch PCA

△ **CAUTION:**  ESD-sensitive part.

1. Open the front door and the right door.
2. Disconnect one connector (callout 1), release two tabs (callout 2), and then remove the PCA (callout 3).

Figure 2-171 Remove the power switch PCA

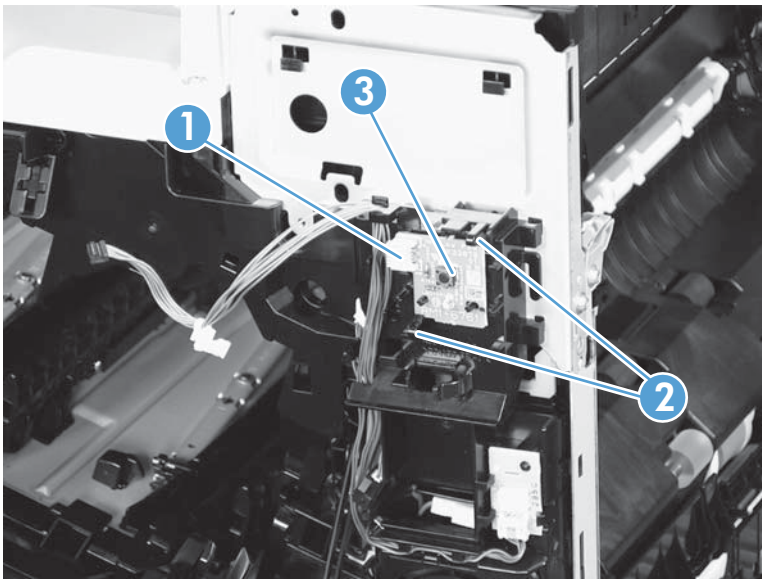

Environmental sensor

Before proceeding, remove the following components:

- Right-front cover and control-panel assembly. See [Right-front cover and control-panel assembly on page 113](#).

Remove the environmental sensor

1. Open the front door and the right door.
2. Disconnect one connector (callout 1), release one tab (callout 2), and then remove the environmental sensor (callout 3).

Figure 2-172 Remove the environmental sensor

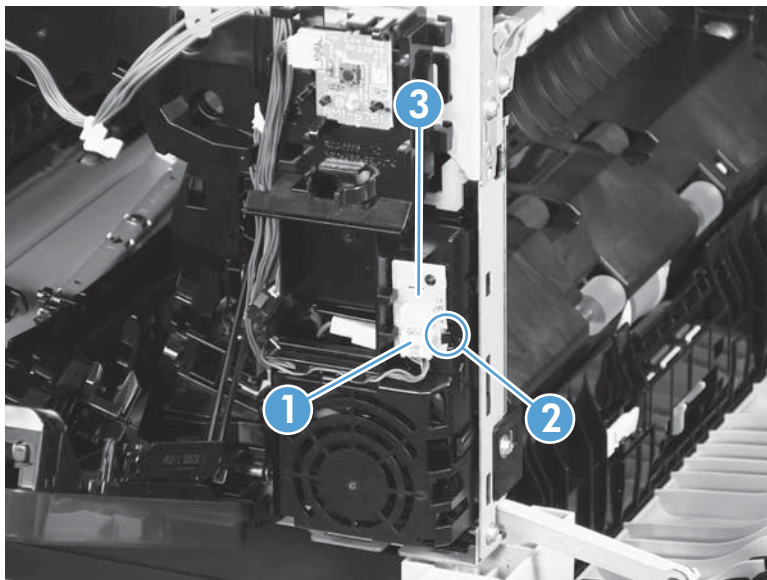

1 x 500-sheet paper feeder assembly

1 x 500 rear cover

Remove two screws (callout 1), and then remove the rear cover (callout 2).

Figure 2-173 Remove the 1 x 500 rear cover

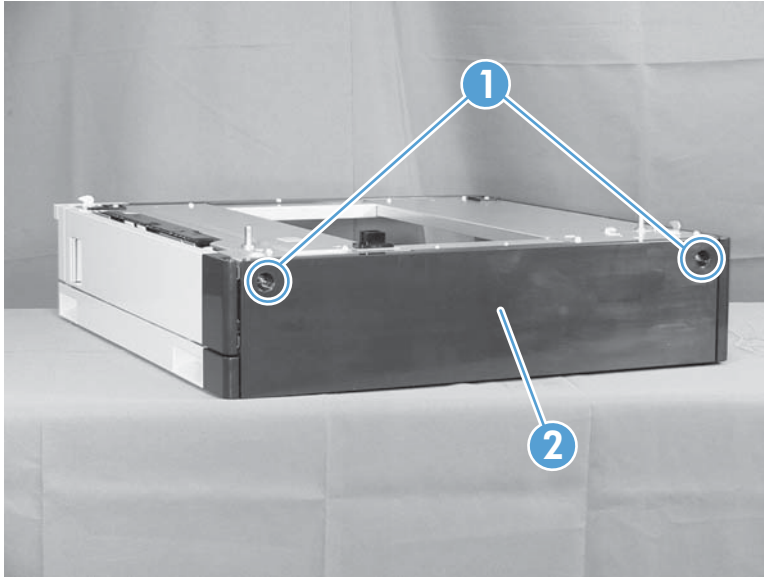

1 x 500 left cover

1. Take the cassette out of the feeder, release one tab (callout 1), and then remove the lever (callout 2).

Figure 2-174 Remove the 1 x 500 left cover (1 of 2)

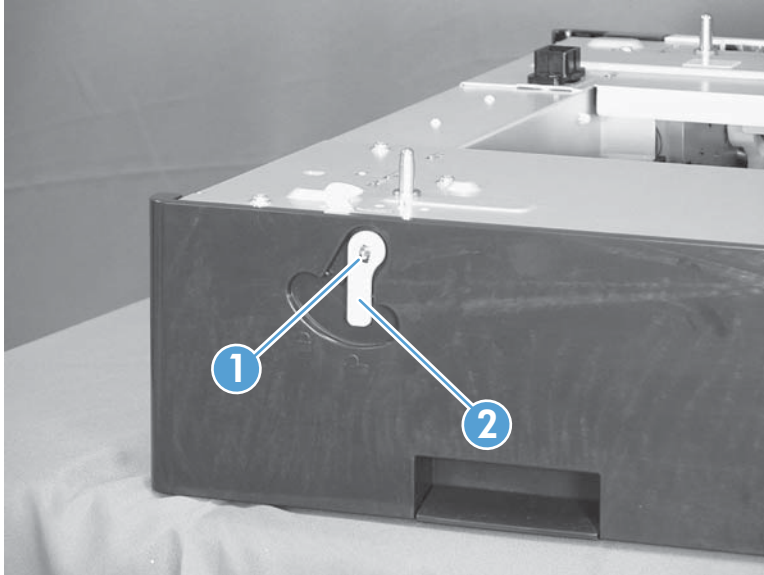

2. Remove one screw (callout 1), release four tabs from the inside (see the tip that follows this step), and then remove the left cover (callout 2).

Figure 2-175 Remove the 1 x 500 left cover (2 of 2)

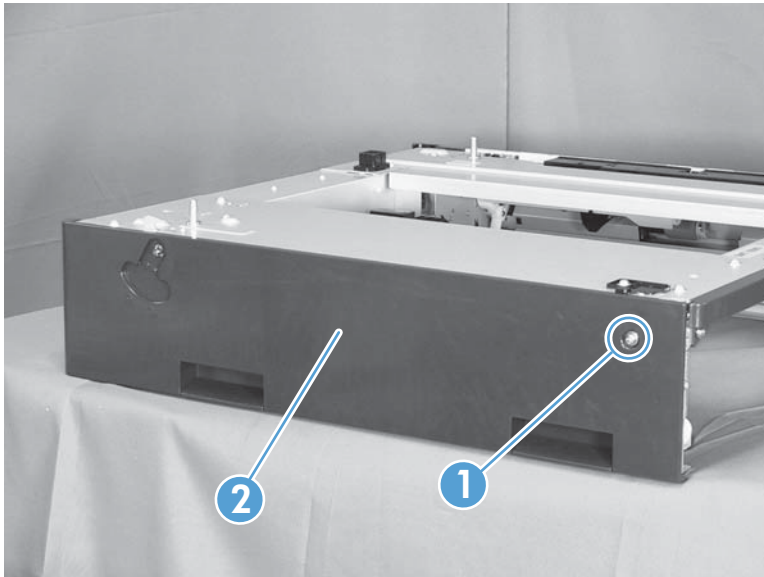

 **TIP:** The following figures show the tabs inside the cover.

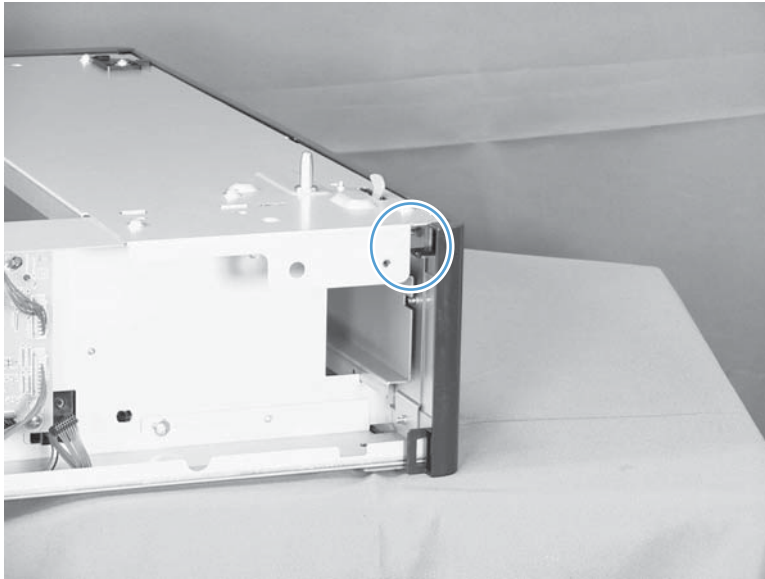
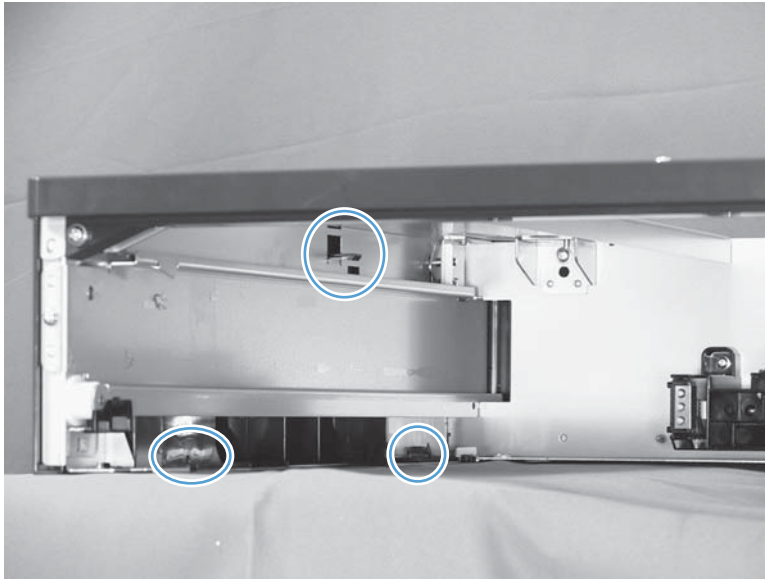

1 x 500 right-front cover

1. Take the cassette out of the feeder, and then open the right door.
2. Remove one screw (callout 1), and then remove the right-front cover (callout 2).

Figure 2-176 Remove the 1 x 500 right-front cover

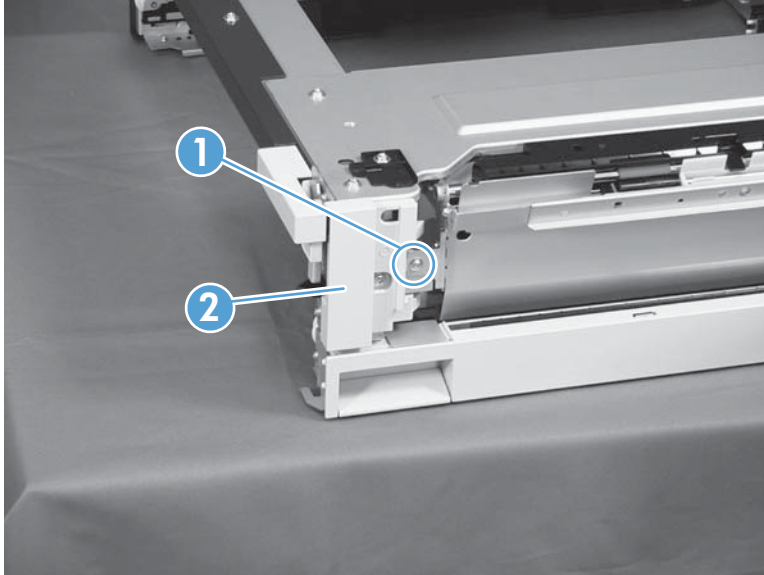

1 x 500 front-upper cover

1. Remove the cassette from the feeder, and then remove the right-front cover (see [1 x 500 right-front cover on page 225](#)).
2. Remove two screws (callout 1), release two tabs (callout 2), and then remove the front upper cover unit (callout 3).

Figure 2-177 Remove the 1 x 500 front-upper cover

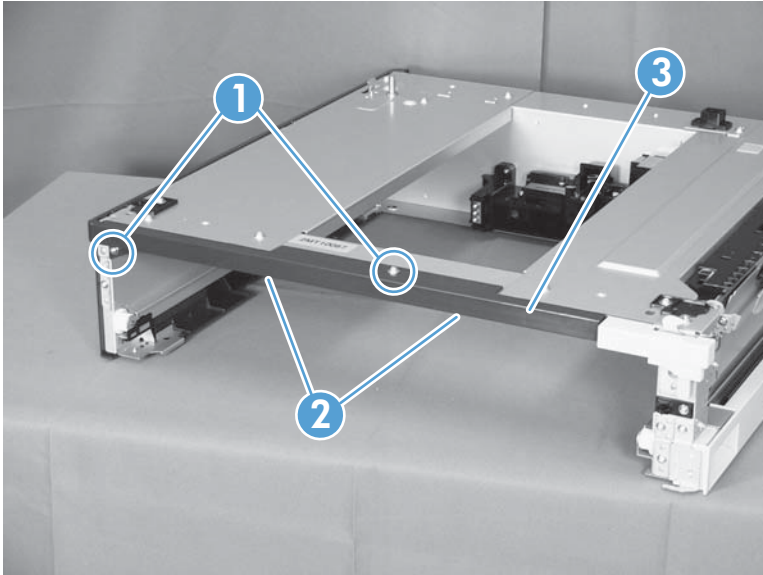

1 x 500 right door

1. Lift the product off the feeder, and then open the tray right door.
2. Release the link arm (callout 1).

Figure 2-178 Remove the 1 x 500 right door (1 of 3)

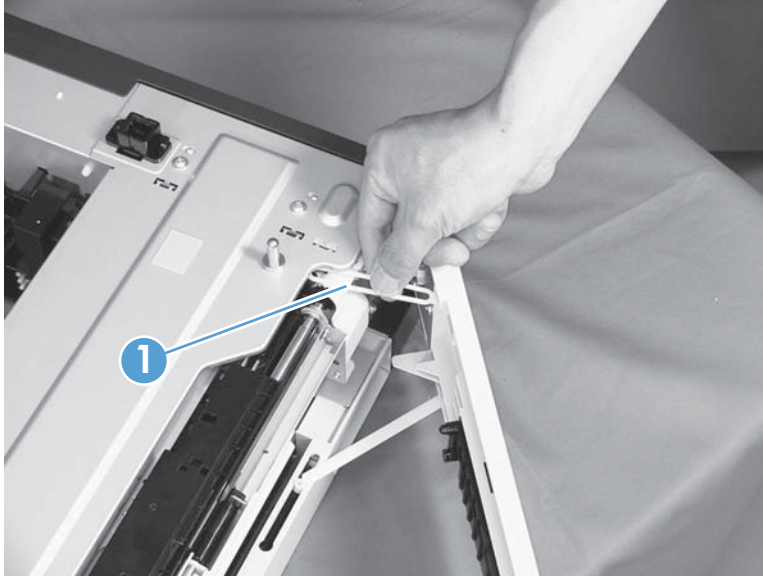

3. Release the stopper (callout 1), and then release the shaft (callout 2).

Figure 2-179 Remove the 1 x 500 right door (2 of 3)

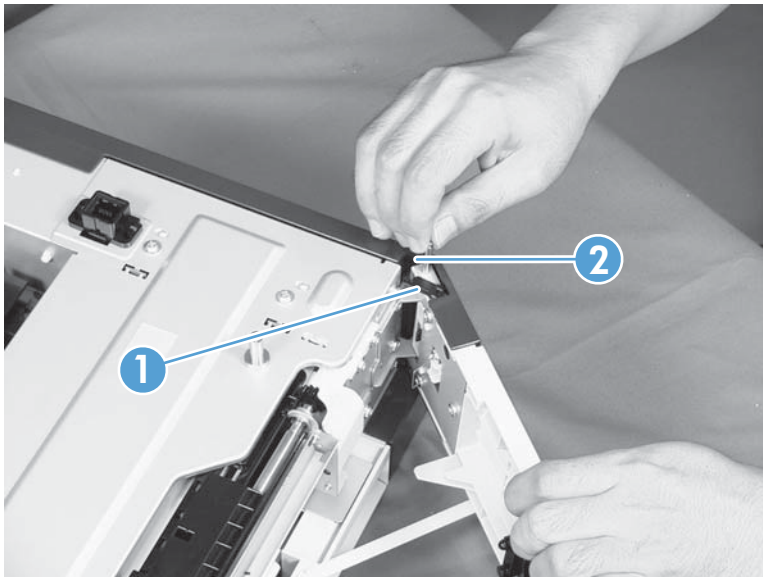

4. Slide the right door (callout 1) and the arm (callout 2) in the direction that the arrow indicates to remove them together, and then remove the arm from the right door unit.

Figure 2-180 Remove the 1 x 500 right door (3 of 3)

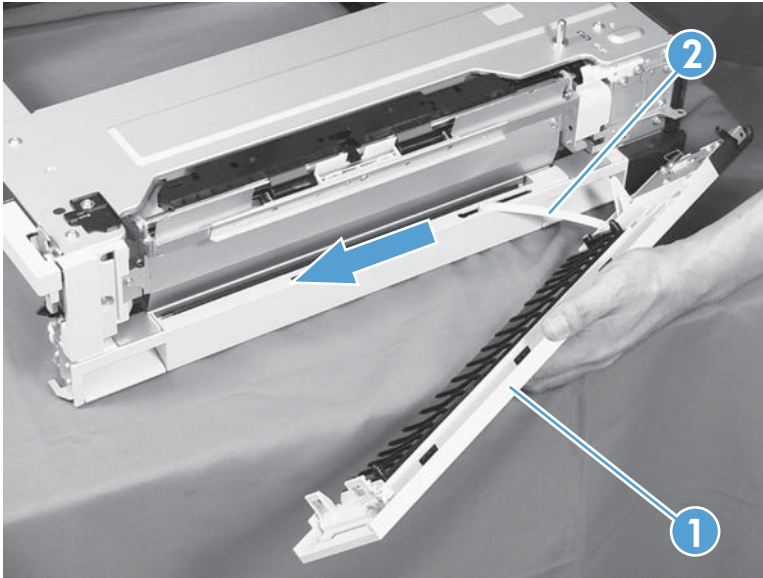

1 x 500 right-lower cover

1. Remove the cassette from the feeder, and then remove the right door (see [1 x 500 right door on page 227](#)).
2. Remove one screw (callout 1), and then slide the cover (callout 2) to the right to clear an alignment pin at the left side of the cover.

Figure 2-181 Remove the 1 x 500 right-lower cover

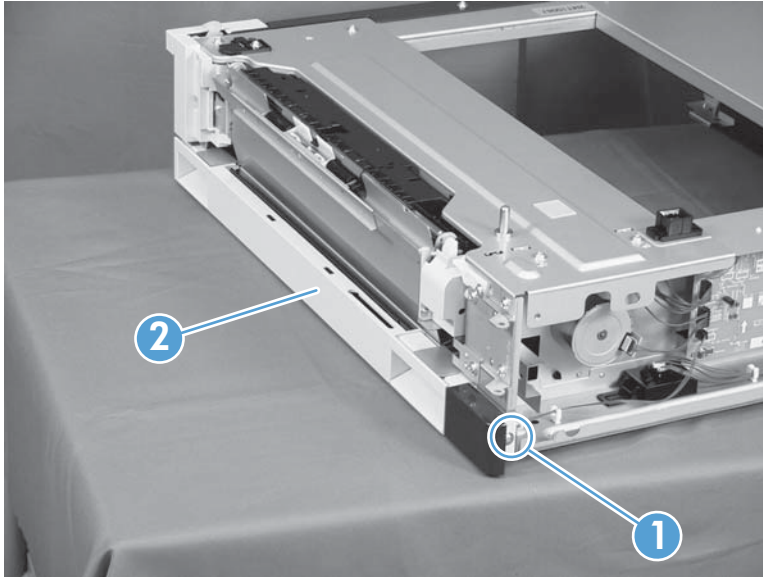

1 x 500 pickup assembly

Before proceeding, remove the following components:

- Rear cover. See [1 x 500 rear cover on page 222](#).
 - Right-front cover. See [1 x 500 right-front cover on page 225](#).
 - Right door. See [1 x 500 right door on page 227](#).
 - Right-lower cover. See [1 x 500 right-lower cover on page 229](#).
1. Disconnect three connectors (callout 1), and then remove one screw (callout 2).

Figure 2-182 Remove the 1 x 500 pickup assembly (1 of 4)

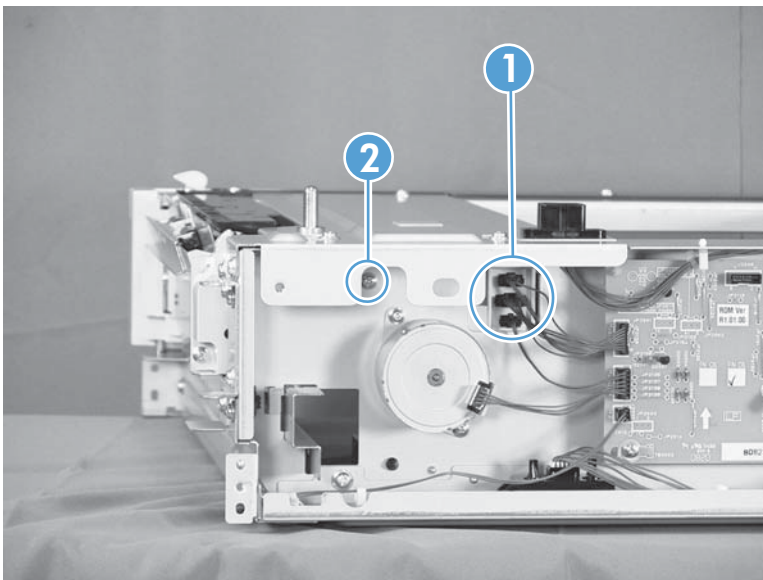

2. Remove one screw (callout 1), and then remove the stopper of the right-door link (callout 2).

Figure 2-183 Remove the 1 x 500 pickup assembly (2 of 4)

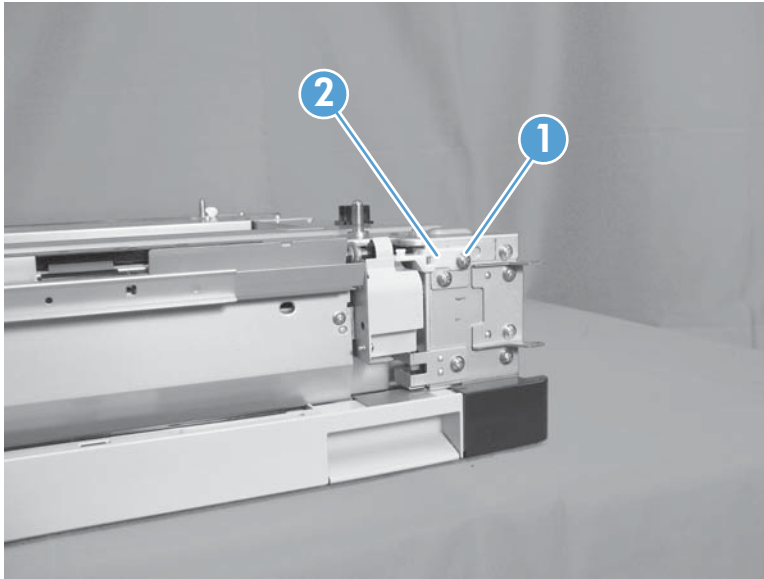

3. Remove one screw (callout 1).

Figure 2-184 Remove the 1 x 500 pickup assembly (3 of 4)

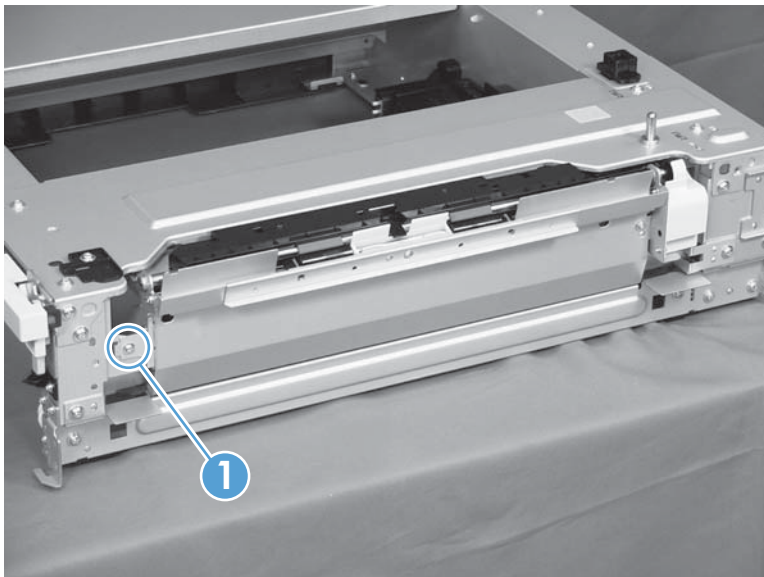

4. Lift the 1 x 500 pickup assembly (callout 1) slightly to clear a tab (callout 2), and then slide it in the direction that the arrow indicates to remove it.

Figure 2-185 Remove the 1 x 500 pickup assembly (4 of 4)

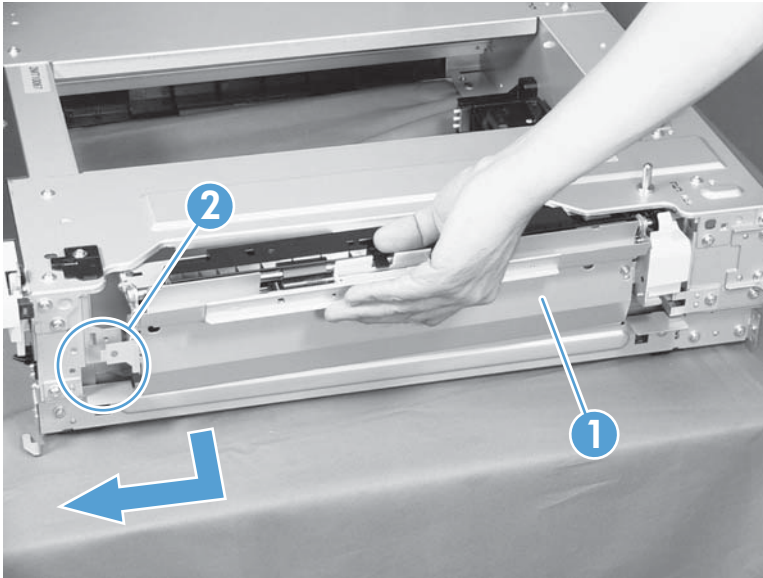

Reinstallation tip When reassembling the 1 x 500 pickup assembly, be sure to fit the shaft (callout 1) on the assembly to the hole (callout 2) in the feeder.

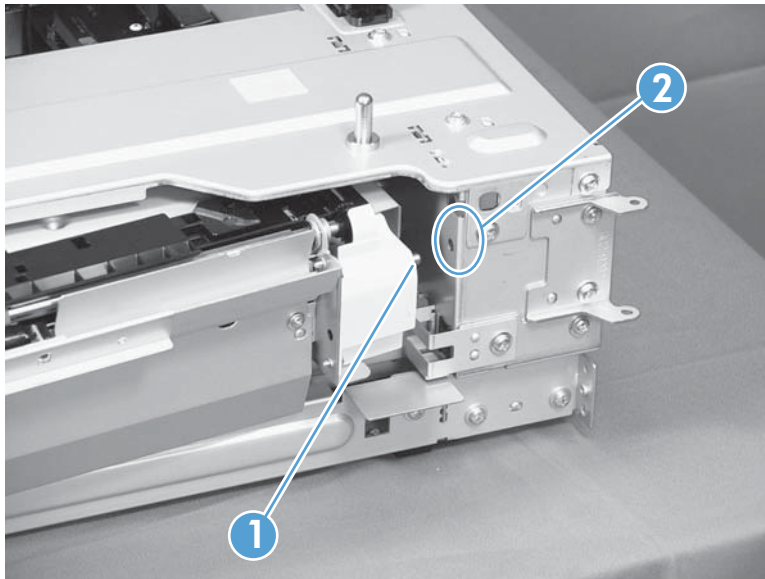

1 x 500 lifter-drive assembly

1. Remove the cassette from the feeder, and then remove the rear cover (see [1 x 500 rear cover on page 222](#)).
2. Disconnect two connectors (callout 1).

Figure 2-186 Remove the 1 x 500 lifter-drive assembly (1 of 2)

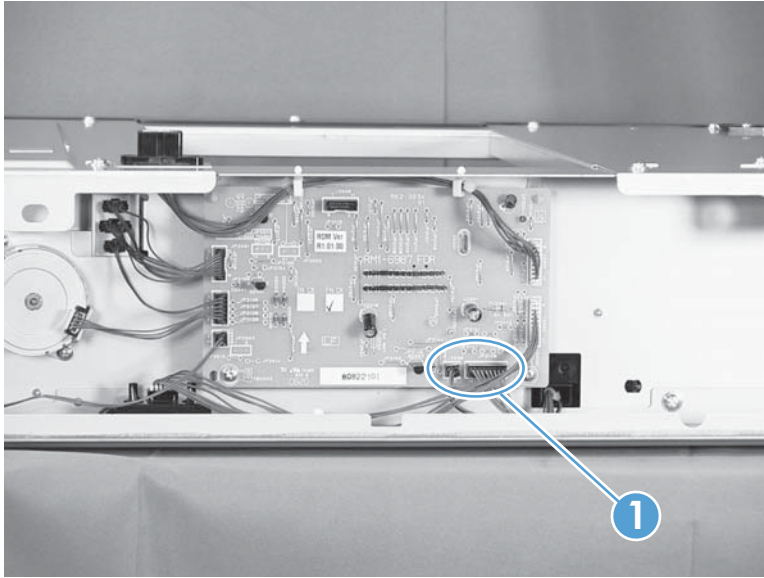

3. From the front, inside the tray cavity, remove three screws (callout 1), release one tab (callout 2), and then remove the 1 x 500 lifter-drive assembly (callout 3).

Figure 2-187 Remove the 1 x 500 lifter-drive assembly (2 of 2)

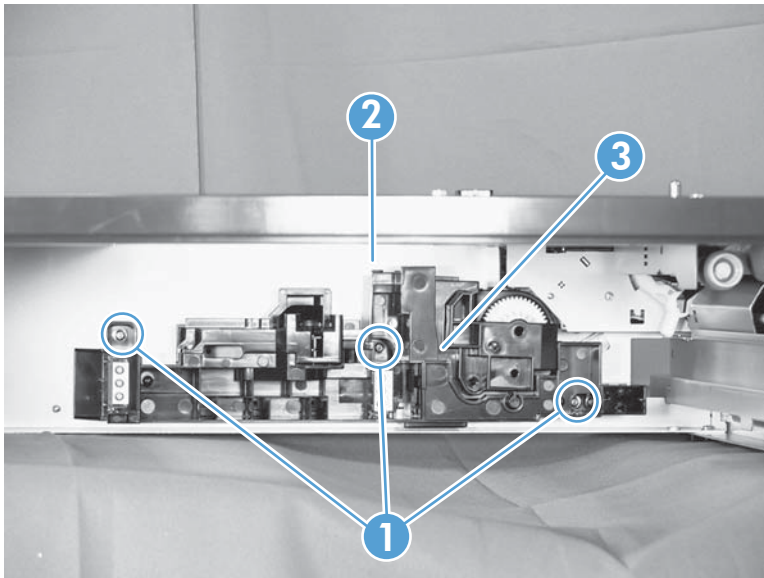

1 x 500 pickup motor

1. Remove the cassette from the feeder, and then remove the rear cover (see [1 x 500 rear cover on page 222](#)).
2. Disconnect one connector (callout 1), remove two screws (callout 2), and then remove the 1 x 500 pickup motor (callout 3).

Figure 2-188 Remove the 1 x 500 pickup motor

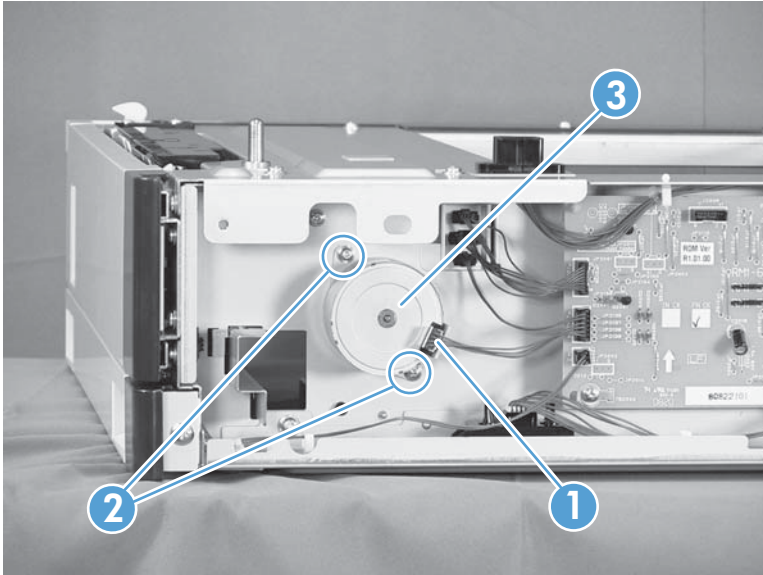

1 x 500 driver PCA

1. Remove the cassette from the feeder, and then remove the rear cover (see [1 x 500 rear cover on page 222](#)).
2. Disconnect seven connectors (callout 1), remove two screws (callout 2), release two tabs (callout 3), and then remove the 1 x 500 driver PCA.

 **NOTE:** One connector (callout 4) on the 1 x 500 driver PCA remains empty.

Figure 2-189 Remove the 1 x 500 driver PCA



3 x 500-sheet paper feeder (optional accessory)

3 x 500 rear cover

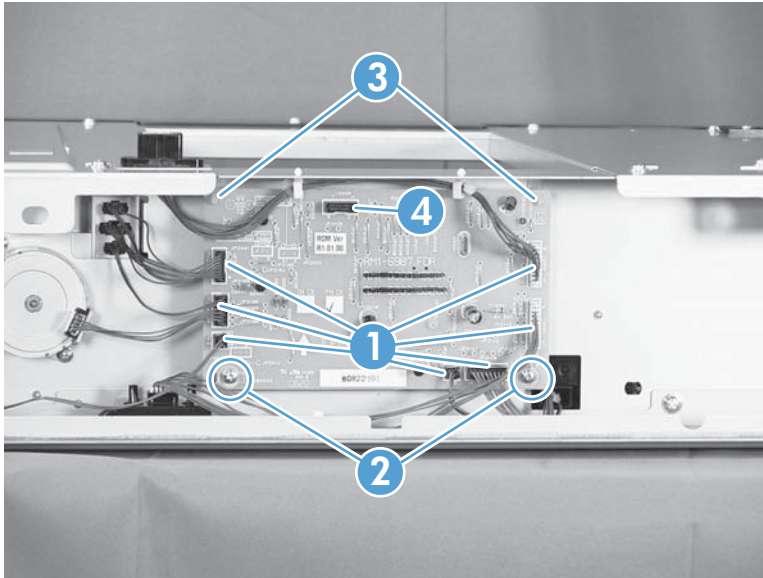
Remove two screws (callout 1), and then remove the 3 x 500 rear cover (callout 2).

Figure 2-190 Remove the 3 x 500 rear cover

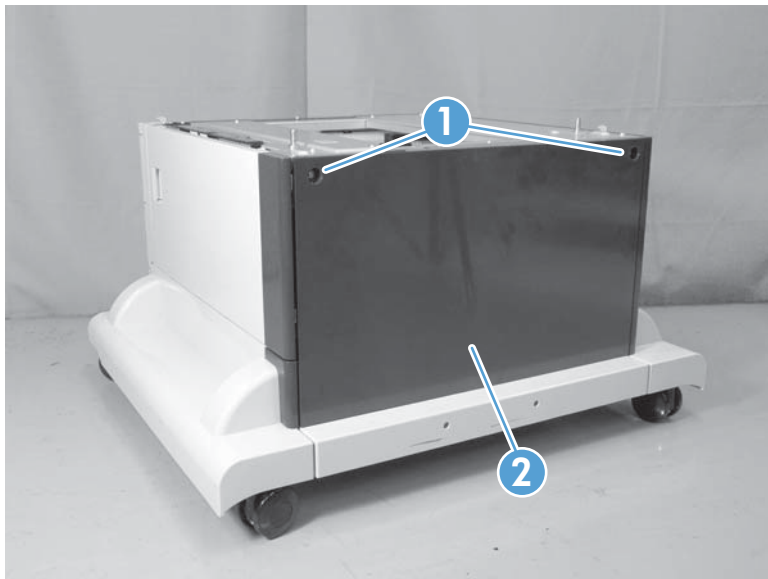

3 x 500 right and left cassette rails

1. Remove a cassette.
2. Remove two screws (callout 1), and then remove the 3 x 500 right (callout 2) and left (callout 3) cassette rails. Repeat this procedure for the remaining cassette rails.

Figure 2-191 Remove the 3 x 500 right and left cassette rails

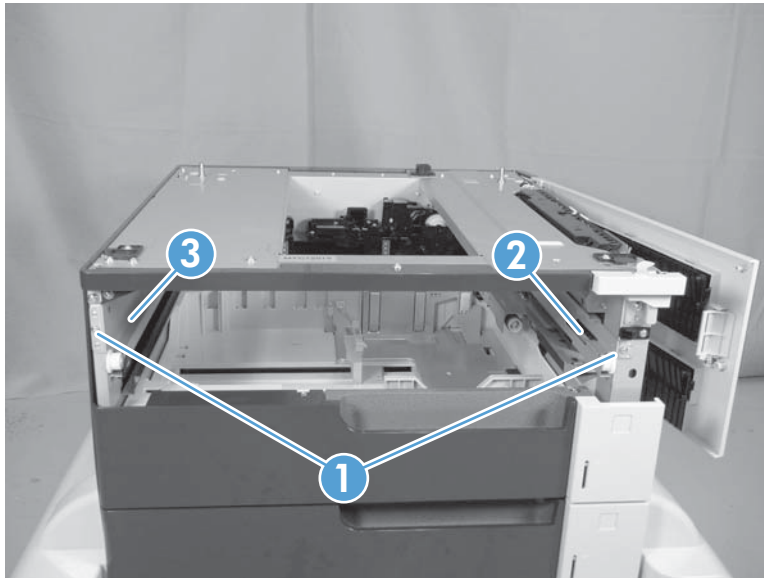

3 x 500 paper deck controller PCAs

1. Remove the 3 x 500 rear cover (see [3 x 500 rear cover on page 236](#)).
2. Disconnect all of the connectors for the desired PCA.
 - The top PCA has seven connectors.
 - The middle PCA has six connectors.
 - The bottom PCA has five connectors.
3. Remove two screws (callout 1), release two tabs (callout 2), and then remove the PCA. Repeat this procedure for the remaining PCAs.

 **NOTE:** Some connectors (callout 3) on the PCAs are not used.

Figure 2-192 Remove the 3 x 500 paper deck controller PCA

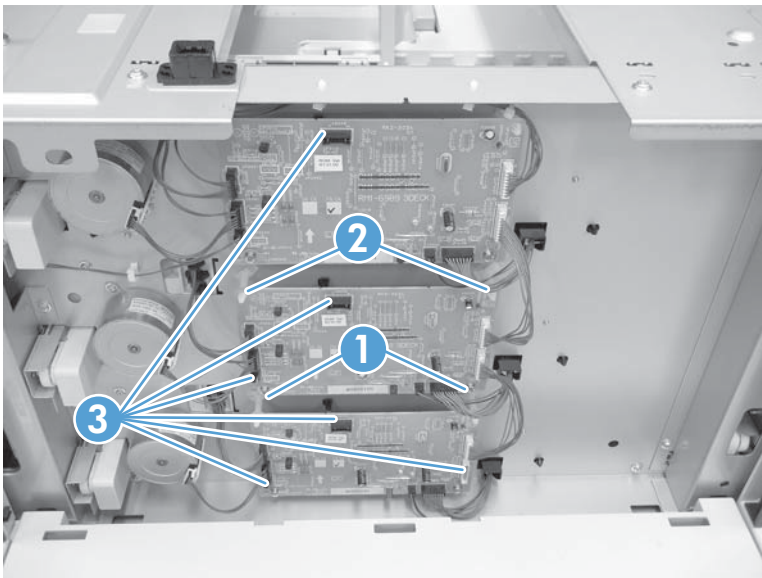

3 x 500 paper deck lifter-drive assembly

This procedure describes removing the paper deck cassette 1 lifter-drive assembly. Use this procedure for any of the paper deck lifter assemblies.

1. Remove the 3 x 500 rear cover. See [3 x 500 rear cover on page 236](#).
2. Disconnect two connectors (callout 1).

Figure 2-193 Remove the 3 x 500 paper deck lifter-drive assembly (1 of 2)

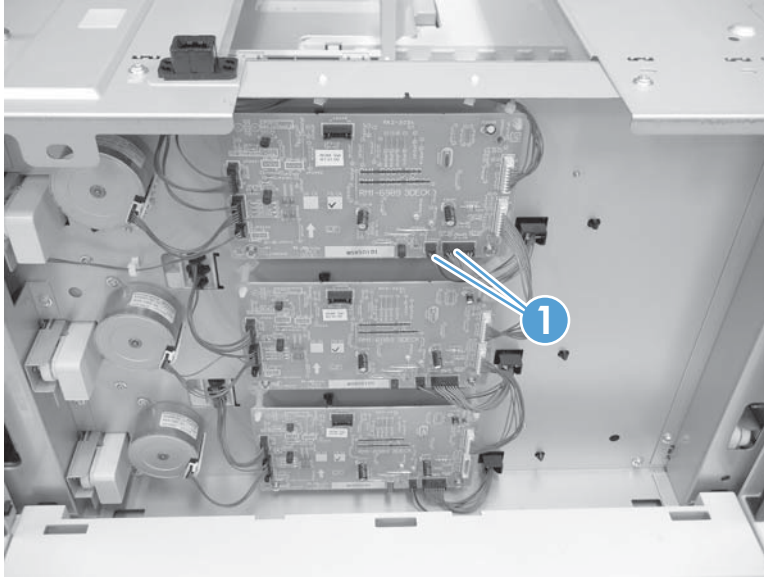

3. Remove all of the cassettes, remove three screws (callout 1), release one tab (callout 2), and then remove the cassette lifter assembly (callout 3).

Figure 2-194 Remove the 3 x 500 paper deck lifter-drive assembly (2 of 2)

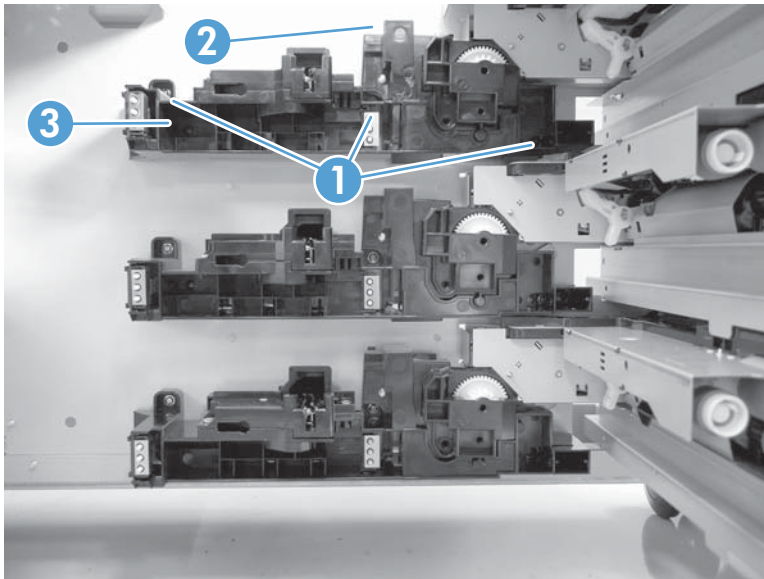

3 x 500 paper deck pickup motor

This procedure describes removing the paper deck cassette 1 pickup motor. Use this procedure for any of the paper deck pickup motors.

1. Remove the 3 x 500 rear cover. See [3 x 500 rear cover on page 236](#).
2. Disconnect one connector (callout 1), remove two screws (callout 2), and then remove the cassette pickup motor (callout 3).

Figure 2-195 Remove the 3 x 500 paper deck pickup motor

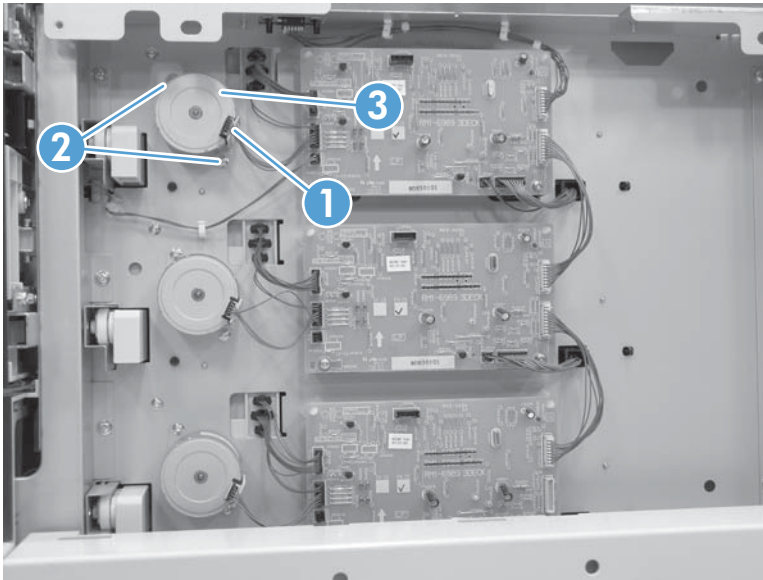

3 x 500 front-lower cover

1. Remove the lowest cassette.
2. Remove one screw (callout 1), and then slide the 3 x 500 front-lower cover (callout 2) toward the left side of the feeder to remove it.

Figure 2-196 Remove the 3 x 500 front-lower cover

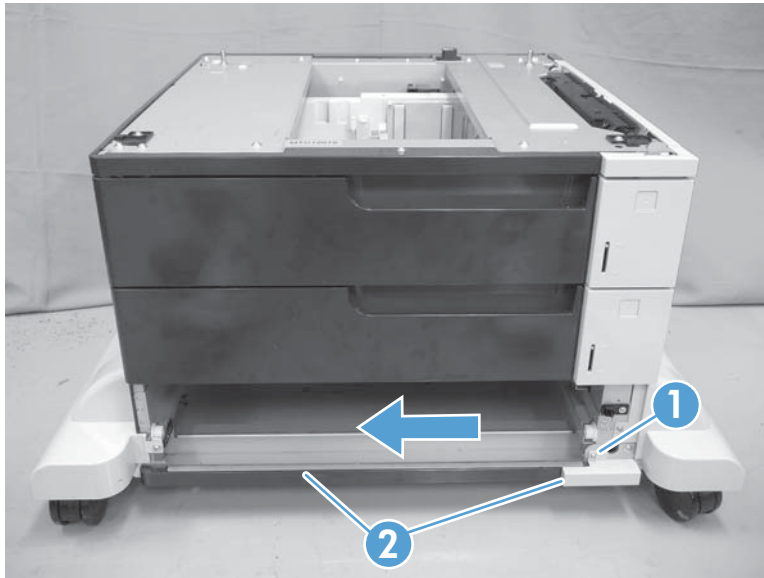

3 x 500 left cover

1. Release one tab (callout 1), and then remove the locking lever (callout 2).

Figure 2-197 Remove the 3 x 500 left cover (1 of 2)

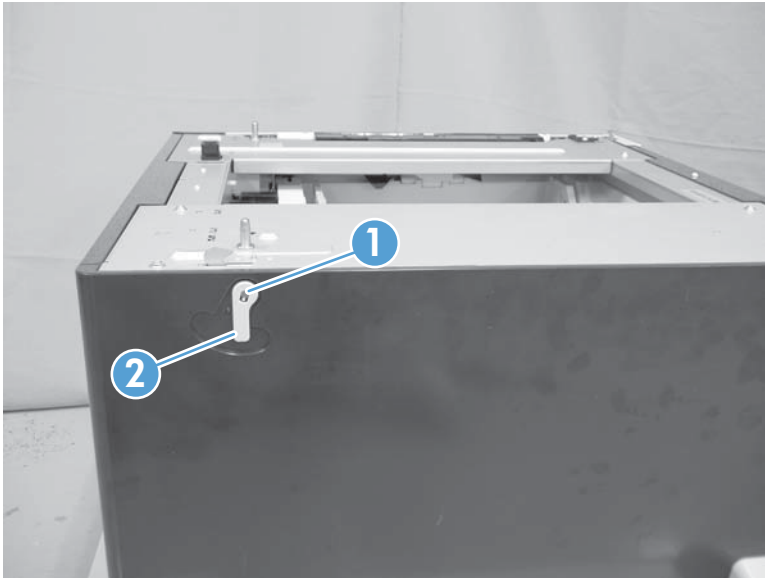

2. Remove one screw (callout 1), and then remove the left cover (callout 2).

Figure 2-198 Remove the 3 x 500 left cover (2 of 2)

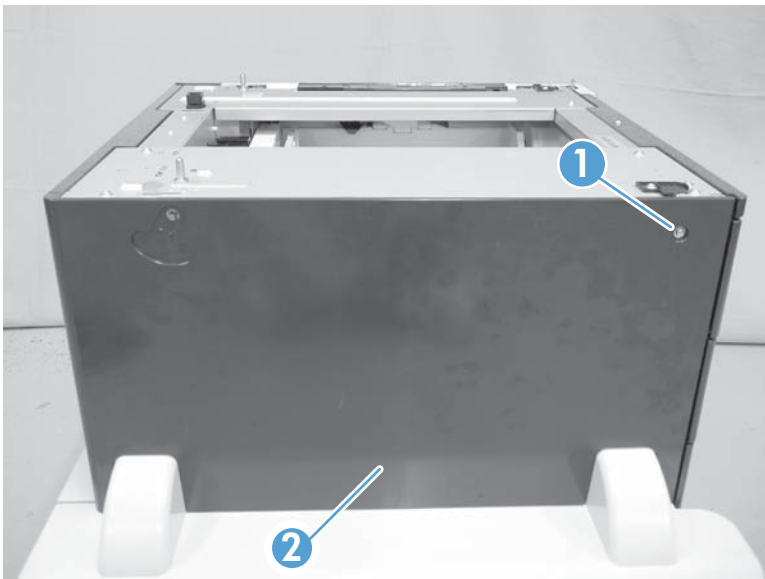

3 x 500 right-corner cover

Open the right door, remove two screws (callout 1), and then remove the 3 x 500 right-corner cover (callout 2).

Figure 2-199 Remove the 3 x 500 right-corner cover

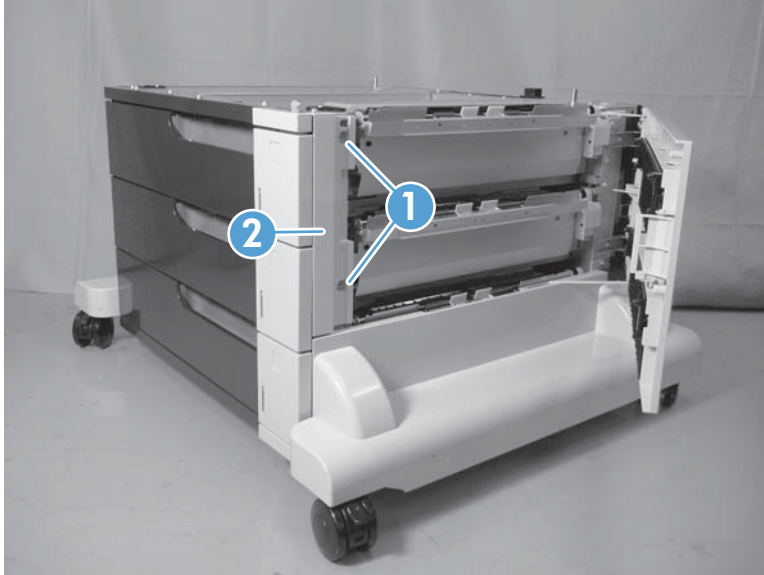

3 x 500 front-upper cover

1. Remove the right-corner cover (see [3 x 500 right-corner cover on page 243](#)).
2. Remove the upper cassette.
3. Remove two screws (callout 1), release two tabs (callout 2), and then remove the front-upper cover (callout 3).

Figure 2-200 Remove the 3 x 500 front-upper cover

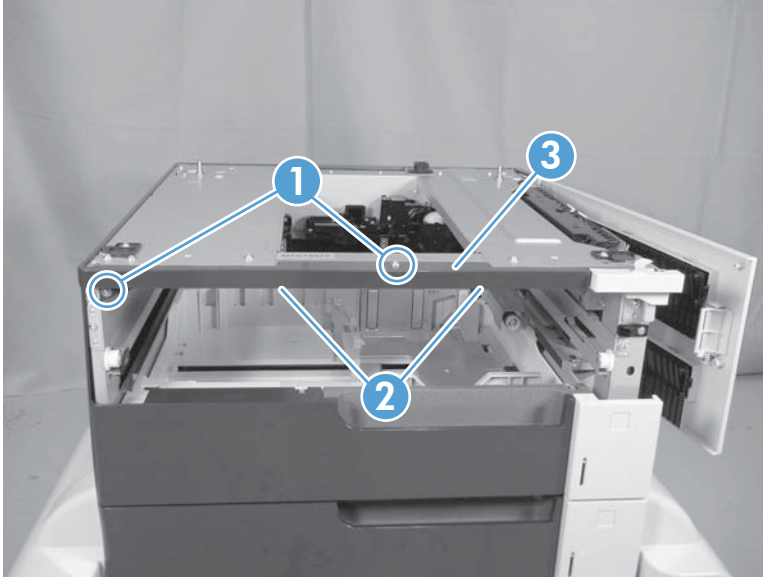

3 x 500 right-door assembly

1. Open the right door, and then release one upper-link arm (callout 1).

Figure 2-201 Remove the 3 x 500 right-door assembly (1 of 3)

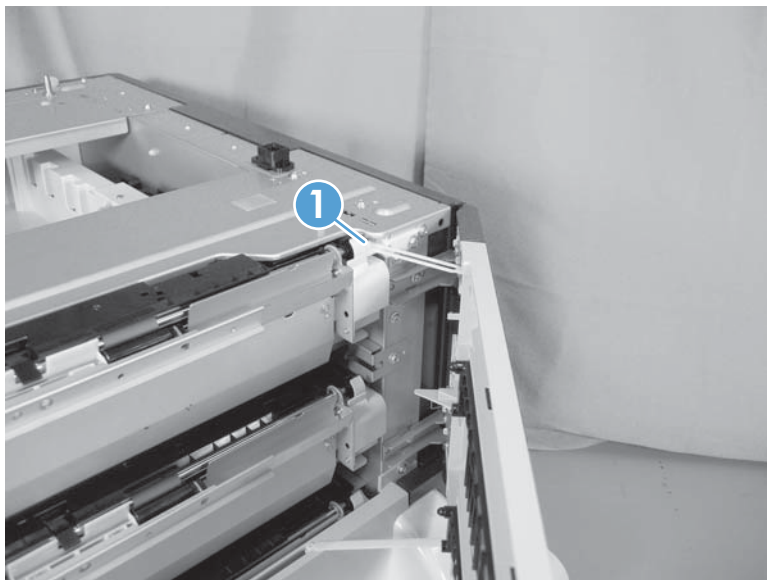

2. Release one tab (callout 1), and then remove the stopper (callout 2).

Figure 2-202 Remove the 3 x 500 right-door assembly (2 of 3)

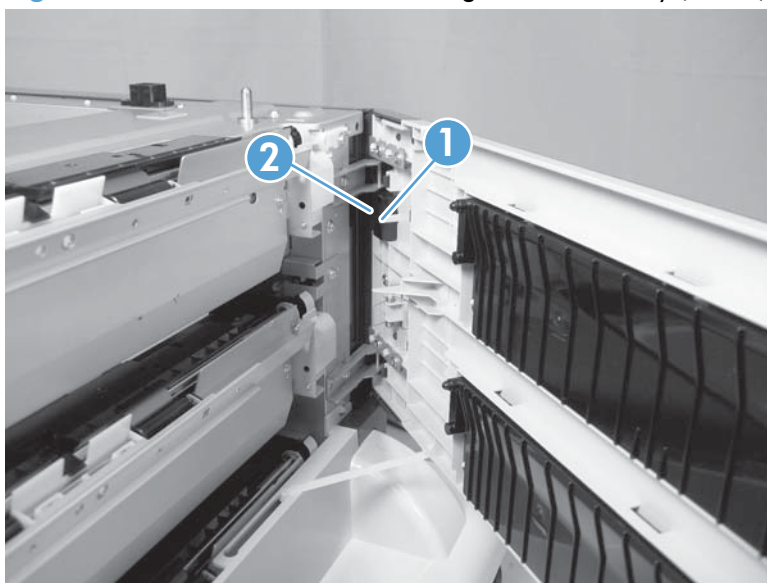

3. Lift up on the door to release it, slide the lower-link arm (callout 1) along the slot in the chassis to the release point (callout 2), and then remove the 3 x 500 right door.

△ **CAUTION:** The door remains attached to the feeder until the link arm is released. Do not damage the link arm when the door is removed.

Figure 2-203 Remove the 3 x 500 right-door assembly (3 of 3)

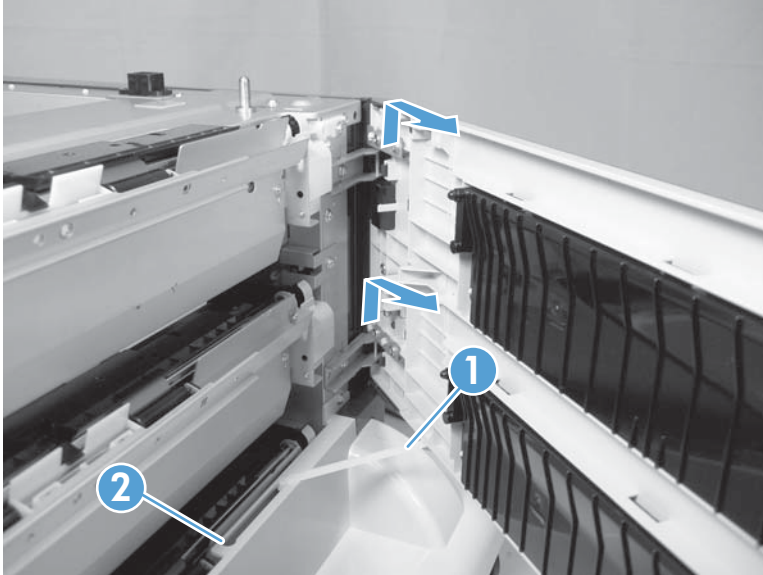

3 x 500 right-lower cover 1

1. Remove the lowest cassette, and then remove the 3 x 500 right door assembly (see [3 x 500 right-door assembly on page 245](#)).
2. Remove three screws (callout 1), loosen the top portion of the cover, and then remove the 3 x 500 right-lower cover 1.

Figure 2-204 Remove the 3 x 500 right-lower cover 1

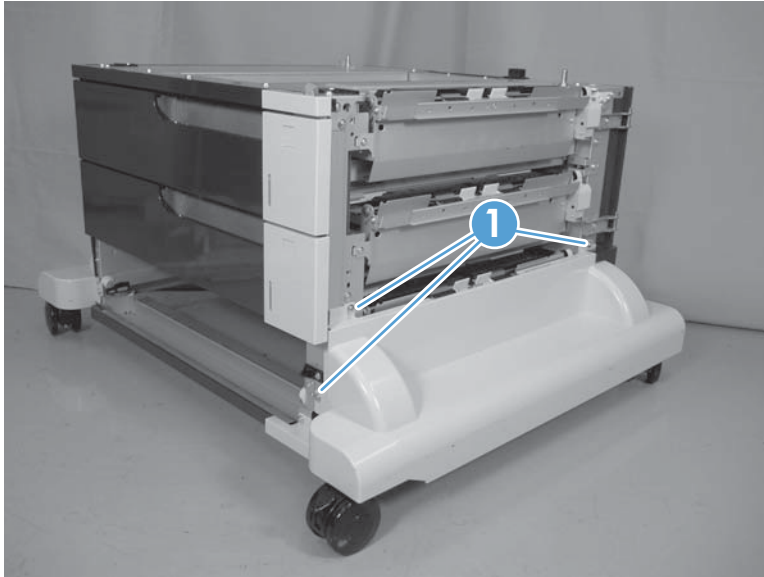

3 x 500 right-lower cover 2

1. Remove the 3 x 500 rear cover (see [3 x 500 rear cover on page 236](#)).
2. Release one tab (not shown), and then slide the 3 x 500 right-lower cover 2 (callout 1) toward the back of the feeder to remove it.

 **NOTE:** The figure in this step does not show the rear cover removed. Remove the rear cover to access the tab.

Figure 2-205 Remove the 3 x 500 right-lower cover 2



3 x 500 left-lower cover

1. Remove the lowest cassette, and then remove the 3 x 500 right door assembly (see [3 x 500 left cover on page 242](#)).
2. Remove three screws (callout 1), and then remove the 3 x 500 left-lower cover.

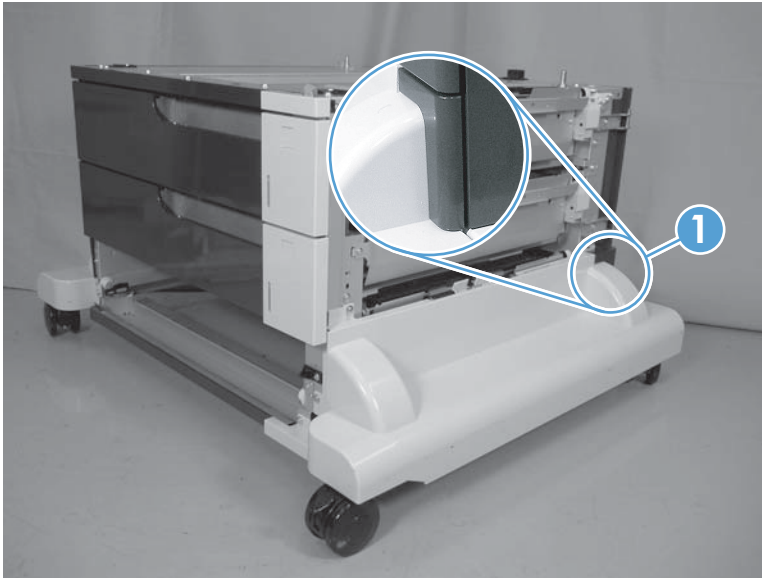
Figure 2-206 Remove the 3 x 500 left-lower cover

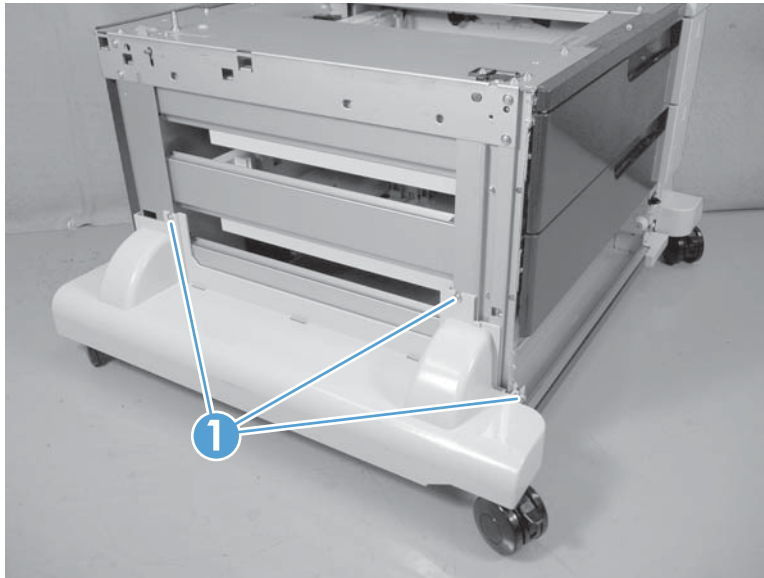

3 x 500 rear-lower cover

Before proceeding, remove the following components:

- Lowest cassette.
- Rear cover. See [3 x 500 rear cover on page 236](#).
- Right door assembly. See [3 x 500 right-door assembly on page 245](#).
- Right-lower cover. See [3 x 500 right-lower cover 1 on page 247](#).
- Left cover. See [3 x 500 left cover on page 242](#).
- Left-lower cover. See [3 x 500 left-lower cover on page 249](#).

Remove the 3 x 500 rear-lower cover

Remove two screws (callout 1), and then remove the 3 x 500 rear-lower cover.

Figure 2-207 Remove the 3 x 500 rear-lower cover

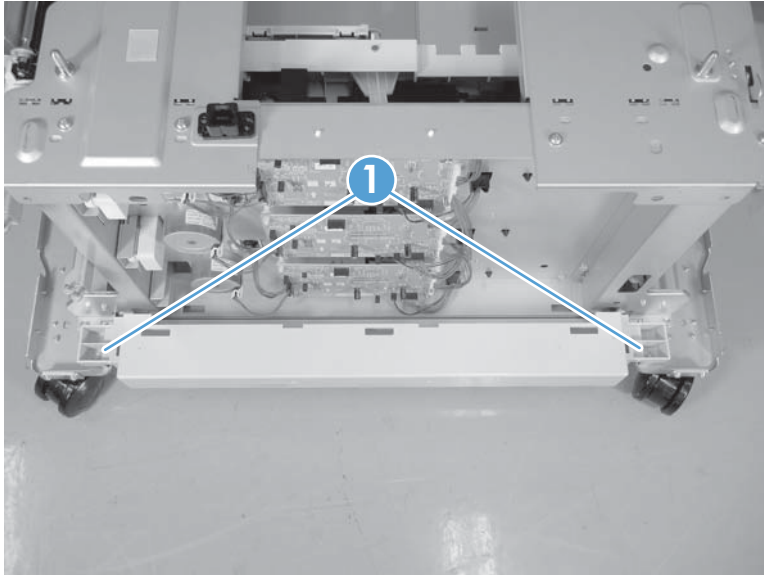

3 x 500 paper deck pickup assembly

Before proceeding, remove the following components:

- 3 x 500 rear cover. See [3 x 500 rear cover on page 236](#).
- Right-corner cover. See [3 x 500 right-corner cover on page 243](#)
- Right door assembly. See [3 x 500 right-door assembly on page 245](#).
- Right-lower cover. See [3 x 500 rear-lower cover on page 250](#).

 **NOTE:** Remove this cover only if you are removing the paper-feeder cassette 3 pickup assembly.

Remove the 3 x 500 paper deck pickup assembly

This procedure describes removing the paper deck cassette 1 assembly. Use this procedure for any of the paper deck pickup assemblies.

1. Remove one screw (callout 1), and then disconnect three connectors (callout 2).

Figure 2-208 Remove the 3 x 500 paper deck pickup assembly (1 of 3)

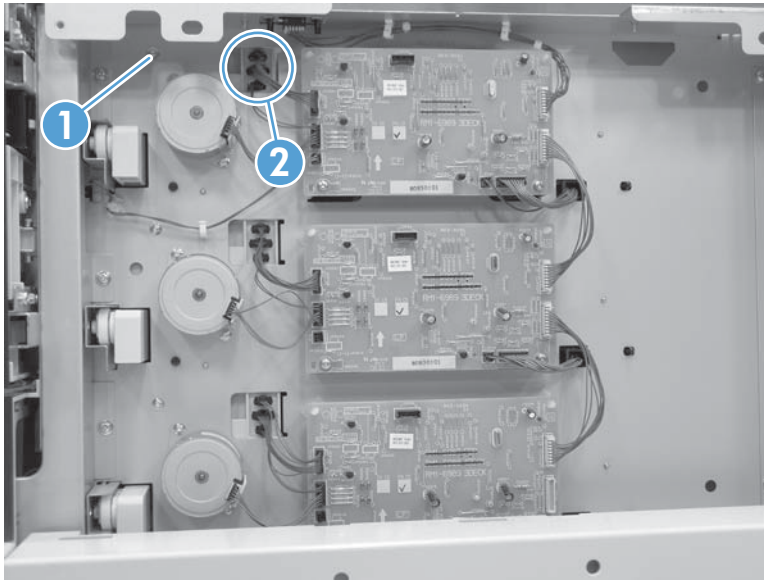

2. Remove the cassette, remove one screw (callout 1), and then remove the right-door link stopper (callout 2).

Figure 2-209 Remove the 3 x 500 paper deck pickup assembly (2 of 3)

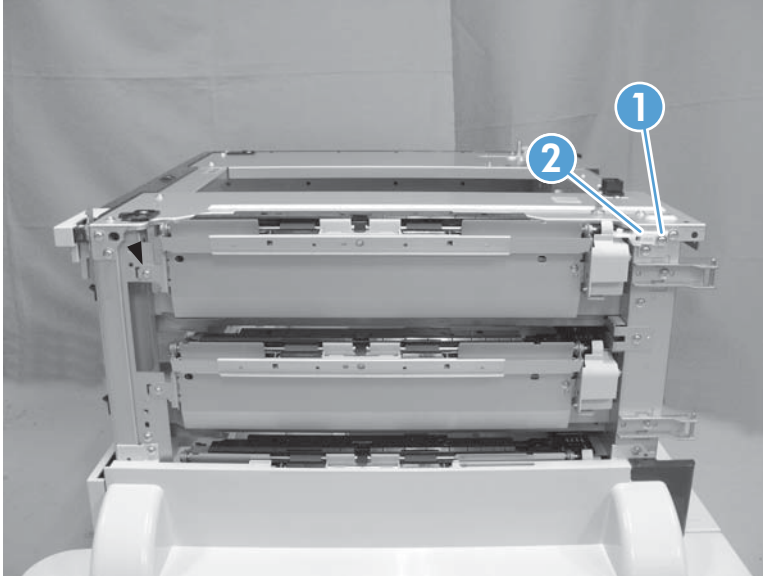

3. Remove one screw (callout 1), and then remove the paper deck pickup assembly (callout 2).

Figure 2-210 Remove the 3 x 500 paper deck pickup assembly (3 of 3)

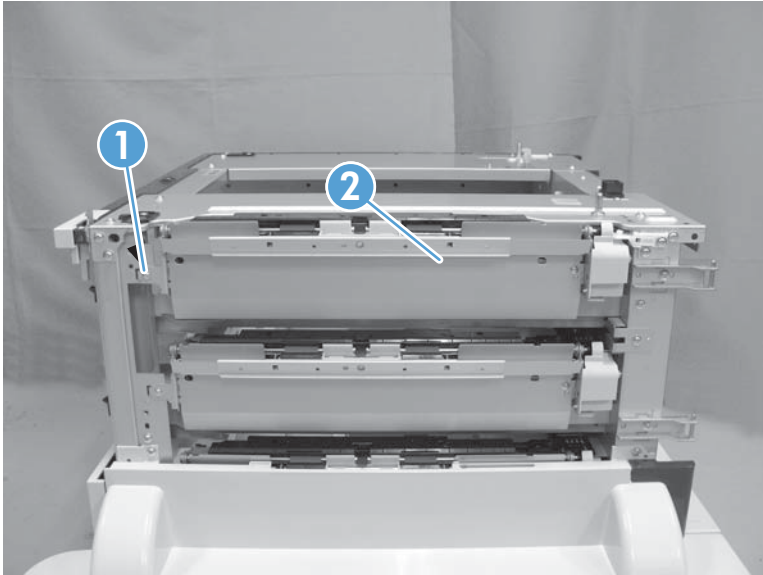

3 Solve problems

To use the information in this chapter, you should have a basic understanding of the HP LaserJet printing process. Explanations of each mechanical assembly, the printer systems, and the basic theory of operation are contained in the English-language service manual. Do not perform any of these troubleshooting processes unless you understand the function of each product component.

- [Solve problems checklist](#)
- [Menu map](#)
- [Troubleshooting process](#)
- [Tools for troubleshooting](#)
- [Clear jams](#)
- [Solve paper-handling problems](#)
- [Use manual print modes](#)
- [Solve image-quality problems](#)
- [Clean the product](#)
- [Solve performance problems](#)
- [Solve connectivity problems](#)
- [Service mode functions](#)
- [Preboot menu options](#)
- [Product updates](#)

Solve problems checklist

If the product is not responding correctly, complete the steps in the following checklist, in order. If the product does not pass a step, follow the corresponding troubleshooting suggestions. If a step resolves the problem, you can stop without performing the other steps on the checklist.

1. Make sure that the control-panel display shows one of the following messages: **Ready, Paused**, or **SLEEP MODE ON**. If no lights are illuminated or the display does not say **Ready, Paused**, or **Sleep Mode**, use the Power-on checks section in the product service manual to troubleshoot the problem.
2. Check the cables.
 - a. Check the cable connection between the product and the computer or network port. Make sure that the connection is secure.
 - b. Make sure that the cable itself is not faulty by using a different cable, if possible.
 - c. Check the network connection.
3. Ensure that the print media that you are using meets specifications.
4. Print a configuration page. If the product is connected to a network, an HP Jetdirect page also prints.
 - a. If the pages do not print, check that at least one tray contains print media.
 - b. If the page jams in the product, see the jams section.
5. If the configuration page prints, check the following items.
 - a. If the page prints correctly, the product hardware is working. The problem is with the computer you are using, with the printer driver, or with the program.
 - b. If the page does not print correctly, the problem is with the product hardware.
6. Does the image quality meet the user's requirements? If yes, see step 7. If no, check the following items:
 - Print the print-quality (PQ) troubleshooting pages.
 - Solve the print-quality problems, and then see step 7.
7. At the computer, check to see if the print queue is stopped, paused, or set to print offline.

Windows: Click **Start**, click **Settings**, and then click **Printers** or **Printers and Faxes**. Double-click the **HP Color LaserJet CP5525n**, **HP Color LaserJet CP5525dn**, or **HP Color LaserJet CP5525xh** item depending on the product model installed.





-or-

Mac OS X: Open **Printer Setup Utility**, and then double-click the line for the **HP Color LaserJet CP5525n**, **HP Color LaserJet CP5525dn**, or **HP Color LaserJet CP5525xh** item depending on the product model installed.

- 8.** Verify that you have installed the HP Color LaserJet Enterprise CP5520 Printer Series printer driver. Check the program to make sure that you are using the HP Color LaserJet Enterprise CP5520 Printer Series printer driver.
- 9.** Print a short document from a different program that has worked in the past. If this solution works, the problem is with the program that you are using. If this solution does not work (the document does not print) complete these steps:
 - a.** Try printing the job from another computer that has the product software installed.
 - b.** If you connected the product to the network, connect the product directly to a computer with a USB cable. Redirect the product to the correct port, or reinstall the software, and select the new connection type that you are using.

Menu map





Print the menu maps

1. At the control panel, press the Home button .
2. Open the following menus:
 - **Administration**
 - **Reports**
 - **Configuration/Status Pages**
3. Use the **Down** arrow button  to highlight the **Administration Menu Map** item, and then press the **OK** button to select it.
4. Use the **Up** arrow button  to highlight the **Print** item, and then press the **OK** button.
5. Press the Home button  or **Back** button  to exit the menus.

Current settings pages

Printing the current settings pages provides a map of the user configurable settings that might be helpful in the troubleshooting process.

Print the current settings pages



1. At the control panel, press the Home button .
2. Open the following menus:
 - **Administration**
 - **Reports**
 - **Configuration/Status Pages**
3. Use the **Down** arrow button  to highlight the **Current Settings Page** item, and then press the **OK** button to select it.
4. Use the **Up** arrow button  to highlight the **Print** item, and then press the **OK** button.
5. Press the Home button  or **Back** button  to exit the menus.

Control panel menus

To use all of the capabilities of this product, a firmware upgrade might be required. HP recommends that you periodically go to www.hp.com/go/ljcp5525series_software to see if a new version of firmware is available.

 **NOTE:** Print a configuration page to determine the version of firmware currently installed in this product.

Navigate the control-panel menus

- Press the Home button  to access the menus.
- Use the up arrow button  and down arrow button  to highlight a desired menu item.
- Press the **OK** button to select the menu item.

Sign In menu

Table 3-1 Sign In menu

First level	Second level	Values
User Access Code	Access Code	
Administrator Access Code	Access Code	
Service Access Code	Access Code	

Retrieve Job From USB menu

Use the **Retrieve Job From USB** menu to view listings of jobs stored on an external USB memory device.

Table 3-2 Retrieve Job From USB menu

First level	Second level	Values
Retrieve Job From USB		OK
		Cancel
	Select a File or Folder	Select from the provided list.

Retrieve Job From Device Memory menu

Use the **Retrieve Job From Device Memory** menu to view listings of jobs stored on the internal product memory.

Table 3-3 Retrieve Job From Device Memory menu

First level	Second level	Third level	Values
Retrieve Job From Device Memory	All Jobs (No PIN) NOTE: Individual job names also appear.	Print	Range: 1 – 9999 Default = 1
		Delete	Select from the provided list.

Supplies menu

In the following table, asterisks (*) indicate the factory default setting.

Table 3-4 Supplies menu

First level	Second level	Third level	Fourth level	Values	
Manage Supplies	Supplies Status	Black Cartridge	Very Low Settings	Stop	
				Prompt to continue*	
					Continue
			Low Threshold Settings		1-100%
		Color Cartridges	Very Low Settings		Stop
	Prompt to continue*				
					Continue
			Low Threshold Settings	Cyan Cartridge	1-100%
				Magenta Cartridge	
				Yellow Cartridge	
	Fuser	Very Low Settings		Stop	
				Prompt to continue*	
				Continue	
		Low Threshold Settings		1-100%	
	Transfer Kit	Very Low Settings		Stop	
				Prompt to continue*	
				Continue	

Table 3-4 Supplies menu (continued)

First level	Second level	Third level	Fourth level	Values
			Low Threshold Settings	1-100%
		Color/Black Mix		Auto*
				Mostly Color Pages
				Mostly Black Pages
	Supply Messages	Low Message		On*
				Off
		Level Gauge		On*
				Off
Black Cartridge				
OK: - Status				
Cyan Cartridge				
OK: - Status				
Magenta Cartridge OK: - Status				
Yellow Cartridge				
OK: - Status				
Toner Collection Unit OK: - Status				
Transfer Kit OK: - Status				
Fuser OK: - Status				

Trays menu

In the following table, asterisks (*) indicate the factory default setting.

Table 3-5 Trays menu

First level	Second level	Values
Manage Trays	Use Requested Tray	Exclusively* First
	Manually Feed Prompt	Always* Unless loaded
	Size/Type Prompt	Display* Do not display
	Use another tray	Enabled* Disabled
	Alternative Letterhead Mode	Disabled*
		Enabled
	Blank Pages	Auto*
		Yes
	Override A4/Letter	Yes*
		No
Tray 1 Size		Select from a provided list.
Tray 1 Type		Select from a provided list.
Tray 2 Size		Select from a provided list.
Tray 2 Type		Select from a provided list.
Tray 3 Size		Select from a provided list.
Tray 3 Type		Select from a provided list.
Tray 4 Size		Select from a provided list.
Tray 4 Type		Select from a provided list.
Tray 5 Size		Select from a provided list.
Tray 5 Type		Select from a provided list.
Tray 6 Size		Select from a provided list.
Tray 6 Type		Select from a provided list.

Administration menu

Reports menu

Table 3-6 Reports menu

First level	Second level	Third level	Values		
Configuration/Status Pages	Print	Administration Menu Map			
		Configuration Page			
		Supplies Status Page			
		Usage Page			
		Paper Path Page			
		File Directory Page			
		Current Settings Page			
		Color Usage Job Log			
		Other Pages	Print	Demonstration Page	
				RGB Samples	
CMYK Samples					
PCL Font List					
PS Font List					

General Settings menu

In the following table, asterisks (*) indicate the factory default setting.

Table 3-7 General Settings menu

First level	Second level	Third level	Fourth level	Values	
Date/Time Settings	Date/Time Format	Date Format		DD/MMM/YYYY	
				MMM/DD/YYYY*	
				YYYY/MMM/DD	
			Time Format		12 hour (AM/PM)*
					24 hours
	Date/Time	Date			
		Time			
		Time Zone			

Table 3-7 General Settings menu (continued)

First level	Second level	Third level	Fourth level	Values
		Adjust for Daylight Savings		On Off*
Energy Settings	Sleep Delay			15* Range: 1 – 120 minutes
	Optimum Speed/ Energy Usage			Faster First Page* Save Energy Save More Energy Save Most Energy
Print Quality	Adjust Color	Highlights	Cyan Density Magenta Density Yellow Density Black Density	-5 to 5 Default = 0
		Midtones	Cyan Density Magenta Density Yellow Density Black Density	-5 to 5 Default = 0
		Shadows	Cyan Density Magenta Density Yellow Density Black Density	-5 to 5 Default = 0
		Restore Color Values		
	Image Registration	Adjust Tray <X>	Print Test Page X1 Shift Y1 Shift X2 Shift Y2 Shift	-5.00 mm to 5.00 mm Default = 0
	Auto Sense Mode	Tray 1 Sensing		Full sensing Expanded sensing* Transparency Only
		Tray X Sensing		Expanded sensing* Transparency Only

Table 3-7 General Settings menu (continued)

First level	Second level	Third level	Fourth level	Values
	Adjust Paper Types	Select from a list of paper types that the product supports. The available options are the same for each paper type.	Print Mode	Select from a list of print modes. Default = Auto Sense Mode
			Resistance Mode	Normal* Up Down
			Humidity Mode	Normal* High
			Fuser Temp Mode	Normal* Up Down
			Paper Curl Mode	Normal* Reduced
	Optimize	Normal Paper		Standard* Smooth
		Light Media		Normal* Smooth
		Heavy Paper		Standard* Smooth
		Envelope Control		Normal* Alternate 1 Alternate 2
		Environment		Normal* Low Temp
		Line Voltage		Normal* Low Voltage
		Tray 1		Normal* Alternate
		Cleaning Control		Normal* Alternate

Table 3-7 General Settings menu (continued)

First level	Second level	Third level	Fourth level	Values
		Background		Normal* Alternate 1 Alternate 2 Alternate 3
		Media Temp		Normal* Alternate
		Uniformity Control		Normal* Alternate 1 Alternate 2 Alternate 3
		Pre-Rotation		Normal* Alternate 1 Alternate 2 Alternate 3
		Registration		Normal* Alternate
		Transfer Control		Normal* Alternate 1 Alternate 2 Alternate 3
		Moisture Control		Normal* Alternate
		Restore Optimize		
	Edge Control			Off Light Normal* Maximum
Jam Recovery				Auto* Off On

Table 3-7 General Settings menu (continued)

First level	Second level	Third level	Fourth level	Values	
Manage Stored Jobs	Quick Copy Job Storage Limit			1-300	
				Default = 32	
	Quick Copy Job Held Timeout				Off*
					1 hour
				4 Hours	
				1 Day	
				1 Week	
	Default Folder Name for Stored Jobs			Select from a list of folder names.	
	Sort Stored Jobs By			Public*	
				Job Name*	
				Date	
Restore Factory Settings	Reset			All	
				Calibration	
				General	
				Print	
				Security	
Restrict Color				Enable	
				Disable	
				Color if Allowed*	

Retrieve From USB Settings menu

Table 3-8 Retrieve From USB Settings menu

First level	Second level	Values
Retrieve From USB Settings	Access Code	Enable*
		Disable

Print Settings menu

In the following table, asterisks (*) indicate the factory default setting.

Table 3-9 Print Settings menu

First level	Second level	Values
Manual Feed		Enabled
		Disabled*
Courier Font		Regular*
		Dark
Wide A4		Enabled
		Disabled*
Print PS Errors		Enabled
		Disabled*
Print PDF Errors		Enabled
		Disabled*
Personality		Auto*
		PCL
		POSTSCRIPT
		PDF
PCL	Form Length	Range: 5 – 128
		Default = 60
	Orientation	Portrait*
		Landscape
	Font Source	Internal*
		Soft
		USB

Table 3-9 Print Settings menu (continued)

First level	Second level	Values
	Font Number	Range: 0 – 999 Default = 0
	Font Pitch	Range: 0.44 – 99.99 Default = 10
	Font Point Size	Range: 4.00 – 999.75 Default = 12.00
	Symbol Set	Select from a list of symbol sets.
	Append CR to LF	No* Yes
	Suppress Blank Pages	No* Yes
	Media Source Mapping	Standard* Classic

Print Options menu

In the following table, asterisks (*) indicate the factory default setting.

Table 3-10 Print Options menu

First level	Second level	Values
Number of Copies		Default = 1
Default Paper Size		Select from a list of sizes that the product supports.
Default Custom Paper Size	Inches	X Dimension Range: 2.99 – 12.28 Default = 12.28
		Y Dimension Range: 5.00 – 18.50 Default = 18.5
	MM	X Dimension Range: 76 – 312 Default = 312
		Y Dimension Range: 127 – 470 Default = 470
Sides		1-sided* 2-sided

Table 3-10 Print Options menu (continued)

First level	Second level	Values
Two-Sided Format		Book-style*
		Flip-style
Enable Edge to Edge Overrides		Enabled
		Disabled*

Display Settings menu

In the following table, asterisks (*) indicate the factory default setting.

Table 3-11 Display Settings menu

First level	Second level	Values
Display Brightness		Range: -10 to 10 Default = 0
Language		Select from a list of languages that the product supports.
Show IP address		Display* Hide
Sleep Mode		Disabled Use sleep delay* Use sleep schedule Balance power savings/Wait time
Inactivity Timeout		Range: 10 – 300 seconds Default = 60
Clearable Warnings		On Job*
Continuable Events		Auto continue (10 seconds)* Press OK to continue

Manage Supplies menu

In the following table, asterisks (*) indicate the factory default setting.

Table 3-12 Manage Supplies menu

First level	Second level	Third level	Fourth level	Values
Supplies Status				
Supply Settings	Black Cartridge	Very Low Settings		Stop
				Prompt to continue*
				Continue
		Low Threshold Settings		1-100%
	Color Cartridges	Very Low Settings		Stop
				Prompt to continue*
				Continue
		Low Threshold Settings	Cyan Cartridge	1-100%
			Magenta Cartridge	
			Yellow Cartridge	
	Fuser	Very Low Settings		Stop
				Prompt to continue*
				Continue
		Low Threshold Settings		1-100%
	Transfer Kit	Very Low Settings		Stop
				Prompt to continue*
				Continue
		Low Threshold Settings		1-100%
	Color/Black Mix			Auto*
				Mostly Color Pages
				Mostly Black Pages
Supply Messages	Low Message			On*
				Off
	Level Gauge			On*
				Off

Table 3-12 Manage Supplies menu (continued)

First level	Second level	Third level	Fourth level	Values
Reset Supplies	New Fuser Kit			No
				Yes
	New Transfer Kit			No
				Yes

Manage Trays menu

In the following table, asterisks (*) indicate the factory default setting.

Table 3-13 Manage Trays menu

First level	Values
Use Requested Tray	Exclusively*
	First
Manually Feed Prompt	Always*
	Unless loaded
Size/Type Prompt	Display*
	Do not display
Use another tray	Enabled*
	Disabled
Alternative Letterhead Mode	Disabled*
	Enabled
Blank Pages	Auto*
	Yes
Override A4/Letter	Yes*
	No

Network Settings menu

In the following table, asterisks (*) indicate the factory default setting.

Table 3-14 Network Settings menu

First level	Values
I/O Timeout	Range: 5 – 300 sec Default = 15
Embedded Jetdirect	See the table that follows for details. These menus have the same structure. If an additional HP Jetdirect network card is installed in the EIO slot, then both menus are available.

Table 3-15 Embedded Jetdirect

First level	Second level	Third level	Fourth level	Fifth level	Values
Information	Print Sec Report				Yes
					No*
TCP/IP	Enable				On*
					Off
	Host Name				Use the arrow buttons to edit the host name. NPXXXXXX*
	IPv4 Settings	Config Method			Bootp*
					DHCP
					Auto IP
					Manual
			Default IP		Auto IP*
					Legacy
			DHCP Release		Yes
					No*
			DHCP Renew		Yes
					No*
			Primary DNS		Range: 0 – 255 Default = xxx.xxx.xx.xx
			Secondary DNS		Range: 0 – 255 Default = 0.0.0.0

Table 3-15 Embedded Jetdirect (continued)

First level	Second level	Third level	Fourth level	Fifth level	Values
	IPv6 Settings	Enable			On* Off
		Address	Manual Settings	Enable	On Off*
				Address	Select from a provided list.
		DHCPV6 Policy			Router Specified Router Unavailable* Always
		Primary DNS			Select from a provided list.
		Secondary DNS			Select from a provided list.
		Proxy Server			Select from a provided list.
		Proxy Port			Default = 0080
		Idle Timeout			Default = 0270
Security	Secure Web				HTTPS Required* HTTPS Optional
		IPSEC			Keep Disable*
	802.1x				Reset Keep*
	Reset Security				Yes No*
Diagnostics	Embedded Test	LAN HW Test			Yes No*
		HTTP Test			Yes No*
	SNMP Test				Yes No*

Table 3-15 Embedded Jetdirect (continued)

First level	Second level	Third level	Fourth level	Fifth level	Values
		Data Path Test			Yes No*
		Select All Tests			Yes No*
		Execution Time			Range: 1 – 60 hours Default = 1
		Execute			Yes No*
	Ping Test	Dest Type			IPv4 IPv6
		Dest IPv4			Range: 0 – 255 Default = 127.0.0.1
		Dest IPv6			Select from a provided list. Default = ::1
		Packet Size			Default = 64
		Timeout			Default = 001
		Count			Default = 004
		Print Results			Yes No*
		Execute			Yes No*
	Ping Results	Packets Sent			Default = 00000
		Packets Received			Default = 00000
		Percent Lost			Default = 000
		RTT Min			Default = 0000
		RTT Max			Default = 0000
		RTT Average			Default = 0000
		Ping In Progress			Yes No*

Table 3-15 Embedded Jetdirect (continued)

First level	Second level	Third level	Fourth level	Fifth level	Values
		Refresh			Yes No*
Link Speed					Auto* 10T Half 10T Full 100TX Half 100TX Full 100TX Auto 1000TX Full

Troubleshooting menu

In the following table, asterisks (*) indicate the factory default setting.

Table 3-16 Troubleshooting menu

First level	Second level	Third level	Fourth level	Values
Exit Troubleshooting				
NOTE: This item only displays if you are backing out of the Troubleshooting menu.				
Print Event Log				
View Event Log				
Print Quality Pages	Print PQ Troubleshooting Pages			
	Diagnostics Page			
	Color Band Test	Print Test Page		
		Copies		Range: 1 – 30 Default = 1
Diagnostic Tests	Disable Cartridge Check			
	Paper Path Sensors			Start Test
	Paper Path Test	Print Test Page		Print
		Source		Select from a list of the available trays.

Table 3-16 Troubleshooting menu (continued)

First level	Second level	Third level	Fourth level	Values
		Test Duplex Path		Off* On
		Number of Copies		Range: 1 – 500 Default = 1
	Manual Sensor Test			Select from a list of the product sensors.
	Tray/Bin Manual Sensor Test			Select from a list of the product sensors.
	Component Test			Select from a list of available components.
		Repeat		Off* On
	Print/Stop Test			
Retrieve Diagnostic Data	Export to USB			
	Diagnostic Files			Device Data File Debug Information File*
	Include Crash Dumps			Off On*
	Cleanup Debug Info			Off On*
General Debug Data				

Device Maintenance menu

Backup/Restore menu

△ **CAUTION:** Data backup and restoration is the responsibility of the customer/administrator of the product. Service personnel should not back up or restore customer data under any circumstances.

In the following table, asterisks (*) indicate the factory default setting.

Table 3-17 Backup/Restore menu

First level	Second level	Third level	Values
Backup Data	Scheduled Backups	Enable Scheduling	Disabled* Enabled
		Backup Time	Default = current time
		Days Between Backups	Default = 1
	Backup Now		
	Export Last Backup		
Restore Data			Insert a USB drive that contains the backup file.

Calibration/Cleaning menu

In the following table, asterisks (*) indicate the factory default setting.

Table 3-18 Calibration/Cleaning menu

First level	Second level	Values
Auto Cleaning		Off* On
	Cleaning Interval	Select from a list of cleaning intervals.
Auto Cleaning Size		Letter* A4
	Print Cleaning Page	
Clean Laser Glass		
Quick Calibration		
Full Calibration		
Delay Calibration at Wake/Power On		Yes* No

USB Firmware Upgrade menu

To display: At the product control panel, select the **Device Maintenance** menu, and then select the **USB Firmware Upgrade** menu.

Insert a USB storage device with a firmware upgrade bundle into the USB port, and follow the on-screen instructions.

Service menu

The personal identification number (PIN; **Service Access Code**) used to access the **Service** menu is 11552010.

In the following table, asterisks (*) indicate the factory default setting.

First level	Second level	Third level	Values
User Access Code			
Administrator Access Code			
Service Access Code	Print Event Log		
	View Event Log		
	Clear Event Log		
	Cycle Counts	Mono Cycle Counts	0* Range: 0 – 9999999
		Color Cycle Count	0* Range: 0 – 9999999
		Refurbish Cycle Count	0* Range: 0 – 9999999
	Serial Number		
	Service ID		20182*
	Cold Reset Paper		Letter* A4
	New Registration Roller		Yes No*
	Media Sensor Value		0* Range: 0 – 4095
	Manual Laser Glass Cleaning		
Test Support	Continuous Print from USB		
	Automatic Calibrations		Disabled Enabled*

Troubleshooting process

When the product malfunctions or encounters an unexpected situation, the product control panel alerts you to the situation. This chapter contains information to help diagnose and solve problems.

- Use the pretroubleshooting checklist to evaluate the source of the problem and to reduce the number of steps that are required to fix the problem.
- Use the troubleshooting flowchart to pinpoint the root cause of hardware malfunctions. The flowchart guides you to the section of this chapter that contains steps for correcting the malfunction.

Before beginning any troubleshooting procedure, check the following issues:

- Are supply items within their rated life?
- Does the configuration page reveal any configuration errors?

 **NOTE:** The customer is responsible for checking supplies and for using supplies that are in good condition.

Determine the problem source

When the product malfunctions or encounters an unexpected situation, the product control panel alerts you to the situation. This section contains a pre-troubleshooting checklist to filter out many possible causes of the problem. A troubleshooting flowchart helps you diagnose the root cause of the problem. The remainder of this chapter provides steps for correcting problems.

Pre-troubleshooting checklist

The following table includes basic questions to ask the customer to quickly help define the problem.

General topic	Questions
Environment	<ul style="list-style-type: none">• Is the product installed on a solid, level surface (+/- 1°)?• Is the power-supply voltage within ± 10 volts of the specified power source?• Is the power-supply plug inserted in the product and the outlet (not a power strip)?• Is the operating environment within the specified parameters?• Is the product exposed to ammonia gas, such as that produced by diazo copiers or office cleaning materials? NOTE: Diazo copiers produce ammonia gas as part of the copying processes. Ammonia gas (from cleaning supplies or a diazo copier) can have an adverse affect on some product components (for example, the print-cartridge OPC).• Is the product exposed to direct sunlight?

General topic	Questions
Media	<ul style="list-style-type: none"> • Does the customer use only supported media? • Is the media in good condition (no curls, folds, or distortion)? • Is the media stored correctly and within environmental limits?
Input trays	<ul style="list-style-type: none"> • Is the amount of media in the tray within specifications? • Is the media correctly placed in the tray? • Are the paper guides aligned with the stack? • Is the cassette correctly installed in the product?
Print cartridges	<ul style="list-style-type: none"> • Is each print cartridge installed correctly? • Are original HP print cartridges installed? • Are the cartridges damaged?
ITB and fuser	<ul style="list-style-type: none"> • Are the ITB and fuser correctly installed? • Is the ITB or fuser damaged?
Doors	<ul style="list-style-type: none"> • Are the right and front doors closed?
Condensation	<ul style="list-style-type: none"> • Does condensation occur following a temperature change (particularly in winter following cold storage)? If so, wipe affected parts dry or leave the product on for 10 to 20 minutes. • Was a print cartridge opened soon after being moved from a cold to a warm room? If so, allow the print cartridge to sit at room temperature for 1 to 2 hours.
Miscellaneous	<ul style="list-style-type: none"> • Check for and remove any non-HP components (for example, print cartridges or memory modules) from the product. • Check to see whether the hardware or software configuration has changed or the problem is not associated with any specific software. • Remove the product from the network and ensure that the failure is associated with the product before beginning troubleshooting. • For any print-quality issues, calibrate the product. See Calibrate the product on page 356.

Troubleshooting flowchart

This flowchart highlights the general processes that you can follow to quickly isolate and solve product hardware problems.

Each row depicts a major troubleshooting step. A “yes” answer to a question allows you to proceed to the next major step. A “no” answer indicates that more testing is needed. Go to the appropriate section in this chapter, and follow the instructions there. After completing the instructions, go to the next major step in this troubleshooting flowchart.

Table 3-19 Troubleshooting flowchart

1 Power on	Is the product on and does a readable message display?		Follow the power-on troubleshooting checks. See Power subsystem on page 282 .
	Yes ↓	No →	After the control panel display is functional, see step 2.
2 Control panel messages	Does the message Ready display on the control panel?		If an error message displays, see Interpret control-panel messages, status-alert messages, and event code errors on page 411 .
	Yes ↓	No →	After the errors have been corrected, go to step 3.
3 Event log	Open the Troubleshooting menu and print an event log to see the history of errors with this product. Does the event log print?		If the event log does not print, see Print an event log on page 493 . If paper jams inside the product, see Clear jams on page 495 . If error messages display on the control panel when you try to print an event log, see Print an event log on page 493 .
	Yes ↓	No →	After successfully printing and evaluating the event log, see step 4.
4 Information pages	Open the Reports menu and print the configuration pages to verify that all the accessories are installed. Are all the accessories installed?		If accessories that are installed are not listed on the configuration page, remove the accessory and reinstall it. After evaluating the configuration pages, see step 5.
	Yes ↓	No →	
5 Image quality	Does the print quality meet the customer's requirements?		Compare the images with the sample defects in the image defect tables. See Print quality examples on page 524 .
	Yes ↓	No →	After the print quality is acceptable, see step 6.
6 Interface	Can the customer print successfully from the host computer?		Verify that all I/O cables are connected correctly and that a valid IP address is listed on the Jetdirect configuration page.
	Yes. This is the end of the troubleshooting process.	No →	If error messages display on the control panel, see Print an event log on page 493 . When the customer can print from the host computer, this is the end of the troubleshooting process.

Power subsystem

Power-on checks

The basic product functions should start up when the product is plugged into an electrical outlet and the power switch is pushed to the *on* position. If the product does not start, use the information in this section to isolate and solve the problem.

Power-on troubleshooting overview

Turn on the product power. If the control panel display remains blank, random patterns display, or asterisks remain on the control panel display, perform power-on checks to find the cause of the problem.

During normal operation, the power supply, fuser, and formatter cooling fans begin to spin after the product power is turned on. Place your hand over the holes in the left-side cover, near the formatter. If the fan is operating, you will feel air passing out of the product. You can also lean close to the product and hear the fan operating. You can also place your hand over the hole in the right-front lower corner. If the fan is operating, you should feel air being drawn into the product. When these fans are operational, the DC side of the power supply is functioning correctly.

After the fans are operating, the motor turn on and off (unless the right or front cover is open, a jam condition is sensed, or the paper-path sensors are damaged). You might be able to visually and audibly determine if the motors turn on and off.

If the fans and motors are operating correctly, the next troubleshooting step is to isolate print engine, formatter, and control panel problems. Perform an engine test (see [Engine test button on page 288](#)). If the formatter is damaged, it might interfere with the engine test. If the engine-test page does not print, try removing the formatter and then performing the engine test again. If the engine test is then successful, the problem is almost certainly with the formatter, the control panel, or the cable that connects them.

If the control panel is blank when you turn on the product, check the following items.

1. Make sure that the product is plugged directly into an active electrical outlet (not a power strip) that delivers the correct voltage.
2. Make sure that the power switch is in the *on* position.
3. Make sure that the fans run briefly, which indicates that the power supply is operational.
4. Make sure that the control panel display wire harness is connected.
5. Make sure that the formatter is seated and operating correctly. Turn off the product and remove the formatter. Reinstall the formatter, and then verify that the heartbeat LED is flashing.
6. Remove any HP Jetdirect or other EIO cards, and then try to turn the product on again.

 **NOTE:** If the control panel display is blank, but the cooling fans run after the product power is turned on, try printing an engine-test page to determine whether the problem is with the control-panel display, formatter, or other product components. See [Engine test button on page 288](#).

Power-on timing (approximate)

Power-on timing from boot sequence to the **Ready** state might change as the firmware is upgraded.

- 00.00 seconds; power-button LED illuminates and fans rotate at high speed
- 00.06 seconds; control panel backlight illuminates and engine noises begin
- 00:10 seconds; HP logo appears on the control-panel display, boot sequence count appears on the control-panel display

Boot sequence

- 1/8 = 10 seconds
 - 2/8 = 15 seconds
-
-  **NOTE:** Depending on how the product was shut down, the product might stay at this point for several minutes while the Disk Check process completes.
-
- 7/8 = 45 seconds
 - 8/8 = 50 seconds
 - 01:30 seconds; fuser fan noise stops and engine noises stop
 - 01:50 seconds; product enters the **Ready** state

Tools for troubleshooting

Component diagnostics

LED diagnostics

LED, engine, and individual diagnostics can identify and troubleshoot product problems.

Understand lights on the formatter

Three LEDs on the formatter indicate that the product is functioning correctly.

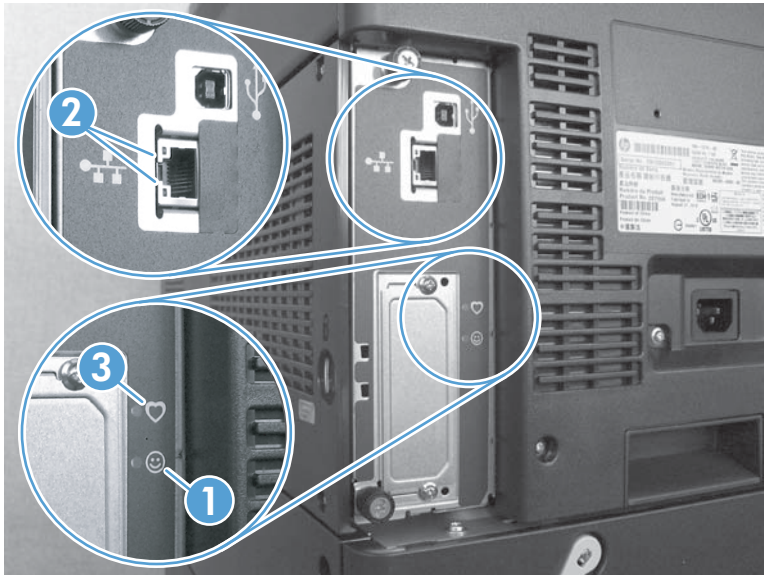



1	Formatter connectivity LED (lit when formatter is correctly seated)
2	HP Jetdirect LEDs
3	Heartbeat LED

HP Jetdirect LEDs

The embedded HP Jetdirect print server has two LEDs. The yellow LED indicates network activity, and the green LED indicates the link status. A blinking yellow LED indicates network traffic. If the green LED is off, a link has failed.

For link failures, check all the network cable connections. In addition, you can try to manually configure the link settings on the embedded print server by using the product control-panel menus.

1. Press the Home button .
2. Press the **Down** arrow  to highlight the **Administration** menu, and then press the **OK** button.
3. Press the **Down** arrow  to highlight the **Network Settings** menu, and then press the **OK** button.

4. Press the **Down** arrow ▼ to highlight the **Embedded Jetdirect** option, and then press the **OK** button.
5. Press the **Down** arrow ▼ to highlight the **Link Speed** menu, and then press the **OK** button.
6. Select the appropriate link speed, and then press the **OK** button.

Heartbeat LED

The heartbeat LED indicates that the formatter is functioning correctly. While the product is initializing after you turn it on, the LED blinks on/off, on/off, pauses for a short duration, then repeats the sequence. This sequence continues after the product has finished the initialization sequence.

Engine diagnostics

This section provides an overview of the engine diagnostics that are available in the HP Color LaserJet Enterprise CP5520 Printer Series product. The product contains extensive internal diagnostics that help in troubleshooting print quality, paper path, noise, component, and timing issues.

Defeating interlocks

Different tests can be used to isolate different types of issues. For component or noise isolation, you can run the diagnostic test when the front and right doors are open. To operate the product with the doors open, the door switch levers must be depressed to simulate a closed-door position.

- ⚠ **WARNING!** Be careful when performing printer diagnostics to avoid risk of injury. Only trained service personnel should open the doors and run the diagnostics with the covers removed. Never touch any of the power supplies when the printer is plugged in or turned on.

Defeat the right-door opening/closing sensor (PS15)

1. Open the right and front doors.
2. Insert a thin piece of paper into the right-door sensor slot (callout 1).

- ⚠ **CAUTION:** Using too thick of a piece of paper to activate this sensor might dislodge the photo-interrupter body from its mounting bracket. Make sure you use a thin piece of paper to activate the sensor.

Figure 3-1 Defeating door interlocks (1 of 2)

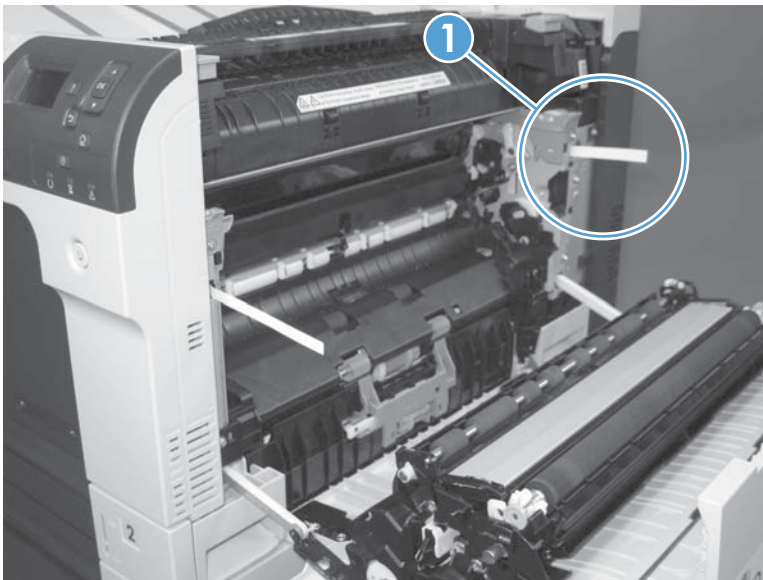

3. Insert a folded piece of paper into the front door switch (callout 2). Wait until the product enters the **Ready** state.



 **NOTE:** The paper must be thick enough to depress and hold in place the sensor actuator arm.

Figure 3-2 Defeating door interlocks (2 of 2)

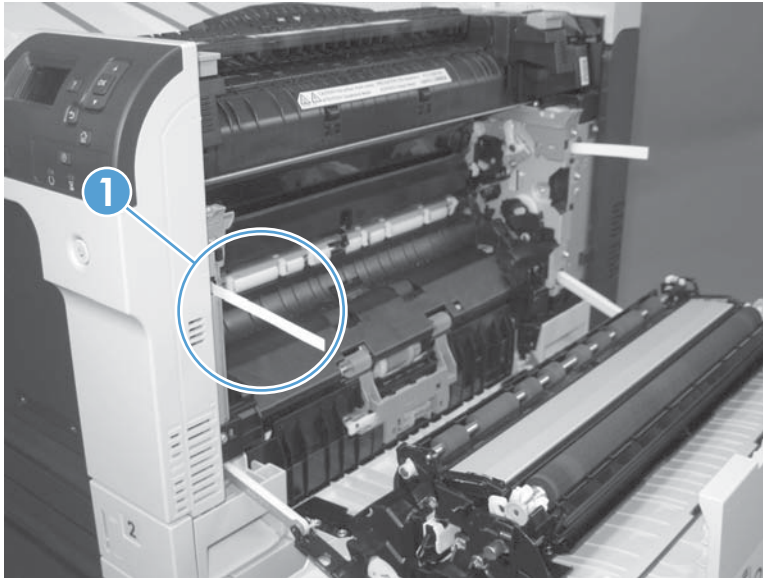

Disable cartridge check

Use this diagnostic test to print internal pages or send an external job to the product when one or more print cartridges are removed or exchanged. Consumable supply errors are ignored while the product is in this mode. When the product is in this mode, you can navigate the troubleshooting menus and print internal pages (the print quality pages will be the most useful). This test can be used isolate problems, such as noise, and to isolate print-quality problems that are related to individual print cartridges.

 **NOTE:** Cartridges are not keyed and can be interchanged. An error will display on the control panel if a print cartridge is installed in the wrong position. The **Supplies Status** menu will explain which print cartridge is misplaced.

NOTE: Do not remove or exchange print cartridges and image drums until after you start the disable cartridge check diagnostic.

1. Press the Home  button.
2. Open the following menus:
 - **Administration**
 - **Troubleshooting**
 - **Diagnostic Tests**
3. Press the **Down** arrow  to highlight **DISABLE CARTRIDGE CHECK**, and then press the **OK** button .

To exit this diagnostic test, press the **Stop** button  and then select **EXIT TROUBLESHOOTING**.

Engine test button

1. Turn the product on.
2. Use a fine-point tool, (for example a precision-slotted screwdriver with a 1 mm (0.04 in) blade width) to press the engine test button.

 **NOTE:** Access the engine test button through a hole in the rear cover.

3. An engine test page (lines in each of the print cartridge colors) prints.

Figure 3-3 Engine test button location





Paper-path test

This diagnostic test generates one or more test pages that you can use to isolate the cause of jams.

To isolate a problem, specify which input tray to use, specify whether to use the duplex path, and specify the number of copies to print. Multiple copies can be printed to help isolate intermittent problems. The following options become available after you start the diagnostic feature:

- **Print Test Page.** Run the paper-path test from the default settings: Tray 2, no duplex, and one copy. To specify other settings, scroll down the menu and select the setting, and then scroll back up and select **Print Test Page** to start the test.
- **Source Tray.** Select Tray 1, Tray 2, or the optional tray.
- **Test Duplex Path.** Enable or disable two-sided printing.

 **NOTE:** Duplex models only.

- **Number of Copies.** Set the numbers of copies to be printed; the choices are 1, 10, 50, 100, or 500.
1. Press the Home  button.
 2. Open the following menus:
 - **Administration**
 - **Troubleshooting**
 - **Diagnostic Tests**
 3. Press the **Down** arrow  to highlight **PAPER PATH TEST**, and then press the **OK** button.
 4. Select the paper-path test options for the test you want to run.

Manual sensor test

Use this diagnostic test to manually test the product sensors and switches. Each sensor is represented by a letter and number on the control panel display.

1. Press the Home button .
2. Open the following menus:
 - **Administration**
 - **Troubleshooting**
 - **Diagnostic Tests**
3. Press the **Down** arrow  to highlight the **Manual Sensor Test** item, and then press the **OK** button.

To exit this diagnostic, press the Stop button , and then select **EXIT TROUBLESHOOTING**.

Menus cannot be opened during this test, so the **OK** button serves the same function as the **Stop** button .

Table 3-20 Manual sensor diagnostic tests

Sensor or switch name	Sensor or switch number
Front door opening/closing switch	PS14
Right door opening/closing sensor	PS15
A TOP (top of page) sensor	PS5
Fuser loop 1 sensor	PS7
Fuser loop 2 sensor	PS8
Fuser pressure-release sensor	PS9
Fuser output sensor	PS6

Table 3-20 Manual sensor diagnostic tests (continued)

Sensor or switch name	Sensor or switch number
Developer alienation sensor	PS11
ITB alienation sensor	SW5

Front-door opening/closing switch (PS14)

 **NOTE:** This switch is also activated by the right door. See [Right-door opening/closing sensor \(PS15\)](#) on page 292. During this test, the right door must remain closed.

1. Open the front-door assembly to disengage the front-door opening/closing switch.
2. Close the front-door assembly, and then check the control panel on the product for sensor response.



 **TIP:** You can leave the front door open and use a folded piece of paper to activate the switch.

Figure 3-4 Test the front-door opening/closing switch

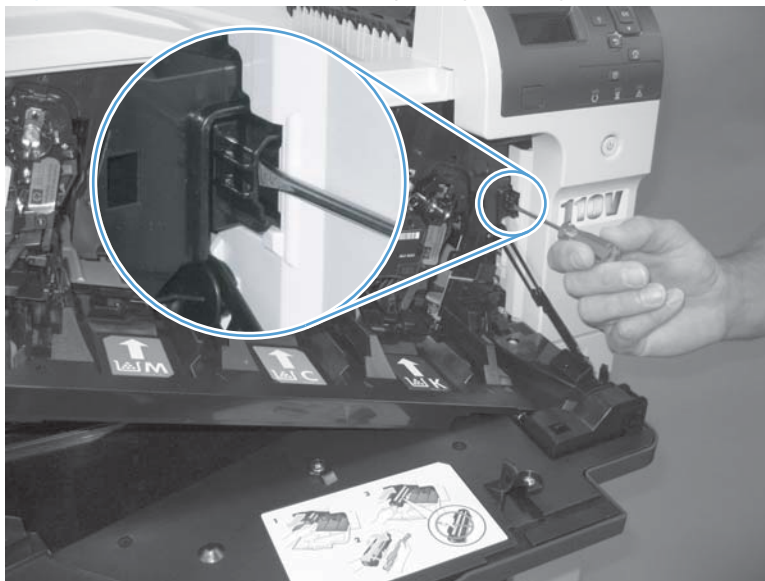

3. Check the control-panel display for sensor response.
4. If there is no response, replace the front-door opening/closing microswitch or the cable.

Right-door opening/closing sensor (PS15)

 **NOTE:** The front-door opening/closing switch (PS14) is also activated by the right door. During this test, the front door must remain closed.

1. Open the right-door assembly to disengage the right-door opening/closing photo-interrupter sensor.
2. Insert a piece of paper (callout 1) to override the front-door opening/closing switch (PS14).

 **NOTE:** The paper must be thick enough to depress and hold in place the sensor actuator arm.

Figure 3-5 Test the right-door opening/closing switch (1 of 2)



3. Insert a thin piece of paper (callout 1) to activate the right-door opening/closing sensor (PS15).

△ **CAUTION:** Using too thick of a piece of paper to activate this sensor might dislodge the photo-interrupter body from its mounting bracket. Make sure you use a thin piece of paper to activate the sensor.

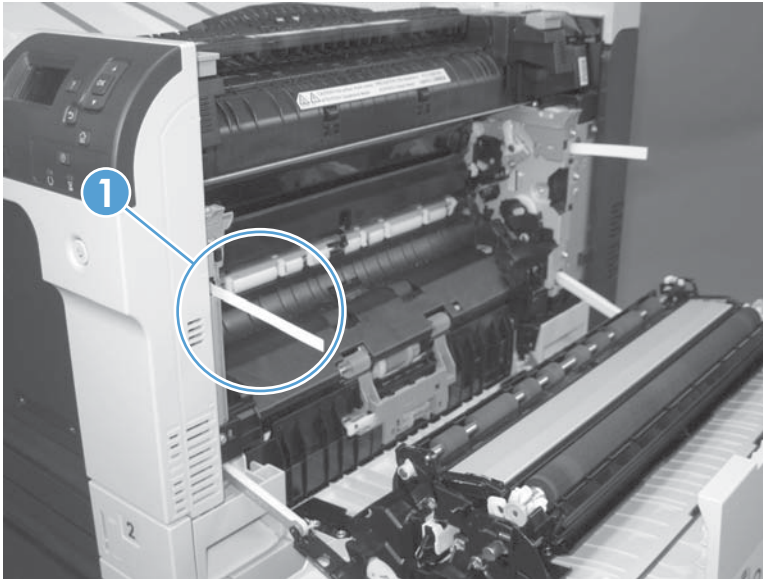
Figure 3-6 Test the right-door opening/closing switch (2 of 2)

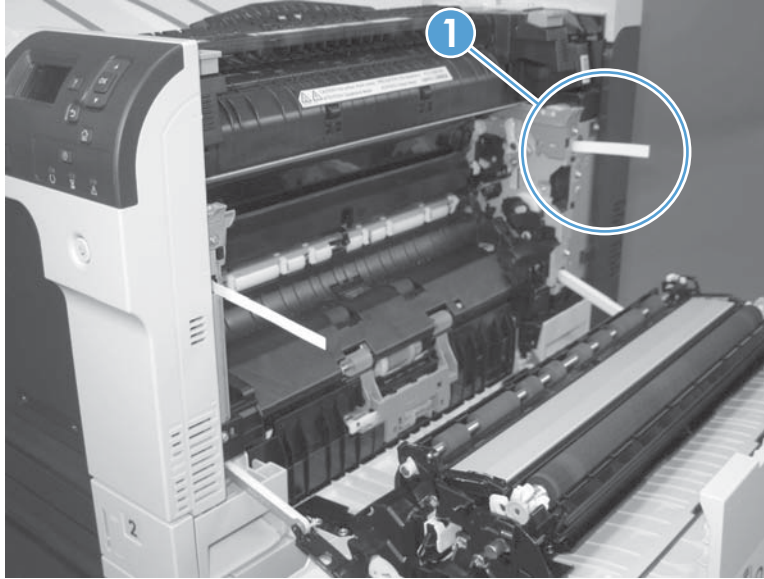

4. If there is no response, replace the right-door sensor.

TOP (top-of-page) sensor (PS5)

1. Open the right door, and then locate the sensor flag (callout 1).

Figure 3-7 Test the TOP sensor (1 of 2)

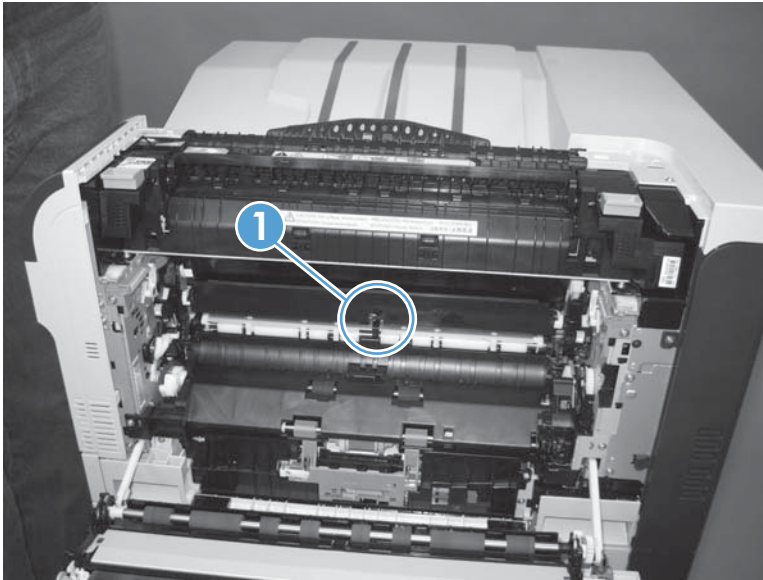

2. Activate the TOP sensor.

Figure 3-8 Test the TOP sensor (2 of 2)

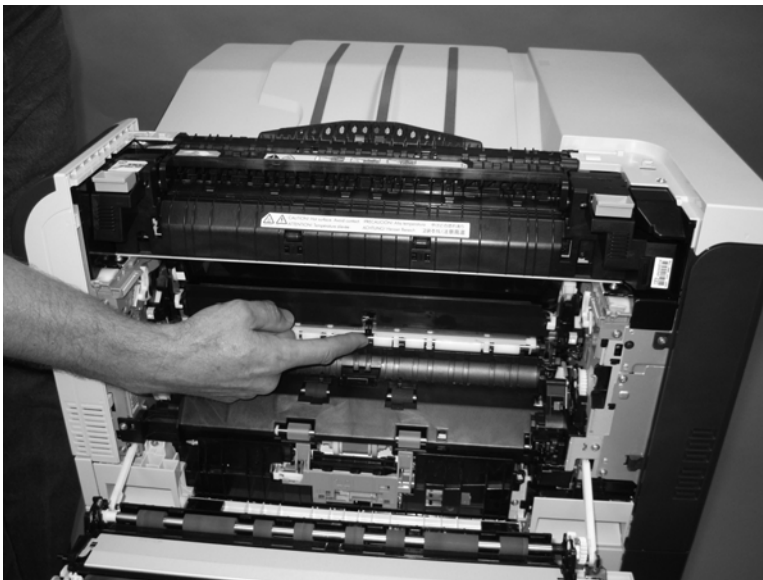

3. Check the control-panel display for sensor response.
4. If there is no response, replace the registration assembly.

Fuser loop sensors 1 and 2 (PS7 and PS8)

1. Open the right door.
2. Slowly insert a piece of paper at the entrance of the fuser to activate the fuser loop sensors 1 and 2 underneath the fuser.

Figure 3-9 Test the fuser loop sensors

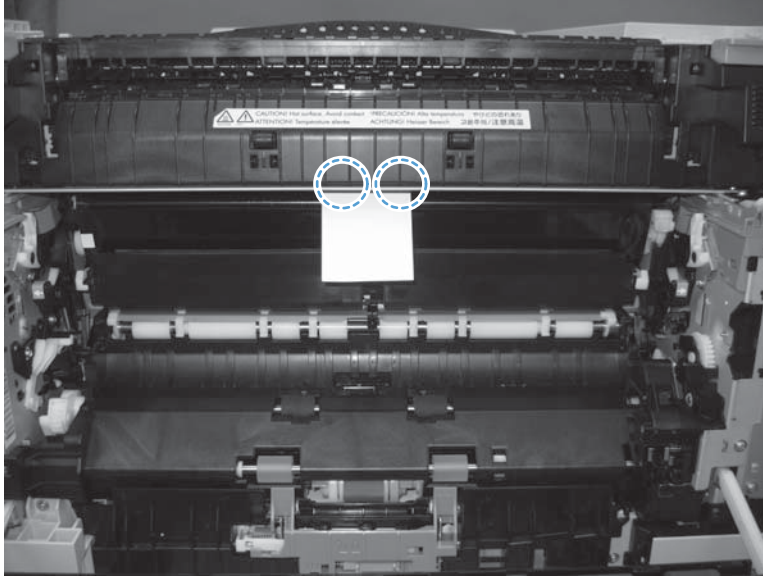

3. Check the control-panel display for a sensor response.
4. If there is no response, replace fuser.

Fuser pressure-release sensor (PS9)

1. Open the right-door assembly.
2. Remove the fuser.
3. Insert a piece of paper as shown to activate the fuser pressure-release sensor.

Figure 3-10 Test the fuser pressure-release sensor

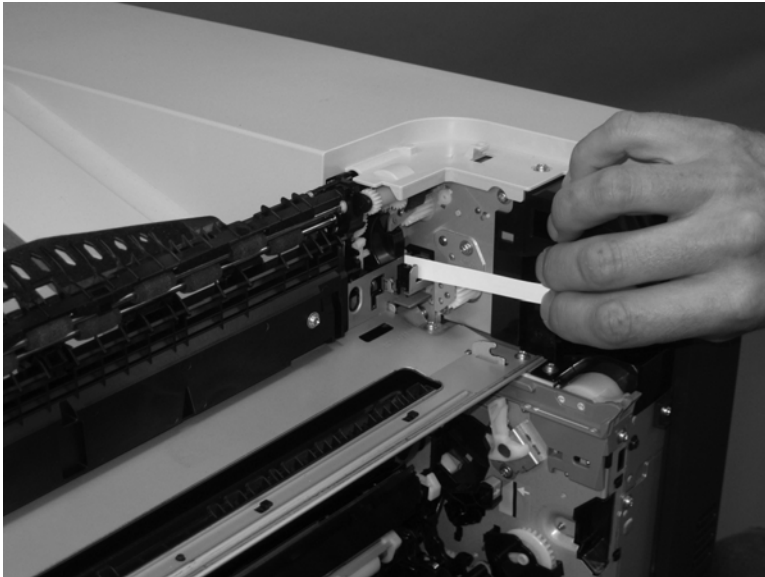

4. Check the control-panel display for sensor response.
5. If there is no response, replace the fuser drive assembly.

Fuser output sensor (PS6)

1. Open the right-door assembly.
2. Open the fuser jam-access flap.

Figure 3-11 Test the fuser output sensor (1 of 2)

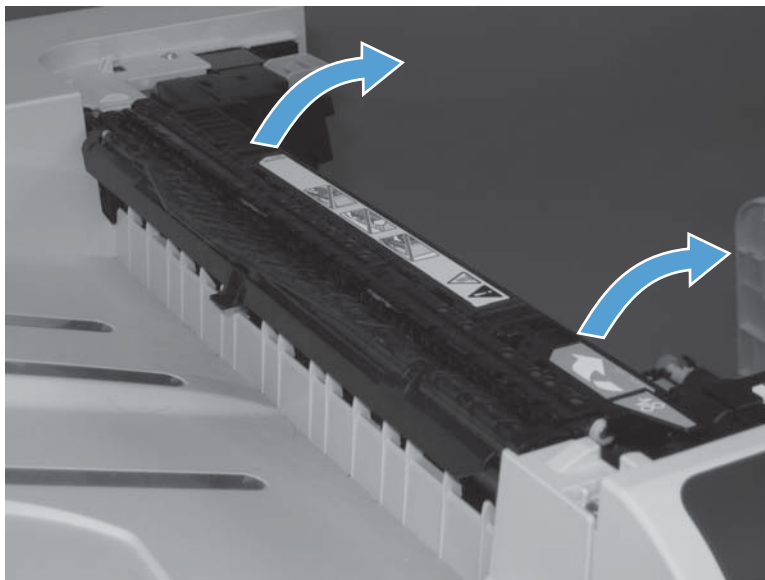

3. Locate the fuser output sensor flag (callout 1), and then activate the sensor flag.

Figure 3-12 Test the fuser output sensor (2 of 2)

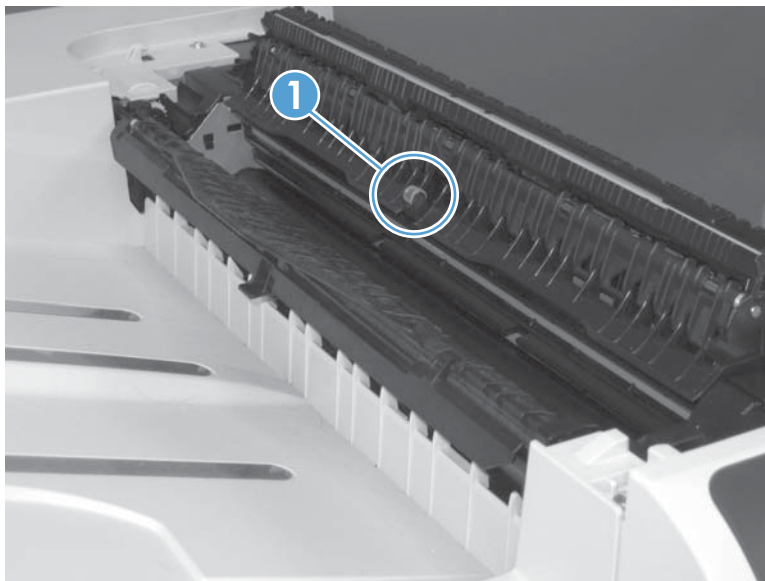

4. Check the control-panel display for a sensor response.
5. If there is no response, replace the fuser.

Developer alienation sensor (PS11)

This sensor is located inside the main-drive assembly and cannot be accessed for direct manual testing. Use the paper path sensor test to test this sensor.

1. Press the Home button .
2. Open the following menus:
 - **Administration**
 - **Troubleshooting**
 - **Diagnostic Tests**
3. Press the **Down** arrow ▼ to highlight the **Paper Path Sensors** item, and then press the **OK** button.
4. Press the **Down** arrow ▼ to highlight **Start**, and then check the control-panel display for sensor response (watch the developer alienation sensor (PS11) in the list).
5. If there is no response, replace the main drive assembly.

ITB alienation switch (SW5)

1. Remove the toner cartridges and the ITB. Activate the sensor by moving the flag located on the rear ITB guide rail.

Figure 3-13 Test the ITB alienation switch



2. Check the control-panel display for sensor response.
3. If there is no response, replace the main drive assembly.

Tray/Bin manual sensor test

Use this test to test the tray and bin sensors and switches manually. The following illustrations and table show the locations of these sensors.

1. Press the Home button .
2. Open the following menus:
 - **Administration**
 - **Troubleshooting**
 - **Diagnostic Tests**
3. Press the **Down** arrow  to highlight the **Tray/Bin Manual Sensor Test** item, and then press the **OK** button.

Table 3-21 Tray/Bin manual sensor test

Sensor or switch name	Sensor or switch number
Tray 1 paper sensor	PS2
Tray 2 paper sensor	PS1
Tray 2 paper surface sensor	PS4
Tray 2 paper size switches	SW7 and SW 8
Tray 3 paper sensor	SR3
Tray 3 paper surface sensor	SR2
Tray 3 paper size switches	SW2 and SW3
Tray 3 feed sensor	SR1
Tray 3 door opening/closing sensor	SW1
Tray 4 paper sensor	SR3
Tray 4 paper surface sensor	SR2
Tray 4 paper size switches	SW2 and SW3
Tray 4 feed sensor	SR1
Tray 4 opening/closing sensor ¹	SW1
Tray 5 paper sensor	SR83
Tray 5 paper surface sensor	SR82
Tray 5 paper size switches	SW82 and SW83
Tray 5 feed sensor	SR81
Tray 5 opening/closing sensor ¹	SW1
Tray 6 paper sensor	SR93
Tray 6 paper surface sensor	SR92

Table 3-21 Tray/Bin manual sensor test (continued)

Sensor or switch name	Sensor or switch number
Tray 6 paper size switches	SW92 and SW93
Tray 6 feed sensor	SR91
Tray 6 opening/closing sensor ¹	SW1
Output bin full sensor	PS10

¹ Tray 4, Tray 5, and Tray 6 use the same opening/closing sensor (SW1) on the right door of the accessory.

Tray 1 paper sensor (PS2)

1. Open Tray 1.
2. Locate the Tray 1 paper-present sensor flag (callout 1), and then toggle the sensor flag to activate the sensor.

Figure 3-14 Test the Tray 1 paper present sensor

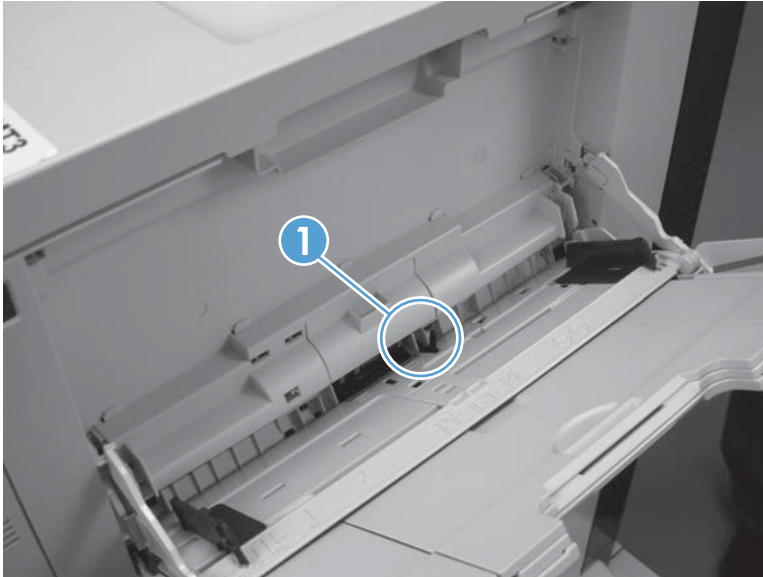

3. Check the control-panel display for sensor response.
4. If there is no response, replace the paper pickup assembly.

Tray 2 paper present sensor (PS1)

1. Remove the tray.
2. In the tray cavity, release the spring loaded tray-present lever to lower the flag (callout 1), and then toggle the flag to activate the sensor.

Figure 3-15 Test the tray 2 paper sensor

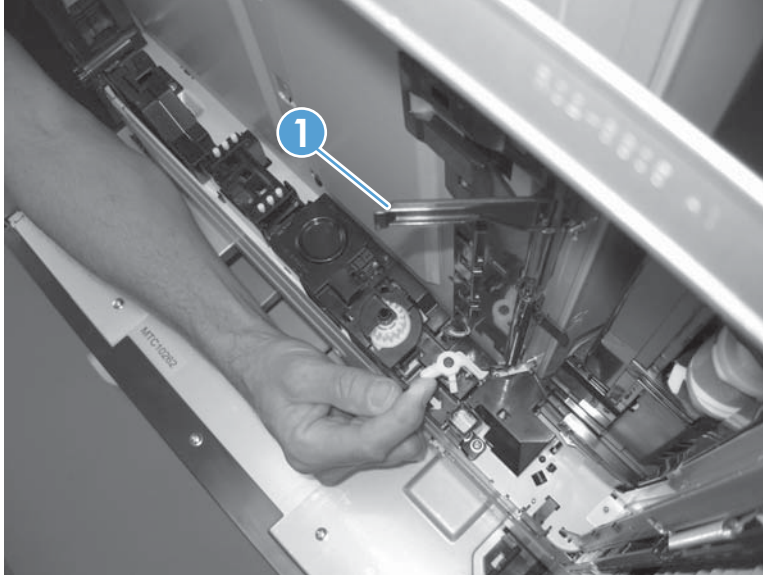

3. Check the control-panel display for sensor response.
4. If there is no response, replace the last paper detect sensor.

Tray 2 paper surface sensor (PS4)

1. Remove the tray.
2. In the tray cavity, insert a slip of paper in the photo sensor receptor and transmitter (callout 1).

Figure 3-16 Tray 2 paper surface sensor

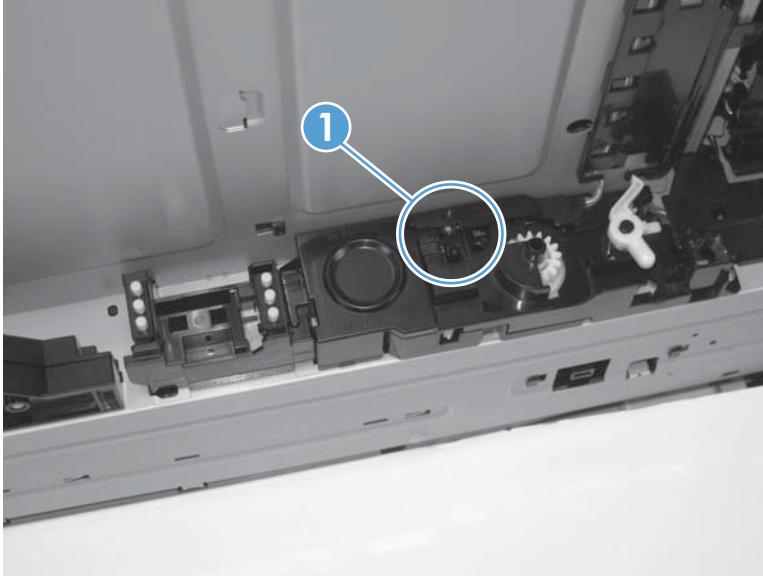

3. Check the control-panel display for sensor response.
4. If there is no response, replace the lifter drive assembly.

Tray 2 paper size switches (SW7 and SW8)

 **NOTE:** These switches also detect cassette presence. If these switches fail, the message **Tray <X> open** could appear on the control-panel display.

1. Remove the tray. From inside the tray cavity, push any of the switch buttons (callout 1).

 **TIP:** You can test these sensors by opening, and then closing the tray.

Figure 3-17 Test the Tray 2 paper size switches



2. Check the control-panel display for sensor response.
3. If there is no response, replace the lifter assembly.

Tray 3 paper sensor (SR3)

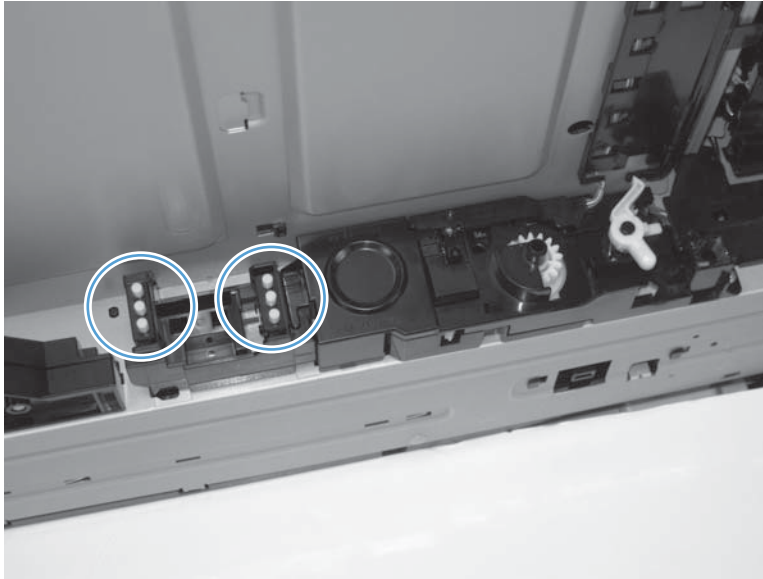
1. Remove the tray.
2. In the tray cavity, release the spring loaded tray-present lever to lower the flag (callout 1), and then toggle the flag to activate the sensor.

Figure 3-18 Test Tray 3 paper sensor

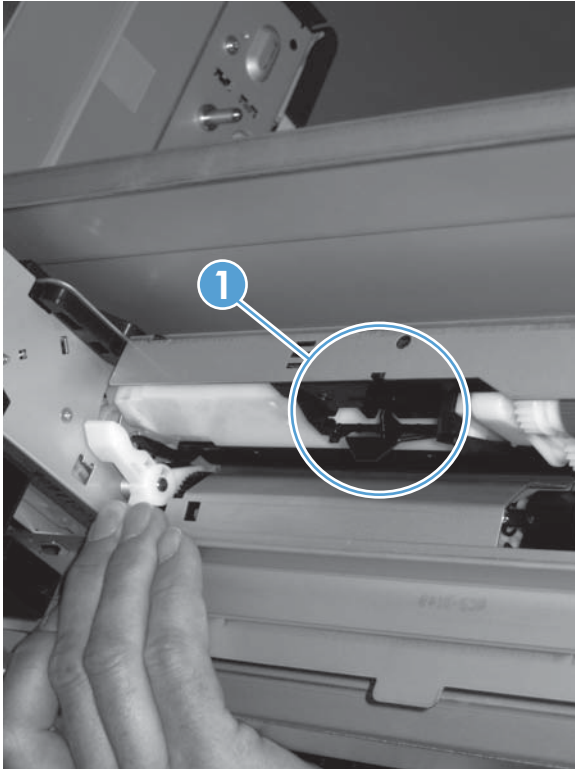

3. Check the control-panel display for sensor response.
4. If there is no response, replace the paper pickup assembly.

Tray 3 paper surface sensor (SR2)

1. Remove the tray.
2. In the tray cavity, release the spring loaded tray-present lever to lower the flag (callout 1), and then toggle the flag to activate the sensor.

Figure 3-19 Test Tray 3 paper sensor

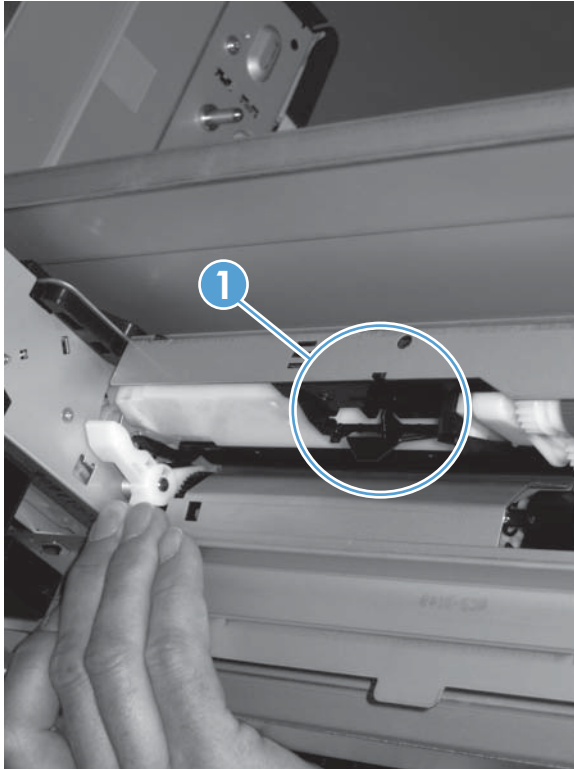

3. Check the control-panel display for sensor response.
4. If there is no response, replace the paper pickup assembly.

Tray 3 paper size sensors (SW2 and SW3)

 **NOTE:** These switches also detect cassette presence. If these switches fail, the message **Tray <X> open** could appear on the control-panel display.

1. Remove the tray. From inside the tray cavity, push any of the switch buttons (callout 1).

 **TIP:** You can test these sensors by opening, and then closing the tray.

Figure 3-20 Test Tray 3 paper size sensors

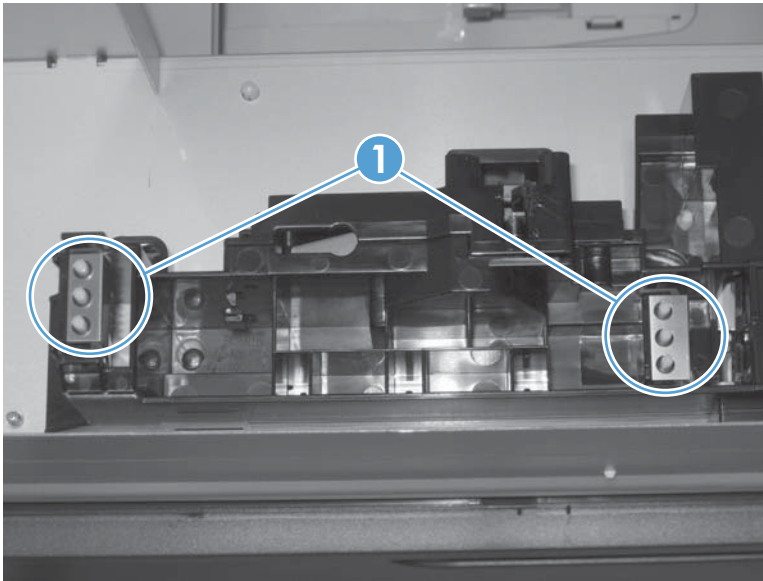

2. Check the control-panel display for sensor response.
3. If no response, replace the lifter drive assembly.

Tray 3 feed sensor (SR1)

1. Open the paper-feeder door.
2. Insert a piece of paper as shown to activate the feed sensor.

 **TIP:** Use stiff paper when performing this test (for example a business card or index card).

Figure 3-21 Test the Tray 3 feed sensor



3. Check the control-panel display for sensor response.
4. If no response, replace the paper pickup assembly.

Tray 3 door opening/closing sensor (SW1)

1. Open and then close the paper-feeder door to activate the sensor. The tab on the door (callout 1) activates the sensor (callout 2).

Figure 3-22 Test the Tray 3 door opening/closing sensor

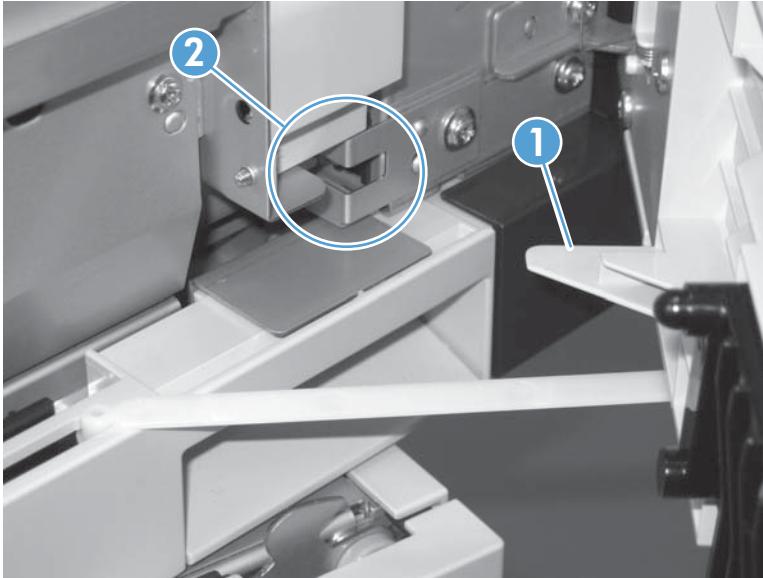

2. Check the control-panel display for sensor response.
3. If no response, replace the button switch.

Tray 4 paper sensor (SR3)

See [Tray 3 paper sensor \(SR3\) on page 306](#).

Tray 4 paper surface sensor (SR2)

See [Tray 3 paper surface sensor \(SR2\) on page 307](#).

Tray 4 paper size sensors (SW2 and SW3)

See [Tray 3 paper size sensors \(SW2 and SW3\) on page 308](#).

Tray 4 feed sensor (SR1)

See [Tray 3 feed sensor \(SR1\) on page 309](#).

Tray 4 door opening/closing door sensor (SW1)

 **NOTE:** Tray 4, Tray 5, and Tray 6 use the same opening/closing door sensor (SW1).

1. Open and then close the paper-feeder door to activate the sensor (the tab on the door (callout 1) activates the sensor (callout 2)).

Figure 3-23 Test the Tray 4 door opening/closing sensor

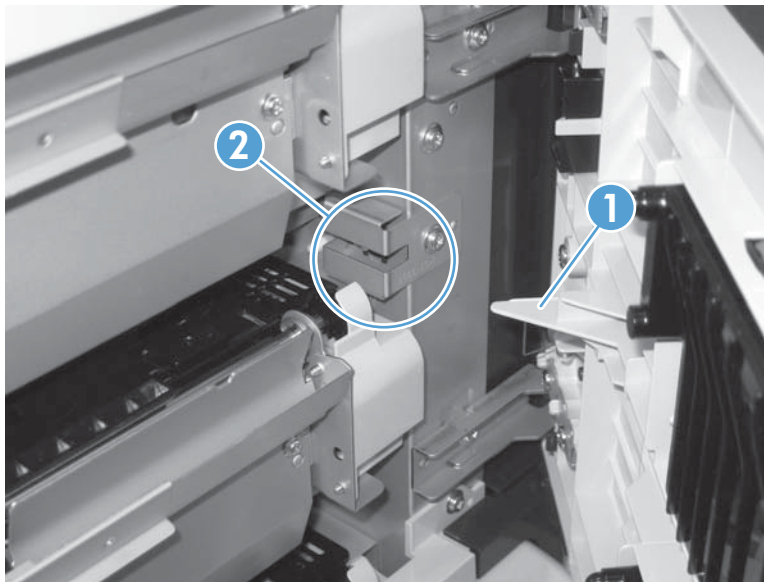

2. Check the control-panel display for sensor response.
3. If no response, replace the button switch.

Tray 5 paper sensor (SR83)

See [Tray 3 paper sensor \(SR3\) on page 306](#).

Tray 5 paper surface sensor (SR82)

See [Tray 3 paper surface sensor \(SR2\) on page 307](#).

Tray 5 paper size sensors (SW82 and SW83)

See [Tray 3 paper size sensors \(SW2 and SW3\) on page 308](#).

Tray 5 feed sensor (SR81)

See [Tray 3 feed sensor \(SR1\) on page 309](#).

Tray 5 door opening/closing sensor (SW1)

See [Tray 4 door opening/closing door sensor \(SW1\) on page 311](#).

Tray 6 paper sensor (SR93)

See [Tray 2 paper present sensor \(PS1\) on page 303](#).

Tray 6 paper surface sensor (SR92)

See [Tray 3 paper surface sensor \(SR2\) on page 307](#).

Tray 6 paper size sensors (SW92 and SW93)

See [Tray 3 paper size sensors \(SW2 and SW3\) on page 308](#).

Tray 6 feed sensor (SR91)

See [Tray 3 feed sensor \(SR1\) on page 309](#).

Tray 6 door opening/closing sensor (SW1)

See [Tray 4 door opening/closing door sensor \(SW1\) on page 311](#).

Output-bin-full sensor (PS10)

1. Locate the output-bin-full sensor flag (callout 1), and then activate the sensor flag.

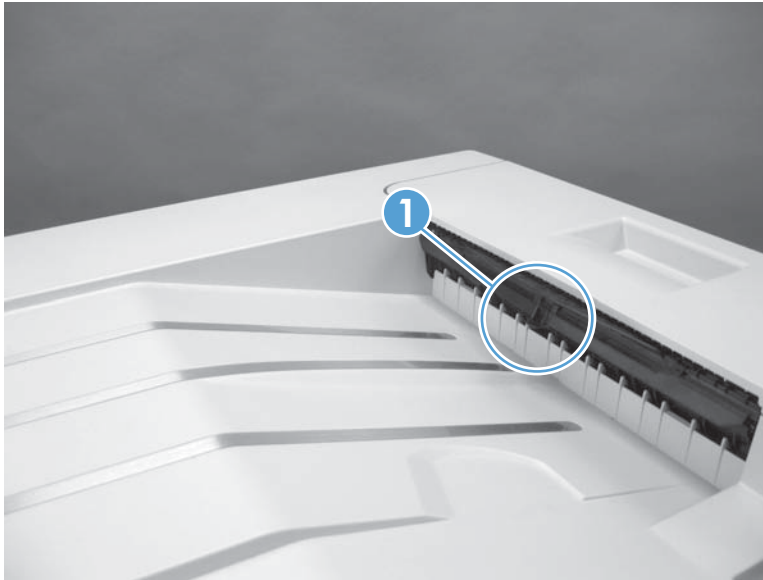

Figure 3-24 Test the output-bin-full sensor



2. Check the control-panel display for sensor response.
3. If there is no response, examine the flag at the left end of the output bin full sensor flag. If the flag is broken, replace the paper delivery assembly. If the flag is not broken, replace the fuser gear assembly.

Paper-path sensors test

This test displays the status of each paper-path sensor and allows viewing of sensor status while printing internal pages.

1. Press the Home  button.
2. Open the following menus:
 - **Administration**
 - **Troubleshooting**
 - **Diagnostic Tests**
3. Press the **Down** arrow  to highlight the **Paper Path Sensors** option, and then press the **OK** button.
4. Select **Start Test**. Press the down arrow  to see the test results.

 **NOTE:** Exiting the Paper-path sensor test menu and then reentering it will clear the test values from the previous test.



Viewing the sensor status before you activate the test should show that the sensors PS9, PS11 and SW5 have already been activated. After running the Paper-path sensor test, sensor PS9 does not show any activation status.



Table 3-22 Paper-path sensors diagnostic tests

Sensor name	Sensor number
TOP (top of page) sensor	PS5
Fuser loop sensor	PS7
Fuser loop sensor	PS8
Fuser delivery sensor	PS6
Output bin full sensor	PS10
Developer alienation	PS11
Fuser pressure-release sensor	PS9
Primary transfer-roller-disengagement sensor	SW5

Print/stop test

Use this diagnostic test to isolate the cause of problems such as image-formation defects and jams within the engine. During this test you can stop the paper anywhere along the product paper path. The test can be programmed to stop printing internal pages or an external print job when the paper reaches a certain position. The test can also be programmed to stop from 0 to 60,000 ms. If the timer is set to a value that is greater than the job-print time, you can recover the product in one of two ways.

- After the print job is completed press the **Stop** button  to return to the **Diagnostic Tests** menu before the timer times out.
- After the timer times out, press the **Stop** button . Activate the door switch to restart the engine and return it to a normal state.

When the timer trips, the control panel display shows the message **Printing stopped To continue, press OK**. Pressing the Home button  will print the previously selected job. If you do not want the previous job to print, press the **Stop** button  first, and then press the Home button .

 **NOTE:** Do not try to perform a print/stop test while the product is calibrating, because you will be required to power-cycle the product. If a jam message displays on the control panel during testing, activate the door switch.

Component tests

Component test (special-mode test)

This test activates individual parts independently to isolate problems.

Each component test can be performed once or repeatedly. If you select the **Repeat** option (at the end of the menu), the test cycles the component on and off. This process continues for two minutes, and then the test terminates.

 **NOTE:** The front or side door interlocks must be defeated to run the component tests. Some tests may require that the ITB and print cartridges be removed. The control panel display prompts you to remove some or all cartridges during certain tests.



1. Press the Home button .
2. Open the following menus:
 - **Administration**
 - **Troubleshooting**
 - **Diagnostic Tests**
3. Press the **Down** arrow  to highlight the **Component Test** item, and then press the **OK** button.
4. Select the component test options for the test you want to run.

Table 3-23 Component tests (1 of 2)

Component test	Component tested	Comments
Transfer Motors	M1 (ITB motor)	Drives the ITB motor and drum motor together at a specified speed for 5 seconds.
	M2 (drum motor)	
Belt Only	M1 (ITB motor)	Drives ITB drive motor at a specified speed for 5 seconds.
Developer Motors	M1 (ITB motor)	Drives the ITB motor at a specified speed for 5 seconds.
	M3 (developer motor)	Drives the developer motor at a specified speed for 5 seconds (drives 3 times).
Cartridge Motors	M1 (ITB motor)	Drives the ITB motor at a specified speed for 5 seconds.
	M2 (drum motor)	Drives the drum motor at a specified speed for 5 seconds (drives 3 times).
Fuser Motor	M4	Drives the fuser motor at a specified speed for 5 seconds.
Alienation Motor (cartridge)	M6 (developer alienation motor)	Drives the developer disengagement motor and engages or disengages the developer (drives the motor four times). If the home position of the developer is not commanded within 5 seconds, the product brings the developer to its home position.

Table 3-23 Component tests (1 of 2) (continued)

Component test	Component tested	Comments
ITB Contact/Alienation Motor	M4 (fuser motor)	<p>Drives the fuser motor M4 (drives the motor four times) and the T1 roller disengagement solenoid SL5, and brings the T1 roller to either one of the following states:</p> <ul style="list-style-type: none"> • 4 rollers are disengaged (home position) • Only K T1 roller is engaged or 4 rollers are engaged <p>If home position of the T1 roller is not commanded within 10 seconds, the printer moves the T1 roller to its home position.</p> <p>Additionally, the printer keeps the state of 4 rollers engagement so that the service technician can access and manually clean the dust-proof glass (open the front door and remove the cartridge).</p>
	SL5 (disengagement solenoid)	
Fuser Contact/Alienation Drive	M4 (fuser motor)	Reverses the fuser motor to rotate the fuser pressure release cam and pressurize or depressurize the pressure roller. If home position of the pressure roller is not commanded within 5 seconds, the printer brings the pressure roller to its home position.
Tray<X> Pickup Motor	M5 (pickup motor)	Drives the pickup motor M5, the 500 sheet paper feeder pickup motor M1, and each of the 3x500 paper deck cassette pickup motors, cassette 1 M1, cassette 2 M81, and cassette 3 M91 individually at a specified speed for 5 seconds.
	M1 (Tray 3 pickup motor)	
	M1 (Tray 4 pickup motor)	
	M81 (Tray 5 pickup motor)	
	M91 (Tray 6 pickup motor)	
DuplexerPickup Motor	M8 (duplex pickup motor)	Drives the duplex feed motor at a specified speed for 5 seconds.
Switchback Motor	M7 (duplex reverse motor)	Drives the duplex reverse motor at a specified speed for 5 seconds.

Table 3-23 Component tests (1 of 2) (continued)

Component test	Component tested	Comments
Tray<X> Pickup Solenoid	SL2 (Tray 1 pickup solenoid)	Drives the Tray 1 pickup solenoid SL2, the Tray 2 cassette pickup solenoid SL1, the 500 sheet feeder pickup solenoid SL1, and each of the 3x500 paper deck cassette solenoids, cassette 1 SL1, cassette 2 SL82, and cassette 3 SL92, individually for 5 seconds.
	SL1 (Tray 2 pickup solenoid)	
	SL1 (Tray 3 pickup solenoid)	
	SL1 (Tray 4 pickup solenoid)	
	SL82 (Tray 5 pickup solenoid)	
	SL92 (Tray 6 pickup solenoid)	
Switchback Flapper Solenoid	SL3 (duplex reverse solenoid)	Drives the duplex reverse solenoid for 10 seconds.
Laser Scanner Motor	M10 (laser/scanner motor)	Drives the laser/scanner motor at a specified speed for 10 seconds.

Additional component tests

The following tests are not supported in the firmware. These component tests are accomplished by manipulating or observing the product during operation or when the power is turned on.

Table 3-24 Component tests (2 of 2)

Component test	Component tested	Comments
Paper Deck Cassette Lifter Motor	M9 (Tray 2 lifter drive assembly)	Open and then close a paper tray. Listen at the back side of the product for the sound of the lift motor for that tray.
	M2 (Tray 3 lifter drive assembly)	
	M2 (Tray 4 lifter drive assembly)	If the lift motor does not make a sound and the paper surface sensor for that tray passes a sensor test (see Tray/Bin manual sensor test on page 300), replace the lifter drive assembly.
	M82 (Tray 5 lifter drive assembly)	
	M92 (Tray 6 lifter drive assembly)	
Power Supply Fan	FM1	Turn the product power off, and then on. Listen at the left-front-lower corner area of the print engine for fan noise while the product initializes.

Full/half speed intake fan

Cools the following areas:

- low-voltage power supply area
- face-down bin
- delivery bin
- laser scanner area

Table 3-24 Component tests (2 of 2) (continued)

Component test	Component tested	Comments
Fuser Fan	FM2	<p>Turn the product power off, and then on. Listen at the front-right-lower corner of the print engine for fan noise while the product initializes.</p> <p>Full speed intake fan</p> <p>Cools the following areas:</p> <ul style="list-style-type: none">• duplex feed• ITB
Formatter Fan	FM3	<p>Turn the product power off, and then on. Listen at the back-lower center area of the rear cover for fan noise while the product initializes.</p> <p>Speed controlled intake fan</p> <p>Cools the following areas:</p> <ul style="list-style-type: none">• DC controller• ICB• formatter <p>NOTE: The formatter controls the speed of this fan depending on product operations.</p>

Diagrams

Block diagrams

Figure 3-25 Product cross section

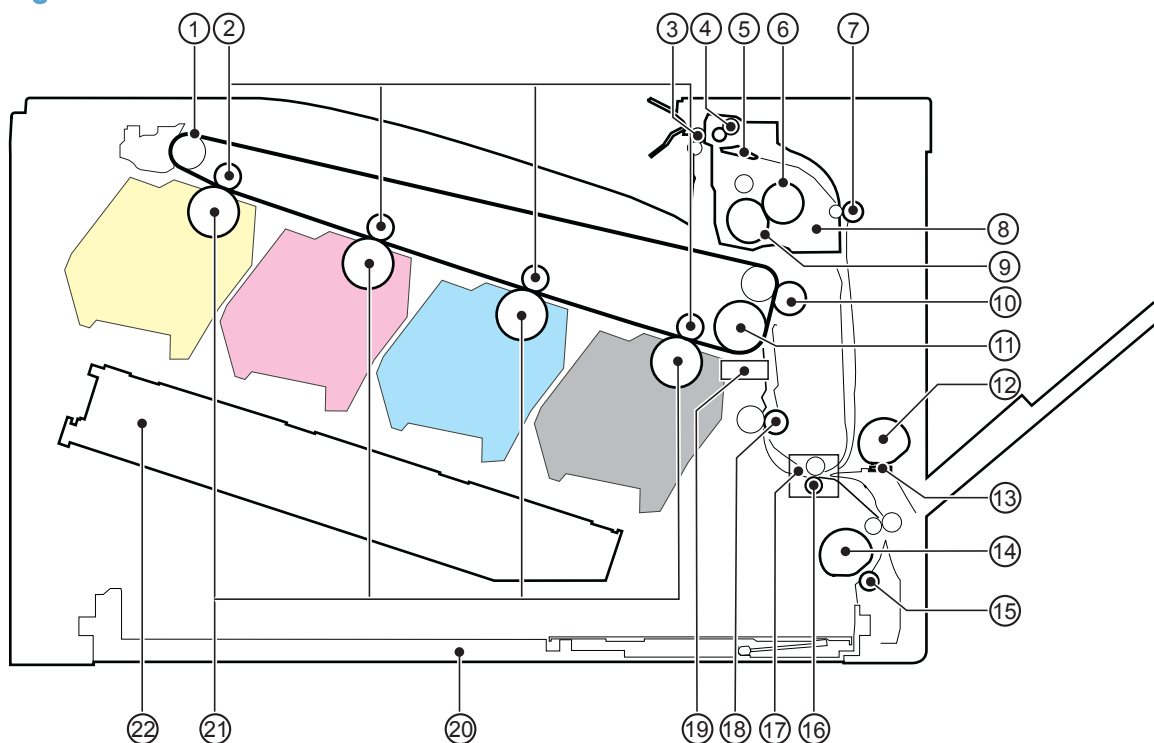

Item	Description	Item	Description
1	ITB	12	MP tray pickup roller
2	Primary transfer roller	13	MP tray separation pad
3	Delivery roller	14	Cassette pickup roller
4	Duplex reverse roller (duplex models only)	15	Cassette separation roller
5	Duplex flapper (duplex models only)	16	Feed roller
6	Pressure roller	17	Media sensor
7	Duplex feed roller (duplex models only)	18	Registration roller
8	IFuser	19	Registration density sensor
9	Fuser sleeve	20	Cassette
10	Secondary transfer roller	21	Photosensitive drum
	ITB drive roller		Laser/scanner assembly

Figure 3-26 Optional paper feeder (Tray 3) cross section

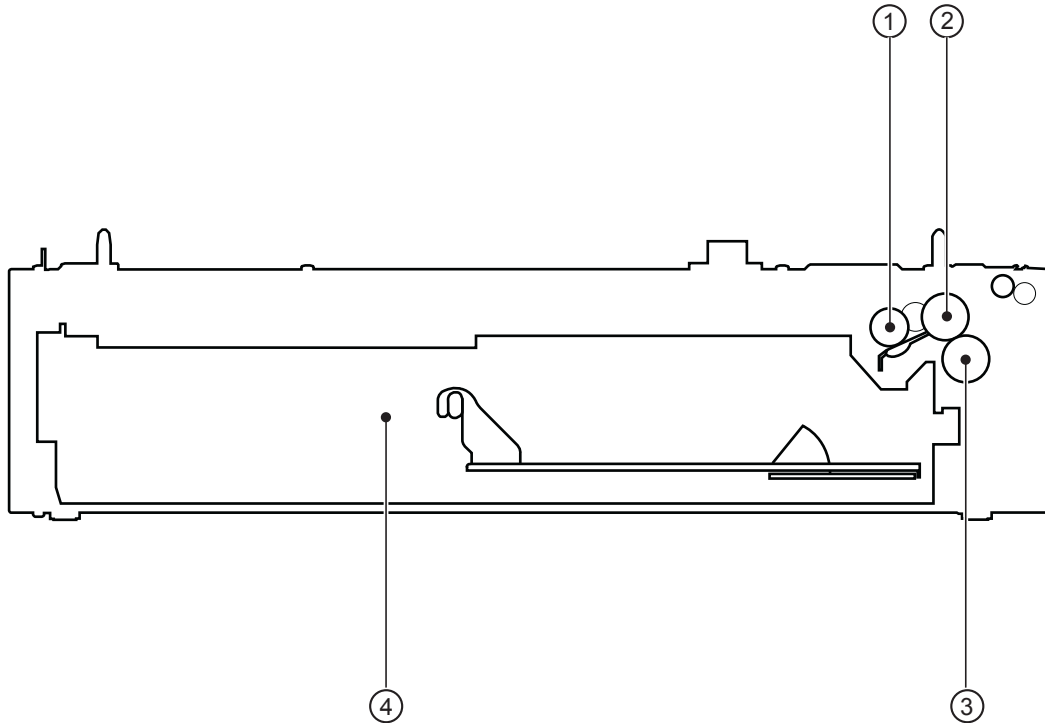

1	Pickup roller
2	Feed roller
3	Separation roller
4	Cassette

Plug/jack locations

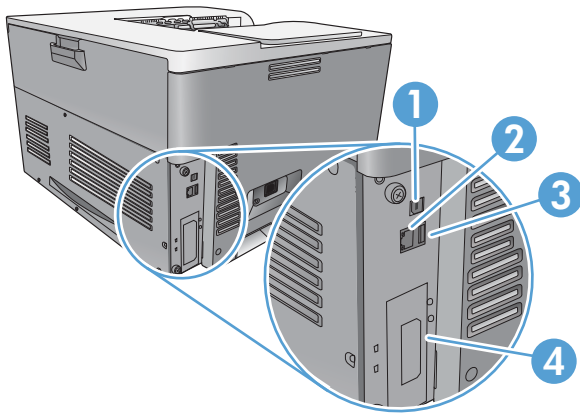

1	Hi-Speed USB 2.0 printing port
2	Local area network (LAN) Ethernet (RJ-45) network port
3	USB port for a third-party device
4	EIO interface expansion slot

Location of connectors

DC controller connections

Figure 3-27 DC controller connections

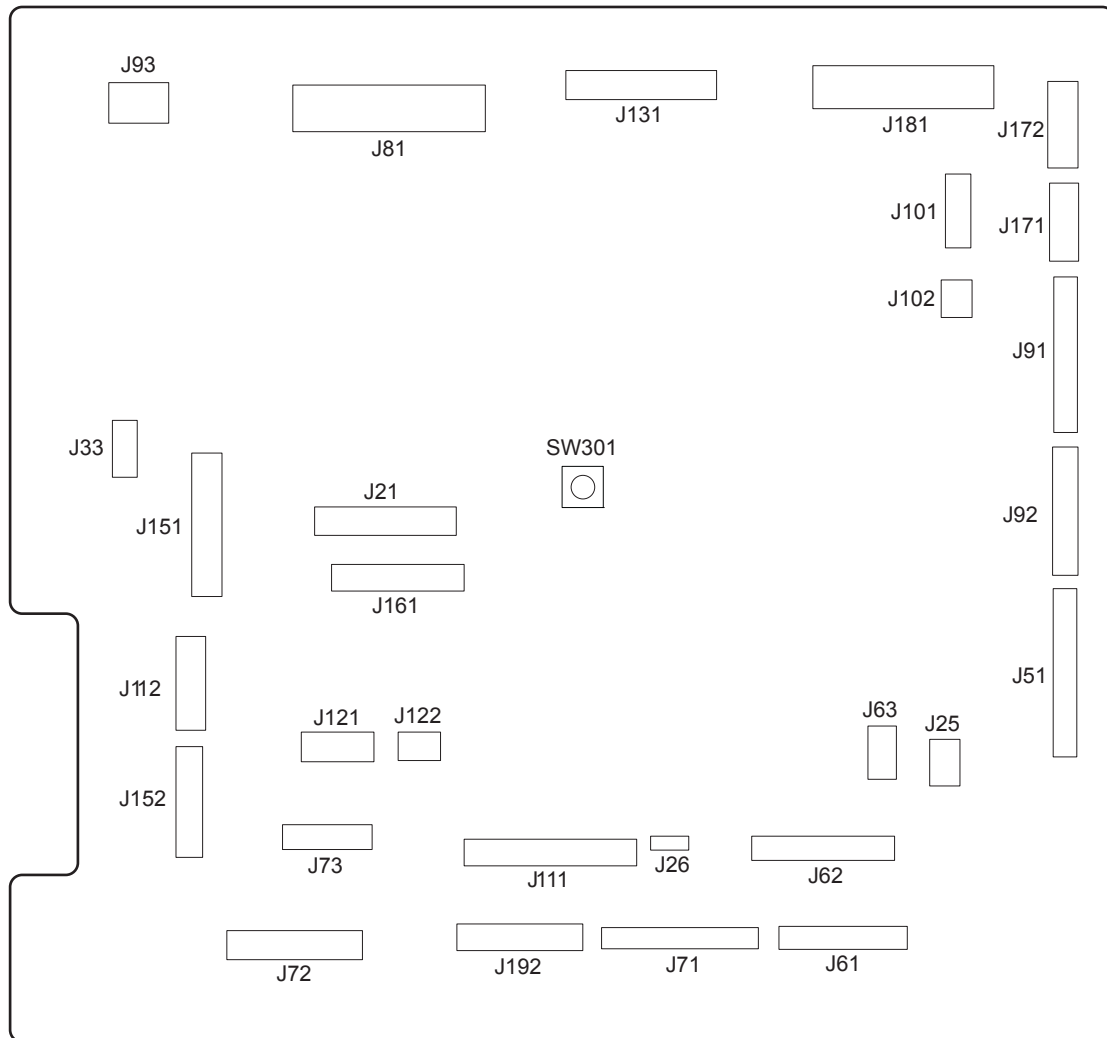

Table 3-25 DC controller connections

Item	Description	Item	Description	Item	Description
J21	DC controller power	J73	Secondary transfer	J122	Top of page sensor
J25	Low-voltage power supply	J81	ITB motor	J131	Fuser
			Fuser motor		
			Drum motor		
			Developing motor		

Table 3-25 DC controller connections (continued)

Item	Description	Item	Description	Item	Description
J33	Environment sensor	J91	Duplex reverse solenoid Cassette pickup solenoid Pickup motor Developing disengagement motor	J151	Cassette paper size Cassette paper presence Cassette lifter motor
J51	Formatter	J92	Duplex feed motor Duplex reverse motor	J152	MP tray paper presence MP tray pickup solenoid
J61	Laser scanner	J93	Driver PCA	J161	Cartridge toner level sensors
J62	Laser scanner	J101	Cartridge memory tag (yellow, magenta, cyan)	J171	Cartridge pre-exposure LEDs
J63	Laser scanner motor	J102	Cartridge memory tag (black)	J172	Cartridge pre-exposure LEDs
J71	Developing high-voltage PCA	J111	Registration and density sensor	J181	Cartridge drum home-position sensors Right door switch Primary transfer disengagement solenoid Fuser pressure release Output bin full sensor Toner collection unit full sensor ITB waste toner full sensor
J72	Cartridge primary transfer	J121	Front door switch Fuser fan	J192	Paper feeder

Product connections

Figure 3-28 Product connections (1 of 6)

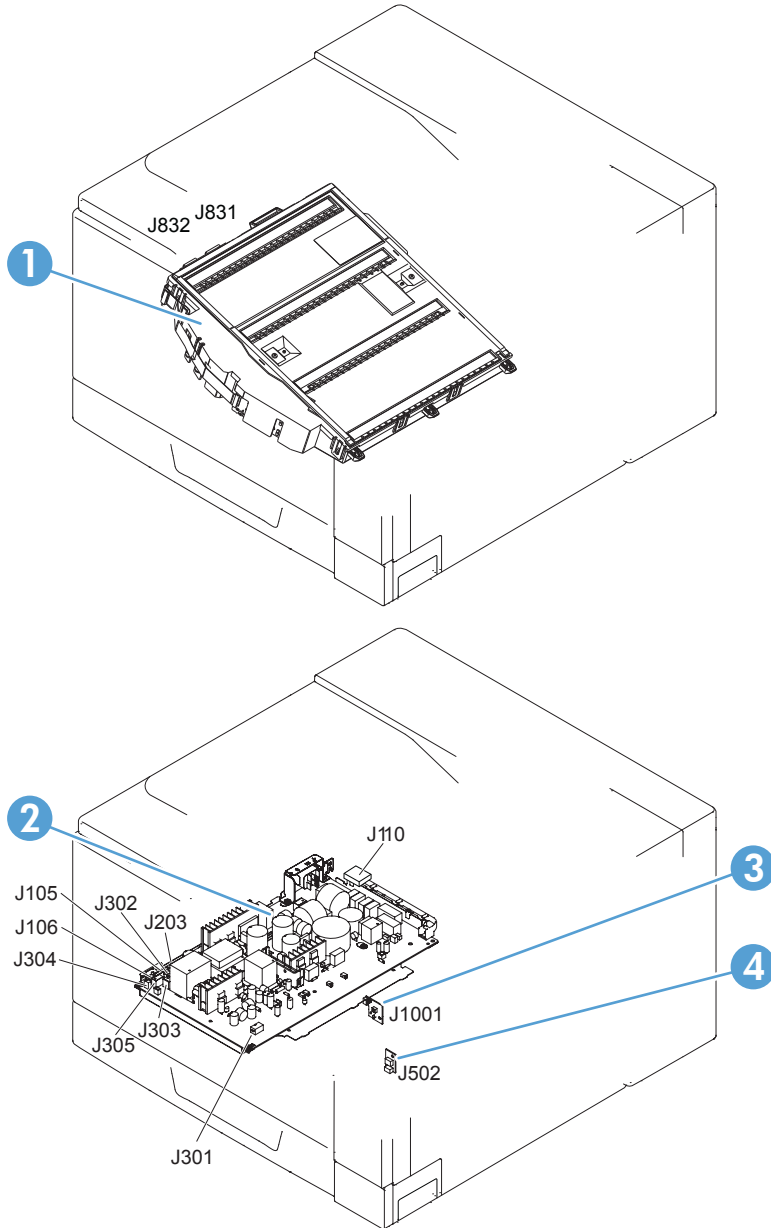

Item	Description
1	Laser scanner unit
2	Low-voltage power supply
3	Power switch PCA
4	Environment sensor

Figure 3-29 Product connections (2 of 6)

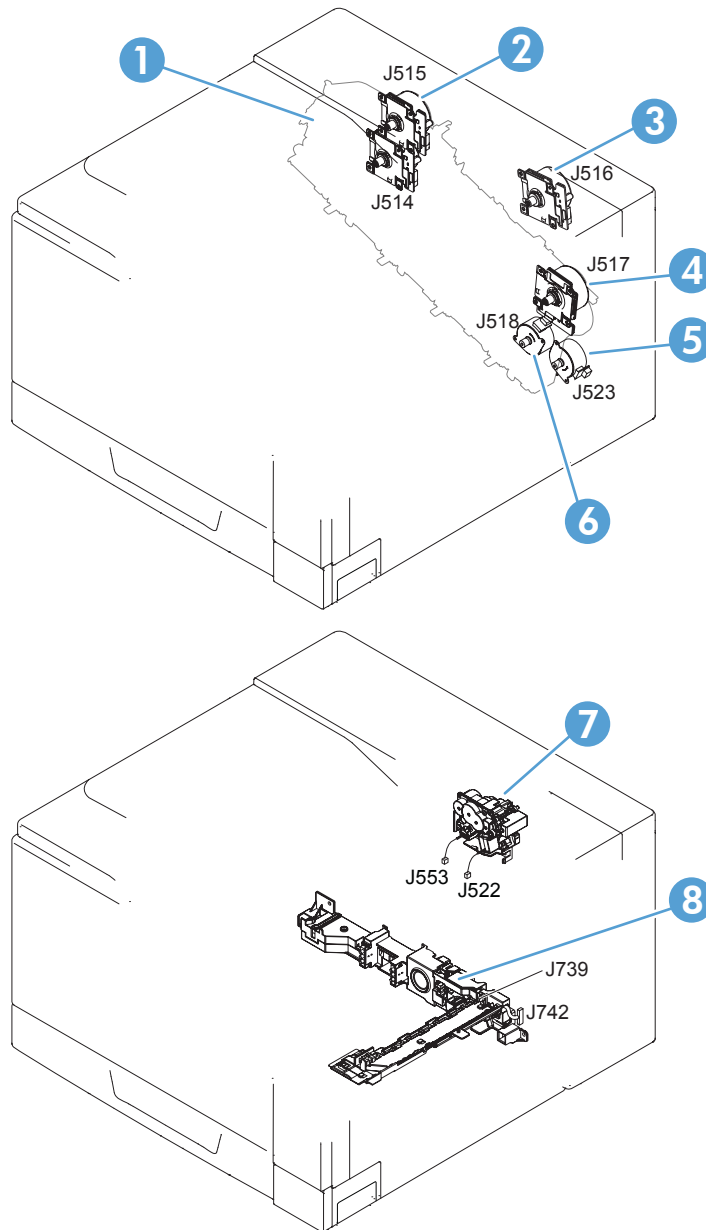

Item	Description
1	Developing motor
2	Drum motor
3	Fuser motor
4	ITB motor
5	Pickup motor
6	Developing disengagement motor

Item	Description
7	Drive unit
8	Lifter drive unit

Figure 3-30 Product connections (3 of 6)

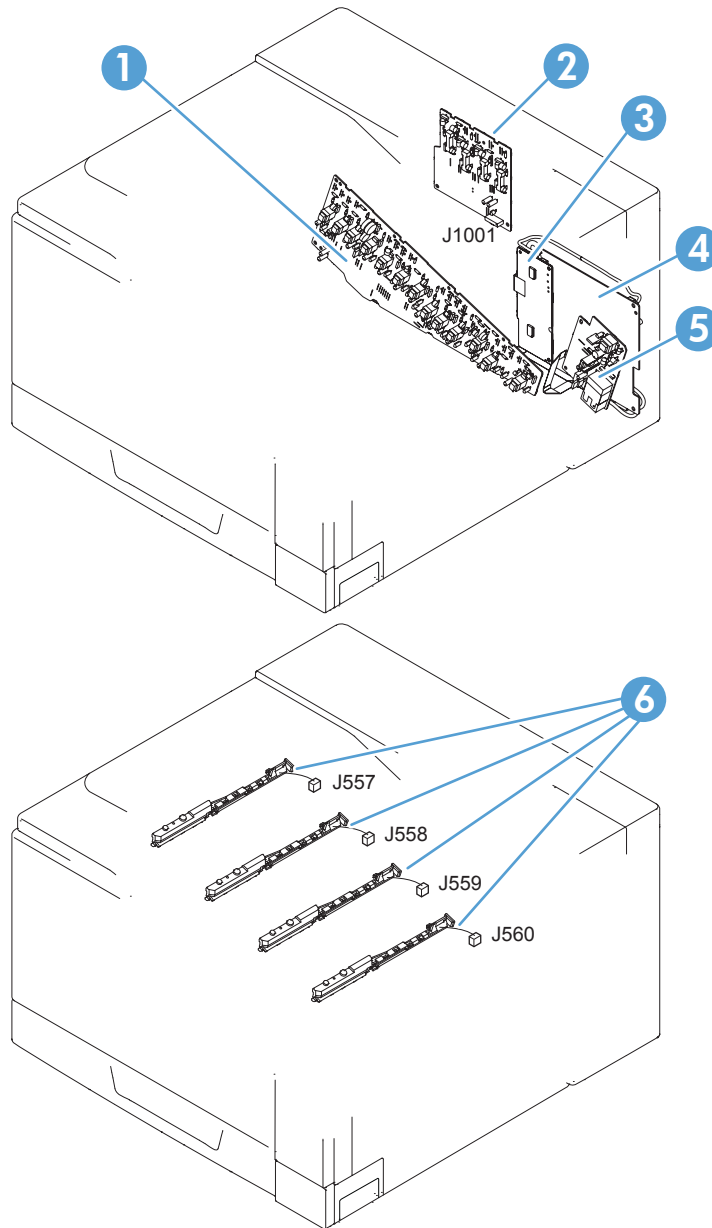

Item	Description
1	High-voltage power supply imaging (developing) PCA
2	High-voltage power supply 1st transfer PCA
3	Driver PCA

Item	Description
4	DC controller PCA
5	High-voltage power supply 2nd transfer PCA
6	Toner remaining detect PCA

Figure 3-31 Product connections (4 of 6)

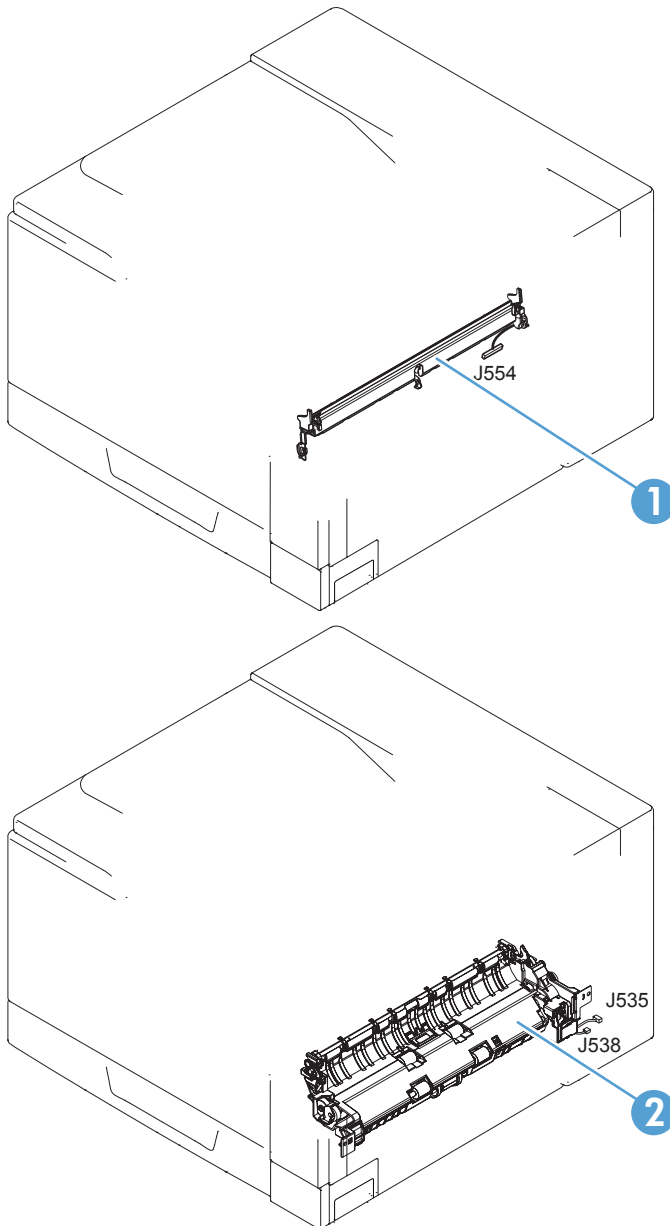

Item	Description
1	Registration sensor assembly
2	Paper pickup drive unit

Figure 3-32 Product connections (5 of 6)

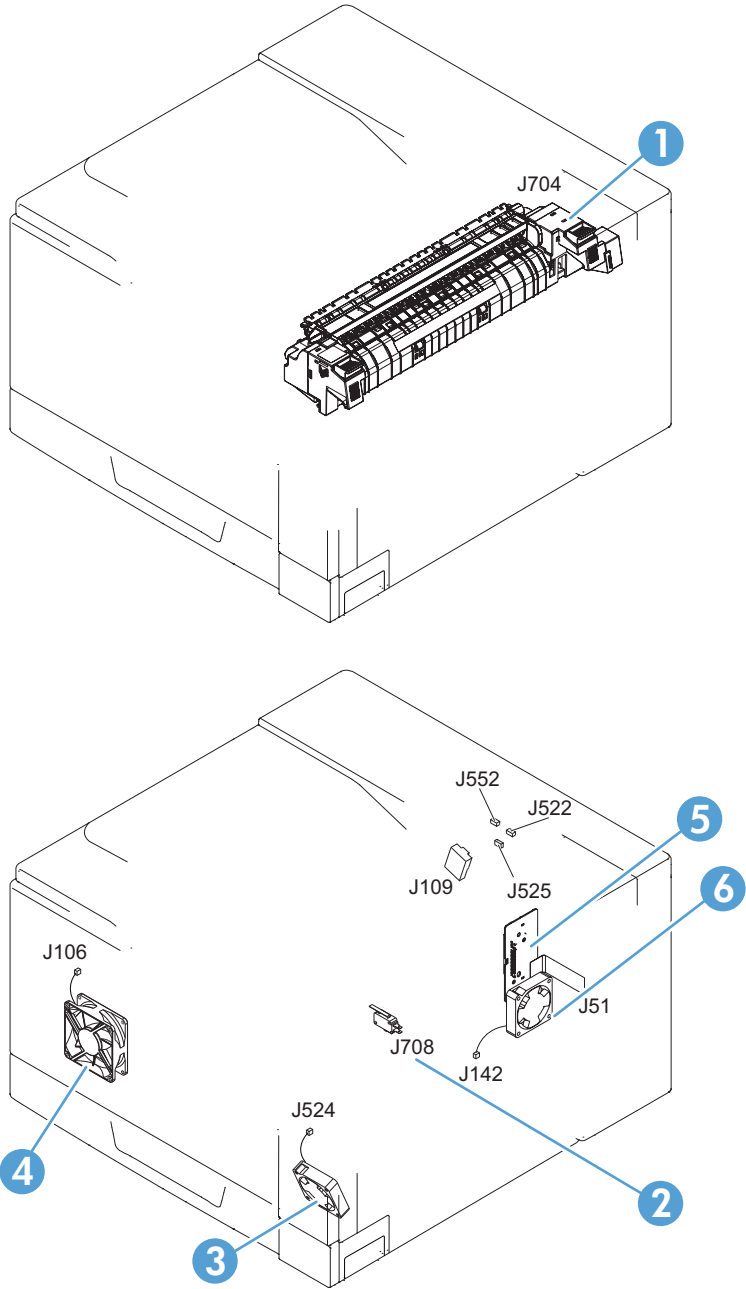

Item	Description
1	Fuser
2	24V interlock switch
3	Fuser fan
4	Power supply fan
5	ICB PCA
6	Formatter fan

Figure 3-33 Product connections (6 of 6)

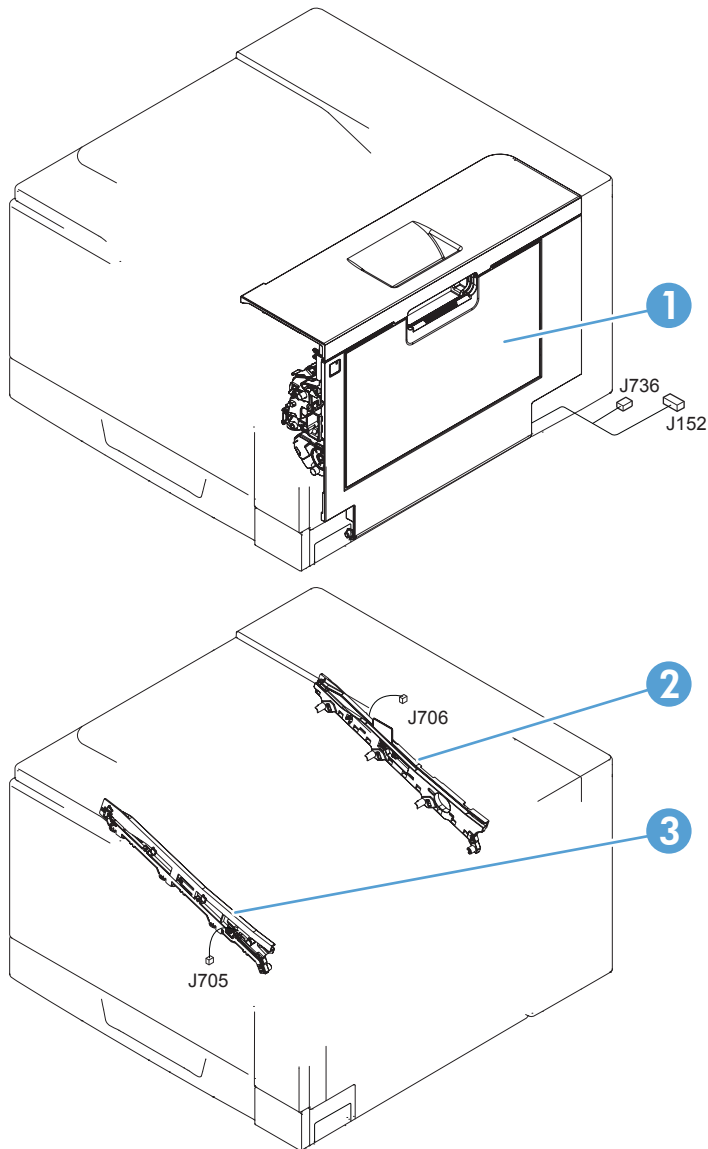

Item	Description
1	Right door assembly
2	ITB rear guide
3	ITB front guide

Figure 3-34 Paper feeder connections

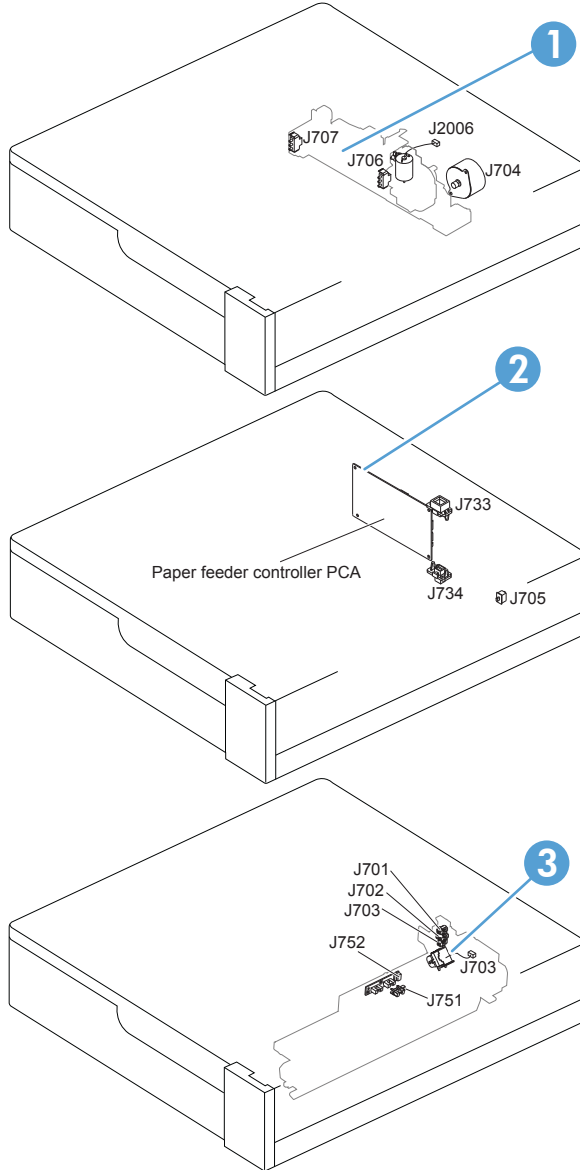

Item	Description
1	Paper feeder lifter-drive assembly
2	Paper feeder PCA
3	Paper feeder paper-pickup assembly

Locations of major components

Figure 3-35 External component locations

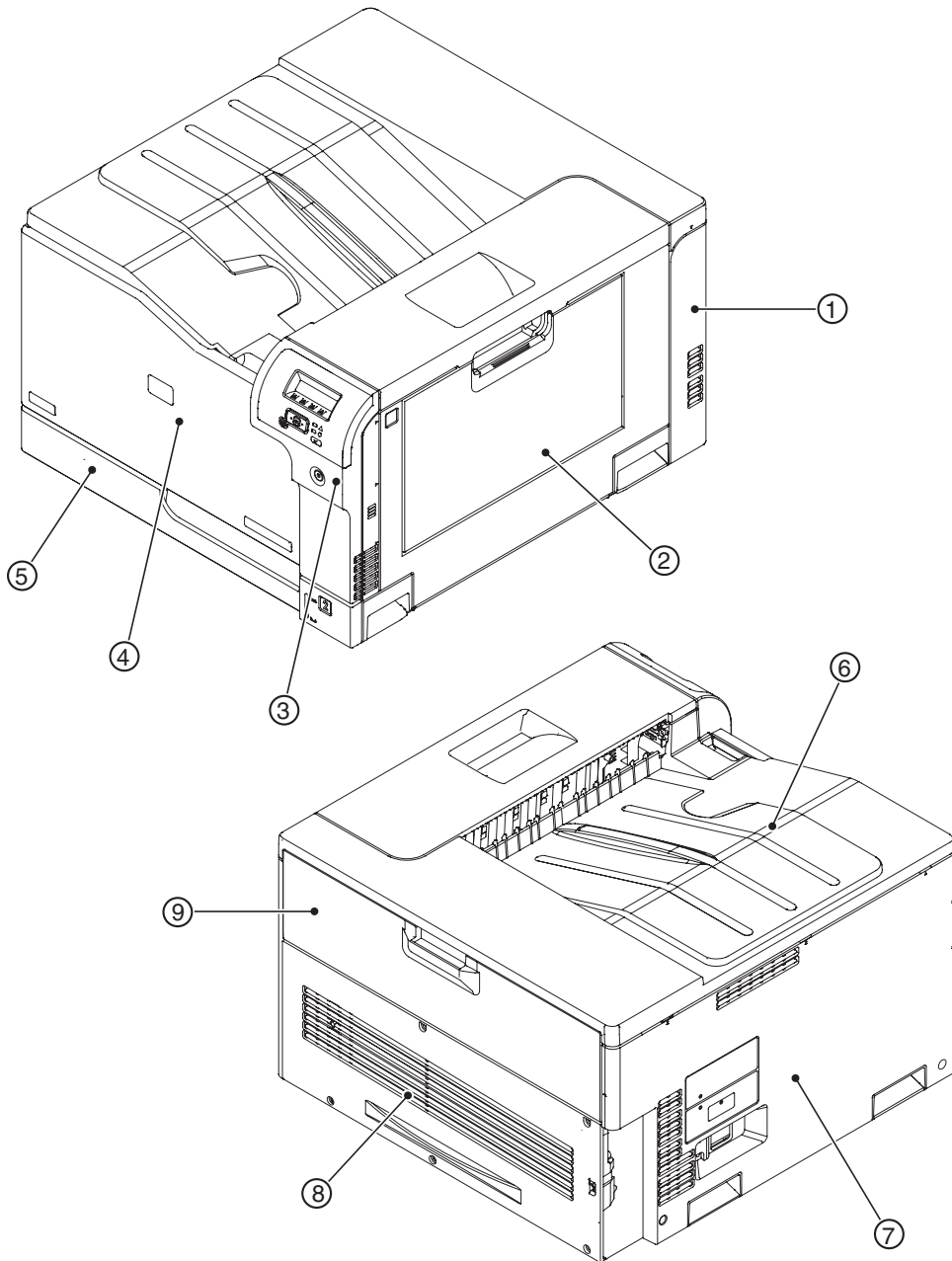

Item	Description	Item	Description
1	Right-rear cover	6	Top cover
2	Right-door assembly	7	Left cover
3	Right-front cover	8	Rear cover
4	Front-door assembly	9	Toner collection unit access-door
5	Cassette (Tray 2)		

Figure 3-36 Major component locations (1 of 3)

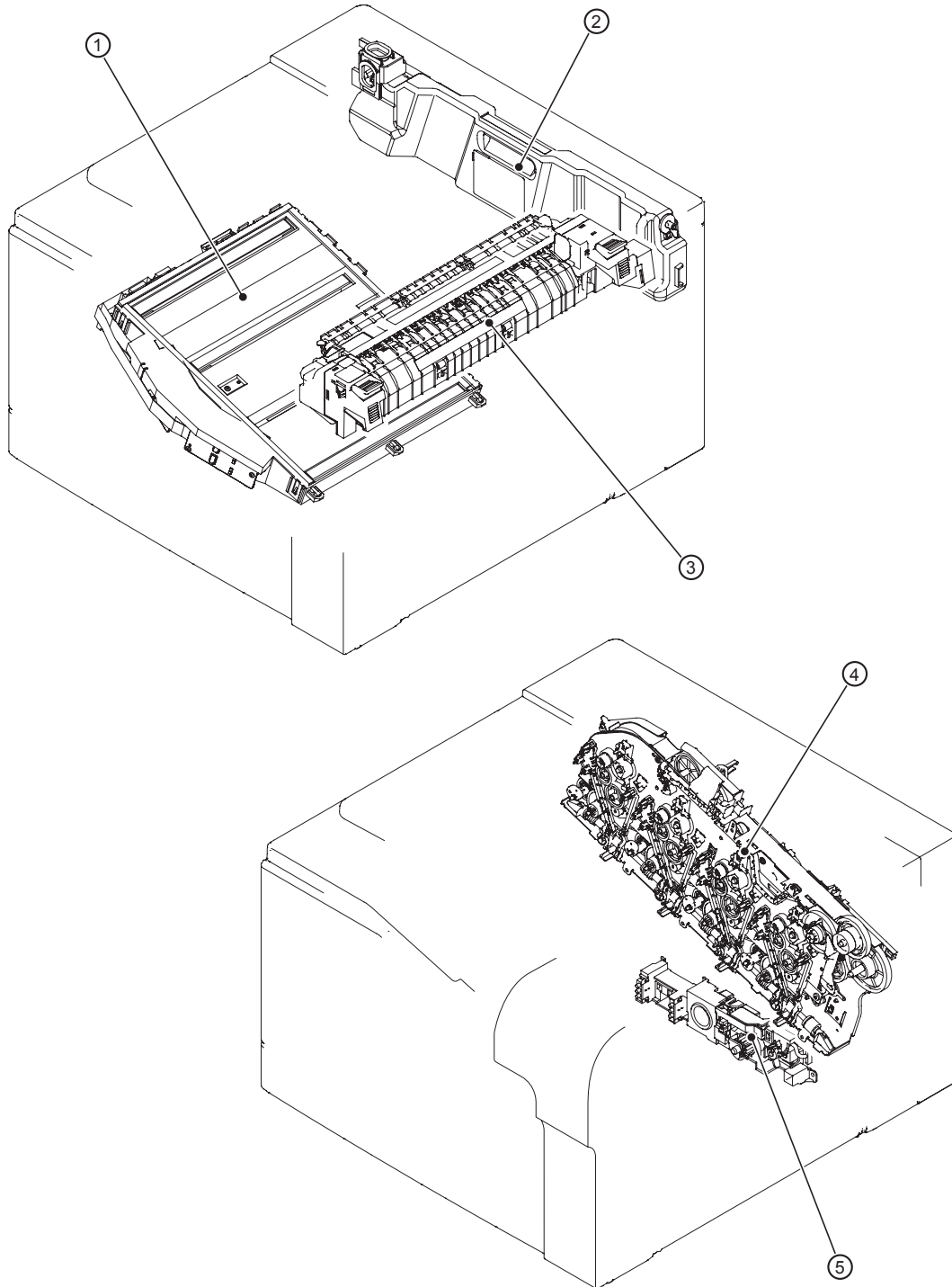

Item	Description
1	Laser scanner unit
2	Toner collection unit
3	Fuser

Item	Description
4	Main drive unit
5	Lifter drive unit

Figure 3-37 Major component locations (2 of 3)

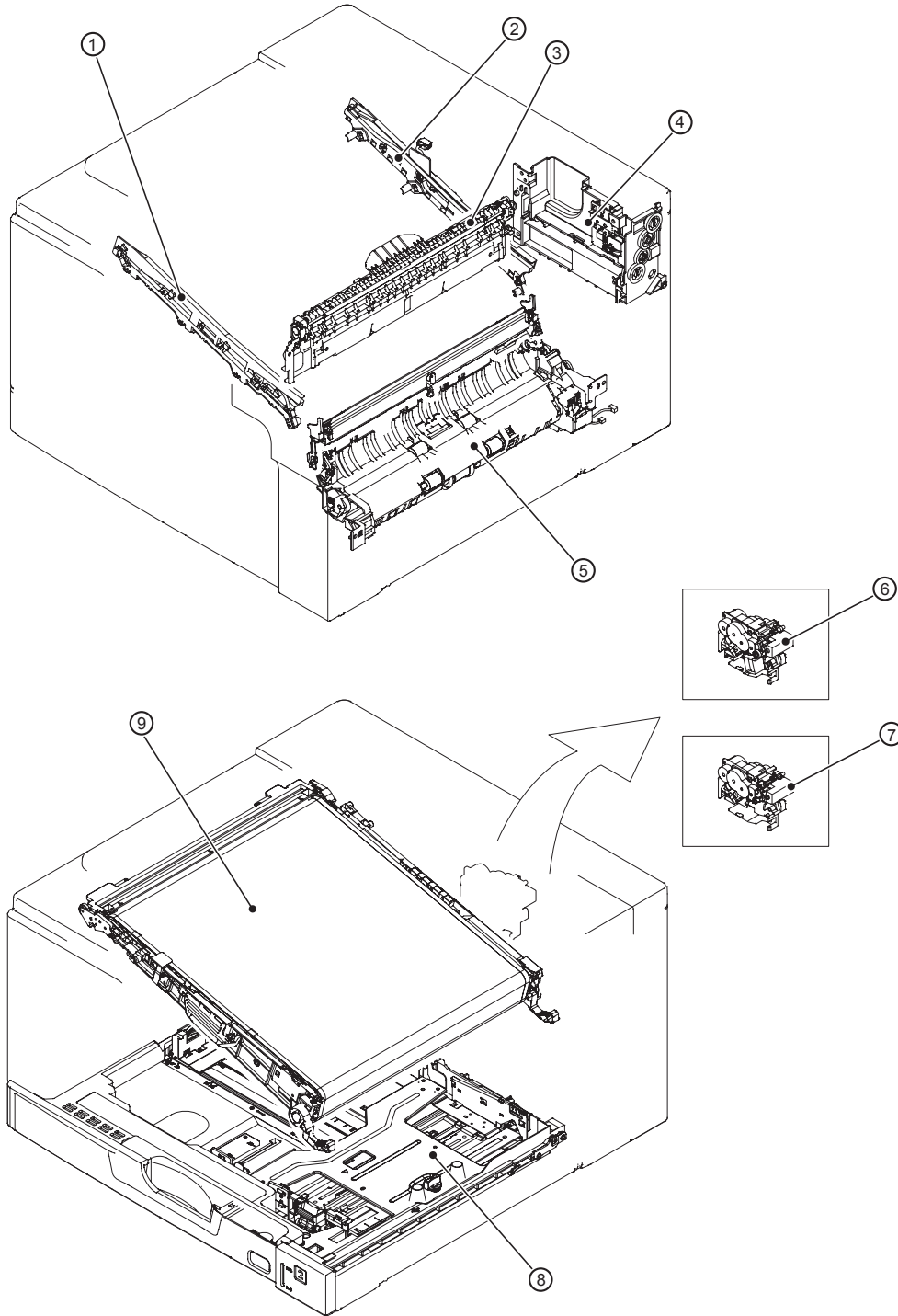

Item	Description	Item	Description
1	ITB front guide unit	6	Duplex drive unit (duplex models only)
2	ITB rear guide unit	7	Delivery drive unit (simplex models only)
3	Delivery unit	8	Cassette (Tray 2)

Item	Description	Item	Description
4	Toner collection unit full sensor	9	ITB unit
5	Cassette pickup drive unit		

Figure 3-38 Major component locations (3 of 3)

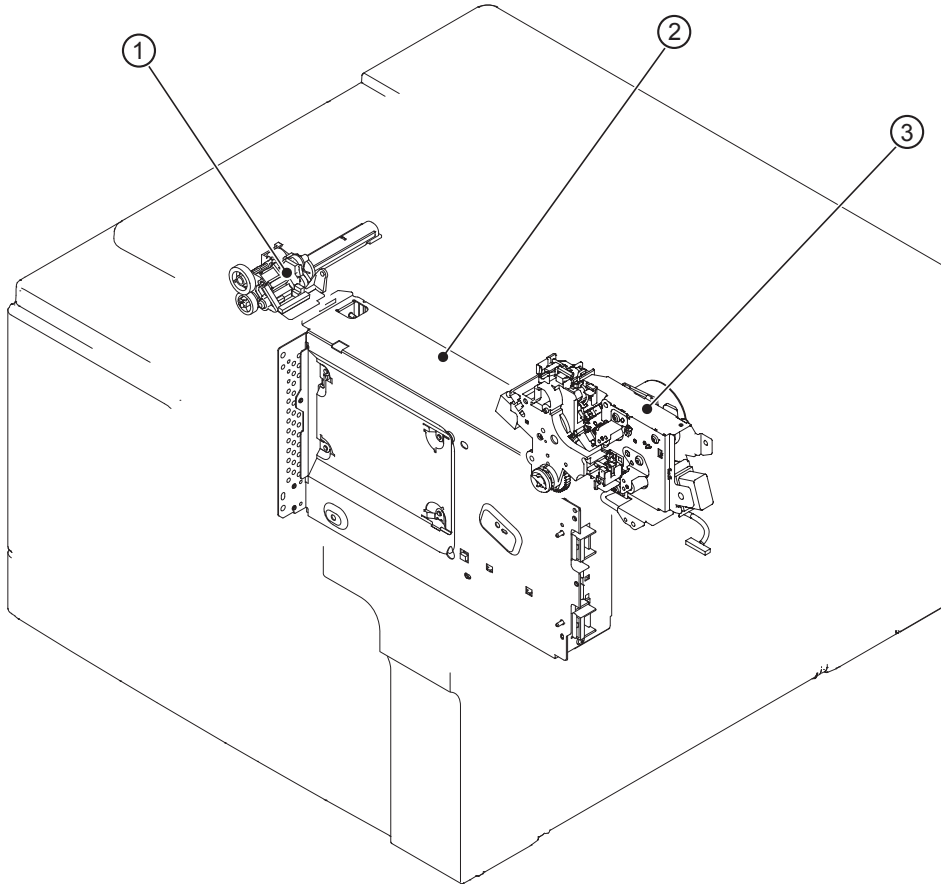

Item	Description
1	Waste toner carrier unit
2	Formatter
3	Fuser drive unit

Figure 3-39 Motors, fans, and rollers component locations

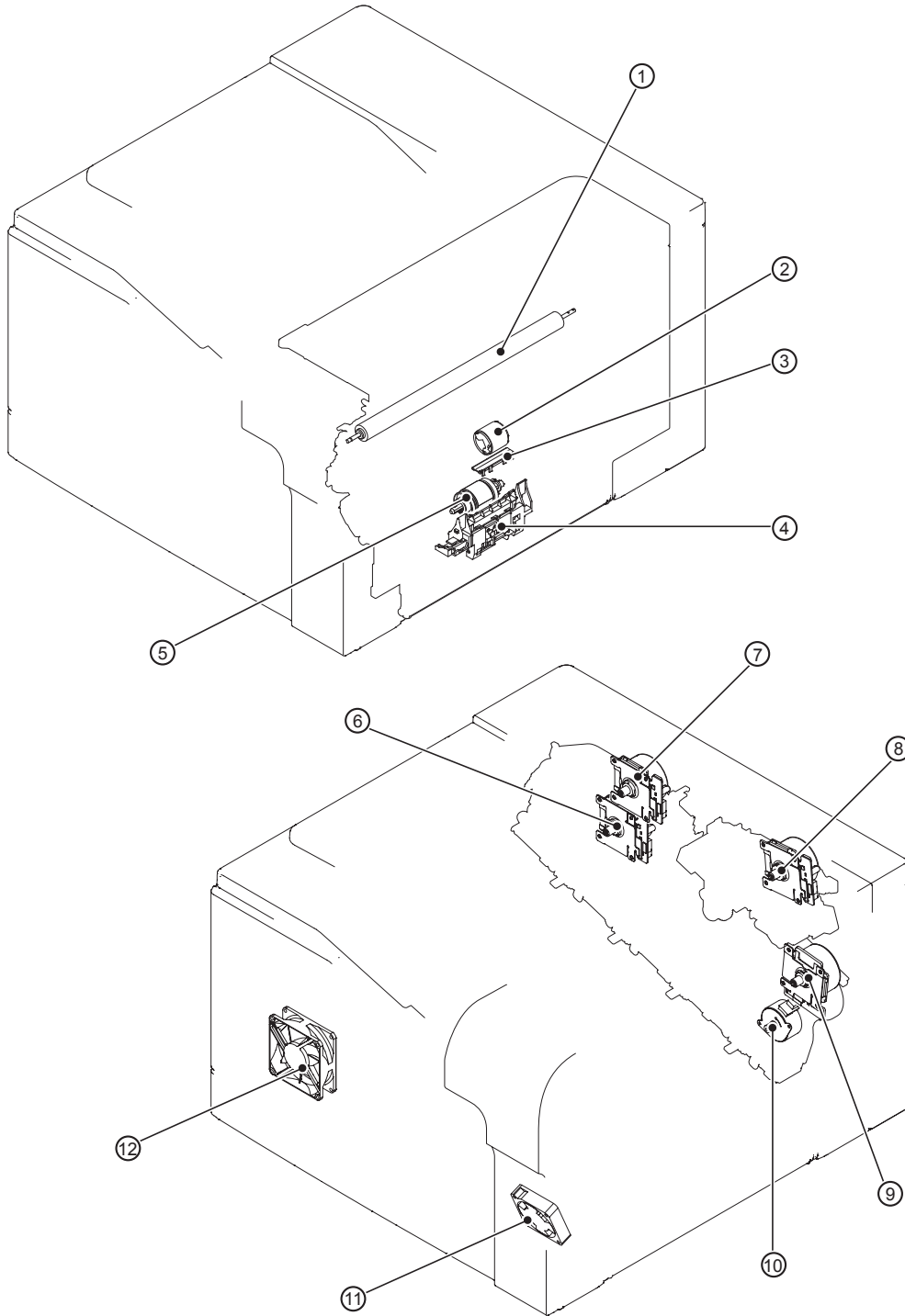

Item	Description	Item	Description
1	Secondary transfer roller unit	7	Drum motor
2	MP tray (Tray 1) pickup roller	8	Fuser motor
3	MP tray (Tray 1) separation pad	9	ITB motor
4	Cassette (Tray 2) separation roller unit	10	Developing disengagement motor

Item	Description	Item	Description
5	Cassette (Tray 2) pickup roller unit	11	Fuser fan
6	Developing motor	12	Power supply fan

Figure 3-40 PCA component locations

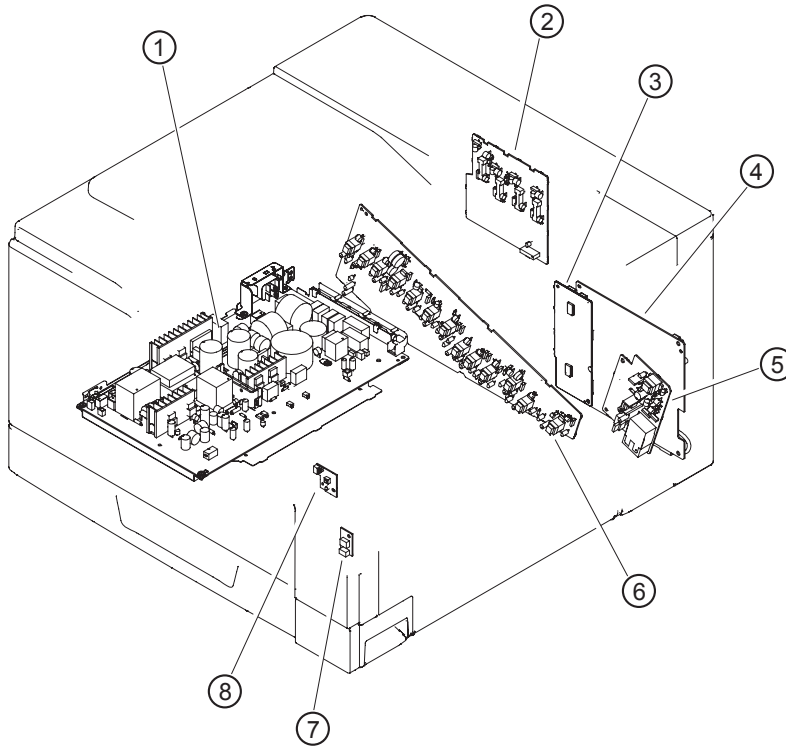

Item	Description	Item	Description
1	Low-voltage power-supply PCA	5	High-voltage power supply 2nd transfer PCA
2	High-voltage power supply 1st transfer PCA	6	High-voltage power supply imaging (development) PCA
3	Driver PCA	7	Environment sensor PCA
4	DC controller PCA	8	Power switch PCA

General timing charts

Figure 3-41 General timing chart (1 of 2)

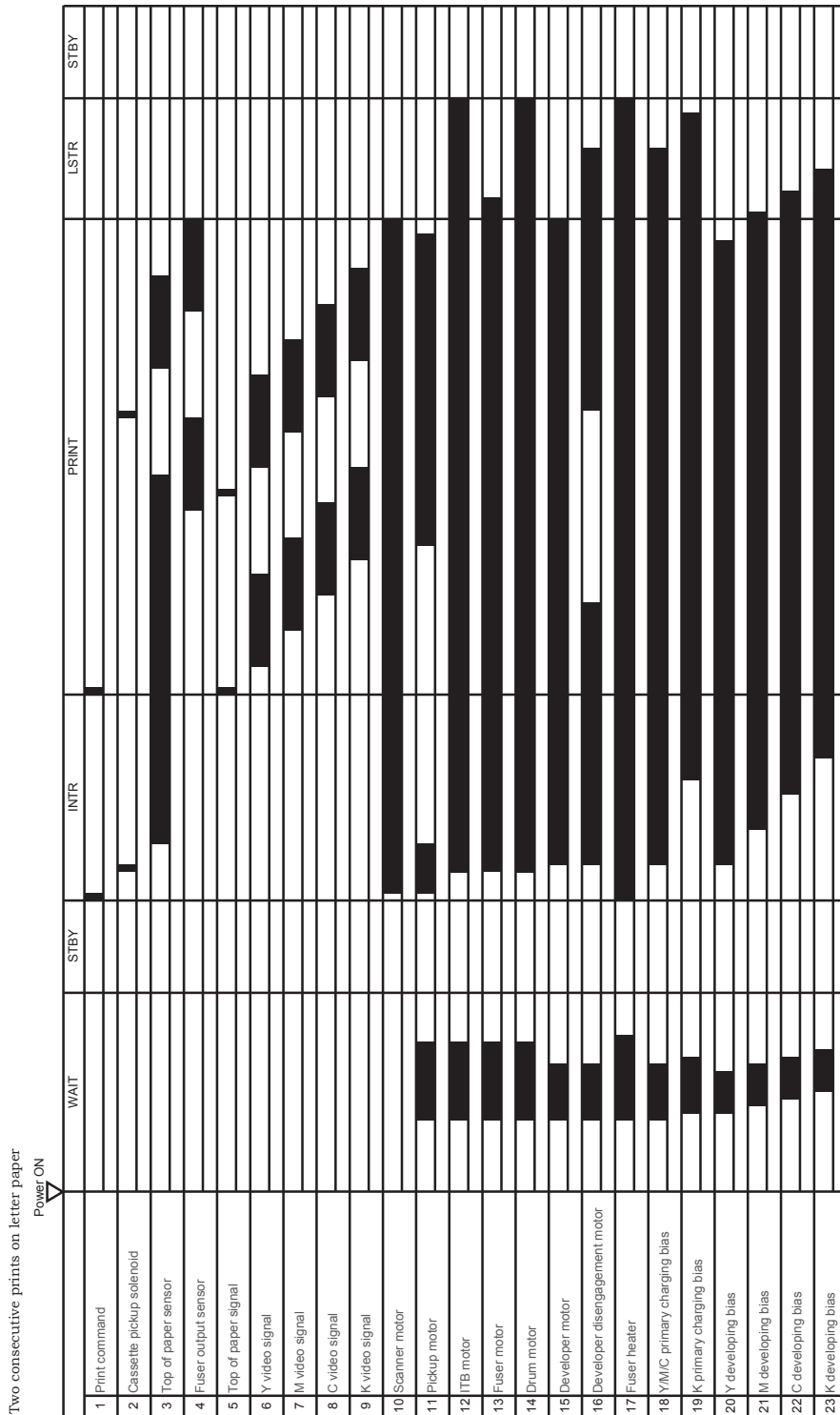
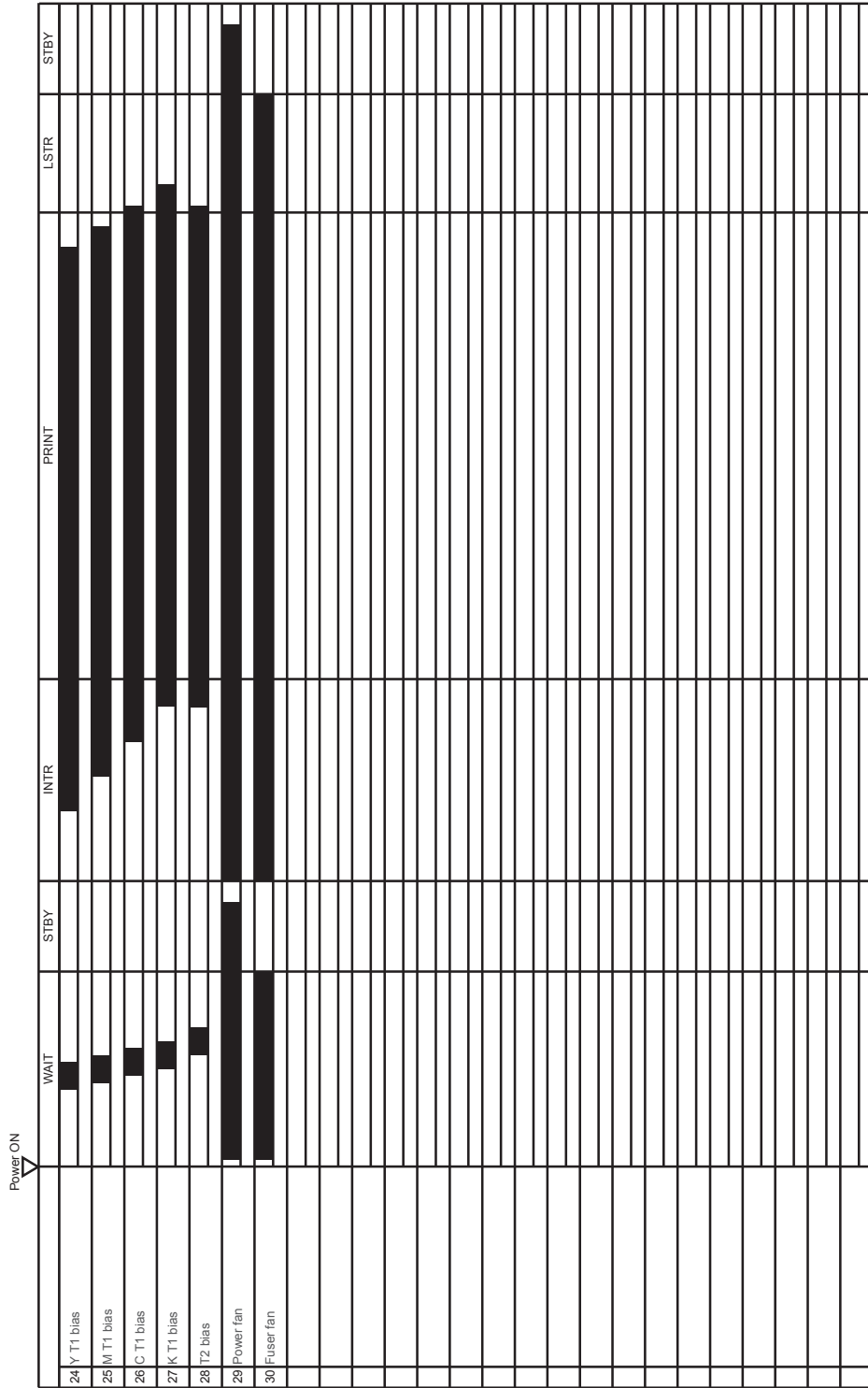

Figure 3-42 General timing chart (2 of 2)



General circuit diagram

Figure 3-43 General circuit diagram (1 of 2)

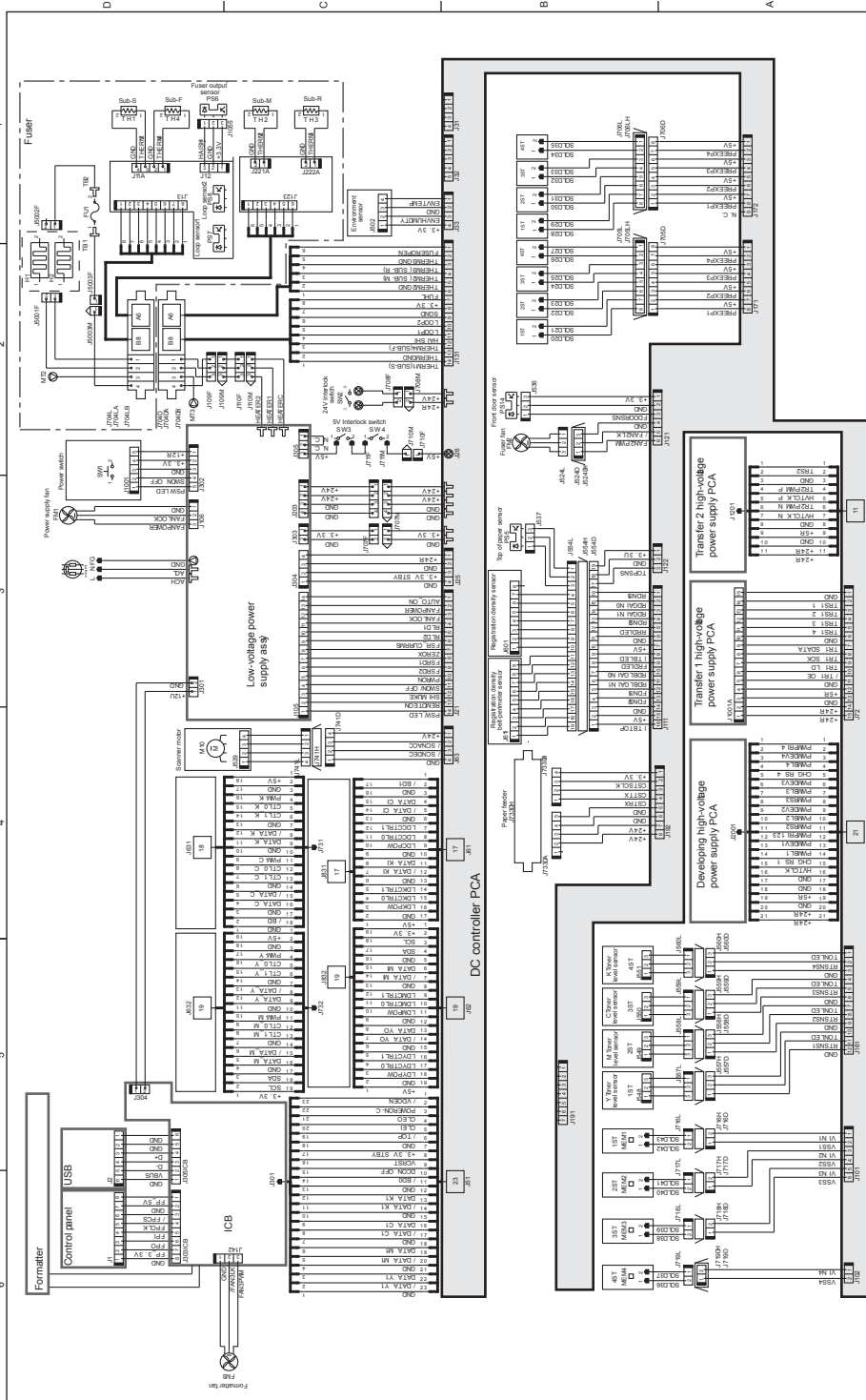

Figure 3-45 Paper feeder general circuit diagram (1 X 500)

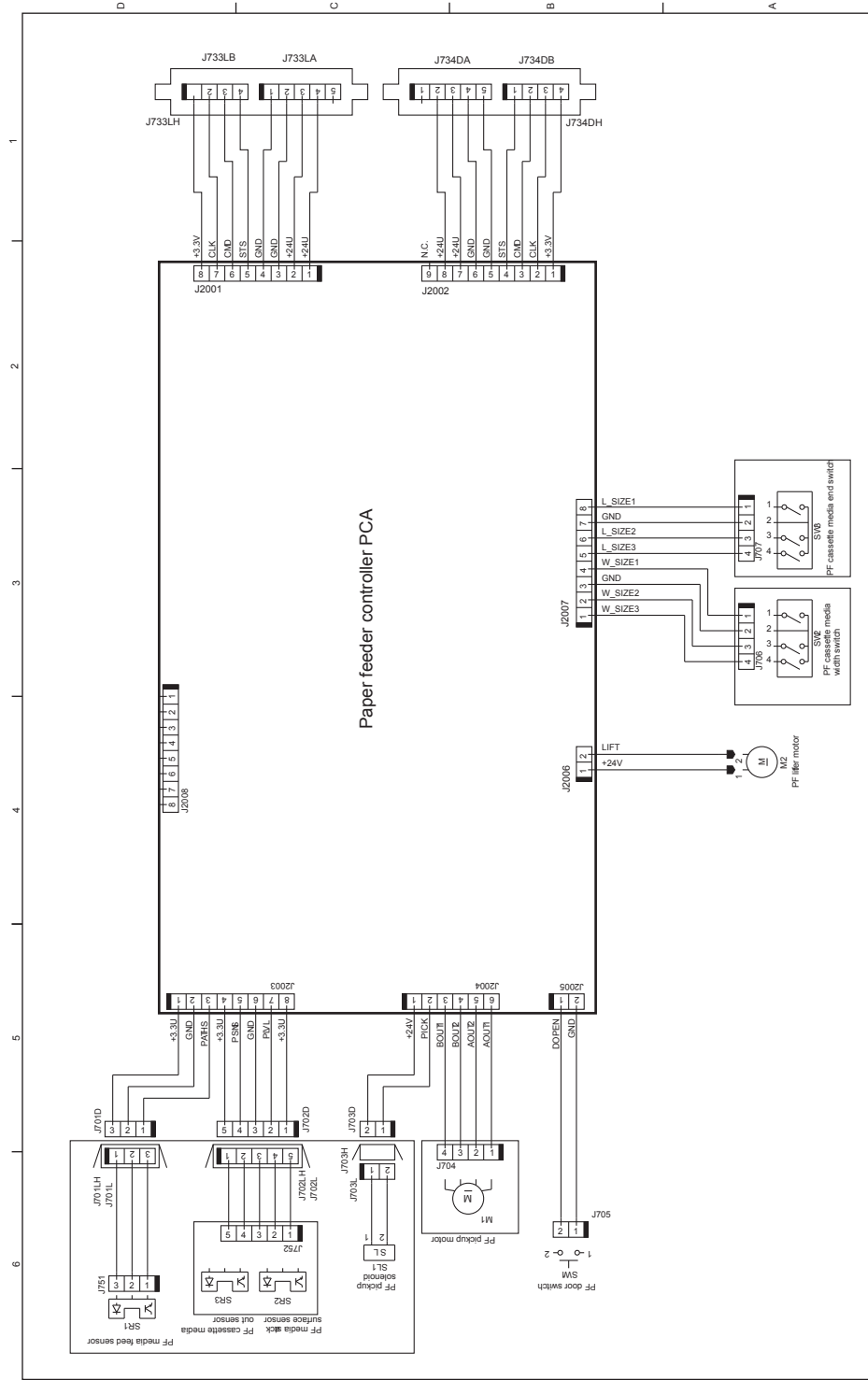
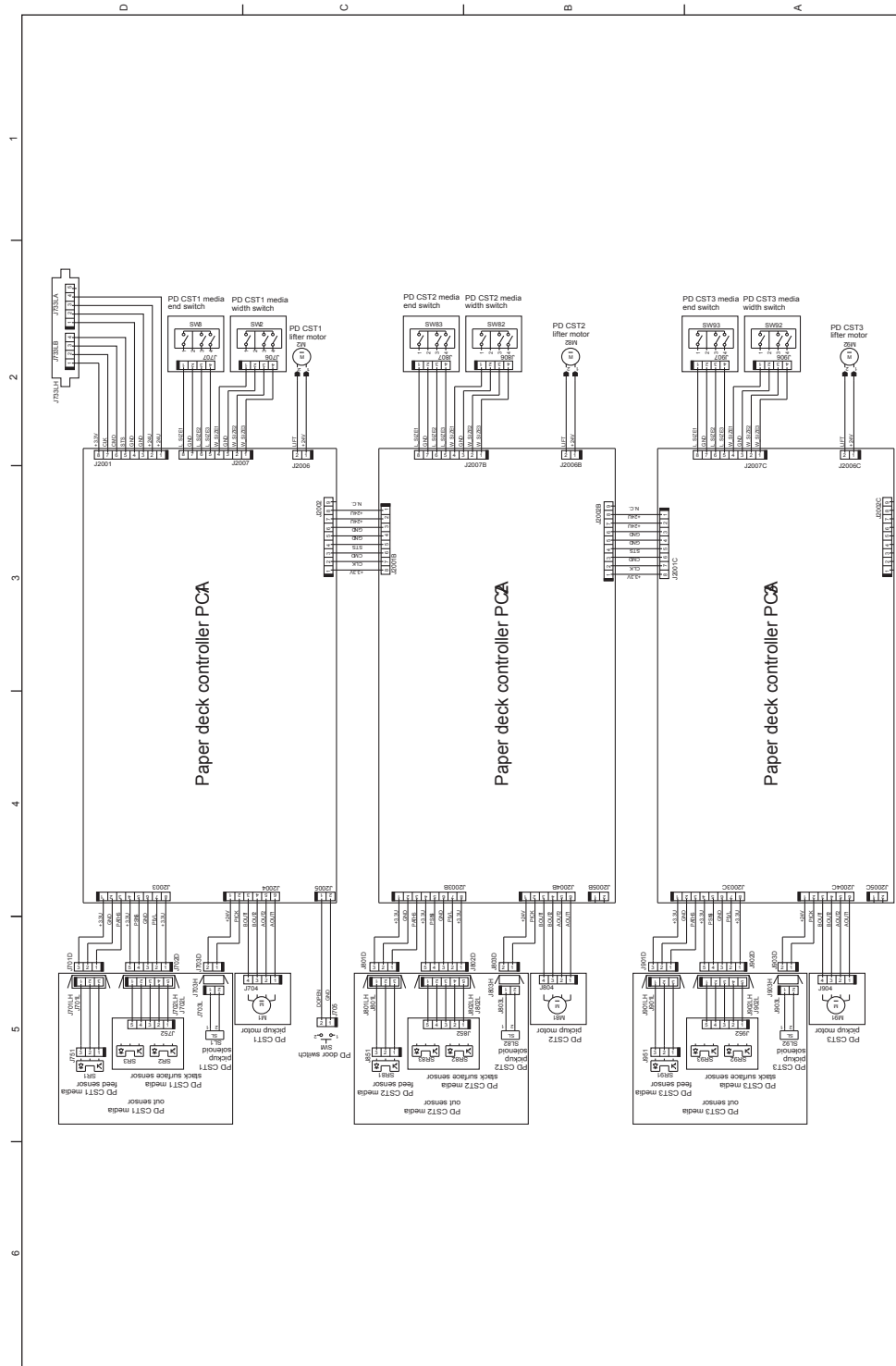



Figure 3-46 Paper deck general circuit diagram (3 X 500)



Internal print-quality test pages

Print-quality-troubleshooting pages

Use the built-in print-quality-troubleshooting pages to help diagnose and solve print-quality problems.

1. Press the Home  button.
2. Open the following menus:
 - **Administration**
 - **Troubleshooting**
 - **Print Quality Pages**
3. Press the **Down** arrow  to highlight the **Print PQ Troubleshooting Pages** item, and then press the **OK** button to print the pages.

The product returns to the **Ready** state after printing the print-quality-troubleshooting pages. Follow the instructions on the pages that print out.

Figure 3-47 Print-quality troubleshooting procedure



Figure 3-48 Yellow print-quality troubleshooting page

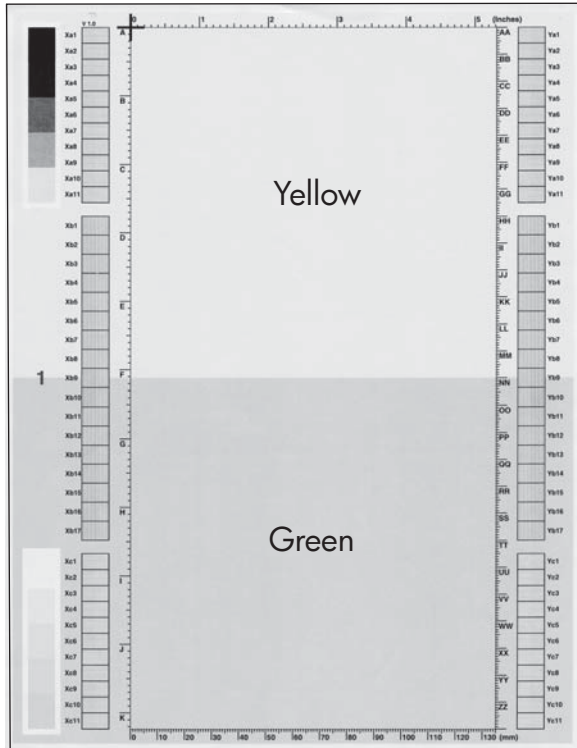
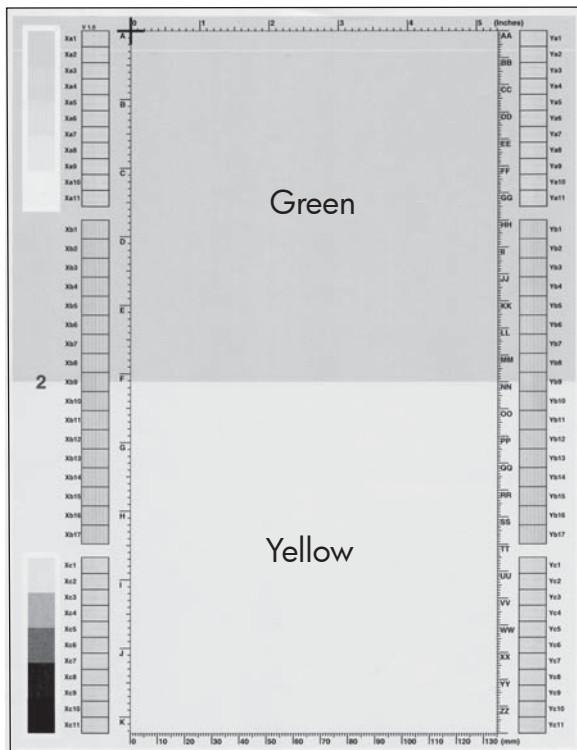
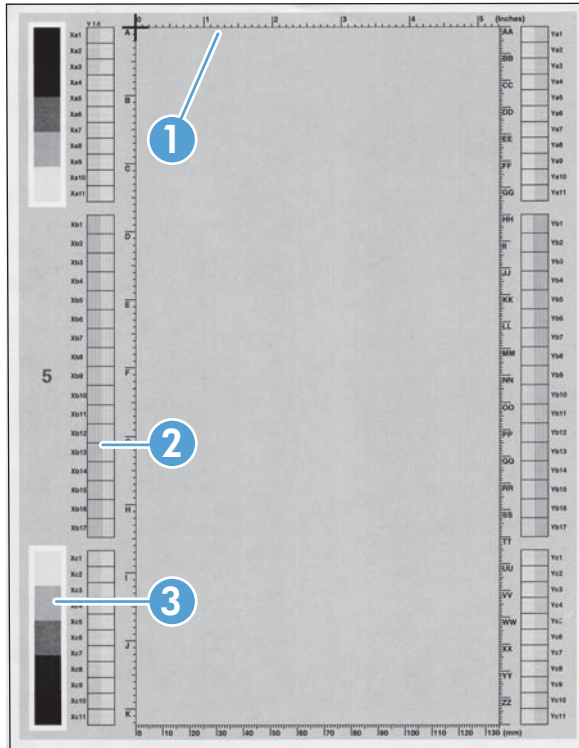

Figure 3-49 Yellow comparison page



Yellow cannot be easily seen unless combined with cyan, so half of each page is yellow and the other half is an amplified version of yellow problems (green half). Compare the yellow on page one with the corresponding green on page two for defects. You can also check the cyan page for defects.

Figure 3-50 Black print-quality troubleshooting page





<p>1. Grids</p>	<p>The grids are in inches and millimeters. They are label with letters and numbers so that defects can be described by position and by distance between repeats.</p>
<p>2. Color plane registration (CPR) bars</p>	<p>After printing, the box with no extra color in each area on each page shows how far off the CPR of that color is. Each page has two process direction areas and three scan direction areas that are labeled x and y and 1–11. The page should be fed by the long edge. Each square from the center equals 42 microns.</p>
<p>3. Color ramp patches</p>	<p>Used to detect offset for the OPC or developer in the image drum or offset in the fuser.</p>

 **NOTE:** To get further assistance in print quality troubleshooting, go to www.hp.com/support/ljcp5520series and select PQ Troubleshooting Tools.

Diagnostics page

Use the diagnostics page to evaluate problems with color plane registration, EP parameters, and print quality.

1. Press the Home  button.
2. Open the following menus:
 - **Administration**
 - **Troubleshooting**
 - **Print Quality Pages**
3. Press the **Down** arrow  to highlight the **Diagnostics Page** item, and then press the **OK** button to print the page.

1	Calibration information
2	Parameters
3	Color density

4	Color plane registration
5	Primary colors
6	Secondary colors
7	Temperature values (21A)
8	Humidity values (21B)

Clean the paper path

Process a cleaning page

1. Press the Home button .
2. Open the following menus:
 - **Device Maintenance**
 - **Calibration/Cleaning**
3. Press the **Down** arrow ▼ to highlight the **Print Cleaning Page** item, and then press the **OK** button.
4. The product prints a cleaning page, and then returns to the main menu. Discard the printed page.

Set up an auto cleaning page

Use the procedure in this section to set up an automatic cleaning page.

1. Press the Home button .
2. Open the following menus:
 - **Device Maintenance**
 - **Calibration/Cleaning**
3. Press the **Down** arrow ▼ to highlight the **Auto Cleaning** item, and then select the **Enabled** item. Press the **OK** button.
4. Press the **Down** arrow ▼ to highlight the **Cleaning Interval** item, and then use the arrow buttons to select an interval. Press the **OK** button.

 **TIP:** HP recommends processing a cleaning page after every 5000 printed pages.



5. Press the **Down** arrow ▼ to highlight the **Auto Cleaning Size** item, and then use the arrow buttons to select the cleaning page size. Press the **OK** button.

Configuration page

Depending on the model, up to three pages print when you print a configuration page. In addition to the main configuration page, the embedded Jetdirect configuration pages print.

Configuration page

Use the configuration page to view current product settings, to help troubleshoot product problems, or to verify installation of optional accessories, such as memory (DIMMs), paper trays, and printer languages.

1. Press the Home button .
2. Open the following menus:
 - **Administration**
 - **Reports**
 - **Configuration/Status Pages**
3. Press the **Down** arrow  to highlight the **Configuration Page** item, and then press the **OK** button.
4. Press the **Up** arrow  to highlight the **Print** item, and then press the **OK** button.

The message **Submitted to Queue** displays on the control panel until the product finishes printing the configuration page. The product returns to the **Ready** state after printing the configuration page.

 **NOTE:** If the product is configured with EIO cards (for example, an HP Jetdirect Print Server) or an optional hard-disk drive, additional pages will print that provide information about those devices.

Figure 3-51 Configuration page

Configuration Page
HP Color LaserJet CP5520 Series
Page 1

1 Device Information

Product Name: HP Color LaserJet CP5520 Series
 Device Name: HP Color LaserJet CP5520 Series
 Model Number: CE709V
 DC Controller Version: 4.89
 Optional Trays Version: 3.103
 Device Serial Number: CN1C882001
 Formatter Number: PW001E9
 Firmware Datecode: 20100826
 Firmware Revision: 103033.1_104646
 Service ID: 202566
 PS Wait Time-out: 300 seconds
 Engine Cycles*: 305
 Color Engine Cycles*: 234
 *Not weighted for billing

2 Installed Personalities and Options

PCL: 20010402
 PCLXL: 20010402
 POSTSCRIPT: 20010402
 PDF: 20050131
 Internal Disk: Hard Disk: Enabled
 Serial Number: 5V81E7M
 Model: HP Secure Hard Disk
 Capacity: 114473 MB
 Hard Disk Encryption Status: Encrypted
 EIO 1: Enabled
 Embedded HP JetDirect 38016E: 15.5.176.177
 Custom Color Table: Not Installed

3 Color Density

	C	M	Y	K
Highlights	0	0	0	0
Mistones	0	0	0	0
Shadows	0	0	0	0

4 Calibration Information

Last CPR (Engine Cycles): 298
 Last CPR: 12 Oct 2010/17:54
 Last IMx/DHalf (Engine Cycles): 231
 Last IMx/DHalf: 12 Oct 2010/17:36

5 Memory

Total RAM: 1024 MB

6 Event Log

Number of Entries in Use: 10
 Three Most Recent Entries:

Number	Cycles	Event
10	0	33.02.01
9	16	10.99.40
8	96	10.99.40

7 Security

Hard Disk Encryption Status: Encrypted
 File Erase Mode: Non-Secure Fast Erase (No overwrite)
 Control Panel Password: Disabled
 Support Key: 66PX-2XK3-8200
 Host: USB plug and play: Enabled
 Device USB: Enabled

8 Paper Trays and Options

Default Paper Size: Letter
 Tray 1 Size: Any Size
 Tray 1 Type: Any Type
 Tray 2 Size: Letter
 Tray 2 Type: Plain
 Tray 3 Size: Letter =
 Tray 3 Type: Plain
 Tray 4 Size: 11x17
 Tray 4 Type: HP Glossy 130g
 Tray 5 Size: Letter
 Tray 5 Type: Plain
 Tray 6 Size: 11x17
 Tray 6 Type: Plain
 Duplex Unit

1: Output Bin 1, 300 Sheets, Standard top bin

Oct12/2010 4:00:04 PM

English (United States)

1	Printer information
2	Installed personalities and options
3	Color density
4	Calibration information
5	Memory
6	Event log
7	Security
8	Paper trays and options

HP embedded Jetdirect page

The second configuration page is the HP embedded Jetdirect page, which contains the following information:

Figure 3-52 HP embedded Jetdirect page

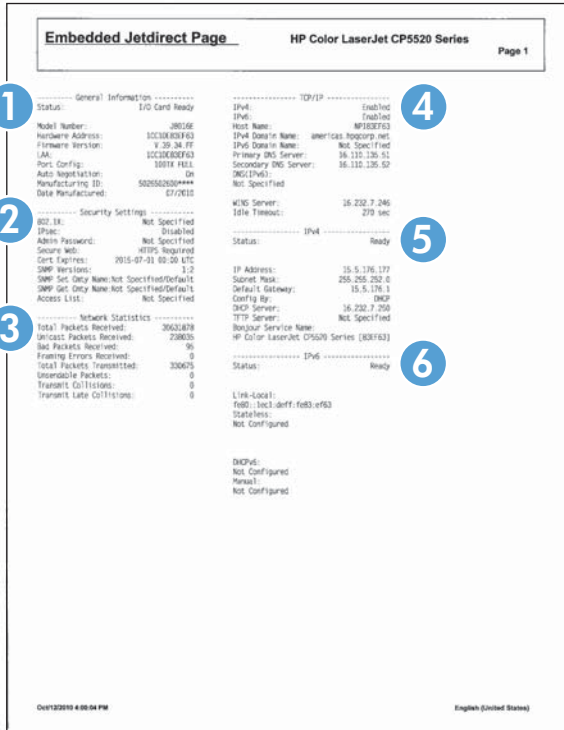

1	HP Jetdirect Configuration indicates the product status, model number, hardware firmware version, port select, port configuration, auto negotiation, manufacturing identification, and manufactured date.
2	Security Settings information
3	Network Statistics indicates the total packets received, unicast packets received, bad packets received, framing errors received, total packets transmitted, undersendable packets, transmit collisions, and transmit late collisions.
4	TCP/IP information, including the IP address
5	IPv4 information
6	IPv6 information

Always make sure the status line under the HP Jetdirect configuration lines indicates "I/O Card Ready".

Finding important information on the configuration pages

Certain information, such as the firmware date codes, the IP address, and the e-mail gateways, is especially helpful while servicing the product. This information is on the various configuration pages.

Table 3-26 Important information on the configuration pages

Type of information	Specific information	Configuration page
<p>Firmware date codes</p> <p>When you use the remote firmware upgrade procedure, all of these firmware components are upgraded.</p>	DC controller	Look on the main configuration page, under "Device Information."
	Firmware datecode	Look on the main configuration page, under "Device Information."
	Embedded Jetdirect firmware version	Look on the embedded Jetdirect page, under "HP Jetdirect Configuration."
<p>Accessories and internal storage</p> <p>All optional devices that are installed on the product should be listed on the main configuration page.</p> <p>In addition, separate pages print for the optional paper handling devices and the fax accessory. These pages list more-detailed information for those devices.</p>	External disk (optional)	Look on the main configuration page, under "Installed Personalities and Options." Shows model and capacity.
	Embedded HP Jetdirect	Look on the main configuration page, under "Installed Personalities and Options." Shows model and ID.
	Total RAM	Look on the main configuration page, under "Memory."
	Duplex unit	Look on the main configuration page, under "Paper Trays and Options."
Additional 500-sheet feeders	Additional 500-sheet feeders	Look on the main configuration page, under "Paper Trays and Options."
<p>Engine cycles and event logs</p> <p>Total page counts and maintenance kit counts are important for ongoing product maintenance.</p> <p>The configuration page lists only the three most recent errors. To see a list of the 50 most recent errors, print an event log from the Diagnostics menu.</p>	Engine cycles	Look on the main configuration page, under "Device Information."
	Event-log information	Event-log information

Color-band test

The color-band test page shows bands of colors that can indicate whether or not the product is producing colors correctly.

1. Press the Home button .
2. Open the following menus:
 - **Administration**
 - **Troubleshooting**
 - **Print Quality Pages**
3. Press the **Down** arrow ▼ to highlight the **Color Band Test** item, and then press the **OK** button.
4. Press the **Down** arrow ▼ to highlight the **Print Test Page** item, and then press the **OK** button.

Print quality troubleshooting tools

Repetitive image-defect ruler

Use a ruler to measure occurrences of repetitive image defects to help solve image quality problems. Place the ruler next to the first occurrence of the defect on the page. Find the distance between identical defects and use the figure below to identify the component that is causing the defect.



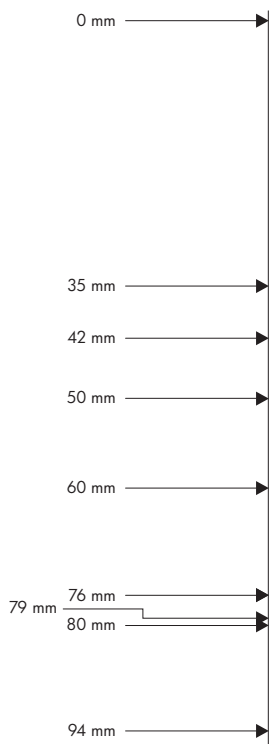

 **NOTE:** When printing this defect ruler, verify that any scaling options in the printer driver are disabled.



Distance between defects	Product components that cause the defect
35 mm	Print cartridge (primary charging roller)
42 mm	Print cartridge (developer roller)
50 mm	Print engine (primary transfer roller)
60 mm	Print engine (secondary transfer roller)
76 mm	Fuser (fuser film)
79 mm	Fuser (pressure roller)
80 mm	Fuser (pressure roller)
94 mm	Print cartridge (OPC)

Calibrate the product

Calibration is a product function that optimizes print quality. If you experience any image-quality problems, calibrate the product.







1. Press the Home button .
2. Press the **Down** arrow  to highlight the **Device Maintenance** menu, and then press the **OK** button.
3. Press the **Down** arrow  to highlight the **Calibration/Cleaning** menu, and then press the **OK** button.
4. Press the **Down** arrow  to highlight the **Full Calibration** or **Quick Calibration** setting, and then press the **OK** button.
 - **Full Calibration:** takes about 70 seconds and performs color plane registration, environment change control, and Dmax and Dhalf adjustments. Use **Full Calibration** if colors are misaligned or appear blurry. **Full Calibration** runs automatically after a replacement transfer belt (ITB) is installed. **Full Calibration** must be run manually after a laser scanner is replaced.
 - **Quick Calibration:** takes about 45 seconds and performs Dmax and Dhalf adjustments. Use **Quick Calibration** if colors are wrong, highlights are missing, or if colors are too dark or too light.

Control panel menus

To use all of the capabilities of this product, a firmware upgrade might be required. HP recommends that you periodically go to www.hp.com/go/ljcp5525series_software to see if a new version of firmware is available.

 **NOTE:** Print a configuration page to determine the version of firmware currently installed in this product.

Navigate the control-panel menus:

- Press the Home button  to access the menus.
- Press the **Up** arrow button  and **Down** arrow button  to highlight a desired menu item.
- Press the **OK** button to select the menu item.
- Press the **Back** arrow button  to navigate backwards in nested menus.
- Press the Home button  again, or the **Back** arrow button  repeatedly, to exit the menus.

Sign In menu

Table 3-27 Sign In menu

First level	Second level	Values	Description
User Access Code	Access Code		Access the product with a user-level personal identification number (PIN). NOTE: Some menus or functions might not be available.
Administrator Access Code	Access Code		Access the product with a administrator-level PIN.
Service Access Code	Access Code		Access the product with a technician-level PIN.

Retrieve Job From USB menu

Use the **Retrieve Job From USB** menu to view listings of jobs stored on an external USB memory device.

 **NOTE:** You must enable this feature by using the control-panel menus or the HP Embedded Web Server before it can be used.

To enable this feature by using the control-panel menus, access the **Administration** menu, **Retrieve From USB Settings** sub menu, and then select **Enable**.

Table 3-28 Retrieve Job From USB menu

First level	Second level	Values	Description
Retrieve Job From USB		OK	Use the Retrieve Job From USB item to view a listing of all jobs stored on a portable storage device.
		Cancel	
	Select a File or Folder	Select from the provided list.	

Retrieve Job From Device Memory menu

Use the **Retrieve Job From Device Memory** menu to view listings of jobs stored on the internal product memory.

Table 3-29 Retrieve Job From Device Memory menu

First level	Second level	Third level	Values	Description
Retrieve Job From Device Memory	All Jobs (No PIN) NOTE: Individual job names also appear.	Print	Range: 1 – 9999 Default = 1	Use the Retrieve Job From Device Memory item to view a listing of all jobs stored in the product memory.
		Delete	Select from the provided list.	

Supplies menu

In the following table, asterisks (*) indicate the factory default setting.

Table 3-30 Supplies menu

First level	Second level	Third level	Fourth level	Values	Description
Manage Supplies	Supplies Status	Black Cartridge	Very Low Settings	Stop	Select what the product should do when the print cartridge is very near the end of its estimated life.
				Prompt to continue*	Stop: The product stops until you replace the cartridge.
	Supply Settings			Continue	Prompt to continue: The product stops until you clear the prompt message. After the prompt message is cleared, there will not be another message indicating that the supply needs to be replaced.
			Low Threshold Settings	1-100%	Continue: The product provides an alert message, but it continues printing. There will not be another message indicating that the supply needs to be replaced.
					Use the arrow buttons to enter the percentage of estimated cartridge life at which you want the product to alert you that the cartridge is low.

Table 3-30 Supplies menu (continued)

First level	Second level	Third level	Fourth level	Values	Description
		Color Cartridges	Very Low Settings		<p>Stop</p> <p>Prompt to continue*</p> <p>Continue</p> <p>Select what the product should do when the print cartridge is very near the end of its estimated life.</p> <p>Stop: The product stops until you replace the cartridge.</p> <p>Prompt to continue: The product stops until you clear the prompt message.</p> <p>Continue: The product provides an alert message, but it continues printing.</p>
			Low Threshold Settings	<p>Cyan Cartridge 1-100%</p> <p>Magenta Cartridge</p> <p>Yellow Cartridge</p>	<p>Use the arrow buttons to enter the percentage of estimated cartridge life at which you want the product to alert you that the cartridge is low.</p>
		Fuser	Very Low Settings		<p>Stop</p> <p>Prompt to continue*</p> <p>Continue</p> <p>Stop: The product stops until you replace the fuser kit.</p> <p>Prompt to continue: The product stops until you clear the prompt message.</p> <p>Continue: The product provides an alert message, but it continues printing.</p>

Table 3-30 Supplies menu (continued)

First level	Second level	Third level	Fourth level	Values	Description
			Low Threshold Settings	1-100%	Use the arrow buttons to enter the percentage of estimated supplies life at which you want the product to alert you that the cartridge is low.
		Transfer Kit	Very Low Settings		<p>Stop</p> <p>Prompt to continue*</p> <p>Continue</p> <p>Stop: The product stops until you replace the transfer kit.</p> <p>Prompt to continue: The product stops until you clear the prompt message.</p> <p>Continue: The product provides an alert message, but it continues printing.</p>
			Low Threshold Settings	1-100%	Use the arrow buttons to enter the percentage of estimated supplies life at which you want the product to alert you that the cartridge is low.
		Color/Black Mix			<p>Auto*</p> <p>Mostly Color Pages</p> <p>Mostly Black Pages</p> <p>Use this feature to instruct the product when to switch between color and monochrome printing modes for the best overall performance. Select the setting depending on the types of jobs you typically print.</p>

Table 3-30 Supplies menu (continued)

First level	Second level	Third level	Fourth level	Values	Description
	Supply Messages	Low Message		On* Off	Select how the product displays the supply information. Low Message: Determines whether or not a low supply message is displayed on the control panel.
		Level Gauge		On* Off	LEVEL GAUGE: Determines whether or not a supply level gauge appears on the control panel.
	Black Cartridge OK: - Status				Supply status message—no action required.
	Cyan Cartridge OK: - Status				Supply status message—no action required.
	Magenta Cartridge OK: - Status				Supply status message—no action required.
	Yellow Cartridge OK: - Status				Supply status message—no action required.
	Toner Collection Unit OK: - Status				Supply status message—no action required.
	Transfer Kit OK: - Status				Supply status message—no action required.
	Fuser OK: - Status				Supply status message—no action required.

Trays menu

In the following table, asterisks (*) indicate the factory default setting.

Table 3-31 Trays menu

First level	Second level	Values	Description
Manage Trays	Use Requested Tray	Exclusively* First	Use this feature to control how the product handles jobs that have specified a specific input tray.
	Manually Feed Prompt	Always* Unless loaded	Use this feature to indicate whether a prompt should appear when the type or size for a job does not match the specified tray and the product pulls from the multipurpose tray instead.
	Size/Type Prompt	Display* Do not display	Use this feature to control whether the tray configuration message appears whenever a tray is closed.
	Use another tray	Enabled* Disabled	Use this feature to turn on or off the control-panel prompt to select another tray when the specified tray is empty.
	Alternative Letterhead Mode	Disabled* Enabled	Use this feature so that you can load letterhead or preprinted paper into the tray the same way for all print jobs, whether you are printing to one side of the sheet or to both sides of the sheet.
	Blank Pages	Auto* Yes	Use this feature to control how the product handles two-sided jobs (duplexing). Auto: This option enables Smart Duplexing, which instructs the product not to process blank pages. Yes: This option disables Smart Duplexing and forces the duplexer to flip the sheet of paper even if it is printed on only one side.
	Override A4/Letter	Yes* No	Use this feature to print on letter-size paper when an A4 job is sent but no A4-size paper is loaded in the product (or to print on A4 paper when a letter-size job is sent but no letter-size paper is loaded).

Table 3-31 Trays menu (continued)

First level	Second level	Values	Description
Tray 1 Size		Select from a provided list.	Allows you to configure the paper size for Tray 1. The default is Any Size . See the product user guide for a complete list of available sizes.
Tray 1 Type		Select from a provided list.	Allows you to configure the paper type for Tray 1. The default is Any Type . See the product user guide for a complete list of available types.
Tray 2 Size		Select from a provided list.	Use this feature to specify the size of paper loaded in the tray.
Tray 2 Type		Select from a provided list.	Use this feature to specify the type of paper loaded in the tray.
Tray 3 Size		Select from a provided list.	Use this feature to specify the size of paper loaded in the tray.
Tray 3 Type		Select from a provided list.	Use this feature to specify the type of paper loaded in the tray.
Tray 4 Size		Select from a provided list.	Use this feature to specify the size of paper loaded in the tray.
Tray 4 Type		Select from a provided list.	Use this feature to specify the type of paper loaded in the tray.
Tray 5 Size		Select from a provided list.	Use this feature to specify the size of paper loaded in the tray.
Tray 5 Type		Select from a provided list.	Use this feature to specify the type of paper loaded in the tray.
Tray 6 Size		Select from a provided list.	Use this feature to specify the size of paper loaded in the tray.
Tray 6 Type		Select from a provided list.	Use this feature to specify the type of paper loaded in the tray.

Administration menu

Reports menu



NOTE: After selecting items from this menu, select **Print** to print the report.

Table 3-32 Reports menu

First level	Second level	Values	Description
Configuration/Status Pages	Print		Select a report, and then select Print to print the report.

Table 3-32 Reports menu (continued)

First level	Second level	Values	Description
	Administration Menu Map		Prints the control-panel menu map, which shows the layout of the control-panel menu items.
	Configuration Page		Shows the printer settings and installed accessories.
	Supplies Status Page		Shows the approximate remaining life for the supplies; reports statistics on total number of pages and jobs processed, serial number, page counts, and maintenance information.
	Usage Page		Prints a count of impressions (letter/A4 equivalents that have passed through the product; lists whether they were monochrome, or color; and reports the count).
	Paper Path Page		Prints a count of all paper sizes that have passed through the product by paper size; lists whether they were simplex, duplex, blank page, source, destination, paper type, and print mode usage.
	File Directory Page		Shows the file name and folder name for files that are stored in the product memory.
	Current Settings Page		Shows the products current settings.
	Color Usage Job Log		Shows information about the number of color and black & white pages that each user has printed. It also indicates from which software program each of the jobs was printed.
Other Pages	Print		This menu contains several other product-related reports and pages.
	Demonstration Page		Print the Demo page for an example of high-quality printing from the product.
	RGB Samples		Print the RGB Samples page for a palette of RGB (red, green, blue) color values. Use this page to match colors.
	CMYK Samples		Print the CMYK Samples page for a palette of CMYK (cyan, magenta, yellow, black) color values. Use this page to match colors.
	PCL Font List		Use this feature to print a list of printer control language (PCL) fonts that are currently available to the product.
	PS Font List		Use this feature to print a list of PostScript (PS) fonts that are currently available to the product.

General Settings menu

In the following table, asterisks (*) indicate the factory default setting.

Table 3-33 General Settings menu

First level	Second level	Third level	Fourth level	Values	Description
Date/Time Settings	Date/Time Format	Date Format		DD/MMM/YYYY	Allows you to choose the order in which the year, month, and day appear in the date.
				MMM/DD/YYYY*	
			YYYY/MMM/DD		
		Time Format		12 hour (AM/PM)*	Time Format
				24 hours	
	Date/Time	Date			Allows you to set the correct date. The range for the year is 2008 to 2037.
		Time			Time
		Time Zone			Allows you to set the correct time zone.
		Adjust for Daylight Savings		On Off*	If you are in an area that observes daylight saving time, select On.
Energy Settings	Sleep Delay			15* Range: 1 – 120 minutes	Reduces power consumption when the product has been inactive for the selected period.

Table 3-33 General Settings menu (continued)

First level	Second level	Third level	Fourth level	Values	Description
	Optimum Speed/ Energy Usage			Faster First Page* Save Energy Save More Energy Save Most Energy	<p>Controls the fuser cool down behavior.</p> <p>Faster First Page: The fuser maintains power and the first page processes faster for any new job that is sent to the product.</p> <p>Save Energy: The fuser reduces power when it is idle.</p> <p>Save More Energy: The fuser reduces more power than the Save Energy option.</p> <p>Save Most Energy: The fuser is turned off and it gradually cools to room temperature. The Save Most Energy option takes the longest time to print the first page.</p>
Print Quality	Adjust Color	Highlights	Cyan Density Magenta Density Yellow Density Black Density	-5 to 5 Default = 0	Adjust the darkness or lightness of highlights on a printed page. Lower values represent lighter highlights on a printed page, and higher values represent darker highlights on a printed page.
		Midtones	Cyan Density Magenta Density Yellow Density Black Density	-5 to 5 Default = 0	Adjust the darkness or lightness of midtones on a printed page. Lower values represent lighter midtones on a printed page, and higher values represent darker midtones on a printed page.

Table 3-33 General Settings menu (continued)

First level	Second level	Third level	Fourth level	Values	Description
		Shadows	Cyan Density	-5 to 5	Shadows
			Magenta Density	Default = 0	
			Yellow Density		
			Black Density		
		Restore Color Values			Restore the color settings by resetting the density values of each color.
	Image Registration	Adjust Tray <X>	Print Test Page		Print Test Page
			X1 Shift	-5.00 mm to 5.00 mm	The scan direction is referred to as X. X1 is the scan direction for a single-sided page or for the second side of a two-sided page. X2 is the scan direction for the first side of a two-sided page.
			Y1 Shift	Default = 0	
			X2 Shift		
			Y2 Shift		
					The feed direction is referred to as Y. Y1 is the feed direction for a single-sided page or for the second side of a two-sided page. Y2 is the feed direction for the first side of a two-sided page.

Table 3-33 General Settings menu (continued)

First level	Second level	Third level	Fourth level	Values	Description
	Auto Sense Mode	Tray 1 Sensing		Full sensing Expanded sensing* Transparency Only	<p>Sets the sensing option for Tray 1 for paper types using AUTO SENSE mode.</p> <p>When Full sensing is selected, the product senses every page and switches modes accordingly. The product can distinguish light paper, plain paper, heavy paper, glossy paper, tough paper, or transparencies. Using this mode significantly reduces print speed. Use it only when you are printing on mixed paper types.</p> <p>When Expanded sensing is selected, the product senses only the first page and assumes the rest of the pages are the same type. The product can distinguish light paper, plain paper, heavy paper, glossy paper, tough paper, or transparencies.</p> <p>When Transparency Only is selected, the product senses only the first page. The product can distinguish transparencies from other paper types.</p>

Table 3-33 General Settings menu (continued)

First level	Second level	Third level	Fourth level	Values	Description
		Tray X Sensing		Expanded sensing* Transparency Only	<p>Sets the sensing option for Trays 2-5 for paper types using AUTO SENSE mode.</p> <p>When Expanded sensing is selected, the product senses only the first few pages and assumes the rest of the pages are the same type. The product can distinguish light paper, plain paper, heavy paper, glossy paper, tough paper, or transparencies. The product senses the paper type when you turn it on and after you open and close a tray.</p> <p>When Transparency Only is selected, the product senses only the first page. The product can distinguish transparencies from other paper types.</p>
	Adjust Paper Types	Select from a list of paper types that the product supports. The available options are the same for each paper type.	Print Mode	Select from a list of print modes. Default = Auto Sense Mode	Configure the print mode that is associated with each media type.

Table 3-33 General Settings menu (continued)

First level	Second level	Third level	Fourth level	Values	Description
			Resistance Mode	Normal* Up Down	Use this setting to correct print quality problems in low-humidity environments and highly resistive paper. The default setting is Normal. Use the Up setting to increase the T2 bias in order to solve print quality problems that are related to poor toner transfer at the T2 stage. Use the Down setting to decrease the T2 bias in the event that small, pin-hole defects occur.
			Humidity Mode	Normal* High	Use this setting to correct print quality problems in high-humidity environments. The default setting is Normal. Use the High setting if you are in a high-humidity environment and you are seeing problems with low toner density on the first page of a job.

Table 3-33 General Settings menu (continued)

First level	Second level	Third level	Fourth level	Values	Description
			Fuser Temp Mode	Normal* Up Down	<p>If you are seeing a faint image of the page repeated at the bottom of the page or on the following page, you should first make sure the Paper Type and Print Mode settings are correct for the type of paper you are using. If you continue to see ghost images on your print jobs, set this feature to the Up or Down setting. Try the Up setting to improve toner fixing performance. Try the Down setting if you are seeing hot offset issues. Using this mode increases wear on product parts and might also slow down the printing process.</p>
			Paper Curl Mode	Normal* Reduced	<p>If excessive curling of paper occurs in warm, high-humidity environments above 23° C (73° F), set this feature to Reduced. This setting reduces the fuser temperature, increases the gap between pages, and increases the frequency of consumable replacements.</p>
	Optimize	Normal Paper		Standard* Smooth	<p>Set to SMOOTH when printing on smooth paper of normal weight.</p>
		Light Media		Normal* Smooth	<p>Set to SMOOTH when printing on smooth paper of light weight.</p>

Table 3-33 General Settings menu (continued)

First level	Second level	Third level	Fourth level	Values	Description
		Heavy Paper		Standard* Smooth	Set to SMOOTH when printing on smooth, heavy media types.
		Envelope Control		Normal* Alternate 1 Alternate 2	Set to REDUCED TEMP if envelopes are sticking due to moisture in the envelop adhesive.
		Environment		Normal* Low Temp	Set to LOW TEMP if the product is operating in a low-temperature environment and you are having problems with print quality such as blisters in the printed image.
		Line Voltage		Normal* Low Voltage	Set to LOW VOLTAGE if the product is operating in a low-voltage environment and you are having problems with print quality such as blisters in the printed image.
		Tray 1		Normal* Alternate	Set the mode to ALTERNATE if you are seeing marks on the back side of the paper when printing from Tray 1. This sets the product to initiate a clean sequence every time a job finishes when the product is set for Any Size and Any Type for Tray 1.
		Cleaning Control		Normal* Alternate	Generates and processes a fuser cleaning page for the printer.

Table 3-33 General Settings menu (continued)

First level	Second level	Third level	Fourth level	Values	Description
		Background		Normal* Alternate 1 Alternate 2 Alternate 3	Set to ALTERNATIVE 1 when a background occurs all over the page. Set to ALTERNATIVE 2 when thin vertical lines appear on the page. Set to ALTERNATIVE 3 when the other alternatives do not correct the problem.
		Media Temp		Normal* Alternate	Set to ALTERNATE if the product is operating in a low-temperature environment and you are having problems with print quality such as blisters in the printed image.
		Uniformity Control		Normal* Alternate 1 Alternate 2 Alternate 3	Set to ALTERNATIVE 1 to improve uniformity on any paper type. Set to ALTERNATIVE 2 to improve uniformity on normal and light paper types. Set to ALTERNATIVE 3 when the other alternatives do not correct the problem.
		Pre-Rotation		Normal* Alternate 1 Alternate 2 Alternate 3	Turn this feature on if horizontal streaks appear on pages. Using this feature increases the first-page-out time by about 3.5 seconds.
		Registration		Normal* Alternate	Set to ALTERNATIVE when color misregistration occurs.

Table 3-33 General Settings menu (continued)

First level	Second level	Third level	Fourth level	Values	Description
		Transfer Control		Normal* Alternate 1 Alternate 2 Alternate 3	Set to ALTERNATIVE 1 to reduce primary transfer bias and to resolve low density or blotchy images. Set to ALTERNATIVE 2 to resolve ghosting outlines that look like a finger or fingers. Set to ALTERNATIVE 3 when the other alternatives do not correct the problem.
		Moisture Control		Normal* Alternate	Use this setting to correct print quality problems in high-humidity environments. The default setting is Normal. Use the Alternate setting if you are in a high-humidity environment and you are seeing problems with low toner density on the first page of a job.
		Restore Optimize			Allows you to optimize various print modes to address print quality issues.

Table 3-33 General Settings menu (continued)

First level	Second level	Third level	Fourth level	Values	Description
	Edge Control			Off Light Normal* Maximum	<p>The Edge Control setting determines how edges are rendered. Edge control has two components: adaptive halftoning and trapping. Adaptive halftoning increases edge sharpness. Trapping reduces the effect of color-plane misregistration by overlapping the edges of adjacent objects slightly.</p> <p>Off turns off both trapping and adaptive halftoning.</p> <p>Light sets trapping at a minimal level, and adaptive halftoning is on.</p> <p>Normal is the default trapping setting. Trapping is at a medium level and adaptive halftoning is on.</p> <p>Maximum is the most aggressive trapping setting. Adaptive halftoning is on.</p>
Jam Recovery				Auto* Off On	<p>Sets whether the product will attempt to reprint pages after a jam. If you select Auto, the product reprints pages if enough memory is available for full-speed two-sided printing.</p>

Table 3-33 General Settings menu (continued)

First level	Second level	Third level	Fourth level	Values	Description
Manage Stored Jobs	Quick Copy Job Storage Limit			1-300 Default = 32	Allows you to specify the number of Quick Copy jobs that can be stored on the product. The default value is 32. The maximum allowed value is 300.
			Quick Copy Job Held Timeout	Off* 1 hour 4 Hours 1 Day 1 Week	Allows you to set the amount of time that Quick Copy jobs are kept before being automatically deleted from the queue.
		Default Folder Name for Stored Jobs		Select from a list of folder names. Public*	use this item to select the default folder name for stored jobs.
		Sort Stored Jobs By		Job Name* Date	use this item to select how stored jobs are listed.

Table 3-33 General Settings menu (continued)

First level	Second level	Third level	Fourth level	Values	Description
Restore Factory Settings	Reset			All	Allows you to clear the page buffer, remove all perishable personality data, reset the printing environment, and return most settings to factory defaults.
				Calibration	
				General	
				Print	
				Security	
Restrict Color				Enable	This menu item controls the authorization of color printing. DISABLE COLOR: All jobs sent to the product print only in monochrome. ENABLE COLOR: All color pages sent to the product print in color. Color if Allowed: A permissions database is referenced to verify if color pages are printed in color or monochrome.
				Disable	
				Color if Allowed*	

Retrieve From USB Settings menu

Table 3-34 Retrieve From USB Settings menu

First level	Second level	Values	Description
Retrieve From USB Settings		Enable	Configure this setting to allow Walk-up USB printing at the control panel.
		Disable*	

Print Settings menu

In the following table, asterisks (*) indicate the factory default setting.

Table 3-35 Print Settings menu

First level	Second level	Values	Description
Manual Feed		Enabled	Setting this option to On makes Manual Feed the default for jobs that do not select a tray. The Autoselect option in the printer driver overrides this option.
		Disabled*	
Courier Font		Regular*	Allows you to select a version of the Courier font. The Dark setting is an internal Courier font available on HP LaserJet Series III printers and older.
		Dark	
Wide A4		Enabled	Allows you to change the printable area of A4 paper. If you select Disabled, the printable area is seventy-eight 10-pitch characters on a single line. If you select Enabled, the printable area is eighty 10-pitch characters on a single line.
		Disabled*	
Print PS Errors		Enabled	Allows you to select to print PS error pages.
		Disabled*	
Print PDF Errors		Enabled	Allows you to select to print PDF error pages.
		Disabled*	
Personality		Auto*	Sets the default personality to automatic switching, PCL, PDF, or POSTSCRIPT modes.
		PCL	
		POSTSCRIPT	
		PDF	
PCL	Form Length	Range: 5 – 128 Default = 60	Allows you to set the Form Length

Table 3-35 Print Settings menu (continued)

First level	Second level	Values	Description
	Orientation	Portrait* Landscape	Allows you to set the default page orientation to portrait or landscape.
	Font Source	Internal* Soft USB	Selects the font source. The default is Internal .
	Font Number	Range: 0 – 999 Default = 0	The product assigns a number to each font and lists the numbers on the PCL font list. The default is 0.
	Font Pitch	Range: 0.44 – 99.99 Default = 10	Selects the font pitch. This item might not appear, depending on the font selected. The default is 10.00.
	Font Point Size	Range: 4.00 – 999.75 Default = 12.00	Selects the font point size. The default is 12.00.
	Symbol Set	Select from a list of symbol sets.	Selects any one of several available symbol sets at the product control panel. A symbol set is a unique grouping of all the characters in a font.
	Append CR to LF	No* Yes	Select Yes to append a carriage return to each line-feed that is encountered in backward-compatible PCL jobs (pure text, no job control). Some environments indicate a new line by only the line-feed control code. Use this option to append the required carriage return to each line feed.

Table 3-35 Print Settings menu (continued)

First level	Second level	Values	Description
	Suppress Blank Pages	No* Yes	When generating your own PCL, extra form feeds are included that would cause a blank page to be printed. Select Yes for form feeds to be ignored if the page is blank.
	Media Source Mapping	Standard* Classic	<p>The Media Source Mapping command selects an input tray by a number that maps to the various available trays and feeders.</p> <p>The Standard numbering is based on newer HP LaserJet printers with updated changes to the numbering of trays and feeders.</p> <p>The Classic numbering is based on HP LaserJet 4 printers and earlier models.</p>

Print Options menu

In the following table, asterisks (*) indicate the factory default setting.

Table 3-36 Print Options menu

First level	Second level	Values	Description
Number of Copies		Default = 1	Allows you to set the default number of copies for print jobs. The default number is 1 .
Default Paper Size		Select from a list of sizes that the product supports.	Allows you to set the default paper size.
Default Custom Paper Size	Inches	Range: 2.99 – 12.28 Default = 12.28	Allows you to set the default size for any custom print job that does not specify the dimensions (in inches).
	X Dimension	Range: 5.00 – 18.50 Default = 18.5	Allows you to set the default size for any custom print job that does not specify the dimensions (in inches).
	Y Dimension	Range: 5.00 – 18.50 Default = 18.5	Allows you to set the default size for any custom print job that does not specify the dimensions (in inches).

Table 3-36 Print Options menu (continued)

First level	Second level	Values	Description
	MM	X Dimension	
		Range: 75 – 311.90 Default = 311.90	Allows you to set the default size for any custom print job that does not specify the dimensions (in millimeters).
		Y Dimension	
		Range: 127 – 470 Default = 470	Allows you to set the default size for any custom print job that does not specify the dimensions (in millimeters).
Sides		1-sided* 2-sided	Use this feature to indicate whether the original document is printed on one or both sides, and whether the copies should be printed on one or both sides.
Two-Sided Format		Book-style* Flip-style	Allows you to change the binding edge for two-sided printing. NOTE: This menu is available only on models that have automatic duplexing.
Enable Edge to Edge Overrides		Enabled Disabled*	Use the feature to turn the edge-to-edge mode on or off for all print jobs. This mode can be overridden inside a print job by an edge-to-edge PJI variable.

Display Settings menu

In the following table, asterisks (*) indicate the factory default setting.

Table 3-37 Display Settings menu

First level	Second level	Values	Description
Display Brightness		Range: -10 to 10 Default = 0	Sets the brightness of the control panel display. The default is 0 . This item also controls the viewing angle at which the display is visible.
Language		Select from a list of languages that the product supports.	Sets the language. The default language is ENGLISH .
Show IP address		Display* Hide	Use this feature to display or hide the IP address on the control-panel display.
Sleep Mode		Use sleep delay* Use sleep schedule Use Both	The sleep delay setting helps save energy by having the product enter a low-power mode after a certain time of inactivity. The sleep schedule automatically wakes up the product at the start of the workday. The sleep schedule can be configured using the EWS.
Inactivity Timeout		Range: 10 – 300 seconds Default = 60	Idle Timeout: The time period, in seconds, after which an idle TCP print data connection is closed (default is 60 seconds, 0 disables the timeout).
Clearable Warnings		On Job*	Sets whether a warning is cleared on the control panel or when another job is sent. Job: The warning message disappears at the end of the job. On: The warning message remains until you press the OK button.
Continuable Events		Auto continue (10 seconds)* Press OK to continue	Determines product behavior when the system generates an Auto Continuable error. On: Allows the product to continue printing. Off: Stops the product from printing until the error is cleared by the user.

Manage Supplies menu

In the following table, asterisks (*) indicate the factory default setting.

Table 3-38 Manage Supplies menu

First level	Second level	Third level	Fourth level	Values	Description
Supplies Status					Use the Supplies Status menu to configure how the product reacts when supplies are reaching the end of their estimated life.
Supply Settings	Black Cartridge	Very Low Settings		Stop Prompt to continue* Continue	Select what the product should do when the print cartridge is very near the end of its estimated life. Stop: The product stops until you replace the cartridge. Prompt to continue: The product stops until you clear the prompt message. After the prompt message is cleared, there will not be another message indicating that the supply needs to be replaced. Continue: The product provides an alert message, but it continues printing. There will not be another message indicating that the supply needs to be replaced.
		Low Threshold Settings		1-100%	Set the percentage at which the product notifies you when the supply is very low.

Table 3-38 Manage Supplies menu (continued)

First level	Second level	Third level	Fourth level	Values	Description
	Color Cartridges	Very Low Settings		Stop Prompt to continue* Continue	<p>Select what the product should do when the print cartridge is very near the end of its estimated life.</p> <p>Stop: The product stops until you replace the cartridge.</p> <p>Prompt to continue: The product stops until you clear the prompt message.</p> <p>Continue: The product provides an alert message, but it continues printing.</p>
		Low Threshold Settings	Cyan Cartridge Magenta Cartridge Yellow Cartridge	1-100%	Set the percentage at which the product notifies you when the supply is very low.
	Fuser	Very Low Settings		Stop Prompt to continue* Continue	<p>Stop: The product stops until you replace the fuser kit.</p> <p>Prompt to continue: The product stops until you clear the prompt message.</p> <p>Continue: The product provides an alert message, but it continues printing.</p>
		Low Threshold Settings		1-100%	Set the percentage at which the product notifies you when the supply is very low.

Table 3-38 Manage Supplies menu (continued)

First level	Second level	Third level	Fourth level	Values	Description
	Transfer Kit	Very Low Settings		Stop Prompt to continue* Continue	<p>Stop: The product stops until you replace the transfer kit.</p> <p>Prompt to continue: The product stops until you clear the prompt message.</p> <p>Continue: The product provides an alert message, but it continues printing.</p>
		Low Threshold Settings		1-100%	Set the percentage at which the product notifies you when the supply is very low.
	Color/Black Mix			Auto* Mostly Color Pages Mostly Black Pages	<p>These menu selections allow you to balance the trade-off between supply life and performance.</p> <p>Auto: The product software uses an algorithm based on printing data to achieve the best output.</p> <p>Mostly Color Pages: This selection provides the highest performance. If most of the printing is in color, this selection will not negatively affect supply life.</p> <p>Mostly Black Pages: This selection conserves the most supply life and is the best choice if most of the printing is done in black and white.</p>

Table 3-38 Manage Supplies menu (continued)

First level	Second level	Third level	Fourth level	Values	Description
Supply Messages	Low Message			On*	Select how the product displays the supply information. Low Message: Determines whether or not a low supply message is displayed on the control panel.
				Off	
		Level Gauge		On*	LEVEL GAUGE: Determines whether or not a supply level gauge appears on the control panel.
				Off	
Reset Supplies	New Fuser Kit			No	Use this menu to notify the product that a new fuser kit has been installed.
				Yes	
		New Transfer Kit		No	Use this menu to notify the product that a new transfer kit has been installed.
				Yes	

Manage Trays menu

In the following table, asterisks (*) indicate the factory default setting.

Table 3-39 Manage Trays menu

First level	Values	Description
Use Requested Tray	Exclusively*	Use Requested Tray handles jobs that have specified a specific input tray. Two options are available: Exclusively: The product never selects a different tray when the user has indicated that a specific tray should be used, even if that tray is empty. First: The product can pull from another tray if the specified tray is empty, even though the user specifically indicated a tray for the job.
	First	

Table 3-39 Manage Trays menu (continued)

First level	Values	Description
Manually Feed Prompt	Always* Unless loaded	<p>This option controls whether a manual feed message should appear when the type or size for a job does not match the size or type configured for Tray 1. Two options are available:</p> <p>Always: A prompt always appears before printing a manual-feed job.</p> <p>Unless loaded: A message appears only if the multipurpose tray is empty or does not match the size or type of the job.</p>
Size/Type Prompt	Display* Do not display	<p>This option controls whether the tray configuration message appears whenever a tray is closed. Two options are available:</p> <p>Display: This option shows the tray configuration message when a tray is closed. You can configure the tray size or type directly from this message.</p> <p>Do not display: This option prevents the tray configuration message from automatically appearing.</p>
Use another tray	Enabled* Disabled	<p>This option turns on or off the control-panel prompt to select another tray when the specified tray is empty.</p>
Alternative Letterhead Mode	Disabled* Enabled	<p>When this option is On you can load letterhead or preprinted paper the same way for every job, whether printing on one or both sides of the page.</p> <p>This option is available only for models that have automatic duplexing.</p>

Table 3-39 Manage Trays menu (continued)

First level	Values	Description
Blank Pages	Auto*	<p>This option controls how the product handles two-sided jobs (duplexing). Two options are available:</p> <p>Auto: Enables Smart Duplexing, which instructs the product not to process both sides if the second side is blank. Letterhead and prepunched paper types are exceptions. This can improve print speed.</p> <p>Yes: Disables Smart Duplexing and forces the duplexer to flip the sheet of paper even if it is printed on only one side.</p> <p>This option is available only for models that have automatic duplexing.</p>
	Yes	
Override A4/Letter	Yes*	<p>Allows you to set the product to print an A4 job on letter-size paper when no tray is configured for A4 paper, or to print on A4-size paper when no tray is configured for letter paper.</p>
	No	

Network Settings menu

In the following table, asterisks (*) indicate the factory default setting.

Table 3-40 Network Settings menu

First level	Values	Description
I/O Timeout	Range: 5 – 300 sec Default = 15	Allows you to set the product I/O Timeout in seconds. The default is 15 seconds. Use this setting to adjust timeout for the best performance. If data from other ports appears in the middle of your print job, increase the timeout value.
Embedded Jetdirect		See the table that follows for details. These menus have the same structure. If an additional HP Jetdirect network card is installed in the EIO slot, then both menus are available.

Table 3-41 Embedded Jetdirect

First level	Second level	Third level	Fourth level	Fifth level	Values	Description
Information	Print Sec Report				Yes No*	Yes: Prints a page that contains the current security settings on the HP Jetdirect print server. No: A security settings page is not printed.
TCP/IP	Enable				On* Off	On: Enable the TCP/IP protocol. Off: Disable the TCP/IP protocol.
	Host Name				Use the arrow buttons to edit the host name. NPXXXXXX*	An alphanumeric string, up to 32 characters, used to identify the product. This name is listed on the HP Jetdirect configuration page. The default host name is NPxxxxxx, where xxxxxx is the last six digits of the LAN hardware (MAC) address.

Table 3-41 Embedded Jetdirect (continued)

First level	Second level	Third level	Fourth level	Fifth level	Values	Description
	IPv4 Settings	Config Method			Bootp* DHCP Auto IP Manual	<p>Specifies the method that TCP/IPv4 parameters will be configured on the HP Jetdirect print server.</p> <p>Use Bootp (Bootstrap Protocol) for automatic configuration from a BootP server.</p> <p>Use DHCP (Dynamic Host Configuration Protocol) for automatic configuration from a DHCPv4 server. If selected and a DHCP lease exists, DHCP Release and DHCP Renew menus are available to set DHCP lease options.</p> <p>Use Auto IP for automatic link-local IPv4 addressing. An address in the form 169.254.x.x is assigned automatically.</p>
		Default IP			Auto IP* Legacy	<p>Specify the IP address to default to when the print server is unable to obtain an IP address from the network during a forced TCP/IP reconfiguration (for example, when manually configured to use BootP or DHCP).</p> <p>This feature assigns a static IP address that might interfere with a managed network.</p> <p>Auto IP: A link-local IP address 169.254.x.x is set.</p> <p>Legacy: The address 192.0.0.192 is set, consistent with older HP Jetdirect products.</p>
		DHCP Release			Yes No*	<p>This menu appears if Config Method is set to DHCP and a DHCP lease for the print server exists.</p> <p>No: The current DHCP lease is saved.</p> <p>Yes: The current DHCP lease and the leased IP address are released.</p>

Table 3-41 Embedded Jetdirect (continued)

First level	Second level	Third level	Fourth level	Fifth level	Values	Description
		DHCP Renew			Yes No*	<p>This menu appears if Config Method is set to DHCP and a DHCP lease for the print server exists.</p> <p>No: The print server does not request to renew the DHCP lease.</p> <p>Yes: The print server requests to renew the current DHCP lease.</p>
		Primary DNS			Range: 0 – 255 Default = xxx.xxx.xx.xx	Specify the IP address (n.n.n.n) of a Primary DNS Server.
		Secondary DNS			Range: 0 – 255 Default = 0.0.0.0	Specify the IP address (n.n.n.n) of a Secondary Domain Name System (DNS) Server.
	IPv6 Settings	Enable			On* Off	<p>Use this item to enable or disable IPv6 operation on the print server.</p> <p>Off: IPv6 is disabled.</p> <p>On: IPv6 is enabled.</p>
		Address	Manual Settings	Enable	On Off*	<p>Use this item to enable and manually configure a TCP/IPv6 address.</p> <p>Enable: Choose On to enable manual configuration, or Off to disable manual configuration. The default is Off.</p>
				Address	Select from a provided list.	Address: Use this item to type a 32 hexadecimal digit IPv6 node address that uses the colon hexadecimal syntax.

Table 3-41 Embedded Jetdirect (continued)

First level	Second level	Third level	Fourth level	Fifth level	Values	Description
		DHCPV6 Policy			Router Specified Router Unavailable* Always	<p>Router Specified: The stateful auto-configuration method to be used by the print server is determined by a router. The router specifies whether the print server obtains its address, its configuration information, or both from a DHCPv6 server.</p> <p>Router Unavailable: If a router is not available, the print server should attempt to obtain its stateful configuration from a DHCPv6 server.</p> <p>Always: Whether or not a router is available, the print server always attempts to obtain its stateful configuration from a DHCPv6 server.</p>
		Primary DNS			Select from a provided list.	Use this item to specify an IPv6 address for a primary DNS server that the print server should use.
		Secondary DNS			Select from a provided list.	Use this item to specify an IPv6 address for a secondary DNS server that the print server should use.
		Proxy Server			Select from a provided list.	<p>Specifies the proxy server to be used by embedded applications in the product. A proxy server is typically used by network clients for Internet access. It caches Web pages, and provides a degree of Internet security, for those clients.</p> <p>To specify a proxy server, enter its IPv4 address or fully-qualified domain name. The name can be up to 255 octets.</p> <p>For some networks, you might need to contact your Internet Service Provider (ISP) for the proxy server address.</p>

Table 3-41 Embedded Jetdirect (continued)

First level	Second level	Third level	Fourth level	Fifth level	Values	Description
		Proxy Port			Default = 0080	Type the port number used by the proxy server for client support. The port number identifies the port reserved for proxy activity on your network, and can be a value from 0 to 65535.
		Idle Timeout			Default = 0270	Idle Timeout: The time period, in seconds, after which an idle TCP print data connection is closed (default is 270 seconds, 0 disables the timeout).
Security	Secure Web				HTTPS Required* HTTPS Optional	For configuration management, specify whether the embedded Web server will accept communications using HTTPS (Secure HTTP) only, or both HTTP and HTTPS. HTTPS Required: For secure, encrypted communications, only HTTPS access is accepted. The print server will appear as a secure site. HTTPS Optional: Access using either HTTP or HTTPS is permitted.
		IPSEC			Keep Disable*	Specify the IPsec status on the print server. Keep: IPsec status remains the same as currently configured. Disable: IPsec operation on the print server is disabled.
		802.1x			Reset Keep*	Specify whether the 802.1X settings on the print server are reset to the factory defaults. Reset: The 802.1X settings are reset to the factory defaults. Keep: The current 802.1X settings are maintained.

Table 3-41 Embedded Jetdirect (continued)

First level	Second level	Third level	Fourth level	Fifth level	Values	Description
	Reset Security				Yes No*	Specify whether the current security settings on the print server will be saved or reset to factory defaults. Yes: Security settings are reset to factory defaults. No: The current security settings are maintained.
Diagnostics	Embedded Test	LAN HW Test			Yes No*	This menu provides tests to help diagnose network hardware or TCP/IP network connection problems. Embedded tests help to identify whether a network fault is internal or external to the product. Use an embedded test to check hardware and communication paths on the print server. After you select and enable a test and set the execution time, you must select Execute to initiate the test. Depending on the execution time, a selected test runs continuously until either the product is turned off, or an error occurs and a diagnostic page is printed. Running this embedded test will erase your TCP/IP configuration. This test performs an internal loopback test. An internal loopback test will send and receive packets only on the internal network hardware. There are no external transmissions on your network. Select Yes to choose this test, or No to not choose it.
		HTTP Test			Yes No*	This test checks operation of HTTP by retrieving predefined pages from the product, and tests the embedded Web server. Select Yes to choose this test, or No to not choose it.

Table 3-41 Embedded Jetdirect (continued)

First level	Second level	Third level	Fourth level	Fifth level	Values	Description
		SNMP Test			Yes No*	This test checks operation of SNMP communications by accessing predefined SNMP objects on the product. Select Yes to choose this test, or No to not choose it.
		Data Path Test			Yes No*	This test helps to identify data path and corruption problems on an HP postscript level 3 emulation product. It sends a predefined PS file to the product, However, the test is paperless; the file will not print. Select Yes to choose this test, or No to not choose it.
		Select All Tests			Yes No*	Use this item to select all available embedded tests. Select Yes to choose all tests. Select No to select individual tests.
		Execution Time			Range: 1 – 60 hours Default = 1	Use this item to specify the length of time (in hours) that an embedded test will be run. You can select a value from 1 to 60 hours. If you select zero (1), the test runs indefinitely until an error occurs or the product is turned off. Data gathered from the HTTP, SNMP, and Data Path tests is printed after the tests have completed.
		Execute			Yes No*	No: Do not initiate the selected tests. Yes: Initiate the selected tests.
	Ping Test	Dest Type			IPv4 IPv6	This test is used to check network communications. This test sends link-level packets to a remote network host, then waits for an appropriate response. To run a ping test, set the following items: Specify whether the target product is an IPv4 or IPv6 node.

Table 3-41 Embedded Jetdirect (continued)

First level	Second level	Third level	Fourth level	Fifth level	Values	Description
		Dest IPv4			Range: 0 – 255 Default = 127.0.0.1	Type the IPv4 address.
		Dest IPv6			Select from a provided list. Default = :::1	Type the IPv6 address.
		Packet Size			Default = 64	Specify the size of each packet, in bytes, to be sent to the remote host. The minimum is 64 (default) and the maximum is 2048.
		Timeout			Default = 001	Specify the length of time, in seconds, to wait for a response from the remote host. The default is 1 and the maximum is 100.
		Count			Default = 004	Specify the number of ping packets to send for this test. Select a value from 0 to 100. The default is 4. To configure the test to run continuously, select 0.
		Print Results			Yes No*	If the ping test was not set for continuous operation, you can choose to print the test results. Select Yes to print results. If you select No , results are not printed.
		Execute			Yes No*	Specify whether to initiate the ping test. Select Yes to initiate the test, or No to not run the test.
	Ping Results	Packets Sent			Default = 00000	Use this item to view the ping test status and results using the control panel display. You can select the following items: Shows the number of packets (0 - 65535) sent to the remote host since the most recent test was initiated or completed. The default is 0.
		Packets Received			Default = 00000	Shows the number of packets (0 - 65535) received from the remote host since the most recent test was initiated or completed. The default is 0.

Table 3-41 Embedded Jetdirect (continued)

First level	Second level	Third level	Fourth level	Fifth level	Values	Description
		Percent Lost			Default = 000	Shows the percent (0 to 100) of ping test packets that were sent with no response from the remote host since the most recent test was initiated or completed. The default is 0.
		RTT Min			Default = 0000	Shows the minimum detected roundtrip-time (RTT), from 0 to 4096 milliseconds, for packet transmission and response. The default is 0.
		RTT Max			Default = 0000	Shows the maximum detected roundtrip-time (RTT), from 0 to 4096 milliseconds, for packet transmission and response. The default is 0.
		RTT Average			Default = 0000	Shows the average round-trip-time (RTT), from 0 to 4096 milliseconds, for packet transmission and response. The default is 0.
		Ping In Progress			Yes No*	Shows whether a ping test is in progress. Yes indicates a test in progress, and No indicates that a test completed or was not run.

Table 3-41 Embedded Jetdirect (continued)

First level	Second level	Third level	Fourth level	Fifth level	Values	Description
		Refresh			Yes No*	When viewing the ping test results, this item updates the ping test data with current results. Select Yes to update the data, or No to maintain the existing data. However, a refresh automatically occurs when the menu times out or you manually return to the main menu.
Link Speed					Auto* 10T Half 10T Full 100TX Half 100TX Full 100TX Auto 1000T Full	<p>The link speed and communication mode of the print server must match the network. The available settings depend on the product and installed print server. Select one of the following link configuration settings:</p> <p>If you change the link setting, network communications with the print server and network product might be lost.</p> <p>Auto: The print server uses auto-negotiation to configure itself with the highest link speed and communication mode allowed. If auto-negotiation fails, either 100TX Half or 10T Half is set depending on the detected link speed of the hub/switch port. (A 1000T half-duplex selection is not supported.)</p> <p>10T Half: 10 Mbps, half-duplex operation.</p> <p>10T Full: 10 Mbps, full-duplex operation.</p> <p>100TX Half: 100 Mbps, half-duplex operation.</p> <p>100TX Full: 100 Mbps, full-duplex operation.</p> <p>100TX Auto: Limits auto-negotiation to a maximum link speed of 100 Mbps.</p> <p>1000T Full: 1000 Mbps, full-duplex operation.</p>

Troubleshooting menu

In the following table, asterisks (*) indicate the factory default setting.

Table 3-42 Troubleshooting menu

First level	Second level	Third level	Fourth level	Values	Description
Exit Troubleshooting					Use this menu to help resolve problems.
<p>NOTE: This item only displays if you are backing out of the Troubleshooting menu.</p>					
	Print Event Log				Prints a report containing the last 50 entries in the product's event log, starting with the most recent.
	View Event Log				Displays the last 50 events, starting with the most recent.
Print Quality Pages	Print PQ Troubleshooting Pages				Prints a page that includes instructions and pages for each color. These pages can help isolate print-quality problems.
	Diagnostics Page				Prints a page that can assist in diagnosing product problems.
	Color Band Test	Print Test Page			Prints a color band test page that is used to identify arcing in the high-voltage power supply and other print-quality defects.
		Copies		Range: 1 – 30 Default = 1	Specify how many copies of the internal page are printed.
Diagnostic Tests	Disable Cartridge Check				This item allows you to remove a print cartridge to help determine which cartridge is the source of a problem.
<p>TIP: When this item is selected, only the diagnostic pages in the Troubleshooting menu can be printed.</p>					

Table 3-42 Troubleshooting menu (continued)

First level	Second level	Third level	Fourth level	Values	Description
	Paper Path Sensors			Start Test	Performs a test on each of the product's sensors to determine if they are working correctly and displays the status of each sensor as the page prints.
	Paper Path Test	Print Test Page		Print	Tests the paper-handling features of the product, such as the configuration of the trays. Generates a page for testing the paper-handling features. You must define the path for the test in order to test specific paper paths.
		Source		Select from a list of the available trays.	Specifies whether the test page is printed from all trays or from a specific tray.
		Test Duplex Path		Off* On	Determines whether the duplexer is included in the test. NOTE: This option is available only for models that have an automatic duplexer.
		Number of Copies		Range: 1 – 500 Default = 1	Determines how many pages should be sent from the specified source as part of the test.

Table 3-42 Troubleshooting menu (continued)

First level	Second level	Third level	Fourth level	Values	Description
	Manual Sensor Test			Select from a list of the product sensors.	<p>Use this feature to exercise individual parts independently to isolate noise, leaking, or other issues.</p> <p>To start the test, select a component. The test runs the number of times specified by the Repeat option.</p> <p>You might be prompted to remove parts from the product during the test. Press the Stop button to abort the test.</p>
	Tray/Bin Manual Sensor Test			Select from a list of the product sensors.	<p>Use this feature to exercise individual parts independently to isolate noise, leaking, or other issues.</p> <p>To start the test, select a component. The test runs the number of times specified by the Repeat option.</p> <p>You might be prompted to remove parts from the product during the test. Press the Stop button to abort the test.</p>

Table 3-42 Troubleshooting menu (continued)

First level	Second level	Third level	Fourth level	Values	Description
	Component Test			Select from a list of available components.	<p>Use this feature to exercise individual parts independently to isolate noise, leaking, or other issues.</p> <p>To start the test, select a component. The test runs the number of times specified by the Repeat option.</p> <p>You might be prompted to remove parts from the product during the test. Press the Stop button to abort the test.</p>
		Repeat		Off* On	<p>The test will run the number of times specified by the Repeat option.</p>
	Print/Stop Test				<p>Isolates print quality faults more accurately by stopping the product in mid-print cycle, which allows you to see where the image begins to degrade. This causes a jam message that might need to be manually cleared. A service representative should perform this test.</p>
Retrieve Diagnostic Data	Export to USB				<p>Stores product diagnostic data on a portable storage device.</p> <p>This function is for the HP lab use to troubleshoot and diagnose system failures.</p>

Table 3-42 Troubleshooting menu (continued)

First level	Second level	Third level	Fourth level	Values	Description
	Diagnostic Files			Device Data File Debug Information File*	Choose the diagnostic data type to be saved. This function is for the HP lab use to troubleshoot and diagnose system failures.
	Include Crash Dumps			Off On*	Enable or disable saving product crash data. This function is for the HP lab use to troubleshoot and diagnose system failures.
	Cleanup Debug Info			Off On*	Enable or disable saving product debug data. This function is for the HP lab use to troubleshoot and diagnose system failures.
General Debug Data					This function is for the HP lab use to troubleshoot and diagnose system failures.

Device Maintenance menu

Backup/Restore menu

△ **CAUTION:** Data backup and restoration is the responsibility of the customer/administrator of the product. Service personnel should not back up or restore customer data under any circumstances.

In the following table, asterisks (*) indicate the factory default setting.

Table 3-43 Backup/Restore menu

First level	Second level	Third level	Values	Description
Backup Data	Scheduled Backups	Enable Scheduling	Disabled* Enabled	This feature allows you to create a backup copy of the products configuration, settings and stored jobs. Restores from backup copy when configuration recovery is necessary.
		Backup Time	Default = current time	Set the time that the scheduled backup executes.
		Days Between Backups	Default = 1	Set the number of days between scheduled backups.
	Backup Now			Use this feature to perform manual backups of the products configuration data to the local drive.
	Export Last Backup			Use this feature to export the last performed backup data to the front panel USB port.
Restore Data			Insert a USB drive that contains the backup file.	Restore locally saved backups of the systems configuration data from the front panel USB drive.

Calibration/Cleaning menu

In the following table, asterisks (*) indicate the factory default setting.

Table 3-44 Calibration/Cleaning menu

First level	Second level	Values	Description
Auto Cleaning		Off* On	When auto-cleaning is on, the product prints a cleaning page when the page count reaches the Cleaning Interval setting.
Cleaning Interval		Select from a list of cleaning intervals.	Specify the number of pages that are printed before a cleaning page is automatically printed. This item appears only when the Auto Cleaning option is set to On .
Auto Cleaning Size		Letter* A4	Specify the paper size that is used to print the cleaning page. This item appears only when the Auto Cleaning option is set to On .
Print Cleaning Page			Allows you to create and process a cleaning page for cleaning the pressure roller in the fuser. When the cleaning process runs, a cleaning page is printed. This page can be discarded.
Clean Laser Glass			Use this menu to perform an automatic laser glass cleaning when white streaks appear on the printed pages.
Quick Calibration			Performs a partial product calibration.

Table 3-44 Calibration/Cleaning menu (continued)

First level	Second level	Values	Description
Full Calibration			Performs all product calibrations.
Delay Calibration at Wake/Power On		Disabled Enabled*	<p>This menu controls the timing of the calibration when the product wakes up or is turned on.</p> <p>Select No to have the product calibrate immediately when it wakes up or is turned on. The product will not print any jobs until it finishes calibrating.</p> <p>Select Yes to enable a product that is asleep to accept print jobs before it calibrates. It may start calibrating before it has printed all the jobs it has received. This option allows quicker printing when coming out of sleep mode or when you turn the product on, but print quality might be reduced.</p> <p>For best results, allow the product to calibrate before printing. Print jobs performed before calibration might not be of the highest quality.</p>

USB Firmware Upgrade menu

To display: At the product control panel, select the **Device Maintenance** menu, and then select the **USB Firmware Upgrade** menu.

Insert a USB storage device with a firmware upgrade bundle into the USB port, and follow the on-screen instructions.

Service menu

The personal identification number (PIN) used to access the **Service** menu is 11552010.

In the following table, asterisks (*) indicate the factory default setting.

First level	Second level	Third level	Values	Description
User Access Code				Access the product with a user-level personal identification number (PIN). NOTE: Some menus or function might not be available.
Administrator Access Code				Access the product with a administrator-level personal identification number (PIN).
Service Access Code				Access the product with a technician-level personal identification number (PIN).
Print Event Log				Prints a report containing the last 50 entries in the product's event log, starting with the most recent.
View Event Log				Displays the last 50 events, starting with the most recent.
<p>TIP: This event log contains more detailed information than the event log in the Troubleshooting menu. This event log contains all events.</p>				
Clear Event Log				Removes all recorded events from the event log.
Cycle Counts		Mono Cycle Counts	0* Range: 0 – 9999999	Shows the number of mono print cycles.
		Color Cycle Count	0* Range: 0 – 9999999	Shows the number of color print cycles.
		Refurbish Cycle Count	0* Range: 0 – 9999999	Used for setting the page count when the product is refurbished at the factory.

First level	Second level	Third level	Values	Description
	Serial Number			Use this item to enter the product serial number.
	Service ID			Use this item to enter the product service ID.
	Cold Reset Paper		Letter* A4	Use this item to select the page size used for a cold reset operation.
	New Registration Roller		Yes No*	Use this item to inform the product that a new roller was installed.
	Media Sensor Value		0* Range: 0 – 4095	Use this item to set the media sensor value when the paper pickup assembly is replaced. The media sensor value is located on a label on the replacement paper pickup assembly.
	Manual Laser Glass Cleaning			Use this menu item to manually clean the glass that covers the laser scanner windows. When executed, the shutters open and reveal the laser-scanner glass. You can then clean the glass.

Interpret control-panel messages, status-alert messages, and event code errors

The control-panel messages indicate the current product status or situations that might require action.

Control-panel messages appear temporarily and might require that you acknowledge the message by pressing the **OK** button to resume printing or by pressing the **Stop** button to cancel the job. With certain messages, the job might not finish printing or the print quality might be affected. If the message is related to printing and the auto-continue feature is on, the product will attempt to resume printing after the message has appeared for 10 seconds without acknowledgement.

For some messages, restarting the product might fix the problem. If a critical error persists, the product might require service.

10.0X.Y0 Supply memory error

Description

The product cannot read or write to at least one print cartridge memory tag or a memory tag is missing from a print cartridge.

Memory error

- **10.00.00** (event code)
Black print cartridge
- **10.01.00** (event code)
Cyan print cartridge
- **10.02.00** (event code)
Magenta print cartridge
- **10.03.00** (event code)
Yellow print cartridge

E-label missing

- **10.00.10** (event code)
Black print cartridge
- **10.01.10** (event code)
Cyan print cartridge
- **10.021.10** (event code)
Magenta print cartridge
- **10.03.10** (event code)

Yellow print cartridge

Recommended action

1. Remove, and then reinstall the indicated print cartridge.
2. If the error reappears, turn the power off, and then on.
3. Check the cartridge e-label. If it is damaged, replace the cartridge.
4. If the error persists, replace the indicated print cartridge.

10.22.50

Description

The transfer kit life was reset above the order threshold.

A new ITB was installed.

Recommended action

No action necessary.

10.22.51

Description

The transfer kit life was reset above the replace threshold.

A new ITB was installed.

Recommended action

No action necessary.

10.22.52

Description

The transfer kit life was reset above the reset threshold.

A new ITB was installed.

Recommended action

No action necessary.

10.23.50

Description

The fuser kit life was reset above the order threshold.

A new ITB was installed.

Recommended action

No action necessary.

10.23.51

Description

The fuser kit life was reset above the replace threshold.

A new ITB was installed.

Recommended action

No action necessary.

10.23.52

Description

The fuser kit life was reset above the reset threshold.

A new ITB was installed.

Recommended action

No action necessary.

10.23.70 Printing past very low

Description

The product indicates when fuser kit is very low. The actual remaining fuse kit life might vary.

You do not need to replace the fuser kit at this time unless print quality is no longer acceptable.

△ **CAUTION:** After an HP supply has reached the very low threshold, the HP premium protection warranty ends.

Recommended action

If print quality is no longer acceptable, replace the fuser kit. See the parts chapter in the service manual for the fuser kit part number.

💡 **TIP:** Advise the customer that HP recommends that they have replacement supplies available to install when the print quality is no longer acceptable.

10.XX.34 Used supply in use

Description

The indicated cartridge is used.

- **10.00.34** (event code)
Black print cartridge
- **10.01.34** (event code)
Cyan print cartridge
- **10.02.34** (event code)
Magenta print cartridge
- **10.03.34** (event code)
Yellow print cartridge

Recommended action

If you believe this is a genuine HP supply, go to www.hp.com/go/anticounterfeit.

 **NOTE:** Removing a cartridge from one product and then installing it in a different product (for testing functionality) will cause this event code.

10.XX.40 Genuine HP supplies installed

Description

More than one genuine HP print cartridge has been installed.

- **10.00.40** (event code)
Black print cartridge
- **10.01.40** (event code)
Cyan print cartridge
- **10.02.40** (event code)
Magenta print cartridge
- **10.03.40** (event code)
Yellow print cartridge

Recommended action

No action necessary.

10.XX.41 Unsupported supply in use

Description

The indicated print cartridge is for a different product.

- **10.00.41** (event code)
Black print cartridge
- **10.01.41** (event code)
Cyan print cartridge
- **10.020.41** (event code)
Magenta print cartridge
- **10.03.41** (event code)
Yellow print cartridge

Recommended action

Remove the indicated print cartridge, and then install the correct cartridge for this product.

 **TIP:** See the parts chapter in the service manual for the correct cartridge part number.

10.XX.70 Printing past very low

Description

The product indicates when a supply level is very low. The actual remaining print cartridge life might vary.

You do not need to replace the print cartridge at this time unless print quality is no longer acceptable.

 **CAUTION:** After an HP supply has reached the very low threshold, the HP premium protection warranty ends.

- **10.00.70**10.00.70 (event code)
Black print cartridge
- **10.01.70** (event code)
Cyan print cartridge
- **10.02.70** (event code)
Magenta print cartridge
- **10.03.70** (event code)
Yellow print cartridge

Recommended action

If print quality is no longer acceptable, replace the indicated print cartridge. See the parts chapter in the service manual for the correct cartridge part number.

 **TIP:** Advise the customer that HP recommends that they have replacement supplies available to install when the print quality is no longer acceptable.

10.YY.15 Install <supply>

Description

The indicated supply has been removed or installed incorrectly.

- **10.00.15** (event code)
Black print cartridge
- **10.01.15** (event code)
Cyan print cartridge
- **10.02.15** (event code)
Magenta print cartridge
- **10.03.15** (event code)
Yellow print cartridge
- **10.23.15**
Fuser kit
- **10.31.15**
TCU

Recommended action

Replace or install the indicated supply.

See the parts chapter in the service manual for the correct supply or kit part number.

10.YY.25 Wrong cartridge in <color> slot

Description

The indicated cartridge is installed in the wrong position.

- **10.00.25** (event code)
Black print cartridge
- **10.01.25** (event code)
Cyan print cartridge

- **10.02.25** (event code)
Magenta print cartridge
- **10.03.25** (event code)
Yellow print cartridge

Recommended action

Install the indicated cartridge in the correct position.

From left to right, the correct cartridge order follows:

- Yellow
- Magenta
- Cyan
- Black

10.YY.35 Incompatible <supply>

Description

The indicated supply is not compatible with this product.

- **10.00.35** (event code)
Black print cartridge
- **10.01.35** (event code)
Cyan print cartridge
- **10.02.35** (event code)
Magenta print cartridge
- **10.03.35** (event code)
Yellow print cartridge
- **10.23.35** (event code)
Fuser

Recommended action

△ **CAUTION:** The fuser might be hot. Be careful when removing the fuser.

Install a supply that is designed for this product.

See the parts chapter in the service manual for the correct supply part number.

11.00.YY Internal clock error

Description

The product real time clock has experienced an error.

- 01=dead clock
- 02=dead real time clock

Recommended action

Whenever the product is turned off and then turned on again, set the time and date at the control panel.

If the error persists, you might need to replace the formatter.

13.00.00

Description

Generic jam event code.

Recommended action

Check the product for a jam. See the clear jams section in the service manual.

13.A3.FF

Description

Power on jam at the Tray 3 feed sensor.

Recommended action

Check the product for a jam. See the clear jams section in the service manual.

13.D3.DZ

Description

Late to duplex re-feed jam

Z = fuser mode

Recommended action

Check the product for a jam. See the clear jams section in the service manual.

13.WX.EE

Description

This jam occurs when a door is opened during printing.

- **13.AA.EE** (event code)
Tray 3, 4, or 5 door open
- **13.AB.EE** (event code)
Tray 4, 5, or 6 door open
- **13.BA.EE** (event code)
Front door open
- **13.BB.EE** (event code)
Right door open

Recommended action

Make sure that the doors are fully closed.

13.WX.FF

Description

Power on residual paper jam

This jam occurs when the paper exists at any of the paper path jam sensors at power on or door close. Due to the current FW timing requirements, the displayed jam code is always 13.FF.FF, only the event log will have 13.WX.FF

- **13.B2.FF** (event code)
Registration sensor - PS5
- **13.B4.FF** (event code)
Loop sensor - PS7 and PS8
- 13.B9.FF (event code)
Fuser output sensor - PS6
- **13.A3.FF** (event code)
Tray 3 feed sensor - SR1
- **13.A4.FF** (event code)
Tray 4 feed sensor - SR1
- **13.A5.FF** (event code)

Tray 5 feed sensor - SR81

- **13.A6.FF** (event code)

Tray 6 feed sensor - SR91

- **13.FF.FF** (event code)

Multiple sensors

Recommended action

Clear the jam. See the clear jams section in the service manual.

13.WX.YZ Fuser area jam

Description

- **13.B9.AZ** (event code)

Stopped at fuser jam

This jam occurs when the paper stays at the fuser output sensor for a designated amount of time after it has reached the fuser output sensor.

Z = fuser mode

- 1 = Normal auto sense
- 2 = Normal non-auto sense
- 3 = Light 1 to 3
- 4 = Heavy 1
- 5 = Heavy 2
- 6 = Heavy 3
- 7 = Glossy 1
- 8 = Glossy 2
- 9 = Glossy 3
- A = Glossy film
- B = Transparency
- C = Label
- D = Envelope 1 to 3

- E = Rough
- 0 = Photo 1 to 3
- **13.B9.DZ** (event code)

Z = the source tray number

This jam occurs when the paper does not reach the fuser output sensor in the designated amount of time.
- **13.E1.DZ** (event code)

Z = fuser mode

This jam occurs when the paper stays at the fuser output sensor for a designated amount of time after it has reached the fuser output sensor.

Recommended action

Clear the jam. See the clear jams section in the service manual.

For a 13.B9.DZ jam: Make sure media is within specifications, check for obstructions in the fuser, check that the T2 roller is installed properly.

13.WX.YZ Fuser wrap jam

Description

- **13.B9.CZ** (event code)

Fuser wrap jam

This jam occurs when the paper disappears from the fuser output sensor before a designated amount of time after the paper reached the fuser output sensor (It is determined that the paper is being wrapped around the fuser roller).

Z = fuser mode

 - 1 = Normal auto sense
 - 2 = Normal non-auto sense
 - 3 = Light 1 to 3
 - 4 = Heavy 1
 - 5 = Heavy 2
 - 6 = Heavy 3
 - 7 = Glossy 1
 - 8 = Glossy 2
 - 9 = Glossy 3
 - A = Glossy film

- B = Transparency
- C = Label
- D = Envelope 1 to 3
- E = Rough
- 0 = Photo 1 to 3

Recommended action

Clear the jam. See the clear jams section in the service manual.

13.WX.YZ Jam below control panel

Description

- **13.B2.9Z** (event code)
Page at duplex switchback jam.
Z = the source tray number

Recommended action

Check the product for a jam. See the clear jams section in the service manual.

13.WX.YZ Jam in lower right door

Description

- **13.A3.D5** (event code)
Late to path jam from Tray 5

This jam occurs when the paper does not reach the Tray 3 feed sensor (SR1) in designated amount of time after the Tray 5 feed sensor (SR81) sensed the leading edge.
- **13.A4.D5** (event code)
Late to path jam from Tray 5

This jam occurs when the paper does not reach the Tray 4 feed sensor (SR1) in designated amount of time after the Tray 5 feed sensor (SR81) sensed the leading edge.
- **13.A5.A5** (event code)
Stopped at tray path jam, from Tray 5
- **13.A3.D6** (event code)
Late to path jam from Tray 6

This jam occurs when the paper does not reach the Tray 3 feed sensor (SR1) in designated amount of time after the Tray 6 feed sensor (SR91) sensed the leading edge.

- **13.A5.D6** (event code)

Late to path jam from Tray 6

This jam occurs when the paper does not reach the Tray 5 feed sensor (SR81) in designated amount of time after the Tray 6 feed sensor (SR91) sensed the leading edge.

Recommended action

Clear the jam. See the clear jams section in the service manual.

13.WX.YZ Jam in middle right door

Description

- **13.A3.D4** (event code)

Late to path jam from Tray 4

This jam occurs when the paper does not reach the Tray 3 feed sensor (SR1) in designated amount of time after the Tray 4 feed sensor (SR1) sensed the leading edge.

Recommended action

Clear the jam. See the clear jams section in the service manual.

13.WX.YZ Jam in right door

Description

- **13.B2.AZ** (event code)

Stopped at registration jam.

This jam occurs when the media is longer than the longest Universal size, (470 mm; 18.50 in), by 40 mm (1.57 in) or more, and printing from Tray 1.

However, this jam occurs when the media that is longer than the designated length by 40 mm (1.57 in) and more is detected, if the media that is longer than the longest Universal is designated. This jam occurs when the media longer than LEDGER-P by 40 mm (1.57 in) or more is detected at printing from Tray 2 through Tray 6.

Z = the source tray number

- **13.B2.DD** (event code)

Late to registration jam, from duplexer

This jam occurs when the paper does not reach the TOP sensor in designated amount of time after it is reversed at the switchback position.

Z = D for duplexer

- **13.B2.DZ** (event code)

Late to registration jam, from tray <Z>

This jam occurs when the paper does not reach the TOP sensor in the designated amount of time after the Tray 3 feed sensor sensed the leading edge at printing from Tray 3, 4, 5, or 6.

Z = source tray

- **13.B9.DD** (event code)

Late to fuser jam, from duplexer

This jam occurs when the paper does not reach the fuser output sensor in designated amount of time.

Recommended action

Clear the jam. See the clear jams section in the service manual.

13.WX.YZ Jam in Tray 1

Description

- **13.B2.D1** (event code)

Late to registration jam, from Tray 1

This jam occurs when the paper does not reach the TOP sensor in designated amount of time from the start of paper pickup at printing from Tray 1 and duplex printing.

Recommended action

Clear the jam. See the clear jams section in the service manual.

13.WX.YZ Jam in Tray <X>

Description

- **13.B2.D2** (event code)

Misfeed jam from Tray 2

This jam occurs when the paper does not reach the TOP sensor in designated amount of time from the start of paper pick-up at printing from Tray 2 and duplex printing.

- **13.A3.D3** (event code)

Misfeed jam from Tray 3

This jam occurs when the paper does not reach the feed sensor of each tray in designated amount of time after the start of paper pickup.

- **13.A4.D4** (event code)

Misfeed from Tray 4

This jam occurs when the paper does not reach the Tray 3 feed sensor (SR1) in designated amount of time after the Tray 4 feed sensor (SR1) sensed the leading edge.

- **13.A5.D5** (event code)

Misfeed from Tray 5

This jam occurs when the paper does not reach the Tray 3 feed sensor (SR1) in designated amount of time after the Tray 4 feed sensor (SR1) sensed the leading edge.

- **13.A6.D6** (event code)

Misfeed jam from Tray 6

This jam occurs when the paper does not reach the feed sensor of each tray in designated amount of time after the start of paper pickup.

Recommended action

Clear the jam. See the clear jams section in the service manual.

20.00.00 Insufficient memory To continue, press OK

Description

The product has experienced a memory error. You might have tried to transfer too many fonts or macros.

Recommended action

Press the **OK** button to print the transferred data (some data might be lost), and then simplify the print job or install additional memory.

21.00.00 Page too complex

Description

The page decompression process was too slow for the printer.

Recommended action

Press the **OK** button to continue printing (some data might be lost).

32.1C.XX

Description

- **32.1C.01** (event code)
NVRAM backup/restore service backup started
- **32.1C.02** (event code)
NVRAM backup/restore service restore started
- **32.1C.03** (event code)

- NVRAM backup/restore administrator backup started
- **32.1C.04** (event code)
NVRAM backup/restore administrator restore started
- **32.1C.05** (event code)
Backup/restore complete
- **32.1C.06** (event code)
Data model failed to clone job ticket
- **32.1C.07** (event code)
Backup restore permissions error
- **32.1C.08** (event code)
Not enough disk space to perform backup/restore or network share issue
- **32.1C.09** (event code)
Tried to restore a backup file that was not valid for this product
- **32.1C.0A** (event code)
Backup file is invalid
- **32.1C.0B** (event code)
Backup is from newer version of FW than what is currently on the product
- **32.1C.0C** (event code)
Backup cancelled from the HP Embedded Web Server
- **32.1C.0D** (event code)
Backup/restore failed, auto-reboot failed, or the product might be busy
- **32.1C.0E** (event code)
Backup/restore timeout while communicating with the formatter
- **32.1C.11** (event code)
Backup/restore timeout while communicating with the engine
- **32.1C.12** (event code)
Backup/restore timeout while communicating with the disk
- **32.1C.13** (event code)
Scheduled backup failure
- **32.1C.14** (event code)

- NVRAM restore timeout while communicating with the formatter
- **32.1C.17** (event code)
NVRAM restore timeout while communicating with the engine
- **32.1C.1B** (event code)
Backup of print subsystem failed
- **32.1C.1C** (event code)
Backup of networking subsystem failed
- **32.1C.21** (event code)
Restore of print subsystem failed
- **32.1C.22** (event code)
Restore of networking subsystem failed
- **32.1C.24** (event code)
NVRAM backup/restore successful
- **32.1C.28** (event code)
Reset of print subsystem failed
- **32.1C.29** (event code)
Reset of networking subsystem failed
- **32.1C.2B** (event code)
Reset formatter timeout
- **32.1C.2E** (event code)
Reset engine timeout
- **32.1C.2F** (event code)
Reset failure

Recommended action

- **32.1C.01** (event code)
No action necessary
- **32.1C.02** (event code)
No action necessary
- **32.1C.03** (event code)
No action necessary

- **32.1C.04** (event code)
No action necessary
- **32.1C.05** (event code)
No action necessary
- **32.1C.06** (event code)
Retry
- **32.1C.07** (event code)
Retry
- **32.1C.08** (event code)
Remove stored jobs and retry
Use larger capacity storage device
Check network share
- **32.1C.09** (event code)
Use a valid backup file
- **32.1C.0A** (event code)
Use a valid backup file
Reboot and observe state of product
Do a partition clean using the Preboot menu
- **32.1C.0B** (event code)
Use a valid backup file or put correct firmware version on the product
- **32.1C.0C** (event code)
No action necessary
- **32.1C.0D** (event code)
Reboot and then retry the backup/restore
- **32.1C.0E** (event code)
Turn the product off then on and retry
- **32.1C.11** (event code)
Turn the product off then on and retry
- **32.1C.12** (event code)
Turn the product off then on and retry

- **32.1C.13** (event code)
Turn the product off then on and retry
- **32.1C.14** (event code)
Turn the product off then on and retry
- **32.1C.17** (event code)
Turn the product off then on and retry
- **32.1C.1B** (event code)
Turn the product off then on and retry
- **32.1C.1C** (event code)
Turn the product off then on and retry
- **32.1C.21** (event code)
Turn the product off then on and retry

If the error persists, clear the firmware image from the active partition by using the **Partial Clean** item in the Preboot menu
- **32.1C.22** (event code)
Turn the product off then on and retry

If the error persists, clear the firmware image from the active partition by using the **Partial Clean** item in the Preboot menu
- **32.1C.24** (event code)
Turn the product off then on and retry.
- **32.1C.28** (event code)
Turn the product off then on and retry.
- **32.1C.29** (event code)
Turn the product off then on and retry.
- **32.1C.2B** (event code)
Turn the product off then on and retry.
- **32.1C.2E** (event code)
Turn the product off then on and retry.
- **32.1C.2f** (event code)
Turn the product off then on and retry.

32.21.00

Description

Corrupt firmware in external accessory

Recommended action

Turn the product off, then on, and retry.

If the error persists, clear the firmware image from the active partition by using the **Partial Clean** item in the Preboot menu

40.00.01 USB I/O buffer overflow To continue, press OK

Description

The USB buffer has overflowed.

Recommended action

Press the **OK** button to print the transferred data (some data might be lost).

Check the host configuration.

40.00.02 Embedded I/O buffer overflow To continue, press OK

Description

The product has experienced a JetDirect buffer overflow.

Recommended action

Press the **OK** button to print the transferred data (some data might be lost).

Check the host configuration.

40.00.03 EIO buffer overflow To continue, press OK

Description

Too much data was sent to the EIO card in the specified slot (x). An incorrect communications protocol might be in use.

Recommended action

Press the **OK** button to print the transferred data (some data might be lost).

40.00.04 Unsupported USB accessory detected To continue, press OK

Description

The connection between the product and the USB device has been broken.

Recommended action

Press the **OK** button to clear the error message and continue printing.

Remove, and then reinstall the USB device.

40.00.05 Embedded I/O bad transmission To continue, press OK**Description**

The USB device has been removed.

Recommended action

Press the **OK** button to clear the error message. (Data will be lost.)

Install the USB device.

41.02.00 Error**Description**

A beam detected misprint error.

Recommended action

Turn the product off, and then on.

If the error persists, replace the laser/scanner assembly.

41.03.YZ Unexpected size in tray <X>**Description**

The product detected a different paper size than expected.

- Y = 0
Size mismatch. Detected media is longer or shorter than expected.
- Y = A
Size mismatch. Detected media too long.
- Y = B
Size mismatch. Detected media too short.
- Z = 1
Source is Tray 1
- Z = 2
Source is Tray 2
- Z = 3

Source is Tray 3

- Z = 4

Source is Tray 4

- Z = 5

Source is Tray 5

- Z = 6

Source is Tray 6

Recommended action

Make sure that the tray is loaded with the correct paper size and that the sliding paper guides are correctly adjusted.

Use the Manual/tray bin sensor test to verify that the cassette media switch is correctly functioning.

If the error persists, replace the lifter assembly.

41.05.YZ Unexpected type in tray <X>

Description

The product detected a different paper type than expected.

- Y = 0 (expected type)

Unknown

- Y = 1 (expected type)

Normal media

- Y = 3 (expected type)

LBP OHT

- Y = 4 (expected type)

Glossy media

- Y = 5 (expected type)

Gloss film

- Y = 6 (expected type)

Non-assured OHT

- Y = 7 (expected type)

Heavy media

- Y = 8 (expected type)

- Light media
- Y = 9 (expected type)
- Rough media
- Y = A (expected type)
- Extra heavy glossy media (glossy media 3)
- Y = B (expected type)
- Heavy glossy media (glossy media 2)
- Y = C (expected type)
- Heavy media 3
- Y = D (expected type)
- Heavy media 2
- Z = 1 (detected type)
- Normal media
- Z = 3 (detected type)
- LBP OHT
- Z = 4 (detected type)
- Glossy media
- Z = 5 (detected type)
- Gloss film
- Z = 6 (detected type)
- Non-assured OHT
- Z = 7 (detected type)
- Heavy media
- Z = 8 (detected type)
- Light media
- Z = 9 (detected type)
- Rough media
- Z = A (detected type)
- Extra heavy glossy media (glossy media 3)
- Z = B (detected type)

Heavy glossy media (glossy media 2)

- Z = C (detected type)

Heavy media 3

- Z = D (detected type)

Heavy media 2

Recommended action

Load the tray with the size and type of paper indicated, or use another tray if available.

If this message appears and the tray is loaded with the correct paper type, check the print driver settings to make sure they match the tray type settings.

Clean the Media Sensor.

If the error persists, replace the paper pickup assembly.

41.07.YZ Error To continue, press OK

Description

A media transportation error has occurred.

- Y = 0

Photo media 1, Photo media 2, Photo media 3, Designated media 2, Designated media 3, or N/A, typed or AutoSense

- Y = 1

AutoSense (Normal): special case distinguished from typed Normal

- Y = 2

Normal: typed (not AutoSense)

- Y = 3

Light media 1, 2, or 3: typed or AutoSense

- Y = 4

Heavy media 1: typed or AutoSense

- Y = 5

Heavy media 2: typed or AutoSense

- Y = 6

Heavy media 3: typed or AutoSense

- Y = 7

- Glossy media 1: typed or AutoSense
- Y = 8
- Glossy media 2: typed or AutoSense
- Y = 9
- Glossy media 3: typed or AutoSense
- Y = A
- Glossy film: typed or AutoSense
- Y = B
- OHT: typed or AutoSense
- Y = C
- Label
- Y = D
- Envelope 1, Envelope 2, or Envelope 3
- Y = E
- Rough (designated media 1): typed or AutoSense
- Z = 1
- Tray 1
- Z = 2
- Tray 2
- Z = 3
- Tray 3
- Z = 41
- Tray 4
- Z = 5
- Tray 5
- Z = 6
- Tray 6
- Z = D
- Duplexer

Recommended action

Turn the product off, and then on.

If the error persists, replace the DC controller PCA.

42.XX.YY**Description**

Internal system failure

Recommended action

Turn the product off, then on, and retry.

If the error persists, clear the firmware image from the active partition by using the **Partial Clean** item in the Preboot menu.

47.00.XX**Description**

Backchannel internal error

Recommended action

Turn the product off, and then on again. Resend the print job.

If the error persists, execute the **Partial Clean** item in the Preboot menu.

47.01.XX**Description**

Image transformer internal error

Recommended action

Turn the product off, and then on again. Resend the print job.

If the error persists, execute the **Partial Clean** item in the Preboot menu.

47.02.XX**Description**

Job parser internal error

Recommended action

Turn the product off, and then on again. Resend the print job.

If the error persists, execute the **Partial Clean** item in the Preboot menu.

47.03.XX

Description

Print job internal error

Recommended action

Turn the product off, and then on again. Resend the print job.

If the error persists, execute the **Partial Clean** item in the Preboot menu.

47.04.XX

Description

Print spooler 9100 internal error

Recommended action

Turn the product off, and then on again. Resend the print job.

If the error persists, execute the **Partial Clean** item in the Preboot menu.

47.05.00

Description

Print spooler framework internal error

Recommended action

Turn the product off, and then on again. Resend the print job.

If the error persists, execute the **Partial Clean** item in the Preboot menu.

47.06.XX

Description

Print App internal error

Recommended action

Turn the product off, and then on again. Resend the print job.

If the error persists, execute the **Partial Clean** item in the Preboot menu.

47.WX.YZ Printer calibration error To continue, press OK

Description

The device is unable to access or implement one of the image patterns files.

Y = calibration type, Z = event

- **47.FC.00** (event code)
Color plane registration (CPR) Image not found at system initialization
- **47.FC.01** (event code)
CPR Store Image failure
- **47.FC.02** (event code)
CPR Image not found
- **47.FC.03** (event code)
CPR Print engine execution failure
- **47.FC.10** (event code)
Consecutive Dmax Dhalf Image not found at system initialization
- **47.FC.11** (event code)
Consecutive Dmax Dhalf Store image failure
- **47.FC.12** (event code)
Consecutive Dmax Dhalf Image not found
- **47.FC.13** (event code)
Consecutive Dmax Dhalf Print engine execution failure
- **47.FC.20** (event code)
Error Diffusion Image not found at system initialization
- **47.FC.21** (event code)
Error Diffusion Store image failure
- **47.FC.22** (event code)
Error Diffusion Image not found
- **47.FC.23**
Error Diffusion Print engine execution failure
- **47.FC.300** (event code)
Drum Speed Adjustment Image not found at system initialization
- **47.FC.31** (event code)
Drum Speed Adjustment Store image failure
- **47.FC.32** (event code)

- Drum Speed Adjustment Image not found
- **47.FC.33** (event code)
- Drum Speed Adjustment Print engine execution failure
- **47.FC.40** (event code)
- Pulse Width Modulation Image not found at system initialization
- **47.FC.41** (event code)
- Pulse Width Modulation Store image failure
- **47.FC.42** (event code)
- Pulse Width Modulation Image not found
- **47.FC.430** (event code)
- Pulse Width Modulation Print engine execution failure

Recommended action

Turn the product off, and then on.

If the error persists, reload the firmware.

50.WX.YZ Fuser error To continue, turn off then on

Description

The fuser has experienced an error.

W = fuser error code, X = fuser mode, Y = previous printer sleep state, Z = next printer sleep state

Recommended action

W = 1 or W = 2

Low fuser temperature and fuser warm-up failure

1. Remove and then reseal the fuser. Make sure there is no residual paper in the fuser. Make sure the device is not located in front of a vent or window where cool air may interfere with the ability of the fuser to heat up.
2. Check the product power source. Make sure the power source meets product requirements. Make sure this is the only device using the circuit.
3. Replace the fuser.
4. Check the connector (J704) between the fuser and the printer. If it is damaged, replace the fuser drive assembly or fuser.

5. If the error persists, replace the low-voltage power supply.
6. If this product has been previously serviced, check the connector (J131) on the DC controller PCA and the connectors (J109 and J110) on the power line between the low-voltage power supply assembly and the fuser.

W = 3

High fuser temperature

1. Remove and then reseal the fuser.
2. Check the paper type setting using the product menus and in the printer driver. Make sure that they match and are correct for the type of media being used.
3. Replace the fuser.
4. If the error persists, replace the low-voltage power supply.
5. If this product has been previously serviced, check the connector (J131) on the DC controller PCA.

W = 4

Drive circuit fault

1. Check the power source. Make sure the power source meets product requirements.

 **NOTE:** If the power source does not meet the power frequency requirement of 43 to 67Hz, the fuser temperature control does not work properly and causes this error.

2. If the error persists, replace the low-voltage power supply.
3. If this product has been previously serviced, check the connector (J21) on the DC controller PCA.

W = 7

Fuser pressure-release mechanism failure

1. Remove and then reseal the fuser. Make sure there is no residual paper in the fuser.
2. Check the fuser pressure-release sensor flag. If it is damaged, replace the fuser.
3. Use the sensor test in the Manual sensor test to verify that the fuser pressure-release sensor (PS9) is properly functioning. If it is not, replace the fuser gear assembly.
4. Use the fuser pressure-release drive test in the component test to verify that the fuser motor (M4) is properly functioning. If it is not, replace the fuser motor.
5. If the error persists, replace the low-voltage power supply.
6. If this product has been previously serviced, check the connector (J181) on the DC controller PCA.

W = 8

Low fuser temperature 2

1. Remove and then reseal the fuser. Make sure there is no residual paper in the fuser. Make sure the device is not located in front of a vent or window where cool air may interfere with the ability of the fuser to heat up.
2. Check the product power source. Make sure the power source meets product requirements. Make sure this is the only device using the circuit.
3. Replace the fuser.
4. Check the connector (J704) between the fuser and the printer. If it is damaged, replace the fuser drive assembly or fuser.
5. If the error persists, replace the low-voltage power supply.
6. If this product has been previously serviced, check the connector (J131) on the DC controller PCA and the connectors (J109 and J110) on the power line between the low-voltage power supply assembly and the fuser.

W = 9

High fuser temperature 2

1. Remove and then reseal the fuser.
2. Check the paper type setting using the product menus and in the printer driver. Making sure that they match and are correct for the type of media being used.
3. Replace the fuser.
4. If this product has been previously serviced, check the connector (J131) on the DC controller PCA.

W = A

Low fuser temperature 3

1. Remove and then reseal the fuser. Make sure there is no residual paper in the fuser. Make sure the device is not located in front of a vent or window where cool air may interfere with the ability of the fuser to heat up.
2. Check the product power source. Make sure the power source meets product requirements. Make sure this is the only device using the circuit.
3. Replace the fuser.
4. Check the connector (J704) between the fuser and the printer. If it is damaged, replace the fuser drive assembly or fuser.
5. If this product has been previously serviced, check the connector (J131) on the DC controller PCA and the connectors (J109 and J110) on the power line between the low-voltage power supply assembly and the fuser.

W = B

High fuser temperature 3

1. Remove and then reseal the fuser.
2. Check the paper type setting using the product menus and in the printer driver. Making sure that they match and are correct for the type of media being used.
3. Replace the fuser.
4. Check the connector (J704) between the fuser and the printer. If it is damaged, replace the fuser drive assembly or fuser.
5. If this product has been previously serviced, check the connector (J131) on the DC controller PCA.

51.00.YY Error

Description

Laser/scanner error

- YY = 20
Black laser/scanner error
- YY = 21
Cyan laser/scanner error
- YY = 22
Magenta laser/scanner error
- YY = 23
Yellow laser/scanner error

Recommended action

Turn the product off, and then on.

If the error persists, replace the laser/scanner assembly.

52.XX.00 Error To continue, turn off then on

Description

Laser/scanner error

- XX = 00
laser/scanner motor startup error
- XX = 20
Laser/scanner rotation error

Recommended action

Use the scanner motor (M10) drive test in the component test to test the motor. If the motor does not run, replace the laser/scanner assembly.

 **NOTE:** Listen for a high pitched whine from the motor.

If the laser/scanner assembly has been removed or replaced, check the connectors (J831 and J832) on the laser-driver PCA and the connectors (J61 and J62) on the DC controller PCA.

54.XX.YY Error

Description

A sensor error has occurred.

Recommended action

54.00.03

Environmental sensor failure

1. Turn the product off, and then on.
2. If the error persists, replace the environment sensor assembly.
3. If the environment sensor has been removed or replaced check the connector (J502) on the environment sensor and the connector (J33) on the DC controller PCA.

54.00.06 or 54.00.14 or 54.00.19

Registration density sensor failure

1. Open and close the right door (or turn on and then off the power switch) to perform the color plane registration.
2. If the error persists, replace the registration density sensor assembly.

54.01.05

Media sensor is out of calibration range

1. Turn the product off, and then clean the media sensor with a lint-free cloth. Turn the product on.
2. If the error persists, replace the paper pickup assembly.

54.06.21

Primary laser/scanner beam detect abnormality

1. Turn the product off, and then on.
2. If the error persists, replace the laser/scanner assembly.
3. If the product has had parts removed or replace, check the connector (J61) on the DC controller PCA.

54.11.05 or 54.12.05

Media Sensor is not functioning properly

1. Clean the media sensor with a lint-free cloth and then turn the product off and then on.
2. **54.11.05:** If the error persists replace the paper pickup assembly. The threshold level for the media sensor (**Media Sensor Value**) is located on a label on the paper pickup assembly. Use the **Service** menu to input this value into the product memory after replacing the paper pickup assembly.

-or-

54.12.05: If the error persists replace the right door assembly.

3. **54.11.05:** If the product has had parts removed or replace check the connector (J1542) on the media sensor and the connector (J112) on the DC controller PCA.

-or-

54.12.05: If the product has had parts removed or replace check the connector (J114) on the media sensor and the connector (J152) on the DC controller PCA.

54.0X.07

Drum home position sensor failure

X = 5 black, X = 6 cyan, X = 7 magenta, X = 8 yellow

1. Turn the product off, and then on.
2. If the error persists, replace the main drive assembly.
3. If the product has had parts removed or replace, check the connector (J181) on the DC controller PCA.

54.0X.0B or 54.0X.0C

Density sensor out of range error or Dhalf calibration failure

X = 0 black, X = 1 cyan, X = 2 magenta, X = 3 yellow

1. Check the supplies status page to make sure the toner cartridges are not past their useful life.
2. Check the ITB for damage.
3. Make sure the CPR sensor is not contaminated with toner or paper dust. Clean the sensor with compressed air and soft brush.
4. If error persists, replace the registration sensor assembly.

54.0X.0D or 54.0X.0E

Optical memory element abnormal or CPR sensor out of range

X = 0 black, X = 1 cyan, X = 2 magenta, X = 3 yellow

1. Check the supplies status page to make sure the toner cartridges are not past their useful life.
2. Check the ITB for damage.
3. Make sure the CPR sensor is not contaminated with toner or paper dust. Clean the sensor with compressed air and soft brush.
4. If error persists, replace the registration sensor assembly.

54.0X.0B or 54.0X.0C

Density sensor out of range error or Dhalf calibration failure

X = 0 black, X = 1 cyan, X = 2 magenta, X = 3 yellow

1. Check the supplies status page to make sure the toner cartridges are not past their useful life.
2. Check the ITB for damage.
3. Make sure the CPR sensor is not contaminated with toner or paper dust. Clean the sensor with compressed air and soft brush.
4. If error persists, replace the registration sensor assembly.

54.0X.0D or 54.0X.0E

Optical memory element abnormal or CPR sensor out of range

X = 0 black, X = 1 cyan, X = 2 magenta, X = 3 yellow

1. Check the supplies status page to make sure the toner cartridges are not past their useful life.
2. Check the ITB for damage.
3. Make sure the CPR sensor is not contaminated with toner or paper dust. Clean the sensor with compressed air and soft brush.
4. If error persists, replace the registration sensor assembly.

55.00.YY DC controller error To continue, turn off then on

Description

DC controller PCA error

- **55.00.01** (event code)

DC controller memory error

- **55.00.03** (event code)

DC controller no engine response

- **55.00.04** (event code)

DC controller communications timeout

Recommended action

Turn the product off, and then on.

If the error persists, replace the DC controller PCA.

55.0X.YY DC controller error To continue, turn off then on**Description**

DC controller PCA error

- **55.01.06** (event code)
NVRAM memory data error warning
- **55.02.06** (event code)
NVRAM memory access error warning

Recommended action

Turn the product off, and then on.

If the error persists, replace the DC controller PCA.

56.00.YY Error To continue, turn off then on**Description**

Optional paper trays communication error

Recommended action

Turn the product off, and then on.

If the error persists, reseal the optional paper trays (1 x 500-sheet feeder and/or 3 x 500-sheet feeder).

Check the input connectors for damage. If a connector is damaged, replace the connector.

57.00.0Y Error To continue, turn off then on**Description**

Fan error

Recommended action**57.00.01**

Power supply fan (FM1) failure

- 1.** Turn the product off, and then on. Listen for fan noise at the front lower-left corner of the product. If no noise is heard, replace the power supply fan (FM1).
- 2.** If this part has been removed or replace, check the connector (J21) on the DC controller PCA and the connector (J106) on the low-voltage power supply assembly.

57.00.02

Fuser fan (FM2) failure

1. Turn the product off, and then on. Listen for fan noise at the front lower-right corner of the product. If no noise is heard, replace the fuser fan (FM2).
2. If this part has been removed or replaced, check the connector (J121) on the DC controller PCA and the intermediate connector (J524).

57.00.03

Formatter fan (FM3) failure

1. Turn the product off, and then on. Listen for fan noise at the lower back-center of the product. If no noise is heard, replace the formatter fan (FM3).
2. If this part has been removed or replaced, check the connector (J142) on the intermediate connect board.

59.00.YY Error To continue, turn off then on

Description

Printing error

Recommended action

59.00.30 or 59.00.04

Fuser motor (M4) start up error or fuser motor (M4) rotational error

1. Use the fuser motor (M4) drive test in the component test to verify that the fuser motor is properly functioning. If it is not, replace the fuser motor assembly.
2. If the product has been serviced, check the connector (J516) on the fuser motor and the connector (J81) on the DC controller PCA.

59.00.90 or 59.00.A0

ITB motor (M1) start up error or ITB motor (M1) abnormal rotational error

1. Use the ITB motor (M1) drive test in the component test to verify that the ITB motor is properly functioning. If it is not, replace the ITB motor assembly.
2. If the product has been serviced, check the connector (J517) on the ITB motor and the connector (J81) on the DC controller PCA.

59.00.C0

Developer alienation motor (M6) error

1. Use the developer engagement and disengagement drive test in the component test to verify that the disengagement mechanism is properly functioning. If it is not, replace the ITB motor assembly.
2. Use the sensor test in the Manual sensor test to verify that the developer disengagement sensor (PS11) is properly functioning. If it is not, replace the main drive assembly.
3. If the product has been serviced, check the connector (J518) on the developer disengagement motor, the connector (J1005) on the driver PCA and the connector (J91) on the DC controller PCA.

59.00.F0

T1 alienation mechanism failure

1. Make sure that the ITB is correctly installed.
2. Use the T1 roller alienation switch (SW5) test in the Manual sensor test to verify that the switch is properly functioning. If it is not, replace the main drive assembly.
3. Use the T1 roller engagement and disengagement drive test in the component test to verify that the T1 roller disengagement mechanism is properly functioning. If it is not, replace the fuser drive assembly.
4. If the product has been serviced, check the connector (J181) on the DC controller PCA.

59.0X.50 Error To continue, turn off then on

Description

Motor startup error

X = 5 black, X = 6 cyan, X = 7 magenta, X = 8 yellow

Recommended action

59.05.50

Black image drum start up error (ITB motor; M1)

1. Use the ITB drum motor (M1) drive test in the Component test to verify that the motor is properly functioning. If it is not, replace the ITB motor assembly.
2. If the product has been serviced, check the connector (J517) on the ITB motor and the connector (J81) on the DC controller PCA.

59.06.50 or 59.07.50 or 59.08.50

CMY drum motor (M2) start up error

1. Use the drum motor (M2) drive test in the Component test to verify that the motor is properly functioning. If it is not, replace the drum motor assembly.
2. If the product has been serviced, check the connector (J515) on the drum motor and the connector (J81) on the DC controller PCA.

59.0X.60 Error To continue, turn off then on

Description

Motor rotational error

X = 5 black, X = 6 cyan, X = 7 magenta, X = 8 yellow

Recommended action

50.06.60 or 50.07.60 or 50.08.60

CMY drum motor (M2) rotation error

1. Use the drum motor (M2) drive test in the Component test to verify that the motor is properly functioning. If it is not, replace the drum motor assembly.
2. If the product has been serviced, check the connector (J515) on the drum motor and the connector (J81) on the DC controller PCA.

59.0X.70 Error To continue, turn off then on

Description

Motor abnormal rotation

Recommended action

50.05.70

Black developer motor abnormal start up error (ITB motor; M1)

1. Use the ITB drum motor (M1) drive test in the Component test to verify that the motor is properly functioning. If it is not, replace the ITB motor assembly.
2. If the product has been serviced, check the connector (J517) on the ITB motor and the connector (J81) on the DC controller PCA.

50.06.70 or 50.07.70 or 50.08.70

CMY developer motor (M3) abnormal start up error

1. Use the developer motor (M3) drive test in the Component test to verify that the motor is properly functioning. If it is not, replace the developer motor assembly.
2. If the product has been serviced, check the connector (J514) on the developer motor and the connector (J81) on the DC controller PCA.

59.0X.80 Error To continue, turn off then on

Description

Developer motor failure

Recommended action

50.05.80

Black developer motor failure error (ITB motor; M1)

1. Use the ITB drum motor (M1) drive test in the Component test to verify that the motor is properly functioning. If it is not, replace the ITB motor assembly.
2. If the product has been serviced, check the connector (J517) on the ITB motor and the connector (J81) on the DC controller PCA.

50.06.80 or 50.07.80 or 50.08.80

CMY developer motor (M3) failure error

1. Use the developer motor (M3) drive test in the Component test to verify that the motor is properly functioning. If it is not, replace the developer motor assembly.
2. If the product has been serviced, check the connector (J514) on the developer motor and the connector (J81) on the DC controller PCA.

60.00.0Y Tray <Y> lifting error

Description

Tray lift motors error

Recommended action

60.00.02

Media input Tray 2 lift-up motor (M9) failure

1. Use the Tray 2 paper surface sensor (PS4) test in the Tray/Bin manual sensor test to verify that the sensor is properly functioning. If it is not, replace the lifter drive assembly.
2. Open and close Tray 2 and listen at the back of the product for the sound of the lifer motor (M9) operating. If it does not operate, replace the lifter drive assembly.
3. If the product has been serviced, check the intermediate connector (J742) and the connector (J151) on the DC controller PCA.
4. If the error persists, replace the cassette tray.

60.00.03 or 60.00.04

Media input Tray 3 lift-up motor (M2) failure or media input Tray 4 lift-up motor (M2) failure

1. Use the Tray 3 paper surface sensor (SR2) or Tray 4 paper surface sensor (SR2) test in the Tray/Bin manual sensor test to verify that the sensor is properly functioning. If it is not, replace the lifter drive assembly.

 **NOTE:** Both the Tray 3 and Tray 4 paper surface sensors are designated as SR2. The first one listed in the Tray/Bin manual test is Tray 3, the second one listed is for Tray 4.

2. Open and close Tray 3 or Tray 4 and listen at the back of the product for the sound of the lifer motor (M2) operating. If it does not operate, replace the lifter drive assembly.

 **NOTE:** Both the Tray 3 and Tray 4 lifter motors are designated as M2. Listen for the appropriate motor to operate.

3. If the product has been serviced, check the connector (J2003) on the paper feeder controller PCA, the intermediate connector (J702) and the connector (J2006) on the paper feeder controller PCA.

 **TIP:** Check the connector (J2006) on the paper feeder controller PCA associated with the tray.

4. If the error persists, replace the cassette tray.

60.00.05 or 60.00.05

Media input Tray 5 lift-up motor (M82) failure or media input Tray 6 lift-up motor (M92) failure

1. Use the Tray 5 paper surface sensor (SR82) or Tray 6 paper surface sensor (SR92) test in the Tray/Bin manual sensor test to verify that the sensor is properly functioning. If it is not, replace the lifter drive assembly.

2. Open and close Tray 5 or Tray 6 and listen at the back of the product for the sound of the lifer motor (M82 or M92) operating. If it does not operate, replace the lifter drive assembly.

3. If the product has been serviced, check the connector (J2003) on the paper feeder controller PCA, the intermediate connector (J702) and the connector (J2006) on the paper feeder controller PCA.

 **TIP:** Check the connector (J2006) on the paper feeder controller PCA associated with the tray.

4. If the error persists, replace the cassette tray.

61.00.01

Description

Color table read failure

Recommended action

Turn the product off, and then on.

If the error persists, reload the firmware. If the error still persists, perform a firmware upgrade.

If the firmware upgrade does not resolve the problem, replace the hard disk.

62.00.00 No system To continue, turn off then on

Description

Internal system failure

Recommended action

Turn the product off, and then on.

If the error persists, reload the firmware. If the error still persists, perform a firmware upgrade.

If the firmware upgrade does not resolve the problem, replace the hard disk.

70.00.00 Error To continue, turn off then on

Description

DC controller failure

Recommended action

Turn the product off, and then on.

If the error persists, replace the DC controller.

80.0X.YY Embedded JetDirect error

Description

Embedded HP JetDirect print server critical error

- **80.01.80** (event code)
No heartbeat
- **80.01.81** (event code)
Reclaim timeout
- **80.01.82** (event code)
Invalid data length
- **80.01.8B** (event code)
Invalid max outstanding packet header field
- **80.01.8C** (event code)
Invalid channel mapping response
- **80.03.01** (event code)
No PGP buffers
- **80.03.02** (event code)

- Channel table full
- **80.03.03** (event code)
Producer index not reset
- **80.03.04** (event code)
Consumer index not reset
- **80.03.05** (event code)
Queue position size too small
- **80.03.06** (event code)
Transport overflow
- **80.03.07** (event code)
No overflow packets
- **80.03.08** (event code)
Invalid identify response
- **80.03.09** (event code)
Invalid channel map return status
- **80.03.10** (event code)
Invalid reclaim return status
- **80.03.11** (event code)
Datagram invalid buffer
- **80.03.12** (event code)
Max stream channels
- **80.03.13** (event code)
Max datagram channels
- **80.03.14** (event code)
Card reset failed
- **80.03.15** (event code)
Self test failure
- **80.03.16** (event code)
Unknown PGP packet
- **80.03.17** (event code)
- **80.03.18** (event code)

Duplicate I/O channel.

Recommended action

Turn the product off, and then on.

If the error persists, replace the formatter.

98.00.01 Corrupt data in firmware volume

Description

Data corruption has occurred in the firmware volume

Recommended action

Turn the product off, and then on.

Use the **Clean Disk** item in the Preboot menu.

Reload the firmware.

98.00.02 Corrupt data in solutions volume

Description

Data corruption has occurred in the solutions volume

Recommended action

Turn the product off, and then on.

Use the **Clean Disk** item in the Preboot menu.

Reload the firmware.

98.00.03 Corrupt data in configuration volume

Description

Data corruption has occurred in the configuration volume

Recommended action

Turn the product off, and then on.

Use the **Clean Disk** item in the Preboot menu.

Reload the firmware.

98.00.04 Corrupt data in job data volume

Description

Data corruption has occurred in the job data volume

Recommended action

Turn the product off, and then on.

Rerun the file erase function.

99.00.01 Upgrade not performed file is corrupt

Description

A remote firmware upgrade (RFU) was not performed.

CRC error in the firmware image (bad image).

Recommended action

Download the RFU file and attempt the upgrade again.

99.00.02 Upgrade not performed timeout during receive

Description

A remote firmware upgrade (RFU) was not performed.

I/O timeout when reading header number and size. Indicates a problem with the network environment, not the device.

Recommended action

The most common cause is an issue with the network environment. Make sure that there is a good connection to the device and attempt the upgrade again, or upgrade using the USB walk-up port.

99.00.03 Upgrade not performed error writing to disk

Description

A remote firmware upgrade (RFU) was not performed.

Disk error. May indicate a problem or a hard disk failure. It might be necessary to check the connection to the hard disk or replace the hard disk.

Recommended action

1. Download the RFU file and attempt the upgrade again.
2. If the error persists, perform the **Clean Disk** process. You will then need to download firmware from the Preboot menu.
3. If the error persists, replace the hard disk.

99.00.04 Upgrade not performed timeout during receive

Description

A remote firmware upgrade (RFU) was not performed.

I/O timeout when reading rest of header.

Recommended action

The most common cause is an issue with the network environment. Make sure that there is a good connection to the device and attempt the upgrade again, or upgrade using the USB walk-up port.

99.00.05 Upgrade not performed timeout during receive

Description

A remote firmware upgrade (RFU) was not performed.

I/O timeout when reading image data.

Recommended action

The most common cause is an issue with the network environment. Make sure that there is a good connection to the device and attempt the upgrade again, or upgrade using the USB walk-up port.

99.00.06 Upgrade not performed error reading upgrade

Description

A remote firmware upgrade (RFU) was not performed.

Unexpected read error when reading header number and size.

Recommended action

1. Download the RFU file and attempt the upgrade again.
2. If the error persists, replace the hard disk.

99.00.07 Upgrade not performed error reading upgrade

Description

A remote firmware upgrade (RFU) was not performed.

Unexpected read error when reading rest of header.

Recommended action

1. Download the RFU file and attempt the upgrade again.
2. If the error persists, replace the hard disk.

99.00.08 Upgrade not performed error reading upgrade

Description

A remote firmware upgrade (RFU) was not performed.

Unexpected read error when reading image data.

Recommended action

1. Download the RFU file and attempt the upgrade again.
2. If the error persists, replace the hard disk.

99.00.09 Upgrade canceled by user**Description**

A remote firmware upgrade (RFU) was not performed.

The RFU was canceled by the user.

Recommended action

Resend the RFU.

99.00.10 Upgrade canceled by user**Description**

A remote firmware upgrade (RFU) was not performed.

Job canceled when reading header number and size.

Recommended action

Resend the RFU.

99.00.11 Upgrade canceled by user**Description**

A remote firmware upgrade (RFU) was not performed.

Job canceled when reading rest of header.

Recommended action

Resend the RFU.

99.00.12 Upgrade not performed the file is invalid**Description**

A remote firmware upgrade (RFU) was not performed.

Header number is 1 but header size doesn't match version 1 size.

Recommended action

Download the RFU file again. Make sure that you download the file for the correct product model.
Resend the RFU.

99.00.13 Upgrade not performed the file is invalid

Description

A remote firmware upgrade (RFU) was not performed.

Header number is 2 but header size doesn't match version 2 size.

Recommended action

Download the RFU file again. Make sure that you download the file for the correct product model.
Resend the RFU.

99.00.14 Upgrade not performed the file is invalid

Description

A remote firmware upgrade (RFU) was not performed.

The file is invalid.

Recommended action

Download the RFU file again. Make sure that you download the file for the correct product model.
Resend the RFU.

99.00.2X

Description

- **99.00.20** (event log)
The bundle is not for this product
- **99.00.21** (event log)
The bundle is not signed with the correct signature, or the signature is invalid
- **99.00.22** (event log)
The bundle header version is not supported by this firmware
- **99.00.23** (event log)
The package header version is not supported by this firmware
- **99.00.24** (event log)
- The format of the bundle is invalid
- **99.00.25** (event log)
The format of the package is invalid
- **99.00.26** (event log)

A CRC32 check did not pass

- **99.00.27** (event log)

An I/O error occurred while downloading the bundle

Recommended action

Download the correct firmware file from www.hp.com/support/cljcp5525 or www.hp.com/go/cljcp5525_firmware, and then resend the firmware upgrade.

99.00.27 only: Turn the product off, and then on again. Resend the firmware upgrade. If the error persists, try the sending the upgrade by another method (USB or Embedded Web Server).

99.09.60 Unsupported disk

Description

Preboot menu error.

The hard disk currently installed is not recognized or supported by the product.

Recommended action

Install the correct hard disk for this product.

99.09.61 Unsupported disk

Description

Preboot menu error.

The installed disk is installed in a product configured for a encrypted hard disk.

Recommended action

Access the Preboot menu and then select **Lock Disk** to lock the disk.

99.09.62 Unknown disk

Description

Preboot menu error.

The installed disk was previously locked in another product.

Recommended action

Install a new disk or use the Preboot menu to unlock this disk. If the disk is to be reused in a different product, execute the **Clean Disk** procedure from the Preboot menu, then reload firmware and lock the disk.

99.09.63 Incorrect disk

Description

A new or blank disk has been installed in a device which previously had an encrypted disk.

Recommended action

Follow the procedure to load firmware on a new hard disk and then lock it to this product.

99.09.64 Disk malfunction

Description

A fatal hard disk failure has occurred.

Recommended action

Replace the hard disk drive.

99.09.65 Disk data error

Description

Disk data corruption has occurred.

Recommended action

Execute the **Clean Disk** procedure from the Preboot menu, and then resend the RFU.

99.09.66 No disk data installed

Description

A disk drive is not installed in the product.

Recommended action

Install a compatible hard disk drive.

99.09.67 Disk is not bootable please download firmware

Description

The product has a non-secure disk (solid state disk) installed as the boot disk, and it has been replaced with a new service part. A new firmware image needs to be downloaded to the device.

Recommended action

1. Press any key to continue to the main Preboot menu.
2. Press the [Help](#) button  to see the help text for the error.
3. Select the Administrator menu.

 **NOTE:** If there is a password assigned to the Administrator, a prompt to enter the password displays.

4. Select the Download item.
5. The user can now download a new firmware bundle to the product.

99.XX.YY

Description

Firmware installation error

Recommended action

Reload the firmware.

<Binname> Full Remove all paper from bin

Description

The specified output bin is full.

Recommended action

Empty the bin to continue printing.

<Supply> almost full

Description

Toner Collection bottle is almost full.

- **10.31.60** (event code)

Toner collection unit

Recommended action

Replace the toner collection unit

<Supply> low OR Supplies low

Description

The product indicates when a supply level, or more than one supply, is low. Actual print cartridge life might vary. You do not need to replace the print cartridge at this time unless print quality is no longer acceptable.

When multiple supplies are low, more than one event code is recorded.

- **10.00.60** (event code)
Black print cartridge
- **10.01.60** (event code)
Cyan print cartridge
- **10.02.60** (event code)
Magenta print cartridge
- **10.03.60** (event code)
Yellow print cartridge
- **10.23.60** (event code)
Fuser Kit
- **10.22.60** (event code)
Transfer kit

Recommended action

If print quality is no longer acceptable, replace the supply.

HP recommends that the customer have a replacement supply available to install when print quality is no longer acceptable.

 **NOTE:** When an HP supply has reached its approximated end of life, the HP Premium Protection Warranty ends.

<Supply>very low OR Supplies very low

Description

The product indicates when a supply level, or more than one supply, is very low. Actual print cartridge life might vary. You do not need to replace the print cartridge at this time unless print quality is no longer acceptable.

When multiple supplies are low, more than one event code is recorded.

- **10.00.70** (event code)
Black print cartridge
- **10.01.70** (event code)
Cyan print cartridge
- **10.02.70** (event code)
Magenta print cartridge

- **10.03.70** (event code)
Yellow print cartridge
- **10.23.70** (event code)
Fuser Kit
- **10.22.70** (event code)
Transfer kit

Recommended action

If print quality is no longer acceptable, replace the supply.

HP recommends that the customer have a replacement supply available to install when print quality is no longer acceptable.

 **NOTE:** When an HP supply has reached its approximated end of life, the HP Premium Protection Warranty ends.

<Tray X> lifting

Description

The product is in the process of lifting paper in the indicated tray.

- X = 2
Tray 2
- X = 3
Tray 3
- X = 4
Tray 4
- X = 5
Tray 5
- X = 6
Tray 6

Recommended action

No action necessary.

[File System] device failure To clear, press OK

Description

The specified device has failed.

Recommended action

Press the **OK** button to clear the error.

[File System] file operation failed To clear, press OK

Description

A PJI file system command attempted to perform an illogical operation.

Recommended action

Press the **OK** button to clear the error.

[File System] file system is full To clear, press OK

Description

A PJI file system command could not store something on the file system because the file system was full.

Recommended action

Press the **OK** button to clear the error.

[File System] is not initialized

Description

This file-storage component must be initialized before use.

Recommended action

Use the HP Embedded Web Server or HP Web Jetadmin to initialize the file system.

[File System] is write protected

Description

The file system device is protected and no new files can be written to it.

Recommended action

Press the **OK** button to clear the error.

Accept bad signature

Description

The product is performing a remote firmware upgrade, and the code signature is invalid.

Recommended action

Download the correct firmware upgrade file for this product, and then reinstall the upgrade. See the product user guide for more information.

Bad optional tray connection

Description

The optional tray is not connected, not connected correctly, or a connection is not working correctly.

Recommended action

1. Turn the product off.
2. Remove and then reinstall the optional tray.
3. Reconnect connectors for the tray.
4. If the problem continues, replace the connector for the tray.

Calibration reset pending

Description

A calibration reset occurs when all jobs are processed.

Recommended action

To begin the reset sooner, cancel all jobs by pressing the **Stop** button ⊗.

Canceling

Description

The product is canceling the current job.

Recommended action

No action is necessary.

Canceling... <jobname>

Description

The product is canceling the current job <jobname>.

Recommended action

No action is necessary.

Checking engine

Description

The product is conducting an internal test.

Recommended action

No action is necessary.

Checking paper path

Description

The product is checking for possible paper jams.

Recommended action

No action is necessary.

Chosen personality not available To continue, press OK

Description

A print job requested a product language (personality) that is not available for this product. The job will not print and will be cleared from memory.

Recommended action

Print the job by using a print driver for a different language, or add the requested language to the product (if possible). To see a list of available personalities, print a configuration page.

Cleaning do not grab paper

Description

The product is performing an automatic cleaning cycle. Printing will continue after the cleaning is complete.

Recommended action

No action is necessary.

Cleaning...

Description

The product is performing an automatic cleaning cycle. Printing will continue after the cleaning is complete.

Recommended action

No action is necessary.

Clearing event log

Description

This message is displayed while the event log is cleared. The product exits the menus when the event log has been cleared.

Recommended action

No action is necessary.

Clearing paper path

Description

The product is attempting to eject jammed paper.

Recommended action

Check progress at the bottom of the display.

Close front door

Description

The front door of the product is open.

Recommended action

Close the door.

Use the switch test in the manual sensor test to verify that the front-door switch is properly functioning. If the switch fails the test, replace the switch.

Check the sensor flag on the front-door assembly. If it is damaged, replace the front-door assembly.

If the product has been recently serviced, check the connector (J708) on the 24V interlock switch and the connector (J121) on the DC controller PCA.

Close lower right door

Description

The 3 x 500-sheet optional paper feeder right door is open.

Recommended action

Close the door.

Use the lower-right door switch (SW1) test in the Tray/Bin manual sensor test to verify that the switch is properly functioning. If the switch fails the test, replace the switch.

Check the sensor flag on the lower-right door assembly. If it is damaged, replace the door assembly.

Close middle right door

Description

The 1 x 500-sheet optional paper feeder right door is open.

Recommended action

Close the door.

Use the right-door switch (SW1) test in the Tray/Bin manual sensor test to verify that the switch is properly functioning. If the switch fails the test, replace the switch.

Check the sensor flag on the right door assembly. If it is damaged, replace the door assembly.

Close right door

Description

The right door of the product is open.

Recommended action

Close the door.

Use the right-door switch (SP15) test in the manual sensor test to verify that the switch is properly functioning. If the switch fails the test, replace the switch.

Check the sensor flag on the right door assembly. If it is damaged, replace the door assembly.

If the product has been recently serviced, check the connector (J708) on the 24V interlock switch and the connector (J181) on the DC controller PCA.

Close upper right door For help press ?

Description

The upper-right door of the product is open.

Recommended action

Close the door.

Use the right-door switch (SP15) test in the manual sensor test to verify that the switch is properly functioning. If the switch fails the test, replace the switch.

Check the sensor flag on the right door assembly. If it is damaged, replace the door assembly.

If the product has been recently serviced, check the connector (J708) on the 24V interlock switch and the connector (J181) on the DC controller PCA.

Cooling device

Description

The product is cooling.

Recommended action

No action is necessary.

Creating cleaning page**Description**

A cleaning page is being generated.

Recommended action

No action is necessary.

Data received To print last page, press OK**Description**

The product is waiting for the command to print the last page.

Recommended action

Press the **OK** button to print the last page of the job.

EIO <X> disk initializing**Description**

The specified EIO disk device is initializing.

Recommended action

No action is necessary.

EIO <X> disk not functional**Description**

The EIO disk in slot <X> is not correctly functioning.

- X = 1
Slot 1
- X = 2
Slot 2

Recommended action

Turn the product off, and then on.

If the error persists, turn the product off, and then remove and reinstall the disk.

EIO <X> disk spinning up

Description

EIO disk device in slot <X> is spinning up its platter. Jobs that require disk access must wait.

- X = 1
Slot 1
- X = 2
Slot 2

Recommended action

No action is necessary.

Event log is empty

Description

No product events are in the log.

Recommended action

No action is necessary.

Expected drive missing

Description

The product cannot find the encrypted hard drive.

Recommended action

Install the encrypted hard drive.

HP Secure Hard Drive disabled

Description

The drive has been encrypted for another product.

Recommended action

Remove the drive or use the Embedded Web Server for more information.

Incompatible <supply>

Description

The indicated supply <supply> is not compatible with this product.

- **10.00.35** (event code)

Black print cartridge

- **10.01.35** (event code)

Cyan print cartridge

- **10.02.35** (event code)

Magenta print cartridge

- **10.03.35** (event code)

Yellow print cartridge

- Fuser kite

10.23.35 (event code)

Recommended action

Replace the supply with one that is designed for this product.

Incompatible supplies

Description

Print cartridges or other supply items are installed that were not designed for this product. The product cannot print with these supplies installed.

Event codes are supply specific.

Recommended action

Press the **OK** button to identify the incompatible supplies.

Replace the supplies with those that are designed for this product.

Initializing...

Description

The product is starting.

Recommended action

No action necessary.

Install <supply>

Description

A supply item is either not installed or installed incorrectly.

- Black cartridge
10.00.15 (event code)
- Cyan cartridge
10.10.15 (event code)
- Magenta cartridge
10.02.15 (event code)
- Yellow cartridge
10.03.15 (event code)
- Fuser kite
10.23.15 (event code)

Recommended action

Install the supply item or make sure that the installed supply item is fully seated.

Install <supply> Close rear door

Description

The toner collection unit has been removed or has been installed incorrectly.

- Toner collection unit
10.31.15 (event code)

Recommended action

Replace or reinstall the toner collection unit correctly to continue printing.

Install Fuser Unit

Description

The fuser has been removed or installed incorrectly.

Recommended action

△ **CAUTION:** The fuser can be hot while the product is in use. Wait for the fuser to cool before handling it.

1. Open the right door.
2. Install or adjust the fuser.
3. Close the right door.

Install supplies

Description

More than one supply is missing or is installed incorrectly.

Recommended action

Press the **OK** button to identify the supplies that need to be replaced.

Press the **OK** button a second time for more information about the specific supply.

Insert the supply or make sure it is correctly installed and fully seated.

Install Transfer Unit

Description

The transfer unit is either not installed or not installed correctly.

Recommended action

1. Open the right door.
2. Install the ITB.

 **NOTE:** If the ITB is already installed, remove it, and then reinstall the ITB.

3. Close the right door.
4. If the error persists, use the ITB alienation sensor switch (SW5) in the manual sensor test to verify that the switch is properly functioning. If it is not, replace the main drive assembly.
5. If the error persists, use the T1 roller engagement and disengagement drive test in the component test to verify that the ITB alienation mechanism is properly functioning. If it is not, replace the fuser drive assembly.
6. If the product was recently serviced, check the connector (J181) on the DC controller PCA.

Internal disk not functional

Description

The internal hard drive is not correctly functioning.

Recommended action

Turn the product off, and then reinstall the hard drive.

If the error persists, replace the internal hard drive.

Internal disk spinning up

Description

Internal disk device is spinning up its platter. Jobs that require disk access must wait.

Recommended action

No action is necessary.

Load Tray <X>: [Type], [Size]

Description

This message appears even though there is media loaded in the tray.

Recommended action

Use the cassette media present sensor test in the Tray/bin manual sensor test to verify that the sensor is correctly functioning.

Make sure that the sensor flag on the media presence sensor is not damaged and moves freely.

Reconnect the corresponding connector:

- MP tray: connector (J736) on the MP tray media out sensor and the connector (J152) on the DC controller PCA.
- Printer cassette: connectors (J739 and J742) on the cassette media out sensor and the connector (J151) on the DC controller PCA.
- 1 X 500-sheet paper feeder cassette: connector (J702D) on the paper feeder cassette media out sensor and the connector (J2003) on the paper feeder controller PCA.
- Paper deck cassette 1: connector (J702D) on the paper deck cassette 1 media out sensor and connector (J2003) on the paper deck controller PCA 1
- Paper deck cassette 2: connector (J802D) on the paper deck cassette 2 media out sensor and connector (J2003B) on the paper deck controller PCA 2.
- Paper deck cassette 3: connector (J902D) on the paper deck cassette 3 media out sensor and connector (J2003C) on the paper deck controller PCA 3.

Load Tray <X>: [Type], [Size] To use another tray, press OK

Description

This message appears when the indicated tray is selected but is not loaded, and other paper trays are available for use. It also appears when the tray is configured for a different paper type or size than the print job requires.

Recommended action

Load the correct paper in the tray.

If prompted, confirm the size and type of paper loaded.

Otherwise, press the **OK** button to select another tray.

Loading program <XX> Do not power off

Description

Programs and fonts can be stored on the product's file system and are loaded into RAM when the product is turned on. The number <XX> specifies a sequence number indicating the current program being loaded.

Recommended action

No action necessary.

 **NOTE:** Do not turn the product off.

Manually feed output stack Then press OK to print second sides

Description

The product has printed the first side of a manual duplex job and is waiting for the user to insert the output stack to print the second side.

Recommended action

1. Maintaining the same orientation, remove pages from the output bin.
2. Flip document printed side up.
3. Load document in Tray 1.
4. Press the **OK** button to print the second side of the job.

Manually feed: [Type], [Size]

Description

This message appears when manual feed is selected, Tray 1 is not loaded, and other trays are empty.

Recommended action

Load tray with requested paper.

If paper is already in tray, press the **Help** button to exit the message and then press the **OK** button to print.

To use another tray, clear paper from Tray 1, press the **Help** button to exit the message and then press the **OK** button.

Manually feed: [Type], [Size] To use another tray, press OK

Description

This message appears when manual feed is selected, Tray 1 is loaded, and other trays are available.

Recommended action

Load tray with requested paper.

If paper is already in tray, press the **Help** button to exit the message and then press the **OK** button to print.

To use another tray, clear paper from Tray 1, press the **Help** button to exit the message and then press the **OK** button.

Moving solenoid

Description

The solenoid is moving as part of a component test.

Recommended action

To exit press ▼

Moving solenoid and motor

Description

The solenoid and a motor are moving as part of a component test.

Recommended action

To exit press ▼

No job to cancel

Description

You have pressed the stop button but the product is not actively processing any jobs.

Recommended action

No action necessary.

Paused

Description

The product is paused, and there are no error messages pending at the display. The I/O continues receiving data until memory is full.

Recommended action

Press the **Stop** button ⊗.

Performing Color Band Test...

Description

A color-band test is being performed.

Recommended action

No action necessary.

Performing Paper Path Test...

Description

A paper-path test is being performed.

Recommended action

No action necessary.

Please wait...

Description

The product is in the process of clearing data.

Recommended action

No action necessary.

Printing CMYK samples...

Description

The product is printing the CMYK Sample pages.

Recommended action

No action necessary.

Printing Color Usage Log...

Description

The product is printing the Color Usage log.

Recommended action

No action necessary.

Printing Configuration...

Description

The product is printing the Configuration page.

Recommended action

No action necessary.

Printing Demo Page...

Description

The product is printing the Demo page.

Recommended action

No action necessary.

Printing Diagnostics Page...

Description

The product is printing the Diagnostics page.

Recommended action

No action necessary.

Printing Engine Test...

Description

The product is printing an engine test page.

Recommended action

No action necessary.

Printing Event Log...

Description

The product is printing the Event Log page.

Recommended action

No action necessary.

Printing File Directory...**Description**

The product is printing the File Directory pages.

Recommended action

No action necessary.

Printing Font List...**Description**

The product is printing the Font List pages.

Recommended action

No action necessary.

Printing Fuser Test Page...**Description**

The product is printing the Fuser Test page.

Recommended action

No action necessary.

Printing Help Page...**Description**

The product is printing the Help page.

Recommended action

No action necessary.

Printing Menu Map...**Description**

The product is printing the Menu Map pages.

Recommended action

No action necessary.

Printing PQ Troubleshooting...

Description

The product is printing the PQ Troubleshooting pages.

Recommended action

No action necessary.

Printing Registration Page...

Description

The product is printing the Registration pages.

Recommended action

No action necessary.

Printing RGB Samples...

Description

The product is printing the RGB Sample pages.

Recommended action

No action necessary.

Printing stopped

Description

Time has expired on the Print/Stop test.

Recommended action

Press the **OK** button to continue.

Printing Supplies Status Page...

Description

The product is printing the Supplies Status page.

Recommended action

No action necessary.

Printing Usage Page...

Description

The product is printing the Usage page.

Recommended action

No action necessary.

Processing duplex job Do not grab paper until job completes**Description**

Paper temporarily comes into the output bin while printing a duplex job.

- △ **CAUTION:** Do not grab paper as it temporarily comes into the output bin. The message disappears when the job is finished.
-

Recommended action

No action necessary.

Processing job from tray <X>... Do not grab paper until job completes**Description**

The product is actively processing a job from the designated tray.

Recommended action

No action necessary.

Processing... <filename>**Description**

The product is currently processing a job but is not yet picking pages. When paper motion begins, this message is replaced by a message that indicates the tray the job is using.

Recommended action

No action necessary.

Processing... copy <X> of <Y>**Description**

The product is currently processing or printing collated copies. The message indicates that copy number <X> of total copies <Y> is currently being processed.

Recommended action

No action necessary.

Ready

Description

The product is online and ready for data. No status or product attendance messages are pending at the display.

Recommended action

No action necessary.

Ready <IP Address>

Description

The product is online and ready for data. No status or product attendance messages are pending at the display. The product IP address displays.

Recommended action

No action necessary.

Remove all print cartridges

Description

The product is testing the transfer unit assembly.

Recommended action

To perform the test, remove all the print cartridges. To cancel the test, press the **Stop** button ⊗.

To exit press ▼

Remove at least one print cartridge

Description

The product is testing the print-cartridge motor.

Recommended action

To perform the test, remove at least one print cartridge. To cancel the test, press the **Stop** button ⊗.

To exit press ▼

Remove shipping lock from Tray 2

Description

The Tray 2 shipping lock was not removed before you turned the product on.

Recommended action

Open tray 2, and then remove the shipping lock.

Replace <supply>

Description

This alert appears only if the product is configured to stop when a supply reaches the very low threshold. The product indicates when a supply level is at its estimated end of life. The actual life remaining might be different than estimated.

The supply does not need to be replaced now unless the print quality is no longer acceptable.

HP recommends that the customer have a replacement supply available to install when print quality is no longer acceptable.

The product can be configured to stop when the supply level is very low. The supply might still be able to produce acceptable print quality.

 **NOTE:** When an HP supply has reached its approximated end of life, the HP Premium Protection Warranty on that supply ends.

- **10.00.70** (event code)

Black print cartridge

- **10.01.70** (event code)

Cyan print cartridge

- **10.02.70** (event code)

Magenta print cartridge

- **10.03.70** (event code)

Yellow print cartridge

- **10.23.70** (event code)

Fuser Kit

- **10.31.70** (event code)

Toner collection unit

- **10.22.70** (event code)

Transfer kit

Recommended action

Replace the specified supply.

Or, configure the product to continue printing by using the **Manage Supplies** menu.

Replace supplies

Description

This alert appears only if the product is configured to stop when a supplies reach the very low threshold. Two or more supplies have reached the estimated end of life. The product indicates when a supply level is at its estimated end of life. The actual life remaining might be different than estimated.

The supply does not need to be replaced now unless the print quality is no longer acceptable.

HP recommends that the customer have a replacement supply available to install when print quality is no longer acceptable.

 **NOTE:** When an HP supply has reached its approximated end of life, the HP Premium Protection Warranty on that supply ends.

Recorded event codes depend on which supplies are at the end of life.

- **10.00.70** (event code)
Black print cartridge
- **10.01.70** (event code)
Cyan print cartridge
- **10.02.70** (event code)
Magenta print cartridge
- **10.03.70** (event code)
Yellow print cartridge
- **10.23.70** (event code)
Fuser Kit
- **10.31.70** (event code)
Toner collection unit
- **10.22.70** (event code)
Transfer kit

Recommended action

Press the **OK** button to find out which supplies need to be replaced.

Or, configure the product to continue printing by using the **Manage Supplies** menu.

Restore Factory Settings

Description

The product is restoring factory settings.

Recommended action

No action necessary.

Restricted from printing in color

Description

This message displays when color printing is disabled for the product or when it is disabled for a particular user or print job.

Recommended action

To enable color printing for the product, change the **Restrict Color Use** setting in the **Manage Supplies** menu.

Rotating <color> motor

Description

A component test is in progress. the component selected is the indicated <color> cartridge motor.

<color> =

- Black
- Cyan
- Magenta
- Yellow

Recommended action

Press the **Stop** button ⊗ when ready to stop this test.

To exit press ▼

Rotating motor

Description

The product is executing a component test and the component selected is a motor.

Recommended action

Press the **Stop** button ⊗ when ready to stop this test.

To exit press ▼

Size mismatch in Tray <X>

Description

The paper in the listed tray does not match the size specified for that tray.

Recommended action

1. Load the correct paper.
2. Verify the paper is positioned correctly.
3. Close the tray, and then verify that the control panel lists the correct size and type for the specified tray.
4. If necessary, use the control-panel menus to reconfigure the size and type settings for the specified tray.

Sleep mode on

Description

The product is in sleep mode. Pressing a control-panel button, receiving of a print job, or an error condition clears this message.

Recommended action

No action necessary.

Supplies in wrong positions

Description

Two or more print-cartridge slots contain the wrong print cartridge.

From left to right, the print cartridges should be installed in the following order:

- Yellow
- Magenta
- Cyan
- Black

Recommended action

Install the correct cartridge in each slot.

Tray <X> empty: [Type], [Size]

Description

The specified tray is empty and the current job does not need this tray to print.

- X = 1
Tray 1
- X = 2
Tray 2

- X = 3
Tray 3
- X = 4
Tray 4
- X = 5
Tray 5
- X = 6
Tray 6

Recommended action

Refill the tray at a convenient time.

 **NOTE:** This could be a false message. If the tray is loaded without removing the shipping lock, the product does not sense that the paper is loaded. Remove the shipping lock and then load the tray.

Tray <X> open

Description

The specified tray is open or not closed completely.

- X = 2
Tray 2
- X = 3
Tray 3
- X = 4
Tray 4
- X = 5
Tray 5
- X = 6
Tray 6

Recommended action

Close the tray.

 **NOTE:** If this message appears after lifter drive assembly was removed or replaced, make sure that the connector on the assembly is correctly connected and fully seated.

If the error persists, use the Media size switches (SW2,3 - SW82,83 - SW92,93) test in the Tray/Bin manual sensor test to test the switches. If they do not respond, replace associated the lifter drive assembly.

Tray <X> overfilled

Description

The tray is filled above the stack-height mark.

- X = 2
Tray 2
- X = 3
Tray 3
- X = 4
Tray 4
- X = 5
Tray 5
- X = 6
Tray 6

Recommended action

Remove enough paper so that the paper stack does not exceed the limit for the tray.

 **NOTE:** If this message appears after lifter drive assembly was removed or replaced, make sure that the connector on the assembly is correctly connected and fully seated.

Troubleshooting

Description

The product is in the Troubleshooting process.

Recommended action

Press the **Stop** button ⊗.

To exit press ▼

Type mismatch Tray <X>

Description

The specified tray contains a paper type that does not match the configured type.

Recommended action

The specified tray will not be used until this condition is addressed. Printing can continue from other trays.

1. Load the correct paper in the specified tray.
2. At the control panel, verify the type configuration.

Unsupported drive installed To continue, press OK

Description

A non-supported hard drive has been installed. The drive is unusable by this product.

Recommended action

1. Turn the product off.
2. Remove the hard drive.
3. Turn the product on.

Unsupported supply in use OR Unsupported supply installed To continue, press OK

Description

A non-supported supply has been installed.

OR

One of the print cartridges is for a different HP product.

- XX = 00
Black print cartridge
- XX = 01
Cyan print cartridge
- XX = 02
Magenta print cartridge
- XX = 03
Yellow print cartridge

Recommended action

Install the correct supplies for this product. See the parts chapter in the service manual for supply part numbers.

Unsupported tray configuration

Description

The product has too many optional trays installed.

Recommended action

Turn the product off, remove the unsupported trays, and then turn the product on.

Unsupported USB accessory detected Remove USB accessory

Description

A non-supported USB accessory has been installed.

Recommended action

Turn the product off, remove the USB accessory, and then turn the product on.

USB accessory needs too much power Remove USB and turn off then on

Description

A USB accessory is drawing too much electrical current. Printing cannot continue.

Recommended action

Turn the product off, remove the USB accessory, and then turn the product on.

Use a USB accessory that uses less power or that contains its own power supply.

USB accessory not functional

Description

A parameter in the USB accessory is not correctly functioning.

Recommended action

1. Turn the product off.
2. Remove the USB accessory.
3. Insert a replacement USB accessory.

Used supply installed To continue, press OK OR Used supply in use

Description

One of the print cartridges has been previously used.

- XX = 00
Black print cartridge
- XX = 01
Cyan print cartridge
- XX = 02
Magenta print cartridge
- XX = 03
Yellow print cartridge

Recommended action

If you believe you purchased a genuine HP supply, go to www.hp.com/go/anticounterfeit.

Wrong cartridge in <color> slot

Description

The indicated slot for a print cartridge contains a cartridge that is not the correct color.

From left to right, the print cartridges should be installed in the following order:

- Yellow
10.03.25 (event code)
- Magenta
10.02.25 (event code)
- Cyan
10.01.25 (event code)
- Black
10.00.25 (event code)

Recommended action

Remove the print cartridge from that slot, and install a cartridge that is the correct color.

Event-log messages

This section describes messages that only appear in the event log. For additional numeric messages, see the control-panel message section of this manual

Figure 3-53 Sample event log

Event Log		HP Color LaserJet CP5520 Series			Page 1	
1 Device Information						
Device Serial Number: CN1088700P						
Number	Date and Time	Cycles	Event	Firmware	Description or Personality	Consecutive Repeats
2	3	4	5	6	7	8
35	10/13/2010 10:42:09 AM	305	10_23_15	103104_104867	Install Supply	0
1	10/13/2010 10:13:16 AM	10	10_23_15	103104_104867	Install Supply	0
1	10/13/2010 9:18:04 AM	17	32_08_A2	103104_104867	Install Supply	0
1	10/13/2010 3:05:14 PM	11	32_08_A2	103104_104867	Install Supply	1
1	10/13/2010 11:39:24 AM	14	32_08_A2	103104_104867	Install Supply	0
30	10/8/2010 5:30:39 PM	50	32_08_A2	103104_104867	Add Link	0
29	10/8/2010 5:30:39 PM	50	47_04_04	103104_104867	Print spooler 9100 internal error	0
28	10/8/2010 5:24:56 PM	49	10_23_15	103104_104867	Install Supply	1
27	10/8/2010 5:02:28 PM	34	10_23_15	103104_104867	Install Supply	4
26	10/8/2010 4:24:52 PM	34	32_08_A3	103104_104867	Add Link	0
25	10/8/2010 3:06:26 PM	34	32_08_A2	103104_104867	Add Link	0
24	10/8/2010 3:06:26 PM	34	47_04_04	103104_104867	Print spooler 9100 internal error	0
23	10/7/2010 5:17:44 PM	23	13_00_EE	103104_104867	Unknown	0
22	10/7/2010 5:17:03 PM	22	13_00_EE	103104_104867	Unknown	0
21	10/6/2010 4:45:52 PM	20	32_08_A3	103104_104867	Add Link	0
20	10/4/2010 3:00:03 PM	20	10_23_15	103104_104867	Install Supply	0
19	10/2/2010 6:17:04 PM	20	32_08_A2	103104_104867	Add Link	0
18	10/2/2010 6:17:04 PM	20	47_04_04	103104_104867	Print spooler 9100 internal error	0
17	10/2/2010 5:54:32 PM	18	10_22_15	103104_104867	Install Supply	0
16	10/2/2010 3:07:20 PM	18	32_08_A2	103104_104867	Add Link	0
15	10/2/2010 3:07:20 PM	18	47_04_04	103104_104867	Print spooler 9100 internal error	0
14	9/28/2010 5:38:32 PM	16	32_08_A3	103104_104867	Add Link	0
13	9/28/2010 5:35:14 PM	16	32_08_A2	103104_104867	Add Link	0
12	9/28/2010 5:35:53 PM	16	47_04_04	103104_104867	Print spooler 9100 internal error	0
11	9/28/2010 5:21:56 PM	16	10_99_40	103104_104867	Genuine HP supplies installed	0
10	9/28/2010 5:21:55 PM	16	33_01_01	103104_104867	Restore occurred	0
9	9/28/2010 5:21:53 PM	16	33_01_01	103104_104867	Restore occurred	0
8	9/28/2010 5:21:52 PM	16	33_01_01	103104_104867	Restore occurred	0
7	9/28/2010 5:21:48 PM	16	33_01_01	103104_104867	Restore occurred	0
6	9/28/2010 5:21:44 PM	16	33_01_01	103104_104867	Restore occurred	0
5	9/28/2010 5:21:44 PM	16	33_01_01	103104_104867	Restore occurred	0
4	9/28/2010 5:21:25 PM	16	00_00_00	103104_104867	Unknown	2
3	9/28/2010 5:20:38 PM	16	33_01_03	103104_104867	[[[UsedPartReplaced]]	0
2	9/28/2010 5:20:31 PM	16	99_02_01	103104_104867	Unknown	0
1	9/28/2010 5:19:58 PM	16	99_02_01	103104_104867	Unknown	0

1	Product information
2	Event number
3	Date and time
4	Engine cycles
5	Event log code
6	Firmware version number
7	Description of personality
8	Consecutive Repeats

Print an event log

 **NOTE:** Printing an event log by using the **Administration** menu shows only a subset of events. To print a complete event log, use the **Service** menu.

Print the event log from the Administration menu

1. Press the Home button .
2. Open the following menus:
 - **Administration**
 - **Troubleshooting**
3. Use the **Down** arrow button  to select the **Print Event Log** item, and then press the **OK** button.

Print the event log from the Service menu



1. Press the Home button .
2. Open the following menus:
 - **Device Maintenance**
 - **Service**

The PIN required for the **Service** menu is 11552010.
3. Use the **Down** arrow button  to select the **Print Event Log** item, and then press the **OK** button.

View an event log

 **NOTE:** Viewing an event log by using the **Administration** menu shows only a subset of events. To print a complete event log, use the **Service** menu.

View an event log from the Administration menu

1. Press the Home button .
2. Open the following menus:
 - **Administration**
 - **Troubleshooting**
3. Use the **Down** arrow button  to select the **View Event Log** item, and then press the **OK** button.

Viewing the event log from the Service menu

1. Press the Home button .
2. Open the following menus:

- **Device Maintenance**
- **Service**

The PIN required for the **Service** menu is 11552010.

3. Use the **Down** arrow button  to select the **View Event Log** item, and then press the **OK** button.

Clear an event log

1. Press the Home button .
2. Open the following menus:

- **Device Maintenance**
- **Service**

The PIN required for the **Service** menu is 11552010.

3. Use the **Down** arrow button  to select the **Clear Event Log** item, and then press the **OK** button.

Clear jams

Common causes of jams

The product is jammed.

Cause	Solution
The paper does not meet specifications.	Use only paper that meets HP specifications. See the product user guide.
A component is installed incorrectly.	Verify that the transfer belt and transfer roller are correctly installed.
You are using paper that has already passed through a printer or copier.	Do not use paper that has been previously printed on or copied.
An input tray is loaded incorrectly.	Remove any excess paper from the input tray. Make sure that the stack is below the maximum stack height mark in the tray.
The paper is skewed.	The input-tray guides are not adjusted correctly. Adjust them so they hold the stack firmly in place without bending it.
The paper is binding or sticking together.	Remove the paper, flex it, rotate it 180°, or flip it over. Reload the paper into the input tray.
The paper is removed before it settles into the output bin.	Reset the product, and then resend the print job. Wait until the page completely settles in the output bin before removing it.
During two-sided printing, you removed the paper before the second side of the document was printed.	Reset the product and print the document again. Wait until the page completely settles in the output bin before removing it.
The paper is in poor condition.	Replace the paper.
The internal tray rollers are not picking up the paper.	If the paper is heavier than the heaviest supported weight for the tray, it might not be picked from the tray. The rollers are worn. Replace the rollers.
The paper has rough or jagged edges.	Replace the paper.
The paper is perforated or embossed.	Perforated or embossed paper does not separate easily. Feed single sheets from Tray 1.
Paper was not stored correctly.	Replace the paper in the trays. Paper should be stored in the original packaging in a controlled environment.
Not all product packing material was removed.	Verify that the packing tape, cardboard, and plastic shipping locks have been removed from the product.

Jam locations

Use this illustration to identify locations of jams. In addition, instructions appear on the control panel to direct you to the location of jammed paper and how to clear it. Internal areas of the product that might need to be opened to clear jams, have green handles or green labels.

⚠ WARNING! To avoid electrical shock, remove any necklaces, bracelets, or other metal items before reaching into the inside of the product.

📄 NOTE: Sensors in the paper path generate event codes if a jam occurs. For sensor locations, see [Figure 3-55 Paper path jam sensors on page 497](#). For jam event code information, see [Table 3-47 Event codes for jams on page 498](#).

Figure 3-54 Jam locations

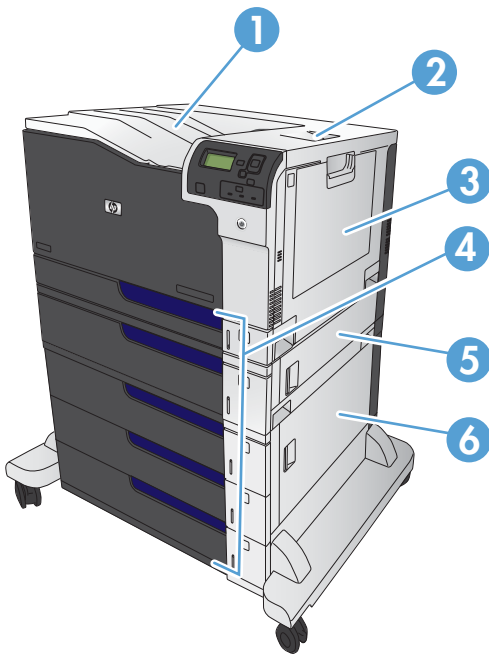

1	Output bin
2	Upper right door
3	Tray 1 area
4	Tray 2, Tray 3, and optional Trays 4, 5, and 6
5	Middle right door
6	Lower right door

Figure 3-55 Paper path jam sensors

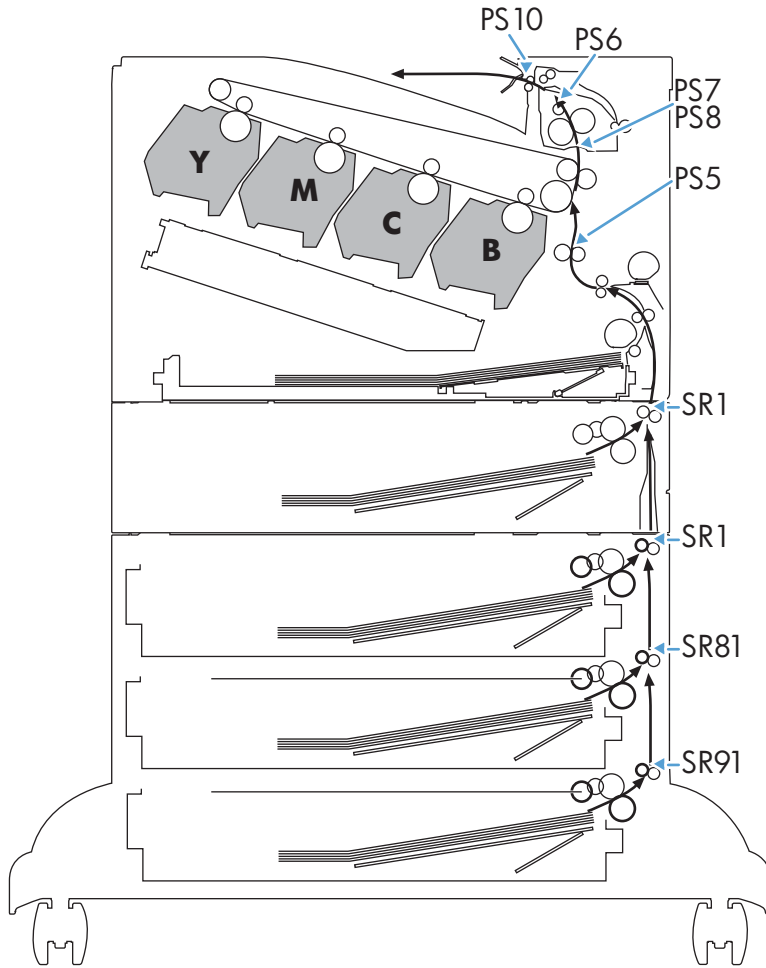

Note: Both the 1 X 500-sheet feeder and the 3 X 500-sheet feeder use a SR1 tray feed sensor.

Table 3-46 Paper path jam sensors

Sensor	Description
PS5	Registration sensor
PS6	Fuser output sensor
PS7	Loop sensor
PS8	
PS10	Bin full sensor
SR1	Tray 3 feed sensor
SR1	Tray 4 feed sensor
SR81	Tray 5 feed sensor
SR91	Tray 6 feed sensor

Table 3-47 Event codes for jams

Jam event code	Jammed paper location
13.A3.D3	Leading edge of paper fed from Tray 3 is stopped before SR1
13.A3.D4	Leading edge of paper fed from Tray 4 is stopped before SR1 after passing Tray 4 SR1
13.A3.D5	Leading edge of paper fed from Tray 5 is stopped before SR1 after passing Tray 4 SR1
13.A3.D6	Leading edge of paper fed from Tray 6 is stopped before SR1 after passing Tray 4 SR1
13.A3.FF	At auto-flushing : Paper stays at SR1
13.A4.D4	Leading edge of paper fed from Tray 4 is stopped before Tray 4 SR1
13.A4.D5	Leading edge of paper fed from Tray 5 is stopped before Tray 4 SR1 after passing SR81
13.A4.D6	Leading edge of paper fed from Tray 6 is stopped before Tray 4 SR1 after passing SR81
13.A4.FF	At auto-flushing : Paper stays at Tray 4 SR1
13.A5.D5	Leading edge of paper fed from Tray 5 is stopped before SR81
13.A5.D6	Leading edge of paper fed from Tray 6 is stopped before SR81 after passing SR91
13.A5.FF	At auto-flushing: paper stays at SR81
13.A6.D6	Leading edge of paper fed from Tray 6 is stopped before SR91
13.A6.FF	At auto-flushing : Paper stays at SR91
13.B2.A1	Paper stays at PS5 – media longer than allowed from Tray 1
13.B2.A2	Paper stays at PS5 - media longer than allowed from Tray 2
13.B2.A3	Paper stays at PS5 - media longer than allowed from Tray 3
13.B2.A4	Paper stays at PS5 - media longer than allowed from Tray 4
13.B2.A5	Paper stays at PS5 - media longer than allowed from Tray 5
13.B2.A6	Paper stays at PS5 - media longer than allowed from Tray 6
13.B2.AD	Paper stays at PS5 - media longer than allowed from Duplexer
13.B2.D1	Leading edge of paper fed from Tray 1 is stopped before PS5
13.B2.D2	Leading edge of paper fed from Tray 2 is stopped before PS5
13.B2.D3	Leading edge of paper fed from Tray 3 is stopped before PS5 after passing SR1
13.B2.D4	Leading edge of paper fed from Tray 4 is stopped before PS5 after passing SR1
13.B2.D5	Leading edge of paper fed from Tray 5 is stopped before PS5 after passing SR1
13.B2.D6	Leading edge of paper fed from Tray 6 is stopped before PS5 after passing SR1
13.B2.DD	Duplex re-feed paper is stopped between PS6 and PS5
13.B2.FF	At power on, door close, or auto-flushing: paper stays at PS5
13.B4.FF	At power on, door close, or auto-flushing : paper stays at PS7/PS8

Table 3-47 Event codes for jams (continued)

Jam event code	Jammed paper location
13.B9.Az	Paper stays at PS6
NOTE: z is the fuser mode, see Fuser modes for jam event codes (Z) on page 499	
13.B9.Cz	Paper is wrapping at fuser
NOTE: z is the fuser mode, see Fuser modes for jam event codes (Z) on page 499	
13.B9.D1	Leading edge of paper is stopped between PS5 and PS6 – fed from tray 1
13.B9.D2	Leading edge of paper is stopped between PS5 and PS6 – fed from Tray 2
13.B9.D3	Leading edge of paper is stopped between PS5 and PS6 – fed from Tray 3
13.B9.D4	Leading edge of paper is stopped between PS5 and PS6 – fed from Tray 4
13.B9.D5	Leading edge of paper is stopped between PS5 and PS6 – fed from Tray 5
13.B9.D6	Leading edge of paper is stopped between PS5 and PS6 – fed from Tray 6
13.B9.DD	Leading edge of paper is stopped between PS5 and PS6 – fed from Duplexer
13.B9.FF	At power on, door close, or auto-flushing: paper stays at PS6
13.E1.Dz	Leading edge of paper is stopped before PS10 after passing PS6
NOTE: z is the fuser mode, see Fuser modes for jam event codes (Z) on page 499	
13.00.EE	Door was opened during printing
13.AA.EE	Tray 3, 4, or 5 right tray access door was opened during print job
13.AB.EE	Tray 4, 5, 6 right tray access door was opened during print job
13.BB.EE	Front door was opened during print job
13.BA.EE	Right door was opened during print job
13.FF.FF	Jams at multiple sensors

Fuser modes for jam event codes (Z)

- 1 = Normal auto sense
- 2 = Normal non-auto sense
- 3 = Light 1 to 3
- 4 = Heavy 1
- 5 = heavy 2

- 6 = Heavy 3
- 7 = Glossy 1
- 8 = Glossy 2
- 9 = Glossy 3
- A = Glossy film
- B = Transparency
- C = Label
- D = Envelope 1 to 3

Clear jams in the upper-right door

⚠ **WARNING!** The fuser can be hot while the product is in use. Wait for the fuser to cool before handling it.

1. Open the upper-right door.

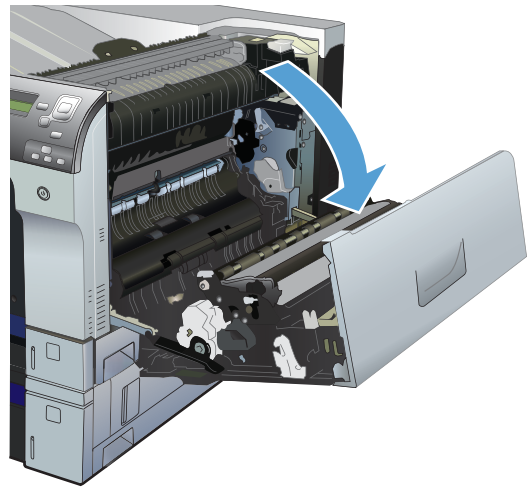

2. Gently pull the paper out of the pickup area.

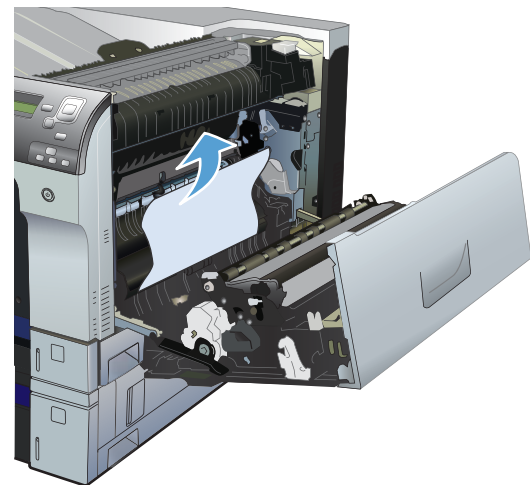

3. If paper is visible entering the bottom of the fuser, gently pull downward to remove it.

CAUTION: Do not touch the transfer roller. Contaminants on the roller can affect print quality.

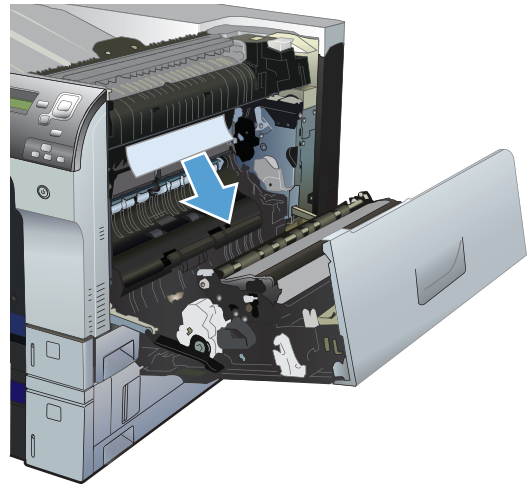

4. Paper could be jammed inside the fuser where it would not be visible. Open the fuser jam access door. If paper is jammed inside the fuser, gently pull it straight up to remove it. If the paper tears, remove all paper fragments.

WARNING! Even if the body of the fuser has cooled, the rollers that are inside could still be hot. Do not touch the fuser rollers until they have cooled.

If no paper is found but the product still reports a jam, remove the fuser to check for jammed paper inside the fuser cavity. Remove any paper, and then reinstall the fuser.

NOTE: Make sure that the fuser is reinstalled correctly before closing the upper right door.

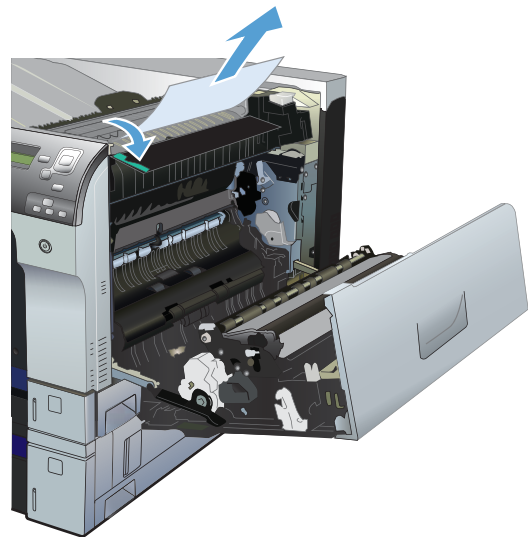

5. Close the upper-right door.

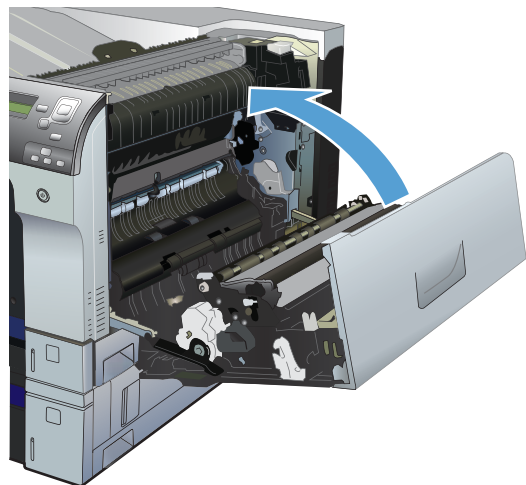

Clear jams in the lower-right door

1. Open the lower-right door.

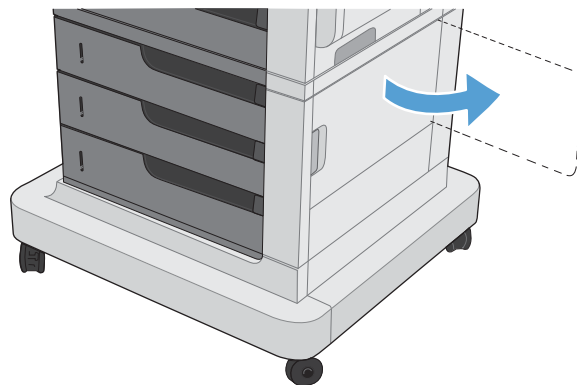

2. If paper is visible, gently pull the jammed paper up or down to remove it.

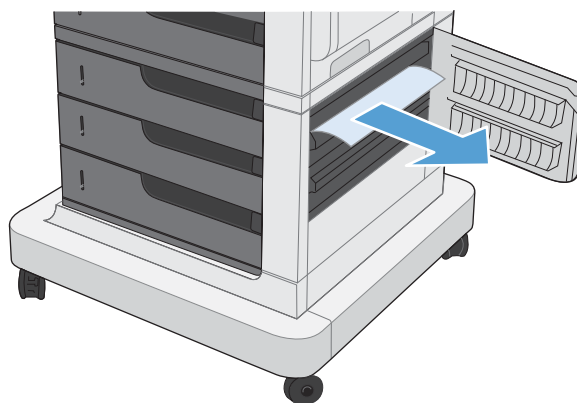

3. Close the lower-right door.

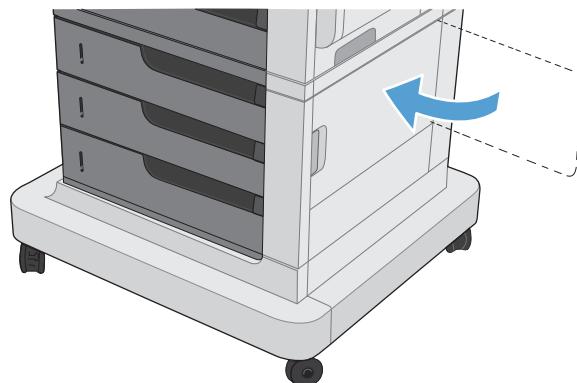

Clear jams in Tray 1

1. If jammed paper is visible in Tray 1, clear the jam by gently pulling the paper straight out. Press the **OK** button to clear the message.

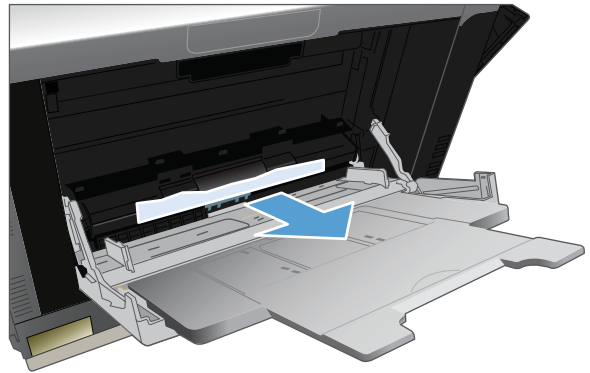

2. If you cannot remove the paper, or if no jammed paper is visible in Tray 1, close Tray 1 and open the upper right door.

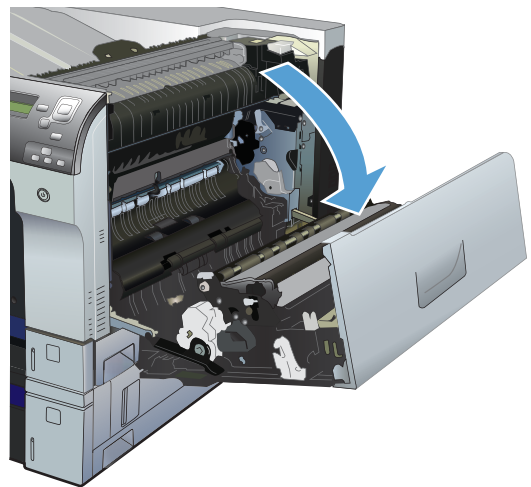

3. Gently pull the paper out of the pick up area.

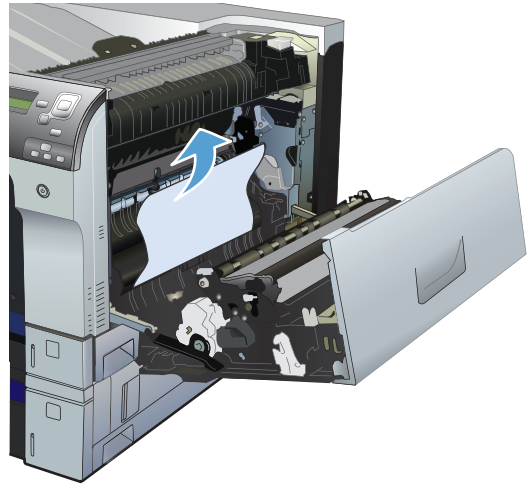

4. Close the upper right door.

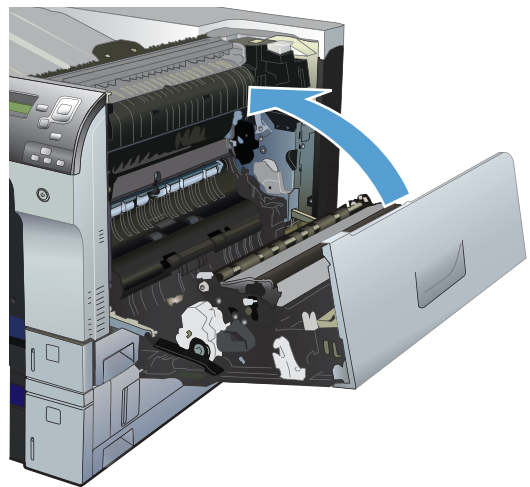

Clear jams from Tray 2, Tray 3, or an optional tray

△ **CAUTION:** Opening a tray when paper is jammed can cause the paper to tear and leave pieces of paper in the tray, which might cause another jam. Be sure to clear jams from the upper and lower right door before opening a tray.

1. Open the tray and make sure that the paper is stacked correctly. Remove any jammed or damaged sheets of paper. To access jammed paper from the tray cavity, remove the tray from the product.

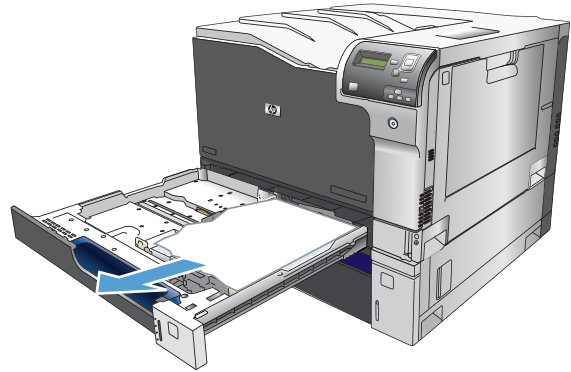

2. Close the tray.

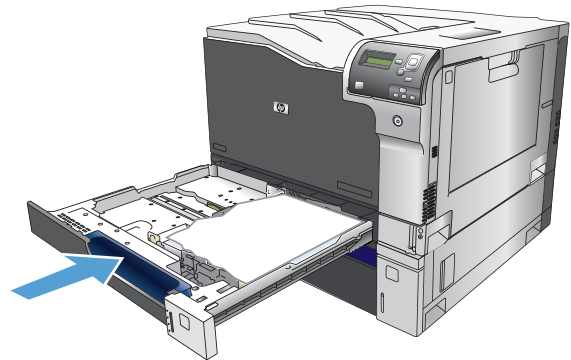

3. If the jam is in Tray 3, you also can open the door on the right side of the tray, remove the jammed paper, and then close the door.

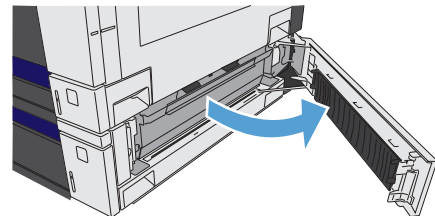

Clear jams in the output bin area

1. If paper is visible from the output bin, grasp the leading edge and remove it.

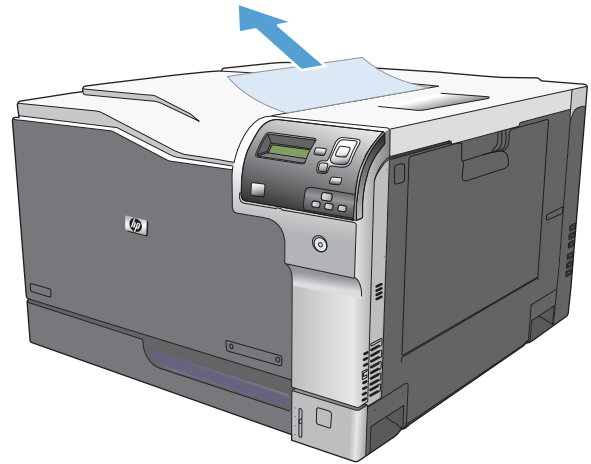

Jam causes and solutions

Jams in the output bin

Table 3-48 Causes and solutions for delivery delay jam

Cause	Solution
The output-bin full sensor flag is damaged.	Examine the output-bin full sensor flag for damage. If the flag is damaged, replace the paper delivery assembly. See Paper delivery assembly on page 184 . See Output-bin-full sensor (PS10) on page 313 for troubleshooting information.
Poor contact of the output-bin full sensor connector.	If the product was recently repaired, check and reconnect the connector (J181) on the DC controller PCA and the intermediate connector (J743).
The output bin full sensor (PS10) is defective.	Check the output bin full sensor (PS10) using the manual sensor test. See Output-bin-full sensor (PS10) on page 313 .
Poor contact of the fuser-motor (M4) connector.	Reconnect the connectors of the fuser motor (J516), and the DC controller PCA (J81).
The fuser motor (M4) is defective.	Execute the fuser-motor driving test in the component test (see Component tests on page 314). If the motor is defective, replace the fuser motor (M4). See Fuser motor (M4) on page 196 .

Jams in the fuser and transfer area

Table 3-49 Causes and solutions for fuser delivery delay jams

Cause	Solution
The fuser-output sensor connector has a poor connection.	Reconnect connector J131 on the DC controller PCA.
The fuser-output sensor (PS6) is defective.	Check the fuser-output sensor (PS6) with the manual sensor test. See Fuser output sensor (PS6) on page 297 . If the sensor is defective, replace the fuser. See Fuser on page 93 .

Table 3-50 Causes and solutions for wrapping jams

Cause	Solution
The fuser roller or pressure roller is dirty.	Print a cleaning page. See Clean the paper path on page 349 .
The fuser roller or the pressure roller is worn or deformed.	Replace the fuser. See Fuser on page 93 .
The output bin full sensor has a poor connection.	Reconnect the connector J181 on the DC controller PCA, and the intermediate connector J743.
The output bin full sensor is defective.	Run the manual sensor test to verify the output bin full sensor is functioning properly. See Output-bin-full sensor (PS10) on page 313 . If not, replace the fuser gear assembly. See Fuser gear assembly on page 176 .

Table 3-51 Causes and solutions for fuser delivery stationary jams

Cause	Solution
The fuser roller or pressure roller is worn or deformed.	Replace the fuser. See Fuser on page 93 .
The fuser-delivery roller is deformed.	
The gear of the fuser-delivery roller is damaged.	
Poor contact of the fuser-output sensor connector.	Reconnect the connector J131 on the DC controller PCA.
The fuser-output sensor (PS6) is defective.	Run the manual sensor test to verify that the fuser-output sensor is functioning properly. See Fuser output sensor (PS6) on page 297 . If it is not, replace the fuser. See Fuser on page 93 .

Jams in the duplex area (duplex models only)

Table 3-52 Causes and solutions for duplexing reverse jams

Cause	Solution
The duplex reverse roller is worn or deformed.	Replace the fuser. See Fuser on page 93 .
The duplex feed roller is worn or deformed.	Replace the right door. See Right-door assembly on page 126 .
Poor contact of the duplex reverse-motor (M7) connector	Reconnect the connectors (J520) on the duplex reverse motor, intermediate connectors (J552L and J552D), connector (J1006) on the driver PCA, and connectors (J93; J92; J91) on the DC controller PCA.
The duplex reverse motor is defective.	Replace the duplex drive assembly. See Duplex drive assembly (duplex models) on page 187 .

Table 3-53 Causes and solutions for duplex repick jams

Cause	Solution
The duplex re-pickup sensor lever is set incorrectly or damaged.	Check the sensor lever to make sure it is set correctly. If it is damaged, replace the right door assembly. See Right-door assembly on page 126 .
The spring of the duplex re-pickup sensor lever is unhooked.	Check the spring and place it in correct position.
Poor contact of the duplex reverse solenoid (SL3) connector	Reconnect the intermediate connectors (J522L and J522D), connector (J1005) on the driver PCA, and connectors (J93; J92; J91) on the DC controller PCA.
The duplex reverse solenoid is defective.	Replace the duplex-drive assembly. See Duplex drive assembly (duplex models) on page 187 .
The duplex flapper is damaged or malfunctioning.	Replace the delivery assembly. See Duplex drive assembly (duplex models) on page 187 .
The duplex reverse solenoid is defective.	Replace the duplex-drive assembly. See Duplex drive assembly (duplex models) on page 187 .

Table 3-53 Causes and solutions for duplex repick jams (continued)

Cause	Solution
The duplex flapper is damaged or malfunctioning.	Replace the paper delivery assembly. See Paper delivery assembly on page 184 .
The duplex repick roller is worn or damaged.	Replace the registration sensor assembly. See Registration sensor assembly on page 142 .
The duplex repick clutch is defective.	Run the solenoid drive test in component test (see Component tests on page 314) to verify that the duplex repick clutch is functioning properly. If it is not, replace the duplex drive assembly. See Duplex drive assembly (duplex models) on page 187 .

Table 3-54 Causes and solutions for residual media jams

Cause	Solution
Poor contact of the fuser loop-sensor connector and fuser loop sensor 1 and 2.	Reconnect the connectors of the fuser loop sensor 1 and 2 (J13) and the connector (J131) on the DC controller PCA.
The loop sensor is defective.	Run the manual sensor test. See Fuser loop sensors 1 and 2 (PS7 and PS8) on page 295 for information. If the sensor is defective, replace fuser. See Fuser on page 93 .
The spring of the fuser-output-sensor lever is unhooked.	Check the spring of the fuser and right door and place it in the correct position.
The fuser-output sensor lever is damaged.	Replace the sensor (PS6).
Poor contact of the fuser-output sensor connector.	Reconnect connector (J1055) of the fuser-output sensor and connector (J131) on the DC controller PCA.
The fuser-output sensor is defective.	Run the manual sensor test to make sure the fuser-delivery sensor is functioning properly. See Fuser output sensor (PS6) on page 297 for information. If the sensor is defective, replace the fuser. See Fuser on page 93 .
The duplex pickup sensor lever is damaged.	Replace the right door assembly. See Right-door assembly on page 126 .

 **NOTE:** Even if jammed paper is visible in Tray 1, clear the jam from the inside of the product by opening the right door.

Jams in Tray 1, Tray 2 and internal paper path

Table 3-55 Causes and solutions for pickup delay jam 1: tray pickup

Cause	Solution
The tray 1 pick up roller or the tray 1 separation pad is worn or deformed.	Replace the tray 1 pickup roller and separation pad. See Pickup roller (Tray 1) on page 94 and Separation pad (Tray 1) on page 95 . Replace the right door. See Right-door assembly on page 126 .
Poor contact of the tray 1 media-presence-sensor connector	Reconnect the connectors of the tray media-feed sensor intermediate connectors (J531L and J531D), and the connector (J152) on the DC controller.
Poor contact of the TOP sensor connector.	Reconnect the intermediate connector (J554L and J554D) of the TOP sensor and connector (J122) on the DC controller PCA.

Table 3-55 Causes and solutions for pickup delay jam 1: tray pickup (continued)

Cause	Solution
The TOP sensor is defective.	Run the manual sensor test to verify that the TOP sensor is functioning properly. If not, replace the registration assembly. See Registration sensor assembly on page 142 .
Poor contact of the MP-pickup-solenoid drive connector	Reconnect the connector of the tray pickup solenoid intermediate connectors (J530L and J530D), and the connector (J152) on the DC controller PCA.
The MP-pickup solenoid is defective.	Execute the tray-pickup-solenoid driving test in the component test (see Component tests on page 314). If the solenoid is defective, replace the right door assembly. See Right-door assembly on page 126 .
Poor contact of the pickup-motor drive connector (M5)	Reconnect the picku-motor connector (J523) and connector (J260), intermediate connectors (J535L and J535D), and the connector (J1003) on the DC controller PCA.
The pickup motor is defective.	Execute the pickup-motor driving test in the component test (see Component tests on page 314). If the motor is defective, replace the paper pickup assembly. See Paper pickup assembly on page 135 .

Table 3-56 Causes and solutions for pickup delay jams Tray 2

Cause	Solution
Poor contact of the pickup motor drive connector.	Reconnect the connector J91 on the DC controller PCA .
The pickup motor is defective.	Execute the Tray 2 pickup motor test in the component test (see Component test (special-mode test) on page 314). If the motor is defective, replace the paper pickup assembly. See Paper pickup assembly on page 135 .
The pickup roller is worn or deformed.	Replace the pickup roller. See Pickup roller (Tray 2) on page 98 .
The tray 2 separation roller is worn or deformed.	Replace the separation roller. See Separation roller assembly (Tray 2) on page 97 .
Poor contact of the TOP sensor connector.	Reconnect the connector J122 on the DC controller PCA.
The TOP sensor (PS5) is defective.	Run the manual sensor test to verify that the TOP sensor is functioning properly. See TOP (top-of-page) sensor (PS5) on page 294 for information. If it is not, replace the registration sensor assembly. See Registration sensor assembly on page 142 .
Poor contact of the Tray 2 pickup solenoid drive connector.	Reconnect the connector J1003 on the DC controller PCA.
The Tray 2 pickup solenoid is defective.	Run the Tray 2 pickup solenoid test in the component test (see Component test (special-mode test) on page 314) to verify that the Tray 2 pickup solenoid is functioning properly. If it is not, replace the paper pickup assembly. See Paper pickup assembly on page 135 .

Table 3-57 Causes and solutions for pickup stationary jams

Cause	Solution
Multiple feed of media	<p>Replace any worn or deformed parts (tray separation pad, tray feed roller, MP tray pickup roller or MP tray separation pad).</p> <p>Check the separation pad and MP tray separation pad to see if they are firmly seated and coupled with the torque limiter.</p> <p>Replace the separation pad and feed roller for the associated tray.</p> <p>If the MP tray pickup roller is defective, replace the roller. See Pickup roller (Tray 1) on page 94. If the MP tray separation pad is defective, replace the separation pad assembly. See Separation pad (Tray 1) on page 95.</p>
The secondary transfer roller is not set correctly.	Place the secondary-transfer-roller unit in the correct position.
The secondary-transfer roller is worn or deformed.	Replace the secondary-transfer-roller assembly. See Secondary transfer roller on page 101 .
Poor contact of the drum drive connector	Reconnect the connectors of the ITB motor (J517) and the DC controller PCA (J81).
The drum motor is defective.	Execute the drum motor driving test in the component test (see Component tests on page 314). If the motor is defective, replace the motor.
The ITB does not rotate smoothly.	Replace the ITB. See Intermediate transfer belt (ITB) on page 102 .
The TOP sensor lever is incorrectly positioned or damaged	Check the sensor lever to make sure it is correctly positioned. If it is damaged, replace the registration sensor assembly. See Registration sensor assembly on page 142 .
Poor contact of the TOP sensor connector	Reconnect the connector J122 on the DC controller PCA.
The TOP sensor is defective.	Run the manual sensor test to verify that the TOP sensor (PS5) is functioning properly. See TOP (top-of-page) sensor (PS5) on page 294 for information. If it is not, replace the registration sensor assembly. See Registration sensor assembly on page 142 .

Table 3-58 Causes and solutions for residual media jams

Cause	Solution
A piece of paper remains at the sensor detecting the jam.	Make sure that all paper, including small bits of paper, are removed from the product when a jam is removed.

Table 3-58 Causes and solutions for residual media jams (continued)

Cause	Solution
The sensor detecting a residual media jam is not working.	<p>Test each sensor using the manual sensor test. See Manual sensor test on page 289 for information. If the sensor does not respond, replace the component indicated:</p> <ul style="list-style-type: none"> • TOP sensor (PS5): Replace the registration sensor assembly. See Registration sensor assembly on page 142. • Fuser-output sensor (PS6): Replace the fuser. See Fuser on page 93. • Fuser loop sensors 1 and 2 (PS7 and PS8): Replace the fuser. See Fuser on page 93.
If service was recently performed on the product, a sensor connector might be disconnected.	<p>Run the manual sensor tests to verify which sensor detects the media. See Manual sensor test on page 289 or Tray/Bin manual sensor test on page 300 for information. Reconnect the corresponding sensor connector:</p> <ul style="list-style-type: none"> • TOP sensor: Connector (J122) on the DC controller PCA • Fuser-output sensor: Connector (J131) on the DC controller PCA • Fuser Loop sensor 1 or 2: Connector (J131) on the DC controller PCA

Jams in Tray 3, 4, 5, and 6

Table 3-59 Causes and solutions for pickup delay and pickup stationary jams

Cause	Solution
The paper-feeder pickup roller is worn or deformed.	Replace the pickup roller. See Pickup roller, separation roller, and feed roller (1 x 500-sheet and 3 x 500-sheet paper feeders) on page 99 .
The paper-feeder separation roller is worn or deformed.	Replace the separation roller. See Pickup roller, separation roller, and feed roller (1 x 500-sheet and 3 x 500-sheet paper feeders) on page 99 .
The paper-feeder feed roller is worn or deformed.	Replace the feed roller. See Pickup roller, separation roller, and feed roller (1 x 500-sheet and 3 x 500-sheet paper feeders) on page 99 .
Poor contact of the paper-feeder media-feed sensor connectorS	
A tray feed sensor is defective.	Run the manual sensor test to verify that the paper-feeder media feed sensor is functioning properly. See Tray/Bin manual sensor test on page 300 for information. If it is not, replace the paper pickup assembly of the specific tray.
Poor contact of a paper-feeder pickup solenoid drive connector	
The paper-feeder pickup solenoid is defective.	Run the solenoid drive test in the component test (see Component tests on page 314) to verify that the paper-feeder pickup solenoid is functioning properly. If it is not, replace the paper pickup assembly of the specific tray.
Poor contact of paper-feeder pickup motor drive connector.	
The paper-feeder pickup motor is defective.	Run the pickup motor drive test in the component test (see Component tests on page 314) to verify that the paper-feeder pickup motor is functioning properly. If it is not, replace the pickup assembly of the specific tray.

Table 3-59 Causes and solutions for pickup delay and pickup stationary jams (continued)

Cause	Solution
Multiple feed of media	If the tray 3 pickup roller, separation roller, or feed roller is worn or deformed, replace any defective parts.
The paper-feeder media-feed sensor lever is set incorrectly or damaged.	Check the sensor lever to make sure it is set correctly. If it is damaged, replace the paper-feeder assembly.
The spring of the paper-feeder media-feed sensor lever is unhooked.	Check the spring and place it in correct position.
Poor contact of the paper-feeder media-feed sensor connector.	Reconnect the connector (J406) on the connector PCA and connector (J22) of the paper-feeder media feed sensor.
A tray feed sensor is defective.	Run the manual sensor test to verify that the tray feed sensor is functioning properly. See Tray/Bin manual sensor test on page 300 for information. If it is not, replace the pickup assembly of the specific tray.

Table 3-60 Causes and solutions for residual media jams

Cause	Solution
The sensor that detects residual paper jams is set incorrectly or damaged.	Run the manual sensor test to verify which sensor detects the paper. See Tray/Bin manual sensor test on page 300 for information. Check the sensor lever to make sure it is set correctly. If it is damaged, replace the corresponding pickup assembly.
The spring of the sensor lever that detects residual paper jams is unhooked.	Run the manual sensor test to verify which sensor detects the paper. See Tray/Bin manual sensor test on page 300 for information. Check the spring of the sensor lever to make sure it is set correctly.
Poor contact exists in the sensor that detects residual paper jams.	Run the manual sensor test to verify which sensor detects the paper. See Tray/Bin manual sensor test on page 300 for information. Reconnect the following corresponding sensor connectors:
The sensor that detects residual paper jams is defective.	Run the sensor test in the sensor monitor mode to verify which sensor detects the paper. Replace media feed sensor.

Change jam recovery





This product provides a jam recovery feature that reprints jammed pages. The following options are available:

- **Auto** — The product attempts to reprint jammed pages when enough memory is available. This is the default setting.
- **Off** — The product does not try to reprint jammed pages. Because no memory is used to store the most recent pages, performance is optimal.

 **NOTE:** When using this option, if the product runs out of paper and the job is being printed on both sides, some pages can be lost.

- **On** — The product always reprints jammed pages. Additional memory is allocated to store the last few pages printed. This might cause overall performance to suffer.

Set the jam recovery feature

1. Press the Home button .
2. Open the following menus:
 - **Administration**
 - **General Settings**
 - **Jam Recovery**
3. Press the **Down** arrow or **Up** arrow / button to highlight the appropriate setting, and then press the **OK** button.
4. Press the Home button  to return to the **Ready** state.

Solve paper-handling problems

Product feeds multiple sheets

Product feeds multiple sheets

Cause	Solution
The input tray is overfilled. Open the tray and verify that the paper stack is below the maximum stack height mark.	Remove excess paper from the input tray.
Print paper is sticking together.	Remove paper, flex it, rotate it 180 degrees or flip it over, and then reload it into the tray. NOTE: Do not fan paper. Fanning can cause static electricity, which can cause paper to stick together.
Paper does not meet the specifications for this product.	Use only paper that meets HP paper specifications for this product.
Trays are not properly adjusted.	Make sure that the paper guides match the size of paper being used.
Tray 2 feeds multiple sheets.	Make sure Tray 2 is not overfilled. Open the tray and verify that the paper stack is below the maximum stack height mark. Remove paper from Tray 2 to avoid jams.

Product feeds incorrect page size

Product feeds incorrect page size

Cause	Solution
The correct size paper is not loaded in the tray.	Load the correct size paper in the tray.
The correct size paper is not selected in the software program or printer driver.	Confirm that the settings in the software program and printer driver are correct, because the software program settings override the printer driver and control panel settings, and the printer driver settings override the control panel settings.
The correct size paper for the tray is not selected in the product control panel.	From the control panel, select the correct size paper for the tray.
The paper size is not configured correctly for the tray.	Print a configuration page or use the control panel to determine the paper size for which the tray is configured.
The guides in the tray are not against the paper.	Verify that the paper guides are touching the paper.

Product pulls from incorrect tray

Product pulls from incorrect tray

Cause	Solution
You are using a driver for a different product.	Use a driver for this product.
The specified tray is empty.	Load paper in the specified tray.
The paper size is not configured correctly for the input tray.	Print a configuration page or use the control panel to determine the paper size for which the tray is configured.
The guides in the tray are not against the paper.	Verify that the guides are touching the paper.

Paper does not feed automatically

Paper does not feed automatically

Cause	Solution
Manual feed is selected in the software program.	Load Tray 1 with paper, or, if the paper is loaded, press the OK button.
The correct size paper is not loaded.	Load the correct size paper.
The input tray is empty.	Load paper into the input tray.
Paper from a previous jam has not been completely removed.	Open the product and remove any paper in the paper path.
The paper size is not configured correctly for the input tray.	Print a configuration page or use the control panel to determine the paper size for which the tray is configured.
The guides in the tray are not against the paper.	Verify that the rear and width paper guides are touching the paper.
The Manually Feed Prompt item is set to Always . The product always prompts for manual feed, even if the tray is loaded.	Open the tray, reload the media, and then close the tray. Or, change the Manually Feed Prompt setting to Unless loaded , so that the product prompts for manual feed only when the tray is empty.
The Use Requested Tray setting on the product is set to Exclusively , and the requested tray is empty. The product will not use another tray.	Load the requested tray. Or, change the setting from Exclusively to First on the Manage Trays menu. The product can use other trays if no media is loaded in the specified tray.

Paper does not feed from Tray 2, 3, 4, 5, or 6

Paper does not feed from Tray 2, 3, 4, 5, or 6

Cause	Solution
The correct size paper is not loaded.	Load the correct size paper.

Paper does not feed from Tray 2, 3, 4, 5, or 6

Cause	Solution
The input tray is empty.	Load paper in the input tray.
The correct paper type for the input tray is not selected in the product control panel.	From the product control panel, select the correct paper type for the input tray. Trays configured for a paper type with a specific weight range will not match a print job that specifies an exact weight, even if the specified weight is within the weight range.
Paper from a previous jam has not been completely removed.	Open the product and remove any paper in the paper path. Closely inspect the fuser area for jams.
None of the optional trays appear as input tray options.	The optional trays only display as available if they are installed. Verify that any optional trays are correctly installed. Verify that the printer driver has been configured to recognize the optional trays.
An optional tray is incorrectly installed.	Print a configuration page to confirm that the optional tray is installed. If not, verify that the tray is correctly attached to the product.
The paper size is not configured correctly for the input tray.	Print a configuration page or use the control panel to determine the paper size for which the tray is configured.
The guides in the tray are not against the paper.	Verify that the guides are touching the paper.

Transparencies or glossy paper will not feed

Transparencies or glossy paper will not feed

Cause	Solution
The correct paper type is not specified in the software or printer driver.	Verify that the correct paper type is selected in the software or printer driver.
The input tray is overfilled.	Remove excess paper from the input tray. Do not exceed the maximum stack height marks for the tray.
Paper in another input tray is the same size as the transparencies, and the product is defaulting to the other tray.	Make sure that the input tray containing the transparencies or glossy paper is selected in the software program or printer driver. Use the product control panel to configure the tray to the paper type loaded.
The tray containing the transparencies or glossy paper is not configured correctly for type.	Make sure that the input tray containing the transparencies or glossy paper is selected in the software program or printer driver. Use the product control panel to configure the tray to the paper type loaded.
Transparencies or glossy paper might not meet supported paper specifications.	Use only paper that meets the HP paper specifications for this product.
High-humidity environments may cause glossy paper not to feed, or to feed too many sheets.	Avoid printing glossy paper in high humidity conditions. When printing glossy paper, removing the paper from the wrapper and letting it rest for a few hours can improve feeding into the product. However, letting paper rest in humid environments may also cause blisters.

Envelopes jam or will not feed in the product

Envelopes jam or will not feed in the product	
Cause	Solution
Envelopes are loaded in an unsupported tray. Only Tray 1 can feed envelopes.	Load envelopes into Tray 1.
Envelopes are curled or damaged.	Try using different envelopes. Store envelopes in a controlled environment.
Envelopes are sealing because the moisture content is too high.	Try using different envelopes. Store envelopes in a controlled environment.
Envelope orientation is incorrect.	Verify that the envelope is loaded correctly.
This product does not support the envelopes being used.	Refer to the <i>HP LaserJet Printer Family Print Media Guide</i> .
Tray 1 is configured for a size other than envelopes.	Configure Tray 1 size for envelopes.

Output is curled or wrinkled

Output is curled or wrinkled	
Cause	Solution
Paper does not meet the specifications for this product.	Use only paper that meets the HP paper specifications for this product.
Paper is damaged or in poor condition.	Remove paper from the input tray and load paper that is in good condition.
Product is operating in an excessively humid environment.	Verify that the printing environment is within humidity specifications.
You are printing large, solid-filled areas.	Large, solid-filled areas can cause excessive curl. Try using a different pattern.
Paper used was not stored correctly and might have absorbed moisture.	Remove paper and replace it with paper from a fresh, unopened package.
Paper has poorly cut edges.	Remove paper, flex it, rotate it 180 degrees or turn it over, and then reload it into the input tray. Do not fan paper. If the problem persists, replace the paper.
The specific paper type was not configured for the tray or selected in the software.	Configure the software for the paper (see the software documentation). Configure the tray for the paper.
The paper has previously been used for a print job.	Do not re-use paper.

Product will not duplex or duplexes incorrectly

Product will not duplex (print 2-sided jobs) or duplexes incorrectly

Cause	Solution
You are trying to duplex on unsupported paper.	Verify that the paper is supported for duplex printing.
The printer driver is not set up for duplex printing.	Set up the printer driver to enable duplex printing.
The first page is printing on the back of preprinted forms or letterhead.	Load preprinted forms and letterhead in Tray 1 with the letterhead or printed side down, with the top of the page leading into the product. For Tray 2 and 3, load the paper printed side up with the top of the page toward the right of the product.
The product model does not support automatic 2-sided printing.	The HP Color LaserJet CP5525n does not support automatic 2-sided printing.
The product configuration is not set for duplexing.	In Windows, run the automatic configuration feature: <ol style="list-style-type: none">1. Click the Start button, point to Settings, and then click Printers (for Windows 2000) or Printers and Faxes (for Windows XP).2. Right-click the HP product icon, and then click Properties or Printing Preferences.3. Click the Device Settings tab.4. Under Installable Options, click Update Now in the Automatic Configuration list.

Use manual print modes

Try the following multi-purpose (MP) modes to see if they solve the image-quality problems. To access the manual print modes, open the following menus:

- **Administration**
- **General Settings**
- **Print Quality**
- **Adjust Paper Types**

Table 3-61 MP modes under the **Adjust Paper Types** sub menu

Print Mode	
	<ul style="list-style-type: none">• AUTOSENSE MODE• NORMAL MODE• LIGHT MODE• HEAVY MODE• CARDSTOCK MODE• TRANSPARENCY MODE• TRANSPARENCY MODE 2• ENVELOPE MODE• LABEL MODE• TOUGH MODE• EXTRA TOUGH MODE• HEAVY GLOSSY MODE• X-HVY GLOSSY MODE• ROUGH MODE• CARD GLOSSY MODE• 4MM TRNS MODE• LIGHT ROUGH MODE
RESISTANCE MODE	Set to Up to resolve print-quality issues caused by poor secondary transfer in low-humidity environments with resistive or rough surface media.

Table 3-61 MP modes under the Adjust Paper Types sub menu (continued)

HUMIDITY MODE	<p>With glossy film, set to High when the product is in a high-humidity environment and print-quality defects occur on HP Tough Paper or Opaque film.</p> <p>With transparencies, set to High when the product is in a high-humidity environment and print-quality defects occur on color transparencies on the first page of a print job.</p> <p>With all other paper types, set to High when the product is in a high-humidity environment and light density occurs on the first page of a print job.</p>
FUSER TEMP MODE	<p>If you are seeing a faint image of the page repeated at the bottom of the page or on the following page, first make sure the Paper Type and Print Mode settings are correct for the type of paper you are using. If you continue to see ghost images on your print jobs, set the Fuser Temp feature to one of the Alternate settings . Try the ALTERNATE 1 setting first and see if it solves the problem. If you continue to see the problem, try ALTERNATE 2 and then ALTERNATE 3. Using the ALTERNATE 2 and ALTERNATE 3 settings might cause an extra delay between jobs.</p>
PAPER CURL MODE	<p>Use in high-humidity and high-temperature environments. The REDUCED setting decreases fuser temperature and increases the interpage gap.</p>

Table 3-62 MP modes under the Optimize submenu

NORMAL PAPER	Set to SMOOTH when printing on smooth paper of normal weight.
HEAVY PAPER	Set to SMOOTH when printing on smooth, heavy media types.
LIGHT MEDIA	Set to SMOOTH when printing on smooth, light media types.
ENVELOPE CONTROL	Set to REDUCED TEMP if envelopes are sticking due to moisture in the envelop adhesive.
ENVIRONMENT	Set to LOW TEMP if the product is operating in a low-temperature environment and you are having problems with print quality such as blisters in the printed image.
LINE VOLTAGE	Set to LOW VOLTAGE if the product is operating in a low-voltage environment and you are having problems with print quality such as blisters in the printed image.
TRAY1	Set to ALTERNATE if you are seeing marks on the back side of the paper when printing from Tray 1. This sets the product to initiate a clean sequence every time a job finishes when the product is set for Any Size and Any Type for Tray 1.
BACKGROUND	Set to ALTERNATIVE 1 when a background occurs all over the page. Set to ALTERNATIVE 2 when thin vertical lines appear on the page. Set to ALTERNATIVE 3 when the other alternatives do not correct the problem.

Table 3-62 MP modes under the Optimize submenu (continued)

CLEANING CONTROL	<p>Changes the control of toner purge. Toner purge is executed with the CRG in contact with the ITB. Toner purge is executed right after this mode is selected at the control panel.</p> <p>ALTERNATIVE 1: Use this option when ITB cleaning failure occurs during lower coverage printing or when abnormal noise occurs from ITB cleaning blade.</p>
MEDIA TEMP	<p>Use ALTERNATIVE 1 to preventing media in the output bin from sticking together.</p>
UNIFORMITY CONTROL	<p>Set to ALTERNATIVE 1 to improve uniformity on any paper type. Set to ALTERNATIVE 2 to improve uniformity on normal and light paper types. Set to ALTERNATIVE 3 when the other alternatives do not correct the problem.</p>
PRE-ROTATION	<p>Set to ALTERNATIVE 1 when horizontal banding occurs with the drum pitch, or when 53 mm band occurs after leaving engine for a long period of time.</p> <p>Set to ALTERNATIVE 2 when the problems like fade finger (trailing edge toner starvation) occur after high coverage continuous printing.</p>
REGISTRATION	<p>Set to ALTERNATIVE when color misregistration occurs.</p>
TRANSFER CONTROL	<p>Set to ALTERNATIVE 1 to reduce primary transfer bias and to resolve low density or blotchy images. Set to ALTERNATIVE 2 to resolve ghosting outlines that look like a finger or fingers. Set to ALTERNATIVE 3 when the other alternatives do not correct the problem.</p>
MOISTURE CONTROL	<p>Set to ALTERNATE when image failure occurs due to water drops.</p>

Solve image-quality problems

Occasionally, you might encounter problems with print quality. The information in the following sections helps you identify and resolve these issues.

Print quality examples





Some print quality problems arise from low or very low cartridges or other supplies. The solution is to replace the low or very low supplies.



Some print quality problems arise from use of inappropriate paper.

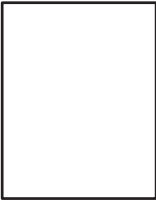

- Use paper that meets HP paper specifications.
- The surface of the paper is too rough. Use paper that meets HP paper specifications.
- The printer driver setting or paper tray setting might be incorrect. Be sure that you have configured the paper tray at the product control panel and have also selected the correct driver setting for the paper that you are using.
- The print mode might be set incorrectly, or the paper might not meet recommended specifications.
- The transparencies you are using are not designed for proper toner adhesion. Use only transparencies designed for HP Color LaserJet products.
- The moisture content of the paper is uneven, too high, or too low. Use paper from a different source or from an unopened ream of paper.
- Some areas of the paper reject toner. Use paper from a different source or from an unopened ream of paper.
- The letterhead you are using is printed on rough paper. Use a smoother, xerographic paper. If this solves your problem, consult with the printer of your letterhead to verify that the paper used meets the specifications for this product.
- Several optimize print modes can be used to address print quality issues. See the print modes section of this manual.

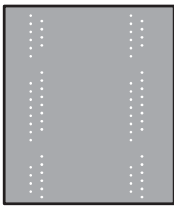

If you are having problems with light streaks in an image, use the **Administration** menu to print the supplies status page. If none of the cartridges has reached its estimated end of life, remove the cartridges from the product, and then reinstall them. The product initiates a cleaning mechanism that might correct the light streaks.

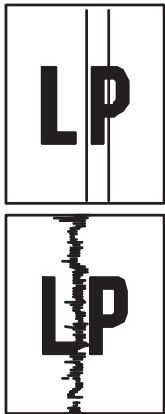
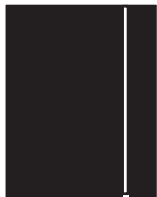



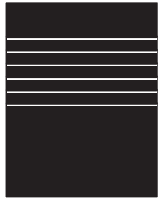
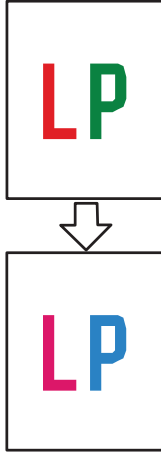

The following examples depict letter-size paper that has passed through the product short-edge first. These examples illustrate problems that would affect all the pages that you print, whether you print in color or in black only. The topics that follow list the typical cause and solution for each of these examples.

Problem	Sample	Cause	Solution
Print is light or faded on entire page.		Poor contacts exist on the ITB unit and the product grounding unit.	Clean the grounding contacts. If the problem remains after cleaning, check the contacts for damage. Replace any deformed or damaged parts.
		Poor secondary transfer contacts exist on the secondary transfer roller and the ITB.	Clean the contacts. If the problem remains after cleaning, check the contacts for damage. Replace any deformed or damaged parts.
Print is light or faded in a particular color.		Poor primary transfer bias contacts on the ITB unit and product.	Clean the contacts of the color that produces the light print. If the problem remains after cleaning, check the contacts for damage. Replace any deformed or damaged parts.
		Poor primary charging bias contacts with the print cartridge and product.	
		Poor developing bias contacts with the print cartridge and product.	
Image is too dark.		The registration density (RD) sensor is defective.	Replace the RD sensor.
Page is blank.		The imaging high-voltage power-supply is defective (no developing bias output).	Replace the imaging high-voltage power-supply .
The page is all black or a solid color.		Poor contact exists in the primary charging bias or developing bias contacts between the print cartridge and the product.	Clean each contact of the color that produces the all black or solid color. If the problem remains after cleaning, check the contacts for damage. Replace any deformed or damaged parts. Replace the affected print cartridge.

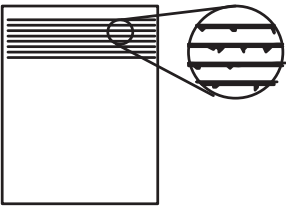
Problem	Sample	Cause	Solution
White spots appear in an image		<p>Poor conductivity caused by dirt on the static eliminator.</p> <p>The primary transfer roller is deformed or has deteriorated.</p> <p>The secondary transfer roller is deformed or has deteriorated.</p>	<p>Clean the static eliminator.</p> <p>Replace the ITB.</p> <p>Replace the secondary-transfer-roller.</p>
The back of the page is dirty.		<p>The secondary transfer roller is dirty.</p> <p>The fuser inlet guide or separation guide is dirty.</p> <p>The pressure roller is dirty.</p>	<p>Replace the secondary transfer roller.</p> <p>Clean the dirty parts. If the dirt does not come off, replace the guide.</p> <p>Run the cleaning page several times. If the dirt does not come off, install a fuser cleaning kit. If the issue persists, replace the fuser.</p>
Vertical streaks or bands appear on the page.		<p>Scratches are present on the circumference of the photosensitive drum.</p> <p>Scratches are present on the circumference of the fuser roller.</p> <p>Scratches are present on the circumference of the ITB.</p> <p>The ITB drive roller is deformed or has deteriorated.</p> <p>The ITB cleaning mechanism is malfunctioning.</p>	<p>Replace the print cartridge of the color that matches the defect.</p> <p>Replace the fuser.</p> <p>Replace the ITB.</p>
Vertical white lines appear in a particular color.		<p>The laser beam window is dirty.</p> <p>Scratches are present on the circumference of the developing cylinder or photosensitive drum.</p> <p>The laser/scanner-unit mirror is dirty.</p>	<p>Execute the Clean Laser Glass item in the Calibration/Cleaning submenu (in the Device Maintenance menu)</p> <p>If the error persists, manually clean the window and remove any foreign substances.</p> <p>Replace the affected print cartridge.</p> <p>If the problem persists, replace the affected print cartridge.</p> <p>Replace the laser/scanner assembly.</p>

Problem	Sample	Cause	Solution
Vertical white lines appear in all colors.		Horizontal scratches on the fuser roller.	Replace the fuser.
		Scratches are present on the circumference of the ITB.	Replace the affected print cartridge. Replace the ITB.
Horizontal lines appear on the page.		Repetitive horizontal lines appear.	Use the repetitive defects ruler to identify the dirty roller. Clean the roller. If the roller cannot be cleaned, replace the fuser.
		Horizontal scratches are present on the photosensitive drum.	Replace the print cartridge of the color that matches the defect.
		Horizontal scratches are present on the fuser roller.	Replace the fuser.
A horizontal white line appears on the page.		Repetitive horizontal white lines appear.	Use the repetitive defects ruler to identify the dirty roller. Clean the roller. If the roller cannot be cleaned, replace the roller.
		Horizontal scratches are present on the photosensitive drum.	Replace the print cartridge of the color that matches the defect.
		Scratches are present on the circumference of the ITB.	Replace the ITB.
Image in a particular color does not print in the correct color.		Poor contact exists in the primary charging bias or developing bias contacts between the print cartridge and the product.	Clean each contact of the color that produces the missing color. If the problem remains after cleaning, check the contacts for damage. Replace any deformed or damaged parts.
		The print cartridge (primary charging roller, developing roller, or photosensitive drum) is defective.	Replace the print cartridge of the color that matches the defect.
		The imaging high-voltage power-supply is defective (no primary charging bias or developing bias output).	Replace the imaging high-voltage power-supply.
		The laser/scanner unit is defective.	Replace the laser/scanner assembly.

Problem	Sample	Cause	Solution
Dropouts appear.		The secondary transfer roller is deformed or has deteriorated.	Replace the secondary-transfer-roller.
		The primary charging roller, developing roller, or photosensitive drum is deformed or has deteriorated.	Replace the print cartridge of the color that matches the defect.
		The fuser roller is deformed or has deteriorated.	Replace the fuser.
		The transfer 1 high-voltage power-supply PCA is defective (no transfer 1 bias output).	Replace the transfer 1 high-voltage power-supply.
		The transfer 2 high-voltage power-supply PCA is defective (no transfer 2 bias output).	Replace the transfer 2 high-voltage power-supply.
The toner is not fully fused to the paper.		The fuser roller or pressure roller is scarred or deformed.	Replace the fuser.
		The fuser control circuit is defective.	Replace the low-voltage power supply.
		The thermistor is defective.	Replace the fuser.
		The fuser heater is defective.	
Some color is misregistered.		The product is incorrectly calibrated.	Calibrate the product.
		The ITB unit is defective.	If the ITB does not rotate smoothly or a cleaning malfunction occurs (ITB is dirty), replace the ITB.
		The drive gear of the ITB motor is worn or chipped.	Check each drive gear between the ITB drive roller and the ITB motor. If the gear is worn or chipped, replace the drive unit.
		The RD sensor is defective.	Open and close the right door several times to clean the RD sensor. If the problem persists, replace the RD sensor.
		The laser/scanner unit is defective.	Replace the laser/scanner assembly.
		The print cartridge is defective.	Replace the print cartridge of the affected color.

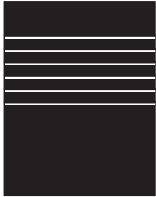
Problem	Sample	Cause	Solution
Toner smears appear on the media.		The product has residual media.	Remove the residual media.
		Poor contact exists in the primary charging bias or developing bias contacts between the print cartridge and the product.	Clean each contact of the color that produces the missing color. If the problem remains after cleaning, check the contacts for damage. Replace any deformed or damaged parts.
The printed page contains misformed characters.		The fuser inlet guide is dirty.	Clean the fuser inlet guide.
		The product is experiencing page skew.	See the "Text or graphics are skewed on the printed page" row in this table.
Text or graphics are skewed on the printed page.		The laser/scanner unit is defective.	Replace the laser/scanner assembly.
		The registration shutter spring is unhooked.	Check the spring and place it in the correct position.
The printed page contains wrinkles or creases.		The registration shutter spring is deformed.	Replace the cassette pickup assembly.
		The roller or media feed guide is dirty.	Clean any dirty components.
		A feed roller is deformed or has deteriorated.	Replace any deformed or deteriorated rollers.
The front of the page is dirty.		The paper feed guide is damaged.	Replace the paper-feed-guide unit.
		The photosensitive drum is dirty.	Replace the print cartridge.
The front of the page is dirty.		The fuser roller or pressure roller is dirty.	Execute a cleaning page to clean the contaminate off the fuser. If the dirt does not come off, replace the fuser.
			NOTE: Cleaning the fuser with HP tough paper provides better results than with plain paper. You might need to execute the cleaning process several times to remove all contaminates on the fuser.
Repetitive horizontal lines		Damaged or dirty roller.	See repetitive image defect ruler. Clean the indicated roller. If the contaminate does not come off, replace appropriate roller or assembly.

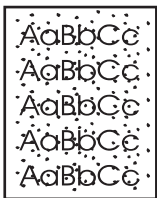
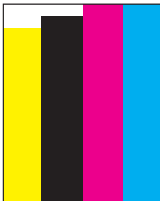
Problem	Sample	Cause	Solution
Pages have flecks of toner		Dirty paper path.	<p>Execute a cleaning page to clean the contaminate off the fuser. The cleaning page may need to be run several time to clean the fuser. Do not replace the fuser.</p> <p>NOTE: Cleaning the fuser with HP tough paper provides better results than with plain paper. You might need to execute the cleaning process several times to remove all contaminates on the fuser. A fuser cleaning kit (CC468-67919) is available.</p>
Pages have one or more skewed color planes (can appear on the right or left side of the page)		Print cartridge incorrectly installed or damaged.	Remove, and then reinstall the print cartridge associated with the defect.

Clean the product

Over time, particles of toner and paper accumulate inside the product. This can cause print-quality problems during printing. Cleaning the product eliminates or reduces these problems.



Clean the paper path and print-cartridge areas every time that you change the print cartridge or whenever print-quality problems occur. As much as possible, keep the product free from dust and debris.

To clean the product exterior, use a soft, water-moistened cloth.

Clean the paper path



 **NOTE:** If you are processing a cleaning page to clean the fuser, repeat the process 1 to 6 times until the paper comes out clean.

Process a cleaning page

1. Press the Home button .
2. Open the following menus:
 - **Device Maintenance**
 - **Calibration/Cleaning**
3. Press the **Down** arrow  to highlight the **Print Cleaning Page** item, and then press the **OK** button.
4. The product prints a cleaning page, and then returns to the main menu. Discard the printed page.

Set up an auto cleaning page

Use the procedure in this section to set up an automatic cleaning page.

1. Press the Home button .
2. Open the following menus:
 - **Device Maintenance**
 - **Calibration/Cleaning**
3. Press the **Down** arrow  to highlight the **Auto Cleaning** item, and then select the **Enabled** item. Press the **OK** button.
4. Press the **Down** arrow  to highlight the **Cleaning Interval** item, and then use the arrow buttons to select an interval. Press the **OK** button.

 **TIP:** HP recommends processing a cleaning page after every 5000 printed pages.

5. Press the **Down** arrow  to highlight the **Auto Cleaning Size** item, and then use the arrow buttons to select the cleaning page size. Press the **OK** button.

Solve performance problems

Problem	Cause	Solution
Pages print but are totally blank.	The document might contain blank pages.	Check the document that you are printing to see if content appears on all of the pages.
	The product might be malfunctioning.	To check the product, print a Configuration page.
	All of the print cartridges might be very low on toner.	Replace the toner cartridges if a Supplies very low message is displayed.
Pages print very slowly.	Heavier paper types can slow the print job.	Print on a different type of paper. Proper fusing may require a slower print speed to ensure the best print quality.
	Complex pages can print slowly.	Simplify the page.
Pages did not print.	The product might not be pulling paper correctly.	Make sure paper is loaded in the tray correctly.
	The paper is jamming in the product.	Clear the jam. See Clear jams on page 495 .
	The USB cable might be defective or incorrectly connected.	<ul style="list-style-type: none">• Disconnect the USB cable at both ends and reconnect it.• Try printing a job that has printed in the past.• Try using a different USB cable.
	Other devices are running on your computer.	The product might not share a USB port. If you have an external hard drive or network switchbox that is connected to the same port as the product, the other device might be interfering. To connect and use the product, you must disconnect the other device or you must use two USB ports on the computer.

Solve connectivity problems

Solve direct-connect problems

If you have connected the product directly to a computer, check the cable.

- Verify that the cable is connected to the computer and to the product.
- Verify that the cable is not longer than 2 m (6.5 ft). Replace the cable if necessary.
- Verify that the cable is working correctly by connecting it to another product. Replace the cable if necessary.

Solve network problems

Check the following items to verify that the product is communicating with the network. Before beginning, print a configuration page. See [Configuration page on page 350](#).

Problem	Solution
Poor physical connection	<p>Verify that the product is attached to the correct network port using a cable of the correct length.</p> <p>Verify that cable connections are secure.</p> <p>Look at the network port connection on the back of the product, and verify that the amber activity light and the green link-status light are lit.</p> <p>If the problem continues, try a different cable or port on the hub.</p>
The computer is unable to communicate with the product.	<p>Use the command prompt to ping the product from your computer. For example:</p> <pre>ping 192.168.45.39</pre> <p>Verify that the ping displays round-trip times, which indicates that it is working.</p> <p>If the ping command failed, verify that the network hubs are on, and then verify that the network settings, the product, and the computer are all configured for the same network.</p>
Incorrect link and duplex settings	<p>Hewlett-Packard recommends leaving this setting in automatic mode (the default setting). See the user guide.</p>
Incorrect IP address for the product on the computer	<p>Use the correct IP address. The IP address is listed on the configuration page.</p> <p>If the IP address is correct, delete the product and then add it again.</p>
New software programs have caused compatibility problems.	<p>Verify that any new software programs are correctly installed and that they use the correct printer driver.</p>
Your computer or workstation is set up incorrectly.	<p>Check the network drivers, printer drivers, and the network redirection.</p> <p>Verify that the operating system is configured correctly.</p>
The protocol is disabled, or other network settings are incorrect.	<p>Review the configuration page to check the status of the protocol. Enable it if necessary.</p> <p>Reconfigure the network settings if necessary. See the user guide.</p>

Service mode functions

Service menu

The **Service** menu is PIN-protected for added security. Only authorized service people have access to the **Service** menu. When you select **Service** from the list of menus, the product prompts you to enter an eight-digit PIN number (**Service Access Code**). The PIN for the HP Color LaserJet Enterprise CP5520 Printer Series is 11552010.

1. Press the Home  button.
2. Open the following menus:
 - **Device Maintenance**
 - **Service**
 - **Service Access Code**
3. Enter the eight-digit PIN using the arrow buttons.

 **NOTE:** Only the **Service Access Code** can be used to access the **Service** menu. The message **Your user account does not have permission to access the selected item** displays if the correct **Service Access Code** is not used.

4. Press the **OK** button to enter the PIN and open the **Service** menu.



The following menu items appear in the **Service** menu:

First level	Second level	Third level	Description
User Access Code			Only the Service Access Code can be used to access the Service menu. The message Your user account does not have permission to access the selected item displays if the correct Service Access Code is not used.
Administrator Access Code			Only the Service Access Code can be used to access the Service menu. The message Your user account does not have permission to access the selected item displays if the correct Service Access Code is not used.
Service Access Code			This item allows access to the Service sub menus.
		Print Event Log	Use this item to print the service event log.

First level	Second level	Third level	Description
	View Event Log		Use this item to view the service event log.
	Clear Event Log		Use this item to clear (erase) the service event log.
	Cycle Counts	Mono Cycle Counts	Use this item to reset the mono print job page count.
		Color Cycle Count	Use this item to reset the color print job page count.
		Refurbish Cycle Count	Use this item to reset the refurbish print job page count.
	Serial Number		Use this item to reset the product serial number.
	Service ID		Use this item to reset the product service identification number.
	Cold Reset Paper		Use this item to set the cold reset paper size.
	New Registration Roller		Use this item to reset the registration roller page count.
	Media Sensor Value		Use this item to record the media sensor value found on a replacement paper pickup assembly.
	Manual Laser Glass Cleaning		Use this item to execute a manual laser glass cleaning. The laser shutters are moved away from the laser glass windows so that they can be manually cleaned.
Test Support	Continuous Print from USB		Use this item to test print from an external USB.
	Automatic Calibrations		Use this item to enable automatic calibrations.

Product resets

Restore factory-set defaults

1. Press the Home button .
2. Open the following menus:
 - **Administration**
 - **General Settings**
 - **Restore Factory Settings**
3. Press the **Down** arrow button  to highlight the select type of reset from a list, and then press the **OK** button.
4. Press the **Down** arrow  to highlight the **Reset** item, and then press the **OK** button.

Restore factory-set defaults values

- **Calibration**
 - Persisted calibration engine data
 - Engine color density data
 - LaserJet engine calibration data
- **General**
 - Display and sound settings for the control panel
 - Localization settings (for example, clock format and date format)
 - Error and warning log behavior
 - Default media settings
 - Sleep mode and delay setting
 - Internal backup file maximum size
 - Oxp installer solutions, tasks and pending tasks
 - Http job defaults
 - Clears the error, warning and info logs
 - Supported media types
 - Resets JetLink connected external devices

- **Print**
 - Print default job, stored job and quick set settings
 - Some print job usage data
 - Print system configuration settings
- **Security**
 - Default Authentication agent
 - Authentication agents
 - Policy agents
 - Color access control

Clean Disk and Partial Clean functions

Active and repository firmware locations

The firmware bundle now consists of multiple parts. The main components are the Windows CE Operating System and the printer/peripheral firmware files.

There are two locations/partitions on the hard drive where the firmware components are stored:

- The Active – where the Operating System and firmware currently are executing
- The Repository – the recovery location

If the Active location is damaged, or a **Partial Clean** was performed, the printer automatically copies over the OS and firmware files from the Repository location and the printer recovers.

If both the Active and Repository locations are damaged, or a **Clean Disk** was performed, then both locations are gone and the error message **99.09.67** appears on the control-panel display. The user must upload the firmware to the printer in order for it to function again

△ **CAUTION:** The **Clean Disk** option performs a disk initialization for the entire disk. The operating system, firmware files, and third party files (among other files) will be completely lost. HP does not recommend this action.

Partial Clean

The **Partial Clean** option erases all partitions and data on the disk drive, except for the firmware repository where a backup copy of the firmware file is stored. This allows the disk drive to be reformatted without having to download a firmware upgrade file to return the product to a bootable state.

Characteristics of a Partial Clean

- Customer-defined settings, third-party solutions, firmware files, and the operating system are deleted.
- Rebooting the product restores the firmware files from the Repository location, but does not restore any customer-defined settings.
- For previous HP products, a Hard Disk Initialization is similar to executing the **Partial Clean** function for this product.

△ **CAUTION:** HP recommends backing-up product configuration data before executing a **Partial Clean** if you need to retain customer-defined settings. See the **Backup/Restore** item in the **Device Maintenance** menu.

Reasons for performing Partial Clean

- The product continually boots up in an error state.

 **NOTE:** Try clearing the error prior to executing a **Partial Clean**.

- The product will not respond to commands from the control panel.
- Executing the **Partial Clean** function is helpful for troubleshooting hard disk problems.
- To reset the product by deleting all solutions and customer-defined settings.
- The product default settings are not properly working.

Execute a Partial Clean

1. Turn the product on.
2. When the Ready, Data, and Attention LEDs are illuminated solid, press the **Stop** button.
3. Press the **Down** arrow button ▼ to highlight **Administration**, and then press the **OK** button.
4. Press the **Down** arrow button ▼ to highlight **Partial Clean**, and then press the **OK** button.
5. Press the **OK** button again.
6. Press the **Back** button to highlight **Continue**, and then press the **OK** button.

 **NOTE:** The product initializes.

Clean Disk

The **Clean Disk** option erases the entire disk drive.

△ **CAUTION:** After executing a **Clean Disk** option, the product is *not* bootable.

Characteristics of a Partial Clean

- Customer-defined settings, third-party solutions, firmware files, and the operating system are deleted.

 **NOTE:** Rebooting the product *does not* restore the firmware files.

- Rebooting the product restores the firmware files from the Repository location, but does not restore any customer-defined settings.
- After executing the **Clean Disk** function, the message **99.09.67** displays on the control panel.
- After executing the **Clean Disk** function, the product firmware must be reloaded.

△ **CAUTION:** HP recommends that you do not use the **Clean Disk** option unless an error occurs and the solution in the product service manual recommends this solution. After executing the **Clean Disk** function, the product is unusable.

HP recommends backing-up product configuration data before executing a **Clean Disk** if you need to retain customer-defined settings. See the **Backup/Restore** item in the **Device Maintenance** menu.

Reasons for performing Clean Disk

- The product continually boots up in an error state.

 **NOTE:** Try clearing the error prior to executing a **Clean Disk**.

- The product will not respond to commands from the control panel.
- Executing the **Clean Disk** function is helpful for troubleshooting hard disk problems.
- To reset the product by deleting all solutions and customer-defined settings.

Execute a Clean Disk

1. Turn the product on.
2. When the Ready, Data, and Attention LEDs are illuminated solid, press the **Stop** button.
3. Press the **Down** arrow button ▼ to highlight **Administration**, and then press the **OK** button.
4. Press the **Down** arrow button ▼ to highlight **Clean Disk**, and then press the **OK** button.
5. Press the **OK** button again.

 **NOTE:** When the **Clean Disk** operation is complete, you will need to reload the product firmware.

Preboot menu options

If an error occurs while the product is booting, an error message appears on the control-panel display. The user can access the Preboot menus. The Error menu item will not be seen if an error did not occur.

Access the Preboot menu

1. Turn the product on.
2. Press the **Stop** ⓧ button when the **Ready**, **Data**, and **Attention** LEDs are illuminated solid.
3. Use the **Down** arrow ▼ button to navigate the Preboot menu options.
4. Press the **OK** button to select a menu item.

Cold reset using the Preboot menu

1. Turn the product on.
2. Press the **Stop** ⓧ button when the **Ready**, **Data**, and **Attention** LEDs are illuminated solid.
3. Use the **Down** arrow ▼ button to highlight **Administrator**, and then press the **OK** button.
4. Use the **Down** arrow ▼ button to highlight **Startup Options**, and then press the **OK** button.
5. Use the **Down** arrow ▼ button to highlight **Cold Reset**, and then press the **OK** button.
6. Press the **Back** button twice to highlight **Continue**, and then press the **OK** button.

 **NOTE:** The product will initialize.

Table 3-63 Preboot menu options (1 of 5)

Menu option	First level	Second level	Third level	Description
Continue				Selecting the Continue item exits the Preboot menu and continues the normal boot process. If a selection is not made in the initial menu within 30 seconds, the product returns to a normal boot (the same as selecting Continue). If the user navigates to another menu, the timeout does not apply.
Sign In				Enter the Administrator PIN or Service PIN if one is required to access the Preboot menu.

Table 3-63 Preboot menu options (1 of 5) (continued)

Menu option	First level	Second level	Third level	Description
Administrator				<p>This item navigates to the Administrator sub menus.</p> <p>If authentication is required (and the user is not already signed in) the Sign In displays. The user is required to sign in.</p>
	Download			<p>This item initiates a preboot firmware download process. A USB device interface or a Network connection can be used to download firmware.</p>
		Network		<p>See Product updates on page 547.</p>
		USB		<p>See Product updates on page 547.</p>
Clean Disk				<p>This item reinitializes the disk and cleans all disk partitions.</p> <p>CAUTION: Selecting the Clean Disk item removes all data.</p> <p>A delete confirmation prompt is not provided.</p> <p>The system is not bootable after this action—a firmware download must be performed to return the system to a bootable state.</p>
Partial Clean				<p>This item reinitializes the disk (removing all data except the firmware repository where the master firmware bundle is downloaded and saved).</p> <p>CAUTION: Selecting the Partial Clean item removes all data except the firmware repository.</p> <p>A delete confirmation prompt is not provided.</p> <p>This allows user to reformat the disk by removing the firmware image from the active directory without having to download new firmware code (product remains bootable).</p>
Change Password				<p>Select this item to set or change the administrator password.</p>
Clear Password				<p>Select the Clear Password item to remove a password from the Administrator menu. Before the password is actually cleared, a message will be shown asking to confirm that the password should be cleared. Press the OK button to confirm the action.</p> <p>When the confirmation prompt appears, press the OK button to clear the password.</p>

Table 3-64 Preboot menu options (2 of 5)

Menu option	First level	Second level	Third level	Description	
Administrator continued	Manage Disk	Clear Disk		Select the Clear Disk item to enable an external device for job storage. Job storage is normally enabled only for the Boot device. This will be grayed out unless the 99.09.68 error is displayed.	
		Lock Disk		Select the Lock Disk item to lock (mate) a new secure disk to this product. The secure disk already locked to this product will remain accessible to this product. Use this function to have more than one encrypted disk accessible by the product when using them interchangeably. The data stored on the secure disk locked to this product always remains accessible to this product.	
		Leave Unlocked		Select the Leave Unlocked item to use a new secure disk in an unlocked mode for single service event. The secure disk that is already locked to this product will remain accessible to this product and uses the old disk's encryption password with the new disk. The secure disk that is already locked to this product remains accessible to this product.	
		Clear Password		Select the Clear Password item to continue using the non-secure disk and clear the password associated with the yet to be installed secure disk. CAUTION: Data on the missing secure disk will be permanently inaccessible.	
		Retain Password		Select the Retain Password item to use the non-secure disk for this session only, and then search for the missing secure disk in future sessions.	
		Boot Device			
		Secure Erase		Select the Secure Erase item to erase all of the data on the disk and unlock it if required. This might take a long time. NOTE: The system will be unusable until the system files are reinstalled. ATA secure-erase command one pass over write. Erases entire disk including firmware. The disk remains an encrypted disk.	
		Erase and Unlock		Select the Erase and Unlock item to cryptographically erase all data on disk and unlock the disk to allow access to it from any product. NOTE: The system will be unusable until the system files are reinstalled. Erases the crypto key. The disk becomes a non-encrypted disk.	
		Get Status		This item provides disk status information if any is available.	

Table 3-65 Preboot menu options (3 of 5)

Menu option	First level	Second level	Third level	Description
Administrator continued	Manage Disk continued	Internal Device		Select the Internal Device item to erase the internal device or get status about the internal device.
			Secure Erase	Select the Secure Erase item to erase all of the data on the disk and unlock it if required. This might take a long time. NOTE: The system will be unusable until the system files are reinstalled. ATA secure-erase command one pass over write. Erases the entire disk, including firmware. The disk remains an encrypted disk.
			Erase and Unlock	Select the Erase and Unlock item to cryptographically erase all data on disk and unlock the disk to allow access to it from any product. NOTE: The system will be unusable until the system files are reinstalled. Erases the crypto key. The disk becomes a non-encrypted disk.
			Get Status	This item provides disk status information if any is available.
		External Device		Select the External Device item to erase the internal device or get status about the internal device.
			Secure Erase	Select the Secure Erase item to erase all of the data on the disk and unlock it if required. This might take a long time. NOTE: The system will be unusable until the system files are reinstalled. ATA secure-erase command one pass over write. Erases the entire disk, including firmware. The disk remains an encrypted disk.
			Erase and Unlock	Select the Erase and Unlock item to cryptographically erase all data on disk and unlock the disk to allow access to it from any product. NOTE: The system will be unusable until the system files are reinstalled. Erases the crypto key. The disk becomes a non-encrypted disk.
			Get Status	This item provides disk status information if any is available.

Table 3-66 Preboot menu options (4 of 5)

Menu option	First level	Second level	Third level	Description
Administrator continued	Configure LAN			Select the Configure LAN item to setup the network settings for the PreBoot menu firmware upgrade. The network can be configured obtain the network settings from a DHCP server or as static.
		DHCP		Use this item for automatic IP address acquisition from the DHCP server.
		Static		Use this item to manually assign the network addresses.
			IP Address	Use this item to manually enter the IP addresses.
			Subnet Mask	Use this item to manually enter the subnet mask.
			Default Gateway	Use this item to manually enter the default gateway.
			Save and Exit	Select the Save and Exit item to save the manual settings.

Table 3-67 Preboot menu options (5 of 5)

Menu option	First level	Second level	Third level	Description
Administrator continued	Startup Options			Select the Startup Options item to specify options that can be set for the next time the product is turned on and initializes to the Ready state.
			Cold Reset	Check the Cold Reset item to clear the IP address and all customer settings (this item also returns all settings to factory defaults). NOTE: Items in the Service menu are not reset.
			First Power	Not currently functional: This item allows the product initialize as if it is the first time it has been turned on. For example, the user is prompted to configure first time settings like Select Date/Time, Select Language, and other settings). Check this item so that it is enabled for the next time the product power is turned on. When the product power is turned on the next time, this item is unchecked so that the pre-configured settings are used during configuration and the first time setting prompt is not used.
			Skip Plug-ins	This item allows the device to be started without loading the third party applications. This means that files including Accessible Architecture on the disk will not be available at bootup. This is useful for troubleshooting problems with the hard disk without having to remove the hard disk. It also applies to flash file system disks on DIMMs. In this case, this function will cause the printer to configure the HP firmware first, followed by the third-party applications. NOTE: The files on the disk will be available after the printer enters the Ready state.
			Skip Cal	Select the Skip Cal item to initialize the product the next time the power is turned on without calibrating.
			Show Revision	Not currently functional: Check the Show Revision item to allow the product to initialize and show the firmware version when the device reaches the Ready state. Once the product power is turned on the next time, the Show Revision item is unchecked so the firmware revision is not shown.
		Lock Service	CAUTION: Select the Lock Service item to lock the Service menu access (both PreBoot and Device Maintenance application). Service personnel must have the Administrator remove the Lock Service setting before they can enter the Service menu.	

Table 3-68 Preboot menu options (5 of 5)

Menu option	First level	Second level	Third level	Description
Administrator continued	Startup Options continued	Skip Disk Scan		Check the Skip Disk Scan item to allow the product to initialize without scanning the disk.
				If the product is crashing on Step 4/8, checking this item may allow the problem to be isolated.
				Once the device is turned on the next time, the Skip Disk Scan item is unchecked and the disk scan is not skipped.
		Embedded Jetdirect Off		Check the Embedded Jetdirect Off item to disable the embedded Jetdirect. By default this item is unchecked so that Jetdirect is always enabled.
Service Tools				This item requires the Service access code.
		Reset Password		Use this item to clear the Administrator password.
		Subsystems		For manufacturing use only. Do not change these values.

Product updates

To download the most recent firmware upgrade for the product, go to www.hp.com/support/cljcp5525 or www.hp.com/go/cljcp5525_firmware.

Determine the installed revision of firmware

Print a configuration page to determine the installed revision of firmware. See [Configuration page on page 350](#).

On the configuration page, look in the section marked Device Information for the firmware datecode and firmware revision.

Firmware datecode and firmware revision examples

- 20100831 (firmware datecode)
- 103067_104746 (firmware revision)

Perform a firmware upgrade

The firmware bundle is a xxxxxxxx.bdl file. This file requires an interactive upgrade method. You cannot upgrade the printer using the traditional FTP, LPR or Port 9100 methods of upgrading. Use one of the following methods to upgrade the firmware for this product.

Embedded Web Server

1. Open an browser window.
2. Enter the product IP address in the URL line.
3. Select the **Firmware upgrade** link from within the **Troubleshooting** tab.

 **NOTE:** If you get a warning screen, follow the instructions for setting an administrator password from the **Security** tab.

4. Browse to the location that the firmware upgrade file was downloaded to, and then select the firmware file. Select the Install button to perform the upgrade.

 **NOTE:** Do not close the browser window until the Embedded Web Server (EWS) displays the confirmation page.

5. Select **Restart Now** from the EWS confirmation page, or turn the product off, and then on again using the power switch.

USB storage device (Preboot menu)

1. Copy the xxxxxxxx .bd1 file to a portable USB flash memory storage device (thumb drive).
2. Turn the product on.
3. Press the **Stop** button when the **Ready**, **Data** and **Attention** LEDs illuminate solid.
4. Press the down arrow ▼ button to highlight **Administrator**, and then press the **OK** button.
5. Press the down arrow ▼ button to highlight **Download**, and then press the **OK** button.
6. Insert the portable USB storage device with the xxxxxxxx .bd1 file on it.

 **NOTE:** If the error message **No USB Thumbdrive Files Found** appears on the control-panel display, you might need to connect the storage device to the external USB connection on the formatter or try using a different portable storage device.

7. Press the down arrow ▼ button to highlight **USB Thumb Drive**, and then press the **OK** button.
8. Press the down arrow ▼ button to highlight the xxxxxxxx .bd1 file, and then press the **OK** button.

 **NOTE:** The upgrade process can take up to 10 minutes to complete.

 **TIP:** If there is more than one xxxxxxxx .bd1 file on the storage device, make sure that you select the correct file for this product.

9. When the message **Complete** appears on the control-panel display, press the **Back** button 3 times.
10. When the message **Continue** appears on the control-panel display, press the **OK** button. The product will initialize.
11. When the upgrade process is complete, print a configuration page and verify that the upgrade firmware version was installed. See [Configuration page on page 350](#) and [Determine the installed revision of firmware on page 547](#).

USB storage device (control-panel menu)

1. Copy the xxxxxxxx .bd1 file to a portable USB flash memory storage device (thumbdrive).
2. Turn the product on, and then wait until it reaches the Ready state.
3. Press the Home button or OK button.
4. Press the down arrow ▼ button to highlight **Device Maintenance**, and then press the OK button.
5. Press the down arrow ▼ button to highlight **USB Firmware Upgrade**, and then press the OK button.
6. Insert the portable USB storage device with the xxxxxxxx .bd1 file on it into the USB port on the front of the product, and then press the OK button.
7. Press the down arrow ▼ button to highlight the xxxxxxxx .bd1 file, and then press the OK button.

 **TIP:** If there is more than one xxxxxxxx .bd1 file on the storage device, make sure that you select the correct file for this product.

8. A prompt to upgrade an older, newer, or reinstall the same version appears. Press the down arrow ▼ button to highlight the desired option, and then press the OK button.

When the upgrade is complete, the product will initialize.

 **NOTE:** The upgrade process can take up to 10 minutes to complete.

9. When the upgrade process is complete, print a configuration page and verify that the upgrade firmware version was installed. See [Configuration page on page 350](#) and [Determine the installed revision of firmware on page 547](#).

4 Parts and diagrams

- [Order parts by authorized service providers](#)
- [How to use the parts lists and diagrams](#)
- [Assembly locations](#)
- [External covers, panels, and doors](#)
- [Right door assembly](#)
- [Internal components \(1 of 9\)](#)
- [Internal components \(2 of 9\)](#)
- [Internal components \(3 of 9\)](#)
- [Internal components \(4 of 9\)](#)
- [Internal components \(5 of 9\)](#)
- [Internal components \(6 of 9\)](#)
- [Internal components \(7 of 9\)](#)
- [Internal components \(8 of 9\)](#)
- [Internal components \(9 of 9\)](#)
- [1x250 cassette](#)
- [Paper pick-up assembly](#)
- [Paper delivery assembly](#)
- [Printed circuit assemblies](#)
- [1x500 paper feeder](#)
- [3x500 paper feeder](#)
- [Alphabetical parts list](#)
- [Numerical parts list](#)

Order parts by authorized service providers

Order parts, accessories, and supplies

Table 4-1 Order parts, accessories, and supplies

Order supplies and paper	www.hp.com/go/suresupply
Order genuine HP parts or accessories	www.partsurfer.hp.com
Order through service or support providers	Contact an HP-authorized service or support provider.
Order using HP software	For information about using the HP software to order parts, accessories, and supplies, see the product user guide.

Related documentation and software

Table 4-2 Related documentation and software

Item	Description	Part number
<i>HP Color LaserJet Enterprise CP5520 Printer Series User Guide</i>	Product user guide	CE707-90901
<i>HP Color LaserJet Enterprise CP5520 Printer Series Service Manual</i>	English service manual (this manual)	CE707-90935

Supplies part numbers

Table 4-3 Supplies part numbers

Item	Description	Part number
HP LaserJet print cartridges with HP ColorSphere toner	Black print cartridge	CE270A (new) CE270-67901 (service)
	Cyan print cartridge	CE271A (new) CE271-67901 (service)
	Yellow print cartridge	CE272A (new) CE272-67901 (service)
	Magenta print cartridge	CE273A (new) CE273-67901 (service)

Customer self repair parts

Each kit includes parts and installation instructions. The customer self repair (CSR) level indicates the expected difficulty the customer will experience when replacing this part:

- A = Easy
- B = Difficult
- C = Very difficult

Item	Part number	CSR level
1x250-sheet feeder (Tray 2)	CE710-67906	A
<ul style="list-style-type: none">• Tray 2 cassette• Installation instructions		
1x500-sheet feeder (Tray 3) kit	CE860-67901	A
<ul style="list-style-type: none">• 1x500-sheet feeder• Installation instructions		
3x500-sheet feeder (Trays 4, 5, and 6) with stand kit	CE725-67901	A
<ul style="list-style-type: none">• 3x500-sheet feeder with stand• Installation instructions		

Item	Part number	CSR level
Encrypted hard disk drive kit <ul style="list-style-type: none"> • Encrypted hard disk drive, 120 GB • Right rail • Left rail • Disk drive cradle • Power/data cable assembly • Installation instructions 	CE709-67901	B
Formatter kit <ul style="list-style-type: none"> • Formatter tray assembly • Formatter assembly • Screws • EIO card guide • Installation instructions 	CE707-69001	A
Fuser kit <ul style="list-style-type: none"> • Fuser assembly • Installation instructions 	110 volt: RM1-6180-000CN 220 volt: RM1-6181-000CN	A
Intermediate transfer belt (ITB) maintenance kit <ul style="list-style-type: none"> • ITB assembly • Secondary transfer roller assembly • Tray 1 pick-up roller • Tray 2 pick-up roller assembly • Tray 2 separation roller assembly • Tray 3, 4, 5, 6 pick-up rollers • Tray 3, 4, 5, 6 feed roller assembly • Installation instructions 	CE979-67901	A
Intermediate transfer belt (ITB) repair kit <ul style="list-style-type: none"> • ITB assembly • Secondary transfer roller assembly • Installation instructions 	CE710-67903	A
Secondary transfer roller (T2) kit <ul style="list-style-type: none"> • Secondary transfer roller assembly • Installation instructions 	CE710-67904	A

Item	Part number	CSR level
Solid state drive kit	CE707-67901	B
<ul style="list-style-type: none"> • Solid state drive, 8 GB • Driver retainer • Installation instructions 		
Toner collection unit kit	CE980-67901	A
<ul style="list-style-type: none"> • Waste toner box assembly • Toner cleaning cloth • Installation instructions 		
Tray 1 paper pick-up roller and separation pad kit	CE710-67909	A
<ul style="list-style-type: none"> • Paper pick-up roller • Separation pad • Installation instructions 		
Tray 2 paper pick-up roller kit	CE710-69007	A
<ul style="list-style-type: none"> • Paper pick-up roller assembly • Separation roller assembly • Installation instructions 		
Tray 3, 4, 5, and 6 paper pick-up roller kit	CE710-69008	A
<ul style="list-style-type: none"> • Paper pick-up roller assembly • Feed roller assembly • Installation instructions 		

Service replacement parts

Item	Part number
DC controller assembly	Simplex: CE707-67906
<ul style="list-style-type: none"> • DC controller assembly • Installation instructions 	Duplex: CE708-67902
Front cover assembly kit	CE707-67902
<ul style="list-style-type: none"> • Front cover assembly • HP logo jewel 	

Item	Part number
Fuser drive unit	CE707-67904
<ul style="list-style-type: none"> • Fuser drive assembly • Installation instructions 	
Inner door assembly	CE707-67909
<ul style="list-style-type: none"> • Inner door assembly • Four color cartridge labels 	
Interconnect board (ICB) PCA	CE707-67907
<ul style="list-style-type: none"> • ICB PCA • Installation instructions 	
Main drive assembly	Simplex: CE707-67905
<ul style="list-style-type: none"> • Main drive assembly • Installation instructions 	Duplex: CE708-67901
Paper pick-up assembly	CE707-67903
<ul style="list-style-type: none"> • Paper pick-up assembly • Installation instructions 	
Toner vacuum kit	110 volt: CC468-69002
<ul style="list-style-type: none"> • Toner vacuum • Instructions for use 	220 volt: CC468-69003
Tray 1 separation pad kit	CE707-67908
<ul style="list-style-type: none"> • Tray 1 separation pad assembly • Installation instructions 	

Accessories part numbers

Table 4-4 Accessories part numbers

Item	Description	Part number
Optional 1x500-sheet tray	Optional tray to increase paper capacity.	CE860A
Optional 3x500-sheet tray and feeder unit	Optional tray to increase paper capacity.	CE725A
USB cable	2-meter A-to-B cable	C6518A
Power cord	China 220V - 10A	8121-0943
	Taiwan 110V - 13A	8121-0964
	Korea 220V - 10A	8121-0731
	Japan 110V - 12A	8121-1143
	India 220V - 6A	8121-0564
	Asia Pacific 220V - 10A	8121-0739
	Australia/New Zealand 220V - 10A	8121-0837
	Israel 220V - 10A	8121-1004
	Denmark 220V - 10A	8121-0733
	South Africa 220V - 10A	8121-0737
	Switzerland 220V - 10A	8121-0738
	Brazil 110V - 10A	8121-0734
	Argentina 220V - 10A	8121-0729
	North America 110V - 13A	8121-1141
	Israel - Unique cord	8120-8913
Switzerland - Unique cord	8121-0844	
Rest of World - Standard 2-wire RJ-11	8121-0811	

How to use the parts lists and diagrams

The figures in this chapter show the major subassemblies in the product and their component parts. A parts list table follows each exploded view assembly diagram. Each table lists the item number, the associated part number, and the description of each part. If a part is not listed in the table, then it is not a field replacement unit (FRU).

△ **CAUTION:** Be sure to order the correct part. When looking for part numbers for electrical components, pay careful attention to the voltage that is listed in the description column. Doing so will ensure that the part number selected is for the correct model.

📄 **NOTE:** In this manual, the abbreviation “PCA” stands for “printed circuit-board assembly.” Components described as a PCA might consist of a single circuit board or a circuit board plus other parts, such as cables and sensors.

Assembly locations

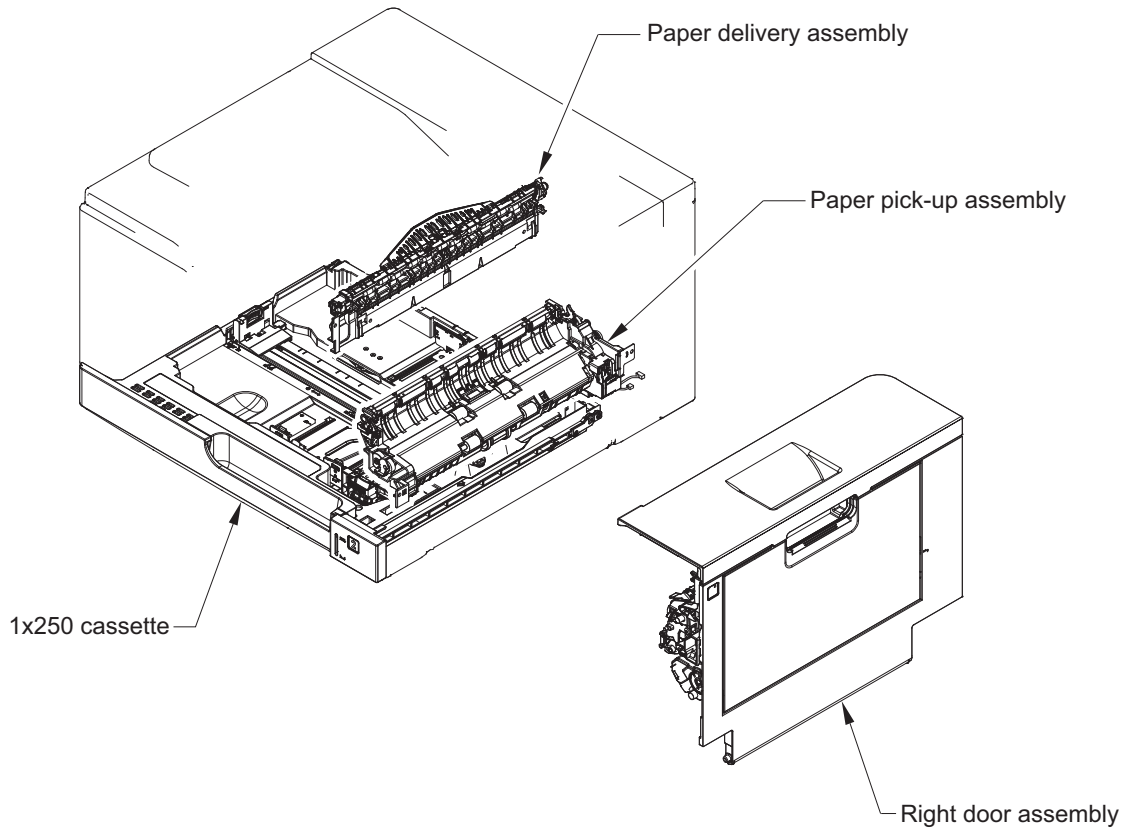

External covers, panels, and doors

Figure 4-1 External covers, panels, and doors

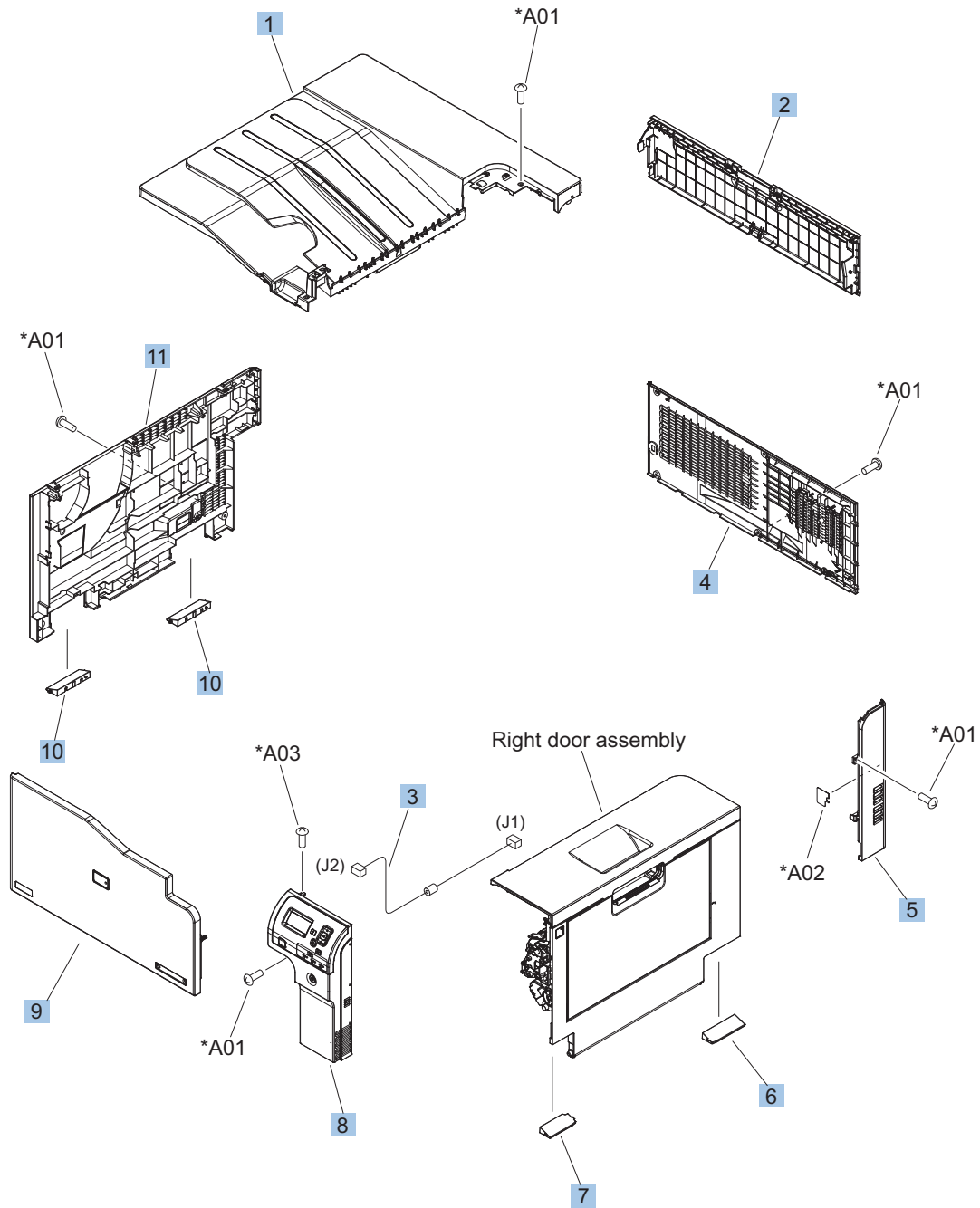

Table 4-5 External covers, panels, and doors

Ref	Description	Part number	Qty
1	Cover, top	RM1-7148-000CN	1
2	Door, toner collection unit access	RC2-7034-000CN	1
3	Cable, USB	RK2-2901-000CN	1
4	Cover, rear	RM1-7147-000CN	1
5	Cover, right rear	RM1-7142-000CN	1
6	Cover, handle, lower-right, rear	RC2-6626-000CN	1
7	Cover, handle, lower-right, front	RC2-6627-000CN	1
8	Cover, right front assembly (includes control panel)	RM1-7144-000CN	1
9	Cover, front assembly	RM1-7133-000CN	1
10	Cover, handle, lower-left	RC2-6625-000CN	2
11	Cover, left assembly	RM1-7143-000CN	1

Right door assembly

Figure 4-2 Right door assembly

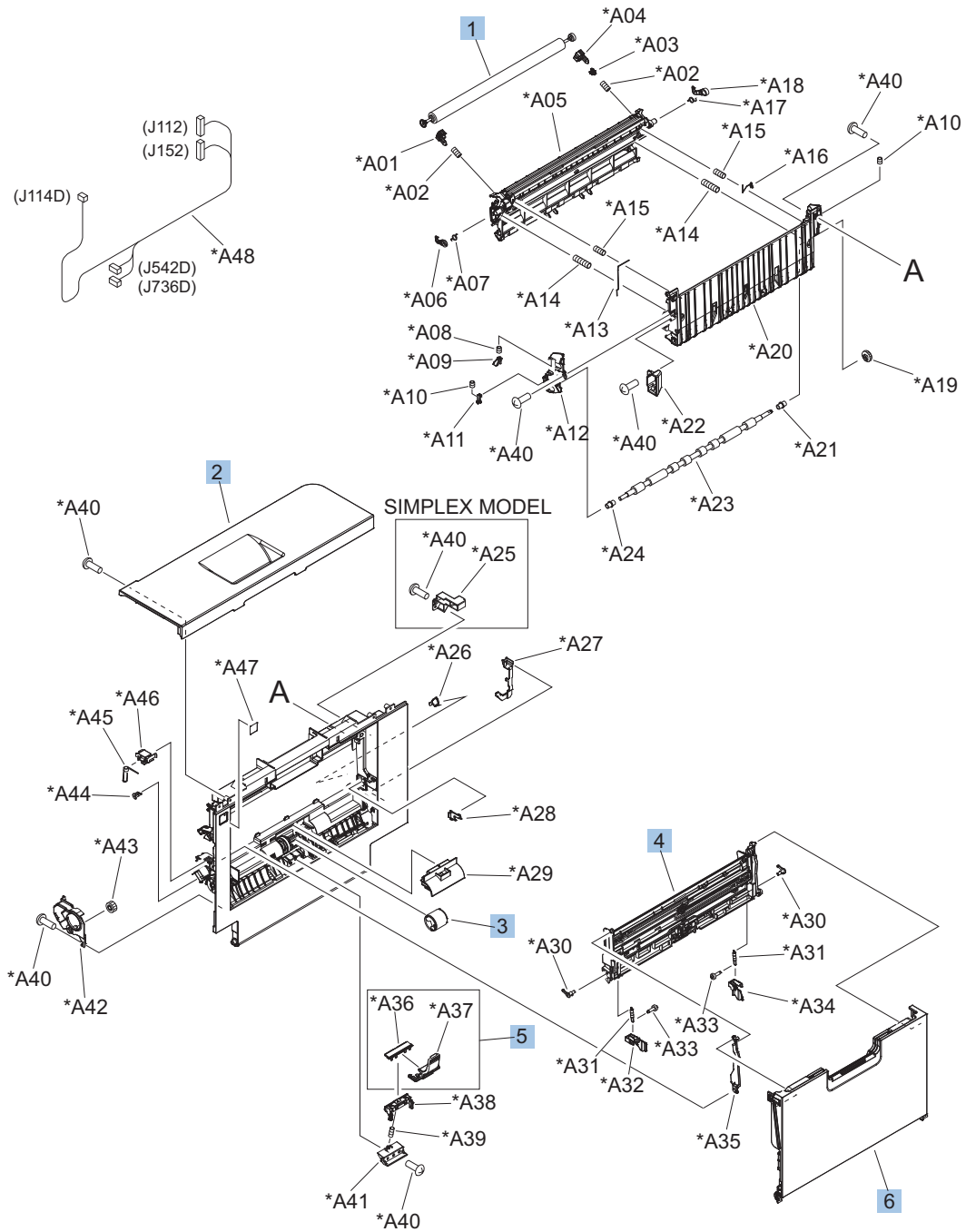

Table 4-6 Right door assembly

Ref	Description	Part number	Qty
	Right door assembly, duplex model	RM1-6007-000CN	1
	Right door assembly, simplex model	RM1-6138-000CN	1
1	Roller, secondary transfer, T2 (included in the service kit)	CE710-67904	1
2	Door, right upper	RC2-7091-000CN	1
3	Roller, paper pick-up, Tray 1 (included in the service kit)	CE710-67906	1
4	Lifter plate assembly, Tray 1	RM1-6043-030CN	1
5	Separation pad, Tray 1 (included in the service kit)	CE710-67909	1
6	Tray 1 (MP tray) assembly	RM1-6045-000CN	1

Internal components (1 of 9)

Figure 4-3 Internal components (1 of 9)

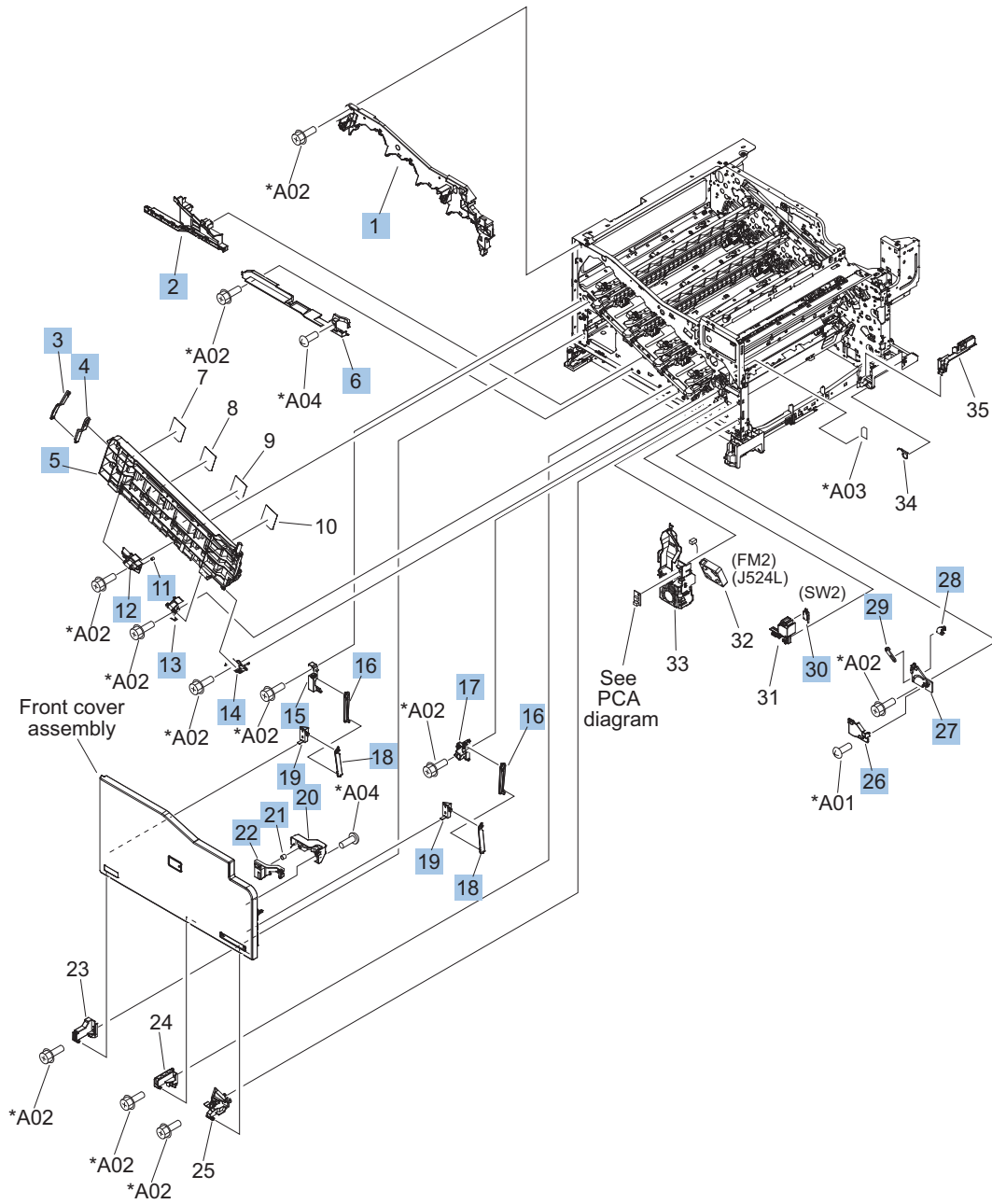

Table 4-7 Internal components (1 of 9)

Ref	Description	Part number	Qty
1	Upper cartridge guide assembly	RM1-5990-000CN	1
2	Duct, front	RC2-7300-000CN	1
3	Stopper, inner door, 1	RC2-6719-000CN	1
4	Stopper, inner door, 2	RC2-6736-000CN	1
5	Door, inner, service kit includes all labels	CE707-67904	1
6	Cover, lower front	RC2-6737-000CN	1
11	Spring, grounding	RC2-7209-000CN	1
12	Hinge, inner door, left	RC2-6716-000CN	1
13	Hinge, inner door, right	RC2-6712-000CN	1
14	Rail, cartridge auxiliary	RC2-6724-000CN	1
15	Mount, cover arm, front	RC2-6735-000CN	1
16	Arm, front cover, 1	RC2-6732-000CN	2
17	Mount, inner door toggle	RC2-6717-000CN	1
18	Arm, front cover, 2	RC2-6733-000CN	2
19	Mount, stopper arm	RC2-6745-000CN	2
20	Mount, inner door rail	RC2-6743-000CN	1
21	Spring, compression	RU6-2721-000CN	1
22	Lever, inner door pressure	RC2-6744-000CN	1
23	Hinge, front cover, left	RC2-6713-000CN	1
24	Hinge, front cover, center	RC2-6738-000CN	1
25	Hinge, front cover, right	RC2-6715-000CN	1
26	Cover, guide	RC2-7204-000CN	1
27	Guide, arm, front	RC2-6632-000CN	1
28	Lever, push	RC2-7198-000CN	1
29	Lever, lift, 2	RC2-7200-000CN	1
30	Microswitch	WC4-5251-000CN	1

Internal components (2 of 9)

Figure 4-4 Internal components (2 of 9)

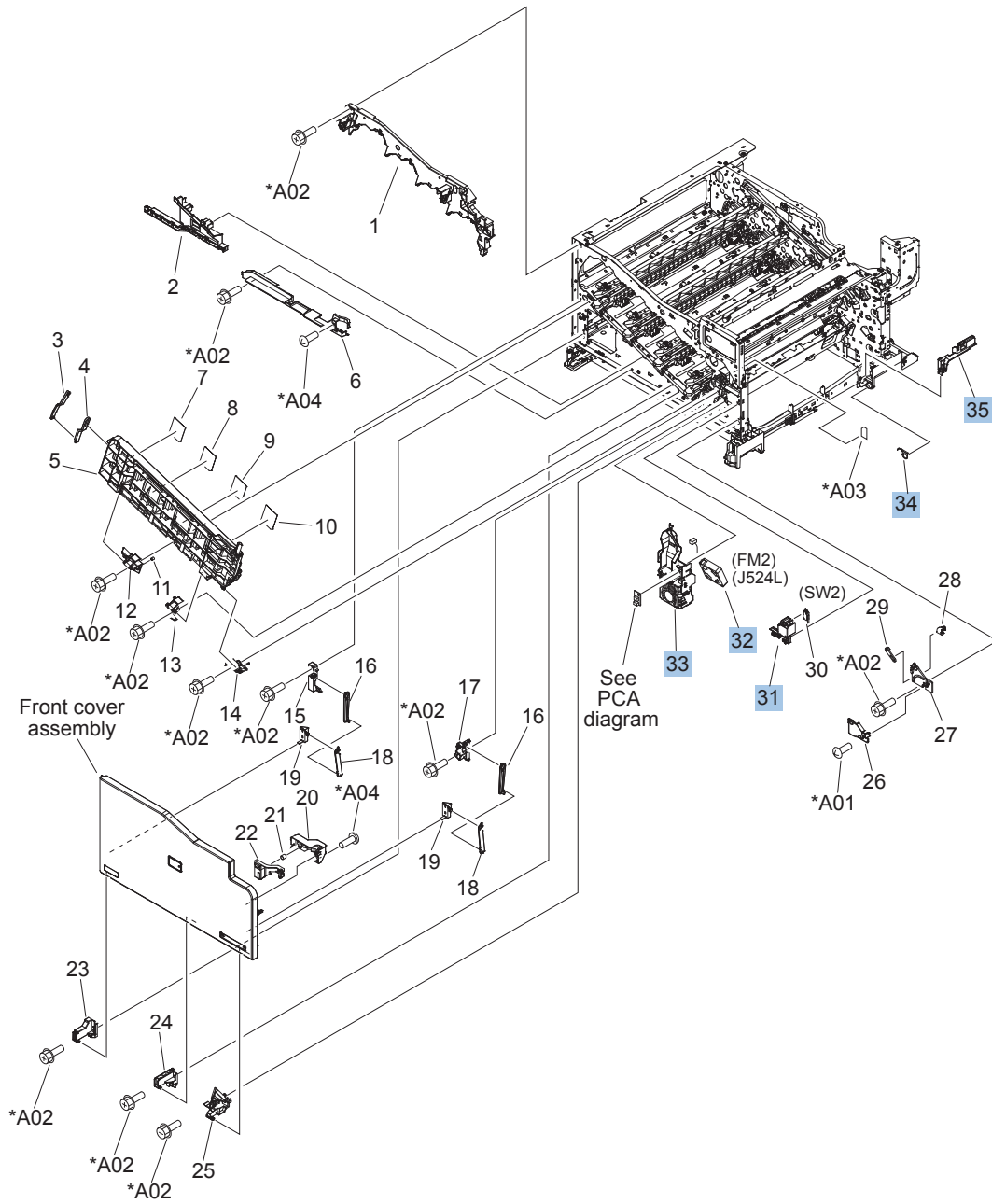

Table 4-8 Internal components (2 of 9)

Ref	Description	Part number	Qty
31	Holder, interlock switch	RC2-6689-000CN	1
32	Fan, fuser	RK2-2728-000CN	1
33	Holder, duplexing fan	RC2-8357-000CN	1
34	Spring, leaf, grounding	RC2-7092-000CN	1
35	Cover, handle guide	RC2-6670-000CN	1

Internal components (3 of 9)

Figure 4-5 Internal components (3 of 9)

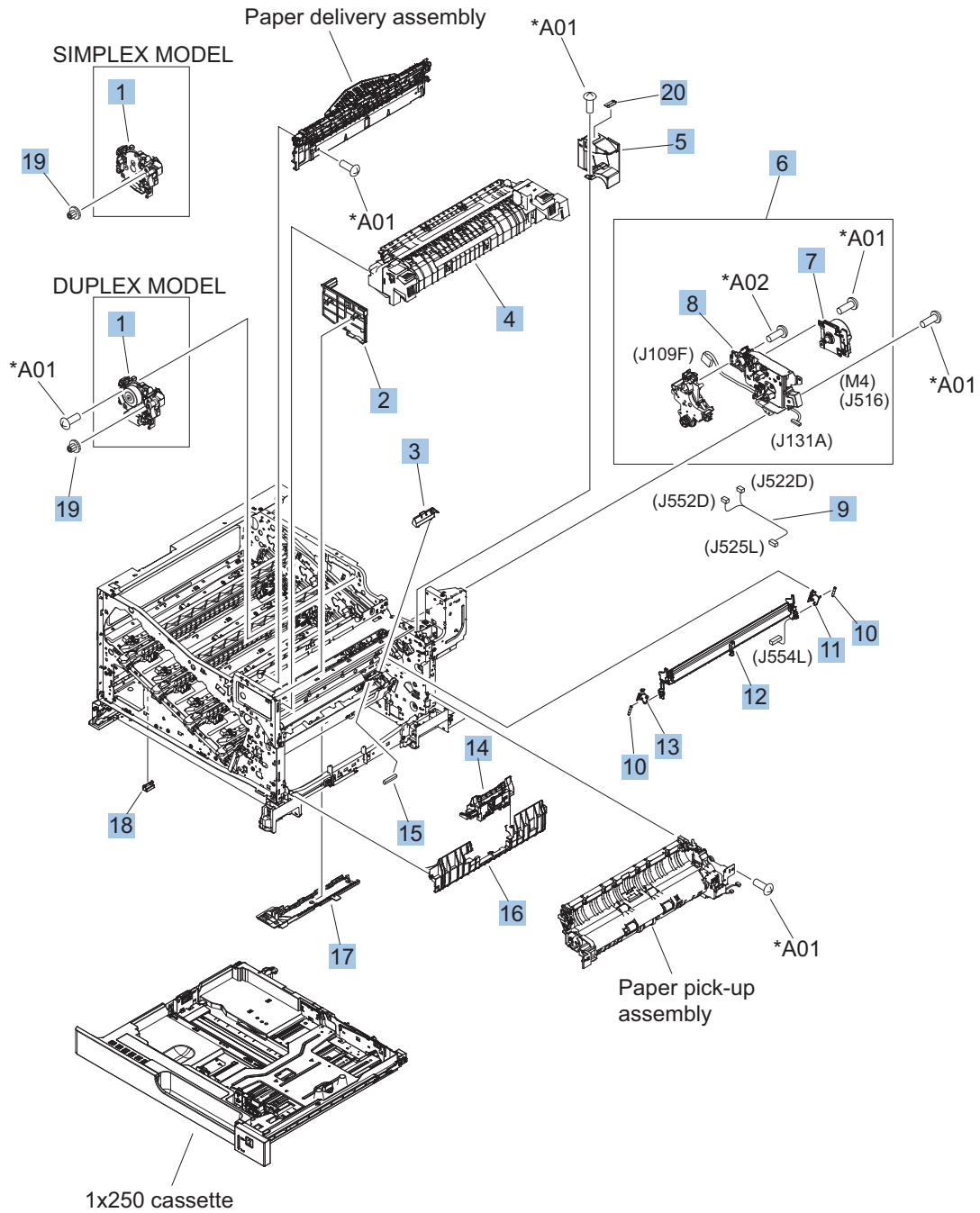

Table 4-9 Internal components (3 of 9)

Ref	Description	Part number	Qty
1	Drive assembly, duplex reverse, duplex model	RM1-6005-000CN	1
1	Drive assembly, simplex reverse, simplex model	RM1-6120-000CN	1
2	Guide, fuser, front	RC2-6546-000CN	1
3	Cover, cable, protective	RC2-6832-000CN	1
4	Fuser assembly, 110V (included in service kit)	RM1-6180-000CN	1
4	Fuser assembly, 220V (included in service kit)	RM1-6181-000CN	1
5	Guide, fuser, rear	RC2-6547-000CN	1
6	Fuser drive assembly	CE707-67904	1
7	Fuser motor assembly	RM1-6074-000CN	1
8	Gear assembly, fuser	RM1-7914-060CN	1
9	Cable, SB joint, low-voltage power supply, duplex model	RM1-6867-000CN	1
10	Spring, tension, registration sensor	RU6-2710-000CN	2
11	Support, frame, rear	RC2-7197-000CN	1
12	Registration sensor assembly	RM1-7922-000CN	1
13	Support, frame, front	RC2-7196-000CN	1
14	Separation roller assembly (included in service kit)	CE710-67907	1
15	Connector, snap tight, black	VS1-7207-019CN	1
16	Guide, paper feed	RC2-7297-000CN	1
17	Sensor, cassette last paper presence	RM1-6164-000CN	1
18	Cover, connector, lower	RC2-6642-000CN	1
19	Gear, 18T/29T	RU6-0775-000CN	1
20	Label, fuser insert	RU6-8042-000CN	1

Internal components (4 of 9)

Figure 4-6 Internal components (4 of 9)

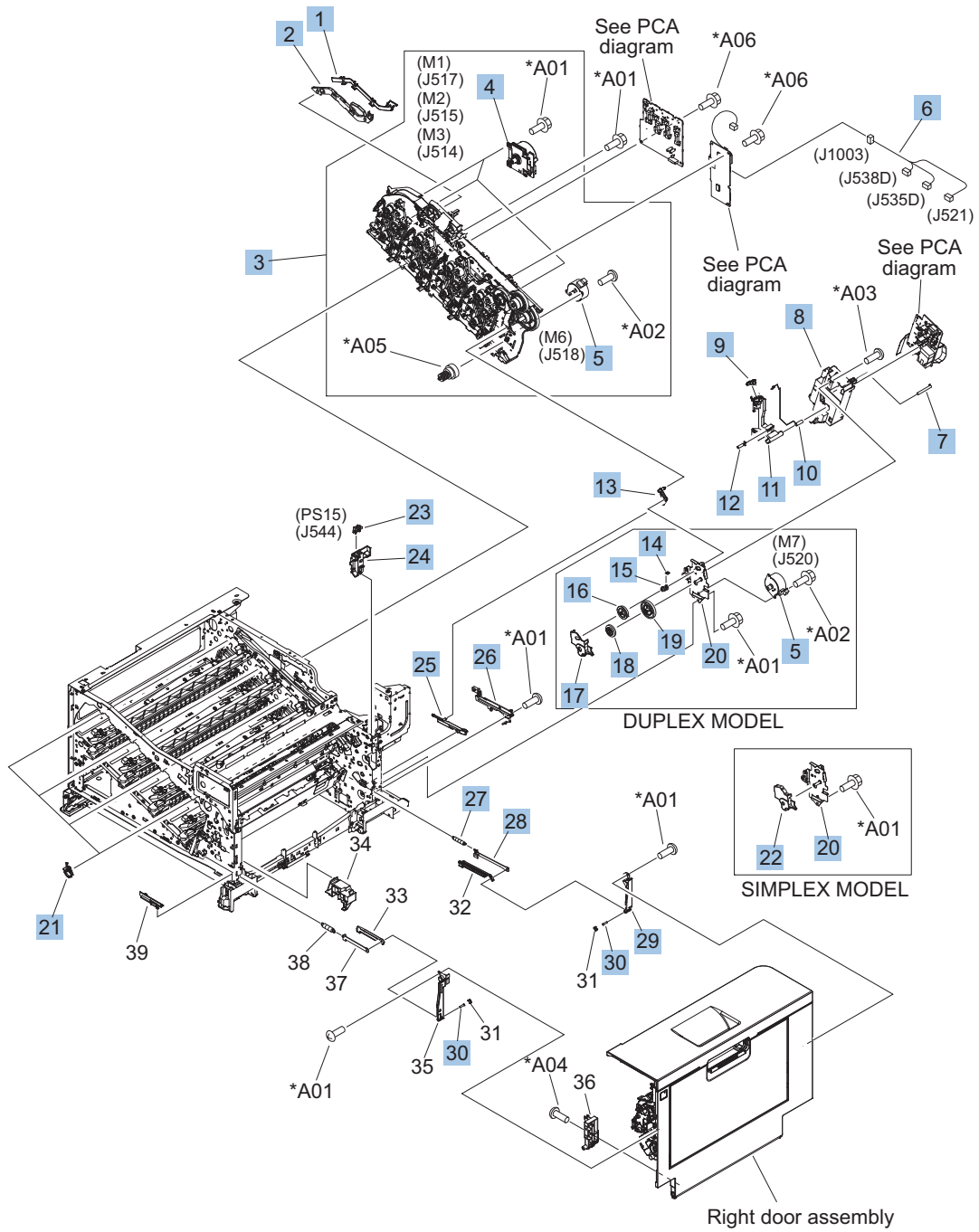

Table 4-10 Internal components (4 of 9)

Ref	Description	Part number	Qty
1	Cover, main drive cable, lower	RC2-6574-000CN	1
2	Guide, main drive cable	RC2-6659-000CN	1
3	Main drive assembly, duplex model	RM1-7931-000CN	1
3	Main drive assembly, simplex model	RM1-6173-000CN	1
4	DC motor assembly	RM1-6088-000CN	3
5	Motor, stepping, DC, duplex model	RK2-3298-000CN	2
5	Motor, stepping, DC, simplex model	RK2-3298-000CN	1
6	Cable, feed joint, duplex model	RM1-6846-000CN	1
7	Spring, grounding, second-transfer high-voltage PCA	RU6-2772-000CN	1
8	Holder, secondary transfer HVT	RC2-6681-010CN	1
9	Cap, T2 contact, second-transfer high-voltage PCA	RC2-6691-000CN	1
10	Spring, contact, second-transfer high-voltage PCA	RU6-2771-000CN	1
11	Holder, secondary transfer, power dispatching	RC2-6682-000CN	1
12	Spring, grounding, second-transfer high-voltage PCA	RC2-6700-000CN	1
13	Link, ITB coupling release	RC2-6823-000CN	1
14	Spring, tension, duplex model	RU6-2671-000CN	1
15	Hook, duplexing spring, duplex model	RC2-6932-000CN	1
16	Gear, 25T, duplex model	RU6-0771-000CN	1
17	Cover, duplexing gear, duplex model	RC2-6931-000CN	1
18	Gear, 25T, duplex model	RU6-0772-000CN	1
19	Gear, 74T, duplex model	RU6-0773-000CN	1
20	Plate, duplexing drive gear	RL1-2266-000CN	1
21	Support, developing coupling	RC2-6811-000CN	4
22	Cover, gear, simplex model	RC3-0688-000CN	1
23	Sensor, right door	WG8-5696-000CN	1
24	Holder, door sensor, right	RC2-6645-000CN	1
25	Arm, ITB coupling release	RC2-6824-000CN	1
26	Rail, door link, rear lower	RC2-6635-000CN	1
27	Spring, tension, rear	RU6-2744-000CN	1
28	Plate, right door link, rear	RC2-7273-000CN	1
29	Plate, right door link, fixed, rear	RL1-2282-000CN	1
30	Shaft, right door link	RU5-4979-000CN	2

Internal components (5 of 9)

Figure 4-7 Internal components (5 of 9)

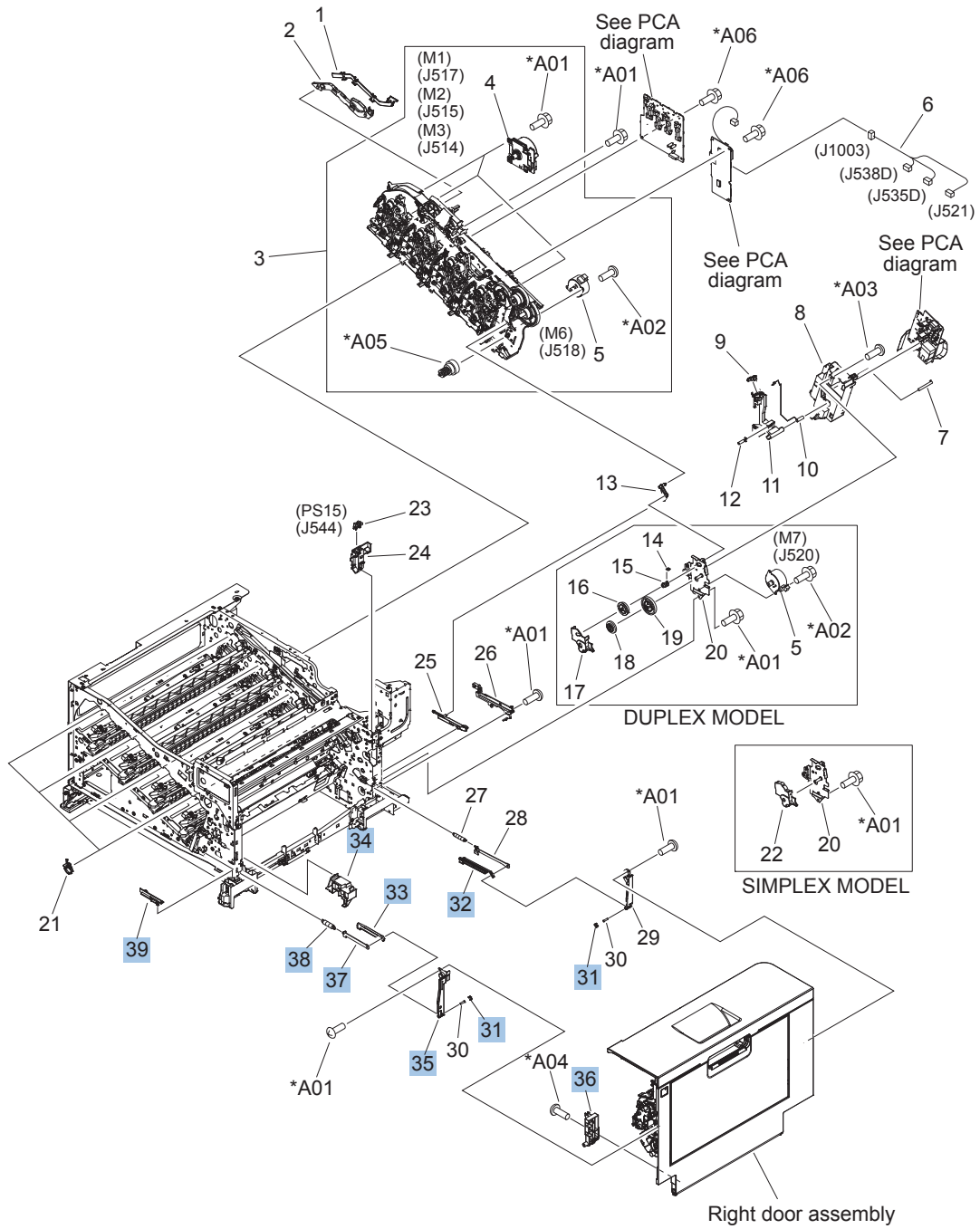

Table 4-11 Internal components (5 of 9)

Ref	Description	Part number	Qty
31	Lock, door link, right	RC2-7234-000CN	2
32	Link, right door, 2 rear	RC2-7236-000CN	1
33	Link, right door, 2 front	RC2-7233-000CN	1
34	Duct, joint	RC2-8360-000CN	1
35	Plate, right door link, fixed, front	RL1-2281-000CN	1
36	Hinge, right door, front	RC2-7094-000CN	1
37	Plate, right door link, front	RC2-7272-000CN	1
38	Spring, tension, front	RU6-2727-000CN	1
39	Rail, door link, front lower	RC2-6634-000CN	1

Internal components (6 of 9)

Figure 4-8 Internal components (6 of 9)

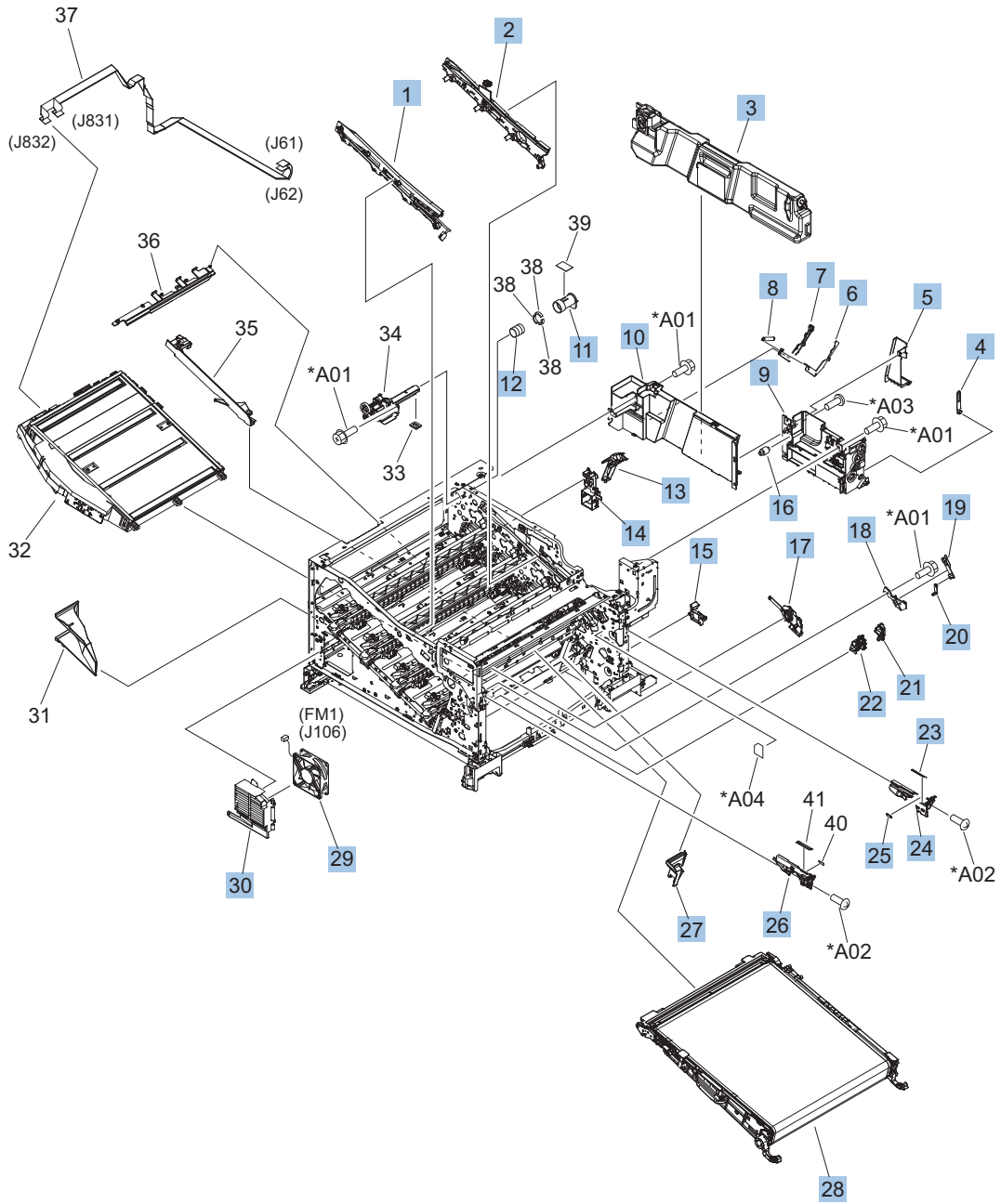

Table 4-12 Internal components (6 of 9)

Ref	Description	Part number	Qty
1	IT belt guide rail assembly	RM1-6018-000CN	1
2	IT belt guide rail R1 assembly	RM1-6037-000CN	1
3	Toner collection unit (included in the service kit)	CE980-67901	1
4	Arm, waste toner, left	RC2-7035-000CN	1
5	Cover, waste toner, 3	RC2-6963-000CN	1
6	Plate, arm reinforcement	RC2-9649-000CN	1
7	Arm, waste toner, right	RC2-7036-000CN	1
8	Spring, tension	RU6-2831-000CN	1
9	Waste toner cover assembly	RM1-6012-000CN	1
10	Cover, waste toner, 2	RC2-6962-000CN	1
11	Shutter, exhaust	RC2-7010-000CN	1
12	Spring, compression	RU6-2683-000CN	1
13	Guide, fuser AC cable	RC2-6693-000CN	1
14	Guide, LVT cable	RC2-6662-000CN	1
15	Clamp, edge	RC2-6663-000CN	1
16	Gear, link worm	RU6-0795-000CN	1
17	ITB guide rail assembly	RM1-6019-000CN	1
18	Guide, slide	RC2-7203-000CN	1
19	Slider, push	RC2-7201-000CN	1
20	Lever, lift, 1	RC2-7199-000CN	1
21	Cover, main cross-member cable	RC2-6650-000CN	1
22	Guide, main cross-member cable	RC2-6600-000CN	1
23	Label, ITB set, RH	RU5-8807-000CN	1
24	Rail, ITB guide	RC2-7185-000CN	1
25	Label, ITB, RV	RU5-8805-000CN	1
26	Rail, ITB guide, F3	RC2-7193-000CN	1
27	Guide, inside cable	RC2-6589-000CN	1
28	ITB assembly (included in the service kit; includes transfer roller)	CE710-67903	1
29	Fan, power supply	RK2-2276-000CN	1
30	Holder, power supply fan	RC2-7299-000CN	1

Internal components (7 of 9)

Figure 4-9 Internal components (7 of 9)

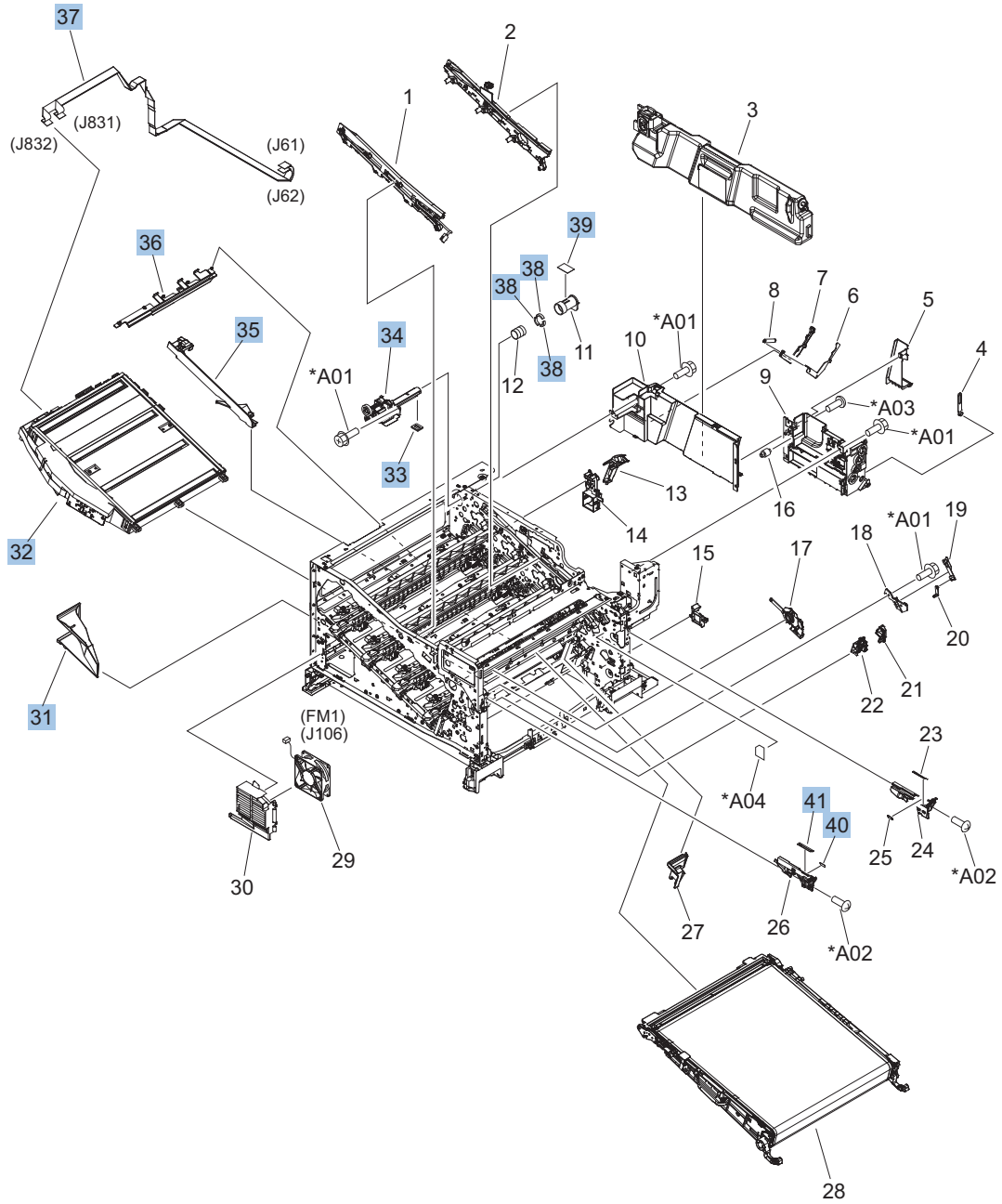

Table 4-13 Internal components (7 of 9)

Ref	Description	Part number	Qty
31	Duct, fan, 1	RC2-8388-000CN	1
32	Laser scanner assembly	RM1-6122-070CN	1
33	Seal, toner supporter guide 1	RC2-7018-000CN	1
34	Toner feed assembly	RM1-6040-000CN	1
35	Guide, laser	RC2-6628-000CN	1
36	Holder, flat flexible cable	RC2-6655-000CN	1
37	Cable assembly, flat-flexible	RM1-6804-000CN	1
38	Seal, slide shutter	RC3-1014-000CN	3
39	Sheet, slide seal	RC3-1013-000CN	1
40	Label, ITB insert, FV	RU5-8804-000CN	1
41	Label, ITB insert, FH	RU5-8806-000CN	1

Internal components (8 of 9)

Figure 4-10 Internal components (8 of 9)

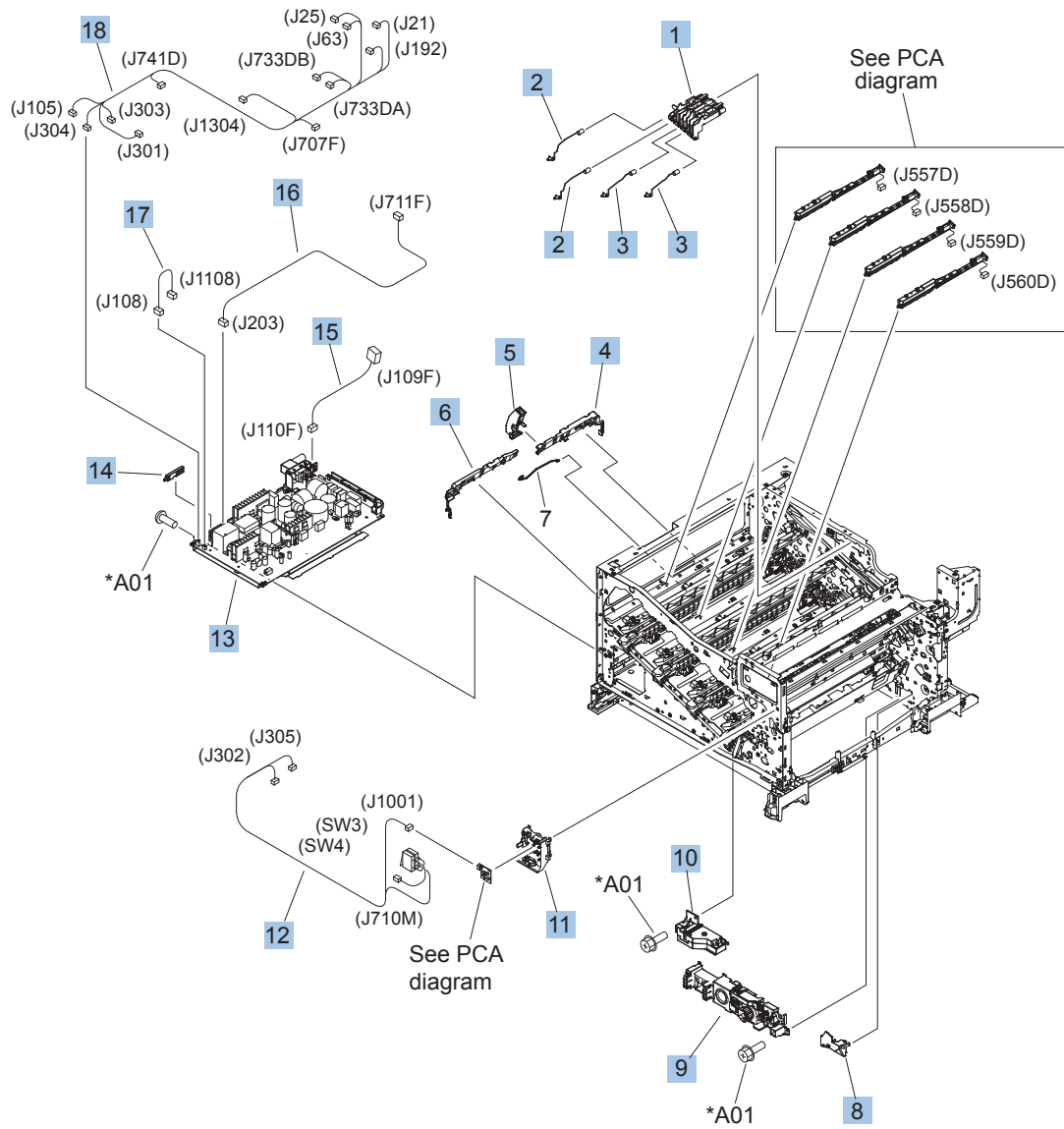

Table 4-14 Internal components (8 of 9)

Ref	Description	Part number	Qty
1	Holder, first power dispatching	RC2-6680-000CN	1
2	Spring, contact	RU6-2767-000CN	2
3	Spring, contact	RU6-2768-000CN	2
4	Guide, cross-member cable, rear	RC2-6588-000CN	1
5	Stopper, laser	RC2-6646-000CN	1
6	Guide, cross-member cable, front	RC2-6587-000CN	1
7	Spring, rod	RC2-6611-000CN	1
8	Cover, cable, right rear	RC2-8424-000CN	1
9	Lifter drive assembly	RM1-6039-000CN	1
10	Auto close assembly	RM1-6036-000CN	1
11	Holder, switch	RC2-6666-000CN	1
12	Cable, switch	RM1-6830-000CN	1
13	Low voltage power supply assembly, 110V	RM1-6753-000CN	1
13	Low voltage power supply assembly, 220V	RM1-6754-000CN	1
14	Guide, cable	RC3-0684-000CN	1
15	Cable, low-voltage AC joint	RM1-6811-000CN	1
16	Cable, low-voltage power supply	RM1-6807-000CN	1
17	Cable, low-voltage power supply, test	RM1-6813-000CN	1
18	Cable, left, high-voltage power supply to low-voltage power supply	RM1-6833-000CN	1

Internal components (9 of 9)

Figure 4-11 Internal components (9 of 9)

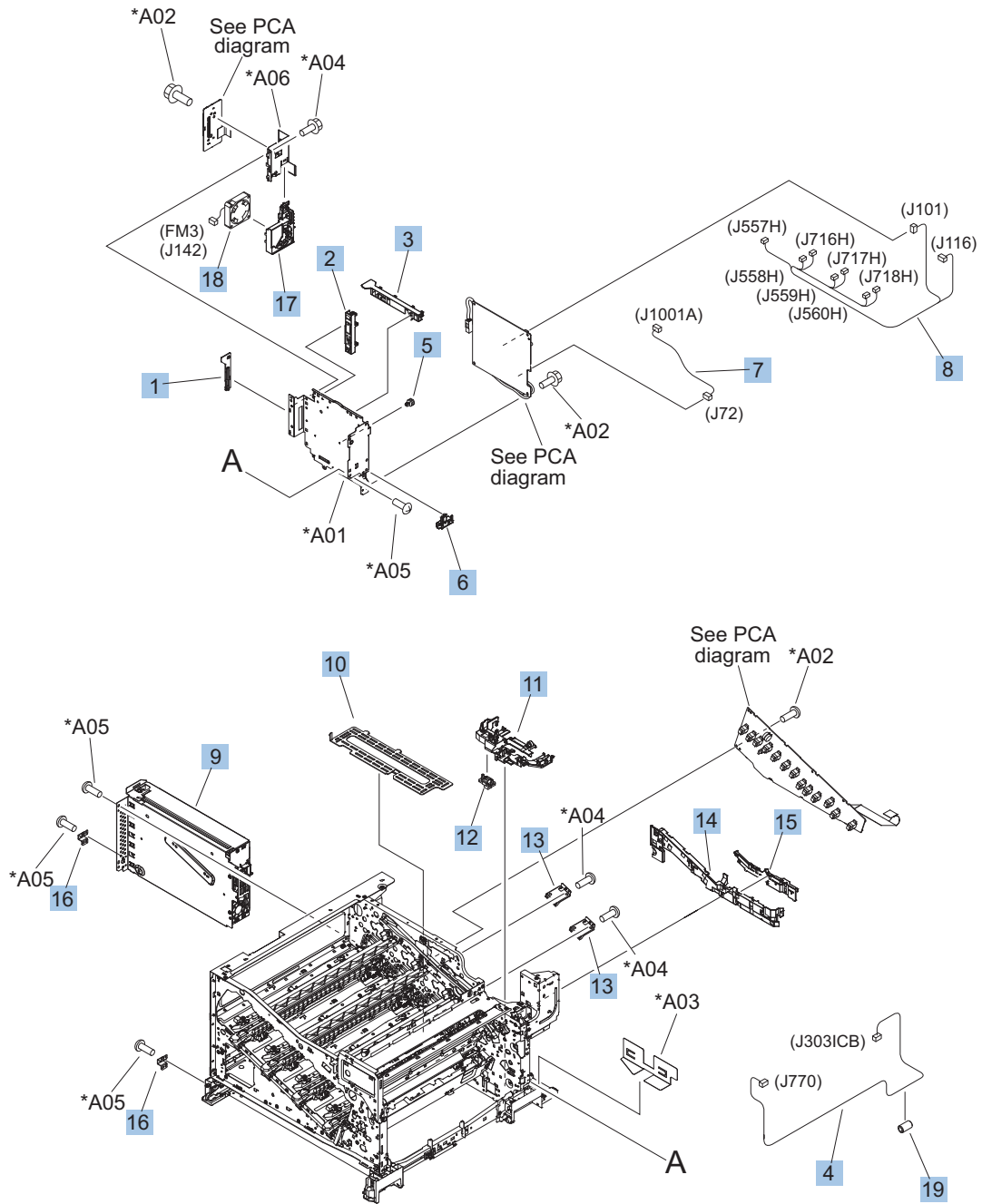

Table 4-15 Internal components (9 of 9)

Ref	Description	Part number	Qty
1	Clamp, edge, D	RC2-6674-000CN	1
2	Guide, cable, right	RC2-6842-000CN	1
3	Guide, cable, upper	RC2-6841-000CN	1
4	Cable, PNL-H-HI	RM1-6849-000CN	1
5	Spacer, DC controller PCA	VT2-5176-004CN	5
6	Guide, DC cont. support cable	RC2-6665-000CN	1
7	Cable, primary transfer	RM1-6822-000CN	1
8	Cable, rear	RM1-6863-000CN	1
9	Formatter case	RM1-6065-000CN	1
10	Plate, FFC protective	RC2-9687-000CN	1
11	Holder, paper pick-up connector	RC2-6638-000CN	1
12	Connector, 8-pin, paper-pick-up	VS1-7514-008CN	1
13	Plate, box pillar	RC2-6673-000CN	2
14	Guide, imaging HVT cable	RC2-6661-000CN	1
15	Cover, imaging HVT cable	RC2-6573-000CN	1
16	Cross-member, cover, left	RC2-6760-000CN	2
17	Holder, formatter fan	RC2-6648-000CN	1
18	Fan, formatter	RK2-3301-000CN	1
19	Core, ring	WE8-6639-000CN	1

1x250 cassette

Figure 4-12 1x250 cassette

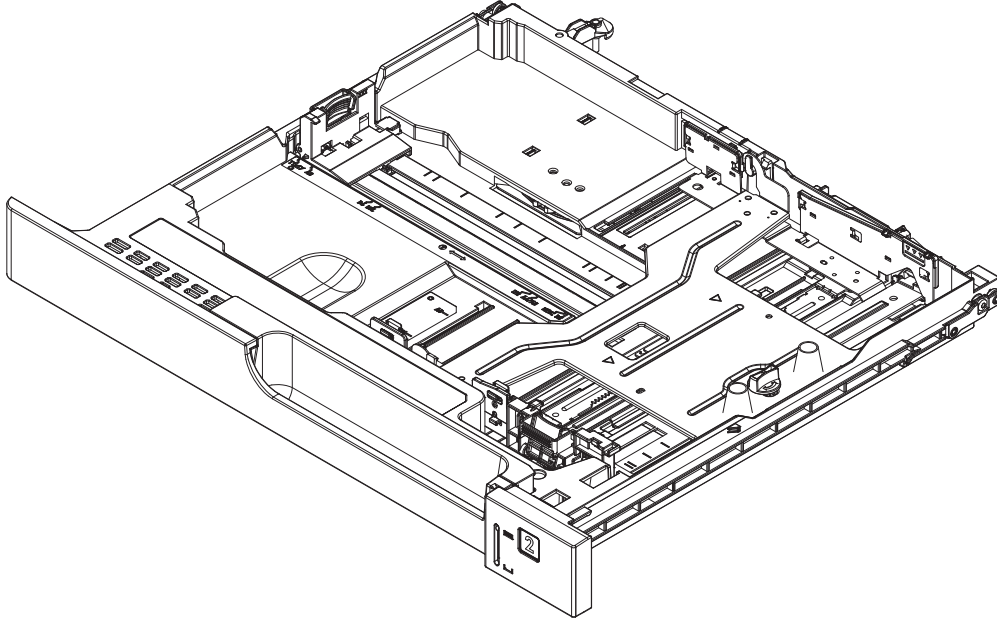

Table 4-16 1x250 cassette

Ref	Description	Part number	Qty
	Cassette	CE710-67906	1

Paper pick-up assembly

Figure 4-13 Paper pick-up assembly

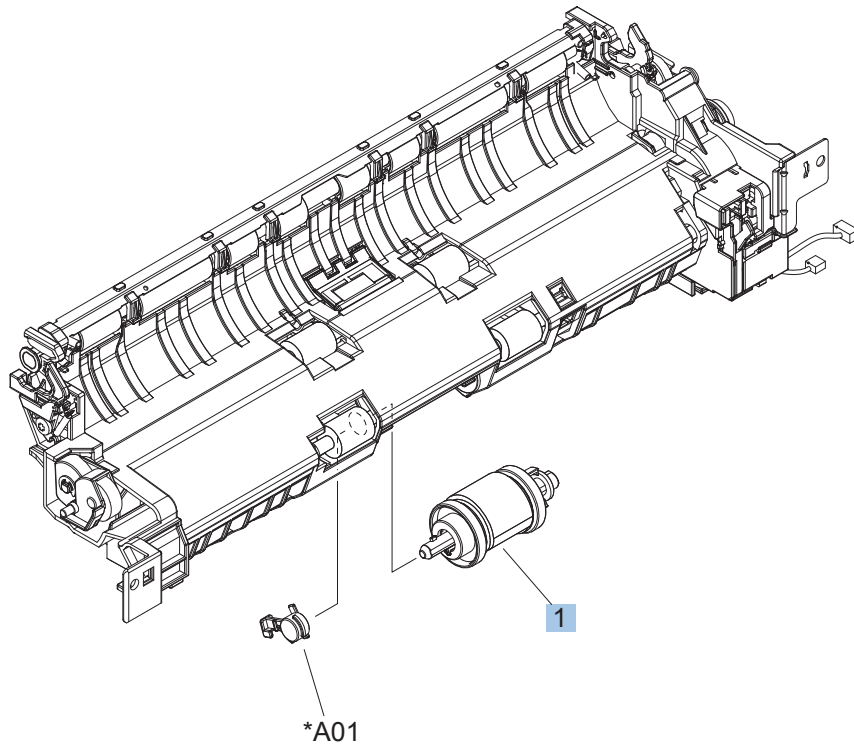

Table 4-17 Paper pick-up assembly

Ref	Description	Part number	Qty
	Paper pick-up assembly	RM1-7916-000CN	1
1	Paper pick-up roller assembly (included in service kit)	CE707-67903	1

Paper delivery assembly

Figure 4-14 Paper delivery assembly

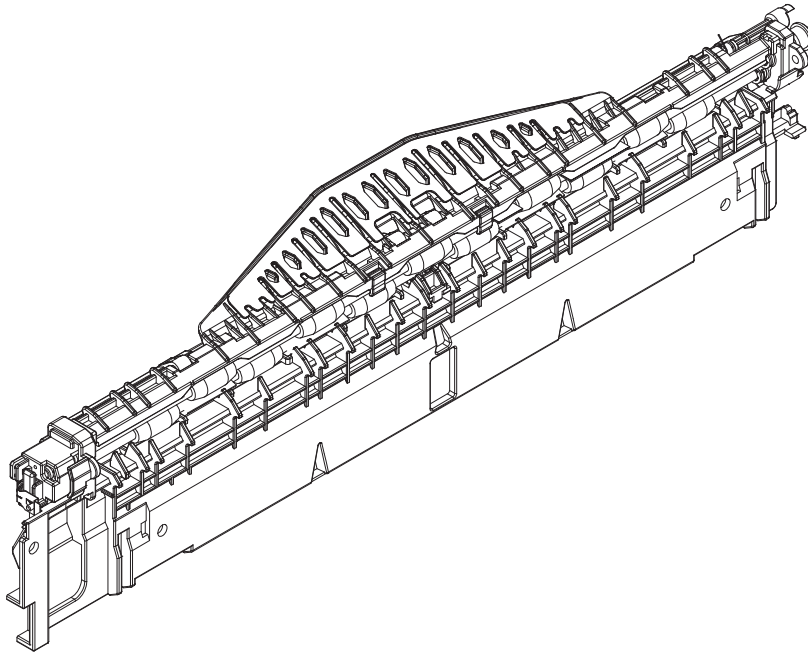

Table 4-18 Paper delivery assembly

Ref	Description	Part number	Qty
	Paper delivery assembly	RM1-6165-000CN	1

Printed circuit assemblies

Figure 4-15 PCAs

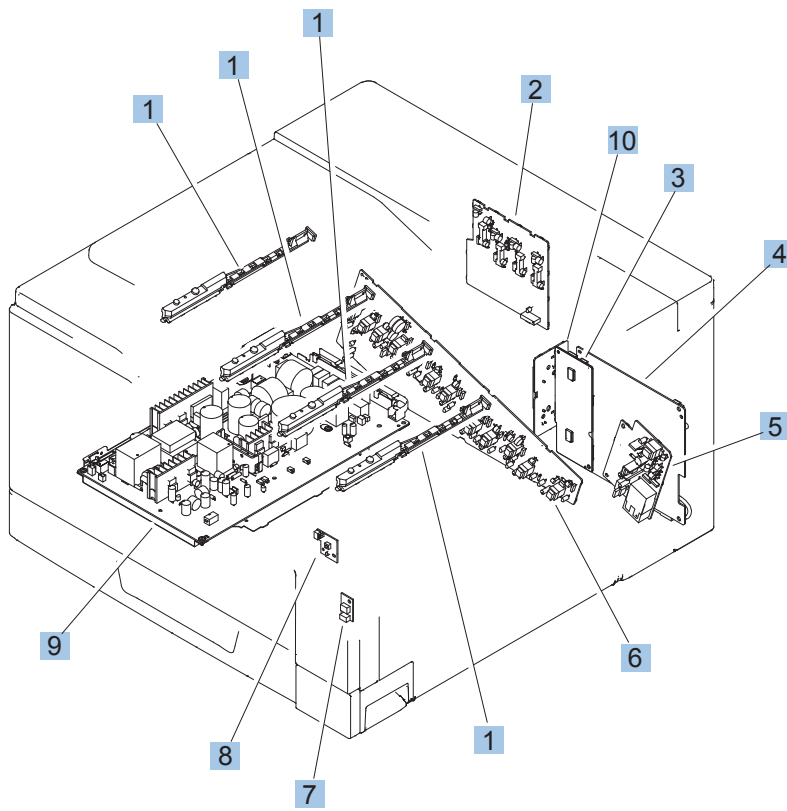

Table 4-19 PCAs

Ref	Description	Part number	Qty
1	Toner remaining detect PCA	RM1-6779-000CN	4
2	Primary transfer high-voltage PCA	RM1-7004-000CN	1
3	Driver PCA (duplex model)	RM1-6742-000CN	1
3	Driver PCA (simplex model)	RM1-6783-000CN	1
4	DC Controller PCA (duplex model)	CE708-67902	1
4	DC Controller PCA (simplex model)	CE707-67906	1
5	Secondary transfer high-voltage PCA	RM1-6802-000CN	1
6	Imaging high-voltage PCA	RM1-6800-000CN	1
7	Environment sensor PCA	RK2-2884-000CN	1
8	Power switch PCA	RM1-6759-000CN	1
9	Low-voltage power supply PCA (110V)	RM1-6753-000CN	1
9	Low-voltage power supply PCA (220V)	RM1-6754-000CN	1
Not shown	Formatter PCA	CE707-69001	1
10	Inter connect board (ICB) PCA	CE707-67907	1

1x500 paper feeder

The 1x500 paper feeder is referred to as the 1x500PF.

1x500PF external components

Figure 4-16 1x500PF external components

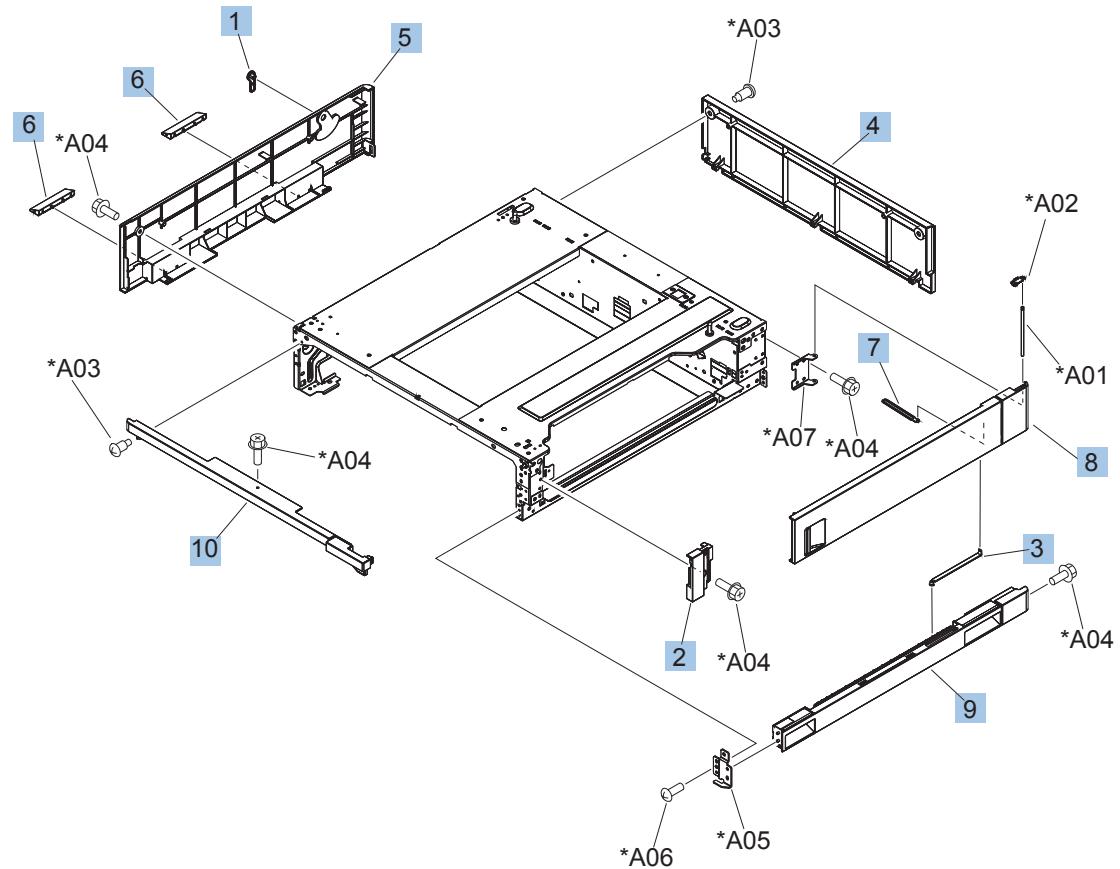

Table 4-20 1x500PF external components

Ref	Description	Part number	Qty
1	Handle, lock, rear (1x500PF)	RC2-9303-000CN	1
2	Cover, right front (1x500PF)	RC2-9320-000CN	1
3	Link, right door, lower (1x500PF)	RC2-9327-000CN	1
4	Cover, rear (1x500PF)	RC2-9330-000CN	1
5	Cover, left (1x500PF)	RC2-9331-000CN	1
6	Cover, handle, lower (1x500PF)	RC2-9332-000CN	2
7	Link, right door, upper (1x500PF)	RC2-9335-000CN	1
8	Right door assembly (1x500PF)	RM1-6946-000CN	1
9	Cover, right lower assembly (1x500PF)	RM1-6948-000CN	1
10	Cover, upper front assembly (1x500PF)	RM1-6949-000CN	1

1x500PF internal components

Figure 4-17 1x500PF internal components

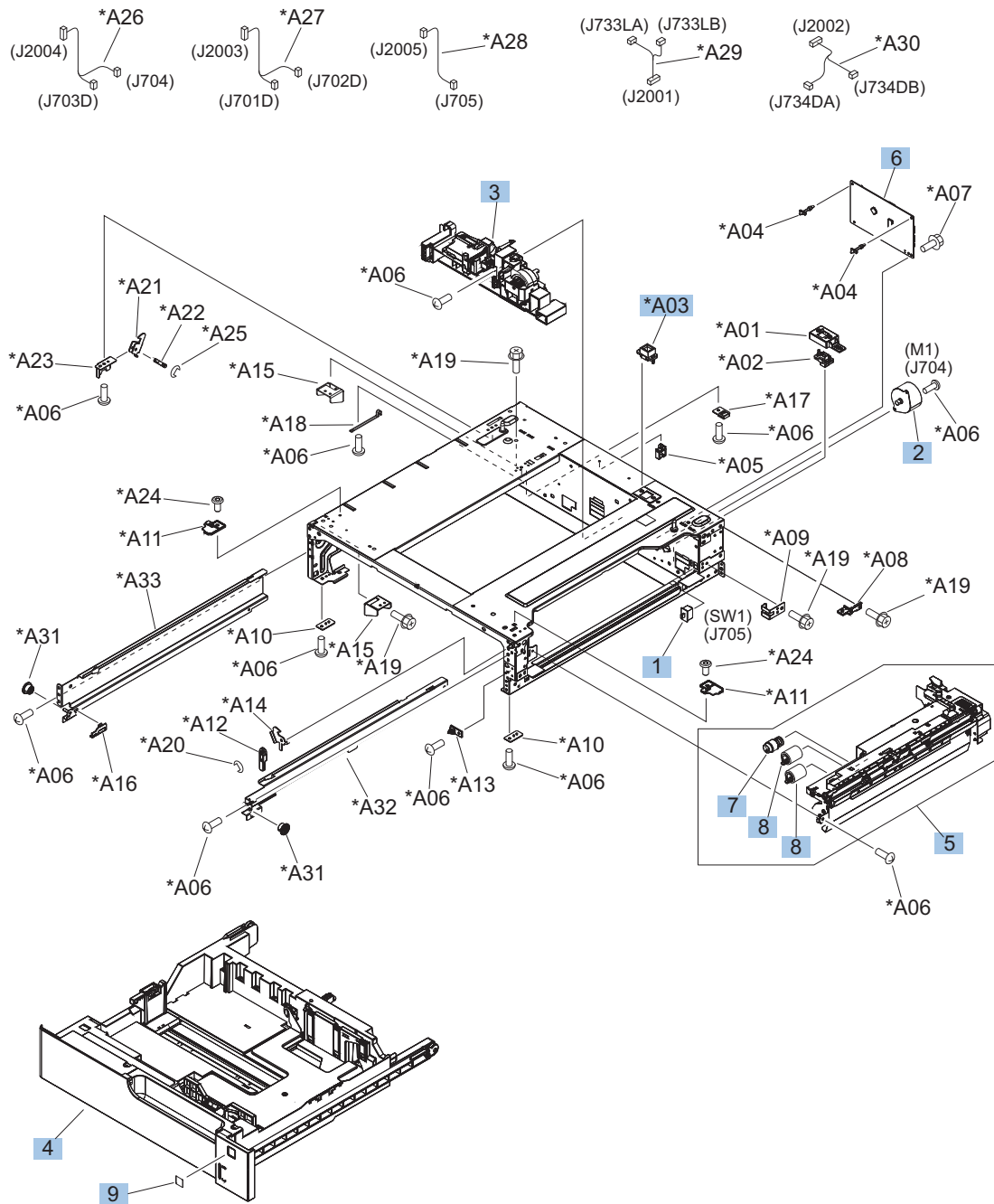

Table 4-21 1x500PF internal components

Ref	Description	Part number	Qty
1	Switch, bottom (1x500PF)	WC2-5512-000CN	1
2	Motor, pick-up (1x500PF)	RK2-1331-000CN	1
3	Lifter drive assembly (1x500PF)	RM1-3819-000CN	1
4	Cassette (1x500PF)	RM1-6942-000CN	1
5	Paper pick-up assembly (1x500PF)	RM1-6944-000CN	1
6	Paper feeder driver PCA (1x500PF)	RM1-6987-000CN	1
7	Roller, pick-up, paper feeder (included in service kit)	CE710-67908	1
8	Roller, feed, paper feeder (included in service kit)	CE710-67908	2
9	Label, cassette number (1x500PF)	RC2-9363-000CN	1
A03	Connector, 8P (1x500PF)	VS1-7514-008CN	1

1x500PF PCA

Figure 4-18 1x500PF PCA

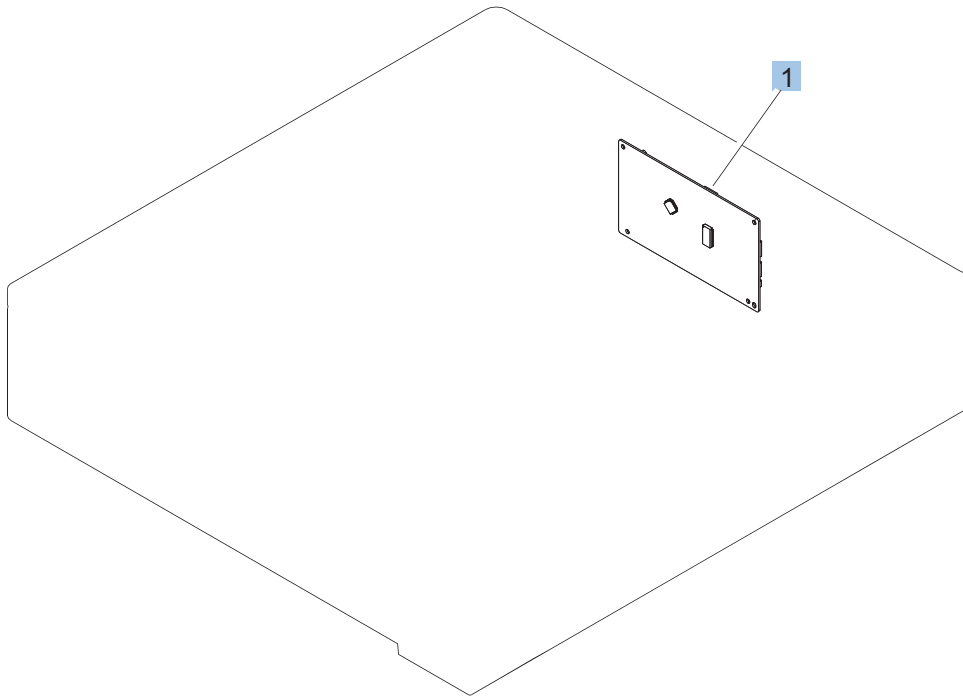

Table 4-22 1x500PF PCA

Ref	Description	Part number	Qty
1	Paper feeder driver PCA (1x500PF)	RM1-6987-000CN	1

3x500 paper feeder

The 3x500 paper feeder is referred to as the 3x500PF.

3x500PF external components

Figure 4-19 3x500PF external components

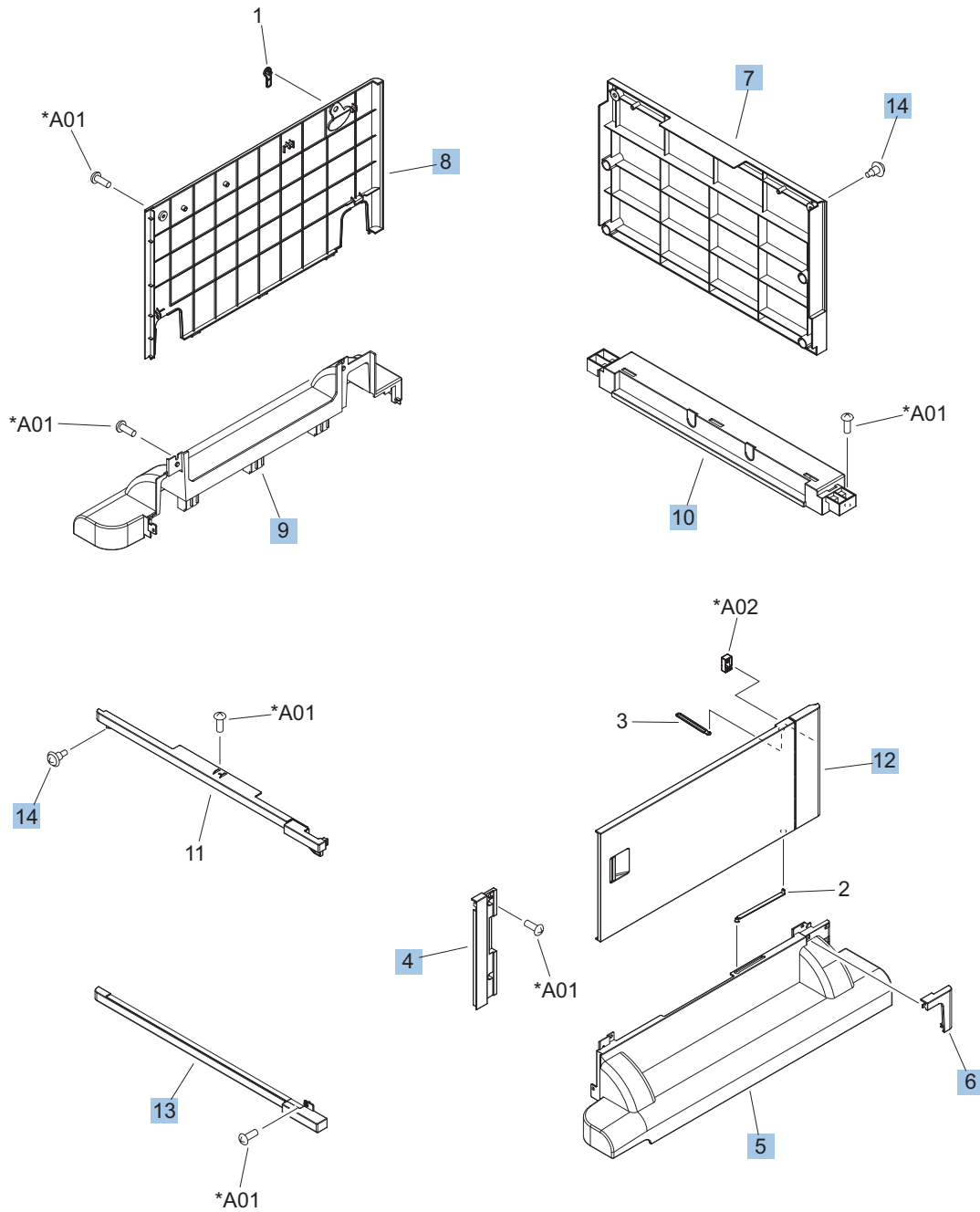

Table 4-23 3x500PF external components

Ref	Description	Part number	Qty
4	Cover, right corner (3x500PF)	RC2-9343-000CN	1
5	Cover, right lower, 1 (3x500PF)	RC2-9346-000CN	1
6	Cover, right lower, 2 (3x500PF)	RC2-9347-000CN	1
7	Cover, rear (3x500PF)	RC2-9348-000CN	1
8	Cover, left (3x500PF)	RC2-9349-000CN	1
9	Cover, left lower (3x500PF)	RC2-9350-000CN	1
10	Cover, rear lower (3x500PF)	RC2-9357-000CN	1
12	Right door assembly (3x500PF)	RM1-6953-000CN	1
13	Front lower cover assembly (3x500PF)	RM1-6958-000CN	1
14	Screw, stepped (3x500PF)	RS5-9099-000CN	3

3x500PF internal components

Figure 4-20 3x500PF internal components

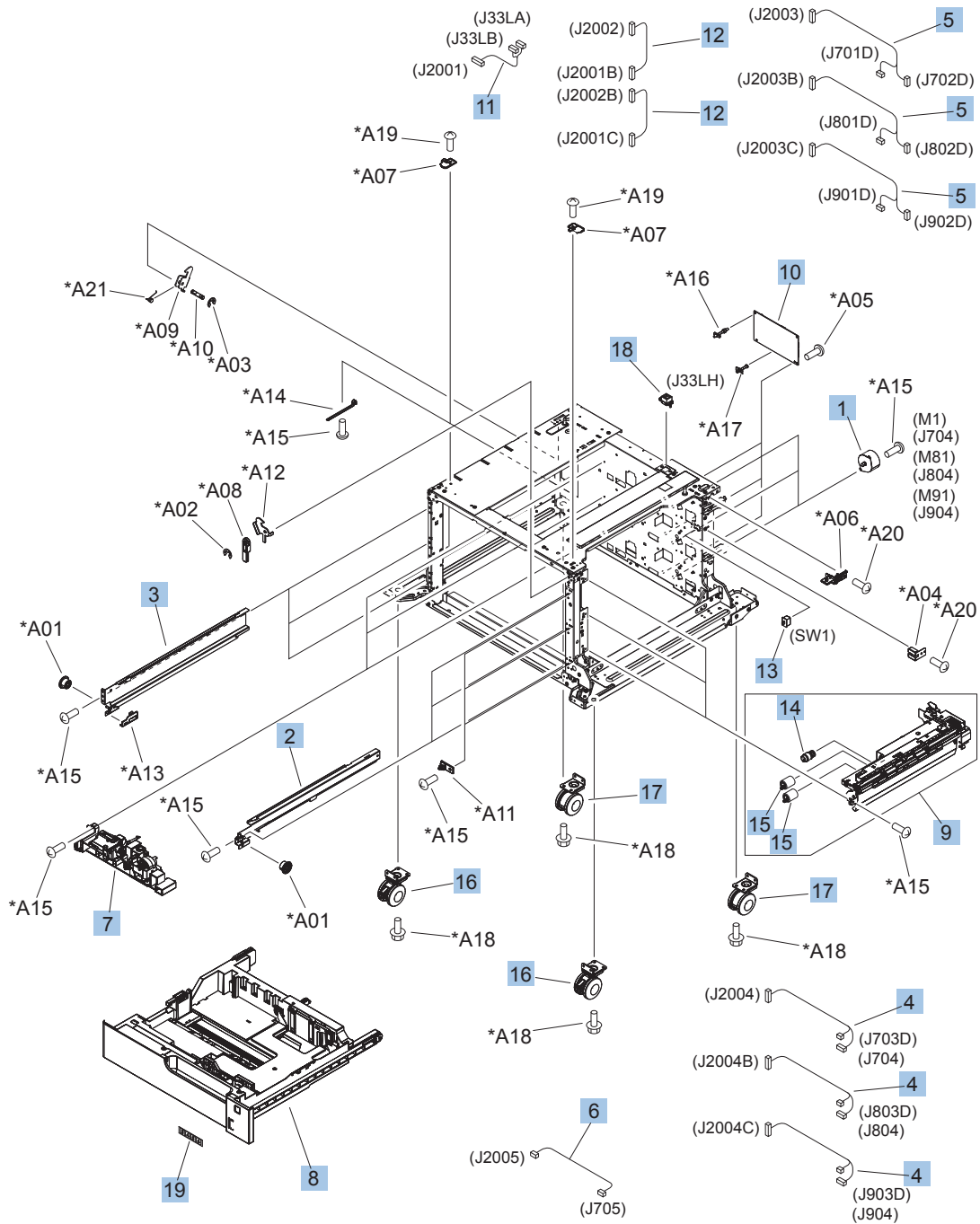

Table 4-24 3x500PF internal components

Ref	Description	Part number	Qty
1	Motor, stepping, DC (3x500PF)	RK2-1331-000CN	3
2	Rail, cassette, right (3x500PF)	RL1-1390-000CN	3
3	Rail, cassette, left (3x500PF)	RL1-1391-000CN	3
4	Cable, paper pick-up option (3x500PF)	RM1-3575-000CN	3
5	Cable, multisensor (3x500PF)	RM1-3647-000CN	3
6	Cable, door open switch (3x500PF)	RM1-3651-000CN	1
7	Lifter drive assembly (3x500PF)	RM1-3819-000CN	3
8	Cassette (3x500PF)	RM1-6942-000CN	1
9	Paper pick-up assembly (3x500PF)	RM1-6944-000CN	3
10	Feeder PCA (3x500PF)	RM1-6989-000CN	1
11	Cable, engine interface (3x500PF)	RM1-6991-000CN	1
12	Cable, PCA joint (3x500PF)	RM1-6992-000CN	2
13	Switch, button (3x500PF)	WC2-5512-000CN	1
14	Roller, pick-up (included in the service kit; 3x500PF)	CE710-67908	1
15	Paper feed roller assembly (included in the service kit; 3x500PF)	CE710-67908	2
16	Caster, double lock, front (3x500PF)	RC1-9896-000CN	2
17	Caster, rear (3x500PF)	RC1-9917-000CN	2
18	Connector, 8P (3x500PF)	VS1-7500-008CN	1
19	Label, cassette number (3x500PF)	RC3-1824-000CN	1

3x500PF cassette

Figure 4-21 3x500PF cassette

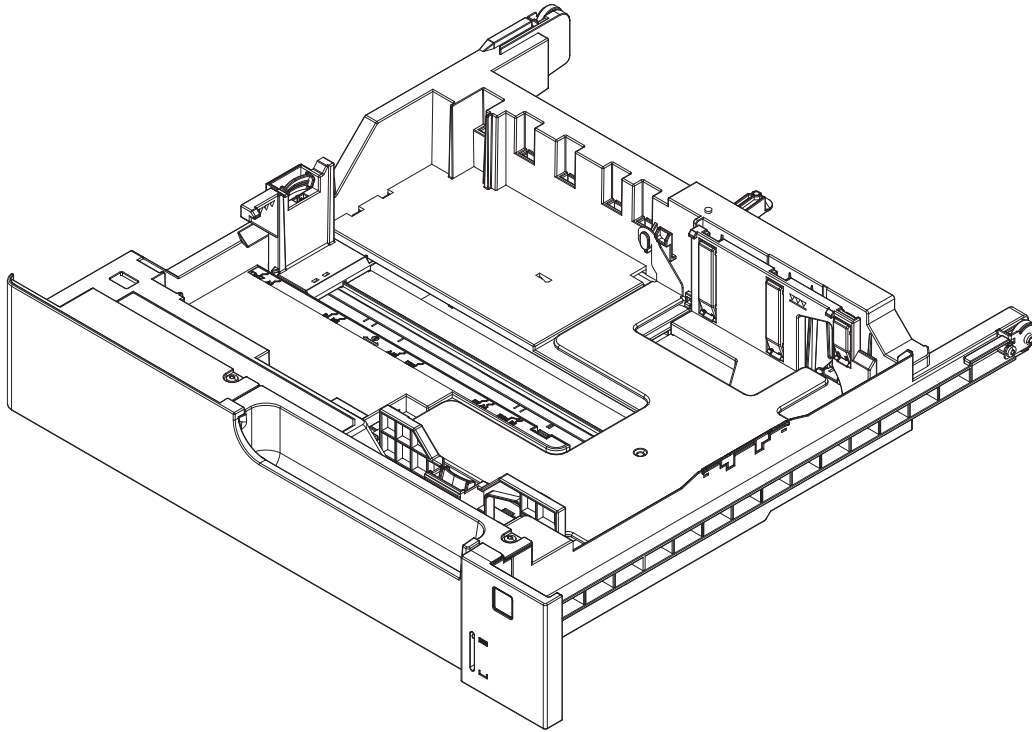

Table 4-25 3x500PF cassette

Ref	Description	Part number	Qty
	Cassette (3x500PF)	RM1-6942-000CN	3

3x500PF PCAs

Figure 4-22 3x500PF PCAs

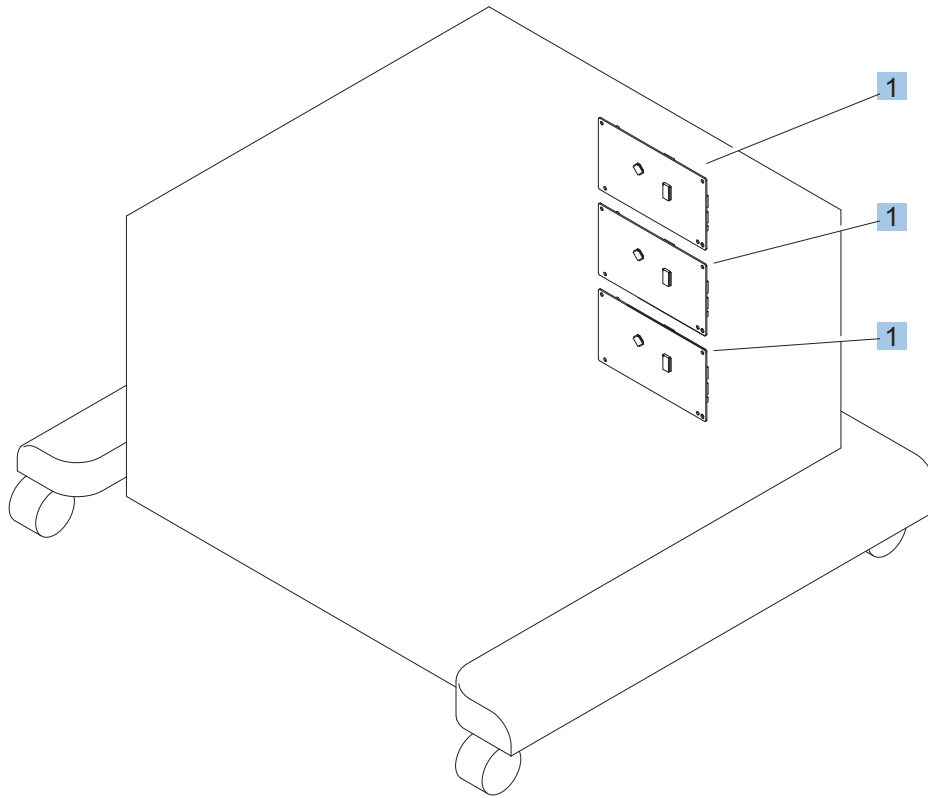

Table 4-26 3x500PF PCAs

Ref	Description	Part number	Qty
1	Feeder PCAs (3x500PF)	RM1-6989-000CN	3

Alphabetical parts list

Table 4-27 Alphabetical parts list

Description	Part number	Table and page
Arm, front cover, 1	RC2-6732-000CN	Internal components (1 of 9) on page 565
Arm, front cover, 2	RC2-6733-000CN	Internal components (1 of 9) on page 565
Arm, ITB coupling release	RC2-6824-000CN	Internal components (4 of 9) on page 571
Arm, waste toner, left	RC2-7035-000CN	Internal components (6 of 9) on page 575
Arm, waste toner, right	RC2-7036-000CN	Internal components (6 of 9) on page 575
Auto close assembly	RM1-6036-000CN	Internal components (8 of 9) on page 579
Cable assembly, flat-flexible	RM1-6804-000CN	Internal components (7 of 9) on page 577
Cable, door open switch (3x500PF)	RM1-3651-000CN	3x500PF internal components on page 599
Cable, engine interface (3x500PF)	RM1-6991-000CN	3x500PF internal components on page 599
Cable, feed joint, duplex model	RM1-6846-000CN	Internal components (4 of 9) on page 571
Cable, left, high-voltage power supply to low-voltage power supply	RM1-6833-000CN	Internal components (8 of 9) on page 579
Cable, low-voltage AC joint	RM1-6811-000CN	Internal components (8 of 9) on page 579
Cable, low-voltage power supply	RM1-6807-000CN	Internal components (8 of 9) on page 579
Cable, low-voltage power supply, test	RM1-6813-000CN	Internal components (8 of 9) on page 579
Cable, multisensor (3x500PF)	RM1-3647-000CN	3x500PF internal components on page 599
Cable, paper pick-up option (3x500PF)	RM1-3575-000CN	3x500PF internal components on page 599
Cable, PCA joint (3x500PF)	RM1-6992-000CN	3x500PF internal components on page 599
Cable, PNL-H-HI	RM1-6849-000CN	Internal components (9 of 9) on page 581
Cable, primary transfer	RM1-6822-000CN	Internal components (9 of 9) on page 581

Table 4-27 Alphabetical parts list (continued)

Description	Part number	Table and page
Cable, rear	RM1-6863-000CN	Internal components (9 of 9) on page 581
Cable, SB joint, low-voltage power supply, duplex model	RM1-6867-000CN	Internal components (3 of 9) on page 569
Cable, switch	RM1-6830-000CN	Internal components (8 of 9) on page 579
Cable, USB	RK2-2901-000CN	External covers, panels, and doors on page 561
Cap, T2 contact, second-transfer high-voltage PCA	RC2-6691-000CN	Internal components (4 of 9) on page 571
Cassette	CE710-67906	1x250 cassette on page 583
Cassette (1x500PF)	RM1-6942-000CN	1x500PF internal components on page 593
Cassette (3x500PF)	RM1-6942-000CN	3x500PF internal components on page 599
Cassette (3x500PF)	RM1-6942-000CN	3x500PF cassette on page 601
Caster, double lock, front (3x500PF)	RC1-9896-000CN	3x500PF internal components on page 599
Caster, rear (3x500PF)	RC1-9917-000CN	3x500PF internal components on page 599
Clamp, edge	RC2-6663-000CN	Internal components (6 of 9) on page 575
Clamp, edge, D	RC2-6674-000CN	Internal components (9 of 9) on page 581
Connector, 8-pin, paper-pick-up	VS1-7514-008CN	Internal components (9 of 9) on page 581
Connector, 8P (1x500PF)	VS1-7514-008CN	1x500PF internal components on page 593
Connector, 8P (3x500PF)	VS1-7500-008CN	3x500PF internal components on page 599
Connector, snap tight, black	VS1-7207-019CN	Internal components (3 of 9) on page 569
Core, ring	WE8-6639-000CN	Internal components (9 of 9) on page 581
Cover, cable, protective	RC2-6832-000CN	Internal components (3 of 9) on page 569
Cover, cable, right rear	RC2-8424-000CN	Internal components (8 of 9) on page 579

Table 4-27 Alphabetical parts list (continued)

Description	Part number	Table and page
Cover, connector, lower	RC2-6642-000CN	Internal components (3 of 9) on page 569
Cover, duplexing gear, duplex model	RC2-6931-000CN	Internal components (4 of 9) on page 571
Cover, front assembly	RM1-7133-000CN	External covers, panels, and doors on page 561
Cover, gear, simplex model	RC3-0688-000CN	Internal components (4 of 9) on page 571
Cover, guide	RC2-7204-000CN	Internal components (1 of 9) on page 565
Cover, handle guide	RC2-6670-000CN	Internal components (2 of 9) on page 567
Cover, handle, lower (1x500PF)	RC2-9332-000CN	1x500PF external components on page 591
Cover, handle, lower-left	RC2-6625-000CN	External covers, panels, and doors on page 561
Cover, handle, lower-right, front	RC2-6627-000CN	External covers, panels, and doors on page 561
Cover, handle, lower-right, rear	RC2-6626-000CN	External covers, panels, and doors on page 561
Cover, imaging HVT cable	RC2-6573-000CN	Internal components (9 of 9) on page 581
Cover, left (1x500PF)	RC2-9331-000CN	1x500PF external components on page 591
Cover, left (3x500PF)	RC2-9349-000CN	3x500PF external components on page 597
Cover, left assembly	RM1-7143-000CN	External covers, panels, and doors on page 561
Cover, left lower (3x500PF)	RC2-9350-000CN	3x500PF external components on page 597
Cover, lower front	RC2-6737-000CN	Internal components (1 of 9) on page 565
Cover, main cross-member cable	RC2-6650-000CN	Internal components (6 of 9) on page 575
Cover, main drive cable, lower	RC2-6574-000CN	Internal components (4 of 9) on page 571
Cover, rear	RM1-7147-000CN	External covers, panels, and doors on page 561
Cover, rear (1x500PF)	RC2-9330-000CN	1x500PF external components on page 591

Table 4-27 Alphabetical parts list (continued)

Description	Part number	Table and page
Cover, rear (3x500PF)	RC2-9348-000CN	3x500PF external components on page 597
Cover, rear lower (3x500PF)	RC2-9357-000CN	3x500PF external components on page 597
Cover, right corner (3x500PF)	RC2-9343-000CN	3x500PF external components on page 597
Cover, right front (1x500PF)	RC2-9320-000CN	1x500PF external components on page 591
Cover, right front assembly (includes control panel)	RM1-7144-000CN	External covers, panels, and doors on page 561
Cover, right lower assembly (1x500PF)	RM1-6948-000CN	1x500PF external components on page 591
Cover, right lower, 1 (3x500PF)	RC2-9346-000CN	3x500PF external components on page 597
Cover, right lower, 2 (3x500PF)	RC2-9347-000CN	3x500PF external components on page 597
Cover, right rear	RM1-7142-000CN	External covers, panels, and doors on page 561
Cover, top	RM1-7148-000CN	External covers, panels, and doors on page 561
Cover, upper front assembly (1x500PF)	RM1-6949-000CN	1x500PF external components on page 591
Cover, waste toner, 2	RC2-6962-000CN	Internal components (6 of 9) on page 575
Cover, waste toner, 3	RC2-6963-000CN	Internal components (6 of 9) on page 575
Cross-member, cover, left	RC2-6760-000CN	Internal components (9 of 9) on page 581
DC Controller PCA (duplex model)	CE708-67902	PCAs on page 589
DC Controller PCA (simplex model)	CE707-67906	PCAs on page 589
DC motor assembly	RM1-6088-000CN	Internal components (4 of 9) on page 571
Door, inner, service kit includes all labels	CE707-67904	Internal components (1 of 9) on page 565
Door, right upper	RC2-7091-000CN	Right door assembly on page 563
Door, toner collection unit access	RC2-7034-000CN	External covers, panels, and doors on page 561
Drive assembly, duplex reverse, duplex model	RM1-6005-000CN	Internal components (3 of 9) on page 569

Table 4-27 Alphabetical parts list (continued)

Description	Part number	Table and page
Drive assembly, simplex reverse, simplex model	RM1-6120-000CN	Internal components (3 of 9) on page 569
Driver PCA (duplex model)	RM1-6742-000CN	PCAs on page 589
Driver PCA (simplex model)	RM1-6783-000CN	PCAs on page 589
Duct, fan, 1	RC2-8388-000CN	Internal components (7 of 9) on page 577
Duct, front	RC2-7300-000CN	Internal components (1 of 9) on page 565
Duct, joint	RC2-8360-000CN	Internal components (4 of 9) on page 571
Environment sensor PCA	RK2-2884-000CN	PCAs on page 589
Fan, formatter	RK2-3301-000CN	Internal components (9 of 9) on page 581
Fan, fuser	RK2-2728-000CN	Internal components (2 of 9) on page 567
Fan, power supply	RK2-2276-000CN	Internal components (6 of 9) on page 575
Feeder PCA (3x500PF)	RM1-6989-000CN	3x500PF internal components on page 599
Feeder PCAs (3x500PF)	RM1-6989-000CN	3x500PF PCAs on page 603
Formatter case	RM1-6065-000CN	Internal components (9 of 9) on page 581
Formatter PCA	CE707-69001	PCAs on page 589
Front lower cover assembly (3x500PF)	RM1-6958-000CN	3x500PF external components on page 597
Fuser assembly, 110V (included in service kit)	RM1-6180-000CN	Internal components (3 of 9) on page 569
Fuser assembly, 220V (included in service kit)	RM1-6181-000CN	Internal components (3 of 9) on page 569
Fuser drive assembly	CE707-67904	Internal components (3 of 9) on page 569
Fuser motor assembly	RM1-6074-000CN	Internal components (3 of 9) on page 569
Gear assembly, fuser	RM1-7914-060CN	Internal components (3 of 9) on page 569
Gear, 18T/29T	RU6-0775-000CN	Internal components (3 of 9) on page 569
Gear, 25T, duplex model	RU6-0771-000CN	Internal components (4 of 9) on page 571

Table 4-27 Alphabetical parts list (continued)

Description	Part number	Table and page
Gear, 25T, duplex model	RU6-0772-000CN	Internal components (4 of 9) on page 571
Gear, 74T, duplex model	RU6-0773-000CN	Internal components (4 of 9) on page 571
Gear, link worm	RU6-0795-000CN	Internal components (6 of 9) on page 575
Guide, arm, front	RC2-6632-000CN	Internal components (1 of 9) on page 565
Guide, cable	RC3-0684-000CN	Internal components (8 of 9) on page 579
Guide, cable, right	RC2-6842-000CN	Internal components (9 of 9) on page 581
Guide, cable, upper	RC2-6841-000CN	Internal components (9 of 9) on page 581
Guide, cross-member cable, front	RC2-6587-000CN	Internal components (8 of 9) on page 579
Guide, cross-member cable, rear	RC2-6588-000CN	Internal components (8 of 9) on page 579
Guide, DC cont. support cable	RC2-6665-000CN	Internal components (9 of 9) on page 581
Guide, fuser AC cable	RC2-6693-000CN	Internal components (6 of 9) on page 575
Guide, fuser, front	RC2-6546-000CN	Internal components (3 of 9) on page 569
Guide, fuser, rear	RC2-6547-000CN	Internal components (3 of 9) on page 569
Guide, imaging HVT cable	RC2-6661-000CN	Internal components (9 of 9) on page 581
Guide, inside cable	RC2-6589-000CN	Internal components (6 of 9) on page 575
Guide, laser	RC2-6628-000CN	Internal components (7 of 9) on page 577
Guide, LVT cable	RC2-6662-000CN	Internal components (6 of 9) on page 575
Guide, main cross-member cable	RC2-6600-000CN	Internal components (6 of 9) on page 575
Guide, main drive cable	RC2-6659-000CN	Internal components (4 of 9) on page 571
Guide, paper feed	RC2-7297-000CN	Internal components (3 of 9) on page 569

Table 4-27 Alphabetical parts list (continued)

Description	Part number	Table and page
Guide, slide	RC2-7203-000CN	Internal components (6 of 9) on page 575
Handle, lock, rear (1x500PF)	RC2-9303-000CN	1x500PF external components on page 591
Hinge, front cover, center	RC2-6738-000CN	Internal components (1 of 9) on page 565
Hinge, front cover, left	RC2-6713-000CN	Internal components (1 of 9) on page 565
Hinge, front cover, right	RC2-6715-000CN	Internal components (1 of 9) on page 565
Hinge, inner door, left	RC2-6716-000CN	Internal components (1 of 9) on page 565
Hinge, inner door, right	RC2-6712-000CN	Internal components (1 of 9) on page 565
Hinge, right door, front	RC2-7094-000CN	Internal components (4 of 9) on page 571
Holder, door sensor, right	RC2-6645-000CN	Internal components (4 of 9) on page 571
Holder, duplexing fan	RC2-8357-000CN	Internal components (2 of 9) on page 567
Holder, first power dispatching	RC2-6680-000CN	Internal components (8 of 9) on page 579
Holder, flat flexible cable	RC2-6655-000CN	Internal components (7 of 9) on page 577
Holder, formatter fan	RC2-6648-000CN	Internal components (9 of 9) on page 581
Holder, interlock switch	RC2-6689-000CN	Internal components (2 of 9) on page 567
Holder, paper pick-up connector	RC2-6638-000CN	Internal components (9 of 9) on page 581
Holder, power supply fan	RC2-7299-000CN	Internal components (6 of 9) on page 575
Holder, secondary transfer HVT	RC2-6681-010CN	Internal components (4 of 9) on page 571
Holder, secondary transfer, power dispatching	RC2-6682-000CN	Internal components (4 of 9) on page 571
Holder, switch	RC2-6666-000CN	Internal components (8 of 9) on page 579
Hook, duplexing spring, duplex model	RC2-6932-000CN	Internal components (4 of 9) on page 571

Table 4-27 Alphabetical parts list (continued)

Description	Part number	Table and page
Imaging high-voltage PCA	RM1-6800-000CN	PCAs on page 589
Inter connect board (ICB) PCA	CE707-67907	PCAs on page 589
IT belt guide rail assembly	RM1-6018-000CN	Internal components (6 of 9) on page 575
IT belt guide rail R1 assembly	RM1-6037-000CN	Internal components (6 of 9) on page 575
ITB assembly (included in the service kit; includes transfer roller)	CE710-67903	Internal components (6 of 9) on page 575
ITB guide rail assembly	RM1-6019-000CN	Internal components (6 of 9) on page 575
Label, cassette number (1x500PF)	RC2-9363-000CN	1x500PF internal components on page 593
Label, cassette number (3x500PF)	RC3-1824-000CN	3x500PF internal components on page 599
Label, fuser insert	RU6-8042-000CN	Internal components (3 of 9) on page 569
Label, ITB insert, FH	RU5-8806-000CN	Internal components (7 of 9) on page 577
Label, ITB insert, FV	RU5-8804-000CN	Internal components (7 of 9) on page 577
Label, ITB set, RH	RU5-8807-000CN	Internal components (6 of 9) on page 575
Label, ITB, RV	RU5-8805-000CN	Internal components (6 of 9) on page 575
Laser scanner assembly	RM1-6122-070CN	Internal components (7 of 9) on page 577
Lever, inner door pressure	RC2-6744-000CN	Internal components (1 of 9) on page 565
Lever, lift, 1	RC2-7199-000CN	Internal components (6 of 9) on page 575
Lever, lift, 2	RC2-7200-000CN	Internal components (1 of 9) on page 565
Lever, push	RC2-7198-000CN	Internal components (1 of 9) on page 565
Lifter drive assembly	RM1-6039-000CN	Internal components (8 of 9) on page 579
Lifter drive assembly (1x500PF)	RM1-3819-000CN	1x500PF internal components on page 593
Lifter drive assembly (3x500PF)	RM1-3819-000CN	3x500PF internal components on page 599

Table 4-27 Alphabetical parts list (continued)

Description	Part number	Table and page
Lifter plate assembly, Tray 1	RM1-6043-030CN	Right door assembly on page 563
Link, ITB coupling release	RC2-6823-000CN	Internal components (4 of 9) on page 571
Link, right door, 2 front	RC2-7233-000CN	Internal components (4 of 9) on page 571
Link, right door, 2 rear	RC2-7236-000CN	Internal components (4 of 9) on page 571
Link, right door, lower (1x500PF)	RC2-9327-000CN	1x500PF external components on page 591
Link, right door, upper (1x500PF)	RC2-9335-000CN	1x500PF external components on page 591
Lock, door link, right	RC2-7234-000CN	Internal components (4 of 9) on page 571
Low voltage power supply assembly, 110V	RM1-6753-000CN	Internal components (8 of 9) on page 579
Low voltage power supply assembly, 220V	RM1-6754-000CN	Internal components (8 of 9) on page 579
Low-voltage power supply PCA (110V)	RM1-6753-000CN	PCAs on page 589
Low-voltage power supply PCA (220V)	RM1-6754-000CN	PCAs on page 589
Main drive assembly, duplex model	RM1-7931-000CN	Internal components (4 of 9) on page 571
Main drive assembly, simplex model	RM1-6173-000CN	Internal components (4 of 9) on page 571
Microswitch	WC4-5251-000CN	Internal components (1 of 9) on page 565
Motor, pick-up (1x500PF)	RK2-1331-000CN	1x500PF internal components on page 593
Motor, stepping, DC (3x500PF)	RK2-1331-000CN	3x500PF internal components on page 599
Motor, stepping, DC, duplex model	RK2-3298-000CN	Internal components (4 of 9) on page 571
Motor, stepping, DC, simplex model	RK2-3298-000CN	Internal components (4 of 9) on page 571
Mount, cover arm, front	RC2-6735-000CN	Internal components (1 of 9) on page 565
Mount, inner door rail	RC2-6743-000CN	Internal components (1 of 9) on page 565
Mount, inner door toggle	RC2-6717-000CN	Internal components (1 of 9) on page 565

Table 4-27 Alphabetical parts list (continued)

Description	Part number	Table and page
Mount, stopper arm	RC2-6745-000CN	Internal components (1 of 9) on page 565
Paper delivery assembly	RM1-6165-000CN	Paper delivery assembly on page 587
Paper feed roller assembly (included in the service kit; 3x500PF)	CE710-67908	3x500PF internal components on page 599
Paper feeder driver PCA (1x500PF)	RM1-6987-000CN	1x500PF internal components on page 593
Paper feeder driver PCA (1x500PF)	RM1-6987-000CN	1x500PF PCA on page 595
Paper pick-up assembly	RM1-7916-000CN	Paper pick-up assembly on page 585
Paper pick-up assembly (1x500PF)	RM1-6944-000CN	1x500PF internal components on page 593
Paper pick-up assembly (3x500PF)	RM1-6944-000CN	3x500PF internal components on page 599
Paper pick-up roller assembly (included in service kit)	CE707-67903	Paper pick-up assembly on page 585
Plate, arm reinforcement	RC2-9649-000CN	Internal components (6 of 9) on page 575
Plate, box pillar	RC2-6673-000CN	Internal components (9 of 9) on page 581
Plate, duplexing drive gear	RL1-2266-000CN	Internal components (4 of 9) on page 571
Plate, FFC protective	RC2-9687-000CN	Internal components (9 of 9) on page 581
Plate, right door link, fixed, front	RL1-2281-000CN	Internal components (4 of 9) on page 571
Plate, right door link, fixed, rear	RL1-2282-000CN	Internal components (4 of 9) on page 571
Plate, right door link, front	RC2-7272-000CN	Internal components (4 of 9) on page 571
Plate, right door link, rear	RC2-7273-000CN	Internal components (4 of 9) on page 571
Power switch PCA	RM1-6759-000CN	PCAs on page 589
Primary transfer high-voltage PCA	RM1-7004-000CN	PCAs on page 589
Rail, cartridge auxiliary	RC2-6724-000CN	Internal components (1 of 9) on page 565
Rail, cassette, left (3x500PF)	RL1-1391-000CN	3x500PF internal components on page 599

Table 4-27 Alphabetical parts list (continued)

Description	Part number	Table and page
Rail, cassette, right (3x500PF)	RL1-1390-000CN	3x500PF internal components on page 599
Rail, door link, front lower	RC2-6634-000CN	Internal components (4 of 9) on page 571
Rail, door link, rear lower	RC2-6635-000CN	Internal components (4 of 9) on page 571
Rail, ITB guide	RC2-7185-000CN	Internal components (6 of 9) on page 575
Rail, ITB guide, F3	RC2-7193-000CN	Internal components (6 of 9) on page 575
Registration sensor assembly	RM1-7922-000CN	Internal components (3 of 9) on page 569
Right door assembly (1x500PF)	RM1-6946-000CN	1x500PF external components on page 591
Right door assembly (3x500PF)	RM1-6953-000CN	3x500PF external components on page 597
Right door assembly, duplex model	RM1-6007-000CN	Right door assembly on page 563
Right door assembly, simplex model	RM1-6138-000CN	Right door assembly on page 563
Roller, feed, paper feeder (included in service kit)	CE710-67908	1x500PF internal components on page 593
Roller, paper pick-up, Tray 1 (included in the service kit)	CE710-67906	Right door assembly on page 563
Roller, pick-up (included in the service kit; 3x500PF)	CE710-67908	3x500PF internal components on page 599
Roller, pick-up, paper feeder (included in service kit)	CE710-67908	1x500PF internal components on page 593
Roller, secondary transfer, T2 (included in the service kit)	CE710-67904	Right door assembly on page 563
Screw, stepped (3x500PF)	RS5-9099-000CN	3x500PF external components on page 597
Seal, slide shutter	RC3-1014-000CN	Internal components (7 of 9) on page 577
Seal, toner supporter guide 1	RC2-7018-000CN	Internal components (7 of 9) on page 577
Secondary transfer high-voltage PCA	RM1-6802-000CN	PCAs on page 589
Sensor, cassette last paper presence	RM1-6164-000CN	Internal components (3 of 9) on page 569

Table 4-27 Alphabetical parts list (continued)

Description	Part number	Table and page
Sensor, right door	WG8-5696-000CN	Internal components (4 of 9) on page 571
Separation pad, Tray 1 (included in the service kit)	CE710-67909	Right door assembly on page 563
Separation roller assembly (included in service kit)	CE710-67907	Internal components (3 of 9) on page 569
Shaft, right door link	RU5-4979-000CN	Internal components (4 of 9) on page 571
Sheet, slide seal	RC3-1013-000CN	Internal components (7 of 9) on page 577
Shutter, exhaust	RC2-7010-000CN	Internal components (6 of 9) on page 575
Slider, push	RC2-7201-000CN	Internal components (6 of 9) on page 575
Spacer, DC controller PCA	VT2-5176-004CN	Internal components (9 of 9) on page 581
Spring, compression	RU6-2721-000CN	Internal components (1 of 9) on page 565
Spring, compression	RU6-2683-000CN	Internal components (6 of 9) on page 575
Spring, contact	RU6-2767-000CN	Internal components (8 of 9) on page 579
Spring, contact	RU6-2768-000CN	Internal components (8 of 9) on page 579
Spring, contact, second-transfer high-voltage PCA	RU6-2771-000CN	Internal components (4 of 9) on page 571
Spring, grounding	RC2-7209-000CN	Internal components (1 of 9) on page 565
Spring, grounding, second-transfer high-voltage PCA	RU6-2772-000CN	Internal components (4 of 9) on page 571
Spring, grounding, second-transfer high-voltage PCA	RC2-6700-000CN	Internal components (4 of 9) on page 571
Spring, leaf, grounding	RC2-7092-000CN	Internal components (2 of 9) on page 567
Spring, rod	RC2-6611-000CN	Internal components (8 of 9) on page 579
Spring, tension	RU6-2831-000CN	Internal components (6 of 9) on page 575
Spring, tension, duplex model	RU6-2671-000CN	Internal components (4 of 9) on page 571

Table 4-27 Alphabetical parts list (continued)

Description	Part number	Table and page
Spring, tension, front	RU6-2727-000CN	Internal components (4 of 9) on page 571
Spring, tension, rear	RU6-2744-000CN	Internal components (4 of 9) on page 571
Spring, tension, registration sensor	RU6-2710-000CN	Internal components (3 of 9) on page 569
Stopper, inner door, 1	RC2-6719-000CN	Internal components (1 of 9) on page 565
Stopper, inner door, 2	RC2-6736-000CN	Internal components (1 of 9) on page 565
Stopper, laser	RC2-6646-000CN	Internal components (8 of 9) on page 579
Support, developing coupling	RC2-6811-000CN	Internal components (4 of 9) on page 571
Support, frame, front	RC2-7196-000CN	Internal components (3 of 9) on page 569
Support, frame, rear	RC2-7197-000CN	Internal components (3 of 9) on page 569
Switch, bottom (1x500PF)	WC2-5512-000CN	1x500PF internal components on page 593
Switch, button (3x500PF)	WC2-5512-000CN	3x500PF internal components on page 599
Toner collection unit (included in the service kit)	CE980-67901	Internal components (6 of 9) on page 575
Toner feed assembly	RM1-6040-000CN	Internal components (7 of 9) on page 577
Toner remaining detect PCA	RM1-6779-000CN	PCAs on page 589
Tray 1 (MP tray) assembly	RM1-6045-000CN	Right door assembly on page 563
Upper cartridge guide assembly	RM1-5990-000CN	Internal components (1 of 9) on page 565
Waste toner cover assembly	RM1-6012-000CN	Internal components (6 of 9) on page 575

Numerical parts list

Table 4-28 Numerical parts list

Part number	Description	Table and page
CE707-67903	Paper pick-up roller assembly (included in service kit)	Paper pick-up assembly on page 585
CE707-67904	Fuser drive assembly	Internal components (3 of 9) on page 569
CE707-67906	DC Controller PCA (simplex model)	PCAs on page 589
CE707-67907	Inter connect board (ICB) PCA	PCAs on page 589
CE707-69001	Formatter PCA	PCAs on page 589
CE707-67904	Door, inner, service kit includes all labels	Internal components (1 of 9) on page 565
CE708-67902	DC Controller PCA (duplex model)	PCAs on page 589
CE710-67903	ITB assembly (included in the service kit; includes transfer roller)	Internal components (6 of 9) on page 575
CE710-67904	Roller, secondary transfer, T2 (included in the service kit)	Right door assembly on page 563
CE710-67906	Roller, paper pick-up, Tray 1 (included in the service kit)	Right door assembly on page 563
CE710-67906	Cassette	1x250 cassette on page 583
CE710-67907	Separation roller assembly (included in service kit)	Internal components (3 of 9) on page 569
CE710-67908	Roller, pick-up, paper feeder (included in service kit)	1x500PF internal components on page 593
CE710-67908	Roller, feed, paper feeder (included in service kit)	1x500PF internal components on page 593
CE710-67908	Roller, pick-up (included in the service kit; 3x500PF)	3x500PF internal components on page 599
CE710-67908	Paper feed roller assembly (included in the service kit; 3x500PF)	3x500PF internal components on page 599
CE710-67909	Separation pad, Tray 1 (included in the service kit)	Right door assembly on page 563
CE980-67901	Toner collection unit (included in the service kit)	Internal components (6 of 9) on page 575
RC1-9896-000CN	Caster, double lock, front (3x500PF)	3x500PF internal components on page 599
RC1-9917-000CN	Caster, rear (3x500PF)	3x500PF internal components on page 599
RC2-6546-000CN	Guide, fuser, front	Internal components (3 of 9) on page 569

Table 4-28 Numerical parts list (continued)

Part number	Description	Table and page
RC2-6547-000CN	Guide, fuser, rear	Internal components (3 of 9) on page 569
RC2-6573-000CN	Cover, imaging HVT cable	Internal components (9 of 9) on page 581
RC2-6574-000CN	Cover, main drive cable, lower	Internal components (4 of 9) on page 571
RC2-6587-000CN	Guide, cross-member cable, front	Internal components (8 of 9) on page 579
RC2-6588-000CN	Guide, cross-member cable, rear	Internal components (8 of 9) on page 579
RC2-6589-000CN	Guide, inside cable	Internal components (6 of 9) on page 575
RC2-6600-000CN	Guide, main cross-member cable	Internal components (6 of 9) on page 575
RC2-6611-000CN	Spring, rod	Internal components (8 of 9) on page 579
RC2-6625-000CN	Cover, handle, lower-left	External covers, panels, and doors on page 561
RC2-6626-000CN	Cover, handle, lower-right, rear	External covers, panels, and doors on page 561
RC2-6627-000CN	Cover, handle, lower-right, front	External covers, panels, and doors on page 561
RC2-6628-000CN	Guide, laser	Internal components (7 of 9) on page 577
RC2-6632-000CN	Guide, arm, front	Internal components (1 of 9) on page 565
RC2-6634-000CN	Rail, door link, front lower	Internal components (4 of 9) on page 571
RC2-6635-000CN	Rail, door link, rear lower	Internal components (4 of 9) on page 571
RC2-6638-000CN	Holder, paper pick-up connector	Internal components (9 of 9) on page 581
RC2-6642-000CN	Cover, connector, lower	Internal components (3 of 9) on page 569
RC2-6645-000CN	Holder, door sensor, right	Internal components (4 of 9) on page 571
RC2-6646-000CN	Stopper, laser	Internal components (8 of 9) on page 579
RC2-6648-000CN	Holder, formatter fan	Internal components (9 of 9) on page 581

Table 4-28 Numerical parts list (continued)

Part number	Description	Table and page
RC2-6650-000CN	Cover, main cross-member cable	Internal components (6 of 9) on page 575
RC2-6655-000CN	Holder, flat flexible cable	Internal components (7 of 9) on page 577
RC2-6659-000CN	Guide, main drive cable	Internal components (4 of 9) on page 571
RC2-6661-000CN	Guide, imaging HVT cable	Internal components (9 of 9) on page 581
RC2-6662-000CN	Guide, LVT cable	Internal components (6 of 9) on page 575
RC2-6663-000CN	Clamp, edge	Internal components (6 of 9) on page 575
RC2-6665-000CN	Guide, DC cont. support cable	Internal components (9 of 9) on page 581
RC2-6666-000CN	Holder, switch	Internal components (8 of 9) on page 579
RC2-6670-000CN	Cover, handle guide	Internal components (2 of 9) on page 567
RC2-6673-000CN	Plate, box pillar	Internal components (9 of 9) on page 581
RC2-6674-000CN	Clamp, edge, D	Internal components (9 of 9) on page 581
RC2-6680-000CN	Holder, first power dispatching	Internal components (8 of 9) on page 579
RC2-6681-010CN	Holder, secondary transfer HVT	Internal components (4 of 9) on page 571
RC2-6682-000CN	Holder, secondary transfer, power dispatching	Internal components (4 of 9) on page 571
RC2-6689-000CN	Holder, interlock switch	Internal components (2 of 9) on page 567
RC2-6691-000CN	Cap, T2 contact, second-transfer high-voltage PCA	Internal components (4 of 9) on page 571
RC2-6693-000CN	Guide, fuser AC cable	Internal components (6 of 9) on page 575
RC2-6700-000CN	Spring, grounding, second-transfer high-voltage PCA	Internal components (4 of 9) on page 571
RC2-6712-000CN	Hinge, inner door, right	Internal components (1 of 9) on page 565
RC2-6713-000CN	Hinge, front cover, left	Internal components (1 of 9) on page 565

Table 4-28 Numerical parts list (continued)

Part number	Description	Table and page
RC2-6715-000CN	Hinge, front cover, right	Internal components (1 of 9) on page 565
RC2-6716-000CN	Hinge, inner door, left	Internal components (1 of 9) on page 565
RC2-6717-000CN	Mount, inner door toggle	Internal components (1 of 9) on page 565
RC2-6719-000CN	Stopper, inner door, 1	Internal components (1 of 9) on page 565
RC2-6724-000CN	Rail, cartridge auxiliary	Internal components (1 of 9) on page 565
RC2-6732-000CN	Arm, front cover, 1	Internal components (1 of 9) on page 565
RC2-6733-000CN	Arm, front cover, 2	Internal components (1 of 9) on page 565
RC2-6735-000CN	Mount, cover arm, front	Internal components (1 of 9) on page 565
RC2-6736-000CN	Stopper, inner door, 2	Internal components (1 of 9) on page 565
RC2-6737-000CN	Cover, lower front	Internal components (1 of 9) on page 565
RC2-6738-000CN	Hinge, front cover, center	Internal components (1 of 9) on page 565
RC2-6743-000CN	Mount, inner door rail	Internal components (1 of 9) on page 565
RC2-6744-000CN	Lever, inner door pressure	Internal components (1 of 9) on page 565
RC2-6745-000CN	Mount, stopper arm	Internal components (1 of 9) on page 565
RC2-6760-000CN	Cross-member, cover, left	Internal components (9 of 9) on page 581
RC2-6811-000CN	Support, developing coupling	Internal components (4 of 9) on page 571
RC2-6823-000CN	Link, ITB coupling release	Internal components (4 of 9) on page 571
RC2-6824-000CN	Arm, ITB coupling release	Internal components (4 of 9) on page 571
RC2-6832-000CN	Cover, cable, protective	Internal components (3 of 9) on page 569
RC2-6841-000CN	Guide, cable, upper	Internal components (9 of 9) on page 581

Table 4-28 Numerical parts list (continued)

Part number	Description	Table and page
RC2-6842-000CN	Guide, cable, right	Internal components (9 of 9) on page 581
RC2-6931-000CN	Cover, duplexing gear, duplex model	Internal components (4 of 9) on page 571
RC2-6932-000CN	Hook, duplexing spring, duplex model	Internal components (4 of 9) on page 571
RC2-6962-000CN	Cover, waste toner, 2	Internal components (6 of 9) on page 575
RC2-6963-000CN	Cover, waste toner, 3	Internal components (6 of 9) on page 575
RC2-7010-000CN	Shutter, exhaust	Internal components (6 of 9) on page 575
RC2-7018-000CN	Seal, toner supporter guide 1	Internal components (7 of 9) on page 577
RC2-7034-000CN	Door, toner collection unit access	External covers, panels, and doors on page 561
RC2-7035-000CN	Arm, waste toner, left	Internal components (6 of 9) on page 575
RC2-7036-000CN	Arm, waste toner, right	Internal components (6 of 9) on page 575
RC2-7091-000CN	Door, right upper	Right door assembly on page 563
RC2-7092-000CN	Spring, leaf, grounding	Internal components (2 of 9) on page 567
RC2-7094-000CN	Hinge, right door, front	Internal components (4 of 9) on page 571
RC2-7185-000CN	Rail, ITB guide	Internal components (6 of 9) on page 575
RC2-7193-000CN	Rail, ITB guide, F3	Internal components (6 of 9) on page 575
RC2-7196-000CN	Support, frame, front	Internal components (3 of 9) on page 569
RC2-7197-000CN	Support, frame, rear	Internal components (3 of 9) on page 569
RC2-7198-000CN	Lever, push	Internal components (1 of 9) on page 565
RC2-7199-000CN	Lever, lift, 1	Internal components (6 of 9) on page 575
RC2-7200-000CN	Lever, lift, 2	Internal components (1 of 9) on page 565

Table 4-28 Numerical parts list (continued)

Part number	Description	Table and page
RC2-7201-000CN	Slider, push	Internal components (6 of 9) on page 575
RC2-7203-000CN	Guide, slide	Internal components (6 of 9) on page 575
RC2-7204-000CN	Cover, guide	Internal components (1 of 9) on page 565
RC2-7209-000CN	Spring, grounding	Internal components (1 of 9) on page 565
RC2-7233-000CN	Link, right door, 2 front	Internal components (4 of 9) on page 571
RC2-7234-000CN	Lock, door link, right	Internal components (4 of 9) on page 571
RC2-7236-000CN	Link, right door, 2 rear	Internal components (4 of 9) on page 571
RC2-7272-000CN	Plate, right door link, front	Internal components (4 of 9) on page 571
RC2-7273-000CN	Plate, right door link, rear	Internal components (4 of 9) on page 571
RC2-7297-000CN	Guide, paper feed	Internal components (3 of 9) on page 569
RC2-7299-000CN	Holder, power supply fan	Internal components (6 of 9) on page 575
RC2-7300-000CN	Duct, front	Internal components (1 of 9) on page 565
RC2-8357-000CN	Holder, duplexing fan	Internal components (2 of 9) on page 567
RC2-8360-000CN	Duct, joint	Internal components (4 of 9) on page 571
RC2-8388-000CN	Duct, fan, 1	Internal components (7 of 9) on page 577
RC2-8424-000CN	Cover, cable, right rear	Internal components (8 of 9) on page 579
RC2-9303-000CN	Handle, lock, rear (1x500PF)	1x500PF external components on page 591
RC2-9320-000CN	Cover, right front (1x500PF)	1x500PF external components on page 591
RC2-9327-000CN	Link, right door, lower (1x500PF)	1x500PF external components on page 591
RC2-9330-000CN	Cover, rear (1x500PF)	1x500PF external components on page 591

Table 4-28 Numerical parts list (continued)

Part number	Description	Table and page
RC2-9331-000CN	Cover, left (1x500PF)	1x500PF external components on page 591
RC2-9332-000CN	Cover, handle, lower (1x500PF)	1x500PF external components on page 591
RC2-9335-000CN	Link, right door, upper (1x500PF)	1x500PF external components on page 591
RC2-9343-000CN	Cover, right corner (3x500PF)	3x500PF external components on page 597
RC2-9346-000CN	Cover, right lower, 1 (3x500PF)	3x500PF external components on page 597
RC2-9347-000CN	Cover, right lower, 2 (3x500PF)	3x500PF external components on page 597
RC2-9348-000CN	Cover, rear (3x500PF)	3x500PF external components on page 597
RC2-9349-000CN	Cover, left (3x500PF)	3x500PF external components on page 597
RC2-9350-000CN	Cover, left lower (3x500PF)	3x500PF external components on page 597
RC2-9357-000CN	Cover, rear lower (3x500PF)	3x500PF external components on page 597
RC2-9363-000CN	Label, cassette number (1x500PF)	1x500PF internal components on page 593
RC2-9649-000CN	Plate, arm reinforcement	Internal components (6 of 9) on page 575
RC2-9687-000CN	Plate, FFC protective	Internal components (9 of 9) on page 581
RC3-0684-000CN	Guide, cable	Internal components (8 of 9) on page 579
RC3-0688-000CN	Cover, gear, simplex model	Internal components (4 of 9) on page 571
RC3-1013-000CN	Sheet, slide seal	Internal components (7 of 9) on page 577
RC3-1014-000CN	Seal, slide shutter	Internal components (7 of 9) on page 577
RC3-1824-000CN	Label, cassette number (3x500PF)	3x500PF internal components on page 599
RK2-1331-000CN	Motor, pick-up (1x500PF)	1x500PF internal components on page 593
RK2-1331-000CN	Motor, stepping, DC (3x500PF)	3x500PF internal components on page 599

Table 4-28 Numerical parts list (continued)

Part number	Description	Table and page
RK2-2276-000CN	Fan, power supply	Internal components (6 of 9) on page 575
RK2-2728-000CN	Fan, fuser	Internal components (2 of 9) on page 567
RK2-2884-000CN	Environment sensor PCA	PCAs on page 589
RK2-2901-000CN	Cable, USB	External covers, panels, and doors on page 561
RK2-3298-000CN	Motor, stepping, DC, duplex model	Internal components (4 of 9) on page 571
RK2-3298-000CN	Motor, stepping, DC, simplex model	Internal components (4 of 9) on page 571
RK2-3301-000CN	Fan, formatter	Internal components (9 of 9) on page 581
RL1-1390-000CN	Rail, cassette, right (3x500PF)	3x500PF internal components on page 599
RL1-1391-000CN	Rail, cassette, left (3x500PF)	3x500PF internal components on page 599
RL1-2266-000CN	Plate, duplexing drive gear	Internal components (4 of 9) on page 571
RL1-2281-000CN	Plate, right door link, fixed, front	Internal components (4 of 9) on page 571
RL1-2282-000CN	Plate, right door link, fixed, rear	Internal components (4 of 9) on page 571
RM1-3575-000CN	Cable, paper pick-up option (3x500PF)	3x500PF internal components on page 599
RM1-3647-000CN	Cable, multisensor (3x500PF)	3x500PF internal components on page 599
RM1-3651-000CN	Cable, door open switch (3x500PF)	3x500PF internal components on page 599
RM1-3819-000CN	Lifter drive assembly (1x500PF)	1x500PF internal components on page 593
RM1-3819-000CN	Lifter drive assembly (3x500PF)	3x500PF internal components on page 599
RM1-5990-000CN	Upper cartridge guide assembly	Internal components (1 of 9) on page 565
RM1-6005-000CN	Drive assembly, duplex reverse, duplex model	Internal components (3 of 9) on page 569
RM1-6007-000CN	Right door assembly, duplex model	Right door assembly on page 563

Table 4-28 Numerical parts list (continued)

Part number	Description	Table and page
RM1-6012-000CN	Waste toner cover assembly	Internal components (6 of 9) on page 575
RM1-6018-000CN	IT belt guide rail assembly	Internal components (6 of 9) on page 575
RM1-6019-000CN	ITB guide rail assembly	Internal components (6 of 9) on page 575
RM1-6036-000CN	Auto close assembly	Internal components (8 of 9) on page 579
RM1-6037-000CN	IT belt guide rail R1 assembly	Internal components (6 of 9) on page 575
RM1-6039-000CN	Lifter drive assembly	Internal components (8 of 9) on page 579
RM1-6040-000CN	Toner feed assembly	Internal components (7 of 9) on page 577
RM1-6043-030CN	Lifter plate assembly, Tray 1	Right door assembly on page 563
RM1-6045-000CN	Tray 1 (MP tray) assembly	Right door assembly on page 563
RM1-6065-000CN	Formatter case	Internal components (9 of 9) on page 581
RM1-6074-000CN	Fuser motor assembly	Internal components (3 of 9) on page 569
RM1-6088-000CN	DC motor assembly	Internal components (4 of 9) on page 571
RM1-6120-000CN	Drive assembly, simplex reverse, simplex model	Internal components (3 of 9) on page 569
RM1-6122-070CN	Laser scanner assembly	Internal components (7 of 9) on page 577
RM1-6138-000CN	Right door assembly, simplex model	Right door assembly on page 563
RM1-6164-000CN	Sensor, cassette last paper presence	Internal components (3 of 9) on page 569
RM1-6165-000CN	Paper delivery assembly	Paper delivery assembly on page 587
RM1-6173-000CN	Main drive assembly, simplex model	Internal components (4 of 9) on page 571
RM1-6180-000CN	Fuser assembly, 110V (included in service kit)	Internal components (3 of 9) on page 569
RM1-6181-000CN	Fuser assembly, 220V (included in service kit)	Internal components (3 of 9) on page 569

Table 4-28 Numerical parts list (continued)

Part number	Description	Table and page
RM1-6742-000CN	Driver PCA (duplex model)	PCAs on page 589
RM1-6753-000CN	Low voltage power supply assembly, 110V	Internal components (8 of 9) on page 579
RM1-6753-000CN	Low-voltage power supply PCA (110V)	PCAs on page 589
RM1-6754-000CN	Low voltage power supply assembly, 220V	Internal components (8 of 9) on page 579
RM1-6754-000CN	Low-voltage power supply PCA (220V)	PCAs on page 589
RM1-6759-000CN	Power switch PCA	PCAs on page 589
RM1-6779-000CN	Toner remaining detect PCA	PCAs on page 589
RM1-6783-000CN	Driver PCA (simplex model)	PCAs on page 589
RM1-6800-000CN	Imaging high-voltage PCA	PCAs on page 589
RM1-6802-000CN	Secondary transfer high-voltage PCA	PCAs on page 589
RM1-6804-000CN	Cable assembly, flat-flexible	Internal components (7 of 9) on page 577
RM1-6807-000CN	Cable, low-voltage power supply	Internal components (8 of 9) on page 579
RM1-6811-000CN	Cable, low-voltage AC joint	Internal components (8 of 9) on page 579
RM1-6813-000CN	Cable, low-voltage power supply, test	Internal components (8 of 9) on page 579
RM1-6822-000CN	Cable, primary transfer	Internal components (9 of 9) on page 581
RM1-6830-000CN	Cable, switch	Internal components (8 of 9) on page 579
RM1-6833-000CN	Cable, left, high-voltage power supply to low-voltage power supply	Internal components (8 of 9) on page 579
RM1-6846-000CN	Cable, feed joint, duplex model	Internal components (4 of 9) on page 571
RM1-6849-000CN	Cable, PNL-H-HI	Internal components (9 of 9) on page 581
RM1-6863-000CN	Cable, rear	Internal components (9 of 9) on page 581
RM1-6867-000CN	Cable, SB joint, low-voltage power supply, duplex model	Internal components (3 of 9) on page 569
RM1-6942-000CN	Cassette (1x500PF)	1x500PF internal components on page 593
RM1-6942-000CN	Cassette (3x500PF)	3x500PF internal components on page 599

Table 4-28 Numerical parts list (continued)

Part number	Description	Table and page
RM1-6942-000CN	Cassette (3x500PF)	3x500PF cassette on page 601
RM1-6944-000CN	Paper pick-up assembly (1x500PF)	1x500PF internal components on page 593
RM1-6944-000CN	Paper pick-up assembly (3x500PF)	3x500PF internal components on page 599
RM1-6946-000CN	Right door assembly (1x500PF)	1x500PF external components on page 591
RM1-6948-000CN	Cover, right lower assembly (1x500PF)	1x500PF external components on page 591
RM1-6949-000CN	Cover, upper front assembly (1x500PF)	1x500PF external components on page 591
RM1-6953-000CN	Right door assembly (3x500PF)	3x500PF external components on page 597
RM1-6958-000CN	Front lower cover assembly (3x500PF)	3x500PF external components on page 597
RM1-6987-000CN	Paper feeder driver PCA (1x500PF)	1x500PF internal components on page 593
RM1-6987-000CN	Paper feeder driver PCA (1x500PF)	1x500PF PCA on page 595
RM1-6989-000CN	Feeder PCA (3x500PF)	3x500PF internal components on page 599
RM1-6989-000CN	Feeder PCAs (3x500PF)	3x500PF PCAs on page 603
RM1-6991-000CN	Cable, engine interface (3x500PF)	3x500PF internal components on page 599
RM1-6992-000CN	Cable, PCA joint (3x500PF)	3x500PF internal components on page 599
RM1-7004-000CN	Primary transfer high-voltage PCA	PCAs on page 589
RM1-7133-000CN	Cover, front assembly	External covers, panels, and doors on page 561
RM1-7142-000CN	Cover, right rear	External covers, panels, and doors on page 561
RM1-7143-000CN	Cover, left assembly	External covers, panels, and doors on page 561
RM1-7144-000CN	Cover, right front assembly (includes control panel)	External covers, panels, and doors on page 561
RM1-7147-000CN	Cover, rear	External covers, panels, and doors on page 561
RM1-7148-000CN	Cover, top	External covers, panels, and doors on page 561

Table 4-28 Numerical parts list (continued)

Part number	Description	Table and page
RM1-7914-060CN	Gear assembly, fuser	Internal components (3 of 9) on page 569
RM1-7916-000CN	Paper pick-up assembly	Paper pick-up assembly on page 585
RM1-7922-000CN	Registration sensor assembly	Internal components (3 of 9) on page 569
RM1-7931-000CN	Main drive assembly, duplex model	Internal components (4 of 9) on page 571
RS5-9099-000CN	Screw, stepped (3x500PF)	3x500PF external components on page 597
RU5-4979-000CN	Shaft, right door link	Internal components (4 of 9) on page 571
RU5-8804-000CN	Label, ITB insert, FV	Internal components (7 of 9) on page 577
RU5-8805-000CN	Label, ITB, RV	Internal components (6 of 9) on page 575
RU5-8806-000CN	Label, ITB insert, FH	Internal components (7 of 9) on page 577
RU5-8807-000CN	Label, ITB set, RH	Internal components (6 of 9) on page 575
RU6-0771-000CN	Gear, 25T, duplex model	Internal components (4 of 9) on page 571
RU6-0772-000CN	Gear, 25T, duplex model	Internal components (4 of 9) on page 571
RU6-0773-000CN	Gear, 74T, duplex model	Internal components (4 of 9) on page 571
RU6-0775-000CN	Gear, 18T/29T	Internal components (3 of 9) on page 569
RU6-0795-000CN	Gear, link worm	Internal components (6 of 9) on page 575
RU6-2671-000CN	Spring, tension, duplex model	Internal components (4 of 9) on page 571
RU6-2683-000CN	Spring, compression	Internal components (6 of 9) on page 575
RU6-2710-000CN	Spring, tension, registration sensor	Internal components (3 of 9) on page 569
RU6-2721-000CN	Spring, compression	Internal components (1 of 9) on page 565
RU6-2727-000CN	Spring, tension, front	Internal components (4 of 9) on page 571

Table 4-28 Numerical parts list (continued)

Part number	Description	Table and page
RU6-2744-000CN	Spring, tension, rear	Internal components (4 of 9) on page 571
RU6-2767-000CN	Spring, contact	Internal components (8 of 9) on page 579
RU6-2768-000CN	Spring, contact	Internal components (8 of 9) on page 579
RU6-2771-000CN	Spring, contact, second-transfer high-voltage PCA	Internal components (4 of 9) on page 571
RU6-2772-000CN	Spring, grounding, second-transfer high-voltage PCA	Internal components (4 of 9) on page 571
RU6-2831-000CN	Spring, tension	Internal components (6 of 9) on page 575
RU6-8042-000CN	Label, fuser insert	Internal components (3 of 9) on page 569
VS1-7207-019CN	Connector, snap tight, black	Internal components (3 of 9) on page 569
VS1-7500-008CN	Connector, 8P (3x500PF)	3x500PF internal components on page 599
VS1-7514-008CN	Connector, 8-pin, paper-pick-up	Internal components (9 of 9) on page 581
VS1-7514-008CN	Connector, 8P (1x500PF)	1x500PF internal components on page 593
VT2-5176-004CN	Spacer, DC controller PCA	Internal components (9 of 9) on page 581
WC2-5512-000CN	Switch, bottom (1x500PF)	1x500PF internal components on page 593
WC2-5512-000CN	Switch, button (3x500PF)	3x500PF internal components on page 599
WC4-5251-000CN	Microswitch	Internal components (1 of 9) on page 565
WE8-6639-000CN	Core, ring	Internal components (9 of 9) on page 581
WG8-5696-000CN	Sensor, right door	Internal components (4 of 9) on page 571

A Service and support

- [Hewlett-Packard limited warranty statement](#)
- [HP's Premium Protection Warranty: LaserJet print cartridge limited warranty statement](#)
- [Color LaserJet Fuser Kit, Transfer Kit, and Toner Collection Unit Limited Warranty Statement](#)
- [Data stored on the print cartridge](#)
- [End User License Agreement](#)
- [Customer self-repair warranty service](#)
- [Customer support](#)

Hewlett-Packard limited warranty statement

HP PRODUCT	DURATION OF LIMITED WARRANTY
HP Color LaserJet CP5525n, CP5525dn, CP5525xh	One-year on-site warranty

HP warrants to you, the end-user customer, that HP hardware and accessories will be free from defects in materials and workmanship after the date of purchase, for the period specified above. If HP receives notice of such defects during the warranty period, HP will, at its option, either repair or replace products which prove to be defective. Replacement products may be either new or equivalent in performance to new.

HP warrants to you that HP software will not fail to execute its programming instructions after the date of purchase, for the period specified above, due to defects in material and workmanship when properly installed and used. If HP receives notice of such defects during the warranty period, HP will replace software which does not execute its programming instructions due to such defects.

HP does not warrant that the operation of HP products will be uninterrupted or error free. If HP is unable, within a reasonable time, to repair or replace any product to a condition as warranted, you will be entitled to a refund of the purchase price upon prompt return of the product.

HP products may contain remanufactured parts equivalent to new in performance or may have been subject to incidental use.

Warranty does not apply to defects resulting from (a) improper or inadequate maintenance or calibration, (b) software, interfacing, parts or supplies not supplied by HP, (c) unauthorized modification or misuse, (d) operation outside of the published environmental specifications for the product, or (e) improper site preparation or maintenance.

TO THE EXTENT ALLOWED BY LOCAL LAW, THE ABOVE WARRANTIES ARE EXCLUSIVE AND NO OTHER WARRANTY OR CONDITION, WHETHER WRITTEN OR ORAL, IS EXPRESSED OR IMPLIED AND HP SPECIFICALLY DISCLAIMS ANY IMPLIED WARRANTIES OR CONDITIONS OF MERCHANTABILITY, SATISFACTORY QUALITY, AND FITNESS FOR A PARTICULAR PURPOSE. Some countries/regions, states or provinces do not allow limitations on the duration of an implied warranty, so the above limitation or exclusion might not apply to you. This warranty gives you specific legal rights and you might also have other rights that vary from country/region to country/region, state to state, or province to province.

HP's limited warranty is valid in any country/region or locality where HP has a support presence for this product and where HP has marketed this product. The level of warranty service you receive may vary according to local standards. HP will not alter form, fit or function of the product to make it operate in a country/region for which it was never intended to function for legal or regulatory reasons.

TO THE EXTENT ALLOWED BY LOCAL LAW, THE REMEDIES IN THIS WARRANTY STATEMENT ARE YOUR SOLE AND EXCLUSIVE REMEDIES. EXCEPT AS INDICATED ABOVE, IN NO EVENT WILL HP OR ITS SUPPLIERS BE LIABLE FOR LOSS OF DATA OR FOR DIRECT, SPECIAL, INCIDENTAL, CONSEQUENTIAL (INCLUDING LOST PROFIT OR DATA), OR OTHER DAMAGE, WHETHER BASED IN CONTRACT, TORT, OR OTHERWISE. Some countries/regions, states or provinces do not allow the exclusion or limitation of incidental or consequential damages, so the above limitation or exclusion may not apply to you.

THE WARRANTY TERMS CONTAINED IN THIS STATEMENT, EXCEPT TO THE EXTENT LAWFULLY PERMITTED, DO NOT EXCLUDE, RESTRICT OR MODIFY AND ARE IN ADDITION TO THE MANDATORY STATUTORY RIGHTS APPLICABLE TO THE SALE OF THIS PRODUCT TO YOU.

HP's Premium Protection Warranty: LaserJet print cartridge limited warranty statement

This HP product is warranted to be free from defects in materials and workmanship.

This warranty does not apply to products that (a) have been refilled, refurbished, remanufactured or tampered with in any way, (b) experience problems resulting from misuse, improper storage, or operation outside of the published environmental specifications for the printer product or (c) exhibit wear from ordinary use.

To obtain warranty service, please return the product to place of purchase (with a written description of the problem and print samples) or contact HP customer support. At HP's option, HP will either replace products that prove to be defective or refund your purchase price.

TO THE EXTENT ALLOWED BY LOCAL LAW, THE ABOVE WARRANTY IS EXCLUSIVE AND NO OTHER WARRANTY OR CONDITION, WHETHER WRITTEN OR ORAL, IS EXPRESSED OR IMPLIED AND HP SPECIFICALLY DISCLAIMS ANY IMPLIED WARRANTIES OR CONDITIONS OF MERCHANTABILITY, SATISFACTORY QUALITY, AND FITNESS FOR A PARTICULAR PURPOSE.

TO THE EXTENT ALLOWED BY LOCAL LAW, IN NO EVENT WILL HP OR ITS SUPPLIERS BE LIABLE FOR DIRECT, SPECIAL, INCIDENTAL, CONSEQUENTIAL (INCLUDING LOST PROFIT OR DATA), OR OTHER DAMAGE, WHETHER BASED IN CONTRACT, TORT, OR OTHERWISE.

THE WARRANTY TERMS CONTAINED IN THIS STATEMENT, EXCEPT TO THE EXTENT LAWFULLY PERMITTED, DO NOT EXCLUDE, RESTRICT OR MODIFY AND ARE IN ADDITION TO THE MANDATORY STATUTORY RIGHTS APPLICABLE TO THE SALE OF THIS PRODUCT TO YOU.

Color LaserJet Fuser Kit, Transfer Kit, and Toner Collection Unit Limited Warranty Statement

This HP product is warranted to be free from defects in materials and workmanship until the printer provides a low-life indicator on the control panel.

This warranty does not apply to products that (a) have been refurbished, remanufactured or tampered with in any way, (b) experience problems resulting from misuse, improper storage, or operation outside of the published environmental specifications for the printer product or (c) exhibit wear from ordinary use.

To obtain warranty service, please return the product to place of purchase (with a written description of the problem) or contact HP customer support. At HP's option, HP will either replace products that prove to be defective or refund your purchase price.

TO THE EXTENT ALLOWED BY LOCAL LAW, THE ABOVE WARRANTY IS EXCLUSIVE AND NO OTHER WARRANTY OR CONDITION, WHETHER WRITTEN OR ORAL, IS EXPRESSED OR IMPLIED AND HP SPECIFICALLY DISCLAIMS ANY IMPLIED WARRANTIES OR CONDITIONS OF MERCHANTABILITY, SATISFACTORY QUALITY, AND FITNESS FOR A PARTICULAR PURPOSE.

TO THE EXTENT ALLOWED BY LOCAL LAW, IN NO EVENT WILL HP OR ITS SUPPLIERS BE LIABLE FOR DIRECT, SPECIAL, INCIDENTAL, CONSEQUENTIAL (INCLUDING LOST PROFIT OR DATA), OR OTHER DAMAGE, WHETHER BASED IN CONTRACT, TORT, OR OTHERWISE.

THE WARRANTY TERMS CONTAINED IN THIS STATEMENT, EXCEPT TO THE EXTENT LAWFULLY PERMITTED, DO NOT EXCLUDE, RESTRICT OR MODIFY AND ARE IN ADDITION TO THE MANDATORY STATUTORY RIGHTS APPLICABLE TO THE SALE OF THIS PRODUCT TO YOU.

Data stored on the print cartridge

The HP print cartridges used with this product contain a memory chip that assists in the operation of the product.

In addition, this memory chip collects a limited set of information about the usage of the product, which might include the following: the date when the print cartridge was first installed, the date when the print cartridge was last used, the number of pages printed using the print cartridge, the page coverage, the printing modes used, any printing errors that might have occurred, and the product model. This information helps HP design future products to meet our customers' printing needs.

The data collected from the print cartridge memory chip does not contain information that can be used to identify a customer or user of the print cartridge or their product.

HP collects a sampling of the memory chips from print cartridges returned to HP's free return and recycling program (HP Planet Partners: www.hp.com/recycle). The memory chips from this sampling are read and studied in order to improve future HP products. HP partners who assist in recycling this print cartridge might have access to this data, as well.

Any third party possessing the print cartridge might have access to the anonymous information on the memory chip. If you prefer to not allow access to this information, you can render the chip inoperable. However, after you render the memory chip inoperable, the memory chip cannot be used in an HP product.

End User License Agreement

PLEASE READ CAREFULLY BEFORE USING THIS SOFTWARE PRODUCT: This End-User License Agreement (“EULA”) is a contract between (a) you (either an individual or the entity you represent) and (b) Hewlett-Packard Company (“HP”) that governs your use of the software product (“Software”). This EULA does not apply if there is a separate license agreement between you and HP or its suppliers for the Software, including a license agreement in online documentation. The term “Software” may include (i) associated media, (ii) a user guide and other printed materials, and (iii) “online” or electronic documentation (collectively “User Documentation”).

RIGHTS IN THE SOFTWARE ARE OFFERED ONLY ON THE CONDITION THAT YOU AGREE TO ALL TERMS AND CONDITIONS OF THIS EULA. BY INSTALLING, COPYING, DOWNLOADING, OR OTHERWISE USING THE SOFTWARE, YOU AGREE TO BE BOUND BY THIS EULA. IF YOU DO NOT ACCEPT THIS EULA, DO NOT INSTALL, DOWNLOAD, OR OTHERWISE USE THE SOFTWARE. IF YOU PURCHASED THE SOFTWARE BUT DO NOT AGREE TO THIS EULA, PLEASE RETURN THE SOFTWARE TO YOUR PLACE OF PURCHASE WITHIN FOURTEEN DAYS FOR A REFUND OF THE PURCHASE PRICE; IF THE SOFTWARE IS INSTALLED ON OR MADE AVAILABLE WITH ANOTHER HP PRODUCT, YOU MAY RETURN THE ENTIRE UNUSED PRODUCT.

- 1. THIRD PARTY SOFTWARE.** The Software may include, in addition to HP proprietary software (“HP Software”), software under licenses from third parties (“Third Party Software” and “Third Party License”). Any Third Party Software is licensed to you subject to the terms and conditions of the corresponding Third Party License. Generally, the Third Party License is in a file such as “license.txt” or a “readme” file. You should contact HP support if you cannot find a Third Party License. If the Third Party Licenses include licenses that provide for the availability of source code (such as the GNU General Public License) and the corresponding source code is not included with the Software, then check the product support pages of HP's website (hp.com) to learn how to obtain such source code.
- 2. LICENSE RIGHTS.** You will have the following rights provided you comply with all terms and conditions of this EULA:
 - a. Use.** HP grants you a license to Use one copy of the HP Software. “Use” means installing, copying, storing, loading, executing, displaying, or otherwise using the HP Software. You may not modify the HP Software or disable any licensing or control feature of the HP Software. If this Software is provided by HP for Use with an imaging or printing product (for example, if the Software is a printer driver, firmware, or add-on), the HP Software may only be used with such product (“HP Product”). Additional restrictions on Use may appear in the User Documentation. You may not separate component parts of the HP Software for Use. You do not have the right to distribute the HP Software.
 - b. Copying.** Your right to copy means you may make archival or back-up copies of the HP Software, provided each copy contains all the original HP Software’s proprietary notices and is used only for back-up purposes.
- 3. UPGRADES.** To Use HP Software provided by HP as an upgrade, update, or supplement (collectively “Upgrade”), you must first be licensed for the original HP Software identified by HP as eligible for the Upgrade. To the extent the Upgrade supersedes the original HP Software, you may no longer use such HP Software. This EULA applies to each Upgrade unless HP provides other terms with the Upgrade. In case of a conflict between this EULA and such other terms, the other terms will prevail.

4. TRANSFER.

- a.** Third Party Transfer. The initial end user of the HP Software may make a one-time transfer of the HP Software to another end user. Any transfer will include all component parts, media, User Documentation, this EULA, and if applicable, the Certificate of Authenticity. The transfer may not be an indirect transfer, such as a consignment. Prior to the transfer, the end user receiving the transferred Software will agree to this EULA. Upon transfer of the HP Software, your license is automatically terminated.
- b.** Restrictions. You may not rent, lease or lend the HP Software or Use the HP Software for commercial timesharing or bureau use. You may not sublicense, assign or otherwise transfer the HP Software except as expressly provided in this EULA.
- 5. PROPRIETARY RIGHTS.** All intellectual property rights in the Software and User Documentation are owned by HP or its suppliers and are protected by law, including applicable copyright, trade secret, patent, and trademark laws. You will not remove any product identification, copyright notice, or proprietary restriction from the Software.
- 6. LIMITATION ON REVERSE ENGINEERING.** You may not reverse engineer, decompile, or disassemble the HP Software, except and only to the extent that the right to do so is allowed under applicable law.
- 7. CONSENT TO USE OF DATA.** HP and its affiliates may collect and use technical information you provide in relation to (i) your Use of the Software or the HP Product, or (ii) the provision of support services related to the Software or the HP Product. All such information will be subject to HP's privacy policy. HP will not use such information in a form that personally identifies you except to the extent necessary to enhance your Use or provide support services.
- 8. LIMITATION OF LIABILITY.** Notwithstanding any damages that you might incur, the entire liability of HP and its suppliers under this EULA and your exclusive remedy under this EULA will be limited to the greater of the amount actually paid by you for the Product or U.S. \$5.00. TO THE MAXIMUM EXTENT PERMITTED BY APPLICABLE LAW, IN NO EVENT WILL HP OR ITS SUPPLIERS BE LIABLE FOR ANY SPECIAL, INCIDENTAL, INDIRECT, OR CONSEQUENTIAL DAMAGES (INCLUDING DAMAGES FOR LOST PROFITS, LOST DATA, BUSINESS INTERRUPTION, PERSONAL INJURY, OR LOSS OF PRIVACY) RELATED IN ANY WAY TO THE USE OF OR INABILITY TO USE THE SOFTWARE, EVEN IF HP OR ANY SUPPLIER HAS BEEN ADVISED OF THE POSSIBILITY OF SUCH DAMAGES AND EVEN IF THE ABOVE REMEDY FAILS OF ITS ESSENTIAL PURPOSE. Some states or other jurisdictions do not allow the exclusion or limitation of incidental or consequential damages, so the above limitation or exclusion may not apply to you.
- 9. U.S. GOVERNMENT CUSTOMERS.** Software was developed entirely at private expense. All Software is commercial computer software within the meaning of the applicable acquisition regulations. Accordingly, pursuant to US FAR 48 CFR 12.212 and DFAR 48 CFR 227.7202, use, duplication and disclosure of the Software by or for the U.S. Government or a U.S. Government subcontractor is subject solely to the terms and conditions set forth in this End User License Agreement, except for provisions which are contrary to applicable mandatory federal laws.
- 10. COMPLIANCE WITH EXPORT LAWS.** You will comply with all laws, rules, and regulations (i) applicable to the export or import of the Software, or (ii) restricting the Use of the Software, including any restrictions on nuclear, chemical, or biological weapons proliferation.
- 11. RESERVATION OF RIGHTS.** HP and its suppliers reserve all rights not expressly granted to you in this EULA.

© 2009 Hewlett-Packard Development Company, L.P.

Rev. 04/09

Customer self-repair warranty service

HP products are designed with many Customer Self Repair (CSR) parts to minimize repair time and allow for greater flexibility in performing defective parts replacement. If during the diagnosis period, HP identifies that the repair can be accomplished by the use of a CSR part, HP will ship that part directly to you for replacement. There are two categories of CSR parts: 1) Parts for which customer self repair is mandatory. If you request HP to replace these parts, you will be charged for the travel and labor costs of this service. 2) Parts for which customer self repair is optional. These parts are also designed for Customer Self Repair. If, however, you require that HP replace them for you, this may be done at no additional charge under the type of warranty service designated for your product.

Based on availability and where geography permits, CSR parts will be shipped for next business day delivery. Same-day or four-hour delivery may be offered at an additional charge where geography permits. If assistance is required, you can call the HP Technical Support Center and a technician will help you over the phone. HP specifies in the materials shipped with a replacement CSR part whether a defective part must be returned to HP. In cases where it is required to return the defective part to HP, you must ship the defective part back to HP within a defined period of time, normally five (5) business days. The defective part must be returned with the associated documentation in the provided shipping material. Failure to return the defective part may result in HP billing you for the replacement. With a customer self repair, HP will pay all shipping and part return costs and determine the courier/carrier to be used.

Customer support

Get telephone support for your country/region	Country/region phone numbers are on the flyer that was in the box with your product or at www.hp.com/support/ .
Have the product name, serial number, date of purchase, and problem description ready.	
Get 24-hour Internet support	www.hp.com/support/ljcp5520series
Get support for products used with a Macintosh computer	www.hp.com/go/macosex
Download software utilities, drivers, and electronic information	www.hp.com/go/ljcp5525series_software
Order additional HP service or maintenance agreements	www.hp.com/go/carepack
Register your product	www.register.hp.com

B Product specifications

- [Physical specifications](#)
- [Power consumption, electrical specifications, and acoustic emissions](#)
- [Environmental specifications](#)

Physical specifications

Table B-1 Product dimensions

Product	Height	Depth	Width	Weight
HP Color LaserJet CP5525n	465 mm (18 in)	586 mm (23 in)	544 mm (21.4 in)	53.3 kg (117.3 lb)
HP Color LaserJet CP5525dn	465 mm (18 in)	586 mm (23 in)	544 mm (21.4 in)	53.5 kg (117.8 lb)
HP Color LaserJet CP5525xh	885 mm (34.8 in)	688 mm (27 in)	745 mm (29.3 in)	84 kg (184.8 lb)

Power consumption, electrical specifications, and acoustic emissions

See www.hp.com/support/cljcp5525 for current information.

Environmental specifications

Environmental condition	Recommended	Allowed
Temperature (product and print cartridge)	17° to 25°C (63° to 77°F)	15° to 27°C (59° to 81°F)
Relative humidity	30% to 70% relative humidity (RH)	10% to 70% RH
Altitude	N/A	0 m (0 ft) to 3000 m (9842 ft)

C Regulatory information

- [FCC regulations](#)
- [Environmental product stewardship program](#)
- [Declaration of Conformity](#)
- [Certificate of Volatility](#)
- [Safety statements](#)

FCC regulations

This equipment has been tested and found to comply with the limits for a Class A digital device, pursuant to Part 15 of the FCC rules. These limits are designed to provide reasonable protection against harmful interference in a residential installation. This equipment generates, uses, and can radiate radio frequency energy, and if not installed and used in accordance with the instruction manual, may cause harmful interference to radio communications. Operation of this equipment in a residential area is likely to cause harmful interference in which case the user will be required to correct the interference at his own expense.

 **NOTE:** Any changes or modifications to the printer that are not expressly approved by HP could void the user's authority to operate this equipment.

Use of a shielded interface cable is required to comply with the Class A limits of Part 15 of FCC rules.

Environmental product stewardship program

Protecting the environment

Hewlett-Packard Company is committed to providing quality products in an environmentally sound manner. This product has been designed with several attributes to minimize impacts on our environment.

Ozone production

This product generates no appreciable ozone gas (O₃).

Power consumption

Power usage drops significantly while in Ready and Sleep mode, which saves natural resources and saves money without affecting the high performance of this product. To determine the ENERGY STAR® qualification status for this product, see the Product Data Sheet or Specifications Sheet. Qualified products are also listed at:

www.hp.com/go/energystar

Paper use

This product's optional automatic duplex feature (two-sided printing) and N-up printing (multiple pages printed on one page) capability can reduce paper usage and the resulting demands on natural resources.

Plastics

Plastic parts over 25 grams are marked according to international standards that enhance the ability to identify plastics for recycling purposes at the end of the product's life.

HP LaserJet print supplies

It's easy to return and recycle your HP LaserJet print cartridges after use—free of charge—with HP Planet Partners. Multilingual program information and instructions are included in every new HP LaserJet print cartridge and supplies package. You help reduce the toll on the environment further when you return multiple cartridges together rather than separately.

HP is committed to providing inventive, high-quality products and services that are environmentally sound, from product design and manufacturing to distribution, customer use and recycling. When you participate in the HP Planet Partners program, we ensure your HP LaserJet print cartridges are recycled properly, processing them to recover plastics and metals for new products and diverting millions of tons of waste from landfills. Since this cartridge is being recycled and used in new materials, it will not be returned to you. Thank you for being environmentally responsible!

 **NOTE:** Use the return label to return original HP LaserJet print cartridges only. Please do not use this label for HP inkjet cartridges, non-HP cartridges, refilled or remanufactured cartridges or warranty returns. For information about recycling your HP inkjet cartridges please go to <http://www.hp.com/recycle>.

Return and recycling instructions

United States and Puerto Rico

The enclosed label in the HP LaserJet toner cartridge box is for the return and recycling of one or more HP LaserJet print cartridges after use. Please follow the applicable instructions below.

Multiple returns (more than one cartridge)

1. Package each HP LaserJet print cartridge in its original box and bag.
2. Tape the boxes together using strapping or packaging tape. The package can weigh up to 31 kg (70 lb).
3. Use a single pre-paid shipping label.

OR

1. Use your own suitable box, or request a free bulk collection box from www.hp.com/recycle or 1-800-340-2445 (holds up to 31 kg (70 lb) of HP LaserJet print cartridges).
2. Use a single pre-paid shipping label.

Single returns

1. Package the HP LaserJet print cartridge in its original bag and box.
2. Place the shipping label on the front of the box.

Shipping

For all HP LaserJet print cartridge recycling returns, give the package to UPS during your next delivery or pickup, or take it to an authorized UPS drop-off center. For the location of your local UPS drop-off center, call 1-800-PICKUPS or visit www.ups.com. If you are returning via USPS label, give the package to a U.S. Postal Service carrier or drop off at a U.S. Postal Service Office. For more information, or to order additional labels or boxes for bulk returns, visit www.hp.com/recycle or call 1-800-340-2445. Requested UPS pickup will be charged normal pickup rates. Information subject to change without notice.

Residents of Alaska and Hawaii

Do not use the UPS label. Call 1-800-340-2445 for information and instructions. The U.S. Postal Service provides no-cost cartridge return transportation services under an arrangement with HP for Alaska and Hawaii.

Non-U.S. returns

To participate in HP Planet Partners return and recycling program, just follow the simple directions in the recycling guide (found inside the packaging of your new product supply item) or visit www.hp.com/recycle. Select your country/region for information on how to return your HP LaserJet printing supplies.

Paper

This product is capable of using recycled papers when the paper meets the guidelines outlined in the *HP LaserJet Printer Family Print Media Guide*. This product is suitable for the use of recycled paper according to EN12281:2002.

Material restrictions

This HP product does not contain added mercury.

This HP product contains a battery that might require special handling at end-of-life. The batteries contained in or supplied by Hewlett-Packard for this product include the following:

HP Color LaserJet Enterprise CP5520 Printer Series	
Type	Carbon monofluoride lithium
Weight	0.8 g
Location	On formatter board
User-removable	No



廢電池請回收

For recycling information, you can go to www.hp.com/recycle, or contact your local authorities or the Electronics Industries Alliance: www.eiae.org.

Disposal of waste equipment by users in private households in the European Union

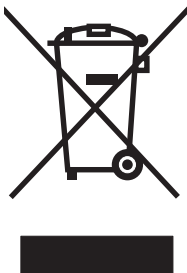

This symbol on the product or on its packaging indicates that this product must not be disposed of with your other household waste. Instead, it is your responsibility to dispose of your waste equipment by handing it over to a designated collection point for the recycling of waste electrical and electronic equipment. The separate collection and recycling of your waste equipment at the time of disposal will help to conserve natural resources and ensure that it is recycled in a manner that protects human health and the environment. For more information about where you can drop off your waste equipment for recycling, please contact your local city office, your household waste disposal service or the shop where you purchased the product.

Chemical substances

HP is committed to providing our customers with information about the chemical substances in our products as needed to comply with legal requirements such as REACH (Regulation EC No 1907/2006 of the European Parliament and the Council). A chemical information report for this product can be found at: www.hp.com/go/reach.

Material Safety Data Sheet (MSDS)

Material Safety Data Sheets (MSDS) for supplies containing chemical substances (for example, toner) can be obtained by accessing the HP Web site at www.hp.com/go/msds or www.hp.com/hpinfo/community/environment/productinfo/safety.

For more information

To obtain information about these environmental topics:

- Product environmental profile sheet for this and many related HP products
- HP's commitment to the environment
- HP's environmental management system
- HP's end-of-life product return and recycling program
- Material Safety Data Sheets

Visit www.hp.com/go/environment or www.hp.com/hpinfo/globalcitizenship/environment.

Declaration of Conformity

Declaration of Conformity

according to ISO/IEC 17050-1 and EN 17050-1

Manufacturer's Name: Hewlett-Packard Company DoC#: BOISB-0905-00 rel.1.0

Manufacturer's Address: 11311 Chinden Boulevard
Boise, Idaho 83714-1021, USA

declares, that the product

Product Name: HP LaserJet Enterprise CP5525 Series

Including:

CE860A – 500-sheet paper tray

CE725A – 3x500-sheet paper tray and stand

Regulatory Model Number²⁾ BOISB-0905-00

Product Options: ALL

Print Cartridges: CE270A, CE271A, CE272A, CE273A

conforms to the following Product Specifications:

SAFETY: IEC 60950-1:2005 / EN60950-1: 2006

IEC 60825-1:2007 / EN 60825-1:2007 (Class 1 Laser/LED Product)

IEC 62311:2007 / EN62311:2008

GB4943-2001

EMC: CISPR22:2005 +A1 / EN55022:2006 +A1 - Class A^{1), 2)}

EN 61000-3-2:2006

EN 61000-3-3:1995 +A1 +A2

EN 55024:1998 +A1 +A2

FCC Title 47 CFR, Part 15 Class A²⁾ / ICES-003, Issue 4

GB9254-2008, GB17625.1-2003

ENERGY USE: Regulation (EC) No. 1275/2008

ENERGY STAR® Qualified Imaging Equipment Typical Electricity Consumption (TEC) Test Procedure

Supplementary Information:

The product herewith complies with the requirements of the EMC Directive 2004/108/EC and the Low Voltage Directive 2006/95/EC, the EuP Directive 2005/32/EC and carries the CE-Marking  accordingly.

This Device complies with Part 15 of the FCC Rules. Operation is subject to the following two Conditions: (1) this device may not cause harmful interference, and (2) this device must accept any interference received, including interference that may cause undesired operation.

1. The product was tested in a typical configuration with Hewlett-Packard Personal Computer Systems.
2. The product meets the requirements of EN55022 & CNS13438 Class A in which case the following applies: "Warning – This is a class A product. In a domestic environment this product may cause radio interference in which case the user may be required to take adequate measures."
3. 3) For regulatory purposes, this product is assigned a Regulatory model number. This number should not be confused with the product name or the product number(s).

Boise, Idaho USA

October 2010

For regulatory topics only:

European Contact: Your Local Hewlett-Packard Sales and Service Office or Hewlett-Packard GmbH, Department HQ-TRE / Standards Europe, Herrenberger Strasse 140, D-71034, Böblingen (FAX: +49-7031-14-3143)
www.hp.com/go/certificates

USA Contact: Product Regulations Manager, Hewlett-Packard Company, PO Box 15, Mail Stop 160, Boise, Idaho 83707-0015 (Phone: 208-396-6000)

Certificate of Volatility

This is a statement regarding the volatility of customer data stored in memory. This statement describes how to securely erase data from the product.

Types of memory

Volatile memory

The product utilizes volatile memory (a total of 1024MB) to support the embedded OS and to store customer data during the printing process. When the product is powered off, this volatile memory is erased.

Non-volatile memory

The product utilizes non-volatile memory (EEPROM) to store system control data and user preference settings. No customer print data is stored in non-volatile memory. This non-volatile memory can be cleared and restored to factory defaults by performing a Cold Reset or Restore Factory Settings at the control panel.

Hard-disk-drive memory

The product contains an internal hard disk drive that may retain data after the product is powered off. The product also might contain additional optional compact flash storage, or an external EIO hard disk. Data stored in these devices might be from stored print jobs or third-party solutions.

Some of this data can be erased by using the product control panel, but most must be erased using the Secure Disk Erase feature available in the device BIOS Menu, the Embedded Web Server (EWS) for the product, and from HP Web Jetadmin. Secure Storage Erase features comply with U.S. NIST Special Publication 800-88 Guidelines for Media Sanitization.

Safety statements

Laser safety

The Center for Devices and Radiological Health (CDRH) of the U.S. Food and Drug Administration has implemented regulations for laser products manufactured since August 1, 1976. Compliance is mandatory for products marketed in the United States. The device is certified as a “Class 1” laser product under the U.S. Department of Health and Human Services (DHHS) Radiation Performance Standard according to the Radiation Control for Health and Safety Act of 1968. Since radiation emitted inside the device is completely confined within protective housings and external covers, the laser beam cannot escape during any phase of normal user operation.

- ⚠ **WARNING!** Using controls, making adjustments, or performing procedures other than those specified in this user guide may result in exposure to hazardous radiation.

Canadian DOC regulations

Complies with Canadian EMC Class A requirements.

« Conforme à la classe A des normes canadiennes de compatibilité électromagnétiques. « CEM ». »

VCCI statement (Japan)

この装置は、クラスA情報技術装置です。この装置を家庭環境で使用すると電波妨害を引き起こすことがあります。この場合には使用者は適切な対策を講ずるよう要求されることがあります。

VCCI-A

Power cord instructions

Make sure your power source is adequate for the product voltage rating. The voltage rating is on the product label. The product uses either 100-127 Vac or 220-240 Vac and 50/60 Hz.

Connect the power cord between the product and a grounded AC outlet.

- ⚠ **CAUTION:** To prevent damage to the product, use only the power cord that is provided with the product.

Power cord statement (Japan)

製品には、同梱された電源コードをお使い下さい。
同梱された電源コードは、他の製品では使用出来ません。

EMC statement (China)

此为 A 级产品，在生活环境中，该产品可能会造成无线电干扰。在这种情况下，可能需要用户对其干扰采取切实可行的措施。

EMC statement (Korea)

A급 기기 (업무용 방송통신기기)	이 기기는 업무용(A급)으로 전자파적합등록을 한 기기이오니 판매자 또는 사용자는 이점을 주의하시기 바라며, 가정 외의 지역에서 사용하는 것을 목적으로 합니다.
-----------------------	--

EMI statement (Taiwan)

<p>警告使用者：</p> <p>這是甲類的資訊產品，在居住的環境中使用時，可能會造成射頻干擾，在這種情況下，使用者會被要求採取某些適當的對策。</p>
--

Laser statement for Finland

Luokan 1 laserlaite

Klass 1 Laser Apparar

HP Color LaserJet CP5525n, CP5525dn, CP5525xh, laserkirjoitin on käyttäjän kannalta turvallinen luokan 1 laserlaite. Normaalisissa käytössä kirjoittimen suojakoteloimint estää lasersäteiden pääsyn laitteen ulkopuolelle. Laitteen turvallisuusluokka on määritetty standardin EN 60825-1 (2007) mukaisesti.

VAROITUS !

Laitteen käyttäminen muulla kuin käyttöohjeessa mainitulla tavalla saattaa altistaa käyttäjän turvallisuusluokan 1 ylittävälle näkymättömälle lasersäteilylle.

VARNING !

Om apparaten används på annat sätt än i bruksanvisning specificerats, kan användaren utsättas för osynlig laserstrålning, som överskrider gränsen för laserklass 1.

HUOLTO

HP Color LaserJet CP5525n, CP5525dn, CP5525xh - kirjoittimen sisällä ei ole käyttäjän huollettavissa olevia kohteita. Laitteen saa avata ja huoltaa ainoastaan sen huoltamiseen koulutettu henkilö. Tällaiseksi huoltotoimenpiteeksi ei katsota väriainekasetin vaihtamista, paperiradan puhdistusta tai muita käyttäjän käsikirjassa lueteltuja, käyttäjän tehtäväksi tarkoitettuja ylläpitotoimia, jotka voidaan suorittaa ilman erikoistyökaluja.

VARO !

Mikäli kirjoittimen suojakotelo avataan, olet alttiina näkymättömälle lasersäteilylle laitteen ollessa toiminnassa. Älä katso säteeseen.

VARNING !

Om laserprinterns skyddshölje öppnas då apparaten är i funktion, utsätts användaren för osynlig laserstrålning. Betrakta ej strålen.

Tiedot laitteessa käytettävän laserdiodin säteilyominaisuuksista: Aallonpituus 775-795 nm Teho 5 m W Luokan 3B laser.

GS statement (Germany)

Das Gerät ist nicht für die Benutzung im unmittelbaren Gesichtsfeld am Bildschirmarbeitsplatz vorgesehen. Um störende Reflexionen am Bildschirmarbeitsplatz zu vermeiden, darf dieses Produkt nicht im unmittelbaren Gesichtsfeld platziert werden.

Substances Table (China)

有毒有害物质表

根据中国电子信息产品污染控制管理办法的要求而出台

部件名称	有毒有害物质和元素					
	铅 (Pb)	汞 (Hg)	镉 (Cd)	六价铬 (Cr(VI))	多溴联苯 (PBB)	多溴二苯醚 (PBDE)
打印引擎	X	0	0	0	0	0
控制面板	0	0	0	0	0	0
塑料外壳	0	0	0	0	0	0
格式化板组件	X	0	0	0	0	0
碳粉盒	X	0	0	0	0	0

0609

0：表示在此部件所用的所有同类材料中，所含的此有毒或有害物质均低于 SJ/T11363-2006 的限制要求。

X：表示在此部件所用的所有同类材料中，至少一种所含的此有毒或有害物质高于 SJ/T11363-2006 的限制要求。

注：引用的“环保使用期限”是根据在正常温度和湿度条件下操作使用产品而确定的。

Restriction on Hazardous Substances statement (Turkey)

Türkiye Cumhuriyeti: EEE Yönetmeliğine Uygundur

Index

Symbols/Numerics

- 1 x 500-sheet paper feeder assembly
 - components, removing 222
- 3 x 500-paper feeder assembly
 - components, removing 236

A

- accessories
 - ordering 552
- accessories installed, information 353
- acoustic specifications 642
- Administration menu, control panel 261, 365
- after-service checklist 86

B

- Backup/Restore menu, control panel 276, 406
- bands, troubleshooting 526
- batteries included 647
- blank pages
 - troubleshooting 532
- blank pages, troubleshooting 525

C

- cable, USB
 - troubleshooting 532
- Calibrate/Cleaning menu, control panel 277, 407
- calibration
 - information, printed 347
 - process 41
- Canadian DOC regulations 652
- cartridge
 - developing unit engagement and disengagement 36
 - life detection 36

- memory tag 36
- ordering 553
- part number 553
- presence detection 36
- toner level detection 36
- cartridges
 - error messages 483
 - recycling 645
 - removing 87
 - replace message 483
 - warranty 633
- cautions iii
- characters, troubleshooting 529
- checklists
 - after-service 86
 - preservice 86
- circuit diagram 340
- clean the paper path
 - cleaning page printing 349, 531
- cleaning
 - product 531
- color
 - diagnostic test 354
 - troubleshooting 347, 527
- components
 - diagnostic tests 314
- configuration page 284
- configuration pages
 - information 353
 - printing 350
- connectivity
 - solving problems 533
- control panel
 - Administration menu 261, 365
 - assembly, removing 113
 - Backup/Restore menu 276, 406

- Calibrate/Cleaning menu 277, 407
- Display Settings menu 269, 384
- General Settings menu 261, 367
- Manage Supplies menu 270, 385
- Manage Trays menu 271, 388
- messages, troubleshooting 411
- Network Settings menu 272, 391
- Print Options menu 267, 382
- Print Settings menu 266, 380
- Reports menu 261, 365
- Service menu 278, 409
- Supplies menu 258, 360
- Trays menu 260, 363
- Troubleshooting menu 275, 401
- USB Firmware Upgrade menu 277, 408
- control-panel menus
 - Retrieve From USB Settings 266, 380
 - retrieve job from device memory 257, 359
 - Retrieve Job From USB 257, 358
 - Sign In 257, 357
- conventions, document iii
- counts
 - page, reset 534
 - reset after replacing formatter 534
 - See also pages counts

- covers
 - control-panel assembly, removing 113
 - front-door assembly, removing 123
 - identification and location 111
 - left, removing 115
 - rear, removing 116
 - right-door assembly, removing 126
 - right-front, removing 113
 - right-rear, removing 119
 - top, removing 121
- creases, troubleshooting 529
- crooked pages
 - troubleshooting 529
- customer support
 - online 639
- D**
- dark image, troubleshooting 525
- date
 - codes for firmware 353
 - manufacture 352
- DC controller
 - PCA, removing 207
- DC controller, operation 9
- defeating
 - interlocks 286
- delivery unit
 - delivery drive assembly (simplex models), removing 189
- demo page 284
- determine the problem source 279
- developing stage 31
- diagnostics
 - component 314
 - engine 285
 - LED 284
 - networks 396
 - page, printing 347
 - See also tests; troubleshooting
- diagrams 551
- Display Settings menu, control panel 269, 384
- disposal, end-of-life 647
- document conventions iii
- doors. See covers
- driver PCA
 - removing 218
- drum cleaning stage 34
- duplex
 - paper path 63
- duplexing unit
 - duplex drive assembly (duplex models), removing 187
 - jam causes 509
- E**
- electrical specifications 642
- electrostatic discharge (ESD) 84
- end-of-life disposal 647
- engine
 - diagnostics 285
- engine speed
 - paper type 59
- engine test button 288
- engine-control system 8
- envelopes
 - jams 519
- environment, specifications 642
- Environmental Product Stewardship Program 645
- error messages, control panel 411
- ESD (electrostatic discharge) 84
- European Union, waste disposal 647
- event log
 - clear 494
 - information 353
 - print 493
 - view 493
- event-log messages 492
- F**
- faded print 525
- fans
 - fuser, removing 201
 - power-supply fan and fan duct, removing 198
- FCC regulations 644
- Finnish laser safety statement 653
- firmware
 - date codes 353
 - version information 352
- firmware, downloading new 547
- flowcharts
 - troubleshooting 280
- formatter
 - case, removing 130
 - PCA, removing 105
 - resets after replacing 534
- formatter fan
 - removing 204
- formatter lights 284
- fuser
 - jam causes 508
 - jams 501
 - motor, removing 196
 - operation 59
 - part number 554
- fuser drive assembly
 - removing 172
- fusing stage 33
- G**
- General Settings menu, control panel 261, 367
- H**
- heartbeat LED 285
- high-voltage power supply
 - removing, first transfer 214
 - removing, imaging (developing) 213
 - removing, second transfer 216
- HP Customer Care 639
- HP Jetdirect print server
 - configuration page 352
 - lights 284
- humidity requirements 642
- humidity values, printed 347
- I**
- ICB PCA
 - removing 204
- image quality
 - calibration process 41
 - print, troubleshooting 524
- imaging drums
 - diagnostic test 287
- installation
 - verify for optional accessories 350
- interlocks
 - defeating 286

intermediate transfer belt (ITB)
102
IPv4 information 352
IPv6 information 352
ITB
part number 554
ITB cleaning stage 34
ITB unit
operation 38

J

jams

common causes of 495
detection theory 66
diagnostic test for 288
duplex area 509
envelopes 519
fuser 501
fuser area 508
locations 496
lower right door 503
output bin 507, 508
recovery 515
Tray 1 504
Tray 1 and Tray 2 510
Tray 2 506
Tray 3 506
Tray 3, 4, and 5 513
Tray 4 506
Tray 4, 5, or 6 503
Tray 5 506
Tray 6 506
upper right door 501
Japanese VCCI statement 652
Jetdirect print server
lights 284

K

Korean EMC statement 653

L

laser beam exposure stage 30
laser safety statements 652, 653
laser/scanner
assembly, removing 132
operations 24
LEDs. See lights
left cover, removing 115
license, software 636
lifter-drive assembly
removing 145

light print, troubleshooting 525
lights
formatter 284
troubleshooting with 284
lines, troubleshooting 526
link speed settings 400
loose toner, troubleshooting 528
low-voltage power supply
removing 209
lower right door
jams 503

M

Macintosh
support 639
main drive assembly
removing 157
Manage Supplies menu, control
panel 270, 385
Manage Trays menu, control
panel 271, 388
manual print modes 521
material restrictions 647
Material Safety Data Sheet
(MSDS) 648
memory
information 350
print cartridge 36
supply errors 411
memory chip, print cartridge
description 635
menus, control panel
Administration 261, 365
Backup/Restore 276, 406
Calibrate/Cleaning 277, 407
Display Settings 269, 384
General Settings 261, 367
Manage Supplies 270, 385
Manage Trays 271, 388
Network Settings 272, 391
Print Options 267, 382
Print Settings 266, 380
Reports 261, 365
Service 278, 409
Supplies 258, 360
Trays 260, 363
Troubleshooting 275, 401
USB Firmware Upgrade 277,
408

menus, control-panel
Retrieve From USB Settings
266, 380
retrieve job from device
memory 257, 359
Retrieve Job From USB 257,
358
Sign In 257, 357
mercury-free product 647
messages, control panel 411
model number 352
motors
developing motor, removing
195
developing-disengagement,
removing 197
drum motor, removing 194
fuser, removing 196
ITB, removing 192
paper path 47

N

Network Settings menu, control
panel 272, 391
networks
diagnostics 396
HP embedded Jetdirect
configuration page 352
link speed settings 400
security 391
notes iii

O

online support 639
operating environment
specifications 642
operations
engine-control system 8
laser/scanner 24
print cartridge memory 36
ordering
500-sheet tray 557
print cartridge 553
product documents 552
supplies and accessories 552
output bin
jam causes 508
jams 507
output quality
print, troubleshooting 524

- P**
- pages
 - blank 532
 - not printing 532
 - printing slowly 532
 - skewed 529
 - pages count
 - reset 534
 - See *also* counts
 - paper
 - pickup assembly, removing 135
 - stop in path for testing 314
 - wrinkled 529
 - paper delivery assembly
 - removing 184
 - paper jams
 - locations 496
 - paper movement
 - operation 44
 - paper path
 - diagnostic test 288
 - operation 55
 - stop movement for testing 314
 - paper-path
 - test, sensors 313
 - parameters, EP, troubleshooting 347
 - part number
 - 500-sheet tray 557
 - print cartridge 553
 - parts 551
 - parts lists and diagrams
 - 1x500 paper feeder 590
 - 3x500 paper feeder 596
 - cassette 582
 - covers, panels, and doors 560
 - internal components 564, 566, 568, 570, 572, 574, 576, 578, 580
 - paper delivery assembly 586
 - paper pick-up assembly 584
 - printed circuit assemblies 588
 - right door components 562
 - using 558
 - password
 - Service menu PIN 534
 - pick-up rollers
 - part numbers 555
 - pliers, required 85
 - port configuration information 352
 - post-service tests 86
 - power
 - consumption 642
 - power supply
 - troubleshooting 282
 - power switch PCA
 - removing 220
 - pre-exposure stage 29
 - pre-troubleshooting checklist 279
 - preservice checklist 86
 - primary charging stage 29
 - primary transfer stage 32
 - print cartridge
 - developing unit engagement and disengagement 36
 - life detection 36
 - memory tag 36
 - ordering 553
 - part number 553
 - presence detection 36
 - toner level detection 36
 - print cartridges
 - diagnostic test 287
 - error messages 483
 - memory chips 635
 - recycling 645
 - removing 87
 - replace message 483
 - warranty 633
 - Print Options menu, control panel 267, 382
 - print quality
 - built-in troubleshooting pages 344
 - manual print modes 521
 - test 86
 - test pages 344
 - troubleshooting 524
 - Print Quality menu options 521
 - Print Settings menu, control panel 266, 380
 - printing
 - modes, manual 521
 - stop for testing 314
 - troubleshooting 532
 - problem source
 - determine 279
 - problem-solving
 - event-log messages 492
 - networks 396
 - product specifications 641
- Q**
- quality
 - print, troubleshooting 524
- R**
- recycling
 - HP printing supplies returns and environmental program 646
 - regulatory statements
 - environmental product stewardship program 645
 - removing parts
 - 1 x 500-sheet paper feeder assembly 222
 - 3 x 500-sheet paper feeder assembly 236
 - cautions for 84
 - checklists 86
 - control-panel assembly 113
 - DC controller PCA 207
 - delivery drive assembly (simplex models) 189
 - developing motor 195
 - developing-disengagement motor 197
 - driver PCA 218
 - drum motor 194
 - duplex drive assembly (duplex models) 187
 - environmental sensor 221
 - formatter case 130
 - formatter fan 204
 - formatter PCA 105
 - front-door assembly 123
 - fuser 93
 - fuser drive assembly 172
 - fuser fan 201
 - fuser gear assembly 176
 - fuser motor 196
 - high-voltage power supply, first transfer 214
 - high-voltage power supply, second transfer 216
 - ICB PCA 204

- imaging (developing) high-voltage power supply 213
- intermediate transfer belt 102
- ITB motor 192
- laser/scanner assembly 132
- left cover 115
- lifter-drive assembly 145
- low-voltage power supply 209
- main drive assembly 157
- paper delivery assembly 184
- paper pickup assembly 135
- pickup roller (tray 1) 94
- pickup roller (tray 2) 98
- power switch PCA 220
- power-supply fan and fan duct 198
- print cartridges 87
- rear cover 116
- registration sensor assembly 142
- residual toner full sensor 152
- residual-toner-feed assembly 190
- right-door assembly 126
- right-front cover 113
- right-rear cover 119
- secondary transfer roller 101
- separation pad (Tray 1) 95
- separation roller (tray 2) 97
- toner-collection unit 91
- tools, required 85
- top cover 121
- replace supplies message 483
- replacing
 - parts 84
- Reports menu, control panel 261, 365
- Retrieve From USB Settings menu 266, 380
- retrieve job from device memory menu 257, 359
- Retrieve Job From USB menu 257, 358
- roller
 - pickup roller (Tray 1), removing 94
 - pickup roller (Tray 2), removing 98
- rollers
 - separation roller (Tray 2), removing 97
- S**
- safety statements 652, 653
- screwdrivers, required 85
- screws
 - replacing 84
- secondary transfer roller
 - part number 554
- secondary transfer roller, removing 101
- secondary transfer stage 32
- security
 - settings 391
- security settings information 352
- sensor tests manual
 - developer alienation sensor (PS11) 298
 - front-door opening/closing switch (PS14) 291
 - fuser loop sensors 1 and 2 (PS7 and PS8) 295
 - fuser output sensor (PS 6) 297
 - fuser pressure-release sensor (PS9) 296
 - ITB alienation switch (SW5) 299
 - output-bin-full sensor (PS10) 313
 - right-door opening/closing sensor (PS15) 292
 - TOP sensor (PS5) 294
 - tray 3 paper size sensors (SW2 and SW3) 308
 - tray 4 paper size sensors (SW2 and SW3) 311
- sensor tests manual tray/bin
 - tray 1 paper sensor (PS2) 302
 - tray 2 paper sensor (PS1) 303
 - tray 2 paper size switches (SW7 and SW8) 305
 - tray 2 paper surface (PS4) 304
 - tray 3 door opening/closing sensor (SW1) 310
 - tray 3 feed sensor (SR1) 309
 - tray 3 paper sensor (SR1) 307
 - tray 3 paper sensor (SR3) 306
- tray 4 door opening/closing door sensor (SW1) 311
- tray 4 feed sensor (X) 311
- tray 4 paper sensor (SR3) 311
- tray 4 paper surface sensor (SR2) 311
- tray 5 door opening/closing sensor (SW1) 312
- tray 5 feed sensor (SR81) 312
- tray 5 paper sensor (SR83) 312
- tray 5 paper size sensors (SW82 and SW83) 312
- tray 5 paper surface sensor (SR82) 312
- tray 6 door opening/closing sensor (SW1) 312
- tray 6 feed sensor (SR91) 312
- tray 6 paper sensor (SR93) 312
- tray 6 paper size sensors (SW92 and SW93) 312
- tray 6 paper surface sensor (SR92) 312
- sensors
 - diagnostic tests 313
 - environmental, removing 221
 - fuser gear assembly, removing 176
 - paper path 46
 - registration sensor assembly, removing 142
 - residual toner full sensor, removing 152
 - tests, manual 289
 - tests, manual tray/bin 300
- separation stage 33
- service
 - tools, required 85
- Service menu options 534
- Service menu, control panel 278, 409
- Sign In menu 257, 357
- skew prevention 57
- skewed pages
 - troubleshooting 529
- smear toner, troubleshooting 529

- software
 - software license agreement 636
- solenoids
 - paper path 47
- solve problems 253
- solving
 - direct-connect problems 533
 - network problems 533
- specifications
 - electrical and acoustic 642
 - operating environment 642
- static precautions 84
- status page 284
- stop printing for test 314
- streaks, troubleshooting 526
- supplies
 - error messages 483
 - memory errors 411
 - ordering 552
 - recycling 645
 - replace message 483
- Supplies menu, control panel 258, 360
- support
 - online 639
- T**
- Taiwan EMI statement 653
- TCP/IP information 352
- technical support
 - online 639
- temperature
 - values, printed 347
- temperature requirements 642
- test page
 - engine 288
- tests
 - color band 354
 - component tests list and descriptions (1 of 2) 315
 - component tests list and descriptions (2 of 2) 317
 - disable cartridge check 287
 - manual sensor 289
 - networks 396
 - paper path 288
 - paper-path sensors 313
 - post-service 86
 - print-quality 86
 - print/stop 314
 - tray/bin manual sensor 300
- text, troubleshooting 529
- tips iii
- toner
 - loose, troubleshooting 528
 - smear, troubleshooting 529
- toner cartridges. *See* print cartridges
- toner collection unit
 - part number 555
 - removing 91
- tools, required 85
- transfer stage 32
- transfer unit
 - operation 38
- Tray 1
 - jams 504
- Tray 2
 - jams 506
- trays
 - jam causes 510, 513
- Trays menu, control panel 260, 363
- troubleshooting
 - about 279
 - blank pages 532
 - checklist 254, 279
 - clean the paper path 349, 531
 - color 347
 - configuration page 284
 - configuration pages for 350
 - control panel messages 411
 - demo page 284
 - direct-connect problems 533
 - duplexing 520
 - EP parameters 347
 - event log 284
 - flowchart 280
 - jams in duplex area 509
 - jams in fuser area 508
 - jams in output bin 508
 - jams in Tray 1 and Tray 2 510
 - jams in Tray 3, 4, and 5 513
 - lights, using 284
 - lines, printed pages 526
 - network problems 533
 - pages not printing 532
 - pages printing slowly 532
 - power 282
 - print quality 524
 - problem source 279
 - reports and tools 284
 - skewed pages 529
 - status page 284
 - text 529
 - toner smear 529
 - transparencies 518
 - USB cables 532
 - wrinkles 529
 - See also* diagnostics
- Troubleshooting menu, control panel 275, 401
- U**
- updates, downloading product 547
- upper right door
 - jams 501
- USB Firmware Upgrade menu, control panel 277, 408
- USB port
 - troubleshooting 532
- V**
- version, hardware firmware 352
- vertical lines, troubleshooting 526
- W**
- warnings iii
- warranty
 - customer self repair 638
 - license 636
 - print cartridges 633
 - product 632
- Web sites
 - customer support 639
 - Macintosh customer support 639
 - Material Safety Data Sheet (MSDS) 648
 - white spots, troubleshooting 526
 - wiring diagram 340
 - wrinkles, troubleshooting 529



CE707-90935

