



Dell 5130cn **Service Manual**

4 Jun 2010

**Information in this document is subject to change without notice.
2010 Dell Inc. All rights reserved.**

Reproduction in any manner whatsoever without the written permission of Dell Inc. is strictly forbidden.
Trademarks used in this text: Dell and the DELL logo are trademarks of Dell Inc.

Other trademarks and trade names may be used in this document to refer to the entities claiming the marks and names of their products. Dell Inc. disclaims any proprietary interest in trademarks and trade names other than its own.

Version record

Refer to the portion indicated by change bar in each section.

Also refer to the reasons in table below.

Version	Issue Date	Note
1 st	Mar 2000	1 st issue
2 nd	June 2000	<p>2nd version issue</p> <p>Introduction The matter of the matter as a whole. The illustration as a whole or a whole.</p> <p>Chapter Troubleshooting The procedure of the troubleshooting as revised according to the specification change.</p> <p>Chapter Generation of Diagnostic The content of the menu tree as revised according to the specification change.</p> <p>Chapter The procedure of the as revised according to the specification change.</p> <p>Chapter Plug-in Connector Locations The illustration as a whole.</p> <p>Chapter Parts List The illustration as a whole.</p> <p>Chapter Principles of Operation The air flow of as a whole to electrical. The relevant Timing of Consumables and Periodic Relevant Parts as a whole.</p> <p>Chapter Wiring Diagrams The parts were corrected.</p> <p>Chapter Printer Specifications The printer specification as revised according to the specification change.</p>
3 rd	Jul 2000	<p>3rd version issue</p> <p>Chapter Troubleshooting The internal result as reflected.</p> <p>Chapter The procedure of the as revised according to the specification change.</p> <p>Chapter Parts List The illustration of the as revised according to the specification change.</p> <p>Chapter Wiring Diagrams The illustration of WTC as a whole as a whole.</p>
4 th	Jul 2000	<p>4th version issue</p> <p>Chapter Troubleshooting The engineer's request as reflected.</p>

		<p>Additional Correction (July 17, 2009)</p> <p>Revision Details.</p> <p>Page 0000</p> <p>The state of the Status Contents column was corrected as follows.</p> <p>Page 0000</p> <p>The explanation of the Status Contents column was revised.</p> <p>Page 0000</p> <p>The explanation of in the solution was revised.</p> <p>Page 0000</p> <p>The explanation of and in the solution was revised.</p>
<p>0000</p>	<p>0000</p>	<p>0000 version issue</p> <p>Chapter Troubleshooting</p> <p>The Dell's request was reflected.</p> <p>Additional Correction 0000</p> <p>Revision Details.</p> <p>Page 0000</p> <p>The content of 0000 was revised. In the illustration of 0000 combinations each 0000 was corrected.</p> <p>Page 0000</p> <p>The illustration that shows the location of the information button was added.</p> <p>Page 0000</p> <p>The flow of the connector connection confirmation was added. In the illustration that shows the location of the connector was added.</p> <p>Page 0000</p> <p>The content of 0000 was revised. Correction according to 0000 of digital output.</p> <p>Chapter Generation of Diagnostic</p> <p>The content of Diagnost was revised.</p> <p>Page 0000</p> <p>The explanation of Digital Output of Customer 0000 was added.</p> <p>Page 0000</p> <p>The operational procedure of Diag was revised.</p> <p>Chapter 0000</p> <p>The procedure of the 0000 was revised.</p> <p>Page 0000</p> <p>Correction according to 0000 of 0000 connection of connector.</p> <p>Chapter 0000</p>

		<p>The Connector not used as clarified. Page [redacted]</p> <p>The latest specification was reflected. Page [redacted]</p> <p>Chapter [redacted]</p> <p>The Connector not used as clarified. Page [redacted]</p> <p>The latest specification was reflected. Page [redacted]</p> <p>Chapter [redacted] Wiring Diagrams The latest specification was reflected. Page [redacted]</p> <p>Chapter [redacted] Definitions The latest specification was reflected. Page [redacted]</p>
[redacted]	January [redacted]	<p>[redacted] version issue</p> <p>Chapter [redacted] Troubleshooting The following [redacted]s were received along with the defective operation of [redacted] Coupling Cover. [redacted] [redacted] [redacted] [redacted] and [redacted] [redacted].</p> <p>The following [redacted]s changed the title name. [redacted] [redacted] [redacted] and [redacted] [redacted]</p>
[redacted]	June [redacted]	<p>[redacted] version issue</p> <p>Chapter [redacted] Troubleshooting The following [redacted]s were received. [redacted]</p>

Cautions

Operation contents of this document may be subject to modification without notice.

Dell Inc. will not assume responsibility for accidental or incidental damages resulting from technical or editorial errors or omissions in this manual, the issue of this manual, the execution of descriptions in this manual, or the use of this manual.

This document is protected by copyright. Do not photocopy or duplicate any part of this document in any form without written permission from Dell Inc.

1. About this manual

This manual is a standard service manual of Dell Inc. containing information required for maintenance of this laser printer (standard specifications).

2. Marks giving caution

Maintenance operations requiring special cautions or additional information regarding descriptions in this manual are presented as "Warning," "Caution," or "Note," depending on their nature.



If instructions are not observed, death or serious injury may result.



If instructions are not observed, injuries to workers or physical damage to assets (including this laser printer) may result.

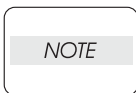

Essentials for procedures, steps, rules, and others.

Reference *Incidental information to descriptions.*

3. Related documents

- Instruction manuals (standard manuals)

Describe the operation and handling of this laser printer.

- Performance specifications

Describe in detail various specifications of this laser printer.

(In the event of a discrepancy between this manual and the performance specifications, the performance specifications take precedence.)

- Spare parts list

Information on maintenance parts (spare parts) for this laser printer.

4. Safety

To prevent possible accidents during maintenance operation, you should observe strictly the "Warning" and "Caution" information in this manual.

Avoid dangerous operations and operations out of the scope of this manual.

Various processes not covered by this manual may be required in actual operations, and should be performed carefully, always giving attention to safety.

4.1 Power source

Keep the power plug disconnected during the maintenance operation to prevent electric shock, burns and other damages.

If the power supply should be kept connected to measure voltage or for other similar reasons, take sufficient care to prevent electric shock, by following the procedures in this manual.



While the printer is on, never touch live parts if not required.



Power is supplied to the power switch / inlet even while the printer is off. Never touch its live components.



Do not touch live parts unless otherwise specified.

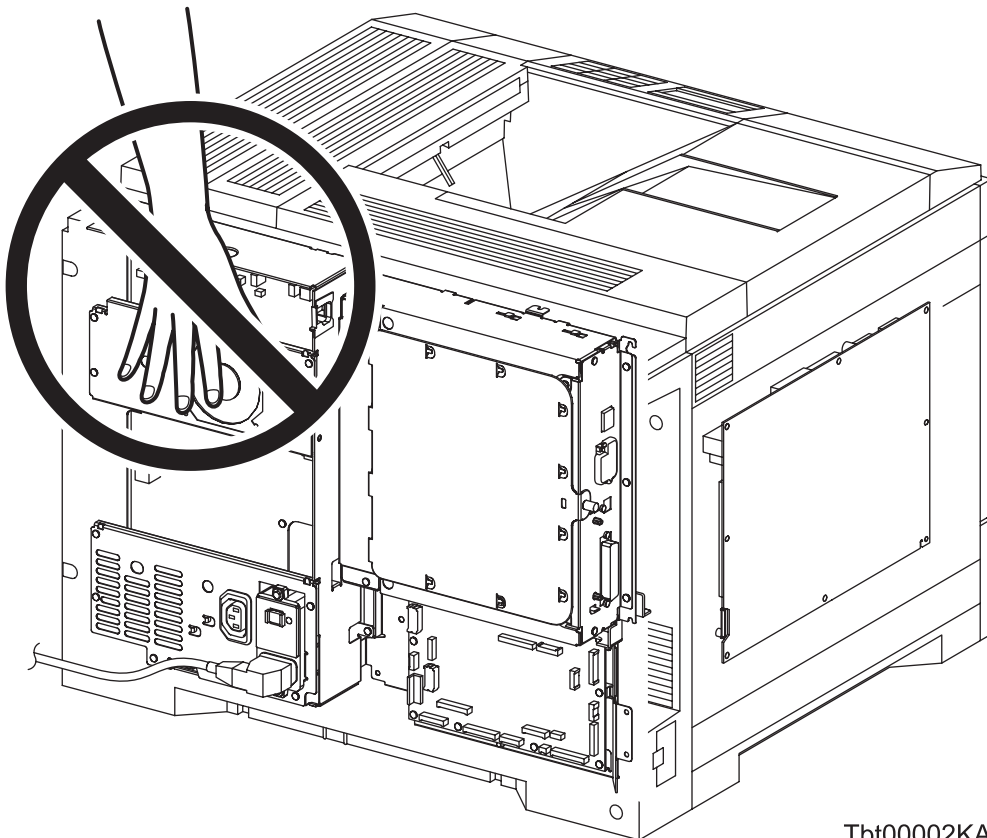

Tbt00002KA

4.2 Driving units

When servicing gears or other driving units, be sure to turn off the power switch and unplug the power cord. Drive them manually when required.



Do not do the print work removing the cover of the printer to confirm the operation of driving part.

4.3 High-temperature units

When servicing high-temperature units (securing unit, etc.), be sure to turn them off to prevent burns, injuries and other troubles. Remove the power plug and start service processes after they have cooled down sufficiently.



Because high-temperature units are still hot after they complete an operation, wait at least 30 minutes before starting maintenance service.

|

4.4 Battery

Lithium Battery is used in the following component.

- PWBA ESS



***There is a danger of a new battery exploding if it is incorrectly installed.
Replace the battery only with the same or equivalent type recommended by the
manufacturer.***

Dispose the battery according to the manufacturer's instruction.

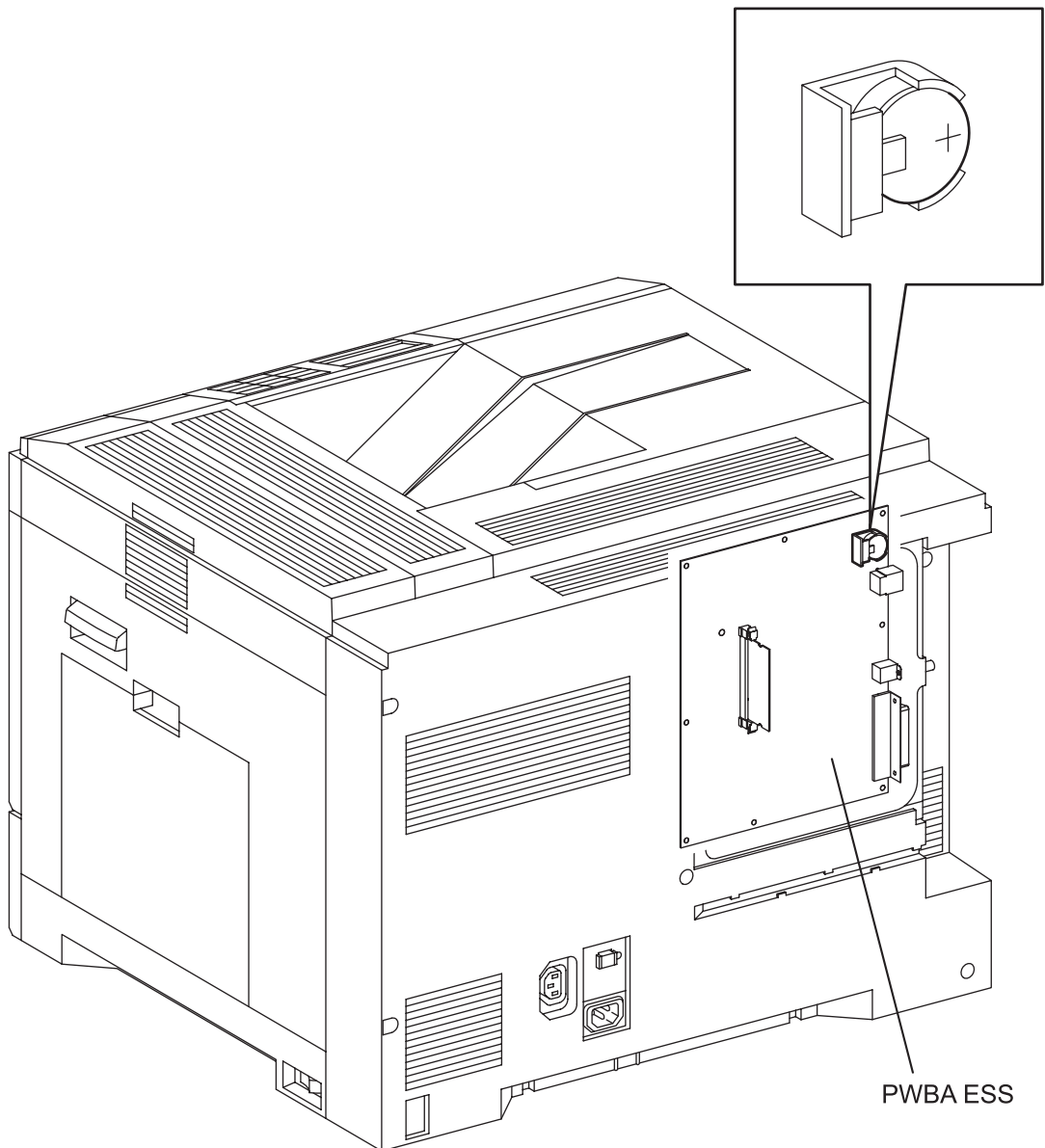

PWBA ESS

Tbt00014KA

4.5 Laser beams



- **Never power on the printer with the REAR COVER removed.**
- **If your eyes are exposed to laser beams, you may lose your eyesight.**
- **Never open the cover of the ROS.**
- **Before disassembling and reassembling this laser printer, be sure to turn it OFF.**
- **When servicing this laser printer while it is running, be sure to follow the procedures specified in this manual.**
- **You should be well aware that the laser beams are capable of injuring you and other people near the printer.**

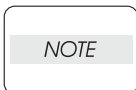

To protect the service engineer from laser radiation risks, this printer is designed to have a structure that does not allow the components (except for consumables and periodic replacement parts) to be removed if the REAR COVER is not removed. The REAR COVER is provided with a switch that cuts off laser radiation upon opening of the REAR COVER.

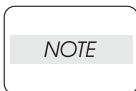

Laser beams have features as follows:

- **Frequencies are smaller in width than other beams (sun and electric bulbs) and phases are uniform so that high monochromatic and convergence performance can be obtained and thin beams of light can reach places at a long distance.**
- **Being highly converged, the laser beams exert a heating action that may be harmful to human body.**

Reference: *The laser beams of this laser printer are invisible rays.*

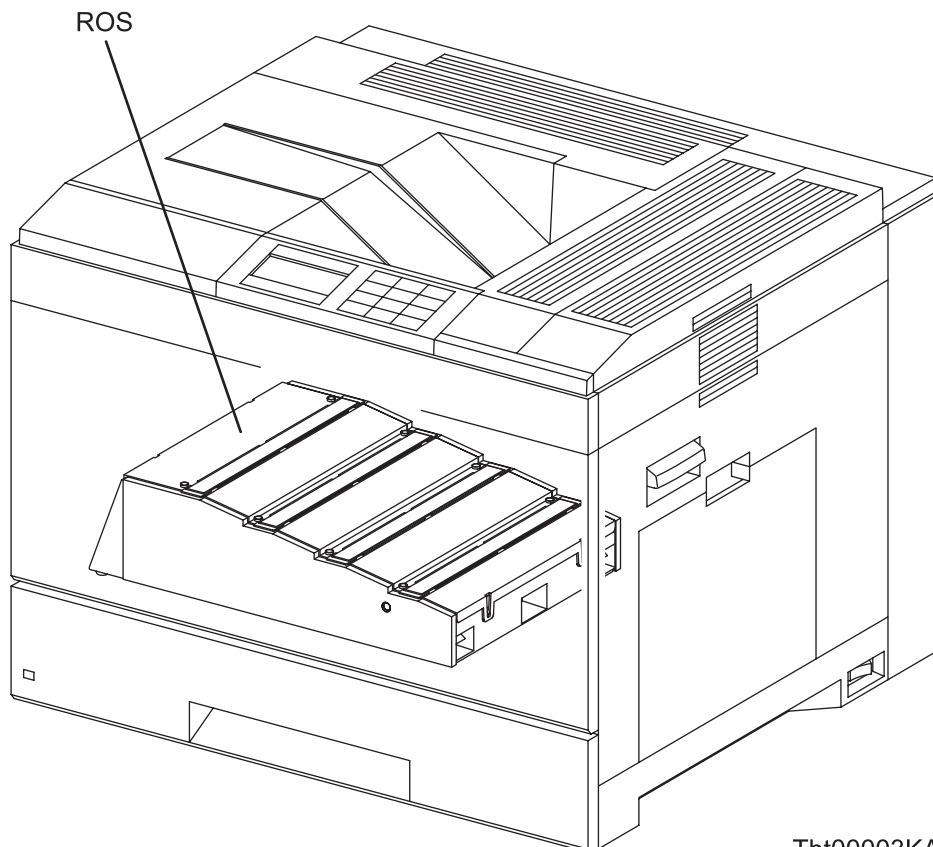

Tbt00003KA

4.6 Warning/caution labels

Warning labels and caution labels are attached to this laser printer to prevent accidents. Check those labels for their peeling or stains when servicing the printer.

4.6.1 Caution label for high-temperature units and cover RH

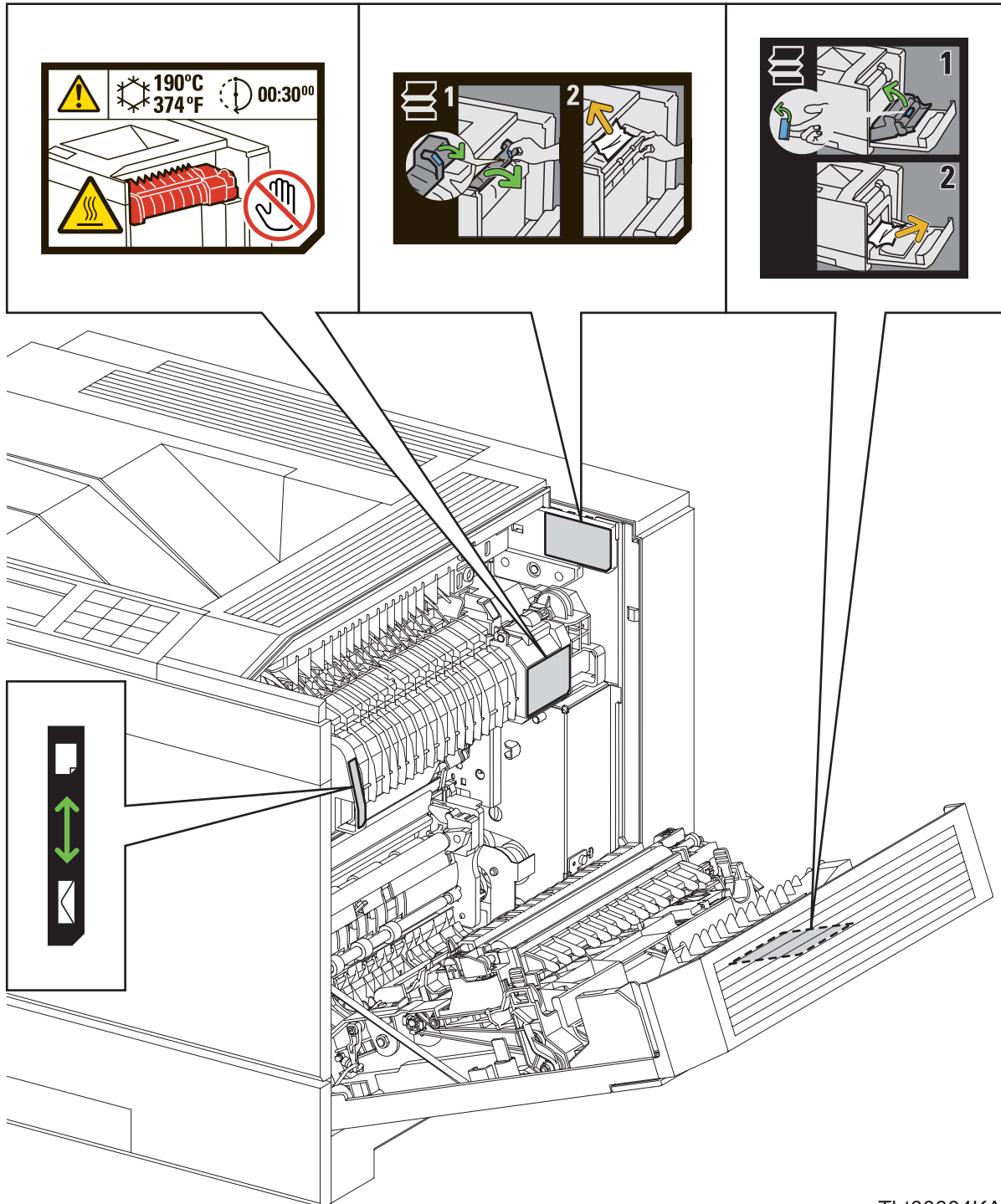

Tbt00004KA

4.6.2 Caution label for frame assy 2ND

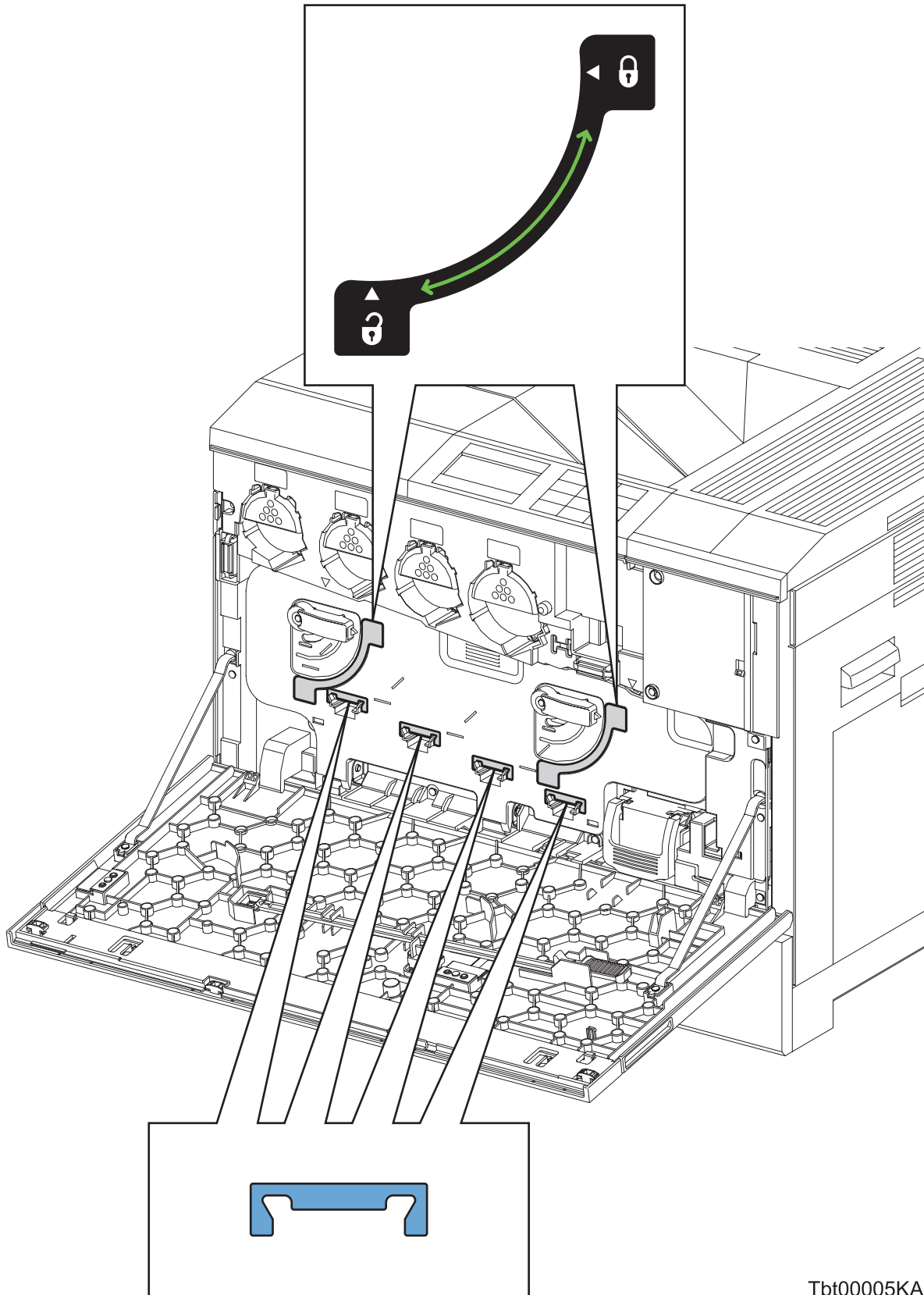

Tbt00005KA

4.6.3 Caution label for inner cover

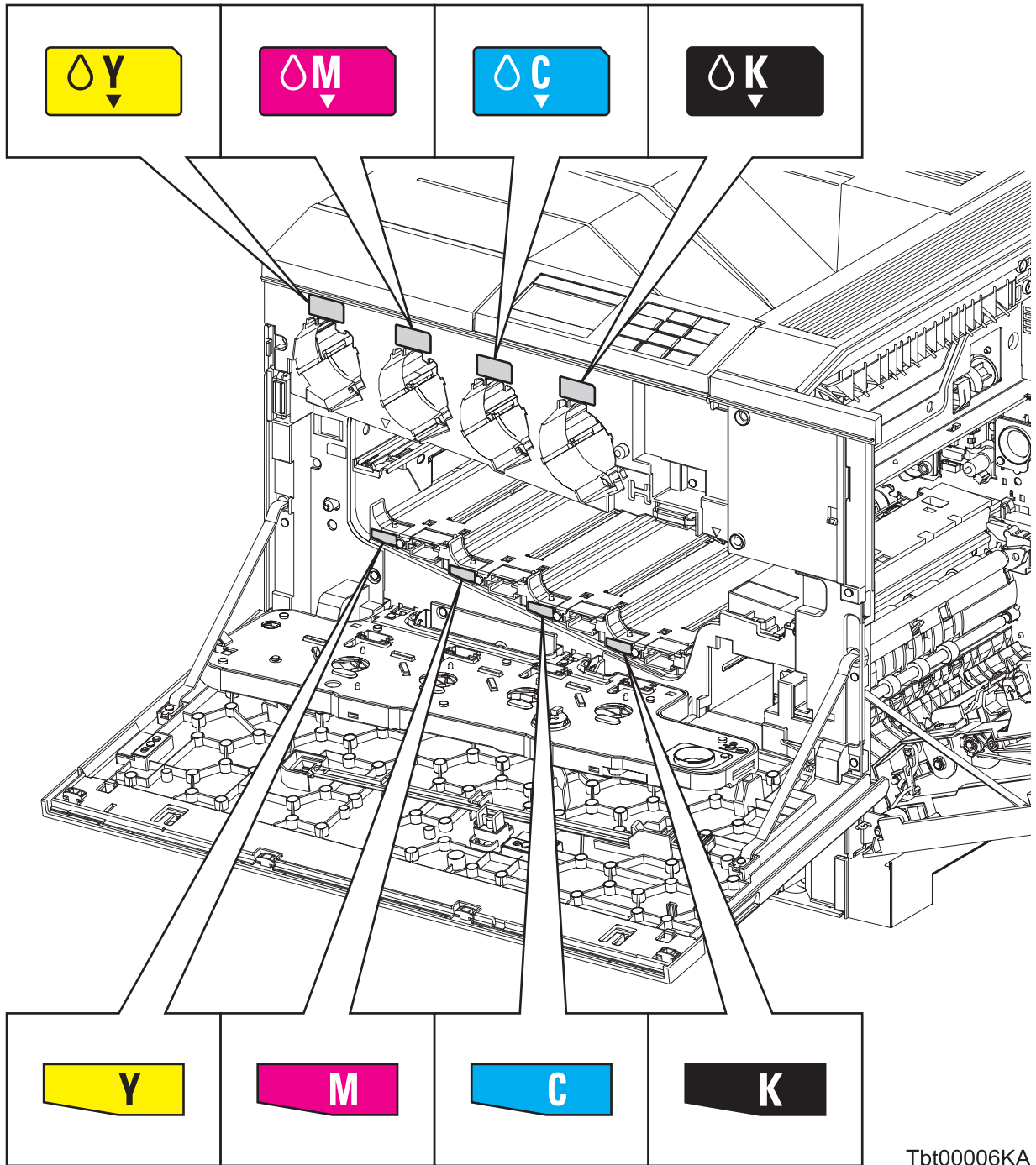

Tbt00006KA

4.6.4 Caution label for MPF

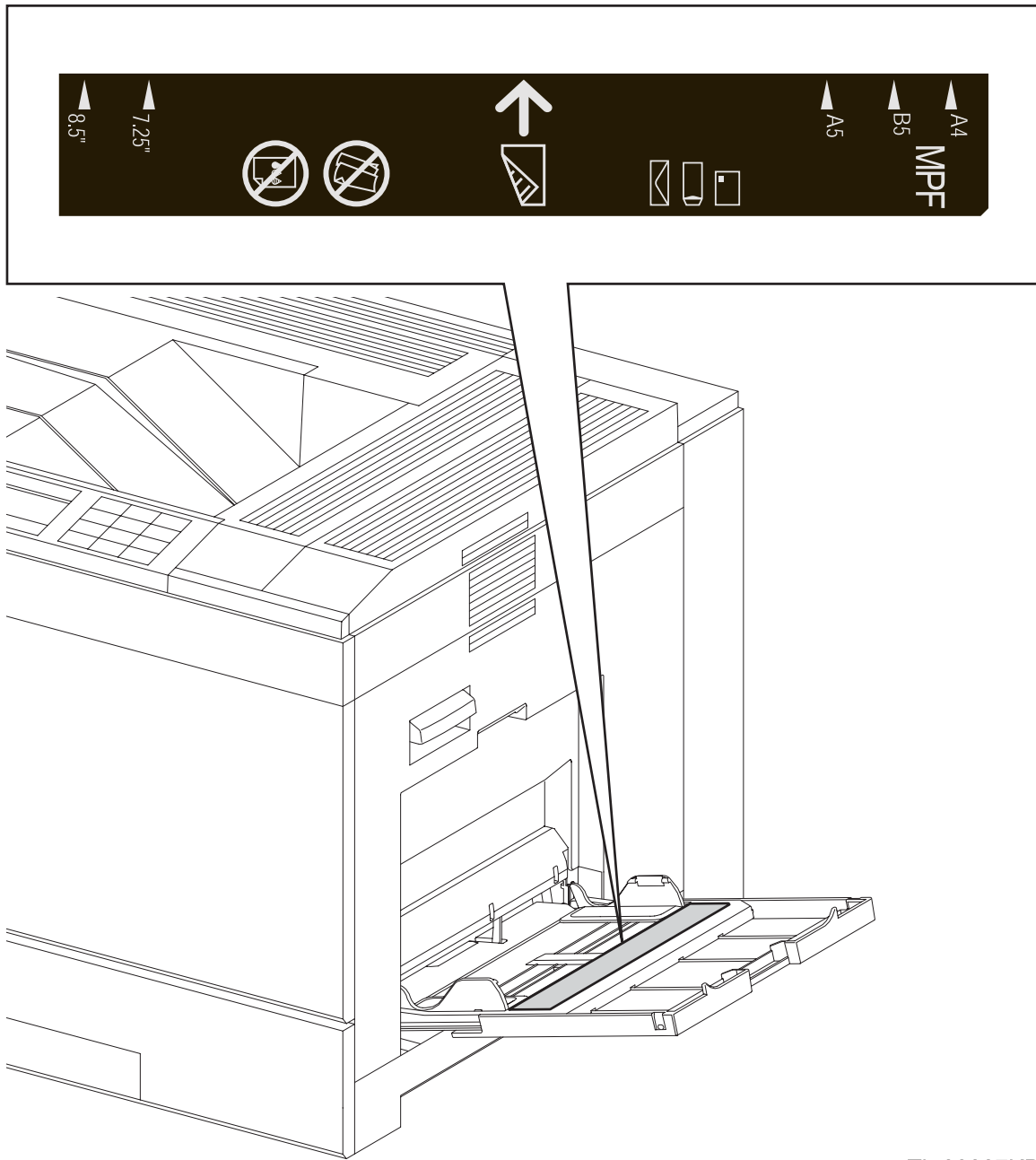

Tbt00007KB

4.6.5 Caution label for tray

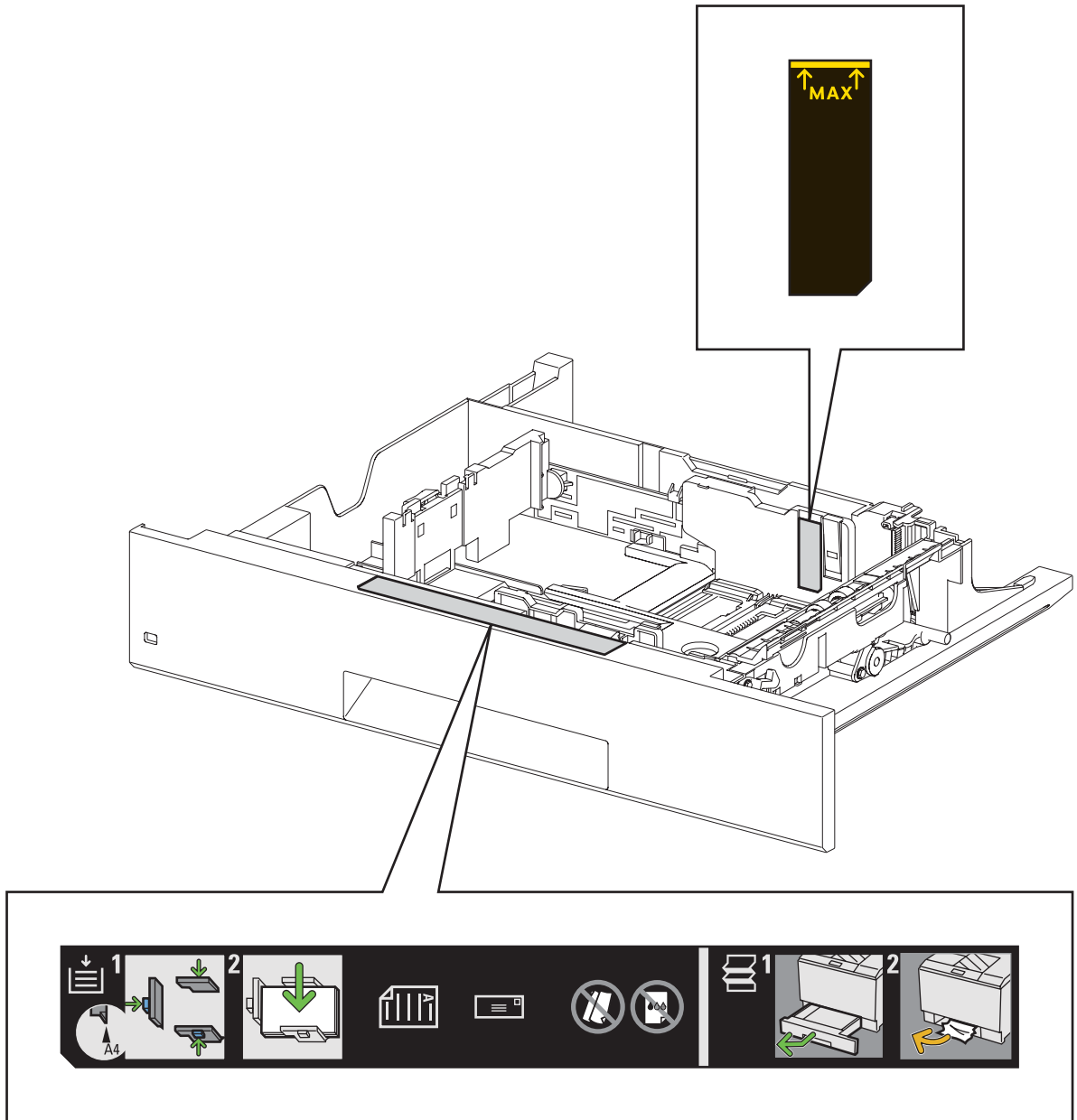

Tbt00008KA

4.6.6 Caution label for toner cartridge

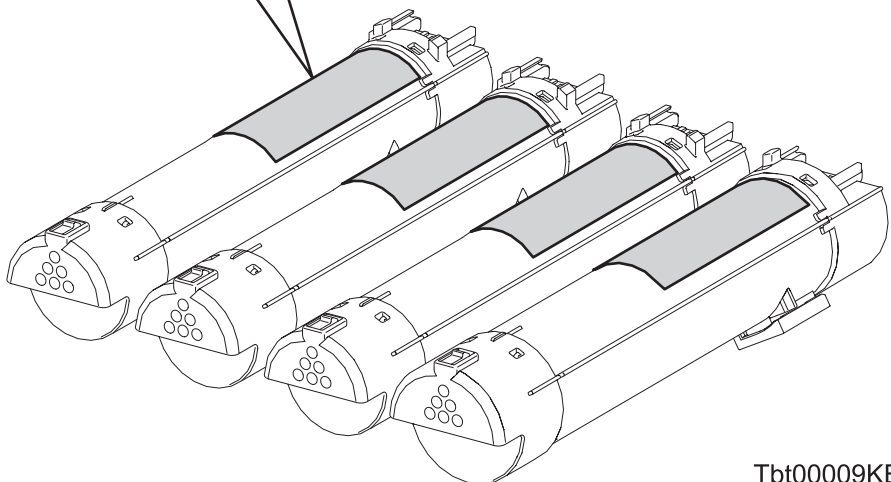

Tbt00009KB

4.6.7 Caution label for belt assy and waste toner box

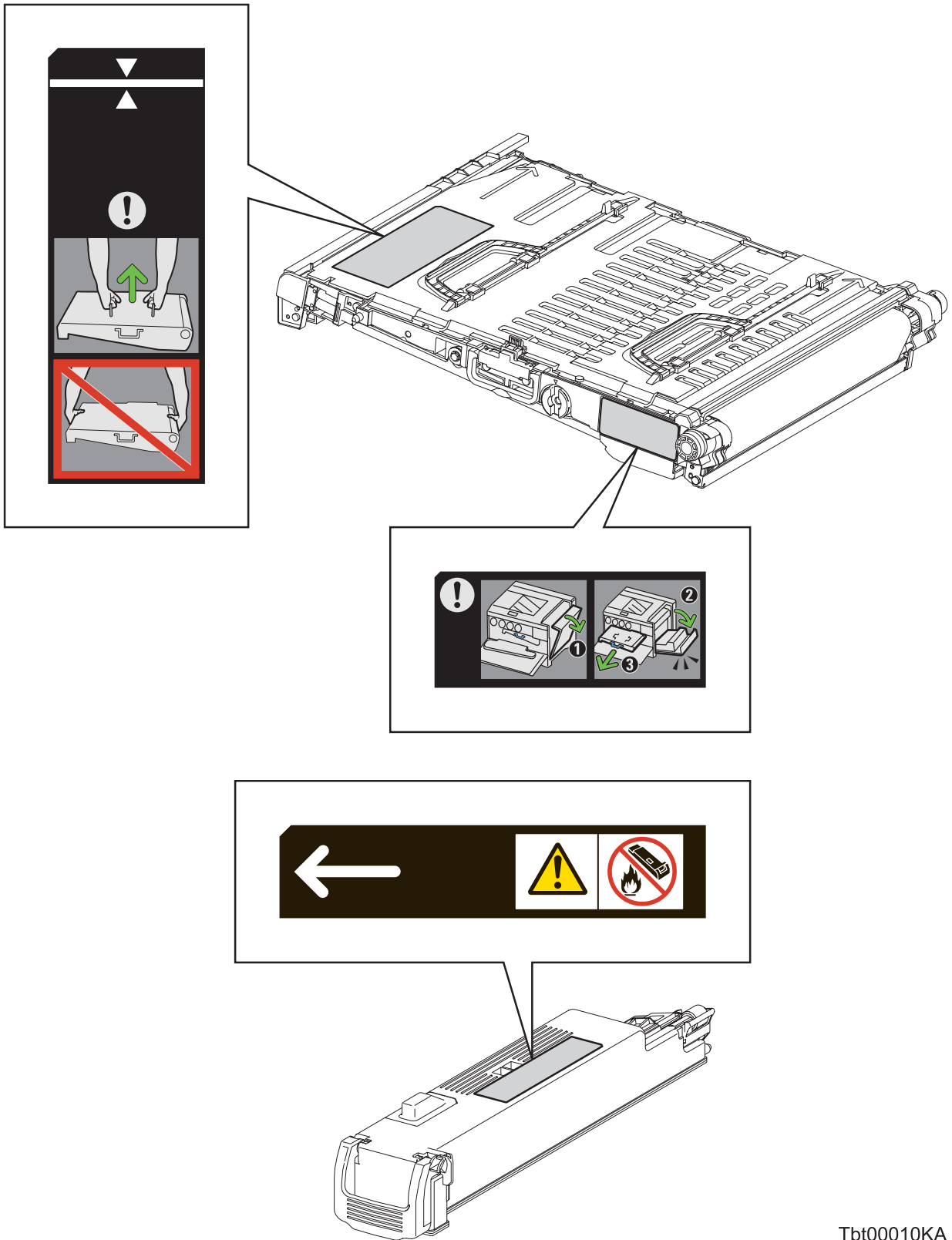

Tbt00010KA

4.6.8 Caution label for option feeder

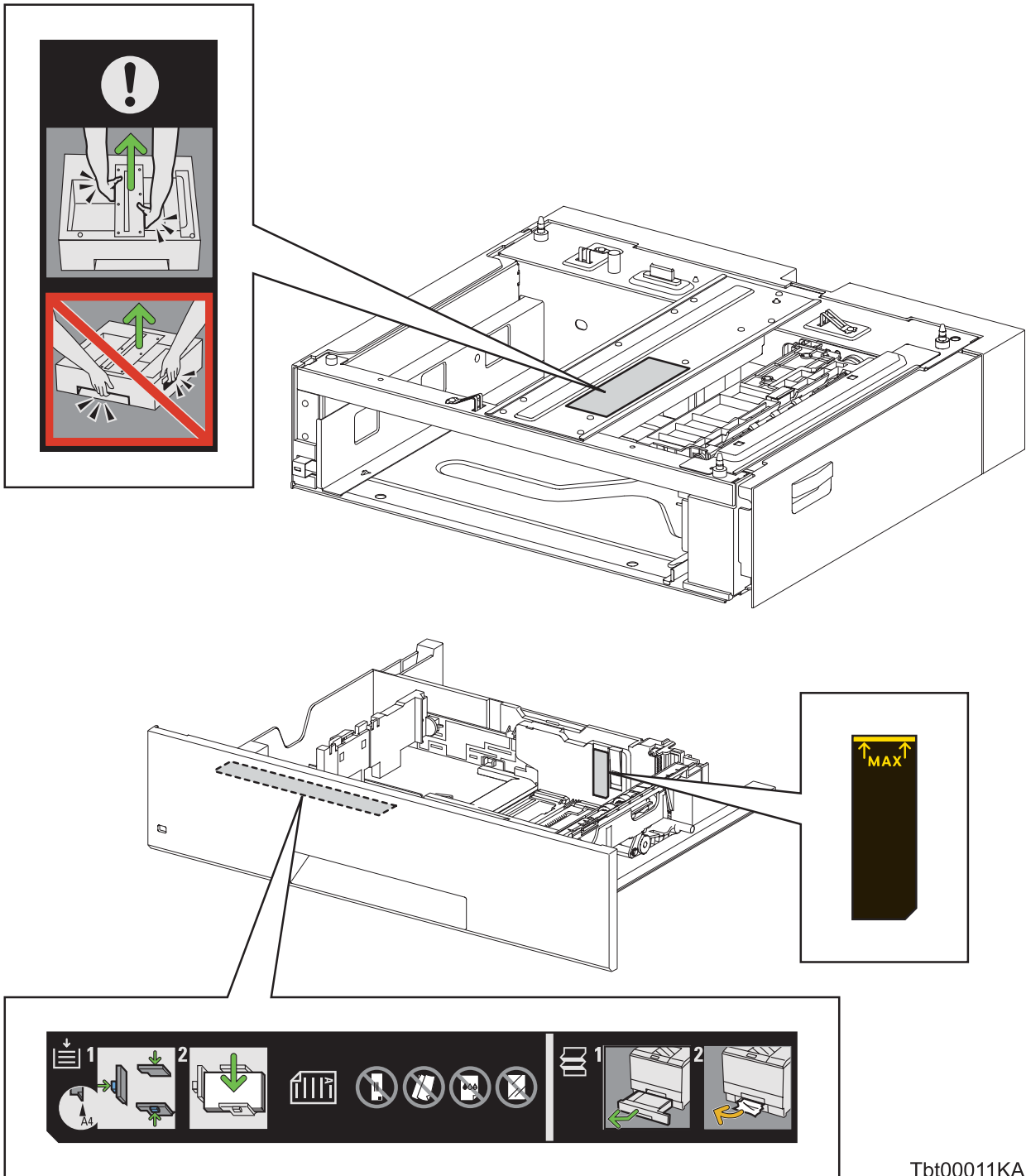

Tbt00011KA

Unpacking the Printer



The printer must be carried horizontally with three or more persons.



Take extreme care to avoid personal injuries.

Check visually the printer for evidence of any damages.

Peel all tapes off the printer.

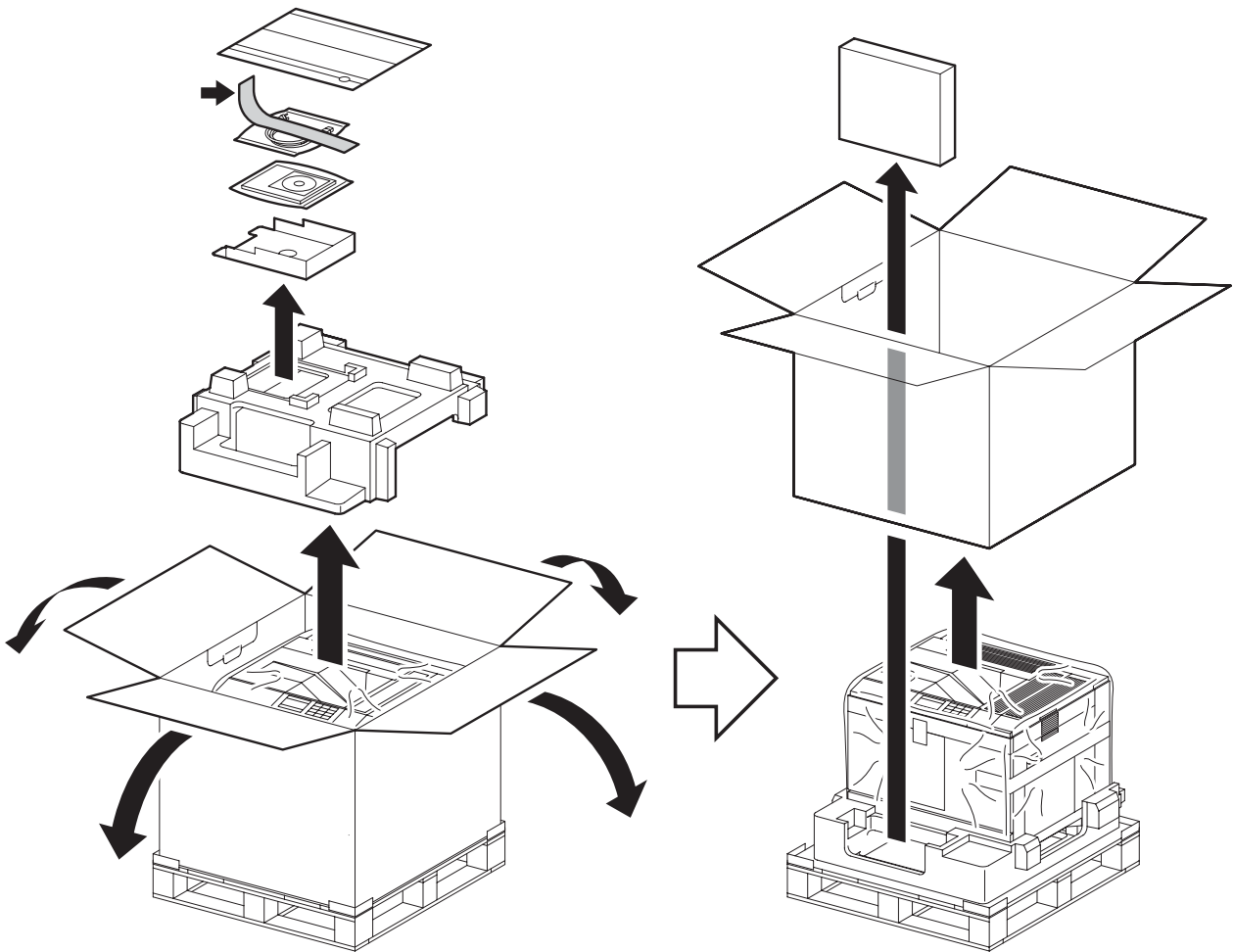

Tbt00012KA

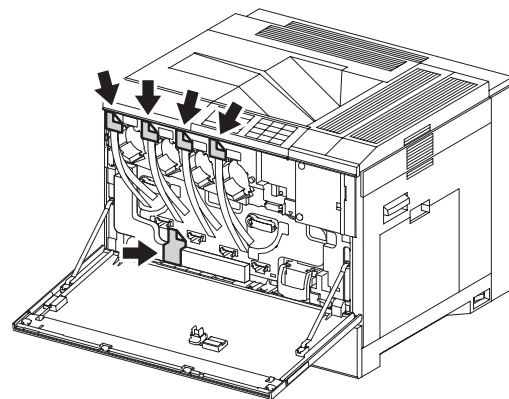
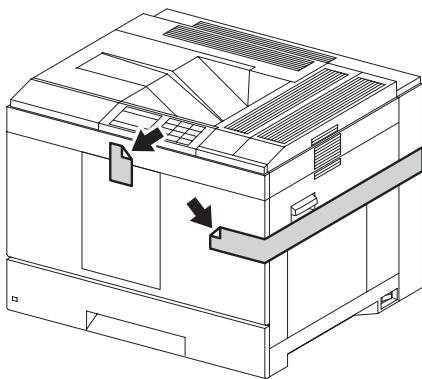
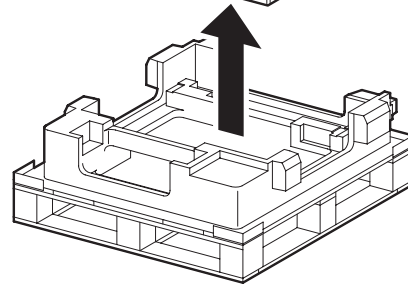
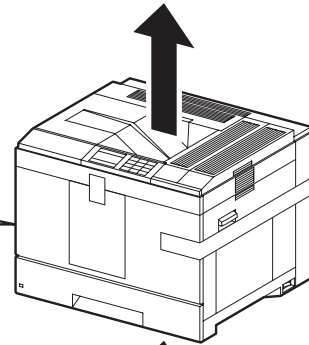
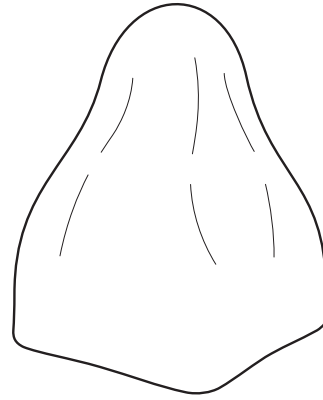
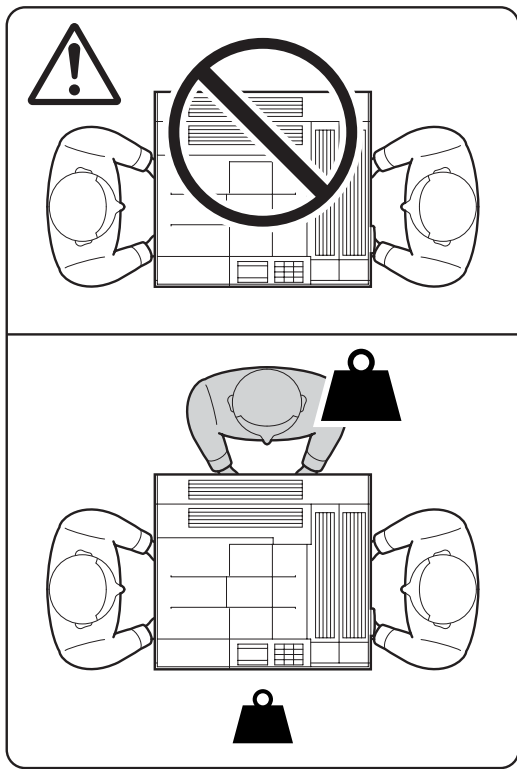

Tbt00013KA

TABLE OF CONTENTS

1. About this manual.....	ii
2. Marks giving caution.....	ii
3. Related documents.....	ii
4. Safety	iii
4.1 Power source	iii
4.2 Driving units	iv
4.3 High-temperature units	iv
4.4 Battery.....	v
4.5 Laser beams	vi
4.6 Warning/caution labels.....	vii
4.6.1 Caution label for high-temperature units and cover RH.....	vii
4.6.2 Caution label for frame assy 2ND	viii
4.6.3 Caution label for inner cover	ix
4.6.4 Caution label for MPF	x
4.6.5 Caution label for tray.....	xi
4.6.6 Caution label for toner cartridge.....	xii
4.6.7 Caution label for belt assy and waste toner box	xiii
4.6.8 Caution label for option feeder.....	xiv
Unpacking the Printer.....	xv
Chapter 1 Troubleshooting.....	1 - 1
Chapter 2 Operation of Diagnostic	2 - 1
Chapter 3 Removal and Replacement Procedures	3 - 1
Chapter 4 Plug/Jack(P/J) Connector Locations.....	4 - 1
Chapter 5 Parts List.....	5 - 1
Chapter 6 Principles of Operation	6 - 1
Chapter 7 Wiring Diagrams and Signal Information	7 - 1
Chapter 8 Printer Specifications	8 - 1

Chapter 1 Troubleshooting CONTENTS

1. Troubleshooting Overview	1 - 1
1.1 Flow of Troubleshooting.....	1 - 1
1.2 Check Installation Status	1 - 2
1.3 Cautions on Service Operations	1 - 3
1.4 Cautions on Using FIP	1 - 4
1.5 Items To Be Confirmed Before Going To FIP Troubleshooting	1 - 6
2. FIP	1 - 12
2.1 FIP	1 - 12
2.2 Flow of FIP	1 - 12
2.3 Status Code List.....	1 - 13
3. Error Code FIP	1 - 60
3.1 Troubleshooting for the call center.....	1 - 60
Flows 1 001-360: IOT LV Fan Motor Failure.....	1 - 60
Flows 2 003-340: IOT Firmware Error	1 - 61
Flows 3 003-356: IOT NVRAM Error	1 - 62
Flows 4 004-310: IOT Option Feeder I/F Failure	1 - 63
Flows 5 004-312: IOT Feeder Configuration Failure.....	1 - 64
Flows 6 006-370: IOT ROS Failure.....	1 - 65
Flows 7 007-340-01: IOT Motor Failure (Deve Motor K).....	1 - 66
Flows 8 007-340-02: IOT Motor Failure (Deve Motor YMC).....	1 - 68
Flows 9 007-340-03: IOT Motor Failure (Xero Motor).....	1 - 70
Flows 10 007-340-04: IOT Motor Failure (PH Motor)	1 - 72
Flows 11 009-340: IOT CTD Sensor Error.....	1 - 74
Flows 12 009-360 / 009-361 / 009-362 / 009-363: IOT Toner (YMCK) CRUM Comm Fail	1 - 75
Flows 13 009-367 / 009-368 / 009-369 / 009-370: IOT Toner Cartridge (YMCK) CRUM Data Error ...	1 - 77
Flows 14 009-371: IOT Belt Unit CRUM Data Error	1 - 79
Flows 15 010-317: IOT Fuser Detached.....	1 - 81
Flows 16 010-330: IOT Fuser Motor Failure	1 - 82
Flows 17 010-351: IOT Fuser Life Over.....	1 - 83
Flows 18 010-354: IOT Environment Sensor Error.....	1 - 84
Flows 19 010-359 / 010-360: IOT Fuser CRUM ID Error / IOT Fuser Comm Fail	1 - 85
Flows 20 010-377: IOT Fuser Failure	1 - 87
Flows 21 010-420 / 010-421: IOT Fuser Near Life	1 - 88
Flows 22 010-910: IOT Fuser Envelope Mode Error	1 - 89
Flows 23 012-151 / 012-903: IOT Output Expander Compile Exit Sensor Off JAM / Paper Remain at Compile Exit.....	1 - 91
Flows 24 012-161 / 012-905: IOT Output Expander Set Eject JAM / Paper Remain at Compile Tray No Paper Sensor.....	1 - 93
Flows 25 012-302: IOT Output Expander Cover Front Open	1 - 94
Flows 26 012-303: IOT Output Expander H Transport Unit Cover Open	1 - 96
Flows 27 012-311 / 012-313: IOT Output Expander Front Tamper Home Sensor On /Off Fail.....	1 - 97
Flows 28 012-312: IOT Output Expander NVM Fail	1 - 98
Flows 29 012-314 / 012-353: IOT Output Expander Rear Tamper Home Sensor Off / On Fail	1 - 99
Flows 30 012-315: IOT Output Expander Stacker Tray Fail	1 - 100
Flows 31 012-316: IOT Output Expander Stacker Upper Limit Fail.....	1 - 101
Flows 32 012-317: IOT Output Expander Stacker Lower Limit Fail.....	1 - 102
Flows 33 012-349 / 012-370: IOT Output Expander Eject Clamp Home Sensor On / Off Fail	1 - 103
Flows 34 012-373 / 012-374: IOT Output Expander Set Clamp Home Sensor On / Off Fail.....	1 - 104
Flows 35 012-381: IOT Output Expander Stapler Fail	1 - 105
Flows 36 016-300 / 016-301 / 016-302 / 016-313 / 016-315 / 016-317 / 016-323 / 016-324 / 016-325 / 016-327 / 016-392 / 016-393 / 016-394: ESS Error.....	1 - 106
Flows 37 016-340 / 016-344 / 016-345 / 016-346 / 016-347 : ESS Error	1 - 107
Flows 38 016-312: ESS Hard Disk Fail.....	1 - 108

Chapter 1 Troubleshooting CONTENTS

Flows 39 016-316 / 016-318: ESS DIMM Slot RAM R/W Check Fail / ESS DIMM Slot RAM Error ...	1 - 109
Flows 40 016-319 / 016-320: Encryption key error/ Encryption setting error.....	1 - 111
Flows 41 016-338: Option Wireless Adapter Error	1 - 112
Flows 42 016-356: Hard Disk clearing error	1 - 113
Flows 43 016-362 / 016-363 / 016-364 / 016-366 / 016-367 / 016-368: PCI Bus# (0 / 1) Host Bridge Controller Error / PCI Bus# (0 / 1) Error Detected / PCI Error Messages received from Bus#0-Device# (0 / 1).....	1 - 114
Flows 44 016-369: Operator Panel - ESS Communication Fail.....	1 - 115
Flows 45 016-370: MCU-ESS Communication Fail	1 - 116
Flows 46 016-383 / 016-384 / 016-385 / 016-386 / 016-387: Download ID Error / Download Range Error / Download header Error / Download Check Sum Error / Download Format Error	1 - 117
Flows 47 016-391: Download Protect Error	1 - 119
Flows 48 016-404 / 016-405 / 016-520 / 016-521 / 016-522 / 016-523 / 016-524 / 016-527: Certificate DB access error / Security setting invalid error / Own device certificate error / Other device certificate error / Client certificate absence error / Server certificate verification error / Server certificate absence error / Certificate DB error	1 - 120
Flows 49 016-531 / 016-532 / 016-533 / 016-534 / 016-535 / 016-536: LDAP, Kerberos Server Error / ColorTrack 3 Error	1 - 121
Flows 50 016-541 / 016-542 / 016-543: Wireless certificate error	1 - 122
Flows 51 016-700: Memory Over flow	1 - 123
Flows 52 016-720: PDL Error	1 - 124
Flows 53 016-756: Auditron Error (Print prohibited time).....	1 - 125
Flows 54 016-757: Auditron Error (Invalid User).....	1 - 126
Flows 55 016-758: Auditron Error (Disabled Function).....	1 - 127
Flows 56 016-759: Auditron Error (Reached Limit).....	1 - 128
Flows 57 016-799: Job Environment Violation.....	1 - 129
Flows 58 016-920: Wireless Setting Error Timeout Error	1 - 130
Flows 59 016-921: Wireless Setting Error Download Error	1 - 131
Flows 60 016-922: Wireless Setting Error Session Overlap Error	1 - 132
Flows 61 016-930 / 016-931: USB HOST Error	1 - 133
Flows 62 016-980: Hard Disk Disc Full.....	1 - 134
Flows 63 016-981: Collate Full	1 - 135
Flows 64 024-338: Video Cable Disconnect.....	1 - 137
Flows 65 024-339: Serial Cable to MCU Disconnect.....	1 - 138
Flows 66 024-362: IOT Start Image Marking Timeout.....	1 - 139
Flows 67 024-910 / 024-911 / 024-912 / 024-913 / 024-915: IOT Paper Size Mismatch.....	1 - 140
Flows 68 024-914: IOT Paper Size Mismatch	1 - 142
Flows 69 024-916 / 024-980: IOT Output Expander Mix Stack Full / IOT Output Expander Stacker Tray Full	1 - 143
Flows 70 024-917: IOT Output Expander Stacker Tray Staple Set Over Count.....	1 - 144
Flows 71 024-920: IOT Exit Tray Stacker Full	1 - 145
Flows 72 024-928: IOT Output Expander Scratch Sheet Compile	1 - 146
Flows 73 024-946 / 024-947 / 024-948 / 024-949 / 024-950: IOT Tray Detached	1 - 147
Flows 74 024-965 / 024-966 / 024-967 / 024-968 / 024-970: IOT No Suitable Paper	1 - 149
Flows 75 024-969: IOT No Suitable Paper	1 - 151
Flows 76 024-976: IOT Output Expander Staple NG.....	1 - 152
Flows 77 024-977: IOT Output Expander Stapler Error.....	1 - 153
Flows 78 024-979: IOT Output Expander Stapler Near Life	1 - 154
Flows 79 024-982: IOT Output Expander Stacker lower Safety Warning.....	1 - 155
Flows 80 041-347: IOT I/F Failure	1 - 156
Flows 81 042-324: IOT Belt Unit Motor Failure.....	1 - 158
Flows 82 042-330: IOT Fuser Fan Failure	1 - 159
Flows 83 042-700 / 142-700: IOT over Heat Stop / IOT over Heat Forced Half Speed.....	1 - 160
Flows 84 046-310: IOT HVPS Error.....	1 - 161
Flows 85 047-216: IOT Option Output Expander Failure.....	1 - 162
Flows 86 047-217: IOT Output Expander I/F Failure	1 - 163

Chapter 1 Troubleshooting CONTENTS

Flows 87 050-101: IOT Remain Zone RH1 JAM	1 - 164
Flows 87-1 Jam at the MPF section (050-101)	1 - 167
Flows 87-2 Jam in the upstream vicinity of the Fuser section (050-101)	1 - 168
Flows 87-3 Jam in the downstream vicinity of the Fuser section (050-101)	1 - 169
Flows 87-4 Jam in the Duplexer section (050-101)	1 - 171
Flows 88 050-102 / 050-103 / 050-104 / 050-105: IOT Remain Zone RH2 JAM / IOT Remain Zone RH3 JAM / IOT Remain Zone RH4 JAM / IOT Remain Zone RH5 JAM	1 - 172
Flows 89 050-121: IOT Remain Zone 1T JAM	1 - 174
Flows 90 050-122 / 050-123 / 050-124 / 050-125: IOT Remain Zone 2T JAM / IOT Remain Zone 3T JAM / IOT Remain Zone 4T JAM / IOT Remain Zone 5T JAM	1 - 176
Flows 91 050-151: IOT Remain Zone HTR JAM	1 - 178
Flows 92 050-152: IOT Remain Zone EXIT JAM	1 - 181
Flows 93 050-153: IOT Remain Zone CMP JAM	1 - 183
Flows 94 072-211-01 / 073-211-01: IOT Option Feeder2 (or Feeder3) Failure	1 - 184
Flows 95 072-211-02 / 073-211-02: IOT Option Feeder Motor2 (or Motor3) Failure	1 - 186
Flows 96 072-300 / 073-300: IOT RH Cover Tray2 (or Tray3) Open	1 - 188
Flows 97 074-211-01 / 076-211-01: IOT Option Feeder4 (or Feeder5) Failure	1 - 189
Flows 98 074-211-02 / 076-211-02: IOT Option Feeder Motor4 (or Motor5) Failure	1 - 191
Flows 99 074-300 / 076-300: IOT Cover Tray4 (or Tray5) Open	1 - 193
Flows 100 077-300: IOT Cover Front Open	1 - 194
Flows 101 077-301: IOT Cover Right Hand Open	1 - 196
Flows 102 091-400: IOT Waste Toner Box Near Life	1 - 198
Flows 103 091-411 / 091-412 / 091-413 / 091-414 / 091-479 / 091-480 / 091-481 / 091-482: IOT Drum Cartridge (YMCK) Near Life	1 - 199
Flows 104 091-911: IOT Waste Toner Box Life Over	1 - 200
Flows 105 091-914 / 091-917 / 091-918 / 091-919: IOT Drum Cartridge (YMCK) CRUM Fail	1 - 201
Flows 106 091-921 / 091-922 / 091-923 / 091-924: IOT Drum Cartridge (YMCK) Detached	1 - 203
Flows 107 091-931 / 091-932 / 091-933 / 091-934: IOT Drum Cartridge (YMCK) Life Over	1 - 204
Flows 108 091-942 / 091-943 / 091-944 / 091-945: IOT DRUM Cartridge (YMCK) CRUM Data Error	1 - 205
Flows 109 091-950 / 091-951 / 091-952 / 091-953: Detect YMCK Drum Cartridge Tape Staying	1 - 207
Flows 110 091-960 / 091-961 / 091-962 / 091-963: IOT (YMCK) CRUM ID Error	1 - 209
Flows 111 092-651: IOT CTD Sensor Rear Error Code2	1 - 211
Flows 112 092-670: Detect Yellow Calibrating Patch Error	1 - 212
Flows 113 092-671: Detect Magenta Calibrating Patch Error	1 - 214
Flows 114 092-672: Detect Cyan Calibrating Patch Error	1 - 216
Flows 115 092-673: Detect Black Calibrating Patch Error	1 - 218
Flows 116 093-423 / 093-424 / 093-425 / 093-426: IOT Toner Cartridge Near Life	1 - 220
Flows 117 093-930 / 093-931 / 093-932 / 093-933: IOT Toner Cartridge Life Over	1 - 221
Flows 118 093-960 / 093-961 / 093-962 / 093-963: IOT (YMCK) CRUM ID Error	1 - 222
Flows 119 093-964: IOT Fuser CRUM ID Error	1 - 224
Flows 120 093-970 / 093-971 / 093-972 / 093-973: IOT Toner Cartridge Detached	1 - 226
Flows 121 094-325-01: IOT Switching Sensor Failure	1 - 227
Flows 122 094-325-02 to 06: IOT Switching Sensor Failure	1 - 229
Flows 123 094-419/ 094-422: IOT Belt Unit Near Life	1 - 231
Flows 124 094-910: IOT Belt Unit Detached	1 - 232
Flows 125 094-911: IOT Belt Unit Life Over	1 - 234
Flows 126 094-912: IOT Belt Unit CRUM Fail	1 - 235
Flows 127 094-913: IOT Transfer Roller Detached	1 - 237
Flows 128 094-960: IOT Belt Unit CRUM ID Mismatch	1 - 238
Flows 129 116-364: Timer Fail	1 - 240
Flows 130 124-310: IOT XPC Error	1 - 241
Flows 131 193-700: Custom Toner Mode	1 - 242
Flows 132 Electrical Noise	1 - 243
Flows 133 Faint print (Image Density)	1 - 245
Flows 134 Blank print (No print)	1 - 248
Flows 135 Solid Print (YMCK)	1 - 251

Chapter 1 Troubleshooting CONTENTS

Flows 136 Vertical blank lines (White stripes in paper transport direction).....	1 - 253
Flows 137 Horizontal band cross out (White stripes in the horizontal direction).....	1 - 256
Flows 138 Vertical stripes	1 - 259
Flows 139 Horizontal stripes.....	1 - 262
Flows 140 Partial Deletion	1 - 265
Flows 141 Spots	1 - 268
Flows 142 Afterimage (Ghost)	1 - 270
Flows 143 High Background	1 - 272
Flows 144 Skew	1 - 274
Flows 145 Paper damage/Wrinkled Paper	1 - 276
Flows 146 Unfusing	1 - 279
Flows 147 Color Registration (Color Shift).....	1 - 281
Flows 148 Color Registration (Image Shift)	1 - 283
Flows 149 Mechanical Noise: When Power is Turned On.....	1 - 285
Flows 150 Mechanical Noise: During Standby	1 - 291
Flows 151 Mechanical Noise: During Printing (Checking for other items than "power on mechanical noise")	1 - 292
Flows 152 AC Power	1 - 294
Flows 153 DC Power	1 - 295
Flows 154 Multiple feed	1 - 296
Flows 155 Paper Remaining Amount Not Displayed Correctly in Status Monitor.....	1 - 297
3.2 Troubleshooting for the repair center.....	1 - 298
FIP1.1 001-360: IOT LV Fan Motor Failure	1 - 298
FIP1.2 003-340: IOT Firmware Error	1 - 299
FIP1.3 003-356: IOT NVRAM Error	1 - 300
FIP1.4 004-310: IOT Feeder I/F Failure.....	1 - 301
FIP1.5 004-312: IOT Feeder Composition Failure.....	1 - 302
FIP1.6 006-370: IOT ROS Failure	1 - 303
FIP1.7 007-340-01: IOT Motor Failure (Deve Motor K)	1 - 304
FIP1.8 007-340-02: IOT Motor Failure (Deve Motor YMC).....	1 - 305
FIP1.9 007-340-03: IOT Motor Failure (Xero Motor).....	1 - 306
FIP1.10 007-340-04: IOT Motor Failure (PH Motor)	1 - 307
FIP1.11 009-340: IOT CTD Sensor Error	1 - 308
FIP1.12 009-360 / 009-361 / 009-362 / 009-363: IOT Toner (YMCK) CRUM Comm Fail	1 - 309
FIP1.13 009-367 / 009-368 / 009-369 / 009-370: IOT Toner Cartridge (YMCK) CRUM Data Error ...	1 - 310
FIP1.14 009-371: IOT Belt Unit CRUM Data Error	1 - 312
FIP1.15 010-317: IOT Fuser Detached.....	1 - 313
FIP1.16 010-330: IOT Fuser Motor Failure	1 - 314
FIP1.17 010-351: IOT Fuser Life Over	1 - 315
FIP1.18 010-354: IOT Environment Sensor Error.....	1 - 316
FIP1.19 010-359 / 010-360: IOT Fuser CRUM ID Error / IOT Fuser Comm Fail.....	1 - 317
FIP1.20 010-377: IOT Fuser Failure	1 - 318
FIP1.21 010-420 / 010-421: IOT Fuser Life Pre Warning / IOT Fuser Quality Life End Warning	1 - 319
FIP1.22 010-910: IOT Fuser Envelope Mode Error	1 - 320
FIP1.23 012-151 / 012-903: IOT Output Expander Compile Exit Sensor Off JAM / Paper Remain at Compile Exit.....	1 - 321
FIP1.24 012-161 / 012-905: IOT Output Expander Set Eject JAM / Paper Remain at Compile Tray No Paper Sensor	1 - 323
FIP1.25 012-302: IOT Output Expander Cover Front Open	1 - 325
FIP1.26 012-303: IOT Output Expander H Transport Unit Cover Open	1 - 326

Chapter 1 Troubleshooting CONTENTS

FIP1.27 012-311 / 012-313: IOT Output Expander Front Tamper Home Sensor On /Off Fail.....	1 - 327
FIP1.28 012-312: IOT Output Expander NVM Fail	1 - 329
FIP1.29 012-314 / 012-353: IOT Output Expander Rear Tamper Home Sensor Off / On Fail	1 - 330
FIP1.30 012-315: IOT Output Expander Stacker Tray Fail.....	1 - 332
FIP1.31 012-316: IOT Output Expander Stacker Upper Limit Fail.....	1 - 334
FIP1.32 012-317: IOT Output Expander Stacker Lower Limit Fail.....	1 - 336
FIP1.33 012-349 / 012-370: IOT Output Expander Eject Clamp Home Sensor On / Off Fail	1 - 339
FIP1.34 012-373 / 012-374: IOT Output Expander Set Clamp Home Sensor On / Off Fail.....	1 - 341
FIP1.35 012-381: IOT Output Expander Stapler Fail.....	1 - 343
FIP1.36 016-300 / 016-301 / 016-302 / 016-313 / 016-315 / 016-317 / 016-323 / 016-324 / 016-325 / 016-327 /016-392 / 016-393 / 016-394: ESS Error.....	1 - 345
FIP1.37 016-340 / 016-344 / 016-345 / 016-346 / 016-347: ESS Error	1 - 346
FIP1.38 016-312: ESS Hard Disk Fail	1 - 347
FIP1.39 016-316 / 016-318: ESS DIMM Slot RAM R/W Check Fail / ESS DIMM Slot RAM Error	1 - 348
FIP1.40 016-319 / 016-320: Encryption key error/ Encryption setting error.....	1 - 349
FIP1.41 016-338: Option Wireless Adapter Error	1 - 350
FIP1.42 016-356: Hard Disk clearing error	1 - 351
FIP1.43 016-362 / 016-363 / 016-364 / 016-366 / 016-367 / 016-368: PCI Bus# (0 / 1) Host Bridge Controller Error / PCI Bus# (0 / 1) Error Detected / PCI Error Messages received from Bus#0-Device# (0 / 1).....	1 - 352
FIP1.44 016-369: Operator Panel - ESS Communication Fail.....	1 - 353
FIP1.45 016-370: MCU-ESS Communication Fail.....	1 - 354
FIP1.46 016-383 / 016-384 / 016-385 / 016-386 / 016-387: Download ID Error / Download Range Error / Download header Error / Download Check Sum Error / Download Format Error.....	1 - 355
FIP1.47 016-391: Download Protect Error.....	1 - 356
FIP1.48 016-404 / 016-405 / 016-520 / 016-521 / 016-522 / 016-523 / 016-524 / 016-527: Certificate DB access error / Security setting invalid error / Own device certificate error / Other device certificate error / Client certificate absence error / Server certificate verification error / Server certificate absence error / Certificate DB error ..	1 - 357
FIP1.49 016-531 / 016-532 / 016-533 / 016-534 / 016-535 / 016-536: LDAP Server Error / ColorTrack 3 Error	1 - 358
FIP1.50 016-541 / 016-542 / 016-543: Wireless certificate error	1 - 359
FIP1.51 016-700: Memory Over flow	1 - 360
FIP1.52 016-720: PDL Error	1 - 361
FIP1.53 016-756: Auditron Error (Print prohibited time)	1 - 362
FIP1.54 016-757: Auditron Error (Invalid User)	1 - 363
FIP1.55 016-758: Auditron Error (Disabled Function).....	1 - 364
FIP1.56 016-759: Auditron Error (Reached Limit)	1 - 365
FIP1.57 016-799: Job Environment Violation	1 - 366
FIP1.58 016-920: Wireless Setting Error Timeout Error	1 - 367
FIP1.59 016-921: Wireless Setting Error Download Error	1 - 368
FIP1.60 016-922: Wireless Setting Error Session Overlap Error.....	1 - 369
FIP1.61 016-930 / 016-931: USB HOST Error.....	1 - 370
FIP1.62 016-980: Hard Disk Disc Full.....	1 - 371
FIP1.63 016-981: Collate Full	1 - 372
FIP1.64 024-338: Video Cable Disconnect.....	1 - 373

Chapter 1 Troubleshooting CONTENTS

FIP1.65 024-339: Serial Cable to MCU Disconnect.....	1 - 374
FIP1.66 024-362: IOT Start Image Marking Timeout.....	1 - 375
FIP1.67 024-910 / 024-911 / 024-912 / 024-913 / 024-915: IOT Paper Size Mismatch	1 - 376
FIP1.68 024-914: IOT Paper Size Mismatch	1 - 377
FIP1.69 024-916 / 024-980: IOT Output Expander Mix Stack Full / IOT Output Expander Stacker Tray Full.....	1 - 378
FIP1.70 024-917: IOT Output Expander Stacker Tray Staple Set Over Count.....	1 - 380
FIP1.71 024-920: IOT Exit Tray Stacker Full	1 - 381
FIP1.72 024-928: IOT Output Expander Scratch Sheet Compile	1 - 382
FIP1.73 024-946 / 024-947 / 024-948 / 024-949 / 024-950: IOT Tray Detached.....	1 - 384
FIP1.74 024-965 / 024-966 / 024-967 / 024-968 / 024-970: IOT No Suitable Paper	1 - 385
FIP1.75 024-969: IOT No Suitable Paper	1 - 386
FIP1.76 024-976: IOT Output Expander Staple NG	1 - 387
FIP1.77 024-977: IOT Output Expander Stapler Error.....	1 - 389
FIP1.78 024-979: IOT Output Expander Stapler Near Life	1 - 391
FIP1.79 024-982: IOT Output Expander Stacker lower Safety Warning.....	1 - 392
FIP1.80 041-347: IOT I/F Failure	1 - 394
FIP1.81 042-324: IOT Belt Unit Motor Failure	1 - 395
FIP1.82 042-330: IOT Fuser Fan Failure	1 - 396
FIP1.83 042-700 / 142-700: IOT over Heat Stop / IOT over Heat Forced Half Speed	1 - 397
FIP1.84 046-310: IOT HVPS Error	1 - 398
FIP1.85 047-216: IOT Option Output Expander Failure	1 - 399
FIP1.86 047-217: IOT Output Expander I/F Failure.....	1 - 400
FIP1.87 050-101: IOT Remain Zone RH1 JAM	1 - 401
FIP1.87-1 Jam at the MPF section	1 - 402
FIP1.87-2 Jam in the upstream vicinity of the Fuser section	1 - 405
FIP1.87-3 Jam in the downstream vicinity of the Fuser section.....	1 - 407
FIP1.87-4 Jam in the Duplexer section.....	1 - 409
FIP1.88 050-102 / 050-103 / 050-104 / 050-105: IOT Remain Zone RH2 JAM / IOT Remain Zone RH3 JAM / IOT Remain Zone RH4 JAM / IOT Remain Zone RH5 JAM..	1 - 412
FIP1.89 050-121: IOT Remain Zone 1T JAM	1 - 415
FIP1.90 050-122 / 050-123 / 050-124 / 050-125: IOT Remain Zone 2T JAM / IOT Remain Zone 3T JAM / IOT Remain Zone 4T JAM / IOT Remain Zone 5T JAM	1 - 418
FIP1.91 050-151: IOT Remain Zone HTR JAM.....	1 - 421
FIP1.92 050-152: IOT Remain Zone EXIT JAM	1 - 423
FIP1.93 050-153: IOT Remain Zone CMP JAM	1 - 425
FIP1.94 072-211-01 / 073-211-01: IOT Option Feeder2 (or Feeder3) Failure.....	1 - 427
FIP1.95 072-211-02 / 073-211-02: IOT Option Feeder Motor2 (or Motor3) Failure.....	1 - 428
FIP1.96 072-300 / 073-300: IOT RH Cover Tray2 (or Tray3) Open	1 - 429
FIP1.97 074-211-01 / 076-211-01: IOT Option Feeder4 (or Feeder5) Failure.....	1 - 430
FIP1.98 074-211-02 / 076-211-02: IOT Option Feeder Motor4 (or Motor5) Failure.....	1 - 431
FIP1.99 074-300 / 076-300: IOT Cover Tray4 (or Tray5) Open.....	1 - 432
FIP1.100 077-300: IOT Cover Front Open	1 - 433
FIP1.101 077-301: IOT Cover Right Hand Open.....	1 - 434
FIP1.102 091-400: IOT Waste Toner Box Near Life.....	1 - 435

Chapter 1 Troubleshooting CONTENTS

FIP1.103 091-411 / 091-412 / 091-413 / 091-414 / 091-479 / 091-480 / 091-481 / 091-482: IOT Drum Cartridge (YMCK) Near Life	1 - 436
FIP1.104 091-911: IOT Waste Toner Box Life Over	1 - 437
FIP1.105 091-914 / 091-917 / 091-918 / 091-919: IOT Drum Cartridge (YMCK) CRUM Fail	1 - 438
FIP1.106 091-921 / 091-922 / 091-923 / 091-924: IOT Drum Cartridge (YMCK) Detached	1 - 439
FIP1.107 091-931 / 091-932 / 091-933 / 091-934: IOT Drum Cartridge (YMCK) Life Over	1 - 440
FIP1.108 091-942 / 091-943 / 091-944 / 091-945: IOT DRUM Cartridge (YMCK) CRUM Data Error	1 - 441
FIP1.109 091-950 / 091-951 / 091-952 / 091-953: Detect YMCK Drum Cartridge Tape Staying	1 - 442
FIP1.110 091-960 / 091-961 / 091-962 / 091-963: IOT (YMCK) CRUM ID Error	1 - 443
FIP1.111 092-651: IOT CTD Sensor Rear Error Code2	1 - 444
FIP1.112 092-670: Detect Yellow Calibrating Patch Error	1 - 445
FIP1.113 092-671: Detect Magenta Calibrating Patch Error	1 - 446
FIP1.114 092-672: Detect Cyan Calibrating Patch Error	1 - 447
FIP1.115 092-673: Detect Black Calibrating Patch Error	1 - 448
FIP1.116 093-423 / 093-424 / 093-425 / 093-426: IOT Toner Cartridge Near Empty	1 - 449
FIP1.117 093-930 / 093-931 / 093-932 / 093-93: IOT Toner Cartridge Life Over	1 - 450
FIP1.118 093-960 / 093-961 / 093-962 / 093-963: IOT (YMCK) CRUM ID Error	1 - 451
FIP1.119 093-964: IOT Fuser CRUM ID Error	1 - 452
FIP1.120 093-970 / 093-971 / 093-972 / 093-973: IOT Toner Cartridge Detached	1 - 453
FIP1.121 094-325-01: IOT Switching Sensor Failure	1 - 454
FIP1.122 094-325-02 to 06: IOT Switching Sensor Failure	1 - 456
FIP1.123 094-419/ 094-422: IOT Belt Unit Near Life	1 - 457
FIP1.124 094-910: IOT Belt Unit Detached	1 - 458
FIP1.125 094-911: IOT Belt Unit Life Over	1 - 459
FIP1.126 094-912: IOT Belt Unit CRUM Fail	1 - 460
FIP1.127 094-913: IOT Transfer Roller Detached	1 - 461
FIP1.128 094-960: IOT Belt Unit CRUM ID Mismatch	1 - 462
FIP1.129 116-364: Timer Fail	1 - 463
FIP1.130 124-310: IOT XPC Error	1 - 464
FIP1.131 193-700: Custom Toner Mode	1 - 465
FIP1.132 Electrical Noise	1 - 466
4. Image Quality Trouble	1 - 467
4.1 Entry Chart for Image Quality Troubleshooting	1 - 467
4.2 Diagnosis Test Chart	1 - 471
4.3 Items to be Confirmed Before Image Quality Troubleshooting	1 - 476
4.4 Print Image Quality Specification	1 - 478
4.5 Image Quality FIP	1 - 481
FIP-1.P1 Faint print (Low contrast)	1 - 481
FIP-1.P2 Blank print (No print)	1 - 484
FIP-1.P3 Solid Print (YMCK)	1 - 486
FIP-1.P4 Vertical blank lines (White stripes in paper transport direction)	1 - 488
FIP-1.P5 Horizontal band cross out (White stripes in the horizontal direction)	1 - 490
FIP-1.P6 Vertical stripes	1 - 492
FIP-1.P7 Horizontal stripes	1 - 494
FIP-1.P8 Partial Deletion	1 - 496

Chapter 1 Troubleshooting CONTENTS

FIP-1.P9 Spots.....	1 - 498
FIP-1.P10 Afterimage (Ghost)	1 - 500
FIP-1.P11 High Background	1 - 502
FIP-1.P12 Skew	1 - 504
FIP-1.P13 Paper damage/Wrinkled Paper].....	1 - 505
FIP-1.P14 Unfusing.....	1 - 507
FIP-1.P15 Color Registration (Color Shift).....	1 - 509
FIP-1.P16 Color Registration (Image Shift)	1 - 511
5. Abnormal Noise Trouble.....	1 - 513
5.1 Entry Chart for Abnormal Noise Troubleshooting	1 - 513
5.2 Operation Mode Table	1 - 514
FIP-1.N1 Noise: When Power is turned on	1 - 514
FIP-1.N2 Noise: During Standby.....	1 - 518
FIP-1.N3 Noise: During Printing (Checking for other items than "power on noise")	1 - 519
6. Other FIP	1 - 520
FIP-AC Power	1 - 520
FIP-DC Power.....	1 - 521
FIP-Multiple feed.....	1 - 522
FIP-Paper Remaining Amount Not Displayed Correctly in Status Monitor	1 - 523
Appendix	1 - 524
Appendix_1 Clearing Jams.....	1 - 524
1.1 Clearing Paper Jams From the MPF	1 - 524
1.2 Clearing Paper Jams From the Standard Tray	1 - 525
1.3 Clearing Paper Jams From the Fuser.....	1 - 526
1.4 Clearing Paper Jams From the Duplexer.....	1 - 527
1.5 Clearing Paper Jams From the Optional Feeder	1 - 528
1.6 Clearing Paper Jams From the Output Expander	1 - 529
1.7 Clear Paper Jams From Horizontal Transport Unit.....	1 - 530
1.8 Clearing Staple Jams From the Output Expander	1 - 531
Appendix_2 Replacing the Main Parts	1 - 532
2.1 Consumables and Periodic Replacement Parts Life.....	1 - 532
2.2 Replacing the Toner Cartridges.....	1 - 536
2.3 Replacing the Drum Cartridges.....	1 - 537
2.4 Replacing the Fuser.....	1 - 540
2.5 Replacing the Separator Rollers	1 - 541
2.6 Replacing the Belt Unit	1 - 544
2.7 Replacing the Transfer Roller	1 - 547
2.8 Replacing the Stapler Cartridge.....	1 - 548
2.9 Replacing the Waste Toner Box	1 - 549
Appendix_3 Cleaning the Printer.....	1 - 550
3.1 Cleaning Inside the Printer.....	1 - 550
3.2 Cleaning the Conductivity Temperature Depth (CTD) Sensor.....	1 - 551

1. Troubleshooting Overview

To increase the efficiency of troubleshooting, ensure that preliminary checks should be made to confirm the trouble status before proceeding to the Fault Isolation Procedure (FIP), Operation of Diagnostic (Chapter 2), Wiring Diagrams (Chapter 7), and Principles of Operation (Chapter 6).

1.1 Flow of Troubleshooting

Flow of the troubleshooting is as follows:

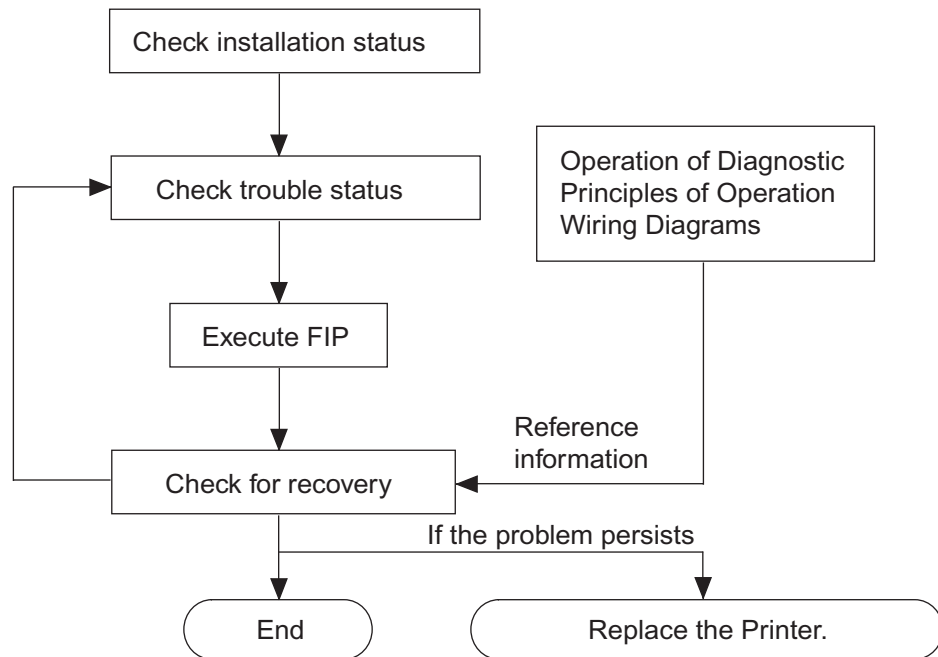

1.2 Check Installation Status

Be sure to check the following items before starting the troubleshooting procedures

- 1) The power supply voltage is within the specifications (measure the voltage at the wall outlet).
- 2) The power cord is free from breakage, short-circuit, open wire, or internal miswiring.
- 3) The printer is properly grounded.
- 4) The printer is not installed at a place subjected to high/low temperature, humidity, and sudden temperature changes.
- 5) The printer is not installed at or near water facilities, humidifier, heating appliance, fire, dust, or in airflow from air conditioner.
- 6) The printer is not installed in a place subjected to volatile or inflammable gas.
- 7) The printer is not installed under direct sunlight.
- 8) The printer is installed in a well-ventilated place.
- 9) The printer is installed on a firm and stable surface.
- 10) The paper meets the specifications (standard paper is recommended).
- 11) The printer is handled properly.
- 12) The high frequency service items are replaced at the recommended print count intervals.

1.3 Cautions on Service Operations

- 1) Be sure to remove the power cord unless otherwise required.



While the printer is powered ON, never touch the conductive parts unless otherwise required.

Never touch the conductive parts of the power switch and inlet of the LVPS, because they are live even while the printer is powered off.

- 2) When making checks on the printer with the front interlock switch and the safety switch turned ON, be sure to remove the rear cover to shut off the electric power supply to the ROS ASSY unless it is necessary to supply the electric power to the ROS ASSY during checks.



When making checks on the printer with the front interlock switch and the safety switch turned ON, there is a risk that the ROS ASSY may emit a laser beam. To prevent this risk, be sure to remove the rear cover to shut off the electric power supply to the ROS ASSY unless it is necessary to supply the electric power to the ROS ASSY during checks.

- 3) When checking some parts with the Front Cover removed and the printer powered ON, be sure to remove the connector (P/J13) on the PWBA MCU unless otherwise required.



When checking some parts with the Front Cover removed and the printer powered ON, be sure to remove the connector (P/J13) on the MCU. Otherwise, a high voltage may be output from the HVPS.

When connecting the connector (P/J13) on the MCU according to the instructions in the FIP, never touch the HVPS and high voltage parts.

- 4) When outputting a high voltage using the Diag Tool, etc., keep all the covers on unless otherwise required.



When outputting a high voltage using the Diag Tool, etc., ensure that:

- The high voltage carrying parts must never be touched.***
- The instructions in this manual must be followed.***

- 5) When operating the drive unit using the Diag Tool, etc., keep all the covers on unless otherwise required.



When operating the drive unit using the Diag Tool, etc., ensure that:

- The drive unit must never be touched.***
- The instructions in this manual must be followed.***

- 6) When touching hot parts, be careful not to get burnt.

- 7) While working, be sure to wear a wrist band or the like to dissipate static charges from your body.

1.4 Cautions on Using FIP

- 1) When troubleshooting according to the FIP, have on hand a normal MCU, LVPS, HVPS, FUSER ASSY, BELT ASSY, etc., for possible fault isolation.
- 2) In the initial check according to the FIP, check only items which can be simply checked.
- 3) In the initial check according to the FIP, check the constitutive parts of the major check parts and related parts, as well as major check parts.
- 4) When working with the printer, be sure to remove the power cord unless otherwise required. Never touch live parts if not required, while the power cord is connected.
- 5) Connector condition is denoted as follows:
 - [P/J12] → Connector (P/J12) is connected.
 - [P12] → Plug side with the connector (P/J12) removed (except when attached directly to the board).
 - [J12] → Jack side with the connector (P/J12) removed (except when attached directly to the board).
- 6) [P/J1-2PIN <=> P/J3-4PIN] in the FIP means measurement with the positive side of the measuring instrument connected to [2PIN] of [P/J1] and the negative side to [4PIN] of [P/J3].
- 7) [P/J1<=> P/J2] in the FIP means measurement for all terminals corresponding between [P/J1] and [P/J2] based on "Wiring Diagrams".
- 8) In [P/J1-2PIN <=> P/J3-4PIN] in the FIP where voltage is measured, [P/J3-4PIN] on the rear negative side is always at the AG (analog ground), SG (signal ground), or RTN (return). Therefore, after checking of proper conductivity between AGs, SGs, or RTNs respectively, the rear negative side can be connected to the PIN of AG, SG or RTN instead of [P/J3-4PIN]. However, care should be taken not to confuse [AG], [SG], and [RTN] because they are not on the same level.
- 9) When measuring the voltage at small connectors, use the dedicated tool. Handle the tool with care because its business end is pointed.
- 10) When measuring the voltage, set the BELT ASSY, toner cartridge and sheet feeder, close the COVERS and power ON unless otherwise required.
- 11) Numerical values in the FIP are only for guideline. Approximate values are acceptable.
- 12) In each step of the FIP, parts removal and other procedures implicitly required for the step are omitted.
- 13) In the FIP, "Replacement" means the replacement of the parts that are considered to be the cause of the trouble. Replacement of those parts means the replacement of the assembly part (HIGH ASSY) that contain them.

- 14) In the FIP, the sheet feeder immediately below the printer main body is called "Tray 1", and the cassette below it is called "Tray 2".
- 15) Some of the instructions in the FIP are branched off depending on the specifications. Follow the applicable instruction.
- 16) For some optional components, you may have to refer to the manual of the relevant component for troubleshooting. Have the relevant manual at hand as needed.

1.5 Items To Be Confirmed Before Going To FIP Troubleshooting

Basic Printer Problems

Some printer problems can be easy to resolve. If a problem occurs with your printer, check each the following:

- 1) If a message is displayed on the LCD of operator panel, see "2.3 Status Code List".
- 2) The printer power cable is plugged into the printer and a properly grounded electrical outlet.
- 3) The printer power is powered ON.
- 4) The electrical outlet is not turned off by any switch or breaker.
- 5) Other electrical equipment plugged into the outlet is working.
- 6) All options are properly installed.
- 7) If you have checked all of the above and still have a problem, turn off the printer, wait for 10 seconds, and then turn on the printer. This often solves the problem.

Display Problems

- 1) If the operator panel displays only diamonds or is blank, check and try the action below. If the problem persists even after checking and executing the items below, execute "Flow 44 Operator Panel-ESS Communication Fail", "Flow 151 AC Power" or "Flow 152 DC Power".
 - a) Turn off the printer, wait for 10 seconds, and turn on the printer.
 - b) Self Test Message appears on the operator panel. When the test is completed, "Ready to Print" is displayed.
- 2) If menu settings changed from the operator panel have no effect, check and try the actions below.

Settings in the software program, the printer driver, or the printer utilities are overriding the settings made on the operator panel.

 - a) Change the menu settings from the printer driver, the printer utilities, or the software program instead of the operator panel.
 - b) Disable the settings in the printer driver, the printer utilities, or the software program so you can change settings on the operator panel.

Printing Problems

- 1) If a job did not print correct or incorrect characters were printed, check and try the actions below.
 - a) Make sure "Ready to Print" appears on the operator panel before sending a job to print. Press **Menu** to return to "Ready to Print".
 - b) Make sure print media is loaded in the printer. Press **Menu** to return to "Ready to Print".
 - c) Verify that you are using the correct printer driver.
 - d) Make sure you are using the correct Ethernet or USB cables and it securely connected at the back of the printer.
 - e) Verify that the correct print media size is selected.
 - f) If using a print spooler, verify that the spooler has not stalled.
 - g) Check the printer interface from the "Configure" menu. Determine the host interface you are using. Print a Panel Setting page to verify that the current interfaces settings are correct.
 - h) Output fonts will not print correctly using the PCL driver in its default mode. To correct this problem, use PostScript driver when using the PCL driver.

- 2) If secure print is not available or not printing, refer to the requirements below.
 - a) Minimum 256 MB is required.
 - b) RAM Disk must be enabled using the operation panel.
 - c) The number of secure print jobs your printer can store is dependent on the job size including number of pages, graphics, color attributes, and the amount of memory installed. To increase this number, add additional memory.
- 3) If print media misfeeds or multiple feeds occur, check and try the actions below.
 - a) Make sure the print media you are using meets the specifications for your printer. Refer to **Print Media Guidelines** of this section.
 - b) Flex print media before loading it in any of the sources.
 - c) Make sure the print media is loaded correctly.
 - d) Make sure the width and length guides on the print media sources are adjusted correctly.
 - e) If the print media are overfilled in sources, reduce the amount of media.
 - f) Load the recommended print side correctly for the type of print media you are using.
 - g) Turn the print media over or around and try printing again to see if feeding improves.
 - h) Check the print media type loaded in the source, and refill only one type of print media, if print media types are mixed.
 - i) Refill a new ream of print media, if some reams are mixed.
 - j) Remove the top and bottom sheets of a ream before loading the print media.
 - k) Do not reload print media until the print media source is empty.
- 4) If envelope misfeeds or multiple feeds occur, check and try the action below.
 - a) Remove the stack of envelopes from the multiple purpose feeder (MPF).
- 5) If page breaks in unexpected places, check and try the action below.
 - a) Check the "Job Timeout" in the Basic Settings menu and increase the value.
- 6) If a job prints from the wrong source or on the wrong print media, check and try the action below.
 - a) Check the "Paper Size" and "Paper Type" in the Tray Settings menu on the printer operator panel and in the printer driver.
- 7) If print media does not stack neatly in the output tray, check and try the action below.
 - a) Turn the print media stack over in the tray or multipurpose feeder.

Print Media Guidelines

Print media is paper, transparencies, labels, envelopes, coated paper among others. Your printer provides high-quality printing on a variety of print media. Selecting the appropriate print media for your printer helps avoid printing troubles. This section describes how to select print media, how to care for print media, and how to load the print media in the optional 550-sheet tray module.

Paper

For the best print quality in color, use 75 g/m² (20 lb.) xerographic, grain long paper. For the best print quality in black and white, use 90 g/m² (24 lb.) xerographic, grain long paper. Before buying large quantities of any print media, Dell recommends trying a sample first.

When loading paper, identify the recommended print side on the paper package, and load the paper accordingly. See "Loading Print Media in Optional Trays" and "Loading the Multipurpose Feeder" for detailed loading instructions.

Paper Characteristics

The following paper characteristics affect print quality and reliability. Dell recommends that you follow these guidelines when evaluating new paper stock.

Weight

The tray automatically feeds paper weights from 60 to 216 g/m² (16 to 57.6 lb. bond) grain long. The multipurpose feeder automatically feeds paper weights from 60 to 216 g/m² (16 to 57.6 lb. bond) grain long. Paper lighter than 60 g/m² (16 lb.) might not be stiff enough to feed properly, and could cause paper jams. For best performance, use 75 g/m² (20 lb. bond) grain long paper.

Curl

Curl is the tendency of print media to curve at its edges. Excessive curl can cause paper feeding problems. Curl usually occurs after the paper passes through the printer, where it is exposed to high temperatures. Storing paper unwrapped in humid conditions, even in the paper tray, can contribute to paper curling prior to printing and cause feeding problems.

Smoothness

The degree of paper smoothness directly affects print quality. If the paper is too rough, the toner does not fuse to the paper properly, resulting in poor print quality. If the paper is too smooth, it can cause paper feeding problems. Smoothness between 150 and 250 Sheffield points produces the best print quality.

Moisture Content

The amount of moisture in the paper affects both print quality and the ability of the printer to feed the paper properly. Leave the paper in its original packaging until you are ready to use it. This limits the exposure of the paper to moisture changes that can degrade its performance.

Grain Direction

Grain refers to the alignment of the paper fibers in a sheet of paper. Grain is either grain long, running the length of the paper, or grain short, running the width of the paper. For 60 to 135 g/m² (16 to 36 lb. bond) paper, grain long fibers are recommended. For papers heavier than 135 g/m² (36 lb. bond), grain short is preferred.

Fiber Content

Most high-quality xerographic paper is made from 100% chemically pulped wood. Paper containing fibers such as cotton possess characteristics that can result in degraded paper handling.

Recommended Paper

To ensure the best print quality and feed reliability, use 75 g/m² (20 lb.) xerographic paper. Business papers designed for general business use also provide acceptable print quality.

Always print several samples before buying large quantities of any type of print media. When choosing any print media, you should consider the weight, fiber content, and color.

The laser printing process heats paper to high temperatures of 225°C (437°F) for Magnetic Ink Character Recognition (MICR) applications, and 205°C (401°F) for non-MICR applications. Only use paper able to withstand these temperatures without discoloring, bleeding, or releasing hazardous emissions. Check with the manufacturer or vendor to determine whether the paper you have chosen is acceptable for laser printers.

Unacceptable Paper

The following paper types are not recommended for use with the printer:

- 1) Chemically treated papers used to make copies without carbon paper, also known as carbonless papers, carbonless copy paper (CCP), or no carbon required (NCR) paper
- 2) Preprinted papers with chemicals that may contaminate the printer
- 3) Preprinted papers that can be affected by the temperature in the printer fuser

- 4) Preprinted papers that require a registration (the precise print location on the page) greater than ± 0.09 in., such as optical character recognition (OCR) forms
In some cases, you can adjust registration with your software program to successfully print on these forms.
- 5) Coated papers (erasable bond), synthetic papers, thermal papers
- 6) Rough-edged, rough or heavily textured surface papers or curled papers
- 7) Recycled papers containing more than 25% post-consumer waste that do not meet DIN 19 309
- 8) Multiple-part forms or documents
- 9) Label paper with Cut

Selecting Paper

Proper paper selection helps prevent jams and ensures trouble-free printing.

To help avoid jams or poor print quality:

1. Always use new, undamaged paper.
2. Before loading the paper, identify the recommended print side of the paper. This information is usually indicated on the paper package.
3. Do not use paper that you have cut or trimmed yourself.
4. Do not mix print media sizes, weights, or types in the same source. This may result in a paper jam.
5. Do not remove trays while a job is printing or Printing is displayed on the operator panel.
6. Make sure the Paper Type and Paper Size settings are correct.
7. Make sure the paper is properly loaded in the tray.
8. Flex paper back and forth, and then fan them. Straighten the edges of the stack on a level surface.
9. When curl is excessive, with plain paper, turn it over and reset it.

Identifying Print Media Sources and Specifications

The following tables provide information on standard and optional print media sources.

Supported Paper Sizes

	MPF	Standard Tray	Option Tray	Duplexer	Finisher (Sheet)	Finisher (Set)
A4 (210 x 297 mm)	Y	Y	Y	Y	N	Y
A5 (148 x 210 mm)	Y	Y	Y	Y	Y	N
B5 (182 x 257 mm)	Y	Y	Y	Y	N	Y
Letter (8.5 x 11 in.)	Y	Y	Y	Y	N	Y
Folio (8.5 x 13 in.)	Y	Y	Y	Y	N	Y
Legal (8.5 x 14 in.)	Y	Y	Y	Y	N	Y
Executive (7.25 x 10.5 in.)	Y	Y	Y	Y	N	Y
Envelope # 10 (4.125 x 9.5 in.)	Y	Y	N	N	Y	N
Monarch (3.875 x 7.5 in.)	Y	Y	N	N	Y	N
DL (4.25 x 8.75 in.)	Y	Y	N	N	Y	N
C5 (9 x 6.5 in.)	Y	Y	N	N	Y	N
Custom	Y	Y	Y	Y	Y	Y

Supported Paper Types

		MPF		Standard Tray		Option Tray		Duplexer		Finisher (Sheet)		Finisher (Set)	
		Side 1	Side 2	Side 1	Side 2	Side 1	Side 2	Side 1	Side 2	Side 1	Side 2	Side 1	Side 2
Plain	Normal	Y	Y	Y	N	Y	N	Y	N	N	N	Y	N
	Thick	Y	Y	Y	N	Y	N	Y	N	N	N	Y	N
Covers	Normal	Y	Y	Y	N	Y	N	Y	N	N	N	Y	N
	Thick	Y	Y	Y	N	Y	N	N	N	N	N	Y	N
Coated	Normal	Y	Y	Y	N	N	N	Y	N	Y	N	N	N
	Thick	Y	Y	Y	N	N	N	N	N	Y	N	N	N
Label	Normal	Y	N	Y	N	N	N	N	N	Y	N	N	N
Envelope		Y	N	Y	N	N	N	N	N	Y	N	N	N
Recycled		Y	Y	Y	N	Y	N	Y	N	N	N	Y	N
Transparency		Y	N	Y	N	N	N	N	N	Y	N	N	N

Paper Type Specifications

Paper type	Weight (gsm)	Remarks
Plain Paper	60-80	-
Plain Thick Paper	81-105	-
Covers	106-162	-
Covers Thick	163-216	-
Coated Normal	106-162	Inkjet printer paper cannot be used.
Coated Thick	163-216	
Transparency	-	
Label Normal	-	
Label Thick	-	
Envelopes	-	-
Recycled	-	-

2. FIP

2.1 FIP

The FIP is the first step for trouble diagnosis. The FIP isolates the presence of various troubles including error codes, and guides the troubleshooting procedure.

2.2 Flow of FIP

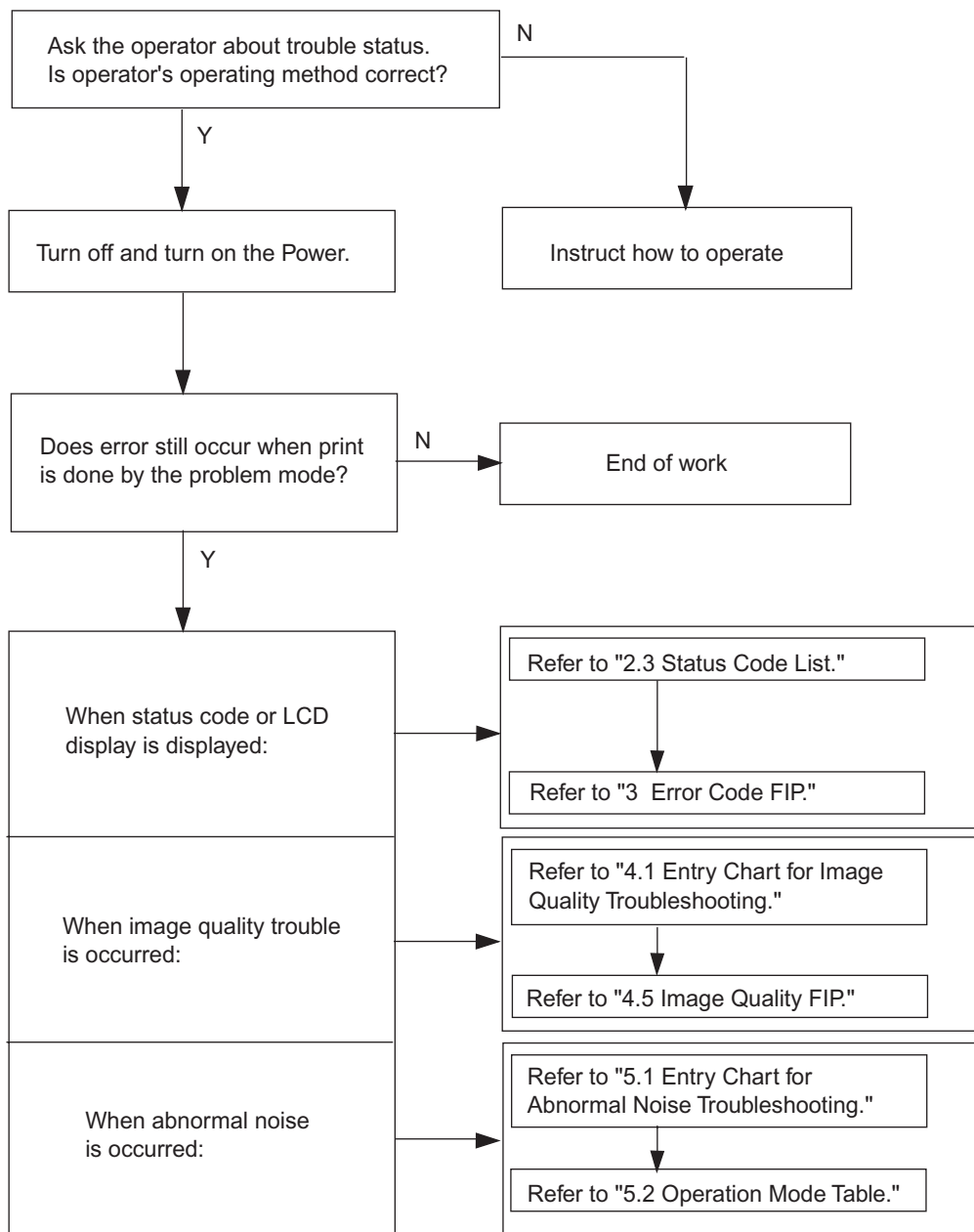

2.3 Status Code List

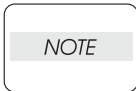

Errors that occur when optional components are installed are gray-shaded.

Status Code		Error Message		Status Contents	FIP to be referred
		LCD	Status Window		
001	360	001-360 Restart Printer Contact Support IfMessageReturns	Printer error. Turn off the printer, and turn it on again. Contact customer support if this failure is repeated.	< IOT LV Fan Motor Failure > MCU detects an error upon receiving error signal from the LVPS Fan.	Flows 1 FIP1.1
			001-360		
003	340	003-340 Restart Printer Contact Support IfMessageReturns	Printer error. Turn off the printer, and turn it on again. Contact customer support if this failure is repeated.	<IOT Firmware Error> MCU firmware error occurs.	Flows 2 FIP1.2
			003-340		
003	356	003-356 Restart Printer Contact Support IfMessageReturns	Printer error. Turn off the printer, and turn it on again. Contact customer support if this failure is repeated.	<IOT NVRAM Error> The operation error of NVM (read/write check error etc.) is detected.	Flows 3 FIP1.3
			003-356		
004	310	004-310 Restart Printer Contact Support IfMessageReturns	Printer error. Turn off the printer. Confirm Feeder is correctly installed. Turn on the printer. Contact customer support if this failure is repeated.	<IOT Option Feeder I/F Failure> The Option Feeder communication failure is detected.	Flows 4 FIP1.4
			004-310		
			This code is given when the Option Sheet Feeder is installed.		
004	312	004-312 Restart Printer Contact Support IfMessageReturns	Printer error. Turn off the printer, and turn it on again. Contact customer support if this failure is repeated.	<IOT Feeder Configuration Failure> Option Sheet Feeder Configuration error is detected.	Flows 5 FIP1.5
			004-312		

Status Code		Error Message		Status Contents	FIP to be referred
		LCD	Status Window		
006	370	006-370 Restart Printer Contact Support IfMessageReturns	Printer error.	<IOT ROS Failure> The operation error of ROS (rotational error etc.) is detected.	Flows 6 FIP1.6
			Turn off the printer, and turn it on again. Contact customer support if this failure is repeated. 006-370		
007	340	007-340 Restart Printer Contact Support IfMessageReturns	Printer error.	<IOT Motor Failure> Motor failure is detected. Pressing the [Information] button shows detail error code (01 to 04). Code: 01: Deve Motor K Error Code: 02: DEVE YMC Motor Error Code: 03: Xero Motor Error Code: 04: PH Motor Error	Flows 7: FIP1.7: Code01 (K Motor) Flows 8: FIP1.8: Code02 (YMC Motor) Flows 9: FIP1.9: Code03 (Xero Motor) Flows 10: FIP1.10: Code04 (PH Motor)
			Turn off the printer, and turn it on again. Contact customer support if this failure is repeated. 007-340-01 to 04		
009	340	009-340 Restart Printer Contact Support IfMessageReturns	Printer error.	<IOT CTD Sensor Error> CTD sensor error (analog-to-digital conversion etc.) was detected.	Flows 11 FIP1.11
			Turn off the printer, and turn it on again. Contact customer support if this failure is repeated. 009-340		
009	360	009-360 Restart Printer Reseat Y Toner Cart Contact Support	Printer error.	<IOT Yellow Toner CRUM Comm Fail> The Yellow Toner Cartridge CRUM communication failure is detected.	Flows 12 FIP1.12
			Turn off the printer. Confirm Yellow Toner Cartridge is correctly installed. Turn on the printer. Contact customer support if this failure is repeated. 009-360		

Status Code	Error Message		Status Contents	FIP to be referred	
	LCD	Status Window			
009	361	009-361 Restart Printer Reseat M Toner Cart Contact Support	Printer error. Turn off the printer. Confirm Magenta Toner Cartridge is correctly installed. Turn on the printer. Contact customer support if this failure is repeated. 009-361	<IOT Magenta Toner CRUM Comm Fail > The Magenta Toner Cartridge CRUM communication failure is detected.	Flows 12 FIP1.12
	362	009-362 Restart Printer Reseat C Toner Cart Contact Support	Printer error. Turn off the printer. Confirm Cyan Toner Cartridge is correctly installed. Turn on the printer. Contact customer support if this failure is repeated. 009-362	<IOT Cyan Toner CRUM Comm Fail> The Cyan Toner Cartridge CRUM communication failure is detected.	Flows 12 FIP1.12
	363	009-363 Restart Printer Reseat K Toner Cart Contact Support	Printer error. Turn off the printer. Confirm Black Toner Cartridge is correctly installed. Turn on the printer. Contact customer support if this failure is repeated. 009-363	<IOT Black Toner CRUM Comm Fail> The Black Toner Cartridge CRUM communication failure is detected.	Flows 12 FIP1.12
	367	 CRUM DATA 009-367 Reseat Yellow Toner Crtrdg	An unsupported Yellow Toner Cartridge is installed. Open the Front Cover. Remove the unsupported Yellow Toner Cartridge and install a supported one. Please click the Show Me How Button for details. 009-367	<IOT Yellow Toner Cartridge CRUM Data Error> The Yellow Toner Cartridge CRUM Data error is detected.	Flows 13 FIP1.13

Status Code	Error Message		Status Contents	FIP to be referred	
	LCD	Status Window			
009	368	<p>i CRUM DATA 009-368 Reseat Magenta Toner Crtrdg</p>	<p>An unsupported Magenta Toner Cartridge is installed.</p> <p>Open the Front Cover. Remove the unsupported Magenta Toner Cartridge and install a supported one. Please click the Show Me How Button for details.</p> <p>009-368</p>	<p><IOT Magenta Toner Cartridge CRUM Data Error> The Magenta Toner Cartridge CRUM Data error is detected.</p>	Flows 13 FIP1.13
	369	<p>i CRUM DATA 009-369 Reseat Cyan Toner Crtrdg</p>	<p>An unsupported Cyan Toner Cartridge is installed.</p> <p>Open the Front Cover. Remove the unsupported Cyan Toner Cartridge and install a supported one. Please click the Show Me How Button for details.</p> <p>009-369</p>	<p><IOT Cyan Toner Cartridge CRUM Data Error> The Cyan Toner Cartridge CRUM Data error is detected.</p>	Flows 13 FIP1.13
	370	<p>i CRUM DATA 009-370 Reseat Black Toner Crtrdg</p>	<p>An unsupported Black Toner Cartridge is installed.</p> <p>Open the Front Cover. Remove the unsupported Black Toner Cartridge and install a supported one. Please click the Show Me How Button for details.</p> <p>009-370</p>	<p><IOT Black Toner Cartridge CRUM Data Error> The Black Toner Cartridge CRUM Data error is detected.</p>	Flows 13 FIP1.13
	371	<p>i CRUM DATA 009-371 Reseat Belt Unit</p>	<p>An unsupported Belt Unit is installed.</p> <p>Open the Front Cover. Remove the unsupported Belt Unit and install a supported one. Please click the Show Me How Button for details.</p> <p>009-371</p>	<p><IOT Belt Unit CRUM Data Error> The Belt Unit CRUM Data error is detected.</p>	Flows 14 FIP1.14

Status Code	Error Message		Status Contents	FIP to be referred	
	LCD	Status Window			
010	317	010-317 Restart Printer Reseat Fuser Contact Support	Printer error. Turn off the printer, and turn it on again. Contact customer support if this failure is repeated. 010-317	<IOT Fuser Detached> Fuser detached is detected.	Flows 15 FIP1.15
	330	010-330 Restart Printer Contact Support IfMessageReturns	Printer error. Turn off the printer, and turn it on again. Contact customer support if this failure is repeated. 010-330	<IOT Fuser Motor Failure> Fuser Motor failure is detected.	Flows 16 FIP1.16
	351	010-351 Restart Printer Replace Fuser Contact Support	The Fuser needs to be replaced now. Contact Customer Support. Please click the Show Me How Button for details. 010-351	<IOT Fuser Life Over> The value of Fuser counter has reached the replacement time.	Flows 17 FIP1.17
	354	010-354 Restart Printer Contact Support IfMessageReturns	Printer error. Turn off the printer, and turn it on again. Contact customer support if this failure is repeated. 010-354	<IOT Environment Sensor Error> The Temperature sensor detected the temperature anomaly.	Flows 18 FIP1.18
	359	010-359 Restart Printer Reseat Fuser Contact Support	An unsupported Fuser is installed. Please contact customer support and click the Show Me How Button for details. 010-359	<IOT Fuser CRUM ID Error> An unsupported Fuser is detected.	Flows 19 FIP1.19

Status Code	Error Message		Status Contents	FIP to be referred	
	LCD	Status Window			
010	360	010-360 Restart Printer Reseat Fuser Contact Support	Printer error. Turn off the printer. Confirm Fuser is correctly installed. Turn on the printer. Contact customer support if this failure is repeated. 010-360	<IOT Fuser Comm Fail> Fuser CRUM communication error is detected.	Flows 19 FIP1.19
	377	010-377 Restart Printer Contact Support IfMessageReturns	Printer error. Turn off the printer. Confirm Fuser is correctly installed. Turn on the printer. Contact customer support if this failure is repeated. 010-377	<IOT Fuser Failure> The operation error of Fuser (Temperature anomaly error etc.) is detected.	Flows 20 FIP1.20
	420	Ready to Print 010-420 Fuser ↕ Flip Ready to Print prepare	Prepare the Fuser. 010-420	<IOT Fuser Near Life> The Fuser is approaching the replacement time.	Flows 21 FIP1.21
	421	Check Cartridge 010-421 Replace Fuser ↕ Flip Check Cartridge Contact Support	Contact customer support if this failure is repeated. 010-421	< IOT Fuser Near Life> The Fuser is approaching the replacement time.	Flows 21 FIP1.21
	910	Env.Mode Error 010-910 1.Open Right Hand Cover and make a Envelope Lever the normal position.	Envelope Mode Error has occurred. Set the Envelope Lever following the steps displayed on the panel. 010-910	<IOT Fuser Envelope Mode Error> The Envelope Mode lever is set to Envelope Mode although "Plain" is selected on the printer driver.	Flows 22 FIP1.22
This code is given when the Option Output Expander is installed.					
012	151	Paper JAM 1.Open Output Expander Front Door. 2.Please turn a knob	-	<IOT Output Expander Compile Exit Sensor Off JAM> The Output Expander Compile Exit Sensor is not turned OFF within the specified time.	Flows 23 FIP1.23
	161	Paper JAM 1.Open Output Expander Front Door, and remove paper. 2.Close Output	-	<IOT Output Expander Set Eject JAM> The Output Expander Compile Tray No Paper Sensor is not turned ON within the specified time.	Flows 24 FIP1.24

Status Code	Error Message		Status Contents	FIP to be referred	
	LCD	Status Window			
012	302	Cover Open 012-302 Close Output Expander Front Door	The Output Expander Front Door is open. Close the Output Expander Front Door. 012-302	<IOT Output Expander Cover Front Open> The Output Expander Front Cover is open.	Flows 25 FIP1.25
	303	Cover Open 012-303 Close Top Cover	The Top Cover is open. Close the Top Cover. 012-303	<Output Expander H Transport Unit Cover Open> The Output Expander H Transport Unit Cover is open.	Flows 26 FIP1.26
	311	012-311 Restart Printer Contact Support IfMessageReturns	Printer error. Turn off the printer, and turn it on again. Contact customer support if this failure is repeated. 012-311	<IOT Output Expander Front Tamper Home Sensor On Fail> The Front Tamper Home Sensor is not turned ON within the specified time after the Front Tamper started traveling to its Home position.	Flows 27 FIP1.27
	312	012-312 Restart Printer Contact Support IfMessageReturns	Printer error. Turn off the printer, and turn it on again. Contact customer support if this failure is repeated. 012-312	<IOT Output Expander NVM Fail> The PWB MAIN A4 FIN NVM read/write error occurred.	Flows 28 FIP1.28
	313	012-313 Restart Printer Contact Support IfMessageReturns	Printer error. Turn off the printer, and turn it on again. Contact customer support if this failure is repeated. 012-313	<IOT Output Expander Front Tamper Home Sensor Off Fail> The Front Tamper Home Sensor is not turned OFF within the specified time after the Front Tamper started leaving its Home position.	Flows 27 FIP1.27
	314	012-314 Restart Printer Contact Support IfMessageReturns	Printer error. Turn off the printer, and turn it on again. Contact customer support if this failure is repeated. 012-314	<IOT Output Expander Rear Tamper Home Sensor Off Fail> The Rear Tamper Home Sensor is not turned OFF within the specified time after the Rear Tamper started leaving its Home position.	Flows 29 FIP1.29

Status Code	Error Message		Status Contents	FIP to be referred	
	LCD	Status Window			
012	315	012-315 Restart Printer Contact Support IfMessageReturns	Printer error. Turn off the printer, and turn it on again. Contact customer support if this failure is repeated. 012-315	<IOT Output Expander Stacker Tray Fail> The Stacker Height Sensor is not turned ON within the specified time after the Stacker Tray started going up.	Flows 30 FIP1.30
	316	012-316 Restart Printer Contact Support IfMessageReturns	Printer error. Turn off the printer, and turn it on again. Contact customer support if this failure is repeated. 012-316	<IOT Output Expander Stacker Upper Limit Fail> The Stacker Tray abnormally went up beyond its specified upper limit (Stacker Height).	Flows 31 FIP1.31
	317	012-317 Restart Printer Contact Support IfMessageReturns	Printer error. Turn off the printer, and turn it on again. Contact customer support if this failure is repeated. 012-317	<IOT Output Expander Stacker Lower Limit Fail> The Stacker Tray abnormally came down beyond its specified lower limit (Full Stack).	Flows 32 FIP1.32
	349	012-349 Restart Printer Contact Support IfMessageReturns	Printer error. Turn off the printer, and turn it on again. Contact customer support if this failure is repeated. 012-349	<IOT Output Expander Eject Clamp Home Sensor On Fail> The Eject Clamp Home Sensor is not turned ON within the specified time after the Eject Clamp started going up.	Flows 33 FIP1.33
	353	012-353 Restart Printer Contact Support IfMessageReturns	Printer error. Turn off the printer, and turn it on again. Contact customer support if this failure is repeated. 012-353	<IOT Output Expander Rear Tamper Home Sensor On Fail> The Rear Tamper Home Sensor is not turned ON within the specified time after the Rear Tamper started traveling to its home position.	Flows 29 FIP1.29
	370	012-370 Restart Printer Contact Support IfMessageReturns	Printer error. Turn off the printer, and turn it on again. Contact customer support if this failure is repeated. 012-370	<IOT Output Expander Eject Clamp Home Sensor Off Fail> The Eject Clamp Home Sensor is not turned OFF within the specified time after the Eject Clamp started coming down.	Flows 33 FIP1.33

Status Code	Error Message		Status Contents	FIP to be referred	
	LCD	Status Window			
012	373	012-373 Restart Printer Contact Support IfMessageReturns	Printer error. Turn off the printer, and turn it on again. Contact customer support if this failure is repeated. 012-373	<IOT Output Expander Set Clamp Home Sensor On Fail> The Set Clamp Home Sensor is not turned ON within the specified time after the Set Clamp started operation.	Flows 34 FIP1.34
	374	012-374 Restart Printer Contact Support IfMessageReturns	Printer error. Turn off the printer, and turn it on again. Contact customer support if this failure is repeated. 012-374	<IOT Output Expander Set Clamp Home Sensor Off Fail> The Set Clamp Home Sensor is not turned OFF within the specified time after the Set Clamp finished operation.	Flows 34 FIP1.34
	381	012-381 Restart Printer Contact Support IfMessageReturns	Printer error. Turn off the printer, and turn it on again. Contact customer support if this failure is repeated. 012-381	<IOT Output Expander Stapler Fail> The changeover of the Stapler Home Sensor from OFF to ON is not detected within the specified time after the Stapler Move Motor was turned ON (Forward operation).	Flows 35 FIP1.35
	903	Paper JAM 1.Open Output Expander Front Door. 2.A knob is turned if necessary, and	-	<IOT Output Expander Paper Remain at Compile Exit> The Compile Exit Sensor detected the presence of paper.	Flows 23 FIP1.23
	905	Paper JAM 1.Open Output Expander Front Door and remove paper. 2.Close Output	-	<IOT Output Expander Paper Remain at Compile Tray No Paper Sensor> The Compile Tray No Paper Sensor detected the presence of paper.	Flows 24 FIP1.24
016	300	016-300 Restart Printer Contact Support IfMessageReturns	Printer error. Turn off the printer, and turn it on again. Contact customer support if this failure is repeated. 016-300	<ESS Data Cache Error> The CPU cache error occurred.	Flows 36 FIP1.36

Status Code	Error Message		Status Contents	FIP to be referred	
	LCD	Status Window			
016	301	016-301 Restart Printer Contact Support IfMessageReturns	Printer error. Turn off the printer, and turn it on again. Contact customer support if this failure is repeated. 016-301	<ESS Instruction Cache Error> The CPU instruction cache error occurred.	Flows 36 FIP1.36
	302	016-302 Restart Printer Contact Support IfMessageReturns	Printer error. Turn off the printer, and turn it on again. Contact customer support if this failure is repeated. 016-302	<ESS Illegal Exception> The Exception error occurred.	Flows 36 FIP1.36
	This code is given when the Option Hard Disk is installed.				
	312	016-312 Restart Printer Contact Support IfMessageReturns	Printer error. Turn off the printer, and turn it on again. Contact customer support if this failure is repeated. 016-312	<ESS Hard Disk Fail> Hard Disk error is detected.	Flows 38 FIP1.38
	313	016-313 Restart Printer Contact Support IfMessageReturns	Printer error. Turn off the printer, and turn it on again. Contact customer support if this failure is repeated. 016-313	<ESS ASIC Fail> The ASIC error occurred.	Flows 36 FIP1.36
315	016-315 Restart Printer Contact Support IfMessageReturns	Printer error. Turn off the printer, and turn it on again. Contact customer support if this failure is repeated. 016-315	<ESS On Board RAM R/W Check Fail> An error occurred during the on-board RAM read/write check at the time of initialization.	Flows 36 FIP1.36	

Status Code	Error Message		Status Contents	FIP to be referred	
	LCD	Status Window			
016	This code is given when the Option Memory is installed.				
	316	016-316 Restart Printer Reseat Memory Contact Support	Printer error. Turn off the printer. Confirm Memory is correctly installed. Turn on the printer. Contact customer support if this failure is repeated. 016-316	<ESS DIMM Slot RAM R/W Check Fail> Unsupported additional memory module was detected in the memory slot.	Flows 39 FIP1.39
	317	016-317 Restart Printer Contact Support IfMessageReturns	Printer error. Turn off the printer, and turn it on again. Contact customer support if this failure is repeated. 016-317	<ESS ROM Check (Main) Fail> Checksum error occurred in the main program ROM.	Flows 36 FIP1.36
	This code is given when the Option Memory is installed.				
	318	016-318 Restart Printer Reseat Memory Contact Support	Printer error. Turn off the printer, and turn it on again. Contact customer support if this failure is repeated. 016-318	<ESS DIMM Slot RAM Error> Additional memory module is not completely inserted in the slot.	Flows 39 FIP1.39
	This code is given when the Option Hard Disk is installed.				
	319	016-319 Restart Printer Contact Support IfMessageReturns	Printer error. Turn off the printer, and turn it on again. Contact customer support if this failure is repeated. 016-319	<Encryption key error> Inconsistency in the encryption setting was detected.	Flows 40 FIP1.40
320	016-320 Restart Printer Contact Support IfMessageReturns	Printer error. Turn off the printer, and turn it on again. Contact customer support if this failure is repeated. 016-320	<Encryption setting error> Inconsistency in the encryption key was detected.	Flows 40 FIP1.40	

Status Code	Error Message		Status Contents	FIP to be referred	
	LCD	Status Window			
016	323	016-323 Restart Printer Contact Support IfMessageReturns	Printer error. Turn off the printer, and turn it on again. Contact customer support if this failure is repeated. 016-323	<ESS NVRAM 1 R/W Check Fail> An error occurred during the master NVRAM 1 read/write check at the time of initialization.	Flows 36 FIP1.36
	324	016-324 Restart Printer Contact Support IfMessageReturns	Printer error. Turn off the printer, and turn it on again. Contact customer support if this failure is repeated. 016-324	<ESS NVRAM 2 R/W Check Fail> An error occurred during the slave NVRAM 2 read/write check at the time of initialization.	Flows 36 FIP1.36
	325	016-325 Restart Printer Contact Support IfMessageReturns	Printer error. Turn off the printer, and turn it on again. Contact customer support if this failure is repeated. 016-325	<ESS NVRAM 3 R/W Check Fail> An error occurred during the slave NVRAM 3 read/write check at the time of initialization.	Flows 36 FIP1.36
	327	016-327 Restart Printer Contact Support IfMessageReturns	Printer error. Turn off the printer, and turn it on again. Contact customer support if this failure is repeated. 016-327	<ESS NVRAM 1 SIZE And ID Check Fail> Upon turning the power ON, an error occurred during checks on consistency of the NVRAM size between the system-required one and actual one and on consistency of the recorded IDs.	Flows 36 FIP1.36
	This code is given when the Option Wireless Adapter is installed.				
	338	016-338 Restart Printer Reseat Wireless Contact Support	Printer error. Turn off the printer, and turn it on again. Contact customer support if this failure is repeated. 016-338	<Option Wireless Adapter Error> The error is detected by Wireless option check.	Flows 41 FIP1.41
340	016-340 Restart Printer Contact Support IfMessageReturns	Printer error. Turn off the printer, and turn it on again. Contact customer support if this failure is repeated. 016-340	<ESS Network Communication Fail> A communication error occurred between the On Board Network and ESS firmware.	Flows 37 FIP1.37	

Status Code	Error Message		Status Contents	FIP to be referred	
	LCD	Status Window			
016	344	016-344 Restart Printer Contact Support IfMessageReturns	Printer error. Turn off the printer, and turn it on again. Contact customer support if this failure is repeated. 016-344	<ESS Network MAC Address Checksum Error> Checksum error occurred in the Network MAC address.	Flows 37 FIP1.37
	345	016-345 Restart Printer Contact Support IfMessageReturns	Printer error. Turn off the printer, and turn it on again. Contact customer support if this failure is repeated. 016-345	<ESS Ethernet Self-diagnostic Error> ESS Ethernet Self-diagnostic error occurred.	Flows 37 FIP1.37
	346	016-346 Restart Printer Contact Support IfMessageReturns	Printer error. Turn off the printer, and turn it on again. Contact customer support if this failure is repeated. 016-346	<ESS Network Internal Loop back Error> An error occurred during the internal loopback test.	Flows 37 FIP1.37
	347	016-347 Restart Printer Contact Support IfMessageReturns	Printer error. Turn off the printer, and turn it on again. Contact customer support if this failure is repeated. 016-347	<ESS Network Fatal Error> An error occurred during the on-board network check.	Flows 37 FIP1.37
	This code is given when the Option Hard Disk is installed.				
	356	016-356 Restart Printer Contact Support IfMessageReturns	Printer error. Turn off the printer, and turn it on again. Contact customer support if this failure is repeated. 016-356	<Hard Disk clearing error> An error occurred during the Hard Disk clearing process.	Flows 42 FIP1.42
362	016-362 Restart Printer Contact Support IfMessageReturns	Printer error. Turn off the printer, and turn it on again. Contact customer support if this failure is repeated. 016-362	<PCI Bus#0 Host Bridge Controller Error > Connection error occurred between the PCI BUS port and the port of peripheral devices.	Flows 43 FIP1.43	

Status Code	Error Message		Status Contents	FIP to be referred	
	LCD	Status Window			
016	363	016-363 Restart Printer Contact Support IfMessageReturns	Printer error. Turn off the printer, and turn it on again. Contact customer support if this failure is repeated. 016-363	<PCI Bus#1 Host Bridge Controller Error > Connection error occurred between the PCI BUS port and the port of peripheral devices.	Flows 43 FIP1.43
	364	016-364 Restart Printer Contact Support IfMessageReturns	Printer error. Turn off the printer, and turn it on again. Contact customer support if this failure is repeated. 016-364	<PCI Bus#0 Error Detected > Connection error occurred between the PCI BUS port and the port of peripheral devices.	Flows 43 FIP1.43
	366	016-366 Restart Printer Contact Support IfMessageReturns	Printer error. Turn off the printer, and turn it on again. Contact customer support if this failure is repeated. 016-366	<PCI Bus#1 Error Detected > Connection error occurred between the PCI BUS port and the port of peripheral devices.	Flows 43 FIP1.43
	367	016-367 Restart Printer Contact Support IfMessageReturns	Printer error. Turn off the printer, and turn it on again. Contact customer support if this failure is repeated. 016-367	<PCI Error Messages received from Bus#0-Device#0 > Connection error occurred between the PCI BUS port and the port of peripheral devices.	Flows 43 FIP1.43
	368	016-368 Restart Printer Contact Support IfMessageReturns	Printer error. Turn off the printer, and turn it on again. Contact customer support if this failure is repeated. 016-368	<PCI Error Messages received from Bus#0-Device#1 > Connection error occurred between the PCI BUS port and the port of peripheral devices.	Flows 43 FIP1.43
	369	-	Printer error. Turn off the printer, and turn it on again. Contact customer support if this failure is repeated. 016-369	<Operator Panel - ESS Communication Fail> Communication Fail with a Operator Panel and ESS F/W.	Flows 44 FIP1.44

Status Code	Error Message		Status Contents	FIP to be referred	
	LCD	Status Window			
016	370	016-370 Restart Printer Contact Support IfMessageReturns	Printer error. Turn off the printer, and turn it on again. Contact customer support if this failure is repeated. 016-370	<MCU-ESS Communication Fail> Communication fail between MCU and ESS.	Flows 45 FIP1.45
	383	Invalid ID 016-383 Data Violation Press ✓	Firmware download ID error has occurred. Press the Set Button. Contact customer support if this failure is repeated. 016-383	<Download ID Error> An error occurred because an invalid firmware is installed.	Flows 46 FIP1.46
	384	Range Chk Error 016-384 Data Violation Press ✓	Firmware download range error has occurred. Press the Set Button. Contact customer support if this failure is repeated. 016-384	<Download Range Error> The address of the write destination is invalid.	Flows 46 FIP1.46
	385	Header Error 016-385 Data Violation Press ✓	Firmware download header checksum error has occurred. Press the Set Button. Contact customer support if this failure is repeated. 016-385	<Download header Error> The header information is invalid.	Flows 46 FIP1.46
	386	Check Sum Error 016-386 Data Violation Press ✓	Firmware download checksum error has occurred. Press the Set Button. Contact customer support if this failure is repeated. 016-386	<Download Check Sum Error> The checksum is invalid.	Flows 46 FIP1.46

Status Code	Error Message		Status Contents	FIP to be referred	
	LCD	Status Window			
016	387	Format Error 016-387 Data Violation Press ✓	Firmware download format error has occurred. Press the Set Button. Contact customer support if this failure is repeated. 016-387	<Download Format Error> The format is invalid.	Flows 46 FIP1.46
	391	Protection Error 016-391 Data Violation Press ✓	Firmware download protect error has occurred. Press the Set Button. Contact customer support if this failure is repeated. 016-391	<Download Protect Error> The Protect is invalid.Download was attempted under the condition where it is prohibited.	Flows 47 FIP1.47
	392	Erase Flash Err. 016-392 Contact Support IfMessageReturns	Firmware download delete error has occurred. Contact customer support if this failure is repeated. 016-392	<Download Delete Error> Flash memory erase error occurred.	Flows 36 FIP1.36
	393	Write Flash Err. 016-393 Contact Support IfMessageReturns	Firmware download write error has occurred. Contact customer support if this failure is repeated. 016-393	<Download Write Error> Flash memory write error occurred.	Flows 36 FIP1.36
	394	Verify Error 016-394 Contact Support IfMessageReturns	Firmware download verify error has occurred. Contact customer support if this failure is repeated. 016-394	<Download Verify Error> Flash memory verify error occurred.	Flows 36 FIP1.36
	404	016-404 Certificate Fail Init Certificate Are You Sure?	Certification error has occurred. Please inquire of the system administrator. 016-404	<Certificate DB access error> Certificate DB is invalid.	Flows 48 FIP1.48

Status Code	Error Message		Status Contents	FIP to be referred	
	LCD	Status Window			
016	405	016-405 Certificate Fail Init Certificate Are You Sure?	Certification error has occurred. Please inquire of the system administrator. 016-405	<Security setting invalid error> Security setting is inconsistent.	Flows 48 FIP1.48
	520	016-520 Restart Printer Certificate Fail Contact Administer	Certification error has occurred. Please inquire of the system administrator. 016-520	<Own device certificate error> Own device certificate is invalid.	Flows 48 FIP1.48
	521	016-521 Restart Printer Certificate Fail Contact Administer	Certification error has occurred. Please inquire of the system administrator. 016-521	<Other device certificate error> The destination client certificate is invalid.	Flows 48 FIP1.48
	522	016-522 Restart Printer Certificate Fail Contact Administer	Certification error has occurred. Please inquire of the system administrator. 016-522	<SSL Client certificate absence error> The SSL client certificate has not yet been set.	Flows 48 FIP1.48
	523	016-523 Restart Printer Certificate Fail Contact Administer	Certification error has occurred. Please inquire of the system administrator. 016-523	<Server certificate verification error> The device cannot verify the SSL certificate of the LDAP server.	Flows 48 FIP1.48
	524	016-524 Restart Printer Certificate Fail Contact Administer	Certification error has occurred. Please inquire of the system administrator. 016-524	<Server certificate absence error> SSL certificate of the LDAP server is invalid.	Flows 48 FIP1.48
	527	016-527 Restart Printer Certificate Fail Contact Administer	Certification error has occurred. Please inquire of the system administrator. 016-527	<Certificate DB error> An SSL authentication error of the Kerberos server or the LDAP server has occurred.	Flows 48 FIP1.48

Status Code	Error Message		Status Contents	FIP to be referred	
	LCD	Status Window			
016	531	Job Fail 016-531 Sign On Error Press ✓	Authentication error has occurred. The account is not registered. Please inquire of the system administrator. 016-531	< LDAP Server Error> LDAP or Kerberos Server Sign on error.	Flows 49 FIP1.49
	532	Job Fail 016-532 Wrong Attribute Press ✓	Authentication error has occurred. The account is not registered. Please inquire of the system administrator. 016-532	< LDAP Server Error> LDAP Wrong Attribute Information on Server.	Flows 49 FIP1.49
	533	Job Fail 016-533 Clock Skew Err. Press ✓	Authentication error has occurred. The account is not registered. Please inquire of the system administrator. 016-533	< ColorTrack 3 Error> Kerberos Server Clock Skew Error.	Flows 49 FIP1.49
	534	Job Fail 016-534 Wrong Server Press ✓	Authentication error has occurred. The account is not registered. Please inquire of the system administrator. 016-534	< ColorTrack 3 Error> LDAP or Kerberos Server Wrong Server Information on Device.	Flows 49 FIP1.49
	535	Job Fail 016-535 Admin Error Press ✓	Authentication error has occurred. The account is not registered. Please inquire of the system administrator. 016-535	< ColorTrack 3 Error> LDAP Admin Information is Wrong.	Flows 49 FIP1.49
	536	Job Fail 016-536 Access Error Press ✓	Authentication error has occurred. The account is not registered. Please inquire of the system administrator. 016-536	< ColorTrack 3 Error> Internal error of LDAP server or Kerberos.	Flows 49 FIP1.49

Status Code	Error Message		Status Contents	FIP to be referred	
	LCD	Status Window			
This code is given when the Option Wireless Adapter is installed.					
016	541	016-541 Restart Printer Certificate Fail Contact Administer	Certification error has occurred. Please inquire of the system administrator. 016-541	<Wireless certificate error> An error occurred while accessing the wireless certificate.	Flows 50 FIP1.50
	542	016-542 Restart Printer Certificate Fail Contact Administer	Certification error has occurred. Please inquire of the system administrator. 016-542	<Wireless certificate error> An error occurred regarding the server certificate.	Flows 50 FIP1.50
	543	016-543 Restart Printer Certificate Fail Contact Administer	Certification error has occurred. Please inquire of the system administrator. 016-543	<Wireless certificate error> The wireless certificate is corrupted.	Flows 50 FIP1.50
	700	Out of Memory 016-700 Job too Large Press ✓	The printer memory is full and cannot continue processing the current print job. Press Set Button to clear the message, cancel the current job. Please click the Show Me How Button for details. 016-700	<Memory Over flow> The current printing job process cannot be continued because the memory capacity is exceeded.	Flows 51 FIP1.51
	720	PDL Request 016-720 Data Violation Press ✓	Error relating to PDL emulation problems occurs. Press Set Button to clear the message, cancel the current print job. Please click the Show Me How Button for details. 016-720	<PDL Error> The print data cannot be processed by PDL.	Flows 52 FIP1.52
	756	Job Fail 016-756 Prohibited Time Press ✓	Now printer is in Prohibited Time. Please inquire of the system administrator. 016-756	<Auditron Error> Printing was executed at the print-prohibited time or the day of the week.	Flows 53 FIP1.53

Status Code	Error Message		Status Contents	FIP to be referred	
	LCD	Status Window			
016	757	Invalid User 016-757 Account Denied Press ✓	Authentication error has occurred. The account is not registered. Please inquire of the system administrator. 016-757	<Auditron Error> An error occurred because the user's account settings did not match those of the Administrator.	Flows 54 FIP1.54
	758	Disabled Func 016-758 Denied Col Print Press ✓	Function unavailable. It is a function that cannot be used. Please inquire of the system administrator. 016-758	<Auditron Error> An error occurred because a user authorized only for B&W print attempted to execute color printing.	Flows 55 FIP1.55
	759	Reached Limit 016-759 Over your limits Press ✓	Printable page limit reached. Printable page limit reached, cannot print. Please inquire of the system administrator. 016-759	<Auditron Error> An attempt was made to print more copies than the print count limit.	Flows 56 FIP1.56
	799	Invalid Job 016-799 Data Violation Press ✓	The configuration of the printer on the printer driver does not conform to the printer. Press the Cancel button to cancel the print job. Make sure that the configuration of the printer on the printer driver conforms to the printer. 016-799	<Job Environment Violation> Detects violation data for the print condition. The print data specifies paper type/ size not available for the printer.	Flows 57 FIP1.57
	This code is given when the Option Wireless Adapter is installed.				
920	Wireless Error 016-920 Timeout Error Press ✓	Timeout Error has occurred thith Wireless. Press set and try again. 016-920	<Wireless Setting Error Timeout Error> The time-out was done to the connection with Register.	Flows 58 FIP1.58	
921	Wireless Error 016-921 Download Error Press ✓	Download Error has occurred thith Wireless. Press set and try again. 016-921	<Wireless Setting Error Download Error> The error occurred while connecting it with Register.	Flows 59 FIP1.59	

Status Code	Error Message		Status Contents	FIP to be referred	
	LCD	Status Window			
016	922	Wireless Error 016-922 Session Overlap Error Press ✓	Session Overlap Error has occurred thugh Wireless. Press set and try again. 016-922	<Wireless Setting Error Session Overlap Error> Two or more Register that operated by WPS-PBC was found.	Flows 60 FIP1.60
	930	USB HOST Error 016-930 Unsupported Device Remove from USB Port	USB host error. The device is not supported. Remove it from USB Font Port. 016-930	< USB HOST Error > Devices not supported have been detected.	Flows 61 FIP1.61
	931	USB HOST Error 016-931 Hub is not supported Remove from USB Port	USB host error. USB hub is not supported. Remove it from USB Font Port. 016-931	< USB HOST Error > It has been found that more stages of hubs than supported are connected.	Flows 61 FIP1.61
This code is given when the Option Hard Disk is installed.					
016	980	Disk Full 016-980 Job too Large Press ✓	Disk space is insufficient and cannot continue processing the current print job. Press Set Button to clear the message, cancel the current print job. Please click the Show Me How Button for details. 016-980	<Hard Disk Disk Full> The current printing job process cannot be continued because the hard disk is full.	Flows 62 FIP1.62
	981	Collate Full 016-981 Job too Large Press ✓	Disk space is insufficient and cannot continue processing the current print job. Press Set Button to clear the message, cancel the current print job. Please click the Show Me How Button for details. 016-981	< Collate Full> Exceeds the memory capacity.	Flows 63 FIP1.63
024	338	024-338 Restart Printer Contact Support IfMessageReturns	Printer error. Turn off the printer, and turn it on again. Contact customer support if this failure is repeated. 024-338	<Video Cable Disconnect> The video cable is not connected to the ESS.	Flows 64 FIP1.64

Status Code	Error Message		Status Contents	FIP to be referred	
	LCD	Status Window			
024	339	024-339 Restart Printer Contact Support IfMessageReturns	Printer error. Turn off the printer, and turn it on again. Contact customer support if this failure is repeated. 024-339	<Serial Cable to MCU Disconnect> The cable for connecting the ESS and MCU is not connected to the MCU.	Flows 65 FIP1.65
	362	024-362 Restart Printer Contact Support IfMessageReturns	Printer error. Turn off the printer, and turn it on again. Contact customer support if this failure is repeated. 024-362	<IOT Start Image Marking Timeout> Start Image Marking is not issued within the limited time.	Flows 66 FIP1.66
	910	Paper Size Mismatch 024-910 Load Tray 1 XXXXXX YYYYYY	Actual paper size in tray and specified paper size are different. Load the specified paper in Tray 1. Paper Size: XXXXXX Paper Type: YYYYYY 024-910	<IOT Paper Size Mismatch> The size of paper in the Tray 1 does not match the specified print size. XXXXXX: Paper Size YYYYYY: Paper Type	Flows 67 FIP1.67
	This code is given when the Option Sheet Feeder is installed.				
	911	Paper Size Mismatch 024-911 Load Tray 2 XXXXXX YYYYYY	Actual paper size in tray and specified paper size are different. Load the specified paper in Tray 2. Paper Size: XXXXXX Paper Type: YYYYYY 024-911	<IOT Paper Size Mismatch> The size of paper in the Tray 2 does not match the specified print size. XXXXXX: Paper Size YYYYYY: Paper Type	Flows 67 FIP1.67
912	Paper Size Mismatch 024-912 Load Tray 3 XXXXXX YYYYYY	Actual paper size in tray and specified paper size are different. Load the specified paper in Tray 3. Paper Size: XXXXXX Paper Type: YYYYYY 024-912	<IOT Paper Size Mismatch> The size of paper in the Tray 3 does not match the specified print size. XXXXXX: Paper Size YYYYYY: Paper Type	Flows 67 FIP1.67	

Status Code	Error Message		Status Contents	FIP to be referred	
	LCD	Status Window			
024	913	Paper Size Mismatch 024-913 Load Tray 4 XXXXXX YYYYYY	Actual paper size in tray and specified paper size are different. Load the specified paper in Tray 4. Paper Size: XXXXXX Paper Type: YYYYYY 024-913	<IOT Paper Size Mismatch> The size of paper in the Tray 4 does not match the specified print size. XXXXXX: Paper Size YYYYYY: Paper Type	Flows 67 FIP1.67
	914	Paper Size Mismatch 024-914 Load MPF XXXXXX YYYYYY	Actual paper size in tray and specified paper size are different. Load the specified paper in MPF. Paper Size: XXXXXX Paper Type: YYYYYY 024-914	<IOT Paper Size Mismatch> The size of paper in the MFP does not match the specified print size. XXXXXX: Paper Size YYYYYY: Paper Type	Flows 68 FIP1.68
	This code is given when the Option Sheet Feeder is installed.				
	915	Paper Size Mismatch 024-915 Load Tray 5 XXXXXX YYYYYY	Actual paper size in tray and specified paper size are different. Load the specified paper in Tray 5. Paper Size: XXXXXX Paper Type: YYYYYY 024-915	<IOT Paper Size Mismatch> The size of paper in the Tray 5 does not match the specified print size. XXXXXX: Paper Size YYYYYY: Paper Type	Flows 67 FIP1.67
	This code is given when the Option Output Expander is installed.				
	916	Stacker Full 024-916 Remove Paper Stacker Tray	The Stacker Tray is full with mixed paper. Remove paper from the Stacker Tray. 024-916	<IOT Output Expander Mix Stack Full> The quantity of mixed-size paper in the Output Expander Stacker Tray reached the specified capacity.	Flows 69 FIP1.69
917	Over Count 024-917 Remove Paper Stacker Tray	Paper are stacked too many to staple. Remove paper from the Stacker Tray. 024-917	<IOT Output Expander Stacker Tray Staple Set Over Count> The number of print stapled by the Output Expander exceeded the capacity of the Stacker Tray.	Flows 70 FIP1.70	
920	Output Tray Full 024-920 Remove Paper Center Output Tray	The Center Output Tray is full. Remove paper from the Center Output Tray. 024-920	<IOT Exit Tray Stacker Full> The quantity of printed paper in the discharge Tray reached the specified capacity.	Flows 71 FIP1.71	

Status Code	Error Message		Status Contents	FIP to be referred	
	LCD	Status Window			
024	This code is given when the Option Output Expander is installed.				
	928	Scratch JAM 024-928 1. Open Output Expander Front Door and remove paper.	Paper Jam has occurred. Remove paper following the steps which displayed on the panel. 024-928	< IOT Finisher Scratch Sheet Compile > Sheets out of specification have been ejected to the Compile Tray while ejecting sets of prints.	Flows 72 FIP1.72
	946	Tray Detached 024-946 Push in Tray 1	Tray 1 cannot be detected. Insert Tray 1. 024-946	<IOT Tray1 Detached> The sheet feeder (Tray1) is detached.	Flows 73 FIP1.73
	This code is given when the Option Sheet Feeder is installed.				
	947	Tray Detached 024-947 Push in Tray 2	Tray 2 cannot be detected. Insert Tray 2. 024-947	<IOT Tray2 Detached> The Option sheet feeder (Tray2) is detached.	Flows 73 FIP1.73
	948	Tray Detached 024-948 Push in Tray 3	Tray 3 cannot be detected. Insert Tray 3. 024-948	<IOT Tray3 Detached> The Option sheet feeder (Tray3) is detached.	Flows 73 FIP1.73
	949	Tray Detached 024-949 Push in Tray 4	Tray 4 cannot be detected. Insert Tray 4. 024-949	<IOT Tray4 Detached> The Option sheet feeder (Tray4) is detached.	Flows 73 FIP1.73
	950	Tray Detached 024-950 Push in Tray 5	Tray 5 cannot be detected. Insert Tray 5. 024-950	<IOT Tray5 Detached> The Option sheet feeder (Tray5) is detached.	Flows 73 FIP1.73

Status Code	Error Message		Status Contents	FIP to be referred	
	LCD	Status Window			
024	965	No Suitable Paper 024-965 Load Tray 1 XXXXXX YYYYYY	<No Paper> No paper detected. Load the specified paper in Tray 1. Paper Size: XXXXXX Paper Type: YYYYYY 024-965 <Specified paper is not> Specified paper is not in Tray 1. Load the specified paper in Tray 1. Paper Size: XXXXXX Paper Type: YYYYYY 024-965	<IOT No Suitable Paper> Tray 1 has run out of paper, or the size (or type) of paper in the Tray 1 does not match the specified print size (or type). XXXXXX: Paper Size YYYYYY: Paper Type	Flows 74 FIP1.74
	This code is given when the Option Sheet Feeder is installed.				
	966	No Suitable Paper 024-966 Load Tray 2 XXXXXX YYYYYY	<No Paper> No paper detected. Load the specified paper in Tray 2. Paper Size: XXXXXX Paper Type: YYYYYY 024-966 <Specified paper is not> Specified paper is not in Tray 2. Load the specified paper in Tray 2. Paper Size: XXXXXX Paper Type: YYYYYY 024-966	<IOT No Suitable Paper> Tray 2 has run out of paper, or the size (or type) of paper in the Tray 2 does not match the specified print size (or type). XXXXXX: Paper Size YYYYYY: Paper Type	Flows 74 FIP1.74

Status Code	Error Message		Status Contents	FIP to be referred	
	LCD	Status Window			
024	967	<p>No Suitable Paper 024-967 Load Tray 3 XXXXXX YYYYYY</p>	<p><No Paper> No paper detected.</p> <p>Load the specified paper in Tray 3. Paper Size: XXXXXX Paper Type: YYYYYY</p> <p>024-967</p> <p><Specified paper is not> Specified paper is not in Tray 3.</p> <p>Load the specified paper in Tray 3. Paper Size: XXXXXX Paper Type: YYYYYY</p> <p>024-967</p>	<p><IOT No Suitable Paper> Tray 3 has run out of paper, or the size (or type) of paper in the Tray 3 does not match the specified print size (or type). XXXXXX: Paper Size YYYYYY: Paper Type</p>	Flows 74 FIP1.74
	968	<p>No Suitable Paper 024-968 Load Tray 4 XXXXXX YYYYYY</p>	<p><No Paper> No paper detected.</p> <p>Load the specified paper in Tray 4. Paper Size: XXXXXX Paper Type: YYYYYY</p> <p>024-968</p> <p><Specified paper is not> Specified paper is not in Tray 4.</p> <p>Load the specified paper in Tray 4. Paper Size: XXXXXX Paper Type: YYYYYY</p> <p>024-968</p>	<p><IOT No Suitable Paper> Tray 4 has run out of paper, or the size (or type) of paper in the Tray 4 does not match the specified print size (or type). XXXXXX: Paper Size YYYYYY: Paper Type</p>	Flows 74 FIP1.74

Status Code	Error Message		Status Contents	FIP to be referred	
	LCD	Status Window			
024	969	No Suitable Paper 024-969 Load MPF XXXXXX YYYYYY	<No Paper> No paper detected. Load the specified paper in MPF. Paper Size: XXXXXX Paper Type: YYYYYY 024-969 <Specified paper is not> Specified paper is not in MPF. Load the specified paper in MPF. Paper Size: XXXXXX Paper Type: YYYYYY 024-969	<IOT No Suitable Paper> MFP has run out of paper, or the size (or type) of paper in the MFP does not match the specified print size (or type). XXXXXX: Paper Size YYYYYY: Paper Type	Flows 75 FIP1.75
	This code is given when the Option Sheet Feeder is installed.				
	970	No Suitable Paper 024-970 Load Tray 5 XXXXXX YYYYYY	<No Paper> No paper detected. Load the specified paper in Tray 5. Paper Size: XXXXXX Paper Type: YYYYYY 024-970 <Specified paper is not> Specified paper is not in Tray 5. Load the specified paper in Tray 5. Paper Size: XXXXXX Paper Type: YYYYYY 024-970	<IOT No Suitable Paper> Tray 5 has run out of paper, or the size (or type) of paper in the Tray 5 does not match the specified print size (or type). XXXXXX: Paper Size YYYYYY: Paper Type	Flows 74 FIP1.74
This code is given when the Option Output Expander is installed.					
976	Staple Fail 024-976 1.Open Output Expander Front Door and remove paper. 2.Close Output Expander Front Door.	Paper Jam has occurred. Remove paper following the steps which displayed on the panel. 024-976	<IOT Output Expander Staple NG> The Staple operation failed.	Flows 76 FIP1.76	

Status Code		Error Message		Status Contents	FIP to be referred
		LCD	Status Window		
024	977	Staple Fail 024-977 Replace Now Stapler Cartridge. Continue without Staple? Are You Sure?	The Stapler Cartridge need to be replaced now. Open the Output Expander Front Door. Then remove the used Stapler Cartridge and install a new one. Please click the Show Me How Button for details. 024-977	<IOT Output Expander Stapler Error> The defective operation of Stapler Cartridge was generated.	Flows 77 FIP1.77
	979	Empty Staple 024-979 Replace Now Stapler Cartridge. Continue without Staple? Are You Sure?	Empty Staple 024-979 Replace Now Stapler Cartridge. Continue without Staple? Are You Sure?	<IOT Output Expander Stapler Near Life> The Stapler Cartridge. is approaching the replacement time.	Flows 78 FIP1.78
	980	Stacker Full 024-980 Remove Paper Stacker Tray	The Stacker Tray is full. Remove paper from the Stacker Tray. 024-980	<IOT Output Expander Stacker Tray Full> The quantity of same-size paper in the Finisher Stacker Tray reached the specified capacity.	Flows 69 FIP1.69
	982	Finisher Error 024-982 Remove Paper Stacker Tray	Output Expander Error has occurred. Remove paper from the Stacker Tray. 024-982	<IOT Output Expander Stacker lower Safty Warning> The Stacker No Paper Sensor is not actuated within the specified time after the Stacker Motor was turned ON (lowering).	Flows 79 FIP1.79
041	347	041-347 Restart Printer Contact Support IfMessageReturns	Printer error. Turn off the printer, and turn it on again. Contact customer support if this failure is repeated. 041-347	< IOT I/F Failure> MCU Internal Error is detected.	Flows 80 FIP1.80
042	324	042-324 Restart Printer Contact Support IfMessageReturns	Printer error. Turn off the printer, and turn it on again. Contact customer support if this failure is repeated. 042-324	<IOT Belt Unit Motor Failure> Belt Unit Motor failure is detected.	Flows 81 FIP1.81

Status Code	Error Message		Status Contents	FIP to be referred
	LCD	Status Window		
042	330	042-330 Restart Printer Contact Support IfMessageReturns	Printer error. Turn off the printer, and turn it on again. Contact customer support if this failure is repeated. 042-330	<IOT Fuser Fan Failure> MCU detects an error upon receiving error signal from the FUSER Fan. Flows 82 FIP1.82
	700	042-700 Restart Printer Contact Support IfMessageReturns	Printer error. Turn off the printer, and turn it on again. Contact customer support if this failure is repeated. 042-700	<IOT Over Heat Stop> The temp. Sensor sensed high temperature. Flows 83 FIP1.83
046	310	046-310 Restart Printer Contact Support IfMessageReturns	Printer error. Turn off the printer, and turn it on again. Contact customer support if this failure is repeated. 046-310	<IOT HVPS Error> MCU detected the HVPS error. Flows 84 FIP1.84
This code is given when the Option Output Expander is installed.				
047	216	047-216 Restart Printer Contact Support IfMessageReturns	Printer error. Turn off the printer, and turn it on again. Contact customer support if this failure is repeated. 047-216	<IOT Option Output Expander Failure> MCU detected the Output Expander Failure. Flows 85 FIP1.85
	217	047-217 Restart Printer Contact Support IfMessageReturns	Printer error. Turn off the printer, and turn it on again. Contact customer support if this failure is repeated. 047-217	<IOT Output Expander I/F Failure> MCU detected the Output Expander I/F Failure. Flows 86 FIP1.86
050	101	Paper JAM 050-101 1.Open Right Hand Cover and remove paper. 2.Close Right Hand Cover.	Paper Jam has occurred. Remove paper following the steps displayed on the panel. 050-101	<IOT Remain Zone RH1 JAM> Paper jam was detected at the Zone RH1 section of the Printer. Flows 87 FIP1.87

Status Code	Error Message		Status Contents	FIP to be referred	
	LCD	Status Window			
This code is given when the Option Sheet Feeder is installed.					
050	102	Paper JAM 050-102 1.Open Right Hand Cover(Tray 2) and remove paper. 2.Close Right Hand Cover(Tray 2)	Paper Jam has occurred. Remove paper following the steps displayed on the panel. 050-102	<IOT Remain Zone RH2 JAM> Paper jam was detected at the Zone RH2 section of the Printer.	Flows 88 FIP1.88
	103	Paper JAM 050-103 1.Open Right Hand Cover(Tray 3) and remove paper. 2.Close Right Hand Cover(Tray 3)	Paper Jam has occurred. Remove paper following the steps displayed on the panel. 050-103	<IOT Remain Zone RH3 JAM> Paper jam was detected at the Zone RH3 section of the Printer.	Flows 88 FIP1.88
	104	Paper JAM 050-104 1.Open Right Hand Cover(Tray 4) and remove paper. 2.Close Right Hand Cover(Tray 4)	Paper Jam has occurred. Remove paper following the steps displayed on the panel. 050-104	<IOT Remain Zone RH4 JAM> Paper jam was detected at the Zone RH4 section of the Printer.	Flows 88 FIP1.88
	105	Paper JAM 050-105 1.Open Right Hand Cover(Tray 5) and remove paper. 2.Close Right Hand Cover(Tray 5)	Paper Jam has occurred. Remove paper following the steps displayed on the panel. 050-105	<IOT Remain Zone RH5 JAM> Paper jam was detected at the Zone RH5 section of the Printer.	Flows 88 FIP1.88
	121	Paper JAM 050-121 1.Open Tray1 and ensure paper not finished sending. 2.Push in Tray1	Paper Jam has occurred. Remove paper following the steps displayed on the panel. 050-121	<IOT Remain Zone 1T JAM> Paper jam was detected at the Zone 1T section of the Printer.	Flows 89 FIP1.89
	This code is given when the Option Sheet Feeder is installed.				
	122	Paper JAM 050-122 1.Open Tray2 and ensure paper not finished sending. 2.Push in Tray2	Paper Jam has occurred. Remove paper following the steps displayed on the panel. 050-122	<IOT Remain Zone 2T JAM> Paper jam was detected at the Zone 2T section of the Printer.	Flows 90 FIP1.90
	123	Paper JAM 050-123 1.Open Tray3 and ensure paper not finished sending. 2.Push in Tray3	Paper Jam has occurred. Remove paper following the steps displayed on the panel. 050-123	<IOT Remain Zone 3T JAM> Paper jam was detected at the Zone 3T section of the Printer.	Flows 90 FIP1.90

Status Code	Error Message		Status Contents	FIP to be referred	
	LCD	Status Window			
050	124	Paper JAM 050-124 1.Open Tray4 and and ensure paper not finished sending. 2.Push in Tray4	Paper Jam has occurred. Remove paper following the steps displayed on the panel. 050-124	<IOT Remain Zone 4T JAM> Paper jam was detected at the Zone 4T section of the Printer.	Flows 90 FIP1.90
	125	Paper JAM 050-125 1.Open Tray5 and and ensure paper not finished sending. 2.Push in Tray5	Paper Jam has occurred. Remove paper following the steps displayed on the panel. 050-125	<IOT Remain Zone 5T JAM> Paper jam was detected at the Zone 5T section of the Printer.	Flows 90 FIP1.90
	This code is given when the Option Output Expander is installed.				
	151	Paper JAM 050-151 1.Open Top Cover and remove paper. 2.Close Top Cover.	Paper Jam has occurred. Remove paper following the steps displayed on the panel. 050-151	<IOT Remain Zone HTR JAM> Paper jam was detected at the Zone HTR section of the Output Expander.	Flows 91 FIP1.91
	152	050-152 1.Open Output Expander Front Door. 2.Please turn a knob if necessary, and remove paper. 3.Close Output Expander Front Door.	Paper Jam has occurred. Remove paper following the steps displayed on the panel. 050-152	<IOT Remain Zone EXIT JAM> Paper jam was detected at the Zone EXIT section of the Output Expander.	Flows 92 FIP1.92
153	050-153 1.Open Output Expander Front Door and remove paper. 2.Close Output Expander Front Door.	Paper Jam has occurred. Remove paper following the steps displayed on the panel. 050-153	<IOT Remain Zone CMP JAM> Paper jam was detected at the Zone CMP section of the Output Expander.	Flows 93 FIP1.93	
This code is given when the Option Sheet Feeder is installed.					
072	211	072-211 Restart Printer Contact Support IfMessageReturns	Printer error. Turn off the printer, and turn it on again. Contact customer sup- port if this failure is repeated. 072-211-01 to 02	<IOT Option Feeder2 Failure & IOT Option Feeder Motor2 Fail- ure> MCU detected the Option Feeder Failure or Option Feeder Motor2 Failure. Pressing the [Information] button shows detail error code (0 to 04). Code: 01h: Option Feeder2 Failure Code: 02h: Option Feeder Motor2	Flows 94: FIP1.94: Code 01 Flows 95: FIP1.95: Code 02

Status Code		Error Message		Status Contents	FIP to be referred
		LCD	Status Window		
072	300	Cover Open 072-300 Close Right Hand Cover (Tray 2)	The Right Hand Cover (Tray 2) is open. Close the Right Hand Cover (Tray 2). 072-300	<IOT RH Cover Tray2 Open> The Right Hand cover of the Tray 2 is open.	Flows 96 FIP1.96
		073	211	073-211 Restart Printer Contact Support IfMessageReturns	Printer error. Turn off the printer, and turn it on again. Contact customer sup- port if this failure is repeated. 073-211-01 to 02
073	300			Cover Open 073-300 Close Right Hand Cover (Tray 3)	The Right Hand Cover (Tray 3) is open. Close the Right Hand Cover (Tray 3). 073-300
		074	211	074-211 Restart Printer Contact Support IfMessageReturns	Printer error. Turn off the printer, and turn it on again. Contact customer sup- port if this failure is repeated. 074-211-01 to 02
074	300			Cover Open 074-300 Close Right Hand Cover (Tray 4)	The Right Hand Cover (Tray 4) is open. Close the Right Hand Cover (Tray 4). 074-300
		This code is given when the Option Sheet Feeder is installed.			
076	211	076-211 Restart Printer Contact Support IfMessageReturns	Printer error. Turn off the printer, and turn it on again. Contact customer sup- port if this failure is repeated. 076-211-01 to 02	<IOT Option Feeder5 Failure & IOT Option Feeder Motor5 Fail- ure> MCU detected the Option Feeder Failure or Option Feeder Motor5 Failure. Pressing the [Information] button shows detail error code (0 to 02). Code: 01h: Option Feeder5 Failure Code: 02h: Option Feeder Motor5	Flows 97: FIP1.97: Code 01 Flows 98: FIP1.98: Code 02

Status Code		Error Message		Status Contents	FIP to be referred
		LCD	Status Window		
076	300	Cover Open 076-300	The Right Hand Cover (Tray 5) is open.	<IOT Cover Tray5 Open> The Right Hand cover of the Tray 5 is open.	Flows 99 FIP1.99
		Close Right Hand Cover (Tray 5)	Close the Right Hand Cover (Tray 5). 076-300		
077	300	Cover Open 077-300	The Right Hand Cover is open.	<IOT Cover Front Open> The Front Cover is open.	Flows 100 FIP1.100
		Close Front Cover	Close the Right Hand Cover. 077-300		
077	301	Cover Open 077-301	The Right Hand Cover is open.	<IOT Cover Right Hand Open> The Right Hand Cover is open..	Flows 101 FIP1.101
		Close Right Hand Cover	Close the Right Hand Cover. 077-301		
091	400	Ready to Print 091-400 Waste Toner Box ↕ Flip Ready to Print Is close to life	The Waste Toner Box needs to be replaced now. 091-400	<IOT Waste Toner Box Near Life> The Waste Toner Box is approaching the replacement time.	Flows 102 FIP1.102
		Ready to Print 091-411 Black Drum Ctrdrg ↕ Flip Ready to Print prepare	Prepare the Black Drum Cartridge. 091-411	<IOT Drum Cartridge Near Life> The Drum Cartridge (K) is approaching the replacement time.	Flows 103 FIP1.103
		Ready to Print 091-412 Yellow Drum Ctrdrg ↕ Flip Ready to Print prepare	Prepare the Yellow Drum Cartridge. 091-412	<IOT Drum Cartridge Near Life> The Drum Cartridge (Y) is approaching the replacement time.	Flows 103 FIP1.103
		Ready to Print 091-413 Magenta Drum Ctrdrg ↕ Flip Ready to Print prepare	Prepare the Magenta Drum Cartridge. 091-413	<IOT Drum Cartridge Near Life> The Drum Cartridge (M) is approaching the replacement time.	Flows 103 FIP1.103
		Ready to Print 091-414 Cyan Drum Ctrdrg ↕ Flip Ready to Print prepare	Prepare the Cyan Drum Cartridge. 091-414	<IOT Drum Cartridge Near Life> The Drum Cartridge (C) is approaching the replacement time.	Flows 103 FIP1.103

Status Code	Error Message		Status Contents	FIP to be referred	
	LCD	Status Window			
091	479	Ready to Print 091-479 Black Drum Ctrtdg ↕ Flip Ready to Print Is close to life	The Black Drum Cartridge needs to be replaced soon. 091-479	<IOT Drum Cartridge(K) Near Life> The Drum Cartridge (K) is approaching the replacement time.	Flows 103 FIP1.103
	480	Ready to Print 091-480 Yellow Drum Ctrtdg ↕ Flip Ready to Print Is close to life	The Yellow Drum Cartridge needs to be replaced soon. 091-480	<IOT Drum Cartridge(Y) Near Life> The Drum Cartridge (Y) is approaching the replacement time.	Flows 103 FIP1.103
	481	Ready to Print 091-481 Magenta Drum Ctrtdg ↕ Flip Ready to Print Is close to life	The Magenta Drum Cartridge needs to be replaced soon. 091-481	<IOT Drum Cartridge(M) Near Life> The Drum Cartridge (M) is approaching the replacement time.	Flows 103 FIP1.103
	482	Ready to Print 091-482 Cyan Drum Ctrtdg ↕ Flip Ready to Print Is close to life	The Cyan Drum Cartridge needs to be replaced soon. 091-482	<IOT Drum Cartridge(C) Near Life> The Drum Cartridge (C) is approaching the replacement time.	Flows 103 FIP1.103
	911	 Life Over 091-911 Replace Now Waste Toner Box	The Waste Toner Box needs to be replaced now. Open the Front Cover. Then remove the used Waste Toner Box and install a new one. Please click the Show Me How Button for details. 091-911	<IOT Waste Toner Box Life Over> The Waste Toner Box has reached the replacement time.	Flows 104 FIP1.104
	914	091-914 Restart Printer Reseat K Drum Crt. Contact Support	Printer error. Turn off the printer. Confirm Black Drum Cartridge is correctly installed. Turn on the printer. Contact customer support if this failure is repeated. 091-914	<IOT Black Drum Cartridge CRUM Fail> Black Drum Cartridge CRUM communication error is detected.	Flows 105 FIP1.105



Status Code	Error Message		Status Contents	FIP to be referred	
	LCD	Status Window			
091	917	091-917 Restart Printer Reseat Y Drum Crt. Contact Support	Printer error. Turn off the printer. Confirm Yellow Drum Cartridge is correctly installed. Turn on the printer. Contact customer support if this failure is repeated. 091-917	<IOT Yellow Drum Cartridge CRUM Fail> Yellow Drum Cartridge CRUM communication error is detected.	Flows 105 FIP1.105
	918	091-918 Restart Printer Reseat M Drum Crt. Contact Support	Printer error. Turn off the printer. Confirm Magenta Drum Cartridge is correctly installed. Turn on the printer. Contact customer support if this failure is repeated. 091-918	<IOT Magenta Drum Cartridge CRUM Fail> Magenta Drum Cartridge CRUM communication error is detected.	Flows 105 FIP1.105
	919	091-919 Restart Printer Reseat C Drum Crt. Contact Support	Printer error. Turn off the printer. Confirm Cyan Drum Cartridge is correctly installed. Turn on the printer. Contact customer support if this failure is repeated. 091-919	<IOT Cyan Drum Cartridge CRUM Fail> Cyan Drum Cartridge CRUM communication error is detected.	Flows 105 FIP1.105
	921	 Cartridge Error 091-921 Insert Black Drum Ctrtdg	The Black Drum Cartridge is either missing or not fully inserted into the printer. Open the Front Cover and the Inner Cover. Then make sure that the Black Drum Cartridge has been fully installed. Please click the Show Me How Button for details. 091-921	<IOT Drum Cartridge (K) Detached> The Drum Cartridge (K) is not installed in the printer.	Flows 106 FIP1.106

Status Code	Error Message		Status Contents	FIP to be referred	
	LCD	Status Window			
091	922	<p>i Cartridge Error 091-922 Insert Yellow Drum Ctrrdg</p>	<p>The Yellow Drum Cartridge is either missing or not fully inserted into the printer.</p> <p>Open the Front Cover and the Inner Cover. Then make sure that the Yellow Drum Cartridge has been fully installed. Please click the Show Me How Button for details.</p> <p>093-922</p>	<p><IOT Drum Cartridge (Y) Detached> The Drum Cartridge (Y) is not installed in the printer.</p>	Flows 106 FIP1.106
	923	<p>i Cartridge Error 091-923 Insert Magenta Drum Ctrrdg</p>	<p>The Magenta Drum Cartridge is either missing or not fully inserted into the printer.</p> <p>Open the Front Cover and the Inner Cover. Then make sure that the Magenta Drum Cartridge has been fully installed. Please click the Show Me How Button for details.</p> <p>093-923</p>	<p><IOT Drum Cartridge (M) Detached> The Drum Cartridge (M) is not installed in the printer.</p>	Flows 106 FIP1.106
	924	<p>i Cartridge Error 091-924 Insert Cyan Drum Ctrrdg</p>	<p>The Cyan Drum Cartridge is either missing or not fully inserted into the printer.</p> <p>Open the Front Cover and the Inner Cover. Then make sure that the Cyan Drum Cartridge has been fully installed. Please click the Show Me How Button for details.</p> <p>093-924</p>	<p><IOT Drum Cartridge (C) Detached> The Drum Cartridge (C) is not installed in the printer.</p>	Flows 106 FIP1.106
	931	<p>i Life Over 091-931 Replace Now Black Drum Ctrrdg</p>	<p>The Black Drum Cartridge need to be replaced now.</p> <p>Open the Front Cover and the Inner Cover. Then remove the used Black Drum Cartridge and install a new one. Please click the Show Me How Button for details.</p> <p>091-931</p>	<p><IOT Drum Cartridge (K) Life Over> The Drum Cartridge (K) has reached the replacement time.</p>	Flows 107 FIP1.107

Status Code	Error Message		Status Contents	FIP to be referred	
	LCD	Status Window			
091	932	<p>i Life Over 091-932 Replace Now Yellow Drum Crtrdg</p>	<p>The Yellow Drum Cartridge need to be replaced now.</p> <p>Open the Front Cover and the Inner Cover. Then remove the used Yellow Drum Cartridge and install a new one. Please click the Show Me How Button for details.</p> <p>091-932</p>	<p><IOT Drum Cartridge (Y) Life Over> The Drum Cartridge (Y) has reached the replacement time.</p>	Flows 107 FIP1.107
	933	<p>i Life Over 091-933 Replace Now Magenta Drum Crtrdg</p>	<p>The Magenta Drum Cartridge need to be replaced now.</p> <p>Open the Front Cover and the Inner Cover. Then remove the used Magenta Drum Cartridge and install a new one. Please click the Show Me How Button for details.</p> <p>091-933</p>	<p><IOT Drum Cartridge (M) Life Over> The Drum Cartridge (M) has reached the replacement time.</p>	Flows 107 FIP1.107
	934	<p>i Life Over 091-934 Replace Now Cyan Drum Crtrdg</p>	<p>The Cyan Drum Cartridge need to be replaced now.</p> <p>Open the Front Cover and the Inner Cover. Then remove the used Cyan Toner Cartridge and install a new one. Please click the Show Me How Button for details.</p> <p>091-934</p>	<p><IOT Drum Cartridge (C) Life Over> The Drum Cartridge (C) has reached the replacement time.</p>	Flows 107 FIP1.107
	942	<p>i CRUM DATA 091-942 Reseat Black Drum Crtrdg</p>	<p>An unsupported Black Drum Cartridge is installed.</p> <p>Open the Front Cover. Remove the unsupported Black Drum Cartridge and install a supported one. Please click the Show Me How Button for details.</p> <p>091-942</p>	<p><IOT DRUM Cartridge (K) CRUM Data Error> The Black Drum Cartridge CRUM Data error is detected.</p>	Flows 108 FIP1.108

Status Code	Error Message		Status Contents	FIP to be referred	
	LCD	Status Window			
091	943	<p>i CRUM DATA 091-943 Reseat Yellow Drum Ctrrdg</p>	<p>An unsupported Yellow Drum Cartridge is installed.</p> <p>Open the Front Cover. Remove the unsupported Yellow Drum Cartridge and install a supported one. Please click the Show Me How Button for details.</p> <p>091-943</p>	<p><IOT DRUM Cartridge (Y) CRUM Data Error> The Yellow Drum Cartridge CRUM Data error is detected.</p>	<p>Flows 108 FIP1.108</p>
	944	<p>i CRUM DATA 091-944 Reseat Magenta Drum Ctrrdg</p>	<p>An unsupported Magenta Drum Cartridge is installed.</p> <p>Open the Front Cover. Remove the unsupported Magenta Drum Cartridge and install a supported one. Please click the Show Me How Button for details.</p> <p>091-944</p>	<p><IOT DRUM Cartridge (M) CRUM Data Error> The Magenta Drum Cartridge CRUM Data error is detected.</p>	<p>Flows 108 FIP1.108</p>
	945	<p>i CRUM DATA 091-945 Reseat Cyan Drum Ctrrdg</p>	<p>An unsupported Cyan Drum Cartridge is installed.</p> <p>Open the Front Cover. Remove the unsupported Cyan Drum Cartridge and install a supported one. Please click the Show Me How Button for details.</p> <p>091-945</p>	<p><IOT DRUM Cartridge (C) CRUM Data Error> The Cyan Drum Cartridge CRUM Data error is detected.</p>	<p>Flows 108 FIP1.108</p>
	950	<p>i Cartridge Error 091-950 Tape Staying Cyan Drum Ctrrdg</p>	<p>The sealing tape is still on the Cyan Drum Cartridge.</p> <p>Please click the Show Me How Button for details.</p> <p>091-950</p>	<p><Detect C Drum Cartridge Tape Staying> Tapes (ribbons) remains on the Drum Cartridge (C).</p>	<p>Flows 109 FIP1.109</p>
	951	<p>i Cartridge Error 091-951 Tape Staying Magenta Drum Ctrrdg</p>	<p>The sealing tape is still on the Magenta Drum Cartridge.</p> <p>Please click the Show Me How Button for details.</p> <p>091-951</p>	<p><Detect M Drum Cartridge Tape Staying> Tapes (ribbons) remains on the Drum Cartridge (M).</p>	<p>Flows 109 FIP1.109</p>

Status Code	Error Message		Status Contents	FIP to be referred	
	LCD	Status Window			
091	952	<p>i Cartridge Error 091-952 Tape Staying Yellow Drum Crtrdg</p>	<p>The sealing tape is still on the Yellow Drum Cartridge. Please click the Show Me How Button for details. 091-952</p>	<p><Detect Y Drum Cartridge Tape Staying> Tapes (ribbons) remains on the Drum Cartridge (Y).</p>	<p>Flows 109 FIP1.109</p>
	953	<p>i Cartridge Error 091-953 Tape Staying Black Drum Crtrdg</p>	<p>The sealing tape is still on the Black Drum Cartridge. Please click the Show Me How Button for details. 091-953</p>	<p><Detect K Drum Cartridge Tape Staying> Tapes (ribbons) remains on the Drum Cartridge (K).</p>	<p>Flows 109 FIP1.109</p>
	960	<p>i CRUM ID 091-960 Reseat Yellow Drum Crtrdg</p>	<p>An unsupported Yellow Drum Cartridge is installed. Open the Front Cover. Remove the unsupported Yellow Drum Cartridge and install a supported one. Please click the Show Me How Button for details. 091-960</p>	<p><IOT (Y) CRUM ID Error> An unsupported Drum Cartridge (Y) is detected.</p>	<p>Flows 110 FIP1.110</p>
	961	<p>i CRUM ID 091-961 Reseat Magenta Drum Crtrdg</p>	<p>An unsupported Magenta Drum Cartridge is installed. Open the Front Cover. Remove the unsupported Magenta Drum Cartridge and install a supported one. Please click the Show Me How Button for details. 091-961</p>	<p><IOT (M) CRUM ID Error> An unsupported Drum Cartridge (M) is detected.</p>	<p>Flows 110 FIP1.110</p>
	962	<p>i CRUM ID 091-961 Reseat Cyan Drum Crtrdg</p>	<p>An unsupported Cyan Drum Cartridge is installed. Open the Front Cover. Remove the unsupported Cyan Drum Cartridge and install a supported one. Please click the Show Me How Button for details. 091-962</p>	<p><IOT (C) CRUM ID Error> An unsupported Drum Cartridge (C) is detected.</p>	<p>Flows 110 FIP1.110</p>



Status Code		Error Message		Status Contents	FIP to be referred
		LCD	Status Window		
091	963	 CRUM ID 091-963 Reseat Black Drum Ctrdrg	<p>An unsupported Black Drum Cartridge is installed.</p> <p>Open the Front Cover. Remove the unsupported Black Drum Cartridge and install a supported one. Please click the Show Me How Button for details.</p> <p>091-963</p>	<p><IOT (K) CRUM ID Error> An unsupported Drum Cartridge (K) is detected.</p>	Flows 110 FIP1.110
092	651	Ready to Print 092-651 CTD Sensor Dirty  Flip Ready to Print Clean CTD Sensor	-	<p><IOT ADC Sensor Rear Error Code2> Contamination of ADC Rear Sensor was detected.</p>	Flows 111 FIP1.111
	670	092-670 Restart Printer Contact Support IfMessageReturns	<p>Printer error.</p> <p>Turn off the printer, and turn it on again. Contact customer support if this failure is repeated.</p> <p>092-670</p>	<p><Detect Yellow Calibrating Patch Error> Yellow Calibrating Patch Error (Low Density) was detected.</p>	Flows 112 FIP1.112
	671	092-671 Restart Printer Contact Support IfMessageReturns	<p>Printer error.</p> <p>Turn off the printer, and turn it on again. Contact customer support if this failure is repeated.</p> <p>092-671</p>	<p><Detect Magenta Calibrating Patch Error> Magenta Calibrating Patch Error (Low Density) was detected.</p>	Flows 113 FIP1.113
	672	092-672 Restart Printer Contact Support IfMessageReturns	<p>Printer error.</p> <p>Turn off the printer, and turn it on again. Contact customer support if this failure is repeated.</p> <p>092-672</p>	<p><Detect Cyan Calibrating Patch Error> Cyan Calibrating Patch Error (Low Density) was detected.</p>	Flows 114 FIP1.114
	673	092-673 Restart Printer Contact Support IfMessageReturns	<p>Printer error.</p> <p>Turn off the printer, and turn it on again. Contact customer support if this failure is repeated.</p> <p>092-673</p>	<p><Detect Black Calibrating Patch Error> Black Calibrating Patch Error (Low Density) was detected.</p>	Flows 115 FIP1.115



Status Code	Error Message		Status Contents	FIP to be referred	
	LCD	Status Window			
093	423	Ready to Print 093-423 Yellow Toner Crtrdg ↕ Flip Ready to Print Is close to life	The Yellow Toner Cartridge needs to be replaced soon. 093-423	<IOT Toner Cartridge (Y) Near Life> The Toner Cartridge (Y) is approaching the replacement time. When all the toner cartridges are simultaneously approaching the replacement time, a warning is indicated on the LCD panel in the following order: 1)Black → 2)Cyan → 3)Magenta → 4)Yellow	Flows 116 FIP1.116
	424	Ready to Print 093-424 Magenta Toner Crtrdg ↕ Flip Ready to Print Is close to life	The Magenta Toner Cartridge needs to be replaced soon. 093-424	<IOT Toner Cartridge (M) Near Life> The Toner Cartridge (M) is approaching the replacement time. When all the toner cartridges are simultaneously approaching the replacement time, a warning is indicated on the LCD panel in the following order: 1)Black → 2)Cyan → 3)Magenta → 4)Yellow	Flows 116 FIP1.116
	425	Ready to Print 093-425 Cyan Toner Crtrdg ↕ Flip Ready to Print Is close to life	The Cyan Toner Cartridge needs to be replaced soon. 093-425	<IOT Toner Cartridge (C) Near Life> The Toner Cartridge (C) is approaching the replacement time. When all the toner cartridges are simultaneously approaching the replacement time, a warning is indicated on the LCD panel in the following order: 1)Black → 2)Cyan → 3)Magenta → 4)Yellow	Flows 116 FIP1.116
	426	Ready to Print 093-426 Black Toner Crtrdg ↕ Flip Ready to Print Is close to life	The Black Toner Cartridge needs to be replaced soon. 093-426	<IOT Toner Cartridge (K) Near Life> The Toner Cartridge (K) is approaching the replacement time. When all the toner cartridges are simultaneously approaching the replacement time, a warning is indicated on the LCD panel in the following order: 1)Black → 2)Cyan → 3)Magenta → 4)Yellow	Flows 116 FIP1.116
	930	 Life Over 093-930 Replace Now Yellow Toner Crtrdg	The Yellow Toner Cartridge needs to be replaced now. Open the Front Cover. Then remove the used Yellow Toner Cartridge and install a new one. Please click the Show Me How Button for details. 093-930	<IOT Toner Cartridge (Y) Life Over> The Toner Cartridge (Y) has reached the replacement time. When all the toner cartridges have simultaneously reached the replacement time, a warning is indicated on the LCD panel in the following order: 1)Black → 2)Cyan → 3)Magenta → 4)Yellow	Flows 117 FIP1.117

Status Code	Error Message		Status Contents	FIP to be referred	
	LCD	Status Window			
093	931	<p>i Life Over 093-931 Replace Now Magenta Toner Crtrdg</p>	<p>The Magenta Toner Cartridge needs to be replaced now.</p> <p>Open the Front Cover. Then remove the used Magenta Toner Cartridge and install a new one. Please click the Show Me How Button for details.</p> <p>093-931</p>	<p><IOT Toner Cartridge (M) Life Over></p> <p>The Toner Cartridge (M) has reached the replacement time. When all the toner cartridges have simultaneously reached the replacement time, a warning is indicated on the LCD panel in the following order: 1)Black → 2)Cyan → 3)Magenta → 4)Yellow</p>	Flows 117 FIP1.117
	932	<p>i Life Over 093-932 Replace Now Cyan Toner Crtrdg</p>	<p>The Cyan Toner Cartridge needs to be replaced now.</p> <p>Open the Front Cover. Then remove the used Cyan Toner Cartridge and install a new one. Please click the Show Me How Button for details.</p> <p>093-932</p>	<p><IOT Toner Cartridge (C) Life Over></p> <p>The Toner Cartridge (C) has reached the replacement time. When all the toner cartridges have simultaneously reached the replacement time, a warning is indicated on the LCD panel in the following order: 1)Black → 2)Cyan → 3)Magenta → 4)Yellow</p>	Flows 117 FIP1.117
	933	<p>i Life Over 093-933 Replace Now Black Toner Crtrdg</p>	<p>The Black Toner Cartridge needs to be replaced now.</p> <p>Open the Front Cover. Then remove the used Black Toner Cartridge and install a new one. Please click the Show Me How Button for details.</p> <p>093-933</p>	<p><IOT Toner Cartridge (K) Life Over></p> <p>The Toner Cartridge (K) has reached the replacement time. When all the toner cartridges have simultaneously reached the replacement time, a warning is indicated on the LCD panel in the following order: 1)Black → 2)Cyan → 3)Magenta → 4)Yellow</p>	Flows 117 FIP1.117
	960	<p>i CRUM ID 093-960 Reseat Yellow Toner Crtrdg</p>	<p>An unsupported Yellow Toner Cartridge is installed.</p> <p>Open the Front Cover. Remove the unsupported Yellow Toner Cartridge and install a supported one. Please click the Show Me How Button for details.</p> <p>093-960</p>	<p><IOT (Y) CRUM ID Error></p> <p>An unsupported Toner Cartridge (Y) is detected.</p>	Flows 118 FIP1.118

Status Code	Error Message		Status Contents	FIP to be referred	
	LCD	Status Window			
093	961	<p>i CRUM ID 093-961 Reseat Magenta Toner Crtrdg</p>	<p>An unsupported Magenta Toner Cartridge is installed.</p> <p>Open the Front Cover. Remove the unsupported Magenta Toner Cartridge and install a supported one. Please click the Show Me How Button for details.</p> <p>093-961</p>	<p><IOT (M) CRUM ID Error> An unsupported Toner Cartridge (M) is detected.</p>	Flows 118 FIP1.118
	962	<p>i CRUM ID 093-962 Reseat Cyan Toner Crtrdg</p>	<p>An unsupported Cyan Toner Cartridge is installed.</p> <p>Open the Front Cover. Remove the unsupported Cyan Toner Cartridge and install a supported one. Please click the Show Me How Button for details.</p> <p>093-962</p>	<p><IOT (C) CRUM ID Error> An unsupported Toner Cartridge (C) is detected.</p>	Flows 118 FIP1.118
	963	<p>i CRUM ID 093-963 Reseat Black Toner Crtrdg</p>	<p>An unsupported Black Toner Cartridge is installed.</p> <p>Open the Front Cover. Remove the unsupported Black Toner Cartridge and install a supported one. Please click the Show Me How Button for details.</p> <p>093-963</p>	<p><IOT (K) CRUM ID Error> An unsupported Toner Cartridge (K) is detected.</p>	Flows 118 FIP1.118
	964	<p>093-964 Restart Printer Reseat Fuser Contact Support</p>	<p>An unsupported Fuser is installed.</p> <p>Please click the Show Me How Button for details.</p> <p>093-964</p>	<p><IOT Fuser CRUM ID Error> An unsupported Fuser is detected.</p>	Flows 119 FIP1.119

Status Code	Error Message		Status Contents	FIP to be referred	
	LCD	Status Window			
093	970	<p>i Cartridge Error 093-970 Insert Yellow Toner Crtrdg</p>	<p>The Yellow Toner Cartridge is either missing or not fully inserted into the printer.</p> <p>Open the Front Cover and make sure that the Yellow Toner Cartridge have been fully installed. Please click the Show Me How Button for details.</p> <p>093-970</p>	<p><IOT Toner Cartridge (Y) Detached> The Toner Cartridge (Y) is not installed in the printer. If no toner cartridge has been installed in the printer, a warning is indicated on the LCD panel in the following order: 1)Black → 2)Cyan → 3)Magenta → 4)Yellow</p>	Flows 120 FIP1.120
	971	<p>i Cartridge Error 093-971 Insert Magenta Toner Crtrdg</p>	<p>The Magenta Toner Cartridge is either missing or not fully inserted into the printer.</p> <p>Open the Front Cover and make sure that the Magenta Toner Cartridge have been fully installed. Please click the Show Me How Button for details.</p> <p>093-971</p>	<p><IOT Toner Cartridge (M) Detached> The Toner Cartridge (M) is not installed in the printer. If no toner cartridge has been installed in the printer, a warning is indicated on the LCD panel in the following order: 1)Black → 2)Cyan → 3)Magenta → 4)Yellow</p>	Flows 120 FIP1.120
	972	<p>i Cartridge Error 093-972 Insert Cyan Toner Crtrdg</p>	<p>The Cyan Toner Cartridge is either missing or not fully inserted into the printer.</p> <p>Open the Front Cover and make sure that the Cyan Toner Cartridge have been fully installed. Please click the Show Me How Button for details.</p> <p>093-972</p>	<p><IOT Toner Cartridge (C) Detached> The Toner Cartridge (C) is not installed in the printer. If no toner cartridge has been installed in the printer, a warning is indicated on the LCD panel in the following order: 1)Black → 2)Cyan → 3)Magenta → 4)Yellow</p>	Flows 120 FIP1.120
	973	<p>i Cartridge Error 093-973 Insert Black Toner Crtrdg</p>	<p>The Black Toner Cartridge is either missing or not fully inserted into the printer.</p> <p>Open the Front Cover and make sure that the Black Toner Cartridge have been fully installed. Please click the Show Me How Button for details.</p> <p>093-973</p>	<p><IOT Toner Cartridge (K) Detached> The Toner Cartridge (K) is not installed in the printer. If no toner cartridge has been installed in the printer, a warning is indicated on the LCD panel in the following order: 1)Black → 2)Cyan → 3)Magenta → 4)Yellow</p>	Flows 120 FIP1.120

Status Code	Error Message		Status Contents	FIP to be referred	
	LCD	Status Window			
094	325	094-325 Restart Printer Contact Support IfMessageReturns	Printer error. Turn off the printer, and turn it on again. Contact customer support if this failure is repeated. 094-325-01 to 06	<IOT Switching Sensor Failure> Detected Switching Sensor Failure. Pressing the [Information] button shows detail error code (0 to 06). Code: 01h Code: 02h to 06	Flows 121: FIP1.121: Code 01 Flows 122: FIP1.122: Code 02 to 06
	419	Ready to Print 094-419 Belt Unit ↕ Flip Ready to Print prepare	Prepare the Belt Unit. 094-419	<IOT Belt Unit Near Life> The Belt Unit is approaching the replacement time.	Flows 123 FIP1.123
	422	Ready to Print 094-422 Belt Unit ↕ Flip Ready to Print Is close to life	Contact customer support if this failure is repeated. 094-422	<IOT Belt Unit Near Life> The Belt Unit has reached the replacement time.	Flows 123 FIP1.123
	910	 Belt Error 094-910 Insert Belt Unit	The Belt Unit is either missing or not fully inserted into the printer. Open the covers in the order of the Right Hand Cover, the Front Cover and the Inner Cover. Then make sure that the Belt Unit has been fully installed. Please click the Show Me How Button for details. 094-910	<IOT Belt Unit Detached> BELT Unit detached is detected.	Flows 124 FIP1.124
	911	 Life Over 094-911 Replace Now Belt Unit	The Belt Unit needs to be replaced now. Contact Customer Support. Please click the Show Me How Button for details. 094-911	<IOT Belt Unit Life Over> The Belt Unit has reached the replacement time.	Flows 125 FIP1.125

Status Code		Error Message		Status Contents	FIP to be referred
		LCD	Status Window		
094	912	094-912 Restart Printer Reseat Belt Unit Contact Support	Printer error. Turn off the printer. Confirm Belt Unit is correctly installed. Turn on the printer. Contact customer support if this failure is repeated. 094-912	<IOT Belt Unit CRUM Fail> Belt Unit CRUM communication error is detected.	Flows 126 FIP1.126
	913	 Trans. Error 094-913 Insert Transfer Roller	The Transfer Roller is either missing or not fully inserted into the printer. Open the covers in the order of the Right Hand Cover, the Front Cover and the Inner Cover. Then make sure that the Transfer Roller has been fully installed. Please click the Show Me How Button for details. 094-913	<IOT Transfer Roller Detached> Transfer Roller detached is detected.	Flows 127 FIP1.127
	960	 CRUM ID 094-960 Reseat Belt Unit	An unsupported Belt Unit is installed. Open the Front Cover. Remove the unsupported Belt Unit and install a supported one. Please click the Show Me How Button for details. 094-960	<IOT Belt Unit CRUM ID Mismatch> An unsupported Belt Unit is detected.	Flows 128 FIP1.128
116	364	116-364 Restart Printer Contact Support IfMessageReturns	Printer error. Turn off the printer, and turn it on again. Contact customer support if this failure is repeated. 116-364	<Timer Fail> The timer fault was detected.	Flows 129 FIP1.129
124	310	124-310 Restart Printer Contact Support IfMessageReturns	Printer error. Turn off the printer, and turn it on again. Contact customer support if this failure is repeated. 124-310	<IOT XPC Error> Detect XPC Error	Flows 130 FIP1.130

Status Code		Error Message		Status Contents	FIP to be referred
		LCD	Status Window		
142	700	Ready to Print 142-700 Slow Speed Printing	-	<IOT Over Heat Forced Half Speed> The printing mode becomes half speed mode, by the high temperature.	Flows 83 FIP1.83
193	700	Ready to Print 193-700 non-Dell Toner Installed	-	<Custom Toner Mode> The printer is in custom toner mode.	Flows 131 FIP1.131

3. Error Code FIP

3.1 Troubleshooting for the call center

Flows 1 001-360: IOT LV Fan Motor Failure

Cause: MCU detects an error upon receiving error signal from the LVPS Fan.

Solution: Turn the power off and on to check that the error recurs. Then, proceed to the troubleshooting following the flowchart given below.

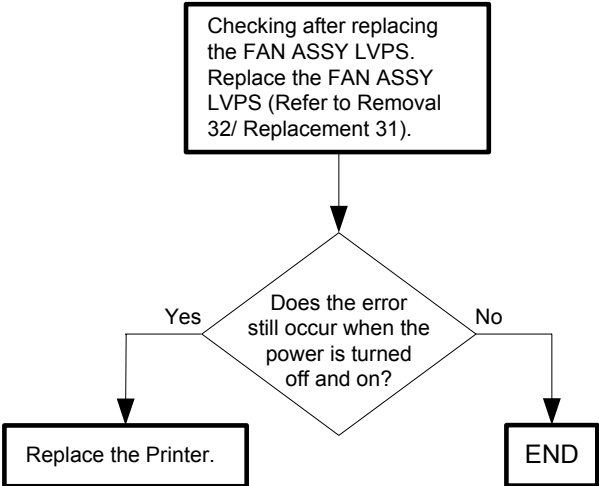

Flows 2 003-340: IOT Firmware Error

Cause: MCU firmware error occurs.

Solution: Proceed to the troubleshooting following the flowchart given below.

NOTE

Never turn off the power to the printer while the firmware is being downloaded. Turning the power off may cause a failure in the printer.

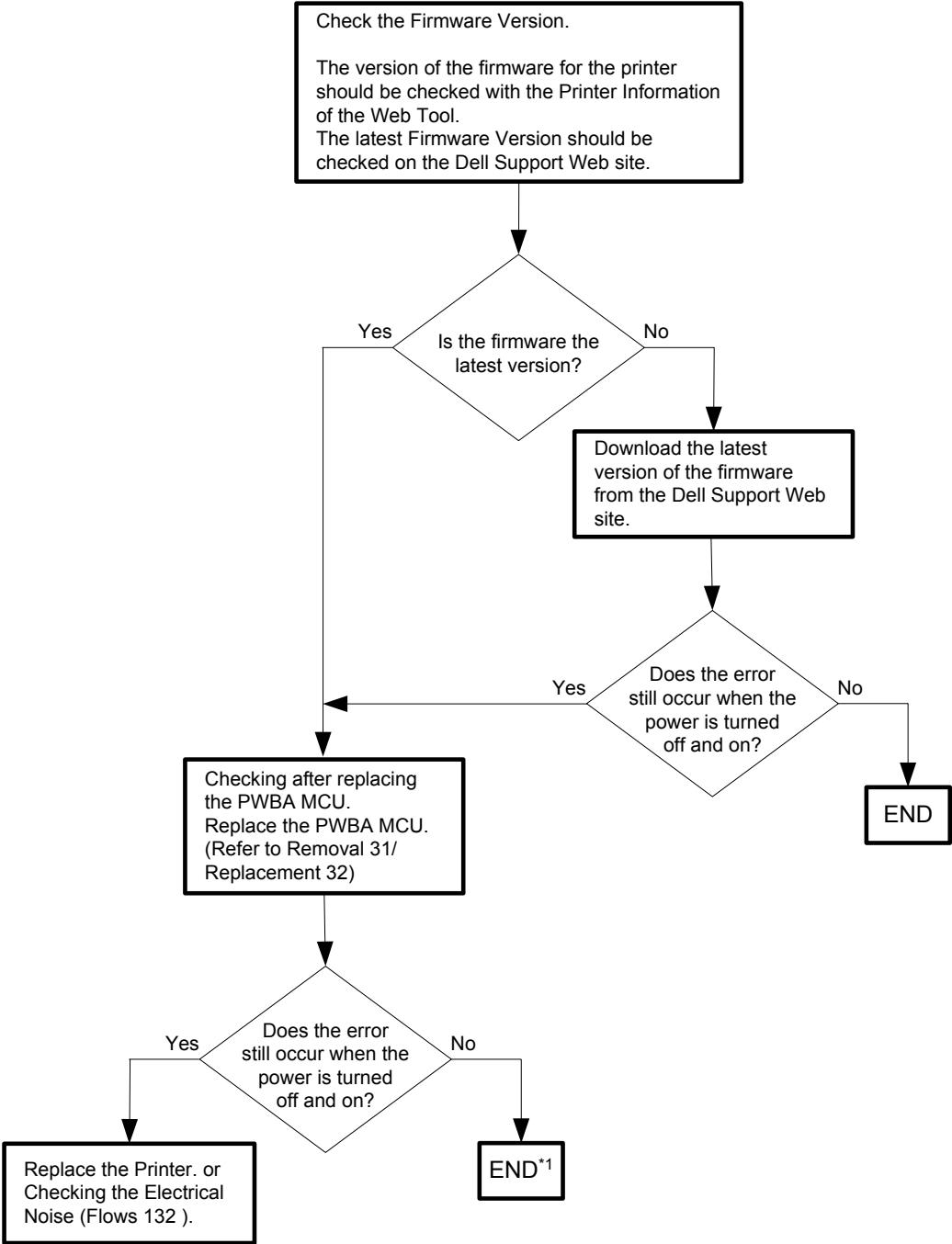

*1: Though some kind of external noise would be possible cause, go to [Flows 132 Electrical Noise] and check, to make sure.

Flows 3 003-356: IOT NVRAM Error

Cause: The operation error of NVM (read/write check error etc.) was detected.
Solution: Proceed to the troubleshooting following the flowchart given below.

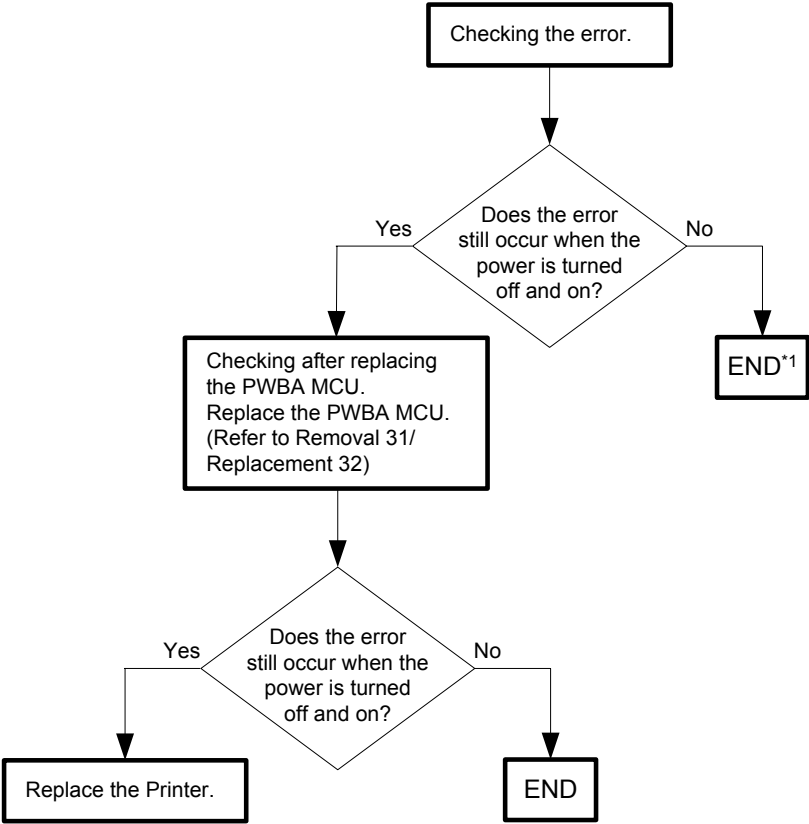

Flows 4 004-310: IOT Option Feeder I/F Failure

Cause: The Option Feeder communication failure is detected.

Solution: Turn the power off and on to check that the error recurs. Then, proceed to the troubleshooting following the flowchart given below.

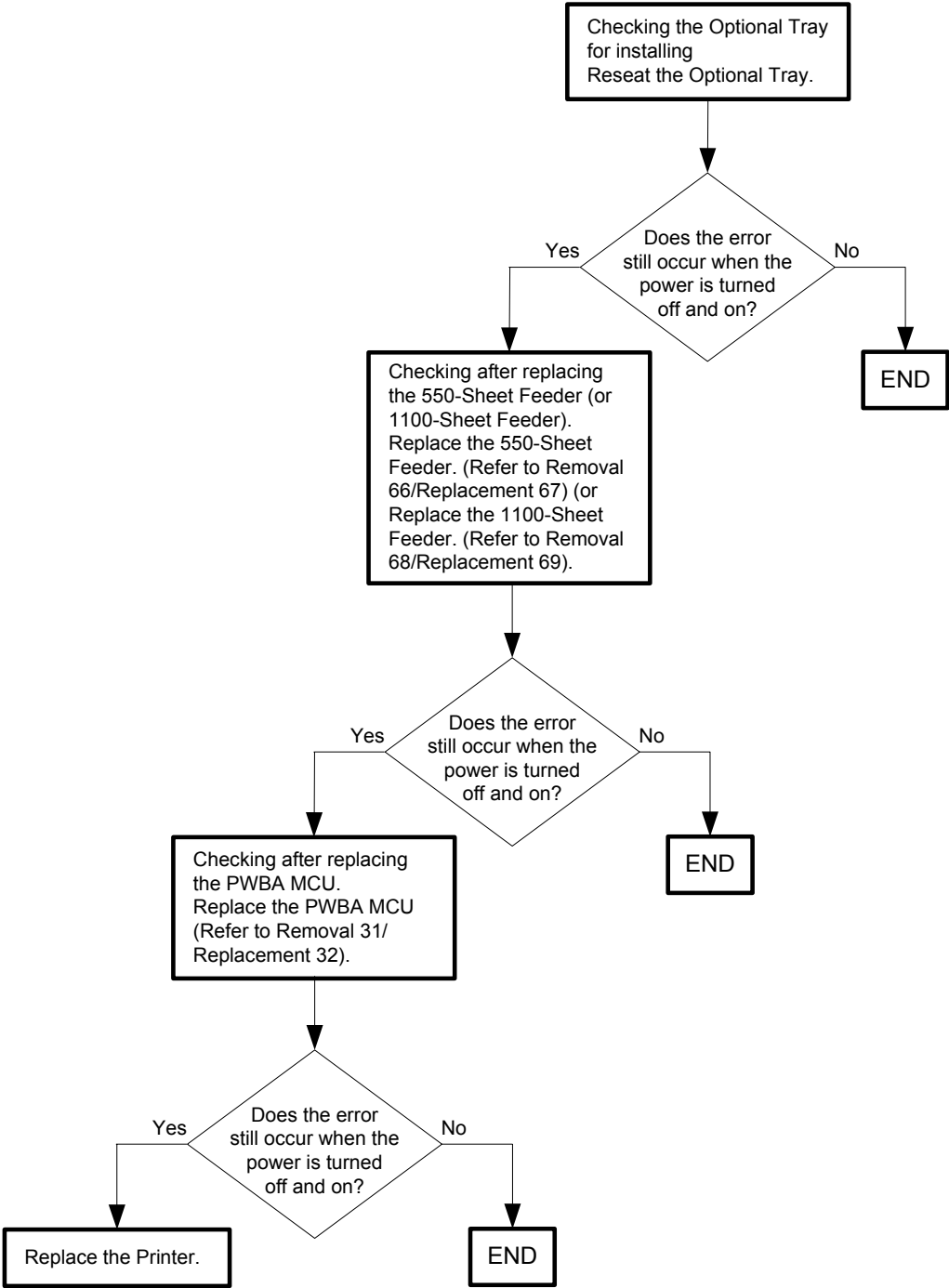

Flows 5 004-312: IOT Feeder Configuration Failure

Cause: Option Sheet Feeder Configuration error is detected.
Solution: The combinations of the Optional Feeder for 5130 cdn is not correct.
Change the combinations to the correct one. (Refer to Reference_1)

NOTE

If the error persists after the action above is taken, ensure that the error replicates after the printer is powered off and then on, and then go to the following steps to continue further fault isolation.

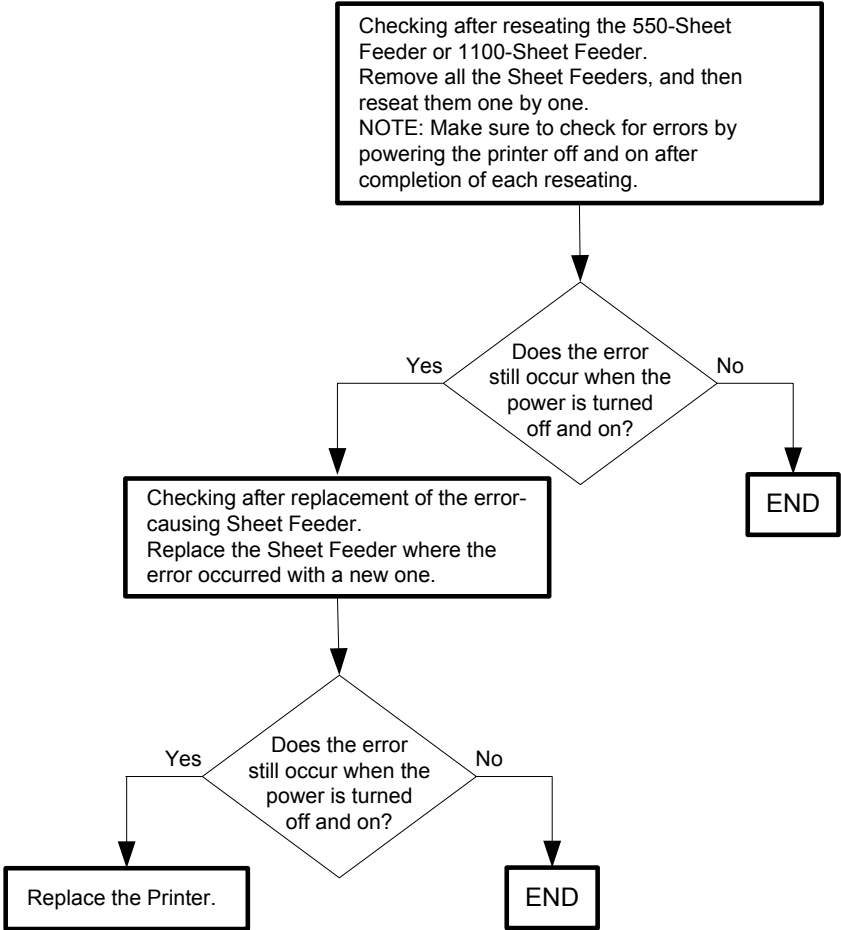

- Reference_1: Combinations example

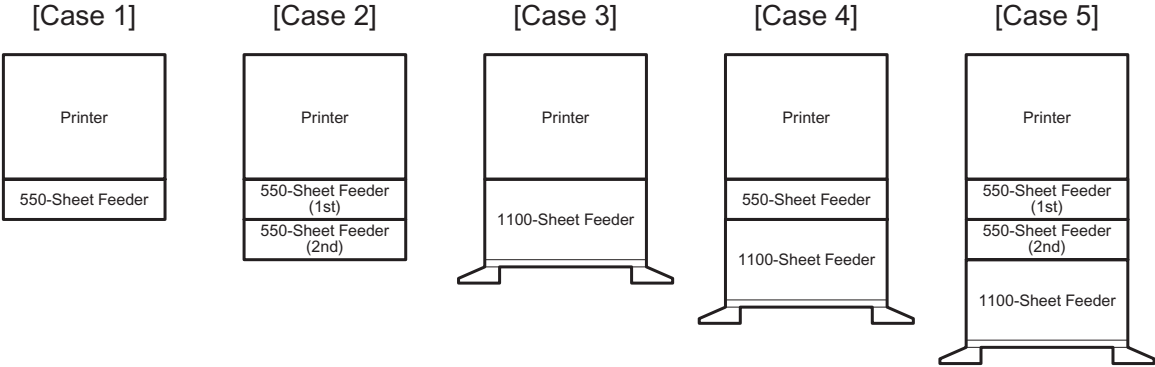

Tbt01028KB

Flows 6 006-370: IOT ROS Failure

Cause: The operation error of ROS (rotational error etc.) was detected.

Solution: Turn the power off and on to check that the error recurs. Then, proceed to the troubleshooting following the flowchart given below.

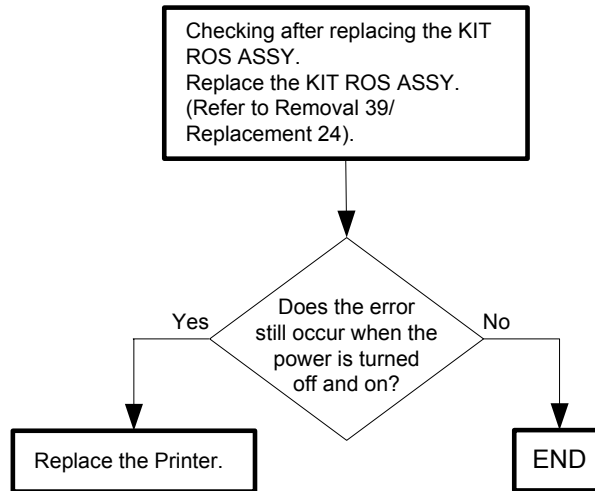

Flows 7 007-340-01: IOT Motor Failure (Deve Motor K)

Cause: Deve Motor K failure is detected.

Solution: Turn the power off and on to check that the error recurs. Then, proceed to the troubleshooting following the flowchart given below.

NOTE

When replacing the Drum Cartridge (YMCK), ensure that the pad of the CLEANER ASSY (cleaning rod) is replaced and that the ROSS ASSY is cleaned. For details of how to replace the Drum Cartridge (YMCK), refer to "Appendix 2.3 Replacing the Drum Cartridges". For details of how to clean the ROS ASSY, refer to "Appendix 3.1 Cleaning Inside the Printer".

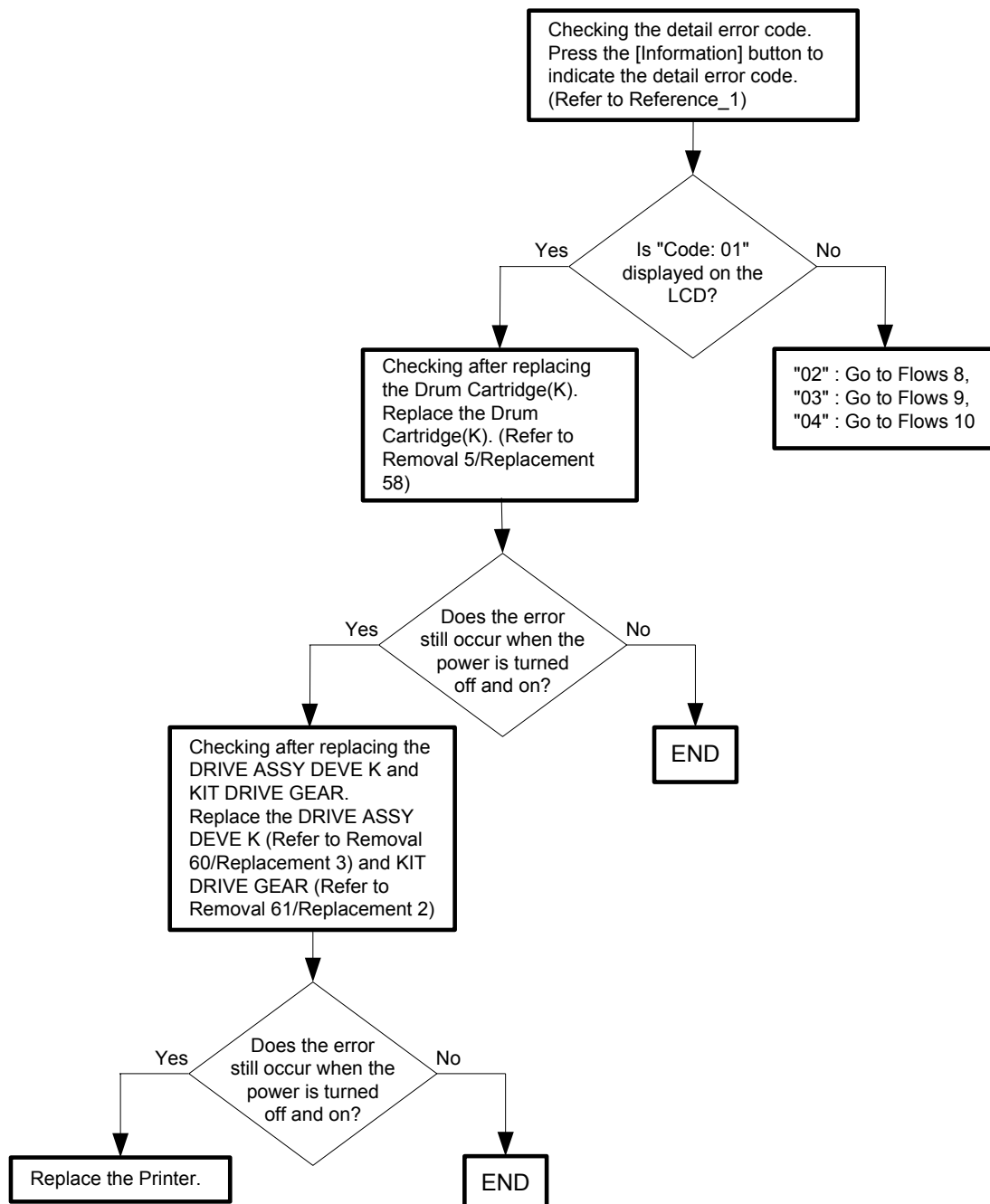

- Reference_1: [Information] button

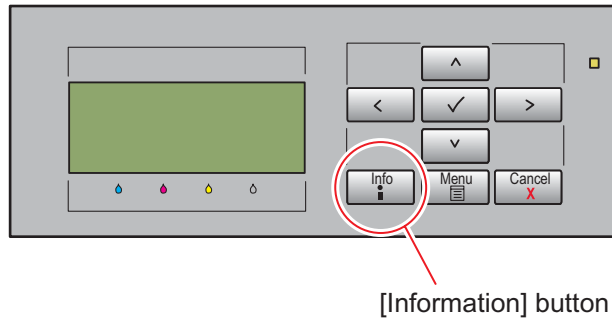

Flows 8 007-340-02: IOT Motor Failure (Deve Motor YMC)

Cause: Deve Motor YMC failure is detected.

Solution: Turn the power off and on to check that the error recurs. Then, proceed to the troubleshooting following the flowchart given below.

NOTE

When replacing the Drum Cartridge (YMCK), ensure that the pad of the CLEANER ASSY (cleaning rod) is replaced and that the ROSS ASSY is cleaned. For details of how to replace the Drum Cartridge (YMCK), refer to "Appendix 2.3 Replacing the Drum Cartridges". For details of how to clean the ROS ASSY, refer to "Appendix 3.1 Cleaning Inside the Printer".

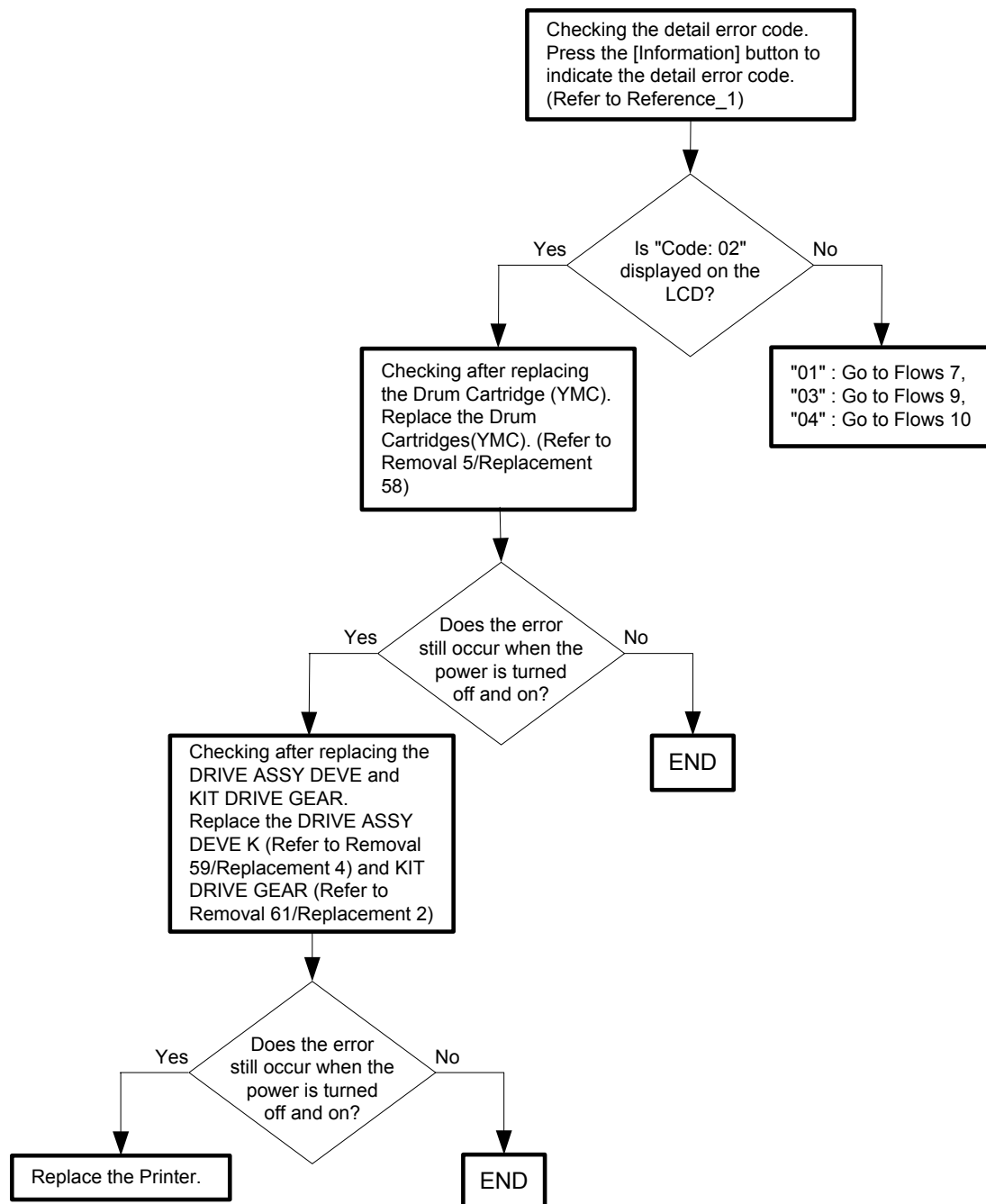

- Reference_1: [Information] button

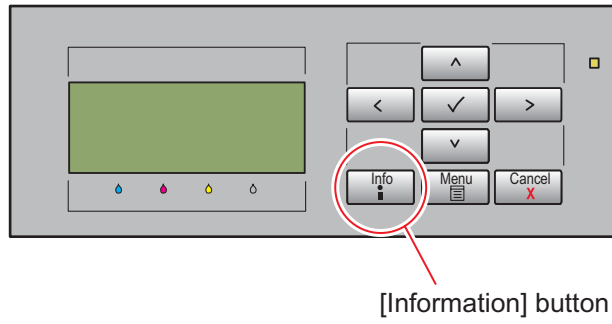

Flows 9 007-340-03: IOT Motor Failure (Xero Motor)

Cause: Xero Motor failure is detected.

Solution: Turn the power off and on to check that the error recurs. Then, proceed to the troubleshooting following the flowchart given below.

NOTE

When replacing the Drum Cartridge (YMCK), ensure that the pad of the CLEANER ASSY (cleaning rod) is replaced and that the ROSS ASSY is cleaned. For details of how to replace the Drum Cartridge (YMCK), refer to "Appendix 2.3 Replacing the Drum Cartridges". For details of how to clean the ROS ASSY, refer to "Appendix 3.1 Cleaning Inside the Printer".

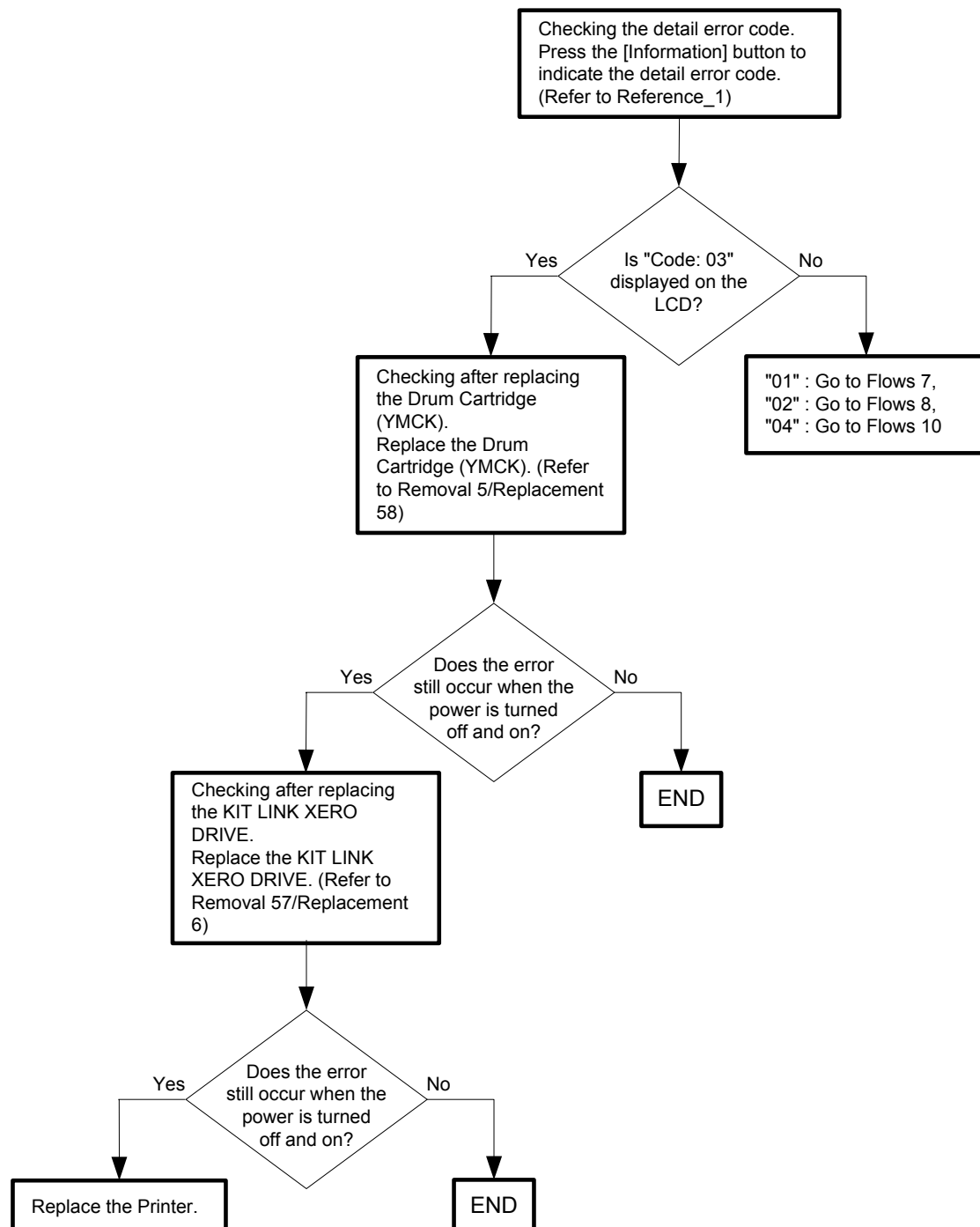

- Reference_1: [Information] button

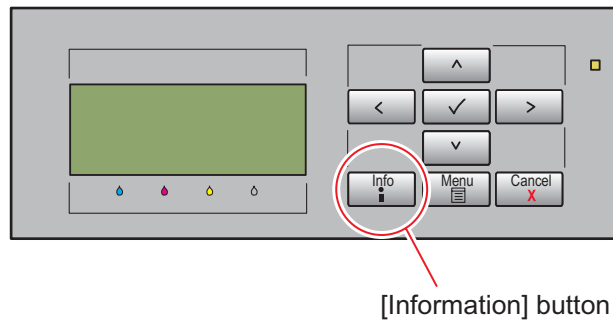

Flows 10 007-340-04: IOT Motor Failure (PH Motor)

Cause: PH Motor failure is detected.

Solution: Turn the power off and on to check that the error recurs. Then, proceed to the troubleshooting following the flowchart given below.

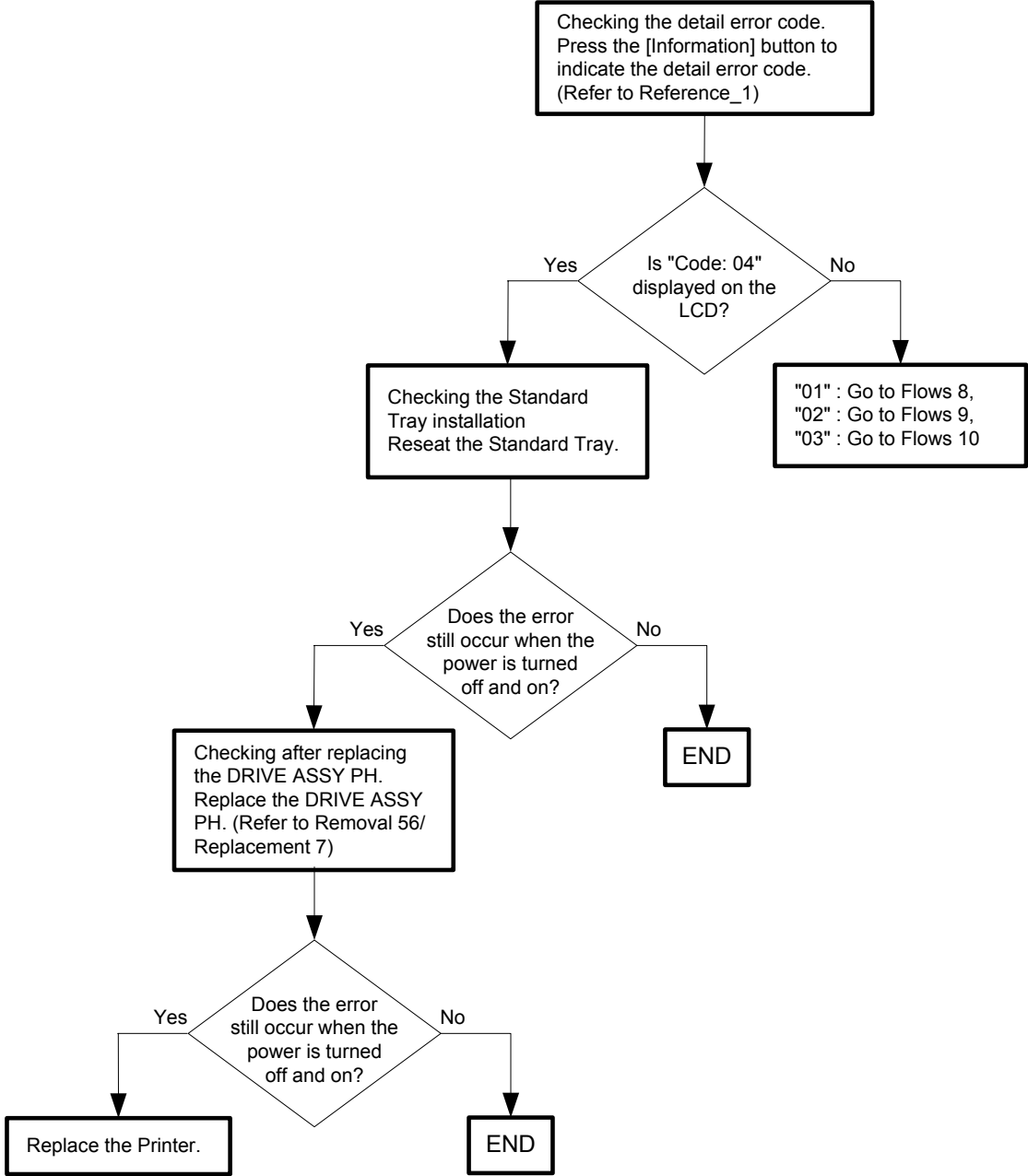

- Reference_1: [Information] button

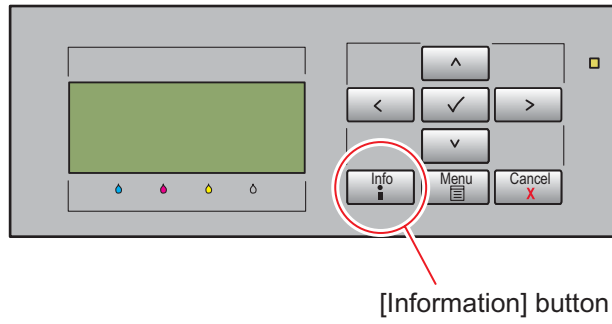

Flows 11 009-340: IOT CTD Sensor Error

Cause: CTD sensor error(analog-to-digital conversion etc.) was detected.

Solution: Turn the power off and on to check that the error recurs. Then, proceed to the troubleshooting following the flowchart given below.

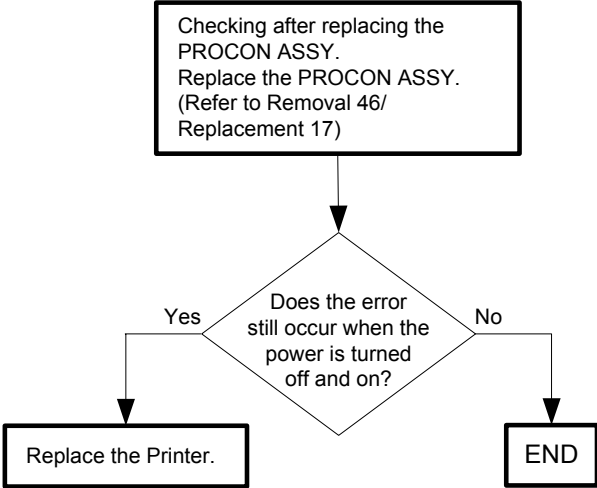

Flows 12 009-360 / 009-361 / 009-362 / 009-363: IOT Toner (YMCK) CRUM Comm Fail

- Cause: 009-360: The Yellow Toner Cartridge CRUM communication failure is detected.
 009-361: The Magenta Toner Cartridge CRUM communication failure is detected.
 009-362: The Cyan Toner Cartridge CRUM communication failure is detected.
 009-363: The Black Toner Cartridge CRUM communication failure is detected.

Solution: Turn the power off and on to check that the error recurs. Then, proceed to the troubleshooting following the flowchart given below.

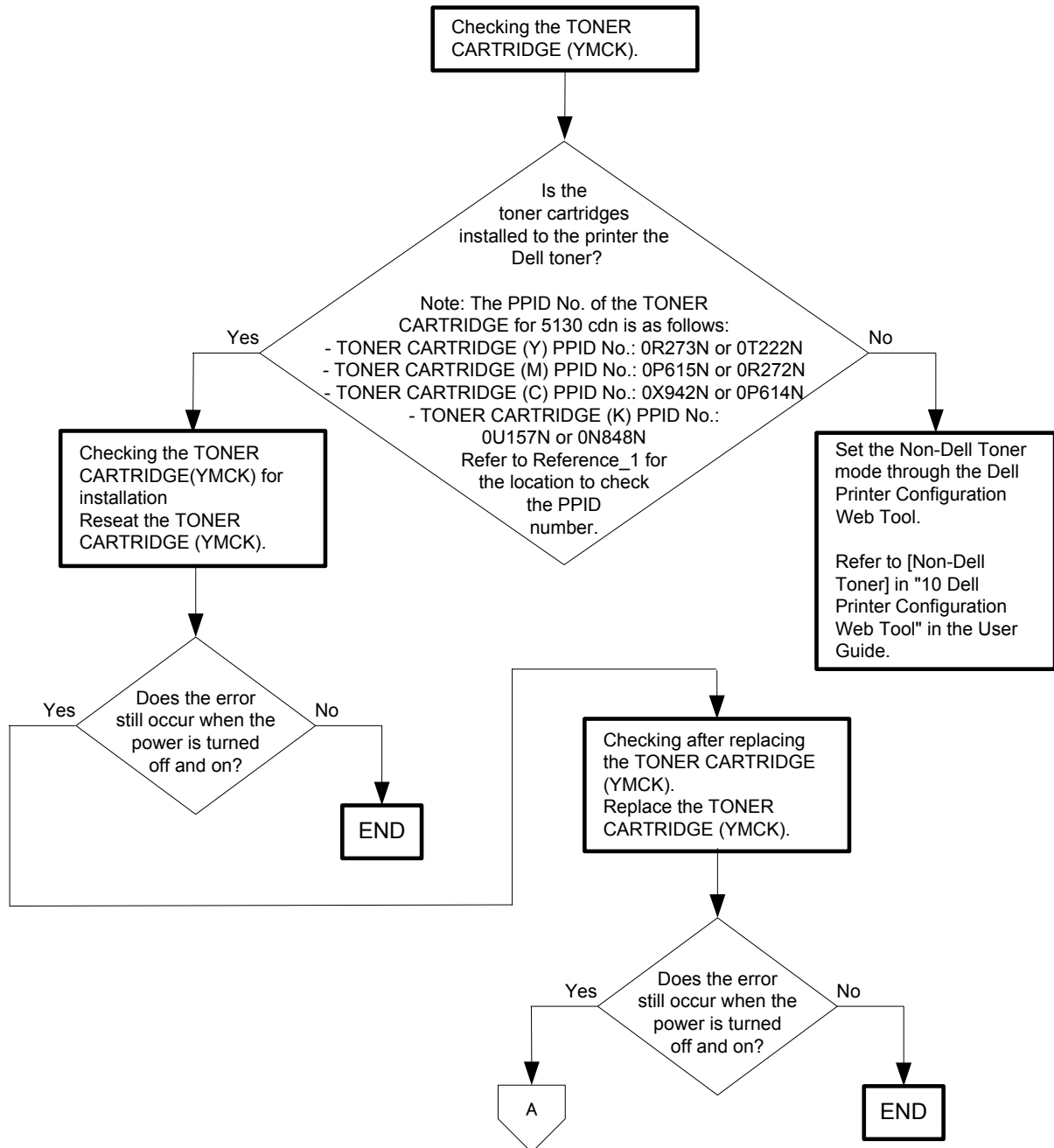

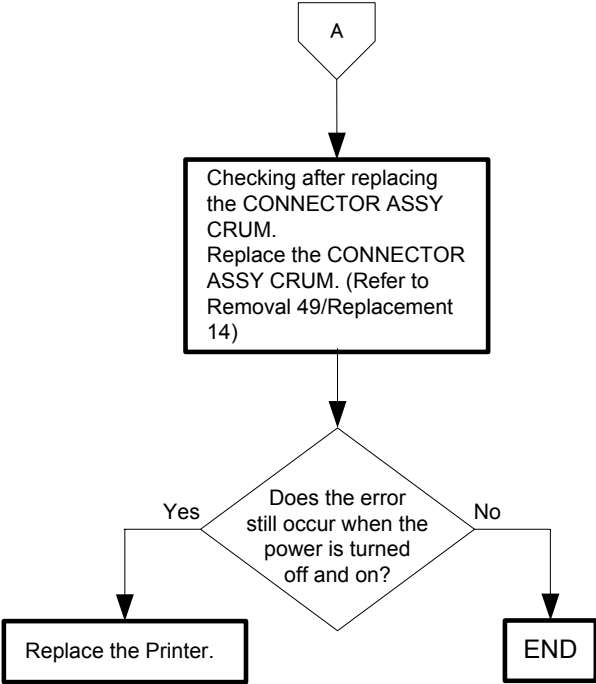

- Reference_1: Position of PPID label.

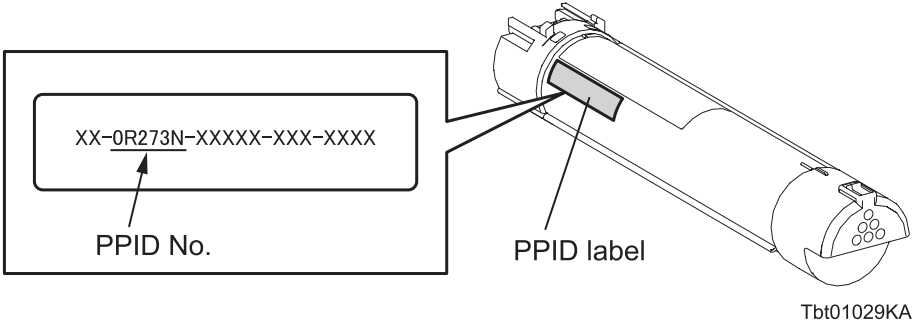

Flows 13 009-367 / 009-368 / 009-369 / 009-370: IOT Toner Cartridge (YMCK) CRUM
Data Error

- Cause: 009-367: The Yellow Toner Cartridge CRUM Data error is detected.
 009-368: The Magenta Toner Cartridge CRUM Data error is detected.
 009-369: The Cyan Toner Cartridge CRUM Data error is detected.
 009-370: The Black Toner Cartridge CRUM Data error is detected.

Solution: Press the [Information] button. Take the remedies in accordance with the description (refer to Reference_1) shown on the display.

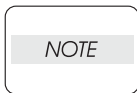

If the error persists after the action above is taken, ensure that the error replicates after the printer is powered off and then on, and then go to the following steps to continue further fault isolation.

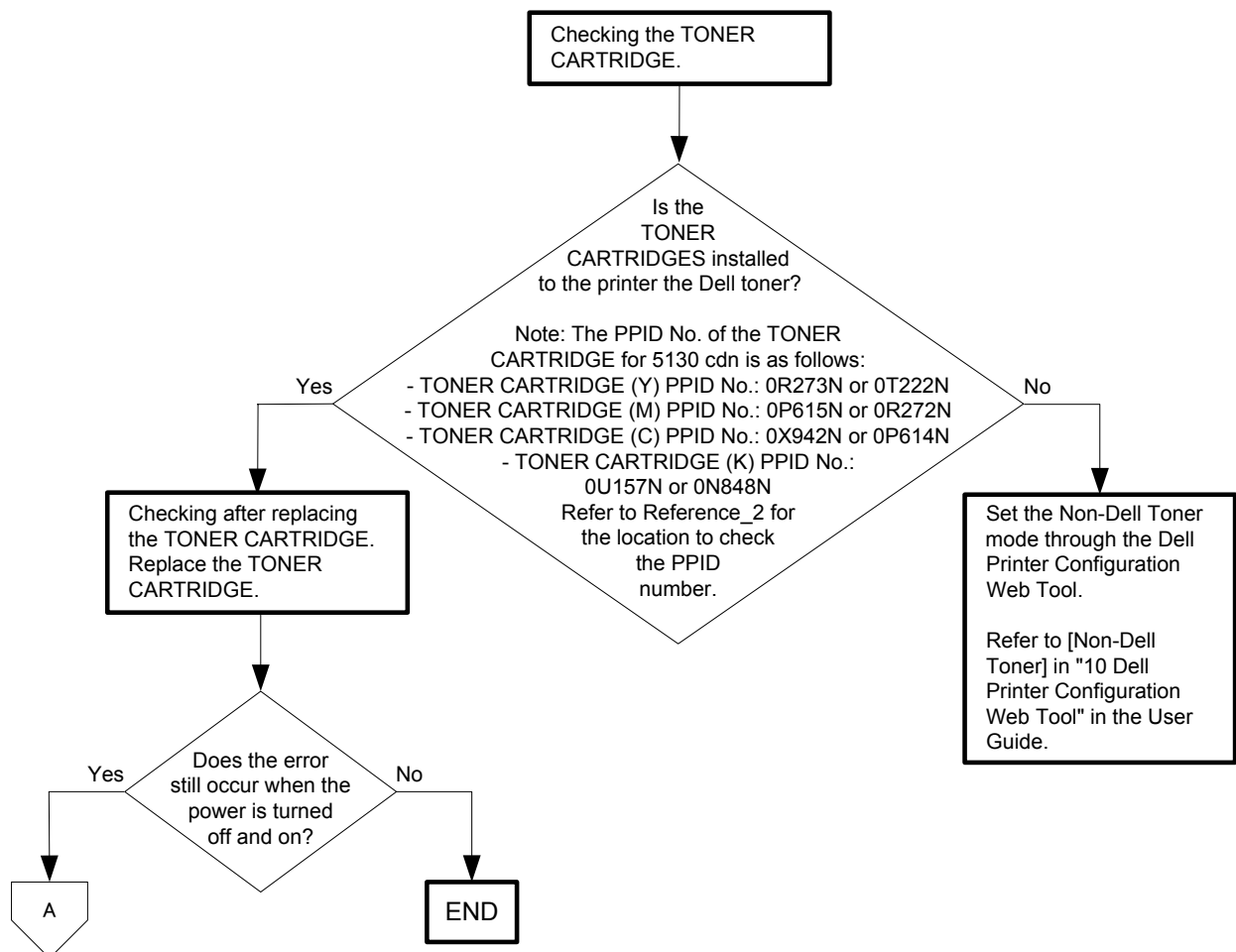

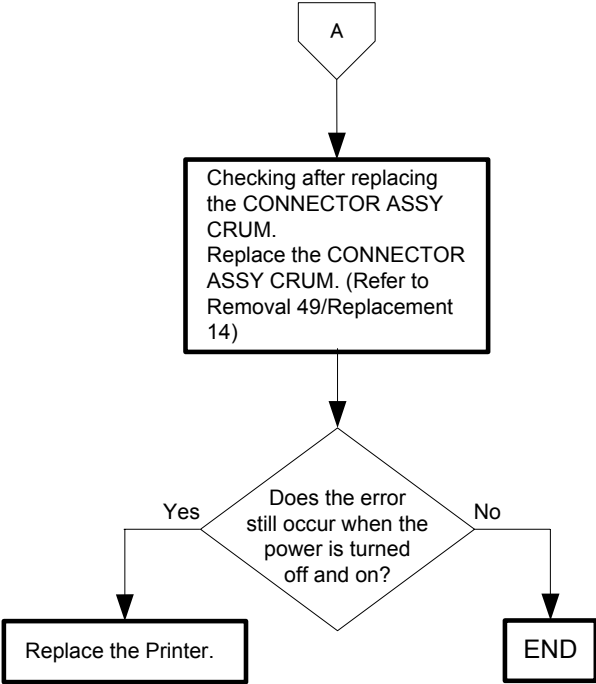

- Reference_1: 1. Open Front Cover. → 2. Reseat Y (or MCK) Toner Cartridge. → 3. Close Front Cover.
- Reference_2: Position of PPID label.

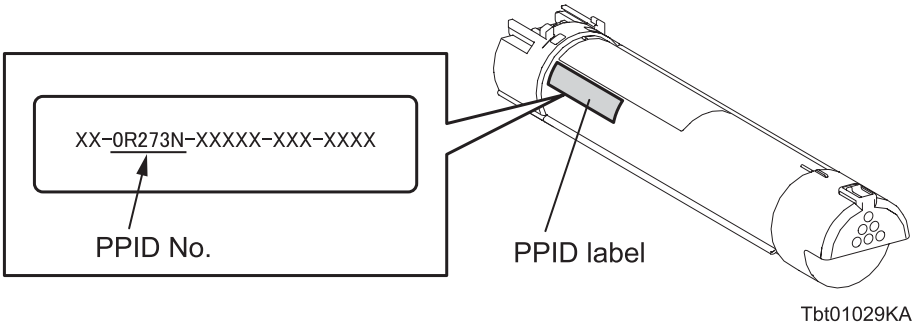

Flows 14 009-371: IOT Belt Unit CRUM Data Error

Cause: The Belt Unit CRUM Data error is detected.

Solution: Press the [Information] button. Take the remedies in accordance with the description (refer to Reference_1) shown on the display.

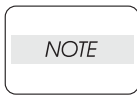

If the error persists after the action above is taken, ensure that the error replicates after the printer is powered off and then on, and then go to the following steps to continue further fault isolation.

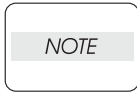

When the BELT ASSY IBT has been replaced, be sure to clean up the CTD Sensor. Refer to "Appendix_3.2 Cleaning the Conductivity Temperature Depth (CTD) Sensor" for how to clean up the CTD Sensor.

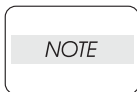

When replacing the BELT Unit, ensure that the Transfer Roller is also replaced. For details, refer to "Appendix_2.1.1 (4) Replacing the Belt Unit and Transfer Roller concurrently".

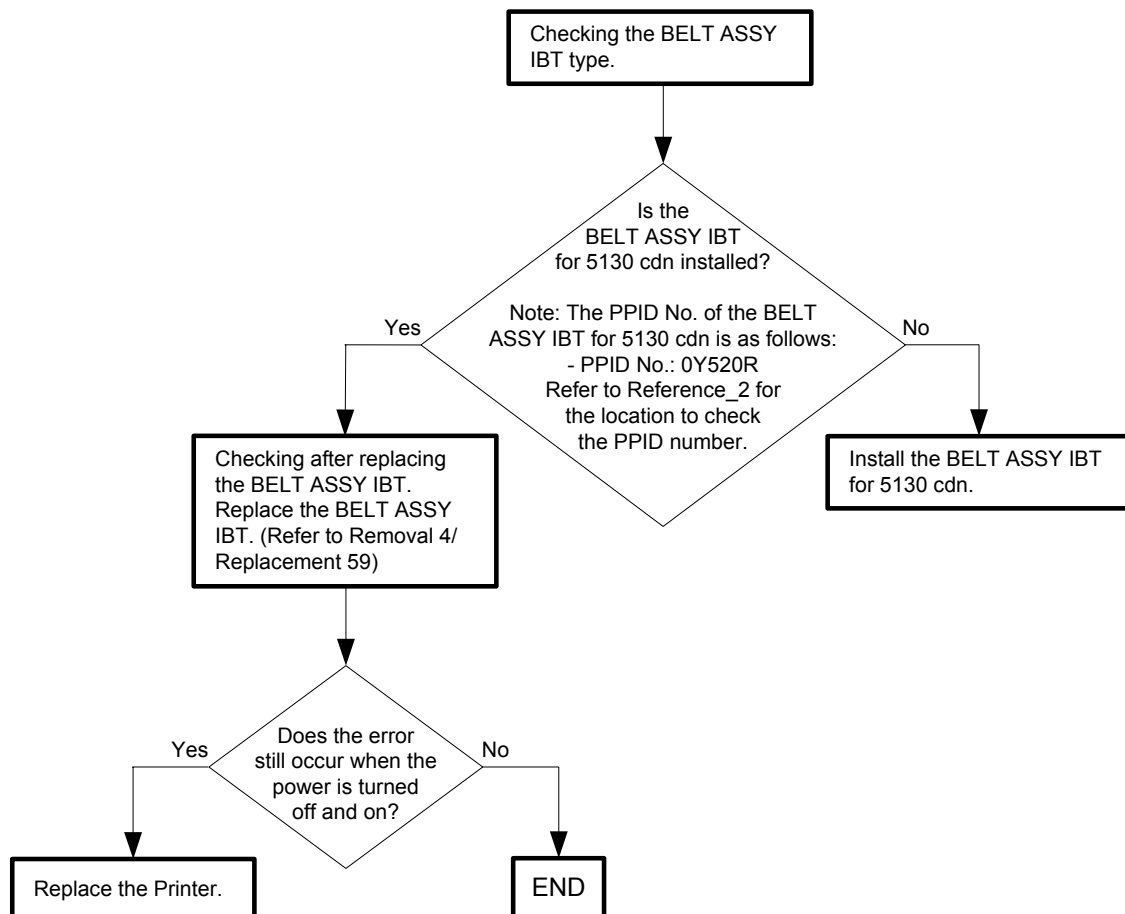

- Reference_1:

- No paper is placed in the MPF

1. Open Right Hand Cover → 2. Open Front Cover. → 3. Open Inner Cover. → 4. Reseat Belt Unit. → 5. Close Inner Cover. → 6. Close Front Cover. → 7. Close Right Hand Cover

- Paper is placed in the MPF

1. Remove all the paper in MPF → 2. Open Right Hand Cover → 3. Open Front Cover. → 4. Open Inner Cover. → 5. Reseat Belt Unit. → 6. Close Inner Cover. → 7. Close Front Cover. → 8. Close Right Hand Cover → 9. Set paper once again to MPF.

- Reference_2: Position of PPID label.

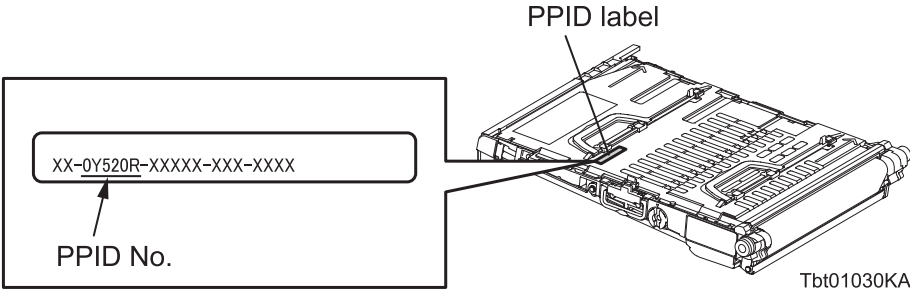

Flows 15 010-317: IOT Fuser Detached

Cause: Fuser detached is detected.

Solution: The Fuser is not installed properly. (Or the Fuser is not installed.) Check to be sure that the Fuser has cooled down, and then install the Fuser properly.



To avoid burns, do not replace the fuser immediately after printing. The fuser becomes extremely hot during use.

Turn off the printer and wait for 30 minutes before removing the fuser.

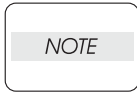

If the error still occurs after having installed the Fuser properly, proceed to the troubleshooting following the flowchart given below.

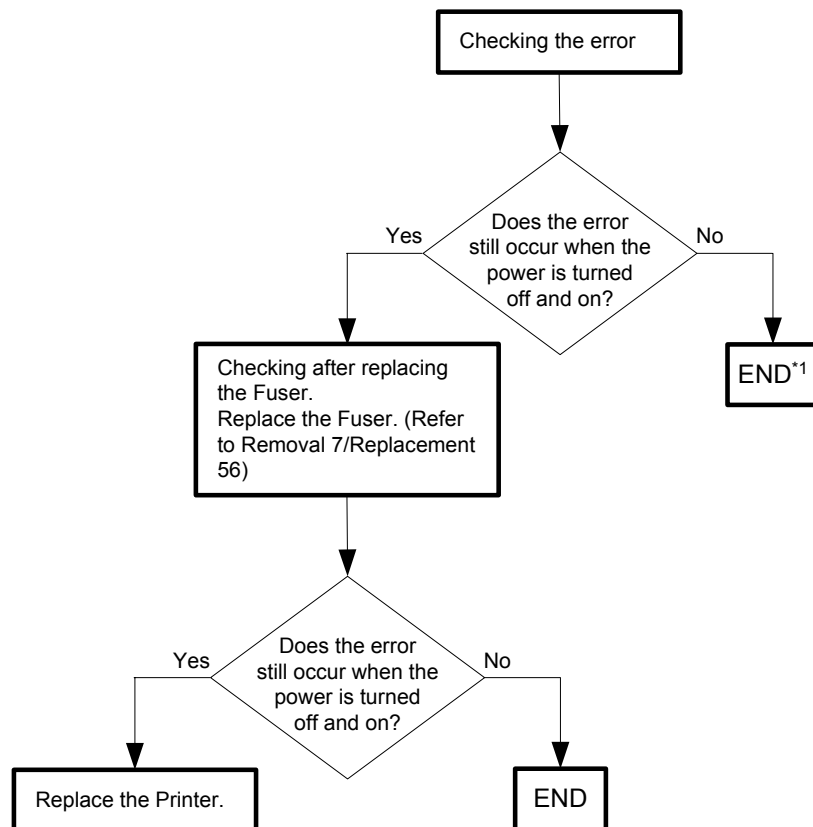

*1: Though some kind of external noise would be possible cause, go to [Flows 132 Electrical Noise] and check, to make sure.

Flows 16 010-330: IOT Fuser Motor Failure

Cause: Fuser Motor failure is detected.

Solution: Turn the power off and on to check that the error recurs. Then, proceed to the troubleshooting following the flowchart given below.



To avoid burns, do not replace the fuser immediately after printing. The fuser becomes extremely hot during use. Turn off the printer and wait for 30 minutes before removing the fuser.

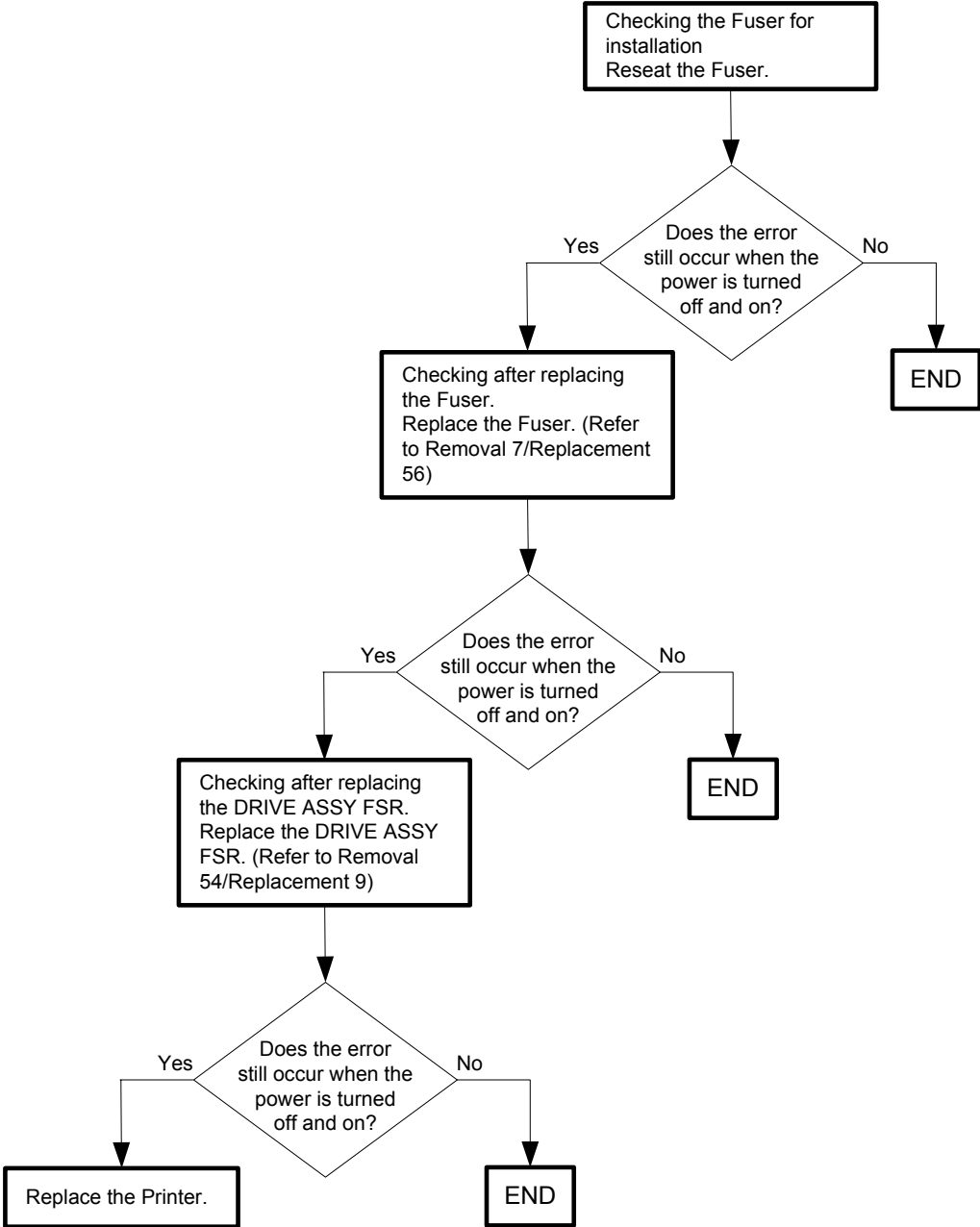

Flows 17 010-351: IOT Fuser Life Over

Cause: The value of Fuser counter has reached the replacement time.

Solution: The Fuser has reached the end of its life. Replace the Fuser with a new one. Refer to "Appendix_2.4 Replacing the Fuser" for how to replace the Fuser.

NOTE

Refer to "Appendix_2.1 Consumables and Periodic Replacement Parts Life" for the timing when the message "Life Over" is indicated.

NOTE

This error code is not related to any hardware fault.

Flows 18 010-354: IOT Environment Sensor Error

Cause: The Temperature sensor detected the temperature anomaly.
Solution: Turn the power off and on to check that the error recurs. Then, proceed to the troubleshooting following the flowchart given below.

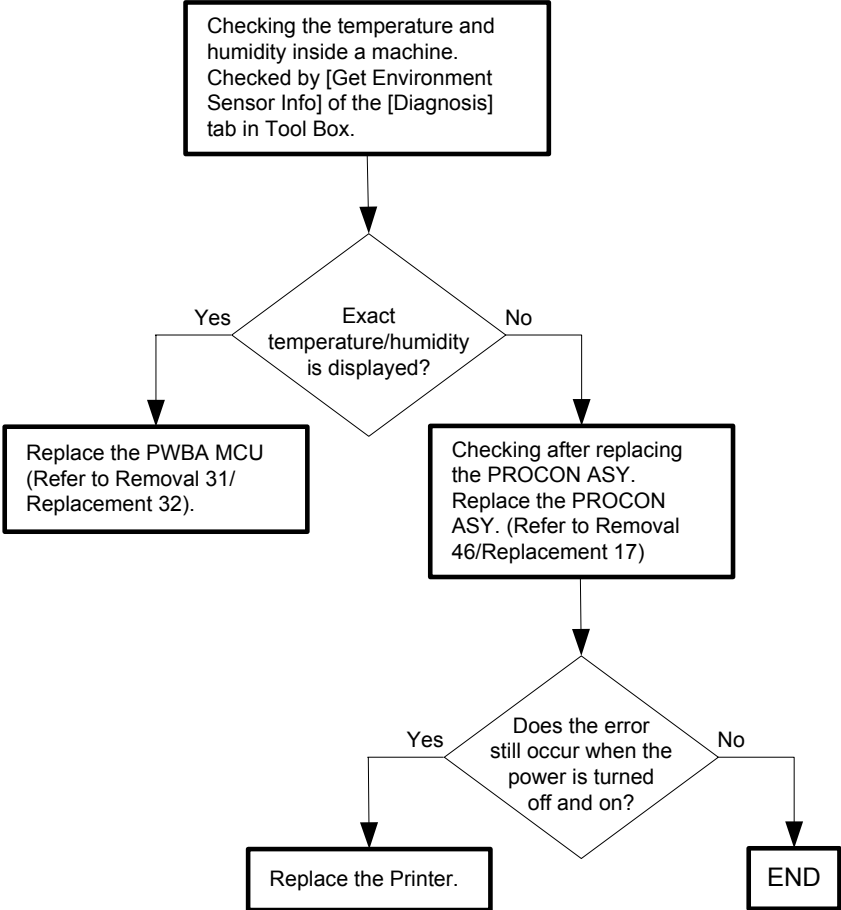

Flows 19 010-359 / 010-360: IOT Fuser CRUM ID Error / IOT Fuser Comm Fail

Cause: 010-359: An unsupported Fuser is detected.
 010-360: The Fuser CRUM communication error is detected.

Solution: Turn the power off and on to check that the error recurs. Then, proceed to the troubleshooting following the flowchart given below.



To avoid burns, do not replace the fuser immediately after printing. The fuser becomes extremely hot during use.

Turn off the printer and wait for 30 minutes before removing the fuser.

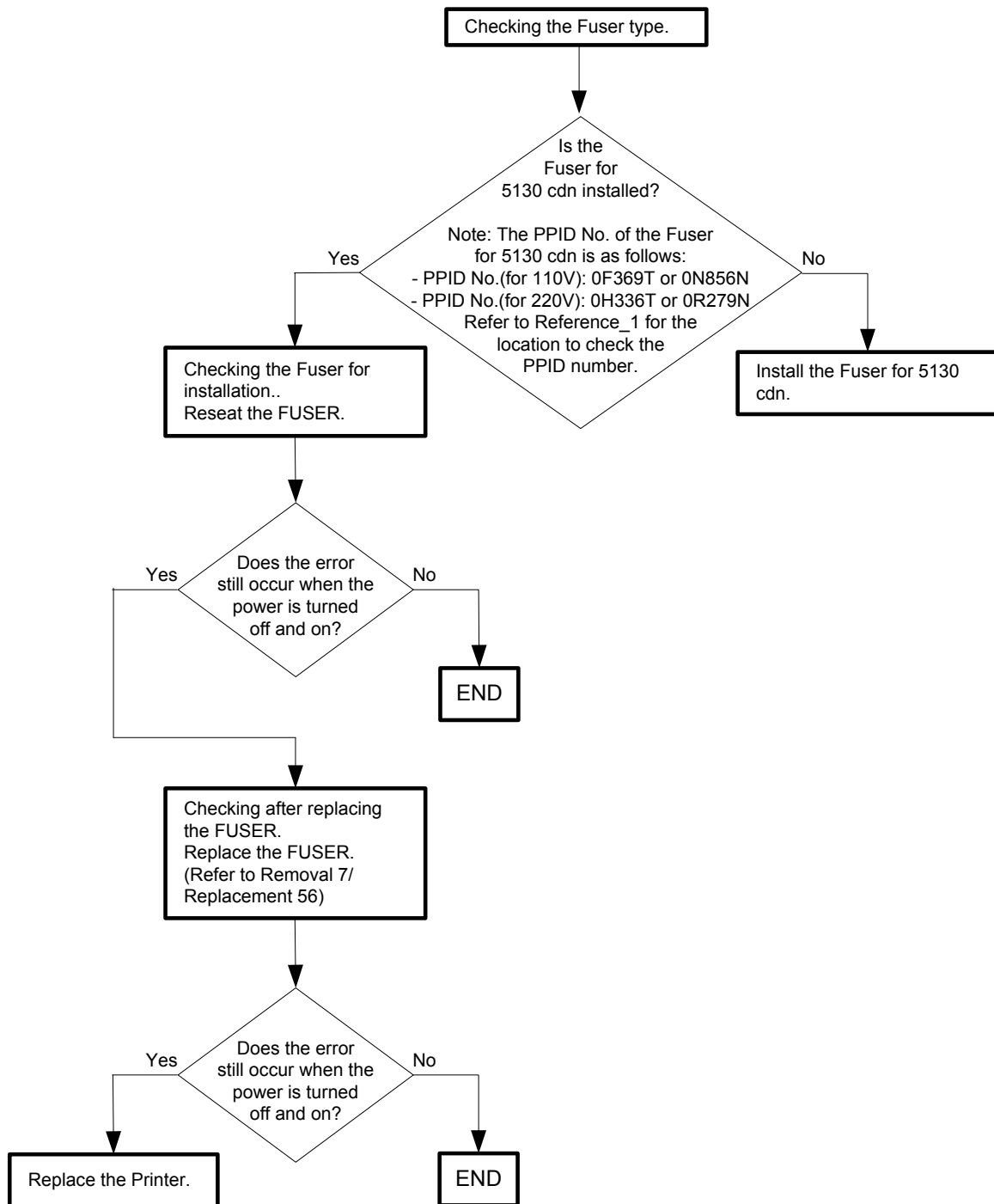

- Reference_1: Position of PPID label.

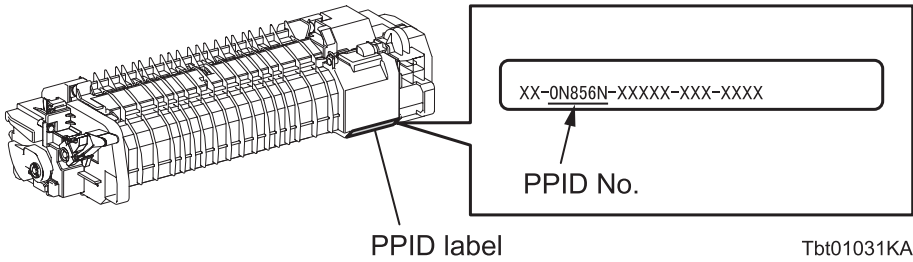

Flows 20 010-377: IOT Fuser Failure

Cause: The operation error of Fuser (Temperature anomaly error etc.) is detected.

Solution: Turn the power off and on to check that the error recurs. Then, proceed to the troubleshooting following the flowchart given below.



To avoid burns, do not replace the fuser immediately after printing. The fuser becomes extremely hot during use.

Turn off the printer and wait for 30 minutes before removing the fuser.

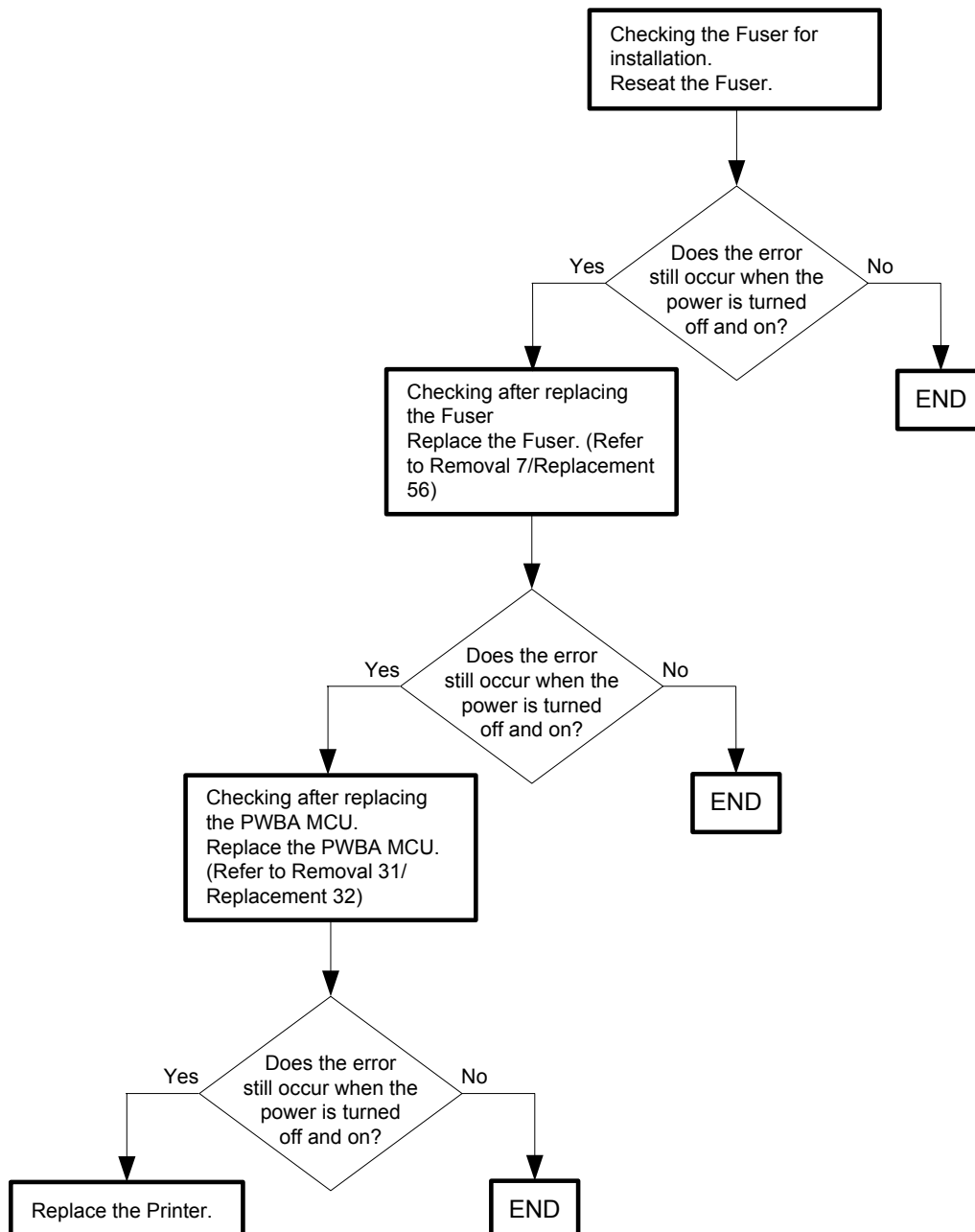

Flows 21 010-420 / 010-421: IOT Fuser Near Life

Cause: 010-420: The Fuser is approaching the replacement time.

010-421: The Fuser is approaching the replacement time.

Solution: The Fuser is approaching the replacement time. Prepare a new Fuser.

NOTE

Refer to "Appendix_2.1 Consumables and Periodic Replacement Parts Life" for the timing when the message "Near Life" is indicated.

NOTE

This error code is not related to any hardware fault.

Flows 22 010-910: IOT Fuser Envelope Mode Error

Cause: The Envelope Mode lever is set to Envelope Mode position when "Plain" is selected on the printer driver.

Solution: Raise the Envelope Mode lever to turn off the Envelope Mode position signal.

Refer to [Loading an envelope in the MPF] in "12. Loading Print Media" in the User Guide for the procedure to be taken to change the setting to the Envelope Mode.



To avoid burns, do not replace the fuser immediately after printing. The fuser becomes extremely hot during use.

Turn off the printer and wait for 30 minutes before removing the fuser.

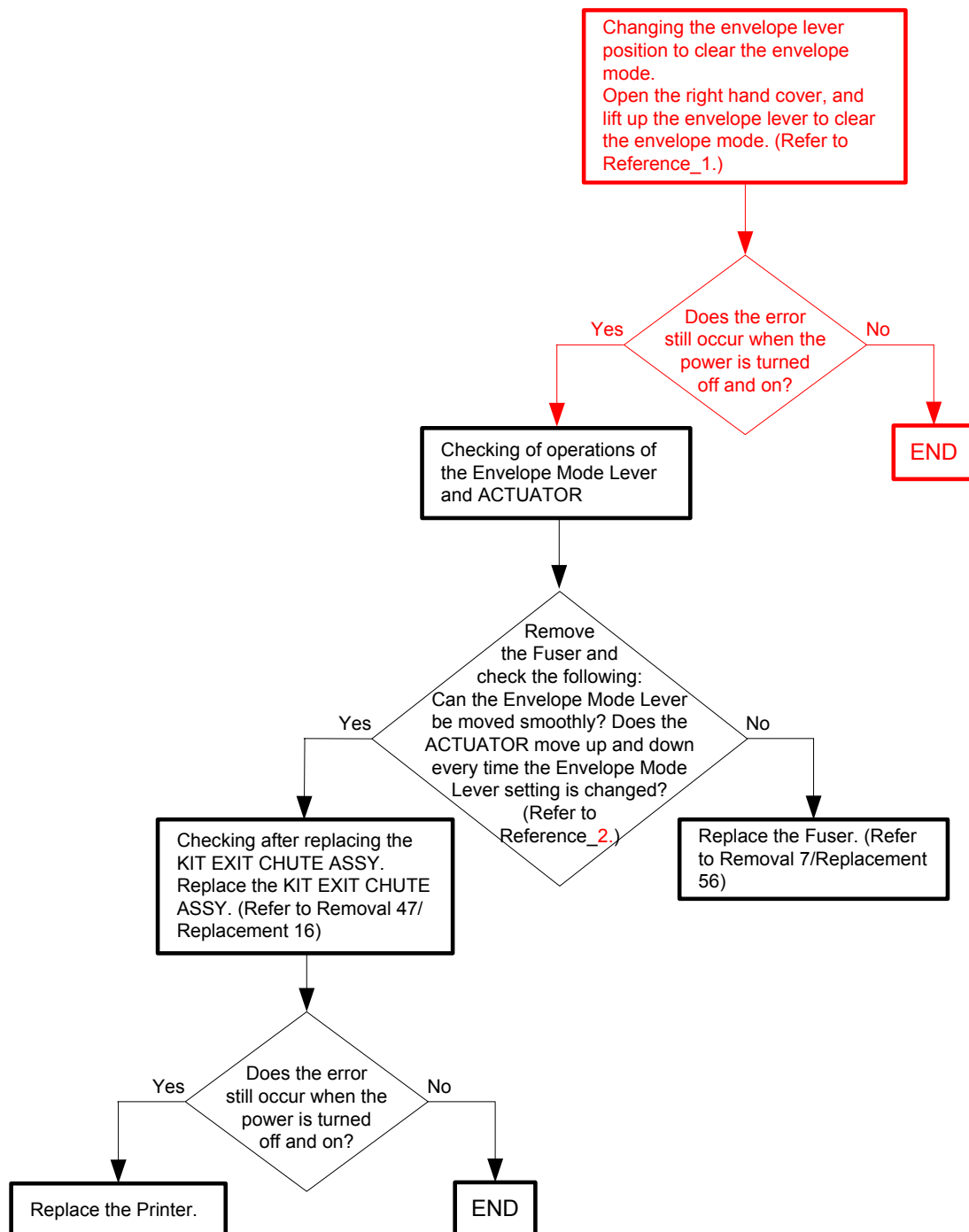

- Reference_1: Lift up the envelope lever.

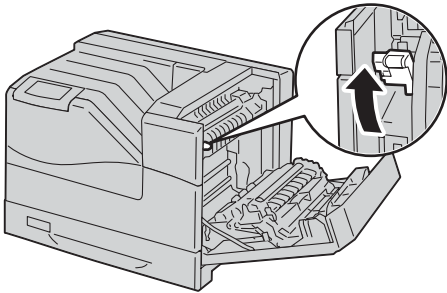

- Reference_2: Section to be checked for operation

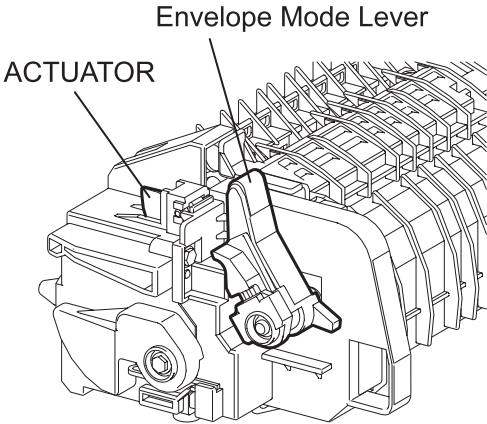

Tbt01002KB

Flows 23 012-151 / 012-903: IOT Output Expander Compile Exit Sensor Off JAM / Paper Remain at Compile Exit

Cause: 012-151: The Output Expander Compile Exit Sensor is not turned OFF within the specified time.

012-903: The Compile Exit Sensor detected the presence of paper.

Solution: Paper jam has occurred. Remove the jammed paper. Refer to "Appendix_1.6 Clearing Paper Jams From the Output Expander" for how to remove the jammed paper.

NOTE

If there is no jammed paper, or the error still occurs after having removed the jammed paper, turn the power off and on to check that the error recurs. Then, proceed to the troubleshooting following the flowchart given below.

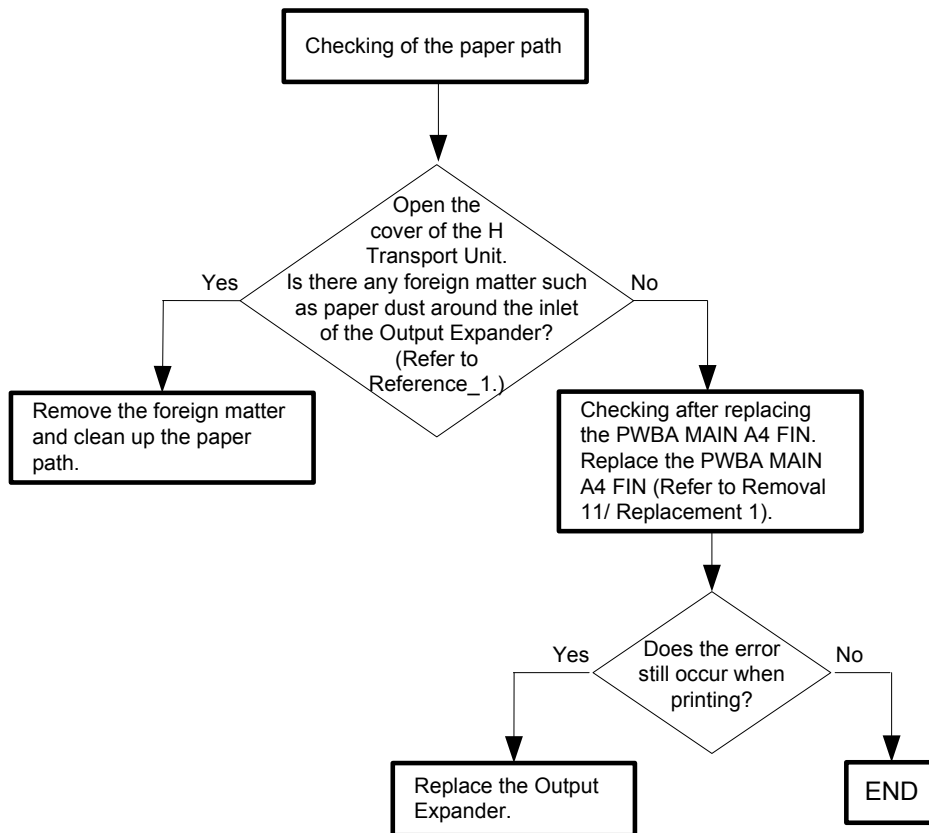

- Reference_1: Section of the paper path to be checked

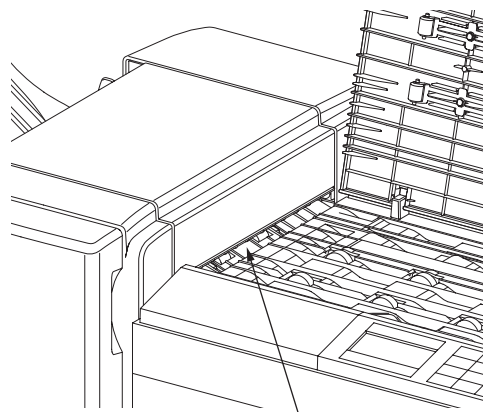

Checking of the paper path

Tb101003KA

Flows 24 012-161 / 012-905: IOT Output Expander Set Eject JAM / Paper Remain at Compile Tray No Paper Sensor

Cause: 012-161: The Output Expander Compile Tray No Paper Sensor is not turned ON within the specified time.

012-905: The Compile Tray No Paper Sensor detected the presence of paper.

Solution: Paper jam has occurred. Remove the jammed paper. Refer to "Appendix_1.6 Clearing Paper Jams From the Output Expander" for how to remove the jammed paper.

NOTE

If there is no jammed paper, or the error still occurs after having removed the jammed paper, turn the power off and on to check that the error recurs. Then, proceed to the troubleshooting following the flowchart given below.

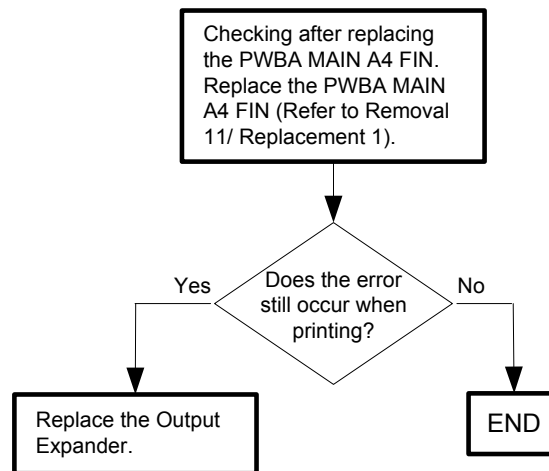

Flows 25 012-302: IOT Output Expander Cover Front Open

Cause: The Output Expander Front Cover is open.

Solution: The front cover of the Output Expander is open. Close the front cover of the Output Expander.

NOTE

If the error persists after the action above is taken, ensure that the error replicates after the printer is powered off and then on, and then go to the following steps to continue further fault isolation.

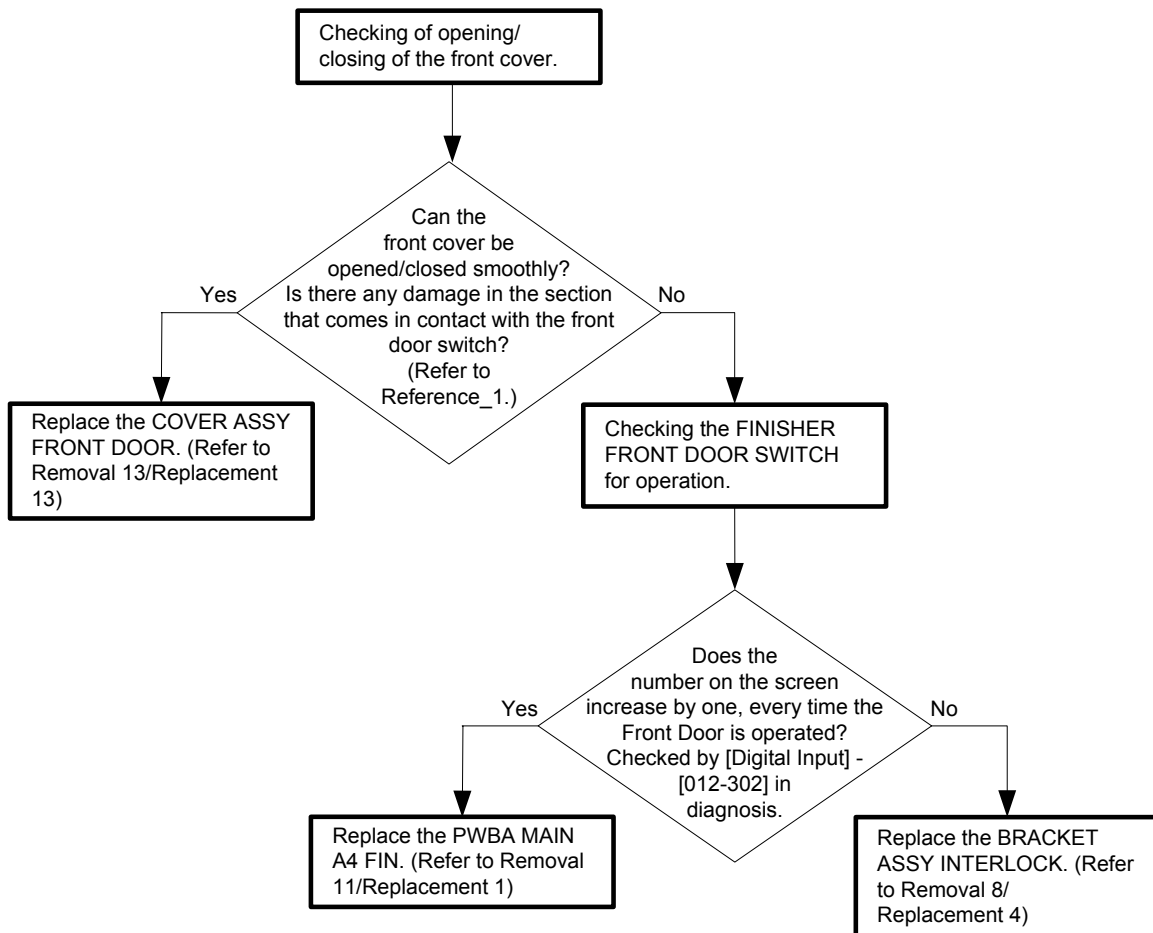

- Reference_1: Section to be checked for damage

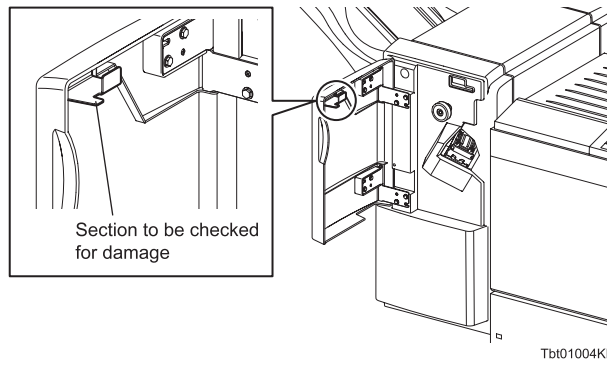

Flows 26 012-303: IOT Output Expander H Transport Unit Cover Open

Cause: The Output Expander H Transport Unit Cover is open.

Solution: The H Transport Unit Cover of the Output Expander is open. Close the H Transport Unit Cover of the Output Expander.

NOTE

If the error persists after the action above is taken, ensure that the error replicates after the printer is powered off and then on, and then go to the following steps to continue further fault isolation.

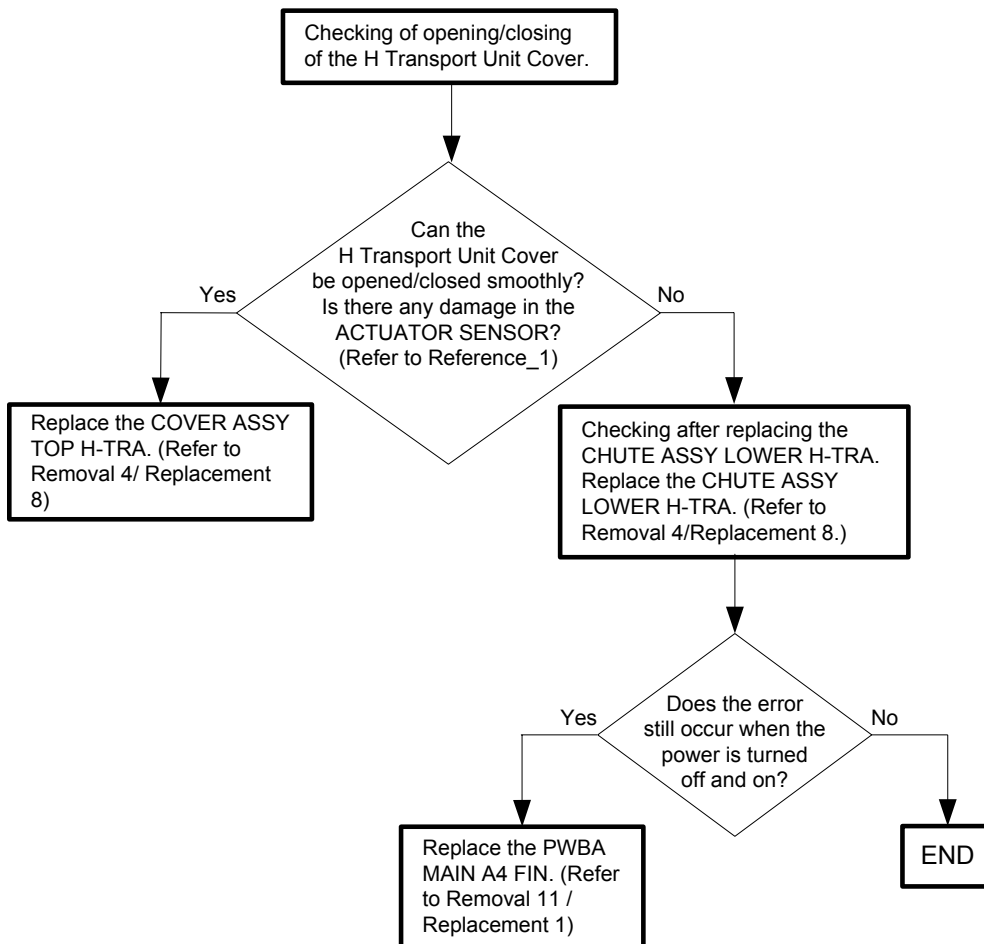

- Reference_1: Section to be checked for damage

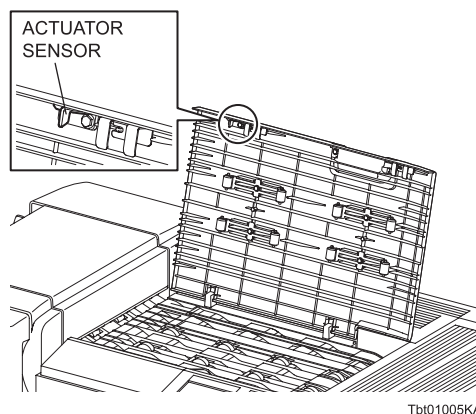

Flows 27 012-311 / 012-313: IOT Output Expander Front Tamper Home Sensor On /Off Fail

Cause: 012-311: The Front Tamper Home Sensor is not turned ON within the specified time after the Front Tamper started traveling to its Home position.

012-313: The Front Tamper Home Sensor is not turned OFF within the specified time after the Front Tamper started leaving its Home position.

Solution: Turn the power off and on to check that the error recurs. Then, proceed to the troubleshooting following the flowchart given below.

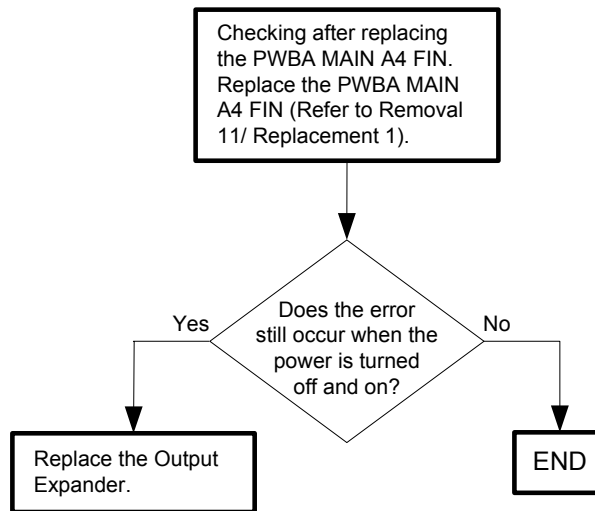

Flows 28 012-312: IOT Output Expander NVM Fail

Cause: The PWB MAIN A4 FIN NVM read/write error occurred.

Solution: Turn the power off and on several times. If the error still occurs, proceed to the troubleshooting following the flowchart given below.

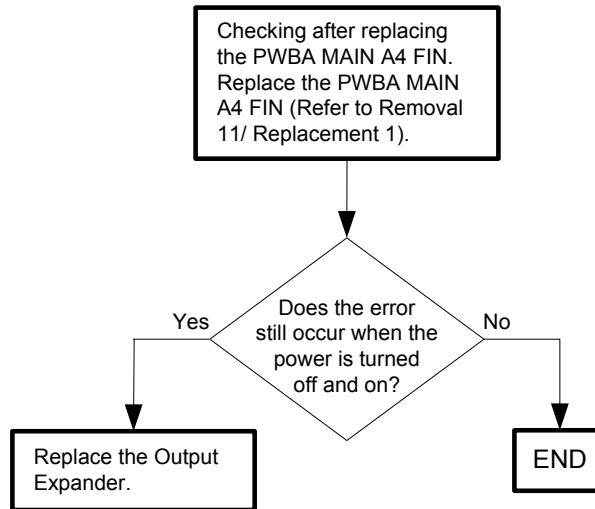

Flows 29 012-314 / 012-353: IOT Output Expander Rear Tamper Home Sensor Off / On Fail

- Cause:** 012-314: The Rear Tamper Home Sensor is not turned OFF within the specified time after the Rear Tamper started leaving its Home position.
012-353: The Rear Tamper Home Sensor is not turned ON within the specified time after the Rear Tamper started traveling to its home position.
- Solution:** Turn the power off and on to check that the error recurs. Then, proceed to the troubleshooting following the flowchart given below.

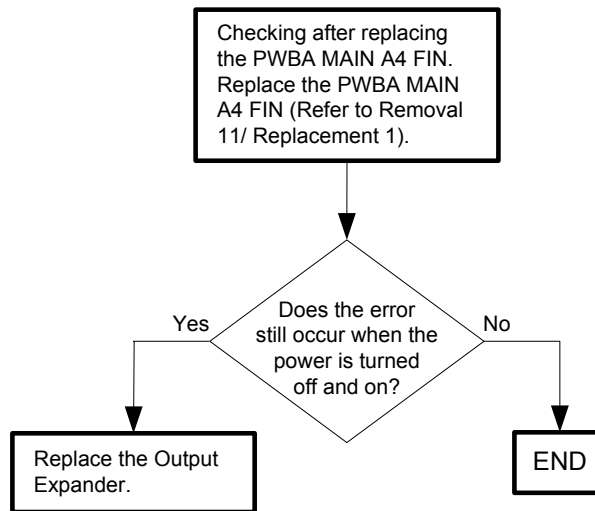

Flows 30 012-315: IOT Output Expander Stacker Tray Fail

Cause: The Stacker Height Sensor is not turned ON within the specified time after the Stacker Tray started going up.

Solution: Turn the power off and on to check that the error recurs. Then, proceed to the troubleshooting following the flowchart given below.

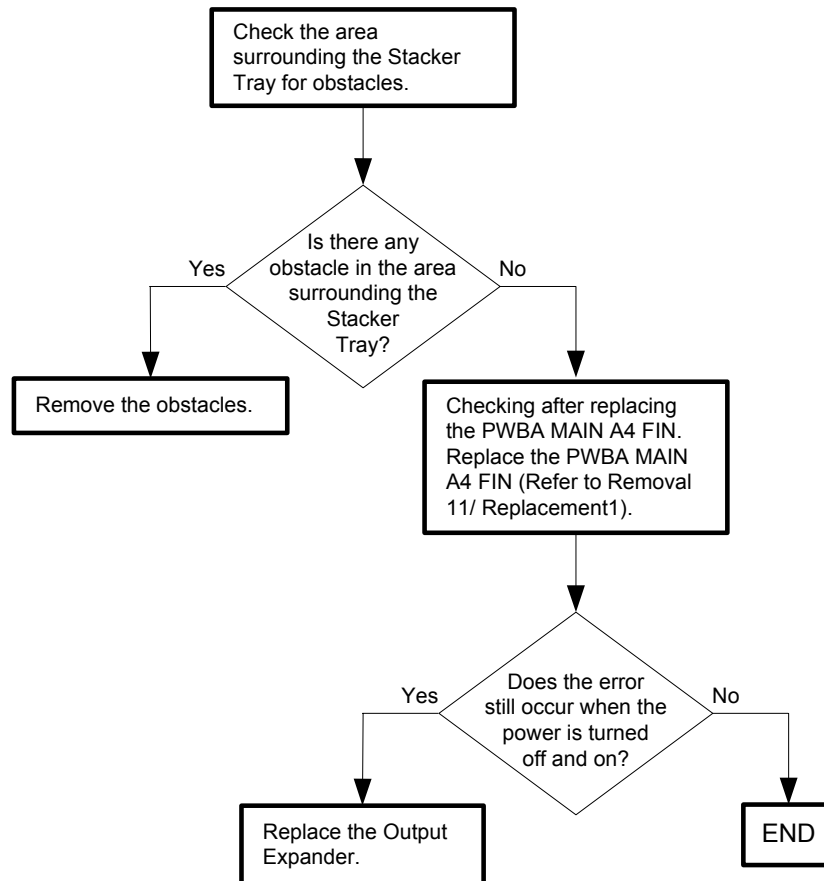

Flows 31 012-316: IOT Output Expander Stacker Upper Limit Fail

Cause: The Stacker Tray abnormally went up beyond its specified upper limit (Stacker Height).

Solution: Turn the power off and on to check that the error recurs. Then, proceed to the troubleshooting following the flowchart given below.

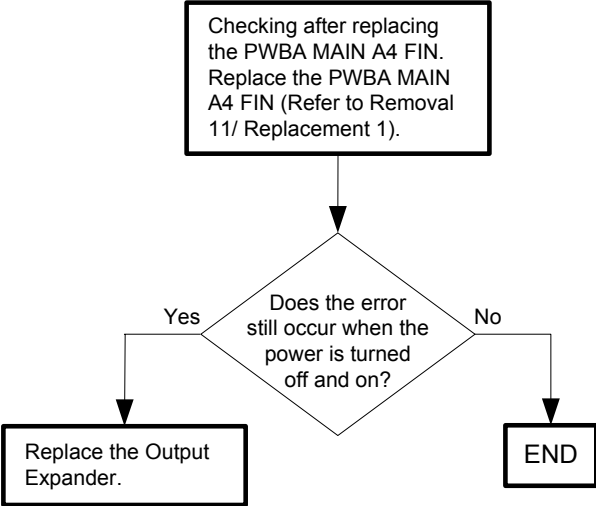

Flows 32 012-317: IOT Output Expander Stacker Lower Limit Fail

Cause: The Stacker Tray abnormally came down beyond its specified lower limit (Full Stack).

Solution: Turn the power off and on to check that the error recurs. Then, proceed to the troubleshooting following the flowchart given below.

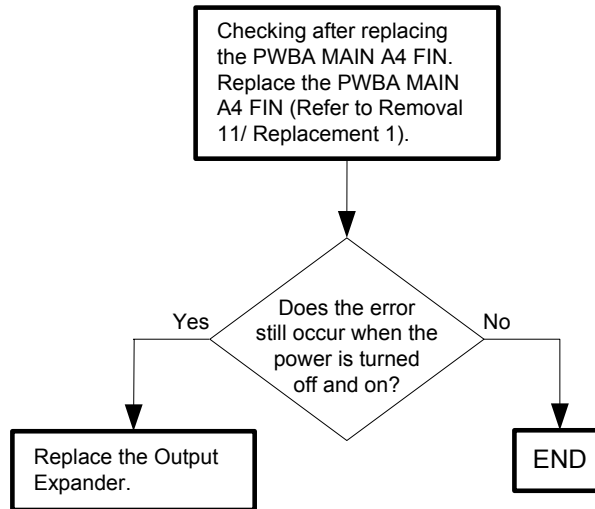

Flows 33 012-349 / 012-370: IOT Output Expander Eject Clamp Home Sensor On / Off Fail

Cause: 012-349: The Eject Clamp Home Sensor is not turned ON within the specified time after the Eject Clamp started going up.

012-370: The Eject Clamp Home Sensor is not turned OFF within the specified time after the Eject Clamp started coming down.

Solution: Turn the power off and on to check that the error recurs. Then, proceed to the troubleshooting following the flowchart given below.

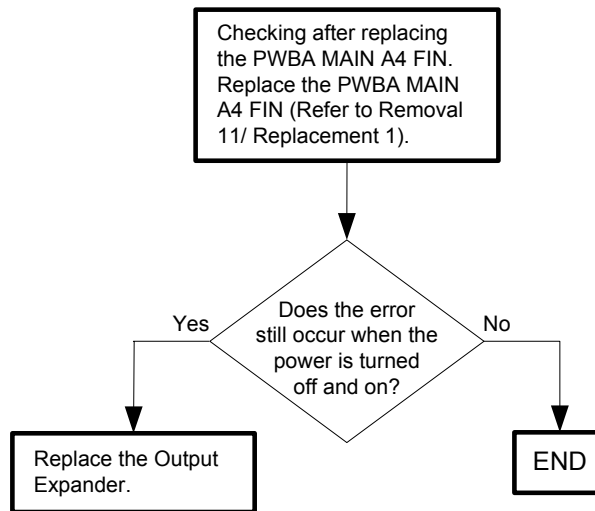

Flows 34 012-373 / 012-374: IOT Output Expander Set Clamp Home Sensor On / Off Fail

Cause: 012-373: The Set Clamp Home Sensor is not turned ON within the specified time after the Set Clamp started operation.

012-374: The Set Clamp Home Sensor is not turned OFF within the specified time after the Set Clamp finished operation.

Solution: Turn the power off and on to check that the error recurs. Then, proceed to the troubleshooting following the flowchart given below.

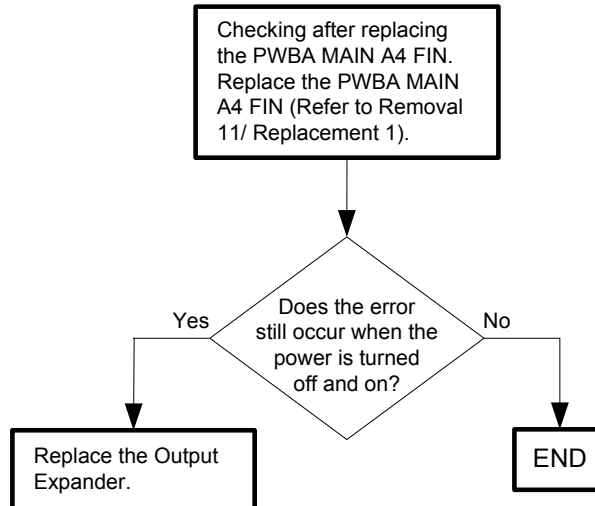

Flows 35 012-381: IOT Output Expander Stapler Fail

Cause: The changeover of the Stapler Home Sensor from OFF to ON is not detected within the specified time after the Stapler Move Motor was turned ON (Forward operation).

Solution: Turn the power off and on to check that the error recurs. Then, proceed to the troubleshooting following the flowchart given below.

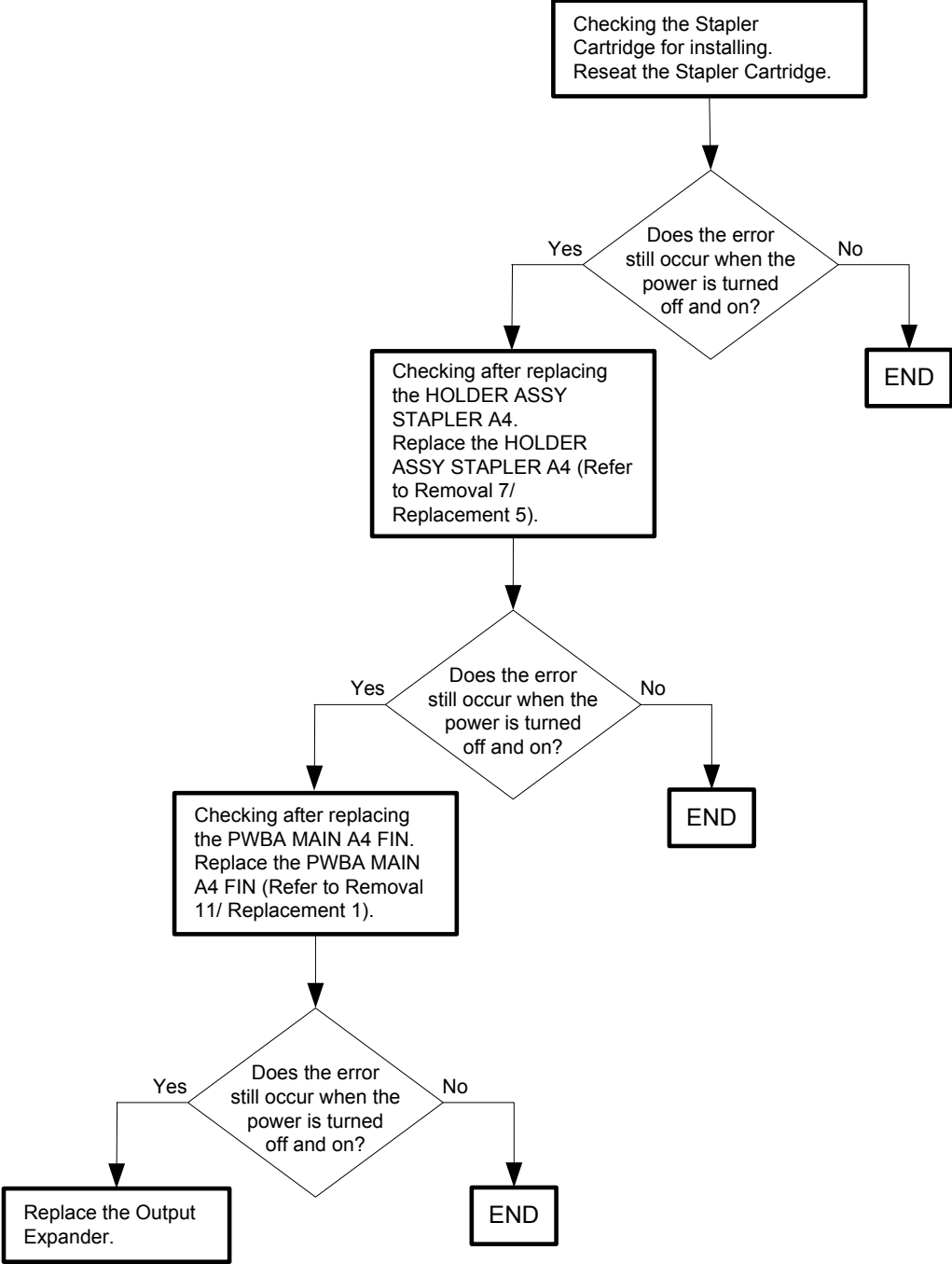

Flows 36 016-300 / 016-301 / 016-302 / 016-313 / 016-315 / 016-317 / 016-323 / 016-324
/ 016-325 / 016-327 / 016-392 / 016-393 / 016-394: ESS Error

Cause: ESS-related error occurred.

Solution: Turn the power off and on to check that the error recurs. Then, proceed to the troubleshooting following the flowchart given below.

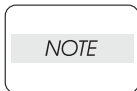

Never turn off the power to the printer while the firmware is being downloaded. Turning the power off may cause a failure in the printer.

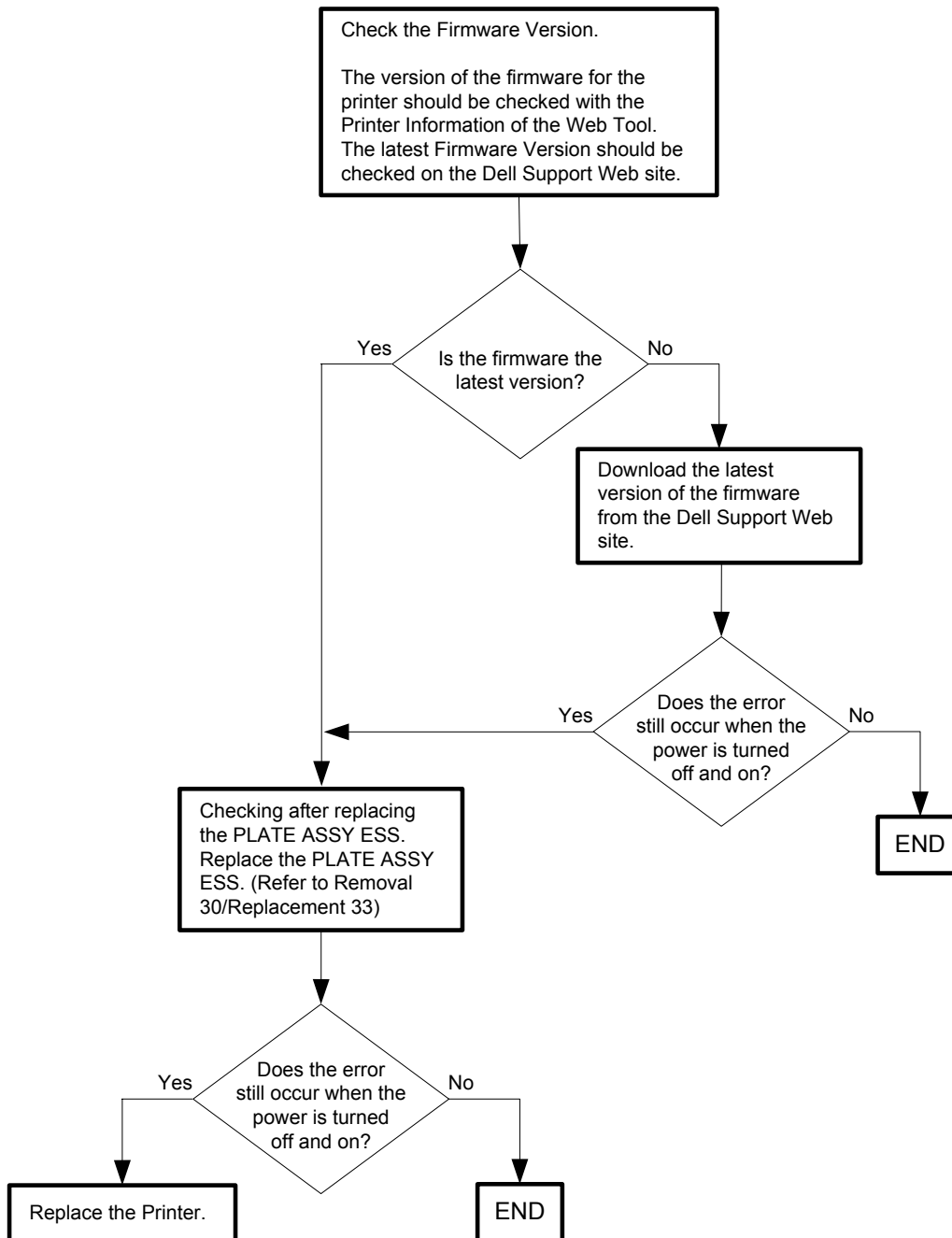

Flows 37 016-340 / 016-344 / 016-345 / 016-346 / 016-347 : ESS Error

Cause: ESS-related error occurred.

Solution: Turn the power off and on to check that the error recurs. Then, proceed to the troubleshooting following the flowchart given below.

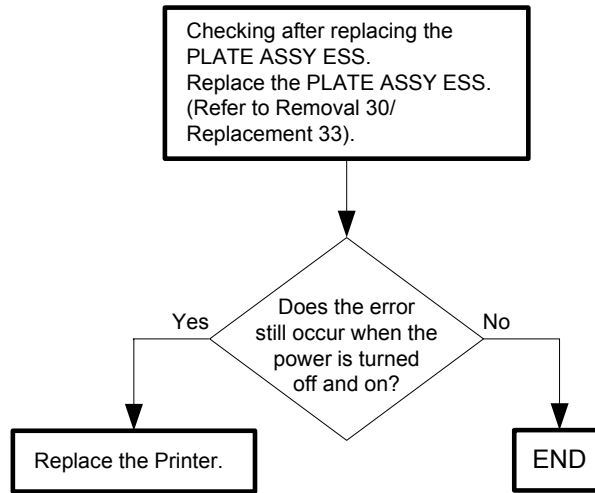

Flows 38 016-312: ESS Hard Disk Fail

Cause: Hard Disk error is detected.

Solution: Turn the power off and on to check that the error recurs. Then, proceed to the troubleshooting following the flowchart given below.

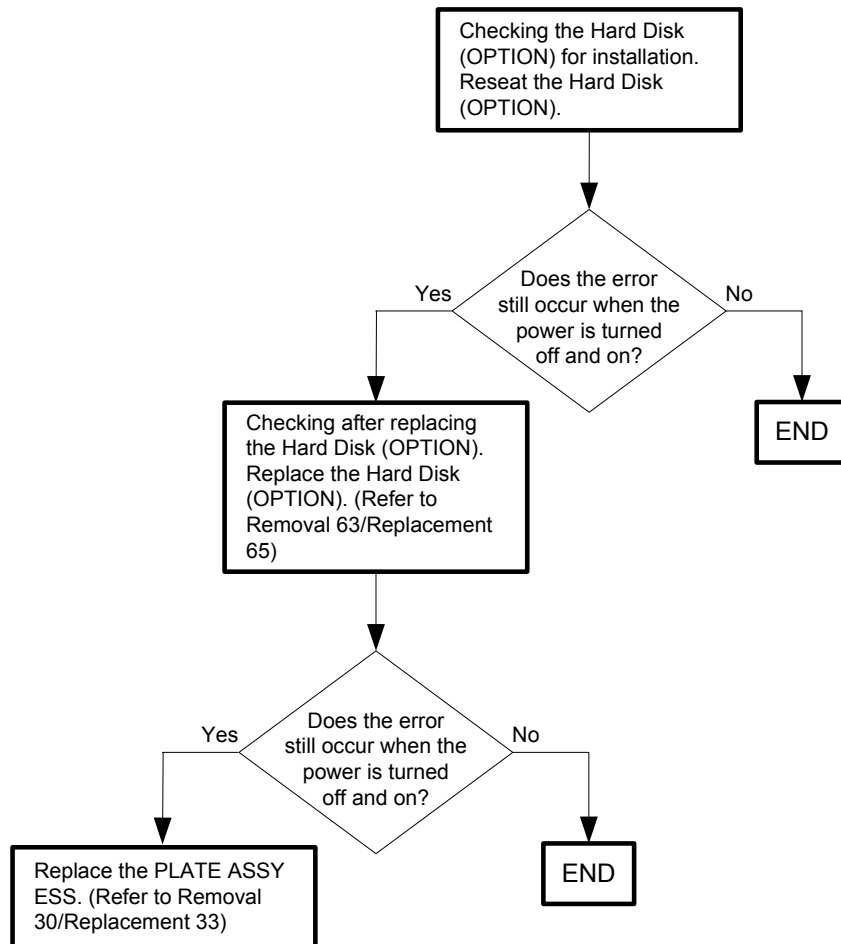

Flows 39 016-316 / 016-318: ESS DIMM Slot RAM R/W Check Fail / ESS DIMM Slot RAM Error

Cause: 016-316: Unsupported additional memory module was detected in the memory slot.

016-318: Additional memory module is not completely inserted in the slot.

Solution: 016-316: Remove the added memory module. To add a memory, use the optional Memory Module.

016-318: Remove the Memory Module and re-install it.

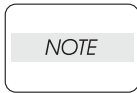

If the error persists after the action above is taken, ensure that the error replicates after the printer is powered off and then on, and then go to the following steps to continue further fault isolation.

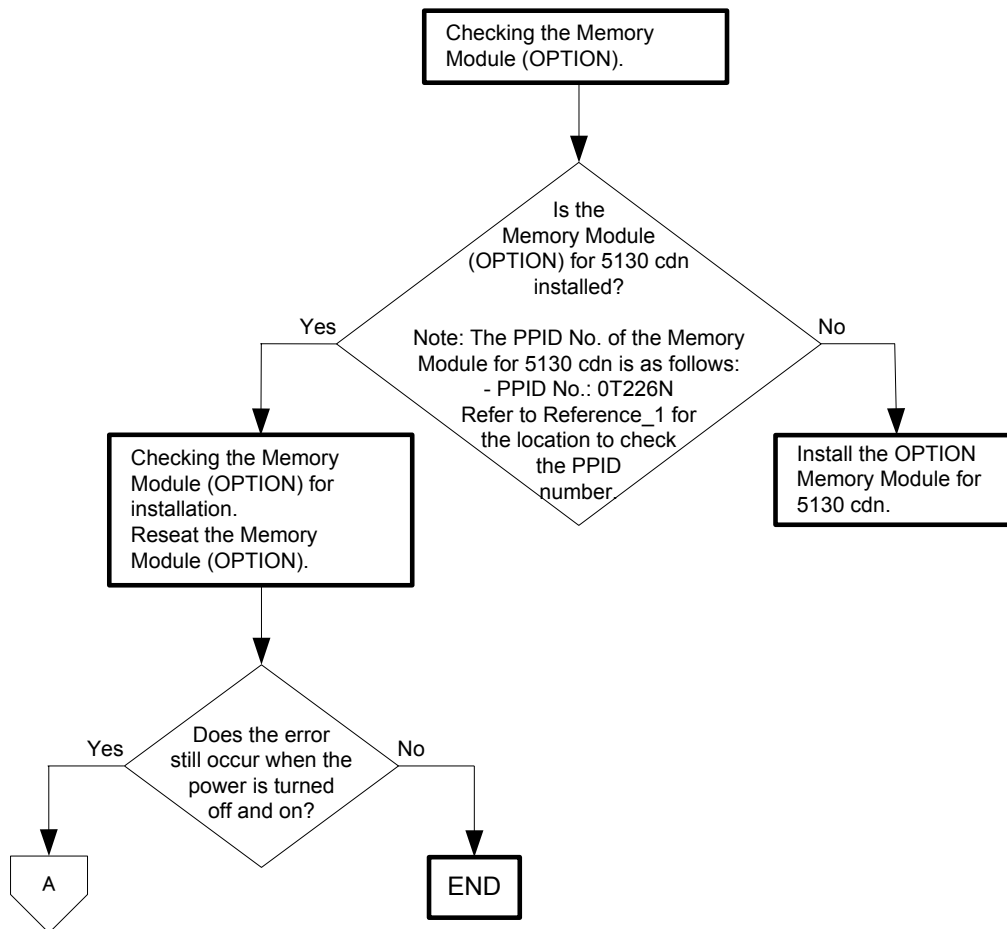

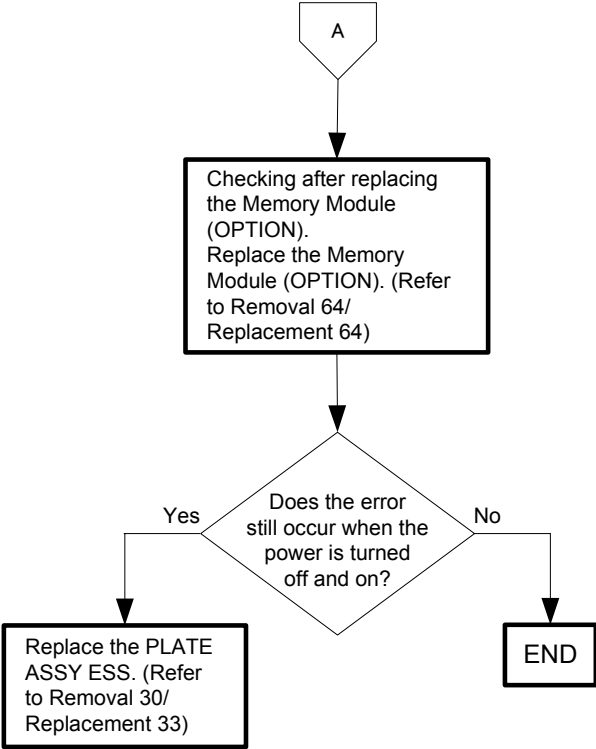

- Reference_1: The PPID number is on the packing box.

XX-0T226N-XXXXX-XXX-XXXX



PPID No.

Flows 40 016-319 / 016-320: Encryption key error/ Encryption setting error

Cause: 016-319: Inconsistency in the encryption setting was detected.

016-320: Inconsistency in the encryption key was detected.

Solution: An error occurred regarding the encryption setting. Contact the system administrator.

016-319: The encryption keys of the Hard Disk and the printer do not match. Ensure that the encryption key of the printer matches that of the Hard Disk.

016-320: Although the printer is encrypted, the Hard Disk is not. Disable the encryption of the printer, connect the Hard Disk, and then configure the encryption setting again.

NOTE

If the error persists after the action above is taken, ensure that the error replicates after the printer is powered off and then on, and then go to the following steps to continue further fault isolation.

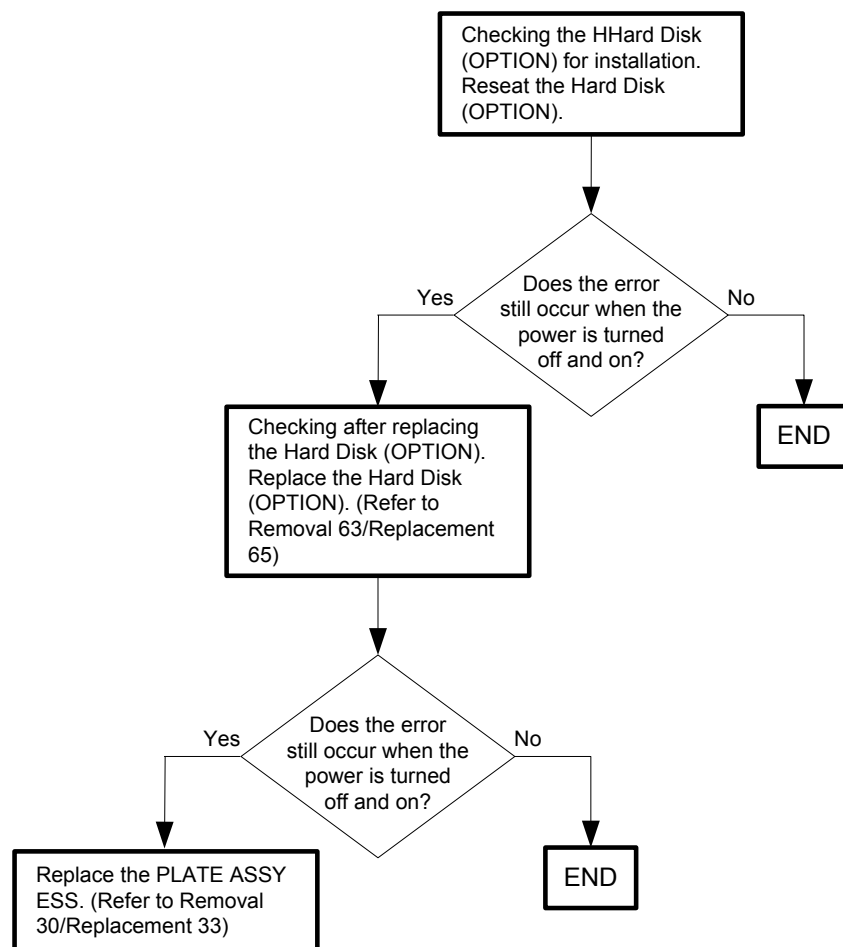

Flows 41 016-338: Option Wireless Adapter Error

Cause: The error is detected by Wireless option check.

Solution: Turn the power off and on to check that the error recurs. Then, proceed to the troubleshooting following the flowchart given below.

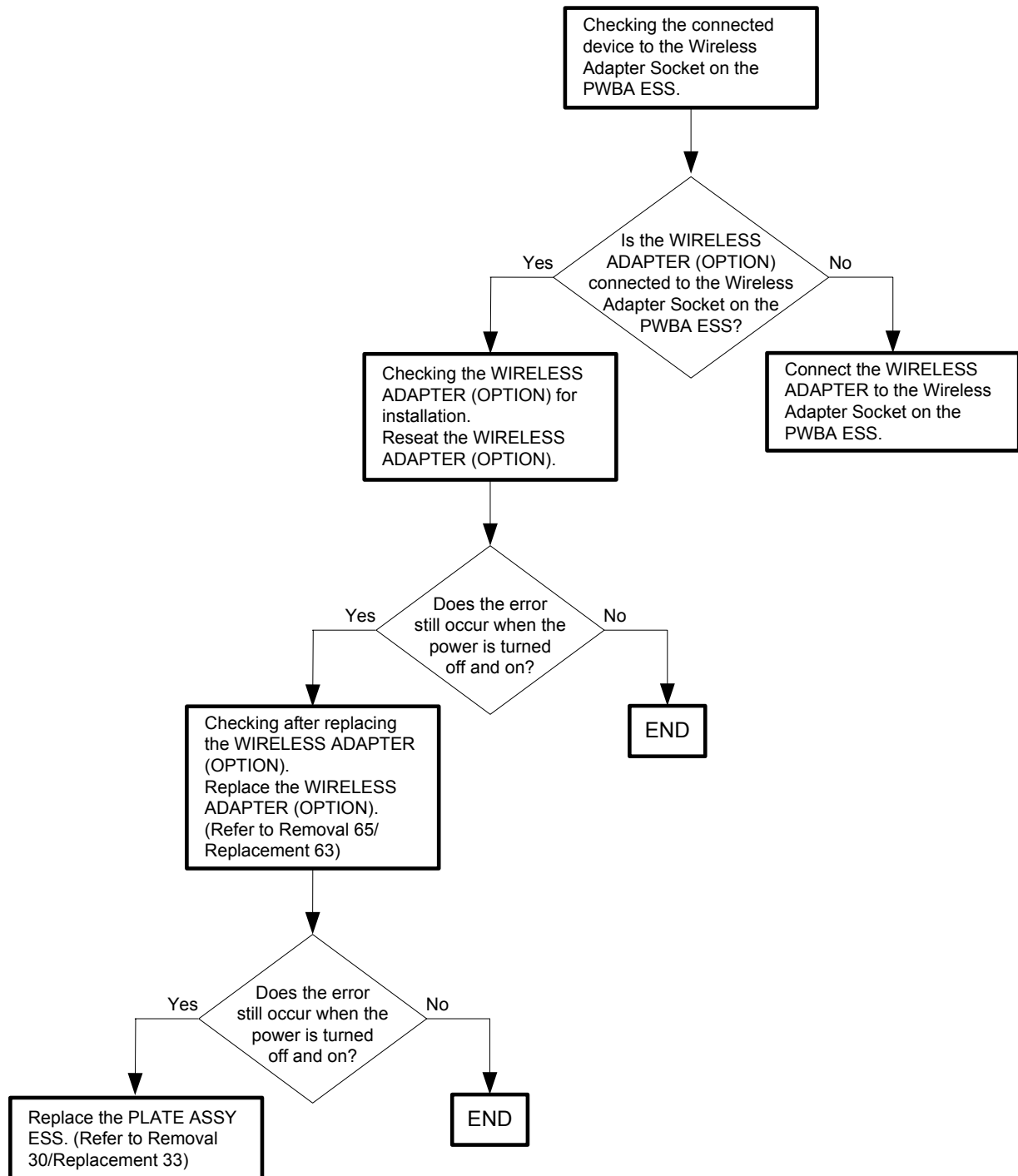

Flows 42 016-356: Hard Disk clearing error

Cause: An error occurred during the Hard Disk clearing process.

Solution: Turn the power off, then re-turn it on. Clearing of the Hard Disk is resumed.

NOTE

If the error persists after the action above is taken, ensure that the error replicates after the printer is powered off and then on, and then go to the following steps to continue further fault isolation.

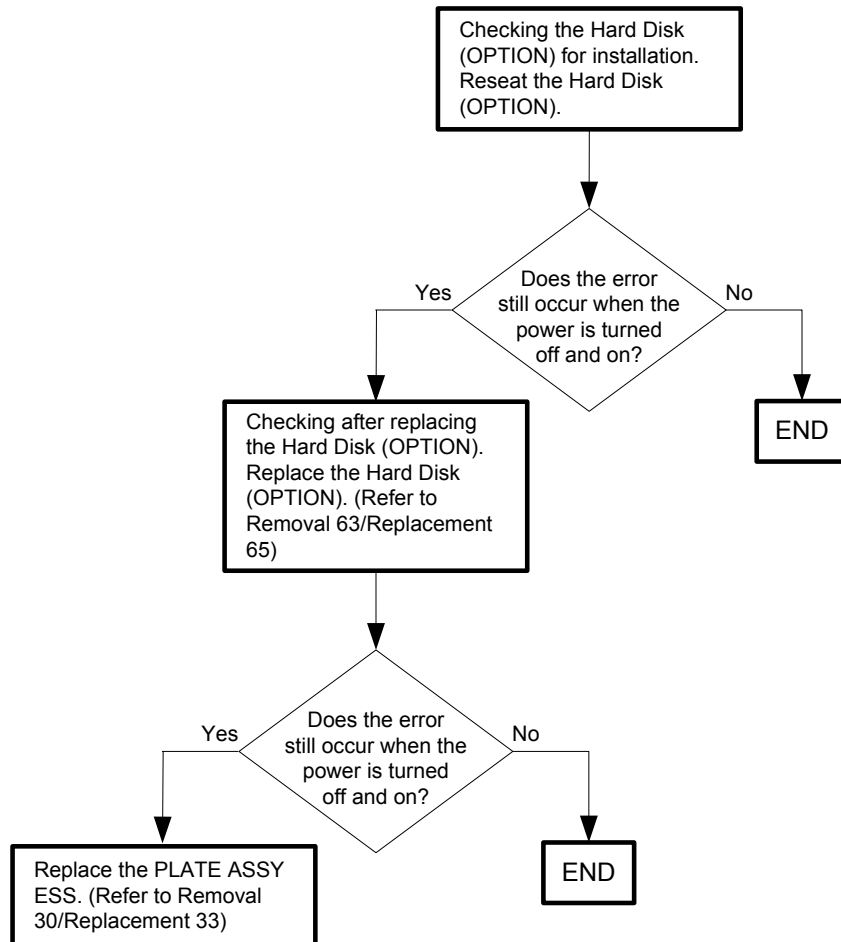

Flows 43 016-362 / 016-363 / 016-364 / 016-366 / 016-367 / 016-368: PCI Bus# (0 / 1)
Host Bridge Controller Error / PCI Bus# (0 / 1) Error Detected / PCI Error Mes-
sages received from Bus#0-Device# (0 / 1)

Cause: Connection error occurred between the PCI BUS port and the port of peripheral devices.

Solution: Turn the power off and on to check that the error recurs. Then, proceed to the troubleshoot-
ing following the flowchart given below.

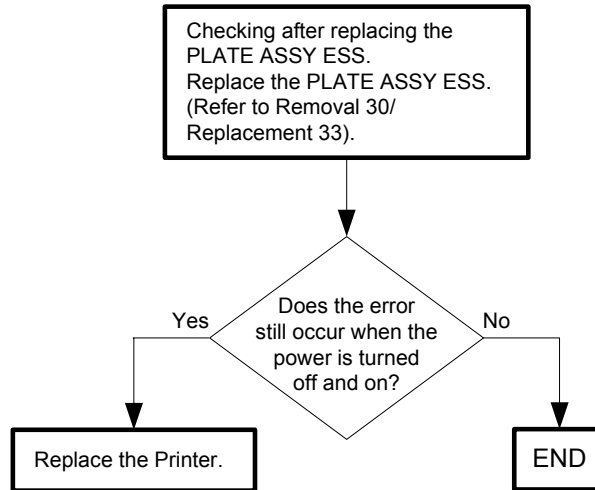

Flows 44 016-369: Operator Panel - ESS Communication Fail

Cause: Communication Fail with a Operator Panel and ESS F/W.

Solution: Turn the power off and on to check that the error recurs. Then, proceed to the troubleshooting following the flowchart given below.

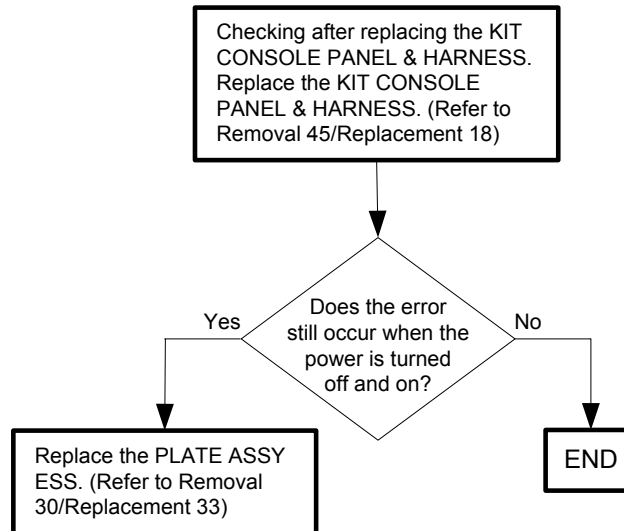

Flows 45 016-370: MCU-ESS Communication Fail

Cause: Communication fail between MCU and ESS.

Solution: Turn the power off and on to check that the error recurs. Then, proceed to the troubleshooting following the flowchart given below.



When replacing the PLATE ASSY ESS and PWBA MCU concurrently, ensure that the ROM chip of the ESS is replaced and that the NVM data of the MCU is saved and reloaded. For details, refer to the supplied technical sheet.

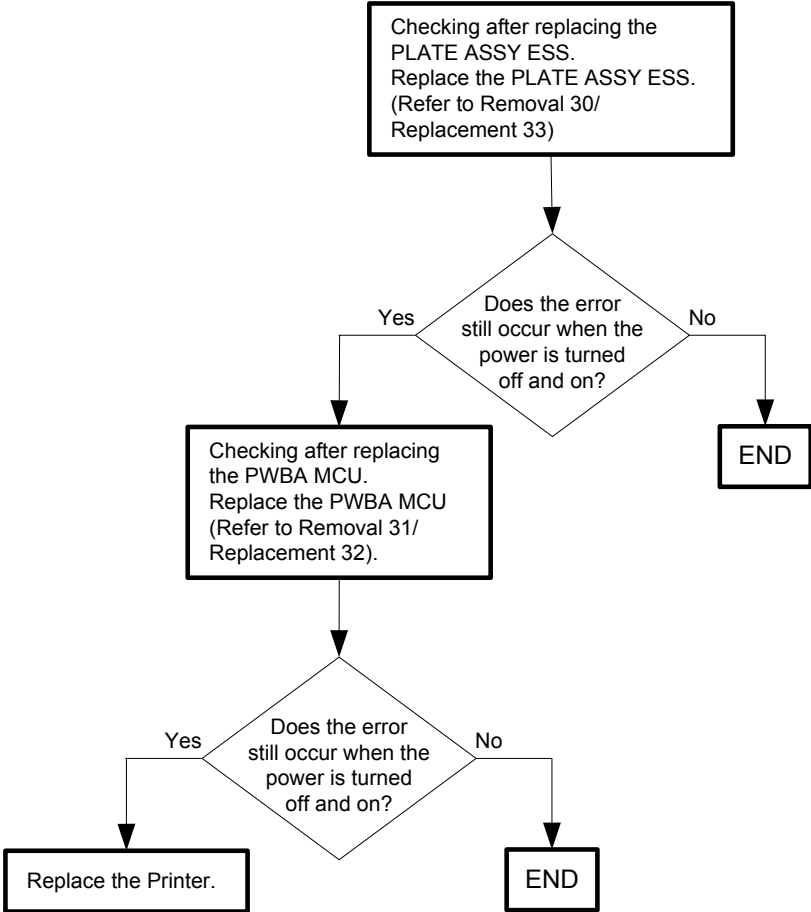

Flows 46 016-383 / 016-384 / 016-385 / 016-386 / 016-387: Download ID Error / Download Range Error / Download header Error / Download Check Sum Error / Download Format Error

Cause: 016-383: An error occurred because an invalid firmware is installed.
 016-384: The address of the write destination is invalid.
 016-385: The header information is invalid.
 016-386: The checksum is invalid.
 016-387: The format is invalid.

Solution: Turn the power off and on to check that the error recurs. Then, proceed to the troubleshooting following the flowchart given below.

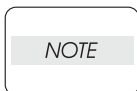

Never turn off the power to the printer while the firmware is being downloaded. Turning the power off may cause a failure in the printer.

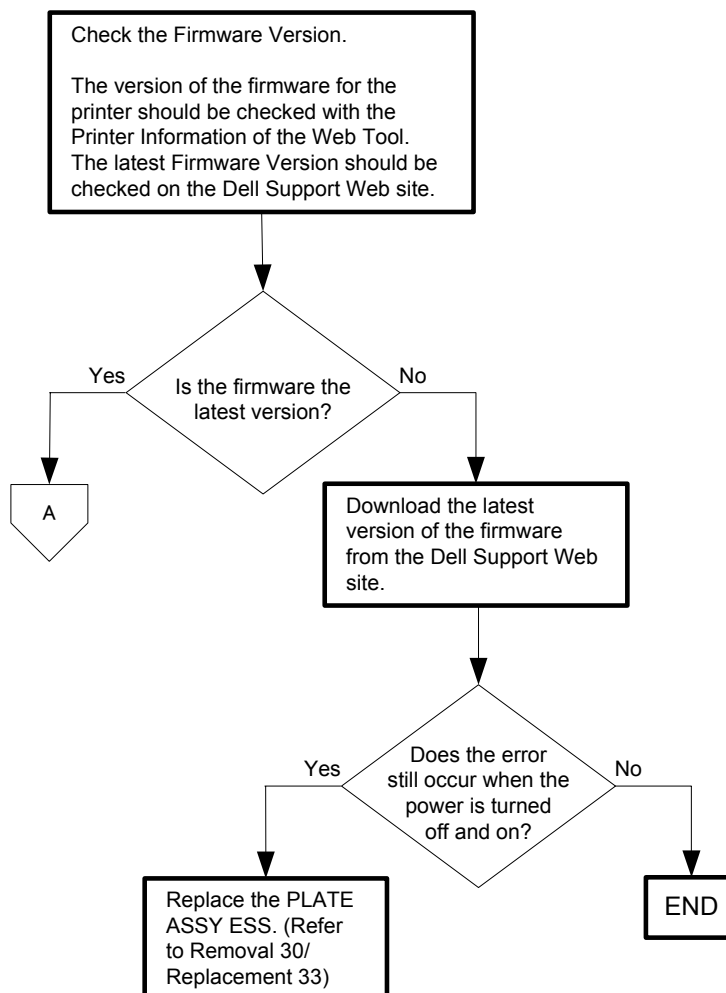

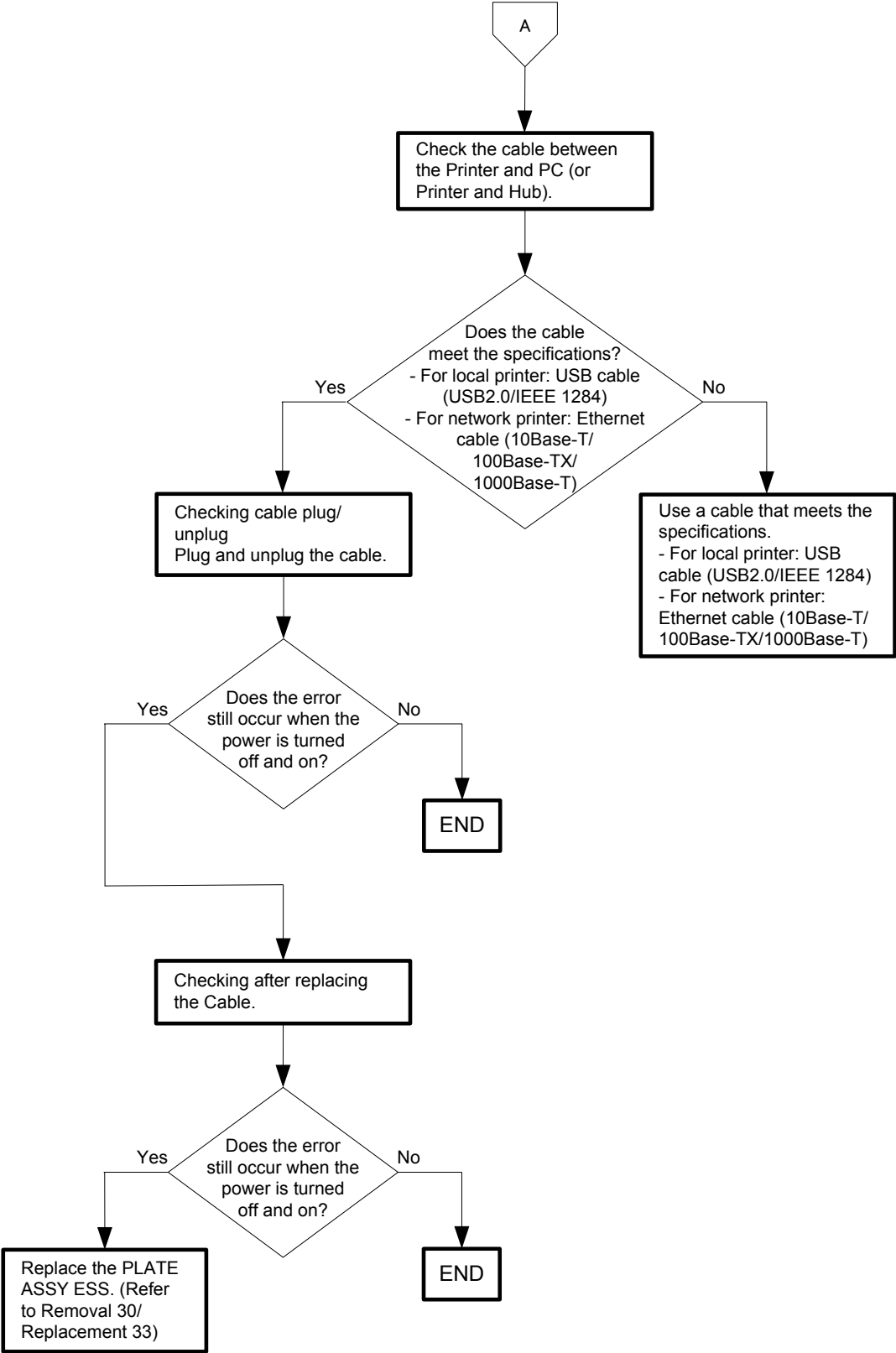

Flows 47 016-391: Download Protect Error

Cause: The Protect is invalid. Download was attempted under the condition where it is prohibited.

Solution: Turn the power off and on to check that the error recurs. Then, proceed to the troubleshooting following the flowchart given below.

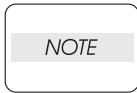

Never turn off the power to the printer while the firmware is being downloaded. Turning the power off may cause a failure in the printer.

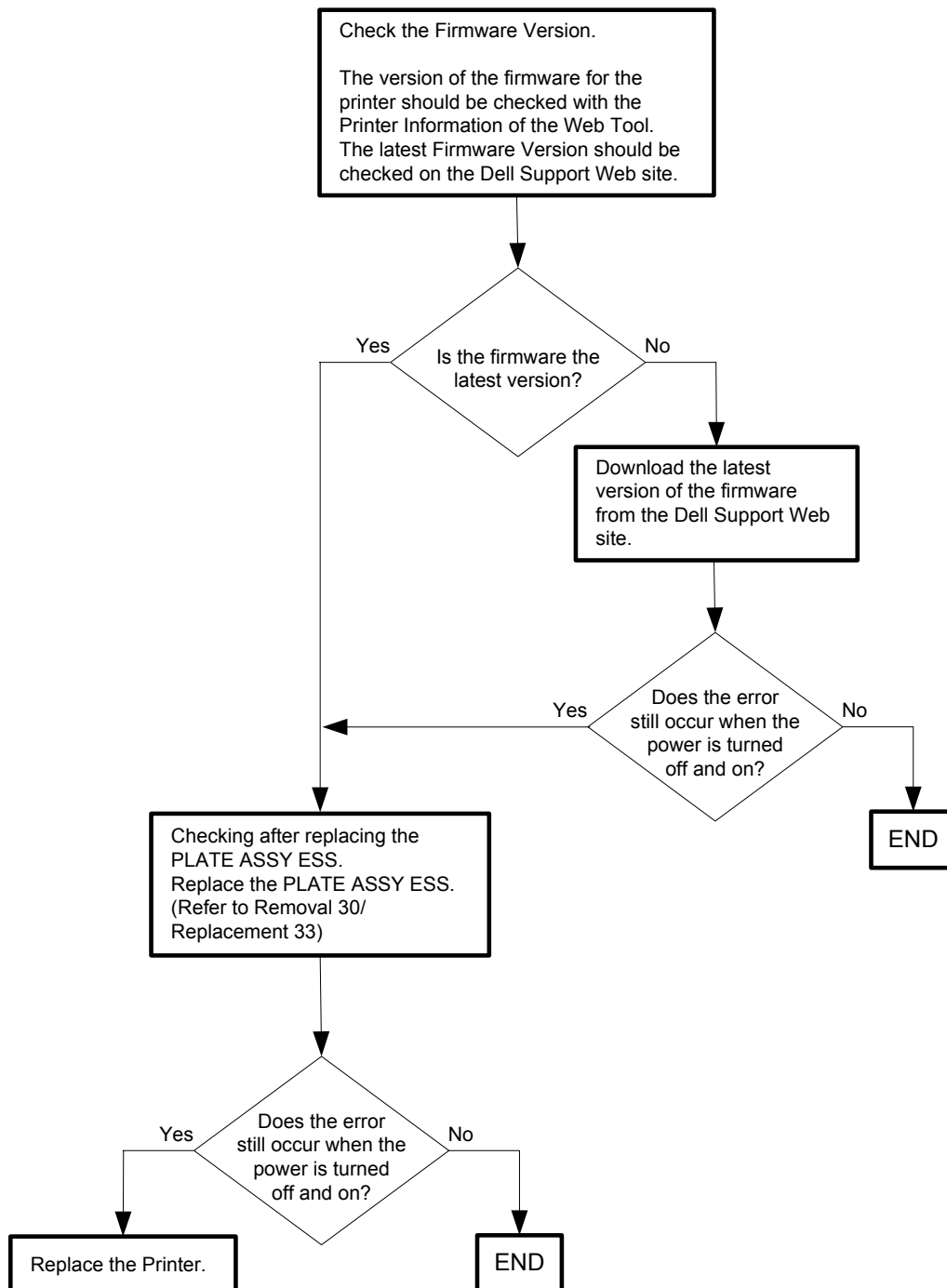

Flows 48 016-404 / 016-405 / 016-520 / 016-521 / 016-522 / 016-523 / 016-524 / 016-527:
Certificate DB access error / Security setting invalid error / Own device certificate
error / Other device certificate error / Client certificate absence error / Server cer-
tificate verification error / Server certificate absence error / Certificate DB error

Cause: 016-404:Certificate DB is invalid.
016-405:Security setting is inconsistent.
016-520:Own device certificate is invalid.
016-521:The destination client certificate is invalid.
016-522:The SSL client certificate has not yet been set.
016-523:The device cannot verify the SSL certificate of the LDAP server.
016-524:SSL certificate of the LDAP server is invalid.
016-527:An error occurred inside the program of the SSL certification.

Solution: A certification error occurred. Contact the system administrator.
Check that all settings are correctly configured. If the problem persists, reformat the Hard
Disk.

NOTE

If the error persists after the action above is taken, ensure that the error replicates after the printer is powered off and then on, and then go to the following steps to continue further fault isolation.

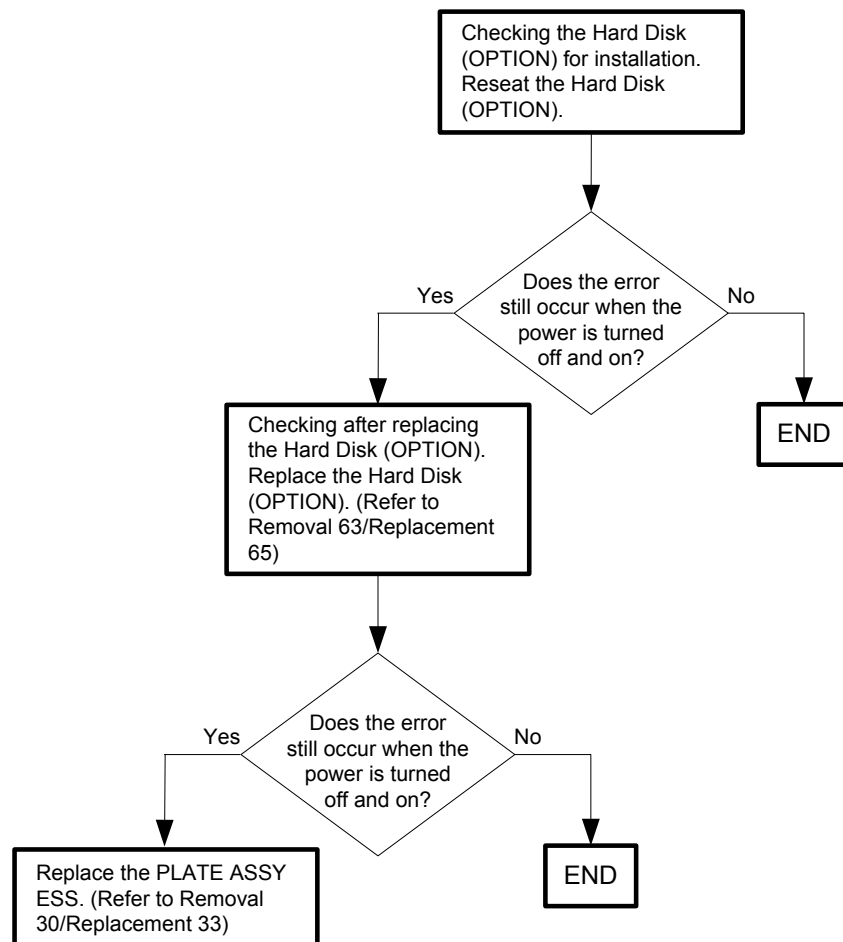

Flows 49 016-531 / 016-532 / 016-533 / 016-534 / 016-535 / 016-536: LDAP, Kerberos Server Error / ColorTrack 3 Error

Cause: 016-531:LDAP or Kerberos Server Sign on error.
 016-532:LDAP Wrong Attribute Information on Server.
 016-533:Kerberos Server Clock Skew Error.
 016-534:LDAP or Kerberos Server Wrong Server Information on Device.
 016-535:LDAP Admin Information is Wrong.
 016-536:Internal error of LDAP server or Kerberos.

Solution: An authentication error occurred. Contact the system administrator.
 016-531:Check that the LDAP server or the Kerberos server is correctly configured.
 016-532:Check that the user information is correctly set on the LDAP server, and that the LDAP server settings are correctly configured on the printer.
 016-533:The time difference between the clock on the printer and that on the Kerberos server exceeds the limit value of the Clock Skew on the Kerberos server. Check that the printer and the Kerberos server share the same time settings including the time zone and summer time options.
 016-534:Check that the LDAP server or the Kerberos server is correctly configured.
 016-535:Check that the administrator account for the LDAP server is correctly configured.
 016-536:Check that the LDAP server or the Kerberos server is correctly configured. This error occurs when the primary server is left blank and only the secondary server is specified.

NOTE

If the error persists after the action above is taken, ensure that the error replicates after the printer is powered off and then on, and then go to the following steps to continue further fault isolation.

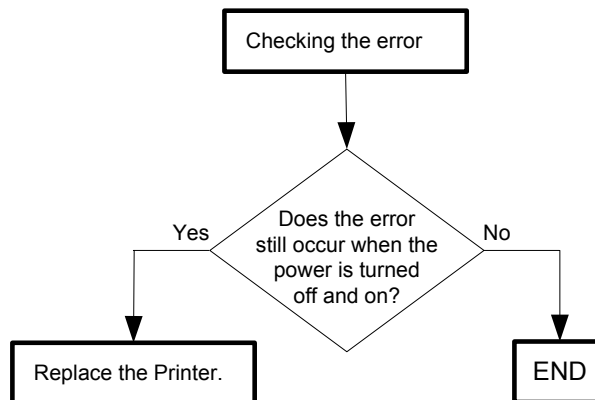

Flows 50 016-541 / 016-542 / 016-543: Wireless certificate error

Cause: 016-541:An error occurred while accessing the wireless certificate.
 016-542:An error occurred regarding the server certificate.
 016-543:The wireless certificate is corrupted.

Solution: A certification error occurred. Contact the system administrator.

016-541:Ask your system administrator to connect the printer with a wired network, initialize the Wireless settings, import the Wireless certificate, and set WPA Enterprise or WPA2 Enterprise again.

016-542:Ask your system administrator to confirm the server certificate being used with the Radius server.

016-543:Ask your system administrator to connect the printer with a wired network, initialize the Wireless settings, import the Wireless certificate, and set WPA Enterprise or WPA2-Enterprise again.

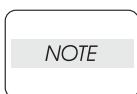

If the error persists after the action above is taken, ensure that the error replicates after the printer is powered off and then on, and then go to the following steps to continue further fault isolation.

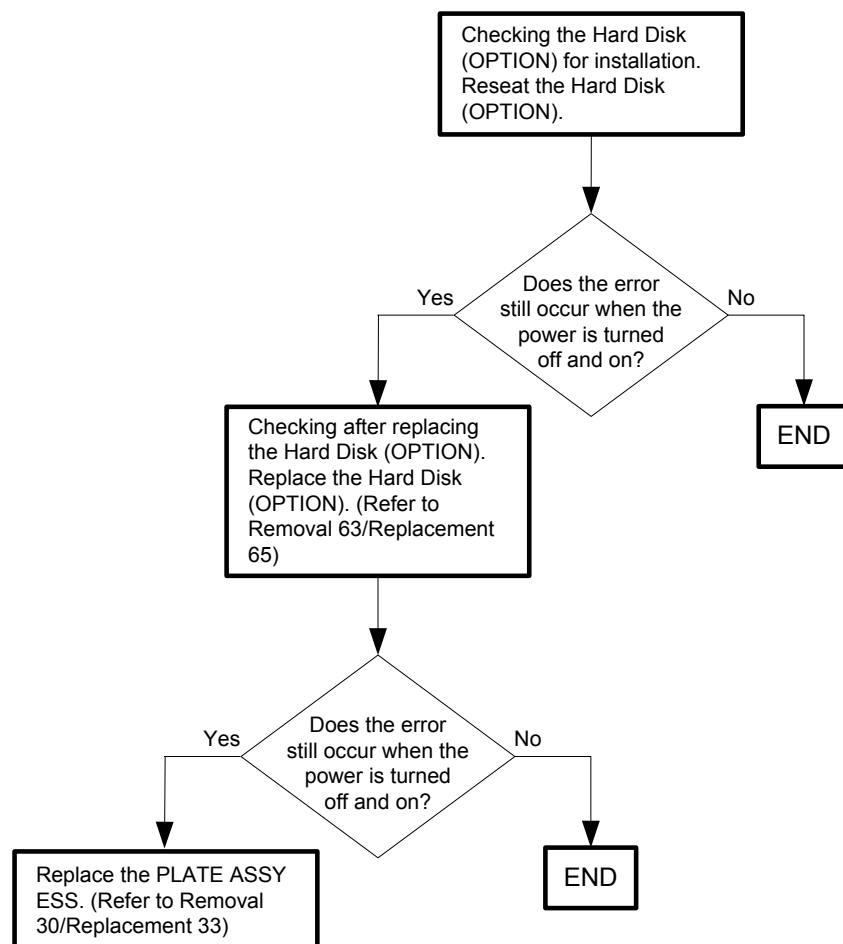

Flows 51 016-700: Memory Over flow

Cause: The current printing job process cannot be continued because the memory capacity is exceeded.

Solution: Turn the power off and on to check that the error recurs. Then, proceed to the troubleshooting following the flowchart given below.

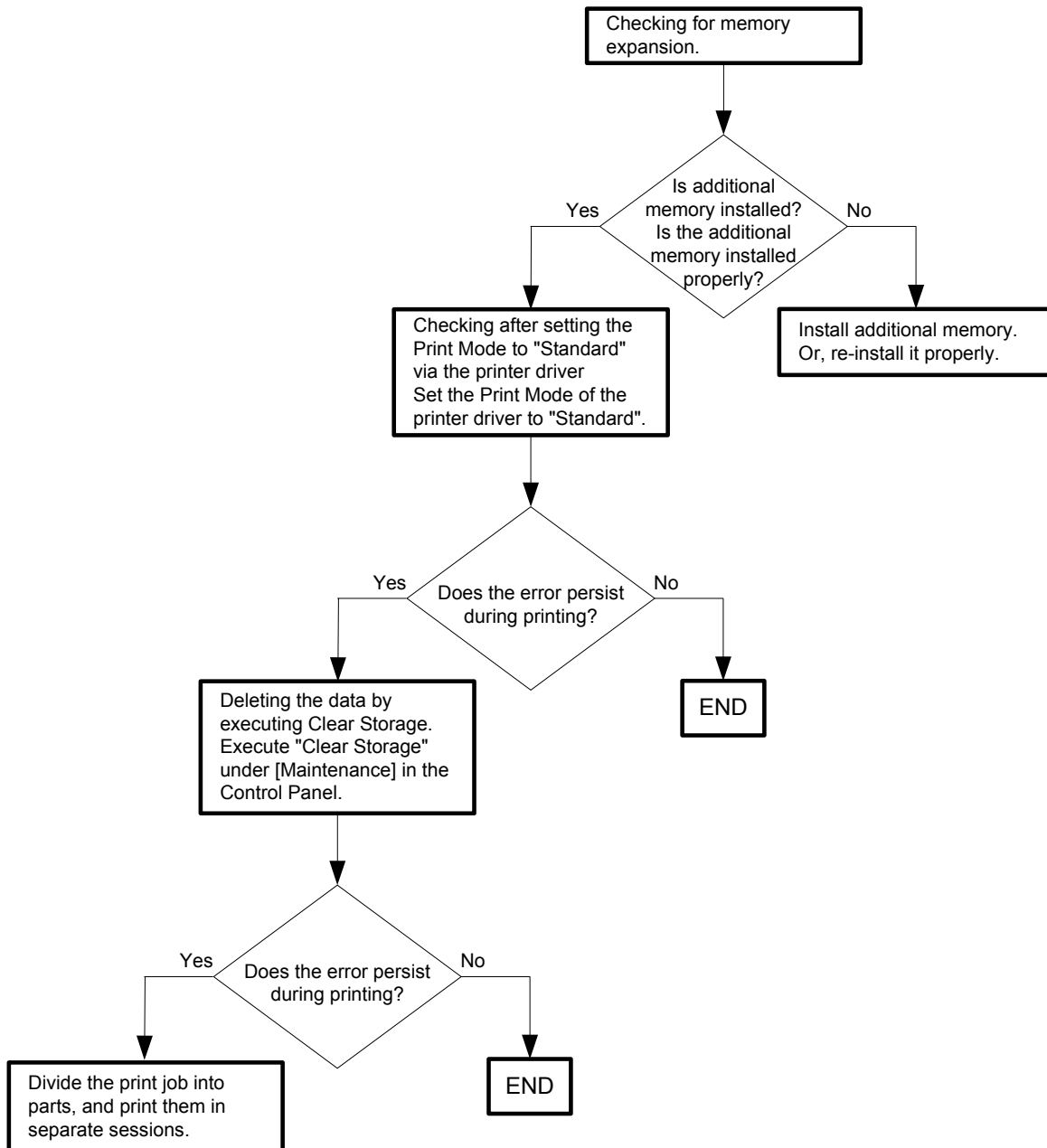

Flows 52 016-720: PDL Error

Cause: The print data cannot be processed by PDL.

Solution: Turn the power off and on to check that the error recurs. Then, proceed to the troubleshooting following the flowchart given below.

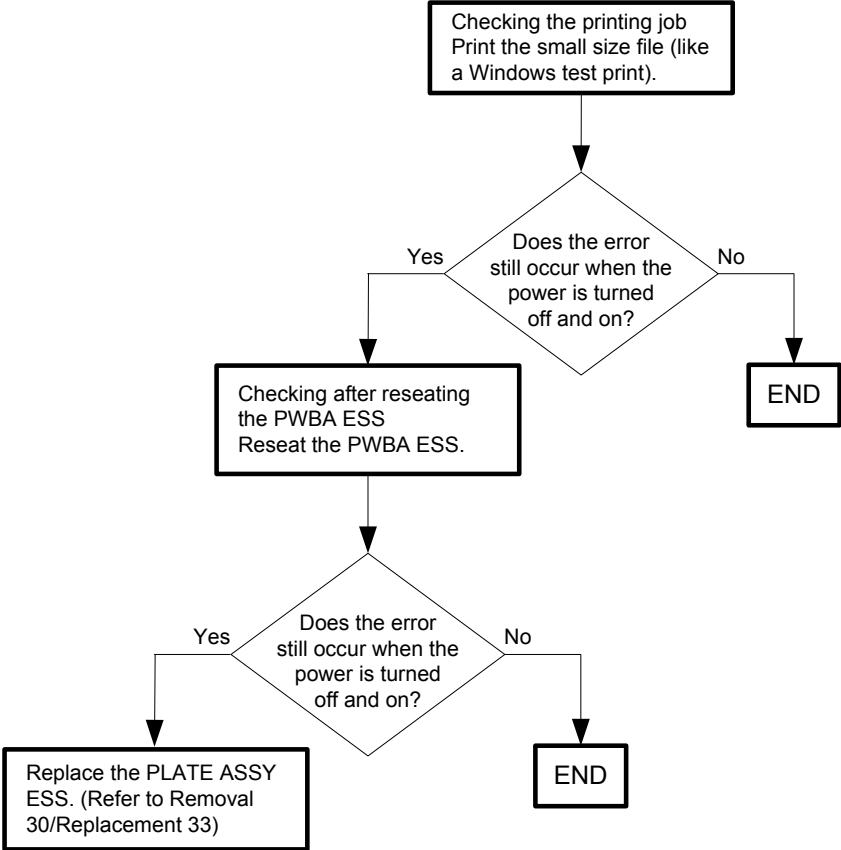

Flows 53 016-756: Auditron Error (Print prohibited time)

Cause: Printing was executed at the print-prohibited time or the day of the week.
Solution: Printing cannot be executed because the printing is set in the print-prohibited day of the week or the time zone.
To execute printing, consult the system administrator.
This error is automatically reset after a lapse of the specified time.

NOTE

If the error persists after the action above is taken, ensure that the error replicates after the printer is powered off and then on, and then go to the following steps to continue further fault isolation.

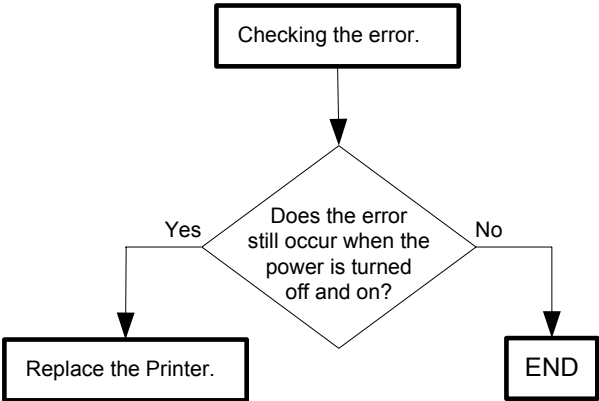

Flows 54 016-757: Auditron Error (Invalid User)

Cause: An error occurred because the user's account settings did not match those of the Administrator.

Solution: Printing cannot be executed because your account (user name and password) has not been registered. To execute printing, consult the system administrator.
This error is automatically reset after a lapse of the specified time.

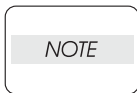

If the error still occurs, then, proceed to troubleshooting following the flowchart given below.

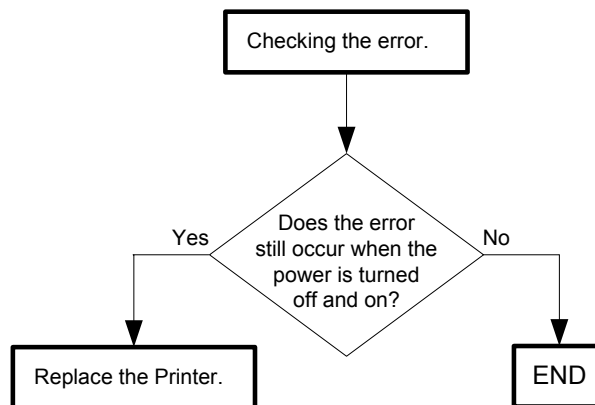

Flows 55 016-758: Auditron Error (Disabled Function)

Cause: An error occurred because a user authorized only for B&W print attempted to execute color printing.

Solution: Color printing cannot be executed because the printer has been set only to enable B&W printing. To use color printing, consult the system administrator.
This error is automatically reset after a lapse of the specified time.

NOTE

If the error still occurs, then, proceed to troubleshooting following the flowchart given below.

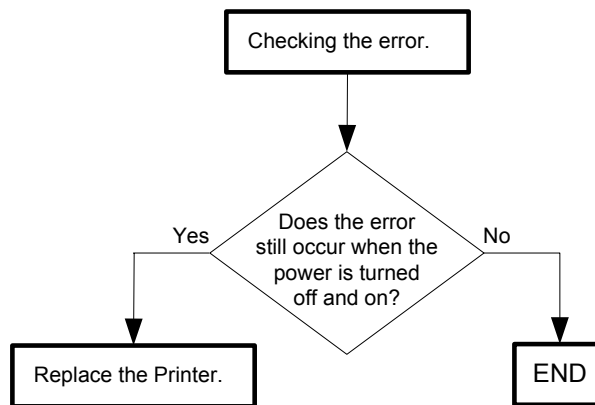

Flows 56 016-759: Auditron Error (Reached Limit)

Cause: An attempt was made to print more copies than the print count limit.

Solution: The printer has been set so that it does not continue printing when the specified number is reached. To continue printing, consult the system administrator.

This error is automatically reset after a lapse of the specified time.



If the error still occurs, then, proceed to troubleshooting following the flowchart given below.

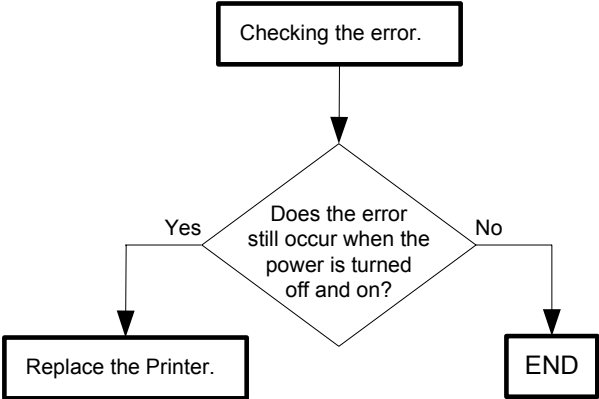

Flows 57 016-799: Job Environment Violation

Cause: Detects violation data for the print condition. The print data specifies paper type/ size not available for the printer.

Solution: Ensure that the printer configuration on the printer driver conforms to the printer you are using.

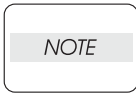

If the error still occurs, then, proceed to troubleshooting following the flowchart given below.

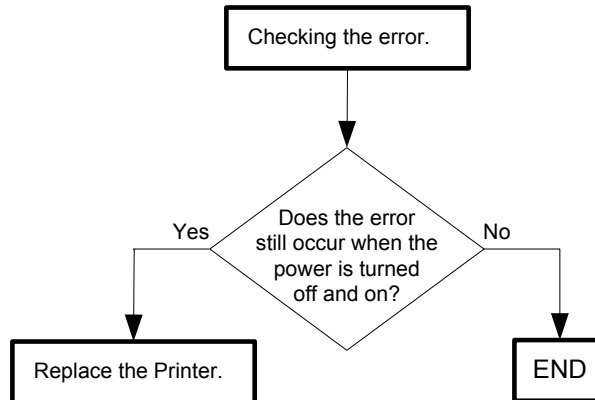

Flows 58 016-920: Wireless Setting Error Timeout Error

Cause: The time-out was done to the connection with Register.

Solution: A timeout error occurred. Contact the system administrator.

The WPS procedure between the wireless LAN access point (Registrar) timed out. Try connecting again.

NOTE

If the error persists after the action above is taken, ensure that the error replicates after the printer is powered off and then on, and then go to the following steps to continue further fault isolation.

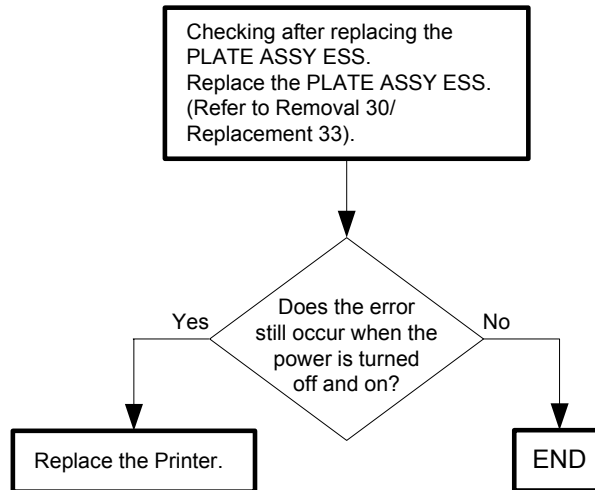

Flows 59 016-921: Wireless Setting Error Download Error

Cause: WPS operation failed.

Solution: An error occurred while connecting. Contact the system administrator.

An error occurred while connecting to the wireless LAN access point (Registrar) in WPS mode. Try connecting again.

NOTE

If the error persists after the action above is taken, ensure that the error replicates after the printer is powered off and then on, and then go to the following steps to continue further fault isolation.

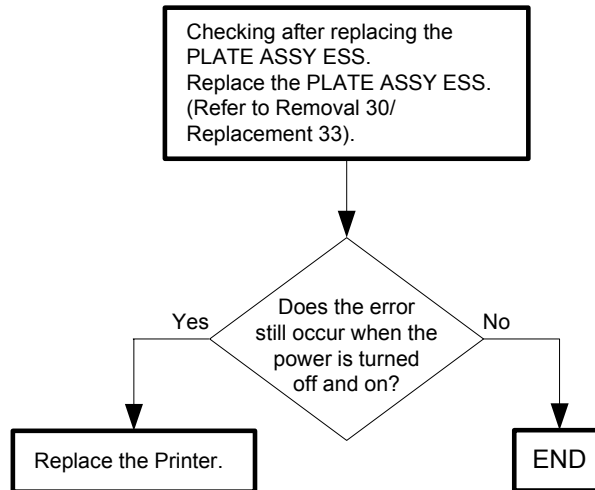

Flows 60 016-922: Wireless Setting Error Session Overlap Error

Cause: WPS operation failed.

Solution: Two or more wireless LAN access points (Registrars) have been found to operate in the WPS-PBC mode.

Set only one wireless access point (Registrar) to operate in the WPS-PBC mode, and execute the process again according to the procedure.

NOTE

If the error persists after the action above is taken, ensure that the error replicates after the printer is powered off and then on, and then go to the following steps to continue further fault isolation.

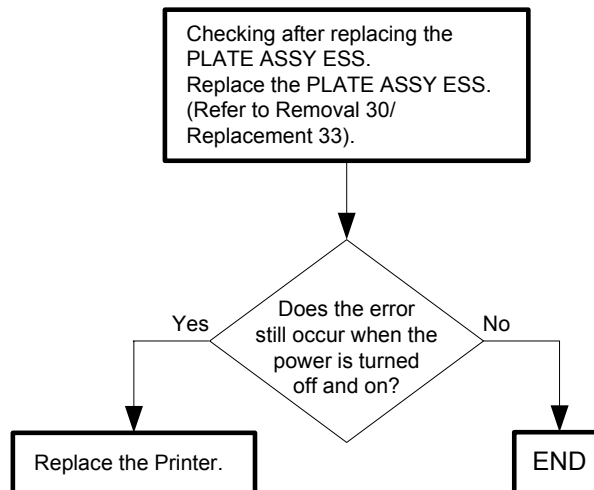

Flows 61 016-930 / 016-931: USB HOST Error

Cause: 016-930: Devices not supported have been detected.

016-931: It has been found that more stages of hubs than supported are connected.

Solution: 016-930: Devices not available are connected to the USB port. Remove the devices from the USB port.

016-931: The number of hub stages exceeds the specified value. Reduce the number of the hub stages.

NOTE

If the error persists after the action above is taken, ensure that the error replicates after the printer is powered off and then on, and then go to the following steps to continue further fault isolation.

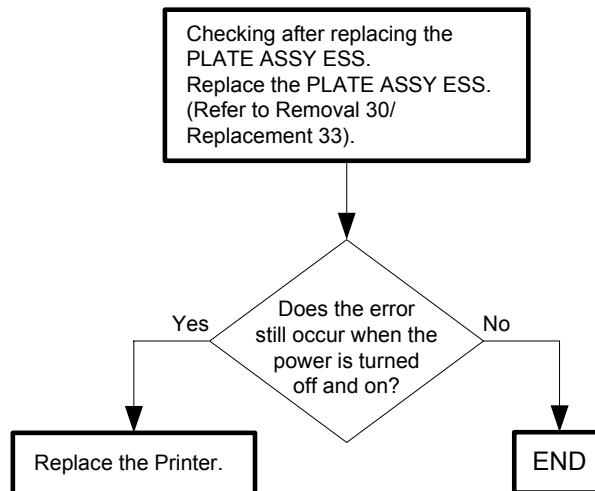

Flows 62 016-980: Hard Disk Disc Full

Cause: The current printing job process cannot be continued because the hard disk is full.
Solution: The current printing job process cannot be continued because the hard disk is full. It is necessary to delete unnecessary data from the hard disk or decrease the number of pages for printing before starting printing.

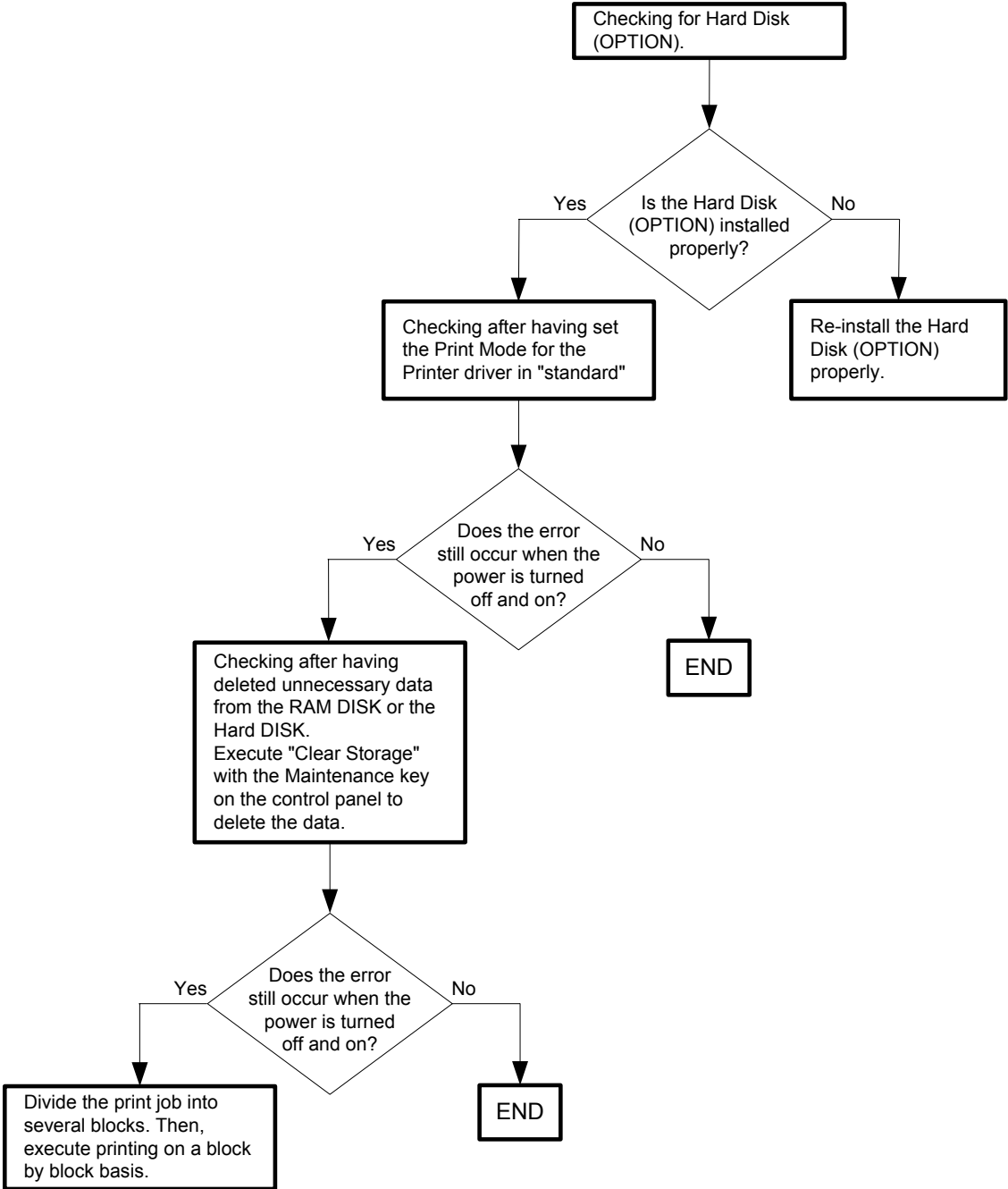

Flows 63 016-981: Collate Full

Cause: Exceeds the memory capacity.

Solution: Turn the power off and on to check that the error recurs. Then, proceed to the troubleshooting following the flowchart given below.

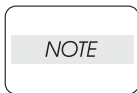

Never turn off the power to the printer while the firmware is being downloaded.

Turning the power off may cause a failure in the printer.

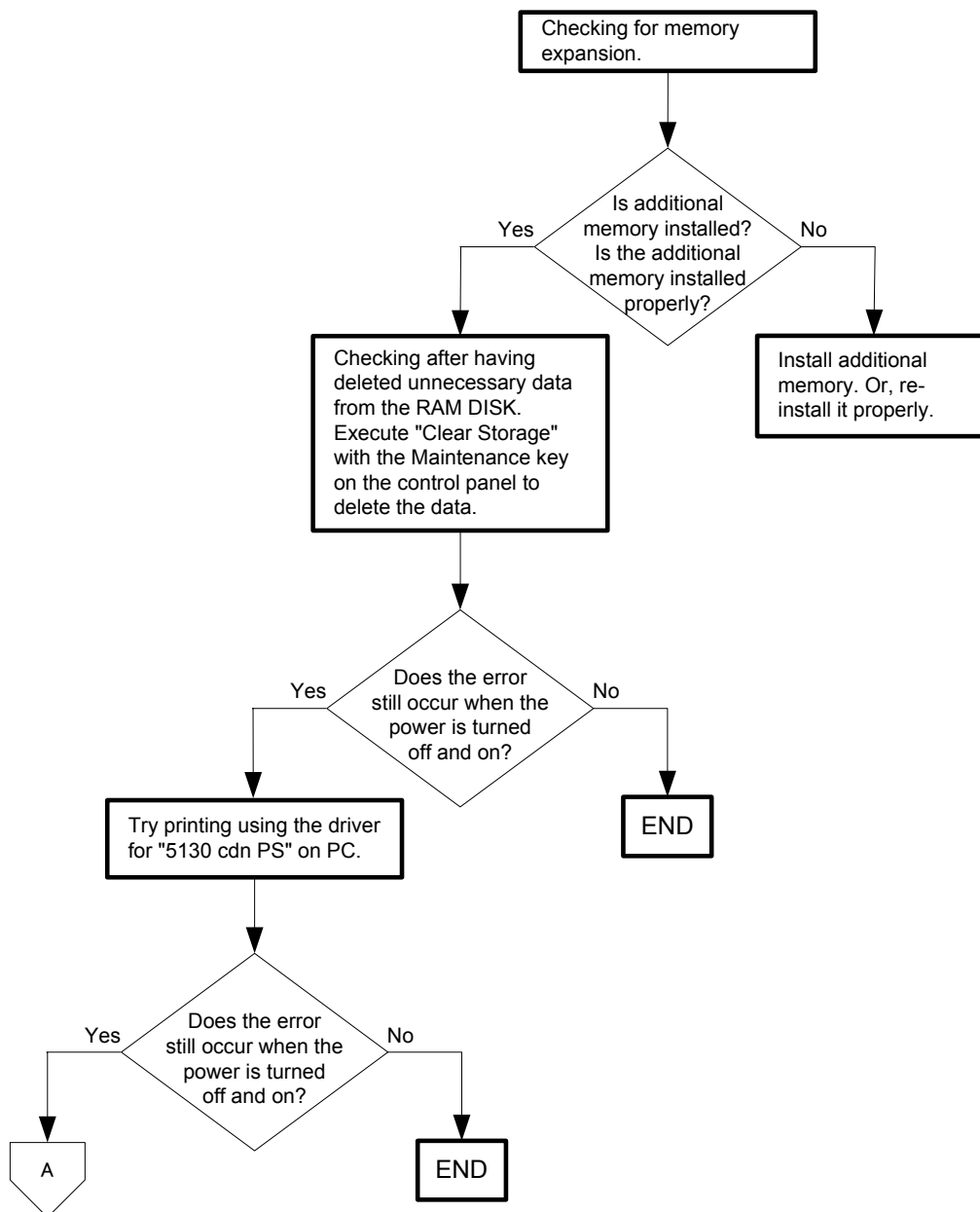

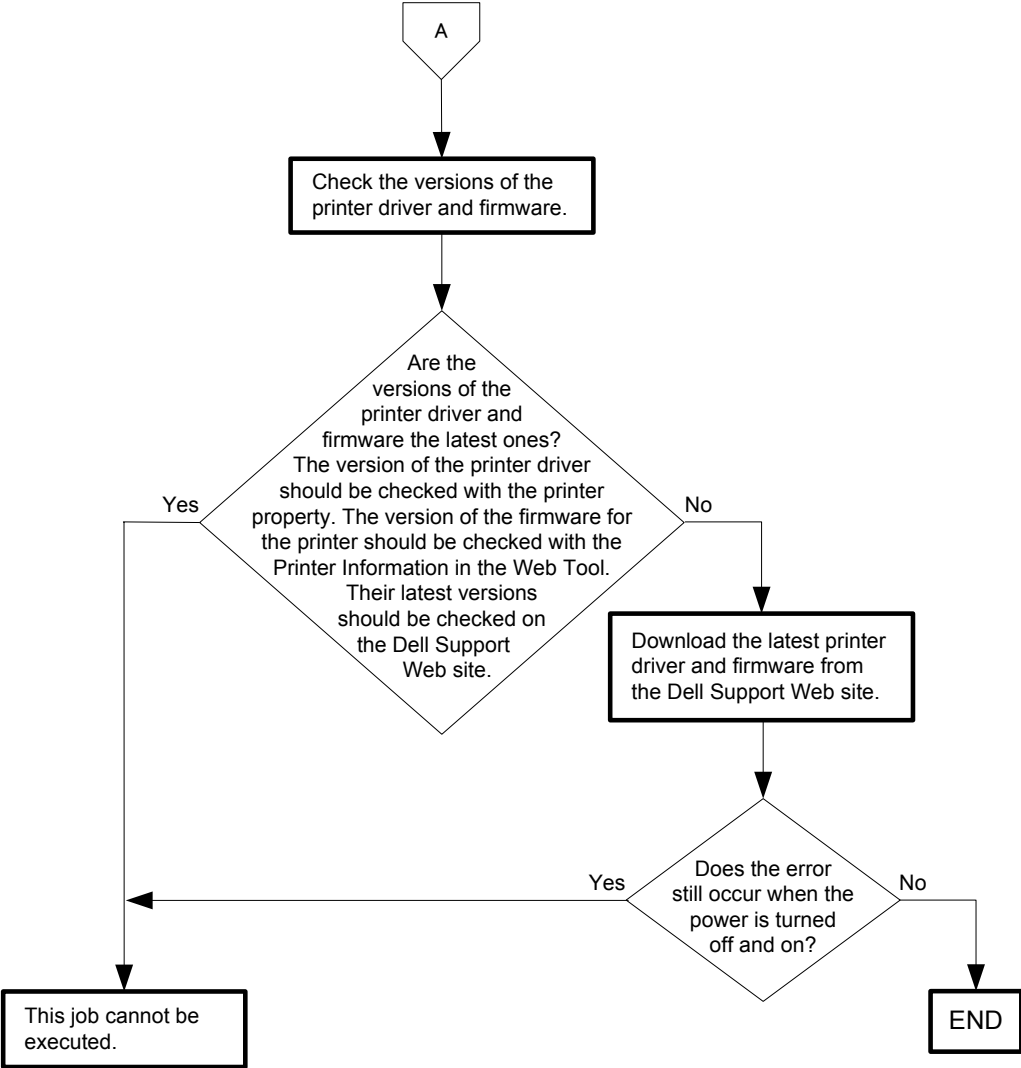

Flows 64 024-338: Video Cable Disconnect

Cause: The video cable is not connected to the ESS.

Solution: Turn the power off and on to check that the error recurs. Then, proceed to the troubleshooting following the flowchart given below.

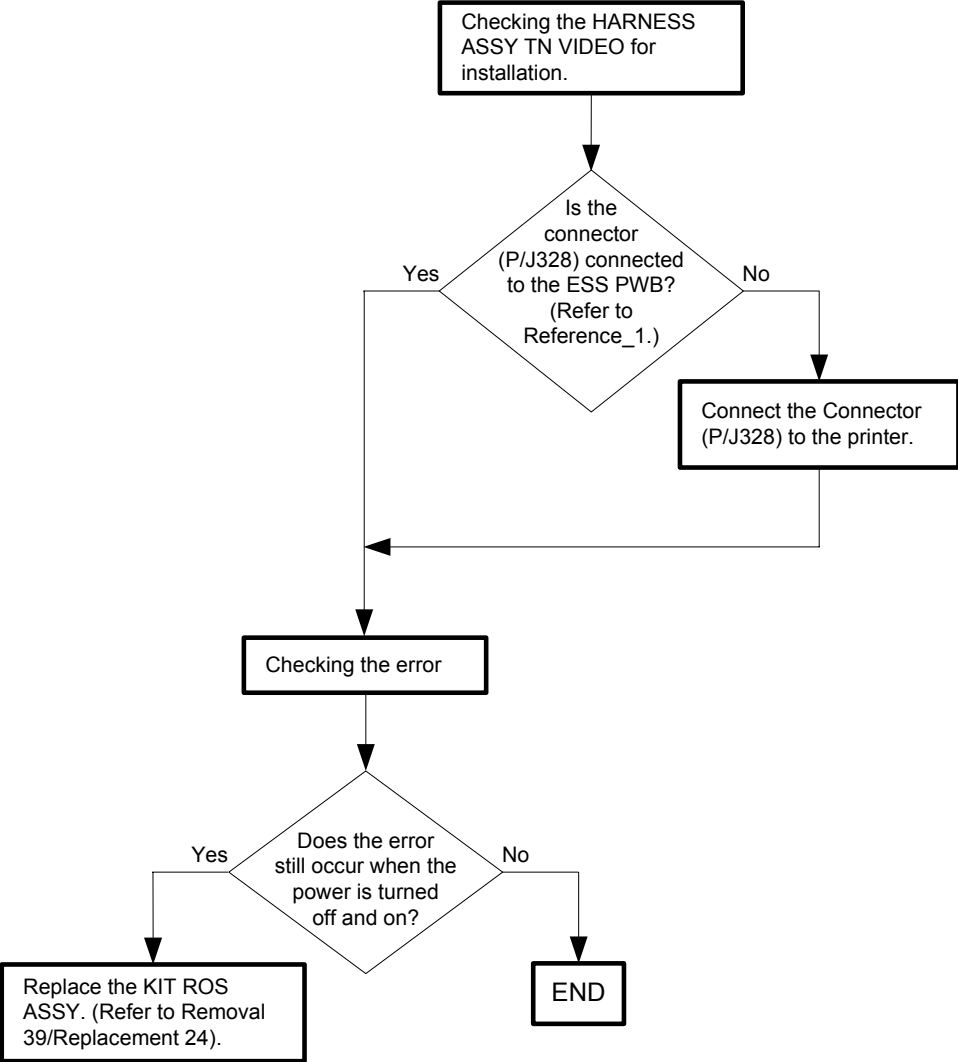

- Reference_1: Section of the connector (P/J328) to be checked.

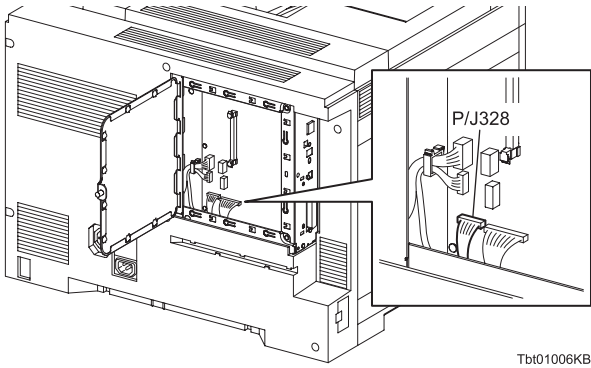

Tbt01006KB

Flows 65 024-339: Serial Cable to MCU Disconnect

Cause: The cable for connecting the ESS and MCU is not connected to the MCU.

Solution: Turn the power off and on to check that the error recurs. Then, proceed to the troubleshooting following the flowchart given below.

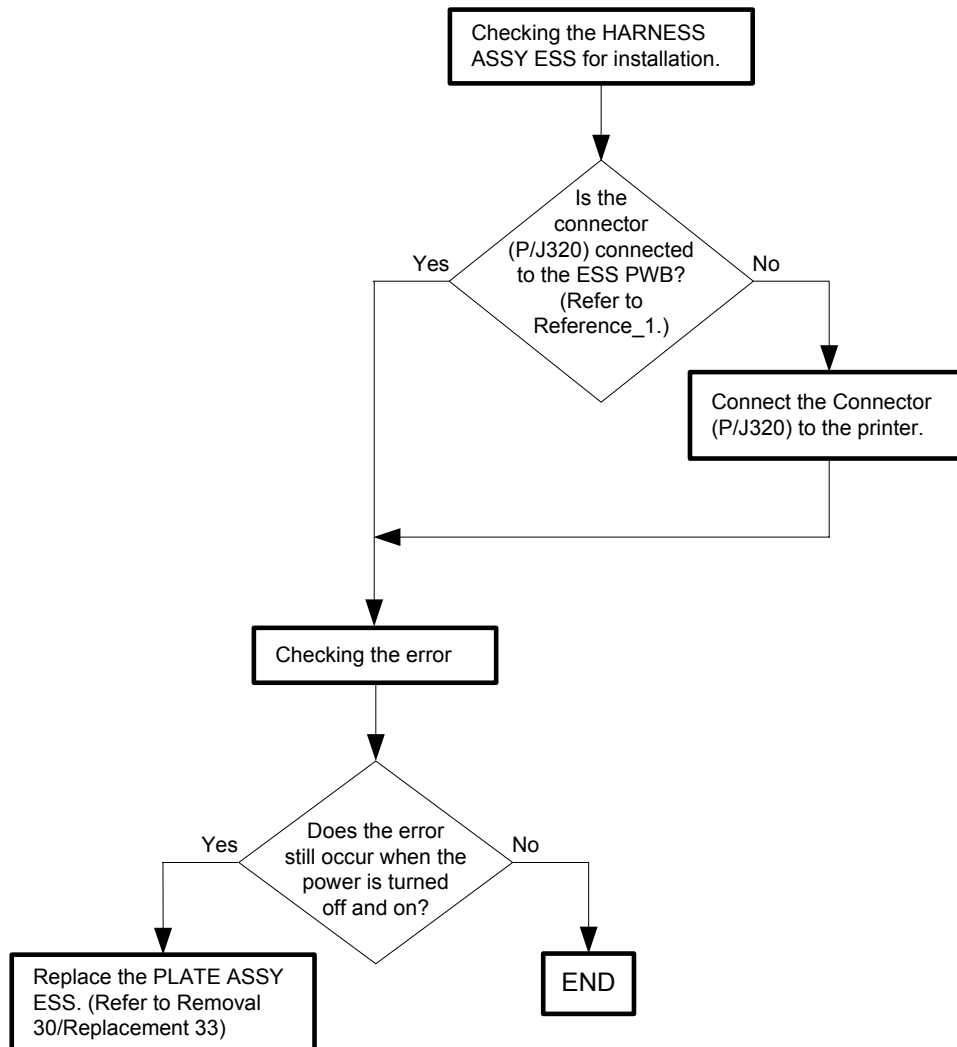

- Reference_1: Section of the connector (P/J320) to be checked.

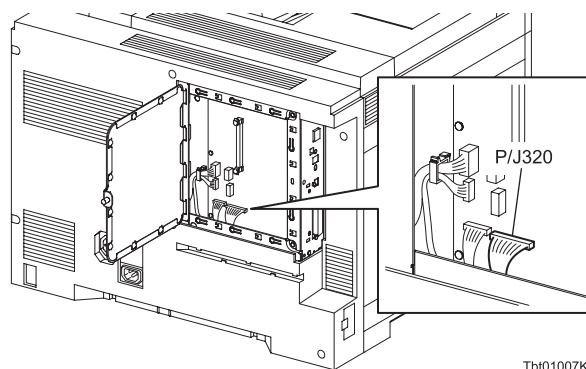

Tbt01007KB

Flows 66 024-362: IOT Start Image Marking Timeout

Cause: "Start Image Making" has not been issued within the time allowed.

Solution: Turn the power off and on to check that the error recurs. Then, proceed to the troubleshooting following the flowchart given below.

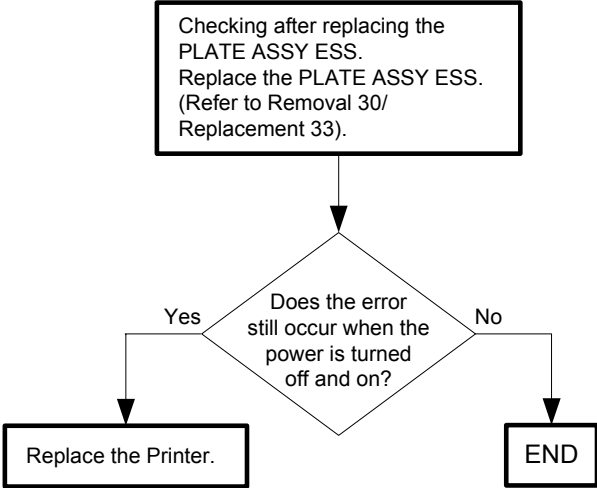

Flows 67 024-910 / 024-911 / 024-912 / 024-913 / 024-915: IOT Paper Size Mismatch

Cause: 024-910: The size of paper in the Tray 1 does not match the specified print size.
 024-911: The size of paper in the Tray 2 does not match the specified print size.
 024-912: The size of paper in the Tray 3 does not match the specified print size.
 024-913: The size of paper in the Tray 4 does not match the specified print size.
 024-915: The size of paper in the Tray 5 does not match the specified print size.

Solution: Place the designated paper in the relevant tray.

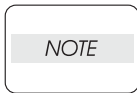

If the error persists after the action above is taken, ensure that the error replicates after the printer is powered off and then on, and then go to the following steps to continue further fault isolation.

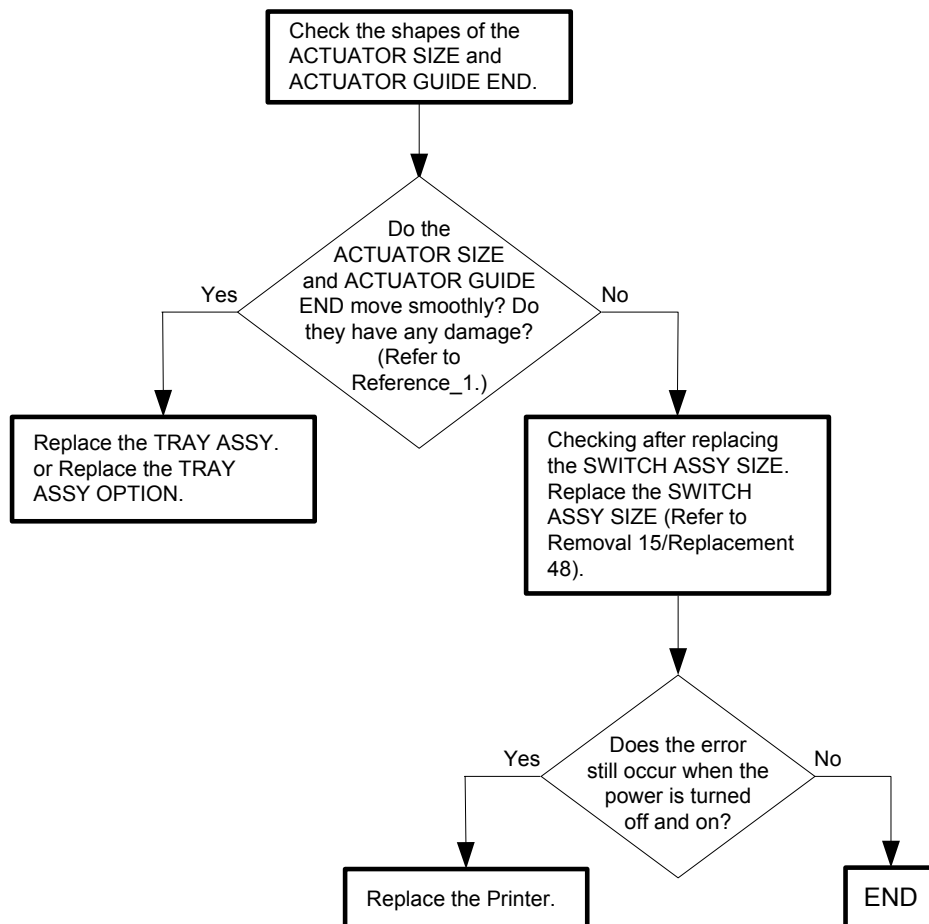

- Reference_1: Section to be checked for damage (for the Tray 1)

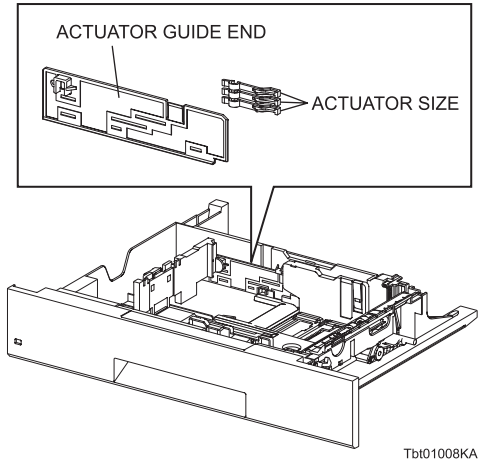

Flows 68 024-914: IOT Paper Size Mismatch

Cause: The size of paper in the MPF does not match the specified print size.

Solution: Place the designated paper in the MPF.

NOTE

If the error persists after the action above is taken, ensure that the error replicates after the printer is powered off and then on, and then go to the following steps to continue further fault isolation.

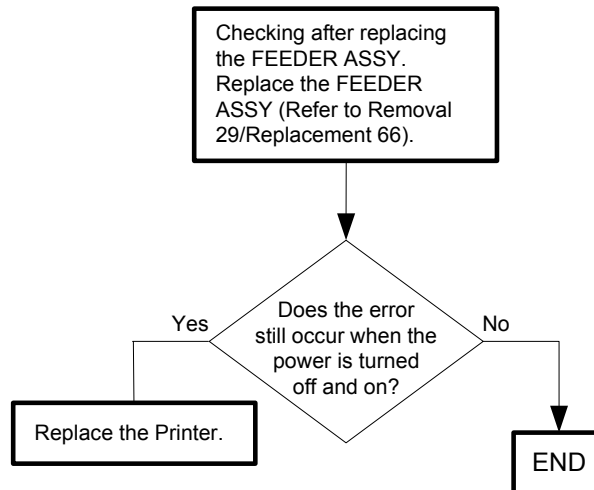

Flows 69 024-916 / 024-980: IOT Output Expander Mix Stack Full / IOT Output Expander Stacker Tray Full

Cause: 024-916: The quantity of mixed-size paper in the Output Expander Stacker Tray reached the specified capacity.

024-980: The quantity of same-size paper in the Output Expander Stacker Tray reached the specified capacity.

Solution: Remove the paper from the Output Expander Stacker Tray.

NOTE

If the error persists after the action above is taken, ensure that the error replicates after the printer is powered off and then on, and then go to the following steps to continue further fault isolation.

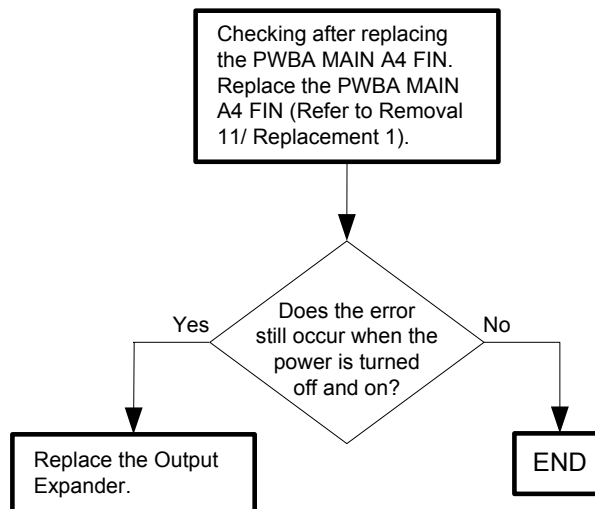

Flows 70 024-917: IOT Output Expander Stacker Tray Staple Set Over Count

Cause: The number of copies stapled by the Output Expander exceeded the capacity of the Stacker Tray.

Solution: Remove the paper from the Output Expander Stacker Tray.-

NOTE

If the error persists after the action above is taken, ensure that the error replicates after the printer is powered off and then on, and then go to the following steps to continue further fault isolation.

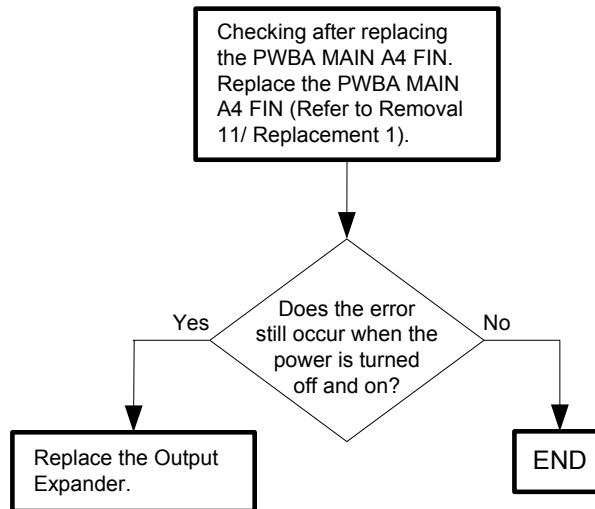

Flows 71 024-920: IOT Exit Tray Stacker Full

Cause: The quantity of printed paper in the discharge Tray reached the specified capacity.
Solution: Remove the paper form the Printer Paper Discharge Tray.

NOTE

If the error persists after the action above is taken, ensure that the error replicates after the printer is powered off and then on, and then go to the following steps to continue further fault isolation.

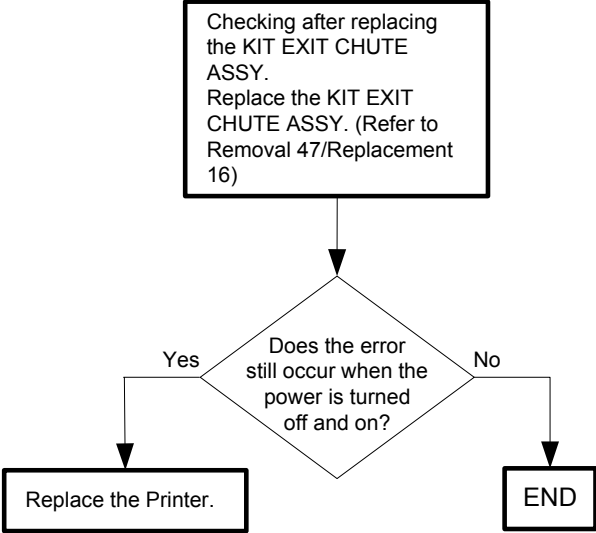

Flows 72 024-928: IOT Output Expander Scratch Sheet Compile

Cause: Sheets out of specification have been ejected to the Compile Tray while ejecting sets of prints.

Solution: Remove the sheets from the Compile Tray. Make sure to use paper that meets the specification.



If the error persists after the action above is taken, ensure that the error replicates after the printer is powered off and then on, and then go to the following steps to continue further fault isolation.

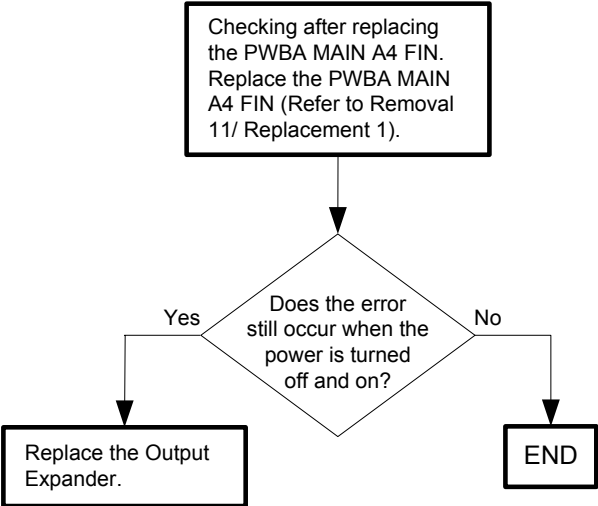

Flows 73 024-946 / 024-947 / 024-948 / 024-949 / 024-950: IOT Tray Detached

Cause: 024-946: The sheet feeder (Tray1) is detached.
 024-947: The Option sheet feeder (Tray2) is detached.
 024-948: The Option sheet feeder (Tray3) is detached.
 024-949: The Option sheet feeder (Tray4) is detached.
 024-950: The Option sheet feeder (Tray5) is detached.

Solution: Install the relevant Tray in the printer.

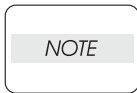

If the error persists after the action above is taken, ensure that the error replicates after the printer is powered off and then on, and then go to the following steps to continue further fault isolation.

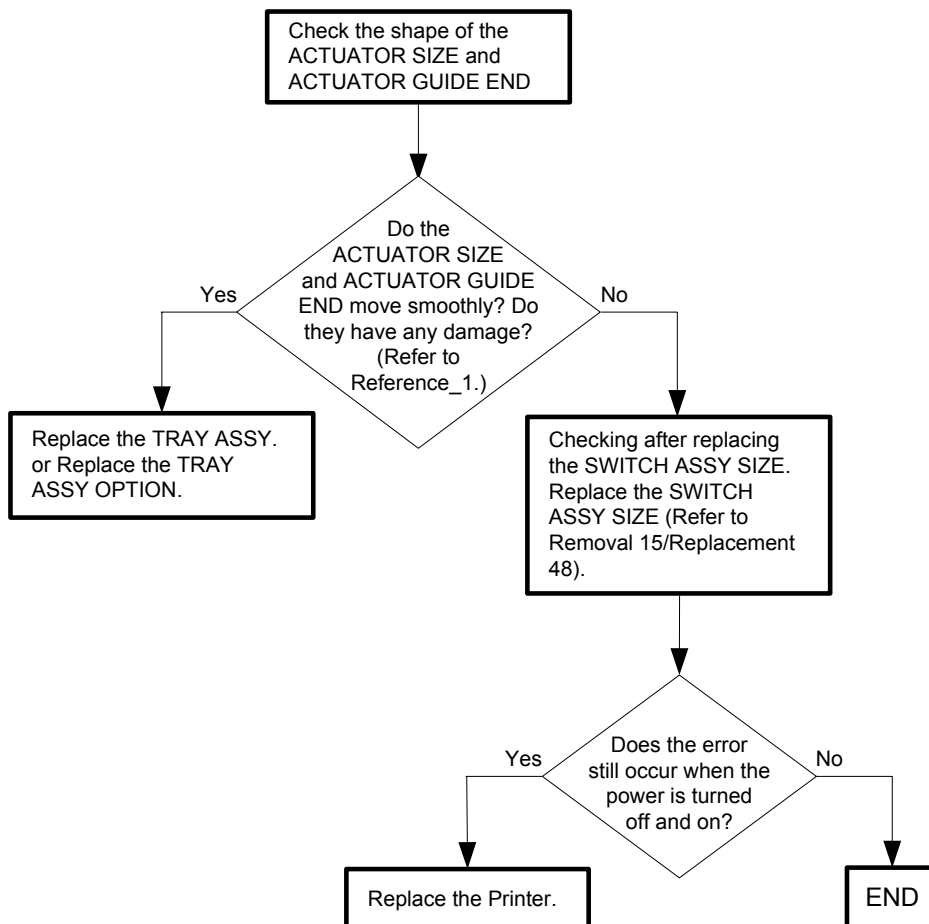

- Reference_1: Section to be checked for damage

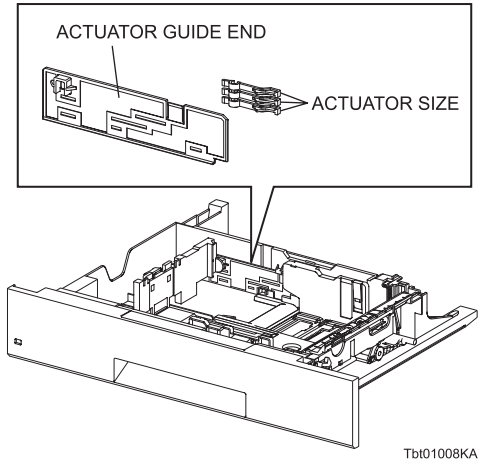

Flows 74 024-965 / 024-966 / 024-967 / 024-968 / 024-970: IOT No Suitable Paper

- Cause: 024-965:Tray 1 has run out of paper, or the size (or type) of paper in the Tray 1 does not match the specified print size (or type).
 024-966:Tray 2 has run out of paper, or the size (or type) of paper in the Tray 2 does not match the specified print size (or type).
 024-967:Tray 3 has run out of paper, or the size (or type) of paper in the Tray 3 does not match the specified print size (or type).
 024-968:Tray 4 has run out of paper, or the size (or type) of paper in the Tray 4 does not match the specified print size (or type).
 024-970:Tray 5 has run out of paper, or the size (or type) of paper in the Tray 5 does not match the specified print size (or type).

Solution: Place the designated paper in the relevant tray.

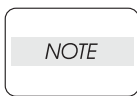

If the error persists after the action above is taken, ensure that the error replicates after the printer is powered off and then on, and then go to the following steps to continue further fault isolation.

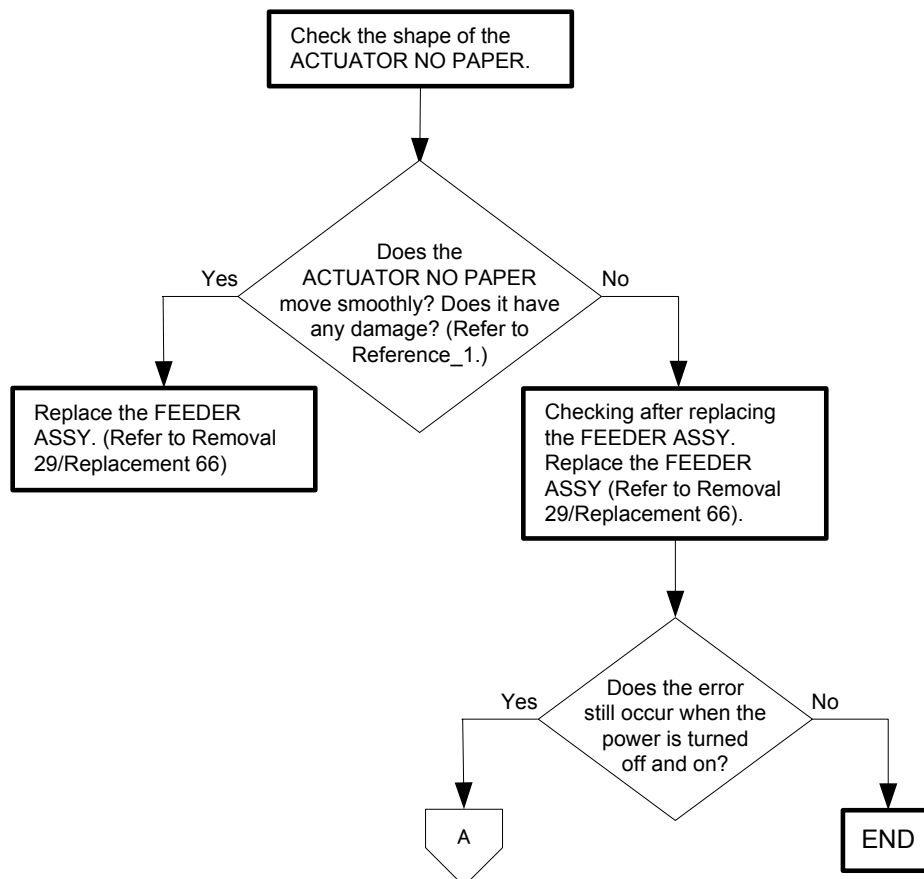

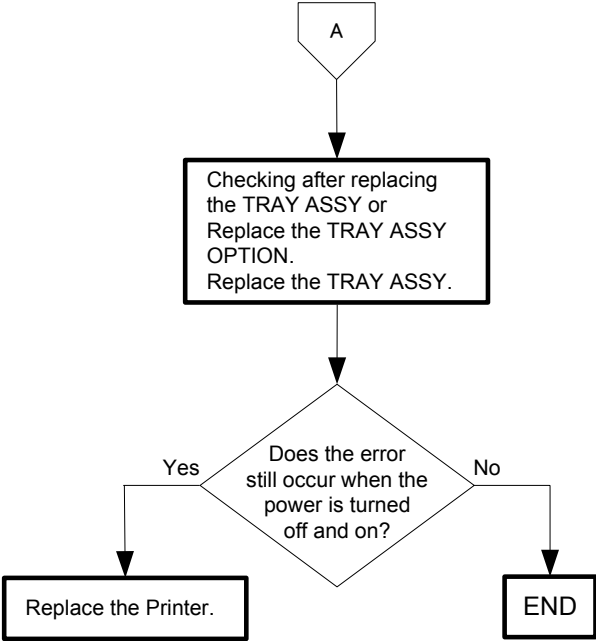

- Reference_1: Section to be checked.

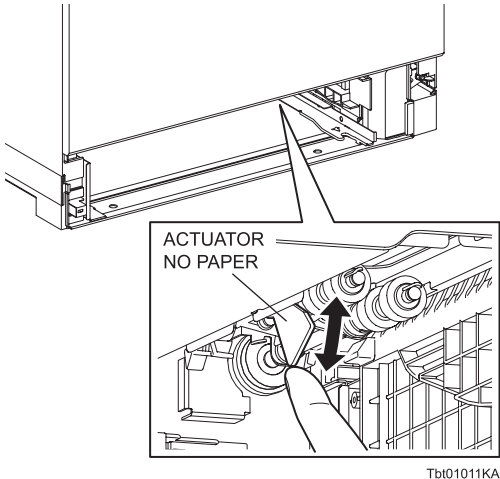

Flows 75 024-969: IOT No Suitable Paper

Cause: MPF has run out of paper, or the size (or type) of paper in the MPF does not match the specified print size (or type).

Solution: Place the designated paper in the MPF.

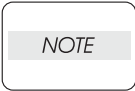

If the error persists after the action above is taken, ensure that the error replicates after the printer is powered off and then on, and then go to the following steps to continue further fault isolation.

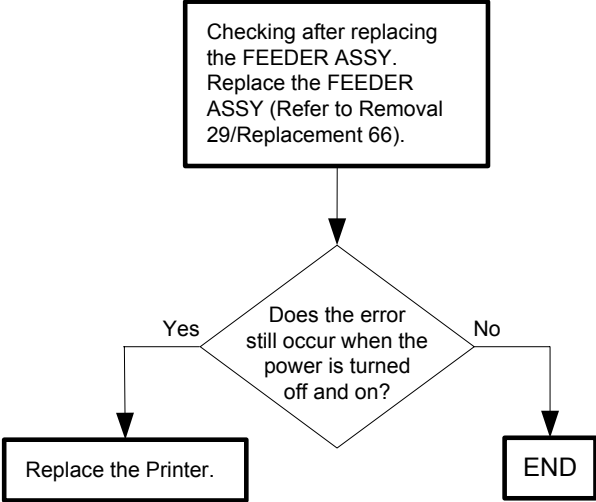

Flows 76 024-976: IOT Output Expander Staple NG

Cause: The Staple operation failed.

Solution: The Staple operation failed. Refer to "LCD Display" for how to remove the paper (Refer to Reference_1).

NOTE

If the error persists after the action above is taken, ensure that the error replicates after the printer is powered off and then on, and then go to the following steps to continue further fault isolation.

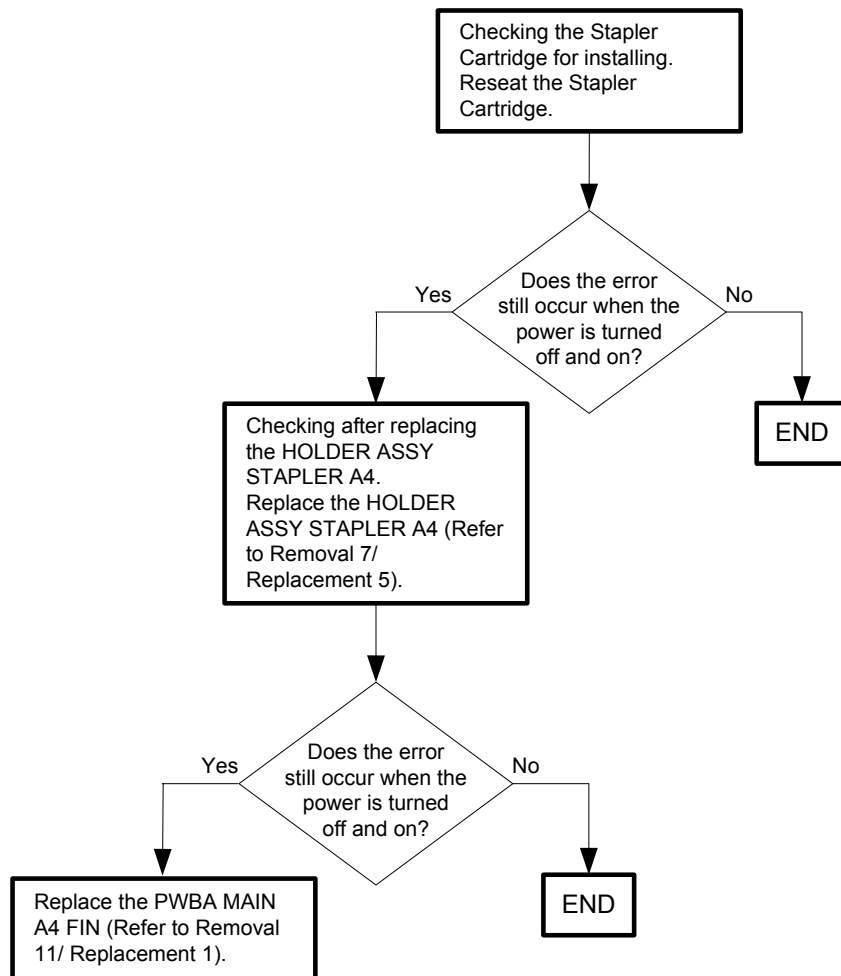

- Reference_1: 1. Open Output Expander Front Door. → 2. Replace Stapler Cartridge. → 3. Close Output Expander Front Door.

Flows 77 024-977: IOT Output Expander Stapler Error

Cause: The defective operation of Stapler Cartridge was generated.

Solution: Turn the power off and on to check that the error recurs. Then, proceed to the troubleshooting following the flowchart given below.

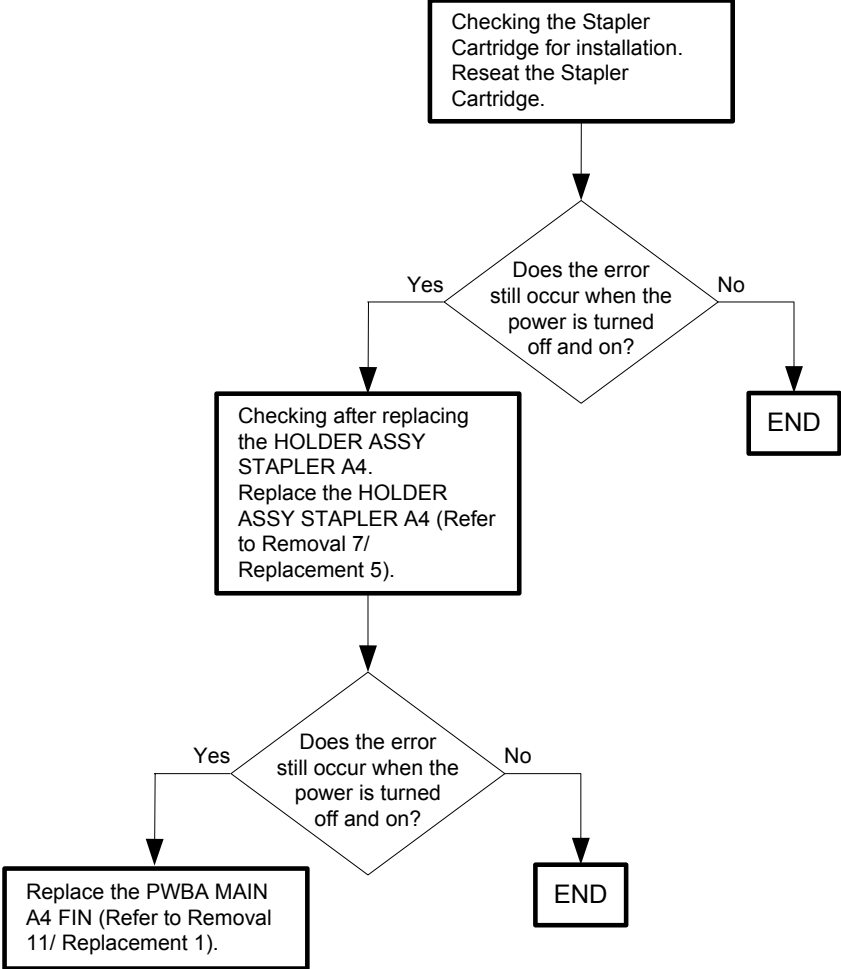

Flows 78 024-979: IOT Output Expander Stapler Near Life

Cause: The Stapler Cartridge is approaching the replacement time.

Solution: The Stapler Cartridge is approaching the replacement time. Prepare a new Stapler Cartridge.

NOTE

Refer to "Appendix_2.1 Consumables and Periodic Replacement Parts Life" for the timing when the message "Near Life" is indicated.

NOTE

This error code is not related to any hardware fault.

Flows 79 024-982: IOT Output Expander Stacker lower Safety Warning

Cause: The Stacker No Paper Sensor is not actuated within the specified time after the Stacker Motor was turned ON (lowering).

Solution: Turn the power off and on to check that the error recurs. Then, proceed to the troubleshooting following the flowchart given below.

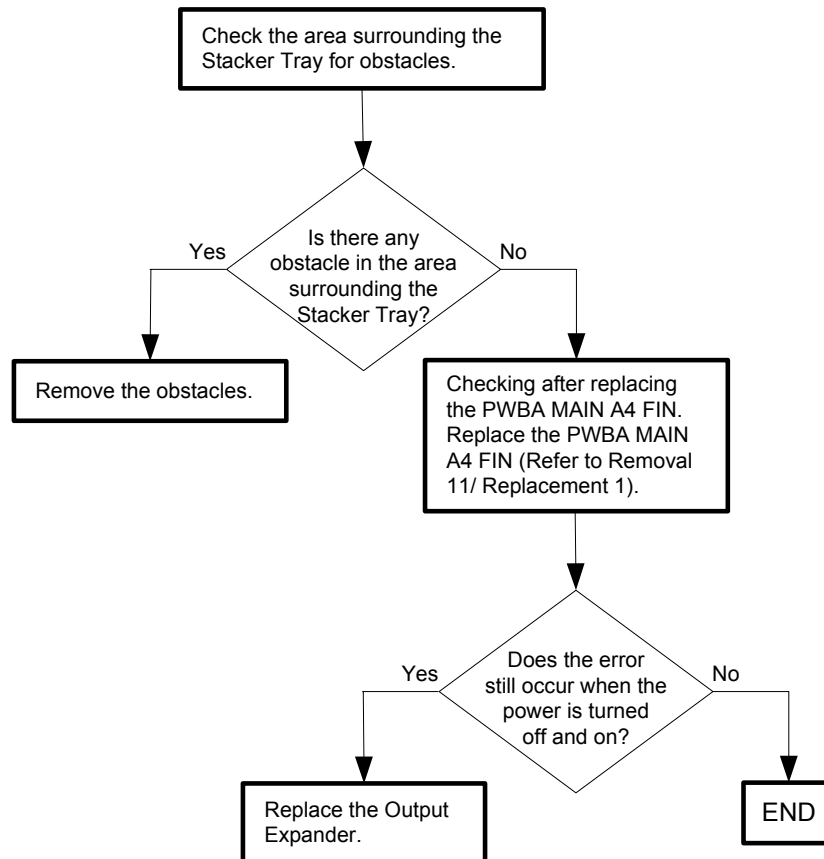

Flows 80 041-347: IOT I/F Failure

Cause: MCU Internal Error is detected.

Solution: Turn the power off and on to check that the error recurs. Then, proceed to the troubleshooting following the flowchart given below.

NOTE Never turn off the power to the printer while the firmware is being downloaded. Turning the power off may cause a failure in the printer.

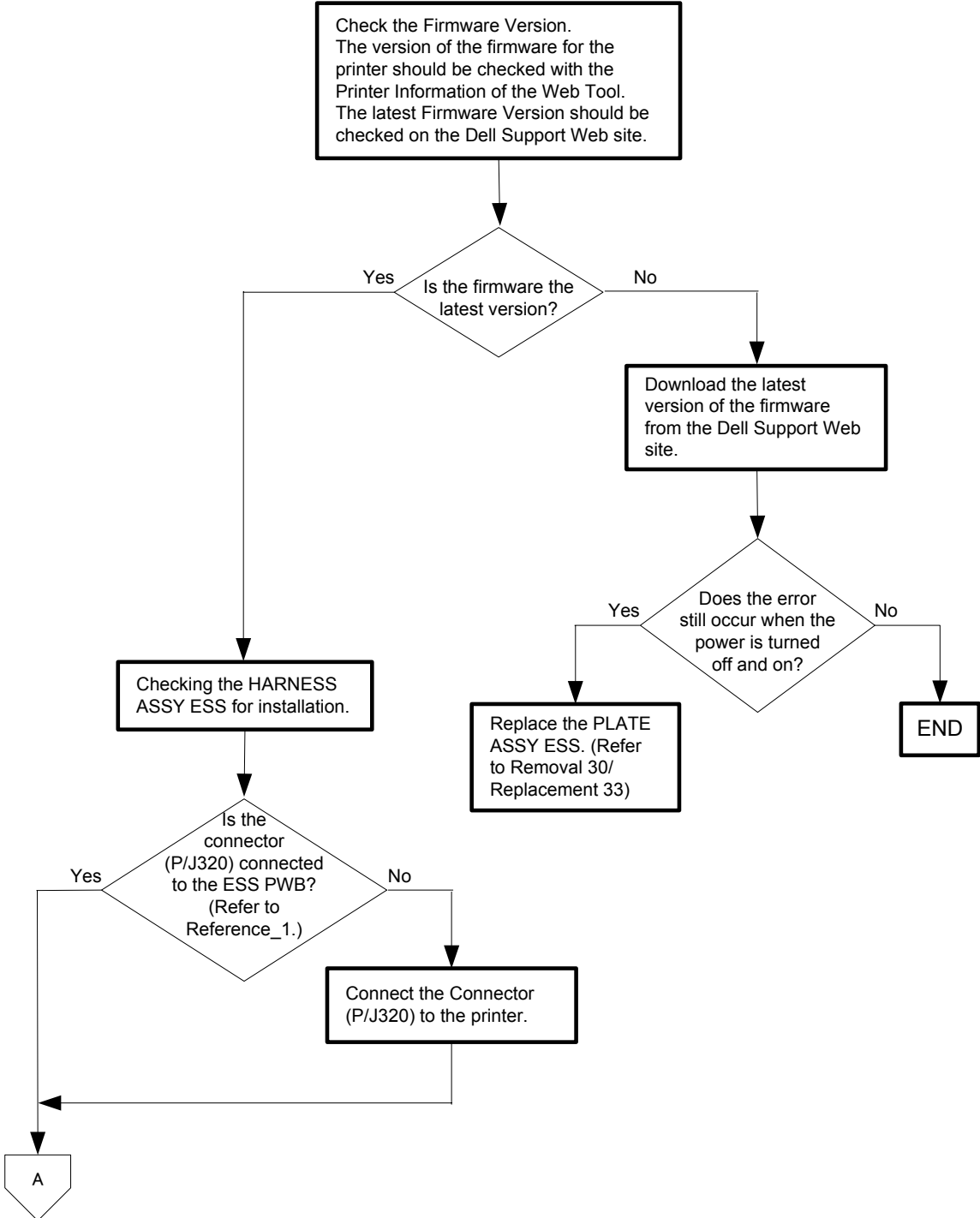

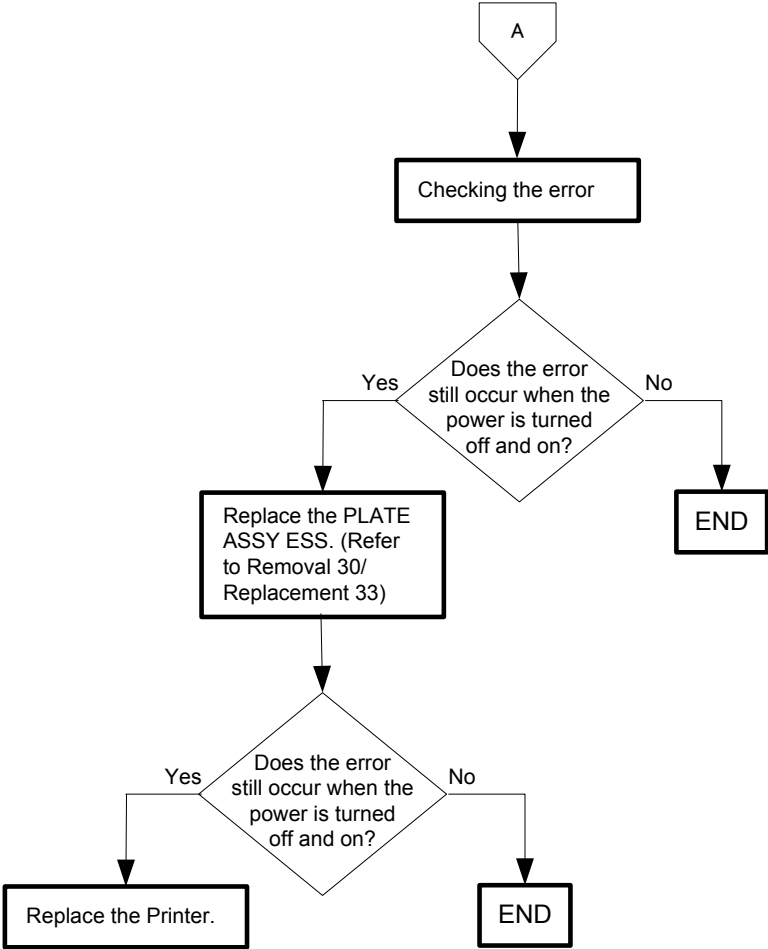

- Reference_1: Section of the connector (P/J320) to be checked.

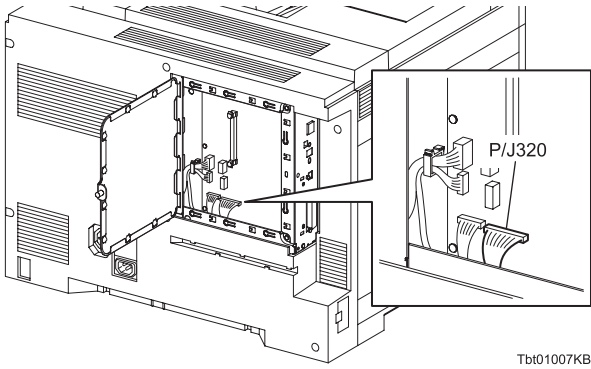

Tb101007KB

Flows 81 042-324: IOT Belt Unit Motor Failure

Cause: Belt Unit Motor failure is detected.

Solution: Turn the power off and on to check that the error recurs. Then, proceed to the troubleshooting following the flowchart given below.

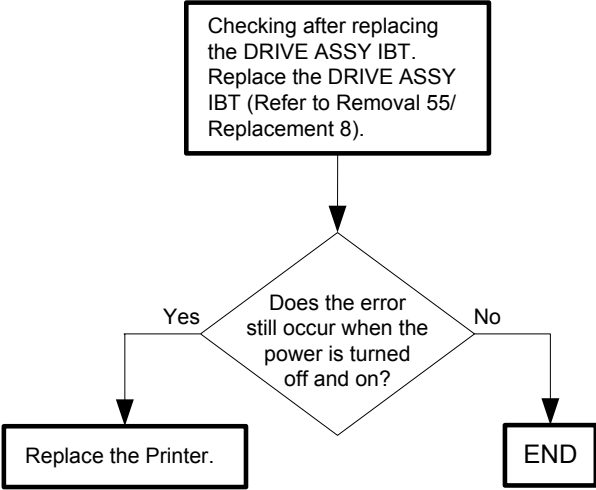

Flows 82 042-330: IOT Fuser Fan Failure

Cause: MCU detects an error upon receiving error signal from the FUSER Fan.

Solution: Turn the power off and on to check that the error recurs. Then, proceed to the troubleshooting following the flowchart given below.

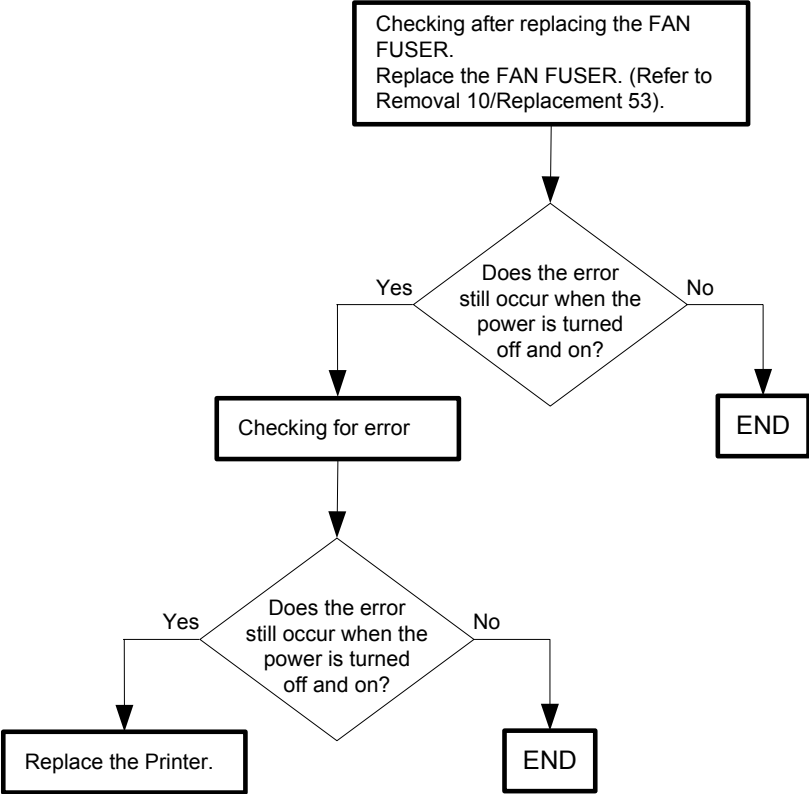

Flows 83 042-700 / 142-700: IOT over Heat Stop / IOT over Heat Forced Half Speed

Cause: 042-700: The temp. Sensor sensed high temperature.

142-700: The printing mode becomes half speed mode, by the high temperature.

Solution: 042-700 : Printing has been suspended because inside of the printer is extraordinarily hot.

Wait until the error message turns off with the power to the printer remained on.

142-700 : The printing speed has decreased because inside of the printer is extraordinarily hot.

Do not start another printing job until the error message turns off.

NOTE

If the error persists after the action above is taken, ensure that the error replicates after the printer is powered off and then on, and then go to the following steps to continue further fault isolation.

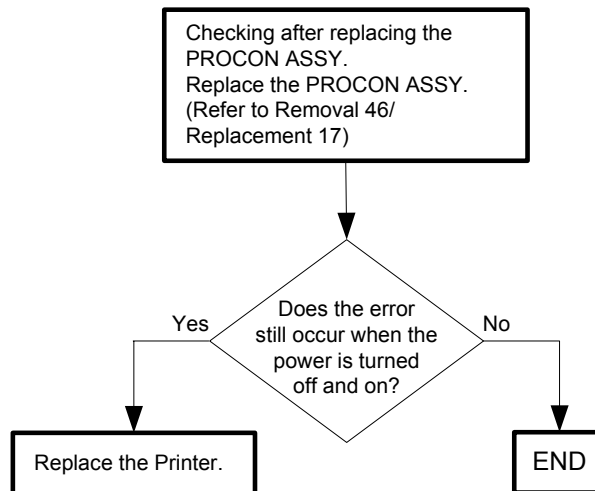

Flows 84 046-310: IOT HVPS Error

Cause: MCU detected the HVPS error.

Solution: Turn the power off and on to check that the error recurs. Then, proceed to the troubleshooting following the flowchart given below.

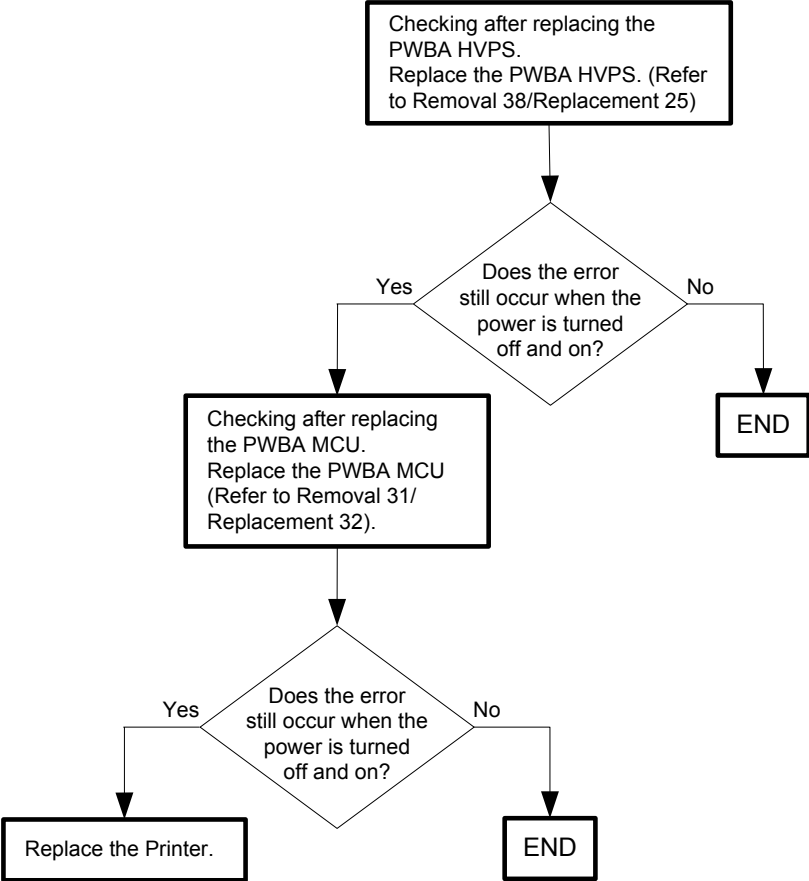

Flows 85 047-216: IOT Option Output Expander Failure

Cause: The MCU has detected a failure in the Output Expander.

Solution: Turn the power off and on to check that the error recurs. Then, proceed to the troubleshooting following the flowchart given below.

NOTE Never turn off the power to the printer while the firmware is being downloaded. Turning the power off may cause a failure in the printer.

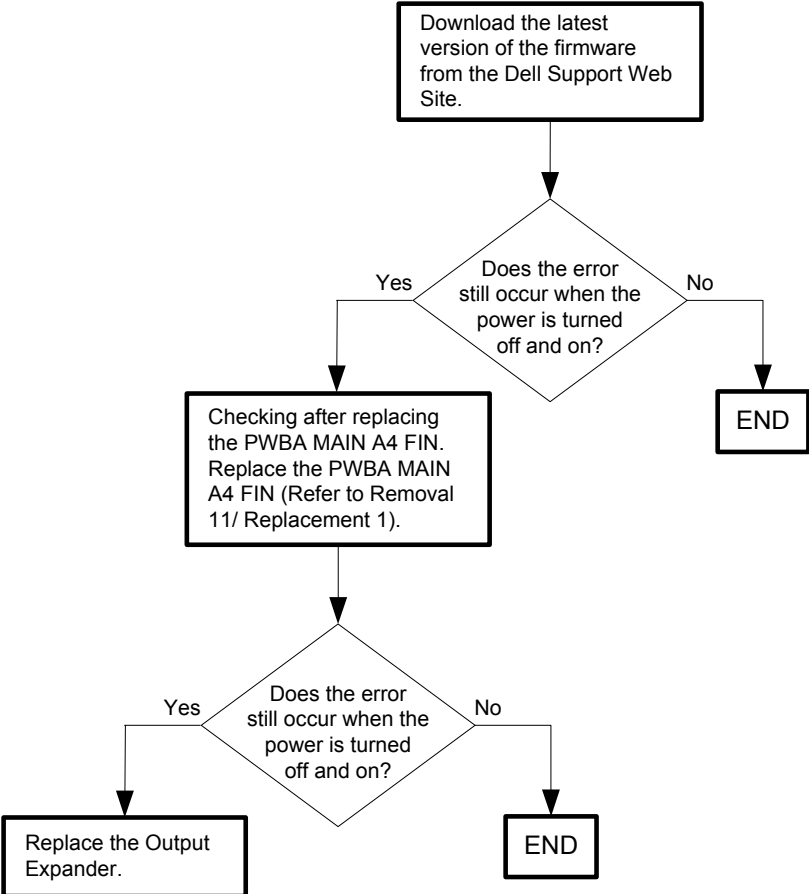

Flows 86 047-217: IOT Output Expander I/F Failure

Cause: MCU detected the Output Expander I/F Failure.

Solution: Turn the power off and on to check that the error recurs. Then, proceed to the troubleshooting following the flowchart given below.

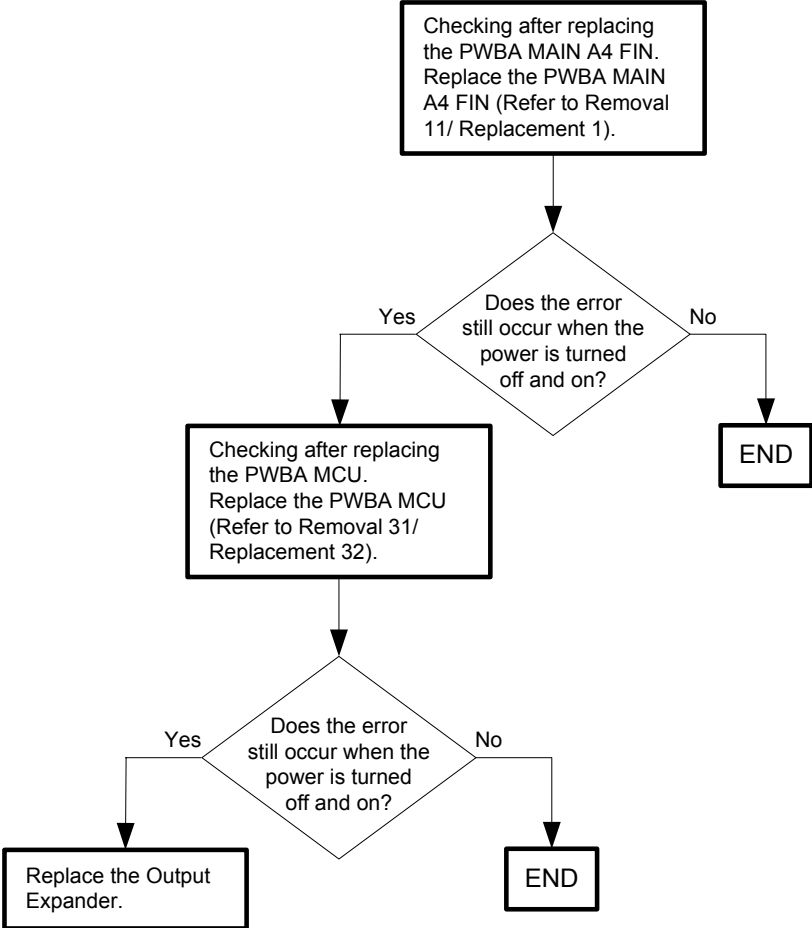

Flows 87 050-101: IOT Remain Zone RH1 JAM

Cause: Paper jam was detected at the Zone RH1 section (Refer to Reference _1) of the Printer.

Solution: Remove the jammed paper. Refer to "Appendix_1.1 Clearing Paper Jams From the MPF", "Appendix_1.3 Clearing Paper Jams From the Fuser" and "Appendix_1.4 Clearing Paper Jams From the Duplexer" for how to remove the jammed paper.

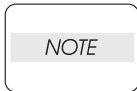

If the error persists after the action above is taken, ensure that the error replicates after the printer is powered off and then on, and then go to the following steps to continue further fault isolation.

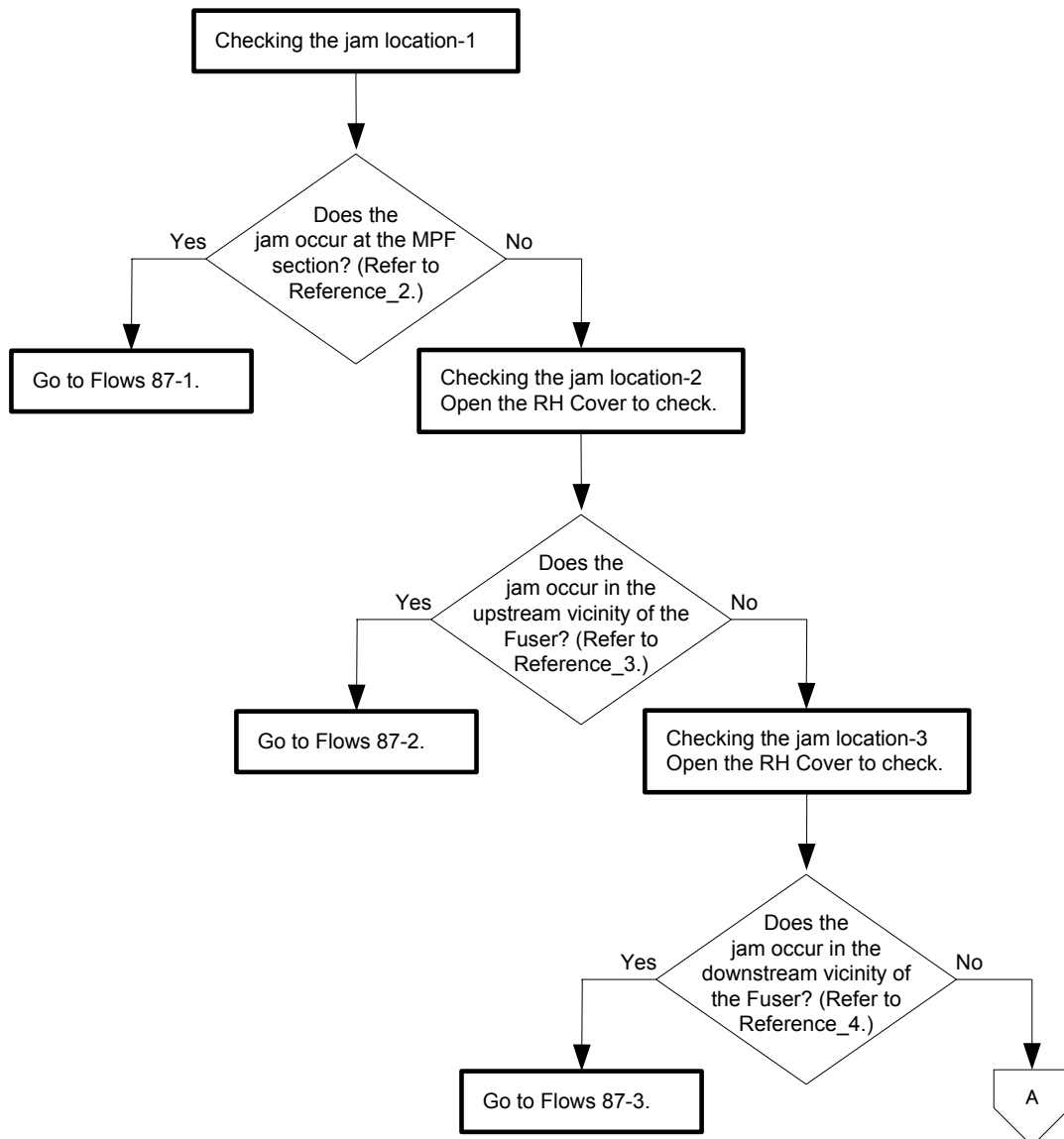

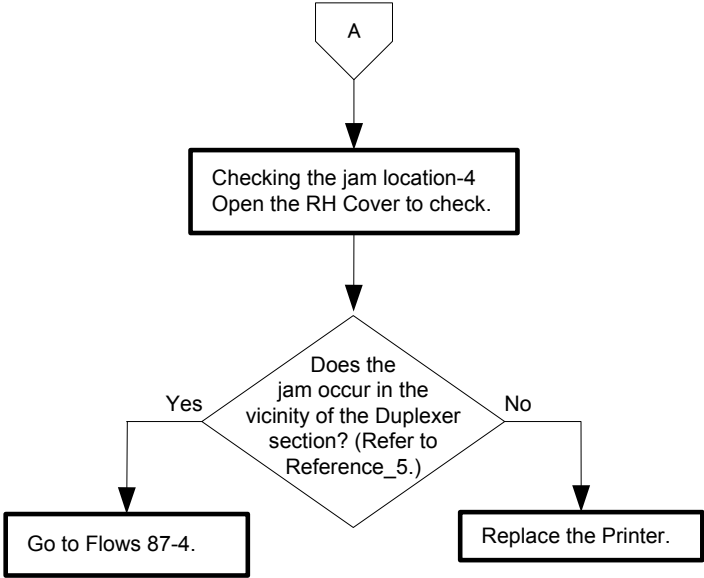

- Reference_1: Location of the RH1 section

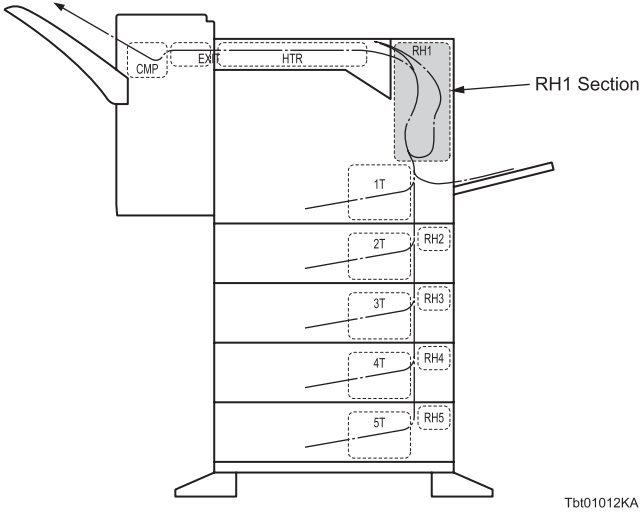

- Reference_2: Jam at the MPF section

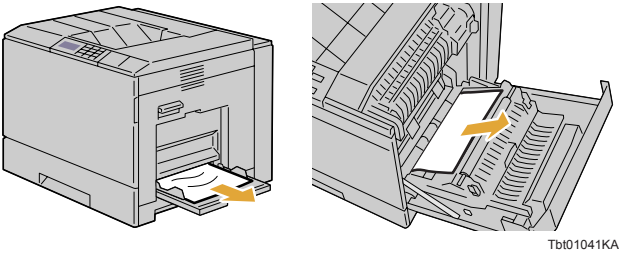

- Reference_3: Jam in the upstream vicinity of the Fuser section

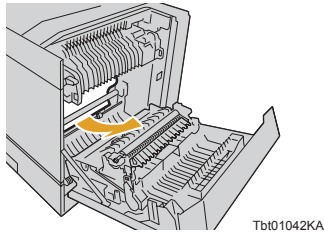

- Reference_4: Jam in the downstream vicinity of the Fuser section

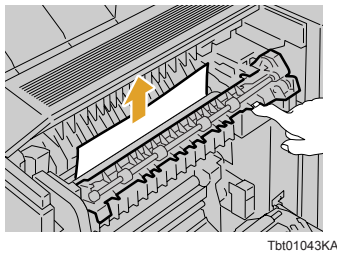

- Reference_5: Jam in the Duplexer section

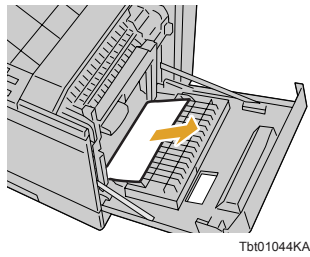

Flows 87-1 Jam at the MPF section (050-101)

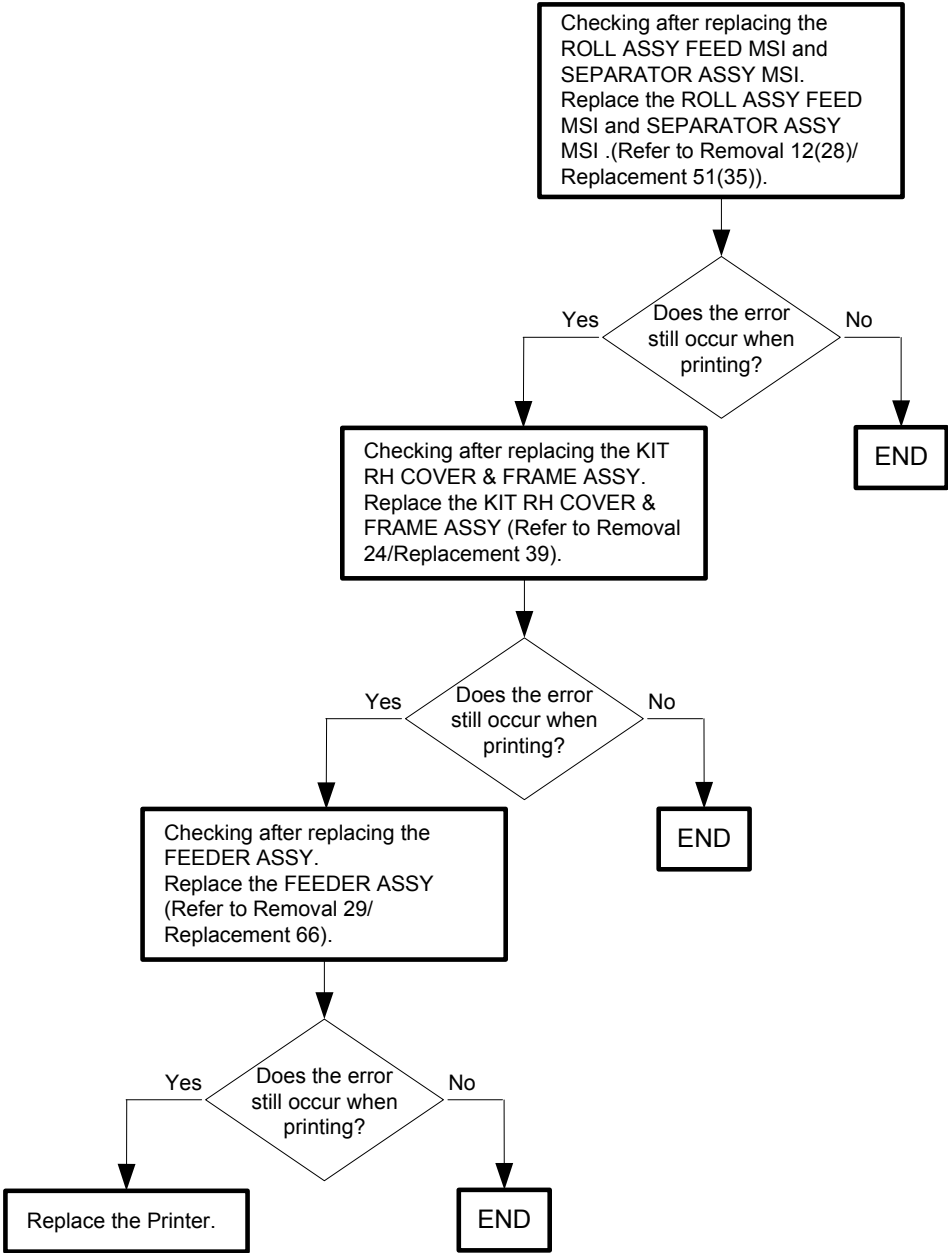

Flows 87-2 Jam in the upstream vicinity of the Fuser section (050-101)

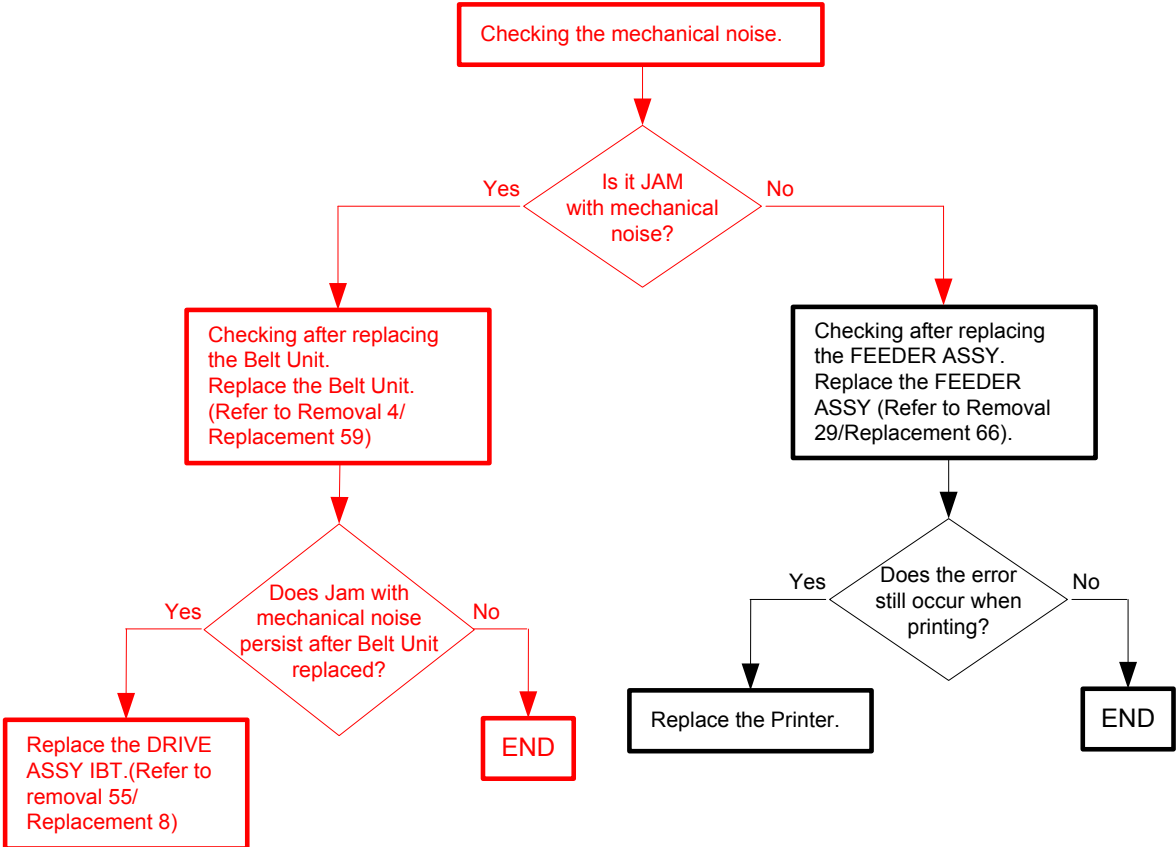

Flows 87-3 Jam in the downstream vicinity of the Fuser section (050-101)



To avoid burns, do not replace the fuser immediately after printing. The fuser becomes extremely hot during use. Turn off the printer and wait for 30 minutes before removing the fuser.

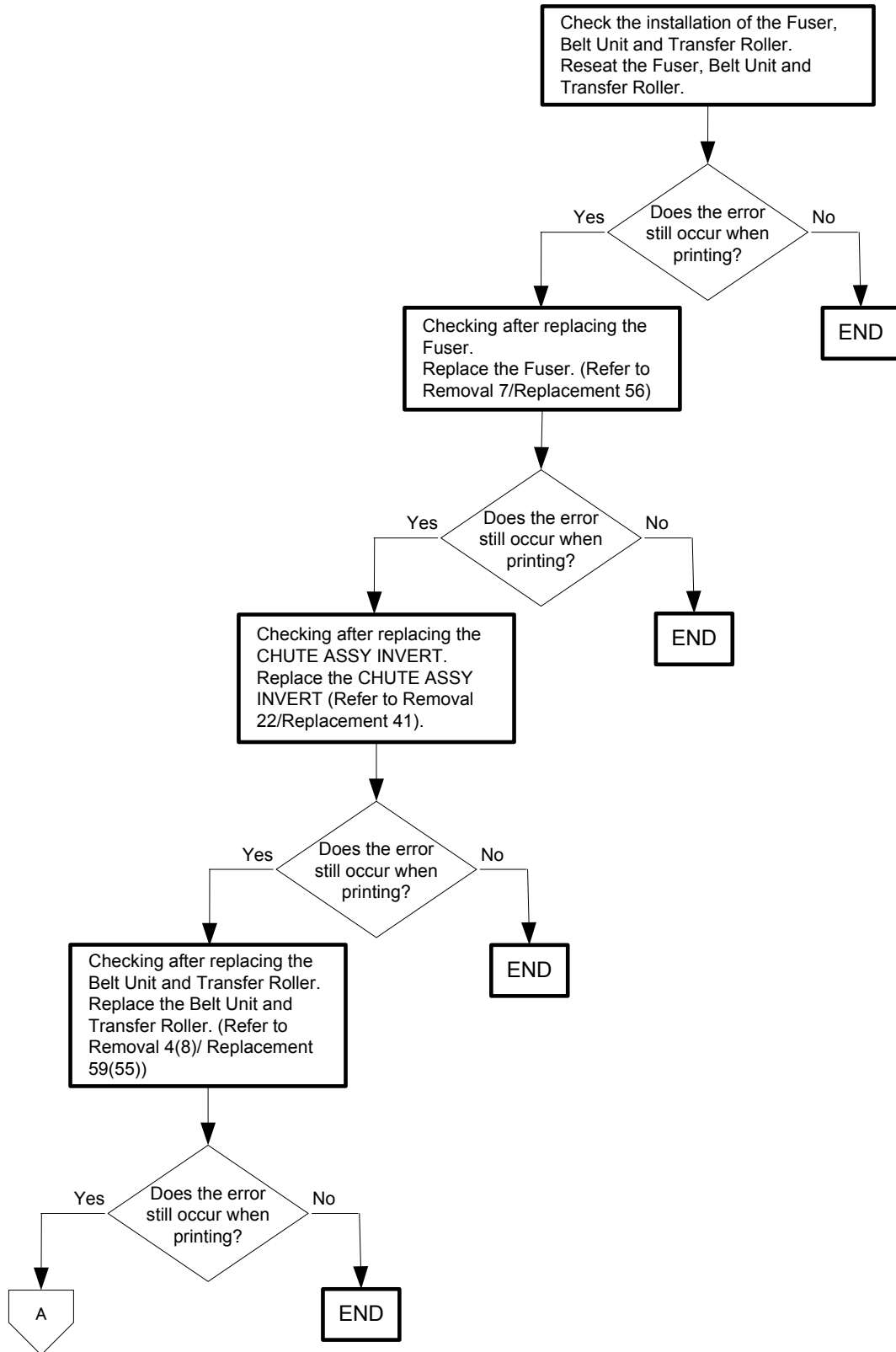

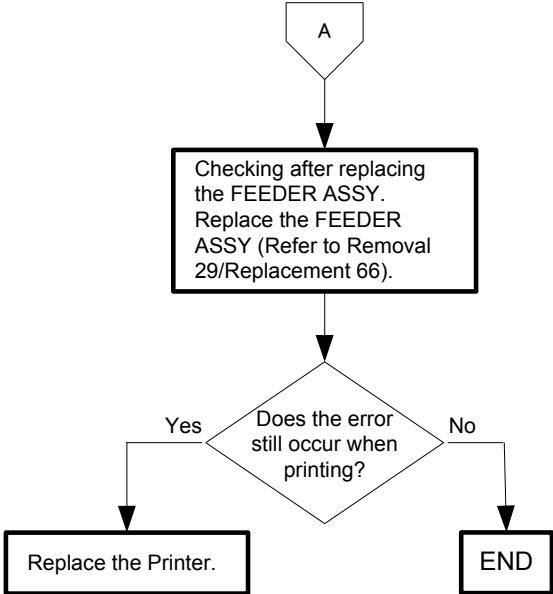

Flows 87-4 Jam in the Duplexer section (050-101)

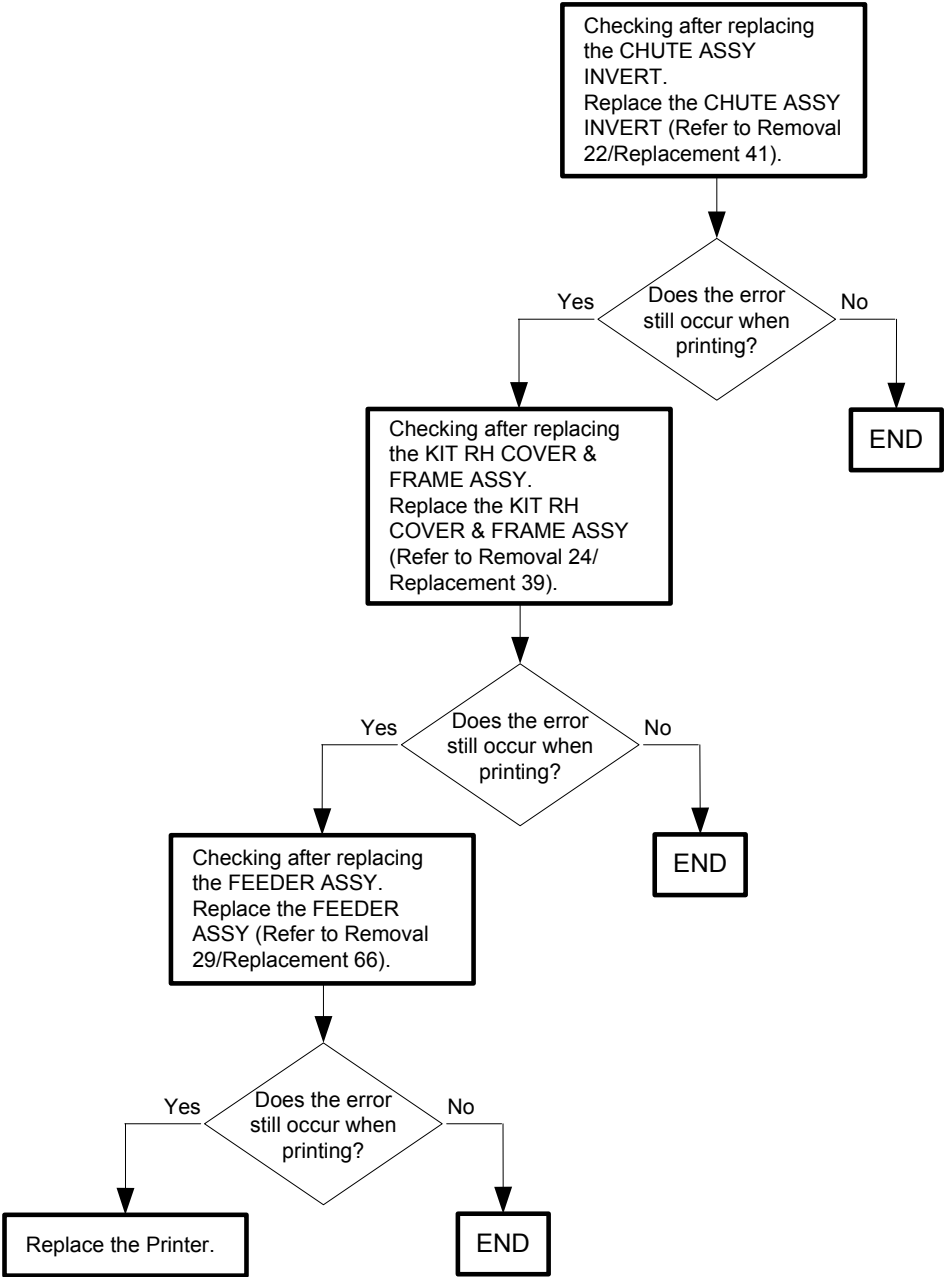

Flows 88 050-102 / 050-103 / 050-104 / 050-105: IOT Remain Zone RH2 JAM / IOT Remain Zone RH3 JAM / IOT Remain Zone RH4 JAM / IOT Remain Zone RH5 JAM

Cause: 050-102: Paper jam was detected at the Zone RH2 section (Refer to Reference _1) of the Printer.

050-103: Paper jam was detected at the Zone RH3 section (Refer to Reference _1) of the Printer.

050-104: Paper jam was detected at the Zone RH4 section (Refer to Reference _1) of the Printer.

050-105: Paper jam was detected at the Zone RH5 section (Refer to Reference _1) of the Printer.

Solution: Remove the jammed paper. Refer to "Appendix_1.5 Clearing Paper Jams From the Optional Feeder" for how to remove the jammed paper.

NOTE

If the error persists after the action above is taken, ensure that the error replicates after the printer is powered off and then on, and then go to the following steps to continue further fault isolation.

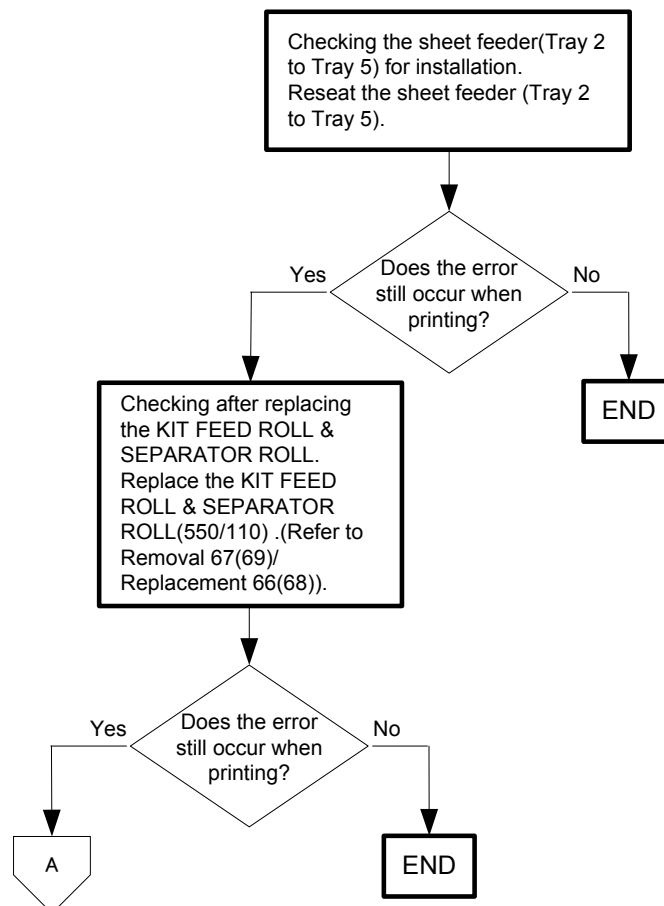

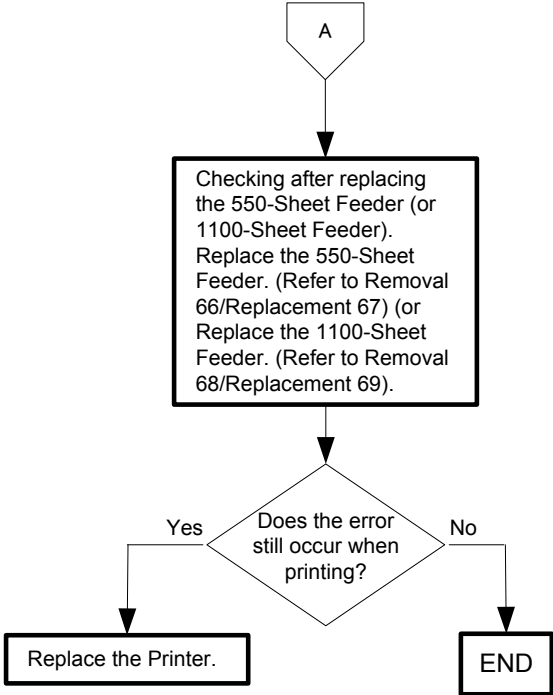

- Reference_1: Location of the RH2 to RH5 sections

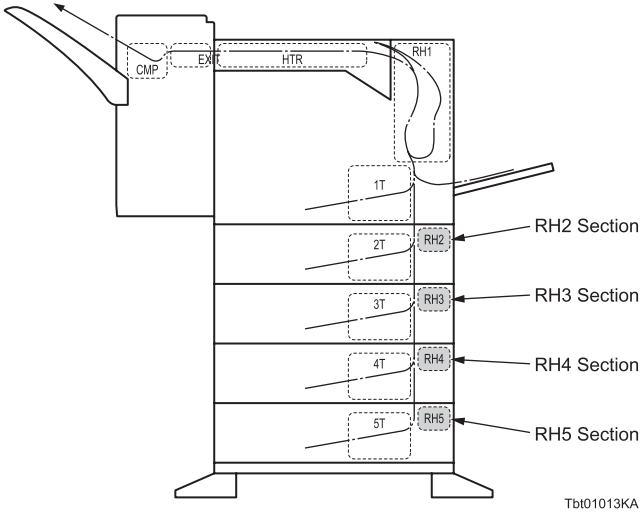

Flows 89 050-121: IOT Remain Zone 1T JAM

Cause: Paper jam was detected at the Zone 1T section (Refer to Reference _1) of the Printer.

Solution: Remove the jammed paper. Refer to "Appendix_1.2 Clearing Paper Jams From the Standard Tray" for how to remove the jammed paper.

NOTE

If the error persists after the action above is taken, ensure that the error replicates after the printer is powered off and then on, and then go to the following steps to continue further fault isolation.

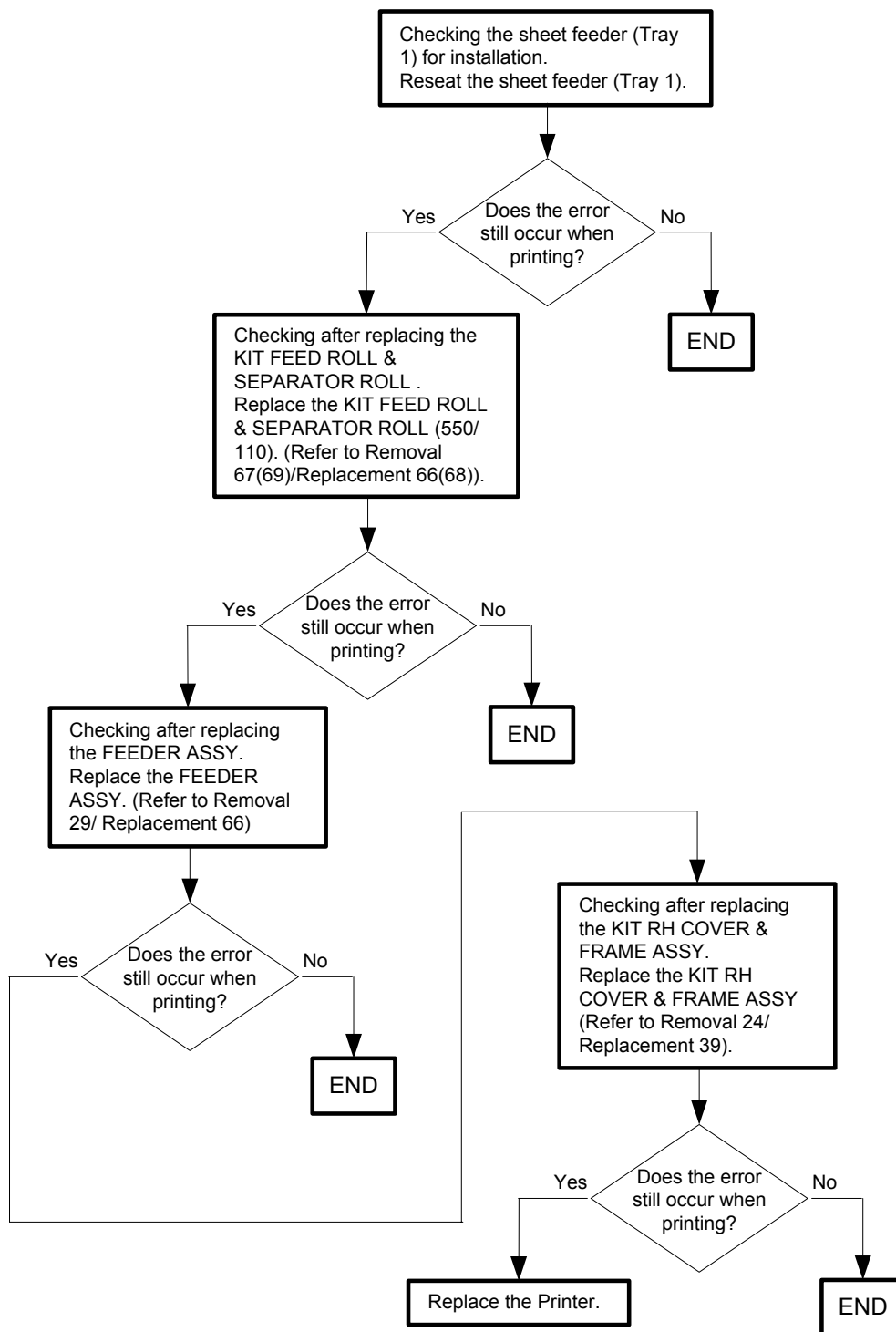

- Reference_1:Location of the 1T section

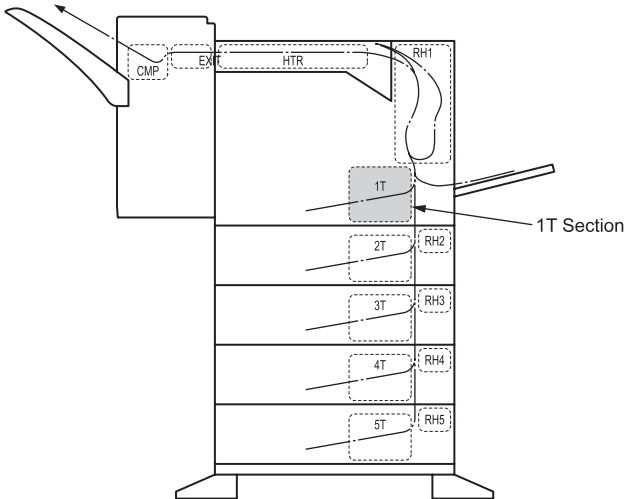

Flows 90 050-122 / 050-123 / 050-124 / 050-125: IOT Remain Zone 2T JAM / IOT Remain Zone 3T JAM / IOT Remain Zone 4T JAM / IOT Remain Zone 5T JAM

- Cause: 050-122: Paper jam was detected at the Zone 2T section (Refer to Reference _1) of the Printer.
 050-123: Paper jam was detected at the Zone 3T section (Refer to Reference _1) of the Printer.
 050-124: Paper jam was detected at the Zone 4T section (Refer to Reference _1) of the Printer.
 050-125: Paper jam was detected at the Zone 5T section (Refer to Reference _1) of the Printer.

Solution: Remove the jammed paper. Refer to "Appendix_1.5 Clearing Paper Jams From the Optional Feeder" for how to remove the jammed paper.

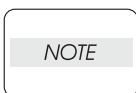

If the error persists after the action above is taken, ensure that the error replicates after the printer is powered off and then on, and then go to the following steps to continue further fault isolation.

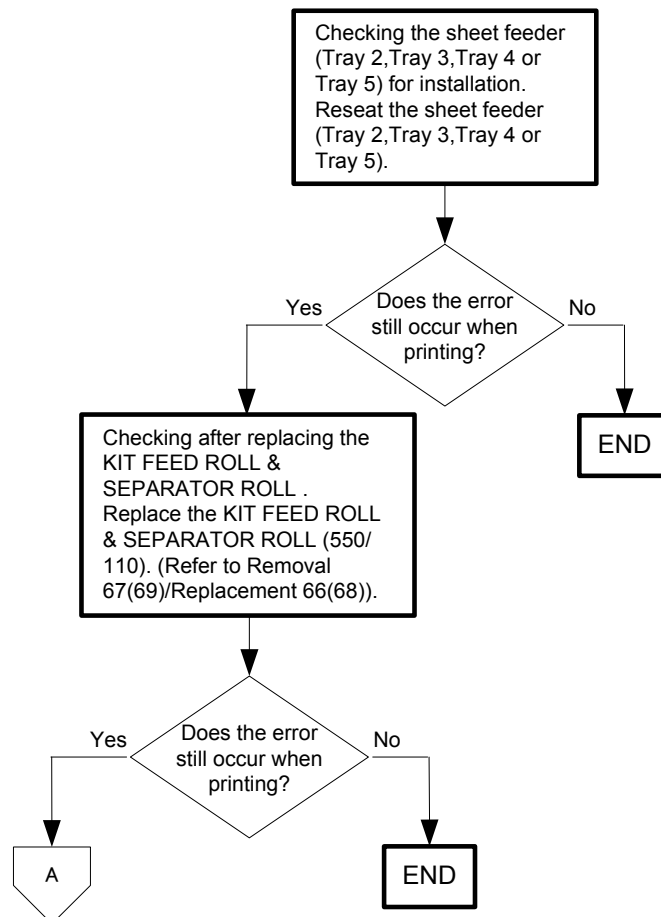

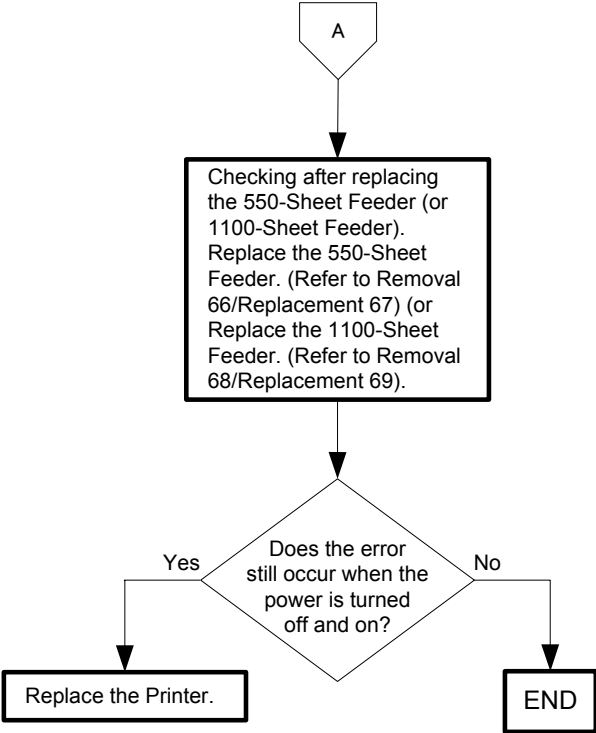

- Reference_1: Location of the 2T to 5T sections

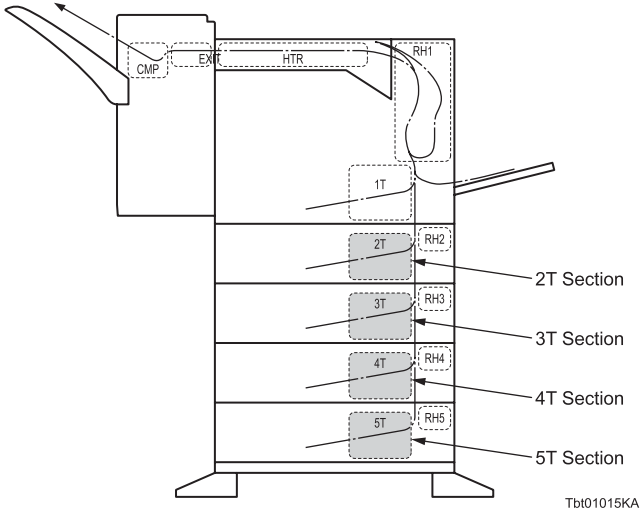

Flows 91 050-151: IOT Remain Zone HTR JAM

Cause: Paper jam was detected at the Zone HTR section (Refer to Reference_1) of the Output Expander.

Solution: Remove the jammed paper. Refer to "Appendix_1.6 Clearing Paper Jams From the Output Expander" for how to remove the jammed paper.

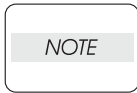

If the error persists after the action above is taken, ensure that the error replicates after the printer is powered off and then on, and then go to the following steps to continue further fault isolation.

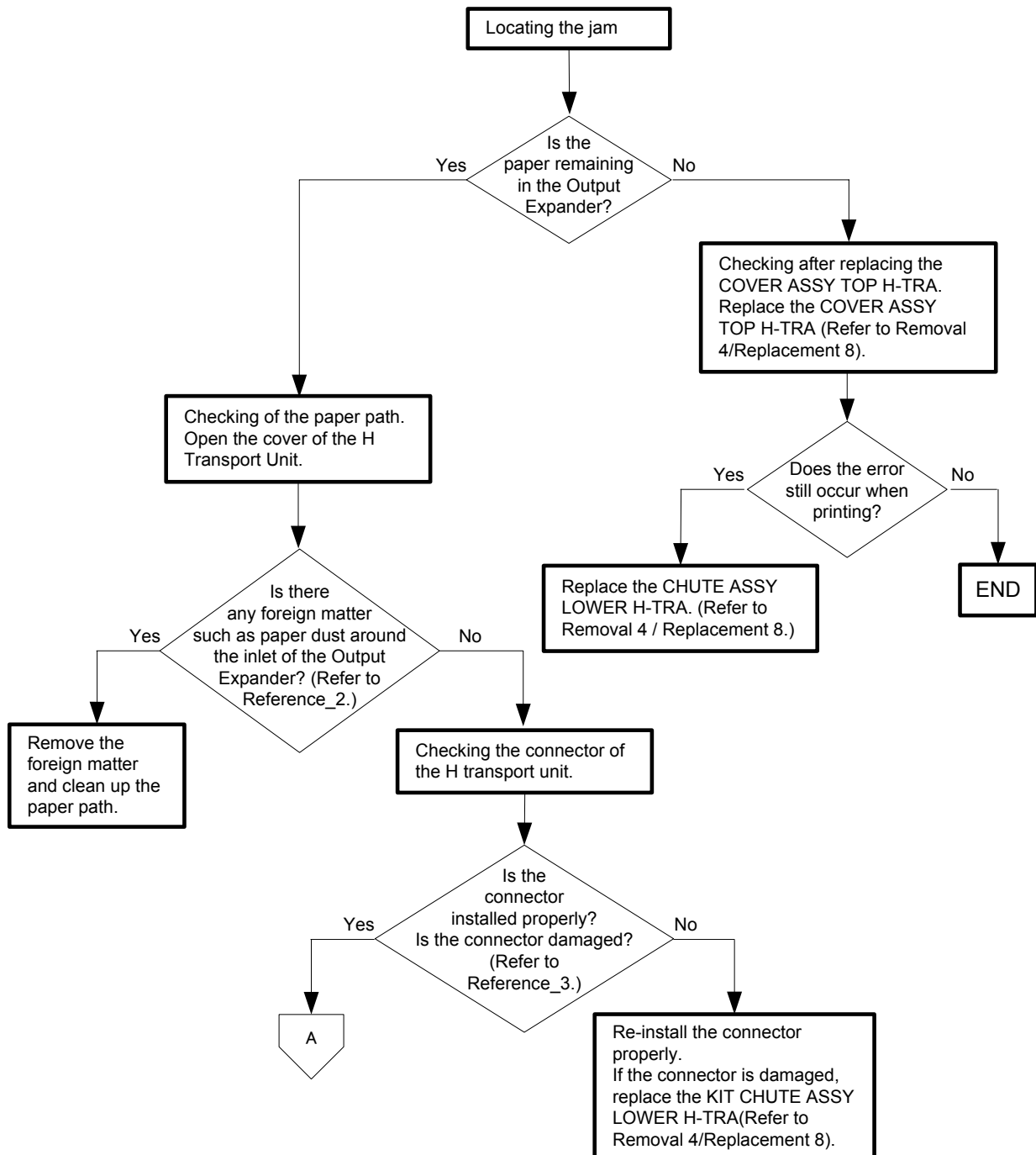

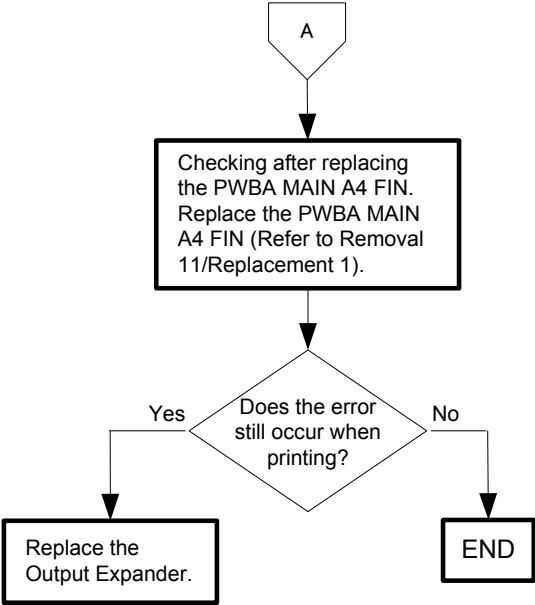

- Reference_1: Location of the HTR section

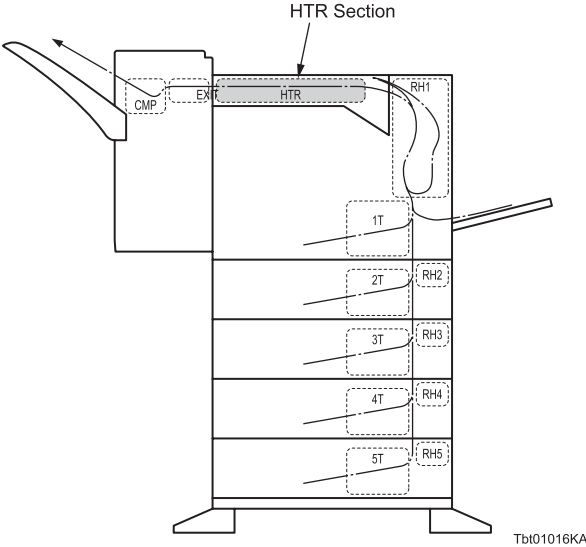

- Reference_2: Section of the paper path to be checked

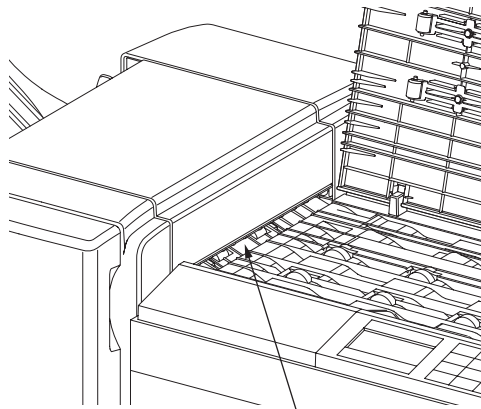

Checking of the paper path

Tb101003KA

- Reference_3: Section of the connector to be checked.

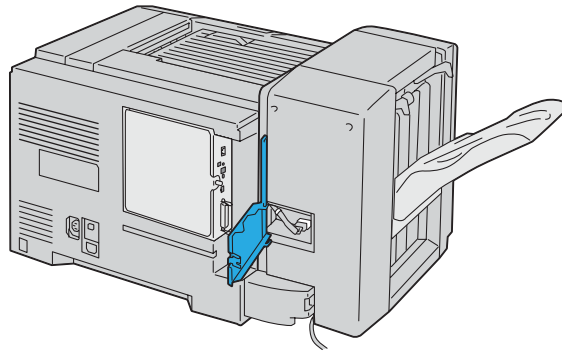

Flows 92 050-152: IOT Remain Zone EXIT JAM

Cause: Paper jam was detected at the Zone EXIT section (Refer to Reference_1.) of the Output Expander.

Solution: Remove the jammed paper. Refer to "Appendix_1.6 Clearing Paper Jams From the Output Expander" for how to remove the jammed paper.

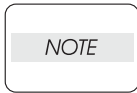

If the error persists after the action above is taken, ensure that the error replicates after the printer is powered off and then on, and then go to the following steps to continue further fault isolation.

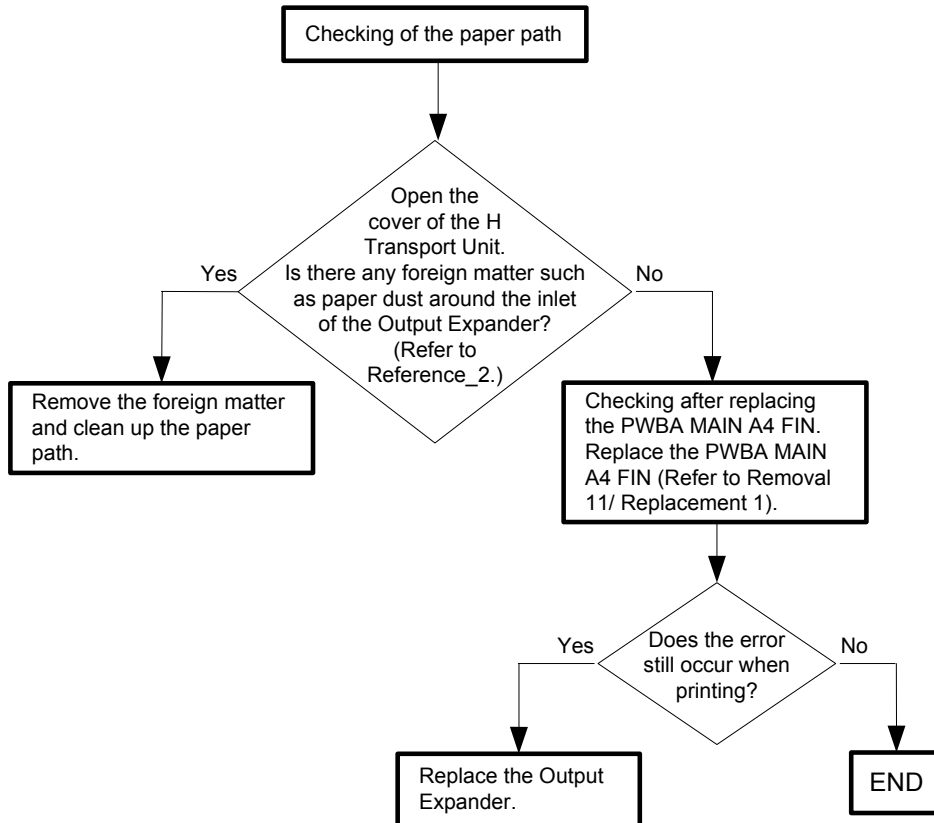

- Reference_1: Location of the EXIT section

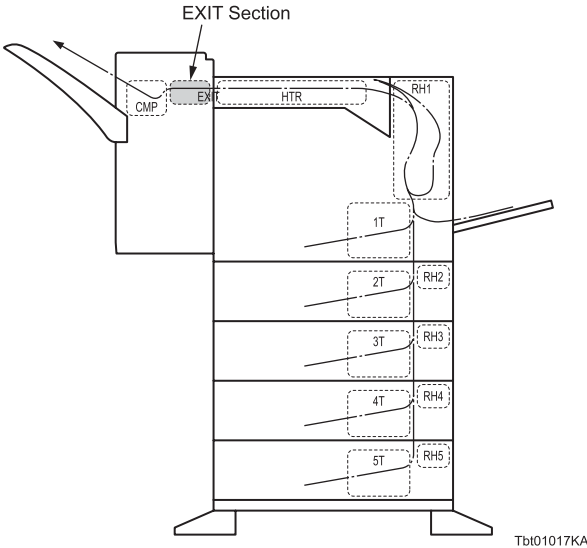

- Reference_2: Section of the paper path to be checked

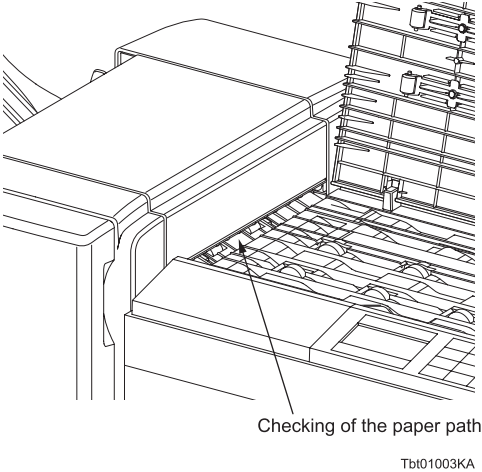

Flows 93 050-153: IOT Remain Zone CMP JAM

Cause: Paper jam was detected at the Zone CMP section (Refer to Reference_1.) of the Output Expander.

Solution: Remove the jammed paper. Refer to "Appendix_1.6 Clearing Paper Jams From the Output Expander" for how to remove the jammed paper.

NOTE

If the error persists after the action above is taken, ensure that the error replicates after the printer is powered off and then on, and then go to the following steps to continue further fault isolation.

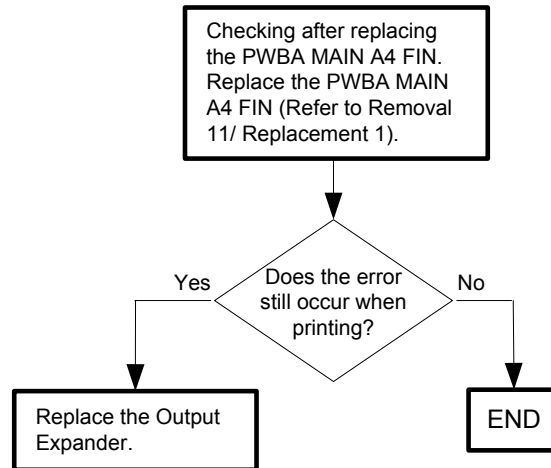

- Reference_1: Location of the CMP section

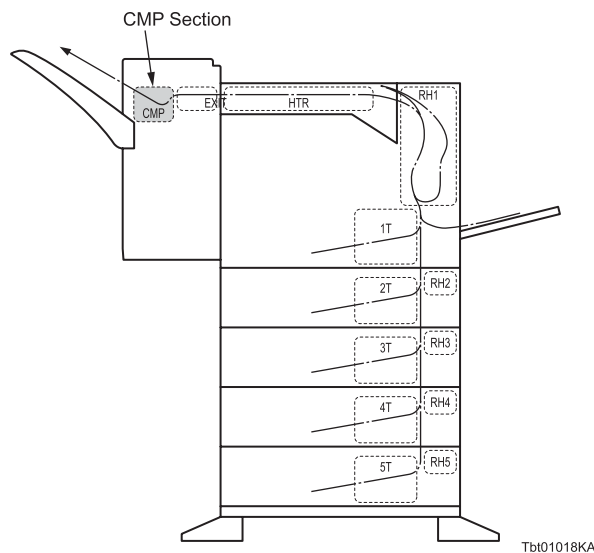

Flows 94 072-211-01 / 073-211-01: IOT Option Feeder2 (or Feeder3) Failure

Cause: 072-211-01:MCU detected the Option Feeder Motor2 Failure.
073-211-01:MCU detected the Option Feeder Motor3 Failure.

Solution: Turn the power off and on to check that the error recurs. Then, proceed to the troubleshooting following the flowchart given below.

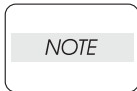

Never turn off the power to the printer while the firmware is being downloaded. Turning the power off may cause a failure in the printer.

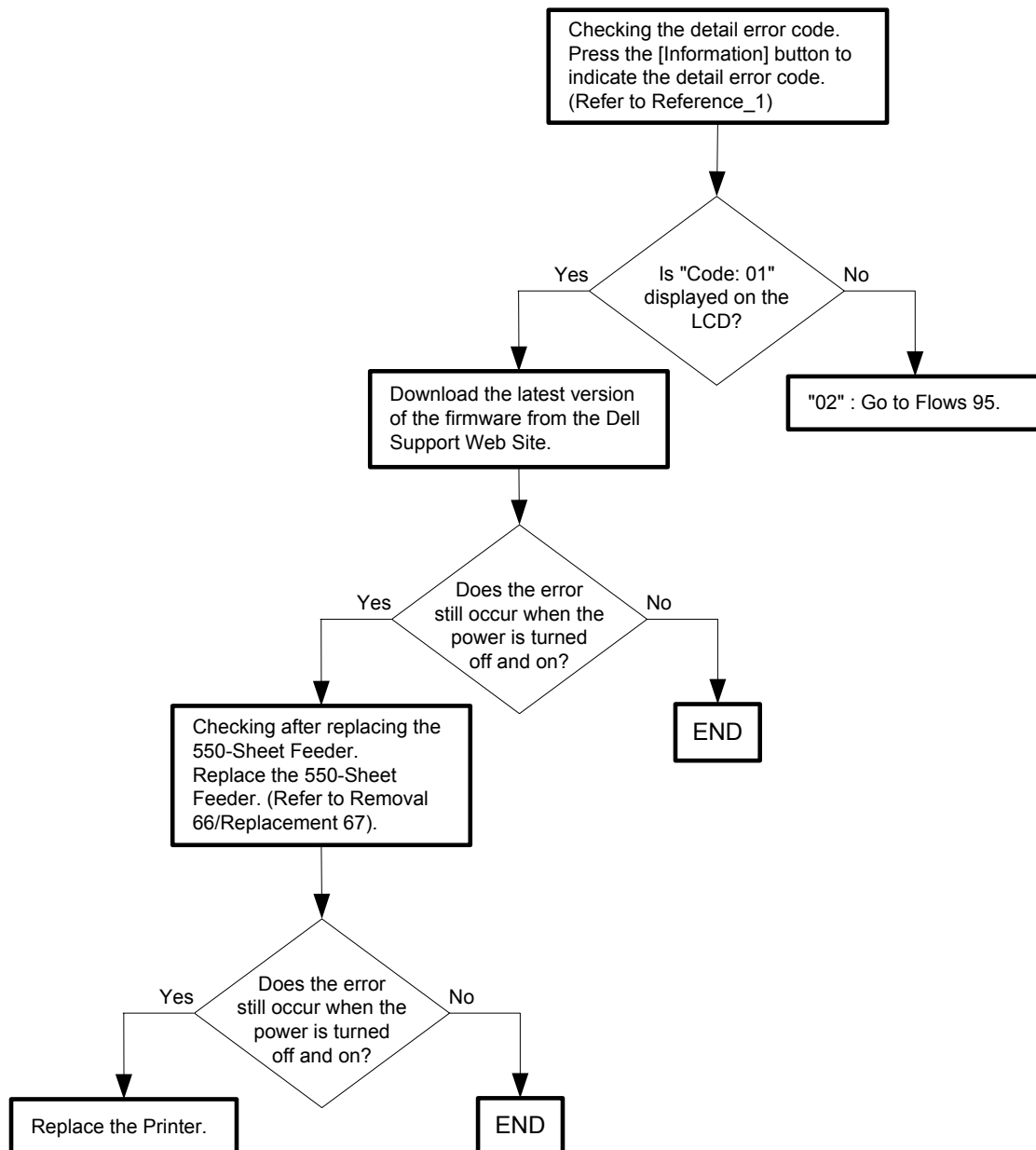

- Reference_1: [Information] button

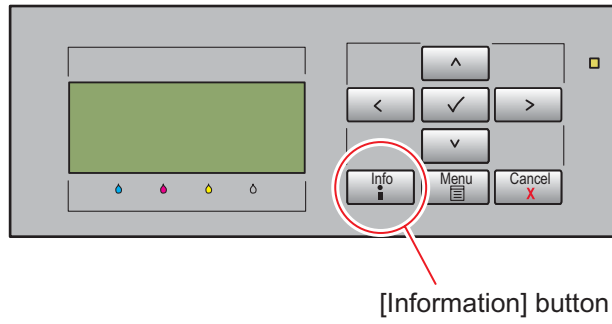

Flows 95 072-211-02 / 073-211-02: IOT Option Feeder Motor2 (or Motor3) Failure

Cause: 072-211-02:MCU detected the Option Feeder Motor2 Failure.

073-211-02:MCU detected the Option Feeder Motor3 Failure.

Solution: Turn the power off and on to check that the error recurs. Then, proceed to the troubleshooting following the flowchart given below.

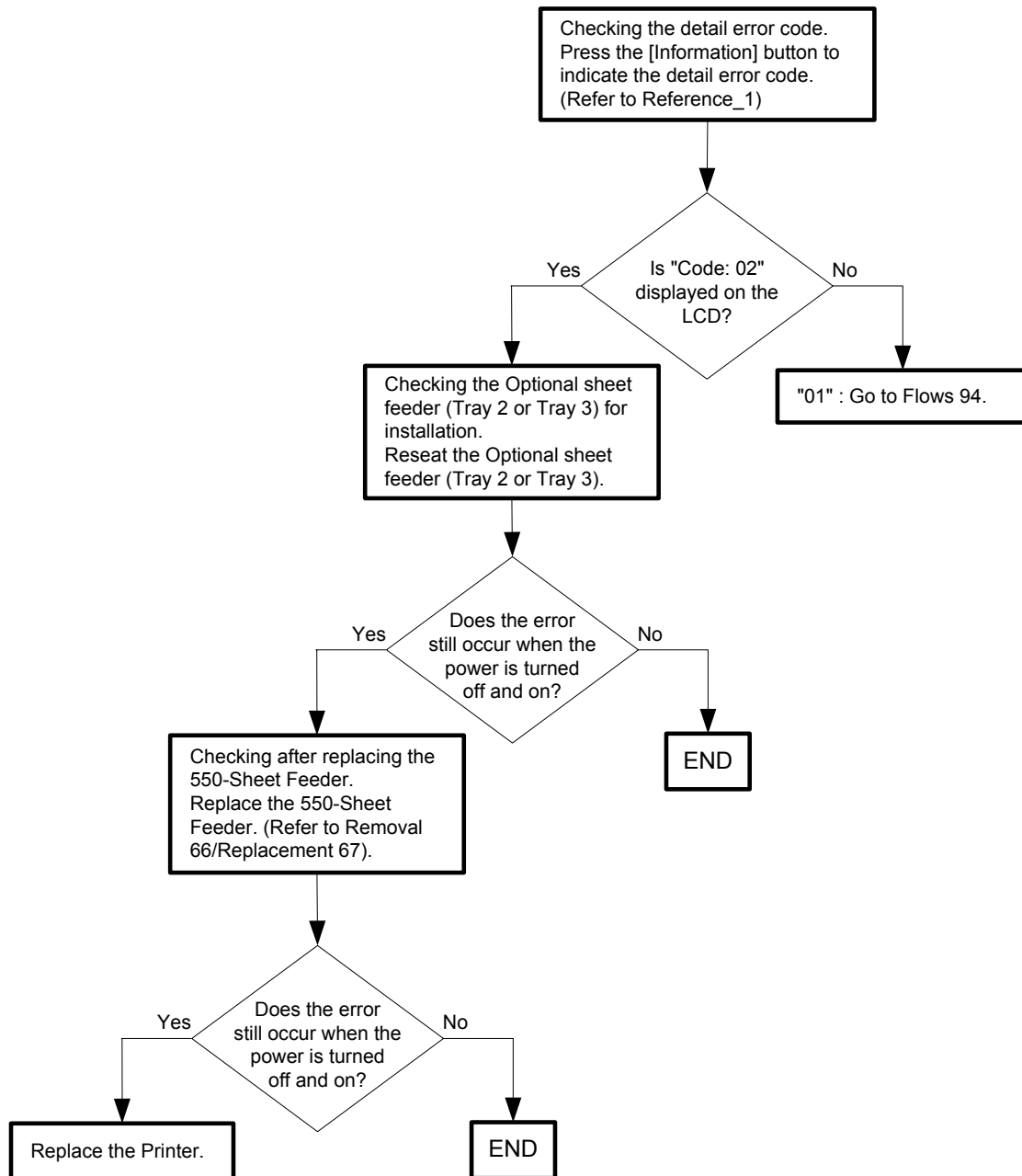

- Reference_1: [Information] button

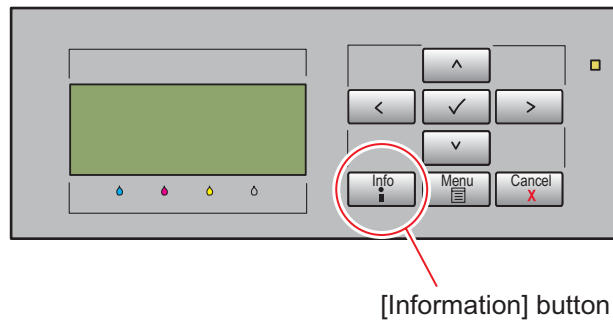

Flows 96 072-300 / 073-300: IOT RH Cover Tray2 (or Tray3) Open

Cause: 072-300: The Right Hand cover of the Tray 2 is open.

073-300: The Right Hand cover of the Tray 3 is open.

Solution: The Right Hand cover is open. Close the Right Hand cover.

NOTE

If the error persists after the action above is taken, ensure that the error replicates after the printer is powered off and then on, and then go to the following steps to continue further fault isolation.

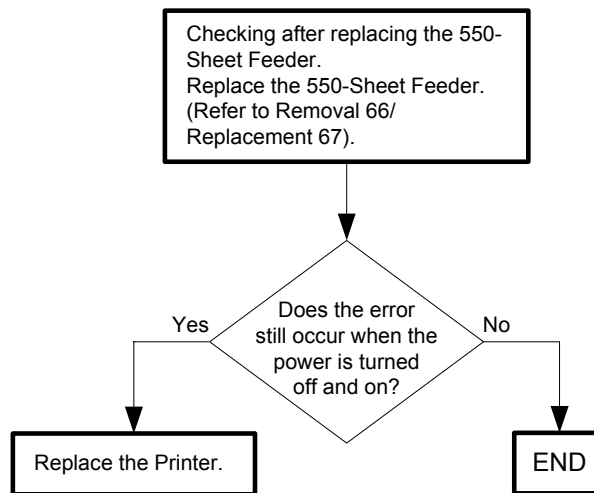

Flows 97 074-211-01 / 076-211-01: IOT Option Feeder4 (or Feeder5) Failure

Cause: 074-211-01:MCU detected the Option Feeder4 Failure.

076-211-01:MCU detected the Option Feeder5 Failure.

Solution: Turn the power off and on to check that the error recurs. Then, proceed to the troubleshooting following the flowchart given below.

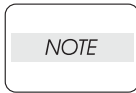

Never turn off the power to the printer while the firmware is being downloaded. Turning the power off may cause a failure in the printer.

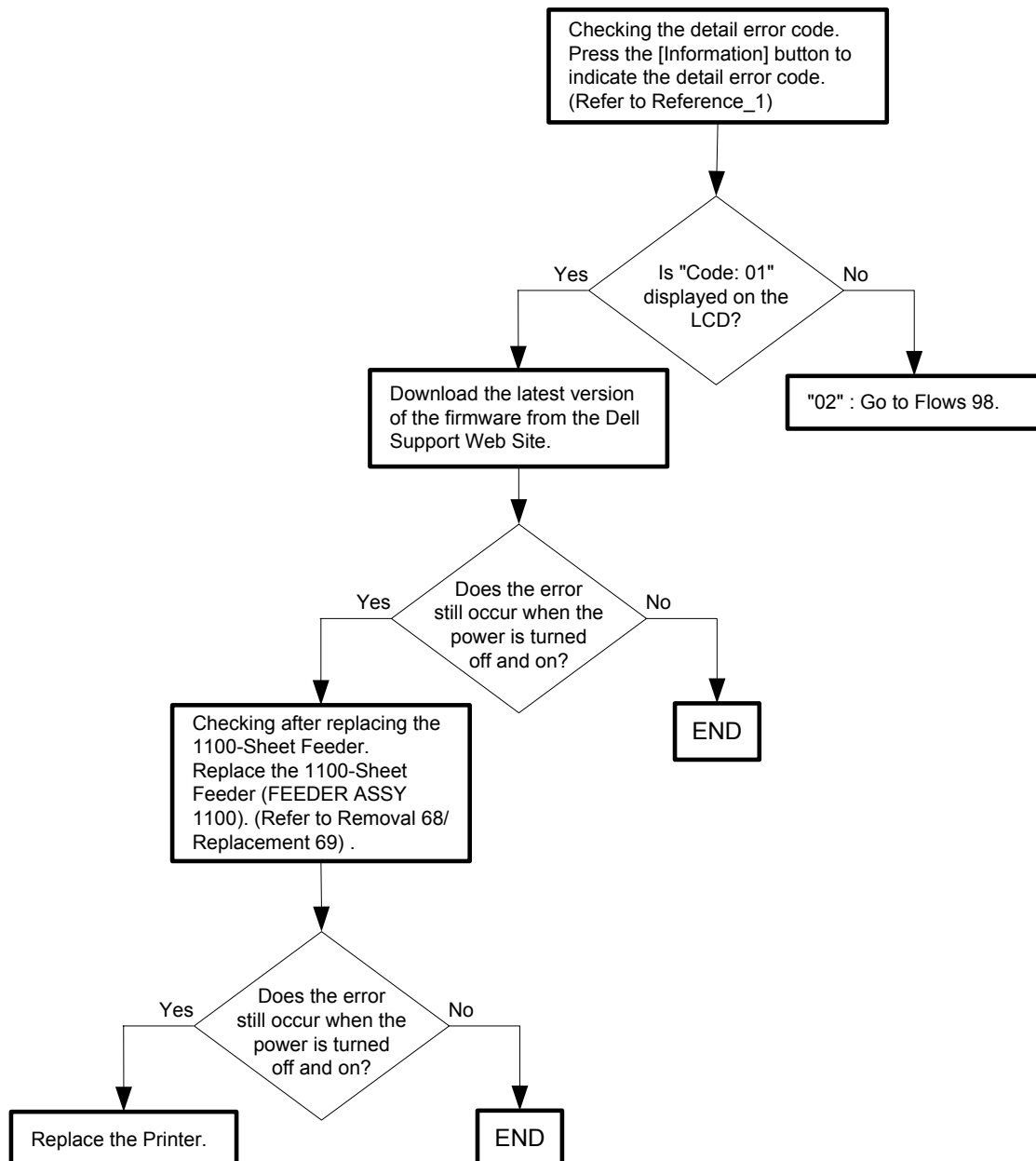

- Reference_1: [Information] button

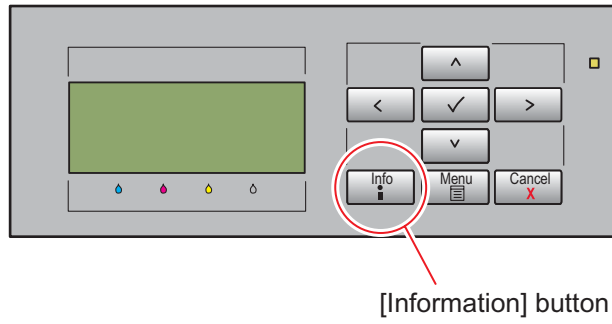

Flows 98 074-211-02 / 076-211-02: IOT Option Feeder Motor4 (or Motor5) Failure

Cause: 074-211-02:MCU detected the Option Feeder Motor4 Failure.

076-211-02:MCU detected the Option Feeder Motor5 Failure.

Solution: Turn the power off and on to check that the error recurs. Then, proceed to the troubleshooting following the flowchart given below.

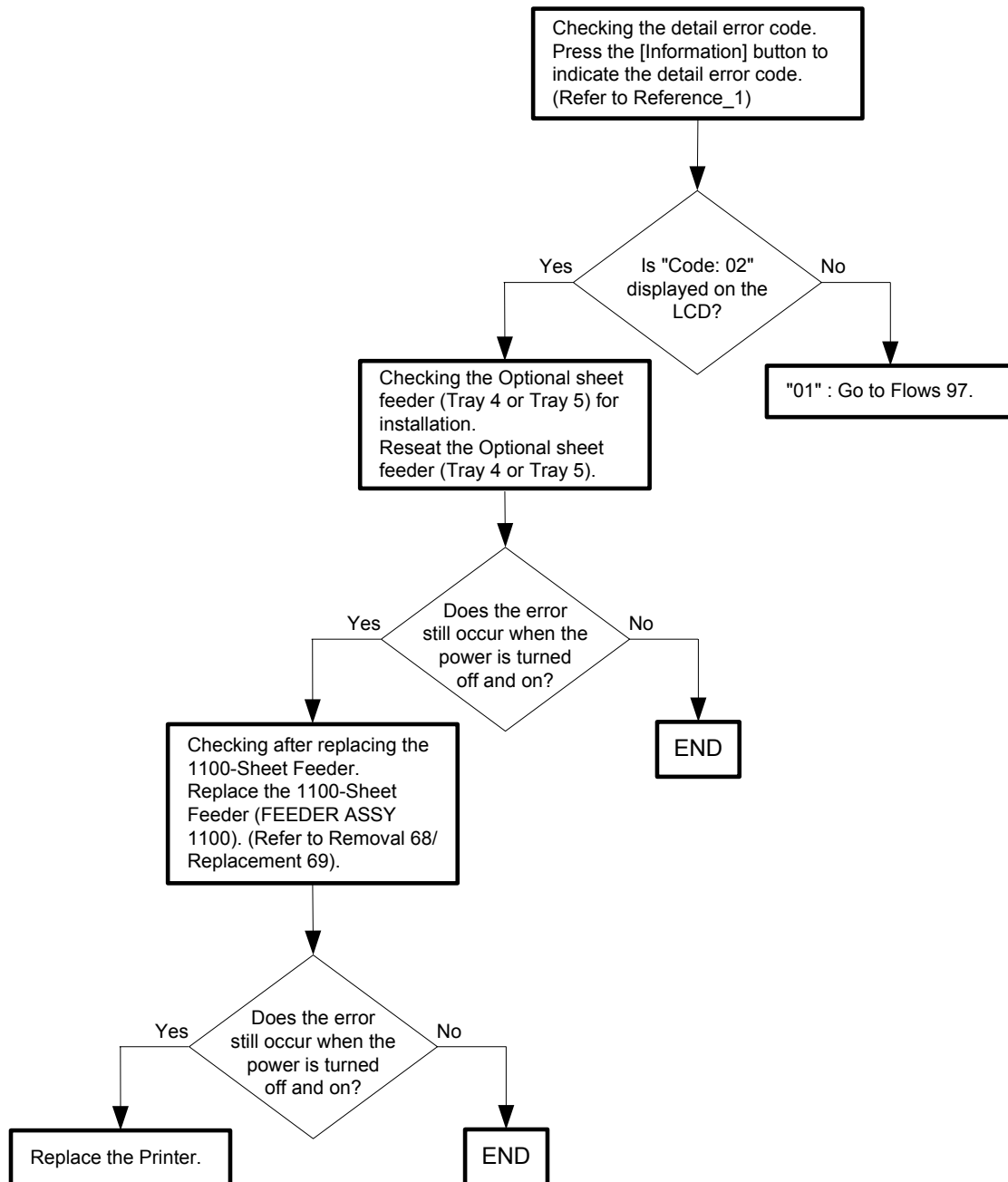

- Reference_1: [Information] button

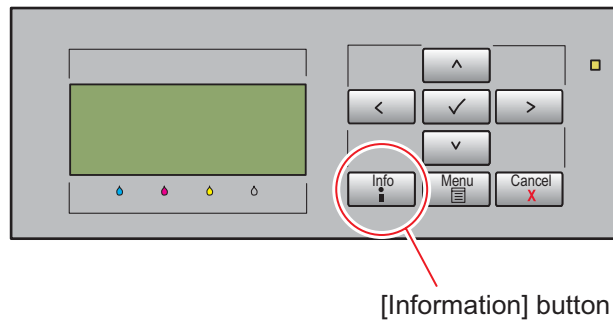

Flows 99 074-300 / 076-300: IOT Cover Tray4 (or Tray5) Open

Cause: 074-300: The Right Hand cover of the Tray 4 is open.
076-300: The Right Hand cover of the Tray 5 is open.

Solution: The Right Hand cover is open. Close the Right Hand cover.

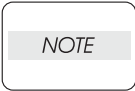

If the error persists after the action above is taken, ensure that the error replicates after the printer is powered off and then on, and then go to the following steps to continue further fault isolation.

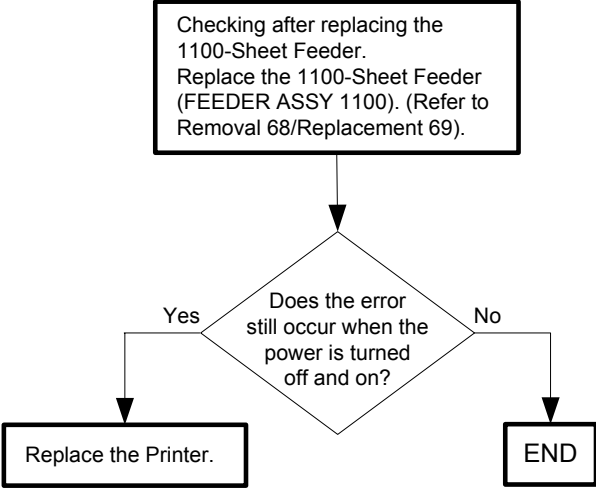

Flows 100 077-300: IOT Cover Front Open

Cause: The Front Cover is open.

Solution: The front cover is open. Close the front cover.

NOTE

If the error persists after the action above is taken, ensure that the error replicates after the printer is powered off and then on, and then go to the following steps to continue further fault isolation.

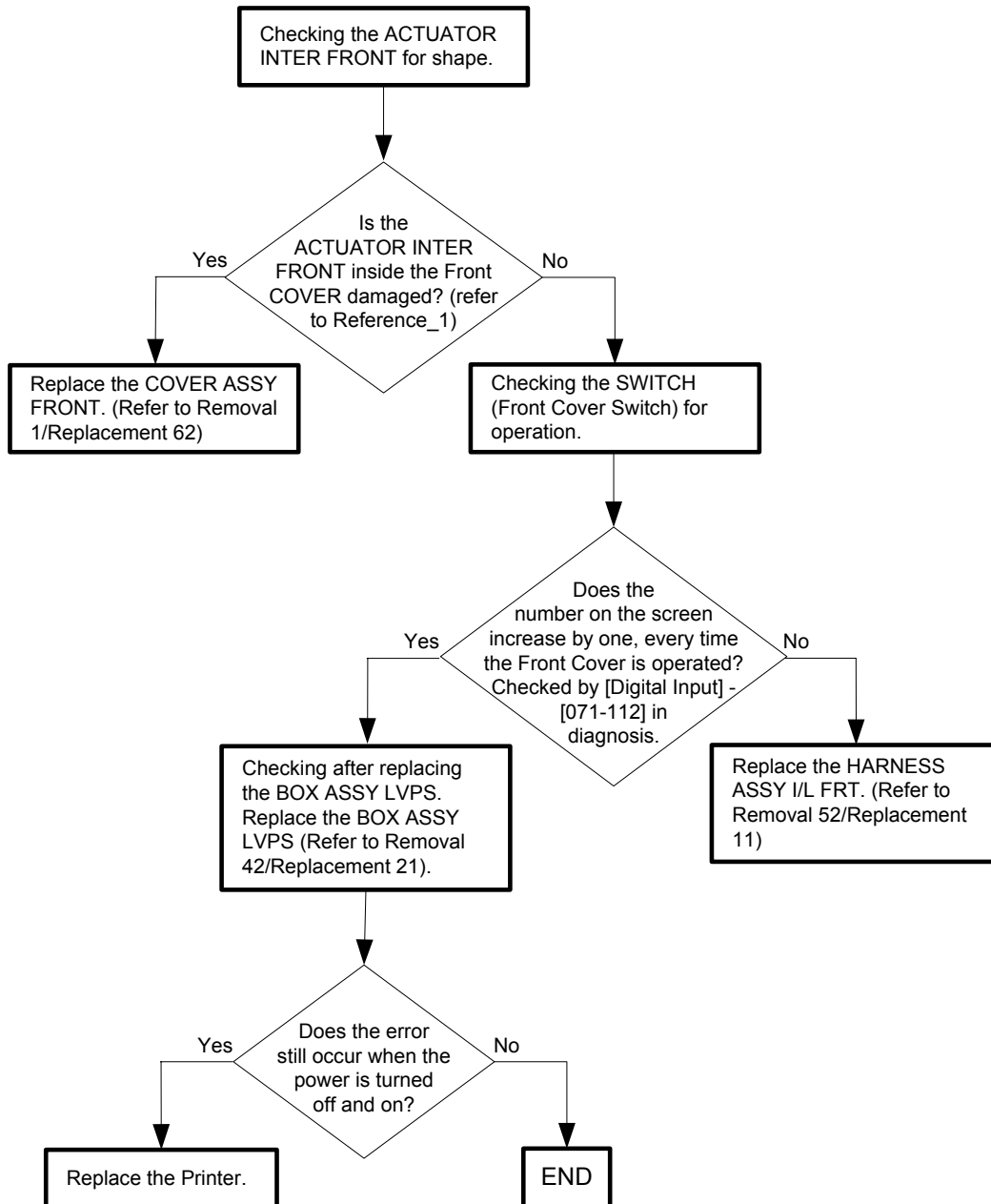

- Reference_1: Section to be checked for damage

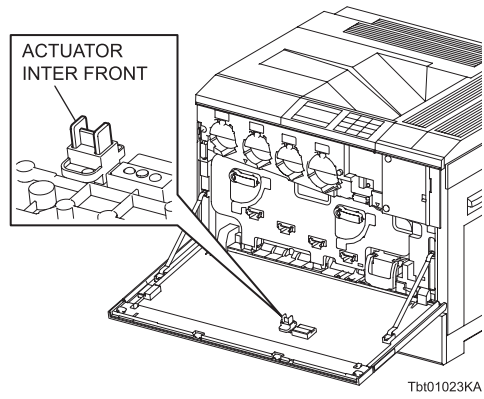

Flows 101 077-301: IOT Cover Right Hand Open

Cause: The Right Hand Cover is open.

Solution: The Right Hand cover is open. Close the Right Hand cover.

NOTE

If the error persists after the action above is taken, ensure that the error replicates after the printer is powered off and then on, and then go to the following steps to continue further fault isolation.

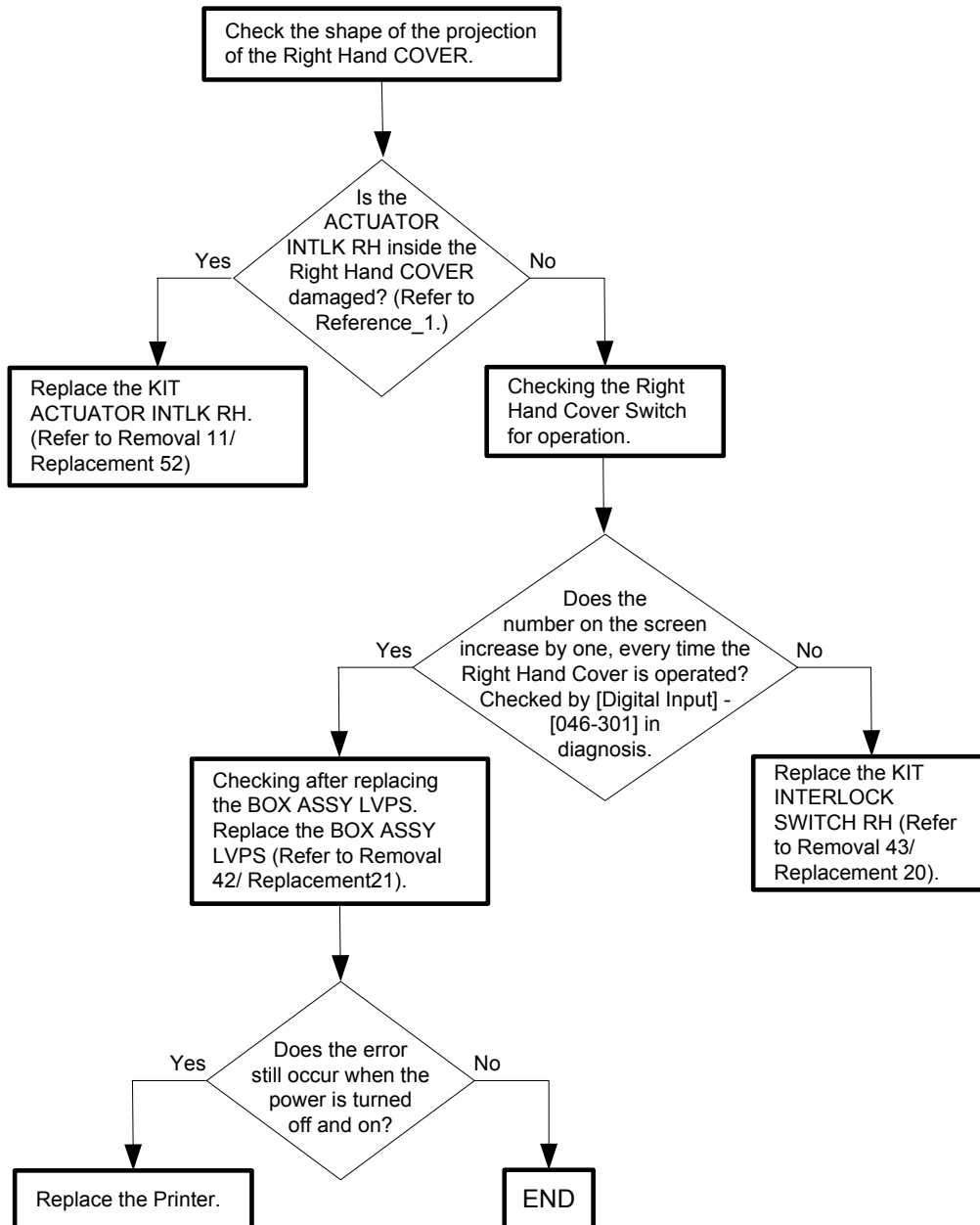

- Reference_1: Section to be checked for damage

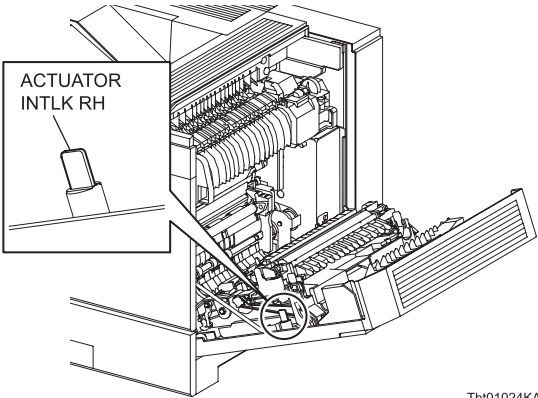

Tbt01024KA

Flows 102 091-400: IOT Waste Toner Box Near Life

Cause: The Waste Toner Box is approaching the replacement time.

Solution: The Waste Toner Box is approaching the replacement time. Prepare a new Waste Toner Box.

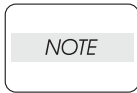

Refer to "Appendix_2.1 Consumables and Periodic Replacement Parts Life" for the timing when the messages "Near Life" is indicated.

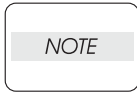

This error code is not related to any hardware fault.

Flows 103 091-411 / 091-412 / 091-413 / 091-414 / 091-479 / 091-480 / 091-481 / 091-482: IOT Drum Cartridge (YMCK) Near Life

Cause: 091-411: The Drum Cartridge (K) is approaching the replacement time.
091-412: The Drum Cartridge (Y) is approaching the replacement time.
091-413: The Drum Cartridge (M) is approaching the replacement time.
091-414: The Drum Cartridge (C) is approaching the replacement time.
091-479: The Drum Cartridge (K) is approaching the replacement time.
091-480: The Drum Cartridge (Y) is approaching the replacement time.
091-481: The Drum Cartridge (M) is approaching the replacement time.
091-482: The Drum Cartridge (C) is approaching the replacement time.

Solution: The Drum Cartridge (YMCK) is approaching the replacement time. Prepare a new Drum Cartridge of the relevant one.

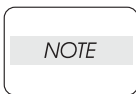

Refer to "Appendix_2.1 Consumables and Periodic Replacement Parts Life" for the timing when the message "Near Life" is indicated.

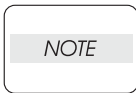

This error code is not related to any hardware fault.

Flows 104 091-911: IOT Waste Toner Box Life Over

Cause: The Waste Toner Box has reached the replacement time.

Solution: The Waste Toner Box is full. Replace it with a new Waste Toner Box. Refer to "Appendix_2.9 Replacing the Waste Toner Box" for how to replace the Waste Toner Box.

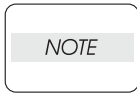

Refer to "Appendix_2.1 Consumables and Periodic Replacement Parts Life" for the timing when the message "Life Over" is indicated.

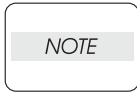

This error code is not related to any hardware fault.

Flows 105 091-914 / 091-917 / 091-918 / 091-919: IOT Drum Cartridge (YMCK) CRUM Fail

Cause: 091-914:Drum Cartridge CRUM (K) communication error is detected.
 091-917:Drum Cartridge CRUM (Y) communication error is detected.
 091-918:Drum Cartridge CRUM (M) communication error is detected.
 091-919:Drum Cartridge CRUM (C) communication error is detected.

Solution: Turn the power off and on to check that the error recurs. Then, proceed to the troubleshooting following the flowchart given below.

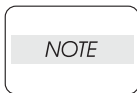

When replacing the Drum Cartridge (YMCK), ensure that the pad of the CLEANER ASSY (cleaning rod) is replaced and that the ROSS ASSY is cleaned. For details of how to replace the Drum Cartridge (YMCK), refer to "Appendix_2.3 Replacing the Drum Cartridges". For details of how to clean the ROS ASSY, refer to "Appendix_3.1 Cleaning Inside the Printer".

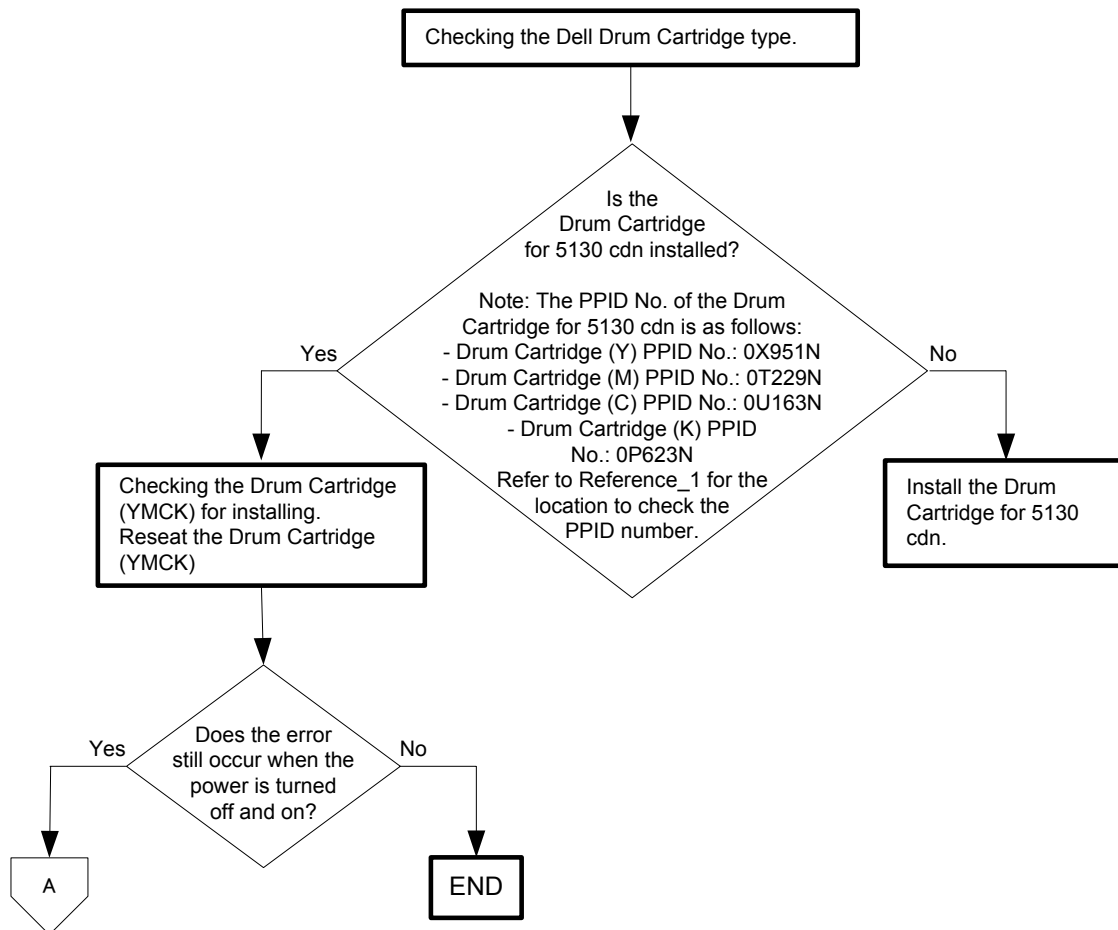

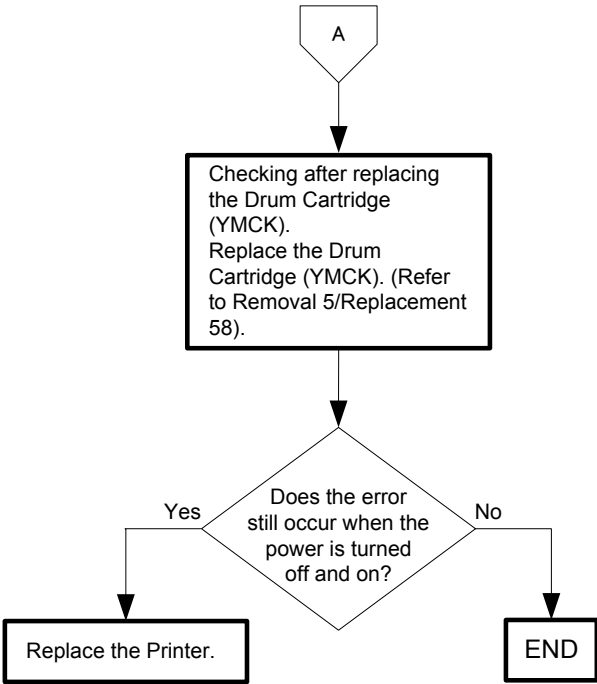

- Reference_1: Position of PPID label.

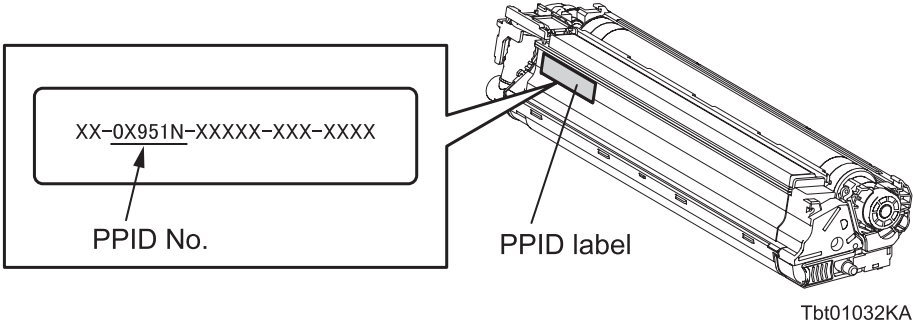

Flows 106 091-921 / 091-922 / 091-923 / 091-924: IOT Drum Cartridge (YMCK) Detached

Cause: 091-921: The Drum Cartridge (K) is not installed in the printer.
 091-922: The Drum Cartridge (Y) is not installed in the printer.
 091-923: The Drum Cartridge (M) is not installed in the printer.
 091-924: The Drum Cartridge (C) is not installed in the printer.

Solution: The Drum Cartridge (YMCK) is not installed. Press the [Information] button. Take the remedies in accordance with the description (refer to Reference_1) shown on the display.

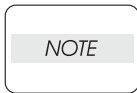

If the error persists after the action above is taken, ensure that the error replicates after the printer is powered off and then on, and then go to the following steps to continue further fault isolation.

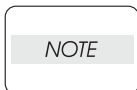

When replacing the Drum Cartridge (YMCK), ensure that the pad of the CLEANER ASSY (cleaning rod) is replaced and that the ROSS ASSY is cleaned. For details of how to replace the Drum Cartridge (YMCK), refer to "Appendix_2.3 Replacing the Drum Cartridges". For details of how to clean the ROS ASSY, refer to "Appendix_3.1 Cleaning Inside the Printer".

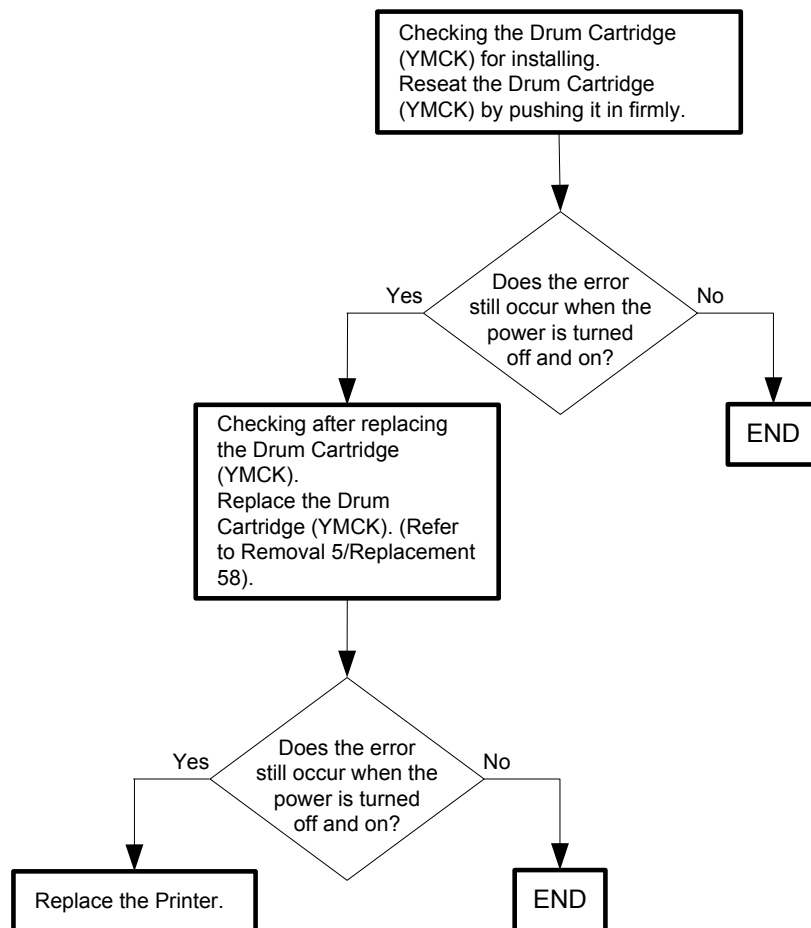

- Reference_1: 1. Open Front Cover. → 2. Open Inner Cover. → 3. Insert Y (or MCK) Drum Cartridge. → 4. Close Inner Cover. → 5. Close Front Cover.

Flows 107 091-931 / 091-932 / 091-933 / 091-934: IOT Drum Cartridge (YMCK) Life Over

Cause: 091-931: The Drum Cartridge (K) has reached the replacement time.
091-932: The Drum Cartridge (Y) has reached the replacement time.
091-933: The Drum Cartridge (M) has reached the replacement time.
091-934: The Drum Cartridge (C) has reached the replacement time.

Solution: The Drum Cartridge (YMCK) has reached the end of its life. Replace the Drum Cartridge (YMCK) with a new one. Refer to "Appendix_2.3 Replacing the Drum Cartridges" for how to replace the Drum Cartridges.

NOTE

Refer to "Appendix_2.1 Consumables and Periodic Replacement Parts Life" for the timing when the message "Life Over" is indicated.

NOTE

This error code is not related to any hardware fault.

Flows 108 091-942 / 091-943 / 091-944 / 091-945: IOT DRUM Cartridge (YMCK) CRUM Data Error

- Cause: 091-942: The Black Drum Cartridge CRUM Data error is detected.
 091-943: The Yellow Drum Cartridge CRUM Data error is detected.
 091-944: The Magenta Drum Cartridge CRUM Data error is detected.
 091-945: The Cyan Drum Cartridge CRUM Data error is detected.

Solution: Press the [Information] button. Take the remedies in accordance with the description (refer to Reference_1) shown on the display.

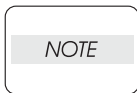

If the error persists after the action above is taken, ensure that the error replicates after the printer is powered off and then on, and then go to the following steps to continue further fault isolation.

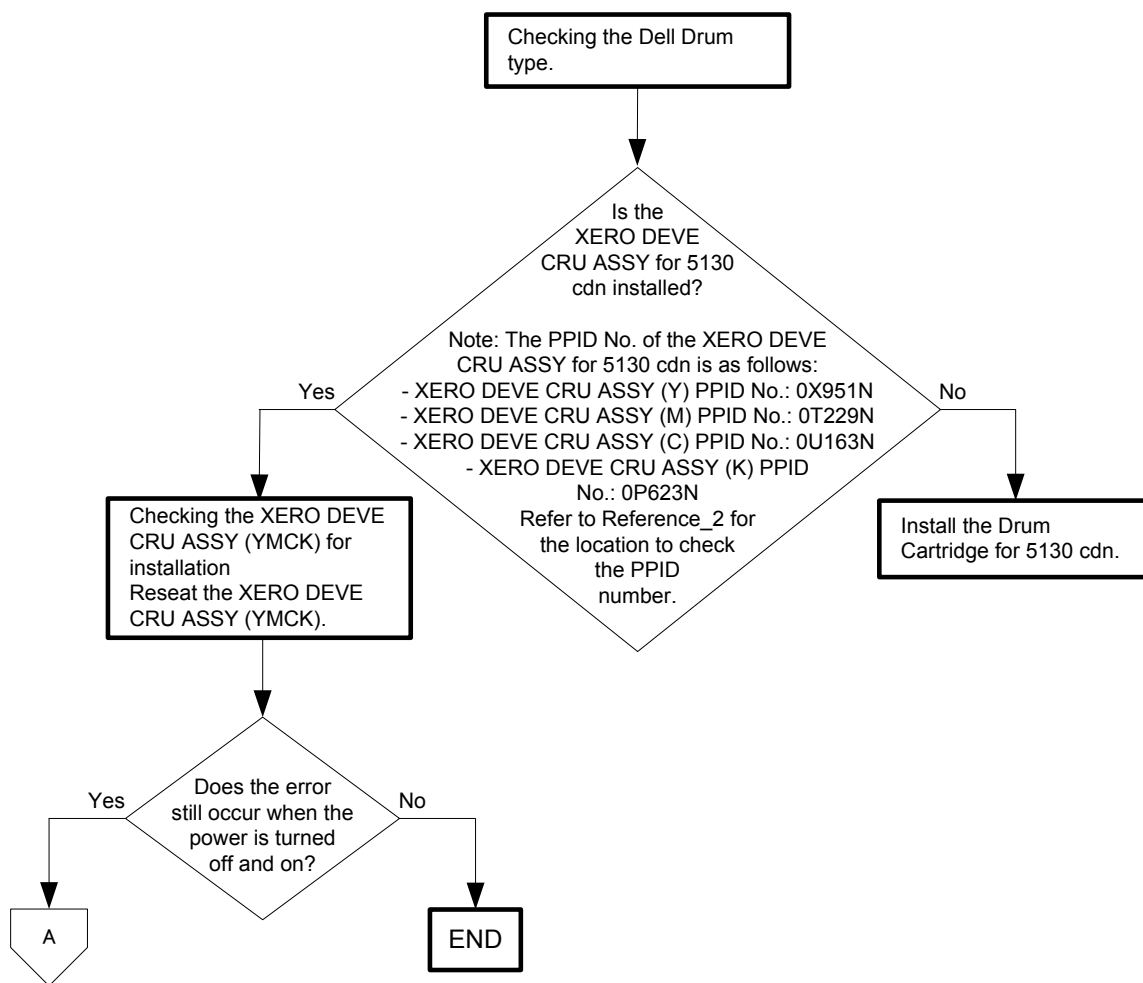

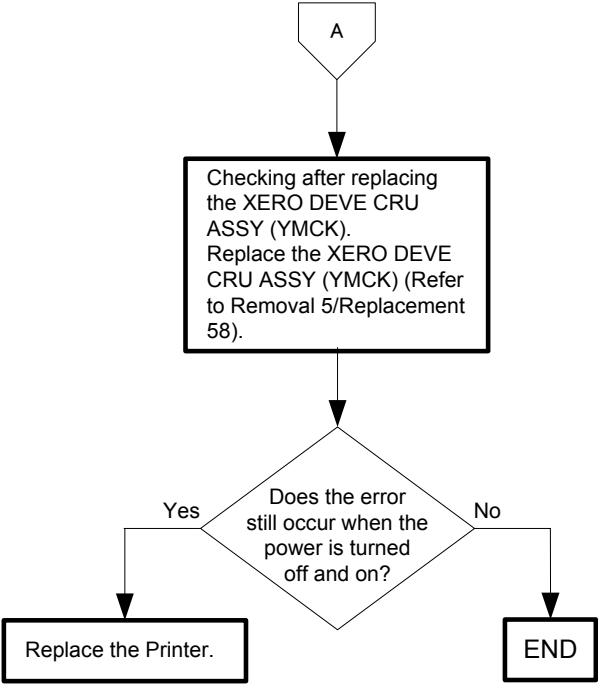

- Reference_1: 1. Open Front Cover. → 2. Open Inner Cover. → 3. Reseat Y (or MCK) Drum Cartridge. → 4. Close Inner Cover. → 5. Close Front Cover.

- Reference_2: Position of PPID label.

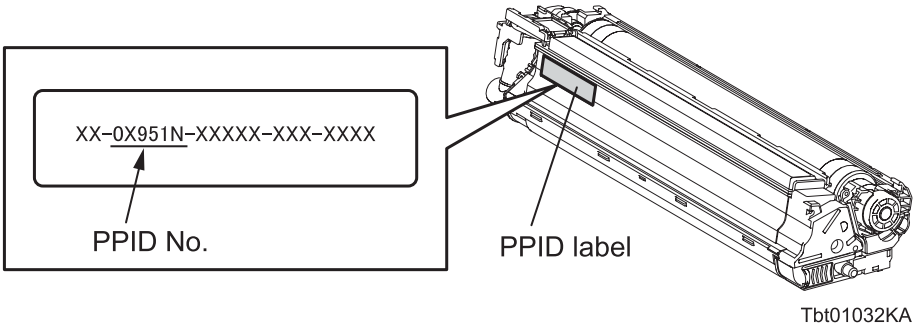

Flows 109 091-950 / 091-951 / 091-952 / 091-953: Detect YMCK Drum Cartridge Tape Staying

Cause: 091-950:Tapes (ribbons) remains on the Drum Cartridge (C).
 091-951:Tapes (ribbons) remains on the Drum Cartridge (M).
 091-952:Tapes (ribbons) remains on the Drum Cartridge (Y).
 091-953:Tapes (ribbons) remains on the Drum Cartridge (K).

Solution: Tape remains on the Drum Cartridge (YMCK). Press the [Information] button. Take the remedies in accordance with the description (refer to Reference_1) shown on the display.

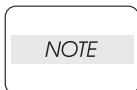

If the error persists after the action above is taken, ensure that the error replicates after the printer is powered off and then on, and then go to the following steps to continue further fault isolation.

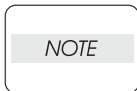

When replacing the Drum Cartridge (YMCK), ensure that the pad of the CLEANER ASSY (cleaning rod) is replaced and that the ROSS ASSY is cleaned. For details of how to replace the Drum Cartridge (YMCK), refer to "Appendix_2.3 Replacing the Drum Cartridges". For details of how to clean the ROS ASSY, refer to "Appendix_3.1 Cleaning Inside the Printer".

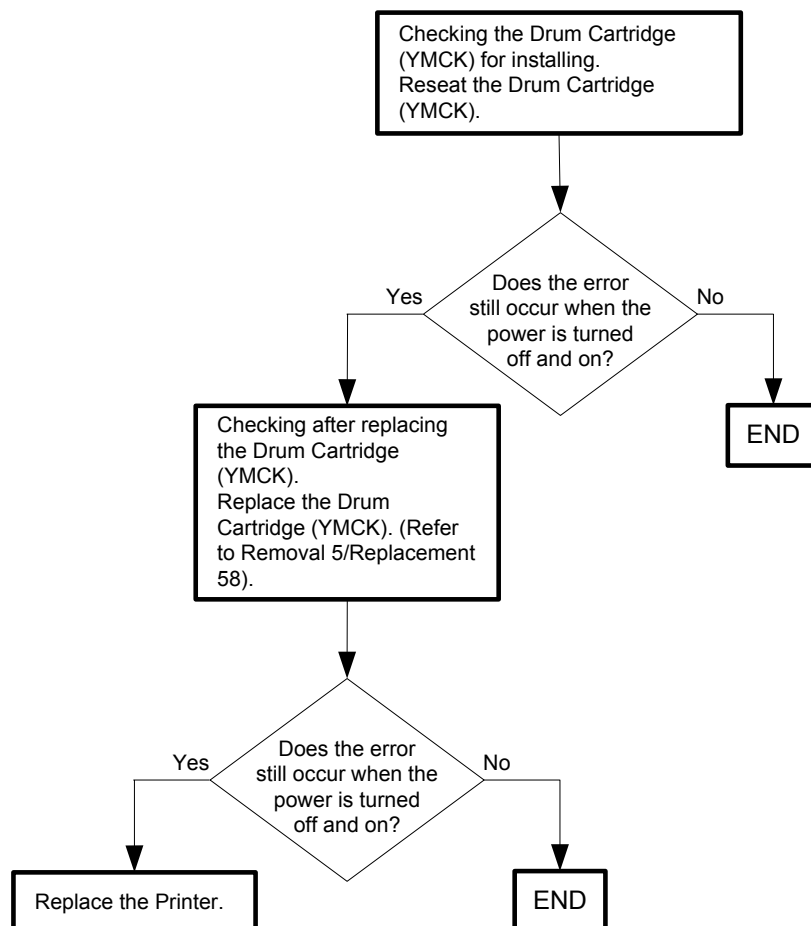

- Reference_1: 1. Open Front Cover. → 2. Open Inner Cover. → 3. Pull out Tape form Y (or MCK) Drum Cartridge . → 4. Close Inner Cover. → 5. Close Front Cover.

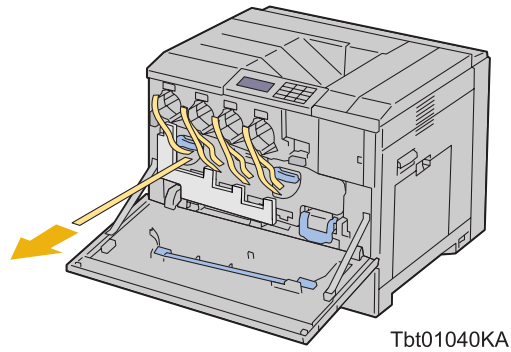

Flows 110 091-960 / 091-961 / 091-962 / 091-963: IOT (YMCK) CRUM ID Error

Cause: 091-960:An unsupported Drum Cartridge (Y) is detected.
 091-961:An unsupported Drum Cartridge (M) is detected.
 091-962:An unsupported Drum Cartridge (C) is detected.
 091-963:An unsupported Drum Cartridge (K) is detected.

Solution: Press the [Information] button. Take the remedies in accordance with the description (refer to Reference_1) shown on the display.

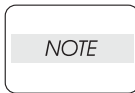

If the error persists after the action above is taken, ensure that the error replicates after the printer is powered off and then on, and then go to the following steps to continue further fault isolation.

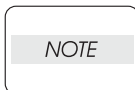

When replacing the Drum Cartridge (YMCK), ensure that the pad of the CLEANER ASSY (cleaning rod) is replaced and that the ROSS ASSY is cleaned. For details of how to replace the Drum Cartridge (YMCK), refer to "Appendix_2.3 Replacing the Drum Cartridges". For details of how to clean the ROS ASSY, refer to "Appendix_3.1 Cleaning Inside the Printer".

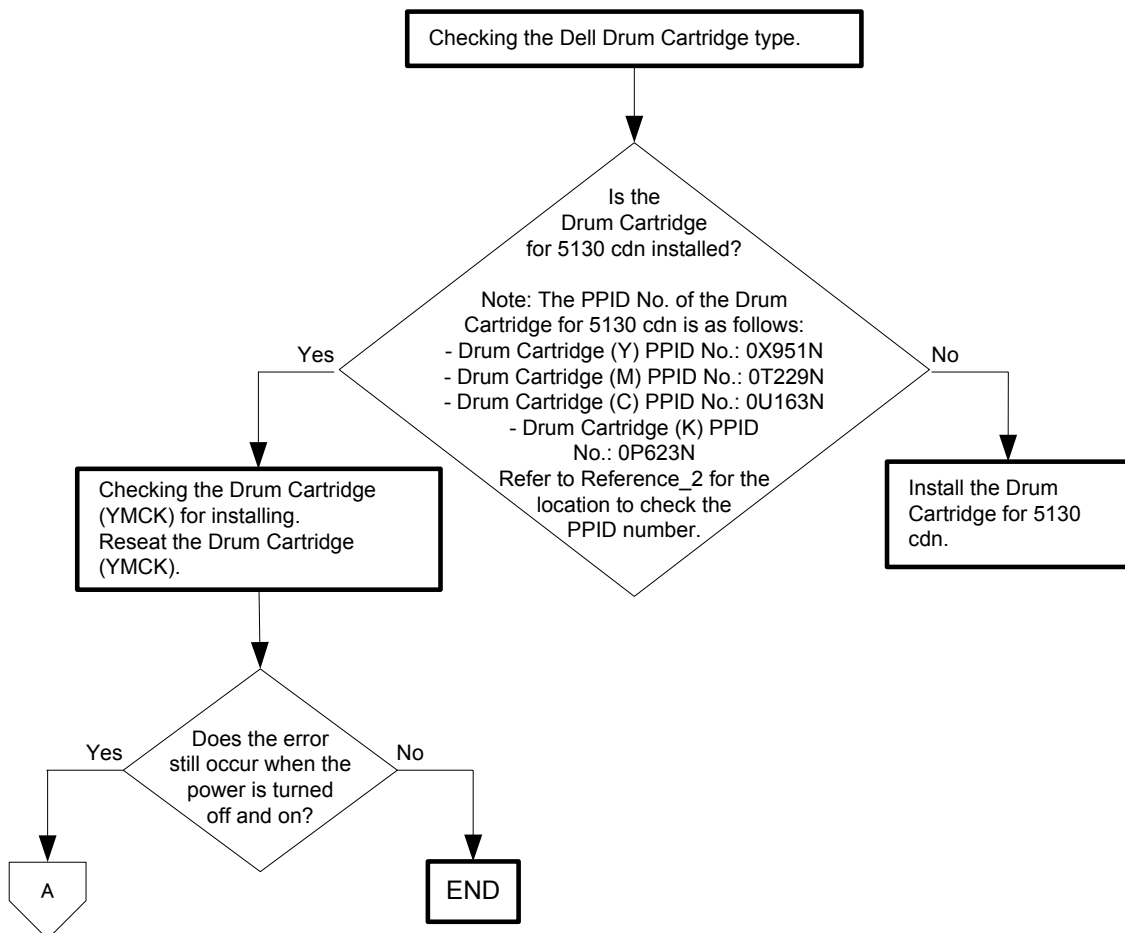

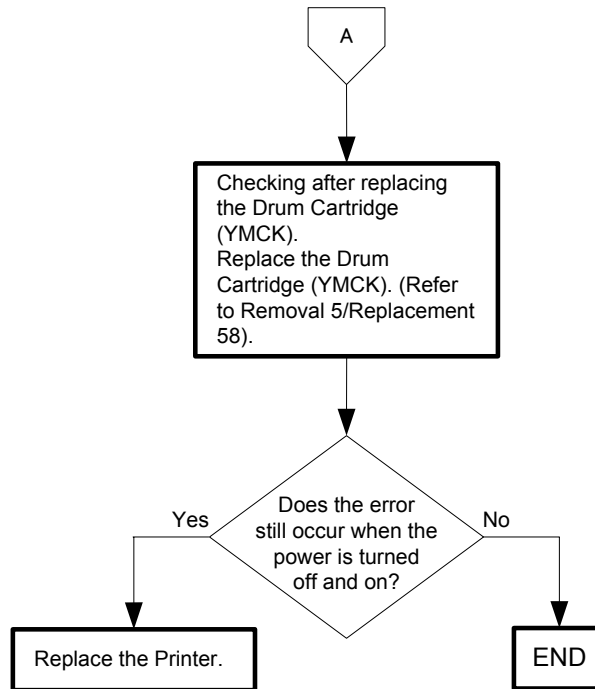

- Reference_1: 1. Open Front Cover. → 2.Open Inner Cover. → 3.Reseat Y (or MCK) Drum Cartridge. → 4.Close Inner Cover. → 5. Close Front Cover.
- Reference_2: Position of PPID label.

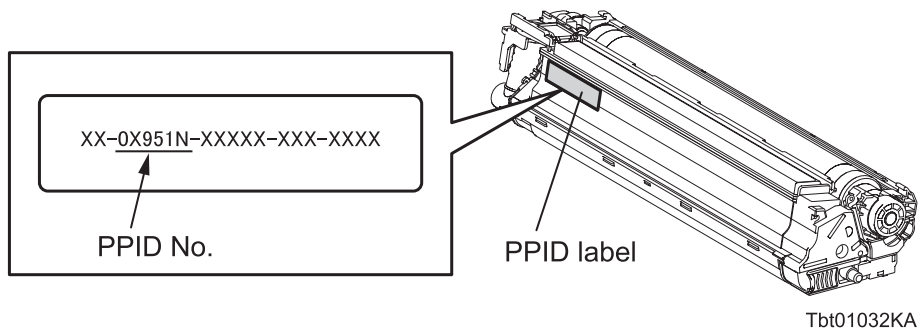

Flows 111 092-651: IOT CTD Sensor Rear Error Code2

Cause: Contamination of CTD Rear Sensor was detected.

Solution: The CTD sensor has reached the cleaning time. Clean up the CTD sensor. Refer to "Appendix_3.2 Cleaning the Conductivity Temperature Depth (CTD) Sensor" for how to clean up the CTD Sensor.

NOTE

If the error persists after the action above is taken, ensure that the error replicates after the printer is powered off and then on, and then go to the following steps to continue further fault isolation.

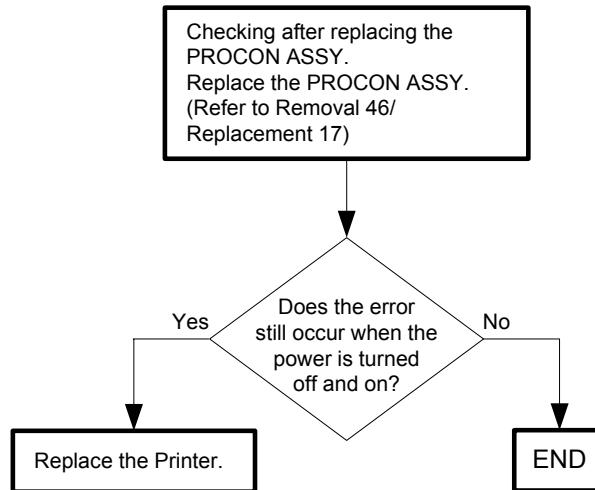

Flows 112 092-670: Detect Yellow Calibrating Patch Error

Cause: Yellow Calibrating Patch Error (Low Density) was detected.

Solution: Turn the power off and on to check that the error recurs. Then, proceed to the troubleshooting following the flowchart given below.

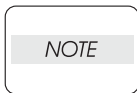

When replacing the Drum Cartridge (YMCK), ensure that the pad of the CLEANER ASSY (cleaning rod) is replaced and that the ROSS ASSY is cleaned. For details of how to replace the Drum Cartridge (YMCK), refer to "Appendix_2.3 Replacing the Drum Cartridges". For details of how to clean the ROS ASSY, refer to "Appendix_3.1 Cleaning Inside the Printer".

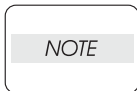

When replacing the BELT Unit, ensure that the Transfer Roller is also replaced. For details, refer to "Appendix_2.1.1 (4) Replacing the Belt Unit and Transfer Roller concurrently".

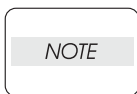

When the Belt Unit has been replaced, be sure to clean up the CTD Sensor. Refer to "Appendix_3.2 Cleaning the Conductivity Temperature Depth (CTD) Sensor" for how to clean up the CTD Sensor.

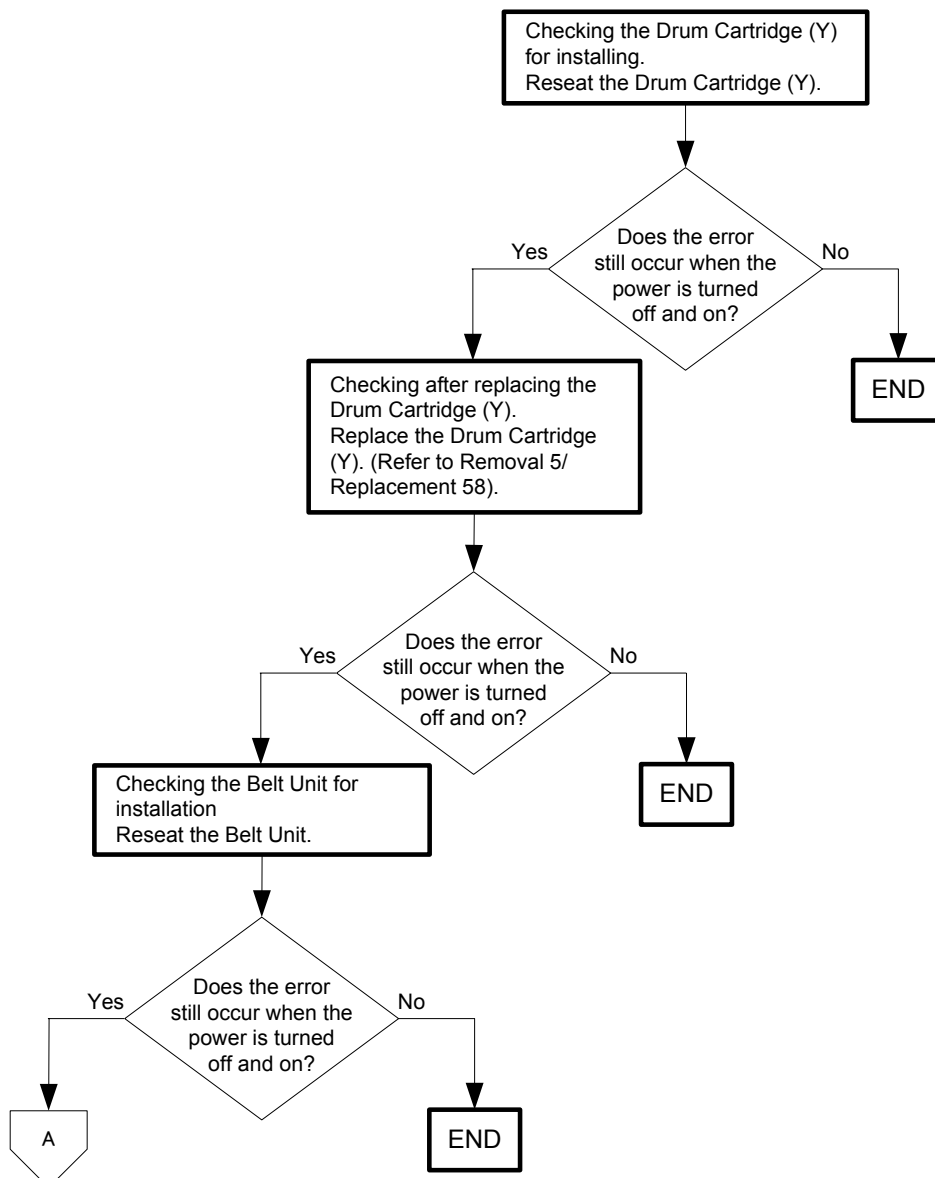

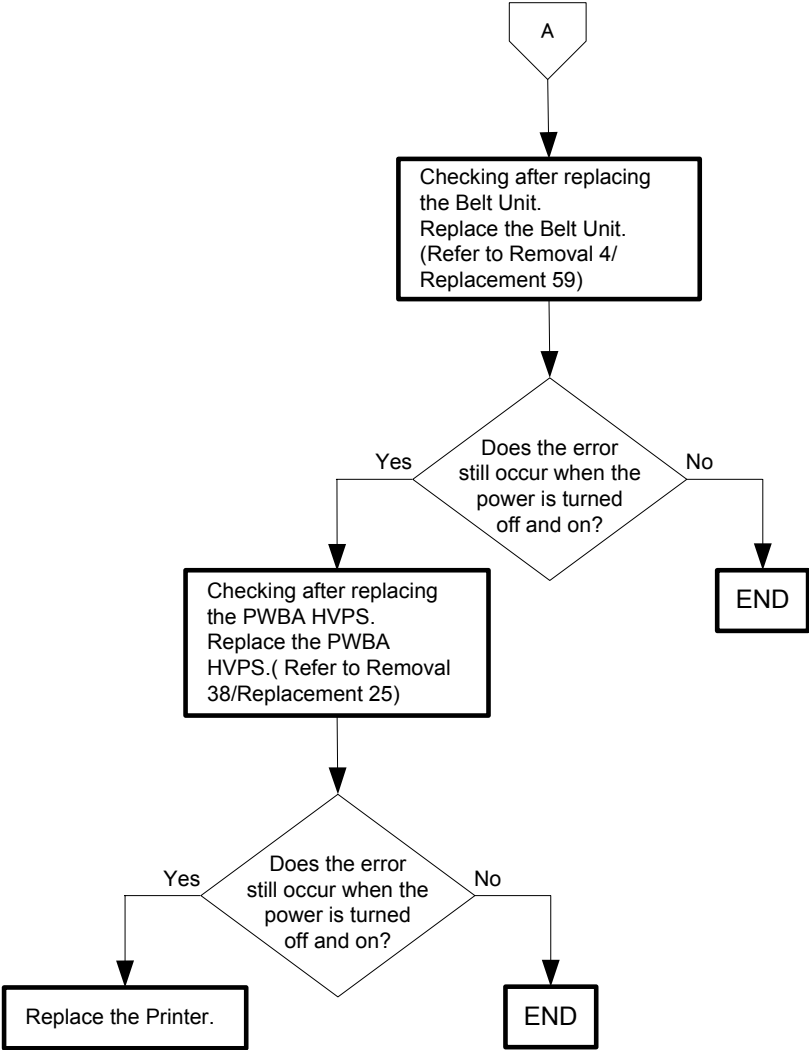

Flows 113 092-671: Detect Magenta Calibrating Patch Error

Cause: Magenta Calibrating Patch Error (Low Density) was detected.

Solution: Turn the power off and on to check that the error recurs. Then, proceed to the troubleshooting following the flowchart given below.

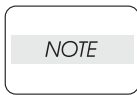

When replacing the Drum Cartridge (YMCK), ensure that the pad of the CLEANER ASSY (cleaning rod) is replaced and that the ROSS ASSY is cleaned. For details of how to replace the Drum Cartridge (YMCK), refer to "Appendix_2.3 Replacing the Drum Cartridges". For details of how to clean the ROS ASSY, refer to "Appendix_3.1 Cleaning Inside the Printer".

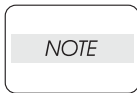

When replacing the BELT Unit, ensure that the Transfer Roller is also replaced. For details, refer to "Appendix_2.1.1 (4) Replacing the Belt Unit and Transfer Roller concurrently".

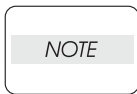

When the Belt Unit has been replaced, be sure to clean up the CTD Sensor. Refer to "Appendix_3.2 Cleaning the Conductivity Temperature Depth (CTD) Sensor" for how to clean up the CTD Sensor.

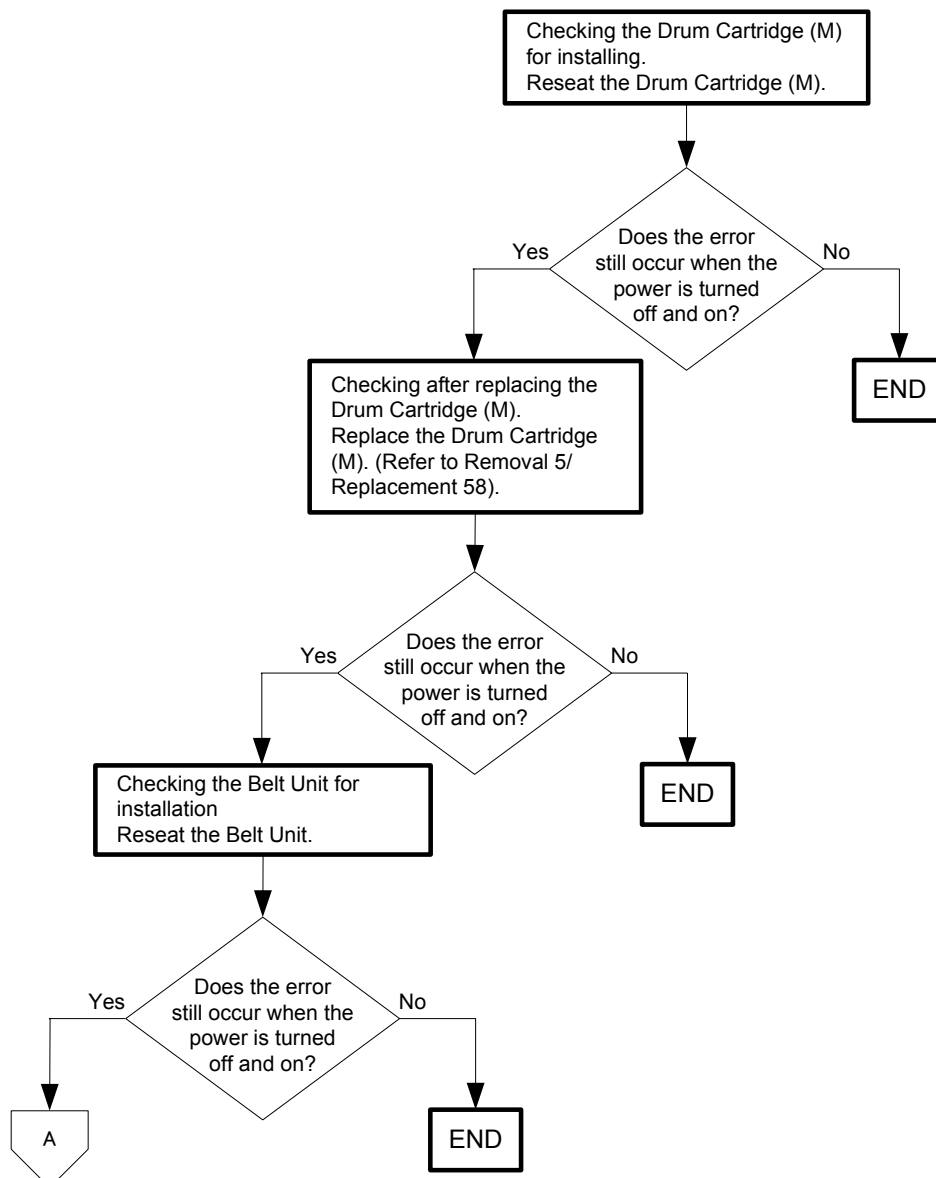

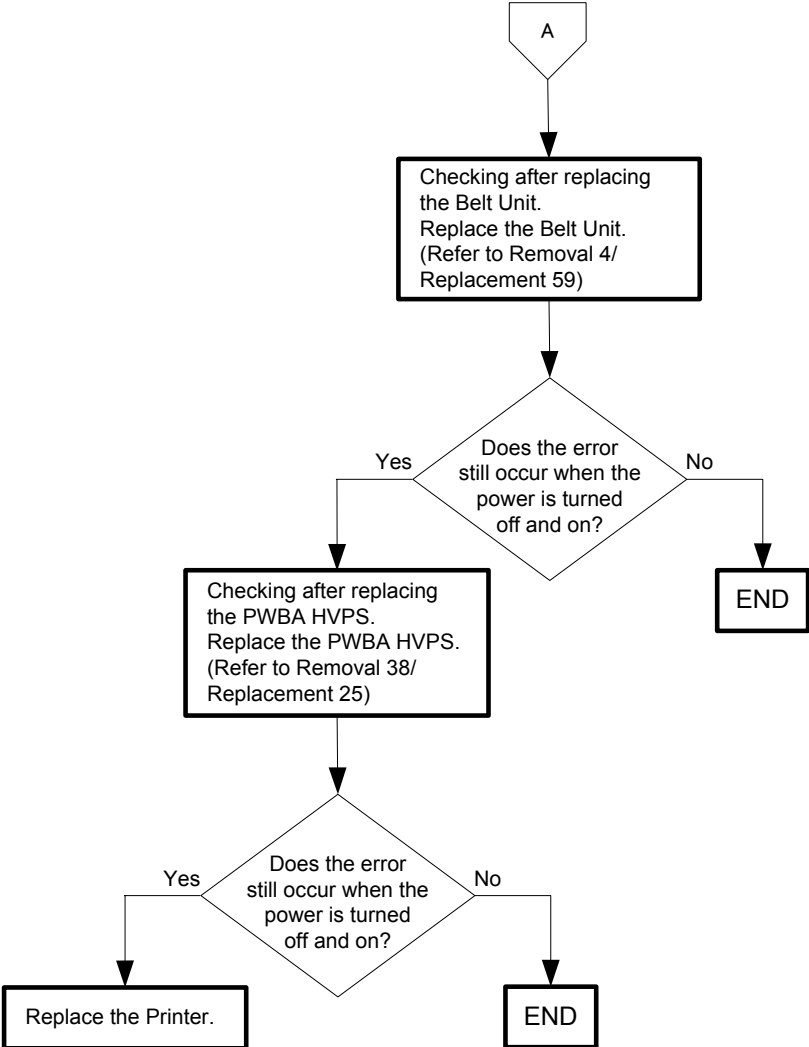

Flows 114 092-672: Detect Cyan Calibrating Patch Error

Cause: Cyan Calibrating Patch Error (Low Density) was detected.

Solution: Turn the power off and on to check that the error recurs. Then, proceed to the troubleshooting following the flowchart given below.

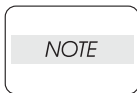

When replacing the Drum Cartridge (YMCK), ensure that the pad of the CLEANER ASSY (cleaning rod) is replaced and that the ROSS ASSY is cleaned. For details of how to replace the Drum Cartridge (YMCK), refer to "Appendix_2.3 Replacing the Drum Cartridges". For details of how to clean the ROS ASSY, refer to "Appendix_3.1 Cleaning Inside the Printer".

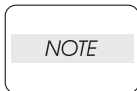

When replacing the BELT Unit, ensure that the Transfer Roller is also replaced. For details, refer to "Appendix_2.1.1 (4) Replacing the Belt Unit and Transfer Roller concurrently".

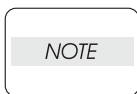

When the Belt Unit has been replaced, be sure to clean up the CTD Sensor. Refer to "Appendix_3.2 Cleaning the Conductivity Temperature Depth (CTD) Sensor" for how to clean up the CTD Sensor.

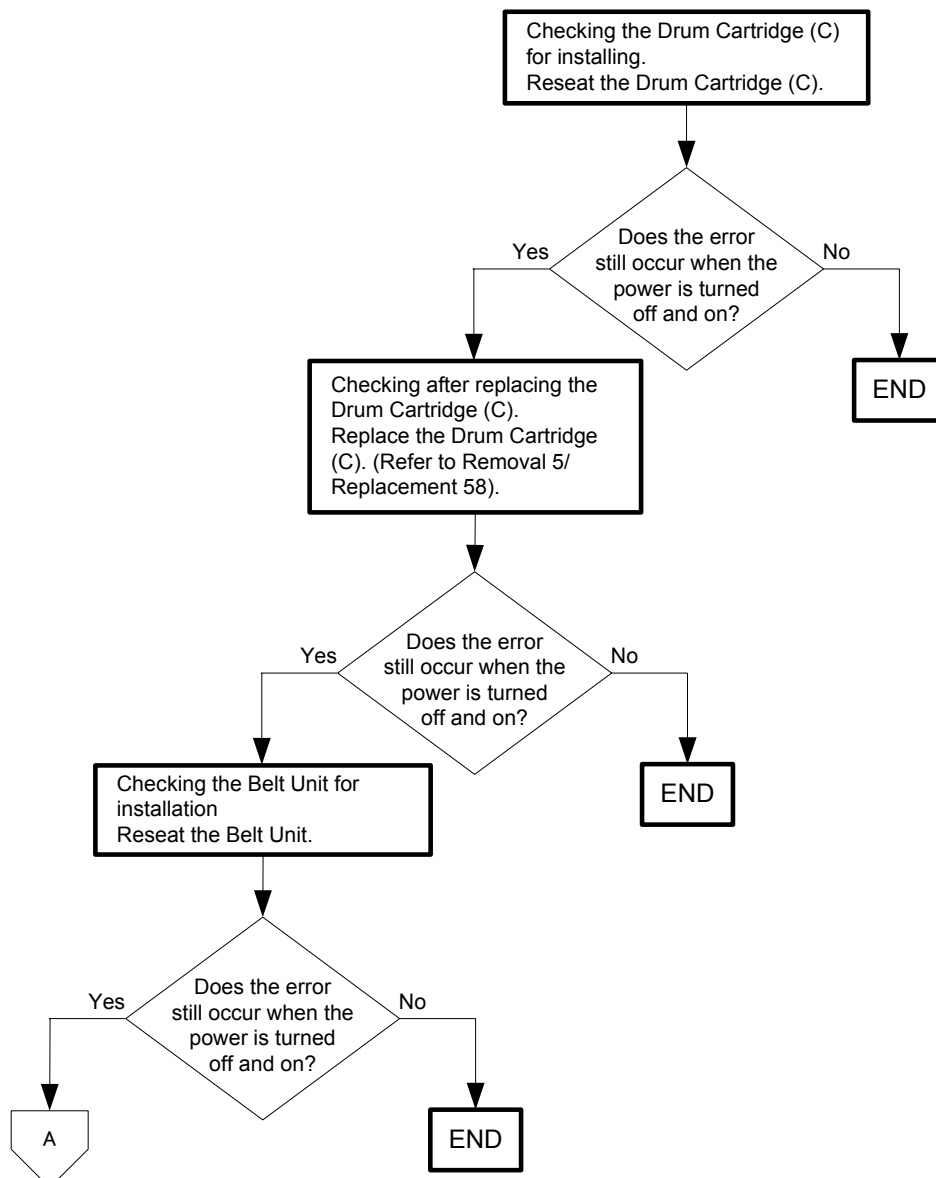

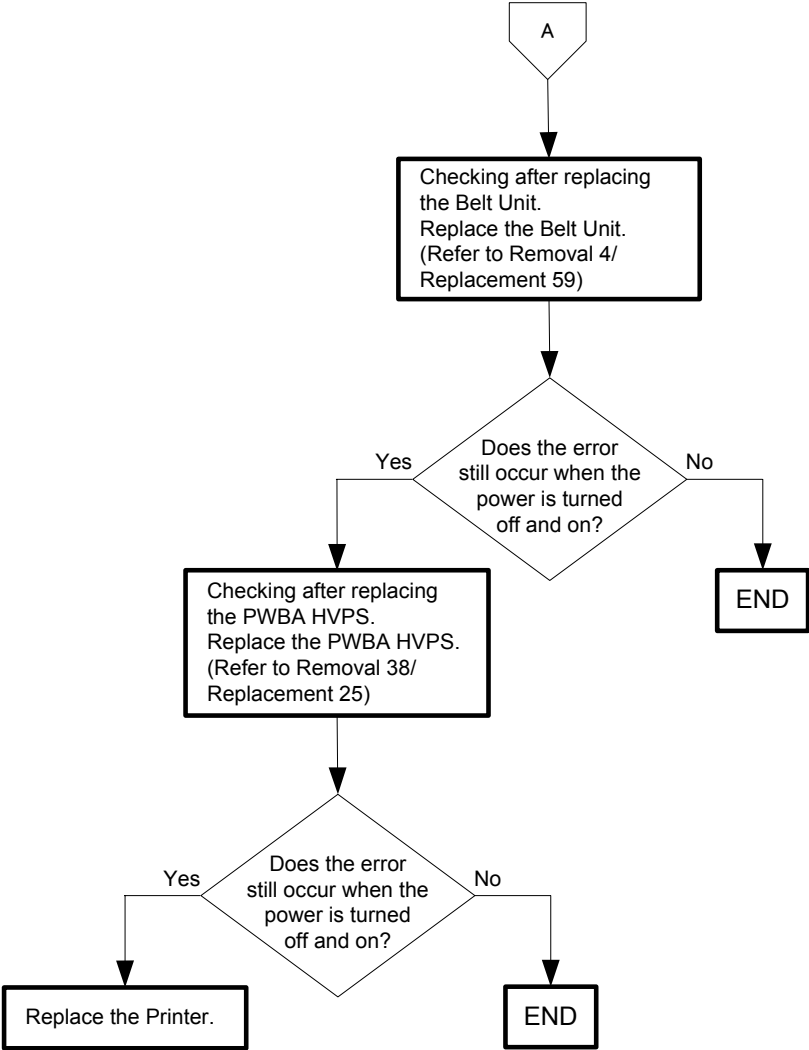

Flows 115 092-673: Detect Black Calibrating Patch Error

Cause: Black Calibrating Patch Error (Low Density) was detected.

Solution: Turn the power off and on to check that the error recurs. Then, proceed to the troubleshooting following the flowchart given below.

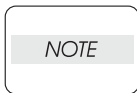

When replacing the Drum Cartridge (YMCK), ensure that the pad of the CLEANER ASSY (cleaning rod) is replaced and that the ROSS ASSY is cleaned. For details of how to replace the Drum Cartridge (YMCK), refer to "Appendix_2.3 Replacing the Drum Cartridges". For details of how to clean the ROS ASSY, refer to "Appendix_3.1 Cleaning Inside the Printer".

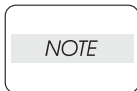

When replacing the BELT Unit, ensure that the Transfer Roller is also replaced. For details, refer to "Appendix_2.1.1 (4) Replacing the Belt Unit and Transfer Roller concurrently".

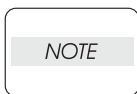

When the Belt Unit has been replaced, be sure to clean up the CTD Sensor. Refer to "Appendix_3.2 Cleaning the Conductivity Temperature Depth (CTD) Sensor" for how to clean up the CTD Sensor.

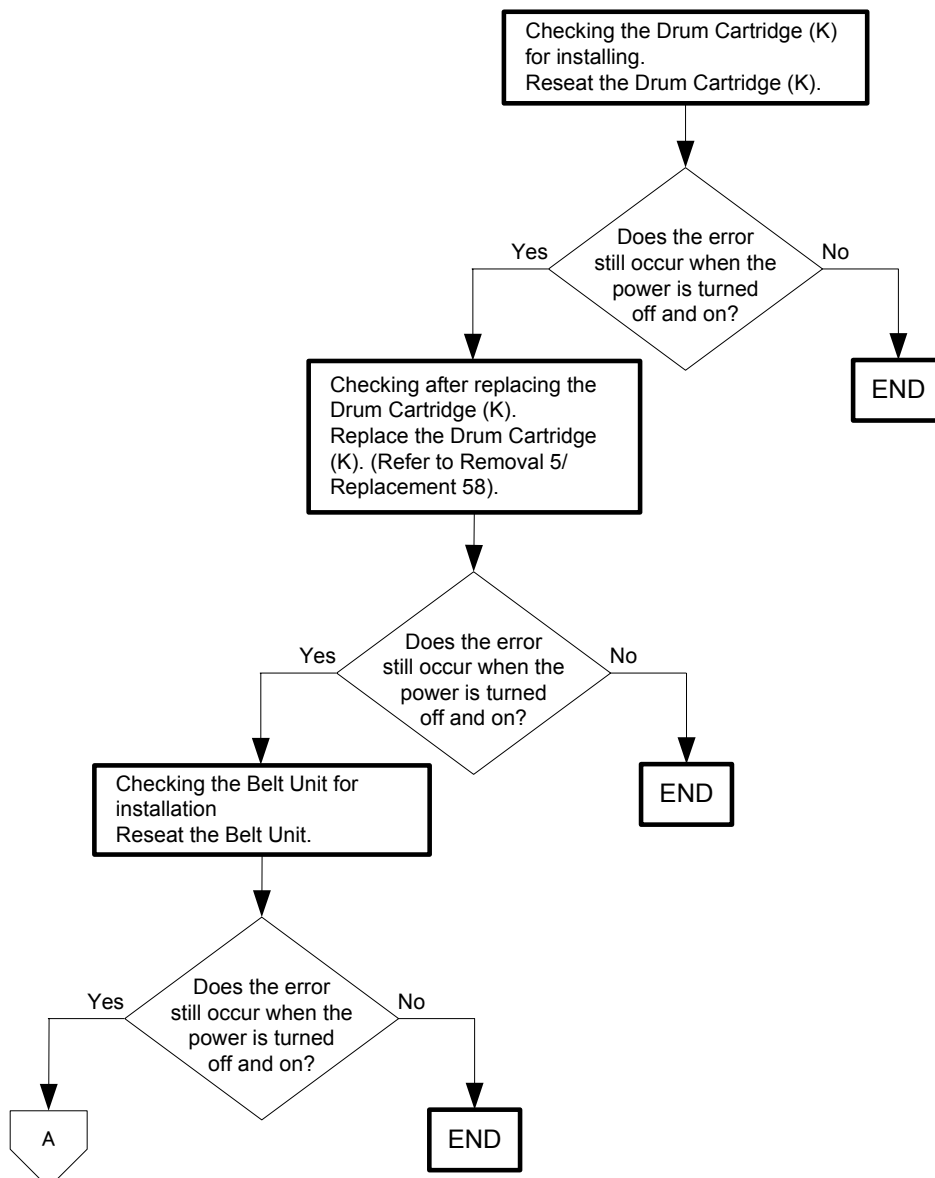

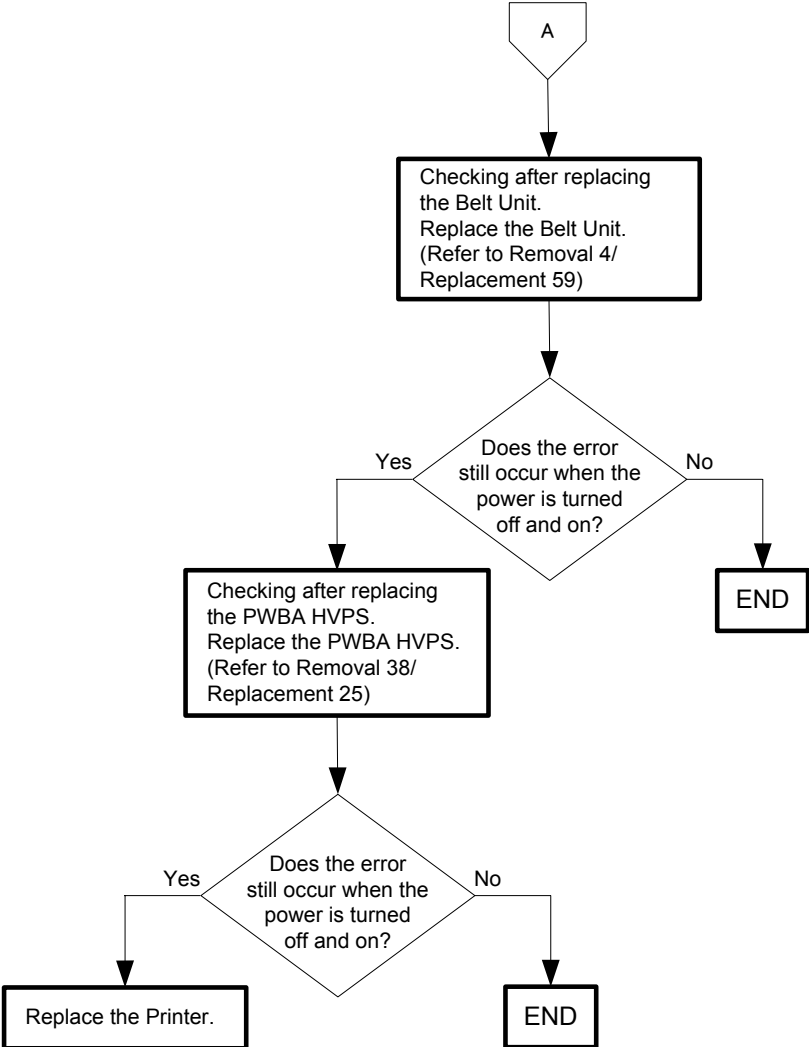

Flows 116 093-423 / 093-424 / 093-425 / 093-426: IOT Toner Cartridge Near Life

Cause: 093-423:The Toner Cartridge (Y) is approaching the replacement time.
093-424:The Toner Cartridge (M) is approaching the replacement time.
093-425:The Toner Cartridge (C) is approaching the replacement time.
093-426:The Toner Cartridge (K) is approaching the replacement time.

Solution: The Toner Cartridge (YMCK) is approaching the replacement time. Prepare a new Toner Cartridge of the relevant one.

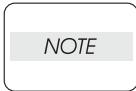

Refer to "Appendix_2.1 Consumables and Periodic Replacement Parts Life" for the timing when the message "Near Life" is indicated.

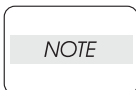

This error code is not related to any hardware fault.

Flows 117 093-930 / 093-931 / 093-932 / 093-933: IOT Toner Cartridge Life Over

Cause: 093-930:The Toner Cartridge (Y) has reached the replacement time.
093-931:The Toner Cartridge (M) has reached the replacement time.
093-932:The Toner Cartridge (C) has reached the replacement time.
093-933:The Toner Cartridge (K) has reached the replacement time.

Solution: The Toner Cartridge (YMCK) has reached the end of its life. Replace the Toner Cartridge (YMCK) with a new one. Refer to "Appendix_2.2 Replacing the Toner Cartridges" for how to replace the Toner Cartridge.

NOTE

Refer to "Appendix_2.1 Consumables and Periodic Replacement Parts Life" for the timing when the message "Life Over" is indicated.

NOTE

This error code is not related to any hardware fault.

Flows 118 093-960 / 093-961 / 093-962 / 093-963: IOT (YMCK) CRUM ID Error

Cause: 093-960:An unsupported Toner Cartridge (Y) is detected.
 093-961:An unsupported Toner Cartridge (M) is detected.
 093-962:An unsupported Toner Cartridge (C) is detected.
 093-963:An unsupported Toner Cartridge (K) is detected.

Solution: Press the [Information] button. Take the remedies in accordance with the description (refer to Reference_1) shown on the display.

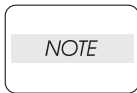

If the error persists after the action above is taken, ensure that the error replicates after the printer is powered off and then on, and then go to the following steps to continue further fault isolation.

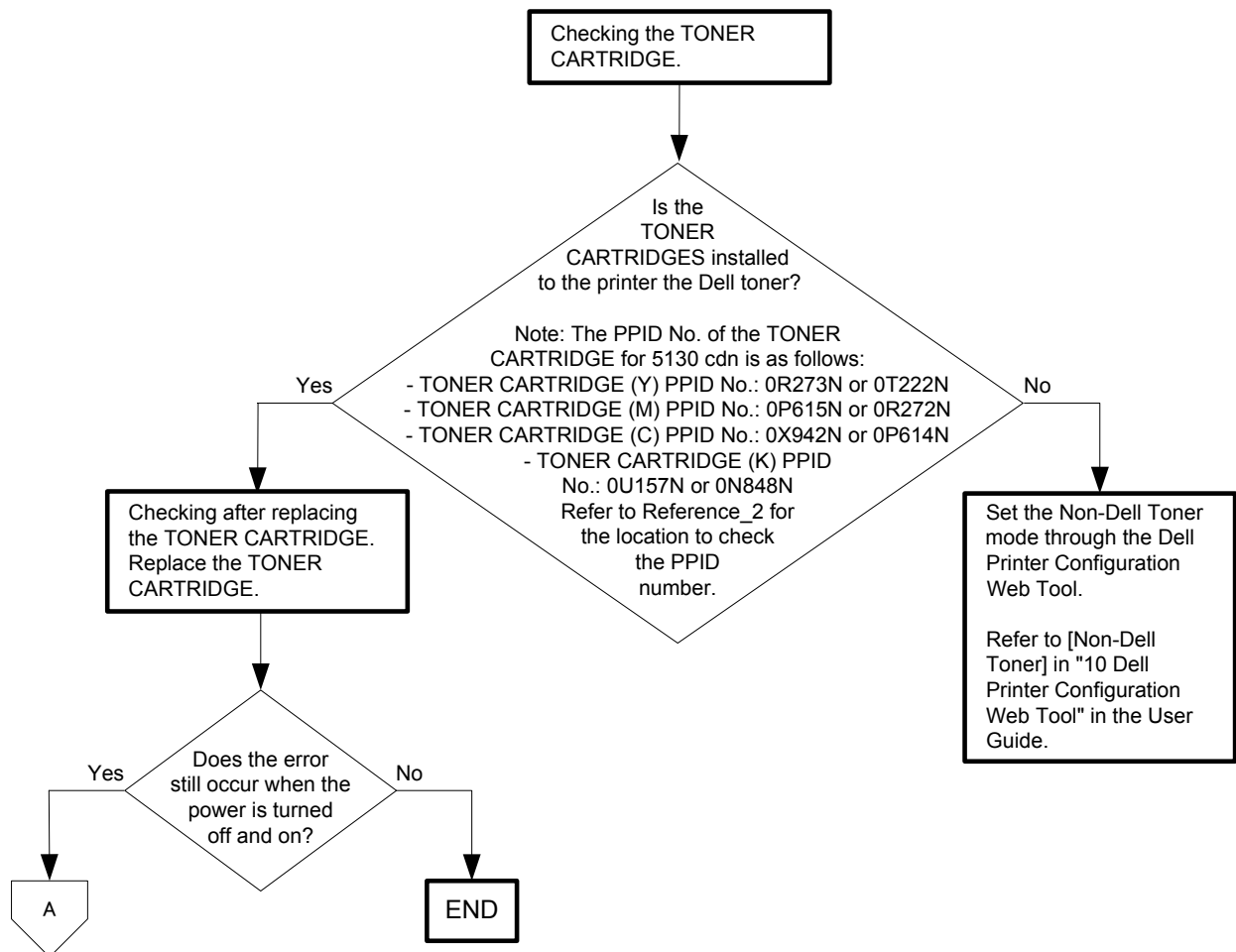

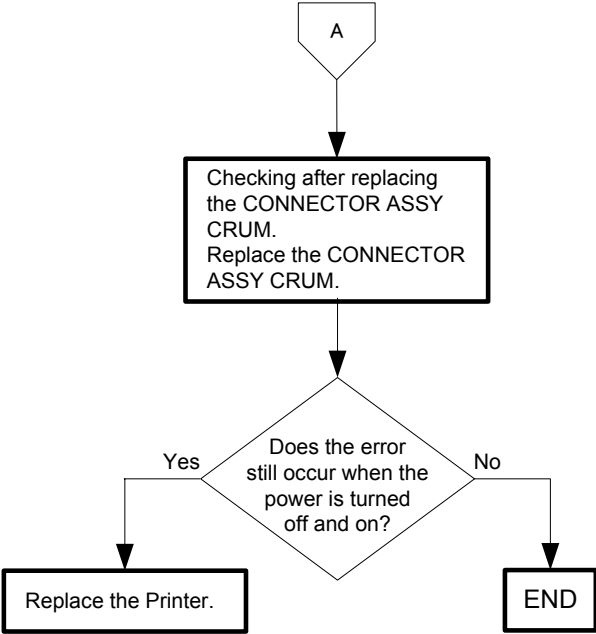

- Reference_1: 1. Open Front Cover. → 2. Reseat Y (or MCK) Toner Cartridge. → 3. Close Front Cover.
- Reference_2: Position of PPID label.

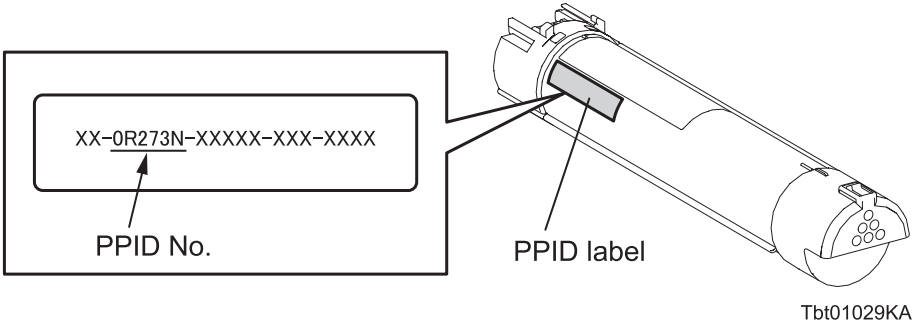

Flows 119 093-964: IOT Fuser CRUM ID Error

Cause: An unsupported Fuser is detected.

Solution: Turn the power off and on to check that the error recurs. Then, proceed to the troubleshooting following the flowchart given below.



To avoid burns, do not replace the fuser immediately after printing. The fuser becomes extremely hot during use. Turn off the printer and wait for 30 minutes before removing the fuser.

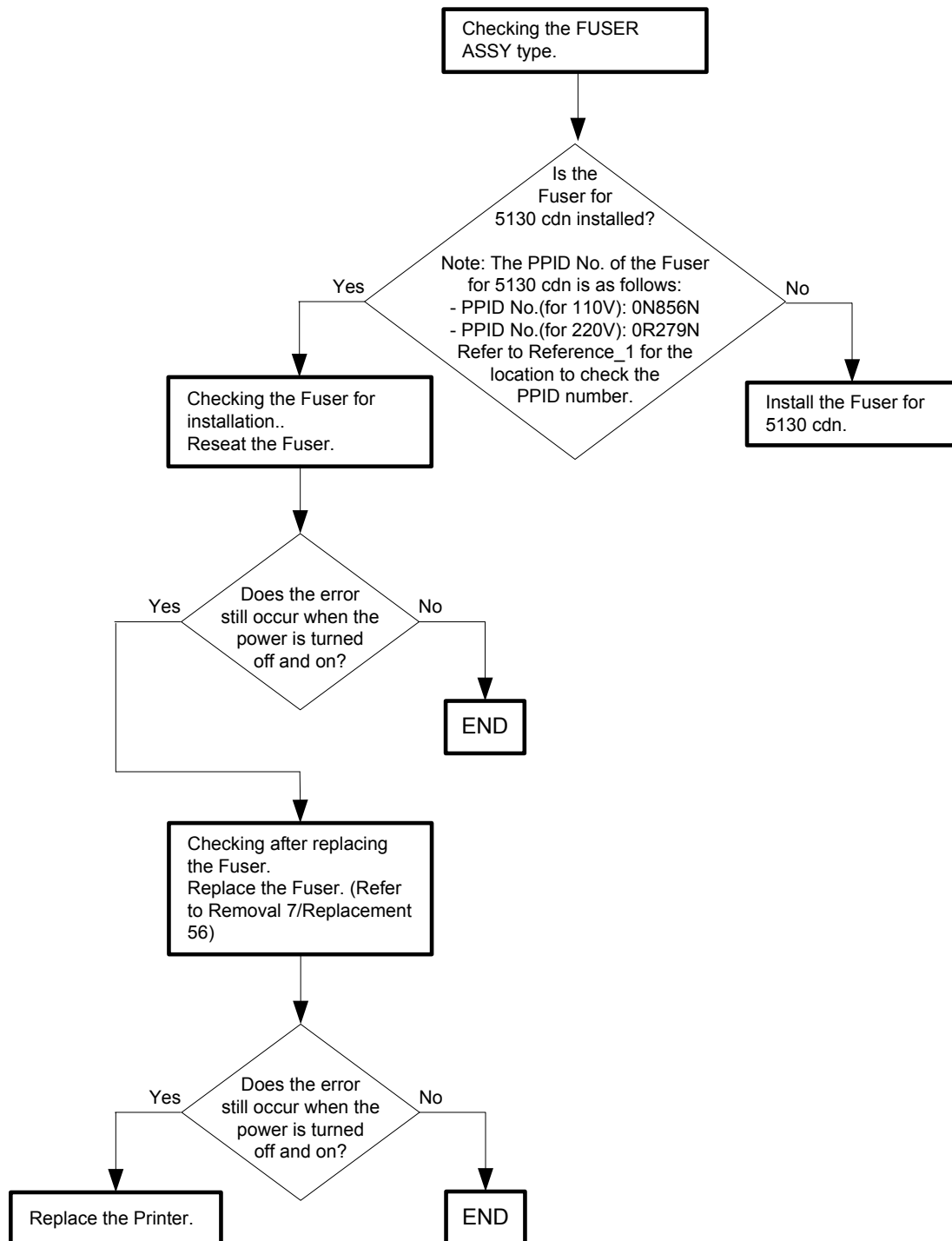

- Reference_1: Position of PPID label.

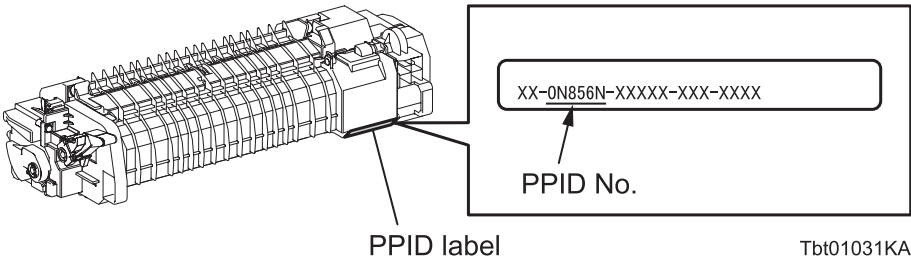

Flows 120 093-970 / 093-971 / 093-972 / 093-973: IOT Toner Cartridge Detached

Cause: 093-970: The Toner Cartridge (Y) is not installed in the printer.
 093-971: The Toner Cartridge (M) is not installed in the printer.
 093-972: The Toner Cartridge (C) is not installed in the printer.
 093-973: The Toner Cartridge (K) is not installed in the printer.

Solution: The Toner Cartridge (YMCK) is not installed. Press the [Information] button. Take the remedies in accordance with the description (refer to Reference_1) shown on the display.

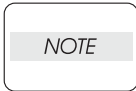

If the error persists after the action above is taken, ensure that the error replicates after the printer is powered off and then on, and then go to the following steps to continue further fault isolation.

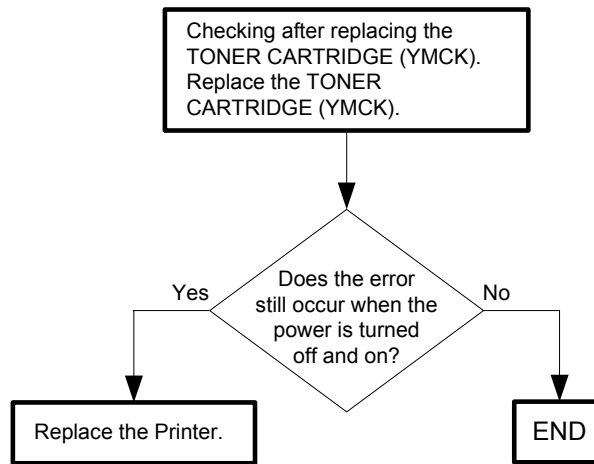

- Reference_1: 1. Open Front Cover. → 2. Insert Y (or MCK) Toner Cartridge. → 3. Close Front Cover.

Flows 121 094-325-01: IOT Switching Sensor Failure

Cause: Detected Switching Sensor Failure.

Solution: Turn the power off and on to check that the error recurs. Then, proceed to the troubleshooting following the flowchart given below.

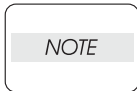

When replacing the BELT Unit, ensure that the Transfer Roller is also replaced.

For details, refer to "Appendix_2.1.1 (4) Replacing the Belt Unit and Transfer Roller concurrently".

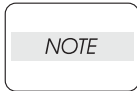

When the Belt Unit has been replaced, be sure to clean up the CTD Sensor.

Refer to "Appendix_3.2 Cleaning the Conductivity Temperature Depth (CTD) Sensor" for how to clean up the CTD Sensor.

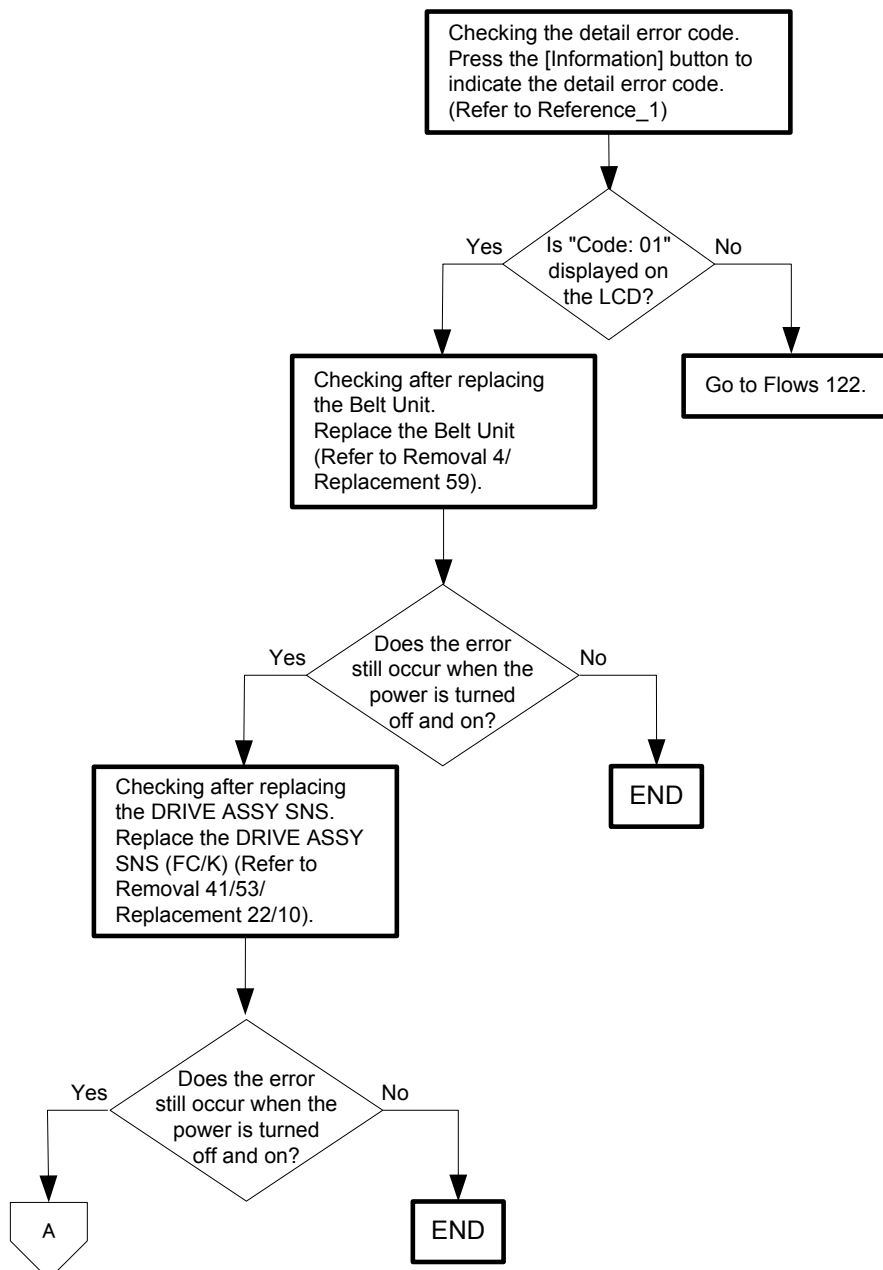

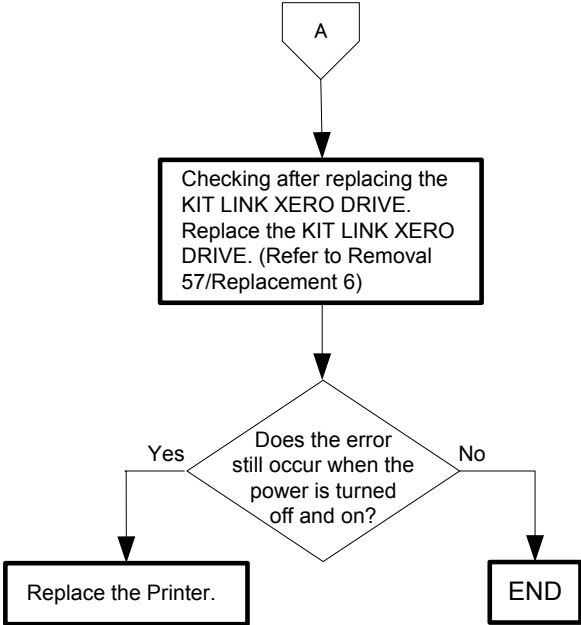

- Reference_1: [Information] button

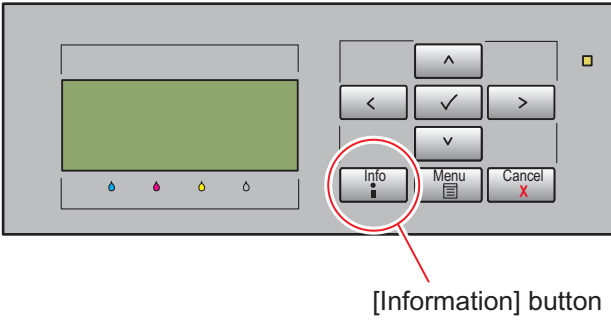

Flows 122 094-325-02 to 06: IOT Switching Sensor Failure

Cause: Detect Switching Sensor Failure

Solution: Turn the power off and on to check that the error recurs. Then, proceed to the troubleshooting following the flowchart given below.

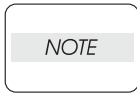

When replacing the BELT Unit, ensure that the Transfer Roller is also replaced.

For details, refer to "Appendix_2.1.1 (4) Replacing the Belt Unit and Transfer Roller concurrently".

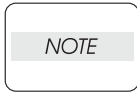

When the Belt Unit has been replaced, be sure to clean up the CTD Sensor.

Refer to "Appendix_3.2 Cleaning the Conductivity Temperature Depth (CTD) Sensor" for how to clean up the CTD Sensor.

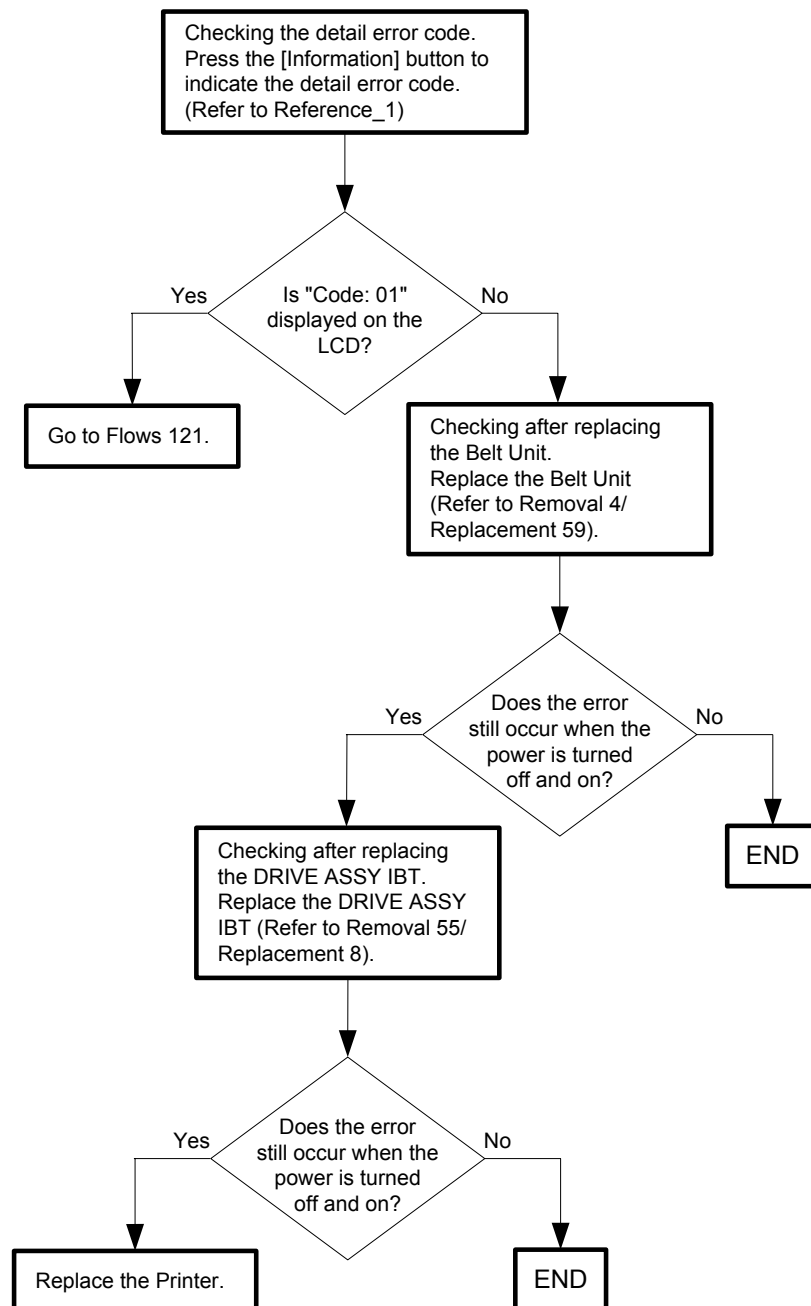

- Reference_1: [Information] button

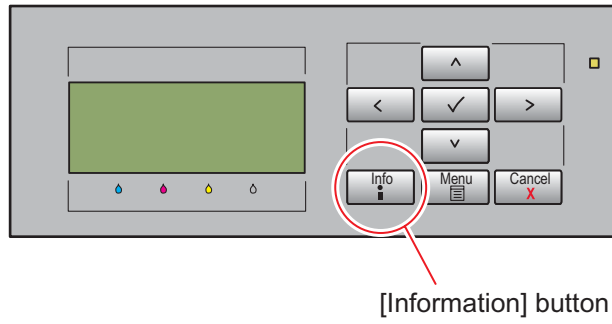

Flows 123 094-419/ 094-422: IOT Belt Unit Near Life

Cause: 094-419: The Belt Unit is approaching the replacement time.
094-422: The Belt Unit has reached the replacement time.

Solution: The Belt Unit is approaching the replacement time. Prepare a new Belt Unit.

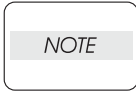

Refer to "Appendix_2.1 Consumables and Periodic Replacement Parts Life" for the timing when the message "Near Life" is indicated.

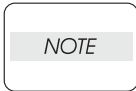

This error code is not related to any hardware fault.

Flows 124 094-910: IOT Belt Unit Detached

Cause: Belt Unit detached is detected.

Solution: The Belt Unit is not installed. Press the [Information] button. Take the remedies in accordance with the description (refer to Reference_1) shown on the display.

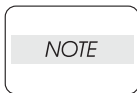

If the error persists after the action above is taken, ensure that the error replicates after the printer is powered off and then on, and then go to the following steps to continue further fault isolation.

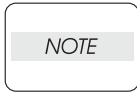

When replacing the BELT Unit, ensure that the Transfer Roller is also replaced. For details, refer to "Appendix_2.1.1 (4) Replacing the Belt Unit and Transfer Roller concurrently".

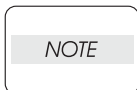

When the Belt Unit has been replaced, be sure to clean up the CTD Sensor. Refer to "Appendix_3.2 Cleaning the Conductivity Temperature Depth (CTD) Sensor" for how to clean up the CTD Sensor.

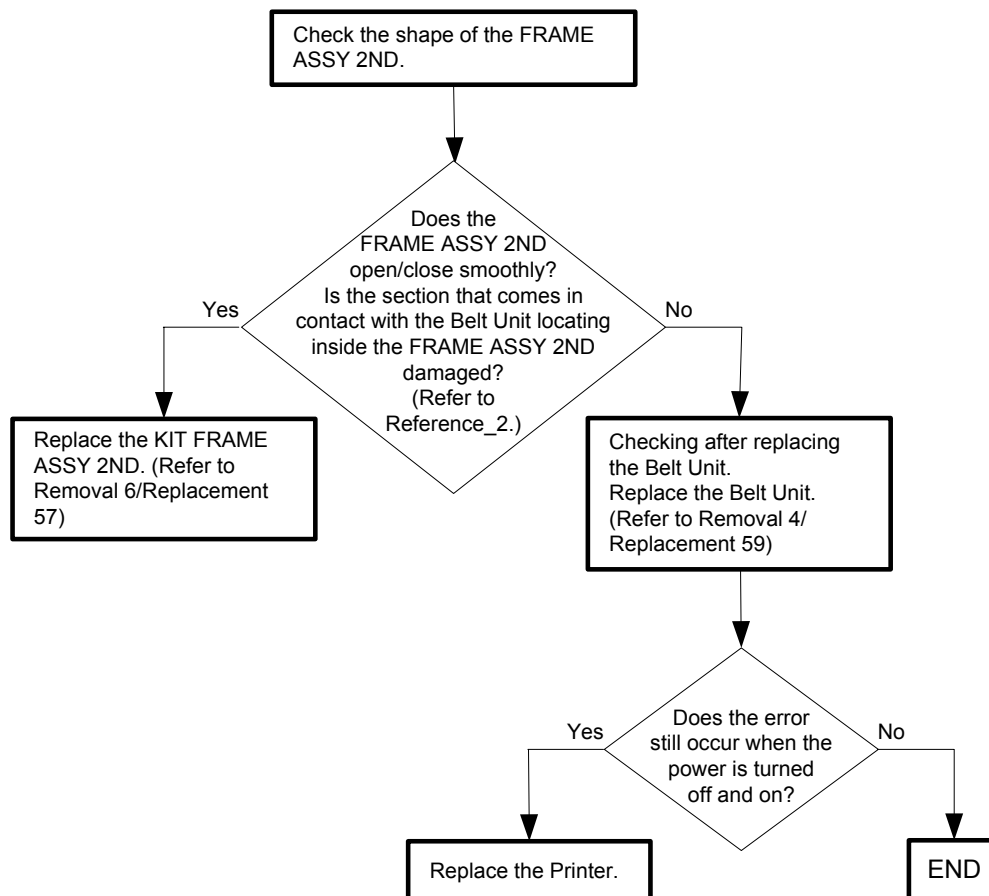

- Reference_1:

- No paper is placed in the MPF

1. Open Right Hand Cover → 2. Open Front Cover. → 3. Open Inner Cover. → 4. Insert Belt Unit. → 5. Close Inner Cover. → 6. Close Front Cover. → 7. Close Right Hand Cover

- Paper is placed in the MPF

1. Remove all the paper in MPF → 2. Open Right Hand Cover → 3. Open Front Cover. → 4. Open Inner Cover. → 5. Insert Belt Unit. → 6. Close Inner Cover. → 7. Close Front Cover. → 8. Close Right Hand Cover → 9. Set paper once again to MPF.

- Reference_2: Section to be checked for damage

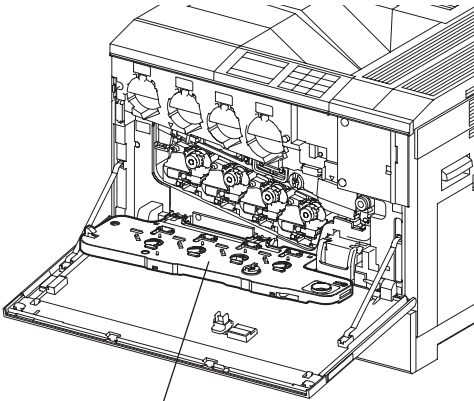

FRAME ASSY 2ND

Tbt01025KA

Flows 125 094-911: IOT Belt Unit Life Over

Cause: TheBelt Unit has reached the replacement time.

Solution: The Belt Unit has reached the end of its life. Replace the Belt Unit with a new one.
Refer to "Appendix_2.6 Replacing the Belt Unit" for how to replace the Belt Unit.

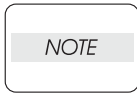

Refer to "Appendix_2.1 Consumables and Periodic Replacement Parts Life" for the timing when the message "Life Over" is indicated.

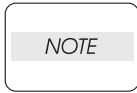

This error code is not related to any hardware fault.

Flows 126 094-912: IOT Belt Unit CRUM Fail

Cause: Belt Unit CRUM communication error is detected.

Solution: Turn the power off and on to check that the error recurs. Then, proceed to the troubleshooting following the flowchart given below.

NOTE

When replacing the BELT Unit, ensure that the Transfer Roller is also replaced. For details, refer to "Appendix_2.1.1 (4) Replacing the Belt Unit and Transfer Roller concurrently".

NOTE

When the Belt Unit has been replaced, be sure to clean up the CTD Sensor. Refer to "Appendix_3.2 Cleaning the Conductivity Temperature Depth (CTD) Sensor" for how to clean up the CTD Sensor.

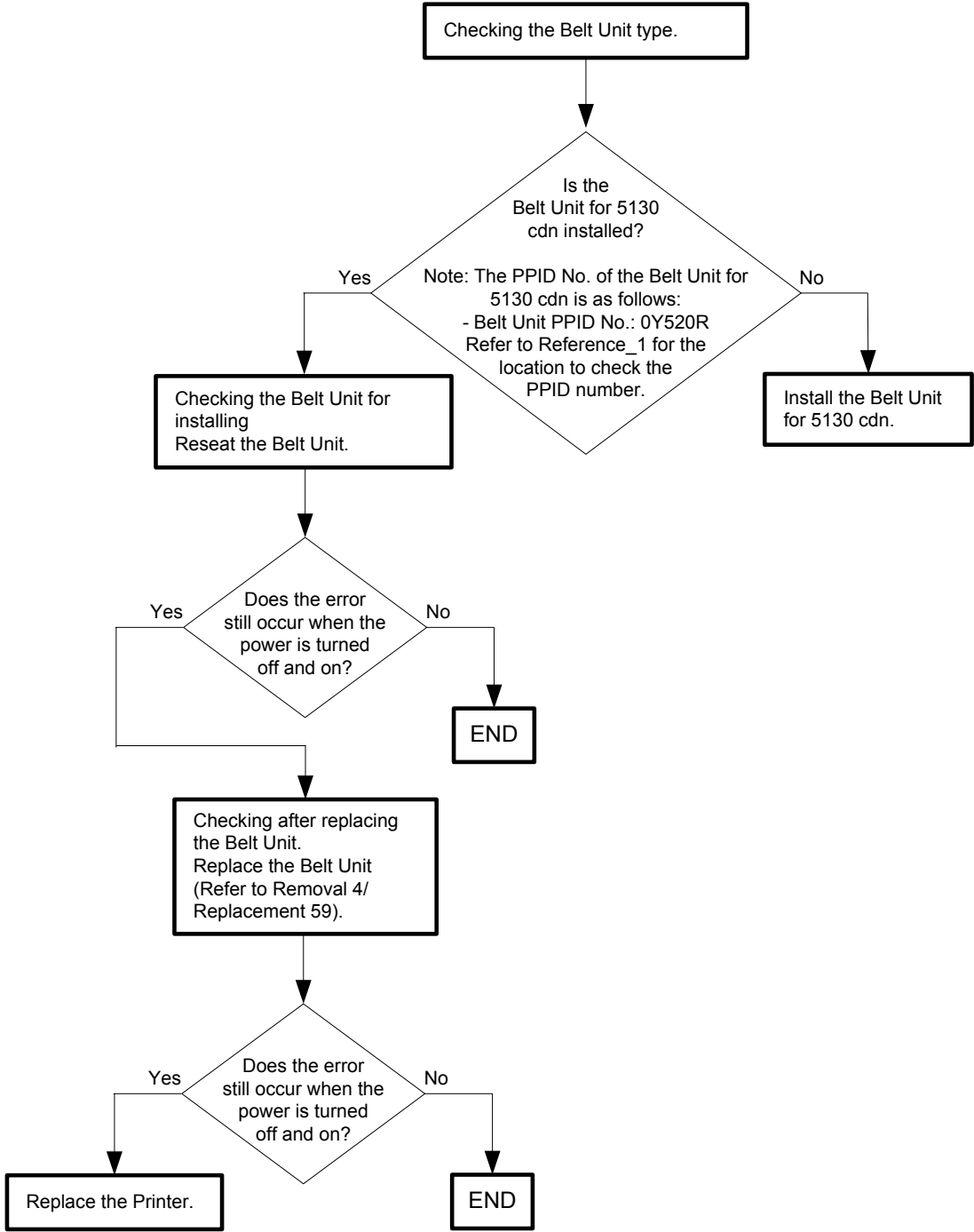

- Reference_1: Position of PPID label.

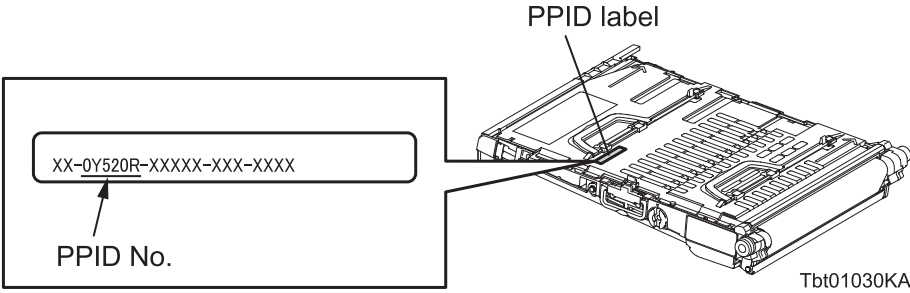

Flows 127 094-913: IOT Transfer Roller Detached

Cause: Transfer Roller detached is detected.

Solution: Solution: The Transfer Roller is not installed. Press the [Information] button. Take the remedies in accordance with the description (refer to Reference_1) shown on the display.

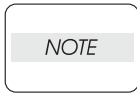

If the error persists after the action above is taken, ensure that the error replicates after the printer is powered off and then on, and then go to the following steps to continue further fault isolation.

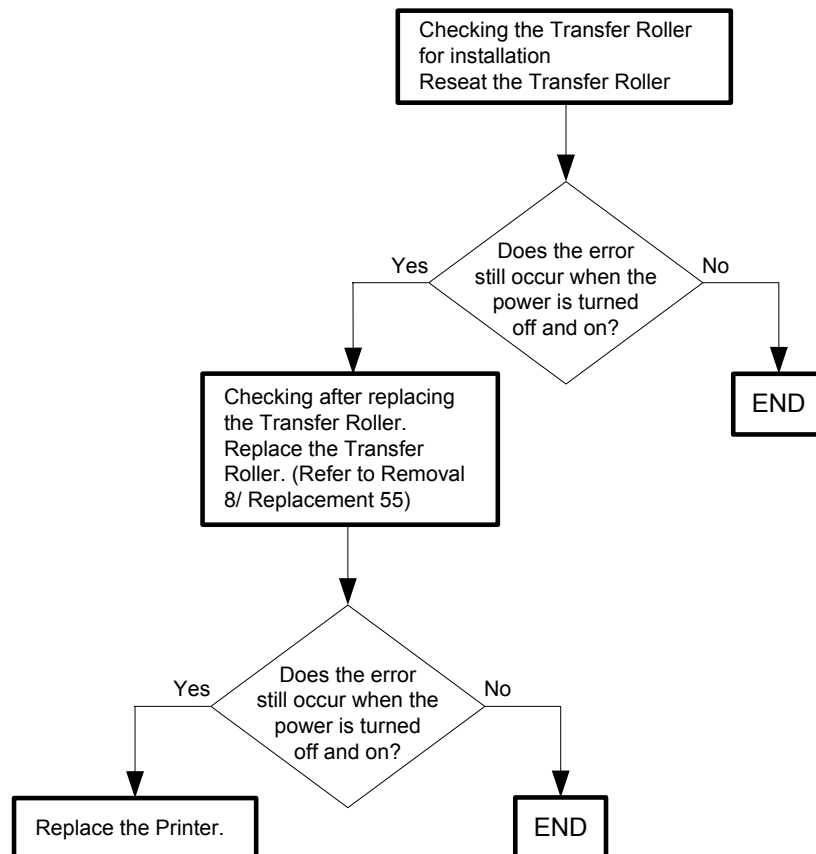

- Reference_1:

- No paper is placed in the MPF

1. Open Right Hand Cover → 2. Insert Transfer Roller. → 3. Close Right Hand Cover

- Paper is placed in the MPF

1. Remove all the paper in MPF → 2. Open Right Hand Cover → 3. Insert Transfer Roller → 4. Close Right Hand Cover → 5. Set paper once again to MPF.

Flows 128 094-960: IOT Belt Unit CRUM ID Mismatch

Cause: An unsupported Belt Unit is detected.

Solution: Press the [Information] button. Take the remedies in accordance with the description (refer to Reference_1) shown on the display.

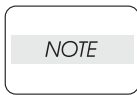

If the error persists after the action above is taken, ensure that the error replicates after the printer is powered off and then on, and then go to the following steps to continue further fault isolation.

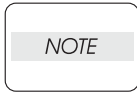

When replacing the BELT Unit, ensure that the Transfer Roller is also replaced. For details, refer to "Appendix_2.1.1 (4) Replacing the Belt Unit and Transfer Roller concurrently".

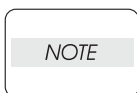

When the Belt Unit has been replaced, be sure to clean up the CTD Sensor. Refer to "Appendix_3.2 Cleaning the Conductivity Temperature Depth (CTD) Sensor" for how to clean up the CTD Sensor.

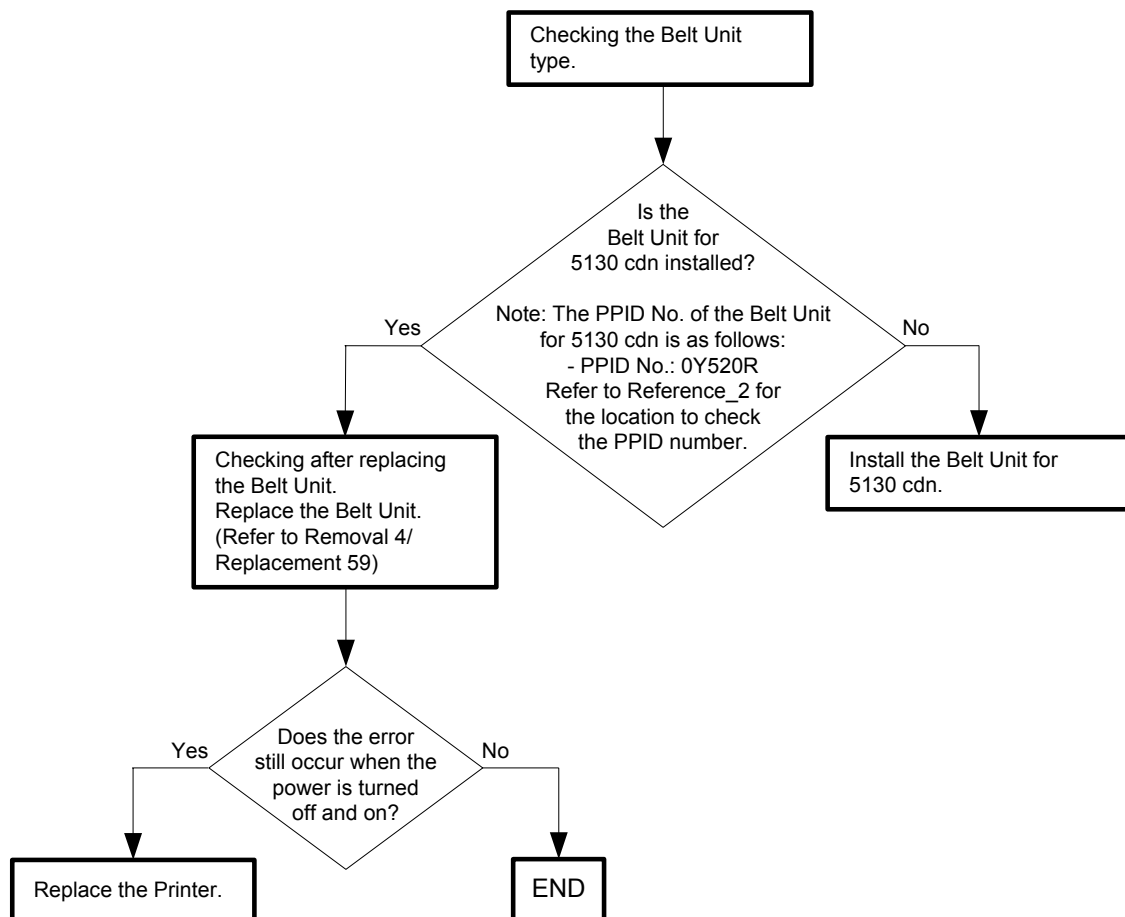

Reference_1:

- No paper is placed in the MPF

1. Open Right Hand Cover → 2. Open Front Cover. → 3. Open Inner Cover. → 4. Reseat Belt Unit. → 5. Close Inner Cover. → 6. Close Front Cover. → 7. Close Right Hand Cover

- Paper is placed in the MPF

1. Remove all the paper in MPF → 2. Open Right Hand Cover → 3. Open Front Cover. → 4. Open Inner Cover. → 5. Reseat Belt Unit. → 6. Close Inner Cover. → 7. Close Front Cover. → 8. Close Right Hand Cover → 9. Set paper once again to MPF.

- Reference_2: Position of PPID label.

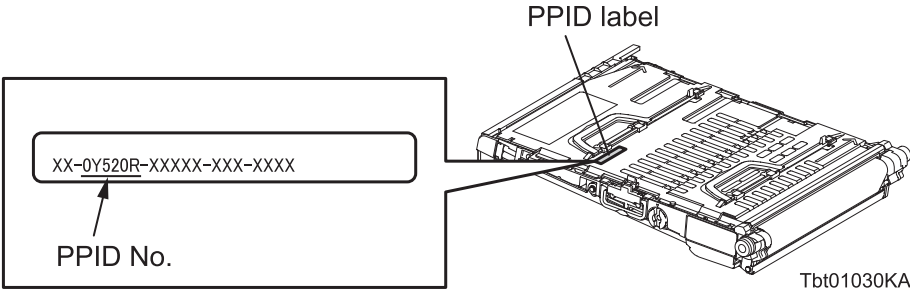

Flows 129 116-364: Timer Fail

Cause: The timer fault was detected.

Solution: Proceed to the troubleshooting following the flowchart given below.

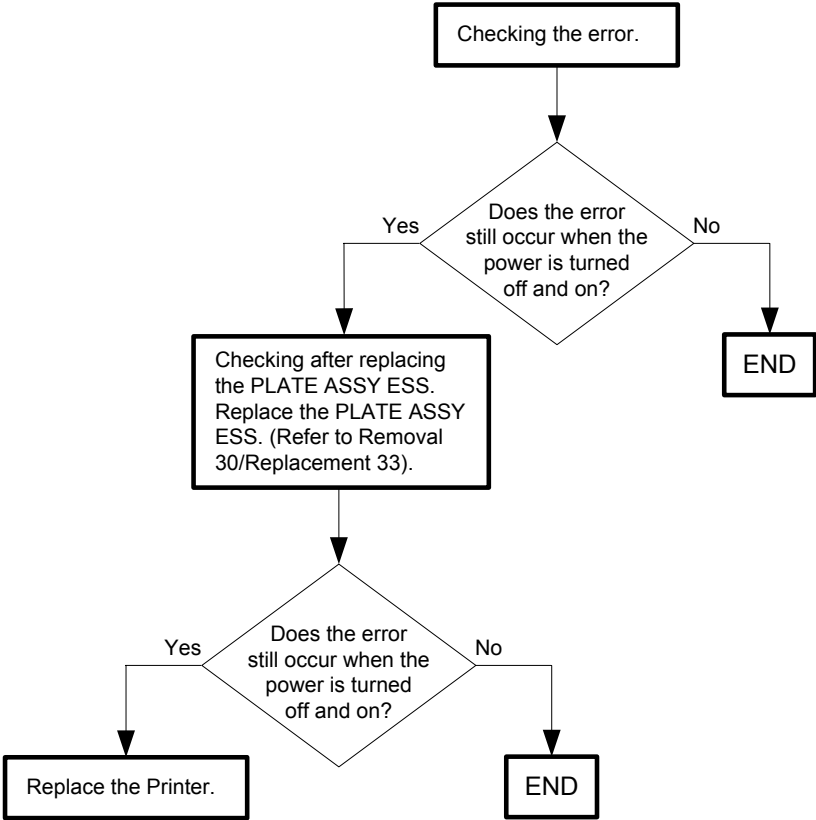

Flows 130 124-310: IOT XPC Error

Cause: Detect XPC Error

Solution: Turn the power off and on to check that the error recurs. Then, proceed to the troubleshooting following the flowchart given below.

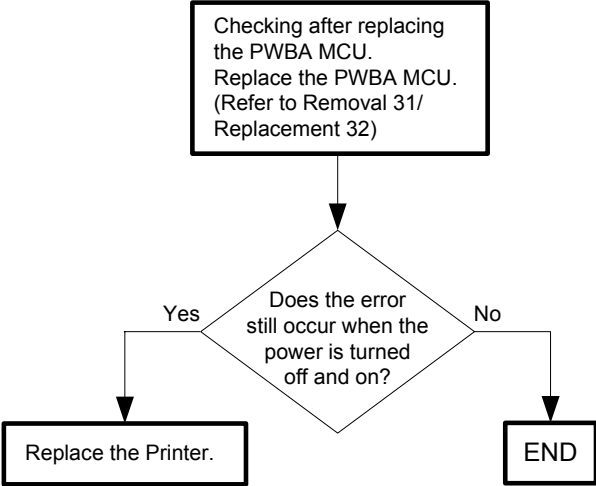

Flows 131 193-700: Custom Toner Mode

Cause: The printer is in custom toner mode.

Solution: The printer has been set to use the toner cartridge made by other manufacturer than Dell (Non Dell Toner Mode). When the Dell-specified toner cartridge is used, set the Non Dell Toner Mode in "Off." Refer to [Non-Dell Toner] in "10. Dell Printer Configuration Web Tool" in the User Guide for how to set the Non Dell Toner Mode.

NOTE

When the toner cartridge made by a manufacturer other than Dell is used, the warranty may not apply to your printer even if it is severely damaged.

NOTE

If the error still occurs when the Dell-specified toner cartridge is installed and the Non Dell Toner Mode is set in "Off," turn the power off and on to check that the error recurs. Then, proceed to troubleshooting following the flowchart given below.

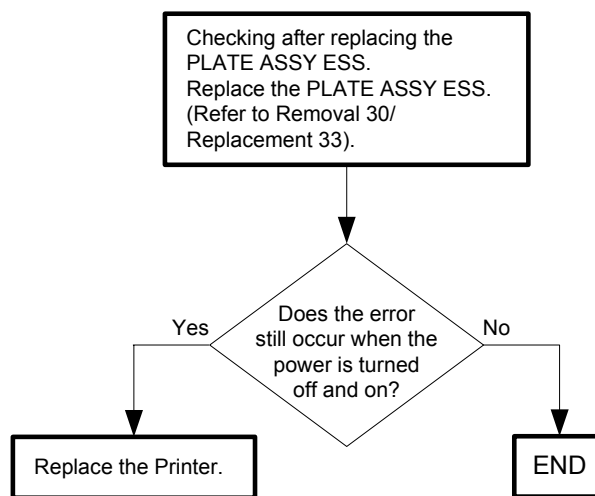

Flows 132 Electrical Noise

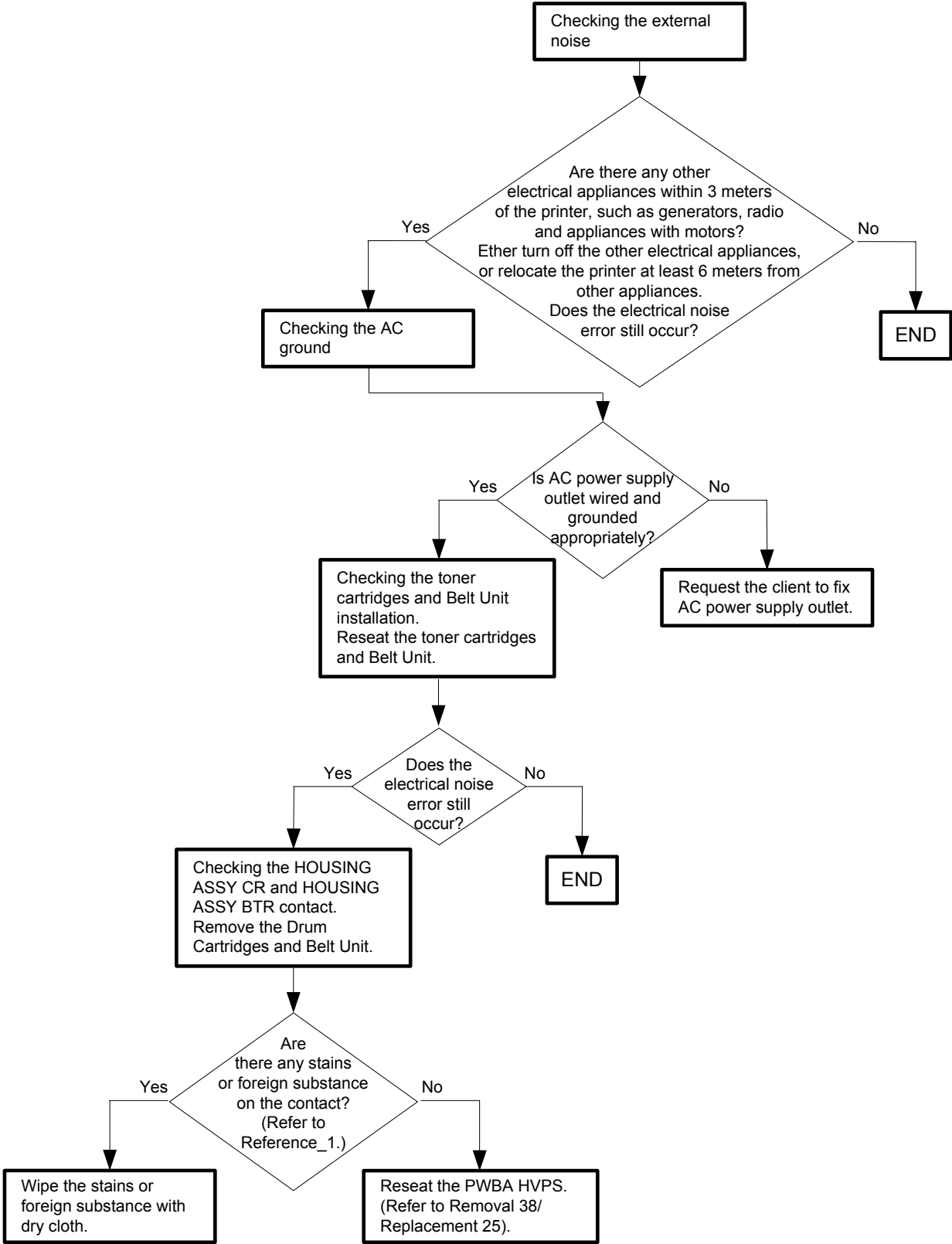

- Reference_1: Section to be checked

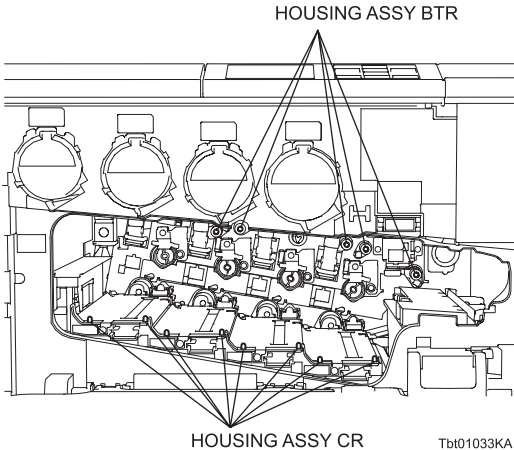

Flows 133 Faint print (Image Density)

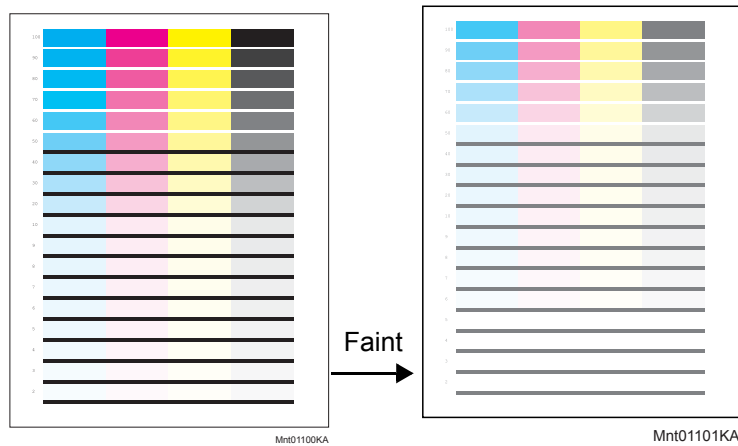

NOTE

When replacing the Drum Cartridge (YMCK), ensure that the pad of the CLEANER ASSY (cleaning rod) is replaced and that the ROSS ASSY is cleaned. For details of how to replace the Drum Cartridge (YMCK), refer to "Appendix_2.3 Replacing the Drum Cartridges". For details of how to clean the ROS ASSY, refer to "Appendix_3.1 Cleaning Inside the Printer".

NOTE

When replacing the BELT Unit, ensure that the Transfer Roller is also replaced. For details, refer to "Appendix_2.1.1 (4) Replacing the Belt Unit and Transfer Roller concurrently".

NOTE

When the Belt Unit has been replaced, be sure to clean up the CTD Sensor. Refer to "Appendix_3.2 Cleaning the Conductivity Temperature Depth (CTD) Sensor" for how to clean up the CTD Sensor.

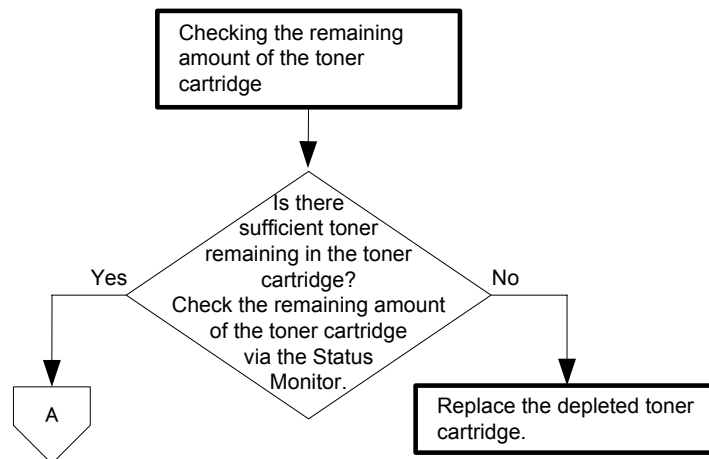

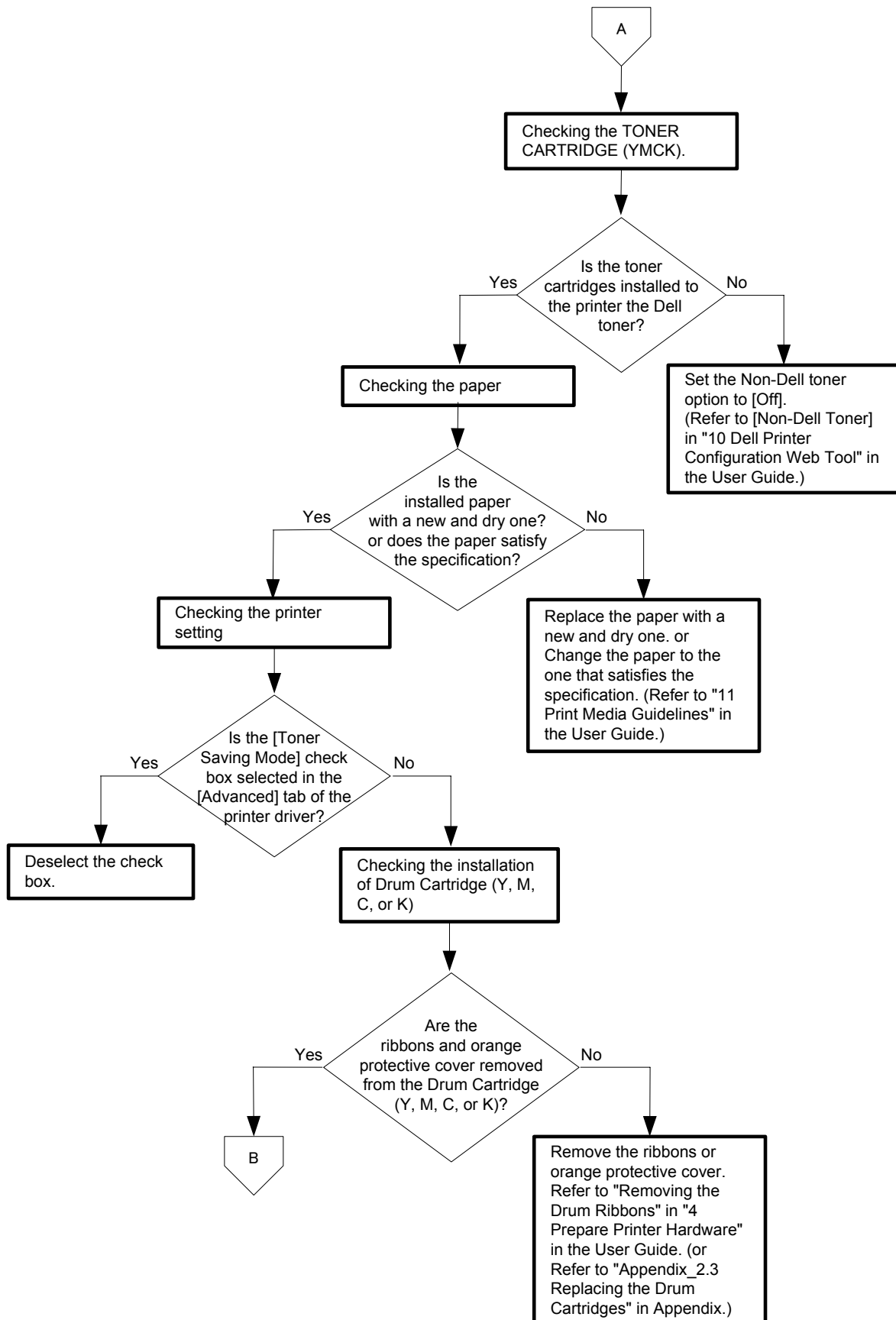

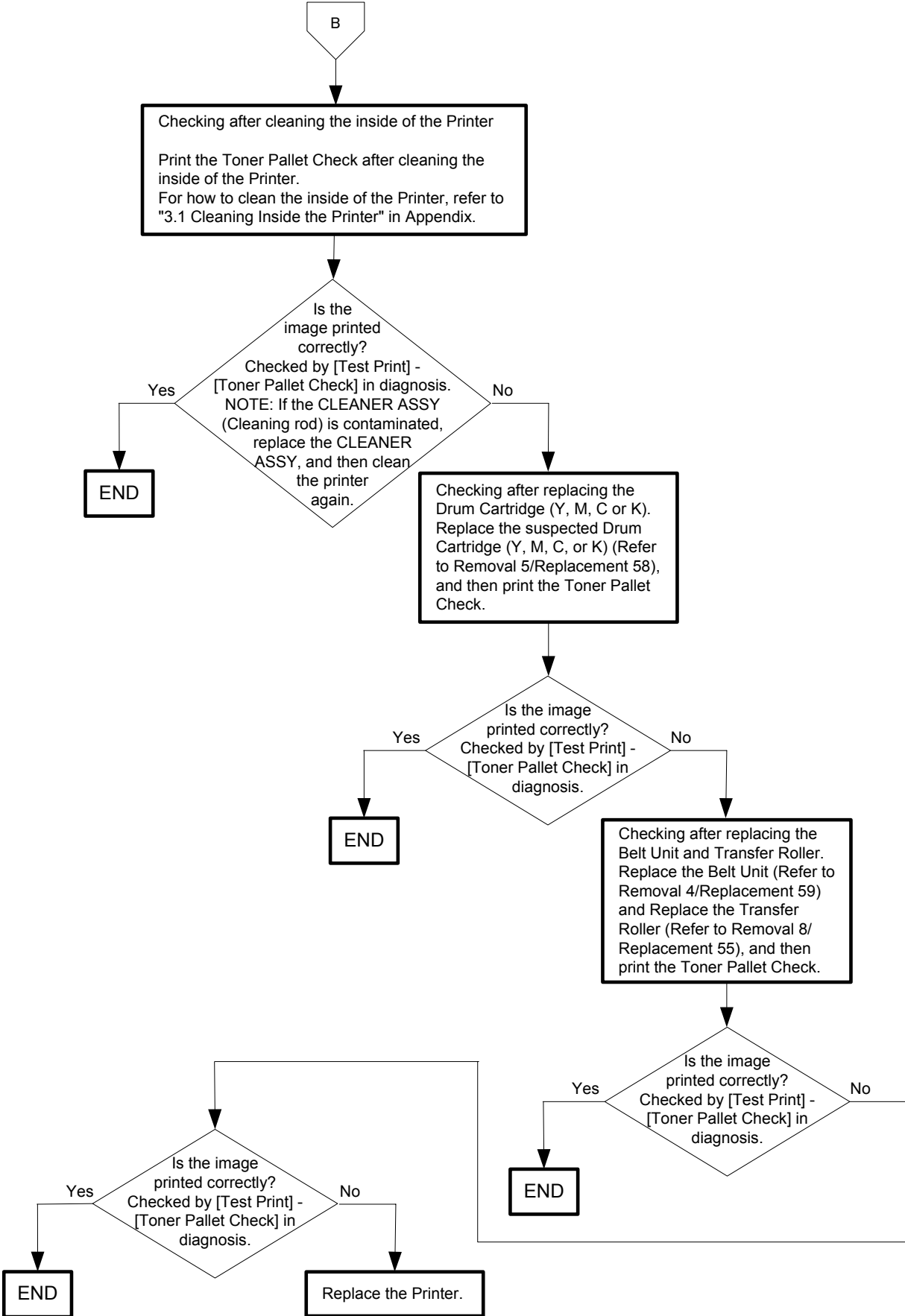

Flows 134 Blank print (No print)



NOTE

When replacing the Drum Cartridge (YMCK), ensure that the pad of the CLEANER ASSY (cleaning rod) is replaced and that the ROSS ASSY is cleaned. For details of how to replace the Drum Cartridge (YMCK), refer to "Appendix_2.3 Replacing the Drum Cartridges". For details of how to clean the ROS ASSY, refer to "Appendix_3.1 Cleaning Inside the Printer".

NOTE

When replacing the BELT Unit, ensure that the Transfer Roller is also replaced. For details, refer to "Appendix_2.1.1 (4) Replacing the Belt Unit and Transfer Roller concurrently".

NOTE

When the Belt Unit has been replaced, be sure to clean up the CTD Sensor. Refer to "Appendix_3.2 Cleaning the Conductivity Temperature Depth (CTD) Sensor" for how to clean up the CTD Sensor.

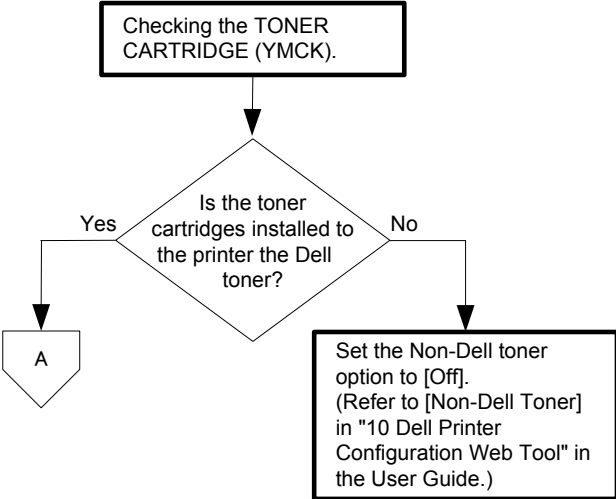

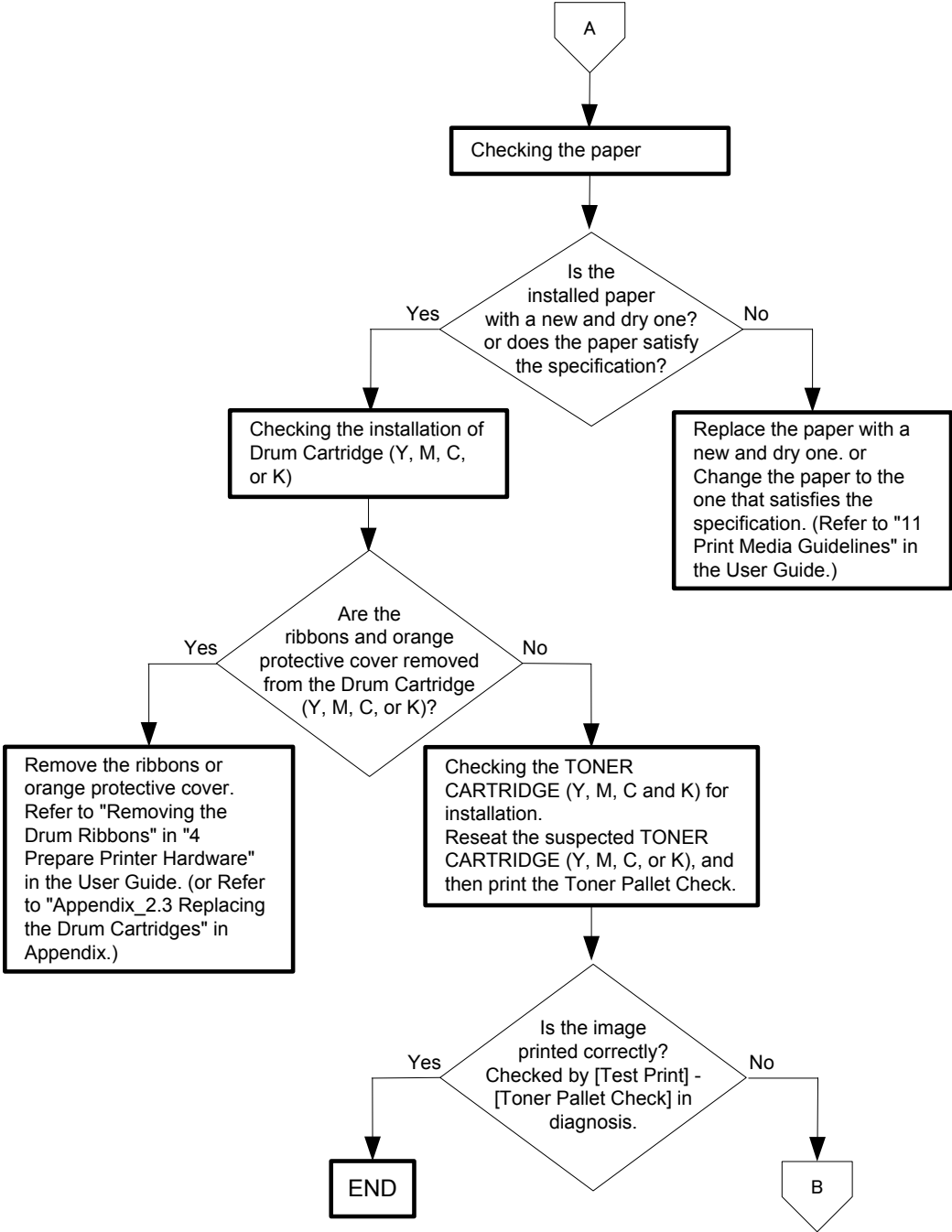

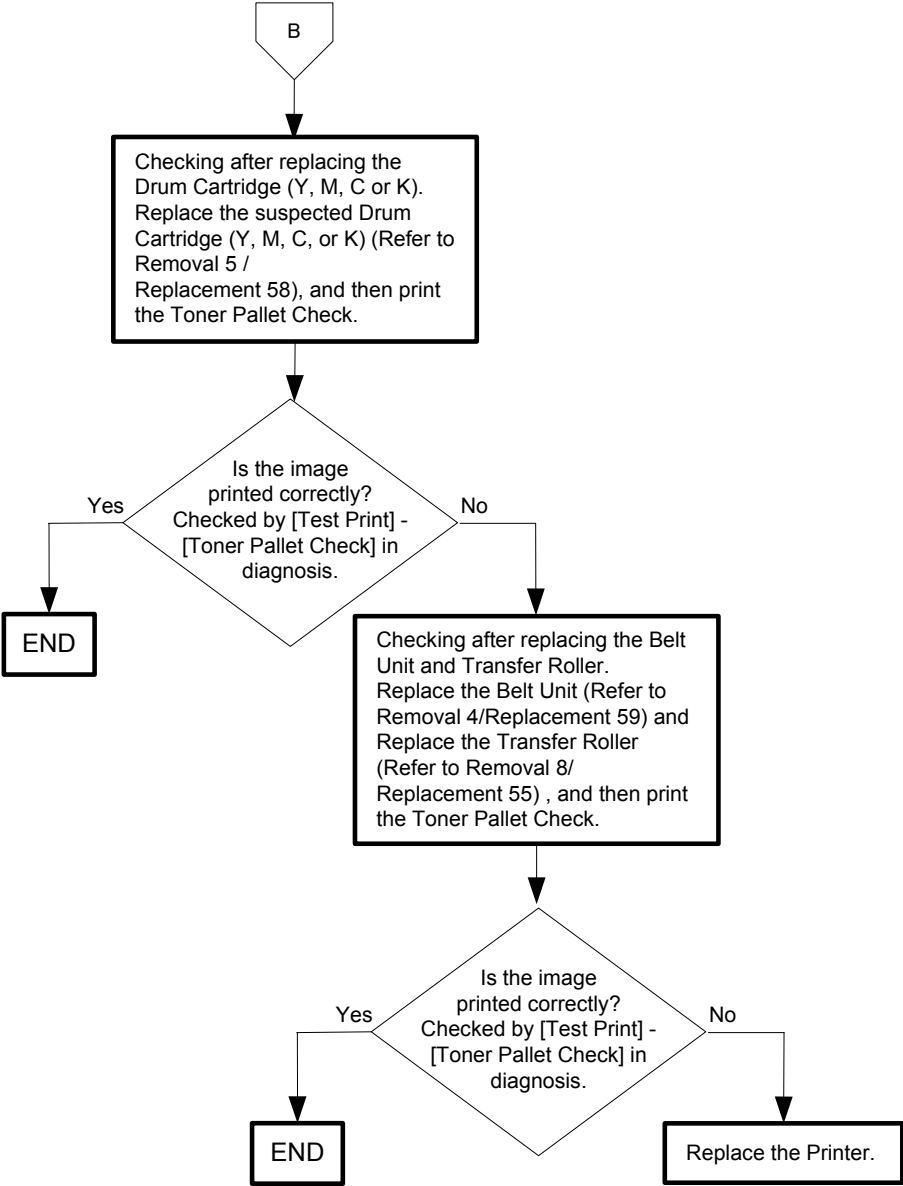

Flows 135 Solid Print (YMCK)

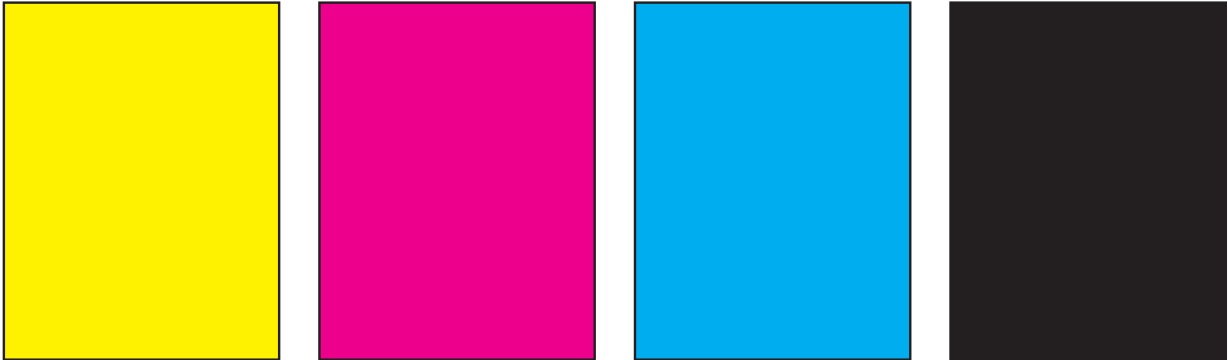

Tbt01034KA

NOTE

When replacing the Drum Cartridge (YMCK), ensure that the pad of the CLEANER ASSY (cleaning rod) is replaced and that the ROSS ASSY is cleaned. For details of how to replace the Drum Cartridge (YMCK), refer to "Appendix_2.3 Replacing the Drum Cartridges". For details of how to clean the ROS ASSY, refer to "Appendix_3.1 Cleaning Inside the Printer".

NOTE

When replacing the BELT Unit, ensure that the Transfer Roller is also replaced. For details, refer to "Appendix_2.1.1 (4) Replacing the Belt Unit and Transfer Roller concurrently".

NOTE

When the Belt Unit has been replaced, be sure to clean up the CTD Sensor. Refer to "Appendix_3.2 Cleaning the Conductivity Temperature Depth (CTD) Sensor" for how to clean up the CTD Sensor.

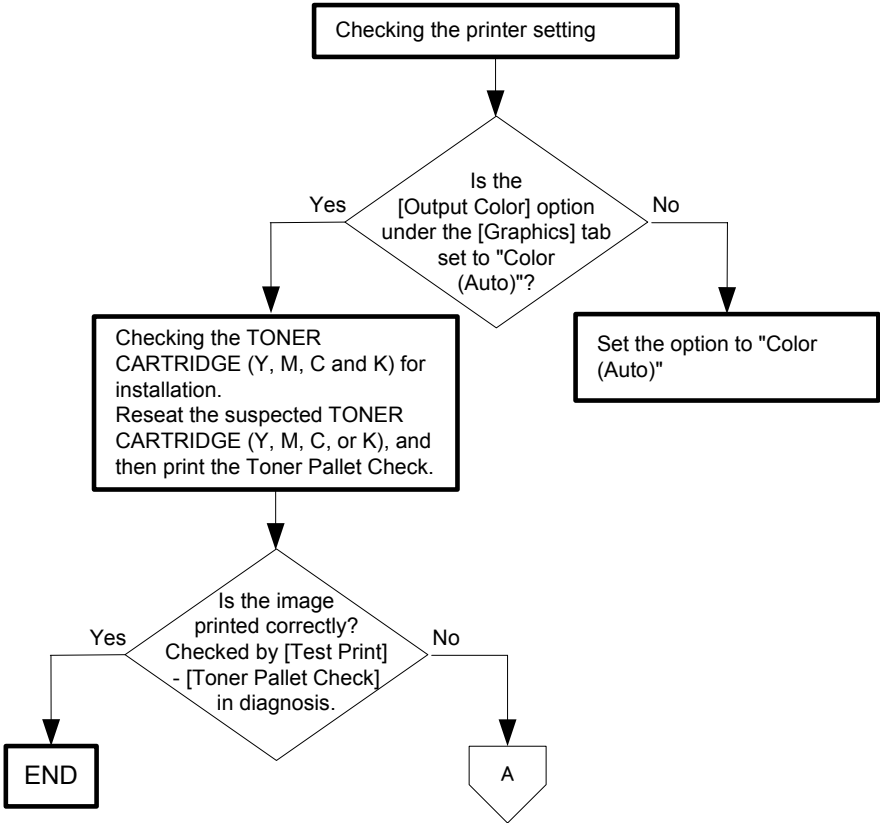

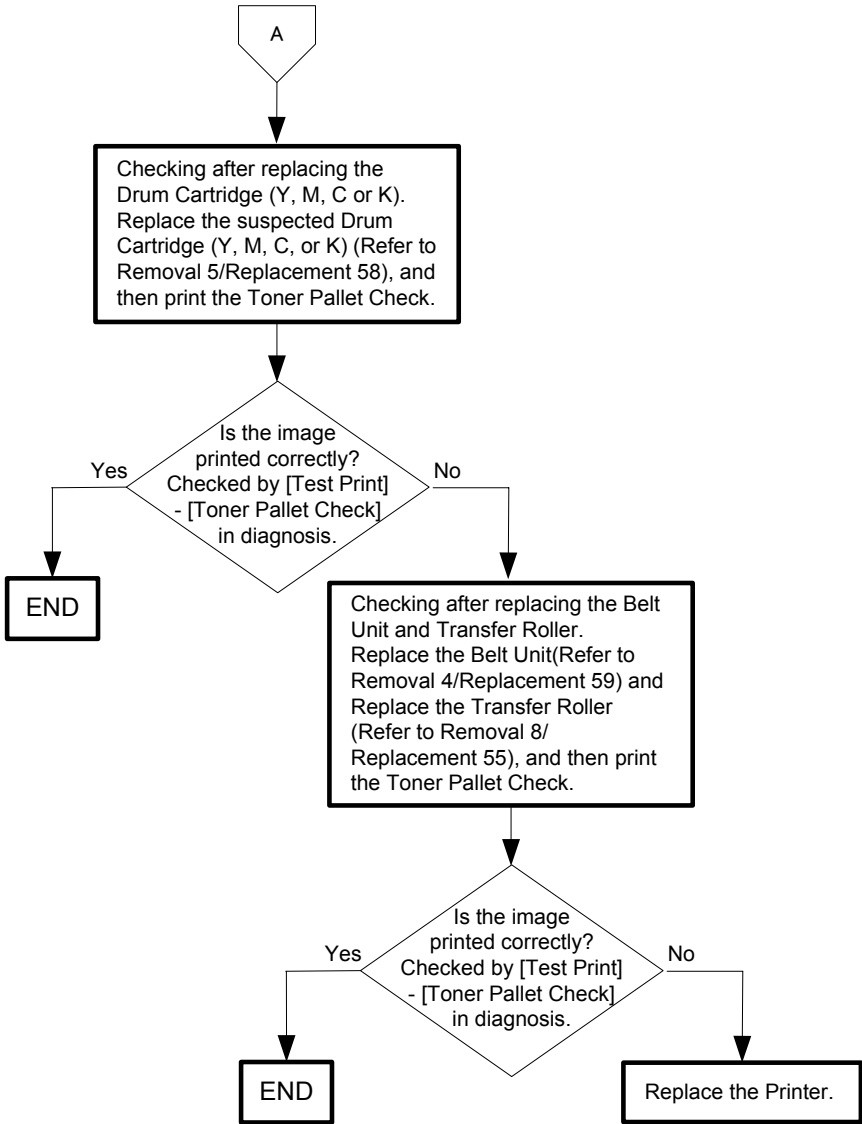

Flows 136 Vertical blank lines (White stripes in paper transport direction)

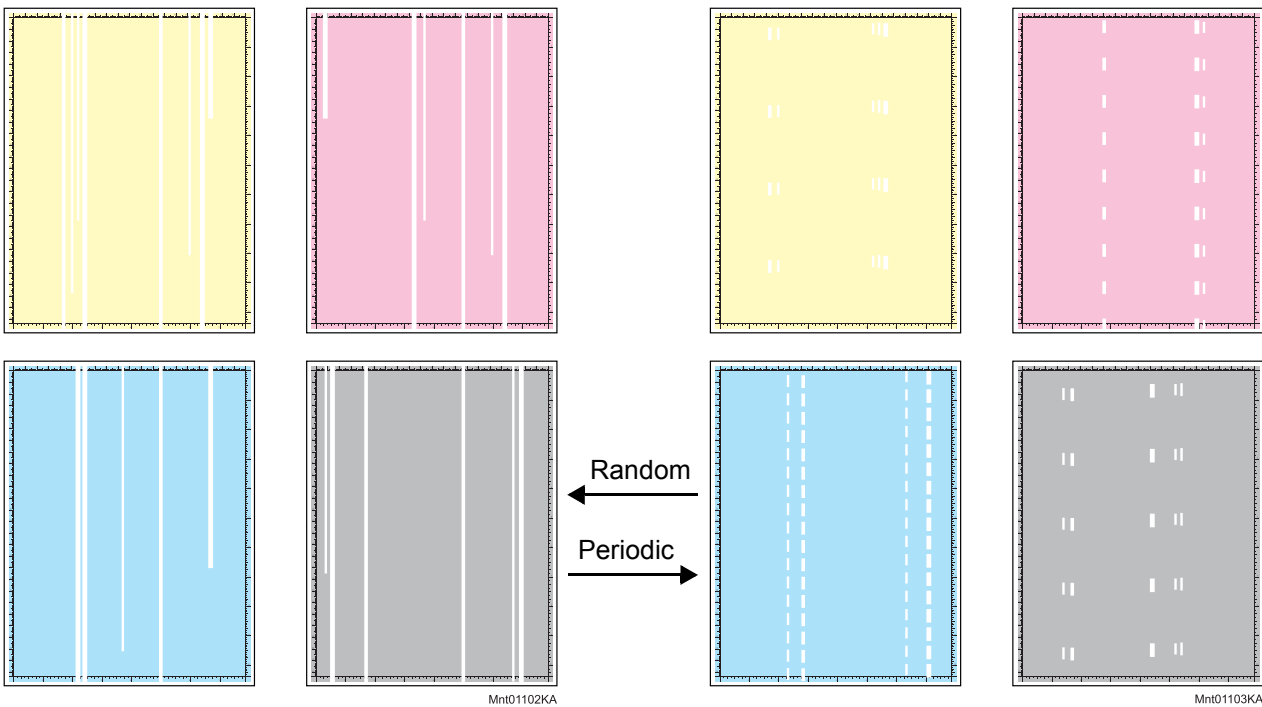

NOTE

When replacing the Drum Cartridge (YMCK), ensure that the pad of the CLEANER ASSY (cleaning rod) is replaced and that the ROSS ASSY is cleaned. For details of how to replace the Drum Cartridge (YMCK), refer to "Appendix_2.3 Replacing the Drum Cartridges". For details of how to clean the ROS ASSY, refer to "Appendix_3.1 Cleaning Inside the Printer".

NOTE

When replacing the BELT Unit, ensure that the Transfer Roller is also replaced. For details, refer to "Appendix_2.1.1 (4) Replacing the Belt Unit and Transfer Roller concurrently".

NOTE

When the Belt Unit has been replaced, be sure to clean up the CTD Sensor. Refer to "Appendix_3.2 Cleaning the Conductivity Temperature Depth (CTD) Sensor" for how to clean up the CTD Sensor.

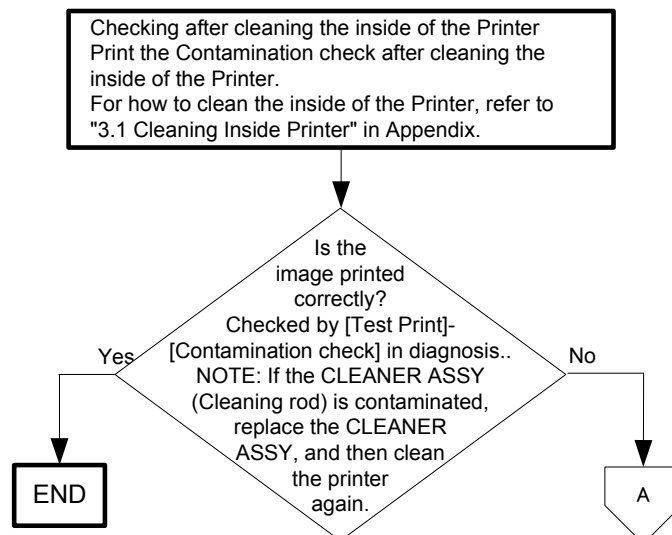

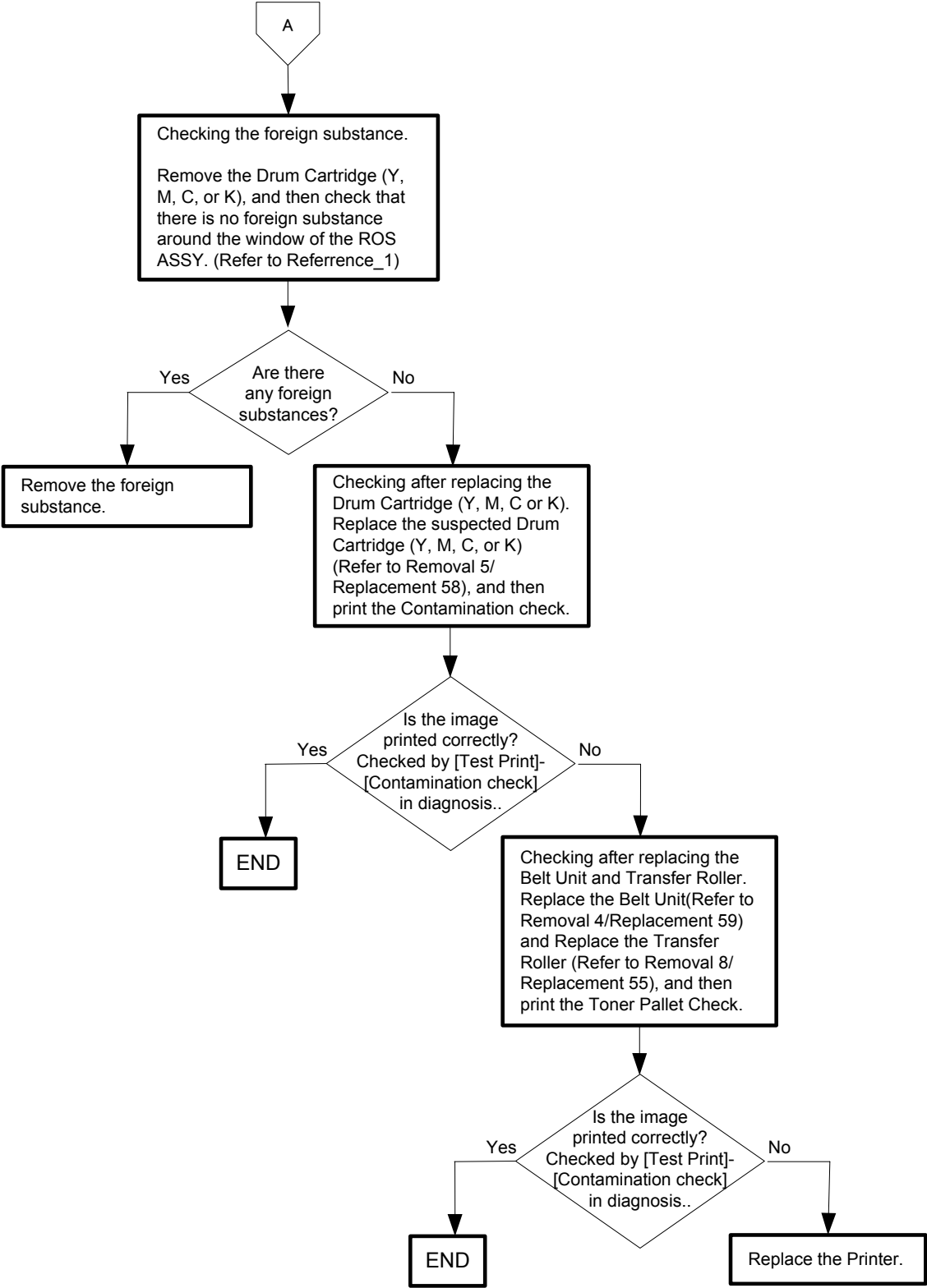

- Reference_1: Section to be checked for damage (for the Tray 1)

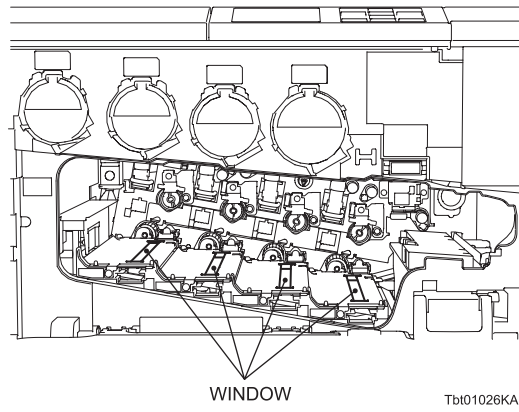

Flows 137 Horizontal band cross out (White stripes in the horizontal direction)

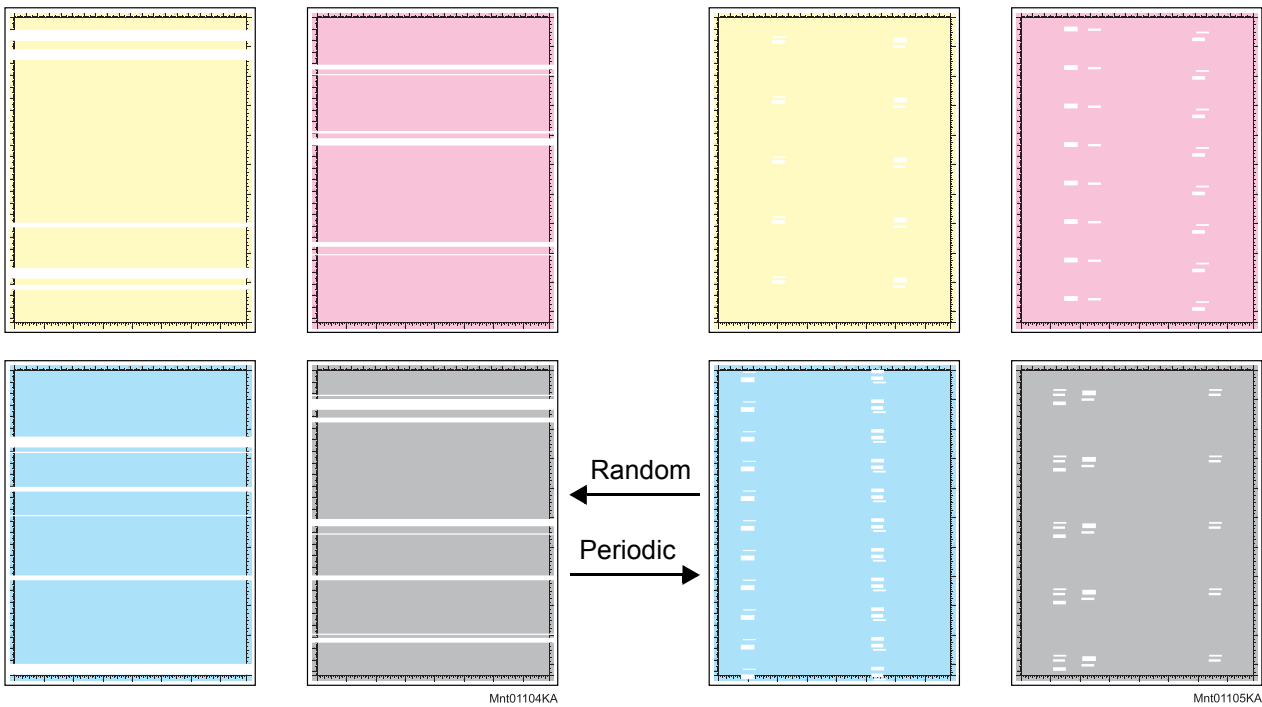

NOTE

When replacing the Drum Cartridge (YMCK), ensure that the pad of the CLEANER ASSY (cleaning rod) is replaced and that the ROSS ASSY is cleaned. For details of how to replace the Drum Cartridge (YMCK), refer to "Appendix_2.3 Replacing the Drum Cartridges". For details of how to clean the ROS ASSY, refer to "Appendix_3.1 Cleaning Inside the Printer".

NOTE

When replacing the BELT Unit, ensure that the Transfer Roller is also replaced. For details, refer to "Appendix_2.1.1 (4) Replacing the Belt Unit and Transfer Roller concurrently".

NOTE

When the Belt Unit has been replaced, be sure to clean up the CTD Sensor. Refer to "Appendix_3.2 Cleaning the Conductivity Temperature Depth (CTD) Sensor" for how to clean up the CTD Sensor.

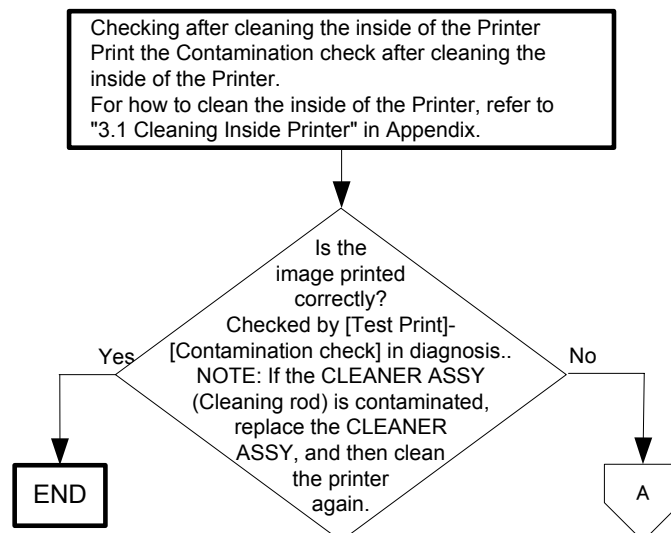

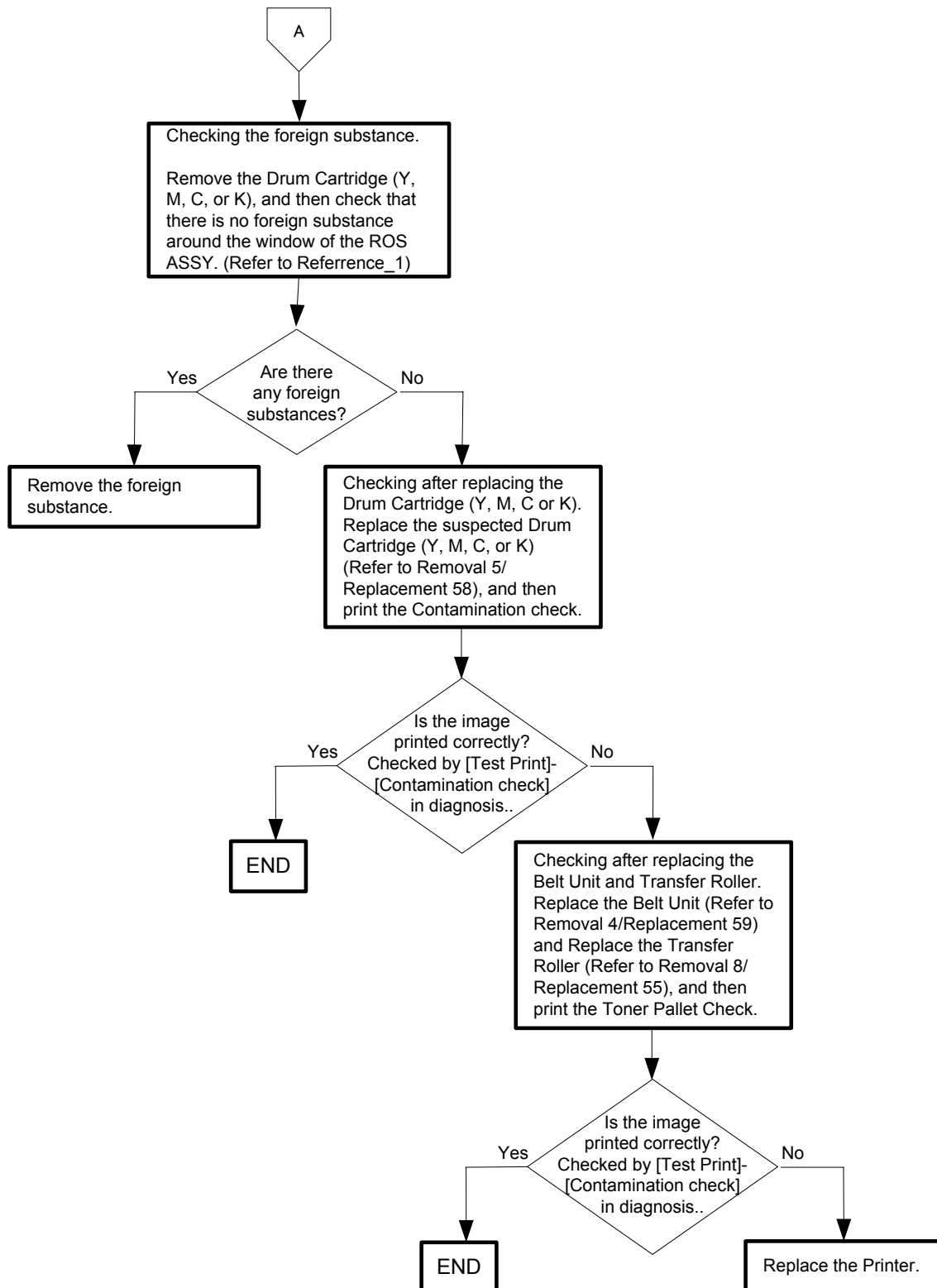

- Reference_1: Section to be checked for damage (for the Tray 1)

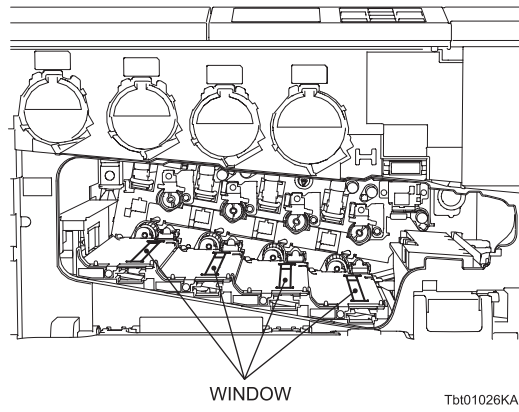

Flows 138 Vertical stripes

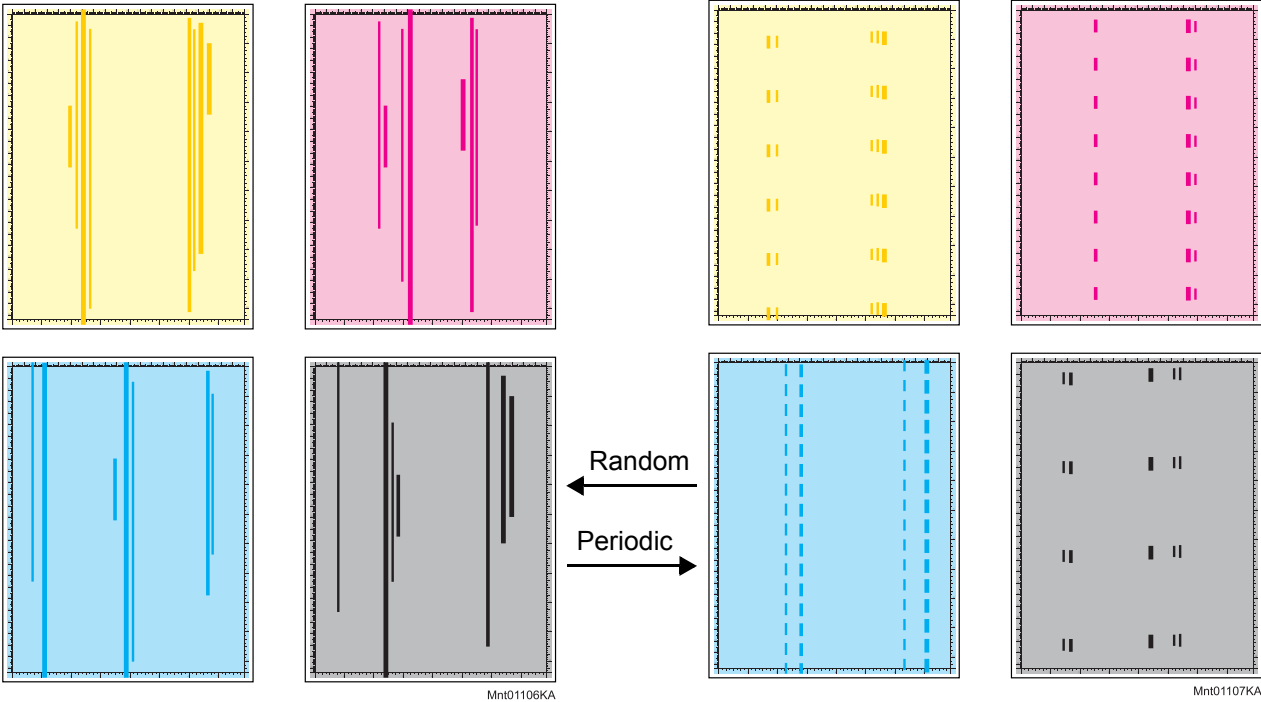

NOTE

When replacing the Drum Cartridge (YMCK), ensure that the pad of the CLEANER ASSY (cleaning rod) is replaced and that the ROSS ASSY is cleaned. For details of how to replace the Drum Cartridge (YMCK), refer to "Appendix_2.3 Replacing the Drum Cartridges". For details of how to clean the ROS ASSY, refer to "Appendix_3.1 Cleaning Inside the Printer".

NOTE

When replacing the BELT Unit, ensure that the Transfer Roller is also replaced. For details, refer to "Appendix_2.1.1 (4) Replacing the Belt Unit and Transfer Roller concurrently".

NOTE

When the Belt Unit has been replaced, be sure to clean up the CTD Sensor. Refer to "Appendix_3.2 Cleaning the Conductivity Temperature Depth (CTD) Sensor" for how to clean up the CTD Sensor.

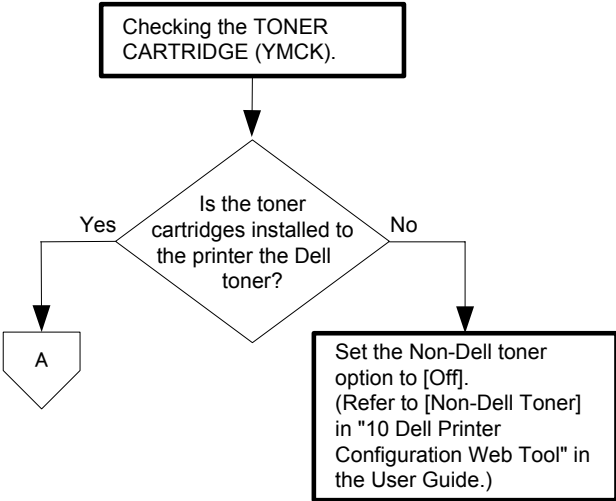

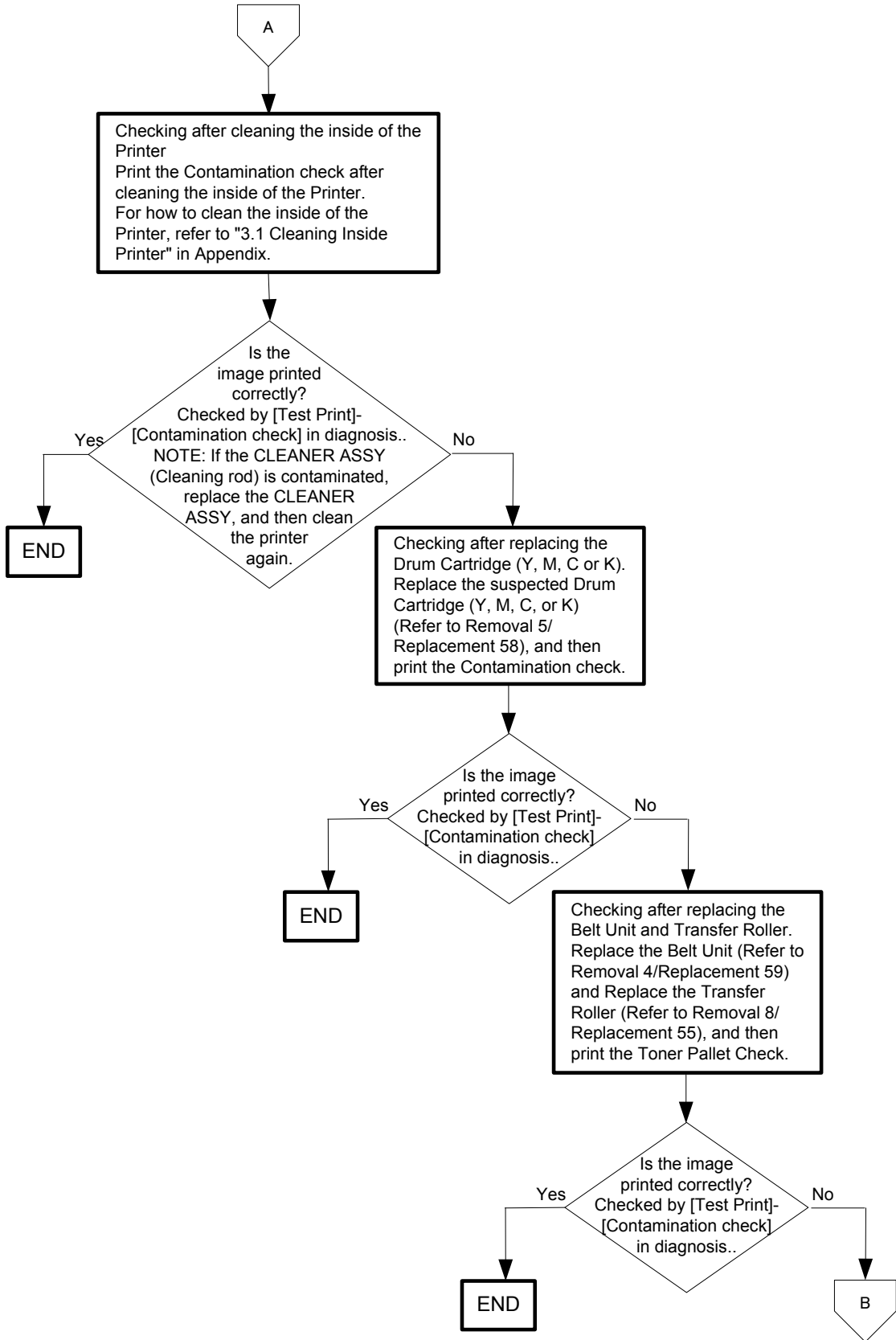

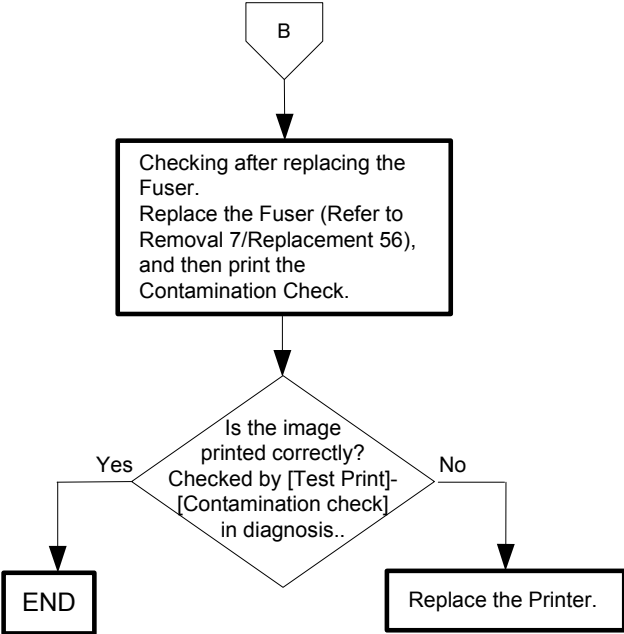

Flows 139 Horizontal stripes

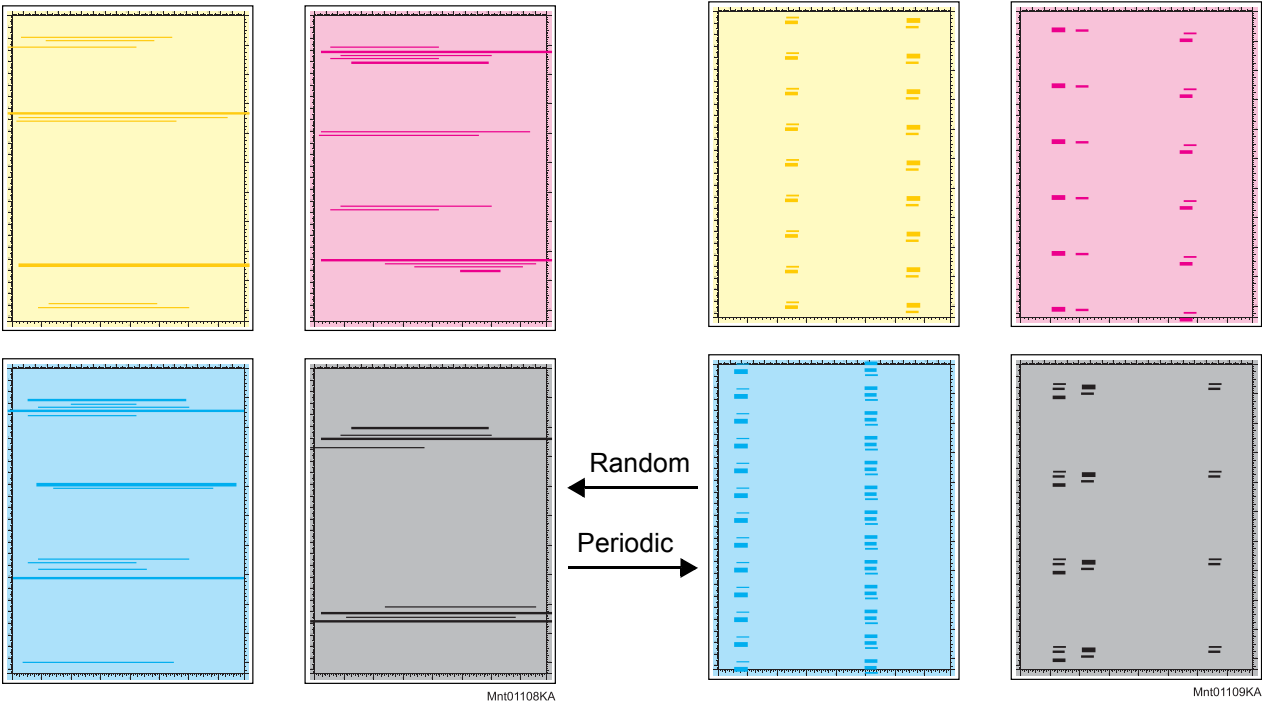

NOTE

When replacing the Drum Cartridge (YMCK), ensure that the pad of the CLEANER ASSY (cleaning rod) is replaced and that the ROSS ASSY is cleaned. For details of how to replace the Drum Cartridge (YMCK), refer to "Appendix_2.3 Replacing the Drum Cartridges". For details of how to clean the ROS ASSY, refer to "Appendix_3.1 Cleaning Inside the Printer".

NOTE

When replacing the BELT Unit, ensure that the Transfer Roller is also replaced. For details, refer to "Appendix_2.1.1 (4) Replacing the Belt Unit and Transfer Roller concurrently".

NOTE

When the Belt Unit has been replaced, be sure to clean up the CTD Sensor. Refer to "Appendix_3.2 Cleaning the Conductivity Temperature Depth (CTD) Sensor" for how to clean up the CTD Sensor.

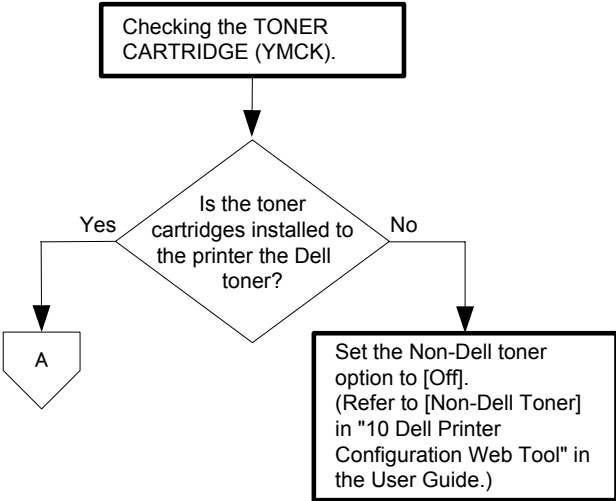

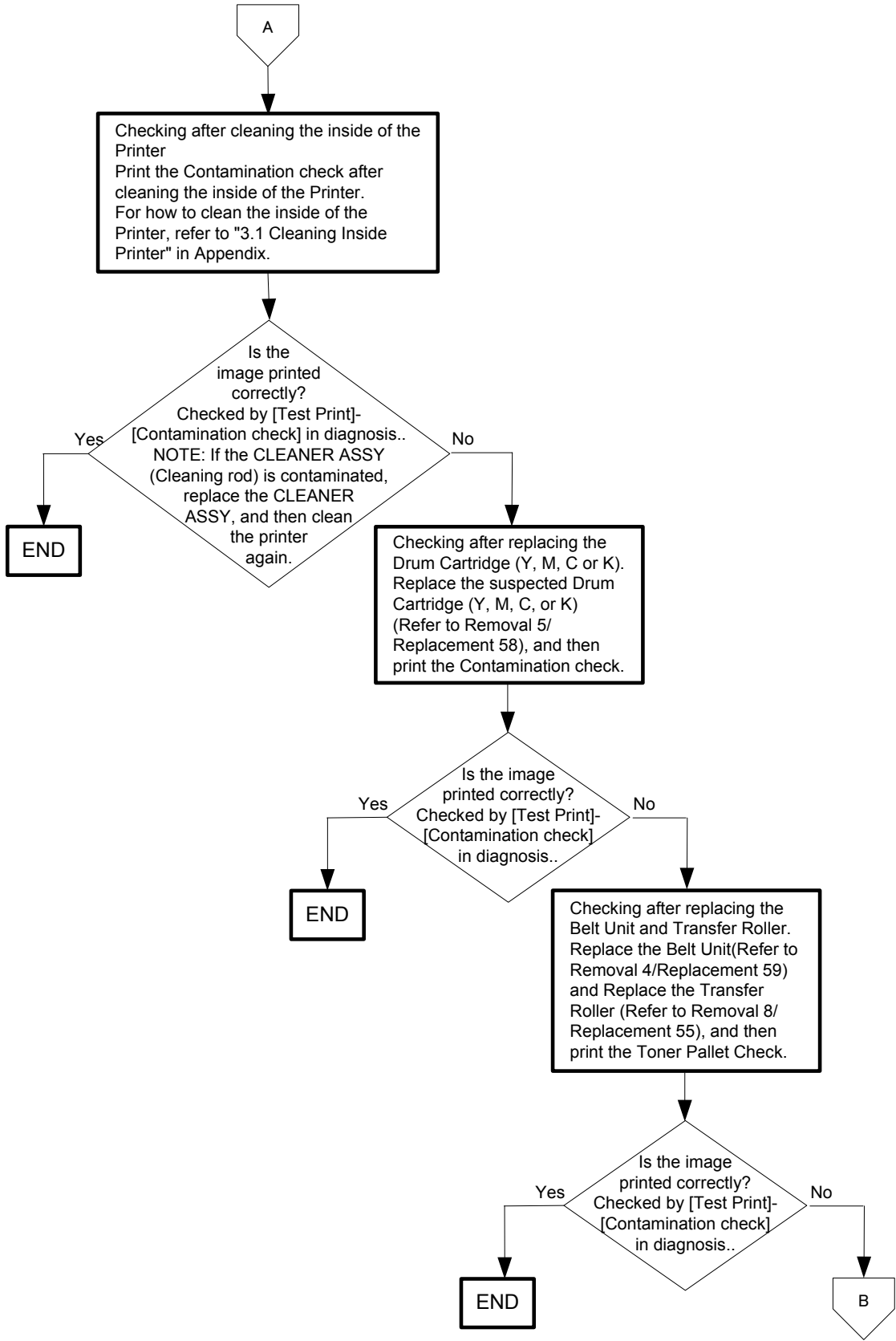

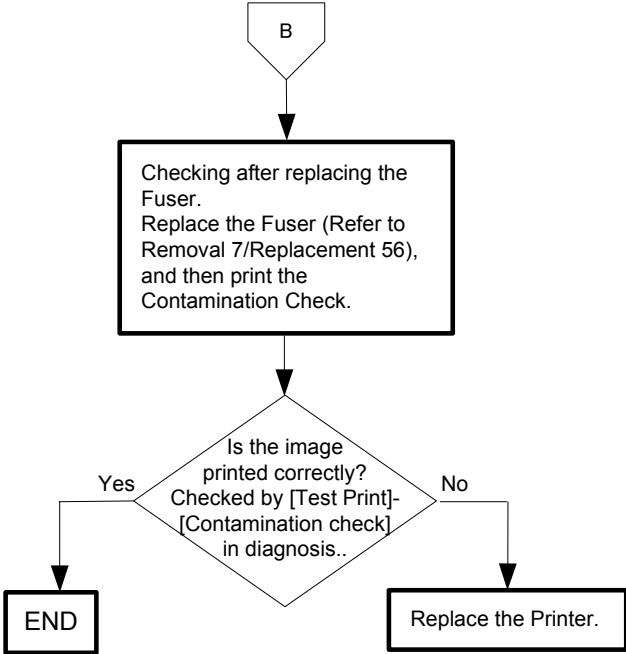

Flows 140 Partial Deletion

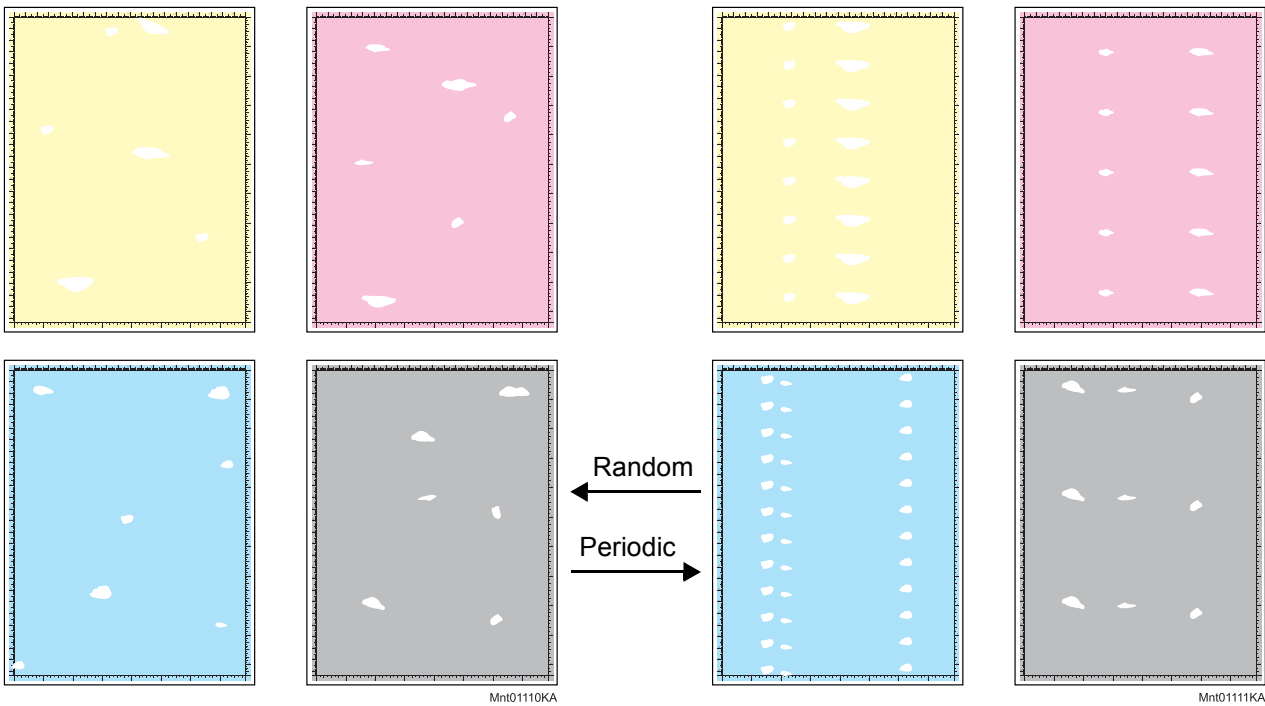

NOTE

When replacing the Drum Cartridge (YMCK), ensure that the pad of the CLEANER ASSY (cleaning rod) is replaced and that the ROSS ASSY is cleaned. For details of how to replace the Drum Cartridge (YMCK), refer to "Appendix_2.3 Replacing the Drum Cartridges". For details of how to clean the ROS ASSY, refer to "Appendix_3.1 Cleaning Inside the Printer".

NOTE

When replacing the BELT Unit, ensure that the Transfer Roller is also replaced. For details, refer to "Appendix_2.1.1 (4) Replacing the Belt Unit and Transfer Roller concurrently".

NOTE

When the Belt Unit has been replaced, be sure to clean up the CTD Sensor. Refer to "Appendix_3.2 Cleaning the Conductivity Temperature Depth (CTD) Sensor" for how to clean up the CTD Sensor.

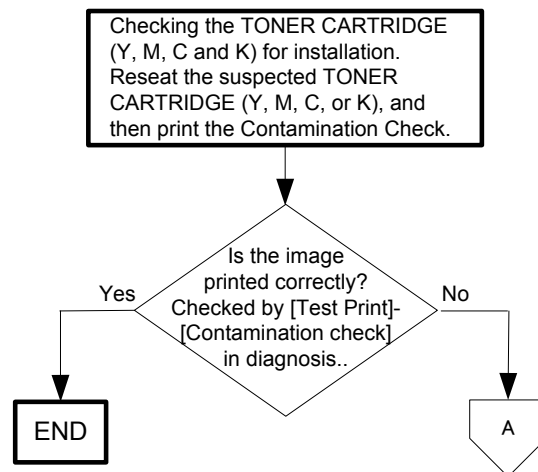

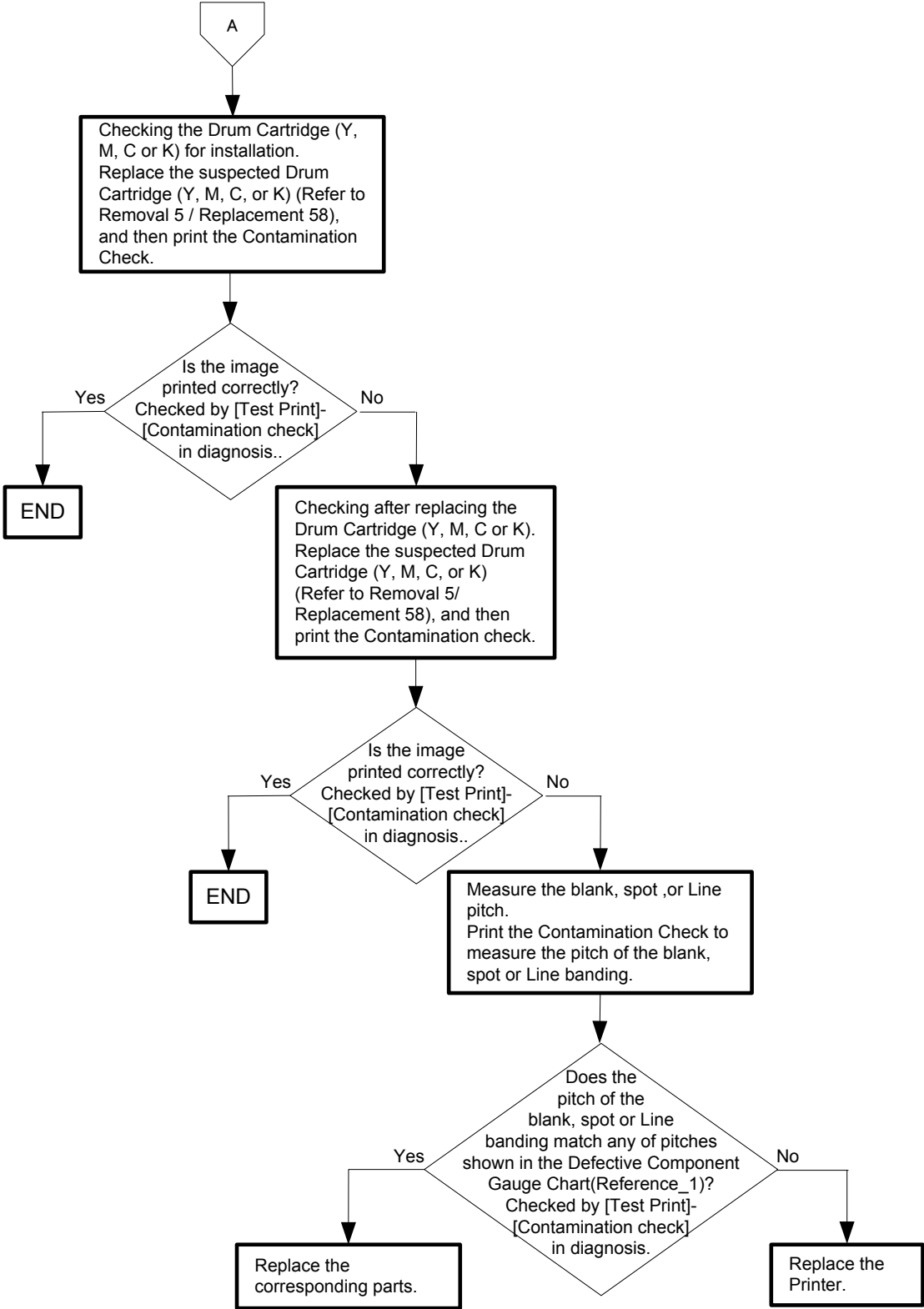

- Reference_1: Defective Component Gauge Chart

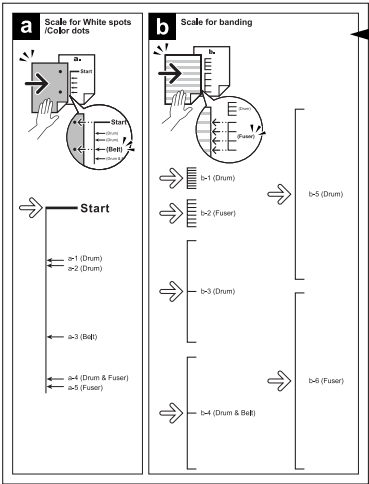

If the pitch of the blank banding matches any of the three pitches (Drum, Fuser, and Belt) shown in the Defective Component Gauge Chart, replace the relevant component:
(Drum): Drum Cartridge
(Fuser): FUSER
(Belt): Belt Unit

Flows 141 Spots

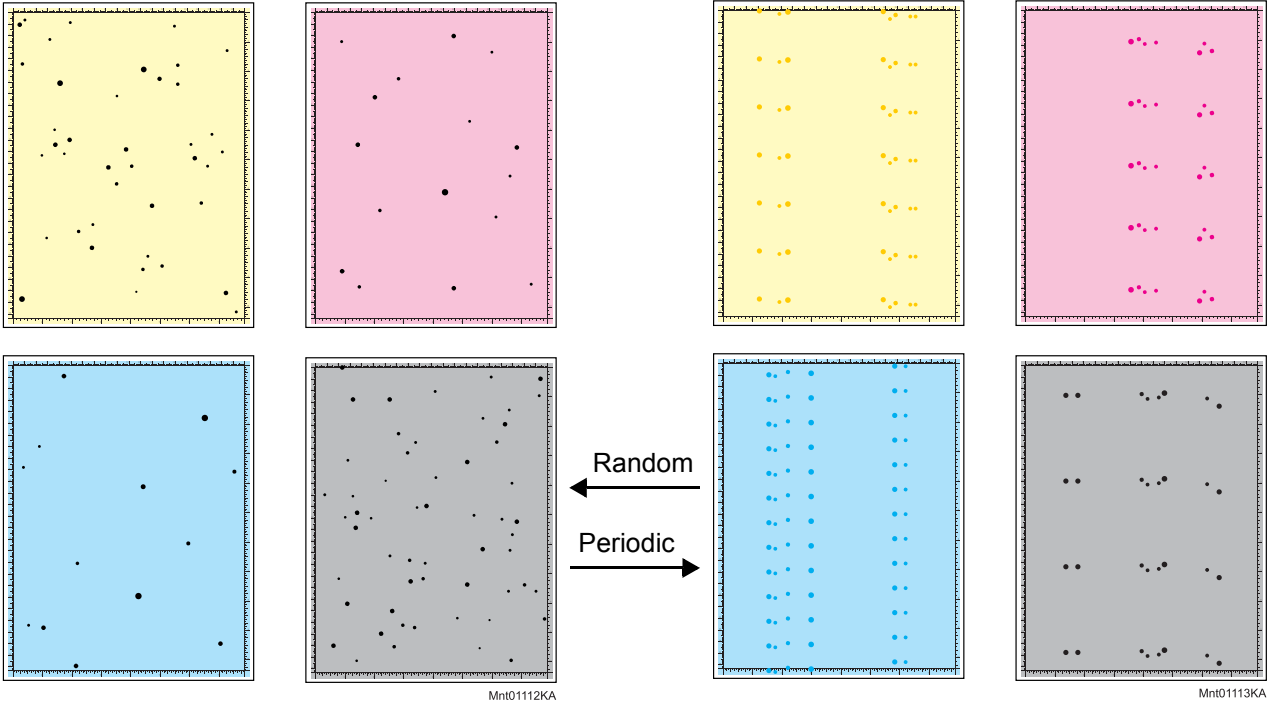

Mnt01112KA

Mnt01113KA

NOTE

When replacing the Drum Cartridge (YMCK), ensure that the pad of the CLEANER ASSY (cleaning rod) is replaced and that the ROSS ASSY is cleaned. For details of how to replace the Drum Cartridge (YMCK), refer to "Appendix_2.3 Replacing the Drum Cartridges". For details of how to clean the ROS ASSY, refer to "Appendix_3.1 Cleaning Inside the Printer".

NOTE

When replacing the BELT Unit, ensure that the Transfer Roller is also replaced. For details, refer to "Appendix_2.1.1 (4) Replacing the Belt Unit and Transfer Roller concurrently".

NOTE

When the Belt Unit has been replaced, be sure to clean up the CTD Sensor. Refer to "Appendix_3.2 Cleaning the Conductivity Temperature Depth (CTD) Sensor" for how to clean up the CTD Sensor.

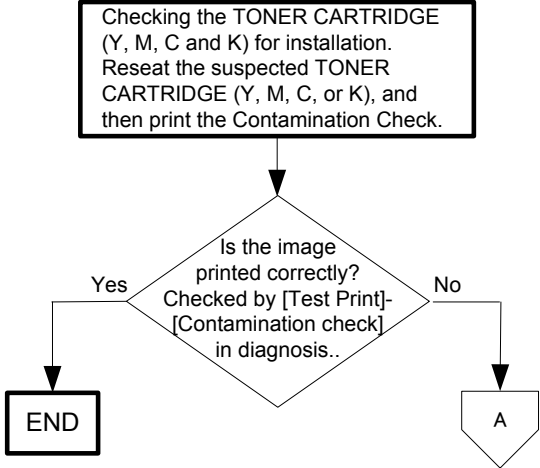

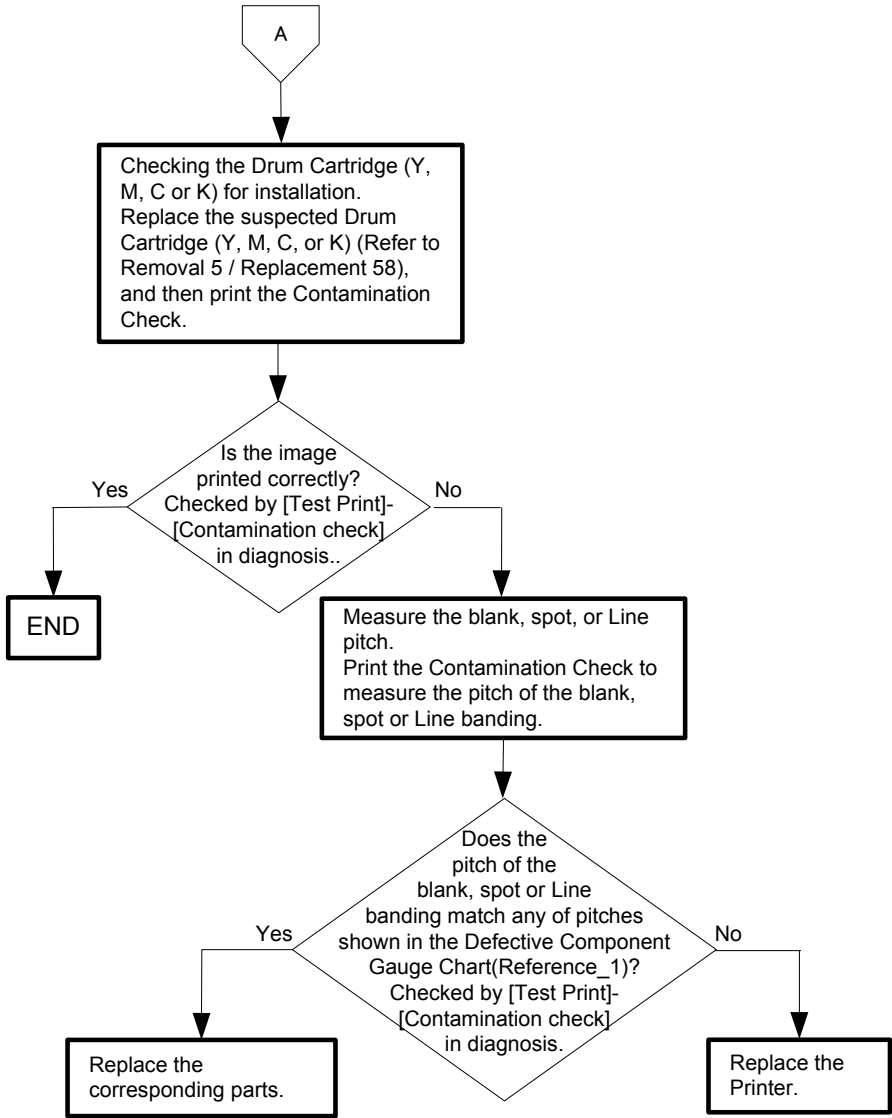

- Reference_1: Defective Component Gauge Chart

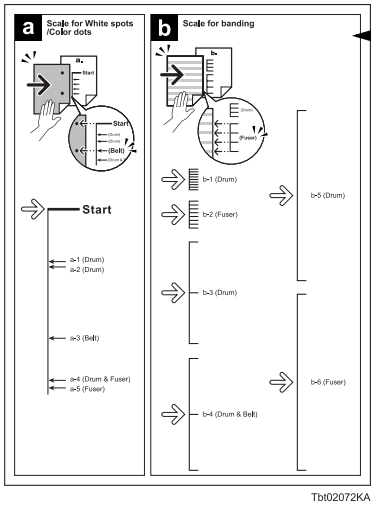

If the pitch of the blank banding matches any of the three pitches (Drum, Fuser, and Belt) shown in the Defective Component Gauge Chart, replace the relevant component:
 (Drum): Drum Cartridge
 (Fuser): FUSER
 (Belt): Belt Unit

Flows 142 Afterimage (Ghost)

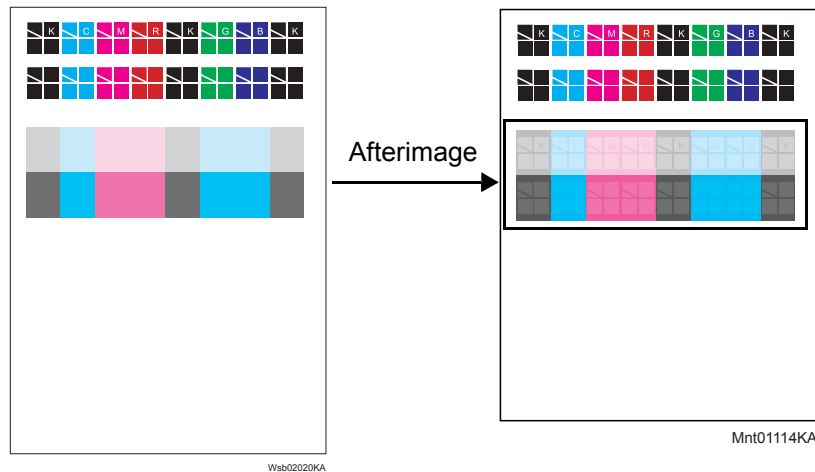

NOTE

When replacing the Drum Cartridge (YMCK), ensure that the pad of the CLEANER ASSY (cleaning rod) is replaced and that the ROSS ASSY is cleaned. For details of how to replace the Drum Cartridge (YMCK), refer to "Appendix_2.3 Replacing the Drum Cartridges". For details of how to clean the ROS ASSY, refer to "Appendix_3.1 Cleaning Inside the Printer".

NOTE

When replacing the BELT Unit, ensure that the Transfer Roller is also replaced. For details, refer to "Appendix_2.1.1 (4) Replacing the Belt Unit and Transfer Roller concurrently".

NOTE

When the Belt Unit has been replaced, be sure to clean up the CTD Sensor. Refer to "Appendix_3.2 Cleaning the Conductivity Temperature Depth (CTD) Sensor" for how to clean up the CTD Sensor.

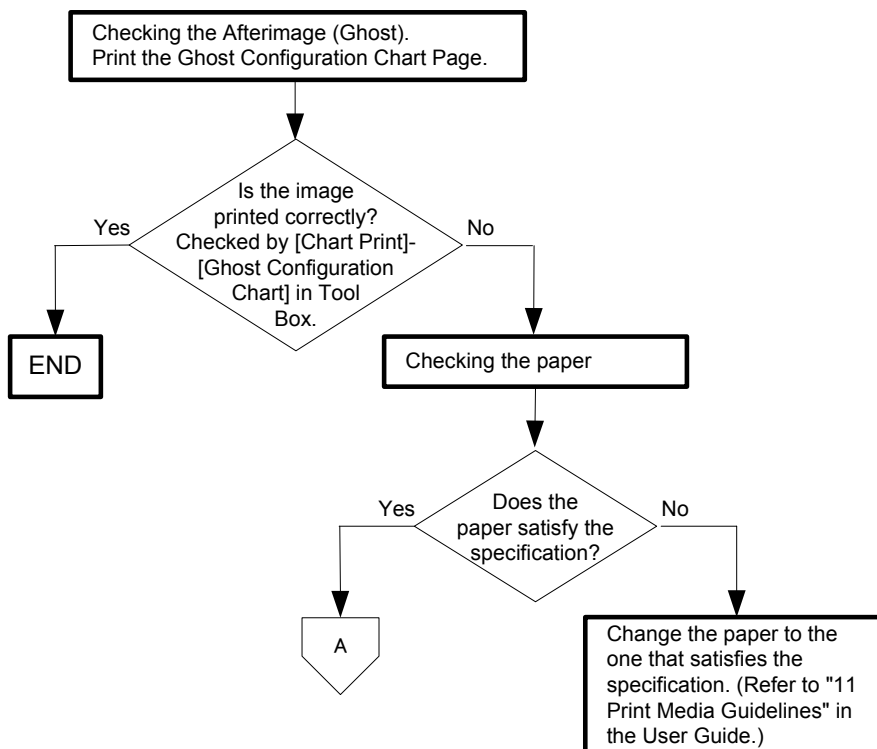

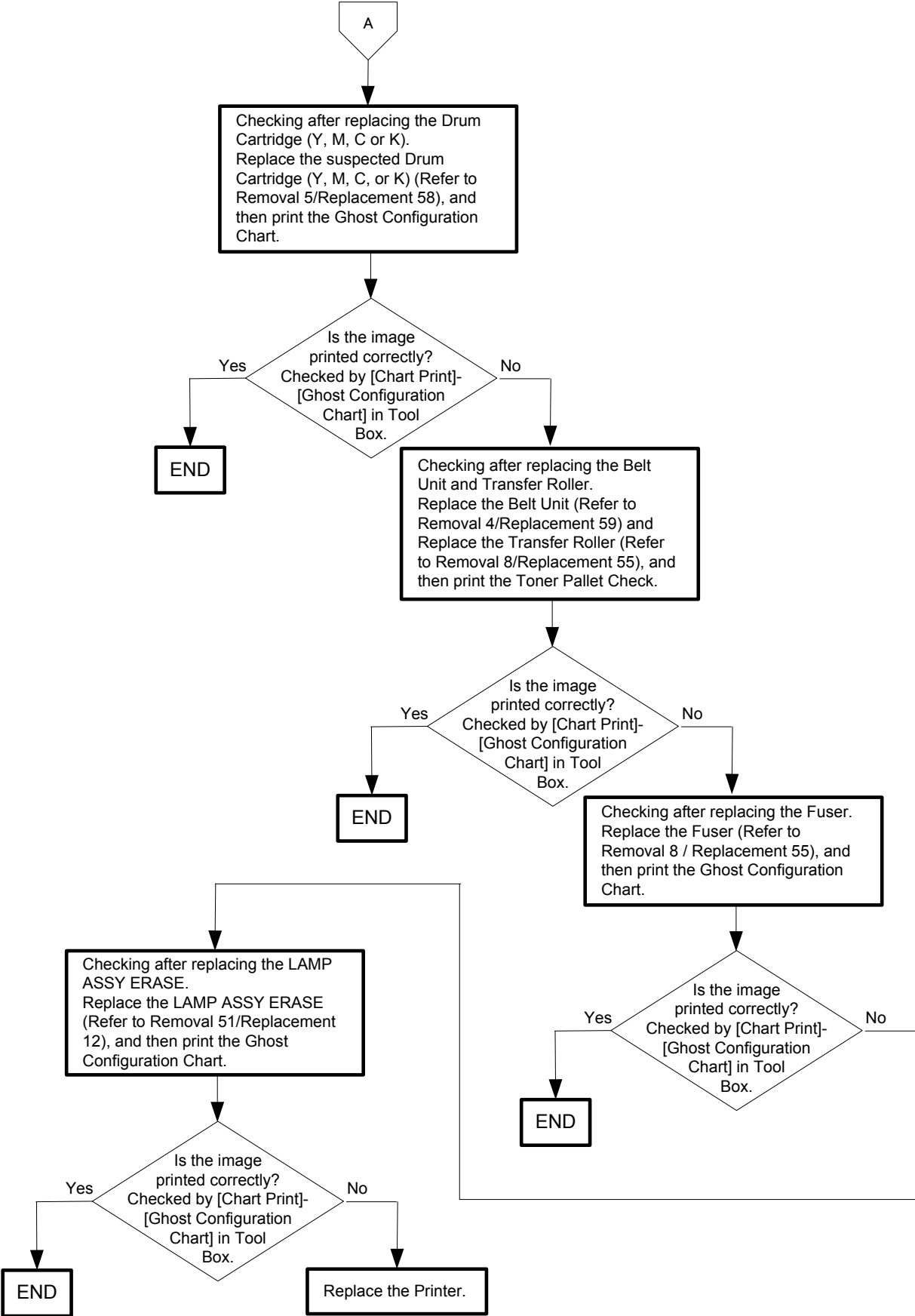

Flows 143 High Background

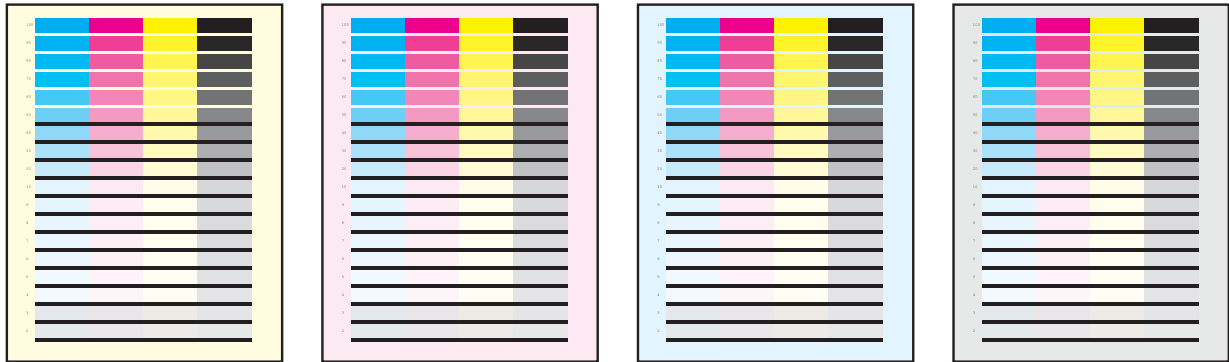

Tbt01035KA

NOTE

When replacing the Drum Cartridge (YMCK), ensure that the pad of the CLEANER ASSY (cleaning rod) is replaced and that the ROSS ASSY is cleaned. For details of how to replace the Drum Cartridge (YMCK), refer to "Appendix_2.3 Replacing the Drum Cartridges". For details of how to clean the ROS ASSY, refer to "Appendix_3.1 Cleaning Inside the Printer".

NOTE

When replacing the BELT Unit, ensure that the Transfer Roller is also replaced. For details, refer to "Appendix_2.1.1 (4) Replacing the Belt Unit and Transfer Roller concurrently".

NOTE

When the Belt Unit has been replaced, be sure to clean up the CTD Sensor. Refer to "Appendix_3.2 Cleaning the Conductivity Temperature Depth (CTD) Sensor" for how to clean up the CTD Sensor.

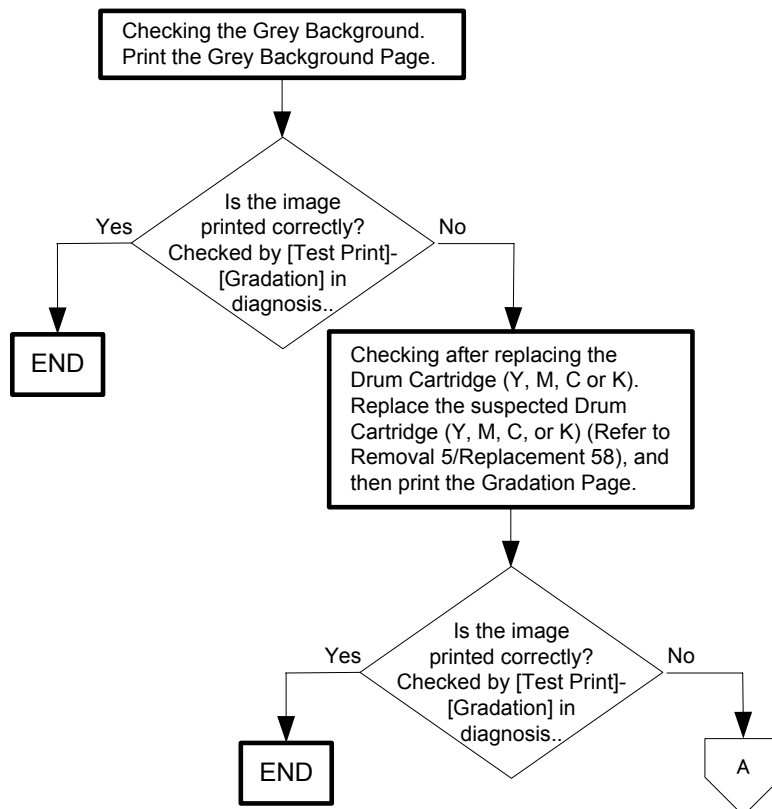

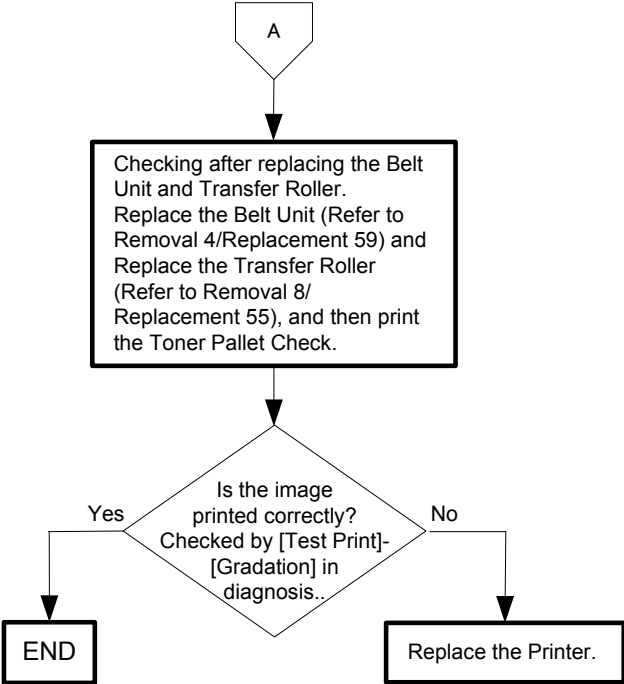

Flows 144 Skew

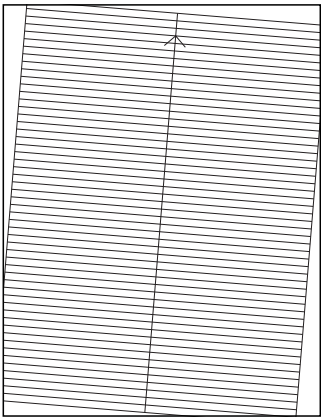

Mnt01116KA

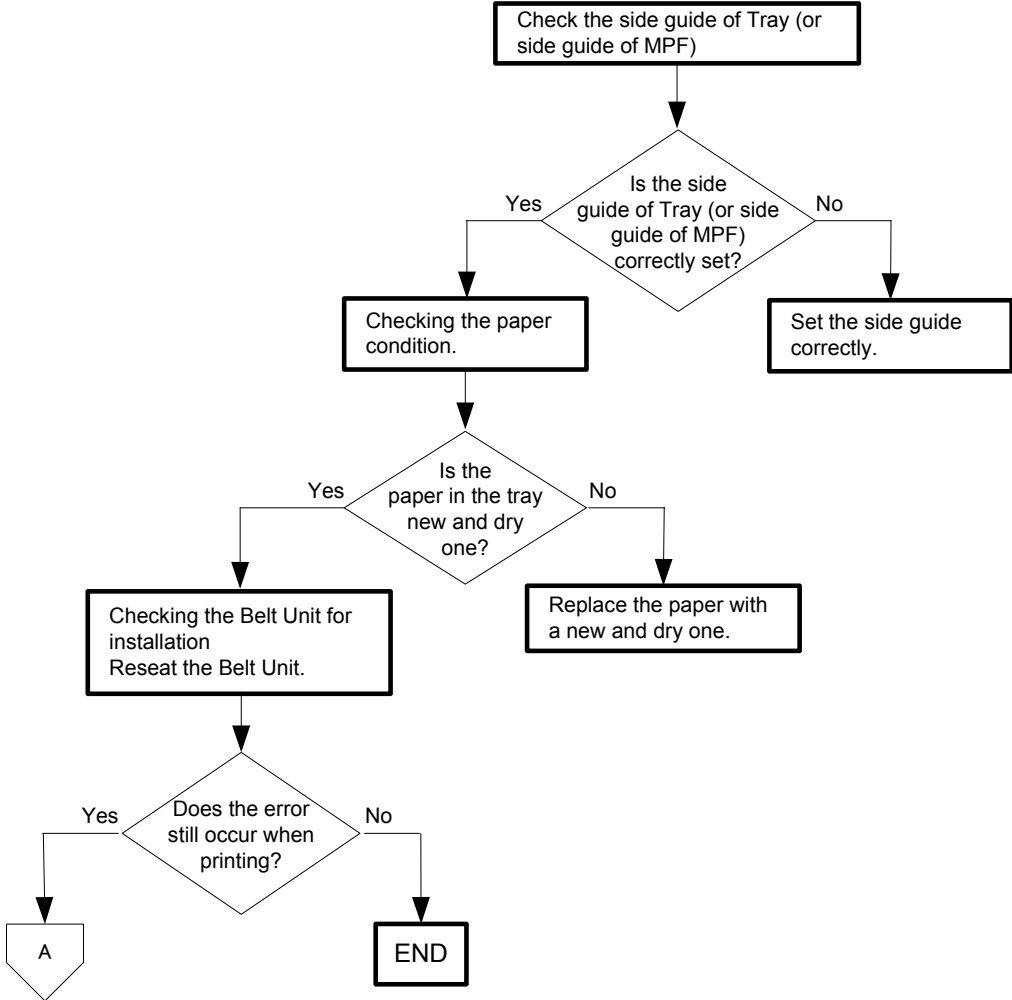

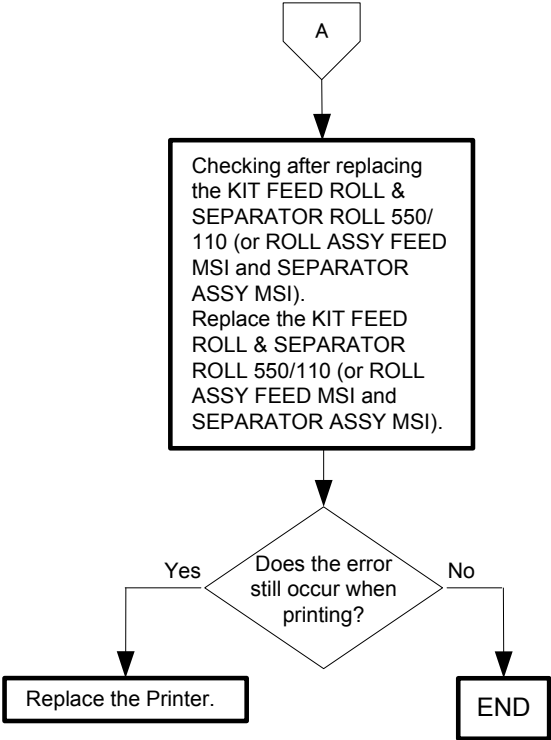

Flows 145 Paper damage/Wrinkled Paper

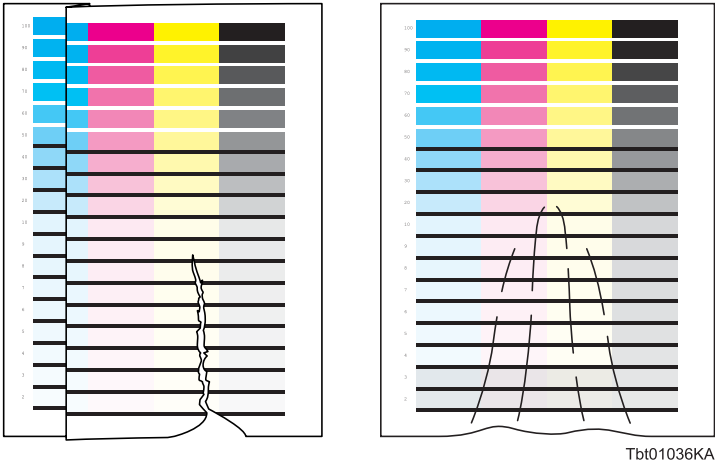

NOTE

When replacing the BELT Unit, ensure that the Transfer Roller is also replaced. For details, refer to "Appendix_2.1.1 (4) Replacing the Belt Unit and Transfer Roller concurrently".

NOTE

When the Belt Unit has been replaced, be sure to clean up the CTD Sensor. Refer to "Appendix_3.2 Cleaning the Conductivity Temperature Depth (CTD) Sensor" for how to clean up the CTD Sensor.

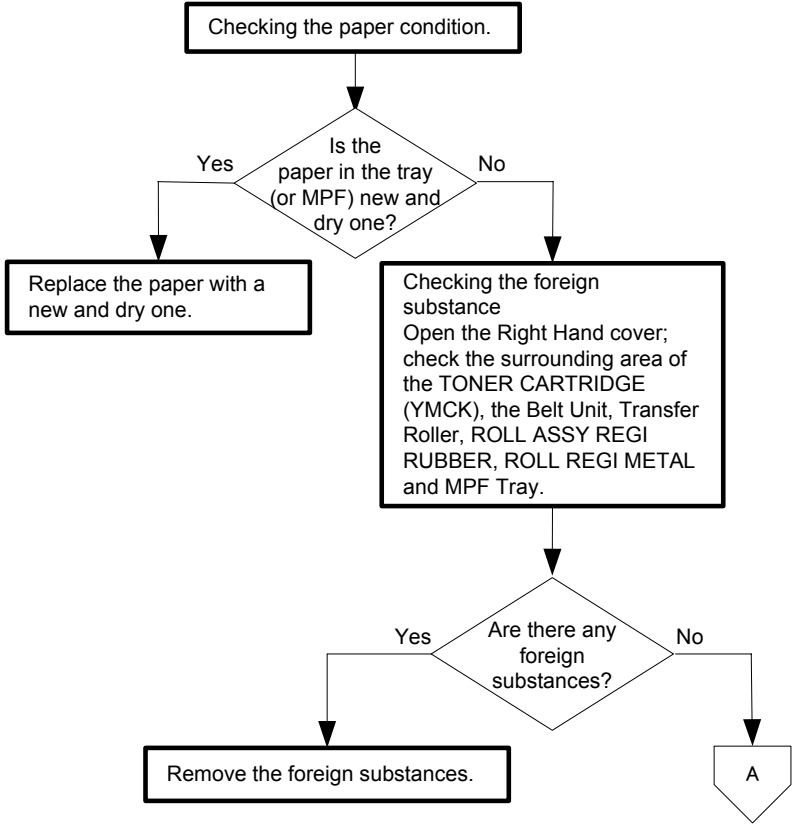

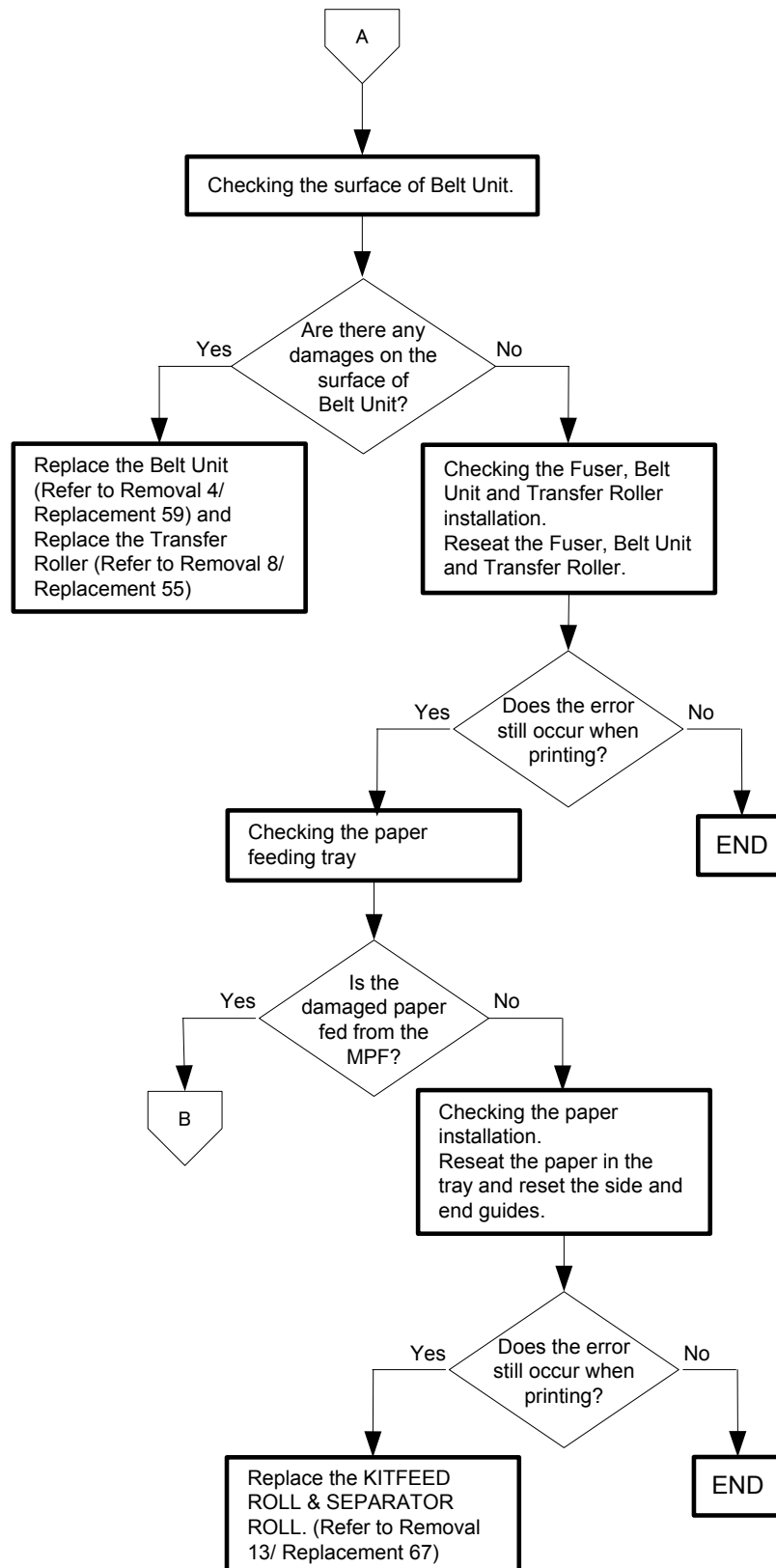

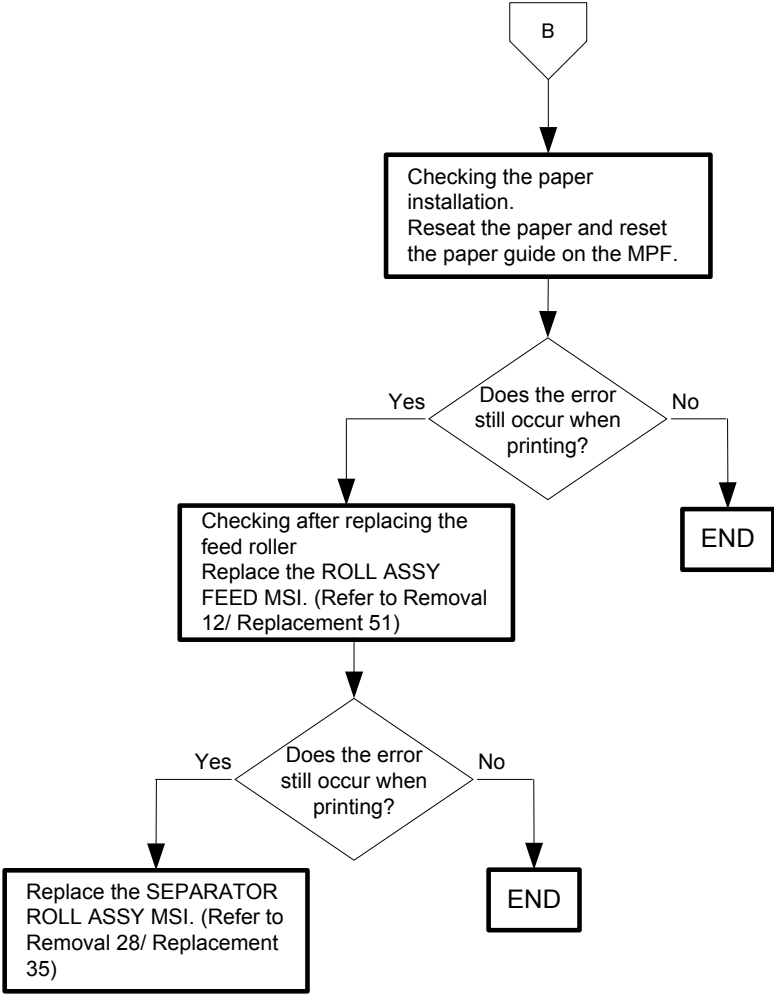

Flows 146 Unfusing

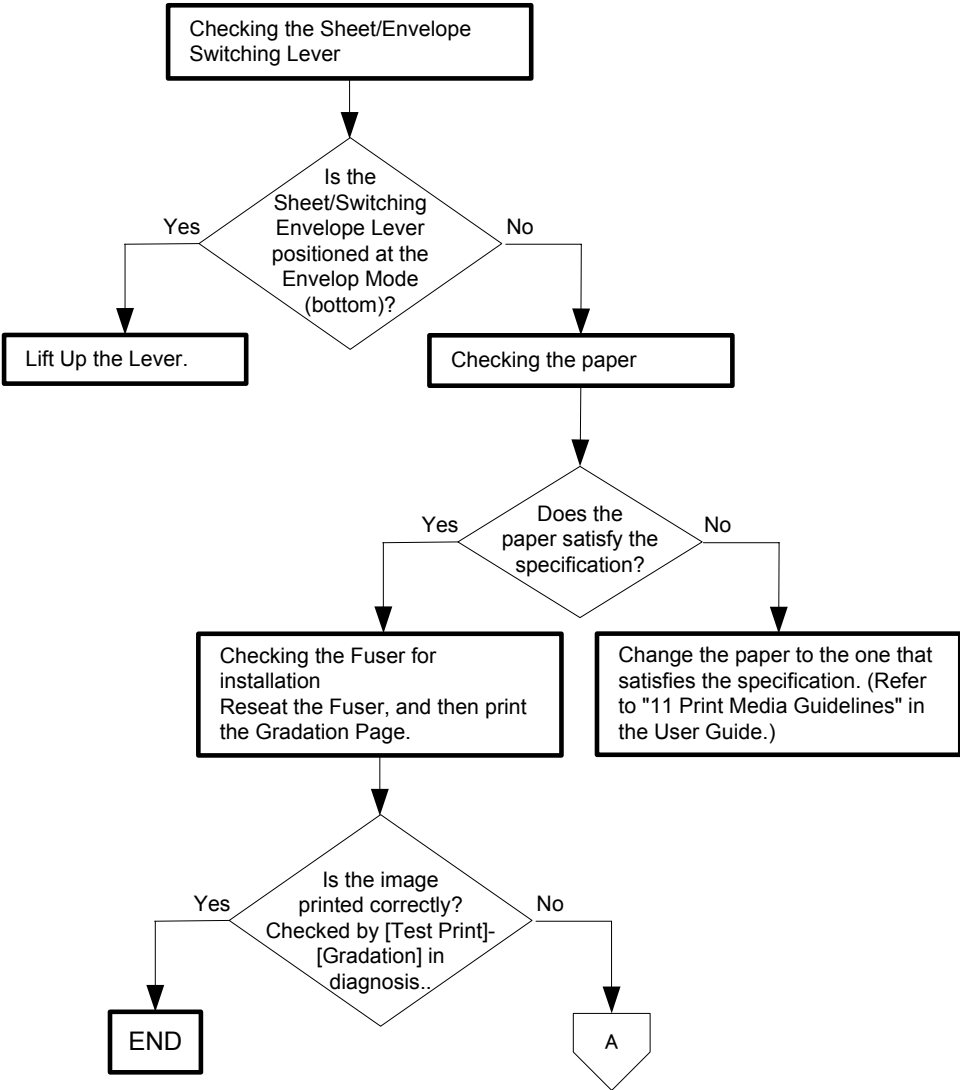
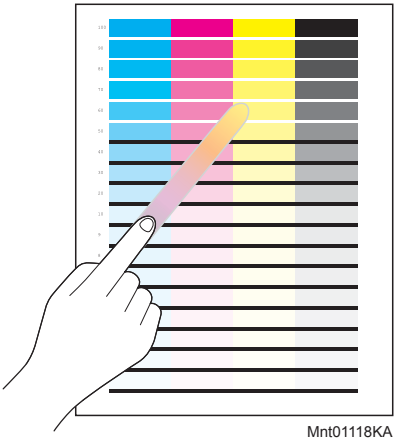

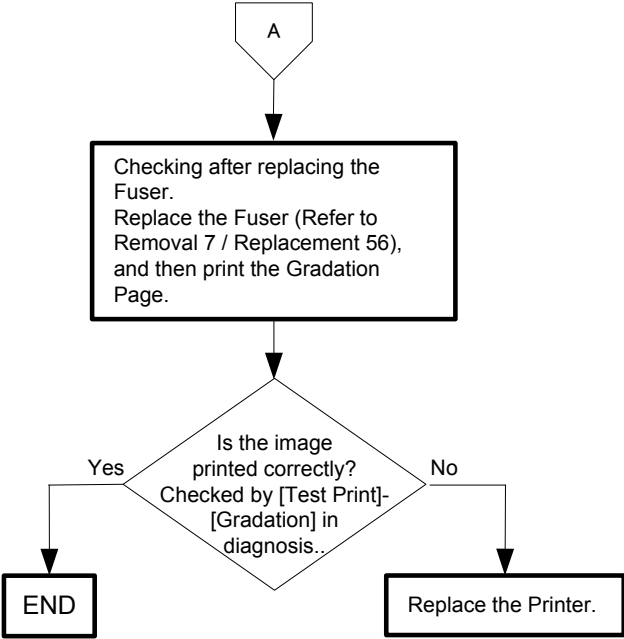

Flows 147 Color Registration (Color Shift)

- Troubleshooting of a control system

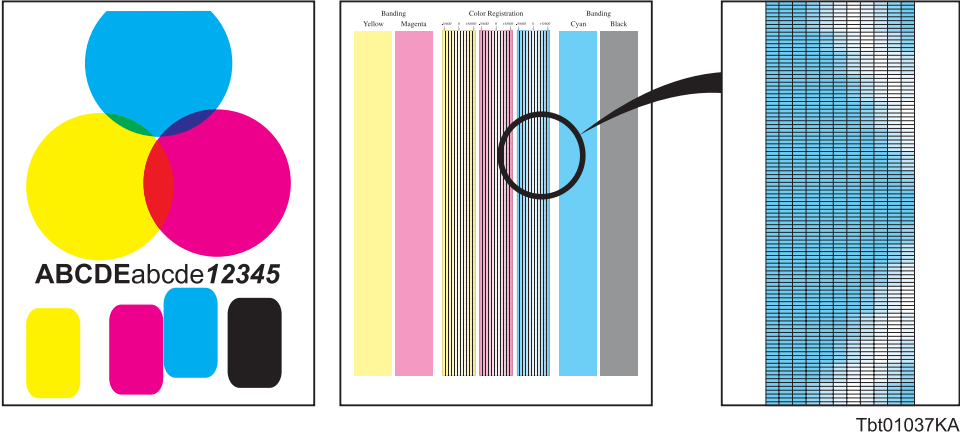

Tbt01037KA

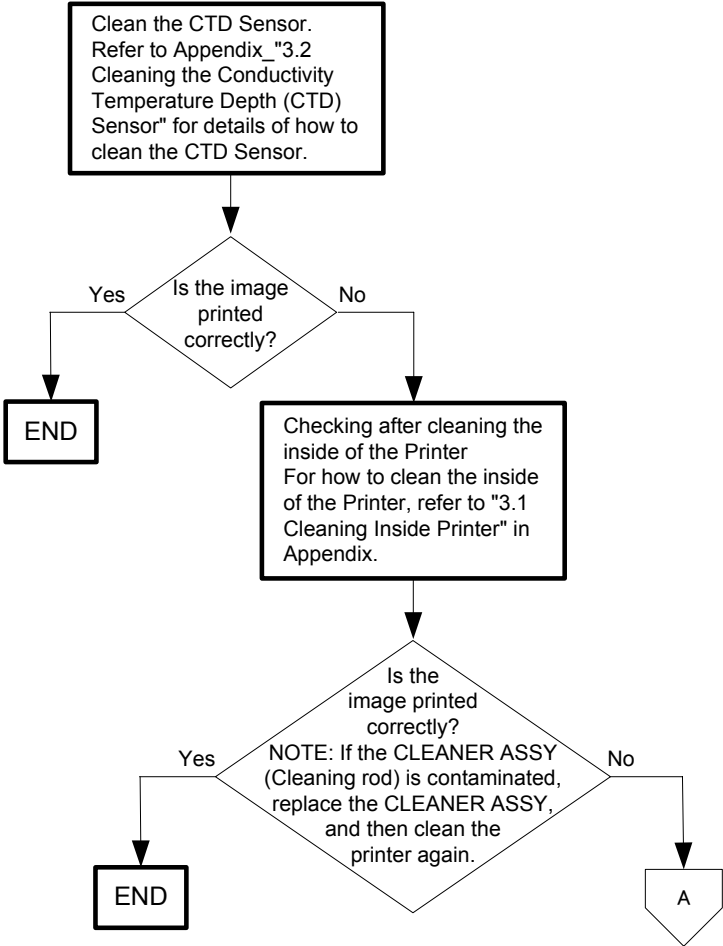

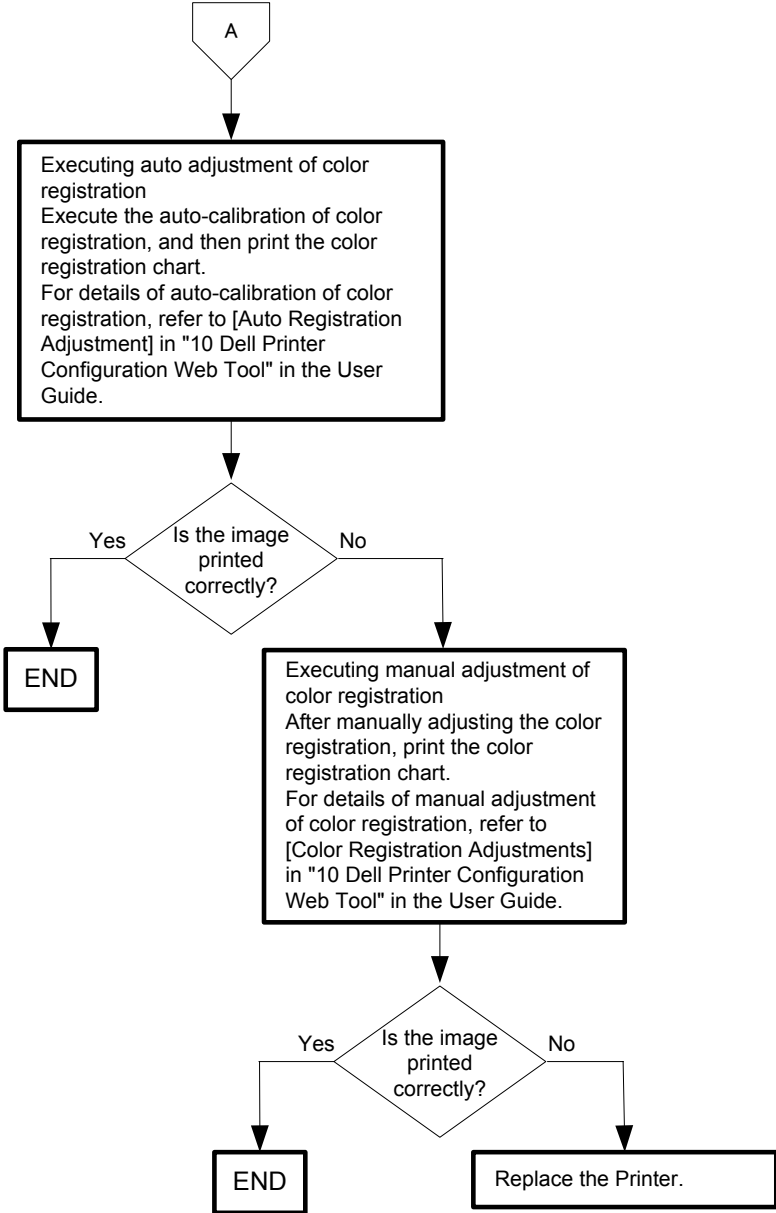

Flows 148 Color Registration (Image Shift)

- Troubleshooting of a paper feeding system

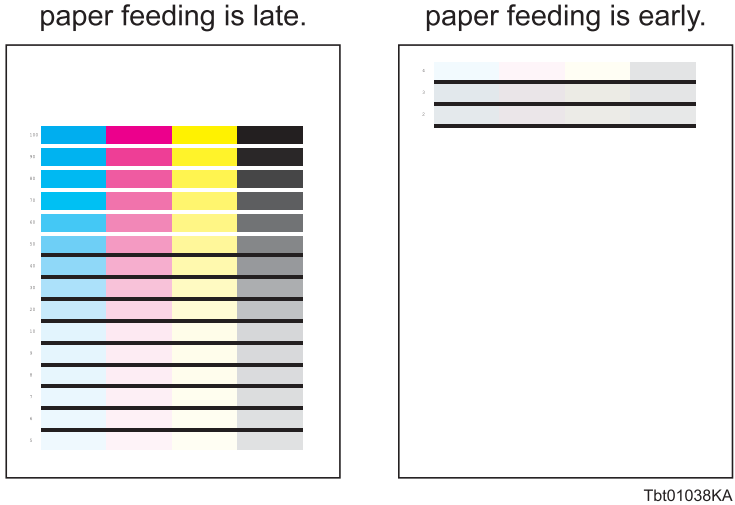

NOTE

When replacing the BELT Unit, ensure that the Transfer Roller is also replaced. For details, refer to "Appendix_2.1.1 (4) Replacing the Belt Unit and Transfer Roller concurrently".

NOTE

When the Belt Unit has been replaced, be sure to clean up the CTD Sensor. Refer to "Appendix_3.2 Cleaning the Conductivity Temperature Depth (CTD) Sensor" for how to clean up the CTD Sensor.

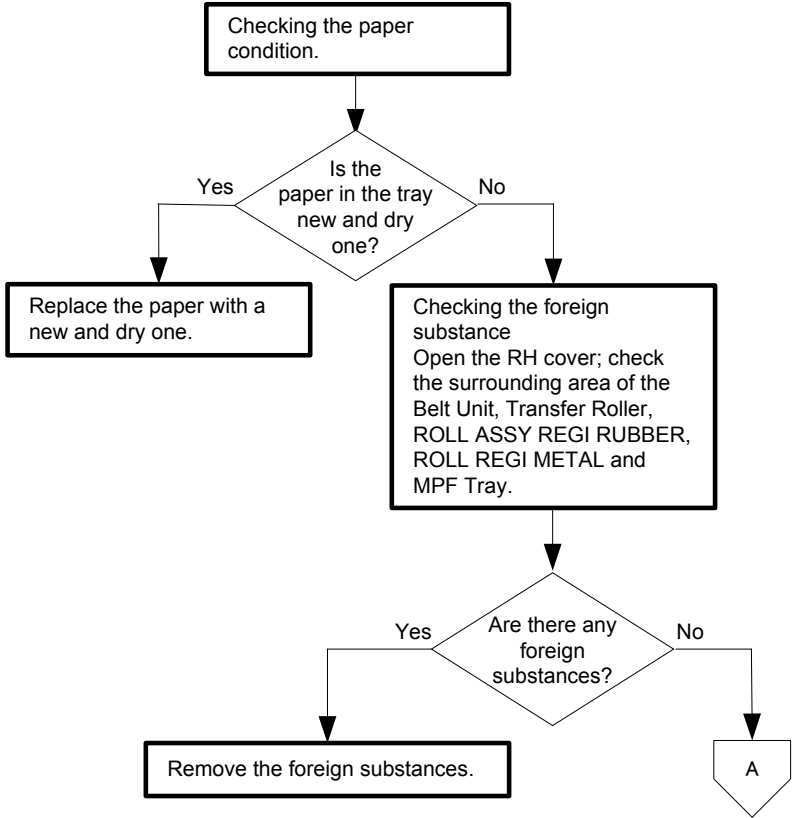

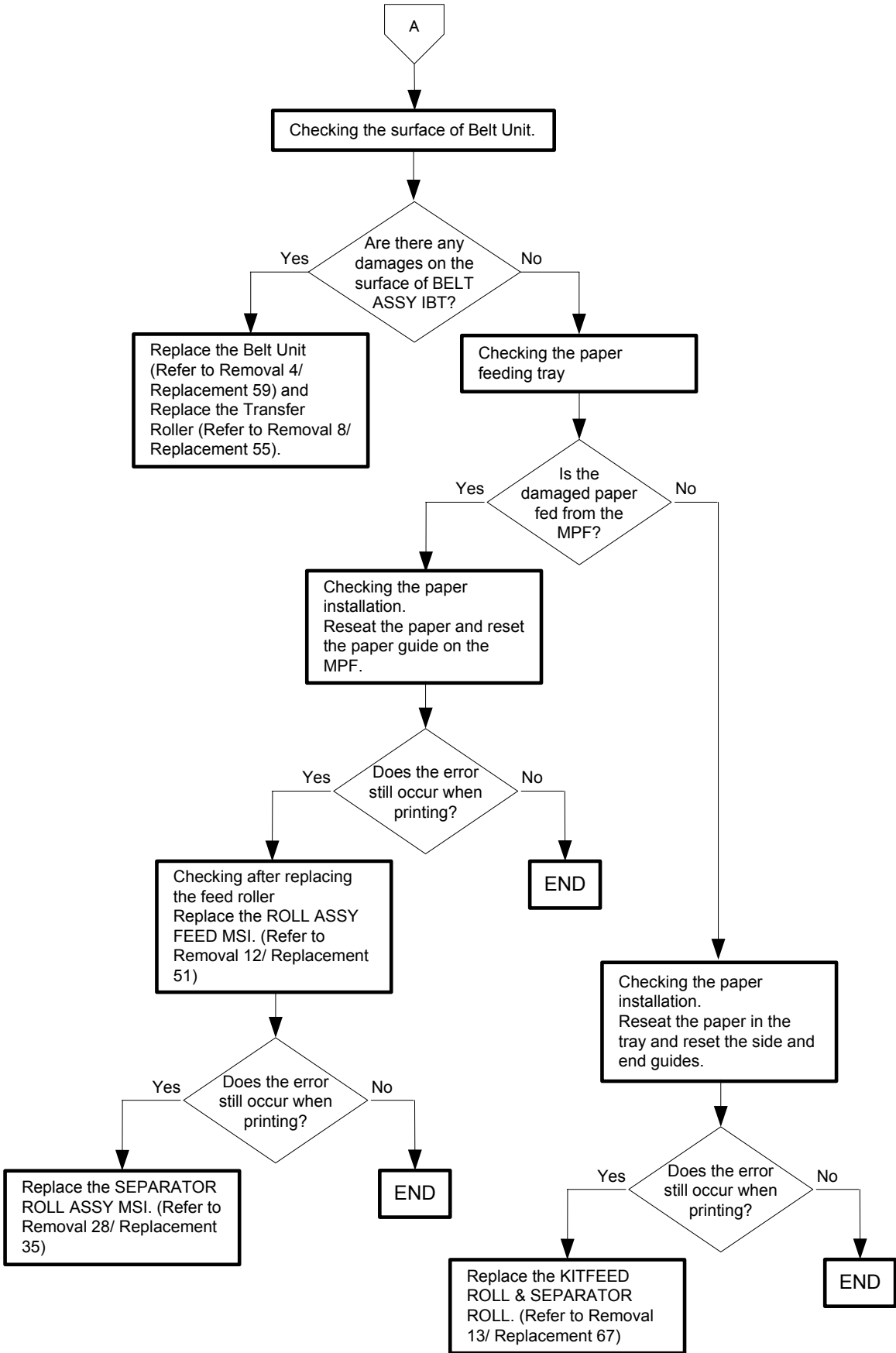

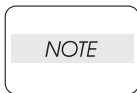
Flows 149 **Mechanical Noise**: When Power is Turned On

When replacing the Drum Cartridge (YMCK), ensure that the pad of the CLEANER ASSY (cleaning rod) is replaced and that the ROS ASSY is cleaned. For details of how to replace the Drum Cartridge (YMCK), refer to "Appendix_2.3 Replacing the Drum Cartridges". For details of how to clean the ROS ASSY, refer to "Appendix_3.1 Cleaning Inside the Printer".

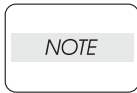

When replacing the BELT Unit, ensure that the Transfer Roller is also replaced. For details, refer to "Appendix_2.1.1 (4) Replacing the Belt Unit and Transfer Roller concurrently".

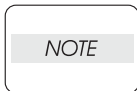

When the Belt Unit has been replaced, be sure to clean up the CTD Sensor. Refer to "Appendix_3.2 Cleaning the Conductivity Temperature Depth (CTD) Sensor" for how to clean up the CTD Sensor.

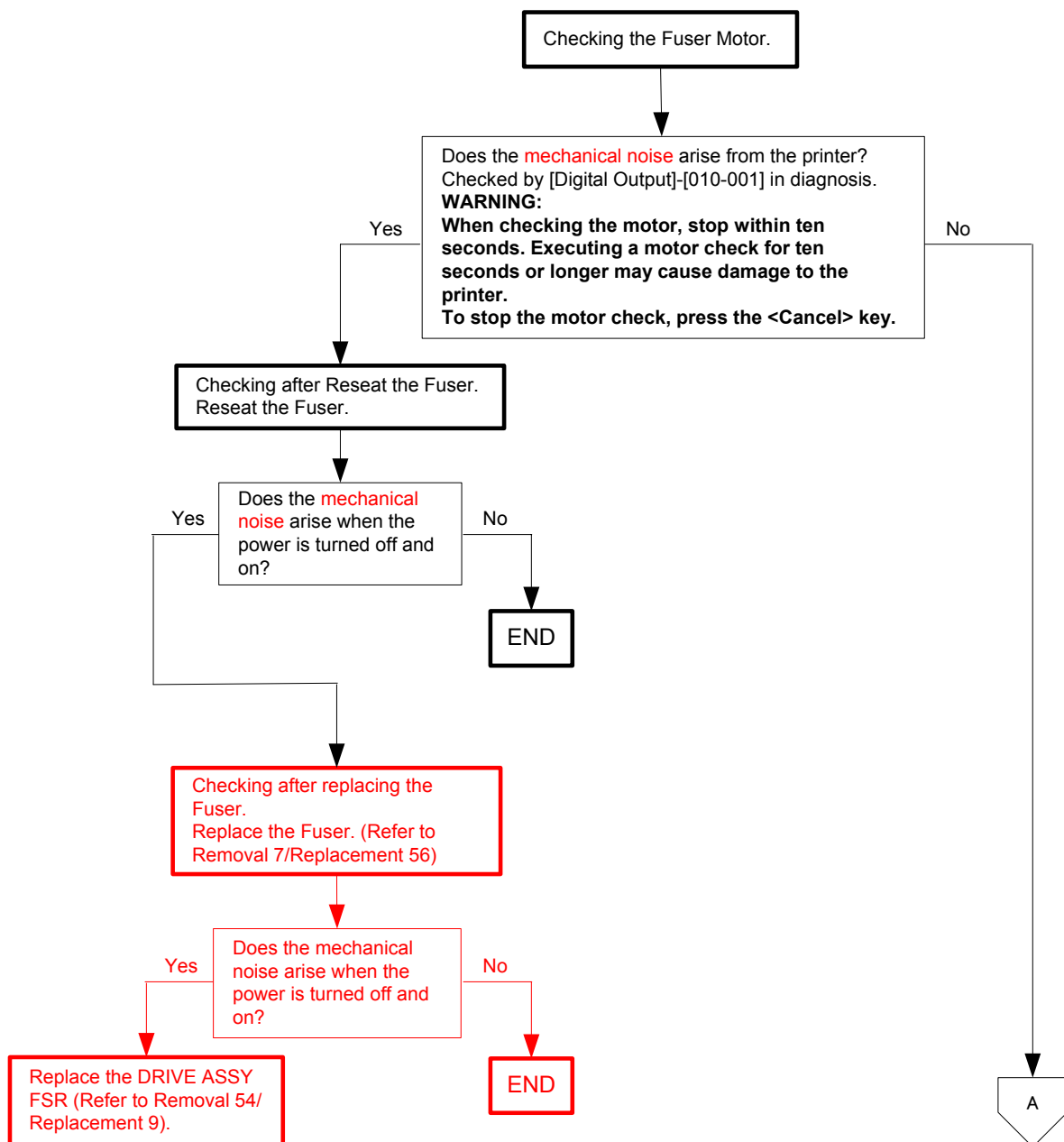

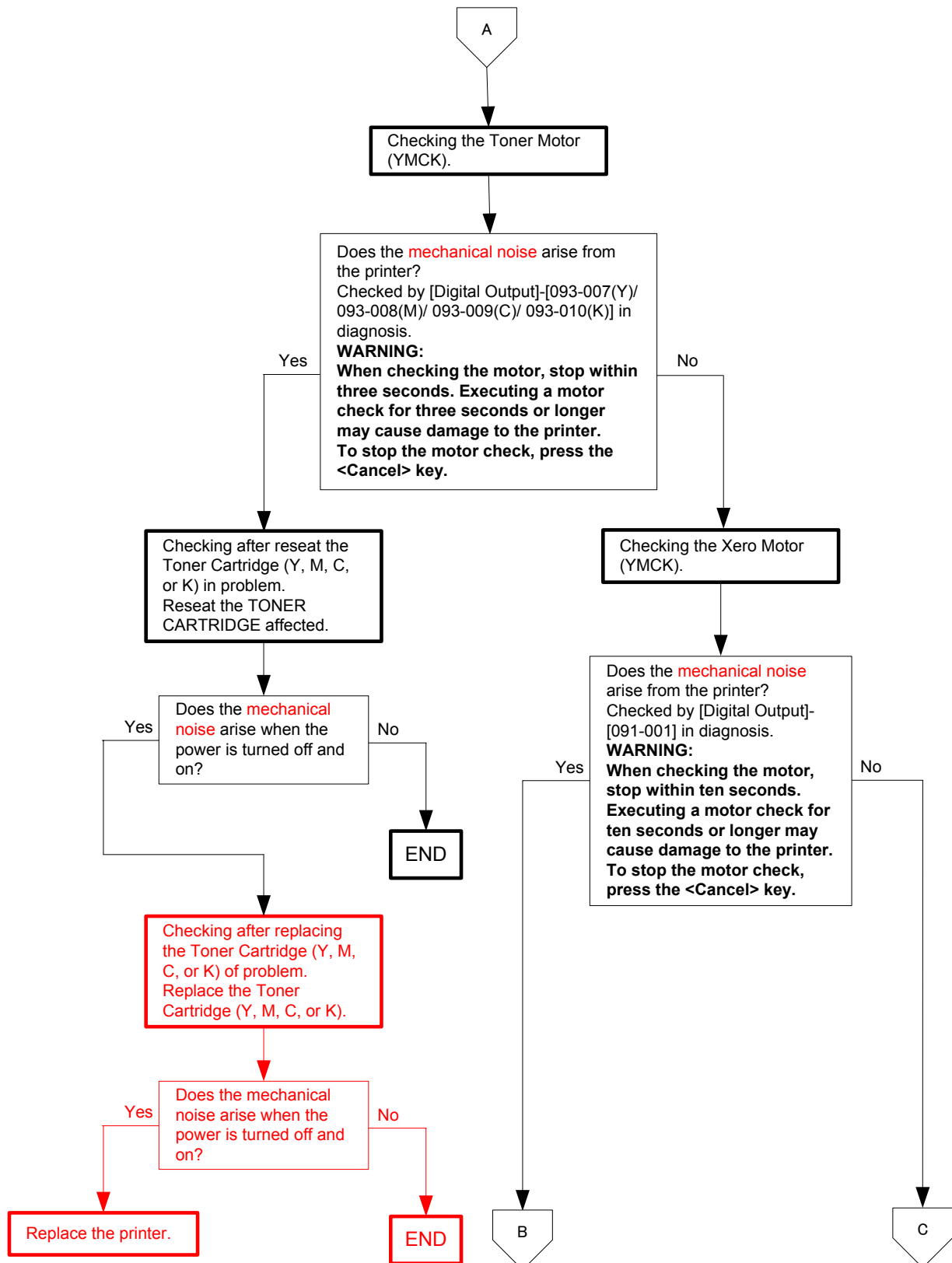

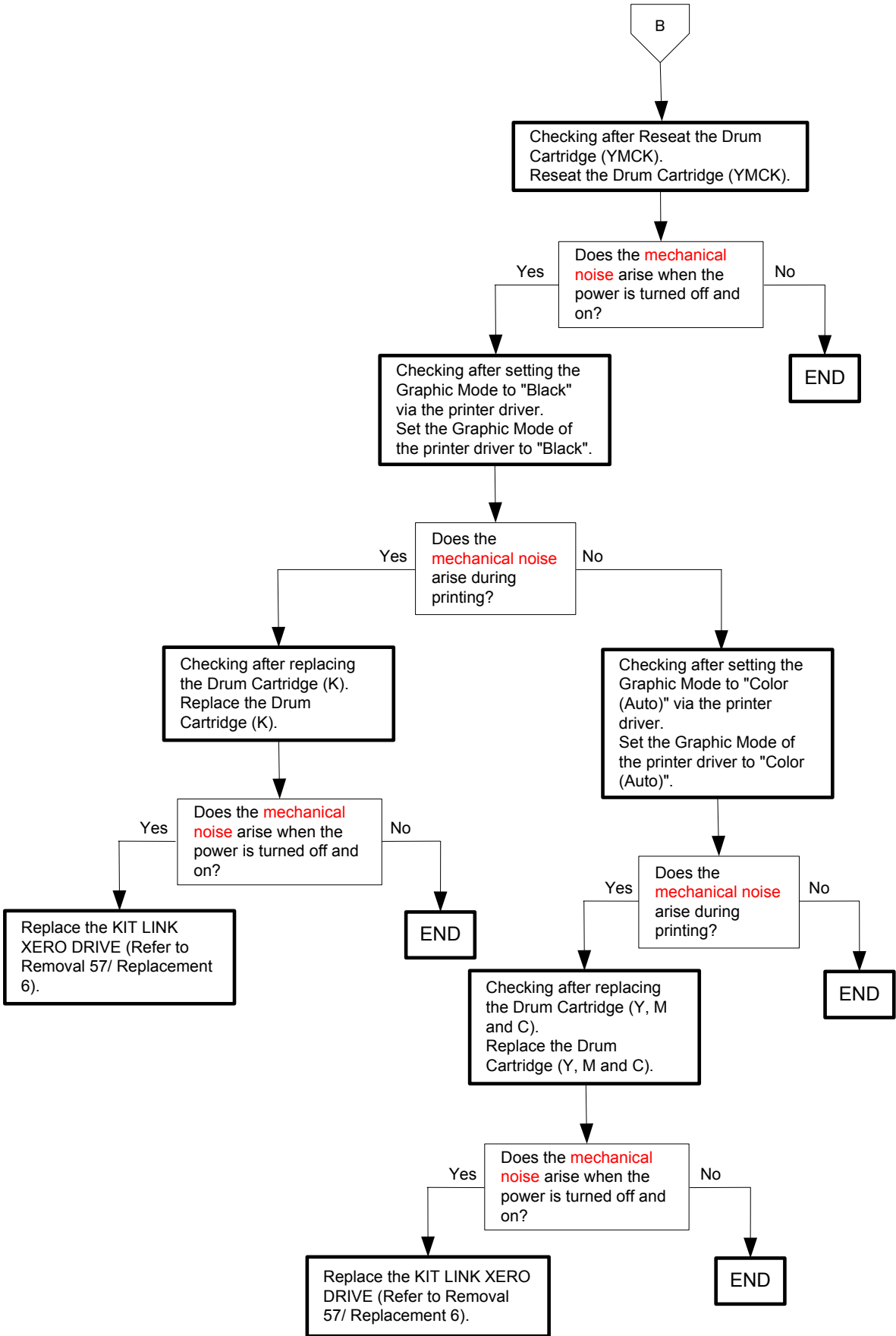

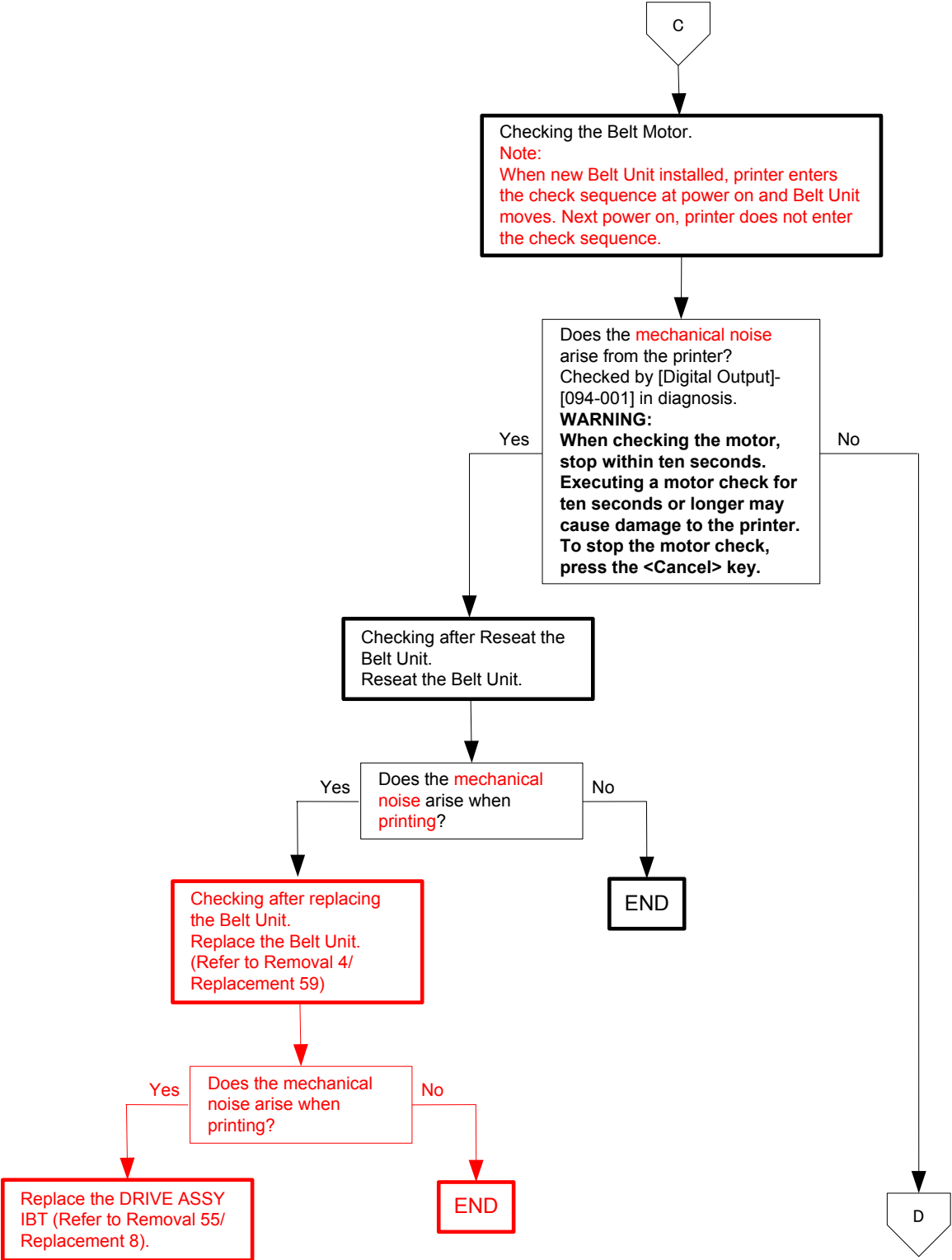

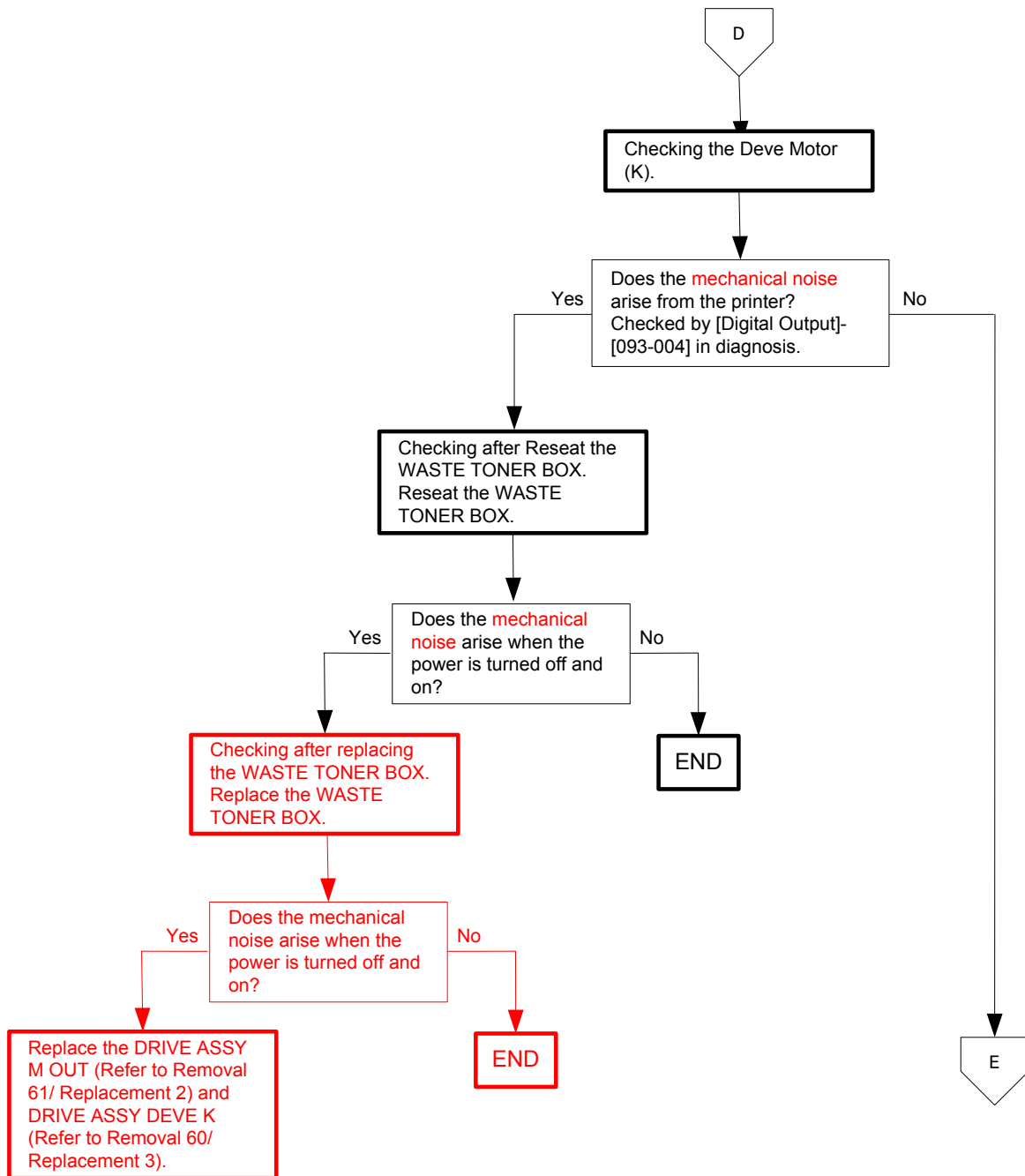

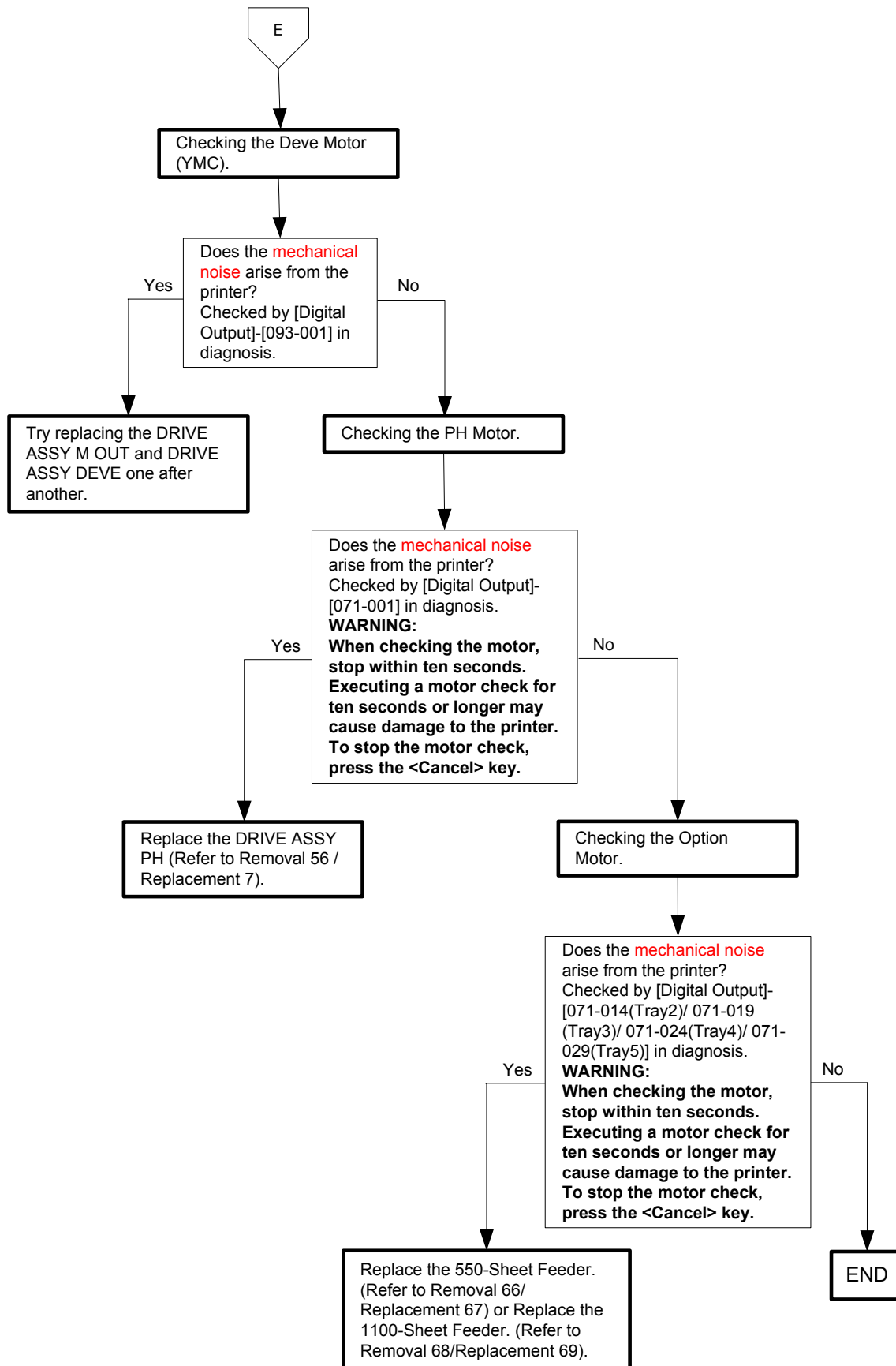

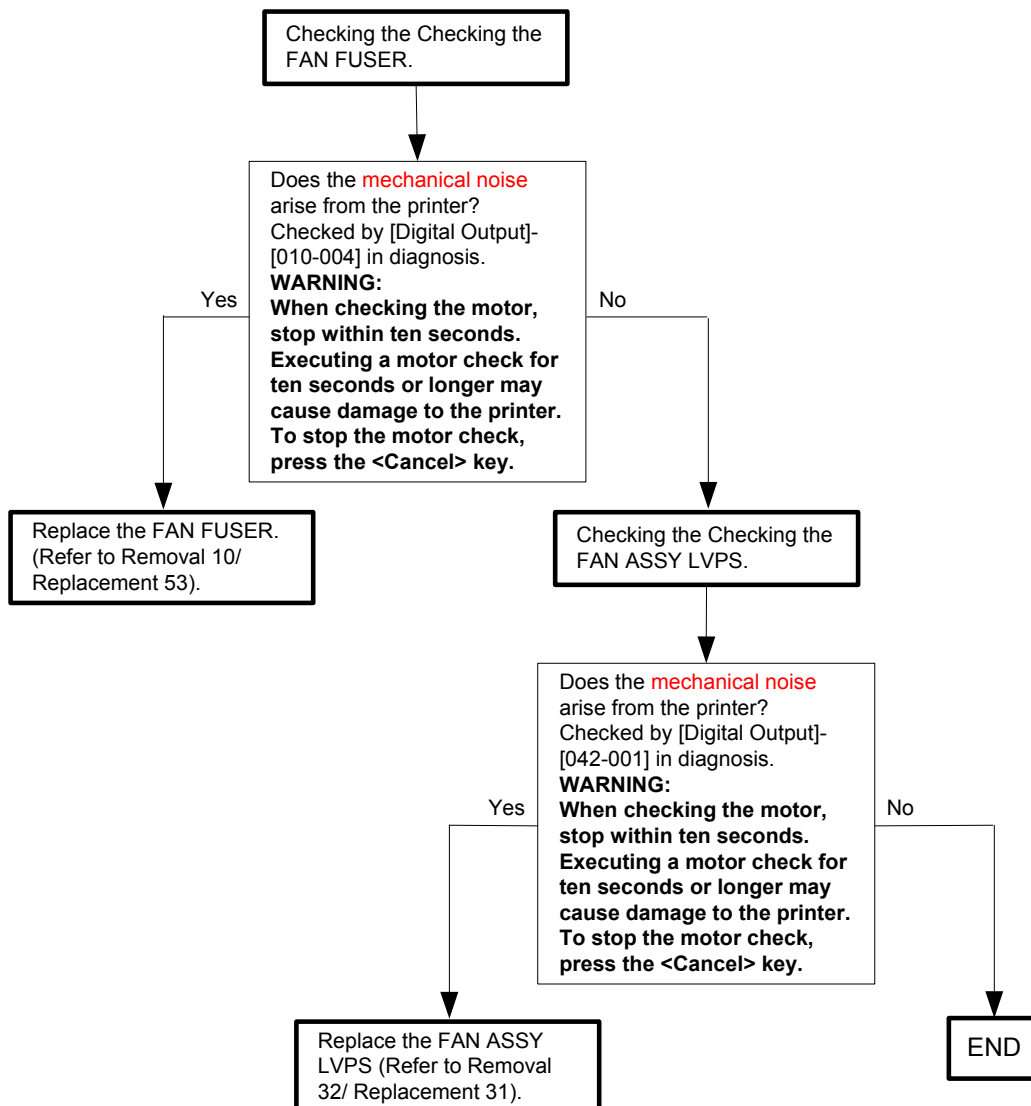
Flows 150 **Mechanical Noise:** During Standby

Flows 151 **Mechanical Noise**: During Printing (Checking for other items than "power on mechanical noise")

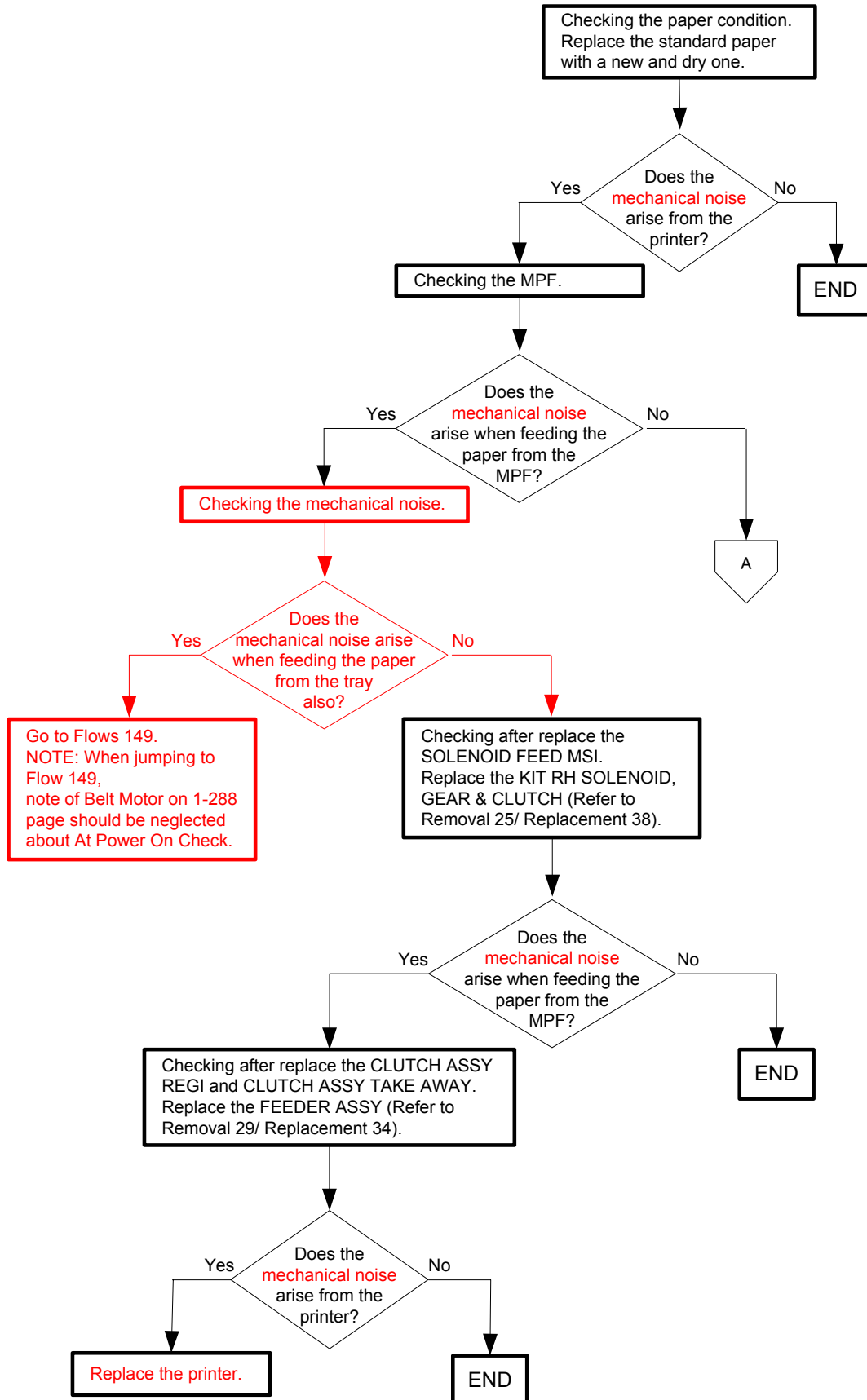

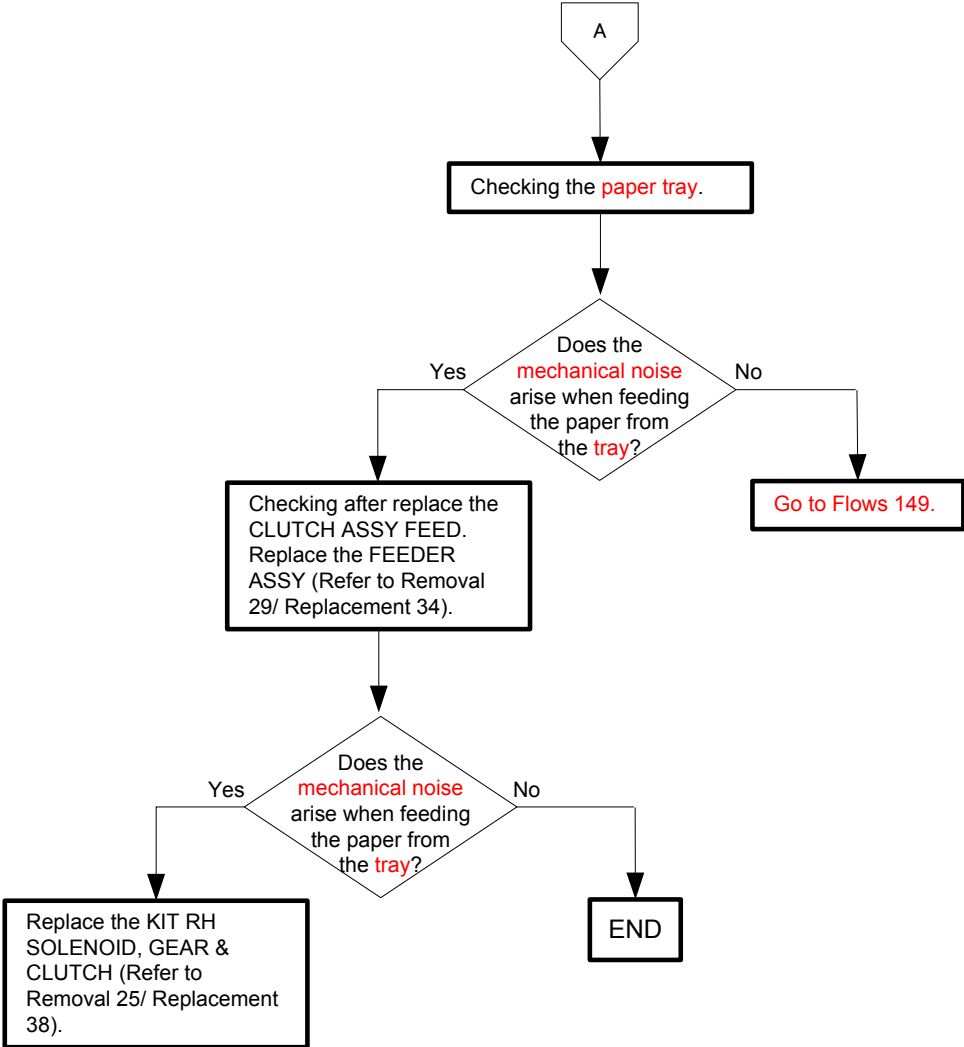

Flows 152 AC Power

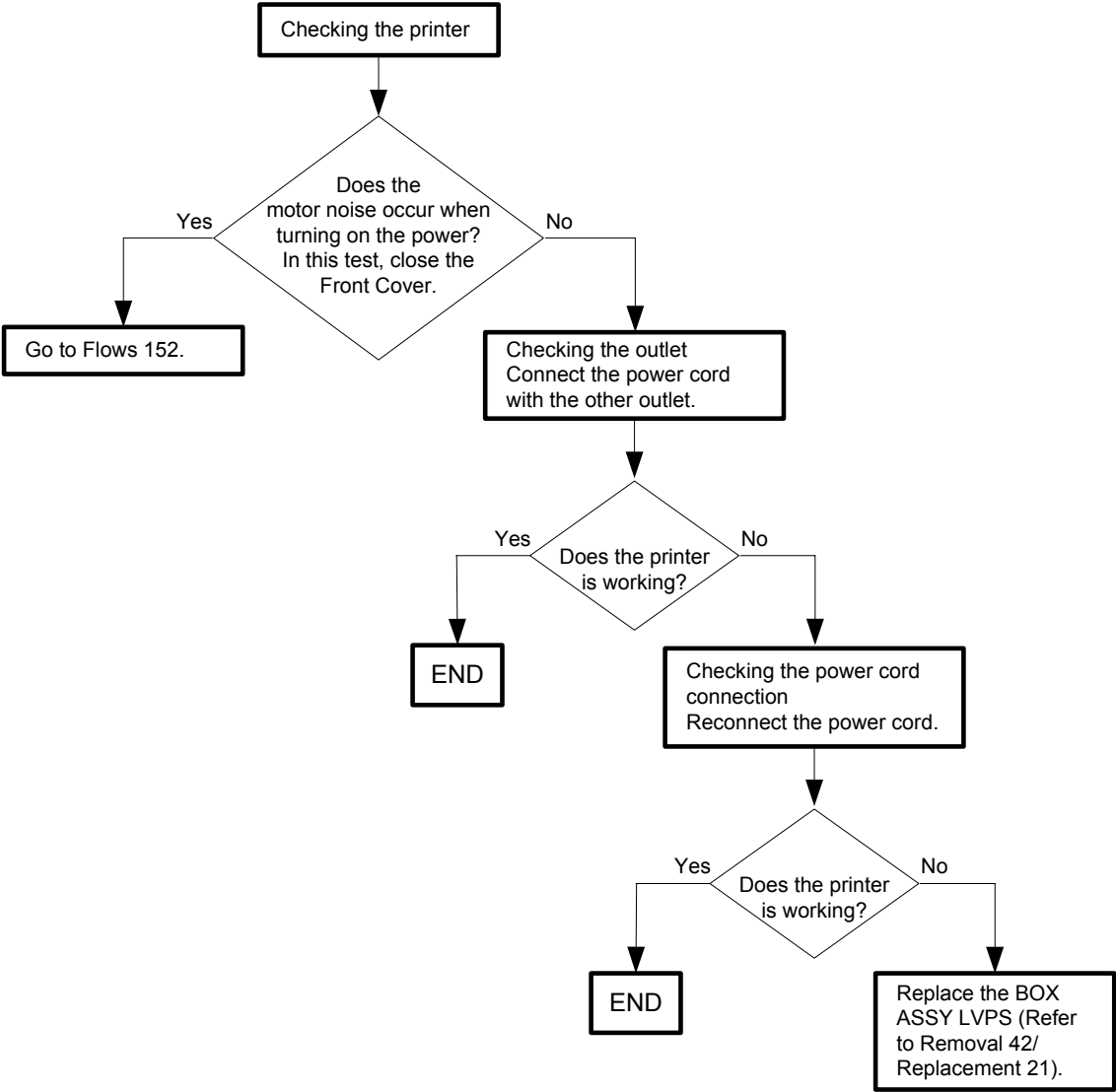

Flows 153 DC Power

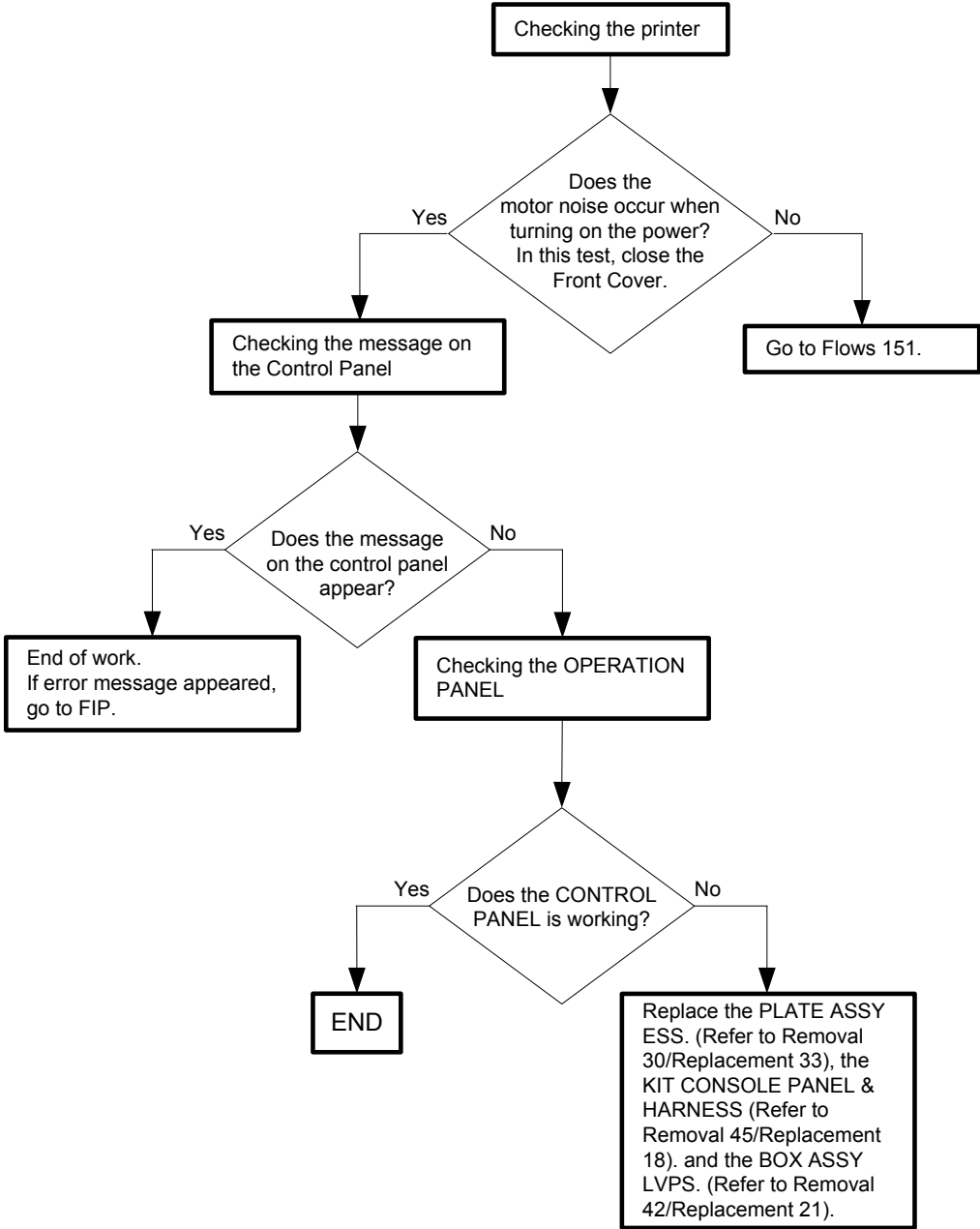

Flows 154 Multiple feed

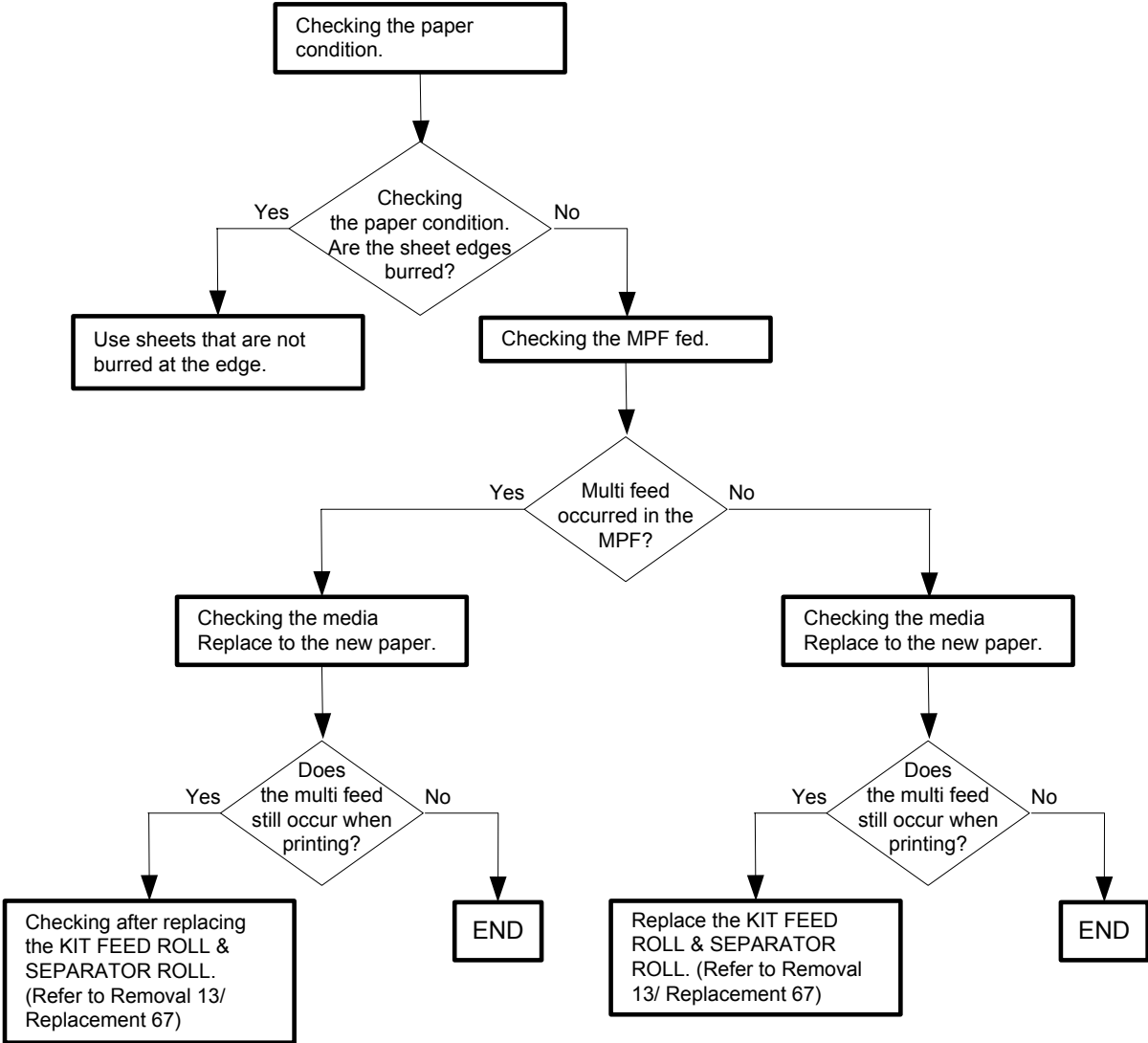

Flows 155 Paper Remaining Amount Not Displayed Correctly in Status Monitor.

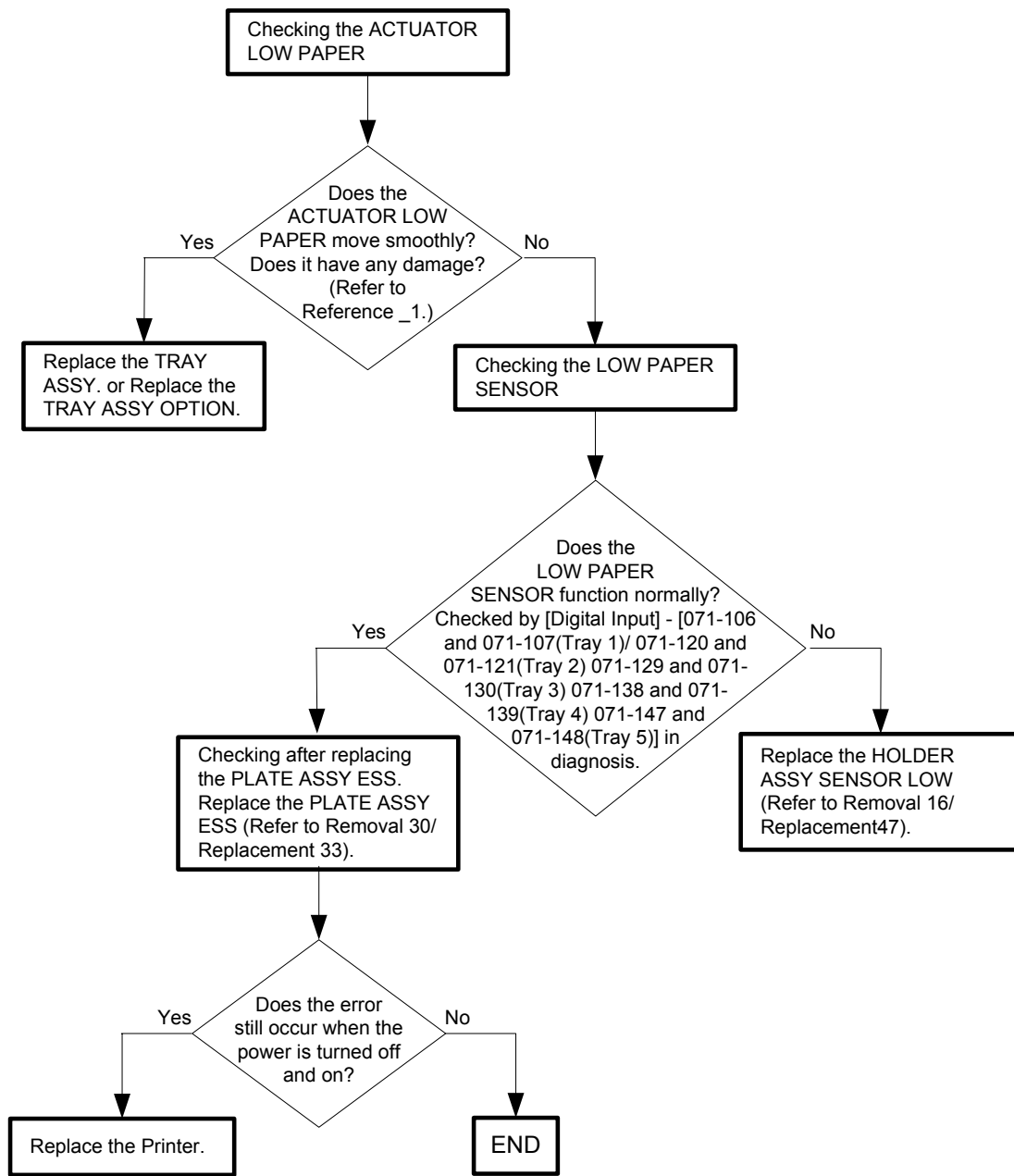

- Reference_1: Section to be checked for damage (for the Tray 1)

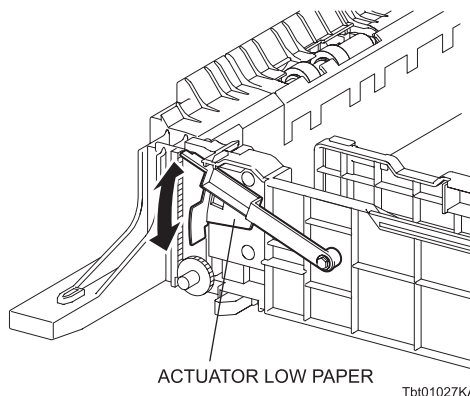

3.2 Troubleshooting for the repair center

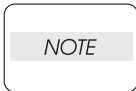

Refer to "3.1 Troubleshooting for the call center" for details of the error.

FIP1.1 001-360: IOT LV Fan Motor Failure

Step	Check	Yes	No
	Possible causative parts: LVPS ASSY (PL10.2.2) FAN LVPS (PL10.1.10) PWBA MCU (PL10.2.18) HARNES ASSY LVPS(PL11.1.9)		
1	Checking the connectors for connection Check the connections between the FAN LVPS and LVPS ASSY. Is P/J309 connected surely?	Go to step 3	Reconnect the connector P/J309 surely, then go to step 2.
2	Does the error still occur when the power is turned off and on?	Go to step 3	End of work
3	Checking the FAN LVPS Does the FAN LVPS function normally? Checked by [Digital Output] - [042-001] in diagnosis.	Replace the PWBA MCU (Refer to Removal 31/ Replacement 32).	Go to step 4
4	Checking the HARN ASSY LVPS for continuity Disconnect P/J305 from the LVPS ASSY. Disconnect P/J23 from the PWBA MCU. Is each cable of P/J305 <=> P/J23 continuous?	Go to step 5	Replace the HARNES ASSY LVPS.
5	Checking the output power of LVPS ASSY. Disconnect P/J309 on the LVPS. Is the voltage across ground <=> J309-1pin on the LVPS ASSY, about +24 VDC when the interlock switch (HARN ASSY I/L FRT) is pushed?	Go to step 6	Replace the BOX LVPS ASSY (Refer to Removal 42/ Replacement 21).
6	Checking after replacing FAN LVPS. Replace the FAN ASSY LVPS (Refer to Removal 32/ Replacement 31). Does the error still occur when the power is turned off and on?	Replace the PWBA MCU (Refer to Removal 31/ Replacement 32).	End of work

FIP1.2 003-340: IOT Firmware Error

Step	Check	Yes	No
	Possible causative parts: PWBA MCU (PL10.2.18)		
1	Check the Firmware Version. The version of the firmware for the printer should be checked with the Printer Information of the Web Tool. The latest Firmware Version should be checked on the Dell Support Web site. Is the firmware the latest version?	Go to step 2	Download the latest version of the firmware from the Dell Support Web site, then go to step 2.
2	Does the error still occur when the power is turned off and on?	Go to step 3	End of work
3	Checking after replacing the PWBA MCU. Replace the PWBA MCU (Refer to Removal 31/ Replacement 32). Does the error still occur when the power is turned off and on?	Checking the Electrical Noise (FIP-132.). or Replace the Printer.	End of work*1

*1: Though some kind of external noise would be possible cause, go to [FIP-132 Electrical Noise] and check, to make sure.

FIP1.3 003-356: IOT NVRAM Error

Step	Check	Yes	No
	Possible causative parts: PWBA MCU (PL10.2.18)		
1	Checking the error. Does the error still occur when the power is turned off and on?	Go to step 2	End of work *1
2	Checking after replacing the PWBA MCU. Replace the PWBA MCU. (Refer to Removal 31/Replacement 32) Does the error still occur when the power is turned off and on?	Replace the Printer.	End of work

*1: Though some kind of foreign noise would be possible cause, go to [FIP1.132 Electrical Noise] in Other FIP and check, to make sure.

FIP1.4 004-310: IOT Feeder I/F Failure

Step	Check	Yes	No
	Possible causative parts: HARNESS ASSY LPP/MOT (PL11.2.5) HARNESS ASSY OPT TOP (PL12.3.1) FEEDER ASSY 550 (PL12.1.2) PWBA OPT FDR (PL12.3.4) PWBA MCU (PL10.2.18)		
1	Checking the Optional Tray for installing Reseat the Optional Tray. Is the Optional Feeder installed correctly?	Go to step 3	Reseat the Optional Tray, then go to step 2.
2	Does the error still occur when the power is turned off and on?	Go to step 3.	End of work
3	Checking the connectors for connection Check the connections between the PWBA OPT FDR and PWBA MCU. Are P/J21, P/J181, and P/J350 connected surely?	Go to step 5.	Reconnect the connector(s) P/J18, P/J181 and/or P/J350 surely, then go to step 4.
4	Does the error still occur when the power is turned off and on?	Go to step 5.	End of work
5	Checking the HARNESS ASSY OPT TOP for continuity Disconnect P/J350 from the PWBA OPT FDR. Disconnect P/J181 from the HARNESS ASSY LPP/MOT. Is each cable of P/J350 <=> P/J181 continuous?	Go to step 6.	Replace the HARNESS ASSY OPT TOP.
6	Checking the HARNESS ASSY LPP/MOT for continuity Disconnect P/J21 from the PWBA MCU. Disconnect P/J181 from the HARNESS ASSY OPT TOP. Is each cable of P/J21 <=> P/J181 continuous?	Go to step 7.	Replace the HARNESS ASSY LPP/MOT.
7	Checking after replacing the PWBA OPT FDR Replace the PWBA OPT FDR. Does the error still occur when the power is turned ON?	Go to step 8.	End of work
8	Checking after replacing the FEEDER ASSY 550 Replace the FEEDER ASSY 550. (Refer to Removal 66/ Replacement 67) Does the error still occur when the power is turned ON?	Replace the PWBA MCU (Refer to Removal 31/ Replacement 32).	End of work

FIP1.5 004-312: IOT Feeder Composition Failure

Step	Check	Yes	No
	Possible causative parts: HARNESS ASSY LPP/MOT (PL11.2.5) HARNESS ASSY OPT TOP (PL12.3.1) FEEDER ASSY 550 (PL12.1.2) PWBA OPT FDR (PL12.3.4) PWBA MCU (PL10.2.18)		
1	Checking the Optional Tray for installing Reseat the Optional Tray. Is the Optional Feeder installed correctly?	Go to step 3	Reseat the Optional Tray, then go to step 2.
2	Does the error still occur when the power is turned off and on?	Go to step 3.	End of work
3	Checking the connectors for connection Check the connections between the PWBA OPT FDR and PWBA MCU. Are P/J21, P/J181, and P/J350 connected surely?	Go to step 5.	Reconnect the connector(s) P/J18, P/J181 and/or P/J350 surely, then go to step 4.
4	Does the error still occur when the power is turned off and on?	Go to step 5.	End of work
5	Checking the HARNESS ASSY OPT TOP for continuity Disconnect P/J350 from the PWBA OPT FDR. Disconnect P/J181 from the HARNESS ASSY LPP/MOT. Is each cable of P/J350 <=> P/J181 continuous?	Go to step 6.	Replace the HARNESS ASSY OPT TOP.
6	Checking the HARNESS ASSY LPP/MOT for continuity Disconnect P/J21 from the PWBA MCU. Disconnect P/J181 from the HARNESS ASSY OPT TOP. Is each cable of P/J21 <=> P/J181 continuous?	Go to step 7.	Replace the HARNESS ASSY LPP/MOT.
7	Checking after replacing the PWBA OPT FDR Replace the PWBA OPT FDR. Does the error still occur when the power is turned ON?	Go to step 8.	End of work
8	Checking after replacing the FEEDER ASSY 550 Replace the FEEDER ASSY 550. (Refer to Removal 66/ Replacement 67) Does the error still occur when the power is turned ON?	Replace the PWBA MCU (Refer to Removal 31/ Replacement 32).	End of work

FIP1.6 006-370: IOT ROS Failure

Step	Check	Yes	No
	Possible causative parts: ROS ASSY (PL5.2.1) PWBA MCU (PL10.2.18)		
1	Checking the ROS ASSY for installation Is the ROS ASSY installed correctly?	Go to step 3.	Reseat the ROS ASSY, then go to step 2.
2	Does the error still occur when the power is turned off and on?	Go to step 3.	End of work
3	Checking the connector for connection Check the connection the PWBA MCU. Are P/J13 and P/J151 connected surely?	Go to step 5.	Reconnect the connector(s) P/J13 and/or P/J151 surely, then go to step 4.
4	Does the error still occur when the power is turned off and on?	Go to step 5.	End of work
5	Checking the PWBA MCU for installation Is the PWBA MCU installed correctly?	Go to step 7.	Reseat the PWBA MCU, then go to step 6.
6	Does the error still occur when the power is turned off and on?	Go to step 7.	End of work
7	Checking after replacing the ROS ASSY Replace the KIT ROS ASSY. (Refer to Removal 39 / Replacement 24) Does the error still occur when the power is turned off and on?	Replace the PWBA MCU (Refer to Removal 31/ Replacement 32).	End of work

FIP1.7 007-340-01: IOT Motor Failure (Deve Motor K)

Step	Check	Yes	No
	Possible causative parts: DRIVE ASSY DEVE K (PL9.2.10) PWBA MCU (PL10.2.18) HARNESS ASSY DISP / FSR (PL11.2.6)		
1	Checking the detail error code. Press the [Information] button to indicate the detail error code. Is "Code: 01" displayed on the LCD?	Go to step 2	"02" : Go to FIP1.8, "03": Go to FIP1.9, "04" : Go to FIP1.10
2	Checking the XERO DEVE CRU ASSY (K) for installation Is the XERO DEVE CRU ASSY (K) installed correctly?	Go to step 4	Reseat the XERO DEVE CRU ASSY (K), then go to step 3.
3	Does the error still occur when the power is turned off and on?	Go to step 4	End of work.
4	Checking the connectors for connection Check the connections between the PWBA MCU and DRIVE ASSY DEVE K. Are P/J6 and P/J253 connected surely?	Go to step 6	Reconnect the connector(s) P/J6 and/or P/J253 surely, then go to step 5.
5	Does the error still occur when the power is turned off and on?	Go to step 6	End of work.
6	Checking the DRIVE ASSY DEVE K for rotation Does the DRIVE ASSY DEVE K function normally? Checked by [Digital Output] - [093-004] in diagnosis.	Replace the PWBA MCU (Refer to Removal 31/ Replacement 32).	Go to step 7
7	Checking the DRIVE ASSY DEVE K for installation Is the DRIVE ASSY DEVE K installed correctly?	Go to step 9	Reseat the DRIVE ASSY DEVE K, then go to step 8.
8	Does the error still occur when the power is turned off and on?	Go to step 9	End of work.
9	Checking the HARNESS ASSY DISP / FSR for continuity Disconnect P/J6 from the PWBA MCU. Disconnect P/J253 from the DRIVE ASSY DEVE K. Is each cable of P/J6 <=> P/J253 continuous?	Go to step 10	Replace the HARNESS ASSY DISP / FSR.
10	Checking the power to DRIVE ASSY DEVE K. Disconnect the connector of P/J6 on the PWBA MCU. Are the voltages across ground <=> J6-2pin/J6-4pin on the PWBA MCU, about +24 VDC when the interlock switch (HARN ASSY I/L FRT) is pushed?	Replace the DRIVE ASSY DEVE K. (Refer to Removal 60/ Replacement 3)	Go to step 11
11	Checking after replacing the KIT DRIVE GEAR. Replace the KIT DRIVE GEAR.(Refer to Removal 61 / Replacement 2) Does the error still occur when the power is turned off and on?	Replace the PWBA MCU (Refer to Removal 31/ Replacement 32).	End of work.

FIP1.8 007-340-02: IOT Motor Failure (Deve Motor YMC)

Step	Check	Yes	No
	Possible causative parts: DRIVE ASSY DEVE (PL9.2.9) PWBA MCU (PL10.2.18) HARNESS ASSY LPP / MOT (PL11.2.5)		
1	Checking the detail error code. Press the [Information] button to indicate the detail error code. Is "Code: 02" displayed on the LCD?	Go to step 2	"01" : Go to FIP1.7, "03": Go to FIP1.9, "04" : Go to FIP1.10
2	Checking the XERO DEVE CRU ASSY (YMC) for installation Is the XERO DEVE CRU ASSY (YMC) installed correctly?	Go to step 4	Reseat the XERO DEVE CRU ASSY (YMC), then go to step 3.
3	Does the error still occur when the power is turned off and on?	Go to step 4	End of work.
4	Checking the connectors for connection Check the connections between the PWBA MCU and DRIVE ASSY DEVE YMC. Are P/J5 and P/J252 connected surely?	Go to step 6	Reconnect the connector(s) P/J5 and/or P/J252 surely, then go to step 5.
5	Does the error still occur when the power is turned off and on?	Go to step 6	End of work.
6	Checking the DRIVE ASSY DEVE YMC for rotation Does the DRIVE ASSY DEVE YMC function normally? Checked by [Digital Output] - [093-001] in diagnosis.	Replace the PWBA MCU (Refer to Removal 31/ Replacement 32).	Go to step 7
7	Checking the DRIVE ASSY DEVE YMC for installation Is the DRIVE ASSY DEVE YMC installed correctly?	Go to step 9	Reseat the DRIVE ASSY DEVE YMC, then go to step 8.
8	Does the error still occur when the power is turned off and on?	Go to step 9	End of work.
9	Checking the HARNESS ASSY LPP / MOT for continuity Disconnect P/J5 from the PWBA MCU. Disconnect P/J252 from the DRIVE ASSY DEVE YMC. Is each cable of P/J5 <=> P/J252 continuous?	Go to step 10	Replace the HARNESS ASSY LPP / MOT.
10	Checking the power to DRIVE ASSY DEVE YMC. Disconnect the connector of P/J5 on the PWBA MCU. Are the voltages across ground <=> J5-2pin/J5-4pin on the PWBA MCU, about +24 VDC when the interlock switch (HARN ASSY I/L FRT) is pushed?	Replace the DRIVE ASSY DEVE. (Refer to Removal 59/ Replacement 4)	Replace the PWBA MCU (Refer to Removal 31/ Replacement 32).

FIP1.9 007-340-03: IOT Motor Failure (Xero Motor)

Step	Check	Yes	No
	Possible causative parts: DRIVE ASSY XERO (PL9.2.6) PWBA MCU (PL10.2.18) HARNESS ASSY DISP / FSR (PL11.2.6)		
1	Checking the detail error code. Press the [Information] button to indicate the detail error code. Is "Code: 03" displayed on the LCD?	Go to step 2	"01" : Go to FIP1.7, "02": Go to FIP1.8, "04" : Go to FIP1.10
2	Checking the XERO DEVE CRU ASSY (YMC) for installation Is the XERO DEVE CRU ASSY (YMC) installed correctly?	Go to step 4	Reseat the XERO DEVE CRU ASSY (YMC), then go to step 3.
3	Does the error still occur when the power is turned off and on?	Go to step 4	End of work.
4	Checking the connectors for connection Check the connections between the PWBA MCU and DRIVE ASSY XERO. Are P/J4A and P/J251 connected surely?	Go to step 6	Reconnect the connector(s) P/J4A and/or P/J251 surely, then go to step 5.
5	Does the error still occur when the power is turned off and on?	Go to step 6	End of work.
6	Checking the DRIVE ASSY XERO for rotation Does the DRIVE ASSY XERO function normally? Checked by [Digital Output] - [091-001] in diagnosis.	Replace the PWBA MCU (Refer to Removal 31/ Replacement 32).	Go to step 7
7	Checking the DRIVE ASSY XERO for installation Is the DRIVE ASSY XERO installed correctly?	Go to step 9	Reseat the DRIVE ASSY XERO, then go to step 8.
8	Does the error still occur when the power is turned off and on?	Go to step 9	End of work.
9	Checking the HARNESS ASSY DISP / FSR for continuity Disconnect P/J4A from the PWBA MCU. Disconnect P/J251 from the DRIVE ASSY XERO. Is each cable of P/J4A <=> P/J251 continuous?	Go to step 10	Replace the HARNESS ASSY DISP / FSR.
10	Checking the power to DRIVE ASSY XERO. Disconnect the connector of P/J4A on the PWBA MCU. Are the voltages across ground <=> J4A-2pin/J4A-4pin on the PWBA MCU, about +24 VDC when the interlock switch (HARN ASSY I/L FRT) is pushed?	Replace the KIT LINK XERO DRIVE. (Refer to Removal 57/ Replacement 6)	Replace the PWBA MCU (Refer to Removal 31/ Replacement 32).

FIP1.10 007-340-04: IOT Motor Failure (PH Motor)

Step	Check	Yes	No
	Possible causative parts: DRIVE ASSY PH (PL9.1.4) PWBA MCU (PL10.2.18) HARNESS ASSY RH / MOT (PL11.2.3)		
1	Checking the detail error code. Press the [Information] button to indicate the detail error code. Is "Code: 04" displayed on the LCD?	Go to step 2	"01" : Go to FIP1.7, "02": Go to FIP1.8, "03" : Go to FIP1.9
2	Checking the Tray1 paper cassette for installation Is the Tray1 paper cassette installed correctly?	Go to step 4	Reseat the Tray1 paper cassette, then go to step 3.
3	Does the error still occur when the power is turned off and on?	Go to step 4	End of work.
4	Checking the connectors for connection Check the connections between the PWBA MCU and DRIVE ASSY PH. Are P/J7B and P/J255 connected surely?	Go to step 6	Reconnect the connector(s) P/J7B and/or P/J255 surely, then go to step 5.
5	Does the error still occur when the power is turned off and on?	Go to step 6	End of work.
6	Checking the DRIVE ASSY PH for rotation Does the DRIVE ASSY PH function normally? Checked by [Digital Output] - [071-001] in diagnosis.	Replace the PWBA MCU (Refer to Removal 31/ Replacement 32).	Go to step 7
7	Checking the DRIVE ASSY PH for installation Is the DRIVE ASSY PH installed correctly?	Go to step 9	Reseat the DRIVE ASSY PH, then go to step 8.
8	Does the error still occur when the power is turned off and on?	Go to step 9	End of work.
9	Checking the HARNESS ASSY RH / MOT for continuity Disconnect P/J7B from the PWBA MCU. Disconnect P/J255 from the DRIVE ASSY PH. Is each cable of P/J7B <=> P/J255 continuous?	Go to step 10	Replace the HARNESS ASSY RH / MOT.
10	Checking the power to DRIVE ASSY PH. Disconnect the connector of P/J4A on the PWBA MCU. Are the voltages across ground <=> J4A-2pin/J4A-4pin on the PWBA MCU, about +24 VDC when the interlock switch (HARN ASSY I/L FRT) is pushed?	Replace the DRIVE ASSY PH. (Refer to Removal 56/ Replacement 7)	Replace the PWBA MCU (Refer to Removal 31/ Replacement 32).

FIP1.11 009-340: IOT CTD Sensor Error

Step	Check	Yes	No
	Possible causative parts: PROCON ASSY (PL5.3.1) PWBA MCU (PL10.2.18) HARNESS ASSY ERASE / EXIT (PL11.2.1)		
1	Checking the connectors for connection Check the connections between the PWBA MCU and PROCON ASSY. Are P/J17 and P/J108 connected surely?	Go to step 3.	Reconnect the connector(s) P/J17 and/or P/J108 surely, then go to step 2.
2	Does the error still occur when the power is turned off and on?	Go to step 3.	End of work.
3	Checking the HARNESS ASSY ERASE / EXIT for continuity Disconnect P/J17 from the PWBA MCU. Disconnect P/J108 from the PROCON ASSY. Is each cable of P/J17 <=> P/J108 continuous?	Go to step 4.	Replace the HARNESS ASSY ERASE / EXIT.
4	Checking the power to PROCON ASSY. Disconnect the connector of P/J17 on the PWBA MCU. Are the voltages across ground <=> J17-9pin/J17-14pin on the PWBA MCU, about +24 VDC when the interlock switch (HARN ASSY I/L FRT) is pushed?	Replace the PROCON ASSY. (Refer to Removal 46/ Replacement 17)	Replace the PWBA MCU (Refer to Removal 31/ Replacement 32).

FIP1.12 009-360 / 009-361 / 009-362 / 009-363: IOT Toner (YMCK) CRUM Comm Fail

Step	Check	Yes	No
	Possible causative parts: TONER CARTRIDGE (Y) (PL6.1.1) TONER CARTRIDGE (M) (PL6.1.2) TONER CARTRIDGE (C) (PL6.1.3) TONER CARTRIDGE (K) (PL6.1.4) CONNECTOR ASSY CRUM (PL6.1.10) PWBA MCU (PL10.2.18) HARNESS ASSY TN CRUM (PL11.1.1)		
1	Checking the TONER CARTRIDGE (Y, M, C or K). Is the toner cartridges installed to the printer the Dell toner? Note: The PPID No. of the TONER CARTRIDGE for 5130 cdn is as follows: - TONER CARTRIDGE (Y) PPID No.: 0R273N or 0T222N - TONER CARTRIDGE (M) PPID No.: 0P615N or 0R272N - TONER CARTRIDGE (C) PPID No.: 0X942N or 0P614N - TONER CARTRIDGE (K) PPID No.: 0U157N or 0N848N	Go to step 2	Set the Non-Dell toner option to [Off]. (Refer to [Non-Dell Toner] in "10 Dell Printer Configuration Web Tool" in the User Guide.)
2	Checking the TONER CARTRIDGE (Y, M, C or K) for installing. Reseat the TONER CARTRIDGE (Y, M, C or K). Does the error still occur when the power is turned off and on?	Go to Step 3	End of work.
3	Checking the connectors for connection Check the connections between the PWBA MCU and CONNECTOR ASSY CRUM (YMCK). Are P/J11 and P/J204(Y) / P/J205 (M) / P/J206(C) / P/J207 (K) connected surely?	Go to step 5	Reconnect the connector(s) surely, then go to step 4.
4	Does the error still occur when the power is turned off and on?	Go to step 5	End of work
5	Checking the HARNESS ASSY TN CRUM for continuity Disconnect P/J11 from the PWBA MCU. Disconnect P/J204(Y) / P/J205 (M) / P/J206(C) / P/J207 (K) from the CONNECTOR ASSY CRUM (YMCK). Is each cable of P/J11 <=> P/J204(Y) / P/J205 (M) / P/J206(C) / P/J207 (K) continuous?	Go to step 6	Replace the HARNESS ASSY TN CRUM.
6	Checking the output power of CONNECTOR ASSY CRUM (YMCK). Disconnect P/J11 on the PWBA MCU. Is the voltage across ground <=> J11-3(Y)/7(M)/11(C)/15(K) pin on the PWBA MCU, about +2.5VDC?	Replace the CONNECTOR ASSY CRUM (YMCK). (Refer to Removal 49/ Replacement 14)	Go to step 7.
7	Checking after replacing the TONER CARTRIDGE (Y, M, C or K). Replace the TONER CARTRIDGE (Y, M, C or K). Does the error still occur when the power is turned off and on?	Replace the PWBA MCU (Refer to Removal 31/ Replacement 32).	End of work.

FIP1.13 009-367 / 009-368 / 009-369 / 009-370: IOT Toner Cartridge (YMCK) CRUM Data
Error

Step	Check	Yes	No
	Possible causative parts: TONER CARTRIDGE (Y) (PL6.1.1) TONER CARTRIDGE (M) (PL6.1.2) TONER CARTRIDGE (C) (PL6.1.3) TONER CARTRIDGE (K) (PL6.1.4) CONNECTOR ASSY CRUM (PL6.1.10) PWBA MCU (PL10.2.18) HARNESS ASSY TN CRUM (PL11.1.1)		
1	Checking the TONER CARTRIDGE (Y, M, C or K). Is the toner cartridges installed to the printer the Dell toner? Note: The PPID No. of the TONER CARTRIDGE for 5130 cdn is as follows: - TONER CARTRIDGE (Y) PPID No.: 0R273N or 0T222N - TONER CARTRIDGE (M) PPID No.: 0P615N or 0R272N - TONER CARTRIDGE (C) PPID No.: 0X942N or 0P614N - TONER CARTRIDGE (K) PPID No.: 0U157N or 0N848N	Go to step 2	Set the Non-Dell toner option to [Off]. (Refer to [Non-Dell Toner] in "10 Dell Printer Configuration Web Tool" in the User Guide.)
2	Checking the TONER CARTRIDGE (Y, M, C or K) for installing. Reseat the TONER CARTRIDGE (Y, M, C or K). Does the error still occur when the power is turned off and on?	Go to Step 3	End of work.
3	Checking the connectors for connection Check the connections between the PWBA MCU and CONNECTOR ASSY CRUM (YMCK). Are P/J11 and P/J204(Y) / P/J205 (M) / P/J206(C) / P/J207 (K) connected surely?	Go to step 5	Reconnect the connector(s) surely, then go to step 4.
4	Does the error still occur when the power is turned off and on?	Go to step 5	End of work
5	Checking the HARNESS ASSY TN CRUM for continuity Disconnect P/J11 from the PWBA MCU. Disconnect P/J204(Y) / P/J205 (M) / P/J206(C) / P/J207 (K) from the CONNECTOR ASSY CRUM (YMCK). Is each cable of P/J11 <=> P/J204(Y) / P/J205 (M) / P/J206(C) / P/J207 (K) continuous?	Go to step 6	Replace the HARNESS ASSY TN CRUM.
6	Checking the output power of CONNECTOR ASSY CRUM (YMCK). Disconnect P/J11 on the PWBA MCU. Is the voltage across ground <=> J11-3(Y)/7(M)/11(C)/15(K) pin on the PWBA MCU, about +2.5VDC?	Replace the CONNECTOR ASSY CRUM (YMCK). (Refer to Removal 49/ Replacement 14)	Go to step 7.

Step	Check	Yes	No
7	Checking after replacing the TONER CARTRIDGE (Y, M, C or K). Replace the TONER CARTRIDGE (Y, M, C or K). Does the error still occur when the power is turned off and on?	Replace the PWBA MCU (Refer to Removal 31/ Replacement 32).	End of work.

FIP1.14 009-371: IOT Belt Unit CRUM Data Error

Step	Check	Yes	No
	Possible causative parts: BELT ASSY IBT (PL5.1.1) CONNECTOR ASSY CRUM (PL5.1.4) HARNESS ASSY ERASE / EXIT (PL11.2.1) PWBA MCU (PL10.2.18)		
1	Checking the BELT ASSY IBT type. Is the BELT ASSY IBT for 5130 cdn installed? Note: The PPID No. of the BELT ASSY IBT for 5130 cdn is as follows: - Belt ASSY IBT PPID No.: 0Y520R	Go to step 2.	Install the BELT ASSY IBT for 5130 cdn.
2	Checking the BELT ASSY IBT for installing. Reseat the BELT ASSY IBT. Does the error still occur when the power is turned off and on?	Go to Step 3	End of work.
3	Checking the connectors for connection Check the connections between the PWBA MCU and CONNECTOR ASSY CRUM. Are P/J16 and P/J215 connected surely?	Go to step 5	Reconnect the connector(s) P/J16 and/or P/J215 surely, then go to step 4.
4	Does the error still occur when the power is turned off and on?	Go to step 5	End of work
5	Checking the HARNESS ASSY ERASE/ EXIT for continuity Disconnect P/J16 from the PWBA MCU. Disconnect P/J215 from the CONNECTOR ASSY CRUM. Is each cable of P/J16 <=> P/J215 continuous?	Go to step 6	Replace the HARNESS ASSY ERASE/ EXIT.
6	Checking the output power of CONNECTOR ASSY CRUM. Disconnect P/J16 on the PWBA MCU. Is the voltage across ground <=> J16-13 pin on the PWBA MCU, about +2.5VDC?	Replace the CONNECTOR ASSY CRUM.	Go to step 7
7	Checking after replacing the CONNECTOR ASSY CRUM. Replace the CONNECTOR ASSY CRUM. Does the error still occur when the power is turned off and on?	Replace the PWBA MCU (Refer to Removal 31/ Replacement 32).	End of work.

FIP1.15 010-317: IOT Fuser Detached

Step	Check	Yes	No
	Possible causative parts: FUSER ASSY (PL7.1.5) HARNESS ASSY FSR (PL7.1.4) PWBA MCU (PL10.2.18)		
1	Checking the FUSER ASSY for installation Is the FUSER ASSY installed correctly?	Go to step 2.	Reseat the FUSER ASSY, and then go to step2.
2	Does the error still occur when the power is turned ON?	Go to step 3.	End of work.*1
3	Checking the connectors for connection Remove the FUSER ASSY. Check the connections between the PWBA MCU and FUSER ASSY. Are P/J1 and P/J180-S connected surely? Warning: Start the operation after the FUSER ASSY has cooled down.	Go to step 4.	Reconnect the connector(s) P/J1 and/or P/J180-S surely, then go to step 4.
4	Checking the HARNESS ASSY FSR for continuity Remove the FUSER ASSY. Disconnect P/J1 from the PWBA MCU. Disconnect P/J180-S from the FUSER ASSY. Is each cable of P/J1 <=> P/J180-S continuous? Warning: Start the operation after the FUSER ASSY has cooled down.	Go to step 5.	Replace the HARNESS ASSY FSR.
5	Checking after replacing the FUSER ASSY. Replace the FUSER ASSY. (Refer to Removal 7 /Replacement 56) Does the error still occur when the power is turned off and on? Warning: Start the operation after the FUSER ASSY has cooled down.	Replace the PWBA MCU (Refer to Removal 31/ Replacement 32).	

*1: Though some kind of external noise would be possible cause, go to [FIP1.132 Electrical Noise] and check, to make sure.

FIP1.16 010-330: IOT Fuser Motor Failure

Step	Check	Yes	No
	Possible causative parts: DRIVE ASSY FSR (PL9.1.1) PWBA MCU (PL10.2.18) HARNESS ASSY DISP / FSR (PL11.2.6)		
1	Checking the Fuser ASSY for installation Is the Fuser ASSY installed correctly? Warning: Start the operation after the FUSER ASSY has cooled down.	Go to step 3	Reseat the Fuser ASSY, then go to step 2.
2	Does the error still occur when the power is turned off and on?	Go to step 3	End of work.
3	Checking the connectors for connection Check the connections between the PWBA MCU and DRIVE ASSY FSR. Are P/J4B and P/J250 connected surely?	Go to step 5	Reconnect the connector(s) P/J4B and/or P/J250 surely, then go to step 4.
4	Does the error still occur when the power is turned off and on?	Go to step 5	End of work.
5	Checking the DRIVE ASSY FSR for rotation Does the DRIVE ASSY FSR function normally? Checked by [Digital Output] - [010-001] in diagnosis.	Replace the PWBA MCU (Refer to Removal 31/ Replacement 32).	Go to step 6
6	Checking the DRIVE ASSY FSR for installation Is the DRIVE ASSY FSR installed correctly?	Go to step 8	Reseat the DRIVE ASSY FSR, then go to step 7.
7	Does the error still occur when the power is turned off and on?	Go to step 8	End of work.
8	Checking the HARNESS ASSY DISP / FSR for continuity Disconnect P/J4B from the PWBA MCU. Disconnect P/J250 from the DRIVE ASSY FSR. Is each cable of P/J4B <=> P/J250 continuous?	Go to step 9	Replace the HARNESS ASSY DISP / FSR.
9	Checking the power to DRIVE ASSY FSR. Disconnect the connector of P/J4B on the PWBA MCU. Are the voltages across ground <=> J4B-2pin/J4B-4pin on the PWBA MCU, about +24 VDC when the interlock switch (HARN ASSY I/L FRT) is pushed?	Replace the DRIVE ASSY FSR. (Refer to Removal 54/ Replacement 9)	Replace the PWBA MCU (Refer to Removal 31/ Replacement 32).

FIP1.17 010-351: IOT Fuser Life Over

Step	Check	Yes	No
	Possible causative parts: FUSER ASSY (PL7.1.5) HARNESS ASSY FSR (PL7.1.4) PWBA MCU (PL10.2.18)		
1	Checking the FUSER ASSY for installation. Reseat the FUSER ASSY. Does the error still occur when the power is turned off and on? Warning: Start the operation after the FUSER ASSY has cooled down.	Go to step 2	End of work.
2	Checking the connectors for connection Check the connections between the PWBA MCU and FUSER CRUM. Are P/J1 and P/J180-S connected surely?	Go to step 4	Reconnect the connector(s) P/J1 and/or P/J180-S surely, then go to step 3.
3	Does the error still occur when the power is turned off and on?	Go to step 4	End of work
4	Checking the HARNESS ASSY FSR for continuity Disconnect P/J1 from the PWBA MCU. Disconnect P/J180-S from the FUSER CRUM. Is each cable of P/J1 <=> P/J180-S continuous?	Go to step 5	Replace the HARNESS ASSY FSR.
5	Checking after replacing the FUSER ASSY. Replace the FUSER ASSY. (Refer to Removal 7 /Replacement 56) Does the error still occur when the power is turned off and on?	Replace the PWBA MCU (Refer to Removal 31/ Replacement 32).	End of work.

FIP1.18 010-354: IOT Environment Sensor Error

Step	Check	Yes	No
	Possible causative parts: SENSOR HUM (PL5.3.15) PROCON ASSY (PL5.3.1) HARNESS ASSY ERASE / EXIT (PL11.2.1) PWBA MCU (PL10.2.18)		
1	Checking the SENSOR HUM for installation Is the SENSOR HUM installed correctly?	Go to step 3.	Reseat the SENSOR HUM, then go to step 2.
2	Does the error still occur when the power is turned off and on?	Go to step 3	End of work
3	Checking the connectors for connection Check the connections between the PWBA MCU and SENSOR HUM. Are P/J16 and P/J106 connected surely?	Go to step 4	Reconnect the connector(s) P/J16 and/or P/J106 surely, then go to step 4.
4	Checking the HARNESS ASSY ERASE/EXIT for continuity Disconnect P/J16 from the PWBA MCU. Disconnect P/J106 from the SENSOR HUM. Is each cable of P/J16 <=> P/J106 continuous?	Go to step 5	Replace the HARNESS ASSY ERASE/EXIT.
5	Checking the power to SENSOR HUM Disconnect the connector of P/J16 on PWBA MCU. Is the voltage across ground <=> J16-10pin on the PWBA MCU, about +5 VDC?	Replace the SENSOR HUM.	Go to step 6
6	Checking after replacing the PROCON ASSY. Replace the PROCON ASSY. (Refer to Removal 46/ Replacement 17) Does the error still occur when the power is turned off and on?	Replace the PWBA MCU (Refer to Removal 31/ Replacement 32).	End of work.

FIP1.19 010-359 / 010-360: IOT Fuser CRUM ID Error / IOT Fuser Comm Fail

Step	Check	Yes	No
	Possible causative parts: FUSER ASSY (PL7.1.5) HARNESS ASSY FSR (PL7.1.4) PWBA MCU (PL10.2.18)		
1	Checking the FUSER ASSY type. Is the FUSER ASSY for 5130 cdn installed? Note: The PPID No. of the FUSER ASSY for 5130 cdn is as follows: - PPID No.(for 110V): 0F369T or 0N856N - PPID No.(for 220V): 0H336T or 0R279N Warning: Start the operation after the FUSER ASSY has cooled down.	Go to step 2	Install the FUSER ASSY for 5130 cdn.
2	Checking the FUSER ASSY for installation.. Reseat the FUSER ASSY. Does the error still occur when the power is turned off and on? Warning: Start the operation after the FUSER ASSY has cooled down.	Go to step 3	End of work.
3	Checking the connectors for connection Check the connections between the PWBA MCU and FUSER CRUM. Are P/J1 and P/J180-S connected surely?	Go to step 5	Reconnect the connector(s) P/J1 and/or P/J180-S surely, then go to step 4.
4	Does the error still occur when the power is turned off and on?	Go to step 5	End of work
5	Checking the HARNESS ASSY FSR for continuity Disconnect P/J1 from the PWBA MCU. Disconnect P/J180-S from the FUSER CRUM. Is each cable of P/J1 <=> P/J180-S continuous?	Go to step 6	Replace the HARNESS ASSY FSR.
6	Checking after replacing the FUSER ASSY. Replace the FUSER ASSY. (Refer to Removal 7 /Replacement 56) Does the error still occur when the power is turned off and on?	Replace the PWBA MCU (Refer to Removal 31/ Replacement 32).	End of work.

FIP1.20 010-377: IOT Fuser Failure

Step	Check	Yes	No
	Possible causative parts: FUSER ASSY (PL7.1.5) HARNESS ASSY FSR (PL7.1.4) PWBA MCU (PL10.2.18)		
1	Checking the FUSER ASSY for installation Is the FUSER ASSY installed correctly? Warning: Start the operation after the FUSER ASSY has cooled down.	Go to step 2.	Reseat the FUSER ASSY, and then go to step2.
2	Does the error still occur when the power is turned ON?	Go to step 3.	End of work.
3	Checking the connectors for connection Remove the FUSER ASSY. Check the connections between the PWBA MCU and FUSER ASSY. Are P/J1and P/J180-S connected surely? Warning: Start the operation after the FUSER ASSY has cooled down.	Go to step 4.	Reconnect the connector(s) P/J1 and/or P/J180-S surely, then go to step 4.
4	Checking the HARNESS ASSY FSR for continuity Remove the FUSER ASSY. Disconnect P/J1 from the PWBA MCU. Disconnect P/J180-S from the FUSER ASSY. Is each cable of P/J1 <=> P/J180-S continuous? Warning: Start the operation after the FUSER ASSY has cooled down.	Go to step 5.	Replace the HARNESS ASSY FSR.
5	Checking after replacing the FUSER ASSY. Replace the FUSER ASSY. (Refer to Removal 7 /Replacement 56) Does the error still occur when the power is turned off and on? Warning: Start the operation after the FUSER ASSY has cooled down.	Replace the PWBA MCU (Refer to Removal 31/ Replacement 32).	

FIP1.21 010-420 / 010-421: IOT Fuser Life Pre Warning / IOT Fuser Quality Life End
Warning

Step	Check	Yes	No
	Possible causative parts: FUSER ASSY (PL7.1.5) HARNESS ASSY FSR (PL7.1.4) PWBA MCU (PL10.2.18)		
1	Checking the FUSER ASSY for installation.. Reseat the FUSER ASSY. Does the error still occur when the power is turned off and on? Warning: Start the operation after the FUSER ASSY has cooled down.	Go to step 2	End of work.
2	Checking the connectors for connection Check the connections between the PWBA MCU and FUSER CRUM. Are P/J1 and P/J180-S connected surely?	Go to step 4	Reconnect the connector(s) P/J1 and/or P/J180-S surely, then go to step 3.
3	Does the error still occur when the power is turned off and on?	Go to step 4	End of work
4	Checking the HARNESS ASSY FSR for continuity Disconnect P/J1 from the PWBA MCU. Disconnect P/J180-S from the FUSER CRUM. Is each cable of P/J1 <=> P/J180-S continuous?	Go to step 5	Replace the HARNESS ASSY FSR.
5	Checking after replacing the FUSER ASSY. Replace the FUSER ASSY. (Refer to Removal 7 /Replacement 56) Does the error still occur when the power is turned off and on?	Replace the PWBA MCU (Refer to Removal 31/ Replacement 32).	End of work.

FIP1.22 010-910: IOT Fuser Envelope Mode Error

Step	Check	Yes	No
	Possible causative parts: ENVELOPE MODE SENSOR (PL7.2.10) PWBA MCU (PL10.2.18) HARNESS ASSY EXIT (PL11.1.7)		
1	Checking of operations of the Envelope Mode Lever and ACTUATOR Remove the FUSER and check the following: Can the Envelope Mode Lever be moved smoothly? Does the ACTUATOR move up and down every time the Envelope Mode Lever setting is changed? Warning: Start the operation after the FUSER ASSY has cooled down.	Go to Step 2	Replace the FUSER ASSY. (Refer to Removal 7 /Replacement 56)
2	Checking the connectors for connection Check the connections between the PWBA MCU and ENVELOPE MODE SENSOR. Are P/J20 and P/J225 connected surely?	Go to step 4	Reconnect the connector(s) P/J20 and/or P/J225 surely, then go to step 3.
3	Does the error still occur when the power is turned off and on?	Go to step 4	End of work.
4	Checking the ENVELOPE MODE SENSOR for operation. Does the number on the screen increase by one, every time the Envelope Mode Lever is operated? Checked by [Digital Input] - [010-203] in diagnosis.	Replace the PWBA MCU (Refer to Removal 31/ Replacement 32).	Go to Step 5
5	Checking the HARNESS ASSY EXIT for continuity Disconnect P/J20 from the PWBA MCU. Disconnect P/J225 from the ENVELOPE MODE SENSOR. Is each cable of P/J20 <=> P/J225 continuous?	Go to step 6	Replace the HARNESS ASSY EXIT.
6	Checking the power to ENVELOPE MODE SENSOR. Disconnect the connector of P/J20 on the PWBA MCU. Are the voltages across ground <=> J20-1pin on the PWBA MCU, about +3.3 VDC when the interlock switch (HARN ASSY I/L FRT) is pushed?	Replace the ENVELOPE MODE SENSOR.	Replace the PWBA MCU (Refer to Removal 31/ Replacement 32).

FIP1.23 012-151 / 012-903: IOT Output Expander Compile Exit Sensor Off JAM / Paper
Remain at Compile Exit

Step	Check	Yes	No
	Possible causative parts: COMPILE EXIT SENSOR (PL14.7.9) DRIVE ASSY TRANS (PL14.7.16) PWBA MAIN A4 FIN (PL14.4.12) HARNESS ASSY SNR2 A4FIN (PL14.11.6) HARNESS ASSY MOT2 A4FIN (PL14.11.4) PWBA MCU (PL10.2.18)		
1	Checking of the paper path Open the cover of the H-TRA. Is there any foreign matter such as paper dust around the inlet of the Finisher? Also, are ROLL ASSY DRIVE ENT and ROLL ASSY DRIVE EXIT not contaminated or damaged, and rotated smoothly?	Clean or replace the appropriate ROLLER, and clean the paper path.	Go to Step 2
2	Checking the connectors for connection Check the connections between the PWBA MAIN A4 FIN and COMPILE EXIT SENSOR. Are P/J8989 and P/J8869 connected surely?	Go to step 4	Reconnect the connector(s) P/J8989 and/or P/J8869 surely, then go to step 3.
3	Does the error still occur when printing?	Go to step 4	End of work.
4	Checking the COMPILE EXIT SENSOR for operation. Does the number on the screen increase by one, every time the COMPILE EXIT SENSOR is operated? Checked by [Digital Input] - [012-150] in diagnosis.	Go to step 7	Go to Step 5
5	Checking the HARNESS ASSY SNR2 A4FIN for continuity Disconnect P/J8989 from the PWBA MAIN A4 FIN. Disconnect P/J8869 from the COMPILE EXIT SENSOR. Is each cable of P/J8989 <=> P/J8869 continuous?	Go to step 6	Replace the HARNESS ASSY SNR2 A4FIN.
6	Checking the power to COMPILE EXIT SENSOR. Disconnect the connector of P/J8989 on the PWBA MAIN A4 FIN. Is the voltage between ground and J8989-12B of the PWBA MAIN A4 FIN, +5 VDC?	Replace the COMPILE EXIT SENSOR.	Go to step 14.
7	Checking the connectors for connection Check the connections between the PWBA MAIN A4 FIN and DRIVE ASSY TRANS. Are P/J8984 and P/J8879 connected surely?	Go to step 9	Reconnect the connector(s) P/J8984 and/or P/J8879 surely, then go to step 8
8	Does the error still occur when printing?	Go to step 9	End of work.
9	Checking the DRIVE ASSY TRANS for rotation Does the DRIVE ASSY TRANS function normally? Checked by [Digital Output] - [012-036(Forward) and 012-018(Reverse)] in diagnosis.	Go to step 14.	Go to step 10

Step	Check	Yes	No
10	Checking the DRIVE ASSY TRANS for installation Is the DRIVE ASSY TRANS installed correctly?	Go to step 12	Reseat the DRIVE ASSY TRANS, then go to step 11.
11	Does the error still occur when printing?	Go to step 12	End of work.
12	Checking the HARNESS ASSY MOT2 A4FIN for continuity Disconnect P/J8984 from the PWBA MAIN A4 FIN. Disconnect P/J8879 from the DRIVE ASSY TRANS. Is each cable of P/J8984 <=> P/J8879 continuous?	Go to step 13	Replace the HARNESS ASSY MOT2 A4FIN.
13	Checking the power to DRIVE ASSY TRANS. Disconnect the connector of P/J8984 on the PWBA MAIN A4 FIN. Are the voltages across ground <=> J8984-9pin, and ground <=> J8984-12pin on the PWBA MAIN A4 FIN, +24 VDC?	Replace the DRIVE ASSY TRANS.	Go to step 14.
14	Checking after replacing the PWBA MAIN A4 FIN. Replace the PWBA MAIN A4 FIN (Refer to Removal 11/ Replacement 1). Does the error still occur when printing?	Replace the PWBA MCU (Refer to Removal 31/ Replacement 32).	End of work.

FIP1.24 012-161 / 012-905: IOT Output Expander Set Eject JAM / Paper Remain at Compile Tray No Paper Sensor

Step	Check	Yes	No
	Possible causative parts: MOTOR ASSY EJECT (PL14.5.6) COMPILE TRAY NO PAPER SENSOR (PL14.8.13) PWBA MAIN A4 FIN (PL14.4.12) HARNESS ASSY SNR1 A4FIN (PL14.11.5) HARNESS ASSY MOT2 A4FIN (PL14.11.4) PWBA MCU (PL10.2.18)		
1	Checking of the paper path Is there the foreign substance on the paper path? Also, are ROLLER ASSY EJECT and ROLL ASSY EJECT PINCH ROLL not contaminated or damaged, and rotated smoothly?	Go to Step 2	Clean or replace the appropriate ROLLER, and clean the paper path.
2	Checking the EJECT CLAMP UP/DOWN. Does the EJECT CLAMP UP/DOWN function normally? Checked by [Digital Output] - [012-052(UP) and 012-053 (DOWN)] in diagnosis.	Go to Step 10	Go to Step 3
3	Checking the connectors for connection Check the connections between the PWBA MAIN A4 FIN and MOTOR ASSY EJECT. Are P/J8984 and P/J8878 connected surely?	Go to step 5	Reconnect the connector(s) P/J8984 and/or P/J8878 surely, then go to step 4
4	Does the error still occur when printing?	Go to step 5	End of work.
5	Checking the MOTOR ASSY EJECT for rotation Does the MOTOR ASSY EJECT function normally? Checked by [Digital Output] - [012-054] in diagnosis.	Go to Step 15	Go to step 6
6	Checking the MOTOR ASSY EJECT for installation Is the MOTOR ASSY EJECT installed correctly?	Go to step 8	Reseat the MOTOR ASSY EJECT, then go to step 7.
7	Does the error still occur when printing?	Go to step 8	End of work.
8	Checking the HARNESS ASSY MOT2 A4FIN for continuity Disconnect P/J8984 from the PWBA MAIN A4 FIN. Disconnect P/J8878 from the MOTOR ASSY EJECT. Is each cable of P/J8984 <=> P/J8878 continuous?	Go to step 9	Replace the HARNESS ASSY MOT2 A4FIN.
9	Checking the power to MOTOR ASSY EJECT. Disconnect the connector of P/J8984 on the PWBA MAIN A4 FIN. Are the voltages across ground <=> J8984-9pin, and ground <=> J8984-12pin on the PWBA MAIN A4 FIN, +24 VDC?	Replace the MOTOR ASSY EJECT.	Go to Step 15
10	Checking the connectors for connection Check the connections between the PWBA MAIN A4 FIN and COMPILE TRAY NO PAPER SENSOR. Are P/J8988 and P/J8880 connected surely?	Go to step 12	Reconnect the connector(s) P/J8988 and/or P/J8880 surely, then go to step 11.
11	Does the error still occur when printing?	Go to step 12	End of work.

Step	Check	Yes	No
12	<p>Checking the COMPILE TRAY NO PAPER SENSOR for operation.</p> <p>Does the number on the screen increase by one, every time the actuator of the COMPILE TRAY NO PAPER SENSOR is operated? Checked by [Digital Input] - [012-151] in diagnosis.</p>	Go to Step 15	Go to Step 13
13	<p>Checking the HARNESS ASSY SNR1 A4FIN for continuity Disconnect P/J8988 from the PWBA MAIN A4 FIN. Disconnect P/J8880 from the COMPILE TRAY NO PAPER SENSOR. Is each cable of P/J8988 <=> P/J8880 continuous?</p>	Go to step 14	Replace the HARNESS ASSY SNR1 A4FIN.
14	<p>Checking the power to COMPILE TRAY NO PAPER SENSOR. Disconnect the connector of P/J8988 on the PWBA MAIN A4 FIN. Is the voltage between ground and J8988-3 of the PWBA MAIN A4 FIN, +5 VDC?</p>	Replace the COMPILE TRAY NO PAPER SENSOR.	Go to Step 15
15	<p>Checking after replacing the PWBA MAIN A4 FIN. Replace the PWBA MAIN A4 FIN (Refer to Removal 11/ Replacement 1). Does the error still occur when printing?</p>	Replace the PWBA MCU (Refer to Removal 31/ Replacement 32).	End of work.

FIP1.25 012-302: IOT Output Expander Cover Front Open

Step	Check	Yes	No
	Possible causative parts: COVER ASSY FRONT DOOR (PL14.3.6) PWBA MAIN A4 FIN (PL14.4.12) LVPS ASSY (PL14.10.10) HARNESS ASSY INTL SW A4FIN (PL14.11.2) HARNESS ASSY LVPS A4FIN (PL14.11.1) PWBA MCU (PL10.2.18)		
1	Checking the COVER ASSY FRONT DOOR for shape Are there any damages on the COVER ASSY FRONT DOOR?	Replace the COVER ASSY FRONT DOOR. (Refer to Removal 3/ Replacement 13)	Go to Step 2.
2	Checking the connectors for connection Check the connections between the PWBA MAIN A4 FIN and SWITCH. Are P/J8982 and P/J8889 connected surely?	Go to step 4	Reconnect the connector(s) P/J8982 and/or P/J8889 surely, then go to step 3.
3	Does the error still occur when the power is turned off and on?	Go to step 4	End of work.
4	Checking the FINISHER FRONT DOOR SWITCH for operation. Does the number on the screen increase by one, every time the Front Door is operated? Checked by [Digital Input] - [012-302] in diagnosis.	Go to step 7	Go to Step 5.
5	Checking the HARNESS ASSY INTL SW A4FIN for continuity Disconnect P/J8988 from the PWBA MAIN A4 FIN. Disconnect P/J8880 from the SWITCH. Is each cable of P/J8982 <=> P/J8889 continuous?	Go to step 6	Replace the HARNESS ASSY INTL SW A4FIN.
6	Checking the power to SWITCH. Disconnect the connector of P/J8982 on the PWBA MAIN A4 FIN. Is the voltage between ground and J8982-1 of the PWBA MAIN A4 FIN, +24VDC?	Replace the SWITCH.	Go to step 7
7	Checking after replacing the PWBA MAIN A4 FIN. Replace the PWBA MAIN A4 FIN (Refer to Removal 11/ Replacement 1). Does the error still occur when the power is turned off and on?	Replace the PWBA MCU (Refer to Removal 31/ Replacement 32).	End of work.

FIP1.26 012-303: IOT Output Expander H Transport Unit Cover Open

Step	Check	Yes	No
	Possible causative parts: COVER ASSY TOP H-TRA (PL14.2.3) PWBA MAIN A4 FIN (PL14.4.12) HARNESS ASSY HTU A4FIN (PL14.2.40) PWBA MCU (PL10.2.18)		
1	Checking the COVER ASSY TOP H-TRA for shape Are there any damages on the COVER ASSY TOP H-TRA?	Replace the COVER ASSY TOP H-TRA. (Refer to Removal 4/ Replacement 8)	Go to Step 2.
2	Checking the connectors for connection Check the connections between the PWBA MAIN A4 FIN and HTU H-PORT OPEN SENSOR. Are P/J8987 and P/J8864 connected surely?	Go to step 4	Reconnect the connector(s) P/J8987 and/or P/J8864 surely, then go to step 3.
3	Does the error still occur when the power is turned off and on?	Go to step 4	End of work.
4	Checking the HTU H-PORT OPEN SENSOR for operation. Does the number on the screen increase by one, every time the H-Xport Cover is operated? Checked by [Digital Input] - [012-303] in diagnosis.	Go to step 7	Go to Step 5.
5	Checking the HARNESS ASSY HTU A4FIN for continuity Disconnect P/J8987 from the PWBA MAIN A4 FIN. Disconnect P/J8864 from the HTU H-PORT OPEN SENSOR. Is each cable of P/J8987 <=> P/J8864 continuous?	Go to step 6	Replace the HARNESS ASSY HTU A4FIN.
6	Checking the power to HTU H-PORT OPEN SENSOR. Disconnect the connector of P/J8987 on the PWBA MAIN A4 FIN. Is the voltage between ground and J8987-3 of the PWBA MAIN A4 FIN, +5VDC?	Replace the HTU H-PORT OPEN SENSOR.	Go to step 7
7	Checking after replacing the PWBA MAIN A4 FIN. Replace the PWBA MAIN A4 FIN (Refer to Removal 11/ Replacement 1). Does the error still occur when the power is turned off and on?	Replace the PWBA MCU (Refer to Removal 31/ Replacement 32).	End of work.

FIP1.27 012-311 / 012-313: IOT Output Expander Front Tamper Home Sensor On /Off
Fail

Step	Check	Yes	No
	Possible causative parts: FRONT TAMPER HOME SENSOR (PL14.8.9) MOTOR ASSY TAMPER (PL14.8.18) PWBA MAIN A4 FIN (PL14.4.12) HARNESS ASSY SNR1 A4FIN (PL14.11.5) HARNESS ASSY MOT1 A4FIN (PL14.11.3) PWBA MCU (PL10.2.18)		
1	Checking the Tamper mechanism for operation. Does the tamper mechanism operate smoothly? Check this item by moving it with your fingers.	Go to Step 2	Replace the TRAY ASSY COMPILE.
2	Checking the connectors for connection Check the connections between the PWBA MAIN A4 FIN and FRONT TAMPER HOME SENSOR. Are P/J8988 and P/J8881 connected surely?	Go to step 4	Reconnect the connector(s) P/J8988 and/or P/J8881 surely, then go to step 3.
3	Does the error still occur when the power is turned off and on?	Go to step 4	End of work.
4	Checking the FRONT TAMPER HOME SENSOR for operation. Does the number on the screen increase by one, every time the actuator of the FRONT TAMPER HOME SENSOR is operated? Checked by [Digital Input] - [012-220] in diagnosis.	Go to step 7	Go to Step 5.
5	Checking the HARNESS ASSY SNR1 A4FIN for continuity Disconnect P/J8988 from the PWBA MAIN A4 FIN. Disconnect P/J8881 from the FRONT TAMPER HOME SENSOR. Is each cable of P/J8988 <=> P/J8881 continuous?	Go to step 6	Replace the HARNESS ASSY SNR1 A4FIN.
6	Checking the power to FRONT TAMPER HOME SENSOR. Disconnect the connector of P/J8988 on the PWBA MAIN A4 FIN. Is the voltage between ground and J8988-6 of the PWBA MAIN A4 FIN, +5VDC?	Replace the FRONT TAMPER HOME SENSOR.	Go to step 14
7	Checking the connectors for connection Check the connections between the PWBA MAIN A4 FIN and MOTOR ASSY TAMPER (Front). Are P/J8983 and P/J8891 connected surely?	Go to step 9	Reconnect the connector(s) P/J8983 and/or P/J8891 surely, then go to step 8
8	Does the error still occur when the power is turned off and on?	Go to step 9	End of work.
9	Checking the MOTOR ASSY TAMPER (Front). Does the MOTOR ASSY TAMPER (Front) function normally? Checked by [Digital Output] - [012-020 and 012-023] in diagnosis.	Go to step 14	Go to step 10

Step	Check	Yes	No
10	Checking the MOTOR ASSY TAMPER (Front) for installation Is the MOTOR ASSY EJECT installed correctly?	Go to step 12	Reseat the MOTOR ASSY TAMPER (Front), then go to step 11.
11	Does the error still occur when the power is turned off and on?	Go to step 12	End of work.
12	Checking the HARNESS ASSY MOT1 A4FIN for continuity Disconnect P/J8983 from the PWBA MAIN A4 FIN. Disconnect P/J8891 from the MOTOR ASSY TAMPER (Front). Is each cable of P/J8983 <=> P/J88891 continuous?	Go to step 13	Replace the HARNESS ASSY MOT1 A4FIN.
13	Checking the power to MOTOR ASSY TAMPER (Front). Disconnect the connector of P/J8983 on the PWBA MAIN A4 FIN. Are the voltages across ground <=> J8983-11pin on the PWBA MAIN A4 FIN, +24 VDC?	Replace the MOTOR ASSY TAMPER (Front).	Go to step 14
14	Checking after replacing the PWBA MAIN A4 FIN. Replace the PWBA MAIN A4 FIN (Refer to Removal 11/ Replacement 1). Does the error still occur when the power is turned off and on?	Replace the PWBA MCU (Refer to Removal 31/ Replacement 32).	End of work.

FIP1.28 012-312: IOT Output Expander NVM Fail

Step	Check	Yes	No
	Possible causative parts: PWBA MAIN A4 FIN (PL14.4.12) PWBA MCU (PL10.2.18) HARNESS ASSY IF A4FIN (PL14.11.7) PWBA MCU (PL10.2.18)		
1	Does Error still occur after several ON/OFF procedures of the power?	Go to step 2	End of work
2	Checking the connectors for connection Check the connections between the PWBA MAIN A4 FIN and Printer. Are CN4 and P/J8990 connected surely?	Go to step 4	Reconnect the connector(s) CN4 and/or P/J8990 surely, then go to step 3.
3	Does the error still occur when the power is turned off and on?	Go to step 4	End of work.
4	Checking the HARNESS ASSY IF A4FIN for continuity Disconnect P/J8983 from the PWBA MAIN A4 FIN. Disconnect CN4 from the Printer. Is each cable of CN4 <=> P/J8990 continuous?	Go to step 5	Replace the HARNESS ASSY IF A4FIN.
5	Checking after replacing the PWBA MAIN A4 FIN. Replace the PWBA MAIN A4 FIN (Refer to Removal 11/ Replacement 1). Does the error still occur when the power is turned off and on?	Replace the PWBA MCU (Refer to Removal 31/ Replacement 32).	End of work.

FIP1.29 012-314 / 012-353: IOT Output Expander Rear Tamper Home Sensor Off / On Fail

Step	Check	Yes	No
	Possible causative parts: REAR TAMPER HOME SENSOR (PL14.8.9) MOTOR ASSY TAMPER (PL14.8.18) PWBA MAIN A4 FIN (PL14.4.12) HARNESS ASSY SNR1 A4FIN (PL14.11.5) HARNESS ASSY MOT1 A4FIN (PL14.11.3) PWBA MCU (PL10.2.18)		
1	Checking the Tamper mechanism for operation. Does the tamper mechanism operate smoothly? Check this item by moving it with your fingers.	Go to Step 2	Replace the TRAY ASSY COMPILE.
2	Checking the connectors for connection Check the connections between the PWBA MAIN A4 FIN and REAR TAMPER HOME SENSOR. Are P/J8988 and P/J8882 connected surely?	Go to step 4	Reconnect the connector(s) P/J8988 and/or P/J8882 surely, then go to step 3.
3	Does the error still occur when the power is turned off and on?	Go to step 4	End of work.
4	Checking the REAR TAMPER HOME SENSOR for operation. Does the number on the screen increase by one, every time the REAR TAMPER HOME SENSOR is operated? Checked by [Digital Input] - [012-221] in diagnosis.	Go to step 7	Go to Step 5.
5	Checking the HARNESS ASSY SNR1 A4FIN for continuity Disconnect P/J8988 from the PWBA MAIN A4 FIN. Disconnect P/J8881 from the REAR TAMPER HOME SENSOR. Is each cable of P/J8988 <=> P/J8882 continuous?	Go to step 6	Replace the HARNESS ASSY SNR1 A4FIN.
6	Checking the power to REAR TAMPER HOME SENSOR. Disconnect the connector of P/J8988 on the PWBA MAIN A4 FIN. Is the voltage between ground and J8988-9 of the PWBA MAIN A4 FIN, +5VDC?	Replace the REAR TAMPER HOME SENSOR.	Go to step 14
7	Checking the connectors for connection Check the connections between the PWBA MAIN A4 FIN and MOTOR ASSY TAMPER (Rear). Are P/J8983 and P/J8891 connected surely?	Go to step 9	Reconnect the connector(s) P/J8983 and/or P/J8883 surely, then go to step 8
8	Does the error still occur when the power is turned off and on?	Go to step 9	End of work.
9	Checking the MOTOR ASSY TAMPER (Rear). Does the MOTOR ASSY TAMPER (Rear) function normally? Checked by [Digital Output] - [012-026 and 012-029] in diagnosis.	Go to step 14	Go to step 10

Step	Check	Yes	No
10	Checking the MOTOR ASSY TAMPER (Rear) for installation Is the MOTOR ASSY EJECT installed correctly?	Go to step 12	Reseat the MOTOR ASSY TAMPER (Rear), then go to step 11.
11	Does the error still occur when the power is turned off and on?	Go to step 12	End of work.
12	Checking the HARNESS ASSY MOT1 A4FIN for continuity Disconnect P/J8983 from the PWBA MAIN A4 FIN. Disconnect P/J8891 from the MOTOR ASSY TAMPER (Rear). Is each cable of P/J8983 <=> P/J8891 continuous?	Go to step 13	Replace the HARNESS ASSY MOT1 A4FIN.
13	Checking the power to MOTOR ASSY TAMPER (Rear). Disconnect the connector of P/J8983 on the PWBA MAIN A4 FIN. Are the voltages across ground <=> J8983-6 pin on the PWBA MAIN A4 FIN, +24 VDC?	Replace the MOTOR ASSY TAMPER (Rear).	Go to step 14
14	Checking after replacing the PWBA MAIN A4 FIN. Replace the PWBA MAIN A4 FIN (Refer to Removal 11/ Replacement 1). Does the error still occur when the power is turned off and on?	Replace the PWBA MCU (Refer to Removal 31/ Replacement 32).	End of work.

FIP1.30 012-315: IOT Output Expander Stacker Tray Fail

Step	Check	Yes	No
	Possible causative parts: STACKER HEIGHT SENSOR 1 / 2 (PL14.4.3) MOTOR ASSY STACKER (PL14.9.7) PWBA MAIN A4 FIN (PL14.4.12) HARNESS ASSY SNR2 A4FIN (PL14.11.6) HARNESS ASSY MOT3 A4FIN (PL14.9.25) PWBA MCU (PL10.2.18)		
1	Checking the vertical transport mechanism of the Stacker Tray for obstacles and deformation Are there any obstacles in the vertical transport mechanism of the Stacker Tray? Is there any deformation in the vertical transport mechanism of the Stacker Tray?	Remove the obstacles or replace deformed part.	Go to Step 2.
2	Checking the connectors for connection Check the connections between the PWBA MAIN A4 FIN and STACKER HEIGHT SENSOR 1. Are P/J8989 and P/J8873 connected surely?	Go to step 4	Reconnect the connector(s) P/J8989 and/or P/J8873 surely, then go to step 3.
3	Does the error still occur when the power is turned off and on?	Go to step 4	End of work.
4	Checking the STACKER HEIGHT SENSOR 1 for operation. Does the number on the screen increase by one, every time the STACKER HEIGHT SENSOR-1 is operated? Checked by [Digital Input] - [012-264] in diagnosis.	Go to step 7	Go to Step 5.
5	Checking the HARNESS ASSY SNR2 A4FIN for continuity Disconnect P/J8989 from the PWBA MAIN A4 FIN. Disconnect P/J8873 from the STACKER HEIGHT SENSOR 1. Is each cable of P/J8989 <=> P/J8873 continuous?	Go to step 6	Replace the HARNESS ASSY SNR2 A4FIN.
6	Checking the power to STACKER HEIGHT SENSOR 1. Disconnect the connector of P/J8989 on the PWBA MAIN A4 FIN. Is the voltage between ground and J8989-6B of the PWBA MAIN A4 FIN, +5VDC?	Replace the STACKER HEIGHT SENSOR 1.	Go to step 19
7	Checking the connectors for connection Check the connections between the PWBA MAIN A4 FIN and STACKER HEIGHT SENSOR 2. Are P/J8989 and P/J8874 connected surely?	Go to step 9	Reconnect the connector(s) P/J8989 and/or P/J8874 surely, then go to step 8.
8	Does the error still occur when the power is turned off and on?	Go to step 9	End of work.
9	Checking the STACKER HEIGHT SENSOR 2 for operation. Does the number on the screen increase by one, every time the STACKER HEIGHT SENSOR-2 is operated? Checked by [Digital Input] - [012-265] in diagnosis.	Go to step 12	Go to Step 10.

Step	Check	Yes	No
10	Checking the HARNESS ASSY SNR2 A4FIN for continuity Disconnect P/J8989 from the PWBA MAIN A4 FIN. Disconnect P/J8874 from the STACKER HEIGHT SENSOR 2. Is each cable of P/J8989 <=> P/J8874 continuous?	Go to step 11	Replace the HARNESS ASSY SNR2 A4FIN.
11	Checking the power to STACKER HEIGHT SENSOR 2. Disconnect the connector of P/J8989 on the PWBA MAIN A4 FIN. Is the voltage between ground and J8989-9B of the PWBA MAIN A4 FIN, +5VDC?	Replace the STACKER HEIGHT SENSOR 2.	Go to step 19
12	Checking the connectors for connection Check the connections between the PWBA MAIN A4 FIN and MOTOR ASSY STACKER. Are P/J8986 and P/J8878 connected surely?	Go to step 14	Reconnect the connector(s) P/J8986 and/or P/J8878 surely, then go to step 13
13	Does the error still occur when the power is turned off and on?	Go to step 14	End of work.
14	Checking the MOTOR ASSY STACKER. Does the MOTOR ASSY STACKER function normally? Checked by [Digital Output] - [012-060(UP) and 012-061(DOWN)] in diagnosis.	Go to step 19	Go to step 15
15	Checking the MOTOR ASSY STACKER for installation Is the MOTOR ASSY STACKER installed correctly?	Go to step 17	Reseat the MOTOR ASSY STACKER, then go to step 16.
16	Does the error still occur when the power is turned off and on?	Go to step 17	End of work.
17	Checking the HARNESS ASSY MOT3 A4FIN for continuity Disconnect P/J8983 from the PWBA MAIN A4 FIN. Disconnect P/J8891 from the MOTOR ASSY STACKER. Is each cable of P/J8986 <=> P/J8878 continuous?	Go to step 18	Replace the HARNESS ASSY MOT3 A4FIN.
18	Checking the power to MOTOR ASSY STACKER. Disconnect the connector of P/J8986 on the PWBA MAIN A4 FIN. Are the voltages across ground <=> J8986-1pin, and ground <=> J8986-3pin on the PWBA MAIN A4 FIN, +24 VDC?	Replace the MOTOR ASSY STACKER.	Go to step 19
19	Checking after replacing the PWBA MAIN A4 FIN. Replace the PWBA MAIN A4 FIN (Refer to Removal 11/ Replacement 1). Does the error still occur when the power is turned off and on?	Replace the PWBA MCU (Refer to Removal 31/ Replacement 32).	End of work.

FIP1.31 012-316: IOT Output Expander Stacker Upper Limit Fail

Step	Check	Yes	No
	Possible causative parts: STACKER HEIGHT SENSOR 1 / 2 (PL14.4.3) MOTOR ASSY STACKER (PL14.9.7) PWBA MAIN A4 FIN (PL14.4.12) HARNESS ASSY SNR2 A4FIN (PL14.11.6) HARNESS ASSY MOT3 A4FIN (PL14.9.25) PWBA MCU (PL10.2.18)		
1	Checking the vertical transport mechanism of the Stacker Tray for obstacles and deformation Are there any obstacles in the vertical transport mechanism of the Stacker Tray? Is there any deformation in the vertical transport mechanism of the Stacker Tray?	Remove the obstacles or replace deformed part.	Go to Step 2.
2	Checking the connectors for connection Check the connections between the PWBA MAIN A4 FIN and STACKER HEIGHT SENSOR 1. Are P/J8989 and P/J8873 connected surely?	Go to step 4	Reconnect the connector(s) P/J8989 and/or P/J8873 surely, then go to step 3.
3	Does the error still occur when the power is turned off and on?	Go to step 4	End of work.
4	Checking the STACKER HEIGHT SENSOR 1 for operation. Does the number on the screen increase by one, every time the STACKER HEIGHT SENSOR-1 is operated? Checked by [Digital Input] - [012-264] in diagnosis.	Go to step 7	Go to Step 5.
5	Checking the HARNESS ASSY SNR2 A4FIN for continuity Disconnect P/J8989 from the PWBA MAIN A4 FIN. Disconnect P/J8873 from the STACKER HEIGHT SENSOR 1. Is each cable of P/J8989 <=> P/J8873 continuous?	Go to step 6	Replace the HARNESS ASSY SNR2 A4FIN.
6	Checking the power to STACKER HEIGHT SENSOR 1. Disconnect the connector of P/J8989 on the PWBA MAIN A4 FIN. Is the voltage between ground and J8989-6B of the PWBA MAIN A4 FIN, +5VDC?	Replace the STACKER HEIGHT SENSOR 1.	Go to step 19
7	Checking the connectors for connection Check the connections between the PWBA MAIN A4 FIN and STACKER HEIGHT SENSOR 2. Are P/J8989 and P/J8874 connected surely?	Go to step 9	Reconnect the connector(s) P/J8989 and/or P/J8874 surely, then go to step 8.
8	Does the error still occur when the power is turned off and on?	Go to step 9	End of work.
9	Checking the STACKER HEIGHT SENSOR 2 for operation. Does the number on the screen increase by one, every time the STACKER HEIGHT SENSOR-2 is operated? Checked by [Digital Input] - [012-265] in diagnosis.	Go to step 12	Go to Step 10.

Step	Check	Yes	No
10	Checking the HARNESS ASSY SNR2 A4FIN for continuity Disconnect P/J8989 from the PWBA MAIN A4 FIN. Disconnect P/J8874 from the STACKER HEIGHT SENSOR 2. Is each cable of P/J8989 <=> P/J8874 continuous?	Go to step 11	Replace the HARNESS ASSY SNR2 A4FIN.
11	Checking the power to STACKER HEIGHT SENSOR 2. Disconnect the connector of P/J8989 on the PWBA MAIN A4 FIN. Is the voltage between ground and J8989-9B of the PWBA MAIN A4 FIN, +5VDC?	Replace the STACKER HEIGHT SENSOR 2.	Go to step 19
12	Checking the connectors for connection Check the connections between the PWBA MAIN A4 FIN and MOTOR ASSY STACKER. Are P/J8986 and P/J8878 connected surely?	Go to step 14	Reconnect the connector(s) P/J8986 and/or P/J8878 surely, then go to step 13
13	Does the error still occur when the power is turned off and on?	Go to step 14	End of work.
14	Checking the MOTOR ASSY STACKER. Does the MOTOR ASSY STACKER function normally? Checked by [Digital Output] - [012-060(UP) and 012-061(DOWN)] in diagnosis.	Go to step 19	Go to step 15
15	Checking the MOTOR ASSY STACKER for installation Is the MOTOR ASSY STACKER installed correctly?	Go to step 17	Reseat the MOTOR ASSY STACKER, then go to step 16.
16	Does the error still occur when the power is turned off and on?	Go to step 17	End of work.
17	Checking the HARNESS ASSY MOT3 A4FIN for continuity Disconnect P/J8983 from the PWBA MAIN A4 FIN. Disconnect P/J8891 from the MOTOR ASSY STACKER. Is each cable of P/J8986 <=> P/J8878 continuous?	Go to step 18	Replace the HARNESS ASSY MOT3 A4FIN.
18	Checking the power to MOTOR ASSY STACKER. Disconnect the connector of P/J8986 on the PWBA MAIN A4 FIN. Are the voltages across ground <=> J8986-1pin, and ground <=> J8986-3pin on the PWBA MAIN A4 FIN, +24 VDC?	Replace the MOTOR ASSY STACKER.	Go to step 19
19	Checking after replacing the PWBA MAIN A4 FIN. Replace the PWBA MAIN A4 FIN (Refer to Removal 11/ Replacement 1). Does the error still occur when the power is turned off and on?	Replace the PWBA MCU (Refer to Removal 31/ Replacement 32).	End of work.

FIP1.32 012-317: IOT Output Expander Stacker Lower Limit Fail

Step	Check	Yes	No
	Possible causative parts: STACKER NO PAPER SENSOR (PL14.9.10) STACKER HEIGHT SENSOR 1 / 2 (PL14.4.3) MOTOR ASSY STACKER (PL14.9.7) PWBA MAIN A4 FIN (PL14.4.12) HARNESS ASSY SNR2 A4FIN (PL14.11.6) HARNESS ASSY MOT3 A4FIN (PL14.9.25) PWBA MCU (PL10.2.18)		
1	Checking the connectors for connection Check the connections between the PWBA MAIN A4 FIN and STACKER NO PAPER SENSOR. Are P/J8989 and P/J8872 connected surely?	Go to step 3	Reconnect the connector(s) P/J8989 and/or P/J8872 surely, then go to step 2.
2	Does the error still occur when the power is turned off and on?	Go to step 3	End of work.
3	Checking the STACKER NO PAPER SENSOR for operation. Does the number on the screen increase by one, every time the STACKER NO PAPER SENSOR is operated? Checked by [Digital Input] - [012-262] in diagnosis.	Go to step 6	Go to Step 4.
4	Checking the HARNESS ASSY SNR2 A4FIN for continuity Disconnect P/J8989 from the PWBA MAIN A4 FIN. Disconnect P/J8872 from the STACKER NO PAPER SENSOR. Is each cable of P/J8989 <=> P/J8873 continuous?	Go to step 5	Replace the HARNESS ASSY SNR2 A4FIN.
5	Checking the power to STACKER NO PAPER SENSOR. Disconnect the connector of P/J8989 on the PWBA MAIN A4 FIN. Is the voltage between ground and J8989-6A of the PWBA MAIN A4 FIN, +5VDC?	Replace the STACKER NO PAPER SENSOR.	Go to step 23
6	Checking the connectors for connection Check the connections between the PWBA MAIN A4 FIN and STACKER HEIGHT SENSOR 1. Are P/J8989 and P/J8873 connected surely?	Go to step 8	Reconnect the connector(s) P/J8989 and/or P/J8873 surely, then go to step 7.
7	Does the error still occur when the power is turned off and on?	Go to step 8	End of work.
8	Checking the STACKER HEIGHT SENSOR 1 for operation. Does the number on the screen increase by one, every time the STACKER HEIGHT SENSOR-1 is operated? Checked by [Digital Input] - [012-264] in diagnosis.	Go to step 11	Go to Step 9.
9	Checking the HARNESS ASSY SNR2 A4FIN for continuity Disconnect P/J8989 from the PWBA MAIN A4 FIN. Disconnect P/J8873 from the STACKER HEIGHT SENSOR 1. Is each cable of P/J8989 <=> P/J8873 continuous?	Go to step 10	Replace the HARNESS ASSY SNR2 A4FIN.

Step	Check	Yes	No
10	Checking the power to STACKER HEIGHT SENSOR 1. Disconnect the connector of P/J8989 on the PWBA MAIN A4 FIN. Is the voltage between ground and J8989-6B of the PWBA MAIN A4 FIN, +5VDC?	Replace the STACKER HEIGHT SENSOR 1.	Go to step 23
11	Checking the connectors for connection Check the connections between the PWBA MAIN A4 FIN and STACKER HEIGHT SENSOR 2. Are P/J8989 and P/J8874 connected surely?	Go to step 13	Reconnect the connector(s) P/J8989 and/or P/J8874 surely, then go to step 12.
12	Does the error still occur when the power is turned off and on?	Go to step 13	End of work.
13	Checking the STACKER HEIGHT SENSOR 2 for operation. Does the number on the screen increase by one, every time the STACKER HEIGHT SENSOR-2 is operated? Checked by [Digital Input] - [012-265] in diagnosis.	Go to step 16	Go to Step 14.
14	Checking the HARNESS ASSY SNR2 A4FIN for continuity Disconnect P/J8989 from the PWBA MAIN A4 FIN. Disconnect P/J8874 from the STACKER HEIGHT SENSOR 2. Is each cable of P/J8989 <=> P/J8874 continuous?	Go to step 15	Replace the HARNESS ASSY SNR2 A4FIN.
15	Checking the power to STACKER HEIGHT SENSOR 2. Disconnect the connector of P/J8989 on the PWBA MAIN A4 FIN. Is the voltage between ground and J8989-9B of the PWBA MAIN A4 FIN, +5VDC?	Replace the STACKER HEIGHT SENSOR 2.	Go to step 23
16	Checking the connectors for connection Check the connections between the PWBA MAIN A4 FIN and MOTOR ASSY STACKER. Are P/J8986 and P/J8878 connected surely?	Go to step 18	Reconnect the connector(s) P/J8986 and/or P/J8878 surely, then go to step 17
17	Does the error still occur when the power is turned off and on?	Go to step 18	End of work.
18	Checking the MOTOR ASSY STACKER. Does the MOTOR ASSY STACKER function normally? Checked by [Digital Output] - [012-060(UP) and 012-061(DOWN)] in diagnosis..	Go to step 23	Go to step 19
19	Checking the MOTOR ASSY STACKER for installation Is the MOTOR ASSY STACKER installed correctly?	Go to step 21	Reseat the MOTOR ASSY STACKER, then go to step 20.
20	Does the error still occur when the power is turned off and on?	Go to step 21	End of work.
21	Checking the HARNESS ASSY MOT3 A4FIN for continuity Disconnect P/J8986 from the PWBA MAIN A4 FIN. Disconnect P/J8878 from the MOTOR ASSY STACKER. Is each cable of P/J8986 <=> P/J8878 continuous?	Go to step 22	Replace the HARNESS ASSY MOT3 A4FIN.

Step	Check	Yes	No
22	Checking the power to MOTOR ASSY STACKER. Disconnect the connector of P/J8986 on the PWBA MAIN A4 FIN. Are the voltages across ground \leftrightarrow J8986-1pin, and ground \leftrightarrow J8986-3pin on the PWBA MAIN A4 FIN, +24 VDC?	Replace the MOTOR ASSY STACKER.	Go to step 23
23	Checking after replacing the PWBA MAIN A4 FIN. Replace the PWBA MAIN A4 FIN (Refer to Removal 11/ Replacement 1). Does the error still occur when the power is turned off and on?	Replace the PWBA MCU (Refer to Removal 31/ Replacement 32).	End of work.

FIP1.33 012-349 / 012-370: IOT Output Expander Eject Clamp Home Sensor On / Off Fail

Step	Check	Yes	No
	Possible causative parts: EJECT CLAMP HOME SENSOR (PL14.4.3) MOTOR ASSY EJECT (PL14.5.6) PWBA MAIN A4 FIN (PL14.4.12) HARNESS ASSY SNR2 A4FIN (PL14.11.6) HARNESS ASSY MOT2 A4FIN (PL14.11.4) PWBA MCU (PL10.2.18)		
1	Checking the Eject clamp for operation Does the eject clamp mechanism move smoothly? Check this item by moving it with your fingers.	Go to step 2	Remove obstacles.
2	Checking the EJECT CLAMP UP/DOWN. Does the EJECT CLAMP UP/DOWN function normally? Checked by [Digital Output] - [012-052(UP) and 012-053 (DOWN)] in diagnosis.	Go to Step 10	Go to Step 3
3	Checking the connectors for connection Check the connections between the PWBA MAIN A4 FIN and MOTOR ASSY EJECT. Are P/J8984 and P/J8878 connected surely?	Go to step 5	Reconnect the connector(s) P/J8984 and/or P/J8878 surely, then go to step 4
4	Does the error still occur when the power is turned off and on?	Go to step 5	End of work.
5	Checking the MOTOR ASSY EJECT for rotation Does the MOTOR ASSY EJECT function normally? Checked by [Digital Output] - [012-054] in diagnosis.	Go to Step 15	Go to step 6
6	Checking the MOTOR ASSY EJECT for installation Is the MOTOR ASSY EJECT installed correctly?	Go to step 8	Reseat the MOTOR ASSY EJECT, then go to step 7.
7	Does the error still occur when the power is turned off and on?	Go to step 8	End of work.
8	Checking the HARNESS ASSY MOT2 A4FIN for continuity Disconnect P/J8984 from the PWBA MAIN A4 FIN. Disconnect P/J8878 from the MOTOR ASSY EJECT. Is each cable of P/J8984 <=> P/J8878 continuous?	Go to step 9	Replace the HARNESS ASSY MOT2 A4FIN.
9	Checking the power to MOTOR ASSY EJECT. Disconnect the connector of P/J8984 on the PWBA MAIN A4 FIN. Are the voltages across ground <=> J8984-5pin, and ground <=> J8984-7pin on the PWBA MAIN A4 FIN, +24 VDC?	Replace the MOTOR ASSY EJECT.	Go to Step 15
10	Checking the connectors for connection Check the connections between the PWBA MAIN A4 FIN and EJECT CLAMP HOME SENSOR. Are P/J8989 and P/J8870 connected surely?	Go to step 12	Reconnect the connector(s) P/J8989 and/or P/J8870 surely, then go to step 11.
11	Does the error still occur when the power is turned off and on?	Go to step 12	End of work.

Step	Check	Yes	No
12	<p>Checking the EJECT CLAMP HOME SENSOR for operation.</p> <p>Does the number on the screen increase by one, every time the EJECT CLAMP HOME SENSOR is operated? Checked by [Digital Input] - [012-250] in diagnosis.</p>	Go to Step 15	Go to Step 13
13	<p>Checking the HARNESS ASSY SNR2 A4FIN for continuity Disconnect P/J8989 from the PWBA MAIN A4 FIN. Disconnect P/J8870 from the EJECT CLAMP HOME SENSOR. Is each cable of P/J8989 <=> P/J8870 continuous?</p>	Go to step 14	Replace the HARNESS ASSY SNR2 A4FIN.
14	<p>Checking the power to EJECT CLAMP HOME SENSOR. Disconnect the connector of P/J8989 on the PWBA MAIN A4 FIN. Is the voltage between ground and J8989-12A of the PWBA MAIN A4 FIN, +5 VDC?</p>	Replace the EJECT CLAMP HOME SENSOR.	Go to Step 15
15	<p>Checking after replacing the PWBA MAIN A4 FIN. Replace the PWBA MAIN A4 FIN (Refer to Removal 11/ Replacement 1). Does the error still occur when the power is turned off and on?</p>	Replace the PWBA MCU (Refer to Removal 31/ Replacement 32).	End of work.

FIP1.34 012-373 / 012-374: IOT Output Expander Set Clamp Home Sensor On / Off Fail

Step	Check	Yes	No
	Possible causative parts: SET CLAMP HOME SENSOR (PL14.4.3) MOTOR ASSY EJECT (PL14.5.6) PWBA MAIN A4 FIN (PL14.4.12) HARNESS ASSY SNR2 A4FIN (PL14.11.6) HARNESS ASSY MOT2 A4FIN (PL14.11.4) PWBA MCU (PL10.2.18)		
1	Checking the Eject clamp block for operation Does the eject clamp mechanism move smoothly? Check this item by moving it with your fingers.	Go to step 2	Remove obstacles.
2	Checking the connectors for connection Check the connections between the PWBA MAIN A4 FIN and SET CLAMP HOME SENSOR. Are P/J8989 and P/J8871 connected surely?	Go to step 4	Reconnect the connector(s) P/J8989 and/or P/J8871 surely, then go to step 3.
3	Does the error still occur when the power is turned off and on?	Go to step 4	End of work.
4	Checking the SET CLAMP HOME SENSOR for operation. Does the number on the screen increase by one, every time the EJECT CLAMP HOME SENSOR is operated? Checked by [Digital Input] - [012-251] in diagnosis.	Go to step 7	Go to Step 5.
5	Checking the HARNESS ASSY SNR2 A4FIN for continuity Disconnect P/J8989 from the PWBA MAIN A4 FIN. Disconnect P/J8871 from the SET CLAMP HOME SENSOR. Is each cable of P/J8989 <=> P/J8871 continuous?	Go to step 6	Replace the HARNESS ASSY SNR2 A4FIN.
6	Checking the power to SET CLAMP HOME SENSOR. Disconnect the connector of P/J8989 on the PWBA MAIN A4 FIN. Is the voltage between ground and J8989-3B of the PWBA MAIN A4 FIN, +5VDC?	Replace the SET CLAMP HOME SENSOR.	Go to step 21
7	Checking the connectors for connection Check the connections between the PWBA MAIN A4 FIN and MOTOR ASSY EXIT. Are P/J8984 and P/J8878 connected surely?	Go to step 9	Reconnect the connector(s) P/J8984 and/or P/J8878 surely, then go to step 8
8	Does the error still occur when the power is turned off and on?	Go to step 9	End of work.
9	Checking the MOTOR ASSY EXIT. Does the MOTOR ASSY EXIT function normally? Checked by [Digital Output] - [012-054] in diagnosis.	Go to step 14	Go to step 10
10	Checking the MOTOR ASSY EXIT for installation Is the MOTOR ASSY STACKER installed correctly?	Go to step 12	Reseat the MOTOR ASSY EXIT, then go to step 11.
11	Does the error still occur when the power is turned off and on?	Go to step 12	End of work.

Step	Check	Yes	No
12	Checking the HARNESS ASSY MOT2 A4FIN for continuity Disconnect P/J8983 from the PWBA MAIN A4 FIN. Disconnect P/J8891 from the MOTOR ASSY EXIT. Is each cable of P/J8986 <=> P/J8878 continuous?	Go to step 13	Replace the HARNESS ASSY MOT2 A4FIN.
13	Checking the power to MOTOR ASSY EXIT. Disconnect the connector of P/J8986 on the PWBA MAIN A4 FIN. Are the voltages across ground <=> J8986-1pin, and ground <=> J8986-3pin on the PWBA MAIN A4 FIN, +24 VDC?	Replace the MOTOR ASSY EXIT.	Go to step 21
14	Checking the connectors for connection Check the connections between the PWBA MAIN A4 FIN and CLUTCH Z34. Are P/J8984 and P/J8877 connected surely?	Go to step 16	Reconnect the connector(s) P/J8984 and/or P/J8877 surely, then go to step 15
15	Does the error still occur when the power is turned off and on?	Go to step 16	End of work.
16	Checking the CLUTCH Z34 (Set Clamp Clutch). Does the CLUTCH Z34 function normally? Checked by [Digital Output] - [012-050] in diagnosis.	Go to step 21	Go to step 17
17	Checking the CLUTCH Z34 for installation Is the CLUTCH Z34 installed correctly?	Go to step 19	Reseat the CLUTCH Z34, then go to step 18.
18	Does the error still occur when the power is turned off and on?	Go to step 19	End of work.
19	Checking the HARNESS ASSY MOT2 A4FIN for continuity Disconnect P/J8984 from the PWBA MAIN A4 FIN. Disconnect P/J8877 from the MOTOR ASSY EXIT. Is each cable of P/J8984 <=> P/J8877 continuous?	Go to step 20	Replace the HARNESS ASSY MOT2 A4FIN.
20	Checking the power to CLUTCH Z34. Disconnect the connector of P/J8986 on the PWBA MAIN A4 FIN. Are the voltages across ground <=> J8984-3pin on the PWBA MAIN A4 FIN, +24 VDC?	Replace the CLUTCH Z34.	Go to step 21
21	Checking after replacing the PWBA MAIN A4 FIN. Replace the PWBA MAIN A4 FIN (Refer to Removal 11/ Replacement 1). Does the error still occur when the power is turned off and on?	Replace the PWBA MCU (Refer to Removal 31/ Replacement 32).	End of work.

FIP1.35 012-381: IOT Output Expander Stapler Fail

Step	Check	Yes	No
	Possible causative parts: STAPLER ASSY(STAPLE HOME SENSOR) (PL14.8.20) MOTOR ASSY EJECT (PL14.5.6) PWBA MAIN A4 FIN (PL14.4.12) HARNESS ASSY SNR1 A4FIN (PL14.11.5) HARNESS ASSY MOT1 A4FIN (PL14.11.3) PWBA MCU (PL10.2.18)		
1	Checking the connectors for connection Check the connections between the PWBA MAIN A4 FIN and STAPLE HOME SENSOR. Are P/J8988 and P/J8886 connected surely?	Go to step 3	Reconnect the connector(s) P/J8988 and/or P/J8886 surely, then go to step 2.
2	Does the error still occur when the power is turned off and on?	Go to step 3	End of work.
3	Checking the STAPLE HOME SENSOR for operation. Does the number on the screen increase by one, every time the STAPLE HOME SENSOR is operated? Checked by [Digital Input] - [012-244] in diagnosis.	Go to step 6	Go to Step 4.
4	Checking the HARNESS ASSY SNR1 A4FIN for continuity Disconnect P/J8988 from the PWBA MAIN A4 FIN. Disconnect P/J8886 from the STAPLE HOME SENSOR. Is each cable of P/J8988 <=> P/J8886 continuous?	Go to step 5	Replace the HARNESS ASSY SNR1 A4FIN.
5	Checking the power to STAPLE HOME SENSOR. Disconnect the connector of P/J8988 on the PWBA MAIN A4 FIN. Is the voltage between ground and J8988-10 of the PWBA MAIN A4 FIN, +5VDC?	Replace the STAPLE HOME SENSOR.	Go to step 13
6	Checking the connectors for connection Check the connections between the PWBA MAIN A4 FIN and STAPLER MOTOR. Are P/J8983 and P/J8887 connected surely?	Go to step 8	Reconnect the connector(s) P/J8983 and/or P/J8887 surely, then go to step 7
7	Does the error still occur when the power is turned off and on?	Go to step 8	End of work.
8	Checking the STAPLER MOTOR. Does the STAPLER MOTOR function normally? Checked by [Digital Output] - [012-046(Forward) and 012-047(Reverse)] in diagnosis.	Go to step 13	Go to step 9
9	Checking the STAPLER MOTOR for installation Is the STAPLER MOTOR installed correctly?	Go to step 11	Reseat the STAPLER MOTOR, then go to step 10.
10	Does the error still occur when the power is turned off and on?	Go to step 11	End of work.

Step	Check	Yes	No
11	Checking the HARNESS ASSY MOT1 A4FIN for continuity Disconnect P/J8983 from the PWBA MAIN A4 FIN. Disconnect P/J8887 from the STAPLER MOTOR. Is each cable of P/J8983 <=> P/J8887 continuous?	Go to step 13	Replace the HARNESS ASSY MOT1 A4FIN.
12	Checking the power to STAPLER MOTOR. Disconnect the connector of P/J8983 on the PWBA MAIN A4 FIN. Are the voltages across ground <=> J8983-1pin, and ground <=> J8983-2pin on the PWBA MAIN A4 FIN, +24 VDC?	Replace the STAPLER MOTOR.	Go to step 13
13	Checking after replacing the PWBA MAIN A4 FIN. Replace the PWBA MAIN A4 FIN (Refer to Removal 11/ Replacement 1). Does the error still occur when the power is turned off and on?	Replace the PWBA MCU (Refer to Removal 31/ Replacement 32).	End of work.

FIP1.36 016-300 / 016-301 / 016-302 / 016-313 / 016-315 / 016-317 / 016-323 / 016-324 /
016-325 / 016-327 / 016-392 / 016-393 / 016-394: ESS Error

Step	Check	Yes	No
	Possible causative parts: PWBA ESS (PL10.1.6) PWBA MCU (PL10.2.18)		
1	Check the Firmware Version. The version of the firmware for the printer should be checked with the Printer Information of the Web Tool. The latest Firmware Version should be checked on the Dell Support Web site. Is the firmware the latest version?	Go to Step 2	Download the latest version of the firmware from the Dell Support Web site, then go to step 2.
2	Does the error still occur when the power is turned off and on?	Go to Step 3	End of work
3	Checking after reseating the PWBA ESS. Reseat the PWBA ESS. Does the error still occur when the power is turned off and on?	Go to Step 4	End of work
4	Checking after replacing the PWBA ESS. Replace the PLATE ASSY ESS (Refer to Removal 30/ Replacement 33) Does the error still occur when the power is turned off and on?	Replace the PWBA MCU (Refer to Removal 31/ Replacement 32).	End of work

FIP1.37 016-340 / 016-344 / 016-345 / 016-346 / 016-347: ESS Error

Step	Check	Yes	No
	Possible causative parts: PWBA ESS (PL10.1.6) PWBA MCU (PL10.2.18)		
1	Checking after reseating the PWBA ESS. Reseat the PWBA ESS. Does the error still occur when the power is turned off and on?	Go to step 2.	End of work
2	Checking after replacing the PWBA ESS. Replace the PLATE ASSY ESS (Refer to Removal 30/ Replacement 33) Does the error still occur when the power is turned off and on?	Replace the PWBA MCU (Refer to Removal 31/ Replacement 32).	End of work

FIP1.38 016-312: ESS Hard Disk Fail

Step	Check	Yes	No
	Possible causative parts: HDD ASSY (PL10.1.23) PWBA ESS (PL10.1.6)		
1	Checking the HDD ASSY (OPTION). Is the HDD ASSY (OPTION) for 5130 cdn installed?	Go to Step 2	Install the OPTION HDD ASSY for 5130 cdn.
2	Checking the HDD ASSY (OPTION) for installation. Reseat the HDD ASSY (OPTION). Does the error still occur when the power is turned off and on?	Go to Step 3	End of work
3	Checking after replacing the HDD ASSY (OPTION). Replace the HDD ASSY (OPTION). (Refer to Removal 63/ Replacement 65) Does the error still occur when the power is turned off and on?	Replace the PLATE ASSY ESS (Refer to Removal 30/ Replacement 33)	End of work

FIP1.39 016-316 / 016-318: ESS DIMM Slot RAM R/W Check Fail / ESS DIMM Slot RAM Error

Step	Check	Yes	No
	Possible causative parts: MEMORY CARD 1G (PL10.1.24) PWBA ESS (PL10.1.6)		
1	Checking the MEMORY CARD (OPTION). Is the MEMORY CARD (OPTION) for 5130 cdn installed? Note: The PPID No. of the MEMORY CARD (OPTION) for 5130 cdn is as follows: - MEMORY CARD (OPTION) PPID No.: 0T226N	Go to Step 2	Install the OPTION MEMORY CARD for 5130 cdn.
2	Checking the MEMORY CARD (OPTION) for installation. Reseat the MEMORY CARD (OPTION). Does the error still occur when the power is turned off and on?	Go to Step 3	End of work
3	Checking after replacing the MEMORY CARD (OPTION). Replace the MEMORY CARD (OPTION). (Refer to Removal 64/ Replacement 64) Does the error still occur when the power is turned off and on?	Replace the PLATE ASSY ESS (Refer to Removal 30/ Replacement 33)	End of work

FIP1.40 016-319 / 016-320: Encryption key error/ Encryption setting error

Step	Check	Yes	No
	Possible causative parts: HDD ASSY (PL10.1.23) PWBA ESS (PL10.1.6)		
1	Checking the HDD ASSY (OPTION) for installation. Reseat the HDD ASSY (OPTION). Does the error still occur when the power is turned off and on?	Go to Step 2	End of work
2	Checking after replacing the HDD ASSY (OPTION). Replace the HDD ASSY (OPTION). (Refer to Removal 63/ Replacement 65) Does the error still occur when the power is turned off and on?	Replace the PLATE ASSY ESS (Refer to Removal 30/ Replacement 33)	End of work

FIP1.41 016-338: Option Wireless Adapter Error

Step	Check	Yes	No
	Possible causative parts: PWBA ESS (PL10.1.6)		
1	Checking the connected device to the USB port on the PWBA ESS. Is the WIRELESS ADAPTER (OPTION) connected to the USB port on the PWBA ESS?	Go to Step 2	Connect the WIRELESS ADAPTER to the USB port on the PWBA ESS.
2	Checking the WIRELESS ADAPTER (OPTION) for installation. Reseat the WIRELESS ADAPTER (OPTION). Does the error still occur when the power is turned off and on?	Go to Step 3	End of work
3	Checking after replacing the WIRELESS ADAPTER (OPTION). Replace the WIRELESS ADAPTER (OPTION). (Refer to Removal 65/ Replacement 63) Does the error still occur when the power is turned off and on?	Replace the PLATE ASSY ESS (Refer to Removal 30/ Replacement 33)	End of work

FIP1.42 016-356: Hard Disk clearing error

Step	Check	Yes	No
	Possible causative parts: HDD ASSY (PL10.1.23) PWBA ESS (PL10.1.6)		
1	Checking the HDD ASSY (OPTION) for installation. Reseat the HDD ASSY (OPTION). Does the error still occur when the power is turned off and on?	Go to Step 2	End of work
2	Checking after replacing the HDD ASSY (OPTION). Replace the HDD ASSY (OPTION). (Refer to Removal 63/ Replacement 65) Does the error still occur when the power is turned off and on?	Replace the PLATE ASSY ESS (Refer to Removal 30/ Replacement 33)	End of work

FIP1.43 016-362 / 016-363 / 016-364 / 016-366 / 016-367 / 016-368: PCI Bus# (0 / 1) Host Bridge Controller Error / PCI Bus# (0 / 1) Error Detected / PCI Error Messages received from Bus#0-Device# (0 / 1)

Step	Check	Yes	No
	Possible causative parts: PWBA ESS (PL10.1.6) PWBA MCU (PL10.2.18)		
1	Check the connection between the printer and the peripheral device (PC or HUB). Is the printer connected with the peripheral device properly?	Go to Step 2	Properly connect the printer to the peripheral device.
2	Checking after the replacement of the cable connecting the printer with the peripheral device. Replace the cable connecting the printer with the peripheral device with a new one. Does the error still occur when the power is turned off and on?	Go to Step 3	End of work
3	Checking after reseating the PWBA ESS. Reseat the PWBA ESS. Does the error still occur when the power is turned off and on?	Go to Step 4	End of work
4	Checking after replacing the PWBA ESS. Replace the PLATE ASSY ESS (Refer to Removal 30/ Replacement 33) Does the error still occur when the power is turned off and on?	Replace the PWBA MCU (Refer to Removal 31/ Replacement 32).	End of work

FIP1.44 016-369: Operator Panel - ESS Communication Fail

Step	Check	Yes	No
	Possible causative parts: CONSOLE ASSY PANEL(PL1.1.1) HARNESS ASSY OPEPANE (PL1.1.2) PWBA ESS (PL10.1.6) PWBA MCU (PL10.2.18)		
1	Checking the connectors for connection Check the connections between the PWBA ESS and CONSOLE PANEL. Are P/J327 and P/J370 connected surely?	Go to step 3	Reconnect the connector(s) P/J327 and/or P/J370 surely, then go to step 2.
2	Does the error still occur when the power is turned off and on?	Go to step 3	End of work.
3	Checking the HARNESS ASSY OPEPANE for continuity Disconnect P/J327 from the PWBA ESS. Disconnect P/J370 from the CONSOLE PANEL. Is each cable of P/J327 <=> P/J370 continuous?	Go to step 4	Replace the HARNESS ASSY OPEPANE.
4	Checking after replacing the CONSOLE ASSY PANEL. Replace the KIT CONSOLE PANEL & HARNESS. (Refer to Removal 45/ Replacement 18) Does the error still occur when the power is turned off and on?	Go to step 5	End of work.
5	Checking after replacing the PWBA ESS. Replace the PLATE ASSY ESS (Refer to Removal 30/ Replacement 33) Does the error still occur when the power is turned off and on?	Replace the PWBA MCU (Refer to Removal 31/ Replacement 32).	End of work

FIP1.45 016-370: MCU-ESS Communication Fail

Step	Check	Yes	No
	Possible causative parts: PWBA ESS (PL10.1.6) PWBA MCU (PL10.2.18)		
1	Checking after reseating the PWBA ESS and PWBA MCU Reseat the PWBA ESS and PWBA MCU. Does the error still occur when the power is turned ON?	Go to Step 2	End of work.
2	Checking after replacing the PWBA ESS. Replace the PLATE ASSY ESS (Refer to Removal 30/ Replacement 33) Does the error still occur when the power is turned off and on?	Replace the PWBA MCU (Refer to Removal 31/ Replacement 32).	End of work

FIP1.46 016-383 / 016-384 / 016-385 / 016-386 / 016-387: Download ID Error / Download Range Error / Download header Error / Download Check Sum Error / Download Format Error

Step	Check	Yes	No
	Possible causative parts: PWBA ESS (PL10.1.6)		
1	Check the Firmware Version. The version of the firmware for the printer should be checked with the Printer Information of the Web Tool. The latest Firmware Version should be checked on the Dell Support Web site. Is the firmware the latest version?	Go to Step 2	Download the latest version of the firmware from the Dell Support Web site, then go to step 2.
2	Does the error still occur when the power is turned off and on?	Go to Step 3	End of work
3	Check the cable between the Printer and PC (or Printer and Hub). Does the cable meet the specifications? - For local printer: USB cable (USB2.0) - For network printer: Ethernet cable (10Base-T/ 100Base-TX)	Go to Step 4	Use a cable that meets the specifications. - For local printer: USB cable (USB2.0) - For network printer: Ethernet cable (10Base-T/ 100Base-TX)
4	Checking cable plug/unplug Plug and unplug the cable. Does the error still occur when the power is turned off and on?	Go to Step 5	End of work.
5	Checking after replacing the Cable. Does the error still occur when the power is turned off and on?	Replace the PLATE ASSY ESS (Refer to Removal 30/ Replacement 33)	End of work.

FIP1.47 016-391: Download Protect Error

Step	Check	Yes	No
	Possible causative parts: PWBA ESS (PL10.1.6)		
1	Check the Firmware Version. The version of the firmware for the printer should be checked with the Printer Information of the Web Tool. The latest Firmware Version should be checked on the Dell Support Web site. Is the firmware the latest version?	Go to Step 2	Download the latest version of the firmware from the Dell Support Web site, then go to step 2.
2	Does the error still occur when the power is turned off and on?	Go to Step 3	End of work
3	Checking after replacing the PWBA ESS. Replace the PLATE ASSY ESS (Refer to Removal 30/ Replacement 33) Does the error still occur when the power is turned off and on?	Replace the PWBA MCU (Refer to Removal 31/ Replacement 32).	End of work.

FIP1.48 016-404 / 016-405 / 016-520 / 016-521 / 016-522 / 016-523 / 016-524 / 016-527:
 Certificate DB access error / Security setting invalid error / Own device certificate
 error / Other device certificate error / Client certificate absence error / Server cer-
 tificate verification error / Server certificate absence error / Certificate DB error

Step	Check	Yes	No
	Possible causative parts: HDD ASSY (PL10.1.23) PWBA ESS (PL10.1.6)		
1	Checking the HDD ASSY (OPTION) for installation. Reseat the HDD ASSY (OPTION). Does the error still occur when the power is turned off and on?	Go to Step 2	End of work
2	Checking after replacing the HDD ASSY (OPTION). Replace the HDD ASSY (OPTION). (Refer to Removal 63/ Replacement 65) Does the error still occur when the power is turned off and on?	Replace the PLATE ASSY ESS (Refer to Removal 30/ Replacement 33)	End of work

FIP1.49 016-531 / 016-532 / 016-533 / 016-534 / 016-535 / 016-536: LDAP Server Error / ColorTrack 3 Error

Step	Check	Yes	No
	Possible causative parts: PWBA MCU (PL10.2.18)		
1	Checking the error. Does the error still occur when the power is turned off and on?	Replace the PWBA MCU (Refer to Removal 31/ Replacement 32).	End of work

FIP1.50 016-541 / 016-542 / 016-543: Wireless certificate error

Step	Check	Yes	No
	Possible causative parts: HDD ASSY (PL10.1.23) PWBA ESS (PL10.1.6)		
1	Checking the HDD ASSY (OPTION) for installation. Reseat the HDD ASSY (OPTION). Does the error still occur when the power is turned off and on?	Go to Step 2	End of work
2	Checking after replacing the HDD ASSY (OPTION). Replace the HDD ASSY (OPTION). (Refer to Removal 63/ Replacement 65) Does the error still occur when the power is turned off and on?	Replace the PLATE ASSY ESS (Refer to Removal 30/ Replacement 33)	End of work

FIP1.51 016-700: Memory Over flow

Step	Check	Yes	No
	Possible causative parts: MEMORY CARD 1G (PL10.1.24)		
1	Checking for memory expansion. Is additional memory installed? Is the additional memory installed properly?	Go to Step 2	Install additional memory. Or, re-install it properly.
2	Checking after setting the Print Mode to "Standard" via the printer driver Set the Print Mode of the printer driver to "Standard". Does the error persist during printing?	Go to Step 3	End of work
3	Deleting the data by executing Clear Storage. Execute "Clear Storage" under [Maintenance] in the Control Panel. Does the error persist during printing?	Divide the print job into parts, and print them in separate sessions.	End of work

FIP1.52 016-720: PDL Error

Step	Check	Yes	No
	Possible causative parts: PWBA ESS (PL10.1.6) PWBA MCU (PL10.2.18)		
1	Checking the printing job Print the small size file (like a Windows test print). Does the error still occur when the power is turned off and on?	Go to Step 2	End of work
2	Checking after reseating the PWBA ESS. Reseat the PWBA ESS. Does the error still occur when the power is turned off and on?	Go to Step 3	End of work
3	Checking after replacing the PWBA ESS. Replace the PLATE ASSY ESS (Refer to Removal 30/ Replacement 33) Does the error still occur when the power is turned off and on?	Replace the PWBA MCU (Refer to Removal 31/ Replacement 32).	End of work

FIP1.53 016-756: Auditron Error (Print prohibited time)

Step	Check	Yes	No
	Possible causative parts: PWBA MCU (PL10.2.18)		
1	Checking the error. Does the error still occur when the power is turned off and on?	Replace the PWBA MCU (Refer to Removal 31/ Replacement 32).	End of work

FIP1.54 016-757: Auditron Error (Invalid User)

Step	Check	Yes	No
	Possible causative parts: PWBA MCU (PL10.2.18)		
1	Checking the error. Does the error still occur when the power is turned off and on?	Replace the PWBA MCU (Refer to Removal 31/ Replacement 32).	End of work

FIP1.55 016-758: Auditron Error (Disabled Function)

Step	Check	Yes	No
	Possible causative parts: PWBA MCU (PL10.2.18)		
1	Checking the error. Does the error still occur when the power is turned off and on?	Replace the PWBA MCU (Refer to Removal 31/ Replacement 32).	End of work

FIP1.56 016-759: Auditron Error (Reached Limit)

Step	Check	Yes	No
	Possible causative parts: PWBA MCU (PL10.2.18)		
1	Checking the error. Does the error still occur when the power is turned off and on?	Replace the PWBA MCU (Refer to Removal 31/ Replacement 32).	End of work

FIP1.57 016-799: Job Environment Violation

Step	Check	Yes	No
	Possible causative parts: PWBA MCU (PL10.2.18)		
1	Checking the error. Does the error still occur when the power is turned off and on?	Replace the PWBA MCU (Refer to Removal 31/ Replacement 32).	End of work

FIP1.58 016-920: Wireless Setting Error Timeout Error

Step	Check	Yes	No
	Possible causative parts: PWBA ESS (PL10.1.6) PWBA MCU (PL10.2.18)		
1	Checking after reseating the PWBA ESS. Reseat the PWBA ESS. Does the error still occur when the power is turned off and on?	Go to step 2.	End of work
2	Checking after replacing the PWBA ESS. Replace the PLATE ASSY ESS (Refer to Removal 30/ Replacement 33) Does the error still occur when the power is turned off and on?	Replace the PWBA MCU (Refer to Removal 31/ Replacement 32).	End of work

FIP1.59 016-921: Wireless Setting Error Download Error

Step	Check	Yes	No
	Possible causative parts: PWBA ESS (PL10.1.6) PWBA MCU (PL10.2.18)		
1	Checking after reseating the PWBA ESS. Reseat the PWBA ESS. Does the error still occur when the power is turned off and on?	Go to step 2.	End of work
2	Checking after replacing the PWBA ESS. Replace the PLATE ASSY ESS (Refer to Removal 30/ Replacement 33) Does the error still occur when the power is turned off and on?	Replace the PWBA MCU (Refer to Removal 31/ Replacement 32).	End of work

FIP1.60 016-922: Wireless Setting Error Session Overlap Error

Step	Check	Yes	No
	Possible causative parts: PWBA ESS (PL10.1.6) PWBA MCU (PL10.2.18)		
1	Checking after reseating the PWBA ESS. Reseat the PWBA ESS. Does the error still occur when the power is turned off and on?	Go to step 2.	End of work
2	Checking after replacing the PWBA ESS. Replace the PLATE ASSY ESS (Refer to Removal 30/ Replacement 33) Does the error still occur when the power is turned off and on?	Replace the PWBA MCU (Refer to Removal 31/ Replacement 32).	End of work

FIP1.61 016-930 / 016-931: USB HOST Error

Step	Check	Yes	No
	Possible causative parts: PWBA ESS (PL10.1.6) PWBA MCU (PL10.2.18)		
1	Checking after reseating the PWBA ESS. Reseat the PWBA ESS. Does the error still occur when the power is turned off and on?	Go to step 2.	End of work
2	Checking after replacing the PWBA ESS. Replace the PLATE ASSY ESS (Refer to Removal 30/ Replacement 33) Does the error still occur when the power is turned off and on?	Replace the PWBA MCU (Refer to Removal 31/ Replacement 32).	End of work

FIP1.62 016-980: Hard Disk Disc Full

Step	Check	Yes	No
	Possible causative parts: HDD ASSY (PL10.1.23)		
1	Checking for HDD (OPTION). Is the HDD (OPTION) installed properly?	Go to Step 2	Re-install the HDD (OPTION) properly.
2	Checking after having set the Print Mode for the Printer driver in "standard" Does the error still occur when the power is turned off and on?	Go to Step 3	End of work
3	Checking after having deleted unnecessary data from the RAM DISK. Execute "Clear Storage" with the Maintenance key on the control panel to delete the data. Does the error still occur when the power is turned off and on?	Divide the print job into several blocks. Then, execute printing on a block by block basis.	End of work

FIP1.63 016-981: Collate Full

Step	Check	Yes	No
	Possible causative parts: MEMORY CARD 1G (PL10.1.24)		
1	Checking for memory expansion. Is additional memory installed? Is the additional memory installed properly?	Go to Step 2	Is additional memory installed? Is the additional memory installed properly?
2	Checking after having deleted unnecessary data from the RAM DISK. Execute "Clear Storage" with the Maintenance key on the control panel to delete the data. Does the error still occur when the power is turned off and on?	Go to Step 3	End of work
3	Try printing using the driver for "5130 cdn PS" on PC. Does the error persist even after retries?	Go to Step 4	End of work
4	Check the versions of the printer driver and firmware. Are the versions of the printer driver and firmware the latest ones? The version of the printer driver should be checked with the printer property. The version of the firmware for the printer should be checked with the Printer Information in the Web Tool. Their latest versions should be checked on the Dell Support Web site.	Go to Step 5.	Download the latest version of the firmware from the Dell Support Web site, then go to step 2.
5	Does the error still occur when the power is turned off and on?	This job cannot be executed.	End of work

FIP1.64 024-338: Video Cable Disconnect

Step	Check	Yes	No
	Possible causative parts: HARNESS ASSY VIDEO (PL11.1.4) PWBA ESS (PL10.1.6) ROS ASSY (PL5.2.1)		
1	Checking the connectors for connection Check the connections between the PWBA ESS and ROS ASSY. Are P/J328 and P/J152 connected surely?	Go to step 3	Reconnect the connector(s) P/J328 and/or P/J152 surely, then go to step 2
2	Does the error still occur when the power is turned off and on?	Go to step 3	End of work.
3	Checking the HARNESS ASSY TN VIDEO for continuity Disconnect P/J328 from the PWBA ESS. Disconnect P/J152 from the ROS ASSY. Is each cable of P/J328 <=> P/J152 continuous?	Go to step 4	Replace the HARNESS ASSY TN VIDEO.
4	Checking the PWBA ESS for installation. Reseat the PWBA ESS Does the error still occur when the power is turned off and on?	Go to step 5	End of work.
5	Checking after replacing the PWBA ESS. Replace the PLATE ASSY ESS (Refer to Removal 30/Replacement 33) Does the error still occur when the power is turned off and on?	Replace the KIT ROS ASSY. (Refer to Removal 39 /Replacement 24)	End of work

FIP1.65 024-339: Serial Cable to MCU Disconnect

Step	Check	Yes	No
	Possible causative parts: HARNESS ASSY ESS PWR (PL11.1.3) PWBA ESS (PL10.1.6) PWBA MCU (PL10.2.18)		
1	Checking the connectors for connection Check the connections between the PWBA ESS and PWBA MCU. Are P/J320 and P/J2 connected surely?	Go to step 3	Reconnect the connector(s) P/J320 and/or P/J2 surely, then go to step 2
2	Does the error still occur when the power is turned off and on?	Go to step 3	End of work.
3	Checking the HARNESS ASSY ESS for continuity Disconnect P/J320 from the PWBA ESS. Disconnect P/J2 from the PWBA MCU. Is each cable of P/J320 <=> P/J2 continuous?	Go to step 4	Replace the HARNESS ASSY ESS.
4	Checking the PWBA ESS for installation. Reseat the PWBA ESS Does the error still occur when the power is turned off and on?	Go to step 5	End of work.
5	Checking after replacing the PWBA ESS. Replace the PLATE ASSY ESS (Refer to Removal 30/ Replacement 33) Does the error still occur when the power is turned off and on?	Replace the PWBA MCU (Refer to Removal 31/ Replacement 32).	End of work

FIP1.66 024-362: IOT Start Image Marking Timeout

Step	Check	Yes	No
	Possible causative parts: PWBA ESS (PL10.1.6) PWBA MCU (PL10.2.18)		
1	Checking after reseating the PWBA ESS. Reseat the PWBA ESS. Does the error still occur when the power is turned off and on?	Go to step 2.	End of work
2	Checking after replacing the PWBA ESS. Replace the PLATE ASSY ESS (Refer to Removal 30/ Replacement 33) Does the error still occur when the power is turned off and on?	Replace the PWBA MCU (Refer to Removal 31/ Replacement 32).	End of work

FIP1.67 024-910 / 024-911 / 024-912 / 024-913 / 024-915: IOT Paper Size Mismatch

Step	Check	Yes	No
	Possible causative parts: ACTUATOR SIZE (PL2.1.14 / PL12.5.14 / PL13.6.14) ACTUATOR GUIDE END (PL2.1.13 / PL12.5.13 / PL13.6.13) SWITCH ASSY SIZE SENSOR (PL3.1.1 / PL12.2.12 / PL13.3.12) HARNESS ASSY LPP/MOT (PL11.2.5) FEEDER ASSY (PL3.2.1) FEEDER ASSY 550 (PL12.1.2) FEEDER ASSY 1100 (PL3.1.2) PWBA MCU (PL10.2.18)		
1	Check the shapes of the ACTUATOR SIZE and ACTUATOR GUIDE END. Do the ACTUATOR SIZE and ACTUATOR GUIDE END move smoothly? Do they have any damage?	Replace the TRAY ASSY. or Replace the TRAY ASSY OPTION.	Go to step 2
2	Checking the connectors for connection Check the connections between the PWBA MCU and SWITCH ASSY SIZE SENSOR. Are P/J18 and P/J219 of Tray 1 connected surely? NOTE: For Trays 2 to 5, make sure that the connectors P/J353 and P/J365 are securely engaged.	Go to step 4	Reconnect the connector surely, then go to step 3.
3	Does the error still occur when the power is turned off and on?	Go to step 4	End of work.
4	Checking the SWITCH ASSY SIZE SENSOR for operation. Does the number on the screen increase by one, every time the SWITCH ASSY SIZE SENSOR is operated? Checked by [Digital Input] - [Tray1: 071-108 to 110, Tray2: 071-117 to 119, Tray3: 071-126 to 128, Tray4: 071-135 to 137, Tray5: 071-144 to 146] in diagnosis.	Go to step 6	Go to Step 5
5	Checking the HARNESS ASSY LPP/MOT for continuity Disconnect P/J18 from the PWBA MCU. Disconnect P/J219 from the SWITCH ASSY SIZE SENSOR. Is each cable of P/J18 <=> P/J219 continuous? NOTE: For Trays 2 to 5, check the continuity of the HARNESS ASSY OPT SW. Check the connectors P/J353 and P/J365 for continuity.	Replace the SWITCH ASSY SIZE. (Refer to Removal 15/ Replacement 48)	Replace the HARNESS ASSY LPP/MOT or HARNESS ASSY OPT SW.
6	Checking after replacing the FEEDER ASSY.(or FEEDER ASSY 550/1100.) Replace the FEEDER ASSY. (Refer to Removal 29/ Replacement 66) (or Replace the FEEDER ASSY 550/ 1100. (Refer to Removal 66(68)/ Replacement 67(69)) Does the error still occur when the power is turned off and on?	Replace the PWBA MCU (Refer to Removal 31/ Replacement 32).	End of work.

FIP1.68 024-914: IOT Paper Size Mismatch

Step	Check	Yes	No
	Possible causative parts: ACTUATOR REGI SNR (PL3.3.20) REGI SENSOR (PL3.3.22) HARNESS ASSY REGI SNR (PL3.3.23) PWBA MCU (PL10.2.18)		
1	Checking the connectors for connection Check the connections between the PWBA MCU and REGI SENSOR. Are P/J10 and P/J105 connected surely?	Go to step 3	Reconnect the connector surely, then go to step 2.
2	Does the error still occur when the power is turned off and on?	Go to step 3	End of work.
3	Checking the REGI SENSOR for operation. Does the number on the screen increase by one, every time the REGI SENSOR is operated? Checked by [Digital Input] - [071-101] in diagnosis.	Replace the PWBA MCU (Refer to Removal 31/ Replacement 32).	Go to Step 4
4	Checking the HARNESS ASSY REGI for continuity Disconnect P/J10 from the PWBA MCU. Disconnect P/J105 from the REGI SENSOR. Is each cable of P/J10 <=> P/J105 continuous?	Go to step 5	Replace the HARNESS ASSY REGI SNR.
5	Checking the power to REGI SENSOR. Disconnect the connector of P/J10 on the PWBAMCU. Is the voltage between ground and J10-7 of the PWBAMCU, +3.3VDC?	Replace the REGI SENSOR.	Replace the PWBA MCU (Refer to Removal 31/ Replacement 32).

FIP1.69 024-916 / 024-980: IOT Output Expander Mix Stack Full / IOT Output Expander
Stacker Tray Full

Step	Check	Yes	No
	Possible causative parts: STACKER HEIGHT SENSOR 1 / 2 (PL14.4.3) MOTOR ASSY STACKER (PL14.9.7) PWBA MAIN A4 FIN (PL14.4.12) HARNESS ASSY SNR2 A4FIN (PL14.11.6) HARNESS ASSY MOT3 A4FIN (PL14.9.25) PWBA MCU (PL10.2.18)		
1	Checking the connectors for connection Check the connections between the PWBA MAIN A4 FIN and STACKER HEIGHT SENSOR 1. Are P/J8989 and P/J8873 connected surely?	Go to step 3	Reconnect the connector(s) P/J8989 and/or P/J8873 surely, then go to step 2.
2	Does the error still occur when the power is turned off and on?	Go to step 3	End of work.
3	Checking the STACKER HEIGHT SENSOR 1 for operation. Does the number on the screen increase by one, every time the STACKER HEIGHT SENSOR-1 is operated? Checked by [Digital Input] - [012-264] in diagnosis.	Go to step 6	Go to Step 4.
4	Checking the HARNESS ASSY SNR2 A4FIN for continuity Disconnect P/J8989 from the PWBA MAIN A4 FIN. Disconnect P/J8873 from the STACKER HEIGHT SENSOR 1. Is each cable of P/J8989 <=> P/J8873 continuous?	Go to step 5	Replace the HARNESS ASSY SNR2 A4FIN.
5	Checking the power to STACKER HEIGHT SENSOR 1. Disconnect the connector of P/J8989 on the PWBA MAIN A4 FIN. Is the voltage between ground and J8989-6B of the PWBA MAIN A4 FIN, +5VDC?	Replace the STACKER HEIGHT SENSOR 1.	Go to step 18
6	Checking the connectors for connection Check the connections between the PWBA MAIN A4 FIN and STACKER HEIGHT SENSOR 2. Are P/J8989 and P/J8874 connected surely?	Go to step 8	Reconnect the connector(s) P/J8989 and/or P/J8874 surely, then go to step 7.
7	Does the error still occur when the power is turned off and on?	Go to step 8	End of work.
8	Checking the STACKER HEIGHT SENSOR 2 for operation. Does the number on the screen increase by one, every time the STACKER HEIGHT SENSOR-2 is operated? Checked by [Digital Input] - [012-265] in diagnosis.	Go to step 11	Go to Step 9.
9	Checking the HARNESS ASSY SNR2 A4FIN for continuity Disconnect P/J8989 from the PWBA MAIN A4 FIN. Disconnect P/J8874 from the STACKER HEIGHT SENSOR 2. Is each cable of P/J8989 <=> P/J8874 continuous?	Go to step 10	Replace the HARNESS ASSY SNR2 A4FIN.

Step	Check	Yes	No
10	Checking the power to STACKER HEIGHT SENSOR 2. Disconnect the connector of P/J8989 on the PWBA MAIN A4 FIN. Is the voltage between ground and J8989-9B of the PWBA MAIN A4 FIN, +5VDC?	Replace the STACKER HEIGHT SENSOR 2.	Go to step 18
11	Checking the connectors for connection Check the connections between the PWBA MAIN A4 FIN and MOTOR ASSY STACKER. Are P/J8986 and P/J8878 connected surely?	Go to step 13	Reconnect the connector(s) P/J8986 and/or P/J8878 surely, then go to step 12
12	Does the error still occur when the power is turned off and on?	Go to step 13	End of work.
13	Checking the MOTOR ASSY STACKER. Does the MOTOR ASSY STACKER function normally? Checked by [Digital Output] - [012-060(UP) and 012-061(DOWN)] in diagnosis..	Go to step 18	Go to step 14
14	Checking the MOTOR ASSY STACKER for installation Is the MOTOR ASSY STACKER installed correctly?	Go to step 16	Reseat the MOTOR ASSY STACKER, then go to step 15.
15	Does the error still occur when the power is turned off and on?	Go to step 16	End of work.
16	Checking the HARNESS ASSY MOT3 A4FIN for continuity Disconnect P/J8983 from the PWBA MAIN A4 FIN. Disconnect P/J8891 from the MOTOR ASSY STACKER. Is each cable of P/J8986 <=> P/J8878 continuous?	Go to step 17	Replace the HARNESS ASSY MOT3 A4FIN.
17	Checking the power to MOTOR ASSY STACKER. Disconnect the connector of P/J8986 on the PWBA MAIN A4 FIN. Are the voltages across ground <=> J8986-1pin, and ground <=> J8986-3pin on the PWBA MAIN A4 FIN, +24 VDC?	Replace the MOTOR ASSY STACKER.	Go to step 18
18	Checking after replacing the PWBA MAIN A4 FIN. Replace the PWBA MAIN A4 FIN (Refer to Removal 11/ Replacement 1). Does the error still occur when the power is turned off and on?	Replace the PWBA MCU (Refer to Removal 31/ Replacement 32).	End of work.

FIP1.70 024-917: IOT Output Expander Stacker Tray Staple Set Over Count

Step	Check	Yes	No
	Possible causative parts: PWBA MAIN A4 FIN (PL14.4.12) PWBA MCU (PL10.2.18)		
1	Checking connectors of the PWBA MAIN A4 FIN connection Are all the connectors connected to the PWBA MAIN A4 FIN connected surely?	Go to step 3.	After reconnecting, go to step 2.
2	Does the error still occur when the power is turned off and on?	Go to step 16	End of work.
3	Checking after replacing the PWBA MAIN A4 FIN. Replace the PWBA MAIN A4 FIN (Refer to Removal 11/ Replacement 1). Does the error still occur when the power is turned off and on?	Replace the PWBA MCU (Refer to Removal 31/ Replacement 32).	End of work.

FIP1.71 024-920: IOT Exit Tray Stacker Full

Step	Check	Yes	No
	Possible causative parts: ACTUATOR FULL STACK (PL7.2.13) FULL STACK SENSOR (PL7.2.10) HARNESS ASSY EXIT (PL11.1.7) PWBA MCU (PL10.2.18)		
1	Check the shape of the ACTUATOR FULL STACK Does the ACTUATOR FULL STACK move smoothly? Does it have any damage?	Go to Step 2.	Replace the ACTUATOR FULL STACK.
2	Checking the connectors for connection Check the connections between the PWBA MCU and FULL STACK SENSOR. Are P/J20 and P/J224 connected surely?	Go to step 4	Reconnect the connector(s) P/J20 and/or P/J224 surely, then go to step 3.
3	Does the error still occur when the power is turned off and on?	Go to step 4	End of work.
4	Checking the FULL STACK SENSOR for operation. Does the number on the screen increase by one, every time the actuator of the FULL STACK SENSOR is operated? Checked by [Digital Input] - [071-102] in diagnosis.	Replace the PWBA MCU (Refer to Removal 31/ Replacement 32).	Go to Step 5.
5	Checking the HARNESS ASSY EXIT for continuity Disconnect P/J20 from the PWBA MCU. Disconnect P/J224 from the FULL STACK SENSOR. Is each cable of P/J20 <=> P/J224 continuous?	Go to step 6	Replace the HARNESS ASSY EXIT.
6	Checking the power to FULL STACK SENSOR. Disconnect the connector of P/J20 on the PWBA MCU. Is the voltage between ground and J20-4 of the PWBA MCU, +3.3VDC?	Replace the FULL STACK SENSOR.	Replace the PWBA MCU (Refer to Removal 31/ Replacement 32).

FIP1.72 024-928: IOT Output Expander Scratch Sheet Compile

Step	Check	Yes	No
	Possible causative parts: REAR TAMPER HOME SENSOR (PL14.8.9) MOTOR ASSY TAMPER (PL14.8.18) PWBA MAIN A4 FIN (PL14.4.12) HARNESS ASSY SNR1 A4FIN (PL14.11.5) HARNESS ASSY MOT1 A4FIN (PL14.11.3) PWBA MCU (PL10.2.18)		
1	Checking the Tamper mechanism for operation. Does the tamper mechanism operate smoothly? Check this item by moving it with your fingers.	Go to Step 2	Replace the TRAY ASSY COMPILE.
2	Checking the connectors for connection Check the connections between the PWBA MAIN A4 FIN and REAR TAMPER HOME SENSOR. Are P/J8988 and P/J8882 connected surely?	Go to step 4	Reconnect the connector(s) P/J8988 and/or P/J8882 surely, then go to step 3.
3	Does the error still occur when the power is turned off and on?	Go to step 4	End of work.
4	Checking the REAR TAMPER HOME SENSOR for operation. Does the number on the screen increase by one, every time the REAR TAMPER HOME SENSOR is operated? Checked by [Digital Input] - [012-221] in diagnosis.	Go to step 7	Go to Step 5.
5	Checking the HARNESS ASSY SNR1 A4FIN for continuity Disconnect P/J8988 from the PWBA MAIN A4 FIN. Disconnect P/J8881 from the REAR TAMPER HOME SENSOR. Is each cable of P/J8988 <=> P/J8882 continuous?	Go to step 6	Replace the HARNESS ASSY SNR1 A4FIN.
6	Checking the power to REAR TAMPER HOME SENSOR. Disconnect the connector of P/J8988 on the PWBA MAIN A4 FIN. Is the voltage between ground and J8988-9 of the PWBA MAIN A4 FIN, +5VDC?	Replace the REAR TAMPER HOME SENSOR.	Go to step 14
7	Checking the connectors for connection Check the connections between the PWBA MAIN A4 FIN and MOTOR ASSY TAMPER (Rear). Are P/J8983 and P/J8891 connected surely?	Go to step 9	Reconnect the connector(s) P/J8983 and/or P/J8883 surely, then go to step 8
8	Does the error still occur when the power is turned off and on?	Go to step 9	End of work.
9	Checking the MOTOR ASSY TAMPER (Rear). Does the MOTOR ASSY TAMPER (Rear) function normally? Checked by [Digital Output] - [012-026 and 012-029] in diagnosis.	Go to step 14	Go to step 10

Step	Check	Yes	No
10	Checking the MOTOR ASSY TAMPER (Rear) for installation Is the MOTOR ASSY EJECT installed correctly?	Go to step 12	Reseat the MOTOR ASSY TAMPER (Rear), then go to step 11.
11	Does the error still occur when the power is turned off and on?	Go to step 12	End of work.
12	Checking the HARNESS ASSY MOT1 A4FIN for continuity Disconnect P/J8983 from the PWBA MAIN A4 FIN. Disconnect P/J8891 from the MOTOR ASSY TAMPER (Rear). Is each cable of P/J8983 <=> P/J8891 continuous?	Go to step 13	Replace the HARNESS ASSY MOT1 A4FIN.
13	Checking the power to MOTOR ASSY TAMPER (Rear). Disconnect the connector of P/J8983 on the PWBA MAIN A4 FIN. Are the voltages across ground <=> J8983-6 pin on the PWBA MAIN A4 FIN, +24 VDC?	Replace the MOTOR ASSY TAMPER (Rear).	Go to step 14
14	Checking after replacing the PWBA MAIN A4 FIN. Replace the PWBA MAIN A4 FIN (Refer to Removal 11/ Replacement 1). Does the error still occur when the power is turned off and on?	Replace the PWBA MCU (Refer to Removal 31/ Replacement 32).	End of work.

FIP1.73 024-946 / 024-947 / 024-948 / 024-949 / 024-950: IOT Tray Detached

Step	Check	Yes	No
	Possible causative parts: ACTUATOR SIZE (PL2.1.14 / PL12.5.14 / PL13.6.14) ACTUATOR GUIDE END (PL2.1.13 / PL12.5.13 / PL13.6.13) SWITCH ASSY SIZE SENSOR (PL3.1.1 / PL12.2.12 / PL13.3.12) HARNESS ASSY LPP/MOT (PL11.2.5) FEEDER ASSY (PL3.2.1) FEEDER ASSY 550 (PL12.1.2) FEEDER ASSY 1100 (PL3.1.2) PWBA MCU (PL10.2.18)		
1	Check the shape of the ACTUATOR SIZE and ACTUATOR GUIDE END Do the ACTUATOR SIZE and ACTUATOR GUIDE END move smoothly? Do they have any damage?	Replace the TRAY ASSY. or Replace the TRAY ASSY OPTION.	Go to step 2
2	Checking the connectors for connection Check the connections between the PWBA MCU and SWITCH ASSY SIZE SENSOR. Are P/J18 and P/J219 of Tray 1 connected surely? NOTE: For Trays 2 to 5, make sure that the connectors P/J353 and P/J365 are securely engaged.	Go to step 4	Reconnect the connector surely, then go to step 3.
3	Does the error still occur when the power is turned off and on?	Go to step 4	End of work.
4	Checking the SWITCH ASSY SIZE SENSOR for operation. Does the number on the screen increase by one, every time the SWITCH ASSY SIZE SENSOR is operated? Checked by [Digital Input] - [Tray1: 071-108 to 110, Tray2: 071-117 to 119, Tray3: 071-126 to 128, Tray4: 071-135 to 137, Tray5: 071-144 to 146] in diagnosis.	Go to step 6	Go to Step 5
5	Checking the HARNESS ASSY LPP/MOT for continuity Disconnect P/J18 from the PWBA MCU. Disconnect P/J219 from the SWITCH ASSY SIZE SENSOR. Is each cable of P/J18 <=> P/J219 continuous? NOTE: For Trays 2 to 5, check the continuity of the HARNESS ASSY OPT SW. Check the connectors P/J353 and P/J365 for continuity.	Replace the SWITCH ASSY SIZE. (Refer to Removal 15/ Replacement 48)	Replace the HARNESS ASSY LPP/MOT or HARNESS ASSY OPT SW.
6	Checking after replacing the FEEDER ASSY.(or FEEDER ASSY 550/1100.) Replace the FEEDER ASSY. (Refer to Removal 29/ Replacement 66) (or Replace the FEEDER ASSY 550/ 1100. (Refer to Removal 66(68)/ Replacement 67(69)) Does the error still occur when the power is turned off and on?	Replace the PWBA MCU (Refer to Removal 31/ Replacement 32).	End of work.

FIP1.74 024-965 / 024-966 / 024-967 / 024-968 / 024-970: IOT No Suitable Paper

Step	Check	Yes	No
	Possible causative parts: ACTUATOR NO PAPER (PL3.2.10 /PL12.4.17/PL13.5.16) ACTUATOR SIZE (PL2.1.14 /PL12.5.14/PL13.6.14) ACTUATOR GUIDE END (PL2.1.13 / PL12.5.13 / PL13.6.13) CST NO PAPER SENSOR (PL3.2.11 / PL12.2.10 / PL13.3.10) FEEDER ASSY (PL3.2.1) HARNESS ASSY REGI SNR (PL3.3.23) HARNESS ASSY OPT SW (PL12.3.11) PWBA MCU (PL10.2.18)		
1	Check the shape of the ACTUATOR NO PAPER. Does the ACTUATOR NO PAPER move smoothly? Does it have any damage?	Replace the ACTUATOR NO PAPER.	Go to step 2
2	Checking the connectors for connection Check the connections between the PWBA MCU and NO PAPER SENSOR. Are P/J10 and P/J110 of Tray 1 connected surely? NOTE: For Trays 2 to 5, make sure that the connectors P/J353 and P/J361 are securely engaged.	Go to step 4	Reconnect the connector surely, then go to step 3.
3	Does the error still occur when the power is turned off and on?	Go to step 4	End of work.
4	Checking the CST NO PAPER SENSOR for operation. Does the number on the screen increase by one, every time the NO PAPER SENSOR is operated? Checked by [Digital Input] - [Tray1: 071-105, Tray2: 071-116, Tray3: 071-125, Tray4: 071-134, Tray5: 071-143] in diagnosis.	Go to step 6	Go to Step 5
5	Checking the HARNESS ASSY REGI SNR(or HARNESS ASSY OPT SW) for continuity Disconnect P/J10 from the PWBA MCU (or PWBA OPT FDR). Disconnect P/J110 from the CST NO PAPER SENSOR. Is each cable of P/J10 <=> P/J110 continuous? NOTE: For Trays 2 to 5, check the continuity of the HARNESS ASSY OPT SW. Check the connectors P/J353 and P/J361 for continuity.	Replace the CST NO PAPER SENSOR.	Replace the HARNESS ASSY REGI SNR or .HARNESSASSY OPT CL.
6	Checking after replacing the FEEDER ASSY. Replace the FEEDER ASSY. (Refer to Removal 29/ Replacement 66) Does the error still occur when the power is turned off and on?	Replace the PWBA MCU (Refer to Removal 31/ Replacement 32).	End of work.

FIP1.75 024-969: IOT No Suitable Paper

Step	Check	Yes	No
	Possible causative parts: ACTUATOR REGI SNR (PL3.3.20) ROLL ASSY REGI RUBBER (PL3.3.10) REGI SENSOR (PL3.3.22) HARNESS ASSY REGI SNR (PL3.3.23) PWBA MCU (PL10.2.18)		
1	Checking the connectors for connection Check the connections between the PWBA MCU and REGI SENSOR. Are P/J10 and P/J105 connected surely?	Go to step 3	Reconnect the connector(s) P/J10 and/or P/J105 surely, then go to step 2.
2	Does the error still occur when the power is turned off and on?	Go to step 3	End of work.
3	Checking the REGI SENSOR for operation. Does the number on the screen increase by one, every time the REGI SENSOR is operated? Checked by [Digital Input] - [071-101] in diagnosis.	Replace the PWBA MCU (Refer to Removal 31/ Replacement 32).	Go to Step 4.
4	Checking the HARNESS ASSY REGI SNR for continuity Disconnect P/J10 from the PWBA MCU. Disconnect P/J105 from the REGI SENSOR. Is each cable of P/J10 <=> P/J105 continuous?	Go to step 5	Replace the HARNESS ASSY REGI SNR.
5	Checking the power to REGI SENSOR. Disconnect the connector of P/J10 on the PWBA MCU. Is the voltage between ground and J10-7 of the PWBA MCU, +3.3VDC?	Replace the REGI SENSOR.	Replace the PWBA MCU (Refer to Removal 31/ Replacement 32).

FIP1.76 024-976: IOT Output Expander Staple NG

Step	Check	Yes	No
	Possible causative parts: STAPLER ASSY (PL14.8.20) PWBA MAIN A4 FIN (PL14.4.12) HARNESS ASSY SNR1 A4FIN (PL14.11.5) HARNESS ASSY MOT1 A4FIN (PL14.11.3) PWBA MCU (PL10.2.18)		
1	Checking the connectors for connection Check the connections between the PWBA MAIN A4 FIN and Staple Motor. Are P/J8983 and P/J8887 connected surely?	Go to step 3	Reconnect the connector(s) P/J8983 and/or P/J8887 surely, then go to step 2
2	Does the error still occur when the power is turned off and on?	Go to step 3	End of work.
3	Checking the STAPLER MOTOR. Does the STAPLER MOTOR function normally? Checked by [Digital Output] - [012-046(Forward) and 012-047(Reverse)] in diagnosis.	Go to step 6	Go to step 4
4	Checking the HARNESS ASSY MOT1 A4FIN for continuity Disconnect P/J8983 from the PWBA MAIN A4 FIN. Disconnect P/J8887 from the Staple Motor. Is each cable of P/J8983 <=> P/J8887 continuous?	Go to step 5	Replace the HARNESS ASSY MOT1 A4FIN.
5	Checking the power to Staple Motor. Disconnect the connector of P/J8983 on the PWBA MAIN A4 FIN. Are the voltages across ground <=> J8983-1pin, and ground <=> J8983-2pin on the PWBA MAIN A4 FIN, +24 VDC?	Replace the MOTOR ASSY STACKER.	Go to step 11
6	Checking the connectors for connection Check the connections between the PWBA MAIN A4 FIN and STAPLE HOME SENSOR. Are P/J8988 and P/J8886 connected surely?	Go to step 8	Reconnect the connector(s) P/J8988 and/or P/J8886 surely, then go to step 7.
7	Does the error still occur when the power is turned off and on?	Go to step 8	End of work.
8	Checking the STAPLE HOME SENSOR for operation. Does the number on the screen increase by one, every time the STAPLE HOME SENSOR is operated? Checked by [Digital Input] - [012-244] in diagnosis.	Go to step 11	Go to Step 9.
9	Checking the HARNESS ASSY SNR1 A4FIN for continuity Disconnect P/J8988 from the PWBA MAIN A4 FIN. Disconnect P/J8886 from the TAPLE HOME SENSOR. Is each cable of P/J8988 <=> P/J8886 continuous?	Go to step 10	Replace the HARNESS ASSY SNR1 A4FIN.
10	Checking the power to STAPLE HOME SENSOR. Disconnect the connector of P/J8988 on the PWBA MAIN A4 FIN. Is the voltage between ground and J8988-10 of the PWBA MAIN A4 FIN, +5VDC?	Replace the STAPLE HOME SENSOR.	Go to step 11

Step	Check	Yes	No
11	Checking after replacing the PWBA MAIN A4 FIN. Replace the PWBA MAIN A4 FIN (Refer to Removal 11/ Replacement 1). Does the error still occur when the power is turned off and on?	Replace the PWBA MCU (Refer to Removal 31/ Replacement 32).	End of work.

FIP1.77 024-977: IOT Output Expander Stapler Error

Step	Check	Yes	No
	Possible causative parts: STAPLER ASSY (PL14.8.20) PWBA MAIN A4 FIN (PL14.4.12) HARNESS ASSY SNR1 A4FIN (PL14.11.5) HARNESS ASSY MOT1 A4FIN (PL14.11.3) PWBA MCU (PL10.2.18)		
1	Checking the connectors for connection Check the connections between the PWBA MAIN A4 FIN and Staple Motor. Are P/J8983 and P/J8887 connected surely?	Go to step 3	Reconnect the connector(s) P/J8983 and/or P/J8887 surely, then go to step 2
2	Does the error still occur when the power is turned off and on?	Go to step 3	End of work.
3	Checking the STAPLER MOTOR. Does the STAPLER MOTOR function normally? Checked by [Digital Output] - [012-046(Forward) and 012-047(Reverse)] in diagnosis.	Go to step 6	Go to step 4
4	Checking the HARNESS ASSY MOT1 A4FIN for continuity Disconnect P/J8983 from the PWBA MAIN A4 FIN. Disconnect P/J8887 from the Staple Motor. Is each cable of P/J8983 <=> P/J8887 continuous?	Go to step 5	Replace the HARNESS ASSY MOT1 A4FIN.
5	Checking the power to Staple Motor. Disconnect the connector of P/J8983 on the PWBA MAIN A4 FIN. Are the voltages across ground <=> J8983-1pin, and ground <=> J8983-2pin on the PWBA MAIN A4 FIN, +24 VDC?	Replace the MOTOR ASSY STACKER.	Go to step 11
6	Checking the connectors for connection Check the connections between the PWBA MAIN A4 FIN and SELF PRINTING SENSOR. Are P/J8988 and P/J8886 connected surely?	Go to step 8	Reconnect the connector(s) P/J8988 and/or P/J8886 surely, then go to step 7.
7	Does the error still occur when the power is turned off and on?	Go to step 8	End of work.
8	Checking the SELF PRINTING SENSOR for operation. Does the number on the screen increase by one, every time the SELF PRINTING SENSOR is operated? Checked by [Digital Input] - [012-243] in diagnosis.	Go to step 11	Go to Step 9.
9	Checking the HARNESS ASSY SNR1 A4FIN for continuity Disconnect P/J8988 from the PWBA MAIN A4 FIN. Disconnect P/J8886 from the SELF PRINTING SENSOR. Is each cable of P/J8988 <=> P/J8886 continuous?	Go to step 10	Replace the HARNESS ASSY SNR1 A4FIN.
10	Checking the power to SELF PRINTING SENSOR. Disconnect the connector of P/J8988 on the PWBA MAIN A4 FIN. Is the voltage between ground and J8988-10 of the PWBA MAIN A4 FIN, +5VDC?	Replace the SELF PRINTING SENSOR.	Go to step 11

Step	Check	Yes	No
11	Checking after replacing the PWBA MAIN A4 FIN. Replace the PWBA MAIN A4 FIN (Refer to Removal 11/ Replacement 1). Does the error still occur when the power is turned off and on?	Replace the PWBA MCU (Refer to Removal 31/ Replacement 32).	End of work.

FIP1.78 024-979: IOT Output Expander Stapler Near Life

Step	Check	Yes	No
	Possible causative parts: STAPLER ASSY (PL14.8.20) PWBA MAIN A4 FIN (PL14.4.12) HARNESS ASSY SNR1 A4FIN (PL14.11.5) PWBA MCU (PL10.2.18)		
1	Checking the connectors for connection Check the connections between the PWBA MAIN A4 FIN and LOW STAPLE SENSOR. Are P/J8988 and P/J8886 connected surely?	Go to step 3	Reconnect the connector(s) P/J8988 and/or P/J8886 surely, then go to step 2.
2	Does the error still occur when the power is turned off and on?	Go to step 3	End of work.
3	Checking the LOW STAPLE SENSOR for operation. Does the number on the screen increase by one, every time the LOW STAPLE SENSOR is operated? Checked by [Digital Input] - [012-242] in diagnosis.	Go to step 6	Go to Step 4.
4	Checking the HARNESS ASSY SNR1 A4FIN for continuity Disconnect P/J8988 from the PWBA MAIN A4 FIN. Disconnect P/J8886 from the LOW STAPLE SENSOR. Is each cable of P/J8988 <=> P/J8886 continuous?	Go to step 5	Replace the HARNESS ASSY SNR1 A4FIN.
5	Checking the power to LOW STAPLE SENSOR. Disconnect the connector of P/J8988 on the PWBA MAIN A4 FIN. Is the voltage between ground and J8988-10 of the PWBA MAIN A4 FIN, +5VDC?	Replace the LOW STAPLE SENSOR.	Go to step 6
6	Checking after replacing the PWBA MAIN A4 FIN. Replace the PWBA MAIN A4 FIN (Refer to Removal 11/ Replacement 1). Does the error still occur when the power is turned off and on?	Replace the PWBA MCU (Refer to Removal 31/ Replacement 32).	End of work.

FIP1.79 024-982: IOT Output Expander Stacker lower Safety Warning

Step	Check	Yes	No
	Possible causative parts: STACKER HEIGHT SENSOR 1 / 2 (PL14.4.3) MOTOR ASSY STACKER (PL14.9.7) PWBA MAIN A4 FIN (PL14.4.12) HARNESS ASSY SNR2 A4FIN (PL14.11.6) HARNESS ASSY MOT3 A4FIN (PL14.9.25) PWBA MCU (PL10.2.18)		
1	Check the area surrounding the Stacker Tray for obstacles. Is there any obstacle in the area surrounding the Stacker Tray?	Remove the obstacles or replace deformed part.	Go to Step 2.
2	Checking the connectors for connection Check the connections between the PWBA MAIN A4 FIN and STACKER HEIGHT SENSOR 1. Are P/J8989 and P/J8873 connected surely?	Go to step 4	Reconnect the connector(s) P/J8989 and/or P/J8873 surely, then go to step 3.
3	Does the error still occur when the power is turned off and on?	Go to step 4	End of work.
4	Checking the STACKER HEIGHT SENSOR 1 for operation. Does the number on the screen increase by one, every time the STACKER HEIGHT SENSOR-1 is operated? Checked by [Digital Input] - [012-264] in diagnosis.	Go to step 7	Go to Step 5.
5	Checking the HARNESS ASSY SNR2 A4FIN for continuity Disconnect P/J8989 from the PWBA MAIN A4 FIN. Disconnect P/J8873 from the STACKER HEIGHT SENSOR 1. Is each cable of P/J8989 <=> P/J8873 continuous?	Go to step 6	Replace the HARNESS ASSY SNR2 A4FIN.
6	Checking the power to STACKER HEIGHT SENSOR 1. Disconnect the connector of P/J8989 on the PWBA MAIN A4 FIN. Is the voltage between ground and J8989-6B of the PWBA MAIN A4 FIN, +5VDC?	Replace the STACKER HEIGHT SENSOR 1.	Go to step 19
7	Checking the connectors for connection Check the connections between the PWBA MAIN A4 FIN and STACKER HEIGHT SENSOR 2. Are P/J8989 and P/J8874 connected surely?	Go to step 9	Reconnect the connector(s) P/J8989 and/or P/J8874 surely, then go to step 8.
8	Does the error still occur when the power is turned off and on?	Go to step 9	End of work.
9	Checking the STACKER HEIGHT SENSOR 2 for operation. Does the number on the screen increase by one, every time the STACKER HEIGHT SENSOR-2 is operated? Checked by [Digital Input] - [012-265] in diagnosis.	Go to step 12	Go to Step 10.

Step	Check	Yes	No
10	Checking the HARNESS ASSY SNR2 A4FIN for continuity Disconnect P/J8989 from the PWBA MAIN A4 FIN. Disconnect P/J8874 from the STACKER HEIGHT SENSOR 2. Is each cable of P/J8989 <=> P/J8874 continuous?	Go to step 11	Replace the HARNESS ASSY SNR2 A4FIN.
11	Checking the power to STACKER HEIGHT SENSOR 2. Disconnect the connector of P/J8989 on the PWBA MAIN A4 FIN. Is the voltage between ground and J8989-9B of the PWBA MAIN A4 FIN, +5VDC?	Replace the STACKER HEIGHT SENSOR 2.	Go to step 19
12	Checking the connectors for connection Check the connections between the PWBA MAIN A4 FIN and MOTOR ASSY STACKER. Are P/J8986 and P/J8878 connected surely?	Go to step 14	Reconnect the connector(s) P/J8986 and/or P/J8878 surely, then go to step 13
13	Does the error still occur when the power is turned off and on?	Go to step 14	End of work.
14	Checking the MOTOR ASSY STACKER. Does the MOTOR ASSY STACKER function normally? Checked by [Digital Output] - [012-060(UP) and 012-061(DOWN)] in diagnosis..	Go to step 19	Go to step 15
15	Checking the MOTOR ASSY STACKER for installation Is the MOTOR ASSY STACKER installed correctly?	Go to step 17	Reseat the MOTOR ASSY STACKER, then go to step 16.
16	Does the error still occur when the power is turned off and on?	Go to step 17	End of work.
17	Checking the HARNESS ASSY MOT3 A4FIN for continuity Disconnect P/J8983 from the PWBA MAIN A4 FIN. Disconnect P/J8891 from the MOTOR ASSY STACKER. Is each cable of P/J8986 <=> P/J8878 continuous?	Go to step 18	Replace the HARNESS ASSY MOT3 A4FIN.
18	Checking the power to MOTOR ASSY STACKER. Disconnect the connector of P/J8986 on the PWBA MAIN A4 FIN. Are the voltages across ground <=> J8986-1pin, and ground <=> J8986-3pin on the PWBA MAIN A4 FIN, +24 VDC?	Replace the MOTOR ASSY STACKER.	Go to step 19
19	Checking after replacing the PWBA MAIN A4 FIN. Replace the PWBA MAIN A4 FIN (Refer to Removal 11/ Replacement 1). Does the error still occur when the power is turned off and on?	Replace the PWBA MCU (Refer to Removal 31/ Replacement 32).	End of work.

FIP1.80 041-347: IOT I/F Failure

Step	Check	Yes	No
	Possible causative parts: HARNESS ASSY ESS PWR (PL11.1.3) PWBA ESS (PL10.1.6) PWBA MCU (PL10.2.18)		
1	Checking the connectors for connection Check the connections between the PWBA ESS and PWBA MCU. Are P/J320 and P/J2 connected surely?	Go to step 3	Reconnect the connector(s) P/J320 and/or P/J2 surely, then go to step 2
2	Does the error still occur when the power is turned off and on?	Go to step 3	End of work.
3	Checking the HARNESS ASSY ESS for continuity Disconnect P/J320 from the PWBA ESS. Disconnect P/J2 from the PWBA MCU. Is each cable of P/J320 <=> P/J2 continuous?	Go to step 4	Replace the HARNESS ASSY ESS.
4	Checking the PWBA ESS for installation. Reseat the PWBA ESS Does the error still occur when the power is turned off and on?	Go to step 5	End of work.
5	Checking after replacing the PWBA ESS. Replace the PLATE ASSY ESS (Refer to Removal 30/ Replacement 33) Does the error still occur when the power is turned off and on?	Replace the PWBA MCU (Refer to Removal 31/ Replacement 32).	End of work

FIP1.81 042-324: IOT Belt Unit Motor Failure

Step	Check	Yes	No
	Possible causative parts: DRIVE ASSY IBT (PL9.1.3) PWBA MCU (PL10.2.18) HARNESS ASSY RH / MOT (PL11.2.3)		
1	Checking the BELT ASSY IBT for installation Is the BELT ASSY IBT installed correctly?	Go to step 3	Reseat the BELT ASSY IBT, then go to step 2.
2	Does the error still occur when the power is turned off and on?	Go to step 3	End of work.
3	Checking the connectors for connection Check the connections between the PWBA MCU and DRIVE ASSY IBT. Are P/J7A and P/J254 connected surely?	Go to step 5	Reconnect the connector(s) P/J7A and/or P/J254 surely, then go to step 4.
4	Does the error still occur when the power is turned off and on?	Go to step 5	End of work.
5	Checking the DRIVE ASSY IBT for rotation Does the DRIVE ASSY IBT function normally? Checked by [Digital Output] - [094-001] in diagnosis.	Replace the PWBA MCU (Refer to Removal 31/ Replacement 32).	Go to step 6
6	Checking the DRIVE ASSY IBT for installation Is the DRIVE ASSY IBT installed correctly?	Go to step 8	Reseat the DRIVE ASSY IBT, then go to step 7.
7	Does the error still occur when the power is turned off and on?	Go to step 8	End of work.
8	Checking the HARNESS ASSY RH / MOT for continuity Disconnect P/J7A from the PWBA MCU. Disconnect P/J254 from the DRIVE ASSY IBT. Is each cable of P/J7A <=> P/J254 continuous?	Go to step 9	Replace the HARNESS ASSY RH / MOT.
9	Checking the power to DRIVE ASSY IBT. Disconnect the connector of P/J7A on the PWBA MCU. Are the voltages across ground <=> J7A-2pin/J7A-4pin on the PWBA MCU, about +24 VDC when the interlock switch (HARN ASSY I/L FRT) is pushed?	Replace the DRIVE ASSY IBT. (Refer to Removal 55/ Replacement 8)	Replace the PWBA MCU (Refer to Removal 31/ Replacement 32).

FIP1.82 042-330: IOT Fuser Fan Failure

Step	Check	Yes	No
	Possible causative parts: FAN FUSER (PL4.1.8) HARNESS ASSY RH / MOT (PL11.2.3) PWBA MCU (PL10.2.18)		
1	Checking the connectors for connection Check the connections between the PWBA MCU and FAN FUSER. Are P/J9 and P/J117 connected surely?	Go to step 3	Reconnect the connector(s) P/J9 and/or P/J117 surely, then go to step 2.
2	Does the error still occur when the power is turned off and on?	Go to step 3	End of work
3	Checking the FAN FUSER Does the FAN FUSER function normally? Checked by [Digital Output] - [010-004] in diagnosis.	Replace the PWBA MCU (Refer to Removal 31/ Replacement 32).	Go to step 4
4	Checking the HARNESS ASSY RH / MOT for continuity Disconnect P/J9 from the PWBA MCU. Disconnect P/J117 from the FAN FUSER. Is each cable of P/J9 <=> P/J117 continuous?	Go to step 5	Replace the HARNESS ASSY RH / MOT.
5	Checking the output power of FAN FUSER. Disconnect P/J9 on the PWBA MCU. Is the voltage across ground <=> J9-7pin on the PWBA MCU, about +24 VDC?	Replace the FAN FUSER (Refer to Removal 10/ Replacement53).	Replace the PWBA MCU (Refer to Removal 31/ Replacement 32).

FIP1.83 042-700 / 142-700: IOT over Heat Stop / IOT over Heat Forced Half Speed

Step	Check	Yes	No
	Possible causative parts: SENSOR HUM (PL5.3.15) HARNESS ASSY ERASE / EXIT (PL11.2.1) PWBA MCU (PL10.2.18)		
1	Checking the connectors for connection Check the connections between the PWBA MCU and SENSOR HUM. Are P/J16 and P/J106 connected surely?	Go to step 3	Reconnect the connector(s) P/J16 and/or P/J106 surely, then go to step 2.
2	Does the error still occur when the power is turned off and on?	Go to step 3	End of work
3	Checking the HARNESS ASSY ERASE / EXIT for continuity Disconnect P/J16 from the PWBA MCU. Disconnect P/J106 from the SENSOR HUM. Is each cable of P/J16 <=> P/J106 continuous?	Go to step 4	Replace the HARNESS ASSY ERASE / EXIT.
4	Checking the output power of SENSOR HUM. Disconnect P/J16 on the PWBA MCU. Is the voltage across ground <=> J16-10pin on the PWBA MCU, about +5VDC?	Replace the SENSOR HUM.	Go to step 5
5	Checking after replacing the PROCON ASSY. Replace the PROCON ASSY. (Refer to Removal 46/ Replacement 17) Does the error still occur when the power is turned off and on?	Replace the PWBA MCU (Refer to Removal 31/ Replacement 32).	End of work.

FIP1.84 046-310: IOT HVPS Error

Step	Check	Yes	No
	Possible causative parts: PWBA HVPS (PL5.2.3) HARNESS ASSY MOS / HV (PL11.2.2) PWBA MCU (PL10.2.18)		
1	Checking the connectors for connection Check the connections between the PWBA MCU and PWBA HVPS. Are P/J13 and P/J331 connected surely?	Go to step 3	Reconnect the connector(s) P/J13 and/or P/J331 surely, then go to step 2
2	Does the error still occur when the power is turned off and on?	Go to step 3	End of work.
3	Checking the HARNESS ASSY MOS / HV for continuity Disconnect P/J13 from the PWBA MCU. Disconnect P/J331 from the PWBA HVPS. Is each cable of P/J13 <=> P/J331 continuous?	Go to step 4	Replace the HARNESS ASSY MOS / HV.
4	Checking after replacing the PWBA HVPS. Replace the PWBA HVPS (Refer to Removal 38/ Replacement 25). Does the error still occur when the power is turned off and on?	Replace the PWBA MCU (Refer to Removal 31/ Replacement 32).	End of work.

FIP1.85 047-216: IOT Option Output Expander Failure

Step	Check	Yes	No
	Possible causative parts: PWBA MAIN A4 FIN (PL14.4.12) FINISHER ASSY (PL14.1.1)		
1	Download the latest version of the firmware from the Dell Support Web Site. Does the error still occur when the power is turned off and on?	Go to step 2.	End of work.
2	Checking after replacing the PWBA MAIN A4 FIN. Replace the PWBA MAIN A4 FIN (Refer to Removal 11/ Replacement 1). Does the error still occur when the power is turned off and on?	Replace the FINISHER ASSY.	End of work.

FIP1.86 047-217: IOT Output Expander I/F Failure

Step	Check	Yes	No
	Possible causative parts: PWBA MAIN A4 FIN (PL14.4.12) FINISHER ASSY (PL14.1.99) PWBA MCU (PL10.2.18)		
1	Checking the connectors for connection Check the connections between the PWBA MAIN A4 FIN and PWBA MCU. Are P/J8990 and CN4 connected surely?	Go to Step 3	Reconnect the connector(s) P/J8990 and/or CN4 surely, then go to step 2.
2	Does the error still occur when the power is turned off and on?	Go to Step 3	End of work.
3	Checking the HARNESS ASSY IF A4FIN for continuity Disconnect P/J8989 from the PWBA MAIN A4 FIN. Disconnect P/J8869 from the PWBA MCU. Is each cable of P/J8990 <=> CN4 continuous?	Go to step 4	Replace the HARNESS ASSY IF A4FIN.
4	Checking after replacing the PWBA MAIN A4 FIN. Replace the PWBA MAIN A4 FIN (Refer to Removal 11/ Replacement 1). Does the error still occur when the power is turned off and on?	Go to Step 5	End of work.
5	Checking after replacing the PWBA MCU. PWBA MCU (Refer to Removal 31/ Replacement 32). Does the error still occur when the power is turned off and	Replace the FINISHER ASSY.	End of work.

FIP1.87 050-101: IOT Remain Zone RH1 JAM

Step	Check	Yes	No
1	Checking the jam location-1 Does the jam occur at the MPF section?	Go to FIP1.87-1.	Go to Step2.
2	Checking the jam location-2 Open the RH Cover to check. Does the jam occur in the upstream vicinity of the Fuser?	Go to FIP1.87-2.	Go to Step3.
3	Checking the jam location-3 Open the RH Cover to check. Does the jam occur in the downstream vicinity of the Fuser?	Go to FIP1.87-3.	Go to Step4.
4	Checking the jam location-4 Open the RH Cover to check. Does the jam occur in the vicinity of the Duplexer section?	Go to FIP1.87-4.	Replace the Printer.

FIP1.87-1 Jam at the MPF section

Step	Check	Yes	No
	Possible causative parts: ROLL ASSY FEED MSI (PL4.2.21) REGI SENSOR (PL3.3.22) DRIVE ASSY PH (PL9.1.4) SOLENOID FEED MSI (PL4.2.32) CLUTCH ASSY TAKE AWAY (PL3.3.12) HARNESS ASSY REGI SNR (PL3.3.23) HARNESS ASSY RH / MOT (PL11.2.3) PWBA MCU (PL10.2.18)		
1	Check the installation and operation of the ROLL ASSY FEED MSI, SEPARATOR ASSY MSI and KIT COVER ASSY MSI. Open the cover of the MSI. Are the ROLL ASSY FEED MSI, SEPARATOR ASSY MSI and KIT COVER ASSY MSI installed properly? Does the ROLL ASSY FEED MSI rotate smoothly without causing fouling?	Go to Step 2	Replace the relevant part.
2	Checking the connectors for connection Check the connections between the PWBA MCU and REGI SENSOR. Are P/J10 and P/J105 connected surely?	Go to step 4	Reconnect the connector(s) P/J10 and/or P/J105 surely, then go to step 3.
3	Does the error still occur when printing?	Go to step 4	End of work.
4	Checking the REGI SENSOR for operation. Does the number on the screen increase by one, every time the REGI SENSOR is operated? Checked by [Digital Input] - [071-101] in diagnosis.	Go to Step 7	Go to Step 5
5	Checking the HARNESS ASSY REGI SNR for continuity Disconnect P/J10 from the PWBA MCU. Disconnect P/J105 from the REGI SENSOR. Is each cable of P/J10 <=> P/J105 continuous?	Go to step 6	Replace the HARNESS ASSY REGI SNR.
6	Checking the power to REGI SENSOR. Disconnect the connector of P/J10 on the PWBA MCU. Is the voltage between ground and J10-7 of the PWBA MCU, +3.3VDC?	Replace the REGI SENSOR.	Replace the PWBA MCU (Refer to Removal 31/ Replacement 32).
7	Checking the connectors for connection Check the connections between the PWBA MCU and DRIVE ASSY PH. Are P/J7B and P/J255 connected surely?	Go to step 9	Reconnect the connector(s) P/J7B and/or P/J255 surely, then go to step 8
8	Does the error still occur when printing?	Go to step 9	End of work.
9	Checking the DRIVE ASSY PH. Does the DRIVE ASSY PH Motor function normally? Checked by [Digital Output] - [071-001] in diagnosis.	Go to step 14.	Go to step 10

Step	Check	Yes	No
10	Checking the DRIVE ASSY PH for installation Is the DRIVE ASSY PH installed correctly?	Go to step 12	Reseat the DRIVE ASSY PH, then go to step 11.
11	Does the error still occur when printing?	Go to step 12	End of work.
12	Checking the HARNESS ASSY RH / MOT for continuity Disconnect P/J7B from the PWBA MCU. Disconnect P/J255 from the DRIVE ASSY PH. Is each cable of P/J7B <=> P/J255 continuous?	Go to step 13	Replace the HARNESS ASSY RH / MOT.
13	Checking the power to DRIVE ASSY PH. Disconnect the connector of P/J7B on the PWBA MCU. Are the voltages across ground <=> J7B-2pin, and ground <=> J7B-4pin on the PWBA MCU, +24 VDC?	Replace the DRIVE ASSY PH. (Refer to Removal 56/ Replacement 7)	Replace the PWBA MCU (Refer to Removal 31/ Replacement 32).
14	Checking the connectors for connection Check the connections between the PWBA MCU and SOLENOID FEED MSI. Are P/J9 and P/J118 connected surely?	Go to step 16	Reconnect the connector(s) P/J9 and/or P/J118 surely, then go to step 15.
15	Does the error still occur when printing?	Go to step 16	End of work.
16	Checking the SOLENOID FEED MSI. Does the SOLENOID FEED MSI function normally? Checked by [Digital Output] - [071-006] in diagnosis.	Go to step 21.	Go to step 17
17	Checking the SOLENOID FEED MSI for installation Is the SOLENOID FEED MSI installed correctly?	Go to step 19	Reseat the SOLENOID FEED MSI, then go to step 18.
18	Does the error still occur when printing?	Go to step 19	End of work.
19	Checking the HARNESS ASSY RH / MOT for continuity Disconnect P/J9 from the PWBA MCU. Disconnect P/J118 from the SOLENOID FEED MSI. Is each cable of P/J9 <=> P/J118 continuous?	Go to step 20	Replace the HARNESS ASSY RH / MOT.
20	Checking the power to SOLENOID FEED MSI. Disconnect the connector of P/J9 on the PWBA MCU. Are the voltages across ground <=> J9-10pin on the PWBA MCU, +24 VDC?	Replace the SOLENOID FEED MSI.	Replace the PWBA MCU (Refer to Removal 31/ Replacement 32).
21	Checking the connectors for connection Check the connections between the PWBA MCU and CLUTCH ASSY TAKE AWAY. Are P/J10 and P/J103 connected surely?	Go to step 23	Reconnect the connector(s) P/J10 and/or P/J103 surely, then go to step 22.
22	Does the error still occur when printing?	Go to step 23	End of work.
23	Checking the CLUTCH ASSY TAKE AWAY. Does the CLUTCH ASSY TAKE AWAY function normally? Checked by [Digital Output] - [071-008] in diagnosis.	Replace the PWBA MCU (Refer to Removal 31/ Replacement 32).	Go to step 24

Step	Check	Yes	No
24	Checking the CLUTCH ASSY TAKE AWAY for installation Is the CLUTCH ASSY TAKE AWAY installed correctly?	Go to step 26	Reseat the CLUTCH ASSY TAKE AWAY, then go to step 25.
25	Does the error still occur when printing?	Go to step 26	End of work.
26	Checking the HARNESS ASSY REGI SNR for continuity Disconnect P/J10 from the PWBA MCU. Disconnect P/J103 from the CLUTCH ASSY TAKE AWAY. Is each cable of P/J10 <=> P/J103 continuous?	Go to step 27	Replace the HARNESS ASSY REGI SNR.
27	Checking the power to CLUTCH ASSY TAKE AWAY. Disconnect the connector of P/J10 on the PWBA MCU. Are the voltages across ground <=> J10-5pin on the PWBA MCU, +24 VDC?	Replace the CLUTCH ASSY TAKE AWAY.	Replace the PWBA MCU (Refer to Removal 31/ Replacement 32).

FIP1.87-2 Jam in the upstream vicinity of the Fuser section

Step	Check	Yes	No
	Possible causative parts: ROLL ASSY REGI RUBBER (PL3.3.10) ROLL REGI METAL (PL3.3.9) ACTUATOR REGI SNR (PL3.3.20) REGI SENSOR (PL3.3.22) CLUTCH ASSY REGI (PL3.3.13) HARNESS ASSY REGI SNR (PL3.3.23) PWBA MCU (PL10.2.18)		
1	Checking the BELT ASSY IBT , ROLL ASSY 2ND BTR and FUSER ASSY for installation Reseat the BELT ASSY IBT, ROLL ASSY 2ND BTR and FUSER ASSY. Does the error still occur when printing? Warning: Start the operation after the FUSER ASSY has cooled down.	Go to Step 2	End of work.
2	Check the installation and operation of the ROLL ASSY REGI RUBBER and ROLL REGI METAL. Is the ROLL ASSY REGI installed properly? Does the ROLL ASSY REGI rotate smoothly without causing fouling?	Go to Step 3	Replace the ROLL ASSY REGI RUBBER or ROLL REGI METAL.
3	Checking the ACTUATOR REGI SNR for shape and operation Are the shape and operation of the ACTUATOR REGI SNR normal?	Go to Step 4	Replace the ACTUATOR REGI SNR.
4	Checking the connectors for connection Check the connections between the PWBA MCU and REGI SENSOR. Are P/J10 and P/J105 connected surely?	Go to step 6	Reconnect the connector(s) P/J10 and/or P/J105 surely, then go to step 5.
5	Does the error still occur when printing?	Go to step 6	End of work.
6	Checking the REGI SENSOR for operation. Does the number on the screen increase by one, every time the REGI SENSOR is operated? Checked by [Digital Input] - [071-101] in diagnosis.	Go to Step 9	Go to Step 7
7	Checking the HARNESS ASSY REGI SNR for continuity Disconnect P/J10 from the PWBA MCU. Disconnect P/J105 from the REGI SENSOR. Is each cable of P/J10 <=> P/J105 continuous?	Go to step 8	Replace the HARNESS ASSY REGI SNR.
8	Checking the power to REGI SENSOR. Disconnect the connector of P/J10 on the PWBA MCU. Is the voltage between ground and J10-7 of the PWBA MCU, +3.3VDC?	Replace the REGI SENSOR.	Replace the PWBA MCU (Refer to Removal 31/ Replacement 32).

Step	Check	Yes	No
9	Checking the connectors for connection Check the connections between the PWBA MCU and CLUTCH ASSY REGI. Are P/J10 and P/J101 connected surely?	Go to step 11	Reconnect the connector(s) P/J10 and/or P/J101 surely, then go to step 10
10	Does the error still occur when printing?	Go to step 11	End of work.
11	Checking the CLUTCH ASSY REGI. Does the CLUTCH ASSY REGI function normally? Checked by [Digital Output] - [071-005] in diagnosis.	Replace the PWBA MCU (Refer to Removal 31/ Replacement 32).	Go to step 12
12	Checking the CLUTCH ASSY REGI for installation Is the CLUTCH ASSY REGI installed correctly?	Go to step 14	Reseat the CLUTCH ASSY REGI, then go to step 13.
13	Does the error still occur when printing?	Go to step 14	End of work.
14	Checking the HARNESS ASSY REGI SNR for continuity Disconnect P/J10 from the PWBA MCU. Disconnect P/J101 from the CLUTCH ASSY REGI. Is each cable of P/J10 <=> P/J101 continuous?	Go to step 15	Replace the HARNESS ASSY REGI SNR.
15	Checking the power to CLUTCH ASSY REGI. Disconnect the connector of P/J10 on the PWBA MCU. Are the voltages across ground <=> J10-1pin on the PWBA MCU, +24 VDC?	Replace the CLUTCH ASSY REGI.	Replace the PWBA MCU (Refer to Removal 31/ Replacement 32).

FIP1.87-3 Jam in the downstream vicinity of the Fuser section

Step	Check	Yes	No
	Possible causative parts: ACTUATOR FUSER SNR (PL7.1.5) FUSER EXIT SENSOR (PL7.1.5) Exit Clutch (PL7.1.5) HARNESS ASSY DISP / FSR (PL11.2.6) HARNESS ASSY FSR (PL7.1.4) PWBA MCU (PL10.2.18)		
1	Checking the BELT ASSY IBT , ROLL ASSY 2ND BTR and FUSER ASSY for installation Reseat the BELT ASSY IBT, ROLL ASSY 2ND BTR and FUSER ASSY. Does the error still occur when the power is turned off and on? Warning: Start the operation after the FUSER ASSY has cooled down.	Go to Step 2	End of work.
2	Checking the ACTUATOR FUSER SNR for shape and operation Are the shape and operation of the ACTUATOR FUSER SNR normal?	Go to Step 3	Replace the ACTUATOR FUSER SNR.
3	Checking the connectors for connection Check the connections between the PWBA MCU and FUSER EXIT SENSOR. Are P/J1 and P/J180-S connected surely?	Go to step 5	Reconnect the connector(s) P/J1 and/or P/J180-S surely, then go to step 4.
4	Does the error still occur when the power is turned off and on?	Go to step 5	End of work.
5	Checking the FUSER EXIT SENSOR for operation. Does the number on the screen increase by one, every time the actuator of the FUSER EXIT SENSOR is operated? Checked by [Digital Input] - [010-202] in diagnosis.	Go to Step 8	Go to Step 6
6	Checking the HARNESS ASSY FSR for continuity Disconnect P/J1 from the PWBA MCU. Disconnect P/J180-S from the FUSER EXIT SENSOR. Is each cable of P/J1 <=> P/J180-S continuous?	Go to step 7	Replace the HARNESS ASSY FSR.
7	Checking the power to FUSER EXIT SENSOR. Disconnect the connector of P/J1 on the PWBA MCU. Is the voltage between ground and J1-4 of the PWBA MCU, +3.3VDC?	Replace the FUSER EXIT SENSOR.	Replace the PWBA MCU (Refer to Removal 31/ Replacement 32).
8	Checking the connectors for connection Check the connections between the PWBA MCU and Exit Clutch. Are P/J20 and P/J116 connected surely?	Go to step 10	Reconnect the connector(s) P/J20 and/or P/J116 surely, then go to step 9
9	Does the error still occur when the power is turned off and on?	Go to step 10	End of work.

Step	Check	Yes	No
10	Checking the Exit Clutch. Does the Exit Clutch function normally? Checked by [Digital Output] - [071-009] in diagnosis.	Replace the PWBA MCU (Refer to Removal 31/ Replacement 32).	Go to step 11
11	Checking the Exit Clutch for installation Is the Exit Clutch installed correctly?	Go to step 13	Reseat the Exit Clutch, then go to step 12.
12	Does the error still occur when the power is turned off and on?	Go to step 13	End of work.
13	Checking the HARNESS ASSY DISP / FSR for continuity Disconnect P/J20 from the PWBA MCU. Disconnect P/J116 from the Exit Clutch. Is each cable of P/J20 <=> P/J116 continuous?	Go to step 14	Replace the HARNESS ASSY DISP / FSR.
14	Checking the power to Exit Clutch. Disconnect the connector of P/J20 on the PWBA MCU. Are the voltages across ground <=> J20-7pin on the PWBA MCU, +24 VDC?	Replace the Exit Clutch.	Replace the PWBA MCU (Refer to Removal 31/ Replacement 32).

FIP1.87-4 Jam in the Duplexer section

Step	Check	Yes	No
	Possible causative parts: ROLL ASSY DUP (PL4.3.10) REGI SENSOR (PL3.3.22) DRIVE ASSY PH (PL9.1.4) CLUTCH ASSY FEED(PL3.2.2) CLUTCH ASSY TAKE AWAY (PL3.3.12) SOLENOID ASSY INVERT (PL7.3.3) HARNESS ASSY REGI SNR (PL3.3.23) HARNESS ASSY RH / MOT (PL11.2.3) HARNESS ASSY DISP / FSR (PL11.2.6) PWBA MCU (PL10.2.18)		
1	Check the installation and operation of the ROLL ASSY DUP. Is the ROLL ASSY DUP installed properly? Does the ROLL ASSY DUP rotate smoothly without causing fouling?	Go to Step 2	Replace the ROLL ASSY DUP.
2	Checking the connectors for connection Check the connections between the PWBA MCU and CLUTCH ASSYDUP. Are P/J9 and P/J120 connected surely?	Go to step 4	Reconnect the connector(s) P/J9 and/or P/J120 surely, then go to step 3.
3	Does the error still occur when the power is turned off and on?	Go to step 4	End of work.
4	Checking the CLUTCH ASSY DUP. Does the CLUTCH ASSY DUP function normally? Checked by [Digital Output] - [071-004] in diagnosis.	Go to step 9.	Go to step 5
5	Checking the CLUTCH ASSY DUP for installation Is the CLUTCH ASSY DUP installed correctly?	Go to step 7	Reseat the CLUTCH ASSY DUP, then go to step 6.
6	Does the error still occur when the power is turned off and on?	Go to step 7	End of work.
7	Checking the HARNESS ASSY RH/MOT for continuity Disconnect P/J9 from the PWBA MCU. Disconnect P/J120 from the CLUTCH ASSY DUP. Is each cable of P/J9 <=> P/J120 continuous?	Go to step 8	Replace the HARNESS ASSY RH/MOT.
8	Checking the power to CLUTCH ASSY DUP. Disconnect the connector of P/J9 on the PWBA MCU. Are the voltages across ground <=> J9-12pin on the PWBA MCU, +24 VDC?	Replace the CLUTCH ASSY DUP.	Replace the PWBA MCU (Refer to Removal 31/ Replacement 32).
9	Checking the connectors for connection Check the connections between the PWBA MCU and DRIVE ASSY PH. Are P/J7B and P/J255 connected surely?	Go to step 11	Reconnect the connector(s) P/J7B and/or P/J255 surely, then go to step 10
10	Does the error still occur when the power is turned off and on?	Go to step 11	End of work.

Step	Check	Yes	No
11	Checking the DRIVE ASSY PH. Does the DRIVE ASSY PH Motor function normally? Checked by [Digital Output] - [071-001] in diagnosis.	Go to step 16.	Go to step 12
12	Checking the DRIVE ASSY PH for installation Is the DRIVE ASSY PH installed correctly?	Go to step 14	Reseat the DRIVE ASSY PH, then go to step 13.
13	Does the error still occur when the power is turned off and on?	Go to step 14	End of work.
14	Checking the HARNESS ASSY RH / MOT for continuity Disconnect P/J7B from the PWBA MCU. Disconnect P/J255 from the DRIVE ASSY PH. Is each cable of P/J7B <=> P/J255 continuous?	Go to step 15	Replace the HARNESS ASSY RH / MOT.
15	Checking the power to DRIVE ASSY PH. Disconnect the connector of P/J7B on the PWBA MCU. Are the voltages across ground <=> J7B-2pin, and ground <=> J7B-4pin on the PWBA MCU, +24 VDC?	Replace the DRIVE ASSY PH. (Refer to Removal 56/ Replacement 7)	Replace the PWBA MCU (Refer to Removal 31/ Replacement 32).
16	Checking the ACTUATOR REGI SNR for shape and operation Are the shape and operation of the ACTUATOR REGI SNR normal?	Go to Step 17	Replace the ACTUATOR REGI SNR.
17	Checking the connectors for connection Check the connections between the PWBA MCU and REGI SENSOR. Are P/J10 and P/J105 connected surely?	Go to step 19	Reconnect the connector(s) P/J10 and/or P/J105 surely, then go to step 18.
18	Does the error still occur when the power is turned off and on?	Go to step 19	End of work.
19	Checking the REGI SENSOR for operation. Does the number on the screen increase by one, every time the REGI SENSOR is operated? Checked by [Digital Input] - [071-101] in diagnosis.	Go to step 21	Go to Step 20
20	Checking the HARNESS ASSY REGI SNR for continuity Disconnect P/J10 from the PWBA MCU. Disconnect P/J105 from the REGI SENSOR. Is each cable of P/J10 <=> P/J105 continuous?	Go to step 21	Replace the HARNESS ASSY REGI SNR.
21	Checking the connectors for connection Check the connections between the PWBA MCU and SOLENOID ASSY INVERT. Are P/J19 and P/J122 connected surely?	Go to step 23	Reconnect the connector(s) P/J19 and/or P/J122 surely, then go to step 22.
22	Does the error still occur when the power is turned off and on?	Go to step 23	End of work.

Step	Check	Yes	No
23	Checking the SOLENOID ASSY INVERT for operation. Does the number on the screen increase by one, every time the SOLENOID ASSY INVERT is operated? Checked by [Digital Output] - [071-013] in diagnosis.	Replace the PWBA MCU (Refer to Removal 31/ Replacement 32).	Go to Step 24
24	Checking the HARNESS ASSY DISP/FSR for continuity Disconnect P/J19 from the PWBA MCU. Disconnect P/J122 from the SOLENOID ASSY INVERT. Is each cable of P/J19 <=> P/J122 continuous?	Go to step 25	Replace the HARNESS ASSY DISP/FSR.
25	Checking the power to SOLENOID ASSY INVERT. Disconnect the connector of P/J19 on the PWBA MCU. Is the voltage between ground and J19-16 of the PWBA MCU, +3.3VDC?	Replace the SOLENOID ASSY INVERT.	Replace the PWBA MCU (Refer to Removal 31/ Replacement 32).

FIP1.88 050-102 / 050-103 / 050-104 / 050-105: IOT Remain Zone RH2 JAM / IOT
Remain Zone RH3 JAM / IOT Remain Zone RH4 JAM / IOT Remain Zone RH5
JAM

Step	Check	Yes	No
	Possible causative parts: ROLL ASSY FEED (PL12.4.24/PL13.5.23) PAPER PATH SENSOR (/PL12.4.3PL13.5.3) DRIVE ASSY OPT (PL12.3.2/PL13.4.2) CLUTCH ASSY FEED(PL12.4.9/PL13.5.9) CLUTCH ASSY TAKE AWAY (PL12.4.5/PL13.5.5) HARNESS ASSY OPT CL (PL12.3.12) HARNESS ASSY OPT MOT (PL12.3.5/PL13.4.6) PWBA OPT FDR (PL12.3.4/PL13.4.5) PWBA MCU (PL10.2.18)		
1	Checking the Optional Paper Cassette (Tray 2, Tray 3, Tray 4 or Tray 5) for installation. Reseat the Optional Paper Cassette (Tray 2, Tray 3, Tray 4 or Tray 5). Does the error still occur when printing?	Go to Step 2	End of work.
2	Check the installation and operation of the relevant ROLL ASSY FEED. Remove the relevant Optional Paper Cassette (Tray 2, Tray 3, Tray 4 or Tray 5). Is the ROLL ASSY FEED installed properly? Does the ROLL ASSY FEED rotate smoothly without causing fouling?	Go to Step 3	Replace the KIT FEED ROLL & SEPARATOR ROLL. (Refer to Removal 50(69)/ Replacement 66(68))
3	Checking the connectors for connection Check the connections between the PWBA OPT FDR and PAPER PATH SENSOR. Are P/J353 and P/J361 connected surely?	Go to step 5	Reconnect the connector(s) P/J353 and/or P/J361 surely, then go to step 4.
4	Does the error still occur when printing?	Go to step 5	End of work.
5	Checking the PAPER PATH SENSOR for operation. Does the number on the screen increase by one, every time the PAPER PATH SENSOR is operated? Checked by [Digital Input] - [071-115(Tray 2) / 071-124(Tray 3) / 071-133(Tray 4) /071-142(Tray 5)] in diagnosis.	Go to Step 8	Go to Step 6
6	Checking the HARNESS ASSY OPT SW for continuity Disconnect P/J353 from the PWBA OPT FDR. Disconnect P/J361 from the PAPER PATH SENSOR. Is each cable of P/J353 <=> P/J361 continuous?	Go to step 7	Replace the HARNESS ASSY OPT SW.
7	Checking the power to PAPER PATH SENSOR. Disconnect the connector of P/J353 on the PWBA OPT FDR. Is the voltage between ground and J353-5 of the PWBA OPT FDR, +3.3VDC?	Replace the PAPER PATH SENSOR.	Go to step 29.

Step	Check	Yes	No
8	Checking the connectors for connection Check the connections between the PWBA OPT FDR and DRIVE ASSY OPT. Are P/J355 and P/J357 connected surely?	Go to step 10	Reconnect the connector(s) P/J355 and/or P/J357 surely, then go to step 9
9	Does the error still occur when printing?	Go to step 10	End of work.
10	Checking the DRIVE ASSY OPT. Does the DRIVE ASSY OPT Motor function normally? Checked by [Digital Output] - [071-014(Tray 2) / 071-019(Tray 3) / 071-024(Tray 4) / 071-029(Tray 5)] in diagnosis.	Go to step 15.	Go to step 11
11	Checking the DRIVE ASSY OPT for installation Is the DRIVE ASSY OPT installed correctly?	Go to step 13	Reseat the DRIVE ASSY OPT, then go to step 12.
12	Does the error still occur when printing?	Go to step 13	End of work.
13	Checking the HARNESS ASSY OPT MOT for continuity Disconnect P/J355 from the PWBA OPT FDR. Disconnect P/J357 from the DRIVE ASSY OPT. Is each cable of P/J355 <=> P/J357 continuous?	Go to step 14	Replace the HARNESS ASSY OPT MOT.
14	Checking the power to DRIVE ASSY OPT. Disconnect the connector of P/J355 on the PWBA OPT FDR. Are the voltages across ground <=> J355-2pin, and ground <=> J355-4pin on the PWBA OPT FDR, +24 VDC?	Replace the DRIVE ASSY OPT.	Go to step 29.
15	Checking the connectors for connection Check the connections between the PWBA OPT FDR and CLUTCH ASSY TAKE AWAY. Are P/J354 and P/J358 connected surely?	Go to step 17	Reconnect the connector(s) P/J354 and/or P/J358 surely, then go to step 16.
16	Does the error still occur when printing?	Go to step 17	End of work.
17	Checking the CLUTCH ASSY TAKE AWAY. Does the CLUTCH ASSY TAKE AWAY function normally? Checked by [Digital Output] - [071-017(Tray 2) / 071-022(Tray 3) / 071-027(Tray 4) / 071-032(Tray 5)] in diagnosis.	Go to step 22.	Go to step 18
18	Checking the CLUTCH ASSY TAKE AWAY for installation Is the CLUTCH ASSY TAKE AWAY installed correctly?	Go to step 20	Reseat the CLUTCH ASSY TAKE AWAY, then go to step 19.
19	Does the error still occur when printing?	Go to step 20	End of work.
20	Checking the HARNESS ASSY OPT CL for continuity Disconnect P/J354 from the PWBA OPT FDR. Disconnect P/J358 from the CLUTCH ASSY TAKE AWAY. Is each cable of P/J354 <=> P/J358 continuous?	Go to step 21	Replace the HARNESS ASSY OPT CL.

Step	Check	Yes	No
21	Checking the power to CLUTCH ASSY TAKE AWAY. Disconnect the connector of P/J354 on the PWBA OPT FDR. Are the voltages across ground <=> J354-1pin on the PWBA OPT FDR, +24 VDC?	Replace the CLUTCH ASSY TAKE AWAY.	Go to step 29.
22	Checking the connectors for connection Check the connections between the PWBA OPT FDR and CLUTCH ASSY FEED. Are P/J354 and P/J359 connected surely?	Go to step 24	Reconnect the connector(s) P/J354 and/or P/J359 surely, then go to step 23.
23	Does the error still occur when printing?	Go to step 24	End of work.
24	Checking the CLUTCH ASSY FEED. Does the CLUTCH ASSY FEED function normally? Checked by [Digital Output] - [071-018(Tray 2 / 071-023(Tray 3) / 071-028(Tray 4 / 071-033(Tray 5))] in diagnosis.	Go to step 29.	Go to step 25
25	Checking the CLUTCH ASSY FEED for installation Is the CLUTCH ASSY FEED installed correctly?	Go to step 27	Reseat the CLUTCH ASSY FEED, then go to step 26.
26	Does the error still occur when printing?	Go to step 27	End of work.
27	Checking the HARNESS ASSY OPT CL for continuity Disconnect P/J354 from the PWBA OPT FDR. Disconnect P/J359 from the CLUTCH ASSY FEED. Is each cable of P/J354 <=> P/J359 continuous?	Go to step 28.	Replace the HARNESS ASSY OPT CL.
28	Checking the power to CLUTCH ASSY FEED. Disconnect the connector of P/J354 on the PWBA OPT FDR. Are the voltages across ground <=> J354-3pin on the PWBA OPT FDR, +24 VDC?	Replace the CLUTCH ASSY FEED.	Go to step 29.
29	Checking after replacing the PWBA OPT FDR. Replace the PWBA OPT FDR. Does the error still occur when printing?	Replace the PWBA MCU (Refer to Removal 31/ Replacement 32).	End of work.

FIP1.89 050-121: IOT Remain Zone 1T JAM

Step	Check	Yes	No
	Possible causative parts: ROLL ASSY FEED (PL3.2.18) REGI SENSOR (PL3.3.22) DRIVE ASSY PH (PL9.1.4) CLUTCH ASSY FEED(PL3.2.2) CLUTCH ASSY TAKE AWAY (PL3.3.12) HARNESS ASSY REGI SNR (PL3.3.23) HARNESS ASSY RH / MOT (PL11.2.3) PWBA MCU (PL10.2.18)		
1	Checking the Paper Cassette(Tray 1) for installation Reseat the paper cassette (Tray 1). Does the error still occur when the power is turned off and on?	Go to Step 2	End of work
2	Check the installation and operation of the ROLL ASSY FEED. Remove the Tray 1. Is the ROLL ASSY FEED installed properly? Does the ROLL ASSY FEED rotate smoothly without causing fouling?	Go to Step 3	Replace the KIT FEED ROLL & SEPARATOR ROLL. (Refer to Removal 13/ Replacement 67)
3	Checking the connectors for connection Check the connections between the PWBA MCU and REGI SENSOR. Are P/J10 and P/J105 connected surely?	Go to step 5	Reconnect the connector(s) P/J10 and/or P/J105 surely, then go to step 4.
4	Does the error still occur when the power is turned off and on?	Go to step 5	End of work.
5	Checking the REGI SENSOR for operation. Does the number on the screen increase by one, every time the REGI SENSOR is operated? Checked by [Digital Input] - [071-101] in diagnosis.	Go to Step 8	Go to Step 6
6	Checking the HARNESS ASSY REGI SNR for continuity Disconnect P/J10 from the PWBA MCU. Disconnect P/J105 from the REGI SENSOR. Is each cable of P/J10 <=> P/J105 continuous?	Go to step 7	Replace the HARNESS ASSY REGI SNR.
7	Checking the power to REGI SENSOR. Disconnect the connector of P/J10 on the PWBA MCU. Is the voltage between ground and J10-7 of the PWBA MCU, +3.3VDC?	Replace the REGI SENSOR.	Replace the PWBA MCU (Refer to Removal 31/ Replacement 32).
8	Checking the connectors for connection Check the connections between the PWBA MCU and DRIVE ASSY PH. Are P/J7B and P/J255 connected surely?	Go to step 10	Reconnect the connector(s) P/J7B and/or P/J255 surely, then go to step 9
9	Does the error still occur when the power is turned off and on?	Go to step 10	End of work.

Step	Check	Yes	No
10	Checking the DRIVE ASSY PH. Does the DRIVE ASSY PH Motor function normally? Checked by [Digital Output] - [071-001] in diagnosis.	Go to step 15.	Go to step 11
11	Checking the DRIVE ASSY PH for installation Is the DRIVE ASSY PH installed correctly?	Go to step 13	Reseat the DRIVE ASSY PH, then go to step 12.
12	Does the error still occur when the power is turned off and on?	Go to step 13	End of work.
13	Checking the HARNESS ASSY RH / MOT for continuity Disconnect P/J7B from the PWBA MCU. Disconnect P/J255 from the DRIVE ASSY PH. Is each cable of P/J7B <=> P/J255 continuous?	Go to step 14	Replace the HARNESS ASSY RH / MOT.
14	Checking the power to DRIVE ASSY PH. Disconnect the connector of P/J7B on the PWBA MCU. Are the voltages across ground <=> J7B-2pin, and ground <=> J7B-4pin on the PWBA MCU, +24 VDC?	Replace the DRIVE ASSY PH. (Refer to Removal 56/ Replacement 7)	Replace the PWBA MCU (Refer to Removal 31/ Replacement 32).
15	Checking the connectors for connection Check the connections between the PWBA MCU and CLUTCH ASSY TAKE AWAY. Are P/J10 and P/J103 connected surely?	Go to step 17	Reconnect the connector(s) P/J10 and/or P/J103 surely, then go to step 16.
16	Does the error still occur when the power is turned off and on?	Go to step 17	End of work.
17	Checking the CLUTCH ASSY TAKE AWAY. Does the CLUTCH ASSY TAKE AWAY function normally? Checked by [Digital Output] - [071-008] in diagnosis.	Go to step 22.	Go to step 18
18	Checking the CLUTCH ASSY TAKE AWAY for installation Is the CLUTCH ASSY TAKE AWAY installed correctly?	Go to step 20	Reseat the CLUTCH ASSY TAKE AWAY, then go to step 19.
19	Does the error still occur when the power is turned off and on?	Go to step 20	End of work.
20	Checking the HARNESS ASSY REGI SNR for continuity Disconnect P/J10 from the PWBA MCU. Disconnect P/J103 from the CLUTCH ASSY TAKE AWAY. Is each cable of P/J10 <=> P/J103 continuous?	Go to step 21	Replace the HARNESS ASSY REGI SNR.
21	Checking the power to CLUTCH ASSY TAKE AWAY. Disconnect the connector of P/J10 on the PWBA MCU. Are the voltages across ground <=> J10-5pin on the PWBA MCU, +24 VDC?	Replace the CLUTCH ASSY TAKE AWAY.	Replace the PWBA MCU (Refer to Removal 31/ Replacement 32).
22	Checking the connectors for connection Check the connections between the PWBA MCU and CLUTCH ASSY FEED. Are P/J10 and P/J102 connected surely?	Go to step 24	Reconnect the connector(s) P/J10 and/or P/J102 surely, then go to step 23.

Step	Check	Yes	No
23	Does the error still occur when the power is turned off and on?	Go to step 24	End of work.
24	Checking the CLUTCH ASSY FEED. Does the CLUTCH ASSY FEED function normally? Checked by [Digital Output] - [071-007] in diagnosis.	Replace the PWBA MCU (Refer to Removal 31/ Replacement 32).	Go to step 25
25	Checking the CLUTCH ASSY FEED for installation Is the CLUTCH ASSY FEED installed correctly?	Go to step 27	Reseat the CLUTCH ASSY FEED, then go to step 26.
26	Does the error still occur when the power is turned off and on?	Go to step 27	End of work.
27	Checking the HARNESS ASSY REGI SNR for continuity Disconnect P/J10 from the PWBA MCU. Disconnect P/J102 from the CLUTCH ASSY FEED. Is each cable of P/J10 <=> P/J102 continuous?	Go to step 28.	Replace the HARNESS ASSY REGI SNR.
28	Checking the power to CLUTCH ASSY FEED. Disconnect the connector of P/J10 on the PWBA MCU. Are the voltages across ground <=> J10-3pin on the PWBA MCU, +24 VDC?	Replace the CLUTCH ASSY FEED.	Replace the PWBA MCU (Refer to Removal 31/ Replacement 32).

FIP1.90 050-122 / 050-123 / 050-124 / 050-125: IOT Remain Zone 2T JAM / IOT Remain Zone 3T JAM / IOT Remain Zone 4T JAM / IOT Remain Zone 5T JAM

Step	Check	Yes	No
	Possible causative parts: ROLL ASSY FEED (PL12.4.24) PAPER PATH SENSOR (/PL12.4.3) DRIVE ASSY OPT (PL12.3.2) CLUTCH ASSY FEED(PL12.4.9) CLUTCH ASSY TAKE AWAY (PL12.4.5) HARNESS ASSY OPT CL (PL12.3.12) HARNESS ASSY OPT MOT (PL12.3.5) PWBA OPT FDR (PL12.3.4) PWBA MCU (PL10.2.18)		
1	Checking the Optional Paper Cassette (Tray 2 Tray 3 , Tray 4 or Tray 5) for installation. Reseat the Optional Paper Cassette (Tray 2 Tray 3 , Tray 4 or Tray 5). Does the error still occur when printing?	Go to Step 2	End of work.
2	Check the installation and operation of the relevant ROLL ASSY FEED. Remove the relevant Optional Paper Cassette (Tray 2 Tray 3 , Tray 4 or Tray 5). Is the ROLL ASSY FEED installed properly? Does the ROLL ASSY FEED rotate smoothly without causing fouling?	Go to Step 3	Replace the KIT FEED ROLL & SEPARATOR ROLL. (Refer to Removal 50/ Replacement 66)
3	Checking the connectors for connection Check the connections between the PWBA OPT FDR and PAPER PATH SENSOR. Are P/J353 and P/J361 connected surely?	Go to step 5	Reconnect the connector(s) P/J353 and/or P/J361 surely, then go to step 4.
4	Does the error still occur when printing?	Go to step 5	End of work.
5	Checking the PAPER PATH SENSOR for operation. Does the number on the screen increase by one, every time the PAPER PATH SENSOR is operated? Checked by [Digital Input] - [071-115 (Tray 2), 071-124 (Tray 3), 071-133 (Tray 4) or 071-142 (Tray 5)] in diagnosis.	Go to Step 8	Go to Step 6
6	Checking the HARNESS ASSY OPT SW for continuity Disconnect P/J353 from the PWBA OPT FDR. Disconnect P/J361 from the PAPER PATH SENSOR. Is each cable of P/J353 <=> P/J361 continuous?	Go to step 7	Replace the HARNESS ASSY OPT SW.
7	Checking the power to PAPER PATH SENSOR. Disconnect the connector of P/J353 on the PWBA OPT FDR. Is the voltage between ground and J353-5 of the PWBA OPT FDR, +3.3VDC?	Replace the PAPER PATH SENSOR.	Go to step 29.

Step	Check	Yes	No
8	Checking the connectors for connection Check the connections between the PWBA OPT FDR and DRIVE ASSY OPT. Are P/J355 and P/J357 connected surely?	Go to step 10	Reconnect the connector(s) P/J355 and/or P/J357 surely, then go to step 9
9	Does the error still occur when printing?	Go to step 10	End of work.
10	Checking the DRIVE ASSY OPT. Does the DRIVE ASSY OPT Motor function normally? Checked by [Digital Output] - [071-014 (Tray 2), 071-019 (Tray 3), 071-024 (Tray 4) or 071-029 (Tray 5)] in diagnosis.	Go to step 15.	Go to step 11
11	Checking the DRIVE ASSY OPT for installation Is the DRIVE ASSY OPT installed correctly?	Go to step 13	Reseat the DRIVE ASSY OPT, then go to step 12.
12	Does the error still occur when printing?	Go to step 13	End of work.
13	Checking the HARNESS ASSY OPT MOT for continuity Disconnect P/J355 from the PWBA OPT FDR. Disconnect P/J357 from the DRIVE ASSY OPT. Is each cable of P/J355 <=> P/J357 continuous?	Go to step 14	Replace the HARNESS ASSY OPT MOT.
14	Checking the power to DRIVE ASSY OPT. Disconnect the connector of P/J355 on the PWBA OPT FDR. Are the voltages across ground <=> J355-2pin, and ground <=> J355-4pin on the PWBA OPT FDR, +24 VDC?	Replace the DRIVE ASSY OPT.	Go to step 29.
15	Checking the connectors for connection Check the connections between the PWBA OPT FDR and CLUTCH ASSY TAKE AWAY. Are P/J354 and P/J358 connected surely?	Go to step 17	Reconnect the connector(s) P/J354 and/or P/J358 surely, then go to step 16.
16	Does the error still occur when printing?	Go to step 17	End of work.
17	Checking the CLUTCH ASSY TAKE AWAY. Does the CLUTCH ASSY TAKE AWAY function normally? Checked by [Digital Output] - [071-017 (Tray 2), 071-022 (Tray 3), 071-027 (Tray 4) or 071-032 (Tray 5)] in diagnosis.	Go to step 22.	Go to step 18
18	Checking the CLUTCH ASSY TAKE AWAY for installation Is the CLUTCH ASSY TAKE AWAY installed correctly?	Go to step 20	Reseat the CLUTCH ASSY TAKE AWAY, then go to step 19.
19	Does the error still occur when printing?	Go to step 20	End of work.
20	Checking the HARNESS ASSY OPT CL for continuity Disconnect P/J354 from the PWBA OPT FDR. Disconnect P/J358 from the CLUTCH ASSY TAKE AWAY. Is each cable of P/J354 <=> P/J358 continuous?	Go to step 21	Replace the HARNESS ASSY OPT CL.

Step	Check	Yes	No
21	Checking the power to CLUTCH ASSY TAKE AWAY. Disconnect the connector of P/J354 on the PWBA OPT FDR. Are the voltages across ground <=> J354-1pin on the PWBA OPT FDR, +24 VDC?	Replace the CLUTCH ASSY TAKE AWAY.	Go to step 29.
22	Checking the connectors for connection Check the connections between the PWBA OPT FDR and CLUTCH ASSY FEED. Are P/J354 and P/J359 connected surely?	Go to step 24	Reconnect the connector(s) P/J354 and/or P/J359 surely, then go to step 23.
23	Does the error still occur when printing?	Go to step 24	End of work.
24	Checking the CLUTCH ASSY FEED. Does the CLUTCH ASSY FEED function normally? Checked by [Digital Output] - [071-018 (Tray 2), 071-023 (Tray 3), 071-028 (Tray 4) or 071-033 (Tray 5)] in diagnosis.	Go to step 29.	Go to step 25
25	Checking the CLUTCH ASSY FEED for installation Is the CLUTCH ASSY FEED installed correctly?	Go to step 27	Reseat the CLUTCH ASSY FEED, then go to step 26.
26	Does the error still occur when printing?	Go to step 27	End of work.
27	Checking the HARNESS ASSY OPT CL for continuity Disconnect P/J354 from the PWBA OPT FDR. Disconnect P/J359 from the CLUTCH ASSY FEED. Is each cable of P/J354 <=> P/J359 continuous?	Go to step 28.	Replace the HARNESS ASSY OPT CL.
28	Checking the power to CLUTCH ASSY FEED. Disconnect the connector of P/J354 on the PWBA OPT FDR. Are the voltages across ground <=> J354-3pin on the PWBA OPT FDR, +24 VDC?	Replace the CLUTCH ASSY FEED.	Go to step 29.
29	Checking after replacing the PWBA OPT FDR. Replace the PWBA OPT FDR. Does the error still occur when printing?	Replace the PWBA MCU (Refer to Removal 31/ Replacement 32).	End of work.

FIP1.91 050-151: IOT Remain Zone HTR JAM

Step	Check	Yes	No
	Possible causative parts: COMPILE EXIT SENSOR (PL14.7.9) DRIVE ASSY TRANS (PL14.7.16) PWBA MAIN A4 FIN (PL14.4.12) HARNESS ASSY SNR2 A4FIN (PL14.11.6) HARNESS ASSY MOT2 A4FIN (PL14.11.4) COVER ASSY TOP H-TRA (PL14.2.3) CHUTE ASSY LOWER (PL14.2.10) PWBA MCU (PL10.2.18)		
1	Locating the jam Is the paper remaining in the Finisher?	Go to Step 2.	Go to Step 17.
2	Checking of the paper path Open the cover of the H-TRA. Is there any foreign matter such as paper dust around the inlet of the Finisher? Also, are ROLL ASSY DRIVE ENT and ROLL ASSY DRIVE EXIT not contaminated or damaged, and rotated smoothly?	Clean or replace the appropriate ROLLER, and clean the paper path.	Go to step 3.
3	Checking the connector of the H transport unit. Is the connector installed properly? Is the connector damaged?	Go to Step 4.	Re-install the connector properly. If the connector is damaged, replace the KIT CHUTE ASSY LOWER H-TRA (Refer to Removal 4/ Replacement 8).
4	Checking the connectors for connection Check the connections between the PWBA MAIN A4 FIN and COMPILE EXIT SENSOR. Are P/J8989 and P/J8869 connected surely?	Go to step 6.	Reconnect the connector(s) P/J8989 and/or P/J8869 surely, then go to step 5.
5	Does the error still occur when printing?	Go to step 6.	End of work.
6	Checking the COMPILE EXIT SENSOR for operation. Does the number on the screen increase by one, every time the COMPILE EXIT SENSOR is operated? Checked by [Digital Input] - [012-150] in diagnosis..	Go to step 9.	Go to Step 7.
7	Checking the HARNESS ASSY SNR2 A4FIN for continuity Disconnect P/J8989 from the PWBA MAIN A4 FIN. Disconnect P/J8869 from the COMPILE EXIT SENSOR. Is each cable of P/J8989 <=> P/J8869 continuous?	Go to step 8.	Replace the HARNESS ASSY SNR2 A4FIN.
8	Checking the power to COMPILE EXIT SENSOR. Disconnect the connector of P/J8989 on the PWBA MAIN A4 FIN. Is the voltage between ground and J8989-12B of the PWBA MAIN A4 FIN, +5 VDC?	Replace the COMPILE EXIT SENSOR.	Go to step 16.

Step	Check	Yes	No
9	Checking the connectors for connection Check the connections between the PWBA MAIN A4 FIN and DRIVE ASSY TRANS. Are P/J8984 and P/J8879 connected surely?	Go to step 11.	Reconnect the connector(s) P/J8984 and/or P/J8879 surely, then go to step 10.
10	Does the error still occur when printing?	Go to step 11.	End of work.
11	Checking the DRIVE ASSY TRANS for rotation Does the DRIVE ASSY TRANS function normally? Checked by [Digital Output] - [012-036(Forward) and 012-018(Reverse)] in diagnosis.	Go to step 16.	Go to step 12.
12	Checking the DRIVE ASSY TRANS for installation Is the DRIVE ASSY TRANS installed correctly?	Go to step 14.	Reseat the DRIVE ASSY TRANS, then go to step 13.
13	Does the error still occur when printing?	Go to step 14.	End of work.
14	Checking the HARNESS ASSY MOT2 A4FIN for continuity Disconnect P/J8984 from the PWBA MAIN A4 FIN. Disconnect P/J8879 from the DRIVE ASSY TRANS. Is each cable of P/J8984 <=> P/J8879 continuous?	Go to step 15.	Replace the HARNESS ASSY MOT2 A4FIN.
15	Checking the power to DRIVE ASSY TRANS. Disconnect the connector of P/J8984 on the PWBA MAIN A4 FIN. Are the voltages across ground <=> J8984-9pin, and ground <=> J8984-12pin on the PWBA MAIN A4 FIN, +24 VDC?	Replace the DRIVE ASSY TRANS.	Go to step 16.
16	Checking after replacing the PWBA MAIN A4 FIN. Replace the PWBA MAIN A4 FIN (Refer to Removal 11/ Replacement 1). Does the error still occur when printing?	Replace the PWBA MCU (Refer to Removal 31/ Replacement 32).	End of work.
17	Checking after replacing the COVER ASSY TOP H-TRA. Replace the COVER ASSY TOP H-TRA. (Refer to Removal 4/ Replacement 8) Does the error still occur when printing?	Replace the CHUTE ASSY LOWER H-TRA. (Refer to Removal 4 / Replacement 8.)	End of work.

FIP1.92 050-152: IOT Remain Zone EXIT JAM

Step	Check	Yes	No
	Possible causative parts: COMPILE EXIT SENSOR (PL14.7.9) DRIVE ASSY TRANS (PL14.7.16) PWBA MAIN A4 FIN (PL14.4.12) HARNESS ASSY SNR2 A4FIN (PL14.11.6) HARNESS ASSY MOT2 A4FIN (PL14.11.4) PWBA MCU (PL10.2.18)		
1	Checking of the paper path Open the cover of the H-TRA. Is there any foreign matter such as paper dust around the inlet of the Finisher? Also, are ROLL ASSY DRIVE ENT and ROLL ASSY DRIVE EXIT not contaminated or damaged, and rotated smoothly?	Clean or replace the appropriate ROLLER, and clean the paper path.	Go to step 2
2	Checking the connectors for connection Check the connections between the PWBA MAIN A4 FIN and COMPILE EXIT SENSOR. Are P/J8989 and P/J8869 connected surely?	Go to step 4	Reconnect the connector(s) P/J8989 and/or P/J8869 surely, then go to step 3.
3	Does the error still occur when the power is turned off and on?	Go to step 4	End of work.
4	Checking the COMPILE EXIT SENSOR for operation. Does the number on the screen increase by one, every time the COMPILE EXIT SENSOR is operated? Checked by [Digital Input] - [012-150] in diagnosis..	Go to step 7	Go to Step 5
5	Checking the HARNESS ASSY SNR2 A4FIN for continuity Disconnect P/J8989 from the PWBA MAIN A4 FIN. Disconnect P/J8869 from the COMPILE EXIT SENSOR. Is each cable of P/J8989 <=> P/J8869 continuous?	Go to step 6	Replace the HARNESS ASSY SNR2 A4FIN.
6	Checking the power to COMPILE EXIT SENSOR. Disconnect the connector of P/J8989 on the PWBA MAIN A4 FIN. Is the voltage between ground and J8989-12B of the PWBA MAIN A4 FIN, +5 VDC?	Replace the COMPILE EXIT SENSOR.	Go to step 14.
7	Checking the connectors for connection Check the connections between the PWBA MAIN A4 FIN and DRIVE ASSY TRANS. Are P/J8984 and P/J8879 connected surely?	Go to step 9	Reconnect the connector(s) P/J8984 and/or P/J8879 surely, then go to step 8
8	Does the error still occur when the power is turned off and on?	Go to step 9	End of work.
9	Checking the DRIVE ASSY TRANS for rotation Does the DRIVE ASSY TRANS function normally? Checked by [Digital Output] - [012-036(Forward) and 012-018(Reverse)] in diagnosis.	Go to step 14.	Go to step 10

Step	Check	Yes	No
10	Checking the DRIVE ASSY TRANS for installation Is the DRIVE ASSY TRANS installed correctly?	Go to step 12	Reseat the DRIVE ASSY TRANS, then go to step 11.
11	Does the error still occur when the power is turned off and on?	Go to step 12	End of work.
12	Checking the HARNESS ASSY MOT2 A4FIN for continuity Disconnect P/J8984 from the PWBA MAIN A4 FIN. Disconnect P/J8879 from the DRIVE ASSY TRANS. Is each cable of P/J8984 <=> P/J8879 continuous?	Go to step 13	Replace the HARNESS ASSY MOT2 A4FIN.
13	Checking the power to DRIVE ASSY TRANS. Disconnect the connector of P/J8984 on the PWBA MAIN A4 FIN. Are the voltages across ground <=> J8984-9pin, and ground <=> J8984-12pin on the PWBA MAIN A4 FIN, +24 VDC?	Replace the DRIVE ASSY TRANS.	Go to step 14.
14	Checking after replacing the PWBA MAIN A4 FIN. Replace the PWBA MAIN A4 FIN (Refer to Removal 11/ Replacement 1). Does the error still occur when the power is turned off and on?	Replace the PWBA MCU (Refer to Removal 31/ Replacement 32).	End of work.

FIP1.93 050-153: IOT Remain Zone CMP JAM

Step	Check	Yes	No
	Possible causative parts: MOTOR ASSY EJECT (PL14.5.6) COMPILE TRAY NO PAPER SENSOR (PL14.8.13) PWBA MAIN A4 FIN (PL14.4.12) HARNESS ASSY SNR1 A4FIN (PL14.11.5) HARNESS ASSY MOT2 A4FIN (PL14.11.4) PWBA MCU (PL10.2.18)		
1	Checking of the paper path Is there the foreign substance on the paper path? Also, are ROLLER ASSY EJECT and ROLL ASSY EJECT PINCH ROLL not contaminated or damaged, and rotated smoothly?	Go to Step 2	Clean or replace the appropriate ROLLER, and clean the paper path.
2	Checking the EJECT CLAMP UP/DOWN. Does the EJECT CLAMP UP/DOWN function normally? Checked by [Digital Output] - [012-052(UP) and 012-053 (DOWN)] in diagnosis.	Go to Step 10	Go to Step 3
3	Checking the connectors for connection Check the connections between the PWBA MAIN A4 FIN and MOTOR ASSY EJECT. Are P/J8984 and P/J8878 connected surely?	Go to step 5	Reconnect the connector(s) P/J8984 and/or P/J8878 surely, then go to step 4
4	Does the error still occur when printing?	Go to step 5	End of work.
5	Checking the MOTOR ASSY EJECT for rotation Does the MOTOR ASSY EJECT function normally? Checked by [Digital Output] - [012-054] in diagnosis.	Go to Step 15	Go to step 6
6	Checking the MOTOR ASSY EJECT for installation Is the MOTOR ASSY EJECT installed correctly?	Go to step 8	Reseat the MOTOR ASSY EJECT, then go to step 7.
7	Does the error still occur when printing?	Go to step 8	End of work.
8	Checking the HARNESS ASSY MOT2 A4FIN for continuity Disconnect P/J8984 from the PWBA MAIN A4 FIN. Disconnect P/J8878 from the MOTOR ASSY EJECT. Is each cable of P/J8984 <=> P/J8878 continuous?	Go to step 9	Replace the HARNESS ASSY MOT2 A4FIN.
9	Checking the power to MOTOR ASSY EJECT. Disconnect the connector of P/J8984 on the PWBA MAIN A4 FIN. Are the voltages across ground <=> J8984-9pin, and ground <=> J8984-12pin on the PWBA MAIN A4 FIN, +24 VDC?	Replace the MOTOR ASSY EJECT.	Go to Step 15
10	Checking the connectors for connection Check the connections between the PWBA MAIN A4 FIN and COMPILE TRAY NO PAPER SENSOR. Are P/J8988 and P/J8880 connected surely?	Go to step 12	Reconnect the connector(s) P/J8988 and/or P/J8880 surely, then go to step 11.
11	Does the error still occur when printing?	Go to step 12	End of work.

Step	Check	Yes	No
12	<p>Checking the COMPILE TRAY NO PAPER SENSOR for operation.</p> <p>Does the number on the screen increase by one, every time the actuator of the COMPILE TRAY NO PAPER SENSOR is operated? Checked by [Digital Input] - [012-151] in diagnosis.</p>	Go to Step 15	Go to Step 13
13	<p>Checking the HARNESS ASSY SNR1 A4FIN for continuity Disconnect P/J8988 from the PWBA MAIN A4 FIN. Disconnect P/J8880 from the COMPILE TRAY NO PAPER SENSOR. Is each cable of P/J8988 <=> P/J8880 continuous?</p>	Go to step 14	Replace the HARNESS ASSY SNR1 A4FIN.
14	<p>Checking the power to COMPILE TRAY NO PAPER SENSOR. Disconnect the connector of P/J8988 on the PWBA MAIN A4 FIN. Is the voltage between ground and J8988-3 of the PWBA MAIN A4 FIN, +5 VDC?</p>	Replace the COMPILE EXIT SENSOR.	Go to Step 15
15	<p>Checking after replacing the PWBA MAIN A4 FIN. Replace the PWBA MAIN A4 FIN (Refer to Removal 11/ Replacement 1). Does the error still occur when printing?</p>	Replace the PWBA MCU (Refer to Removal 31/ Replacement 32).	End of work.

FIP1.94 072-211-01 / 073-211-01: IOT Option Feeder2 (or Feeder3) Failure

Step	Check	Yes	No
	Possible causative parts: FEEDER ASSY 550 (PL12.1.2) PWBA MCU (PL10.2.18)		
1	Checking the detail error code. Press the [Information] button to indicate the detail error code. Is "Code: 01" displayed on the LCD?	Go to step 2	"02" : Go to FIP1.95.
2	Download the latest version of the firmware from the Dell Support Web Site. Does the error still occur when the power is turned off and on?	Go to Step 3	End of work.
3	Checking after replacing the FEEDER ASSY 550. Replace the FEEDER ASSY 550. (Refer to Removal 66/ Replacement 67) Does the error still occur when the power is turned off and on?	Replace the PWBA MCU (Refer to Removal 31/ Replacement 32).	End of work.

FIP1.95 072-211-02 / 073-211-02: IOT Option Feeder Motor2 (or Motor3) Failure

Step	Check	Yes	No
	Possible causative parts: DRIVE ASSY OPT (PL12.3.2) HARNESS ASSY OPT MOT (PL12.3.5) PWBA OPT FDR (PL12.3.4) PWBA MCU (PL10.2.18)		
1	Checking the detail error code. Press the [Information] button to indicate the detail error code. Is "Code: 02" displayed on the LCD?	Go to step 2	"01" : Go to FIP1.94.
2	Checking the Optional Paper Cassette (Tray 2 or Tray 3) for installation. Reseat the Optional Paper Cassette (Tray 2 or Tray 3). Does the error still occur when the power is turned off and on?	Go to Step 3	End of work.
3	Checking the connectors for connection Check the connections between the PWBA OPT FDR and DRIVE ASSYOPT. Are P/J355 and P/J357 connected surely?	Go to step 5	Reconnect the connector(s) P/J355 and/or P/J357 surely, then go to step 4.
4	Does the error still occur when the power is turned off and on?	Go to step 5	End of work.
5	Checking the DRIVE ASSY OPT. Does the DRIVE ASSY OPT Motor function normally? Checked by [Digital Output] - [071-014(Tray 2) or 071-019(Tray 3)] in diagnosis.	Go to step 10.	Go to step 6
6	Checking the DRIVE ASSY OPT for installation Is the DRIVE ASSY OPT installed correctly?	Go to step 8	Reseat the DRIVE ASSY OPT, then go to step 7.
7	Does the error still occur when the power is turned off and on?	Go to step 8	End of work.
8	Checking the HARNESS ASSY OPT MOT for continuity Disconnect P/J355 from the PWBA OPT FDR. Disconnect P/J357 from the DRIVE ASSY OPT. Is each cable of P/J355 <=> P/J357 continuous?	Go to step 9	Replace the HARNESS ASSY OPT MOT.
9	Checking the power to DRIVE ASSY OPT. Disconnect the connector of P/J355 on the PWBA OPT FDR. Are the voltages across ground <=> J355-2pin, and ground <=> J355-4pin on the PWBA OPT FDR, +24 VDC?	Replace the DRIVE ASSY OPT.	Go to step 10.
10	Checking after replacing the PWBA OPT FDR. Replace the PWBA OPT FDR. Does the error still occur when the power is turned off and on?	Replace the PWBA MCU (Refer to Removal 31/ Replacement 32).	End of work.

FIP1.96 072-300 / 073-300: IOT RH Cover Tray2 (or Tray3) Open

Step	Check	Yes	No
	Possible causative parts: COVER RH OPT (PL12.1.14) RH COVER SWITCH (PL12.2.2) HARNESS ASSY OPT SW (PL12.3.11) PWBA OPT FDR (PL12.3.4) PWBA MCU (PL10.2.18)		
1	Checking the shape of COVER RH OPT Is the boss inside the COVER RH OPT damaged?	Replace the COVER RH OPT.	Go to step 2
2	Checking the connectors for connection Check the connections between the PWBA OPT FDR and RH Cover Switch (Tray 2 or 3) Are P/J353 and P/J360 connected surely?	Go to step 4	Reconnect the connector(s) P/J353 and/or P/J360 surely, then go to step 3.
3	Does the error still occur when the power is turned off and on?	Go to step 4	End of work.
4	Checking the RH COVER SWITCH for operation. Does the number on the screen increase by one, every time the RH Cover is operated? Checked by [Digital Input] - [071-122(Tray 2) or 071-131(Tray 3)] in diagnosis.	Go to Step 4	Go to Step 5
5	Checking the HARNESS ASSY OPT SW for continuity Disconnect P/J353 from the PWBA OPT FDR. Disconnect P/J360 from the RH COVER SWITCH. Is each cable of P/J353 <=> P/J360 continuous?	Go to step 6	Replace the HARNESS ASSY OPT SW.
6	Checking the power to RH COVER SWITCH. Disconnect the connector of P/J353 on the PWBA OPT FDR. Is the voltage between ground and J353-1 of the PWBA OPT FDR, +3.3VDC?	Replace the RH COVER SWITCH.	Go to step 7.
7	Checking after replacing the PWBA OPT FDR. Replace the PWBA OPT FDR. Does the error still occur when the power is turned off and on?	Replace the PWBA MCU (Refer to Removal 31/ Replacement 32).	End of work.

FIP1.97 074-211-01 / 076-211-01: IOT Option Feeder4 (or Feeder5) Failure

Step	Check	Yes	No
	Possible causative parts: FEEDER ASSY 1100 (PL3.1.2) PWBA MCU (PL10.2.18)		
1	Checking the detail error code. Press the [Information] button to indicate the detail error code. Is "Code: 01" displayed on the LCD?	Go to step 2	"02" : Go to FIP1.98.
2	Download the latest version of the firmware from the Dell Support Web Site. Does the error still occur when the power is turned off and on?	Go to Step 3	End of work.
3	Checking after replacing the FEEDER ASSY 1100. Replace the FEEDER ASSY 1100 (Refer to Removal 68/ Replacement 69). Does the error still occur when the power is turned off and on?	Replace the PWBA MCU (Refer to Removal 31/ Replacement 32).	End of work.

FIP1.98 074-211-02 / 076-211-02: IOT Option Feeder Motor4 (or Motor5) Failure

Step	Check	Yes	No
	Possible causative parts: DRIVE ASSY OPT (PL13.4.2) HARNESS ASSY OPT MOT (PL13.4.6) PWBA OPT FDR (PL13.4.5) PWBA MCU (PL10.2.18)		
1	Checking the detail error code. Press the [Information] button to indicate the detail error code. Is "Code: 02" displayed on the LCD?	Go to step 2	"01" : Go to FIP1.97.
2	Checking the Optional Paper Cassette (Tray 4 or Tray 5) for installation. Reseat the Optional Paper Cassette (Tray 4 or Tray 5). Does the error still occur when the power is turned off and on?	Go to Step 3	End of work.
3	Checking the connectors for connection Check the connections between the PWBA OPT FDR and DRIVE ASSYOPT. Are P/J355 and P/J357 connected surely?	Go to step 5	Reconnect the connector(s) P/J355 and/or P/J357 surely, then go to step 4.
4	Does the error still occur when the power is turned off and on?	Go to step 5	End of work.
5	Checking the DRIVE ASSY OPT. Does the DRIVE ASSY OPT Motor function normally? Checked by [Digital Output] - [071-024(Tray 4) or 071-029(Tray 5)] in diagnosis.	Go to step 10.	Go to step 6
6	Checking the DRIVE ASSY OPT for installation Is the DRIVE ASSY OPT installed correctly?	Go to step 8	Reseat the DRIVE ASSY OPT, then go to step 7.
7	Does the error still occur when the power is turned off and on?	Go to step 8	End of work.
8	Checking the HARNESS ASSY OPT MOT for continuity Disconnect P/J355 from the PWBA OPT FDR. Disconnect P/J357 from the DRIVE ASSY OPT. Is each cable of P/J355 <=> P/J357 continuous?	Go to step 9	Replace the HARNESS ASSY OPT MOT.
9	Checking the power to DRIVE ASSY OPT. Disconnect the connector of P/J355 on the PWBA OPT FDR. Are the voltages across ground <=> J355-2pin, and ground <=> J355-4pin on the PWBA OPT FDR, +24 VDC?	Replace the DRIVE ASSY OPT.	Go to step 10.
10	Checking after replacing the PWBA OPT FDR. Replace the PWBA OPT FDR. Does the error still occur when the power is turned off and on?	Replace the PWBA MCU (Refer to Removal 31/ Replacement 32).	End of work.

FIP1.99 074-300 / 076-300: IOT Cover Tray4 (or Tray5) Open

Step	Check	Yes	No
	Possible causative parts: COVER RH OPT (PL13.2.12) RH COVER SWITCH (PL13.3.2) HARNESS ASSY OPT SW (PL13.4.7) PWBA OPT FDR (PL13.4.5) PWBA MCU (PL10.2.18)		
1	Checking the shape of COVER RH OPT Is the boss inside the COVER RH OPT damaged?	Replace the COVER RH OPT.	Go to step 2
2	Checking the connectors for connection Check the connections between the PWBA OPT FDR and RH Cover Switch (Tray 4 or 5) Are P/J353 and P/J360 connected surely?	Go to step 4	Reconnect the connector(s) P/J353 and/or P/J360 surely, then go to step 3.
3	Does the error still occur when the power is turned off and on?	Go to step 4	End of work.
4	Checking the RH COVER SWITCH for operation. Does the number on the screen increase by one, every time the RH Cover is operated? Checked by [Digital Input] - [071-140(Tray 4) or 071-149(Tray 5)] in diagnosis.	Go to Step 4	Go to Step 5
5	Checking the HARNESS ASSY OPT SW for continuity Disconnect P/J353 from the PWBA OPT FDR. Disconnect P/J360 from the RH COVER SWITCH. Is each cable of P/J353 <=> P/J360 continuous?	Go to step 6	Replace the HARNESS ASSY OPT SW.
6	Checking the power to RH COVER SWITCH. Disconnect the connector of P/J353 on the PWBA OPT FDR. Is the voltage between ground and J353-1 of the PWBA OPT FDR, +3.3VDC?	Replace the RH COVER SWITCH.	Go to step 7.
7	Checking after replacing the PWBA OPT FDR. Replace the PWBA OPT FDR. Does the error still occur when the power is turned off and on?	Replace the PWBA MCU (Refer to Removal 31/ Replacement 32).	End of work.

FIP1.100 077-300: IOT Cover Front Open

Step	Check	Yes	No
	Possible causative parts: ACTUATOR INTER FRONT (PL1.2.15) SWITCH (Front Cover Switch) (PL1.2.3) HARNESS ASSY I/L FRT (PL1.2.1) HARNESS ASSY EXIT (PL11.1.7) LVPS ASSY (PL10.2.2) PWBA MCU (PL10.2.18)		
1	Checking the ACTUATOR INTER FRONT for shape. Is there any damage on the two projections on the ACTUATOR INTER FRONT inside the Front Cover?	Replace the ACTUATOR INTER FRONT.	Go to Step 2
2	Checking the connectors for connection Check the connections between the PWBA MCU and SWITCH (Front Cover Switch). Are P/J20 and P/J212 connected surely?	Go to step 4	Reconnect the connector(s) P/J20 and/or P/J212 surely, then go to step 3.
3	Does the error still occur when the power is turned off and on?	Go to step 4	End of work.
4	Checking the SWITCH (Front Cover Switch) for operation. Does the number on the screen increase by one, every time the Front Cover is operated? Checked by [Digital Input] - [071-112] in diagnosis.	Go to Step 7.	Go to Step 5.
5	Checking the HARNESS ASSY EXIT for continuity Disconnect P/J20 from the PWBA MCU. Disconnect P/J212 from the SWITCH (Front Cover Switch). Is each cable of P/J20 <=> P/J212 continuous?	Go to step 6	Replace the HARNESS ASSY EXIT.
6	Checking the power to SWITCH (Front Cover Switch). Disconnect the connector of P/J20 on the PWBA MCU. Is the voltage between ground and J20-11 of the PWBA MCU, +3.3VDC?	Replace the SWITCH (Front Cover Switch).	Go to step 7
7	Checking after replacing the LVPS ASSY. Replace the BOX LVPS ASSY (Refer to Removal 42/ Replacement 21). Does the error still occur when the power is turned off and on?	Replace the PWBA MCU (Refer to Removal 31/ Replacement 32).	End of work.

FIP1.101 077-301: IOT Cover Right Hand Open

Step	Check	Yes	No
	Possible causative parts: ACTUATOR INTLK RH (PL4.1.19) SWITCH (Front Cover Switch) (PL1.2.3) HARNESS ASSY I/L RH (PL4.1.1) LVPS ASSY (PL10.2.2) PWBA MCU (PL10.2.18)		
1	Check the shape of the projection of the RH COVER. Is the ACTUATOR INTLK RH inside the RH COVER damaged?	Replace the ACTUATOR INTLK RH.	Go to Step 2
2	Checking the RH Cover Switch for operation. Does the number on the screen increase by one, every time the RH Cover is operated? Checked by [Digital Input] - [046-301] in diagnosis.	Go to step 4	Go to step 3
3	Checking after replacing the HARNESS ASSY I/L RH. Replace the KIT INTERLOCK SWITCH RH (Refer to Removal 43/ Replacement 20). Does the error still occur when the power is turned off and on?	Go to step 4	End of work.
4	Checking after replacing the LVPS ASSY. Replace the BOX LVPS ASSY (Refer to Removal 42/ Replacement 21). Does the error still occur when the power is turned off and on?	Replace the PWBA MCU (Refer to Removal 31/ Replacement 32).	End of work.

FIP1.102 091-400: IOT Waste Toner Box Near Life

Step	Check	Yes	No
	Possible causative parts: SENSOR TNR FULL (PL5.3.13) PROCON ASSY (PL5.3.1) HARNESS ASSY ERASE / EXIT (PL11.2.1) PWBA MCU (PL10.2.18)		
1	Checking the WASTE TONER BOX for installation. Reseat the WASTE TONER BOX. Does the error still occur when the power is turned off and on?	Go to Step 2	End of work.
2	Checking the connectors for connection Check the connections between the PWBA MCU and SENSOR TNR FULL. Are P/J16 and P/J106 connected surely?	Go to step 4	Reconnect the connector(s) P/J16 and/or P/J106 surely, then go to step 3.
3	Does the error still occur when the power is turned off and on?	Go to step 4	End of work
4	Checking the SENSOR TNR FULL for operation. Does the number on the screen increase by one, every time the SENSOR TNR FULL is operated? Checked by [Digital Input] - [093-204] in diagnosis.	Go to Step 7	Go to Step 5
5	Checking the HARNESS ASSY ERASE / EXIT for continuity Disconnect P/J16 from the PWBA MCU. Disconnect P/J106 from the SENSOR TNR FULL. Is each cable of P/J16 <=> P/J106 continuous?	Go to step 6	Replace the HARNESS ASSY ERASE / EXIT.
6	Checking the output power of SENSOR TNR FULL. Disconnect P/J16 on the PWBA MCU. Is the voltage across ground <=> J16-6pin on the PWBA MCU, about +5VDC?	Replace the SENSOR TNR FULL.	Go to step 7
7	Checking after replacing the PROCON ASSY. Replace the PROCON ASSY. (Refer to Removal 46/ Replacement 17) Does the error still occur when the power is turned off and on?	Replace the PWBA MCU (Refer to Removal 31/ Replacement 32).	End of work.

FIP1.103 091-411 / 091-412 / 091-413 / 091-414 / 091-479 / 091-480 / 091-481 / 091-482:
IOT Drum Cartridge (YMCK) Near Life

Step	Check	Yes	No
	Possible causative parts: XERO DEVE CRU ASSY (Y) (PL5.1.8) XERO DEVE CRU ASSY (M) (PL5.1.9) XERO DEVE CRU ASSY (C) (PL5.1.10) XERO DEVE CRU ASSY (K) (PL5.1.11) CONNECTOR ASSY CRUM (PL5.2.4) HARNESS ASSY CRUM / DISP (PL11.2.4) PWBA MCU (PL10.2.18)		
1	Checking the XERO DEVE CRU ASSY (Y, M, C or K) for installing. Reseat the XERO DEVE CRU ASSY (Y, M, C or K). Does the error still occur when the power is turned off and on?	Go to Step 2	End of work.
2	Checking the connectors for connection Check the connections between the PWBA MCU and XERO CRUM (YMCK). Are P/J12 and P/J208(Y) / P/J209 (M) / P/J210(C) / P/J211 (K) connected surely?	Go to step 4	Reconnect the connector(s) surely, then go to step 3.
3	Does the error still occur when the power is turned off and on?	Go to step 4	End of work
4	Checking the HARNESS ASSY CRUM / DISP for continuity Disconnect P/J12 from the PWBA MCU. Disconnect P/J208(Y) / P/J209 (M) / P/J210(C) / P/J211 (K) from the XERO CRUM (YMCK). Is each cable of P/J12 <=> P/J208(Y) / P/J209 (M) / P/J210(C) / P/J211 (K) continuous?	Go to step 5	Replace the HARNESS ASSY CRUM / DISP.
5	Checking the output power of XERO CRUM (YMCK). Disconnect P/J12 on the PWBA MCU. Is the voltage across ground <=> J12-3/(Y) 7(M)/11(C)/15(K) pin on the PWBA MCU, about +2.5VDC?	Replace the CONNECTOR ASSY CRUM.	Go to step 6
6	Checking after replacing the XERO DEVE CRU ASSY (Y, M, C or K). Replace the XERO DEVE CRU ASSY (Y, M, C or K). (Refer to Removal 5 / Replacement 58) Does the error still occur when the power is turned off and on?	Replace the PWBA MCU (Refer to Removal 31/ Replacement 32).	End of work.

FIP1.104 091-911: IOT Waste Toner Box Life Over

Step	Check	Yes	No
	Possible causative parts: SENSOR TNR FULL (PL5.3.13) PROCON ASSY (PL5.3.1) HARNESS ASSY ERASE / EXIT (PL11.2.1) PWBA MCU (PL10.2.18)		
1	Checking the WASTE TONER BOX for installation. Reseat the WASTE TONER BOX. Does the error still occur when the power is turned off and on?	Go to Step 2	End of work.
2	Checking the connectors for connection Check the connections between the PWBA MCU and SENSOR TNR FULL. Are P/J16 and P/J106 connected surely?	Go to step 4	Reconnect the connector(s) P/J16 and/or P/J106 surely, then go to step 3.
3	Does the error still occur when the power is turned off and on?	Go to step 4	End of work
4	Checking the SENSOR TNR FULL for operation. Does the number on the screen increase by one, every time the SENSOR TNR FULL is operated? Checked by [Digital Input] - [093-204] in diagnosis.	Go to Step 7	Go to Step 5
5	Checking the HARNESS ASSY ERASE / EXIT for continuity Disconnect P/J16 from the PWBA MCU. Disconnect P/J106 from the SENSOR TNR FULL. Is each cable of P/J16 <=> P/J106 continuous?	Go to step 6	Replace the HARNESS ASSY ERASE / EXIT.
6	Checking the output power of SENSOR TNR FULL. Disconnect P/J16 on the PWBA MCU. Is the voltage across ground <=> J16-6pin on the PWBA MCU, about +5VDC?	Replace the SENSOR TNR FULL.	Go to step 7
7	Checking after replacing the PROCON ASSY. Replace the PROCON ASSY. (Refer to Removal 46/ Replacement 17) Does the error still occur when the power is turned off and on?	Replace the PWBA MCU (Refer to Removal 31/ Replacement 32).	End of work.

FIP1.105 091-914 / 091-917 / 091-918 / 091-919: IOT Drum Cartridge (YMCK) CRUM Fail

Step	Check	Yes	No
	Possible causative parts: XERO DEVE CRU ASSY (Y) (PL5.1.8) XERO DEVE CRU ASSY (M) (PL5.1.9) XERO DEVE CRU ASSY (C) (PL5.1.10) XERO DEVE CRU ASSY (K) (PL5.1.11) CONNECTOR ASSY CRUM (PL5.2.4) HARNESS ASSY CRUM / DISP (PL11.2.4) PWBA MCU (PL10.2.18)		
1	Checking the Dell Drum type. Is the XERO DEVE CRU ASSY for 5130 cdn installed? Note: The PPID No. of the XERO DEVE CRU ASSY for 5130 cdn is as follows: - XERO DEVE CRU ASSY (Y) PPID No.: 0X951N - XERO DEVE CRU ASSY (M) PPID No.: 0T229N - XERO DEVE CRU ASSY (C) PPID No.: 0U163N - XERO DEVE CRU ASSY (K) PPID No.: 0P623N	Go to step 2	Install the Drum Cartridge for 5130 cdn.
2	Checking the XERO DEVE CRU ASSY (Y, M, C or K) for installing. Reseat the XERO DEVE CRU ASSY (Y, M, C or K). Does the error still occur when the power is turned off and on?	Go to step 3	End of work
3	Checking the connectors for connection Check the connections between the PWBA MCU and XERO CRUM (YMCK). Are P/J12 and P/J208(Y) / P/J209 (M) / P/J210(C) / P/J211 (K) connected surely?	Go to step 5	Reconnect the connector(s) surely, then go to step 4.
4	Does the error still occur when the power is turned off and on?	Go to step 5	End of work
5	Checking the HARNESS ASSY CRUM / DISP for continuity Disconnect P/J12 from the PWBA MCU. Disconnect P/J208/ P/J209/ P/J210/ P/J211 from the XERO CRUM (YMCK). Is each cable of P/J12 <=> P/J208/ P/J209/ P/J210/ P/J211 continuous?	Go to step 6	Replace the HARNESS ASSY CRUM / DISP.
6	Checking the output power of XERO CRUM (YMCK). Disconnect P/J12 on the PWBA MCU. Is the voltage across ground <=> J12-3/7/11/15pin on the PWBA MCU, about +2.5VDC?	Replace the XERO CRUM (YMCK.).	Go to step 7
7	Checking after replacing the XERO DEVE CRU ASSY (Y, M, C or K). Replace the XERO DEVE CRU ASSY (Y, M, C or K). (Refer to Removal 5 / Replacement 58) Does the error still occur when the power is turned off and on?	Replace the PWBA MCU (Refer to Removal 31/ Replacement 32).	End of work.

FIP1.106 091-921 / 091-922 / 091-923 / 091-924: IOT Drum Cartridge (YMCK) Detached

Step	Check	Yes	No
	Possible causative parts: XERO DEVE CRU ASSY (Y) (PL5.1.8) XERO DEVE CRU ASSY (M) (PL5.1.9) XERO DEVE CRU ASSY (C) (PL5.1.10) XERO DEVE CRU ASSY (K) (PL5.1.11) CONNECTOR ASSY CRUM (PL5.2.4) HARNESS ASSY CRUM / DISP (PL11.2.4) PWBA MCU (PL10.2.18)		
1	Checking the XERO DEVE CRU ASSY (Y, M, C or K) for installing. Reseat the XERO DEVE CRU ASSY (Y, M, C or K) by pushing it in firmly. Does the error still occur when the power is turned off and on?	Go to step 2	End of work.
2	Checking the connectors for connection Check the connections between the PWBA MCU and XERO CRUM (YMCK). Are P/J12 and P/J208(Y) / P/J209 (M) / P/J210(C) / P/J211 (K) connected surely?	Go to step 4	Reconnect the connector(s) surely, then go to step 3.
3	Does the error still occur when the power is turned off and on?	Go to step 4	End of work
4	Checking the HARNESS ASSY CRUM / DISP for continuity Disconnect P/J12 from the PWBA MCU. Disconnect P/J208/ P/J209/ P/J210/ P/J211 from the XERO CRUM (YMCK). Is each cable of P/J12 <=> P/J208/ P/J209/ P/J210/ P/J211 continuous?	Go to step 5	Replace the HARNESS ASSY CRUM / DISP.
5	Checking the output power of XERO CRUM (YMCK). Disconnect P/J12 on the PWBA MCU. Is the voltage across ground <=> J12-3/7/11/15pin on the PWBA MCU, about +2.5VDC?	Replace the CONNECTOR ASSY CRUM.	Go to step 6
6	Checking after replacing the XERO DEVE CRU ASSY (Y, M, C or K). Replace the XERO DEVE CRU ASSY (Y, M, C or K). (Refer to Removal 5 / Replacement 58) Does the error still occur when the power is turned off and on?	Replace the PWBA MCU (Refer to Removal 31/ Replacement 32).	End of work.

FIP1.107 091-931 / 091-932 / 091-933 / 091-934: IOT Drum Cartridge (YMCK) Life Over

Step	Check	Yes	No
	Possible causative parts: XERO DEVE CRU ASSY (Y) (PL5.1.8) XERO DEVE CRU ASSY (M) (PL5.1.9) XERO DEVE CRU ASSY (C) (PL5.1.10) XERO DEVE CRU ASSY (K) (PL5.1.11) CONNECTOR ASSY CRUM (PL5.2.4) HARNESS ASSY CRUM / DISP (PL11.2.4) PWBA MCU (PL10.2.18)		
1	Checking the XERO DEVE CRU ASSY (Y, M, C or K) for installing. Reseat the XERO DEVE CRU ASSY (Y, M, C or K). Does the error still occur when the power is turned off and on?	Go to Step 2	End of work.
2	Checking the connectors for connection Check the connections between the PWBA MCU and XERO CRUM (YMCK). Are P/J12 and P/J208(Y) / P/J209 (M) / P/J210(C) / P/J211 (K) connected surely?	Go to step 4	Reconnect the connector(s) surely, then go to step 3.
3	Does the error still occur when the power is turned off and on?	Go to step 4	End of work
4	Checking the HARNESS ASSY CRUM / DISP for continuity Disconnect P/J12 from the PWBA MCU. Disconnect P/J208/ P/J209/ P/J210/ P/J211 from the XERO CRUM (YMCK). Is each cable of P/J12 <=> P/J208/ P/J209/ P/J210/ P/J211 continuous?	Go to step 5	Replace the HARNESS ASSY CRUM / DISP.
5	Checking the output power of XERO CRUM (YMCK). Disconnect P/J12 on the PWBA MCU. Is the voltage across ground <=> J12-3/7/11/15pin on the PWBA MCU, about +2.5VDC?	Replace the CONNECTOR ASSY CRUM..	Go to step 6
6	Checking after replacing the XERO DEVE CRU ASSY (Y, M, C or K). Replace the XERO DEVE CRU ASSY (Y, M, C or K). (Refer to Removal 5 / Replacement 58) Does the error still occur when the power is turned off and on?	Replace the PWBA MCU (Refer to Removal 31/ Replacement 32).	End of work.

FIP1.108 091-942 / 091-943 / 091-944 / 091-945: IOT DRUM Cartridge (YMCK) CRUM
Data Error

Step	Check	Yes	No
	Possible causative parts: XERO DEVE CRU ASSY (Y) (PL5.1.8) XERO DEVE CRU ASSY (M) (PL5.1.9) XERO DEVE CRU ASSY (C) (PL5.1.10) XERO DEVE CRU ASSY (K) (PL5.1.11) CONNECTOR ASSY CRUM (PL5.2.4) HARNESS ASSY CRUM / DISP (PL11.2.4) PWBA MCU (PL10.2.18)		
1	Checking the Dell Drum type. Is the XERO DEVE CRU ASSY for 5130 cdn installed? Note: The PPID No. of the XERO DEVE CRU ASSY for 5130 cdn is as follows: - XERO DEVE CRU ASSY (Y) PPID No.: 0X951N - XERO DEVE CRU ASSY (M) PPID No.: 0T229N - XERO DEVE CRU ASSY (C) PPID No.: 0U163N - XERO DEVE CRU ASSY (K) PPID No.: 0P623N	Go to step 2	Install the Drum Cartridge for 5130 cdn.
2	Checking the XERO DEVE CRU ASSY (Y, M, C or K) for installing. Reseat the XERO DEVE CRU ASSY (Y, M, C or K). Does the error still occur when the power is turned off and on?	Go to step 3	End of work
3	Checking the connectors for connection Check the connections between the PWBA MCU and XERO CRUM (YMCK). Are P/J12 and P/J208(Y) / P/J209 (M) / P/J210(C) / P/J211 (K) connected surely?	Go to step 5	Reconnect the connector(s) surely, then go to step 4.
4	Does the error still occur when the power is turned off and on?	Go to step 5	End of work
5	Checking the HARNESS ASSY CRUM / DISP for continuity Disconnect P/J12 from the PWBA MCU. Disconnect P/J208/ P/J209/ P/J210/ P/J211 from the XERO CRUM (YMCK). Is each cable of P/J12 <=> P/J208/ P/J209/ P/J210/ P/J211 continuous?	Go to step 6	Replace the HARNESS ASSY CRUM / DISP.
6	Checking the output power of XERO CRUM (YMCK). Disconnect P/J12 on the PWBA MCU. Is the voltage across ground <=> J12-3/7/11/15pin on the PWBA MCU, about +2.5VDC?	Replace the CONNECTOR ASSY CRUM.	Go to step 7
7	Checking after replacing the XERO DEVE CRU ASSY (Y, M, C or K). Replace the XERO DEVE CRU ASSY (Y, M, C or K). (Refer to Removal 5 / Replacement 58) Does the error still occur when the power is turned off and on?	Replace the PWBA MCU (Refer to Removal 31/ Replacement 32).	End of work.

FIP1.109 091-950 / 091-951 / 091-952 / 091-953: Detect YMCK Drum Cartridge Tape Staying

Step	Check	Yes	No
	Possible causative parts: XERO DEVE CRU ASSY (Y) (PL5.1.8) XERO DEVE CRU ASSY (M) (PL5.1.9) XERO DEVE CRU ASSY (C) (PL5.1.10) XERO DEVE CRU ASSY (K) (PL5.1.11) CONNECTOR ASSY CRUM (PL5.2.4) HARNESS ASSY CRUM / DISP (PL11.2.4) PWBA MCU (PL10.2.18)		
1	Checking the XERO DEVE CRU ASSY (Y, M, C or K) for installing. Reseat the XERO DEVE CRU ASSY (Y, M, C or K). Does the error still occur when the power is turned off and on?	Go to Step 2	End of work.
2	Checking the connectors for connection Check the connections between the PWBA MCU and XERO CRUM (YMCK). Are P/J12 and P/J208(Y) / P/J209 (M) / P/J210(C) / P/J211 (K) connected surely?	Go to step 4	Reconnect the connector(s) surely, then go to step 3.
3	Does the error still occur when the power is turned off and on?	Go to step 4	End of work
4	Checking the HARNESS ASSY CRUM / DISP for continuity Disconnect P/J12 from the PWBA MCU. Disconnect P/J208(Y) / P/J209 (M) / P/J210(C) / P/J211 (K) from the XERO CRUM (YMCK). Is each cable of P/J12 <=> P/J208(Y) / P/J209 (M) / P/J210(C) / P/J211 (K) continuous?	Go to step 5	Replace the HARNESS ASSY CRUM / DISP.
5	Checking the output power of XERO CRUM (YMCK). Disconnect P/J12 on the PWBA MCU. Is the voltage across ground <=> J12-3/(Y) 7(M)/11(C)/15(K) pin on the PWBA MCU, about +2.5VDC?	Replace the CONNECTOR ASSY CRUM.	Go to step 6
6	Checking after replacing the XERO DEVE CRU ASSY (Y, M, C or K). Replace the XERO DEVE CRU ASSY (Y, M, C or K). (Refer to Removal 5 / Replacement 58) Does the error still occur when the power is turned off and on?	Replace the PWBA MCU (Refer to Removal 31/ Replacement 32).	End of work.

FIP1.110 091-960 / 091-961 / 091-962 / 091-963: IOT (YMCK) CRUM ID Error

Step	Check	Yes	No
	Possible causative parts: XERO DEVE CRU ASSY (Y) (PL5.1.8) XERO DEVE CRU ASSY (M) (PL5.1.9) XERO DEVE CRU ASSY (C) (PL5.1.10) XERO DEVE CRU ASSY (K) (PL5.1.11) CONNECTOR ASSY CRUM (PL5.2.4) HARNESS ASSY CRUM / DISP (PL11.2.4) PWBA MCU (PL10.2.18)		
1	Checking the Dell Drum type. Is the XERO DEVE CRU ASSY for 5130 cdn installed? Note: The PPID No. of the XERO DEVE CRU ASSY for 5130 cdn is as follows: - XERO DEVE CRU ASSY (Y) PPID No.: 0X951N - XERO DEVE CRU ASSY (M) PPID No.: 0T229N - XERO DEVE CRU ASSY (C) PPID No.: 0U163N - XERO DEVE CRU ASSY (K) PPID No.: 0P623N	Go to step 2	Install the Drum Cartridge for 5130 cdn.
2	Checking the XERO DEVE CRU ASSY (Y, M, C or K) for installing. Reseat the XERO DEVE CRU ASSY (Y, M, C or K). Does the error still occur when the power is turned off and on?	Go to step 3	End of work
3	Checking the connectors for connection Check the connections between the PWBA MCU and XERO CRUM (YMCK). Are P/J12 and P/J208(Y) / P/J209 (M) / P/J210(C) / P/J211 (K) connected surely?	Go to step 5	Reconnect the connector(s) surely, then go to step 4.
4	Does the error still occur when the power is turned off and on?	Go to step 5	End of work
5	Checking the HARNESS ASSY CRUM / DISP for continuity Disconnect P/J12 from the PWBA MCU. Disconnect P/J208/ P/J209/ P/J210/ P/J211 from the XERO CRUM (YMCK). Is each cable of P/J12 <=> P/J208/ P/J209/ P/J210/ P/J211 continuous?	Go to step 6	Replace the HARNESS ASSY CRUM / DISP.
6	Checking the output power of XERO CRUM (YMCK). Disconnect P/J12 on the PWBA MCU. Is the voltage across ground <=> J12-3/7/11/15pin on the PWBA MCU, about +2.5VDC?	Replace the XERO CRUM (YMCK).	Go to step 7
7	Checking after replacing the XERO DEVE CRU ASSY (Y, M, C or K). Replace the XERO DEVE CRU ASSY (Y, M, C or K). (Refer to Removal 5 / Replacement 58) Does the error still occur when the power is turned off and on?	Replace the PWBA MCU (Refer to Removal 31/ Replacement 32).	End of work.

FIP1.111 092-651: IOT CTD Sensor Rear Error Code2

Step	Check	Yes	No
	Possible causative parts: SENSOR TNR FULL (PL5.3.13) PROCON ASSY (PL5.3.1) HARNESS ASSY ERASE / EXIT (PL11.2.1) PWBA MCU (PL10.2.18)		
1	Clean up the CTD (ADC) sensor. Does the error still occur when the power is turned off and on?	Go to step 2	End of work.
2	Checking the connectors for connection Check the connections between the PWBA MCU and CTD (ADC) SENSOR. Are P/J17 and P/J108 connected surely?	Go to step 4	Reconnect the connector(s) P/J17 and/or P/J108 surely, then go to step 3.
3	Does the error still occur when the power is turned off and on?	Go to step 4	End of work
4	Checking the HARNESS ASSY ERASE / EXIT for continuity Disconnect P/J17 from the PWBA MCU. Disconnect P/J108 from the CTD (ADC) SENSOR. Is each cable of P/J17 <=> P/J108 continuous?	Go to step 5	Replace the HARNESS ASSY ERASE / EXIT.
5	Checking the output power of CTD (ADC) SENSOR. Disconnect P/J17 on the PWBA MCU. Is the voltage across ground <=> J17-9 pin and ground <=> J17-14 pin on the PWBA MCU, about +5VDC?	Replace the CTD (ADC) SENSOR.	Go to step 6
6	Checking after replacing the PROCON ASSY. Replace the PROCON ASSY. (Refer to Removal 46/ Replacement 17) Does the error still occur when the power is turned off and on?	Replace the PWBA MCU (Refer to Removal 31/ Replacement 32).	End of work.

FIP1.112 092-670: Detect Yellow Calibrating Patch Error

Step	Check	Yes	No
	Possible causative parts: XERO DEVE CRU ASSY (Y) (PL5.1.8) BELT ASSY IBT (PL5.1.1) PWBA HVPS (PL5.2.3) HARNESS ASSY MOS / HV (PL11.2.2) PWBA MCU (PL10.2.18)		
1	Checking the XERO DEVE CRU ASSY (Y) for installation Reseat the XERO DEVE CRU ASSY (Y). Does the error still occur when the power is turned off and on?	Go to step 2	End of work.
2	Checking after replacing the XERO DEVE CRU ASSY (Y). Replace the XERO DEVE CRU ASSY (Y). (Refer to Removal 5 / Replacement 58) Does the error still occur when the power is turned off and on?	Go to step 3	End of work.
3	Checking the BELT ASSY IBT for installation Reseat the BELT ASSY IBT. Does the error still occur when the power is turned off and on?	Go to step 4	End of work.
4	Checking after replacing the BELT ASSY IBT. Replace the BELT ASSY IBT. (Refer to Removal 4/ Replacement 59) Does the error still occur when the power is turned off and on?	Go to step 5.	End of work.
5	Checking the connectors for connection Check the connections between the PWBA HVPS and XERO DEVE CRU ASSY (Y) / BCR / 1st BTR. Are P/J13 and P/J331 connected surely?	Go to step 7	Reconnect the connector(s) surely, then go to step 6
6	Checking the connectors for connection Check the connections between the PWBA MCU and PWBA HVPS. Are P/J13 and P/J331 connected surely?	Go to step 8	Reconnect the connector(s) P/J13 and/or P/J331 surely, then go to step 7
7	Does the error still occur when the power is turned off and on?	Go to step 8	End of work.
8	Checking the HARNESS ASSY MOS / HV for continuity Disconnect P/J13 from the PWBA MCU. Disconnect P/J331 from the PWBA HVPS. Is each cable of P/J13 <=> P/J331 continuous?	Go to step 9	Replace the HARNESS ASSY MOS / HV.
9	Checking after replacing the PWBA HVPS. Replace the PWBA HVPS (Refer to Removal 38/ Replacement 25). Does the error still occur when the power is turned off and on?	Replace the PWBA MCU (Refer to Removal 31/ Replacement 32).	End of work.

FIP1.113 092-671: Detect Magenta Calibrating Patch Error

Step	Check	Yes	No
	Possible causative parts: XERO DEVE CRU ASSY (M) (PL5.1.9) BELT ASSY IBT (PL5.1.1) PWBA HVPS (PL5.2.3) HARNESS ASSY MOS / HV (PL11.2.2) PWBA MCU (PL10.2.18)		
1	Checking the XERO DEVE CRU ASSY (M) for installation Reseat the XERO DEVE CRU ASSY (M). Does the error still occur when the power is turned off and on?	Go to step 2	End of work.
2	Checking after replacing the XERO DEVE CRU ASSY (M). Replace the XERO DEVE CRU ASSY (M). (Refer to Removal 5 / Replacement 58) Does the error still occur when the power is turned off and on?	Go to step 3	End of work.
3	Checking the BELT ASSY IBT for installation Reseat the BELT ASSY IBT. Does the error still occur when the power is turned off and on?	Go to step 4	End of work.
4	Checking after replacing the BELT ASSY IBT. Replace the BELT ASSY IBT. (Refer to Removal 4/ Replacement 59) Does the error still occur when the power is turned off and on?	Go to step 5.	End of work.
5	Checking the connectors for connection Check the connections between the PWBA HVPS and XERO DEVE CRU ASSY (M) / BCR / 1st BTR. Are P/J13 and P/J331 connected surely?	Go to step 7	Reconnect the connector(s) surely, then go to step 6
6	Checking the connectors for connection Check the connections between the PWBA MCU and PWBA HVPS. Are P/J13 and P/J331 connected surely?	Go to step 8	Reconnect the connector(s) P/J13 and/or P/J331 surely, then go to step 7
7	Does the error still occur when the power is turned off and on?	Go to step 8	End of work.
8	Checking the HARNESS ASSY MOS / HV for continuity Disconnect P/J13 from the PWBA MCU. Disconnect P/J331 from the PWBA HVPS. Is each cable of P/J13 <=> P/J331 continuous?	Go to step 9	Replace the HARNESS ASSY MOS / HV.
9	Checking after replacing the PWBA HVPS. Replace the PWBA HVPS (Refer to Removal 38/ Replacement 25). Does the error still occur when the power is turned off and on?	Replace the PWBA MCU (Refer to Removal 31/ Replacement 32).	End of work.

FIP1.114 092-672: Detect Cyan Calibrating Patch Error

Step	Check	Yes	No
	Possible causative parts: XERO DEVE CRU ASSY (C) (PL5.1.10) BELT ASSY IBT (PL5.1.1) PWBA HVPS (PL5.2.3) HARNESS ASSY MOS / HV (PL11.2.2) PWBA MCU (PL10.2.18)		
1	Checking the XERO DEVE CRU ASSY (C) for installation Reseat the XERO DEVE CRU ASSY (C). Does the error still occur when the power is turned off and on?	Go to step 2	End of work.
2	Checking after replacing the XERO DEVE CRU ASSY (C). Replace the XERO DEVE CRU ASSY (C). (Refer to Removal 5 / Replacement 58) Does the error still occur when the power is turned off and on?	Go to step 3	End of work.
3	Checking the BELT ASSY IBT for installation Reseat the BELT ASSY IBT. Does the error still occur when the power is turned off and on?	Go to step 4	End of work.
4	Checking after replacing the BELT ASSY IBT. Replace the BELT ASSY IBT. (Refer to Removal 4/ Replacement 59) Does the error still occur when the power is turned off and on?	Go to step 5.	End of work.
5	Checking the connectors for connection Check the connections between the PWBA HVPS and XERO DEVE CRU ASSY (C) / BCR / 1st BTR. Are P/J13 and P/J331 connected surely?	Go to step 7	Reconnect the connector(s) surely, then go to step 6
6	Checking the connectors for connection Check the connections between the PWBA MCU and PWBA HVPS. Are P/J13 and P/J331 connected surely?	Go to step 8	Reconnect the connector(s) P/J13 and/or P/J331 surely, then go to step 7
7	Does the error still occur when the power is turned off and on?	Go to step 8	End of work.
8	Checking the HARNESS ASSY MOS / HV for continuity Disconnect P/J13 from the PWBA MCU. Disconnect P/J331 from the PWBA HVPS. Is each cable of P/J13 <=> P/J331 continuous?	Go to step 9	Replace the HARNESS ASSY MOS / HV.
9	Checking after replacing the PWBA HVPS. Replace the PWBA HVPS (Refer to Removal 38/ Replacement 25). Does the error still occur when the power is turned off and on?	Replace the PWBA MCU (Refer to Removal 31/ Replacement 32).	End of work.

FIP1.115 092-673: Detect Black Calibrating Patch Error

Step	Check	Yes	No
	Possible causative parts: XERO DEVE CRU ASSY (K) (PL5.1.11) BELT ASSY IBT (PL5.1.1) PWBA HVPS (PL5.2.3) HARNESS ASSY MOS / HV (PL11.2.2) PWBA MCU (PL10.2.18)		
1	Checking the XERO DEVE CRU ASSY (K) for installation Reseat the XERO DEVE CRU ASSY (K). Does the error still occur when the power is turned off and on?	Go to step 2	End of work.
2	Checking after replacing the XERO DEVE CRU ASSY (K). Replace the XERO DEVE CRU ASSY (K). (Refer to Removal 5 / Replacement 58) Does the error still occur when the power is turned off and on?	Go to step 3	End of work.
3	Checking the BELT ASSY IBT for installation Reseat the BELT ASSY IBT. Does the error still occur when the power is turned off and on?	Go to step 4	End of work.
4	Checking after replacing the BELT ASSY IBT. Replace the BELT ASSY IBT. (Refer to Removal 4/ Replacement 59) Does the error still occur when the power is turned off and on?	Go to step 5.	End of work.
5	Checking the connectors for connection Check the connections between the PWBA HVPS and XERO DEVE CRU ASSY (K) / BCR / 1st BTR. Are P/J13 and P/J331 connected surely?	Go to step 7	Reconnect the connector(s) surely, then go to step 6
6	Checking the connectors for connection Check the connections between the PWBA MCU and PWBA HVPS. Are P/J13 and P/J331 connected surely?	Go to step 8	Reconnect the connector(s) P/J13 and/or P/J331 surely, then go to step 7
7	Does the error still occur when the power is turned off and on?	Go to step 8	End of work.
8	Checking the HARNESS ASSY MOS / HV for continuity Disconnect P/J13 from the PWBA MCU. Disconnect P/J331 from the PWBA HVPS. Is each cable of P/J13 <=> P/J331 continuous?	Go to step 9	Replace the HARNESS ASSY MOS / HV.
9	Checking after replacing the PWBA HVPS. Replace the PWBA HVPS (Refer to Removal 38/ Replacement 25). Does the error still occur when the power is turned off and on?	Replace the PWBA MCU (Refer to Removal 31/ Replacement 32).	End of work.

FIP1.116 093-423 / 093-424 / 093-425 / 093-426: IOT Toner Cartridge Near Empty

Step	Check	Yes	No
	Possible causative parts: TONER CARTRIDGE (Y) (PL6.1.1) TONER CARTRIDGE (M) (PL6.1.2) TONER CARTRIDGE (C) (PL6.1.3) TONER CARTRIDGE (K) (PL6.1.4) CONNECTOR ASSY CRUM (PL6.1.10) HARNESS ASSY TN CRUM (PL11.1.1) PWBA MCU (PL10.2.18)		
1	Checking the TONER CARTRIDGE (Y, M, C or K) for installing. Reseat the TONER CARTRIDGE (Y, M, C or K). Does the error still occur when the power is turned off and on?	Go to Step 2	End of work.
2	Checking the connectors for connection Check the connections between the PWBA MCU and CONNECTOR ASSY CRUM (YMCK). Are P/J11 and P/J204(Y) / P/J205 (M) / P/J206(C) / P/J207 (K) connected surely?	Go to step 4	Reconnect the connector(s) surely, then go to step 3.
3	Does the error still occur when the power is turned off and on?	Go to step 4	End of work
4	Checking the HARNESS ASSY TN CRUM for continuity Disconnect P/J11 from the PWBA MCU. Disconnect P/J204(Y) / P/J205 (M) / P/J206(C) / P/J207 (K) from the CONNECTOR ASSY CRUM (YMCK). Is each cable of P/J11 <=> P/J204(Y) / P/J205 (M) / P/J206(C) / P/J207 (K) continuous?	Go to step 5	Replace the HARNESS ASSY TN CRUM.
5	Checking the output power of CONNECTOR ASSY CRUM (YMCK). Disconnect P/J11 on the PWBA MCU. Is the voltage across ground <=> J11-3(Y)/7(M)/11(C)/15(K)pin on the PWBA MCU, about +2.5VDC?	Replace the CONNECTOR ASSY CRUM (YMCK). (Refer to Removal 49/ Replacement 14).	Go to step 6
6	Checking after replacing the TONER CARTRIDGE (Y, M, C or K). Replace the TONER CARTRIDGE (Y, M, C or K). Does the error still occur when the power is turned off and on?	Replace the PWBA MCU (Refer to Removal 31/ Replacement 32).	End of work.

FIP1.117 093-930 / 093-931 / 093-932 / 093-93: IOT Toner Cartridge Life Over

Step	Check	Yes	No
	Possible causative parts: TONER CARTRIDGE (Y) (PL6.1.1) TONER CARTRIDGE (M) (PL6.1.2) TONER CARTRIDGE (C) (PL6.1.3) TONER CARTRIDGE (K) (PL6.1.4) CONNECTOR ASSY CRUM (PL6.1.10) HARNESS ASSY TN CRUM (PL11.1.1) PWBA MCU (PL10.2.18)		
1	Checking the TONER CARTRIDGE (Y, M, C or K) for installing. Reseat the TONER CARTRIDGE (Y, M, C or K). Does the error still occur when the power is turned off and on?	Go to Step 2	End of work.
2	Checking the connectors for connection Check the connections between the PWBA MCU and CONNECTOR ASSY CRUM (YMCK). Are P/J11 and P/J204(Y) / P/J205 (M) / P/J206(C) / P/J207 (K) connected surely?	Go to step 4	Reconnect the connector(s) surely, then go to step 3.
3	Does the error still occur when the power is turned off and on?	Go to step 4	End of work
4	Checking the HARNESS ASSY TN CRUM for continuity Disconnect P/J11 from the PWBA MCU. Disconnect P/J204(Y) / P/J205 (M) / P/J206(C) / P/J207 (K) from the CONNECTOR ASSY CRUM (YMCK). Is each cable of P/J11 <=> P/J204(Y) / P/J205 (M) / P/J206(C) / P/J207 (K) continuous?	Go to step 5	Replace the HARNESS ASSY TN CRUM.
5	Checking the output power of CONNECTOR ASSY CRUM (YMCK). Disconnect P/J11 on the PWBA MCU. Is the voltage across ground <=> J11-3(Y)/7(M)/11(C)/15(K) pin on the PWBA MCU, about +2.5VDC?	Replace the CONNECTOR ASSY CRUM (YMCK). (Refer to Removal 49/ Replacement 14).	Go to step 6
6	Checking after replacing the TONER CARTRIDGE (Y, M, C or K). Replace the TONER CARTRIDGE (Y, M, C or K). Does the error still occur when the power is turned off and on?	Replace the PWBA MCU (Refer to Removal 31/ Replacement 32).	End of work.

FIP1.118 093-960 / 093-961 / 093-962 / 093-963: IOT (YMCK) CRUM ID Error

Step	Check	Yes	No
	Possible causative parts: TONER CARTRIDGE (Y) (PL6.1.1) TONER CARTRIDGE (M) (PL6.1.2) TONER CARTRIDGE (C) (PL6.1.3) TONER CARTRIDGE (K) (PL6.1.4) CONNECTOR ASSY CRUM (PL6.1.10) HARNESS ASSY TN CRUM (PL11.1.1) PWBA MCU (PL10.2.18)		
1	Checking the TONER CARTRIDGE. Is the TONER CARTRIDGES installed to the printer the Dell toner? Note: The PPID No. of the TONER CARTRIDGE for 5130 cdn is as follows: - TONER CARTRIDGE (Y) PPID No.: 0R273N or 0T222N - TONER CARTRIDGE (M) PPID No.: 0P615N or 0R272N - TONER CARTRIDGE (C) PPID No.: 0X942N or 0P614N - TONER CARTRIDGE (K) PPID No.: 0U157N or 0N848N	Go to step 2	Set the Non-Dell toner option to [Off]. (Refer to [Non-Dell Toner] in "10 Dell Printer Configuration Web Tool" in the User Guide.)
2	Checking the TONER CARTRIDGE (Y, M, C or K) for installing. Reseat the TONER CARTRIDGE (Y, M, C or K). Does the error still occur when the power is turned off and on?	Go to Step 3	End of work.
3	Checking the connectors for connection Check the connections between the PWBA MCU and CONNECTOR ASSY CRUM (YMCK). Are P/J11 and P/J204(Y) / P/J205 (M) / P/J206(C) / P/J207 (K) connected surely?	Go to step 5	Reconnect the connector(s) surely, then go to step 4.
4	Does the error still occur when the power is turned off and on?	Go to step 5	End of work
5	Checking the HARNESS ASSY TN CRUM for continuity Disconnect P/J11 from the PWBA MCU. Disconnect P/J204(Y) / P/J205 (M) / P/J206(C) / P/J207 (K) from the CONNECTOR ASSY CRUM (YMCK). Is each cable of P/J11 <=> P/J204(Y) / P/J205 (M) / P/J206(C) / P/J207 (K) continuous?	Go to step 6	Replace the HARNESS ASSY TN CRUM.
6	Checking the output power of CONNECTOR ASSY CRUM (YMCK). Disconnect P/J11 on the PWBA MCU. Is the voltage across ground <=> J11-3(Y)/7(M)/11(C)/15(K)pin on the PWBA MCU, about +2.5VDC?	Replace the CONNECTOR ASSY CRUM (YMCK). (Refer to Removal 49/ Replacement 14).	Go to step 7
7	Checking after replacing the TONER CARTRIDGE (Y, M, C or K). Replace the TONER CARTRIDGE (Y, M, C or K). Does the error still occur when the power is turned off and on?	Replace the PWBA MCU (Refer to Removal 31/ Replacement 32).	End of work.

FIP1.119 093-964: IOT Fuser CRUM ID Error

Step	Check	Yes	No
	Possible causative parts: FUSER ASSY (PL7.1.5) HARNESS ASSY FSR (PL7.1.4) PWBA MCU (PL10.2.18)		
1	Checking the FUSER ASSY type. Is the FUSER ASSY for 5130 cdn installed? Note: The PPID No. of the FUSER ASSY for 5130 cdn is as follows: - PPID No.(for 110V): 0N856N - PPID No.(for 220V): 0R279N Warning: Start the operation after the FUSER ASSY has cooled down.	Go to step 2	Install the FUSER ASSY for 5130 cdn.
2	Checking the FUSER ASSY for installation. Reseat the FUSER ASSY. Does the error still occur when the power is turned off and on? Warning: Start the operation after the FUSER ASSY has cooled down.	Go to step 3	End of work.
3	Checking the connectors for connection Check the connections between the PWBA MCU and FUSER CRUM. Are P/J1 and P/J180-S connected surely?	Go to step 5	Reconnect the connector(s) P/J1 and/or P/J180-S surely, then go to step 4.
4	Does the error still occur when the power is turned off and on?	Go to step 5	End of work
5	Checking the HARNESS ASSY FSR for continuity Disconnect P/J1 from the PWBA MCU. Disconnect P/J180-S from the FUSER CRUM. Is each cable of P/J1 <=> P/J180-S continuous?	Go to step 6	Replace the HARNESS ASSY FSR.
6	Checking the output power of FUSER CRUM. Disconnect P/J11 on the PWBA MCU. Is the voltage across ground <=> J1-9pin on the PWBA MCU, about +3.3VDC?	Replace the FUSER CRUM..	Go to step 7
7	Checking after replacing the FUSER ASSY. Replace the FUSER ASSY. (Refer to Removal 7 /Replacement 56) Does the error still occur when the power is turned off and on?	Replace the PWBA MCU (Refer to Removal 31/ Replacement 32).	End of work.

FIP1.120 093-970 / 093-971 / 093-972 / 093-973: IOT Toner Cartridge Detached

Step	Check	Yes	No
	Possible causative parts: TONER CARTRIDGE (Y) (PL6.1.1) TONER CARTRIDGE (M) (PL6.1.2) TONER CARTRIDGE (C) (PL6.1.3) TONER CARTRIDGE (K) (PL6.1.4) CONNECTOR ASSY CRUM (PL6.1.10) HARNESS ASSY TN CRUM (PL11.1.1) PWBA MCU (PL10.2.18)		
1	Checking the TONER CARTRIDGE (Y, M, C or K) for installing. Reseat the TONER CARTRIDGE (Y, M, C or K). Does the error still occur when the power is turned off and on?	Go to Step 2	End of work.
2	Checking the connectors for connection Check the connections between the PWBA MCU and CONNECTOR ASSY CRUM (YMCK). Are P/J11 and P/J204(Y) / P/J205 (M) / P/J206(C) / P/J207 (K) connected surely?	Go to step 4	Reconnect the connector(s) surely, then go to step 3.
3	Does the error still occur when the power is turned off and on?	Go to step 4	End of work
4	Checking the HARNESS ASSY TN CRUM for continuity Disconnect P/J11 from the PWBA MCU. Disconnect P/J204(Y) / P/J205 (M) / P/J206(C) / P/J207 (K) from the CONNECTOR ASSY CRUM (YMCK). Is each cable of P/J11 <=> P/J204(Y) / P/J205 (M) / P/J206(C) / P/J207 (K) continuous?	Go to step 5	Replace the HARNESS ASSY TN CRUM.
5	Checking the output power of CONNECTOR ASSY CRUM (YMCK). Disconnect P/J11 on the PWBA MCU. Is the voltage across ground <=> J11-3(Y)/7(M)/11(C)/15(K) pin on the PWBA MCU, about +2.5VDC?	Replace the CONNECTOR ASSY CRUM (YMCK). (Refer to Removal 49/ Replacement 14).	Go to step 6
6	Checking after replacing the TONER CARTRIDGE (Y, M, C or K). Replace the TONER CARTRIDGE (Y, M, C or K). Does the error still occur when the power is turned off and on?	Replace the PWBA MCU (Refer to Removal 31/ Replacement 32).	End of work.

FIP1.121 094-325-01: IOT Switching Sensor Failure

Step	Check	Yes	No
	Possible causative parts: BELT ASSY IBT (PL5.1.1) GUIDE ASSY LINK (PL9.2.5) SWITCHING SENSOR (K) (PL9.2.4) SWITCHING SENSOR (FC) (PL9.2.4) HARNESS ASSY RH / MOT (PL11.2.3) PWBA MCU (PL10.2.18)		
1	Checking after replacing the BELT ASSY IBT. Replace the BELT ASSY IBT. Does the error still occur when the power is turned off and on?	Go to step 2	End of work.
2	Checking of operations of the GUIDE ASSY LINK. Can the GUIDE ASSY LINK be moved smoothly?	Go to step 3	Replace the GUIDE ASSY LINK.
3	Checking the connectors for connection Check the connections between the PWBA MCU and SWITCHING SENSOR (K). Are P/J9 and P/J200 connected surely?	Go to step 5	Reconnect the connector(s) P/J9 and/or P/J200 surely, then go to step 4.
4	Does the error still occur when the power is turned off and on?	Go to step 5	End of work.
5	Checking the SWITCHING SENSOR (K) for operation. Does the number on the screen increase by one, every time the SWITCHING SENSOR (K) is operated? Checked by [Digital Input] - [091-201] in diagnosis.	Go to Step 8	Go to Step 6
6	Checking the HARNESS ASSY RH/MOT for continuity Disconnect P/J9 from the PWBA MCU. Disconnect P/J200 from the SWITCHING SENSOR (K). Is each cable of P/J9 <=> P/J200 continuous?	Go to step 7	Replace the HARNESS ASSY RH/MOT.
7	Checking the power to SWITCHING SENSOR (K). Disconnect the connector of P/J9 on the PWBA MCU. Is the voltage between ground and J9-16 of the PWBA MCU, +3.3VDC?	Replace the DRIVE ASSY ANS (K). (Refer to Removal 53/ Replacement 10).	Replace the PWBA MCU (Refer to Removal 31/ Replacement 32).
8	Checking the connectors for connection Check the connections between the PWBA MCU and SWITCHING SENSOR (FC). Are P/J15 and P/J201 connected surely?	Go to step 10	Reconnect the connector(s) P/J15 and/or P/J201 surely, then go to step 9.
9	Does the error still occur when the power is turned off and on?	Go to step 10	End of work.
10	Checking the SWITCHING SENSOR (FC) for operation. Does the number on the screen increase by one, every time the SWITCHING SENSOR (FC) is operated? Checked by [Digital Input] - [091-202] in diagnosis.	Go to Step 13	Go to Step 11

Step	Check	Yes	No
11	Checking the HARNESS ASSY RH/MOT for continuity Disconnect P/J15 from the PWBA MCU. Disconnect P/J201 from the SWITCHING SENSOR (FC). Is each cable of P/J15 <=> P/J201 continuous?	Go to step 12	Replace the HARNESS ASSY RH/MOT.
12	Checking the power to SWITCHING SENSOR (FC). Disconnect the connector of P/J15 on the PWBA MCU. Is the voltage between ground and J15-1 of the PWBA MCU, +3.3VDC?	Replace the DRIVE ASSY ANS (FC). (Refer to Removal 41/ Replacement 22).	Replace the PWBA MCU (Refer to Removal 31/ Replacement 32).

FIP1.122 094-325-02 to 06: IOT Switching Sensor Failure

Step	Check	Yes	No
	Possible causative parts: BELT ASSY IBT (PL5.1.1) DRIVE ASSY IBT (PL9.1.3) PWBA MCU (PL10.2.18) HARNESS ASSY RH / MOT (PL11.2.3)		
1	Checking after replacing the BELT ASSY IBT. Replace the BELT ASSY IBT. Does the error still occur when the power is turned off and on?	Go to step 2	End of work.
2	Checking the connectors for connection Check the connections between the PWBA MCU and DRIVE ASSY IBT. Are P/J7A and P/J254 connected surely?	Go to step 4	Reconnect the connector(s) P/J7A and/or P/J254 surely, then go to step 3.
3	Does the error still occur when the power is turned off and on?	Go to step 4	End of work.
4	Checking the DRIVE ASSY IBT for rotation Does the DRIVE ASSY IBT function normally? Checked by [Digital Output] - [094-001] in diagnosis.	Replace the PWBA MCU (Refer to Removal 31/ Replacement 32).	Go to step 5
5	Checking the DRIVE ASSY IBT for installation Is the DRIVE ASSY IBT installed correctly?	Go to step 7	Reseat the DRIVE ASSY IBT, then go to step 6.
6	Does the error still occur when the power is turned off and on?	Go to step 7	End of work.
7	Checking the HARNESS ASSY RH / MOT for continuity Disconnect P/J7A from the PWBA MCU. Disconnect P/J254 from the DRIVE ASSY IBT. Is each cable of P/J7A <=> P/J254 continuous?	Go to step 8	Replace the HARNESS ASSY RH / MOT.
8	Checking the power to DRIVE ASSY IBT. Disconnect the connector of P/J7A on the PWBA MCU. Are the voltages across ground <=> J7A-2pin/J7A-4pin on the PWBA MCU, about +24 VDC when the interlock switch (HARN ASSY I/L FRT) is pushed?	Replace the DRIVE ASSY IBT. (Refer to Removal 55/ Replacement 8)	Replace the PWBA MCU (Refer to Removal 31/ Replacement 32).

FIP1.123 094-419/ 094-422: IOT Belt Unit Near Life

Step	Check	Yes	No
	Possible causative parts: BELT ASSY IBT (PL5.1.1) CONNECTOR ASSY CRUM (PL5.1.4) HARNESS ASSY ERASE / EXIT (PL11.2.1) PWBA MCU (PL10.2.18)		
1	Checking the BELT ASSY IBT for installing. Reseat the BELT ASSY IBT. Does the error still occur when the power is turned off and on?	Go to Step 2	End of work.
2	Checking the connectors for connection Check the connections between the PWBA MCU and CONNECTOR ASSY CRUM. Are P/J16 and P/J215 connected surely?	Go to step 4	Reconnect the connector(s) P/J16 and/or P/J215 surely, then go to step 3.
3	Does the error still occur when the power is turned off and on?	Go to step 4	End of work
4	Checking the HARNESS ASSY ERASE/ EXIT for continuity Disconnect P/J16 from the PWBA MCU. Disconnect P/J215 from the CONNECTOR ASSY CRUM. Is each cable of P/J16 <=> P/J215 continuous?	Go to step 5	Replace the HARNESS ASSY ERASE/ EXIT.
5	Checking the output power of CONNECTOR ASSY CRUM. Disconnect P/J16 on the PWBA MCU. Is the voltage across ground <=> J16-13 pin on the PWBA MCU, about +2.5VDC?	Replace the CONNECTOR ASSY CRUM.	Go to step 6
6	Checking after replacing the CONNECTOR ASSY CRUM. Replace the CONNECTOR ASSY CRUM. Does the error still occur when the power is turned off and on?	Replace the PWBA MCU (Refer to Removal 31/ Replacement 32).	End of work.

FIP1.124 094-910: IOT Belt Unit Detached

Step	Check	Yes	No
	Possible causative parts: BELT ASSY IBT (PL5.1.1) CONNECTOR ASSY CRUM (PL5.1.4) HARNESS ASSY ERASE / EXIT (PL11.2.1) PWBA MCU (PL10.2.18)		
1	Check the shape of the FRAME ASSY 2ND. Does the FRAME ASSY 2ND open/close smoothly? Is the section that comes in contact with the BELT ASSY IBT locating inside the FRAME ASSY 2ND damaged?	Replace the KIT FRAME ASSY 2ND. (Refer to Removal 6/ Replacement 57)	Go to Step 2
2	Checking the BELT ASSY IBT for installing. Reseat the BELT ASSY IBT. Does the error still occur when the power is turned off and on?	Go to Step 2	End of work.
3	Checking the connectors for connection Check the connections between the PWBA MCU and CONNECTOR ASSY CRUM. Are P/J16 and P/J215 connected surely?	Go to step 5	Reconnect the connector(s) P/J16 and/or P/J215 surely, then go to step 3.
4	Does the error still occur when the power is turned off and on?	Go to step 5	End of work
5	Checking the HARNESS ASSY ERASE/ EXIT for continuity Disconnect P/J16 from the PWBA MCU. Disconnect P/J215 from the CONNECTOR ASSY CRUM. Is each cable of P/J16 <=> P/J215 continuous?	Go to step 6	Replace the HARNESS ASSY ERASE/ EXIT.
6	Checking the output power of CONNECTOR ASSY CRUM. Disconnect P/J16 on the PWBA MCU. Is the voltage across ground <=> J16-13 pin on the PWBA MCU, about +2.5VDC?	Replace the CONNECTOR ASSY CRUM.	Go to step 7
7	Checking after replacing the CONNECTOR ASSY CRUM. Replace the CONNECTOR ASSY CRUM. Does the error still occur when the power is turned off and on?	Replace the PWBA MCU (Refer to Removal 31/ Replacement 32).	End of work.

FIP1.125 094-911: IOT Belt Unit Life Over

Step	Check	Yes	No
	Possible causative parts: BELT ASSY IBT (PL5.1.1) CONNECTOR ASSY CRUM (PL5.1.4) HARNESS ASSY ERASE / EXIT (PL11.2.1) PWBA MCU (PL10.2.18)		
1	Checking the BELT ASSY IBT for installing. Reseat the BELT ASSY IBT. Does the error still occur when the power is turned off and on?	Go to Step 2	End of work.
2	Checking the connectors for connection Check the connections between the PWBA MCU and CONNECTOR ASSY CRUM. Are P/J16 and P/J215 connected surely?	Go to step 4	Reconnect the connector(s) P/J16 and/or P/J215 surely, then go to step 3.
3	Does the error still occur when the power is turned off and on?	Go to step 4	End of work
4	Checking the HARNESS ASSY ERASE/ EXIT for continuity Disconnect P/J16 from the PWBA MCU. Disconnect P/J215 from the CONNECTOR ASSY CRUM. Is each cable of P/J16 <=> P/J215 continuous?	Go to step 5	Replace the HARNESS ASSY ERASE/ EXIT.
5	Checking the output power of CONNECTOR ASSY CRUM. Disconnect P/J16 on the PWBA MCU. Is the voltage across ground <=> J16-13 pin on the PWBA MCU, about +2.5VDC?	Replace the CONNECTOR ASSY CRUM.	Go to step 6
6	Checking after replacing the CONNECTOR ASSY CRUM. Replace the CONNECTOR ASSY CRUM. Does the error still occur when the power is turned off and on?	Replace the PWBA MCU (Refer to Removal 31/ Replacement 32)	End of work.

FIP1.126 094-912: IOT Belt Unit CRUM Fail

Step	Check	Yes	No
	Possible causative parts: BELT ASSY IBT (PL5.1.1) CONNECTOR ASSY CRUM (PL5.1.4) HARNESS ASSY ERASE / EXIT (PL11.2.1) PWBA MCU (PL10.2.18)		
1	Checking the BELT ASSY type. Is the BELT ASSY IBT for 5130 cdn installed? Note: The PPID No. of the BELT ASSY IBT for 5130 cdn is as follows: - Belt ASSY IBT PPID No.: 0Y520R	Go to step 2	Install the BELT ASSY IBT for 5130 cdn.
1	Checking the BELT ASSY IBT for installing. Reseat the BELT ASSY IBT. Does the error still occur when the power is turned off and on?	Go to Step 2	End of work.
2	Checking the connectors for connection Check the connections between the PWBA MCU and CONNECTOR ASSY CRUM. Are P/J16 and P/J215 connected surely?	Go to step 4	Reconnect the connector(s) P/J16 and/or P/J215 surely, then go to step 3.
3	Does the error still occur when the power is turned off and on?	Go to step 4	End of work
4	Checking the HARNESS ASSY ERASE/ EXIT for continuity Disconnect P/J16 from the PWBA MCU. Disconnect P/J215 from the CONNECTOR ASSY CRUM. Is each cable of P/J16 <=> P/J215 continuous?	Go to step 5	Replace the HARNESS ASSY ERASE/ EXIT.
5	Checking the output power of CONNECTOR ASSY CRUM. Disconnect P/J16 on the PWBA MCU. Is the voltage across ground <=> J16-13 pin on the PWBA MCU, about +2.5VDC?	Replace the CONNECTOR ASSY CRUM.	Go to step 6
6	Checking after replacing the CONNECTOR ASSY CRUM. Replace the CONNECTOR ASSY CRUM. Does the error still occur when the power is turned off and on?	Replace the PWBA MCU (Refer to Removal 31/ Replacement 32).	End of work.

FIP1.127 094-913: IOT Transfer Roller Detached

Step	Check	Yes	No
	Possible causative parts: ROLL ASSY 2ND BTR (PL4.4.1) HARNESS ASSY ERASE / EXIT (PL11.2.1) PWBA HVPS (PL5.2.3)		
1	Checking the ROLL ASSY 2ND BTR for installing. Reseat the ROLL ASSY 2ND BTR. Does the error still occur when the power is turned off and on?	Go to Step 2	End of work.
2	Checking the connectors for connection Check the connections between the PWBA MCU and PWBA HVPS. Are P/J13 and P/J331 connected surely?	Go to step 4	Reconnect the connector(s) P/J13 and/or P/J331 surely, then go to step 3.
3	Does the error still occur when the power is turned off and on?	Go to step 4	End of work
4	Checking the HARNESS ASSY ROS/ HV for continuity Disconnect P/J13 from the PWBA MCU. Disconnect P/J331 from the PWBA HVPS. Is each cable of P/J13 <=> P/J331 continuous?	Go to step 5	Replace the HARNESS ASSY ROS/ HV.
5	Checking after replacing the ROLL ASSY 2ND BTR. Replace the ROLL ASSY 2ND BTR.(Refer to Removal 8 / Replacement 55) Does the error still occur when the power is turned off and on?	Replace the PWBA HVPS (Refer to Removal 38/ Replacement 25).	End of work.

FIP1.128 094-960: IOT Belt Unit CRUM ID Mismatch

Step	Check	Yes	No
	Possible causative parts: BELT ASSY IBT (PL5.1.1) CONNECTOR ASSY CRUM (PL5.1.4) HARNESS ASSY ERASE / EXIT (PL11.2.1) PWBA MCU (PL10.2.18)		
1	Checking the BELT ASSY type. Is the BELT ASSY IBT for 5130 cdn installed? Note: The PPID No. of the BELT ASSY IBT for 5130 cdn is as follows: - Belt ASSY IBT PPID No.: 0Y520R	Go to step 2	Install the BELT ASSY IBT for 5130 cdn.
1	Checking the BELT ASSY IBT for installing. Reseat the BELT ASSY IBT. Does the error still occur when the power is turned off and on?	Go to Step 2	End of work.
2	Checking the connectors for connection Check the connections between the PWBA MCU and CONNECTOR ASSY CRUM. Are P/J16 and P/J215 connected surely?	Go to step 4	Reconnect the connector(s) P/J16 and/or P/J215 surely, then go to step 3.
3	Does the error still occur when the power is turned off and on?	Go to step 4	End of work
4	Checking the HARNESS ASSY ERASE/ EXIT for continuity Disconnect P/J16 from the PWBA MCU. Disconnect P/J215 from the CONNECTOR ASSY CRUM. Is each cable of P/J16 <=> P/J215 continuous?	Go to step 5	Replace the HARNESS ASSY ERASE/ EXIT.
5	Checking the output power of CONNECTOR ASSY CRUM. Disconnect P/J16 on the PWBA MCU. Is the voltage across ground <=> J16-13 pin on the PWBA MCU, about +2.5VDC?	Replace the CONNECTOR ASSY CRUM.	Go to step 6
6	Checking after replacing the CONNECTOR ASSY CRUM. Replace the CONNECTOR ASSY CRUM. Does the error still occur when the power is turned off and on?	Replace the PWBA MCU (Refer to Removal 31/ Replacement 32).	End of work.

FIP1.129 116-364: Timer Fail

Step	Check	Yes	No
	Possible causative parts: PWBA ESS (PL10.1.6) PWBA MCU (PL10.2.18)		
1	Checking after reseating the PWBA ESS. Reseat the PWBA ESS. Does the error still occur when the power is turned off and on?	Go to step 2.	End of work
2	Checking after replacing the PWBA ESS. Replace the PLATE ASSY ESS (Refer to Removal 30/ Replacement 33) Does the error still occur when the power is turned off and on?	Replace the PWBA MCU (Refer to Removal 31/ Replacement 32).	End of work

FIP1.130 124-310: IOT XPC Error

Step	Check	Yes	No
	Possible causative parts: PWBA MCU (PL10.2.18)		
1	Checking after replacing the PWBA MCU. Replace the PWBA MCU (Refer to Removal 31/ Replacement 32). Does the error still occur when the power is turned off and on?	Replace the Printer.	End of work

FIP1.131 193-700: Custom Toner Mode

Step	Check	Yes	No
	Possible causative parts: PWBA ESS (PL10.1.6) PWBA MCU (PL10.2.18)		
1	Checking after reseating the PWBA ESS. Reseat the PWBA ESS. Does the error still occur when the power is turned off and on?	Go to step 2.	End of work
2	Checking after replacing the PWBA ESS. Replace the PLATE ASSY ESS (Refer to Removal 30/ Replacement 33) Does the error still occur when the power is turned off and on?	Replace the PWBA MCU (Refer to Removal 31/ Replacement 32).	End of work

FIP1.132 Electrical Noise

Step	Check	Yes	No
1	Checking the external noise Are there any other electrical appliances within 3 meters of the printer, such as generators, radio and appliances with motors? Either turn off the other electrical appliances, or relocate the printer at least 6 meters from other appliances. Does the electrical noise error still occur?	Go to step 2.	End of work
2	Checking the AC ground Is AC power supply outlet wired and grounded appropriately?	Go to step 3.	Request the client to fix AC power supply outlet.
3	Checking the TONER CARTRIDGE and BELT ASSY IBT installation Reseat the TONER CARTRIDGE and BELT ASSY IBT. Does the electrical noise error still occur?	Go to step 4.	End of work
4	Checking the HOUSING ASSY CR and HOUSING ASSY BTR contact. Remove the all TONER CARTRIDGE s. Are there any stains or foreign substance on the contact?	Wipe the stains or foreign substance with dry cloth.	Reseat the PWBA HVPS. (Refer to Removal 38/Replacement 25).

4. Image Quality Trouble

4.1 Entry Chart for Image Quality Troubleshooting

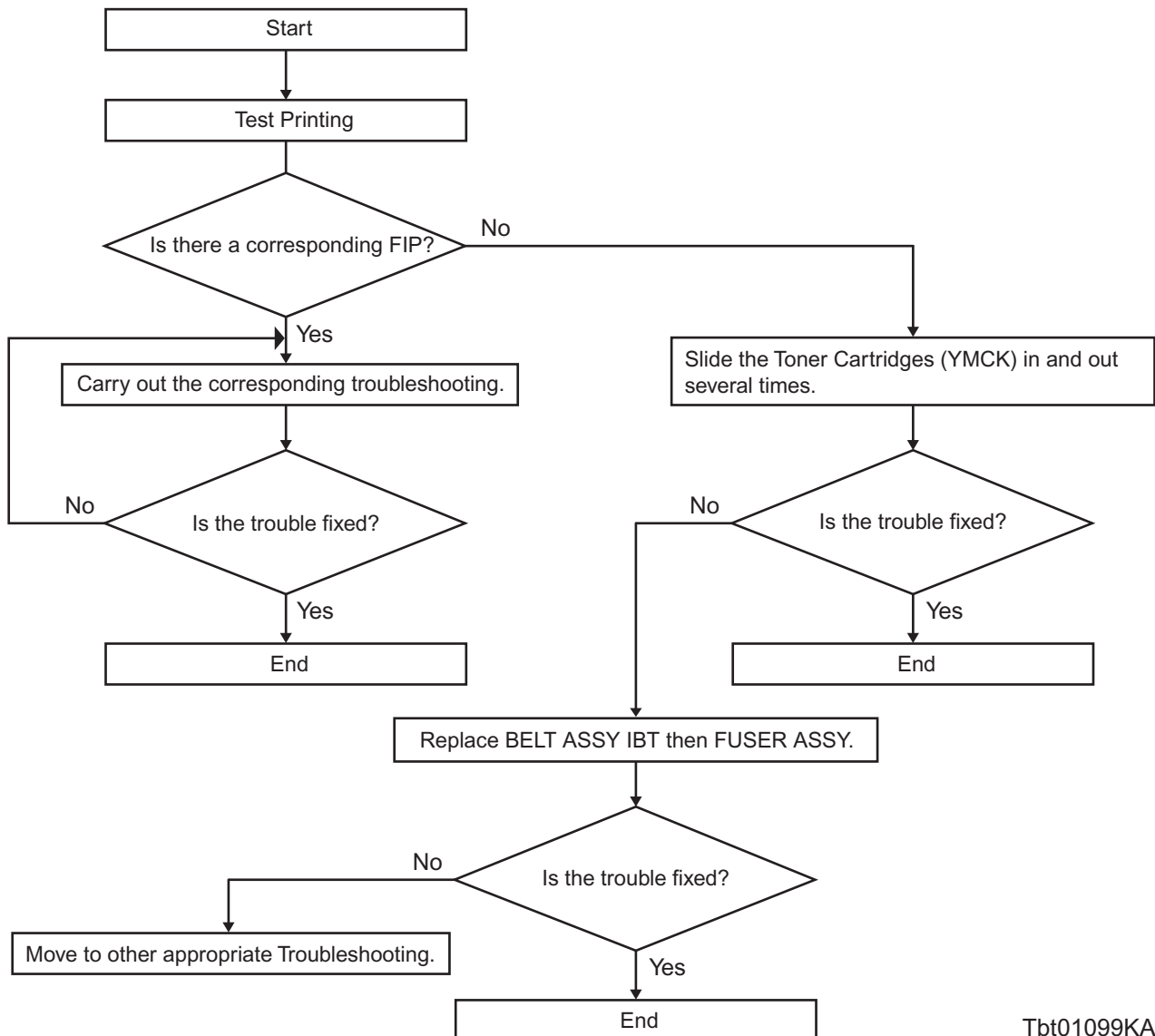

Tbt01099KA

NOTE

By performing a test print with the engine only, you can determine if the failure is Printer Controller-caused or engine-caused, except for phenomena that cannot be determined by test print.

- Test print result with the engine only is normal. ---> Malfunction on Printer Controller side

- Test print result with the engine only is also abnormal. ---> Malfunction on the engine side

When Printer-Controller-caused is more likely, replace with normal

Printer Controller and normal Interface Cable, and then confirm the operation.

When the trouble persists even after replacement, check the host, and then operate Troubleshooting efficiently, using the following image quality FIP for each phenomenon.

When the image quality trouble of print occurs, get a print to judge, understand and treat the trouble substance precisely and appropriately, and then troubleshoot efficiently, using the image quality FIP table according to each phenomenon.

When trouble restoration with image quality FIP is not possible, check again with the image quality FIP, and then replace [ESS and possible causative parts] in order and check, and operate Troubleshooting, using [Chapter 2 Diagnostic].

Image quality FIP states regarding the typical image quality trouble, as follows.

- FIP-1.P1 Faint print (Image Density)
- FIP-1.P2 Blank print (No print)
- FIP-1.P3 Solid Print (YMCK)
- FIP-1.P4 Vertical blank lines (White stripes in paper transport direction)
- FIP-1.P5 Horizontal band cross out (White stripes in the horizontal direction)
- FIP-1.P6 Vertical stripes
- FIP-1.P7 Horizontal stripes
- FIP-1.P8 Partial Deletion
- FIP-1.P9 Spots
- FIP-1.P10 Afterimage (Ghost)
- FIP-1.P11 High ground
- FIP-1.P12 Skew
- FIP-1.P13 Paper damage/Wrinkled Paper
- FIP-1.P14 Unfusing
- FIP-1.P15 Color Registration (Color Shift)
- FIP-1.P16 Color Registration (Image Shift)

NOTE

When horizontal lines and/or spot occur periodically, it is possibly caused by the trouble of a particular roll. In this case, measure the trouble interval on the test print, and check the relation to the roll in the table below. The interval does not necessarily match circumference of the roll. The trouble may be solved easily by the check.

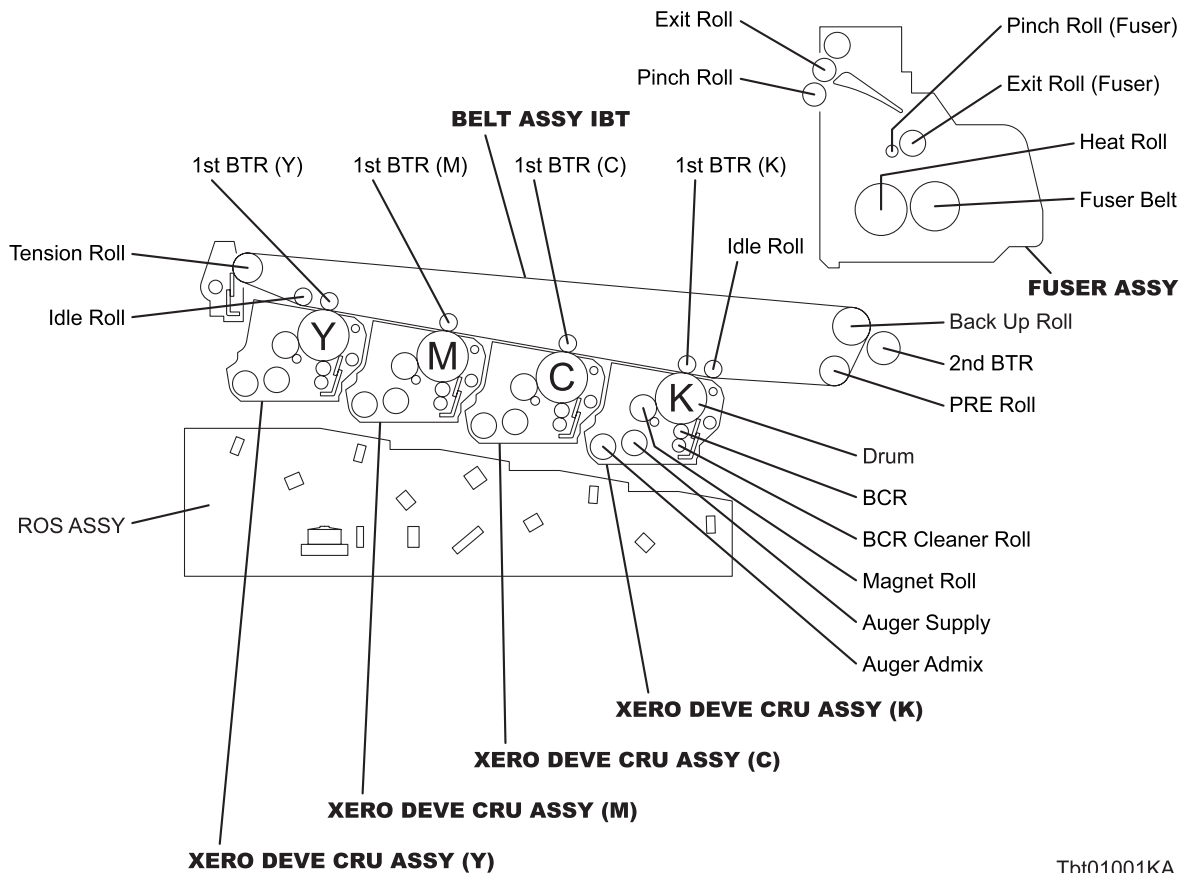

Tbt01001KA

Parts Name	Roll Name	Parts No.	Roll Diameter(mm)	Interval(mm)
XERO DEVE CRU ASSY	Drum	PL5.1.8 to 11	30	94.5
	BCR		9	28.3
	BCR-CLN		8	25.1
	MAG ROLL	PL5.3.8 to 11	16	31.3
	AUGER SUPPLY		15	41.6
	AUGER ADMIX		15	41.6
BELT ASSY IBT	1st BTR	PL5.1.1	10	31.4
	BUR + IBT		22.6	71.0
	Tension ROLL		18	56.5
	ROLL IDLE		10	314.
	2nd BTR		19.8	62.2
FUSER ASSY	H/R	PL7.1.5	31.3	98.3
	BELT		30.1	94.6
	EXIT ROLL		15.1	47.4
	PINCH ROLL		8	25.1
ROLL ASSY EXIT	EXIT ROLL	PL7.2.2	14.1	44.3
ROLL PINCH EXIT	PINCH ROLL	PL7.2.3	10	31.4

-Pitch Chart

The chart is printed [Pitch Configuration Chart] in the [Tool Box].

Page 1

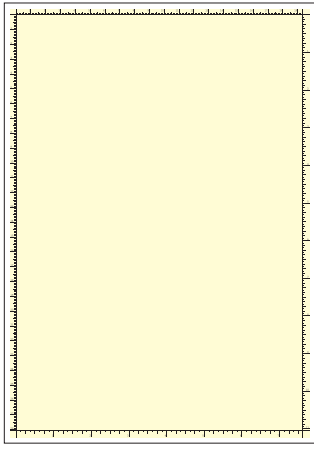

Wsb02027KA

Page 2

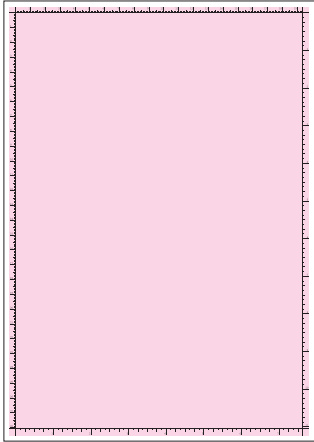

Wsb02028KA

Page 3

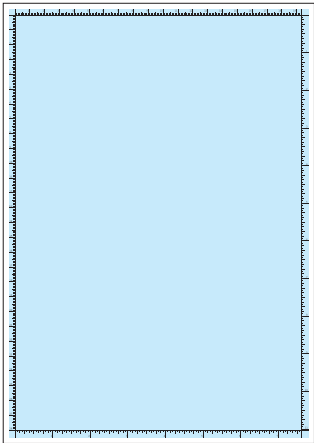

Wsb02029KA

Page 4



Wsb02030KA

Page 5

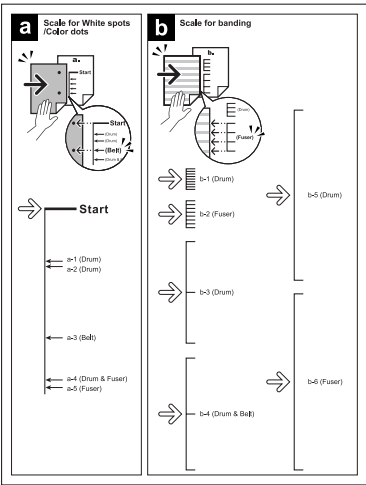

Tbt02072KA

4.2 Diagnosis Test Chart

The test charts to improve a defective image quality or to specify the cause of generation when a defective image was generated are in [Tool Box].

Use the following test charts properly by the state of a defective image quality.

-Drum Refresh

When the result of [Contamination Check] corresponds to b-6 (Drum) of the pitch chart, performing this test print may improve image quality.

The chart is printed [Drum Refresh Configuration Chart] in the [Tool Box].

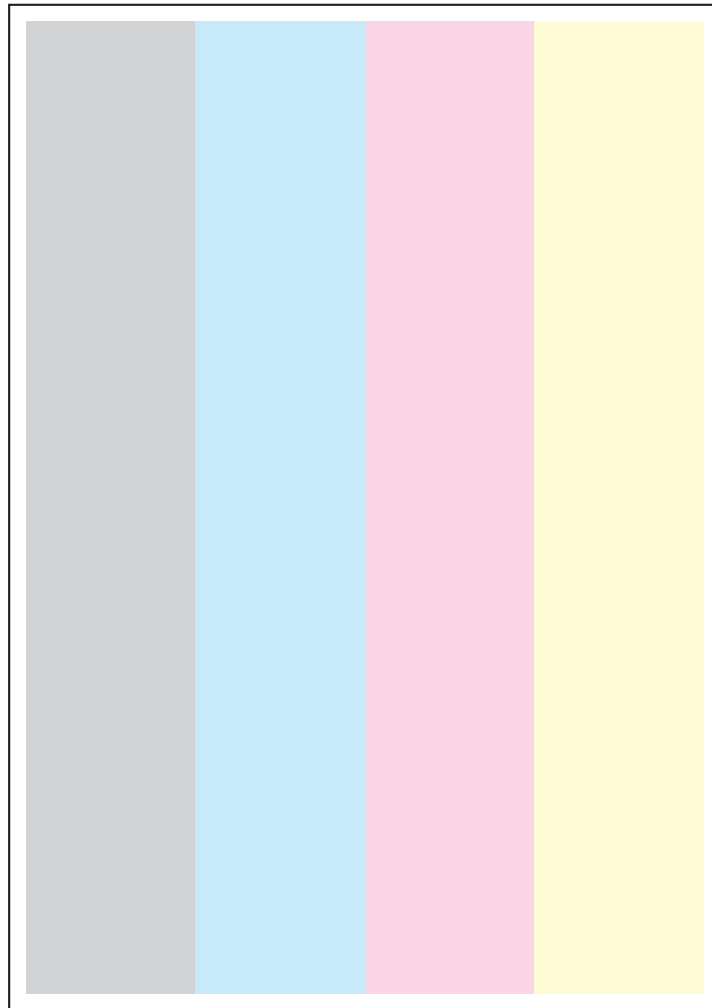

Wsb02021KA

-MQ Chart

This chart allows you to check for a banding if any occurs.

The chart is printed [MQ Chart] in the [Tool Box].

When the image quality is normal, the waves of Y, M, and C are confined within the frame. When the image quality is abnormal, the wave runs out the frame. Compare the pitch of the wave with the pitch chart of second page.

Parts Name	Roll Name	Parts No.	Roll Diameter(mm)	Interval(mm)
XERO DEVE CRU ASSY	Drum	PL5.1.8 to 11	30	94.5
	BCR		9	28.3
	BCR-CLN		8	25.1
	MAG ROLL	PL5.3.8 to 11	16	31.3
	AUGER SUPPLY		15	41.6
	AUGER ADMIX		15	41.6
BELT ASSY IBT	1st BTR	PL5.1.1	10	31.4
	BUR + IBT		22.6	71.0
	Tension ROLL		18	56.5
	ROLL IDLE		10	31.4
	2nd BTR		19.8	62.2
FUSER ASSY	H/R	PL7.1.5	31.3	98.3
	BELT		30.1	94.6
	EXIT ROLL		15.1	47.4
	PINCH ROLL		8	25.1
ROLL ASSY EXIT	EXIT ROLL	PL7.2.2	14.1	44.3
ROLL PINCH EXIT	PINCH ROLL	PL7.2.3	10	31.4

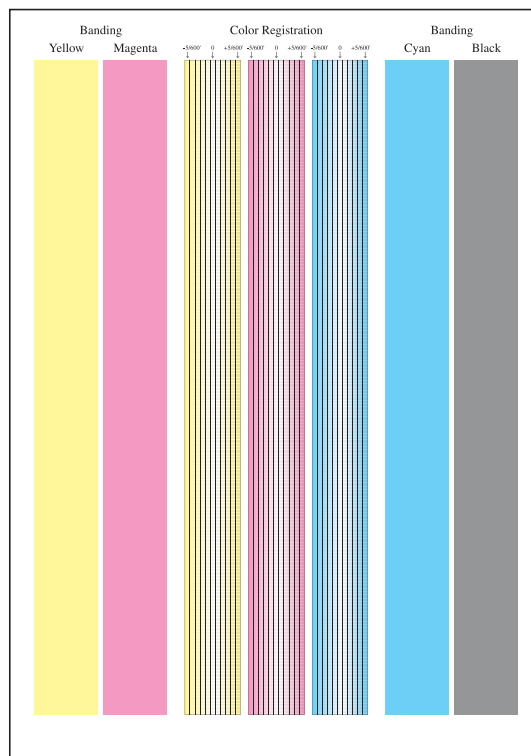

Tbt01039KA

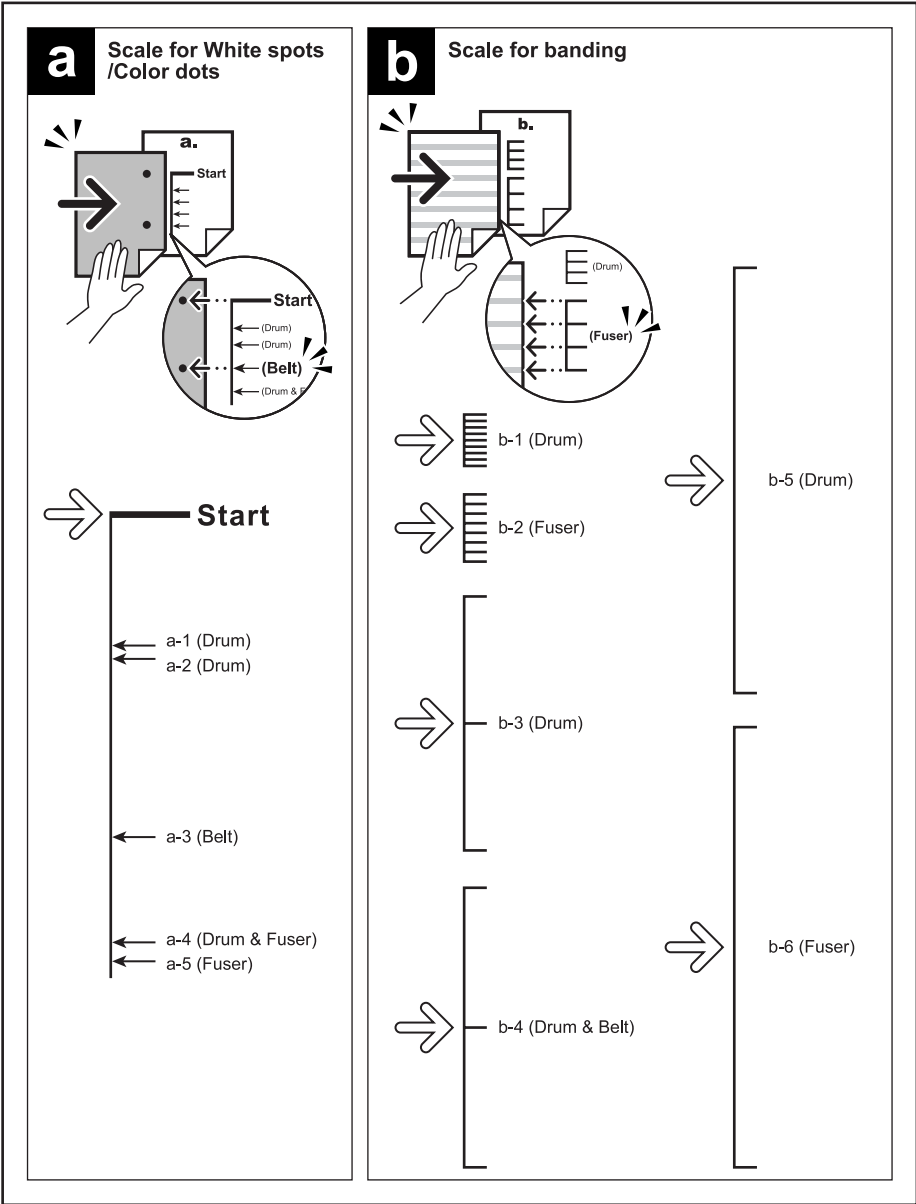

Tbt02072KA

-Alignment Chart

This chart allows you to check for the skewed paper if any occurs.
The chart is printed [Alignment Chart] in the [Tool Box].

When the sheet is fed normally, the vertical and horizontal lines are aligned parallel to the edges of the sheet. When there is a problem, this alignment is skewed.

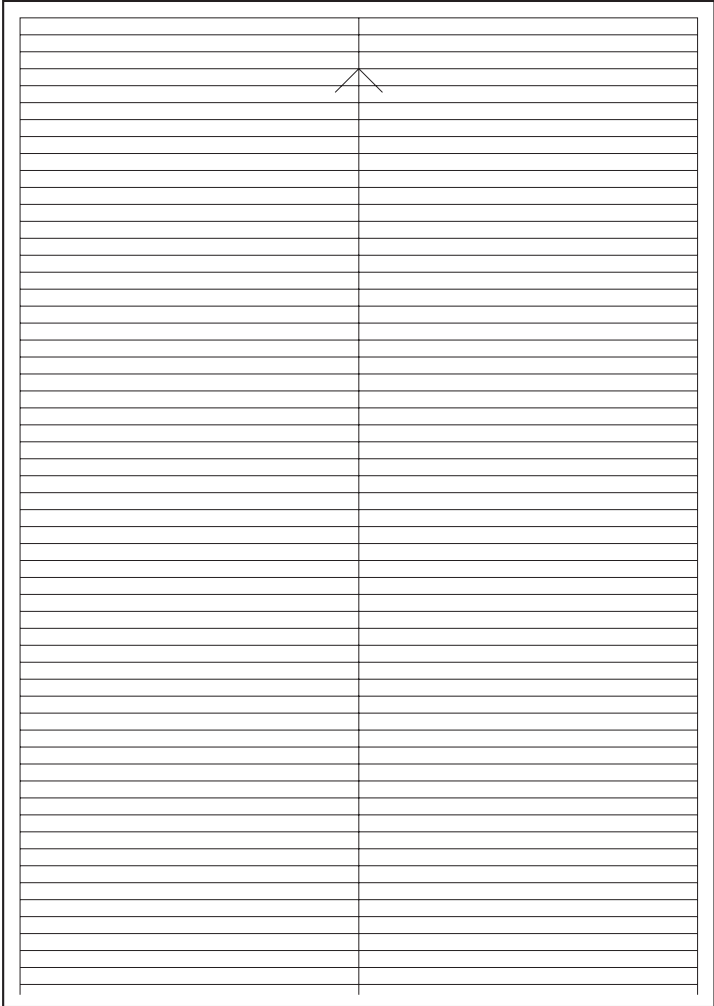

Wsb02022KA

-Ghost Chart

This chart allows you to check for a ghost if any occurs.

The chart is printed [Ghost Configuration Chart] in the [Tool Box].

When a ghost occurs, the patches with open cross and character K/B/G/R/M/C appear on the light-colored patches K/C/M in the lower half of the chart, and the patches with open cross only appears on the dark-colored patches K/C/M below the light-colored patches.

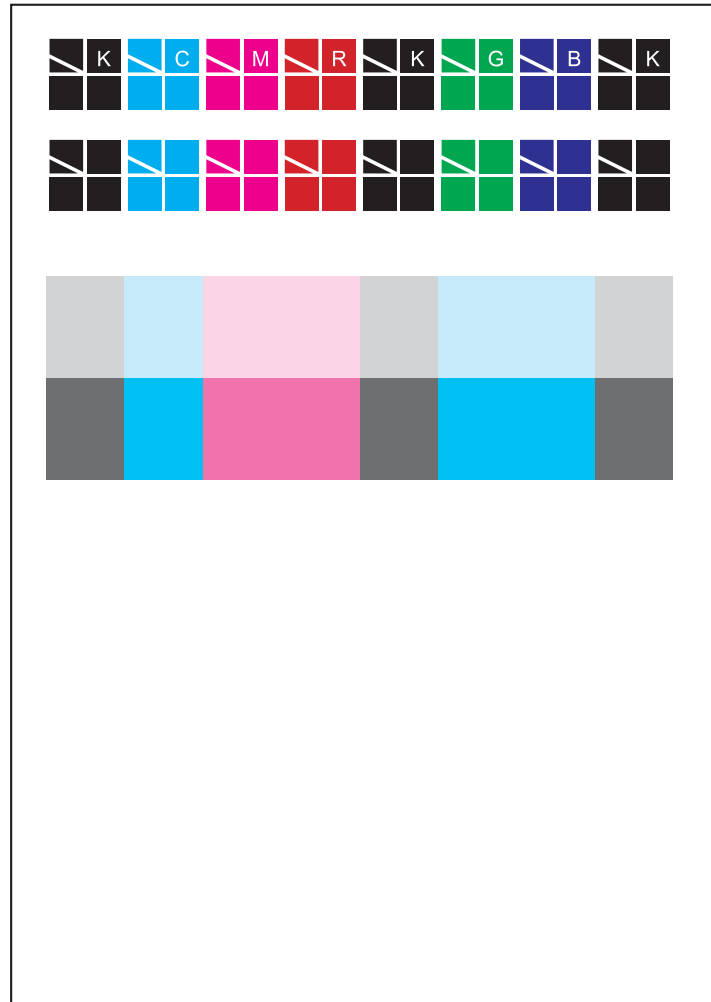

Wsb02020KA

4.3 Items to be Confirmed Before Image Quality Troubleshooting

Print Quality Problems

Customers may need your help determining the cause of print quality issues such as streaking, fading, or dropouts. Here are some questions that may help you determine why your customer's printer is not printing optionally. First, confirm the following items to understand customer's operating condition.

1. Does your customer's print media fall within the Printer Media Guidelines? (Go to 1.5 of this chapter and refer to "**Printer Media Guidelines**").
2. Is there enough toner?
3. Has the printer been cleaned recently?

Checking printer condition

Toner

Low toner can cause print quality problems such as fading, streaking, white lines, or dropouts.

Have your customer print a small document from a different application to replicate the problem and verify the amount of toner available for printing. When your customers print a document, the Laser Printer Status Monitor should display a dialog box that estimates the amount of toner left in the cartridge.

If the toner is low, your customers can something extend the cartridge life by removing the cartridge from the 5130 cdn, gently shaking it from side-to-side, and replacing it (Rocking the toner cartridge from side-to-side loosens toner that may get stuck).

Cleaning

Paper, toner, and dust particles can accumulate inside the 5130 cdn printer and cause print quality problems, such as smearing or toner specks. Clean inside the 5130 cdn to prevent these problems.

Prior checks before troubleshooting

Check the following items if any print quality problems occur before going to each troubleshooting. Those actions may solve problems easily and simply.

If the any problems below have occurred, check and take actions described in each item.

- 1) Color is out of alignment:
 - a) Clean inside of the printer.
 - b) If you install a new black toner cartridge and a Print Head cleaning has not been done, this problem will happen. Clean inside of the printer.
- 2) Print is too light:
 - a) The toner may be low. Confirm the amount of the toner and change the toner cartridges if necessary.
 - b) Set the **Draft Mode** check box to off in the Advanced in the printer driver.
 - c) If you are printing on an uneven print surface, change the Paper Type settings in the Tray Settings menu.
 - d) Verify that the correct print media is being used.
 - e) The toner cartridge may need to be replaced. Change the toner cartridge.
- 3) Toner smears or print comes off page:
 - a) If you are printing on an uneven print surface, change the Paper Type settings in the Tray Settings menu.
 - b) Verify that the print media is within the printer specifications. (Go to 1.5 of this chapter and refer to "**Printer Media Guidelines**").

- 4) Toner spots appear on the page/printing is blurred:
 - a) Check the toner cartridge to make sure it is installed correctly.
 - b) Change the toner cartridge.
- 5) Entire page is white:
 - a) Make sure the packaging material is removed from the toner cartridge.
 - b) Check the toner cartridge to make sure it is installed correctly.
 - c) The toner may be low. Change the toner cartridge.
- 6) Streaks appear on the page:
 - a) The toner may be low. Change the toner cartridge.
 - b) If you are using preprinted forms, make sure the toner can withstand temperatures of 0°C to 35°C.
- 7) Characters have jagged or uneven edges:
 - a) Change the **Print Mode** in the **Graphics** tab (or **Advanced** dialog box) to **Standard** in the printer driver.
 - b) If you are using downloaded fonts, verify that the fonts are supported by the printer, the host computer, and the software program.
- 8) Part or all of the page prints in black:
 - a) Check the toner cartridge to make sure it is installed correctly.
- 9) The job prints, but the top and side margins are incorrect:
 - a) Make sure the Paper Size setting in the Tray Settings is correct.
 - b) Make sure the margins are set correctly in your software program.
- 10) Printing on both ends of the transparencies is faded:
 - a) This occurs when the printer is operating in a location where relative humidity reaches 85% or more. Adjust the humidity or relocate the printer to an appropriate environment.

4.4 Print Image Quality Specification

Image Quality Guarantee Conditions

The image quality is specified and guaranteed under the following conditions.

1) Environmental Condition

Temperature: 15°C - 28°C

Humidity: 20% RH - 70% RH (85% RH at 28°C)

Note that defect may occur due to condensation after around 30 minutes if the printer is turned on in an critical environment such as 85% at 10°C.

2) Guaranteed Paper

The print image quality specified in this chapter should be guaranteed when the standard paper is fed from the paper tray. The print image quality is evaluated on the maximum size of each standard paper.

Color print quality: X-Pression paper

Black and White quality: 4200 paper

3) Paper condition

The paper used is fresh paper immediately after unpacked, which has been left in the operating environment for 12 hours before unpacking.

4) Printer condition

The print image quality specified in this chapter is guaranteed with the printer in normal condition.

6) Criterion for judgment

The print image quality is guaranteed with Spec. In rate = 90% ($\gamma = 90\%$).

5) For **Color chart**, **Parallelism**, **Perpendicularity**, **Skew**, **Linearity**, **Magnification Error**, **Registration** and **Printed Guaranteed Area**, refer to each chart below.

Chart

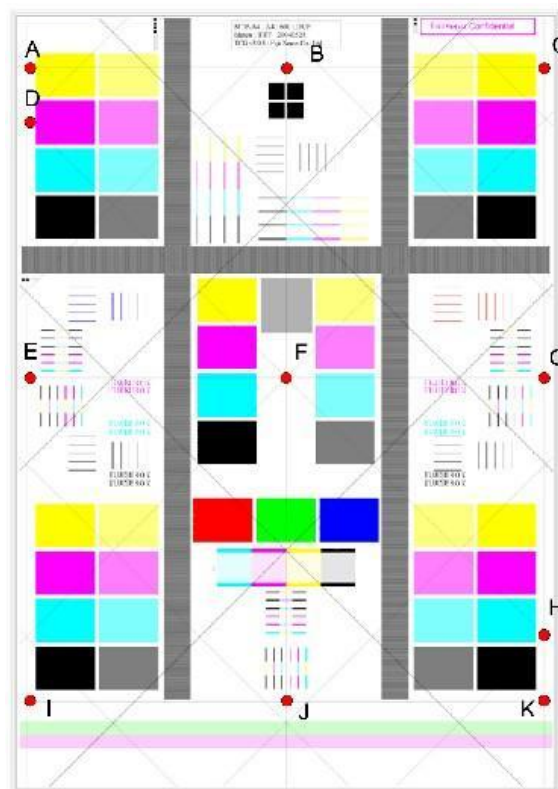

Parallelism

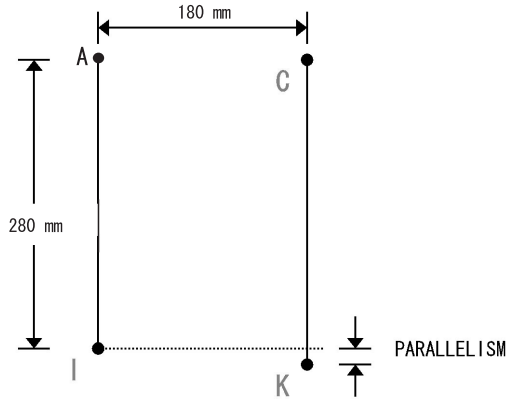

Perpendicularity

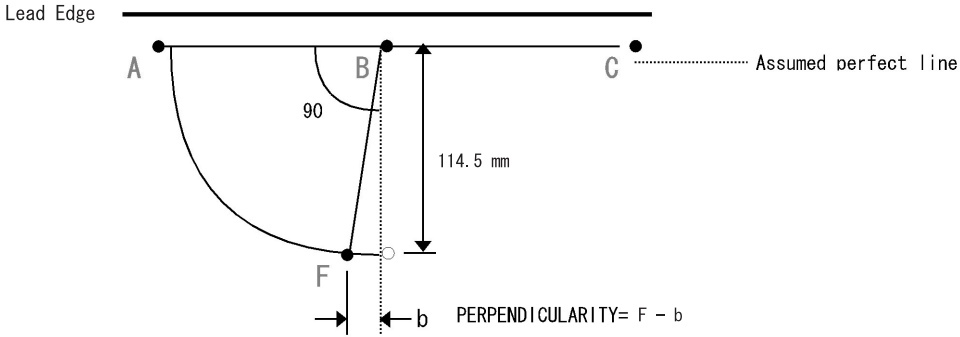

Skew

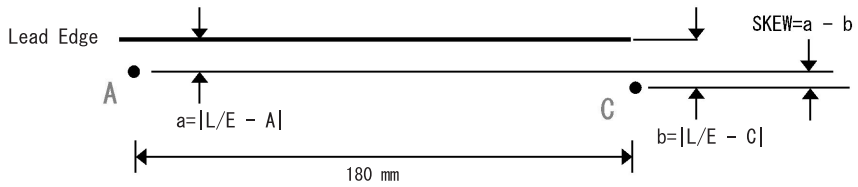

Linearity

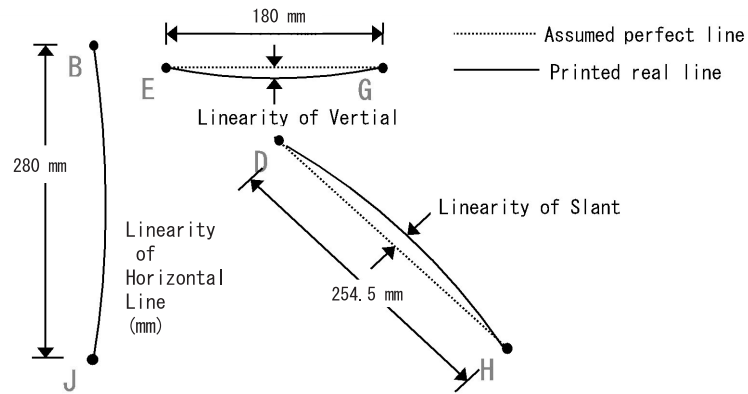

Magnification Error

$$\text{Magnification} = \text{measured length} \div \text{Nominal}$$

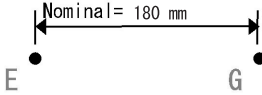
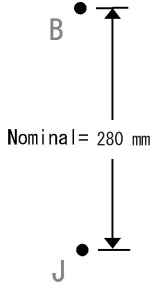

Registration

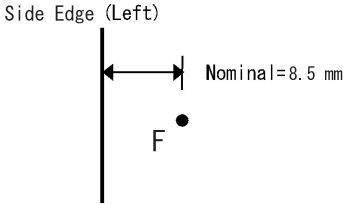
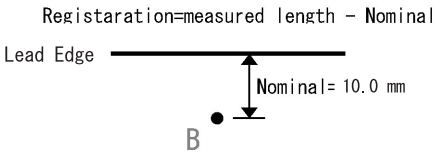

Printed Guaranteed Area

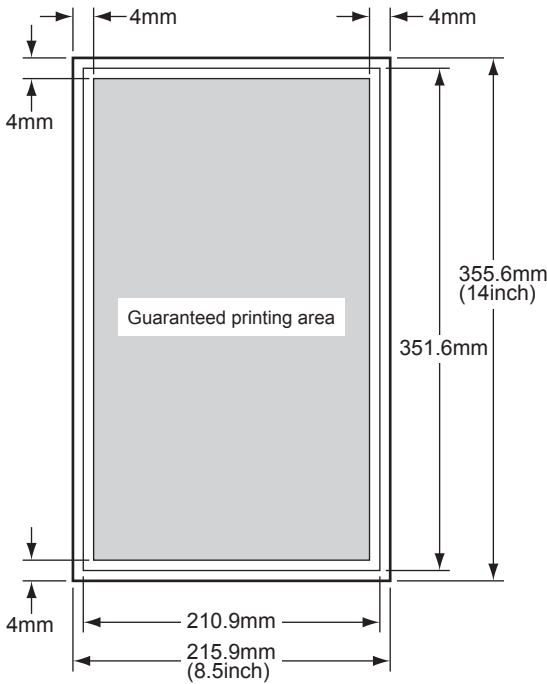

Kmy01001KA

4.5 Image Quality FIP

FIP-1.P1 Faint print (Low contrast)

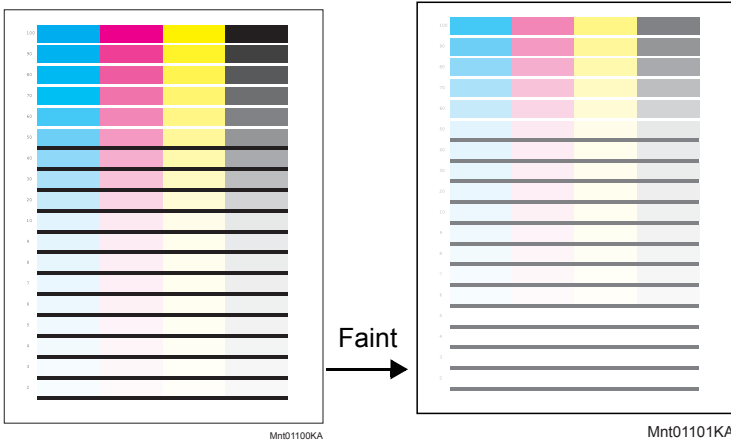

Trouble substance

The density of the image is entirely too faint.

Possible causative parts

- TONER CARTRIDGE (Y) (PL6.1.1)/
- TONER CARTRIDGE (M) (PL6.1.2)/
- TONER CARTRIDGE (C) (PL6.1.3)/
- TONER CARTRIDGE (K) (PL6.1.4)
- XERO DEVE CRU ASSY (Y) (PL5.1.8)/
- XERO DEVE CRU ASSY (M) (PL5.1.9)/
- XERO DEVE CRU ASSY (C) (PL5.1.10)/
- XERO DEVE CRU ASSY (K) (PL5.1.11)
- ROLL ASSY 2ND BTR (PL4.4.1)
- MOTOR ASSY DISPENSE (PL6.1.9)
- BELT ASSY IBT (PL5.1.1)

Before commencing troubleshooting, check the paper transfer path. Make sure there is no foreign materials on the transfer path, such as staples, paper clips, scraps of paper and so on.

Step	Check	Yes	No
1	<p>Checking the remaining amount of the toner cartridge</p> <p>Is there sufficient toner remaining in the toner cartridge? Check the remaining amount of the toner cartridge via the Status Monitor.</p>	Go to step 2.	Replace the depleted toner cartridge.
2	<p>Checking the TONER CARTRIDGE (YMCK).</p> <p>Is the toner cartridges installed to the printer the Dell toner?</p>	Go to step 3.	Set the Non-Dell toner option to [Off]. (Refer to [Non-Dell Toner] in "10 Dell Printer Configuration Web Tool" in the User Guide.)
3	<p>Checking the paper</p> <p>Is the installed paper with a new and dry one? or does the paper satisfy the specification?</p>	Go to step 4.	Replace the paper with a new and dry one. or Change the paper to the one that satisfies the specification. (Refer to "11 Print Media Guidelines" in the User Guide.)

Step	Check	Yes	No
4	<p>Checking the printer setting</p> <p>Is the [Toner Saving Mode] check box selected in the [Advanced] tab of the printer driver?</p>	Deselect the check box.	Go to step 5
5	<p>Checking the installation of XERO DRIVE CRU ASSY (Y, M, C, or K)</p> <p>Are the ribbons and orange protective cover removed from the XERO DRIVE CRU ASSY (Y, M, C, or K)?</p>	Go to step 6	Remove the ribbons or orange protective cover. Refer to "Removing the Drum Ribbons" in "4 Prepare Printer Hardware" in the User Guide. (or Refer to "Appendix_2.3 Replacing the Drum Cartridges" in Appendix.)
6	<p>Checking after cleaning the inside of the Printer</p> <p>Print the Toner Pallet Check after cleaning the inside of the Printer.</p> <p>For how to clean the inside of the Printer, refer to "3.1 Cleaning Inside the Printer" in Appendix.</p> <p>Is the image printed correctly? Checked by [Test Print] - [Toner Pallet Check] in diagnosis. NOTE: If the CLEANER ASSY (Cleaning rod) is contaminated, replace the CLEANER ASSY, and then clean the printer again.</p>	End of work.	Go to step 7
7	<p>Checking the TONER CARTRIDGE (Y, M, C or K) for installation.</p> <p>Reseat the suspected TONER CARTRIDGE (Y, M, C, or K), and then print the Toner Pallet Check.</p> <p>Is the image printed correctly? Checked by [Test Print] - [Toner Pallet Check] in diagnosis.</p>	End of work.	Go to step 8
8	<p>Checking after replacing the MOTOR ASSY DISPENSE.</p> <p>Replace the suspected MOTOR ASSY DISPENSE (Y, M, C, or K) (Refer to Removal 50 / Replacement 13), and then print the Toner Pallet Check.</p> <p>Is the image printed correctly? Checked by [Test Print] - [Toner Pallet Check] in diagnosis.</p>	End of work.	Go to step 9
9	<p>Checking after replacing the XERO DEVE CRU ASSY (Y, M, C or K)</p> <p>Replace the suspected XERO DEVE CRU ASSY (Y, M, C, or K) (Refer to Removal 5 / Replacement 58), and then print the Toner Pallet Check.</p> <p>Is the image printed correctly? Checked by [Test Print] - [Toner Pallet Check] in diagnosis.</p>	End of work.	Go to step 10

Step	Check	Yes	No
10	Checking after replacing the BELT ASSY IBT. Replace the BELT ASSY IBT (Refer to Removal 4 / Replacement 59), and then print the Toner Pallet Check Is the image printed correctly? Checked by [Test Print] - [Toner Pallet Check] in diagnosis.	End of work.	Go to step 11
11	Checking after replacing the ROLL ASSY 2ND BTR Replace the ROLL ASSY 2ND BTR (Refer to Removal 8 / Replacement 55), and then print the Toner Pallet Check. Is the image printed correctly? Checked by [Test Print] - [Toner Pallet Check] in diagnosis.	End of work.	Replace the Printer.

FIP-1.P2 Blank print (No print)

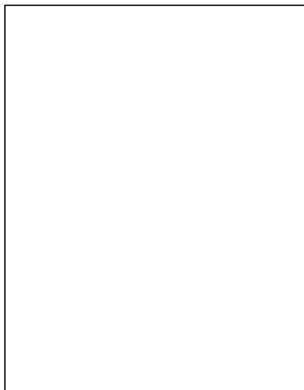
**Trouble substance**

The entire paper is printed pure white.

Possible causative parts

- TONER CARTRIDGE (Y) (PL6.1.1)/TONER CARTRIDGE (M) (PL6.1.2)/
TONER CARTRIDGE (C) (PL6.1.3)/TONER CARTRIDGE (K) (PL6.1.4)
- XERO DEVE CRU ASSY (Y) (PL5.1.8)/XERO DEVE CRU ASSY (M)
(PL5.1.9)/XERO DEVE CRU ASSY (C) (PL5.1.10)/XERO DEVE CRU ASSY
(K) (PL5.1.11)
- ROLL ASSY 2ND BTR (PL4.4.1)
- MOTOR ASSY DISPENSE (PL6.1.9)
- BELT ASSY IBT (PL5.1.1)

Before commencing troubleshooting, check the paper transfer path. Make sure there is no foreign materials on the transfer path, such as staples, paper clips, scraps of paper and so on.

Step	Check	Yes	No
1	<p>Checking the TONER CARTRIDGE (YMCK).</p> <p>Is the toner cartridges installed to the printer the Dell toner?</p>	Go to step 2.	<p>Set the Non-Dell toner option to [Off]. (Refer to [Non-Dell Toner] in "10 Dell Printer Configuration Web Tool" in the User Guide.)</p>
2	<p>Checking the paper</p> <p>Is the installed paper with a new and dry one? or does the paper satisfy the specification?</p>	Go to step 3.	<p>Replace the paper with a new and dry one. or Change the paper to the one that satisfies the specification. (Refer to "11 Print Media Guidelines" in the User Guide.)</p>
3	<p>Checking the installation of XERO DEVE CRU ASSY (Y, M, C, or K)</p> <p>Are the ribbons and orange protective cover removed from the XERO DEVE CRU ASSY (Y, M, C, or K)?</p>	<p>Remove the ribbons or orange protective cover. Refer to "Removing the Drum Ribbons" in "4 Prepare Printer Hardware" in the User Guide. (or Refer to "Appendix_2.3 Replacing the Drum Cartridges" in Appendix.)</p>	Go to step 4.

Step	Check	Yes	No
4	<p>Checking the TONER CARTRIDGE (Y, M, C and K) for installation. Reseat the suspected TONER CARTRIDGE (Y, M, C, or K), and then print the Toner Pallet Check.</p> <p>Is the image printed correctly? Checked by [Test Print] - [Toner Pallet Check] in diagnosis.</p>	End of work.	Go to step 5.
5	<p>Checking after replacing the MOTOR ASSY DISPENSE. Replace the suspected MOTOR ASSY DISPENSE (Y, M, C, or K) (Refer to Removal 50 / Replacement 13), and then print the Toner Pallet Check.</p> <p>Is the image printed correctly? Checked by [Test Print] - [Toner Pallet Check] in diagnosis.</p>	End of work.	Go to step 6.
6	<p>Checking after replacing the XERO DEVE CRU ASSY (Y, M, C or K) Replace the suspected XERO DEVE CRU ASSY (Y, M, C, or K) (Refer to Removal 5 / Replacement 58), and then print the Toner Pallet Check.</p> <p>Is the image printed correctly? Checked by [Test Print] - [Toner Pallet Check] in diagnosis.</p>	End of work.	Go to step 7.
7	<p>Checking after replacing the BELT ASSY IBT. Replace the BELT ASSY IBT (Refer to Removal 4 / Replacement 59), and then print the Toner Pallet Check.</p> <p>Is the image printed correctly? Checked by [Test Print] - [Toner Pallet Check] in diagnosis.</p>	End of work.	Go to step 8.
8	<p>Checking after replacing the ROLL ASSY 2ND BTR Replace the ROLL ASSY 2ND BTR (Refer to Removal 8 / Replacement 55), and then print the Gradation Page.</p> <p>Is the image printed correctly? Checked by [Test Print] - [Toner Pallet Check] in diagnosis.</p>	End of work.	Replace the Printer.

FIP-1.P3 Solid Print (YMCK)

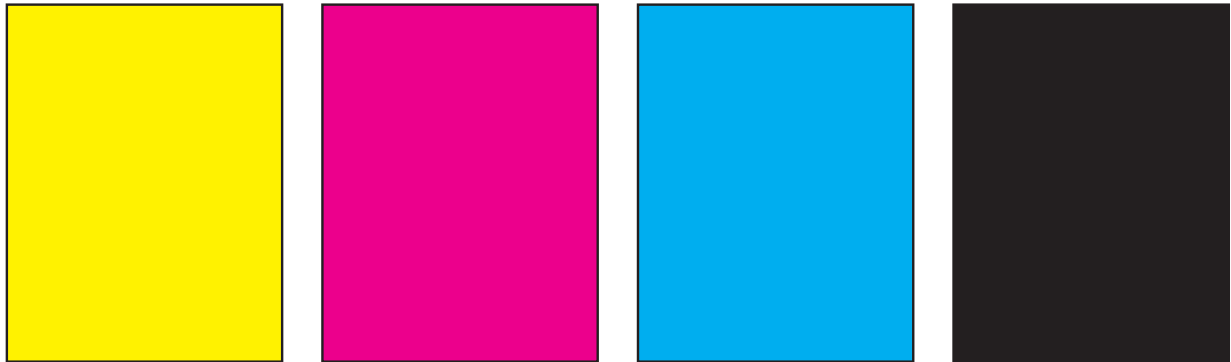

Tbt01034KA

Trouble substance

The entire paper is printed jet-black.

Possible causative parts

- TONER CARTRIDGE (Y) (PL6.1.1)/TONER CARTRIDGE (M) (PL6.1.2)/TONER CARTRIDGE (C) (PL6.1.3)/TONER CARTRIDGE (K) (PL6.1.4)
- XERO DEVE CRU ASSY (Y) (PL5.1.8)/XERO DEVE CRU ASSY (M) (PL5.1.9)/XERO DEVE CRU ASSY (C) (PL5.1.10)/XERO DEVE CRU ASSY (K) (PL5.1.11)
- BELT ASSY IBT (PL5.1.1)

Before commencing troubleshooting, check the paper transfer path. Make sure there is no foreign materials on the transfer path, such as staples, paper clips, scraps of paper and so on.

Step	Check	Yes	No
1	Checking the printer setting Is the [Output Color] option under the [Graphics] tab set to "Color (Auto)"?	Go to step 2	Set the option to "Color (Auto)"
2	Checking the TONER CARTRIDGE (Y, M, C and K) for installation. Reseat the suspected TONER CARTRIDGE (Y, M, C, or K), and then print the Toner Pallet Check. Is the image printed correctly? Checked by [Test Print] - [Toner Pallet Check] in diagnosis.	End of work.	Go to step 3
3	Checking after replacing the XERO DEVE CRU ASSY (Y, M, C or K) Replace the suspected XERO DEVE CRU ASSY (Y, M, C, or K) (Refer to Removal 5 / Replacement 58), and then print the Toner Pallet Check. Is the image printed correctly? Checked by [Test Print] - [Toner Pallet Check] in diagnosis.	End of work.	Go to step 4

Step	Check	Yes	No
4	Checking after replacing the BELT ASSY IBT Replace the BELT ASSY IBT (Refer to Removal 4 / Replacement 59), and then print the Toner Pallet Check. Is the image printed correctly? Checked by [Test Print] - [Toner Pallet Check] in diagnosis.	End of work.	Replace the Printer.

FIP-1.P4 Vertical blank lines (White stripes in paper transport direction)

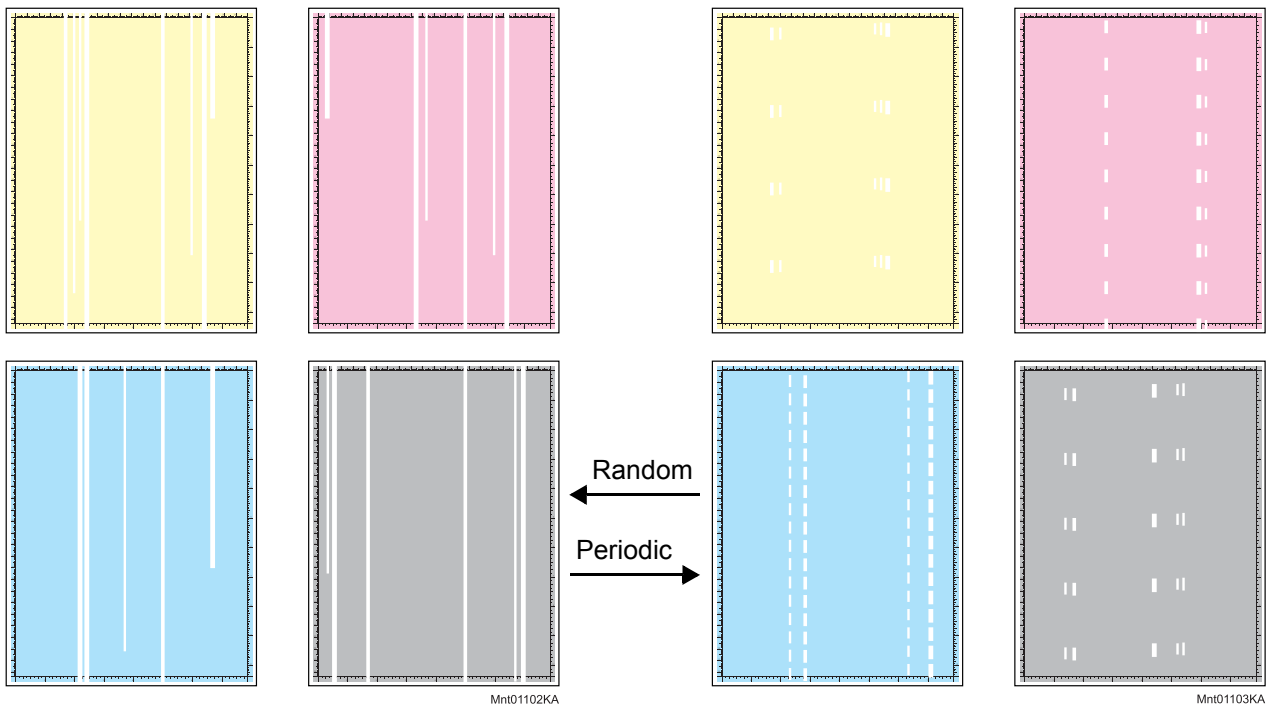
**Trouble substance**

There are some extremely faint or completely non-printed parts. Those non-printed parts cover a wide area vertically, along the paper feeding direction.

Possible causative parts

- TONER CARTRIDGE (Y) (PL6.1.1)/TONER CARTRIDGE (M) (PL6.1.2)/TONER CARTRIDGE (C) (PL6.1.3)/TONER CARTRIDGE (K) (PL6.1.4)
- XERO DEVE CRU ASSY (Y) (PL5.1.8)/XERO DEVE CRU ASSY (M) (PL5.1.9)/XERO DEVE CRU ASSY (C) (PL5.1.10)/XERO DEVE CRU ASSY (K) (PL5.1.11)
- BELT ASSY IBT (PL5.1.1)
- ROLL ASSY 2ND BTR (PL4.4.1)
- FUSER ASSY (PL7.1.5)

Before commencing troubleshooting, check the paper transfer path. Make sure there is no foreign materials on the transfer path, such as staples, paper clips, scraps of paper and so on.

Step	Check	Yes	No
1	<p>Checking after cleaning the inside of the Printer Print the Contamination check after cleaning the inside of the Printer. For how to clean the inside of the Printer, refer to "3.1 Cleaning Inside Printer" in Appendix.</p> <p>Is the image printed correctly? Checked by [Test Print]- [Contamination check] in diagnosis.. NOTE: If the CLEANER ASSY (Cleaning rod) is contaminated, replace the CLEANER ASSY, and then clean the printer again.</p>	End of work.	Go to step 4
2	<p>Checking the foreign substance.</p> <p>Remove the XERO DEVE CRY ASSY (Y, M, C, or K), and then check that there is no foreign substance around the window of the ROSS ASSY.</p> <p>Are there any foreign substances?</p>	Remove the foreign substance.	Go to step 5
3	<p>Checking after replacing the XERO DEVE CRU ASSY (Y, M, C or K) Replace the suspected XERO DEVE CRU ASSY (Y, M, C, or K) (Refer to Removal 5 / Replacement 58), and then print the Contamination check.</p> <p>Is the image printed correctly? Checked by [Test Print]- [Contamination check] in diagnosis..</p>	End of work.	Go to step 6
4	<p>Measure the blank line pitch. Print the Contamination Check to measure the pitch of the blank banding.</p> <p>Does the pitch of the blank banding match any of pitches shown in the Defective Component Gauge Chart? Checked by [Test Print]- [Contamination check] in diagnosis.</p>	Replace the corresponding parts.	Replace the Printer.

FIP-1.P5 Horizontal band cross out (White stripes in the horizontal direction)

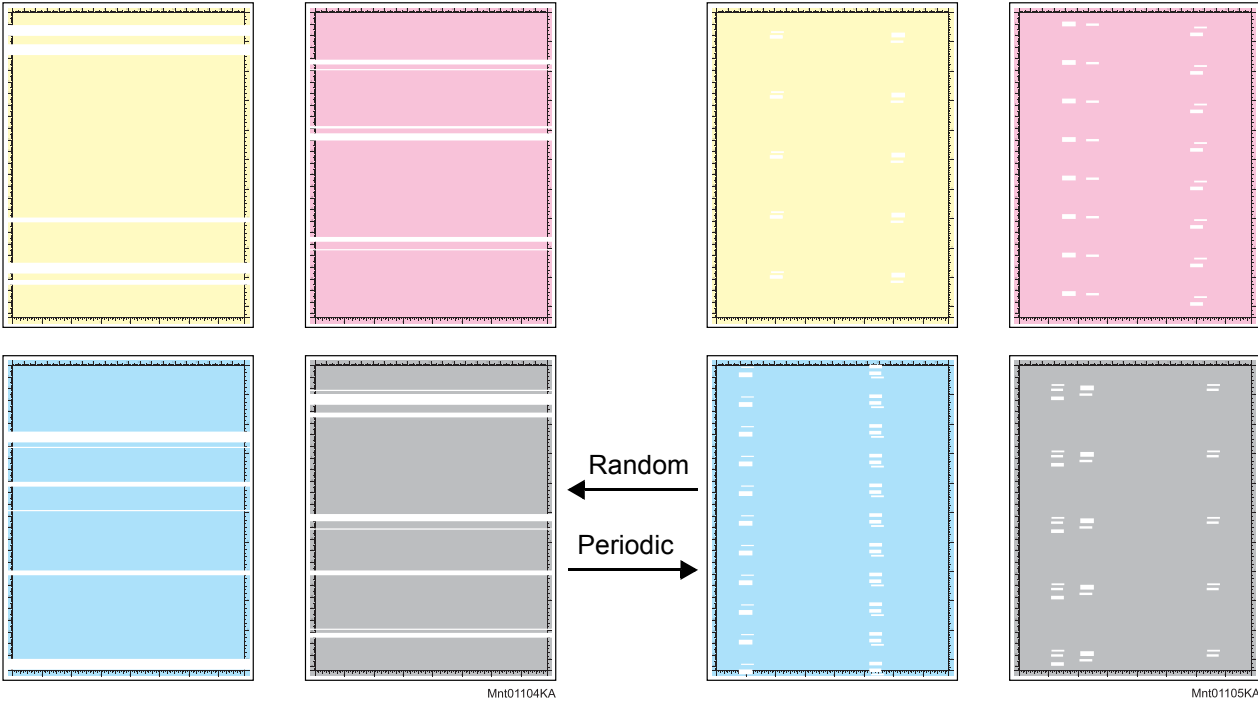

Trouble substance

There are some extremely faint or completely non-printed parts. Those non-printed parts cover a wide area horizontally, perpendicular to the paper feeding direction.

Possible causative parts

- TONER CARTRIDGE (Y) (PL6.1.1)/TONER CARTRIDGE (M) (PL6.1.2)/TONER CARTRIDGE (C) (PL6.1.3)/TONER CARTRIDGE (K) (PL6.1.4)
- XERO DEVE CRU ASSY (Y) (PL5.1.8)/XERO DEVE CRU ASSY (M) (PL5.1.9)/XERO DEVE CRU ASSY (C) (PL5.1.10)/XERO DEVE CRU ASSY (K) (PL5.1.11)
- BELT ASSY IBT (PL5.1.1)
- ROLL ASSY 2ND BTR (PL4.4.1)
- FUSER ASSY (PL7.1.5)

Before commencing troubleshooting, check the paper transfer path. Make sure there is no foreign materials on the transfer path, such as staples, paper clips, scraps of paper and so on.

Step	Check	Yes	No
1	Checking the remaining amount of the toner cartridge Is there sufficient toner remaining in the toner cartridge? Check the remaining amount of the toner cartridge via the Status Monitor.	Go to step 2	Replace the depleted toner cartridge.

Step	Check	Yes	No
2	<p>Checking the TONER CARTRIDGE (YMCK).</p> <p>Is the toner cartridges installed to the printer the Dell toner?</p>	Go to step 3.	Set the Non-Dell toner option to [Off]. (Refer to [Non-Dell Toner] in "10 Dell Printer Configuration Web Tool" in the User Guide.)
3	<p>Checking after cleaning the inside of the Printer</p> <p>Print the Contamination check after cleaning the inside of the Printer. For how to clean the inside of the Printer, refer to "3.1 Cleaning Inside Printer" in Appendix.</p> <p>Is the image printed correctly? Checked by [Test Print]- [Contamination check] in diagnosis.. NOTE: If the CLEANER ASSY (Cleaning rod) is contaminated, replace the CLEANER ASSY, and then clean the printer again.</p>	End of work.	Go to step 4
4	<p>Checking the foreign substance.</p> <p>Remove the XERO DEVE CRY ASSY (Y, M, C, or K), and then check that there is no foreign substance around the window of the ROSS ASSY.</p> <p>Are there any foreign substances?</p>	Remove the foreign substance.	Go to step 5
5	<p>Checking after replacing the XERO DEVE CRU ASSY (Y, M, C or K)</p> <p>Replace the suspected XERO DEVE CRU ASSY (Y, M, C, or K) (Refer to Removal 5 / Replacement 58), and then print the Contamination check.</p> <p>Is the image printed correctly? Checked by [Test Print]- [Contamination check] in diagnosis..</p>	End of work.	Go to step 6
6	<p>Measure the blank line pitch. Print the Contamination Check to measure the pitch of the blank banding.</p> <p>Does the pitch of the blank banding match any of pitches shown in the Defective Component Gauge Chart ? Checked by [Test Print]- [Contamination check] in diagnosis.</p>	Replace the corresponding parts.	Replace the Printer.

FIP-1.P6 Vertical stripes

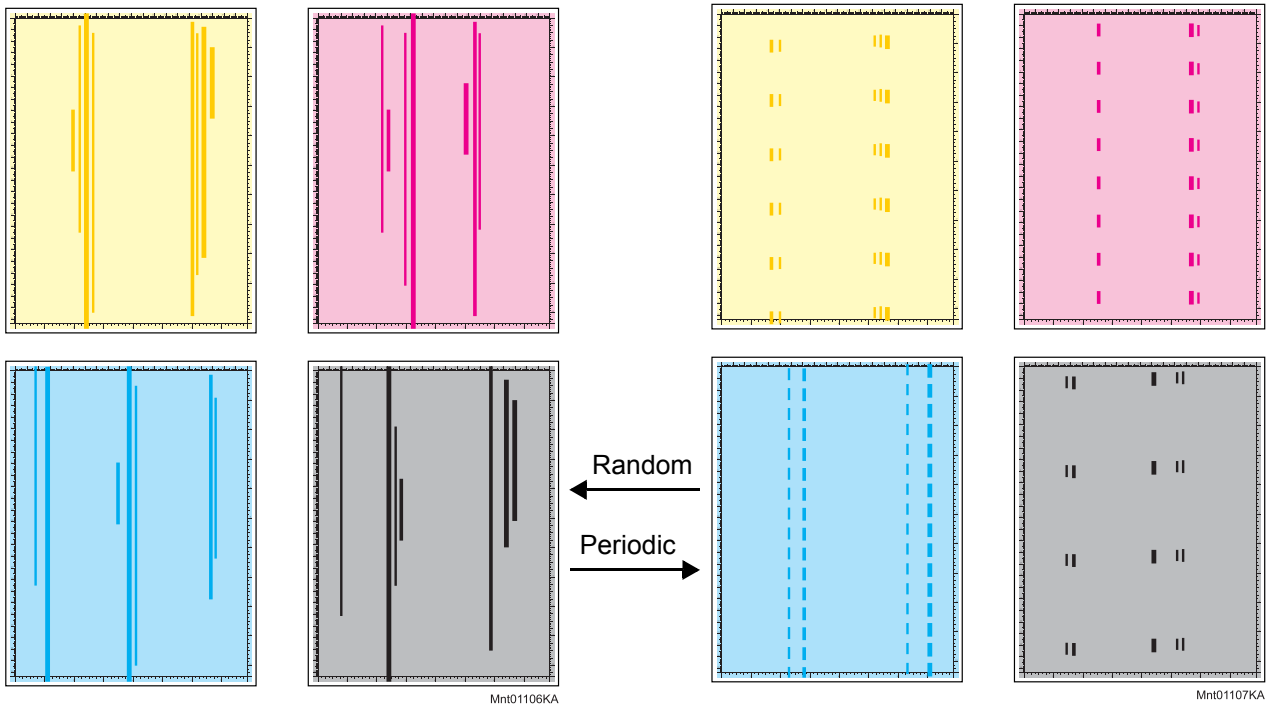
**Trouble substance**

There are vertical black stripes along the paper.

Possible causative parts

- TONER CARTRIDGE (Y) (PL6.1.1)/TONER CARTRIDGE (M) (PL6.1.2)/TONER CARTRIDGE (C) (PL6.1.3)/TONER CARTRIDGE (K) (PL6.1.4)
- XERO DEVE CRU ASSY (Y) (PL5.1.8)/XERO DEVE CRU ASSY (M) (PL5.1.9)/XERO DEVE CRU ASSY (C) (PL5.1.10)/XERO DEVE CRU ASSY (K) (PL5.1.11)
- BELT ASSY IBT (PL5.1.1)
- ROLL ASSY 2ND BTR (PL4.4.1)
- FUSER ASSY (PL7.1.5)

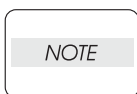

If the stripes at the top or back of the paper, replace the BELT ASSY IBT only.

Before commencing troubleshooting, check the paper transfer path. Make sure there is no foreign materials on the transfer path, such as staples, paper clips, scraps of paper and so on.

Step	Check	Yes	No
1	<p>Checking the TONER CARTRIDGE (YMCK).</p> <p>Is the toner cartridges installed to the printer the Dell toner?</p>	Go to step 2.	Set the Non-Dell toner option to [Off]. (Refer to [Non-Dell Toner] in "10 Dell Printer Configuration Web Tool" in the User Guide.)
2	<p>Checking after cleaning the inside of the Printer Print the Contamination check after cleaning the inside of the Printer. For how to clean the inside of the Printer, refer to "3.1 Cleaning Inside Printer" in Appendix.</p> <p>Is the image printed correctly? Checked by [Test Print]- [Contamination check] in diagnosis.. NOTE: If the CLEANER ASSY (Cleaning rod) is contaminated, replace the CLEANER ASSY, and then clean the printer again.</p>	End of work.	Go to step 3.
3	<p>Checking after replacing the XERO DEVE CRU ASSY (Y, M, C or K) Replace the suspected XERO DEVE CRU ASSY (Y, M, C, or K) (Refer to Removal 5 / Replacement 58), and then print the Contamination check.</p> <p>Is the image printed correctly? Checked by [Test Print]- [Contamination check] in diagnosis..</p>	End of work.	Go to step 4.
4	<p>Measure the blank line pitch. Print the Contamination Check to measure the pitch of the blank banding.</p> <p>Does the pitch of the blank banding match any of pitches shown in the Defective Component Gauge Chart ? Checked by [Test Print]- [Contamination check] in diagnosis.</p>	Replace the corresponding parts.	Replace the Printer.

FIP-1.P7 Horizontal stripes

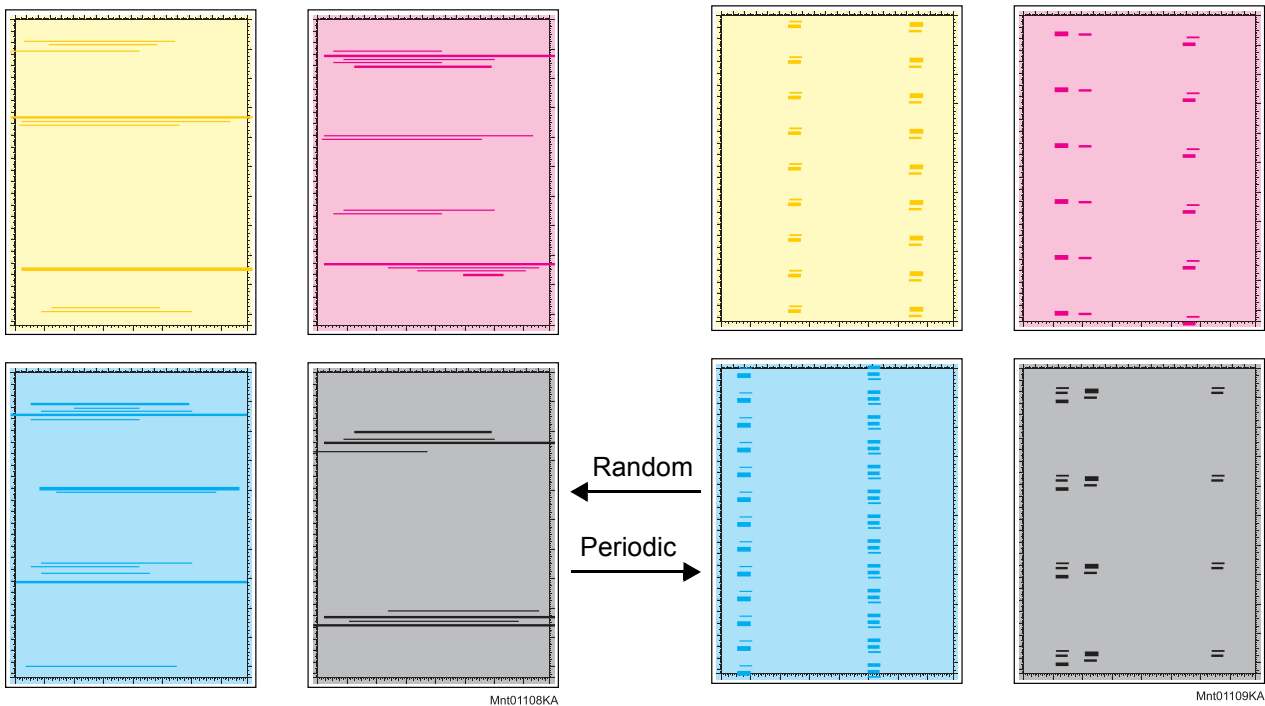

Trouble substance

There are horizontal black stripes (perpendicular to the paper path direction) along the paper.

Possible causative parts

- TONER CARTRIDGE (Y) (PL6.1.1)/TONER CARTRIDGE (M) (PL6.1.2)/TONER CARTRIDGE (C) (PL6.1.3)/TONER CARTRIDGE (K) (PL6.1.4)
- XERO DEVE CRU ASSY (Y) (PL5.1.8)/XERO DEVE CRU ASSY (M) (PL5.1.9)/XERO DEVE CRU ASSY (C) (PL5.1.10)/XERO DEVE CRU ASSY (K) (PL5.1.11)
- BELT ASSY IBT (PL5.1.1)
- ROLL ASSY 2ND BTR (PL4.4.1)
- FUSER ASSY (PL7.1.5)

Before commencing troubleshooting, check the paper transfer path. Make sure there is no foreign materials on the transfer path, such as staples, paper clips, scraps of paper and so on.

Step	Check	Yes	No
1	Checking the remaining amount of the toner cartridge Is there sufficient toner remaining in the toner cartridge? Check the remaining amount of the toner cartridge via the Status Monitor.	Go to step 2	Replace the depleted toner cartridge.

Step	Check	Yes	No
2	<p>Checking the TONER CARTRIDGE (YMCK).</p> <p>Is the toner cartridges installed to the printer the Dell toner?</p>	Go to step 3.	<p>Set the Non-Dell toner option to [Off]. (Refer to [Non-Dell Toner] in "10 Dell Printer Configuration Web Tool" in the User Guide.)</p>
3	<p>Checking after cleaning the inside of the Printer Print the Contamination check after cleaning the inside of the Printer. For how to clean the inside of the Printer, refer to "3.1 Cleaning Inside Printer" in Appendix.</p> <p>Is the image printed correctly? Checked by [Test Print]- [Contamination check] in diagnosis.. NOTE: If the CLEANER ASSY (Cleaning rod) is contaminated, replace the CLEANER ASSY, and then clean the printer again.</p>	End of work.	Go to step 4
4	<p>Checking after replacing the XERO DEVE CRU ASSY (Y, M, C or K) Replace the suspected XERO DEVE CRU ASSY (Y, M, C, or K) (Refer to Removal 5 / Replacement 58), and then print the Contamination check.</p> <p>Is the image printed correctly? Checked by [Test Print]- [Contamination check] in diagnosis..</p>	End of work.	Go to step 5
5	<p>Measure the blank line pitch. Print the Contamination Check to measure the pitch of the blank banding.</p> <p>Does the pitch of the blank banding match any of pitches shown in the Defective Component Gauge Chart ? Checked by [Test Print]- [Contamination check] in diagnosis.</p>	Replace the corresponding parts.	Replace the Printer.

FIP-1.P8 Partial Deletion

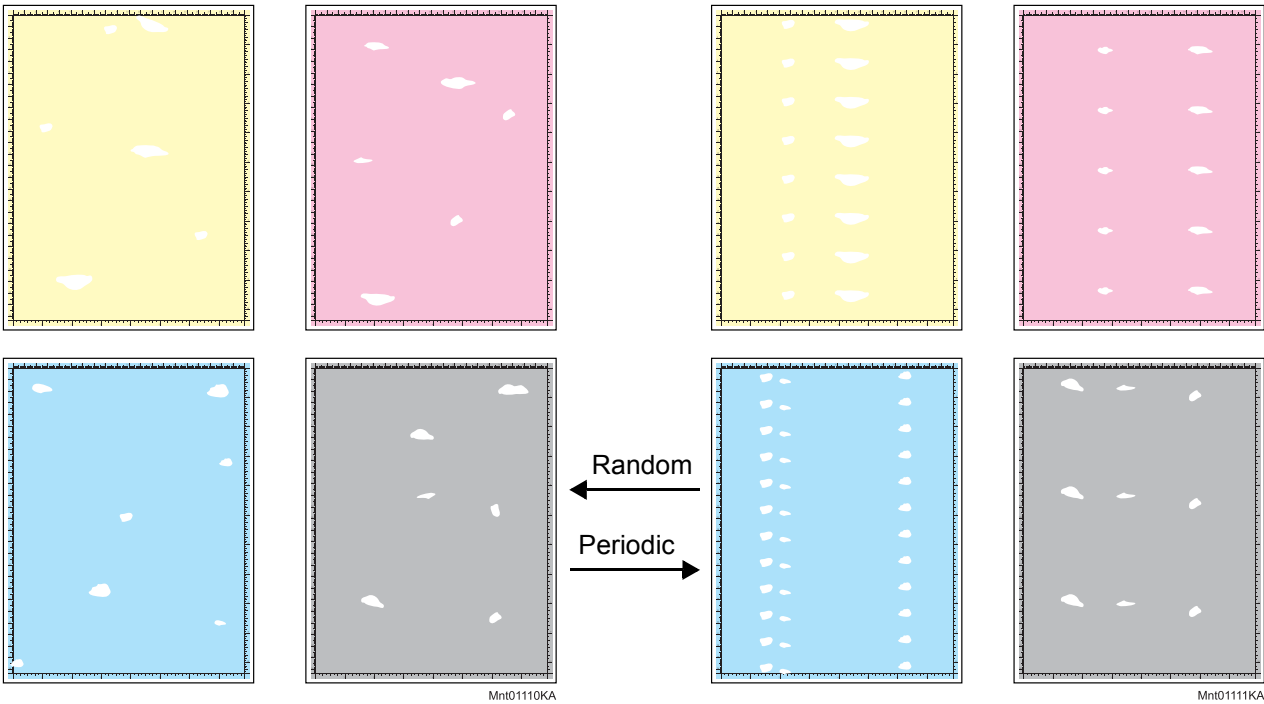

Trouble substance

There are some extremely faint or completely missing parts in a limited area on the paper.

Possible causative parts

- TONER CARTRIDGE (Y) (PL6.1.1)/TONER CARTRIDGE (M) (PL6.1.2)/TONER CARTRIDGE (C) (PL6.1.3)/TONER CARTRIDGE (K) (PL6.1.4)
- XERO DEVE CRU ASSY (Y) (PL5.1.8)/XERO DEVE CRU ASSY (M) (PL5.1.9)/XERO DEVE CRU ASSY (C) (PL5.1.10)/XERO DEVE CRU ASSY (K) (PL5.1.11)
- BELT ASSY IBT (PL5.1.1)
- ROLL ASSY 2ND BTR (PL4.4.1)
- FUSER ASSY (PL7.1.5)

Before commencing troubleshooting, check the paper transfer path. Make sure there is no foreign materials on the transfer path, such as staples, paper clips, scraps of paper and so on.

Step	Check	Yes	No
1	Checking the TONER CARTRIDGE (Y, M, C and K) for installation. Reseat the suspected TONER CARTRIDGE (Y, M, C, or K), and then print the Contamination Check. Is the image printed correctly? Checked by [Test Print]- [Contamination check] in diagnosis.	End of work.	Go to step 2

Step	Check	Yes	No
2	<p>Checking the XERO DEVE CRU ASSY (Y, M, C or K) for installation. Replace the suspected XERO DEVE CRU ASSY (Y, M, C, or K) (Refer to Removal 5 / Replacement 58), and then print the Contamination Check.</p> <p>Is the image printed correctly? Checked by [Test Print]- [Contamination check] in diagnosis.</p>	End of work.	Go to step 3
3	<p>Checking after replacing the XERO DEVE CRU ASSY (Y, M, C or K) Replace the suspected XERO DEVE CRU ASSY (Y, M, C, or K) (Refer to Removal 5 / Replacement 58), and then print the Contamination check.</p> <p>Is the image printed correctly? Checked by [Test Print]- [Contamination check] in diagnosis..</p>	End of work.	Go to step 4.
4	<p>Measure the blank, spot, or Line pitch. Print the Contamination Check to measure the pitch of the blank, spot or Line banding.</p> <p>Does the pitch of the blank, spot or Line banding match any of pitches shown in the Defective Component Gauge Chart (Reference_1)? Checked by [Test Print] - [Contamination check] in diagnosis.</p>	Replace the corresponding parts.	Replace the Printer.

FIP-1.P9 Spots

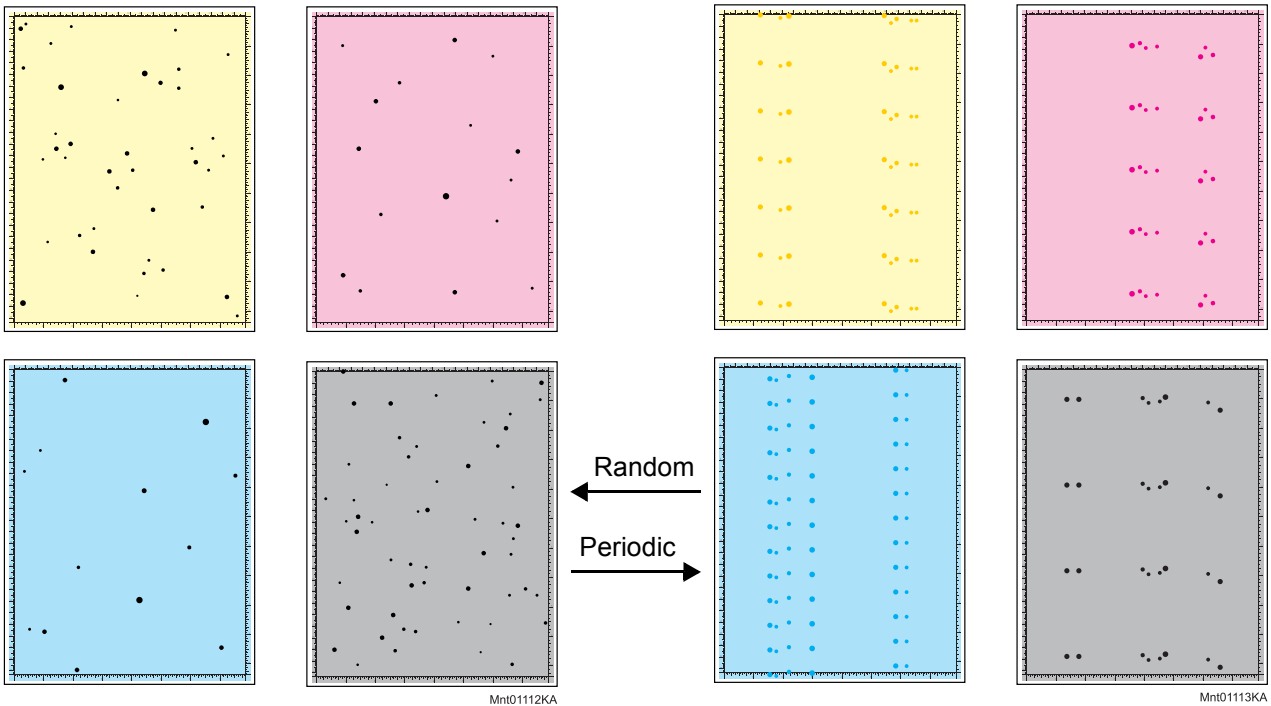

Trouble substance

There are toner spots all over the paper disorderedly.

Possible causative parts

- TONER CARTRIDGE (Y) (PL6.1.1)/TONER CARTRIDGE (M) (PL6.1.2)/TONER CARTRIDGE (C) (PL6.1.3)/TONER CARTRIDGE (K) (PL6.1.4)
- XERO DEVE CRU ASSY (Y) (PL5.1.8)/XERO DEVE CRU ASSY (M) (PL5.1.9)/XERO DEVE CRU ASSY (C) (PL5.1.10)/XERO DEVE CRU ASSY (K) (PL5.1.11)
- BELT ASSY IBT (PL5.1.1)
- ROLL ASSY 2ND BTR (PL4.4.1)
- FUSER ASSY (PL7.1.5)

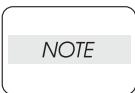

If the toner spot at the top or back of the paper, replace the BELT ASSY IBT only.

Before commencing troubleshooting, check the paper transfer path. Make sure there is no foreign materials on the transfer path, such as staples, paper clips, scraps of paper and so on.

Step	Check	Yes	No
1	Checking the TONER CARTRIDGE (Y, M, C and K) for installation. Reseat the suspected TONER CARTRIDGE (Y, M, C, or K), and then print the Contamination Check. Is the image printed correctly? Checked by [Test Print]- [Contamination check] in diagnosis.	End of work.	Go to step 2

Step	Check	Yes	No
2	<p>Checking the XERO DEVE CRU ASSY (Y, M, C or K) for installation. Replace the suspected XERO DEVE CRU ASSY (Y, M, C, or K) (Refer to Removal 5 / Replacement 58), and then print the Contamination Check.</p> <p>Is the image printed correctly? Checked by [Test Print]- [Contamination check] in diagnosis.</p>	End of work.	Go to step 3
3	<p>Measure the blank, spot, or Line pitch. Print the Contamination Check to measure the pitch of the blank, spot or Line banding.</p> <p>Does the pitch of the blank, spot or Line banding match any of pitches shown in the Defective Component Gauge Chart (Reference_1)? Checked by [Test Print] - [Contamination check] in diagnosis.</p>	Replace the corresponding parts.	Replace the Printer.

FIP-1.P10 Afterimage (Ghost)

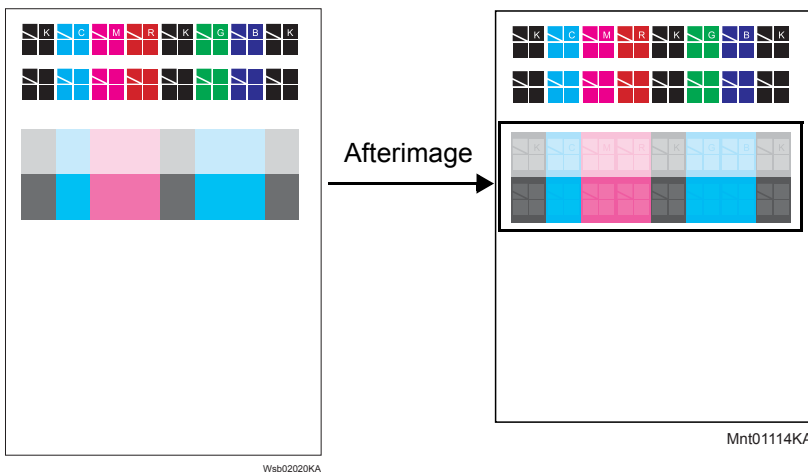

Web02020KA

Mnt01114KA

Trouble substance

The ghost appears on the paper. The ghost may be the image of the previous page, or a part of the page currently printing.

Possible causative parts

- XERO DEVE CRU ASSY (Y) (PL5.1.8)/XERO DEVE CRU ASSY (M) (PL5.1.9)/XERO DEVE CRU ASSY (C) (PL5.1.10)/XERO DEVE CRU ASSY (K) (PL5.1.11)
- BELT ASSY IBT (PL5.1.1)
- ROLL ASSY 2ND BTR (PL4.4.1)
- FUSER ASSY (PL7.1.5)

Before commencing troubleshooting, check the paper transfer path. Make sure there is no foreign materials on the transfer path, such as staples, paper clips, scraps of paper and so on.

Step	Check	Yes	No
1	Checking the Afterimage (Ghost). Print the Ghost Configuration Chart Page. Is the image printed correctly? Checked by [Chart Print]- [Ghost Configuration Chart] in Tool Box.	End of work.	Go to step 2
2	Checking the paper Does the paper satisfy the specification?	Go to step 3.	Change the paper to the one that satisfies the specification. (Refer to "11 Print Media Guidelines" in the User Guide.)
3	Checking the ERASE LAMP. Does the ERASE LAMP function normally? Checked by [Digital Output] - [091-005(YMC) / 091-006(K)] in diagnosis.	Go to step 4.	Replace the LAMP ASSY ERASE. (Refer to Removal 51/ Replacement 12)
4	Checking after replacing the XERO DEVE CRU ASSY (Y, M, C or K) Replace the suspected XERO DEVE CRU ASSY (Y, M, C, or K) (Refer to Removal 5 / Replacement 58), and then print the Ghost Configuration Chart. Is the image printed correctly? Checked by [Chart Print]- [Ghost Configuration Chart] in Tool Box.	End of work.	Go to step 5.

Step	Check	Yes	No
5	<p>Checking after replacing the BELT ASSY IBT Replace the BELT ASSY IBT (Refer to Removal 4 / Replacement 59), and then print the Ghost Configuration Chart.</p> <p>Is the image printed correctly? Checked by [Test Print] - [Ghost Configuration Chart] in diagnosis.</p>	End of work.	Go to step 6.
6	<p>Checking after replacing the ROLL ASSY 2ND BTR Replace the ROLL ASSY 2ND BTR (Refer to Removal 8 / Replacement 55), and then print the Ghost Configuration Chart.</p> <p>Is the image printed correctly? Checked by [Test Print] - [Ghost Configuration Chart] in diagnosis.</p>	End of work.	Go to step 7.
7	<p>Checking after replacing the FUSER ASSY. Replace the Fuser ASSY, and then print the Ghost Configuration Chart.</p> <p>Is the image printed correctly? Checked by [Chart Print]- [Ghost Configuration Chart] in Tool Box.</p>	End of work.	Replace the Printer.

FIP-1.P11 High Background

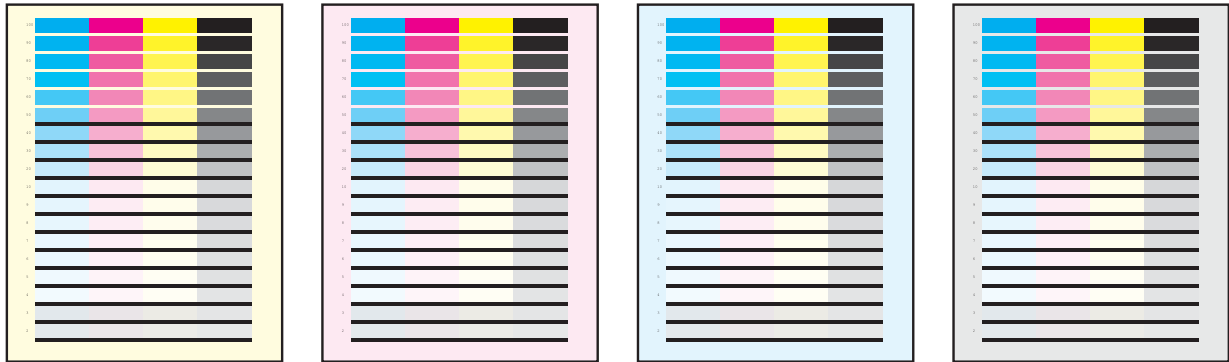

Tbt01035KA

Trouble substance

There is toner stain all over or a part of the page. The stain appears as very bright color (Y, M, C, K or etc.) stain.

Possible causative parts

- TONER CARTRIDGE (Y) (PL6.1.1)/TONER CARTRIDGE (M) (PL6.1.2)/TONER CARTRIDGE (C) (PL6.1.3)/TONER CARTRIDGE (K) (PL6.1.4)
- XERO DEVE CRU ASSY (Y) (PL5.1.8)/XERO DEVE CRU ASSY (M) (PL5.1.9)/XERO DEVE CRU ASSY (C) (PL5.1.10)/XERO DEVE CRU ASSY (K) (PL5.1.11)
- BELT ASSY IBT (PL5.1.1)
- ROLL ASSY 2ND BTR (PL4.4.1)

Before commencing troubleshooting, check the paper transfer path. Make sure there is no foreign materials on the transfer path, such as staples, paper clips, scraps of paper and so on.

Step	Check	Yes	No
1	Checking the Grey Background. Print the Grey Background Page. Is the image printed correctly? Checked by [Test Print]- [Gradation] in diagnosis..	End of work.	Go to step 2
2	Checking after replacing the XERO DEVE CRU ASSY (Y, M, C or K) Replace the suspected XERO DEVE CRU ASSY (Y, M, C, or K) (Refer to Removal 5 / Replacement 58), and then print the Gradation Page. Is the image printed correctly? Checked by [Test Print]- [Gradation] in diagnosis..	End of work.	Go to step 3

Step	Check	Yes	No
3	Checking after replacing the BELT ASSY IBT Replace the BELT ASSY IBT (Refer to Removal 4 / Replacement 59), and then print the Gradation Page. Is the image printed correctly? Checked by [Test Print]- [Gradation] in diagnosis..	End of work.	Go to step 4
4	Checking after replacing the ROLL ASSY 2ND BTR Replace the ROLL ASSY 2ND BTR (Refer to Removal 8 / Replacement 55), and then print the Gradation Page. Is the image printed correctly? Checked by [Test Print]- [Gradation] in diagnosis..	End of work.	Replace the Printer.

FIP-1.P12 Skew

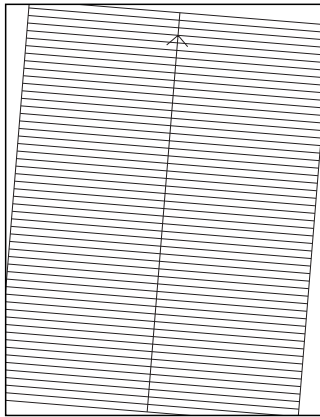

Mnt01116KA

Trouble substance

The printed image is not paralleled with both sides of the paper.

Possible causative parts

- ROLL ASSY FEED MSI (PL4.2.21)
- KIT MSI SEPARATOR ROLL (PL3.1.99)
- KITFEED ROLL & SEPARATOR ROLL (PL2.1.99)

Before commencing troubleshooting, check the paper transfer path. Make sure there is no foreign materials on the transfer path, such as staples, paper clips, scraps of paper and so on.

Step	Check	Yes	No
1	Check the side guide of Tray (or side guide of MPF) Is the side guide of Tray (or side guide of MPF) correctly set?	Go to Step2.	Set the side guide correctly.
2	Checking the paper condition. Is the paper in the tray new and dry one?	Go to Step3.	Replace the paper with a new and dry one.
3	Checking the Belt Unit for installation Reseat the Belt Unit. Does the error still occur when printing?	Go to Step4.	End of work.
4	Checking after replacing the KIT FEED ROLL & SEPARATOR ROLL 550/110 (or ROLL ASSY FEED MSI and SEPARATOR ASSY MSI). Replace the KIT FEED ROLL & SEPARATOR ROLL 550/110 (or ROLL ASSY FEED MSI and SEPARATOR ASSY MSI). Does the error still occur when printing?	Replace the Printer.	End of work.

FIP-1.P13 Paper damage/Wrinkled Paper]

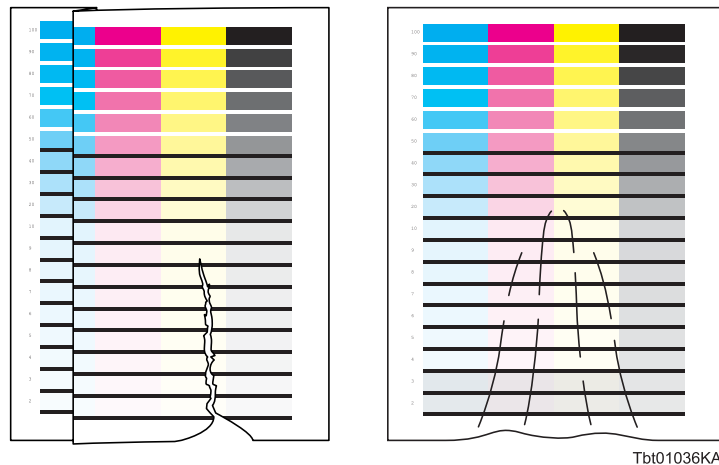
**Trouble substance**

The paper comes out from the printer wrinkled, folded or worn-out.

Possible causative parts

- ROLL ASSY FEED MSI (PL4.2.21)
- KIT MSI SEPARATOR ROLL (PL3.1.99)
- KITFEED ROLL & SEPARATOR ROLL (PL2.1.99)

Before commencing troubleshooting, check the paper transfer path. Make sure there is no foreign materials on the transfer path, such as staples, paper clips, scraps of paper and so on.

Step	Check	Yes	No
1	Checking the paper condition. Is the paper in the tray new and dry one?	Replace the paper with a new and dry one.	Go to step 2
2	Checking the foreign substance Open the Front cover; check the surrounding area of the TONER CARTRIDGE (YMCK), the BELT ASSY IBT, ROLL ASSY 2ND BTR, ROLL ASSY REGI RUBBER, ROLL REGI METAL and MPF Tray. Are there any foreign substances?	Remove the foreign substances.	Go to step 3
3	Checking the surface of BELT ASSY IBT. Are there any damages on the surface of BELT ASSY IBT?	Replace the BELT ASSY IBT. (Refer to Removal 4/ Replacement 59)	Go to step 4.
4	Checking the TONER CARTRIDGE (YMCK) , XERO DEVE CRU ASSY (YMCK) , and FUSER ASSY installation Reseat the TONER CARTRIDGE (YMCK), XERO DEVE CRU ASSY (YMCK) and FUSER ASSY. Does the error still occur when printing?	Go to step 5.	End of work.
5	Checking the paper feeding tray Is the damaged paper fed from the MPF?	Go to step 6.	Go to step 8.

Step	Check	Yes	No
6	Checking the paper installation. Reseat the paper and reset the paper guide on the MPF. Does the error still occur when printing?	Go to step 7.	End of work.
7	Checking after replacing the feed roller Replace the ROLL ASSY FEED MSI. Does the error still occur when printing?	Replace the KIT MSI SEPARATOR ROLL MSI. (Refer to Removal 12/ Replacement 51)	End of work.
8	Checking the paper installation Reseat the paper in the paper cassette and reset the side and end guides. Does the error still occur when printing?	Replace the KIT MSI SEPARATOR ROLL MSI. (Refer to Removal 12/ Replacement 51)	End of work.

FIP-1.P14 Unfusing

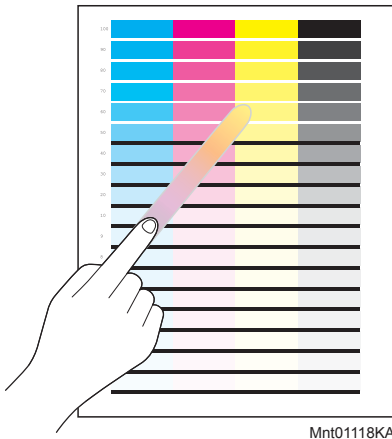
**Trouble substance**

The printed image is not fixed on the paper properly. The image easily comes off when rubbed.

Possible causative parts

- XERO DEVE CRU ASSY (Y) (PL5.1.8)/XERO DEVE CRU ASSY (M) (PL5.1.9)/XERO DEVE CRU ASSY (C) (PL5.1.10)/XERO DEVE CRU ASSY (K) (PL5.1.11)
- FUSER ASSY (PL7.1.5)
- ROLL ASSY 2ND BTR (PL4.4.1)

Before commencing troubleshooting, check the paper transfer path. Make sure there is no foreign materials on the transfer path, such as staples, paper clips, scraps of paper and so on.

Step	Check	Yes	No
1	Checking the Sheet/Envelope Switching Lever Is the Sheet/Switching Envelope Lever positioned at the Envelop Mode (bottom)?	Lift Up the Lever.	Go to step 2
2	Checking the paper Does the paper satisfy the specification?	Go to step 3.	Change the paper to the one that satisfies the specification. (Refer to "11 Print Media Guidelines" in the User Guide.)
3	Checking the Fuser ASSY for installation Reseat the Fuser ASSY, and then print the Gradation Page. Is the image printed correctly? Checked by [Test Print]- [Gradation] in diagnosis..	End of work.	Go to step 4
4	Checking after replacing the FUSER ASSY. Replace the Fuser ASSY (Refer to Removal 7 / Replacement 56), and then print the Gradation Page. Is the image printed correctly? Checked by [Test Print]- [Gradation] in diagnosis..	End of work.	Go to step 5
5	Checking after replacing the XERO DEVE CRU ASSY (Y, M, C and K) Replace the suspected XERO DEVE CRU ASSY (Y, M, C, or K) (Refer to Removal 5 / Replacement 58), and then print the Gradation Page. Is the image printed correctly? Checked by [Test Print]- [Gradation] in diagnosis..	End of work.	Replace the Printer.

Step	Check	Yes	No
6	Checking after replacing the ROLL ASSY 2ND BTR Replace the ROLL ASSY 2ND BTR (Refer to Removal 8 / Replacement 55), and then print the Gradation Page. Is the image printed correctly? Checked by [Test Print]- [Gradation] in diagnosis..	End of work.	Replace the Printer.

FIP-1.P15 Color Registration (Color Shift)

- Troubleshooting of a control system

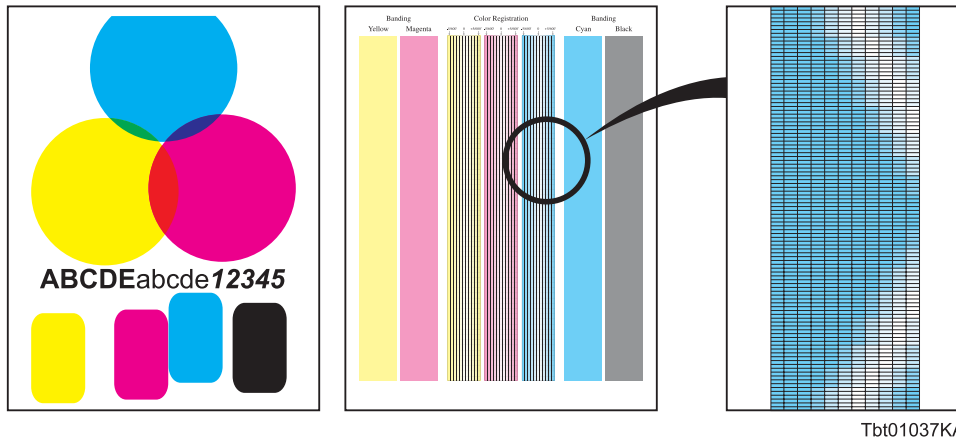

Trouble substance

A yellow or black image printed is not overlapped on a cyan or magenta image correctly.

Possible causative parts

- PWBA MCU (PL10.2.18)

Before commencing troubleshooting, check the paper transfer path. Make sure there is no foreign materials on the transfer path, such as staples, paper clips, scraps of paper and so on.

Step	Check	Yes	No
1	Clean the CTD (ADC) Sensor. Refer to Appendix_ "3.2 Cleaning the Conductivity Temperature Depth (CTD) Sensor" for details of how to clean the CTD Sensor. Is the image printed correctly?	End of work.	Go to step 2
2	Checking after cleaning the inside of the Printer For how to clean the inside of the Printer, refer to "3.1 Cleaning Inside Printer" in Appendix. Is the image printed correctly? NOTE: If the CLEANER ASSY (Cleaning rod) is contaminated, replace the CLEANER ASSY, and then clean the printer again.	End of work.	Go to step 3
3	Executing auto adjustment of color registration Execute the auto-calibration of color registration, and then print the color registration chart For details of auto-calibration of color registration, refer to [Auto Registration Adjustment] in "10 Dell Printer Configuration Web Tool" in the User Guide. Is the image printed correctly?	End of work.	Go to step 4

Step	Check	Yes	No
4	Executing manual adjustment of color registration After manually adjusting the color registration, print the color registration chart. For details of manual adjustment of color registration, refer to [Color Registration Adjustments] in "10 Dell Printer Configuration Web Tool" in the User Guide. Is the image printed correctly?	End of work.	Replace the Printer.

FIP-1.P16 Color Registration (Image Shift)

- Troubleshooting of a paper feeding system

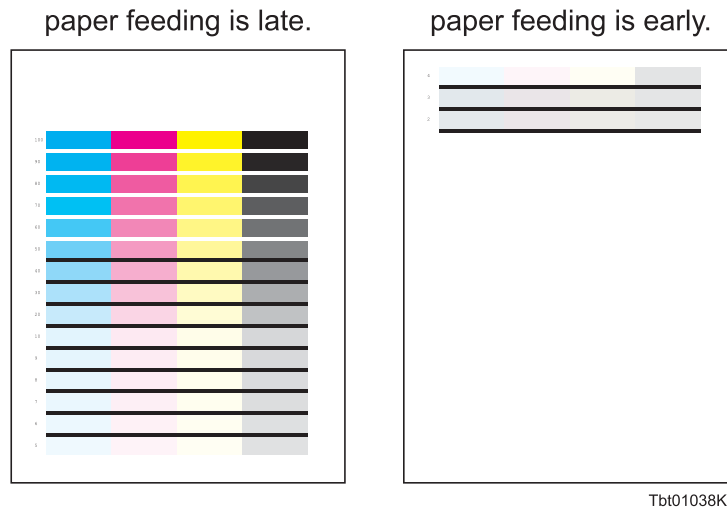
**Trouble substance**

A yellow or black image printed is not overlapped on a cyan or magenta image correctly.

Possible causative parts

- FEEDER ASSY (PL3.2.1)

Before commencing troubleshooting, check the paper transfer path. Make sure there is no foreign materials on the transfer path, such as staples, paper clips, scraps of paper and so on.

Step	Check	Yes	No
1	Checking the paper condition. Is the paper in the tray new and dry one?	Replace the paper with a new and dry one.	Go to step 2
2	Checking the foreign substance Open the Front cover; check the surrounding area of the BELT ASSY IBT, ROLL ASSY 2ND BTR, ROLL ASSY REGI RUBBER, ROLL REGI METAL and MPF Tray. Are there any foreign substances?	Remove the foreign substances.	Go to step 3
3	Checking the surface of BELT ASSY IBT. Are there any damages on the surface of BELT ASSY IBT?	Replace the BELT ASSY IBT. (Refer to Removal 4/ Replacement 59)	Go to step 4.
4	Checking the paper feeding tray Is the damaged paper fed from the MPF?	Go to step 5.	Go to step 7.
5	Checking the paper installation. Reseat the paper and reset the paper guide on the MPF. Does the error still occur when printing?	Go to step 6.	End of work.

Step	Check	Yes	No
6	Checking after replacing the feed roller Replace the ROLL ASSY FEED MSI. Does the error still occur when printing?	Replace the KIT MSI SEPARATOR ROLL MSI. (Refer to Removal 12/ Replacement 51)	End of work.
7	Checking the paper installation Reseat the paper in the paper cassette and reset the side and end guides. Does the error still occur when printing?	Replace the KIT MSI SEPARATOR ROLL MSI. (Refer to Removal 12/ Replacement 51)	End of work.

5. Abnormal Noise Trouble

5.1 Entry Chart for Abnormal Noise Troubleshooting

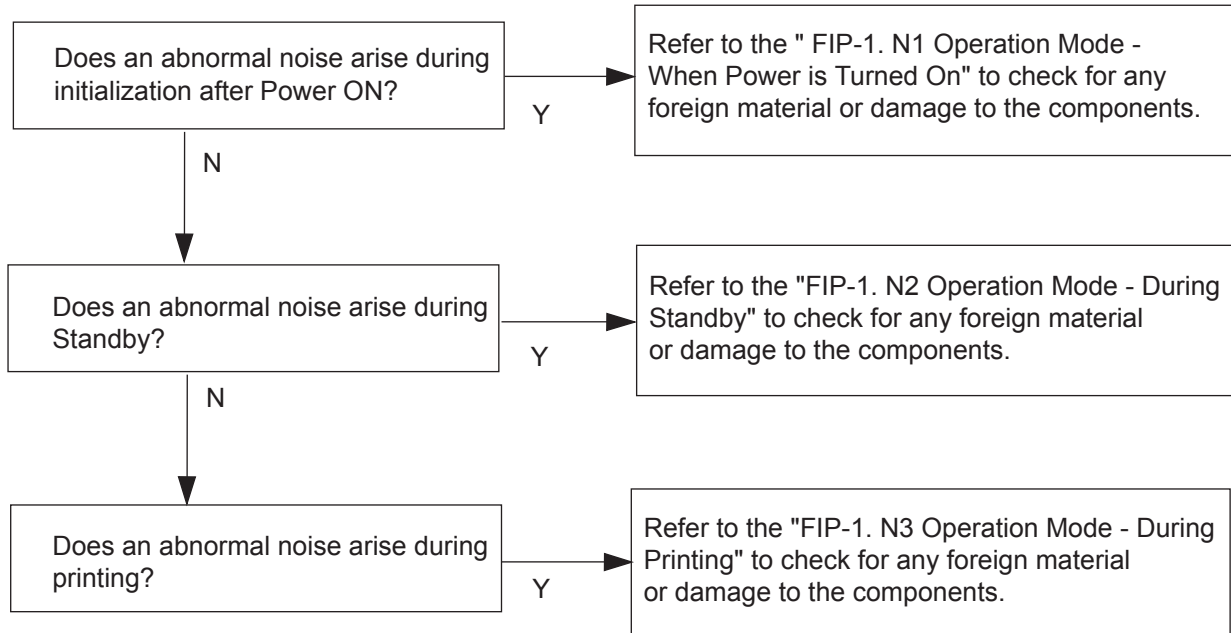

5.2 Operation Mode Table

FIP-1.N1 Noise: When Power is turned on

Step	Check	Yes	No
	Possible causative parts: FUSER ASSY (PL7.1.5) TONER CARTRIDGE (Y) (PL6.1.1) TONER CARTRIDGE (M) (PL6.1.2) TONER CARTRIDGE (C) (PL6.1.3) TONER CARTRIDGE (K) (PL6.1.4) XERO DEVE CRU ASSY (Y) (PL5.1.8) XERO DEVE CRU ASSY (M) (PL5.1.9) XERO DEVE CRU ASSY (C) (PL5.1.10) XERO DEVE CRU ASSY (K) (PL5.1.11) BELT ASSY IBT (PL5.1.1) WASTE TONER BOX (PL6.1.13) DRIVE ASSY FSR (PL9.1.1) MOTOR ASSY DISP (PL6.1.9) KIT LINK XERO DRIVE (PL9.2.98) DRIVE ASSY IBT (PL9.1.3) DRIVE ASSY DEVE K (PL9.2.10) DRIVE ASSY PH (PL9.1.4) FEEDER ASSY 550 (PL12.1.2)		
1	Check the Firmware Version. The version of the firmware for the printer should be checked with the Printer Information of the Web Tool. The latest Firmware Version should be checked on the Dell Support Web site. Is the firmware the latest version?	Go to step 2.	Download the latest version of the firmware from the Dell Support Web site. and then go to step 2.
2	Checking the Fuser Motor. Does the noise arise from the printer? Checked by [Digital Output]-[010-001] in diagnosis. Warning: When checking the motor, stop within ten seconds. Executing a motor check for ten seconds or longer may cause damage to the printer. To stop the motor check, press the <Cancel> key.	Go to step 3.	Go to step 4.
3	Checking after Reseat the FUSER ASSY. Reseat the FUSER ASSY. Does the noise arise when the power is turned off and on? Warning: Start the operation after the FUSER ASSY has cooled down.	Replace the Fuser. If not, replace the DRIVE ASSY FSR (Refer to Removal 54/Replacement 9).	End of work.

Step	Check	Yes	No
4	<p>Checking the Toner Motor (YMCK).</p> <p>Does the noise arise from the printer? Checked by [Digital Output]-[093-007(Y)/ 093-008(M)/ 093-009(C)/ 093-010(K)] in diagnosis.</p> <p>Warning: When checking the motor, stop within three seconds. Executing a motor check for three seconds or longer may cause damage to the printer. To stop the motor check, press the <Cancel> key.</p>	Go to step 5.	Go to step 6.
5	<p>Checking after reseal the Toner Cartridge (Y, M, C, or K) in problem.</p> <p>Reseat the TONER CARTRIDGE affected.</p> <p>Does the noise arise when the power is turned off and on?</p>	<p>Replace the Toner Cartridge (Y, M, C, or K) in problem.</p> <p>If the problem persists, replace the printer.</p>	End of work.
6	<p>Checking the Xero Motor (YMCK).</p> <p>Does the noise arise from the printer? Checked by [Digital Output]-[091-001] in diagnosis.</p> <p>Warning: When checking the motor, stop within ten seconds. Executing a motor check for ten seconds or longer may cause damage to the printer. To stop the motor check, press the <Cancel> key.</p>	Go to step 7.	Go to step 12.
7	<p>Checking after Reseat the XERO DEVE CRU ASSY (YMCK).</p> <p>Reseat the XERO DEVE CRU ASSY (YMCK).</p> <p>Does the noise arise when the power is turned off and on?</p>	Go to step 12.	End of work.
8	<p>Checking after setting the Graphic Mode to "Black" via the printer driver.</p> <p>Set the Graphic Mode of the printer driver to "Black".</p> <p>Does the noise arise during printing?</p>	Go to step 10.	Go to step 9.
9	<p>Checking after setting the Graphic Mode to "Color (Auto)" via the printer driver.</p> <p>Set the Graphic Mode of the printer driver to "Color (Auto)".</p> <p>Does the noise arise during printing?</p>	Go to step 11.	End of work.
10	<p>Checking after replacing the Drum Cartridge (K).</p> <p>Replace the Drum Cartridge (K).</p> <p>Does the noise arise when the power is turned off and on?</p>	Replace the KIT LINK XERO DRIVE (Refer to Removal 57/ Replacement 6).	End of work.
11	<p>Checking after replacing the Drum Cartridge (Y, M and C).</p> <p>Replace the Drum Cartridge (Y, M and C).</p> <p>Does the noise arise when the power is turned off and on?</p>	Replace the KIT LINK XERO DRIVE (Refer to Removal 57/ Replacement 6).	End of work.

Step	Check	Yes	No
12	<p>Checking the Belt Motor.</p> <p>Does the noise arise from the printer? Checked by [Digital Output]-[094-001] in diagnosis.</p> <p>Warning: When checking the motor, stop within ten seconds. Executing a motor check for ten seconds or longer may cause damage to the printer. To stop the motor check, press the <Cancel> key.</p>	Go to step 13.	Go to step 14.
13	<p>Checking after Reseat the BELT ASSY IBT. Reseat the BELT ASSY IBT.</p> <p>Does the noise arise when the power is turned off and on?</p>	Replace the Belt Unit. If not, replace the DRIVE ASSY IBT (Refer to Removal 55/ Replacement 8).	End of work.
14	<p>Checking the Deve Motor (K).</p> <p>Does the noise arise from the printer? Checked by [Digital Output]-[093-004] in diagnosis.</p>	Go to step 15.	Go to step 17.
15	<p>Checking after Reseat the WASTE TONER BOX. . Reseat the WASTE TONER BOX.</p> <p>Does the noise arise when the power is turned off and on?</p>	Replace the WASTE TONER BOX. If not, replace the DRIVE ASSY M OUT (Refer to Removal 61/ Replacement 2) and DRIVE ASSY DEVE K (Refer to Removal 60/ Replacement 3).	End of work.
16	<p>Checking the Deve Motor(YMC).</p> <p>Does the noise arise from the printer? Checked by [Digital Output]-[093-001] in diagnosis.</p>	Try replacing the DRIVE ASSY M OUT and DRIVE ASSY DEVE one after another.	Go to step 17.
17	<p>Checking the PH Motor.</p> <p>Does the noise arise from the printer? Checked by [Digital Output]-[071-001] in diagnosis.</p> <p>Warning: When checking the motor, stop within ten seconds. Executing a motor check for ten seconds or longer may cause damage to the printer. To stop the motor check, press the <Cancel> key.</p>	Replace the DRIVE ASSY PH (Refer to Removal 56 / Replacement 7).	Go to step 18.

Step	Check	Yes	No
18	<p>Checking the Option Motor.</p> <p>Does the noise arise from the printer? Checked by [Digital Output]-[071-014(Tray2)/ 071-019(Tray3)/ 071-024(Tray4)/ 071-029(Tray5)] in diagnosis.</p> <p>Warning: When checking the motor, stop within ten seconds. Executing a motor check for ten seconds or longer may cause damage to the printer. To stop the motor check, press the <Cancel> key.</p>	<p>Replace the FEEDER ASSY 550. (Refer to Removal 66 / Replacement 67)</p>	<p>End of work.</p>

FIP-1.N2 Noise: During Standby

Step	Check	Yes	No
	Possible causative parts: FAN FUSER (PL4.1.8) FAN ASSY LVPS (PL10.1.9)		
1	Check the Firmware Version. The version of the firmware for the printer should be checked with the Printer Information of the Web Tool. The latest Firmware Version should be checked on the Dell Support Web site. Is the firmware the latest version?	Go to step 2.	Download the latest version of the firmware from the Dell Support Web site. And then go to step 2.
2	Checking the Checking the FAN FUSER. Does the noise arise from the printer? Checked by [Digital Output]-[010-004] in diagnosis. Warning: When checking the motor, stop within ten seconds. Executing a motor check for ten seconds or longer may cause damage to the printer. To stop the motor check, press the <Cancel> key.	Replace the FAN FUSER. (Refer to Removal 10/ Replacement 53).	Go to step 3.
3	Checking the Checking the FAN ASSY LVPS. Does the noise arise from the printer? Checked by [Digital Output]-[042-001] in diagnosis. Warning: When checking the motor, stop within ten seconds. Executing a motor check for ten seconds or longer may cause damage to the printer. To stop the motor check, press the <Cancel> key.	Replace the FAN ASSY LVPS (Refer to Removal 32/ Replacement 31).	End of work.

FIP-1.N3 Noise: During Printing (Checking for other items than "power on noise")

Step	Check	Yes	No
	Possible causative parts: SOLENOID FEED MSI (PL4.2.32) CLUTCH ASSY FEED (PL3.2.2) CLUTCH ASSY REGI (PL3.3.13) CLUTCH ASSY TAKE AWAY (PL3.3.12) CLUTCH ASSY DUP (PL4.3.9)		
1	Checking the paper condition. Replace the standard paper with a new and dry one. Does the noise arise from the printer?	Go to step 2.	End of work.
2	Checking the MPF. Does the noise arise when feeding the paper from the MPF?	Go to step 3.	Go to step 4.
3	Checking after replace the SOLENOID FEED MSI. Replace the KIT RH SOLENOID, GEAR & CLUTCH (Refer to Removal 25/ Replacement 38). Does the noise arise when feeding the paper from the MPF?	Go to step 6.	End of work.
4	Checking the feeder. Does the noise arise when feeding the paper from the feeder?	Go to step 5.	END. If the problem persists, go to FIP-1.N1.
5	Checking after replace the CLUTCH ASSY FEED. Replace the FEEDER ASSY (Refer to Removal 29/ Replacement 34). Does the noise arise when feeding the paper from the feeder?	Replace the KIT RH SOLENOID, GEAR & CLUTCH (Refer to Removal 25/Replacement 38).	End of work.
6	Checking after replace the CLUTCH ASSY REGI and CLUTCH ASSY TAKE AWAY. Replace the FEEDER ASSY (Refer to Removal 29/ Replacement 34). Does the noise arise from the printer?	FIP-1.N1.	End of work.

6. Other FIP

Other FIP covers the power supply trouble FIP, except error code FIP, Noise FIP and image quality FIP.

FIP-AC Power

Step	Check	Yes	No
	Possible causative parts: LVPS ASSY (PL10.2.2)		
1	Checking the printer Does the motor noise occur when turning on the power? In this test, close the Front Cover.	Go to FIP-DC Power.	Go to step 2.
2	Checking the outlet Connect the power cord with the other outlet. Does the printer is working?	End of work.	Go to step 3.
3	Checking the power cord connection Reconnect the power cord. Does the printer is working?	End of work.	Go to step 4.
4	Checking the connector of LVPS ASSY connecting Disconnect the power cord and wait for one minute. Reseat the all connectors of LVPS ASSY. Does the printer is working?	End of work.	Go to step 5.
5	Checking the connector of MAIN SWITCH connecting Disconnect the power cord and wait for one minute. Reseat the connector of MAIN SWITCH. Does the printer is working?	End of work.	Replace the BOX ASSY LVPS. (Refer to Removal 42/ Replacement 21)

FIP-DC Power

Step	Check	Yes	No
	Possible causative parts: LVPS ASSY (PL10.2.2) PWBA ESS (PL10.1.6) CONSOLE ASSY PANEL(PL1.1.1)		
1	Checking the printer Does the motor noise occur when turning on the power? In this test, close the Front Cover.	Go to step 2.	Go to step 5.
2	Checking the message on the Control Panel Does the message on the control panel appear?	End of work. If error message appeared, go to FIP.	Go to step 3.
3	Checking the connector of CONTROL PANEL connecting. Reseat the connector (P/ J370) of CONTROL PANEL. Does the CONTROL PANEL is working?	End of work.	Go to step 4.
4	Checking the PWBA ESS installation Reseat the PLATE ASSY ESS. (Refer to Removal 30/ Replacement 33) Does the message on the control panel appear?	End of work.	Replace the PLATE ASSY ESS. (Refer to Removal 30/ Replacement 33) and the KIT CONSOLE PANEL & HARNESS (Refer to Removal 445 Replacement 18).
5	Go to FIP-AC Power. If not Checking the PWBA MCU installation Reseat the PWBA MCU. (Refer to Removal 31/ Replacement 32) Does the printer is working?	End of work.	Replace the BOX ASSY LVPS. (Refer to Removal 42/ Replacement 21)

FIP-Multiple feed

Step	Check	Yes	No
1	Checking the paper condition. Are the sheet edges burred?	Use sheets that are not burred at the edge.	Go to step 2.
2	Checking the MPF fed. Multi feed occurred in the MPF?	Go to step 3.	Go to step 4.
3	Checking the media Replace to the new paper. Does the multi feed still occur when printing?	Checking after replacing the KIT FEED ROLL & SEPARATOR ROLL. (Refer to Removal 13/ Replacement 67)	End of work.
4	Checking the media Replace to the new paper. Does the multi feed still occur when printing?	Replace the KIT FEED ROLL & SEPARATOR ROLL. (Refer to Removal 13/ Replacement 67)	End of work.

FIP-Paper Remaining Amount Not Displayed Correctly in Status Monitor.

Step	Check	Yes	No
	Possible causative parts: ACTUATOR LOW PAPER (PL2.1.24 / PL12.5.24 / PL13.6.23) LOW PAPER SENSOR (PL3.1.4 / PL12.2.10 / PL13.3.10) HARNESS ASSY LPP/MOT (PL11.2.5) HARNESS ASSY OPT CL (PL12.3.12) PWBA ESS (PL10.1.6) PWBA MCU (PL10.2.18)		
1	Checking the ACTUATOR LOW PAPER Does the ACTUATOR LOW PAPER move smoothly? Does it have any damage?	Replace the TRAY ASSY. or Replace the TRAY ASSY OPTION.	Go to step 2
2	Checking the connectors for connection Check the connections between the PWBA MCU and LOW PAPER SENSOR. Are P/J18 and P/J221/222 of Tray 1 connected surely? NOTE: For Trays 2 to 5, make sure that the connectors P/J362 and P/J366/367 are securely engaged.	Go to step 4	Reconnect the connector surely, then go to step 3.
3	Does the error still occur when the power is turned off and on?	Go to step 4	End of work.
4	Checking the LOW PAPER SENSOR Does the LOW PAPER SENSOR function normally? Checked by [Digital Input] - [071-106 and 071-107(Tray 1)/ 071-120 and 071-121(Tray 2) 071-129 and 071-130(Tray 3) 071-138 and 071-139(Tray 4) 071-147 and 071-148(Tray 5)] in diagnosis.	Go to step 6	Go to Step5
5	Checking the HARNESS ASSY LPP/MOT for continuity Disconnect P/J18 from the PWBA MCU. Disconnect P/J221/222 from the LOW PAPER SENSOR. Is each cable of P/J18 <=> P/J221/222 continuous? NOTE: For Trays 2 to 5, check the continuity of the HARNESS ASSY OPT CL. Check the connectors P/J362 and P/J366/367 for continuity.	Replace the LOW PAPER SENSOR.	Replace the HARNESS ASSY LPP/MOT or .HARNESS ASSY OPT CL.
6	Checking after replacing the PLATE ASSY ESS. Replace the PLATE ASSY ESS (Refer to Removal 30/ Replacement 33). Does the error still occur when the power is turned off and on?	Replace the PWBA MCU(Refer to Removal 31/ Replacement 32)	End of work.

Appendix

This section describes procedure of clearing paper jams, procedure of replacing the main parts, and procedure of cleaning the printer.

Appendix_1 Clearing Jams

1.1 Clearing Paper Jams From the MPF

- 1) Remove any paper loaded on or jammed in the MPF.

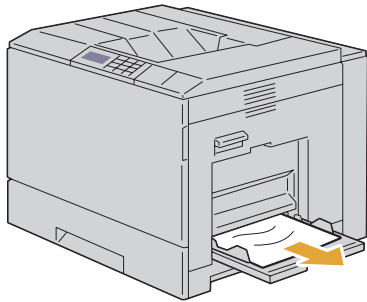

- 2) Close the MPF.

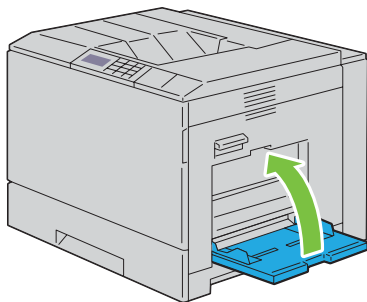

- 3) Raise the latch on the handle of the right hand cover to open the cover.

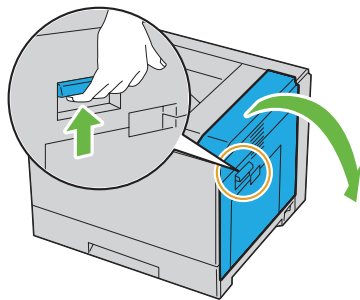

- 4) Remove any remaining pieces of paper jammed in the MPF.

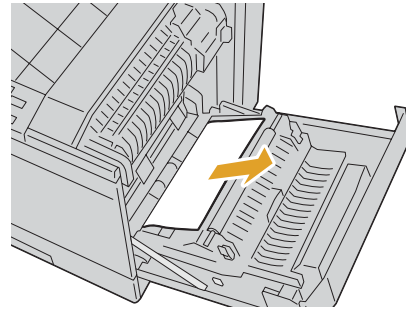

- 5) Use the handle to lift the duplexer.

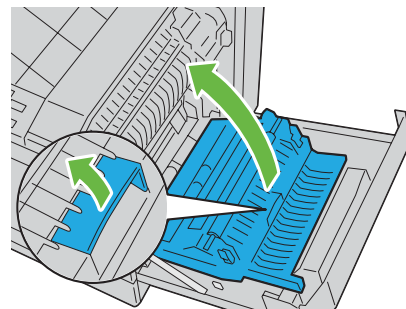

- 6) Remove any remaining pieces of paper.

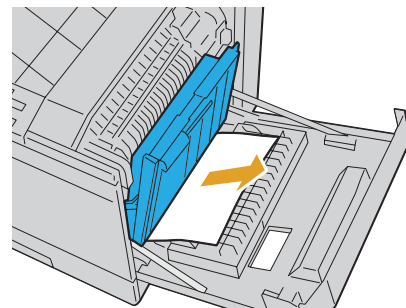

- 7) Close the right hand cover.

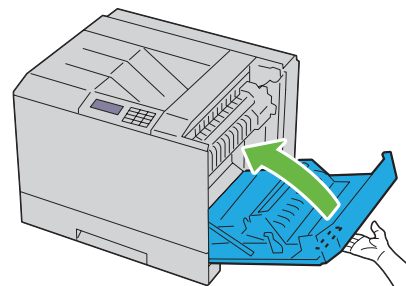

1.2 Clearing Paper Jams From the Standard Tray

- 1) Raise the latch on the handle of the right hand cover to open the cover.

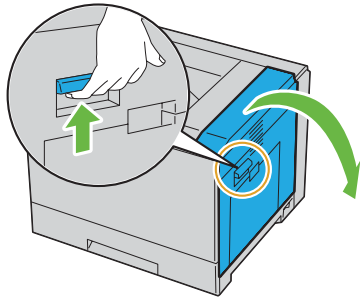

- 2) Remove the jammed paper.

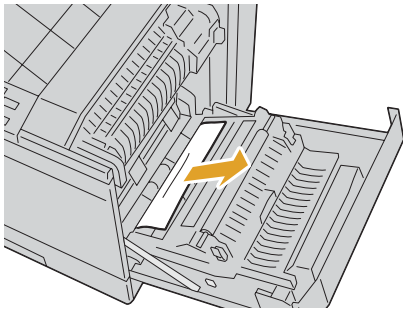

- 3) Use the handle to lift the duplexer.

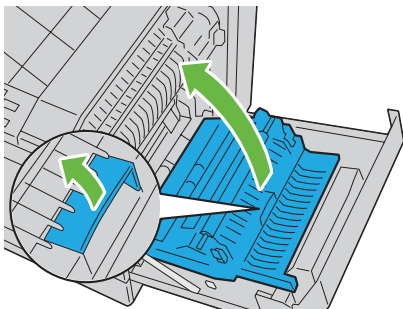

- 4) Remove any remaining pieces of paper.

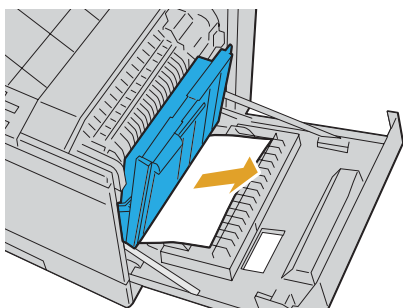

- 5) Close the right hand cover.

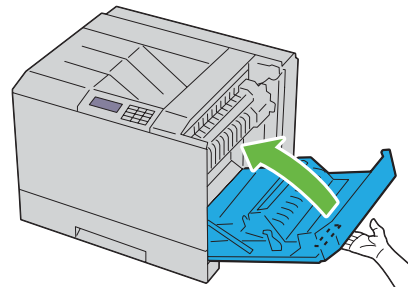

- 6) Remove tray 1 from the printer.

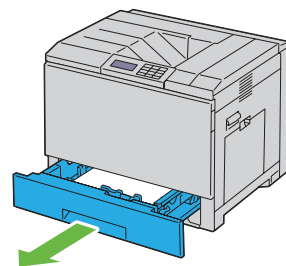

- 7) Remove any paper jammed, creased or both from tray 1.

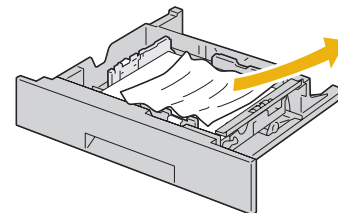

- 8) Replace tray 1 in the printer.

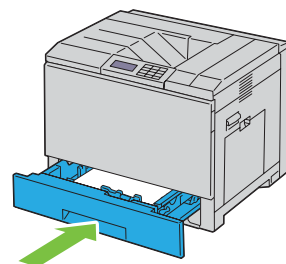

1.3 Clearing Paper Jams From the Fuser

- 1) Raise the latch on the handle of the right hand cover to open the cover.

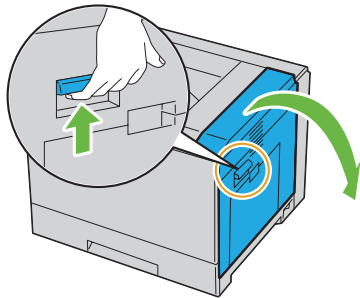

- 5) Close the right hand cover.

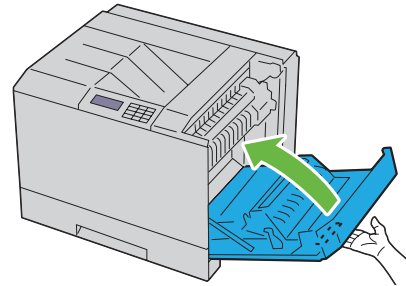

- 2) Hold and lower the tab to open the inner part.

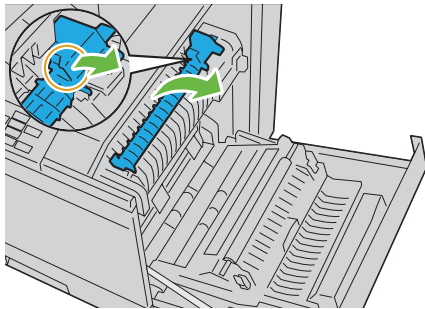

- 3) Remove the jammed paper.

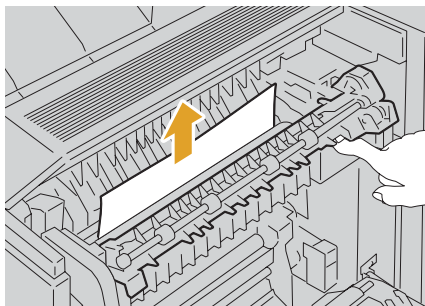

- 4) Replace the inner part.

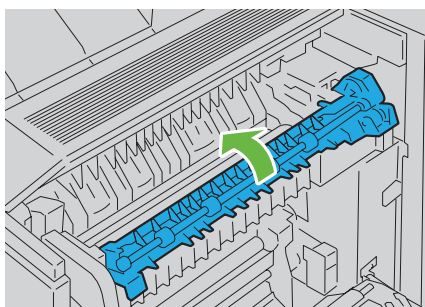

1.4 Clearing Paper Jams From the Duplexer

- 1) Open the right hand cover.

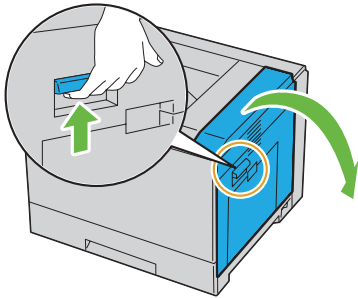

- 2) Use the handle to lift the duplexer.

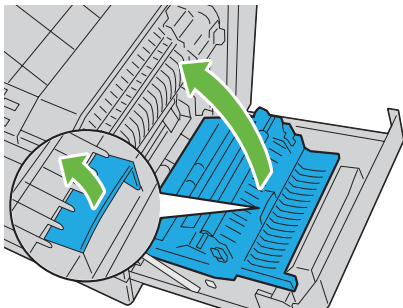

- 3) Remove any paper from the duplexer.

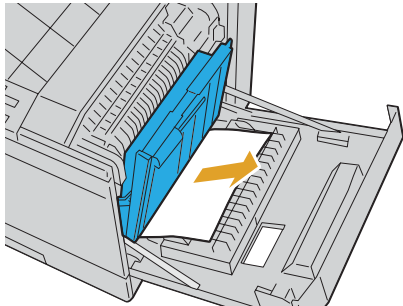

- 4) Close the right hand cover.

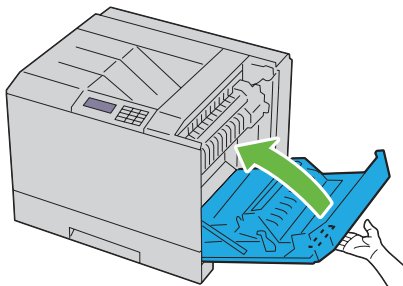

1.5 Clearing Paper Jams From the Optional Feeder

- 1) Open the right hand cover of the optional feeder where paper is jammed.

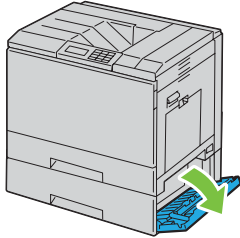

- 2) Remove the jammed paper.



- 3) Close the right hand cover of the optional feeder.

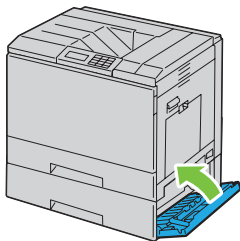

- 4) Remove the tray from the same feeder.

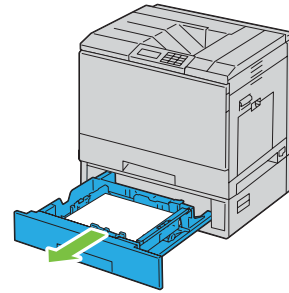

- 5) Remove any paper jammed, creased or both from the feeder.

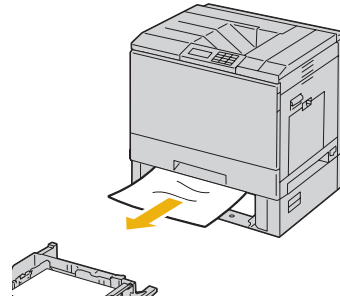

- 6) Replace the feeder in the printer.

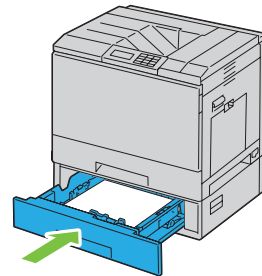

1.6 Clearing Paper Jams From the Output Expander

- 1) Ensure that the printer is not in operation, and open the front door of the output expander.

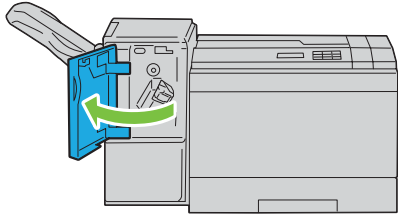

- 2) Rotate the knob clockwise and remove the jammed paper from the paper exit of the output expander.

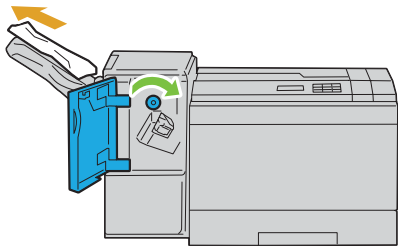

- 3) Close the front door of the output expander.

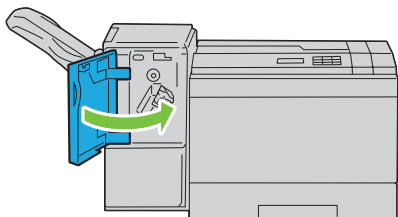

- 4) If the paper jam message remains, repeat the steps 1 and 2.

- 5) Close the front door of the output expander.

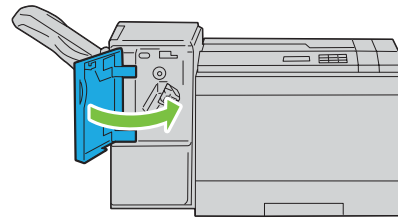

1.7 Clear Paper Jams From Horizontal Transport Unit

- 1) Grasp the top cover handle of the output expander and open the cover.

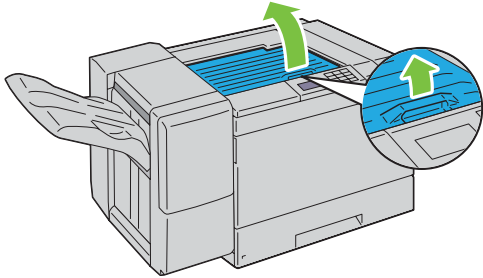

- 2) Remove the jammed paper.

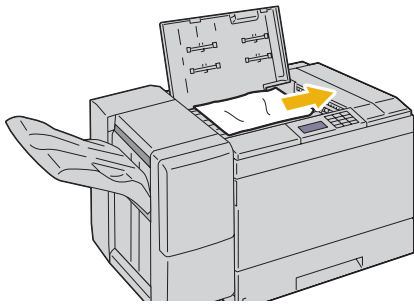

- 3) Close the top cover of the output expander.

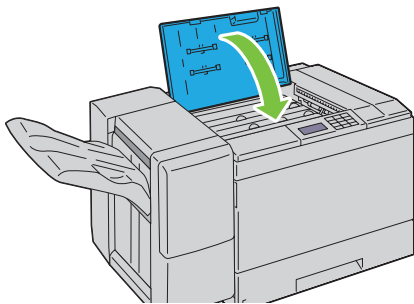

1.8 Clearing Staple Jams From the Output Expander

- 1) Ensure that the printer is not in operation, and open the front door of the output expander.

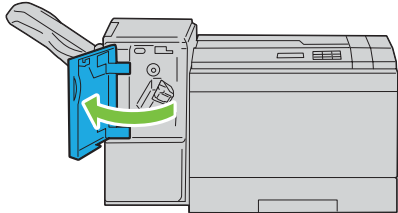

- 2) Grasp the orange lever on the stapler cartridge and pull out the cartridge.

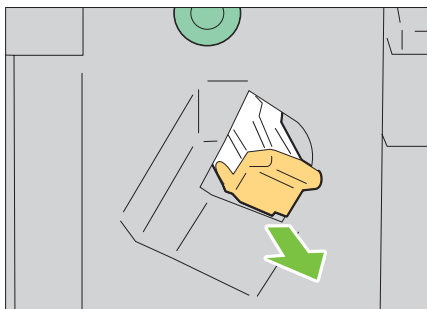

- 3) Visually check inside the output expander for any remaining staples.
- 4) Lift the metal part of the stapler cartridge.
- 5) Remove any staples jammed in the stapler cartridge.

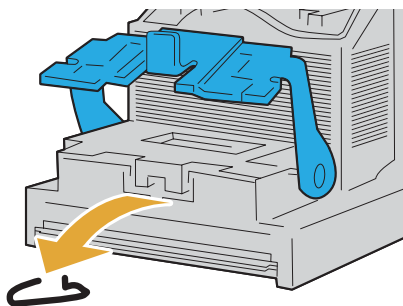

- 6) Close the metal part.

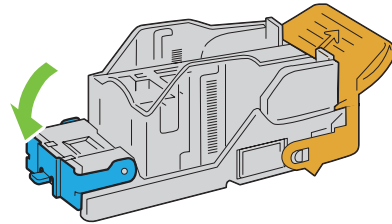

- 7) Grasp the orange lever on the stapler cartridge and push the cartridge in the printer until it clicks into place.

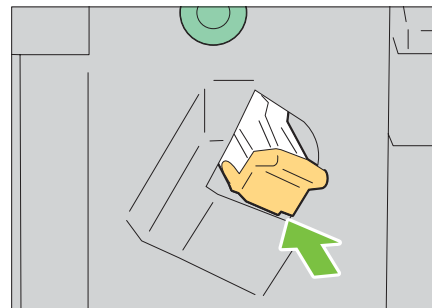

- 8) Close the front door of the output expander.

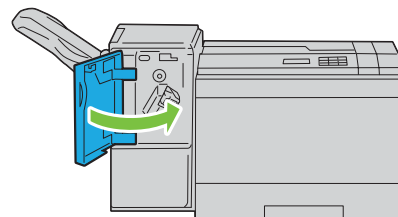

Appendix_2 Replacing the Main Parts

2.1 Consumables and Periodic Replacement Parts Life

2.1.1 Replacement Timing of Consumables and Periodic Replacement Parts

(1) Types of Consumables and Periodic Replacement Parts

Listed below are the consumables and periodic replacement parts for this printer (including options).



	Product Name	Lifespan (approximate)*1
Consumables	TONER CARTRIDGE (K) (Starter capacity)	9,000 pages
	TONER CARTRIDGE (YMC) (Starter capacity)	6,000 pages
	TONER CARTRIDGE (K) (Standard capacity)	18,000 pages
	TONER CARTRIDGE (YMC) (Standard capacity)	12,000 pages
	DRUM CARTRIDGE (YMCK)	50,000 pages
	WASTE TONER BOX	25,000 pages
	STAPLER CARTRIDGE(OPTION)	5,000 staples
Periodic Replacement Parts	FUSER	100,000 pages
	BELT UNIT	150,000 pages
	TRANSFER ROLLER	150,000 pages
	PAPER FEED ROLL	150,000 pages
	SEPARATOR ROLLERS	150,000 pages

*1: The page counts are for reference only.

The actual page count may vary greatly depending on conditions such as print settings, document contents, or power-on/off frequency.

(2) Replacement Timing of Consumables

When a consumable part is about to reach its replacement period, one of the following messages appears on the Operator Panel:

	Message	Meaning	Detection device
TONER CARTRIDGE (YMCK) *5	<Near Life> Ready to Print 093-XXX*1 YYY*1 Toner Crtrdg ↕ Flip Ready to Print Is close to life	The TONER CARTRIDGE (Y, M, C, or K) is near its replacement period. Have ready a new TONER CARTRIDGE (Y, M, C, or K). You can still print approximately another 900 pages (Standard capacity: 1,800 pages) in K, and 600 (Standard capacity: 1,200 pages) in Y, M, and C.	The TONER CRUM detects the replacement period from the remaining toner amount. The CTD Sensor detects the life end.
	<Life Over>  Life Over 093-XXX*2 Replace Now YYY*2 Toner Crtrdg	The TONER CARTRIDGE (Y, M, C, or K) has reached its replacement period. The printer stops operating. Immediately replace the TONER CARTRIDGE (Y, M, C, or K) with a new one.	
XERO DEVE CRU ASSY (YMCK)	<Near Life> Ready to Print 091- XXX*3 YYY*3 Drum Crtrdg ↕ Flip Ready to Print Is close to life	The DRUM CARTRIDGE (Y, M, C, or K) is near its replacement period. Have ready a new DRUM CARTRIDGE (Y, M, C, or K). You can still print approximately another 5,000 pages before the Life Over message appears.	The XERO CRUM detects the replacement period.
	<Life Over>  Life Over 091- XXX*4 Replace Now YYY*4 Drum Crtrdg	The DRUM CARTRIDGE (Y, M, C, or K) has reached its replacement period. You can still print some more pages, but the print quality will not be assured. It is recommended that you replace the DRUM CARTRIDGE (Y, M, C, or K) with a new one immediately. Once the Life Over message appears, you can print approximately another 10,000 pages before the printer stops operating.	
WASTE TONER BOX	<Near Life> Ready to Print 091-400 Waste Toner Box ↕ Flip Ready to Print Is close to life	The WASTE TONER BOX is near its replacement period. Have ready a new WASTE TONER BOX. You can still print approximately another 2,500 pages	The SENSOR TNR FULL detects the replacement period from the waste toner amount.
	<Life Over>  Life Over 091-911 Replace Now	The WASTE TONER BOX has reached its replacement period. The printer stops operating. Immediately replace the WASTE TONER BOX with a new one.	
STAPLE CARTRIDGE	<Near Life> Empty Staple 024-979 Replace Now Stapler Cartridge. Continue without Staple? Are You Sure?	The STAPLER CARTRIDGE has reached its replacement period. Immediately replace the STAPLER CARTRIDGE with a new one. Approximately another 20 staples are left.	The STAPLE LOW SENSOR detects the replacement period.

*1- *4: XXX/YYY in the message denotes the following.

*1: 423/Yellow, 424/Magenta, 425/Cyan, 426/Black

*2: 930/Yellow, 931/Magenta, 932/Cyan, 933/Black

*3: 412/Yellow, 413/Magenta, 414/Cyan, 411/Black

*4: 932/Yellow, 933/Magenta, 944/Cyan, 931/Black

*5: Standard capacity

(3) Replacement Timing of Periodic Replacement Parts

When a periodic replacement part is about to reach its replacement period, one of the following messages appears on the Operator Panel:

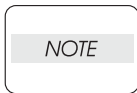

No replacement timing message is displayed for the ROLL ASSY 2ND BTR, FEED ROLL, and SEPARATOR ROLL.

Ensure that the ROLL ASSY 2ND BTR is replaced concurrently with the BELT ASSY IBT. It is recommended that the FEED ROLL and the SEPARATOR ROLL are also replaced concurrently with the BELT ASSY IBT.

	Message	Meaning	Detection device
FUSER ASSY	<Near Life> Ready to Print 010-420 Fuser ↕ Flip Ready to Print Prepare	The FUSER is near its replacement period. Have ready a new FUSER. You can still print approximately another 10,000 pages before the Life Over message appears.	The FUSER CRUM detects the replacement period.
	<Life Over> 010-351 Restart Printer Replace Fuser Contact Support	The FUSER has reached its replacement period. You can still print some more pages, but the print quality will not be assured. It is recommended that you replace the FUSER with a new one immediately. Once the Life Over message appears, you can print approximately another 25,000 pages before the printer stops operating.	
BELT ASSY IBT	<Near Life> Ready to Print Ready to Print 094- 419 Belt Unit ↕ Flip Ready to Print Prepare	The BELT UNIT is near its replacement period. Have ready a new BELT UNIT. You can still print approximately another 15,000 pages before the Life Over message appears.	The BELT CRUM detects the replacement period.
	<Life Over> Life Over 094- 911 Replace Now Belt Unit	The BELT UNIT has reached its replacement period. You can still print some more pages, but the print quality will not be assured. It is recommended that you replace the BELT UNIT with a new one immediately. Once the Life Over message appears, you can print approximately another 50,000 pages before the printer stops operating.	

(4) Replacing the Belt Unit and Transfer Roller concurrently

Ensure that the BELT ASSY IBT and ROLL ASSY 2ND BTR are replaced at the same time.

The replacement period notification messages such as "Life Over" and "Near Life" are displayed when the component has reached its specific life count value. After replacing the component, the life count value must be reset to zero. Otherwise, the replacement period notification messages will not be displayed at the correct timing.

The life count value of the BELT UNIT is reset at replacement by the CRUM of the BELT UNIT. Since this life count value is common to the BELT UNIT and TRANSFER ROLLER, the TRANSFER ROLLER has no CRUM of its own, and its life count value is reset by the CRUM of the BELT UNIT.

If the BELT UNIT and the TRANSFER ROLLER are not replaced at the same time, the following situations might occur:

Case 1: When only the BELT UNIT is replaced:

Problems such as transfer error might occur because the life count value of the TRANSFER ROLLER is reset to zero, and is operated beyond its design life.

Case 2: When only the TRANSFER ROLLER is replaced:

When periodic replacement parts such as BELT UNIT and TRANSFER ROLLER are replaced due to their end of life (approx. 150,000 pages), the TRANSFER ROLLER might be replaced well before it reaches its end of life.

2.2 Replacing the Toner Cartridges

- Removing the Toner Cartridges

- 1) Turn off the printer.

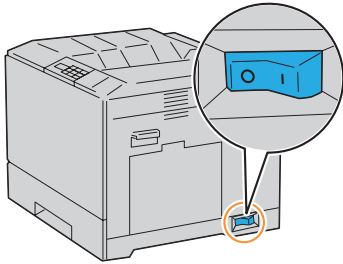

- 2) Open the front cover.

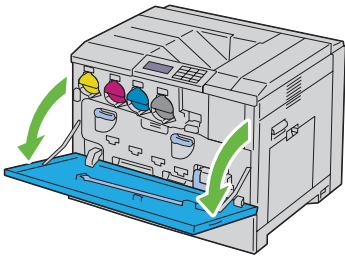

- 3) Pull out the toner cartridge you want to replace.

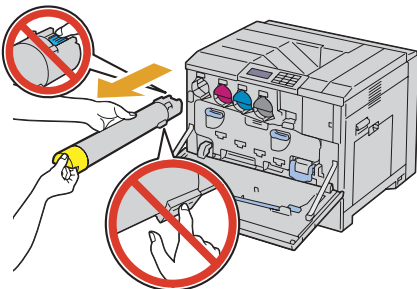

- Installing a Toner Cartridge

- 1) Unpack a new toner cartridge of the desired color.
- 2) Shake the toner cartridge 5 to 6 times to distribute the toner evenly.

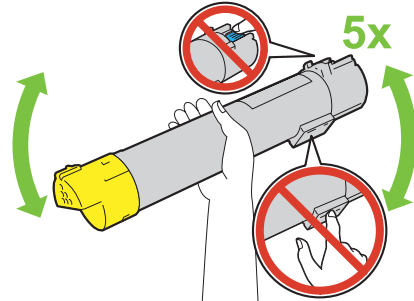

- 3) Align the arrow on the cartridge with the arrow on the printer, and slide in the cartridge until it stops.

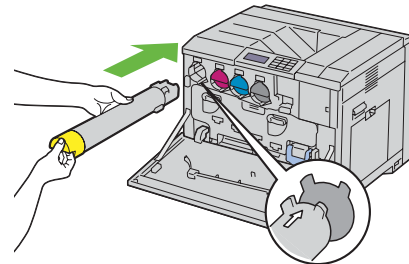

- 4) Close the front cover.

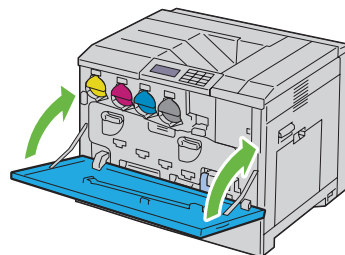

2.3 Replacing the Drum Cartridges

- Removing the Drum Cartridges

- 1) Turn off the printer.

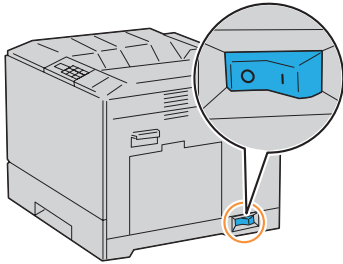

- 2) Open the front cover.

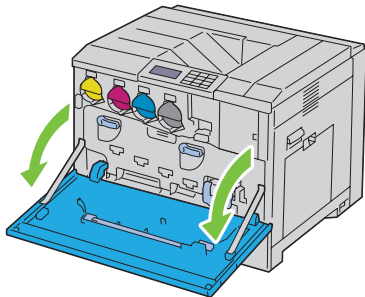

- 3) Rotate the lock levers of the inner cover to open it.

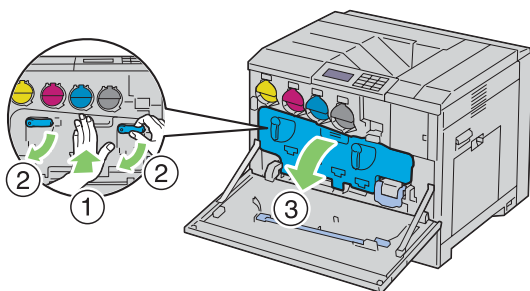

- 4) Grasp the handles on the drum cartridge you want to replace and pull out the cartridge halfway.

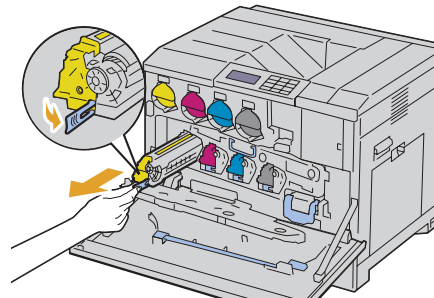

- 5) Grasp one side of the drum cartridge with the other hand and pull out the cartridge from the printer.

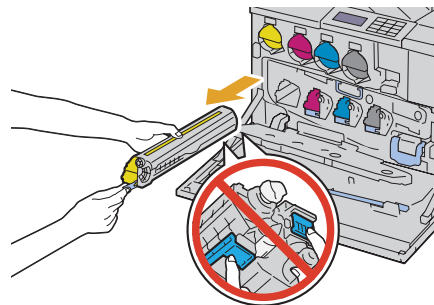

- Installing a Drum Cartridges

- 1) Unpack a new drum cartridge.
- 2) Pull out the two ribbons.

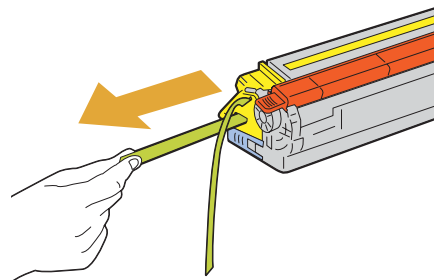

- 3) Slide the cartridge into the correct slot.

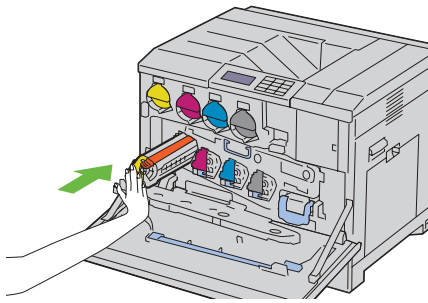

- 4) Remove the orange protective covering of the installed drum cartridge and discard.

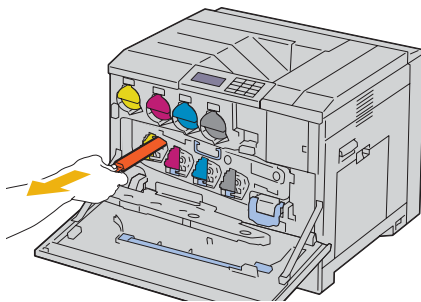
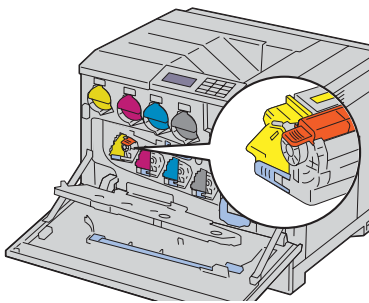

- 5) Close the inner cover.

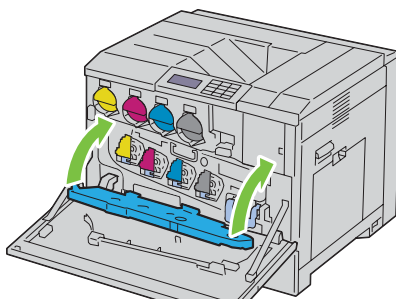

- 6) Rotate the lock levers to secure the inner cover while pressing the cover with the other hand.

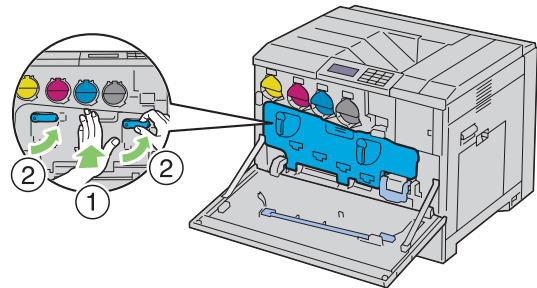

- 7) Remove the cleaning rod from the back-side of the front cover.

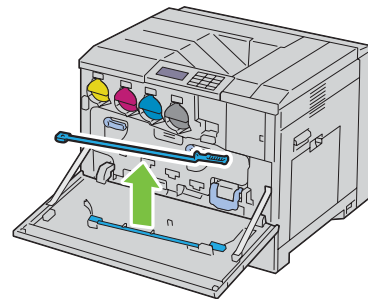

- 8) Remove the cleaning pad by pressing the white tabs between your thumb and index finger.

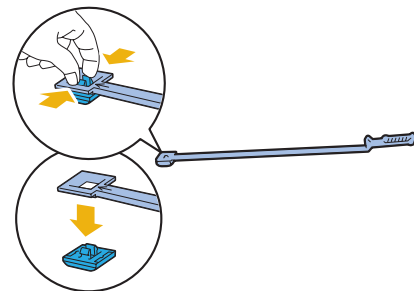

- 9) Unpack a new cleaning pad.
- 10) Attach the new cleaning pad to the cleaning rod.

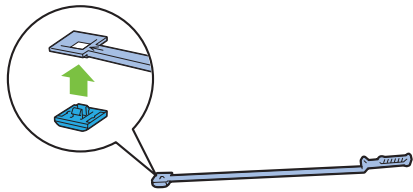

- 14) Close the front cover.

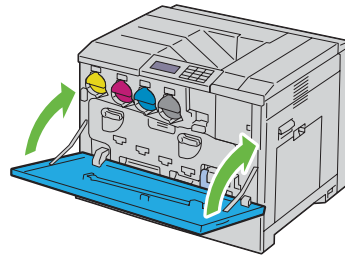

- 11) Insert the cleaning rod fully into one of the four holes until it clicks into the interior of the printer as illustrated below, and then pull it out.

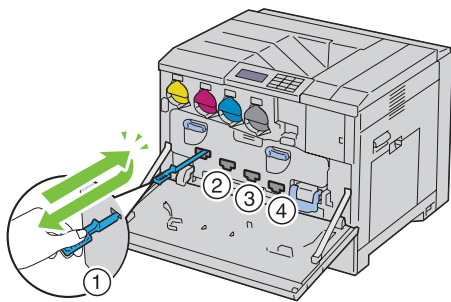

- 12) Repeat step 11 also on the other three holes. One time insertion is enough for each hole.
- 13) Return the cleaning rod to its original location.

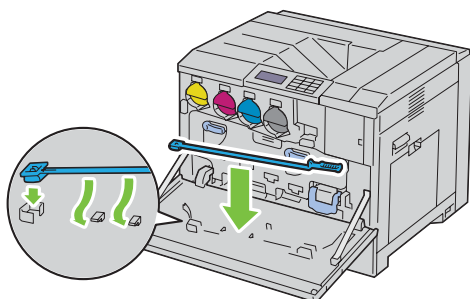

2.4 Replacing the Fuser

- Removing the Fuser

- 1) Turn off the printer and wait 30 minutes before removing the fuser.

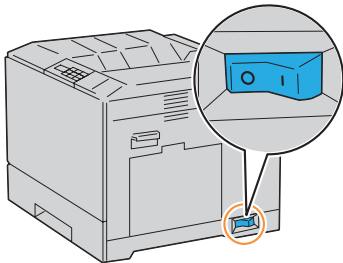
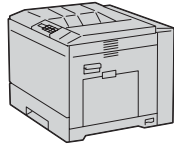
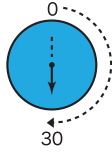

- 2) Raise the latch on the handle of the right hand cover to open the cover.

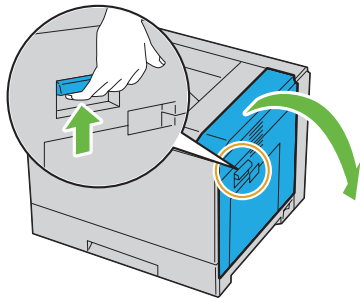

- 3) Grasp both sides of the installed fuser with your hands and pull it out.

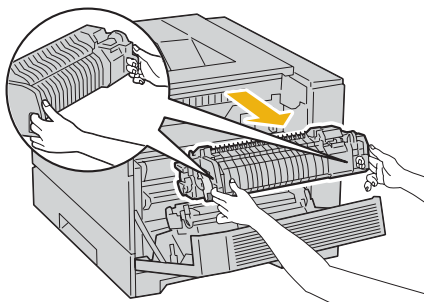

- Installing a Fuser

- 1) Unpack a new Fuser.
- 2) Grasp both sides of the fuser with your hands and install the fuser in the printer.
- 3) Close the right hand cover.

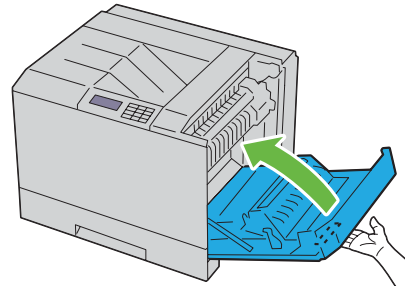

2.5 Replacing the Separator Rollers

- Removing the Separator Roller in a Tray

- 1) Remove the tray from the printer.

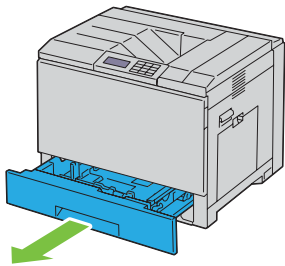

- 2) Turn the separator roller cover to the left to open it, and then hold the cover.

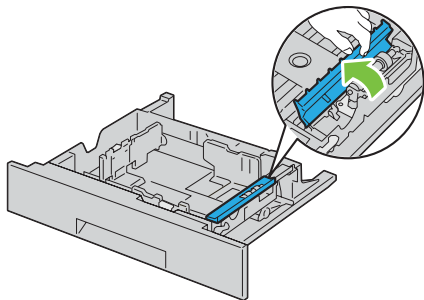

- 3) Turn the separator roller cartridge to the right.

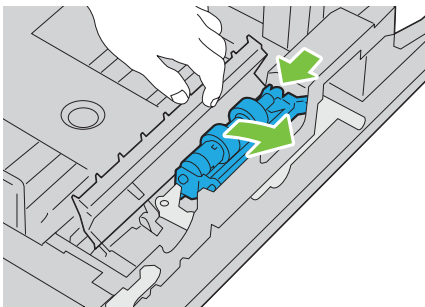

- 4) Pull out the rear axle, then the front axle from the holes of the tray and remove the separator roller cartridge.

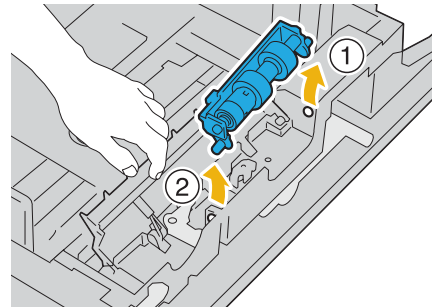

- Installing a Separator Roller in a Tray

- 1) Turn the separator roller cover to the left to open it, and then hold the cover.

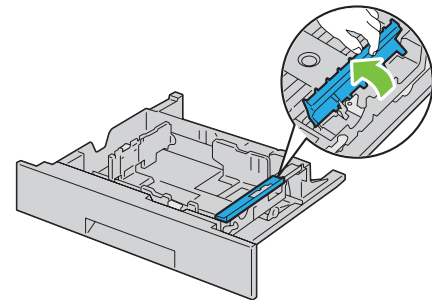

- 2) Slide the front axle, then the rear axle of the separator roller cartridge in the holes of the tray.

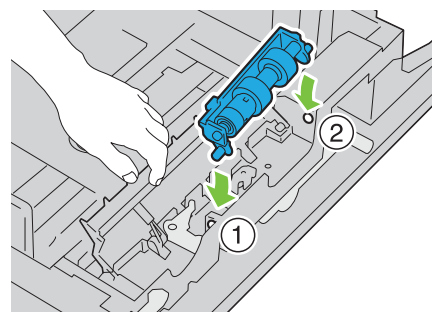

- 3) Turn the separator roller cartridge to the left to fix it in place.

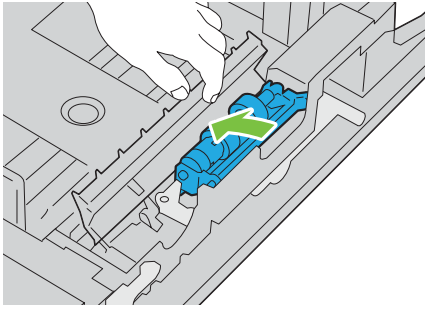

- 4) Turn the separator roller cover to the right to close it.

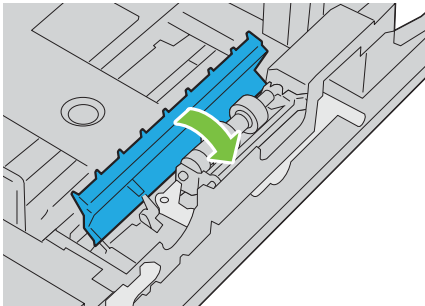

- 5) Load paper in the tray and replace the tray in the printer.

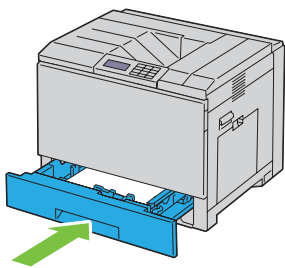

- Removing the Separator Rollers Inside the Printer

- 1) Remove the tray from the printer.

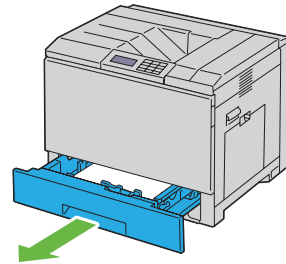

- 2) Turn the separator roller until the roller hook is visible.

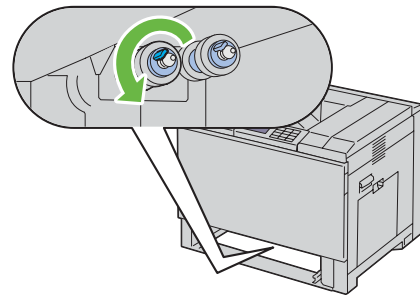

- 3) Pull the separator roller hook out of the groove on the axle, and then slide the separator roller to the front.

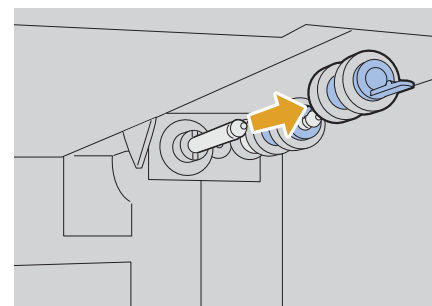
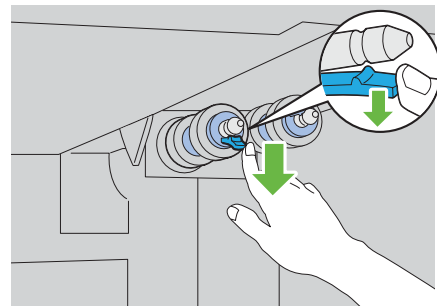

- 4) Repeat steps 2 and 3 to remove other separator rollers from inside of the printer.

- Installing Separator Rollers Inside the Printer

- 1) Align the hole of the new separator roller with the axle.

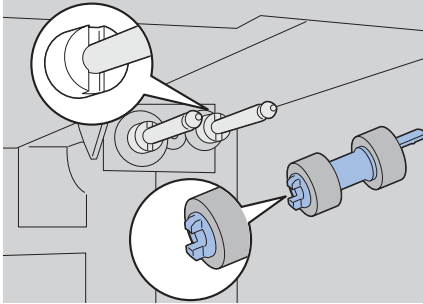

- 2) Slide the separator roller along the axle so the protrusions fit completely into the slots and the roller hook reseats into the groove on the axle.

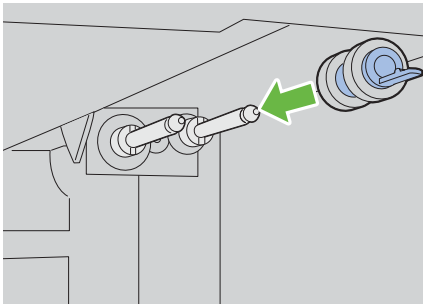

- 3) Replace the tray into the printer.

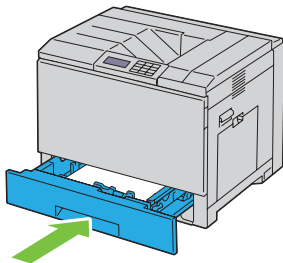

2.6 Replacing the Belt Unit

- Removing the Belt Unit

- 1) Turn off the printer and wait 30 minutes before removing the belt unit.
- 2) Raise the latch of the right hand cover and open the cover.

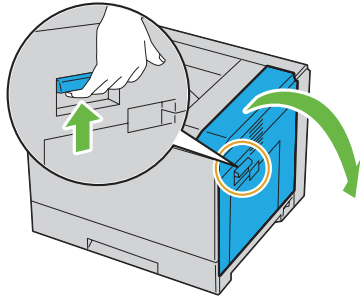

- 3) Open the front cover.

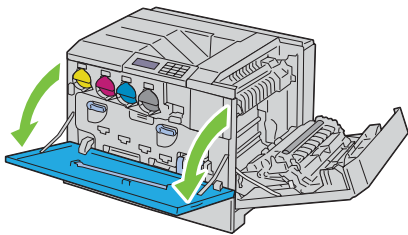

- 4) Rotate the lock levers of the inner cover to open it.

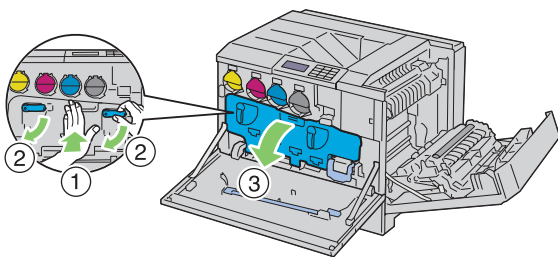

- 5) Grasp the handle on the front of the belt unit.

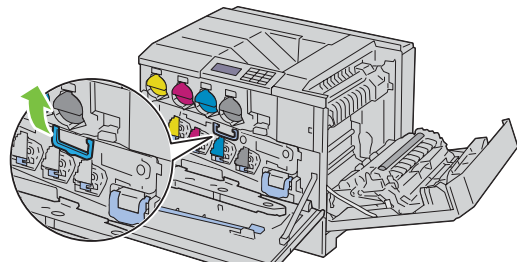

- 6) Pull out the belt unit until the line on the unit becomes completely visible.

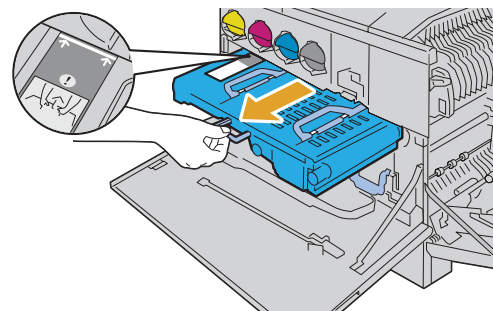

- 7) Grasp the handles on the top of the belt unit. Pull out the unit to remove it from the printer.

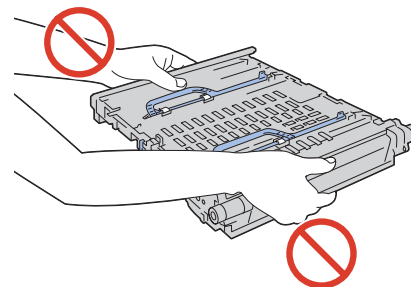
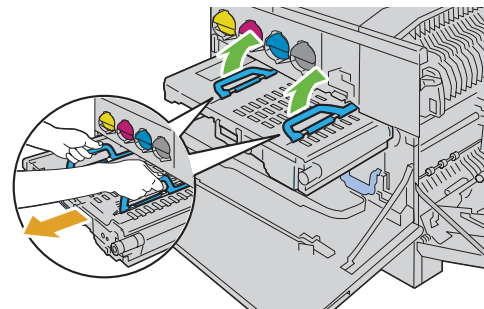

- 8) Slide the blue tab back-and-forth five times to clean the conductivity temperature depth sensor.

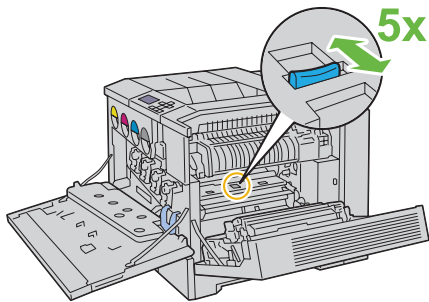

- Installing a Belt Unit

- 1) Unpack a new belt unit and place the unit on a level surface.

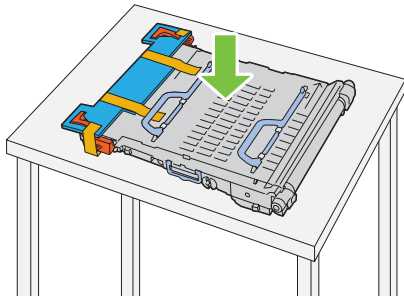

- 2) Remove the protective parts shown in the illustration.

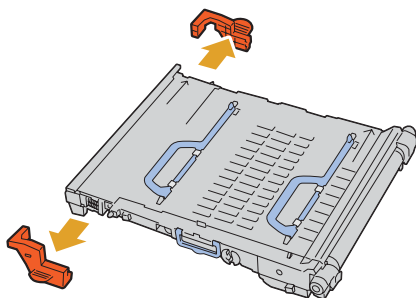
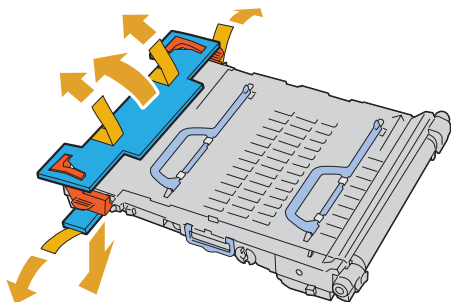

- 3) Grasp the handles on top of the belt unit.

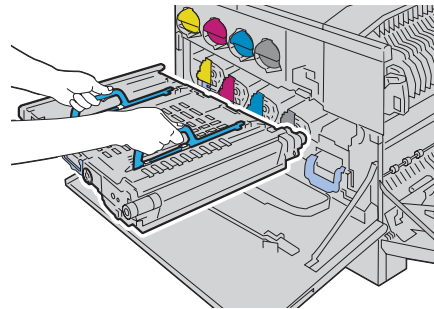

- 4) Align the arrows on the belt unit with the arrows on the printer.

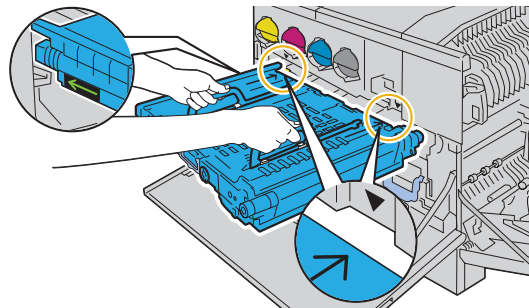

- 5) Slide the unit into the printer and stop when the visible line reaches the printer.

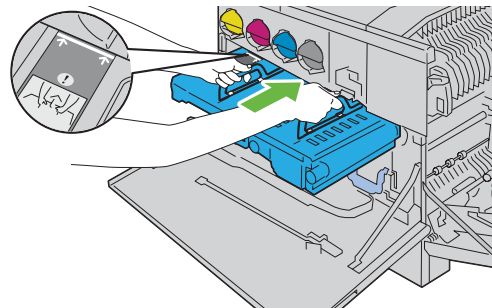

- 6) Lower the handles.

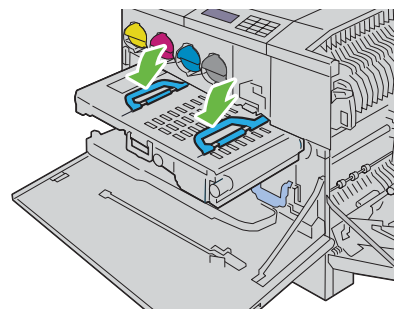

- 7) Push the front of the belt unit to reinstall it in the printer and until it stops.

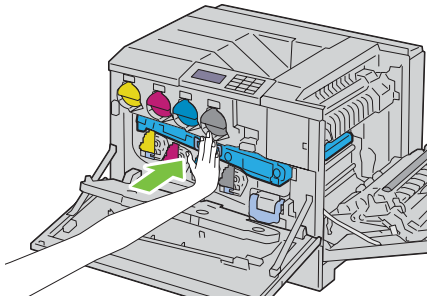

- 8) Close the inner cover.

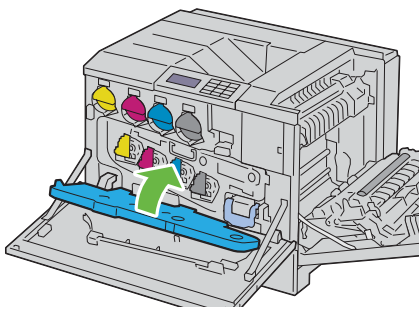

- 9) Rotate the lock levers to secure the inner cover while pressing the cover with the other hand.

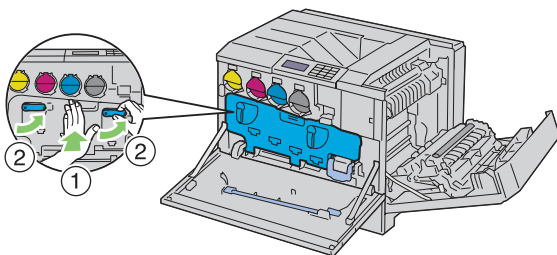

- 10) Close the front cover.
- 11) Close the right hand cover.

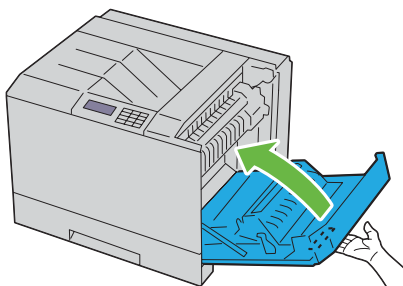

2.7 Replacing the Transfer Roller

- Removing the Transfer Roller

- 1) Turn off the printer.
- 2) Raise the latch of the right hand cover and open the cover.

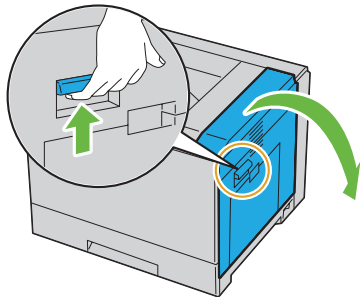

- 3) Unlock the two levers on the transfer roller and lift up the roller to remove it.

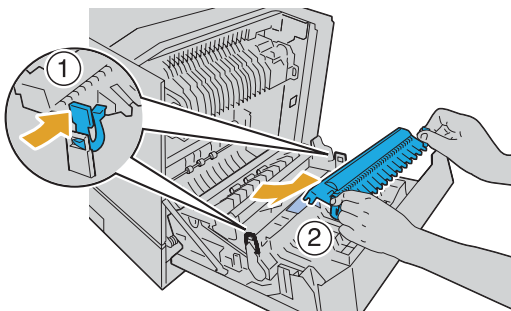

- Installing a Transfer Roller

- 1) Grasp the levers on both sides of the new transfer roller and align the arrows on the transfer roller with the arrows inside the printer.

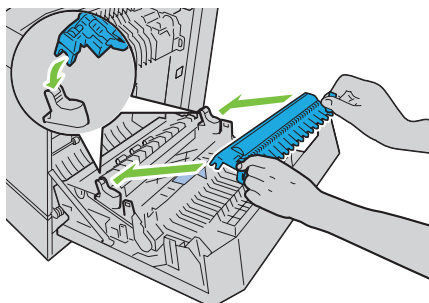

- 2) Lower the front of the transfer roller until the roller clicks into place.

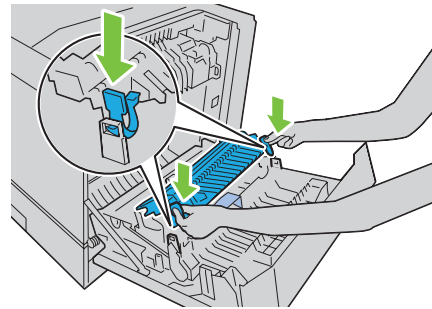

- 3) Close the right hand cover.

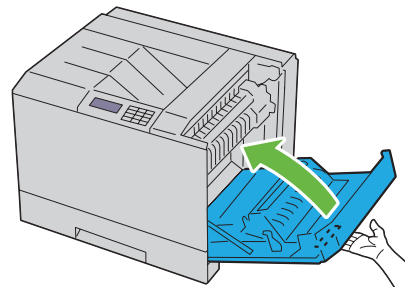

2.8 Replacing the Stapler Cartridge

- Removing the Stapler Cartridge

- 1) Confirm that the printer is not in operation, and open the front door of the output expander.

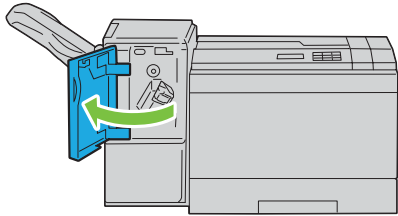

- 2) Press the orange lever of the staple cartridge holder and pull out the cartridge.

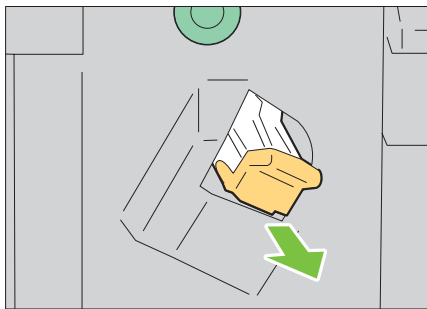

- 3) Squeeze the sides of the empty staple case and remove it from the cartridge.

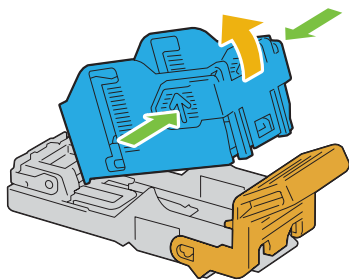

- Installing a Stapler Cartridge

- 1) Slide the tip of the new staple case into the cartridge and press the end into place.

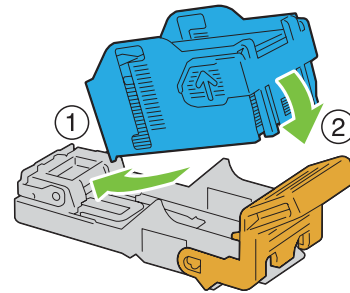

- 2) Holding the orange lever, push the staple cartridge back into the holder until it clicks into place.

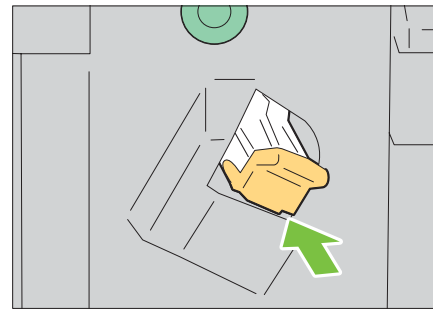

- 3) Close the front door of the output expander.

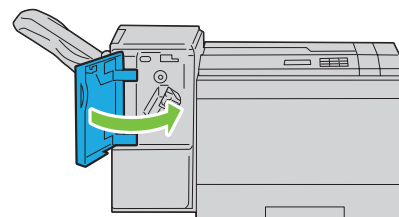

2.9 Replacing the Waste Toner Box

- Removing the Waste Toner Box

- 1) Confirm that the printer is not in operation, and open the front cover.

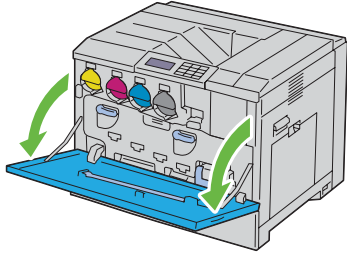

- 2) Hook your finger over the top of the waste toner box and pull it out towards you.

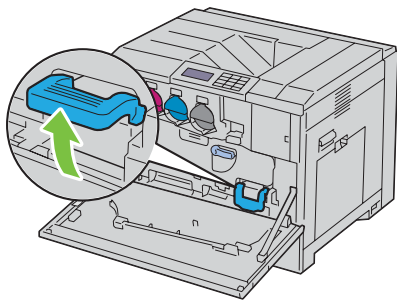

- 3) Grasp the waste toner box with your other hand as shown in the illustration, and pull it out of the printer.

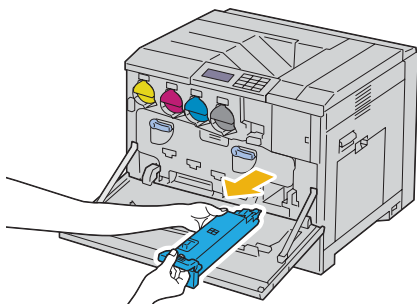

- 4) Insert the used waste toner box into the plastic bag that came with the new waste toner box and seal the bag.

- Installing a Waste Toner Box

- 1) Insert the new waste toner box into the slot and press it in until it stops.

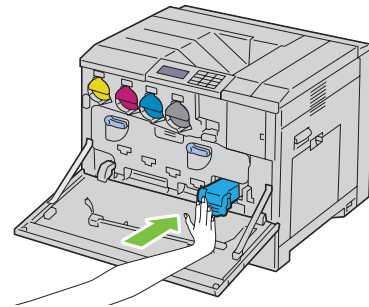

- 2) Close the front cover.

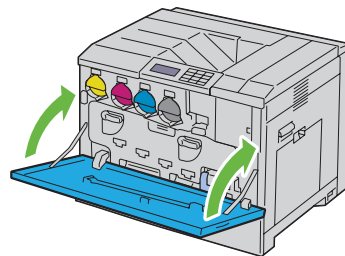

Appendix_3 Cleaning the Printer

3.1 Cleaning Inside the Printer

- 1) Confirm that the printer is not in operation, and open the front cover.

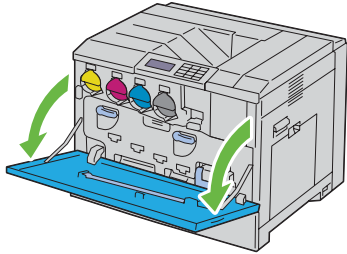

- 2) Remove the cleaning rod from the back-side of the front cover.

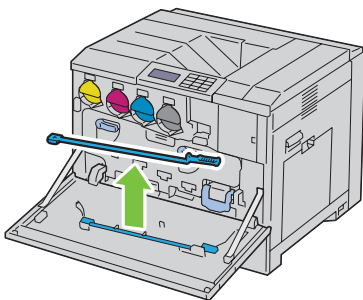

- 3) Insert the cleaning rod fully into one of the four holes until it clicks into the interior of the printer as illustrated below, and then pull it out.

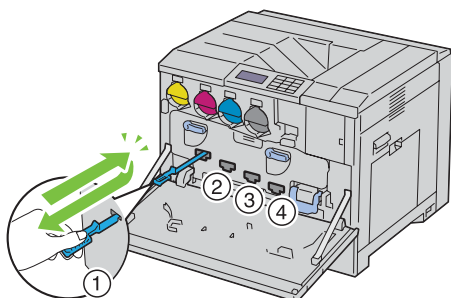

- 4) Repeat step 3 also on the other three holes.
- 5) Return the cleaning rod to its original location.

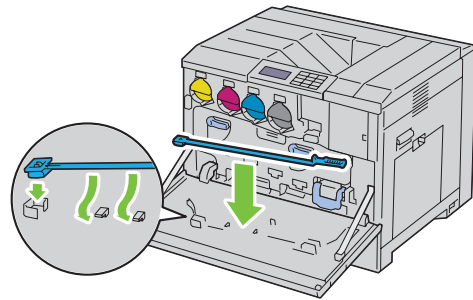

- 6) Close the front cover.

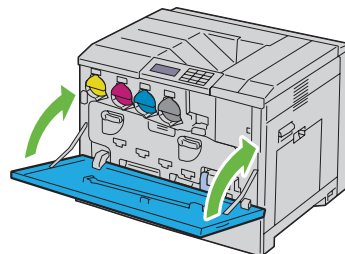

3.2 Cleaning the Conductivity Temperature Depth (CTD) Sensor

- 1) Turn off the printer.
- 2) Raise the latch of the right hand cover and open the cover.

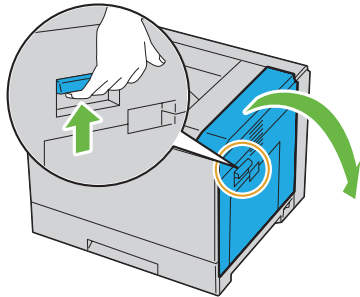

- 3) Open the front cover.

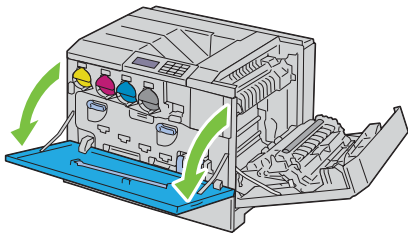

- 4) Rotate the lock levers of the inner cover to open it.

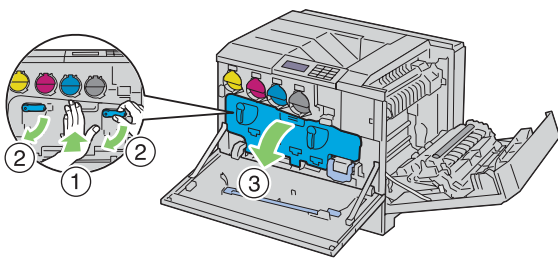

- 5) Grasp the handle on the front of the belt unit.

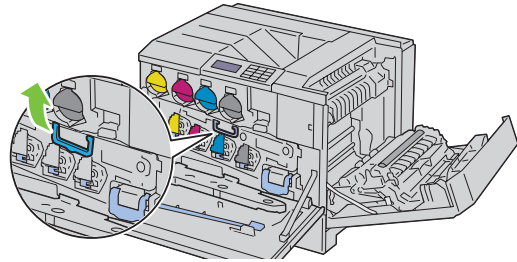

- 6) Pull out the belt unit until the line on the unit becomes completely visible.

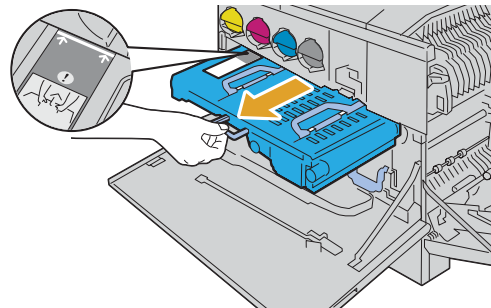

- 7) Grasp the handles on the top of the belt unit. Pull out the unit to remove it from the printer.

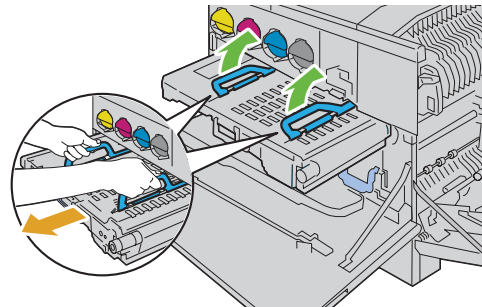

- 8) Slide the blue tab back and forth five times.

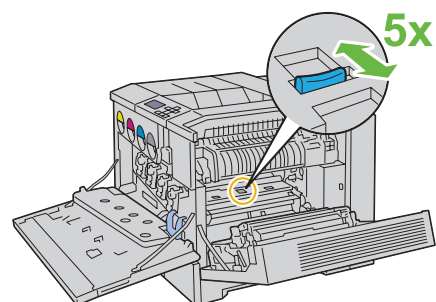

- 9) Grasp the handles on top of the belt unit.

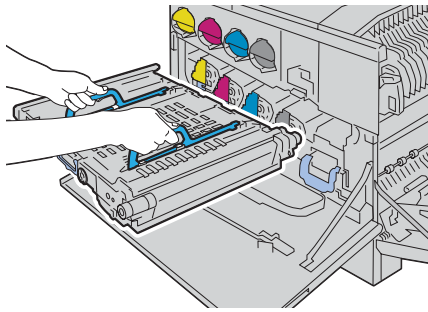

- 13) Push the front of the belt unit to reinstall it in the printer and until it stops.

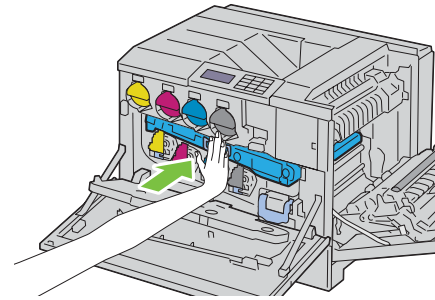

- 10) Align the arrows on the belt unit with the arrows on the printer.

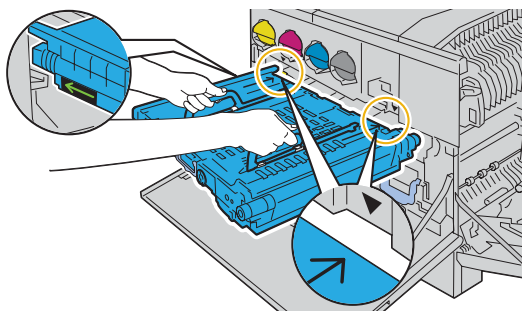

- 14) Close the inner cover.

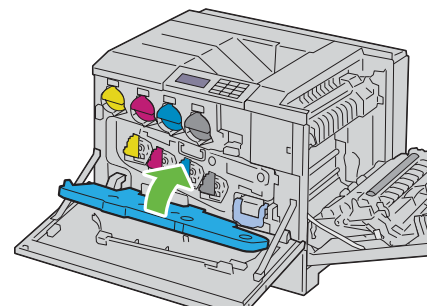

- 11) Slide the unit into the printer and stop when the visible line reaches the printer.

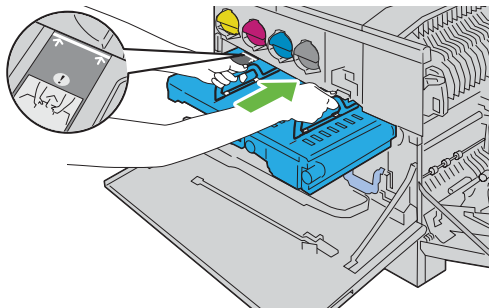

- 15) Rotate the lock levers to secure the inner cover while pressing the cover with the other hand.

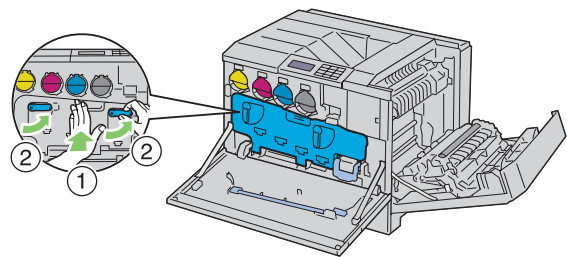

- 12) Lower the handles.

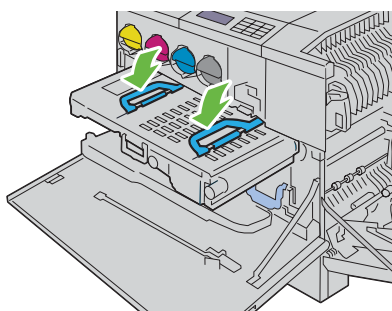

- 16) Close the front cover.

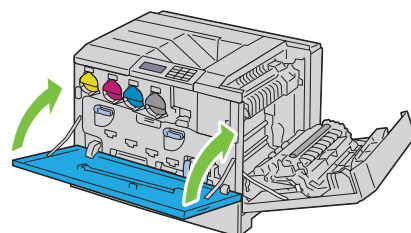

17) Close the right hand cover.

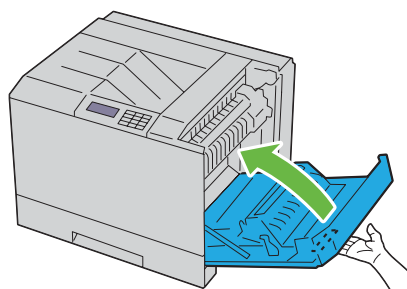

Chapter 2 Operation of Diagnostic CONTENTS

1. Overview.....	2 - 1
1.1 Purpose of This Software.....	2 - 1
1.2 Operating Methods	2 - 1
2. Configuration	2 - 2
3. How to use Diag in Customer Mode.....	2 - 3
3.1 Control Panel Functions for Diag	2 - 3
3.2 Entering Customer Mode	2 - 4
3.3 Selecting Diag Item.....	2 - 4
3.4 Changing Parameter Values	2 - 4
3.5 Executing/Exiting Diag Mode	2 - 4
3.6 Diag Mode Menu Tree	2 - 5
4. Diag Types and Test Contents	2 - 7
4.1 IOT Diag.....	2 - 7
4.1.1 Digital Input (DI) Test.....	2 - 7
4.1.2 Executing Digital Input (DI) Test	2 - 7
4.1.3 Digital Output (DO) Test of Customer Mode	2 - 38
4.1.4 Executing Digital Output (DO) Test of Customer Mode	2 - 38
4.1.5 Digital Output(DO) Test of CE Mode	2 - 45
4.1.6 Executing Digital Output (DO) Test of CE Mode.....	2 - 45
4.2 Print Info.....	2 - 83
4.2.1 Executing Print Info.....	2 - 83
4.2.2 Config Page	2 - 83
4.2.3 Print Settings.....	2 - 83
4.3 Test Print.....	2 - 84
4.3.1 Executing Test Print.....	2 - 84
4.3.2 No Image [IOT]	2 - 84
4.3.3 Test Pattern 600 [IOT]	2 - 84
4.3.4 Grid 2	2 - 85
4.3.5 Cyan 20%	2 - 86
4.3.6 Magenta 20%.....	2 - 86
4.3.7 Yellow 20%	2 - 87
4.3.8 Black 20%	2 - 87
4.3.9 CMY 20%.....	2 - 88
4.3.10 Gradation	2 - 89
4.3.11 Toner Pallet Check	2 - 90
4.3.12 Contamination Check.....	2 - 91
4.4 Parameter	2 - 92
4.4.1 Executing Parameter (Registration Adjustment).....	2 - 92
4.4.2 Executing Parameter (Life Counter)	2 - 94
4.4.3 Executing Parameter (Printing the parameter list).....	2 - 94
4.5 Complete.....	2 - 95
4.5.1 Executing Complete.....	2 - 95

Chapter 2 Operation of Diagnostic CONTENTS

1. Overview

1.1 Purpose of This Software

This software is mainly intended for the following purposes:

- ESS diagnosis to locate a chip which causes a problem
- Diagnosing IOT
- Setting parameters such as registration in the feeding direction.

1.2 Operating Methods

This software can be operated via the Control Panel.

2. Configuration

The operation of this Diag can be selected from the following three modes according to the purpose, target user, and function.

Only "Customer Mode" is detailed in this manual.

Customer Mode:

This mode is intended for the end user to use for isolating a problem to a replaceable unit level.

This mode allows operations such as ESS diagnostic, test printing, and parameter setting to be performed via the Control Panel.

CE (Customer Engineer) Mode:

This mode is intended for the customer engineer (CE) to use for isolating a problem to a replaceable unit level. This mode allows operations such as ESS diagnostic, test printing, and parameter setting to be performed via the Control Panel.

This mode is protected by password.

Production Line Mode:

This mode is intended for the production line to use for isolating a problem.

The diag is executed by sending commands via a serial debug terminal.

This mode is protected by password.

3. How to use Diag in Customer Mode

3.1 Control Panel Functions for Diag

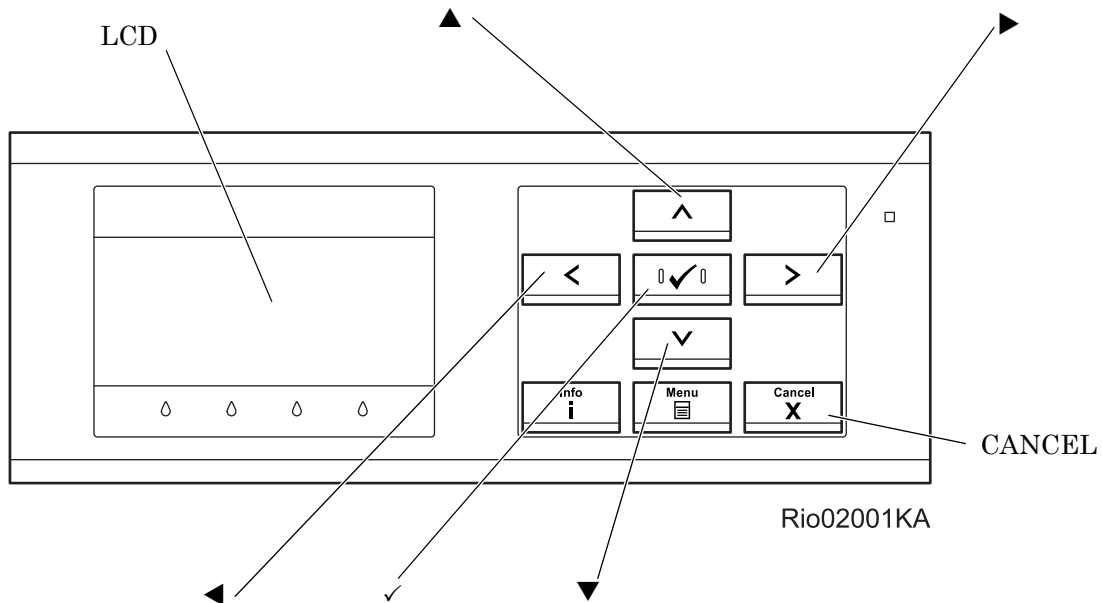

LCD : Displays the Diag item and its results.

▲, ▼ : Selects the Diag item or parameter value.

◀, ▶ : Moves the cursor to the left or right.

✓ : Confirms or executes the Diag item or parameter value selected.

MENU : Returns to the previous menu from any test item of the Digital Input or Digital Output test.

Cancel : Cancels the Diag menu (Returns to the menu one level higher).

3.2 Entering Customer Mode

- 1) Power off the printer.
- 2) Power on the printer while pressing "▲" and "▼" keys.
- 3) Release the keys when "Diagnosing..." is displayed.
- 4) "Customer Mode" and "IOT Diag" are displayed. (Now in the Diag mode.)

3.3 Selecting Diag Item

The Diag setting menu can be operated via the control panel keys.

Select the menu item with the arrow keys, and press "✓" key to execute the operation.

3.4 Changing Parameter Values

To change the parameter setting, select the currently set value and press "✓" key. Select a numeric value using "▼" and "▲" keys, and then press "✓" key to write the value into the NVM (Non-Volatile Memory).

3.5 Executing/Exiting Diag Mode

To execute the Diag, use the following procedure:

- 1) A test item is displayed. Press "✓" key to confirm the selection.
- 2) The display prompts the user to start the test. Press "✓" key to start the test.

To exit the Diag, use the following procedure:

- 1) During the Diag test, press the "Cancel" key.
- 2) The Diag is stopped, and the display moves to a menu one level higher.

3.6 Diag Mode Menu Tree

The menu tree of the Customer Mode is as follows:

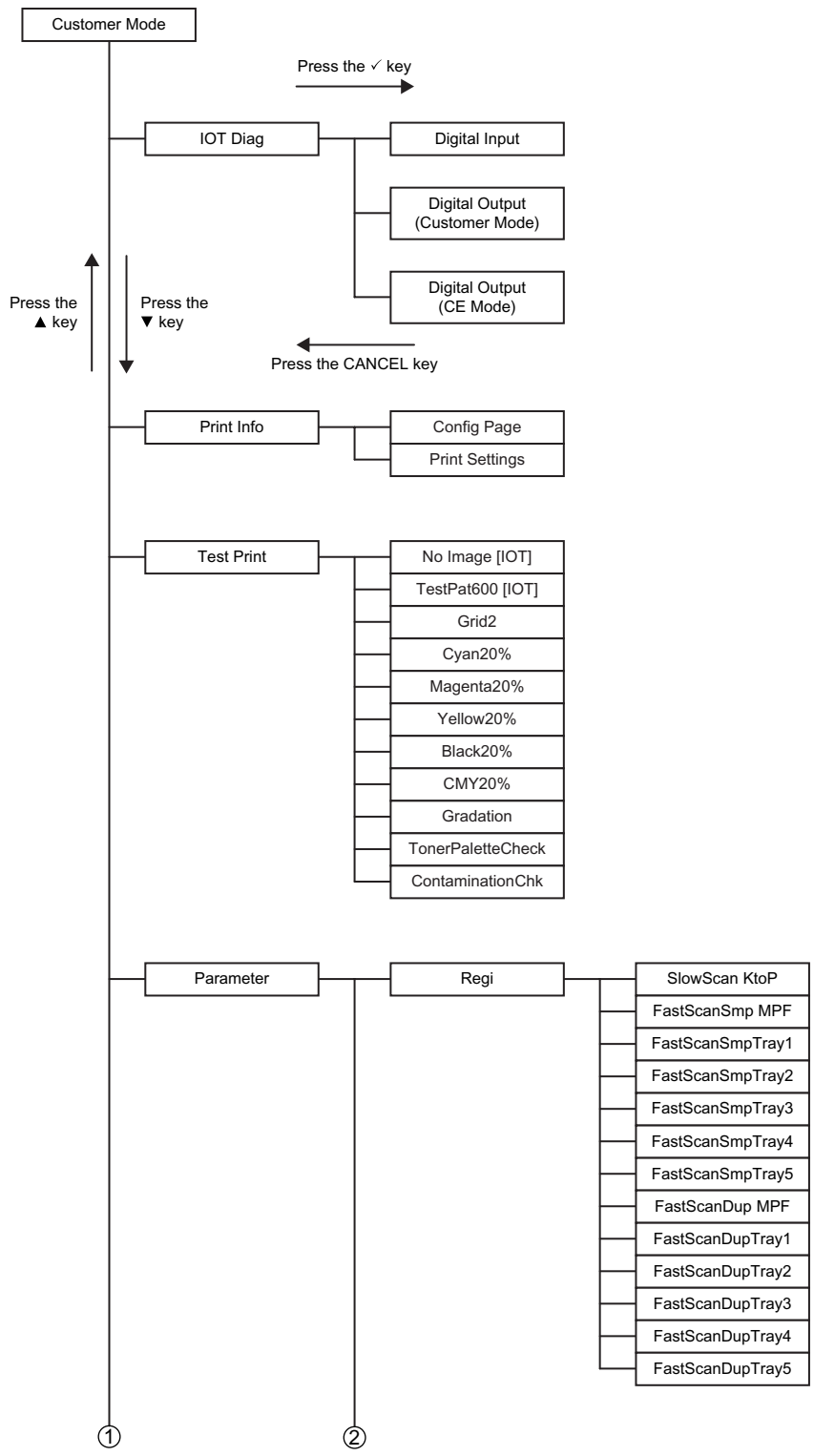

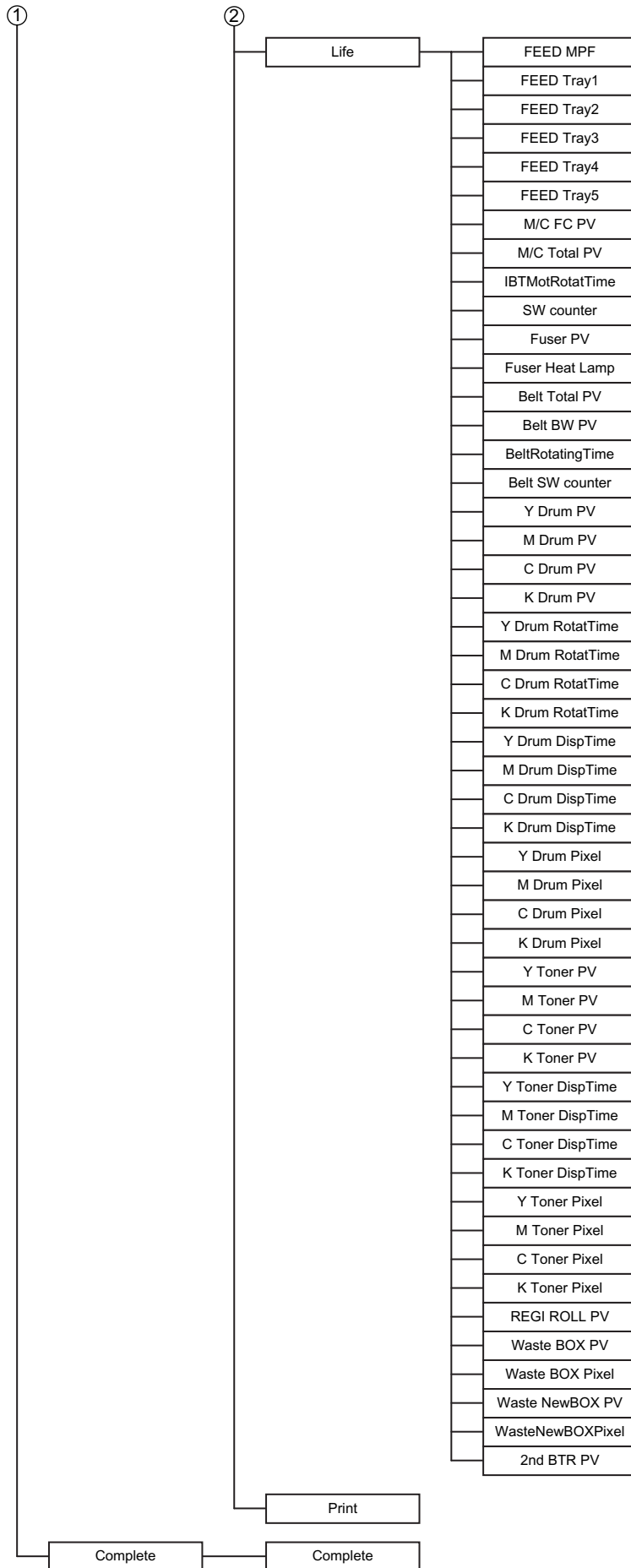

4. Diag Types and Test Contents

4.1 IOT Diag

4.1.1 Digital Input (DI) Test

This function checks whether the DI components operate normally.

The DI test is performed for all DI components.

Exiting the DI Test moves the Control Panel display to the Customer Diag Functions menu.

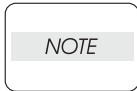

During the DI test, other Customer Diag functions cannot be performed simultaneously. Therefore, the printer does not accept any operation except operations for the DI components and exit operation of the DI test.

At the start of the DI test, number "0" is displayed on the control panel. This number is counted up when a DI component is turned on from off, allowing the user to know that the component is active.

When a paper jam has occurred, or an error message or code is displayed, execute this test to locate the faulty parts.

Before executing the test, isolate the faulty parts by examining the jam or error in detail. (Refer to the FIP in Chapter 1.)

Test Result: NG (Go to the FIP or replace the parts.)

OK (Power off the printer and then on.)

4.1.2 Executing Digital Input (DI) Test

- 1) Power off the printer.
- 2) Power on the printer while pressing "▲" and "▼" keys.
- 3) Release the keys when "Diagnosing..." is displayed.
- 4) "Customer Mode" and "IOT Diag" are displayed. (Now in the Diag mode.)
- 5) Press "✓" key.
- 6) Press "▼" key to select "Digital Input", and then press "✓" key.
- 7) Press "▲" or "▼" key to select the test item.
- 8) Press "✓" key twice to execute the test.

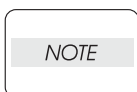

To exit the test, press the "Cancel" key. To return to the previous menu, press the "Menu" key.

<Example of Digital Input Test Operation>

Checking Interlock Front Switch (046-300) via Digital Input Test

This test is intended for checking whether the Interlock (open/close detection) Switch of the Front Cover functions properly.

- 1) Power on the machine and enter the Diag mode.
- 2) Execute Interlock Front Switch (046-300).

The LCD Panel displays the following:

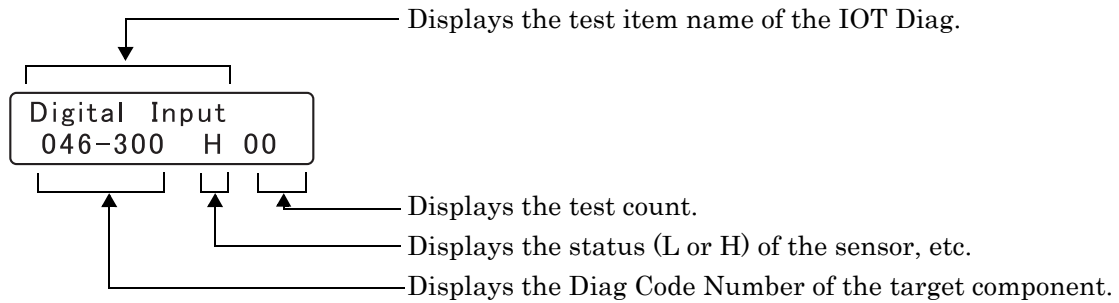

- 3) Check the operation of the sensor.

Opening the Front Cover turns off the Interlock Front Switch, changing "H" in the bottom line of the display to "L".



Closing the Front Cover turns on the Interlock Front Switch, changing "L" in the bottom line to "H". Meanwhile, the rightmost number in the bottom line changes from "0" to "1", indicating that the sensor check has been completed once.

**NOTE**

When the rightmost number in the bottom line of the display changes from "0" to "1", the Interlock Front Switch is functioning properly.

Otherwise, it is suspected that a component related to the Front Cover Interlock Switch is faulty.

Parameters for the Digital Input Test are as follows.

- Printer

Code	Component
010-200	Alarm Fuser Motor (Internal signal)
010-201	Alarm Fuser Fan (Internal signal)
010-202	Exit Sensor
010-203	Envelope Mode Sensor
010-204	Fuser Enable (Internal signal)
042-200	Alarm LV Fan (Internal signal)
046-300	Interlock Front Switch
046-301	Interlock Right Hand Switch
047-200	Detect Commander (Internal signal)
047-201	Detect Finisher (Internal signal)
071-100	Alarm Paper Hand (PH) Motor (Internal signal)
071-101	Regi Sensor
071-102	Full Stack Sensor
071-103	Duplex Jam Sensor (Not in use)
071-104	MSI No Paper Sensor
071-105	Cassette No Paper Sensor
071-106	Cassette Low Paper Sensor2
071-107	Cassette Low Paper Sensor1
071-108	Cassette Size Sensor2
071-109	Cassette Size Sensor1
071-110	Cassette Size Sensor0
071-111	OHP Sensor (Not in use)
071-112	Front Cover Switch
071-114	Cassette2 Option Motor Alarm (Internal signal)
071-115	Cassette2 Paper Path Sensor
071-116	Cassette2 No Paper Sensor
071-117	Cassette2 Size Sensor2
071-118	Cassette2 Size Sensor1
071-119	Cassette2 Size Sensor0
071-120	Cassette2 Low Paper Sensor2
071-121	Cassette2 Low Paper Sensor1
071-122	Cassette2 RH Cover Switch
071-123	Cassette3 Option Motor Alarm (Internal signal)

Code	Component
071-124	Cassette3 Paper Path Sensor
071-125	Cassette3 No Paper Sensor
071-126	Cassette3 Size Sensor2
071-127	Cassette3 Size Sensor1
071-128	Cassette3 Size Sensor0
071-129	Cassette3 Low Paper Sensor2
071-130	Cassette3 Low Paper Sensor1
071-131	Cassette3 RH Cover Switch
071-132	Cassette4 Option Motor Alarm (Internal signal)
071-133	Cassette4 Paper Path Sensor
071-134	Cassette4 No Paper Sensor
071-135	Cassette4 Size Sensor2
071-136	Cassette4 Size Sensor1
071-137	Cassette4 Size Sensor0
071-138	Cassette4 Low Paper Sensor2
071-139	Cassette4 Low Paper Sensor1
071-140	Cassette4 RH Cover Switch
071-141	Cassette5 Option Motor Alarm (Internal signal)
071-142	Cassette5 Paper Path Sensor
071-143	Cassette5 No Paper Sensor
071-144	Cassette5 Size Sensor2
071-145	Cassette5 Size Sensor0
071-146	Cassette5 Size Sensor1
071-147	Cassette5 Low Paper Sensor2
071-148	Cassette5 Low Paper Sensor1
071-149	Cassette5 RH Cover Switch
091-200	Alarm Xero Motor (Internal signal)
091-201	Switching Sensor K
091-202	Switching Sensor FC
093-200	Alarm Deve K Motor (Internal signal)
093-201	Alarm Deve YMC Motor (Internal signal)
093-204	Waste Box Full Sensor
094-200	Alarm IBT Motor (Internal signal)

- Option Output Expander (Finisher)

Code	Component
012-150	Compile Exit Sensor
012-151	Compile Tray No Paper Sensor
012-220	Front Tamper Home Sensor
012-221	Rear Tamper Home Sensor
012-242	Low Staple Sensor
012-243	Self Priming Sensor
012-244	Staple Home Sensor

Code	Component
012-250	Eject Clamp Home Sensor
012-251	Set Clamp Home Sensor
012-262	Stacker No Paper Sensor
012-264	Stack Height Sensor 1
012-265	Stack Height Sensor 2
012-302	Finisher Front Door Switch
012-303	H-Xport Cover Sensor

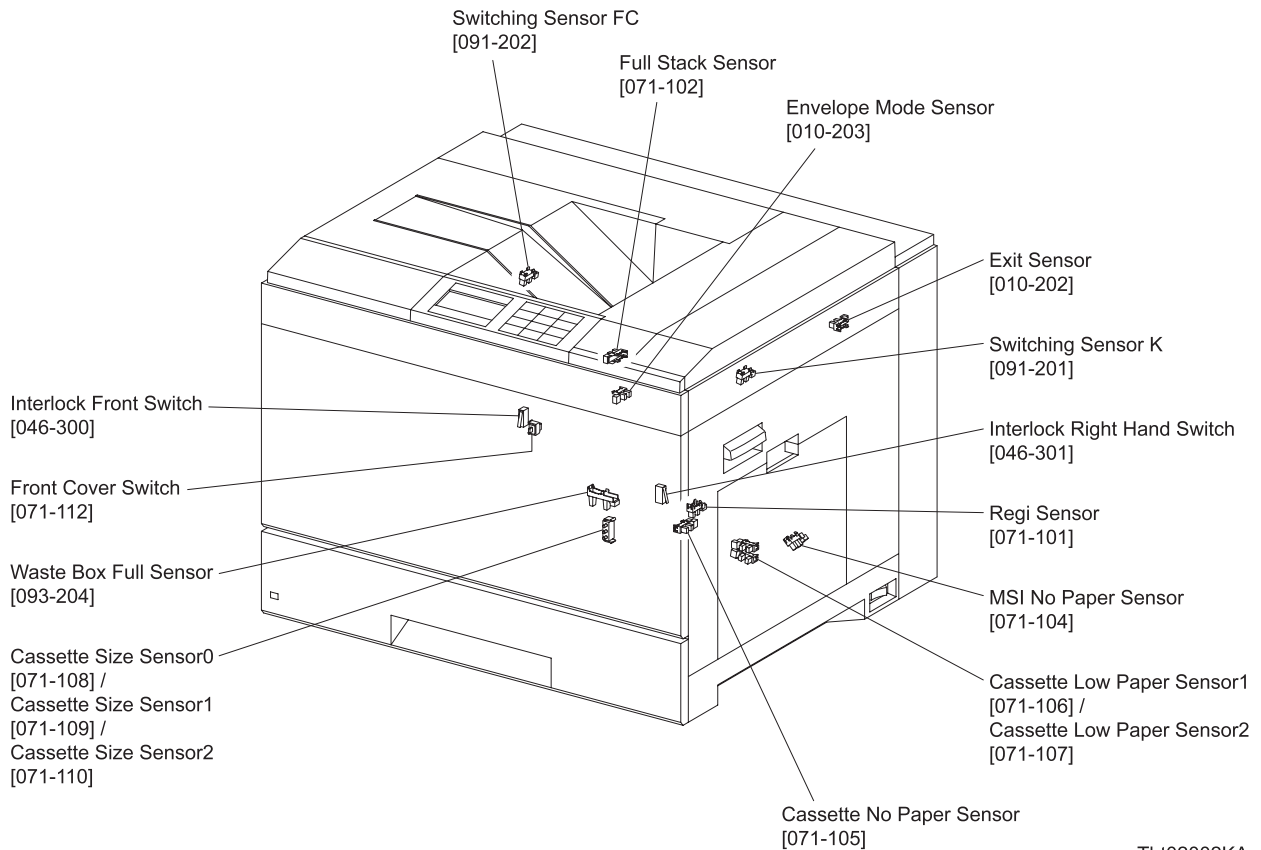

Tbt02002KA

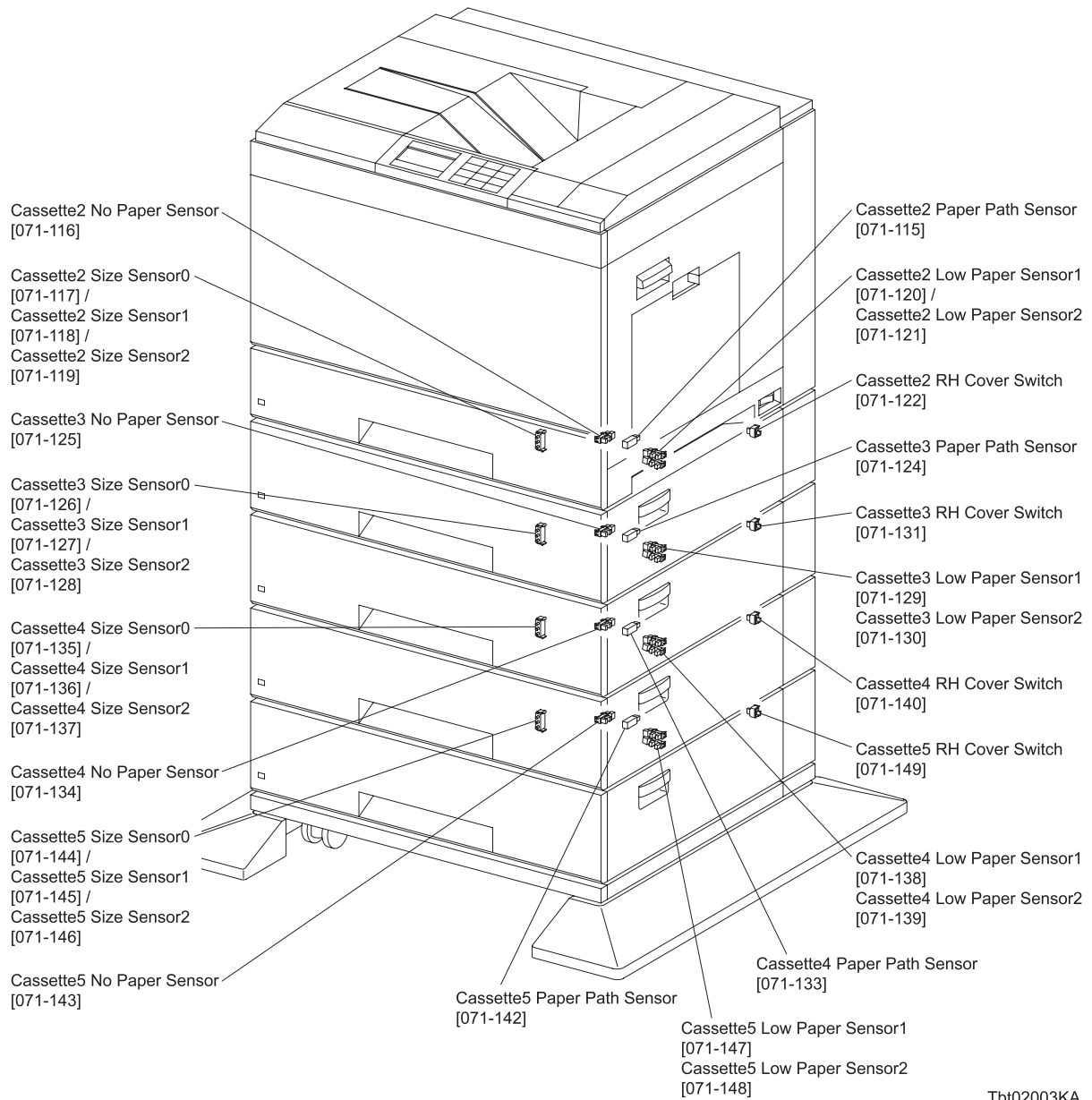

Tbt02003KA

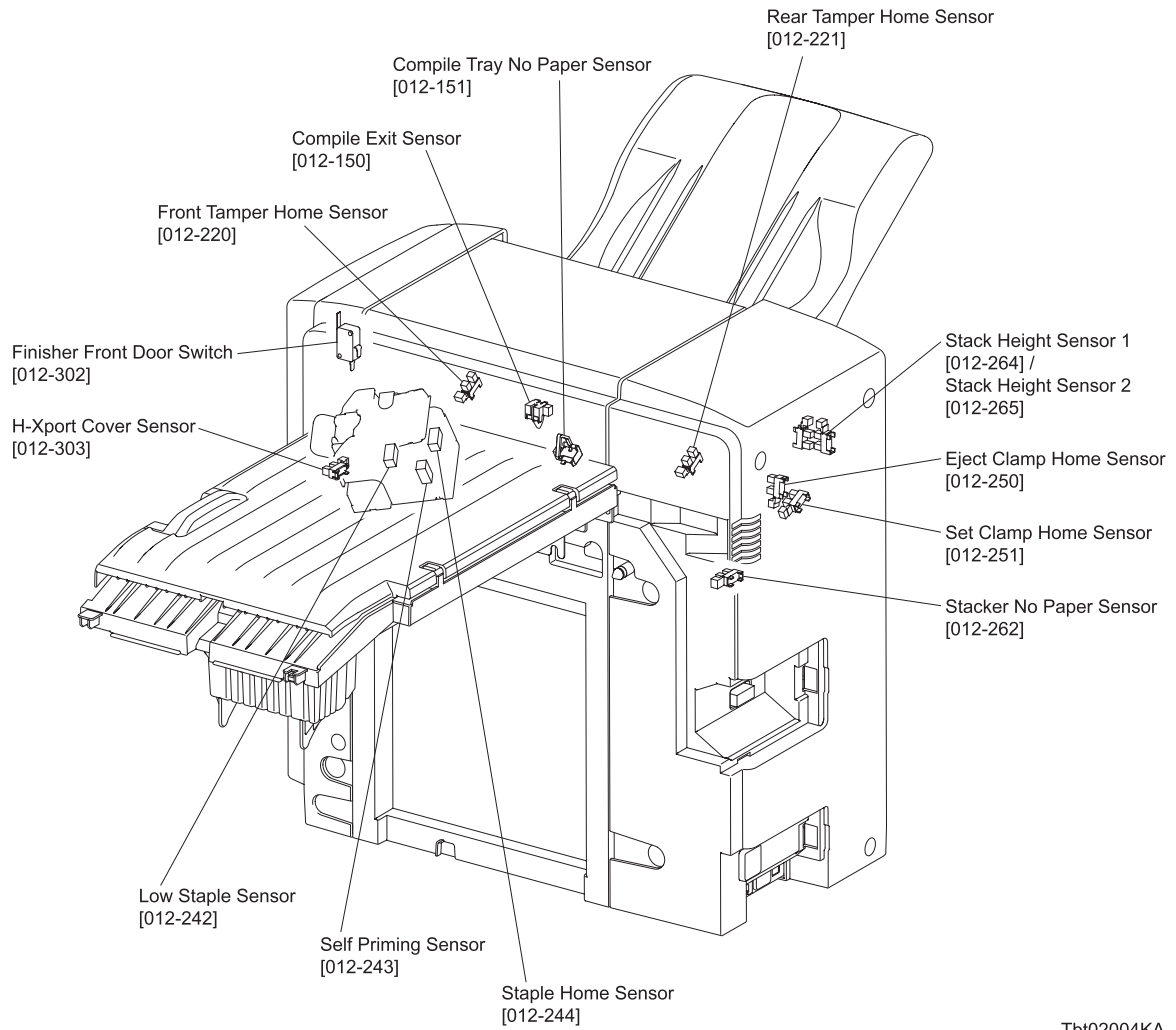

Tbt02004KA

- About Sensor

A transmission type sensor is composed of the light-emitting side and the light-receiving side that are placed opposite to each other, allowing the light to pass from the former to the latter. On the basis of whether or not the light path is blocked by the actuator, etc., the sensor detects the paper absence/presence or the moving part position such as at the home position or elsewhere.

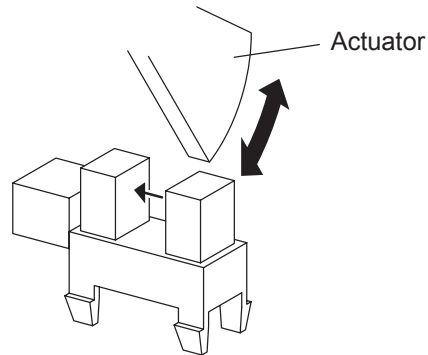

Leg_Sec02_016FA

- About Switch

A micro-switch closes the internal contacts via the button which is pushed down under the provided leaf spring which is held down by the actuator of the cover or door that is being closed. When the door or cover is opened, the leaf spring returns to its original position, and the button is pushed up by the spring in the switch, allowing the internal contacts to open.

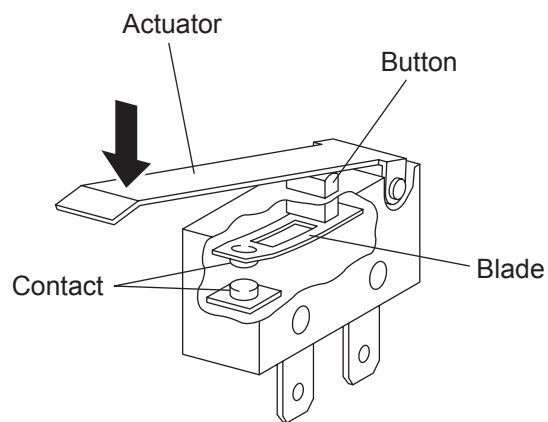

Leg_Sec02_018FA

- Printer

Checking the Sensor and Switch

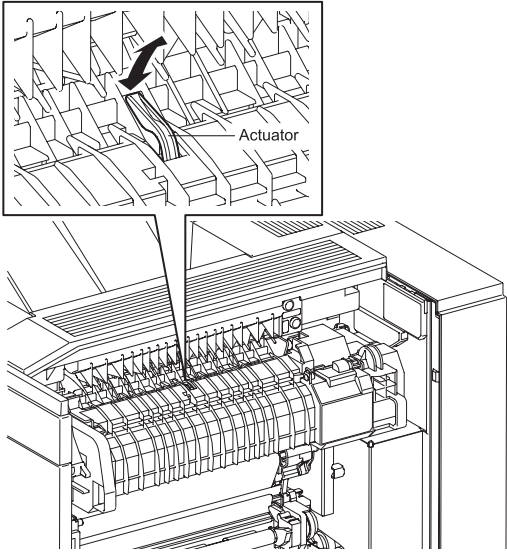
Sensor name (Diag. Code)	Check Procedure
Alarm Fuser Motor (010-200)	Internal signal
Alarm Fuser Fan (010-201)	Internal signal
Exit Sensor (010-202)	<p>NOTE: Because the Fuser is very hot, be careful not to burn yourself.</p> <ol style="list-style-type: none"> 1) Power on the printer, and enter the Diag Mode. 2) Open the RH Cover. 3) Execute 010-202. The bottom line of the LCD displays: [010-202 H 00] 4) Manually operate the actuator to check whether the sensor functions properly. <div style="text-align: center;">  <p style="text-align: right; font-size: small;">Tbt02005KA</p> </div> <ol style="list-style-type: none"> 5) Check that the number in the bottom line of the display increases by one every time the actuator is operated. [010-202 H 01] 6) Press the "Cancel" key to stop the test. 7) Close the RH Cover.

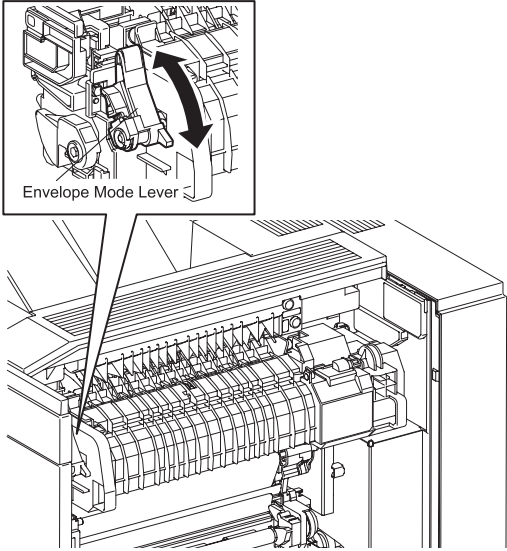
Sensor name (Diag. Code)	Check Procedure
Envelope Mode Sensor (010-203)	<p>NOTE: Because the Fuser is very hot, be careful not to burn yourself.</p> <ol style="list-style-type: none"> 1) Power on the printer, and enter the Diag Mode. 2) Open the RH Cover. 3) Execute 010-203. The bottom line of the LCD displays: [010-203 H 00] 4) Toggle the Envelope Mode Lever to check whether the sensor operates properly. <div style="text-align: center;">  <p style="text-align: right; font-size: small;">Tbt02006KA</p> </div> <ol style="list-style-type: none"> 5) Check that the number in the bottom line of the display increases by one every time the Envelope Mode Lever is toggled. [010-203 H 01] 6) Press the "Cancel" key to stop the test. 7) Close the RH Cover.
Fuser Enable (010-204)	Internal signal
Alarm LV Fan (042-200)	Internal signal

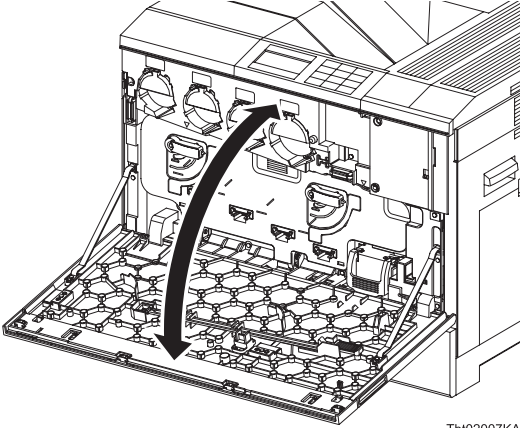
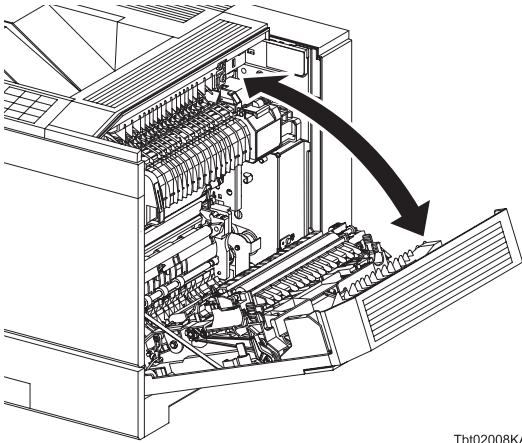
Sensor name (Diag. Code)	Check Procedure
<p>Interlock Front Switch (046-300)</p>	<ol style="list-style-type: none"> 1) Power on the printer, and enter the Diag Mode. 2) Execute 046-300. The bottom line of the LCD displays: [046-300 H 00] 3) Open or close the Front Cover to check whether the sensor functions properly.  <p style="text-align: right; font-size: small;">Tb102007KA</p> <ol style="list-style-type: none"> 4) Check that the number in the bottom line of the display increases by one every time the Front Cover is opened or closed. [046-300 H 01] 5) Press the "Cancel" key to stop the test. 6) Close the Front Cover.
<p>Interlock Right Hand Switch (046-301)</p>	<ol style="list-style-type: none"> 1) Power on the printer, and enter the Diag Mode. 2) Execute 046-301. The bottom line of the LCD displays: [046-301 L 0] 3) Open or close the RH Cover to check whether the sensor functions properly.  <p style="text-align: right; font-size: small;">Tb102008KA</p> <ol style="list-style-type: none"> 4) Check that the number in the bottom line of the display increases by one every time the RH Cover is opened or closed. [046-301 H 01] 5) Press the "Cancel" key to stop the test. 6) Close the RH Cover.
<p>Detect Commander (047-200)</p>	<p>Internal signal</p>
<p>Detect Finisher (047-201)</p>	<p>Internal signal</p>
<p>Alarm Paper Hand (PH) Motor (071-100)</p>	<p>Internal signal</p>

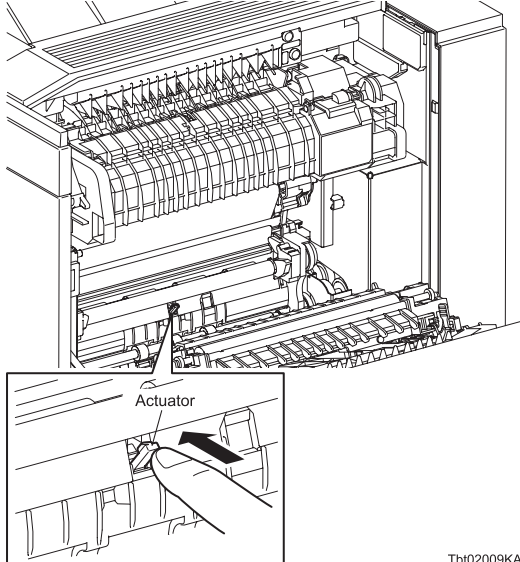
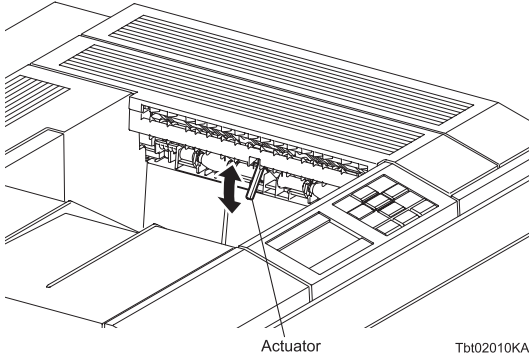
Sensor name (Diag. Code)	Check Procedure
<p>Regi Sensor (071-101)</p>	<ol style="list-style-type: none"> 1) Power on the printer, and enter the Diag Mode. 2) Open the RH Cover. 3) Execute 071-101. The bottom line of the LCD displays: [071-101 H 00] 4) Manually operate the actuator to check whether the sensor functions properly.  <p style="text-align: right; font-size: small;">Tb102009KA</p> <ol style="list-style-type: none"> 5) Check that the number in the bottom line of the display increases by one every time the actuator is operated. [071-101 H 01] 6) Press the "Cancel" key to stop the test. 7) Close the RH Cover.
<p>Full Stack Sensor (071-102)</p>	<ol style="list-style-type: none"> 1) Power on the printer, and enter the Diag Mode. 2) Execute 071-102. The bottom line of the LCD displays: [071-102 H 00] 3) Manually operate the actuator to check whether the sensor functions properly.  <p style="text-align: right; font-size: small;">Tb102010KA</p> <ol style="list-style-type: none"> 4) Check that the number in the bottom line of the display increases by one every time the actuator is operated. [071-102 H 01] 5) Press the "Cancel" key to stop the test.
<p>Duplex Jam Sensor (071-103)</p>	<p>Not in use</p>

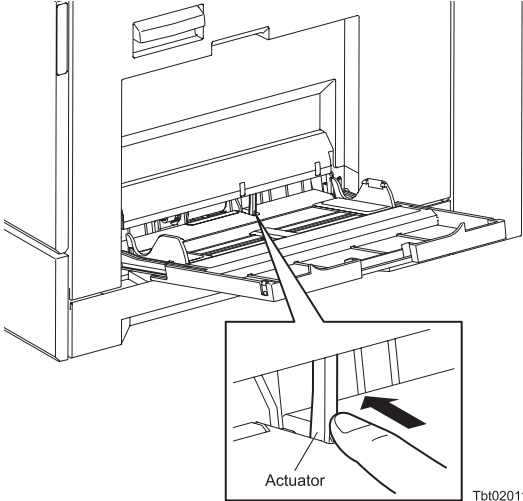
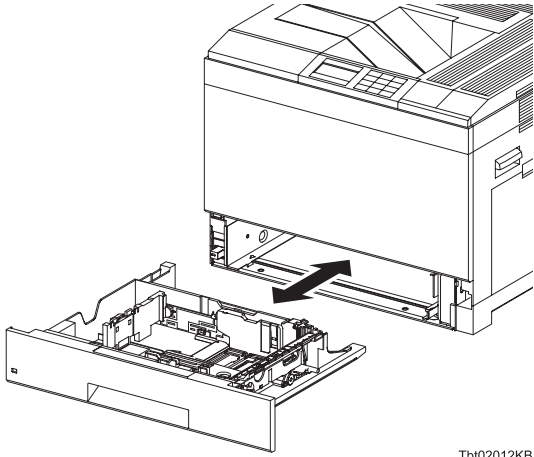
Sensor name (Diag. Code)	Check Procedure
<p>MSI No Paper Sensor (071-104)</p>	<ol style="list-style-type: none"> 1) Power on the printer, and enter the Diag Mode. 2) Open the MSI Cover. 3) Execute 071-104. The bottom line of the LCD displays: [071-104 H 00] 4) Manually operate the actuator to check whether the sensor functions properly.  <ol style="list-style-type: none"> 5) Check that the number in the bottom line of the display increases by one every time the actuator is operated. [071-104 H 01] 6) Press the "Cancel" key to stop the test. 7) Close the MSI Cover.
<p>Cassette No Paper Sensor (071-105)</p>	<ol style="list-style-type: none"> 1) Power on the printer, and enter the Diag Mode. 2) Remove the paper from 550 paper cassette. 3) Execute the 071-105. The bottom line of the LCD displays: [071-105 L 00] 4) Check whether the sensor functions properly by removing and replacing the 550 paper cassette.  <ol style="list-style-type: none"> 5) Confirm that the number in the lower section of the display increases each time the 550 paper cassette is removed and replaced. [071-105 L 01] 6) Press the "Cancel" key to stop the test.

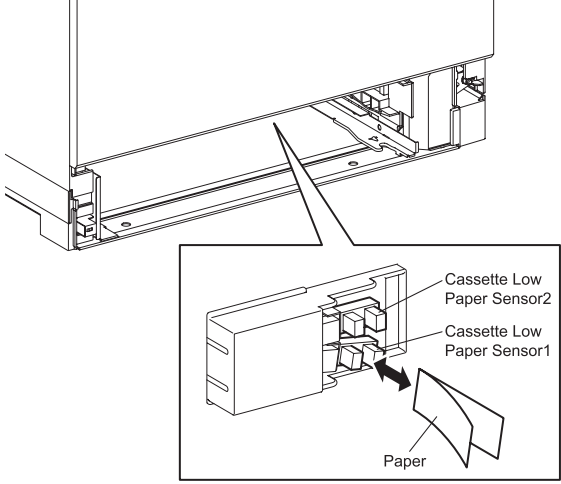
Sensor name (Diag. Code)	Check Procedure
Cassette Low Paper Sensor2 (071-106) / Cassette Low Paper Sensor1 (071-107)	<ol style="list-style-type: none"> 1) Power on the printer, and enter the Diag Mode. 2) Remove the 550 paper cassette. 3) Execute 071-106. The bottom line of the LCD displays: [071-106 L 00] 4) Block the sensor light path by placing a piece of paper or the like between the light emitting unit and the light receiving unit to check whether the sensor functions properly. <div style="text-align: center; margin: 10px 0;">  </div> <ol style="list-style-type: none"> 5) Check that the number in the bottom line of the display increases by one every time the sensor light path is blocked. [071-106 L 01] 6) Press the "Cancel" key to stop the test. 7) Replace the 550 paper cassette. 8) The check procedure for 071-107 is the same as that for 071-106 described above.

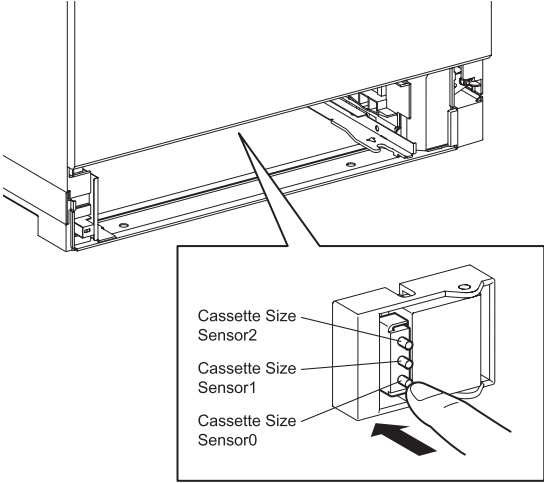
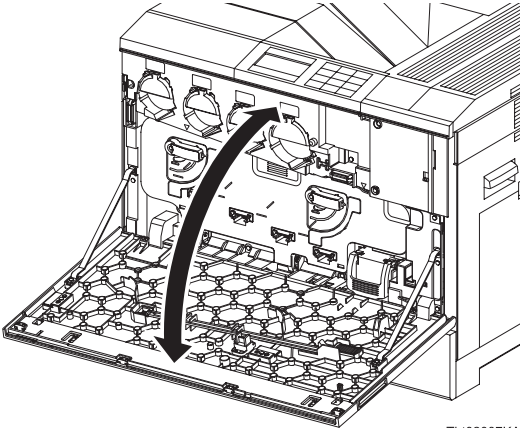
Sensor name (Diag. Code)	Check Procedure
Cassette Size Sensor2 (071-108) / Cassette Size Sensor1 (071-109) / Cassette Size Sensor0 (071-110)	<ol style="list-style-type: none"> 1) Power on the printer, and enter the Diag Mode. 2) Remove the 550 paper cassette. 3) Execute 071-108. The bottom line of the LCD displays: [071-108 H 00] 4) Press the Size Sensor0 with a finger to check whether the sensor functions properly.  <p style="text-align: right; font-size: small;">Tbt02014KB</p> <ol style="list-style-type: none"> 5) Check that the number in the bottom line of the display increases by one every time the Size Sensor0 is pressed. [071-108 H 01] 6) Press the "Cancel" key to stop the test. 7) Replace the 550 paper cassette. 8) The check procedure for 071-109 and 071-110 are the same as that for 071-108 described above.
OHP Sensor (071-111)	Not in use
Front Cover Switch (071-112)	<ol style="list-style-type: none"> 1) Power on the printer, and enter the Diag Mode. 2) Execute 071-112. The bottom line of the LCD displays: [071-112 H 00] 3) Open or close the Front Cover to check whether the sensor functions properly.  <p style="text-align: right; font-size: small;">Tbt02007KA</p> <ol style="list-style-type: none"> 4) Check that the number in the bottom line of the display increases by one every time the Front Cover is opened or closed. [071-112 H 01] 5) Press the "Cancel" key to stop the test. 6) Close the Front Cover.

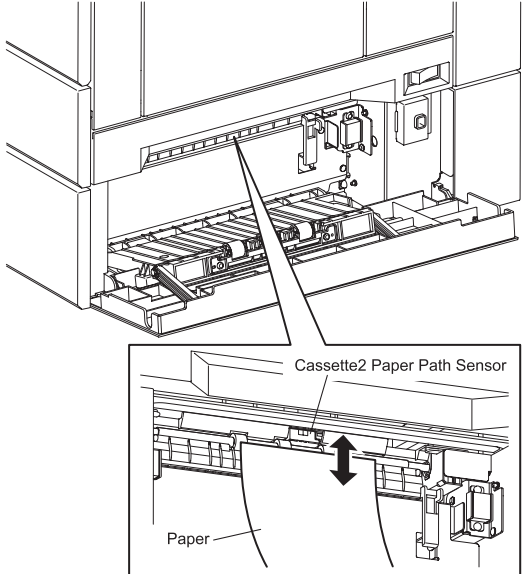
Sensor name (Diag. Code)	Check Procedure
Cassette2 Option Motor Alarm (071-114) / Cassette3 Option Motor Alarm (071-123) / Cassette4 Option Motor Alarm (071-132) / Cassette5 Option Motor Alarm (071-141)	Internal signal
Cassette2 Paper Path Sensor (071-115) / Cassette3 Paper Path Sensor (071-124) / Cassette4 Paper Path Sensor (071-133) / Cassette5 Paper Path Sensor (071-142)	<p>Example: Cassette2 Paper Path Sensor</p> <ol style="list-style-type: none"> 1) Power on the printer, and enter the Diag Mode. 2) Open the RH Cover. 3) Execute 071-115. The bottom line of the LCD displays: [071-115 H 00] 4) Insert and remove a sheet to and from the paper path to check whether the sensor functions properly.  <ol style="list-style-type: none"> 5) Check that the number in the bottom line of the display increases by one every time the sheet is inserted to or removed from the paper path. [071-115 H 01] 6) Press the "Cancel" key to stop the test. 7) Close the RH Cover. <p>NOTE: The check procedure for Cassette3, Cassette4, and Cassette5 are the same as that for Cassette2 described above.</p>

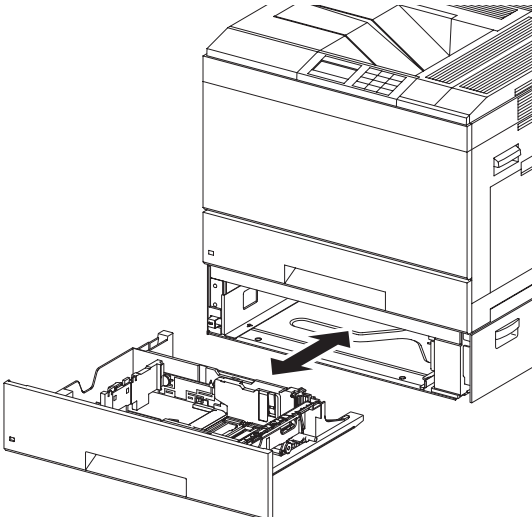
Sensor name (Diag. Code)	Check Procedure
<p>Cassette2 No Paper Sensor (071-116) / Cassette3 No Paper Sensor (071-125) / Cassette4 No Paper Sensor (071-134) / Cassette5 No Paper Sensor (071-143)</p>	<p>Example: Cassette2 No Paper Sensor</p> <ol style="list-style-type: none"> 1) Power on the printer, and enter the Diag Mode. 2) Remove the paper from 550 paper cassette. 3) Execute 071-116. The bottom line of the LCD displays: [071-116 L 00] 4) Check whether the sensor functions properly by removing and replacing the 550 paper cassette.  <p style="text-align: right; font-size: small;">Tbi02016KB</p> <ol style="list-style-type: none"> 5) Confirm that the number in the lower section of the display increases each time the 550 paper cassette is removed and replaced. [071-116 L 01] 6) Press the "Cancel" key to stop the tes. <p>NOTE: The check procedure for Cassette3, Cassette4, and Cassette5 are the same as that for Cassette2 described above.</p>

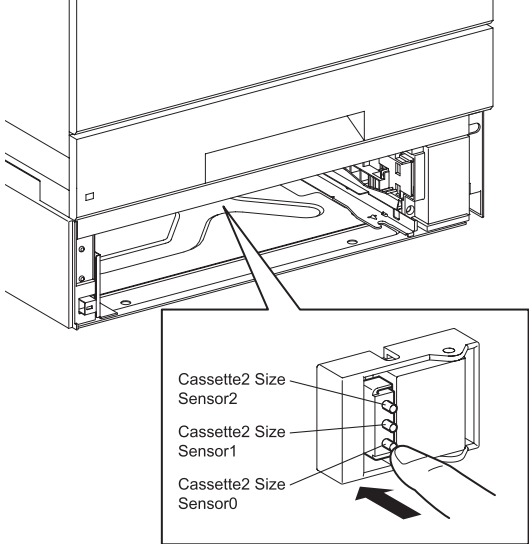
Sensor name (Diag. Code)	Check Procedure
<p>Cassette2 Size Sensor2 (071-117) / Cassette2 Size Sensor1 (071-118) / Cassette2 Size Sensor0 (071-119) /</p> <p>Cassette3 Size Sensor2 (071-126) / Cassette3 Size Sensor1 (071-127) / Cassette3 Size Sensor0 (071-128)</p> <p>Cassette4 Size Sensor2 (071-135) / Cassette4 Size Sensor1 (071-136) / Cassette4 Size Sensor0 (071-137)</p> <p>Cassette5 Size Sensor2 (071-144) / Cassette5 Size Sensor0 (071-145) / Cassette5 Size Sensor1 (071-146)</p>	<p>Example: Cassette2 Size Sensor(0 to 2)</p> <ol style="list-style-type: none"> 1) Power on the printer, and enter the Diag Mode. 2) Remove the Option 550 paper cassette. 3) Execute 071-117. The bottom line of the LCD displays: [071-117 H 00] 4) Press the Size Sensor0 with a finger to check whether the sensor functions properly. <div style="text-align: center;">  <p style="text-align: right; font-size: small;">Tbi02017KB</p> </div> <ol style="list-style-type: none"> 5) Check that the number in the bottom line of the display increases by one every time the Size Sensor0 is pressed. [071-117 H 01] 6) Press the "Cancel" key to stop the test. 7) Replace the Option 550 paper cassette. 8) The check procedure for 071-118 and 071-119 are the same as that for 071-117 described above. <p>NOTE: The check procedure for Cassette3, Cassette4, and Cassette5 are the same as that for Cassette2 described above.</p>

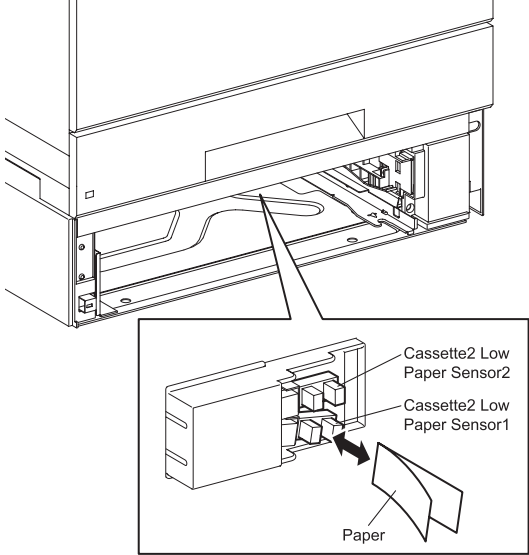
Sensor name (Diag. Code)	Check Procedure
<p>Cassette2 Low Paper Sensor2 (071-120) / Cassette2 Low Paper Sensor1 (071-121)</p> <p>Cassette3 Low Paper Sensor2 (071-129) / Cassette3 Low Paper Sensor1 (071-130)</p> <p>Cassette4 Low Paper Sensor2 (071-138) / Cassette4 Low Paper Sensor1 (071-139)</p> <p>Cassette5 Low Paper Sensor2 (071-147) / Cassette5 Low Paper Sensor1 (071-148)</p>	<p>Example: Cassette2 Low Paper Sensor (1 to 2)</p> <ol style="list-style-type: none"> 1) Power on the printer, and enter the Diag Mode. 2) Remove the 550 paper cassette. 3) Execute 071-120. The bottom line of the LCD displays: [071-120 H 00] 4) Block the sensor light path by placing a piece of paper or the like between the light emitting unit and the light receiving unit to check whether the sensor functions properly.  <p style="text-align: right; font-size: small;">Tbt02018KB</p> <ol style="list-style-type: none"> 5) Check that the number in the bottom line of the display increases by one every time the sensor light path is blocked. [071-120 H 01] 6) Press the "Cancel" key to stop the test. 7) Replace the 550 paper cassette. 8) The check procedure for 071-121 are the same as that for 071-120 described above. The bottom line of the LCD displays: [071-121 H 01] <p>NOTE: The check procedure for Cassette3, Cassette4, and Cassette5 are the same as that for Cassette2 described above.</p>

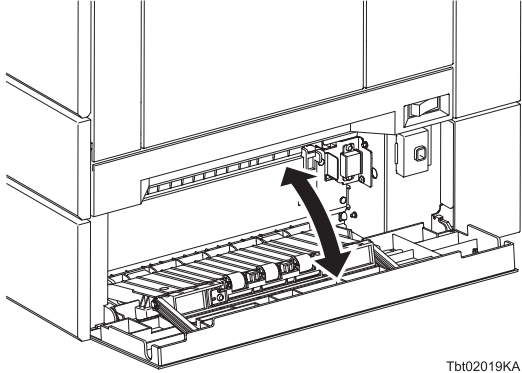
Sensor name (Diag. Code)	Check Procedure
Cassette2 RH Cover Switch (071-122) / Cassette3 RH Cover Switch (071-131) / Cassette4 RH Cover Switch (071-140) / Cassette5 RH Cover Switch (071-149)	<p>Example: Cassette2 RH Cover Switch</p> <ol style="list-style-type: none"> 1) Power on the printer, and enter the Diag Mode. 2) Execute 071-122. The bottom line of the LCD displays: [071-122 H 00] 3) Open or close the Option RH Cover to check whether the sensor functions properly.  <p style="text-align: right; font-size: small;">Tbt02019KA</p> <ol style="list-style-type: none"> 4) Check that the number in the bottom line of the display increases by one every time the Option RH Cover is opened or closed. [071-122 H 01] 5) Press the "Cancel" key to stop the test. 6) Close the Option RH Cover. <p>NOTE: The check procedure for Cassette3, Cassette4, and Cassette5 are the same as that for Cassette2 described above.</p>
Alarm Xero Motor (091-200)	Internal signal

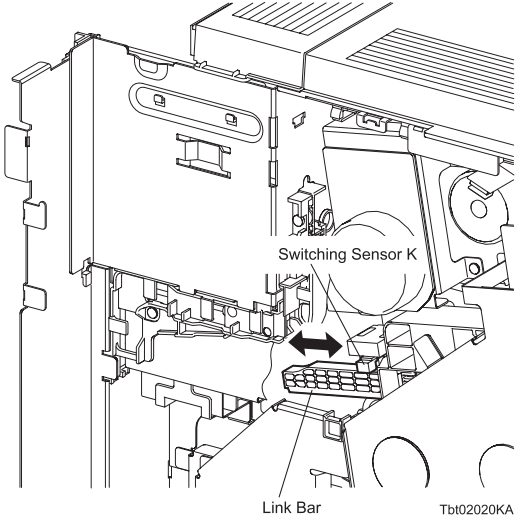
Sensor name (Diag. Code)	Check Procedure
Switching Sensor K (091-201)	<p>NOTE: This procedure is for the technical staff.</p> <ol style="list-style-type: none"> 1) Remove parts until the Link Bar is accessible. (Refer to Removal 53) When the harness was removed, replace and connect it before starting the check. 2) Power on the printer, and enter the Diag Mode. 3) Execute 091-201. The bottom line of the LCD displays: [091-201 H 00] 4) Slide the Link Bar to check whether the sensor functions properly.  <ol style="list-style-type: none"> 5) Check that the number in the bottom line of the display increases by one every time the Link Bar is slid. [091-201 H 01] 6) Press the "Cancel" key to stop the test. 7) Power off the printer. 8) Replace the Printer (Refer to Replacement 10).

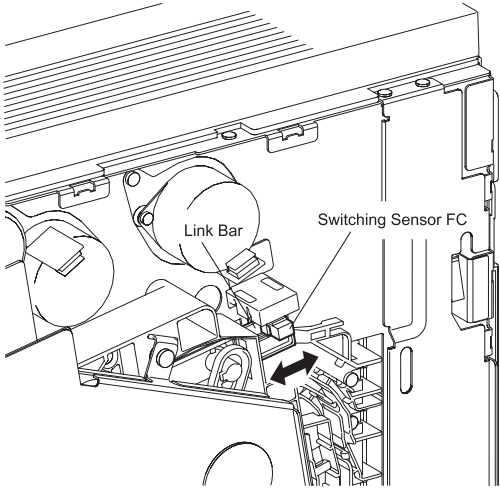
Sensor name (Diag. Code)	Check Procedure
Switching Sensor FC (091-202)	<p>NOTE: This procedure is for the technical staff.</p> <ol style="list-style-type: none"> 1) Remove parts until the Link Bar is accessible. (Refer to Removal 41) When the harness was removed, replace and connect it before starting the check. 2) Power on the printer, and enter the Diag Mode. 3) Execute 091-202. The bottom line of the LCD displays: [091-202 H 00] 4) Slide the Link Bar to check whether the sensor functions properly. <div style="text-align: center;">  <p style="text-align: right; font-size: small;">Tbt02021KA</p> </div> <ol style="list-style-type: none"> 5) Check that the number in the bottom line of the display increases by one every time the Link Bar is slid. [091-202 H 01] 6) Press the "Cancel" key to stop the test. 7) Power off the printer. 8) Replace the Printer (Refer to Replacement 22).
Alarm Deve K Motor (093-200)	Internal signal
Alarm Deve YMC Motor (093-201)	Internal signal

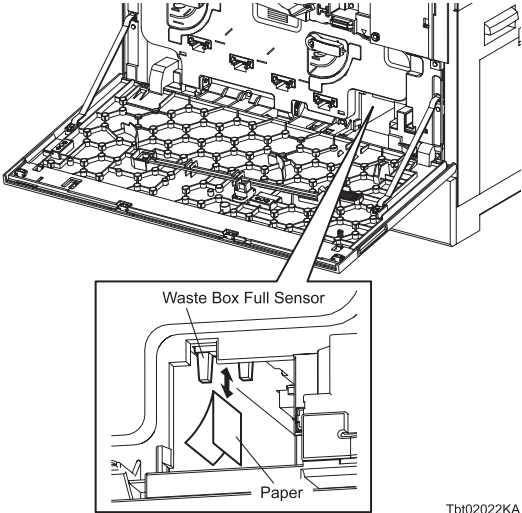
Sensor name (Diag. Code)	Check Procedure
Waste Box Full Sensor (093-204)	<ol style="list-style-type: none"> 1) Power on the printer, and enter the Diag Mode. 2) Remove the Front Cover. 3) Open the Waste Toner Box. 4) Execute 093-204. The bottom line of the LCD displays: [093-204 H 00] 5) Block the sensor light path by placing a piece of paper or the like between the light emitting unit and the light receiving unit to check whether the sensor functions properly. <div style="text-align: center; margin: 10px 0;">  <p>The diagram consists of two parts. The upper part is a perspective view of the printer's waste toner box assembly, showing the sensor's location. The lower part is a cross-sectional view of the sensor mechanism, with a piece of paper placed between the light-emitting unit and the light-receiving unit to block the path. Labels include 'Waste Box Full Sensor' and 'Paper'. A reference code 'Tbt02022KA' is located at the bottom right of the diagram area.</p> </div> <ol style="list-style-type: none"> 6) Check that the number in the bottom line of the display increases by one every time the sensor light path is blocked. [093-204 H 01] 7) Press the "Cancel" key to stop the test. 8) Replace the Waste Toner Box. 9) Close the Front Cover.
Alarm IBT Motor (094-200)	Internal signal

- Option Output Expander (Finisher)

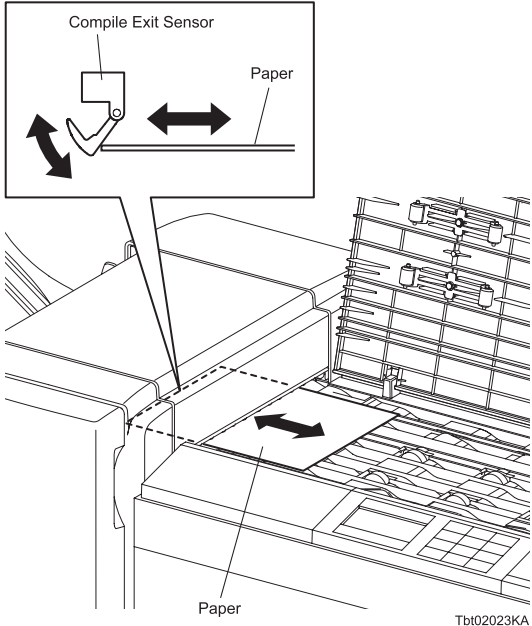
Sensor name (Diag. Code)	Confirmation procedures
<p>Compile Exit Sensor (012-150)</p>	<ol style="list-style-type: none"> 1) Power on the printer, and enter the Diag Mode. 2) Execute 012-150. The bottom line of the LCD displays: [012-150 H 00] 3) Insert and remove a sheet to and from the paper path to check whether the sensor functions properly. NOTE: Open the front door of the Finisher and rotate the knob clockwise. <div style="text-align: center; margin: 10px 0;">  </div> <ol style="list-style-type: none"> 4) Check that the number in the bottom line of the display increases by one every time the sheet is inserted to or removed from the paper path. [012-150 H 01] 5) Press the "Cancel" key to stop the test.

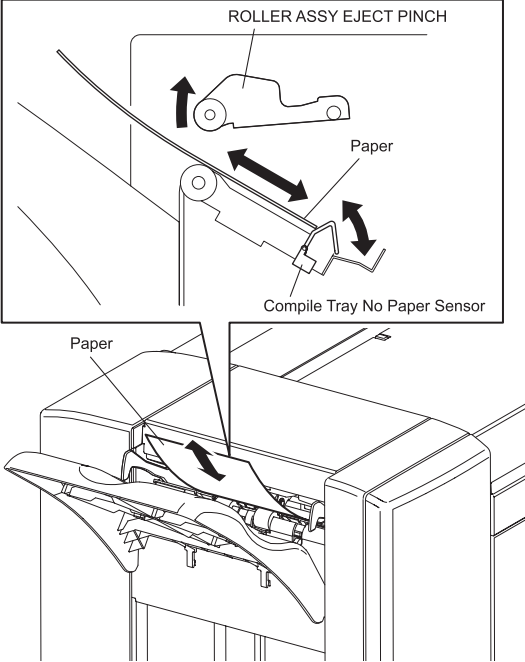
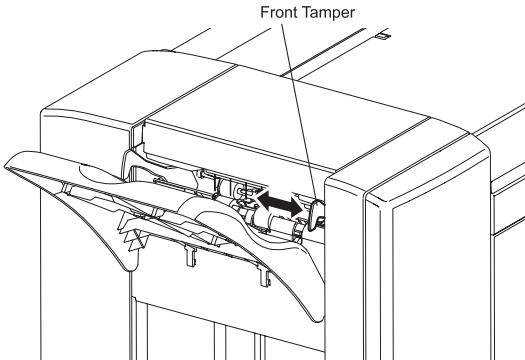
Sensor name (Diag. Code)	Confirmation procedures
<p>Compile Tray No Paper Sensor (012-151)</p>	<ol style="list-style-type: none"> 1) Power on the printer, and enter the Diag Mode. 2) Execute 012-151. The bottom line of the LCD displays: [012-151 H 00] 3) Lift up the ROLLER EJECT PINCH and pass a sheet in and out of the paper path to check the sensor operation.  <p style="text-align: right; font-size: small;">Tbi02024KB</p> <ol style="list-style-type: none"> 4) Check that the number in the bottom line of the display increases by one every time the sheet is inserted to or removed from the paper path. [012-151 H 01] 5) Press the "Cancel" key to stop the test.
<p>Front Tamper Home Sensor (012-220)</p>	<ol style="list-style-type: none"> 1) Power on the printer, and enter the Diag Mode. 2) Execute 012-220. The bottom line of the LCD displays: [012-220 H 00] 3) Slide the Front Tamper to check whether the sensor functions properly.  <p style="text-align: right; font-size: small;">Tbi02025KA</p> <ol style="list-style-type: none"> 4) Check that the number in the bottom line of the display increases by one every time the Front Tamper is slid. [012-220 H 01] 5) Press the "Cancel" key to stop the test.

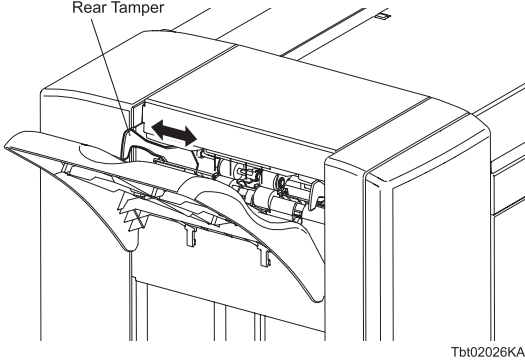
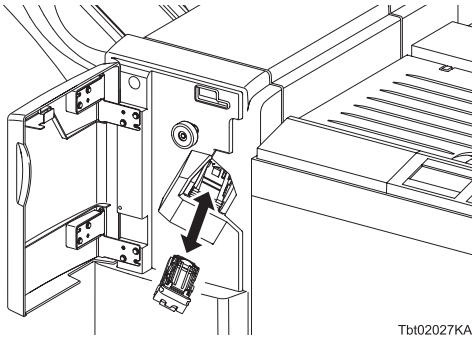
Sensor name (Diag. Code)	Confirmation procedures
<p>Rear Tamper Home Sensor (012-221)</p>	<ol style="list-style-type: none"> 1) Power on the printer, and enter the Diag Mode. 2) Execute 012-221. The bottom line of the LCD displays: [012-221 H 00] 3) Slide the Rear Tamper to check whether the sensor functions properly.  <ol style="list-style-type: none"> 4) Check that the number in the bottom line of the display increases by one every time the Rear Tamper is slid. [012-221 H 01] 5) Press the "Cancel" key to stop the test.
<p>Low Staple Sensor (012-242)</p>	<ol style="list-style-type: none"> 1) Power on the printer, and enter the Diag Mode. 2) Execute 012-242. The bottom line of the LCD displays: [012-242 H 00] 3) Remove the Staple Cartridge.  <ol style="list-style-type: none"> 4) Check that the number in the bottom line of the display increases by one every time the Staple Cartridge is removed or replaced. [012-242 H 01] 5) Press the "Cancel" key to stop the test. 6) Replace the Staple Cartridge.

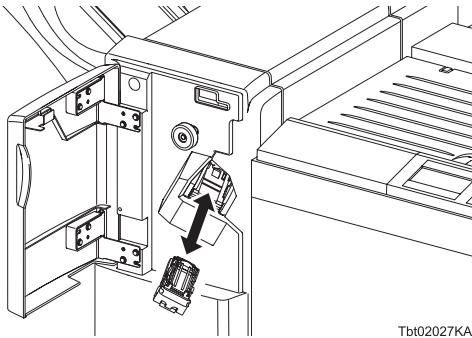
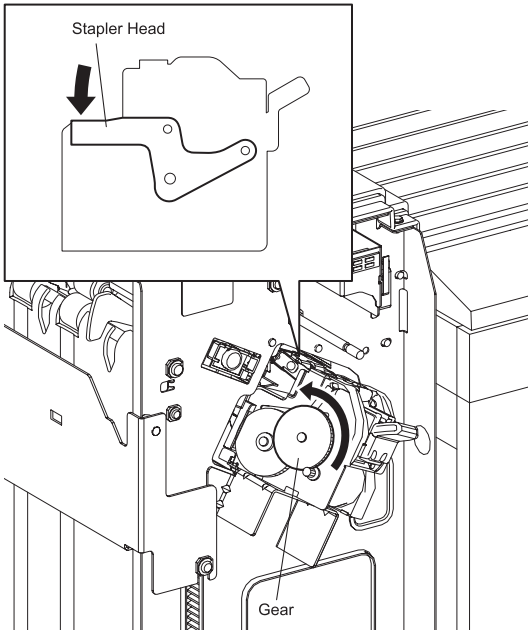
Sensor name (Diag. Code)	Confirmation procedures
<p>Self Priming Sensor (012-243)</p>	<ol style="list-style-type: none"> 1) Power on the printer, and enter the Diag Mode. 2) Execute 012-243. <p>The bottom line of the LCD displays: [012-243 H 00]</p> <ol style="list-style-type: none"> 3) Remove the Staple Cartridge.  <p style="text-align: right; font-size: small;">Tbt02027KA</p> <ol style="list-style-type: none"> 4) Check that the number in the bottom line of the display increases by one every time the Staple Cartridge is removed or replaced. [012-243 H 01] 5) Press the "Cancel" key to stop the test. 6) Replace the Staple Cartridge.
<p>Staple Home Sensor (012-244)</p>	<ol style="list-style-type: none"> 1) Remove the COVER ASSY FRONT (Refer to Removal 5). 2) Power on the printer, and enter the Diag Mode. 3) Execute 012-244. <p>The bottom line of the LCD displays: [012-244 L 00]</p> <ol style="list-style-type: none"> 4) Turn the gear until the Stapler Head comes down.  <p style="text-align: right; font-size: small;">Tbt02073KA</p> <ol style="list-style-type: none"> 5) Confirm that the number in the lower section of the display increases each time the gear is turned. [012-244 L 01] 6) Press the "Cancel" key to stop the test. 7) Replace the COVER ASSY FRONT (Refer to Replace 7).

Sensor name (Diag. Code)	Confirmation procedures
<p>Eject Clamp Home Sensor (012-250)</p>	<p>NOTE: This procedure is for the technical staff.</p> <ol style="list-style-type: none"> 1) Remove the Rear Cover (Refer to Removal 20). 2) Power on the printer, and enter the Diag Mode. 3) Execute 012-250. The bottom line of the LCD displays: [012-250 H 00] 4) Rotates the GEAR ASSY SECTOR A4. <div data-bbox="751 421 1294 1131" style="text-align: center;"> <p style="text-align: right; font-size: small;">Tbt02028KB</p> </div> <ol style="list-style-type: none"> 5) Check that the number in the bottom line of the display increases. [012-250 H 01] 6) Press the "Cancel" key to stop the test. 7) Power off the printer. 8) Replace the Rear Cover (Refer to Replacement 43).

Sensor name (Diag. Code)	Confirmation procedures
Set Clamp Home Sensor (012-251)	<p>NOTE: This procedure is for the technical staff.</p> <ol style="list-style-type: none"> 1) Remove the Rear Cover (Refer to Removal 20). 2) Power on the printer, and enter the Diag Mode. 3) Execute 012-251. The bottom line of the LCD displays: [012-251 H 00] 4) Block the sensor light path by placing a piece of paper or the like between the light emitting unit and the light receiving unit to check whether the sensor functions properly. <div data-bbox="751 488 1295 1030" style="text-align: center;"> <p style="text-align: right; font-size: small;">Tbt02029KB</p> </div> <ol style="list-style-type: none"> 5) Check that the number in the bottom line of the display increases by one every time the sensor light path is blocked. [012-251 H 01] 6) Press the "Cancel" key to stop the test. 7) Power off the printer. 8) Replace the Rear Cover (Refer to Replacement 43).

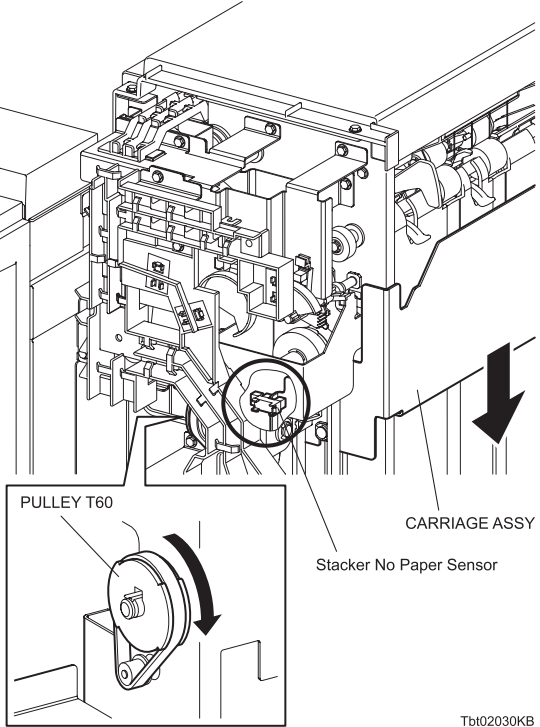
Sensor name (Diag. Code)	Confirmation procedures
<p>Stacker No Paper Sensor (012-262)</p>	<p>NOTE: This procedure is for the technical staff.</p> <ol style="list-style-type: none"> 1) Remove the Rear Cover (Refer to Removal 20). 2) Power on the printer, and enter the Diag Mode. 3) Execute 012-262. The bottom line of the LCD displays: [012-262 L 00] 4) Rotates the PULLEY T60.  <p style="text-align: right;">Tbt02030KB</p> <ol style="list-style-type: none"> 5) Check that the number in the bottom line of the display increases. [012-262 L 01] 6) Press the "Cancel" key to stop the test. 7) Power off the printer. 8) Replace the Rear Cover (Refer to Replacement 43).

Sensor name (Diag. Code)	Confirmation procedures
<p>Stack Height Sensor 1 (012-264) / Stack Height Sensor 2 (012-265)</p>	<p>NOTE: This procedure is for the technical staff.</p> <ol style="list-style-type: none"> 1) Remove the Rear Cover (Refer to Removal 20). 2) Power on the printer, and enter the Diag Mode. 3) Execute 012-264. The bottom line of the LCD displays: [012-264 H 00] 4) Block the sensor light path by placing a piece of paper or the like between the light emitting unit and the light receiving unit to check whether the sensor functions properly. <div data-bbox="751 488 1294 1043" style="text-align: center;"> <p style="text-align: right; font-size: small;">Tbt02031KA</p> </div> <ol style="list-style-type: none"> 5) Check that the number in the bottom line of the display increases by one every time the sensor light path is blocked. [012-264 H 01] 6) Press the "Cancel" key to stop the test. 7) Power off the printer. 8) Replace the Rear Cover (Refer to Replacement 43). 9) The check procedure for 012-265 are the same as that for 012-264 described above.

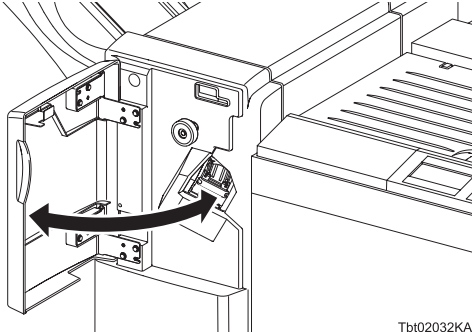
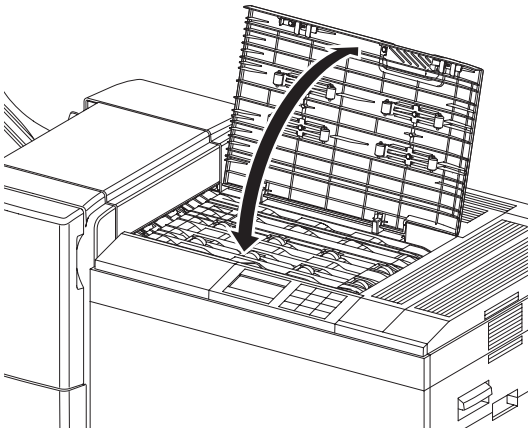
Sensor name (Diag. Code)	Confirmation procedures
Finisher Front Door Switch (012-302)	<ol style="list-style-type: none"> 1) Power on the printer, and enter the Diag Mode. 2) Execute 012-302. The bottom line of the LCD displays: [012-302 H 00] 3) Open or close the Finisher Front Door to check whether the sensor functions properly.  <p style="text-align: right; font-size: small;">Tbt02032KA</p> <ol style="list-style-type: none"> 4) Check that the number in the bottom line of the display increases by one every time the Finisher Front Door is opened or closed. [012-302 H 01] 5) Press the "Cancel" key to stop the test. 6) Close the Finisher Front Door.
H-Xport Cover Sensor (012-303)	<ol style="list-style-type: none"> 1) Power on the printer, and enter the Diag Mode. 2) Execute 012-303. The bottom line of the LCD displays: [012-303 H 00] 3) Open or close the H-Xport Cover to check whether the sensor functions properly.  <p style="text-align: right; font-size: small;">Tbt02033KA</p> <ol style="list-style-type: none"> 4) Check that the number in the bottom line of the display increases by one every time the H-Xport Cover is opened or closed. [012-303 H 01] 5) Press the "Cancel" key to stop the test. 6) Close the H-Xport Cover.

4.1.3 Digital Output (DO) Test of Customer Mode

This function checks whether the DO components operate normally.

The DO test is performed for some of DO components in Customer Mode.

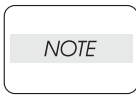

During the DO test, other Customer Diag functions cannot be performed simultaneously. Therefore, the printer does not accept any operation except operations for the DO components and exit operation of the DO test.

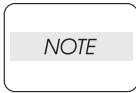

When a noise problem occurs, this test enables to pinpoint the faulty part.

4.1.4 Executing Digital Output (DO) Test of Customer Mode

- 1) Power off the printer.
- 2) Power on the printer while pressing "▲" and "▼" keys.
- 3) Release the keys when "Diagnosing..." is displayed.
- 4) "Customer Mode" and "IOT Diag" are displayed. (Now in the Diag mode.)
- 5) Press "✓" key.
- 6) Press "▼" key to select "Digital Output", and then press "✓" key.
- 7) Press "▲" or "▼" key to select the test item.
- 8) Press "✓" key twice to execute the test.

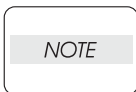

To exit the test, press the "Cancel" key. To return to the previous menu, press the "Menu" key.

<Example of Digital Output Test Operation>

Checking Fuser Fan (010-004) via Digital Output Test

This test is intended for checking whether the Fan functions properly.

- 1) Power on the printer, and enter the Customer Diag Mode.
- 2) Execute Fuser Fan (010-004) to check whether the Fuser Fan is rotating. If rotating, the Fan is functioning properly. Otherwise, it is suspected that a component related to the Fuser Fan is faulty.

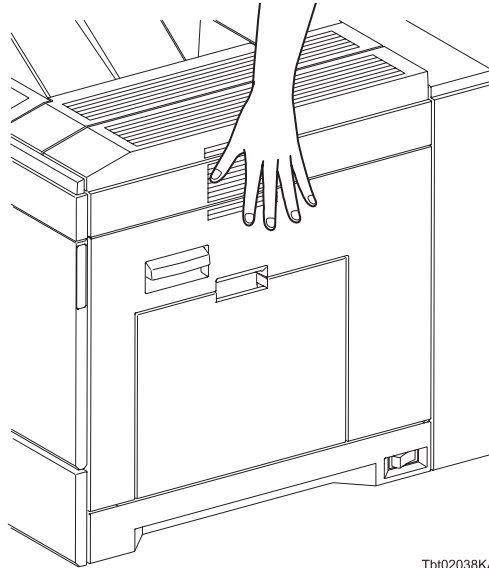

Tbt02038KA

Parameters for the Digital Output Test are as follows.

- Printer

Code	Component
010-001	Fuser Motor
010-004	Fuser Fan
042-001	LV Fan
071-001	Paper Hand (PH) Motor
071-014	Cassette2 Option Motor
071-019	Cassette3 Option Motor
071-024	Cassette4 Option Motor
071-029	Cassette5 Option Motor
091-001	XERO Motor
093-001	DEVE YMC Motor
093-004	DEVE K Motor
093-007	Toner Motor Y
093-008	Toner Motor M
093-009	Toner Motor C
093-010	Toner Motor K
094-001	IBT Motor

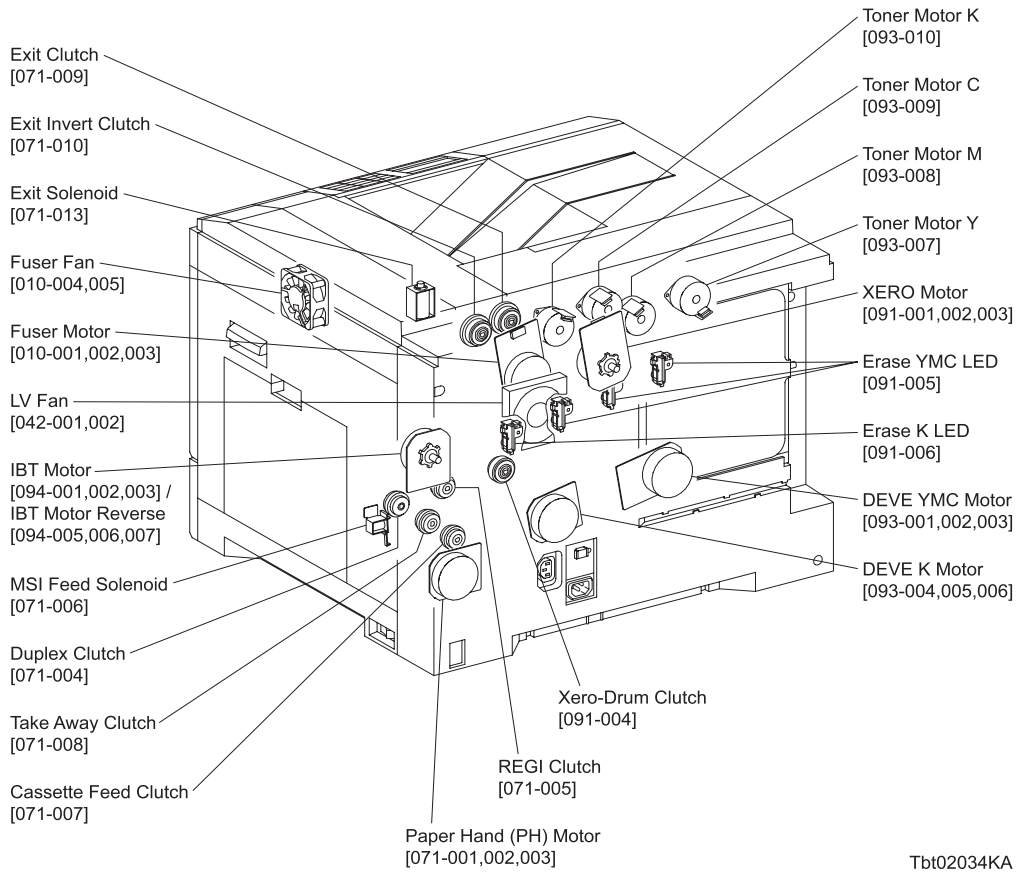

Tbt02034KA

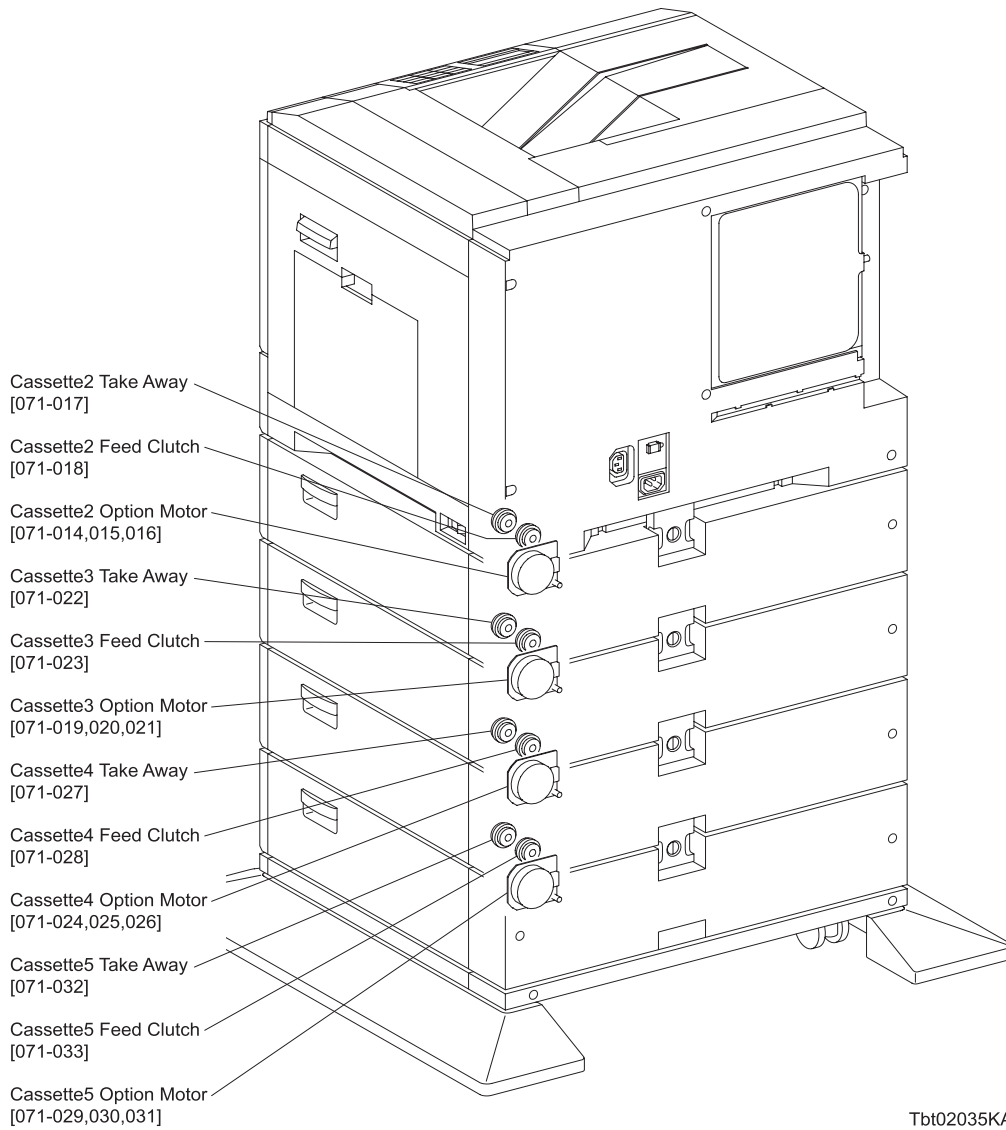

Tbt02035KA

- Checking Motor

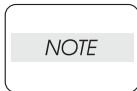

Before executing the DO test, close all covers and doors.

- Printer

Motor Name (Diag. Code)	Check procedure
Fuser Motor (010-001)	<p>WARNING: When checking the motor, stop within ten seconds. Executing a motor check for ten seconds or longer may cause damage to the printer.</p> <ol style="list-style-type: none"> 1) Power on the printer, and enter the Diag Mode. 2) Execute the 010-001. Upon pressing the " ✓ " key, the operating noise of the motor will be heard. 3) Press the "Cancel" key to stop the motor.
Fuser Fan (010-004)	<p>WARNING: When checking the motor, stop within ten seconds. Executing a motor check for ten seconds or longer may cause damage to the printer.</p> <ol style="list-style-type: none"> 1) Power on the printer, and enter the Diag Mode. 2) Execute the 010-004. Upon pressing the " ✓ " key, the operating noise of the motor will be heard. 3) Press the "Cancel" key to stop the test.
LV Fan (042-001)	<p>WARNING: When checking the motor, stop within ten seconds. Executing a motor check for ten seconds or longer may cause damage to the printer.</p> <ol style="list-style-type: none"> 1) Power on the printer, and enter the Diag Mode. 2) Execute the 042-001. Upon pressing the " ✓ " key, the operating noise of the motor will be heard. 3) Press the "Cancel" key to stop the test.
Paper Hand (PH) Motor (071-001)	<p>WARNING: When checking the motor, stop within ten seconds. Executing a motor check for ten seconds or longer may cause damage to the printer.</p> <ol style="list-style-type: none"> 1) Power on the printer, and enter the Diag Mode. 2) Execute 071-001. Upon pressing the " ✓ " key, the operating noise of the motor will be heard. 3) Press the "Cancel" key to stop the motor.
Cassette2 Option Motor (071-014) / Cassette3 Option Motor (071-019) / Cassette4 Option Motor (071-024) / Cassette5 Option Motor (071-029)	<p>WARNING: When checking the motor, stop within ten seconds. Executing a motor check for ten seconds or longer may cause damage to the printer.</p> <p>Example: Cassette2 Option Motor</p> <ol style="list-style-type: none"> 1) Power on the printer, and enter the Diag Mode. 2) Execute the 071-014. Upon pressing the " ✓ " key, the operating noise of the motor will be heard. 3) Press the "Cancel" key to stop the test. <p>NOTE: The check procedure for Cassette3, Cassette4, and Cassette5 are the same as that for Cassette2 described above.</p> <p>-Cassette3:Execute the 071-019. -Cassette4:Execute the 071-024. -Cassette5:Execute the 071-029.</p>

Motor Name (Diag. Code)	Check procedure
XERO Motor (091-001)	<p>WARNING: When checking the motor, stop within ten seconds. Executing a motor check for ten seconds or longer may cause damage to the printer.</p> <ol style="list-style-type: none"> 1) Power on the printer, and enter the Diag Mode. 2) Execute 091-001. Upon pressing the " ✓ " key, the operating noise of the motor will be heard. 3) Press the "Cancel" key to stop the motor.
DEVE YMC Motor (093-001)	<p>WARNING: When checking the motor, stop within ten seconds. Executing a motor check for ten seconds or longer may cause damage to the printer.</p> <ol style="list-style-type: none"> 1) Power on the printer, and enter the Diag Mode. 2) Execute the 093-001. Upon pressing the " ✓ " key, the operating noise of the motor will be heard. 3) Press the "Cancel" key to stop the motor.
DEVE K Motor (093-004)	<p>WARNING: When checking the motor, stop within ten seconds. Executing a motor check for ten seconds or longer may cause damage to the printer.</p> <ol style="list-style-type: none"> 1) Power on the printer, and enter the Diag Mode. 2) Execute the 093-004. Upon pressing the " ✓ " key, the operating noise of the motor will be heard. 3) Press the "Cancel" key to stop the motor.
Toner Motor Y (093-007)	<p>WARNING: When checking the motor, stop within three seconds. Executing a motor check for three seconds or longer may cause damage to the printer.</p> <ol style="list-style-type: none"> 1) Power on the printer, and enter the Diag Mode. 2) Execute 093-007. Upon pressing the " ✓ " key, the operating noise of the motor will be heard. 3) Press the "Cancel" key to stop the motor.
Toner Motor M (093-008)	<p>WARNING: When checking the motor, stop within three seconds. Executing a motor check for three seconds or longer may cause damage to the printer.</p> <ol style="list-style-type: none"> 1) Power on the printer, and enter the Diag Mode. 2) Execute 093-008. Upon pressing the " ✓ " key, the operating noise of the motor will be heard. 3) Press the "Cancel" key to stop the motor.
Toner Motor C (093-009)	<p>WARNING: When checking the motor, stop within three seconds. Executing a motor check for three seconds or longer may cause damage to the printer.</p> <ol style="list-style-type: none"> 1) Power on the printer, and enter the Diag Mode. 2) Execute 093-009. Upon pressing the " ✓ " key, the operating noise of the motor will be heard. 3) Press the "Cancel" key to stop the motor.
Toner Motor K (093-010)	<p>WARNING: When checking the motor, stop within three seconds. Executing a motor check for three seconds or longer may cause damage to the printer.</p> <ol style="list-style-type: none"> 1) Power on the printer, and enter the Diag Mode. 2) Execute 093-010. Upon pressing the " ✓ " key, the operating noise of the motor will be heard. 3) Press the "Cancel" key to stop the motor.
IBT Motor (094-001)	<p>WARNING: When checking the motor, stop within ten seconds. Executing a motor check for ten seconds or longer may cause damage to the printer.</p> <ol style="list-style-type: none"> 1) Power on the printer, and enter the Diag Mode. 2) Execute 094-001. Upon pressing the " ✓ " key, the operating noise of the motor will be heard. 3) Press the "Cancel" key to stop the motor.

4.1.5 Digital Output(DO) Test of CE Mode

This function checks whether the DO components operate normally.

The DO test is performed for all DO components in CE Mode.

If the interlock is opened during the DO test, each component comes to rest.

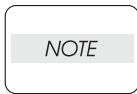

In this Test Mode, each DO component can be turned on individually.

When all the Diag functions are stopped, all DO components can be turned off.

DO test can operate all components at the same time.

When a paper jam or PQ problem occurs, or an error message or code is displayed, this test enables to pinpoint the faulty part.

Before executing the test, examine the details of the jam, PQ problem, or error, and isolate the faulty parts. (Refer to the FIP in Chapter 1.)

Test result: NG (Go to the FIP or replace the parts.)

OK (Power off the printer and then on.)

4.1.6 Executing Digital Output (DO) Test of CE Mode

- 1) Turn off the power.
- 2) Turn on the power while holding down "→", "←" and "MENU" keys.
- 3) Release the fingers from these keys when the "CE/Developr" and "Password" is displayed.
- 4) Press "▲" key twice and press "✓" key.
- 5) The "CE Mode" and "ESS Diag" are displayed. (Entered the CE Diag. mode.)
- 6) Press "▼" to select "IOT Diag" and then press "✓" key.
- 7) Press "▼" key to select "Digital Output" and then press "✓" key.
- 8) Press "▲" or "▼" key to select the test item.
- 9) Press "✓" key twice to execute the test.

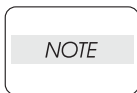

To exit the test, press the "Cancel" key. To return to the previous menu, press the "Menu" key.

<Example of Digital Output Test Operation>

Checking Fuser Fan (010-004, 010-005) via Digital Output Test

This test is intended for checking whether the Fan functions properly.

- 1) Power on the printer, and enter the CE Diag Mode.
- 2) Execute Fuser Fan (010-004, 010-005) to check whether the Fuser Fan is rotating. If rotating, the Fan is functioning properly. Otherwise, it is suspected that a component related to the Fuser Fan is faulty.

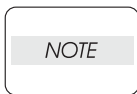
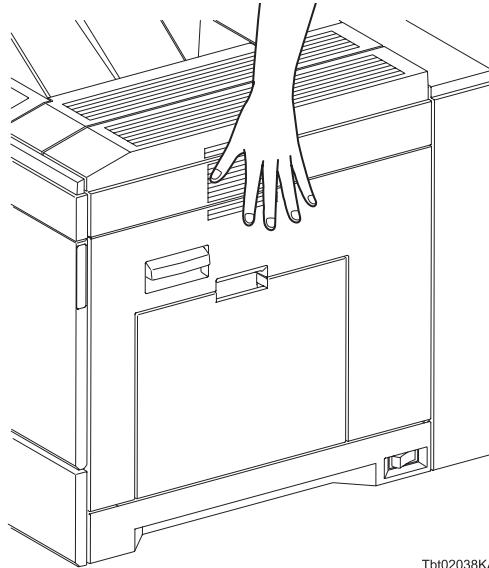

010-004 and 010-115 differ in the rotational speed of the Fan.

Parameters for the Digital Output Test are as follows.

- Printer

Code	Component
010-001, 002, 003	Fuser Motor (High, Middle, Low)
010-004, 005	Fuser Fan (High, Low)
010-006	Fuser Control (Internal Signal)
042-001, 002	LV Fan
061-001	ROS Motor
071-001, 002, 003	Paper Hand (PH) Motor (High, Middle, Low)
071-004	Duplex Clutch
071-005	REGI Clutch
071-006	MSI Feed Solenoid
071-007	Cassette Feed Clutch
071-008	Take Away Clutch
071-009	Exit Clutch
071-010	Exit Invert Clutch
071-011	CTD Solenoid Pull (Not in use)
071-012	CTD Solenoid Push (Not in use)
071-013	Exit Solenoid
071-014, 015, 016	Cassette2 Option Motor (High, Middle, Low)
071-017	Cassette2 Take Away Clutch
071-018	Cassette2 Feed Clutch
071-019, 020, 021	Cassette3 Option Motor (High, Middle, Low)
071-022	Cassette3 Take Away Clutch
071-023	Cassette3 Feed Clutch
071-024, 025, 026	Cassette4 Option Motor (High, Middle, Low)

Code	Component
071-027	Cassette4 Take Away Clutch
071-028	Cassette4 Feed Clutch
071-029, 030, 031	Cassette5 Option Motor (High, Middle, Low)
071-032	Cassette5 Take Away Clutch
071-033	Cassette5 Feed Clutch
071-034	4Paper Hand Motor (PH) Reverse (Not in use)
071-035	5Paper Hand Motor (PH) Reverse (Not in use)
071-036	6Paper Hand Motor (PH) Reverse (Not in use)
091-001, 002, 003	XERO Motor (High, Middle, Low)
091-004	Xero-Drum Clutch
091-005	Erase YMC LED
091-006	Erase K LED
093-001, 002, 003	DEVE YMC Motor (High, Middle, Low)
093-004, 005, 006	DEVE K Motor (High, Middle, Low)
093-007	Toner Motor Y
093-008	Toner Motor M
093-009	Toner Motor C
093-010	Toner Motor K
094-001, 002, 003	IBT Motor (High, Middle, Low)
094-005, 006, 007	IBT Motor Reverse (High, Middle, Low) (Not in use)
094-008, 009, 010	IBT Motor + Xero (Not in use)
094-011	IBT Color Mode (Not in use)

- Option Output Expander (Finisher)

Code	Component
012-013	Sub Paddle Solenoid
012-018	Transport Motor Reverse (Not in use)
012-020, 022	Front Tamper Motor Front (High, Low)
012-023, 025	Front Tamper Motor Rear (High, Low)
012-026, 028	Rear Tamper Motor Front (High, Low)
012-029, 031	Rear Tamper Motor Rear (High, Low)
012-032, 033, 034, 035	Xport Motor Forward
012-036, 037, 038	Transport Motor Forward (High, Middle, Low)
012-039	Xport Motor Reverse (Not in use)
012-040	Xport Motor 5 ON/OFF (Not in use)

Code	Component
012-046	Staple Motor Forward
012-047	Staple Motor Reverse (Not in use)
012-050	Set Clamp Clutch
012-052	Eject Clamp Up (Not in use)
012-053	Eject Clamp Down (Not in use)
012-054, 055	Eject Motor Forward (High, Low)
012-060	Stacker Motor Up
012-061	Stacker Motor Down
012-062	Stacker Motor Mid UP ON/OFF (Not in use)
012-063	Stacker Motor Low UP ON/OFF (Not in use)

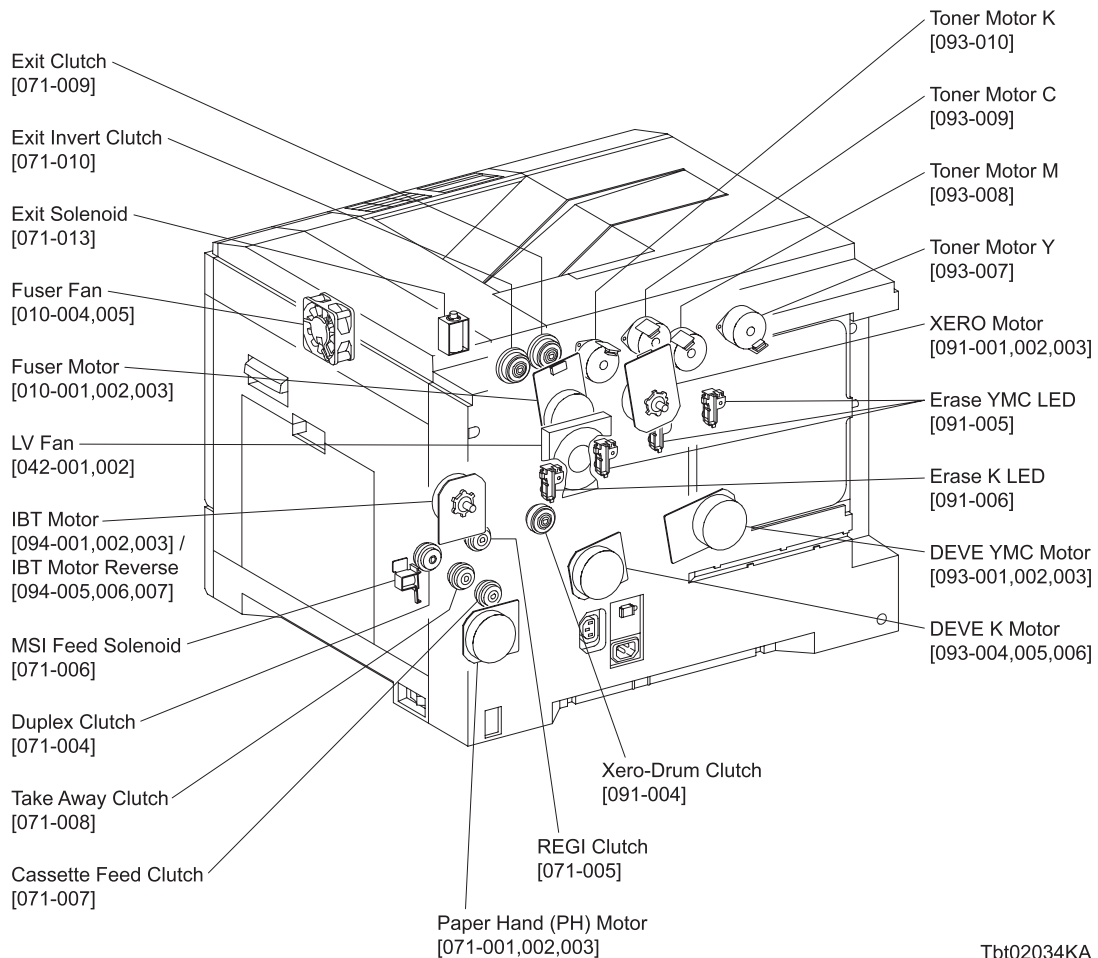

Tbt02034KA

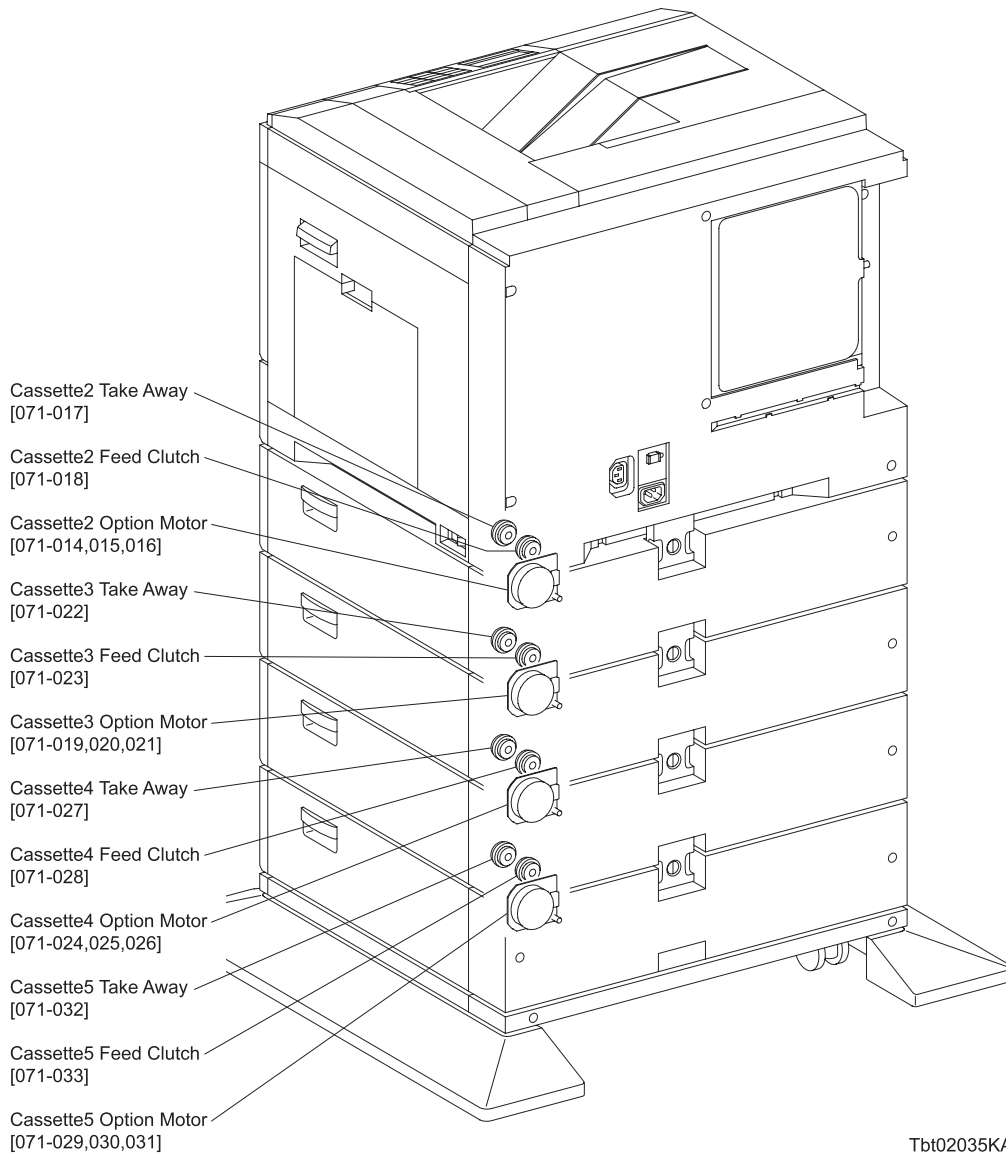

Tbt02035KA

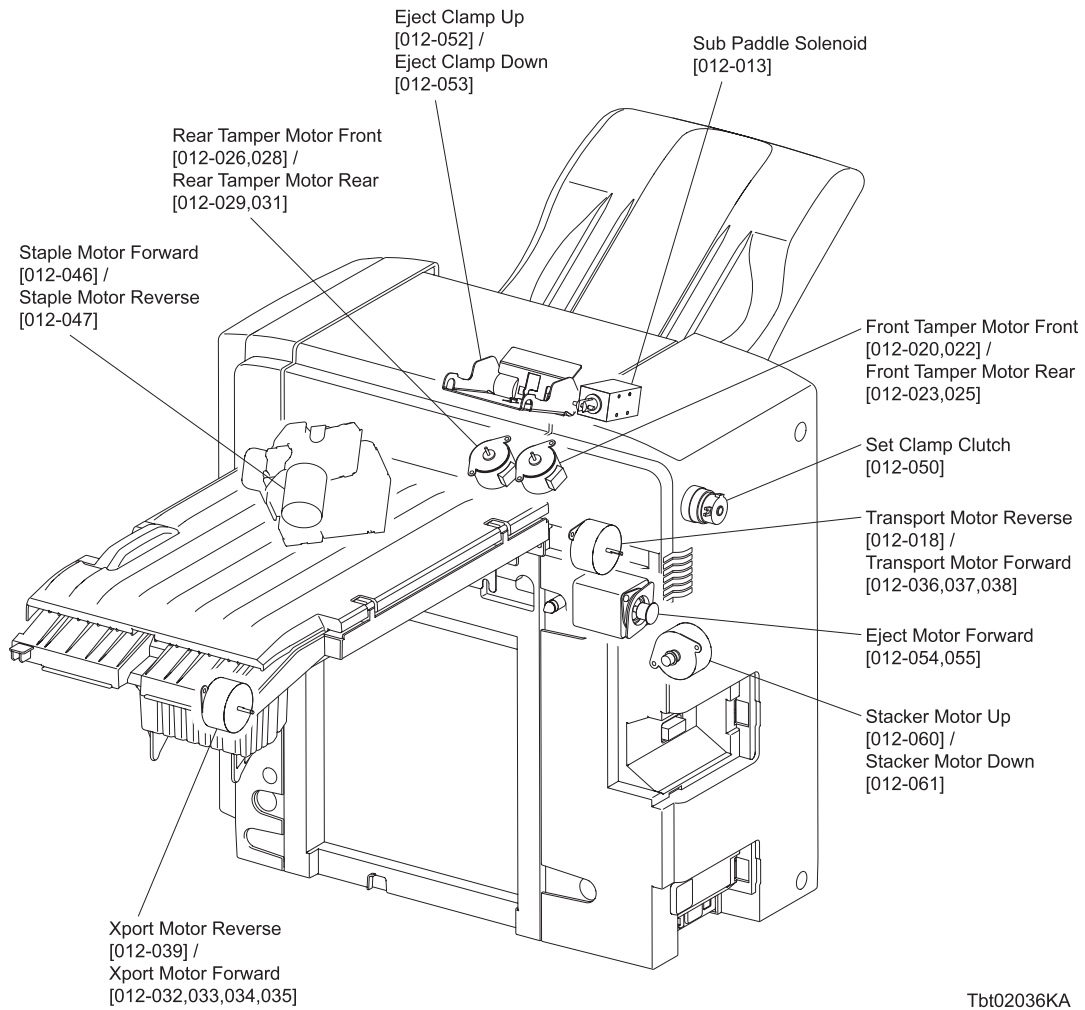

Tbt02036KA

- About Clutch

The electromagnetic clutch in the printer controls the rotation of the roller by allowing or interrupting the torque transmission from the motor to the roller.

By the passage of electric current through the coil inside the case, the electromagnetic clutch becomes an electromagnet, and attracts the armature and gear to the rotating rotor, thereby rotating the gear.

Upon the loss of power to the coil, electromagnetic force is lost and the armature comes off the rotor, and the gear comes to rest.

The clutch makes so soft noises that you must be close the component to audibly confirm the operation of the component.

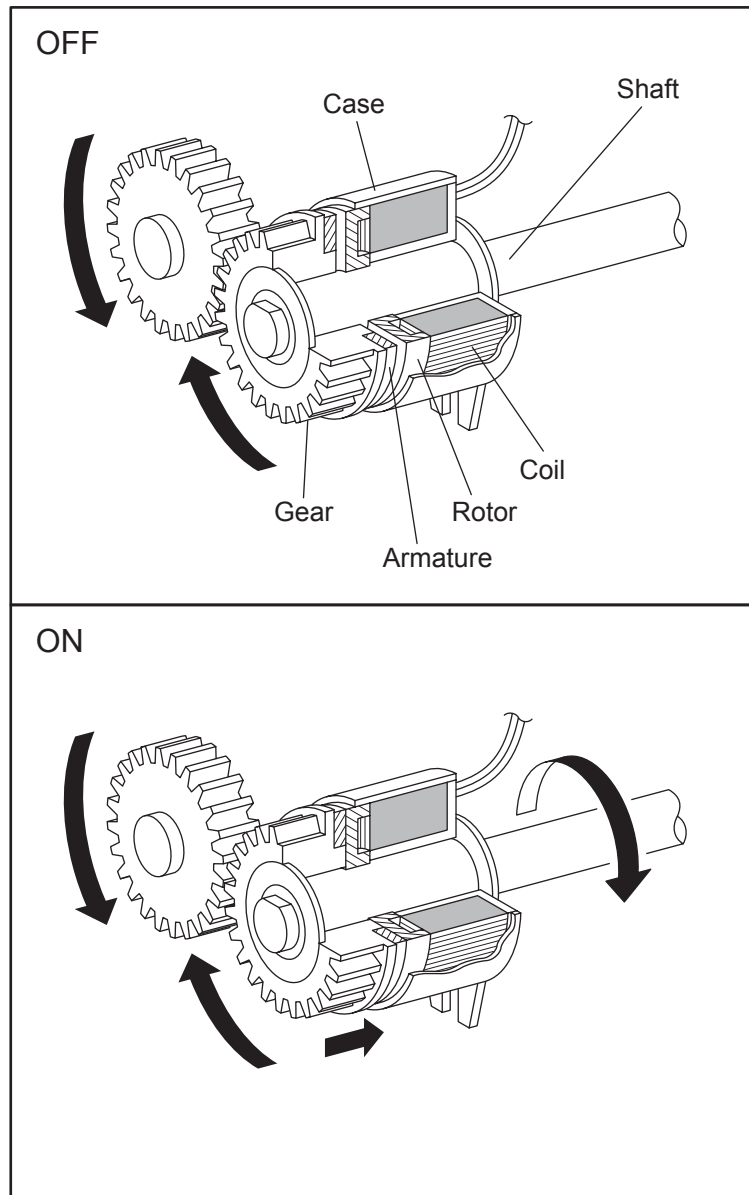

Leg_Sec02_050FA

- About Solenoid

The solenoid in the printer opens or closes the shutter, or controls the position of the gear for transferring the torque of the motor to the roller.

By the passage of electric current through the coil inside the case, the solenoid becomes an electro-magnet and attracts the plunger.

Upon the loss of power to the coil, electromagnetic force is lost, and the plunger returns to its original position by spring action, thereby allowing the shutter to operate or the gear to move to the predefined position.

Unlike a clutch, a solenoid generates a loud operation noise.

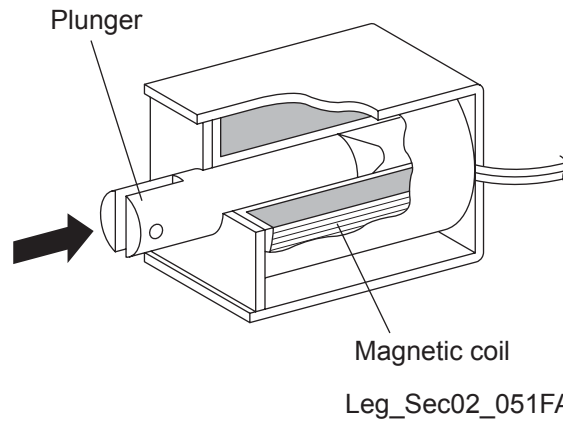

- About Interlock

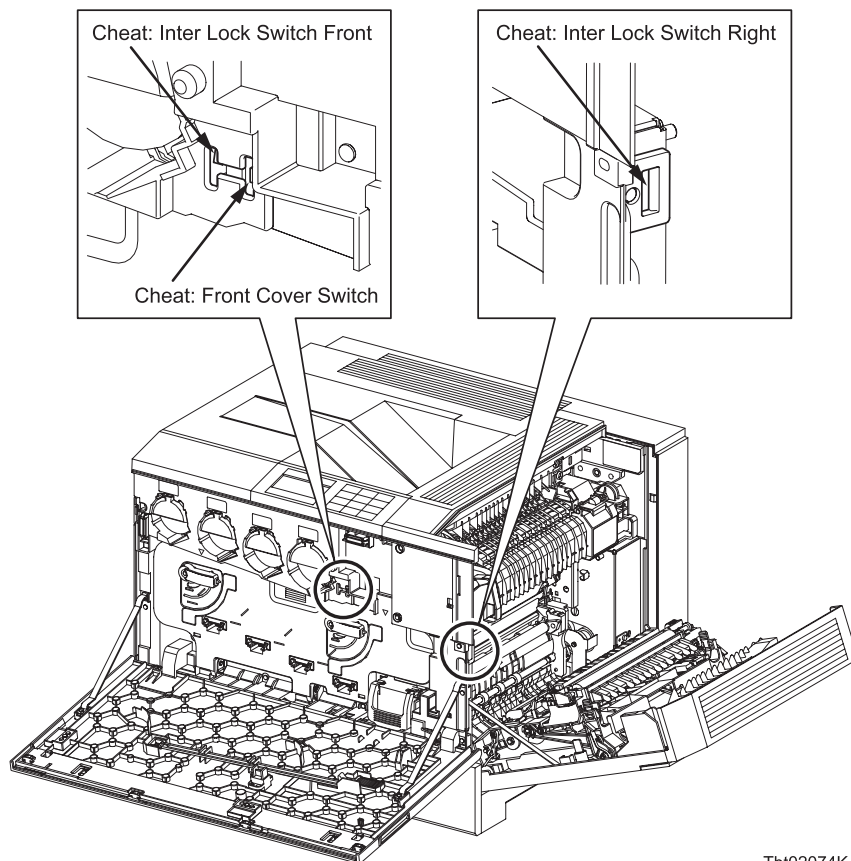

- Checking Motor, Clutch and Solenoid

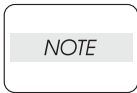

Before executing the DO test, close all covers and doors.

- Printer

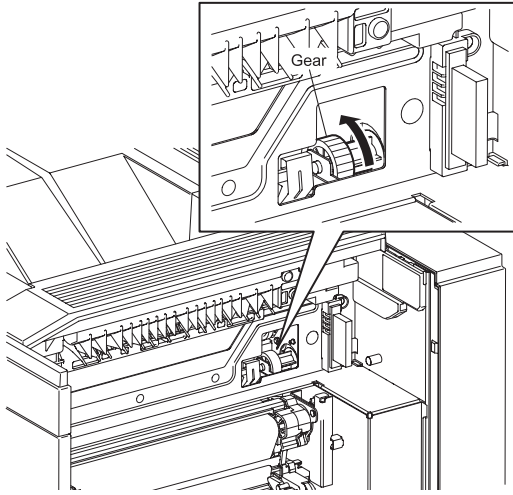
Motor/Clutch/Solenoid Name (Diag. Code)	Check procedure
<p>Fuser Motor (010-001,002,003)</p>	<p>NOTE: This procedure is for the Customer.</p> <ol style="list-style-type: none"> 1) Power on the printer, and enter the Diag Mode. 2) Execute the 010-001. Upon pressing the " ✓ " key, the operating noise of the motor will be heard. 3) Press the "Cancel" key to stop the motor. <p>NOTE: This procedure is for the technical staff. Because the Fuser is very hot, be careful not to burn yourself.</p> <ol style="list-style-type: none"> 1) Power on the printer, and enter the Diag Mode. 2) Open the RH Cover 3) Remove the Fuser. 4) Cheat the Safety Interlock System. 5) Execute 010-001. 6) Check that the Roller rotates.  <p style="text-align: right; font-size: small;">Tbi02037KA</p> <ol style="list-style-type: none"> 7) Press the "Cancel" key to stop the test. 8) Replace the Fuser. 9) Remove the cheater. 10) Close the RH Cover.

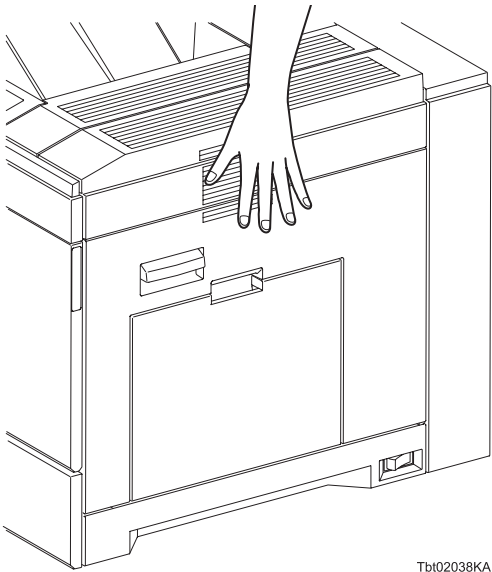
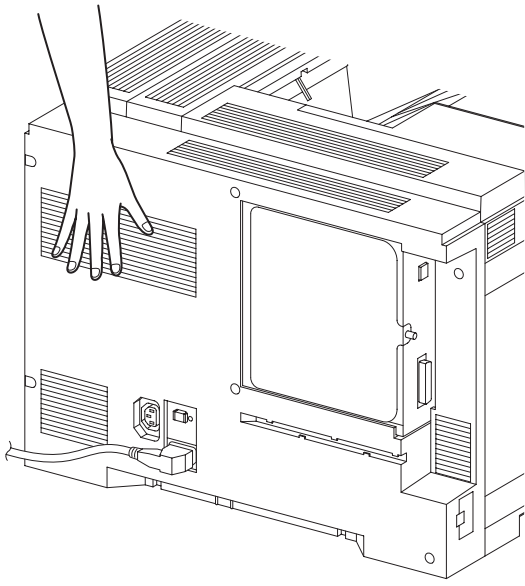
Motor/Clutch/Solenoid Name (Diag. Code)	Check procedure
Fuser Fan (010-004,005)	<ol style="list-style-type: none"> 1) Power on the printer, and enter the Diag Mode. 2) Execute 010-004. 3) Check that the FUSER Fan rotates.  <p style="text-align: right; font-size: small;">Tbt02038KA</p> <ol style="list-style-type: none"> 4) Press the "Cancel" key to stop the test.
Fuser Control (010-006)	Internal signal
LV Fan (042-001,002)	<ol style="list-style-type: none"> 1) Power on the printer, and enter the Diag Mode. 2) Execute 042-001. 3) Check that the LV Fan rotates.  <p style="text-align: right; font-size: small;">Tbt02039KA</p> <ol style="list-style-type: none"> 4) Press the "Cancel" key to stop the test.
ROS Motor (061-001)	Internal signal

Motor/Clutch/Solenoid Name (Diag. Code)	Check procedure
Paper Hand (PH) Motor (071-001,002,003)	<p>NOTE: This procedure is for the Customer.</p> <ol style="list-style-type: none"> 1) Power on the printer, and enter the Diag Mode. 2) Execute 071-001. Upon pressing the "✓" key, the operating noise of the motor will be heard. 3) Press the "Cancel" key to stop the motor. <p>NOTE: This procedure is for the technical staff.</p> <ol style="list-style-type: none"> 1) Power on the printer, and enter the Diag Mode. 2) Open the RH Cover. 3) Cheat the Safety Interlock System. 4) Execute 071-001. 5) Check that the Roller rotates. <div data-bbox="730 645 1257 1093" style="text-align: center;"> <p style="text-align: right; font-size: small;">Tb102040KA</p> </div> <ol style="list-style-type: none"> 6) Press the "Cancel" key to stop the test. 7) Remove the cheater. 8) Close the RH Cover.

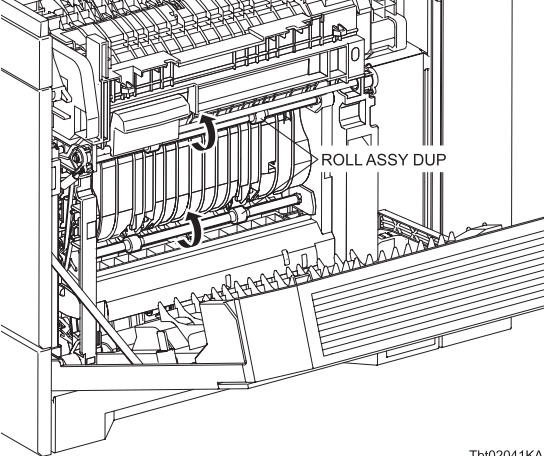
Motor/Clutch/Solenoid Name (Diag. Code)	Check procedure
Duplex Clutch (071-004)	<p>NOTE: This procedure is for the Customer. Since the clutch noise is so soft that it may be hard to recognize, the noise check described below should be performed in as silent an environment as possible.</p> <ol style="list-style-type: none"> 1) Power on the printer, and enter the Diag Mode. 2) Execute 071-004. Upon pressing the " ✓ " key, the operating noise of the clutch will be heard. 3) Press the "Cancel" key to stop the clutch. <p>NOTE: This procedure is for the technical staff. Combination test is as follows: The ROLL ASSY DUP rotates when 071-001(PH Motor) and 071-004 are executed.</p> <ol style="list-style-type: none"> 1) Power on the printer, and enter the Diag Mode. 2) Open the RH Cover. 3) Close the RH FRAME. 4) Cheat the Safety Interlock System. 5) Execute 071-001 and 071-004. 6) Check that the Roller rotates.  <p style="text-align: right; font-size: small;">Tbt02041KA</p> <ol style="list-style-type: none"> 7) Press the "Cancel" key to stop the clutch. 8) Press the " ▼ " key to display 071-001. 9) Press the "Cancel" key to stop the motor. 10) Remove the cheater. 11) Close the RH Cover.

Motor/Clutch/Solenoid Name (Diag. Code)	Check procedure
REGI Clutch (071-005)	<p>NOTE: This procedure is for the Customer. Since the clutch noise is so soft that it may be hard to recognize, the noise check described below should be performed in as silent an environment as possible.</p> <ol style="list-style-type: none"> 1) Power on the printer, and enter the Diag Mode. 2) Execute 071-005. Upon pressing the "✓" key, the operating noise of the clutch will be heard. 3) Press the "Cancel" key to stop the clutch. <p>NOTE: This procedure is for the technical staff. Combination test is as follows: The ROLL REGI rotates when 071-001(PH Motor) and 071-005 are executed.</p> <ol style="list-style-type: none"> 1) Power on the printer, and enter the Diag Mode. 2) Open the RH Cover. 3) Cheat the Safety Interlock System. 4) Execute 071-001 and 071-005. 5) Check that the Roller rotates. <div data-bbox="715 835 1177 1176" style="text-align: center;"> </div> <p style="text-align: right; font-size: small;">Tbi02042KA</p> <ol style="list-style-type: none"> 6) Press the "Cancel" key to stop the clutch. 7) Press the "▼" key to display 071-001. 8) Press the "Cancel" key to stop the motor. 9) Remove the cheater. 10) Close the RH Cover.

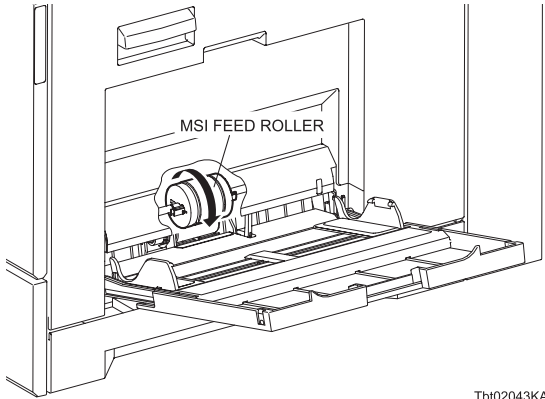
Motor/Clutch/Solenoid Name (Diag. Code)	Check procedure
MSI Feed Solenoid (071-006)	<p>NOTE: This procedure is for the Customer. Since the solenoid noise is so soft that it may be hard to recognize, the noise check described below should be performed in as silent an environment as possible.</p> <ol style="list-style-type: none"> 1) Power on the printer, and enter the Diag Mode. 2) Execute 071-006. Upon pressing the " ✓ " key, the operating noise of the solenoid will be heard. 3) Press the "Cancel" key to stop the solenoid. <p>NOTE: This procedure is for the technical staff. Combination test is as follows: The MSI FEED ROLLER rotates when 071-001(PH Motor) and 071-006 are executed.</p> <ol style="list-style-type: none"> 1) Power on the printer, and enter the Diag Mode. 2) Open the MSI Cover. 3) Execute 071-001 and 071-006. 4) Check that the Roller rotates. <div data-bbox="710 801 1257 1198" style="text-align: center;">  <p>The diagram shows a cross-section of the printer's internal mechanism. A roller is labeled 'MSI FEED ROLLER'. It is positioned within a housing that is part of the MSI cover. The roller is shown in a position where it can rotate and feed paper. The diagram is a technical drawing with clear lines and labels.</p> </div> <p style="text-align: right; font-size: small;">Tbt02043KA</p> <ol style="list-style-type: none"> 5) Press the "Cancel" key to stop the clutch. 6) Press the " ▼ " key to display 071-001. 7) Press the "Cancel" key to stop the motor. 8) Close the MSI Cover.

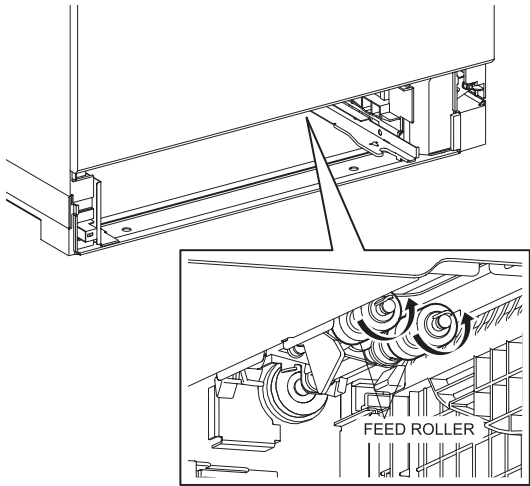
Motor/Clutch/Solenoid Name (Diag. Code)	Check procedure
Cassette Feed Clutch (071-007)	<p>NOTE: This procedure is for the Customer. Since the clutch noise is so soft that it may be hard to recognize, the noise check described below should be performed in as silent an environment as possible.</p> <ol style="list-style-type: none"> 1) Power on the printer, and enter the Diag Mode. 2) Execute 071-007. Upon pressing the " ✓ " key, the operating noise of the clutch will be heard. 3) Press the "Cancel" key to stop the clutch. <p>NOTE: This procedure is for the technical staff. Combination test is as follows: The FEED ROLLER rotates when 071-001(PH Motor) and 071-007 are executed.</p> <ol style="list-style-type: none"> 1) Power on the printer, and enter the Diag Mode. 2) Remove the paper cassette. 3) Execute 071-001 and 071-007. 4) Check that the Roller rotates.  <p style="text-align: right; font-size: small;">Tbt02044KA</p> <ol style="list-style-type: none"> 5) Press the "Cancel" key to stop the clutch. 6) Press the " ▼ " key to display 071-001. 7) Press the "Cancel" key to stop the motor. 8) Remove the paper cassette.

Motor/Clutch/Solenoid Name (Diag. Code)	Check procedure
Take Away Clutch (071-008)	<p>NOTE: This procedure is for the Customer. Since the clutch noise is so soft that it may be hard to recognize, the noise check described below should be performed in as silent an environment as possible.</p> <ol style="list-style-type: none"> 1) Power on the printer, and enter the Diag Mode. 2) Execute 071-008. Upon pressing the " ✓ " key, the operating noise of the clutch will be heard. 3) Press the "Cancel" key to stop the clutch. <p>NOTE: This procedure is for the technical staff. Combination test is as follows: The ROLL ASSY TAKE AWAY rotates when 071-001(PH Motor) and 071-008 are executed.</p> <ol style="list-style-type: none"> 1) Power on the printer, and enter the Diag Mode. 2) Open the RH Cover. 3) Cheat the Safety Interlock System. 4) Execute 071-001 and 071-008. 5) Check that the Roller rotates. <div data-bbox="715 833 1177 1176" style="text-align: center;"> </div> <ol style="list-style-type: none"> 6) Press the "Cancel" key to stop the clutch. 7) Press the " ▼ " key to display 071-001. 8) Press the "Cancel" key to stop the motor. 9) Remove the cheater. 10) Replace the RH Cover.

Motor/Clutch/Solenoid Name (Diag. Code)	Check procedure
Exit Clutch (071-009)	<p>NOTE: This procedure is for the Customer. Since the clutch noise is so soft that it may be hard to recognize, the noise check described below should be performed in as silent an environment as possible.</p> <ol style="list-style-type: none"> 1) Power on the printer, and enter the Diag Mode. 2) Execute the 071-009. Upon pressing the "✓" key, the operating noise of the clutch will be heard. 3) Press the "Cancel" key to stop the clutch. <p>NOTE: This procedure is for the technical staff. Combination test is as follows: The EXIT ROLL rotates when 010-001(Fuser Motor) and 071-009 are executed.</p> <ol style="list-style-type: none"> 1) Power on the printer, and enter the Diag Mode. 2) Execute 010-001 and 071-009. 3) Check that the Roller rotates. <div data-bbox="710 772 1260 1108" style="text-align: center;"> <p style="text-align: right; font-size: small;">Tb102046KA</p> </div> <ol style="list-style-type: none"> 4) Press the "Cancel" key to stop the clutch. 5) Press the "▼" key to display 010-001. 6) Press the "Cancel" key to stop the motor.

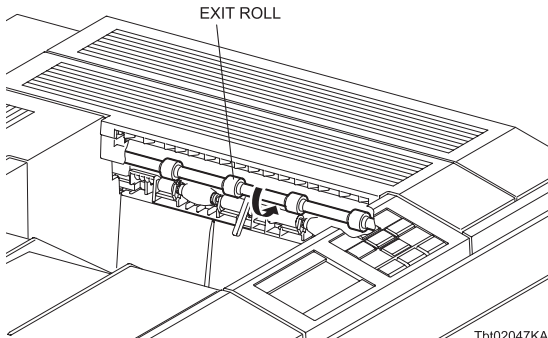
Motor/Clutch/Solenoid Name (Diag. Code)	Check procedure
Exit Invert Clutch (071-010)	<p>NOTE: This procedure is for the Customer. Since the clutch noise is so soft that it may be hard to recognize, the noise check described below should be performed in as silent an environment as possible.</p> <ol style="list-style-type: none"> 1) Power on the printer, and enter the Diag Mode. 2) Execute 071-010. Upon pressing the " ✓ " key, the operating noise of the clutch will be heard. 3) Press the "Cancel" key to stop the clutch. <p>NOTE: This procedure is for the technical staff. Combination test is as follows: The EXIT ROLL rotates when the 010-001(Fuser Motor) and the 071-010 are executed.</p> <ol style="list-style-type: none"> 1) Power on the printer, and enter the Diag Mode. 2) Execute 010-001 and 071-010. 3) Check that the Roller rotates.  <p style="text-align: right; font-size: small;">Tb102047KA</p> <ol style="list-style-type: none"> 4) Press the "Cancel" key to stop the clutch. 5) Press the " ▼ " key to display 010-001. 6) Press the "Cancel" key to stop the motor.
CTD Solenoid Pull (071-011)	Not in use
CTD Solenoid Push (071-012)	Not in use

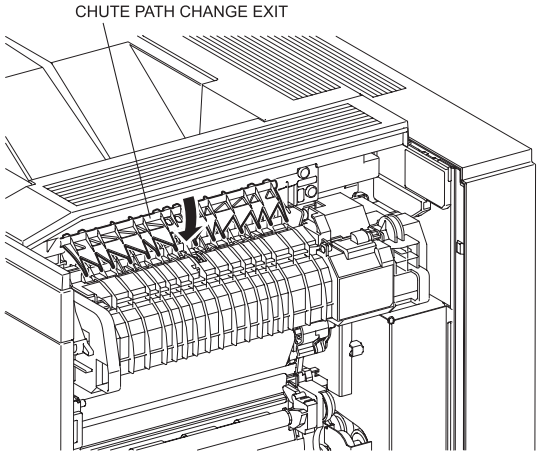
Motor/Clutch/Solenoid Name (Diag. Code)	Check procedure
Exit Solenoid (071-013)	<p>NOTE: This procedure is for the Customer. Since the solenoid noise is so soft that it may be hard to recognize, the noise check described below should be performed in as silent an environment as possible.</p> <ol style="list-style-type: none"> 1) Power on the printer, and enter the Diag Mode. 2) Execute 071-013. Upon pressing the " ✓ " key, the operating noise of the solenoid will be heard. 3) Press the "Cancel" key to stop the solenoid. <p>NOTE: This procedure is for the technical staff.</p> <ol style="list-style-type: none"> 1) Power on the printer, and enter the Diag Mode. 2) Open the RH Cover. 3) Cheat the Safety Interlock System. 4) Execute 071-013. 5) Check that the CHUTE PATH CHANGE EXIT comes down. <div style="text-align: center;">  </div> <ol style="list-style-type: none"> 6) Press the "Cancel" key to stop the test. 7) Remove the cheater. 8) Replace the RH Cover.

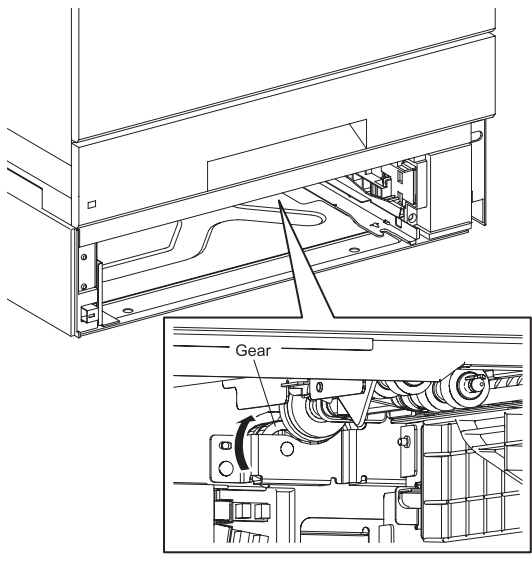
Motor/Clutch/Solenoid Name (Diag. Code)	Check procedure
<p>Cassette2 Option Motor (071-014,015,016) / Cassette3 Option Motor (071-019,020,021) / Cassette4 Option Motor (071-024,025,026) / Cassette5 Option Motor (071-029,030,031)</p>	<p>Example: Cassette2 Option Motor</p> <ol style="list-style-type: none"> 1) Remove the Option Cassette. 2) Power on the printer, and enter the Diag Mode. 3) Execute 071-014. 4) Check that the Motor rotates.  <p style="text-align: right; font-size: small;">Tbt02049KA</p> <ol style="list-style-type: none"> 5) Press the "Cancel" key to stop the test. 6) Power off the printer. 7) Replace the Option Cassette. <p>NOTE: The check procedure for Cassette3, Cassette4, and Cassette5 are the same as that for Cassette2 described above.</p>

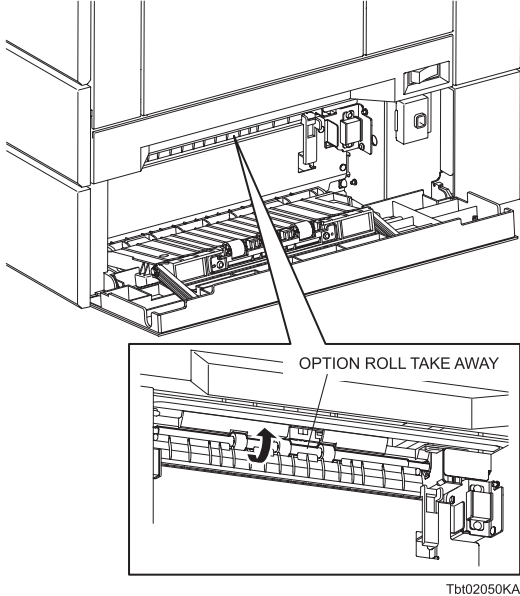
Motor/Clutch/Solenoid Name (Diag. Code)	Check procedure
<p>Cassette2 Take Away Clutch (071-017) / Cassette3 Take Away Clutch (071-022) / Cassette4 Take Away Clutch (071-027) / Cassette5 Take Away Clutch (071-032)</p>	<p>Example: Cassette2 Take Away Clutch NOTE: This procedure is for the Customer. Since the clutch noise is so soft that it may be hard to recognize, the noise check described below should be performed in as silent an environment as possible.</p> <ol style="list-style-type: none"> 1) Power on the printer, and enter the Diag Mode. 2) Execute 071-017. Upon pressing the "✓" key, the operating noise of the clutch will be heard. 3) Press the "Cancel" key to stop the clutch. <p>NOTE: This procedure is for the technical staff. Combination test is as follows: The OPTION ROLL TAKE AWAY rotates when 071-014 (Cassette2 Option Motor) and 071-017 are executed.</p> <ol style="list-style-type: none"> 1) Power on the printer, and enter the Diag Mode. 2) Open the Option RH Cover. 3) Cheat the Safety Interlock System. 4) Execute 071-014 and 071-017. 5) Check that the Roller rotates. <div data-bbox="724 869 1246 1462" style="text-align: center;">  <p style="text-align: right; font-size: small;">Tbt02050KA</p> </div> <ol style="list-style-type: none"> 6) Press the "Cancel" key to stop the clutch. 7) Press the "▼" key to display 071-014. 8) Press the "Cancel" key to stop the motor. 9) Remove the cheater. 10) Replace the Option RH Cover. <p>NOTE: The check procedure for Cassette3, Cassette4, and Cassette5 are the same as that for Cassette2 described above. When executing a combination test, specify the following codes for optional motors:</p> <ul style="list-style-type: none"> - Cassette3 Option Motor: 071-019 - Cassette4 Option Motor: 071-024 - Cassette5 Option Motor: 071-029

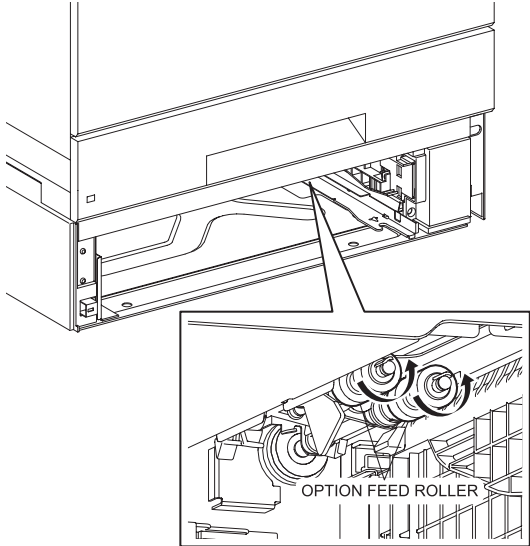
Motor/Clutch/Solenoid Name (Diag. Code)	Check procedure
<p>Cassette2 Feed Clutch (071-018) / Cassette3 Feed Clutch (071-023) / Cassette4 Feed Clutch (071-028) / Cassette5 Feed Clutch (071-033)</p>	<p>Example: Cassette2 Feed Clutch NOTE: This procedure is for the Customer. Since the clutch noise is so soft that it may be hard to recognize, the noise check described below should be performed in as silent an environment as possible.</p> <ol style="list-style-type: none"> 1) Power on the printer, and enter the Diag Mode. 2) Execute 071-018. Upon pressing the " ✓ " key, the operating noise of the clutch will be heard. 3) Press the "Cancel" key to stop the clutch. <p>NOTE: This procedure is for the technical staff. Combination test is as follows. The OPTION ROLL ASSY TAKE AWAY rotates when 071-014 (Cassette2 Option Motor) and 071-018 are executed.</p> <ol style="list-style-type: none"> 1) Power on the printer, and enter the Diag Mode. 2) Remove the Option paper cassette 2. 3) Execute 071-014 and 071-018. 4) Check that both feed rollers rotate momentarily.  <p style="text-align: right; font-size: small;">Tbt02051KA</p> <ol style="list-style-type: none"> 5) Press the "Cancel" key to stop the clutch. 6) Press the " ▼ " key to display 071-014. 7) Press the "Cancel" key to stop the motor. 8) Replace the Option paper cassette 2. <p>NOTE: The check procedure for Cassette3, Cassette4, and Cassette5 are the same as that for Cassette2 described above. When executing a combination test, specify the following codes for optional motors:</p> <ul style="list-style-type: none"> - Cassette3 Option Motor: 071-019 - Cassette4 Option Motor: 071-024 - Cassette5 Option Motor: 071-029
<p>4Paper Hand Motor (PH) Reverse (071-034) / 5Paper Hand Motor (PH) Reverse (071-035) / 6Paper Hand Motor (PH) Reverse (071-036)</p>	<p>Not in use.</p>

Motor/Clutch/Solenoid Name (Diag. Code)	Check procedure
<p>XERO Motor (091-001,002,003)</p>	<p>NOTE: This procedure is for the Customer.</p> <ol style="list-style-type: none"> 1) Power on the printer, and enter the Diag Mode. 2) Execute 091-001. Upon pressing the " ✓ " key, the operating noise of the motor will be heard. 3) Press the "Cancel" key to stop the motor. <p>NOTE: This procedure is for the technical staff.</p> <p>When performing any operation for five minutes or longer with the Front Cover open, cover the drum to avoid exposure to light.</p> <ol style="list-style-type: none"> 1) Power on the printer, and enter the Diag Mode. 2) Open the Front Cover. 3) Open the RH Cover. 4) Open the FRAME ASSY 2ND. 5) Remove the BELT ASSY IBT. 6) Close the RH Cover. 7) Remove the XERO DEVE CRU ASSY (YMCK). 8) Cheat the Safety Interlock System. 9) Execute the 091-001. 10) Check that the coupling rotates. <div data-bbox="730 869 1244 1265" style="text-align: center;"> </div> <ol style="list-style-type: none"> 11) Press the "Cancel" key to stop the test. 12) Replace the XERO DEVE CRU ASSY (YMCK). 13) Open the RH Cover. 14) Replace the BELT ASSY IBT. 15) Close the FRAME ASSY 2ND 16) Close the RH Cover 17) Remove the cheater and close the Front Cover

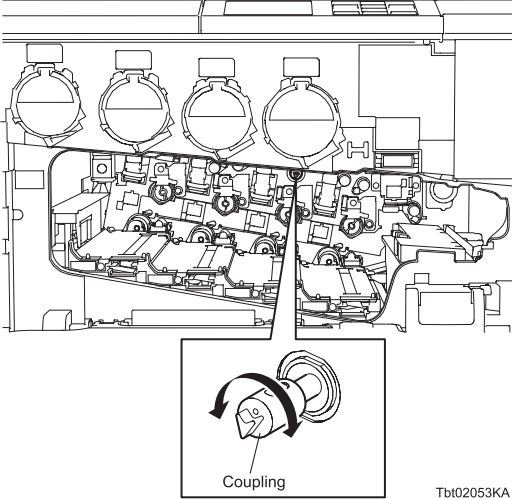
Motor/Clutch/Solenoid Name (Diag. Code)	Check procedure
Xero-Drum Clutch (091-004)	<p>NOTE: This procedure is for the Customer. Since the clutch noise is so soft that it may be hard to recognize, the noise check described below should be performed in as silent an environment as possible.</p> <ol style="list-style-type: none"> 1) Power on the printer, and enter the Diag Mode. 2) Execute 091-004. Upon pressing the "✓" key, the operating noise of the clutch will be heard. 3) Press the "Cancel" key to stop the clutch. <p>NOTE: This procedure is for the technical staff. Combination test is as follows: Executing 071-001 (PH Motor) and 091-004 should slide the LINK BAR.</p> <ol style="list-style-type: none"> 1) Remove the Toner Cassette, XERO DEVE CRU ASSY and BELT ASSY IBT. 2) Power on the printer, and enter the Diag Mode. 3) Cheat the Safety Interlock System. 4) Execute 071-001 and 091-004. 5) Check that the Link Bar slides. <div style="text-align: center;">  <p>The diagram shows a cross-section of the printer's internal drum and clutch mechanism. A callout box provides a detailed view of a component labeled 'Coupling', which is a small gear-like part with a curved shape. Arrows indicate its rotation.</p> </div> <p style="text-align: right; font-size: small;">Tb102053KA</p> <ol style="list-style-type: none"> 6) Press the "Cancel" key to stop the clutch. 7) Press the "▼" key to display 071-001. 8) Press the "Cancel" key to stop the motor. 9) Remove the cheater. 10) Replace the Toner Cassette, XERO DEVE CRU ASSY and BELT ASSY IBT.

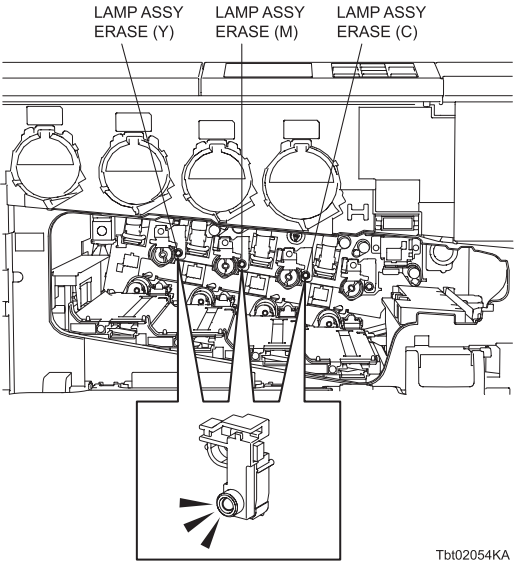
Motor/Clutch/Solenoid Name (Diag. Code)	Check procedure
Erase YMC LED (091-005)	<p>NOTE: This procedure is for the technical staff. When performing any operation for five minutes or longer with the Front Cover open, cover the drum to avoid exposure to light.</p> <ol style="list-style-type: none"> 1) Power on the printer, and enter the Diag Mode. 2) Open the Front Cover. 3) Open the RH Cover. 4) Open the FRAME ASSY 2ND. 5) Remove the BELT ASSY IBT. 6) Remove the XERO DEVE CRU ASSY (YMC). 7) Cheat the Safety Interlock System. 8) Execute 091-005. 9) Check that the LAMP ASSY ERASE (YMC) illuminates. <div style="text-align: center;">  <p style="text-align: right; font-size: small;">Tb102054KA</p> </div> <ol style="list-style-type: none"> 10) Press the "Cancel" key to stop the test. 11) Replace the XERO DEVE CRU ASSY (YMC). 12) Replace the BELT ASSY IBT. 13) Close the FRAME ASSY 2ND 14) Close the RH Cover 15) Remove the cheater and close the Front Cover.

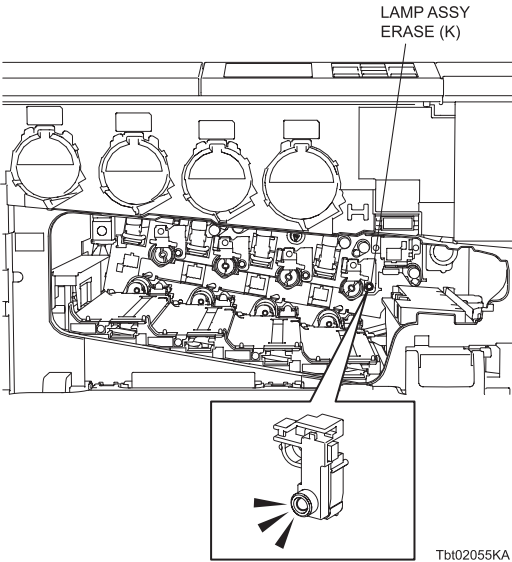
Motor/Clutch/Solenoid Name (Diag. Code)	Check procedure
Erase K LED (091-006)	<p>NOTE: This procedure is for the technical staff. When performing any operation for five minutes or longer with the Front Cover open, cover the drum to avoid exposure to light.</p> <ol style="list-style-type: none"> 1) Power on the printer, and enter the Diag Mode. 2) Open the Front Cover. 3) Open the RH Cover. 4) Open the FRAME ASSY 2ND. 5) Remove the BELT ASSY IBT. 6) Remove the XERO DEVE CRU ASSY (K). 7) Cheat the Safety Interlock System. 8) Execute 091-006. 9) Check that the LAMP ASSY ERASE (YMC) illuminates. <div style="text-align: center;">  </div> <ol style="list-style-type: none"> 10) Press the "Cancel" key to stop the test. 11) Replace the XERO DEVE CRU ASSY (K). 12) Replace the BELT ASSY IBT. 13) Close the FRAME ASSY 2ND 14) Close the RH Cover 15) Remove the cheater and close the Front Cover.

Motor/Clutch/Solenoid Name (Diag. Code)	Check procedure
<p>DEVE YMC Motor (093-001,002,003)</p>	<p>NOTE: This procedure is for the Customer.</p> <ol style="list-style-type: none"> 1) Power on the printer, and enter the Diag Mode. 2) Execute the 093-001. Upon pressing the "✓" key, the operating noise of the motor will be heard. 3) Press the "Cancel" key to stop the motor. <p>NOTE: This procedure is for the technical staff.</p> <p>When performing any operation for five minutes or longer with the Front Cover open, cover the drum to avoid exposure to light.</p> <ol style="list-style-type: none"> 1) Power on the printer, and enter the Diag Mode. 2) Open the Front Cover. 3) Open the RH Cover. 4) Open the FRAME ASSY 2ND. 5) Remove the BELT ASSY IBT. 6) Remove the XERO DEVE CRU ASSY (YMC). 7) Cheat the Safety Interlock System. 8) Execute the 093-001. 9) Check that the coupling rotates. <div data-bbox="730 837 1246 1218" style="text-align: center;"> <p style="text-align: right;">Tbi02056KA</p> </div> <ol style="list-style-type: none"> 10) Press the "Cancel" key to stop the test. 11) Replace the XERO DEVE CRU ASSY (YMC). 12) Replace the BELT ASSY IBT. 13) Close the FRAME ASSY 2ND 14) Close the RH Cover 15) Remove the cheater and close the Front Cover.

Motor/Clutch/Solenoid Name (Diag. Code)	Check procedure
DEVE K Motor (093-004,005,006)	<p>NOTE: This procedure is for the Customer.</p> <ol style="list-style-type: none"> 1) Power on the printer, and enter the Diag Mode. 2) Execute the 093-004. Upon pressing the "✓" key, the operating noise of the motor will be heard. 3) Press the "Cancel" key to stop the motor. <p>NOTE: This procedure is for the technical staff. When performing any operation for five minutes or longer with the Front Cover open, cover the drum to avoid exposure to light.</p> <ol style="list-style-type: none"> 1) Power on the printer, and enter the Diag Mode. 2) Open the Front Cover. 3) Open the RH Cover. 4) Open the FRAME ASSY 2ND. 5) Remove the BELT ASSY IBT. 6) Remove the XERO DEVE CRU ASSY (K). 7) Cheat the Safety Interlock System. 8) Execute 093-004. 9) Check that the coupling rotates. <div data-bbox="730 837 1246 1218" style="text-align: center;"> <p style="text-align: right;">Tb102057KA</p> </div> <ol style="list-style-type: none"> 10) Press the "Cancel" key to stop the test. 11) Replace the XERO DEVE CRU ASSY (K). 12) Close the FRAME ASSY 2ND 13) Close the RH Cover 14) Remove the cheater and close the Front Cover.

Motor/Clutch/Solenoid Name (Diag. Code)	Check procedure
Toner Motor Y (093-007)	<p>NOTE: This procedure is for the Customer.</p> <ol style="list-style-type: none"> 1) Power on the printer, and enter the Diag Mode. 2) Execute 093-007. Upon pressing the "✓" key, the operating noise of the motor will be heard. 3) Press the "Cancel" key to stop the motor. <p>NOTE: This procedure is for the technical staff. When performing any operation for five minutes or longer with the Front Cover open, cover the drum to avoid exposure to light.</p> <ol style="list-style-type: none"> 1) Power on the printer, and enter the Diag Mode. 2) Open the Front Cover. 3) Open the RH Cover. 4) Open the FRAME ASSY 2ND. 5) Remove the yellow toner cartridge. 6) Cheat the Safety Interlock System. 7) Execute 093-007. 8) Check that the coupling rotates. <div data-bbox="683 801 1292 1243" style="text-align: center;"> </div> <ol style="list-style-type: none"> 9) Press the "Cancel" key to stop the test. 10) Replace the yellow toner cartridge. 11) Close the FRAME ASSY 2ND 12) Close the RH Cover 13) Remove the cheater and close the Front Cover.

Motor/Clutch/Solenoid Name (Diag. Code)	Check procedure
<p>Toner Motor M (093-008)</p>	<p>NOTE: This procedure is for the Customer.</p> <ol style="list-style-type: none"> 1) Power on the printer, and enter the Diag Mode. 2) Execute 093-008. Upon pressing the " ✓ " key, the operating noise of the motor will be heard. 3) Press the "Cancel" key to stop the motor. <p>NOTE: This procedure is for the technical staff.</p> <p>When performing operation for five minutes or longer with the front cover open, cover the drum to avoid exposure to light.</p> <ol style="list-style-type: none"> 1) Power on the printer, and enter the Diag Mode. 2) Open the Front Cover. 3) Open the RH Cover. 4) Open the FRAME ASSY 2ND. 5) Remove the magenta toner cartridge. 6) Cheat the Safety Interlock System. 7) Execute 093-008. 8) Check that the coupling rotates. <div data-bbox="687 801 1286 1240" style="text-align: center;"> </div> <ol style="list-style-type: none"> 9) Press the "Cancel" key to stop the test. 10) Replace the magenta toner cartridge. 11) Close the FRAME ASSY 2ND 12) Close the RH Cover 13) Remove the cheater and close the Front Cover.

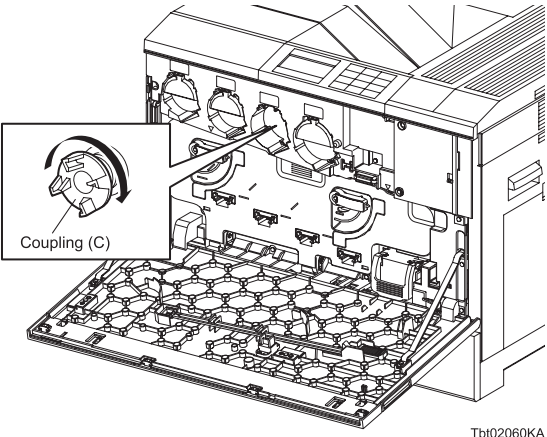
Motor/Clutch/Solenoid Name (Diag. Code)	Check procedure
Toner Motor C (093-009)	<p>NOTE: This procedure is for the Customer.</p> <ol style="list-style-type: none"> 1) Power on the printer, and enter the Diag Mode. 2) Execute 093-009. Upon pressing the " ✓ " key, the operating noise of the motor will be heard. 3) Press the "Cancel" key to stop the motor. <p>NOTE: This procedure is for the technical staff. When performing operation for five minutes or longer with the front cover open, cover the drum to avoid exposure to light.</p> <ol style="list-style-type: none"> 1) Power on the printer, and enter the Diag Mode. 2) Open the Front Cover. 3) Open the RH Cover. 4) Open the FRAME ASSY 2ND. 5) Remove the cyan toner cartridge. 6) Cheat the Safety Interlock System. 7) Execute 093-009. 8) Check that the coupling rotates.  <p style="text-align: right; font-size: small;">Tbt02060KA</p> <ol style="list-style-type: none"> 9) Press the "Cancel" key to stop the test. 10) Replace the cyan toner cartridge. 11) Close the FRAME ASSY 2ND 12) Close the RH Cover 13) Remove the cheater and close the Front Cover.

Motor/Clutch/Solenoid Name (Diag. Code)	Check procedure
Toner Motor K (093-010)	<p>NOTE: This procedure is for the Customer.</p> <ol style="list-style-type: none"> 1) Power on the printer, and enter the Diag Mode. 2) Execute 093-010. Upon pressing the "✓" key, the operating noise of the motor will be heard. 3) Press the "Cancel" key to stop the motor. <p>NOTE: This procedure is for the technical staff. When performing operation for five minutes or longer with the front cover open, cover the drum to avoid exposure to light.</p> <ol style="list-style-type: none"> 1) Power on the printer, and enter the Diag Mode. 2) Open the Front Cover. 3) Open the RH Cover. 4) Open the FRAME ASSY 2ND. 5) Remove the black toner cartridge. 6) Cheat the Safety Interlock System. 7) Execute 093-010. 8) Check that the coupling rotates. <div data-bbox="730 801 1254 1240" style="text-align: center;"> <p style="text-align: right; font-size: small;">Tbt02061KA</p> </div> <ol style="list-style-type: none"> 9) Press the "Cancel" key to stop the test. 10) Replace the black toner cartridge. 11) Close the FRAME ASSY 2ND 12) Close the RH Cover 13) Remove the cheater and close the Front Cover.

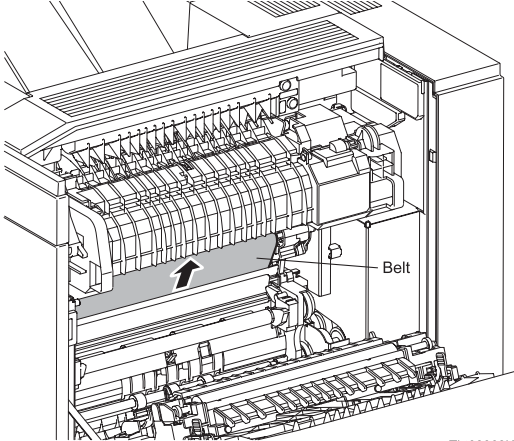
Motor/Clutch/Solenoid Name (Diag. Code)	Check procedure
IBT Motor (094-001,002,003)	<p>NOTE: This procedure is for the Customer.</p> <ol style="list-style-type: none"> 1) Power on the printer, and enter the Diag Mode. 2) Execute 094-001. Upon pressing the " ✓ " key, the operating noise of the motor will be heard. 3) Press the "Cancel" key to stop the motor. <p>NOTE: This procedure is for the technical staff.</p> <ol style="list-style-type: none"> 1) Power on the printer, and enter the Diag Mode. 2) Open the RH Cover. 3) Cheat the Safety Interlock System. 4) Execute 094-001. 5) Check that the Belt rotates. <div style="text-align: center;">  </div> <ol style="list-style-type: none"> 6) Press the "Cancel" key to stop the test. 7) Remove the cheater and close the RH Cover.
IBT Motor Reverse (094-005,006,007)	Not in use.
IBT Motor + Xero (094-008,009,010)	Not in use.
IBT Color Mode (094-011)	Not in use.

- Option Output Expander (Finisher)

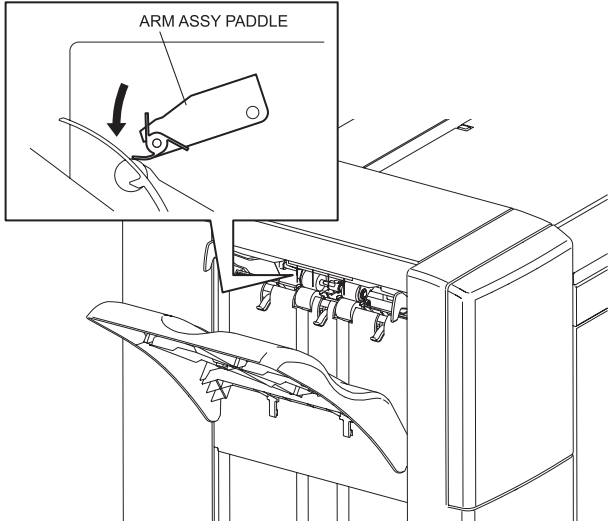
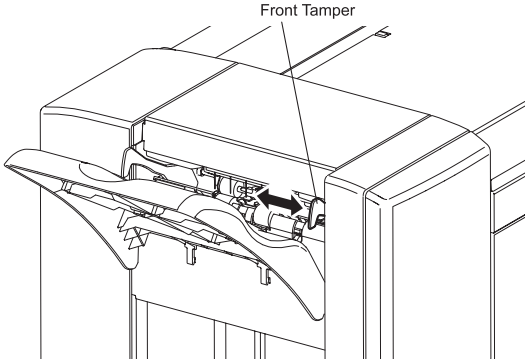
Motor, Clutch and Solenoid name (Diag. Code)	Confirmation procedures
<p>Sub Paddle Solenoid (012-013)</p>	<ol style="list-style-type: none"> 1) Power on the printer, and enter the Diag Mode. 2) Execute 012-013. 3) Check that the ARM ASSY PADDLE moves up and down. <p>NOTE: Cycles Down and Up once per test cycle.</p>  <p style="text-align: right; font-size: small;">Tbt02063KA</p> <ol style="list-style-type: none"> 4) Press the "Cancel" key to stop the test.
<p>Front Tamper Motor Front (012-020,022) / Front Tamper Motor Rear (012-023,025)</p>	<ol style="list-style-type: none"> 1) Power on the printer, and enter the Diag Mode. 2) Execute 012-020 and 012-023. 3) Check that the Front Tamper slides. <p>NOTE: If test produces grinding sound, manually slide paddle to opposite limit.</p>  <p style="text-align: right; font-size: small;">Tbt02025KA</p> <ol style="list-style-type: none"> 4) Press the "Cancel" key to stop the test.

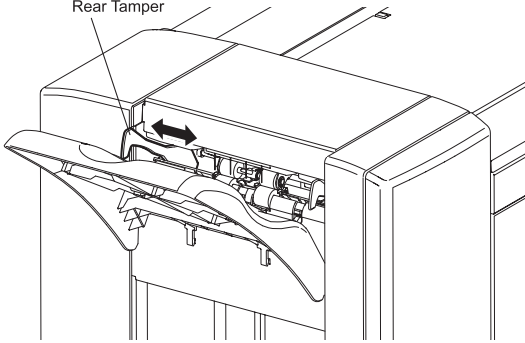
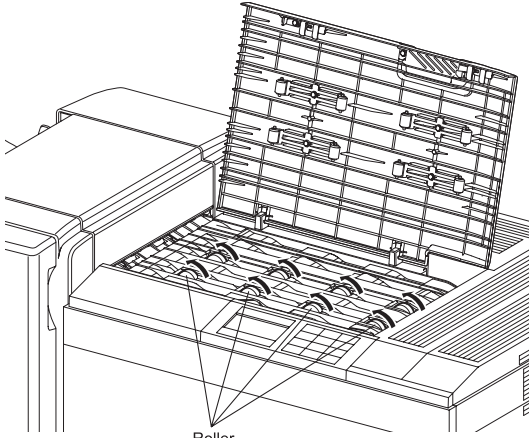
Motor, Clutch and Solenoid name (Diag. Code)	Confirmation procedures
<p>Rear Tamper Motor Front (012-026,028) / Rear Tamper Motor Rear (012-029,031)</p>	<ol style="list-style-type: none"> 1) Power on the printer, and enter the Diag Mode. 2) Execute 012-026 and 012-029. 3) Check that the Rear Tamper slides. <p>NOTE: If test produces grinding sound, manually slide paddle to opposite limit.</p>  <p style="text-align: right; font-size: small;">Tbt02026KA</p> <ol style="list-style-type: none"> 4) Press the "Cancel" key to stop the test.
<p>Xport Motor Forward (012-032,033,034,035)</p>	<ol style="list-style-type: none"> 1) Power on the printer, and enter the Diag Mode. 2) Open the H-TRA Cover. 3) Execute the 012-032. 4) Check that the Roller rotates.  <p style="text-align: right; font-size: small;">Tbt02064KA</p> <ol style="list-style-type: none"> 5) Press the "Cancel" key to stop the test. 6) Close the H-TRA Cover.

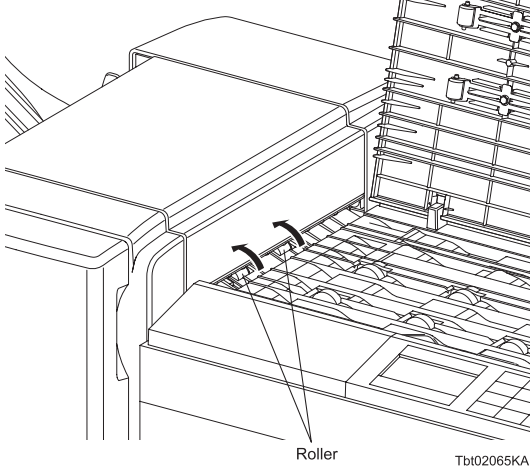
Motor, Clutch and Solenoid name (Diag. Code)	Confirmation procedures
<p>Transport Motor Forward (012-036,037,038)</p>	<ol style="list-style-type: none"> 1) Power on the printer, and enter the Diag Mode. 2) Open the H-TRA Cover. 3) Execute 012-036. 4) Check that the Roller rotates.  <ol style="list-style-type: none"> 5) Press the "Cancel" key to stop the test. 6) Close the H-TRA Cover.
<p>Transport Motor Reverse (012-018)</p>	<p>Not in use.</p>
<p>Xport Motor Reverse (012-039)</p>	<p>Not in use.</p>
<p>Xport Motor 5 ON/OFF (012-040)</p>	<p>Not in use.</p>

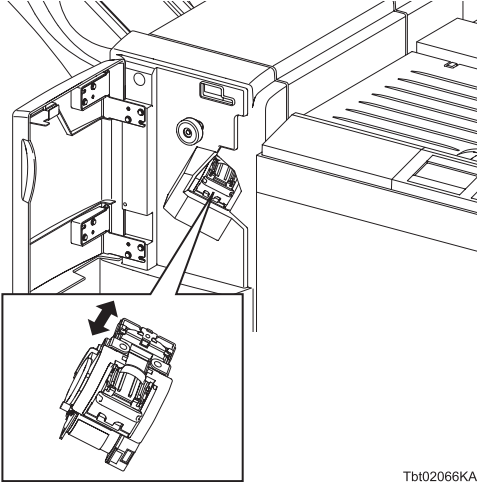
Motor, Clutch and Solenoid name (Diag. Code)	Confirmation procedures
Staple Motor Forward (012-046)	<p>NOTE: This procedure is for the Customer.</p> <ol style="list-style-type: none"> 1) Power on the printer, and enter the Diag Mode. 2) Execute 012-046. Upon pressing the "✓" key, the operating noise of the motor will be heard. 3) Press the "Cancel" key to stop the motor. <p>NOTE: This procedure is for the technical staff.</p> <ol style="list-style-type: none"> 1) Power on the printer, and enter the Diag Mode. 2) Open the Finisher Front Door. 3) Cheat the Safety Interlock System. 4) Execute 012-046. 5) Check that the stapling operation is executed.  <p style="text-align: right; font-size: small;">Tbt02066KA</p> <ol style="list-style-type: none"> 6) Press the "Cancel" key to stop the test. 7) Remove the cheater and close the Finisher Front Door.
Staple Motor Reverse (012-047)	Not in use.
Set Clamp Clutch (012-050)	<p>NOTE: Since the clutch noise is so soft that it may be hard to recognize, the noise check described below should be performed in as silent an environment as possible.</p> <ol style="list-style-type: none"> 1) Power on the printer, and enter the Diag Mode. 2) Execute 012-050. Upon pressing the "✓" key, the operating noise of the clutch will be heard. 3) Press the "Cancel" key to stop the clutch.
Eject Clamp Up (012-052) / Eject Clamp Down (012-053)	Not in use.

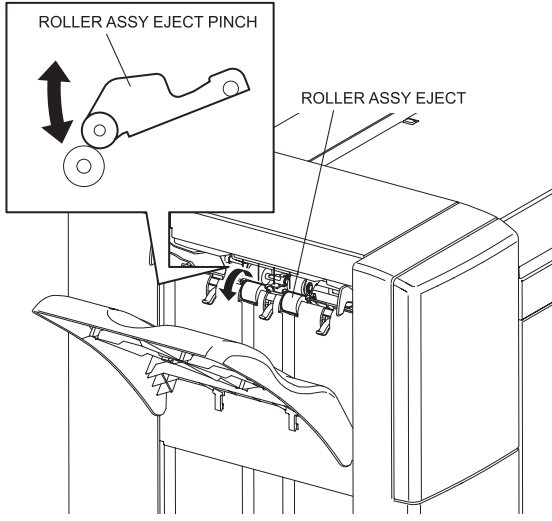
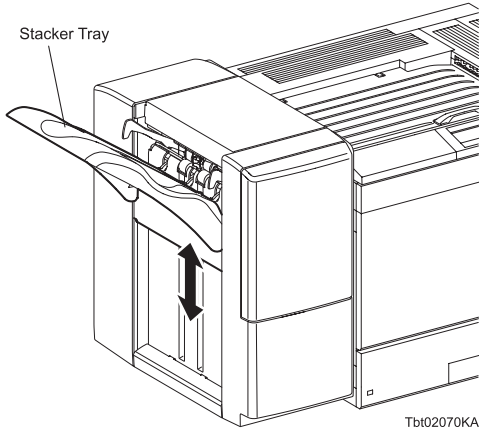
Motor, Clutch and Solenoid name (Diag. Code)	Confirmation procedures
<p>Eject Motor Forward (012-054,055)</p>	<p>NOTE: This procedure is for the Customer.</p> <ol style="list-style-type: none"> 1) Power on the printer, and enter the Diag Mode. 2) Execute 012-054. Upon pressing the " ✓ " key, the operating noise of the motor will be heard. 3) Press the "Cancel" key to stop the motor. <p>NOTE: This procedure is for the technical staff.</p> <ol style="list-style-type: none"> 1) Power on the printer, and enter the Diag Mode. 2) Execute 012-054. 3) Check that the Roller rotates and the ROLLER ASSY EJECT PINCH moves up and down.  <p style="text-align: right;">Tbt02069KB</p>
<p>Stacker Motor Up (012-060) / Stacker Motor Down (012-061)</p>	<ol style="list-style-type: none"> 1) Power on the printer, and enter the Diag Mode. 2) Execute 012-060 and 012-061. 3) Check that the Stacker tray moves up and down.  <p style="text-align: right;">Tbt02070KA</p>
<p>Stacker Motor Mid UP ON/ OFF (012-062)</p>	<p>Not in use.</p>
<p>Stacker Motor Low UP ON/ OFF (012-063)</p>	<p>Not in use.</p>

4.2 Print Info

Outputs the detailed information on the printer settings and configuration.

4.2.1 Executing Print Info

- 1) Power off the printer.
- 2) Power on the printer while pressing "▲" and "▼" keys.
- 3) Release the keys when "Diagnosing..." is displayed.
- 4) "Customer Mode" and "IOT Diag" are displayed. (Now in the Diag mode.)
- 5) Press "▼" key to select "Print Info", and then press "✓" key.
- 6) Press "▲" or "▼" key to select an item from "Print Info".
- 7) Press "✓" key twice to execute the process.

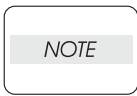

To exit the print or to return to one step higher menu, press the "Cancel" key.

4.2.2 Config Page

Allows you to check the IOT software version or printer configuration.

4.2.3 Print Settings

Allows you to check the service tag, print count, and error count.

4.3 Test Print

Outputs test patterns stored in the printer. If an error such as paper jam or paper out occurs during printing, the test is suspended until the problem is solved.

4.3.1 Executing Test Print

- 1) Power off the printer.
- 2) Power on the printer while pressing "▲" and "▼" keys.
- 3) Release the keys when "Diagnosing..." is displayed.
- 4) "Customer Mode" and "IOT Diag" are displayed. (Now in the Diag mode.)
- 5) Press "▼" key to select "Test Print", and then press "✓" key.
- 6) Press "▲" or "▼" key to select an item from "Test Print".
- 7) Press "✓" key twice to execute the process.

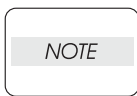

To stop the test or to return to one step higher menu, press "Cancel" key.

4.3.2 No Image [IOT]

Outputs a blank sheet.

4.3.3 Test Pattern 600 [IOT]

Outputs the 600dpi pattern stored in the IOT.

When a PQ problem occurs, this test isolates the problem to the print process or PWBA ESS by comparing the print with the sample chart.

Check result: NG (Check the print process.) OK (Check the PWBA ESS.)

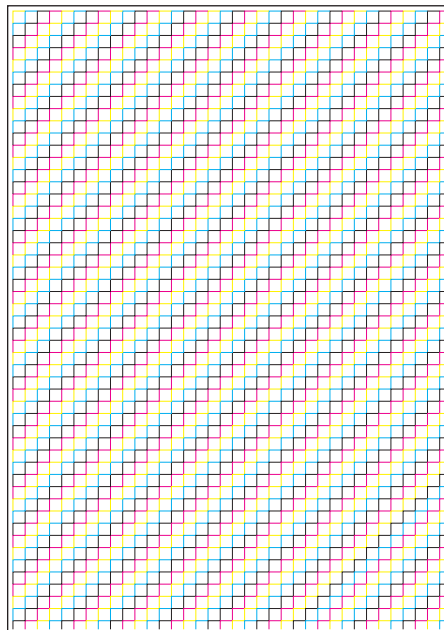

Kmy02001KA

4.3.4 Grid 2

Outputs the grid pattern stored in the ESS.

When a PQ problem occurs, this test isolates the trouble to the printer or other causes by comparing the print with the sample chart.

Check result: NG (Check the print process and PWBA ESS.) OK (Check the network, cable, PC, etc.)

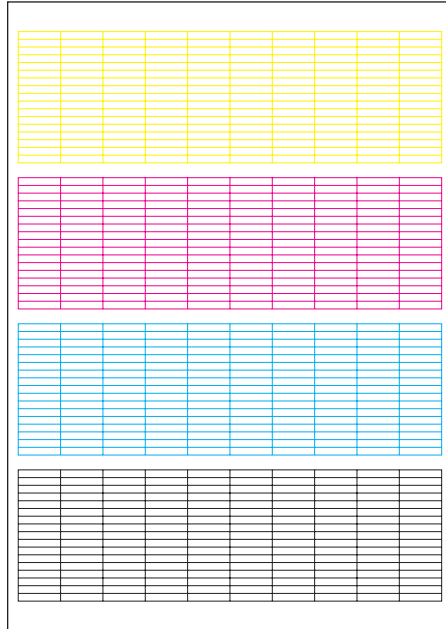

Leg_Sec02_004FA

4.3.5 Cyan 20%

Outputs the cyan 20% density solid pattern on the whole area of an A4 sheet.

When a PQ problem occurs, this test isolates the problem to the cyan toner or other color toners by comparing the print with the sample chart.

Check result: NG (Check the cyan toner.) OK (Check other color toners.)

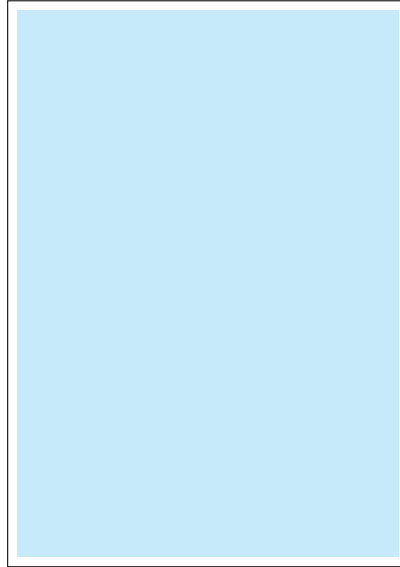

Leg_Sec02_005FA

4.3.6 Magenta 20%

Outputs the magenta 20% density solid pattern on the whole area of an A4 sheet.

When a PQ problem occurs, this test isolates the problem to the magenta toner or other color toners by comparing the print with the sample chart.

Check result: NG (Check the magenta toner.) OK (Check other color toners.)

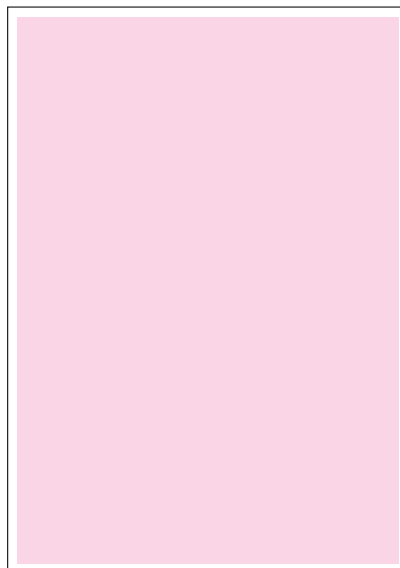

Leg_Sec02_006FA

4.3.7 Yellow 20%

Outputs the yellow 20% density solid pattern on the whole area of an A4 sheet.

When a PQ problem occurs, this test isolates the problem to the yellow toner or other color toners by comparing the print with the sample chart.

Check result: NG (Check the yellow toner.) OK (Check other color toners.)

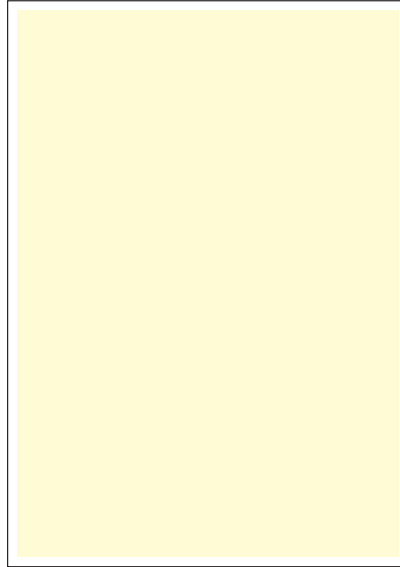

Leg_Sec02_007FA

4.3.8 Black 20%

Outputs the black 20% density solid pattern on the whole area of an A4 sheet.

When a PQ problem occurs, this test isolates the problem to the black toner or other color toners by comparing the print with the sample chart.

Check result: NG (Check the black toner.) OK (Check other color toners.)

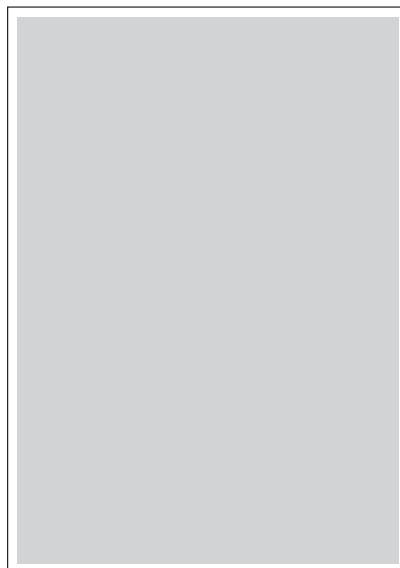

Leg_Sec02_008FA

4.3.9 CMY 20%

Outputs C/M/Y 20% density solid pattern on the whole area of an A4 sheet.

When a PQ problem occurs, this test isolates the problem to the imbalance of C/M/Y toners or the black toner by comparing the print with the sample chart.

Check result: NG (Check the yellow, magenta, and cyan toners.) OK (Check the black toner.)

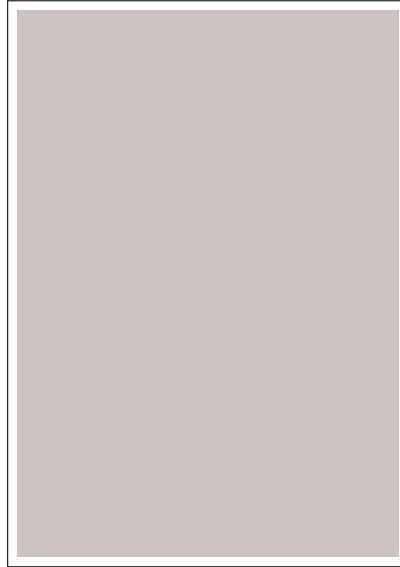

Leg_Sec02_009FA

4.3.10 Gradation

Outputs the gradation pattern of 2 to 100% density on an A4 sheet for each of the four colors.

When a PQ problem occurs, this test isolates the problem to the print process or PWBA ESS by comparing the sample chart with the print.

Check result: NG (Check the print process.) OK (Check the PWBA ESS.)

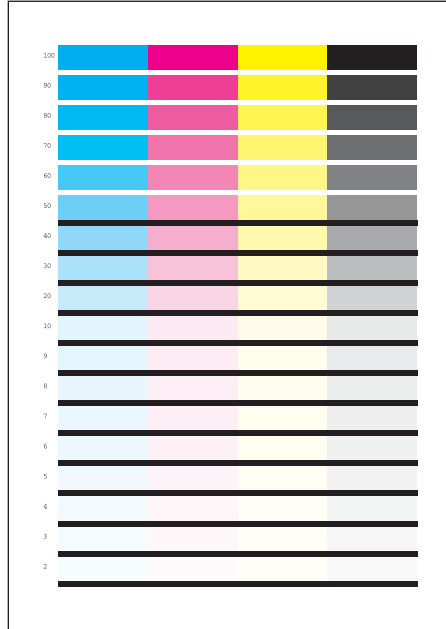

Leg_Sec02_010FA

4.3.11 Toner Pallet Check

Outputs the 100% density color pattern of C/M/Y/K.

When a PQ problem occurs, this test isolates the problem to the toner or otherwise by comparing the sample chart with the print.

Check result: NG (Check the toner.) OK (Check the print job or print data.)

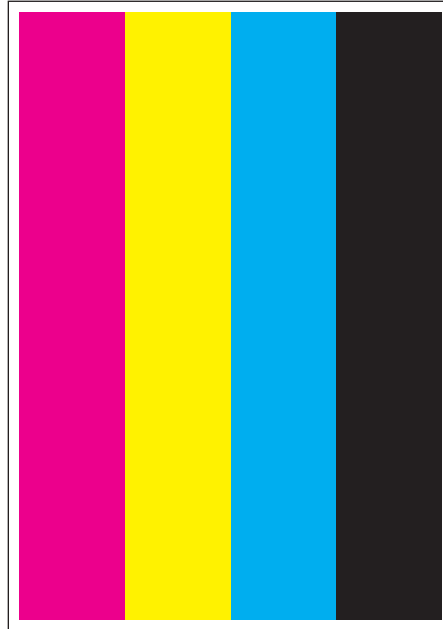

Leg_Sec02_011FA

4.3.12 Contamination Check

Allows you to check the print for any regular lines or toner spots when encountering PQ problems. From the interval of regular lines or spots, you can determine the parts that have caused the problem.

Page 1 to 4: Outputs the scale patterns in vertical and horizontal directions for evaluating regularity and intervals.

Page 5: Outputs the correspondence between interval and faulty component.

Page 1

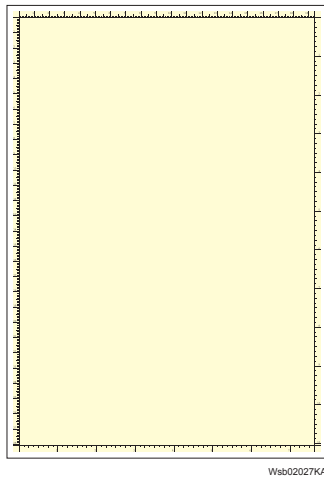

Wsb02027KA

Page 2

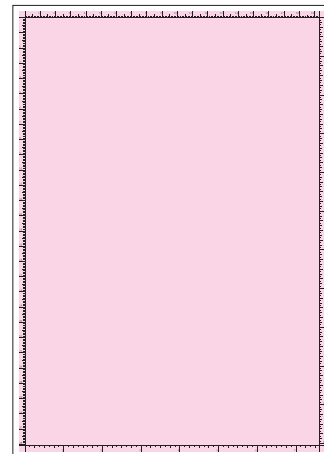

Wsb02028KA

Page 3

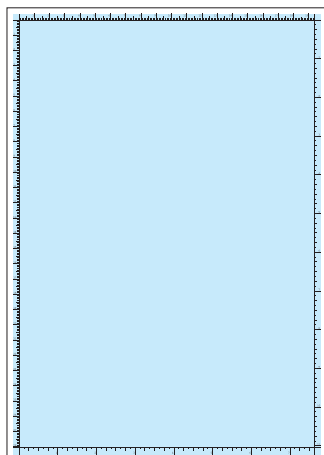

Wsb02029KA

Page 4

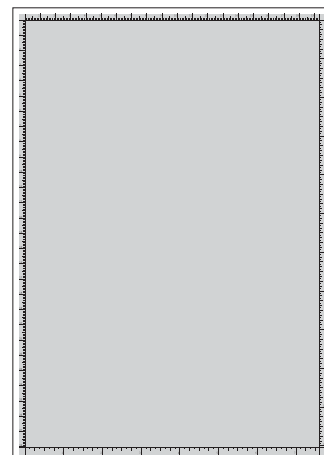

Wsb02030KA

Page 5

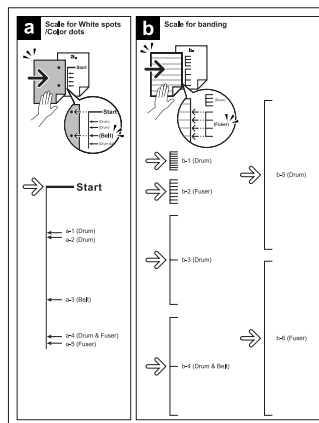

Tb02072KA

4.4 Parameter

This function reads/writes the following parameters stored in the printer.

4.4.1 Executing Parameter (Registration Adjustment)

- 1) Turn off the power.
- 2) Turn on the power while holding down "▲" and "▼" keys.
- 3) Release the fingers from these keys when "Diagnosing..." is displayed.
- 4) The "Customer Mode" and "IOT Diag" are displayed. (Entered the Diag. mode.)
- 5) Press "▼" to select "Parameter", and then press "✓" key.
- 6) Press "▼" key to select the "Regi", and then press "✓" key.
- 7) Press "▲" and "▼" key to select the item, and then press "✓" key.

The current registration adjustment value is displayed.

- 8) Press "✓" key to execute the setting.

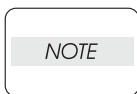

To exit the test or to returning to one step higher menu, press "CANCEL" key.

Item	Description	Function	Adjustable range
Slow Scan K to P	Sets the registration in the paper feeding direction.	Black registration adjustment	-15 to 15
Fast Scan Sim MPF, Tray 2 to Tray 5	Sets the registration in the scanning direction.	Black registration adjustment at side 1 print	-32 to 32
Fast Scan Dup MPF, Tray 2 to Tray 5		Black registration adjustment at side 2 print	-32 to 32

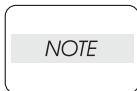

Print the parameter list using the Print function of Parameter Menu in diagnosis before changing the value of the registration.

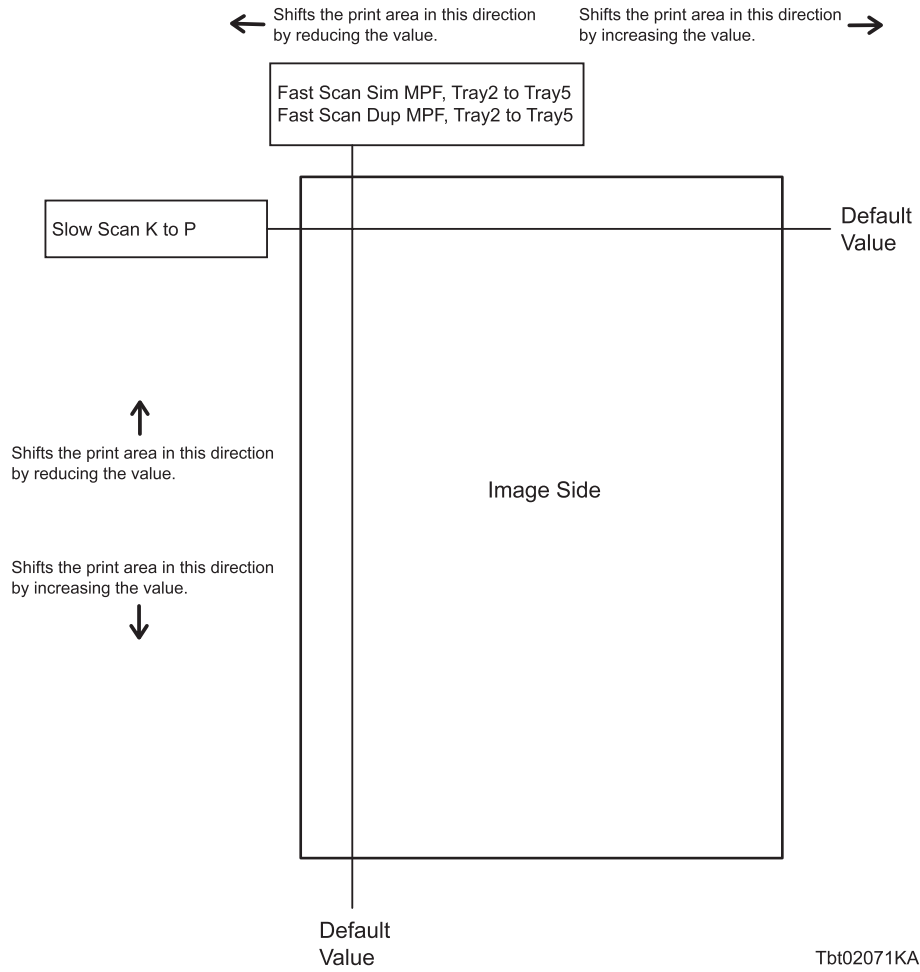

4.4.2 Executing Parameter (Life Counter)

- 1) Turn off the power.
- 2) Turn on the power while holding down "▲" and "▼" keys.
- 3) Release the fingers from these keys when "Diagnosing..." is displayed.
- 4) The "Customer Mode" and "IOT Diag" are displayed. (Entered the Diag. mode.)
- 5) Press "▼" to select "Parameter", and then press "✓" key.
- 6) Press "▼" key to select the "Life", and then press "✓" key.
- 7) Press "▲" and "▼" key to select the item, and then press "✓" key.
- 8) Press "✓" key to execute the setting.

The current life counter value is displayed.

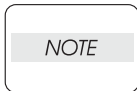

To exit the test or to returning to one step higher menu, press "CANCEL" key.

- Reference Counter Values

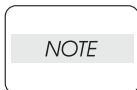

These counter values are reference only. Do not use as the official value.

Counter Name	Value of life warning
Life Y Toner	Std.:6000/High:12000
Life M Toner	Std.:6000/High:12000
Life C Toner	Std.:6000/High:12000
Life K Toner	Std.:9000/High:18000
Life Waste BOX	25000
Life Y Drum	50000
Life M Drum	50000
Life C Drum	50000
Life K Drum	50000
Life Belt	150000
Life Fuser	100000

4.4.3 Executing Parameter (Printing the parameter list)

- 1) Turn off the power.
- 2) Turn on the power while holding down "▲" and "▼" keys.
- 3) Release the fingers from these keys when "Diagnosing..." is displayed.
- 4) The "Customer Mode" and "IOT Diag" are displayed. (Entered the Diag. mode.)
- 5) Press "▼" to select "Parameter", and then press "✓" key.
- 6) Press "▼" key to select the "Print", and then press "✓" key.

The parameter list is printed.

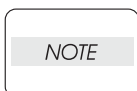

To exit the test or to returning to one step higher menu, press "CANCEL" key.

4.5 Complete

Completes the Diag operation and reloads the data.

4.5.1 Executing Complete

- 1) Power off the printer.
- 2) Power on the printer while pressing "▲" and "▼" keys.
- 3) Release the keys when "Diagnosing..." is displayed.
- 4) "Customer Mode" and "IOT Diag" are displayed. (Now in the Diag mode.)
- 5) Press "▼" key to select "Complete", and then press "✓" key.
- 6) Press "✓" key twice to execute the process.

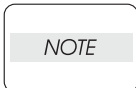

To exit the print or to return to one step higher menu, press the "Cancel" key.

Chapter 3 Removal and Replacement Procedures (RRPs) CONTENTS

1. Removal and Replacement Procedures (RRPs)	3 - 1
1.1 Before Starting Service Procedure	3 - 1
1.2 General Notes	3 - 3
Removal Flows	3 - 4
Replacement Flows	3 - 10
2. Removal Steps	3 - 16
Removal 1 COVER ASSY FRONT (PL1.2.17)	3 - 16
Removal 2 STRAP COVER FRONT (PL1.2.18)	3 - 17
Removal 3 WASTE TONER BOX (PL6.1.13)	3 - 18
Removal 4 KIT BELT ASSY IBT (PL5.1.99)	3 - 20
Removal 5 XERO DEVE CRU ASSY (Y), (M), (C), (K) (PL5.1.8~5.1.11)	3 - 22
Removal 6 KIT FRAME ASSY 2ND (PL8.1.99)	3 - 24
Removal 7 FUSER ASSY (PL7.1.5)	3 - 26
Removal 8 KIT ROLL ASSY 2ND BTR (PL4.4.99)	3 - 27
Removal 9 KIT MSI SEPARATOR ROLL (PL3.1.99)	3 - 28
Removal 10 FAN FUSER (PL4.1.8)	3 - 30
Removal 11 KIT ACTUATOR INTLK RH (PL4.1.97)	3 - 32
Removal 12 ROLL ASSY FEED MSI (PL4.2.21)	3 - 34
Removal 13 KIT FEED ROLL & SEPARATOR ROLL (PL2.1.99)	3 - 36
Removal 14 COVER TRAY (PL2.1.39)	3 - 38
Removal 15 SWITCH ASSY SIZE (PL3.1.1)	3 - 39
Removal 16 HOLDER ASSY SENSOR LOW (PL3.1.2)	3 - 40
Removal 17 COVER ASSY TOP ADD TRAY (Reference only)	3 - 42
Removal 18 COVER FRONT RH (PL1.2.5)	3 - 44
Removal 19 KIT COVER ASSY MSI (PL4.1.98)	3 - 45
Removal 20 COVER ASSY REAR (PL1.3.5)	3 - 46
Removal 21 COVER ASSY TOP EXIT (PL1.1.9)	3 - 47
Removal 22 CHUTE ASSY INVERT (PL7.3.1)	3 - 48
Removal 23 COVER RH UNDER (PL1.1.11)	3 - 49
Removal 24 KIT RH COVER & FRAME ASSY (PL4.1.99)	3 - 50
Removal 25 KIT RH SOLENOID, GEAR & CLUTCH (PL4.2.99)	3 - 54
Removal 26 CAM MSI (PL4.2.16)	3 - 58
Removal 27 COVER ASSY RH (PL4.1.31)	3 - 64
Removal 28 SEPARATOR ASSY MSI (PL3.1.7)	3 - 68
Removal 29 FEEDER ASSY (PL3.2.1)	3 - 70
Removal 30 KIT PLATE ASSY ESS (PL10.1.99)	3 - 74
Removal 31 KIT PWBA MCU (PL10.2.99)	3 - 76
Removal 32 FAN ASSY LVPS (PL10.1.9)	3 - 78
Removal 33 PLATE ASSY LVPS POWER (PL10.1.12)	3 - 80
Removal 34 COVER LH ASSY (PL1.3.2)	3 - 82
Removal 35 COVER ASSY INNER FRONT (PL1.2.6)	3 - 84
Removal 36 SWITCH (Front Cover Switch) (PL1.2.3)	3 - 85
Removal 37 COVER FR UNDER (PL8.1.16)	3 - 86
Removal 38 PWBA HVPS (PL5.2.3)	3 - 88
Removal 39 KIT ROS ASSY (PL5.2.99)	3 - 92

Chapter 3 Removal and Replacement Procedures (RRPs) CONTENTS

Removal 40 BOX ASSY ESS PWB (PL10.1.1)	3 - 94
Removal 41 DRIVE ASSY SNS (FC) (PL9.2.1).....	3 - 98
Removal 42 BOX ASSY LVPS (PL10.2.1).....	3 - 100
Removal 43 KIT INTERLOCK SWITCH RH (PL4.1.96)	3 - 104
Removal 44 COVER ASSY TOP (PL1.1.3)	3 - 110
Removal 45 KIT CONSOLE PANEL & HARNESS (PL1.1.99)	3 - 114
Removal 46 PROCON ASSY (PL5.3.1).....	3 - 118
Removal 47 KIT CHUTE ASSY EXIT (PL7.2.99)	3 - 122
Removal 48 DRIVE ASSY EXIT (PL7.1.1)	3 - 126
Removal 49 CONNECTOR ASSY CRUM (Toner CRUM) (Y), (M), (C), (K) (PL6.1.10).....	3 - 130
Removal 50 DISP ASSY (Y), (M), (C), (K) (PL6.1.5~6.1.8).....	3 - 132
Removal 51 LAMP ASSY ERASE (PL5.1.2)	3 - 134
Removal 52 HARNESS ASSY I/L FRT (PL1.2.1).....	3 - 138
Removal 53 DRIVE ASSY SNS (K) (PL9.2.1)	3 - 142
Removal 54 DRIVE ASSY FSR (PL9.1.1)	3 - 144
Removal 55 DRIVE ASSY IBT (PL9.1.3).....	3 - 148
Removal 56 DRIVE ASSY PH (PL9.1.4)	3 - 152
Removal 57 KIT LINK XERO DRIVE (PL9.2.98)	3 - 156
Removal 58 BOX ASSY MCU (PL10.2.15).....	3 - 160
Removal 59 DRIVE ASSY DEVE (PL9.2.9).....	3 - 164
Removal 60 DRIVE ASSY DEVE K (PL9.2.10)	3 - 166
Removal 61 KIT DRIVE GEAR (PL9.2.99)	3 - 168
Removal 62 CONNECTOR ASSY CRUM (XERO CRUM) (Y), (M), (C), (K) (PL5.2.4).....	3 - 172
Removal 63 HDD ASSY (PL10.1.23).....	3 - 177
Removal 64 MEMORY CARD (PL10.1.24).....	3 - 178
Removal 65 WIRELESS ADAPTER (PL10.1.25)	3 - 179
Removal 66 KIT FEEDER ASSY 550 (PL12.1.99)	3 - 180
Removal 67 KIT FEED ROLL & SEPARATOR ROLL (FEEDER ASSY 550) (PL12.4.99).....	3 - 182
Removal 68 KIT FEEDER ASSY 1100 (PL13.1.99)	3 - 184
Removal 69 KIT FEED ROLL & SEPARATOR ROLL (FEEDER ASSY 1100) (PL13.5.99).....	3 - 186
3. Replacement Steps	3 - 188
Replacement 1 CONNECTOR ASSY CRUM (XERO CRUM) (Y), (M), (C), (K) (PL5.2.4).....	3 - 188
Replacement 2 KIT DRIVE GEAR (PL9.2.99)	3 - 192
Replacement 3 DRIVE ASSY DEVE K (PL9.2.10)	3 - 195
Replacement 4 DRIVE ASSY DEVE (PL9.2.9).....	3 - 196
Replacement 5 BOX ASSY MCU (PL10.2.15).....	3 - 198
Replacement 6 KIT LINK XERO DRIVE (PL9.2.98)	3 - 200
Replacement 7 DRIVE ASSY PH (PL9.1.4)	3 - 204
Replacement 8 DRIVE ASSY IBT (PL9.1.3).....	3 - 206
Replacement 9 DRIVE ASSY FSR (PL9.1.1)	3 - 208
Replacement 10 DRIVE ASSY SNS (K) (PL9.2.1)	3 - 210
Replacement 11 HARNESS ASSY I/L FRT (PL1.2.1)	3 - 212
Replacement 12 LAMP ASSY ERASE (PL5.1.2)	3 - 214
Replacement 13 DISP ASSY (Y), (M), (C), (K) (PL6.1.5~6.1.8).....	3 - 216
Replacement 14 CONNECTOR ASSY CRUM (Toner CRUM) (Y), (M), (C), (K) (PL6.1.10).....	3 - 217

Chapter 3 Removal and Replacement Procedures (RRPs) CONTENTS

Replacement 15 DRIVE ASSY EXIT (PL7.1.1)	3 - 218
Replacement 16 KIT CHUTE ASSY EXIT (PL7.2.99)	3 - 220
Replacement 17 PROCON ASSY (PL5.3.1).....	3 - 222
Replacement 18 KIT CONSOLE PANEL & HARNESS (PL1.1.99)	3 - 224
Replacement 19 COVER ASSY TOP (PL1.1.3)	3 - 226
Replacement 20 KIT INTERLOCK SWITCH RH (PL4.1.96)	3 - 228
Replacement 21 BOX ASSY LVPS (PL10.2.1).....	3 - 232
Replacement 22 DRIVE ASSY SNS (FC) (PL9.2.1).....	3 - 234
Replacement 23 BOX ASSY ESS PWB (PL10.1.1)	3 - 236
Replacement 24 KIT ROS ASSY (PL5.2.99)	3 - 240
Replacement 25 PWBA HVPS (PL5.2.3).....	3 - 242
Replacement 26 COVER FR UNDER (PL8.1.16).....	3 - 244
Replacement 27 SWITCH (Front Cover Switch) (PL1.2.3).....	3 - 245
Replacement 28 COVER ASSY INNER FRONT (PL1.2.6).....	3 - 246
Replacement 29 COVER LH ASSY (PL1.3.2).....	3 - 248
Replacement 30 PLATE ASSY LVPS POWER (PL10.1.12)	3 - 250
Replacement 31 FAN ASSY LVPS (PL10.1.9).....	3 - 252
Replacement 32 KIT PWBA MCU (PL10.2.99).....	3 - 254
Replacement 33 KIT PLATE ASSY ESS (PL10.1.99)	3 - 256
Replacement 34 FEEDER ASSY (PL3.2.1).....	3 - 260
Replacement 35 SEPARATOR ASSY MSI (PL3.1.7).....	3 - 264
Replacement 36 COVER ASSY RH (PL4.1.31)	3 - 266
Replacement 37 CAM MSI (PL4.2.16).....	3 - 270
Replacement 38 KIT RH SOLENOID, GEAR & CLUTCH (PL4.2.99)	3 - 274
Replacement 39 KIT RH COVER & FRAME ASSY (PL4.1.99).....	3 - 278
Replacement 40 COVER RH UNDER (PL1.1.11)	3 - 281
Replacement 41 CHUTE ASSY INVERT (PL7.3.1).....	3 - 282
Replacement 42 COVER ASSY TOP EXIT (PL1.1.9)	3 - 283
Replacement 43 COVER ASSY REAR (PL1.3.5).....	3 - 284
Replacement 44 KIT COVER ASSY MSI (PL4.1.98).....	3 - 285
Replacement 45 COVER FRONT RH (PL1.2.5).....	3 - 286
Replacement 46 COVER ASSY TOP ADD TRAY (Reference only)	3 - 288
Replacement 47 HOLDER ASSY SENSOR LOW (PL3.1.2)	3 - 290
Replacement 48 SWITCH ASSY SIZE (PL3.1.1)	3 - 291
Replacement 49 COVER TRAY (PL2.1.39).....	3 - 292
Replacement 50 KIT FEED ROLL & SEPARATOR ROLL (PL2.1.99)	3 - 294
Replacement 51 ROLL ASSY FEED MSI (PL4.2.21)	3 - 296
Replacement 52 KIT ACTUATOR INTLK RH (PL4.1.97)	3 - 298
Replacement 53 FAN FUSER (PL4.1.8).....	3 - 300
Replacement 54 KIT MSI SEPARATOR ROLL (PL3.1.99)	3 - 302
Replacement 55 KIT ROLL ASSY 2ND BTR (PL4.4.99)	3 - 303
Replacement 56 FUSER ASSY (PL7.1.5)	3 - 304
Replacement 57 KIT FRAME ASSY 2ND (PL8.1.99).....	3 - 305
Replacement 58 XERO DEVE CRU ASSY (Y), (M), (C), (K) (PL5.1.8~5.1.11).....	3 - 306
Replacement 59 KIT BELT ASSY IBT (PL5.1.99)	3 - 308
Replacement 60 WASTE TONER BOX (PL6.1.13).....	3 - 311



Chapter 3 Removal and Replacement Procedures (RRPs) CONTENTS

Replacement 61 STRAP COVER FRONT (PL1.2.18).....	3 - 312
Replacement 62 COVER ASSY FRONT (PL1.2.17)	3 - 313
Replacement 63 WIRELESS ADAPTER (PL10.1.25)	3 - 314
Replacement 64 MEMORY CARD (PL10.1.24).....	3 - 315
Replacement 65 HDD ASSY (PL10.1.23).....	3 - 316
Replacement 66 KIT FEED ROLL & SEPARATOR ROLL (FEEDER ASSY 550) (PL12.4.99).....	3 - 318
Replacement 67 KIT FEEDER ASSY 550 (PL12.1.99)	3 - 320
Replacement 68 KIT FEED ROLL & SEPARATOR ROLL (FEEDER ASSY 1100) (PL13.5.99).....	3 - 322
Replacement 69 KIT FEEDER ASSY 1100 (PL13.1.99)	3 - 324

1. Removal and Replacement Procedures (RRPs)

1.1 Before Starting Service Procedure

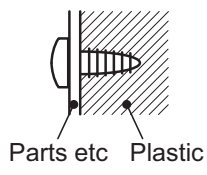
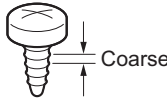
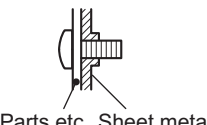
- Start the procedure after turning off the power, and removing the power cord from the outlet.
- When performing the service operation around the FUSER ASSY, ensure that the FUSER ASSY and its surrounding area have cooled down sufficiently.
- Do not apply excessive force to parts to avoid functional damage.
- Since various types of screws are used, ensure that the right screws are used in their right positions. Use special caution not to confuse the screws for plastic and the ones for sheet metal, because using the wrong type of screw may result in damage to the screw threads or other troubles.

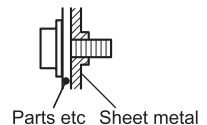
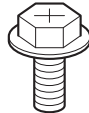
No.	Type	Application	Shape	How to Distinguish	Points to Be Noted	Major Location
1	<ul style="list-style-type: none"> • Screw for plastic • Silver, tapping 	Plastic  Parts etc Plastic	 Coarse	<ul style="list-style-type: none"> • Silver-colored. • The thread is coarser than that of the sheet metal type. • The thread is tapered toward the tip. 	<ul style="list-style-type: none"> • Oblique screwing damages the thread because this screw cuts female threads in the base material as it rotates. 	
2	<ul style="list-style-type: none"> • Screw for metal sheet • Silver 	Sheet metal  Parts etc Sheet metal		<ul style="list-style-type: none"> • Silver-colored. • The thread is parallel. 		
3	<ul style="list-style-type: none"> • Screw for metal sheet • Silver, with a flange 	Sheet metal  Parts etc Sheet metal		<ul style="list-style-type: none"> • Silver-colored • It has a flange. • Diameter of the thread section is uniform. 		

- Wear a wristband or the like wherever possible to remove electrostatic buildup from your body.
- Keep the front cover closed. Buzzer goes off when the machine is left powered on with the front cover open for five minutes or longer, to prevent the drum deterioration due to exposure to light.
- When opening the front door in a removal/replacement operation, cover the drum to keep it from being exposed to light.
- Remove the TRAY ASSY, BELT ASSY, 2ND BTR, DRUM CARTRIDGE, TONER CARTRIDGE, WASTE TONER BOX, and FUSER, and put them in a place where they do not affect the procedure. (Note that the service procedures can be performed with those parts in place depending on the target section of removal/replacement.).

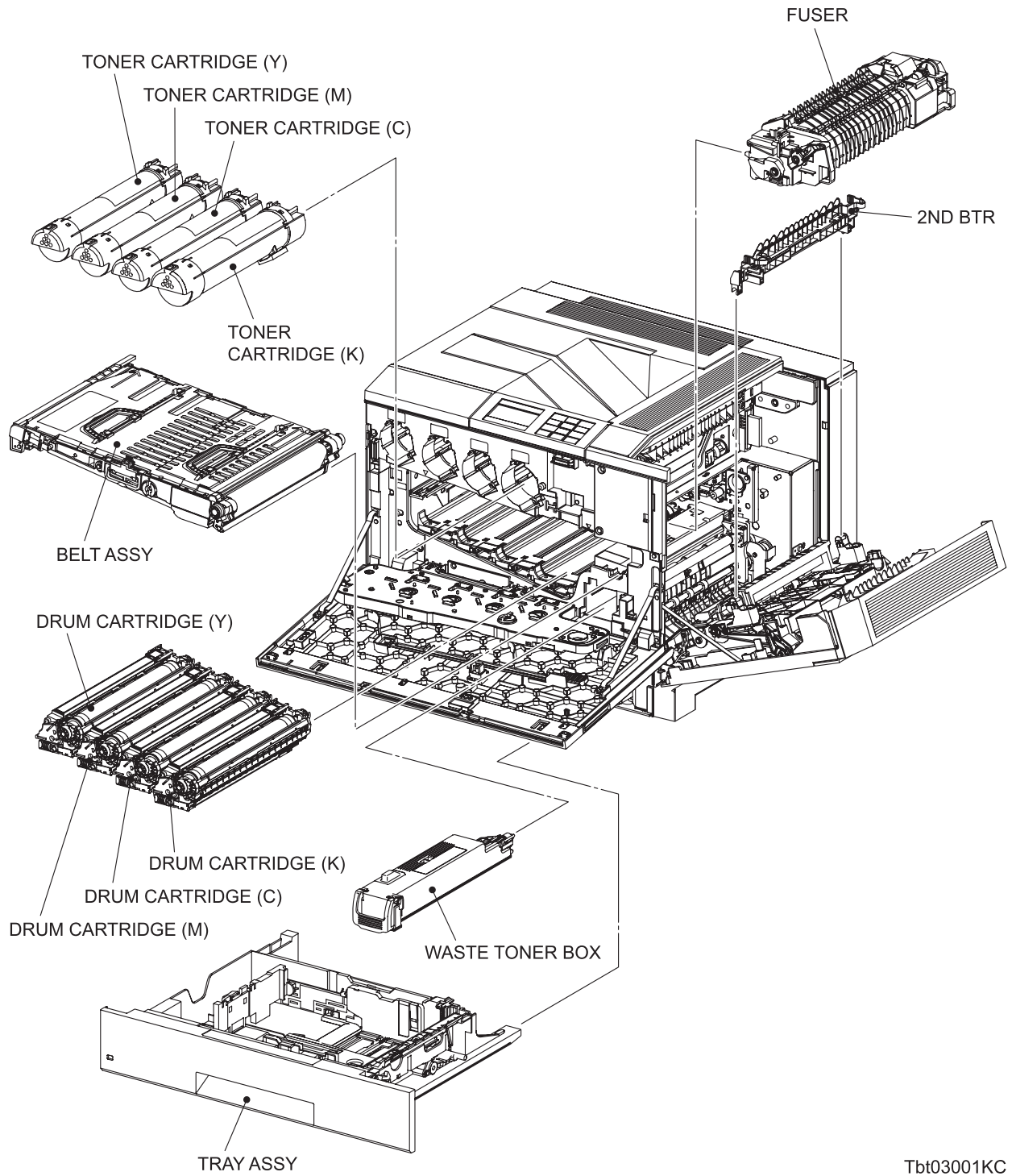

Tbt03001KC

1.2 General Notes

- The string "(PL X.Y.Z)" appended to the part name in the procedure denotes that the part corresponds to the plate (PL) "X.Y", item "Z" of the Engineering Parts list, and its shape and fitting position can be checked in the Engineering Parts list.
- Directional descriptions used in the procedures are defined as follows:
 - Front : Direction toward you when facing the front of the printer.
 - Rear : Direction opposite to the front when facing the front of the printer.
 - Left : Left-hand direction when facing the front of the printer.
 - Right : Right-hand direction when facing the front of the printer.

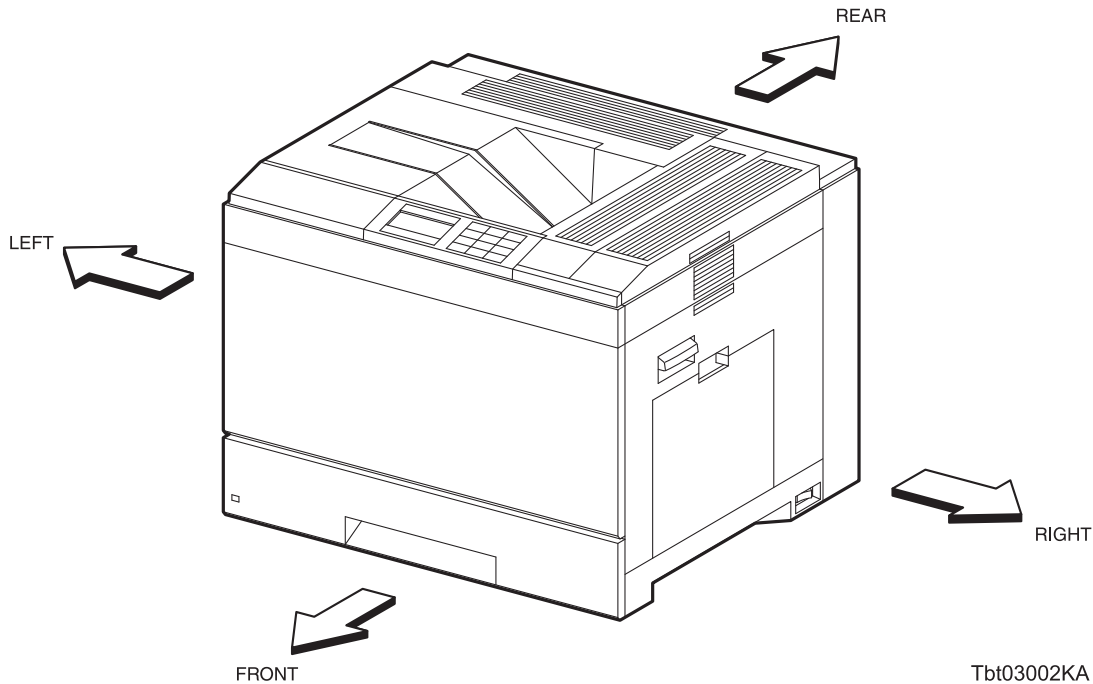

Fig.: Directions Regarding the Printer

- The string "(RRP X.Y)" that appears in or at the end of the procedure denotes that the related service procedure is described in [RRP X.Y].
- Unless otherwise specified, use a Phillips-head screwdriver to remove the screws shown in the illustrations.
- Black arrows shown in the illustrations denote moving directions. The numbers assigned to these arrows refer to the order in the procedure.
- Refer to [Chapter 4 Plug/Jack (P/J) Connector Locations] for the positions of connectors (P/J).

Removal Flows

The components not connected with arrows in the flow below can be removed independently.

Removal FLOW (Removal 1~20)

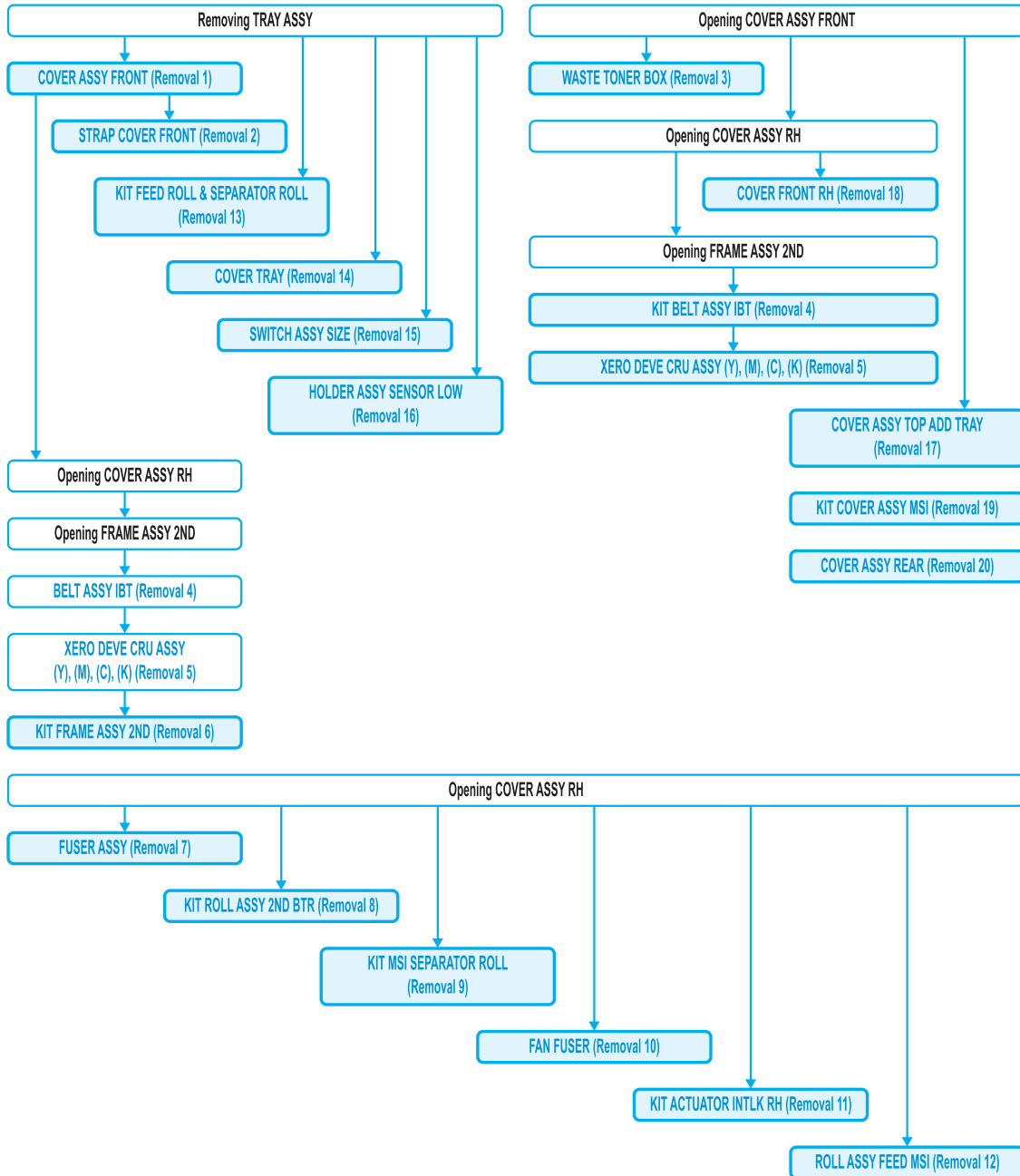

Removal FLOW (Removal 21~34)

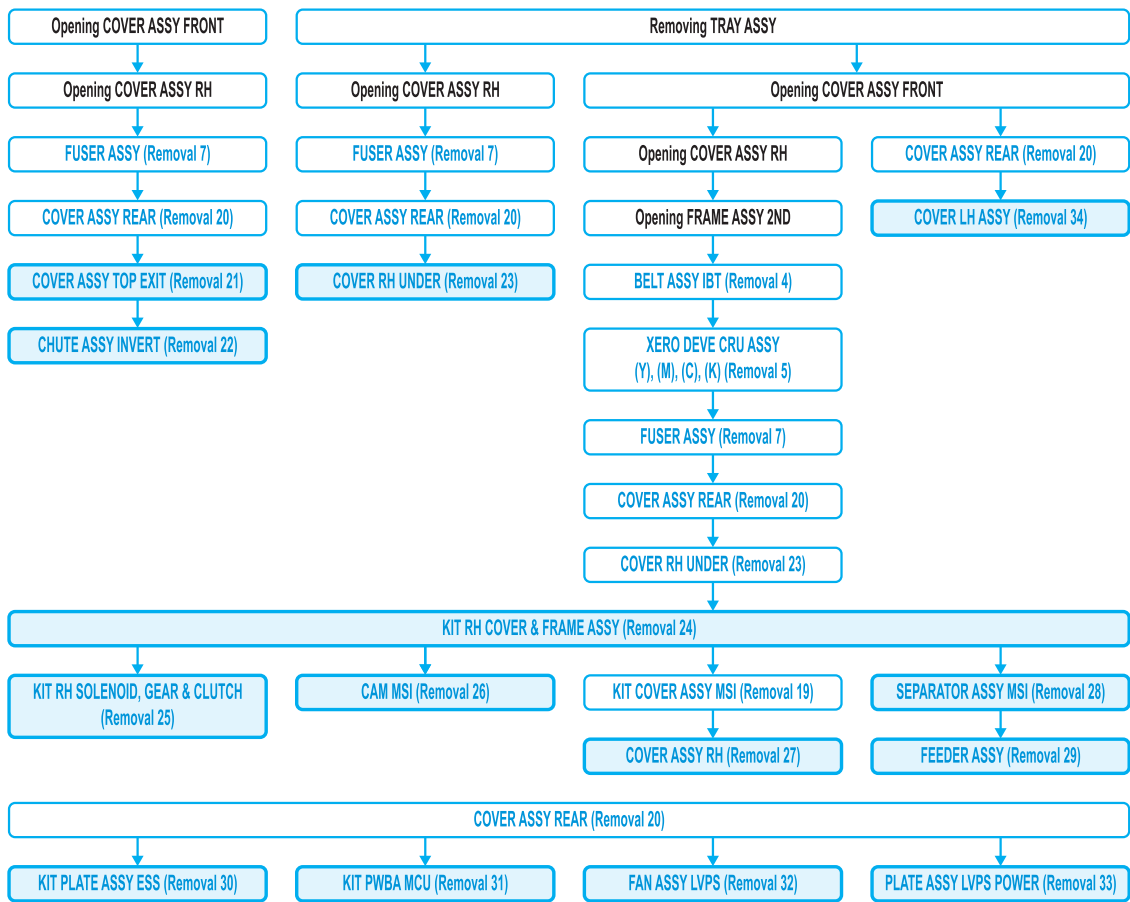

Removal FLOW (Removal 35~43)

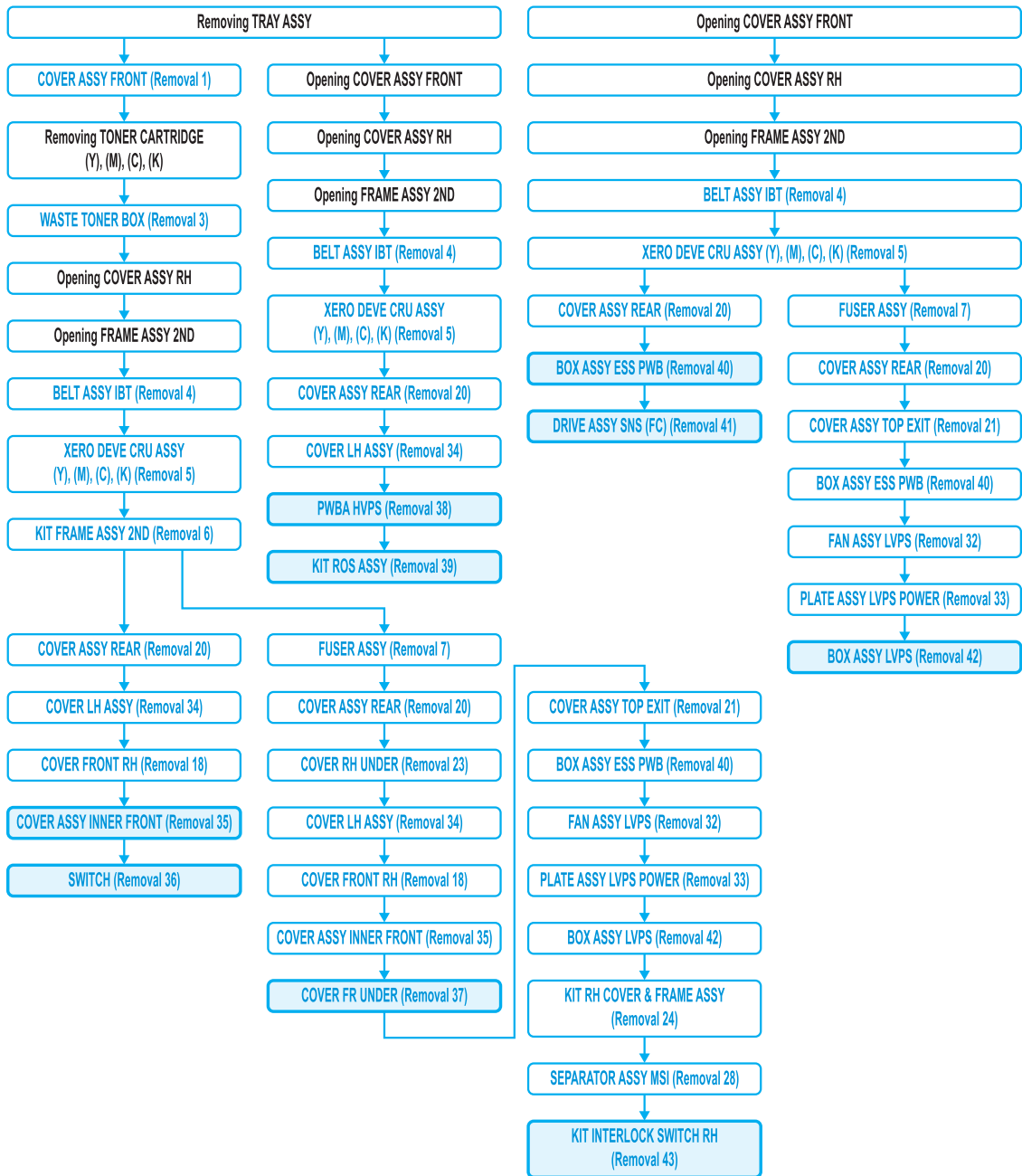

Removal FLOW (Removal 44~52)

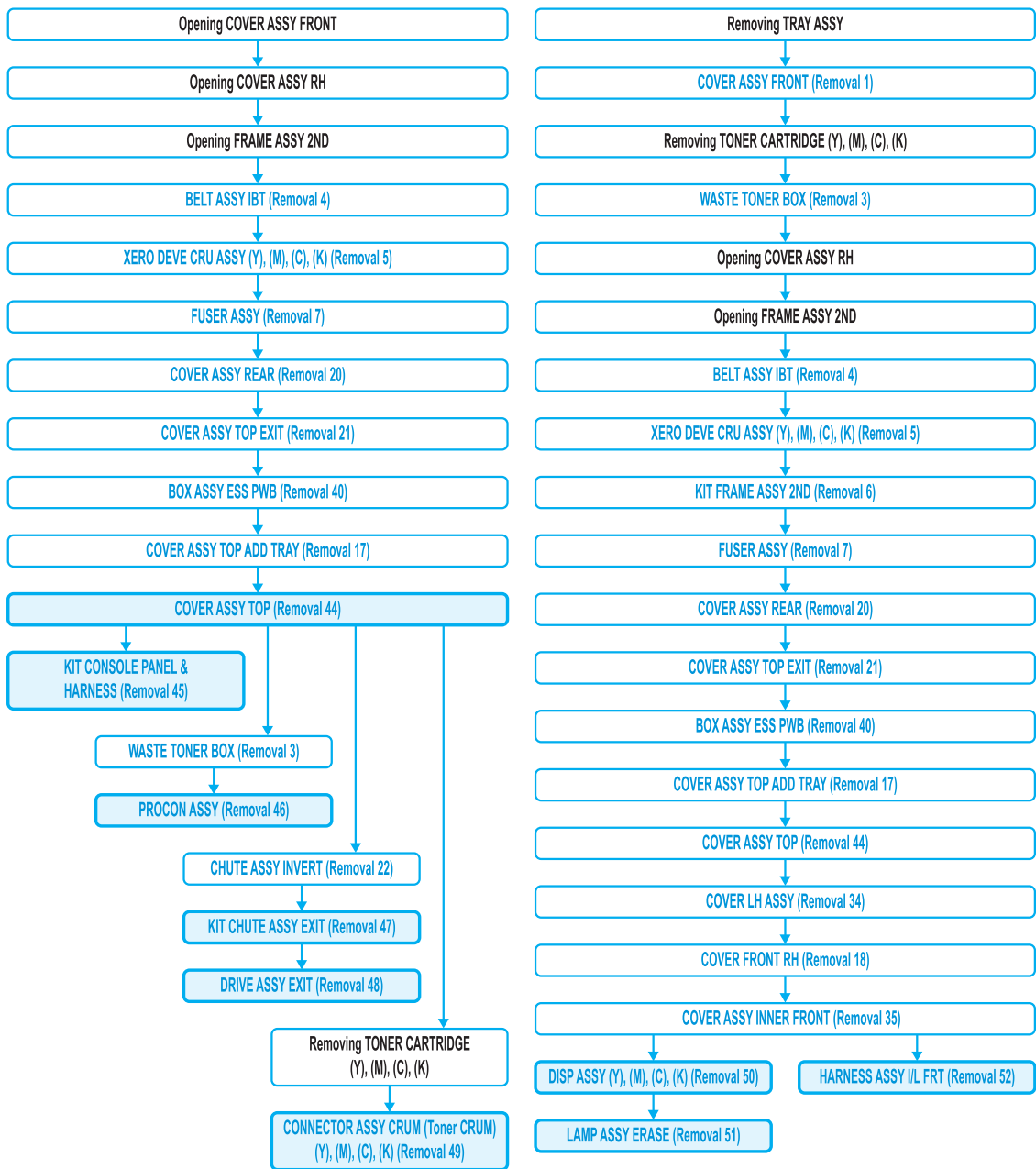

Removal FLOW (Removal 53~62)

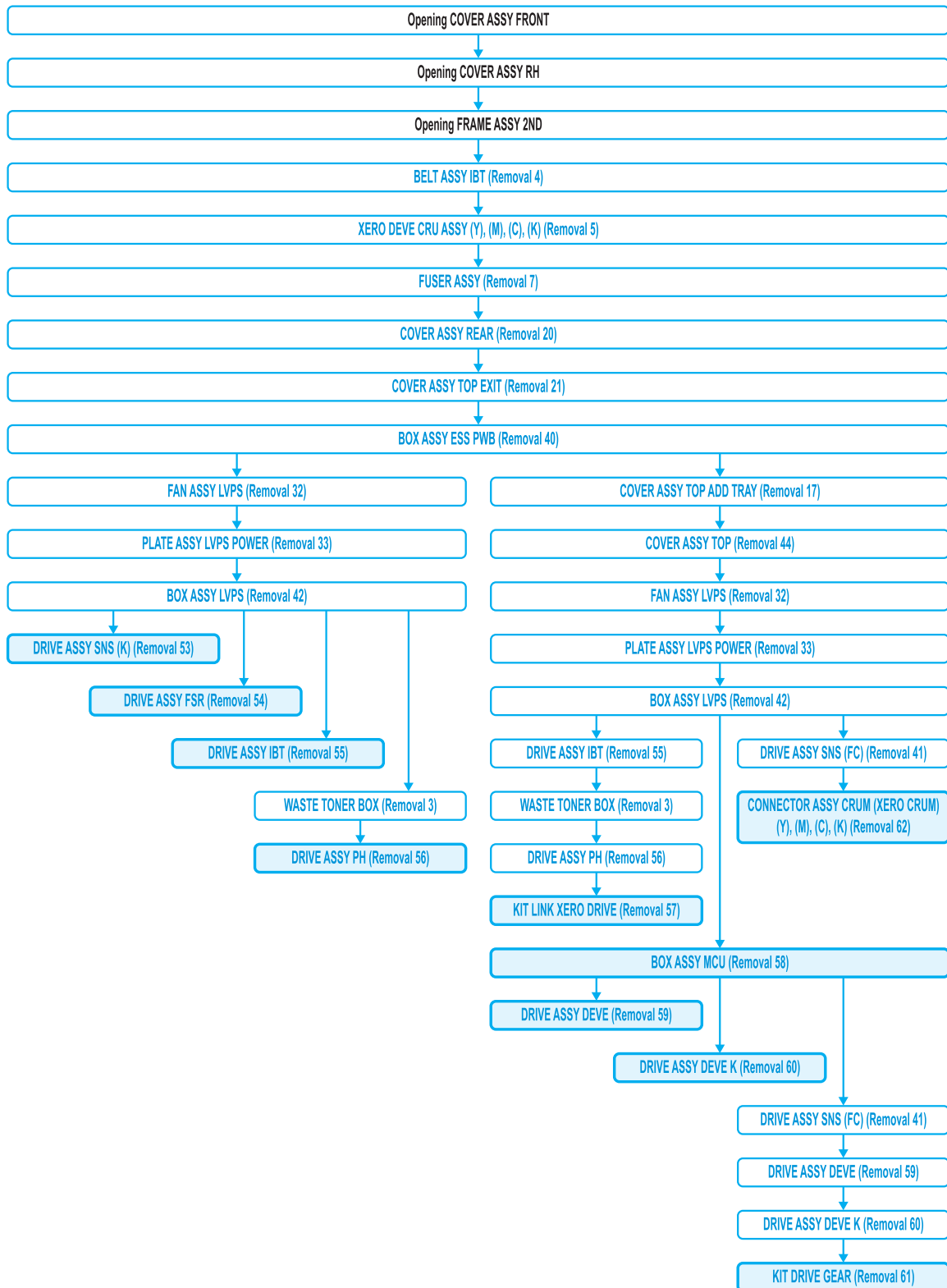

Removal FLOW (Removal 63~69)

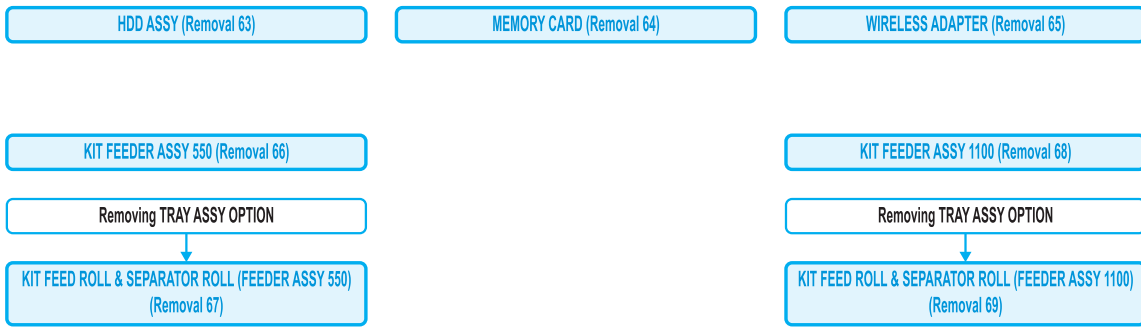

Replacement Flows

The components not connected with arrows in the flow below can be replaced independently.

Replacement FLOW (Replacement 1~10)

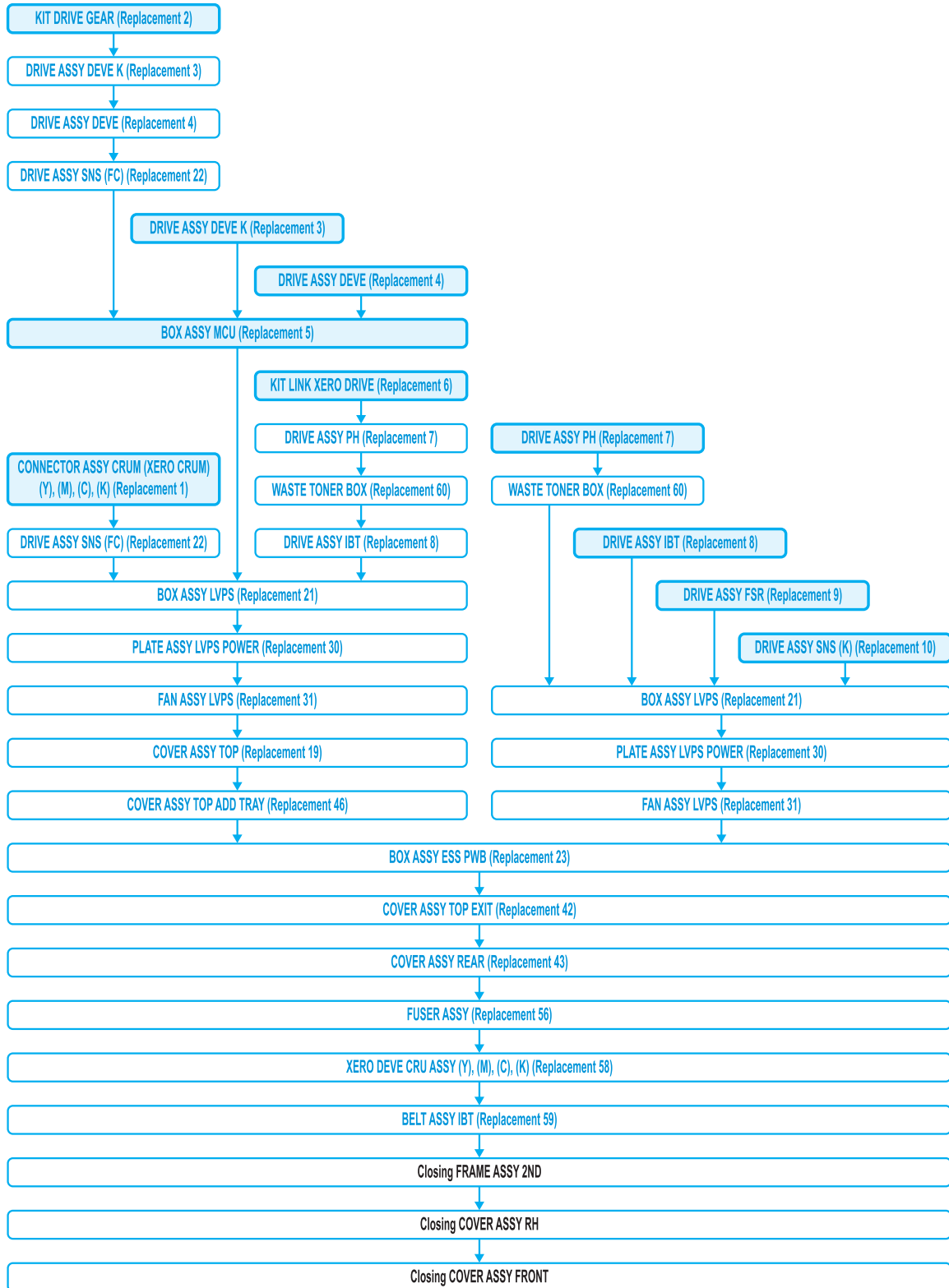

Replacement FLOW (Replacement 11~19)

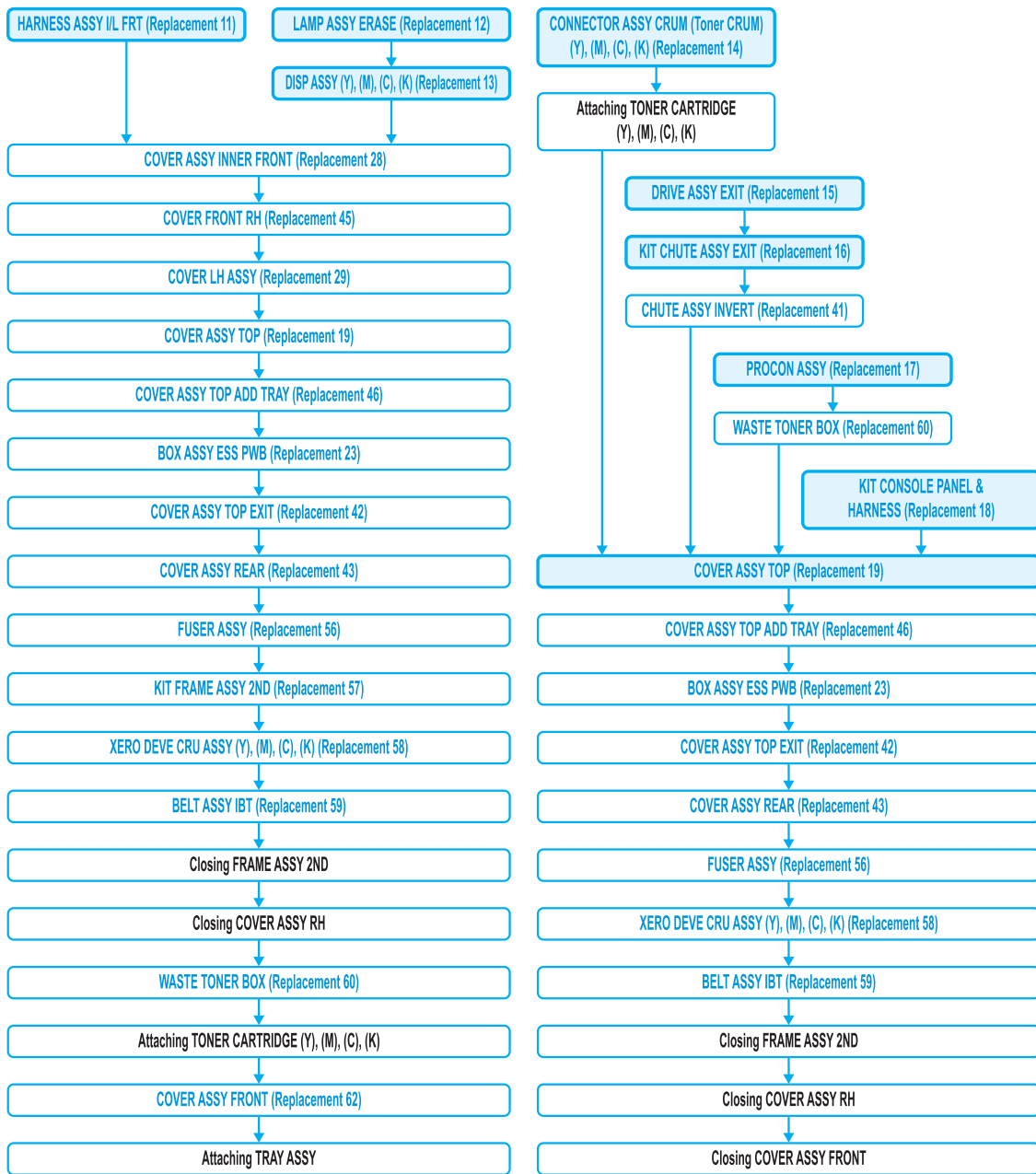

Replacement FLOW (Replacement 20~28)

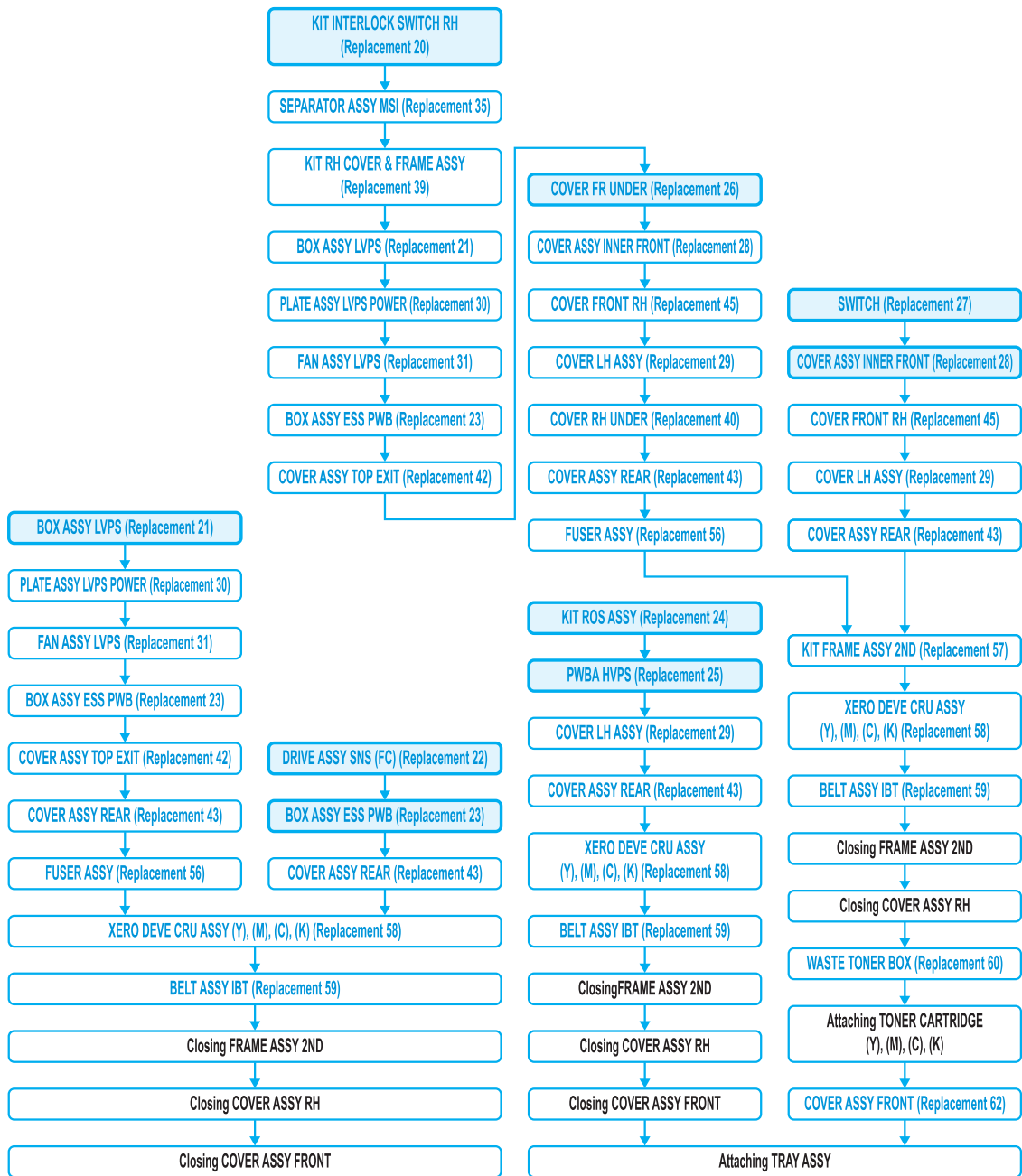

Replacement FLOW (Replacement 43~62)

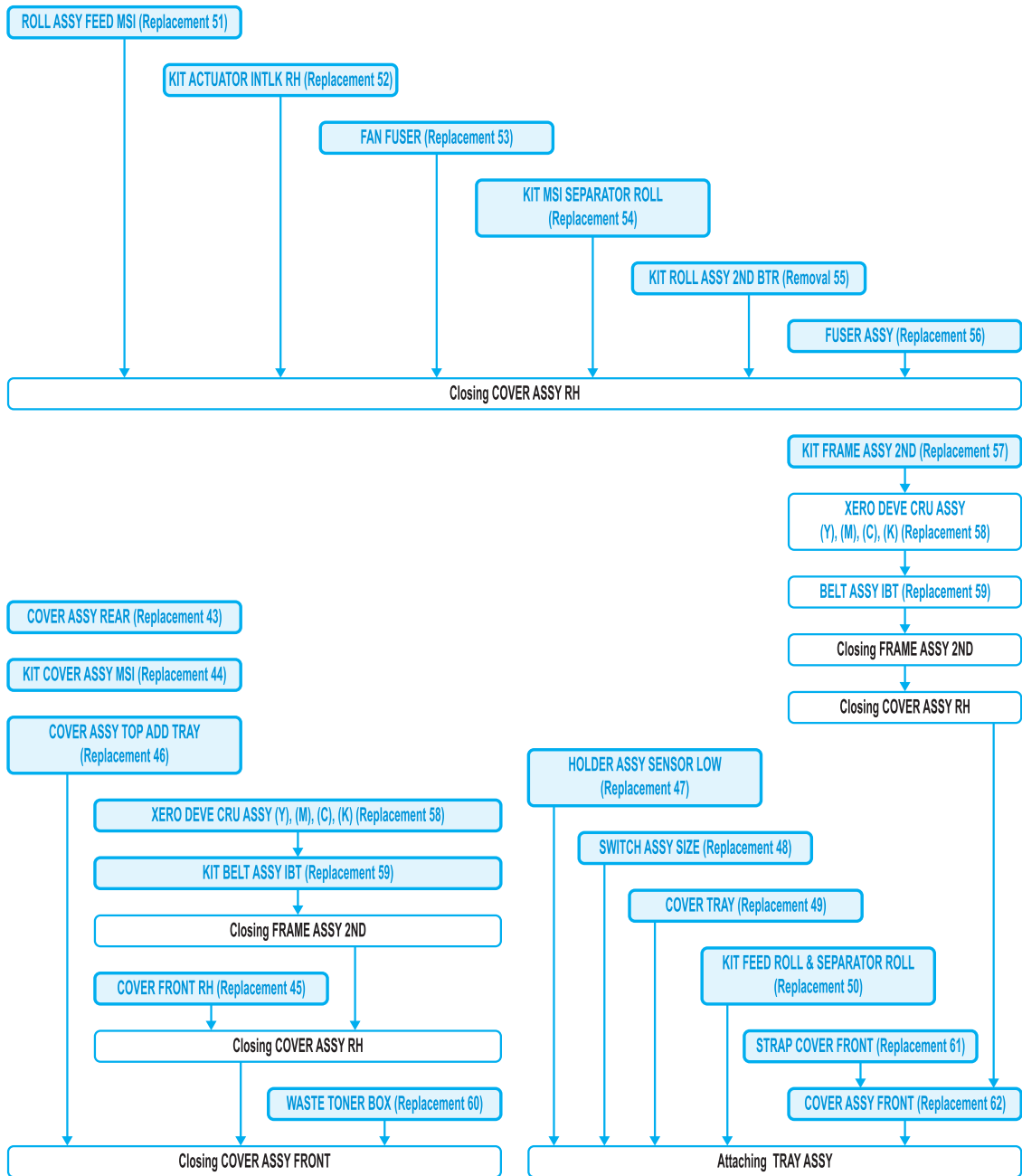

Replacement FLOW (Replacement 63~69)

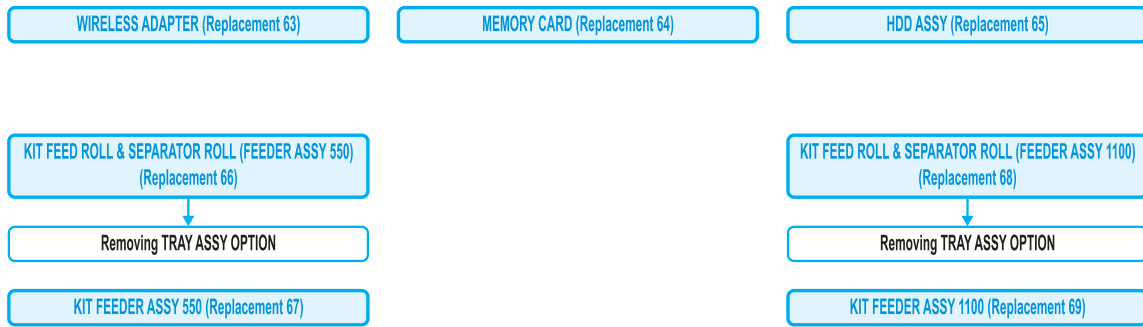

2. Removal Steps

Removal 1 COVER ASSY FRONT (PL1.2.17)

In the following steps, the details of Steps 1 and 2 are omitted because they are described earlier in this chapter. Go to the steps in parentheses to execute the necessary steps, and then go to Step 3 onward.

- 1) Remove the TRAY ASSY (PL2.1.1) from the printer.
- 2) Open the COVER ASSY FRONT (PL1.2.17).

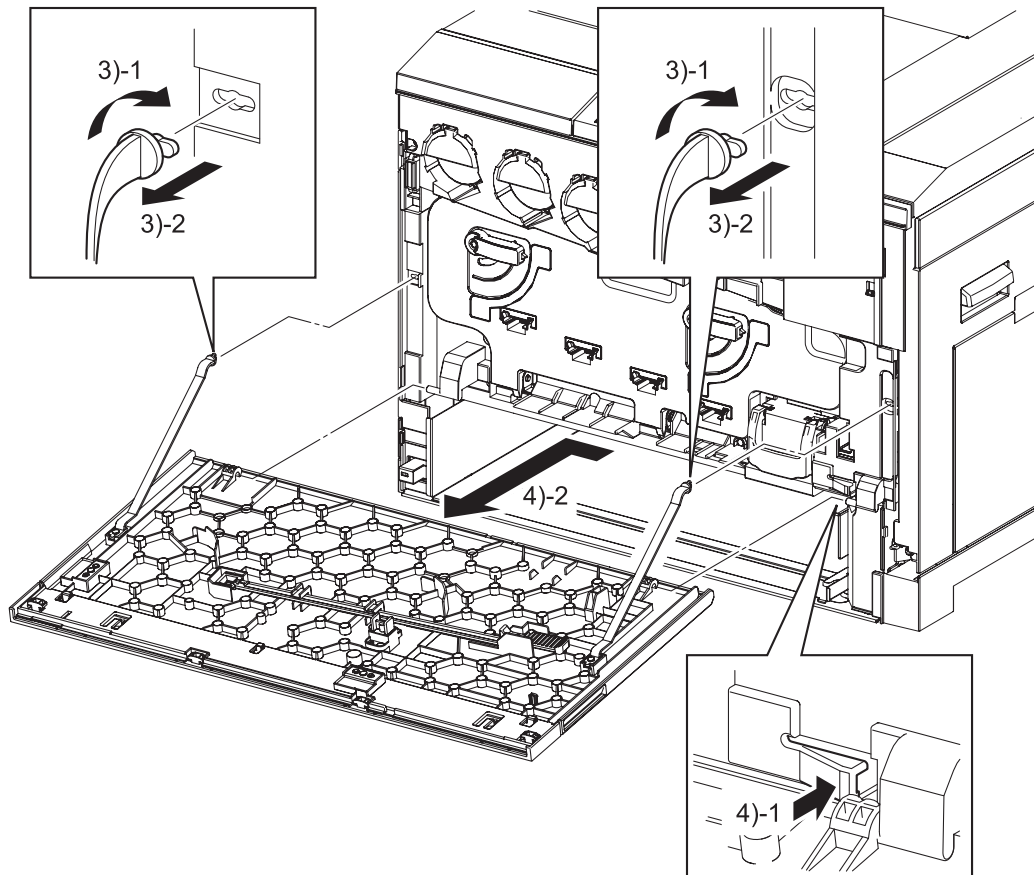

Tbt03003KB

NOTE

When performing the following step, use caution not to drop the COVER ASSY FRONT.

- 3) Remove the STRAP COVER FRONT (PL1.2.18) from the COVER INNER FRONT (PL1.2.7) by rotating the COVER INNER FRONT side of the two STRAP COVERs FRONT; one on the right and the other on the left, by 90 degrees to align the tab of the STRAP COVER FRONT with the notch in the COVER INNER FRONT.
- 4) Release the hook of the COVER INNER FRONT, and then slide the COVER ASSY FRONT to the left to remove the COVER ASSY FRONT from the printer.

Removal 2 STRAP COVER FRONT (PL1.2.18)

In the following steps, the details of Steps 1 and 2 are omitted because they are described earlier in this chapter. Go to the steps in parentheses to execute the necessary steps, and then go to Step 3 onward.

- 1) Remove the TRAY ASSY (PL2.1.1) from the printer.
- 2) Remove the COVER ASSY FRONT. (Removal 1)

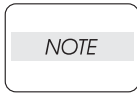

The removal step of the STRAP COVER FRONT described below is common to the left and right parts.

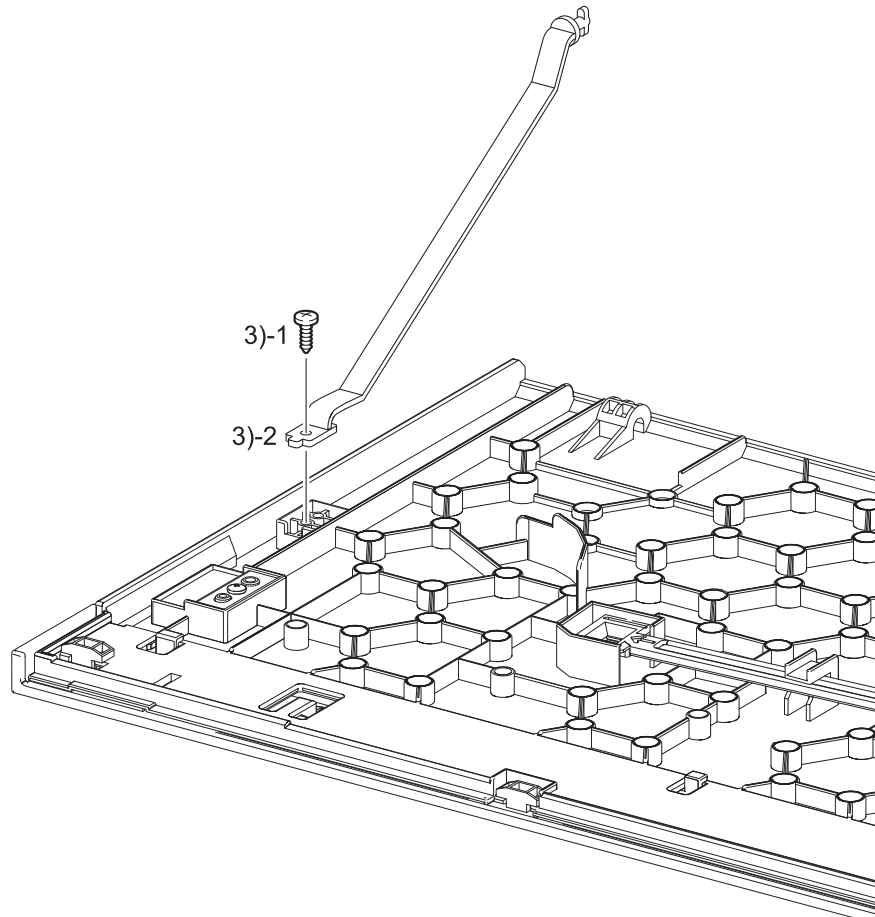

Tbt03202KA

- 3) Remove the STRAP COVER FRONT (PL1.2.18) from the COVER ASSY FRONT (PL1.2.17) by removing the one screw (silver, tapping, 8mm).

Removal 3 WASTE TONER BOX (PL6.1.13)

- 1) Open the COVER ASSY FRONT (PL1.2.17).

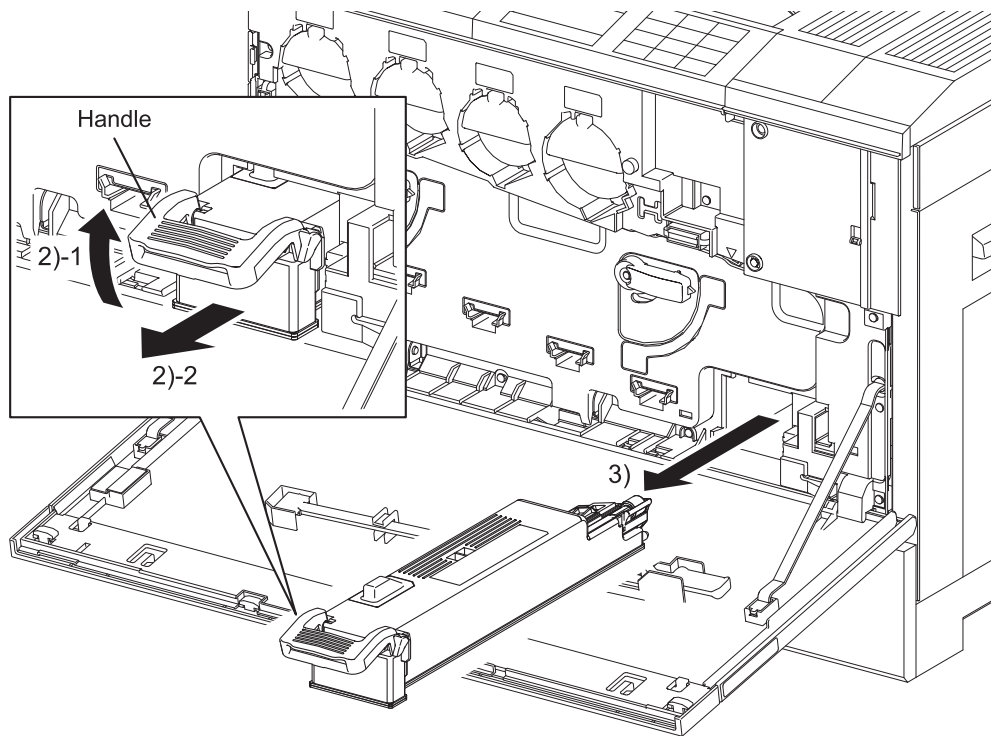

Tbt03004KA

- 2) Raise the handle of the WASTE TONER BOX (PL6.1.3) to unlock.
- 3) Holding the handle, pull the WASTE TONER BOX out of the printer.

Blank Page

Removal 4 KIT BELT ASSY IBT (PL5.1.99)

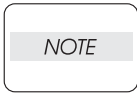

Place the BELT ASSY IBT in a safe place to prevent damage to its belt.

- 1) Open the COVER ASSY FRONT (PL1.2.17).
- 2) Open the COVER ASSY RH.
- 3) Unlock the handle of the FRAME ASSY 2ND (PL8.1.9) to open the FRAME ASSY 2ND.

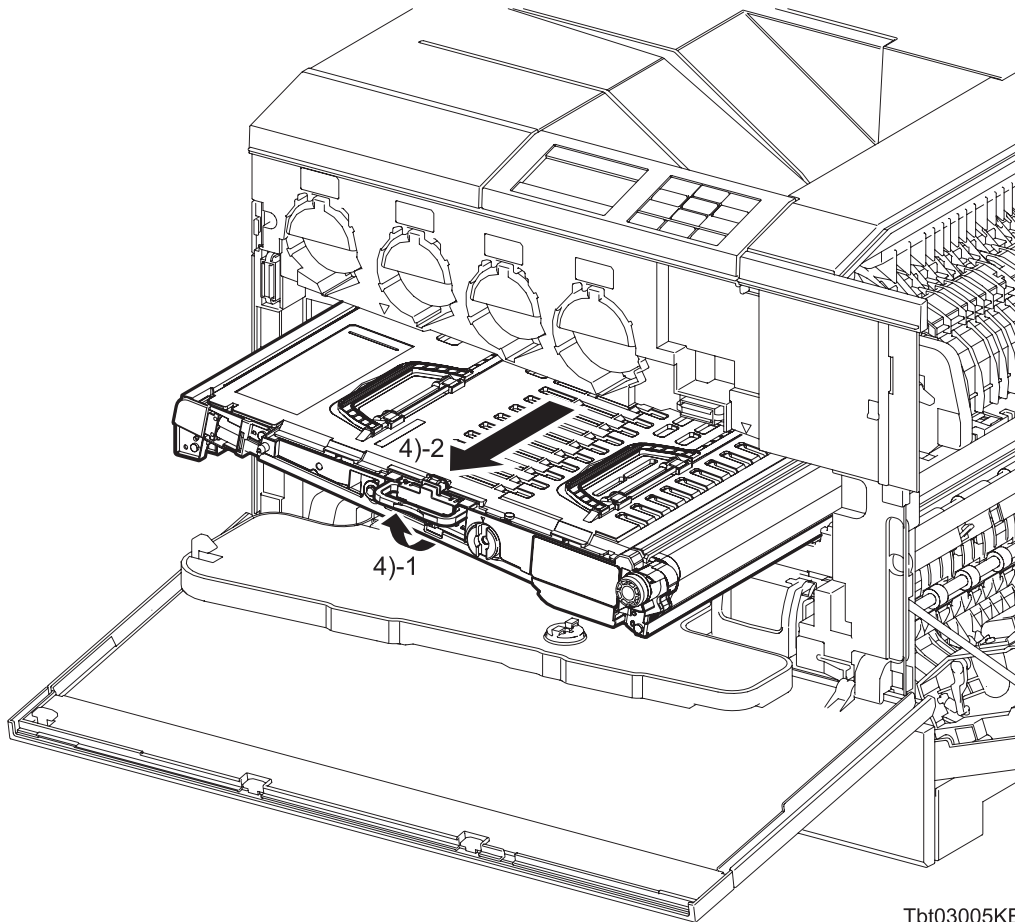

- 4) Holding the FRONT HANDLE of the BELT ASSY IBT (PL5.1.1), pull out the BELT ASSY IBT slowly until it will go no further.

Continues to the next page.

Removal 4 KIT BELT ASSY IBT (PL5.1.99)

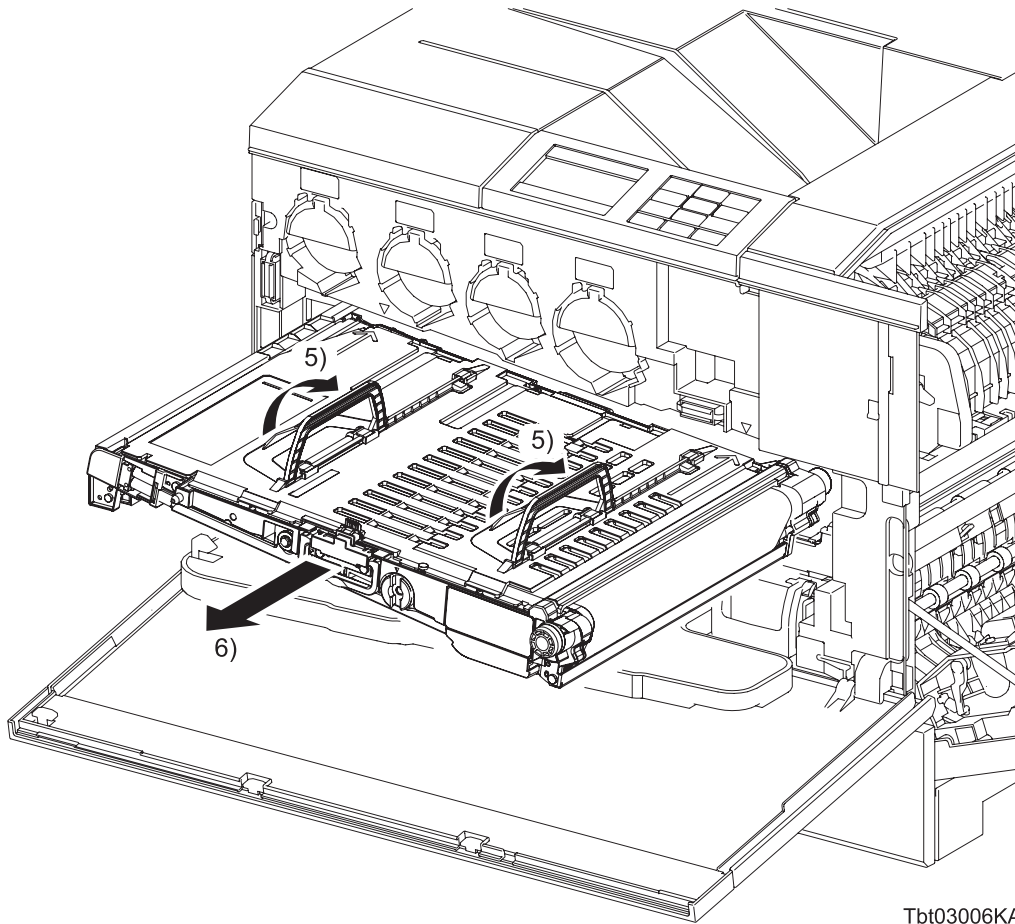

Tbt03006KA

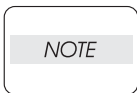

To keep the BELT ASSY IBT in position, be sure to hold the handle, taking care not to touch the belt with your hand.

- 5) Raise the right and left TOP HANDLEs of the BELT ASSY IBT.
- 6) Holding the TOP HANDLE, remove the BELT ASSY IBT from the printer.

Go to the next removal step:

Removal 5 XERO DEVE CRU ASSY (Y), (M), (C), (K) (PL5.1.8~5.1.11)

Removal 5 XERO DEVE CRU ASSY (Y), (M), (C), (K) (PL5.1.8~5.1.11)

NOTE

Described below is the removal procedure common among the four XERO DEVE CRU ASSY.

NOTE

Cover the drum of the XERO DEVE CRU ASSY to prevent damage by light.

In the following steps, the details of Steps 1 through 4 are omitted because they are described earlier in this chapter. Go to the steps in parentheses to execute the necessary steps, and then go to Step 5 onward.

- 1) Open the COVER ASSY FRONT (PL1.2.17).
- 2) Open the COVER ASSY RH.
- 3) Unlock the handle of the FRAME ASSY 2ND (PL8.1.9) to open the FRAME ASSY 2ND.

NOTE

Place the BELT ASSY IBT in a safe place to prevent damage to its belt.

- 4) Remove the BELT ASSY IBT. (Removal 4)

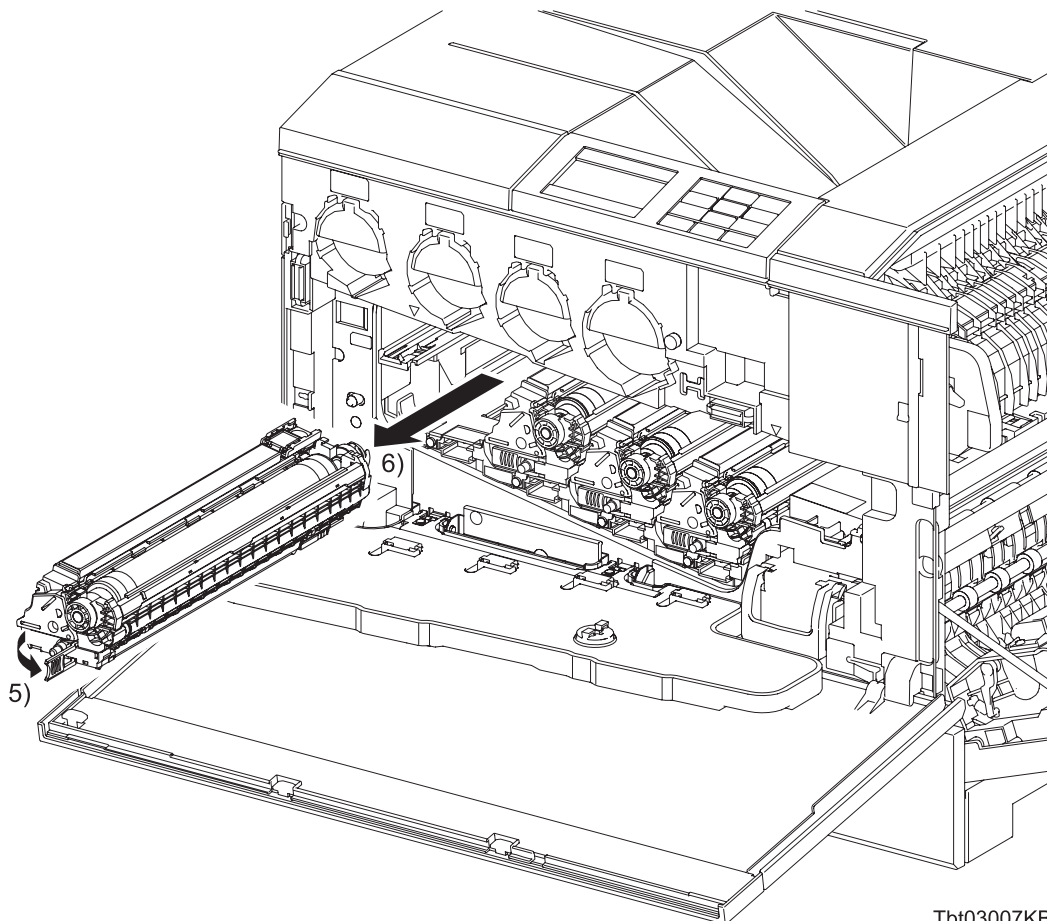

Tbt03007KB

- 5) Raise the handle of the XERO DEVE CRU ASSY.
- 6) Holding the handle, pull out the XERO DEVE CRU ASSY slowly to remove the XERO DEVE CRU ASSY from the printer.

Blank Page

Removal 6 KIT FRAME ASSY 2ND (PL8.1.99)

In the following steps, the details of Steps 1 through 6 are omitted because they are described earlier in this chapter. Go to the steps in parentheses to execute the necessary steps, and then go to Step 7 onward.

- 1) Remove the TRAY ASSY (PL2.1.1) from the printer.
- 2) Remove the COVER ASSY FRONT. (Removal 1)
- 3) Open the COVER ASSY RH.
- 4) Open the FRAME ASSY 2ND (PL8.1.9).

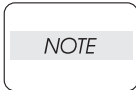

Place the BELT ASSY IBT in a safe place to prevent damage to its belt.

- 5) Remove the BELT ASSY IBT. (Removal 4)

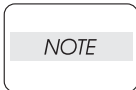

Cover the drum of the XERO DEVE CRU ASSY to prevent damage by light.

- 6) Remove the XERO DEVE CRU ASSY (Y), (M), (C), (K). (Removal 5)
- 7) Close the FRAME ASSY 2ND to lock the handle.

Continues to the next page.

Removal 6 KIT FRAME ASSY 2ND (PL8.1.99)

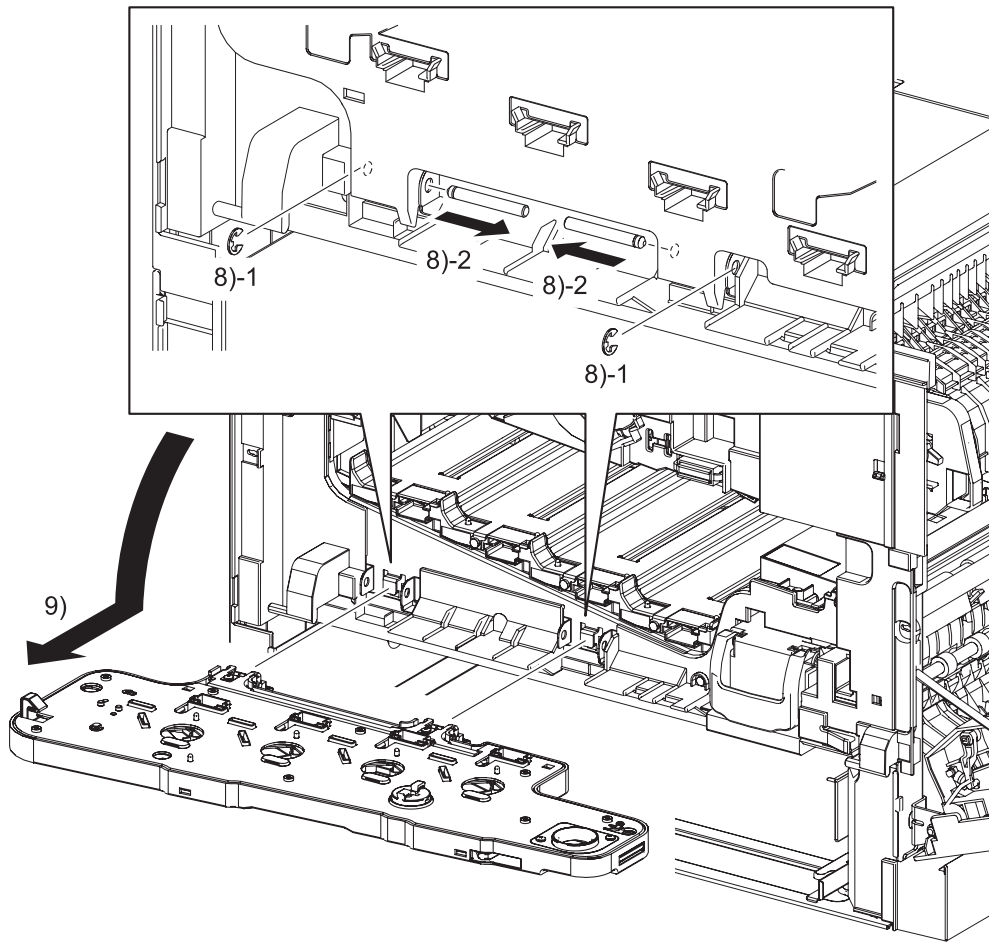

Tbt03008KA

- 8) Remove the E-rings that fix the right and left SHAFT PIVOT FRAMEs 2ND (PL8.1.15). Pull out the right and left SHAFT PIVOT FRAMEs 2ND respectively inward to remove them from the printer.
- 9) Unlock the handle, open the FRAME ASSY 2ND and remove the FRAME ASSY 2ND from the printer.

Removal 7 FUSER ASSY (PL7.1.5)

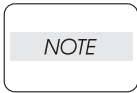

The FUSER section is very hot. Use extra caution not to burn yourself when performing the service operation.

- 1) Open the COVER ASSY RH.

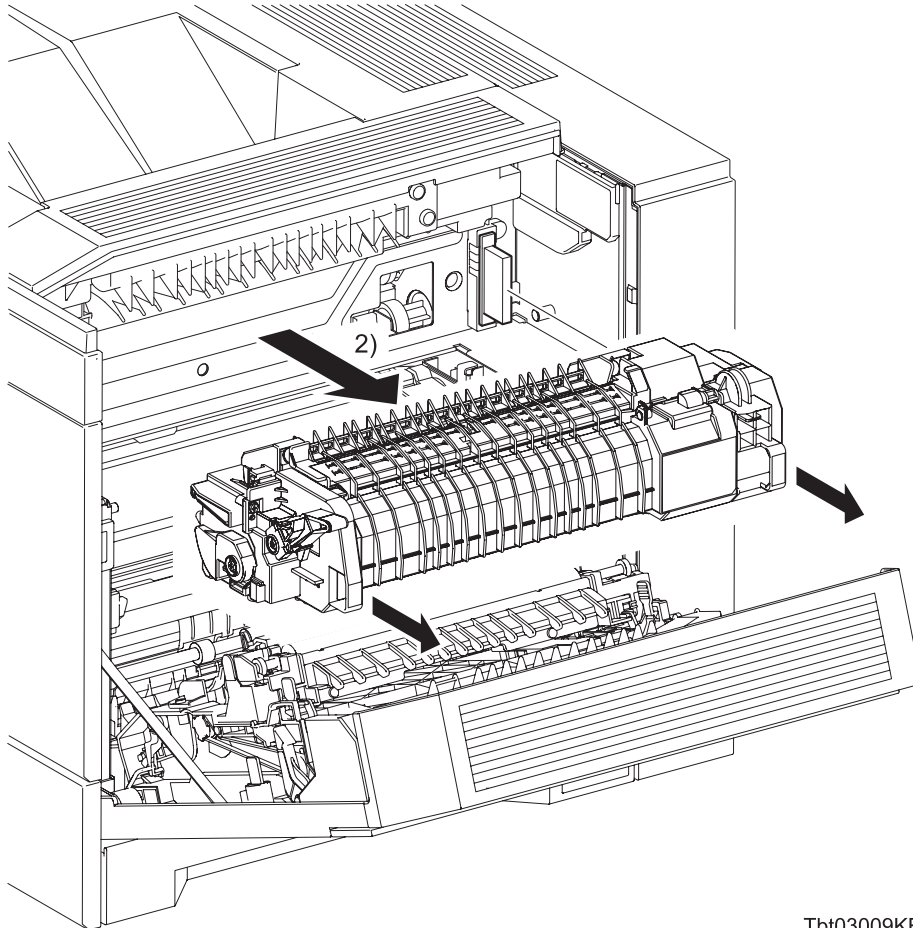

Tbt03009KB

- 2) Holding the front and rear handles of the FUSER ASSY, pull the FUSER ASSY toward you until it comes off the printer.

Removal 8 KIT ROLL ASSY 2ND BTR (PL4.4.99)

- 1) Open the COVER ASSY RH.

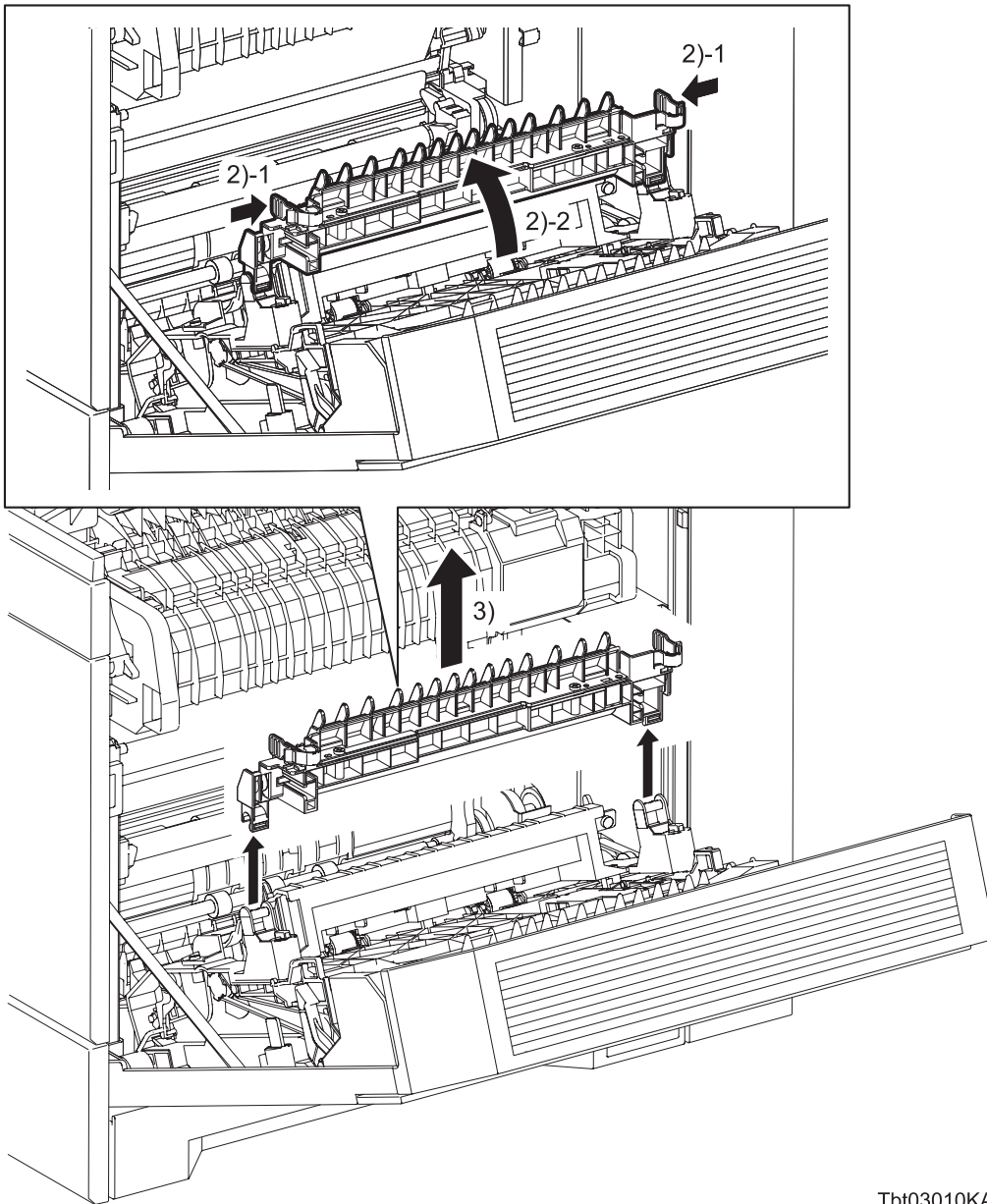

Tbt03010KA

- 2) Release the front and rear hooks of the ROLL ASSY 2ND BTR (PL4.4.1) and raise the ROLL ASSY 2ND BTR.
- 3) Remove the ROLL ASSY 2ND BTR from the COVER ASSY RH.

Removal 9 KIT MSI SEPARATOR ROLL (PL3.1.99)

- 1) Open the COVER ASSY RH.

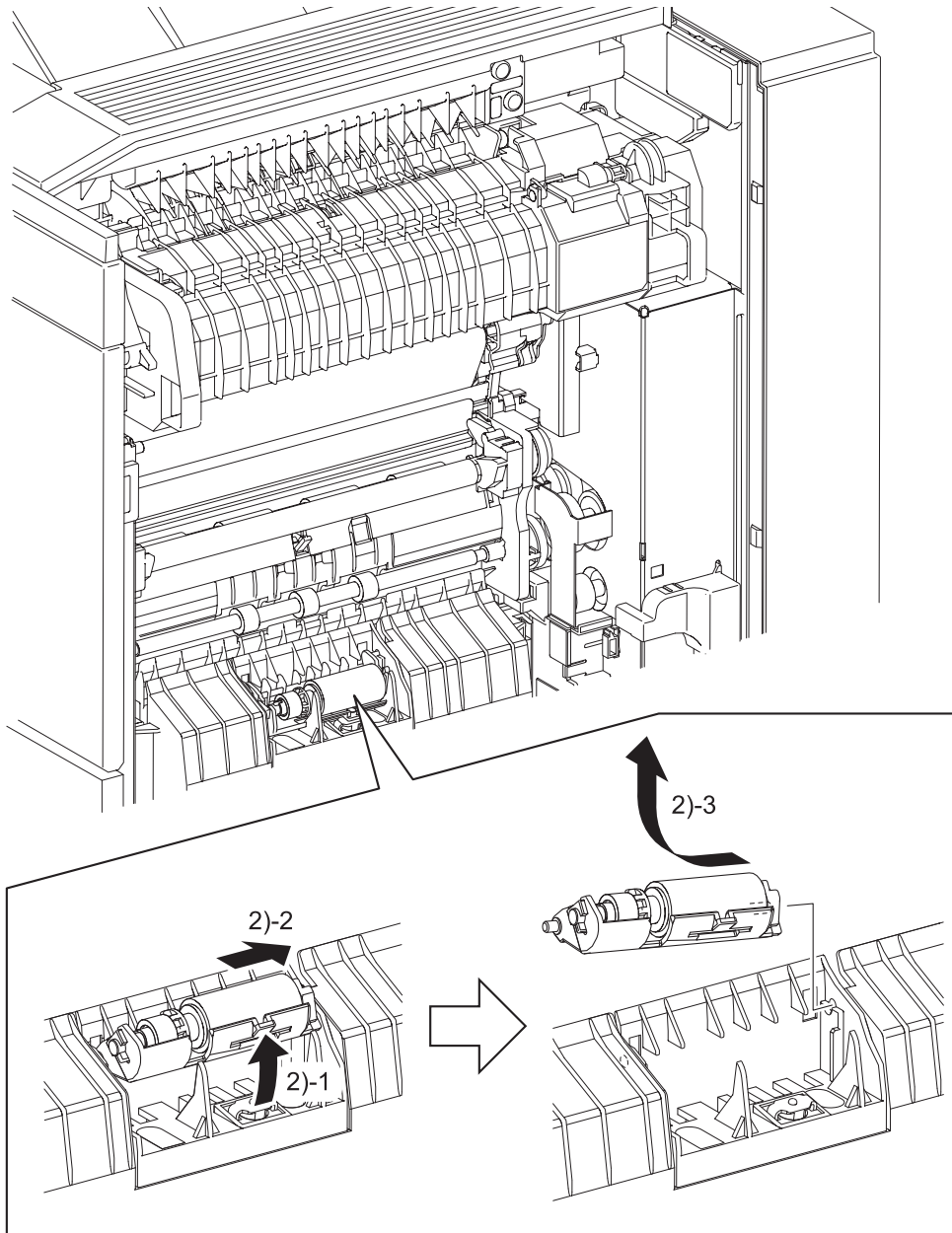

Tbt03011KA

- 2) Raise the HOLDER ASSY SEPARATOR MSI (PL3.1.8), and then slide it backward to release the boss of the HOLDER ASSY SEPARATOR MSI from the printer. Then, remove the HOLDER ASSY SEPARATOR MSI.

Blank Page

Removal 10 FAN FUSER (PL4.1.8)

- 1) Open the COVER ASSY RH.

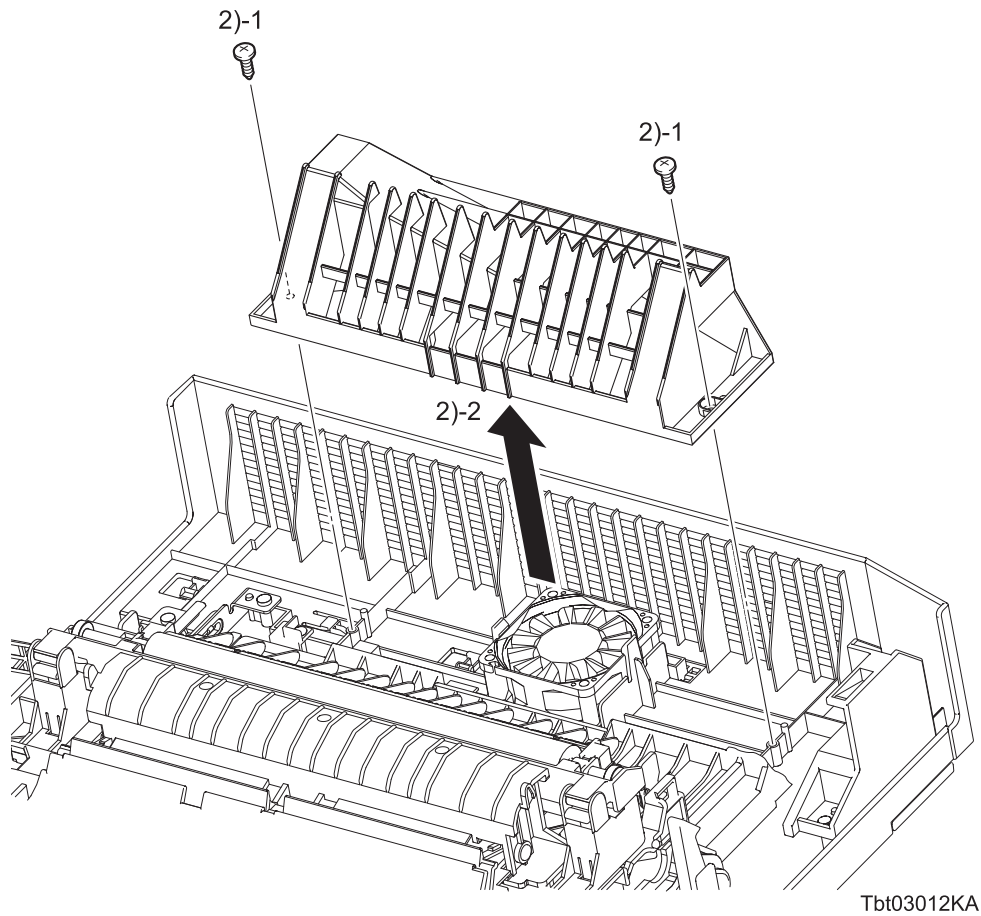

- 2) Remove the CHUTE DUP RH (PL4.1.7) from the COVER ASSY RH by removing the two screws (silver, tapping, 8mm).

Continues to the next page.

Removal 10 FAN FUSER (PL4.1.8)

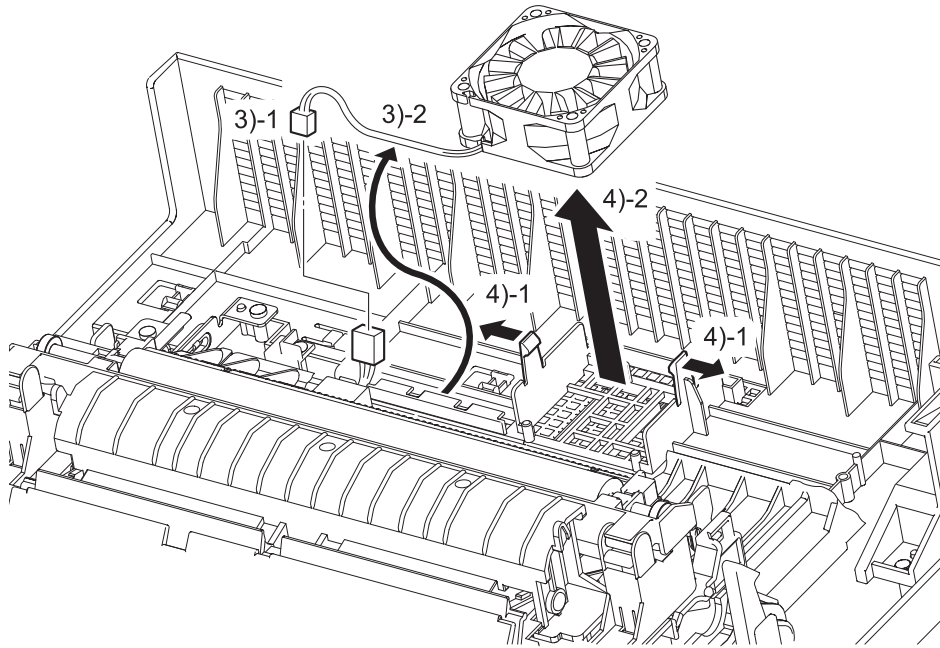

Tbt03013KA

- 3) Disengage the connectors (P/J119) of the FAN FUSER (PL4.1.8), and then release the harness of the FAN FUSER from the hooks of the COVER ASSY RH.
- 4) Remove the FAN FUSER from the COVER ASSY RH by releasing the two hooks of the COVER ASSY RH.

Removal 11 KIT ACTUATOR INTLK RH (PL4.1.97)

- 1) Open the COVER ASSY RH.

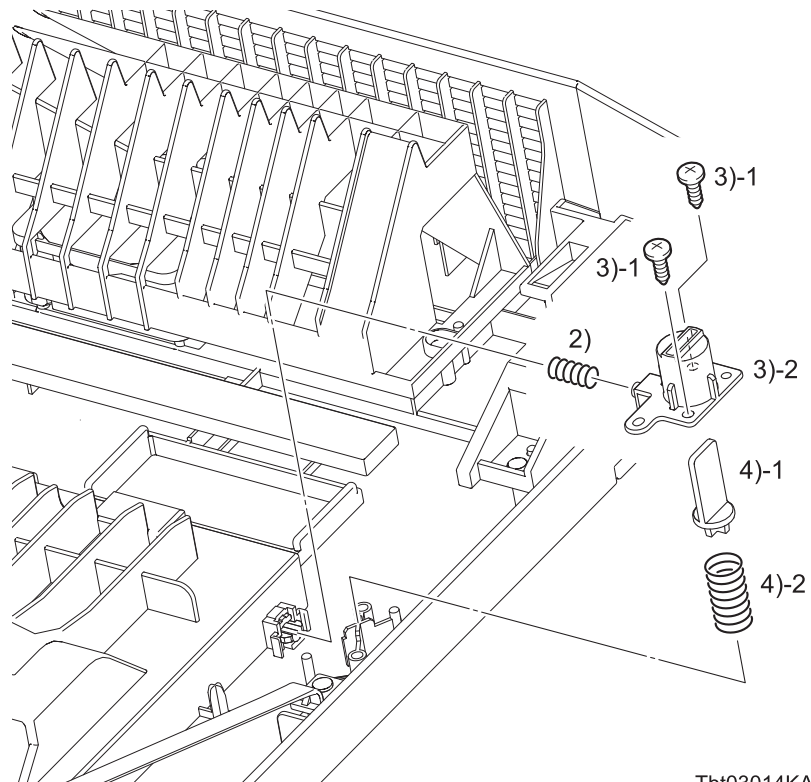

Tbt03014KA

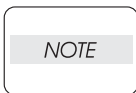

When performing the following step, use caution not to drop and lose the SPRING STOPPER MSI.

- 2) Remove the SPRING STOPPER MSI (PL4.1.24) from the STOPPER MSI (PL4.1.25) and the boss of the HOLDER INTLK RH (PL4.1.18).
- 3) Remove the HOLDER INTLK RH (PL4.1.18) from the COVER ASSY RH by removing the two screws (silver, tapping, 8mm).
- 4) Remove the ACTUATOR INTLK RH (PL4.1.19) and SPRING INTLK RH (PL4.1.20) from the COVER ASSY RH.

Blank Page

Removal 12 ROLL ASSY FEED MSI (PL4.2.21)

- 1) Open the COVER ASSY RH.

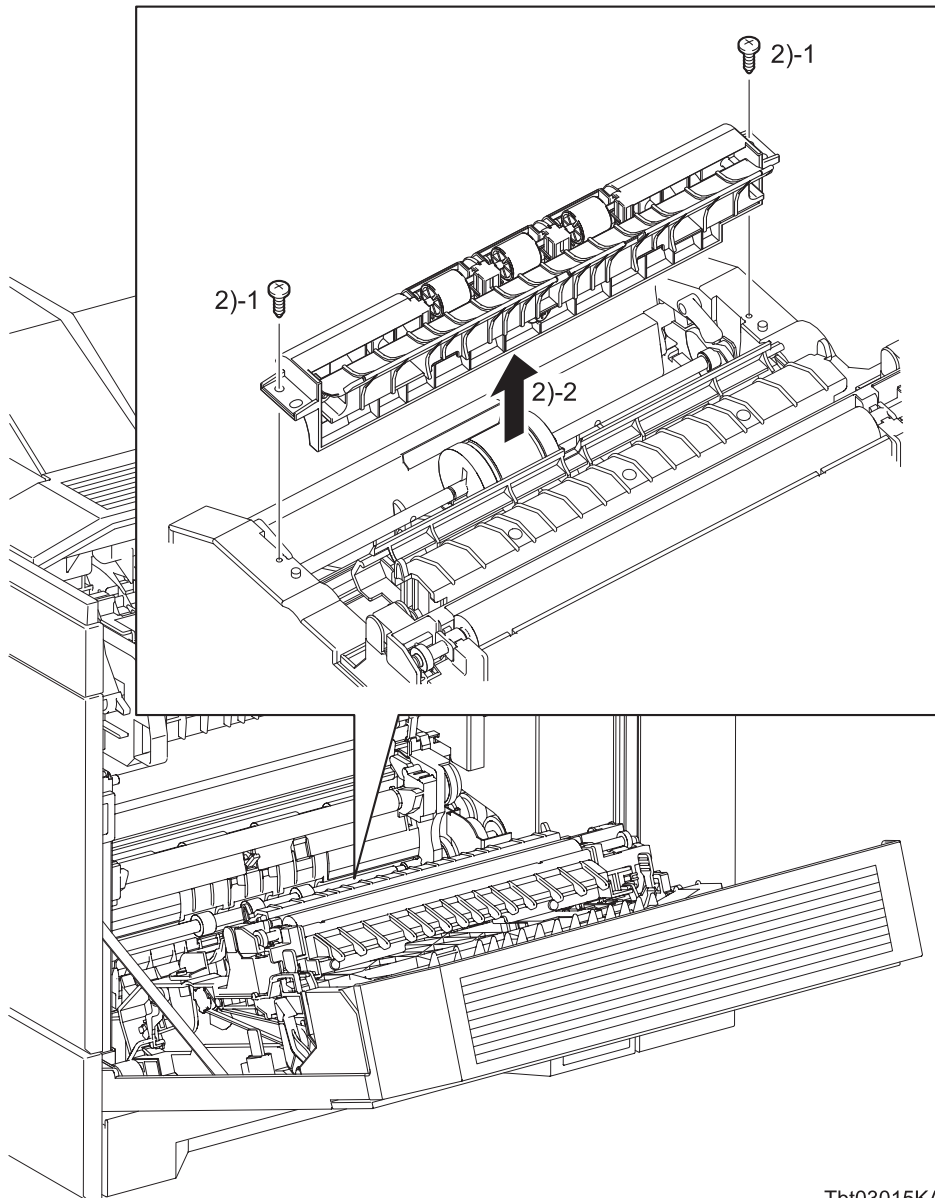

Tbt03015KA

- 2) Remove the CHUTE ASSY MSI (PL4.2.5) from the COVER ASSY RH by removing the two screws (silver, tapping, 8mm).

Continues to the next page.

Removal 12 ROLL ASSY FEED MSI (PL4.2.21)

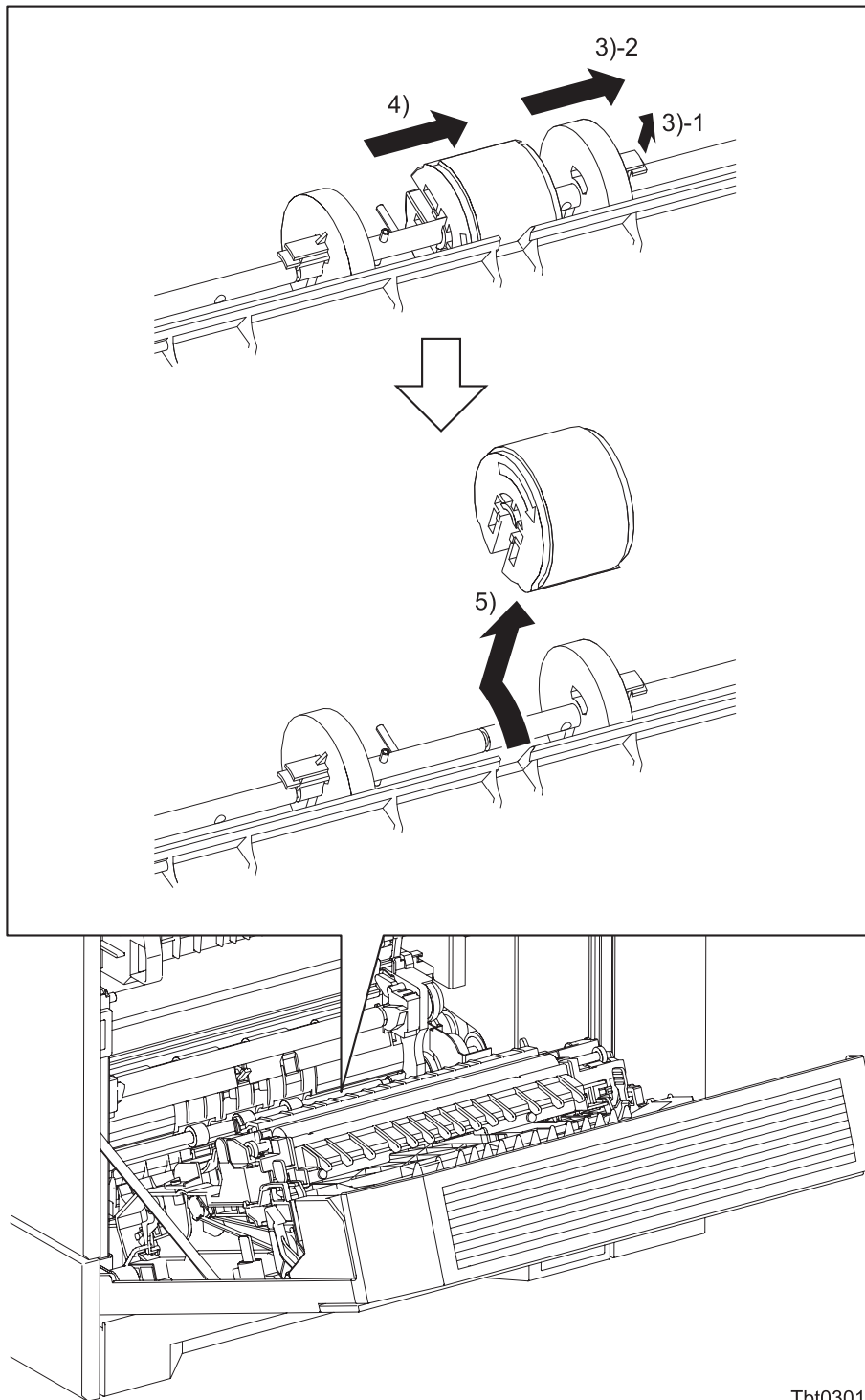

Tbt03016KB

- 3) Release the hook of the ROLL CORE MSI (PL4.2.17) on the rear of the ROLL ASSY FEED MSI (PL 4.2.21), and then slide the ROLL CORE MSI to the rear.
- 4) Release the groove on the ROLL ASSY FEED MSI from the vertical pin mounted on the SHAFT ASSY MSI (PL4.2.20) by sliding the ROLL ASSY FEED MSI to the rear.
- 5) Remove the ROLL ASSY FEED MSI from the SHAFT ASSY MSI by rotating the ROLL ASSY FEED MSI 180 degrees.

Removal 13 KIT FEED ROLL & SEPARATOR ROLL (PL2.1.99)

NOTE

When replacing the SEPARATOR ROLL or the FEED ROLL replace the SEPARATOR ROLL and the two FEED ROLLS at the same time.

- 1) Remove the TRAY ASSY (PL2.1.1) from the printer.

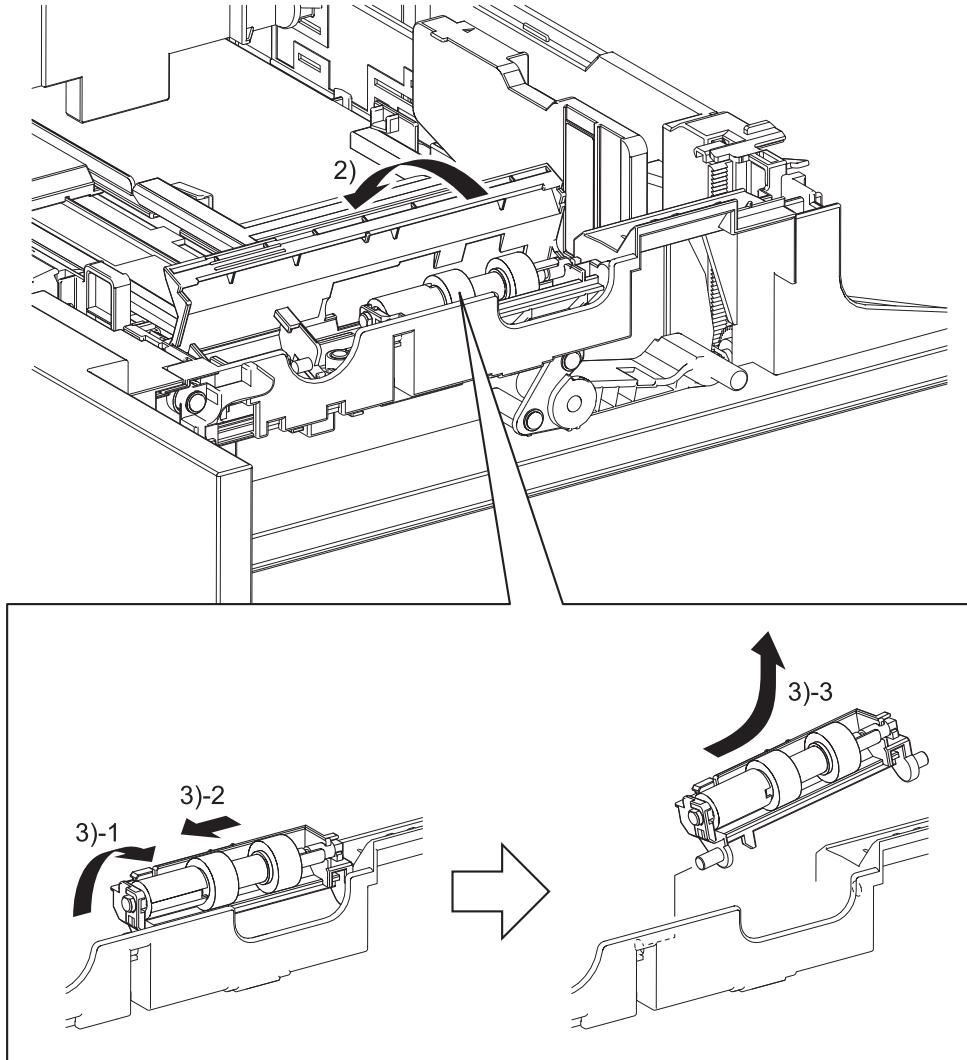

Tbt03017KA

- 2) Open and hold the COVER SEPARATOR (PL2.1.20).
- 3) Raise the HOLDER ASSY SEPARATOR (PL2.1.21), and then slide it forward to release the boss of the HOLDER ASSY SEPARATOR from the TRAY ASSY. Then, remove the HOLDER ASSY SEPARATOR.

Continues to the next page.

Removal 13 KIT FEED ROLL & SEPARATOR ROLL (PL2.1.99)

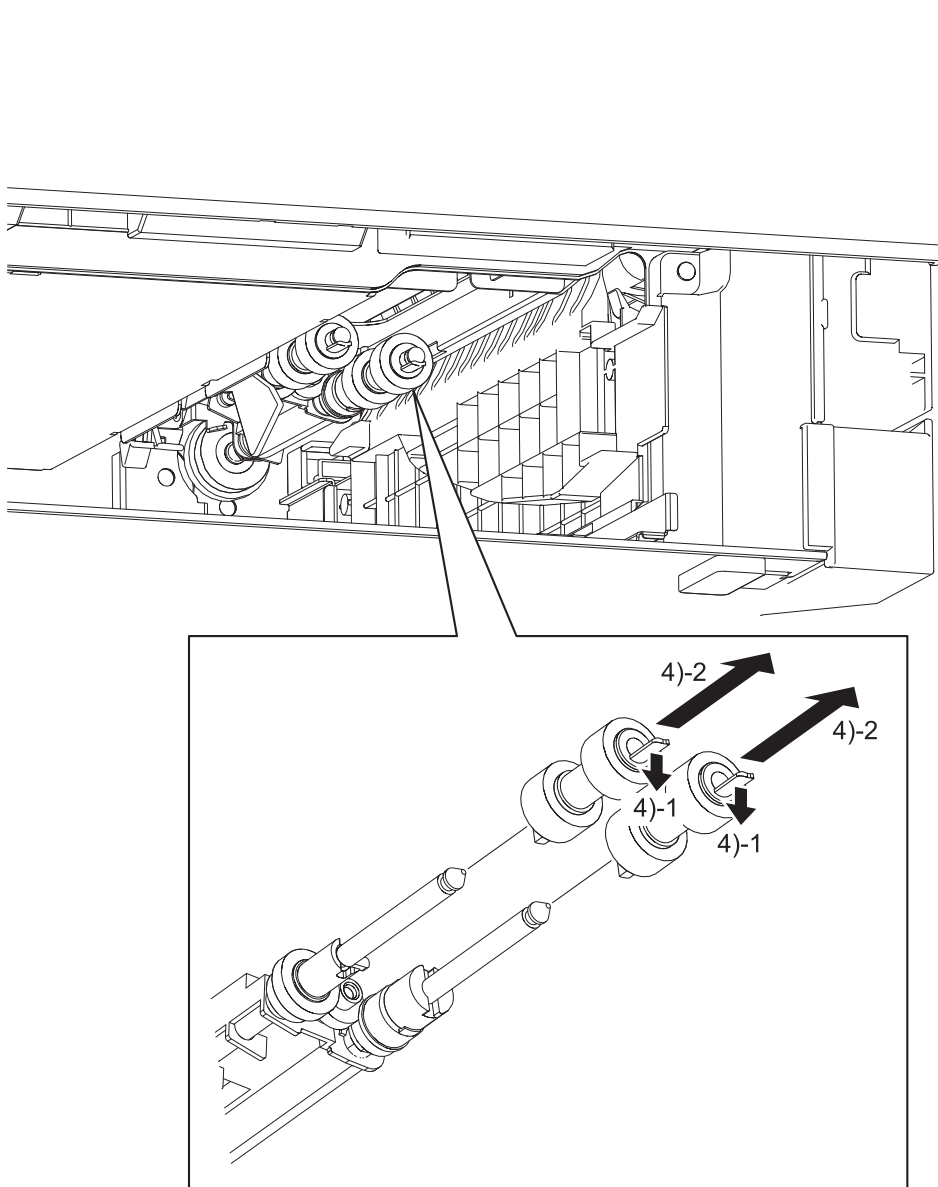

Tbt03018KA

- 4) Remove the ROLL ASSY FEEDs (PL3.2.18) from the shafts by releasing the hooks of the ROLL ASSY FEEDs

Removal 14 COVER TRAY (PL2.1.39)

- 1) Remove the TRAY ASSY (PL2.1.1) from the printer.

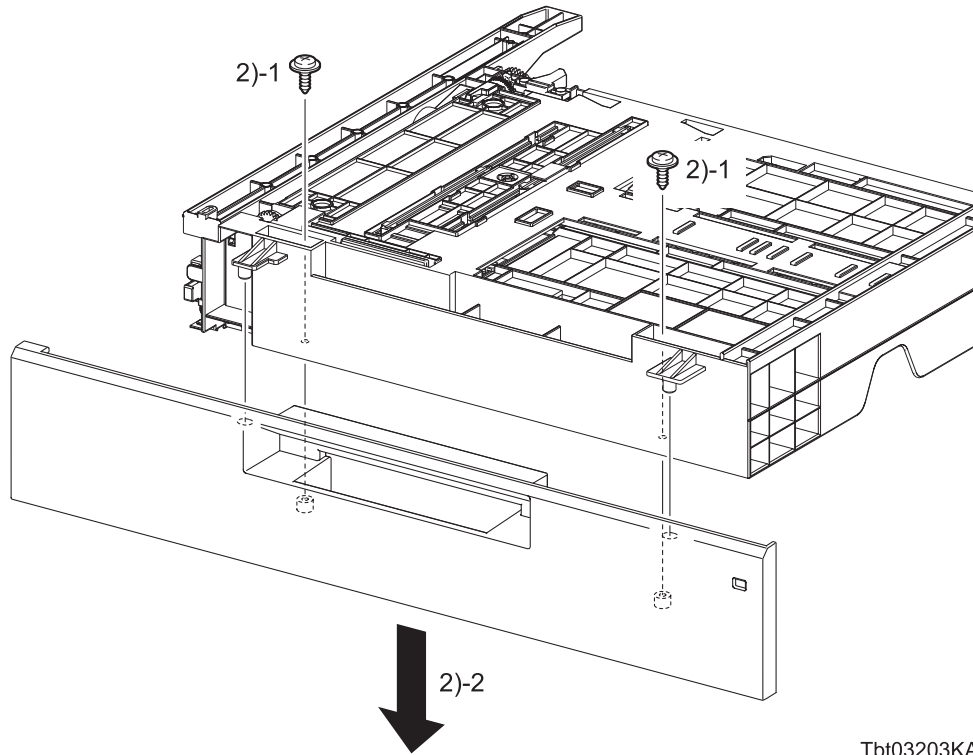

- 2) Remove the COVER TRAY (PL2.1.39) from the TRAY ASSY by removing the two screws (silver, tapping, flanged, 8mm).

Removal 15 SWITCH ASSY SIZE (PL3.1.1)

- 1) Remove the TRAY ASSY (PL2.1.1) from the printer.

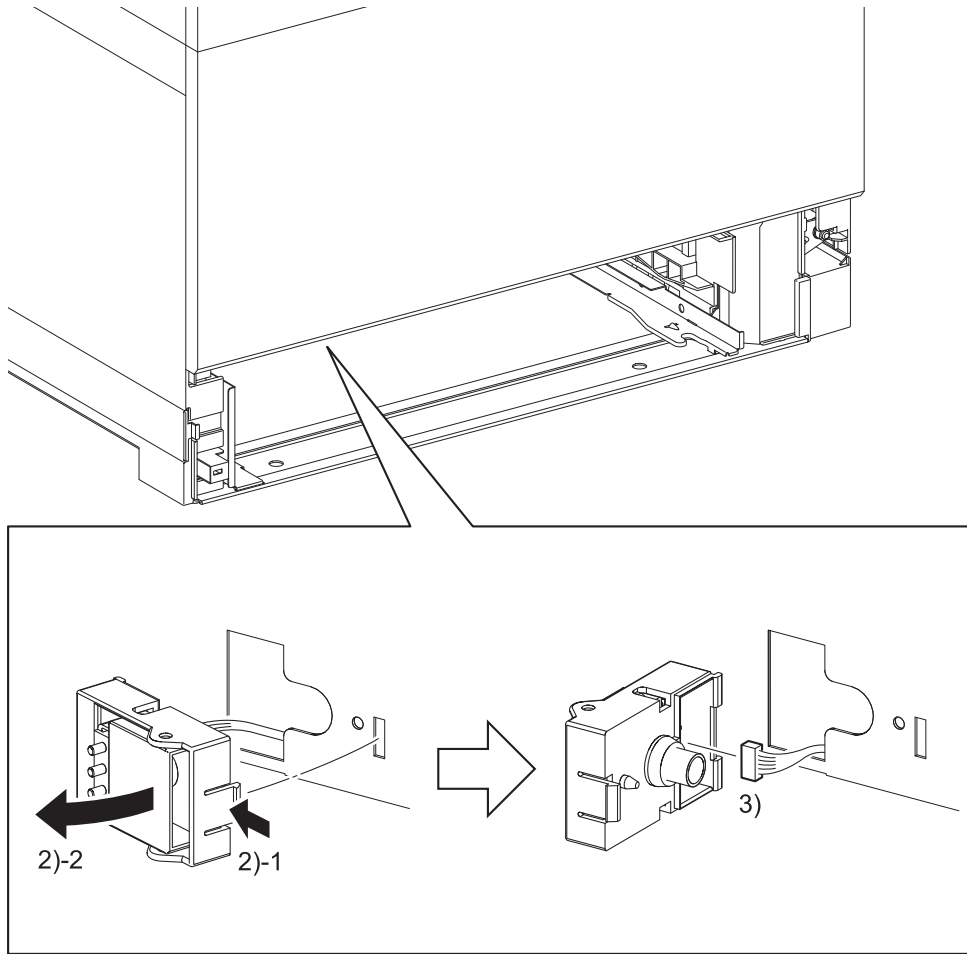

Tbt03019KA

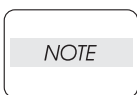

When performing the following step, use caution not to move the SWITCH ASSY SIZE from the printer too far because they are connected with the harness.

- 2) Remove the SWITCH ASSY SIZE (PL3.1.1) from the printer by releasing the hook of the SWITCH ASSY SIZE.
- 3) Disengage the connectors (P/J219) of the SWITCH ASSY SIZE.

Removal 16 HOLDER ASSY SENSOR LOW (PL3.1.2)

- 1) Remove the TRAY ASSY (PL2.1.1) from the printer.

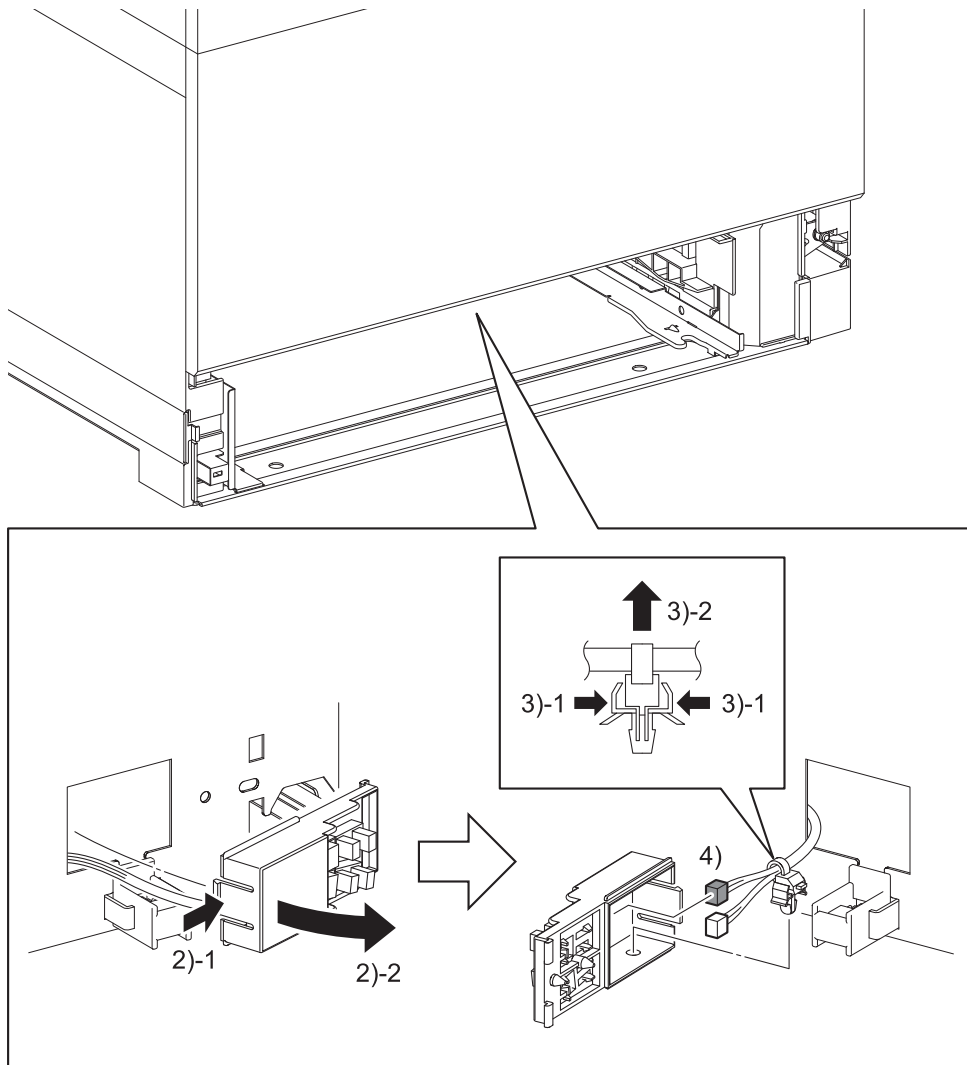

Tbt03020KA

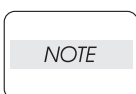

When performing the following step, use caution not to move the HOLDER ASSY SENSOR LOW from the printer too far because they are connected with the harness.

- 2) Remove the HOLDER ASSY SENSOR LOW (PL3.1.2) from the printer by releasing the hook of the HOLDER ASSY SENSOR LOW.
- 3) Release the clamp that fixes the harness to the HOLDER ASSY SENSOR LOW.
- 4) Disengage the two sets of connectors (P/J221, 222) of the HOLDER ASSY SENSOR LOW.

Blank Page

Removal 17 COVER ASSY TOP ADD TRAY (Reference only)

- 1) Open the COVER ASSY FRONT (PL1.2.17).

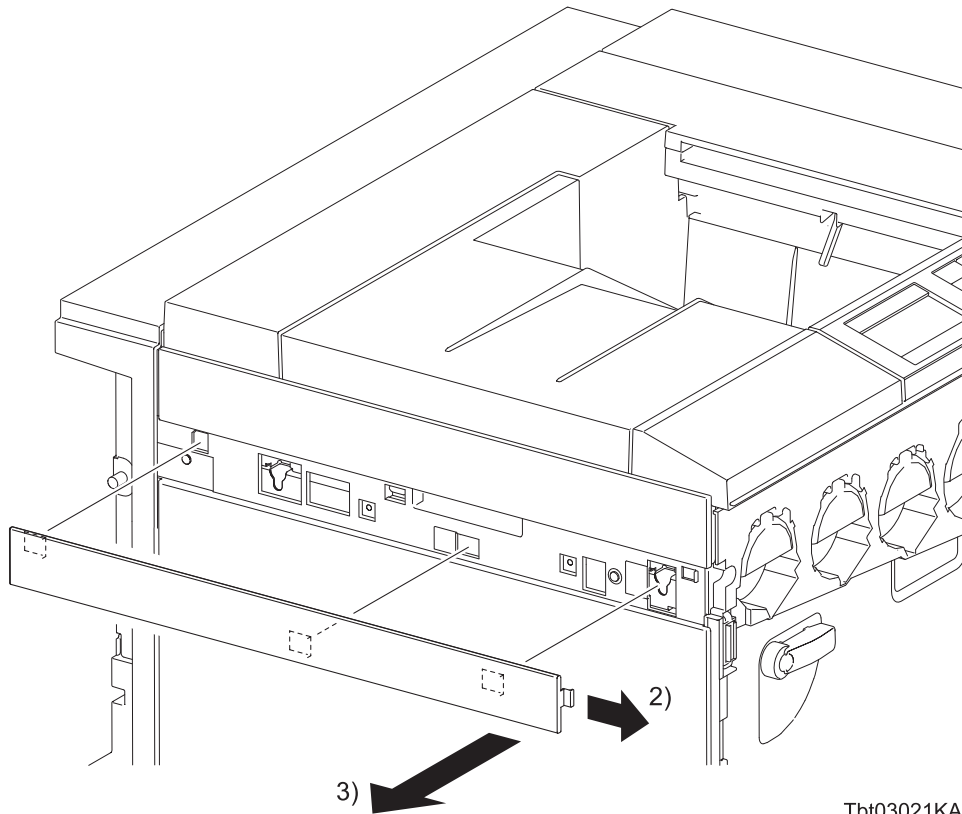

Tbt03021KA

- 2) Shift the upper COVER LH FINISHER to front side, and then release the three hooks of the upper COVER LH FINISHER.
- 3) Remove the upper COVER LH FINISHER from the printer.

Continues to the next page.

Removal 17 COVER ASSY TOP ADD TRAY (Reference only)

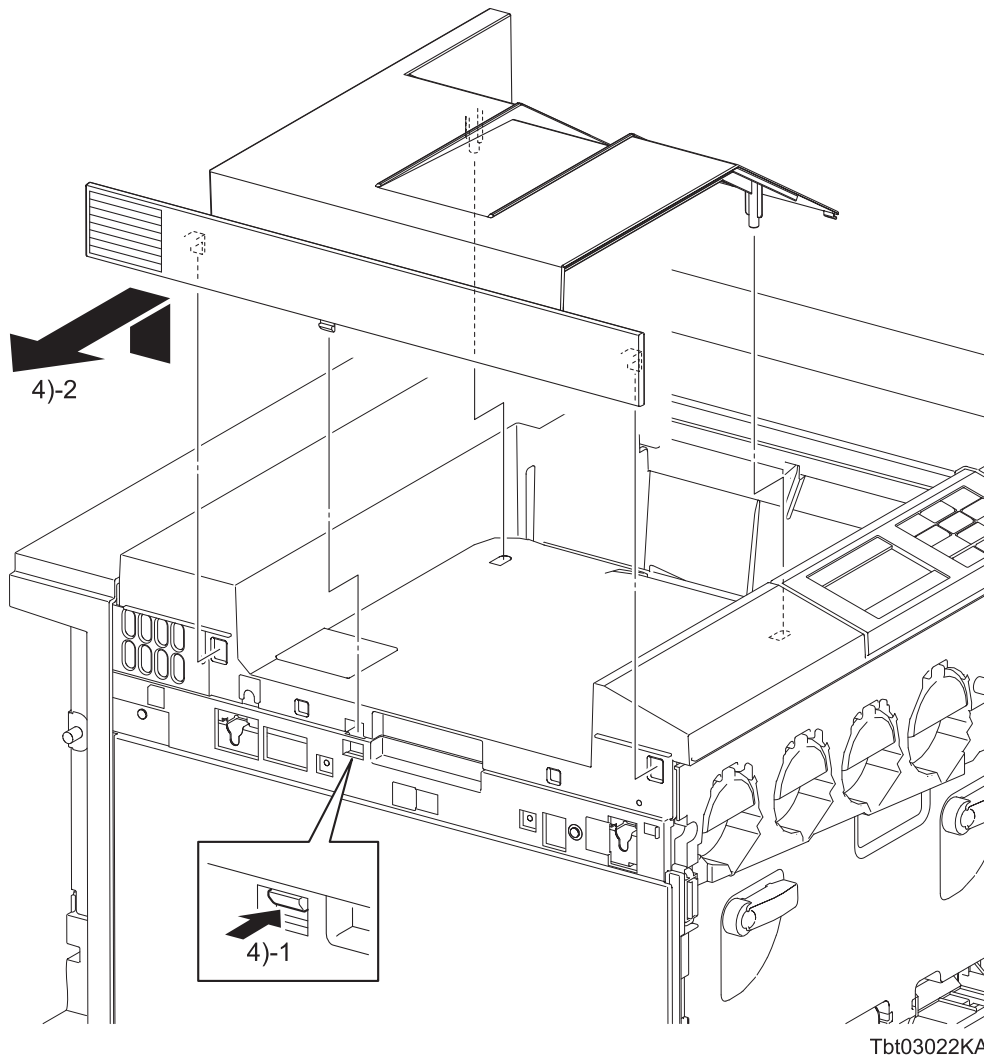

- 4) Remove the COVER ASSY TOP ADD TRAY from the printer by releasing the three hooks of the COVER ASSY TOP ADD TRAY.

Removal 18 COVER FRONT RH (PL1.2.5)

In the following steps, the details of Steps 1 and 2 are omitted because they are described earlier in this chapter. Go to the steps in parentheses to execute the necessary steps, and then go to Step 3 onward.

- 1) Open the COVER ASSY FRONT (PL1.2.17).
- 2) Open the COVER ASSY RH.

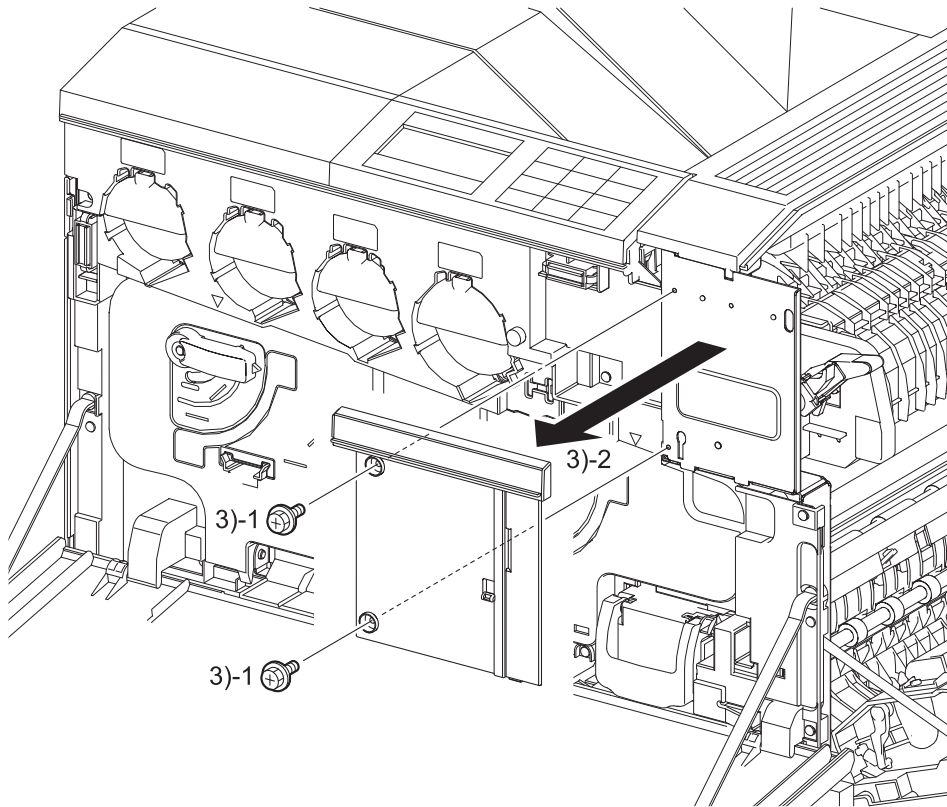

Tbt03204KB

- 3) Remove the COVER FRONT RH (PL1.2.5) from the printer by removing the two screws (silver, flanged, 6mm).

Removal 19 KIT COVER ASSY MSI (PL4.1.98)

- 1) Open the COVER ASSY MSI (PL4.1.26).

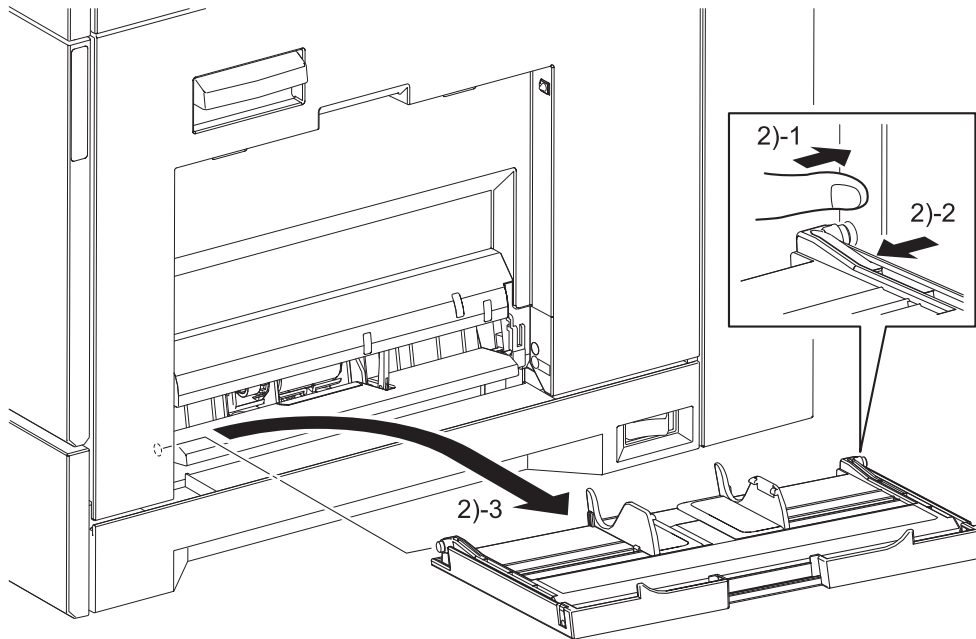

Tbt03023KA

- 2) Remove the COVER ASSY MSI from the printer by releasing the bosses of the COVER ASSY MSI.

Removal 20 COVER ASSY REAR (PL1.3.5)

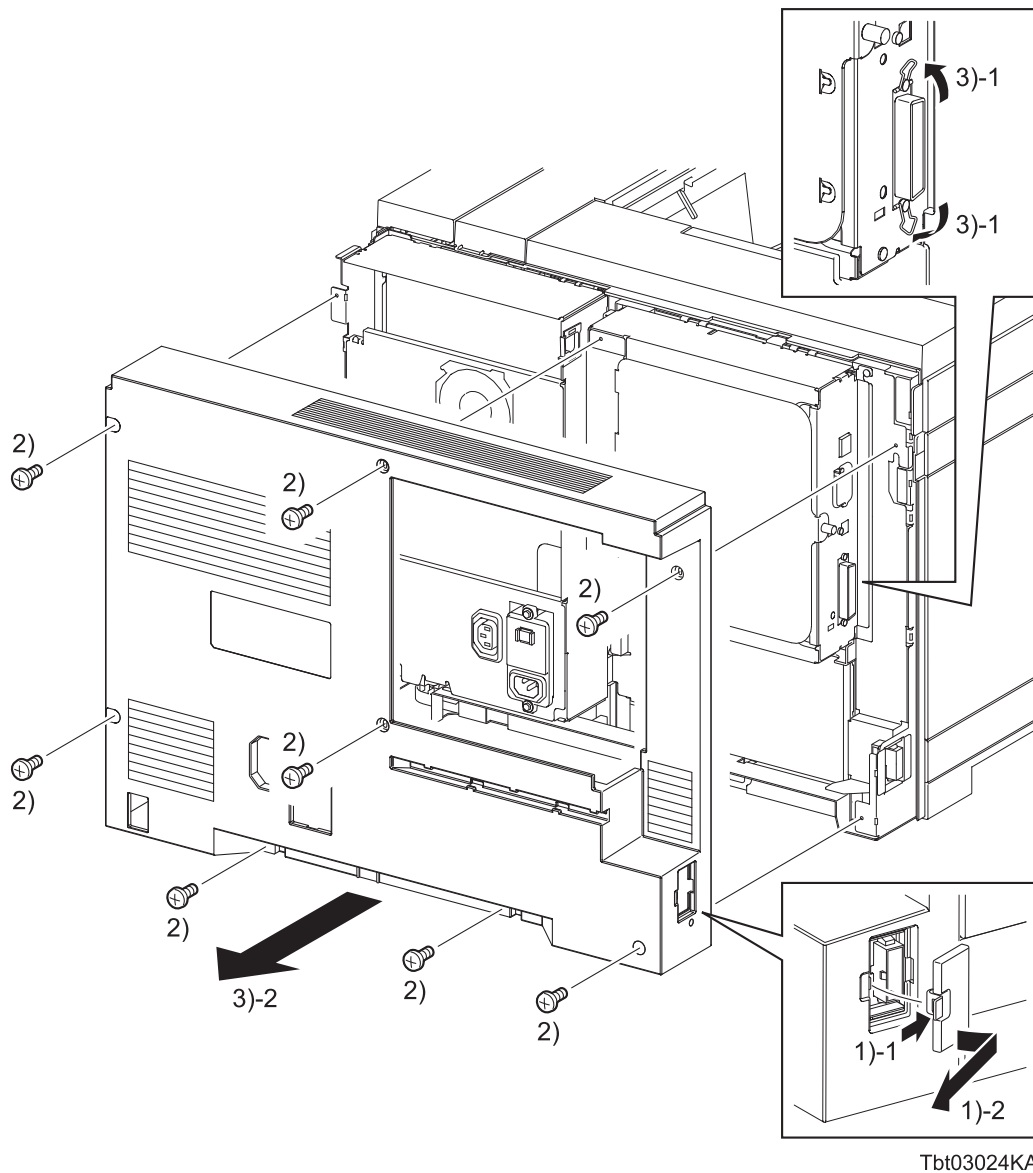

- 1) Remove the COVER REAR LH (PL1.3.4) from the printer by releasing the hook of the COVER REAR LH.
- 2) Remove the eight screws (silver, 6mm) that fix the COVER ASSY REAR (PL1.3.5) to the printer.
- 3) Remove the COVER ASSY REAR from the printer while expanding the clip of the parallel port.

Go to the next removal step:

Removal 21 COVER ASSY TOP EXIT (PL1.1.9)

Removal 23 COVER RH UNDER (PL1.1.11)

Removal 30 KIT PLATE ASSY ESS (PL10.1.99)

Removal 31 KIT PWBA MCU (PL10.2.99)

Removal 32 FAN ASSY LVPS (PL10.1.9)

Removal 33 PLATE ASSY LVPS POWER (PL10.1.12)

Removal 34 COVER LH ASSY (PL1.3.2)

Removal 21 COVER ASSY TOP EXIT (PL1.1.9)

In the following steps, the details of Steps 1 through 4 are omitted because they are described earlier in this chapter. Go to the steps in parentheses to execute the necessary steps, and then go to Step 5 onward.

- 1) Open the COVER ASSY FRONT (PL1.2.17).
- 2) Open the COVER ASSY RH.

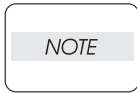

The FUSER section is very hot. Use extra caution not to burn yourself when performing the service operation.

- 3) Remove the FUSER ASSY. (Removal 7)
- 4) Remove the COVER ASSY REAR. (Removal 20)

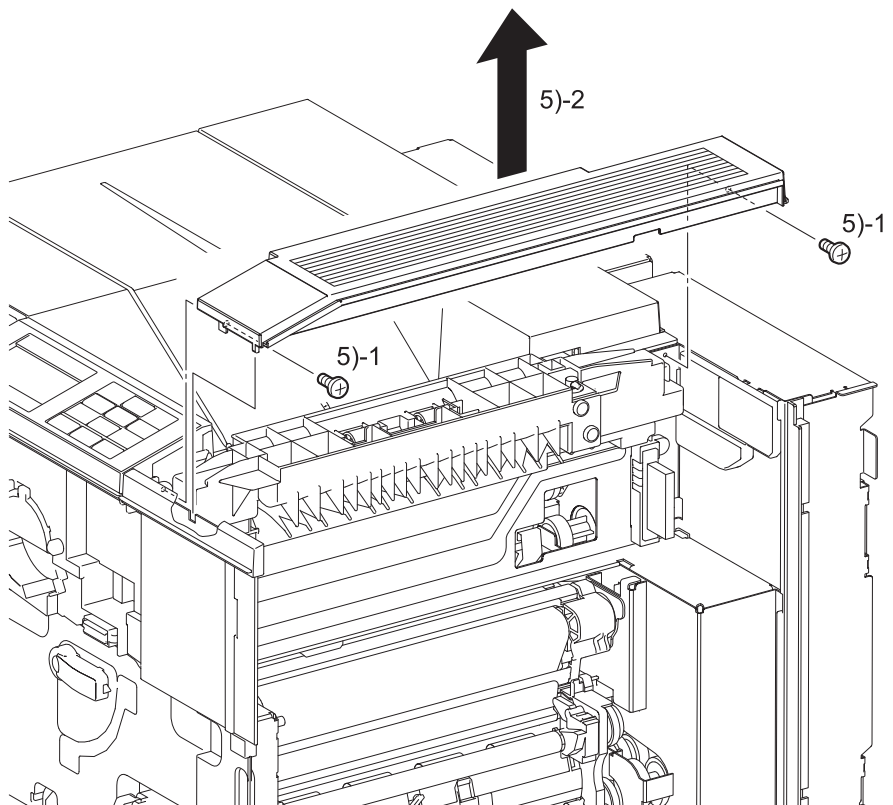

Tbt03025KA

- 5) Remove the COVER ASSY TOP EXIT (PL1.1.9) from the printer by removing the two screws (silver, 6mm).

Go to the next removal step:

Removal 22 CHUTE ASSY INVERT (PL7.3.1)

Removal 22 CHUTE ASSY INVERT (PL7.3.1)

In the following steps, the details of Steps 1 through 5 are omitted because they are described earlier in this chapter. Go to the steps in parentheses to execute the necessary steps, and then go to Step 6 onward.

- 1) Open the COVER ASSY FRONT (PL1.2.17).
- 2) Open the COVER ASSY RH.

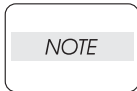

The FUSER section is very hot. Use extra caution not to burn yourself when performing the service operation.

- 3) Remove the FUSER ASSY. (Removal 7)
- 4) Remove the COVER ASSY REAR. (Removal 20)
- 5) Remove the COVER ASSY TOP EXIT. (Removal 21)

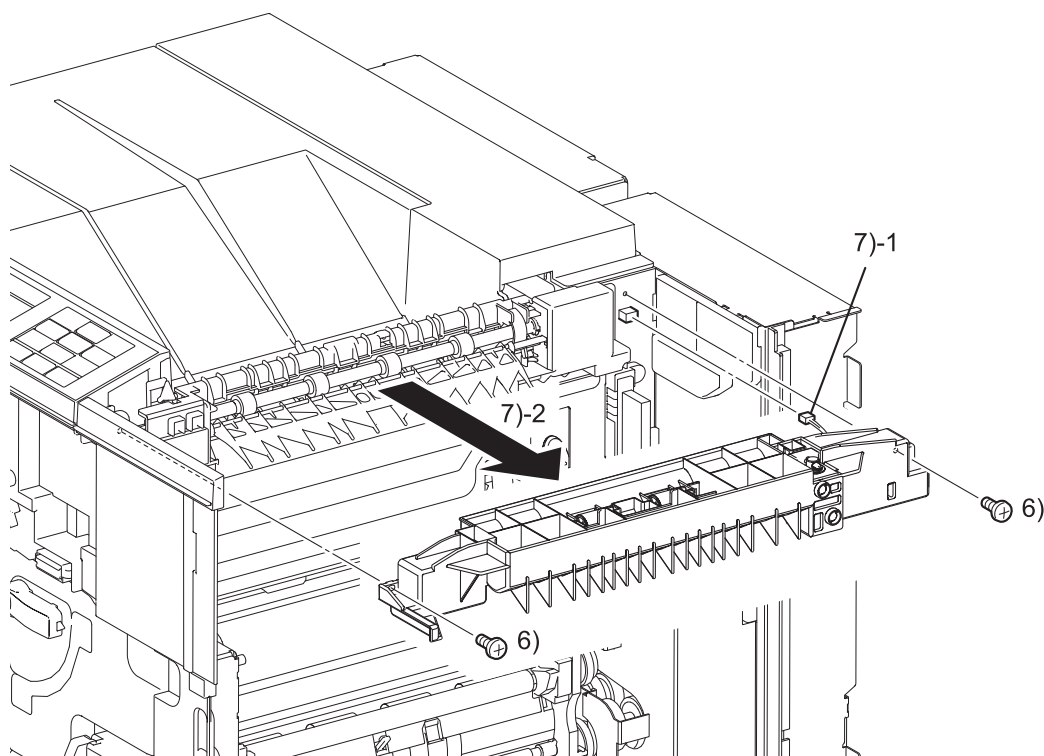

Tbt03026KA

- 6) Remove the two screws (silver, 6mm) that fix the CHUTE ASSY INVERT (PL7.3.1).

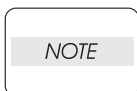

When performing the following step, use caution not to move the CHUTE ASSY INVERT from the printer too far because they are connected with the harness.

- 7) Slightly move the CHUTE ASSY INVERT away from the printer to disengage the connector (P/J122). Then, remove the CHUTE ASSY INVERT from the printer.

Removal 23 COVER RH UNDER (PL1.1.11)

In the following steps, the details of Steps 1 through 4 are omitted because they are described earlier in this chapter. Go to the steps in parentheses to execute the necessary steps, and then go to Step 5 onward.

- 1) Remove the TRAY ASSY (PL2.1.1) from the printer.
- 2) Open the COVER ASSY RH.

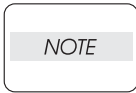

The FUSER section is very hot. Use extra caution not to burn yourself when performing the service operation.

- 3) Remove the FUSER ASSY. (Removal 7)
- 4) Remove the COVER ASSY REAR. (Removal 20)

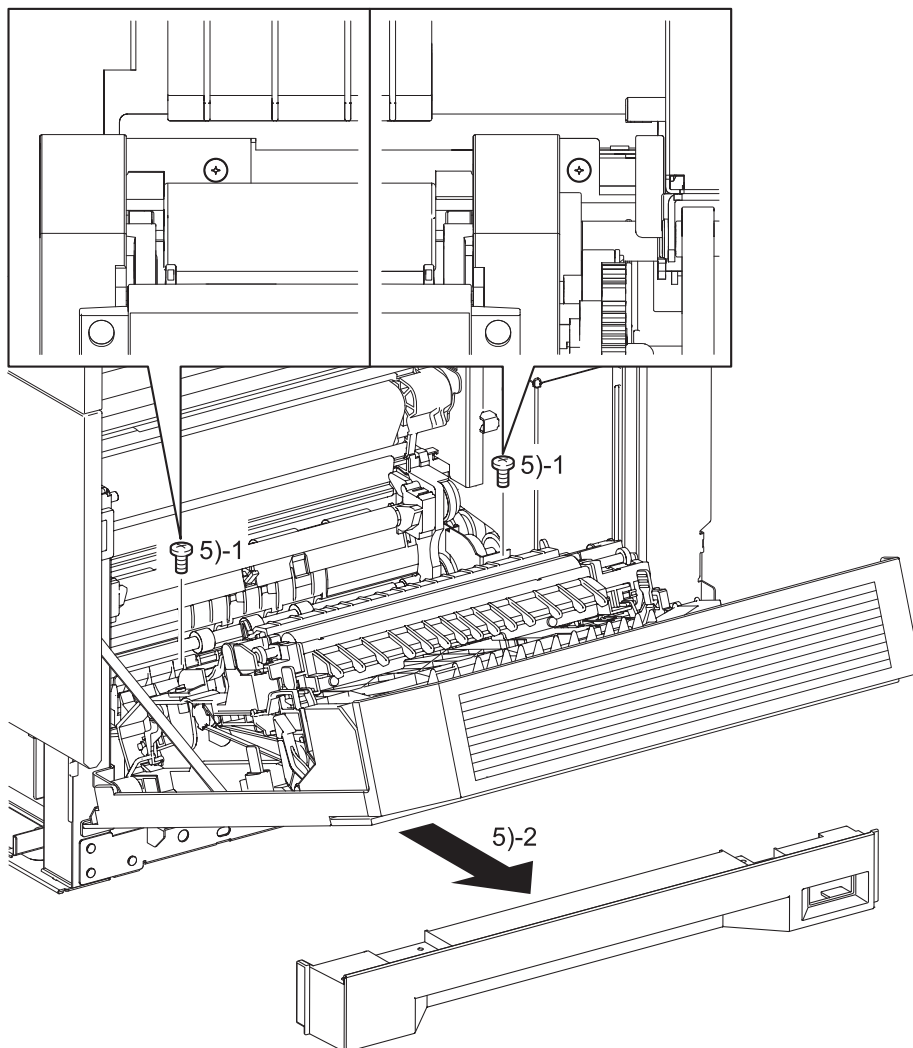

Tbt03027KA

- 5) Remove the COVER RH UNDER (PL1.1.11) from the printer by removing the two screws (silver, 6mm).

Go to the next removal step:

Removal 24 KIT RH COVER & FRAME ASSY (PL4.1.99)

Removal 24 KIT RH COVER & FRAME ASSY (PL4.1.99)

In the following steps, the details of Steps 1 through 9 are omitted because they are described earlier in this chapter. Go to the steps in parentheses to execute the necessary steps, and then go to Step 10 onward.

- 1) Remove the TRAY ASSY (PL2.1.1) from the printer.
- 2) Open the COVER ASSY FRONT (PL1.2.17).
- 3) Open the COVER ASSY RH.
- 4) Open the FRAME ASSY 2ND (PL8.1.9).

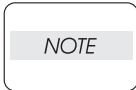

Place the BELT ASSY IBT in a safe place to prevent damage to its belt.

- 5) Remove the BELT ASSY IBT. (Removal 4)

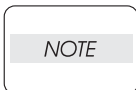

Cover the drum of the XERO DEVE CRU ASSY to prevent damage by light.

- 6) Remove the XERO DEVE CRU ASSY (Y), (M), (C), (K). (Removal 5)

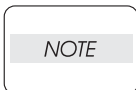

The FUSER section is very hot. Use extra caution not to burn yourself when performing the service operation.

- 7) Remove the FUSER ASSY. (Removal 7)
- 8) Remove the COVER ASSY REAR. (Removal 20)
- 9) Remove the COVER RH UNDER. (Removal 23)

Continues to the next page.

Removal 24 KIT RH COVER & FRAME ASSY (PL4.1.99)

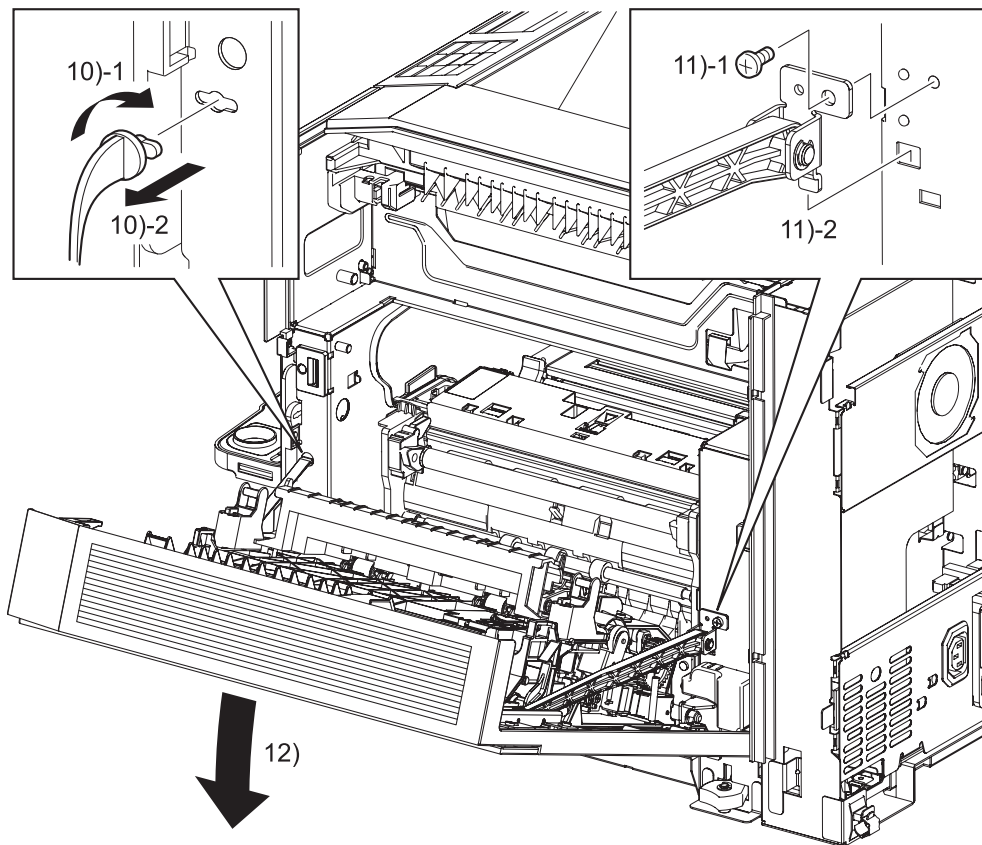

Tbt03028KA

- 10) Remove the STRAP RH (PL4.1.21) from the printer by rotating the printer-frame side of the STRAP RH by 90 degrees so as to align the tab of the STRAP RH with the notch in the printer frame.

NOTE

When performing the following step, use caution not to drop the KIT RH COVER & FRAME ASSY.

- 11) Remove the one screw (silver, M4, 6mm) that fixes the LINK ASSY (PL4.1.11) to the printer.
- 12) Tilt the KIT RH COVER & FRAME ASSY (PL4.1.99) slowly.

Continues to the next page.

Removal 24 KIT RH COVER & FRAME ASSY (PL4.1.99)

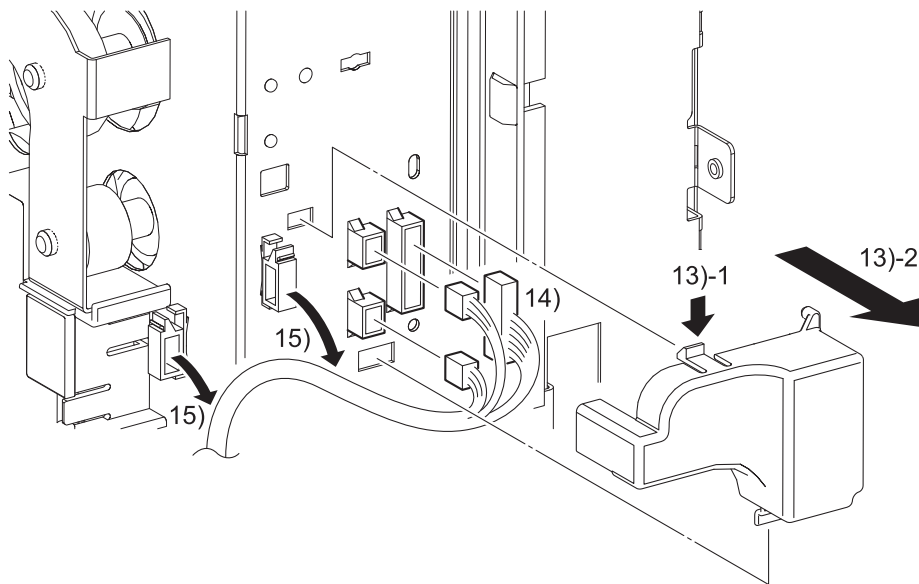

Tbt03029KA

- 13) Remove the COVER CONNECTOR (PL4.1.3) from the printer by releasing the two hooks of the COVER CONNECTOR.
- 14) Disengage the three sets of connectors (P/J117, 118, 120) of the KIT RH COVER & FRAME ASSY.
- 15) Release the harness of the KIT RH COVER & FRAME ASSY from the two clamps.
- 16) Close the KIT RH COVER & FRAME ASSY.

Continues to the next page.

Removal 24 KIT RH COVER & FRAME ASSY (PL4.1.99)

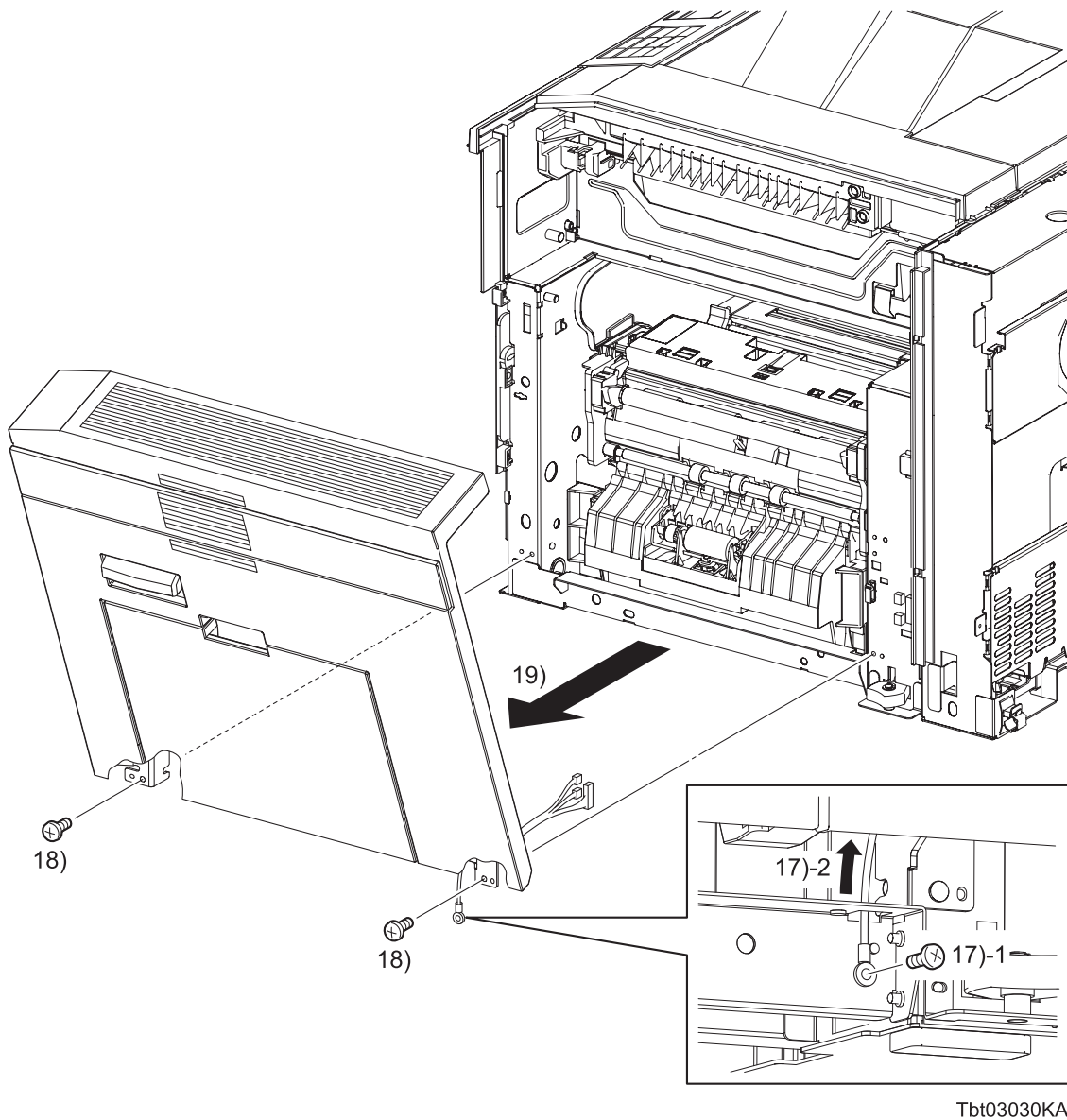

- 17) Remove the one screw (silver, 6mm) that fixes the grounding terminal of the WIRE ASSY EARTH (PL4.2.33). Then, route the WIRE ASSY EARTH through the hole in the frame to the outside.
- 18) Remove the two screws (silver, M4, 6mm) that fix the BRACKET ASSY PIVOT FRONT (PL4.1.4) and the BRACKET ASSY PIVOT REAR (PL4.1.6) to the printer.
- 19) Remove the KIT RH COVER & FRAME ASSY from the printer.

Go to the next removal step:

Removal 25 KIT RH SOLENOID, GEAR & CLUTCH (PL4.2.99)

Removal 26 CAM MSI (PL4.2.16)

Removal 27 COVER ASSY RH (PL4.1.31)

Removal 28 SEPARATOR ASSY MSI (PL3.1.7)

Removal 25 KIT RH SOLENOID, GEAR & CLUTCH (PL4.2.99)

In the following steps, the details of Steps 1 through 10 are omitted because they are described earlier in this chapter. Go to the steps in parentheses to execute the necessary steps, and then go to Step 11 onward.

- 1) Remove the TRAY ASSY (PL2.1.1) from the printer.
- 2) Open the COVER ASSY FRONT (PL1.2.17).
- 3) Open the COVER ASSY RH.
- 4) Open the FRAME ASSY 2ND (PL8.1.9).

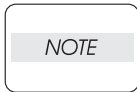

Place the BELT ASSY IBT in a safe place to prevent damage to its belt.

- 5) Remove the BELT ASSY IBT. (Removal 4)

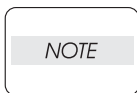

Cover the drum of the XERO DEVE CRU ASSY to prevent damage by light.

- 6) Remove the XERO DEVE CRU ASSY (Y), (M), (C), (K). (Removal 5)

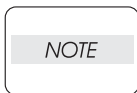

The FUSER section is very hot. Use extra caution not to burn yourself when performing the service operation.

- 7) Remove the FUSER ASSY. (Removal 7)
- 8) Remove the COVER ASSY REAR. (Removal 20)
- 9) Remove the COVER RH UNDER. (Removal 23)
- 10) Remove the KIT RH COVER & FRAME ASSY. (Removal 24)

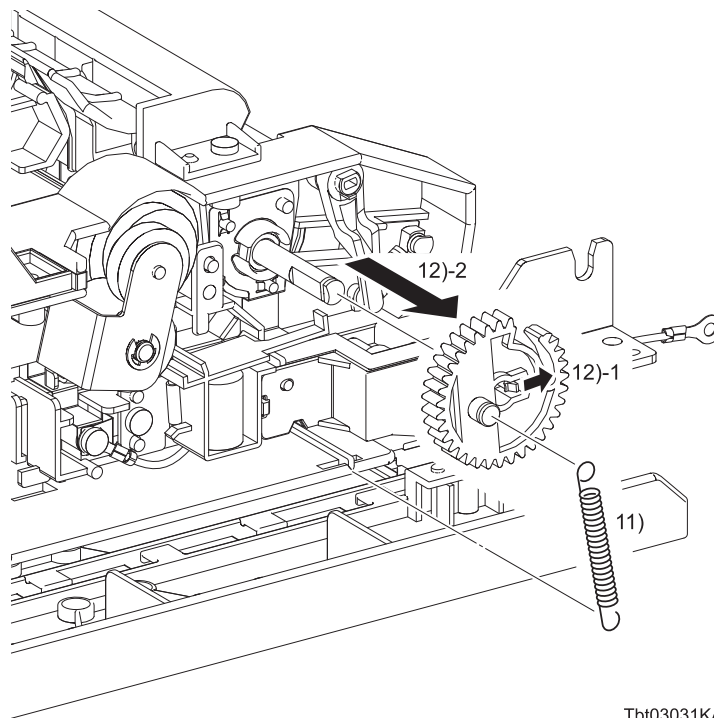

Tbt03031KA

- 11) Remove the SPRING FEED MSI (PL4.2.29) from the GEAR FEED MSI (PL4.2.28) and FRAME RH (PL4.2.10).
- 12) Remove the GEAR FEED MSI from the SHAFT ASSY MSI (PL4.2.20) by releasing the hook of the GEAR FEED MSI.

Continues to the next page.

Removal 25 KIT RH SOLENOID, GEAR & CLUTCH (PL4.2.99)

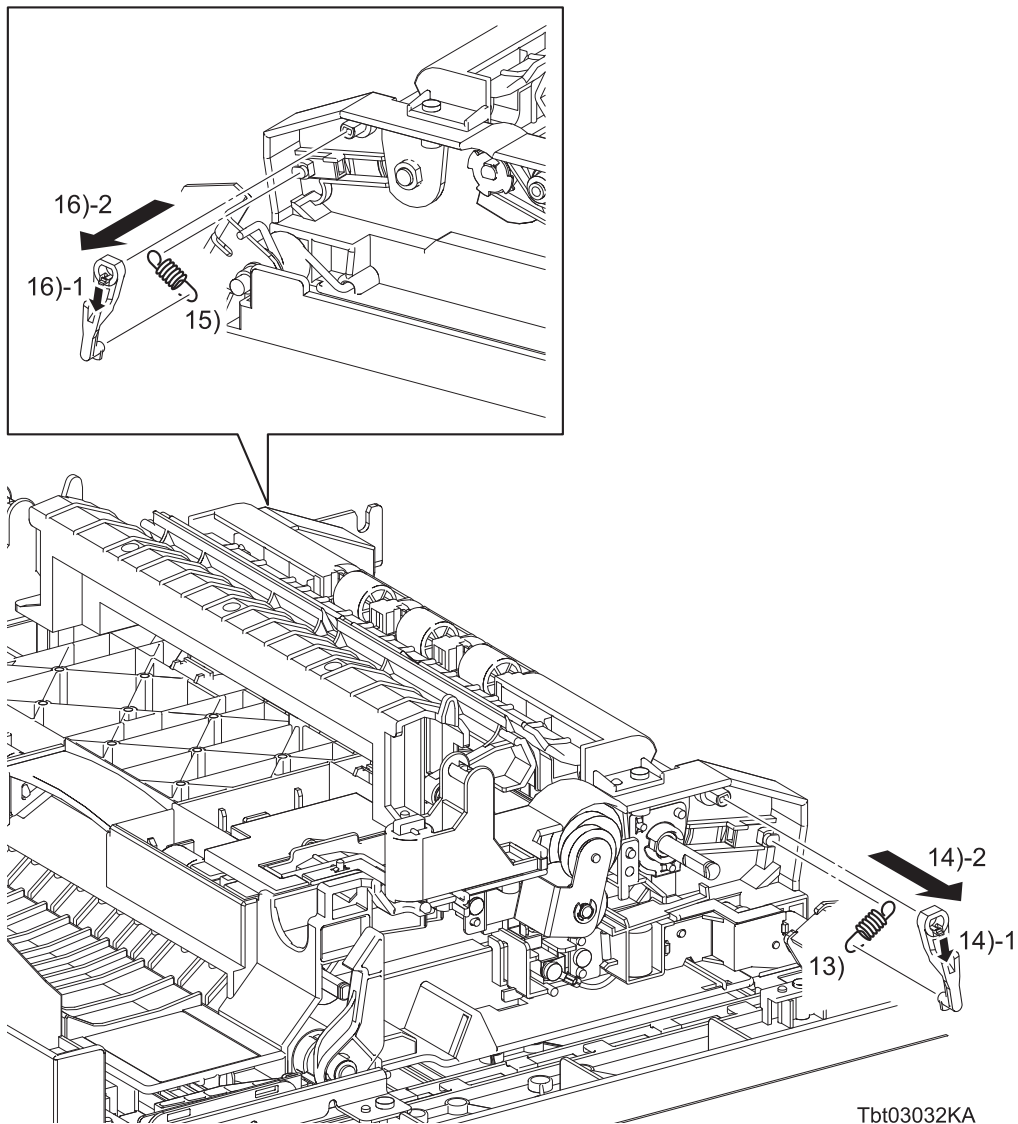

Tbt03032KA

- 13) Remove the rear SPRING NF MSI (PL4.2.11) from the rear ARM MSI (PL4.2.12) and PLATE ASSY BOTTOM MSI (PL4.2.22).
- 14) Remove the rear ARM MSI from the FOLLOWER REAR (PL4.2.23) by releasing the hook of the rear ARM MSI.
- 15) Remove the front SPRING NF MSI from the front ARM MSI and PLATE ASSY BOTTOM MSI.
- 16) Remove the front ARM MSI from the FOLLOWER FRONT (PL4.2.24) by releasing the hook of the front ARM MSI.

Continues to the next page.

Removal 25 KIT RH SOLENOID, GEAR & CLUTCH (PL4.2.99)

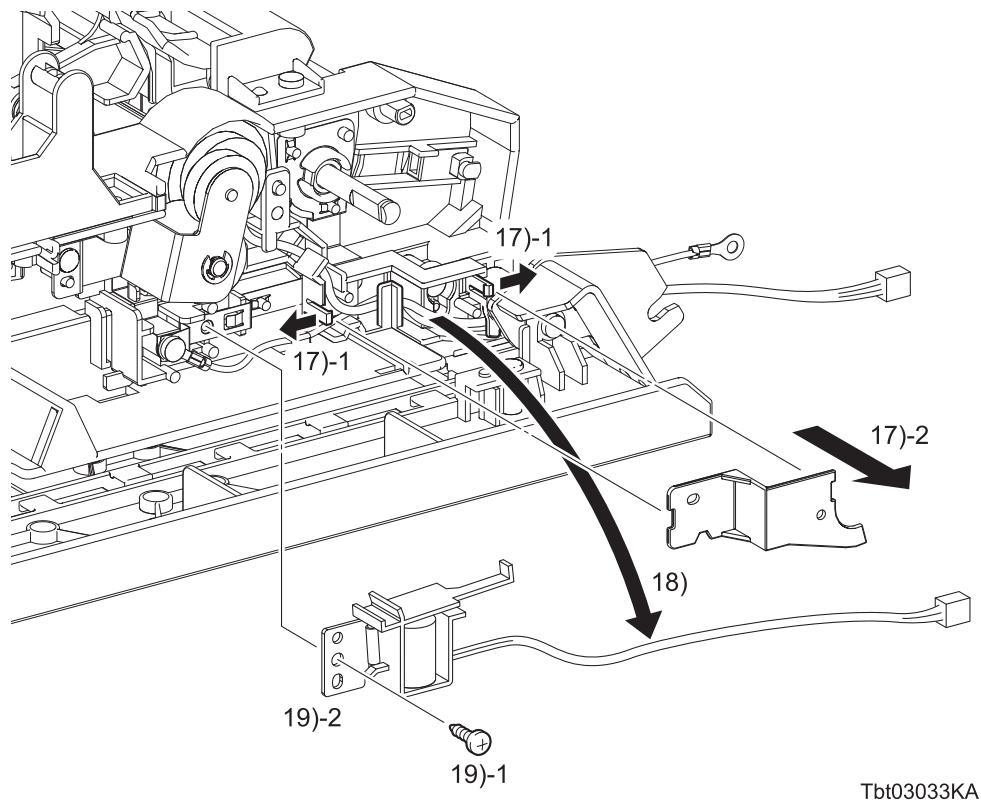

Tbt03033KA

- 17) Remove the COVER HARN GUIDE RH (PL4.2.30) from the GUIDE HARNESS RH (PL4.2.31) by releasing the two hooks of the GUIDE HARNESS RH.
- 18) Release the harness of the SOLENOID FEED MSI (PL4.2.32) and harness of the CLUTCH ASSY DUP (PL4.3.9) from the hooks of the GUIDE HARNESS RH
- 19) Remove the SOLENOID FEED MSI from the FRAME RH by removing the one screw (silver, tapping, 8mm).

Continues to the next page.

Removal 25 KIT RH SOLENOID, GEAR & CLUTCH (PL4.2.99)

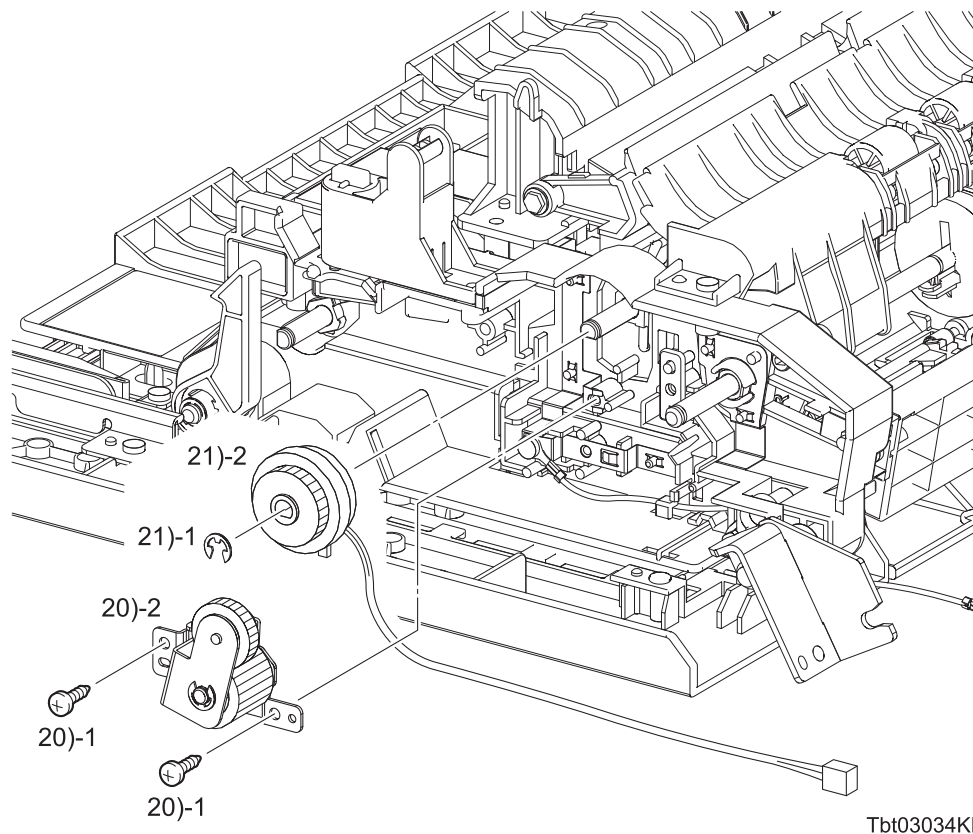

- 20) Remove the GEAR ASSY DUP (PL4.3.8) from the FRAME RH by removing the two screws (silver, tapping, 8mm).
- 21) Remove the CLUTCH ASSY DUP (PL4.3.9) from the lower ROLL ASSY DUP (PL4.3.10) by removing the E-ring.

Removal 26 CAM MSI (PL4.2.16)

In the following steps, the details of Steps 1 through 10 are omitted because they are described earlier in this chapter. Go to the steps in parentheses to execute the necessary steps, and then go to Step 11 onward.

- 1) Remove the TRAY ASSY (PL2.1.1) from the printer.
- 2) Open the COVER ASSY FRONT (PL1.2.17).
- 3) Open the COVER ASSY RH.
- 4) Open the FRAME ASSY 2ND (PL8.1.9).

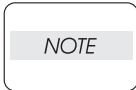

Place the BELT ASSY IBT in a safe place to prevent damage to its belt.

- 5) Remove the BELT ASSY IBT. (Removal 4)

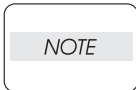

Cover the drum of the XERO DEVE CRU ASSY to prevent damage by light.

- 6) Remove the XERO DEVE CRU ASSY (Y), (M), (C), (K). (Removal 5)

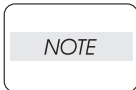

The FUSER section is very hot. Use extra caution not to burn yourself when performing the service operation.

- 7) Remove the FUSER ASSY. (Removal 7)
- 8) Remove the COVER ASSY REAR. (Removal 20)
- 9) Remove the COVER RH UNDER. (Removal 23)
- 10) Remove the KIT RH COVER & FRAME ASSY. (Removal 24)

Continues to the next page.

Removal 26 CAM MSI (PL4.2.16)

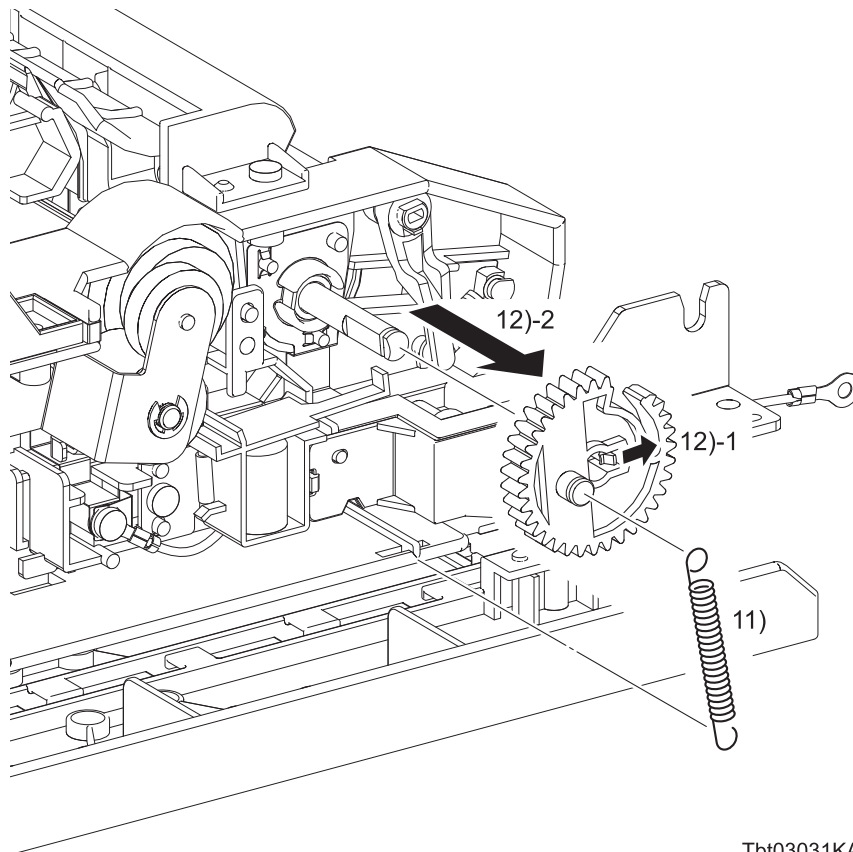

Tbt03031KA

- 11) Remove the SPRING FEED MSI (PL4.2.29) from the GEAR FEED MSI (PL4.2.28) and FRAME RH (PL4.2.10).
- 12) Remove the GEAR FEED MSI from the SHAFT ASSY MSI (PL4.2.20) by releasing the hook of the GEAR FEED MSI.

Continues to the next page.

Removal 26 CAM MSI (PL4.2.16)

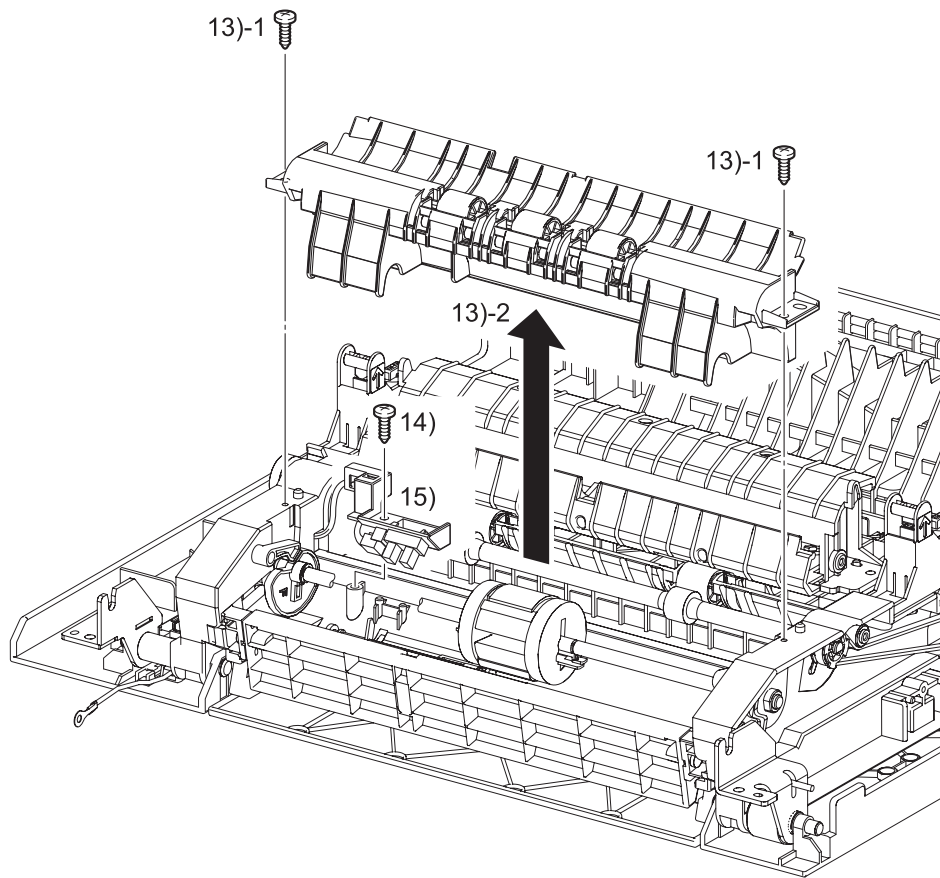

Tbt03205KA

- 13) Remove the CHUTE ASSY MSI (PL4.2.5) from the FRAME RH (PL4.2.10) by removing the two screws (silver, tapping, 8mm).

NOTE

When performing the following step, the connectors of the MSI NO PAPER SENSOR need not be disengaged.

- 14) Remove the one screw (silver, tapping, 8mm) that fixes the BRACKET SENSOR (PL4.2.13) to the FRAME RH.
- 15) Slide the BRACKET SENSOR along with the MSI NO PAPER SENSOR.

Continues to the next page.

Removal 26 CAM MSI (PL4.2.16)

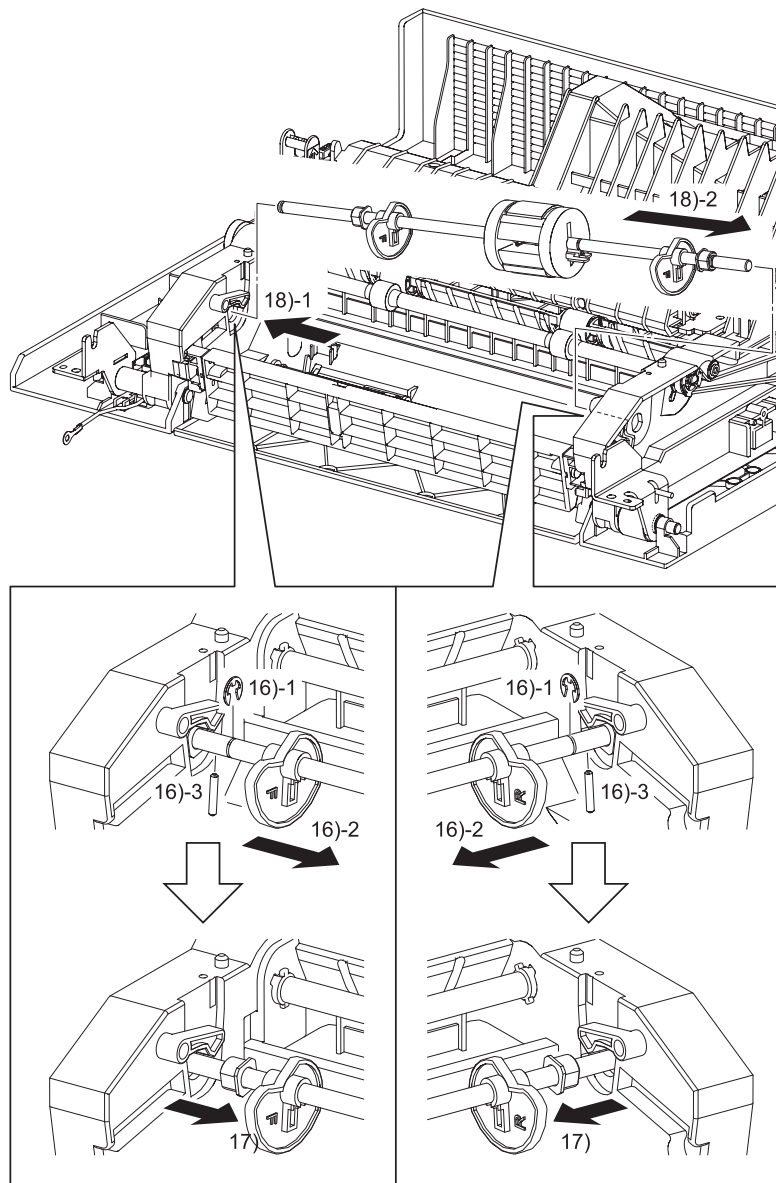

Tbt03206KA

NOTE

When performing the following step, use caution not to drop and lose the PIN MSI.

- 16) Remove the E-rings from the front and rear CAM MSIs (PL4.2.16), slide each CAM MSI inward, and then remove the two PIN MSIs (PL4.2.18) from the SHAFT ASSY MSI (PL4.2.20).
- 17) Slide the front and rear BEARING EARTHS (PL4.2.15) inward.

NOTE

When performing the following step, use caution not to drop and lose the BEARING EARTH.

- 18) Slide the SHAFT ASSY MSI rearward, and pull it out from the FRAME RH by disengaging the front pivot and then the rear pivot, along with the CAM MSI and the BEARING EARTH.

Continues to the next page.

Removal 26 CAM MSI (PL4.2.16)

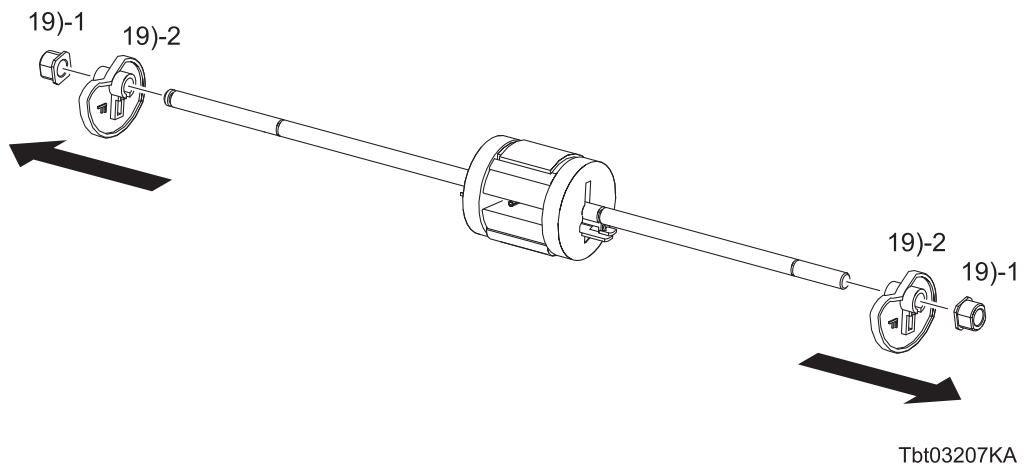

- 19) Slide the BEARING EARTH and the CAM MSI outward and off the SHAFT ASSY MSI.

Blank Page

Removal 27 COVER ASSY RH (PL4.1.31)

In the following steps, the details of Steps 1 through 11 are omitted because they are described earlier in this chapter. Go to the steps in parentheses to execute the necessary steps, and then go to Step 12 onward.

- 1) Remove the TRAY ASSY (PL2.1.1) from the printer.
- 2) Open the COVER ASSY FRONT (PL1.2.17).
- 3) Open the COVER ASSY RH.
- 4) Open the FRAME ASSY 2ND (PL8.1.9).

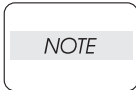

Place the BELT ASSY IBT in a safe place to prevent damage to its belt.

- 5) Remove the BELT ASSY IBT. (Removal 4)

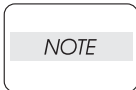

Cover the drum of the XERO DEVE CRU ASSY to prevent damage by light.

- 6) Remove the XERO DEVE CRU ASSY (Y), (M), (C), (K). (Removal 5)

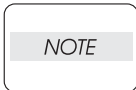

The FUSER section is very hot. Use extra caution not to burn yourself when performing the service operation.

- 7) Remove the FUSER ASSY. (Removal 7)
- 8) Remove the COVER ASSY REAR. (Removal 20)
- 9) Remove the COVER RH UNDER. (Removal 23)
- 10) Remove the KIT RH COVER & FRAME ASSY. (Removal 24)
- 11) Remove the KIT COVER ASSY MSI. (Removal 19)

Continues to the next page.

Removal 27 COVER ASSY RH (PL4.1.31)

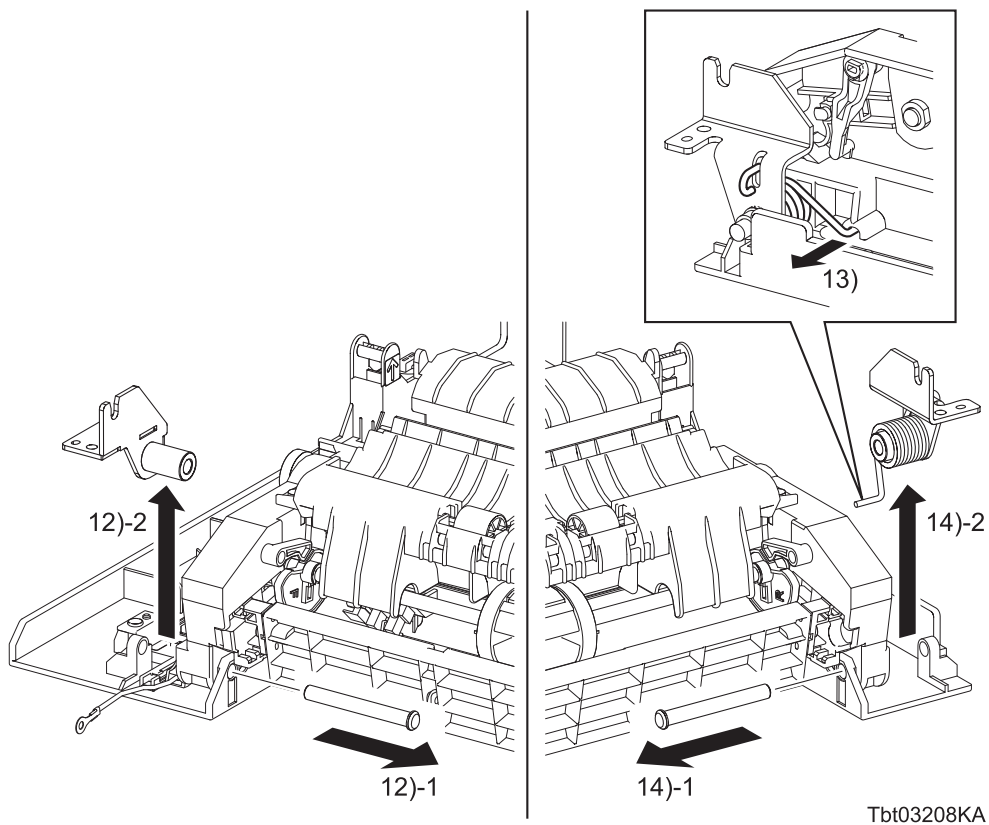

- 12) Pull out the SHAFT PIVOT (PL4.1.30) inward, and remove the BRACKET ASSY PIVOT REAR (PL4.1.6).
- 13) Pull out the SPRING RH FRAME (PL4.1.5) from the hole on the FRAME RH (PL4.2.10).
- 14) Pull out the front SHAFT PIVOT inward, and remove the BRACKET ASSY PIVOT FRONT (PL4.1.4) along with the SPRING RH FRAME.

Continues to the next page.

Removal 27 COVER ASSY RH (PL4.1.31)

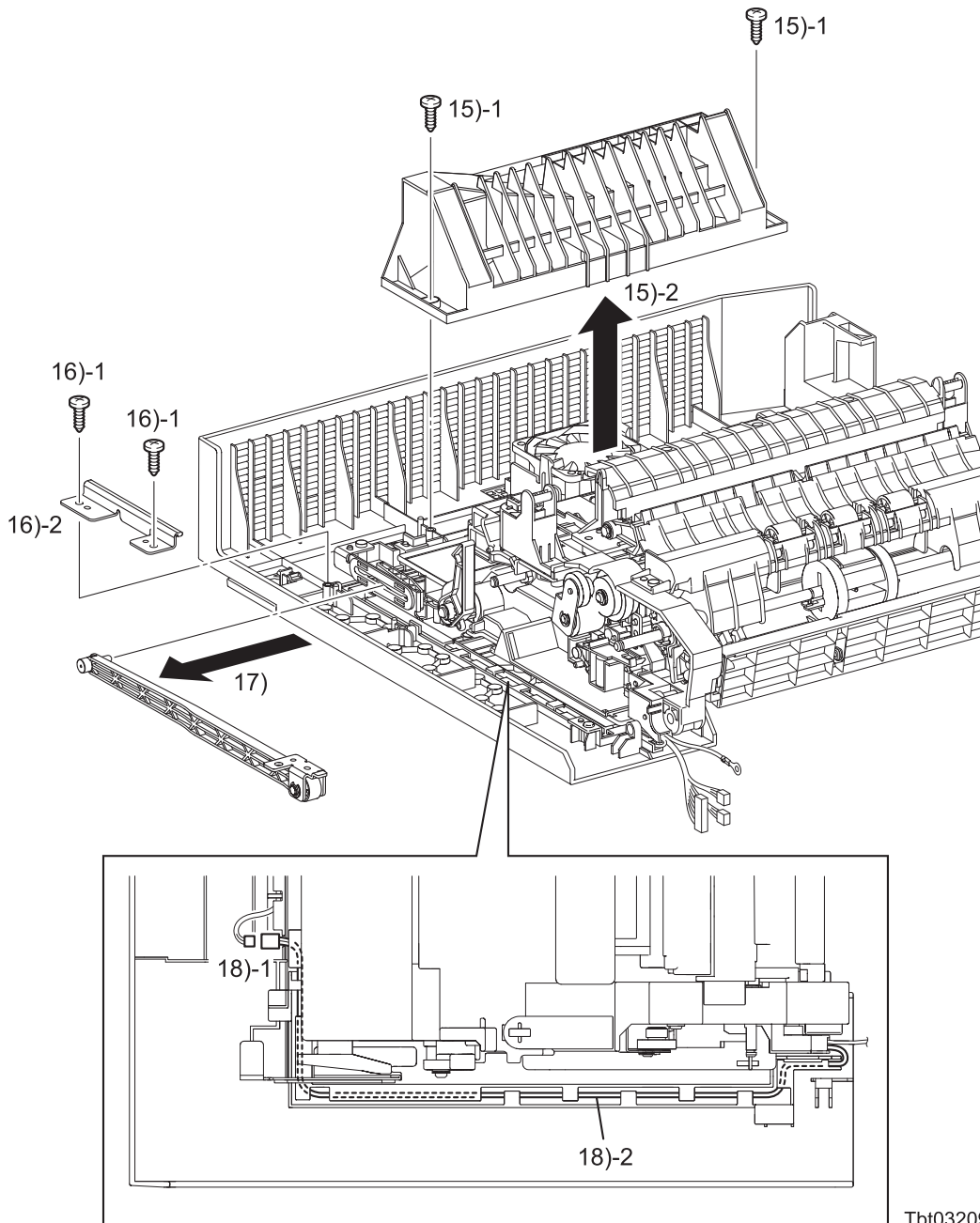

Tbt03209KA

- 15) Remove the CHUTE DUP RH (PL4.1.7) from the COVER ASSY RH (PL4.1.31) by removing the two screws (silver, tapping, 8mm).
- 16) Remove the GUIDE SLIDE LATCH (PL4.1.10) from the COVER ASSY RH by removing the two screws (silver, tapping, 8mm).
- 17) Pull out the shaft of the LINK ASSY (PL4.1.11) from the GUIDE SUPPORT LINK (PL4.1.12), and remove the LINK ASSY from the COVER ASSY RH.
- 18) Disengage the connectors (P/J119) of the FAN FUSER (PL4.1.8), and then release the HARNESS ASSY RH COVER (PL4.3.16) from the hooks of the GUIDE HARNESS RH FAN (PL4.1.9).

Continues to the next page.

Removal 27 COVER ASSY RH (PL4.1.31)

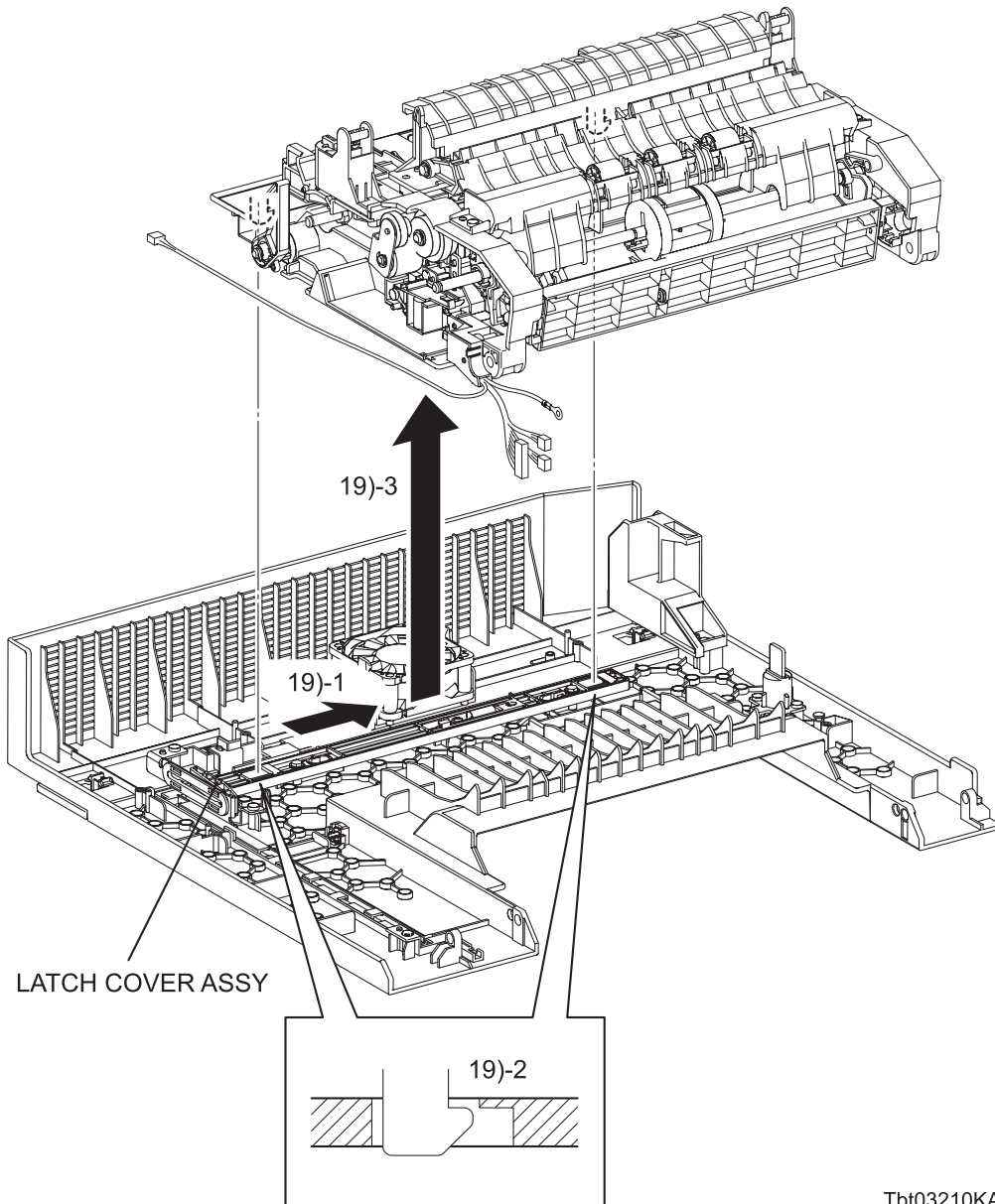

Tbt03210KA

- 19) Slide the LATCH COVER RH (PL4.1.14) frontward until it is released from the two hooks on the FRAME RH, and remove the COVER ASSY RH.

Removal 28 SEPARATOR ASSY MSI (PL3.1.7)

In the following steps, the details of Steps 1 through 10 are omitted because they are described earlier in this chapter. Go to the steps in parentheses to execute the necessary steps, and then go to Step 11 onward.

- 1) Remove the TRAY ASSY (PL2.1.1) from the printer.
- 2) Open the COVER ASSY FRONT (PL1.2.17).
- 3) Open the COVER ASSY RH.
- 4) Open the FRAME ASSY 2ND (PL8.1.9).

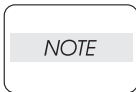

Place the BELT ASSY IBT in a safe place to prevent damage to its belt.

- 5) Remove the BELT ASSY IBT. (Removal 4)

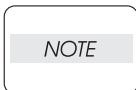

Cover the drum of the XERO DEVE CRU ASSY to prevent damage by light.

- 6) Remove the XERO DEVE CRU ASSY (Y), (M), (C), (K). (Removal 5)

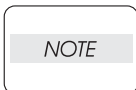

The FUSER section is very hot. Use extra caution not to burn yourself when performing the service operation.

- 7) Remove the FUSER ASSY. (Removal 7)
- 8) Remove the COVER ASSY REAR. (Removal 20)
- 9) Remove the COVER RH UNDER. (Removal 23)
- 10) Remove the KIT RH COVER & FRAME ASSY. (Removal 24)

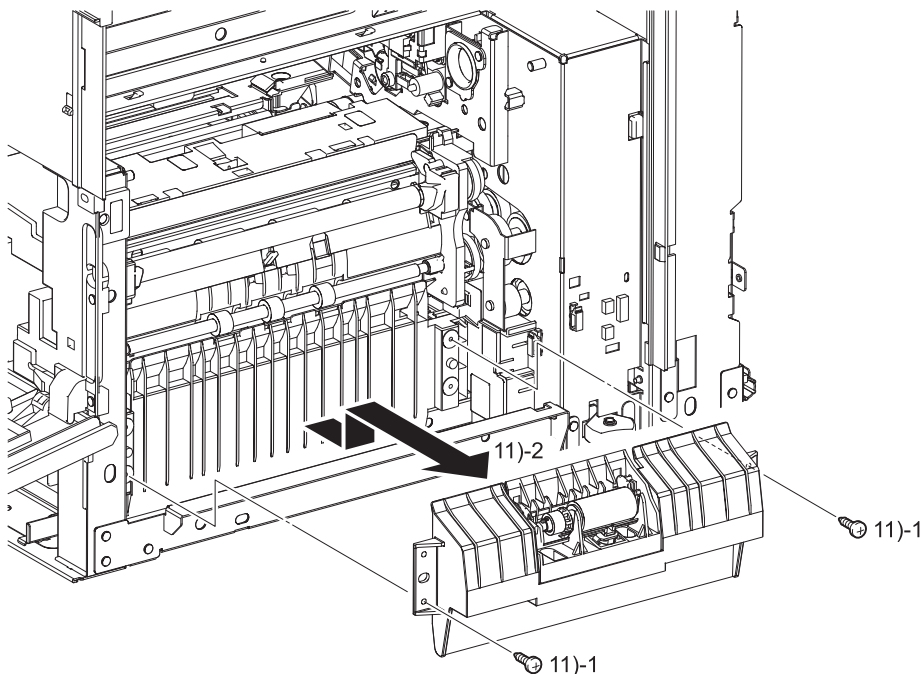

Tbt03035KB

- 11) Remove the SEPARATOR ASSY MSI (PL3.1.7) from the printer by removing the two screws (silver, tapping, 8mm).

Go to the next removal step:

Removal 29 FEEDER ASSY (PL3.2.1)

Blank Page

Removal 29 FEEDER ASSY (PL3.2.1)

In the following steps, the details of Steps 1 through 11 are omitted because they are described earlier in this chapter. Go to the steps in parentheses to execute the necessary steps, and then go to Step 12 onward.

- 1) Remove the TRAY ASSY (PL2.1.1) from the printer.
- 2) Open the COVER ASSY FRONT (PL1.2.17).
- 3) Open the COVER ASSY RH.
- 4) Open the FRAME ASSY 2ND (PL8.1.9).

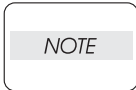

Place the BELT ASSY IBT in a safe place to prevent damage to its belt.

- 5) Remove the BELT ASSY IBT. (Removal 4)

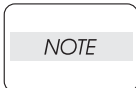

Cover the drum of the XERO DEVE CRU ASSY to prevent damage by light.

- 6) Remove the XERO DEVE CRU ASSY (Y), (M), (C), (K). (Removal 5)

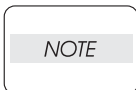

The FUSER section is very hot. Use extra caution not to burn yourself when performing the service operation.

- 7) Remove the FUSER ASSY. (Removal 7)
- 8) Remove the COVER ASSY REAR. (Removal 20)
- 9) Remove the COVER RH UNDER. (Removal 23)
- 10) Remove the KIT RH COVER & FRAME ASSY. (Removal 24)
- 11) Remove the SEPARATOR ASSY MSI. (Removal 28)

Continues to the next page.

Removal 29 FEEDER ASSY (PL3.2.1)

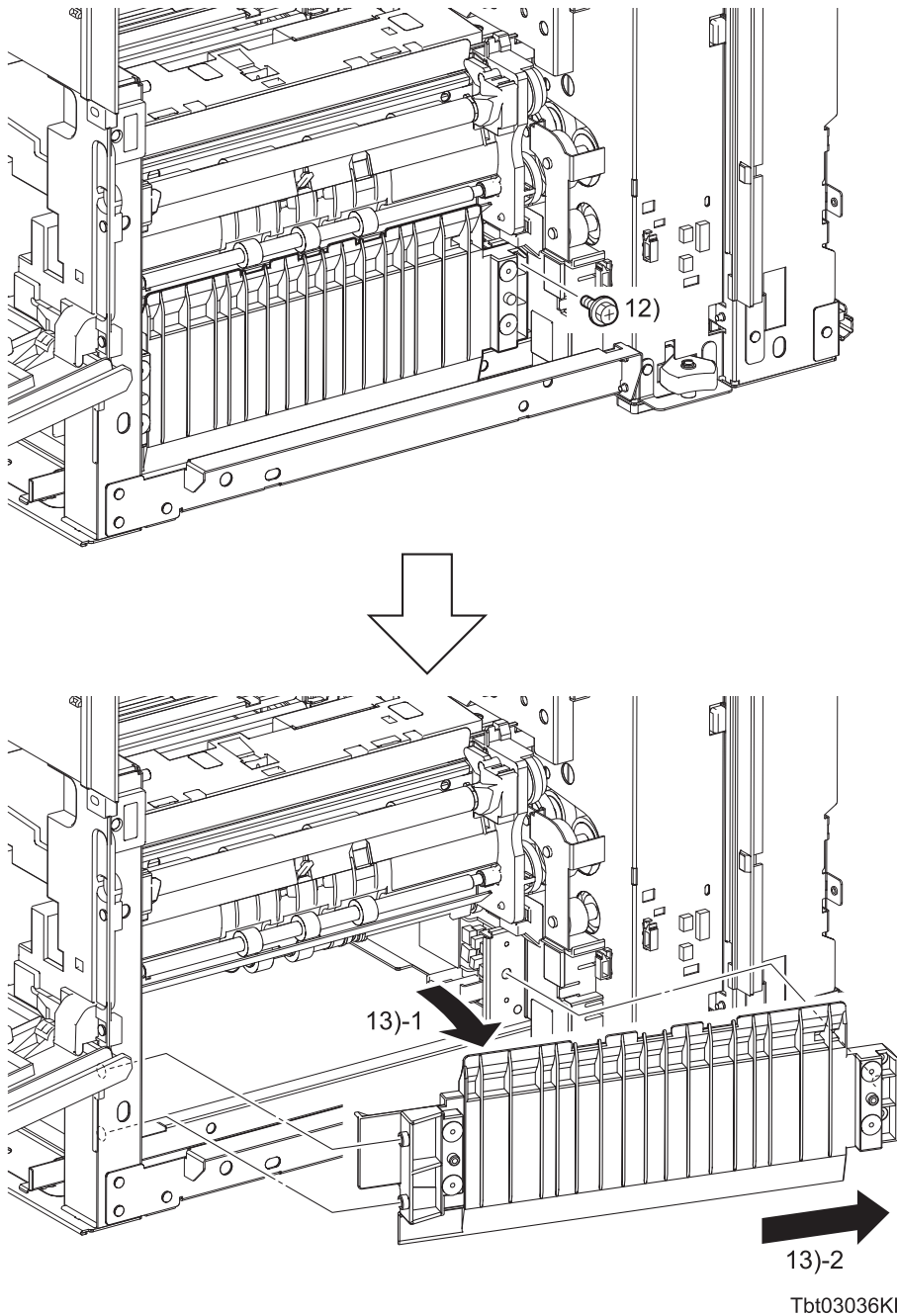

- 12) Remove the one screw (silver, flanged, 6mm) that fixes the GUIDE TRAY (PL3.1.6) to the printer.
- 13) Release the boss on the rear side of the GUIDE TRAY, and then slide the GUIDE TRAY backward to release the two bosses on the front side of the GUIDE TRAY. Then, remove the GUIDE TRAY from the printer.

Continues to the next page.

Removal 29 FEEDER ASSY (PL3.2.1)

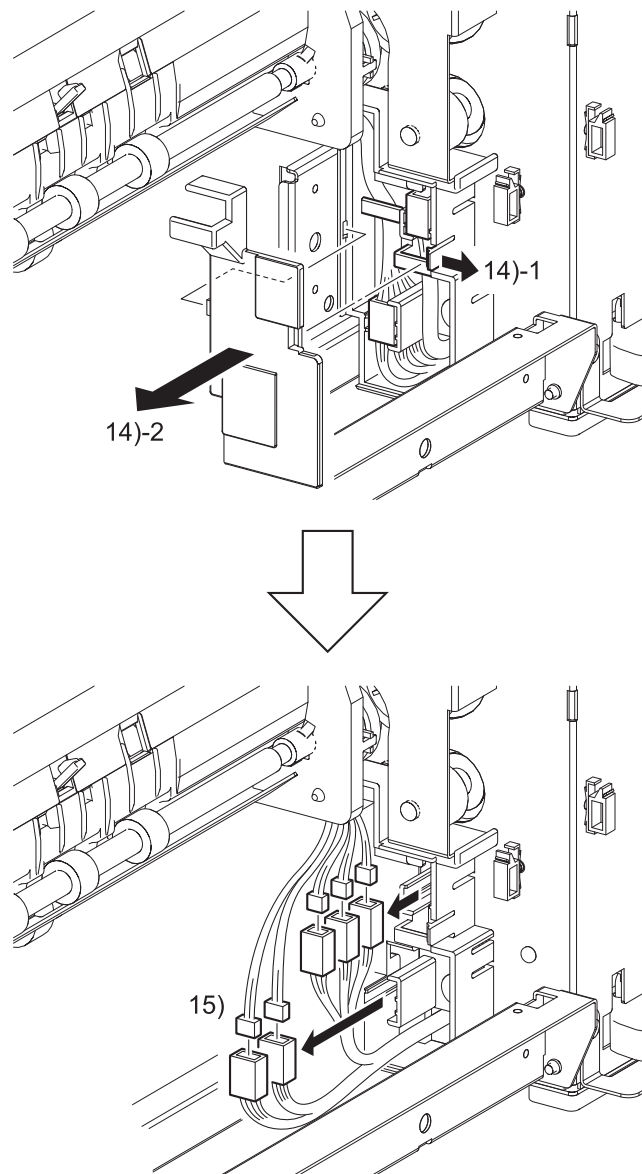

- 14) Remove the COVER GUIDE HARNESS (PL3.1.13) from the GUIDE HARNESS (PL3.1.14) by releasing the hook of the GUIDE HARNESS.

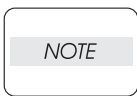

When performing the following step, use caution, leave the relay connector on the printer harness side.

- 15) Pull out all the connectors from the GUIDE HARNESS to disengage them.

Continues to the next page.

Removal 29 FEEDER ASSY (PL3.2.1)

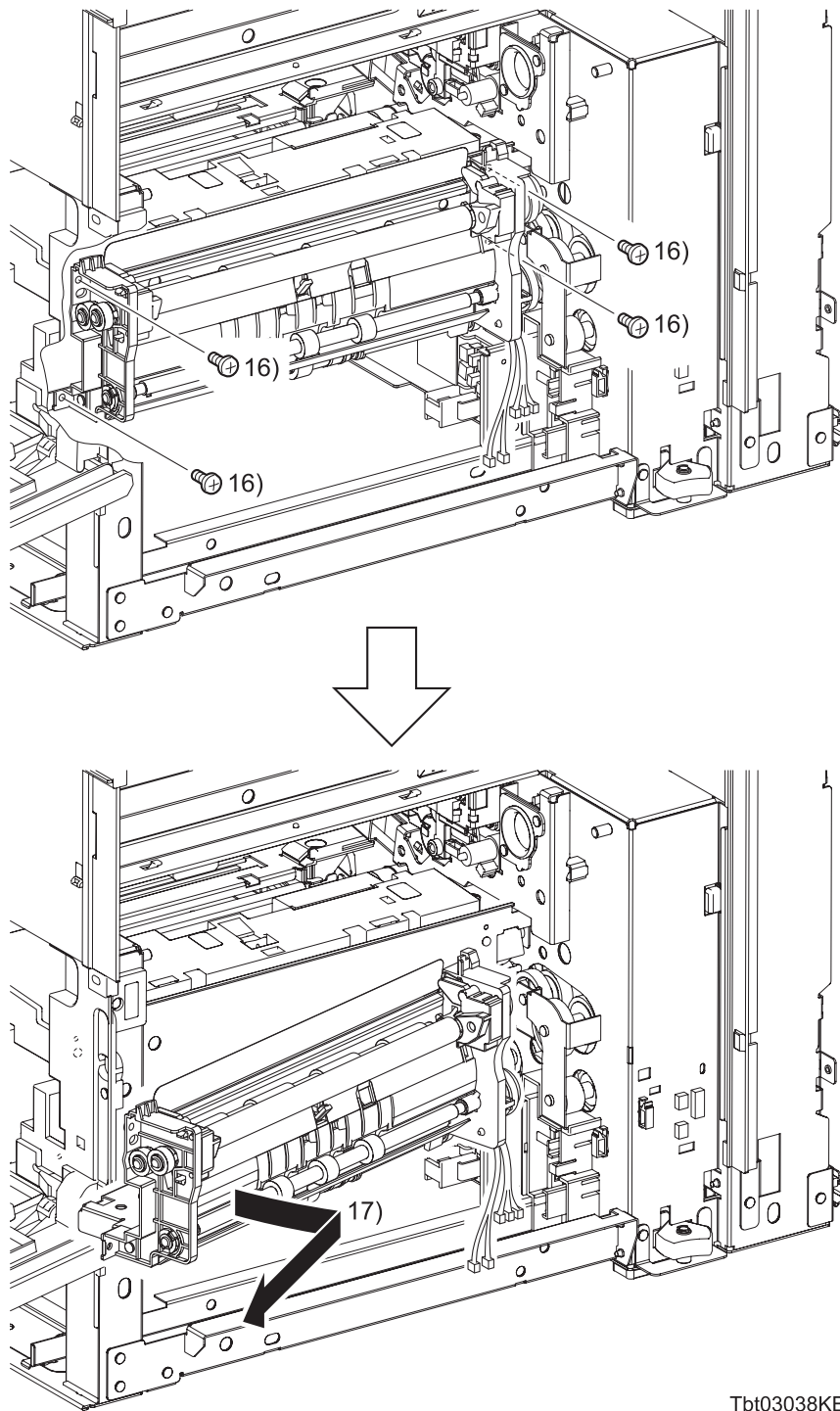

Tbt03038KB

- 16) Remove the four screws (silver, 6mm) that fix the FEEDER ASSY (PL3.2.1) to the printer.
- 17) Slide the front side of the FEEDER ASSY toward you, and remove it by disengaging the three clutches on its rear side from the gears of the DRIVE ASSY PH (PL9.1.4).

Removal 30 KIT PLATE ASSY ESS (PL10.1.99)

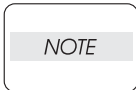

Use a wrist strap to protect the PWB from electrostatic damage.

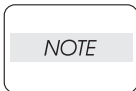

If there is the WIRELESS ADAPTER, the MEMORY CARD and the HDD ASSY on the PWBA ESS, remove it before working.

In the following steps, the details of Step 1 are omitted because they are described earlier in this chapter. Go to the step in parentheses to execute the necessary steps, and then go to Step 2 onward.

- 1) Remove the COVER ASSY REAR. (Removal 20)

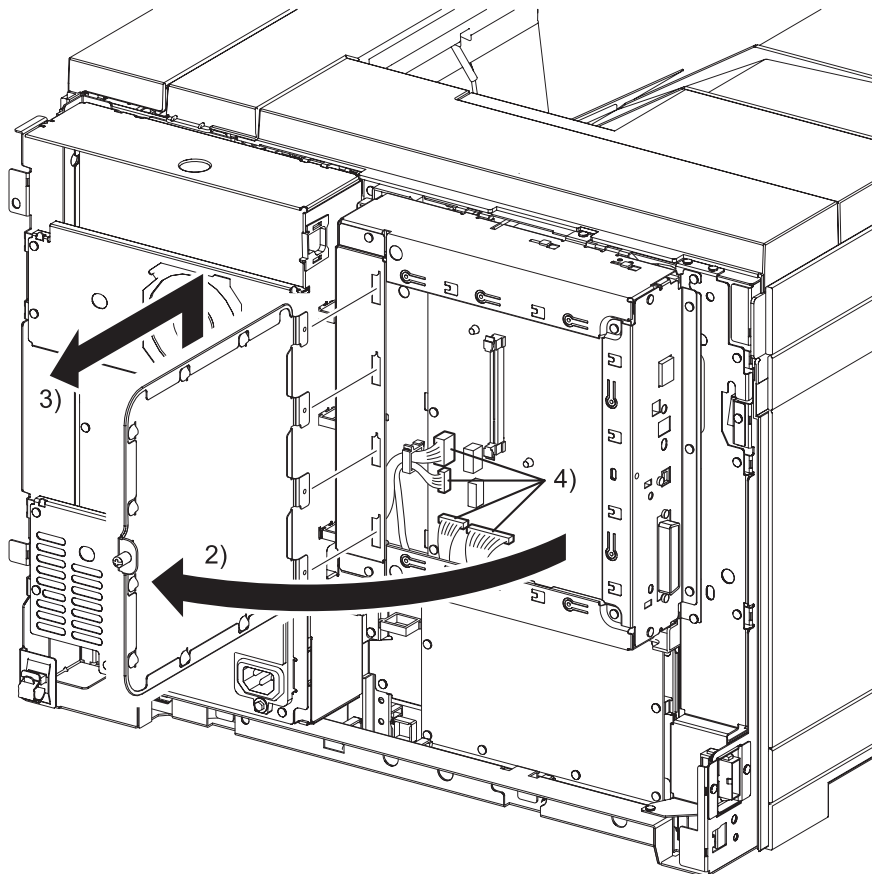

Tbt03039KA

- 2) Loosen the SCREW KNURLING (PL10.1.3), and then open the PLATE WINDOW ESS (PL10.1.2).
- 3) Lift the PLATE WINDOW ESS slightly up to release the four tabs of the PLATE WINDOW ESS from the holes of the BOX ASSY BASE (PL10.1.4).
- 4) Disengage all the connectors of the PWBA ESS (PL10.1.6).

Continues to the next page.

Removal 30 KIT PLATE ASSY ESS (PL10.1.99)

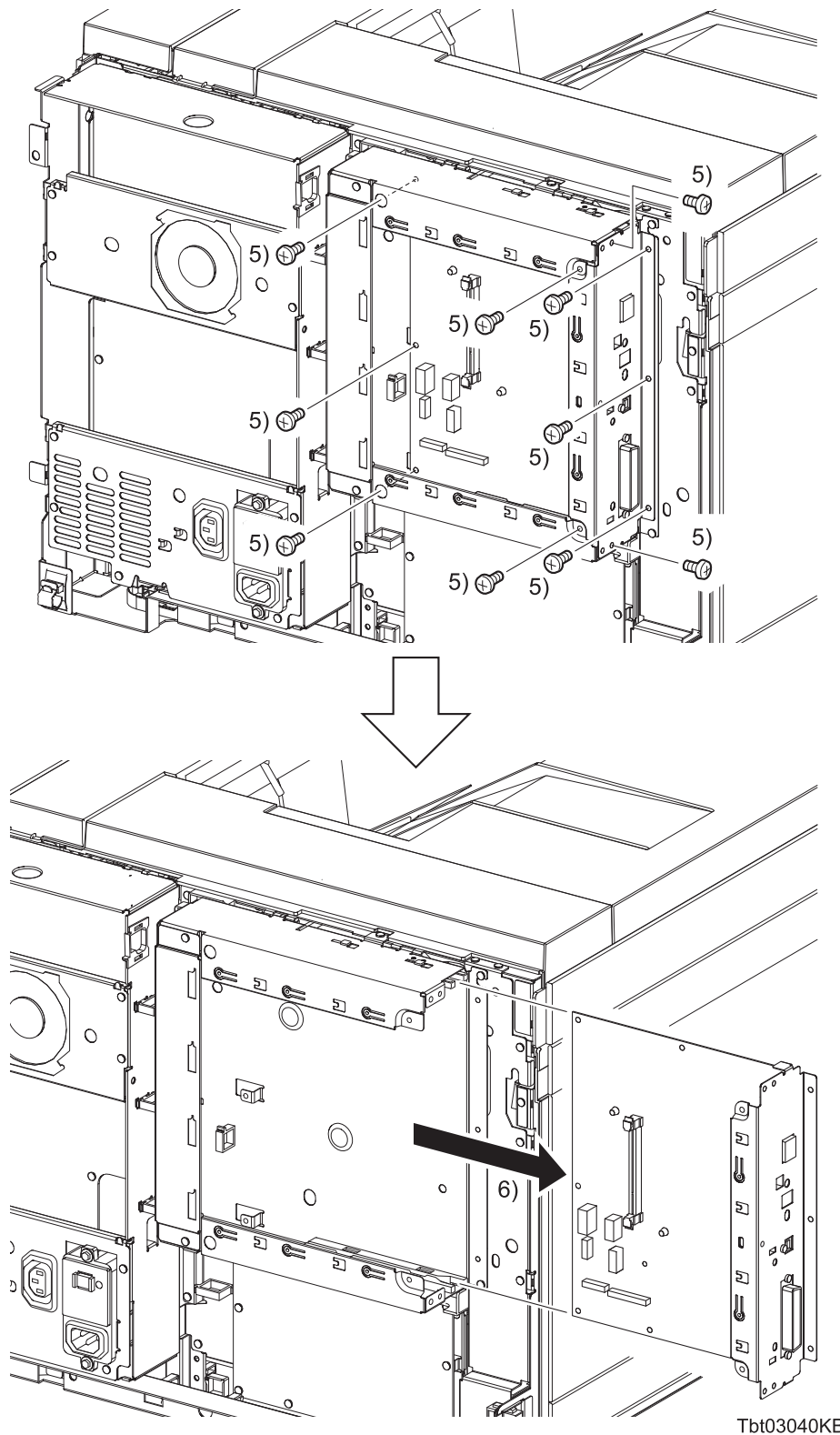

- 5) Remove the ten screws (silver, 6mm) that fix the PLATE ASSY ESS (PL10.1.5) to the printer.
- 6) Pull the PLATE ASSY ESS out of the printer.

Removal 31 KIT PWBA MCU (PL10.2.99)

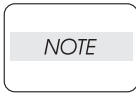

Never fail to perform the diagnostic operation. Otherwise the data will be lost in the worst case.

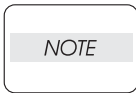

Use a wrist strap to protect the PWB from electrostatic damage.

- 1) Perform NVM Save to evacuate the MCU data.
- 2) Turn on the power while pressing the "▶" key, "◀" key, and [MENU] key on the control panel.
- 3) Enter the password, press the "▲" key twice, and press the "✓" key once. The diagnostic screen comes up.
- 4) Press the "▼" key several times until "IOT Diag" is displayed. Press the "✓" key once.
- 5) Press the "▼" key several until "NVM Settings" is displayed. Press the "✓" key once.
- 6) Press the "▼" key several times until "SaveNVM to ESS" is displayed. Press the "✓" key once.
- 7) Press the "?" key twice, and SaveNVM to ESS is performed.
- 8) After SaveNVM to ESS is complete, press the [CANCEL] key several times until "IOT Diag" is displayed.
- 9) Press the "▼" key several times until "Complete" is displayed.
- 10) Press the "✓" key three times. "Ready to Print" is displayed.
- 11) Turn off the power.
- 12) Remove the POWER CORD from the AC outlet.

In the following steps, the details of Step 13 are omitted because they are described earlier in this chapter. Go to the step in parentheses to execute the necessary steps, and then go to Step 14 onward.

- 13) Remove the COVER ASSY REAR. (Removal 20)

Continues to the next page.

Removal 31 KIT PWBA MCU (PL10.2.99)

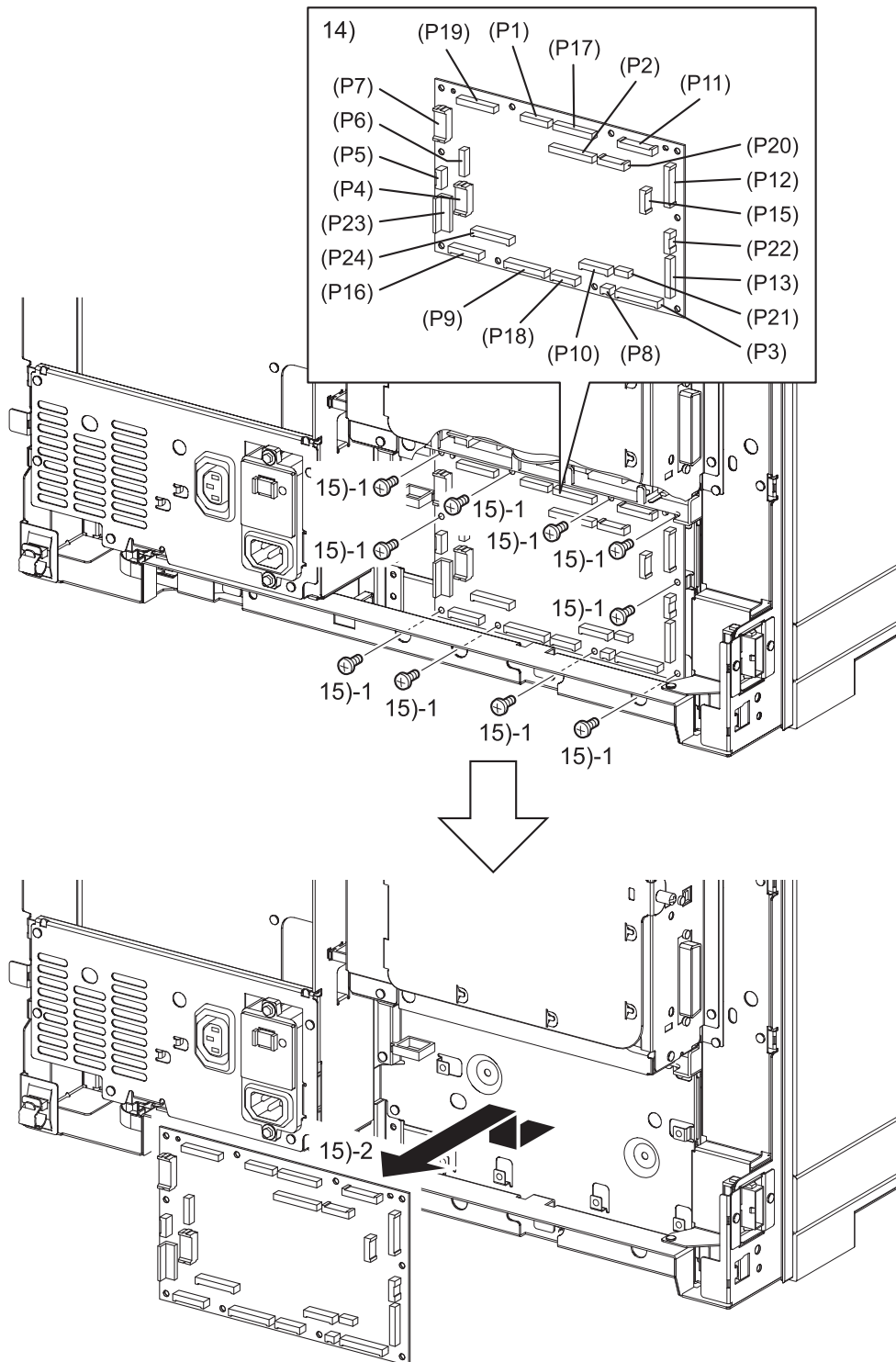

Tbt03041KB

- 14) Disengage all the connectors of the PWBA MCU (PL10.2.18).
- 15) Remove the PWBA MCU from the printer by removing the ten screws (silver, 6mm).

Removal 32 FAN ASSY LVPS (PL10.1.9)

In the following steps, the details of Step 1 are omitted because they are described earlier in this chapter. Go to the step in parentheses to execute the necessary steps, and then go to Step 2 onward.

- 1) Remove the COVER ASSY REAR. (Removal 20)

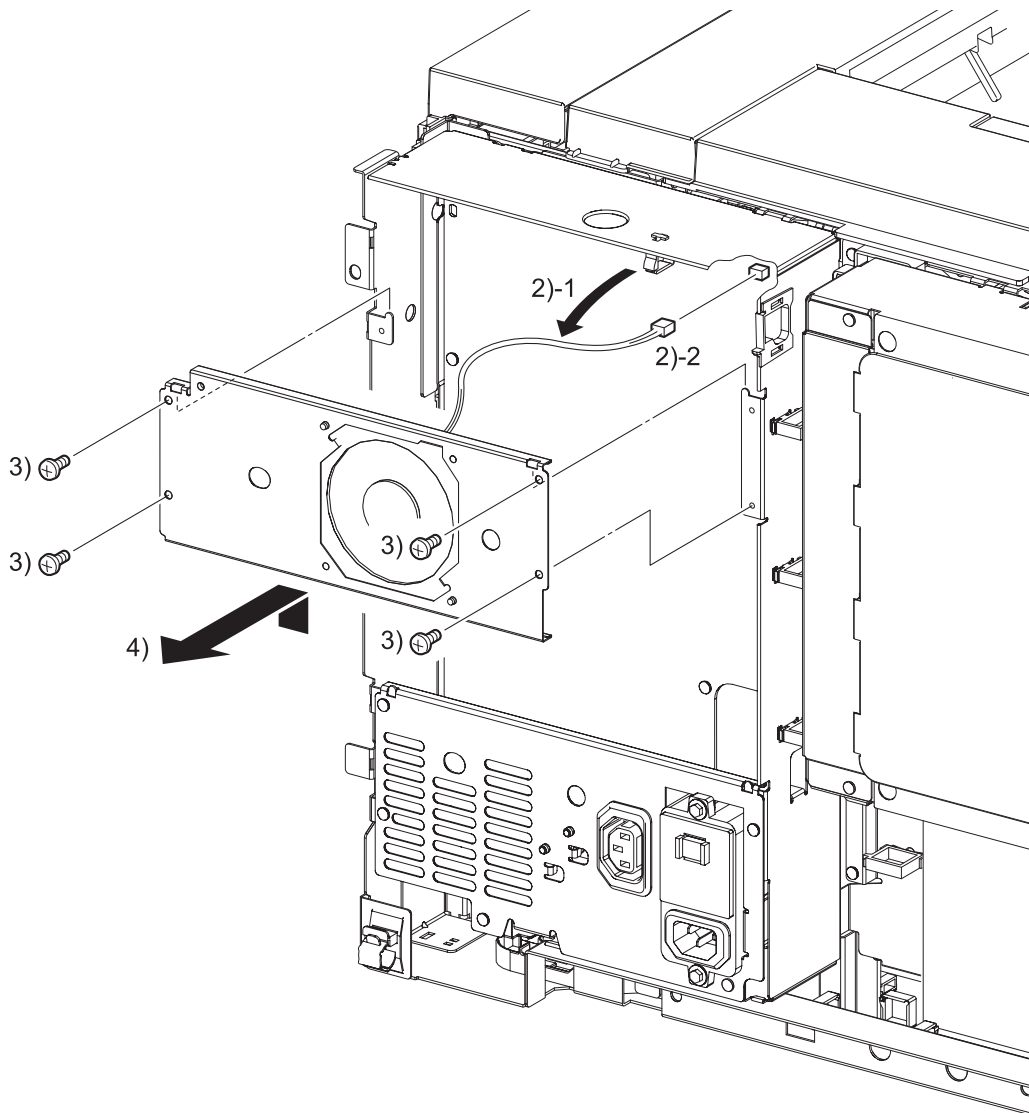

Tbt03042KB

- 2) Disengage the connectors (P/J309) of the FAN LVPS (PL10.1.10), and then release the harness of the FAN LVPS from the clamp of the BOX ASSY LVPS (PL10.2.1).
- 3) Remove the four screws (silver, 6mm) that fix the FAN ASSY LVPS (PL10.1.9) to the printer.
- 4) Remove the FAN ASSY LVPS from the printer by slightly lifting the FAN ASSY LVPS to release the two holes in the FAN ASSY LVPS from the tabs of the printer.

Blank Page

Removal 33 PLATE ASSY LVPS POWER (PL10.1.12)

In the following steps, the details of Step 1 are omitted because they are described earlier in this chapter. Go to the step in parentheses to execute the necessary steps, and then go to Step 2 onward.

- 1) Remove the COVER ASSY REAR. (Removal 20)

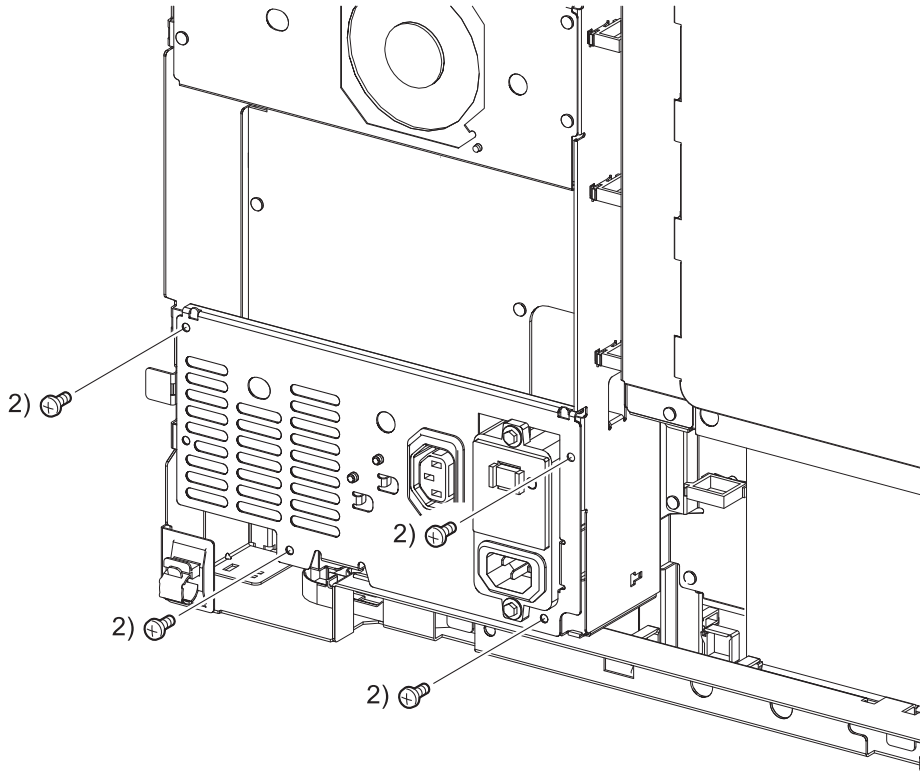

Tbt03043KB

- 2) Remove the four screws (silver, 6mm) that fix the PLATE ASSY LVPS POWER (PL10.1.12) to the printer.

Continues to the next page.

Removal 33 PLATE ASSY LVPS POWER (PL10.1.12)

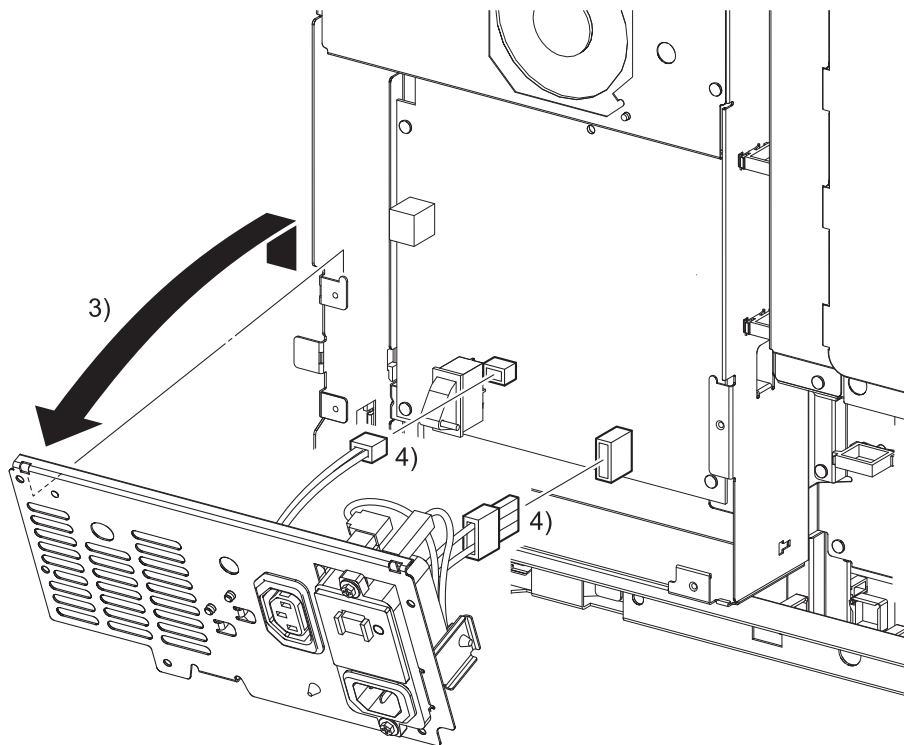

Tbt03044KB

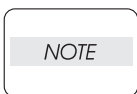

When performing the following step, use caution not to move the PLATE ASSY LVPS POWER from the printer too far because they are connected with the harness.

- 3) Release the two holes in the PLATE ASSY LVPS POWER from the tabs of the printer and tilt the PLATE ASSY LVPS POWER toward you.
- 4) Disengage the two sets of connectors (P/J300, 311) of the PLATE ASSY LVPS POWER on the LVPS ASSY (PL10.2.2), and then remove the PLATE ASSY LVPS POWER from the printer.

Removal 34 COVER LH ASSY (PL1.3.2)

In the following steps, the details of Steps 1 through 3 are omitted because they are described earlier in this chapter. Go to the steps in parentheses to execute the necessary steps, and then go to Step 4 onward.

- 1) Remove the TRAY ASSY (PL2.1.1) from the printer.
- 2) Open the COVER ASSY FRONT (PL1.2.17).
- 3) Remove the COVER ASSY REAR. (Removal 20)

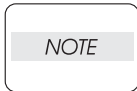

The two COVER LH FINISHERS are mounted; one is located at the top and the other is at the bottom. Remove both COVER LH FINISHERS.

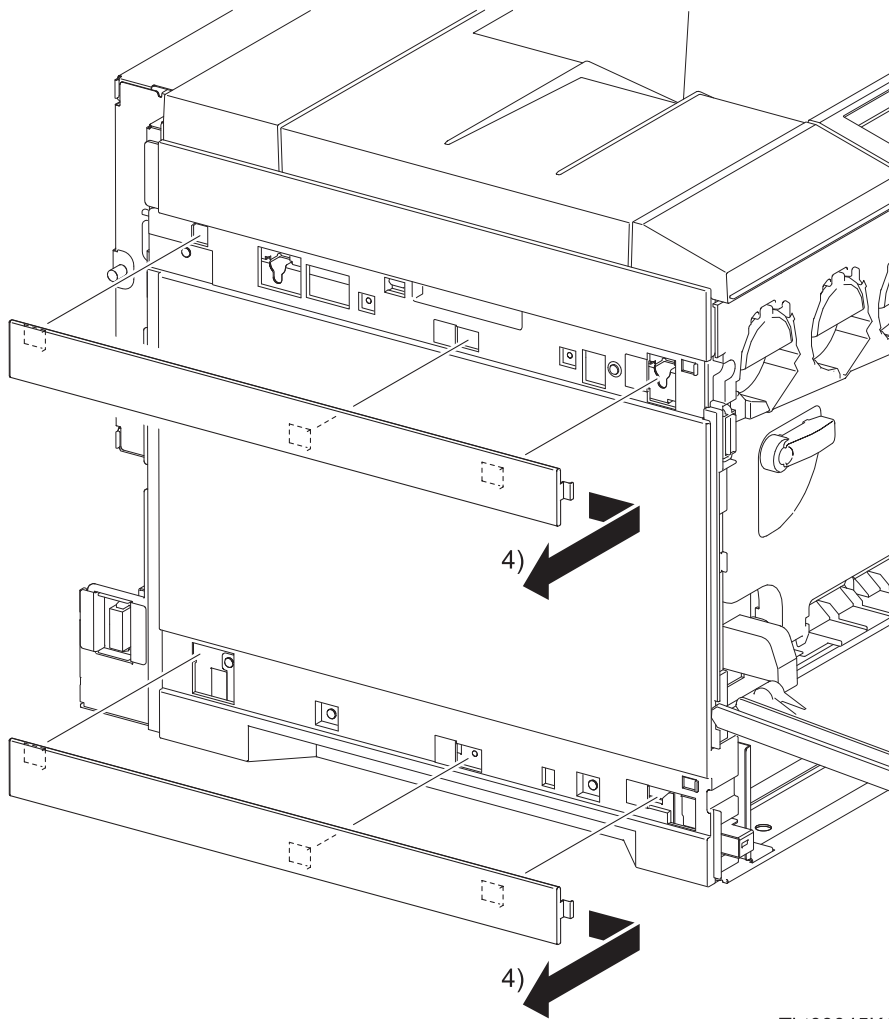

Tbt03045KA

- 4) Slide the COVER LH FINISHER (PL1.3.3) to the front side and release the three hooks to remove the COVER LH FINISHER from the printer.

Continues to the next page.

Removal 34 COVER LH ASSY (PL1.3.2)

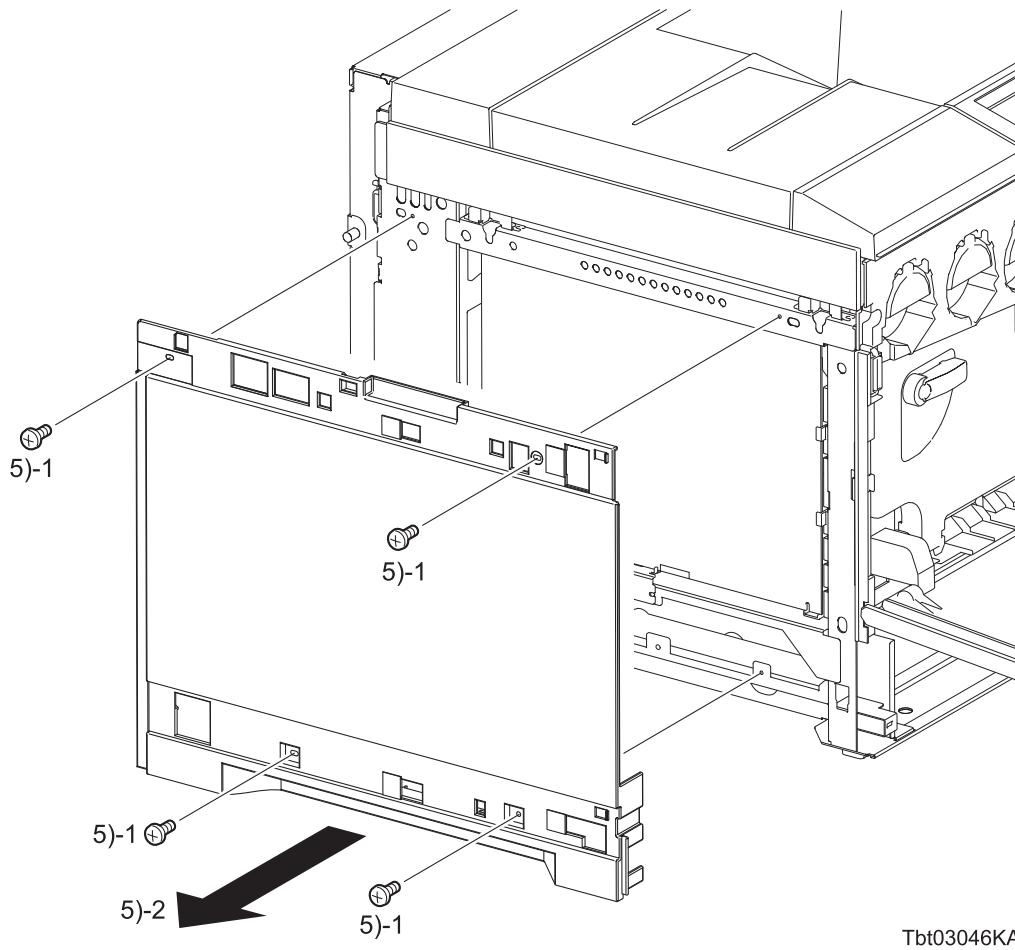

- 5) Remove the COVER LH from the printer by removing the four screws (silver, 6mm).

Removal 35 COVER ASSY INNER FRONT (PL1.2.6)

In the following steps, the details of Steps 1 through 12 are omitted because they are described earlier in this chapter. Go to the steps in parentheses to execute the necessary steps, and then go to Step 13 onward.

- 1) Remove the TRAY ASSY (PL2.1.1) from the printer.
- 2) Remove the COVER ASSY FRONT. (Removal 1)
- 3) Remove the TONER CARTRIDGE (Y), (M), (C), (K) (PL6.1.1~6.1.4) from the printer.
- 4) Remove the WASTE TONER BOX. (Removal 3)
- 5) Open the COVER ASSY RH.
- 6) Open the FRAME ASSY 2ND (PL8.1.9).

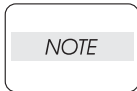

Place the BELT ASSY IBT in a safe place to prevent damage to its belt.

- 7) Remove the BELT ASSY IBT. (Removal 4)

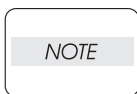

Cover the drum of the XERO DEVE CRU ASSY to prevent damage by light.

- 8) Remove the XERO DEVE CRU ASSY (Y), (M), (C), (K). (Removal 5)
- 9) Remove the KIT FRAME ASSY 2ND. (Removal 6)
- 10) Remove the COVER ASSY REAR. (Removal 20)
- 11) Remove the COVER LH ASSY. (Removal 34)
- 12) Remove the COVER FRONT RH. (Removal 18)

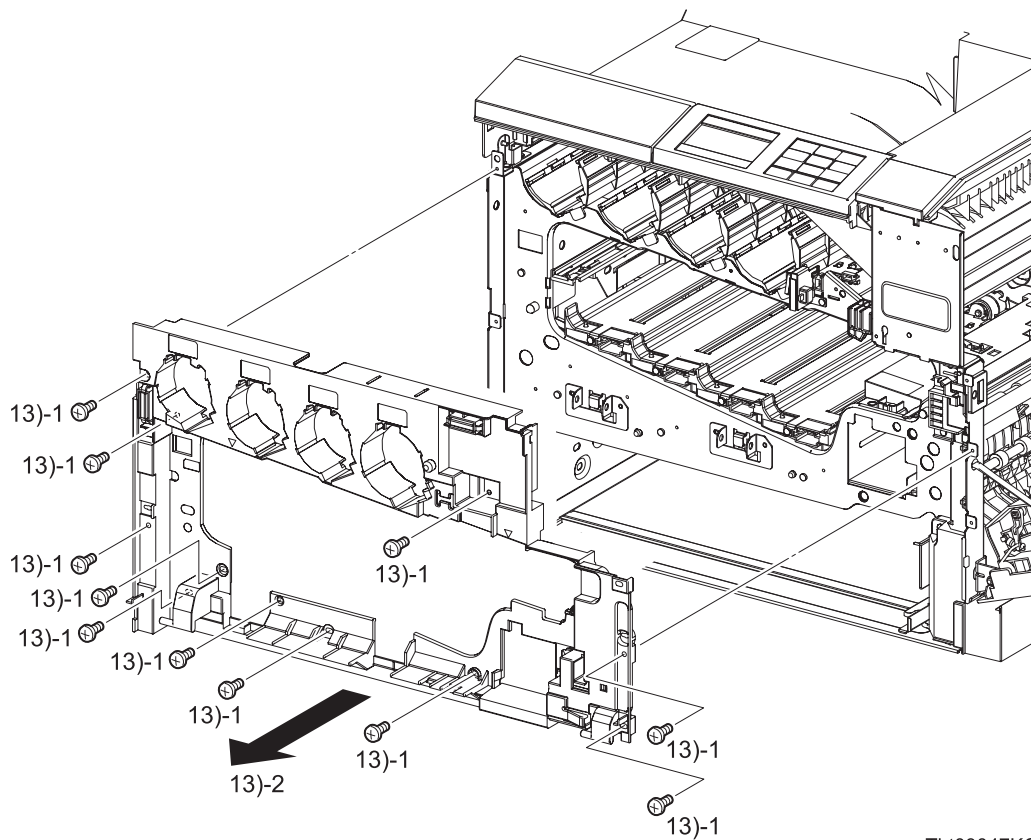

Tbt03047KC

- 13) Remove the COVER ASSY INNER FRONT (PL1.2.6) from the printer by removing the eleven screws (silver, 6mm).

Removal 36 SWITCH (Front Cover Switch) (PL1.2.3)

In the following steps, the details of Steps 1 through 13 are omitted because they are described earlier in this chapter. Go to the steps in parentheses to execute the necessary steps, and then go to Step 14 onward.

- 1) Remove the TRAY ASSY (PL2.1.1) from the printer.
- 2) Remove the COVER ASSY FRONT. (Removal 1)
- 3) Remove the TONER CARTRIDGE (Y), (M), (C), (K) (PL6.1.1~6.1.4) from the printer.
- 4) Remove the WASTE TONER BOX. (Removal 3)
- 5) Open the COVER ASSY RH.
- 6) Open the FRAME ASSY 2ND (PL8.1.9).

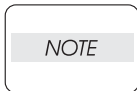

Place the BELT ASSY IBT in a safe place to prevent damage to its belt.

- 7) Remove the BELT ASSY IBT. (Removal 4)

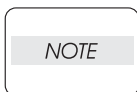

Cover the drum of the XERO DEVE CRU ASSY to prevent damage by light.

- 8) Remove the XERO DEVE CRU ASSY (Y), (M), (C), (K). (Removal 5)
- 9) Remove the KIT FRAME ASSY 2ND. (Removal 6)
- 10) Remove the COVER ASSY REAR. (Removal 20)
- 11) Remove the COVER LH ASSY. (Removal 34)
- 12) Remove the COVER FRONT RH. (Removal 18)
- 13) Remove the COVER ASSY INNER FRONT (Removal 35)

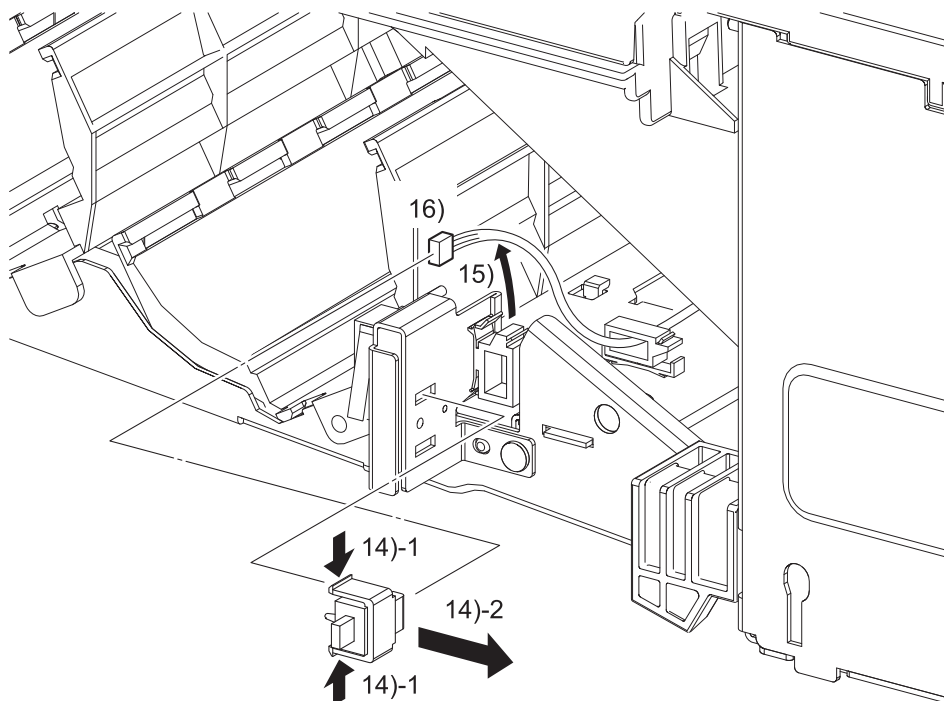

Tbt03048KB

- 14) Remove the SWITCH (PL1.2.3) from the printer by releasing the two hooks of the SWITCH.
- 15) Release the harness of the SWITCH from the clamp.
- 16) Disengage the connectors (P/J212) of the SWITCH.

Removal 37 COVER FR UNDER (PL8.1.16)

In the following steps, the details of Steps 1 through 15 are omitted because they are described earlier in this chapter. Go to the steps in parentheses to execute the necessary steps, and then go to Step 16 onward.

- 1) Remove the TRAY ASSY (PL2.1.1) from the printer.
- 2) Remove the COVER ASSY FRONT. (Removal 1)
- 3) Remove the TONER CARTRIDGE (Y), (M), (C), (K) (PL6.1.1~6.1.4) from the printer.
- 4) Remove the WASTE TONER BOX. (Removal 3)
- 5) Open the COVER ASSY RH.
- 6) Open the FRAME ASSY 2ND (PL8.1.9).

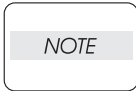

Place the BELT ASSY IBT in a safe place to prevent damage to its belt.

- 7) Remove the BELT ASSY IBT. (Removal 4)

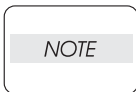

Cover the drum of the XERO DEVE CRU ASSY to prevent damage by light.

- 8) Remove the XERO DEVE CRU ASSY (Y), (M), (C), (K). (Removal 5)
- 9) Remove the KIT FRAME ASSY 2ND. (Removal 6)

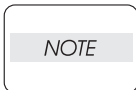

The FUSER section is very hot. Use extra caution not to burn yourself when performing the service operation.

- 10) Remove the FUSER ASSY. (Removal 7)
- 11) Remove the COVER ASSY REAR. (Removal 20)
- 12) Remove the COVER RH UNDER. (Removal 23)
- 13) Remove the COVER LH ASSY. (Removal 34)
- 14) Remove the COVER FRONT RH. (Removal 18)
- 15) Remove the COVER ASSY INNER FRONT. (Removal 35)

Continues to the next page.

Removal 37 COVER FR UNDER (PL8.1.16)

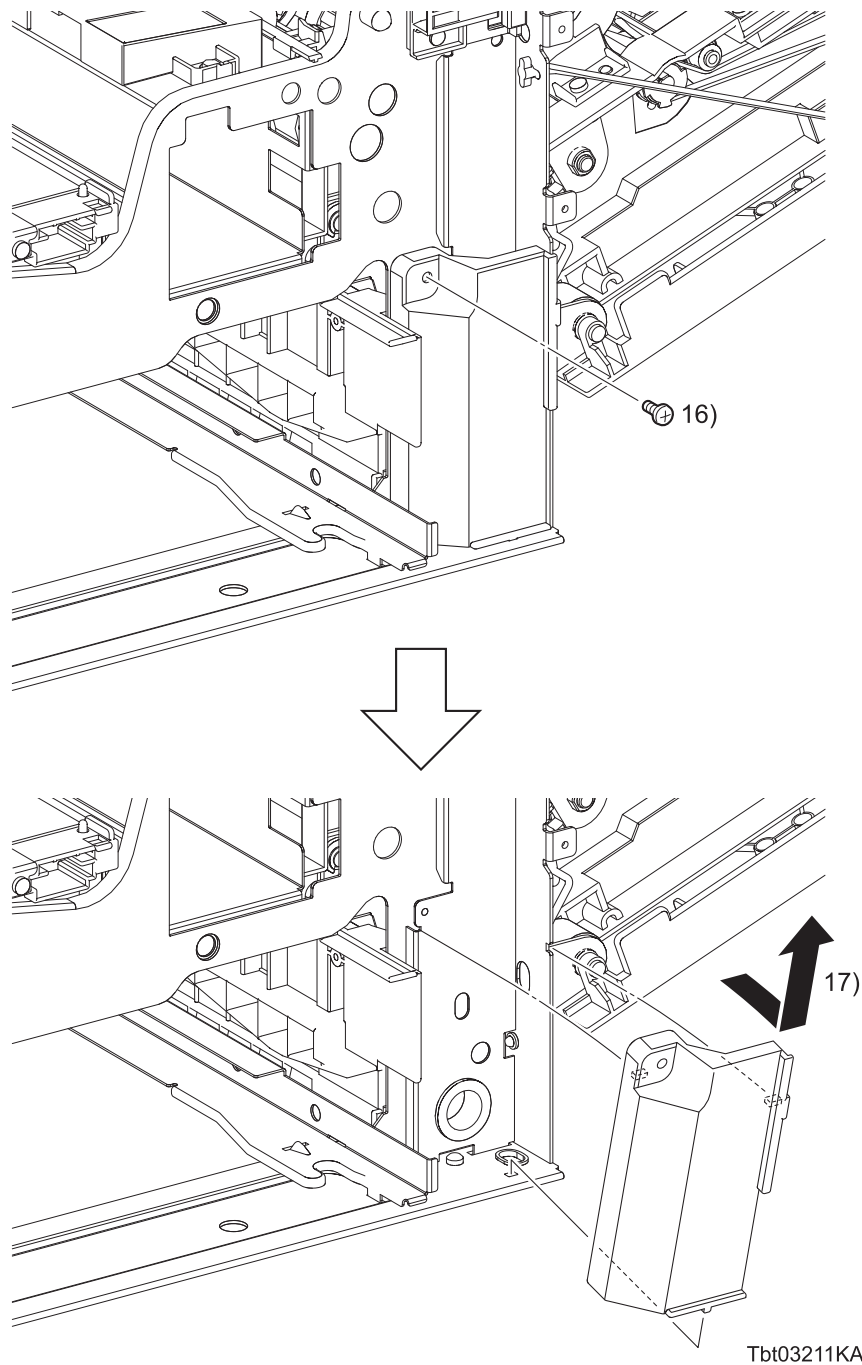

Tbt03211KA

- 16) Remove the one screw (silver, 6mm) that fixes the COVER FR UNDER (PL8.1.16) to the printer.
- 17) Tilt the COVER FR UNDER slightly toward you so that the two tabs on its rear side are released from the notches on the printer, and then remove it upward until its bottom tab is released from the hole on the printer.

Removal 38 PWBA HVPS (PL5.2.3)

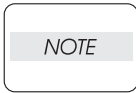

Use a wrist strap to protect the PWB from electrostatic damage.

In the following steps, the details of Steps 1 through 8 are omitted because they are described earlier in this chapter. Go to the steps in parentheses to execute the necessary steps, and then go to Step 9 onward.

- 1) Remove the TRAY ASSY (PL2.1.1) from the printer.
- 2) Open the COVER ASSY FRONT (PL1.2.17).
- 3) Open the COVER ASSY RH.
- 4) Open the FRAME ASSY 2ND (PL8.1.9).

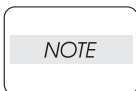

Place the BELT ASSY IBT in a safe place to prevent damage to its belt.

- 5) Remove the BELT ASSY IBT. (Removal 4)

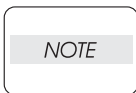

Cover the drum of the XERO DEVE CRU ASSY to prevent damage by light.

- 6) Remove the XERO DEVE CRU ASSY (Y), (M), (C), (K). (Removal 5)
- 7) Remove the COVER ASSY REAR. (Removal 20)
- 8) Remove the COVER LH ASSY. (Removal 34)

Continues to the next page.

Removal 38 PWBA HVPS (PL5.2.3)

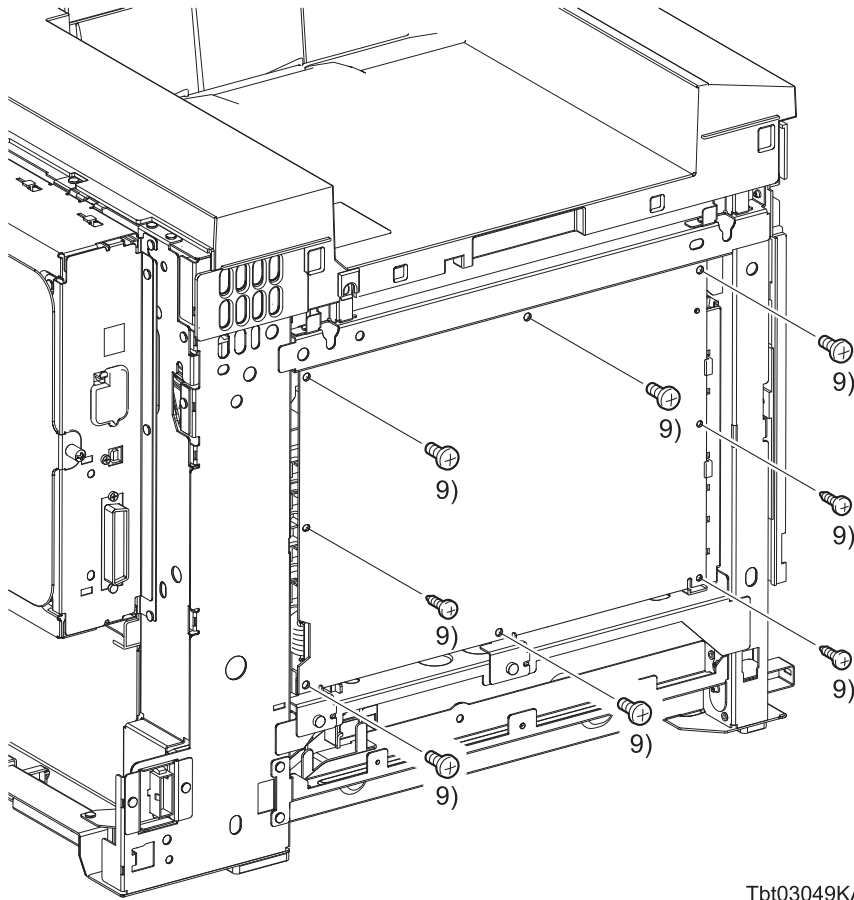

Tbt03049KA

- 9) Remove the five screws (silver, M4, 6mm) and three screws (silver, tapping, 8mm) that fix the PWBA HVPS (PL5.2.3) to the printer.

Continues to the next page.

Removal 38 PWBA HVPS (PL5.2.3)

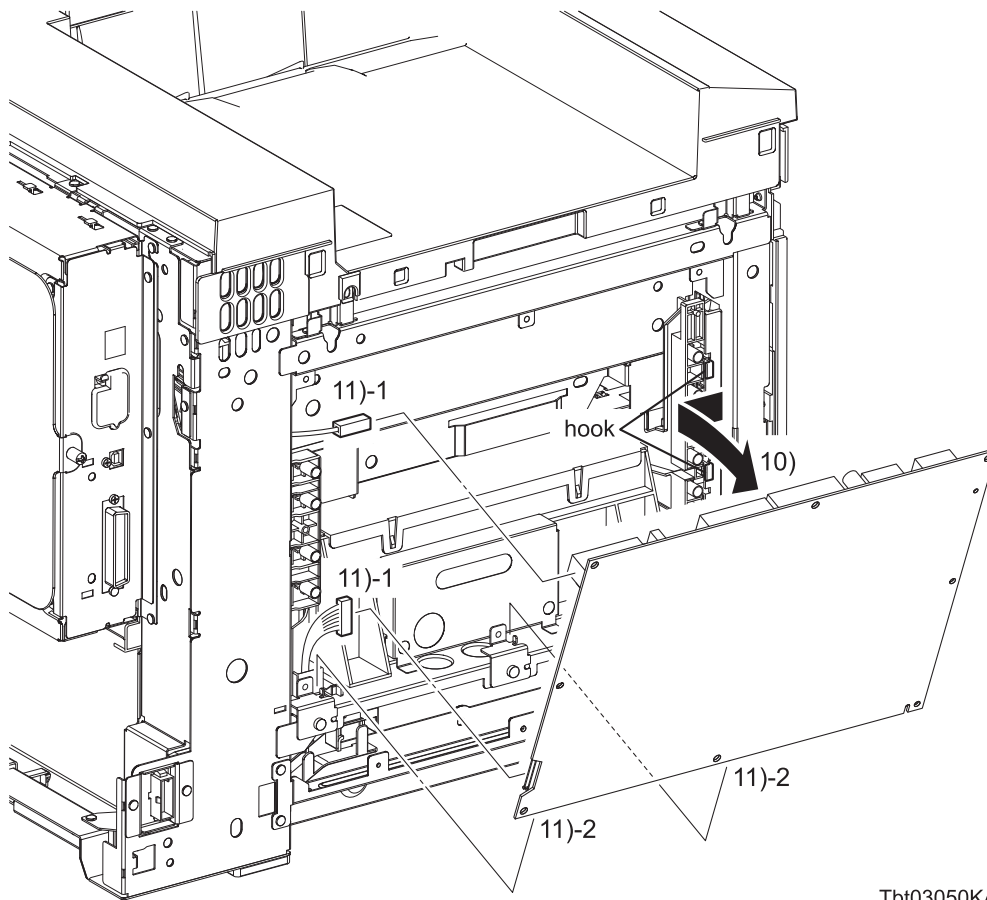

Tbt03050KA

NOTE

When performing the following step, use caution not to move the PWBA HVPS from the printer too far because they are connected with the harness.

- 10) Release the PWBA HVPS from the two hooks on the HOUSING ASSY CR (PL5.2.2) and tilt the PWBA HVPS toward you.
- 11) Disengage the two sets of connectors (P/J331, 332) of the PWBA HVPS, and then remove the PWBA HVPS from the printer.

**Go to the next removal step:
Removal 39 KIT ROS ASSY (PL5.2.99)**

Blank Page

Removal 39 KIT ROS ASSY (PL5.2.99)

NOTE

Take care not to touch the window of the ROS ASSY with your hands.

In the following steps, the details of Steps 1 through 9 are omitted because they are described earlier in this chapter. Go to the steps in parentheses to execute the necessary steps, and then go to Step 10 onward.

- 1) Remove the TRAY ASSY (PL2.1.1) from the printer.
- 2) Open the COVER ASSY FRONT (PL1.2.17).
- 3) Open the COVER ASSY RH.
- 4) Open the FRAME ASSY 2ND (PL8.1.9).

NOTE

Place the BELT ASSY IBT in a safe place to prevent damage to its belt.

- 5) Remove the BELT ASSY IBT. (Removal 4)

NOTE

Cover the drum of the XERO DEVE CRU ASSY to prevent damage by light.

- 6) Remove the XERO DEVE CRU ASSY (Y), (M), (C), (K). (Removal 5)
- 7) Remove the COVER ASSY REAR. (Removal 20)
- 8) Remove the COVER LH ASSY. (Removal 34)
- 9) Remove the PWBA HVPS. (Removal 38)

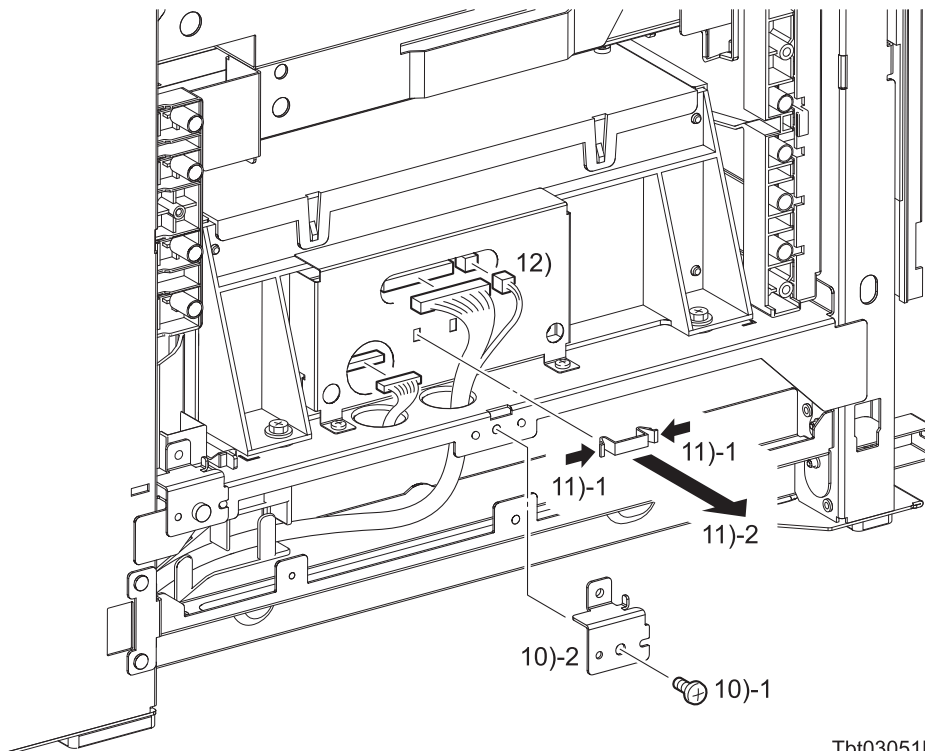

Tbt03051KA

- 10) Remove the PLATE HV from the printer by removing the one screw (silver, M4, 6mm).
- 11) Remove the CLAMP PRESS REC-14 (PL5.2.7) from the ROS ASSY (PL5.2.1) by releasing the two hooks of the CLAMP PRESS REC-14.
- 12) Disengage the three sets of connectors (P/J151, 152, 153) of the ROS ASSY.

Continues to the next page.

Removal 39 KIT ROS ASSY (PL5.2.99)

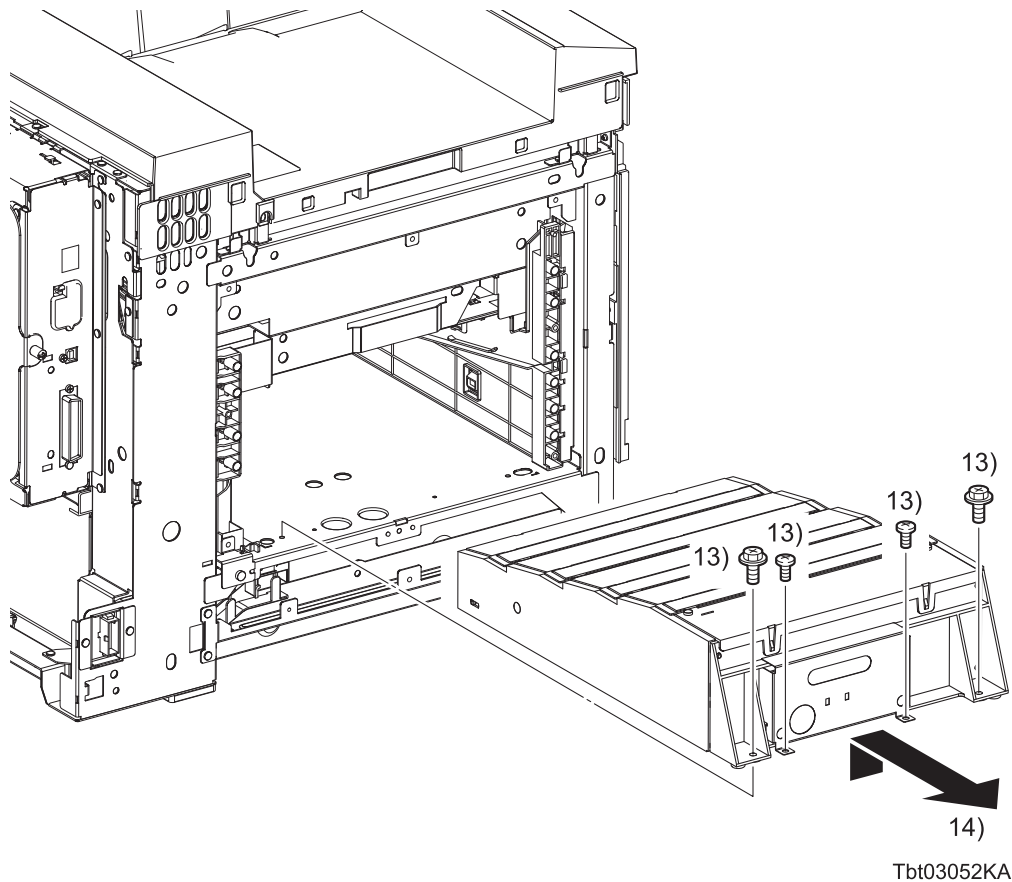

- 13) Remove the two screws (silver, flanged, M4, 8mm) and two screws (silver, 6mm) that fix the ROS ASSY to the printer.

NOTE

When performing the following step, use caution not to allow the window of the ROS ASSY to hit against the printer frame.

- 14) Release the two bosses of the ROS ASSY from the holes in the printer by slightly lifting the ROS ASSY. Then, pull the ROS ASSY out of the printer.

Removal 40 BOX ASSY ESS PWB (PL10.1.1)

In the following steps, the details of Steps 1 through 6 are omitted because they are described earlier in this chapter. Go to the steps in parentheses to execute the necessary steps, and then go to Step 7 onward.

NOTE

Use a wrist strap to protect the PWB from electrostatic damage.

- 1) Open the COVER ASSY FRONT (PL1.2.17).
- 2) Open the COVER ASSY RH.
- 3) Open the FRAME ASSY 2ND (PL8.1.9).

NOTE

Place the BELT ASSY IBT in a safe place to prevent damage to its belt.

- 4) Remove the BELT ASSY IBT. (Removal 4)

NOTE

Cover the drum of the XERO DEVE CRU ASSY to prevent damage by light.

- 5) Remove the XERO DEVE CRU ASSY (Y), (M), (C), (K). (Removal 5)
- 6) Remove the COVER ASSY REAR. (Removal 20)

Continues to the next page.

Removal 40 BOX ASSY ESS PWB (PL10.1.1)

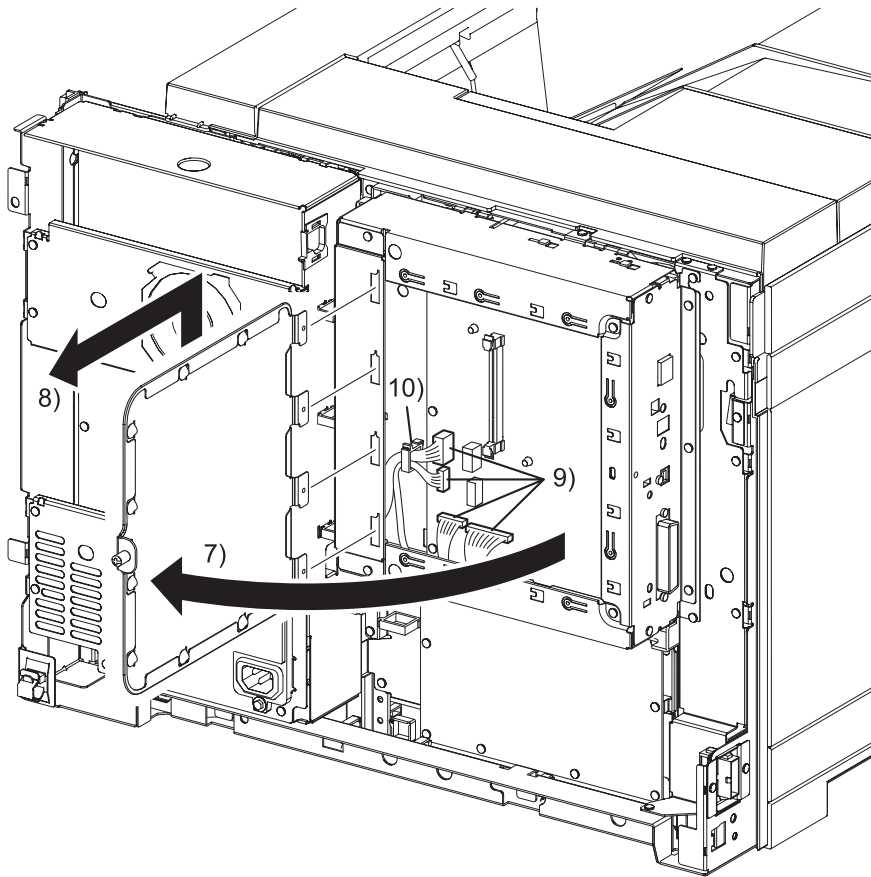

Tbt03053KA

- 7) Loosen the SCREW KNURLING (PL10.1.3), and then open the PLATE WINDOW ESS (PL10.1.2).
- 8) Lift the PLATE WINDOW ESS slightly up to release the four tabs of the PLATE WINDOW ESS from the holes of the BOX ASSY BASE (PL10.1.4).
- 9) Disengage all the connectors of the PWBA ESS (PL10.1.6).
- 10) Release the HARNESS ASSY OPEPANE (PL1.1.2) and HARNESS ASSY ESS PWR (PL11.1.3) from the CLAMP LOCKING (PL10.1.26).

Continues to the next page.

Removal 40 BOX ASSY ESS PWB (PL10.1.1)

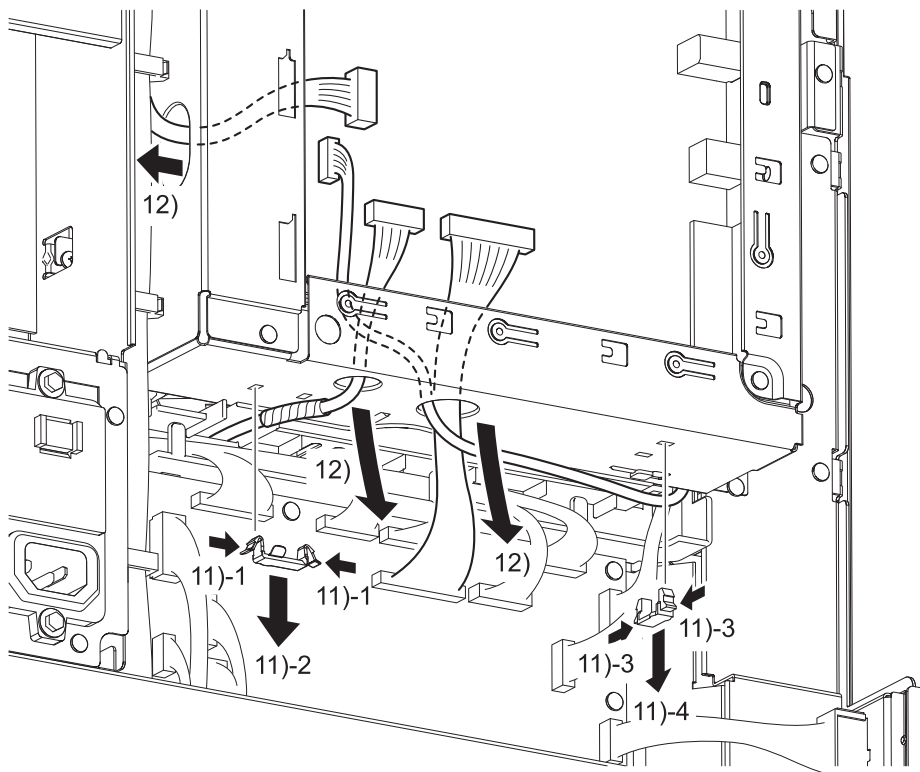

Tbt03054KB

- 11) Remove the CLAMP PRESS REC-16 (PL10.1.27) and CLAMP (PL10.1.35) from the BOX ASSY ESS PWB (PL10.1.1) by releasing the hooks.
- 12) Route all the harnesses through the hole in the BOX ASSY ESS PWB to the outside.

Continues to the next page.

Removal 40 BOX ASSY ESS PWB (PL10.1.1)

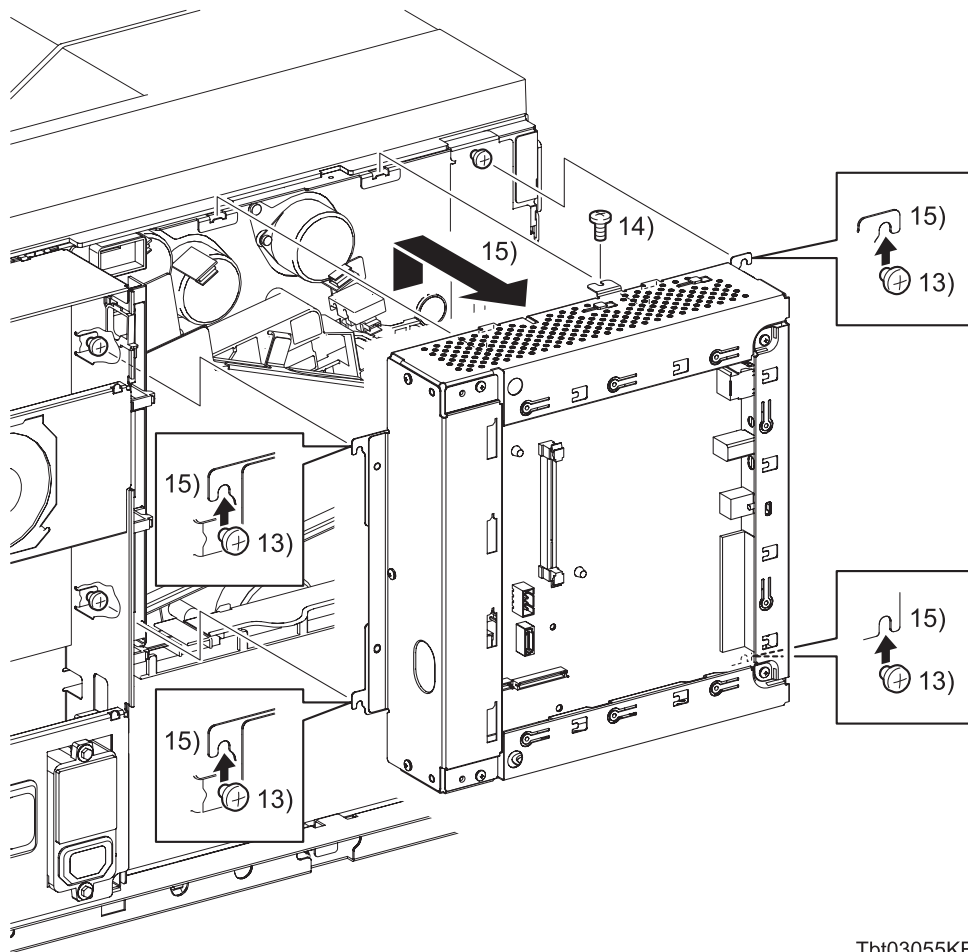

Tbt03055KB

- 13) Loosen the four screws (silver, 6mm) that fix the BOX ASSY ESS PWB to the printer.
- 14) Remove the one screw (silver, 6mm) that fixes the BOX ASSY ESS PWB to the printer.
- 15) Release the two hooks of the BOX ASSY ESS PWB from the holes in the printer by slightly lifting the BOX ASSY ESS PWB. Then, remove the BOX ASSY ESS PWB from the printer.

Go to the next removal step:

Removal 41 DRIVE ASSY SNS (FC) (PL9.2.1)

Removal 41 DRIVE ASSY SNS (FC) (PL9.2.1)

In the following steps, the details of Steps 1 through 7 are omitted because they are described earlier in this chapter. Go to the steps in parentheses to execute the necessary steps, and then go to Step 8 onward.

- 1) Open the COVER ASSY FRONT (PL1.2.17).
- 2) Open the COVER ASSY RH.
- 3) Open the FRAME ASSY 2ND (PL8.1.9).

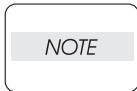

Place the BELT ASSY IBT in a safe place to prevent damage to its belt.

- 4) Remove the BELT ASSY IBT. (Removal 4)

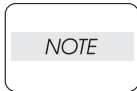

Cover the drum of the XERO DEVE CRU ASSY to prevent damage by light.

- 5) Remove the XERO DEVE CRU ASSY (Y), (M), (C), (K). (Removal 5)
- 6) Remove the COVER ASSY REAR. (Removal 20)
- 7) Remove the BOX ASSY ESS PWB. (Removal 40)

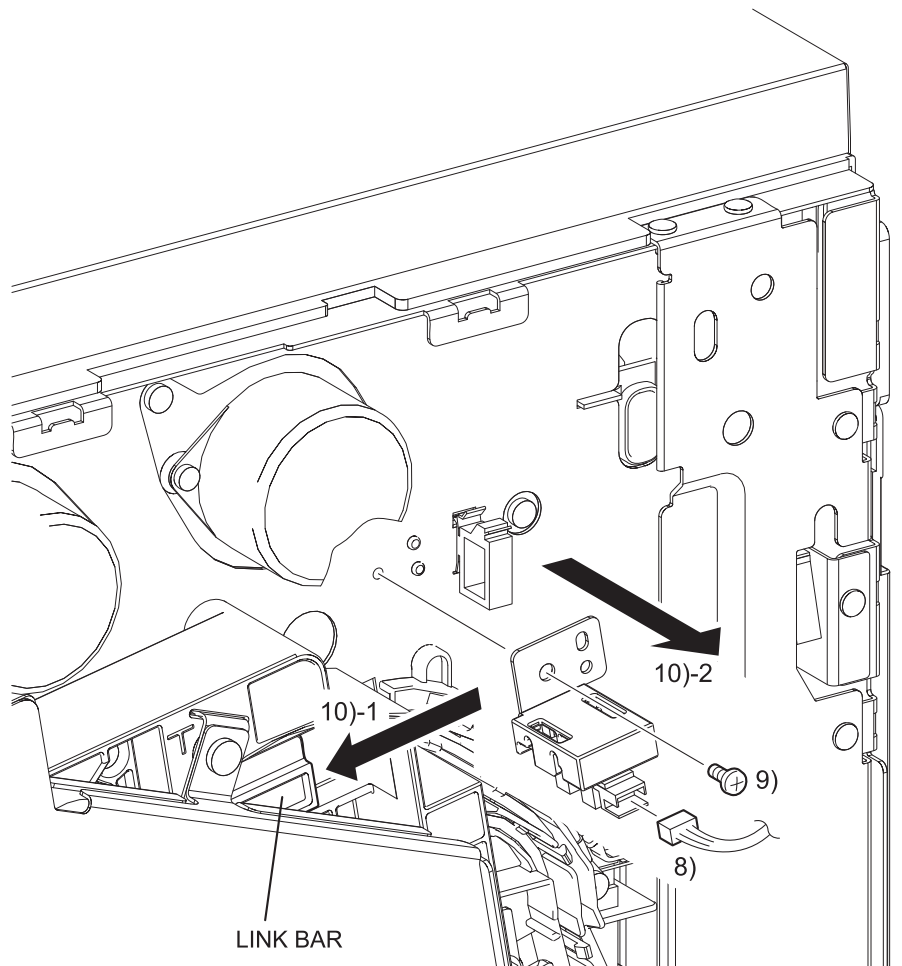

Tbt03056KA

- 8) Disengage the connectors (P/J201) of the DRIVE ASSY SNS (FC) (PL9.2.1).
- 9) Remove the one screw (silver, 6mm) that fixes the DRIVE ASSY SNS (FC) to the printer.
- 10) Slide the LINK BAR actuator away from the switching sensor (FC) and remove the DRIVE ASSY SNS (FC) from the printer.

Blank Page

Removal 42 BOX ASSY LVPS (PL10.2.1)

In the following steps, the details of Steps 1 through 11 are omitted because they are described earlier in this chapter. Go to the steps in parentheses to execute the necessary steps, and then go to Step 12 onward.

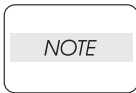

Use a wrist strap to protect the PWB from electrostatic damage.

- 1) Open the COVER ASSY FRONT (PL1.2.17).
- 2) Open the COVER ASSY RH.
- 3) Open the FRAME ASSY 2ND (PL8.1.9).

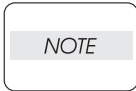

Place the BELT ASSY IBT in a safe place to prevent damage to its belt.

- 4) Remove the BELT ASSY IBT. (Removal 4)

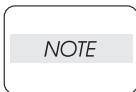

Cover the drum of the XERO DEVE CRU ASSY to prevent damage by light.

- 5) Remove the XERO DEVE CRU ASSY (Y), (M), (C), (K). (Removal 5)

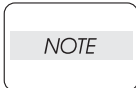

The FUSER section is very hot. Use extra caution not to burn yourself when performing the service operation.

- 6) Remove the FUSER ASSY. (Removal 7)
- 7) Remove the COVER ASSY REAR. (Removal 20)
- 8) Remove the COVER ASSY TOP EXIT. (Removal 21)
- 9) Remove the BOX ASSY ESS PWB. (Removal 40)
- 10) Remove the FAN ASSY LVPS. (Removal 32)
- 11) Remove the PLATE ASSY LVPS POWER. (Removal 33)

Continues to the next page.

Removal 42 BOX ASSY LVPS (PL10.2.1)

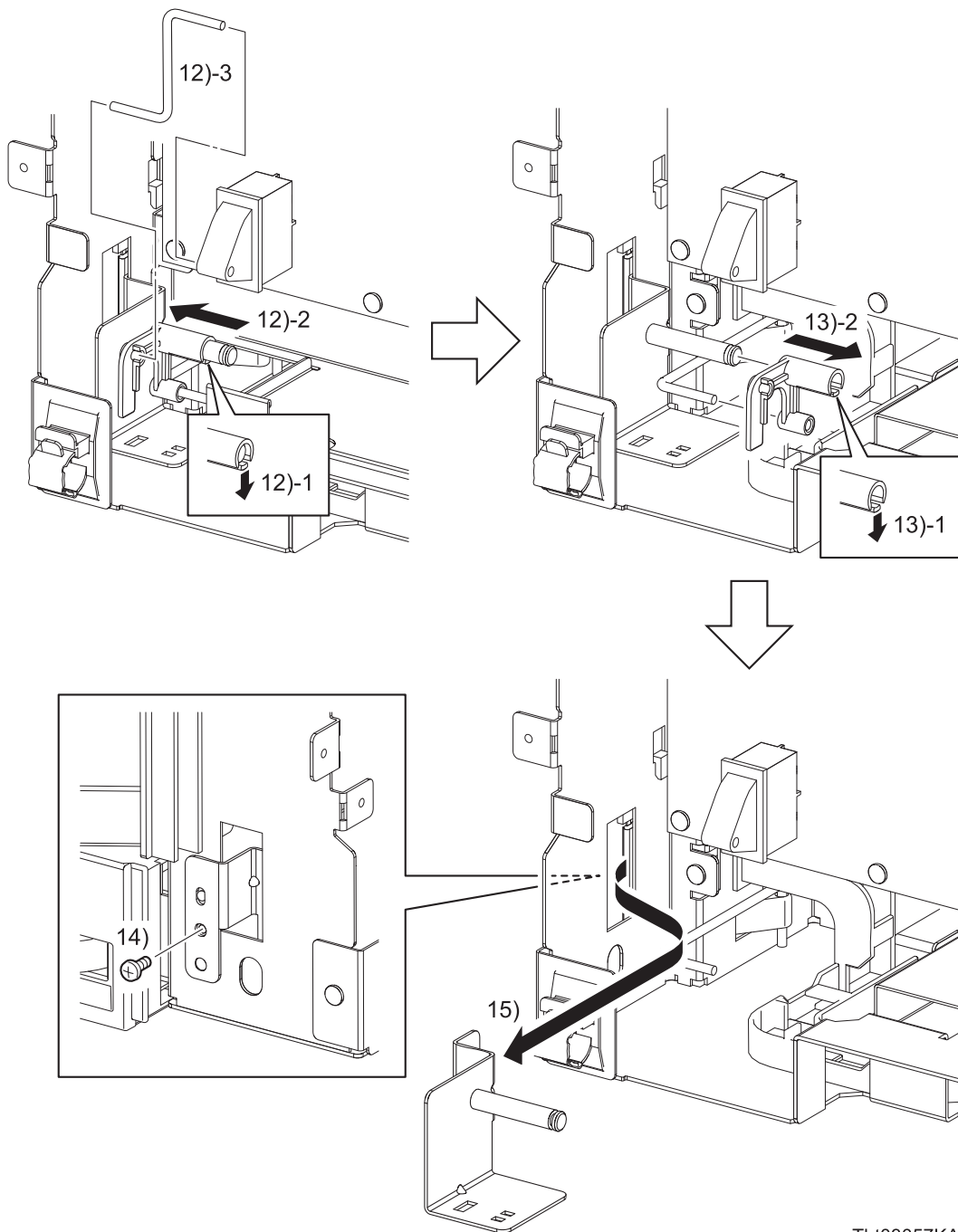

Tbt03057KA

- 12) Release the hook on the LINK REAR (PL10.2.10) and slide the LINK REAR until it comes in contact with the BRACKET ASSY REAR (PL10.2.11), and then remove the WIRE SHORT (PL10.2.9) from the power switch for the LINK REAR and LVPS ASSY (PL10.2.2).
- 13) Remove the LINK REAR from the stud of the BRACKET ASSY REAR by releasing the hook of the LINK REAR.
- 14) Remove the one screw (silver, 6mm) that fixes the BRACKET ASSY REAR to the printer.
- 15) Place the screw-fixed section of the BRACKET ASSY REAR inside the frame by passing it through the hole in the frame, and then remove the BRACKET ASSY REAR.

Continues to the next page.

Removal 42 BOX ASSY LVPS (PL10.2.1)

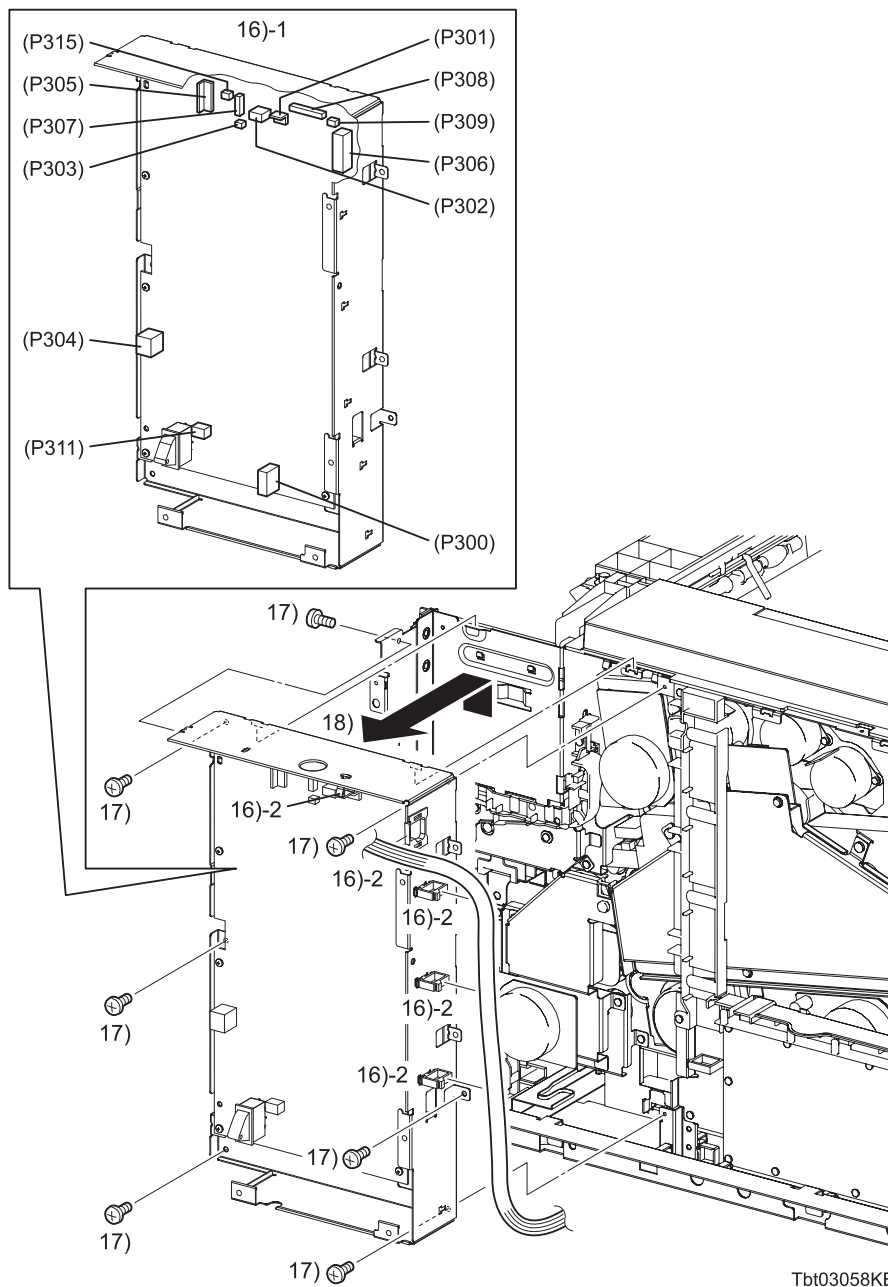

- 16) Disengage all the connectors from the LVPS ASSY and release all the harnesses from all clamps of the BOX ASSY LVPS (PL10.2.1).
- 17) Remove the seven screws (silver, 6mm) that fix the BOX ASSY LVPS to the printer.
- 18) Release the two hooks of the BOX ASSY LVPS from the holes in the printer by slightly lifting the BOX ASSY LVPS. Then, remove the BOX ASSY LVPS from the printer.

Go to the next removal step:

Removal 53 DRIVE ASSY SNS (K) (PL9.2.1)

Removal 54 DRIVE ASSY FSR (PL9.1.1)

Removal 55 DRIVE ASSY IBT (PL9.1.3)

Removal 56 DRIVE ASSY PH (PL9.1.4)

Removal 58 BOX ASSY MCU (PL10.2.15)

Blank Page

Removal 43 KIT INTERLOCK SWITCH RH (PL4.1.96)

In the following steps, the details of Steps 1 through 23 are omitted because they are described earlier in this chapter. Go to the steps in parentheses to execute the necessary steps, and then go to Step 24 onward.

- 1) Remove the TRAY ASSY (PL2.1.1) from the printer.
- 2) Remove the COVER ASSY FRONT. (Removal 1)
- 3) Remove the TONER CARTRIDGE (Y), (M), (C), (K) (PL6.1.1~6.1.4) from the printer.
- 4) Remove the WASTE TONER BOX. (Removal 3)
- 5) Open the COVER ASSY RH.
- 6) Open the FRAME ASSY 2ND (PL8.1.9).

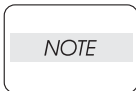

Place the BELT ASSY IBT in a safe place to prevent damage to its belt.

- 7) Remove the BELT ASSY IBT. (Removal 4)

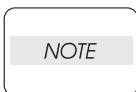

Cover the drum of the XERO DEVE CRU ASSY to prevent damage by light.

- 8) Remove the XERO DEVE CRU ASSY (Y), (M), (C), (K). (Removal 5)
- 9) Remove the KIT FRAME ASSY 2ND. (Removal 6)

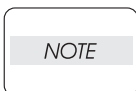

The FUSER section is very hot. Use extra caution not to burn yourself when performing the service operation.

- 10) Remove the FUSER ASSY. (Removal 7)
- 11) Remove the COVER ASSY REAR. (Removal 20)
- 12) Remove the COVER RH UNDER. (Removal 23)
- 13) Remove the COVER LH ASSY. (Removal 34)
- 14) Remove the COVER FRONT RH. (Removal 18)
- 15) Remove the COVER ASSY INNER FRONT. (Removal 35)
- 16) Remove the COVER FR UNDER. (Removal 37)
- 17) Remove the COVER ASSY TOP EXIT. (Removal 21)
- 18) Remove the BOX ASSY ESS PWB. (Removal 40)
- 19) Remove the FAN ASSY LVPS. (Removal 32)
- 20) Remove the PLATE ASSY LVPS POWER. (Removal 33)
- 21) Remove the BOX ASSY LVPS. (Removal 42)
- 22) Remove the KIT RH COVER & FRAME ASSY. (Removal 24)
- 23) Remove the SEPARATOR ASSY MSI. (Removal 28)

Continues to the next page.

Removal 43 KIT INTERLOCK SWITCH RH (PL4.1.96)

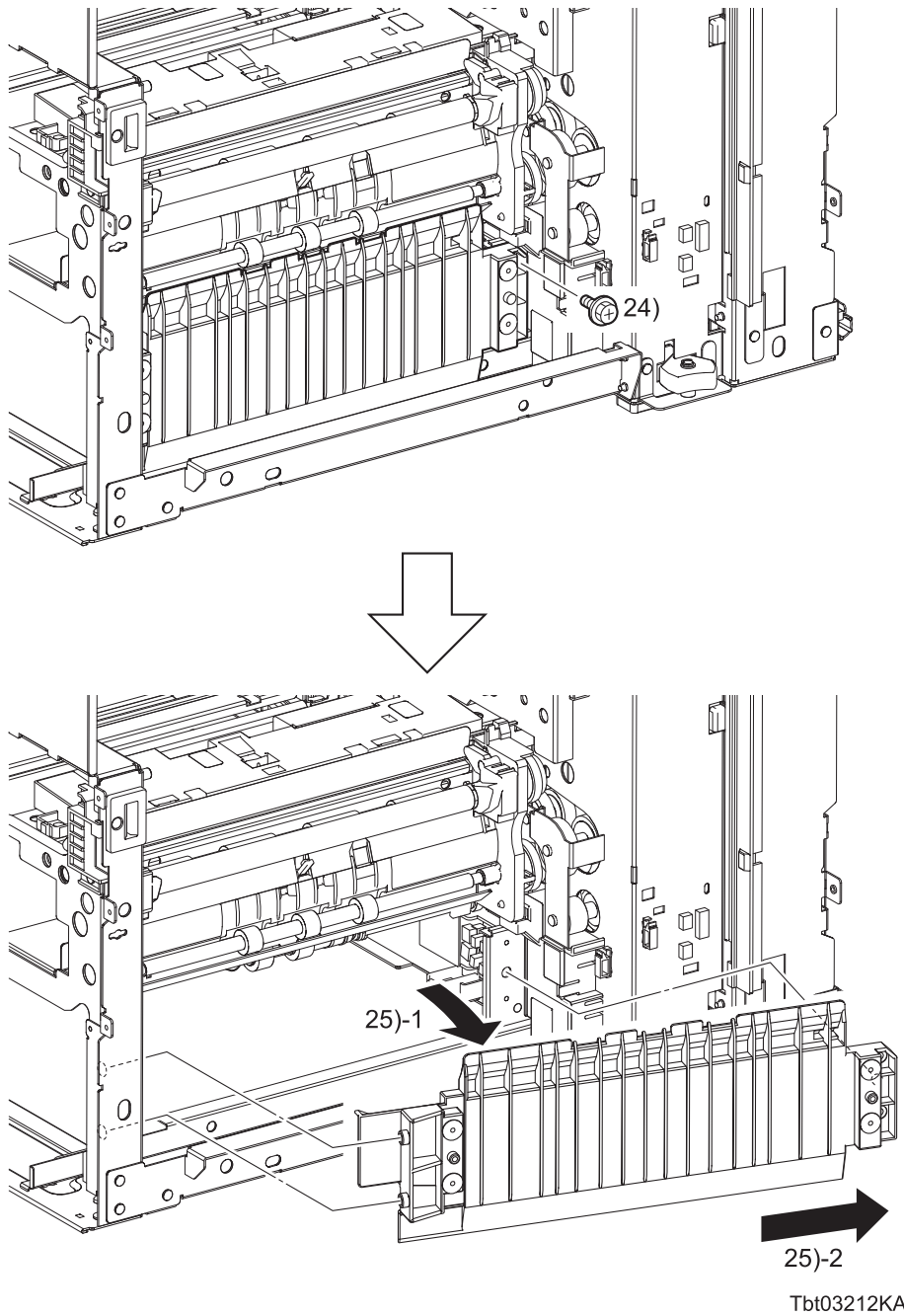

- 24) Remove the one screw (silver, flanged, 6mm) that fixes the GUIDE TRAY (PL3.1.6) to the printer.
- 25) Release the boss on the rear side of the GUIDE TRAY, and then slide the GUIDE TRAY backward to release the two bosses on the front side of the GUIDE TRAY. Then, remove the GUIDE TRAY from the printer.

Continues to the next page.

Removal 43 KIT INTERLOCK SWITCH RH (PL4.1.96)

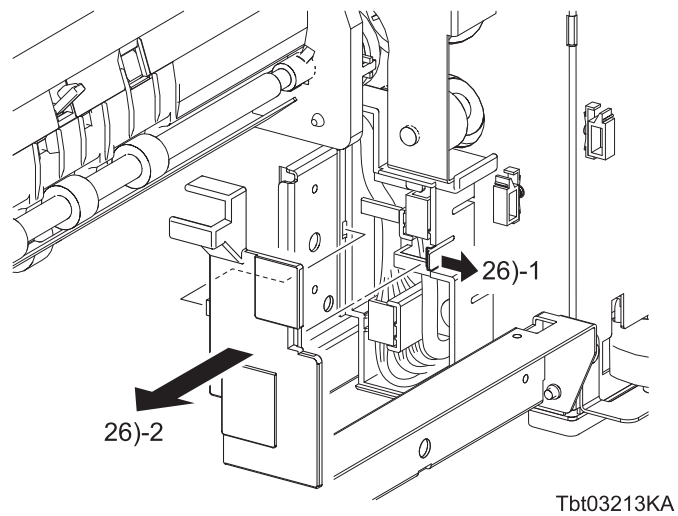

- 26) Remove the COVER GUIDE HARNESS (PL3.1.13) from the GUIDE HARNESS (PL3.1.14) by releasing the hook of the GUIDE HARNESS.

Continues to the next page.

Removal 43 KIT INTERLOCK SWITCH RH (PL4.1.96)

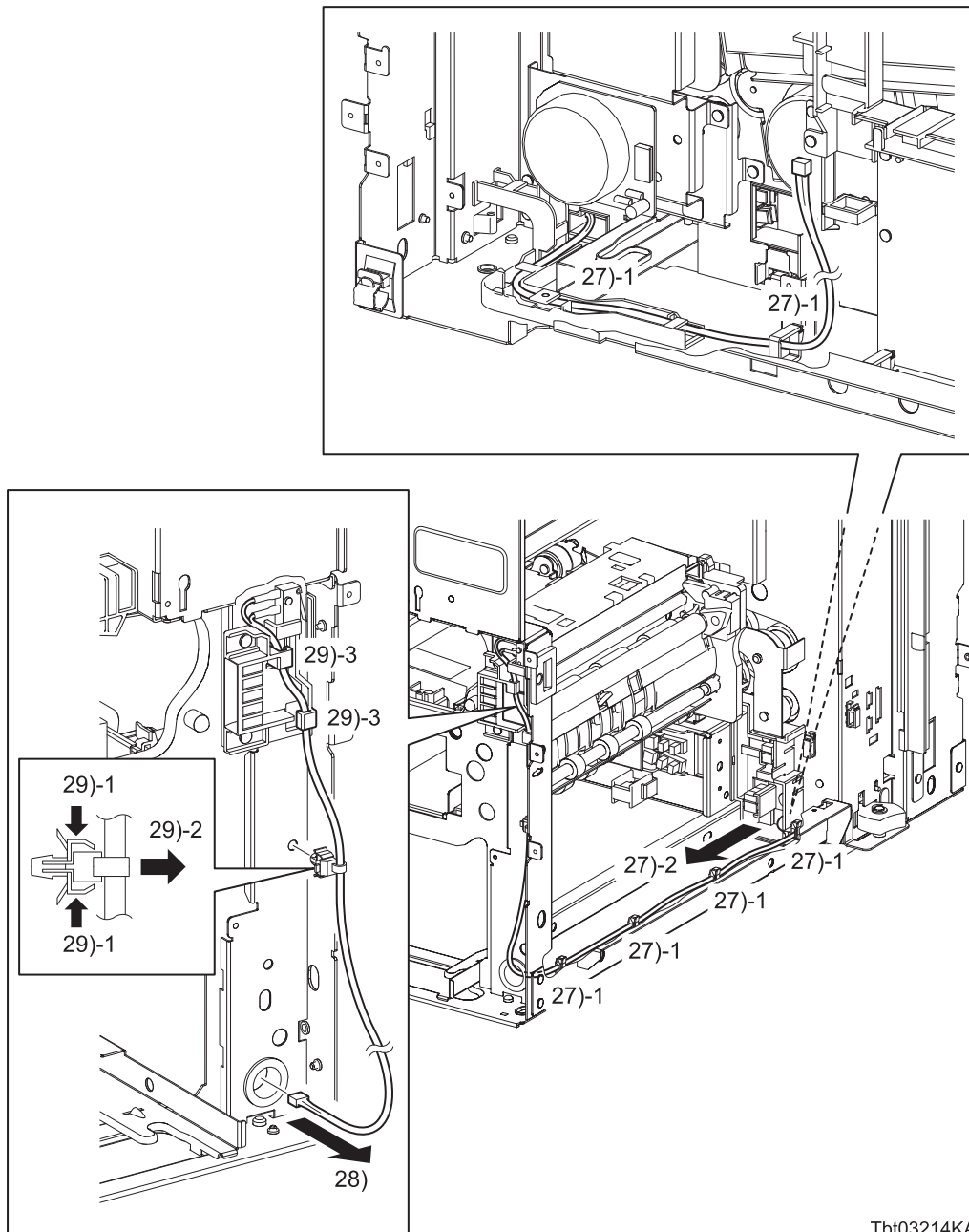

Tbt03214KA

- 27) Release the harness of the HARNESS ASSY I/L RH (PL4.1.1) from the GUIDE HARNESS WIRE (PL8.2.13) and the four CLAMP LOCKINGS (PL8.1.20), and pass the connector (J301) of the HARNESS ASSY I/L RH through the GUIDE HARNESS into the printer frame.
- 28) Pass the connector (J301) of the HARNESS ASSY I/L RH through the BUSH CLOSE-TYPE (PL8.1.21) out of the front side of the printer frame.
- 29) Remove the clamp that fixes the harness of the HARNESS ASSY I/L RH from the printer, and then release the harness of the HARNESS ASSY I/L RH from the hooks of the GUIDE FRAME LOCK H (PL8.1.13).

Continues to the next page.

Removal 43 KIT INTERLOCK SWITCH RH (PL4.1.96)

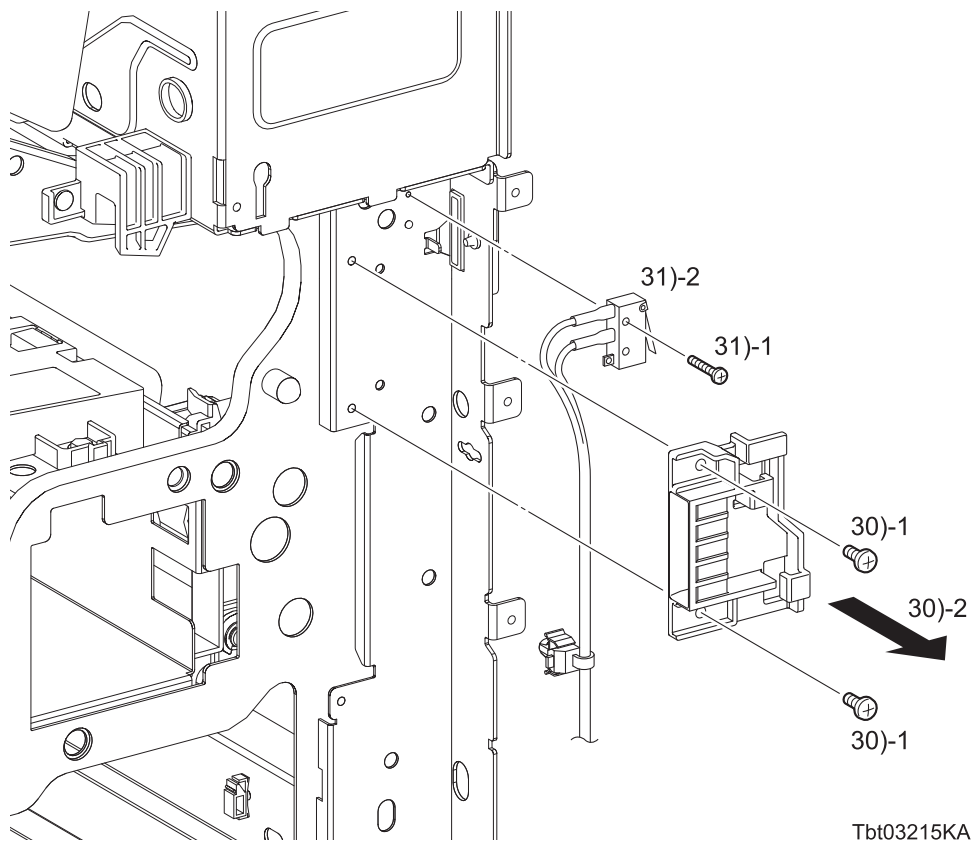

30) Remove the GUIDE FRAME LOCK H from the printer by removing the two screws (silver, 6mm).

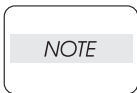

When performing the following step, make sure to use the screwdriver included in the KIT.

31) Remove the one screw (silver, M2, 8mm) that fixes the switch section of the HARNESS ASSY I/L RH, and remove the HARNESS ASSY I/L RH from the printer.

Blank Page

Removal 44 COVER ASSY TOP (PL1.1.3)

In the following steps, the details of Steps 1 through 10 are omitted because they are described earlier in this chapter. Go to the steps in parentheses to execute the necessary steps, and then go to Step 11 onward.

- 1) Open the COVER ASSY FRONT (PL1.2.17).
- 2) Open the COVER ASSY RH.
- 3) Open the FRAME ASSY 2ND (PL8.1.9).

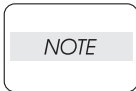

Place the BELT ASSY IBT in a safe place to prevent damage to its belt.

- 4) Remove the BELT ASSY IBT. (Removal 4)

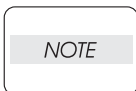

Cover the drum of the XERO DEVE CRU ASSY to prevent damage by light.

- 5) Remove the XERO DEVE CRU ASSY (Y), (M), (C), (K). (Removal 5)

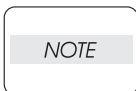

The FUSER section is very hot. Use extra caution not to burn yourself when performing the service operation.

- 6) Remove the FUSER ASSY. (Removal 7)
- 7) Remove the COVER ASSY REAR. (Removal 20)
- 8) Remove the COVER ASSY TOP EXIT. (Removal 21)
- 9) Remove the BOX ASSY ESS PWB. (Removal 40)
- 10) Remove the COVER ASSY TOP ADD TRAY. (Removal 17)

Continues to the next page.

Removal 44 COVER ASSY TOP (PL1.1.3)

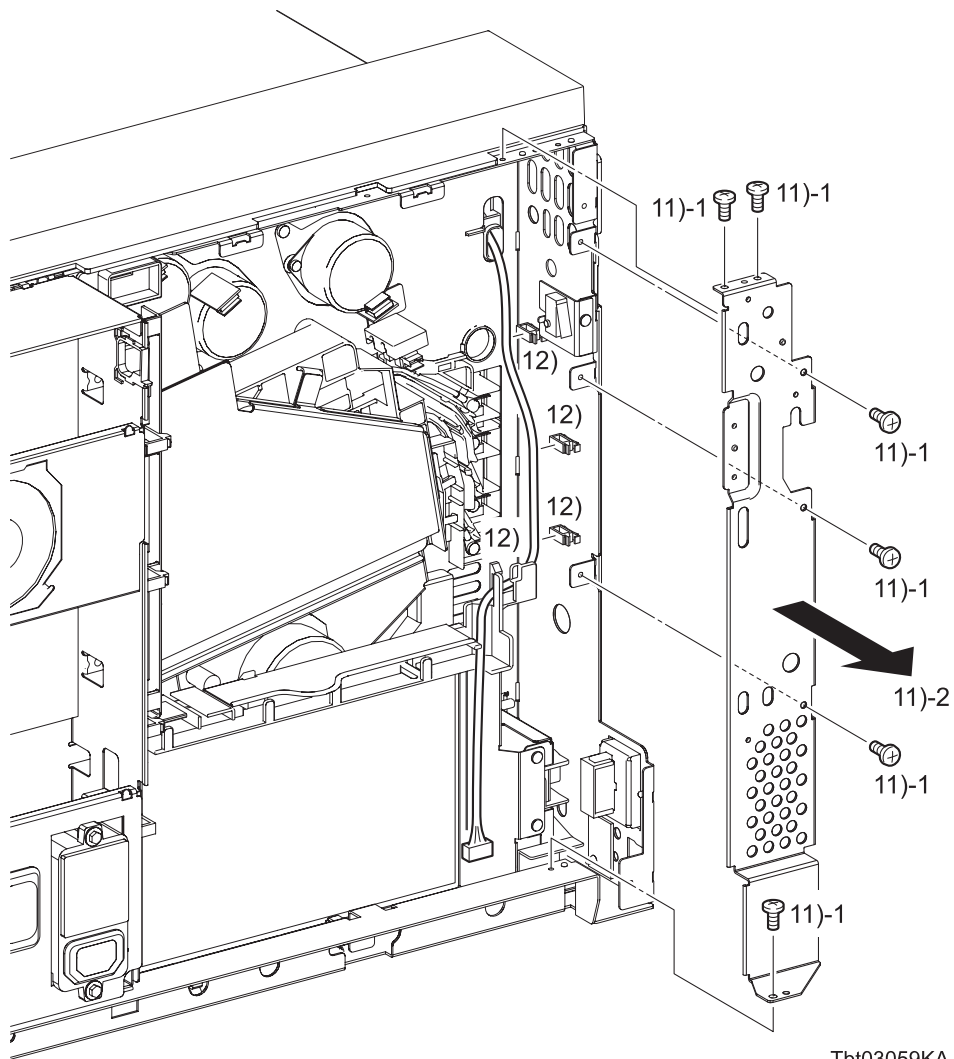

- 11) Remove the PLATE SUPPORT EM (PL8.2.14) from the printer by removing the six screws (silver, 6mm).
- 12) Release the HARNESS ASSY OPEPANE (PL1.1.2) from the hooks of the GUIDE HARNESS MCU UPR (PL10.2.17) and the three clamps.

Continues to the next page.

Removal 44 COVER ASSY TOP (PL1.1.3)

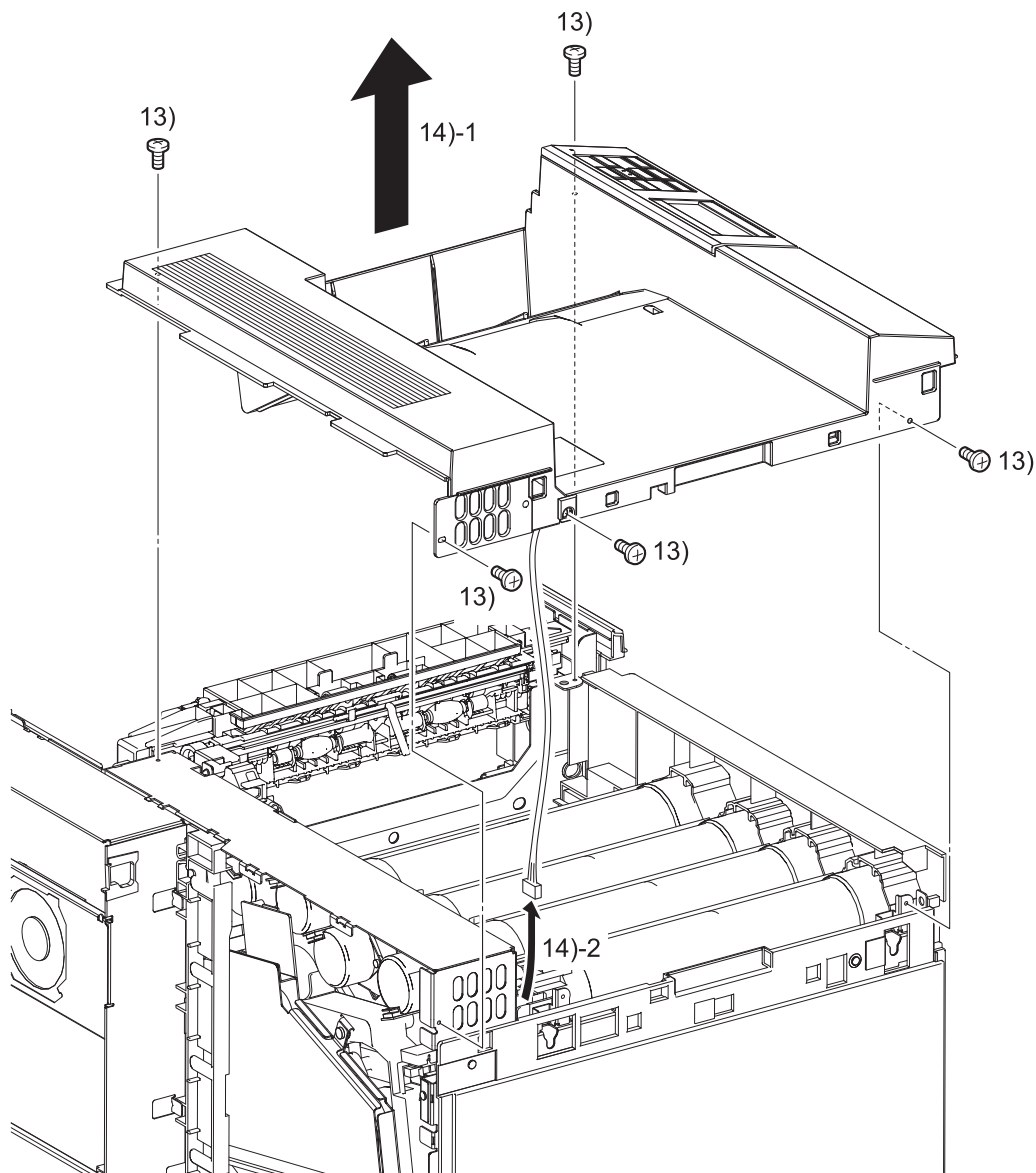

Tbt03060KA

13) Remove the five screws (silver, 6mm) that fix the COVER ASSY TOP (PL1.1.3) to the printer.

NOTE

When performing the following step, use caution not to damage the ACTUATOR FULL STACK (PL7.2.13) of the printer.

14) Slowly lifting the COVER ASSY TOP, pull the HARNESS ASSY OPEPANE out of the GUIDE HARNESS OP PANEL (PL8.1.10) to remove the COVER ASSY TOP.

Go to the next removal step:

Removal 45 KIT CONSOLE PANEL & HARNESS (PL1.1.99)

Blank Page

Removal 45 KIT CONSOLE PANEL & HARNESS (PL1.1.99)

In the following steps, the details of Steps 1 through 11 are omitted because they are described earlier in this chapter. Go to the steps in parentheses to execute the necessary steps, and then go to Step 12 onward.

- 1) Open the COVER ASSY FRONT (PL1.2.17).
- 2) Open the COVER ASSY RH.
- 3) Open the FRAME ASSY 2ND (PL8.1.9).

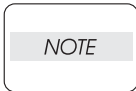

Place the BELT ASSY IBT in a safe place to prevent damage to its belt.

- 4) Remove the BELT ASSY IBT. (Removal 4)

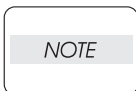

Cover the drum of the XERO DEVE CRU ASSY to prevent damage by light.

- 5) Remove the XERO DEVE CRU ASSY (Y), (M), (C), (K). (Removal 5)

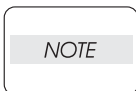

The FUSER section is very hot. Use extra caution not to burn yourself when performing the service operation.

- 6) Remove the FUSER ASSY. (Removal 7)
- 7) Remove the COVER ASSY REAR. (Removal 20)
- 8) Remove the COVER ASSY TOP EXIT. (Removal 21)
- 9) Remove the BOX ASSY ESS PWB. (Removal 40)
- 10) Remove the COVER ASSY TOP ADD TRAY. (Removal 17)
- 11) Remove the COVER ASSY TOP. (Removal 44)

Continues to the next page.

Removal 45 KIT CONSOLE PANEL & HARNESS (PL1.1.99)

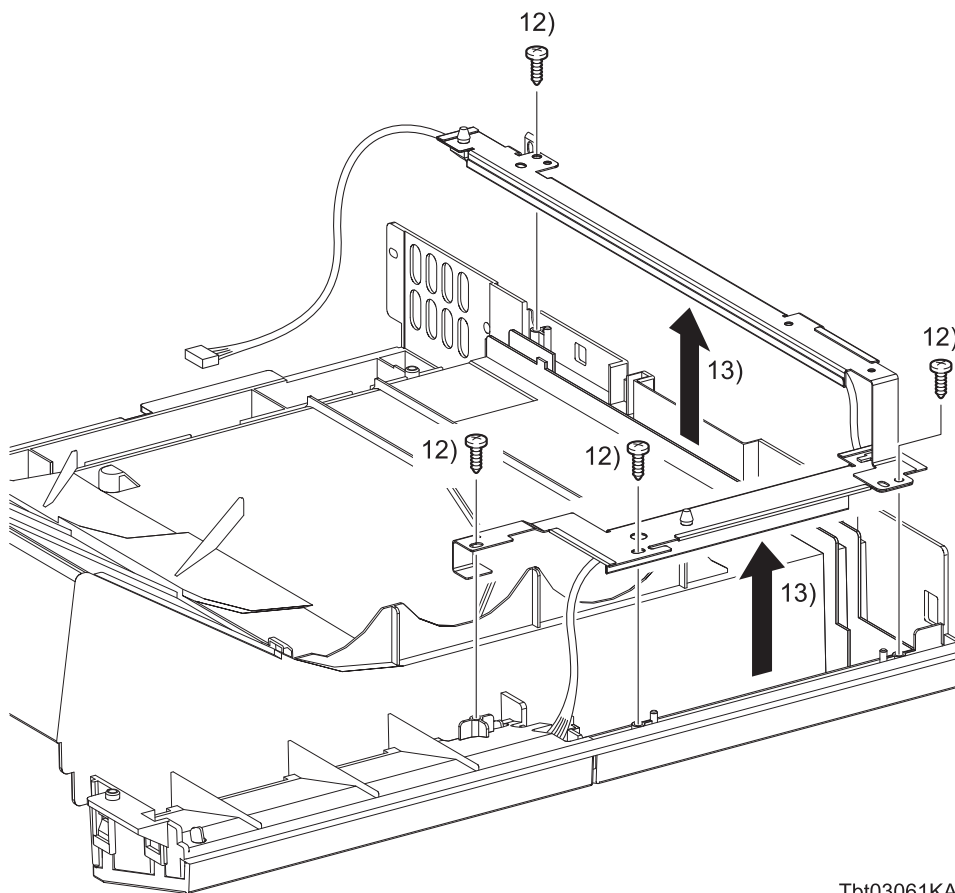

Tbt03061KA

- 12) Remove the four screws (silver, tapping, 8mm) that fix the GUIDE HARNESS UI (PL1.1.7) and the GUIDE HARNESS UI FRONT (PL1.1.8) to the COVER TOP (PL1.1.6).

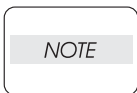

When performing the following step, use caution not to move the GUIDE HARNESS UI and the GUIDE HARNESS UI FRONT from the COVER TOP too far because they are connected with the harness.

- 13) Remove the GUIDE HARNESS UI and the GUIDE HARNESS UI FRONT from the COVER TOP together with the HARNESS ASSY OPEPANE (PL1.1.2).

Continues to the next page.

Removal 45 KIT CONSOLE PANEL & HARNESS (PL1.1.99)

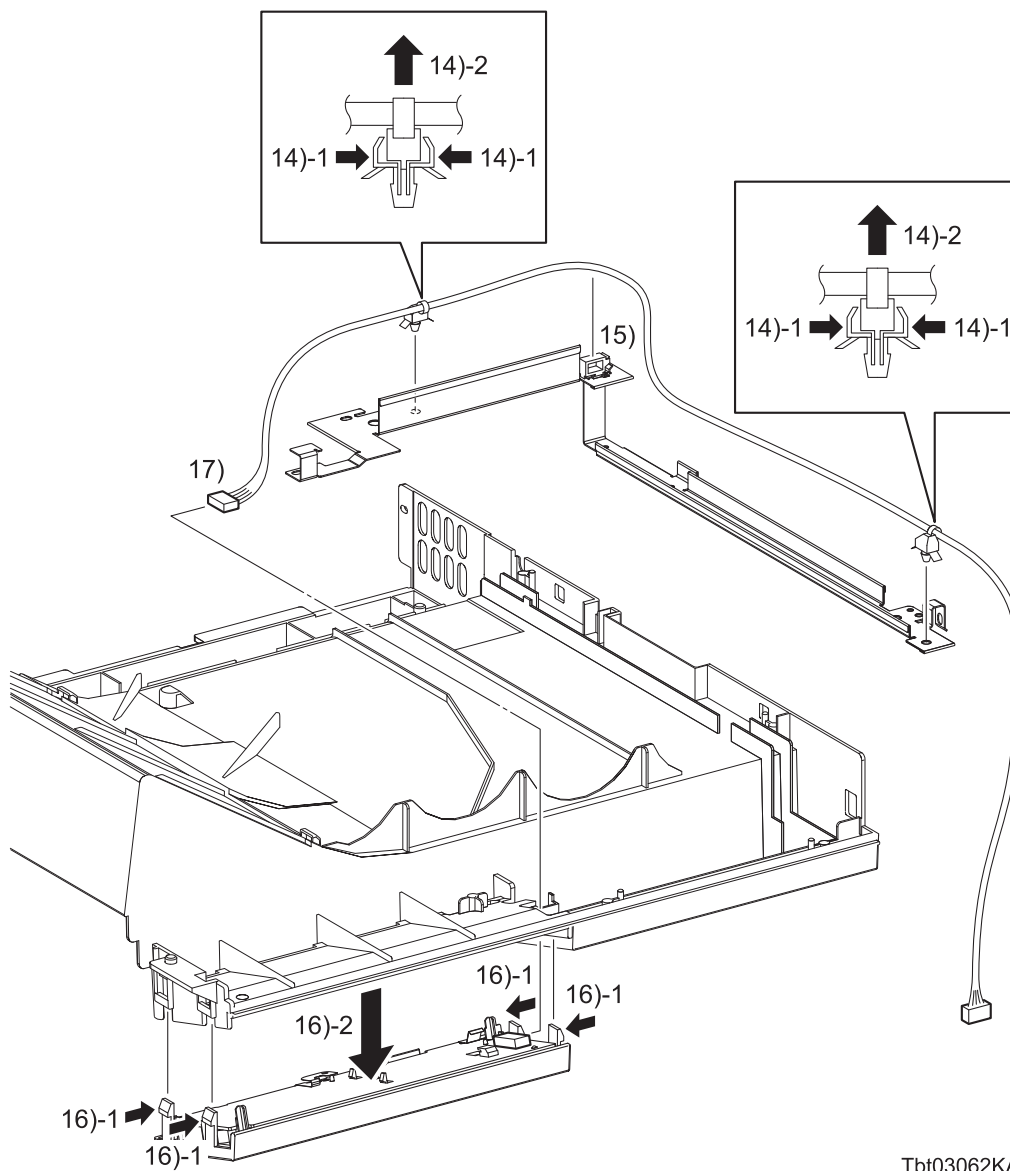

Tbt03062KA

- 14) Release the two clamps that fix the HARNESS ASSY OPEPANE to the GUIDE HARNESS UI and the GUIDE HARNESS UI FRONT.
- 15) Release the HARNESS ASSY OPEPANE from the two clamps on the GUIDE HARNESS UI and the GUIDE HARNESS UI FRONT.
- 16) Remove the CONSOLE ASSY PANEL (PL1.1.1) from the COVER TOP by releasing the four hooks of the CONSOLE ASSY PANEL.
- 17) Disengage the connectors (P/J370) of the CONSOLE ASSY PANEL, and then remove the CONSOLE ASSY PANEL.

Blank Page

Removal 46 PROCON ASSY (PL5.3.1)

In the following steps, the details of Steps 1 through 12 are omitted because they are described earlier in this chapter. Go to the steps in parentheses to execute the necessary steps, and then go to Step 13 onward.

- 1) Open the COVER ASSY FRONT (PL1.2.17).
- 2) Open the COVER ASSY RH.
- 3) Open the FRAME ASSY 2ND (PL8.1.9).

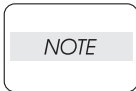

Place the BELT ASSY IBT in a safe place to prevent damage to its belt.

- 4) Remove the BELT ASSY IBT. (Removal 4)

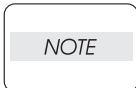

Cover the drum of the XERO DEVE CRU ASSY to prevent damage by light.

- 5) Remove the XERO DEVE CRU ASSY (Y), (M), (C), (K). (Removal 5)

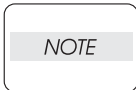

The FUSER section is very hot. Use extra caution not to burn yourself when performing the service operation.

- 6) Remove the FUSER ASSY. (Removal 7)
- 7) Remove the COVER ASSY REAR. (Removal 20)
- 8) Remove the COVER ASSY TOP EXIT. (Removal 21)
- 9) Remove the BOX ASSY ESS PWB. (Removal 40)
- 10) Remove the COVER ASSY TOP ADD TRAY. (Removal 17)
- 11) Remove the COVER ASSY TOP. (Removal 44)
- 12) Remove the WASTE TONER BOX. (Removal 3)

Continues to the next page.

Removal 46 PROCON ASSY (PL5.3.1)

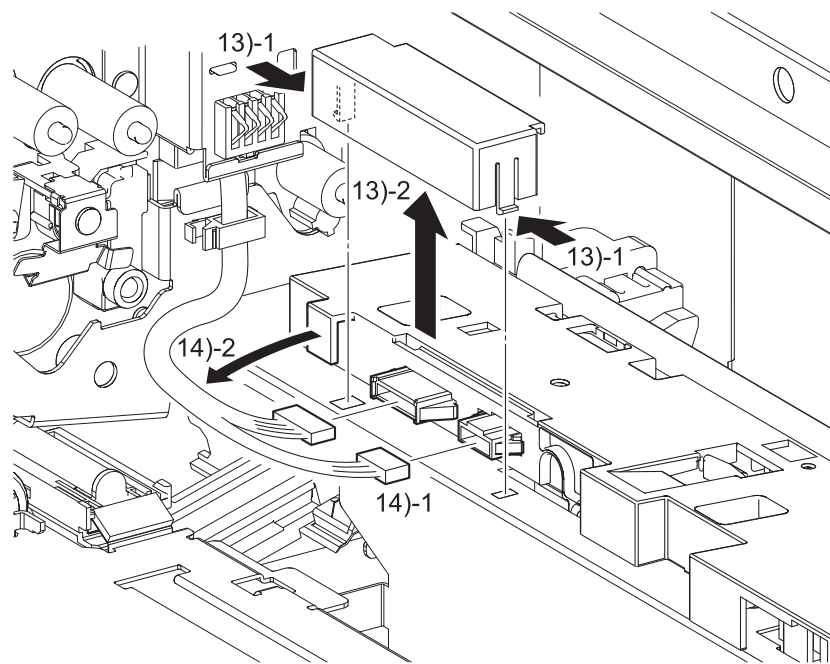

Tbt03063KA

- 13) Remove the COVER CONNECTOR (PL5.1.14) from the printer by releasing the two hooks of the COVER CONNECTOR.
- 14) Disengage the two sets of connectors (P/J106, 108) of the PROCON ASSY (PL5.3.1), and then release the harness from the hook of the PROCON ASSY.

Continues to the next page.

Removal 46 PROCON ASSY (PL5.3.1)

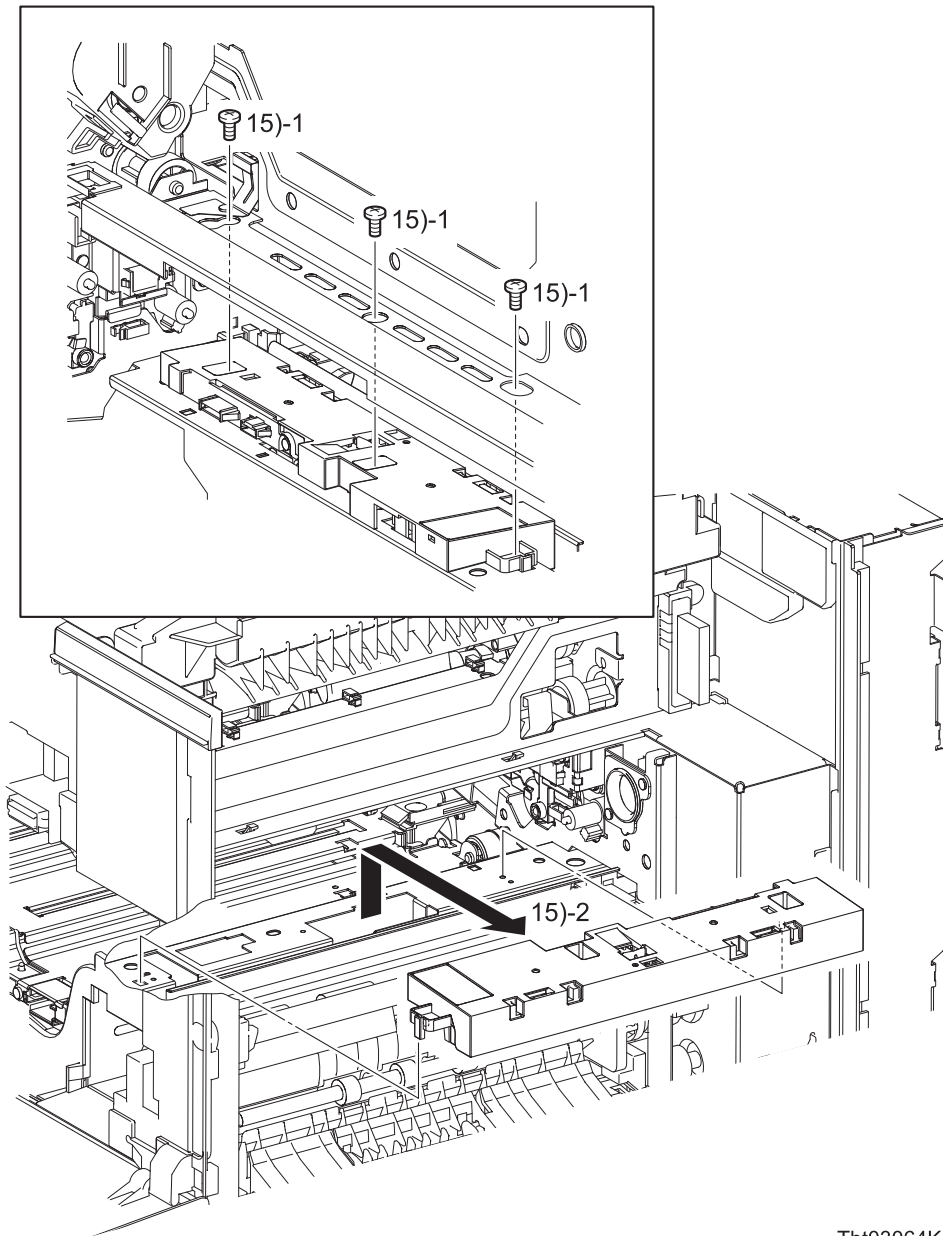

Tbt03064KB

- 15) Remove the PROCON ASSY from the printer by removing the three screws (silver, 6mm).

Blank Page

Removal 47 KIT CHUTE ASSY EXIT (PL7.2.99)

In the following steps, the details of Steps 1 through 12 are omitted because they are described earlier in this chapter. Go to the steps in parentheses to execute the necessary steps, and then go to Step 13 onward.

- 1) Open the COVER ASSY FRONT (PL1.2.17).
- 2) Open the COVER ASSY RH.
- 3) Open the FRAME ASSY 2ND (PL8.1.9).

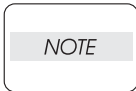

Place the BELT ASSY IBT in a safe place to prevent damage to its belt.

- 4) Remove the BELT ASSY IBT. (Removal 4)

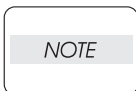

Cover the drum of the XERO DEVE CRU ASSY to prevent damage by light.

- 5) Remove the XERO DEVE CRU ASSY (Y), (M), (C), (K). (Removal 5)

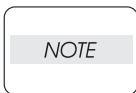

The FUSER section is very hot. Use extra caution not to burn yourself when performing the service operation.

- 6) Remove the FUSER ASSY. (Removal 7)
- 7) Remove the COVER ASSY REAR. (Removal 20)
- 8) Remove the COVER ASSY TOP EXIT. (Removal 21)
- 9) Remove the BOX ASSY ESS PWB. (Removal 40)
- 10) Remove the COVER ASSY TOP ADD TRAY. (Removal 17)
- 11) Remove the COVER ASSY TOP. (Removal 44)
- 12) Remove the CHUTE ASSY INVERT. (Removal 22)

Continues to the next page.

Removal 47 KIT CHUTE ASSY EXIT (PL7.2.99)

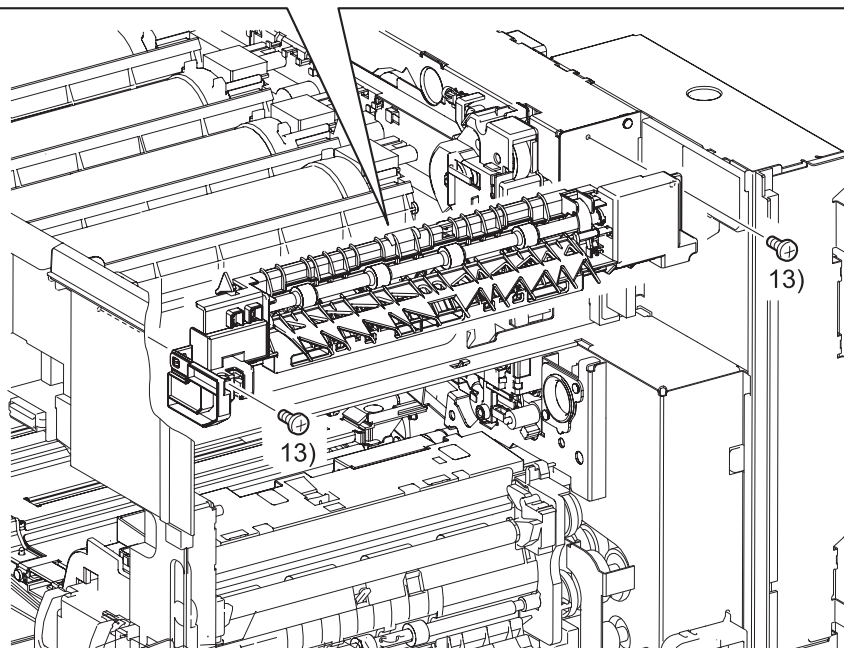
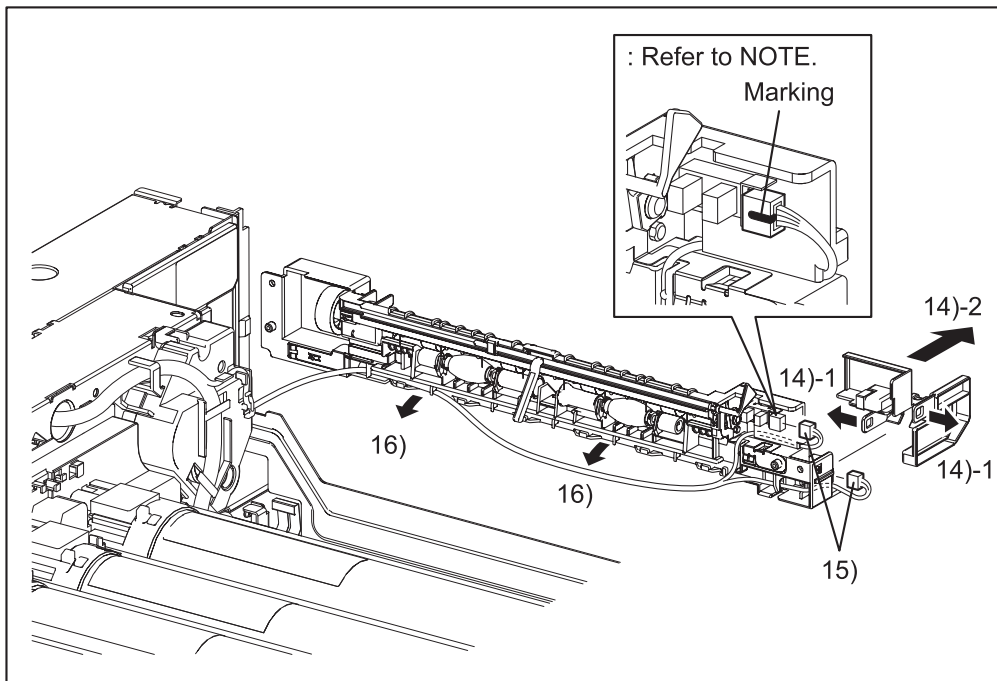

Tbt03065KB

- 13) Remove the two screws (silver, 6mm) that fix the KIT CHUTE ASSY EXIT (PL7.2.99) to the printer.

Continues to the next page.

Removal 47 KIT CHUTE ASSY EXIT (PL7.2.99)

- 14) Remove the COVER SNR EXIT (PL7.2.11) from the KIT CHUTE ASSY EXIT by releasing the two hooks of the COVER SNR EXIT.

NOTE

When performing the following step, use caution not to move the CHUTE ASSY EXIT from the printer too far because they are connected with the harness.

NOTE

If the pair of the connectors (P/J224) on the Full Stack Sensor is white and not marked in blue, ensure to mark the both sides of the connectors in blue before performing the following step.

- 15) Slightly move the KIT CHUTE ASSY EXIT away from the printer to disengage the connector (P/J224) of the Full Stack Sensor and the connector (P/J225) of the Envelope Mode Sensor.
- 16) Release the harness from the hooks of the KIT CHUTE ASSY EXIT, and then remove the KIT CHUTE ASSY EXIT from the printer.

Go to the next removal step:

Removal 48 DRIVE ASSY EXIT (PL7.1.1)

| Blank Page

Removal 48 DRIVE ASSY EXIT (PL7.1.1)

In the following steps, the details of Steps 1 through 13 are omitted because they are described earlier in this chapter. Go to the steps in parentheses to execute the necessary steps, and then go to Step 14 onward.

- 1) Open the COVER ASSY FRONT (PL1.2.17).
- 2) Open the COVER ASSY RH.
- 3) Open the FRAME ASSY 2ND (PL8.1.9).

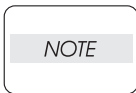

Place the BELT ASSY IBT in a safe place to prevent damage to its belt.

- 4) Remove the BELT ASSY IBT. (Removal 4)

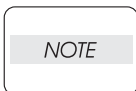

Cover the drum of the XERO DEVE CRU ASSY to prevent damage by light.

- 5) Remove the XERO DEVE CRU ASSY (Y), (M), (C), (K). (Removal 5)

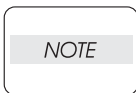

The FUSER section is very hot. Use extra caution not to burn yourself when performing the service operation.

- 6) Remove the FUSER ASSY. (Removal 7)
- 7) Remove the COVER ASSY REAR. (Removal 20)
- 8) Remove the COVER ASSY TOP EXIT. (Removal 21)
- 9) Remove the BOX ASSY ESS PWB. (Removal 40)
- 10) Remove the COVER ASSY TOP ADD TRAY. (Removal 17)
- 11) Remove the COVER ASSY TOP. (Removal 44)
- 12) Remove the CHUTE ASSY INVERT. (Removal 22)
- 13) Remove the KIT CHUTE ASSY EXIT. (Removal 47)

Continues to the next page.

Removal 48 DRIVE ASSY EXIT (PL7.1.1)

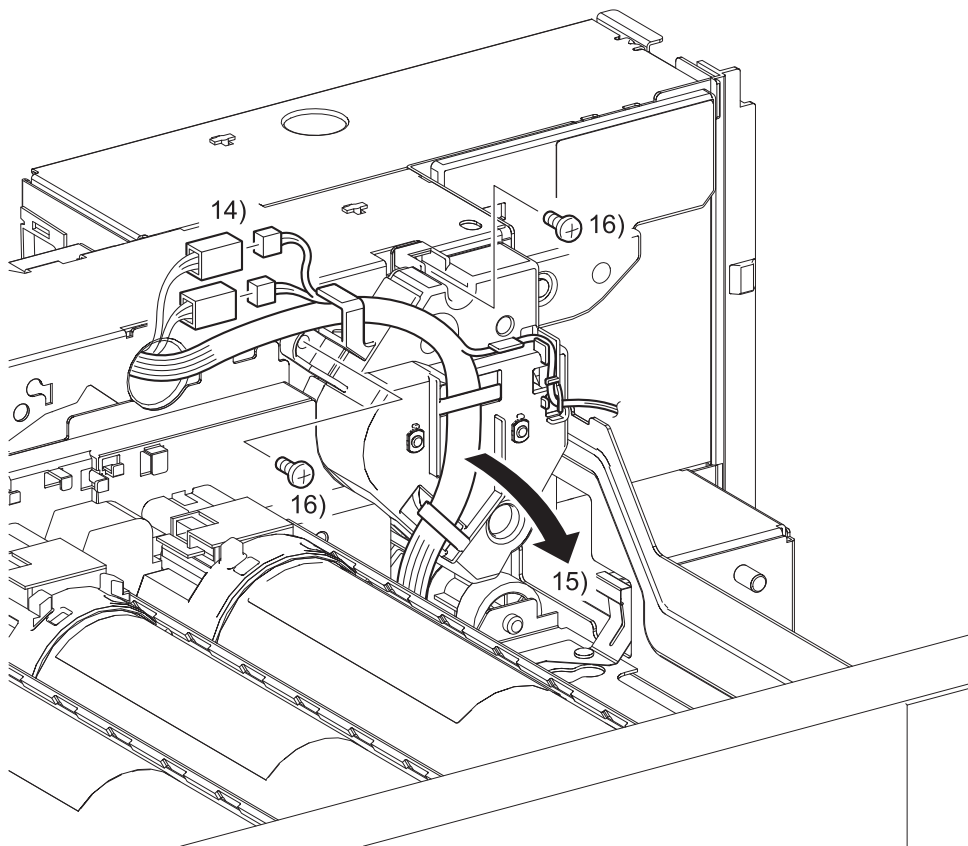

Tbt03066KA

14) Disengage the two sets of connectors (P/J115, 116) of the DRIVE ASSY EXIT (PL7.1.1).

NOTE

When performing the following step, use caution not to damage the harnesses.

15) Release all the harness from the hooks of the DRIVE ASSY EXIT.

16) Remove the two screws (silver, 6mm) that fix the DRIVE ASSY EXIT to the printer.

Continues to the next page.

Removal 48 DRIVE ASSY EXIT (PL7.1.1)

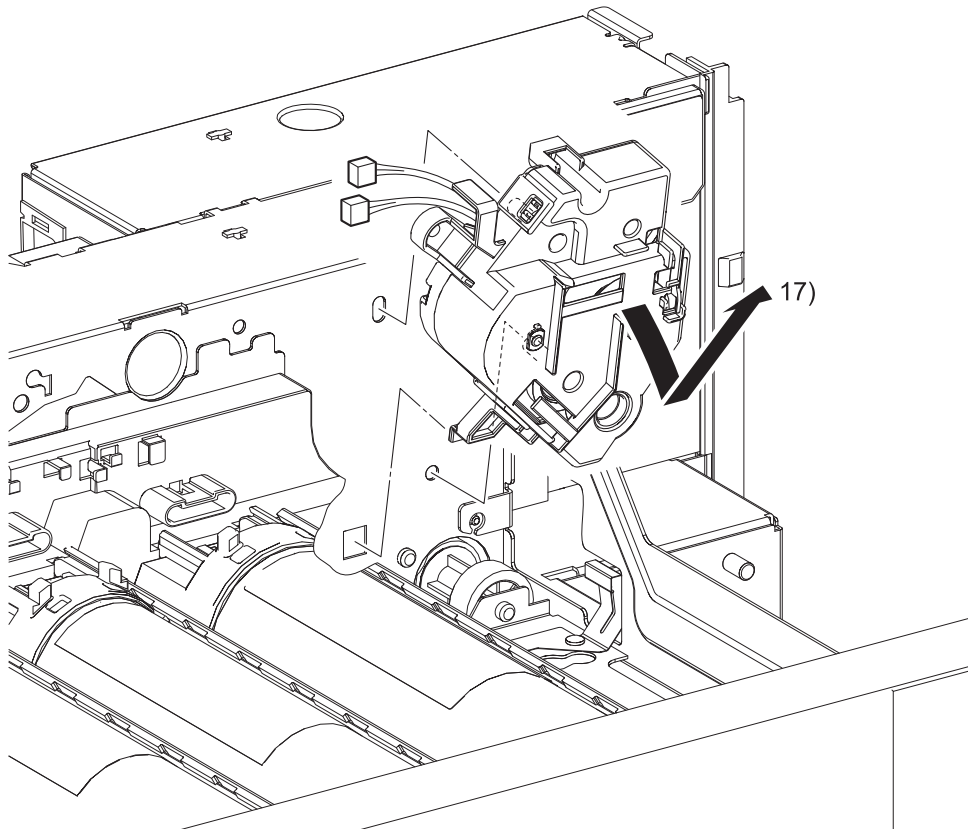

Tbt03067KA

- 17) Release the two bosses on the backside from the holes in the frame with the DRIVE ASSY EXIT slightly tilted toward the front side. Then, release the hook of the DRIVE ASSY EXIT from the frame and remove the DRIVE ASSY EXIT.

Blank Page

Removal 49 CONNECTOR ASSY CRUM (Toner CRUM) (Y), (M), (C), (K) (PL6.1.10)**NOTE**

Described below is the removal procedure common among the four CONNECTOR ASSY CRUM.

In the following steps, the details of Steps 1 through 12 are omitted because they are described earlier in this chapter. Go to the steps in parentheses to execute the necessary steps, and then go to Step 13 onward.

- 1) Open the COVER ASSY FRONT (PL1.2.17).
- 2) Open the COVER ASSY RH.
- 3) Open the FRAME ASSY 2ND (PL8.1.9).

NOTE

Place the BELT ASSY IBT in a safe place to prevent damage to its belt.

- 4) Remove the BELT ASSY IBT. (Removal 4)

NOTE

Cover the drum of the XERO DEVE CRU ASSY to prevent damage by light.

- 5) Remove the XERO DEVE CRU ASSY (Y), (M), (C), (K). (Removal 5)

NOTE

The FUSER section is very hot. Use extra caution not to burn yourself when performing the service operation.

- 6) Remove the FUSER ASSY. (Removal 7)
- 7) Remove the COVER ASSY REAR. (Removal 20)
- 8) Remove the COVER ASSY TOP EXIT. (Removal 21)
- 9) Remove the BOX ASSY ESS PWB. (Removal 40)
- 10) Remove the COVER ASSY TOP ADD TRAY. (Removal 17)
- 11) Remove the COVER ASSY TOP. (Removal 44)
- 12) Remove the DISP ASSY that corresponds to the CONNECTOR ASSY CRUM (PL6.1.10) to be replaced.

Continues to the next page.

Removal 49 CONNECTOR ASSY CRUM (Toner CRUM) (Y), (M), (C), (K) (PL6.1.10)

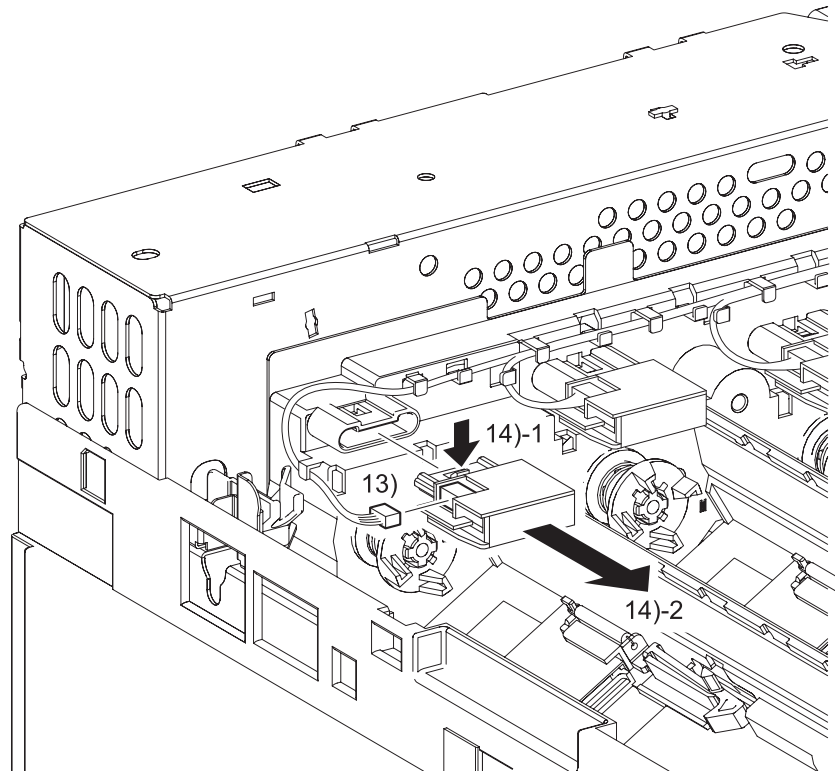

Tbt03068KB

- 13) Disengage the connectors of the CONNECTOR ASSY CRUM.
- 14) Remove the CONNECTOR ASSY CRUM from the MOTOR ASSY DISP (PL6.1.9) by releasing the hook of the CONNECTOR ASSY CRUM.

Removal 50 DISP ASSY (Y), (M), (C), (K) (PL6.1.5~6.1.8)

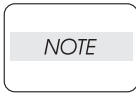

Described below is the removal procedure common among the four DISP ASSY.

In the following steps, the details of Steps 1 through 18 are omitted because they are described earlier in this chapter. Go to the steps in parentheses to execute the necessary steps, and then go to Step 19 onward.

- 1) Remove the TRAY ASSY (PL2.1.1) from the printer.
- 2) Remove the COVER ASSY FRONT. (Removal 1)
- 3) Remove the TONER CARTRIDGE (Y), (M), (C), (K) (PL6.1.1~6.1.4) from the printer.
- 4) Remove the WASTE TONER BOX. (Removal 3)
- 5) Open the COVER ASSY RH.
- 6) Open the FRAME ASSY 2ND (PL8.1.9).

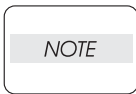

Place the BELT ASSY IBT in a safe place to prevent damage to its belt.

- 7) Remove the BELT ASSY IBT. (Removal 4)

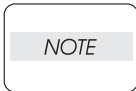

Cover the drum of the XERO DEVE CRU ASSY to prevent damage by light.

- 8) Remove the XERO DEVE CRU ASSY (Y), (M), (C), (K). (Removal 5)
- 9) Remove the KIT FRAME ASSY 2ND. (Removal 6)

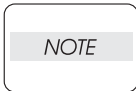

The FUSER section is very hot. Use extra caution not to burn yourself when performing the service operation.

- 10) Remove the FUSER ASSY. (Removal 7)
- 11) Remove the COVER ASSY REAR. (Removal 20)
- 12) Remove the COVER ASSY TOP EXIT. (Removal 21)
- 13) Remove the BOX ASSY ESS PWB. (Removal 40)
- 14) Remove the COVER ASSY TOP ADD TRAY. (Removal 17)
- 15) Remove the COVER ASSY TOP. (Removal 44)
- 16) Remove the COVER LH ASSY. (Removal 34)
- 17) Remove the COVER FRONT RH. (Removal 18)
- 18) Remove the COVER ASSY INNER FRONT. (Removal 35)

Continues to the next page.

Removal 50 DISP ASSY (Y), (M), (C), (K) (PL6.1.5~6.1.8)

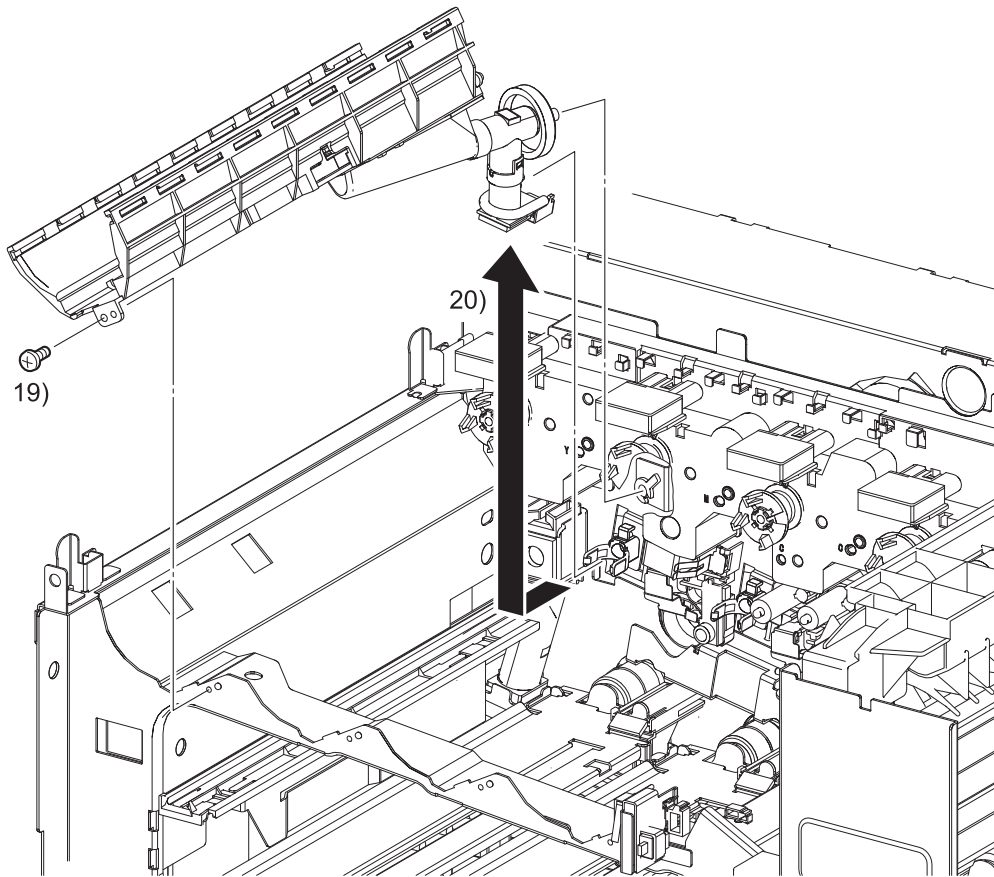

Tbt03069KB

19) Remove the one screw (silver, 6mm) that fixes the DISP ASSY to the printer.

NOTE

When performing the following step, place a sheet of paper under the unit so as to prevent smudges due to toner particles spilling from the DISP ASSY.

20) Slide the DISP ASSY toward the front side, disengage the joint section of the DISP ASSY from the CLAMP PIPE DISP (PL6.1.11) and remove the DISP ASSY from the printer.

Go to the next removal step:

Removal 51 LAMP ASSY ERASE (PL5.1.2)

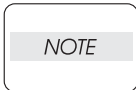
Removal 51 LAMP ASSY ERASE (PL5.1.2)

Described below is the removal procedure common among the four LAMP ASSY ERASE.

In the following steps, the details of Steps 1 through 19 are omitted because they are described earlier in this chapter. Go to the steps in parentheses to execute the necessary steps, and then go to Step 20 onward.

- 1) Remove the TRAY ASSY (PL2.1.1) from the printer.
- 2) Remove the COVER ASSY FRONT. (Removal 1)
- 3) Remove the TONER CARTRIDGE (Y), (M), (C), (K) (PL6.1.1~6.1.4) from the printer.
- 4) Remove the WASTE TONER BOX. (Removal 3)
- 5) Open the COVER ASSY RH.
- 6) Open the FRAME ASSY 2ND (PL8.1.9).

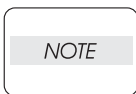

Place the BELT ASSY IBT in a safe place to prevent damage to its belt.

- 7) Remove the BELT ASSY IBT. (Removal 4)

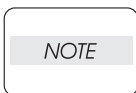

Cover the drum of the XERO DEVE CRU ASSY to prevent damage by light.

- 8) Remove the XERO DEVE CRU ASSY (Y), (M), (C), (K). (Removal 5)
- 9) Remove the KIT FRAME ASSY 2ND. (Removal 6)

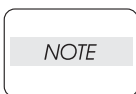

The FUSER section is very hot. Use extra caution not to burn yourself when performing the service operation.

- 10) Remove the FUSER ASSY. (Removal 7)
- 11) Remove the COVER ASSY REAR. (Removal 20)
- 12) Remove the COVER ASSY TOP EXIT. (Removal 21)
- 13) Remove the BOX ASSY ESS PWB. (Removal 40)
- 14) Remove the COVER ASSY TOP ADD TRAY. (Removal 17)
- 15) Remove the COVER ASSY TOP. (Removal 44)
- 16) Remove the COVER LH ASSY. (Removal 34)
- 17) Remove the COVER FRONT RH (Removal 18)
- 18) Remove the COVER ASSY INNER FRONT. (Removal 35)

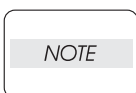

When performing the following step, replace the DISP ASSY that corresponds to the LAMP ASSY ERASE to be replaced.

When replacing the LAMP ASSY ERASE (Y), remove the DISP ASSY (Y) and DISP ASSY (M).

When replacing the LAMP ASSY ERASE (M), remove the DISP ASSY (M) and DISP ASSY (C).

When replacing the LAMP ASSY ERASE (C), remove the DISP ASSY (C) and DISP ASSY (K).

When replacing the LAMP ASSY ERASE (K), remove the DISP ASSY (K).

- 19) Remove the DISP ASSY. (Removal 50)

Continues to the next page.

Removal 51 LAMP ASSY ERASE (PL5.1.2)

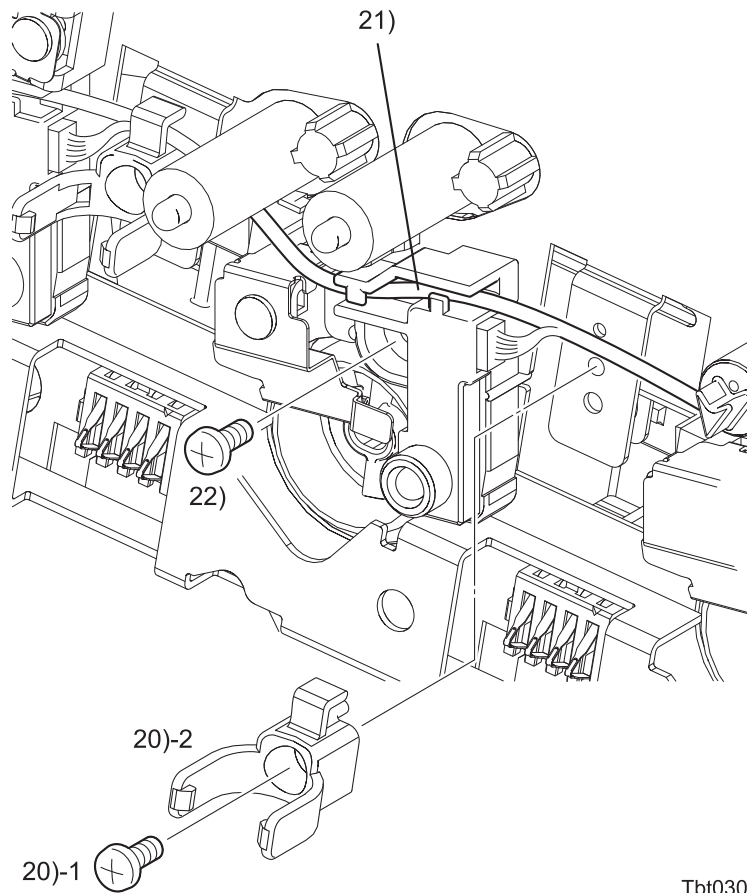

Tbt03070KB

NOTE

The following step is not necessary for the LAMP ASSY ERASE for black.

- 20) Remove the CLAMP PIPE from the printer by removing the one screw that fixes the CLAMP PIPE DISP (PL6.1.11) to the right side of the LAMP ASSY ERASE (PL5.1.2) to be replaced.

NOTE

The following step is not necessary for the LAMP ASSY ERASE for yellow.

- 21) Release the harness from the hooks of the LAMP ASSY ERASE.
- 22) Remove the one screw (silver, 6mm) that fixes the LAMP ASSY ERASE.

Continues to the next page.

Removal 51 LAMP ASSY ERASE (PL5.1.2)

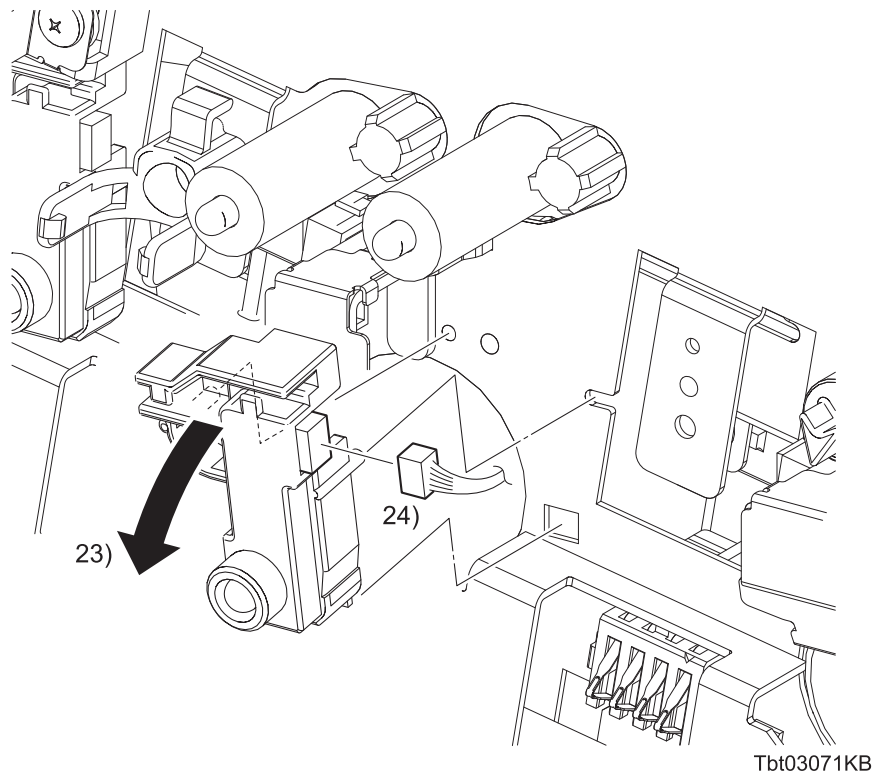

NOTE

When performing the following step, use caution not to move the LAMP ASSY ERASE from the printer too far because they are connected with the harness.

- 23) Release the boss on the backside from the hole in the frame with the LAMP ASSY ERASE slightly tilted toward the front side. Then, release the hook of the LAMP ASSY ERASE from the frame and remove the LAMP ASSY ERASE.
- 24) Disengage the connectors of the LAMP ASSY ERASE.

Blank Page

Removal 52 HARNESS ASSY I/L FRT (PL1.2.1)

In the following steps, the details of Steps 1 through 18 are omitted because they are described earlier in this chapter. Go to the steps in parentheses to execute the necessary steps, and then go to Step 19 onward.

- 1) Remove the TRAY ASSY (PL2.1.1) from the printer.
- 2) Remove the COVER ASSY FRONT. (Removal 1)
- 3) Remove the TONER CARTRIDGE (Y), (M), (C), (K) (PL6.1.1~6.1.4) from the printer.
- 4) Remove the WASTE TONER BOX. (Removal 3)
- 5) Open the COVER ASSY RH.
- 6) Open the FRAME ASSY 2ND (PL8.1.9).

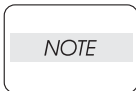

Place the BELT ASSY IBT in a safe place to prevent damage to its belt.

- 7) Remove the BELT ASSY IBT. (Removal 4)

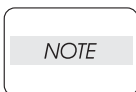

Cover the drum of the XERO DEVE CRU ASSY to prevent damage by light.

- 8) Remove the XERO DEVE CRU ASSY (Y), (M), (C), (K). (Removal 5)
- 9) Remove the KIT FRAME ASSY 2ND. (Removal 6)

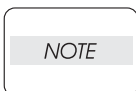

The FUSER section is very hot. Use extra caution not to burn yourself when performing the service operation.

- 10) Remove the FUSER ASSY. (Removal 7)
- 11) Remove the COVER ASSY REAR. (Removal 20)
- 12) Remove the COVER ASSY TOP EXIT. (Removal 21)
- 13) Remove the BOX ASSY ESS PWB. (Removal 40)
- 14) Remove the COVER ASSY TOP ADD TRAY. (Removal 17)
- 15) Remove the COVER ASSY TOP. (Removal 44)
- 16) Remove the COVER LH ASSY. (Removal 34)
- 17) Remove the COVER FRONT RH. (Removal 18)
- 18) Remove the COVER ASSY INNER FRONT. (Removal 35)

Continues to the next page.

Removal 52 HARNESS ASSY I/L FRT (PL1.2.1)

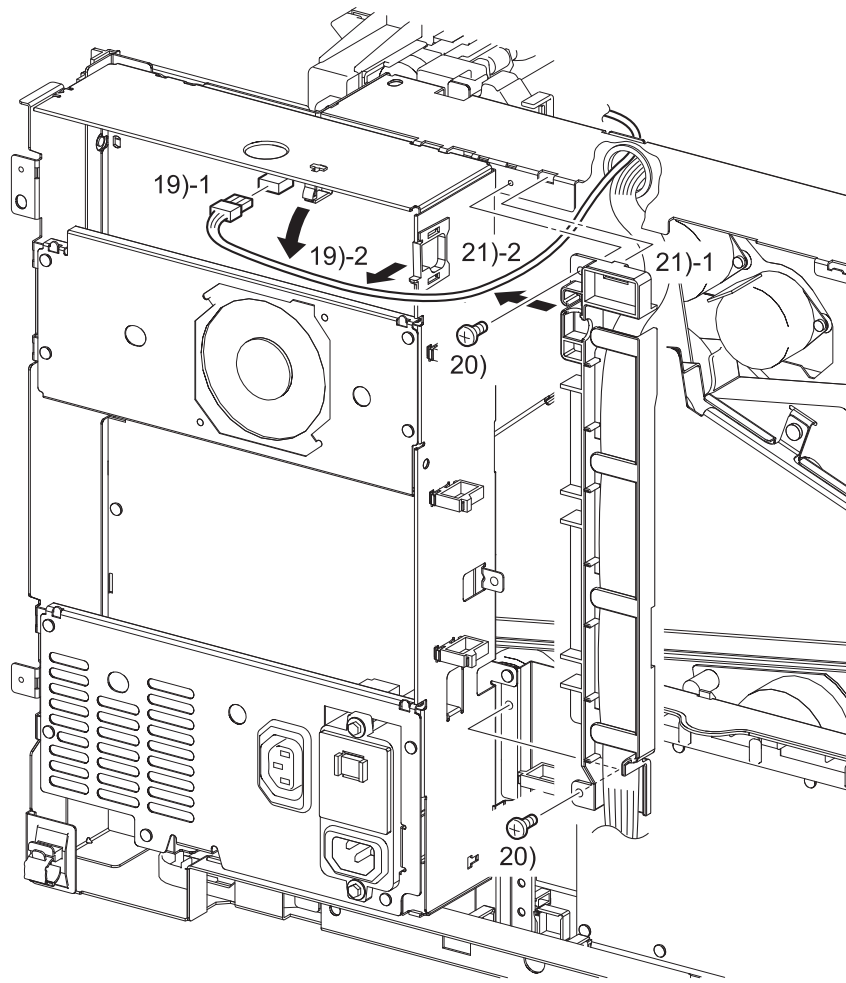

Tbt03072KB

- 19) Disengage the connectors (P/J302) on the LVPS ASSY (PL10.2.2), and then release the harness of the HARNESS ASSY I/L FRT (PL1.2.1) from the two clamps of the BOX ASSY LVPS (PL10.2.1).
- 20) Remove the two screws (silver, 6mm) that fix the GUIDE HARNESS REAR CTR (PL10.2.6) to the printer.
- 21) Release the hook of the GUIDE HARNESS REAR CTR from the hole in the frame and slightly slide the GUIDE HARNESS REAR CTR together with the harness. And then release the harness of the HARNESS ASSY I/L FRT from the GUIDE HARNESS REAR CTR.

Continues to the next page.

Removal 52 HARNESS ASSY I/L FRT (PL1.2.1)

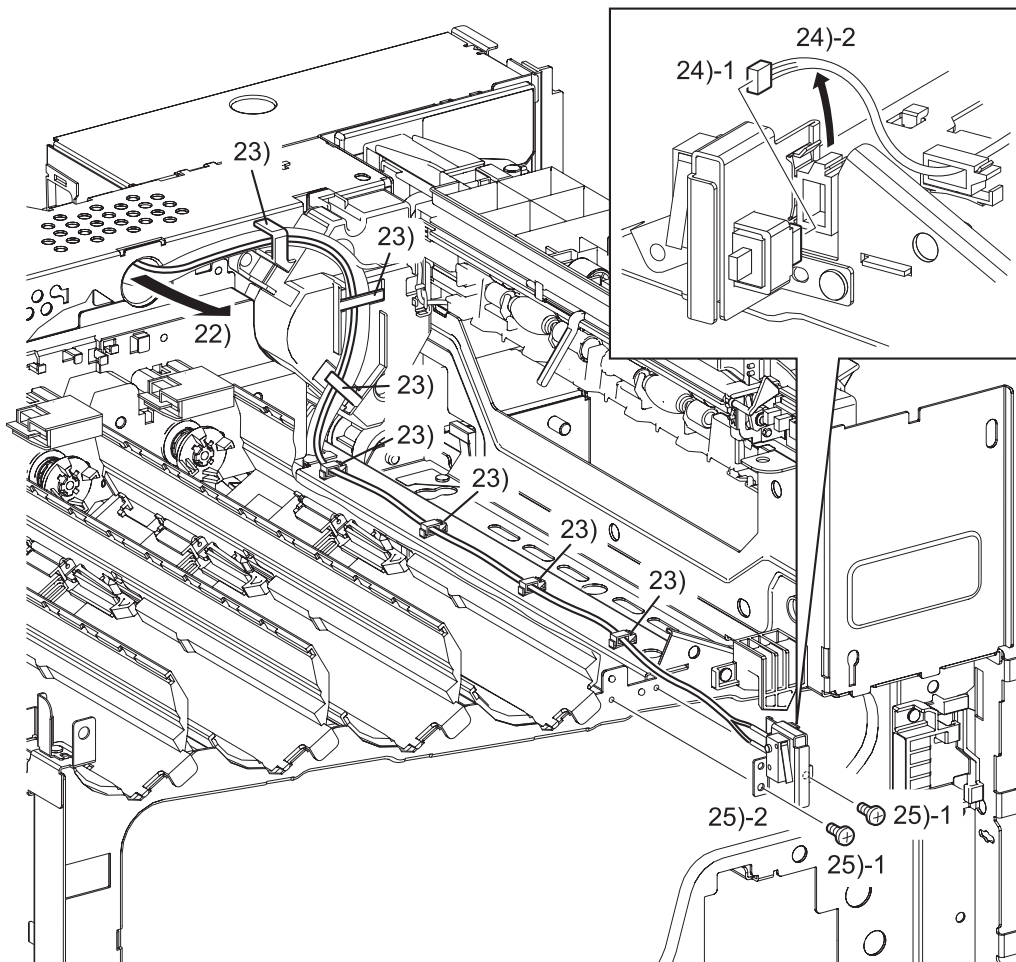

Tbt03073KB

- 22) Pull the harness of the HARNESS ASSY I/L FRT out from the hole of the frame.
- 23) Release the harness of the HARNESS ASSY I/L FRT from the hooks of the DRIVE ASSY EXIT (PL7.1.1) and the four clamps.
- 24) Disengage the connectors (P/J212) of the SWITCH (PL1.2.3), and then release the harness from the CLAMP LOCKING (PL1.2.4).
- 25) Remove the HARNESS ASSY I/L FRT from the printer by removing the two screws (silver, 6mm).

Blank Page

Removal 53 DRIVE ASSY SNS (K) (PL9.2.1)

In the following steps, the details of Steps 1 through 12 are omitted because they are described earlier in this chapter. Go to the steps in parentheses to execute the necessary steps, and then go to Step 13 onward.

- 1) Open the COVER ASSY FRONT (PL1.2.17).
- 2) Open the COVER ASSY RH.
- 3) Open the FRAME ASSY 2ND (PL8.1.9).

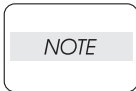

Place the BELT ASSY IBT in a safe place to prevent damage to its belt.

- 4) Remove the BELT ASSY IBT. (Removal 4)

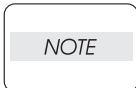

Cover the drum of the XERO DEVE CRU ASSY to prevent damage by light.

- 5) Remove the XERO DEVE CRU ASSY (Y), (M), (C), (K). (Removal 5)

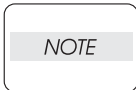

The FUSER section is very hot. Use extra caution not to burn yourself when performing the service operation.

- 6) Remove the FUSER ASSY. (Removal 7)
- 7) Remove the COVER ASSY REAR. (Removal 20)
- 8) Remove the COVER ASSY TOP EXIT. (Removal 21)
- 9) Remove the BOX ASSY ESS PWB. (Removal 40)
- 10) Remove the FAN ASSY LVPS. (Removal 32)
- 11) Remove the PLATE ASSY LVPS POWER. (Removal 33)
- 12) Remove the BOX ASSY LVPS. (Removal 42)

Continues to the next page.

Removal 53 DRIVE ASSY SNS (K) (PL9.2.1)

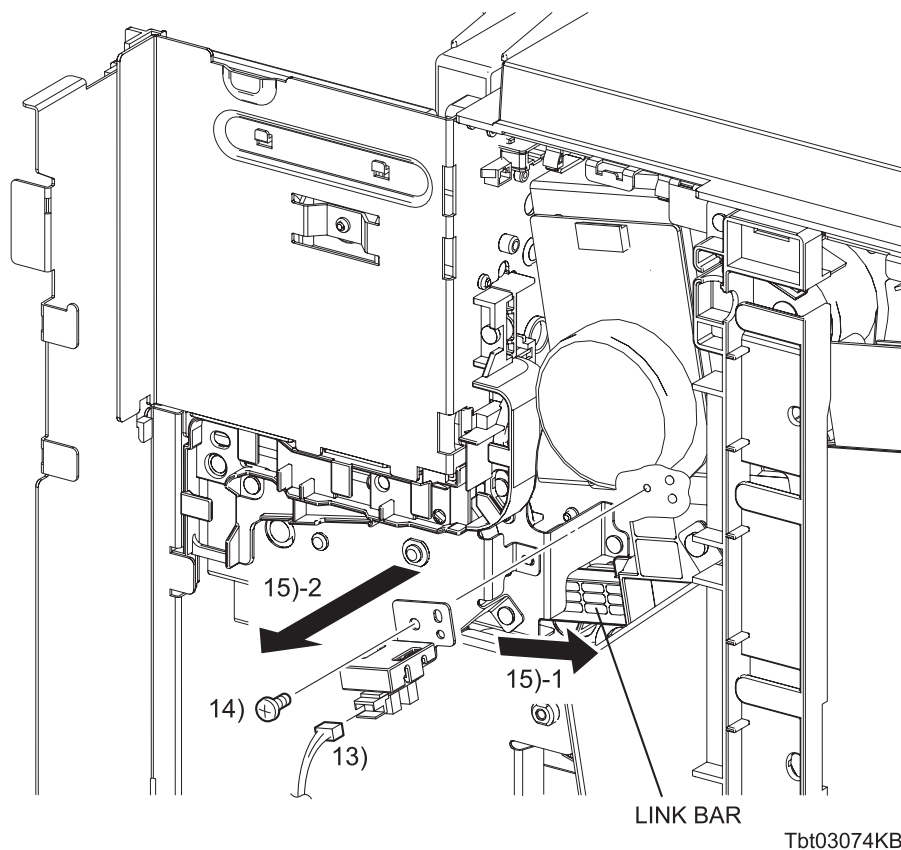

- 13) Disengage the connectors (P/J200) of the DRIVE ASSY SNS (K) (PL9.2.1).
- 14) Remove the one screw (silver, 6mm) that fixes the DRIVE ASSY SNS (K) to the printer.
- 15) Slide the LINK BAR actuator away from the switching sensor (K) and remove the DRIVE ASSY SNS (K) from the printer.

Removal 54 DRIVE ASSY FSR (PL9.1.1)

In the following steps, the details of Steps 1 through 12 are omitted because they are described earlier in this chapter. Go to the steps in parentheses to execute the necessary steps, and then go to Step 13 onward.

- 1) Open the COVER ASSY FRONT (PL1.2.17).
- 2) Open the COVER ASSY RH.
- 3) Open the FRAME ASSY 2ND (PL8.1.9).

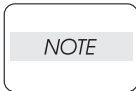

Place the BELT ASSY IBT in a safe place to prevent damage to its belt.

- 4) Remove the BELT ASSY IBT. (Removal 4)

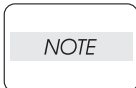

Cover the drum of the XERO DEVE CRU ASSY to prevent damage by light.

- 5) Remove the XERO DEVE CRU ASSY (Y), (M), (C), (K). (Removal 5)

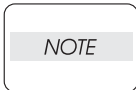

The FUSER section is very hot. Use extra caution not to burn yourself when performing the service operation.

- 6) Remove the FUSER ASSY. (Removal 7)
- 7) Remove the COVER ASSY REAR. (Removal 20)
- 8) Remove the COVER ASSY TOP EXIT. (Removal 21)
- 9) Remove the BOX ASSY ESS PWB. (Removal 40)
- 10) Remove the FAN ASSY LVPS. (Removal 32)
- 11) Remove the PLATE ASSY LVPS POWER. (Removal 33)
- 12) Remove the BOX ASSY LVPS. (Removal 42)

Continues to the next page.

Removal 54 DRIVE ASSY FSR (PL9.1.1)

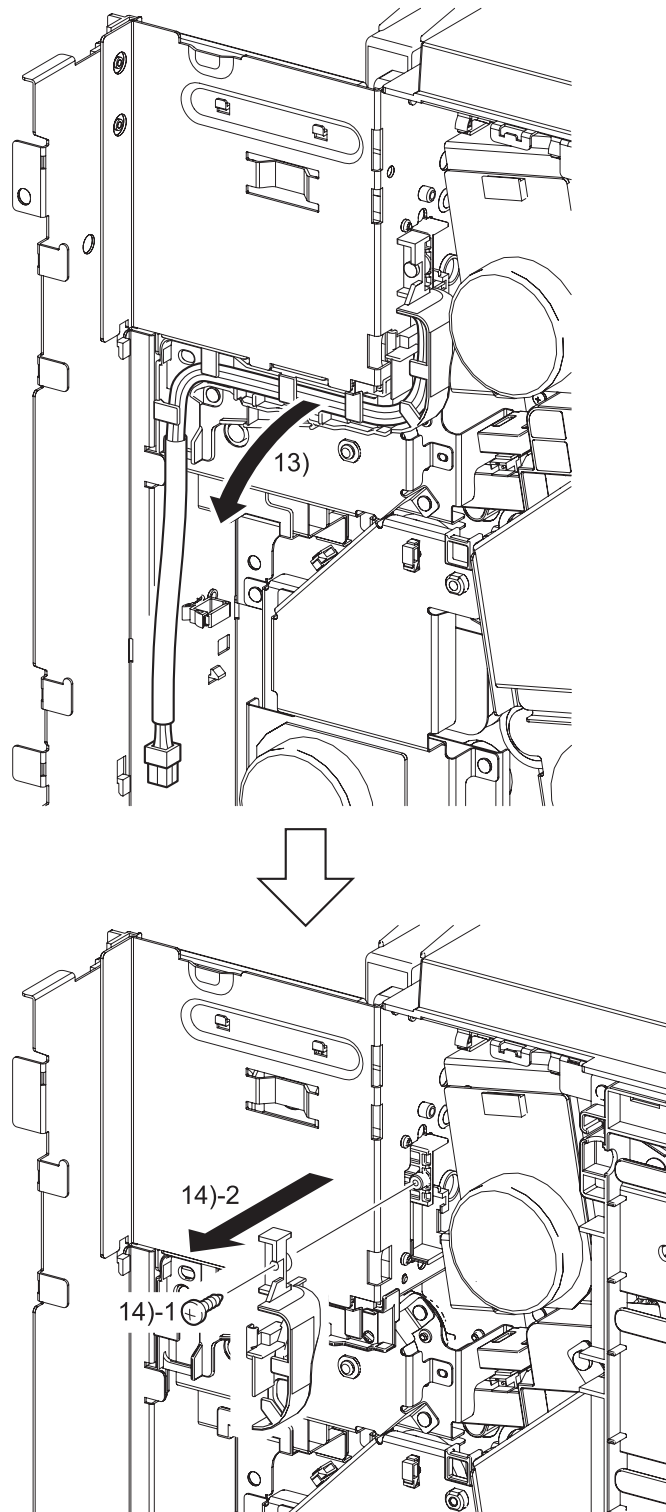

Tbt03075KB

- 13) Release the HARNESS ASSY FSR (PL7.1.4) from the GUIDE HARNESS FUSER AC (PL9.1.2) and BRACKET FUSER HNS.
- 14) Remove the BRACKET FUSER HNS from the printer by removing the one screw (silver, tapping, 8mm).

Continues to the next page.

Removal 54 DRIVE ASSY FSR (PL9.1.1)

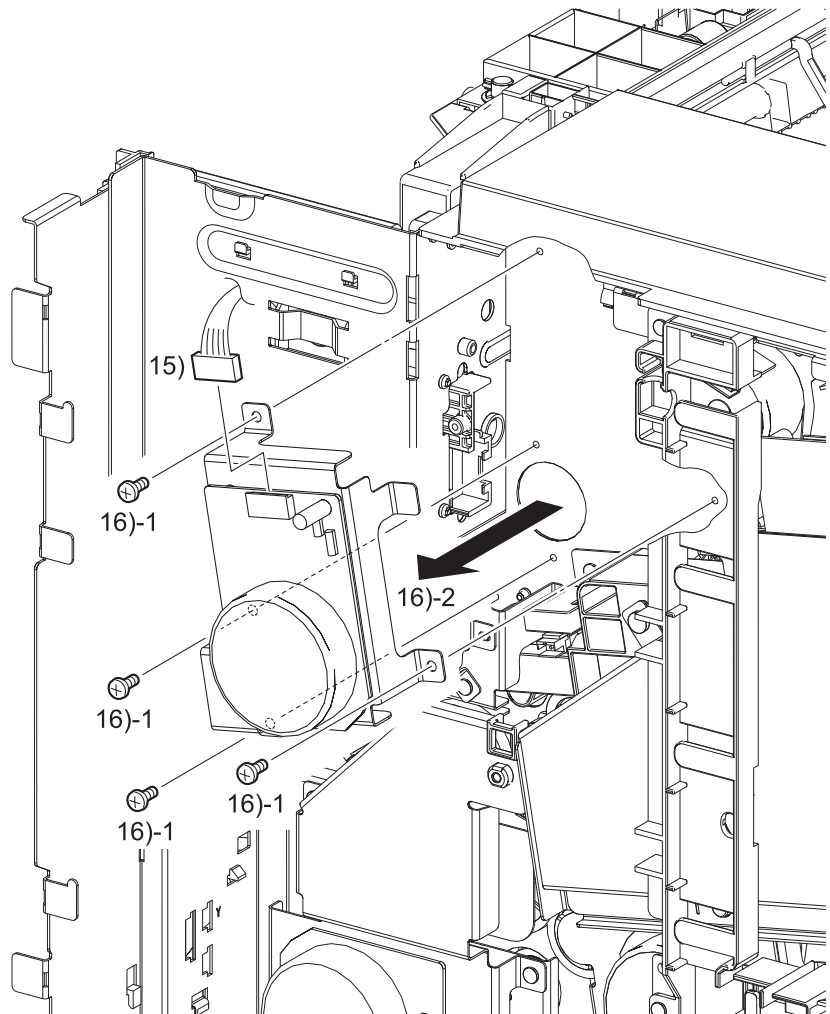

Tbt03076KB

15) Disengage the connectors (P/J250) of the DRIVE ASSY FSR (PL9.1.1).

16) Remove the DRIVE ASSY FSR from the printer by removing the four screws (silver, 6mm).

Blank Page

Removal 55 DRIVE ASSY IBT (PL9.1.3)

In the following steps, the details of Steps 1 through 12 are omitted because they are described earlier in this chapter. Go to the steps in parentheses to execute the necessary steps, and then go to Step 13 onward.

- 1) Open the COVER ASSY FRONT (PL1.2.17).
- 2) Open the COVER ASSY RH.
- 3) Open the FRAME ASSY 2ND (PL8.1.9).

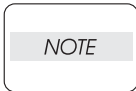

Place the BELT ASSY IBT in a safe place to prevent damage to its belt.

- 4) Remove the BELT ASSY IBT. (Removal 4)

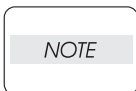

Cover the drum of the XERO DEVE CRU ASSY to prevent damage by light.

- 5) Remove the XERO DEVE CRU ASSY (Y), (M), (C), (K). (Removal 5)

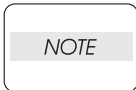

The FUSER section is very hot. Use extra caution not to burn yourself when performing the service operation.

- 6) Remove the FUSER ASSY. (Removal 7)
- 7) Remove the COVER ASSY REAR. (Removal 20)
- 8) Remove the COVER ASSY TOP EXIT. (Removal 21)
- 9) Remove the BOX ASSY ESS PWB. (Removal 40)
- 10) Remove the FAN ASSY LVPS. (Removal 32)
- 11) Remove the PLATE ASSY LVPS POWER. (Removal 33)
- 12) Remove the BOX ASSY LVPS. (Removal 42)

Continues to the next page.

Removal 55 DRIVE ASSY IBT (PL9.1.3)

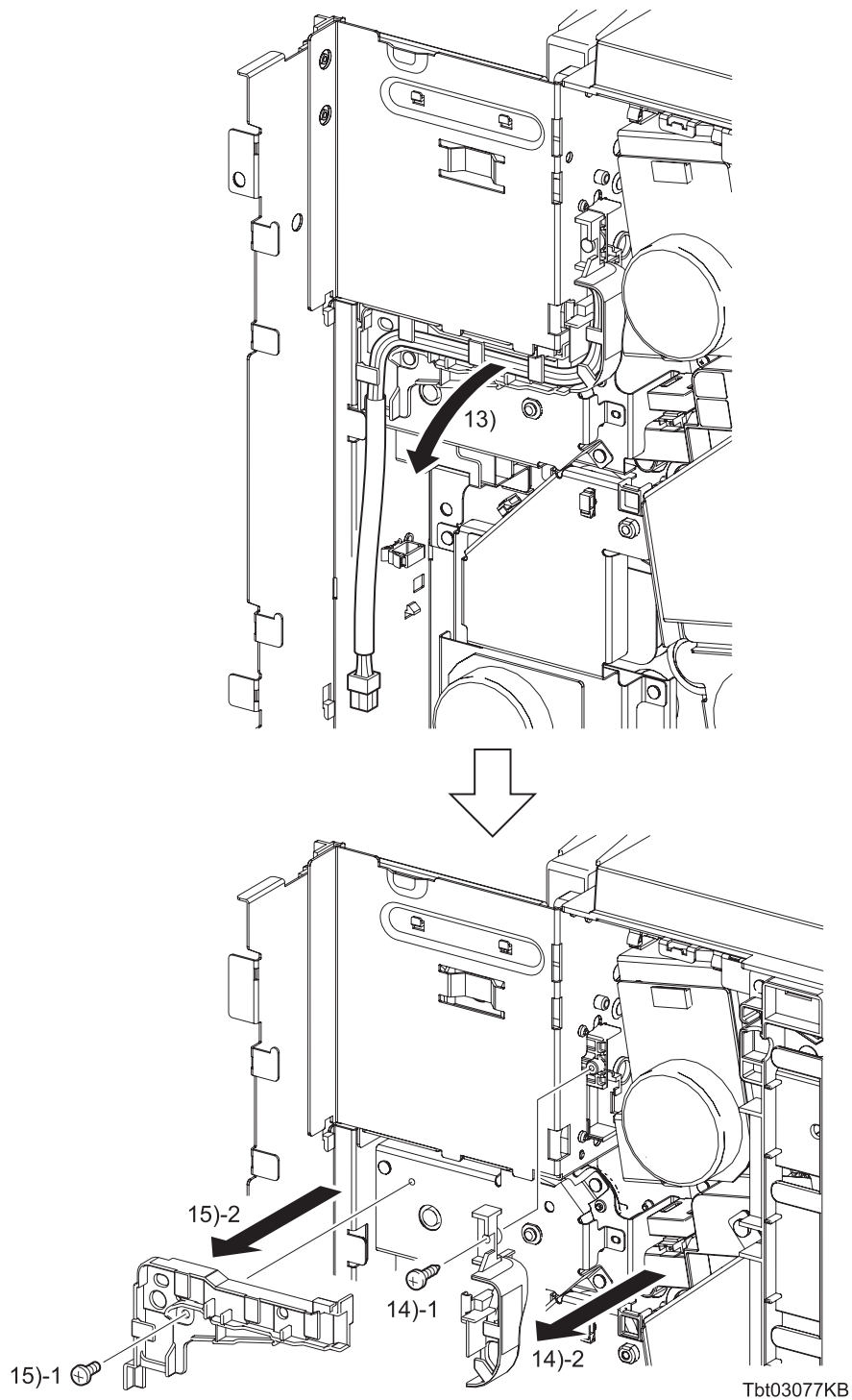

- 13) Release the HARNESS ASSY FSR (PL7.1.4) from the GUIDE HARNESS FUSER AC (PL9.1.2) and BRACKET FUSER HNS.
- 14) Remove the BRACKET FUSER HNS from the printer by removing the one screw (silver, tapping, 8mm).
- 15) Remove the GUIDE HARNESS FUSER AC from the DRIVE ASSY IBT (PL9.1.3) by removing the one screw (silver, 6mm).

Continues to the next page.

Removal 55 DRIVE ASSY IBT (PL9.1.3)

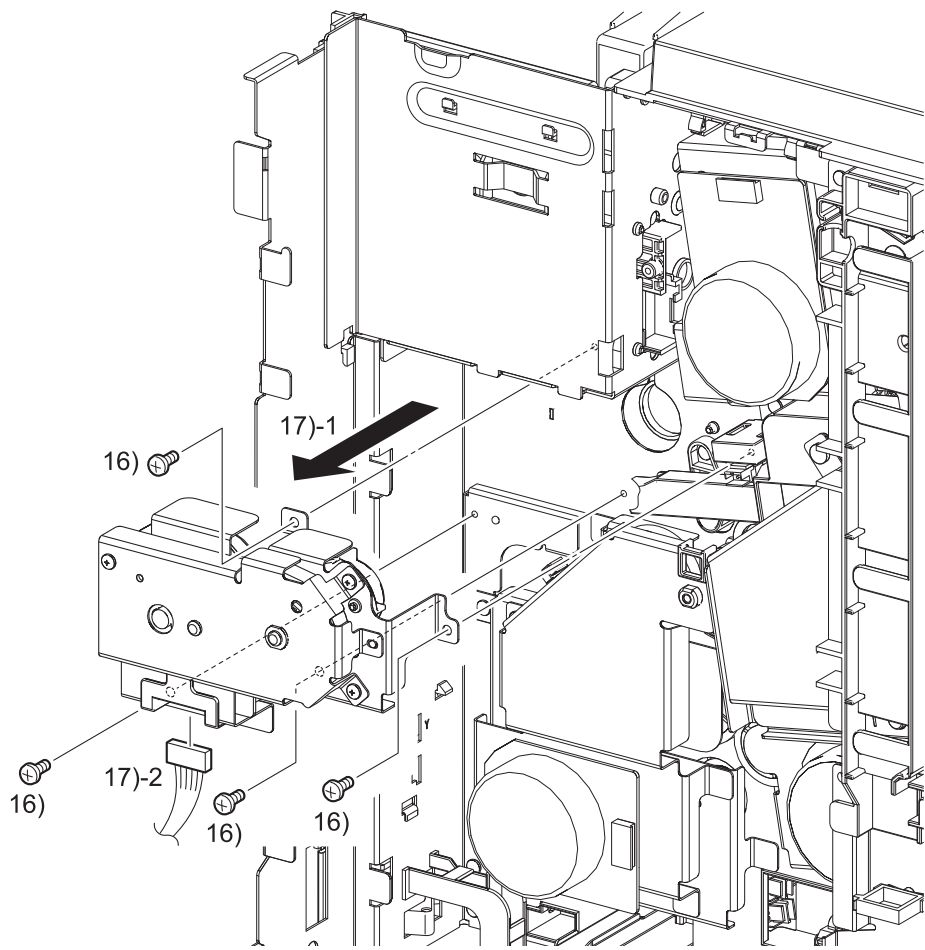

Tbt03078KB

- 16) Remove the four screws (silver, 6mm) that fix the DRIVE ASSY IBT to the printer.
- 17) Disengage the connectors (P/J254) of the DRIVE ASSY IBT, and then remove the DRIVE ASSY IBT from the printer.

Blank Page

Removal 56 DRIVE ASSY PH (PL9.1.4)

In the following steps, the details of Steps 1 through 13 are omitted because they are described earlier in this chapter. Go to the steps in parentheses to execute the necessary steps, and then go to Step 14 onward.

- 1) Open the COVER ASSY FRONT (PL1.2.17).
- 2) Open the COVER ASSY RH.
- 3) Open the FRAME ASSY 2ND (PL8.1.9).

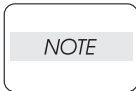

Place the BELT ASSY IBT in a safe place to prevent damage to its belt.

- 4) Remove the BELT ASSY IBT. (Removal 4)

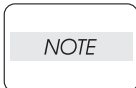

Cover the drum of the XERO DEVE CRU ASSY to prevent damage by light.

- 5) Remove the XERO DEVE CRU ASSY (Y), (M), (C), (K). (Removal 5)

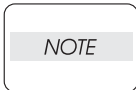

The FUSER section is very hot. Use extra caution not to burn yourself when performing the service operation.

- 6) Remove the FUSER ASSY. (Removal 7)
- 7) Remove the COVER ASSY REAR. (Removal 20)
- 8) Remove the COVER ASSY TOP EXIT. (Removal 21)
- 9) Remove the BOX ASSY ESS PWB. (Removal 40)
- 10) Remove the FAN ASSY LVPS. (Removal 32)
- 11) Remove the PLATE ASSY LVPS POWER. (Removal 33)
- 12) Remove the BOX ASSY LVPS. (Removal 42)
- 13) Remove the WASTE TONER BOX. (Removal 3)

Continues to the next page.

Removal 56 DRIVE ASSY PH (PL9.1.4)

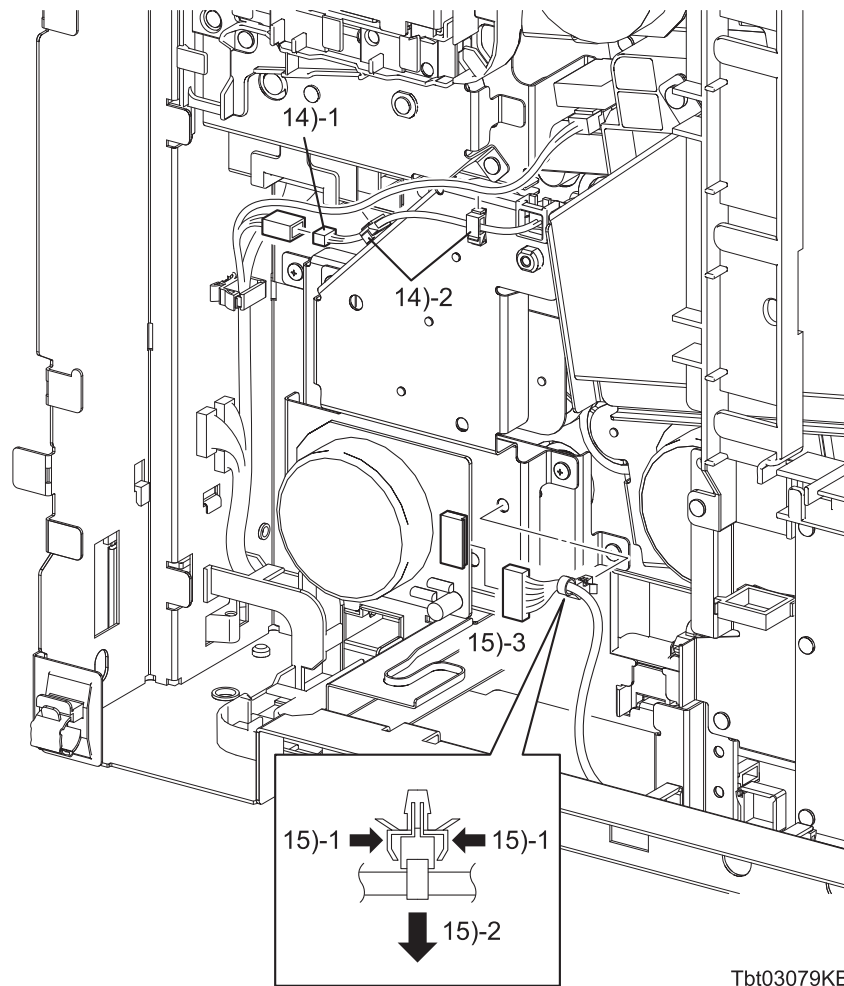

Tbt03079KB

NOTE

When performing the following step, use caution, leave the relay connector on the printer harness side.

- 14) Disengage the connectors (P/J100) of the Switching Clutch, and then release the harness of the DRIVE ASSY SNS (K) (PL9.2.1) from the two clamps on the DRIVE ASSY PH (PL9.1.4).
- 15) Release the clamp that fixes the harness to the DRIVE ASSY PH, and then disengage the connectors (P/J255) of the DRIVE ASSY PH.

Continues to the next page.

Removal 56 DRIVE ASSY PH (PL9.1.4)

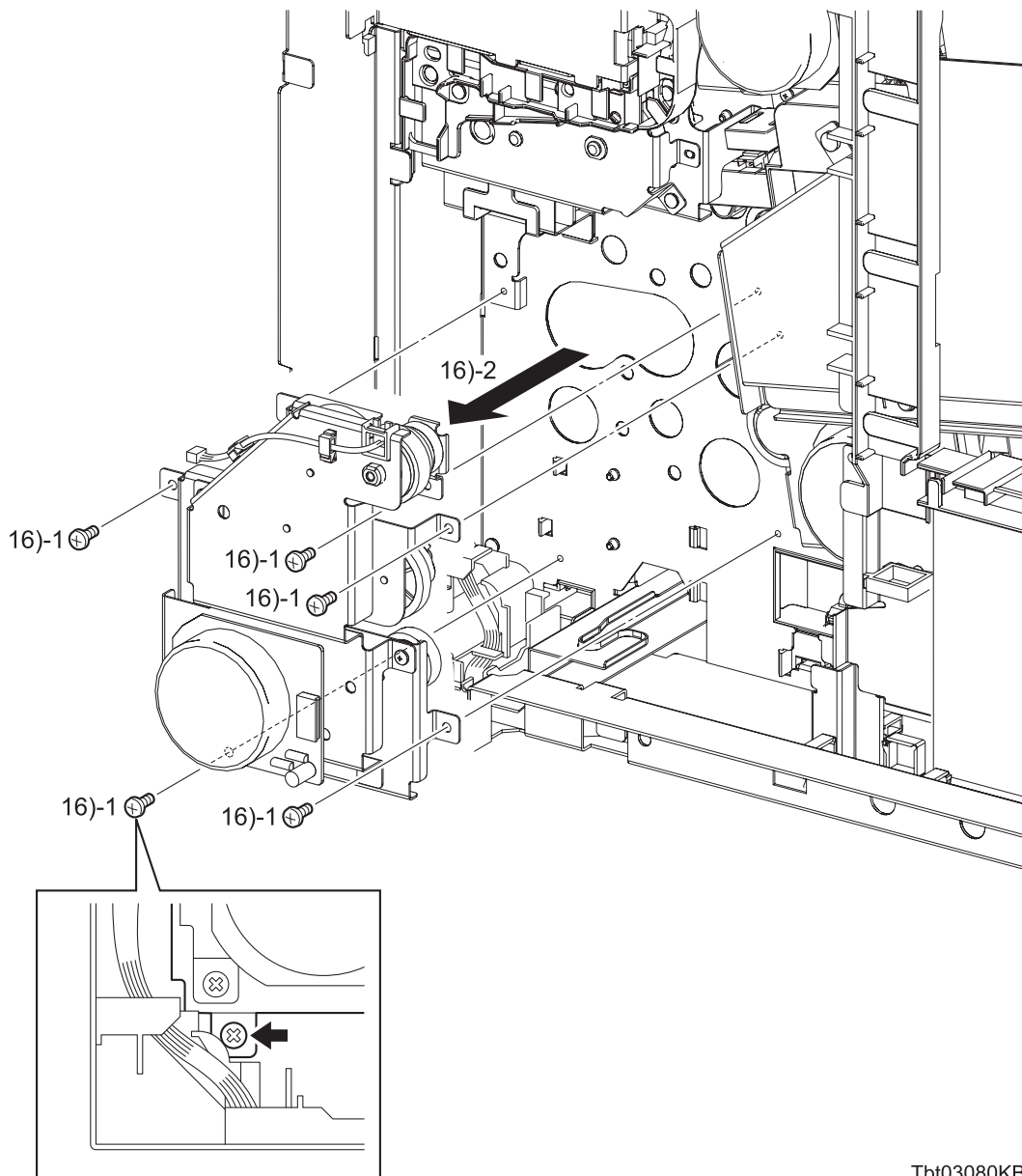

Tbt03080KB

16) Remove the DRIVE ASSY PH from the printer by removing the five screws (silver, 6mm).

Go to the next removal step:

Removal 57 KIT LINK XERO DRIVE (PL9.2.98)

Blank Page

Removal 57 KIT LINK XERO DRIVE (PL9.2.98)

In the following steps, the details of Steps 1 through 17 are omitted because they are described earlier in this chapter. Go to the steps in parentheses to execute the necessary steps, and then go to Step 18 onward.

- 1) Open the COVER ASSY FRONT (PL1.2.17).
- 2) Open the COVER ASSY RH.
- 3) Open the FRAME ASSY 2ND (PL8.1.9).

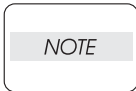

Place the BELT ASSY IBT in a safe place to prevent damage to its belt.

- 4) Remove the BELT ASSY IBT. (Removal 4)

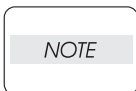

Cover the drum of the XERO DEVE CRU ASSY to prevent damage by light.

- 5) Remove the XERO DEVE CRU ASSY (Y), (M), (C), (K). (Removal 5)

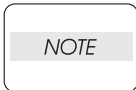

The FUSER section is very hot. Use extra caution not to burn yourself when performing the service operation.

- 6) Remove the FUSER ASSY. (Removal 7)
- 7) Remove the COVER ASSY REAR. (Removal 20)
- 8) Remove the COVER ASSY TOP EXIT. (Removal 21)
- 9) Remove the BOX ASSY ESS PWB. (Removal 40)
- 10) Remove the COVER ASSY TOP ADD TRAY. (Removal 17)
- 11) Remove the COVER ASSY TOP. (Removal 44)
- 12) Remove the FAN ASSY LVPS. (Removal 32)
- 13) Remove the PLATE ASSY LVPS POWER. (Removal 33)
- 14) Remove the BOX ASSY LVPS. (Removal 42)
- 15) Remove the DRIVE ASSY IBT. (Removal 55)
- 16) Remove the WASTE TONER BOX. (Removal 3)
- 17) Remove the DRIVE ASSY PH. (Removal 56)

Continues to the next page.

Removal 57 KIT LINK XERO DRIVE (PL9.2.98)

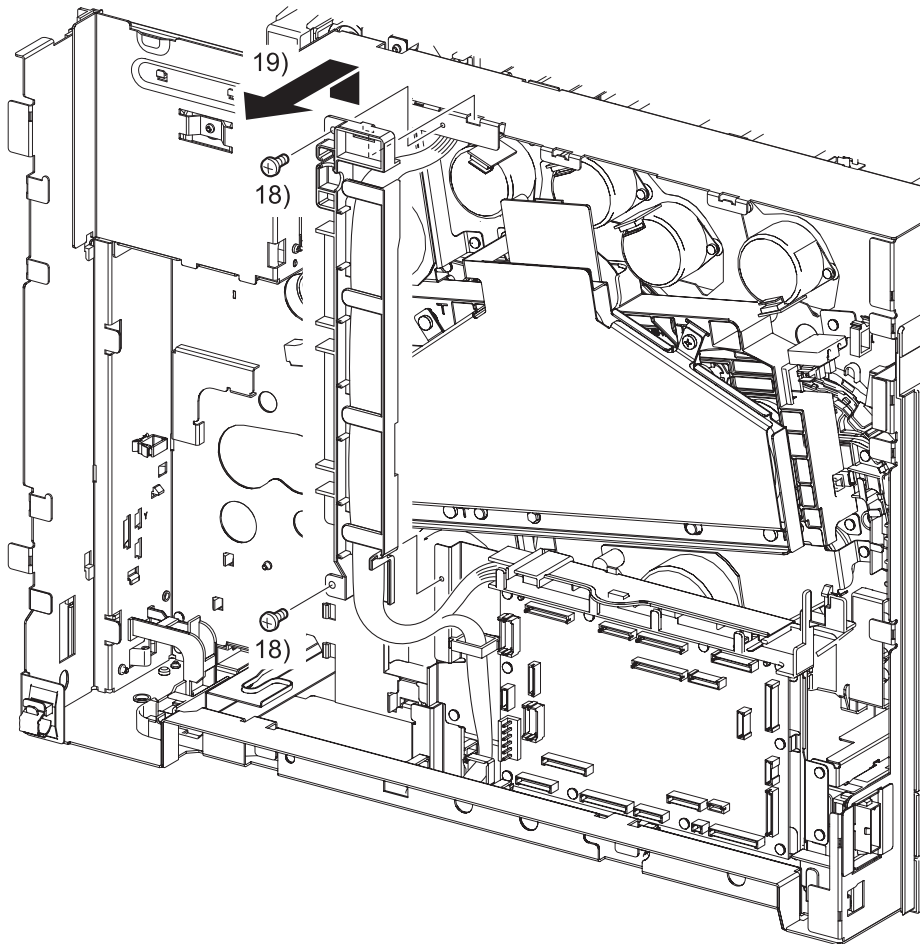

Tbt03216KA

- 18) Remove the two screws (silver, 6mm) that fix the GUIDE HARNESS REAR CTR (PL10.2.6) to the printer.
- 19) Release the hook of the GUIDE HARNESS REAR CTR from the hole in the frame and slightly slide the GUIDE HARNESS REAR CTR together with the harness.

Continues to the next page.

Removal 57 KIT LINK XERO DRIVE (PL9.2.98)

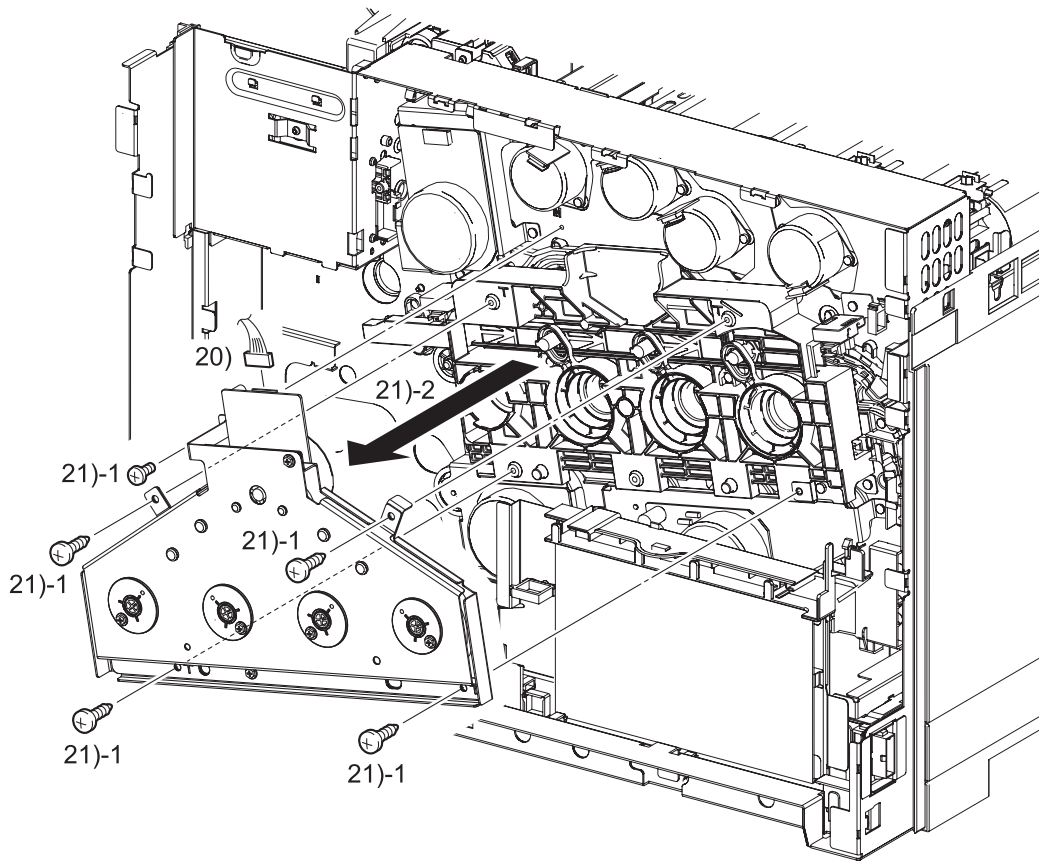

Tbt03081KB

20) Disengage the connectors (P/J251) of the DRIVE ASSY XERO (PL9.2.6).

NOTE

Never loosen the red screws used with the DRIVE ASSY XERO.

21) Remove the DRIVE ASSY XERO from the printer by removing the four screws (silver, tapping, M4, 10mm) and the one screw (silver, 6mm).

Continues to the next page.

Removal 57 KIT LINK XERO DRIVE (PL9.2.98)

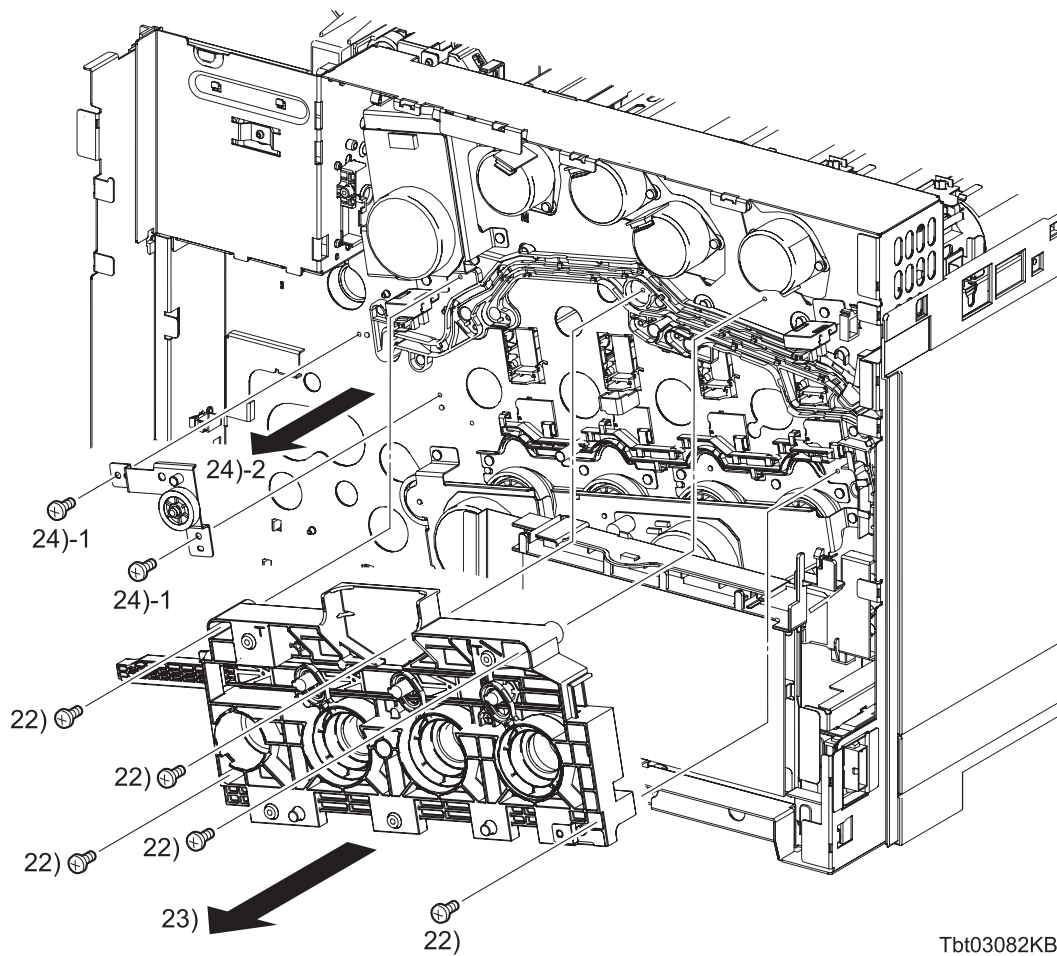

Tbt03082KB

- 22) Remove the five screws (silver, 6mm) that fix the GUIDE ASSY LINK (PL9.2.5) to the printer.
- 23) Slide the LINK BAR actuator away from the switching sensor and remove the GUIDE ASSY LINK from the printer.
- 24) Remove the DRIVE ASSY RACK (PL9.2.7) from the printer by removing the two screws (silver, 6mm).

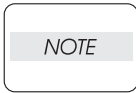
Removal 58 BOX ASSY MCU (PL10.2.15)

Use a wrist strap to protect the PWB from electrostatic damage.

In the following steps, the details of Steps 1 through 14 are omitted because they are described earlier in this chapter. Go to the steps in parentheses to execute the necessary steps, and then go to Step 15 onward.

- 1) Open the COVER ASSY FRONT (PL1.2.17).
- 2) Open the COVER ASSY RH.
- 3) Open the FRAME ASSY 2ND (PL8.1.9).

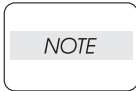

Place the BELT ASSY IBT in a safe place to prevent damage to its belt.

- 4) Remove the BELT ASSY IBT. (Removal 4)

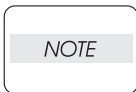

Cover the drum of the XERO DEVE CRU ASSY to prevent damage by light.

- 5) Remove the XERO DEVE CRU ASSY (Y), (M), (C), (K). (Removal 5)

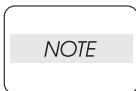

The FUSER section is very hot. Use extra caution not to burn yourself when performing the service operation.

- 6) Remove the FUSER ASSY. (Removal 7)
- 7) Remove the COVER ASSY REAR. (Removal 20)
- 8) Remove the COVER ASSY TOP EXIT. (Removal 21)
- 9) Remove the BOX ASSY ESS PWB. (Removal 40)
- 10) Remove the COVER ASSY TOP ADD TRAY. (Removal 17)
- 11) Remove the COVER ASSY TOP. (Removal 44)
- 12) Remove the FAN ASSY LVPS. (Removal 32)
- 13) Remove the PLATE ASSY LVPS POWER. (Removal 33)
- 14) Remove the BOX ASSY LVPS. (Removal 42)

Continues to the next page.

Removal 58 BOX ASSY MCU (PL10.2.15)

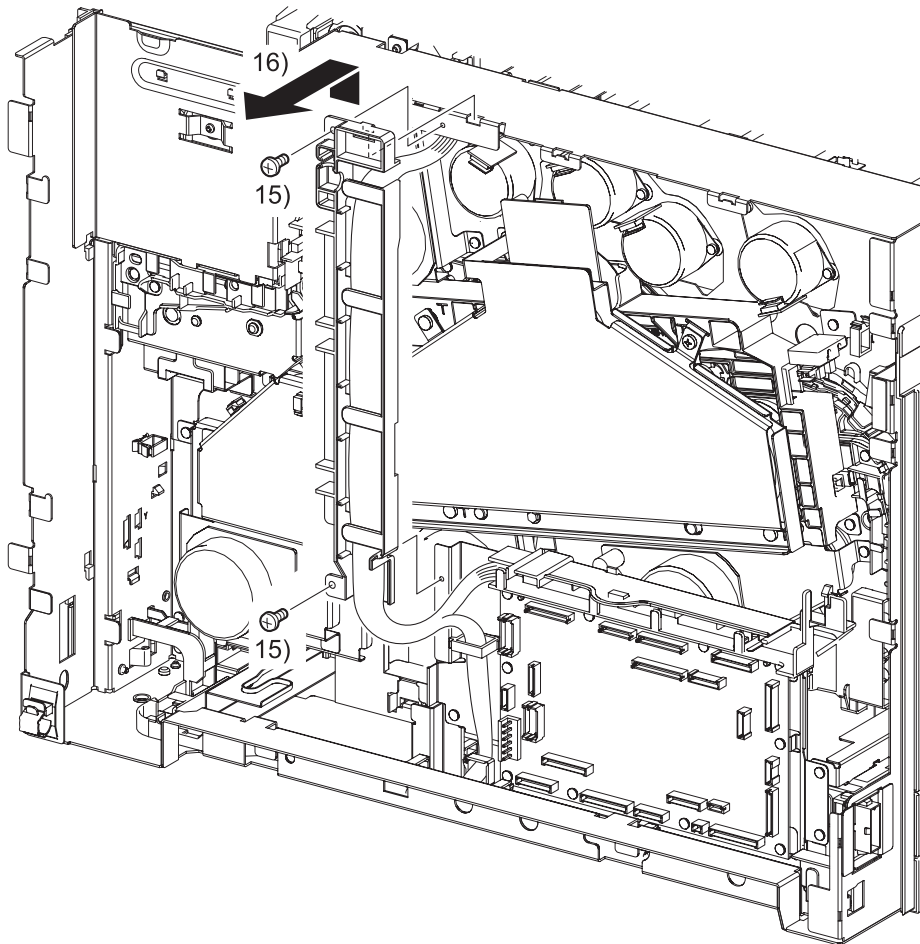

Tbt03083KA

- 15) Remove the two screws (silver, 6mm) that fix the GUIDE HARNESS REAR CTR (PL10.2.6) to the printer.
- 16) Release the hook of the GUIDE HARNESS REAR CTR from the hole in the frame and slightly slide the GUIDE HARNESS REAR CTR together with the harness.

Continues to the next page.

Removal 58 BOX ASSY MCU (PL10.2.15)

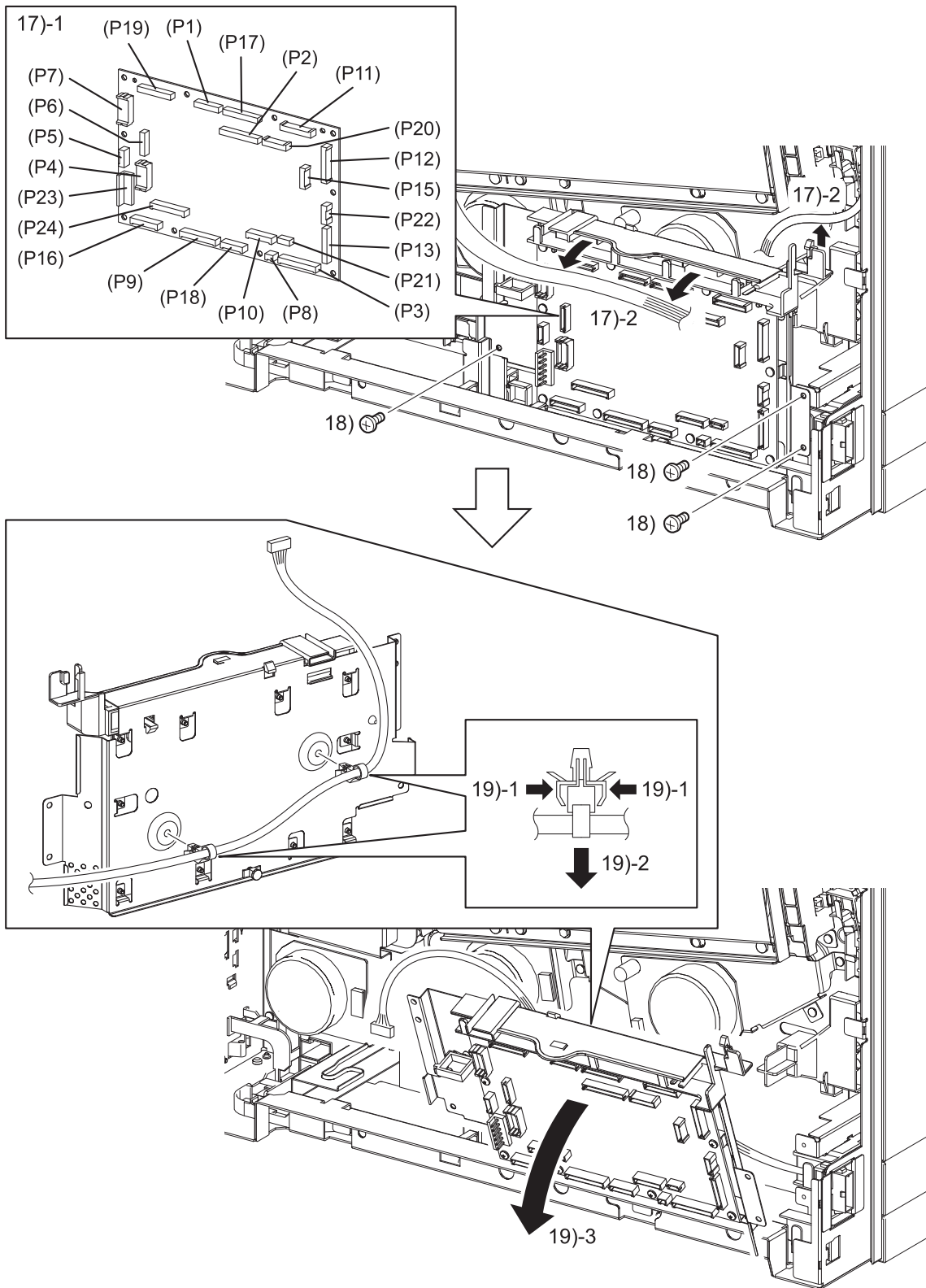

Tbt03084KB

17) Disengage all the connectors of the PWBA MCU (PL10.2.18), and then release all the harness from the GUIDE HARNESS MCU UPR (PL10.2.17).

Continues to the next page.

Removal 58 BOX ASSY MCU (PL10.2.15)

- 18) Remove the three screws (silver, 6mm) that fix the BOX ASSY MCU (PL10.2.15) to the printer.

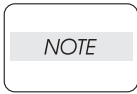

When performing the following step, use caution not to move the BOX ASSY MCU from the printer too far because they are connected with the harness.

- 19) Remove the two clamps that fix the HARNESS ASSY VIDEO (PL11.1.4) from the backside of the BOX ASSY MCU. Then, remove the BOX ASSY MCU from the printer.

Go to the next removal step:

Removal 59 DRIVE ASSY DEVE (PL9.2.9)

Removal 60 DRIVE ASSY DEVE K (PL9.2.10)

Removal 59 DRIVE ASSY DEVE (PL9.2.9)

In the following steps, the details of Steps 1 through 15 are omitted because they are described earlier in this chapter. Go to the steps in parentheses to execute the necessary steps, and then go to Step 16 onward.

- 1) Open the COVER ASSY FRONT (PL1.2.17).
- 2) Open the COVER ASSY RH.
- 3) Open the FRAME ASSY 2ND (PL8.1.9).

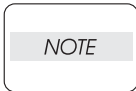

Place the BELT ASSY IBT in a safe place to prevent damage to its belt.

- 4) Remove the BELT ASSY IBT. (Removal 4)

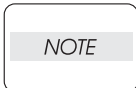

Cover the drum of the XERO DEVE CRU ASSY to prevent damage by light.

- 5) Remove the XERO DEVE CRU ASSY (Y), (M), (C), (K). (Removal 5)

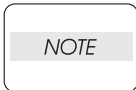

The FUSER section is very hot. Use extra caution not to burn yourself when performing the service operation.

- 6) Remove the FUSER ASSY. (Removal 7)
- 7) Remove the COVER ASSY REAR. (Removal 20)
- 8) Remove the COVER ASSY TOP EXIT. (Removal 21)
- 9) Remove the BOX ASSY ESS PWB. (Removal 40)
- 10) Remove the COVER ASSY TOP ADD TRAY. (Removal 17)
- 11) Remove the COVER ASSY TOP. (Removal 44)
- 12) Remove the FAN ASSY LVPS. (Removal 32)
- 13) Remove the PLATE ASSY LVPS POWER. (Removal 33)
- 14) Remove the BOX ASSY LVPS. (Removal 42)
- 15) Remove the BOX ASSY MCU. (Removal 58)

Continues to the next page.

Removal 59 DRIVE ASSY DEVE (PL9.2.9)

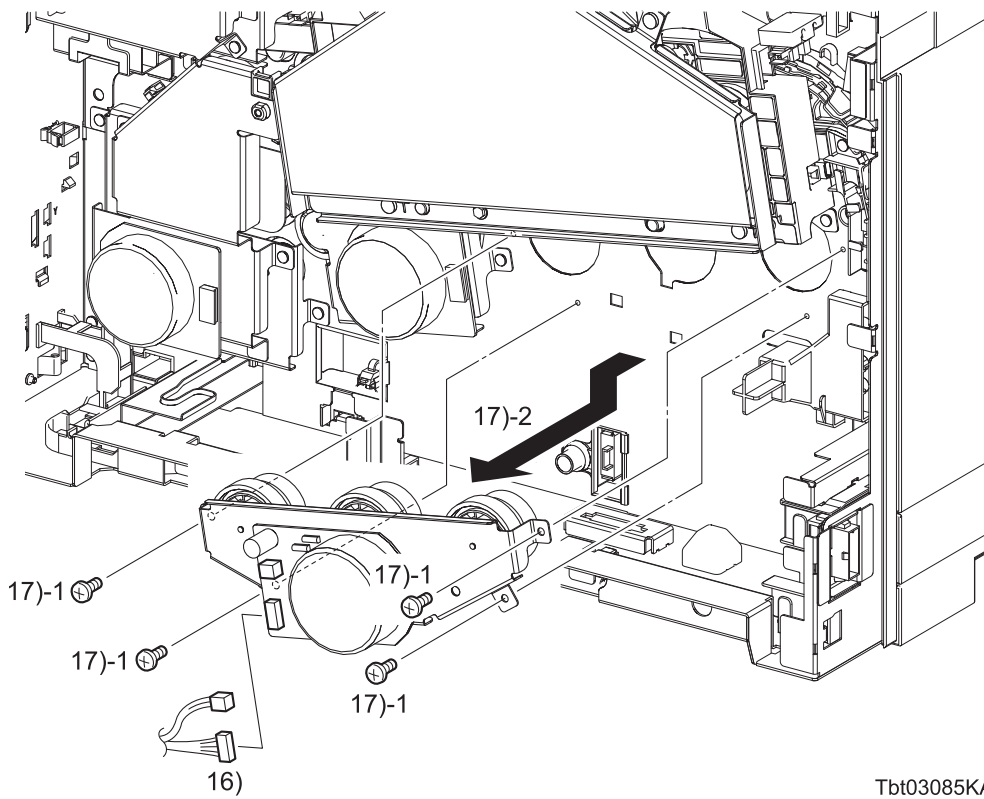

Tbt03085KA

- 16) Disengage the two sets of connectors (P/J252, 260) of the DRIVE ASSY DEVE (PL9.2.9).
- 17) Remove the DRIVE ASSY DEVE from the printer by removing the four screws (silver, 6mm).

Removal 60 DRIVE ASSY DEVE K (PL9.2.10)

In the following steps, the details of Steps 1 through 15 are omitted because they are described earlier in this chapter. Go to the steps in parentheses to execute the necessary steps, and then go to Step 16 onward.

- 1) Open the COVER ASSY FRONT (PL1.2.17).
- 2) Open the COVER ASSY RH.
- 3) Open the FRAME ASSY 2ND (PL8.1.9).

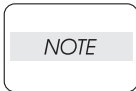

Place the BELT ASSY IBT in a safe place to prevent damage to its belt.

- 4) Remove the BELT ASSY IBT. (Removal 4)

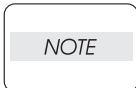

Cover the drum of the XERO DEVE CRU ASSY to prevent damage by light.

- 5) Remove the XERO DEVE CRU ASSY (Y), (M), (C), (K). (Removal 5)

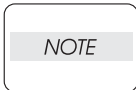

The FUSER section is very hot. Use extra caution not to burn yourself when performing the service operation.

- 6) Remove the FUSER ASSY. (Removal 7)
- 7) Remove the COVER ASSY REAR. (Removal 20)
- 8) Remove the COVER ASSY TOP EXIT. (Removal 21)
- 9) Remove the BOX ASSY ESS PWB. (Removal 40)
- 10) Remove the COVER ASSY TOP ADD TRAY. (Removal 17)
- 11) Remove the COVER ASSY TOP. (Removal 44)
- 12) Remove the FAN ASSY LVPS. (Removal 32)
- 13) Remove the PLATE ASSY LVPS POWER. (Removal 33)
- 14) Remove the BOX ASSY LVPS. (Removal 42)
- 15) Remove the BOX ASSY MCU. (Removal 58)

Continues to the next page.

Removal 60 DRIVE ASSY DEVE K (PL9.2.10)

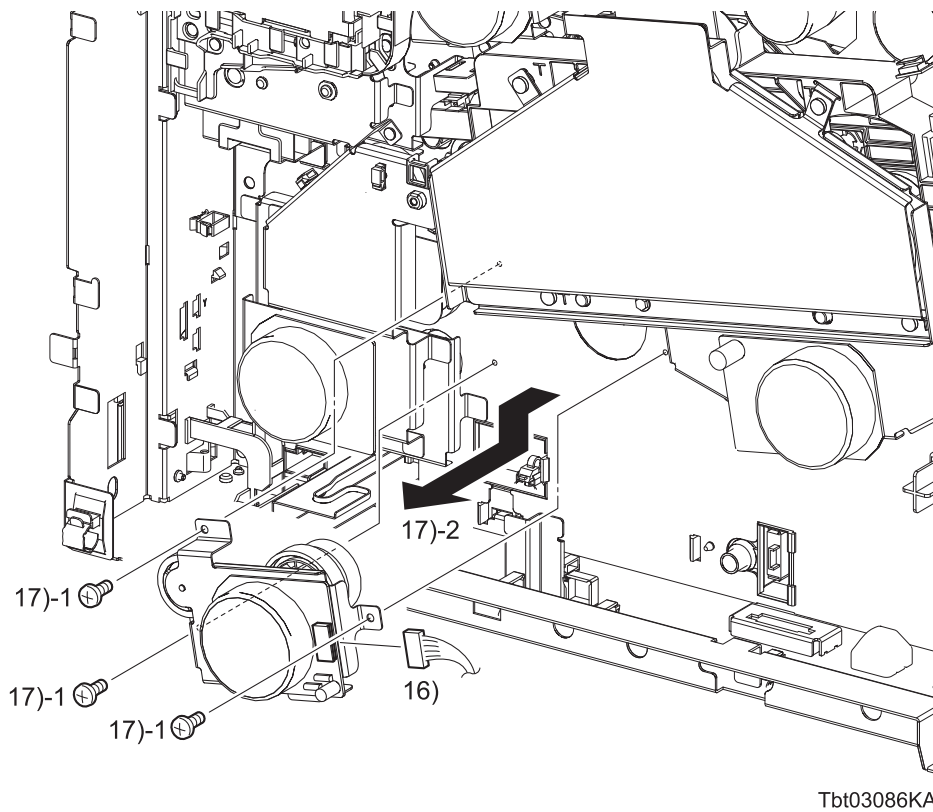

- 16) Disengage the connectors (P/J253) of the DRIVE ASSY DEVE K (PL9.2.10).
- 17) Remove the DRIVE ASSY DEVE K from the printer by removing the three screws (silver, 6mm).

Go to the next removal step:

Removal 61 KIT DRIVE GEAR (PL9.2.99)

Removal 61 KIT DRIVE GEAR (PL9.2.99)

In the following steps, the details of Steps 1 through 18 are omitted because they are described earlier in this chapter. Go to the steps in parentheses to execute the necessary steps, and then go to Step 19 onward.

- 1) Open the COVER ASSY FRONT (PL1.2.17).
- 2) Open the COVER ASSY RH.
- 3) Open the FRAME ASSY 2ND (PL8.1.9).

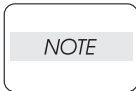

Place the BELT ASSY IBT in a safe place to prevent damage to its belt.

- 4) Remove the BELT ASSY IBT. (Removal 4)

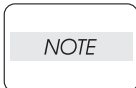

Cover the drum of the XERO DEVE CRU ASSY to prevent damage by light.

- 5) Remove the XERO DEVE CRU ASSY (Y), (M), (C), (K). (Removal 5)

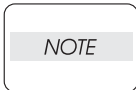

The FUSER section is very hot. Use extra caution not to burn yourself when performing the service operation.

- 6) Remove the FUSER ASSY. (Removal 7)
- 7) Remove the COVER ASSY REAR. (Removal 20)
- 8) Remove the COVER ASSY TOP EXIT. (Removal 21)
- 9) Remove the BOX ASSY ESS PWB. (Removal 40)
- 10) Remove the COVER ASSY TOP ADD TRAY. (Removal 17)
- 11) Remove the COVER ASSY TOP. (Removal 44)
- 12) Remove the FAN ASSY LVPS. (Removal 32)
- 13) Remove the PLATE ASSY LVPS POWER. (Removal 33)
- 14) Remove the BOX ASSY LVPS. (Removal 42)
- 15) DRIVE ASSY SNS (FC). (Removal 41)
- 16) BOX ASSY MCU. (Removal 58)
- 17) Remove the DRIVE ASSY DEVE. (Removal 59)
- 18) Remove the DRIVE ASSY DEVE K. (Removal 60)

Continues to the next page.

Removal 61 KIT DRIVE GEAR (PL9.2.99)

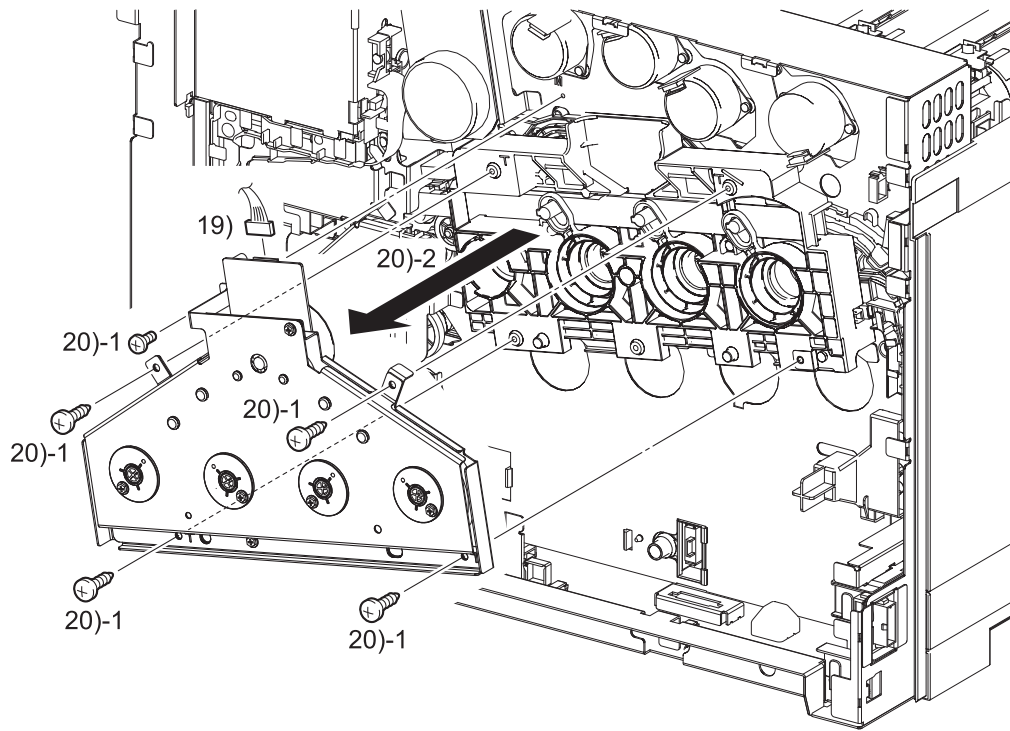

Tbt03087KB

19) Disengage the connectors (P/J251) of the DRIVE ASSY XERO (PL9.2.6).

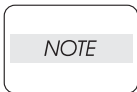

Never loosen the red screws used with the DRIVE ASSY XERO.

20) Remove the DRIVE ASSY XERO from the printer by removing the four screws (silver, tapping, M4, 10mm) and the one screw (silver, 6mm).

Continues to the next page.

Removal 61 KIT DRIVE GEAR (PL9.2.99)

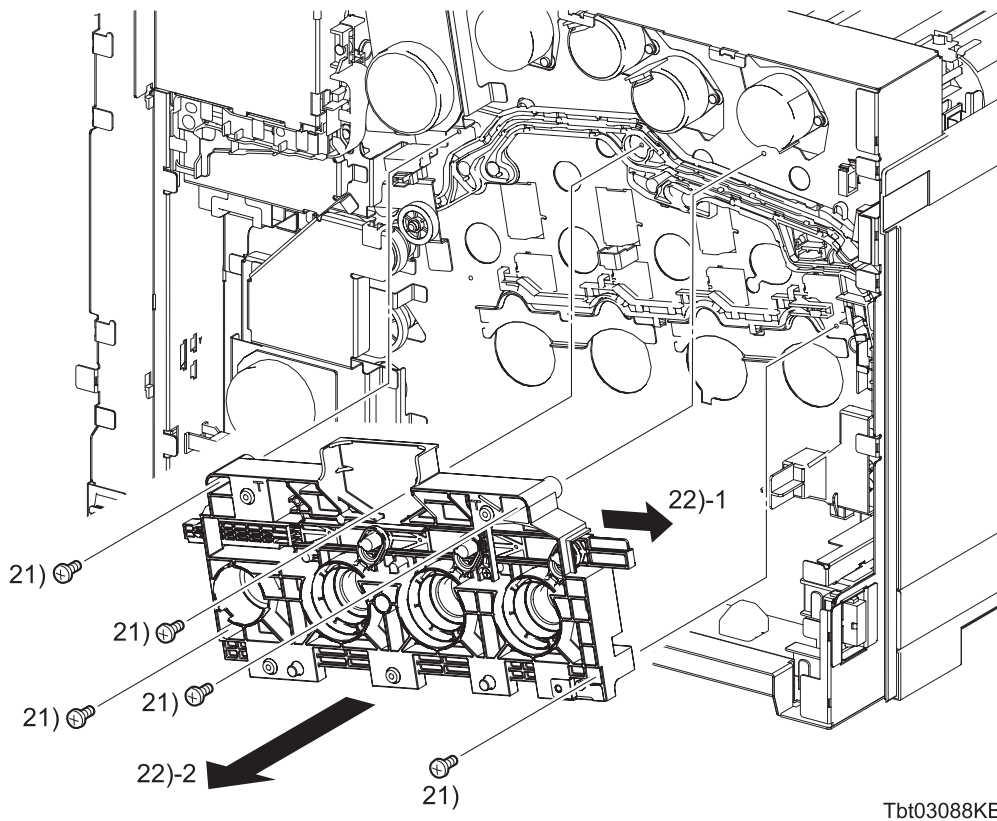

- 21) Remove the five screws (silver, 6mm) that fix the GUIDE ASSY LINK (PL9.2.5) to the printer.
- 22) Remove the GUIDE ASSY LINK from the printer by sliding the LINK BAR of the GUIDE ASSY LINK leftward to avoid interference with the DRIVE ASSY IBT (PL9.1.3).

Continues to the next page.

Removal 61 KIT DRIVE GEAR (PL9.2.99)

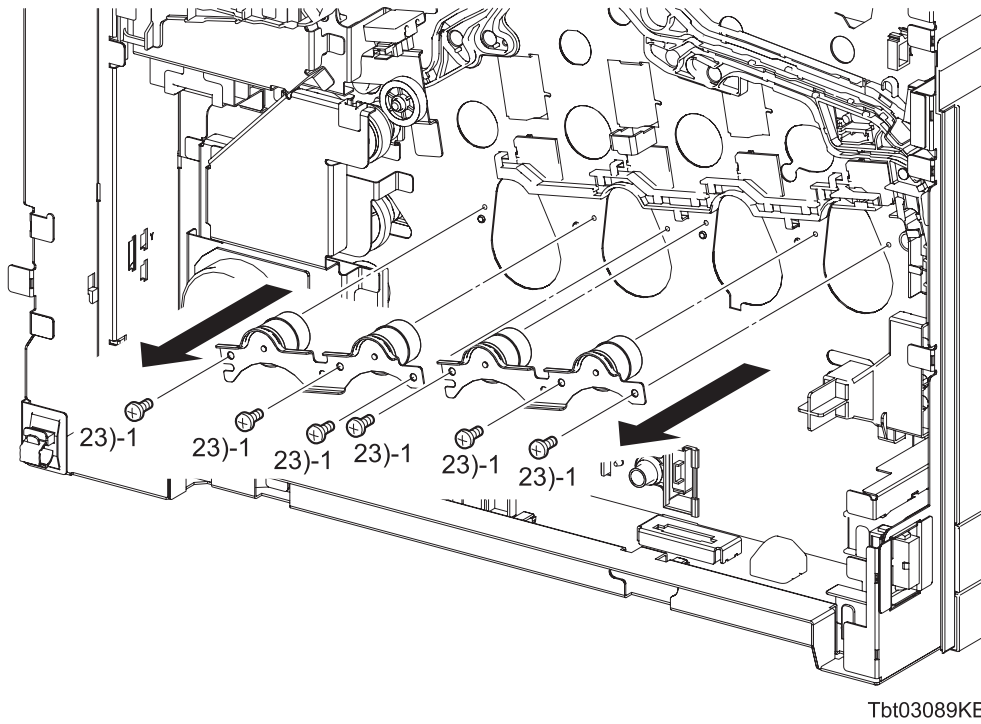

- 23) Remove the two DRIVE ASSY M OUTs from the printer by removing the six screws (silver, 6mm).

Removal 62 CONNECTOR ASSY CRUM (XERO CRUM) (Y), (M), (C), (K) (PL5.2.4)

NOTE

Described below is the removal procedure common among the four CONNECTOR ASSY CRUM.

In the following steps, the details of Steps 1 through 15 are omitted because they are described earlier in this chapter. Go to the steps in parentheses to execute the necessary steps, and then go to Step 16 onward.

- 1) Open the COVER ASSY FRONT (PL1.2.17).
- 2) Open the COVER ASSY RH.
- 3) Open the FRAME ASSY 2ND (PL8.1.9).

NOTE

Place the BELT ASSY IBT in a safe place to prevent damage to its belt.

- 4) Remove the BELT ASSY IBT. (Removal 4)

NOTE

Cover the drum of the XERO DEVE CRU ASSY to prevent damage by light.

- 5) Remove the XERO DEVE CRU ASSY (Y), (M), (C), (K). (Removal 5)

NOTE

The FUSER section is very hot. Use extra caution not to burn yourself when performing the service operation.

- 6) Remove the FUSER ASSY. (Removal 7)
- 7) Remove the COVER ASSY REAR. (Removal 20)
- 8) Remove the COVER ASSY TOP EXIT. (Removal 21)
- 9) Remove the BOX ASSY ESS PWB. (Removal 40)
- 10) Remove the COVER ASSY TOP ADD TRAY. (Removal 17)
- 11) Remove the COVER ASSY TOP. (Removal 44)
- 12) Remove the FAN ASSY LVPS. (Removal 32)
- 13) Remove the PLATE ASSY LVPS POWER. (Removal 33)
- 14) Remove the BOX ASSY LVPS. (Removal 42)
- 15) Remove the DRIVE ASSY SNS (FC). (Removal 41)

Continues to the next page.

Removal 62 CONNECTOR ASSY CRUM (XERO CRUM) (Y), (M), (C), (K) (PL5.2.4)

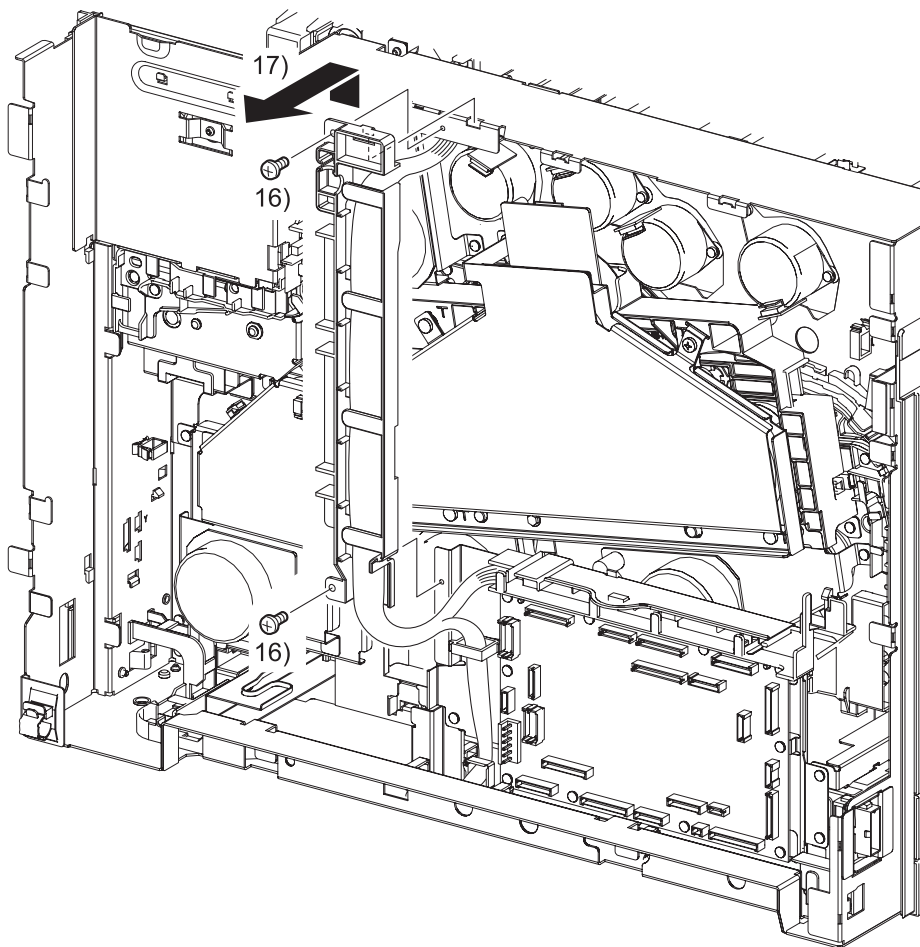

Tbt03217KA

- 16) Remove the two screws (silver, 6mm) that fix the GUIDE HARNESS REAR CTR (PL10.2.6) to the printer.
- 17) Release the hook of the GUIDE HARNESS REAR CTR from the hole in the frame and slightly slide the GUIDE HARNESS REAR CTR together with the harness.

Continues to the next page.

Removal 62 CONNECTOR ASSY CRUM (XERO CRUM) (Y), (M), (C), (K) (PL5.2.4)

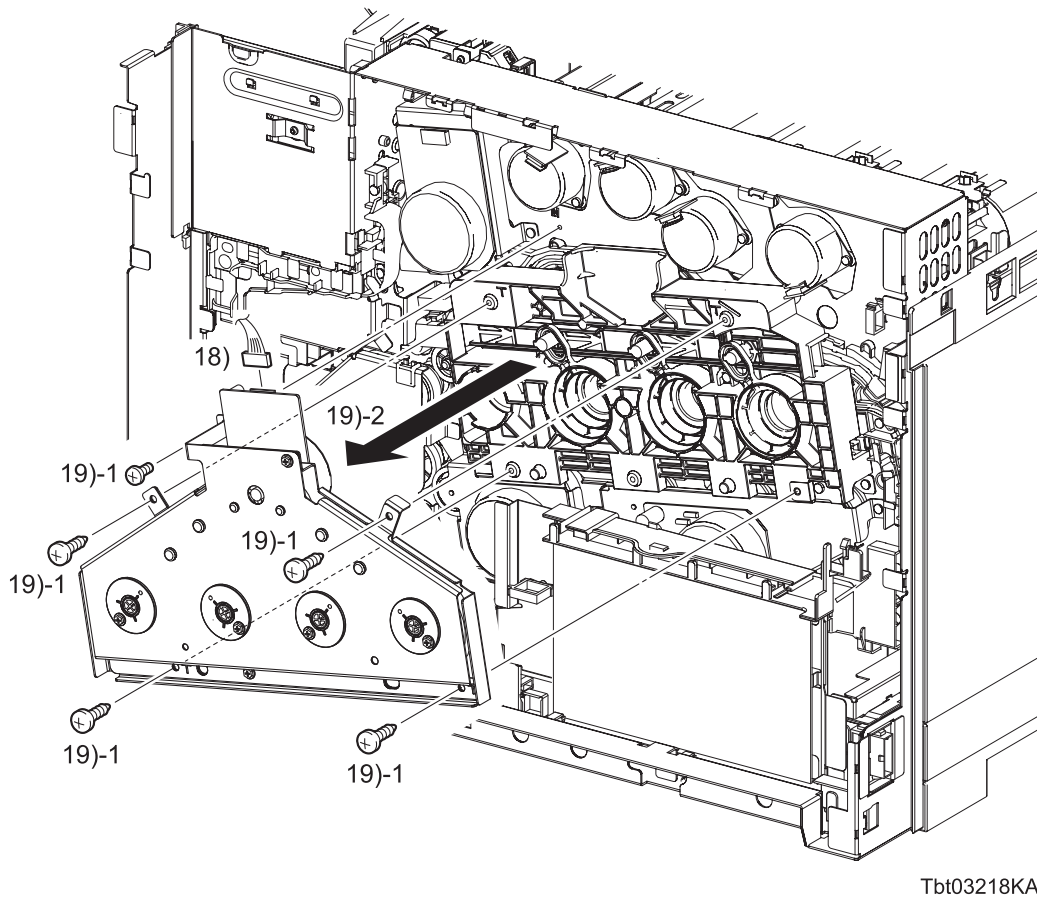

Tbt03218KA

18) Disengage the connectors (P/J251) of the DRIVE ASSY XERO (PL9.2.6).

NOTE

Never loosen the red screws used with the DRIVE ASSY XERO.

19) Remove the DRIVE ASSY XERO from the printer by removing the four screws (silver, tapping, M4, 10mm) and the one screw (silver, 6mm).

Continues to the next page.

Removal 62 CONNECTOR ASSY CRUM (XERO CRUM) (Y), (M), (C), (K) (PL5.2.4)

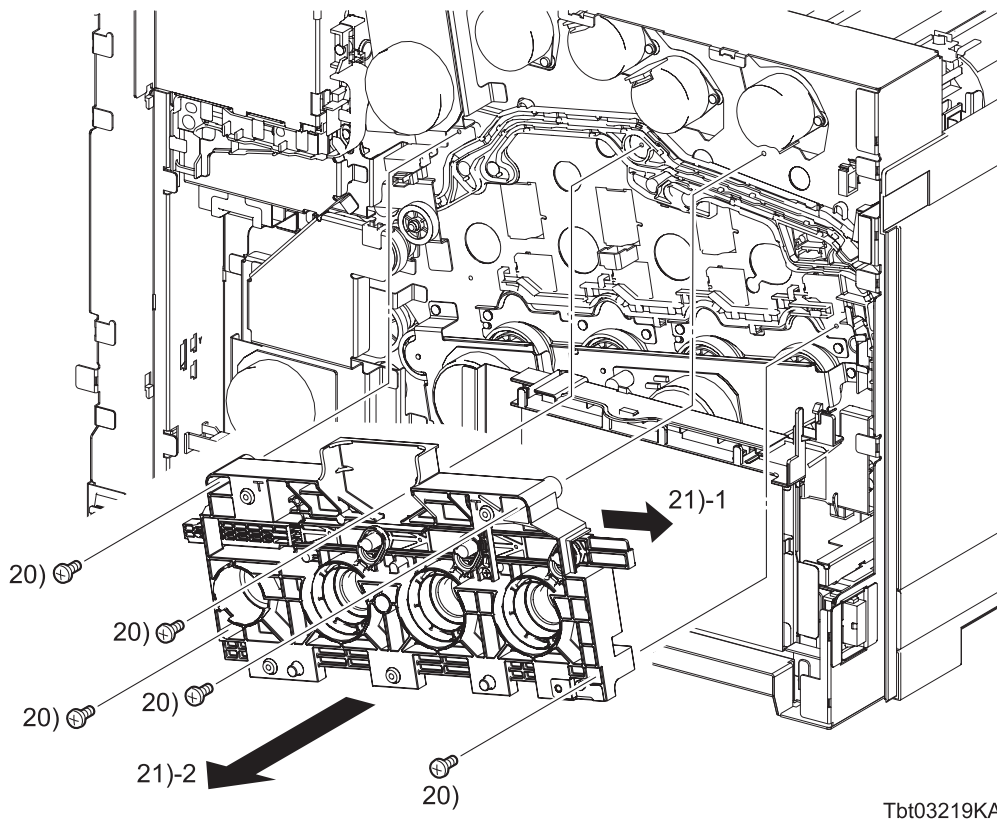

- 20) Remove the five screws (silver, 6mm) that fix the GUIDE ASSY LINK (PL9.2.5) to the printer.
- 21) Remove the GUIDE ASSY LINK from the printer by sliding the LINK BAR of the GUIDE ASSY LINK leftward to avoid interference with the DRIVE ASSY IBT (PL9.1.3).

Continues to the next page.

Removal 62 CONNECTOR ASSY CRUM (XERO CRUM) (Y), (M), (C), (K) (PL5.2.4)

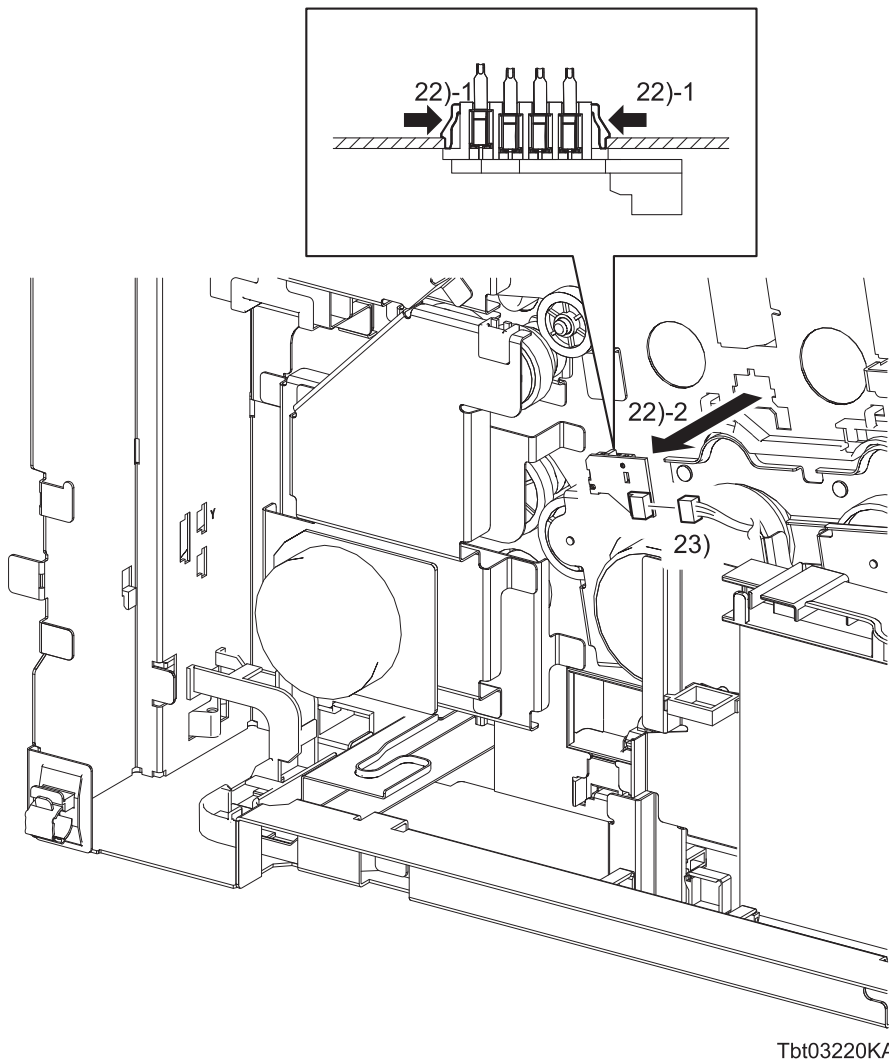

Tbt03220KA

- 22) Remove the CONNECTOR ASSY CRUM (PL5.2.4) from the printer by releasing the two hooks of the CONNECTOR ASSY CRUM.
- 23) Disengage the connectors of the CONNECTOR ASSY CRUM.

Removal 63 HDD ASSY (PL10.1.23)

NOTE

Use a wrist strap to protect the HDD ASSY from electrostatic damage.

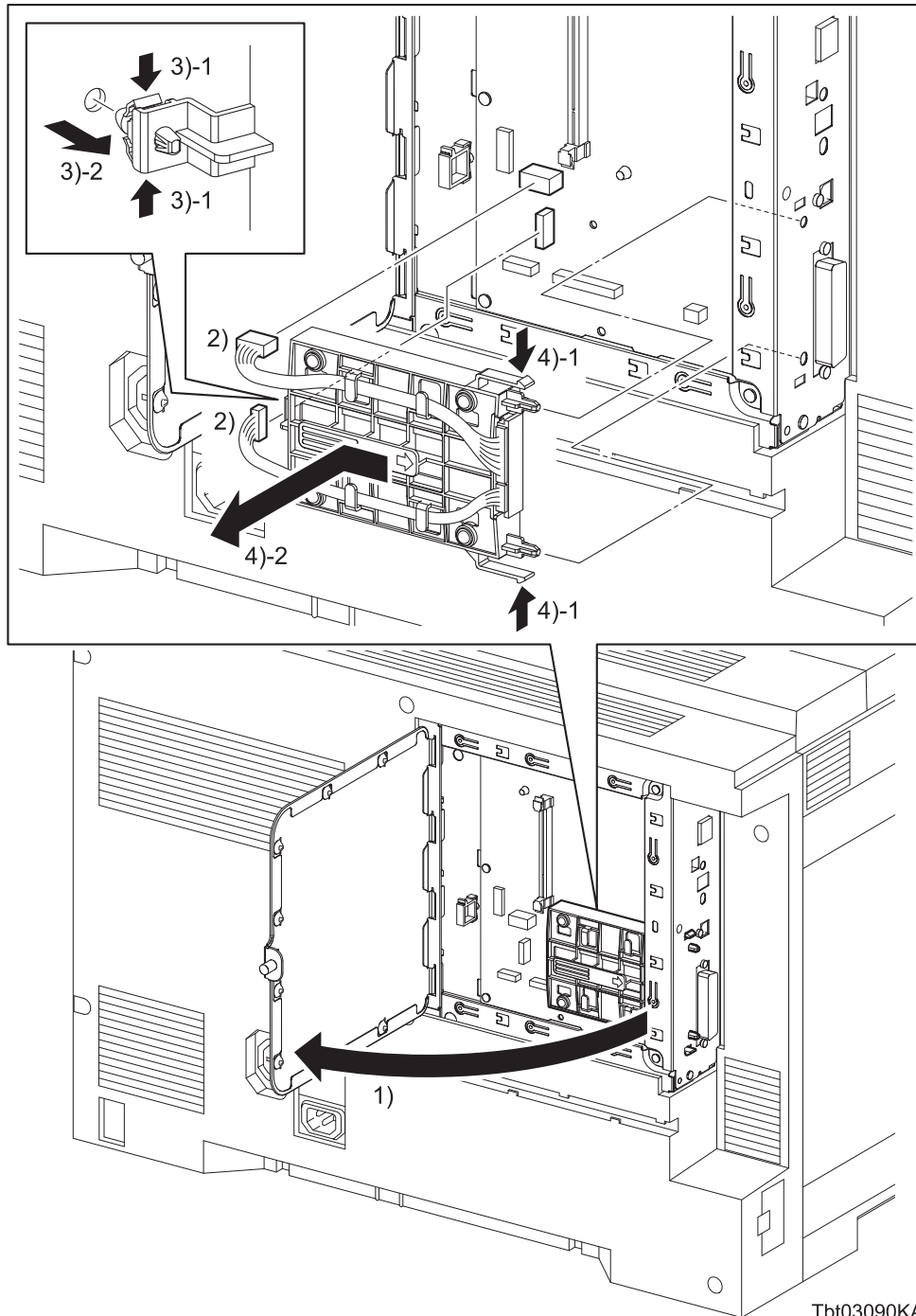

Tbt03090KA

- 1) Loosen the SCREW KNURLING (PL10.1.3), and then open the PLATE WINDOW ESS (PL10.1.2).
- 2) Disengage the two sets of connectors (P/J11, 12) of the HDD ASSY (PL10.1.23) on the PWBA ESS (PL10.1.6)
- 3) Release the clamp that fixes the HDD ASSY to the PWBA ESS.
- 4) Remove the HDD ASSY from the printer by releasing the two hooks of the HDD ASSY.

Removal 64 MEMORY CARD (PL10.1.24)

NOTE

Use a wrist strap to protect the MEMORY CARD from electrostatic damage.

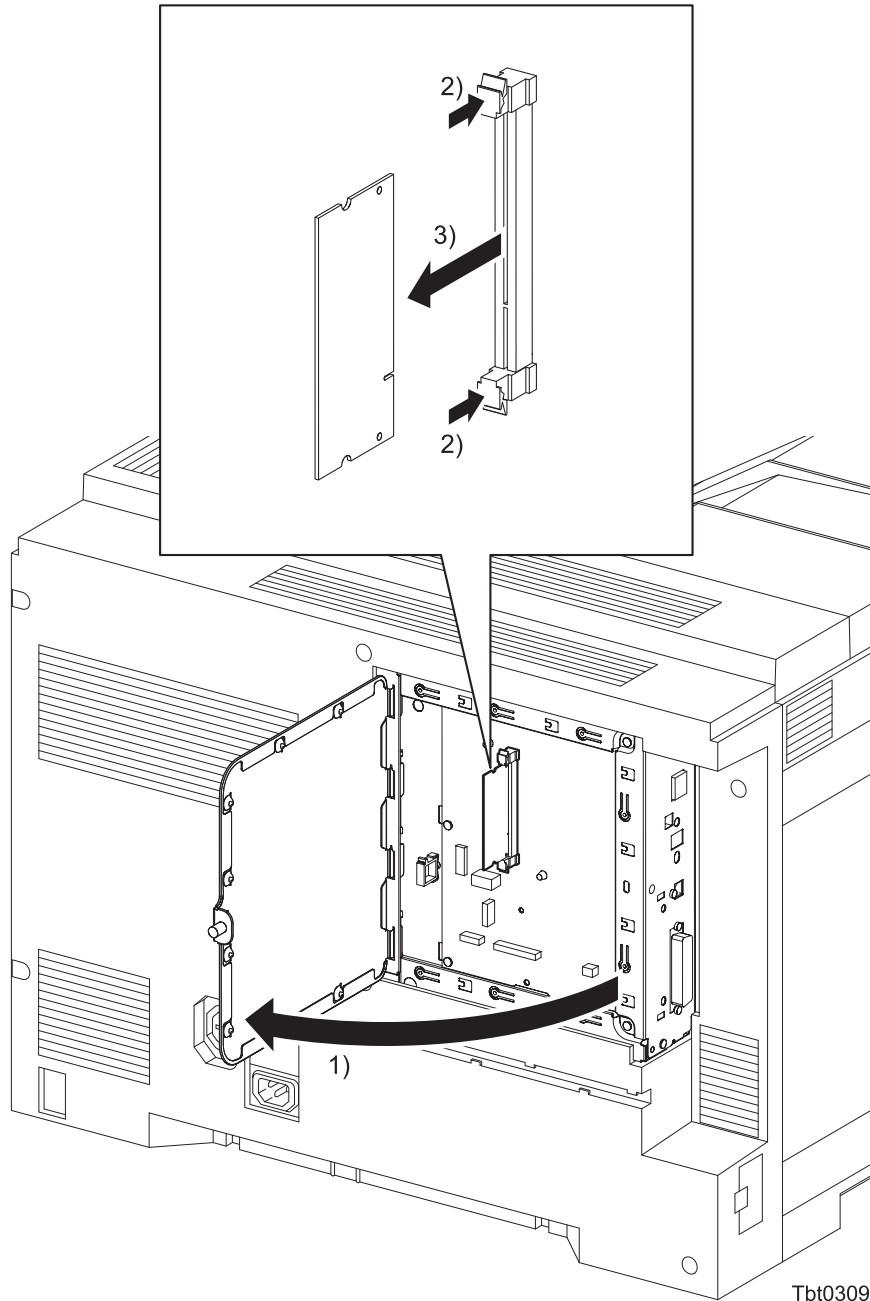

Tbt03091KA

- 1) Loosen the SCREW KNURLING (PL10.1.3), and then open the PLATE WINDOW ESS (PL10.1.2).
- 2) Push the release latches of the socket to release the MEMORY CARD (PL10.1.24).
- 3) Remove the MEMORY CARD.

Removal 65 WIRELESS ADAPTER (PL10.1.25)

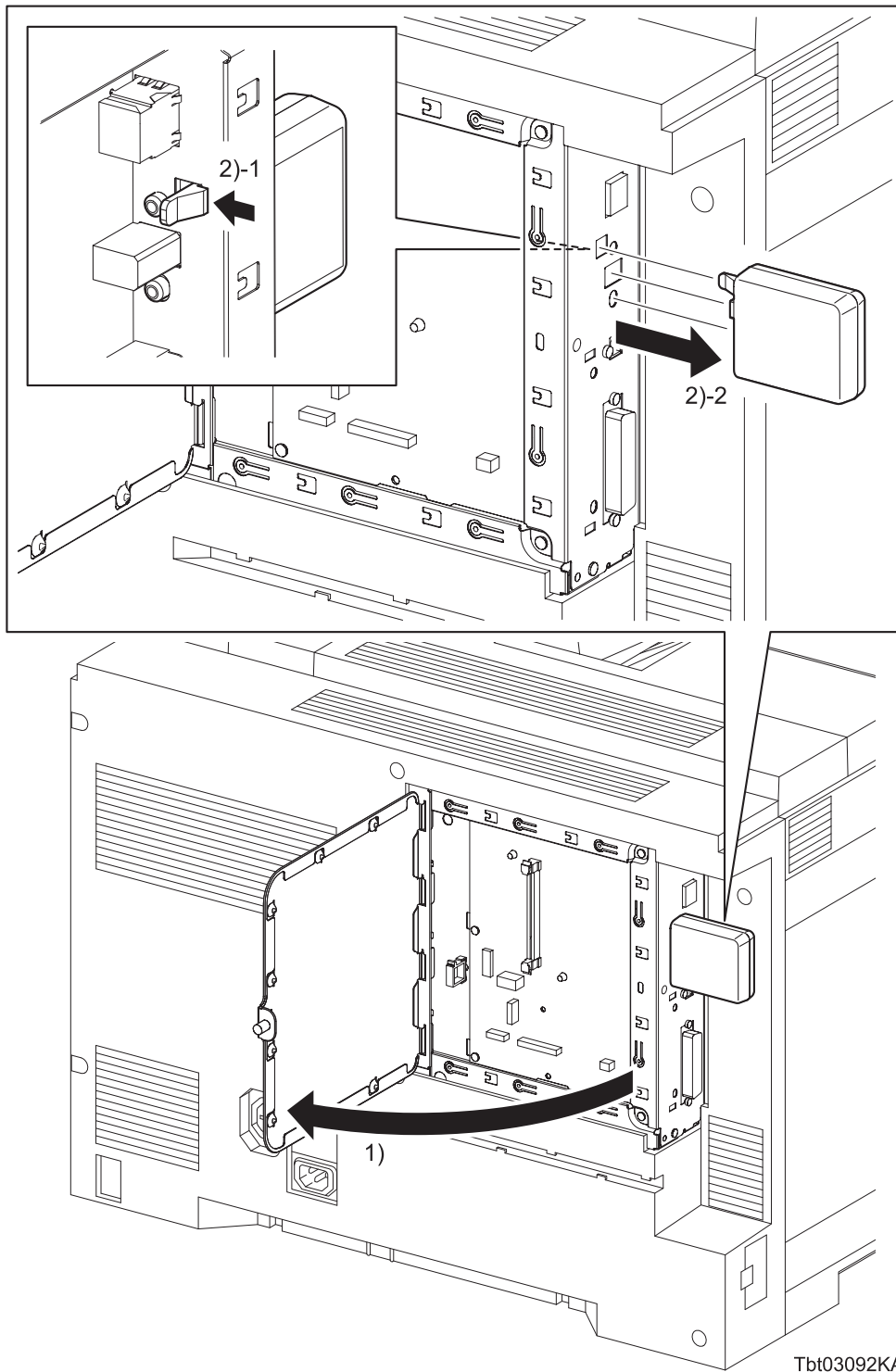

Tbt03092KA

- 1) Loosen the SCREW KNURLING (PL10.1.3), and then open the PLATE WINDOW ESS (PL10.1.2).
- 2) Remove the WIRELESS ADAPTER (PL10.1.25) from the printer by releasing the hook of the WIRELESS ADAPTER.

Removal 66 KIT FEEDER ASSY 550 (PL12.1.99)

- 1) Remove the TRAY ASSY (PL2.1.1) from the printer.

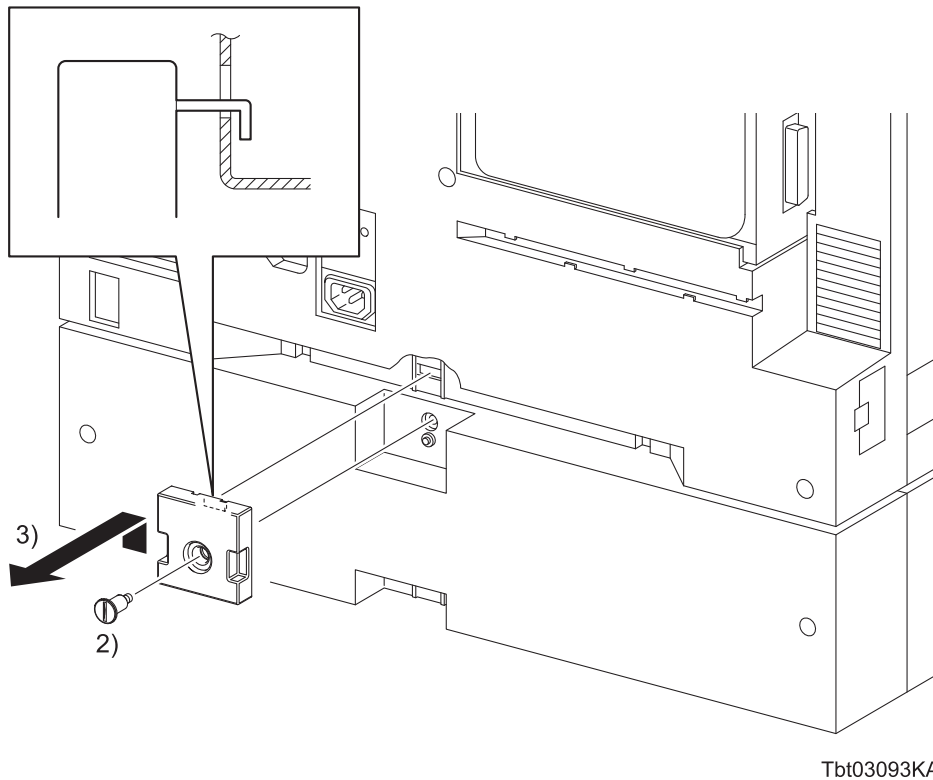

- 2) Remove the SCREW LOCK REAR (PL12.1.6) that fixes the PLATE LOCK REAR ASSY (PL12.1.5) to the FEEDER ASSY 550 (PL12.1.2).
- 3) Release the hook of the PLATE LOCK REAR ASSY from the hole in the printer and remove the PLATE LOCK REAR ASSY from the FEEDER ASSY 550.

Continues to the next page.

Removal 66 KIT FEEDER ASSY 550 (PL12.1.99)

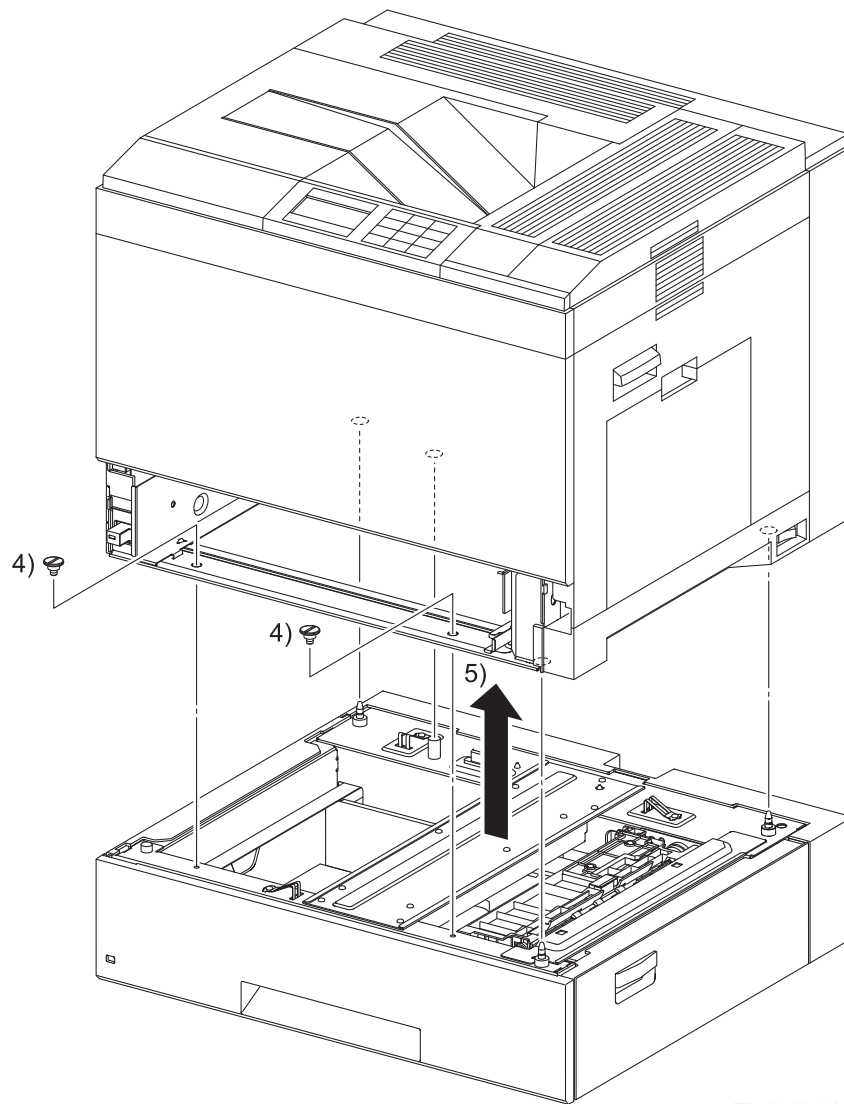

- 4) Remove the two SCREW LOCKs (PL12.1.3) that fix the FEEDER ASSY 550 to the printer.

NOTE

The printer must be lifted by three people.

- 5) Lift up the printer to separate it from the FEEDER ASSY 550.

Removal 67 KIT FEED ROLL & SEPARATOR ROLL (FEEDER ASSY 550) (PL12.4.99)

NOTE

When replacing the SEPARATOR ROLL or the FEED ROLL replace the SEPARATOR ROLL and the two FEED ROLLS at the same time.

- 1) Remove the TRAY ASSY OPTION (PL12.5.1) from the FEEDER ASSY 550 (PL12.1.2).

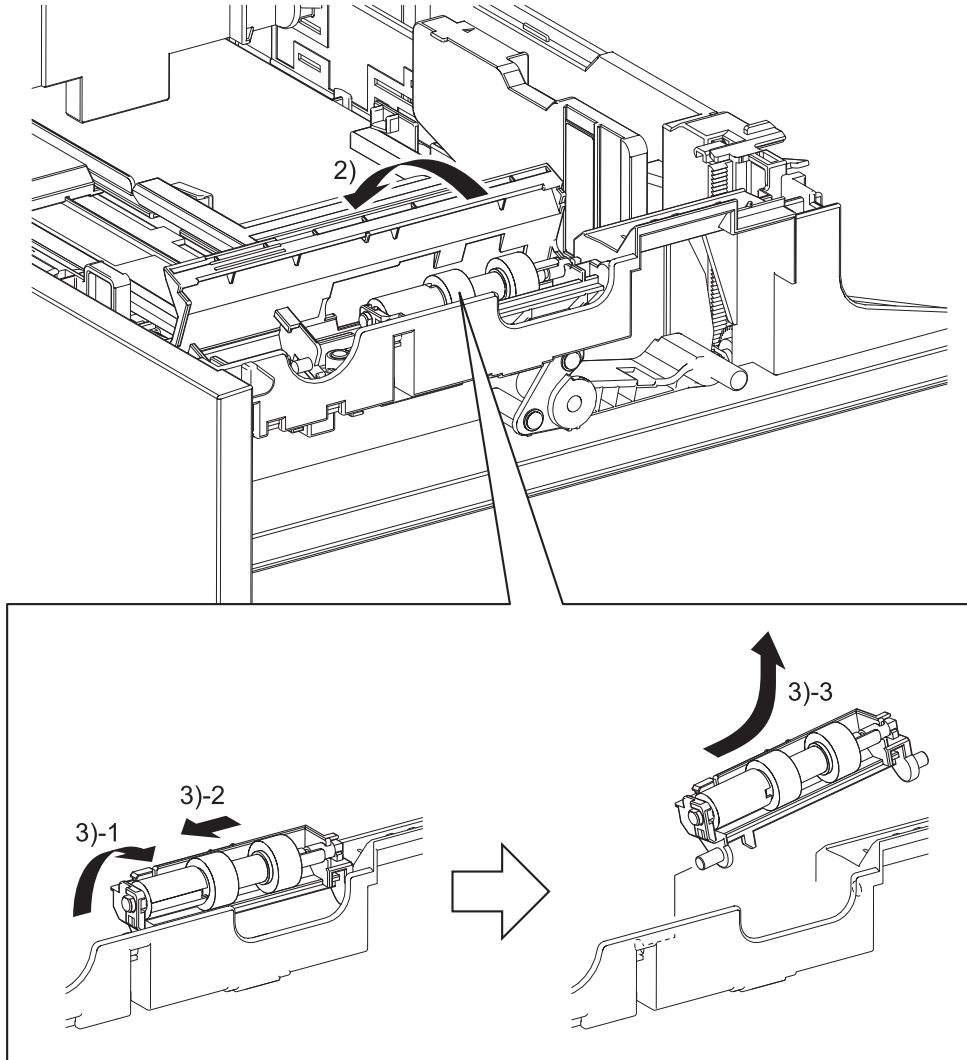

Tbt03095KA

- 2) Open and hold the COVER SEPARATOR (PL12.5.20).
- 3) Raise the HOLDER ASSY SEPARATOR, and then slide it forward to release the boss of the HOLDER ASSY SEPARATOR from the TRAY ASSY OPTION (PL12.5.1). Then, remove the HOLDER ASSY SEPARATOR.

Continues to the next page.

Removal 67 KIT FEED ROLL & SEPARATOR ROLL (FEEDER ASSY 550) (PL12.4.99)

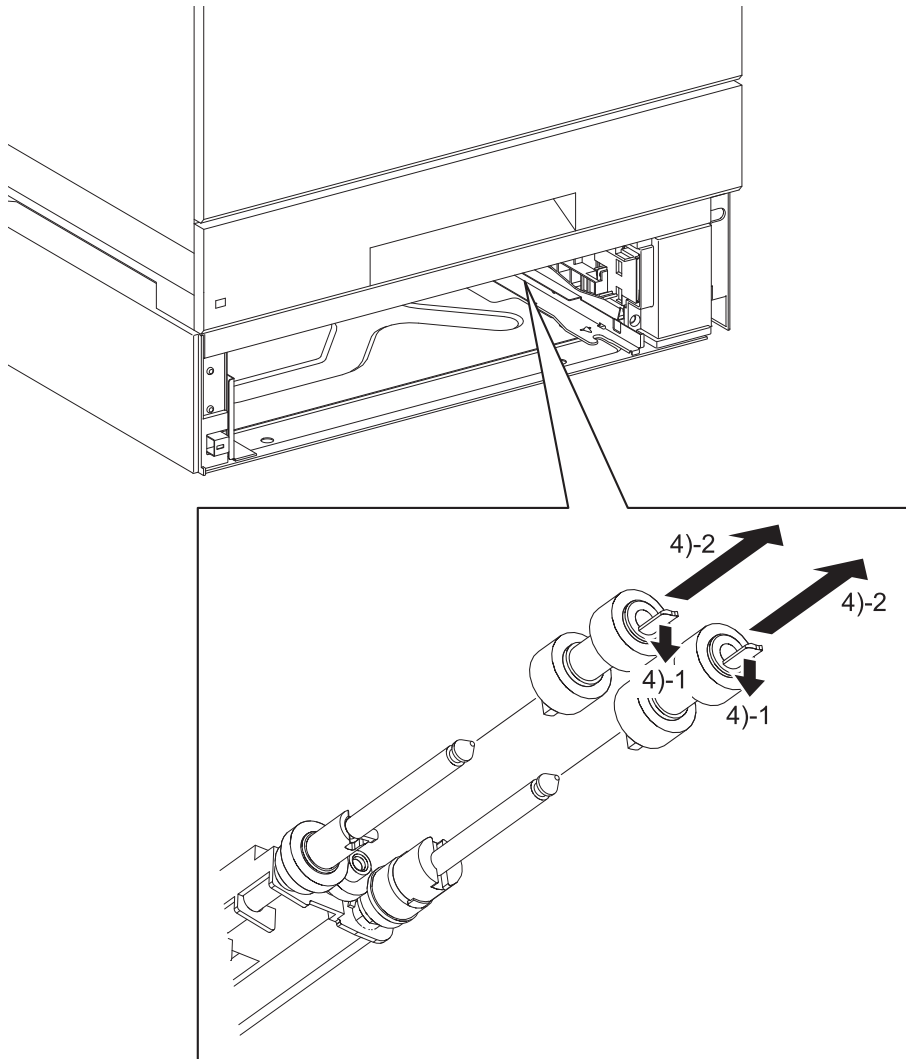

Tbt03096KA

- 4) Remove the ROLL ASSY FEEDs (PL12.4.24) from the shafts by releasing the hooks of the ROLL ASSY FEEDs

Removal 68 KIT FEEDER ASSY 1100 (PL13.1.99)

- 1) Remove the TRAY ASSY (PL2.1.1) from the printer.

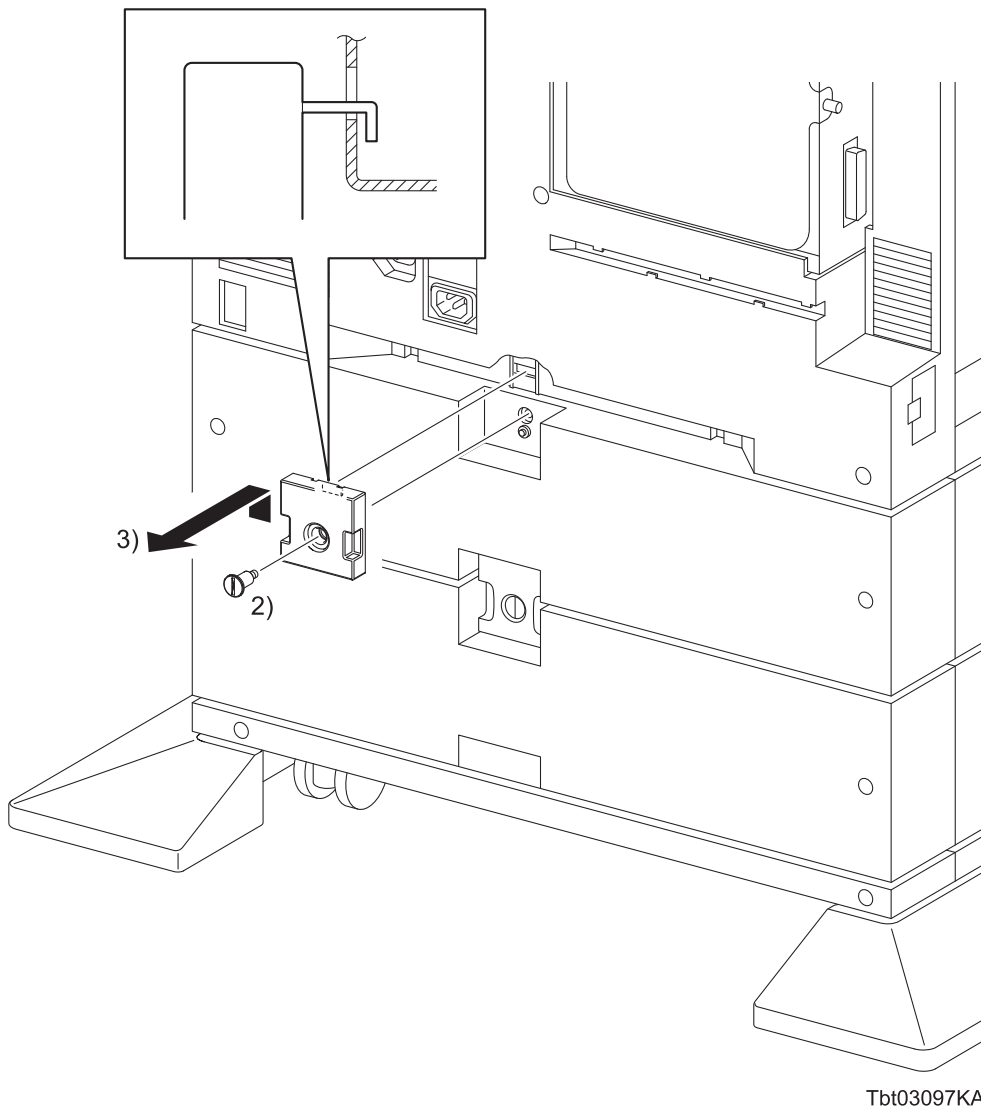

- 2) Remove the SCREW LOCK REAR (PL13.1.12) that fixes the PLATE LOCK REAR ASSY (PL13.1.11) to the FEEDER ASSY 1100 (PL13.1.2).
- 3) Release the hook of the PLATE LOCK REAR ASSY from the hole in the printer and remove the PLATE LOCK REAR ASSY from the FEEDER ASSY 1100.

Continues to the next page.

Removal 68 KIT FEEDER ASSY 1100 (PL13.1.99)

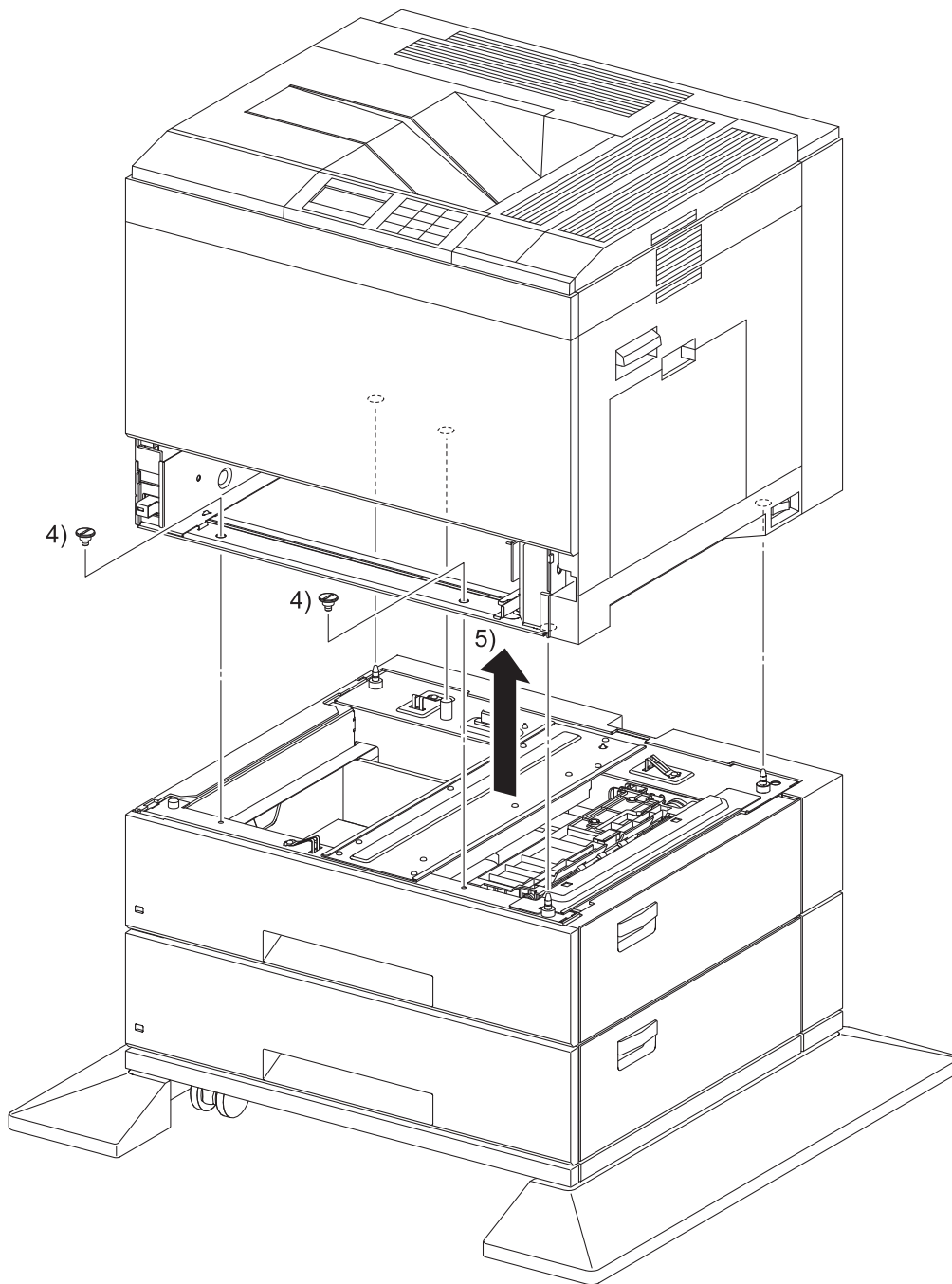

Tbt03098KA

- 4) Remove the two SCREW LOCKs (PL13.1.10) that fix the FEEDER ASSY 1100 to the printer.
The printer must be lifted by three people.

NOTE

- 5) Lift up the printer to separate it from the FEEDER ASSY 1100.

Removal 69 KIT FEED ROLL & SEPARATOR ROLL (FEEDER ASSY 1100) (PL13.5.99)

NOTE

Since the KIT FEED ROLL and SEPARATOR ROLL are removed in the same manner for the upper and lower stages, only the removal procedure for the upper stage is described below.

NOTE

When replacing the SEPARATOR ROLL or the FEED ROLL replace the SEPARATOR ROLL and the two FEED ROLLS at the same time.

- 1) Remove the TRAY ASSY OPTION (PL13.6.1) from the FEEDER ASSY 1100 (PL13.1.2).

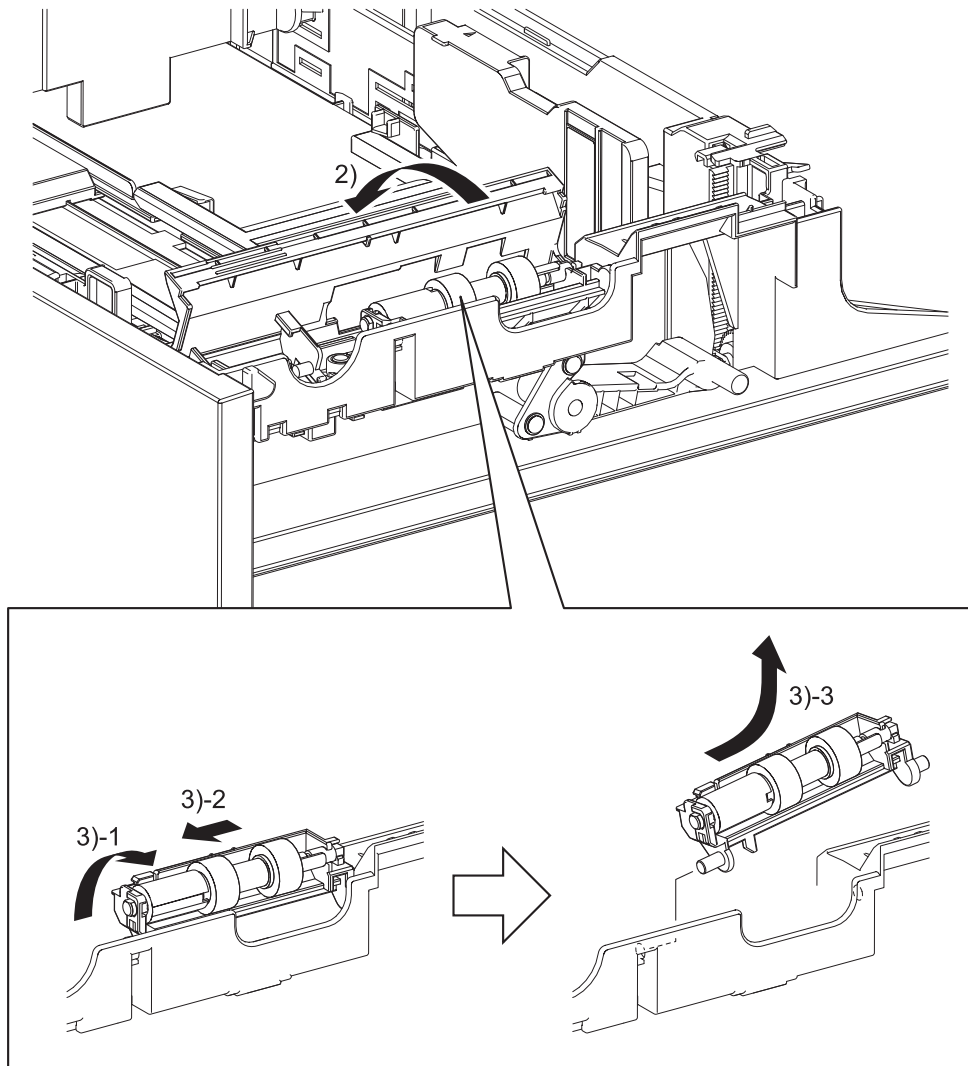

Tbt03099KA

- 2) Open and hold the COVER SEPARATOR (PL13.6.19).
- 3) Raise the HOLDER ASSY SEPARATOR (PL13.6.20), and then slide it forward to release the boss of the HOLDER ASSY SEPARATOR from the TRAY ASSY OPTION. Then, remove the HOLDER ASSY SEPARATOR.

Continues to the next page.

Removal 69 KIT FEED ROLL & SEPARATOR ROLL (FEEDER ASSY 1100) (PL13.5.99)

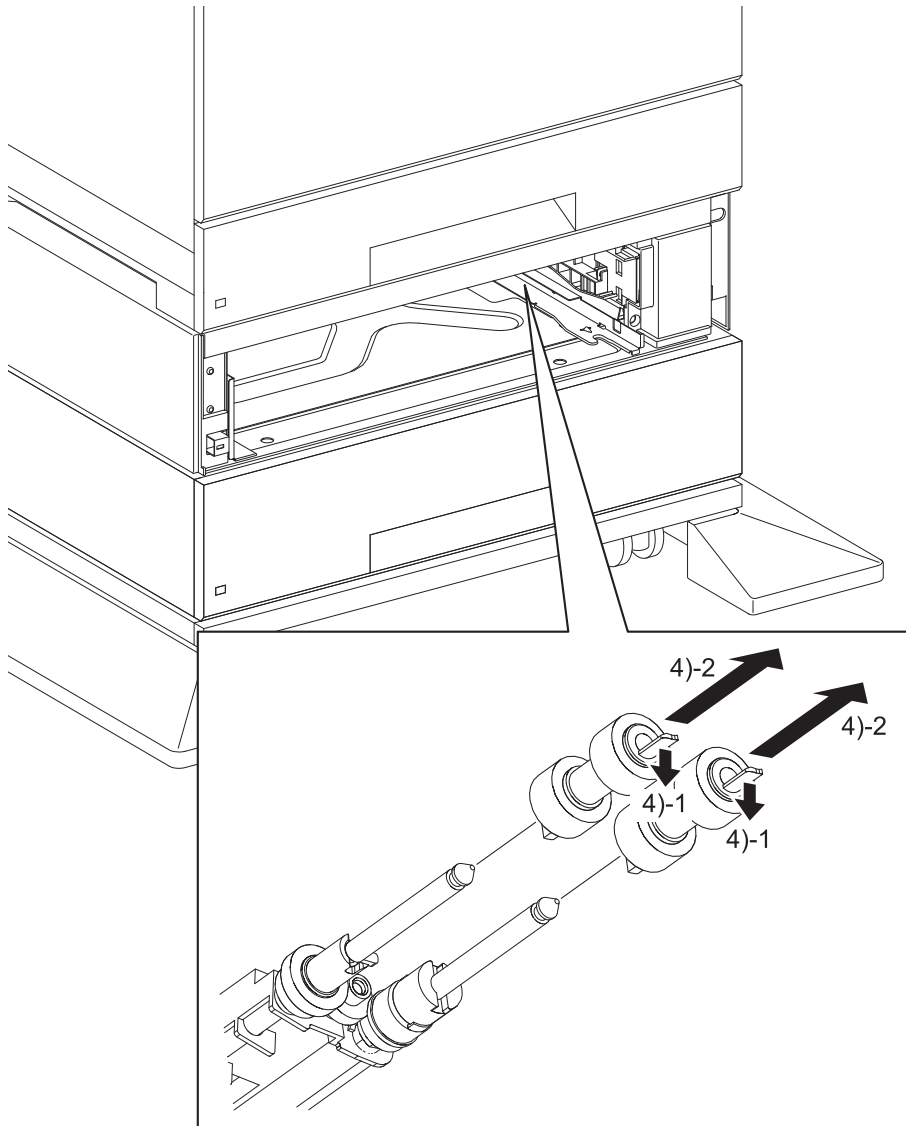

Tbt03100KA

- 4) Remove the ROLL ASSY FEEDs (PL13.5.23) from the shafts by releasing the hooks of the ROLL ASSY FEEDs

3. Replacement Steps

Replacement 1 CONNECTOR ASSY CRUM (XERO CRUM) (Y), (M), (C), (K) (PL5.2.4)

NOTE

Described below is the replacement procedure common among the four CONNECTOR ASSY CRUM.

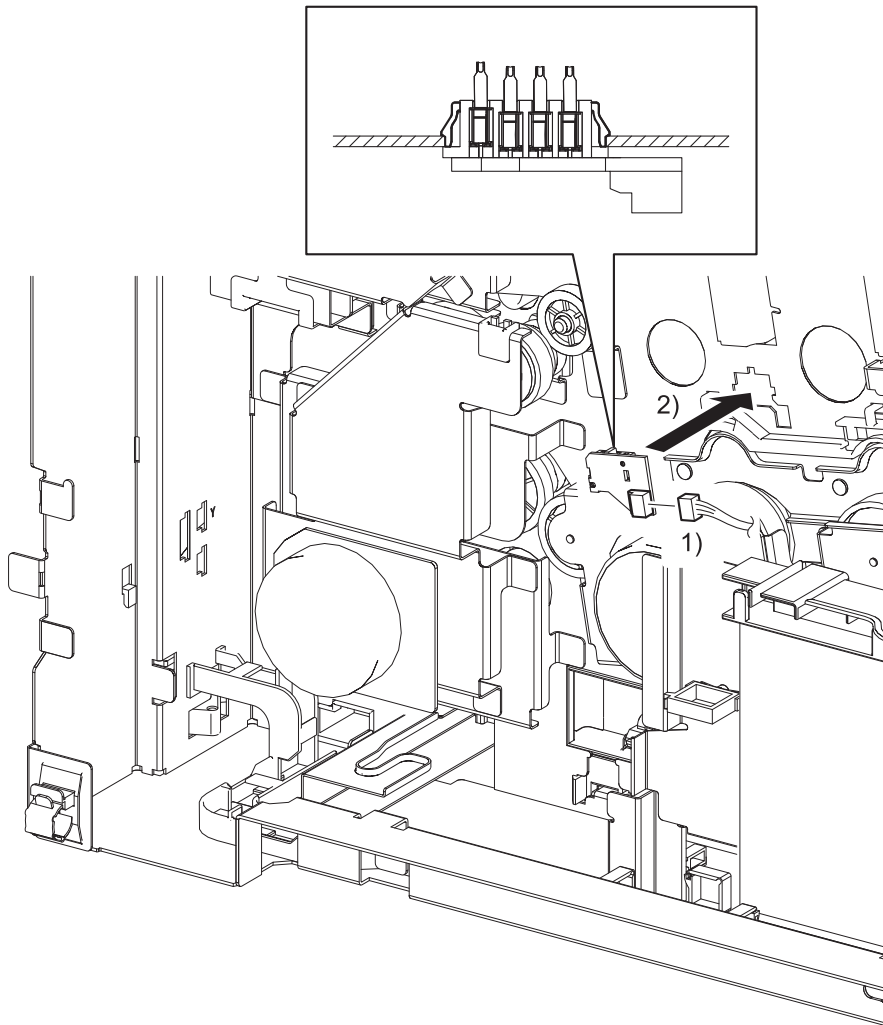

Tbt03222KA

- 1) Engage the connectors of the CONNECTOR ASSY CRUM.
- 2) Replace the CONNECTOR ASSY CRUM to the printer, and then secure with the two hooks.

Continues to the next page.

Replacement 1 CONNECTOR ASSY CRUM (XERO CRUM) (Y), (M), (C), (K) (PL5.2.4)

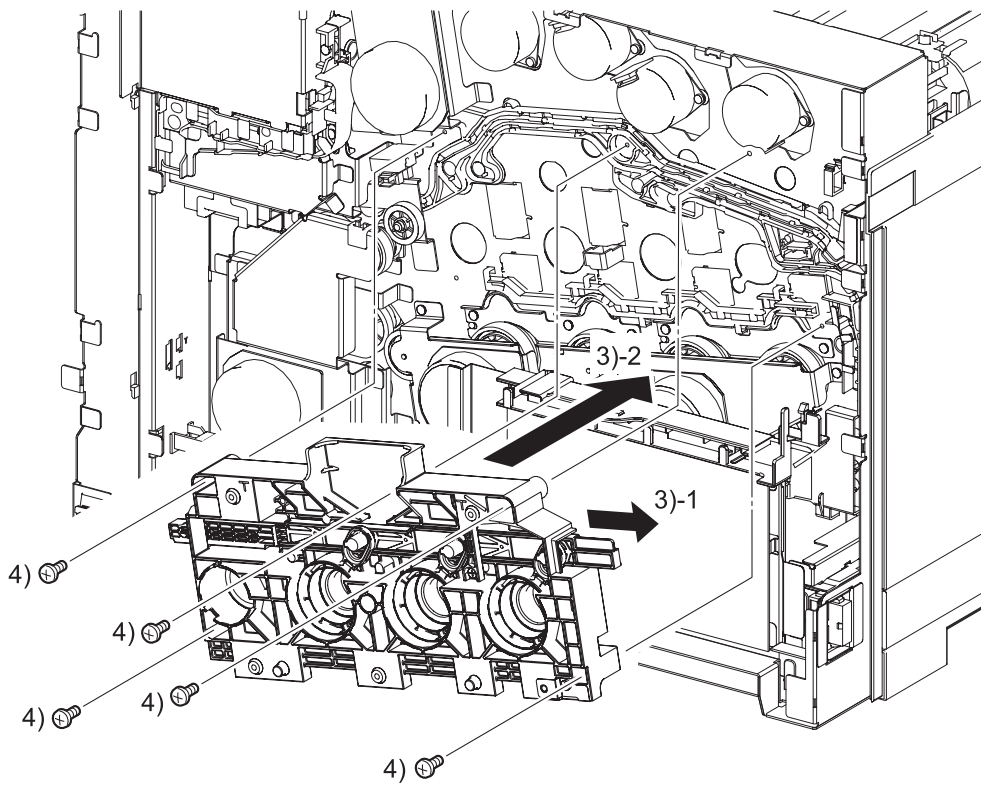

Tbt03223KA

- 3) Install the GUIDE ASSY LINK to the printer with the LINK BAR retracted leftward.
- 4) Secure the GUIDE ASSY LINK to the printer with the five screws (silver, 6mm).

Continues to the next page.

Replacement 1 CONNECTOR ASSY CRUM (XERO CRUM) (Y), (M), (C), (K) (PL5.2.4)

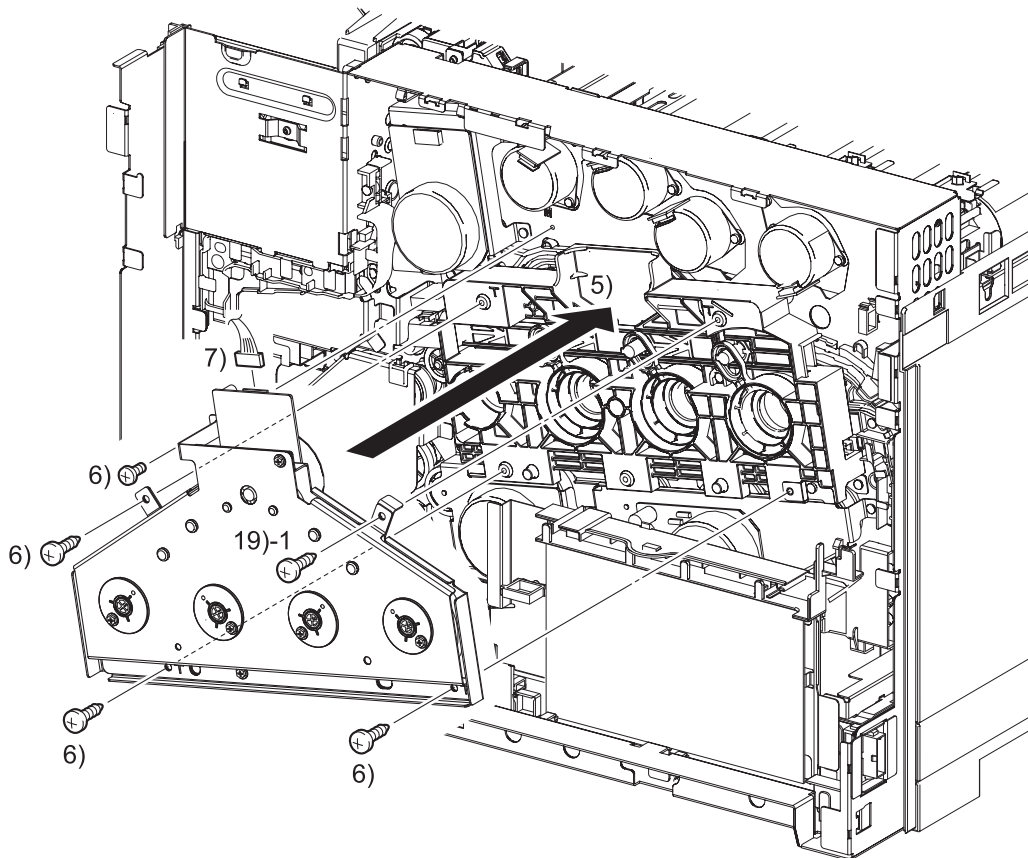

Tbt03224KA

- 5) Fit the tab of the DRIVE ASSY XERO in the hole in the GUIDE ASSY LINK and align the two holes in the DRIVE ASSY XERO with the bosses of the GUIDE ASSY LINK to attach the DRIVE ASSY XERO to the printer.

NOTE

Since two types of screws are used for securing the DRIVE ASSY XERO, ensure that the right screws are used at their right securing positions.

- 6) Secure the DRIVE ASSY XERO to the printer with the four screws (silver, tapping, M4, 10mm) and the one screw (silver, 6mm).
- 7) Engage the connectors (P/J251) of the DRIVE ASSY XERO.

Continues to the next page.

Replacement 1 CONNECTOR ASSY CRUM (XERO CRUM) (Y), (M), (C), (K) (PL5.2.4)

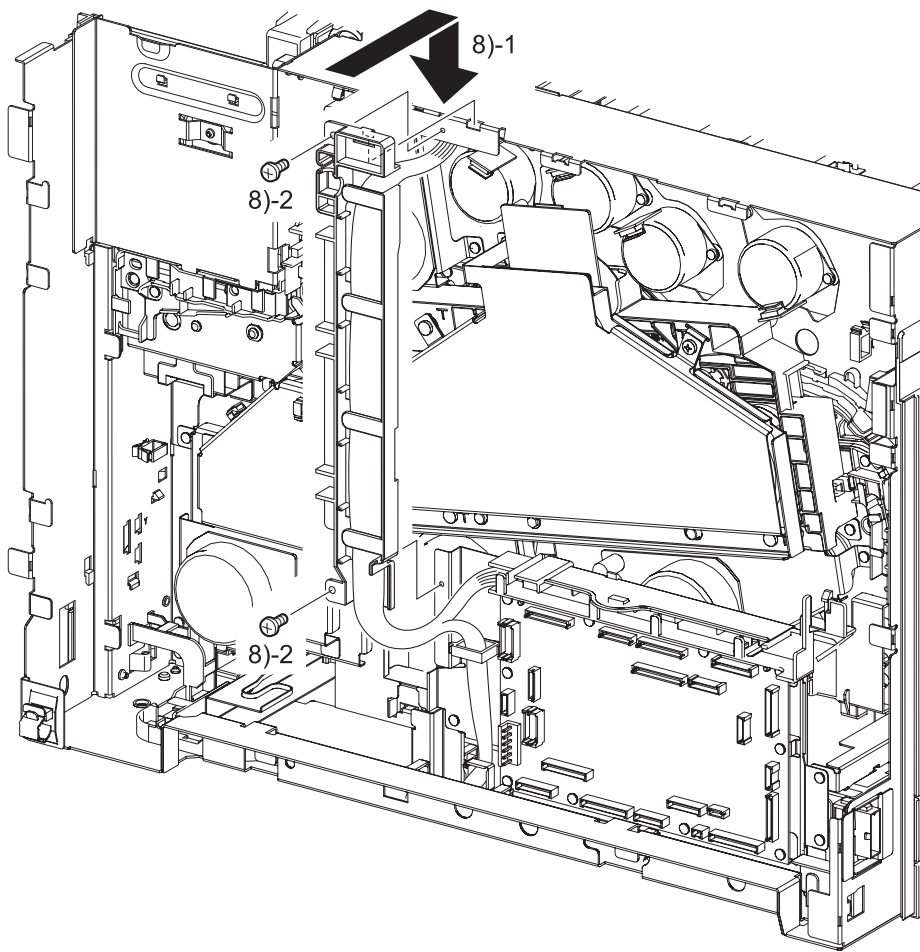

Tbt03225KA

- 8) Fit the hook of the GUIDE HARNESS REAR CTR into the hole in the frame and fix with the two screws (silver, 6 mm).

Go to the next replacement step:

Replacement 22 DRIVE ASSY SNS (FC) (PL9.2.1)

Replacement 2 KIT DRIVE GEAR (PL9.2.99)

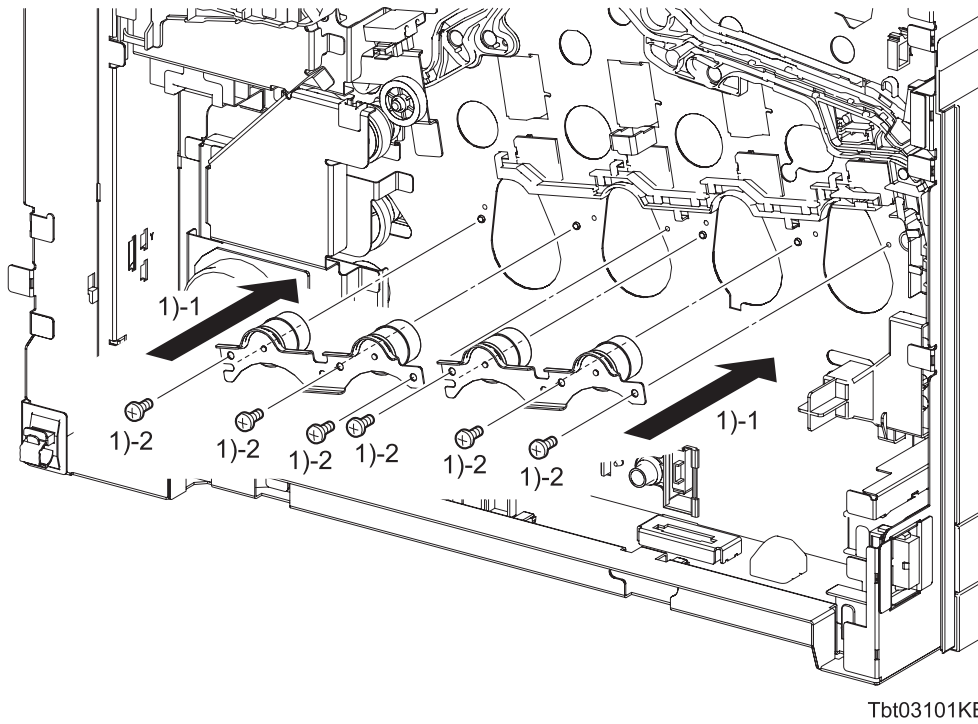

- 1) Replace the two DRIVE ASSY M OUTs to the printer, and then secure with the six screws (silver, 6mm).

Continues to the next page.

Replacement 2 KIT DRIVE GEAR (PL9.2.99)

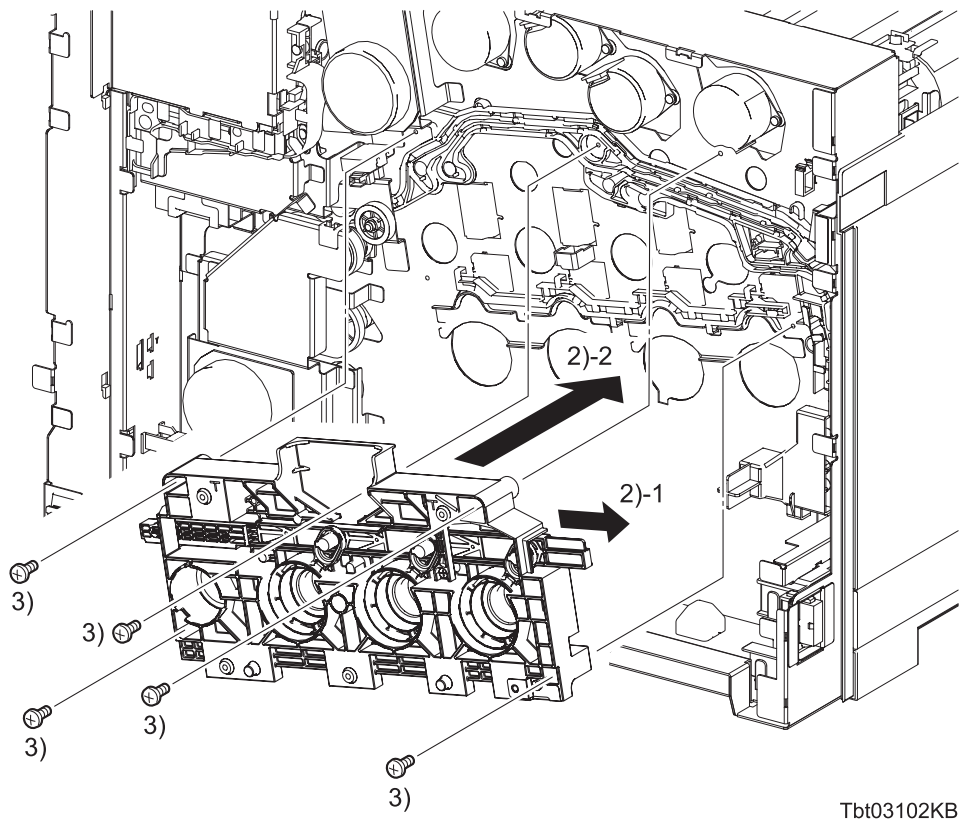

- 2) Install the GUIDE ASSY LINK to the printer with the LINK BAR retracted leftward.
- 3) Secure the GUIDE ASSY LINK to the printer with the five screws (silver, 6mm).

Continues to the next page.

Replacement 2 KIT DRIVE GEAR (PL9.2.99)

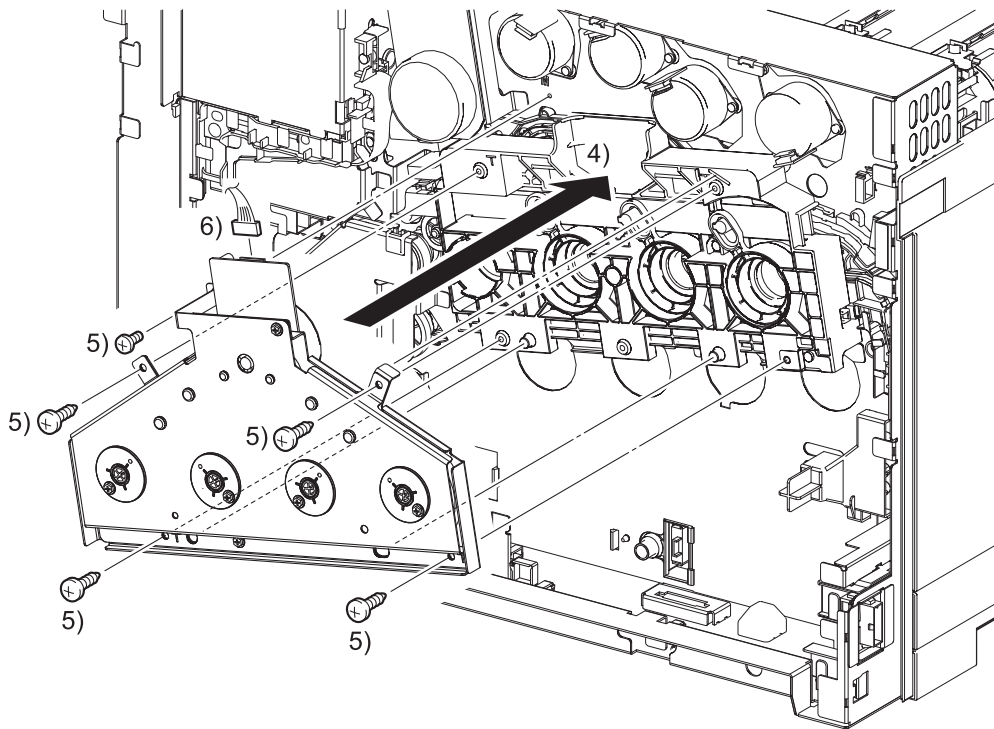

Tbt03103KB

- 4) Fit the tab of the DRIVE ASSY XERO in the hole in the GUIDE ASSY LINK and align the two holes in the DRIVE ASSY XERO with the bosses of the GUIDE ASSY LINK to attach the DRIVE ASSY XERO to the printer.

NOTE

Since two types of screws are used for securing the DRIVE ASSY XERO, ensure that the right screws are used at their right securing positions.

- 5) Secure the DRIVE ASSY XERO to the printer with the four screws (silver, tapping, M4, 10mm) and the one screw (silver, 6mm).
- 6) Engage the connectors (P/J251) of the DRIVE ASSY XERO.

Go to the next replacement step:

Replacement 3 DRIVE ASSY DEVE K (PL9.2.10)

Replacement 3 DRIVE ASSY DEVE K (PL9.2.10)

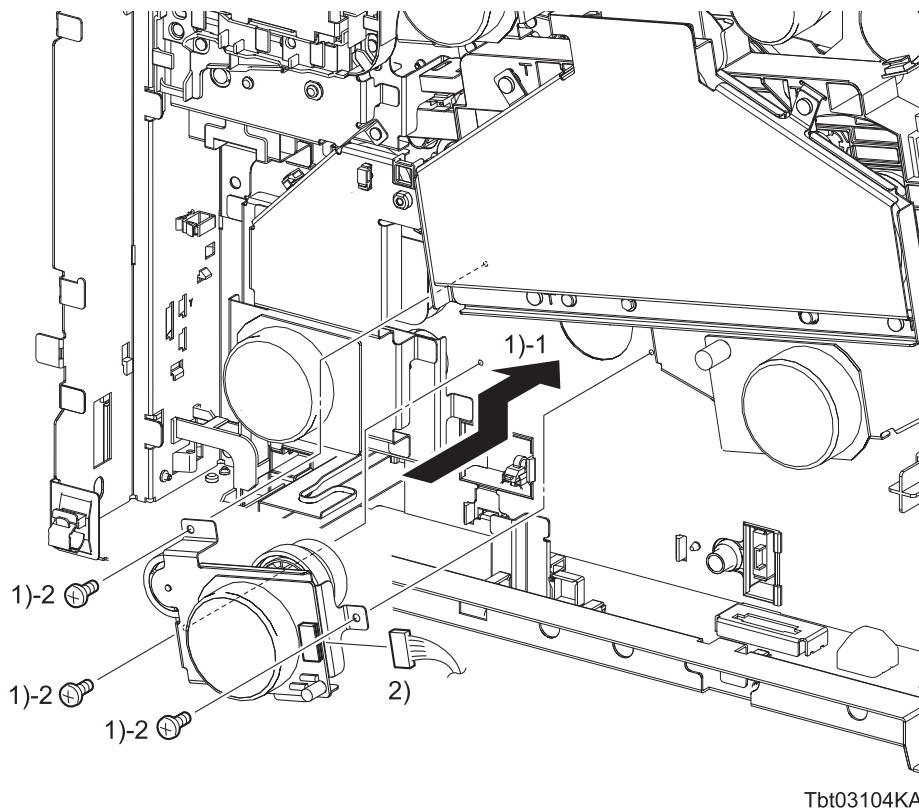

- 1) Replace the DRIVE ASSY DEVE K to the printer, and then secure with the three screws (silver, 6mm).
- 2) Engage the connectors (P/J253) of the DRIVE ASSY DEVE K.

**Go to the next replacement step:
Replacement 5 BOX ASSY MCU (PL10.2.15)**

Replacement 4 DRIVE ASSY DEVE (PL9.2.9)

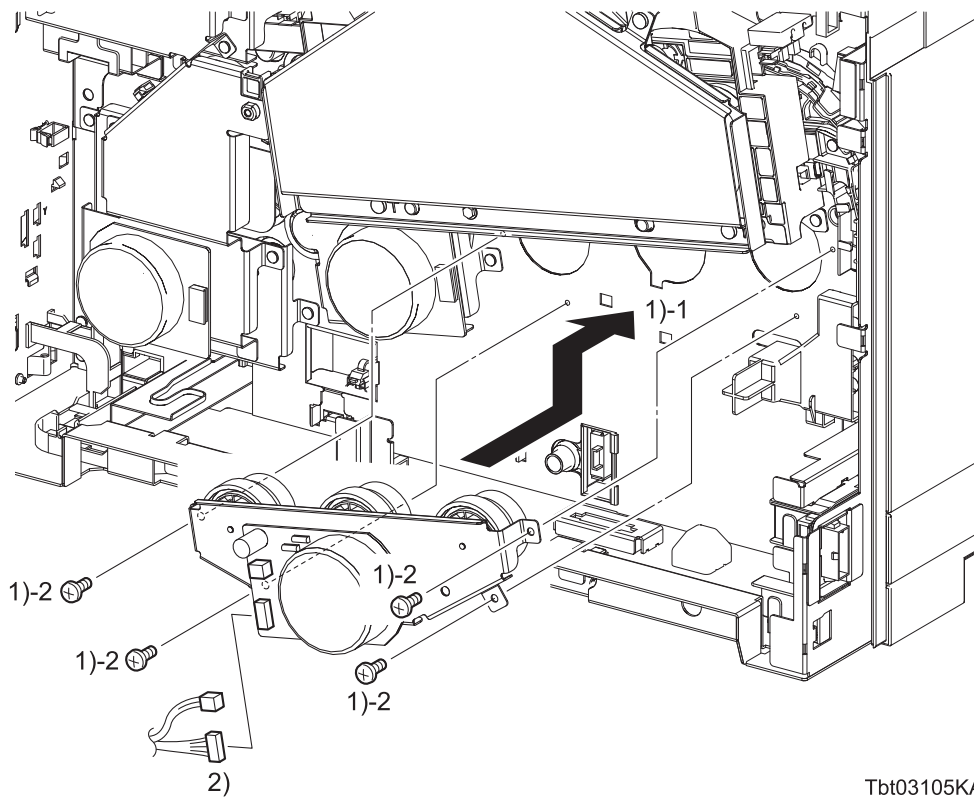

Tbt03105KA

- 1) Replace the DRIVE ASSY DEVE to the printer, and then secure with the four screws (silver, 6mm).
- 2) Engage the two sets of connectors (P/J252, 260) of the DRIVE ASSY DEVE.

Go to the next replacement step:

Replacement 5 BOX ASSY MCU (PL10.2.15)

Blank Page

Replacement 5 BOX ASSY MCU (PL10.2.15)

NOTE

Use a wrist strap to protect the PWB from electrostatic damage.

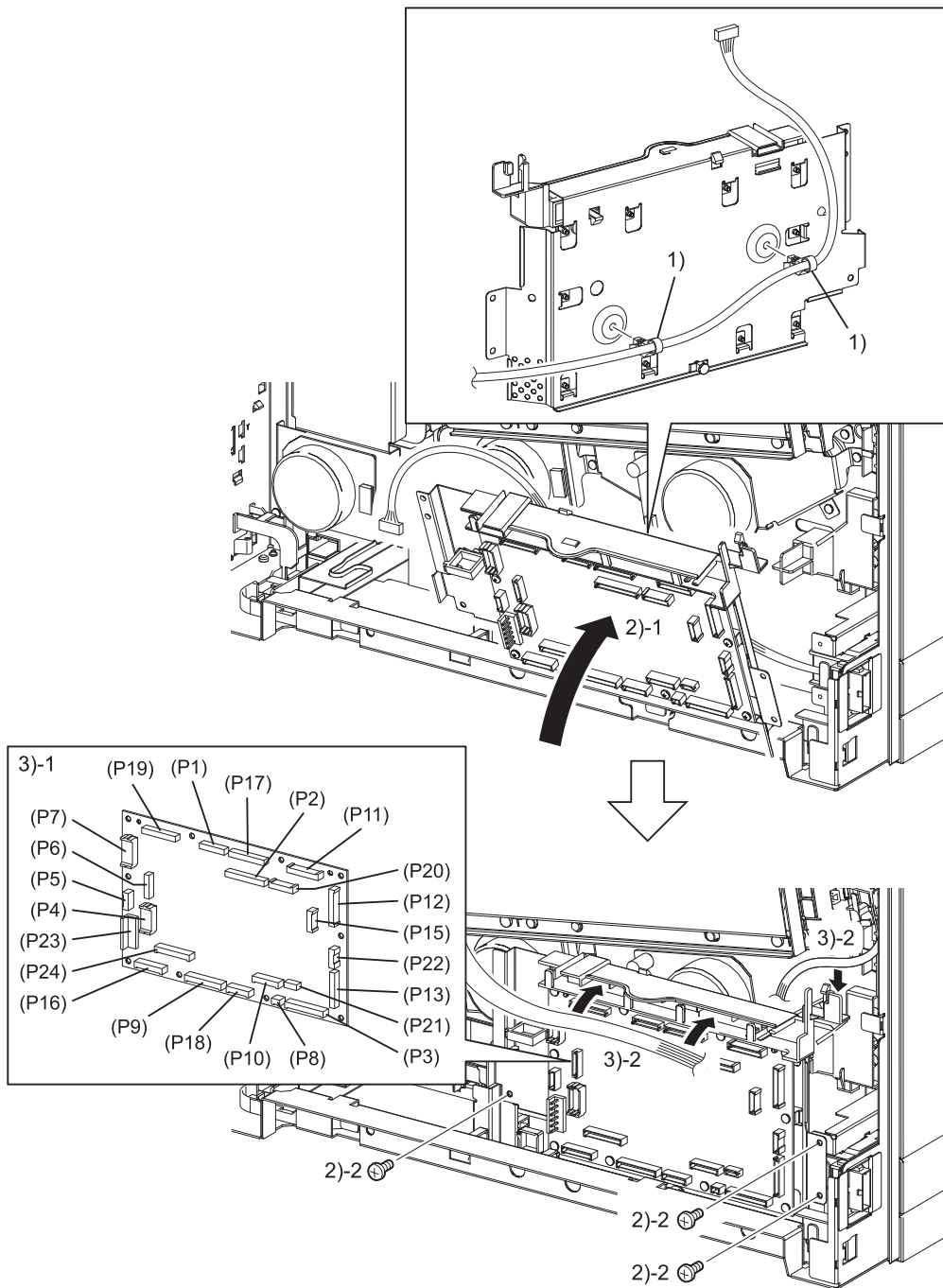

Tbt03106KB

- 1) Attach the two clamps that fix the HARNESS ASSY VIDEO (PL11.1.4) on the backside of the BOX ASSY MCU.
- 2) Attach the BOX ASSY MCU to the printer, and then secure with the three screws (silver, 6mm).
- 3) Engage all the connectors of the PWBA MCU, and then route all the harness through the GUIDE HARNESS MCU UPR.

Continues to the next page.

Replacement 5 BOX ASSY MCU (PL10.2.15)

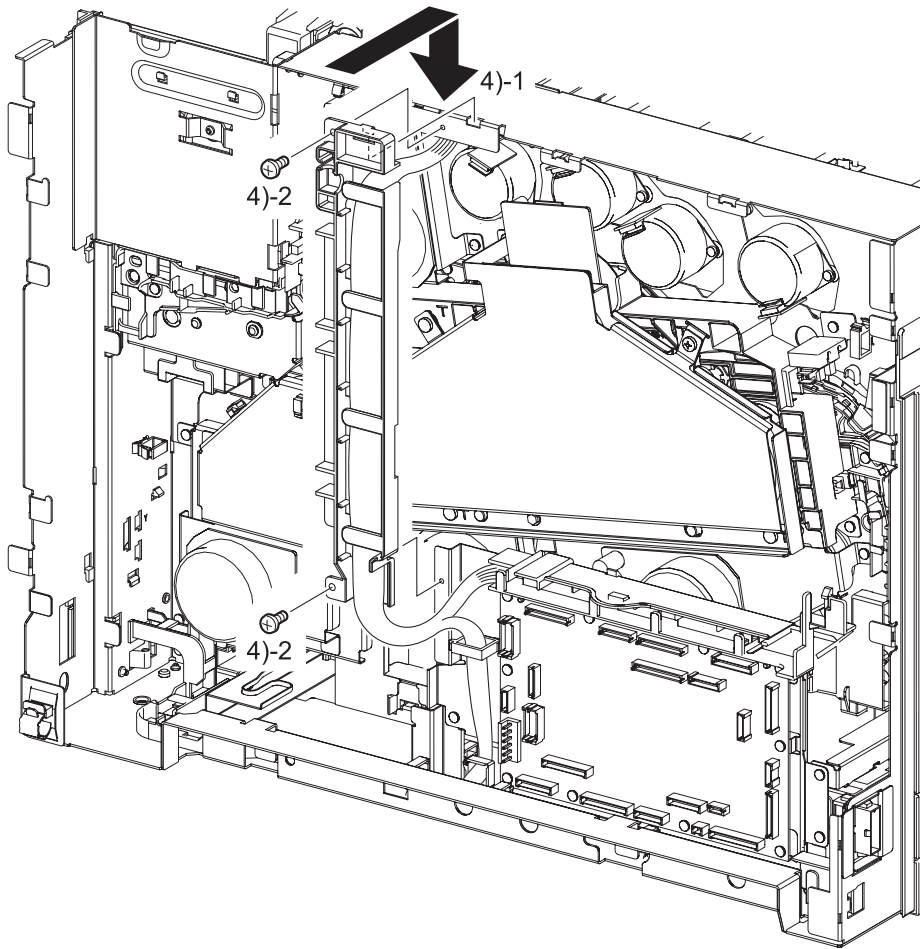

Tbt03107KA

- 4) Fit the hook of the GUIDE HARNESS REAR CTR into the hole in the frame and fix with the two screws (silver, 6 mm).

Go to the next replacement step:

Replacement 21 BOX ASSY LVPS (PL10.2.1)

Replacement 6 KIT LINK XERO DRIVE (PL9.2.98)

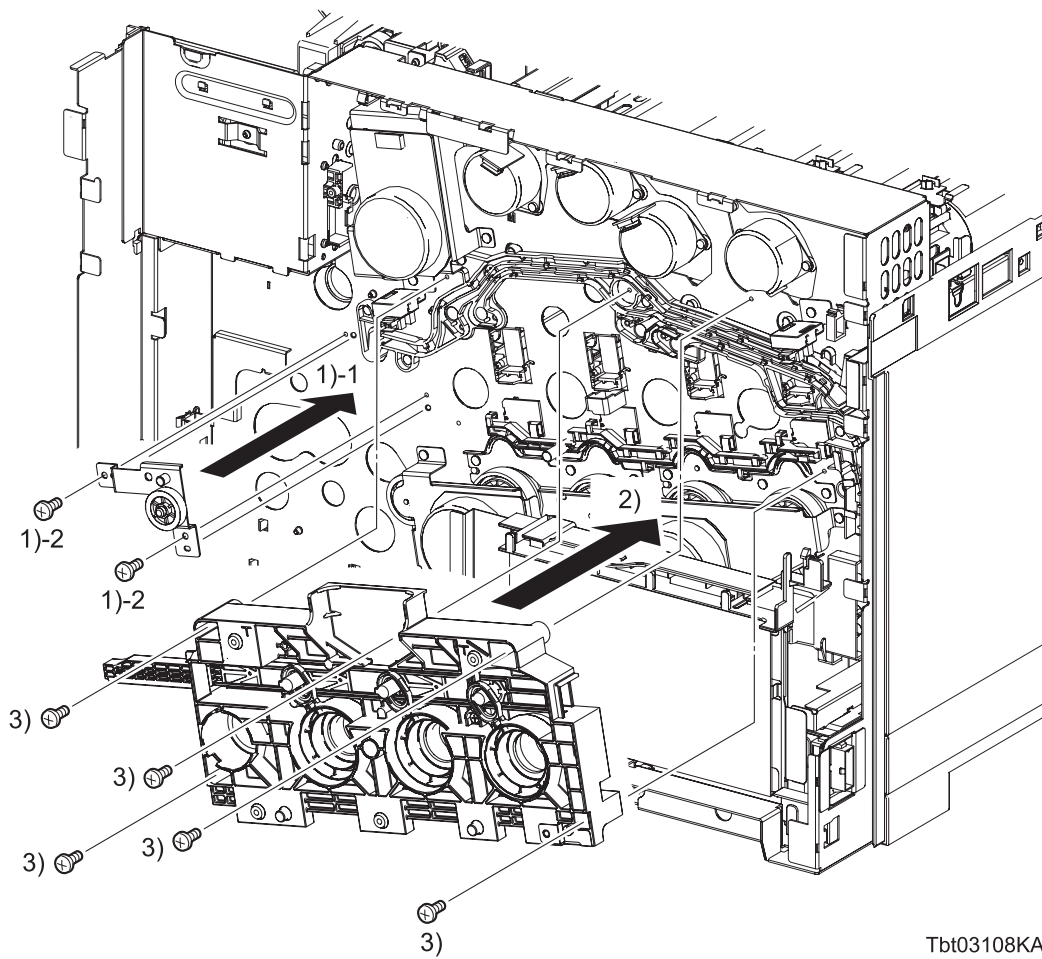

Tbt03108KA

- 1) Mate the two holes of the DRIVE ASSY RACK with the bosses of the printer, and then secure with the two screws (silver, 6mm).
- 2) Sliding the actuator of the LINK BAR from the switching sensor, replace the GUIDE ASSY LINK to the printer.
- 3) Secure the GUIDE ASSY LINK to the printer with the five screws (silver, 6mm).

Continues to the next page.

Replacement 6 KIT LINK XERO DRIVE (PL9.2.98)

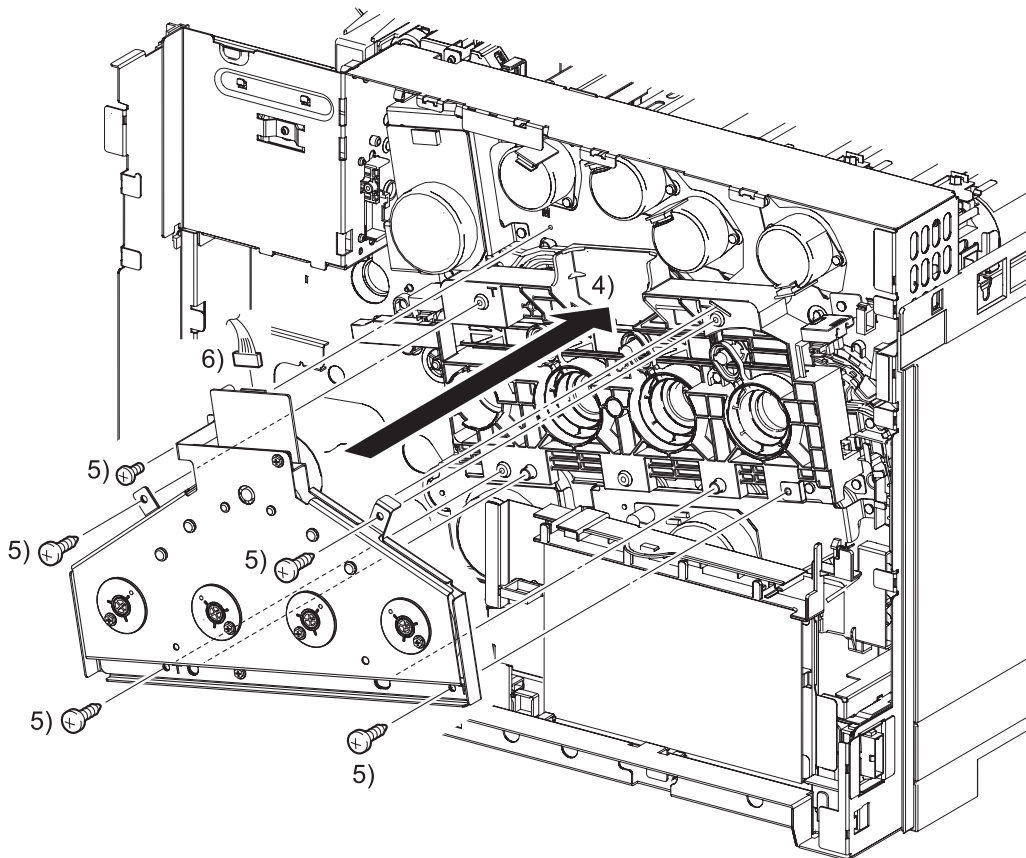

Tbt03109KA

- 4) Fit the tab of the DRIVE ASSY XERO in the hole in the GUIDE ASSY LINK and align the two holes in the DRIVE ASSY XERO with the bosses of the GUIDE ASSY LINK to attach the DRIVE ASSY XERO to the printer.

NOTE

Since two types of screws are used for securing the DRIVE ASSY XERO, ensure that the right screws are used at their right securing positions.

- 5) Secure the DRIVE ASSY XERO to the printer with the four screws (silver, tapping, M4, 10mm) and the one screw (silver, 6mm).
- 6) Engage the connectors (P/J251) of the DRIVE ASSY XERO.

Continues to the next page.

Replacement 6 KIT LINK XERO DRIVE (PL9.2.98)

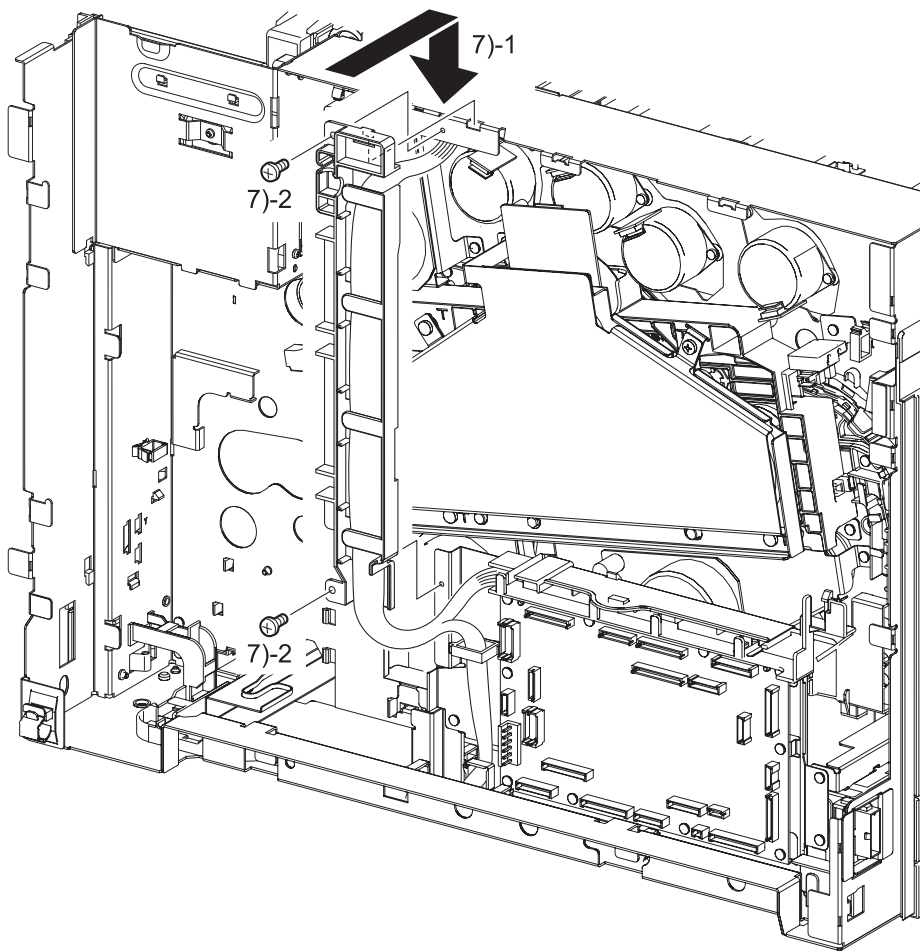

Tbt03221KA

- 7) Fit the hook of the GUIDE HARNESS REAR CTR into the hole in the frame and fix with the two screws (silver, 6 mm).

**Go to the next replacement step:
Replacement 7 DRIVE ASSY PH (PL9.1.4)**

Blank Page

Replacement 7 DRIVE ASSY PH (PL9.1.4)

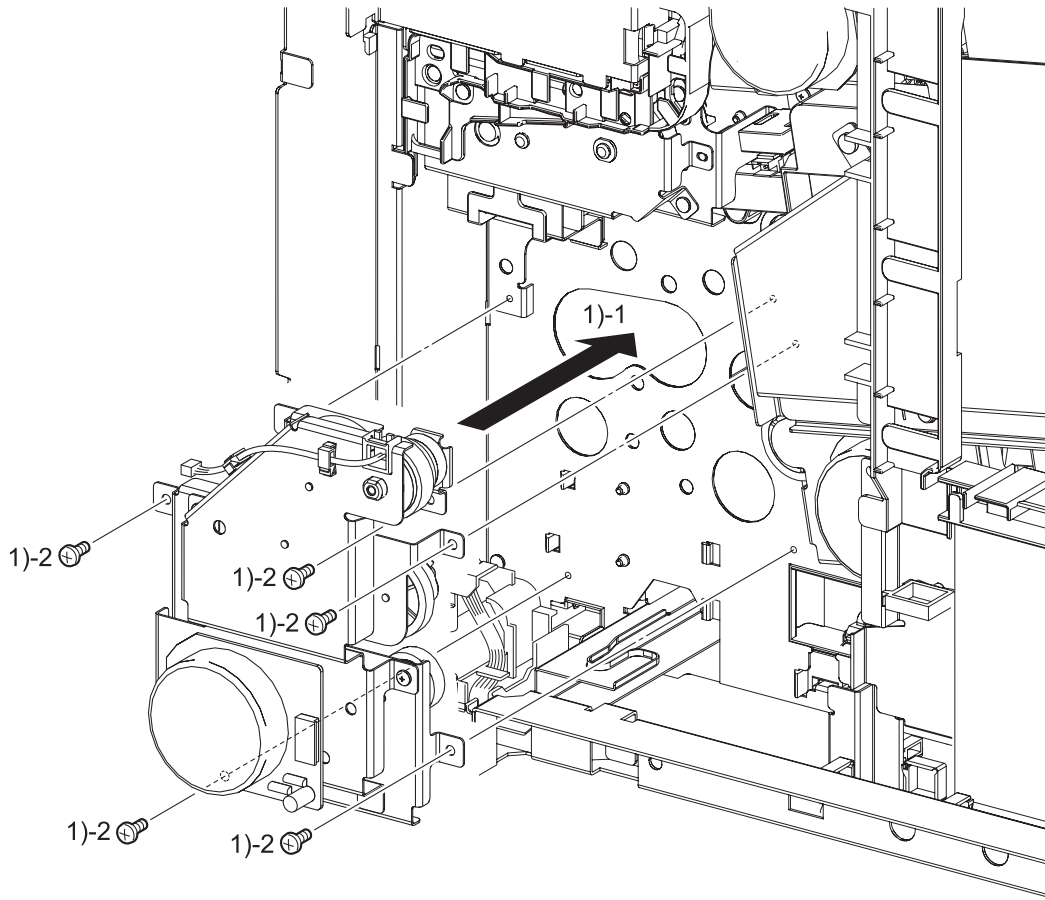

Tbt03110KB

- 1) Replace the DRIVE ASSY PH to the printer, and then secure with the five screws (silver, 6mm).

Continues to the next page.

Replacement 7 DRIVE ASSY PH (PL9.1.4)

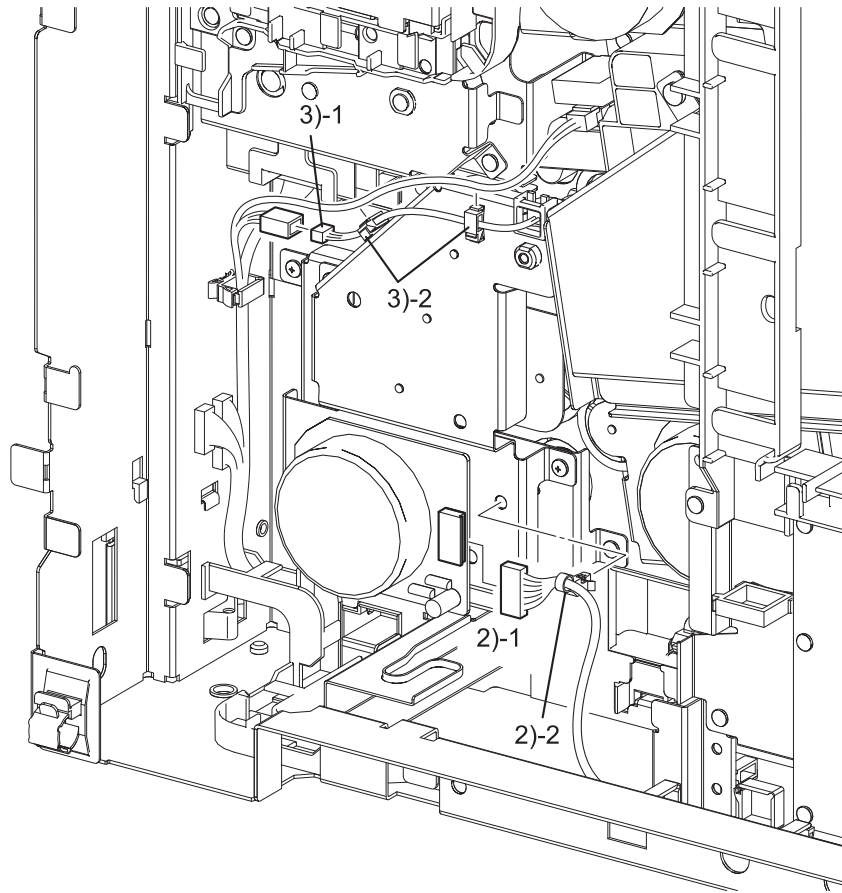

Tbt03111KB

- 2) Engage the connectors (P/J255) of the DRIVE ASSY PH, and then secure the harness to the DRIVE ASSY PH with the clamp.
- 3) Engage the connectors (P/J100) of the Switching Clutch, and then secure the harness of the DRIVE ASSY SNS (K) with the two clamps on the DRIVE ASSY PH.

Go to the next replacement step:

Replacement 21 BOX ASSY LVPS (PL10.2.1)

Replacement 8 DRIVE ASSY IBT (PL9.1.3)

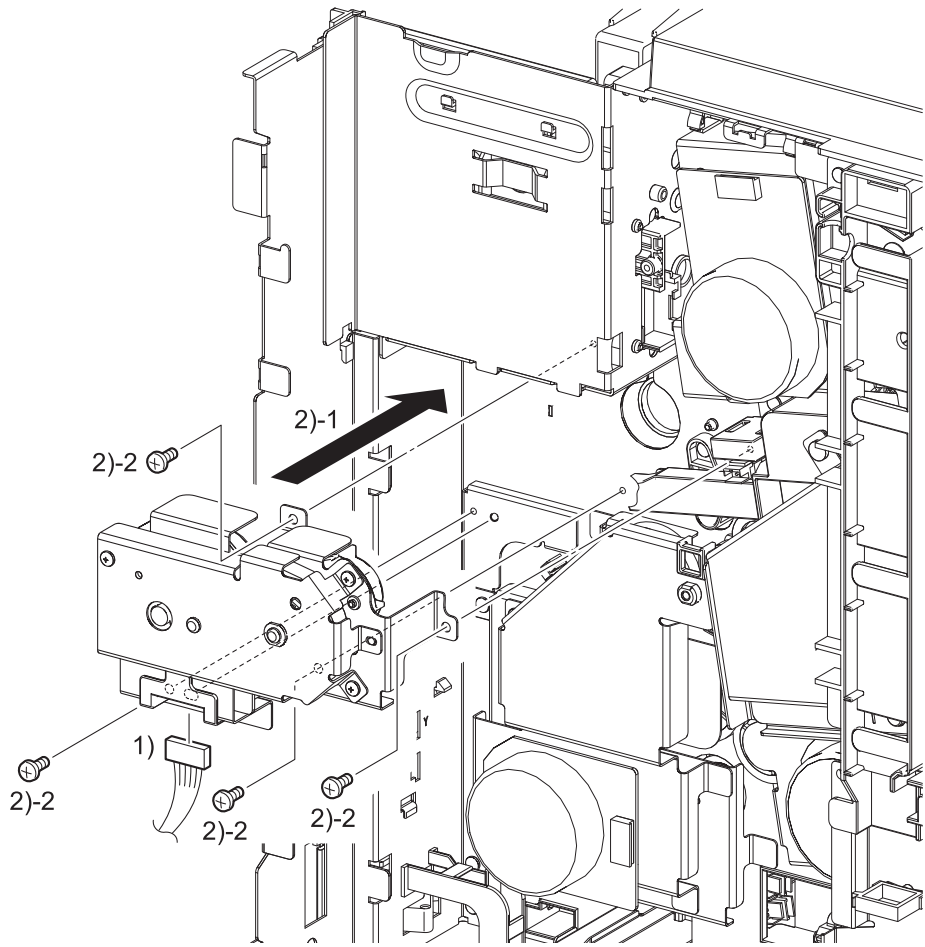

Tbt03112KA

- 1) Engage the connectors (P/J254) of the DRIVE ASSY IBT.
- 2) Mate the hole of the DRIVE ASSY IBT with the boss of the printer, and then secure with the four screws (silver, 6mm).

Continues to the next page.

Replacement 8 DRIVE ASSY IBT (PL9.1.3)

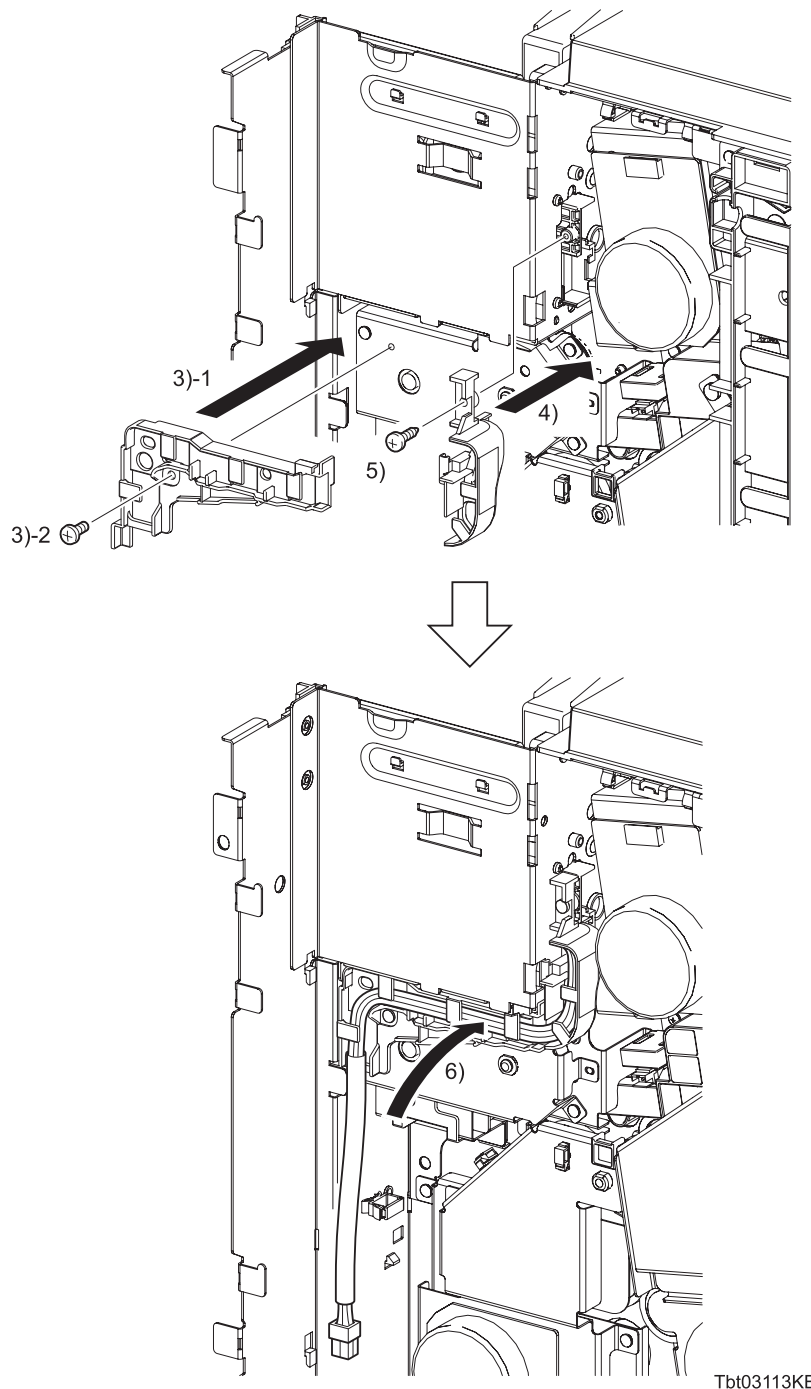

Tbt03113KB

- 3) Attach the GUIDE HARNESS FUSER AC to the DRIVE ASSY IBT, and then secure with the one screw (silver, 6mm).
- 4) Fit the hook of the BRACKET FUSER HNS into the hole in the printer and install the BRACKET FUSER HNS in position.
- 5) Secure the BRACKET FUSER HNS to the printer with the one screw (silver, tapping, 8mm).
- 6) Route the HARNESS ASSY FSR through the GUIDE HARNESS FUSER AC and BRACKET FUSER HNS.

Go to the next replacement step:

Replacement 21 BOX ASSY LVPS (PL10.2.1)

Replacement 9 DRIVE ASSY FSR (PL9.1.1)

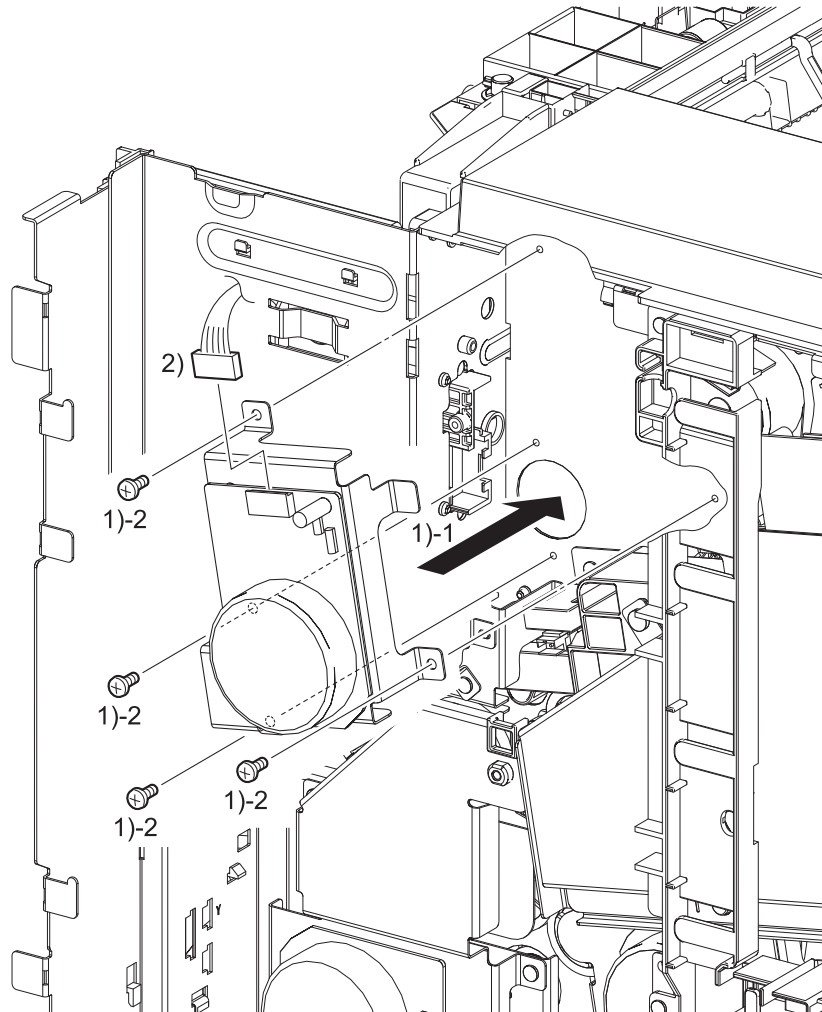

Tbt03114KA

- 1) Replace the DRIVE ASSY FSR to the printer, and then secure with the four screws (silver, 6mm).
- 2) Engage the connectors (P/J250) of the DRIVE ASSY FSR.

Continues to the next page.

Replacement 9 DRIVE ASSY FSR (PL9.1.1)

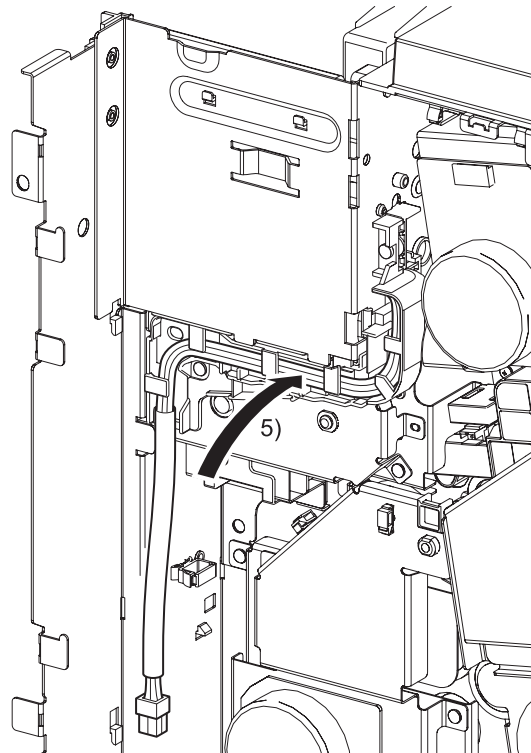
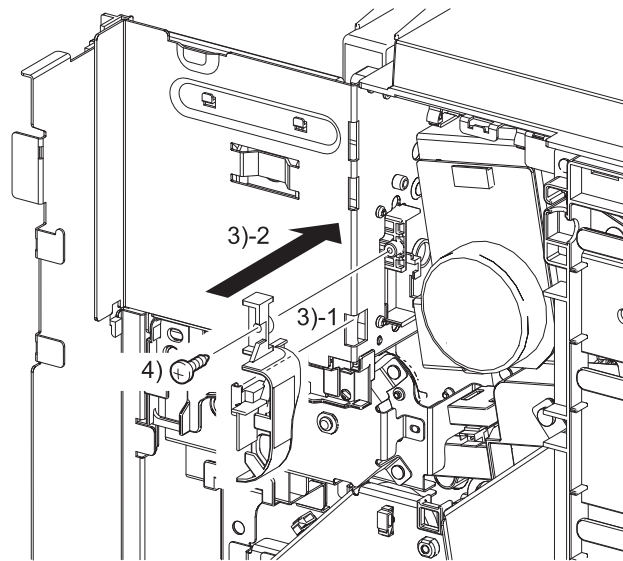

Tbt03115KA

- 3) Fit the hook of the BRACKET FUSER HNS into the hole in the printer and install the BRACKET FUSER HNS in position.
- 4) Secure the BRACKET FUSER HNS to the printer with the one screw (silver, tapping, 8mm).
- 5) Route the HARNESS ASSY FSR through the GUIDE HARNESS FUSER AC and BRACKET FUSER HNS.

**Go to the next replacement step:
Replacement 21 BOX ASSY LVPS (PL10.2.1)**

Replacement 10 DRIVE ASSY SNS (K) (PL9.2.1)

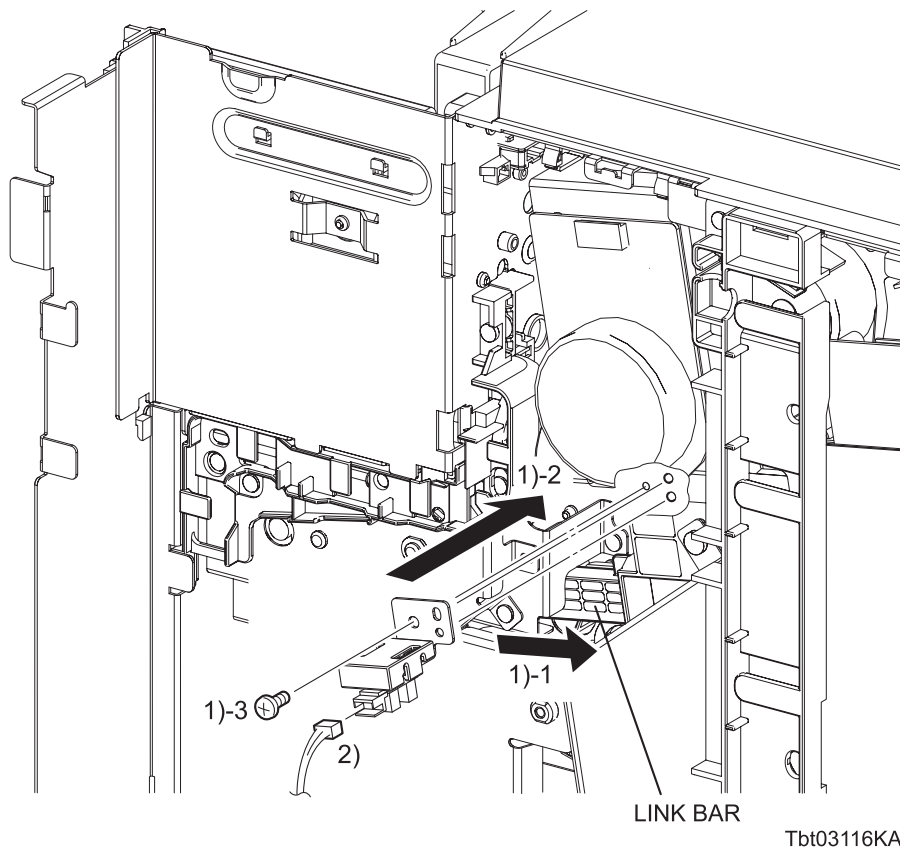

- 1) Slide the LINK BAR, mate the two holes of the DRIVE ASSY SNS (K) with the bosses of the printer, and then secure with the one screw (silver, 6mm).
- 2) Engage the connectors (P/J200) of the DRIVE ASSY SNS (K).

Go to the next replacement step:

Replacement 21 BOX ASSY LVPS (PL10.2.1)

Blank Page

Replacement 11 HARNESS ASSY I/L FRT (PL1.2.1)

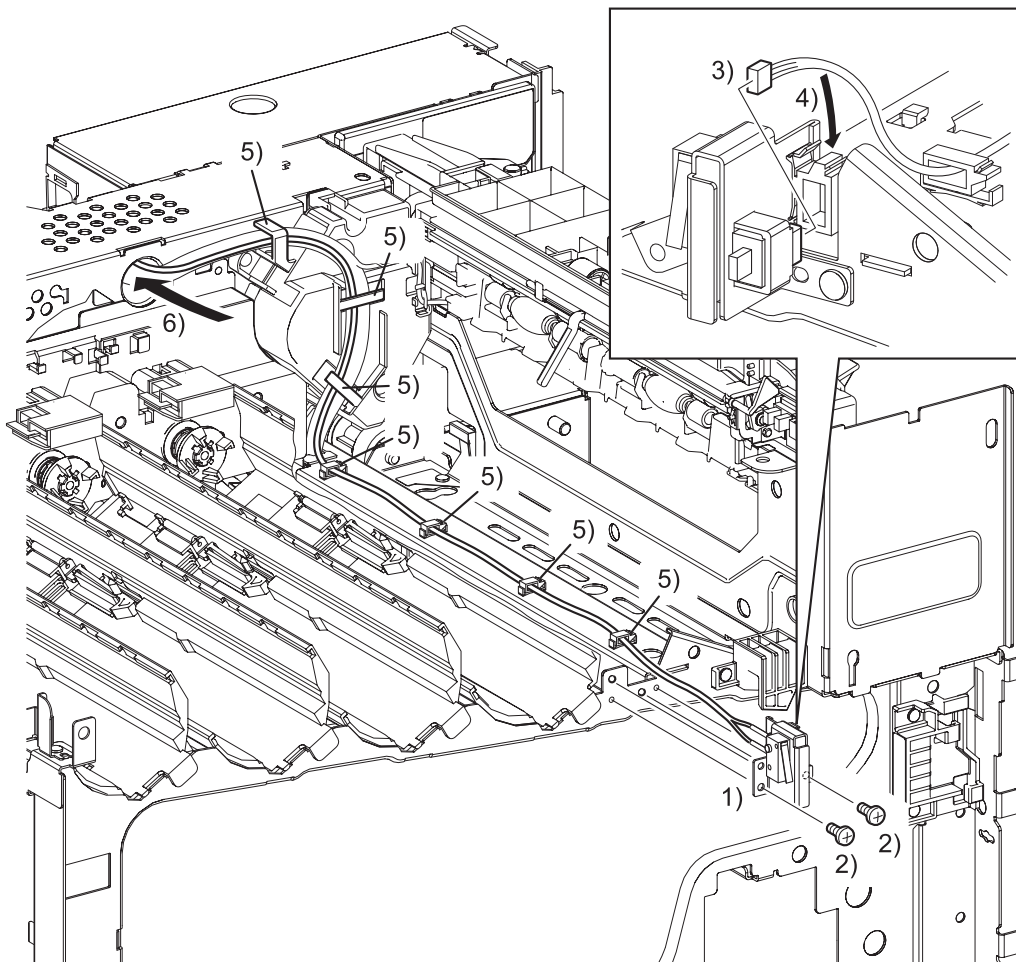

Tbt03117KB

- 1) Mate the two holes of the BRACKET INTER LOCK FRONT with the bosses of the printer, and then replace the BRACKET INTER LOCK FRONT to the printer together with the switch of the HARNESS ASSY I/L FRT.
- 2) Secure the BRACKET INTER LOCK FRONT to the printer with the two screws (silver, 6mm).
- 3) Engage the connectors (P/J212) of the SWITCH.
- 4) Secure the harness of the SWITCH with the clamp.
- 5) Secure the harness of the HARNESS ASSY I/L FRT with the four clamps and the hooks of the DRIVE ASSY EXIT.
- 6) Route the harness of the HARNESS ASSY I/L FRT into the hole of the frame.

Continues to the next page.

Replacement 11 HARNESS ASSY I/L FRT (PL1.2.1)

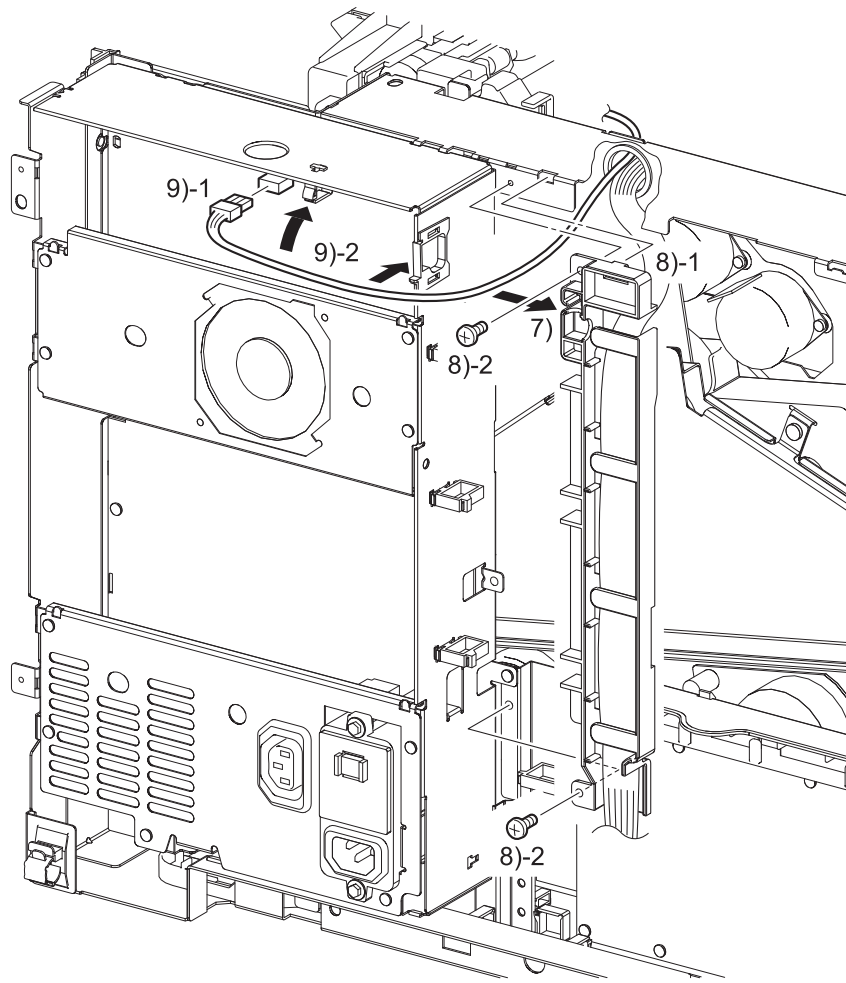

Tbt03118KB

- 7) Route the harness of the HARNESS ASSY I/L FRT along the GUIDE HARNESS REAR CTR.
- 8) Fit the hook of the GUIDE HARNESS REAR CTR into the hole in the frame and fix with the two screws (silver, 6 mm).
- 9) Engage the connectors (P/J302) on the LVPS ASSY, and then secure the harness of the HARNESS ASSY I/L FRT with the two clamps of the BOX ASSY LVPS.

Go to the next replacement step:

Replacement 28 COVER ASSY INNER FRONT (PL1.2.6)

Replacement 12 LAMP ASSY ERASE (PL5.1.2)

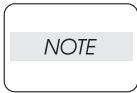

Described below is the replacement procedure common among the four LAMP ASSY ERASE.

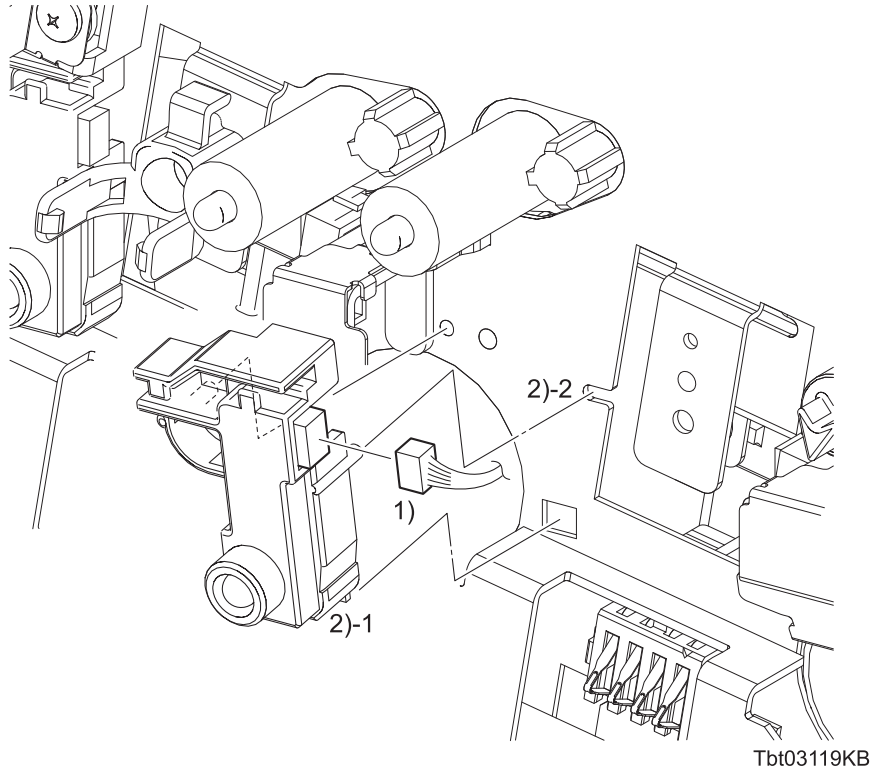

- 1) Engage the connectors of the LAMP ASSY ERASE.
- 2) After fitting the hook of the LAMP ASSY ERASE into the frame, put the boss on the backside into the hole in the frame and install the LAMP ASSY ERASE.

Continues to the next page.

Replacement 12 LAMP ASSY ERASE (PL5.1.2)

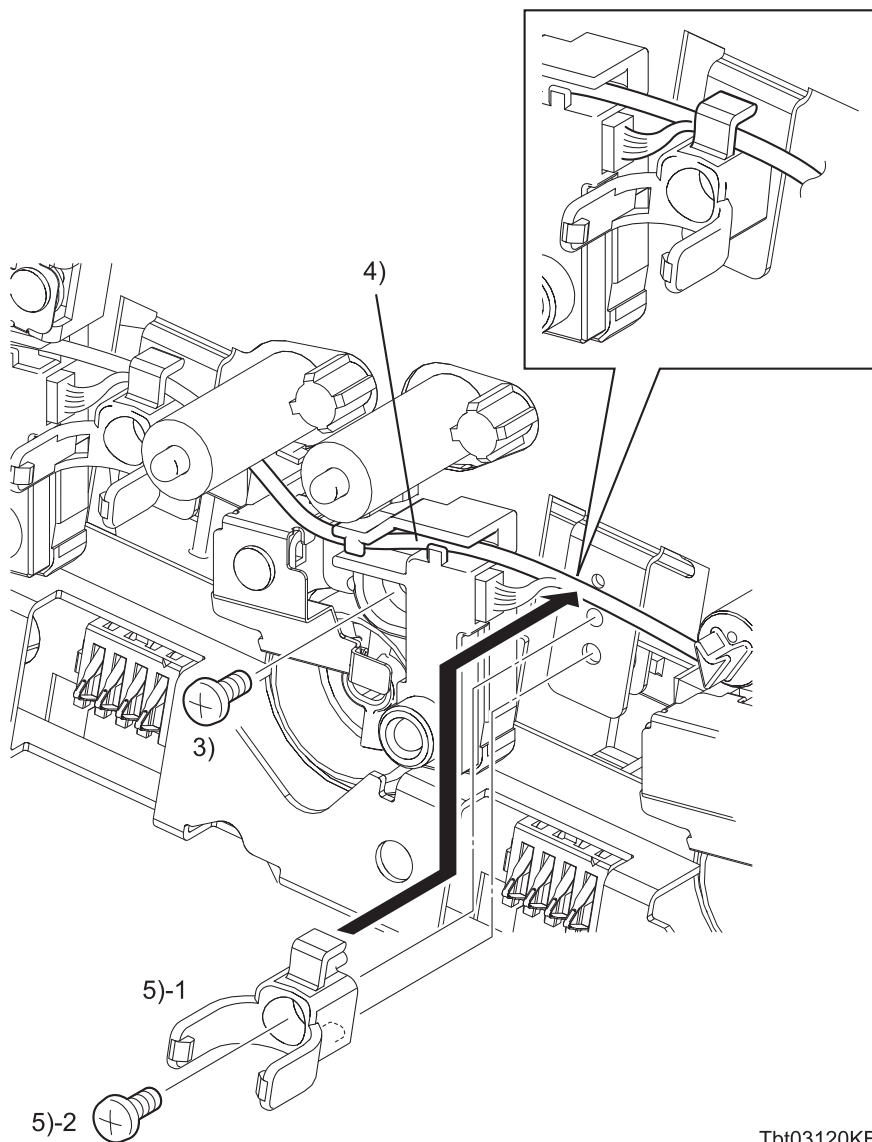

Tbt03120KB

- 3) Secure the LAMP ASSY ERASE to the printer with the one screw (silver, 6mm).

NOTE

The following step is not necessary for the LAMP ASSY ERASE for yellow.

- 4) Route the harness through the hooks of the LAMP ASSY ERASE.

NOTE

The following step is not necessary for the LAMP ASSY ERASE for black.

- 5) Mate the two bosses on the CLAMP PIPE DISP to the holes on the printer with the harness routed between the hook of the CLAMP PIPE DISP and the printer frame, and secure using the one screw (silver, 6 mm).

Go to the next replacement step:

Replacement 13 DISP ASSY (Y), (M), (C), (K) (PL6.1.5~6.1.8)

Replacement 13 DISP ASSY (Y), (M), (C), (K) (PL6.1.5~6.1.8)

Described below is the replacement procedure common among the four DISP ASSY.

NOTE

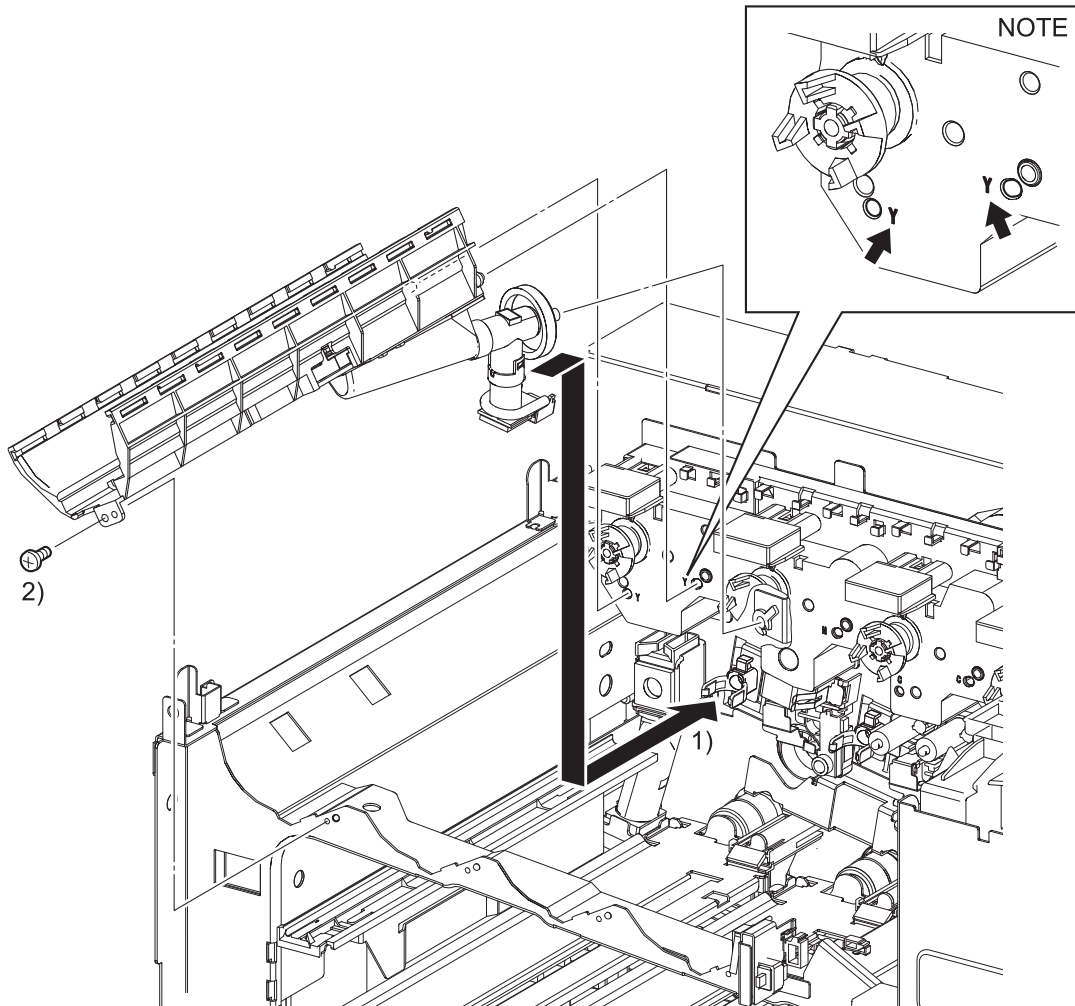

Tbt03121KB

NOTE

When performing the following step, place a sheet of paper under the unit so as to prevent smudges due to toner particles spilling from the DISP ASSY.

NOTE

The locating holes in the MOTOR ASSY DISP have markings Y, M, C and K respectively. Install the DISP ASSY of the respective color according to the markings Y, M, C and K.

- 1) Align the two bosses of the DISP ASSY with the locating holes in the MOTOR ASSY DISP, and fix the joint section of the DISP ASSY with the CLAMP PIPE DISP while inserting the boss on the DISP ASSY gear into the bearing of the MOTOR ASSY DISP.
- 2) Mate the hole of the DISP ASSY with the boss of the printer, and then secure with the one screw (silver, 6mm).

Go to the next replacement step:

Replacement 28 COVER ASSY INNER FRONT (PL1.2.6)

Replacement 14 CONNECTOR ASSY CRUM (Toner CRUM) (Y), (M), (C), (K) (PL6.1.10)

NOTE

Described below is the replacement procedure common among the four CONNECTOR ASSY CRUM

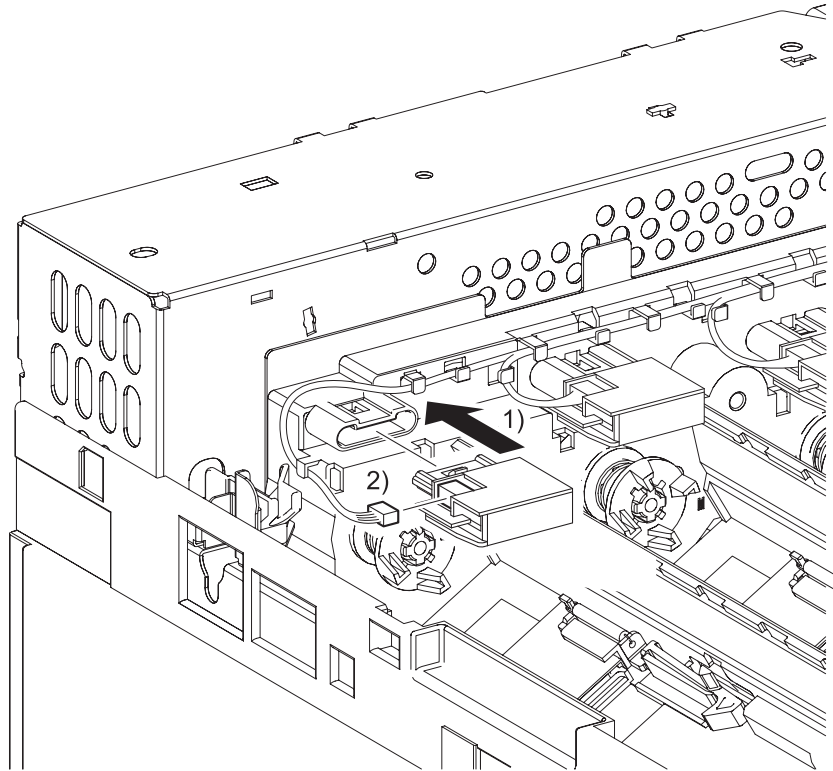

Tbt03122KB

- 1) Replace the CONNECTOR ASSY CRUM to the MOTOR ASSY DISP, and then secure with the hook.
- 2) Engage the connectors of the CONNECTOR ASSY CRUM.

Go to the next replacement step:

Replacement 19 COVER ASSY TOP (PL1.1.3)

Replacement 15 DRIVE ASSY EXIT (PL7.1.1)

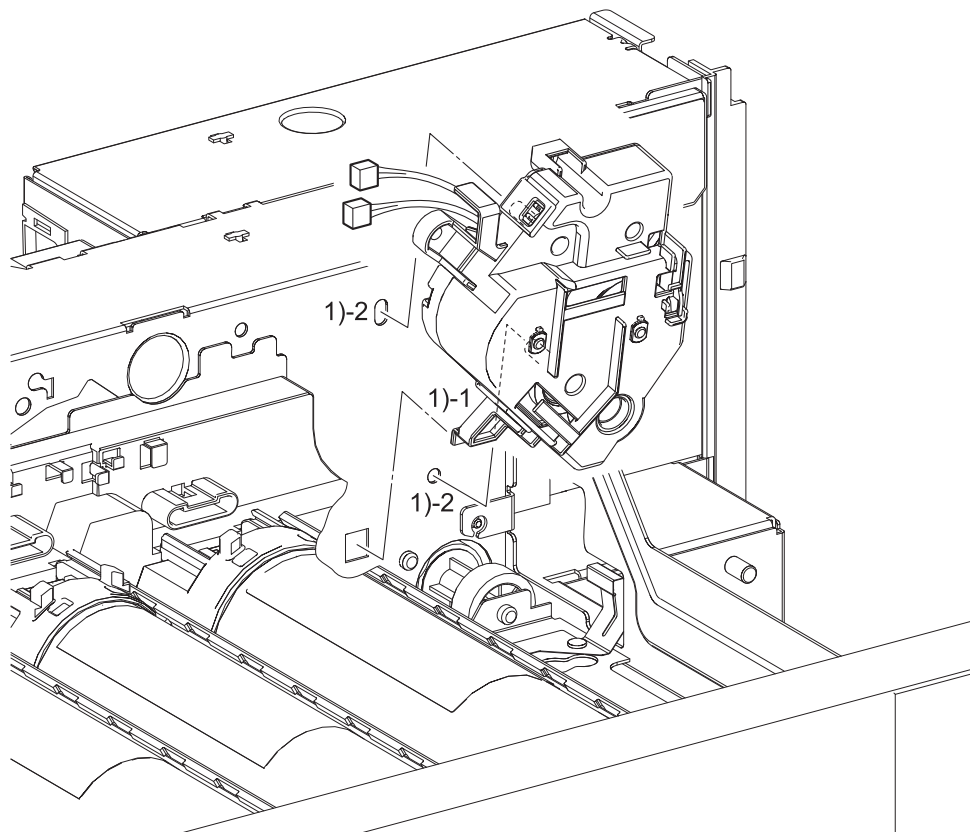

Tbt03123KA

- 1) After fitting the hook of the DRIVE ASSY EXIT into the frame, put the two bosses on the backside into the holes in the frame and install the DRIVE ASSY EXIT.

Continues to the next page.

Replacement 15 DRIVE ASSY EXIT (PL7.1.1)

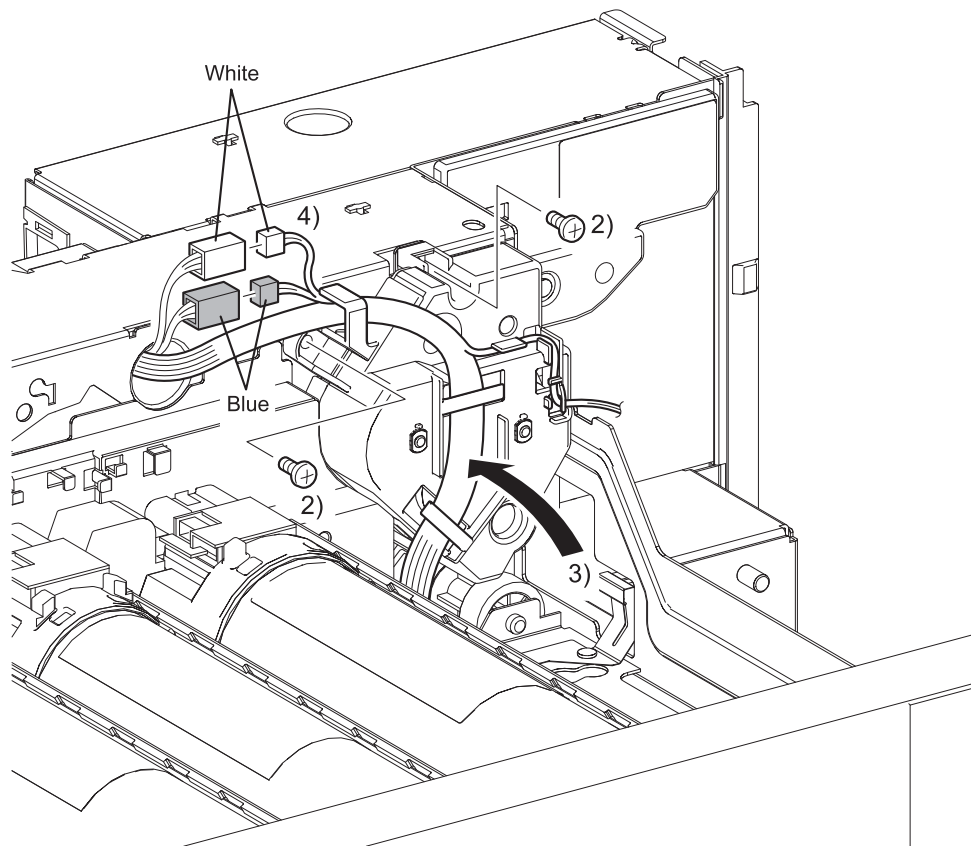

Tbt03124KA

- 2) Secure the DRIVE ASSY EXIT to the printer with the two screws (silver, 6mm).

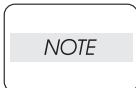

When performing the following step, use caution not to damage the harnesses.

- 3) Route all the harness through the hooks of the DRIVE ASSY EXIT.

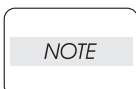

When performing the following steps, engage the connectors of the same color.

The connector of the Exit INV Clutch is white in color.

The connector of the Exit Clutch is blue in color.

- 4) Engage the two sets of connectors (P/J115, 116) of the DRIVE ASSY EXIT (PL7.1.1).

Go to the next replacement step:

Replacement 16 KIT CHUTE ASSY EXIT (PL7.2.99)

Replacement 16 KIT CHUTE ASSY EXIT (PL7.2.99)

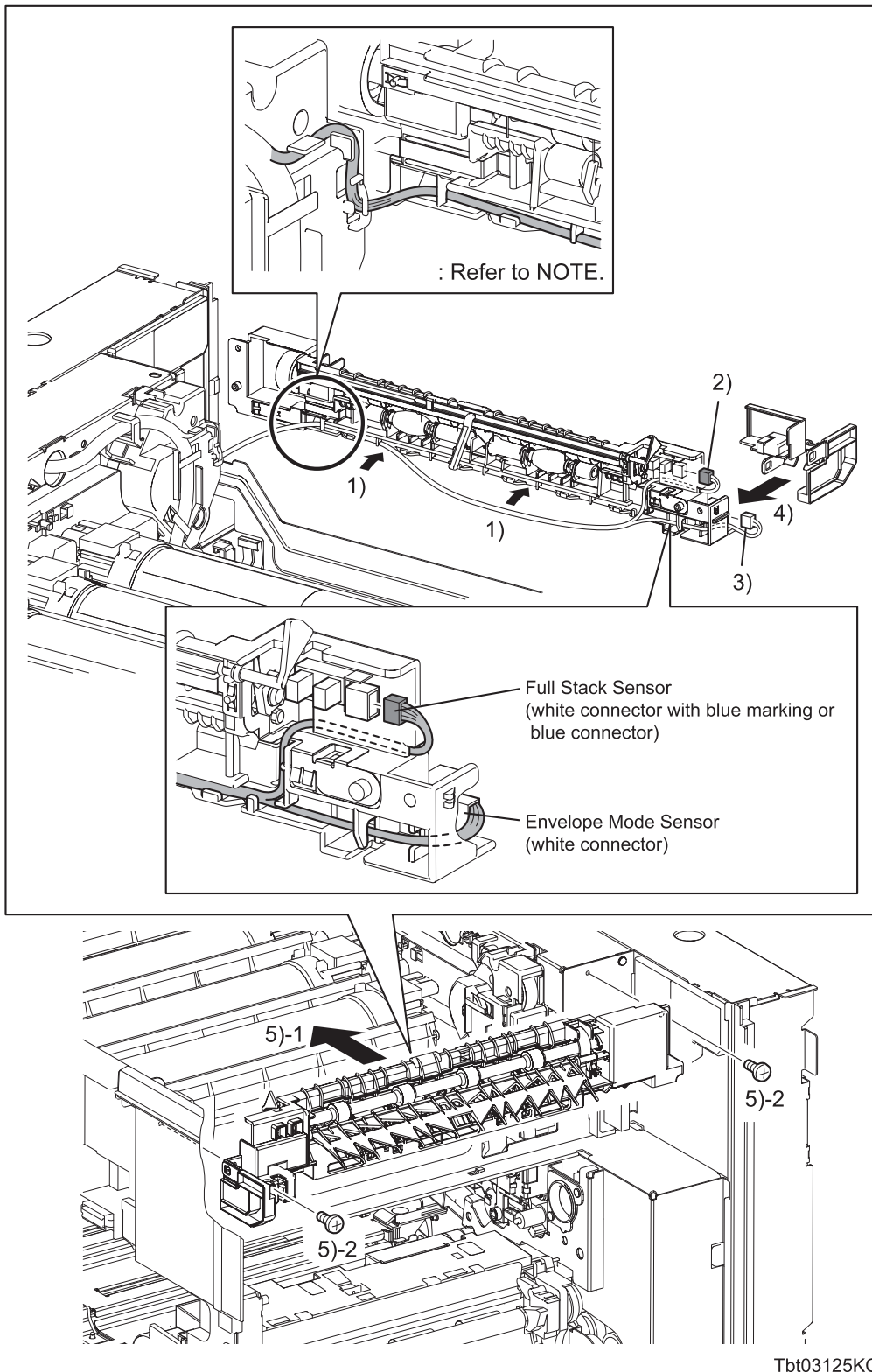

Tbt03125KC

Continues to the next page.

Replacement 16 KIT CHUTE ASSY EXIT (PL7.2.99)

- 1) Route the harness through the hooks of the KIT CHUTE ASSY EXIT.

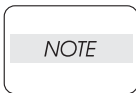

For how to route the harness on the KIT CHUTE ASSY EXIT, refer to the illustration.

- 2) Engage the white connector with blue marking (J224) or the blue connector (J224) with the connector on the Full Stack Sensor (P224).
For how to route the harness, refer to the illustration.
- 3) Engage the white connector (J225) with the connector on the Envelope Mode Sensor (P225).
- 4) Attach the COVER SNR EXIT to the KIT CHUTE ASSY EXIT, and then secure with the two hooks of the COVER SNR EXIT.
- 5) Mate the two bosses of the KIT CHUTE ASSY EXIT with the holes of the printer, and then secure with the two screws (silver, 6mm).

Go to the next replacement step:

Replacement 41 CHUTE ASSY INVERT (PL7.3.1)

Replacement 17 PROCON ASSY (PL5.3.1)

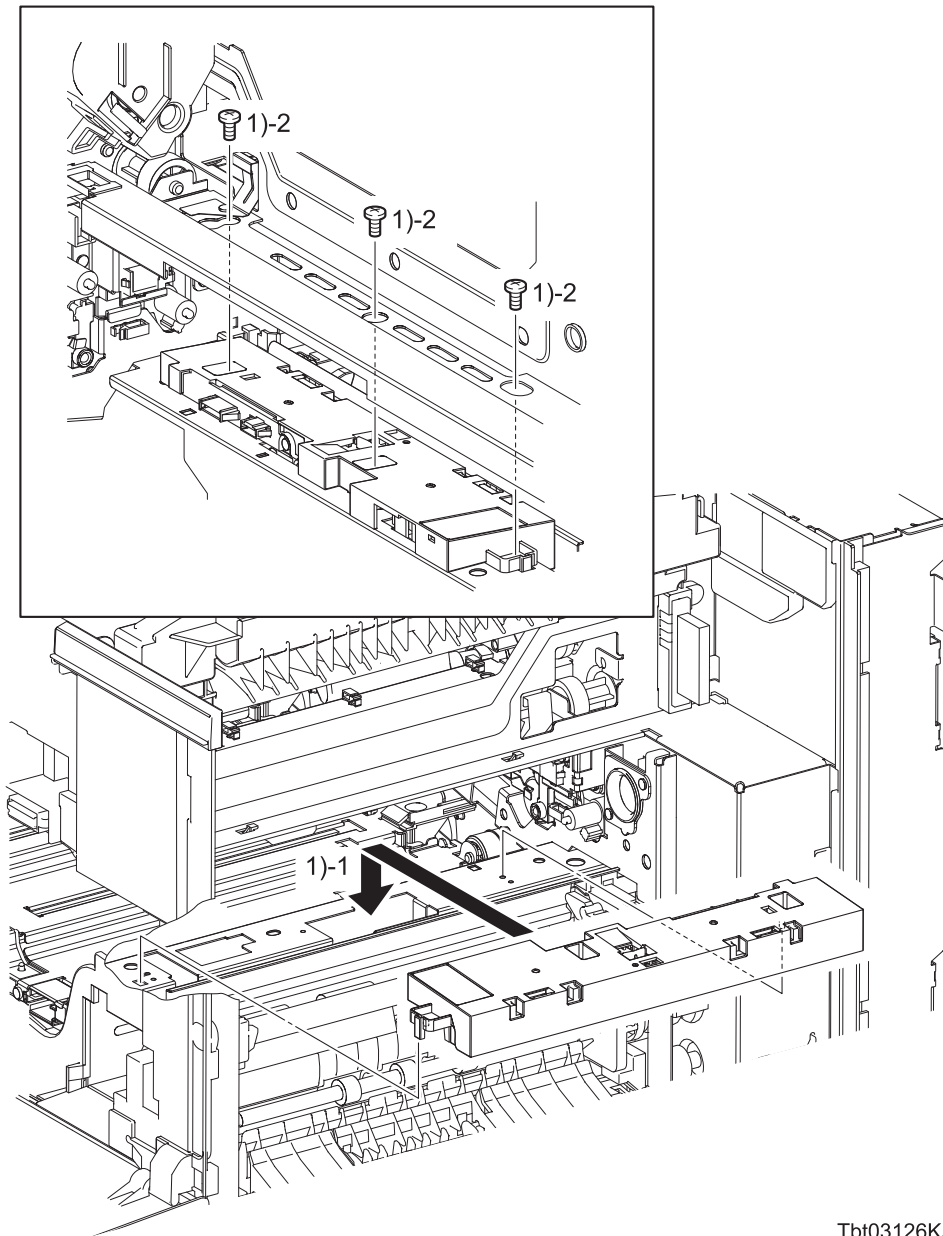

Tbt03126KA

- 1) Mate the two holes of the PROCON ASSY with the bosses of the printer, and then secure with the three screws (silver, 6mm).

Continues to the next page.

Replacement 17 PROCON ASSY (PL5.3.1)

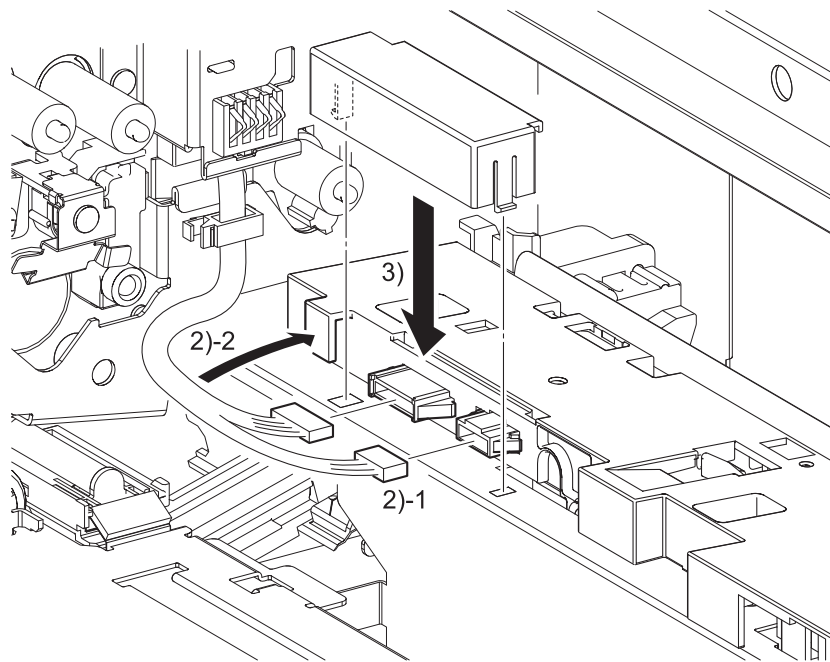

Tbt03127KA

- 2) Engage the two sets of connectors (P/J106, 108) of the PROCON ASSY, and then route the harness through the hook of the PROCON ASSY.
- 3) Attach the COVER CONNECTOR to the printer, and then secure with the two hooks of the COVER CONNECTOR.

Go to the next replacement step:

Replacement 60 WASTE TONER BOX (PL6.1.13)

Replacement 18 KIT CONSOLE PANEL & HARNESS (PL1.1.99)

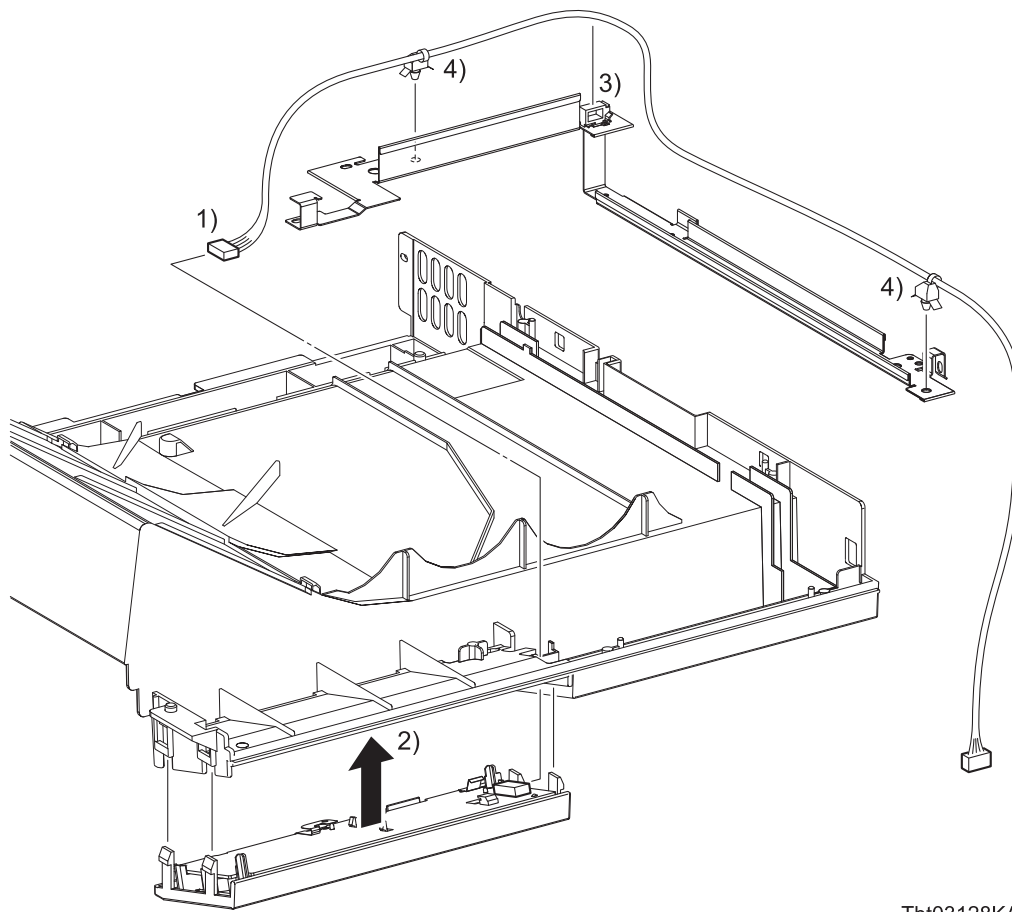

Tbt03128KA

- 1) Engage the connectors (P/370) of the CONSOLE ASSY PANEL.
- 2) Replace the CONSOLE ASSY PANEL to the COVER TOP, and then secure with the four hooks.
- 3) Secure the HARNESS ASSY OPEPANE using the two clamps on the GUIDE HARNESS UI and the GUIDE HARNESS UI FRONT.
- 4) Secure the HARNESS ASSY OPEPANE to the GUIDE HARNESS UI and the GUIDE HARNESS UI FRONT with the two clamps.

Continues to the next page.

Replacement 18 KIT CONSOLE PANEL & HARNESS (PL1.1.99)

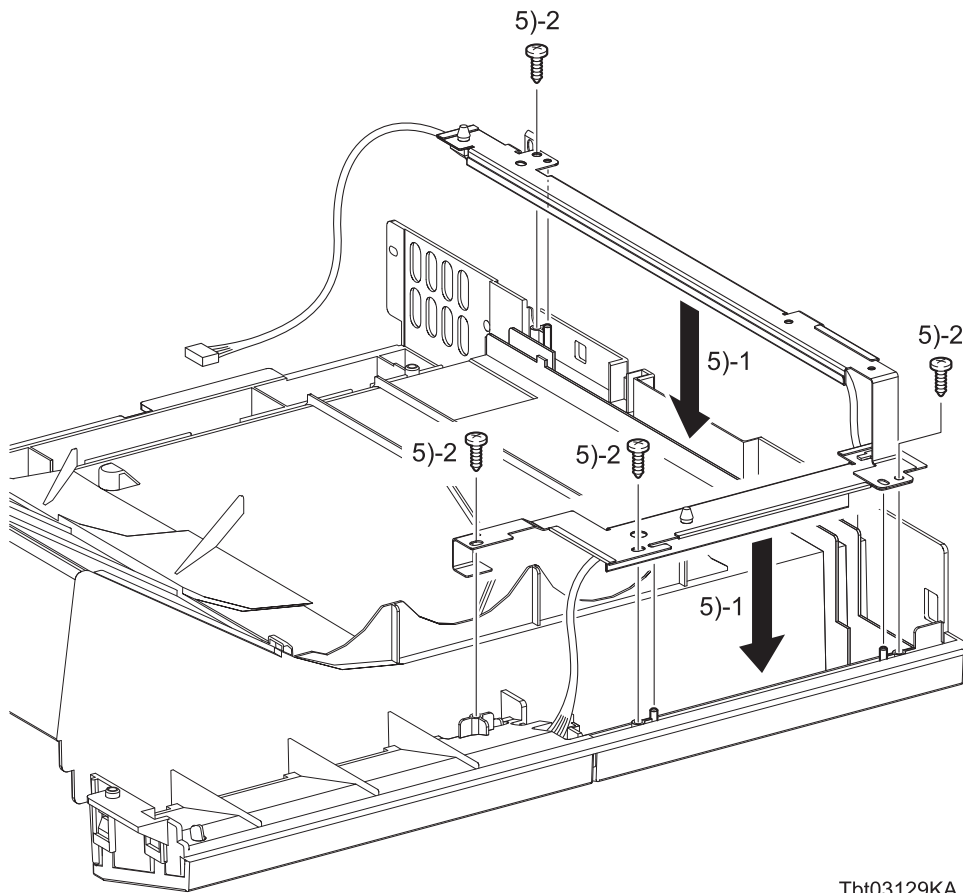

Tbt03129KA

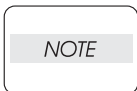

When performing the following step, use caution ensure that the harness will not be caught between the COVER TOP and the GUIDE HARNESS UI.

- 5) Mate the three holes of the GUIDE HARNESS UI and the GUIDE HARNESS UI FRONT with the bosses of the COVER TOP, and then secure with the four screws (silver, tapping, 8mm).

**Go to the next replacement step:
Replacement 19 COVER ASSY TOP (PL1.1.3)**

Replacement 19 COVER ASSY TOP (PL1.1.3)

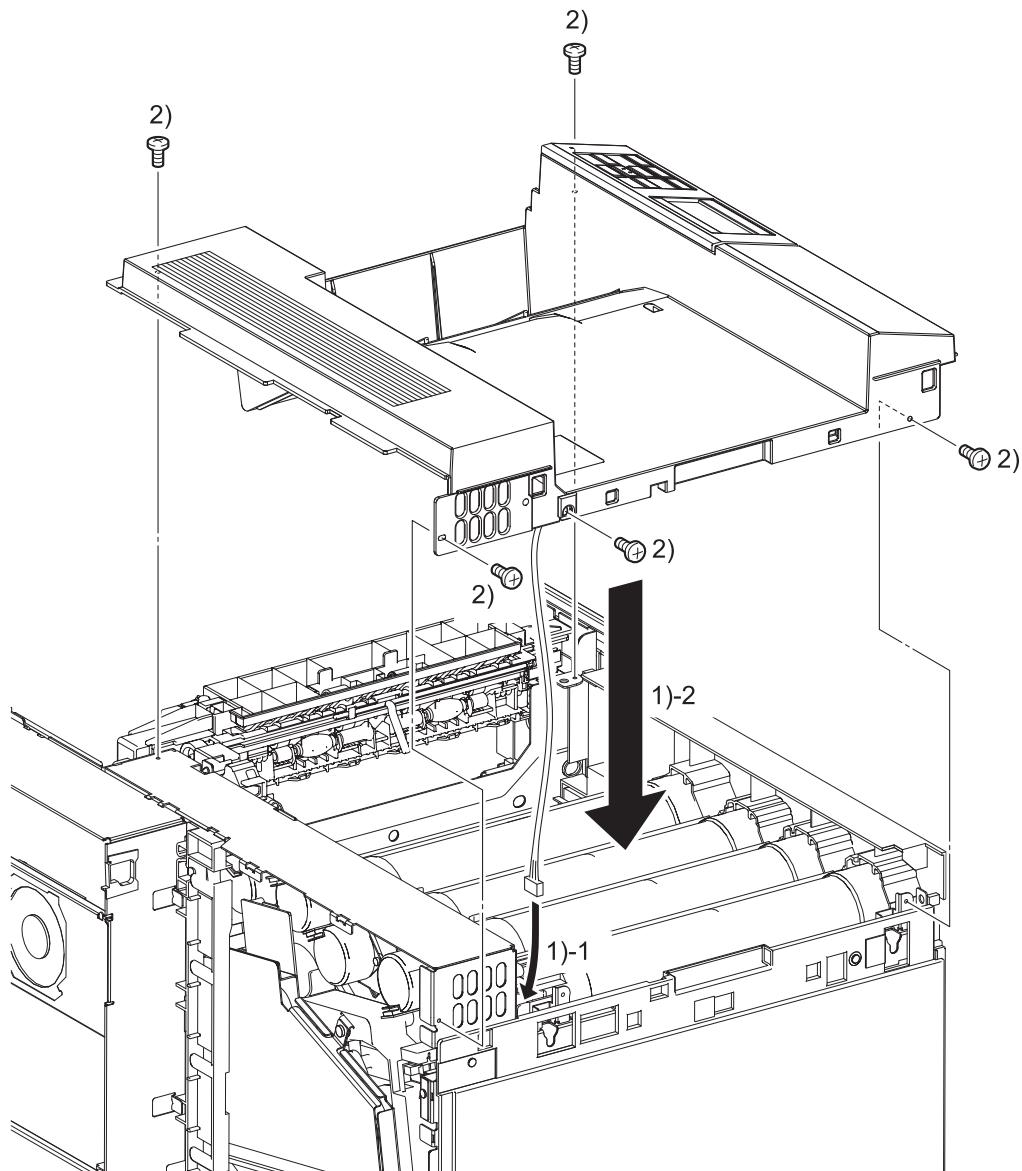

Tbt03130KA

NOTE

When performing the following step, use caution not to damage the ACTUATOR FULL STACK (PL7.2.13) of the printer.

- 1) Pass the HARNESS ASSY OPEPANE through the GUIDE HARNESS OP PANEL and attach the COVER ASSY TOP to the printer.
- 2) Secure the COVER ASSY TOP to the printer with the five screws (silver, 6mm).

Continues to the next page.

Replacement 19 COVER ASSY TOP (PL1.1.3)

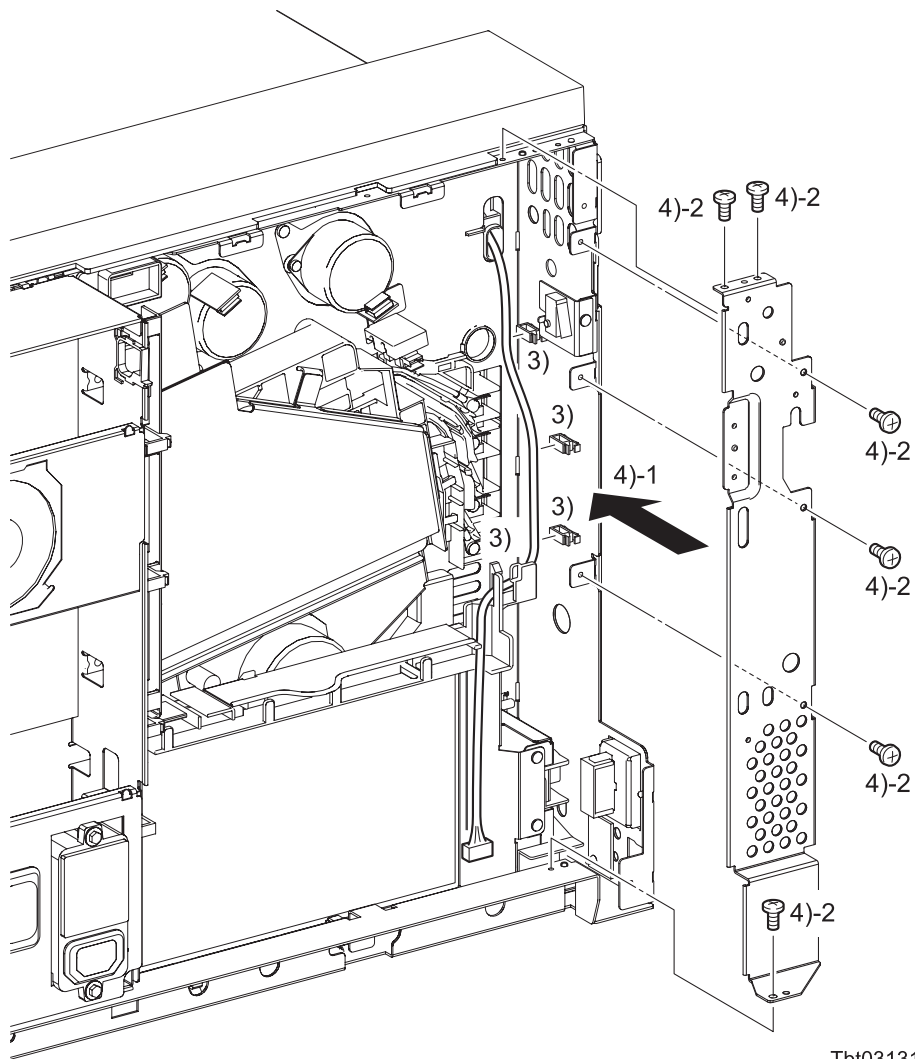

Tbt03131KA

- 3) Secure the HARNESS ASSY OPEPANE with the three clamps and the hooks of the GUIDE HARNESS MCU UPR.
- 4) Mate the two holes of the PLATE SUPPORT EM with the bosses of the printer, and then secure with the six screws (silver, 6mm).

Go to the next replacement step:

Replacement 46 COVER ASSY TOP ADD TRAY (Reference only)

Replacement 20 KIT INTERLOCK SWITCH RH (PL4.1.96)

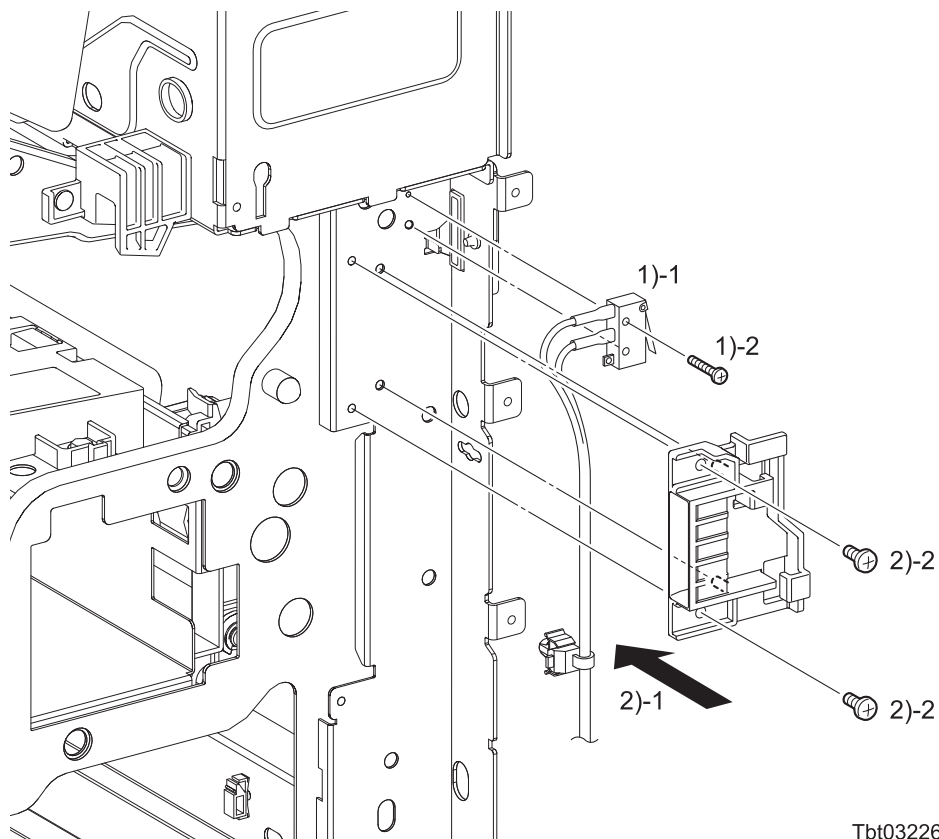

Tbt03226KA

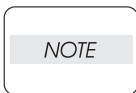

When performing the following step, make sure to use the screwdriver included in the KIT.

- 1) Fit the switch section of the HARNESS ASSY I/L RH to the printer with its hole mated with the boss on the printer, and then secure using the one screw (silver, M2, 8mm)
- 2) Mate the two bosses of the GUIDE FRAME LOCK H with the holes of the printer, and then secure with the two screws (silver, 6mm).

Continues to the next page.

Replacement 20 KIT INTERLOCK SWITCH RH (PL4.1.96)

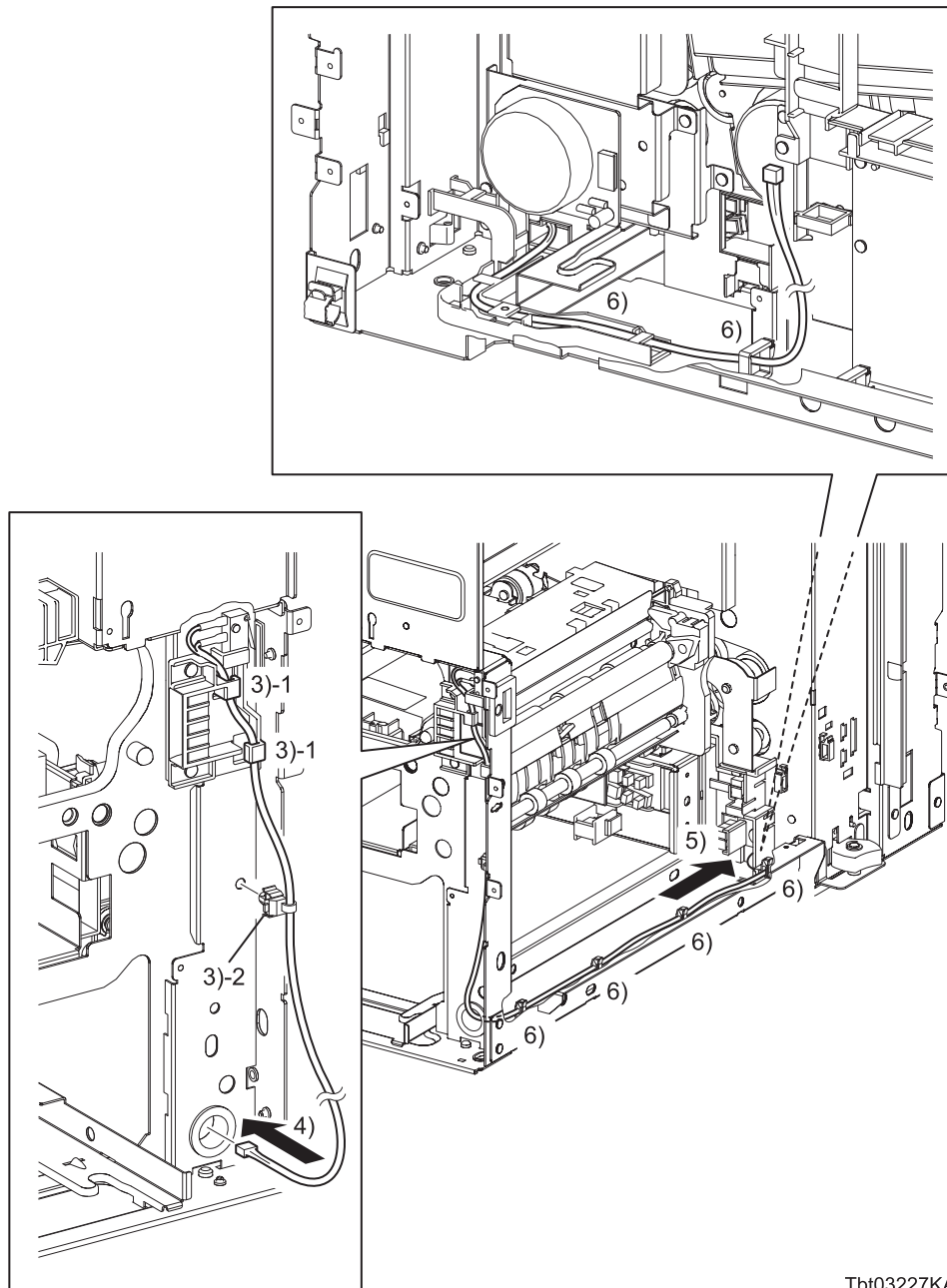

Tbt03227KA

- 3) Route the harness of the HARNESS ASSY I/L RH through the hooks of the GUIDE FRAME LOCK H, and then secure the harness of the HARNESS ASSY I/L RH to the printer with the clamp.
- 4) Pass the connector (J301) of the HARNESS ASSY I/L RH through the BUSH CLOSE-TYPE into the printer frame.
- 5) Pass the connector (J301) of the HARNESS ASSY I/L RH through the GUIDE HARNESS out of the rear side of the printer frame.
- 6) Route the harness of the HARNESS ASSY I/L RH along the GUIDE HARNESS WIRE, and secure using the four CLAMP LOCKINGs

Continues to the next page.

Replacement 20 KIT INTERLOCK SWITCH RH (PL4.1.96)

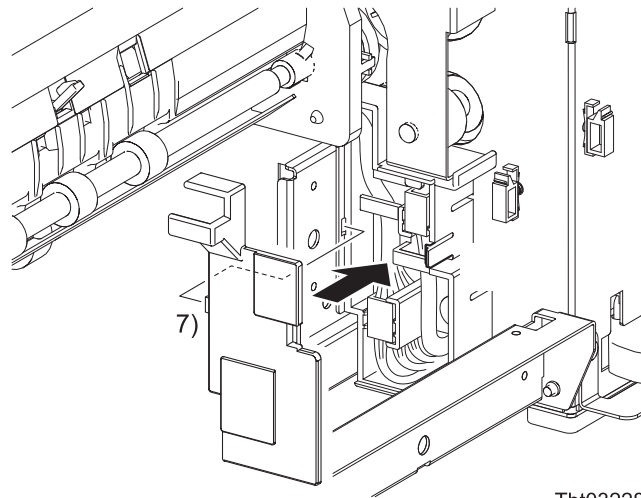

- 7) Insert the tab on the COVER GUIDE HARNESS into the GUIDE HARNESS, and then secure with the hook.

Continues to the next page.

Replacement 20 KIT INTERLOCK SWITCH RH (PL4.1.96)

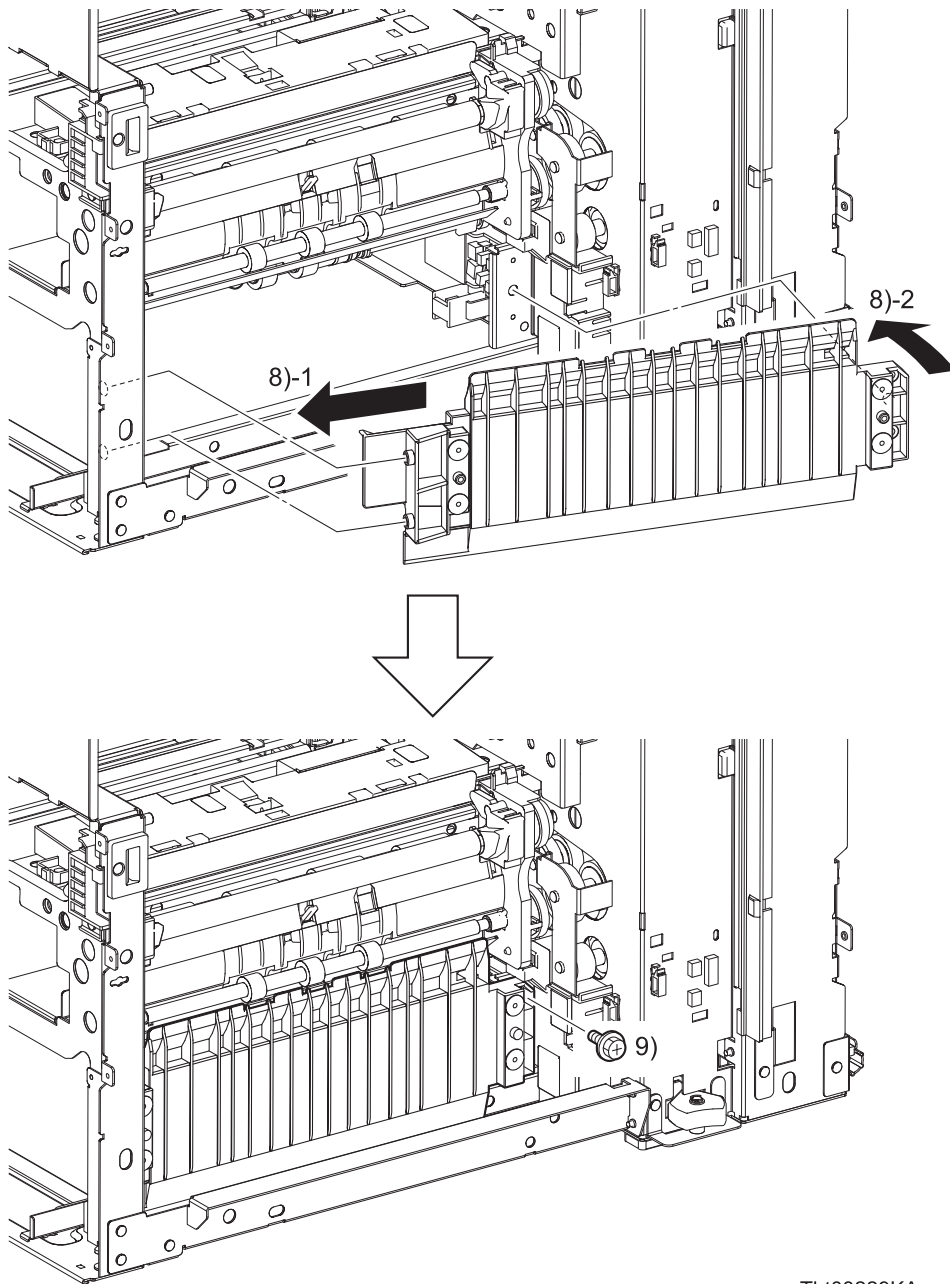

Tbt03229KA

- 8) Insert the two bosses on the front side of the GUIDE TRAY into the holes in the printer. Then, insert the boss on the rear side of the GUIDE TRAY into the mating hole to attach the GUIDE TRAY to the printer.
- 9) Secure the GUIDE TRAY to the printer with the one screw (silver, flanged, 6mm).

Go to the next replacement step:

Replacement 35 SEPARATOR ASSY MSI (PL3.1.7)

Replacement 21 BOX ASSY LVPS (PL10.2.1)

NOTE

Use a wrist strap to protect the PWB from electrostatic damage.

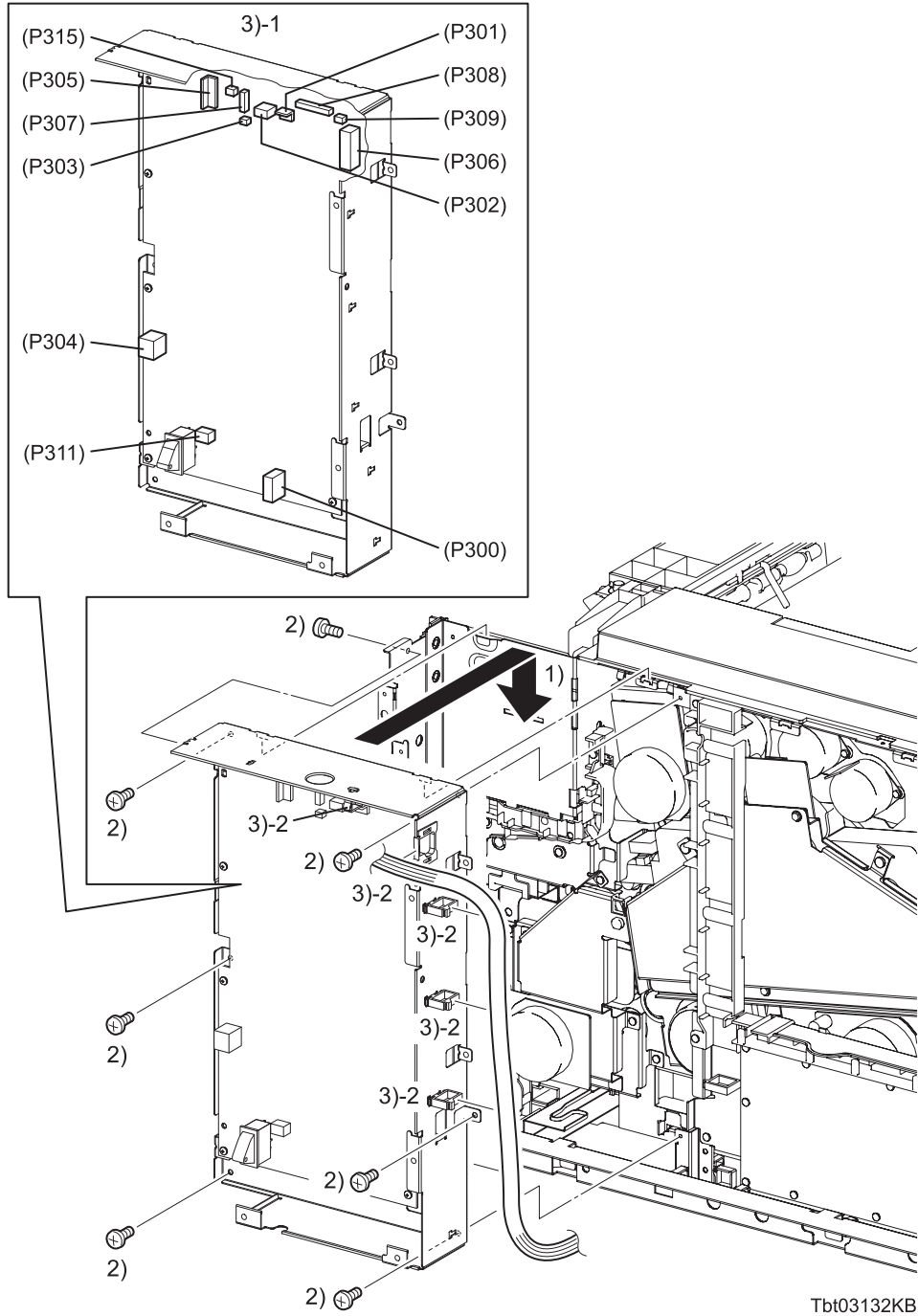

Tbt03132KB

- 1) Fit the two hooks of the BOX ASSY LVPS into the holes in the printer and install the BOX ASSY LVPS in position.
- 2) Secure the BOX ASSY LVPS to the printer with the seven screws (silver, 6mm).
- 3) Engage all the connectors of the LVPS ASSY, and then secure all the harnesses with all the clamps of the BOX ASSY LVPS.

Continues to the next page.

Replacement 21 BOX ASSY LVPS (PL10.2.1)

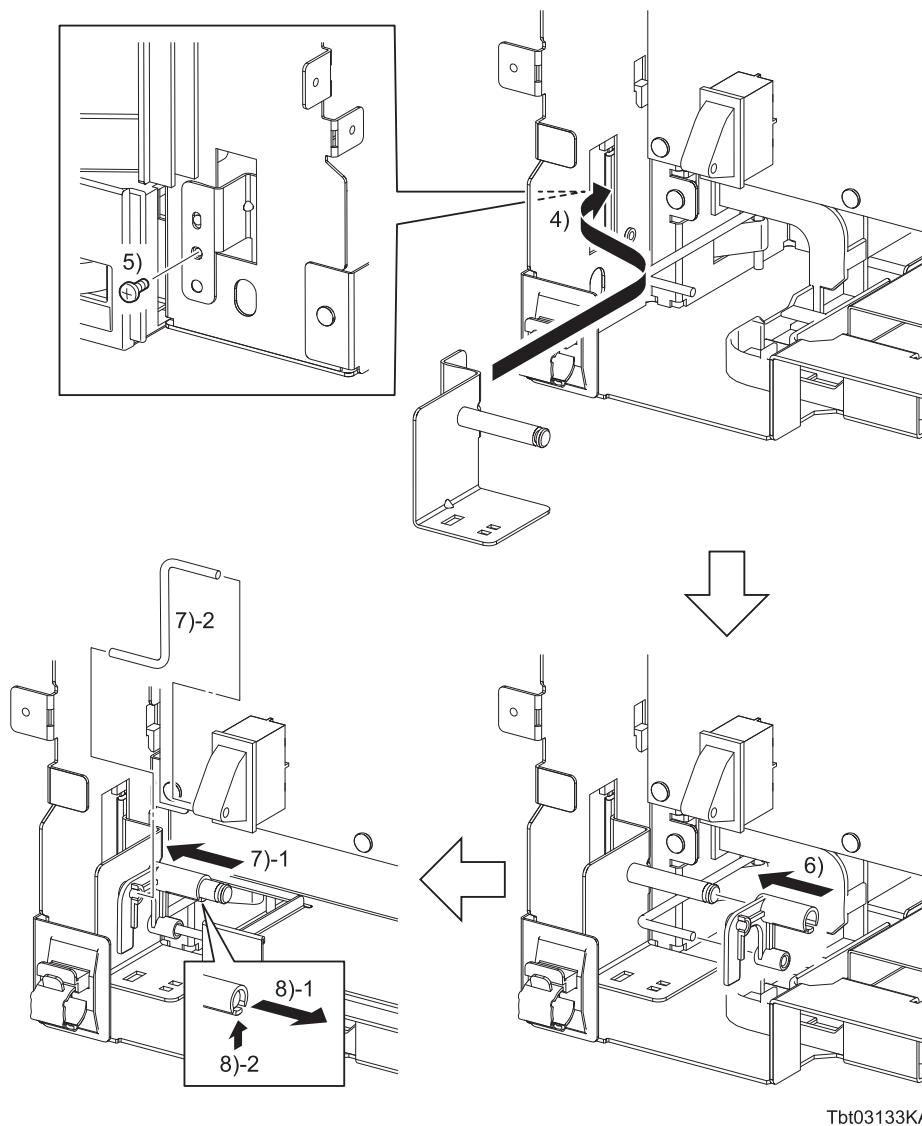

- 4) Put the screw-secured section of the BRACKET ASSY REAR from inside to outside through the hole in the frame.
- 5) Mate the two holes of the BRACKET ASSY REAR with the bosses of the printer, and then secure with the one screw (silver, 6mm).
- 6) Inserting the WIRE LONG (PL10.2.12) into the LINK REAR, attach the WIRE LONG to the stud of the BRACKET ASSY REAR.

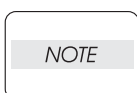

When performing the following step, be sure to keep the power switch for the LVPS ASSY in the OFF state.

- 7) Slide the LINK REAR until it comes in contact with the BRACKET ASSY REAR, and then insert the WIRE SHORT into the power switch for the LINK REAR and LVPS ASSY.
- 8) Slide the LINK REAR to secure the hook of the LINK REAR in the groove in the stud of the BRACKET ASSY REAR.

Go to the next replacement step:

Replacement 30 PLATE ASSY LVPS POWER (PL10.1.12)

Replacement 22 DRIVE ASSY SNS (FC) (PL9.2.1)

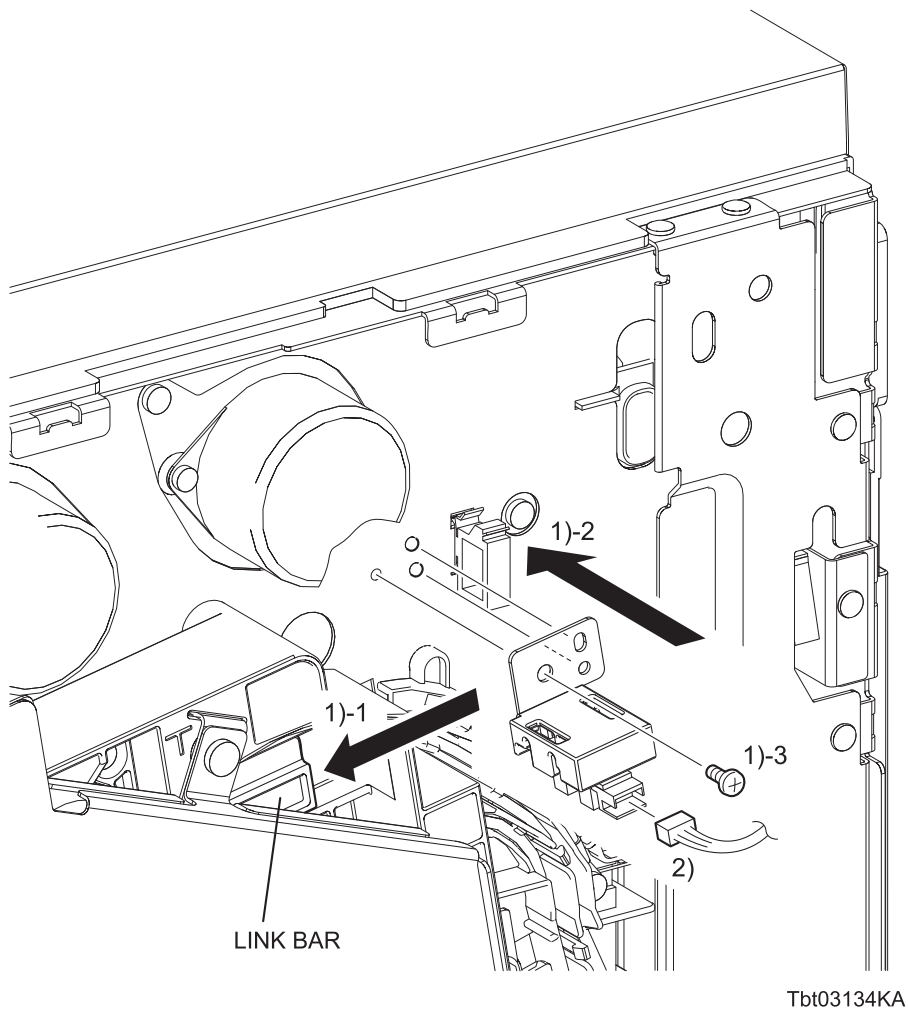

- 1) Slide the LINK BAR, mate the two holes of the DRIVE ASSY SNS (FC) with the bosses of the printer, and then secure with the one screw (silver, 6mm).
- 2) Engage the connectors (P/J201) of the DRIVE ASSY SNS (FC).

Go to the next replacement step:

Replacement 23 BOX ASSY ESS PWB (PL10.1.1)

Blank Page

Replacement 23 BOX ASSY ESS PWB (PL10.1.1)

NOTE

Use a wrist strap to protect the PWB from electrostatic damage.

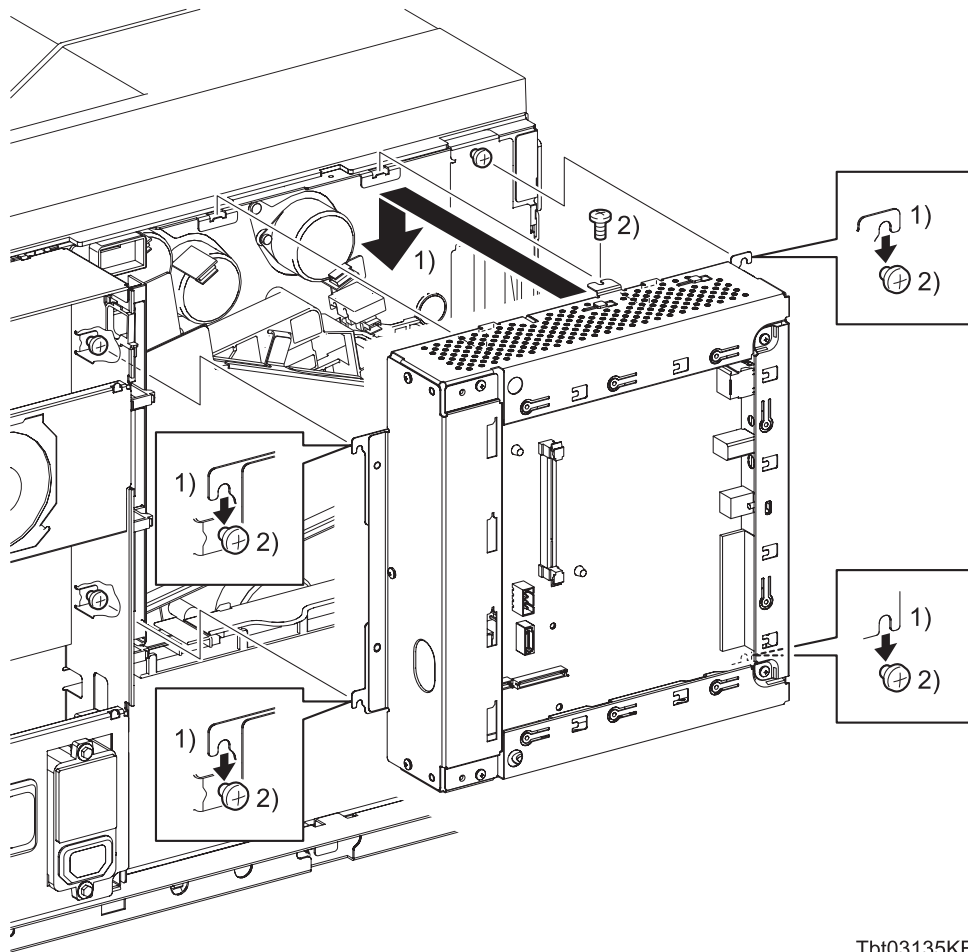

Tbt03135KB

- 1) With the two hooks of the BOX ASSY ESS PWB hooked in the holes on the printer, fit the BOX ASSY ESS PWB to the printer by aligning the four notches with the loosened screws.
- 2) Secure the BOX ASSY ESS PWB to the printer with the five screws (silver, 6mm).

Continues to the next page.

Replacement 23 BOX ASSY ESS PWB (PL10.1.1)

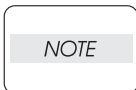
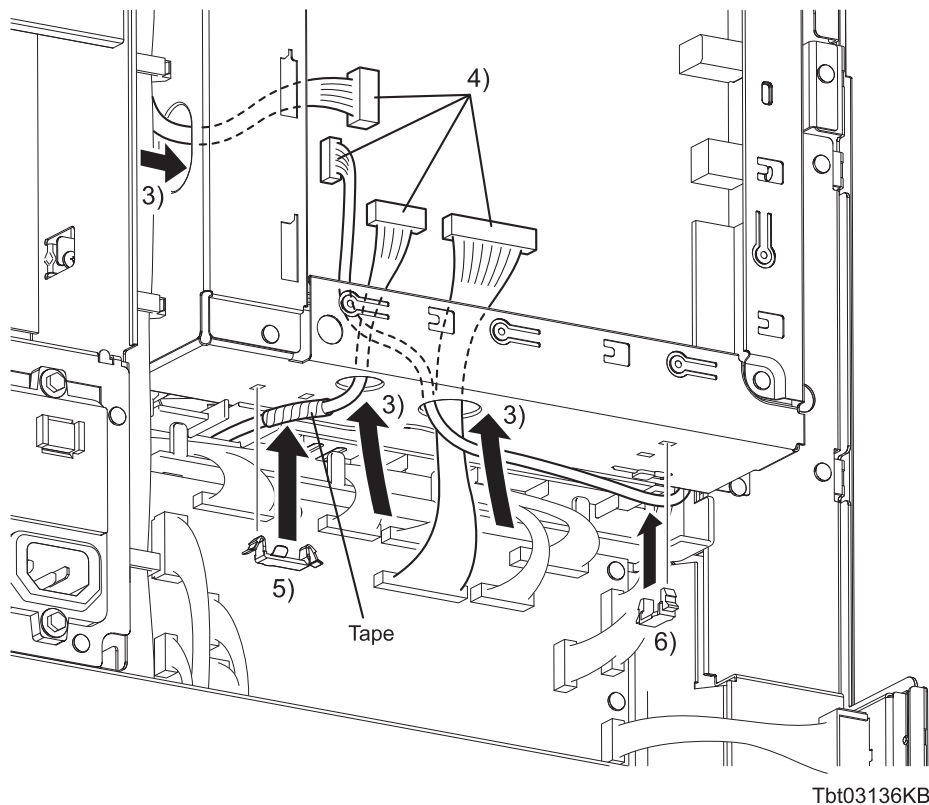

When performing the following step, use caution not to mistake the hole locations into which the respective harnesses are passed.

- 3) Put the HARNESS ASSY VIDEO, HARNESS ASSY ESS, HARNESS ASSY OPEPANE and HARNESS ASSY ESS PWR into the BOX ASSY ESS PWB through the hole in the BOX ASSY ESS PWB.
- 4) Engage all the connectors of the PWBA ESS.

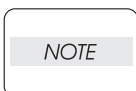

When performing the following step, secure the tape of the HARNESS ASSY VIDEO using the CLAMP PRESS REC-16.

- 5) Attach the CLAMP PRESS REC-16 to the BOX ASSY ESS PWB, and then secure the HARNESS ASSY VIDEO.
- 6) Secure the HARNESS ASSY OPEPANE with the clamp.

Continues to the next page.

Replacement 23 BOX ASSY ESS PWB (PL10.1.1)

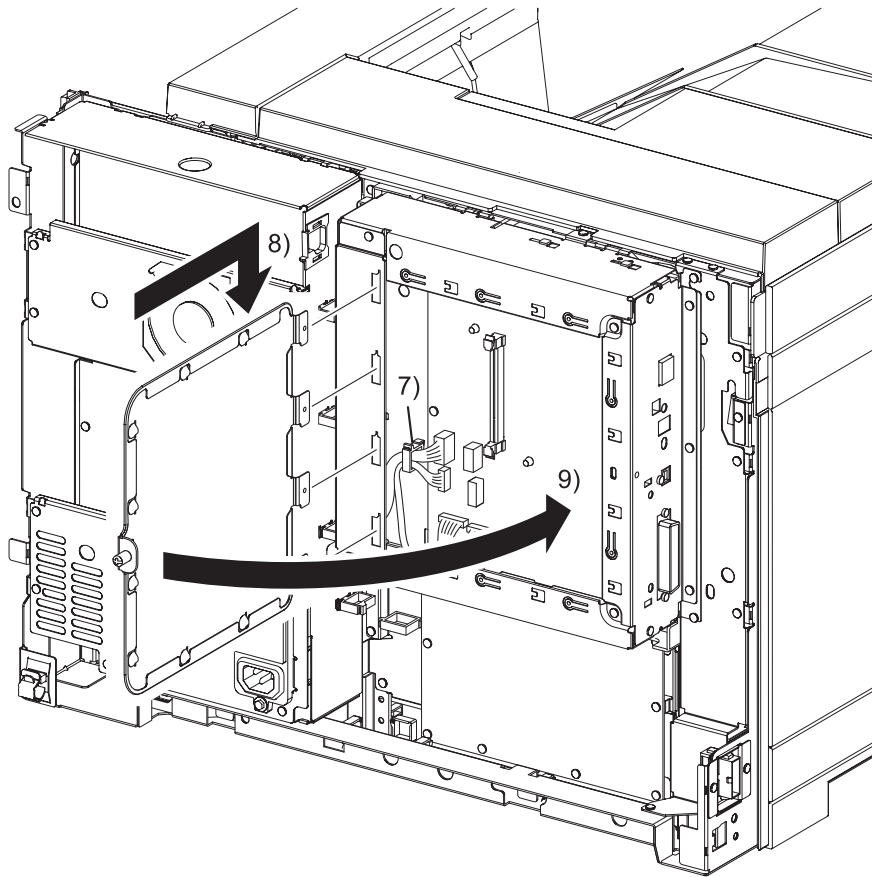

Tbt03137KA

- 7) Secure the HARNESS ASSY OPEPANE and HARNESS ASSY ESS PWR with the CLAMP LOCKING.
- 8) Engage the four tabs of PLATE WINDOW ESS to the holes of the BOX ASSY BASE with opening the PLATE WINDOW ESS.
- 9) Close the PLATE WINDOW ESS and secure the SCREW KNURLING.

Go to the next replacement step:

Replacement 43 COVER ASSY REAR (PL1.3.5)

Blank Page

Replacement 24 KIT ROS ASSY (PL5.2.99)

NOTE

Take care not to touch the window of the ROS ASSY with your hands.

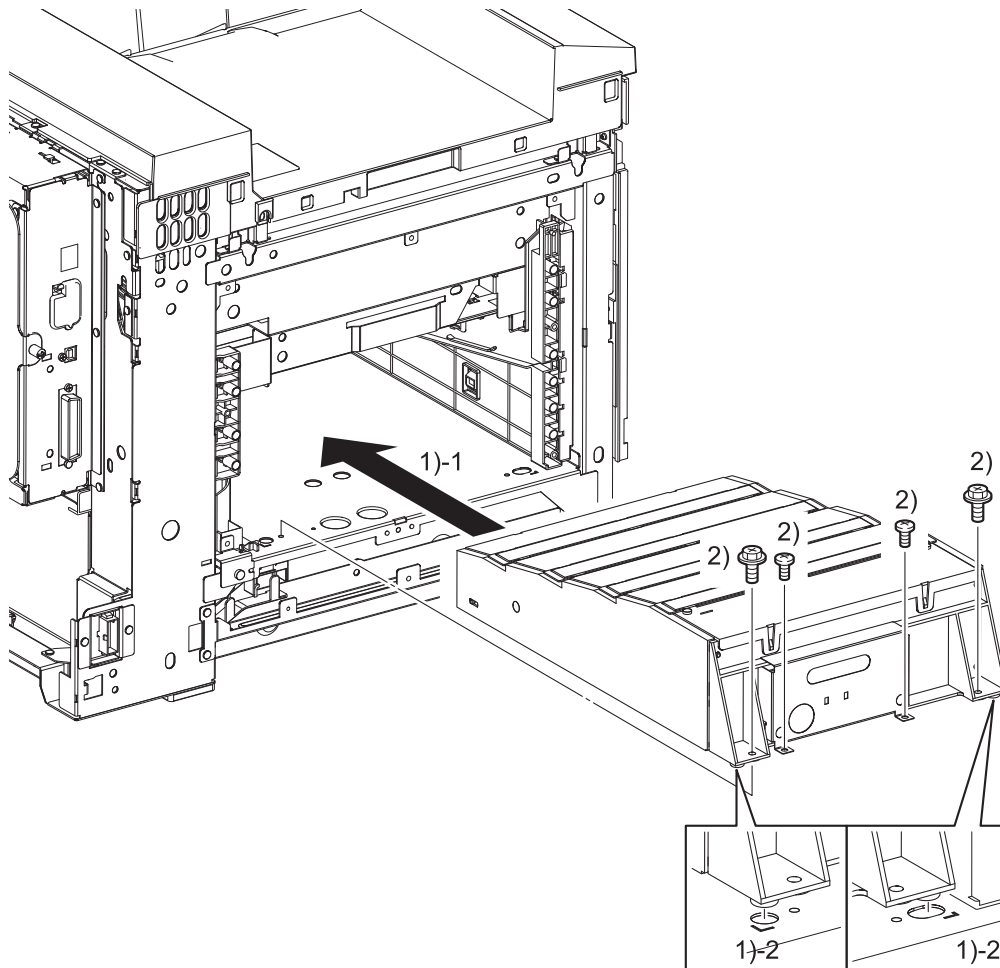

Tbt03138KA

NOTE

When performing the following step, use caution not to allow the window of the ROS ASSY to hit against the printer frame.

- 1) Inserting the ROS ASSY slowly into the printer, put the two bosses into the holes in the printer with the front and rear corners of the ROS ASSY aligned with the L marks inscribed on the printer frame.

NOTE

Since two types of screws are used for securing the ROS ASSY, ensure that the right screws are used at their right securing positions.

- 2) Secure the ROS ASSY to the printer with the two screws (silver, flanged, M4, 8mm) and two screws (silver, 6mm).

Continues to the next page.

Replacement 24 KIT ROS ASSY (PL5.2.99)

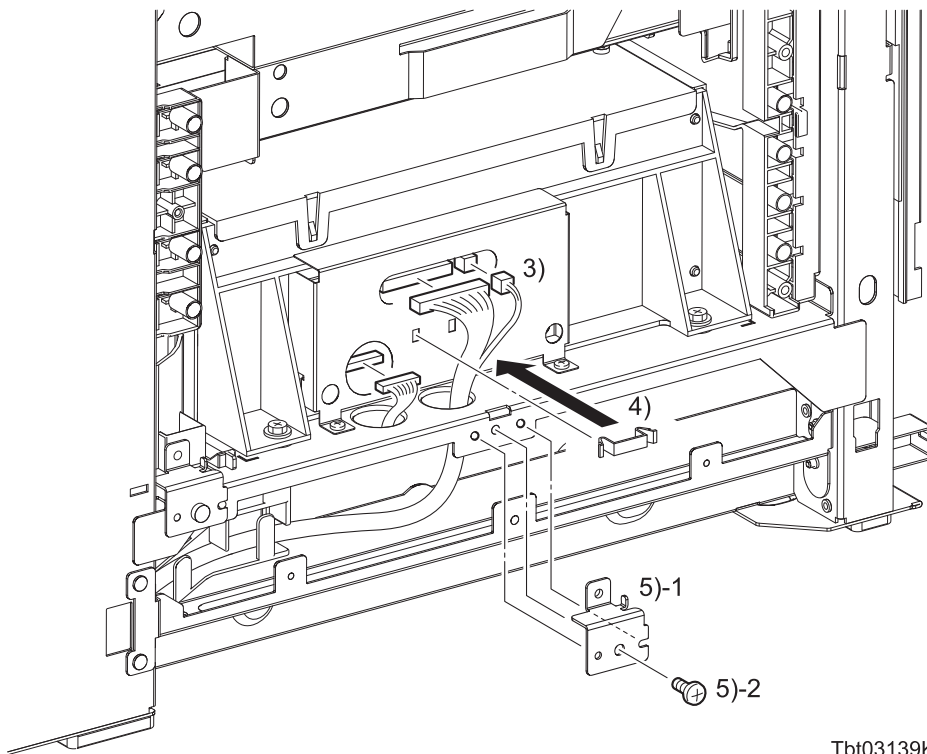

Tbt03139KA

- 3) Engage the three sets of connectors (P/J151, 152, 153) of the ROS ASSY.
- 4) Attach the CLAMP PRESS REC-14 to the ROS ASSY, and then secure the harness.
- 5) Mate the hole and notch of the PLATE HV with the bosses of the printer, and then secure with the one screw (silver, M4, 6mm).

Go to the next replacement step:

Replacement 25 PWBA HVPS (PL5.2.3)

Replacement 25 PWBA HVPS (PL5.2.3)

NOTE

Use a wrist strap to protect the PWB from electrostatic damage.

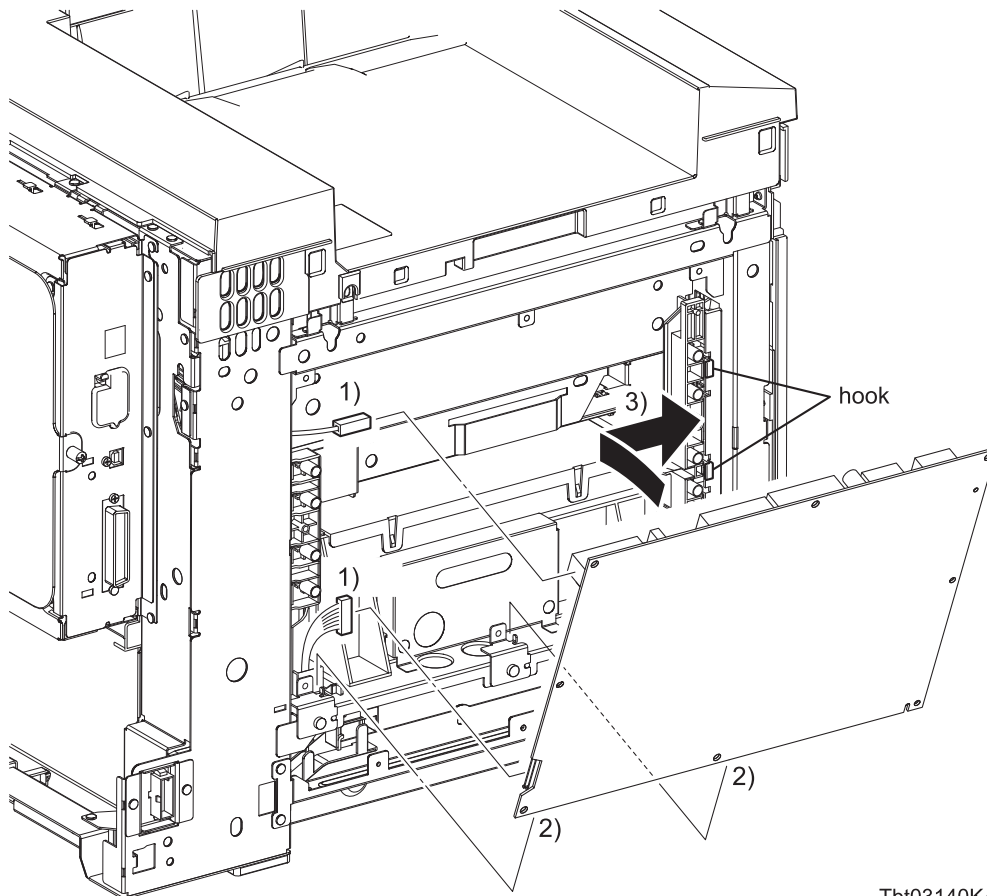

Tbt03140KA

- 1) Engage the two sets of connectors (P/J331, 332) of the PWBA HVPS.
- 2) Put the lower side of the PWBA HVPS into the space between the two tabs on the PLATE HV.
- 3) Secure the front side of the PWBA HVPS with the two hooks of the HOUSING ASSY CR, while taking care not to bend the springs of the HOUSING ASSY CR and HOUSING ASSY BTR (PL5.2.6).

NOTE

Check to be sure that the respective terminals of the PWBA HVPS are in secure contact with the springs of the HOUSING ASSY CR and HOUSING ASSY BTR.

Continues to the next page.

Replacement 25 PWBA HVPS (PL5.2.3)

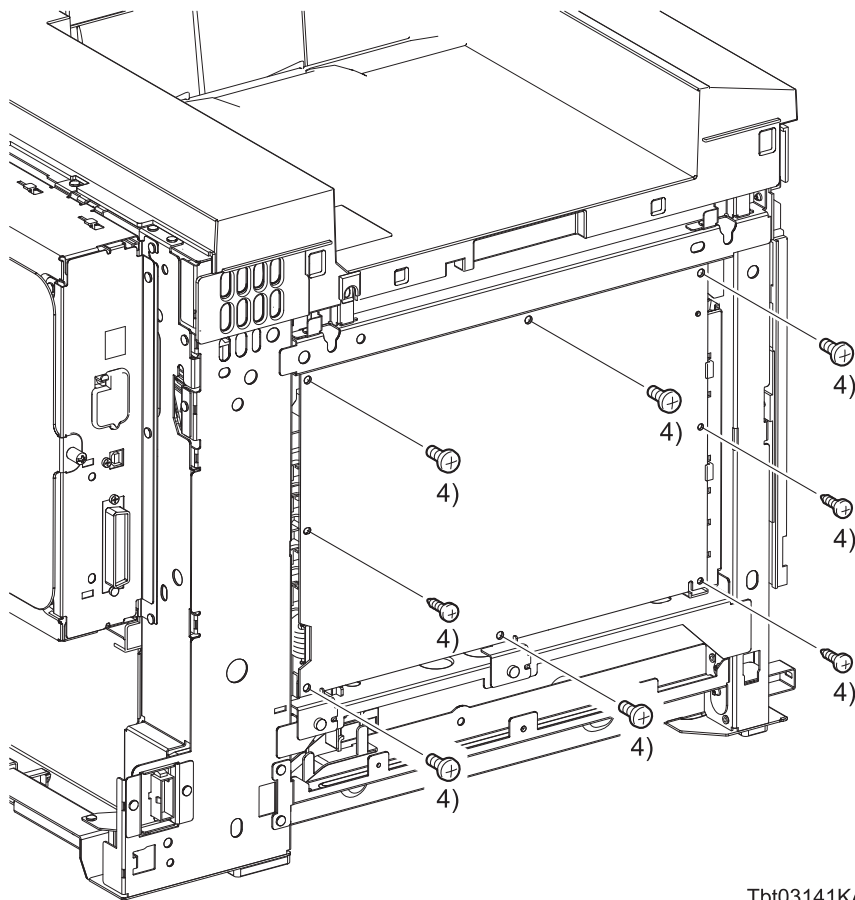

Tbt03141KA

NOTE

Since two types of screws are used for securing the PWBA HVPS, ensure that the right screws are used at their right securing positions.

- 4) Secure the PWBA HVPS to the printer with the five screws (silver, M4, 6mm) and three screws (silver, tapping, 8mm).

**Go to the next replacement step:
Replacement 29 COVER LH ASSY (PL1.3.2)**

Replacement 26 COVER FR UNDER (PL8.1.16)

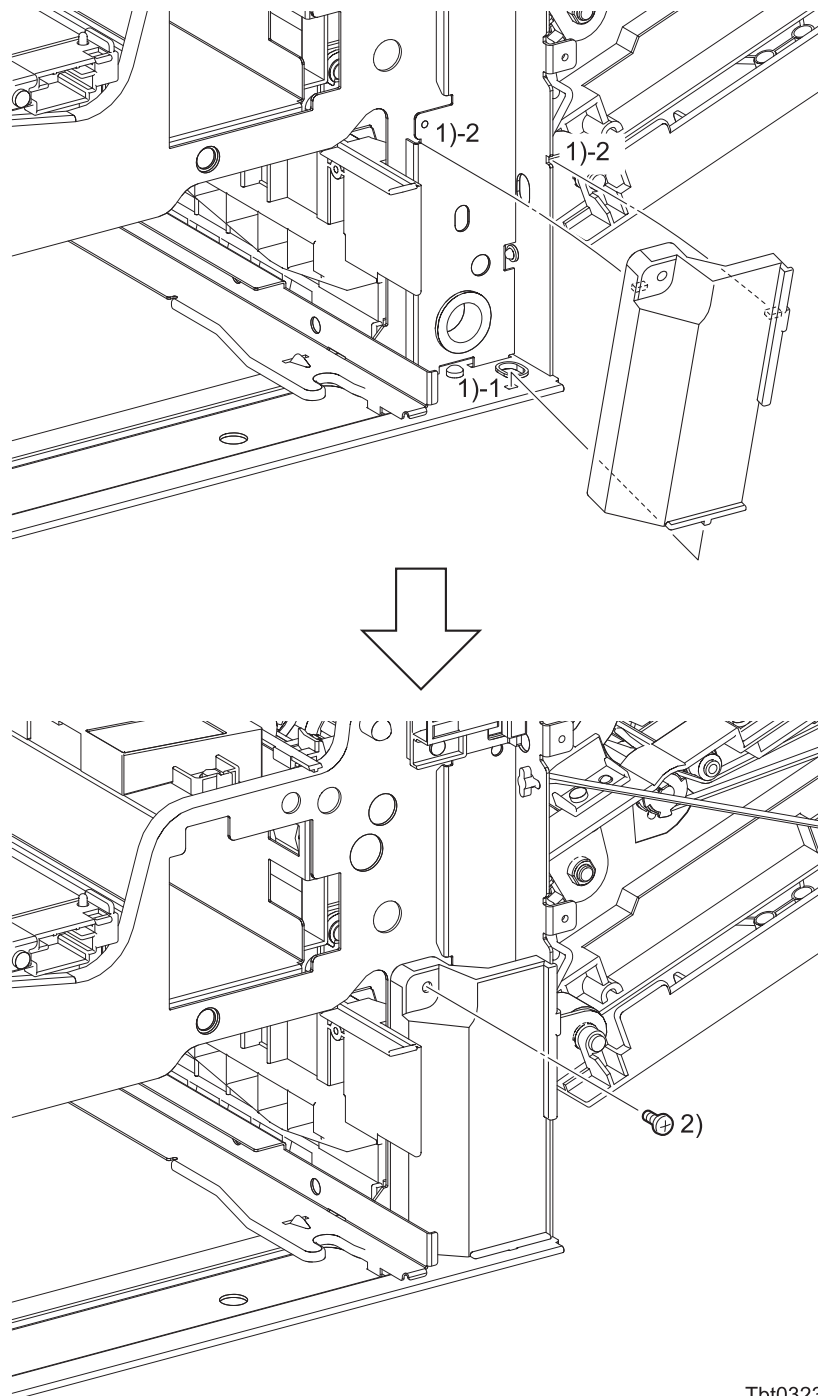

Tbt03230KA

- 1) Replace the COVER FR UNDER by fitting its bottom tab into the hole of the printer and fitting the two tabs on its backside into the notches of the printer.
- 2) Secure the COVER FR UNDER to the printer with the one screw (silver, 6mm).

Go to the next replacement step:

Replacement 28 COVER ASSY INNER FRONT (PL1.2.6)

Replacement 27 SWITCH (Front Cover Switch) (PL1.2.3)

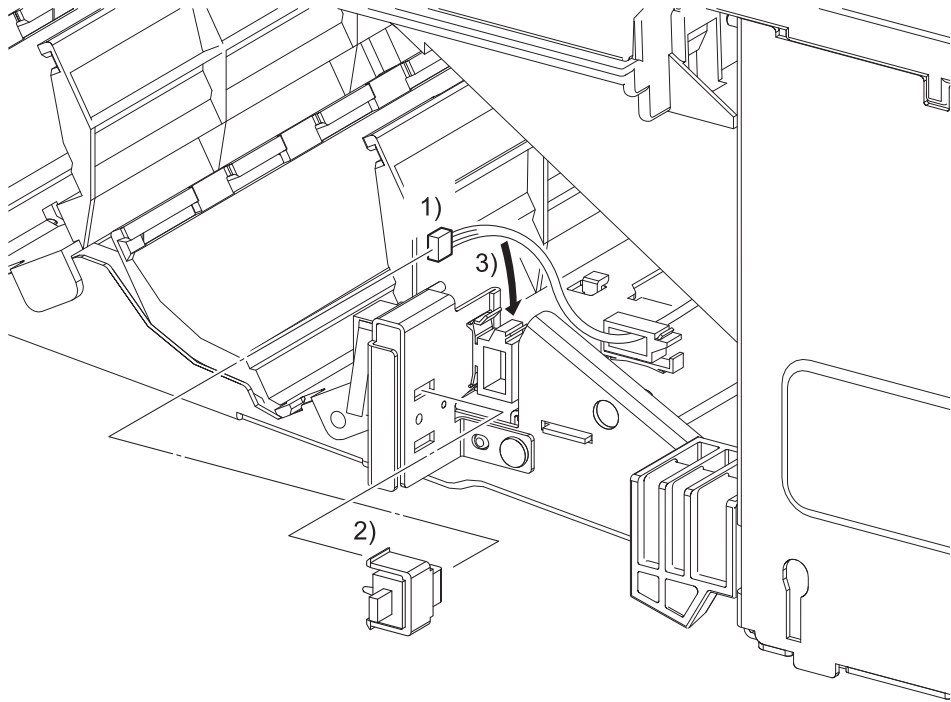

Tbt03142KA

- 1) Engage the connectors (P/J212) of the SWITCH.
- 2) Replace the SWITCH to the printer, and then secure with the two hooks.
- 3) Secure the harness of the SWITCH with the clamp.

Go to the next replacement step:

Replacement 28 COVER ASSY INNER FRONT (PL1.2.6)

Replacement 28 COVER ASSY INNER FRONT (PL1.2.6)

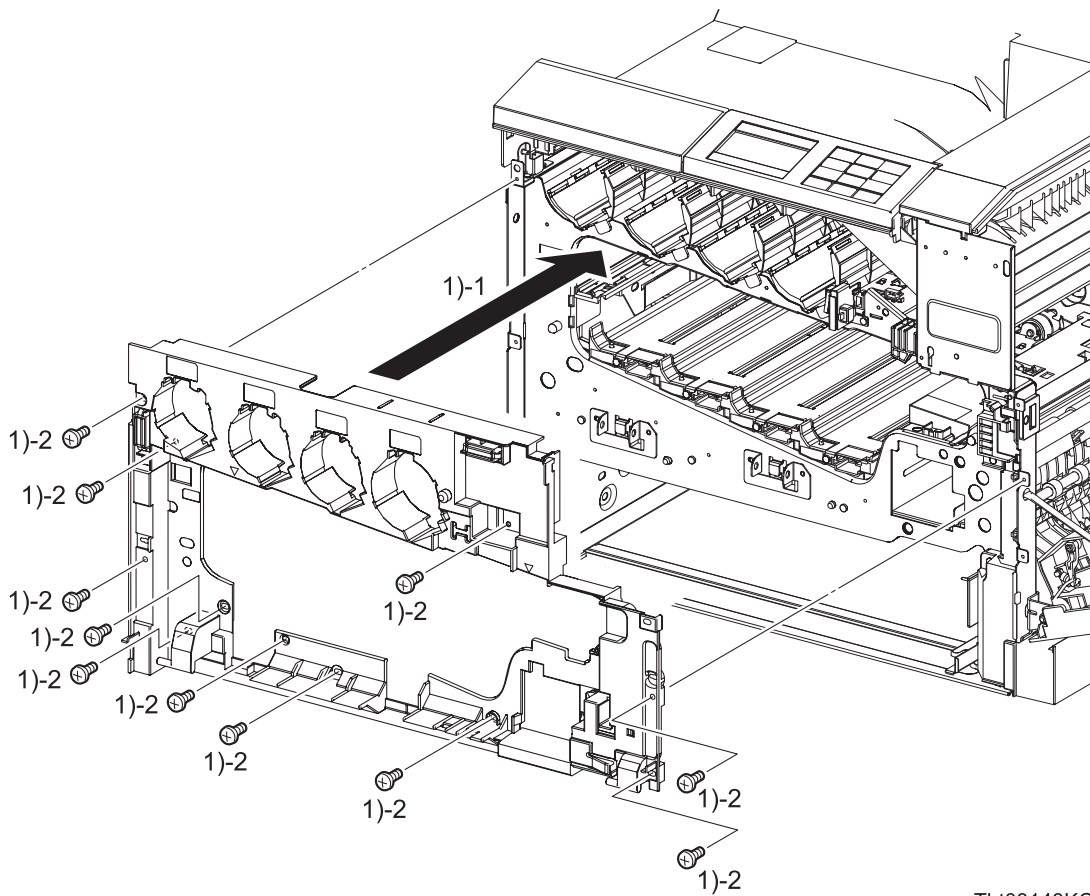

Tbt03143KC

- 1) Replace the COVER ASSY INNER FRONT to the printer, and then secure with the eleven screws (silver, 6mm).

Go to the next replacement step:

Replacement 45 COVER FRONT RH (PL1.2.5)

Blank Page

Replacement 29 COVER LH ASSY (PL1.3.2)

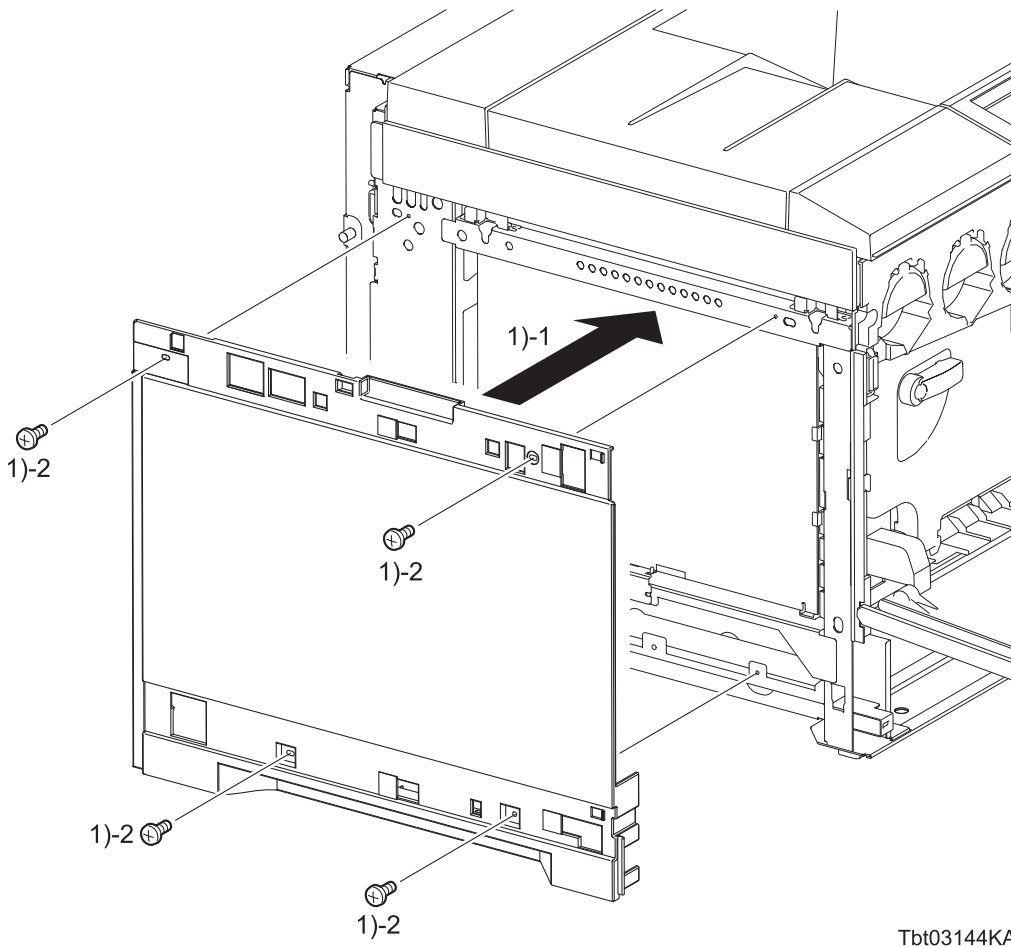

Tbt03144KA

- 1) Replace the COVER LH to the printer, and then secure with the four screws (silver, 6mm).

Continues to the next page.

Replacement 29 COVER LH ASSY (PL1.3.2)

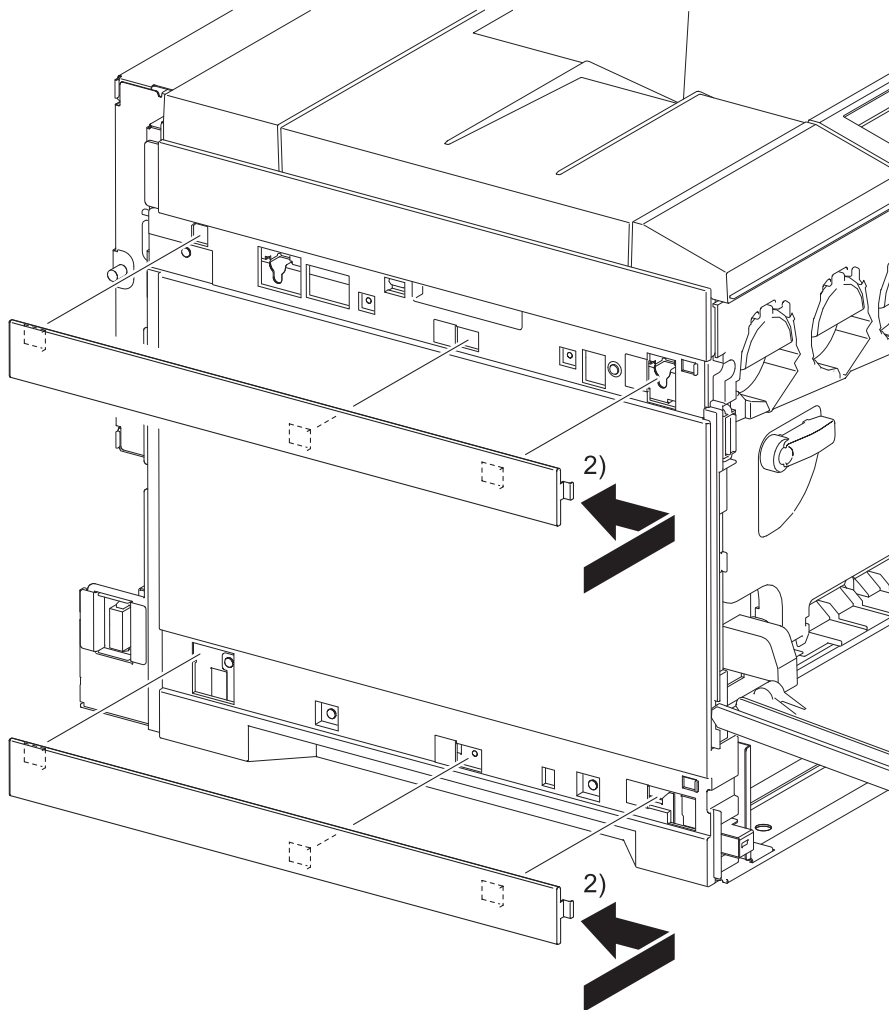

Tbt03145KA

NOTE

Install the COVER LH FINISHERs to the two locations; one is the upper part and the other is the lower part.

- 2) Install the COVER LH FINISHER on the printer with its three hooks fitted into the holes in the printer. Slide the COVER LH FINISHER to the rear side to secure it there.

Go to the next replacement step:

Replacement 43 COVER ASSY REAR (PL1.3.5)

Replacement 30 PLATE ASSY LVPS POWER (PL10.1.12)

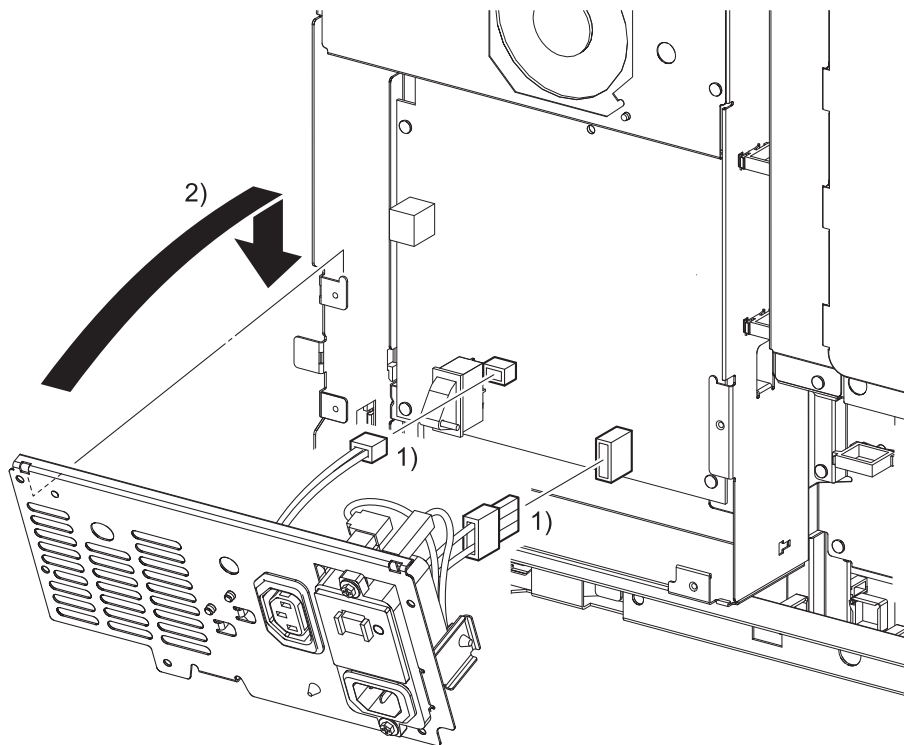

Tbt03146KB

- 1) Engage the two sets of connectors (P/J300, 311) of the PLATE ASSY LVPS POWER to the LVPS ASSY.
- 2) Install the PLATE ASSY LVPS POWER in position with its two holes hooked over the tabs of the printer.

Continues to the next page.

Replacement 30 PLATE ASSY LVPS POWER (PL10.1.12)

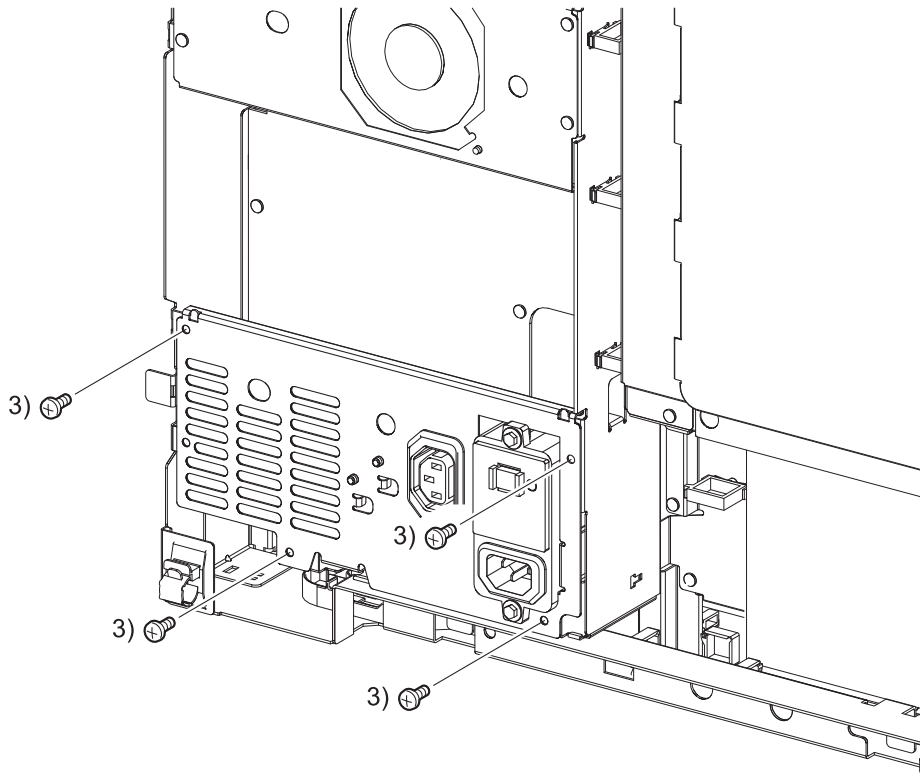

Tbt03147KB

- 3) Secure the PLATE ASSY LVPS POWER to the printer with the four screws (silver, 6mm).

Go to the next replacement step:

Replacement 43 COVER ASSY REAR (PL1.3.5)

Replacement 31 FAN ASSY LVPS (PL10.1.9)

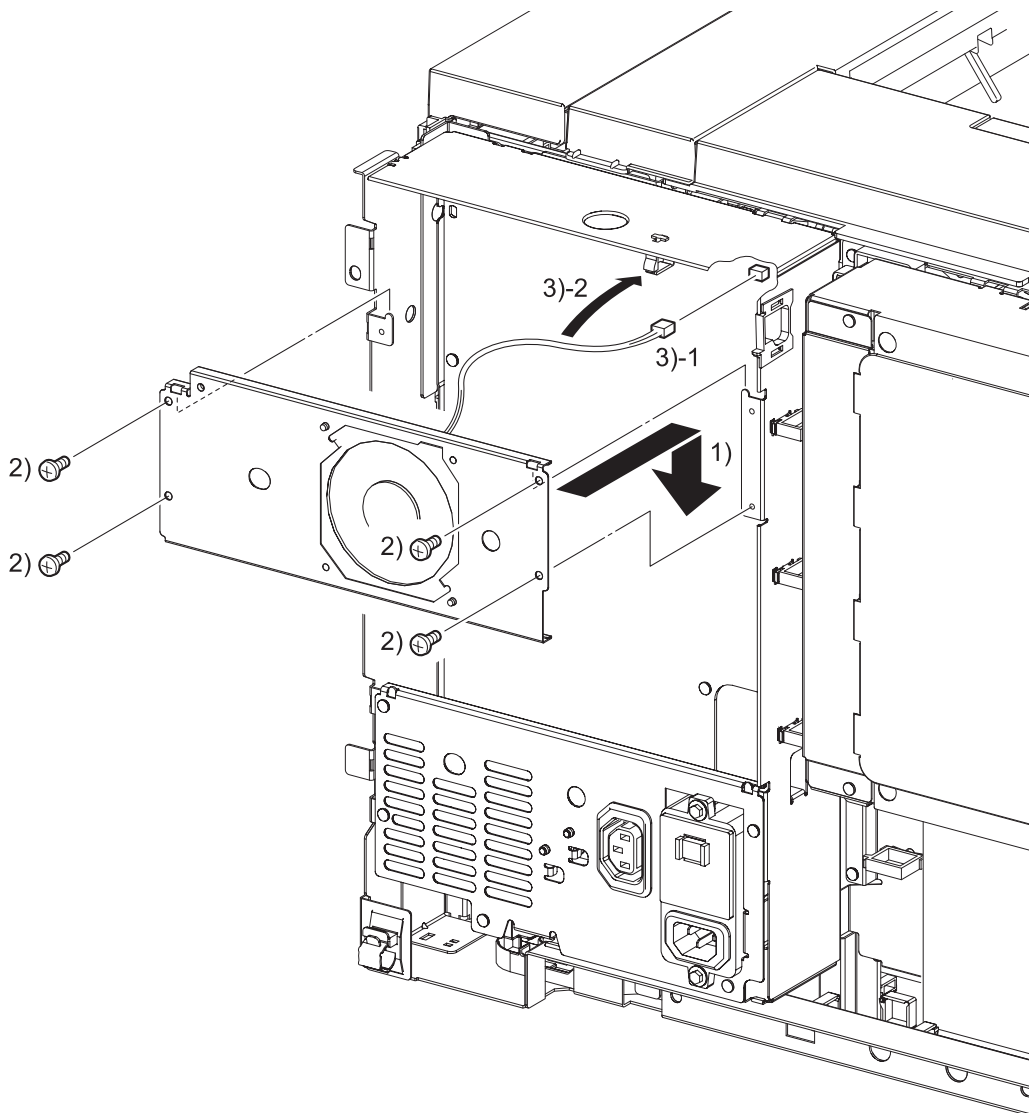

Tbt03148KB

- 1) Install the FAN ASSY LVPS in position with its two holes hooked over the tabs of the printer.
- 2) Secure the FAN ASSY LVPS to the printer with the four screws (silver, 6mm).
- 3) Engage the connectors (P/J309) of the FAN LVPS, and then secure the harness of the FAN LVPS with the clamp of the BOX ASSY LVPS.

Go to the next replacement step:

Replacement 43 COVER ASSY REAR (PL1.3.5)

Blank Page

Replacement 32 KIT PWBA MCU (PL10.2.99)

NOTE

Use a wrist strap to protect the PWB from electrostatic damage.

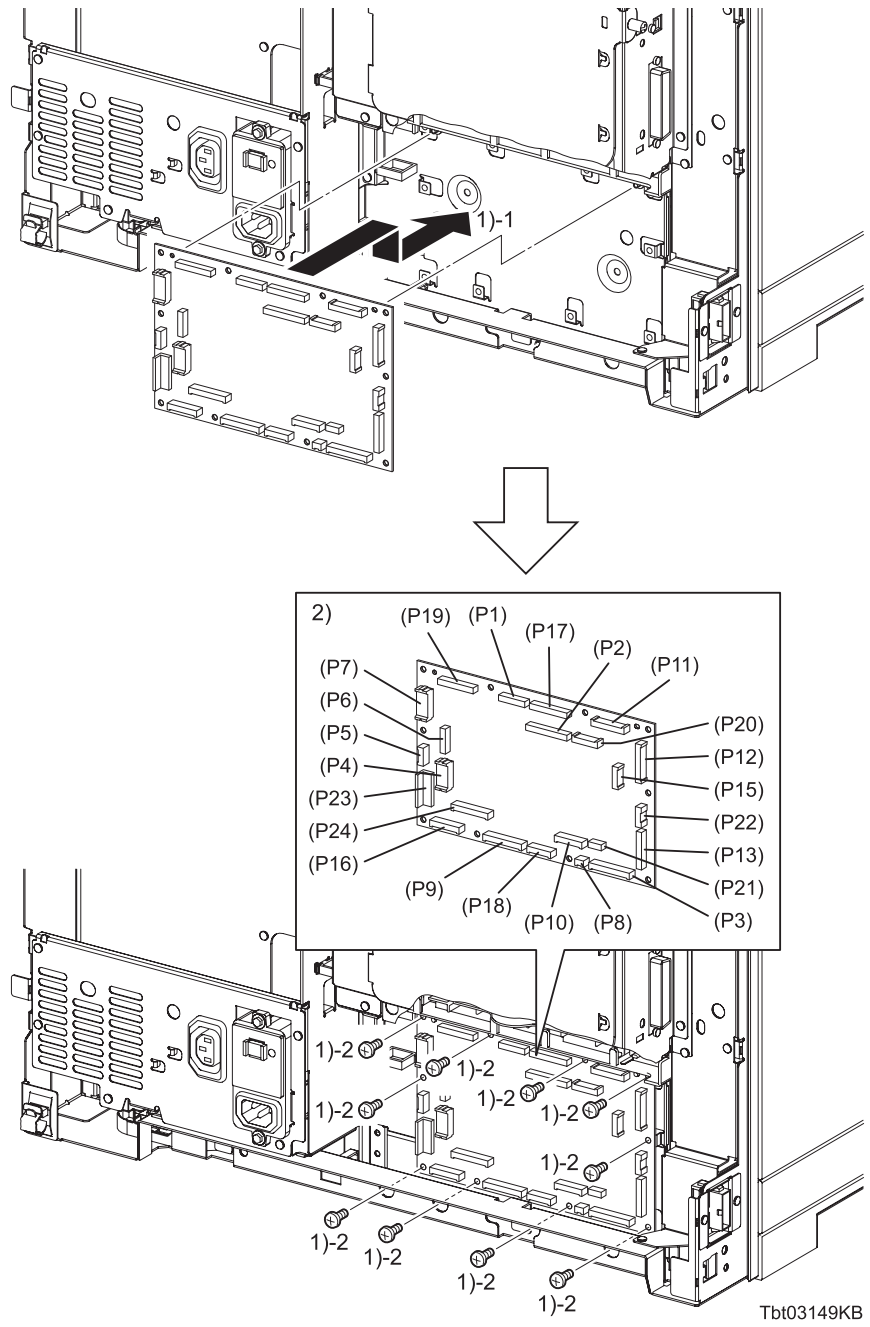

- 1) Mate the two holes of the PWBA MCU with the bosses of the GUIDE HARNESS MCU UPR (PL10.2.17), and then secure with the ten screws (silver, 6mm).
- 2) Engage all the connectors of the PWBA MCU.

**Go to the next replacement step:
Replacement 43 COVER ASSY REAR (PL1.3.5)**

Continues to the next page.

Replacement 32 KIT PWBA MCU (PL10.2.99)

NOTE

When the PWBA MCU is replaced with a new one, perform the following steps.
(After completing all steps up to Replacement 61.)

- 3) Plug in the power cord to the outlet, and power on the printer.
- 4) Perform the diagnostic operation of NVM Load, and write the data into MCU.
- 5) Turn on the power while pressing the "▶" key, "◀" key and the [MENU] key on the control panel.
- 6) Enter the password, push the "▲" key twice and push the "✓" key once. The diagnostic screen comes up.
- 7) Press the "▼" key several times until "IOT Diag" is displayed. Press the "✓" key once.
- 8) Press the "▼" key several times until "NVM Settings" is displayed. Press the "✓" key once.
- 9) Press the "▼" key several times until "LoadNVM from ESS" is displayed. Press the "✓" key once.
- 10) Press the "✓" key twice, and LoadNVM from ESS is performed.
- 11) After the LoadNVM from ESS is complete, press the [CANCEL] key several times until "IOT Diag" is displayed.
- 12) Press the "▼" key several times until "Complete" is displayed.
- 13) Press the "✓" key three times, and "Ready to Print" is displayed.

Replacement 33 KIT PLATE ASSY ESS (PL10.1.99)

NOTE

Use a wrist strap to protect the PWB from electrostatic damage.

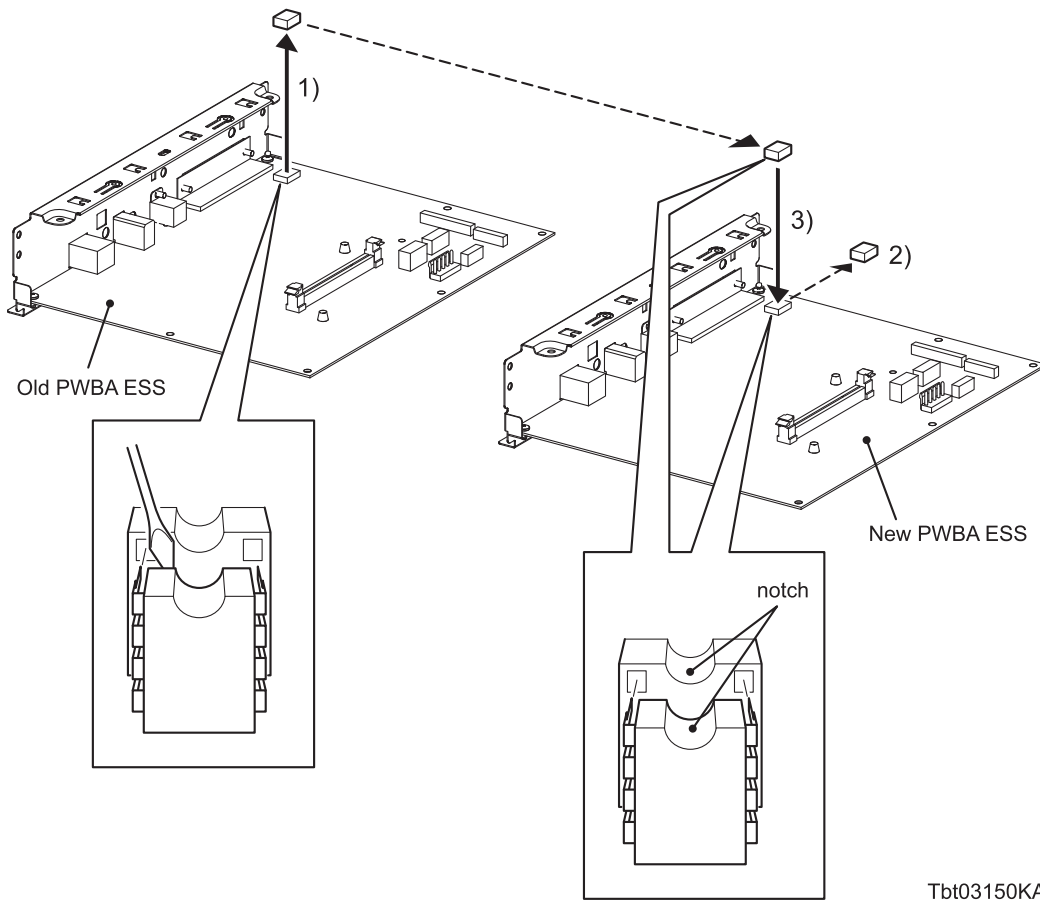

Tbt03150KA

NOTE

The replacement steps of procedure 1) to 3) are to be required for changing the PLATE ASSY ESS. Those steps are not required for only removing it.

NOTE

Avoid applying excessive pressure when removing and replacing the ROM chips.

NOTE

Take care not to bend the terminal section of ROM when carrying out the job described below.

1) Remove the ROM, using a miniature screwdriver or the like, from the IC sockets on old PWBA ESS that was removed from the printer.

2) Remove the ROM from IC socket on new PWBA ESS using a miniature screwdriver or the like.

NOTE

Do not use ROM removed from new PWBA ESS.

3) Attach the ROM that were removed from old PWBA ESS on IC sockets of new PWBA ESS with its notch aligned with the notch in IC socket.

Continues to the next page.

Replacement 33 KIT PLATE ASSY ESS (PL10.1.99)

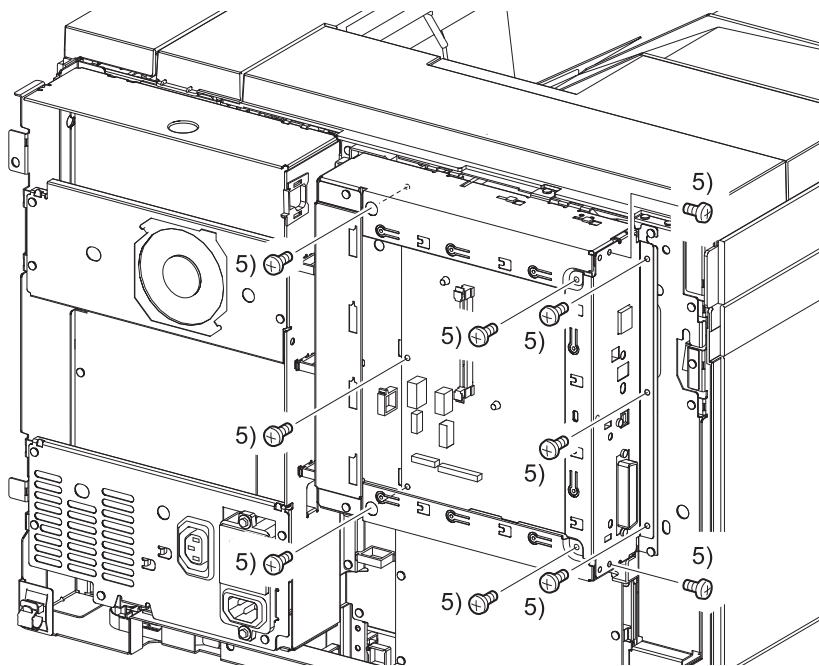
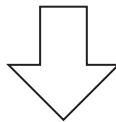
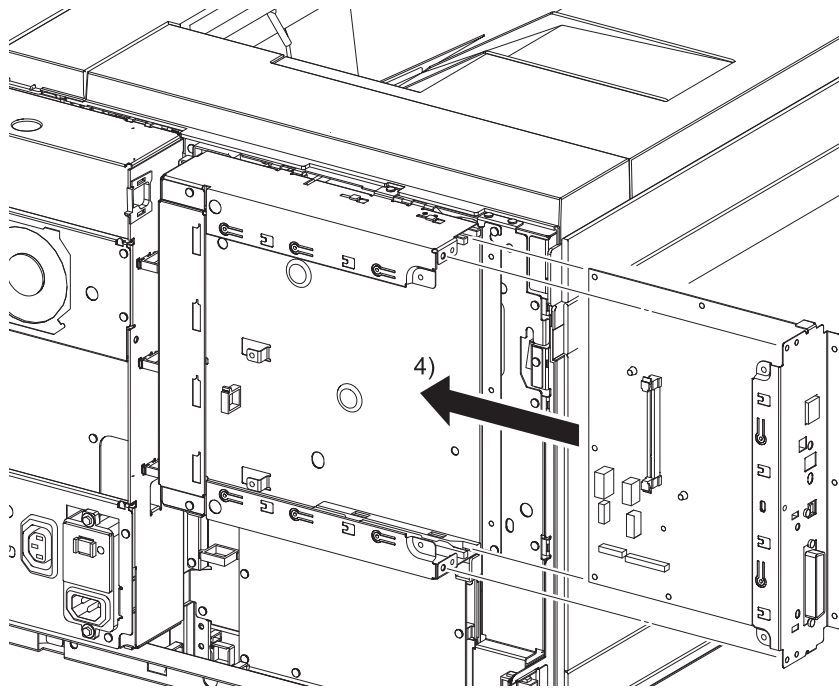

Tbt03151KB

- 4) Inserting the PLATE ASSY ESS into the upper and lower GUIDE BOAD ESS (PL10.1.28), align the two holes in the PLATE ASSY ESS with the bosses of the BOX ASSY BASE.
- 5) Secure the PLATE ASSY ESS to the printer with the ten screws (silver, 6mm).

Continues to the next page.

Replacement 33 KIT PLATE ASSY ESS (PL10.1.99)

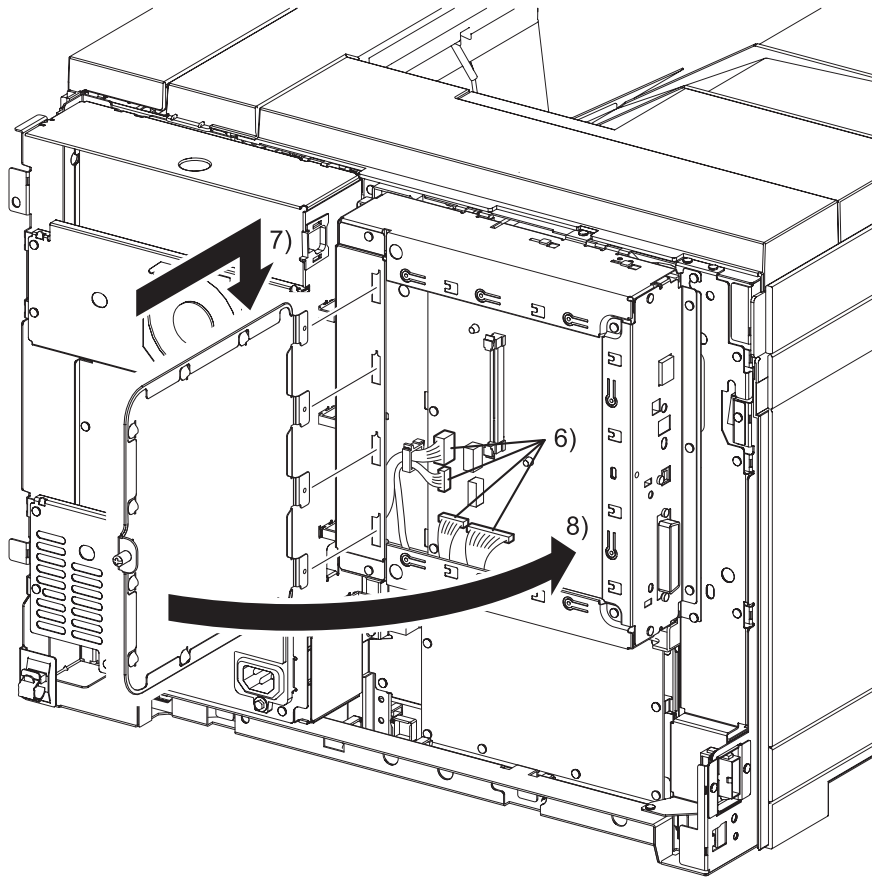

Tbt03152KA

- 6) Engage all the connectors of the PWBA ESS.
- 7) Engage the four tabs of PLATE WINDOW ESS to the holes of the BOX ASSY BASE with opening the PLATE WINDOW ESS.
- 8) Close the PLATE WINDOW ESS and secure the SCREW KNURLING.

Go to the next replacement step:

Replacement 43 COVER ASSY REAR (PL1.3.5)

Blank Page

Replacement 34 FEEDER ASSY (PL3.2.1)

Reference: To prevent misplacement of the clutches in the FEEDER ASSY, the initial letters ("W", "Y", "B") of the color of the connector for clutches (White/Yellow/Blue) are engraved on the frame.

Example of CST Feed Clutch:

The CST Feed Clutch whose connector color is "White" must be installed on the frame at the position where "W" is engraved.

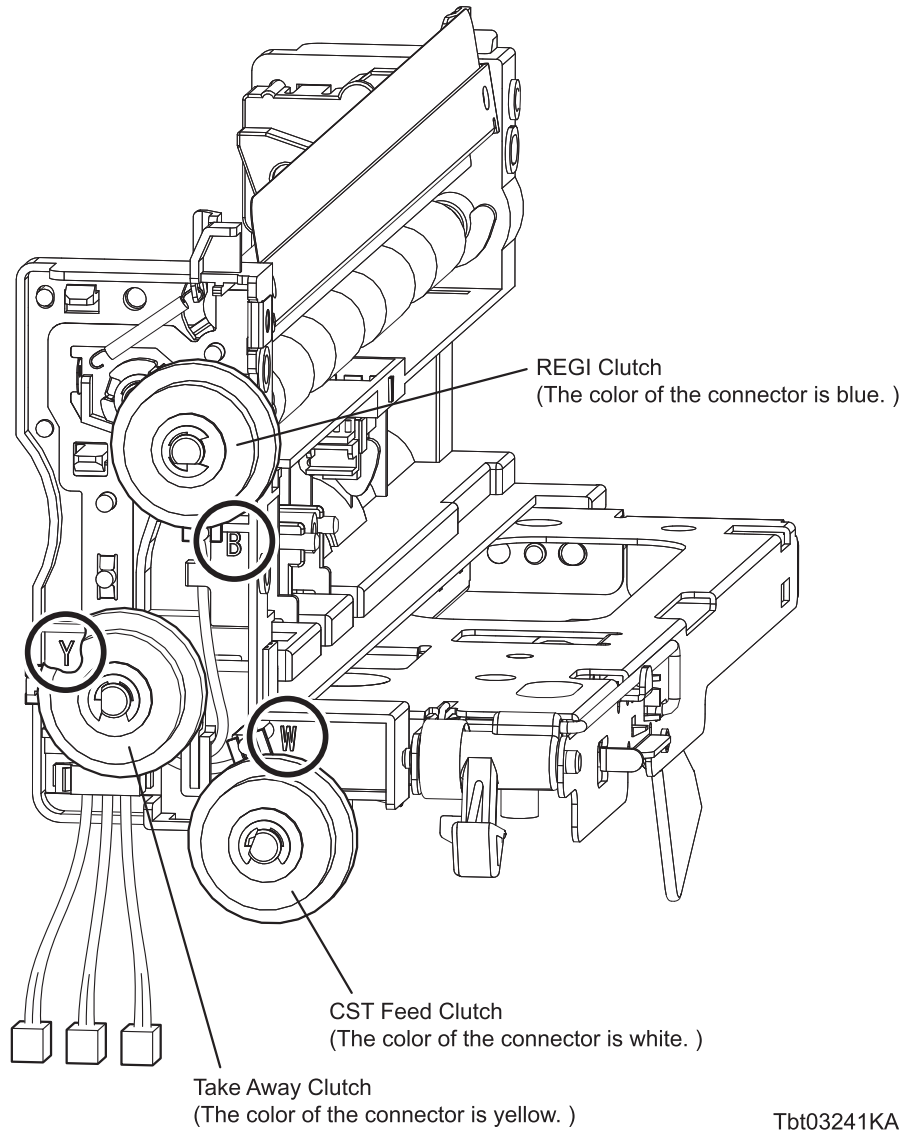

Tbt03241KA

Continues to the next page.

Replacement 34 FEEDER ASSY (PL3.2.1)

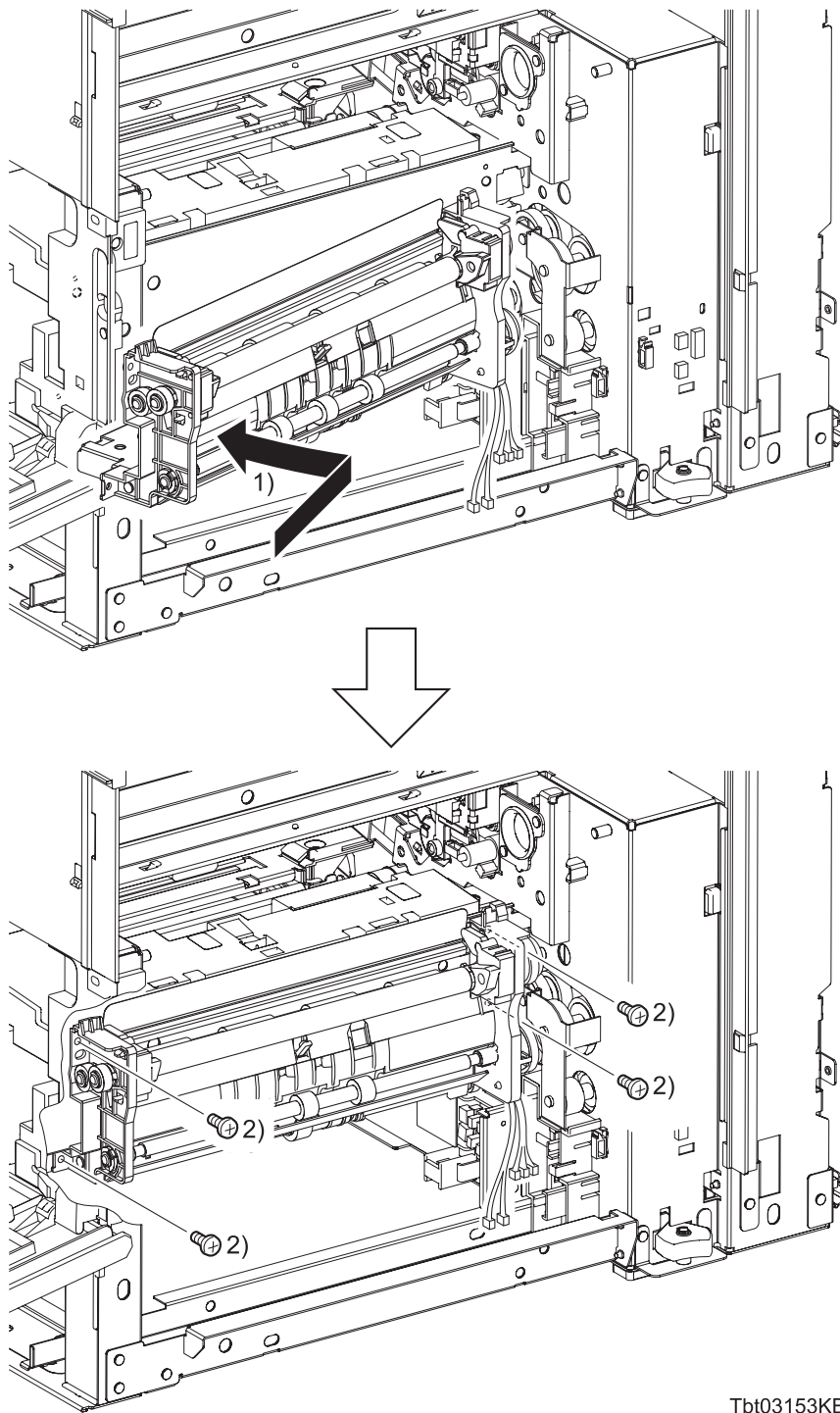

Tbt03153KB

- 1) Replace the FEEDER ASSY by engaging the three clutches on its rear side with the gears of the DRIVE ASSY PH and mating the two holes on the FEEDER ASSY with the bosses on the printer.
- 2) Secure the FEEDER ASSY to the printer with the four screws (silver, 6mm).

Continues to the next page.

Replacement 34 FEEDER ASSY (PL3.2.1)

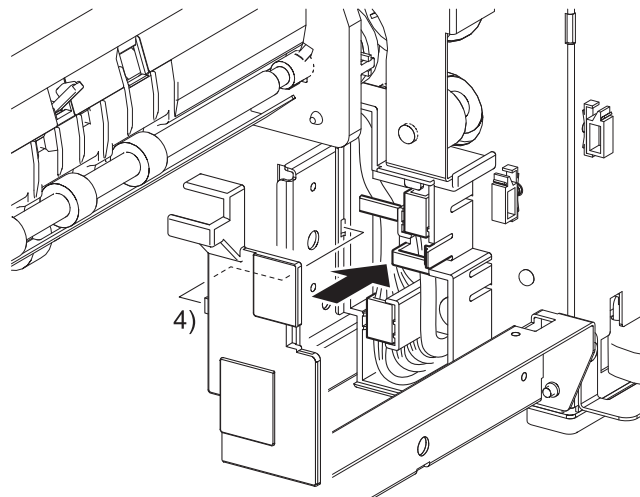
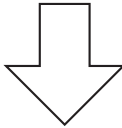
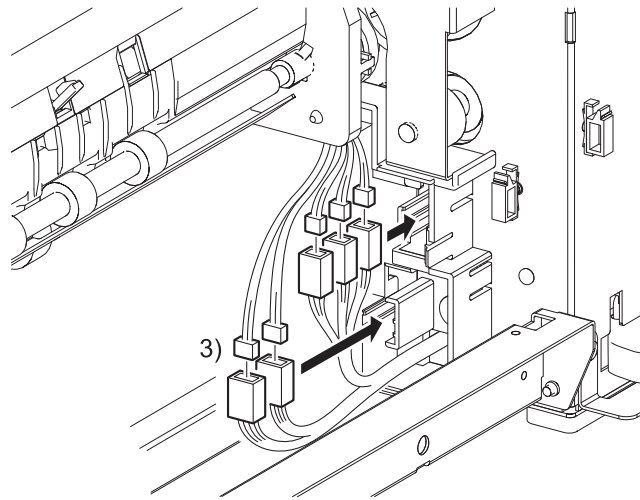

Tbt03154KB

NOTE

When performing the following steps, engage the connectors of the same color.

The CST Feed Clutch connector is 2-pin white connector.

The REGI Clutch connector is 2-pin blue connector.

The Take Away Clutch connector is 2-pin yellow connector.

The REGI Sensor connector is 3-pin white connector.

The CST No Paper Sensor connector is 3-pin yellow connector.

- 3) Engage all the connectors, put them in the GUIDE HARNESS, and route all the harnesses to the GUIDE HARNESS.

NOTE

When performing the following step, use caution to prevent the harness from being caught between the GUIDE HARNESS and the COVER GUIDE HARNESS and to prevent the COVER GUIDE HARNESS from rising.

- 4) Insert the tab on the COVER GUIDE HARNESS into the GUIDE HARNESS, and then secure with the hook.

Continues to the next page.

Replacement 34 FEEDER ASSY (PL3.2.1)

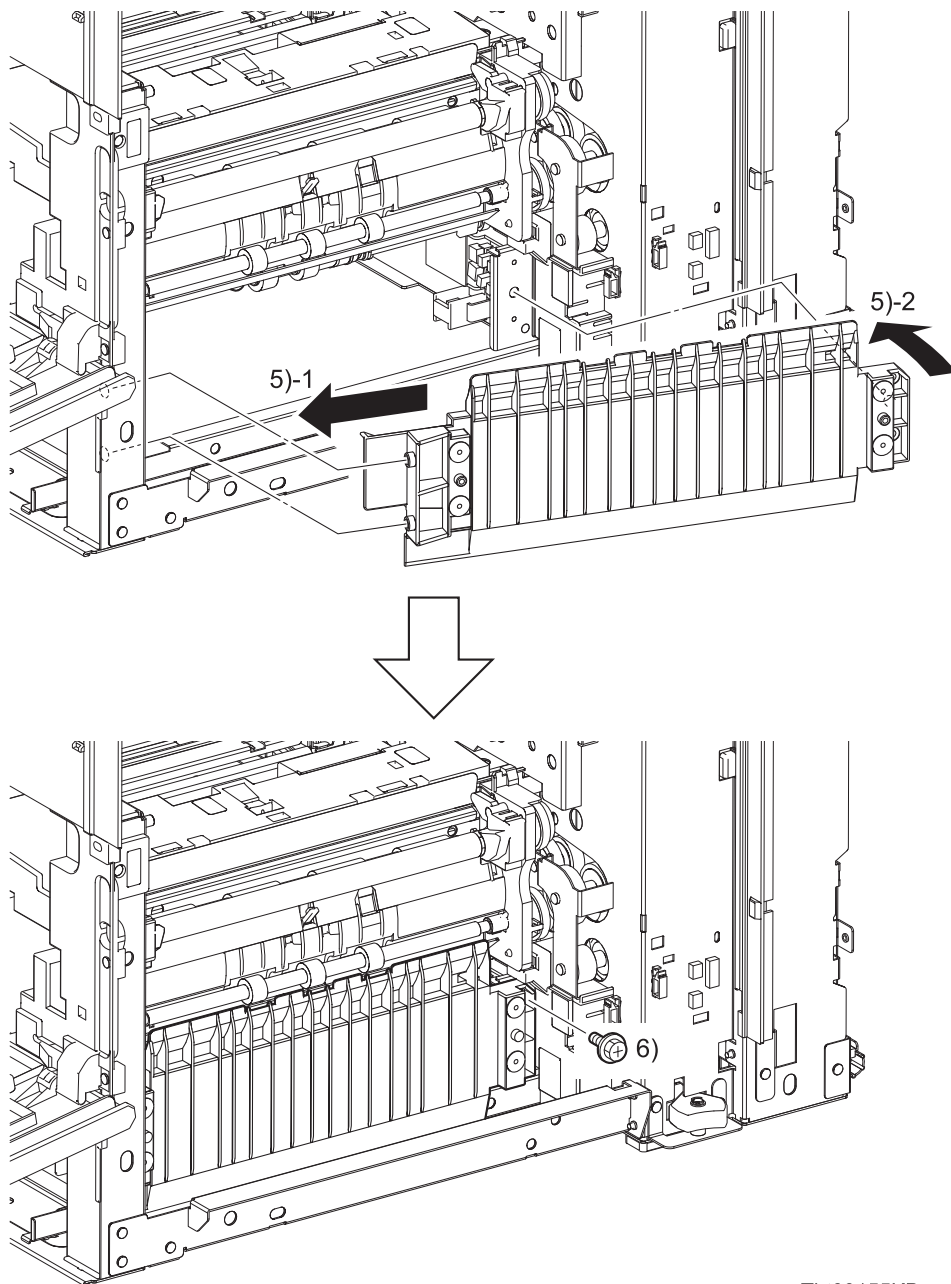

Tbt03155KB

- 5) Insert the two bosses on the front side of the GUIDE TRAY into the holes in the printer. Then, insert the boss on the rear side of the GUIDE TRAY into the mating hole to attach the GUIDE TRAY to the printer.
- 6) Secure the GUIDE TRAY to the printer with the one screw (silver, flanged, 6mm).

Go to the next replacement step:

Replacement 35 SEPARATOR ASSY MSI (PL3.1.7)

Replacement 35 SEPARATOR ASSY MSI (PL3.1.7)

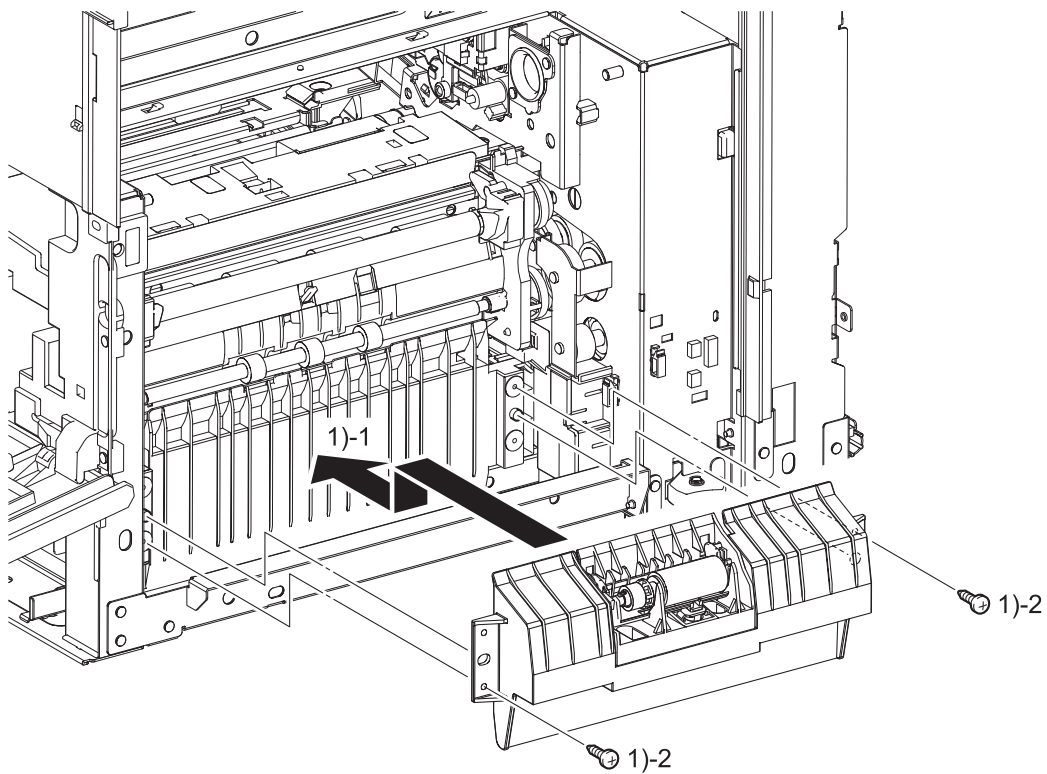

Tbt03156KB

- 1) Mate the two holes of the SEPARATOR ASSY MSI with the bosses of the printer, and then secure with the two screws (silver, tapping, 8mm).

Go to the next replacement step:

Replacement 39 KIT RH COVER & FRAME ASSY (PL4.1.99)

Blank Page

Replacement 36 COVER ASSY RH (PL4.1.31)

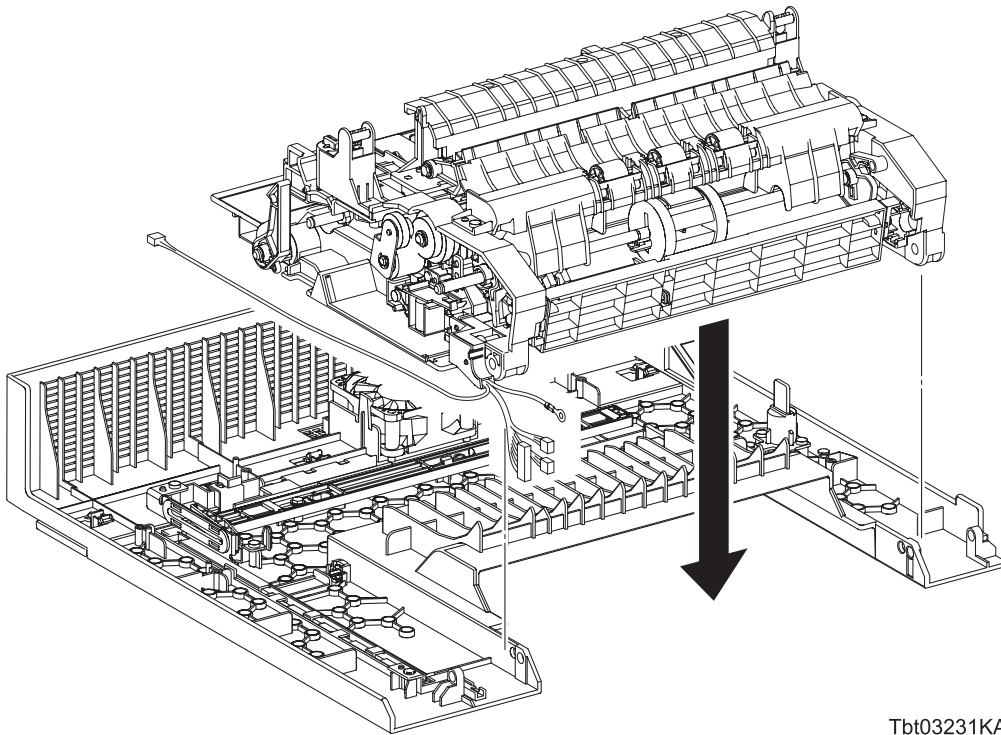

Tbt03231KA

- 1) Fit the COVER ASSY RH to the FRAME RH with the holes for the SHAFT PIVOTs aligned.

Continues to the next page.

Replacement 36 COVER ASSY RH (PL4.1.31)

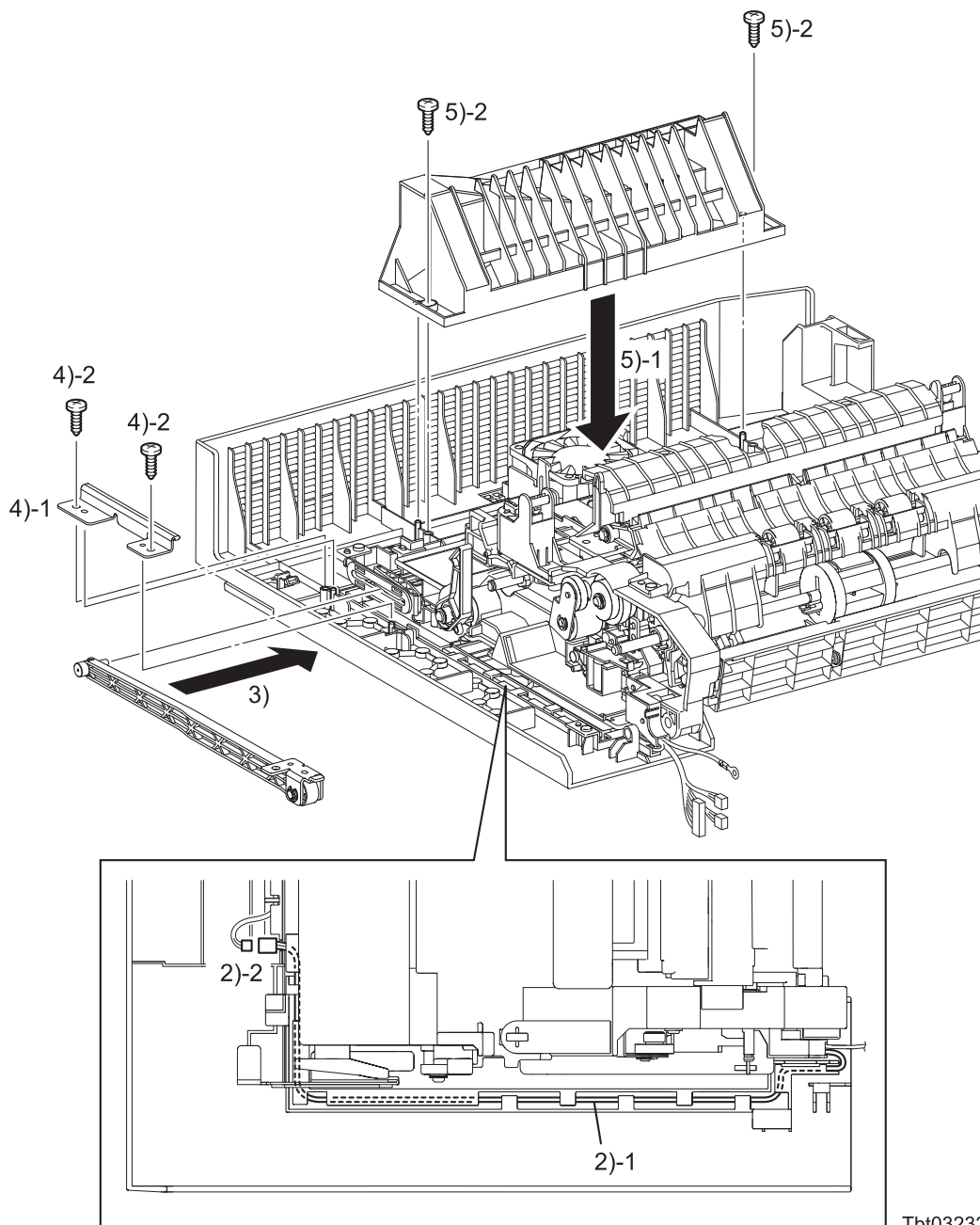

Tbt03232KA

- 2) Route the HARNESS ASSY RH COVER through the hooks of the GUIDE HARNESS RH FAN, and then engage the connectors (P/J119) of the FAN FUSER.
- 3) Install the LINK ASSY to the COVER ASSY RH by fitting the shaft of the LINK ASSY into the GUIDE SUPPORT LINK.
- 4) Mate the two holes of the GUIDE SLIDE LATCH with the bosses of the COVER ASSY RH, and then secure with the two screws (silver, tapping, 8mm).
- 5) Mate the two holes of the CHUTE DUP RH with the bosses of the COVER ASSY RH, and then secure with the two screws (silver, tapping, 8mm).

Continues to the next page.

Replacement 36 COVER ASSY RH (PL4.1.31)

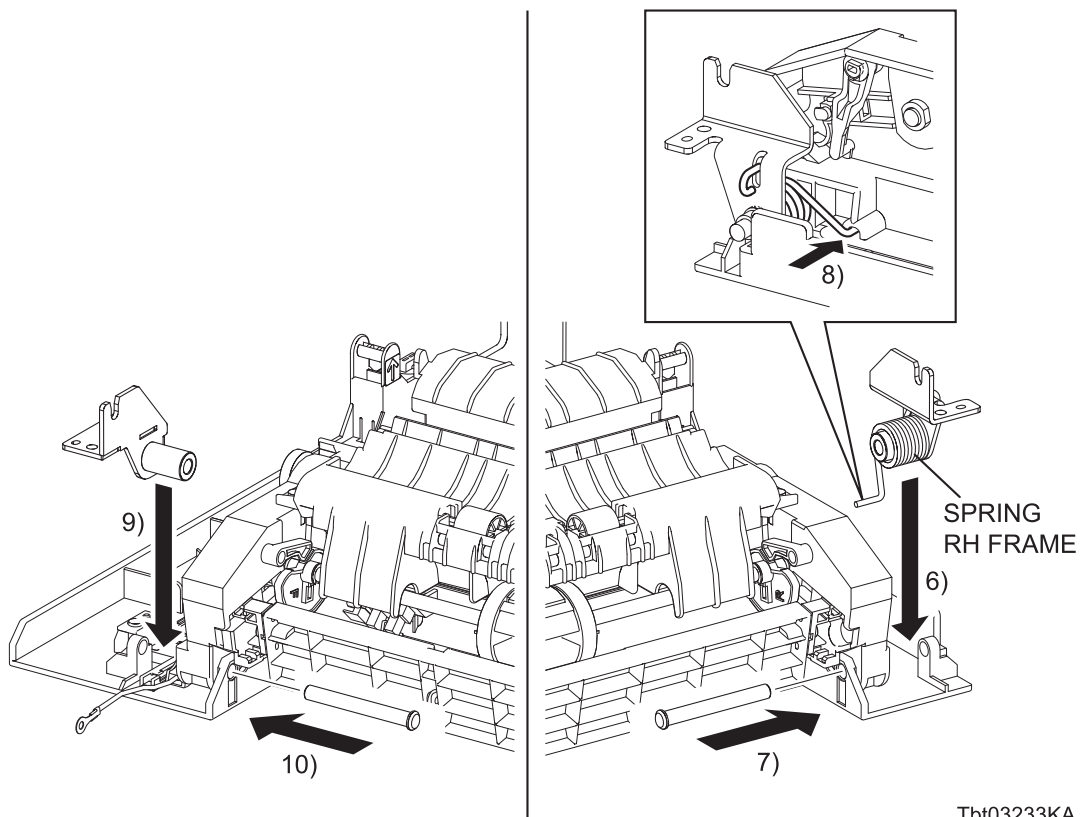

Tbt03233KA

- 6) Fit the SPRING RH FRAME to the stud of the BRACKET ASSY PIVOT FRONT, and then fit the BRACKET ASSY PIVOT FRONT to the COVER ASSY RH.
- 7) Insert the SHAFT PIVOT from the inside of the COVER ASSY RH so that it passes through the holes on the COVER ASSY RH, FRAME RH, and BRACKET ASSY PIVOT FRONT.
- 8) Fit the SPRING RH FRAME into the FRAME RH.
- 9) Fit the BRACKET ASSY PIVOT REAR to the COVER ASSY RH.
- 10) Secure the COVER ASSY RH by inserting the SHAFT PIVOT from the inside of the COVER ASSY RH so that it passes through the holes on COVER ASSY RH, FRAME RH, and BRACKET ASSY PIVOT REAR.

Go to the next replacement step:

Replacement 44 KIT COVER ASSY MSI (PL4.1.98)

Blank Page

Replacement 37 CAM MSI (PL4.2.16)

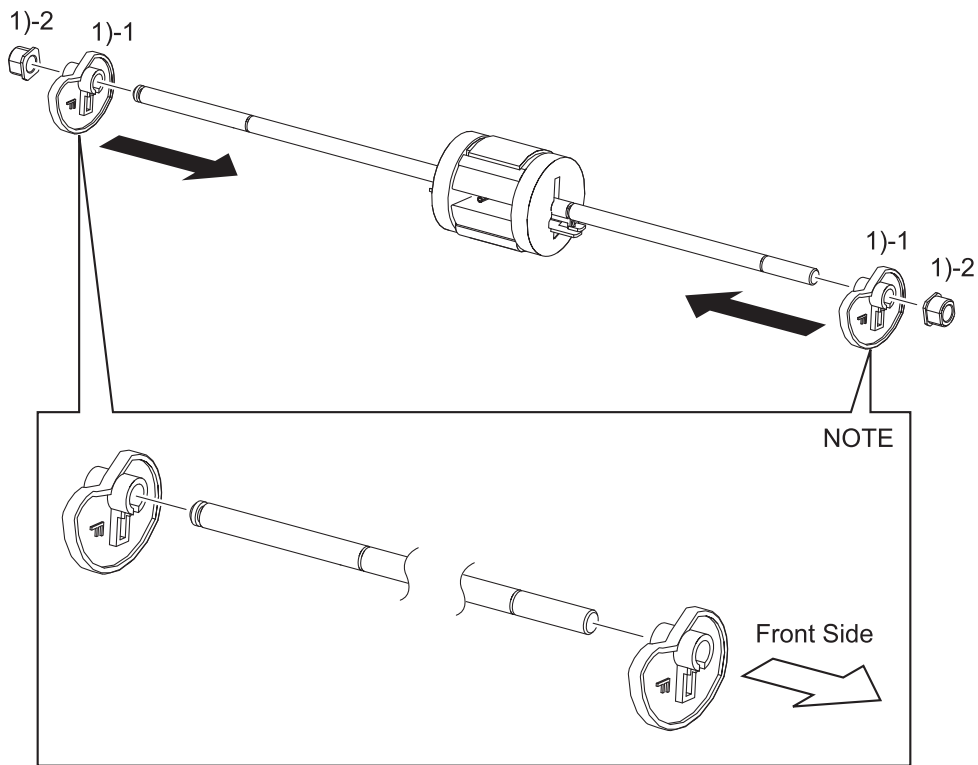

Tbt03234KA

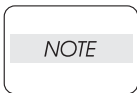

Ensure that the side marked with [F] faces frontward when installing the CAM MSI.

- 1) Fit the front and rear BEARING EARTHs and CAM MSIs onto the SHAFT ASSY MSI.

Continues to the next page.

Replacement 37 CAM MSI (PL4.2.16)

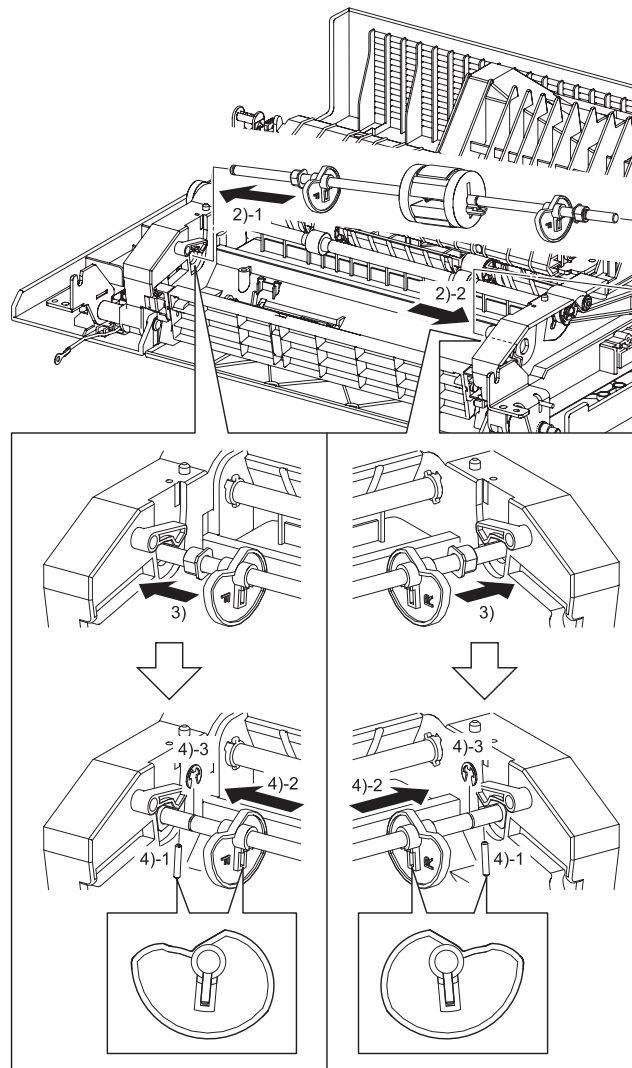

Tb103235KA

NOTE

When performing the following step, use caution not to drop and lose the BEARING EARTH.

- 2) Install the SHAFT ASSY MSI to the FRAME RH by fitting the rear end into the pivot hole on the FRAME RH and then fitting the front end likewise.
- 3) Slide the front and rear BEARING EARTHS outward until they fit into the pivot holes on the FRAME RH.

NOTE

The step described below is common to the front and rear sides.

NOTE

When performing the following step, use caution not to drop and lose the PIN MSI.

- 4) Insert PIN MSI into the hole on the SHAFT ASSY MSI, slide the CAM MSI outward with its slit aligned with the PIN MSI, and secure with one E-ring.

Continues to the next page.

Replacement 37 CAM MSI (PL4.2.16)

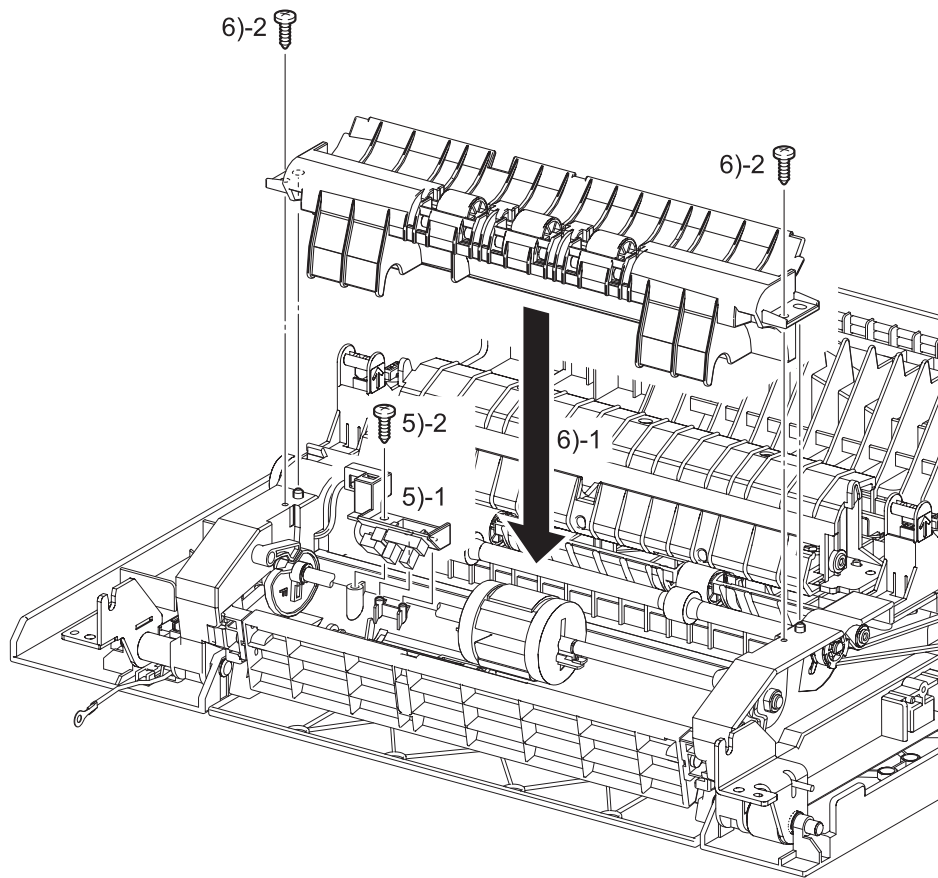

Tbt03236KA

- 5) Mate the two holes of the BRACKET SENSOR with the bosses of the FRAME RH, and then secure with the one screw (silver, tapping, 8mm).
- 6) Mate the tow holes of the CHUTE ASSY MSI with the bosses of the FRAME RH, and then secure with the two screws (silver, tapping, 8mm).

Continues to the next page.

Replacement 37 CAM MSI (PL4.2.16)

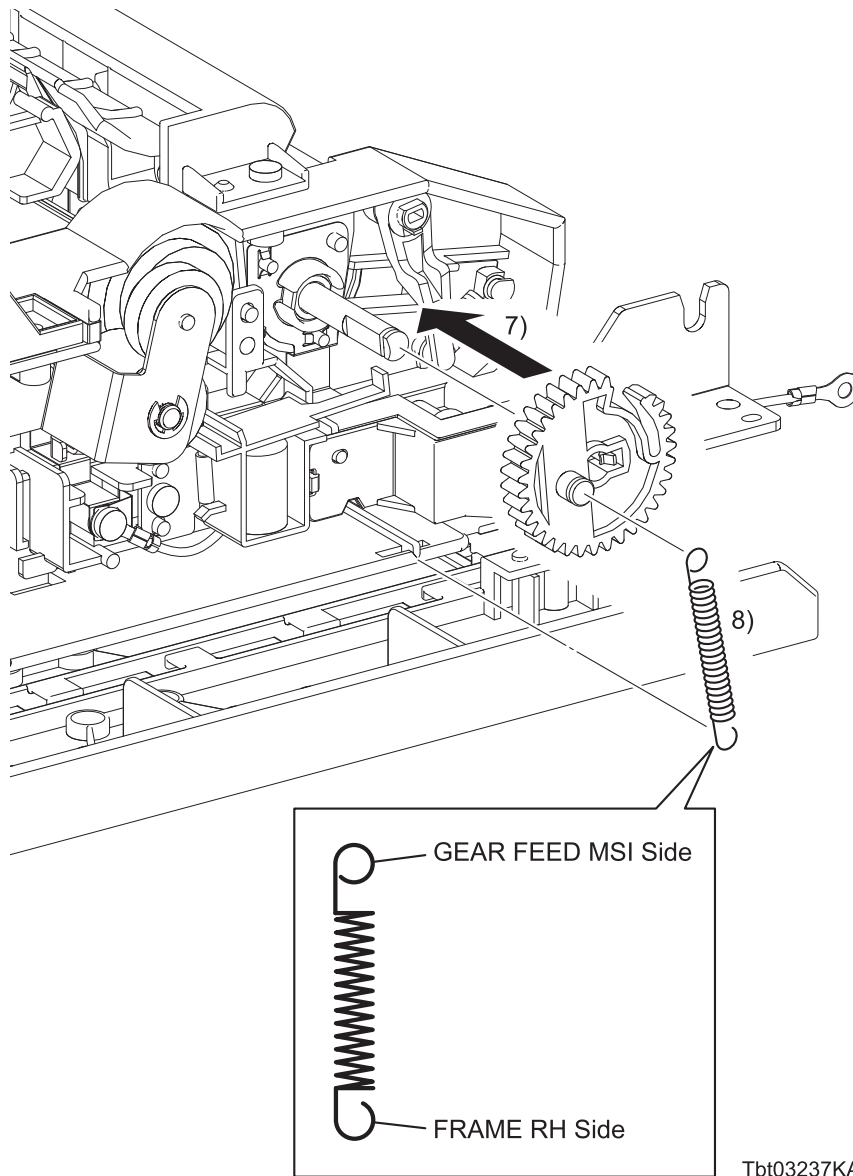

- 7) Attach the GEAR FEED MSI to the SHAFT ASSY MSI, and then secure the groove of the SHAFT ASSY MSI with the hook of the GEAR FEED MSI.

NOTE

Ensure that the SPRING FEED MSI is oriented to the direction shown in the right.

- 8) Hang the SPRING FEED MSI to the GEAR FEED MSI and FRAME RH.

Go to the next replacement step:

Replacement 39 KIT RH COVER & FRAME ASSY (PL4.1.99)

Replacement 38 KIT RH SOLENOID, GEAR & CLUTCH (PL4.2.99)

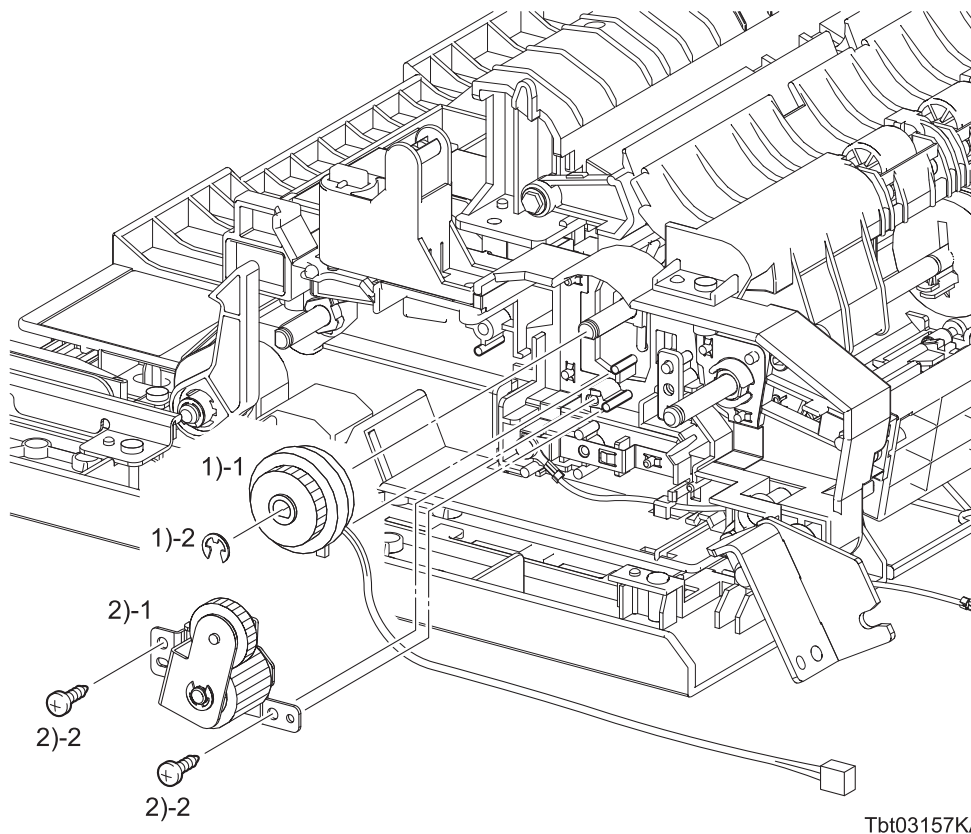

- 1) Mate the notch of the CLUTCH ASSY DUP with the boss of the FRAME RH, and then secure the CLUTCH ASSY DUP to the lower ROLL ASSY DUP with the E-ring.
- 2) Mate the two holes of the GEAR ASSY DUP with the bosses of the FRAME RH, and then secure with the two screws (silver, tapping, 8mm).

Continues to the next page.

Replacement 38 KIT RH SOLENOID, GEAR & CLUTCH (PL4.2.99)

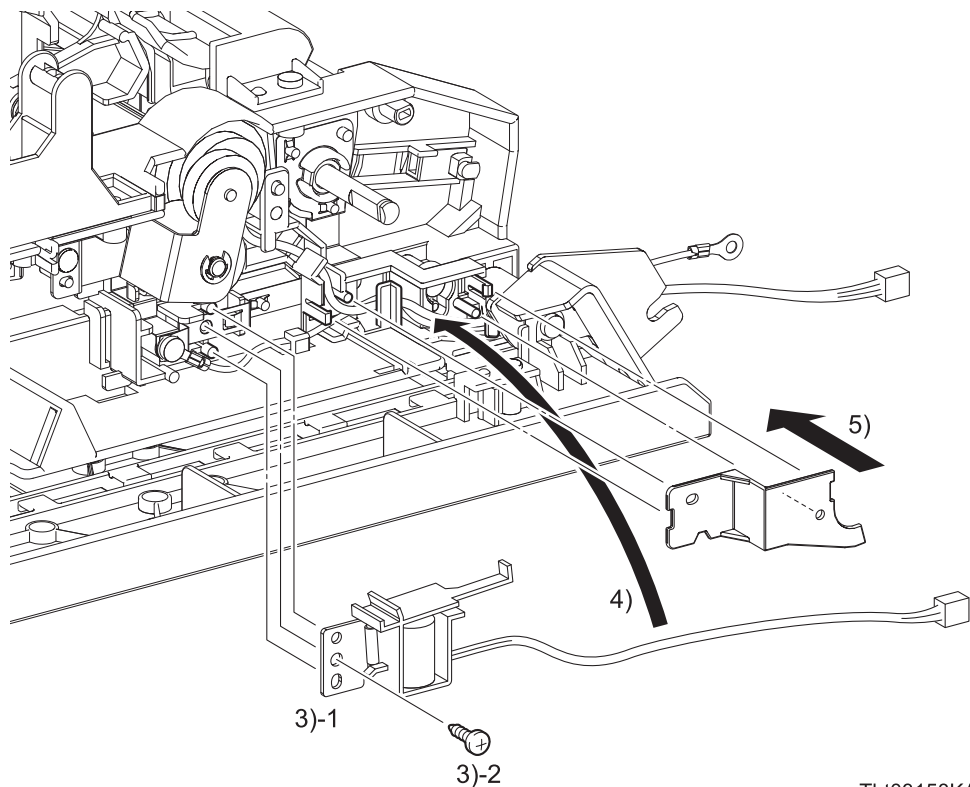

- 3) Mate the two holes of the SOLENOID FEED MSI with the bosses of the FRAME RH, and then secure with the one screw (silver, tapping, 8mm).
- 4) Route the harness of the SOLENOID FEED MSI and harness of the CLUTCH ASSY DUP through the hooks of the GUIDE HARNESS RH.

NOTE

When performing the following step, use caution to prevent the harness from being caught between the GUIDE HARNESS RH and the COVER HARN GUIDE RH and to prevent the COVER HARN GUIDE RH from rising.

- 5) Mate the two holes of the COVER HARN GUIDE RH with the bosses of the GUIDE HARNESS RH, and then secure with the two hooks.

Continues to the next page.

Replacement 38 KIT RH SOLENOID, GEAR & CLUTCH (PL4.2.99)

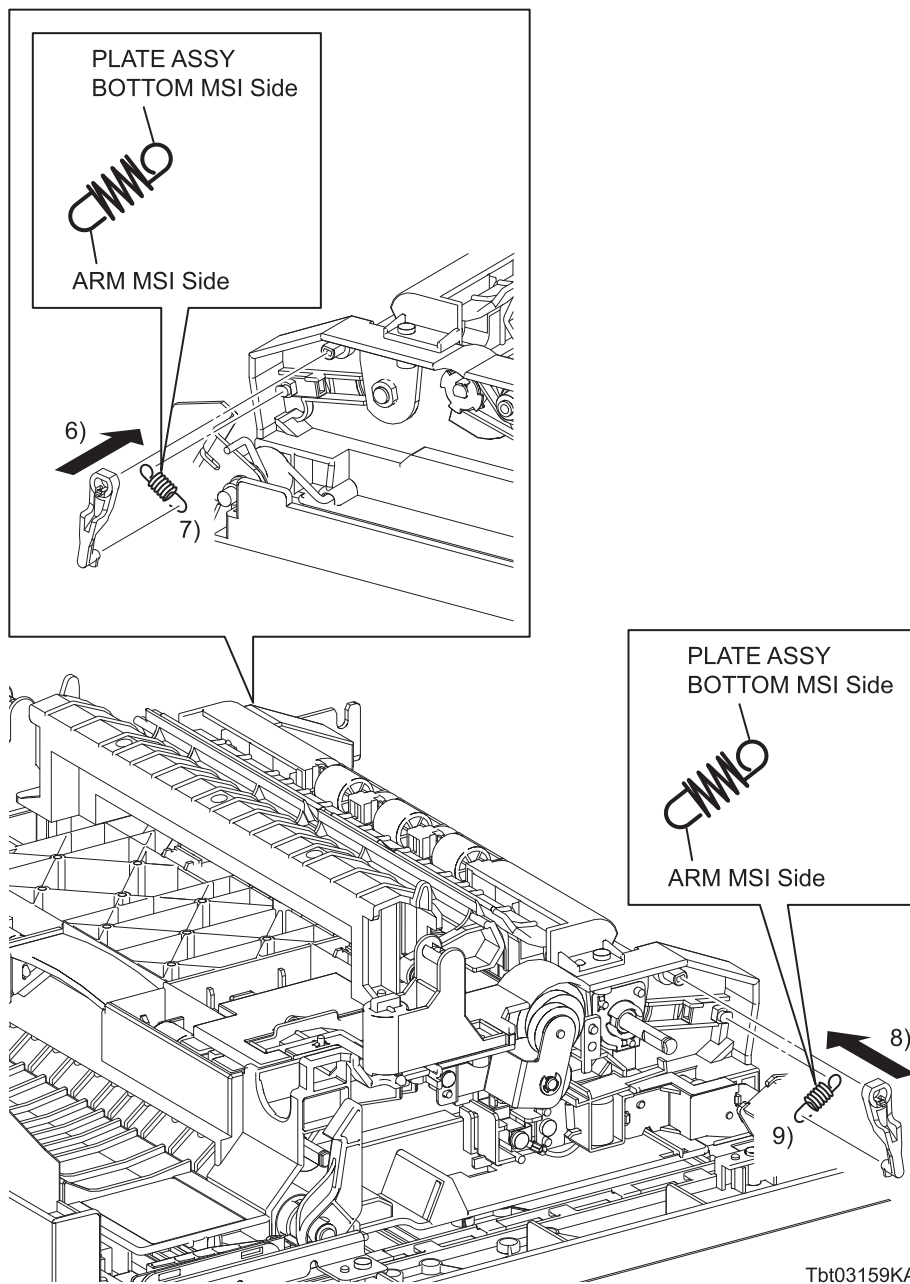

Tbt03159KA

- 6) Replace the front ARM MSI to the FOLLOWER FRONT, and then secure with the hook.

Ensure that the SPRING NF MSI is oriented to the direction shown in the right.

NOTE

- 7) Hang the front SPRING NF MSI to the front ARM MSI and PLATE ASSY BOTTOM MSI.
 8) Replace the rear ARM MSI to the FOLLOWER REAR, and then secure with the hook.

Ensure that the SPRING NF MSI is oriented to the direction shown in the right.

NOTE

- 9) Hang the rear SPRING NF MSI to the rear ARM MSI and PLATE ASSY BOTTOM MSI.

Continues to the next page.

Replacement 38 KIT RH SOLENOID, GEAR & CLUTCH (PL4.2.99)

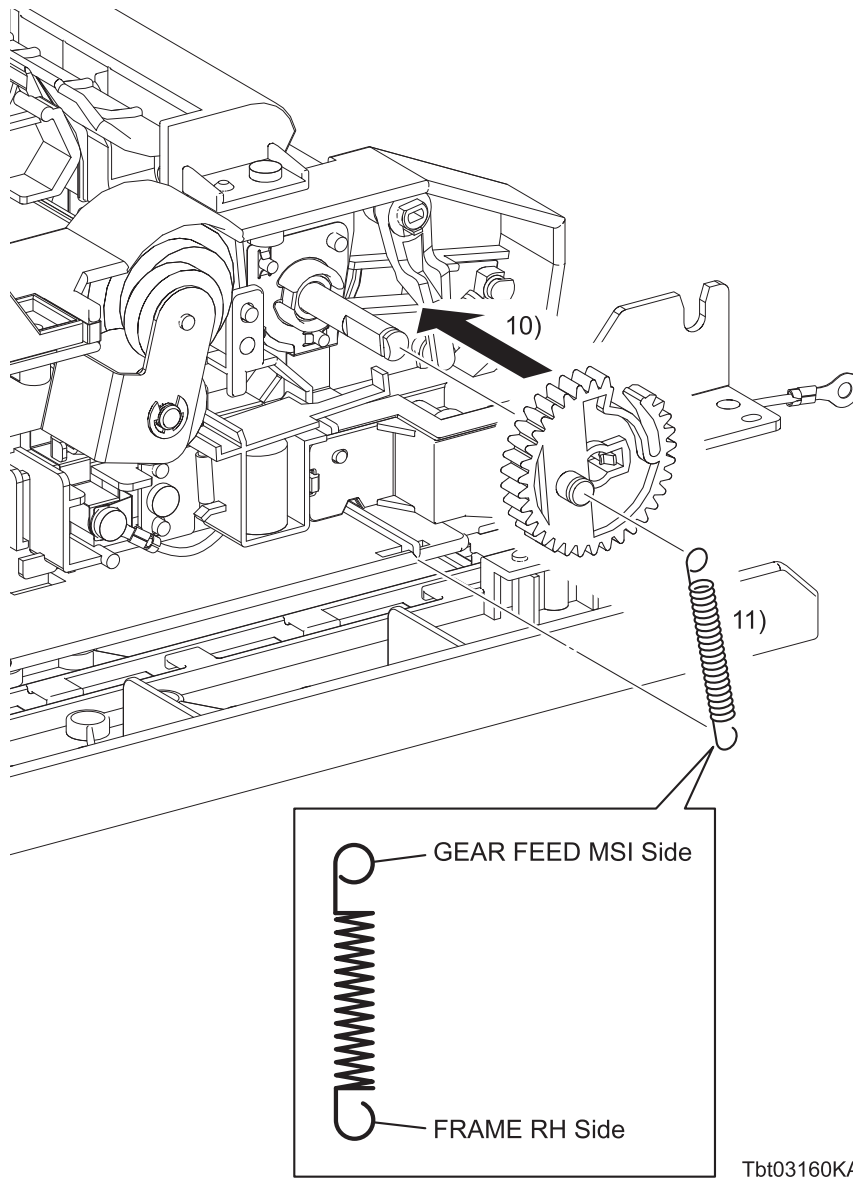

- 10) Replace the GEAR FEED MSI to the SHAFT ASSY MSI, and then secure the groove of the SHAFT ASSY MSI with the hook of the GEAR FEED MSI.

NOTE

Ensure that the SPRING FEED MSI is oriented to the direction shown in the right.

- 11) Hang the SPRING FEED MSI to the GEAR FEED MSI and FRAME RH.

Go to the next replacement step:

Replacement 39 KIT RH COVER & FRAME ASSY (PL4.1.99)

Replacement 39 KIT RH COVER & FRAME ASSY (PL4.1.99)

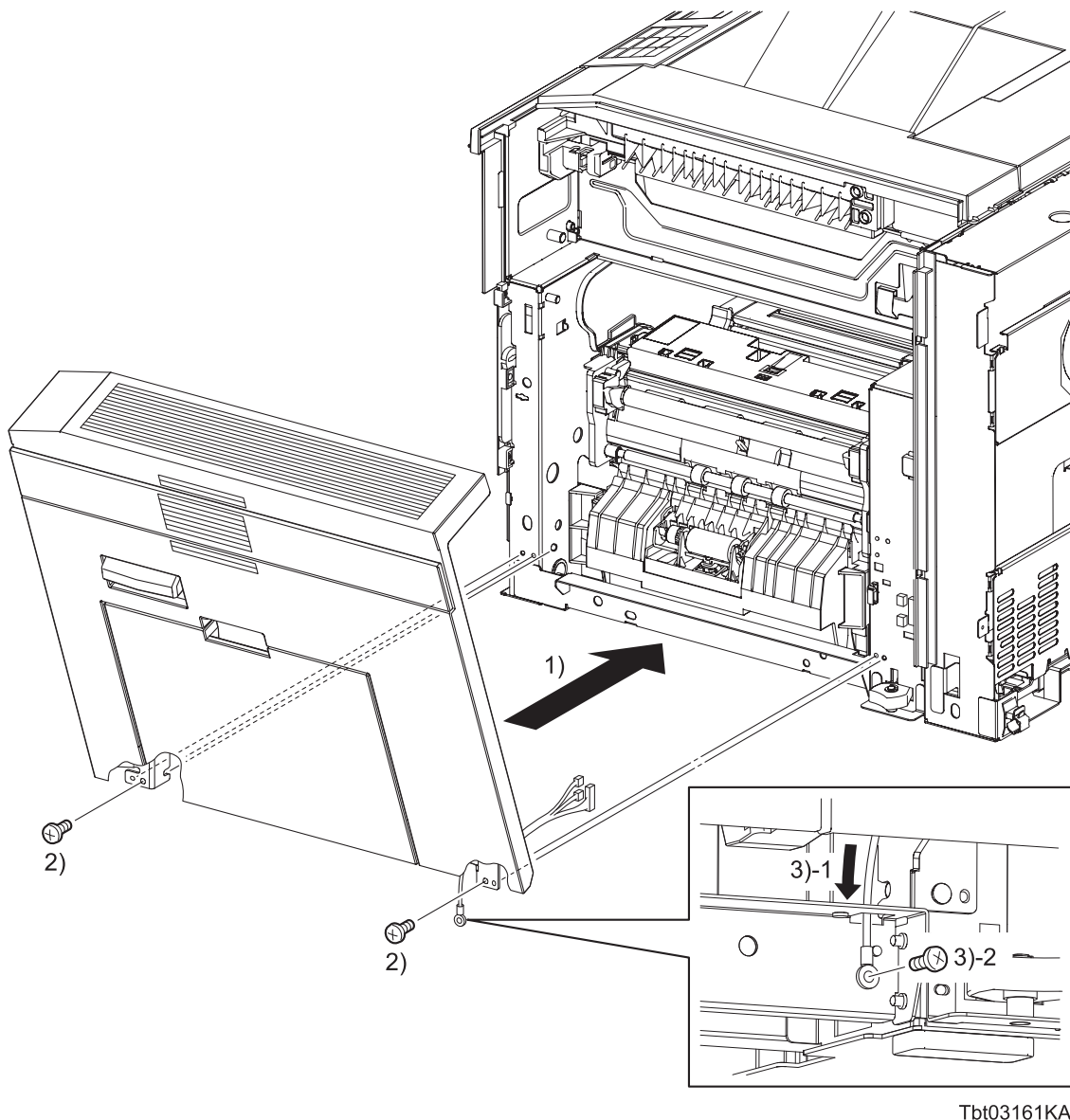

- 1) Mate the notches and holes of the BRACKET ASSY PIVOT FRONT and the BRACKET ASSY PIVOT REAR with the bosses of the printer, attach it.
- 2) Secure the BRACKET ASSY PIVOT FRONT and the BRACKET ASSY PIVOT REAR to the printer with the two screws (silver, M4, 6mm).
- 3) Put the WIRE ASSY EARTH through the hole in the frame, then secure the grounding terminal of the WIRE ASSY EARTH to the printer with the one screw (silver, 6 mm).

Continues to the next page.

Replacement 39 KIT RH COVER & FRAME ASSY (PL4.1.99)

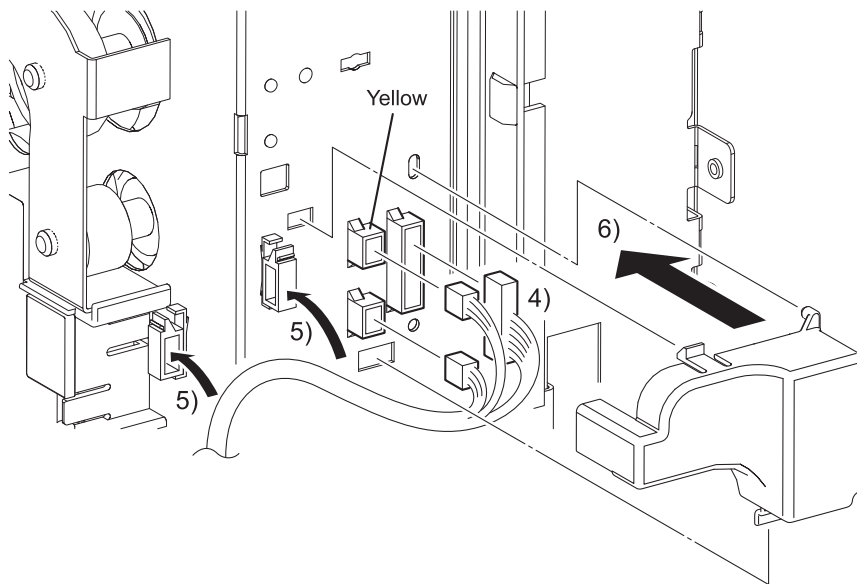

Tbt03162KA

NOTE

When performing the following steps, engage the connectors of the same color.
The connector of the MSI Feed Solenoid is white in color.
The connector of the DUP Clutch is yellow in color.

- 4) Engage the three sets of connectors (P/J117, 118, 120) of the KIT RH COVER & FRAME ASSY.
- 5) Secure the harness of the KIT RH COVER & FRAME ASSY with the two clamps.

NOTE

When performing the following step, use caution, ensure that the harness will not be caught between the COVER CONNECTOR and the printer.

- 6) Mate the two bosses of the COVER CONNECTOR with the holes of the printer, and then secure with the two hooks.

Continues to the next page.

Replacement 39 KIT RH COVER & FRAME ASSY (PL4.1.99)

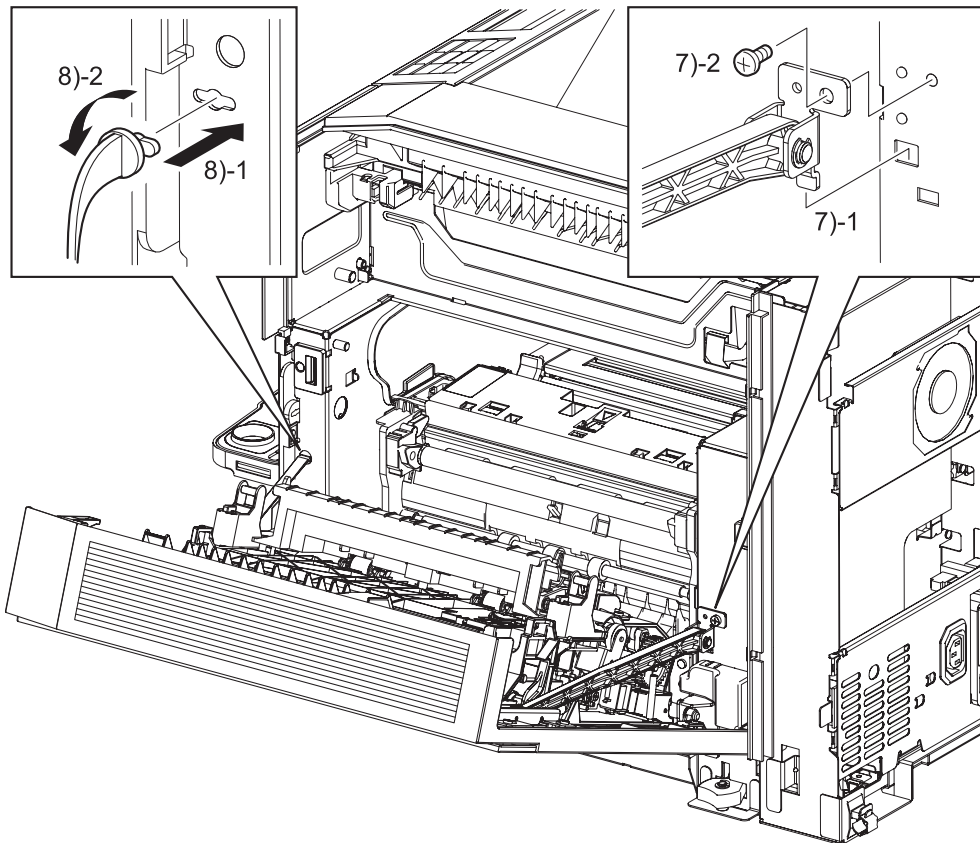

Tbt03163KA

- 7) Insert the tab on the LINK ASSY into the printer, and then secure with the one screw (silver, M4, 6mm).
- 8) Attach the STRAP RH to the printer frame with its tab fitted in the notch of the printer frame, and then rotate the STRAP RH by 90 degrees to secure it in position.

Go to the next replacement step:

Replacement 40 COVER RH UNDER (PL1.1.11)

Replacement 40 COVER RH UNDER (PL1.1.11)

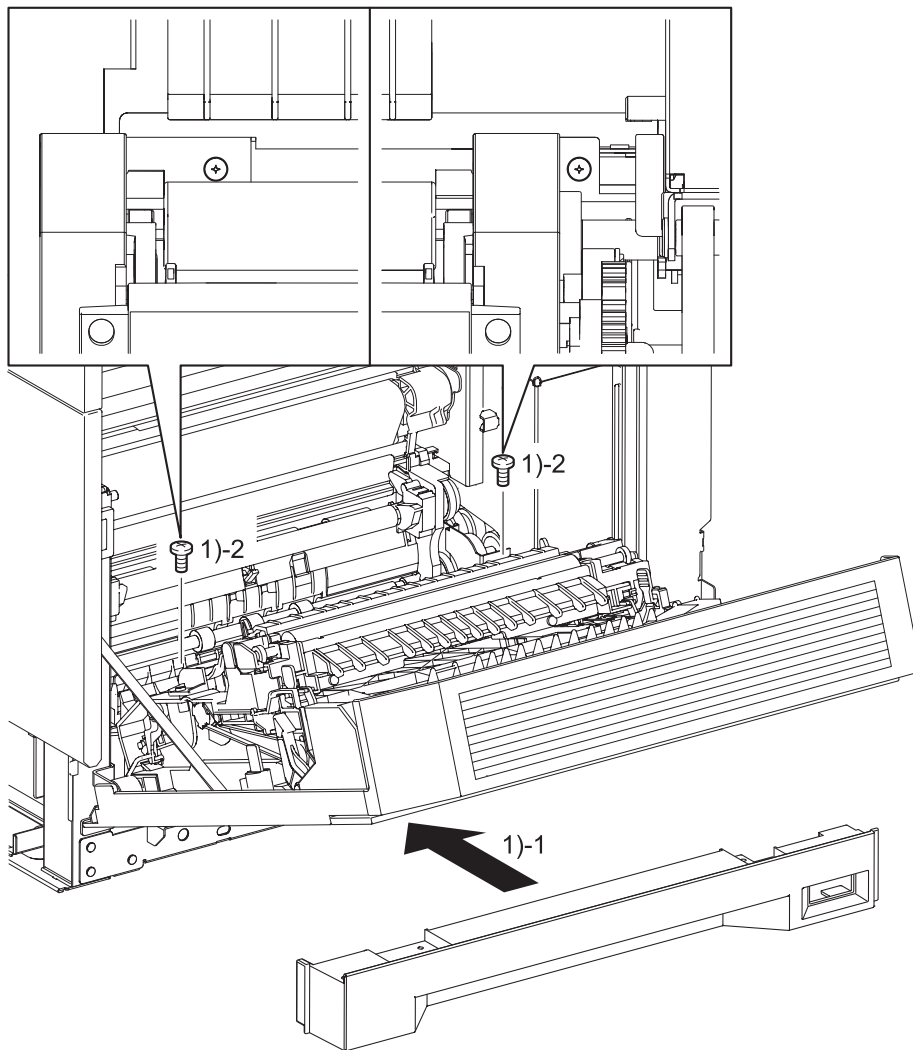

Tbt03164KA

- 1) Replace the COVER RH UNDER to the printer, and then secure with the two screws (silver, 6mm).

Go to the next replacement step:

Replacement 43 COVER ASSY REAR (PL1.3.5)

Replacement 41 CHUTE ASSY INVERT (PL7.3.1)

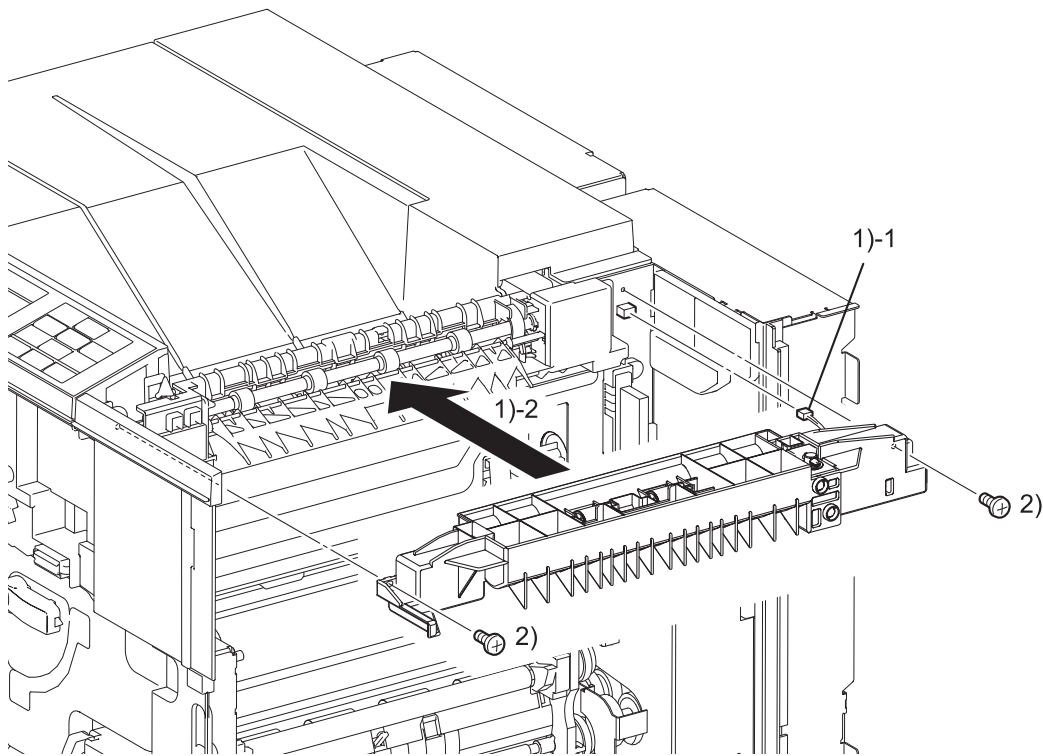

Tbt03165KA

- 1) Engage the connector (P/J122) of the CHUTE ASSY INVERT, and attach the CHUTE ASSY INVERT to the printer.
- 2) Secure the CHUTE ASSY INVERT to the printer with the two screws (silver, 6mm).

Go to the next replacement step:

Replacement 42 COVER ASSY TOP EXIT (PL1.1.9)

Replacement 42 COVER ASSY TOP EXIT (PL1.1.9)

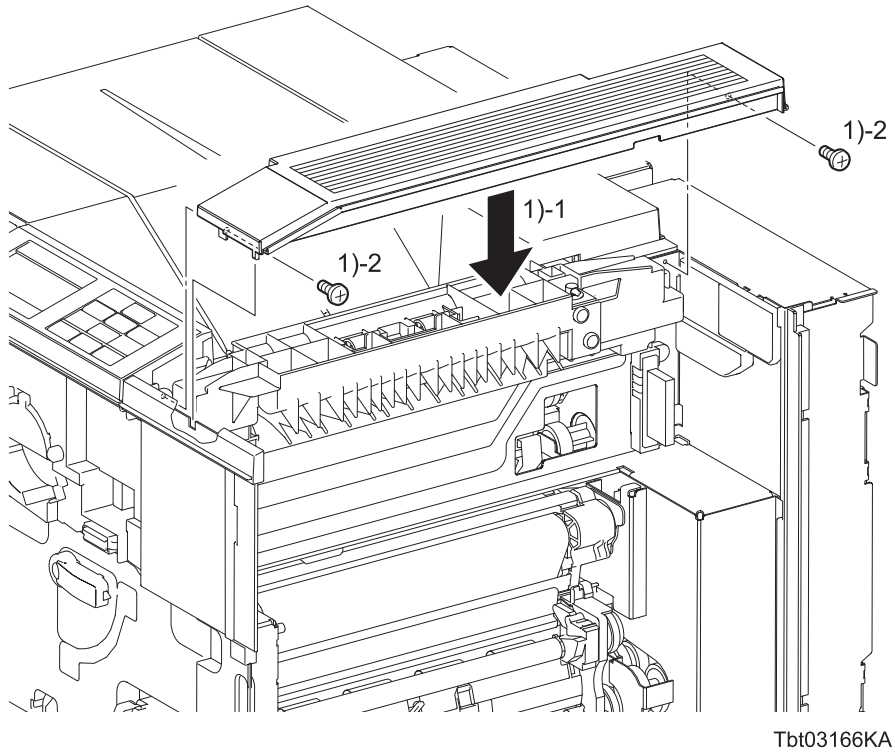

- 1) Replace the COVER ASSY TOP EXIT to the printer, and then secure with the two screws (silver, 6mm).

Go to the next replacement step:

Replacement 43 COVER ASSY REAR (PL1.3.5)

Replacement 43 COVER ASSY REAR (PL1.3.5)

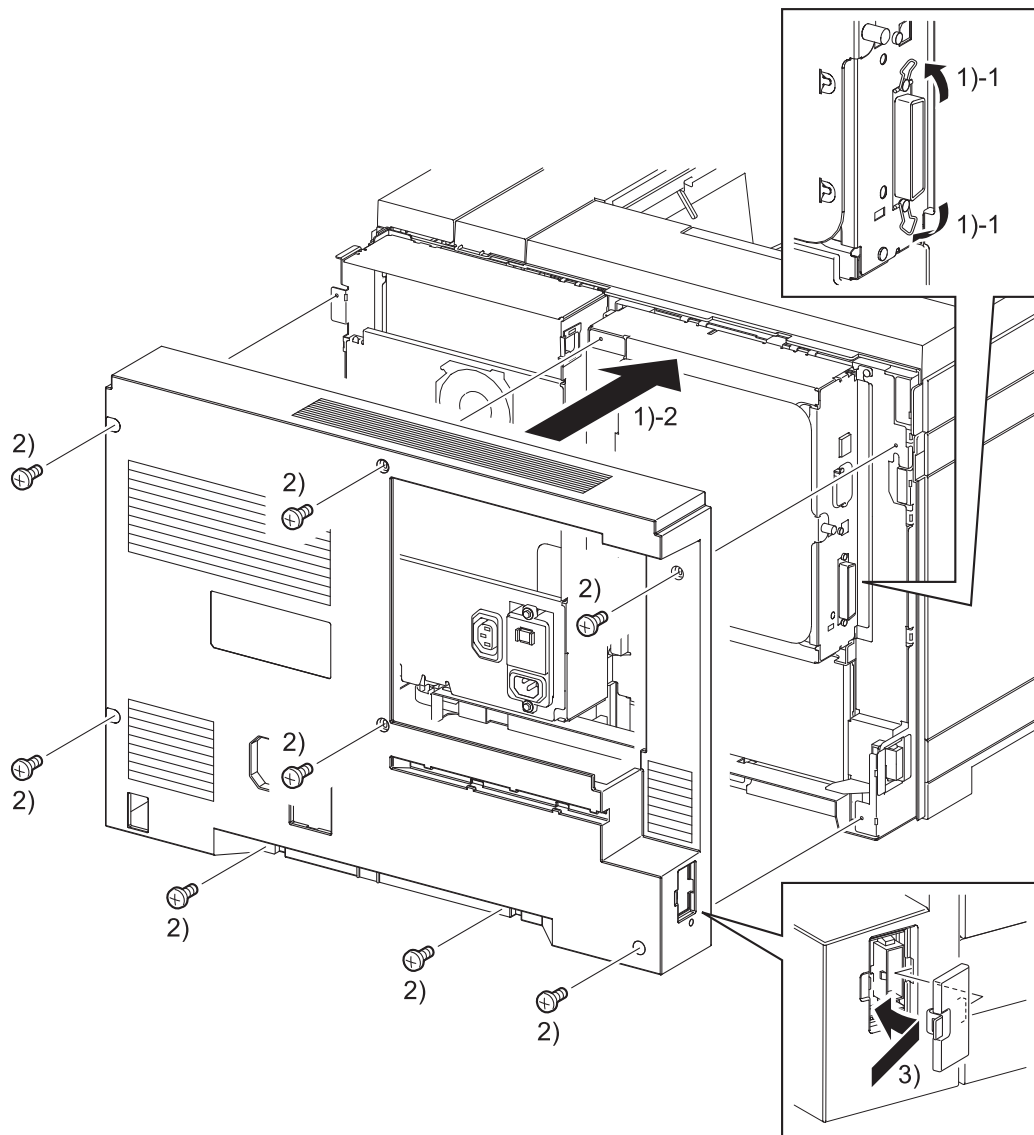

Tbt03167KA

- 1) Attach the COVER ASSY REAR to the printer while expanding the clip of the parallel port.
- 2) Secure the COVER ASSY REAR to the printer with the eight screws (silver, 6mm).
- 3) Insert the tab on the COVER REAR LH into the COVER ASSY REAR, and then secure with the hook.

Replacement 44 KIT COVER ASSY MSI (PL4.1.98)

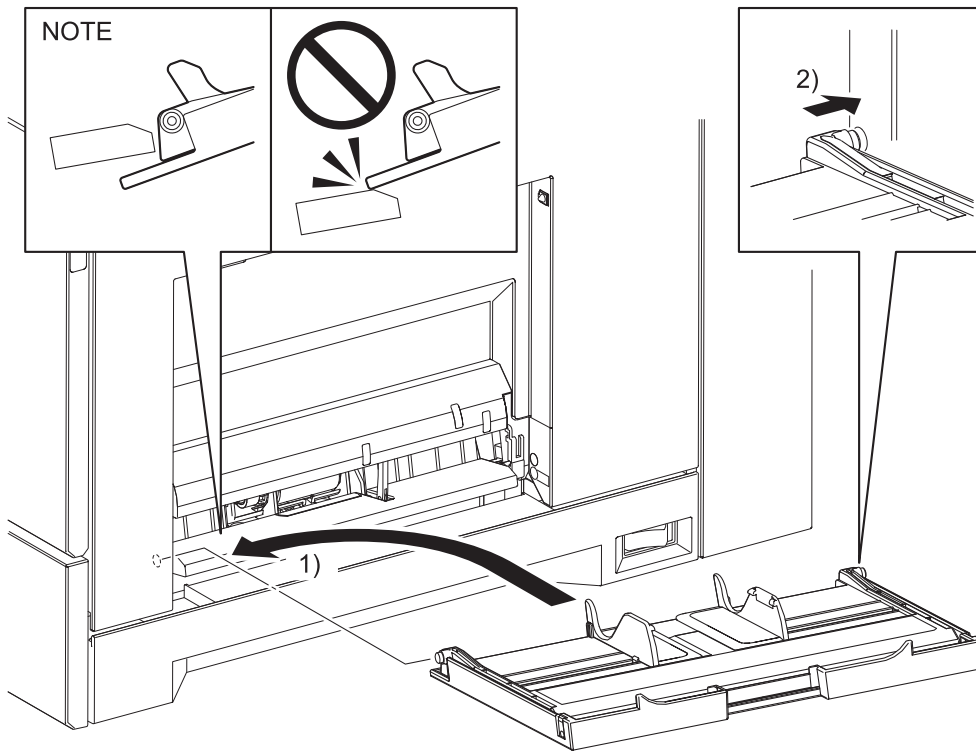

Tbt03168KB

NOTE

When performing the following step, ensure that the COVER ASSY MSI does not fall on the PLATE ASSY BOTTOM MSI (PL4.2.22).

- 1) Mate the boss of the COVER ASSY MSI with the hole of the COVER ASSY RH.
- 2) Mate the other boss of the COVER ASSY MSI with the hole of the COVER ASSY TOP, attach the COVER ASSY MSI.

Replacement 45 COVER FRONT RH (PL1.2.5)

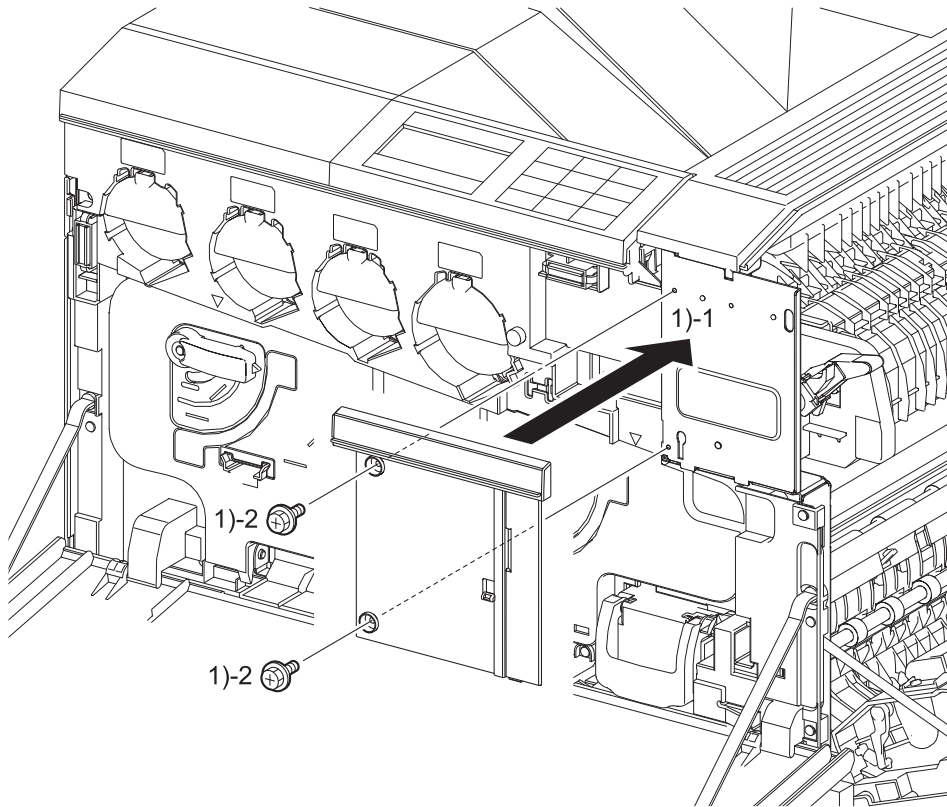

Tbt03238KB

- 1) Mate the two bosses of the COVER FRONT RH with the holes of the printer, and then secure with the two screws (silver, flanged, 6mm).
- 2) Close the COVER ASSY RH.
- 3) Close the COVER ASSY FRONT.

Blank Page

Replacement 46 COVER ASSY TOP ADD TRAY (Reference only)

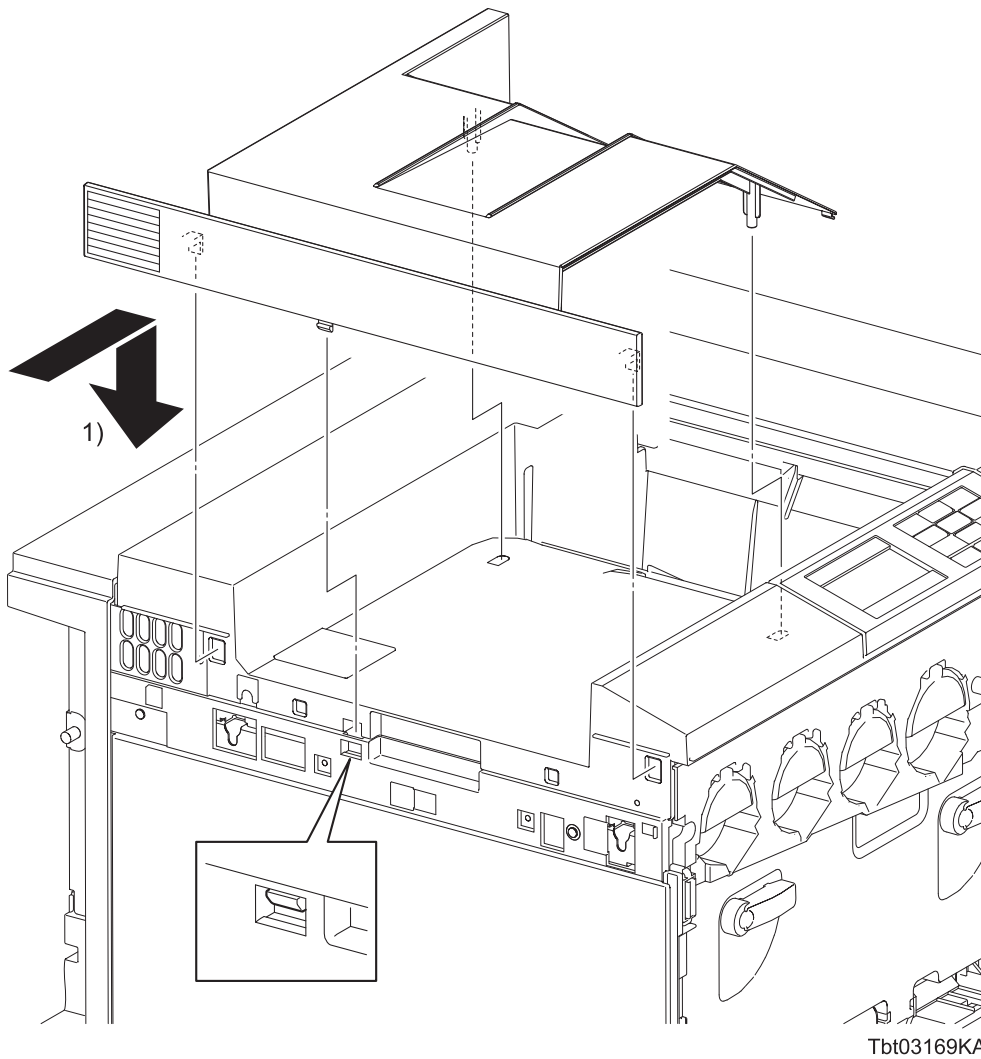

- 1) Replace the COVER ASSY TOP ADD TRAY to the printer, and then secure with the three hooks.

Continues to the next page.

Replacement 46 COVER ASSY TOP ADD TRAY (Reference only)

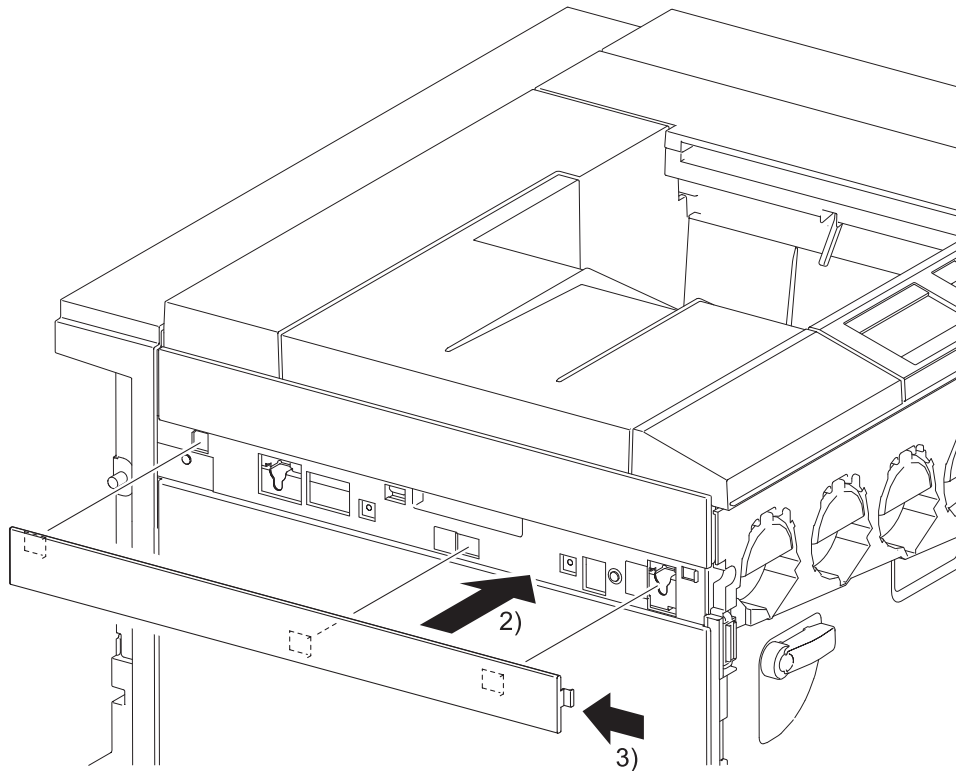

Tbt03170KA

- 2) Mate the three hooks of the upper COVER LH FINISHER with the holes of the printer.
- 3) Shift the upper COVER LH FINISHER to rear side, secure the three hooks of the upper COVER LH FINISHER to the printer.
- 4) Close the COVER ASSY FRONT.

Replacement 47 HOLDER ASSY SENSOR LOW (PL3.1.2)

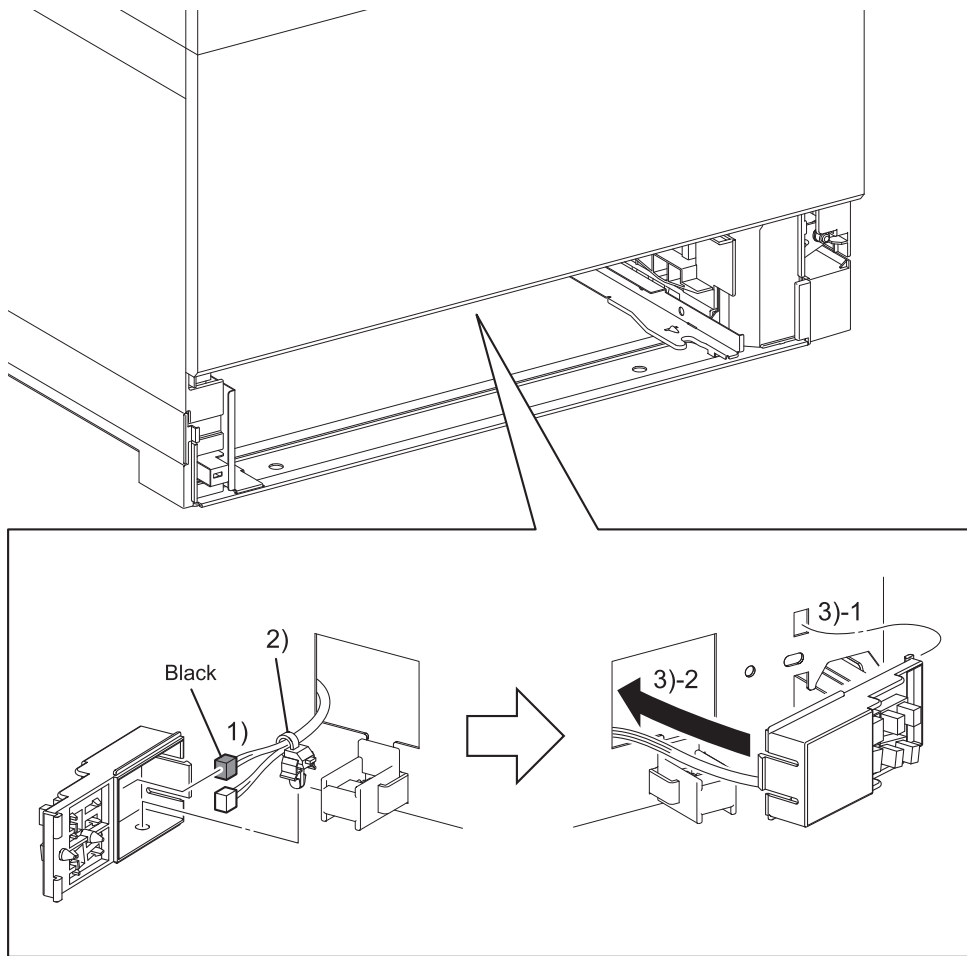

Tbt03171KA

NOTE

When carrying out the work described next procedure, be sure to engage the black connector in the sensor on the upper side.

- 1) Engage the two sets of connectors (P/J221, 222) of the HOLDER ASSY SENSOR LOW.
- 2) Secure the harness to the HOLDER ASSY SENSOR LOW with the clamp.
- 3) Insert the two tabs on the HOLDER ASSY SENSOR LOW into the printer, and then secure with the hook.
- 4) Attach the TRAY ASSY to the printer.

Replacement 48 SWITCH ASSY SIZE (PL3.1.1)

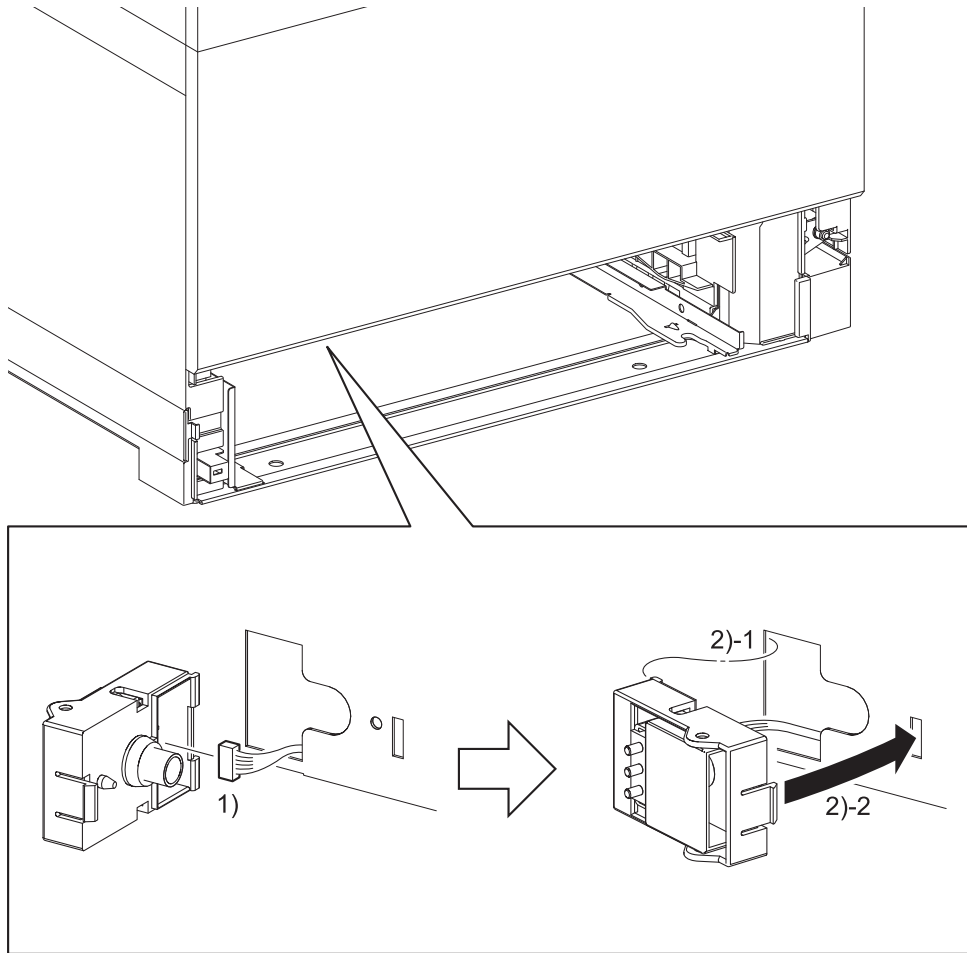

Tbt03172KA

- 1) Engage the connectors (P/J219) of the SWITCH ASSY SIZE.
- 2) Insert the two tabs of the SWITCH ASSY SIZE into the printer, and then secure with the hook.
- 3) Attach the TRAY ASSY to the printer.

Replacement 49 COVER TRAY (PL2.1.39)

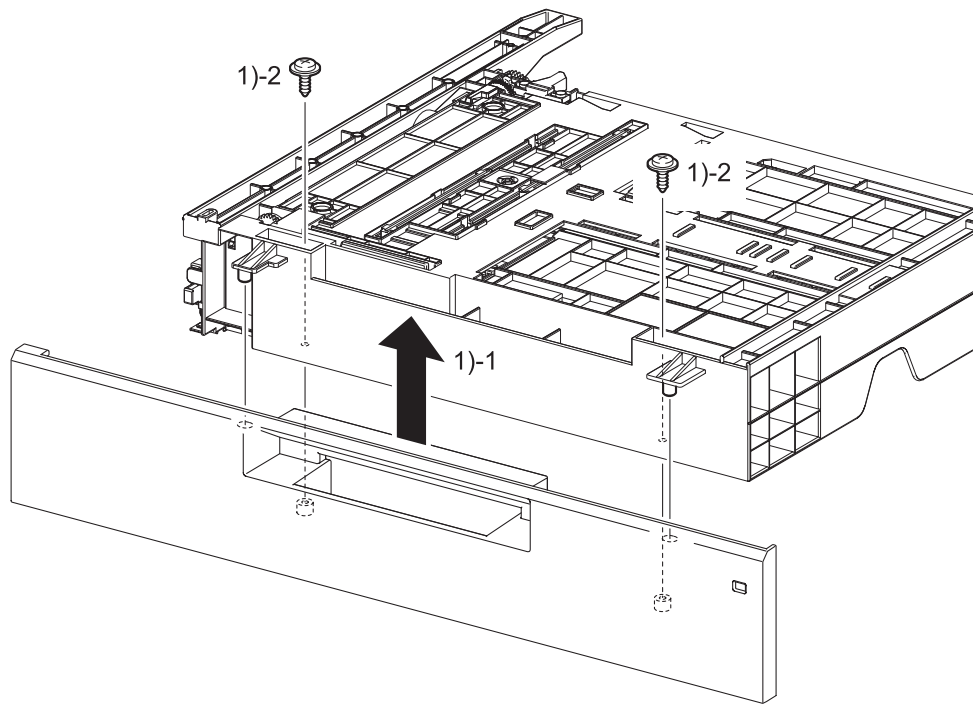

Tbt03239KA

- 1) Mate the two holes of the COVER TRAY with the bosses of the TRAY ASSY, and then secure with the two screws (silver, tapping, flanged, 8mm).
- 1) Attach the TRAY ASSY to the printer.

Blank Page

Replacement 50 KIT FEED ROLL & SEPARATOR ROLL (PL2.1.99)

NOTE

When replacing the SEPARATOR ROLL or the FEED ROLL replace the SEPARATOR ROLL and the two FEED ROLLS at the same time.

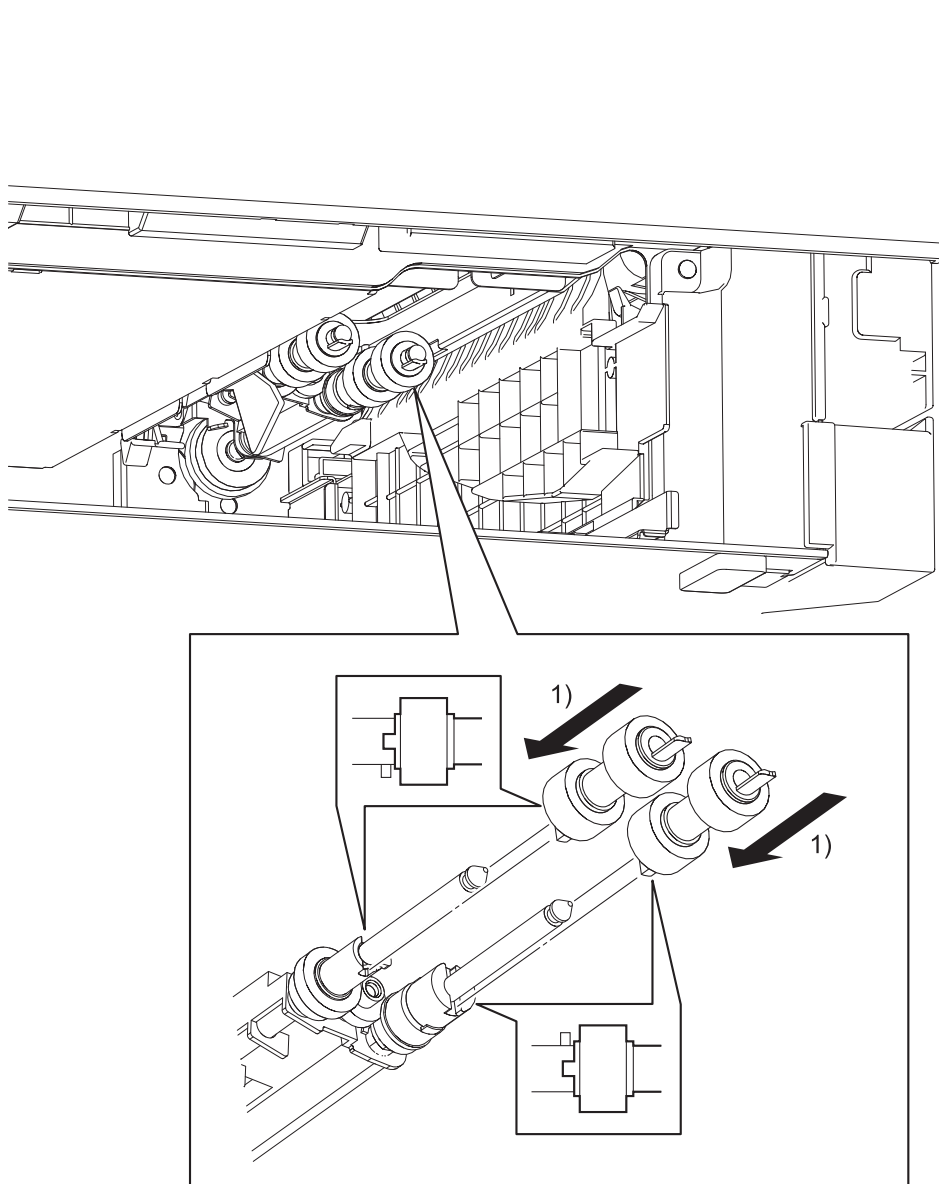

Tbt03173KA

- 1) Slide the ROLL ASSY FEEDs onto the shafts so that the lugs of the ROLL ASSY FEEDs are mated with the notches of the CLUTCH ASSY ONEWAY FEED (PL3.2.17) and ROLL ASSY GEAR NUDGER (PL3.2.20). Lock the hooks of the FEED ROLLERs into the grooves of the shafts.

Continues to the next page.

Replacement 50 KIT FEED ROLL & SEPARATOR ROLL (PL2.1.99)

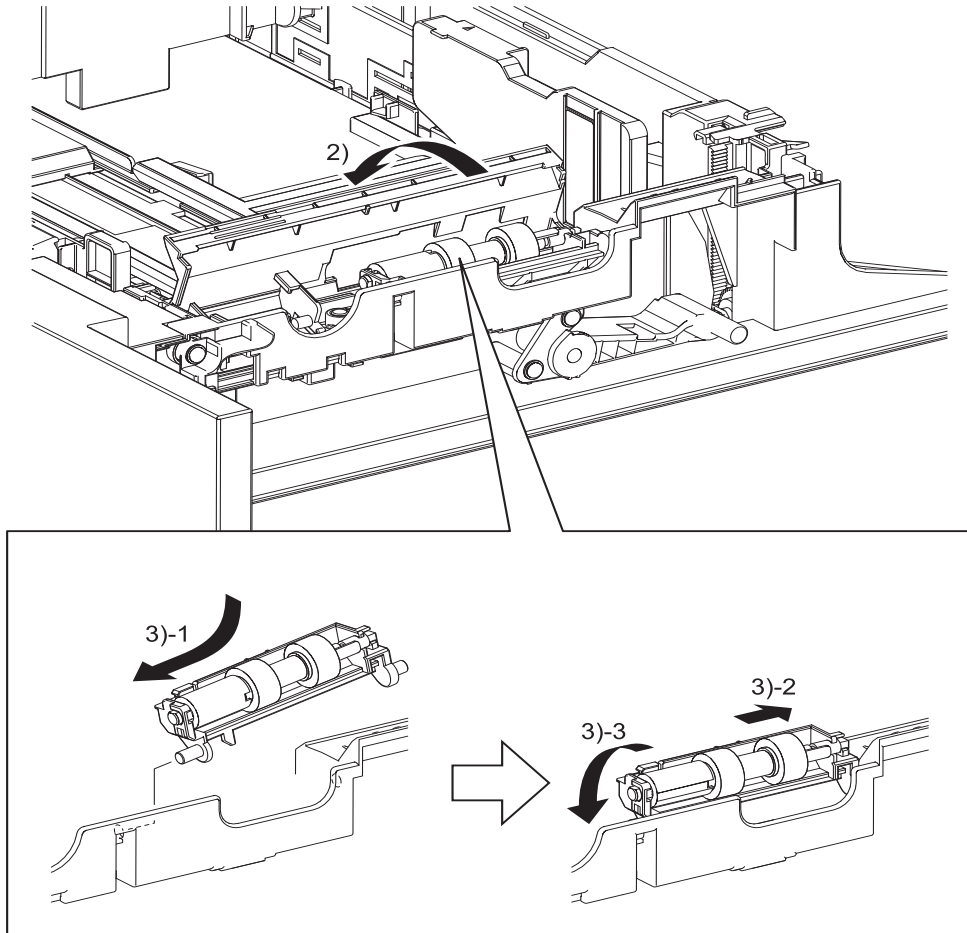

Tbt03174KB

- 2) Hold and open the COVER SEPARATOR.
- 3) Insert the boss on the rear side of the HOLDER ASSY SEPARATOR into the TRAY ASSY. Then, insert the boss on the front side of the HOLDER ASSY SEPARATOR into the TRAY ASSY to install the HOLDER ASSY SEPARATOR in position.
- 4) Close the COVER SEPARATOR.
- 5) Attach the TRAY ASSY to the printer.

Replacement 51 ROLL ASSY FEED MSI (PL4.2.21)

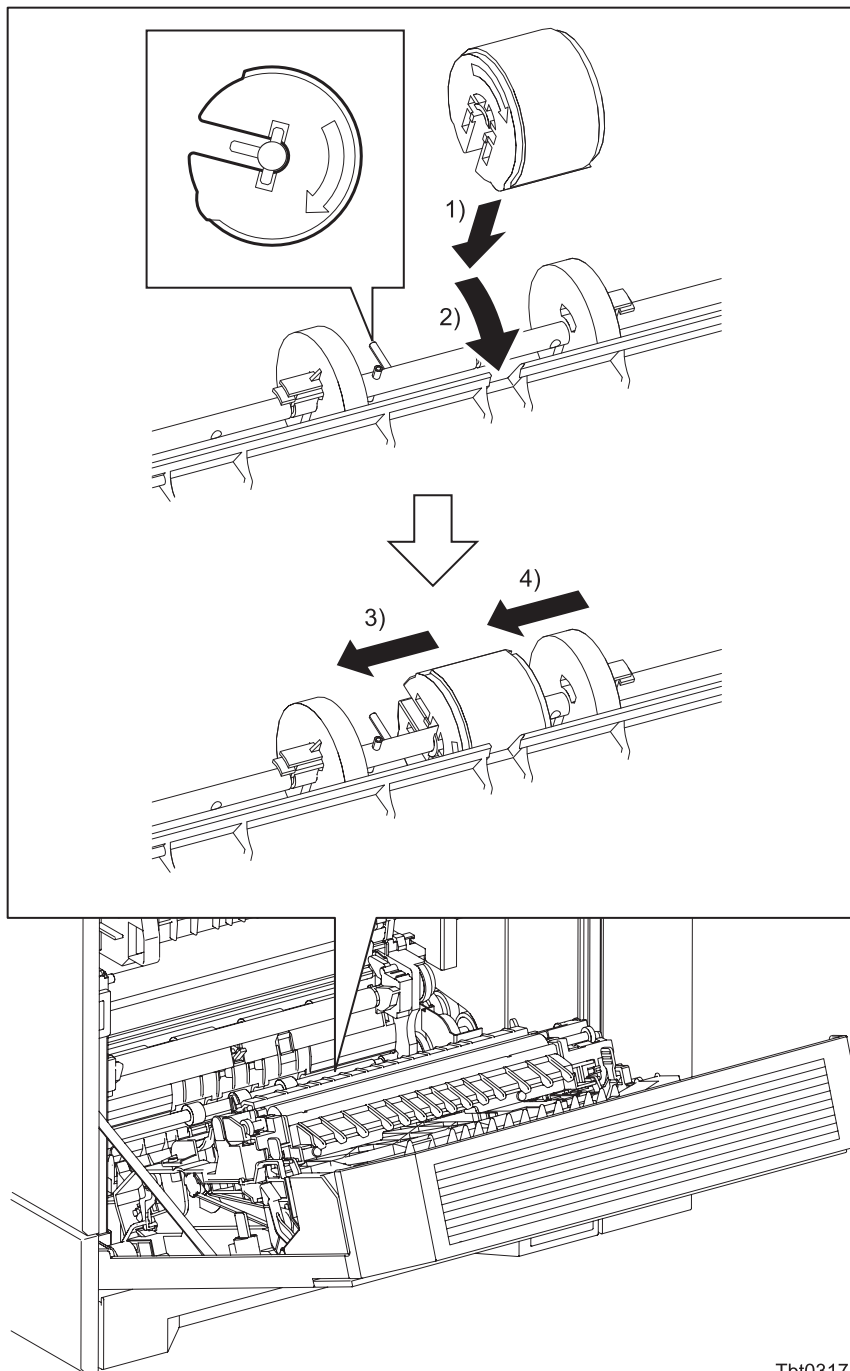

Tbt03175KA

- 1) Fit the ROLL ASSY FEED MSI to the SHAFT ASSY MSI with the groove of the ROLL ASSY FEED MSI facing upward.
- 2) Rotate the ROLL ASSY FEED MSI 180 degrees so that the pin on the SHAFT ASSY MSI is aligned with the groove on the ROLL ASSY FEED MSI.
- 3) Slide the ROLL ASSY FEED MSI to the front side, and then put the groove of the ROLL ASSY FEED MSI on the pin of the SHAFT ASSY MSI.
- 4) Slide the ROLL CORE MSI to the front side, to secure the hook of the ROLL CORE MSI with the groove of the SHAFT ASSY MSI.

Continues to the next page.

Replacement 51 ROLL ASSY FEED MSI (PL4.2.21)

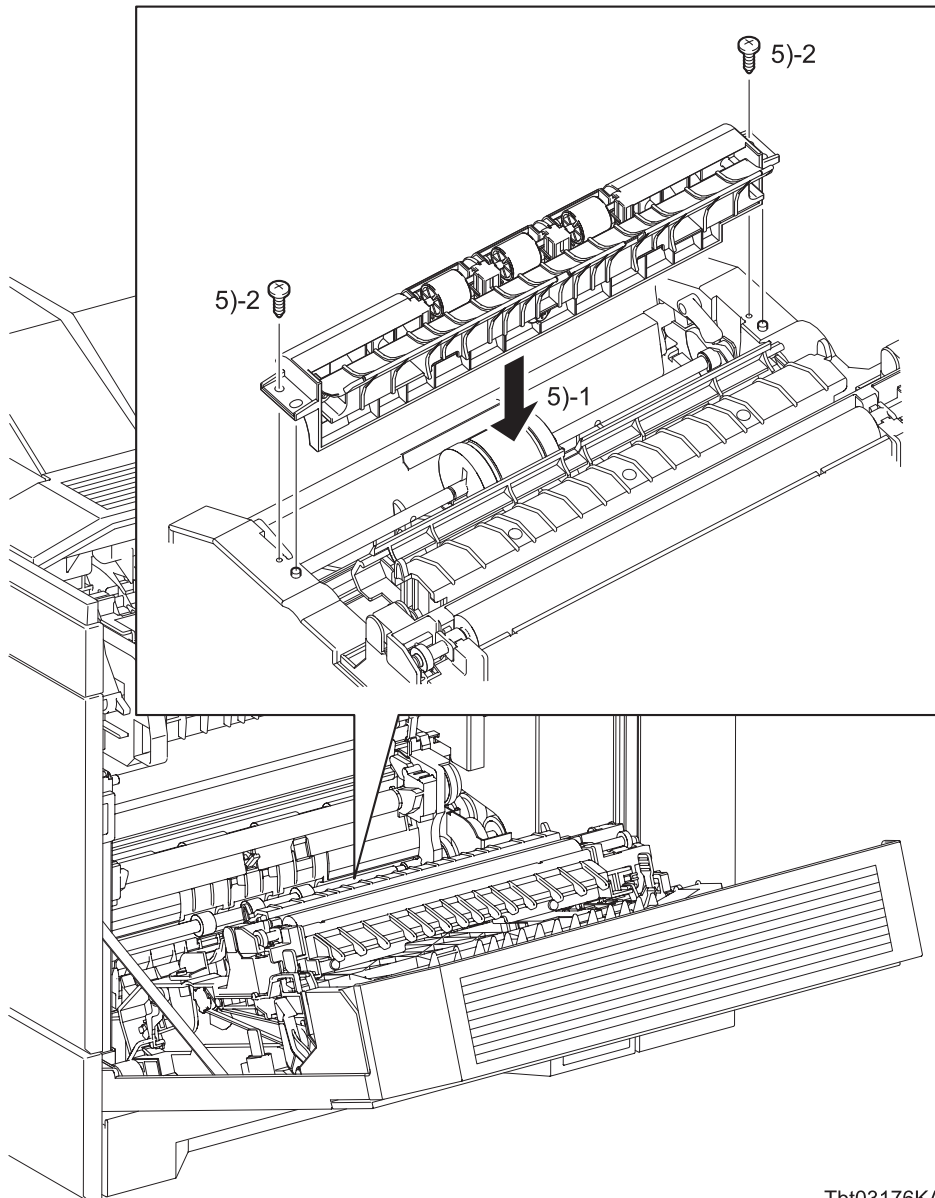

Tbt03176KA

- 5) Mate the tow holes of the CHUTE ASSY MSI with the bosses of the COVER ASSY RH, and then secure with the two screws (silver, tapping, 8mm)
- 6) Close the COVER ASSY RH.

Replacement 52 KIT ACTUATOR INTLK RH (PL4.1.97)

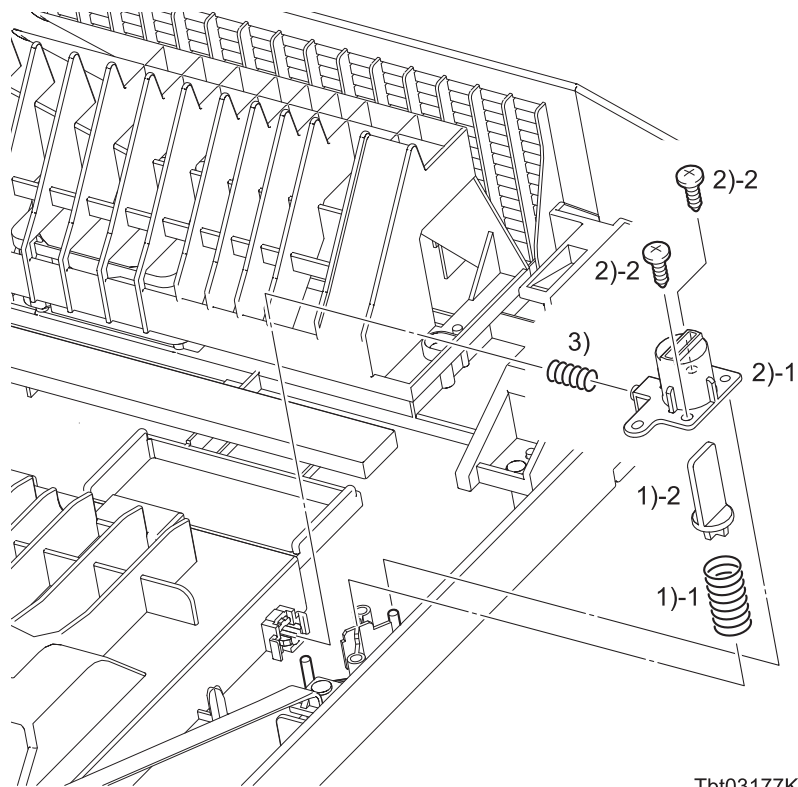

Tbt03177KA

- 1) Replace the SPRING INTLK RH and ACTUATOR INTLK RH to the COVER ASSY RH.
- 2) Mate the two holes of the HOLDER INTLK RH with the bosses of the COVER ASSY RH, and then secure with the two screws (silver, tapping, 8mm).
- 3) Attach the SPRING STOPPER MSI to the boss of the HOLDER INTLK RH and STOPPER MSI.
- 4) Close the COVER ASSY RH.

Blank Page

Replacement 53 FAN FUSER (PL4.1.8)

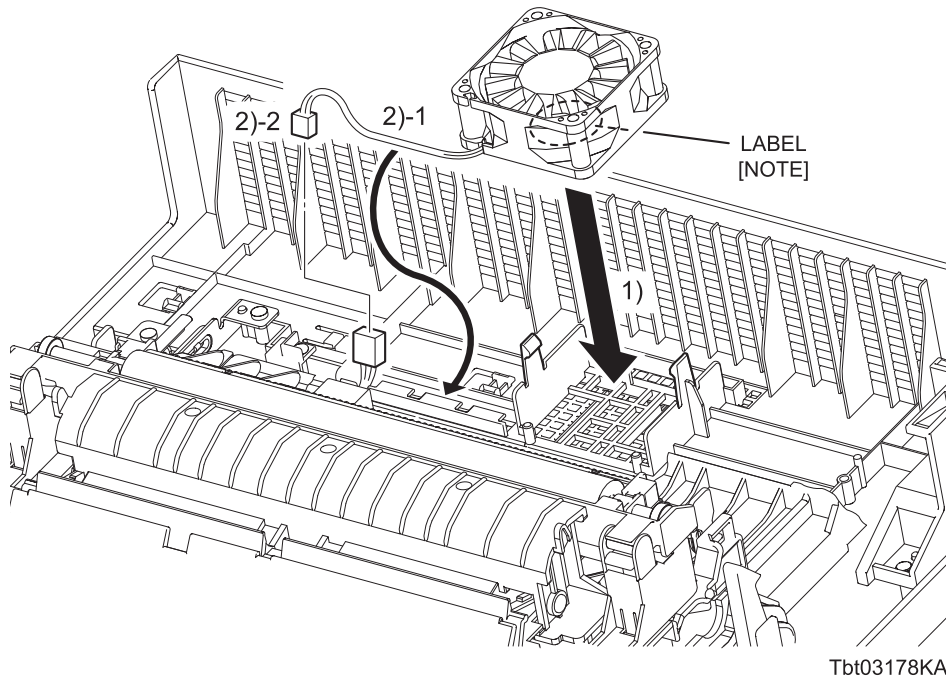

Tbt03178KA

NOTE

When performing the following step, use caution to check the orientation of the FAN.
(Attach the FAN so that its labeled surface faces right side.)

- 1) Mate the four holes of the FAN FUSER with the bosses of the COVER ASSY RH, and secure the FAN FUSER with the two hooks of the COVER ASSY RH.
- 2) Route the harness of the FAN FUSER through the hooks of the COVER ASSY RH, and then engage the connectors (P/J119) of the FAN FUSER.

Continues to the next page.

Replacement 53 FAN FUSER (PL4.1.8)

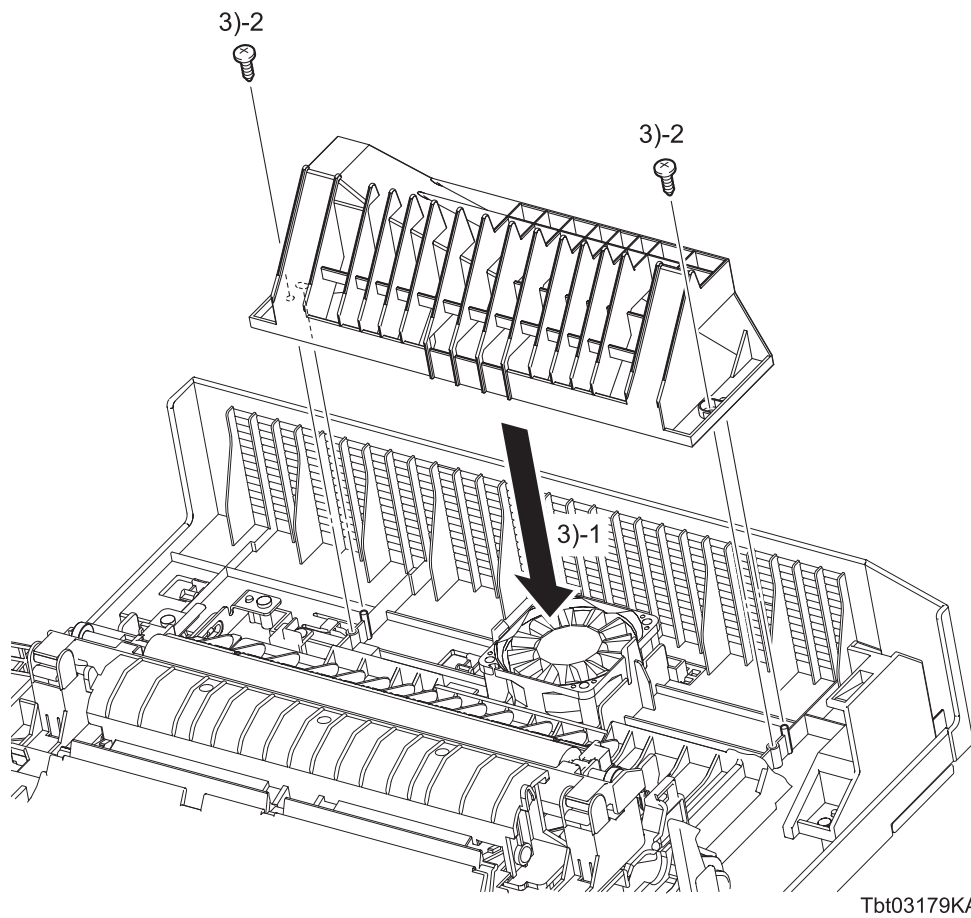

Tbt03179KA

- 3) Mate the two holes of the CHUTE DUP RH with the bosses of the COVER ASSY RH, and then secure with the two screws (silver, tapping, 8mm).
- 4) Close the COVER ASSY RH.

Replacement 54 KIT MSI SEPARATOR ROLL (PL3.1.99)

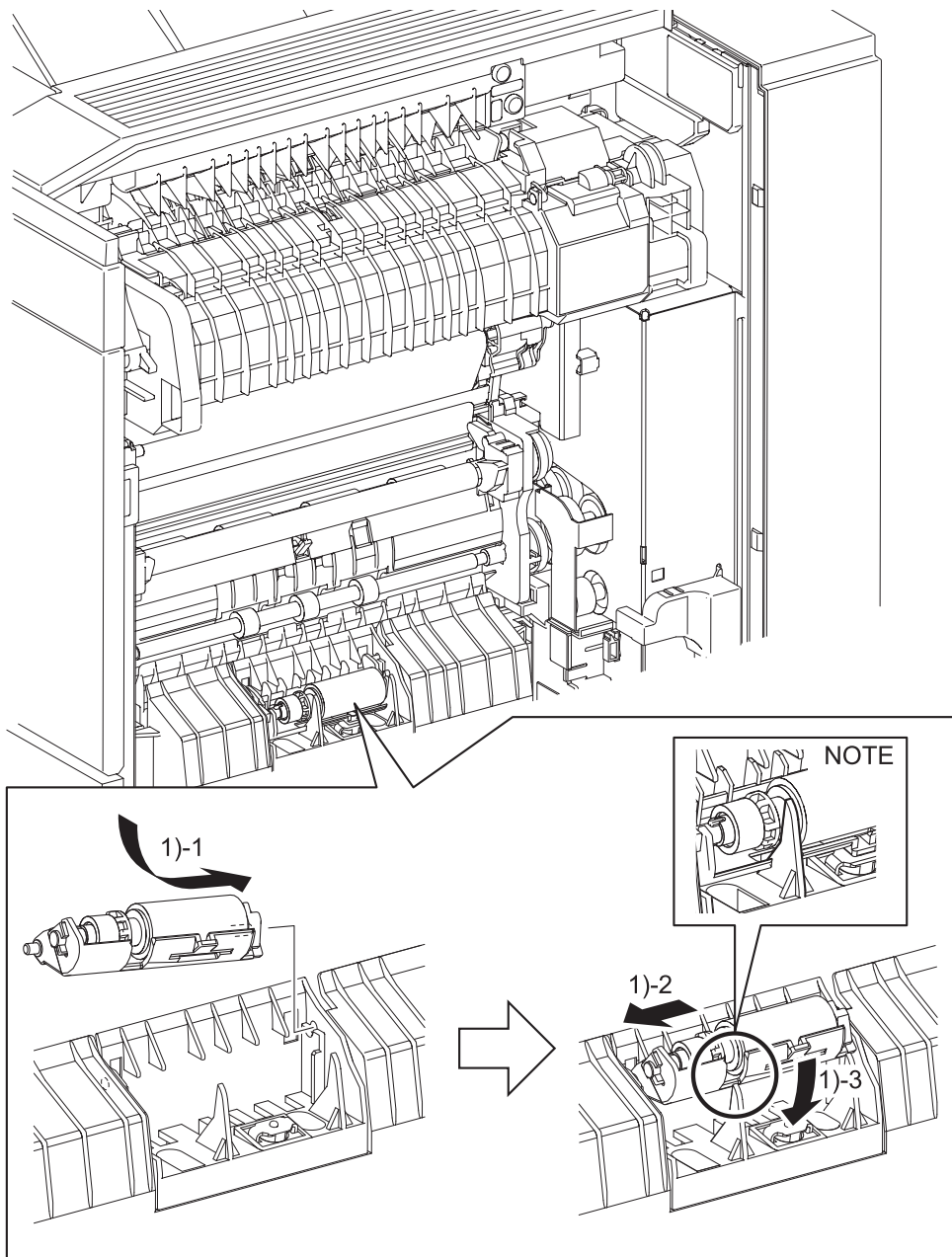

Tbt03180KB

NOTE

When performing the following step, ensure that the tapered rib on the BRACKET SEPARATOR (PL3.1.11) fits into the notch of the HOLDER ASSY SEPARATOR MSI.

- 1) Insert the boss on the front side of the HOLDER ASSY SEPARATOR MSI into the printer. Then, insert the boss on the rear side of the HOLDER ASSY SEPARATOR MSI into the printer to install the HOLDER ASSY SEPARATOR MSI in position.
- 2) Close the COVER ASSY RH.

Replacement 55 KIT ROLL ASSY 2ND BTR (PL4.4.99)

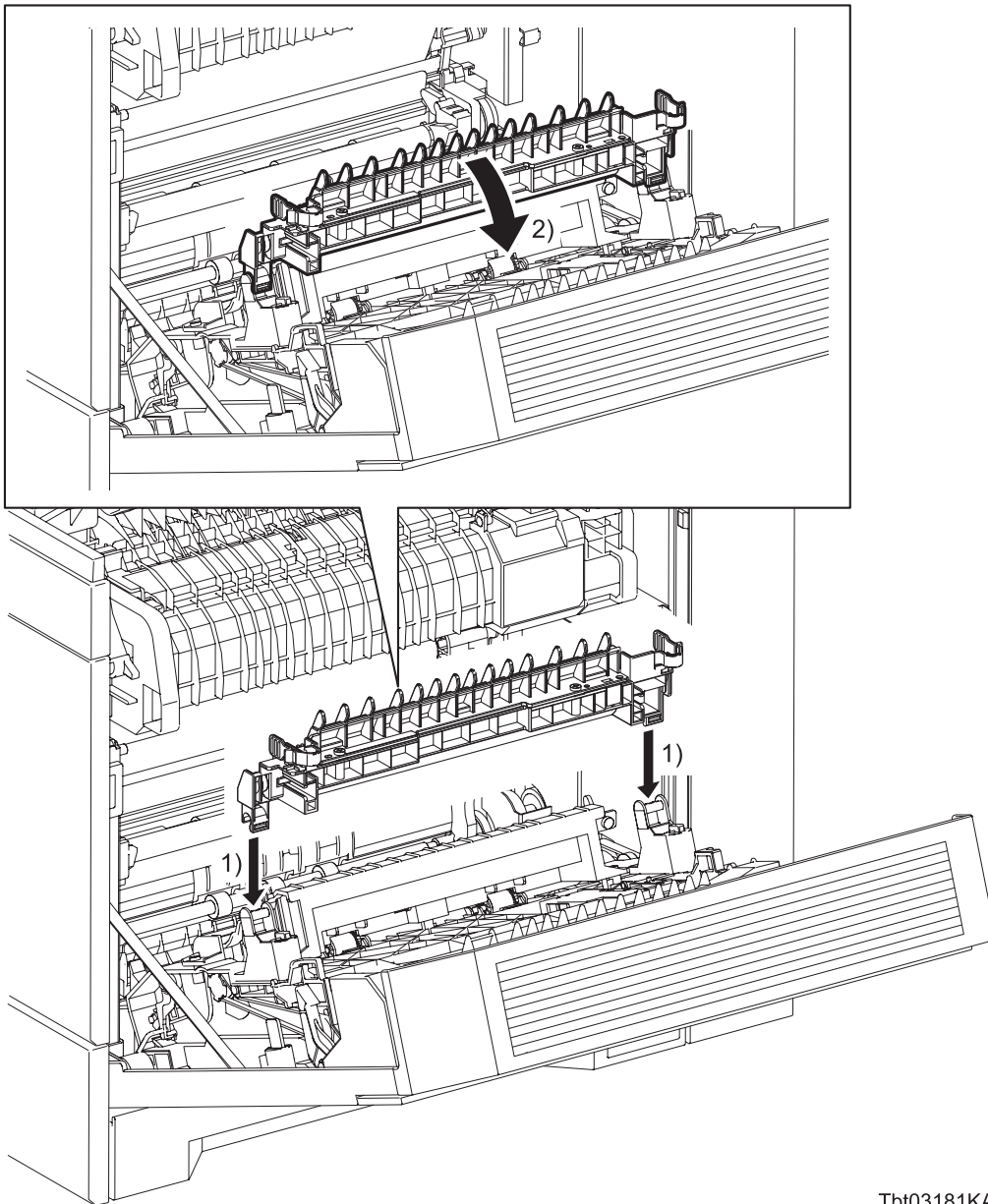

Tbt03181KA

- 1) Attach the ROLL ASSY 2ND BTR to the COVER ASSY RH with the front and rear notches of the ROLL ASSY 2ND BTR aligned with the shaft section of the BRACKET 2ND BTR (PL4.4.2).
- 2) Tilt the ROLL ASSY 2ND BTR to lock the front and rear hooks.
- 3) Close the COVER ASSY RH.

Replacement 56 FUSER ASSY (PL7.1.5)

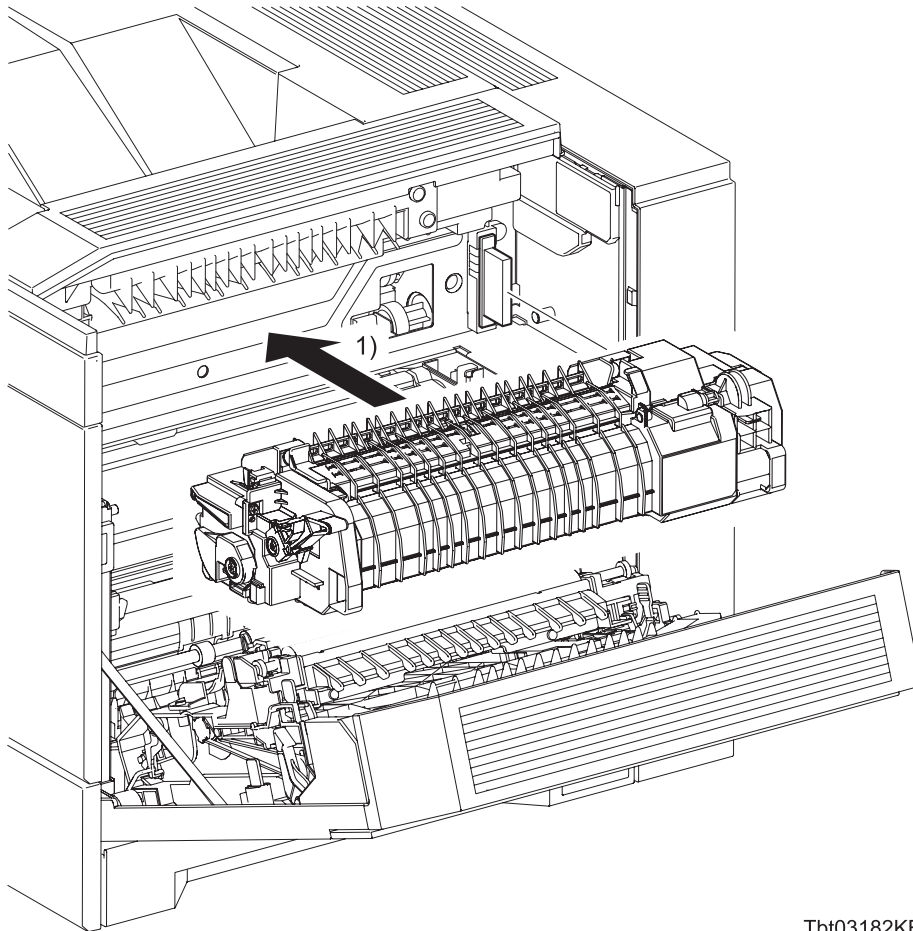

Tbt03182KB

- 1) Attach the FUSER ASSY to the printer, and push it forward until the lever of the FUSER ASSY locks.
- 2) Close the COVER ASSY RH.

Replacement 57 KIT FRAME ASSY 2ND (PL8.1.99)

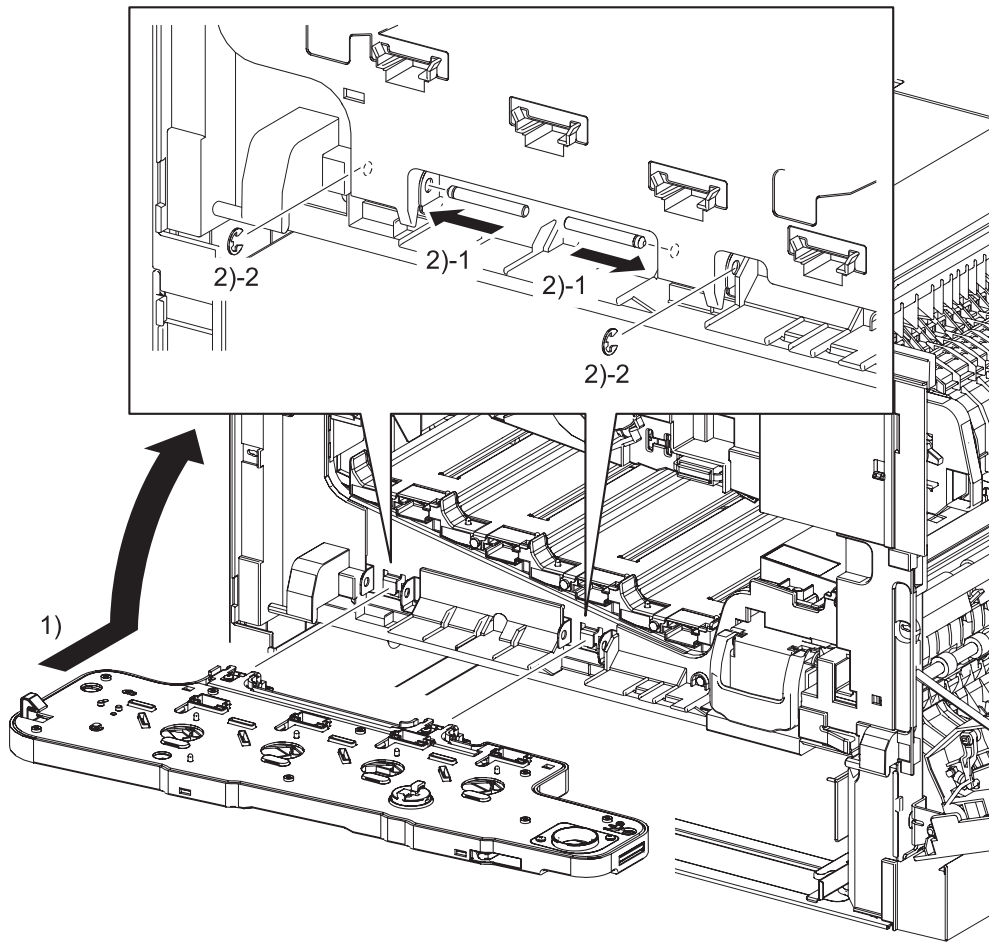

Tbt03183KA

- 1) Attach the FRAME ASSY 2ND to the printer. Then, close the FRAME ASSY 2ND and lock the handle.
- 2) Insert the SHAFT PIVOT FRAME 2ND into the right and left hinge sections of the FRAME ASSY 2ND respectively from inside and secure with the E-rings.

Go to the next replacement step:

Replacement 62 COVER ASSY FRONT (PL1.2.17)

Replacement 58 XERO DEVE CRU ASSY (Y), (M), (C), (K) (PL5.1.8~5.1.11)

NOTE

Described below is the replacement procedure common among the four XERO DEVE CRU ASSY.

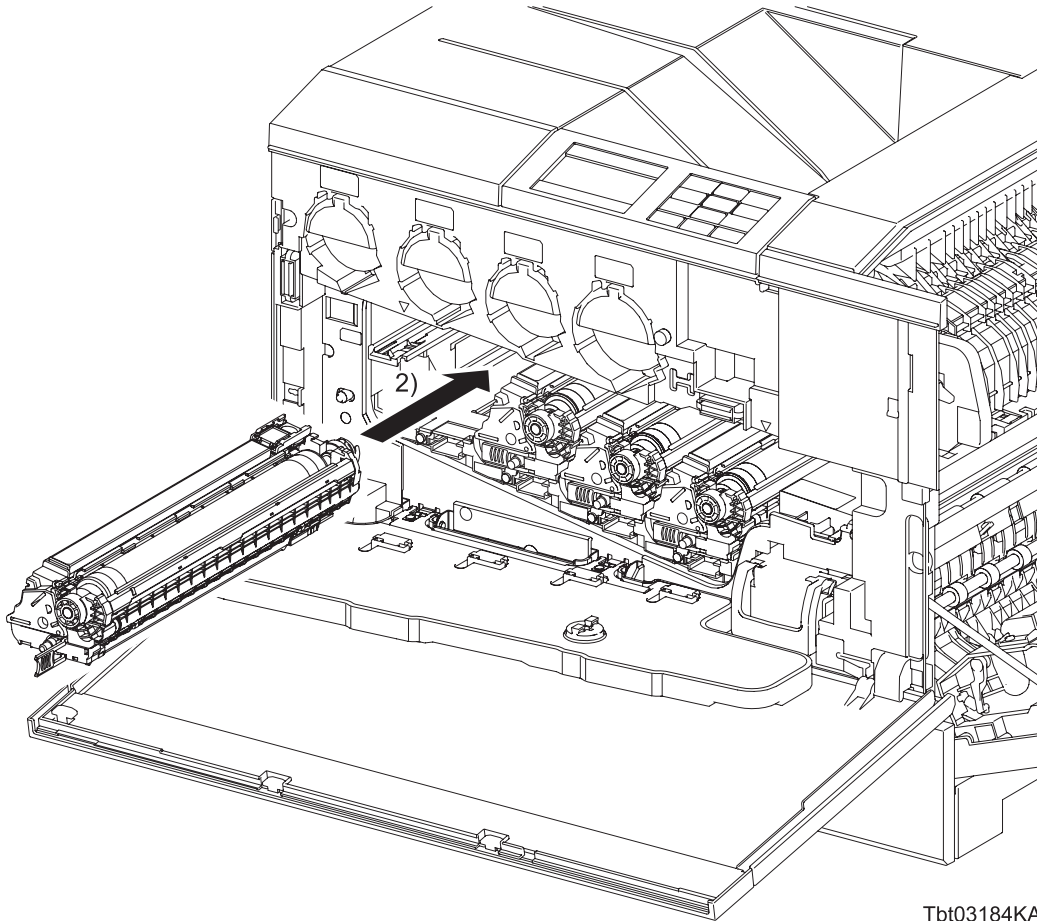

Tbt03184KA

- 1) Place the XERO DEVE CRU ASSY on the GUIDE ASSY CRU.
- 2) Push the XERO DEVE CRU ASSY into the printer until it will go no further.

Go to the next replacement step:

Replacement 59 KIT BELT ASSY IBT (PL5.1.99)

Continues to the next page.

Replacement 58 XERO DEVE CRU ASSY (Y), (M), (C), (K) (PL5.1.8~5.1.11)

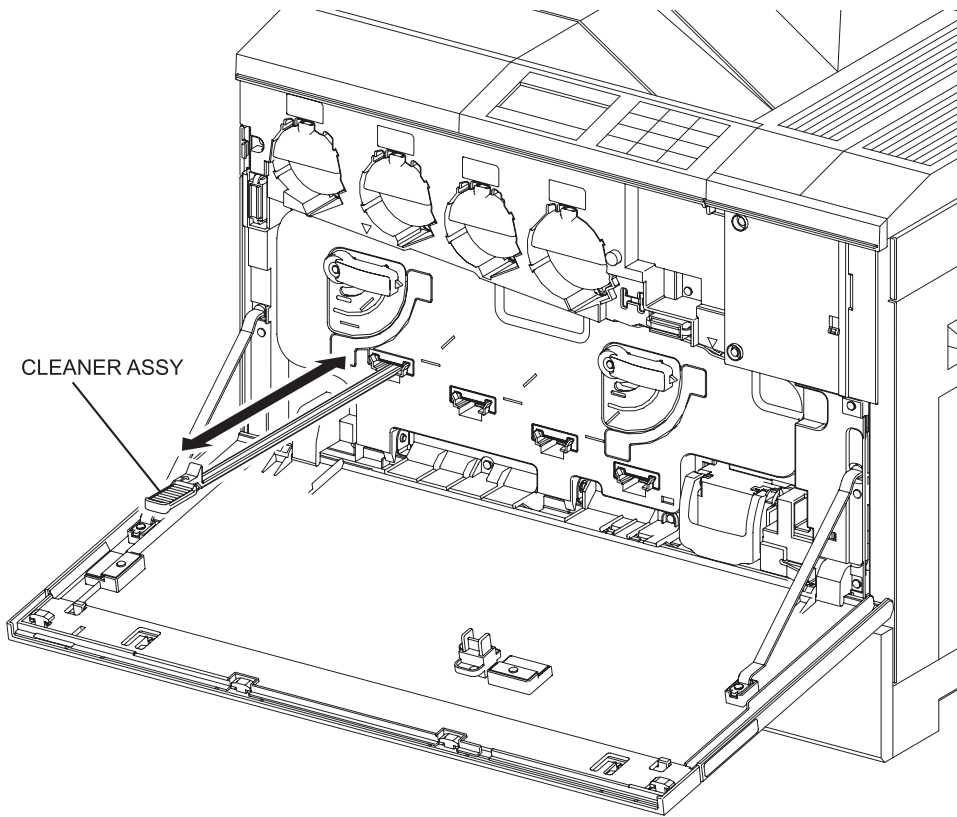

Tbt03185KA

NOTE

When the XERO DEVE CRU ASSY is removed or attached, be sure to clean up the window of the ROS ASSY using the CLEANER ASSY after the completion of all steps of procedure.

Replacement 59 KIT BELT ASSY IBT (PL5.1.99)

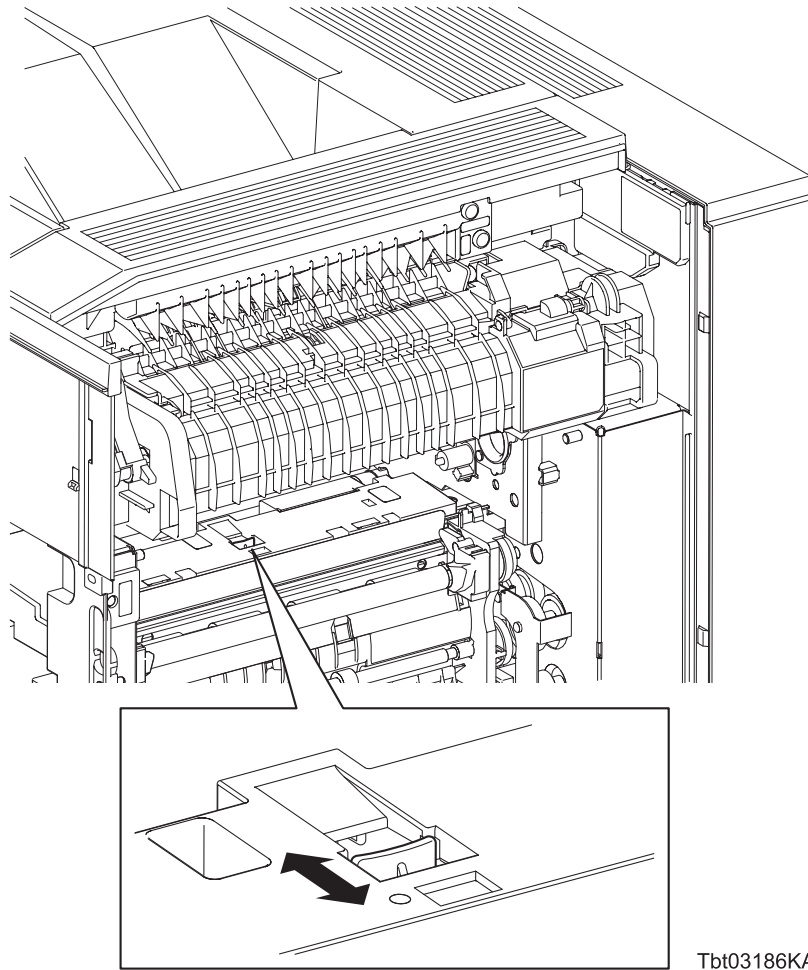

Tbt03186KA

NOTE

Before inserting the BELT ASSY IBT into the printer, be sure to slide the shutter of the PROCON ASSY (PL5.3.1) to clean up the ADC sensor.

Continues to the next page.

Replacement 59 KIT BELT ASSY IBT (PL5.1.99)

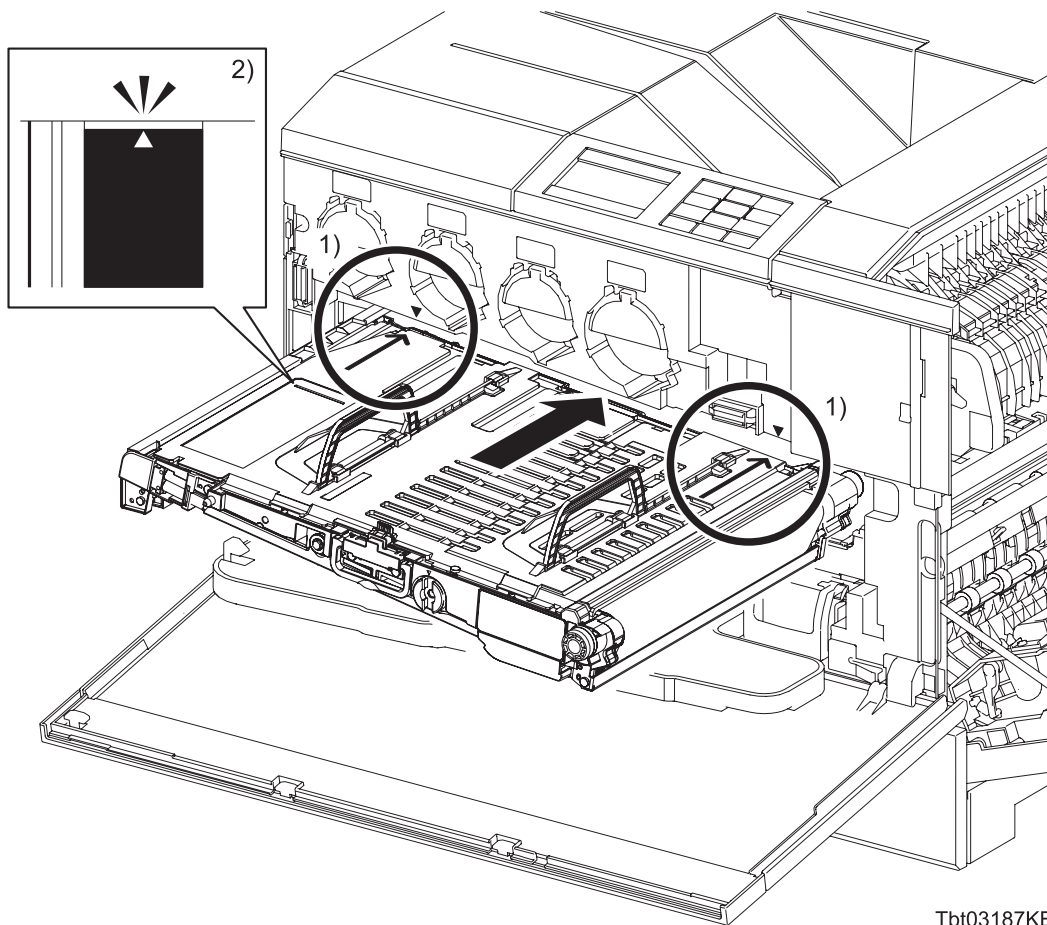

Tbt03187KB

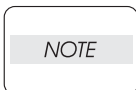

Place the BELT ASSY IBT in a safe place to prevent damage to its belt.

- 1) Place the BELT ASSY IBT on the right and left GUIDE BELTs with the right and left arrows on the top surface of the BELT ASSY IBT aligned with the triangular markings on the COVER INNER FRONT.
- 2) Insert the BELT ASSY IBT slowly into the COVER INNER FRONT until the guideline on the top surface of the BELT ASSY IBT aligns with the front side of the COVER INNER FRONT.

Continues to the next page.

Replacement 59 KIT BELT ASSY IBT (PL5.1.99)

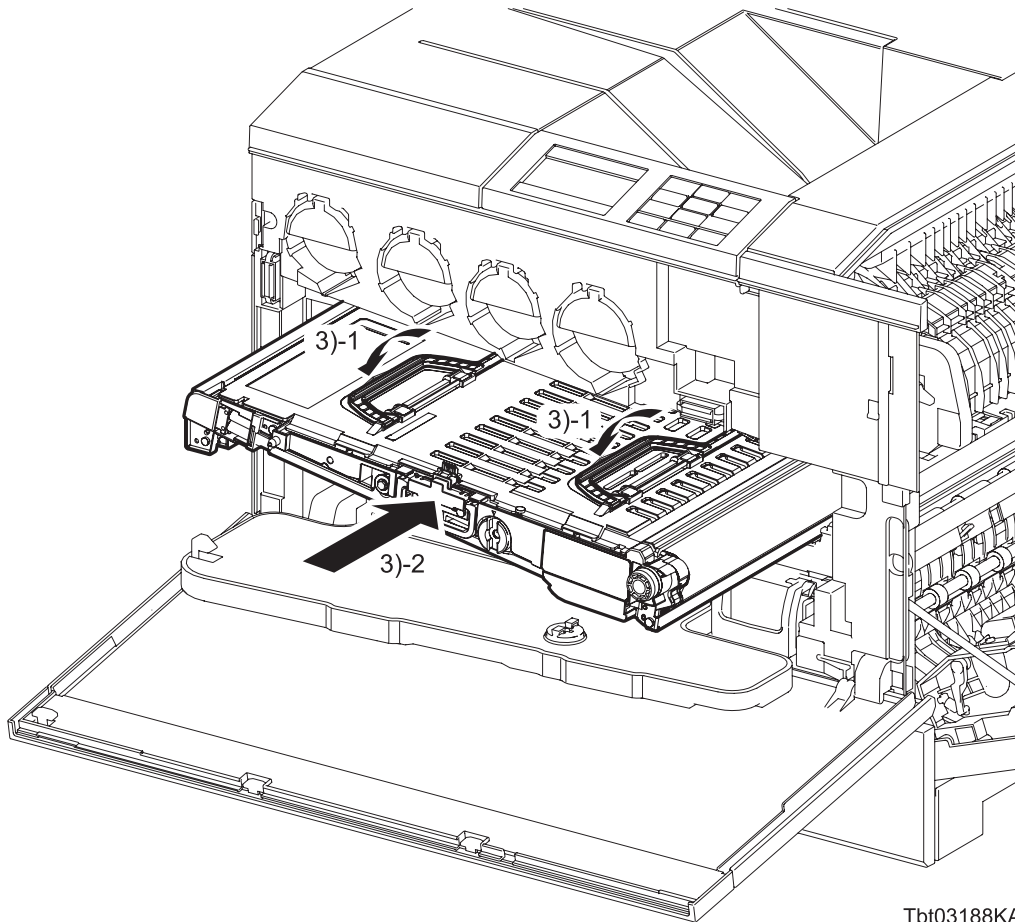

- 3) Tilt the right and left TOP HANDLEs of the BELT ASSY IBT to the left, and push the BELT ASSY IBT until it locks.
- 4) Close the FRAME ASSY 2ND and lock the handle.
- 5) Close the COVER ASSY RH.
- 6) Close the COVER ASSY FRONT.

Replacement 60 WASTE TONER BOX (PL6.1.13)

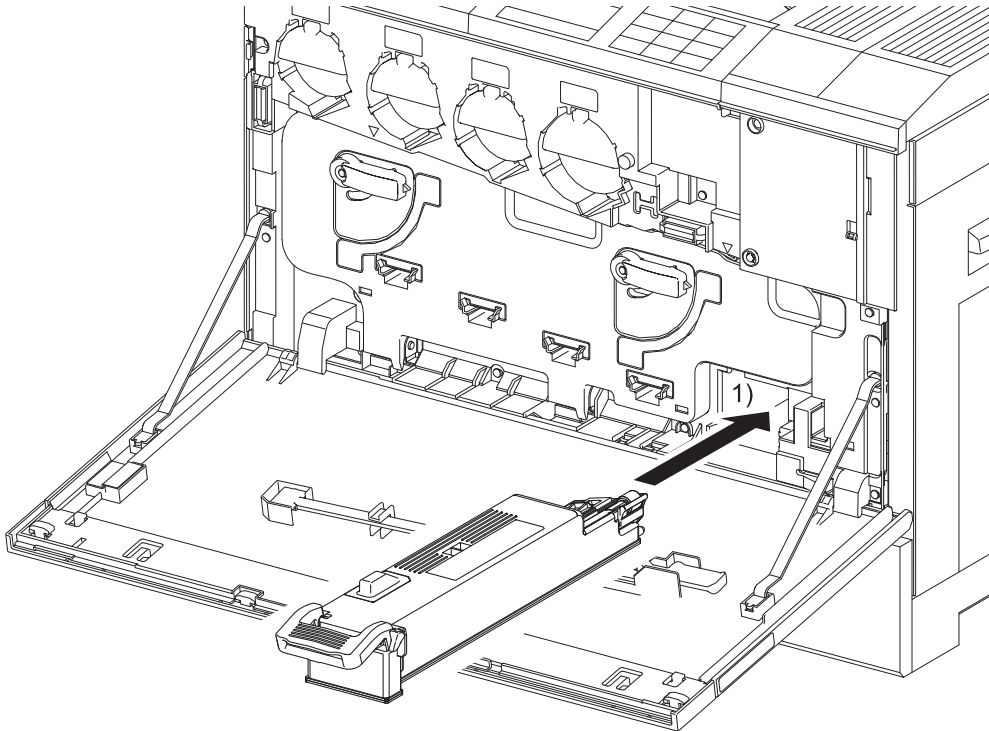

Tbt03189KA

- 1) Push the WASTE TONER BOX into the printer until it locks.
- 2) Close the COVER ASSY FRONT.

Replacement 61 STRAP COVER FRONT (PL1.2.18)

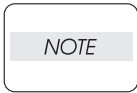

The removal step of the STRAP COVER FRONT described below is common to the left and right parts.

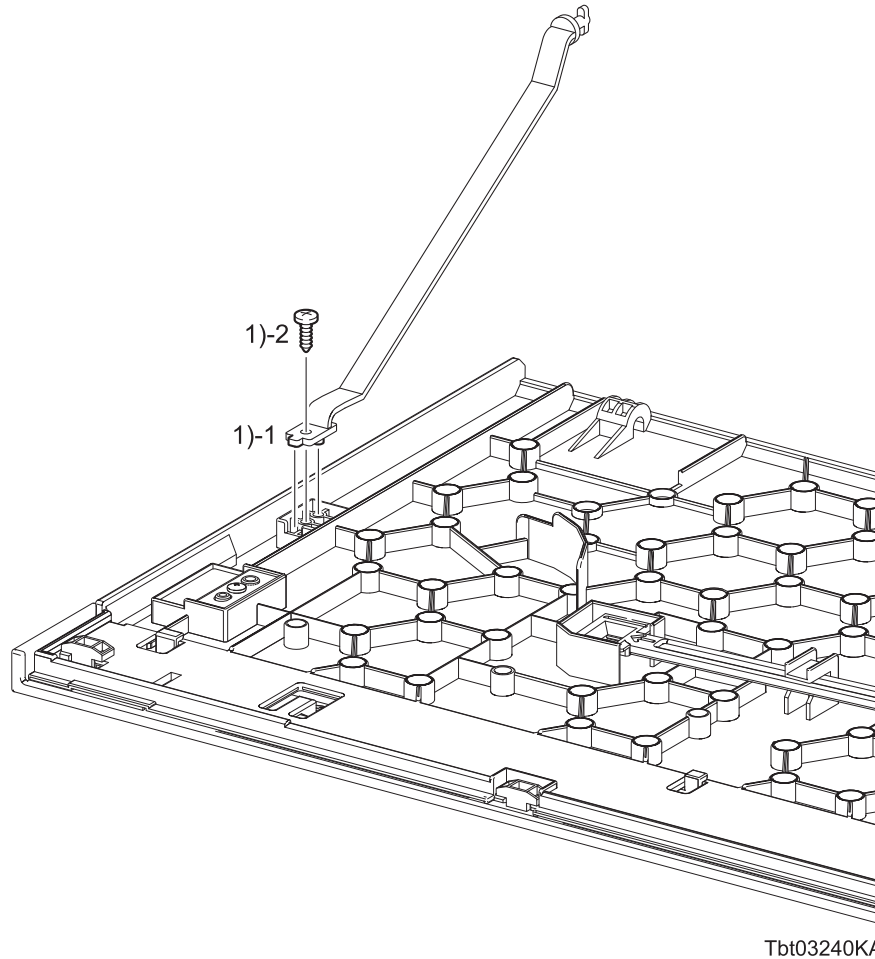

- 1) Mate the boss of the STRAP COVER FRONT with the hole of the COVER ASSY FRONT, and then secure with the one screw (silver, tapping, 8mm).

Go to the next replacement step:

Replacement 62 COVER ASSY FRONT (PL1.2.17)

Replacement 62 COVER ASSY FRONT (PL1.2.17)

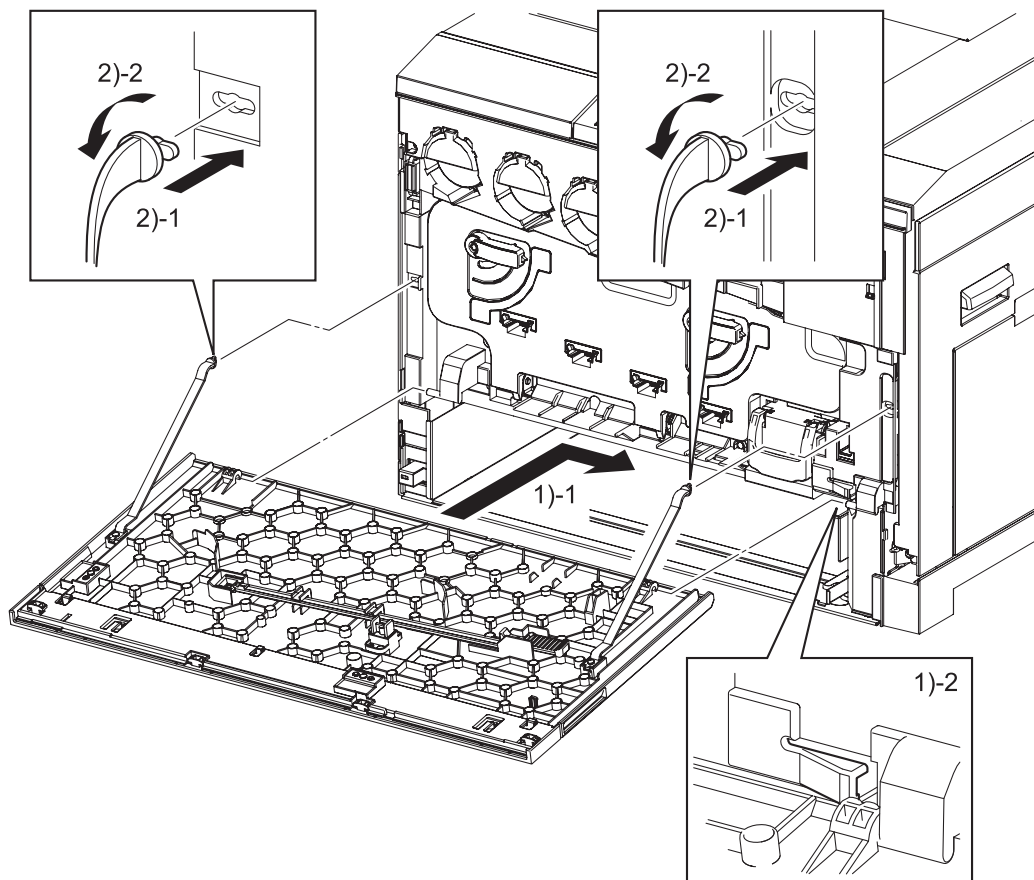

Tbt03190KB

- 1) Attach the COVER ASSY FRONT to the right and left bosses of the COVER INNER FRONT. Then, slide the COVER ASSY FRONT to the right until it locks in the hooks of the COVER INNER FRONT.
- 2) Attach the STRAP COVER FRONT to the COVER INNER FRONT with the two right and left tabs of the STRAP COVER FRONT fitted in the notches in the COVER INNER FRONT. Then, rotate the STRAP COVER FRONT by 90 degrees to secure it in position.
- 3) Close the COVER ASSY FRONT.
- 4) Attach the TRAY ASSY to the printer.

Replacement 63 WIRELESS ADAPTER (PL10.1.25)

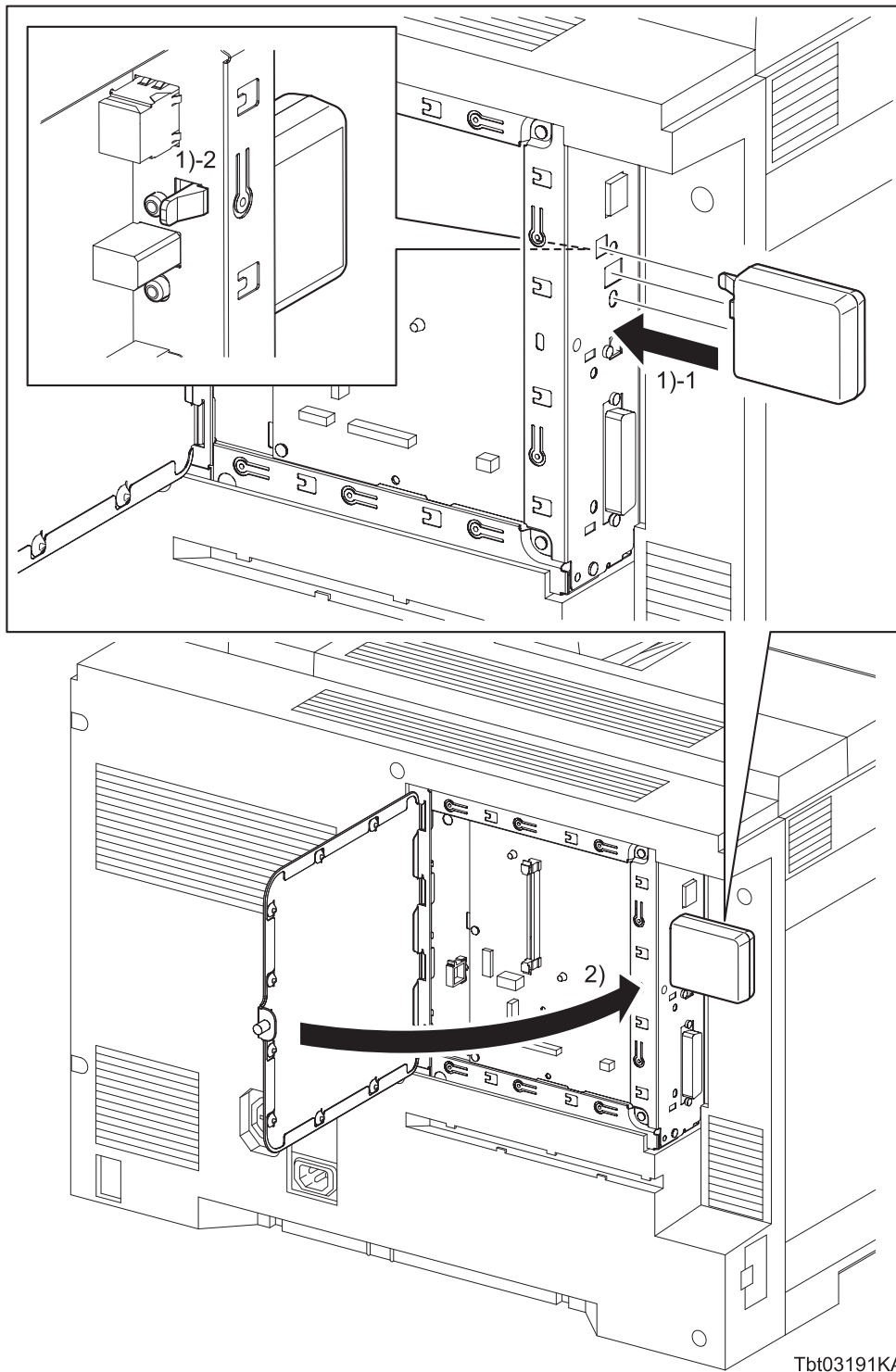

- 1) Mate the two bosses of the WIRELESS ADAPTER with the holes of the printer, and then secure with the hook.
- 2) Close the PLATE WINDOW ESS and secure the SCREW KNURLING.

Replacement 64 MEMORY CARD (PL10.1.24)

NOTE

Use a wrist strap to protect the MEMORY CARD from electrostatic damage.

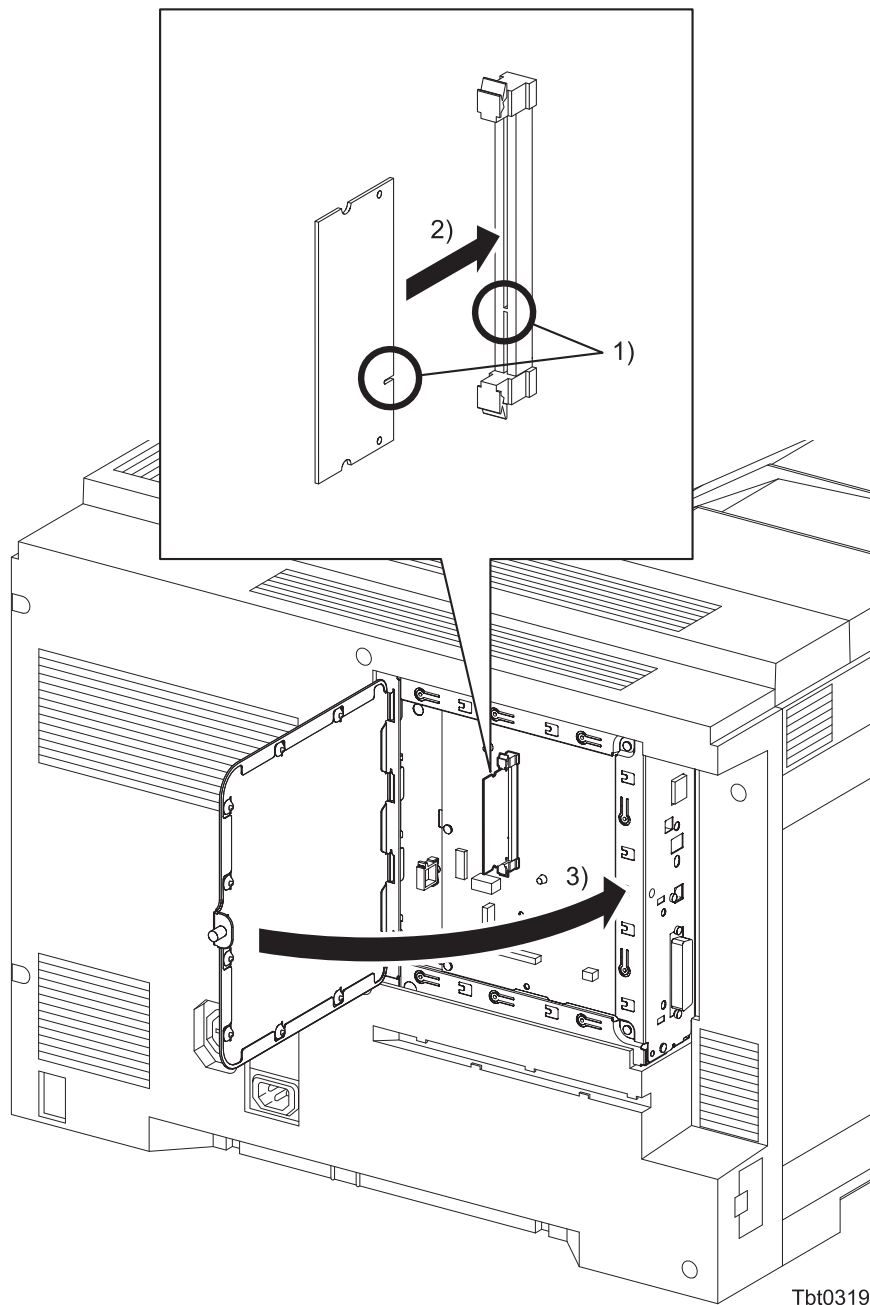

Tbt03192KA

- 1) Fit the MEMORY CARD into the socket by mating the notch of the MEMORY CARD with the lug on the socket.
- 2) Insert the MEMORY CARD to the socket until it locks.
- 3) Close the PLATE WINDOW ESS and secure the SCREW KNURLING.

Replacement 65 HDD ASSY (PL10.1.23)

NOTE

Use a wrist strap to protect the HDD ASSY from electrostatic damage.

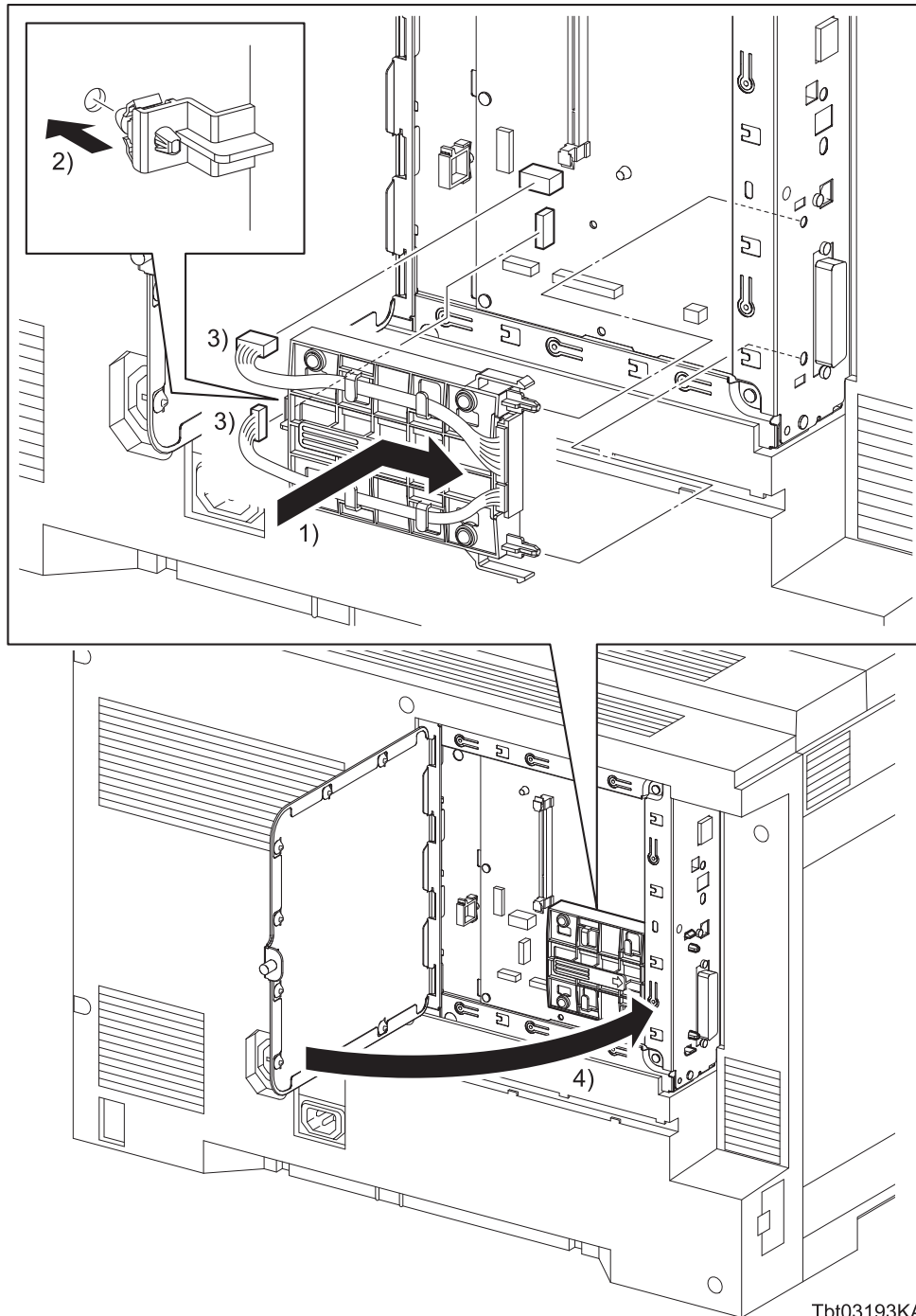

Tbt03193KA

- 1) Mate the two bosses of the HDD ASSY with the holes of the printer, and then secure with the two hooks.
- 2) Secure the HDD ASSY to the PWBA ESS with the clamp.
- 3) Engage the two sets of connectors (P/J11, 12) of the HDD ASSY to the LVPS ASSY.
- 4) Close the PLATE WINDOW ESS and secure the SCREW KNURLING.

Blank Page

Replacement 66 KIT FEED ROLL & SEPARATOR ROLL (FEEDER ASSY 550)
(PL12.4.99)

NOTE

When replacing the SEPARATOR ROLL or the FEED ROLL replace the SEPARATOR ROLL and the two FEED ROLLS at the same time.

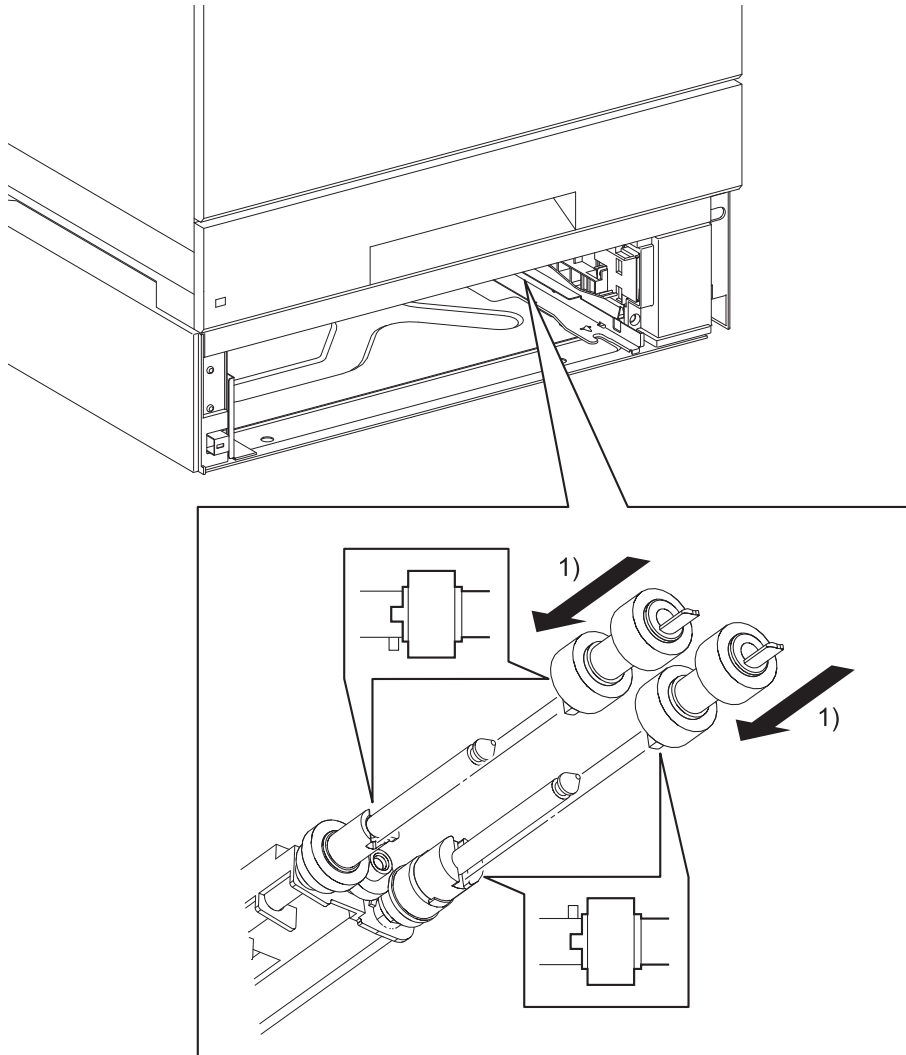

Tbt03194KA

- 1) Slide the ROLL ASSY FEEDs onto the shafts so that the lugs of the ROLL ASSY FEEDs are mated with the notches of the CLUTCH ASSY ONEWAY FEED (PL12.4.23) and ROLL ASSY GEAR NUDGER (PL12.4.26). Lock the hooks of the FEED ROLLERS into the grooves of the shafts.

Continues to the next page.

Replacement 66 KIT FEED ROLL & SEPARATOR ROLL (FEEDER ASSY 550)
(PL12.4.99)

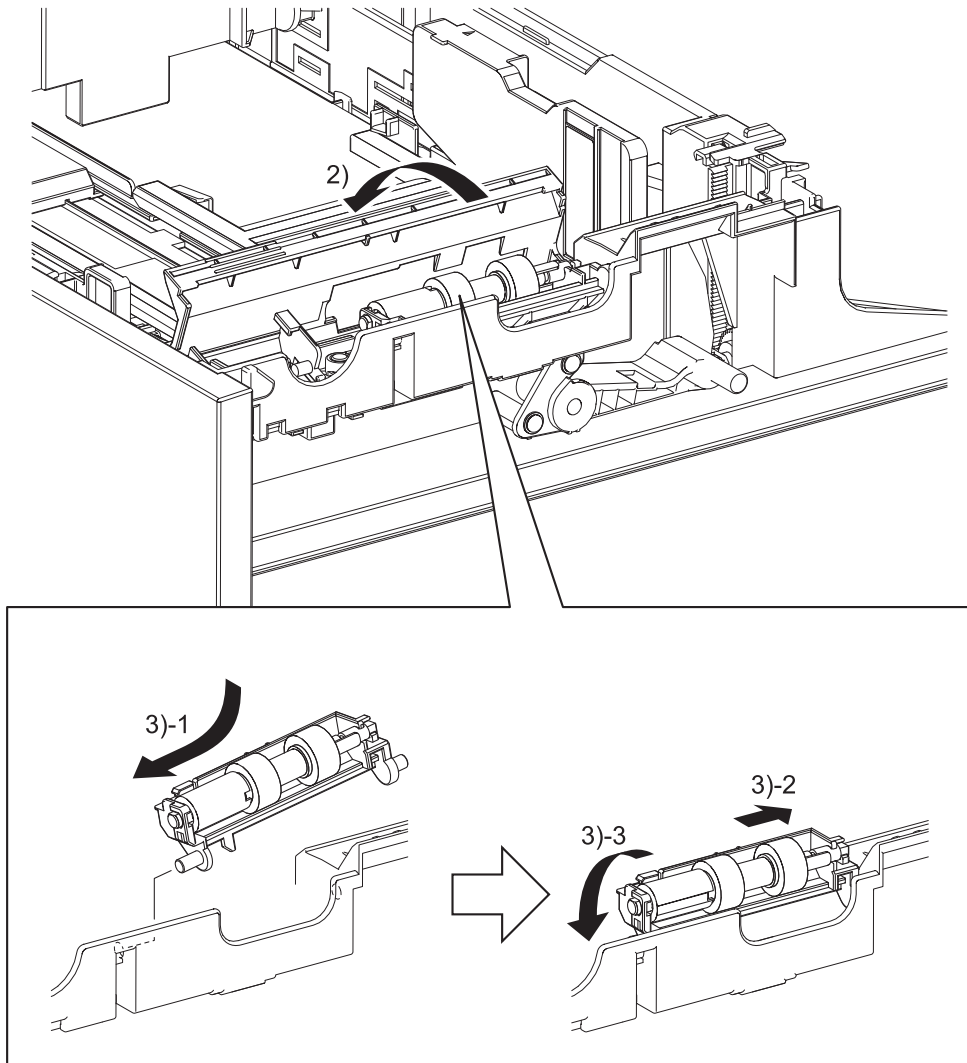

Tbt03195KB

- 2) Open and hold the COVER SEPARATOR.
- 3) Insert the boss on the rear side of the HOLDER ASSY SEPARATOR into the TRAY ASSY OPTION. Then, insert the boss on the front side of the HOLDER ASSY SEPARATOR into the TRAY ASSY OPTION to install the HOLDER ASSY SEPARATOR in position.
- 4) Close the COVER SEPARATOR.
- 5) Attach the TRAY ASSY OPTION to the FEEDER ASSY 550.

Replacement 67 KIT FEEDER ASSY 550 (PL12.1.99)

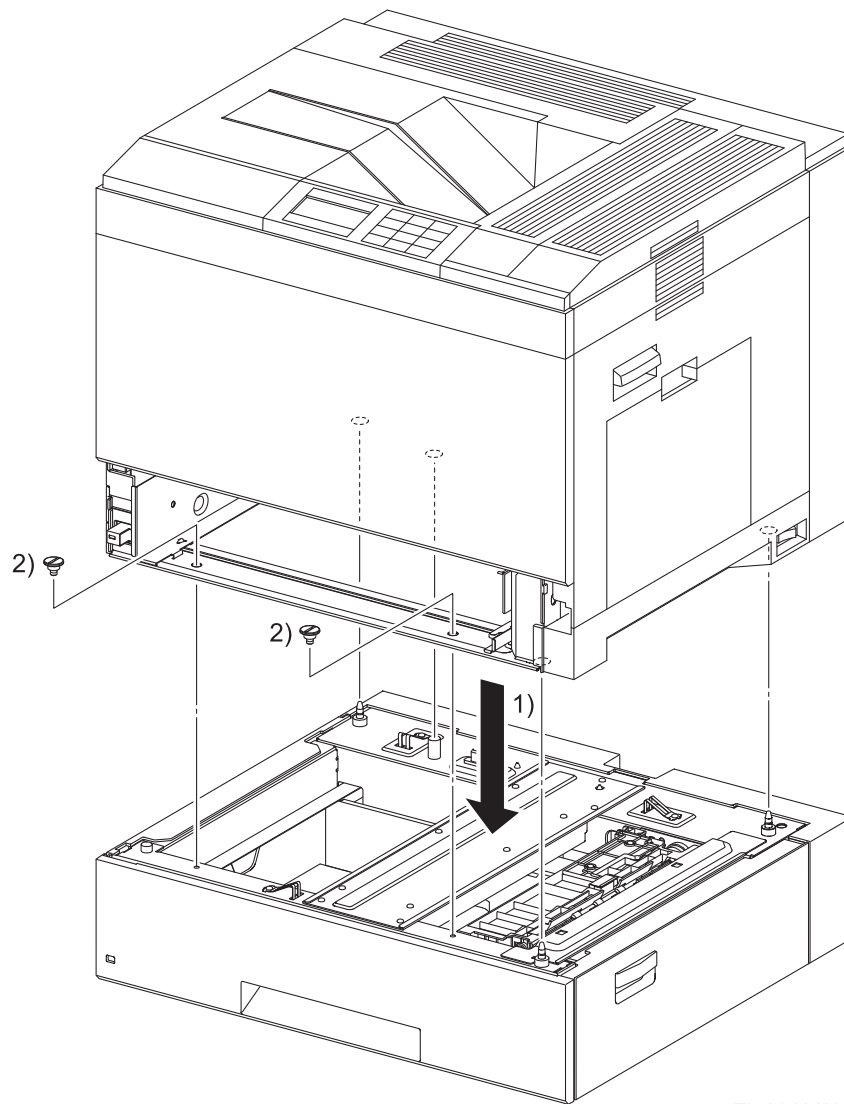

Tbt03196KA

NOTE

The printer must be lifted by three people.

- 1) Place the printer on the FEEDER ASSY 550 with the four holes on the bottom of the printer aligned with the studs on the FEEDER ASSY 550.
- 2) Secure the printer to the FEEDER ASSY 550 using the two SCREW LOCKs.

Continues to the next page.

Replacement 67 KIT FEEDER ASSY 550 (PL12.1.99)

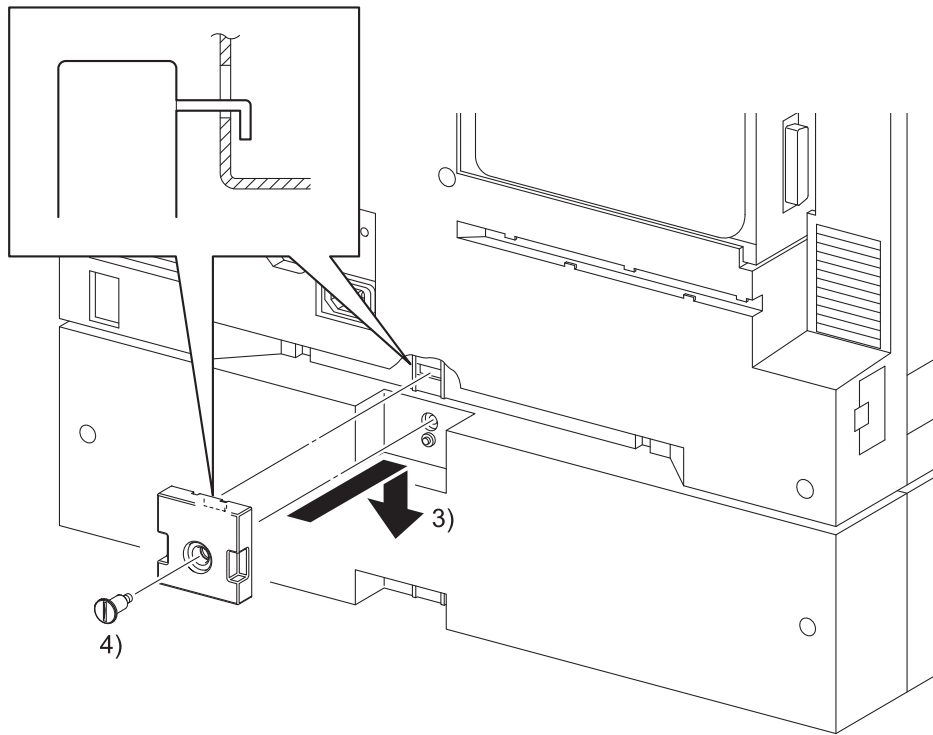

Tbt03197KA

- 3) Fit the hook of the PLATE LOCK REAR ASSY into the hole in the printer and attach the PLATE LOCK REAR ASSY to the FEEDER ASSY 550.
- 4) Secure the PLATE LOCK REAR ASSY to the FEEDER ASSY 550 using the SCREW LOCK REAR.
- 5) Attach the TRAY ASSY to the printer.

Replacement 68 KIT FEED ROLL & SEPARATOR ROLL (FEEDER ASSY 1100)
(PL13.5.99)

NOTE

Since the KIT FEED ROLL and SEPARATOR ROLL are installed in the same manner for the upper and lower stages, only the installation procedure for the upper stage is described below.

NOTE

When replacing the SEPARATOR ROLL or the FEED ROLL replace the SEPARATOR ROLL and the two FEED ROLLS at the same time.

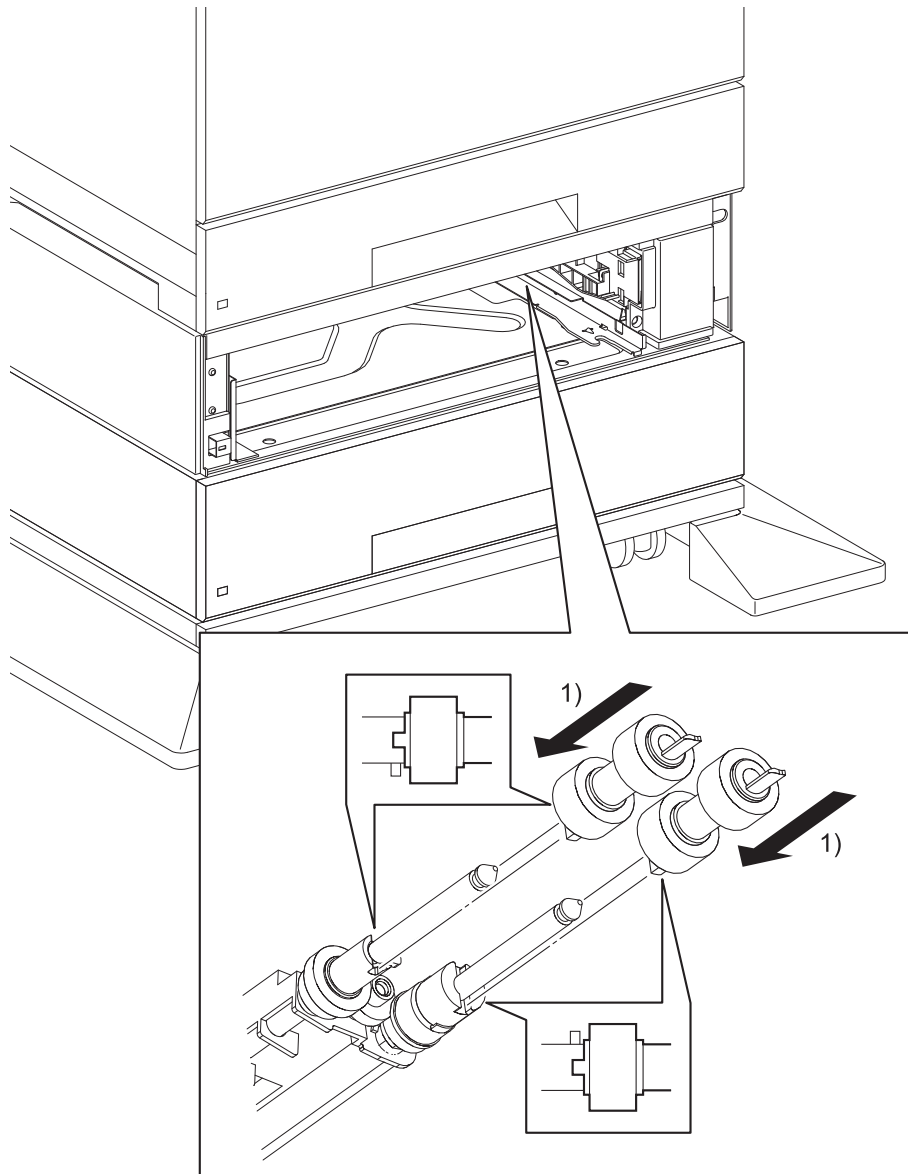

Tbt03198KA

- 1) Slide the ROLL ASSY FEEDs onto the shafts so that the lugs of the ROLL ASSY FEEDs are mated with the notches of the CLUTCH ASSY ONEWAY FEED (PL13.5.22) and ROLL ASSY GEAR NUDGER (PL13.5.25). Lock the hooks of the FEED ROLLERs into the grooves of the shafts.

Continues to the next page.

Replacement 68 KIT FEED ROLL & SEPARATOR ROLL (FEEDER ASSY 1100)
(PL13.5.99)

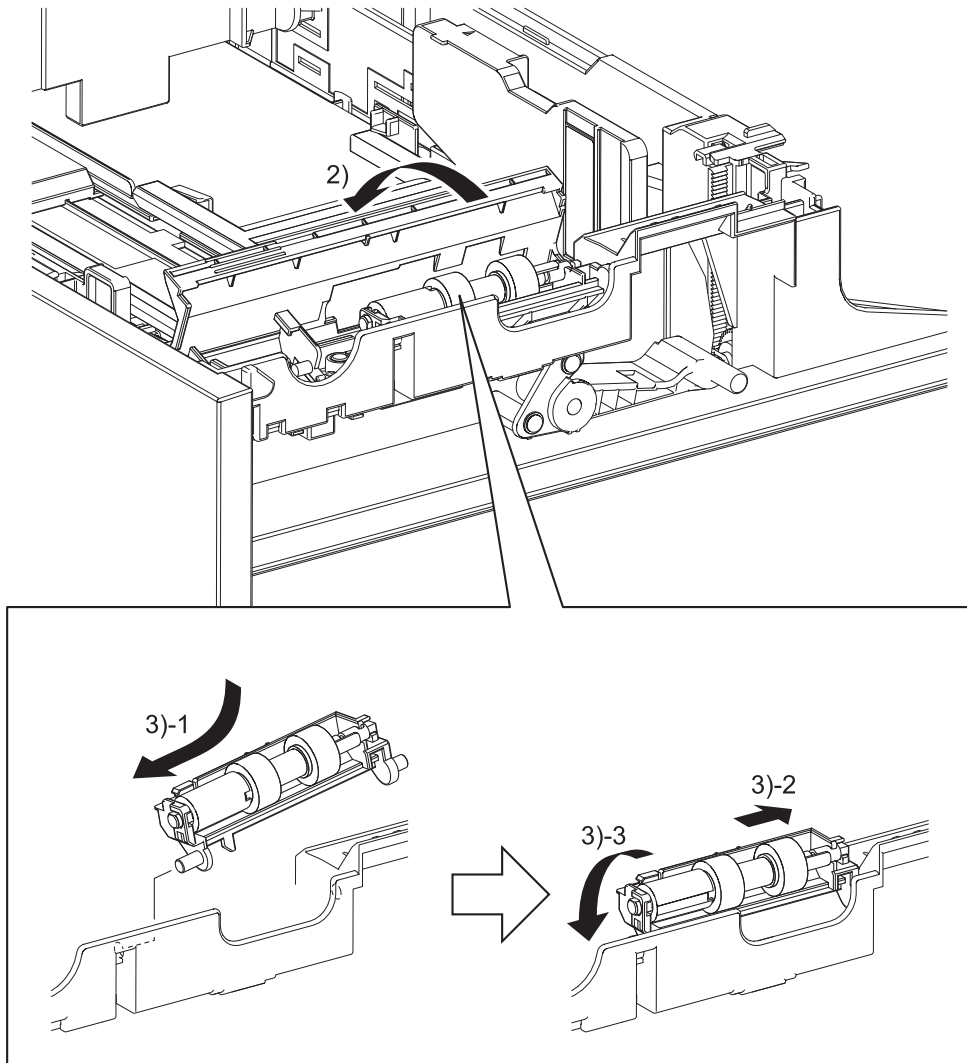

Tbt03199KB

- 2) Open and hold the COVER SEPARATOR.
- 3) Insert the boss on the rear side of the HOLDER ASSY SEPARATOR into the TRAY ASSY OPTION. Then, insert the boss on the front side of the HOLDER ASSY SEPARATOR into the TRAY ASSY OPTION to install the HOLDER ASSY SEPARATOR in position.
- 4) Close the COVER SEPARATOR.
- 5) Attach the TRAY ASSY OPTION to the FEEDER ASSY 1100.

Replacement 69 KIT FEEDER ASSY 1100 (PL13.1.99)

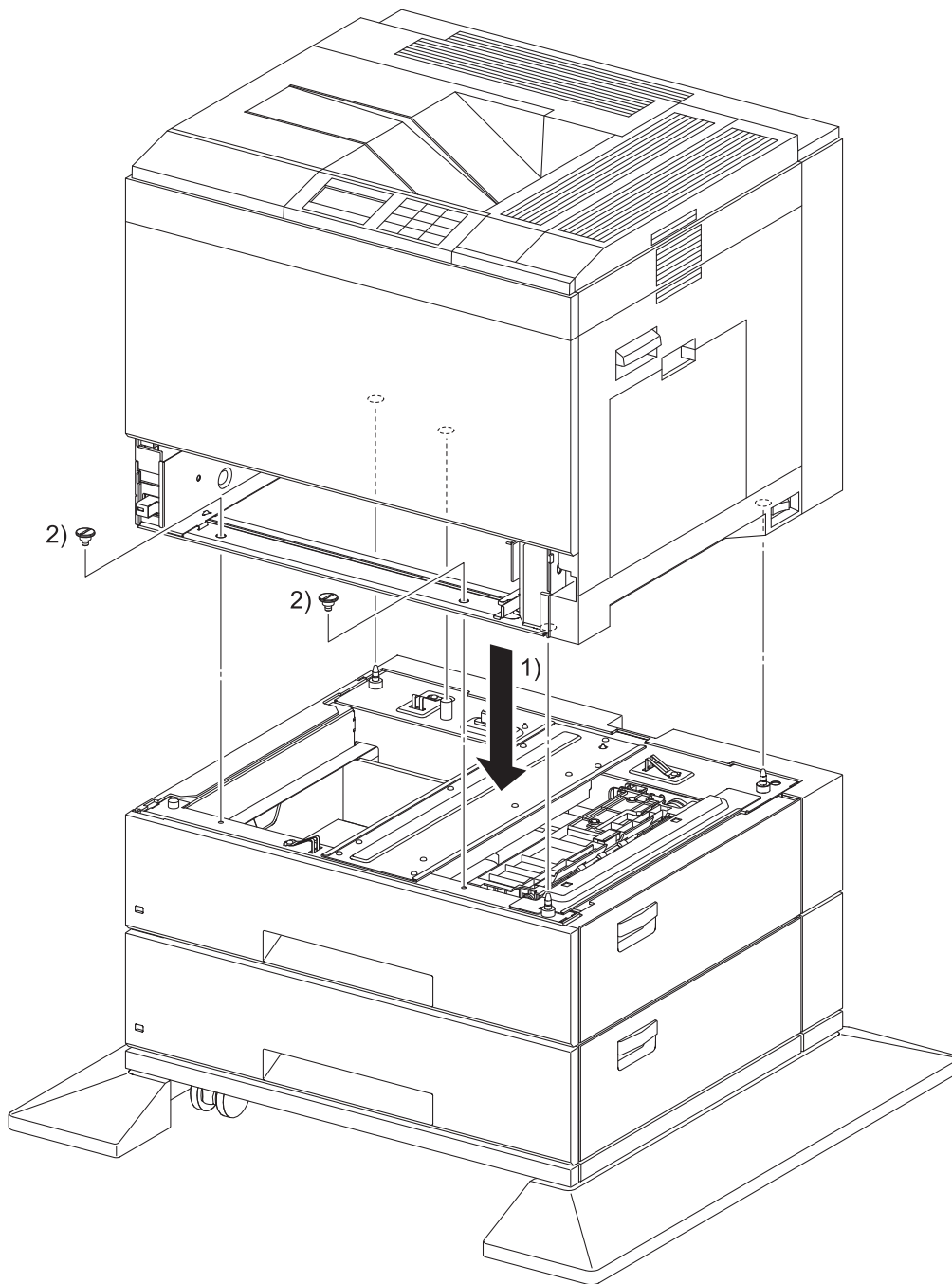

Tbt03200KA

NOTE

The printer must be lifted by three people.

- 1) Place the printer on the FEEDER ASSY 1100 with the four holes on the bottom of the printer aligned with the studs on the FEEDER ASSY 1100.
- 2) Secure the printer to the FEEDER ASSY 1100 using the two SCREW LOCKS.

Continues to the next page.

Replacement 69 KIT FEEDER ASSY 1100 (PL13.1.99)

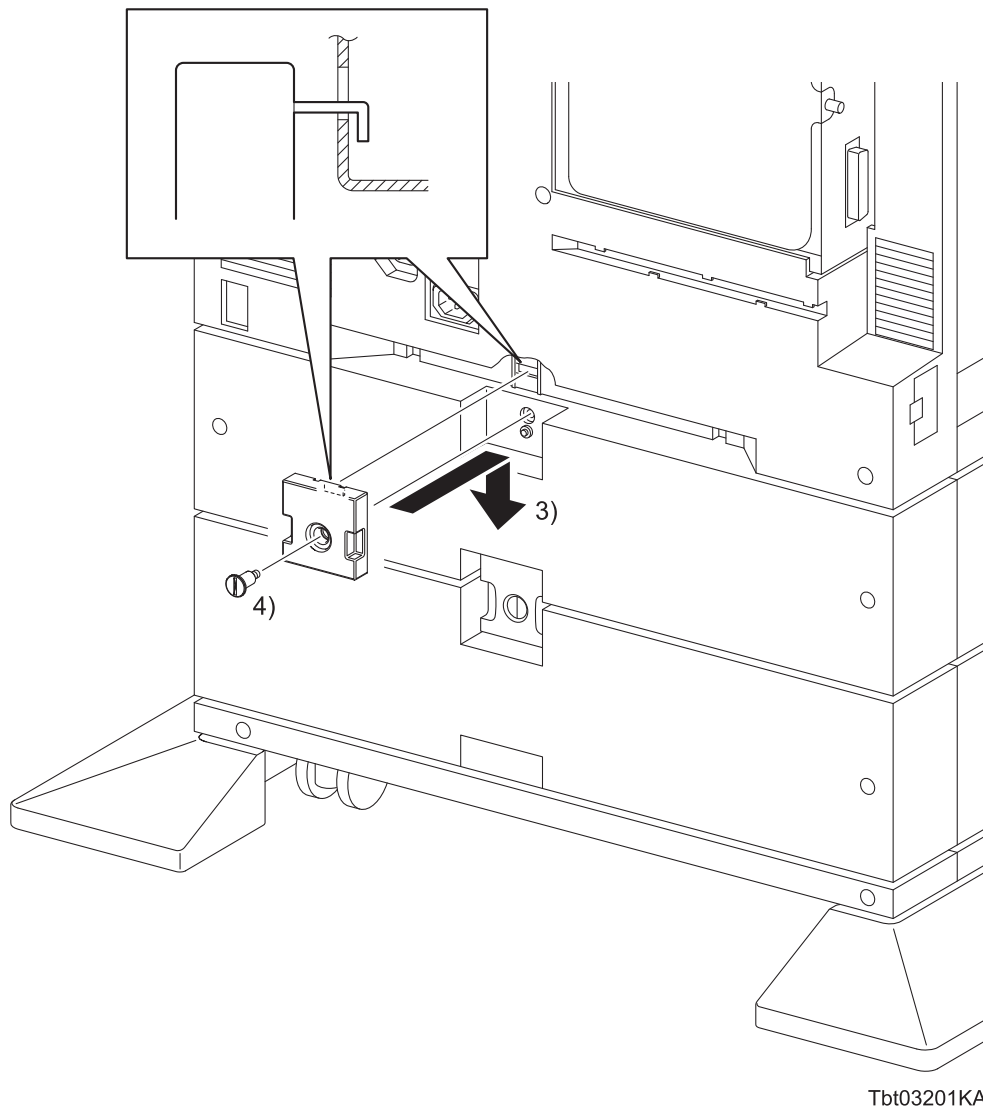

- 3) Fit the hook of the PLATE LOCK REAR ASSY into the hole in the printer and attach the PLATE LOCK REAR ASSY to the FEEDER ASSY 1100.
- 4) Secure the PLATE LOCK REAR ASSY to the FEEDER ASSY 1100 using the SCREW LOCK REAR.
- 5) Attach the TRAY ASSY to the printer.

Chapter 4 Plug/Jack(P/J) Connector Locations CONTENTS

1. Connector [P (plug) / J (jack)].....	4 - 1
1.1 List of P/J	4 - 1
1.2 IOT P/J layout diagram	4 - 5
1.3 550 OPTION FEEDER P/J layout diagram.....	4 - 11
1.4 HCF P/J layout diagram.....	4 - 12

1. Connector [P (plug) / J (jack)]

1.1 List of P/J

Printer

P/J	Coordinates	Remarks
1	B-172	Connects PWBA MCU and HARNESS ASSY FSR
2	C-172	Connects PWBA MCU and HARNESS ASSY ESS CORE
3	C-174	Connects PWBA MCU and HARNESS ASSY ROS/HV
4	A-173	Connects PWBA MCU and HARNESS ASSY DISP/FSR
5	A-173	Connects PWBA MCU and HARNESS ASSY LPP/MOT
6	A-172	Connects PWBA MCU and HARNESS ASSY LPP/MOT
7	A-172	Connects PWBA MCU and HARNESS ASSY RH/MOT
8	C-174	Not Connect
9	B-173	Connects PWBA MCU and HARNESS ASSY RH/MOT
10	C-173	Connects PWBA MCU and HARNESS ASSY REGI
11 (ESS)	F-154	Connects PWBA ESS and HDD ASSY
11 (MCU)	C-172	Connects PWBA MCU and HARNESS ASSY TN CRUM
12 (ESS)	F-154	Connects PWBA ESS and HDD ASSY
12 (MCU)	D-173	Connects PWBA MCU and HARNESS ASSY CRUM/DISP
13	D-173	Connects PWBA MCU and HARNESS ASSY ROS/HV
15	C-173	Connects PWBA MCU and HARNESS ASSY CRUM/DISP
16	A-173	Connects PWBA MCU and HARNESS ASSY ERASE/EXIT
17	C-172	Connects PWBA MCU and HARNESS ASSY ERASE/EXIT
18	B-173	Connects PWBA MCU and HARNESS ASSY LPP/MOT
19	A-172	Connects PWBA MCU and HARNESS ASSY DISP/FSR
20	C-172	Connects PWBA MCU and HARNESS ASSY EXIT
21	C-173	Connects PWBA MCU and HARNESS ASSY LPP/MOT
22	D-173	Connects PWBA MCU and HARNESS ASSY FIN
23	A-173	Connects PWBA MCU and HARNESS ASSY LV PWR
24	B-173	Connects PWBA MCU and HARNESS ASSY LVPS
29	C-173	Not Connect (Test print only)
100	C-183	Connects DRIVE ASSY PH (Switching Clutch) and HARNESS ASSY RH/MOT
101 (REGI)	H-125	Connects REGI Unit (REGI Clutch) and HARNESS ASSY REGI
101 (MCU)	B-172	Not Connect (Debug only)
102	H-125	Connects REGI Unit (Feed Clutch) and HARNESS ASSY REGI
103	H-125	Connects REGI Unit (Take Away Clutch) and HARNESS ASSY REGI
105	H-125	Connects REGI Unit (HARNESS ASSY REGI SNR) and HARNESS ASSY REGI
106	H-108	Connects PROCON ASSY (HARNESS ASSY CTD/HUM) and HARNESS ASSY ERASE/EXIT
108	H-108	Connects PROCON ASSY (HARNESS ASSY CTD SNR) and HARNESS ASSY ERASE/EXIT
110	H-125	Connects REGI Unit (HARNESS ASSY NPP SNR) and HARNESS ASSY REGI

P/J	Coordinates	Remarks
115	F-119	Connects DRIVE ASSY EXIT (Exit INV Clutch) and HARNESS ASSY EXIT
116	F-120	Connects DRIVE ASSY EXIT (Exit Clutch) and HARNESS ASSY EXIT
117	F-141	Connects RH Cover Unit (HARNESS ASSY RH COVER) and HARNESS ASSY RH/MOT
118	F-141	Connects RH Cover Unit (MSI Feed Solenoid) and HARNESS ASSY RH/MOT
119	E-136	Connects FAN FUSER and HARNESS ASSY RH COVER
120	F-141	Connects RH Cover Unit (DUP Clutch) and HARNESS ASSY RH/MOT
121	F-169	Connects HARNESS ASSY FIN and Finisher (HARNESS ASSY IF A4FIN)
122	H-120	Connects CHUTE ASSY INVERT (Invert Solenoid) and HARNESS ASSY DISP/FSR
151	H-167	Connects ROS ASSY and HARNESS ASSY ROS/HV
152	H-168	Connects ROS ASSY and HARNESS ASSY VIDEO
153	H-167	Connects ROS ASSY and HARNESS ASSY ROS/HV
173	D-154	Connects BREAKER GFI INLET and HARNESS ASSY AC
174	D-154	Connects BREAKER GFI INLET and HARNESS ASSY AC
175	D-155	Connects BREAKER GFI INLET and WIRE ASSY GFI EARTH
180	H-121	Connects FUSER ASSY and HARNESS ASSY FSR
181	G-156	Connects HARNESS ASSY LPP/MOT and Option Feeder (HARNESS ASSY OPT TOP)
200	D-183	Connects Switching Sensor (K) and HARNESS ASSY RH/MOT
201	I-183	Connects Switching Sensor (FC) and HARNESS ASSY CRUM/DISP
203	F-124	Connects REGI Sensor and HARNESS ASSY REGI SNR
204	D-105	Connects CONNECTOR ASSY CRUM (TN CRUM Y) and HARNESS ASSY TN CRUM
205	E-105	Connects CONNECTOR ASSY CRUM (TN CRUM M) and HARNESS ASSY TN CRUM
206	F-106	Connects CONNECTOR ASSY CRUM (TN CRUM C) and HARNESS ASSY TN CRUM
207	G-106	Connects CONNECTOR ASSY CRUM (TN CRUM K) and HARNESS ASSY TN CRUM
208	E-107	Connects CONNECTOR ASSY CRUM (XERO CRUM Y) and HARNESS ASSY CRUM/DISP
209	F-107	Connects CONNECTOR ASSY CRUM (XERO CRUM M) and HARNESS ASSY CRUM/DISP
210	G-107	Connects CONNECTOR ASSY CRUM (XERO CRUM C) and HARNESS ASSY CRUM/DISP
211	H-108	Connects CONNECTOR ASSY CRUM (XERO CRUM K) and HARNESS ASSY CRUM/DISP
212	F-108	Connects Front Cover Switch and HARNESS ASSY EXIT
213	G-109	Connects HUM Sensor and HARNESS ASSY CTD/HUM
214	F-170	Connects PWBA EEPROM and HARNESS ASSY ROS/HV
215	I-107	Connects CONNECTOR ASSY CRUM (Belt CRUM) and HARNESS ASSY ERASE/EXIT
216	G-109	Connects Waste Toner Box Full Sensor and HARNESS ASSY CTD/HUM
217	H-109	Connects ADC Sensor (Front) and HARNESS ASSY CTD SNR
218	I-109	Connects ADC Sensor (Rear) and HARNESS ASSY CTD SNR
219	D-125	Connects CST Size Switch and HARNESS ASSY LPP/MOT
220	F-124	Connects CST No Paper Sensor and HARNESS ASSY NPP SNR
221	G-125	Connects Low Paper Sensor and HARNESS ASSY LPP/MOT

P/J	Coordinates	Remarks
222	G-125	Connects Low Paper 50% Sensor and HARNESS ASSY LPP/MOT
224	D-122	Connects CHUTE ASSY EXIT (Full Stack Sensor) and HARNESS ASSY EXIT
225	D-122	Connects CHUTE ASSY EXIT (Envelope Mode Sensor) and HARNESS ASSY EXIT
226	E-140	Connects MSI No Paper Sensor and HARNESS ASSY RH COVER
228	I-108	Connects LAMP ASSY ERASE (K) and HARNESS ASSY ERASE/EXIT
229	H-107	Connects LAMP ASSY ERASE (C) and HARNESS ASSY ERASE/EXIT
230	G-107	Connects LAMP ASSY ERASE (M) and HARNESS ASSY ERASE/EXIT
231	F-106	Connects LAMP ASSY ERASE (Y) and HARNESS ASSY ERASE/EXIT
250	D-181	Connects DRIVE ASSY FSR and HARNESS ASSY DISP/FSR
251	F-181	Connects DRIVE ASSY XERO and HARNESS ASSY DISP/FSR
252	G-185	Connects DRIVE ASSY DEVE and HARNESS ASSY LPP/MOT
253	F-185	Connects DRIVE ASSY DEVE K and HARNESS ASSY LPP/MOT
254	C-183	Connects DRIVE ASSY IBT and HARNESS ASSY RH/MOT
255	D-185	Connects DRIVE ASSY PH (PH Motor) and HARNESS ASSY RH/MOT
256	E-181	Connects MOTOR ASSY DISP (Dispense Motor K) and HARNESS ASSY DISP/FSR
257	F-181	Connects MOTOR ASSY DISP (Dispense Motor C) and HARNESS ASSY DISP/FSR
258	G-182	Connects MOTOR ASSY DISP (Dispense Motor M) and HARNESS ASSY DISP/FSR
259	H-182	Connects MOTOR ASSY DISP (Dispense Motor Y) and HARNESS ASSY CRUM/DISP
260	G-185	Connects DRIVE ASSY DEVE and HARNESS ASSY LPP/MOT
300	C-155	Connects LVPS ASSY and HARNESS ASSY AC
301	D-151	Connects LVPS ASSY and HARNESS ASSY I/L RH
302	C-151	Connects LVPS ASSY and HARNESS ASSY I/L FRT
303	C-151	Connects LVPS ASSY and HARNESS ASSY ROS/HV
304	B-154	Connects LVPS ASSY and HARNESS ASSY FSR
305	C-151	Connects LVPS ASSY and HARNESS ASSY LV PWR
306	D-151	Connects LVPS ASSY and HARNESS ASSY ESS PWR
307	C-151	Connects LVPS ASSY and HARNESS ASSY LPP/MOT
308	D-151	Connects LVPS ASSY and HARNESS ASSY LVPS
309	D-151	Connects LVPS ASSY and FAN LVPS
311	C-155	Connects LVPS ASSY and HARNESS ASSY FIN PWR
315	C-151	Connects LVPS ASSY and HARNESS ASSY LPP/MOT
320	F-154	Connects PWBA ESS and HARNESS ASSY ESS CORE
321	F-154	Connects PWBA ESS and HARNESS ASSY ESS PWR
327	F-154	Connects PWBA ESS and HARNESS ASSY OPEPANE
328	F-154	Connects PWBA ESS and HARNESS ASSY VIDEO
331	J-155	Connects PWBA HVPS and HARNESS ASSY ROS/HV
332	J-153	Connects PWBA HVPS and HOUSING ASSY BTR
2200	D-106	Connects CONSOLE ASSY PANEL and HARNESS ASSY OPEPANE

550 Option Feeder

P/J	Coordinates	Remarks
181	F-199	Connects 550 Option Feeder (HARNESS ASSY OPT TOP) and Printer (HARNESS ASSY LPP/MOT)
183	G-195	Connects HARNESS ASSY OPT SW and Option Feeder (HARNESS ASSY OPT TOP)
350	F-194	Connects PWBA OPT FDR and HARNESS ASSY OPT TOP
351	F-194	Connects PWBA OPT FDR and HARNESS ASSY OPT SW
352	F-195	Connects PWBA OPT FDR and HARNESS ASSY OPT CL
353	F-194	Connects PWBA OPT FDR and HARNESS ASSY OPT SW
354	E-194	Connects PWBA OPT FDR and HARNESS ASSY OPT CL
355	E-194	Connects PWBA OPT FDR and HARNESS ASSY OPT MOT
356	F-194	Not Connect
357	C-193	Connects DRIVE ASSY OPT and HARNESS ASSY OPT MOT
358	E-194	Connects Take Away Clutch and HARNESS ASSY OPT CL
359	E-194	Connects Feed Clutch and HARNESS ASSY OPT CL
360	J-200	Connects RH Cover Switch and HARNESS ASSY OPT SW
361	F-193	Connects HARNESS ASSY OPT PATH and HARNESS ASSY OPT SW
363	H-200	Connects Paper Path Sensor and HARNESS ASSY OPT PATH
364	G-200	Connects OPT CST No Paper Sensor and HARNESS ASSY OPT PATH
365	F-200	Connects OPT CST Size Switch and HARNESS ASSY LPP/MOT
366	H-201	Connects OPT Low Paper 50% Sensor and HARNESS ASSY OPT CL
367	H-201	Connects OPT Low Paper Sensor and HARNESS ASSY OPT CL

HCF

P/J	Coordinates	Remarks
181	F-213	Connects HCF (HARNESS ASSY OPT TOP) and Printer (HARNESS ASSY LPP/MOT)
183/ 181	G-210	Connects Upper Feeder (HARNESS ASSY OPT SW) and Lower Feeder (HARNESS ASSY OPT TOP)
350	F-208	Connects PWBA OPT FDR and HARNESS ASSY OPT TOP
351	F-208	Connects PWBA OPT FDR and HARNESS ASSY OPT SW
352	F-209	Connects PWBA OPT FDR and HARNESS ASSY OPT CL
353	F-209	Connects PWBA OPT FDR and HARNESS ASSY OPT SW
354	F-209	Connects PWBA OPT FDR and HARNESS ASSY OPT CL
355	F-209	Connects PWBA OPT FDR and HARNESS ASSY OPT MOT
356	F-208	Not Connect
357	C-208	Connects DRIVE ASSY OPT and HARNESS ASSY OPT MOT
358	E-209	Connects Take Away Clutch and HARNESS ASSY OPT CL
359	E-209	Connects Feed Clutch and HARNESS ASSY OPT CL
360	J-215	Connects RH Cover Switch and HARNESS ASSY OPT SW
361	F-208	Connects HARNESS ASSY OPT PATH and HARNESS ASSY OPT SW
363	H-215	Connects Paper Path Sensor and HARNESS ASSY OPT PATH
364	G-215	Connects OPT CST No Paper Sensor and HARNESS ASSY OPT PATH
365	F-225	Connects OPT CST Size Switch and HARNESS ASSY LPP/MOT
366	H-215	Connects OPT Low Paper 50% Sensor and HARNESS ASSY OPT CL
367	H-215	Connects OPT Low Paper Sensor and HARNESS ASSY OPT CL

1.2 IOT P/J layout diagram

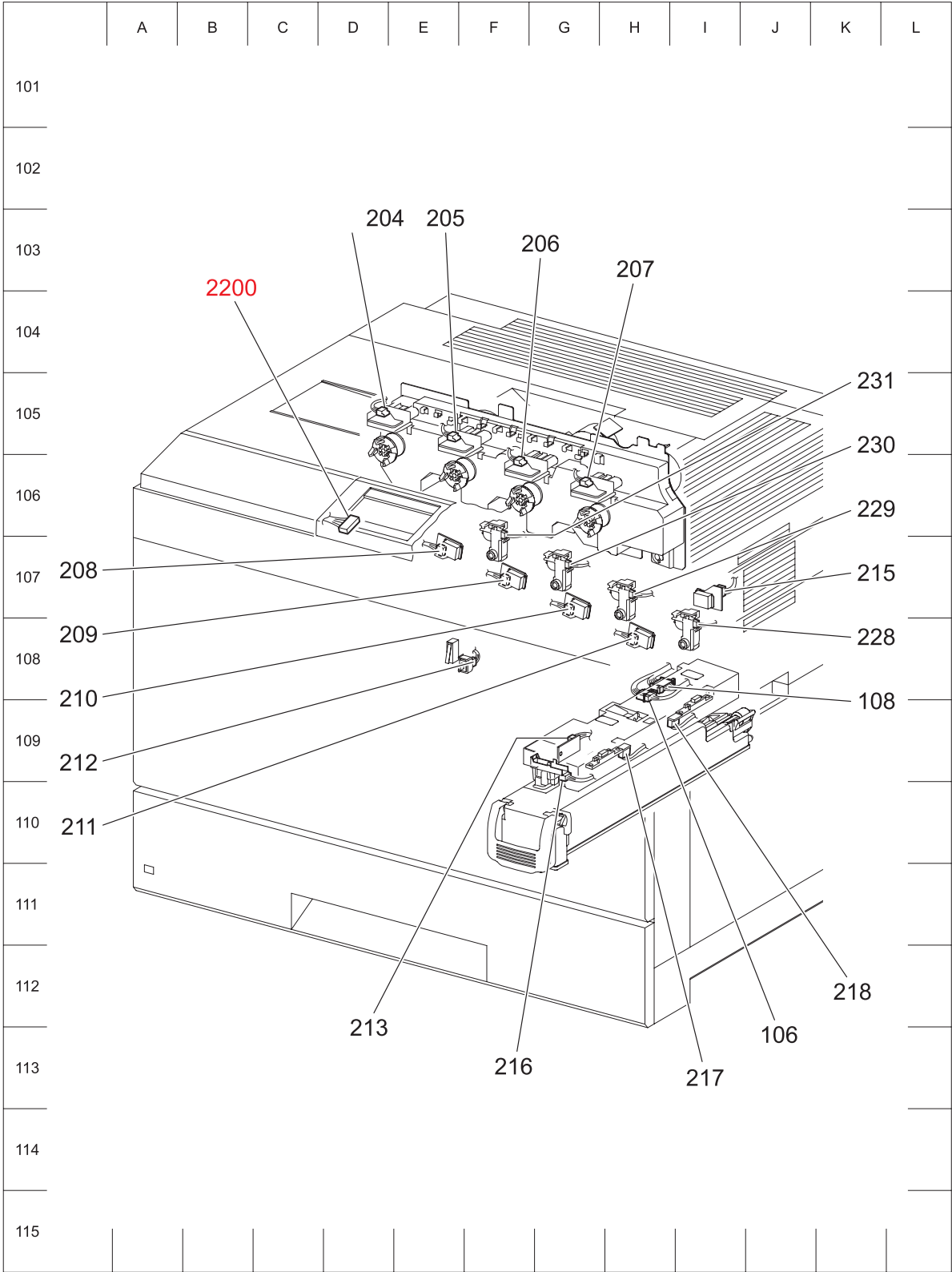

Tbt04001KB

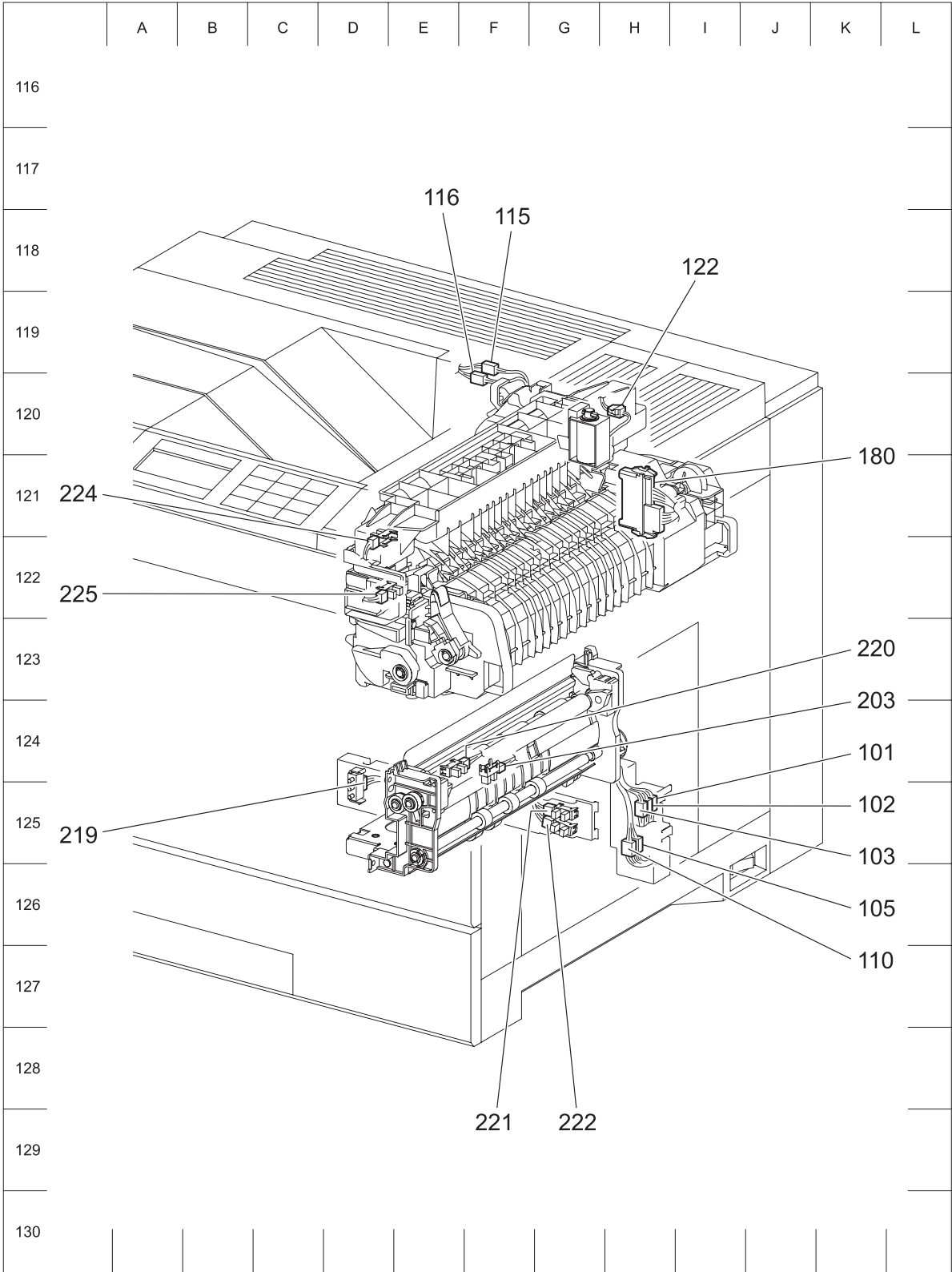

Tbt04002KA

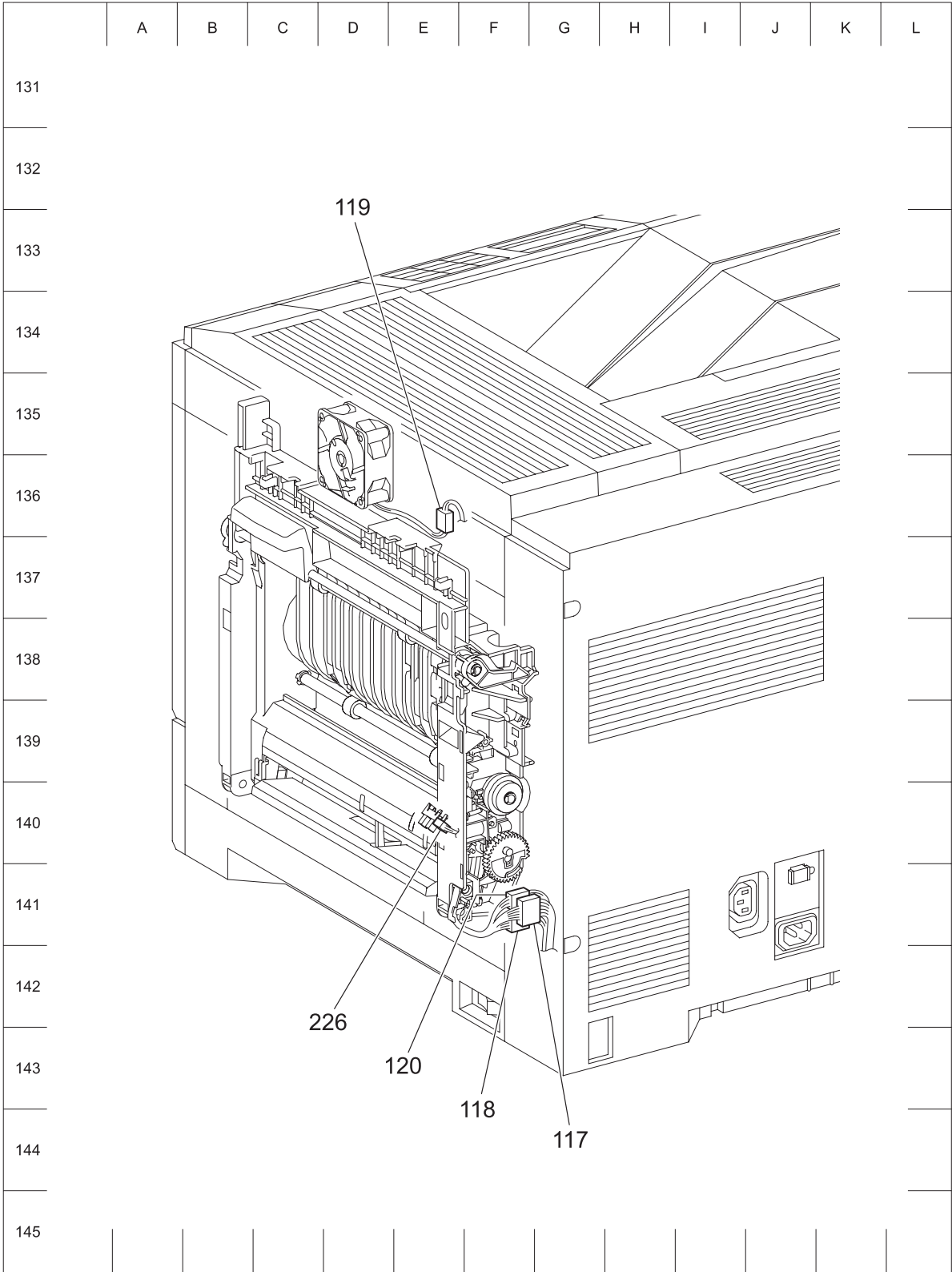

Tbt04003KA

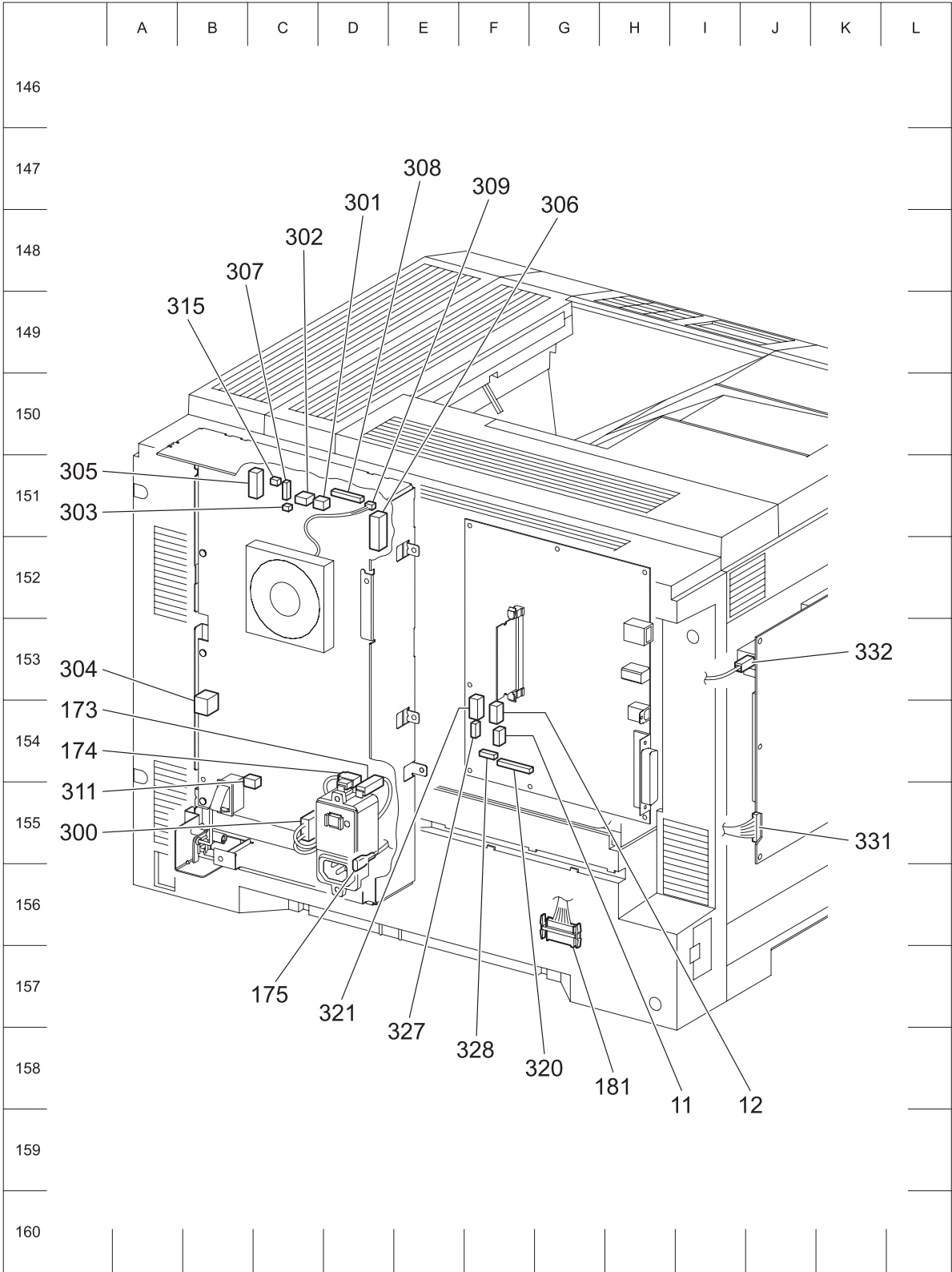

Tbt04004KA

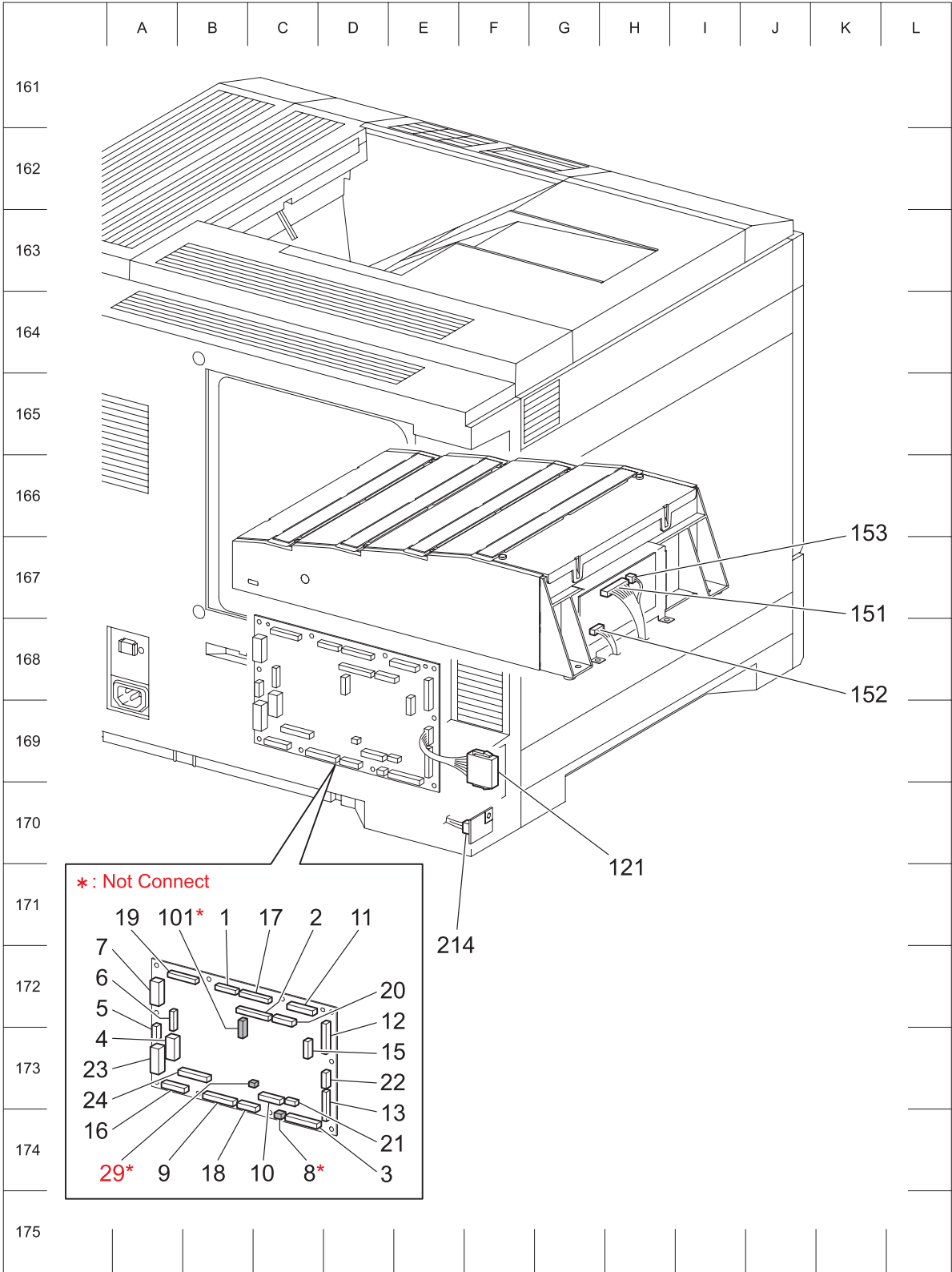

Tbt04005KC

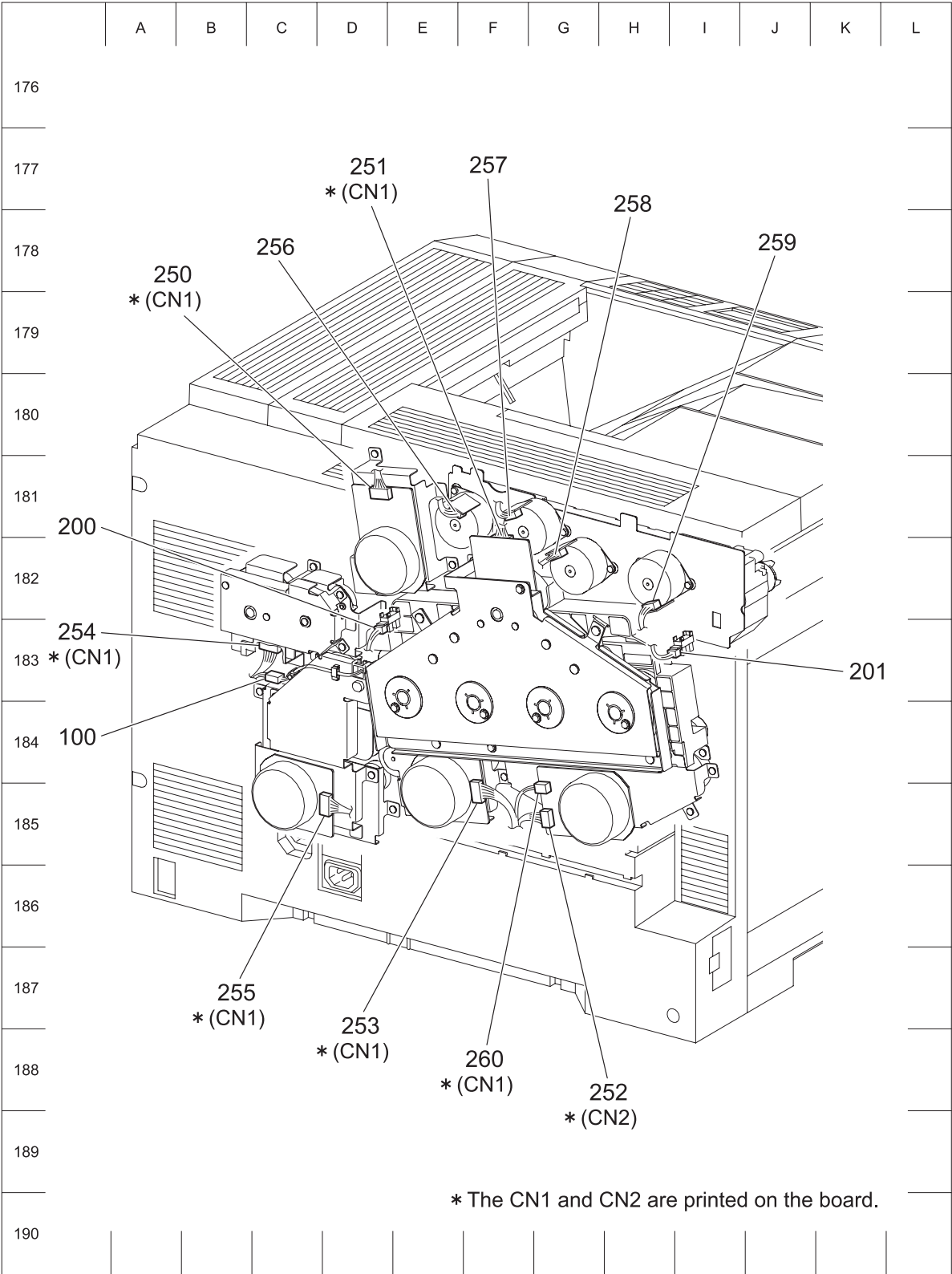

Tbt04006KA

1.3 550 OPTION FEEDER P/J layout diagram

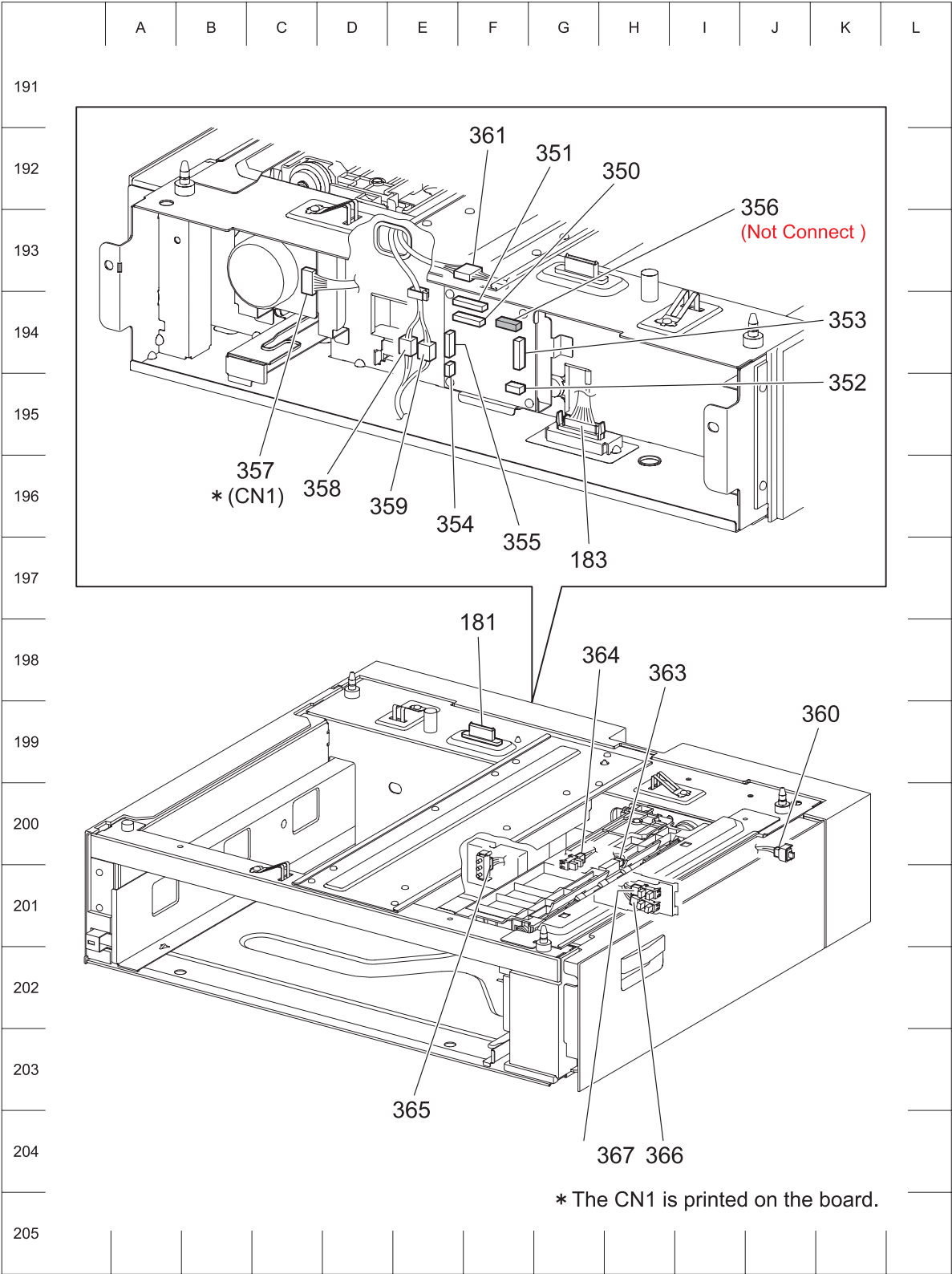

Tbt04007KB

1.4 HCF P/J layout diagram

NOTE

The P/J layout of the HCF is common among the upper and lower sections. (Shown below is the P/J layout of the upper section.)

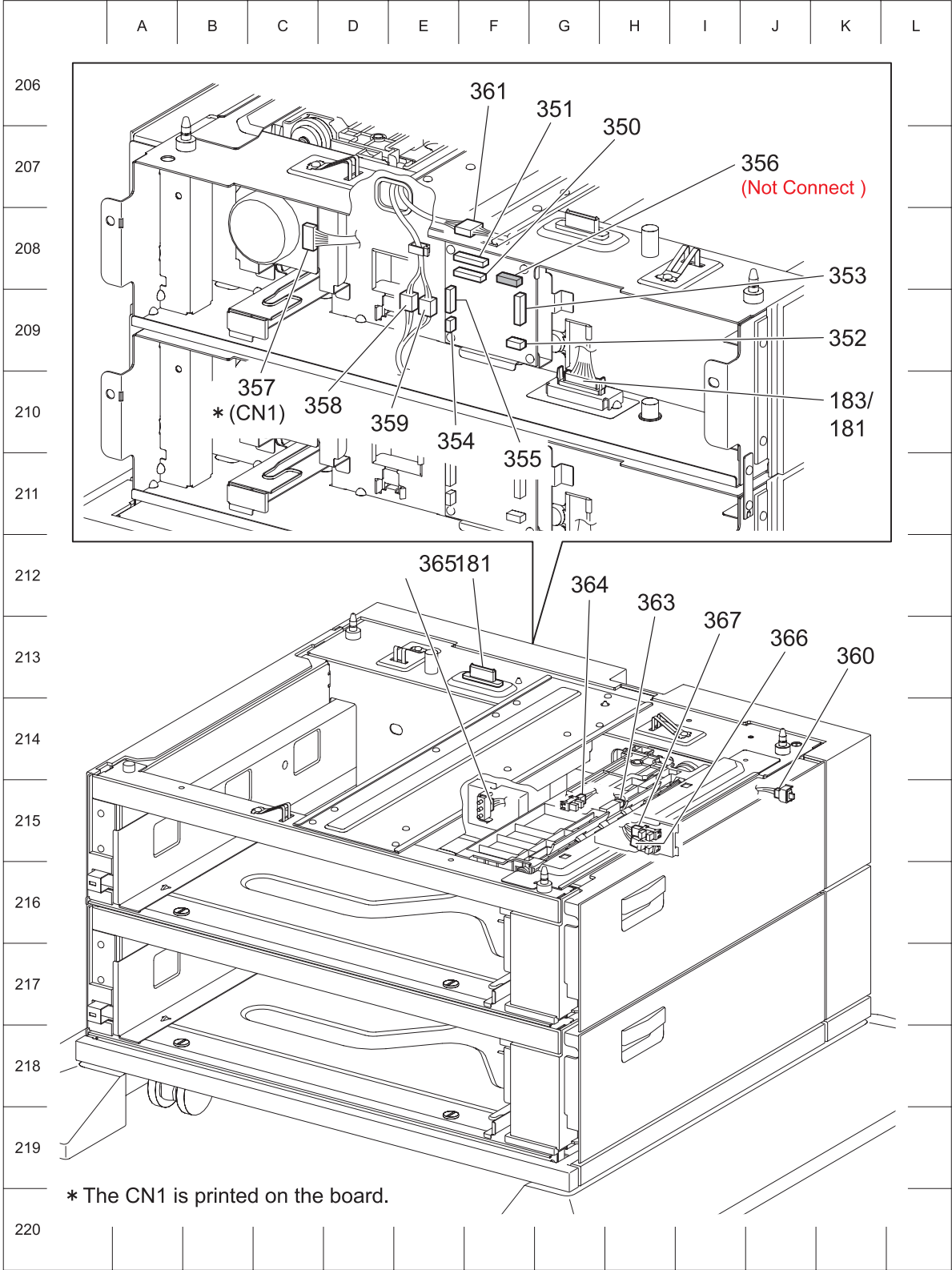

Tbt04008KB

Chapter 5 Parts List CONTENTS

1. Parts List.....	5 - 1
1.1 Caution for use of spare parts illustration	5 - 1
1.2 Caution for use of engineering parts list	5 - 1
Customer Replaceable Parts Illustration.....	5 - 4
Engineering parts list	5 - 12
PL1.1 Cover (1/3) [Illustration]	5 - 12
PL1.1 Cover (1/3) [List].....	5 - 13
PL1.2 Cover (2/3) [Illustration]	5 - 14
PL1.2 Cover (2/3) [List].....	5 - 15
PL1.3 Cover (3/3) [Illustration]	5 - 16
PL1.3 Cover (3/3) [List].....	5 - 17
PL2.1 Paper Tray [Illustration]	5 - 18
PL2.1 Paper Tray [List].....	5 - 19
PL3.1 Paper Feeder (1/3) [Illustration].....	5 - 20
PL3.1 Paper Feeder (1/3) [List].....	5 - 21
PL3.2 Paper Feeder (2/3) [Illustration].....	5 - 22
PL3.2 Paper Feeder (2/3) [List].....	5 - 23
PL3.3 Paper Feeder (3/3) [Illustration].....	5 - 24
PL3.3 Paper Feeder (3/3) [List].....	5 - 25
PL4.1 RH Cover & RH Frame (1/4) [Illustration].....	5 - 26
PL4.1 RH Cover & RH Frame (1/4) [List].....	5 - 27
PL4.2 RH Cover & RH Frame (2/4) (MSI) [Illustration]	5 - 28
PL4.2 RH Cover & RH Frame (2/4) (MSI) [List].....	5 - 29
PL4.3 RH Cover & RH Frame (3/4) (DUPLEX) [Illustration]	5 - 30
PL4.3 RH Cover & RH Frame (3/4) (DUPLEX) [List]	5 - 31
PL4.4 RH Cover & RH Frame (4/4) (2ND BTR) [Illustration]	5 - 32
PL4.4 RH Cover & RH Frame (4/4) (2ND BTR) [List]	5 - 33
PL5.1 Xerographics (1/3) [Illustration].....	5 - 34
PL5.1 Xerographics (1/3) [List]	5 - 35
PL5.2 Xerographics (2/3) [Illustration].....	5 - 36
PL5.2 Xerographics (2/3) [List]	5 - 37
PL5.3 Xerographics (3/3) [Illustration].....	5 - 38
PL5.3 Xerographics (3/3) [List]	5 - 39
PL6.1 Dispenser [Illustration]	5 - 40
PL6.1 Dispenser [List].....	5 - 41
PL7.1 Fuser & Exit (1/3) [Illustration]	5 - 42
PL7.1 Fuser & Exit (1/3) [List].....	5 - 43
PL7.2 Fuser & Exit (2/3) [Illustration]	5 - 44
PL7.2 Fuser & Exit (2/3) [List].....	5 - 45
PL7.3 Fuser & Exit (3/3) [Illustration]	5 - 46
PL7.3 Fuser & Exit (3/3) [List].....	5 - 47
PL8.1 Frame (1/2) [Illustration]	5 - 48
PL8.1 Frame (1/2) [List]	5 - 49
PL8.2 Frame (2/2) [Illustration]	5 - 50
PL8.2 Frame (2/2) [List]	5 - 51

Chapter 5 Parts List CONTENTS

PL9.1 Drive (1/2) [Illustration]	5 - 52
PL9.1 Drive (1/2) [List]	5 - 53
PL9.2 Drive (2/2) [Illustration]	5 - 54
PL9.2 Drive (2/2) [List]	5 - 55
PL10.1 Electrical (1/2) [Illustration]	5 - 56
PL10.1 Electrical (1/2) [List]	5 - 57
PL10.2 Electrical (2/2) [Illustration]	5 - 58
PL10.2 Electrical (2/2) [List]	5 - 59
PL11.1 Harness (1/2) [Illustration]	5 - 60
PL11.1 Harness (1/2) [List]	5 - 61
PL11.2 Harness (2/2) [Illustration]	5 - 62
PL11.2 Harness (2/2) [List]	5 - 63
PL12.1 550 Option Feeder (1/5) [Illustration]	5 - 64
PL12.1 550 Option Feeder (1/5) [List]	5 - 65
PL12.2 550 Option Feeder (2/5) [Illustration]	5 - 66
PL12.2 550 Option Feeder (2/5) [List]	5 - 67
PL12.3 550 Option Feeder (3/5) [Illustration]	5 - 68
PL12.3 550 Option Feeder (3/5) [List]	5 - 69
PL12.4 550 Option Feeder (4/5) [Illustration]	5 - 70
PL12.4 550 Option Feeder (4/5) [List]	5 - 71
PL12.5 550 Option Feeder (5/5) [Illustration]	5 - 72
PL12.5 550 Option Feeder (5/5) [List]	5 - 73
PL13.1 HCF (1/6) [Illustration]	5 - 74
PL13.1 HCF (1/6) [List]	5 - 75
PL13.2 HCF (2/6) [Illustration]	5 - 76
PL13.2 HCF (2/6) [List]	5 - 77
PL13.3 HCF (3/6) [Illustration]	5 - 78
PL13.3 HCF (3/6) [List]	5 - 79
PL13.4 HCF (4/6) [Illustration]	5 - 80
PL13.4 HCF (4/6) [List]	5 - 81
PL13.5 HCF (5/6) [Illustration]	5 - 82
PL13.5 HCF (5/6) [List]	5 - 83
PL13.6 HCF (6/6) [Illustration]	5 - 84
PL13.6 HCF (6/6) [List]	5 - 85
PL14.1 Finisher (1/11) [Illustration]	5 - 86
PL14.1 Finisher (1/11) [List]	5 - 87
PL14.2 Finisher (2/11) [Illustration]	5 - 88
PL14.2 Finisher (2/11) [List]	5 - 89
PL14.3 Finisher (3/11) [Illustration]	5 - 90
PL14.3 Finisher (3/11) [List]	5 - 91
PL14.4 Finisher (4/11) [Illustration]	5 - 92
PL14.4 Finisher (4/11) [List]	5 - 93
PL14.5 Finisher (5/11) [Illustration]	5 - 94
PL14.5 Finisher (5/11) [List]	5 - 95
PL14.6 Finisher (6/11) [Illustration]	5 - 96
PL14.6 Finisher (6/11) [List]	5 - 97

Chapter 5 Parts List CONTENTS

PL14.7 Finisher (7/11) [Illustration]	5 - 98
PL14.7 Finisher (7/11) [List]	5 - 99
PL14.8 Finisher (8/11) [Illustration]	5 - 100
PL14.8 Finisher (8/11) [List]	5 - 101
PL14.9 Finisher (9/11) [Illustration]	5 - 102
PL14.9 Finisher (9/11) [List]	5 - 103
PL14.10 Finisher (10/11) [Illustration]	5 - 104
PL14.10 Finisher (10/11) [List]	5 - 105
PL14.11 Finisher (11/11) [Illustration]	5 - 106
PL14.11 Finisher (11/11) [List]	5 - 107

Chapter 5 Parts List CONTENTS

1. Parts List

1.1 Caution for use of spare parts illustration

- Available spare parts are shown in the illustration by name.
- [Ref PL X.Y.Z] shown below the part name denotes the item is "Z" in the plate "PL X.Y" of the engineering part list.
- For the detailed composition of the KIT parts, check with the engineering part list.

1.2 Caution for use of engineering parts list

- The figures indicating the illustrations are the item No. in the list and present correspondence between the illustrations and parts.
- The notation of PL "X.Y.Z" is composed of the plate (PL), item "X.Y", and parts "Z".
- The alphabet characters in the illustrations represent screws and clips as follows:

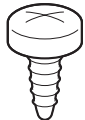
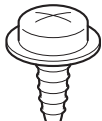
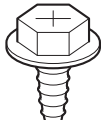
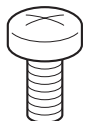
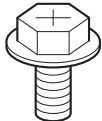
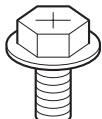
Type	Shape	PL No.	Size	PARTS No.
Screw for plastic Silver, tapping		ST1	M3X8mm	153W27878
		ST2	M3X16mm	826E17350
		ST4	M3X6mm	153W27678
		ST5	M3X10mm	153W28078
		ST6	M4X10mm	826E12570
Screw for plastic Silver, tapping, with flange		ST7	M3X8mm	826E12560
Screw for plastic Silver, tapping, with flange		ST8	M3X6mm	153W17688
		ST9	M3X8mm	153W17888
Screw for metal sheet Silver		SM1	M3X4mm	113W27488
		SM2	M3X6mm	826E12480
		SM3	M4X6mm	113W35688
		SM6	M2X8mm	113W15888
		SM7	M3X6mm	113W27688
		SM8	M3X8mm	113W27888
Screw for metal sheet Silver, with flange		SM4	M3X6mm	113W20678
		SM9	M3X5mm	113W20578
		SM10	M3X6mm	113W20698
		SM11	M3X6mm	158W27678
		SM12	M3X8mm	158W27878
		SM13	M3X14mm	113W21478
		SM14	M3X18mm	113W21778
		SM15	M4X8mm	113W35878
Screw for metal sheet Red, with flange		SM16	M3X10mm	158W28078
		SM17	M3X8mm	158W27877

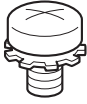
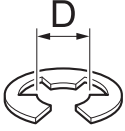
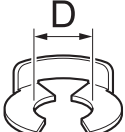
Type	Shape	PL No.	Size	PARTS No.
Screw for metal sheet Silver, with an external tooth washer		SM5	M4X6mm	826E25760
Ring-E		E1	D3	354W21278
		E2	D4	354W24278
		E3	D1.5	354W13278
		E4	D2	354W15278
		E5	D2.5	354W19278
		E6	D6	354W27278
		E7	D8	354W29278
Ring-KL		KL1	D4	354W24254

- "▼" mark in the illustrations are attached to items indicating assembly parts in the illustrations.
- Encircled alphabetical figures in the illustrations indicate interrupted leader lines. Same characters in the illustrations represent lines to be connected.
- The mark "(with 2-5)" attached to assembly parts on the illustrations and lists represents that the items "2, 3, 4, and 5" of that plate are contained and the mark "(with 2-5, PL6.1.1)" represent that the item "2, 3, 4, and 5" of that plate and the item "1" of the plate "6.1" are contained.
- The mark "[Ref PLX.Y.Z]" attached to parts in the illustrations and lists represents that the parts is the same as the parts of the item "Z" of the plate "X.Y".
- The mark "*" attached to parts in the list represents "Note" or "Reference" about that parts is contained in the same page.

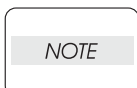

For spare parts, refer to the "Spare parts list" which is issued separately.

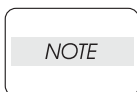

For the connector (P/J), parts such as harness, wire, etc. in the list, refer to "Chapter 7, Electric wiring"

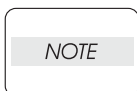

It should be noted that configuration of parts may be different or some parts are not used depending on specifications of OEM.

Blank Page

Customer Replaceable Parts Illustration

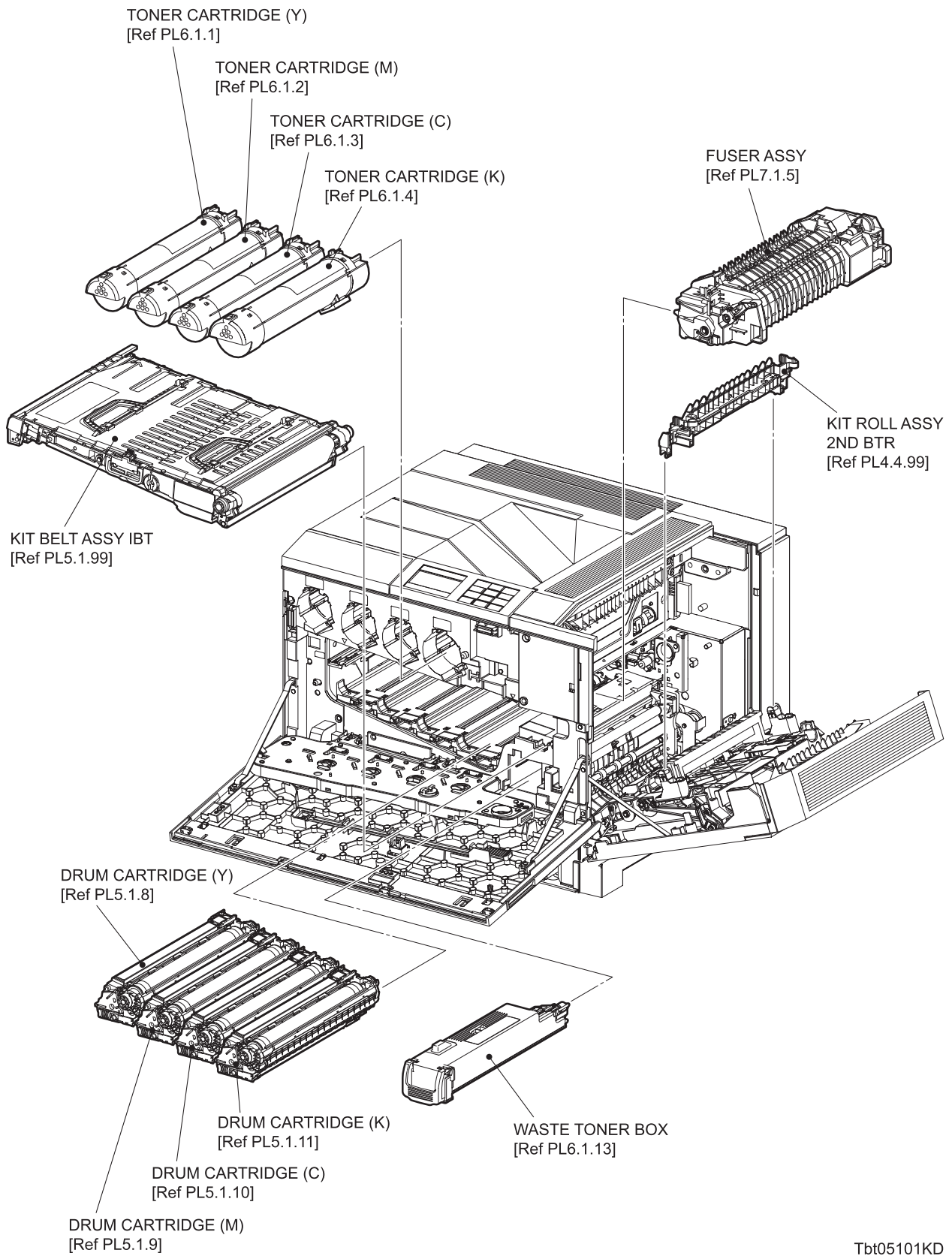

Tbt05101KD

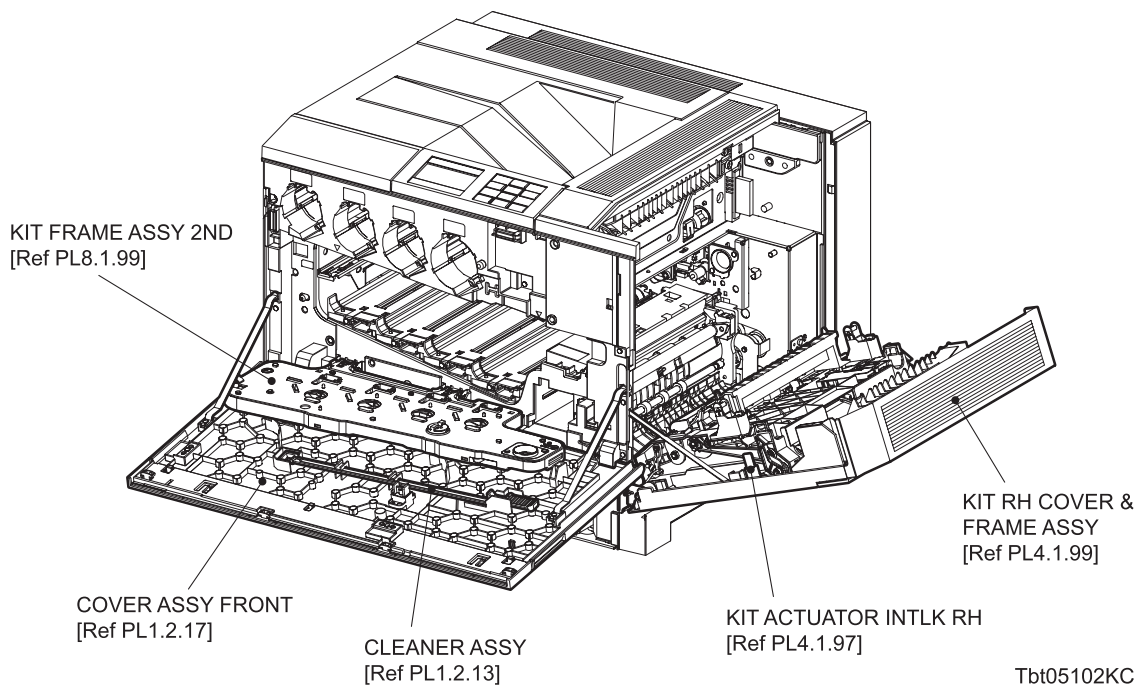
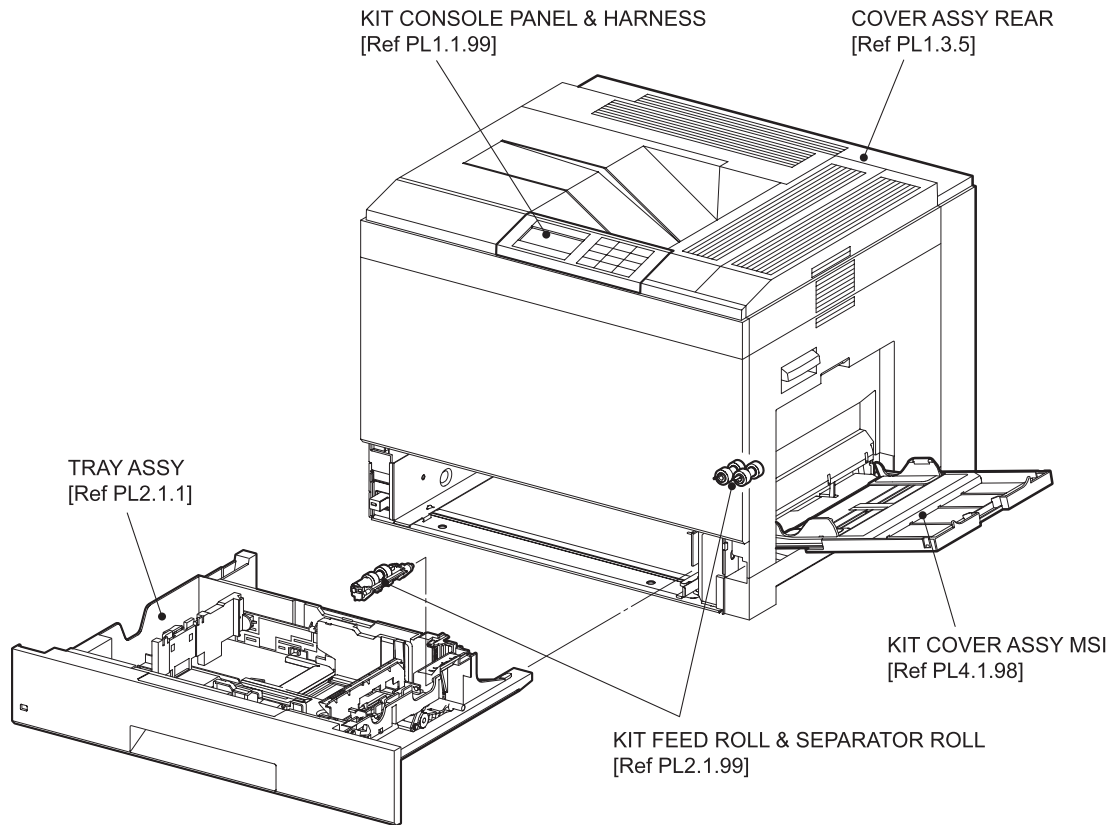

Tbt05102KC

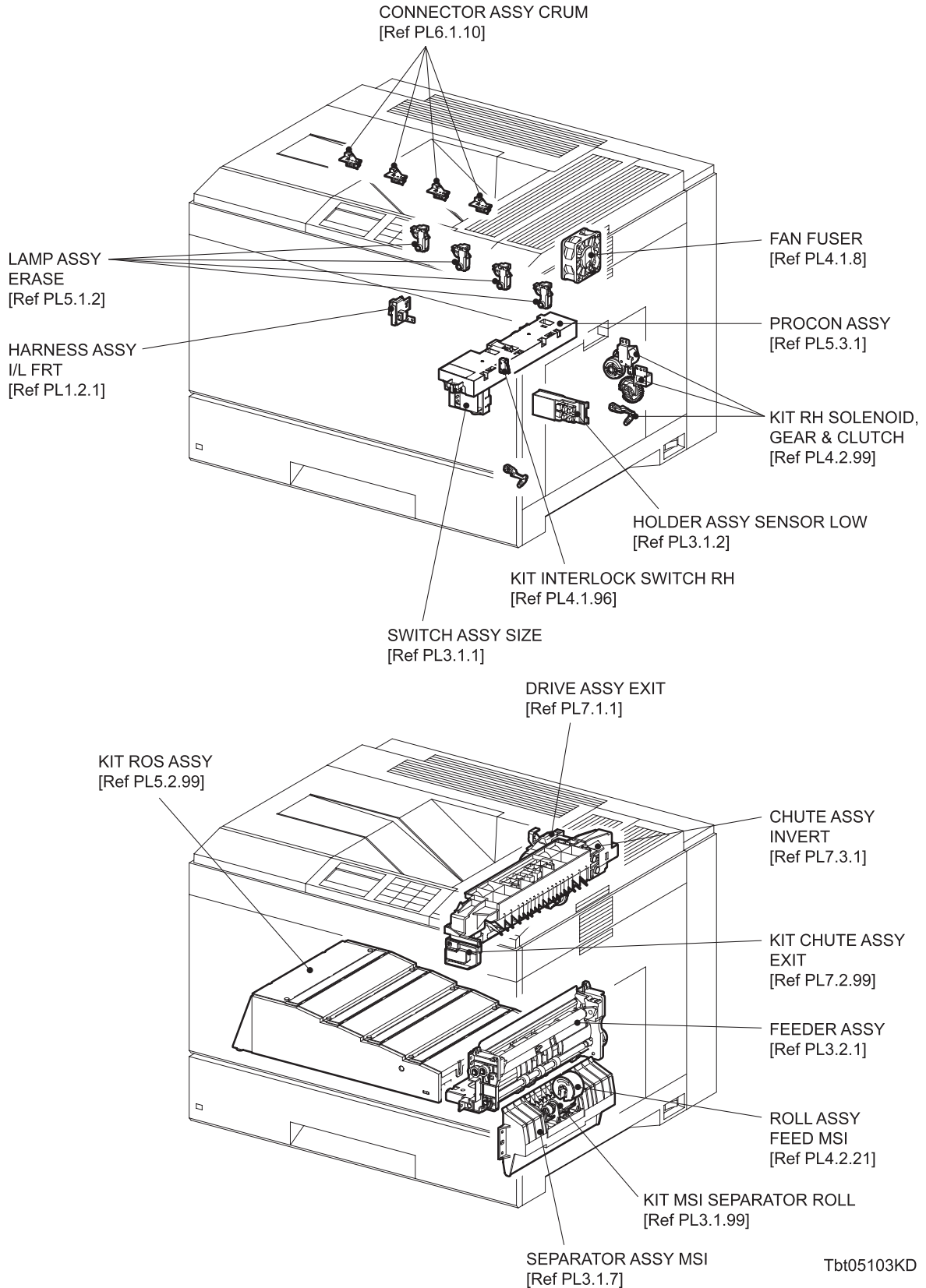

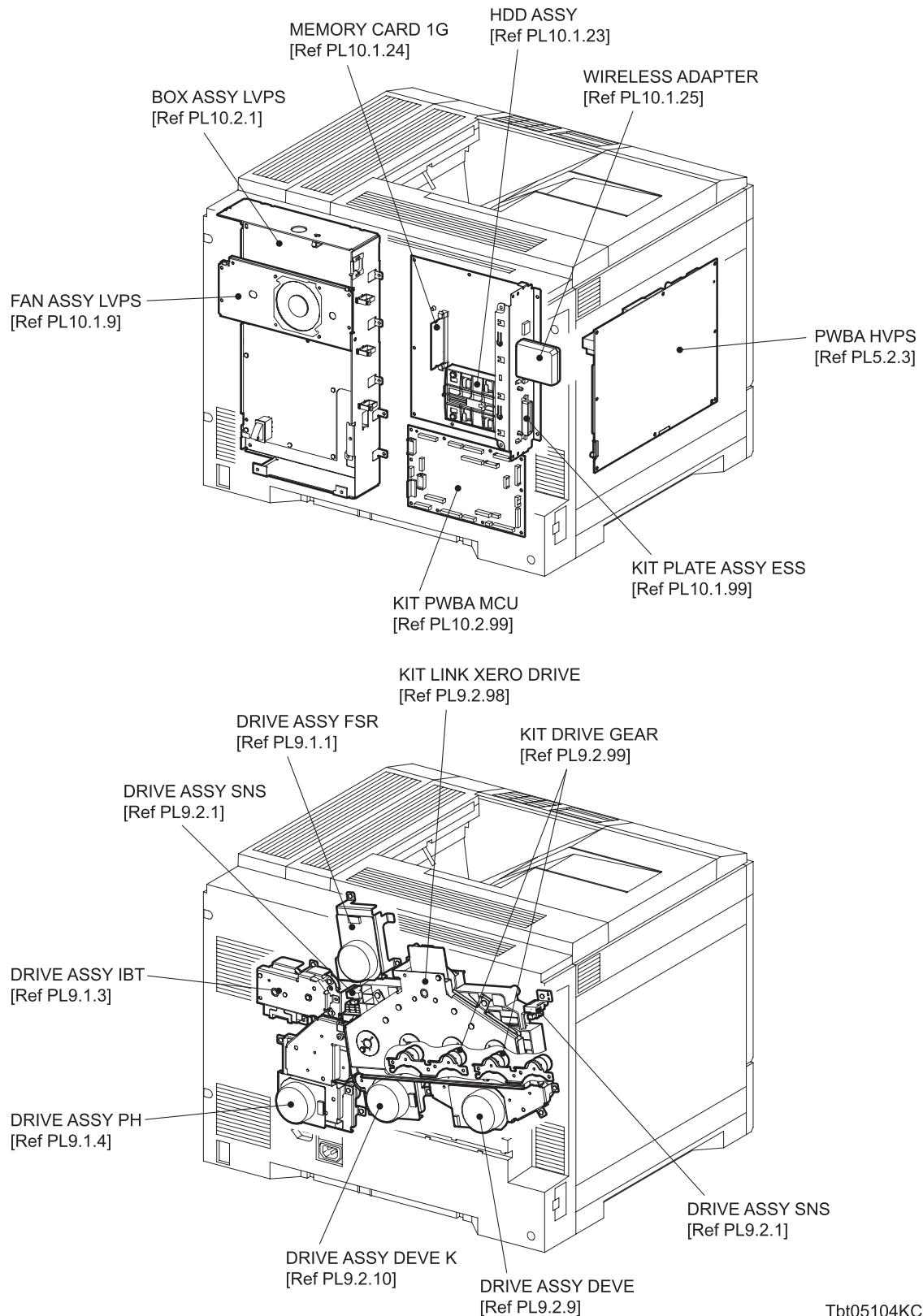

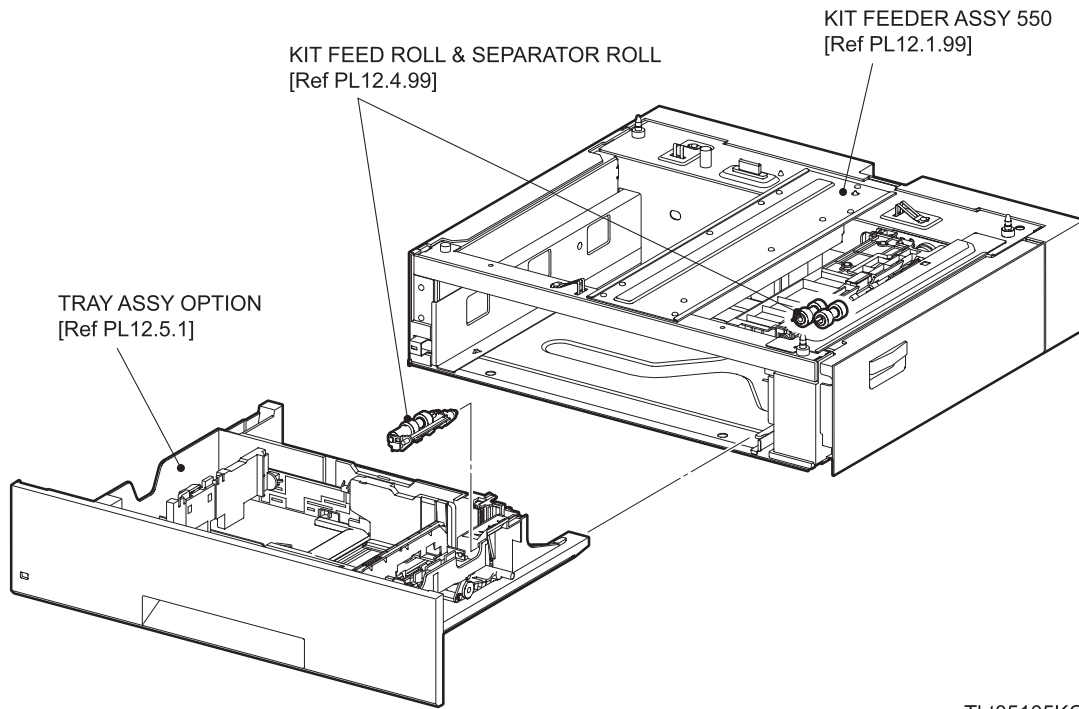

Tbt05105KC

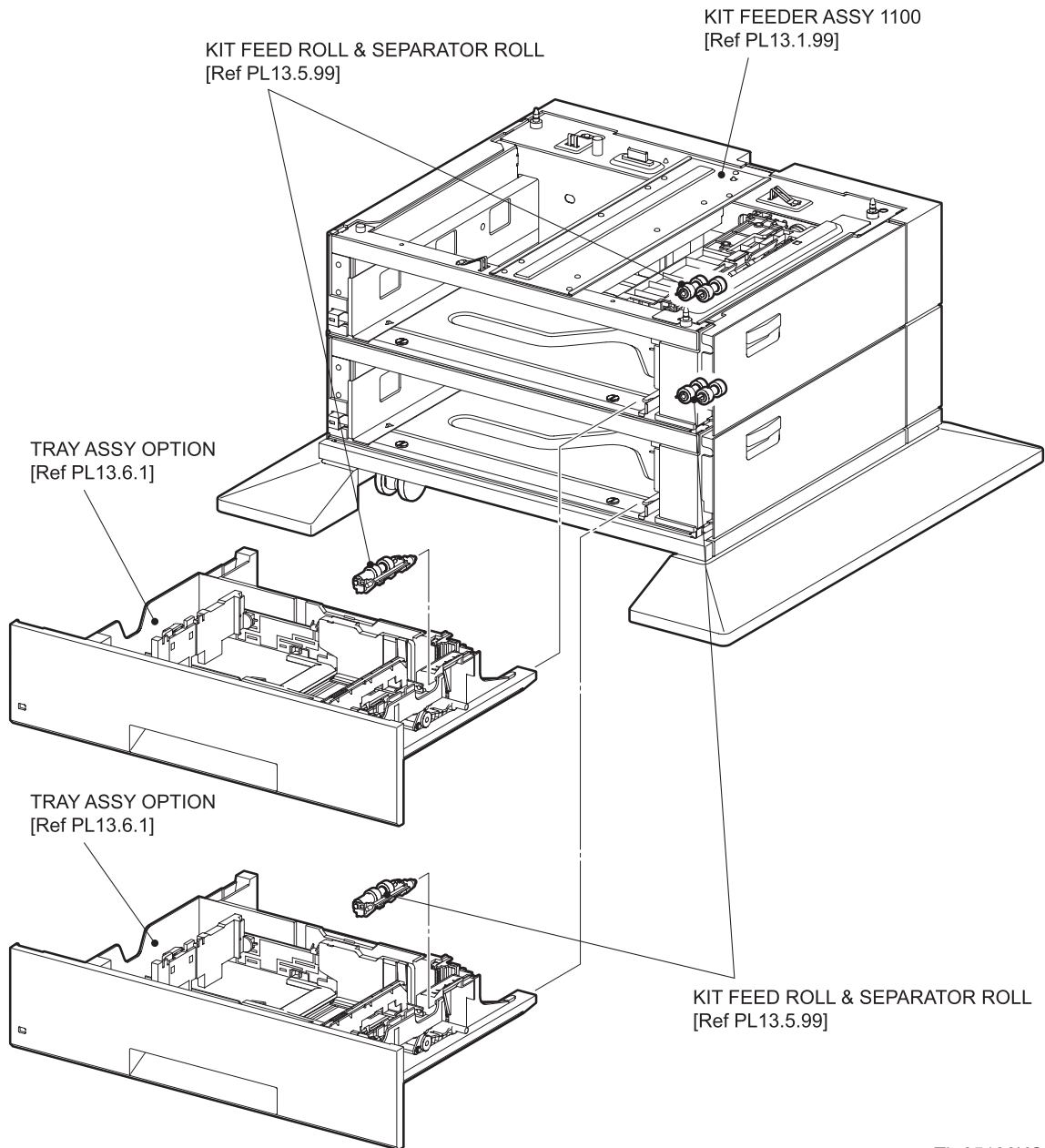

Tbt05106KC

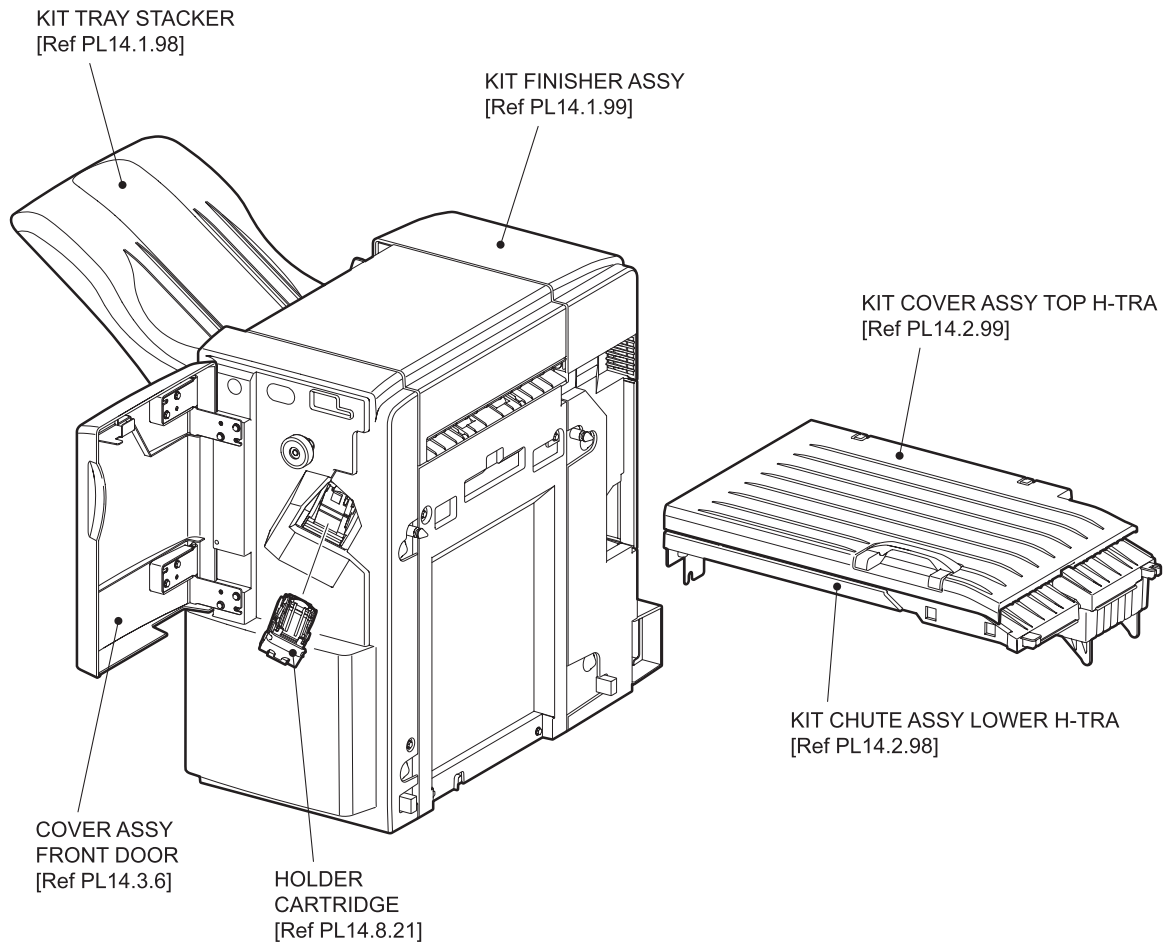

Tbt05107KD

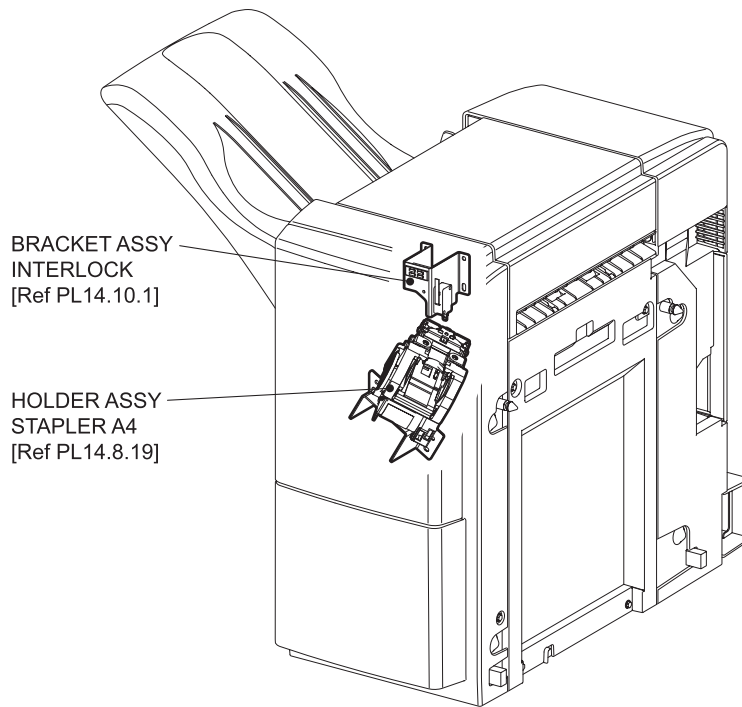
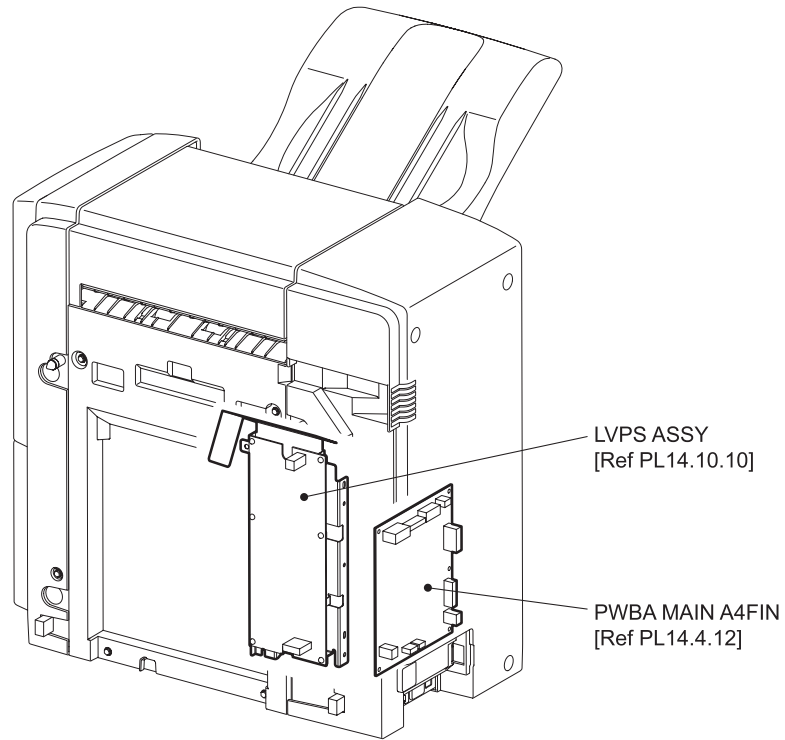

Tbt05108KC

Engineering parts list

PL1.1 Cover (1/3) [Illustration]

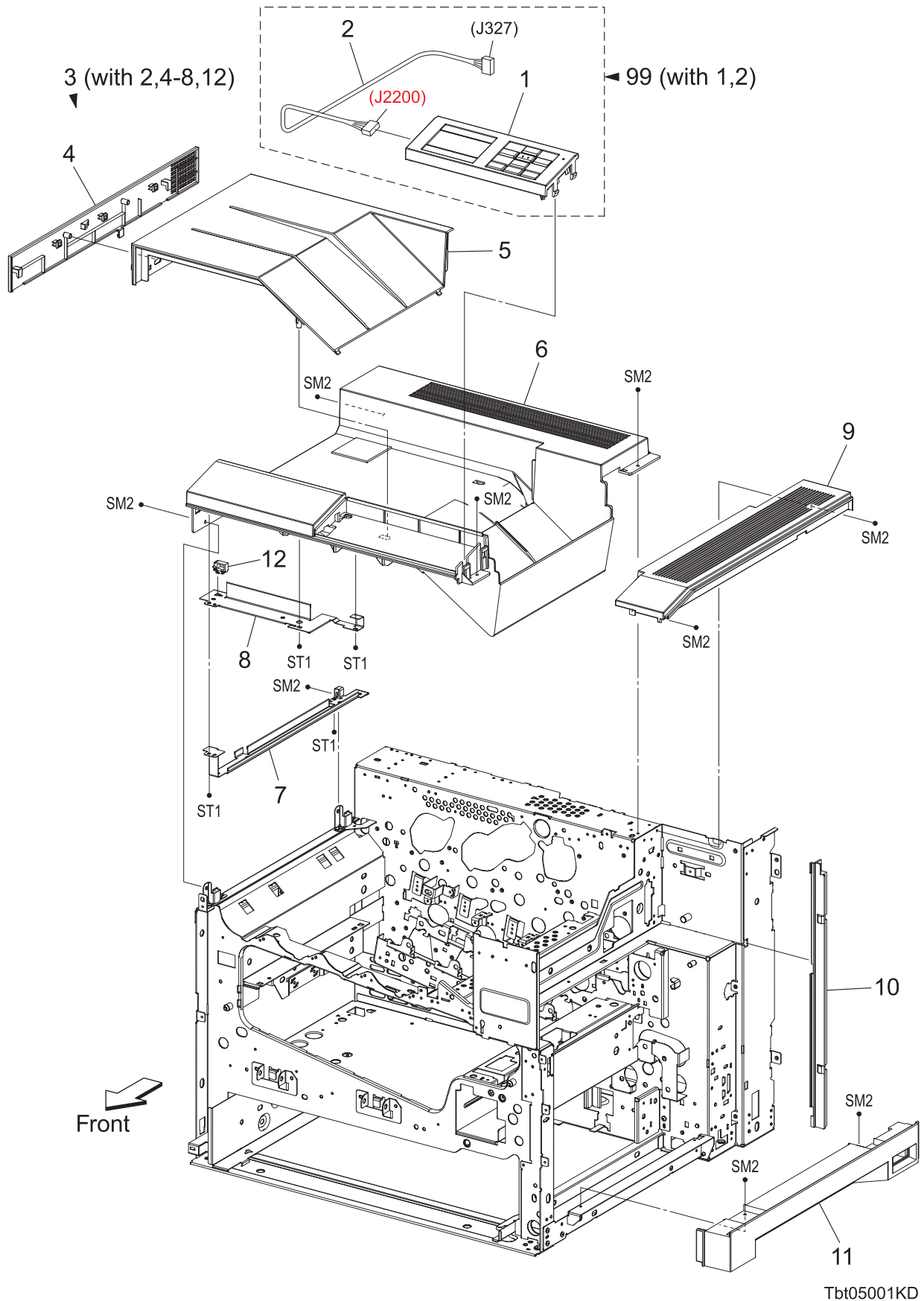

PL1.1 Cover (1/3) [List]

Item	Parts name
1	CONSOLE ASSY PANEL
2	HARNESS ASSY OPEPANE (J327-J2200)
3	COVER ASSY TOP (with 2,4-8,12)
4	COVER LH BAND
5	COVER TOP ADD TRAY
6	COVER TOP
7	GUIDE HARNESS UI
8	GUIDE HARNESS UI FRONT
9	COVER ASSY TOP EXIT
10	GUIDE RH RIB
11	COVER RH UNDER
12	CLAMP LOCKING
99	KIT CONSOLE PANEL & HARNESS (with 1,2)

PL1.2 Cover (2/3) [Illustration]

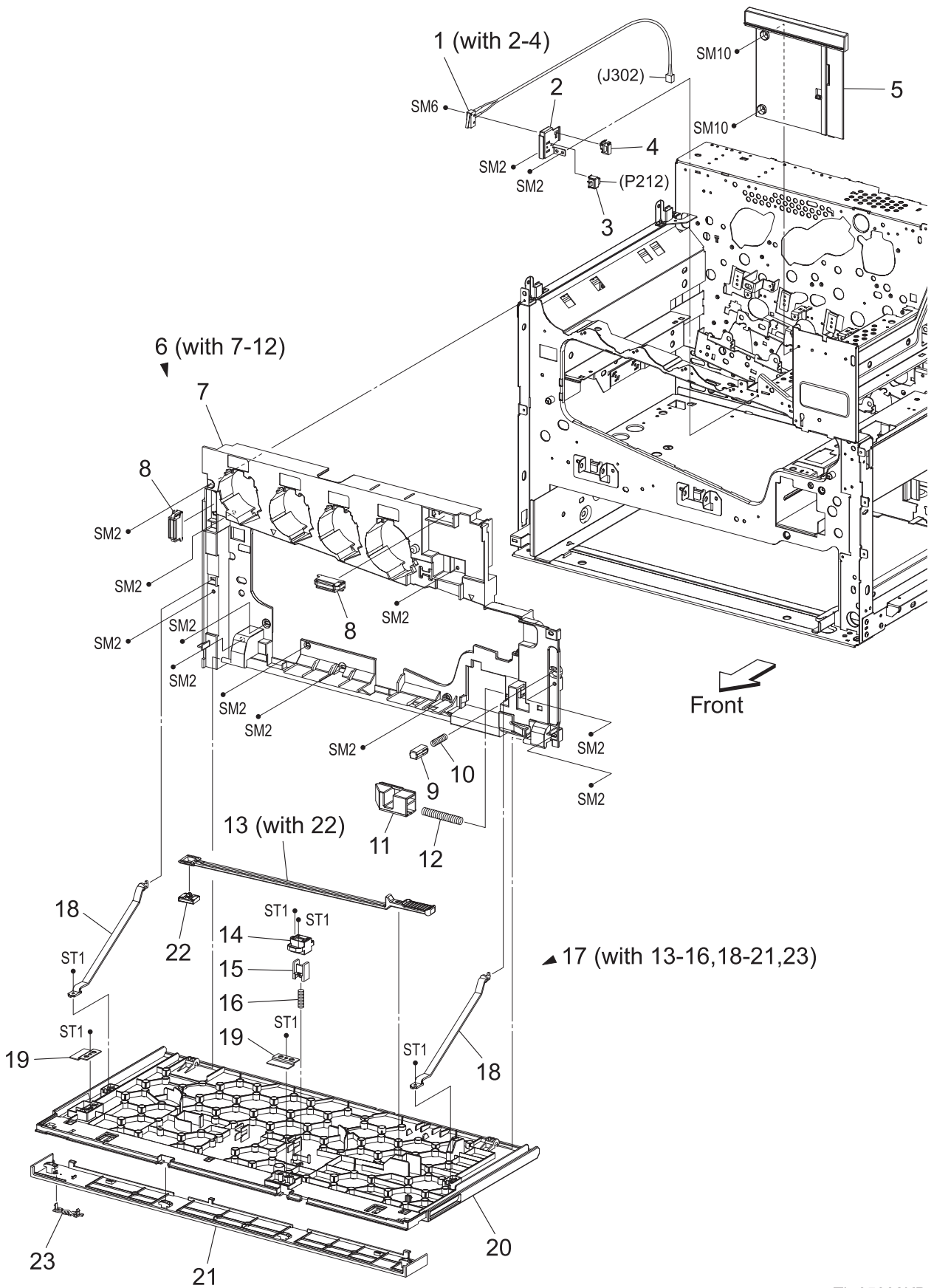

Tbt05002KD

PL1.2 Cover (2/3) [List]

Item	Parts name
1	HARNESS ASSY I/L FRT (I/L SW-J302) (with 2-4)
2	BRACKET INTER LOCK FRONT
3	SWITCH
4	CLAMP LOCKING
5	COVER FRONT RH
6	COVER ASSY INNER FRONT (with 7-12)
7	COVER INNER FRONT
8	MAGNET CATCH
9	HOLDER SPRING BOX
10	SPRING WASTE
11	LATCH WASTE BOX
12	SPRING WASTE BOX
13	CLEANER ASSY (with 22)
14	HOLDER INTER LOCK FRONT
15	ACTUATOR INTER FRONT
16	SPRING INTER LOCK FRONT
17	COVER ASSY FRONT (with 13-16,18-21,23)
18	STRAP COVER FRONT
19	BRACKET MAG
20	COVER FRONT
21	COVER FRONT BAND
22	CLEANING PAD
23	PLATE NAME

PL1.3 Cover (3/3) [Illustration]

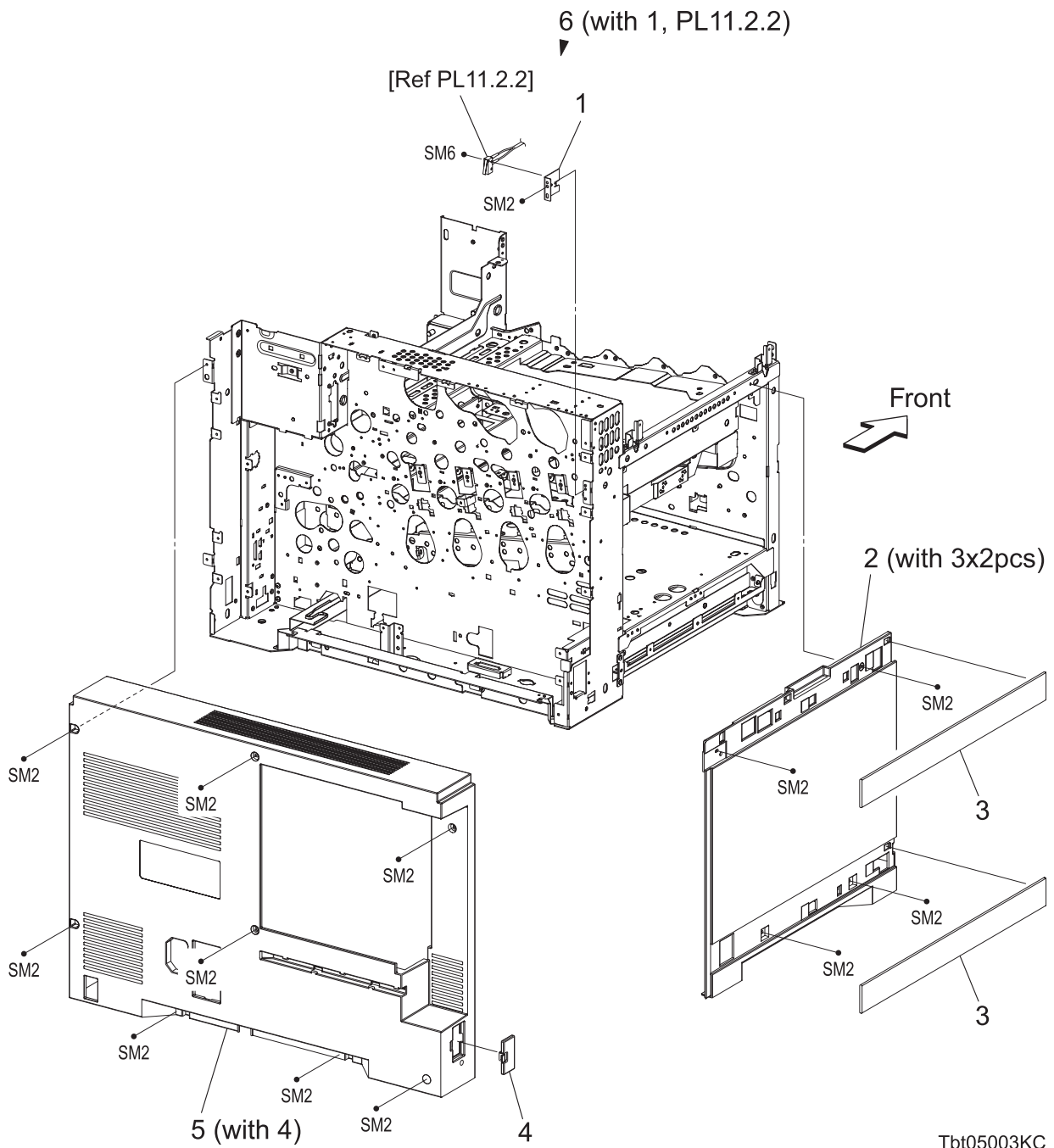

Tbt05003KC

PL1.3 Cover (3/3) [List]

Item	Parts name
1	BRACKET IL REAR
2	COVER LH ASSY (with 3x2pcs)
3	COVER LH FINISHER
4	COVER REAR LH
5	COVER ASSY REAR (with 4)
6	SW ASSY I/L REAR (with 1, PL11.2.2)

PL2.1 Paper Tray [Illustration]

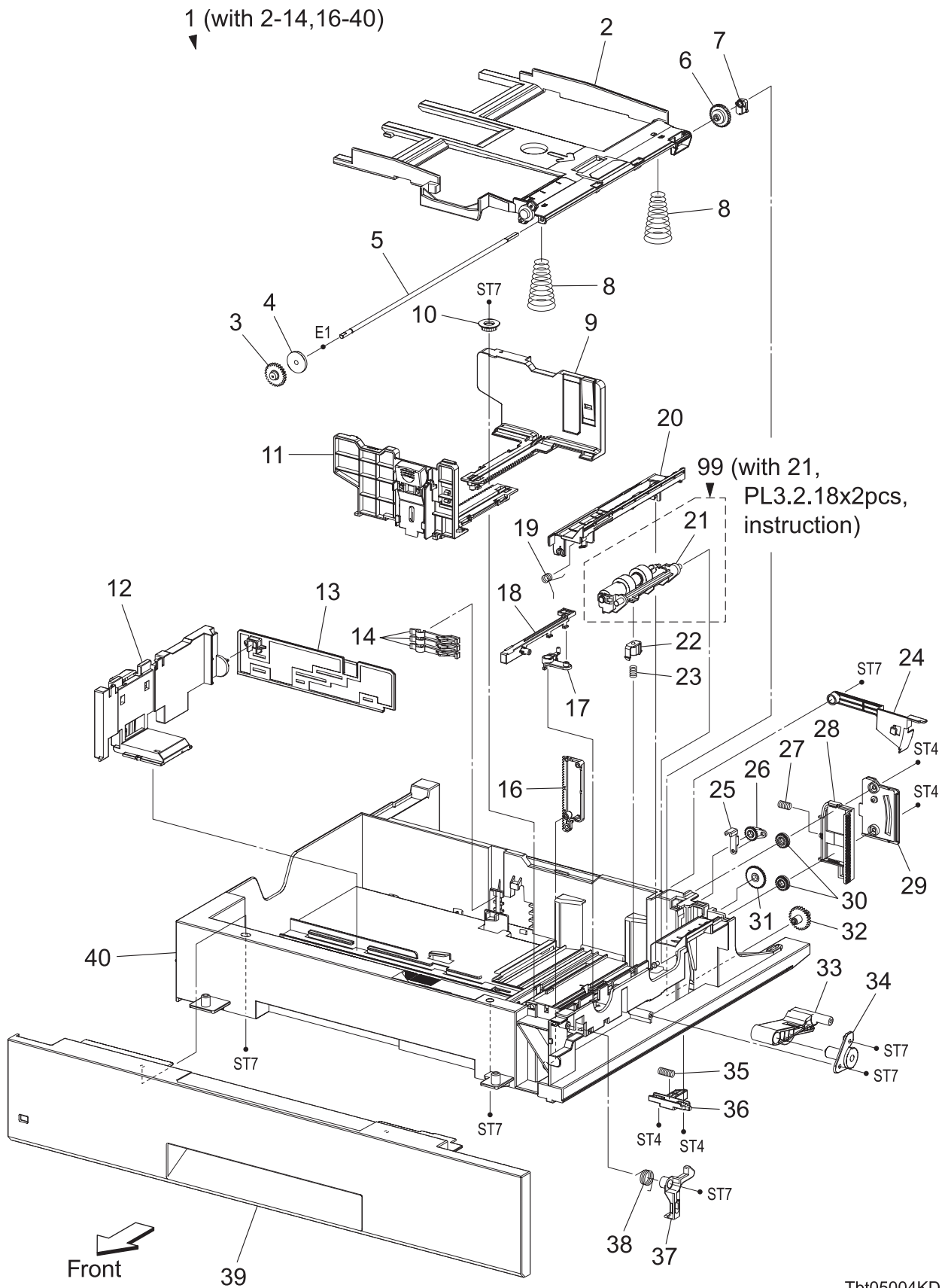

Tbt05004KD

PL2.1 Paper Tray [List]

Item	Parts name
1	TRAY ASSY (with 2-14,16-40)
2	PLATE ASSY BOTTOM
3	GEAR PB FRONT
4	GEAR BTM DMP ONEWAY
5	SHAFT PB A4
6	GEAR BTM LOCK ONEWAY
7	STOPPER PB
8	SPRING BTM UP 550 A4
9	GUIDE ASSY SIDE R
10	GEAR PINION
11	GUIDE ASSY SIDE F
12	GUIDE ASSY END
13	ACTUATOR GUIDE END
14	ACTUATOR SIZE
15	--
16	PLATE GEAR LOCK
17	LEVER SEPARATOR
18	LEVER LATCH
19	SPRING COVER SEPARATOR
20	COVER SEPARATOR
21	HOLDER ASSY SEPARATOR
22	HOLDER SPRING SEPARATOR
23	SPRING SEPARATOR
24	ACTUATOR LOW PAPER
25	LEVER BTM LOCK
26	GEAR LEVER BTM LOCK
27	SPRING BTM LOCK
28	RACK BTM LOCK
29	COVER BTM UP
30	GEAR BTM LOCK PINION
31	GEAR 40 BTM LOCK
32	GEAR PB REAR
33	LINK PB
34	COVER LINK
35	SPRING STOPPER GEAR
36	ACTUATOR PLS PB
37	LATCH TRAY
38	SPRING LATCH
39	COVER TRAY
40	HOUSING BASE
99	KIT FEED ROLL & SEPARATOR ROLL (with 21, PL3.2.18x2pcs, instruction) *1

*1 : Periodic Replacing Parts (150KPV)

PL3.1 Paper Feeder (1/3) [Illustration]

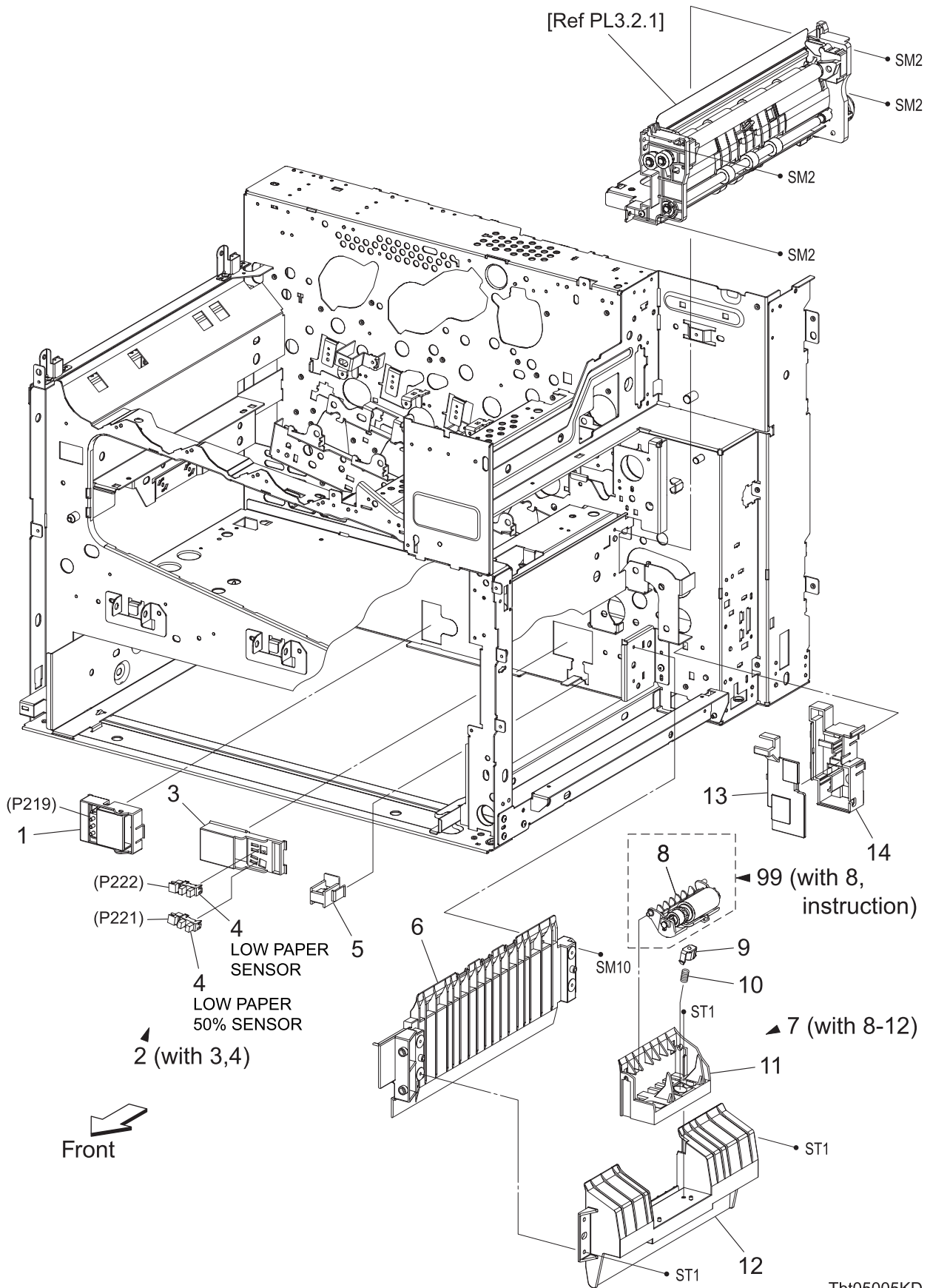

Tbt05005KD

PL3.1 Paper Feeder (1/3) [List]

Item	Parts name
1	SWITCH ASSY SIZE
2	HOLDER ASSY SENSOR LOW (with 3,4)
3	HOLDER SENSOR
4	SENSOR PHOTO
5	BLOCK RELEASE
6	GUIDE TRAY
7	SEPARATOR ASSY MSI (with 8-12)
8	HOLDER ASSY SEPARATOR MSI
9	HOLDER SPRING SEPARATOR
10	SPRING SEPARATOR MSI
11	BRACKET SEPARATOR
12	CHUTE BASE SEPARATOR
13	COVER GUIDE HARNESS
14	GUIDE HARNESS
99	KIT MSI SEPARATOR ROLL (with 8, instruction)

PL3.2 Paper Feeder (2/3) [Illustration]

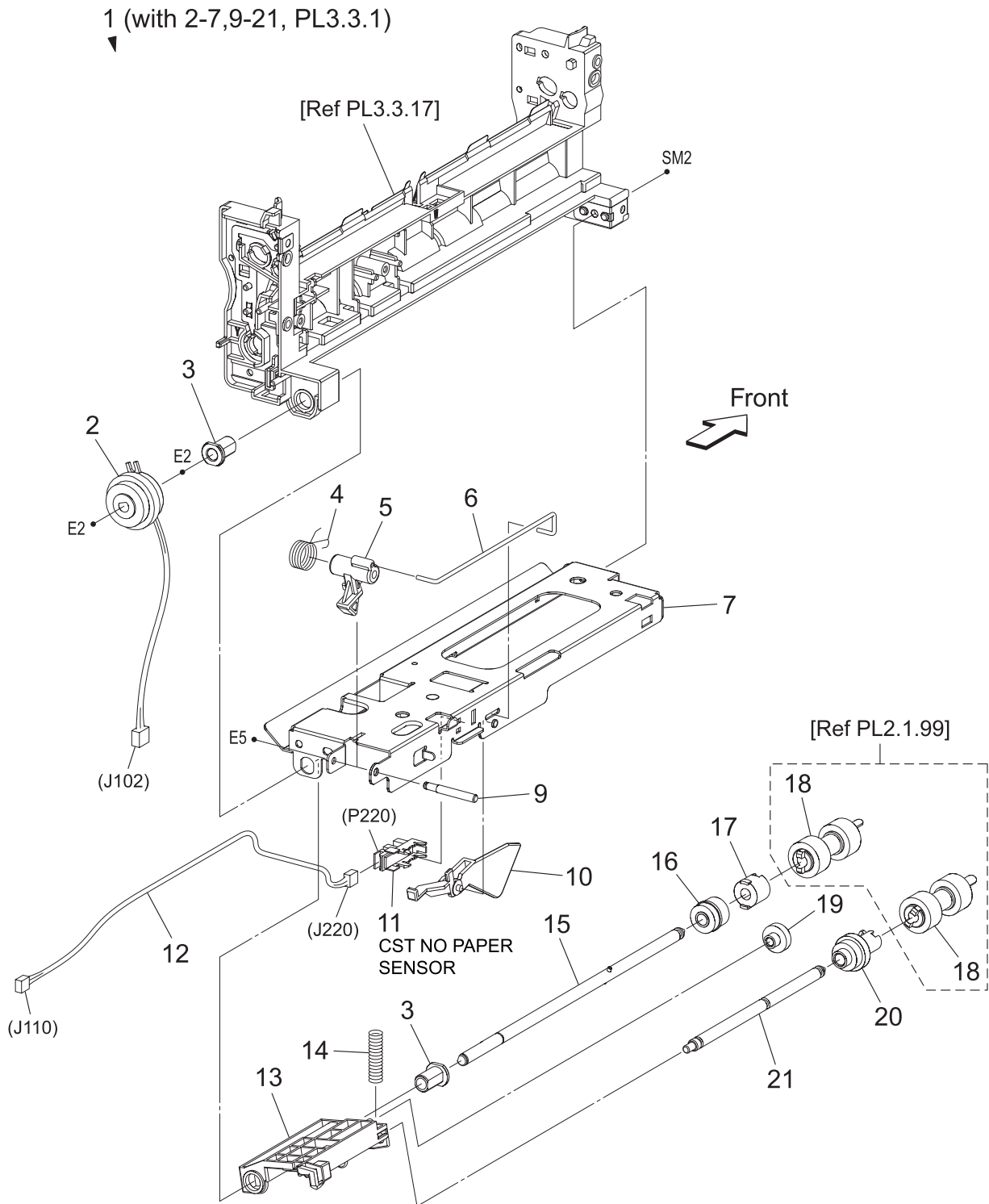

Tbt05006KC

PL3.2 Paper Feeder (2/3) [List]

Item	Parts name
1	FEEDER ASSY (with 2-7,9-21, PL3.3.1)
2	CLUTCH ASSY FEED
3	BEARING NUDGER
4	SPRING LEVER NUDGER
5	LEVER NUDGER
6	LINK ACTUATOR
7	CHUTE FRAME TOP
8	--
9	SHAFT LEVER NUDGER
10	ACTUATOR NO PAPER
11	SENSOR PHOTO
12	HARNESS ASSY NPP SNR (J110-J220)
13	SUPPORT NUDGER
14	SPRING NUDGER
15	SHAFT ASSY FEED
16	GEAR FEED
17	CLUTCH ASSY ONEWAY FEED
18	ROLL ASSY FEED
19	GEAR IDLER NUDGER
20	ROLL ASSY GEAR NUDGER
21	SHAFT NUDGER

PL3.3 Paper Feeder (3/3) [Illustration]

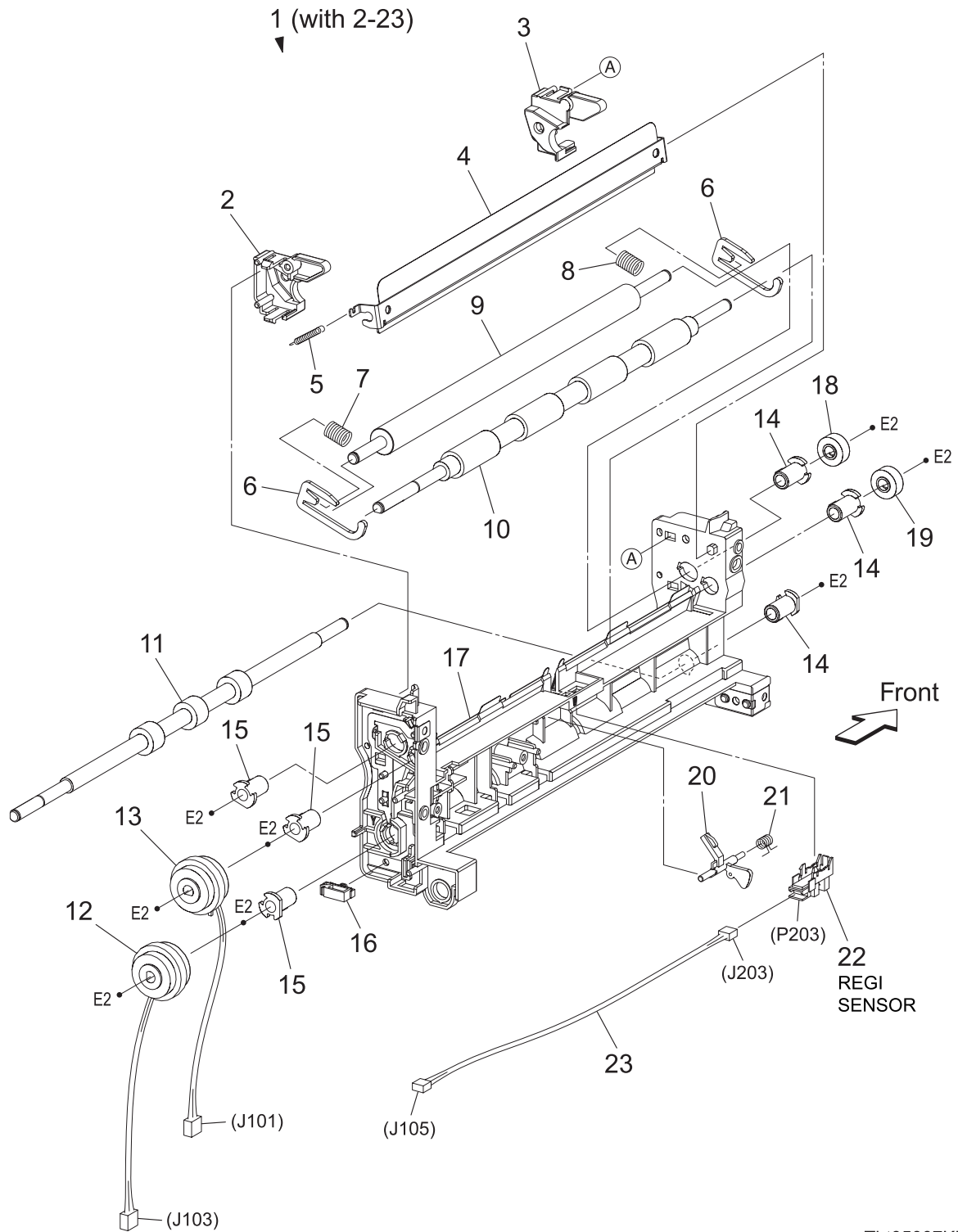

Tbt05007KB

PL3.3 Paper Feeder (3/3) [List]

Item	Parts name
1	CHUTE ASSY REGI (with 2-23)
2	COVER SPRING REAR
3	COVER SPRING FRONT
4	CHUTE ASSY UPPER REGI
5	SPRING CHUTE UPPER
6	BRACKET NIP
7	SPRING REGI R
8	SPRING REGI F
9	ROLL REGI METAL
10	ROLL ASSY REGI RUBBER
11	ROLL ASSY TAKE AWAY
12	CLUTCH ASSY TAKE AWAY
13	CLUTCH ASSY REGI
14	BEARING REGI
15	BEARING REGI EARTH
16	CLAMP LOCKING
17	CHUTE REGI
18	GEAR REGI METAL
19	GEAR REGI RUBBER
20	ACTUATOR REGI SNR
21	SPRING SENSOR REGI
22	SENSOR PHOTO
23	HARNESS ASSY REGI SNR (J105-J203)
24	--
25	--
26	--
27	--

PL4.1 RH Cover & RH Frame (1/4) [Illustration]

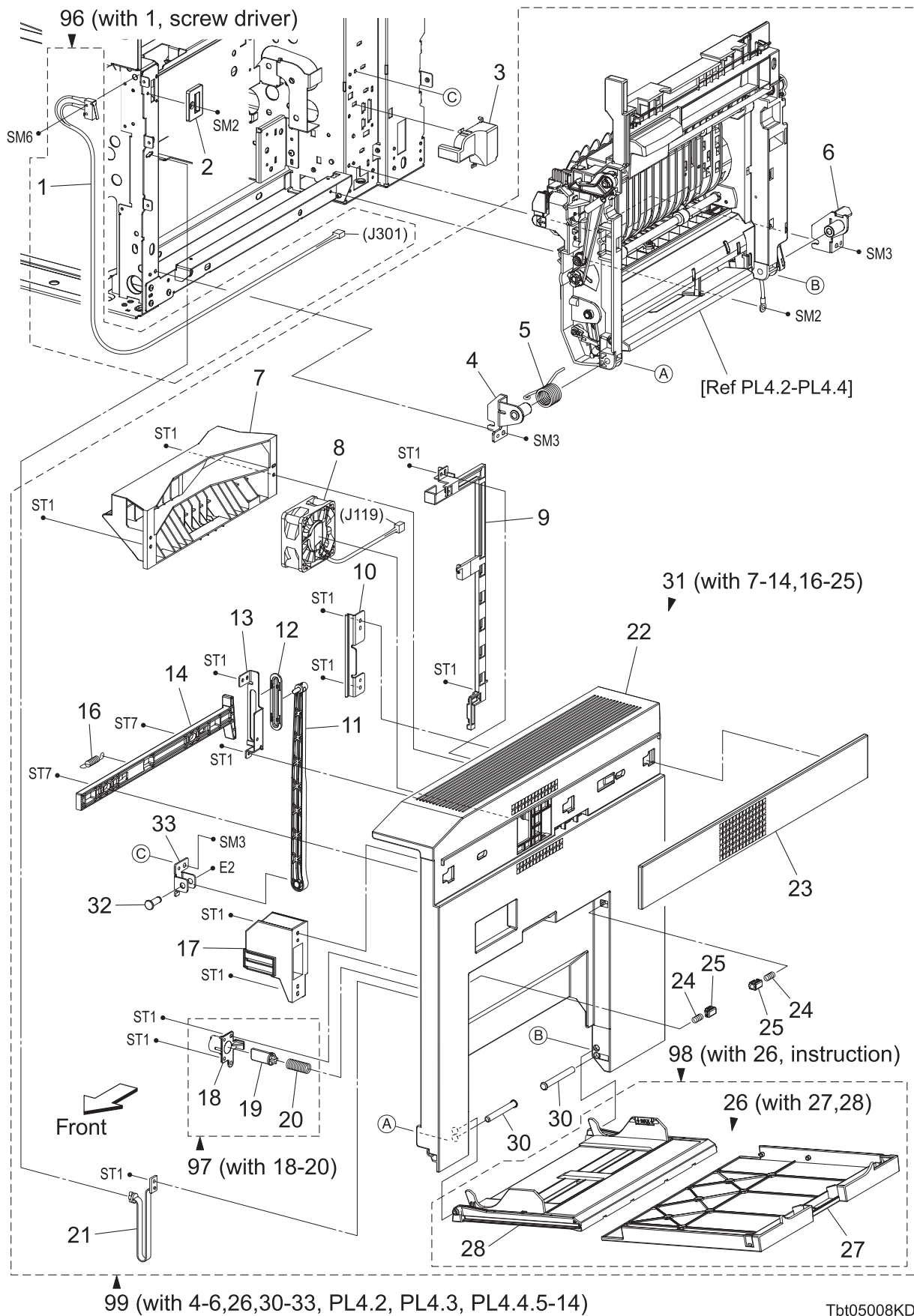

Tbt05008KD

PL4.1 RH Cover & RH Frame (1/4) [List]

Item	Parts name
1	HARNESS ASSY I/L RH (I/L SW-J301)
2	COVER INTLK
3	COVER CONNECTOR
4	BRACKET ASSY PIVOT FRONT
5	SPRING RH FRAME
6	BRACKET ASSY PIVOT REAR
7	CHUTE DUP RH
8	FAN FUSER
9	GUIDE HARNESS RH FAN
10	GUIDE SLIDE LATCH
11	LINK ASSY
12	GUIDE SUPPORT LINK
13	GUIDE PLATE LATCH
14	LATCH COVER RH
15	--
16	SPRING LATCH COVER
17	GUIDE FUSER RH
18	HOLDER INTLK RH
19	ACTUATOR INTLK RH
20	SPRING INTLK RH
21	STRAP RH
22	COVER RH
23	COVER RH BAND
24	SPRING STOPPER MSI
25	STOPPER MSI
26	COVER ASSY MSI (with 27,28)
27	COVER MSI
28	TRAY ASSY MSI
29	--
30	SHAFT PIVOT
31	COVER ASSY RH (with 7-14,16-25)
32	SHAFT LINK
33	BRACKET LINK
96	KIT INTERLOCK SWITCH RH (with 1, screw driver)
97	KIT ACTUATOR INTLK RH (with 18-20)
98	KIT COVER ASSY MSI (with 26, instruction)
99	KIT RH COVER & FRAME ASSY (with 4-6,26,30-33, PL4.2, PL4.3, PL4.4.5-14)

PL4.2 RH Cover & RH Frame (2/4) (MSI) [Illustration]

[Ref PL4.1.99]

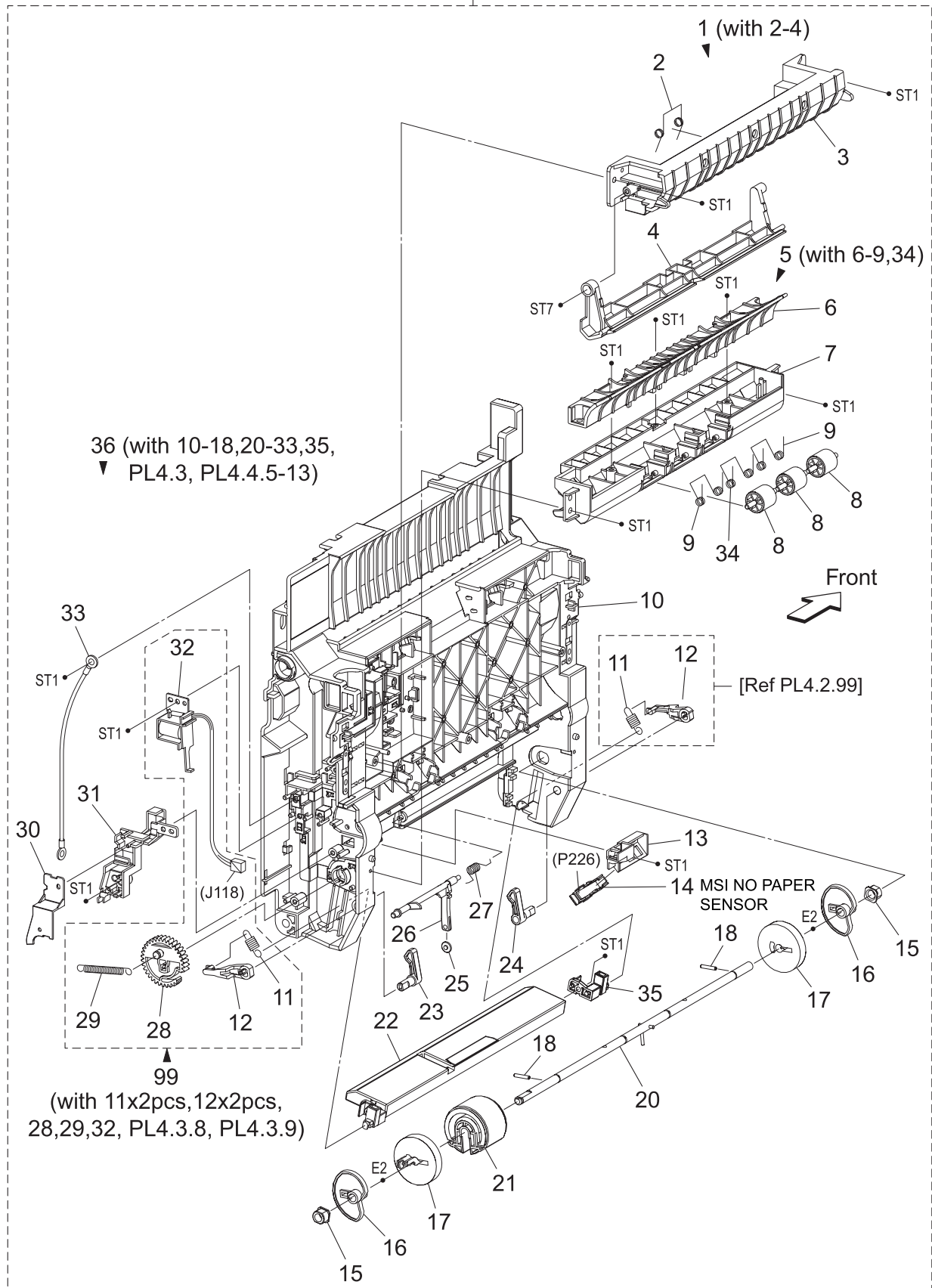

Tbt05009KC

PL4.2 RH Cover & RH Frame (2/4) (MSI) [List]

Item	Parts name
1	CHUTE ASSY PINCH REGI (with 2-4)
2	SPRING CHUTE SWING
3	CHUTE REGI PINCH
4	CHUTE REGI SWING
5	CHUTE ASSY MSI (with 6-9,34)
6	CHUTE LOOP MSI
7	CHUTE FEED UPPER
8	ROLL PINCH TA
9	SPRING PINCH TA
10	FRAME RH
11	SPRING NF MSI
12	ARM MSI
13	BRACKET SENSOR
14	SENSOR PHOTO
15	BEARING EARTH
16	CAM MSI
17	ROLL CORE MSI
18	PIN MSI
19	--
20	SHAFT ASSY MSI
21	ROLL ASSY FEED MSI
22	PLATE ASSY BOTTOM MSI
23	FOLLOWER REAR
24	FOLLOWER FRONT
25	ROLL ACTUATOR NO PAPER
26	ACTUATOR NO PAPER MSI
27	SPRING NO PAPER MSI
28	GEAR FEED MSI
29	SPRING FEED MSI
30	COVER HARN GUIDE RH
31	GUIDE HARNESS RH
32	SOLENOID FEED MSI
33	WIRE ASSY EARTH
34	SPRING PINCH TA CTR
35	HOLDER MSI FRONT
36	FRAME ASSY RH (with 10-18,20-33,35, PL4.3, PL4.4.5-13)
99	KIT RH SOLENOID, GEAR & CLUTCH (with 11x2pcs,12x2pcs,28,29,32, PL4.3.8, PL4.3.9)

PL4.3 RH Cover & RH Frame (3/4) (DUPLEX) [Illustration]

[Ref PL4.1.99]

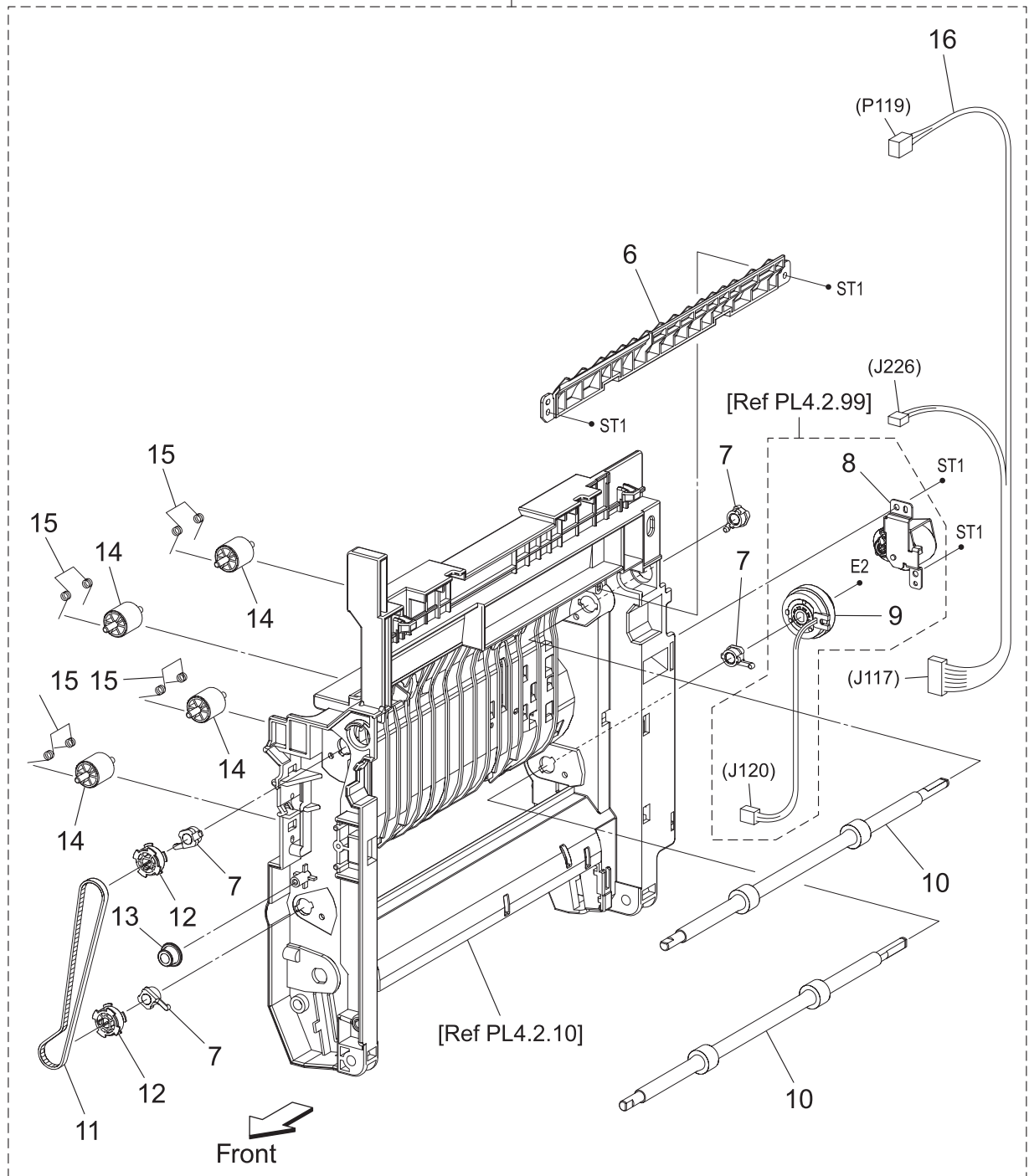

Tbt05010KA

PL4.3 RH Cover & RH Frame (3/4) (DUPLEX) [List]

Item	Parts name
1	--
2	--
3	--
4	--
5	--
6	CHUTE DUP OUT
7	BEARING EXIT
8	GEAR ASSY DUP
9	CLUTCH ASSY DUP
10	ROLL ASSY DUP
11	BELT DUP
12	PULLEY DUP
13	ROLLER BELT GUIDE
14	ROLL PINCH TA
15	SPRING PINCH DUP
16	HARNESS ASSY RH COVER (J117-P119,J226)

PL4.4 RH Cover & RH Frame (4/4) (2ND BTR) [Illustration]

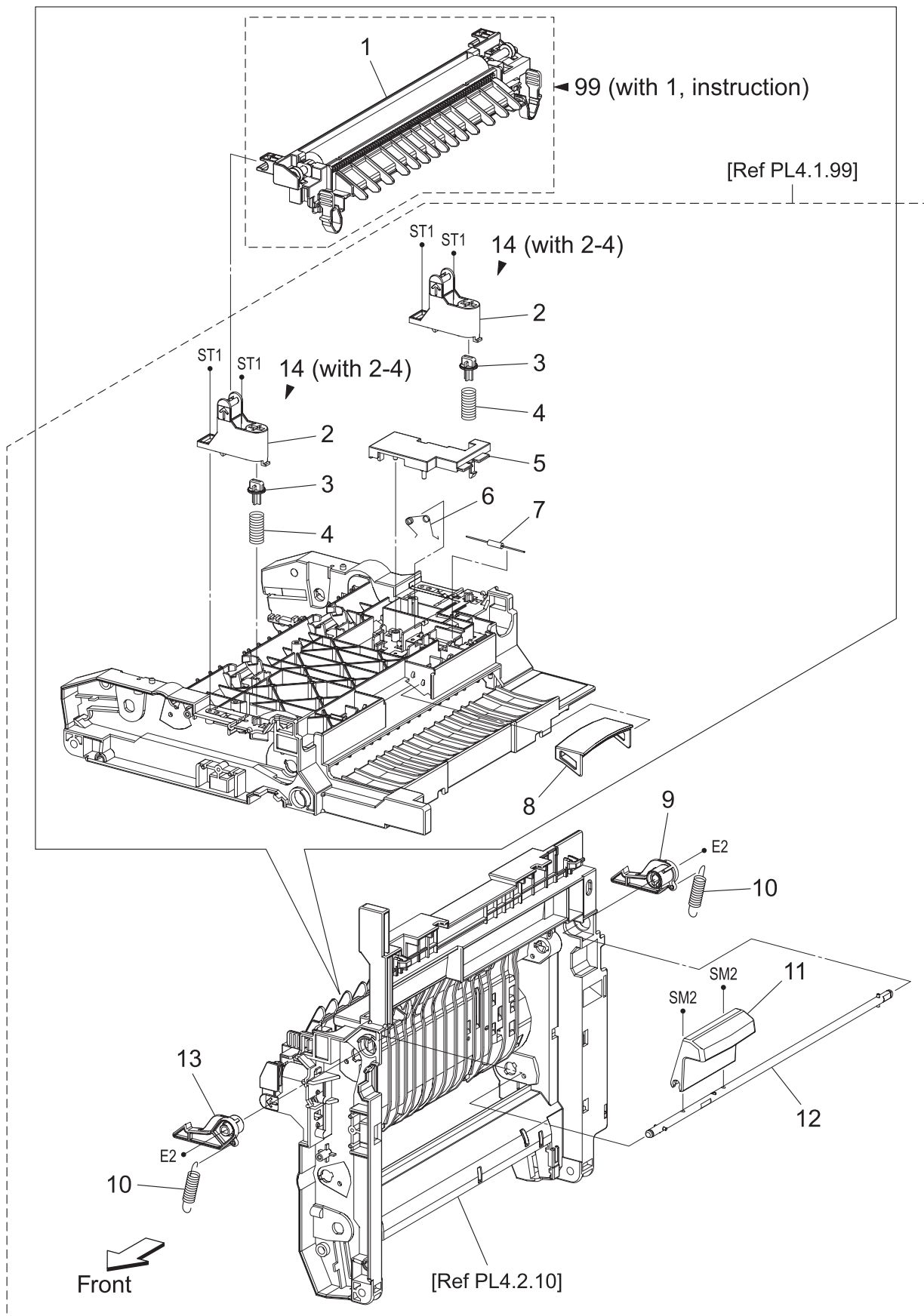

Tbt05011KD

PL4.4 RH Cover & RH Frame (4/4) (2ND BTR) [List]

Item	Parts name
1	ROLL ASSY 2ND BTR *1
2	BRACKET 2ND BTR
3	CAP SPRING 2ND BTR
4	SPRING 2ND BTR
5	COVER RESISTOR
6	SPRING EARTH
7	RESISTOR
8	HANDLE RH
9	LATCH REAR RH
10	SPRING LATCH
11	HANDLE LATCH
12	SHAFT ASSY LATCH
13	LATCH FRONT RH
14	BRACKET ASSY 2ND (with 2-4)
99	KIT ROLL ASSY 2ND BTR (with 1, instruction)

*1 : Periodic Replacing Parts (150KPV)

PL5.1 Xerographics (1/3) [Illustration]

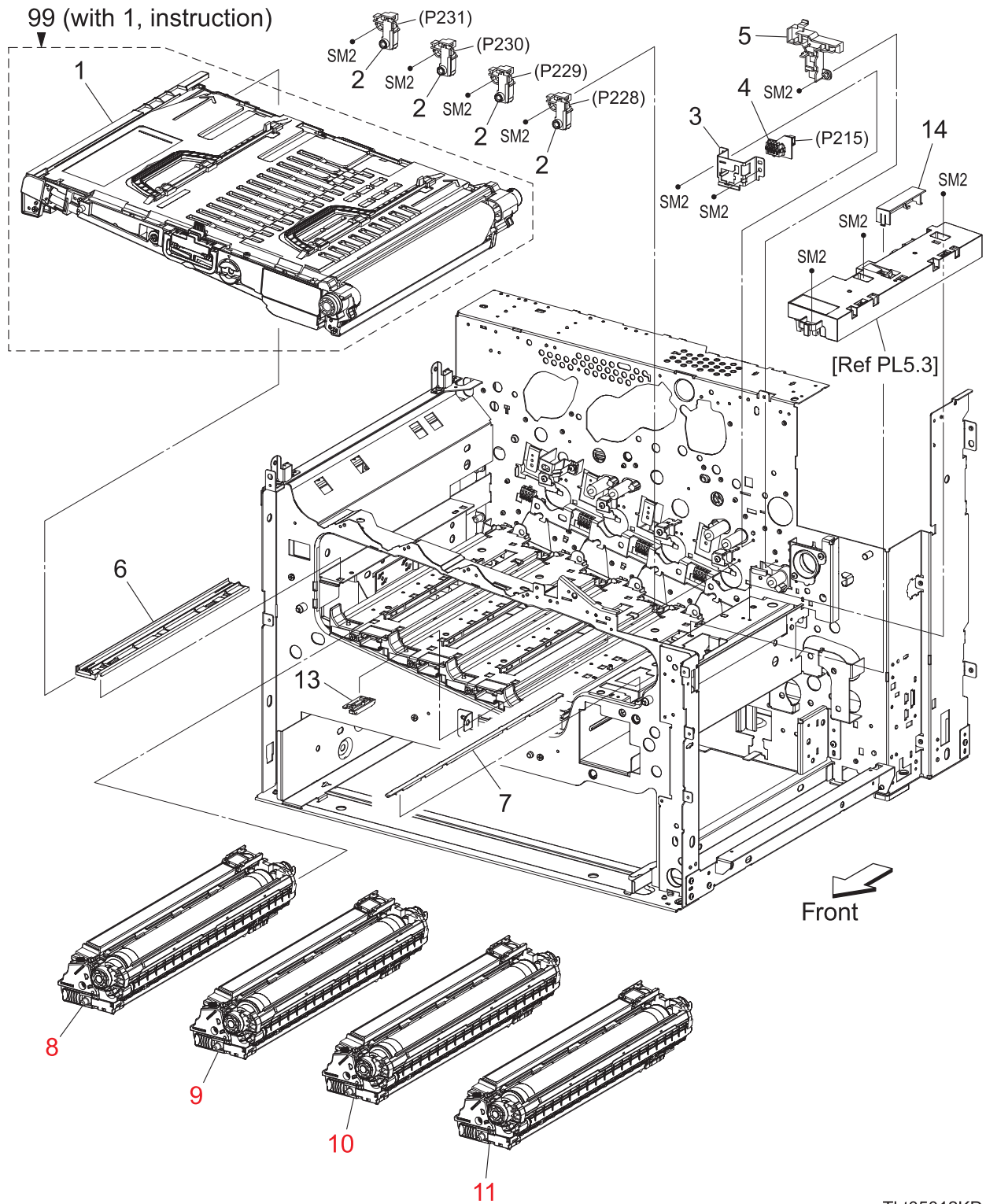

Tbt05012KD

PL5.1 Xerographics (1/3) [List]

Item	Parts name
1	BELT ASSY IBT *1
2	LAMP ASSY ERASE
3	BRACKET CONT CRUM BTR
4	CONNECTOR ASSY CRUM
5	GUIDE ERASE ADC
6	GUIDE BELT L
7	GUIDE BELT R
8	XERO DEVE CRU ASSY Y *2
9	XERO DEVE CRU ASSY M *2
10	XERO DEVE CRU ASSY C *2
11	XERO DEVE CRU ASSY K *2
12	--
13	GUIDE HANDLE
14	COVER CONNECTOR
99	KIT BELT ASSY IBT (with 1, instruction)

*1 : Periodic Replacing Parts (150KPV)

*2 : Periodic Replacing Parts (50KPV)

PL5.2 Xerographics (2/3) [Illustration]

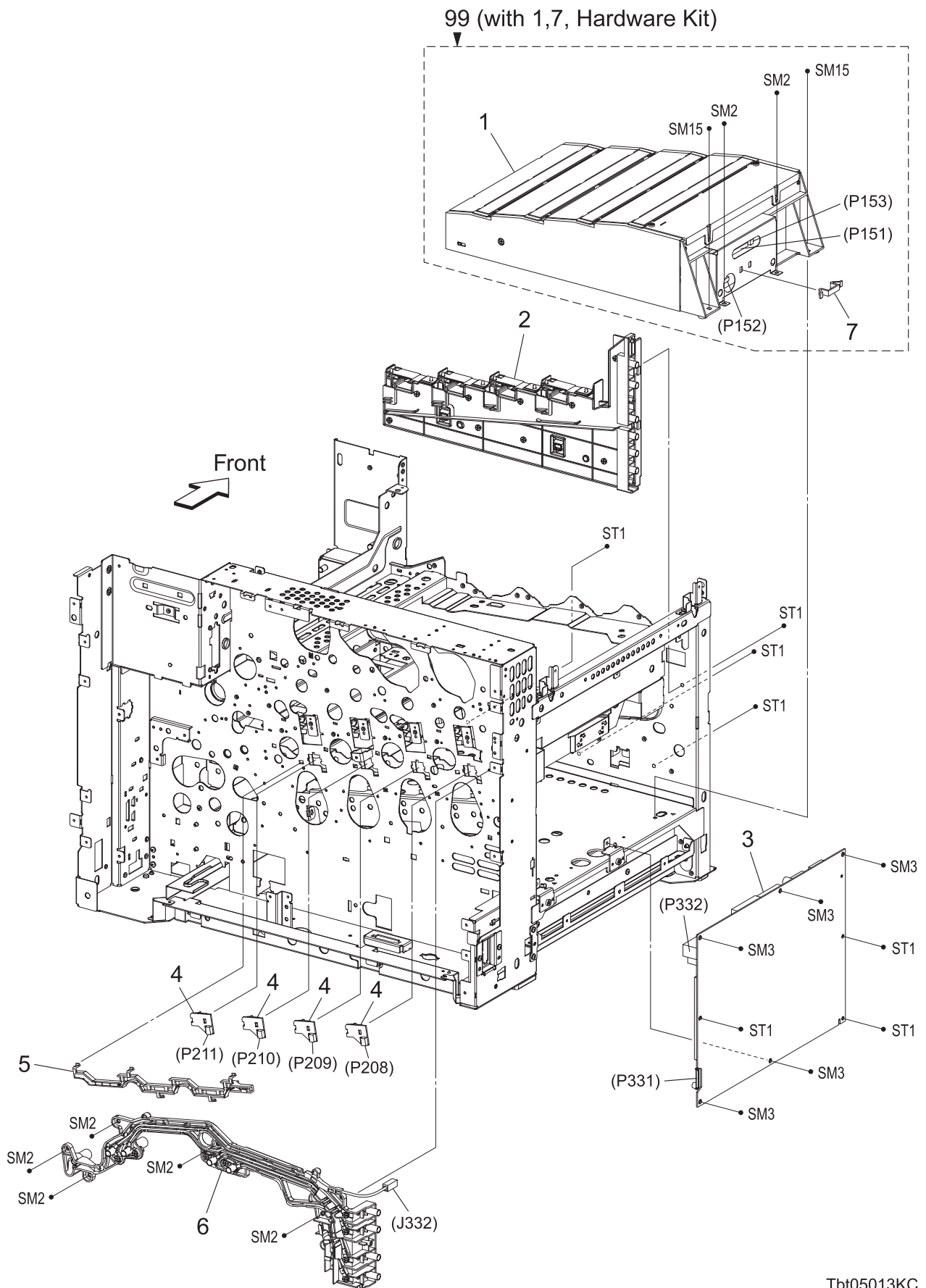

Tbt05013KC

PL5.2 Xerographics (2/3) [List]

Item	Parts name
1	ROS ASSY
2	HOUSING ASSY CR
3	PWBA HVPS
4	CONNECTOR ASSY CRUM
5	GUIDE CRUM CRU
6	HOUSING ASSY BTR
7	CLAMP PRESS REC-14
99	KIT ROS ASSY (with 1,7, Hardware Kit)

PL5.3 Xerographics (3/3) [Illustration]

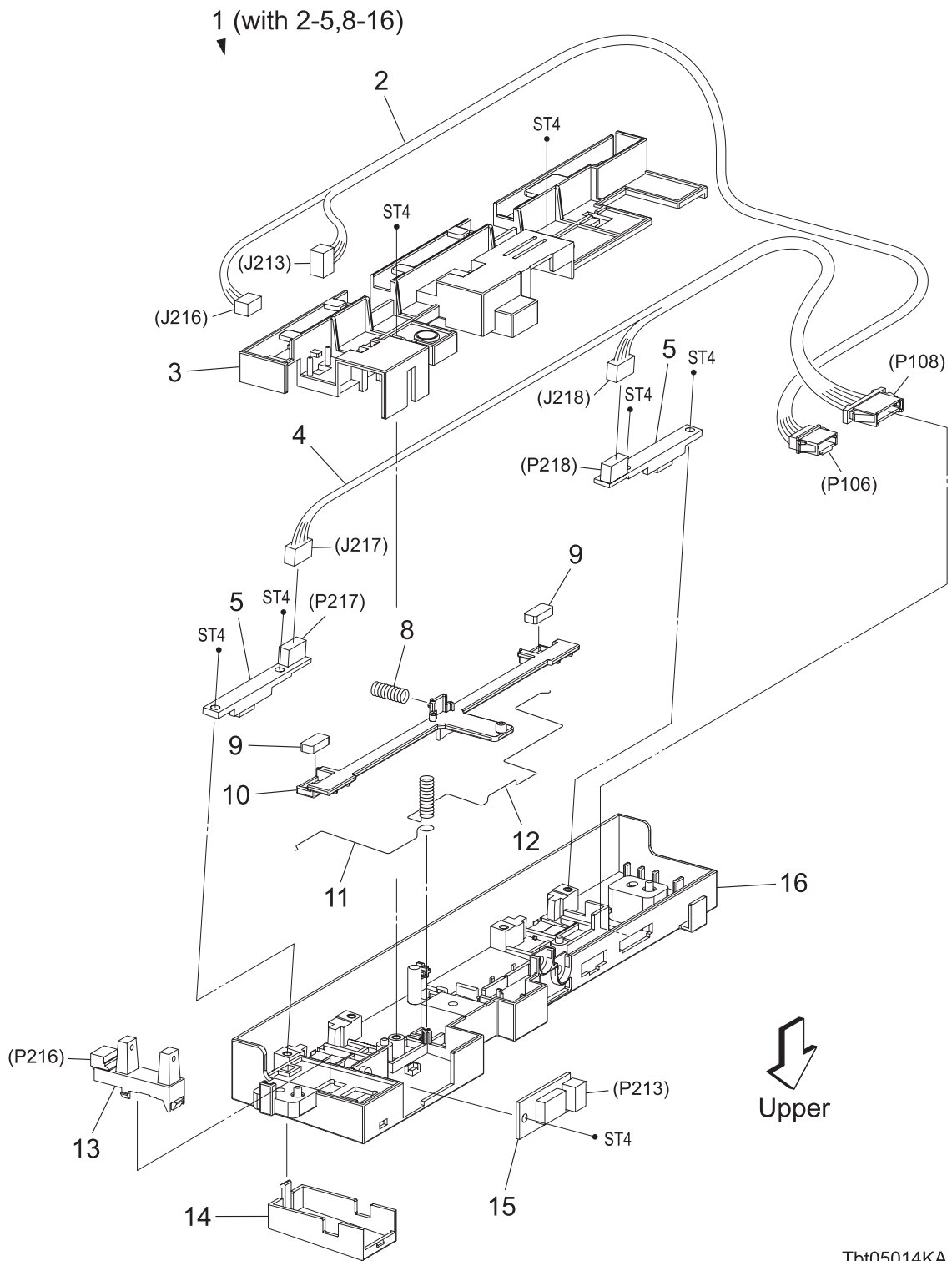

PL5.3 Xerographics (3/3) [List]

Item	Parts name
1	PROCON ASSY (with 2-5,8-16)
2	HARNESS ASSY CTD/HUM (P106-J213,J216)
3	COVER ADC
4	HARNESS ASSY CTD SNR (P108-J217,J218)
5	SENSOR ADC
6	--
7	--
8	SPRING SHUTTER
9	PAD ADC
10	SHUTTER ADC
11	CONDUCTOR GND F
12	CONDUCTOR GND R
13	SENSOR TNR FULL
14	COVER SENSOR
15	SENSOR HUM
16	HOUSING ADC

PL6.1 Dispenser [Illustration]

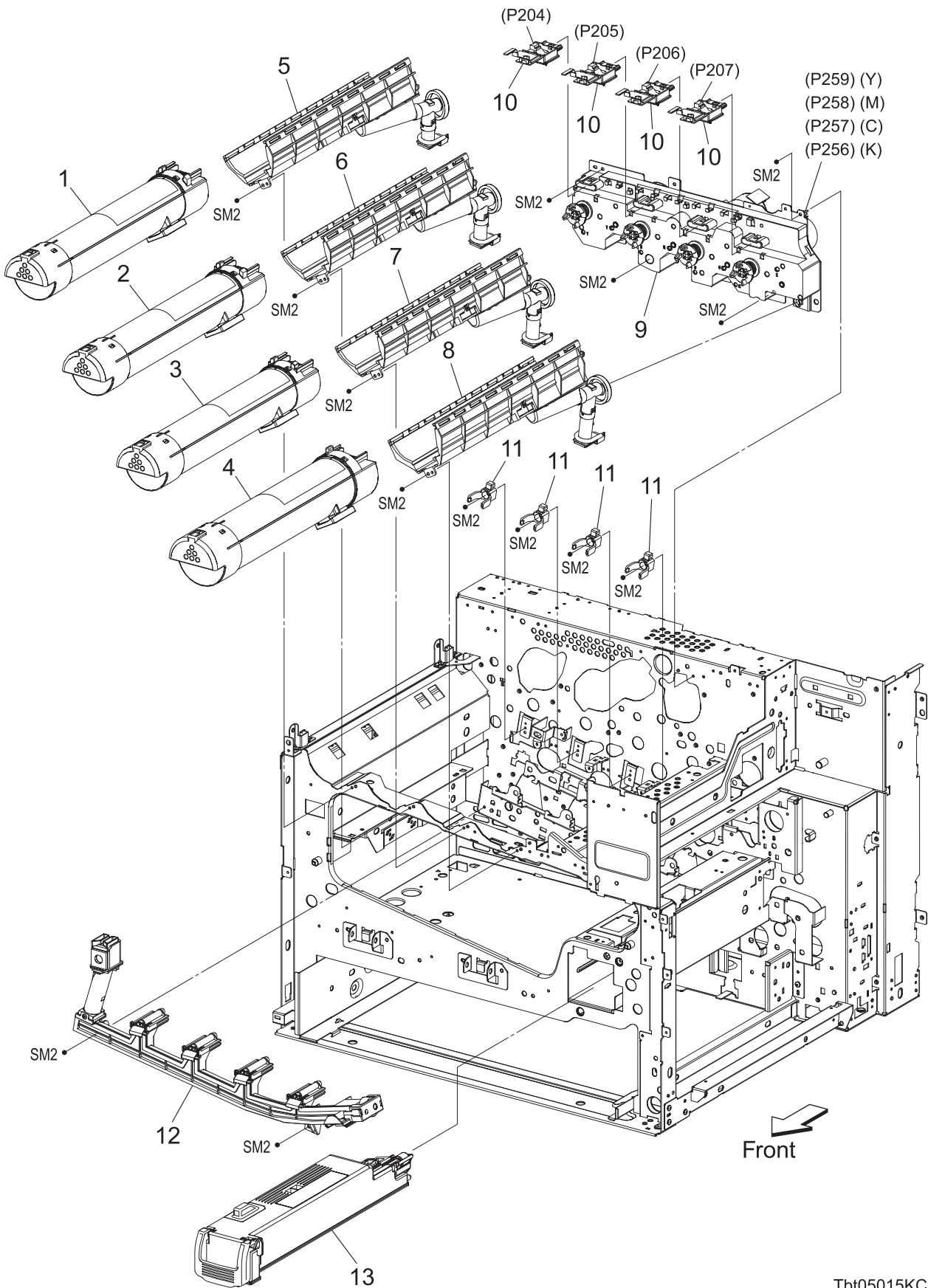

Tbt05015KC

PL6.1 Dispenser [List]

Item	Parts name
1	TONER CARTRIDGE (Y) *1
2	TONER CARTRIDGE (M) *1
3	TONER CARTRIDGE (C) *1
4	TONER CARTRIDGE (K) *2
5	DISP ASSY (Y)
6	DISP ASSY (M)
7	DISP ASSY (C)
8	DISP ASSY (K)
9	MOTOR ASSY DISP
10	CONNECTOR ASSY CRUM
11	CLAMP PIPE DISP
12	PIPE ASSY
13	WASTE TONER BOX *3

*1 : Periodic Replacing Parts (6KPV/12KPV)

*2 : Periodic Replacing Parts (9KPV/18KPV)

*3 : Periodic Replacing Parts (25KPV)

PL7.1 Fuser & Exit (1/3) [Illustration]

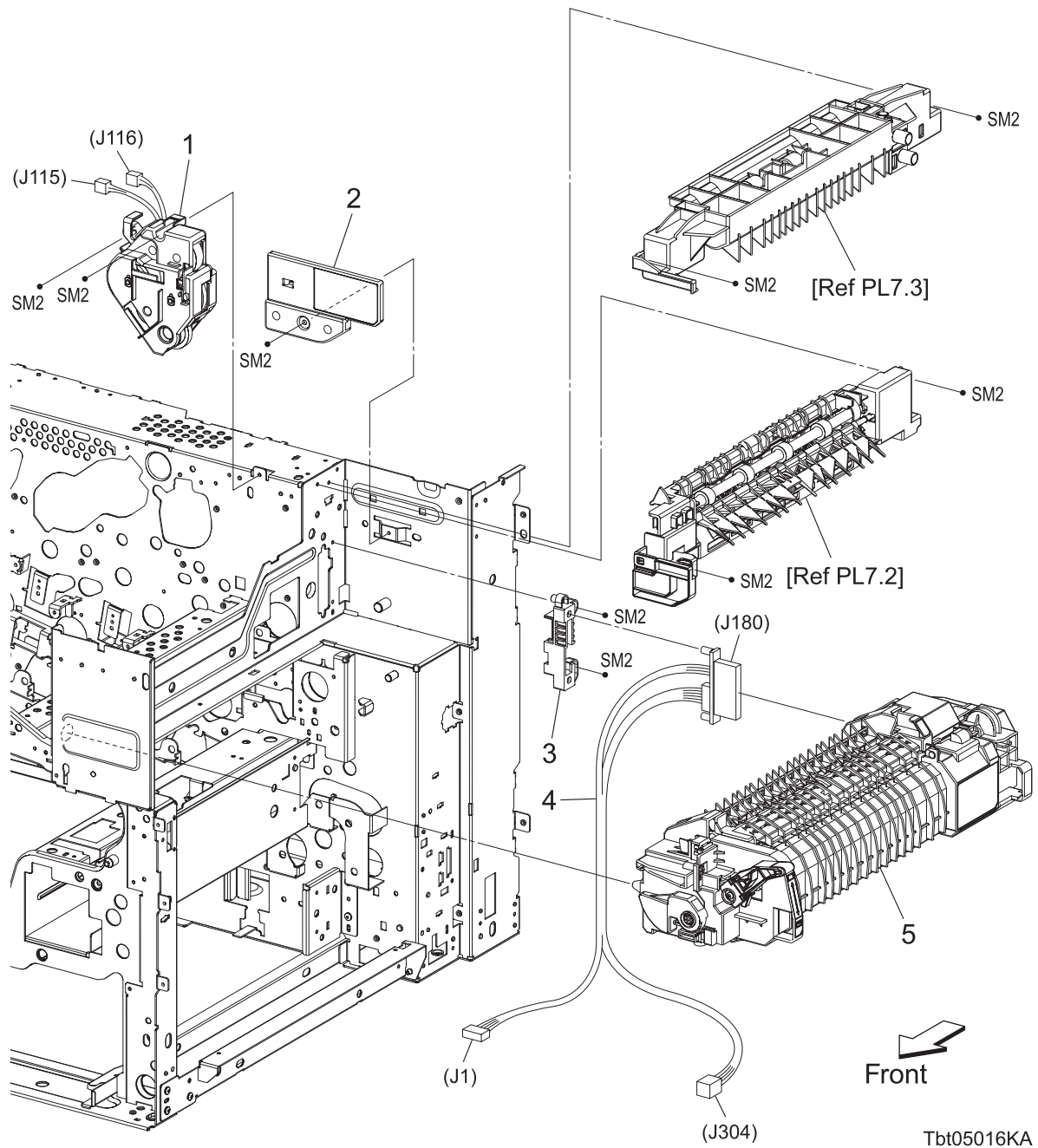

PL7.1 Fuser & Exit (1/3) [List]

Item	Parts name
1	DRIVE ASSY EXIT
2	GUIDE INVERT
3	BRACKET DRAWER FUSER
4	HARNESS ASSY FSR (J180-J1,J304)
5	FUSER ASSY *1

*1 : Periodic Replacing Parts (100KPV)

PL7.2 Fuser & Exit (2/3) [Illustration]

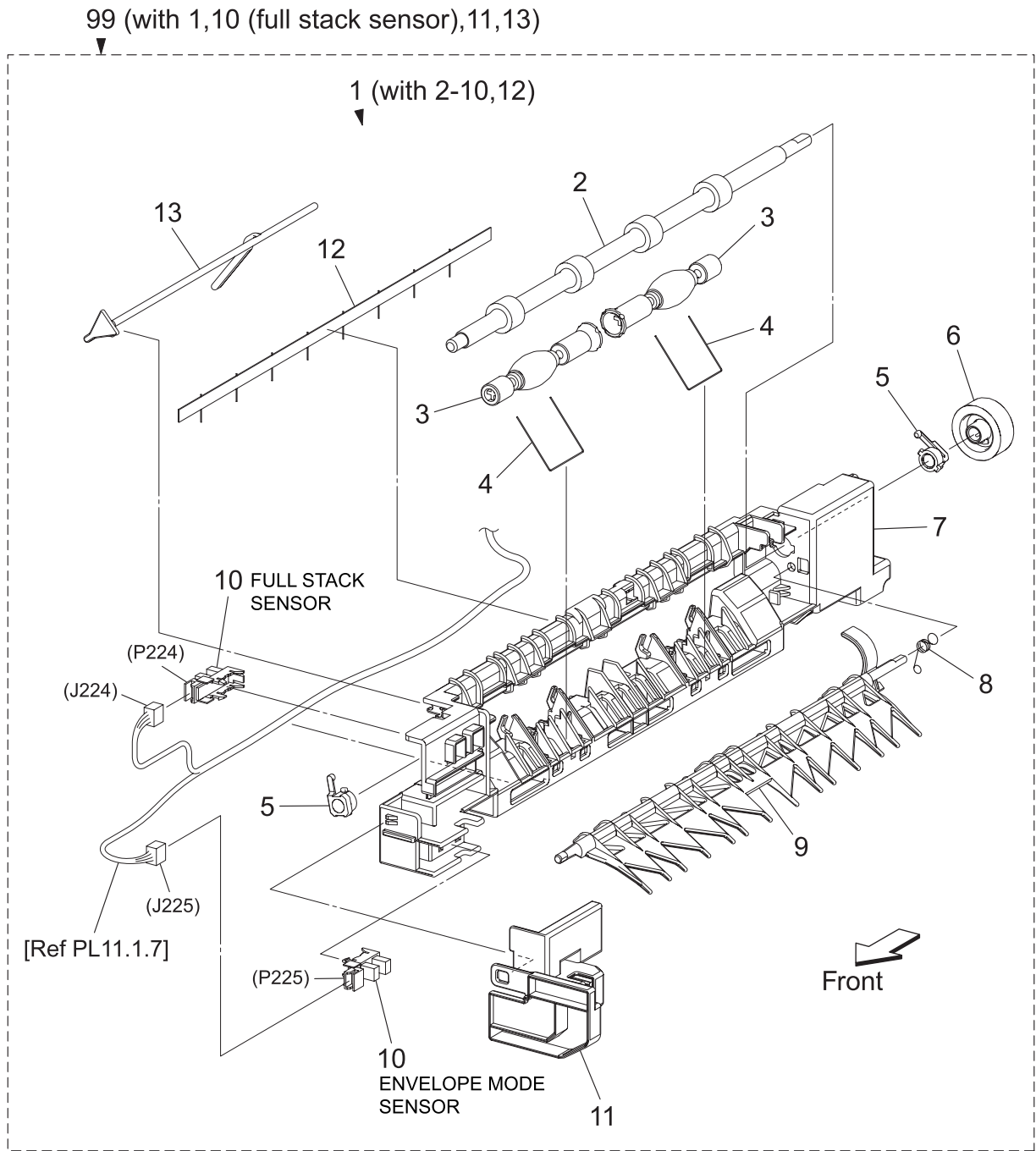

Tbt05017KC

PL7.2 Fuser & Exit (2/3) [List]

Item	Parts name
1	CHUTE ASSY EXIT (with 2-10,12)
2	ROLL ASSY EXIT
3	ROLL PINCH EXIT
4	SPRING PINCH EXIT
5	BEARING EXIT
6	GEAR EXIT ROLL
7	CHUTE LOWER EXIT
8	SPRING PATH CHANGE
9	CHUTE PATH CHANGE EXIT
10	SENSOR PHOTO
11	COVER SNR EXIT
12	ELIMINATOR EXIT
13	ACTUATOR FULL STACK
99	KIT CHUTE ASSY EXIT (with 1,10 (full stack sensor),11,13)

PL7.3 Fuser & Exit (3/3) [Illustration]

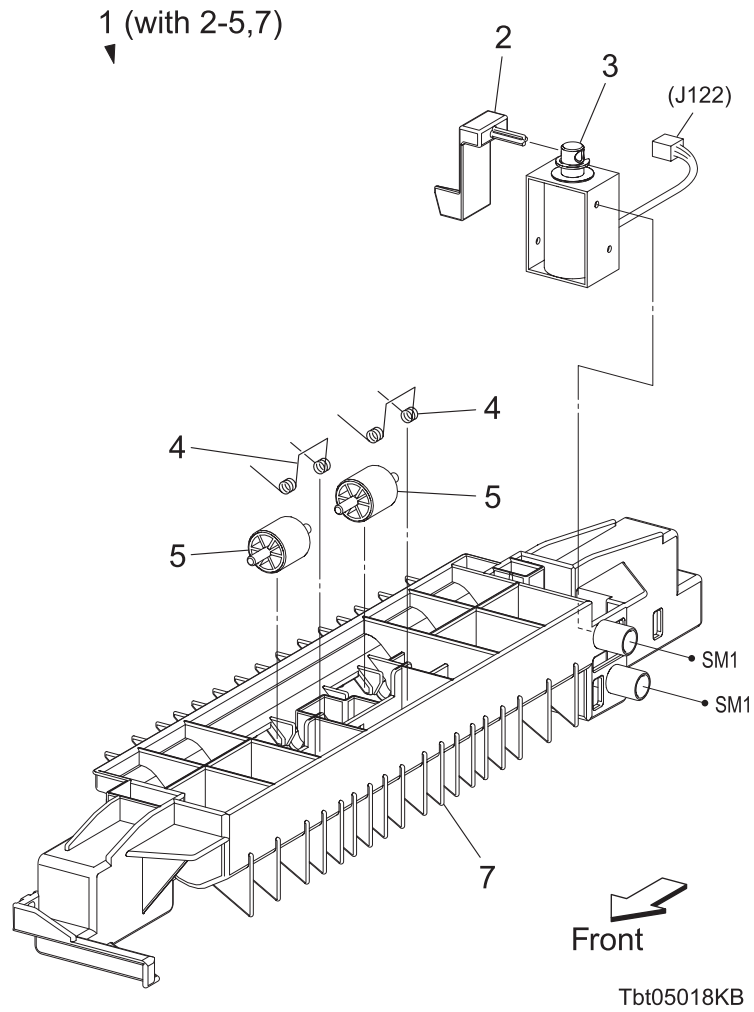

PL7.3 Fuser & Exit (3/3) [List]

Item	Parts name
1	CHUTE ASSY INVERT (with 2-5,7)
2	ACT PATH CHANGE
3	SOLENOID ASSY INVERT
4	SPRING PINCH DUP
5	ROLL PINCH TA
6	--
7	CHUTE INVERT
8	--

PL8.1 Frame (1/2) [Illustration]

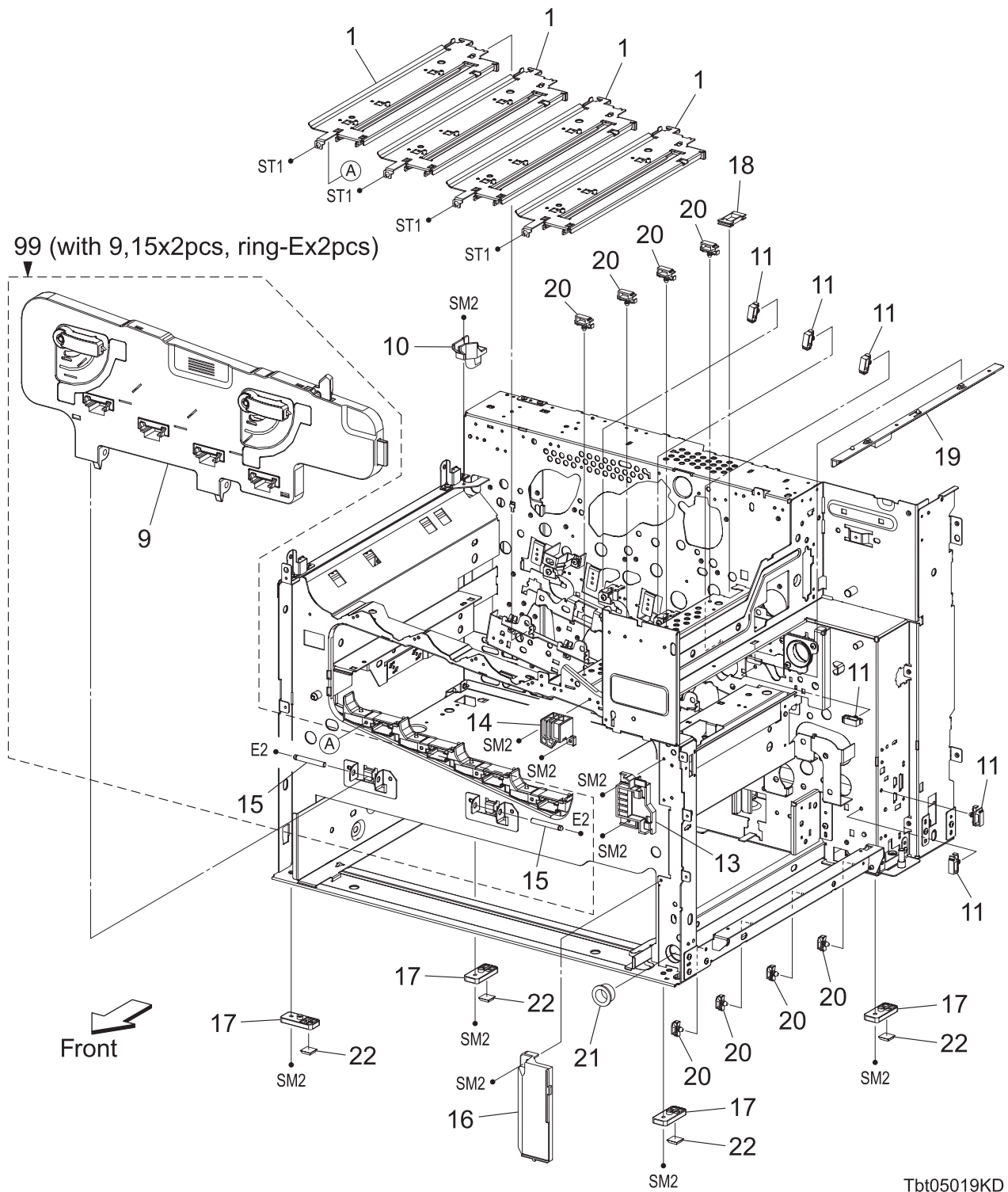

Tbt05019KD

PL8.1 Frame (1/2) [List]

Item	Parts name
1	GUIDE ASSY CRU
2	--
3	--
4	--
5	--
6	--
7	--
8	--
9	FRAME ASSY 2ND
10	GUIDE HARNESS OP PANEL
11	CLAMP LOCKING
12	--
13	GUIDE FRAME LOCK H
14	GUIDE FRAME LOCK V
15	SHAFT PIVOT FRAME 2ND
16	COVER FR UNDER
17	FOOT
18	BUSH
19	GUIDE AIR TRANS
20	CLAMP LOCKING
21	BUSH CLOSE-TYPE
22	FOOT RUBBER
99	KIT FRAME ASSY 2ND (with 9,15x2pcs, ring-Ex2pcs)

PL8.2 Frame (2/2) [Illustration]

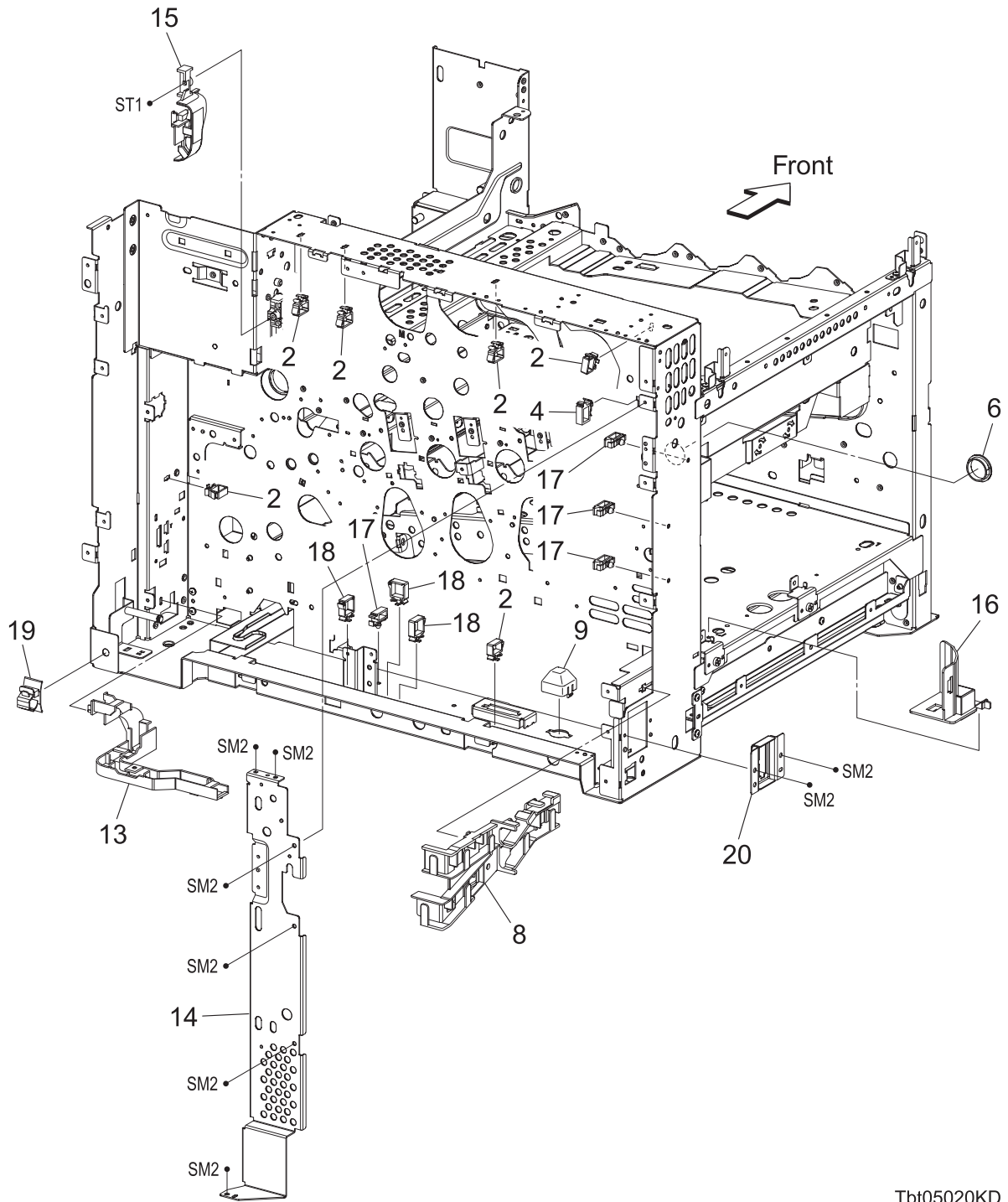

Tbt05020KD

PL8.2 Frame (2/2) [List]

Item	Parts name
1	--
2	CLAMP RLWT-2V0
3	--
4	CLAMP LOCKING
5	--
6	BUSH CLOSE-TYPE
7	--
8	GUIDE HARNESS REAR
9	COVER PIN
10	--
11	--
12	--
13	GUIDE HARNESS WIRE
14	PLATE SUPPORT EM
15	BRACKET FUSER HNS
16	GUIDE AIR REAR
17	CLAMP LOCKING
18	CLAMP
19	CLAMP CKS BK
20	BRACKET FIN CONT

PL9.1 Drive (1/2) [Illustration]

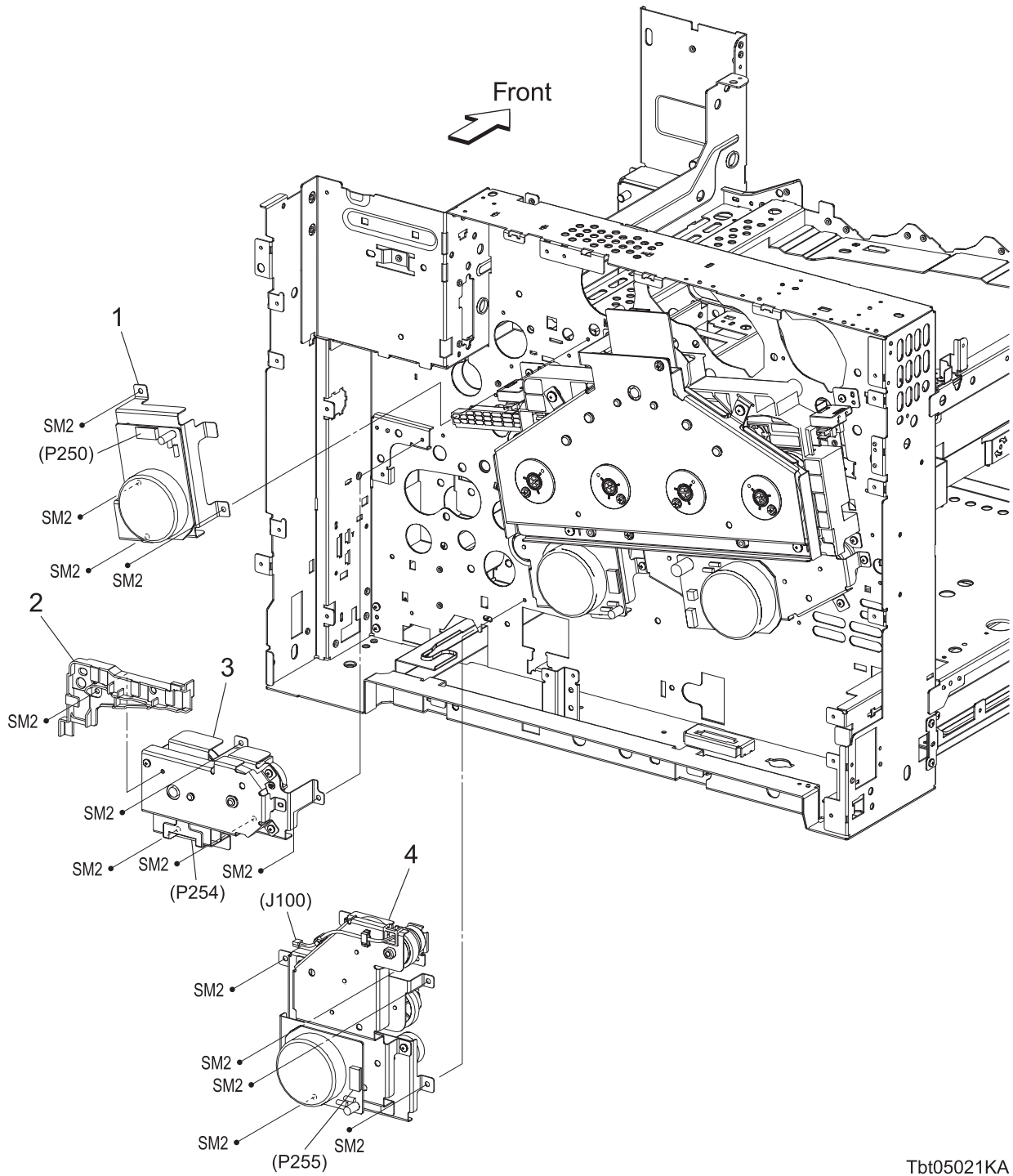

Tbt05021KA

PL9.1 Drive (1/2) [List]

Item	Parts name
1	DRIVE ASSY FSR
2	GUIDE HARNESS FUSER AC
3	DRIVE ASSY IBT
4	DRIVE ASSY PH

PL9.2 Drive (2/2) [Illustration]

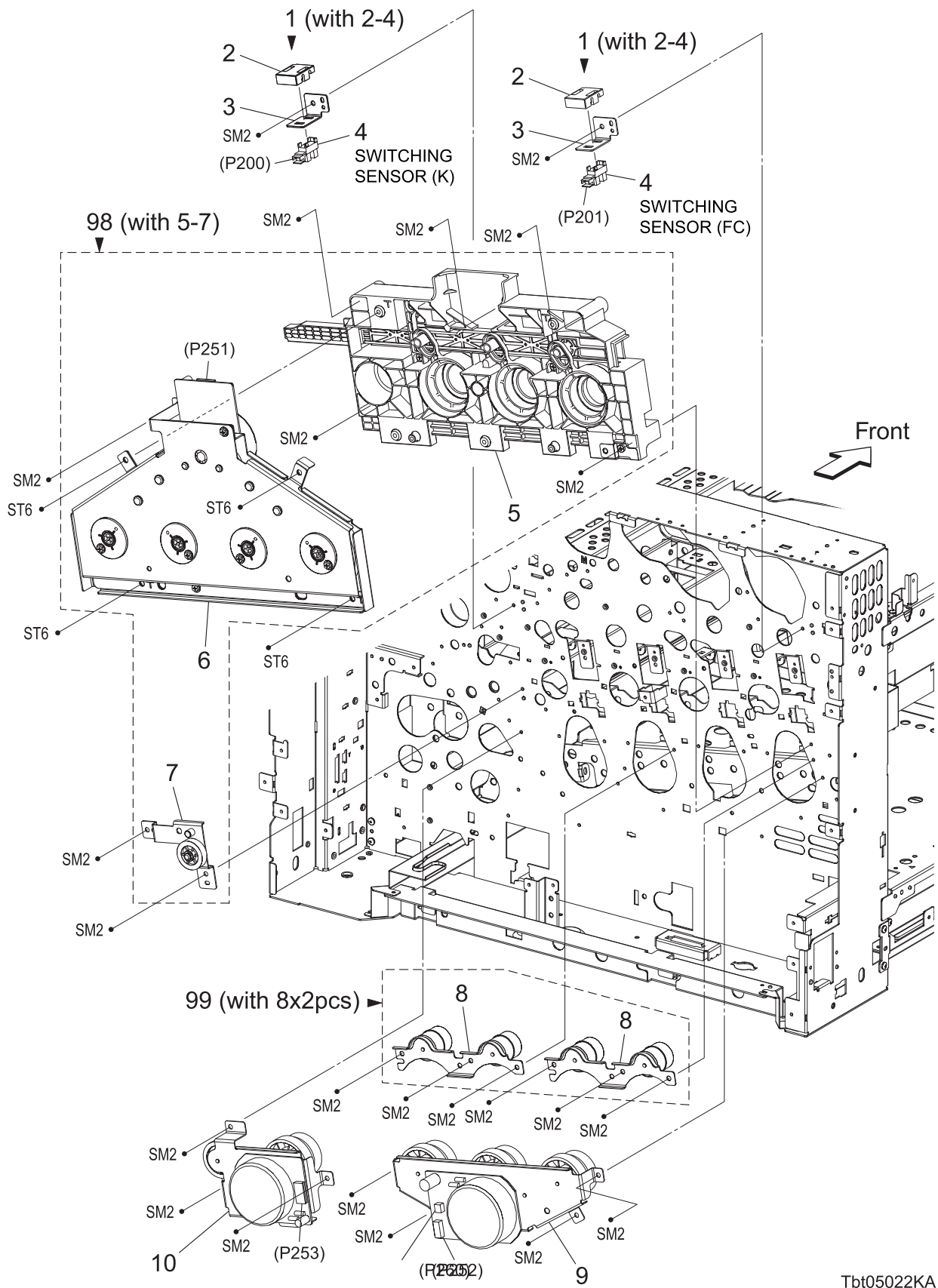

Tbt05022KA

PL9.2 Drive (2/2) [List]

Item	Parts name
1	DRIVE ASSY SNS (with 2-4)
2	GUIDE SNS
3	PLATE SNS
4	SENSOR PHOTO
5	GUIDE ASSY LINK
6	DRIVE ASSY XERO
7	DRIVE ASSY RACK
8	DRIVE ASSY M OUT
9	DRIVE ASSY DEVE
10	DRIVE ASSY DEVE K
98	KIT LINK XERO DRIVE (with 5-7)
99	KIT DRIVE GEAR (with 8x2pcs)

PL10.1 Electrical (1/2) [Illustration]

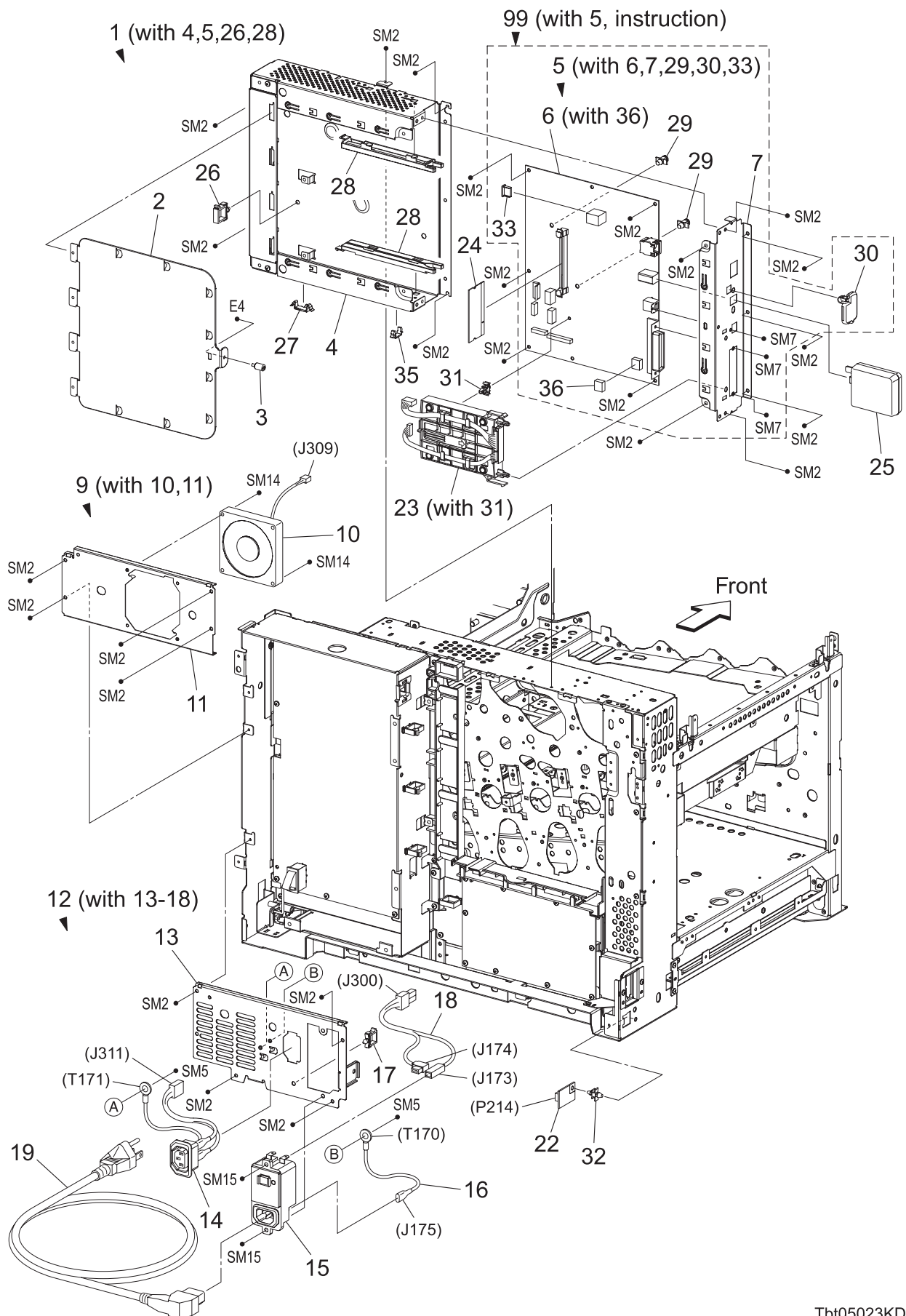

Tbt05023KD

PL10.1 Electrical (1/2) [List]

Item	Parts name
1	BOX ASSY ESS PWB (with 4,5,26,28)
2	PLATE WINDOW ESS
3	SCREW KNURLING
4	BOX ASSY BASE
5	PLATE ASSY ESS (with 6,7,29,30,33)
6	PWBA ESS (with 36)
7	PLATE ESS IF
8	--
9	FAN ASSY LVPS (with 10,11)
10	FAN LVPS
11	PLATE LVPS FAN
12	PLATE ASSY LVPS POWER (with 13-18)
13	PLATE LVPS POWER
14	HARNESS ASSY FIN PWR (OUTLET-J311,T171)
15	BREAKER GFI INLET
16	WIRE ASSY GFI EARTH (J175-T170)
17	CLAMP LOCKING
18	HARNESS ASSY AC (J300-J173,J174)
19	POWER CORD
20	--
21	--
22	PWBA EEPROM
23	HDD ASSY (with 31) (OPTION)
24	MEMORY CARD 1G (OPTION)
25	WIRELESS ADAPTER (OPTION)
26	CLAMP LOCKING
27	CLAMP PRESS REC-16
28	GUIDE BOAD ESS
29	SUPPORT
30	CAP WIRELESS
31	SPACER BOAD
32	SUPPORT
33	CAP USB
34	--
35	CLAMP
36	NVM ROM
99	KIT PLATE ASSY ESS (with 5, instruction)

PL10.2 Electrical (2/2) [Illustration]

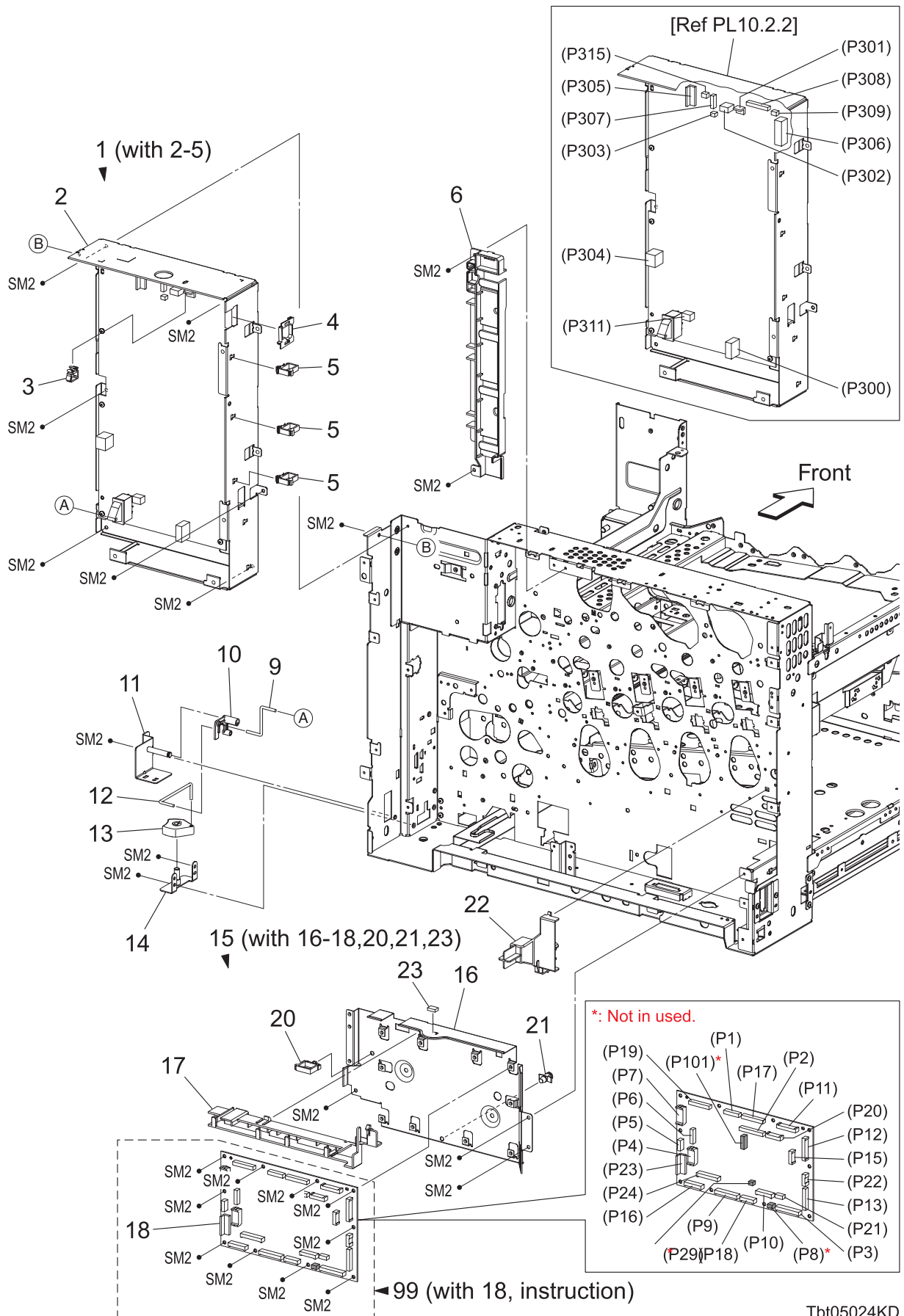

Tbt05024KD

PL10.2 Electrical (2/2) [List]

Item	Parts name
1	BOX ASSY LVPS (with 2-5)
2	LVPS ASSY
3	CLAMP RLWT-2V0
4	BUSH
5	CLAMP LOCKING
6	GUIDE HARNESS REAR CTR
7	--
8	--
9	WIRE SHORT
10	LINK REAR
11	BRACKET ASSY REAR
12	WIRE LONG
13	KNOB MAIN SWITCH
14	BRACKET ASSY FRONT
15	BOX ASSY MCU (with 16-18,20,21,23)
16	BOX MCU
17	GUIDE HARNESS MCU UPR
18	PWBA MCU
19	--
20	CLAMP LOCKING
21	SUPPORT
22	HOLDER BOX MCU
23	GASKET SHIELD
99	KIT PWBA MCU (with 18, instruction)

PL11.1 Harness (1/2) [Illustration]

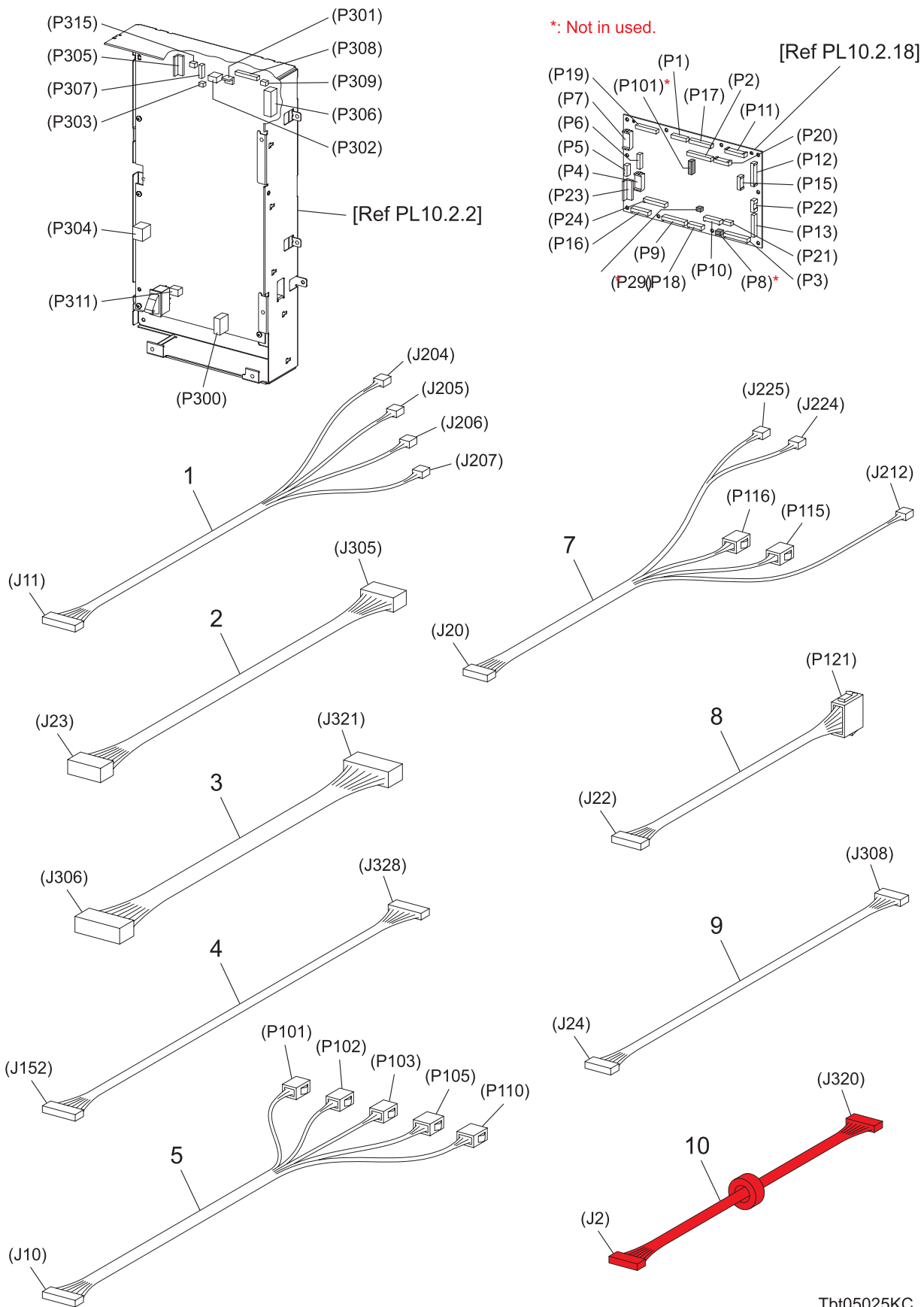

Tbt05025KC

PL11.1 Harness (1/2) [List]

Item	Parts name
1	HARNESS ASSY TN CRUM (J11-J204,J205,206,J207)
2	HARNESS ASSY LV PWR (J23-J305)
3	HARNESS ASSY ESS PWR (J306-J321)
4	HARNESS ASSY VIDEO (J152-J328)
5	HARNESS ASSY REGI (J10-P101,P102,P103,P105,P110)
6	--
7	HARNESS ASSY EXIT (J20-P115,P116,J212,J224,J225)
8	HARNESS ASSY FIN (J22-P121)
9	HARNESS ASSY LVPS (J24-J308)
10	HARNESS ASSY ESS CORE (J2-J320)
11	--

PL11.2 Harness (2/2) [Illustration]

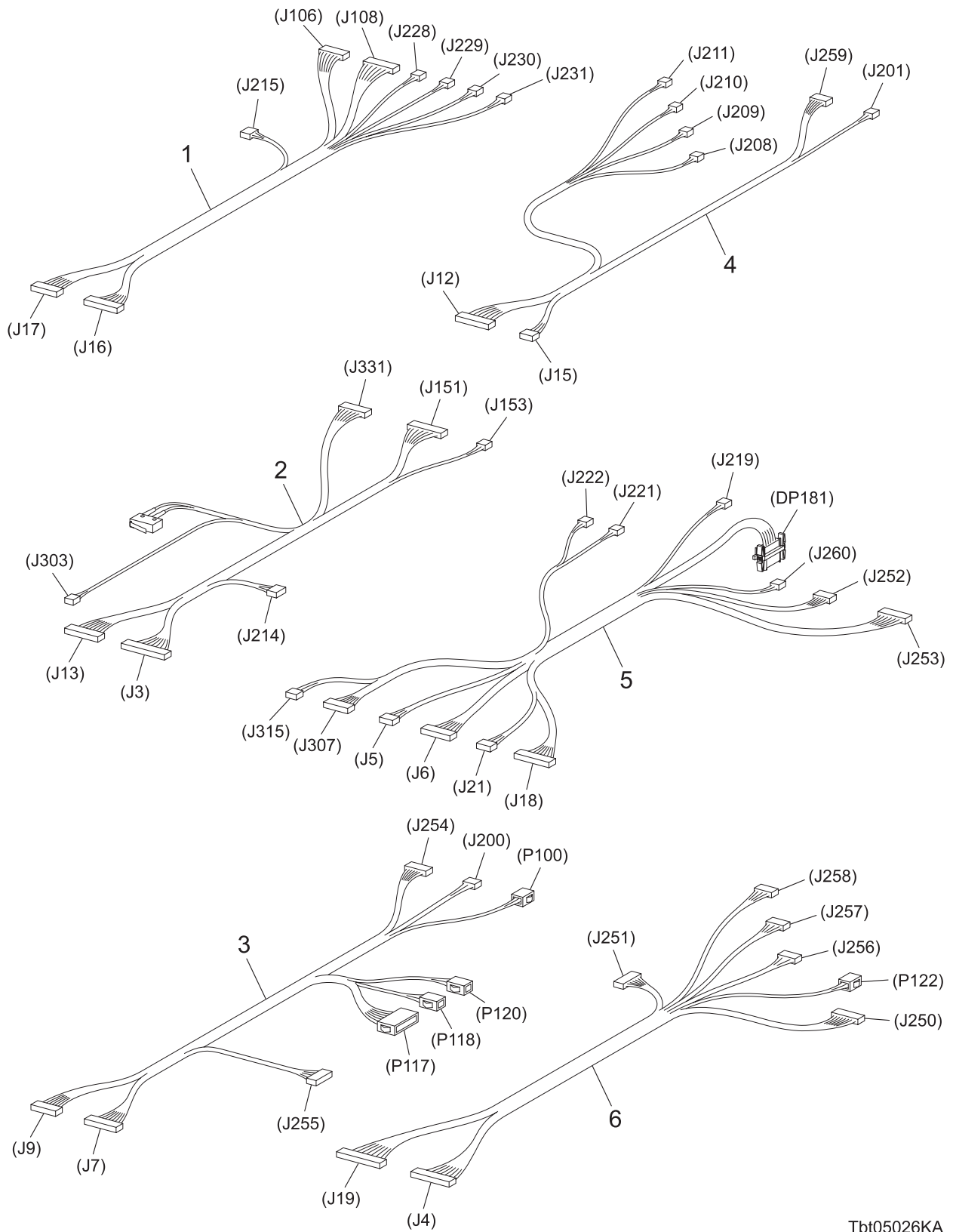

Tbt05026KA

PL11.2 Harness (2/2) [List]

Item	Parts name
1	HARNESS ASSY ERASE/EXIT (J16,J17-J106,J108,J215,J228,J229,J230,J231)
2	HARNESS ASSY ROS/HV (J3,J13-I/L SW,J151,J153,J214,J303,J331)
3	HARNESS ASSY RH/MOT (J7,J9-P100,P117,P118,P120,J200,J254,J255)
4	HARNESS ASSY CRUM/DISP (J12,J15-J201,J208,J209,J210,J211,J259)
5	HARNESS ASSY LPP/MOT (J5,J6,J18,J21-DP181,J219,J221,J222,J252,J253,J260, J307,J315)
6	HARNESS ASSY DISP/FSR (J4,J19-P122,J250,J251,J256,J257,J258)

PL12.1 550 Option Feeder (1/5) [Illustration]

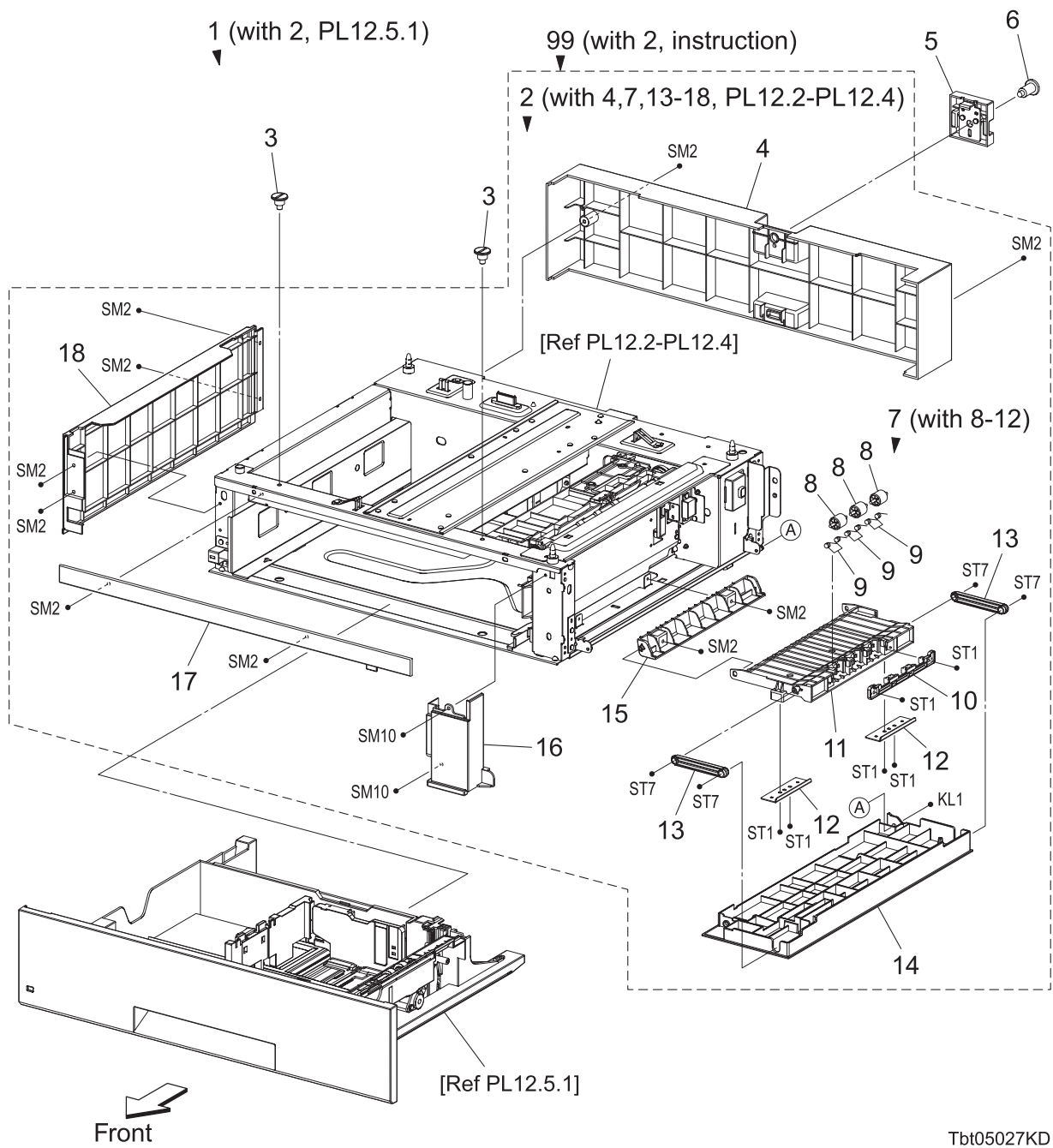

Tbt05027KD

PL12.1 550 Option Feeder (1/5) [List]

Item	Parts name
1	550 OPTION FEEDER (with 2,PL12.5.1)
2	FEEDER ASSY 550 (with 4,7,13-18,PL12.2-PL12.4)
3	SCREW LOCK
4	COVER REAR
5	PLATE LOCK REAR ASSY
6	SCREW LOCK REAR
7	CHUTE UPPER ASSY (with 8-12)
8	ROLL PINCH TA
9	SPRING PINCH TA
10	CHUTE UPPER TOP
11	CHUTE UPPER
12	PLATE MAGNET
13	ARM CHUTE
14	COVER RH OPT
15	CHUTE UNDER
16	COVER RIGHT
17	COVER FRONT
18	COVER LEFT
99	KIT FEEDER ASSY 550 (with 2, instruction)

PL12.2 550 Option Feeder (2/5) [Illustration]

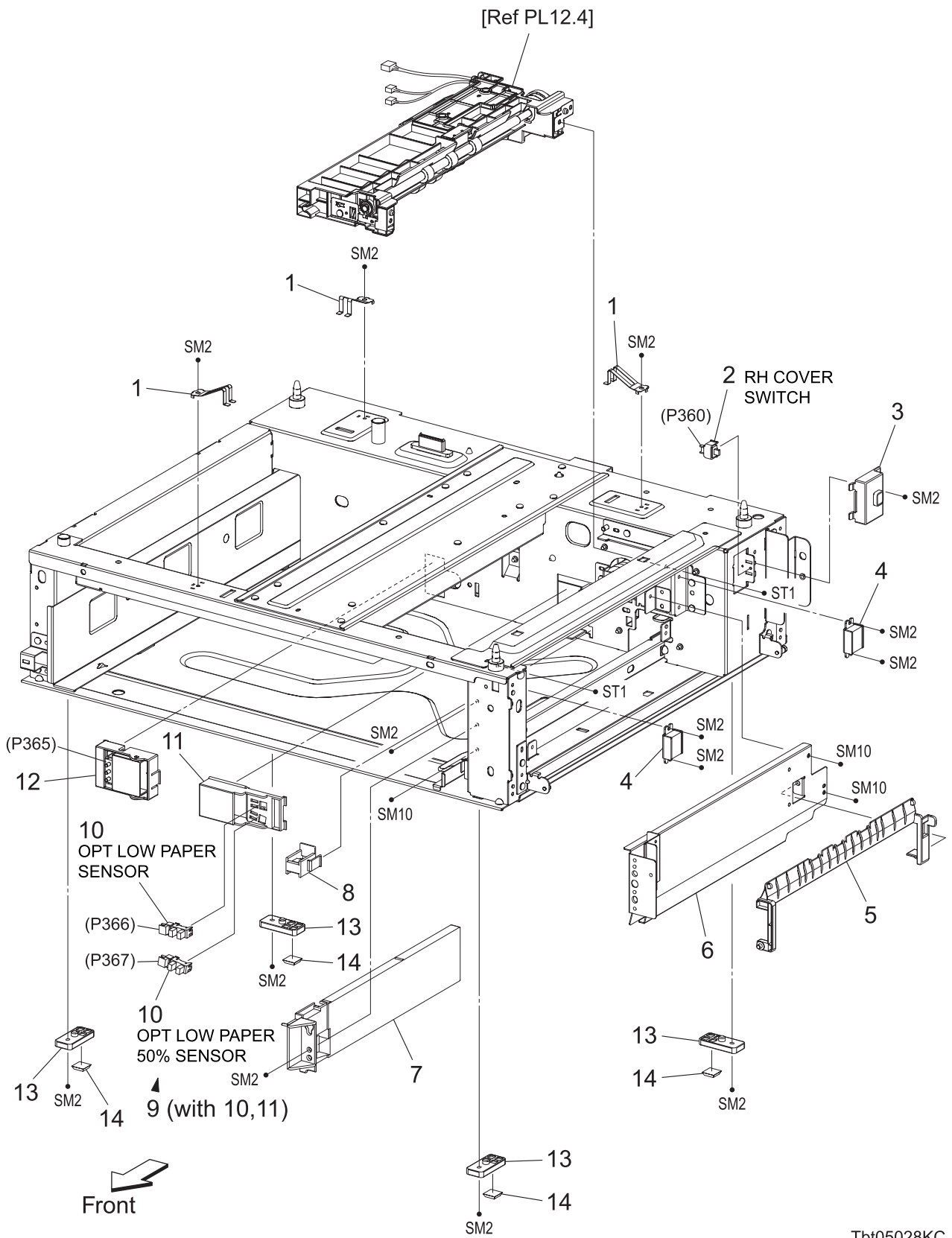

PL12.2 550 Option Feeder (2/5) [List]

Item	Parts name
1	EARTH SPRING
2	SWITCH
3	BRACKET SENSOR
4	MAGNET
5	CHUTE FEED
6	CHUTE ASSY LOWER
7	GUIDE TRAY OPT
8	BLOCK RELEASE
9	HOLDER ASSY SENSOR LOW (with 10,11)
10	SENSOR PHOTO
11	HOLDER SENSOR
12	SWITCH ASSY SIZE
13	FOOT
14	FOOT RUBBER

PL12.3 550 Option Feeder (3/5) [Illustration]

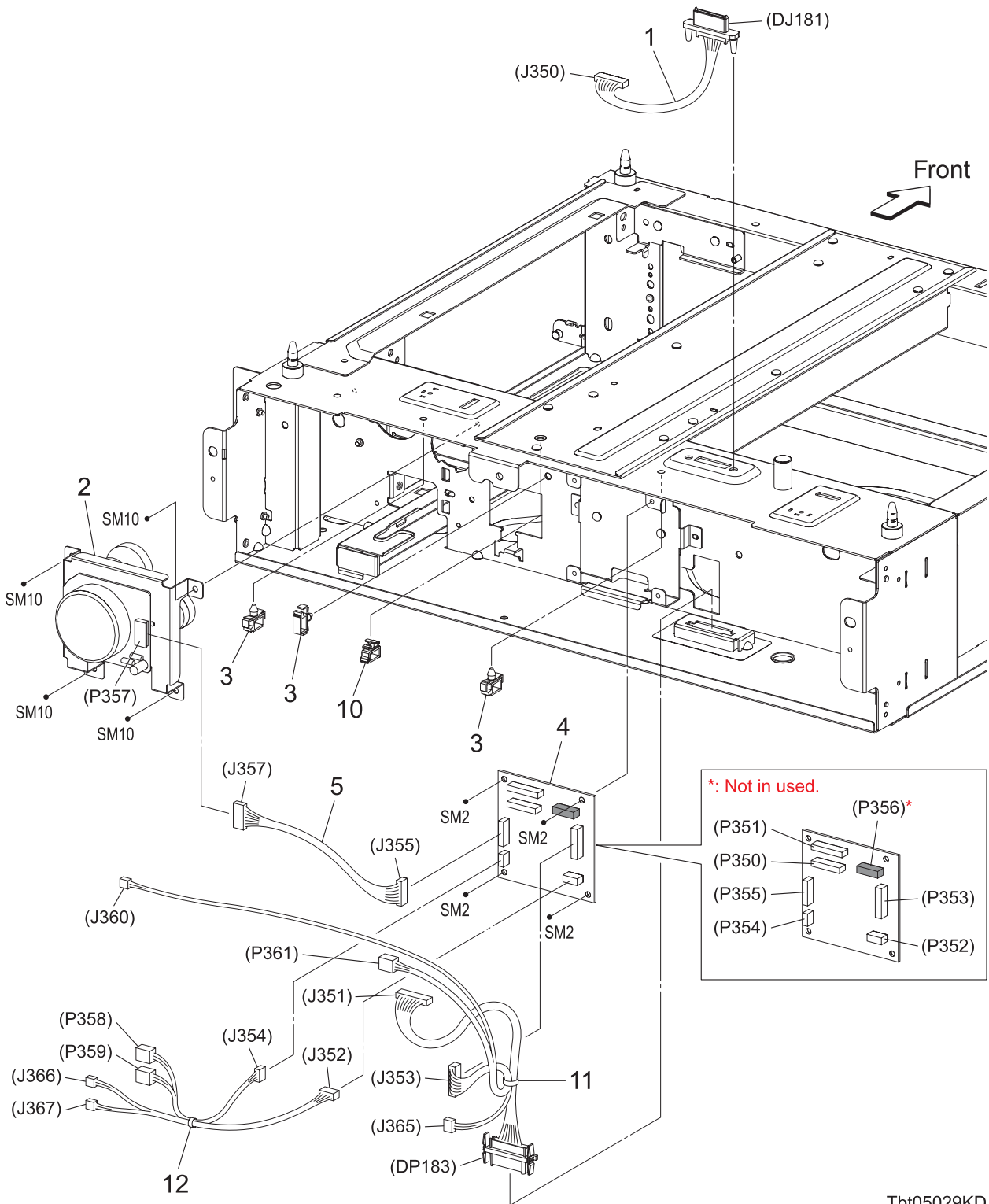

Tbt05029KD

PL12.3 550 Option Feeder (3/5) [List]

Item	Parts name
1	HARNESS ASSY OPT TOP (J350-DJ181)
2	DRIVE ASSY OPT
3	CLAMP LOCKING
4	PWBA OPT FDR
5	HARNESS ASSY OPT MOT (J355-J357)
6	--
7	--
8	--
9	--
10	CLAMP
11	HARNESS ASSY OPT SW (J351,J353-J360,P361,J365,DP183)
12	HARNESS ASSY OPT CL (J352,J354-P358,P359,J366,J367)

PL12.4 550 Option Feeder (4/5) [Illustration]

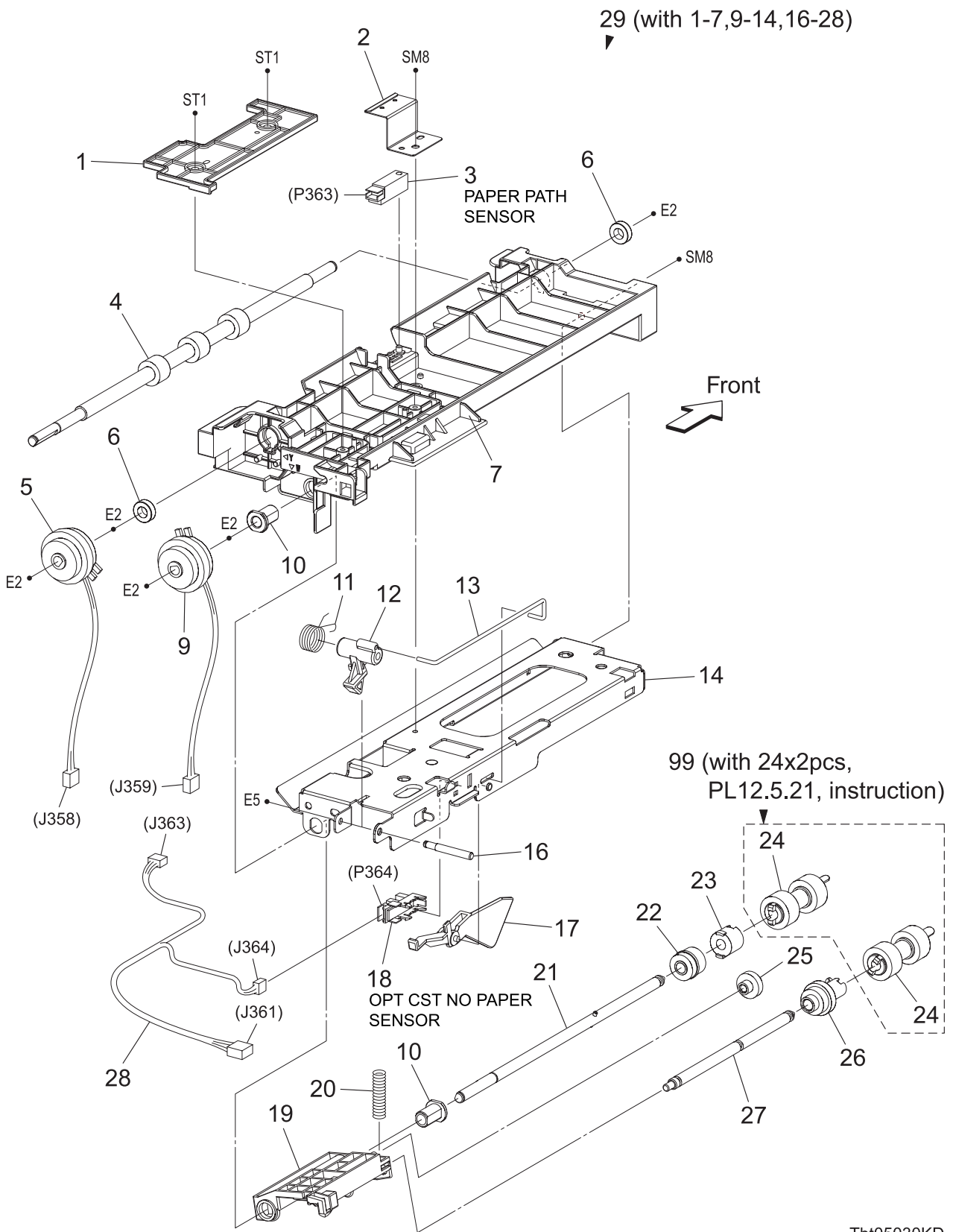

Tbt05030KD

PL12.4 550 Option Feeder (4/5) [List]

Item	Parts name
1	COVER FDR OPT
2	PLATE SENSOR
3	SENSOR
4	ROLL ASSY TAKE AWAY
5	CLUTCH ASSY TAKE AWAY
6	BEARING BALL
7	CHUTE FDR OPT
8	--
9	CLUTCH ASSY FEED
10	BEARING NUDGER
11	SPRING LEVER NUDGER
12	LEVER NUDGER
13	LINK ACTUATOR
14	CHUTE FRAME TOP
15	--
16	SHAFT LEVER NUDGER
17	ACTUATOR NO PAPER
18	SENSOR PHOTO
19	SUPPORT NUDGER
20	SPRING NUDGER
21	SHAFT ASSY FEED
22	GEAR FEED
23	CLUTCH ONEWAY FEED
24	ROLL ASSY FEED
25	GEAR IDLER NUDGER
26	ROLL ASSY GEAR NUDGER
27	SHAFT NUDGER
28	HARNES ASSY OPT PATH (J361-J363,J364)
29	FEEDER ASSY SUB OPT (with 1-7,9-14,16-28)
99	KIT FEED ROLL & SEPARATOR ROLL (with 24x2pcs, PL12.5.21, instruction) *1

*1 : Periodic Replacing Parts (150KPV)

PL12.5 550 Option Feeder (5/5) [Illustration]

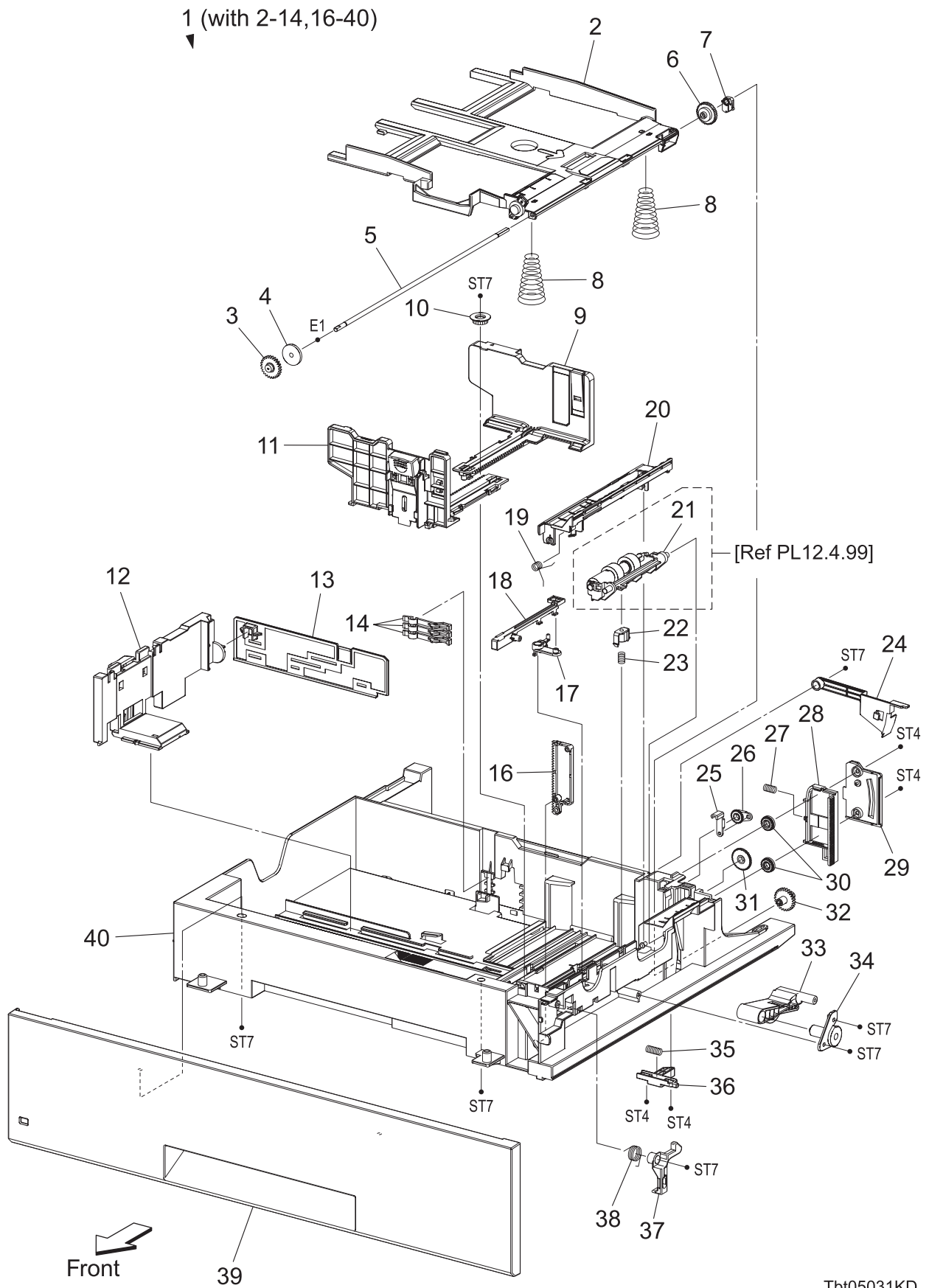

Tbt05031KD

PL12.5 550 Option Feeder (5/5) [List]

Item	Parts name
1	TRAY ASSY OPTION (with 2-14,16-40)
2	PLATE ASSY BOTTOM
3	GEAR PB FRONT
4	GEAR BTM DMP ONEWAY
5	SHAFT PB A4
6	GEAR BTM LOCK ONEWAY
7	STOPPER PB
8	SPRING BTM UP 550 A4
9	GUIDE ASSY SIDE R
10	GEAR PINION
11	GUIDE ASSY SIDE F
12	GUIDE ASSY END
13	ACTUATOR GUIDE END
14	ACTUATOR SIZE
15	--
16	PLATE GEAR LOCK
17	LEVER SEPARATOR
18	LEVER LATCH
19	SPRING COVER SEPARATOR
20	COVER SEPARATOR
21	HOLDER ASSY SEPARATOR
22	HOLDER SPRING SEPARATOR
23	SPRING SEPARATOR
24	ACTUATOR LOW PAPER
25	LEVER BTM LOCK
26	GEAR LEVER BTM LOCK
27	SPRING BTM LOCK
28	RACK BTM LOCK
29	COVER BTM UP
30	GEAR BTM LOCK PINION
31	GEAR 40 BTM LOCK
32	GEAR PB REAR
33	LINK PB
34	COVER LINK
35	SPRING STOPPER GEAR
36	ACTUATOR PLS PB
37	LATCH TRAY
38	SPRING LATCH
39	COVER TRAY OPT
40	HOUSING BASE

PL13.1 HCF (1/6) [List]

Item	Parts name
1	1100 OPTION FEEDER (with 2,10-12, PL13.6.1x2pcs)
2	FEEDER ASSY 1100 (with 3-9, PL13.2-PL13.5)
3	COVER REAR C
4	COVER RIGHT C
5	COVER FRONT C
6	COVER LEFT C
7	CASTER FRONT
8	CASTER REAR
9	FOOT
10	SCREW LOCK
11	PLATE LOCK REAR ASSY
12	SCREW LOCK REAR
99	KIT FEEDER ASSY 1100 (with 2, instruction)

PL13.2 HCF (2/6) [Illustration]

NOTE

The upper and lower sections of the HCF consist of the same components.
(Shown below are the components of the upper section.)

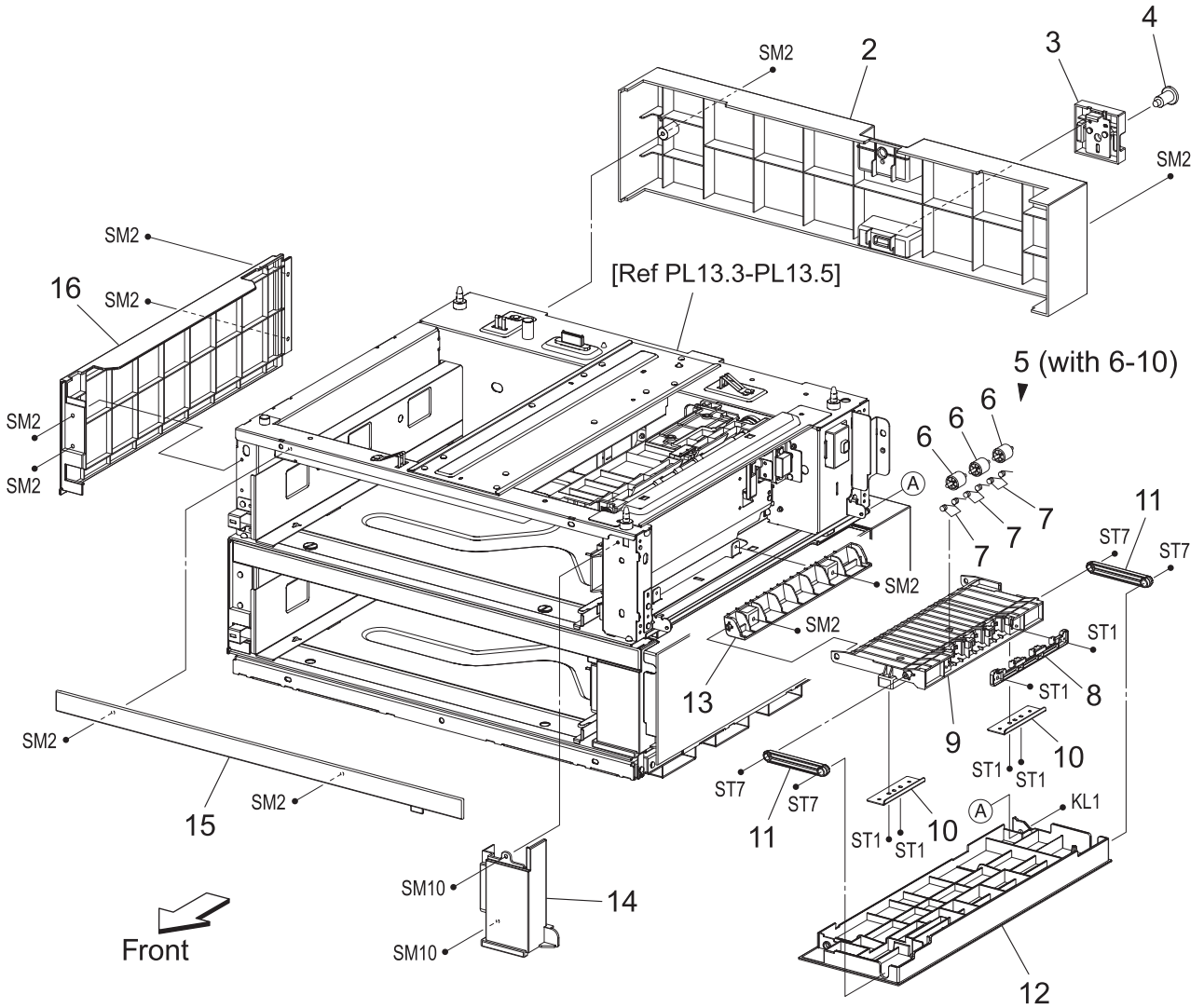

Tbt05044KC

PL13.2 HCF (2/6) [List]

Item	Parts name
1	--
2	COVER REAR
3	PLATE LOCK REAR ASSY
4	SCREW LOCK REAR
5	CHUTE UPPER ASSY (with 6-10)
6	ROLL PINCH TA
7	SPRING PINCH TA
8	CHUTE UPPER TOP
9	CHUTE UPPER
10	PLATE MAGNET
11	ARM CHUTE
12	COVER RH OPT
13	CHUTE UNDER
14	COVER RIGHT
15	COVER FRONT
16	COVER LEFT

PL13.3 HCF (3/6) [Illustration]

NOTE

The upper and lower sections of the HCF consist of the same components.
(Shown below are the components of the upper section.)

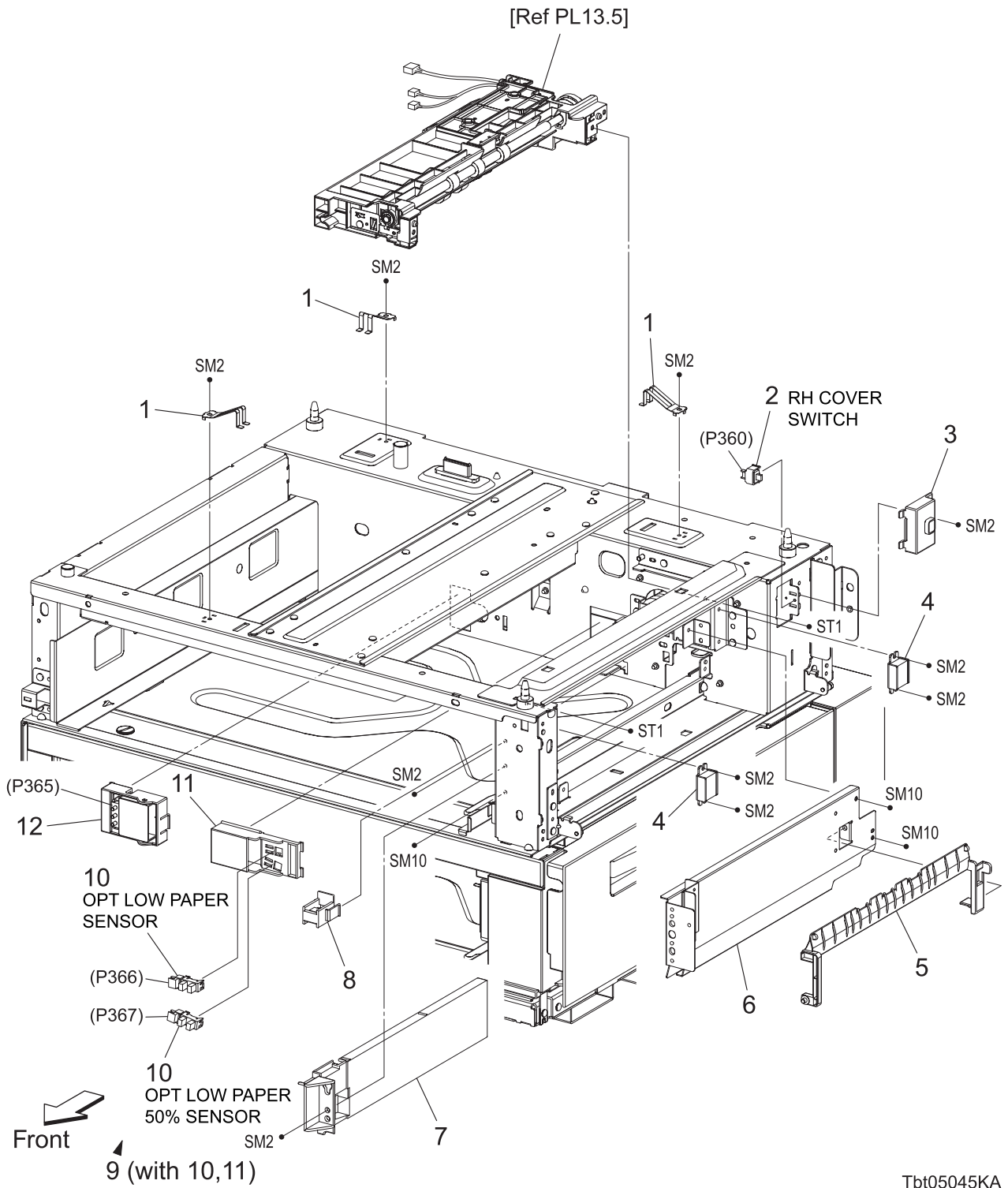

Tbt05045KA

PL13.3 HCF (3/6) [List]

Item	Parts name
1	EARTH SPRING
2	SWITCH
3	BRACKET SENSOR
4	MAGNET
5	CHUTE FEED
6	CHUTE ASSY LOWER
7	GUIDE TRAY OPT
8	BLOCK RELEASE
9	HOLDER ASSY SENSOR LOW (with 10,11)
10	SENSOR PHOTO
11	HOLDER SENSOR
12	SWITCH ASSY SIZE

PL13.4 HCF (4/6) [Illustration]

NOTE

The upper and lower sections of the HCF consist of the same components.
(Shown below are the components of the upper section.)

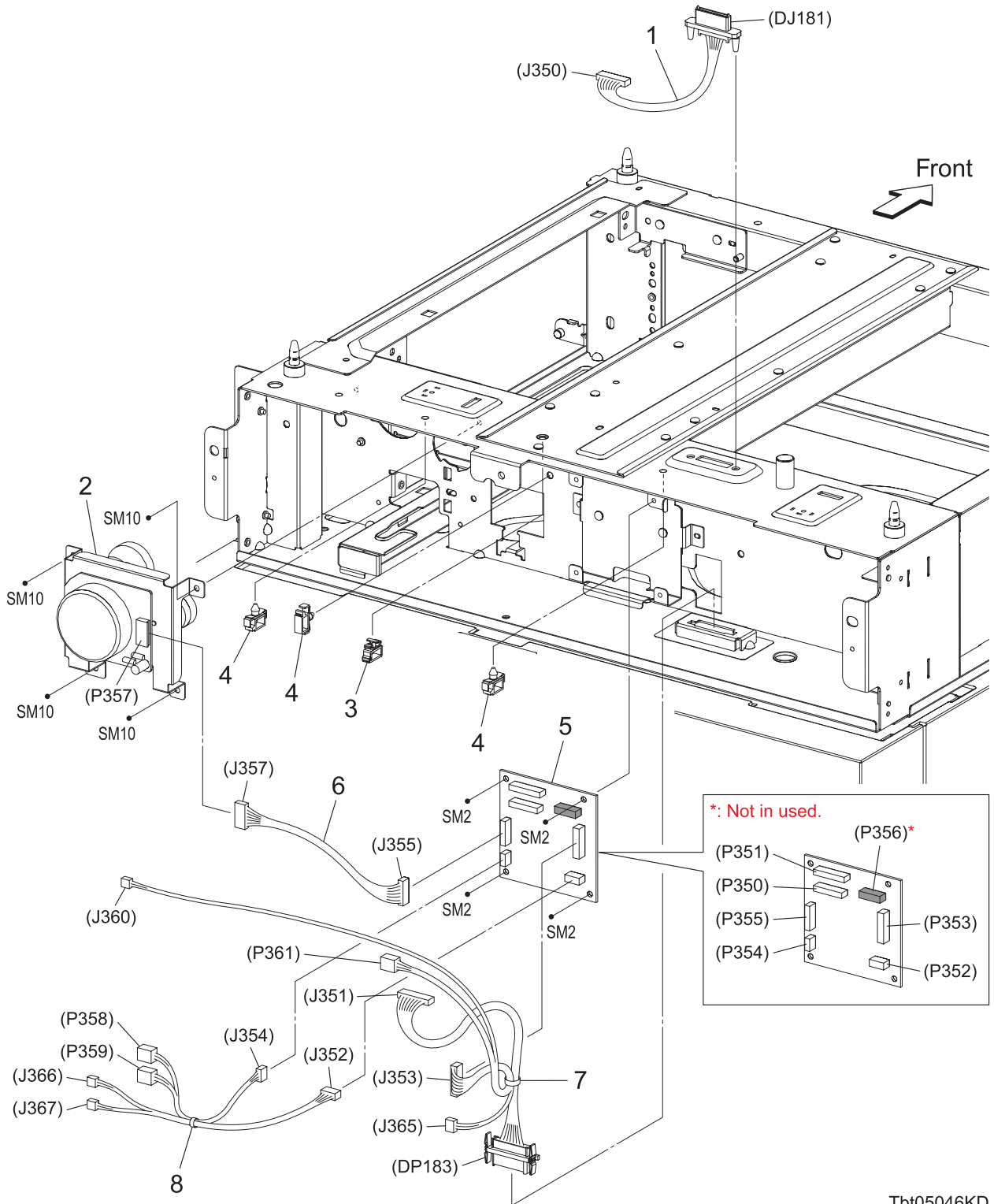

Tbt05046KD

PL13.4 HCF (4/6) [List]

Item	Parts name
1	HARNESS ASSY OPT TOP (J350-DJ181)
2	DRIVE ASSY OPT
3	CLAMP
4	CLAMP LOCKING
5	PWBA OPT FDR
6	HARNESS ASSY OPT MOT (J355-J357)
7	HARNESS ASSY OPT SW (J351,J353-J360,P361,J365,DP183)
8	HARNESS ASSY OPT CL (J352,J354-P358,P359,J366,J367)

PL13.5 HCF (5/6) [Illustration]

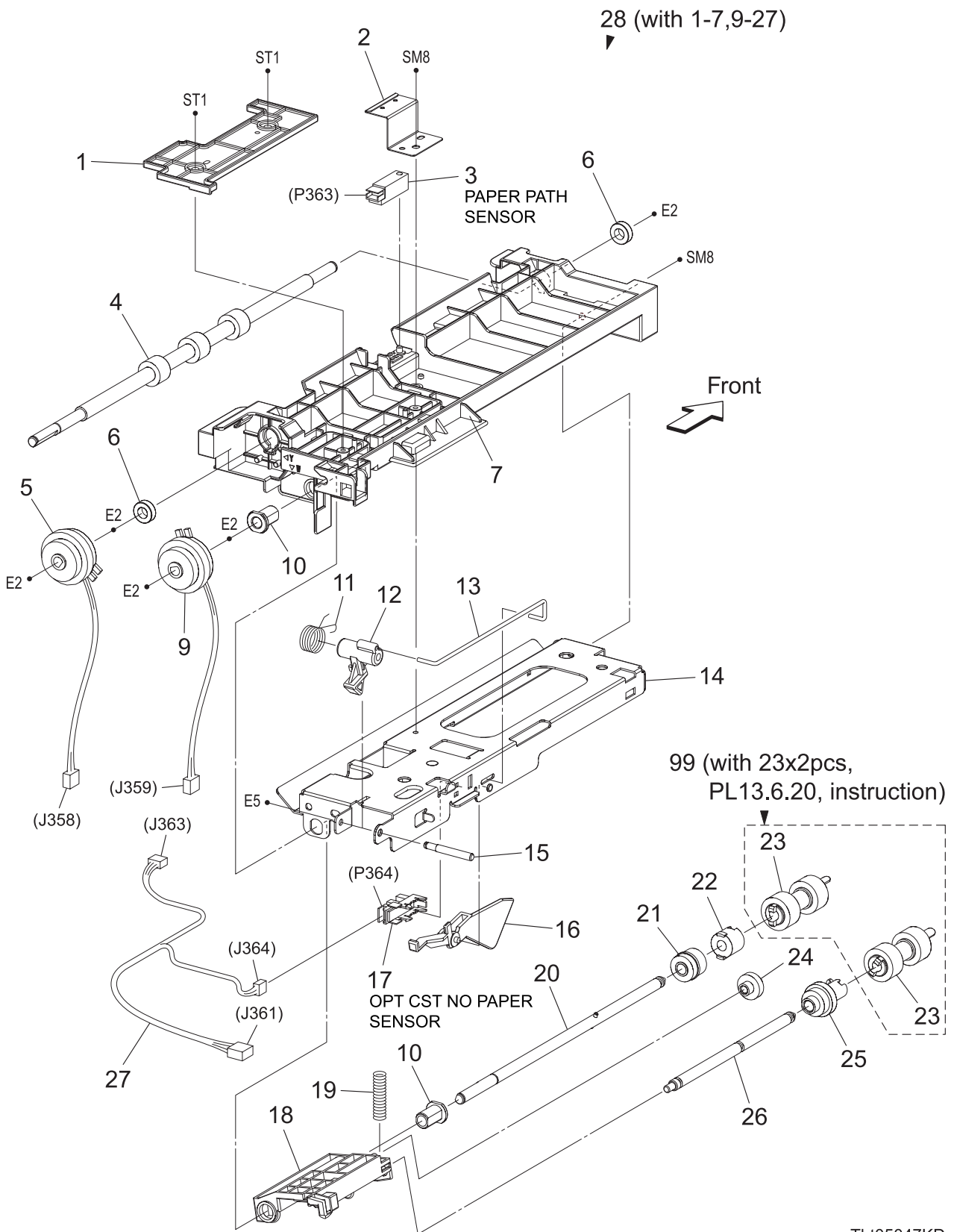

Tbt05047KD

PL13.5 HCF (5/6) [List]

Item	Parts name
1	COVER FDR OPT
2	PLATE SENSOR
3	SENSOR
4	ROLL ASSY TAKE AWAY
5	CLUTCH ASSY TAKE AWAY
6	BEARING BALL
7	CHUTE FDR OPT
8	--
9	CLUTCH ASSY FEED
10	BEARING NUDGER
11	SPRING LEVER NUDGER
12	LEVER NUDGER
13	LINK ACTUATOR
14	CHUTE FRAME TOP
15	SHAFT LEVER NUDGER
16	ACTUATOR NO PAPER
17	SENSOR PHOTO
18	SUPPORT NUDGER
19	SPRING NUDGER
20	SHAFT ASSY FEED
21	GEAR FEED
22	CLUTCH ONEWAY FEED
23	ROLL ASSY FEED
24	GEAR IDLER NUDGER
25	ROLL ASSY GEAR NUDGER
26	SHAFT NUDGER
27	HARNESS ASSY OPT PATH (J361-J363,J364)
28	FEEDER ASSY SUB OPT (with 1-7,9-27)
99	KIT FEED ROLL & SEPARATOR ROLL (with 23x2pcs, PL13.6.20, instruction) *1

*1 : Periodic Replacing Parts (150KPV)

PL13.6 HCF (6/6) [Illustration]

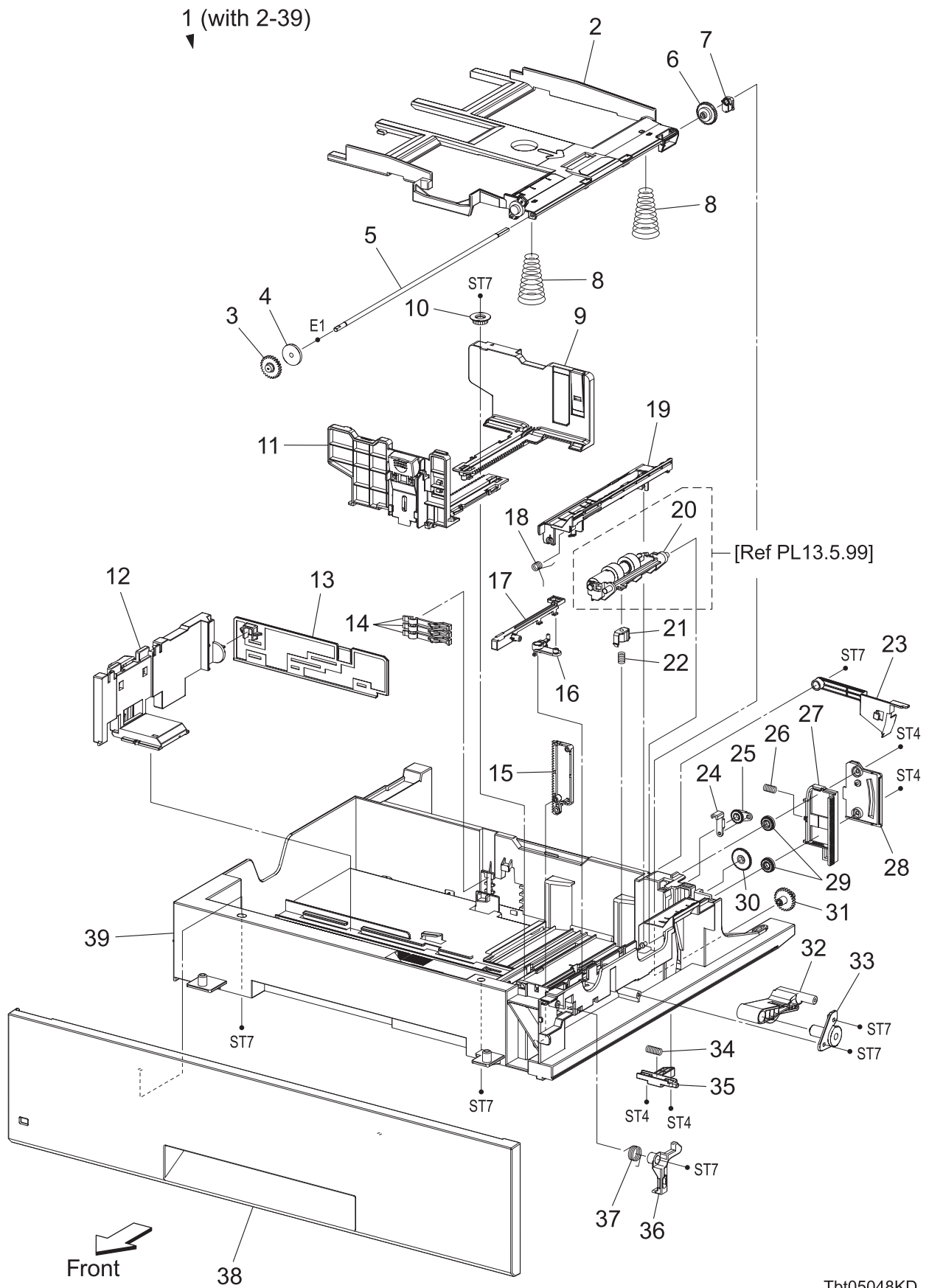

Tbt05048KD

PL13.6 HCF (6/6) [List]

Item	Parts name
1	TRAY ASSY OPTION (with 2-39)
2	PLATE ASSY BOTTOM
3	GEAR PB FRONT
4	GEAR BTM DMP ONEWAY
5	SHAFT PB A4
6	GEAR BTM LOCK ONEWAY
7	STOPPER PB
8	SPRING BTM UP 550 A4
9	GUIDE ASSY SIDE R
10	GEAR PINION
11	GUIDE ASSY SIDE F
12	GUIDE ASSY END
13	ACTUATOR GUIDE END
14	ACTUATOR SIZE
15	PLATE GEAR LOCK
16	LEVER SEPARATOR
17	LEVER LATCH
18	SPRING COVER SEPARATOR
19	COVER SEPARATOR
20	HOLDER ASSY SEPARATOR
21	HOLDER SPRING SEPARATOR
22	SPRING SEPARATOR
23	ACTUATOR LOW PAPER
24	LEVER BTM LOCK
25	GEAR LEVER BTM LOCK
26	SPRING BTM LOCK
27	RACK BTM LOCK
28	COVER BTM UP
29	GEAR BTM LOCK PINION
30	GEAR 40 BTM LOCK
31	GEAR PB REAR
32	LINK PB
33	COVER LINK
34	SPRING STOPPER GEAR
35	ACTUATOR PLS PB
36	LATCH TRAY
37	SPRING LATCH
38	COVER TRAY OPT
39	HOUSING BASE

PL14.1 Finisher (1/11) [Illustration]

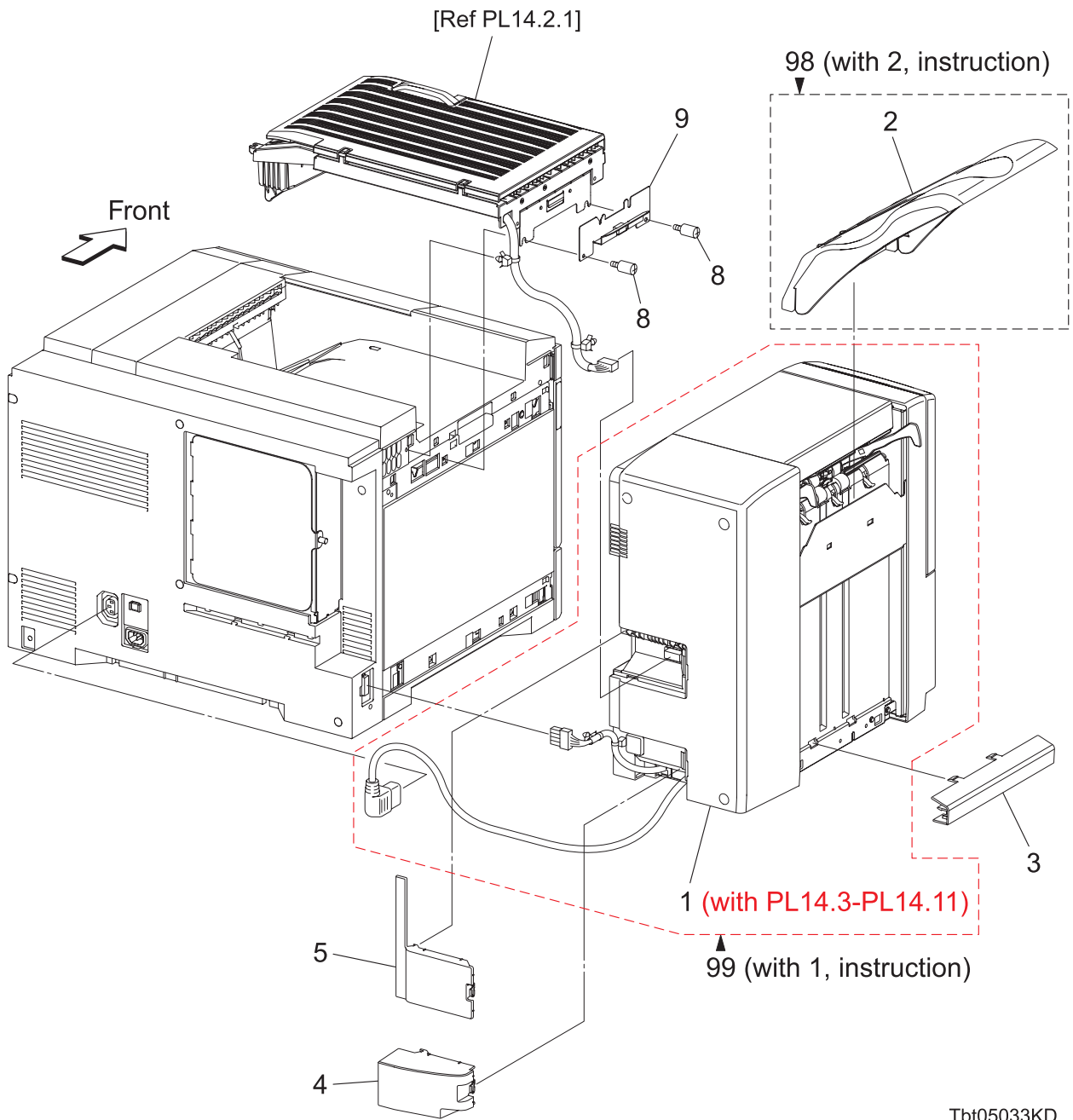

PL14.1 Finisher (1/11) [List]

Item	Parts name
1	FINISHER ASSY (with PL14.3-PL14.11)
2	TRAY STACKER
3	COVER GUIDE TRAY
4	COVER CONNECTOR2
5	COVER CONNECTOR
6	--
7	--
8	SCREW M4 STEEL
9	BRACKET ASSY GUIDE ADD
98	KIT TRAY STACKER (with 2, instruction)
99	KIT FINISHER ASSY (with 1, instruction)

PL14.2 Finisher (2/11) [List]

Item	Parts name
1	TRANSPORT ASSY A4 (with 3,10)
2	--
3	COVER ASSY TOP H-TRA (with 4-8,43)
4	COVER HANDLE
5	COVER TOP H-TRA
6	BRACKET MAGNET A4
7	ACTUATOR SENSOR
8	ROLL ASSY PINCH H-TRA
9	--
10	CHUTE ASSY LOWER H-TRA (with 12-14,20,22-24,26-35,38-41,44)
11	--
12	MAGNET
13	CHUTE LOW H-TRA
14	DRIVE ASSY H-TRA (with 15-20,39)
15	FAN A4
16	MOTOR ASSY PM HTU
17	BRACKET ASSY MOTOR
18	BELT MOTOR
19	PULLEY IDLER
20	PULLEY TENSION
21	--
22	COVER MOTOR
23	BEARING HTU A4
24	ROLL ASSY ENT
25	--
26	ROLL ASSY EXIT
27	SPRING EXTENSION
28	BRACKET ASSY TENSION
29	BRACKET ASSY DRIVE
30	BEARING E COND
31	BELT TRANSPORT
32	PULLEY 22T
33	PULLEY ASSY ONEWAY
34	PULLEY T17
35	BRACKET ASSY SENSOR (with 36,37)
36	SENSOR PHOTO
37	BRACKET SENSOR
38	SPRING SENSOR
39	CLAMP LOCKING
40	HARNESS ASSY HTU A4FIN (J8987-J8863,J8864)
41	BRACKET GUIDE
42	--
43	COVER BRACKET
44	SPACER HTU
98	KIT CHUTE ASSY LOWER H-TRA (with 10, instruction)
99	KIT COVER ASSY TOP H-TRA (with 3, instruction)

PL14.3 Finisher (3/11) [Illustration]

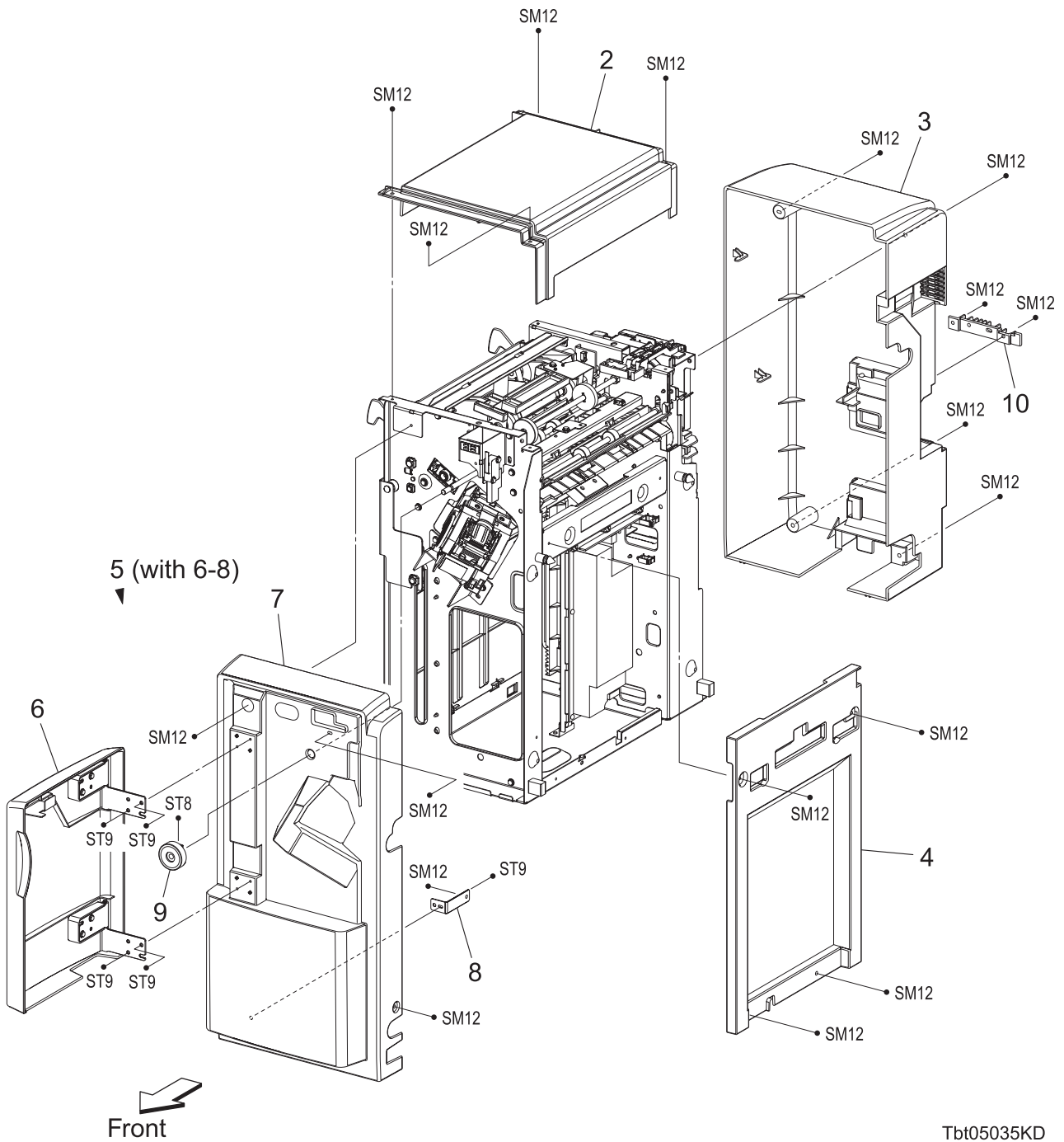

Tbt05035KD

PL14.3 Finisher (3/11) [List]

Item	Parts name
1	--
2	COVER TOP
3	COVER REAR
4	COVER RH
5	COVER ASSY FRONT (with 6-8)
6	COVER ASSY FRONT DOOR
7	COVER FRONT
8	BRACKET COVER FRONT
9	KNOB ASSY EXIT
10	HANDLE

PL14.4 Finisher (4/11) [Illustration]

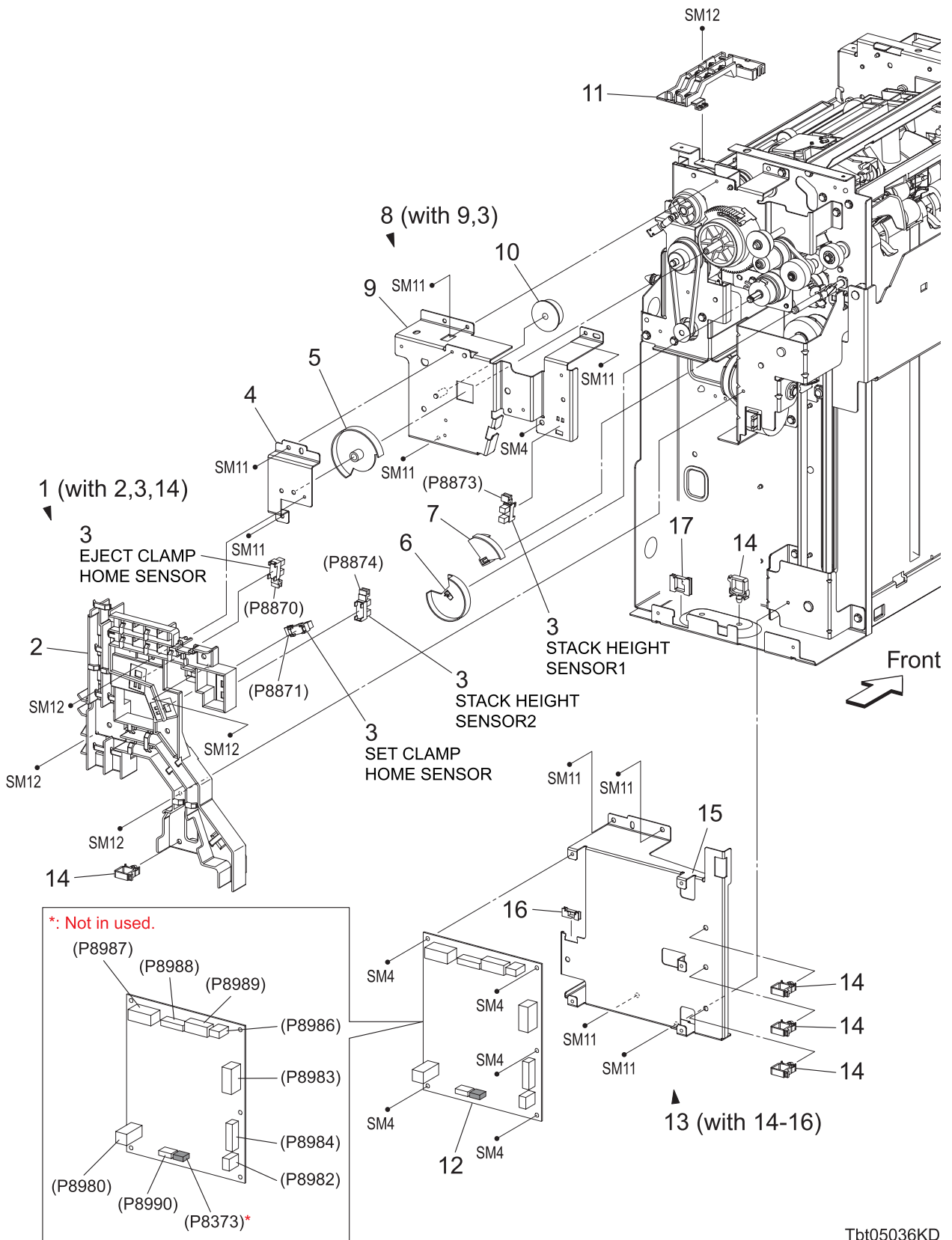

Tbt05036KD

PL14.4 Finisher (4/11) [List]

Item	Parts name
1	GUIDE ASSY HARNESS (with 2,3,14)
2	GUIDE HARNESS 1
3	SENSOR PHOTO
4	SUPPORT STUD
5	ACTUATOR GEAR SECT
6	ACTUATOR SET CLAMP CAM
7	ACTUATOR HIGHT
8	BRACKET ASSY SENSOR HIGHT (with 9,3)
9	BRACKET ASSY SENSOR
10	GEAR Z30 R
11	GUIDE HARNESS 3
12	PWBA MAIN A4FIN
13	BRACKET ASSY PWBA (with 14-16)
14	CLAMP LOCKING
15	BRACKET PWBA
16	BUSHING SADDLE
17	BUSHING SADDLE

PL14.5 Finisher (5/11) [Illustration]

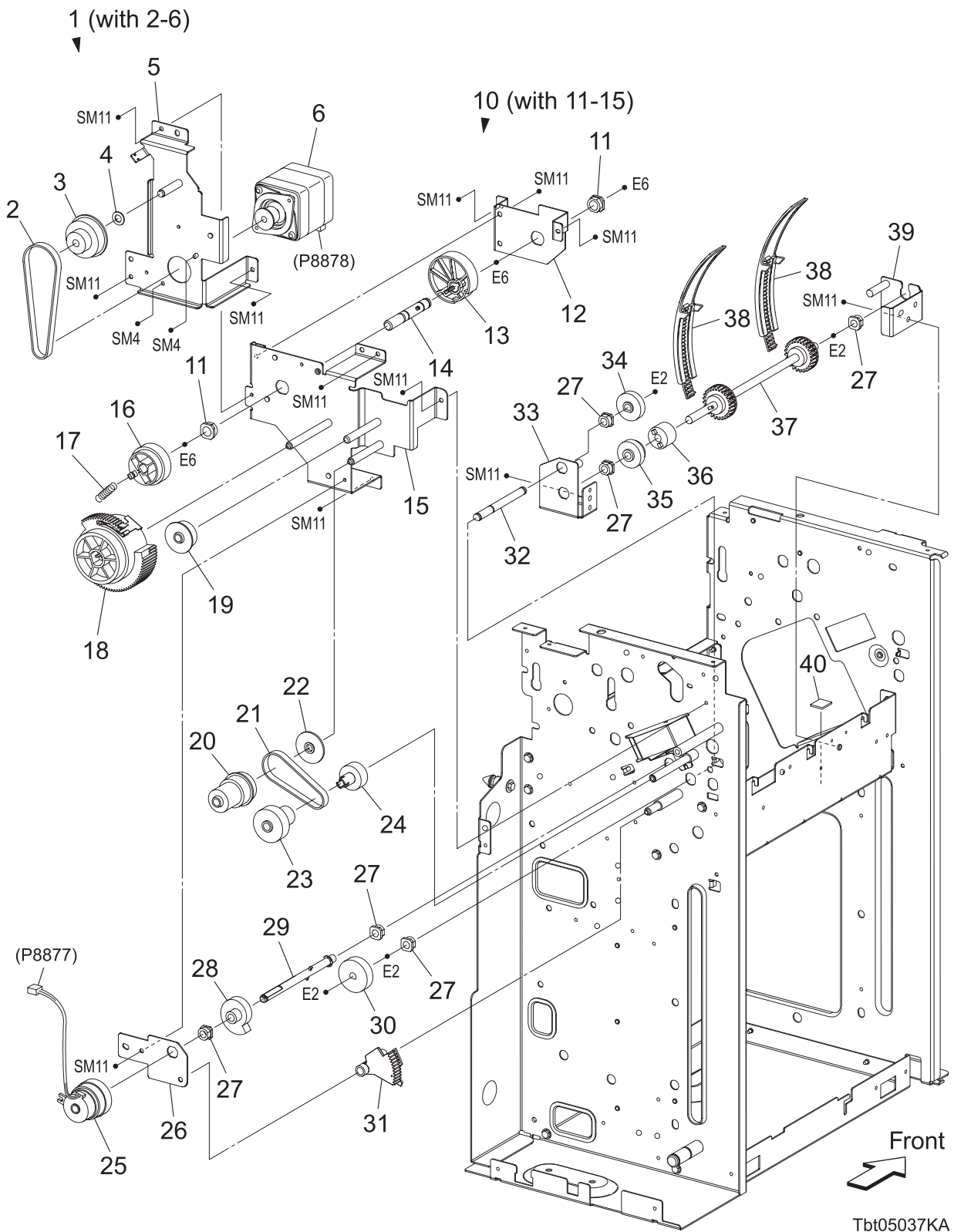

PL14.5 Finisher (5/11) [List]

Item	Parts name
1	MOTOR ASSY EJECT DRIVE (with 2-6)
2	BELT
3	GEAR PULLEY Z20 T49
4	WASHER
5	BRACKET ASSY MOTOR
6	MOTOR ASSY EJECT
7	--
8	--
9	--
10	BRACKET ASSY EJECT DRIVE (with 11-15)
11	BEARING SLEEVE
12	BRACKET CAM
13	CAM EJECT CLAMP
14	SHAFT ASSY CAM
15	BRACKET ASSY DRIVE EJ
16	GEAR Z38 S
17	SPRING CLAMP CAM
18	GEAR ASSY SECTOR A4
19	GEAR Z25 S
20	GEAR Z28 Z22 T38
21	BELT
22	FLANGE DRIVE EJ
23	GEAR PULLEY Z32L T25
24	GEAR Z23L
25	CLUTCH Z34
26	BRACKET CL
27	BEARING SLEEVE
28	CAM SET CLAMP MOVE
29	SHAFT ASSY SET DRIVE
30	GEAR Z31 R
31	GEAR Z72 SECTOR
32	SHAFT GUIDE PAPER M
33	BRACKET ASSY SHELF R
34	GEAR Z26 R
35	GEAR Z25 L
36	CLUTCH TL400
37	SHAFT ASSY GUIDE PAPER
38	GUIDE PAPER 240
39	BRACKET ASSY SHELF F
40	DAMPER SOLENOID

PL14.6 Finisher (6/11) [Illustration]

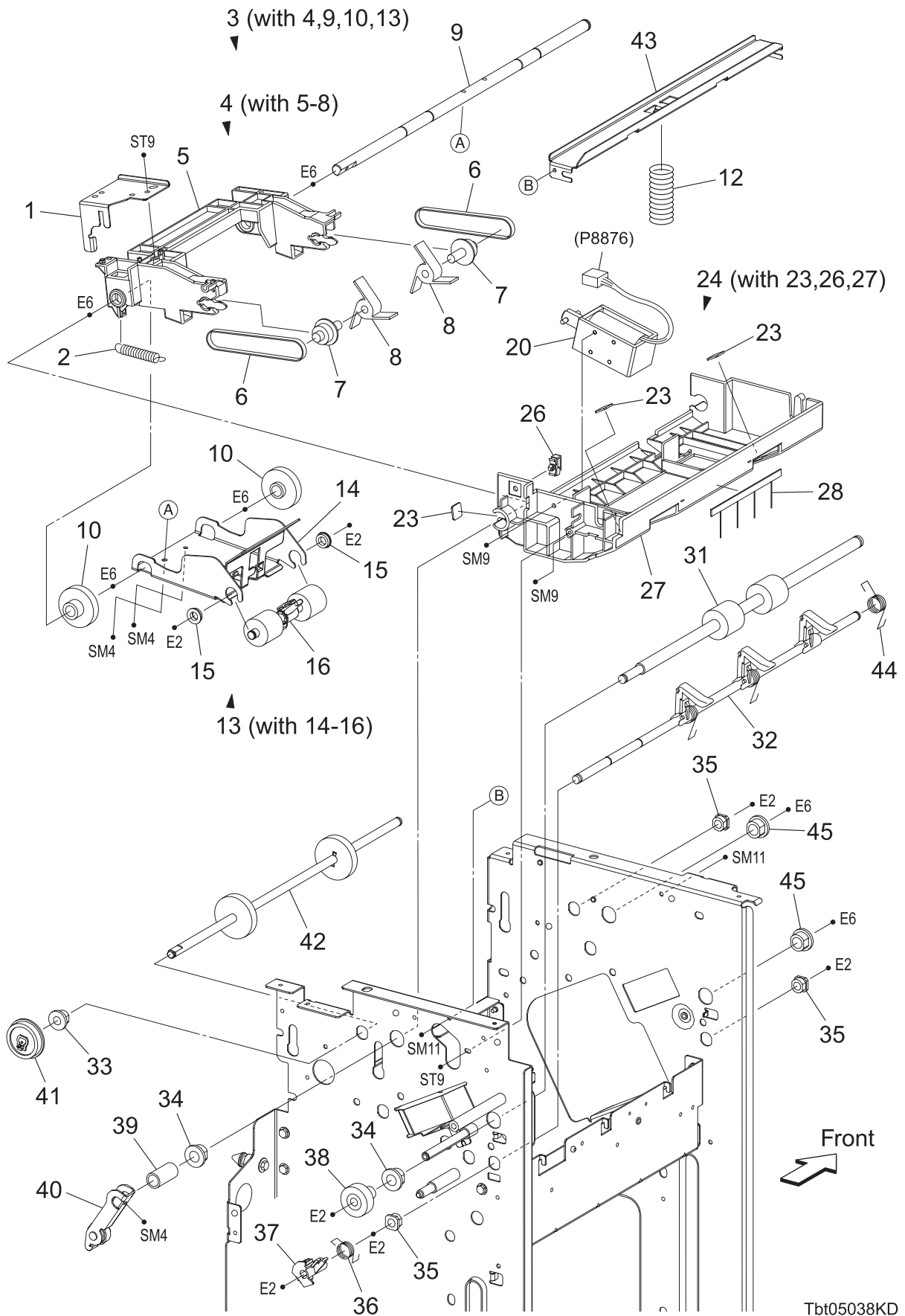

Tbt05038KD

PL14.6 Finisher (6/11) [List]

Item	Parts name
1	SUPPORT ARM
2	SPRING SUB PADDLE
3	ROLLER ASSY EJECT A4 (with 4,9,10,13)
4	ARM ASSY PADDLE (with 5-8)
5	ARM SUB PADDLE
6	BELT
7	PULLEY T22
8	PADDLE SUB
9	SHAFT EJECT CLAMP
10	GEAR PULLEY Z31 T20
11	--
12	SPRING PINCH
13	ROLLER ASSY EJECT PINCH (with 14-16)
14	BRACKET EJECT PINCH
15	BEARING
16	ROLLER EJECT PINCH
17	--
18	--
19	--
20	SOLENOID ASSY
21	--
22	--
23	DAMPER SOLENOID
24	CHUTE ASSY EJECT (with 23,26,27)
25	--
26	CLAMP LOCKING
27	CHUTE EJECT
28	ELIMINATOR EJECT RH
29	--
30	--
31	ROLLER ASSY EJECT
32	SHAFT ASSY SET CLAMP
33	BEARING POWDERED
34	BEARING POWDERED
35	BEARING SLEEVE
36	SPRING SET LINK
37	GEAR Z18
38	GEAR ASSY Z25 R ONEWAY
39	SPACER EJECT CLAMP
40	ARM ASSY CLAMP
41	PULLEY T41
42	SHAFT ASSY DRIVE EJECT
43	PLATE TIE EJECT PINCH
44	SPRING SET CLAMP
45	BEARING SLEEVE

PL14.7 Finisher (7/11) [Illustration]

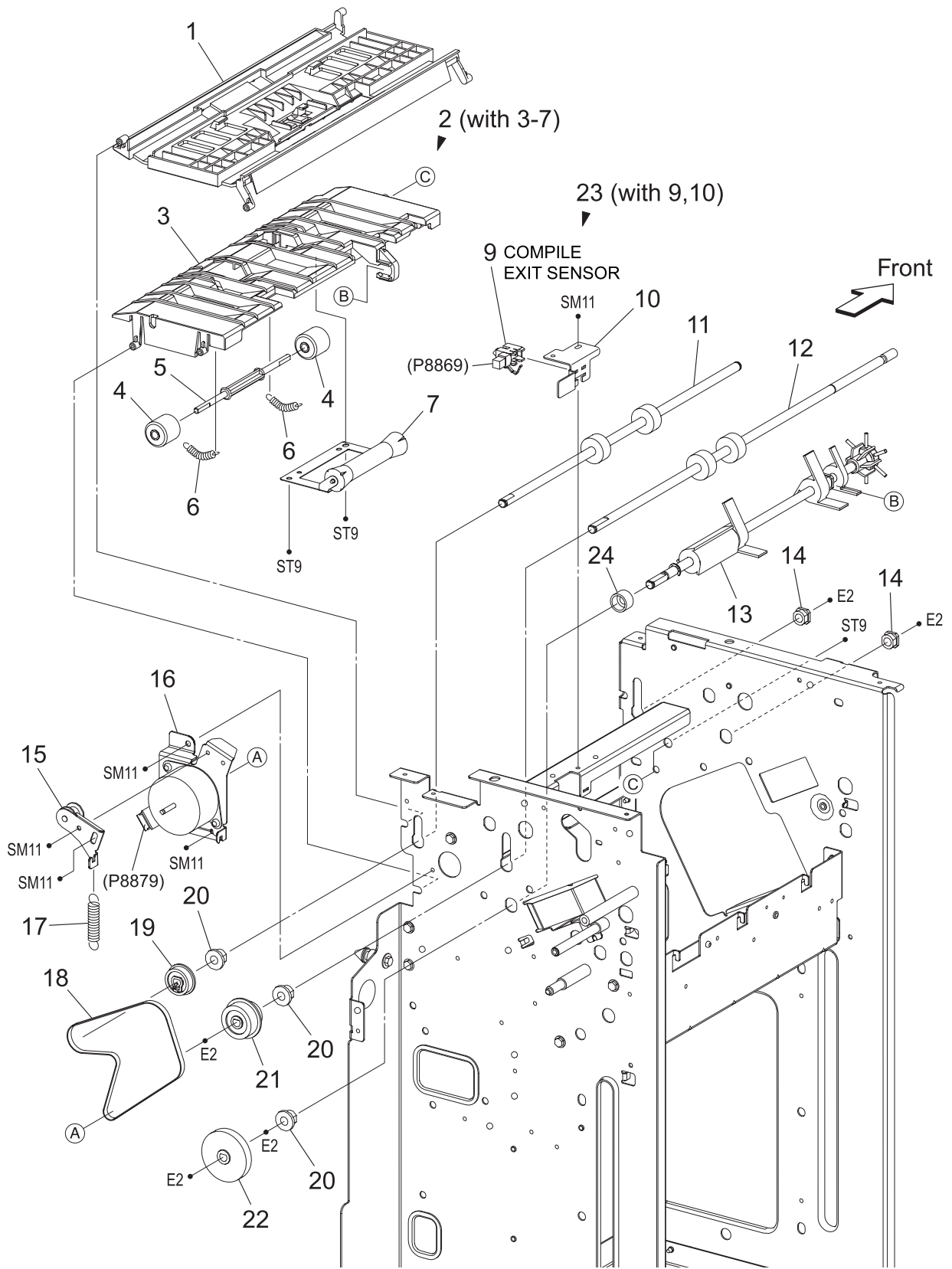

Tbt05039KC

PL14.7 Finisher (7/11) [List]

Item	Parts name
1	CHUTE ASSY UPPER
2	CHUTE ASSY LOWER (with 3-7)
3	CHUTE FIN LOWER
4	ROLL PINCH ENT
5	SHAFT PINCH ENT
6	SPRING PINCH ENT
7	ROLL ASSY PINCH EXIT
8	--
9	SENSOR ASSY
10	BRACKET SENSOR EXIT
11	ROLL ASSY DRIVE ENT
12	ROLL ASSY DRIVE EXIT
13	SHAFT ASSY MAIN PADDLE
14	BEARING SLEEVE
15	BRACKET ASSY TENSION2
16	DRIVE ASSY TRANS
17	SPRING TENSION
18	BELT
19	PULLEY T30
20	BEARING POWDERED
21	GEAR PULLEY Z27 T30
22	GEAR Z42 L
23	SENSOR ASSY EXIT (with 9,10)
24	CAP BEARING

PL14.8 Finisher (8/11) [Illustration]

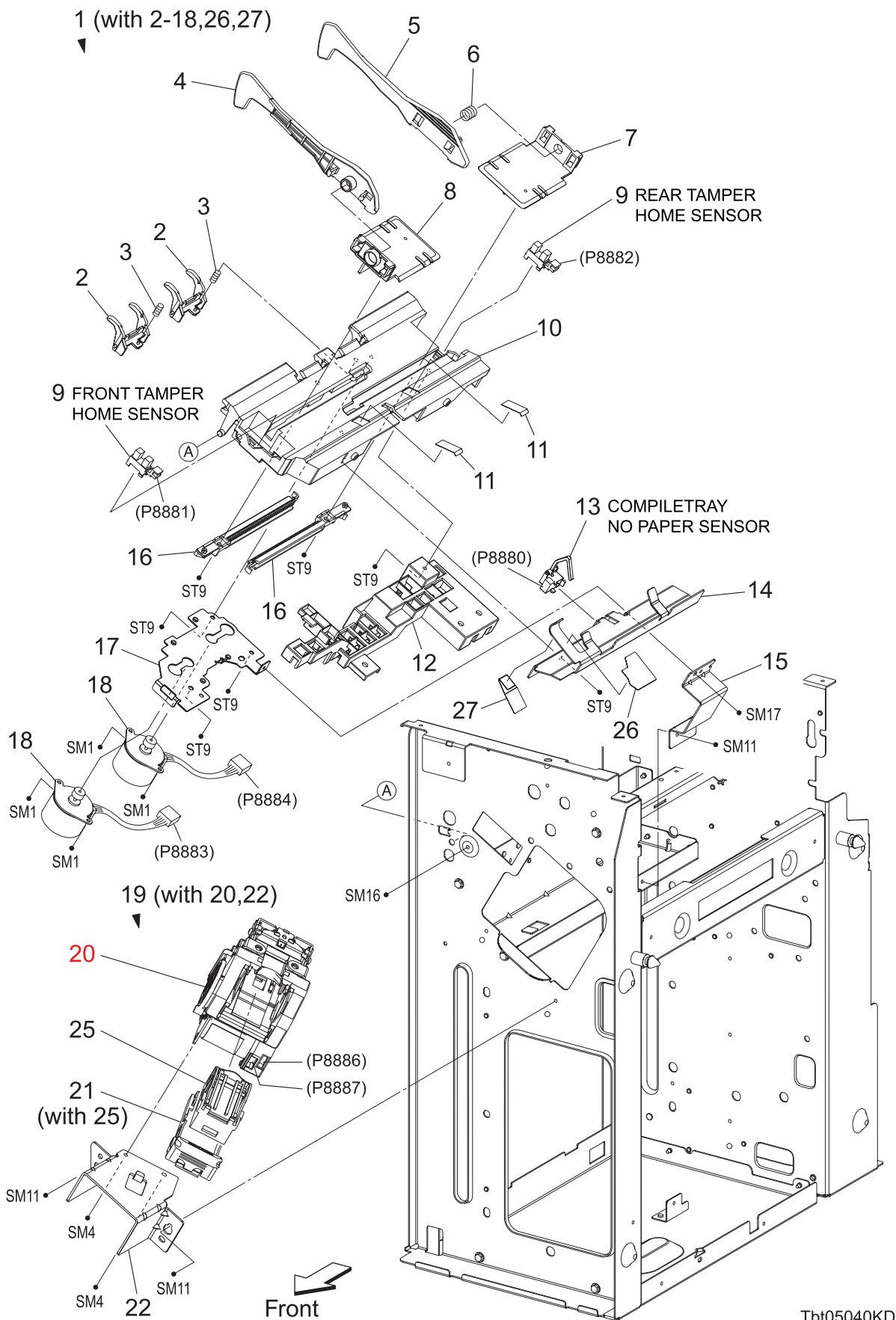

PL14.8 Finisher (8/11) [List]

Item	Parts name
1	TRAY ASSY COMPILE (with 2-18,26,27)
2	GUIDE PAPER TRAY
3	SPRING GUIDE PAPER
4	GUIDE TAMPER FRONT A4
5	GUIDE TAMPER REAR A4
6	SPRING TAMPER REAR
7	BASE TAMPER REAR A4
8	BASE TAMPER FRONT A4
9	SENSOR PHOTO
10	TRAY COMPILE
11	GUIDE PAPER PADDLE
12	GUIDE HARNESS COMPILE CENTER
13	SENSOR ASSY
14	GUIDE PAPER COMPILE CENTER
15	BRACKET COMPILE
16	RACK TAMPER
17	BRACKET MOTOR TAMPER
18	MOTOR ASSY TAMPER
19	HOLDER ASSY STAPLER A4 (with 20,22)
20	STAPLER ASSY
21	HOLDER CARTRIDGE (with 25)
22	BRACKET STAPLER LOW
23	--
24	--
25	CARTRIDGE STAPLE
26	GUIDE PAPER STAPLE
27	GUIDE PAPER END FRONT A4 FIN

PL14.9 Finisher (9/11) [Illustration]

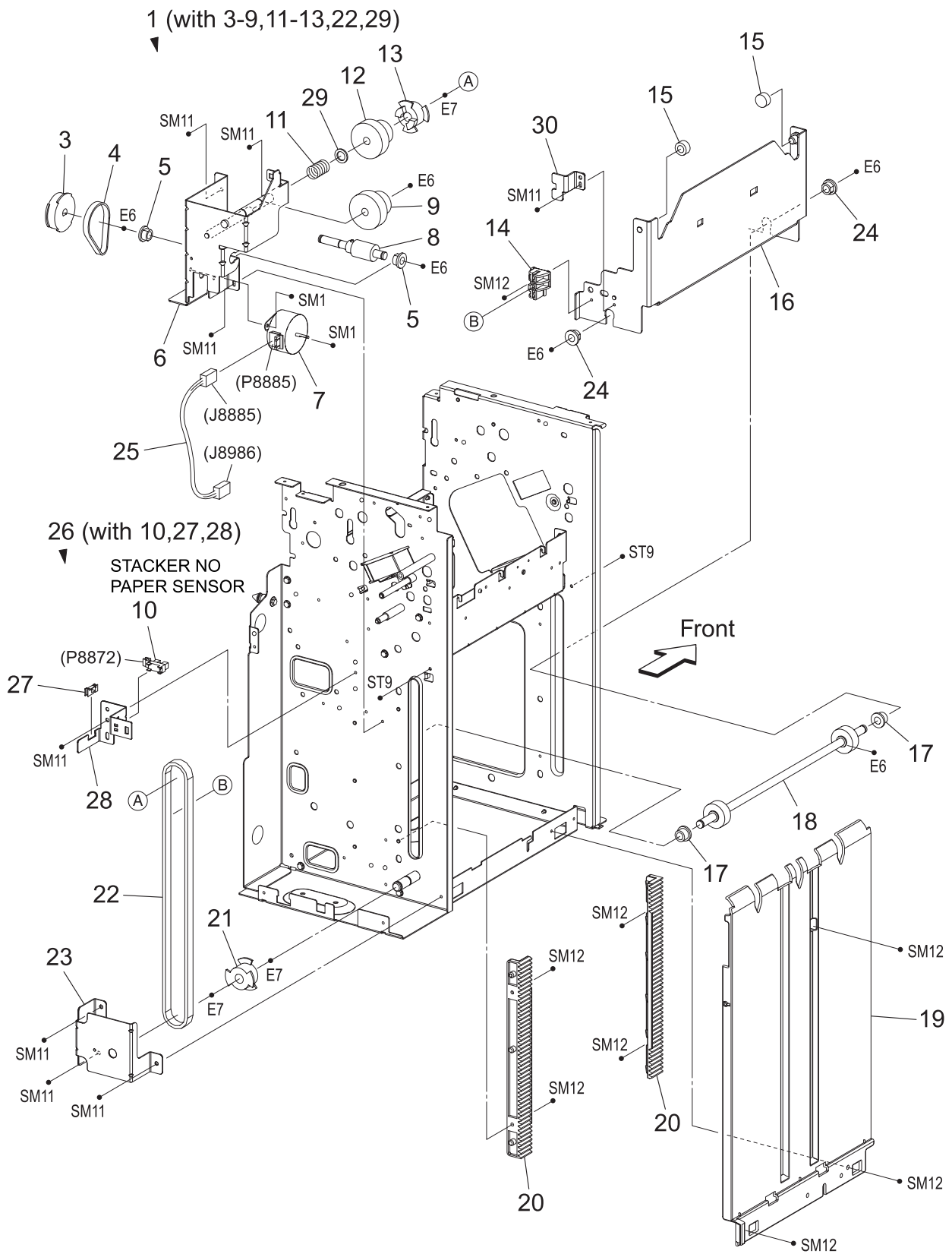

Tbt05041KD

PL14.9 Finisher (9/11) [List]

Item	Parts name
1	DRIVE ASSY STACKER (with 3-9,11-13,22,29)
2	--
3	PULLEY T60
4	BELT
5	BEARING POWDERED
6	BRACKET ASSY ELEV
7	MOTOR ASSY STACKER
8	SHAFT ASSY WORM
9	GEAR Z15 Z37
10	SENSOR PHOTO
11	SPRING DOC
12	GEAR DOC CLUTCH B
13	PULLEY DOC CLUTCH B
14	CLAMP BELT
15	BEARING CARRIAGE
16	CARRIAGE ASSY
17	BEARING POWDERED
18	SHAFT ASSY STACKER
19	GUIDE TRAY
20	RACK A4
21	PULLEY T18
22	BELT STACKER
23	BRACKET STUD
24	BEARING SLEEVE
25	HARNESS ASSY MOT3 A4FIN (J8885-J8986)
26	SENSOR ASSY NO PAPER (with 10,27,28)
27	BUSHING SADDLE
28	BRACKET SENSOR NO PAPER
29	WASHER NYLON
30	BRACKET CLAMP

PL14.10 Finisher (10/11) [Illustration]

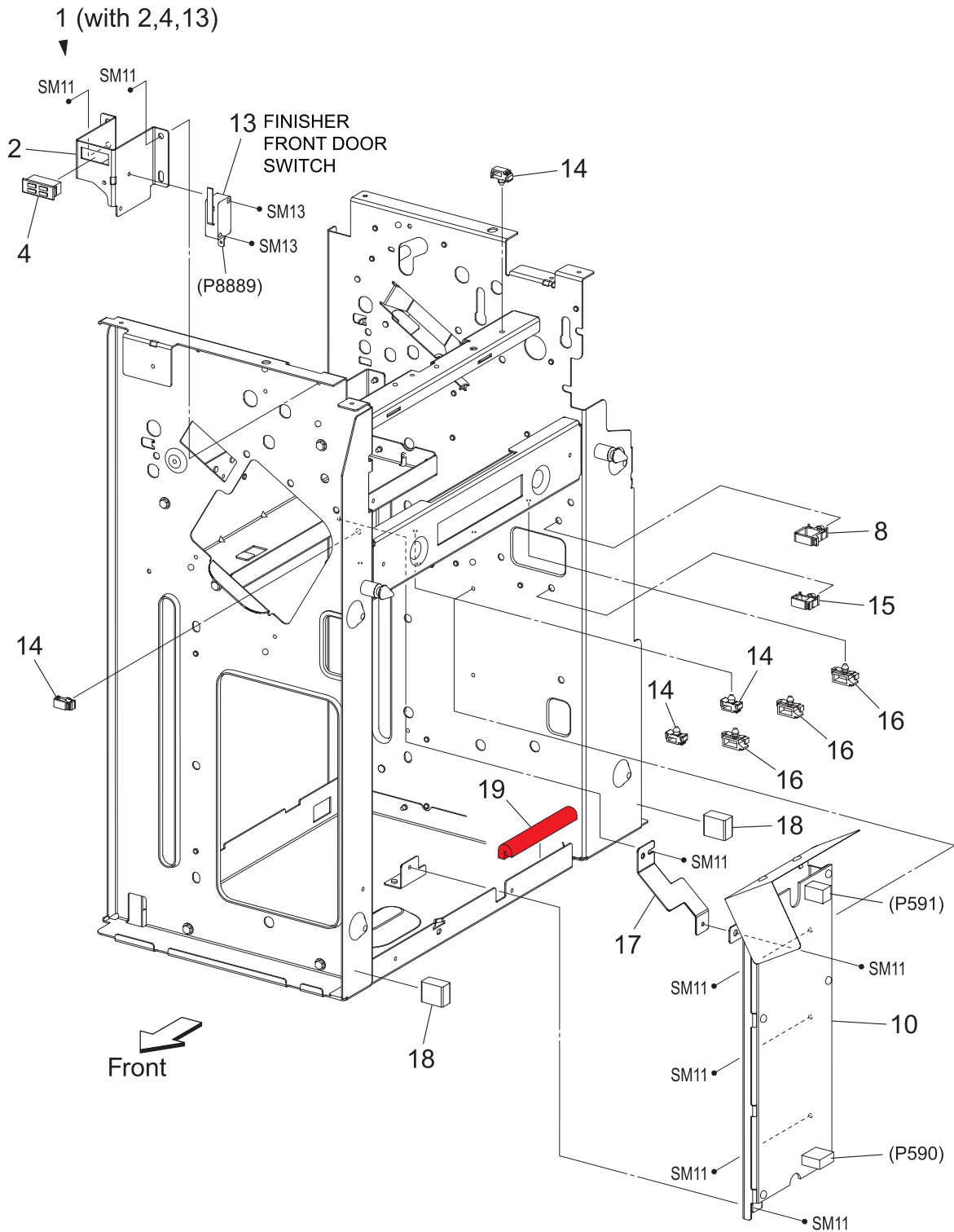

Tbt05042KD

PL14.10 Finisher (10/11) [List]

Item	Parts name
1	BRACKET ASSY INTERLOCK (with 2,4,13)
2	BRACKET INTERLOCK
3	--
4	MAGNET
5	--
6	--
7	--
8	CLAMP LOCKING
9	--
10	LVPS ASSY
11	--
12	--
13	SWITCH
14	CLAMP LOCKING
15	CLAMP LOCKING
16	CLAMP LOCKING
17	BRACKET EME
18	GASKET
19	GUIDE EDGE

PL14.11 Finisher (11/11) [Illustration]

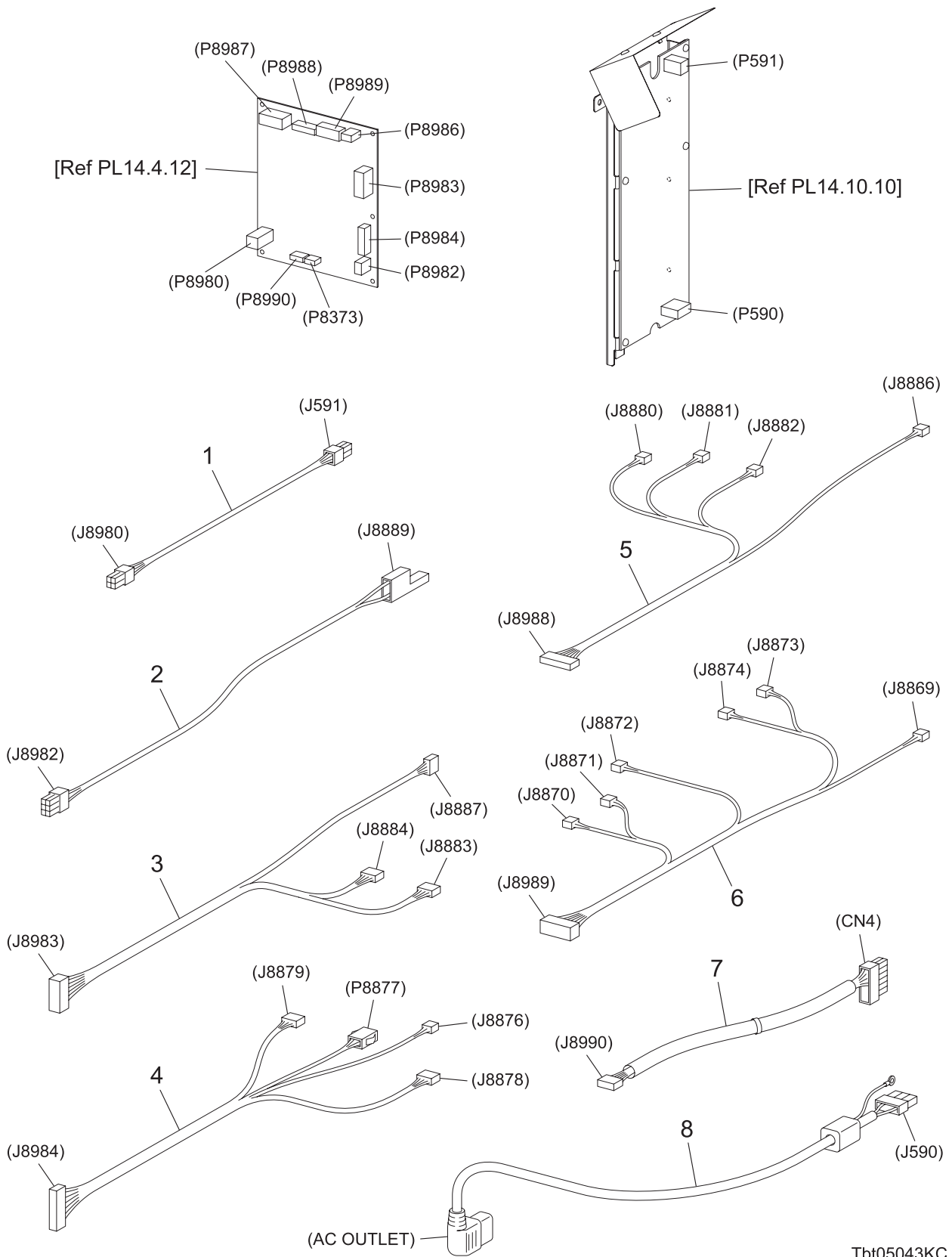

Tbt05043KC

PL14.11 Finisher (11/11) [List]

Item	Parts name
1	HARNESS ASSY LVPS A4FIN (J8980-J591)
2	HARNESS ASSY INTL SW A4FIN (J8982-J8889)
3	HARNESS ASSY MOT1 A4FIN (J8983-J8883,J8884,J8887)
4	HARNESS ASSY MOT2 A4FIN (J8984-J8876,P8877,J8878,J8879)
5	HARNESS ASSY SNR1 A4FIN (J8988-J8880,J8881,J8882,J8886)
6	HARNESS ASSY SNR2 A4FIN (J8989-J8869,J8870,J8871,J8872,J8873,J8874)
7	HARNESS ASSY IF A4FIN (J8990-CN4)
8	CABLE ASSY POWER A4FIN (J590-AC OUTLET)

Chapter 6 Principles of Operation CONTENTS

1. Printing Process	6 - 1
1.1 Summary of Printing Process	6 - 1
1.2 Schematic Diagram of Printing Process	6 - 2
1.3 Description of Printing Process	6 - 3
1.3.1 Charging	6 - 3
1.3.2 Exposure	6 - 4
1.3.3 Development	6 - 6
1.3.4 Primary Transfer	6 - 8
1.3.5 Cleaning	6 - 10
1.3.6 Secondary Transfer	6 - 11
1.3.7 Neutralization	6 - 12
1.3.8 Cleaning	6 - 13
1.3.9 Fusing	6 - 14
1.3.10 Waste Toner Collection	6 - 15
2. Paper Path	6 - 16
2.1 Paper Path	6 - 16
2.2 Layout of Paper Path	6 - 17
2.3 Feeding from Paper Cassette	6 - 18
2.3.1 Multiple Sheet Feed Prevention	6 - 19
2.4 Feeding from MSI	6 - 20
2.4.1 Multiple Sheet Feed Prevention	6 - 20
2.5 Feeding in Registration Section	6 - 22
2.5.1 Lead-edge Registration	6 - 23
2.6 Transfer/Fusing/Exit	6 - 24
2.7 Feeding in Duplex Section	6 - 26
3. Functions of Major Functional Components	6 - 30
3.1 Paper Cassette	6 - 30
3.1.1 Major Functions	6 - 30
3.1.2 Operation of HOLDER ASSY SEPARATOR at Removal and Replacement of Paper Cassette	6 - 32
3.2 Paper Feeder	6 - 34
3.2.1 Major Functions	6 - 34
3.3 MSI & Regi Assy	6 - 38
3.3.1 Major Functions	6 - 38
3.4 Process Control (PROCON ASSY)	6 - 42
3.4.1 Major Functions	6 - 42
3.5 ROS ASSY	6 - 44
3.5.1 Major Functions	6 - 44
3.6 Dispenser	6 - 46
3.6.1 Major Functions	6 - 46
3.7 XERO DEVE CRU ASSY	6 - 48
3.7.1 Major Functions	6 - 48
3.8 Transfer Belt & Fuser	6 - 50
3.8.1 Major Functions	6 - 50
3.8.2 Operation of Transfer Belt (BELT ASSY IBT) at Removal	6 - 52

Chapter 6 Principles of Operation CONTENTS

3.9 FUSER.....	6 - 54
3.9.1 Major Functions	6 - 54
3.9.2 Sheet/Envelope Switching Lever	6 - 56
3.10 Exit Section	6 - 57
3.10.1 Major Functions	6 - 57
3.11 Duplex.....	6 - 60
3.11.1 Major Functions	6 - 60
3.12 Drive.....	6 - 62
3.12.1 Major Functions	6 - 62
3.12.2 Full Color Mode and B/W Mode.....	6 - 64
3.13 Electrical	6 - 68
3.13.1 Major Functions	6 - 68
3.13.2 Data Flow.....	6 - 71
3.14 Optional 550 Feeder & Optional High Capacity Feeder (HCF or 1100 FEEDER).....	6 - 72
3.14.1 Major Functions	6 - 72
4. Operation Modes / Consumables and Periodic Replacement Parts	6 - 75
4.1 Operation Modes	6 - 75
4.2 Replacement Timing of Consumables and Periodic Replacement Parts	6 - 76
4.2.1 Types of Consumables and Periodic Replacement Parts.....	6 - 76
4.2.2 Replacement Timing of Consumables.....	6 - 77
4.2.3 Replacement Timing of Periodic Replacement Parts	6 - 78
5. Control	6 - 80
5.1 Paper Size Control.....	6 - 80
5.2 ROS ASSY Light Quantity Control.....	6 - 81
5.3 Process Control	6 - 82
5.3.1 Potential Control	6 - 82
5.3.2 Toner Density Control.....	6 - 83
5.3.3 High Area Coverage Mode	6 - 83
5.3.4 Admix Mode.....	6 - 83
5.3.5 ADC Sensor Adjustment.....	6 - 83
5.4 Color Registration Control.....	6 - 84
5.5 Fuser Control	6 - 85
5.5.1 Fuser temperature control.....	6 - 85
5.5.2 Cooling down	6 - 85
5.5.3 Sensor Warm-up.....	6 - 85
6. Drive Transmission Route	6 - 86
6.1 DRIVE ASSY PH	6 - 86
6.2 DRIVE ASSY FSR	6 - 88
6.3 TONER DISPENSER (Y, M, C, K).....	6 - 90
6.4 DRIVE ASSY DEVE and DRIVE ASSY DEVE K.....	6 - 92
6.5 DRIVE ASSY XERO	6 - 94
6.6 DRIVE ASSY IBT.....	6 - 96
6.7 EXCESS TONER COLLECTING.....	6 - 98
6.8 SWITCH TO BLACK and WHITE MODE.....	6 - 100
6.9 SWITCH TO FULL COLOR MODE	6 - 102

Chapter 6 Principles of Operation CONTENTS

6.10 DRIVE ASSY OPT 6 - 104

Chapter 6 Principles of Operation CONTENTS

Blank Page

1. Printing Process

1.1 Summary of Printing Process

This equipment is a full-color xerographic laser printer based on a tandem printing system that has four color-specific drum/developer sets for yellow, magenta, cyan, and black (Y, M, C, K).

The four color-separated images of the original document are created with toner on the drums and then transferred in registration onto the IBT Belt (IBT = Intermediate Belt Transfer) to reproduce a full color image. The completed toner image is transferred and fixed on the print medium, and then output as a print.

The printing process of this printer is composed of the following basic steps:

- (1) Charging: The drum surface is electrically charged.
- (2) Exposure: The imaging unit is irradiated with laser light.
- (3) Development: The image is developed with toner.
- (4) Primary Transfer: The four color separation images on the drums are transferred onto the IBT Belt.
- (5) Cleaning: The drums are electrically neutralized and the toner remaining on the drums and BCRs is removed.
- (6) Secondary Transfer: The toner image on the IBT Belt is transferred onto the medium.
- (7) Neutralization: Electric charge of the paper is eliminated.
- (8) Cleaning: The toner remaining on the IBT Belt and 2nd BTR is removed.
- (9) Fusing: The toner is fixed to the print medium by heat and pressure.

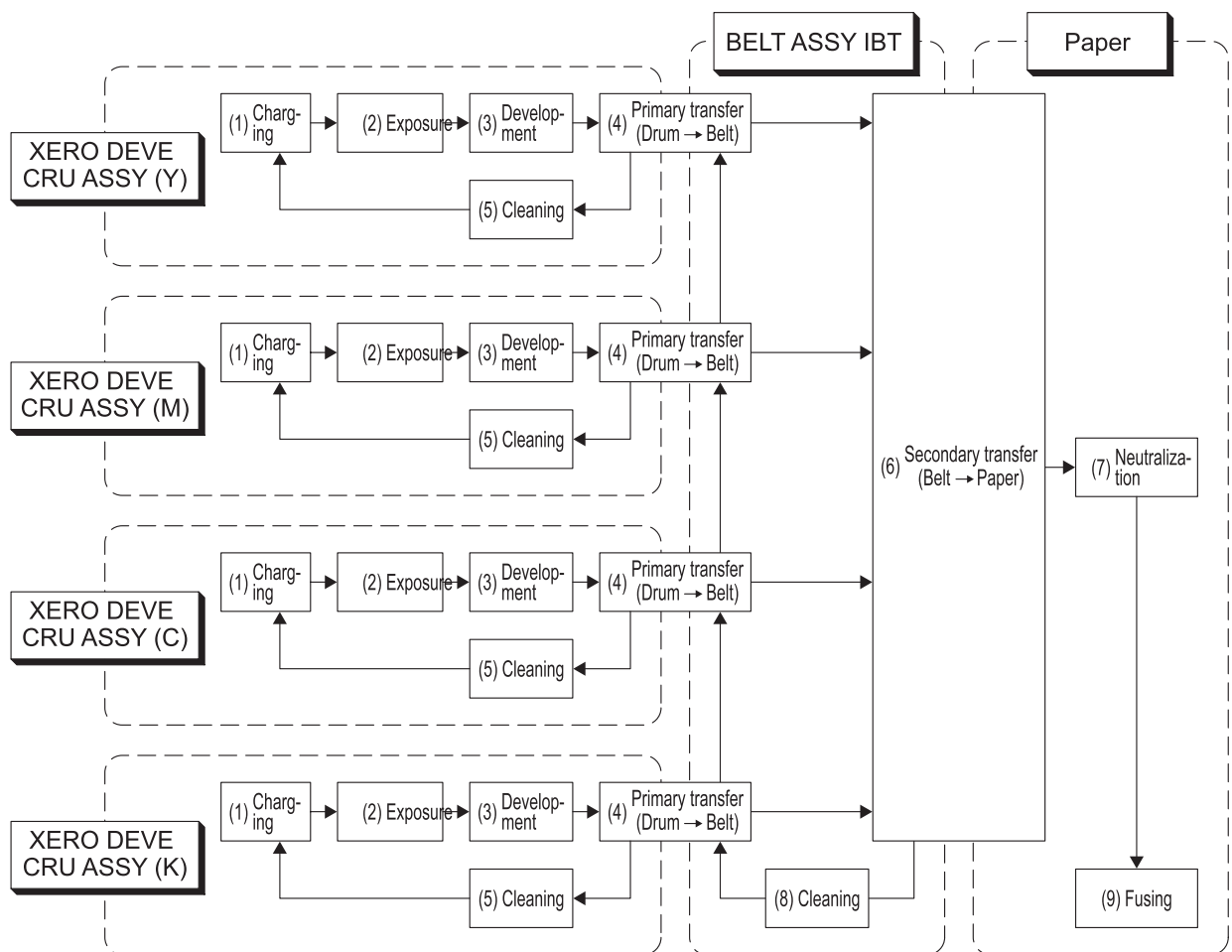

Tbt06001KA

1.2 Schematic Diagram of Printing Process

The outline of the printing process is shown in the figure below.

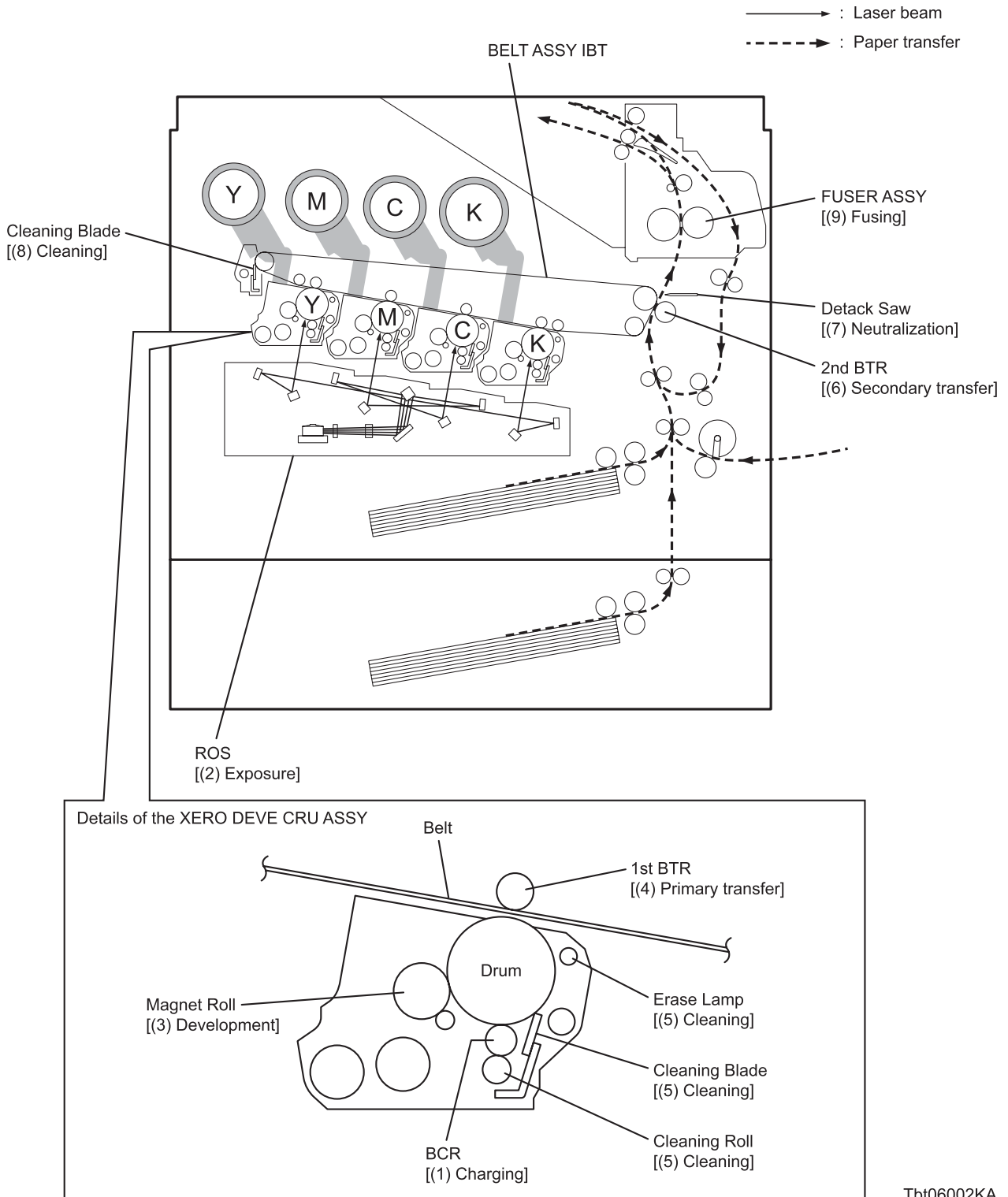

Tbt06002KA

1.3 Description of Printing Process

1.3.1 Charging

In the charging process, the surface of the drum rotating at a constant speed is uniformly charged with negative polarity by the discharge from the BCR (Bias Charge Roll).

This process is performed in parallel for yellow, magenta, cyan and black colors.

- BCR (Bias Charge Roll)

The BCR is kept in contact with the drum and rotates following the rotations of the drum. The BCR is a conductive roll that uniformly and negatively charges the drum surface with the negative voltage applied by the HVPS.

- Drum

The drum surface is uniformly and negatively charged with DC bias voltage.

The drum surface consists of a photoreceptor (which is an insulator in the dark and a conductor in the light) backed with a conductor.

- Cleaning Roll

The Cleaning Roll contacts with the BCR to remove the toner from it.

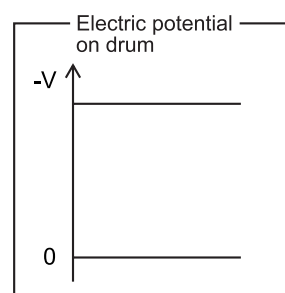
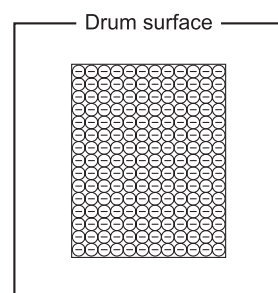
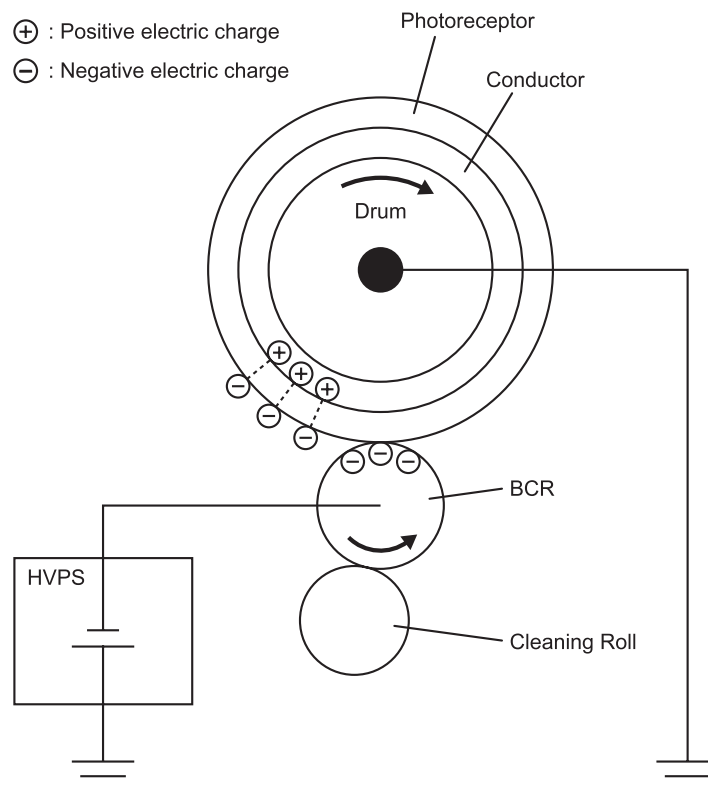

Tbt06003KA

1.3.2 Exposure

The exposure process forms an invisible electrostatic latent image on the negatively charged drum surface by scanning it with laser beams.

This process is performed in parallel for yellow, magenta, cyan and black colors.

- Laser beams are emitted from the laser diode in the ROS ASSY. The surface of each color drum is scanned from end to end in the axial direction by the rotating polygon mirror, the fixed mirror, and the lens attached to the Scanner Motor Assy of the ROS ASSY.

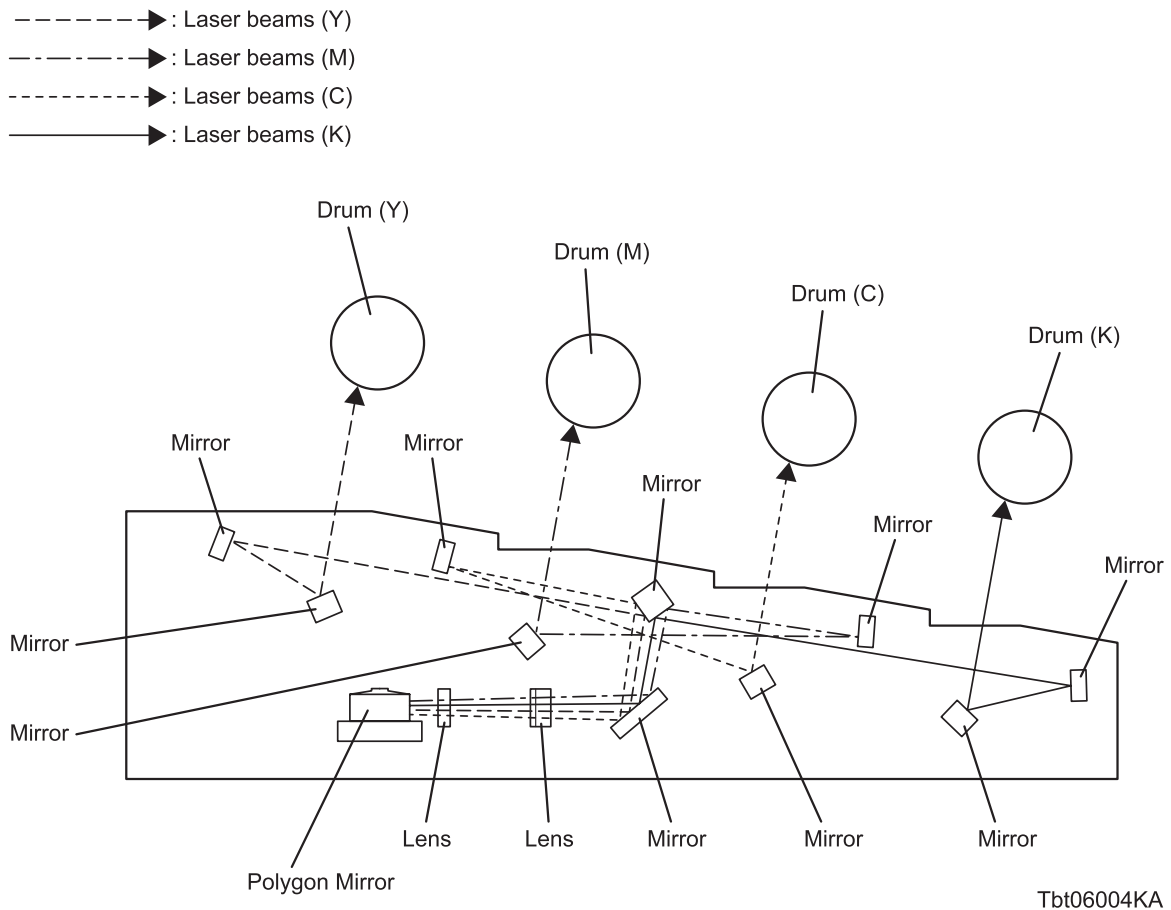

- The laser beam is emitted according to the printing data (image data) output from the printer controller. The laser diode irradiates only the points on the drum corresponding to the pixels (micro points composing characters or pictures) of the printing data (The laser diode illuminates only at the areas that should bear toner, but goes off elsewhere).
The areas on the drum irradiated with laser becomes conductive. This allows the negative charge on the drum surface to flow to the positive side and to cancel out the positive charge, lowering the potential on the drum surface. This low-potential area becomes the electrostatic latent image.

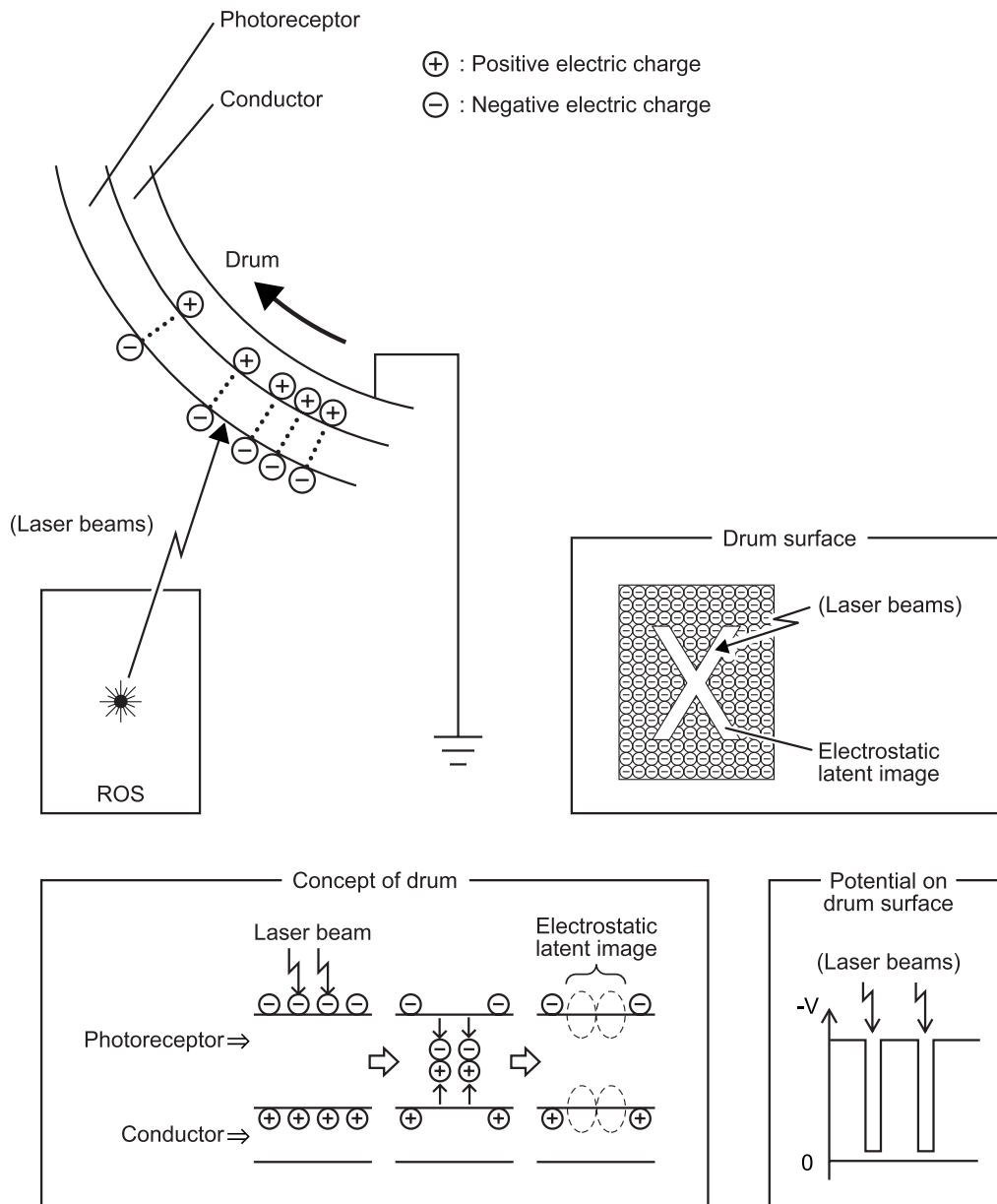

Tbt06005KA

1.3.3 Development

The development process makes a visible image appear on the drum surface by electrically attracting toner particles to the electrostatic latent image.

This process is performed in parallel for yellow, magenta, cyan and black color independently.

- The toner in the toner cartridge section is fed into the developer section by the Agitator and Auger driven by the Dispense Motor. The amount of the toner to be fed is determined according to the print count. This is called "toner dispensation", which is controlled by two types of control, "PCDC" and "ADC". (Refer to 5.3.2 Toner Density Control)

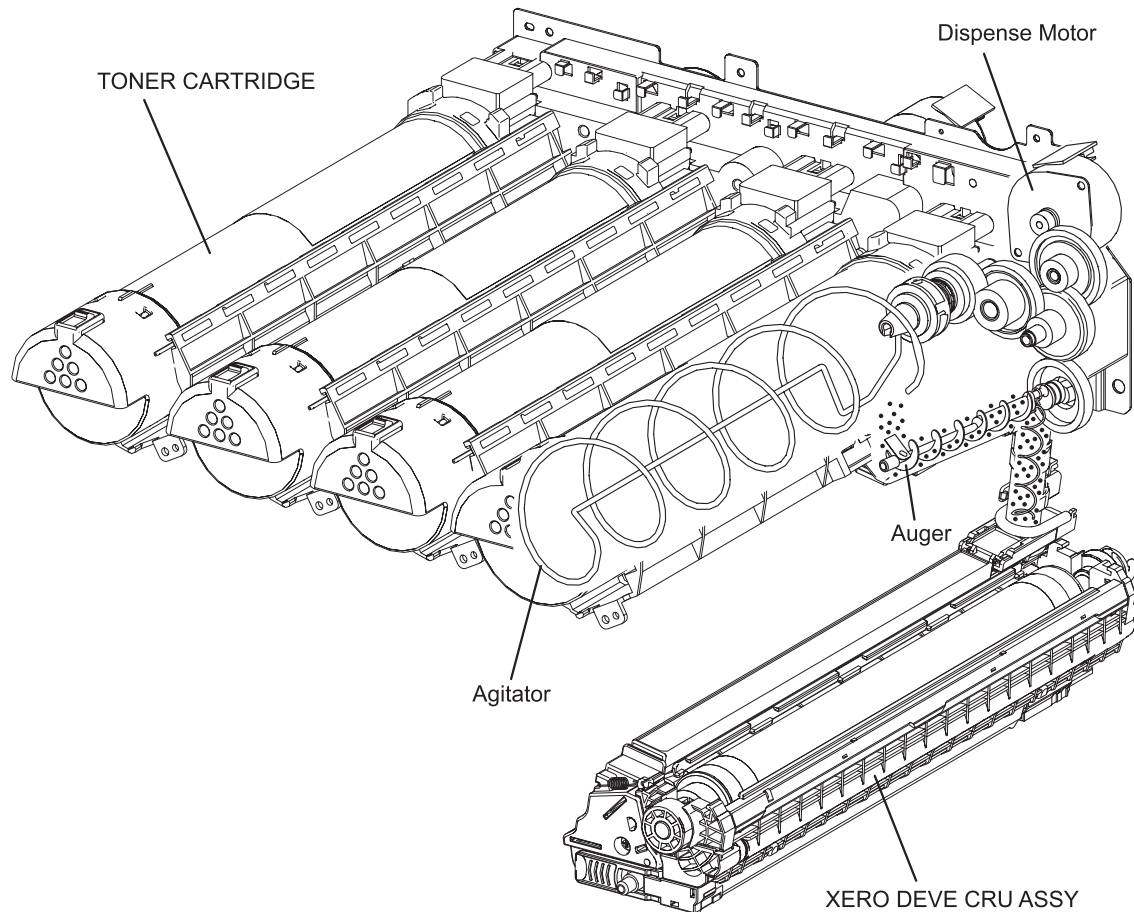

Tbt06006KA

- In the developer section, the incoming toner is mixed with the existing developer (toner/carrier mixture) by the Auger, and then supplied to the Magnet Roll located near the drum surface. The toner and carrier are charged by friction due to agitation (toner in negative, carrier in positive), and they attract each other electrically. The carrier, due to its magnetic properties, is attracted to the Magnet Roll, and then uniformly leveled by the Trimmer Rod.
- The magnet roll is covered by a thin semi-conductive sleeve all over the surface. The DB (Developing Bias) voltage is supplied to this semiconductor sleeve from the High Voltage Power Supply (HVPS). The DB voltage is negative DC voltage combined with AC voltage. The DC voltage keeps the magnet roll at a constant negative voltage against the photoreceptor layer of the drum. Therefore, at the area where the negative electric charge on the drum surface does not decrease, the potential is lower than that of the magnet roll, while the potential is higher than that of the

magnet roll at the area where the negative charge on the drum surface decreases. The AC voltage shakes the developer on the surface of the magnet roll so that the toner easily flies to the drum. Thus, only the portions of the drum surface where the negative charge has decreased below that of the magnet roll (electrostatic latent image) attract the toner to form an image on the drum. Once the toner is deposited on the drum, the potential and the toner-attracting force of the corresponding portion decreases because the increase of negative charge lowers the potential at that portion.

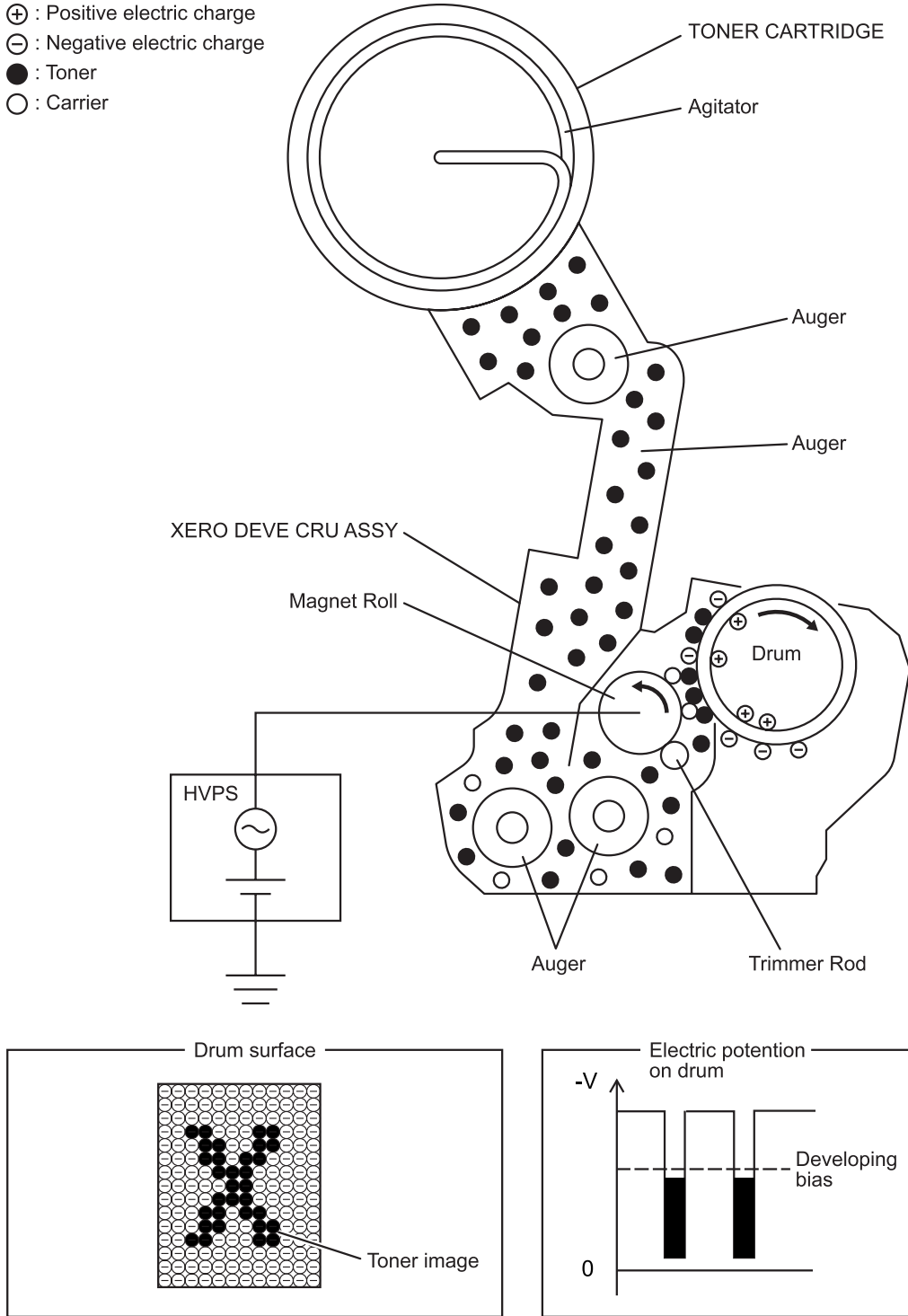

Tbt06007KA

1.3.4 Primary Transfer

In the Primary Transfer process, the toner images formed on the drums are transferred onto the IBT Belt via the 1st BTR (First Bias Transfer Roll). The four color separation images are transferred from the drums onto the IBT Belt in the order of Y, M, C, and K.

- Primary Transfer

The 1st BTR is a metal roll, to which the positive voltage from the High Voltage Power Supply (HVPS) is applied. The 1st BTR positively charges the backside of the IBT Belt with the voltage generated by the contact resistance with the IBT Belt.

The toner images on the drums are transferred to the IBT Belt due to the attracting force generated between the negative polarity of the toner image and the positive polarity on the IBT Belt.

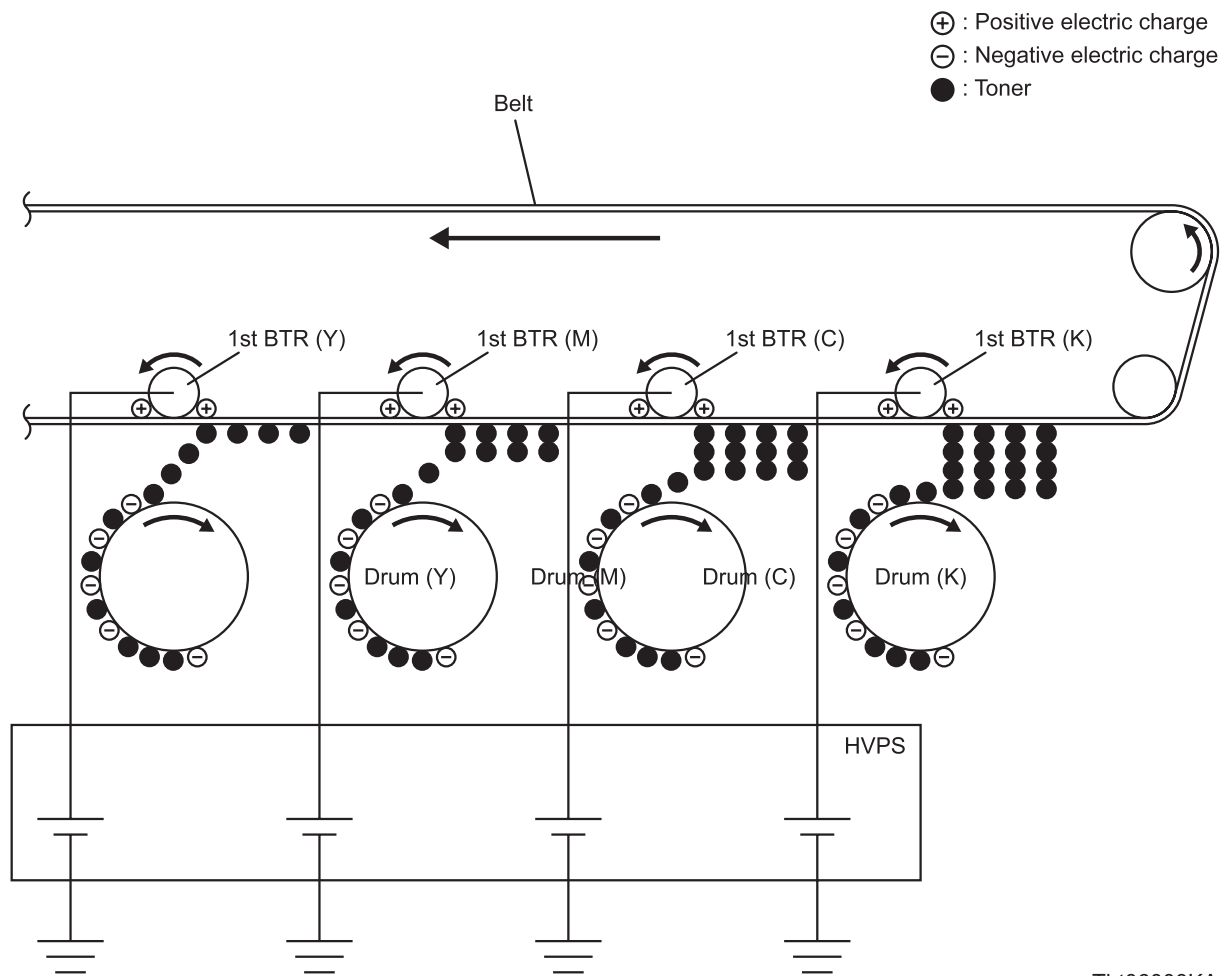

Tbt06008KA

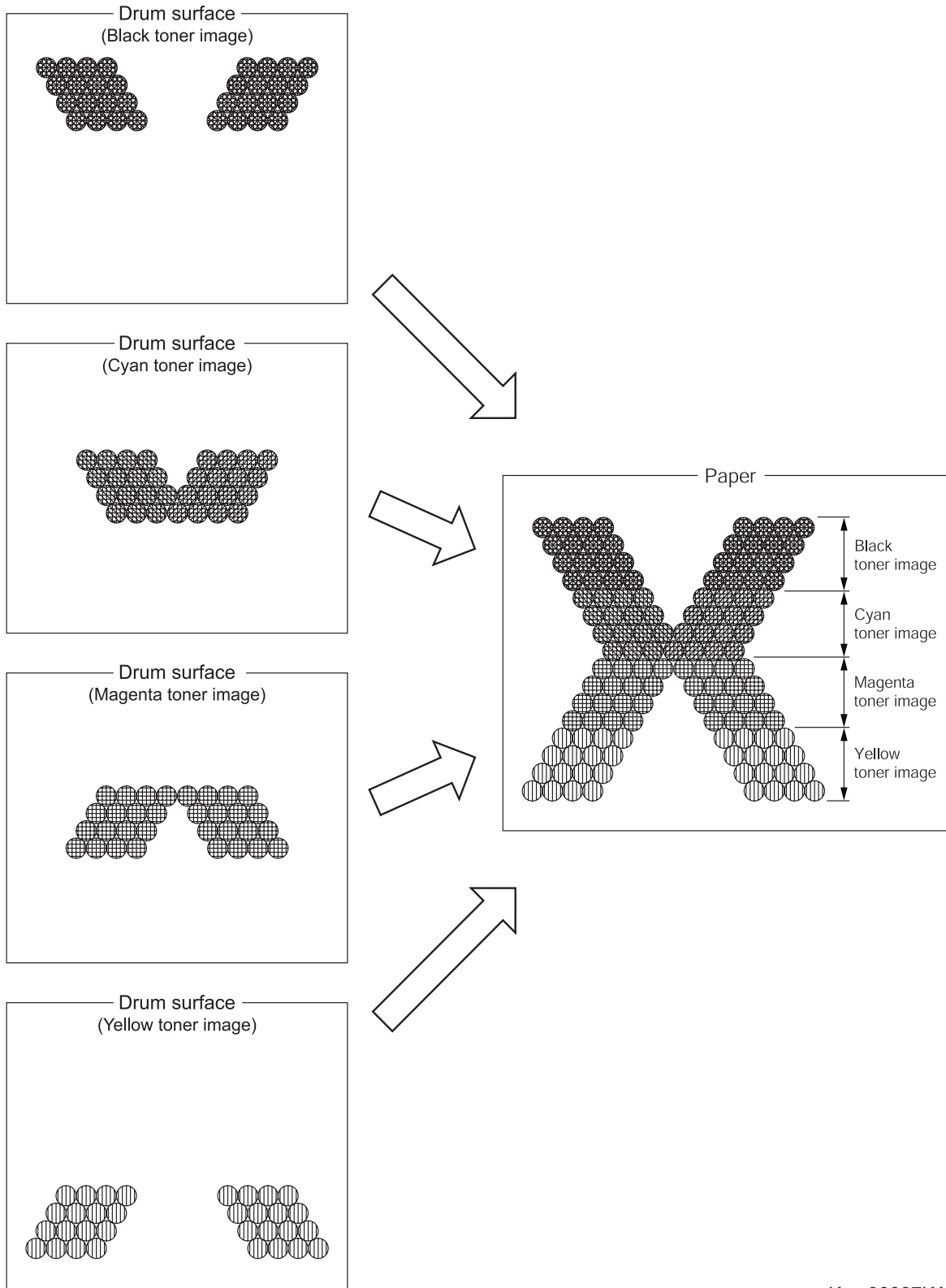

Kmy06007KA

1.3.5 Cleaning

In the Cleaning process, excess toner and charge is removed from the drum and BCR surfaces.

- Drum cleaning
The excess toner that was not transferred to the IBT Belt remains on the drum surface. To prevent troubles in the subsequent processes, the excess toner is scraped off by the Cleaning Blade in contact with the drum, and then collected into the WASTE TONER BOX as described in “1.3.10 Waste Toner Collection”.
- BCR cleaning
The excess toner remaining on the BCR is wiped off by the Cleaning Roll made of spongy material, and then collected into the WASTE TONER BOX as described in “1.3.10 Waste Toner Collection”.
- Charge cleaning
After the Primary Transfer, the charge remaining on the drum is eliminated by the irradiation from the Erase Lamp.

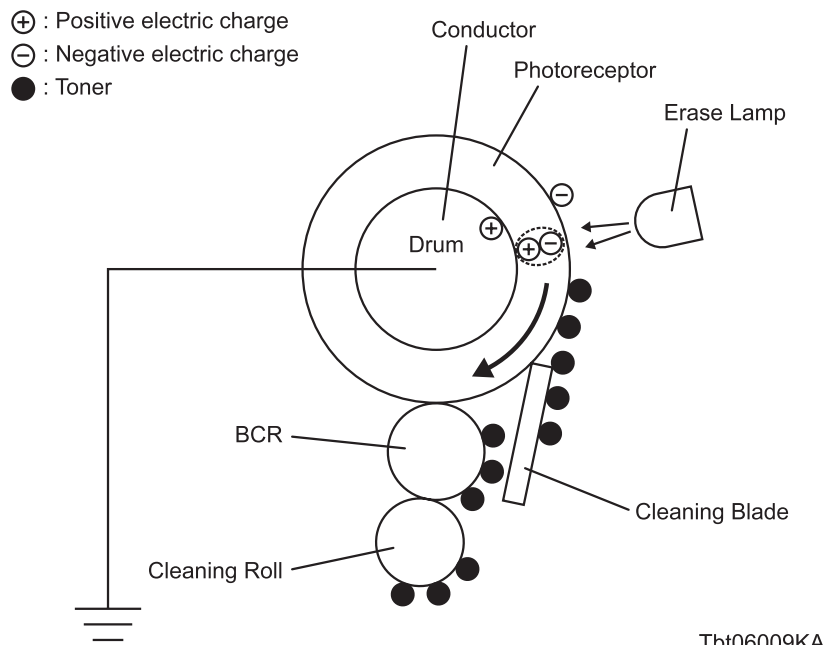

1.3.6 Secondary Transfer

In the Secondary Transfer process, the toner image completed on the surface of the IBT Belt is transferred onto the print medium using the 2nd BTR (Second Bias Transfer Roll).

The print medium passes between the 2nd BTR and the IBT Belt that runs in contact with the conductive roll (Back Up Roll).

The toner image on the IBT Belt moves onto the print medium due to the attracting force generated between the Back Up Roll negatively charged by the High Voltage Power Supply (HVPS) and the 2nd BTR grounded and positively polarized.

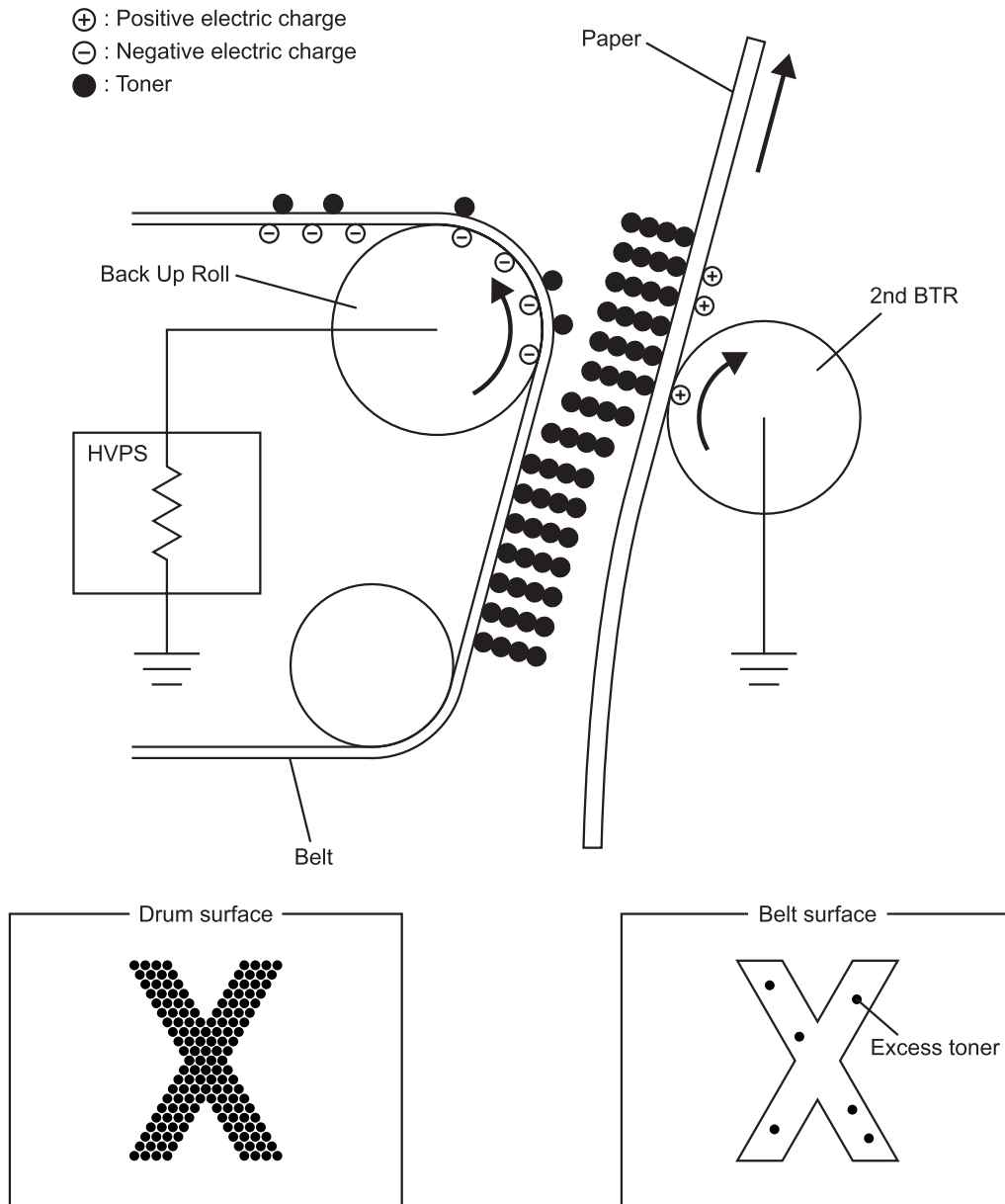

Tbt06010KA

1.3.7 Neutralization

In the Neutralization process, the charge on the paper is neutralized or eliminated by the Detack Saw.

- Detack Saw

The charge is neutralized (removed) because otherwise the toner on the paper will spread over the surrounding metal surfaces.

The Detack Saw is a metal sheet that is held at the ground level. The Detack Saw is installed at several millimeters away from the backside of the belt.

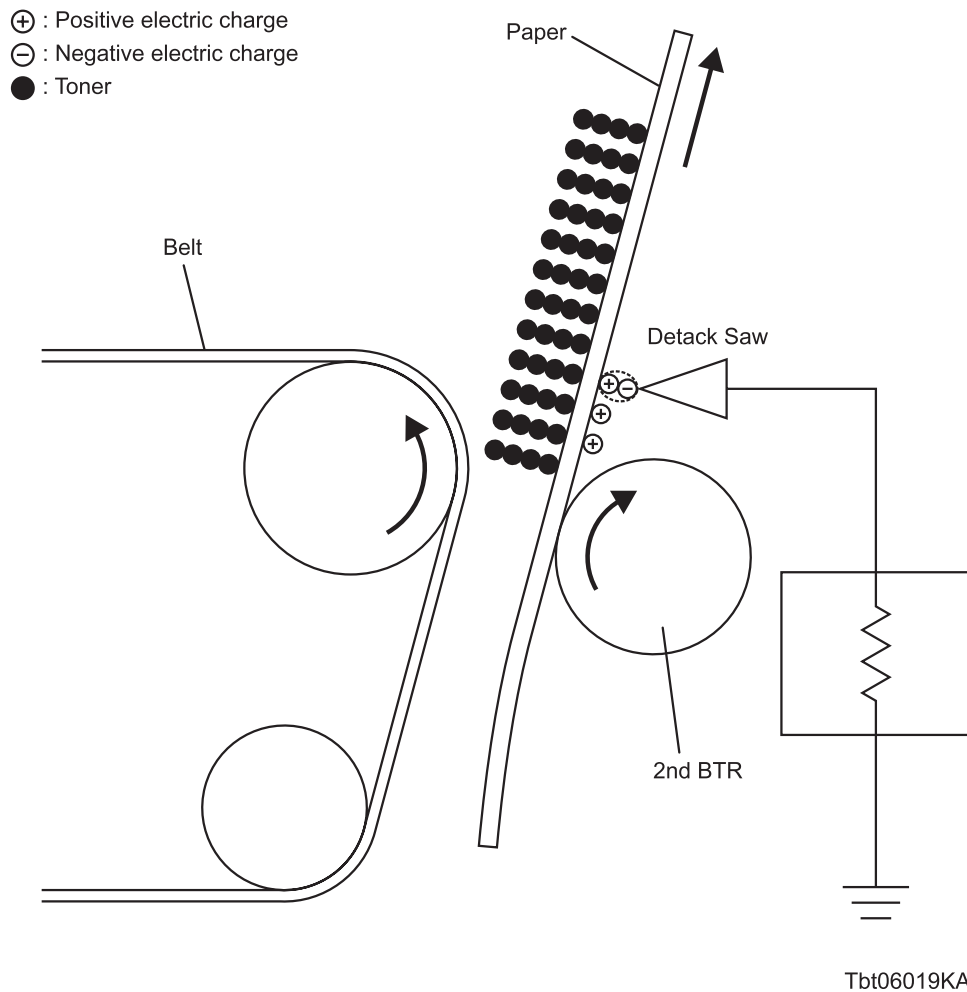

1.3.8 Cleaning

In the Cleaning process, the toner and charge remaining on the IBT Belt and the toner remaining on the 2nd BTR are removed after the toner image is transferred onto the print medium.

- Belt cleaning

The excess toner that was not transferred to the print medium remains on the Belt surface. Since toner particles cause troubles in the subsequent processes, this residual toner is scraped off by the Cleaning Blade in contact with the drum, and then collected into the WASTE TONER BOX as described in "1.3.10 Waste Toner Collection".

- 2nd BTR cleaning

The excess toner deposited on the 2nd BTR in the Secondary Transfer process soils subsequent print media. To prevent this trouble, the residual toner on the 2nd BTR is transferred back onto the IBT Belt due to the attracting force generated by the Back Up Roll positively polarized by the HVPS. The excess toner remaining on the IBT Belt is scraped off by the Cleaning Blade that is in contact with the drum, and then collected into the WASTE TONER BOX as described in "1.3.10 Waste Toner Collection".

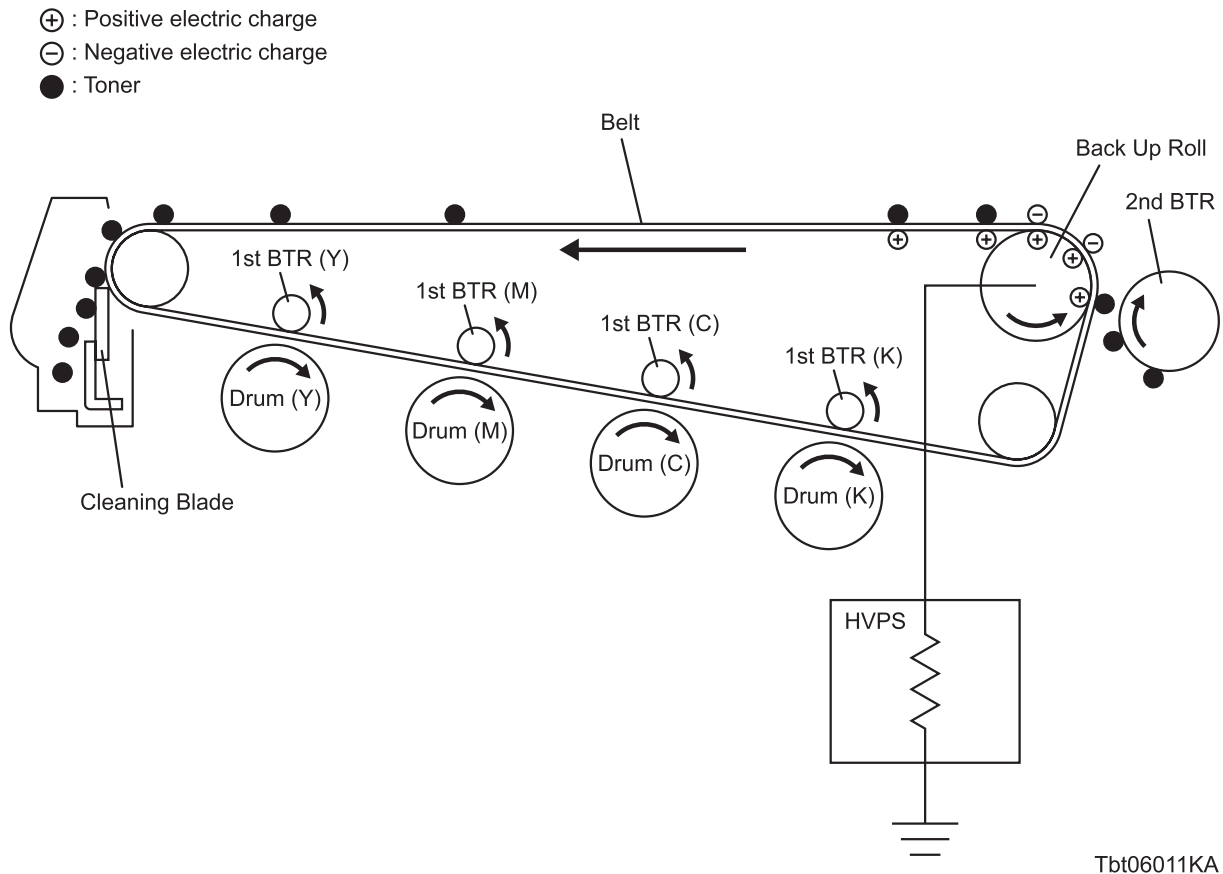

1.3.9 Fusing

In the Fusing process, toner is fixed onto the print medium by heat and pressure.

- The toner particles are melted by the Heat Roll heated by the Heater lamp, and fused onto the print medium by the pressure between the Heat Roll and the Belt Assy.
- The Belt Assy friction-driven by the Heat Roll nips the print media against the Heat Roll using the the pressurizing mechanism it contains.

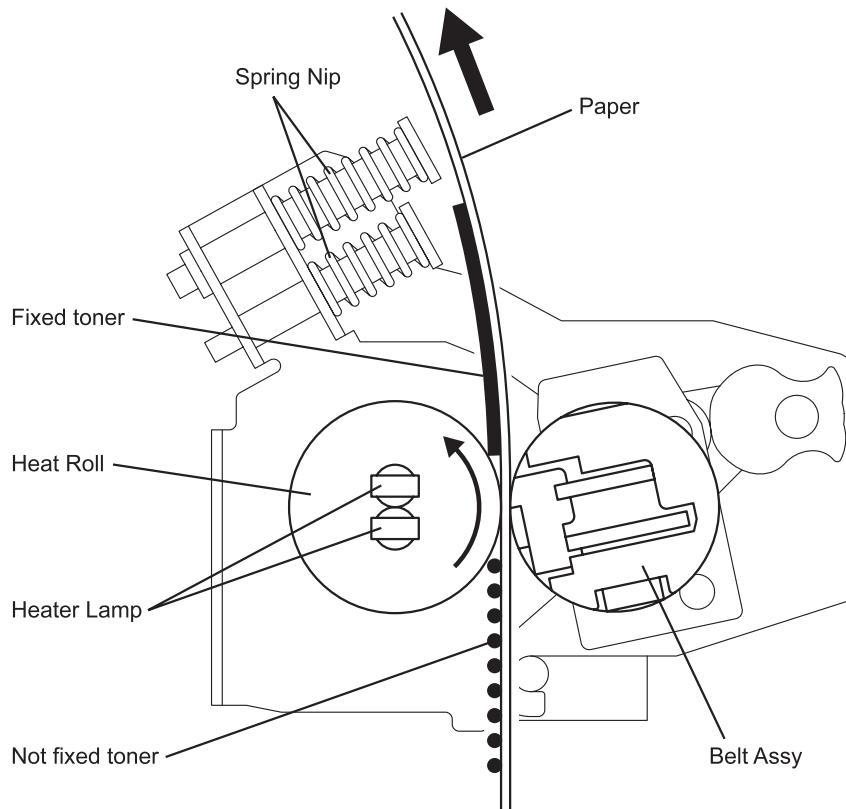

Tbt06013KA

1.3.10 Waste Toner Collection

The waste toner generated during the Drum/Belt cleaning and the degraded developer exhausted from each developer unit are transported to the WASTE TONER BOX via the Auger in the PIPE ASSY.

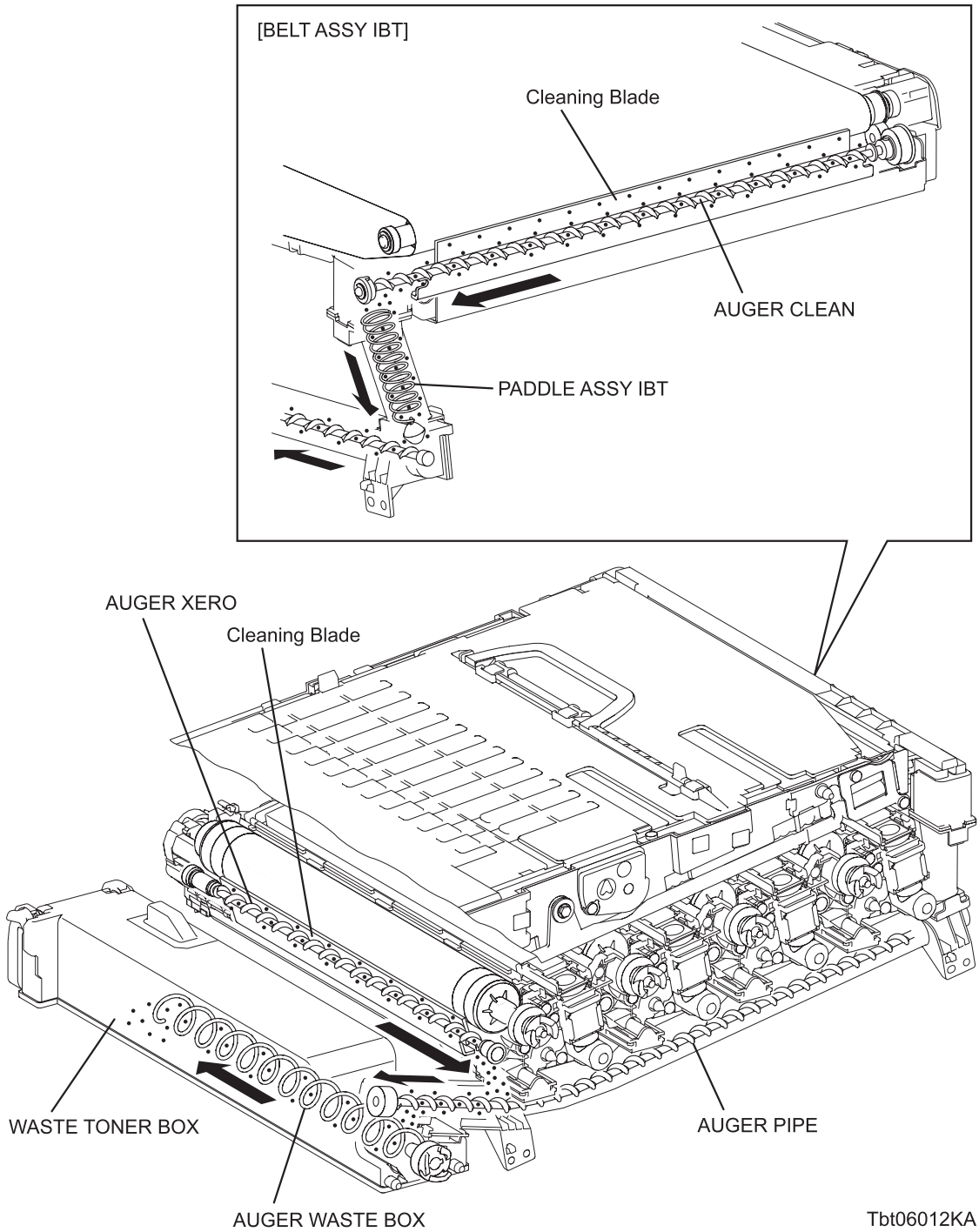

2. Paper Path

2.1 Paper Path

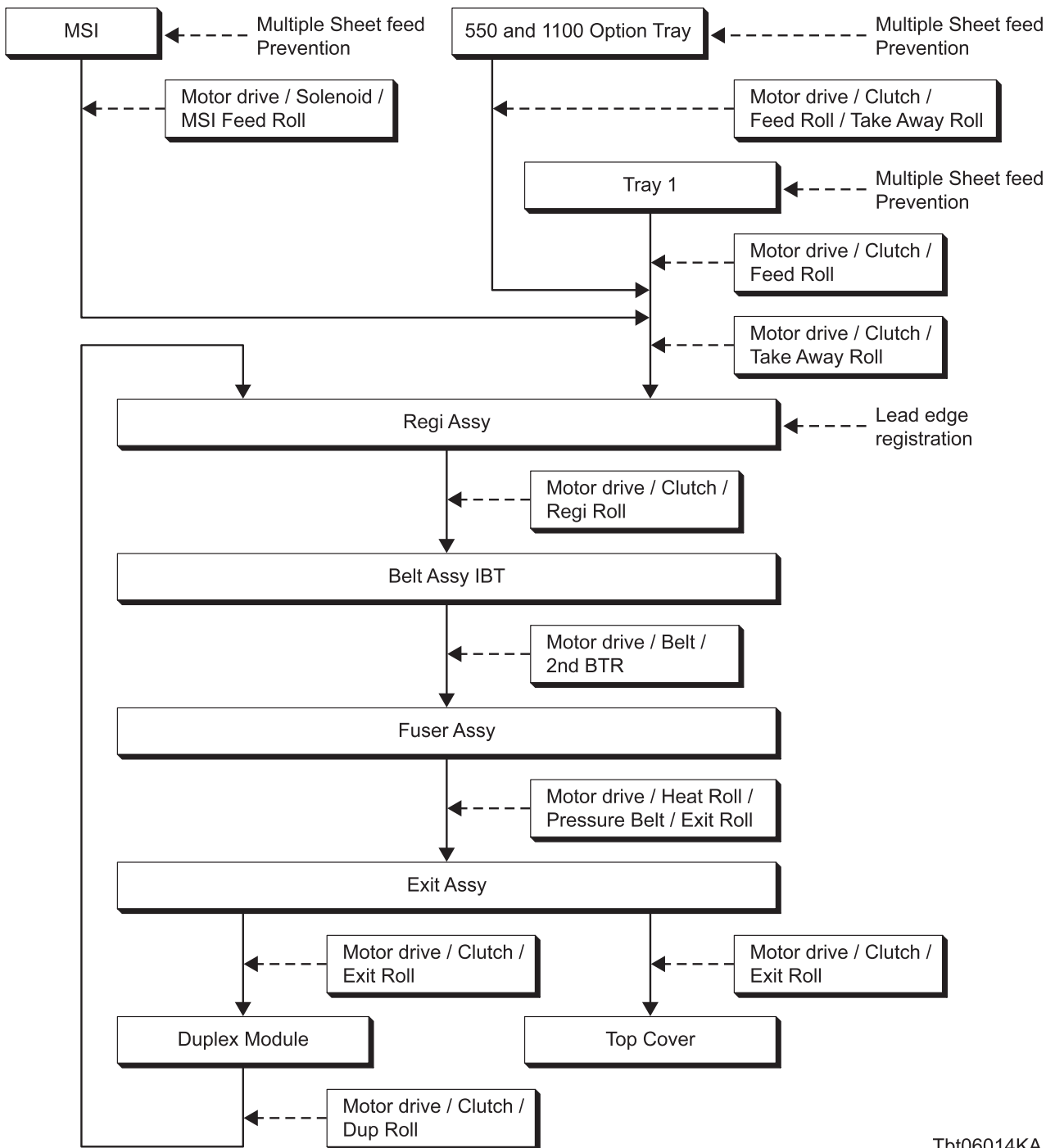

Tbt06014KA

2.2 Layout of Paper Path

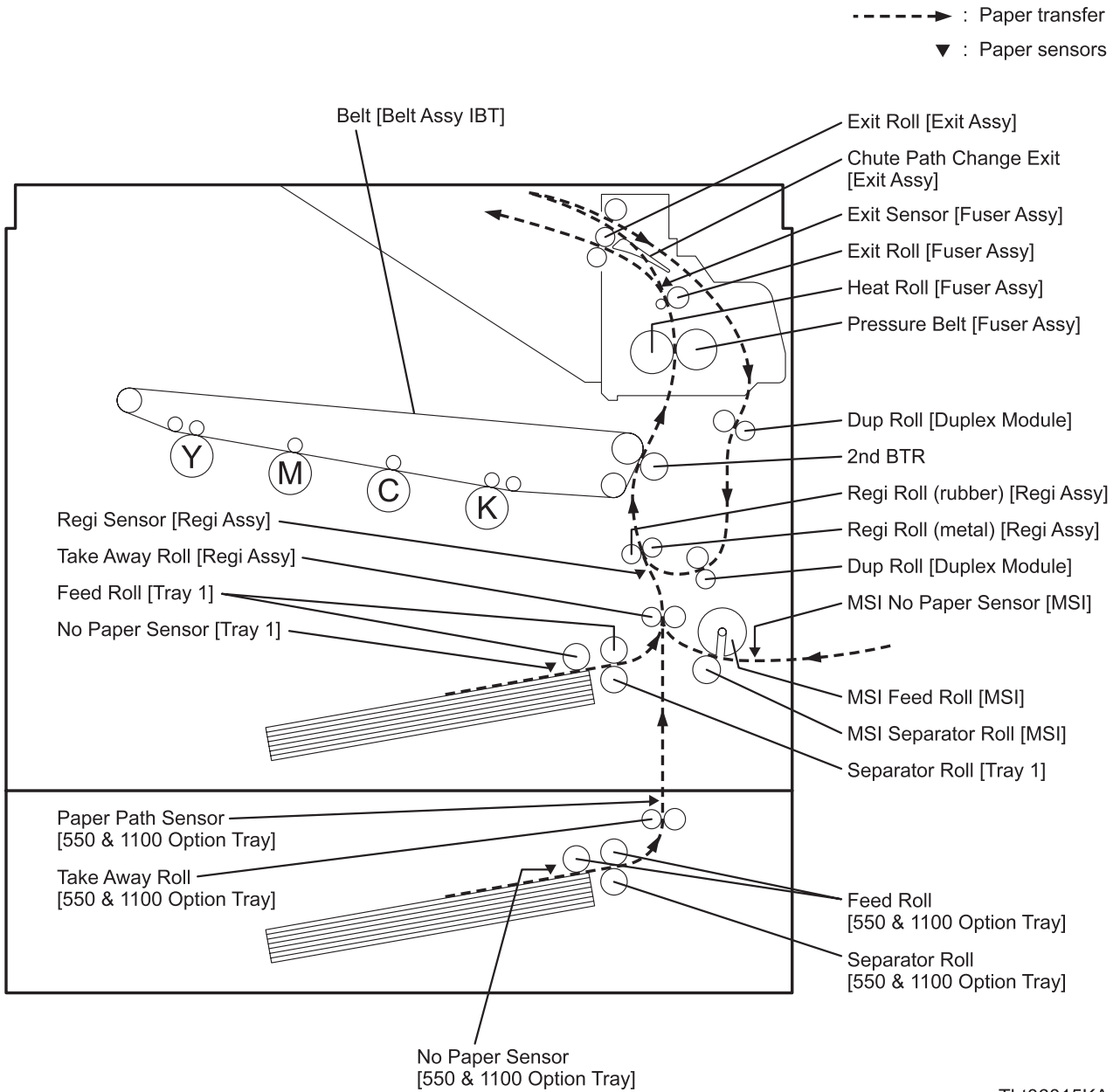

Tbt06015KA

2.3 Feeding from Paper Cassette

Inserting the paper cassette into the feeder section unlocks the GEAR BTM LOCK ONEWAY (PL 2.1.6).

When the paper cassette is pushed in until it stops, the SUPPORT NUDGER (PL 3.2.13) pushes the LEVER BTM LOCK (PL 2.1.25) and disengages the gear teeth of the RACK BTM LOCK from those of GEAR BTM LOCK ONEWAY, allowing the PLATE ASSY BTM (PL 2.1.2) to rise to the paper feeding level by the pressure of the spring (SPRING BTM UP 550 A4: PL 2.1.8).

When feeding from the paper cassette starts, the Nudger Roll (ROLL ASSY FEED: PL 3.2.18) and Feed Roll (ROLL ASSY FEED: PL 3.2.18) rotate, driven by the DRIVE ASSY PH (PL 9.1.4) and controlled by the CLUTCH ASSY FEED, and the Nudger Roll feeds the print media to the position where it is nipped between the Feed Roll and the Separator.

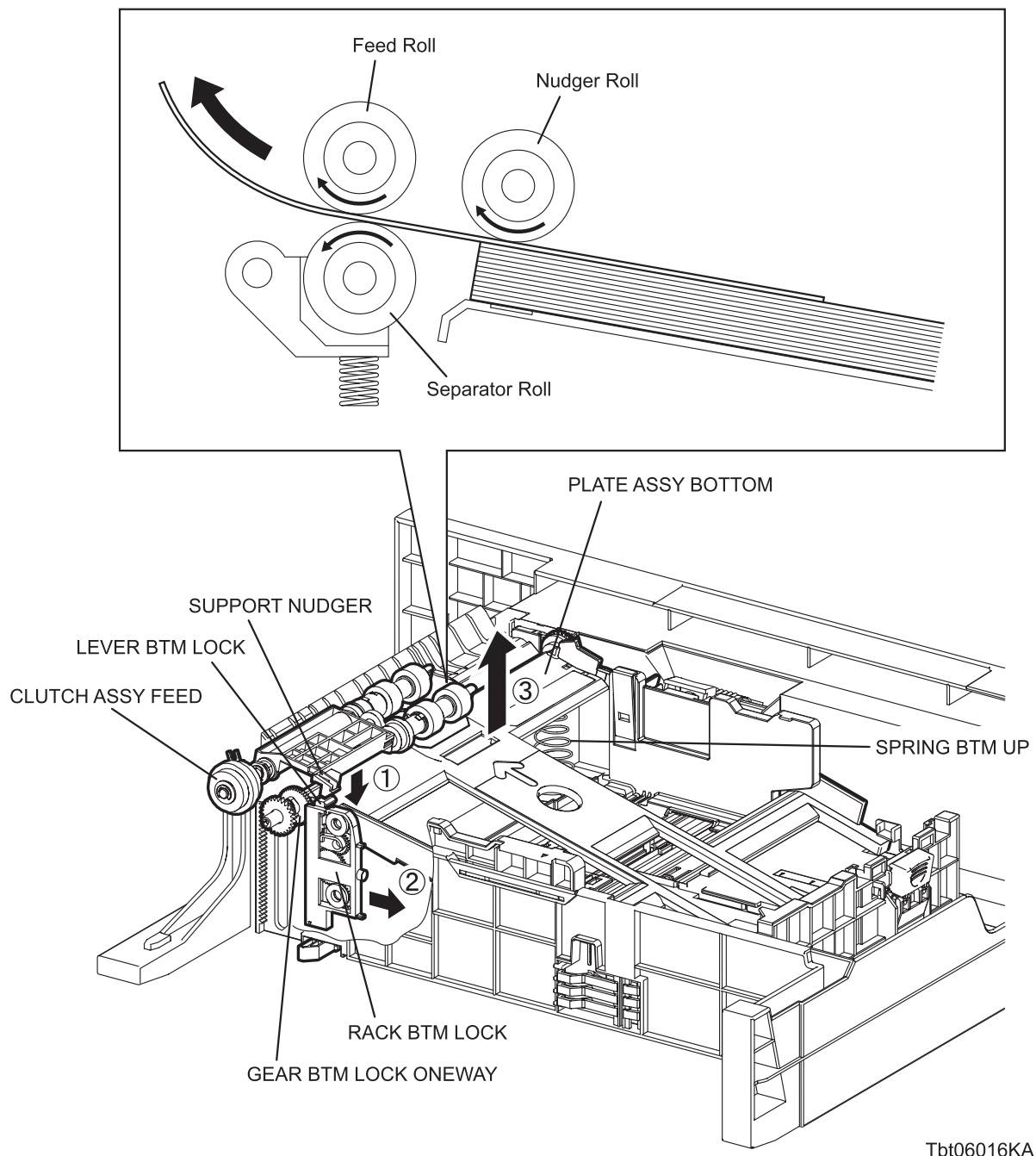

Tbt06016KA

2.3.1 Multiple Sheet Feed Prevention

The sheets set in a tray or cassette are occasionally stuck together along the edges. The stuck sheets cause a multiple sheet feed or a jam. The sheets are fed by the Nudger Roll (ROLL ASSY FEED: PL 3.2.18) to a position between the Feed Roll (ROLL ASSY FEED: PL 3.2.18) and the Separator Roll (HOLDER ASSY SEPARATOR: PL 2.1.21). Normally, when only one sheet is fed, both the Feed Roll and Separator Roll rotate to allow the sheet to pass. However, when two sheets are fed concurrently, only the Feed Roll rotates and the Separator Roll is locked, allowing the upper sheet to pass by being separated from the lower sheet that is stopped by the friction with the Separator Roll that will not rotate. The Separator Roll is being pushed toward the Feed Roll by spring pressure, and controlled by the torque limiter (Clutch Assy Friction) with which it is coupled.

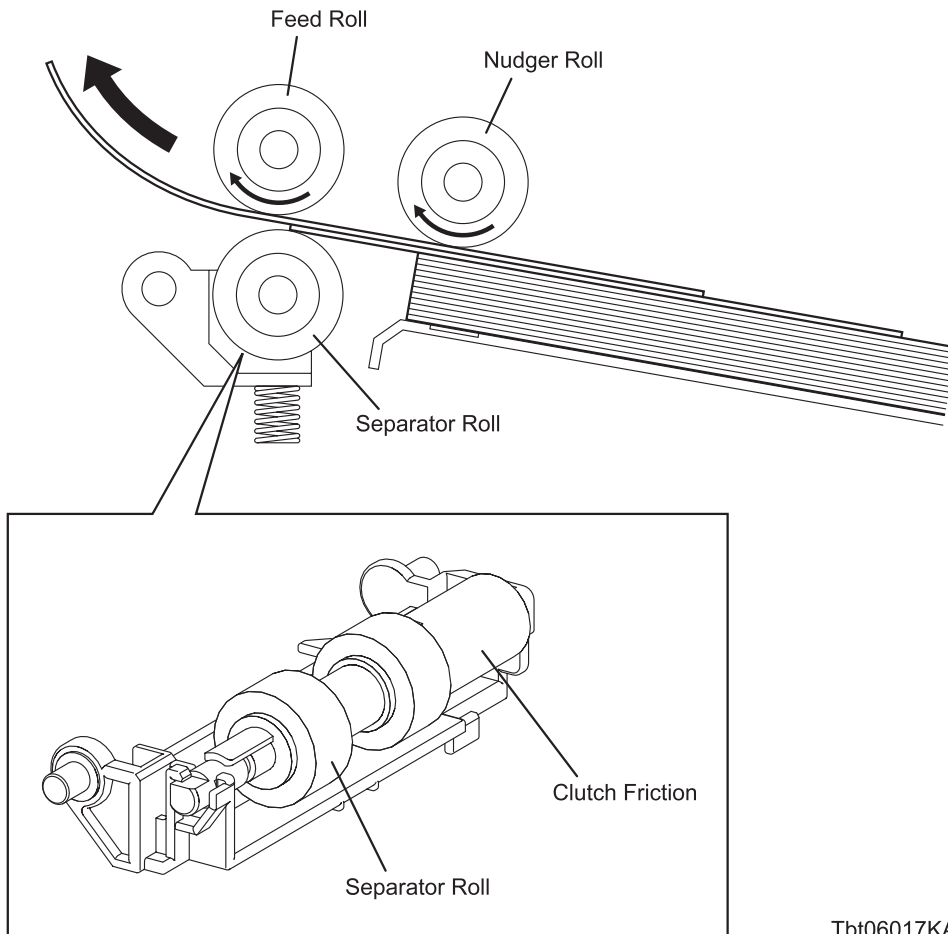

Tbt06017KA

2.4 Feeding from MSI

When feeding from the MSI starts, the Feed Roll (ROLL ASSY FEED: PL 4.2.21) rotates, driven by the DRIVE ASSY PH (PL 9.1.4) and controlled by the SOLENOID FEED MSI (PL 4.2.32), and feeds the print media to the position where it is nipped between the Feed Roll and the Separator.

2.4.1 Multiple Sheet Feed Prevention

The sheets set in the MSI are occasionally stuck together at the edges. The stuck sheets cause a multiple sheet feed or a jam. Normally, when only one sheet is fed, both the Feed Roll (ROLL ASSY FEED: PL 4.2.21) and Separator Roller (HOLDER ASSY SEPARATOR MSI: PL 3.1.8) rotate to allow the sheet to pass. However, when two sheets are fed concurrently, only the Feed Roll rotates and the Separator Roller is locked, allowing the upper sheet to pass by being separated from the lower sheet that is stopped by the friction with the Separator Roller that will not rotate.

The Separator Roller is being pushed toward the Feed Roll by spring pressure, and controlled by the torque limiter with which it is coupled.

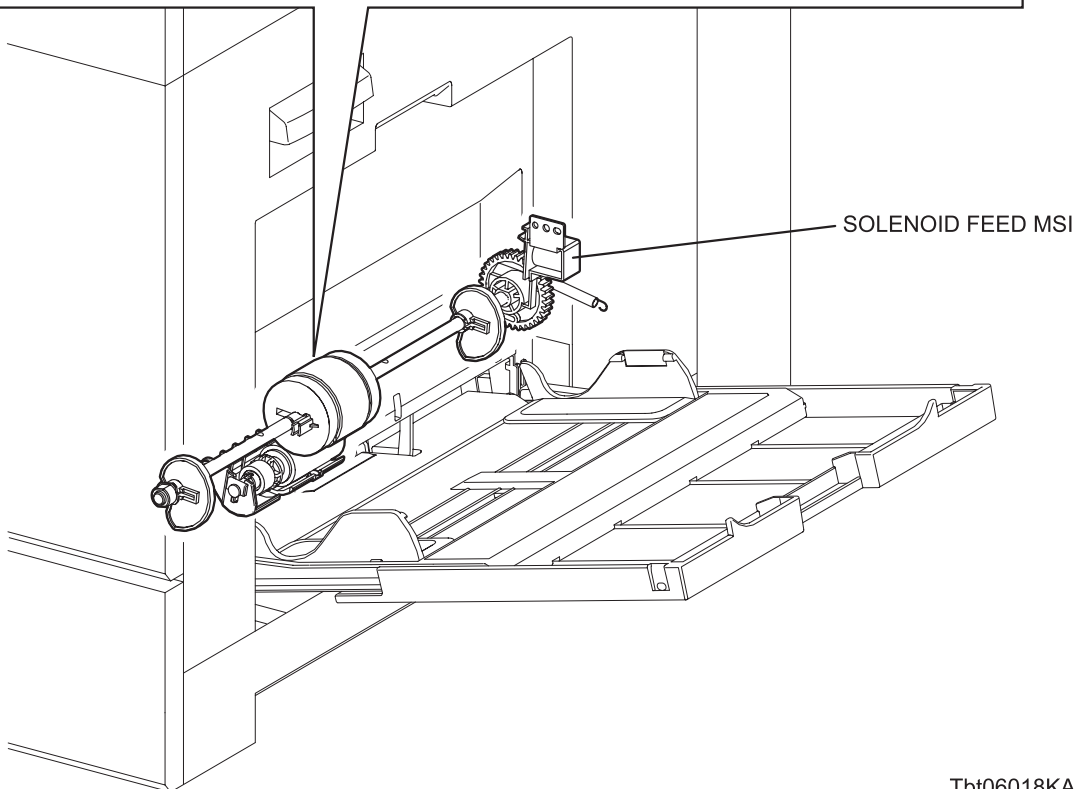
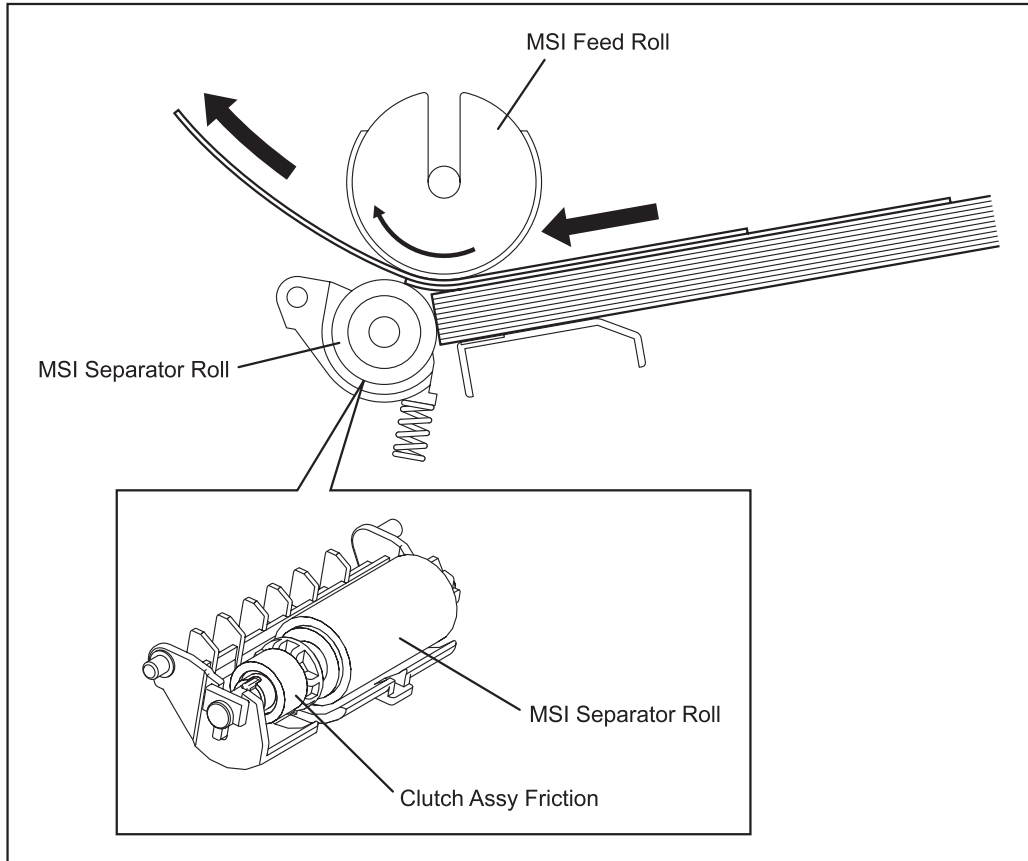

Tbt06018KA

2.5 Feeding in Registration Section

The sheets fed from the paper cassette or MSI are guided into the registration section by the Take Away Roll (ROLL ASSY TAKE AWAY: PL 3.3.11) rotatively driven by the DRIVE ASSY PH (PL 9.1.4) and controlled by the CLUTCH ASSY TAKE AWAY (PL 3.3.12). The sheets fed from the Duplex section are guided into the registration section by the ROLL ASSY DUP (Duplex Roller Upper and Duplex Roller Lower). (Refer to 2.7 Feeding in Duplex Section)

The sheets are then brought into registration at the lead edge (Refer to 2.5.1 Lead-edge Registration), and then fed to the toner transfer section (2nd BTR).

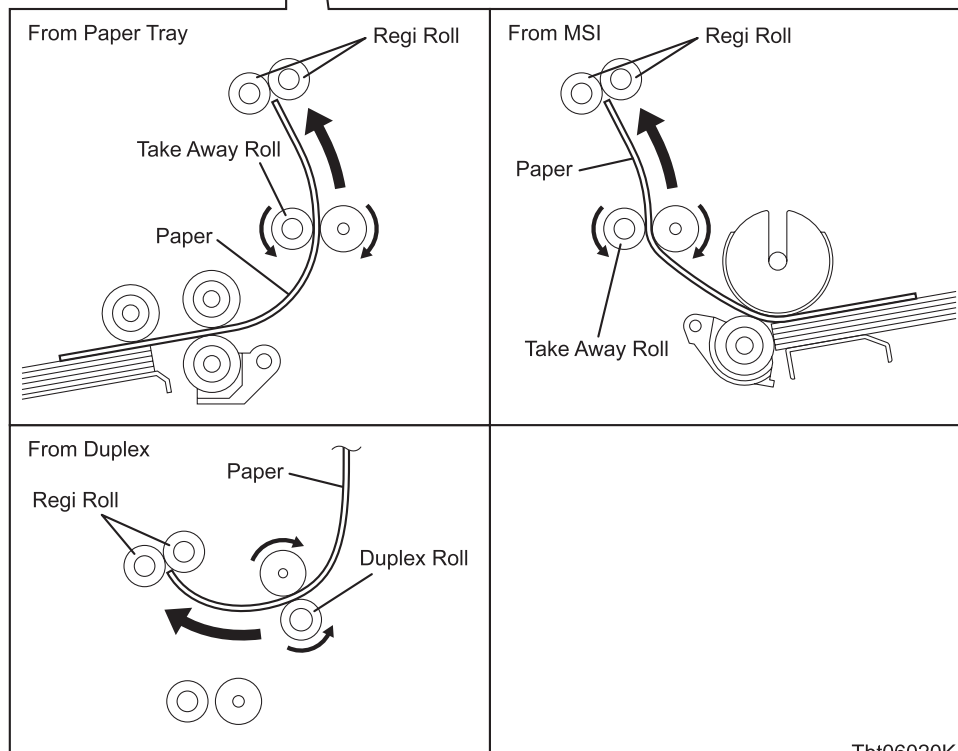
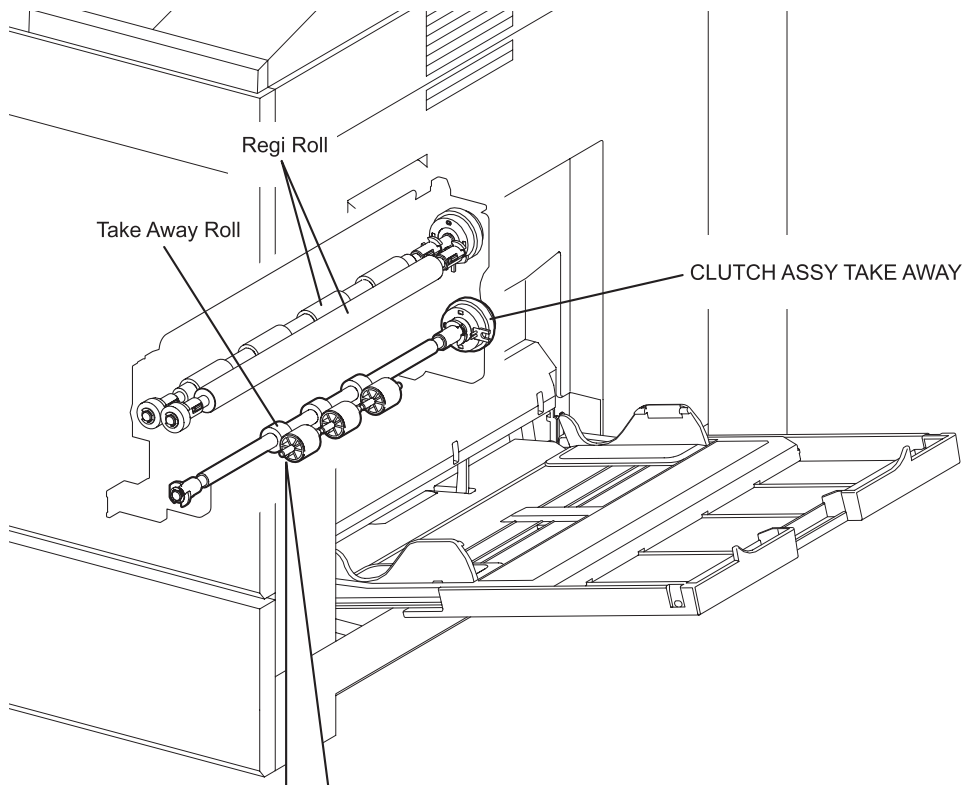

Tbt06020KA

2.5.1 Lead-edge Registration

When a sheet is fed from the MPF, Tray or Duplex to the toner transfer position, the registration of the sheet may not be correctly maintained due to such troubles as misalignment of lead edges in the tray/cassette. To avoid this trouble, the lead edge position needs to be aligned at the registration section before the sheet is fed to the toner transfer position.

By thrusting the edge of the sheet coming out of the MSI or paper cassette against the Regi Roll (ROLL REGI METAL: PL 3.3.9/ROLL ASSY REGI RUBBER: PL 3.3.10) that is locked, the lead edge of the sheet is registered.

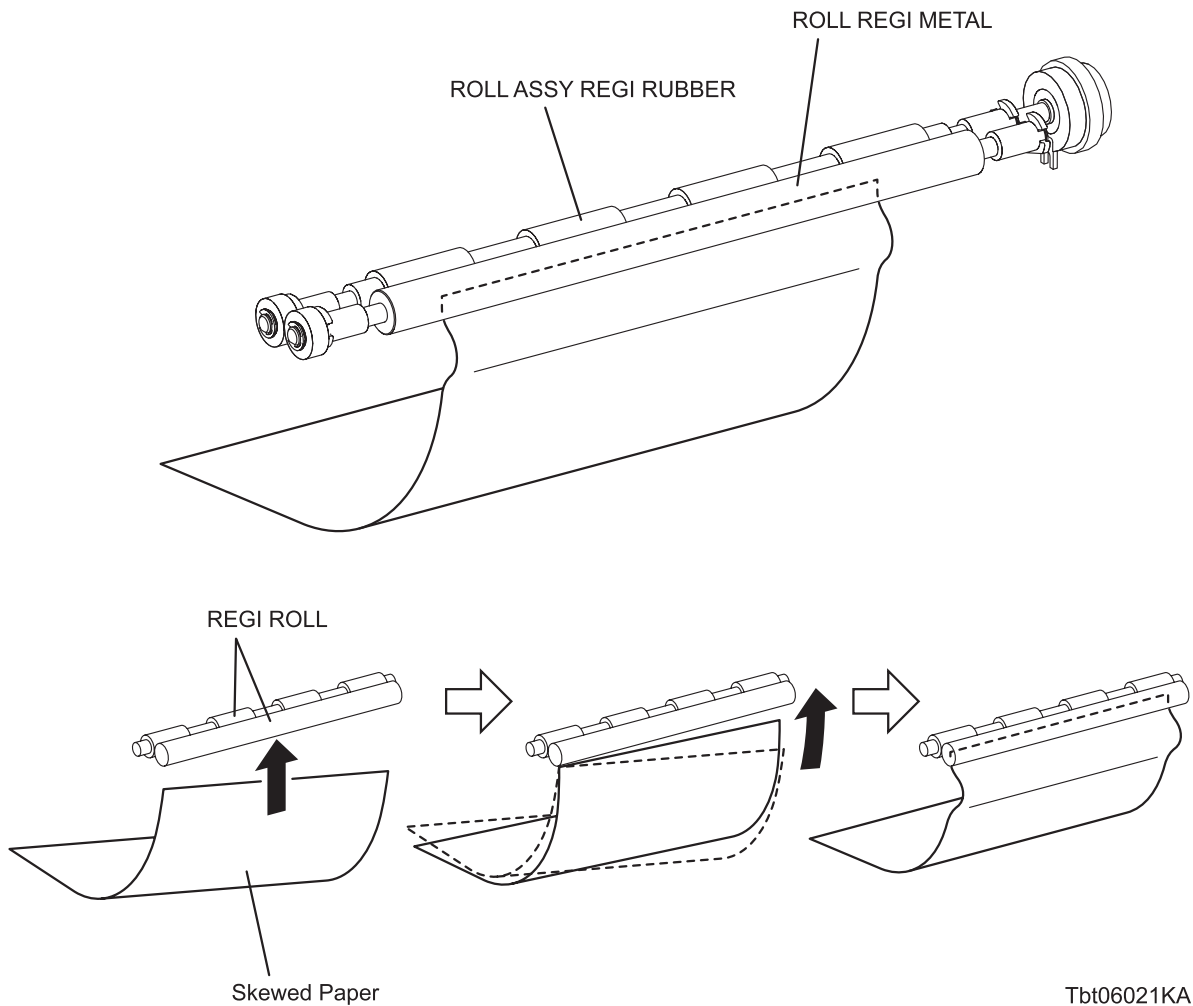

Tbt06021KA

2.6 Transfer/Fusing/Exit

The sheet that passed the registration section reaches the transfer position where it is nipped between the IBT Belt and 2nd BTR driven by the IBT Drive Motor (DRIVE ASSY IBT: PL 9.1.3). The toner image on the Belt is transferred onto the sheet, and then fused by the Heat Roll that rotates driven by the Fuser Drive Motor (DRIVE ASSY FSR (PL 9.1.1) while the sheet is being fed to the Exit section. In the exit section, the sheet whose side 1 or side 2 has been printed is fed to the exit direction by the Exit Roll (ROLL ASSY EXIT: PL 7.2.2) driven by the DRIVE ASSY FSR (PL 9.1.1) and controlled by the Exit Clutch (ROLL ASSY EXIT: PL 7.2.2) in the DRIVE ASSY EXIT.

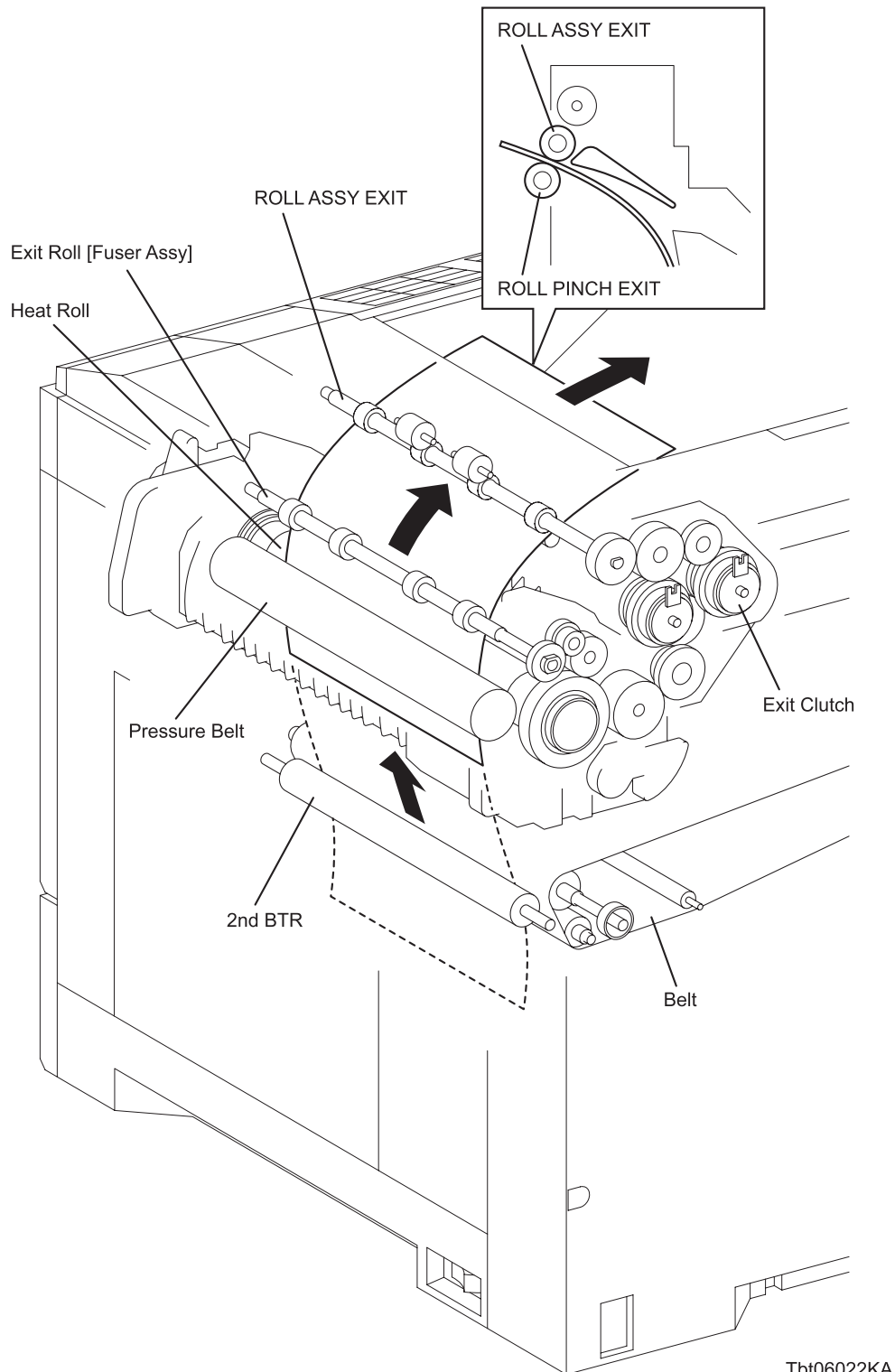

Blank Page

2.7 Feeding in Duplex Section

When the lead-edge of the sheet exits from the Fuser after the printing on the side 1 is completed, the SOLENOID ASSY INVERT (PL 7.3.3) turns ON, lowering the CHUTE PATH CHANGE EXIT (PL 7.2.9) to allow the sheet to travel along the upper side of the CHUTE PATH CHANGE EXIT to the position where it becomes nipped between the ROLL ASSY EXIT (PL 7.2.2) and the ROLL PINCH TA (PL 7.3.5). The sheet is then fed to the Exit section by the ROLL ASSY EXIT that rotates toward the Exit section (reverse direction), driven by the DRIVE ASSY FSR (PL 9.1.1) and controlled by the EXIT INVERT CLUTCH in the DRIVE ASSY EXIT.

After the trail-edge of the single-side-printed sheet exits the Fuser section, the SOLENOID ASSY INVERT (PL 7.3.3) turns OFF, raising the CHUTE PATH CHANGE EXIT (PL 7.2.9) to its original position to allow the single-side-printed sheet to be fed back to the Duplex section from the Exit section by the ROLL ASSY EXIT that rotates toward the Duplex section (normal direction), driven by the DRIVE ASSY FSR (PL 9.1.1) and controlled by the EXIT CLUTCH in the DRIVE ASSY EXIT.

In the Duplex Section, the single-side-printed sheet is fed to the registration section by the Duplex Roller Upper and Duplex Roller Lower that rotate driven by the DRIVE ASSY PH (PL 9.1.4) and controlled by the CLUTCH ASSY DUP (PL 4.3.9).

After the printing on the side 2 is completed, the sheet exits in the same manner as it does after the printing on the side 1 is completed.

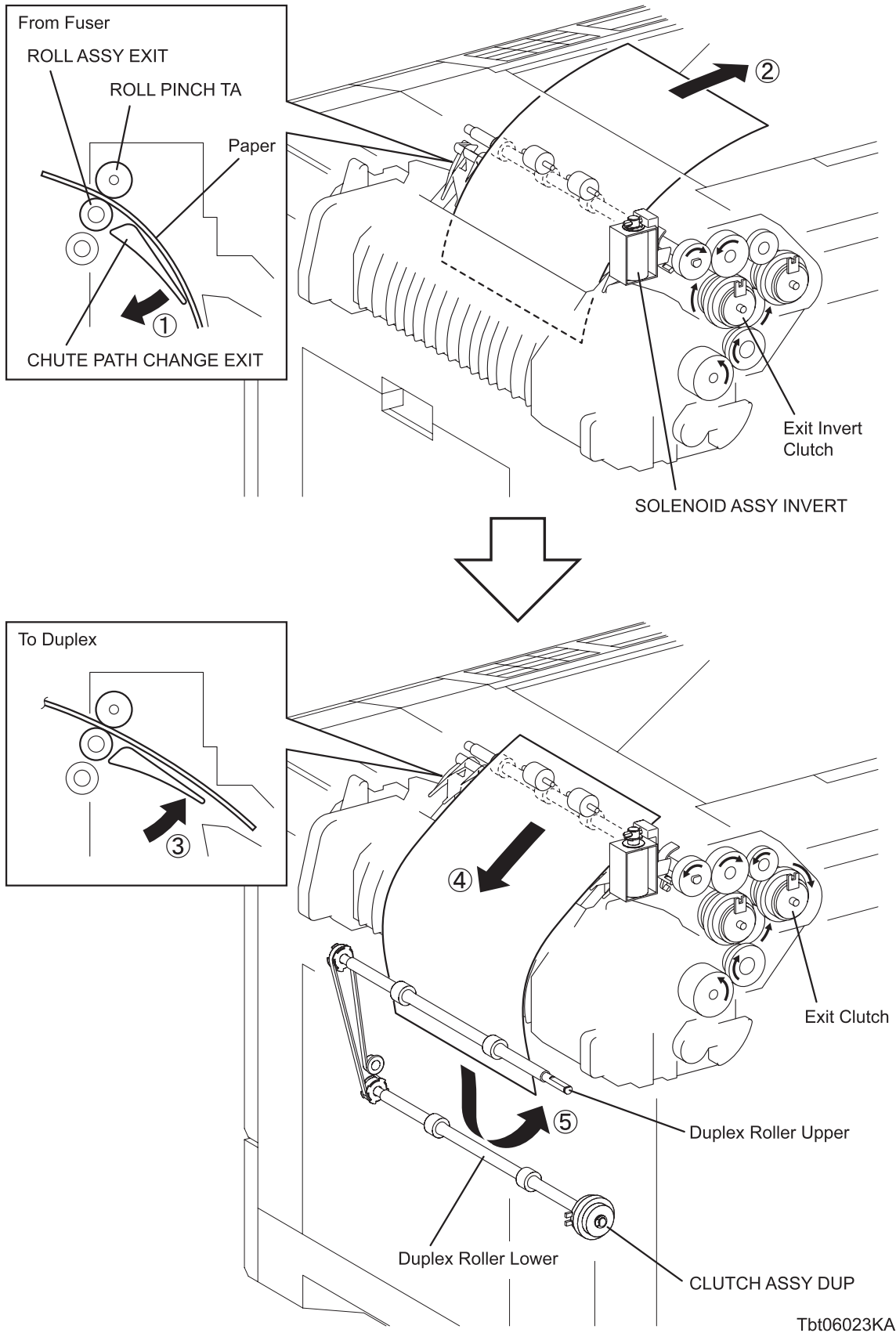

<2-sided Printing on Multiple Sheets>

NOTE

This section describes an example of 2-sheet 2-sided printing as a cycle that may be repeated in larger jobs.

After the first single-side-printed sheet has reached the Duplex section, the SOLENOID ASSY INVERT turns ON, lowering the CHUTE PATH CHANGE EXIT to allow the second single-side-printed sheet to travel along the upper side of CHUTE PATH CHANGE EXIT to the upper part of the Exit section.

When the lead-edge of the first double-side-printed sheet exits from the Fuser section, the SOLENOID ASSY INVERT turns OFF, raising the CHUTE PATH CHANGE EXIT to its original position to allow the double-side-printed sheet to be nipped between the ROLL ASSY EXIT and the ROLL PINCH TA and to be fed to the Exit section by the ROLL ASSY EXIT that rotates toward the Exit section.

When the second single-side-printed sheet is fed to the Duplex section, the preceding sheet is fed to the Output Tray at the same time. By feeding the first sheet below and the second sheet above the CHUTE PATH CHANGE EXIT, ejection to the Output Tray and feeding to the Duplex section are performed concurrently.

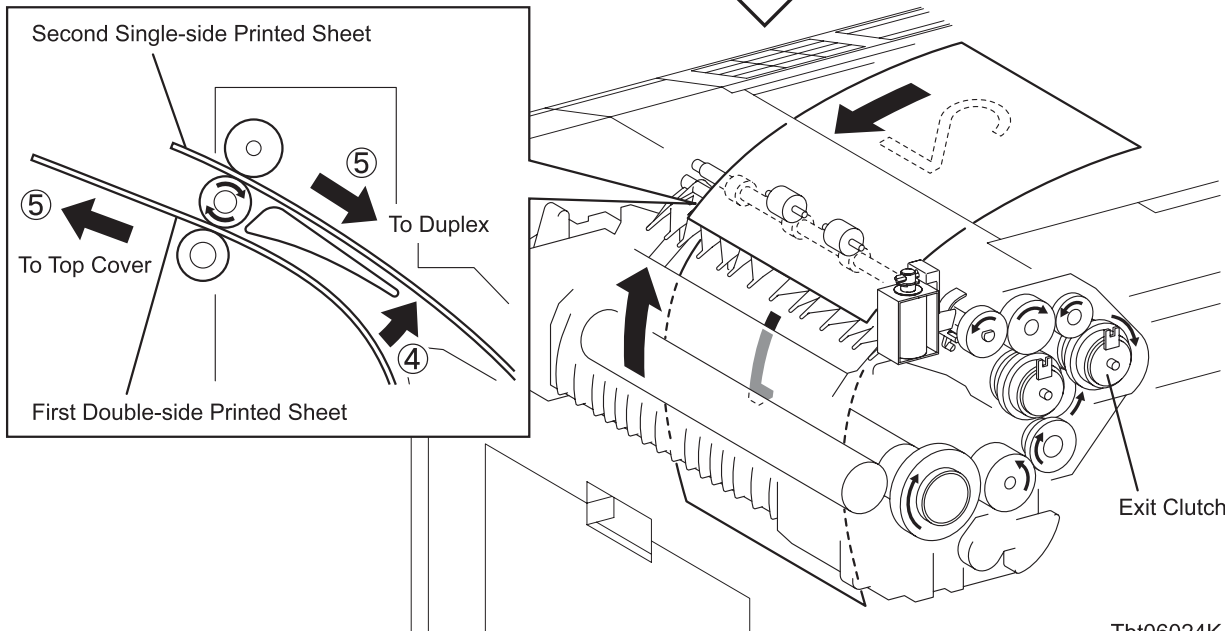
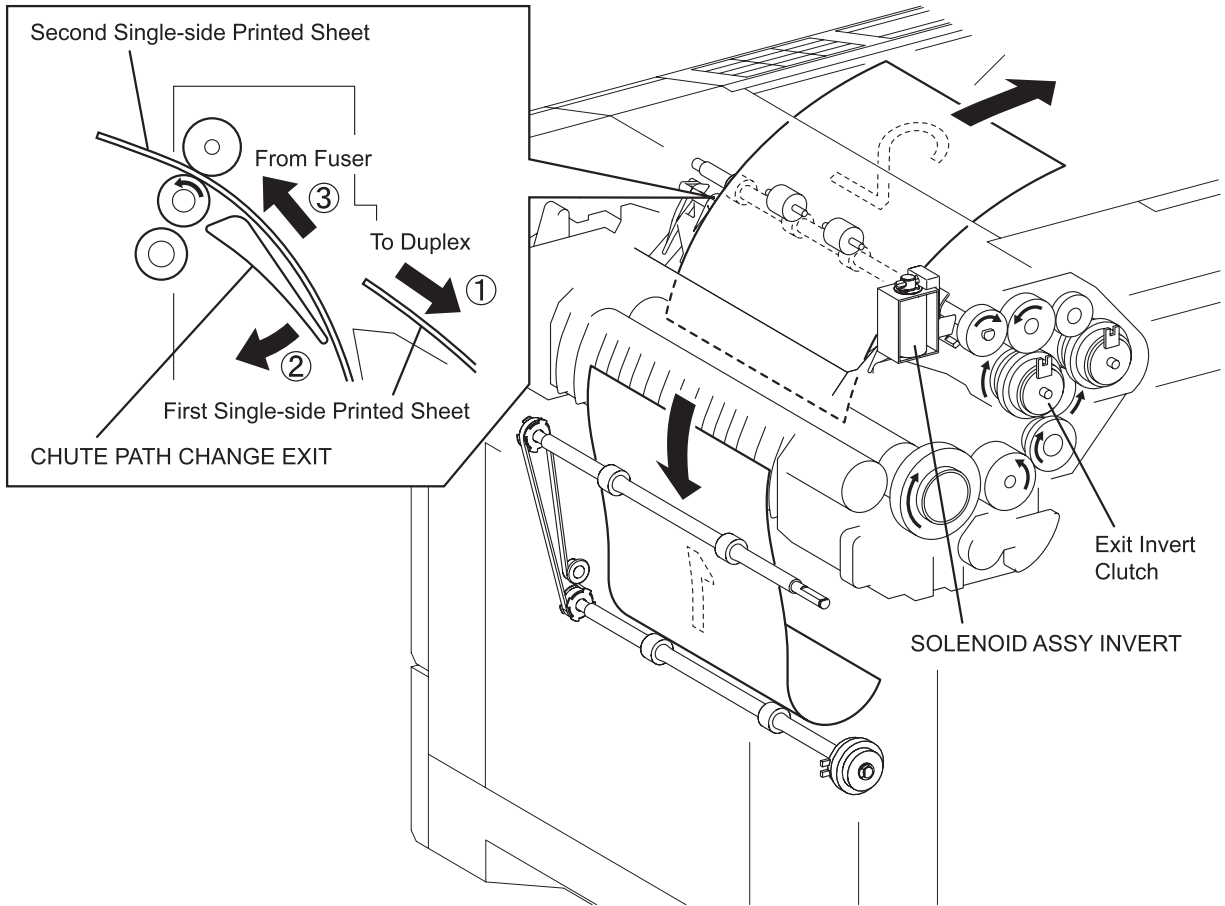

Tbt06024KA

3. Functions of Major Functional Components

Major functional components of the printer are described below with illustrations.

These components are classified into the following functional blocks.

- Paper Cassette
- Paper Feeder
- MSI & Regi Assy
- Process Control (PROCON ASSY)
- ROS ASSY
- Dispenser
- XERO DRIVE CRU ASSY
- Transfer Belt (BELT ASSY IBT)
- FUSER
- Exit
- Duplex
- Drive
- Electrical
- Optional 550 Paper Feeder & Optional High Capacity Feeder (HCF) (1100 FEEDER)

3.1 Paper Cassette

3.1.1 Major Functions

- GUIDE ASSY SIDE R (PL 2.1.9)/GUIDE ASSY SIDE F (PL 2.1.11)
The GUIDE ASSY SIDE R and GUIDE ASSY SIDE F aligns the print media stack in the width direction by moving perpendicularly to the paper feeding direction.

- GUIDE ASSY END (PL 2.1.12)
The GUIDE ASSY END aligns the print media stack in the length direction and determines the paper size by moving in the paper feeding direction. The paper size is detected based on the combination of the three switches on the SWITCH ASSY SIZE ([Refer to 5.1 Paper Size Control](#)) that turn on or off according to the position of the GUIDE ASSY END.

- HOLDER ASSY SEPARATOR (PL 2.1.21)
The HOLDER ASSY SEPARATOR and the ROLL ASSY FEED nip the print medium to prevent multiple sheet feed.
([Refer to 2.3.1 Multiple Sheet Feed Prevention](#))

- PLATE ASSY BOTTOM (PL 2.1.2)

When the paper cassette is pulled out from the paper feeder section, the PLATE ASSY BOTTOM is lowered and locked to the bottom of the cassette. Replacing the paper cassette to the paper feeding section releases the PLATE ASSY BOTTOM from the GEAR BTM LOCK ONEWAY, pressing the print media stack against the Nudger Roll by the spring pressure of the SPRING BTM UP 550 A4. (Refer to 2.3 Feeding from Paper Cassette)

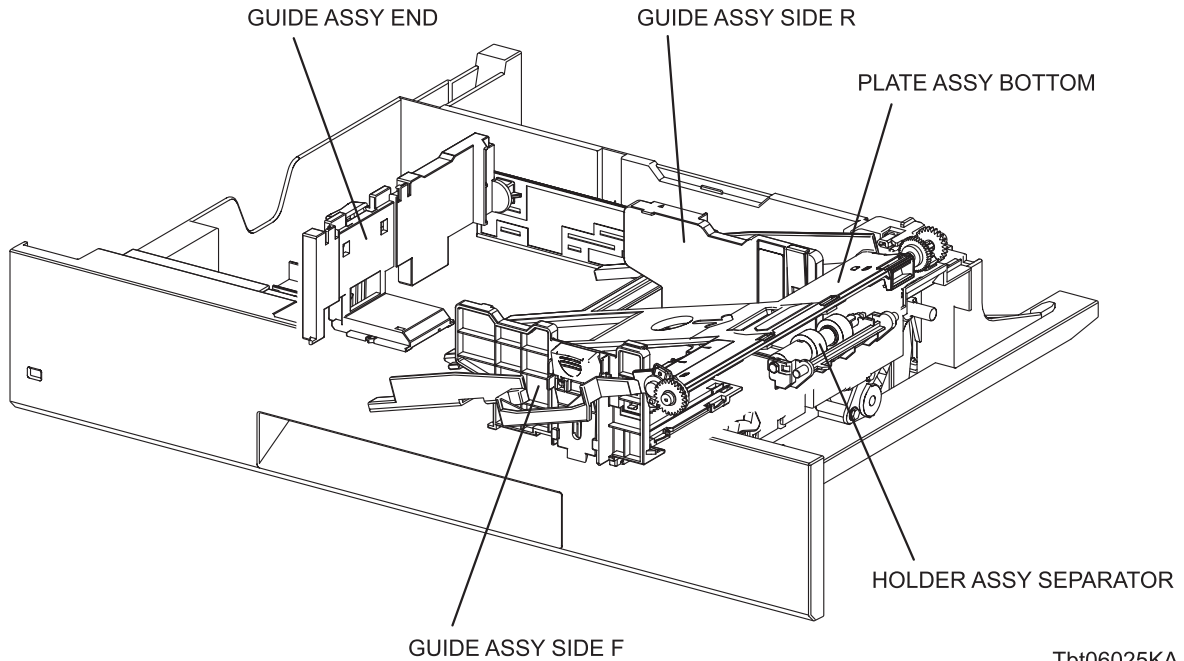

Tbt06025KA

3.1.2 Operation of HOLDER ASSY SEPARATOR at Removal and Replacement of Paper Cassette

- 1) Inserting the paper cassette into the feeder section presses the LATCH TRAY (PL 2.1.37) against the rail of the GUIDE TRAY (PL 3.1.6), swinging the LATCH TRAY downward and moving the LEVER LATCH (PL 2.1.18) forward.
- 2) The LEVER LATCH swings the LEVER SEPARATOR (PL 2.1.17) forward, which swings the HOLDER ASSY SEPARATOR (PL 2.1.21) downward, making clearance enough for the paper cassette to go in.

When the paper cassette is inserted until it stops, the LATCH TRAY comes off from the rail of the GUIDE TRAY, allowing the LATCH TRAY, LEVER LATCH, and LEVER SEPARATOR to return to their positions.

Once disengaged from the LEVER SEPARATOR, the HOLDER ASSY SEPARATOR is pressed against the ROLL ASSY FEED in the feeder section by the spring pressure of the SPRING SEPARATOR (PL 2.1.23).

When the paper cassette is pulled out halfway, the LATCH TRAY, LEVER LATCH, and LEVER SEPARATOR operates in the same fashion as when the paper cassette is inserted, swinging the HOLDER ASSY SEPARATOR downward to allow the paper cassette to be removed.

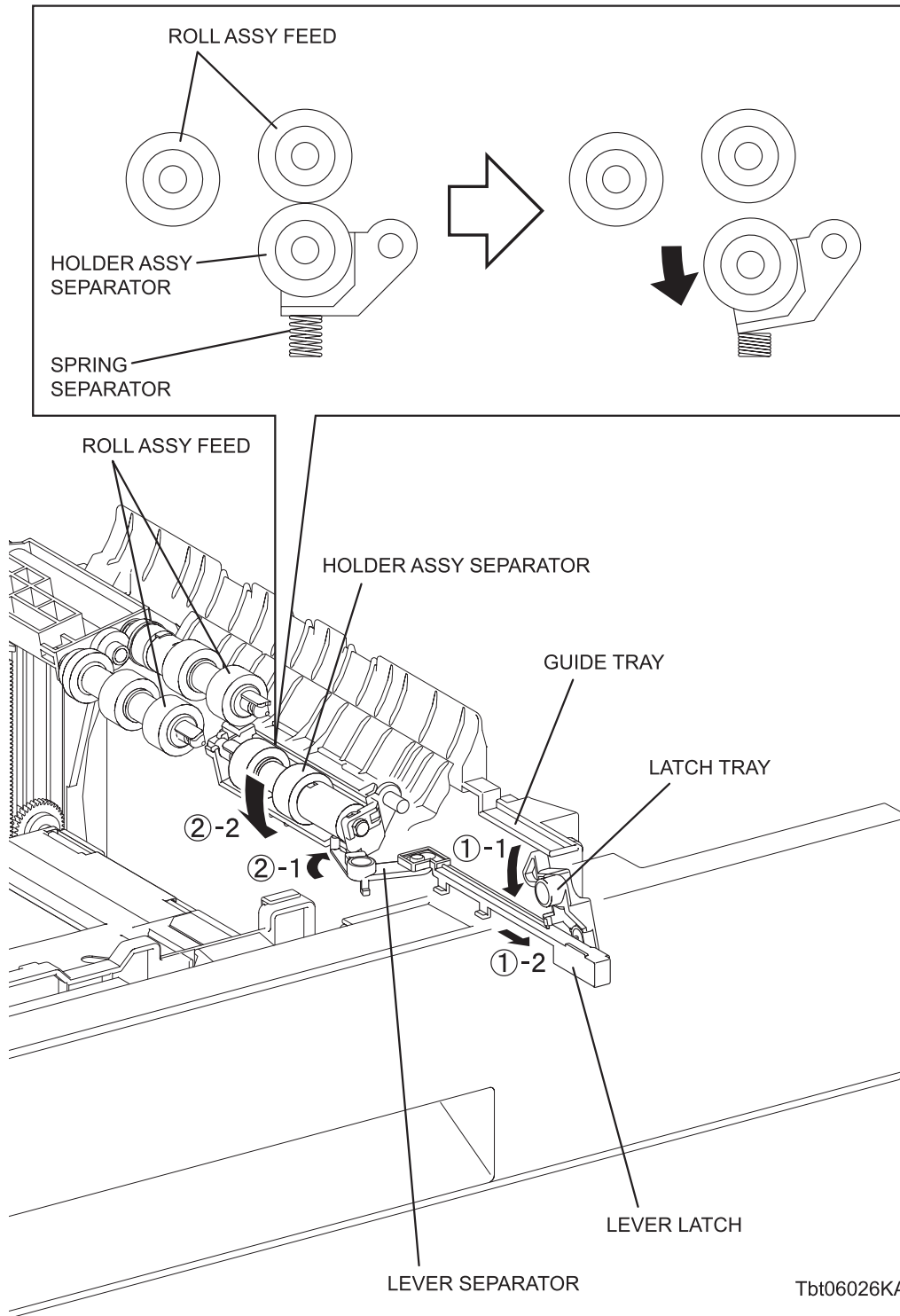

Tbt06026KA

3.2 Paper Feeder

3.2.1 Major Functions

- SWITCH ASSY SIZE (PL 3.1.1)

SWITCH ASSY SIZE detects paper size and the presence/absence of the paper cassette.

Aligning the GUIDE ASSY END (PL 2.1.12) to the end of the print media stack changes the position of the ACTUATOR SIZE (PL 2.1.14) that is coupled to the GUIDE ASSY END, turning ON or OFF the switches on the SWITCH ASSY SIZE.

The print media size is determined by the combination of ON/OFF states of these switches.

(Refer to 5.1 Paper Size Control for the combination of switches.)

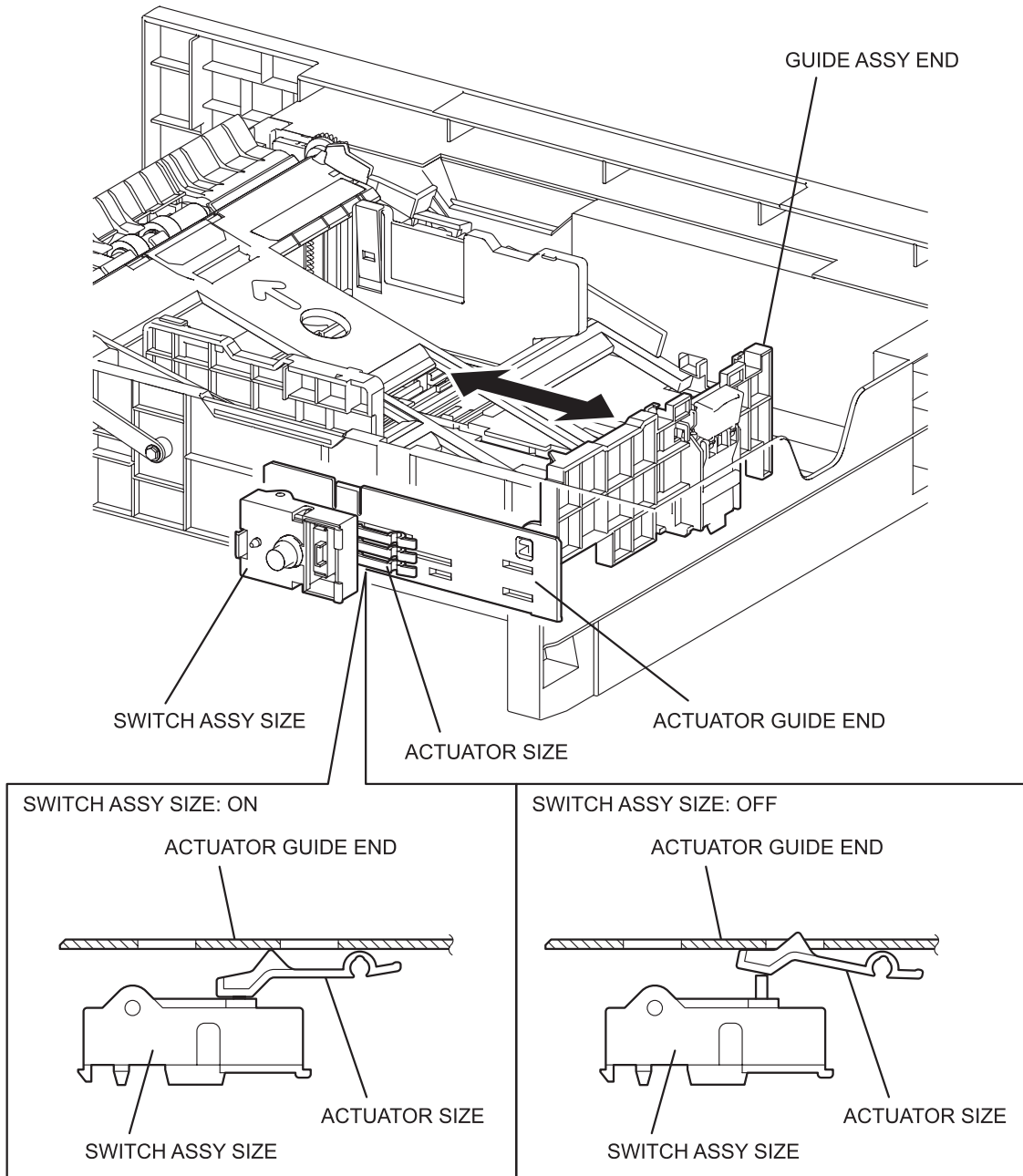

Tbt06027KA

- CST No Paper Sensor (SENSOR PHOTO: PL 3.2.11)

The CST No Paper Sensor detects the presence/absence of print media in the paper tray based on the position of ACTUATOR NO PAPER. (No paper: Sensor beam is blocked)

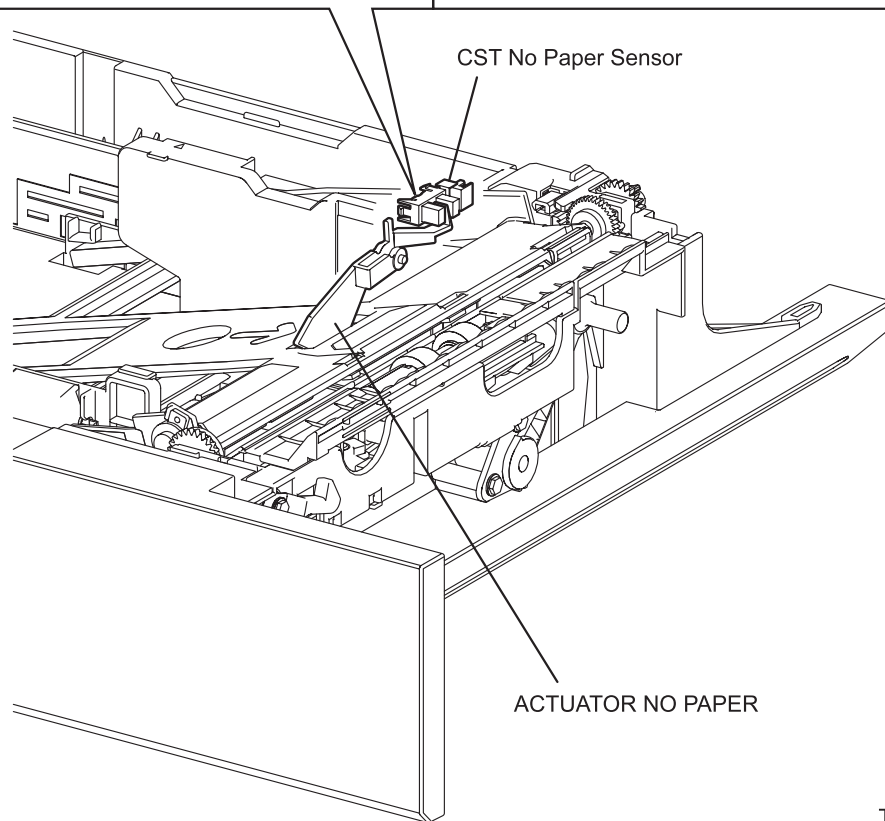
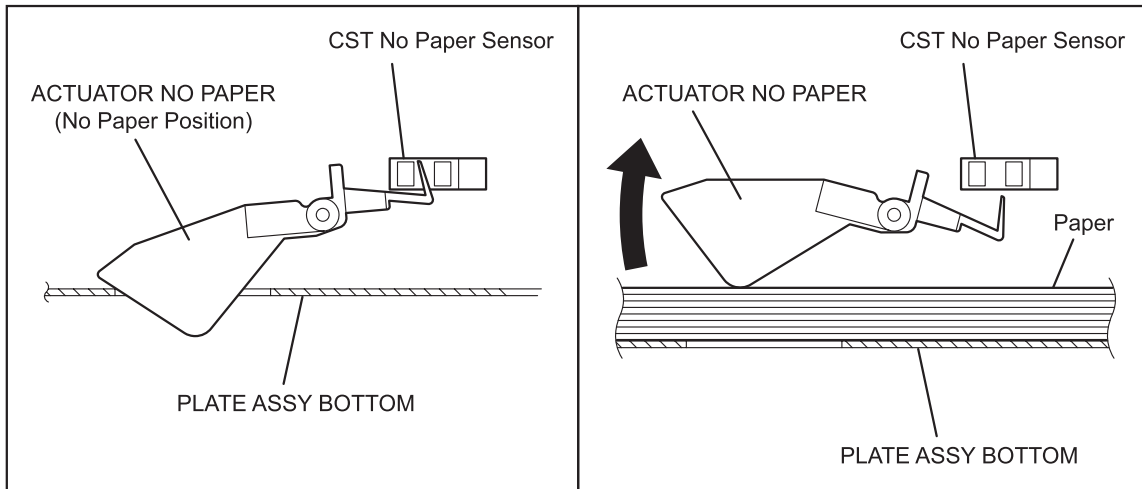

Tbt06028KA

- Low Paper Sensor (SENSOR PHOTO: PL 3.1.4)

The Low Paper Sensor detects the amount of the print media remaining in the paper cassette in three levels (50, 25, and 10%). (No paper: Sensor beam is blocked)

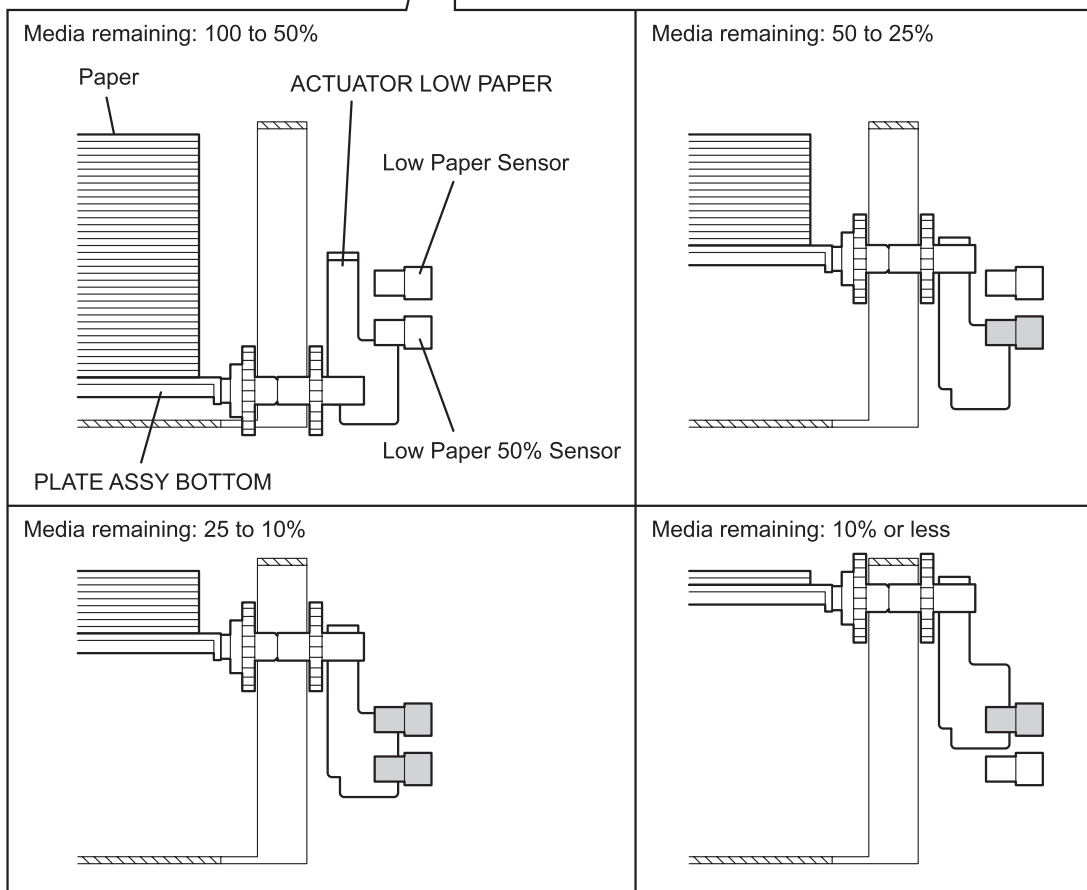
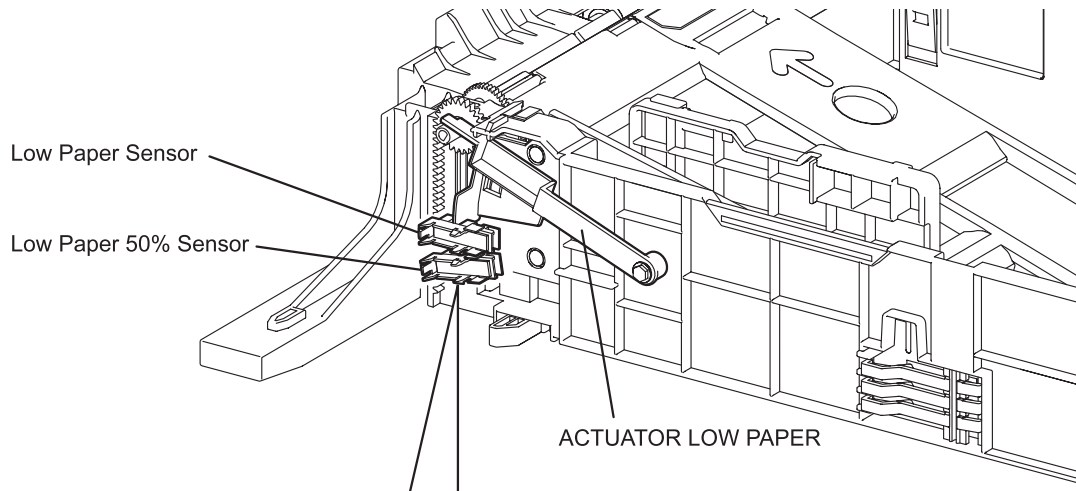

Tbt06029KA

- CLUTCH ASSY FEED (PL 3.2.2)

The CLUTCH ASSY FEED transmits the driving torque from the FEED DRIVE ASSEMBLY to the ROLL ASSY FEED. (Refer to 6.3 TONER DISPENSER (Y, M, C, K))

- ROLL ASSY FEED (PL 3.2.18)

When the CLUTCH ASSY FEED operates, the ROLL ASSY FEED starts rotating to feed the print medium. (Refer to 6.3 TONER DISPENSER (Y, M, C, K))

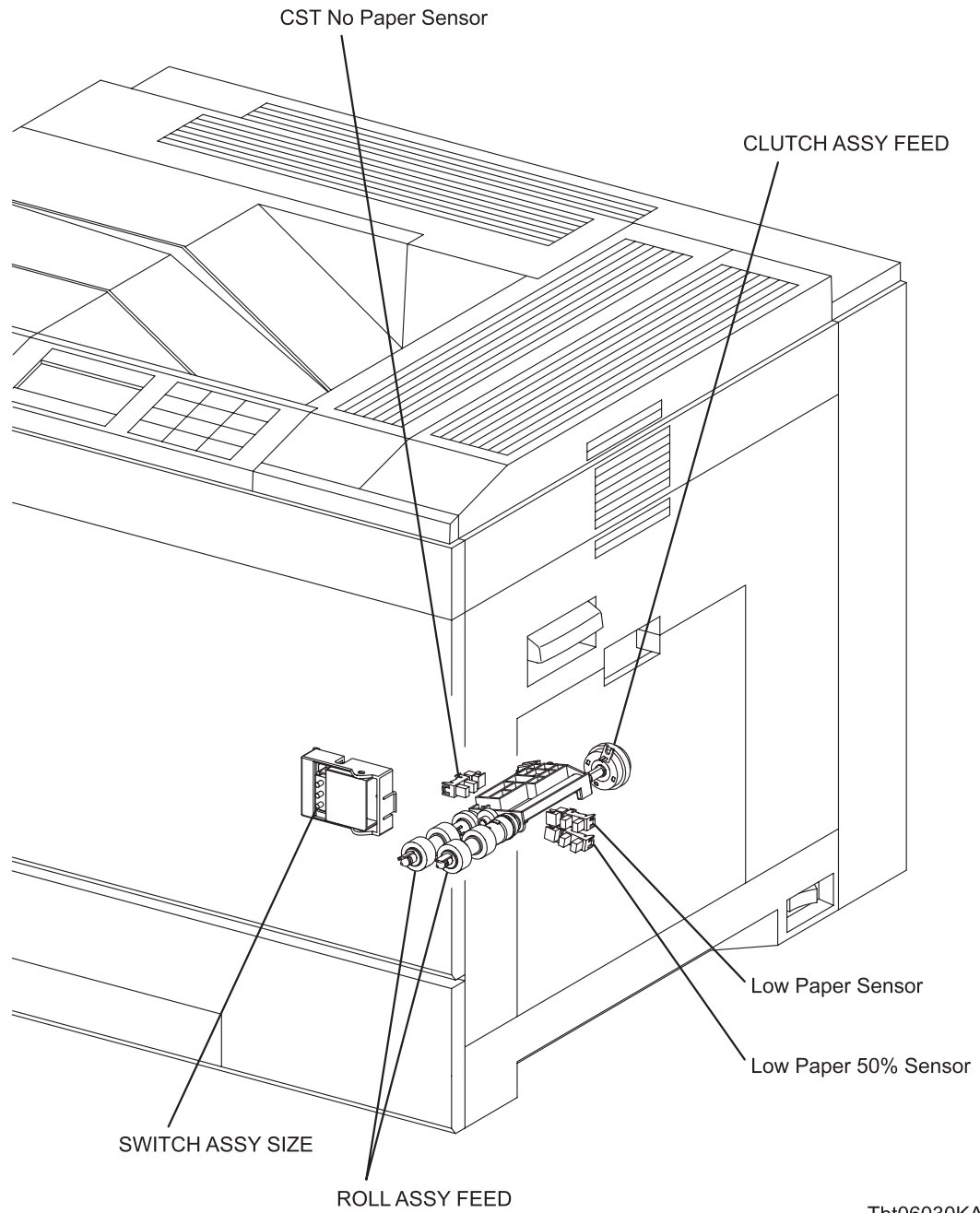

Tbt06030KA

3.3 MSI & Regi Assy

3.3.1 Major Functions

- SOLENOID FEED MSI (PL 4.2.32)
The SOLENOID FEED MSI controls the driving torque from the DRIVE ASSY PH to the ROLL ASSY FEED MSI. (Refer to 6.3 TONER DISPENSER (Y, M, C, K))
- CLUTCH ASSY TAKE AWAY (PL 3.3.12)
The CLUTCH ASSY TAKE AWAY transmits the driving torque from the DRIVE ASSY PH to the ROLL ASSY TAKE AWAY. (Refer to 6.3 TONER DISPENSER (Y, M, C, K))
- ROLL ASSY TAKE AWAY (PL 3.3.11)
The ROLL ASSY TAKE AWAY starts rotating by the drive from the CLUTCH ASSY TAKE AWAY to feed the print medium from the MSI or paper cassette to the registration section. (Refer to 6.3 TONER DISPENSER (Y, M, C, K))
- MSI No Paper Sensor (SENSOR PHOTO: PL 4.2.14)
The MSI No Paper Sensor detects the presence/absence of print media in the MSI tray by the change in the actuator position.

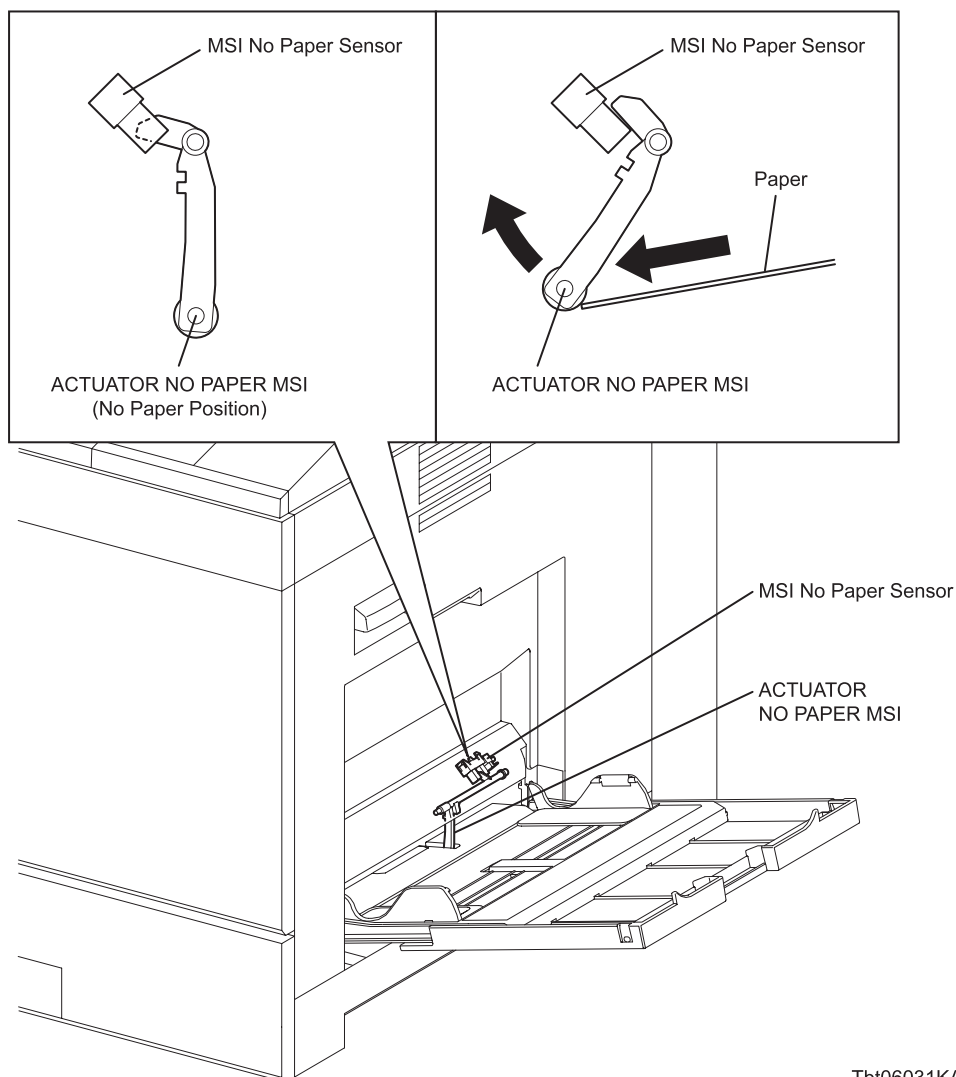

Tbt06031KA

- Regi Sensor (SENSOR PHOTO: PL 3.3.22)

The Regi Sensor detects that the lead edge of the print medium has reached the registration section. (No paper: Sensor beam is blocked)

When the print medium is fed from the MSI, the Regi Sensor measures the sheet length (size). The duration for which the Regi Sensor is ON is converted into the paper length.

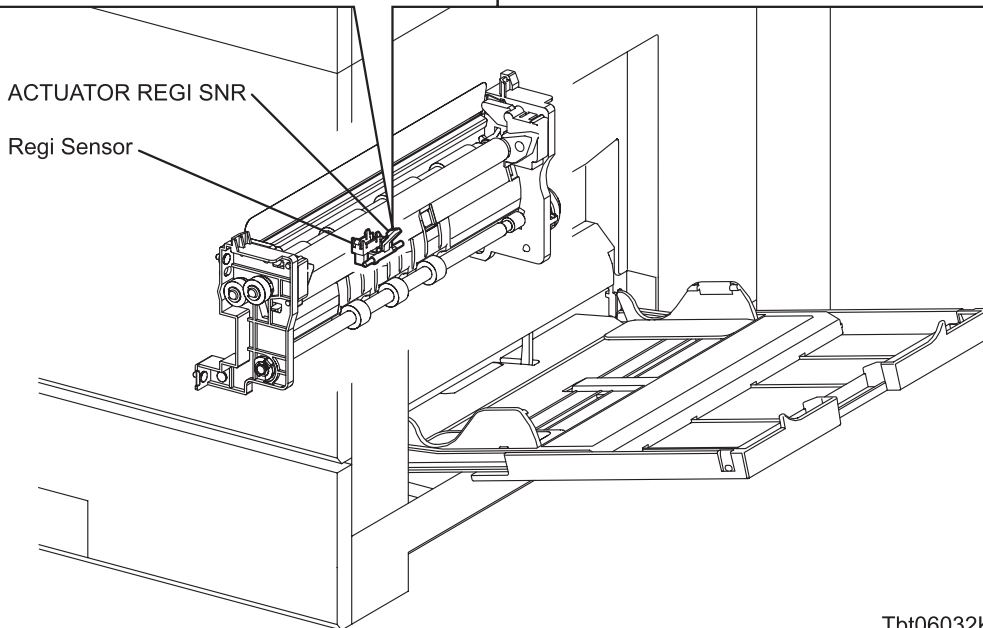
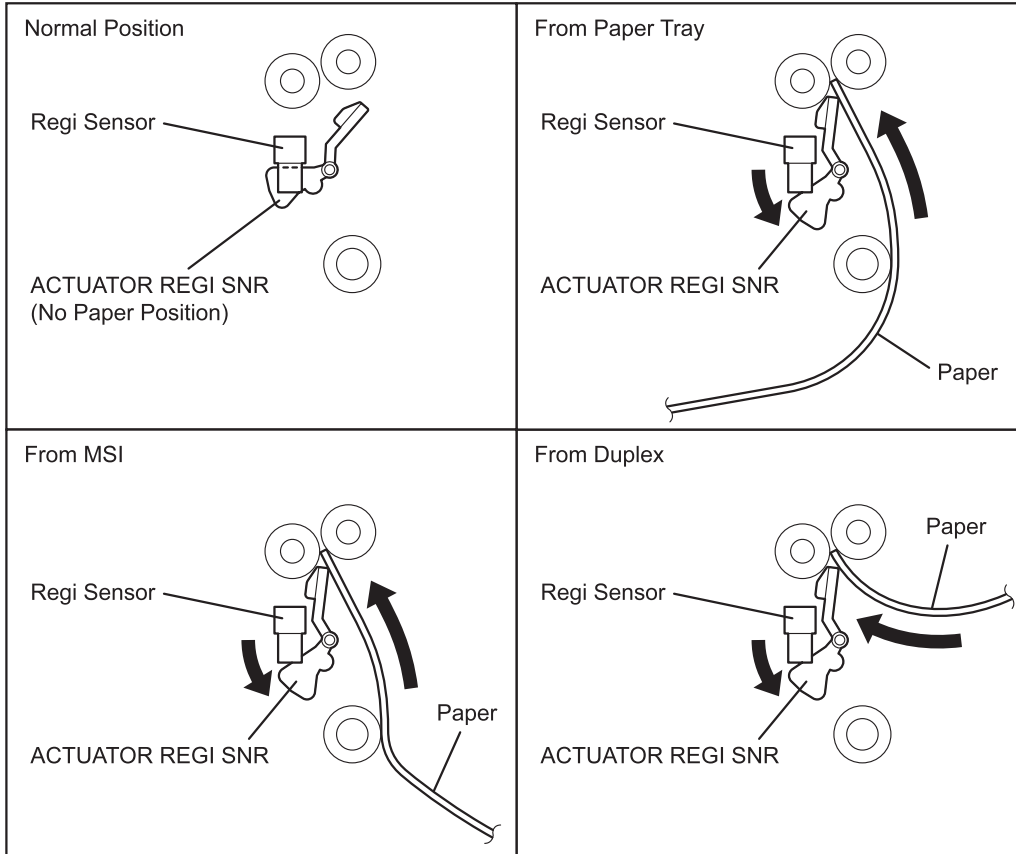

Tbt06032KA

- CLUTCH ASSY REGI (PL 3.3.13)

The CLUTCH ASSY REGI transmits the driving torque from the DRIVE ASSY PH to ROLL REGI RUBBER to feed the print medium to the Fuser section from the paper cassette, MSI, or Duplex section. (Refer to 6.3 TONER DISPENSER (Y, M, C, K))

To place the toner image at an appropriate position on the print medium, the timing of feeding from the Regi Assy is adjusted by the duration for which the CLUTCH ASSY REGI operates.

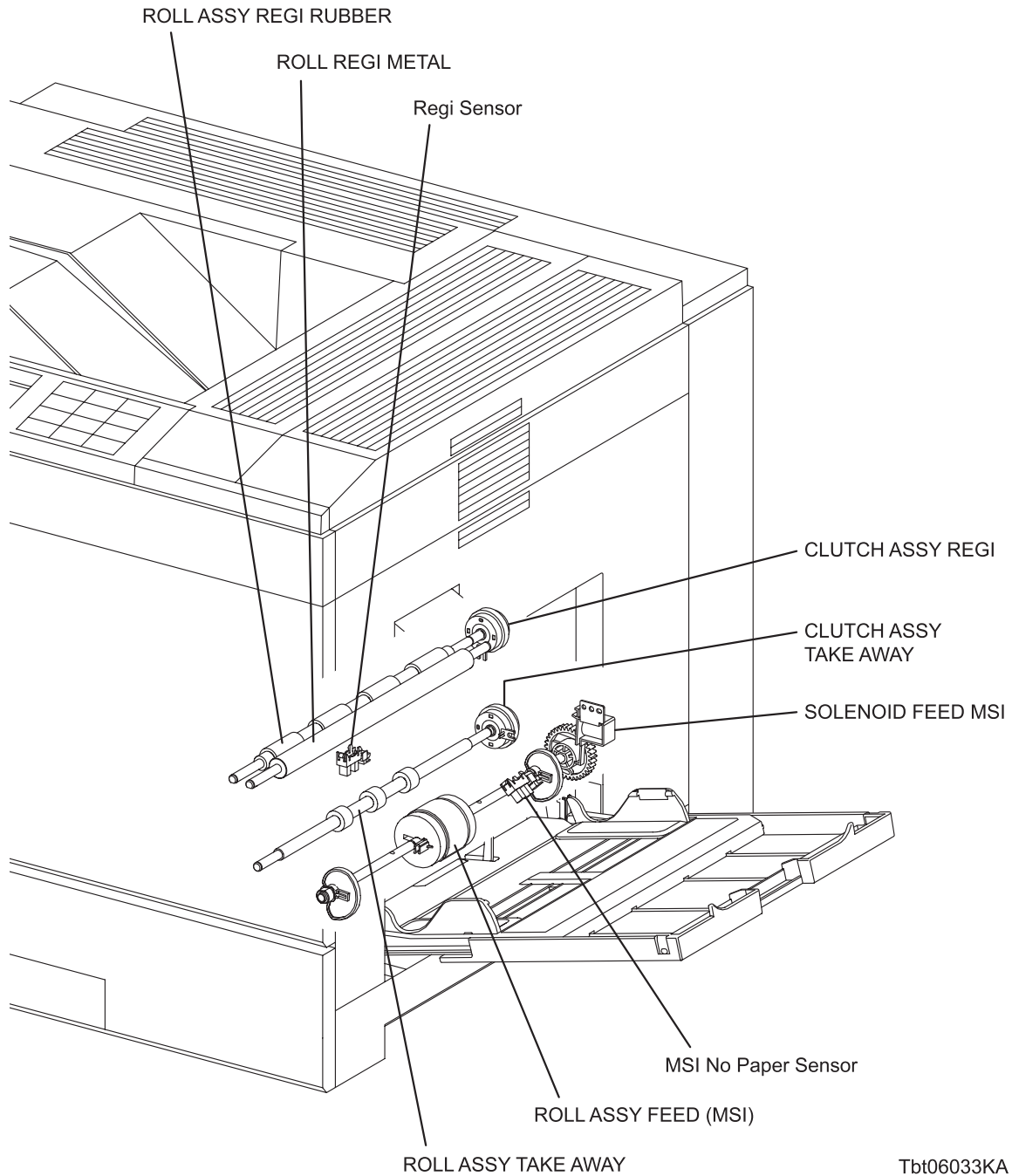

Tbt06033KA

Blank Page

3.4 Process Control (PROCON ASSY)

3.4.1 Major Functions

- Front ADC Sensor (SENSOR ADC: PL 5.3.5)
The Front ADC Sensor detects the color registration errors of Y, M, C, and K by reading the marks placed on the front side of the Belt. The value measured is used for the adjustment of the ROS and the DEVE BIAS.

- Rear ADC Sensor (SENSOR ADC: PL 5.3.5)
The Rear ADC Sensor detects the color registration errors of Y, M, C, and K by reading the marks placed on the rear side of the Belt.
This sensor also measures the density of the toner patches on the Belt before the second transfer, and then converts the density value into a voltage value for toner density control.

- WASTE TONER BOX Full Sensor (SENSOR TNR FULL: PL 5.3.13)
The WASTE TONER BOX Full Sensor detects that the WASTE TONER BOX has become filled to capacity with the waste toner collected.
The transparent window on the upper part of the WASTE TONER BOX blocks the sensor light and detects the toner full status when the WASTE TONER BOX is full. (Toner full: Sensor beam is blocked)

- HUMIDITY Sensor (SENSOR HUM: PL5.3.15)
The HUMIDITY Sensor measures the temperature and humidity within the printer and converts them into voltage values.

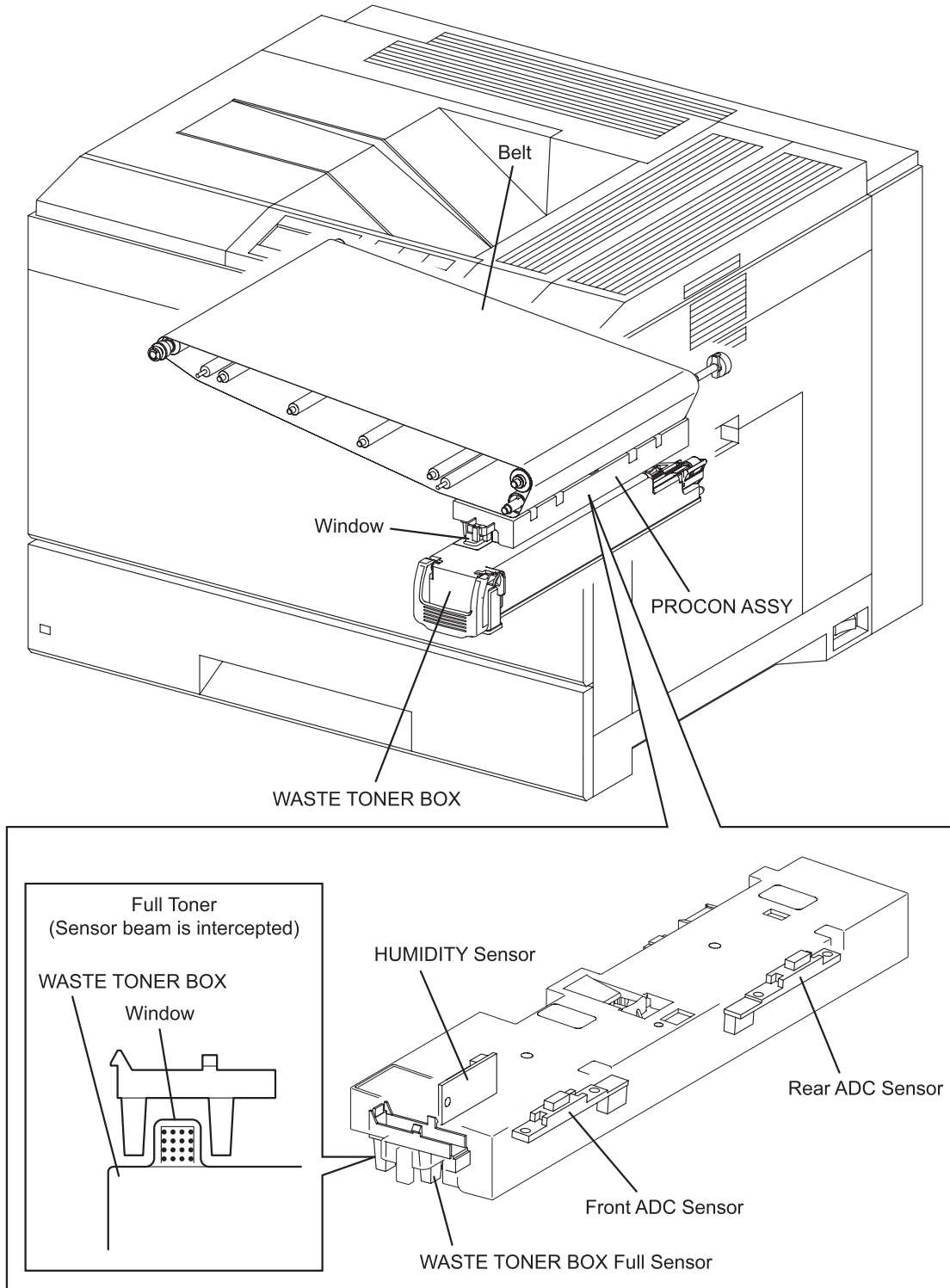

Tbt06034KA

3.5 ROS ASSY

3.5.1 Major Functions

- ROS ASSY

The ROS ASSY is an exposure unit that generates laser beams to form electrostatic latent image on the drum surface.

The ROS ASSY mainly consists of the following parts:

- LD PWB
- Scanner Assy
- SOS PWB
- Lens
- Mirror
- Window

* LD PWB

The LD PWB consists of four LDs (laser diodes) corresponding to Y, M, C, and K.

Each LD converts the electric signals of incoming image data into laser wave or pulse. In order to stabilize the laser light quantity during the formation of an electrostatic latent image, the PWBA LD always monitors the laser light quantity to adjust it to the appropriate level. This is called "APC (Auto Power Control)".

* Scanner Assy

The Scanner Assy consists of the Scanner Motor that rotates at a constant speed and the Polygon Mirror that is mounted on the motor shaft.

The laser light output from the LD is irradiated onto the Polygon Mirror via the Mirror.

The Polygon Mirror, provided with the twelve reflecting mirror faces, changes the reflection angle of the laser light as it rotates driven by the Scanner Motor, allowing the laser light to scan the drum along its axial direction. Scanning is performed using one reflecting mirror face for each line.

* Mirror

* Window

* Lens

The laser light reflected from the Polygon Mirror reaches the drum surface via the Lens, Mirror, and Window. The Lens corrects aberration, the Mirror secures an optical path, and the Window prevents foreign substance from entering the ROS.

* SOS PWB

The SOS (Start Of Scan) sensor on the SOS PWB converts an incoming laser beam, upon detection, to an electric signal as the reference signal for starting scanning and transmits this signal to the PWBA MCU.

The SOS sensor signals are used to synchronize the starting point of the laser-beam scanning with the starting point of the image writing.

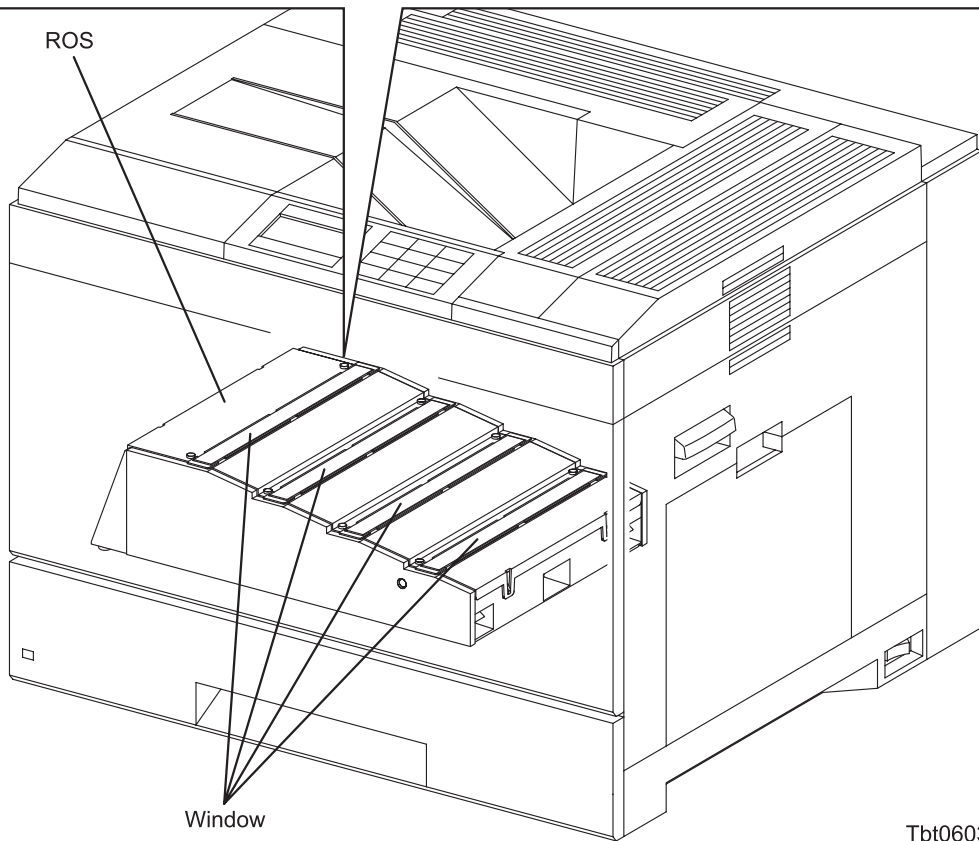
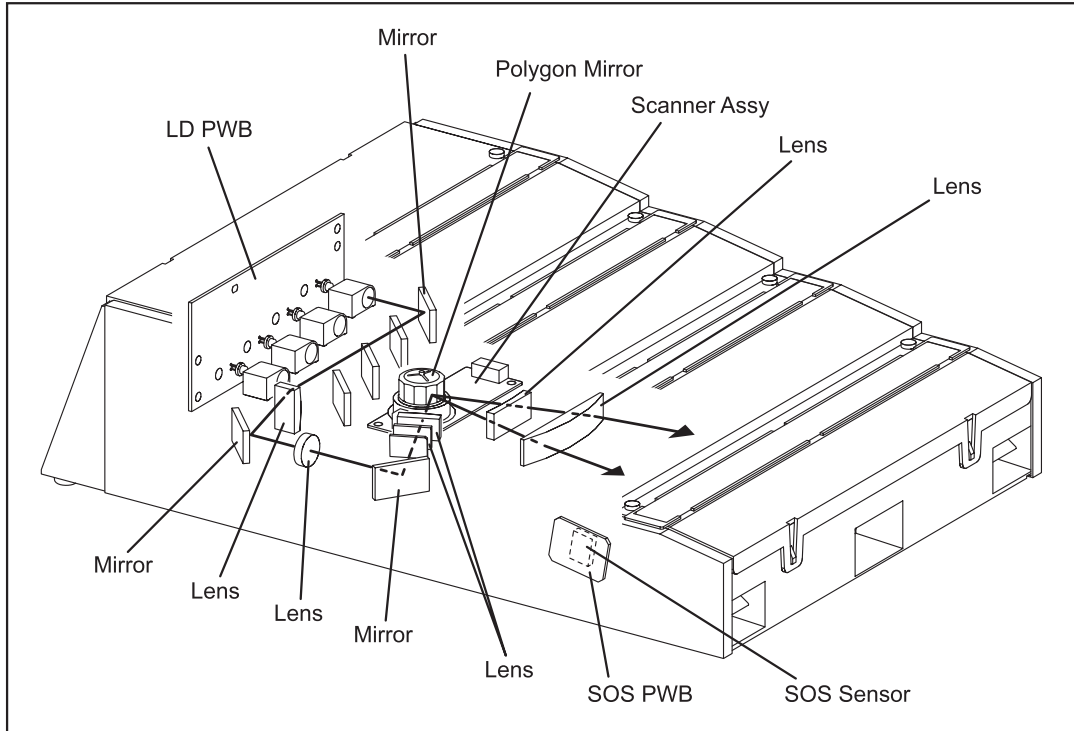

Tbt06035KA

3.6 Dispenser

3.6.1 Major Functions

- TONER CARTRIDGE Y/M/C/K (PL 6.1.1-4)
The TONER CARTRIDGES contain a mixture of toner and a small amount of carrier. Each cartridge is provided with a CONNECTOR ASSY CRUM (Toner CRUM) that stores printer-specific information.
- MOTOR ASSY DISPENSER Y/M/C/K (PL 6.1.9)
The MOTOR ASSY DISPENSERS are provided, one for each of Yellow, Magenta, Cyan, and Black, to feed toner from the TONER CARTRIDGES to the XERO DEVE CRU ASSY by driving the Agitators in the TONER CARTRIDGES and Augers in the toner feeding route.

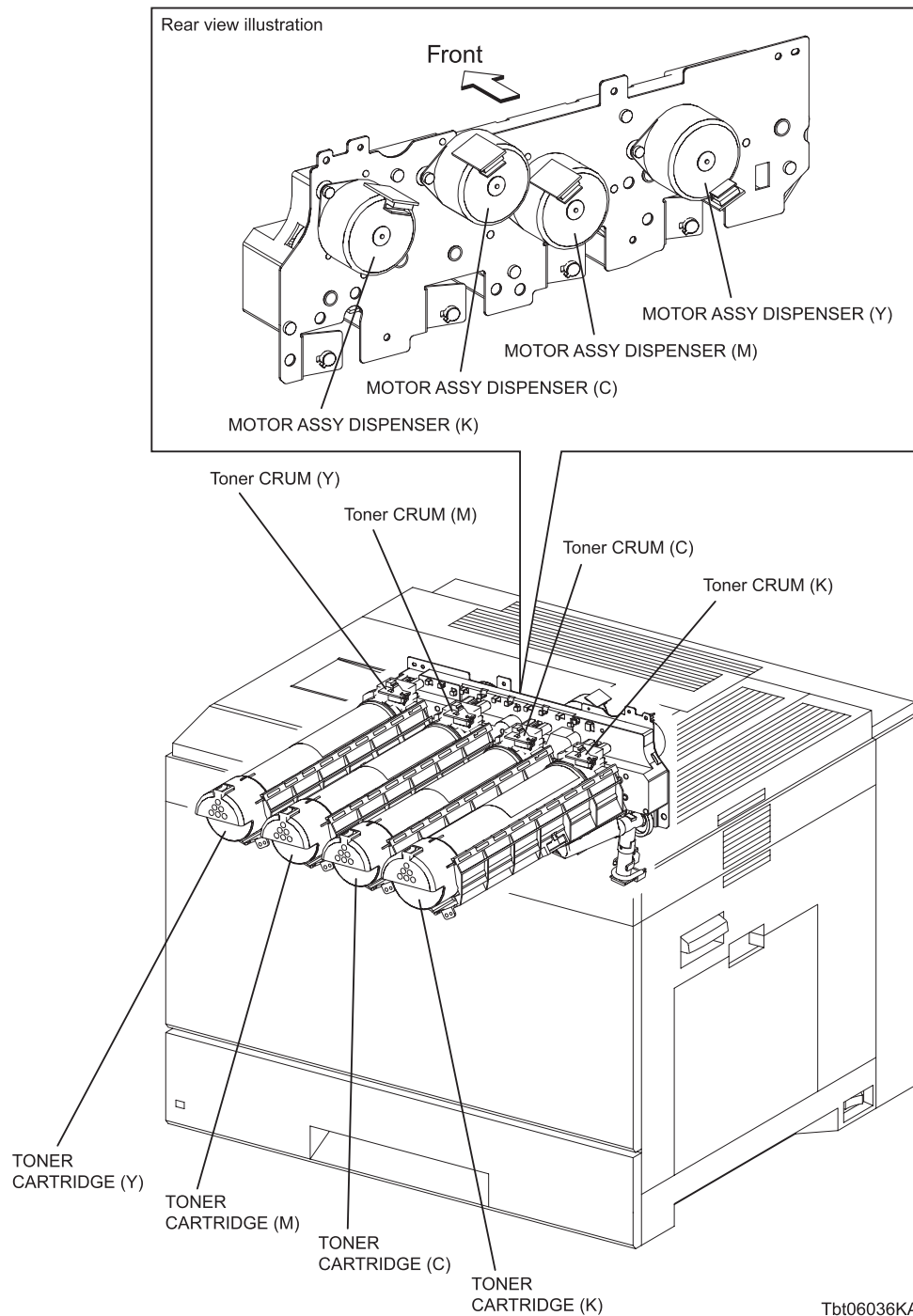

Tbt06036KA

Blank Page

3.7 XERO DEVE CRU ASSY

3.7.1 Major Functions

- DRUM

The DRUMs are the units provided one for each of Yellow, Magenta, Cyan, and Black for creating electrostatic latent images and toner images.

- BCR

Charges the DRUM electrically.

- Cleaning Roll

Removes the toner remaining on the BCR.

- Cleaning Blade

Removes the toner remaining on the DRUM after the toner image is transferred to the print medium.

- Erase Lamp (LAMP ASSY ERASE: PL 5.1.2)

The Erase Lamp is provided one for each of Yellow, Magenta, Cyan, and Black for removing electrical charge from the DRUM surface after the toner image is transferred onto the Transfer Belt (BELT ASSY IBT: PL 5.1.1).

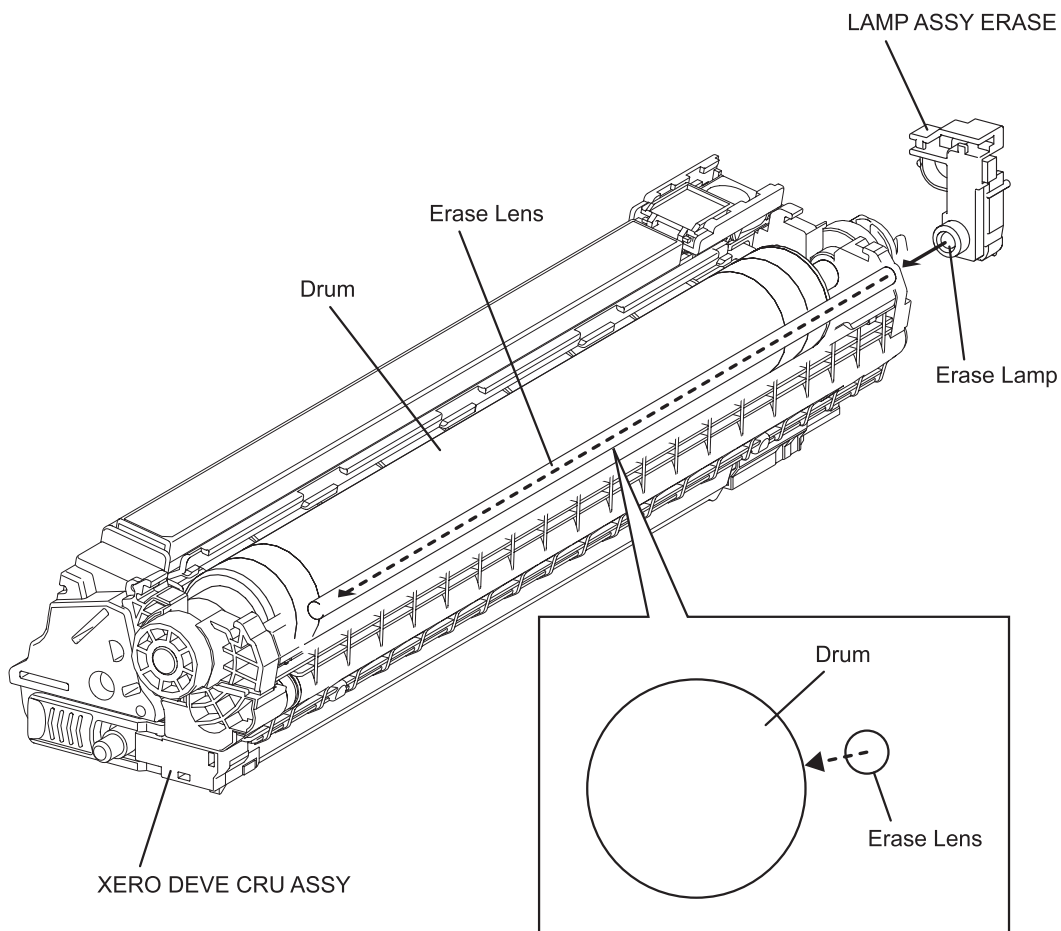

Tbt06037KA

- XERO CRUM (CONNECTOR ASSY CRUM: PL 5.1.2)

The XERO CRUM stores, reads, and writes printer-specific information regarding the CRU (Customer-Replaceable Unit).

- Magnet Roll

The Magnet Roll contacts the DRUM to form the toner image on the DRUM surface.

- Auger
The Auger agitates the toner particles.
- Trimmer
The Trimmer uniformly levels the toner/carrier particles deposited on the surface of the Magnet Roll.

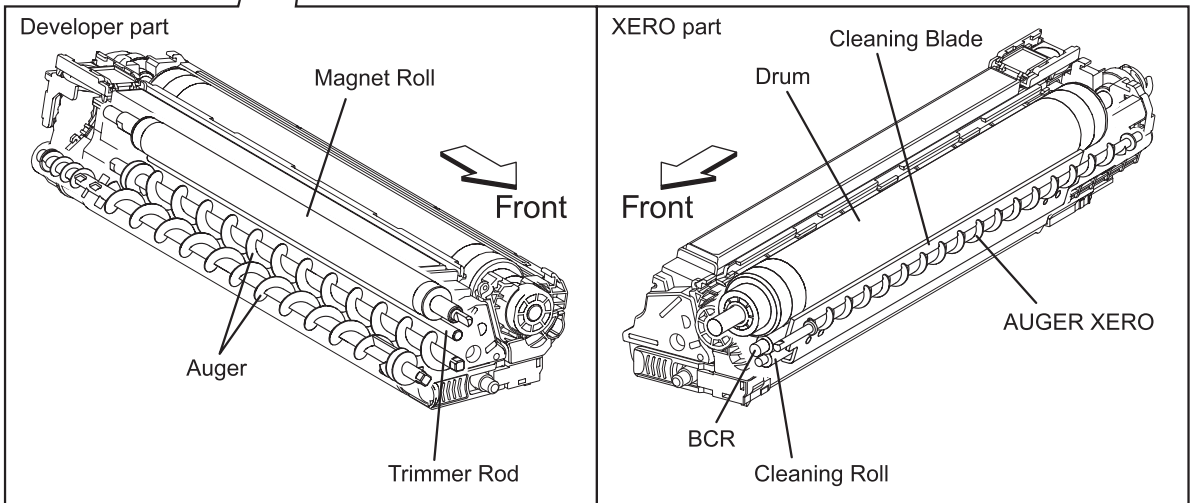
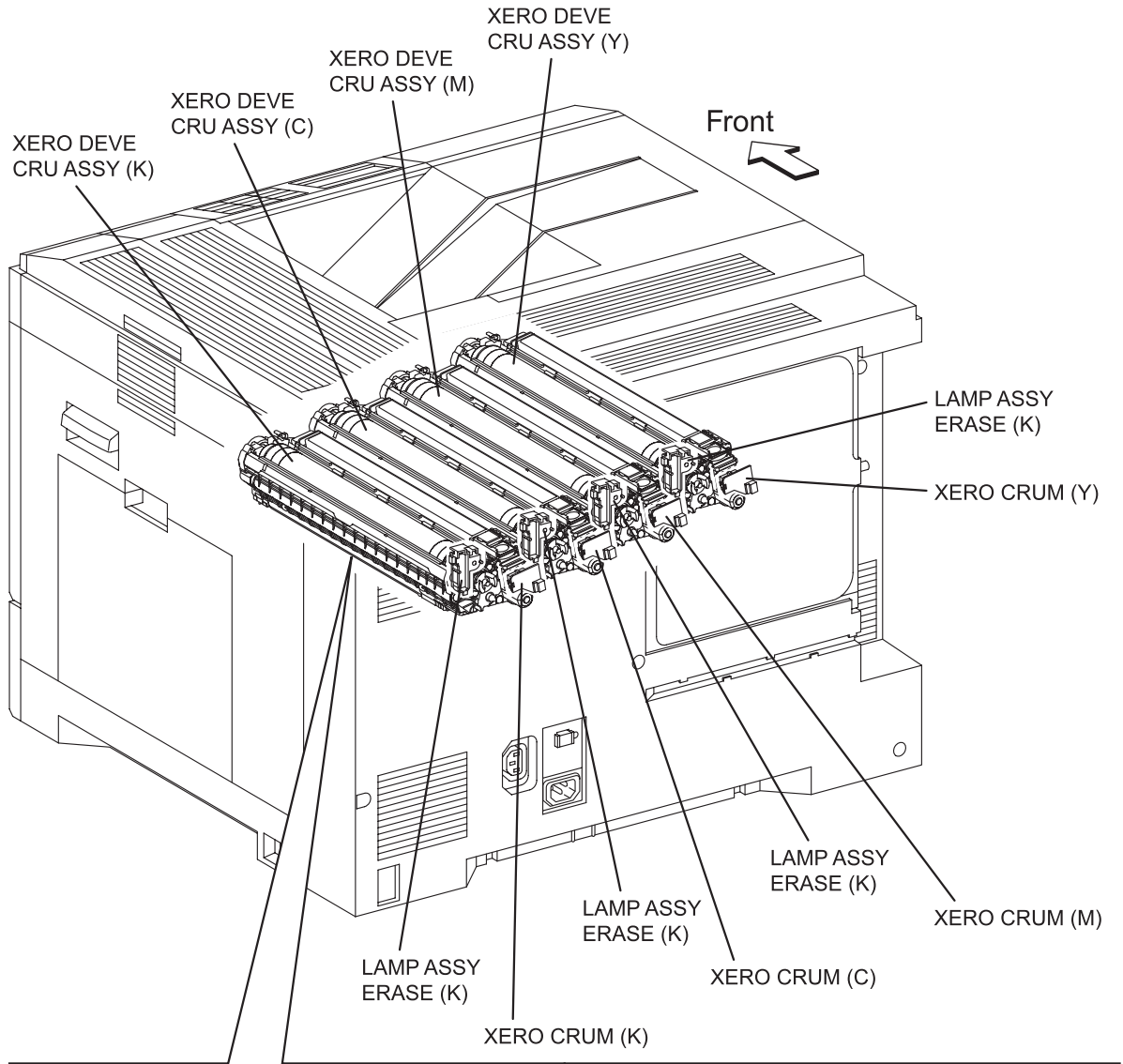

Tbt06038KA

3.8 Transfer Belt & Fuser

3.8.1 Major Functions

- BELT ASSY IBT (PL 5.1.2)
 - 1st BTR Roll (Y/M/C/K)

Attracts the toner image on the drum to the IBT Belt by positively charging the IBT Belt from the backside.
 - IBT Belt

Receives the four color-separated toner images from each drum in registration with one another.
 - Backup Roll

Helps the toner particles migrate onto the IBT Belt by retaining the Belt at a position where it nearly contacts the print media during the Second Transfer process.
 - Cleaning Blade

Scrapes off the excess toner remaining on the IBT Belt.

- BELT CRUM (CONNECTOR ASSY CRUM: PL 5.1.4)

The CONNECTOR ASSY CRUM stores, reads, and writes printer-specific data regarding the CRU (Customer-Replaceable Unit).

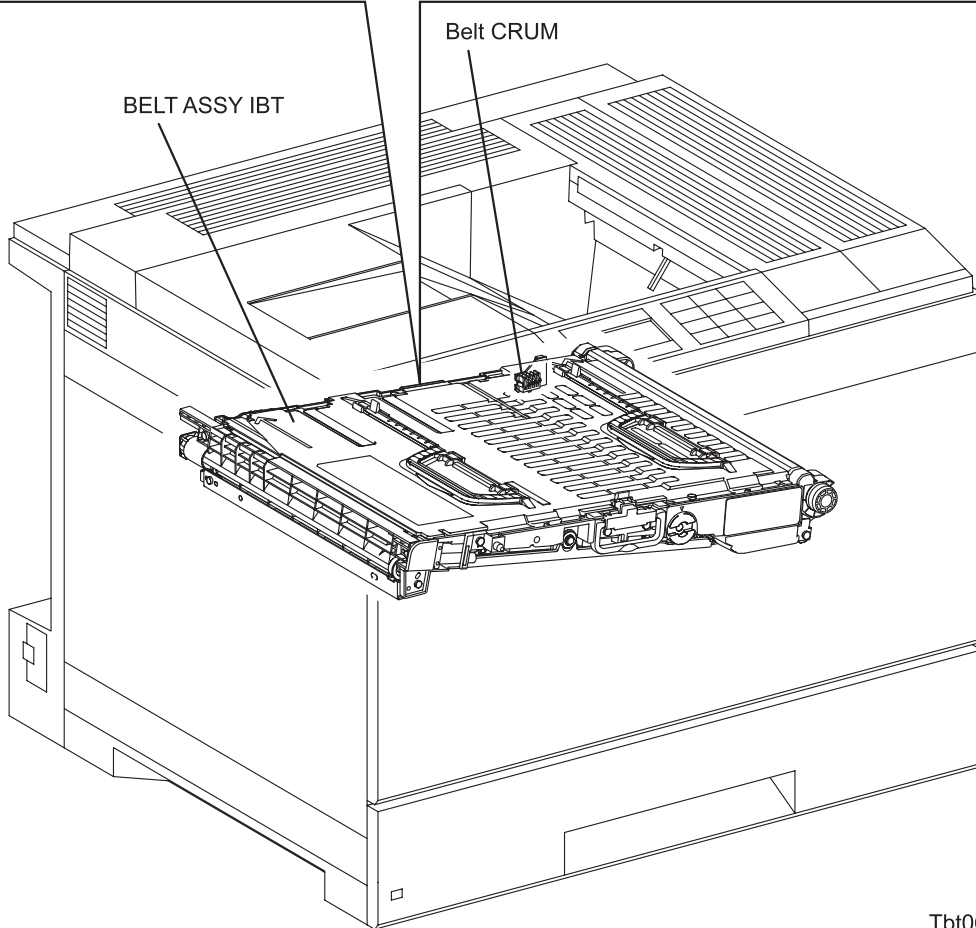
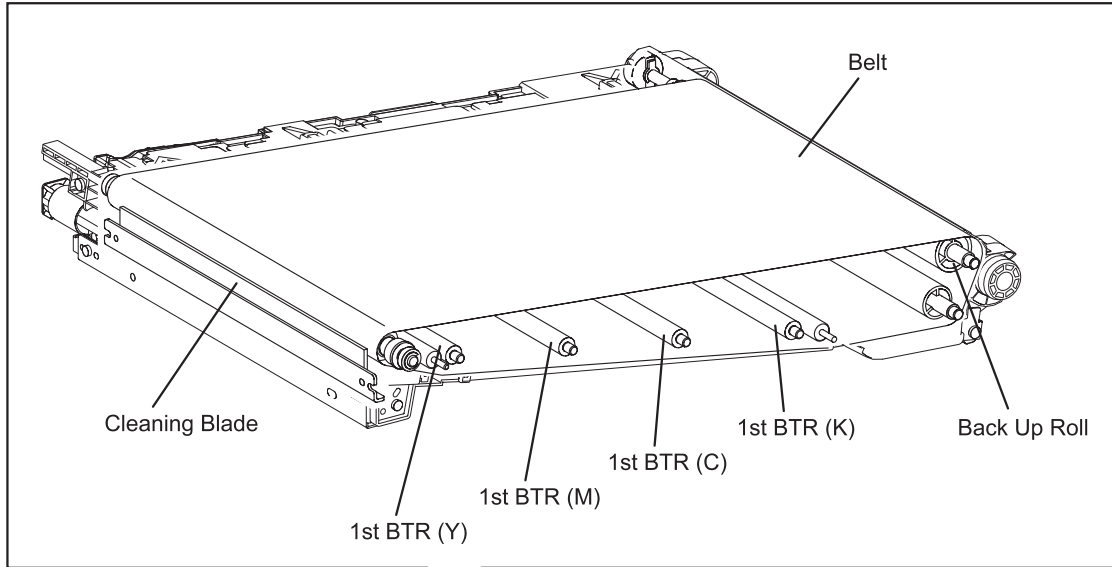

Tbt06039KA

3.8.2 Operation of Transfer Belt (BELT ASSY IBT) at Removal

Since the Transfer Belt is positioned close to the drum, pulling out the Belt to remove a jam or replace the Transfer Belt causes the Belt to contact the drum, which may damage both parts, degrading the image quality. To avoid this problem, the Belt moves away far enough from the drum. This operation is called "Retraction".

Rotating the open/close handle of the FRAME ASSY 2ND (PL 8.1.9) to the close direction rotates the Cam Retract of the Transfer Belt via the coupling.

The rotation of the Cam Retract allows the left and right Roll idles and the four 1st BTRs to rise via the Link Retract and Lever Link YMC, moving the Belt away from the drum to allow enough clearance for removal.

[Refer to 3.12.2 Full Color Mode and B/W Mode](#) for the contact/retract operation of the 1st BTR at printing.

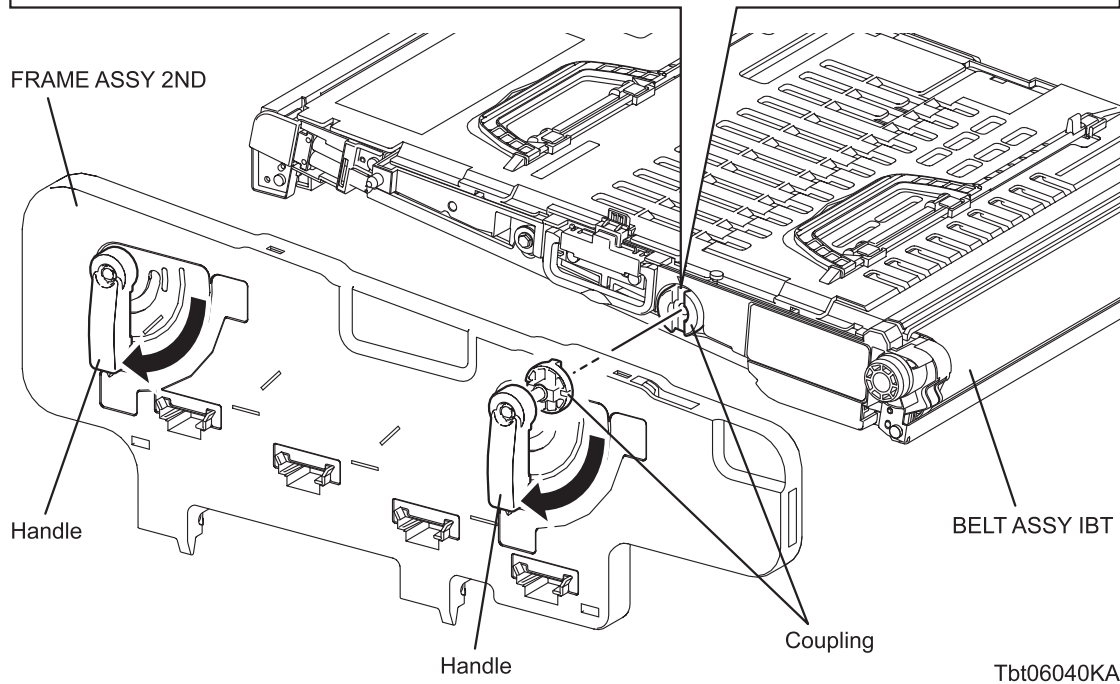
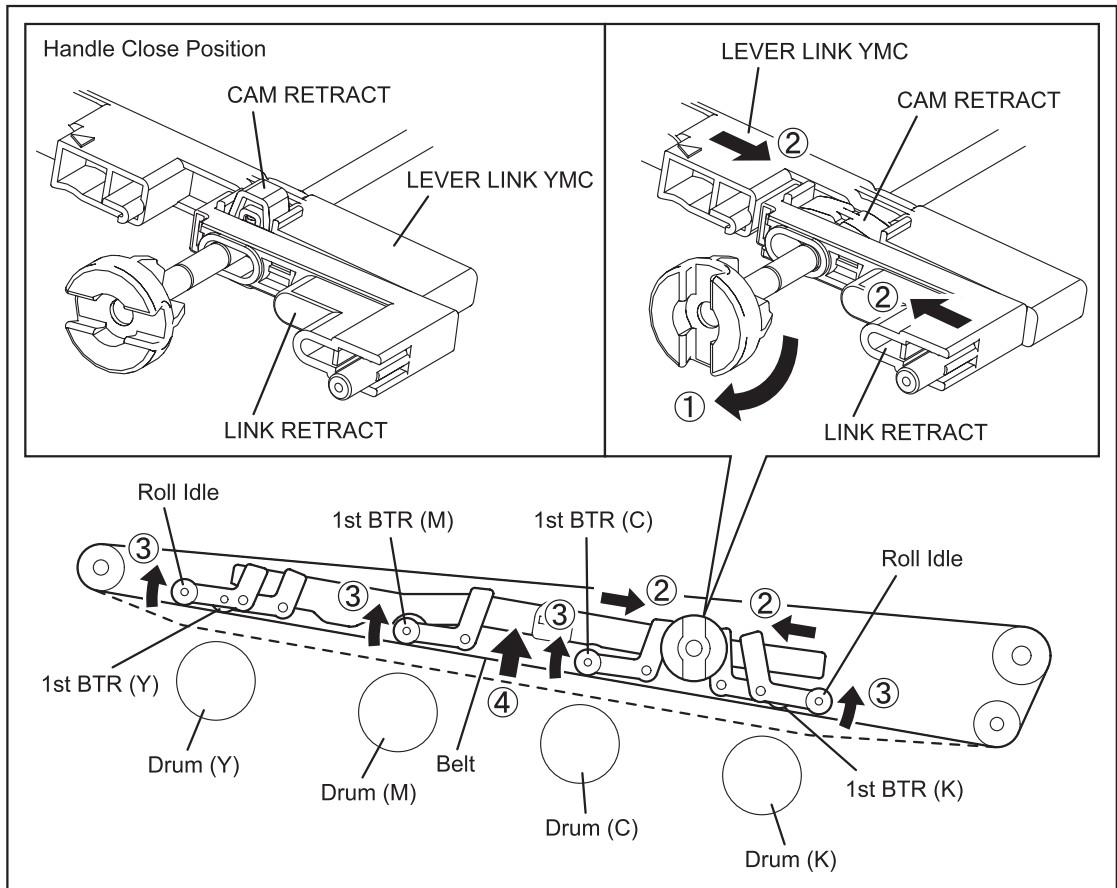

3.9 FUSER

3.9.1 Major Functions

The FUSER fixes the toner image onto the sheet by heat and pressure and guides the sheet into and out of the fixing position.

- Heat Roll
A metal roll that transfers heat to the sheet to fuse the toner particles onto the sheet surface.
- Pressure Belt
A combination of a belt and a pressurizing system for pressing the sheet against the Heat Roll.
- Main Heater Lamp
A heating-coil-enclosed lamp located in the Heat Roll to heat its entire length.
- Sub Heater Lamp
A heating-coil-enclosed lamp located in the Heat Roll to heat its left and right sections.
- Center Temp. Sensor (non-contact type)
A thermistor (temperature-responsive resistance) positioned close to the Heat Roll in a non-contact manner to detect its surface temperature and to control the switching on/off of the Heater Lamp.
- Rear Temp. Sensor (contact type)
A thermistor (temperature-responsive resistance) positioned in contact with the Heat Roll to detect its surface temperature and to prevent the Heater Lamp from overheating.
- Thermostat
A component connected in series with the power supply for the Heater Lamp. Prevents the overheating of the Heat Roll by releasing the contacts when the contact section has reached a certain temperature due to a failure of overheating prevention by Temp. Sensors (thermistors).
- Fuser Exit Sensor
Detects whether the fused print has passed through the FUSER section based on the change of the actuator position. (Sheet passed: Sensor beam received)
- Sheet/Envelope Switching Lever
Changes the nipping pressure between the Heat Roll and Belt Assy depending on the print media type (sheet or envelope) to prevent envelopes from being wrinkled. ([Refer to 3.9.2 Sheet/Envelope Switching Lever](#))

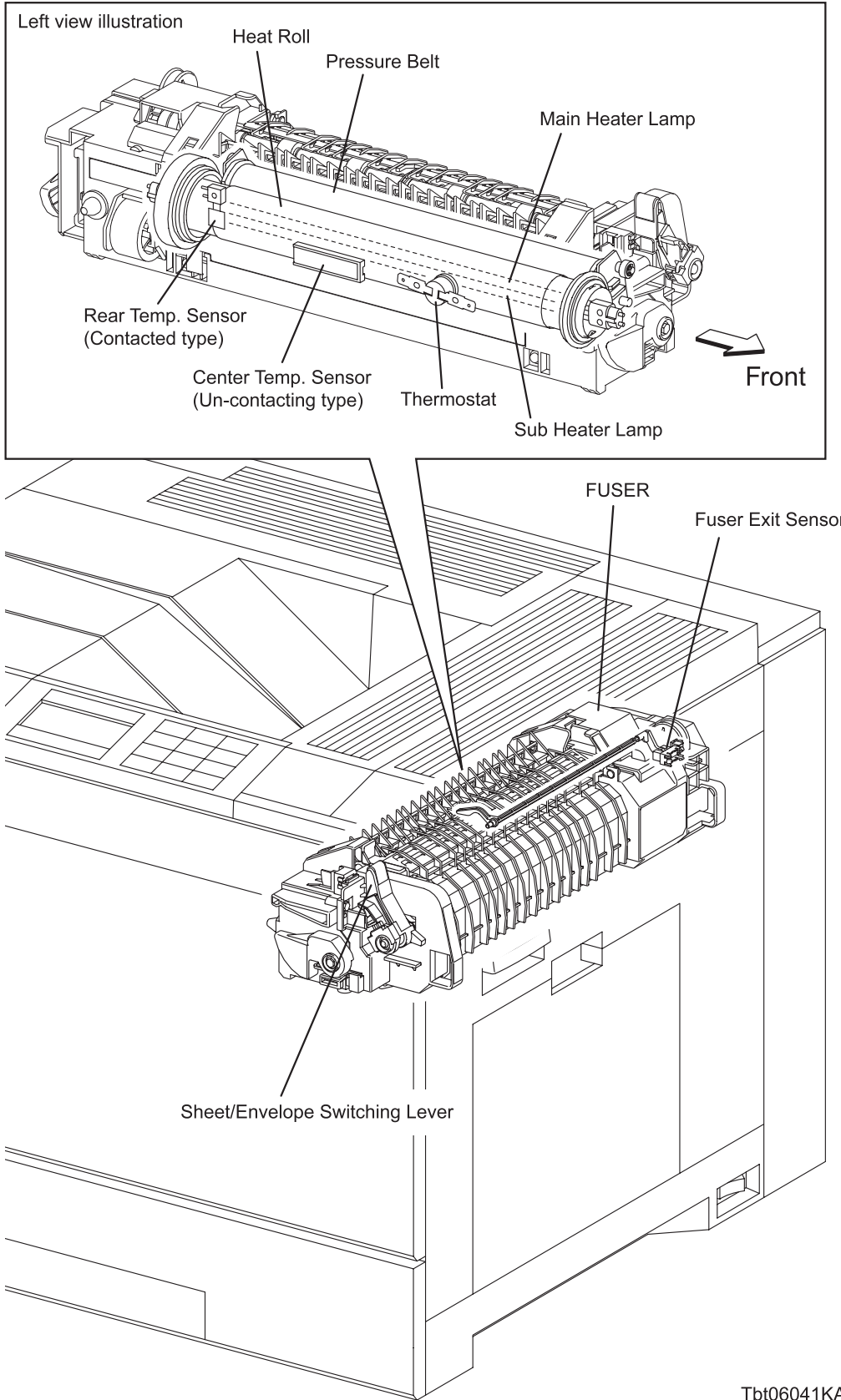

Tbt06041KA

3.9.2 Sheet/Envelope Switching Lever

The Sheet/Envelope Switching Lever can be switched to the “Sheet Mode” or “Envelope Mode” position depending on the print media to be used.

The “Envelope Mode” reduces the nipping pressure to prevent wrinkles or slacks on envelopes due to heat and pressure during fusing.

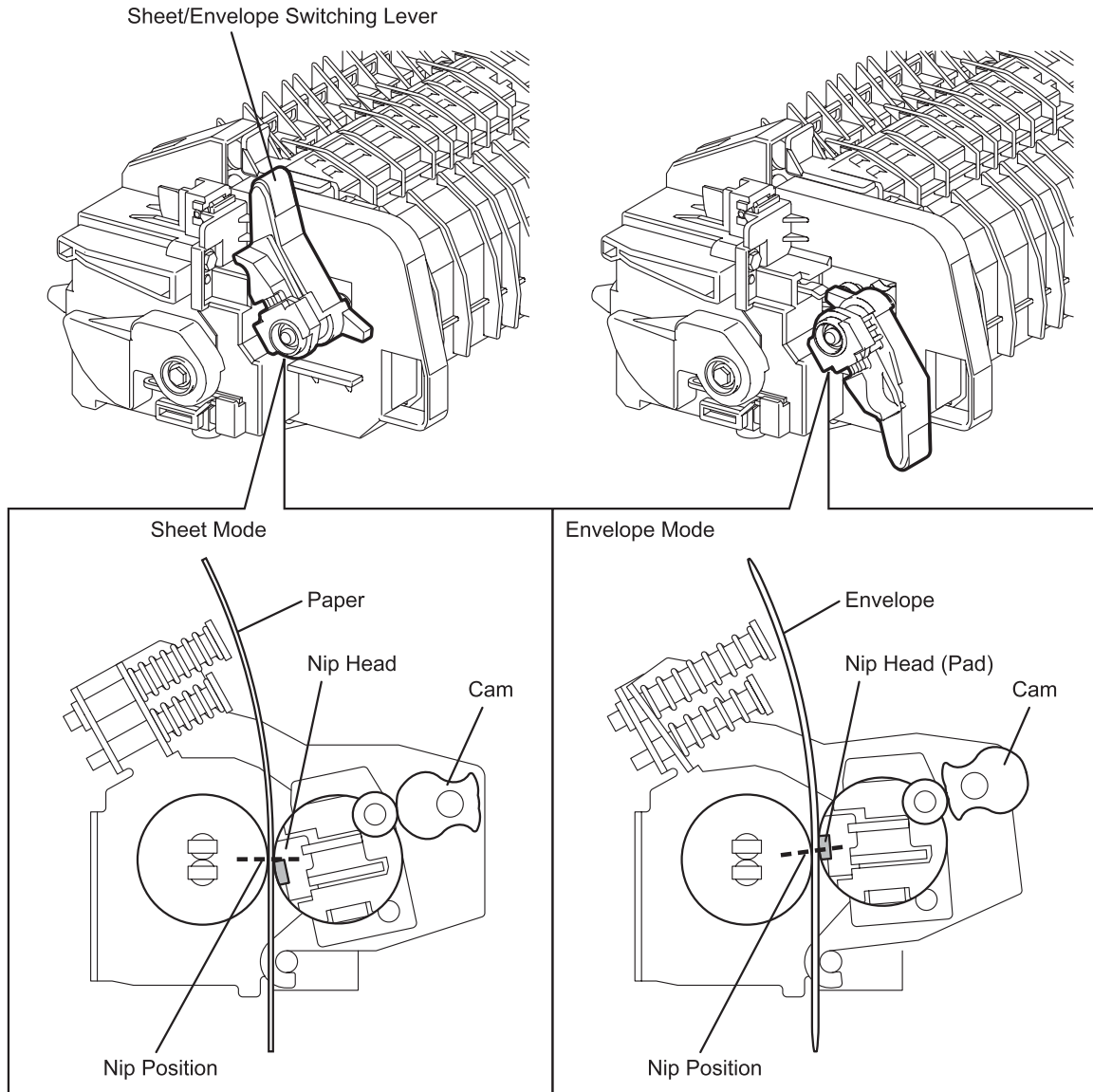

Tbt06042KB

3.10 Exit Section

3.10.1 Major Functions

- SOLENOID ASSY INVERT (PL 7.3.3)
Lowers the CHUTE PATH CHANGE EXIT (PL 7.2.9) when turned on, and raises it when turned off, to switch the paper path when executing 2-sided printing.

- ENVELOPE MODE DETECTION SENSOR (SENSOR PHOTO: PL 7.2.10)
Detects that the Sheet/Envelop Switching Lever is positioned to the "Envelope Mode". (Envelope Mode: Sensor beam blocked)

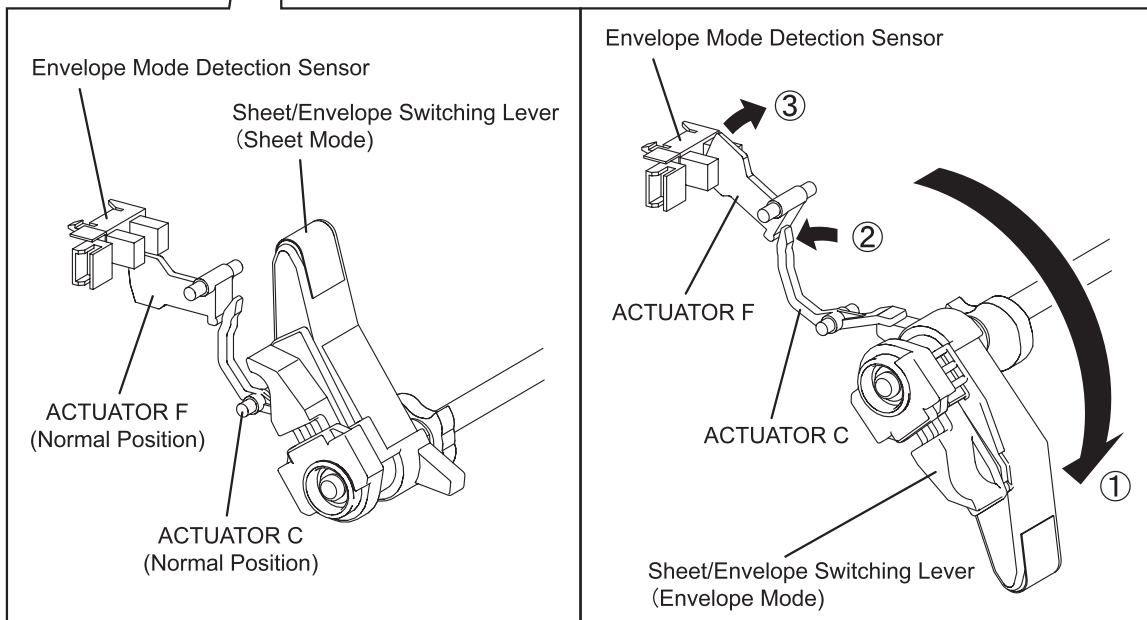
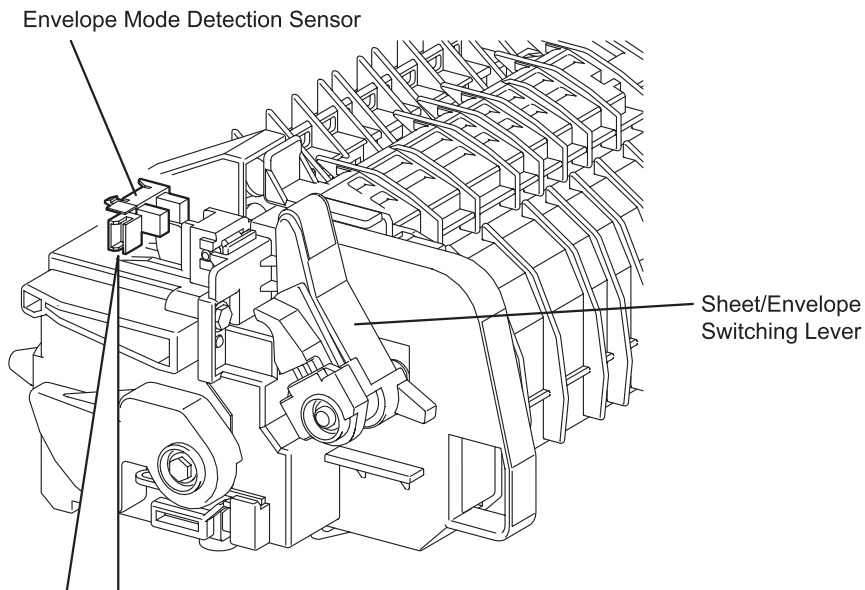

Tbt06043KA

- FULL STACK SENSOR (SENSOR PHOTO: PL 7.2.10)

Detects that the output tray has reached its capacity. (Tray full: Sensor beam blocked)

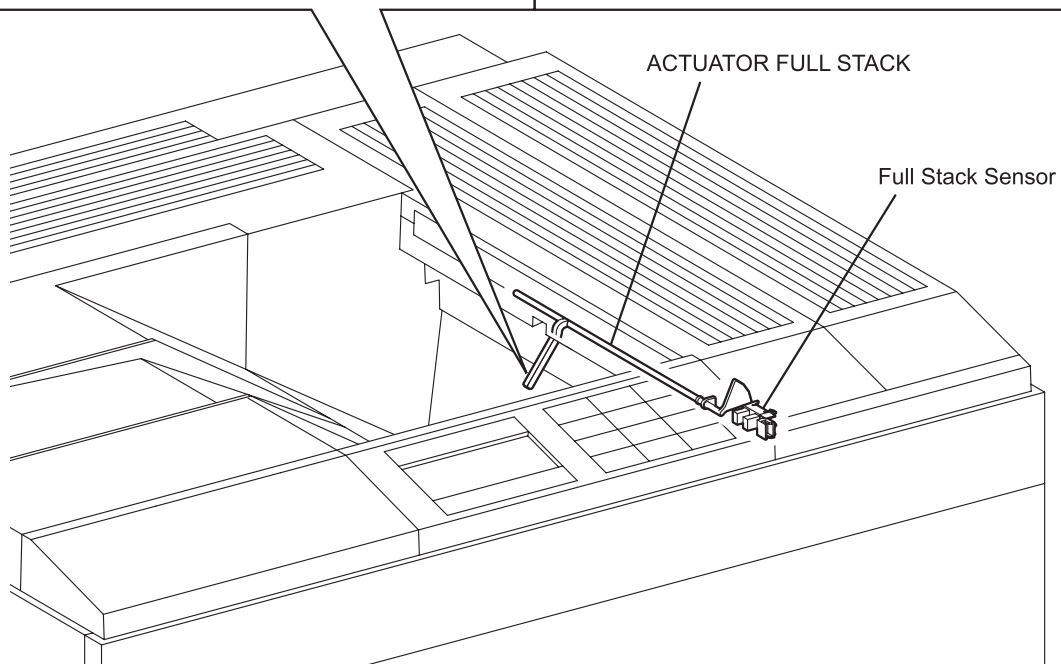
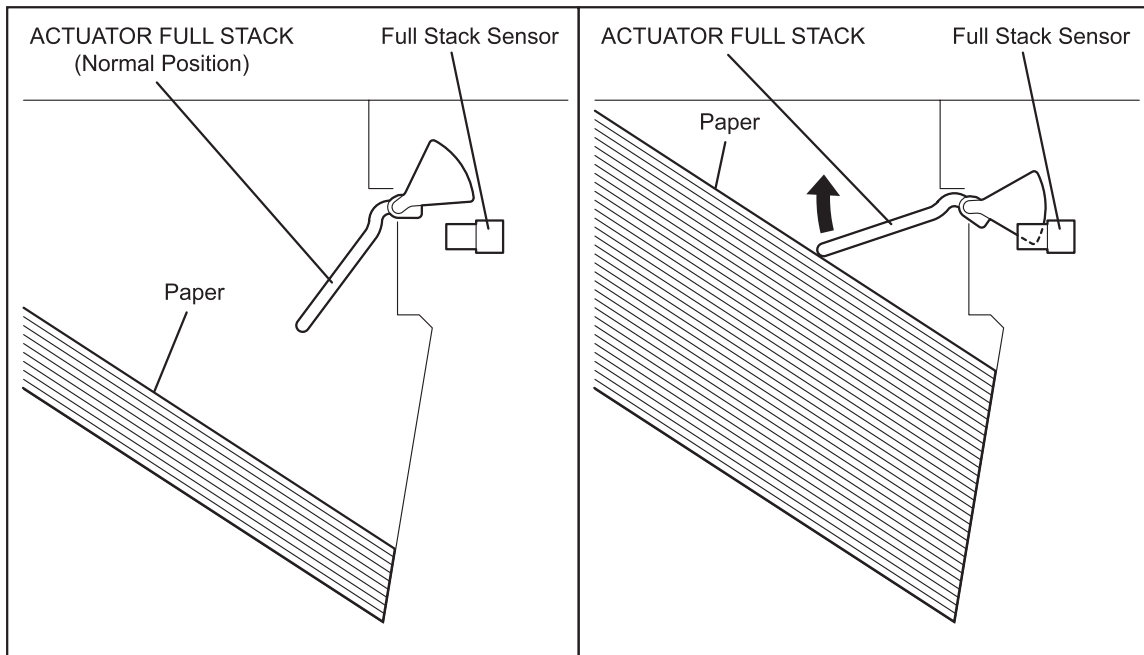

Tbt06044KA

- EXIT CLUTCH (DRIVE ASSY EXIT: PL 7.1.1)
Transmits the torque from the Fuser Motor to the Exit Roll to rotate the Exit Roll to the exit direction.
- EXIT INV CLUTCH (DRIVE ASSY EXIT: PL 7.1.1)
Transmits the torque from the Fuser Motor to the Exit Roll to rotate the Exit Roll to the Duplex direction.

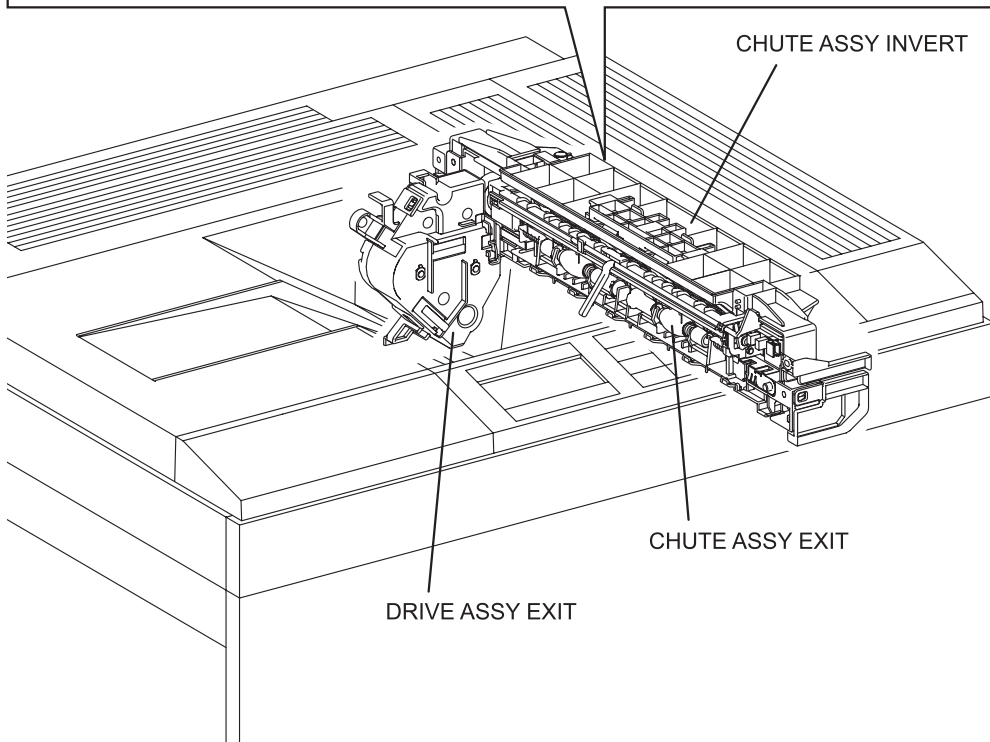
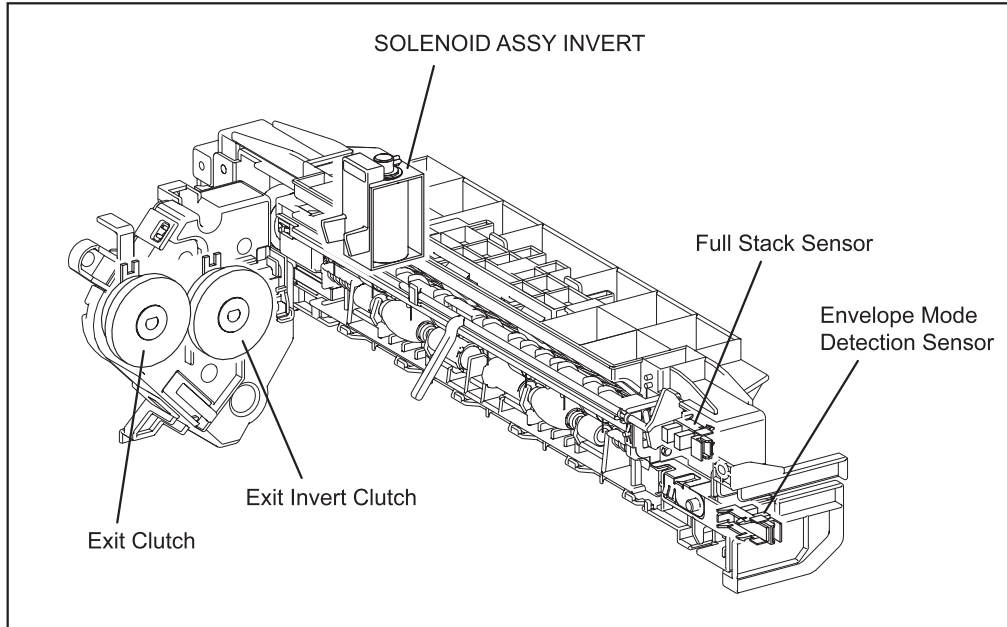

Tbt06045KA

3.11 Duplex

3.11.1 Major Functions

- CLUTCH ASSY DUP (PL 4.3.9)

Transmits the torque from the DRIVE ASSY PH to the ROLL ASSY DUPs (PL 4.3.10).

Allows the ROLL ASSY DUPs to rotate to feed the print media to the registration section.

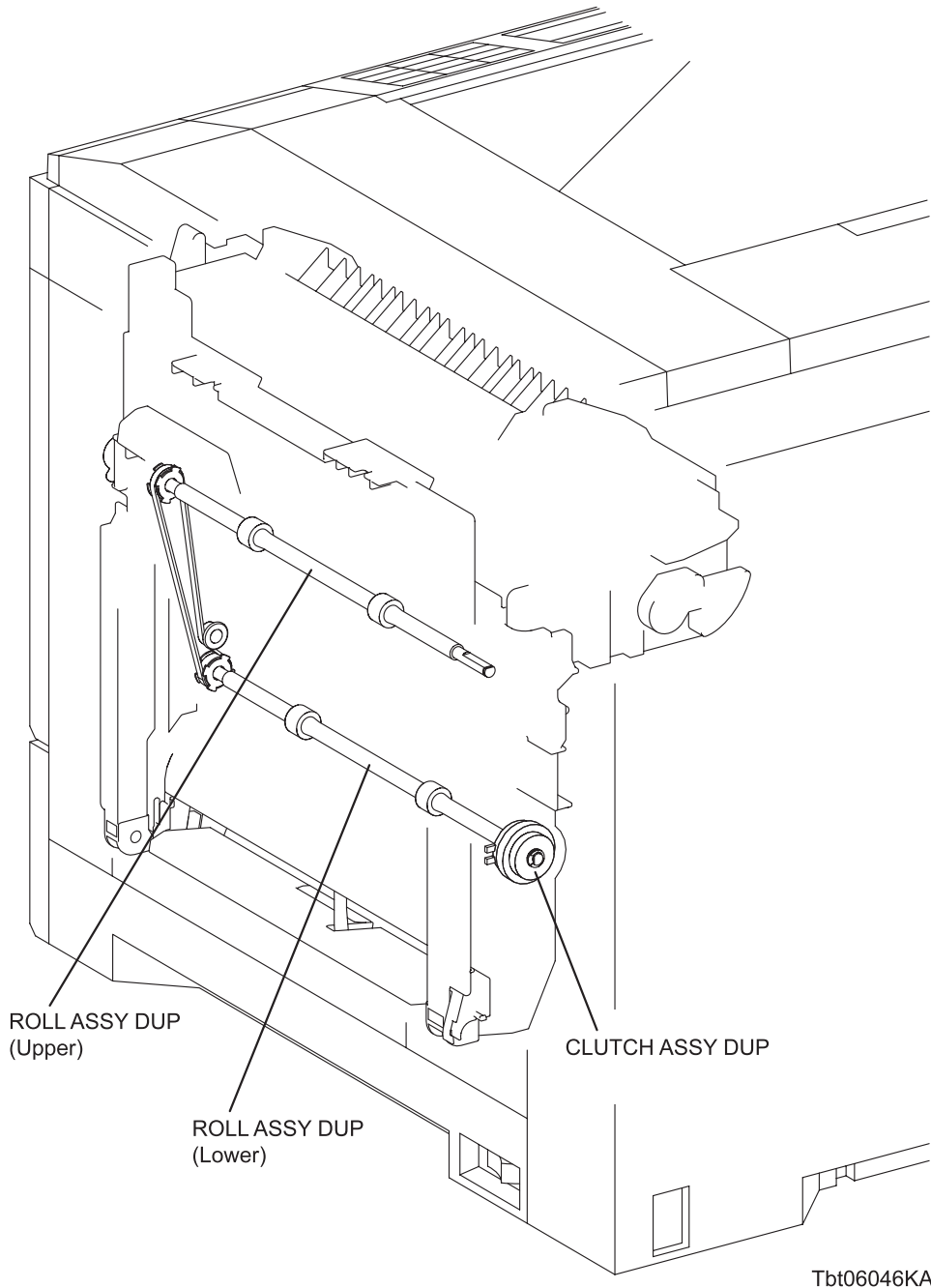

Tbt06046KA

Blank Page

3.12 Drive

3.12.1 Major Functions

- DRIVE ASSY DEVE (PL 9.2.9)
A motor that drives the Auger and Magnet Roll of the XERO DEVE CRU ASSY (Y/M/C).
- DRIVE ASSY DEVE K (PL 9.2.10)
A motor that drives the Auger and Magnet Roll of the XERO DEVE CRU ASSY (K).
- DRIVE ASSY XERO (PL 9.2.6)
A motor that drives the drum of the XERO DEVE CRU ASSY (Y/M/C/K).
- DRIVE ASSY FSR (PL 9.1.1)
A motor that drives the Fuser and Exit sections.
- DRIVE ASSY IBT (PL 9.1.3)
A motor that drives the Transfer Belt (BELT ASSY IBT) and the 2nd BTR.
- DRIVE ASSY PH (PL 9.1.4)
A motor that drives the Paper Feed, Regi, MSI, and Duplex sections.
Contains the Switching Clutch that transmits the torque of the DRIVE ASSY PH to the GUIDE ASSY LINK to switch between the full color mode and the B/W mode.
- Switching Sensor FC/K (SENSOR PHOTO: PL 9.2.4)
Detects whether the printer is running in the Full Color mode or B/W mode based on the position of the LINK BAR.
The torque from the DRIVE ASSY PH (normal or reverse) and switching on of the Switching Clutch moves the LINK BAR to the Full Color or B/W position. (Full color mode: Beam blocked at FC Sensor, beam received at K Sensor. BW mode: Beam received at FC Sensor, beam blocked at K Sensor.)

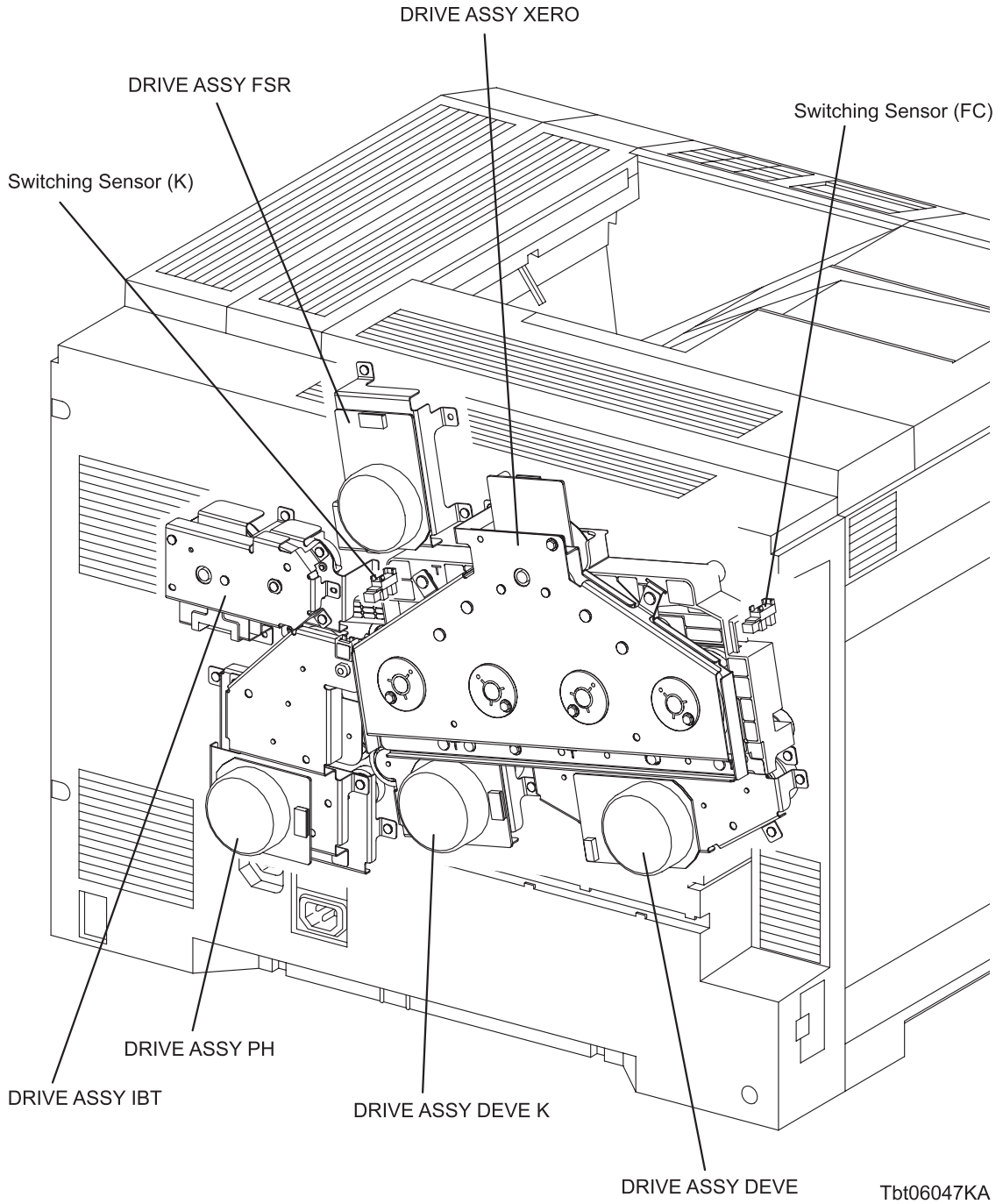

3.12.2 Full Color Mode and B/W Mode

The Full Color mode uses the four colors of Y, M, C, and K while the B/W mode uses K only.

To deactivate the components for Y, M, and C during the B/W mode operation, the torque transmission route is changed between the Full Color and B/W modes.

- Operation in Full Color mode

In the Full Color mode, the Belt contacts the four color drums and the corresponding 1st BTRs. The torque from the DRIVE ASSY XERO, DRIVE ASSY DEVE, and DRIVE ASSY DEVE K drives the drums and the corresponding Magnet Rolls to form a visible color-separated toner image on each of the drums.

- Operation in B/W mode

In the B/W mode, the Belt contacts the 1st BTR (K) and the Drum (K) only, and only the Drum (K) is driven by the torque from the DRIVE ASSY XERO. The DRIVE ASSY DEVE is at rest, and only the DRIVE ASSY DEVE K rotates to drive the Magnet Roll (K) to form a visible toner image on the Drum (K) only.

[FULL COLOR MODE]

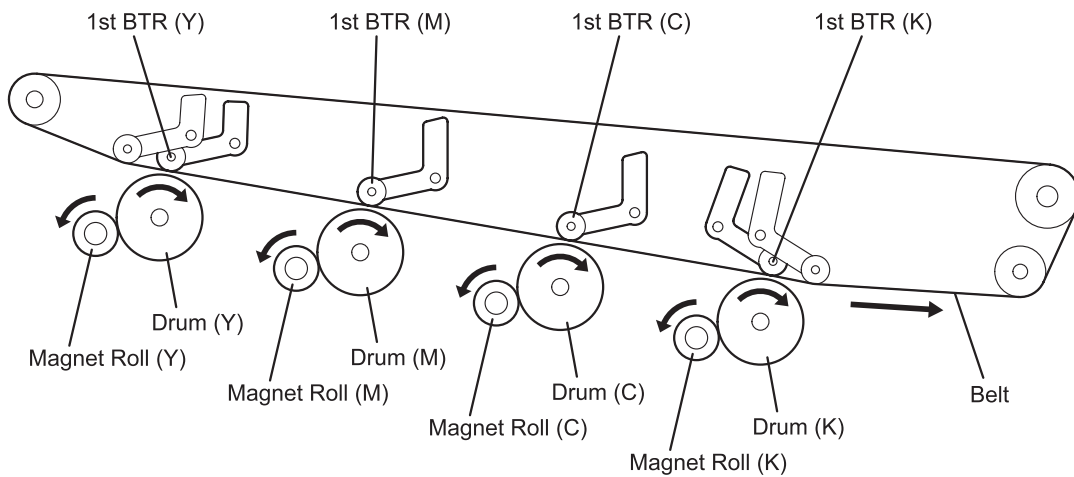

[BLACK and WHITE MODE]

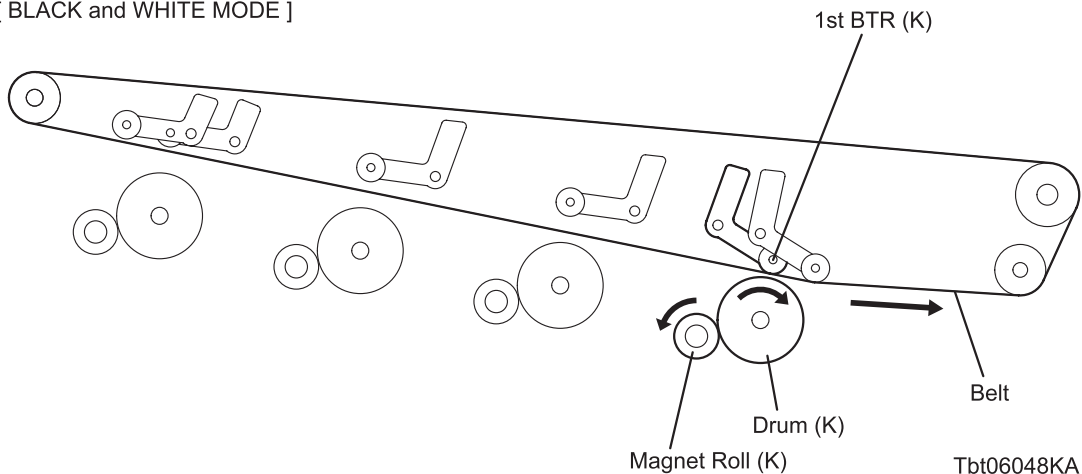

Tbt06048KA

Blank Page

- Switching between Full Color mode and B/W mode

The switching between the Full Color mode and B/W mode is controlled by the rotation of the DRIVE ASSY PH (B/W mode: reverse, Full Color mode: normal) and the engagement of the Switching Clutch.

When the Switching Clutch is turned ON, the torque from the DRIVE ASSY PH horizontally drives the Link Bar in the GUIDE ASSY LINK via the DRIVE ASSY RACK (PL 9.2.7) to rotate the Coupling Assy Link and the three Link Couplings (Y/M/C). The position of the Link Bar is detected by the two sensors.

- a) Rotation of the Coupling Assy Link

The Coupling Assy Link rotatively drives the Shaft Assy Cam Sw in the Belt Unit via the Coupling, moving the Lever Link YMC horizontally inside the Belt Unit to control the three 1st BTRs for Y, M, and C.

- B/W mode: 1st BTRs for Y, M, and C are positioned near the Belt and the drums.
- Full Color mode: 1st BTRs for Y, M, and C are in contact with the Belt and the drums.

- b) Rotation of the Link Coupling

The Link Couplings rotate to engage or disengage the Couplings for the torque transmission between the DRIVE ASSY PH and the three Drums (Y, M, C).

- B/W mode: The Couplings are disengaged to interrupt the torque transmission from the DRIVE ASSY PH to the Drums (Y, M, C).
- Full Color mode: The Couplings are engaged to transmit the torque from the DRIVE ASSY PH to the Drums (Y, M, C).

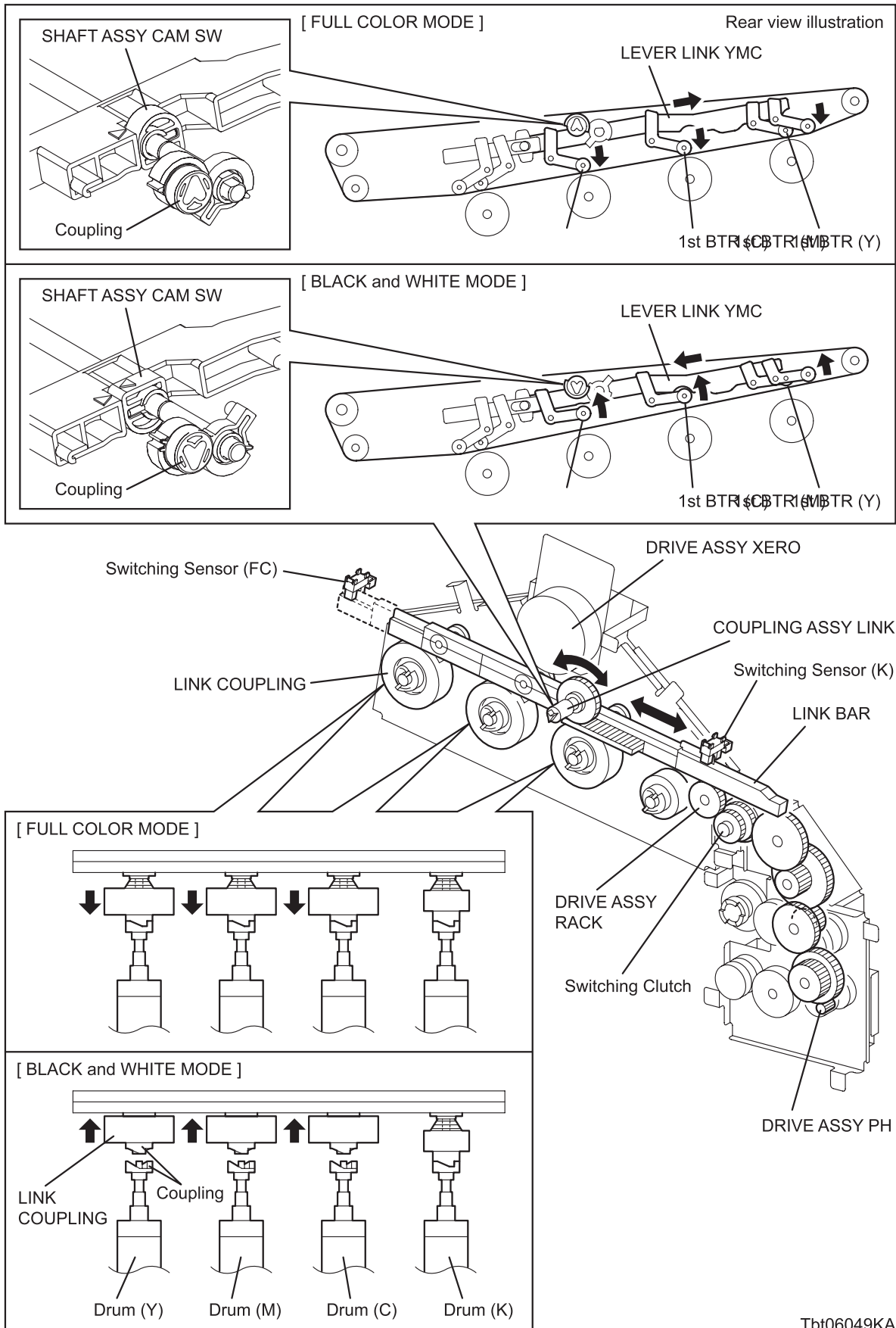

3.13 Electrical

3.13.1 Major Functions

- FAN
 - FUSER FAN (PL 4.1.8)
 - Exhausts heat generated at the FUSER section.
 - FAN LVPS (PL 10.1.11)
 - Exhausts heat generated in the BOX ASSY LVPS. Since the BOX ASSY LVPS is designed to trap in the heat from the transformer, the FAN LVPS is provided to help exhaust the heat.

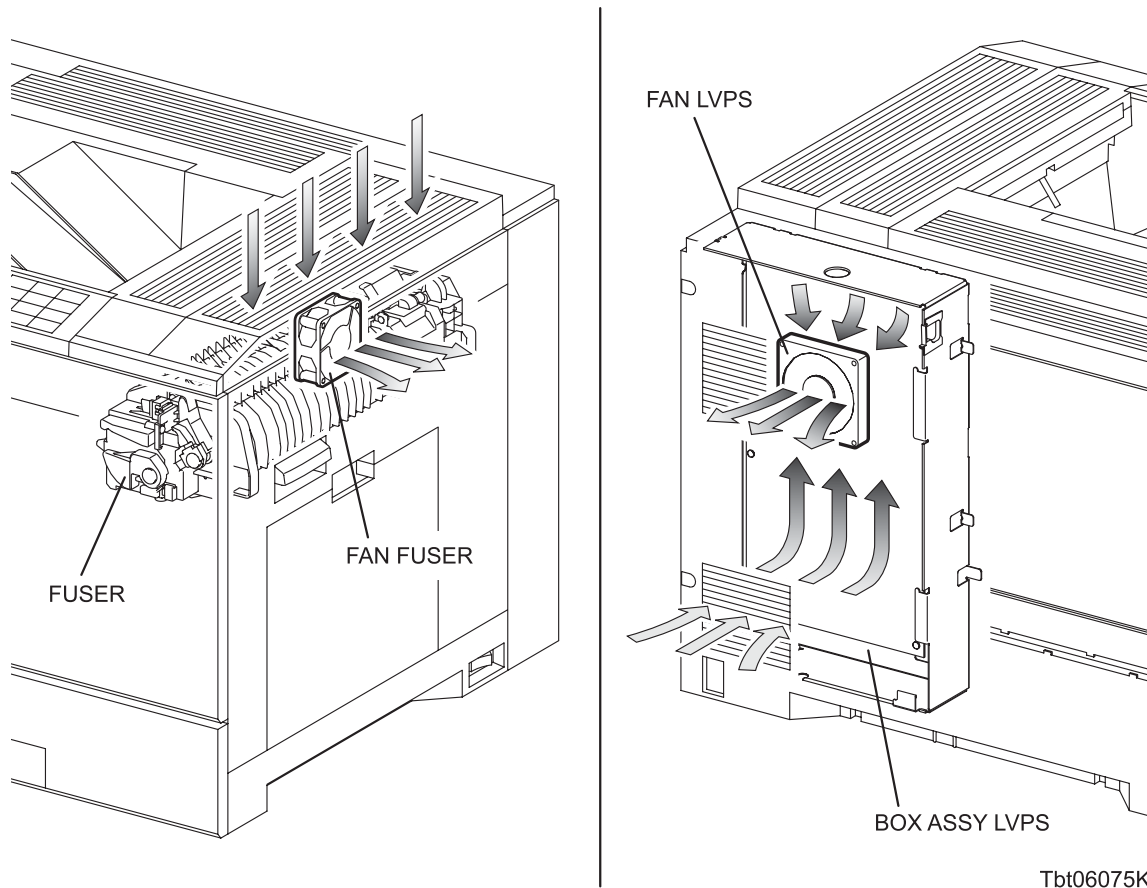

Tbt06075KA

- SWITCH
 - MAIN POWER SWITCH
 - Turns on/off the AC power to the printer.
 - HARNESS ASSY I/L FRT (Inter Lock Switch Front: PL 1.2.1)
 - Detects the open/close of the Front Cover. Interrupts the DC power to the printer (+24VDC) when the Front Cover is opened.
 - SWITCH (Front Cover Switch: PL 1.2.3)
 - Detects the open/close of the Front Cover.
 - HARNESS ASSY I/L RH (Inter Lock Switch Right: PL 4.1.1)
 - Detects the open/close of the Right-hand Cover (RH). Interrupts the DC power to the printer (+24VDC) when the Right-hand Cover is opened.
 - HARNESS ASSY ROS/HV (Inter Lock Switch Rear: PL 11.2.2)
 - Detects the presence/absence of the Rear Cover. Interrupts the DC power to the ROS ASSY (+5VDC) when the Rear Cover is removed.

- PWBA
 - LVPS (Low Voltage Power Supply) ASSY (PL 10.2.2)
 - Supplies the AC power from the power supply to the heater section of the FUSER and generates stable low DC voltage to be used by the logic circuits and other components.
 - HVPS (High Voltage Power Supply)
 - Supplies high voltage to the BCRs and the Magnet Rolls for each color.
 - Machine Control Unit (MCU)
 - Controls the print operation based on the communication with the print controller and on the information from the sensors or switches.
 - Electronic Sub System (ESS)
 - The ESS is the print controller of the printer. The PWBA ESS connected to the PWBA MCU controls the entire system (diagnostic, interface, image processing, etc.).
 - PWBA EEPROM
 - Stores the printer-specific information.
 - OPERATOR PANEL
 - Allows the user to view the printer status or execute operations via the LCD, LED, and buttons.
 - BREAKER GFI INLET
 - Opens the circuit when the leakage current of the AC power supply exceeds the rated value.

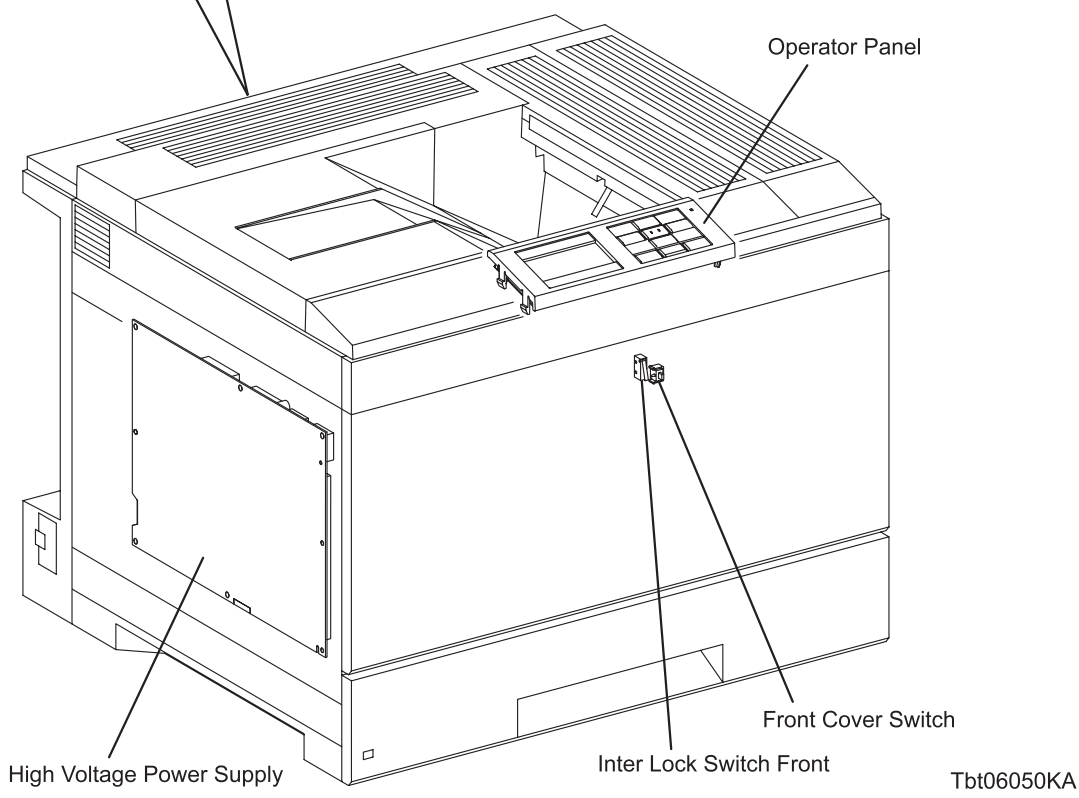
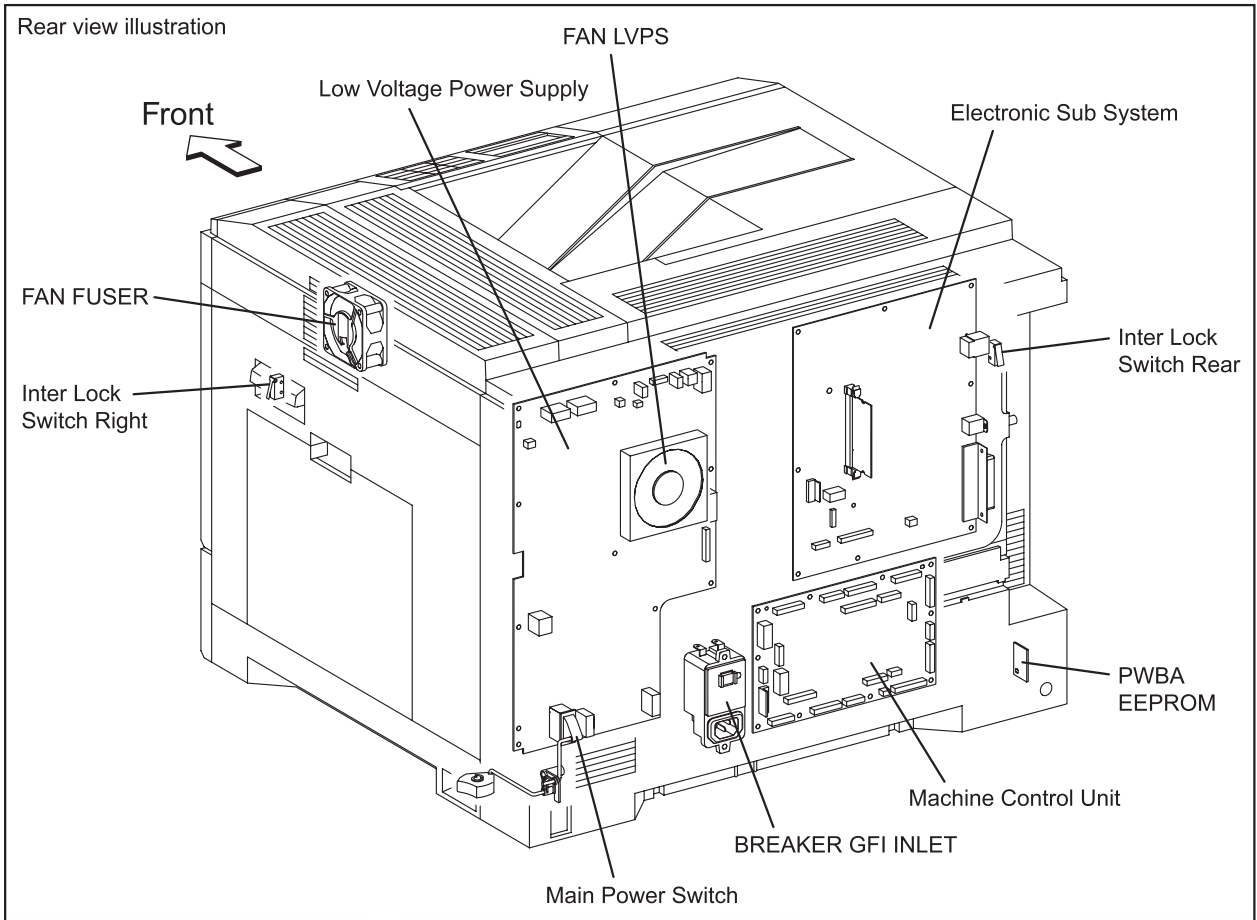

3.13.2 Data Flow

The print data (electric signal) from the printer controller flows as shown below before it is turned into a print.

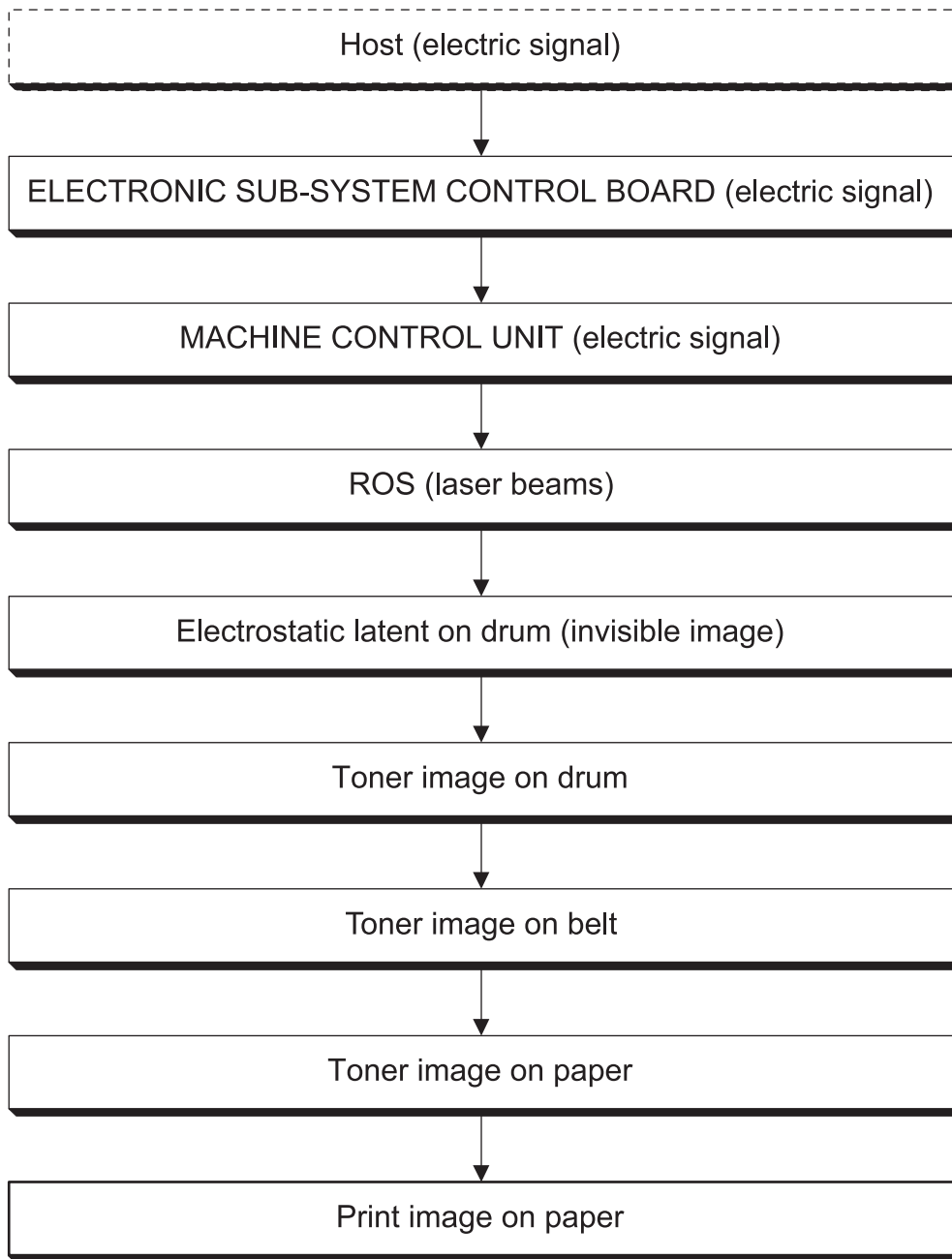

Tbt06051KA

3.14 Optional 550 Feeder & Optional High Capacity Feeder (HCF or 1100 FEEDER)

3.14.1 Major Functions

- GUIDE ASSY SIDE R (PL 12.5.9)/GUIDE ASSY SIDE F (PL 12.5.11)
The GUIDE ASSY SIDE R and GUIDE ASSY SIDE F aligns the print media stack in the width direction by moving perpendicularly to the paper feeding direction.
- GUIDE ASSY END (PL 12.5.12)
The GUIDE ASSY END aligns the print media stack in the length direction and determines the paper size by moving in the paper feeding direction. The paper size is detected by the SWITCH ASSY SIZE (Refer to 5.1 Paper Size Control) that turns ON or OFF according to the position of the GUIDE ASSY END.
- HOLDER ASSY SEPARATOR (PL 12.5.21)
The HOLDER ASSY SEPARATOR and the ROLL ASSY FEED nip the print medium to prevent multiple sheet feed.
(Refer to 2.3.1 Multiple Sheet Feed Prevention)
- PLATE ASSY BOTTOM (PL 2.1.2)
When the paper cassette is pulled out from the paper feeder section, the PLATE ASSY BOTTOM is lowered and locked to the bottom of the cassette. Replacing the paper cassette to the paper feeding section releases the PLATE ASSY BOTTOM from the GEAR BTM LOCK ONEWAY, pressing the print media stack against the Nudger Roll by the spring pressure of the SPRING BTM UP 550 A4.
(Refer to 2.3 Feeding from Paper Cassette)

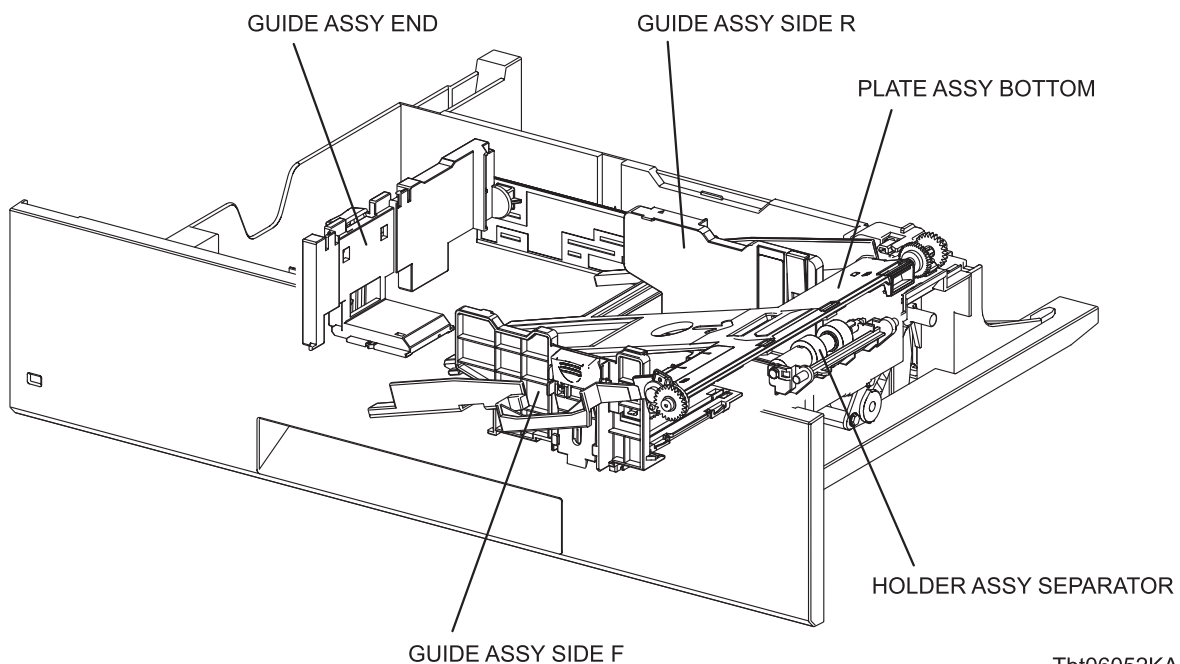

Tbt06052KA

- SWITCH ASSY SIZE (PL 12.2.12)
SWITCH ASSY SIZE detects paper size and the presence/absence of the paper cassette. Aligning the GUIDE ASSY END (PL 12.5.12) to the end of the print media stack changes the position of the ACTUATOR SIZE (PL 12.5.14) that is coupled to the GUIDE ASSY END, turning ON or OFF the switches on the SWITCH ASSY SIZE.
The print media size is determined by the combination of ON/OFF states of these switches.
(Refer to 5.1 Paper Size Control for the combination of switches.)

- OPT CST NO PAPER SENSOR (SENSOR PHOTO: PL 12.4.18)
Detects the presence/absence of print media in the paper tray based on the position of ACTUATOR NO PAPER. (No paper: Sensor beam is blocked)
- OPT LOW PAPER SENSOR (SENSOR PHOTO: PL 12.2.10)
Detects the amount of the print media remaining in the paper cassette in three levels (50, 25, and 10%). (No paper: Sensor beam is blocked)
- CLUTCH ASSY FEED (PL 12.4.9)
Transmits the driving torque from the DRIVE ASSY PH to the FEED ROLLER. ([Refer to 6.5 DRIVE ASSY XERO](#))
- ROLL ASSY FEED (PL 12.4.24)
When the CLUTCH ASSY FEED operates, the ROLL ASSY FEED starts rotating to feed the print medium. ([Refer to 6.5 DRIVE ASSY XERO](#))
- CLUTCH ASSY TAKE AWAY (PL 12.4.5)
Transmits the torque from the DRIVE ASSY OPT to the ROLL ASSY TAKE AWAY. ([Refer to 6.5 DRIVE ASSY XERO](#))
- ROLL ASSY TAKE AWAY (PL 12.4.4)
Rotates by the drive from the DRIVE ASSY OPT via the CLUTCH ASSY TAKE AWAY to feed the print medium from the optional paper cassette to the registration section. ([Refer to 6.5 DRIVE ASSY XERO](#))
- PAPER PATH SENSOR (SENSOR PHOTO: PL 12.4.3)
Detects that the print medium has reached the registration section.
- DRIVE ASSY OPT (PL 12.3.2)
Drives the rolls in the Option Feeder. ([Refer to 6.5 DRIVE ASSY XERO](#))
- PWBA OPT FDR (PL 12.3.4)
Controls the motors, sensors, and clutches in the Option Feeder.
- RH COVER SWITCH (SWITCH: PL 12.2.2)
Detects the open/close of the COVER RH OPT (PL 12.1.14). Interrupts the DC power supply (+24VDC) when the COVER RH OPT is opened.

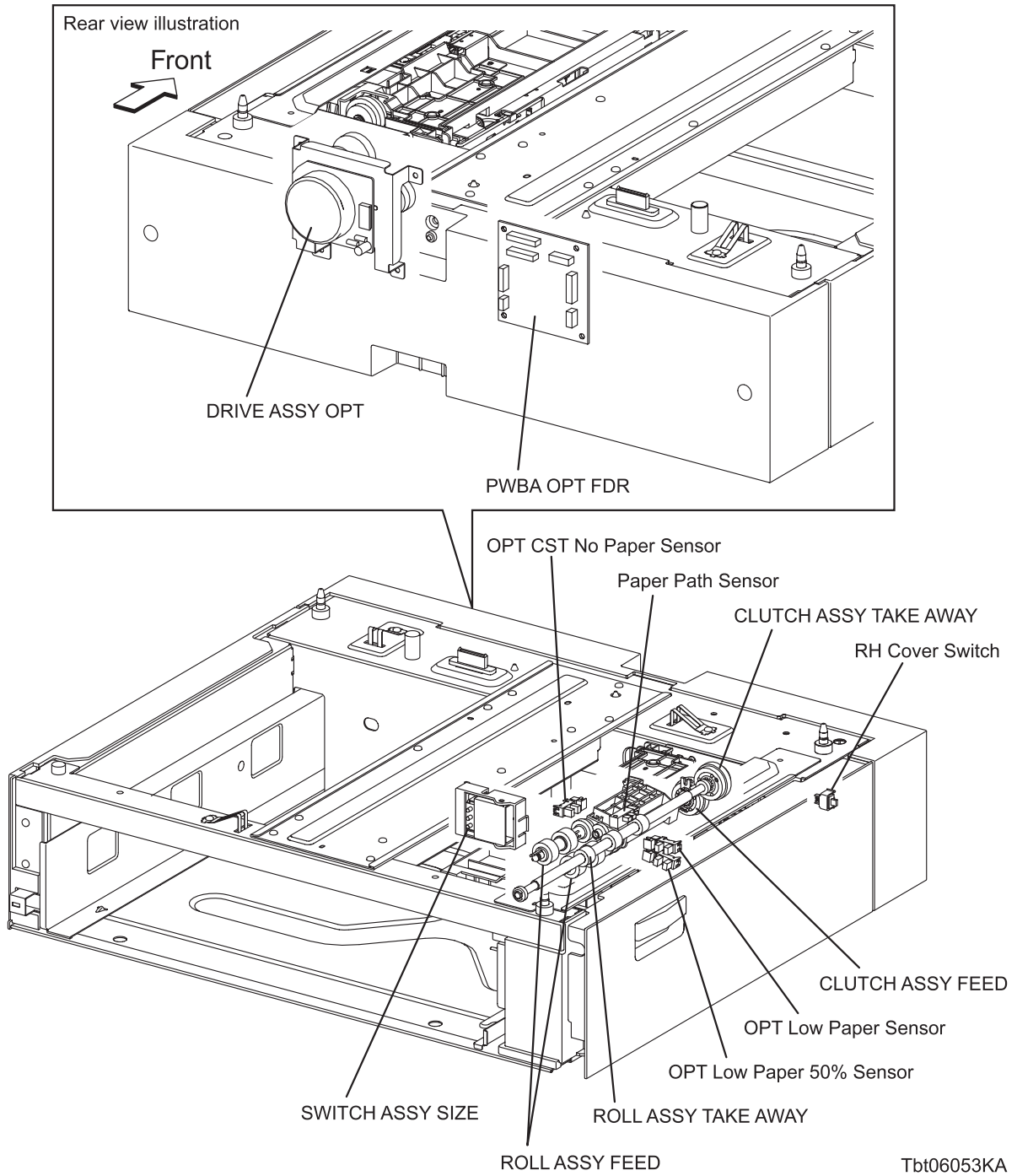

4. Operation Modes / Consumables and Periodic Replacement Parts

4.1 Operation Modes

The printer can be operated in the following four modes:

Mode	Status	Operation
Printing Mode	Running or recording	Fixing system: Held at operating temperature. Exposure system: Operating status Printing system: Operating status Cooling fan: Operating status (High)
Ready Mode	Ready	Fixing system: Held at ready temperature. Exposure system: Stop status Printing system: Stop status Cooling fan: Operating status (Low)
Sleep Mode	Completely resting	Fixing system: Low Temperature Exposure system: Stop status Printing system: Stop status Cooling fan: Operating status (Low)
Deep Sleep Mode	More power-saving than the Sleep Mode	Fixing system: Stop status Exposure system: Stop status Printing system: Stop status Cooling fan: Stop status

4.2 Replacement Timing of Consumables and Periodic Replacement Parts

4.2.1 Types of Consumables and Periodic Replacement Parts

Listed below are the consumables and periodic replacement parts for this printer (including options).



	Product Name	Lifespan (approximate)*1
Consumables	TONER CARTRIDGE (K) (Starter capacity)	9,000 pages
	TONER CARTRIDGE (YMC) (Starter capacity)	6,000 pages
	TONER CARTRIDGE (K) (Standard capacity)	18,000 pages
	TONER CARTRIDGE (YMC) (Standard capacity)	12,000 pages
	XERO DEVE CRU ASSY (YMCK)	50,000 pages
	WASTE TONER BOX	25,000 pages
	STAPLE CARTRIDGE(OPTION)	5,000 staples
Periodic Replacement Parts	Fuser ASSY	100,000 pages
	BELT ASSY IBT	150,000 pages
	Roll ASSY 2ND BTR	150,000 pages
	Paper Feed Roll	150,000 pages
	Separatoe Roll	150,000 pages

*1: The page counts are for reference only.

The actual page count may vary greatly depending on conditions such as print settings, document contents, or power-on/off frequency.

4.2.2 Replacement Timing of Consumables

When a consumable part is about to reach its replacement period, one of the following messages appears on the Operator Panel:

	Message	Meaning	Detection device
TONER CARTRIDGE (YMCK) *5	<Near Life> Ready to Print 093-XXX*1 YYY*1 Toner Crtrdg ↕ Flip Ready to Print Is close to life	The TONER CARTRIDGE (Y, M, C, or K) is near its replacement period. Have ready a new TONER CARTRIDGE (Y, M, C, or K). You can still print approximately another 900 pages in K, and 600 in Y, M, and C.	The TONER CRUM detects the replacement period from the remaining toner amount. The ADC Sensor detects the life end.
	<Life Over>  Life Over 093-XXX*2 Replace Now YYY*2 Toner Crtrdg	The TONER CARTRIDGE (Y, M, C, or K) has reached its replacement period. The printer stops operating. Immediately replace the TONER CARTRIDGE (Y, M, C, or K) with a new one.	
XERO DEVE CRU ASSY (YMCK)	<Near Life> Ready to Print 091- XXX*3 YYY*3 Drum Crtrdg ↕ Flip Ready to Print Is close to life	The XERO DEVE CRU ASSY (Y, M, C, or K) is near its replacement period. Have ready a new XERO DEVE CRU ASSY (Y, M, C, or K). You can still print approximately another 5,000 pages before the Life Over message appears.	The XERO CRUM detects the replacement period.
	<Life Over>  Life Over 091- XXX*4 Replace Now YYY*4 Drum Crtrdg	The XERO DEVE CRU ASSY (Y, M, C, or K) has reached its replacement period. You can still print some more pages, but the print quality will not be assured. It is recommended that you replace the XERO DEVE CRU ASSY (Y, M, C, or K) with a new one immediately. Once the Life Over message appears, you can print approximately another 10,000 pages before the printer stops operating.	
WASTE TONER BOX	<Near Life> Ready to Print 091-400 Waste Toner Box ↕ Flip Ready to Print Is close to life	The WASTE TONER BOX is near its replacement period. Have ready a new WASTE TONER BOX. You can still print approximately another 2,500 pages	The SENSOR TNR FULL detects the replacement period from the waste toner amount.
	<Life Over>  Life Over 091-911 Replace Now	The WASTE TONER BOX has reached its replacement period. The printer stops operating. Immediately replace the WASTE TONER BOX with a new one.	
STAPLE CARTRIDGE	<Life Over> Empty Staple 024-979 Replace Now Stapler Cartridge. Continue without Staple? Are You Sure?	The STAPLE CARTRIDGE has reached its replacement period. Immediately replace the STAPLE CARTRIDGE with a new one. Approximately another 20 staples are left.	The STAPLE LOW SENSOR detects the replacement period.

*1- *4: XXX/YYY in the message denotes the following.

*1: 423/Yellow, 424/Magenta, 425/Cyan, 426/Black

*2: 930/Yellow, 931/Magenta, 932/Cyan, 933/Black

*3: 412/Yellow, 413/Magenta, 414/Cyan, 411/Black

*4: 932/Yellow, 933/Magenta, 944/Cyan, 931/Black

*5: Standard capacity

4.2.3 Replacement Timing of Periodic Replacement Parts

When a periodic replacement part is about to reach its replacement period, one of the following messages appears on the Operator Panel:

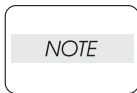

No message is displayed regarding the replacement timing of the ROLL ASSY 2ND BTR, FEED ROLL, and SEPARATOR ROLL. It is recommended that the ROLL ASSY 2ND BTR, FEED ROLL, and SEPARATOR ROLL be replaced when the BELT ASSY IBT is replaced.

	Message	Meaning	Detection device
FUSER ASSY	<Near Life> Ready to Print 010-420 Fuser ↕ Flip Ready to Print Prepare	The FUSER ASSY is near its replacement period. Have ready a new FUSER ASSY. You can still print approximately another 10,000 pages before the Life Over message appears.	The FUSER CRUM detects the replacement period.
	<Life Over> 010-351 Restart Printer Replace Fuser Contact Support	The FUSER ASSY has reached its replacement period. You can still print some more pages, but the print quality will not be assured. It is recommended that you replace the FUSER ASSY with a new one immediately. Once the Life Over message appears, you can print approximately another 25,000 pages before the printer stops operating.	
BELT ASSY IBT	<Near Life> Ready to Print Ready to Print 094- 419 Belt Unit ↕ Flip Ready to Print Prepare	The BELT ASSY IBT is near its replacement period. Have ready a new BELT ASSY IBT. You can still print approximately another 15,000 pages before the Life Over message appears.	The BELT CRUM detects the replacement period.
	<Life Over> i Life Over 094- 911 Replace Now Belt Unit	The BELT ASSY IBT has reached its replacement period. You can still print some more pages, but the print quality will not be assured. It is recommended that you replace the BELT ASSY IBT with a new one immediately. Once the Life Over message appears, you can print approximately another 50,000 pages before the printer stops operating.	

Blank Page

5. Control

5.1 Paper Size Control

When the paper cassette is inserted, the SWITCH ASSY SIZE (PL 3.1.1) detects the paper size.

Aligning the GUIDE ASSY END (PL 2.1.12) to the end of the print media stack changes the position of the ACTUATOR SIZE (PL 2.1.14) that is coupled to the GUIDE ASSY END, turning ON or OFF the switches on the SWITCH ASSY SIZE.

The print media size is determined by the combination of ON/OFF states of these switches.

The following table shows the correspondence between the on/off status of the paper size switches and the paper size.

This detection method is common to the Optional 550 Feeder and Optional High Capacity Feeder (HCF or 1100 FEEDER)

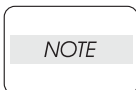

The Paper Size Switches are referred to as SW1, SW2, and SW3 from top to bottom.

Paper Size	Paper Size Switch			Diag indication data
	SW1	SW2	SW3	
LEGAL14" (SEF)	ON	ON	ON	00
LEGAL13" (SEF)	ON	ON	OFF	01
EXECUTIVE (SEF)	ON	OFF	ON	02
B5 (SEF)	ON	OFF	OFF	03
A4 (SEF)	OFF	ON	ON	04
LETTER (SEF)	OFF	OFF	ON	06
A5	OFF	ON	OFF	05
No cassette	OFF	OFF	OFF	07

ON: The actuator is pushing the size switch.

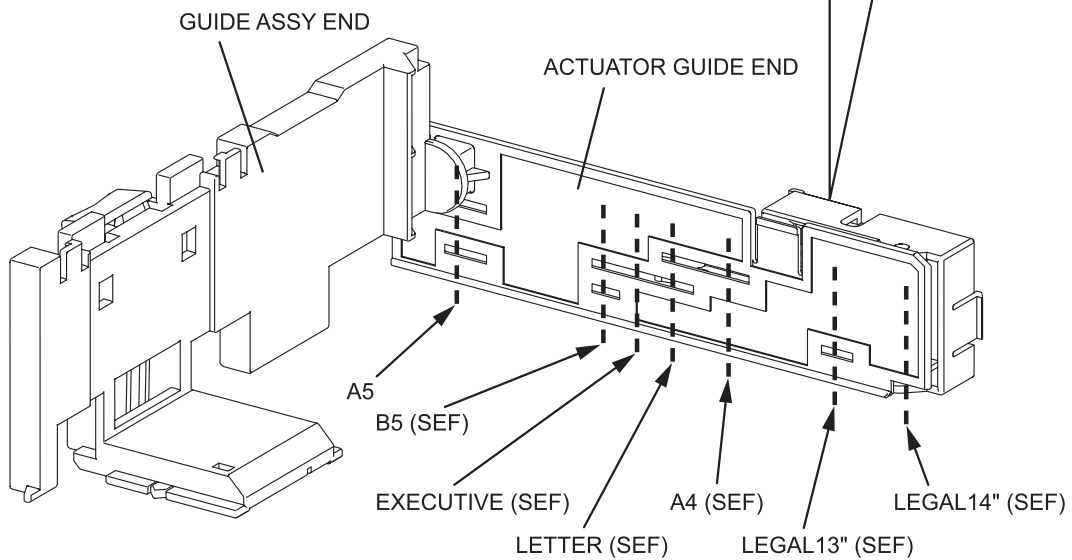
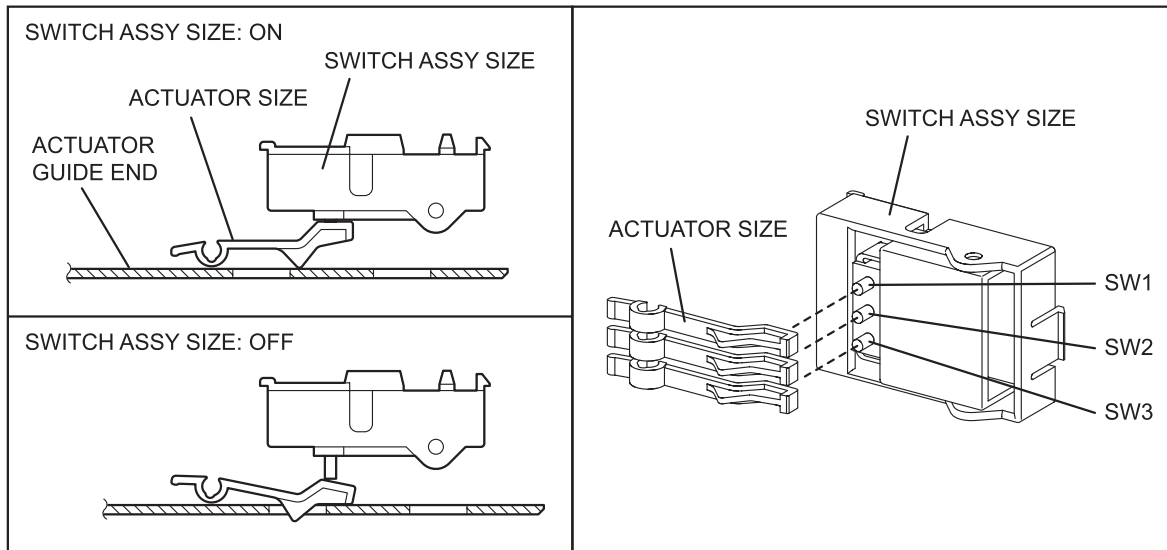

5.2 ROS ASSY Light Quantity Control

The image data is input to the laser diodes in the ROS ASSY as electric signals (represented by high and low voltage values), and then converted by the laser diodes to optical signals (represented by blinks of laser beam).

Since variations in light quantity of laser beams or variations in optical system (such as lenses) or drum sensitivity cannot attain a proper electrostatic image, the laser beam light quantity is monitored and controlled by the laser diodes.

The ROS ASSY in this printer has four laser diodes for yellow, magenta, cyan, and black respectively, and the light quantity is automatically adjusted for each color.

5.3 Process Control

The parameters related to image formation must be corrected to stabilize printing. The control of the entire printing process including the parameter correction control is called "process control".

The process control is performed by the following two methods after every 30 cumulative prints upon termination of a print run or during a continuous run:

- Potential Control
- Toner Density Control

To supplement these two controls, the following controls are provided:

- High Area Coverage Mode
- Admix Mode

5.3.1 Potential Control

To attain stable print image density, the drum charging voltage, the developing DC voltage and the PRINT HEAD light amount are adjusted according to the developing capability of each color carrier that varies momentarily. The adjusted drum charging voltage, the developing DC voltage and the PRINT HEAD light amount are fed back to keep the print image density constant.

The outline of control is as follows:

- 1) The HUMIDITY SENSOR (temperature and humidity sensor) detects the temperature and humidity.
- 2) The patches of respective colors (yellow, magenta, cyan, and black) for the potential control are generated and transferred onto the Belt.
- 3) The ADC Sensor (density sensor) detects the density of the patches on the Belt.
- 4) The drum charging voltage, the developing DC voltage and the ROS light quantity are adjusted for each color according to the detected patch density.

5.3.2 Toner Density Control

The toner density must be kept constant to stabilize the print image quality. The control system for this purpose is called toner density control.

1) PCDC (Pixel Count Dispense Control)

The quantity of the toner to be consumed in the developing process is calculated in terms of toner-dispensing time based on the quantity of the video signals that have been input to the ROS ASSY. The amount of the toner to be fed to the developer section is controlled by turning on the Toner Motor for the toner-dispensing time thus calculated.

2) ADC (Auto Density Control)

The patches of respective colors (yellow, magenta, cyan, and black) for the toner density control are generated under the specified potential condition, and then transferred onto the Belt. The ADC Sensor measures the densities of these patches and compares them with the reference value. If the toner density is lower than the reference value, the toner dispense quantity is increased at the next printing. If the toner density is higher than the reference value, the toner dispense quantity is reduced at the next printing. The toner dispense quantity is calculated in terms of the toner-dispensing time on a color-by-color basis.

5.3.3 High Area Coverage Mode

A continuous printing of a high area coverage data that exceeds the extra toner dispense capability causes the toner density in the developer to be lowered.

The High Area Coverage Mode postpones the next page feed and dispenses the toner during this time if the toner dispense time has reached the specified value during a continuous printing.

5.3.4 Admix Mode

This mode executes extra toner dispensation to prevent the toner density from being lowered whenever the value of the toner density control patch measured by the ADC Sensor falls far below the reference value. If the toner density level cannot be recovered even after this operation, it is determined that the toner has run out.

5.3.5 ADC Sensor Adjustment

The ADC Sensor is a reflection type sensor that irradiates the light from its LED onto the target and detects the reflected light at its photoreceptor and outputs electric signals responsive to the amount of the detected light. To ensure an accurate patch density measurement, the surfaces of the ADC Sensor is cleaned to remove soil due to toner, etc., and the light quantity adjustment is made so that the reflected light quantity satisfies the predetermined value when the patch for potential control and toner density control are created.

5.4 Color Registration Control

The printer uses a tandem system where the drums and developers are arranged respectively for each of yellow, magenta, cyan, and black colors. Since the four color-separated images are overlaid one another onto the print medium, a color shift may occur. The color registration control calculates how much the registration is shifted, and adjusts the ROS ASSY write timing.

The lateral registration control adjusts all of the four colors in lateral directions.

The color registration control is executed during a process control based on the change in the internal temperature and the print count.

The control is outlined below:

- 1) With no toner on the Belt, the output value of the ADC Sensor is measured to determine the threshold value.
- 2) The patch for color registration control is generated on the Belt. This patch is composed of four cycles of a color pattern, each containing 10mm-wide color bars starting with a black trigger line followed by K, C, K, M, K, and Y (in this order).

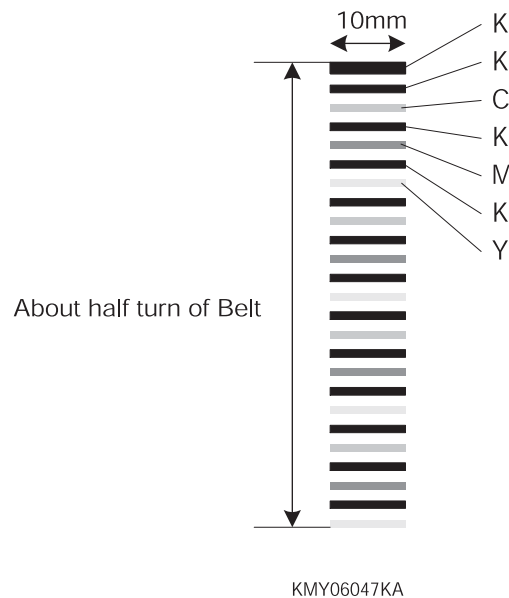

- 3) The density of the patch is measured by the ADC Sensor.
- 4) The shift correction amount is calculated from the threshold value determined in 1) and the patch density measured in 3).
- 5) The ROS ASSY write timing is changed according to the shift correction amount.

5.5 Fuser Control

5.5.1 Fuser temperature control

To control the Fuser temperature, the target temperature is set, and then the Heater Lamp is turned on/off so that the surface temperature of the Heat Roll satisfies the target value.

The surface temperature of the Heat Roll is detected by the Temp. Sensor (NCS = Non-Contact Sensor) in the middle of the Heat Roll and the Temp. Sensors (STS = Soft Touch Sensor) at the end sections. When the temperature detected is higher than the target value, the Heater Lamp will be turned OFF. When the temperature is below the target value, the Heater Lamp will be turned ON. However, the STS may detect a temperature lower than the actual value when an error occurs during the temperature detection. To prevent, in such a case, the Heater Lamp from activating for too long a duration until it melts or burns the Fuser Assy, the Heater Lamp is turned off unless Warm-up is completed within the specified time.

The target temperature varies depending on the printer status such as Warm-up, Printing, or Process Control, and is calibrated according to the interior temperature detected by the Sensor Hum Temp, the temperature difference between the middle and the ends of the Heat Roll, the printing mode, and the input power supply voltage.

5.5.2 Cooling down

As the printing continues, the temperature of the Heat Roll becomes nonuniform between the area that contacts the sheet and the area that does not. In such a case, the paper feeding is suspended for a certain duration to compensate for the temperature nonuniformity of the Heat Roll. This is called "Cooling Down".

When the temperature of the Heat Roll end is high, cooling down is performed to lower the temperature to the target value.

5.5.3 Sensor Warm-up

The Temp. Sensor (NCS) in the middle section of the Heat Roll loses its measuring accuracy when the temperature of the sensor itself is -5°C or below. Therefore, the sensor will be warmed up to 0°C when its temperature is -5°C or below. This is called "Sensor Warm-up".

6. Drive Transmission Route

6.1 DRIVE ASSY PH

The torque of the DRIVE ASSY PH is transmitted through the route below.

[PAPER FEED DRIVE]

[Name of moving parts]

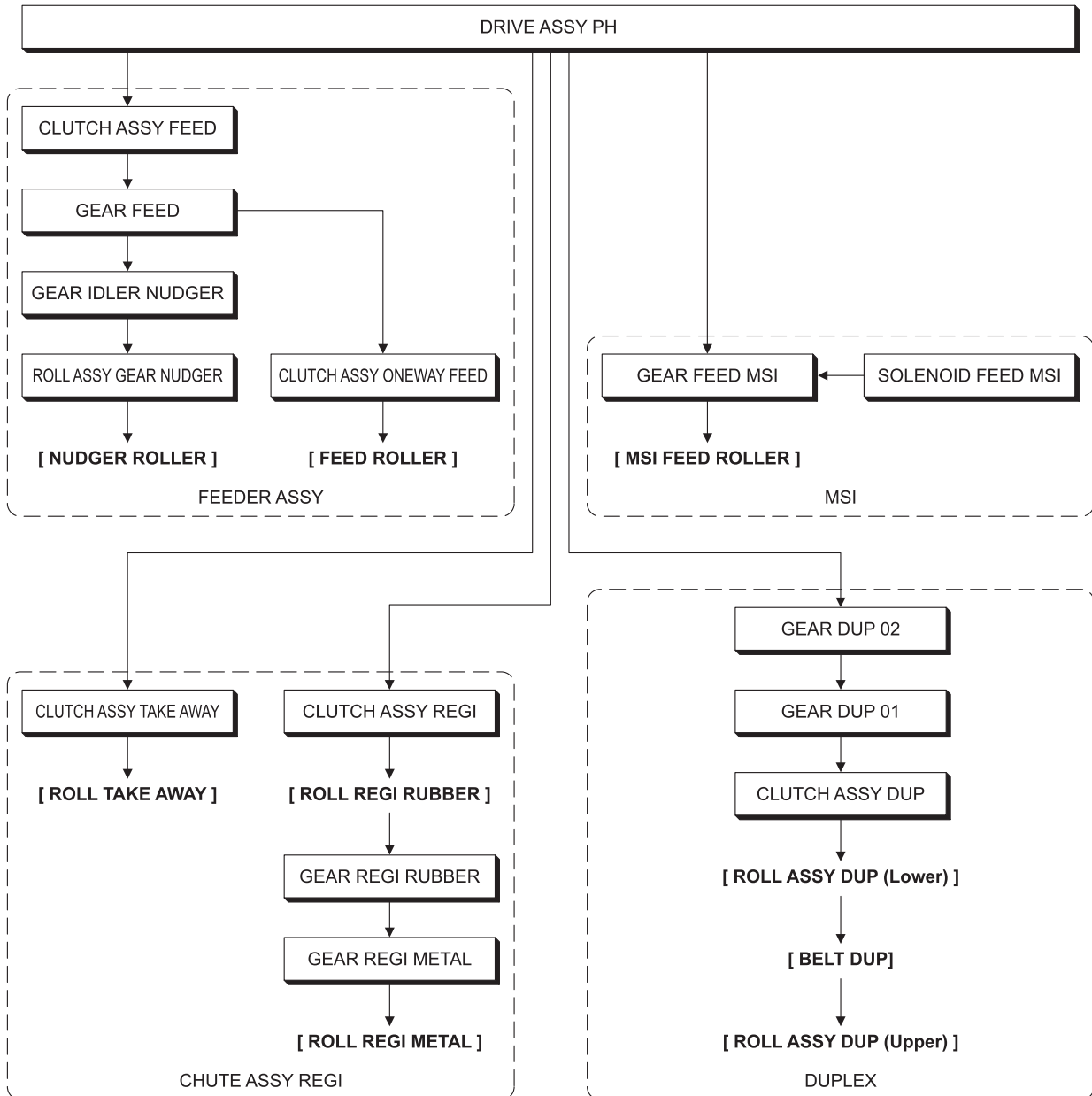

Tbt06055KA

[PAPER FEED DRIVE]

[Name of moving parts]

▬ : Indicates the engagement of gears.

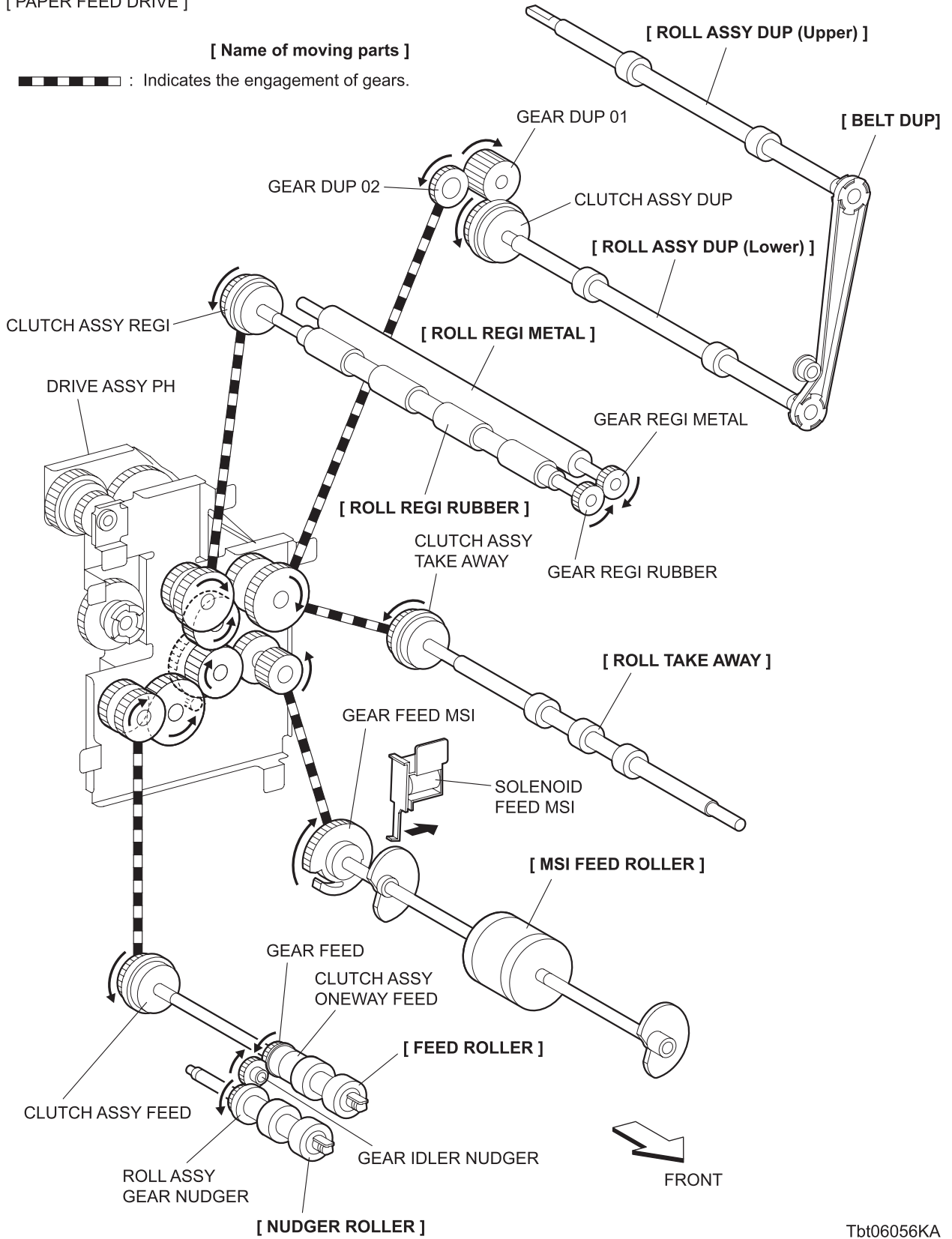

Tbt06056KA

6.2 DRIVE ASSY FSR

The torque of the DRIVE ASSY FSR is transmitted through the route below.

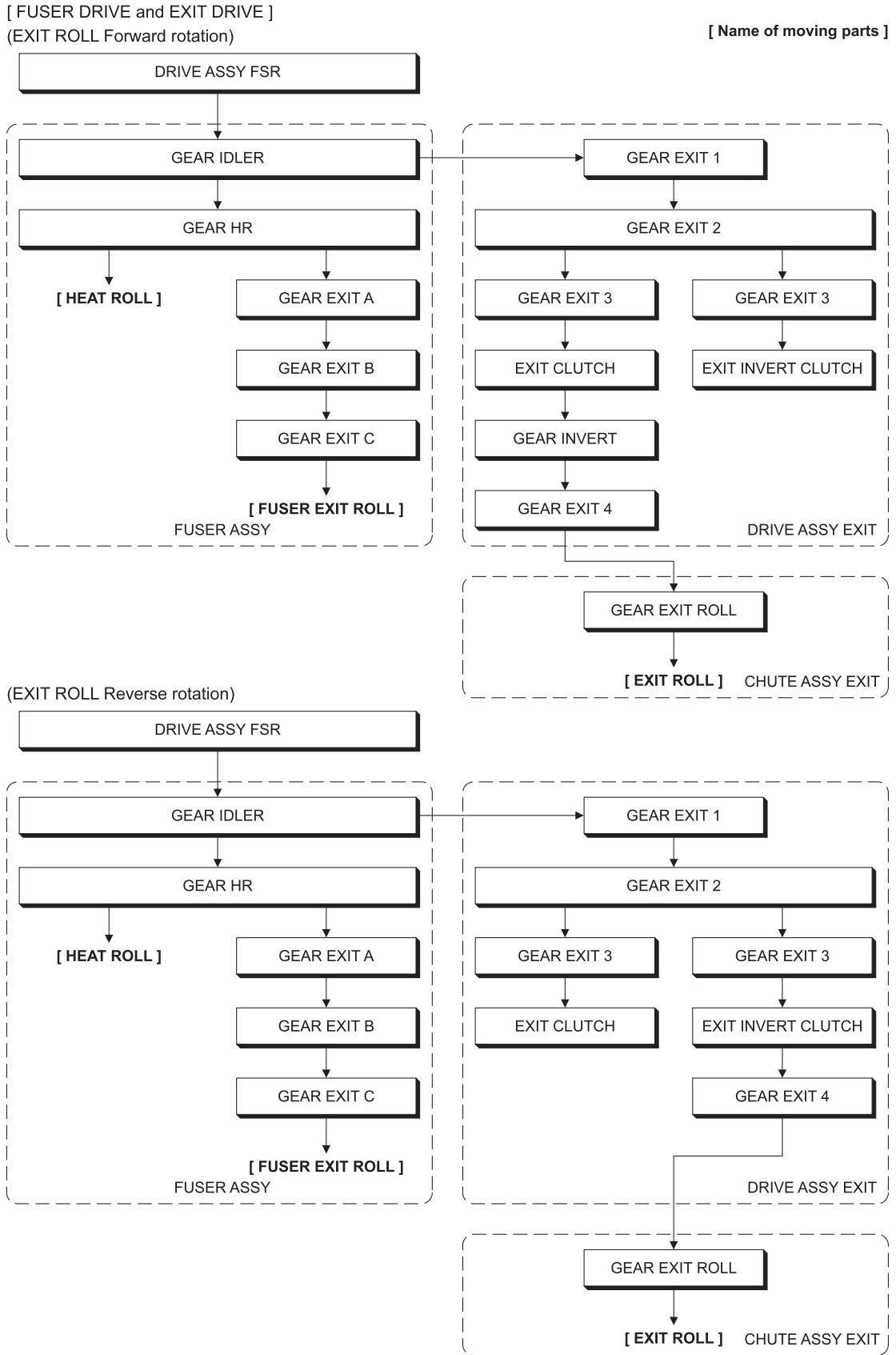

Tbt06057KA

[FUSER DRIVE and EXIT DRIVE]
 (EXIT ROLL Forward rotation)

[Name of moving parts]

▬ : Indicates the engagement of gears.

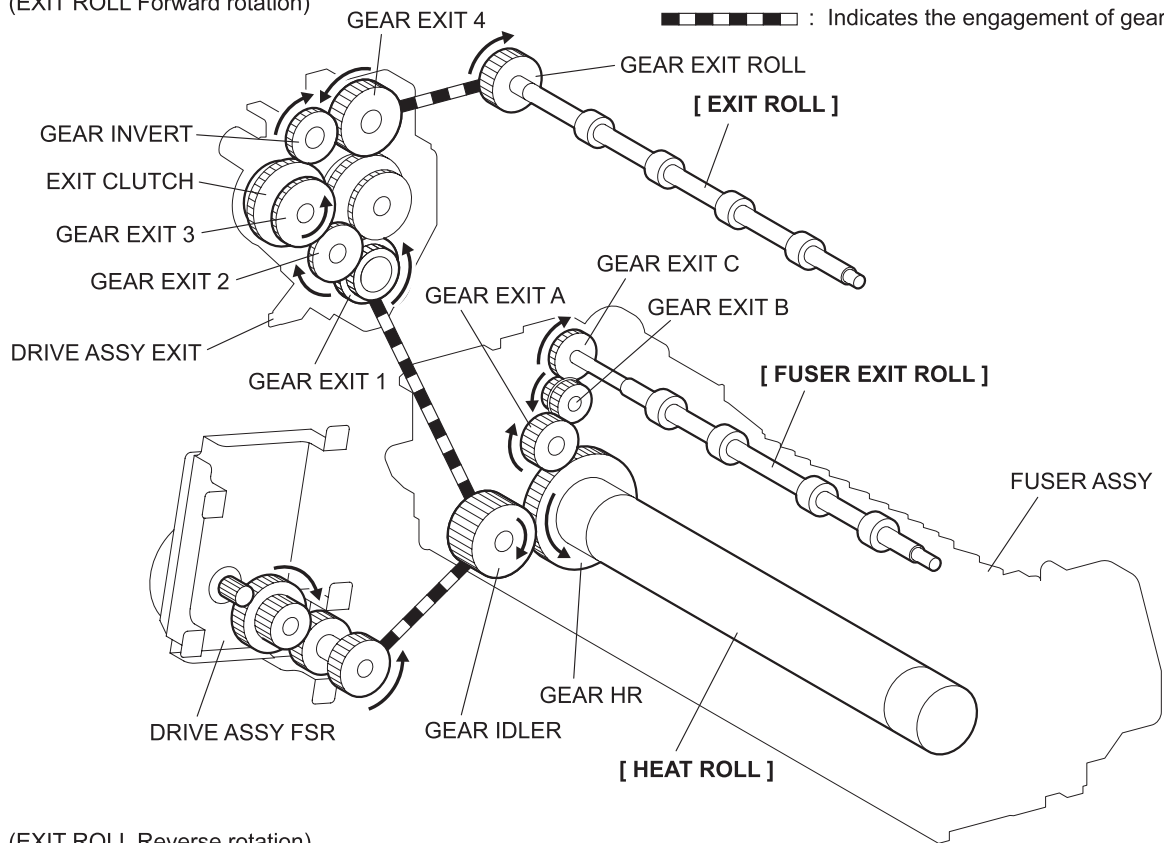

(EXIT ROLL Reverse rotation)

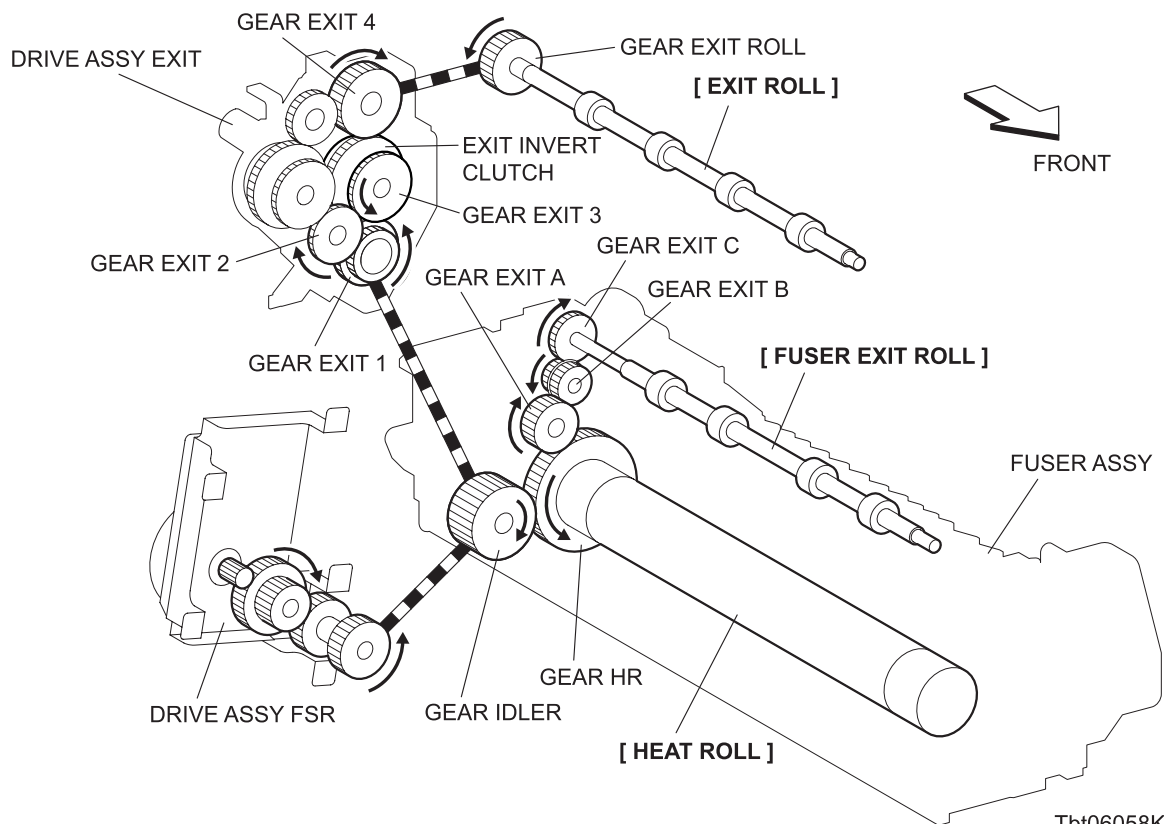

Tbt06058KA

6.3 TONER DISPENSER (Y, M, C, K)

The torque of the TONER DISPENSER drives the agitator and the auger in the TONER CARTRIDGE. The operation is common among the TONER DISPENSERS Y, M, C and K.

[TONER DISPENSER]

[Name of moving parts]

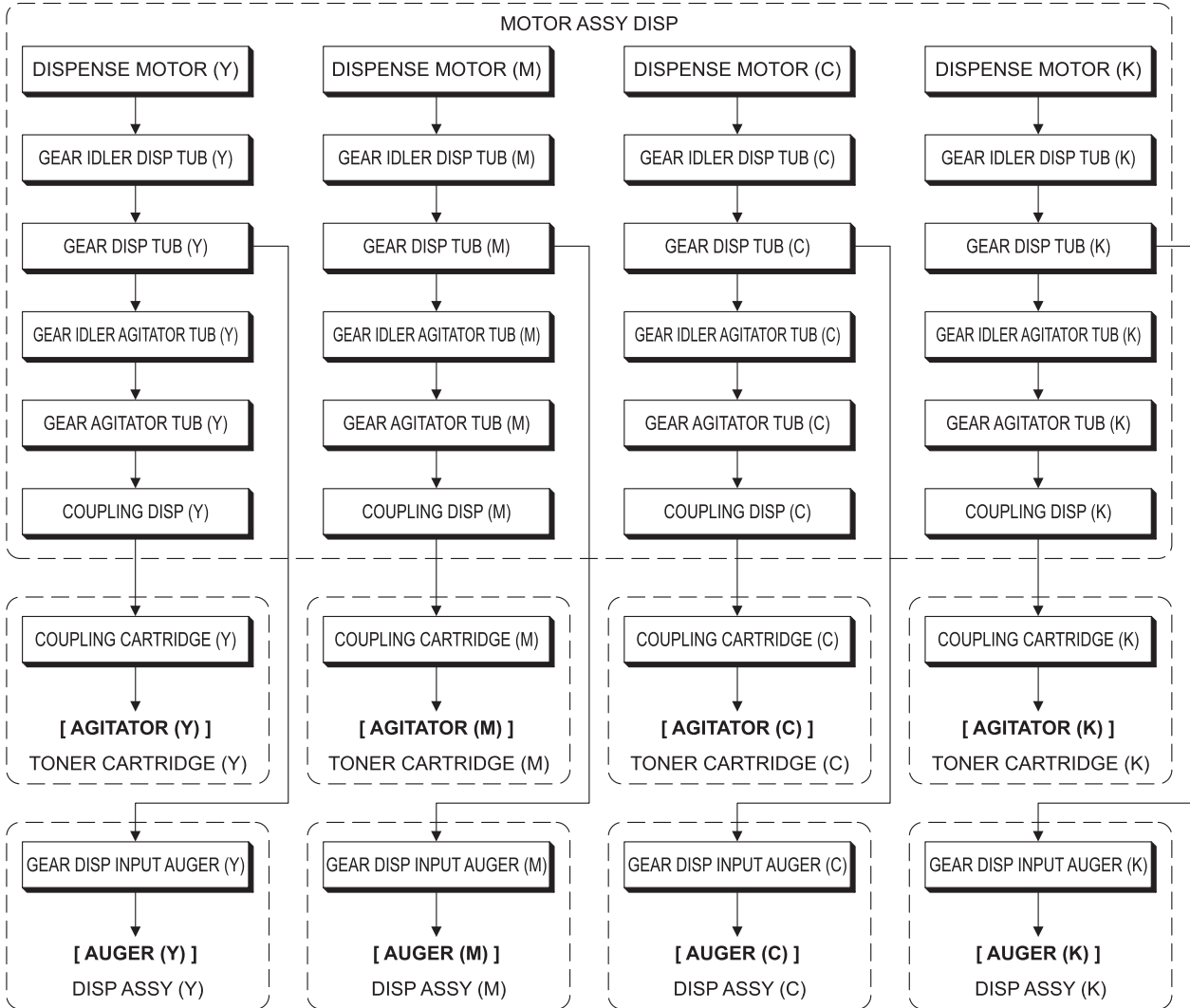

Tbt06059KA

[TONER DISPENSER]

[Name of moving parts]

▬ : Indicates the engagement of gears.

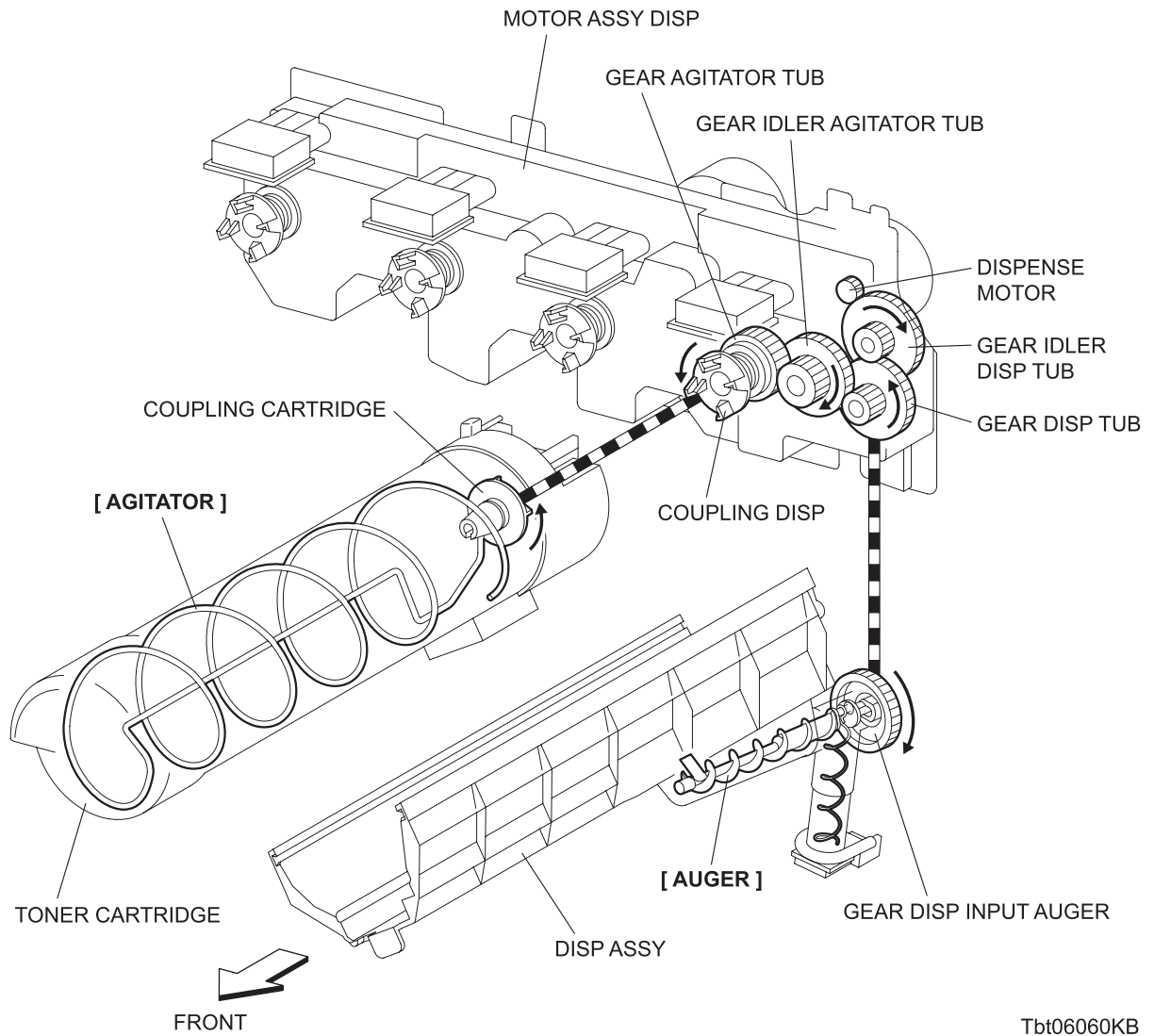

Tbt06060KB

6.4 DRIVE ASSY DEVE and DRIVE ASSY DEVE K

The torque of the DRIVE ASSY DEVE and DRIVE ASSY DEVE K are transmitted through the route below.

[DEVELOPMENT DRIVE]

[Name of moving parts]

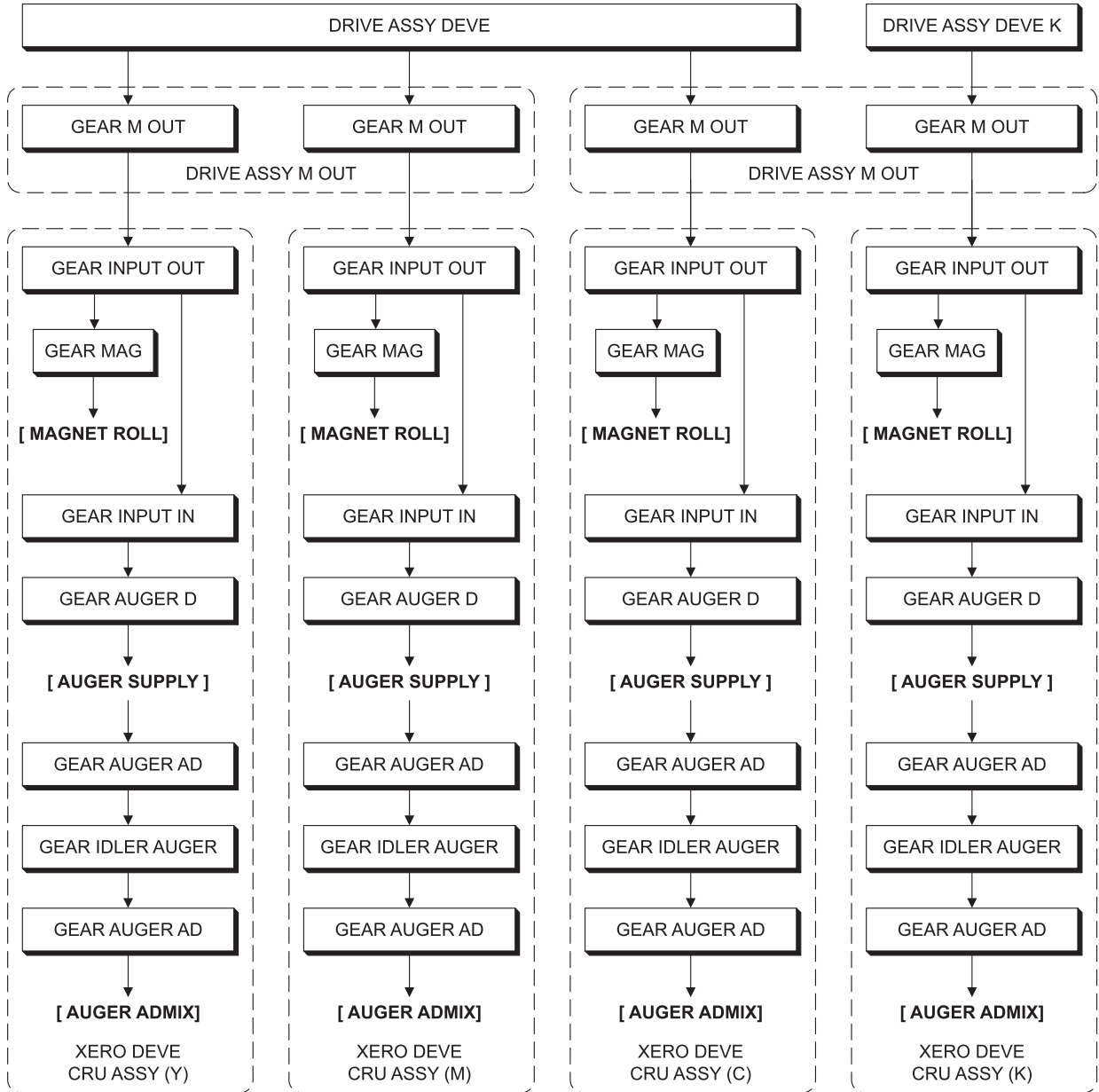

Tbt06061KA

[DEVELOPMENT DRIVE]

[Name of moving parts]

▬ : Indicates the engagement of gears.

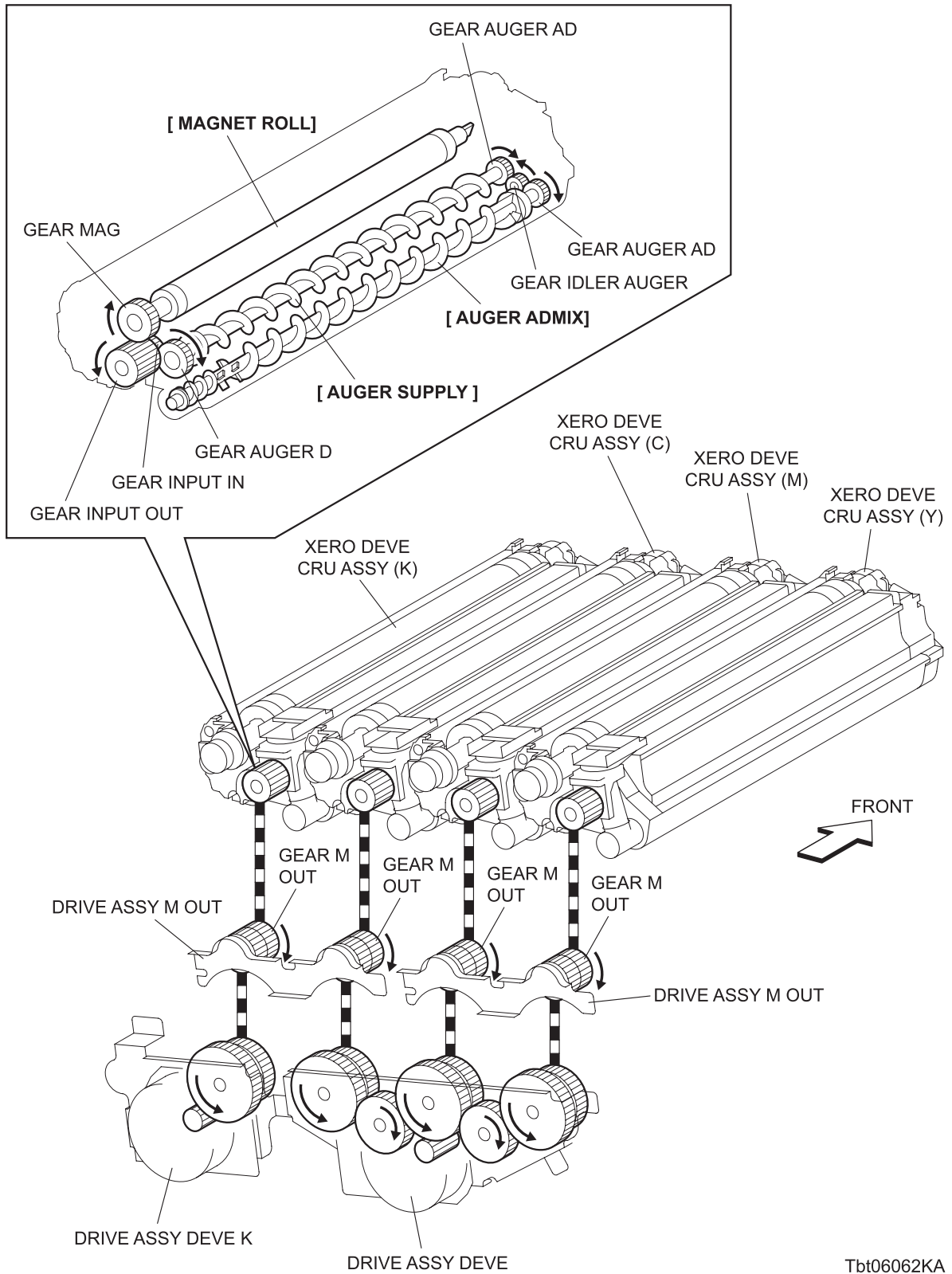

Tbt06062KA

6.5 DRIVE ASSY XERO

The torque of the DRIVE ASSY XERO is transmitted through the route below.

[DRUM DRIVE and EXCESS TONER COLLECTING]

[Name of moving parts]

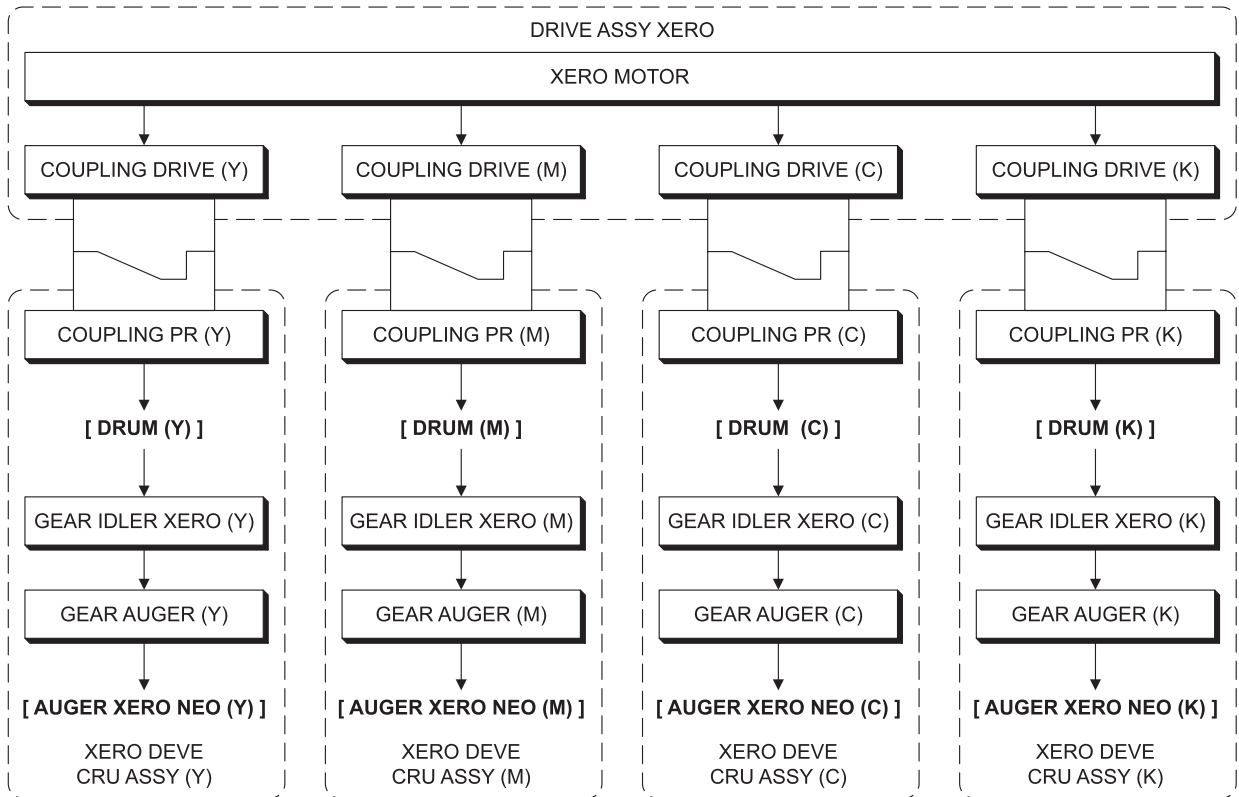

Tbt06063KA

[DRUM DRIVE and EXCESS TONER COLLECTING]

[Name of moving parts]

▬ : Indicates the engagement of gears.

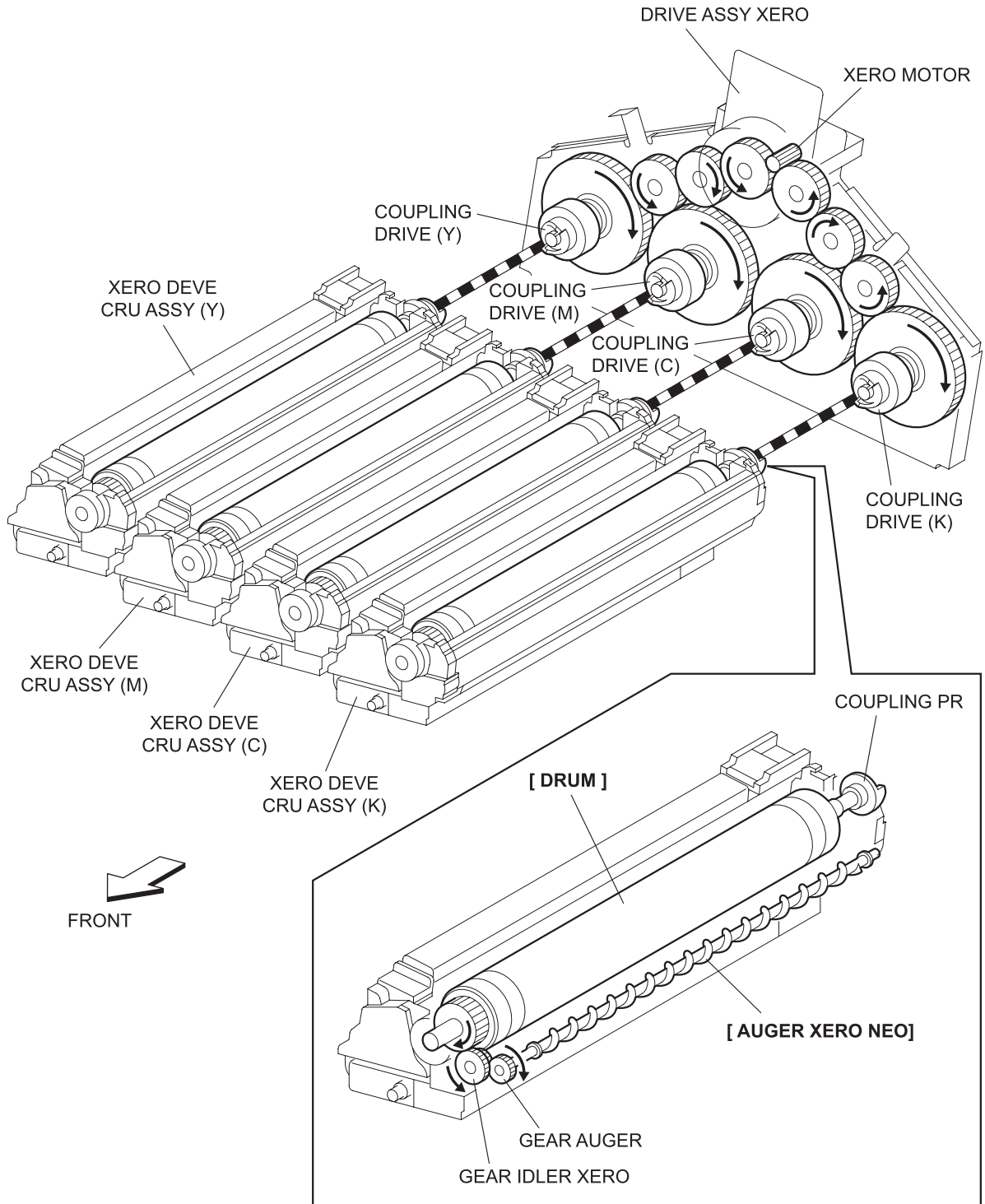

Tbt06064KA

6.6 DRIVE ASSY IBT

The torque of the DRIVE ASSY IBT is transmitted through the route below.

[BELT DRIVE and EXCESS TONER COLLECTING]

[Name of moving parts]

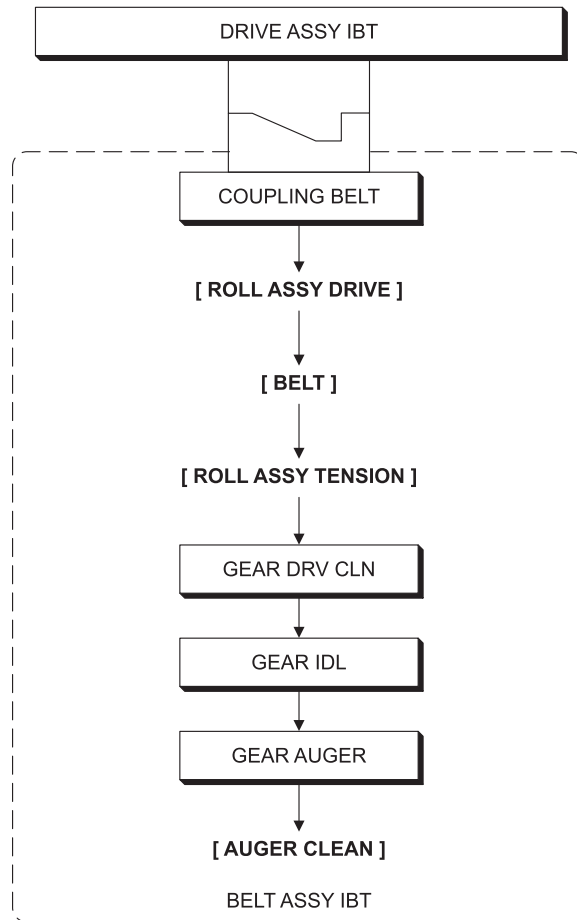

Tbt06065KA

[BELT DRIVE and EXCESS TONER COLLECTING]

[Name of moving parts]

■ : Indicates the engagement of gears.

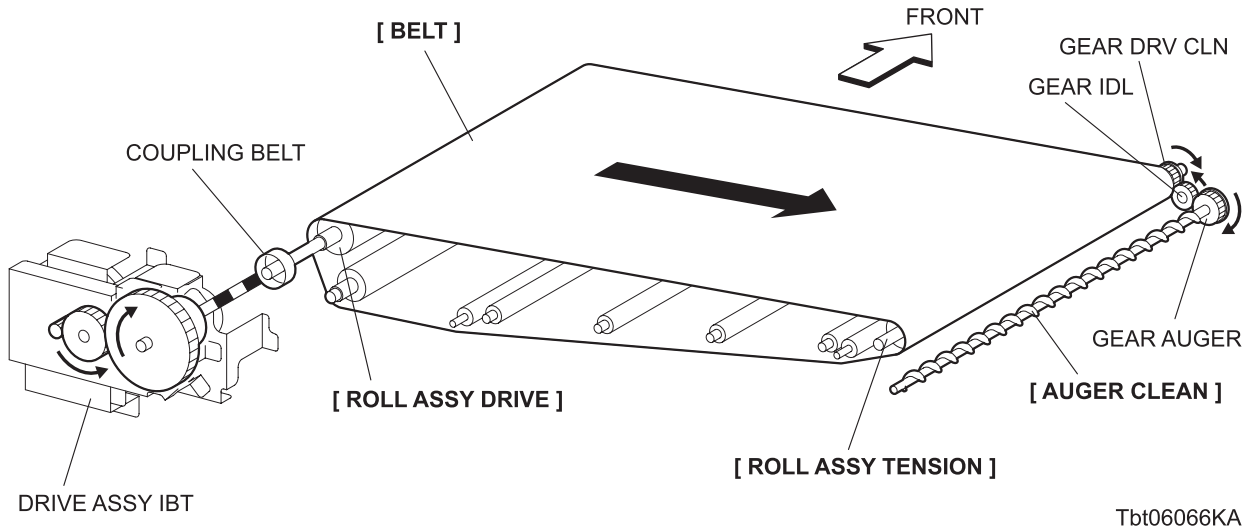

Tbt06066KA

6.7 EXCESS TONER COLLECTING

The torque of the DRIVE ASSY DEVE K drives the AUGERs of the WASTE BOX and the PIPE ASSY.

[EXCESS TONER COLLECTING]

[Name of moving parts]

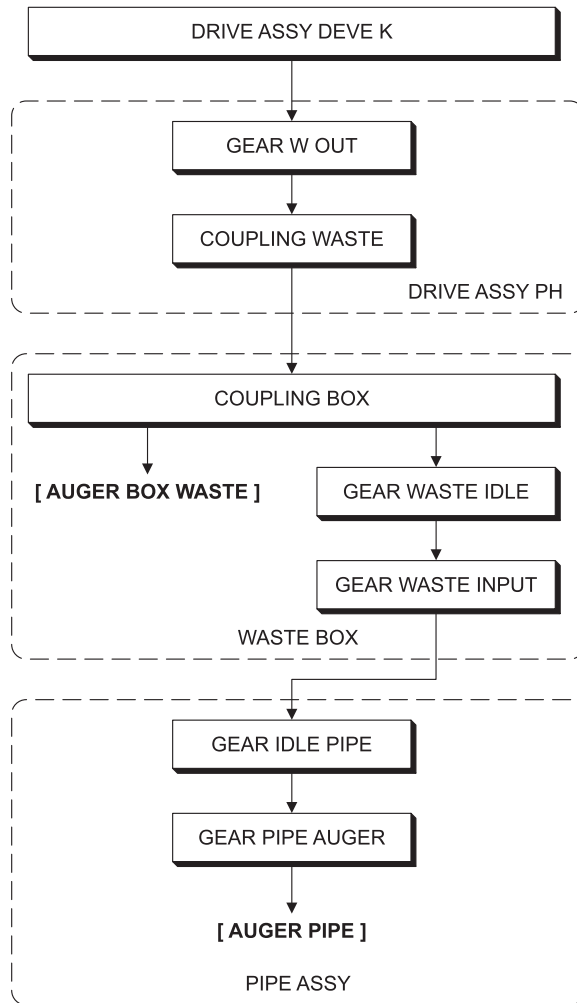

Tbt06067KA

[EXCESS TONER COLLECTING]

[Name of moving parts]

▣ : Indicates the engagement of gears.

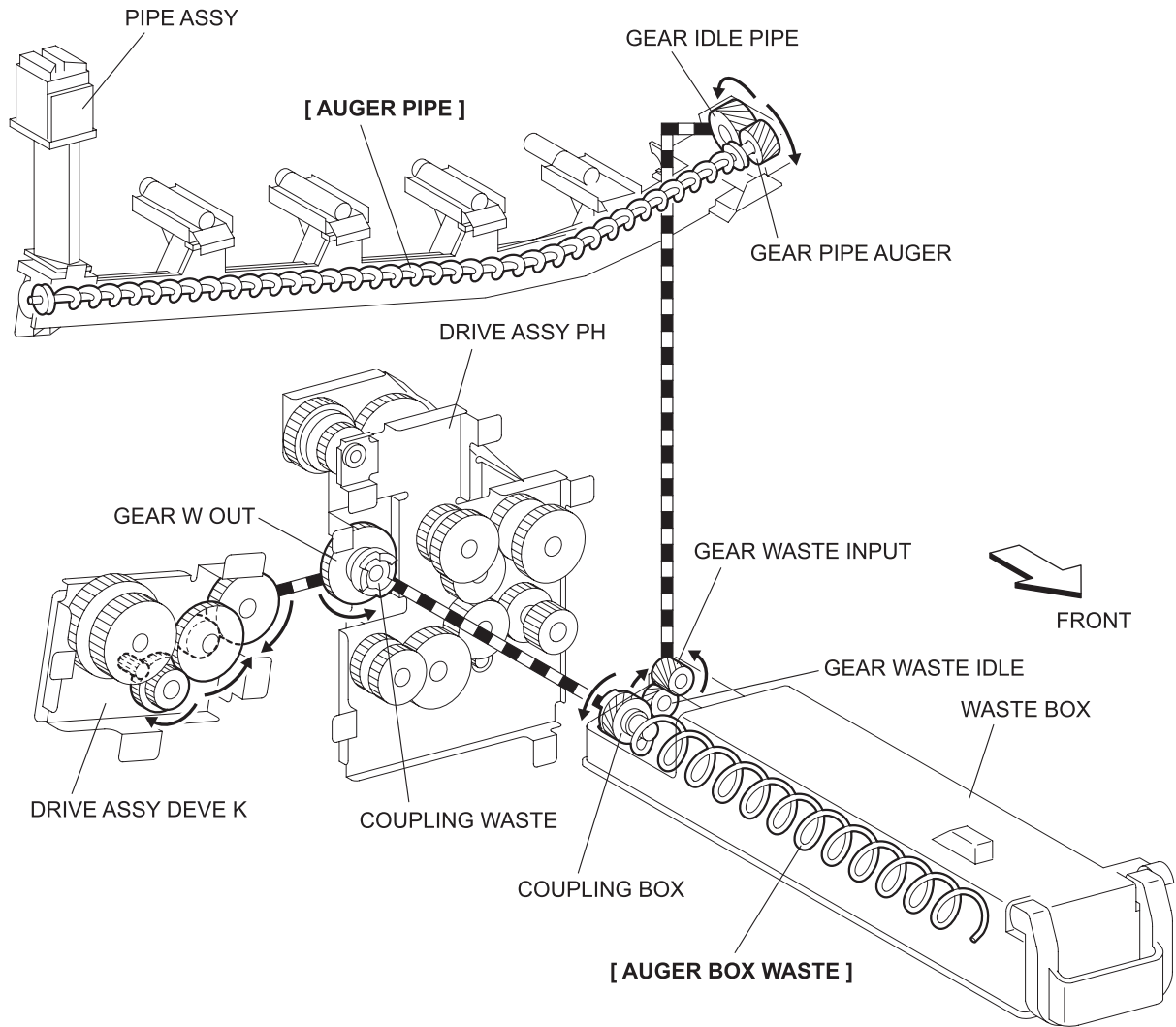

Tbt06068KA

6.8 SWITCH TO BLACK and WHITE MODE

The switching to the Black and White mode is transmitted through the route below.

[SWITCH TO BLACK and WHITE MODE]

[Name of moving parts]

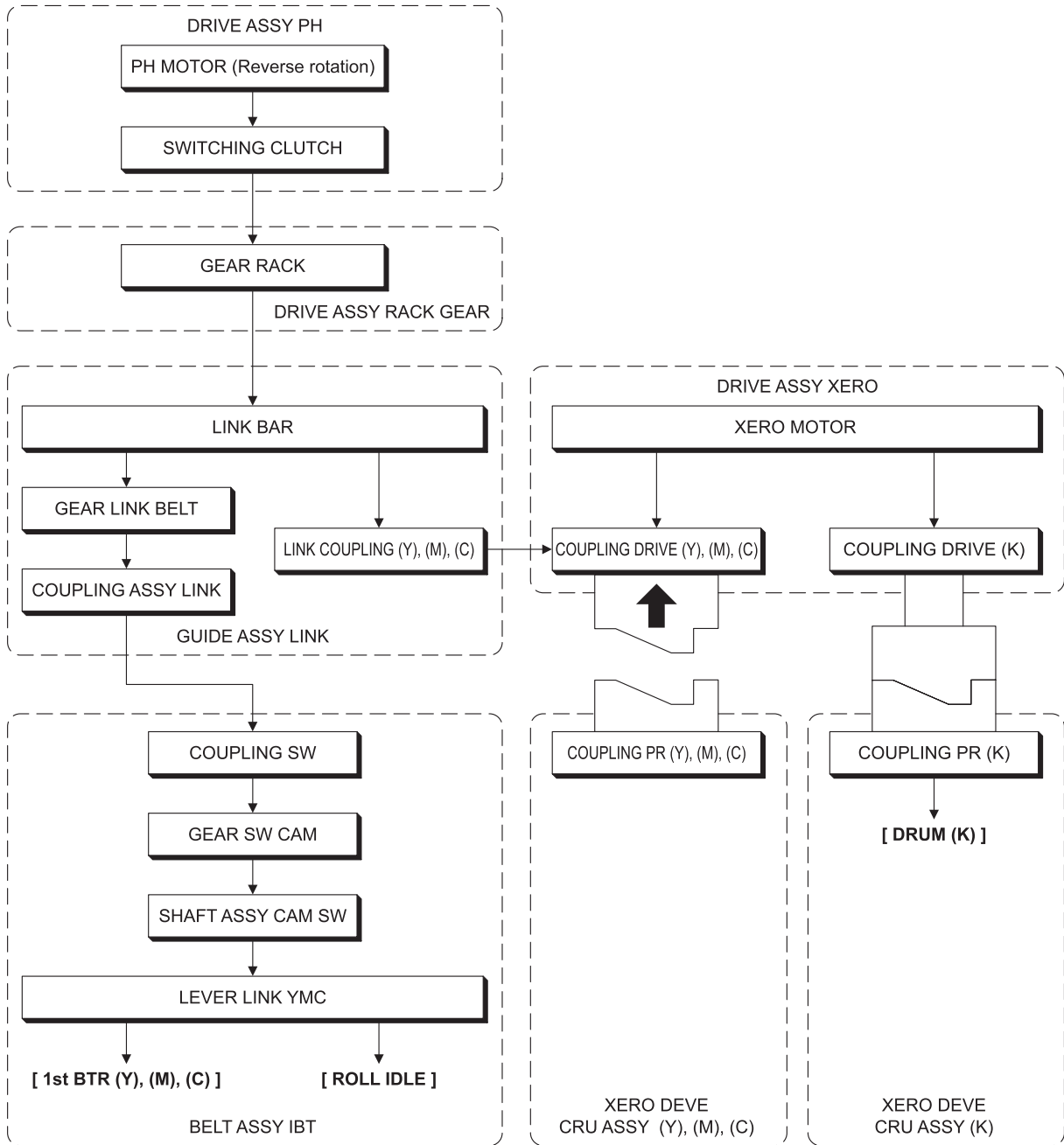

Tbt06069KA

[SWITCH TO BLACK and WHITE MODE]

[Name of moving parts]

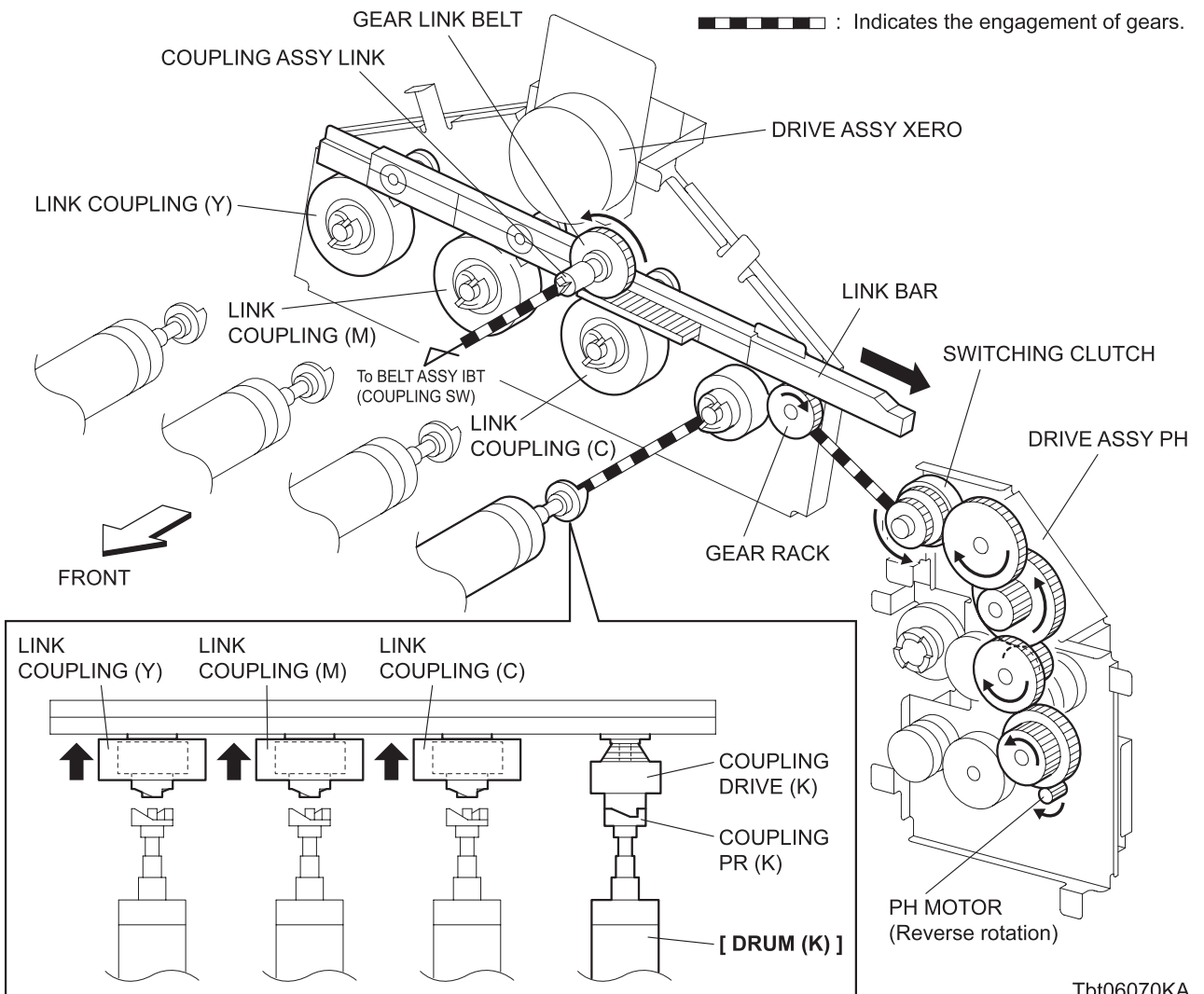
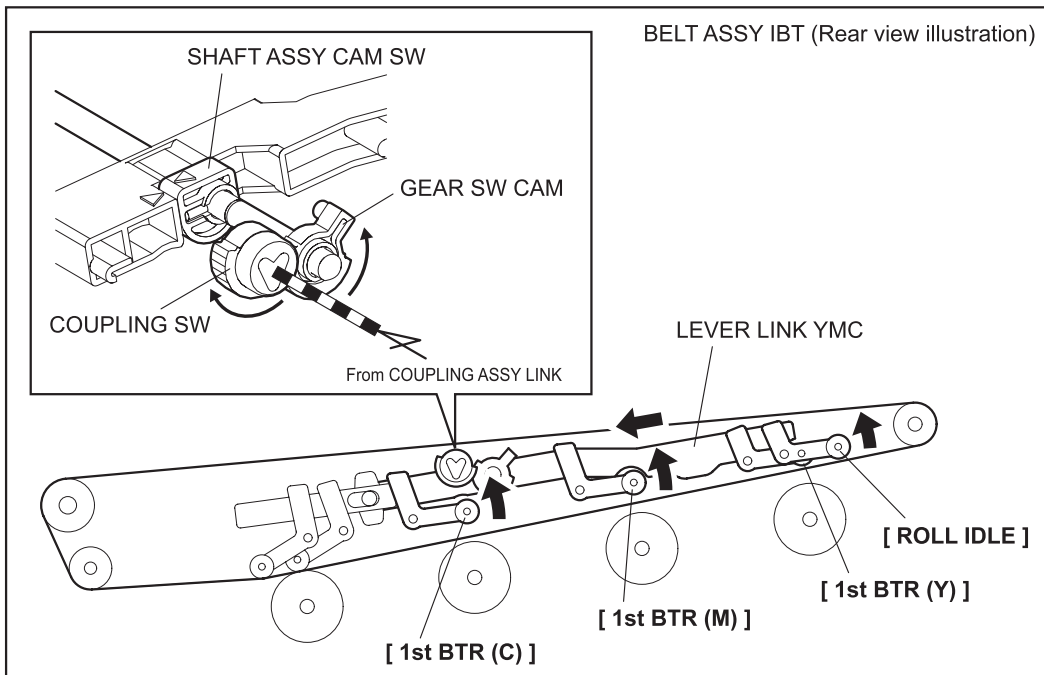

Tbt06070KA

6.9 SWITCH TO FULL COLOR MODE

The switching to the Full Color mode is transmitted through the route below.

[SWITCH TO FULL COLOR MODE]

[Name of moving parts]

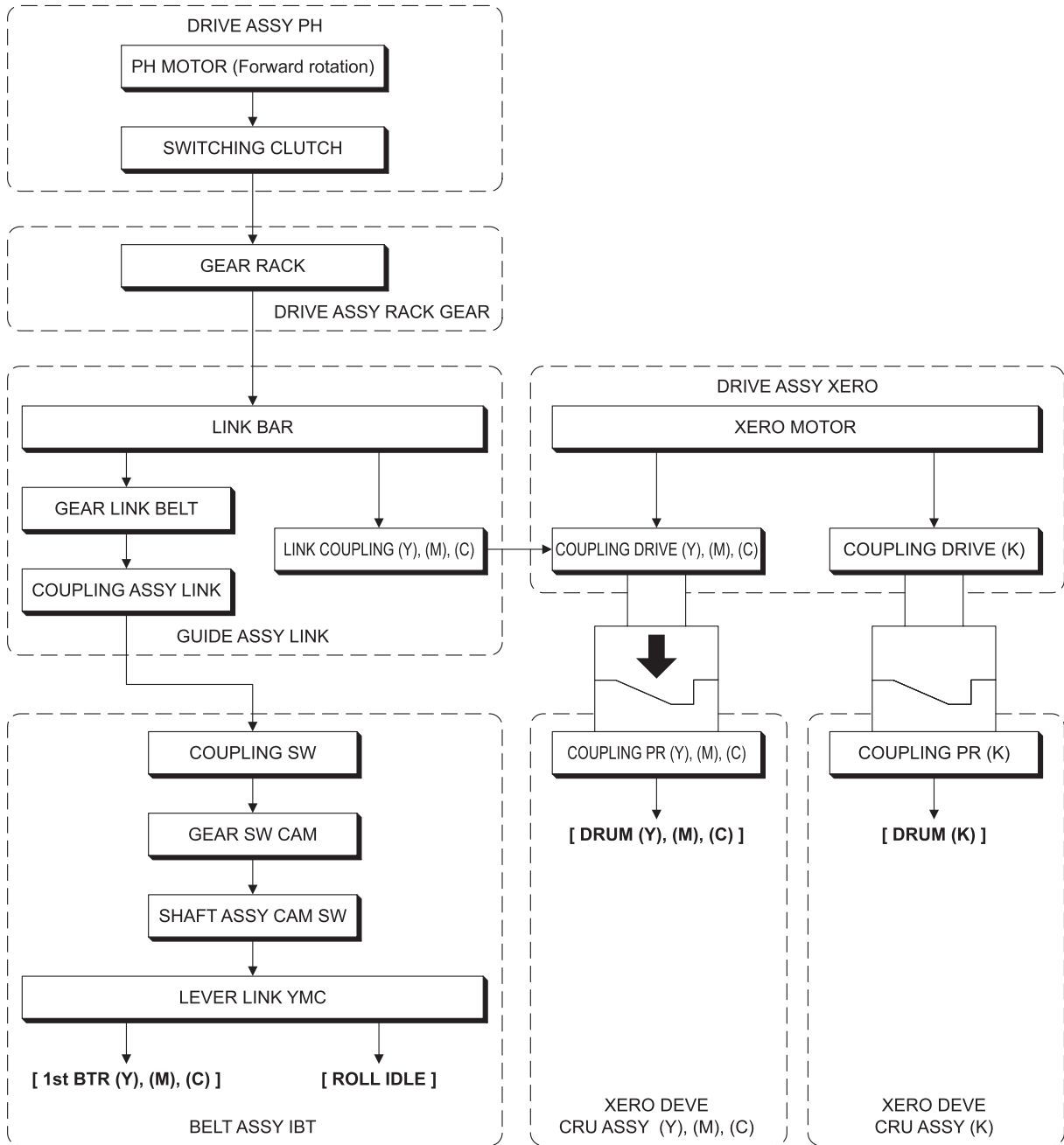

Tbt06071KA

[SWITCH TO FULL COLOR MODE]

[Name of moving parts]

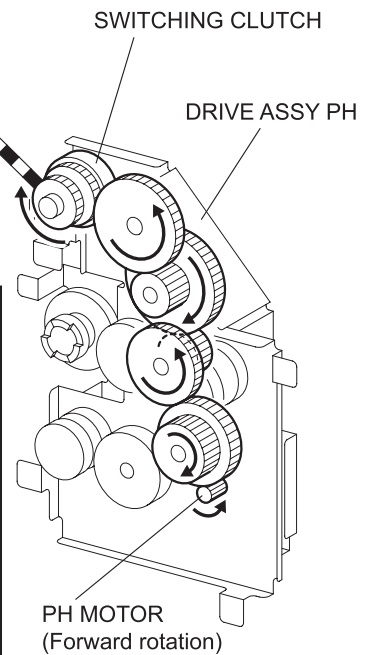
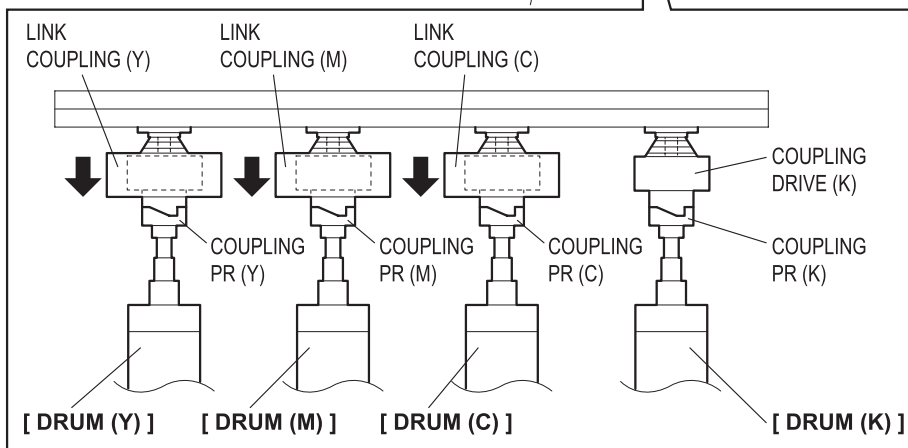
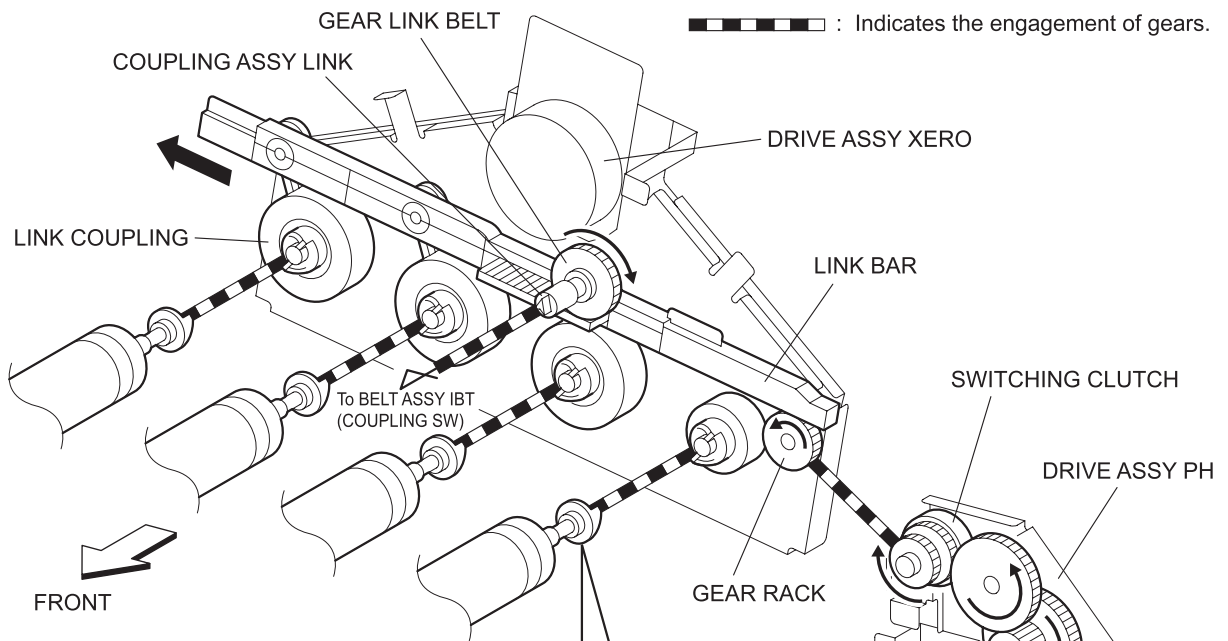
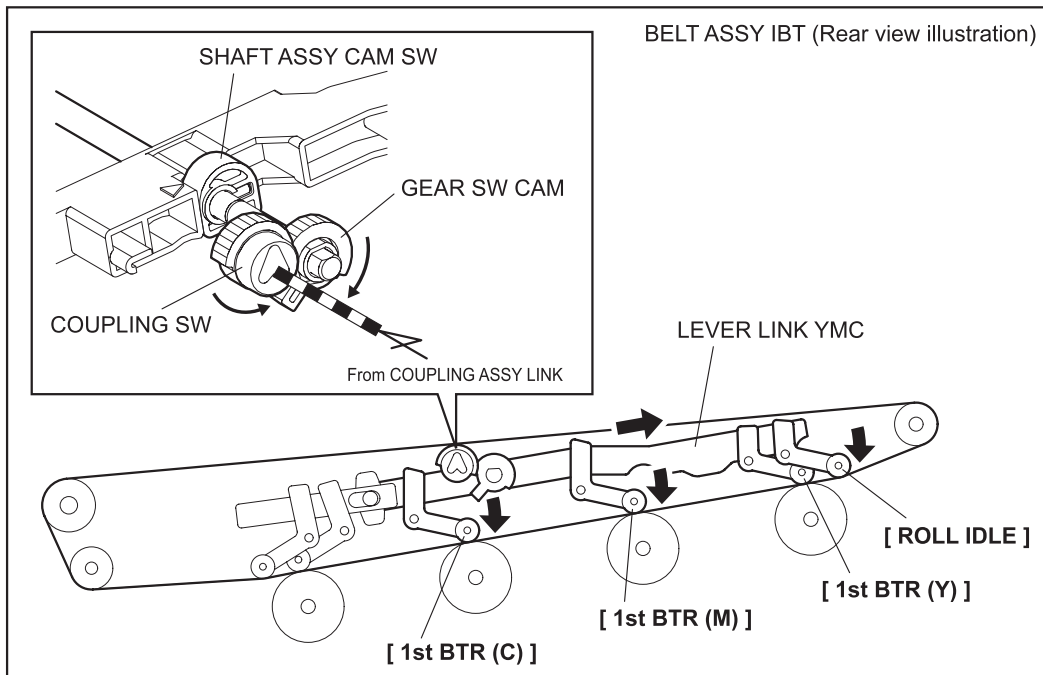

Tbt06072KA

6.10 DRIVE ASSY OPT

The torque of the DRIVE ASSY OPT is transmitted through the route below.

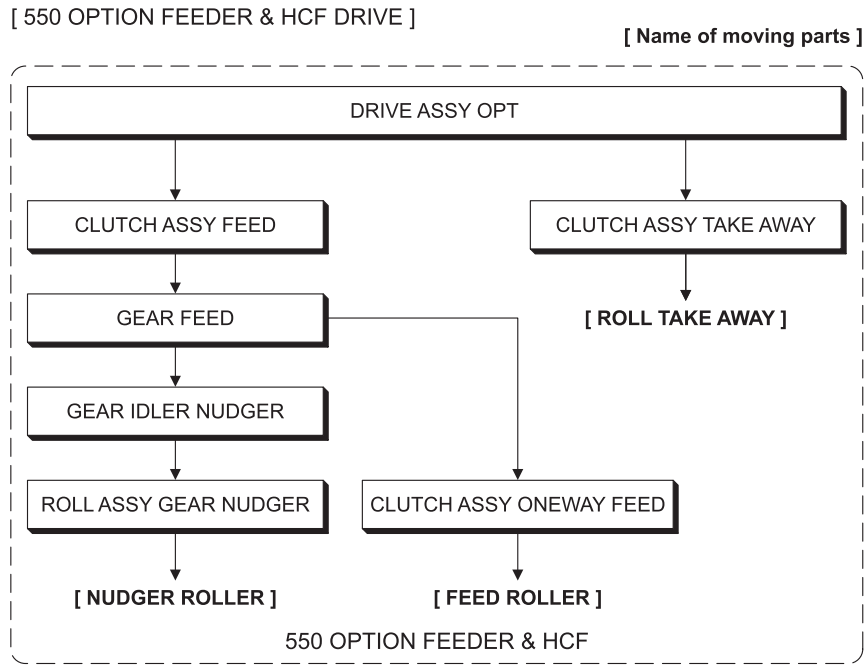

Tbt06073KA

[550 OPTION FEEDER & HCF DRIVE]

[Name of moving parts]

▣ : Indicates the engagement of gears.

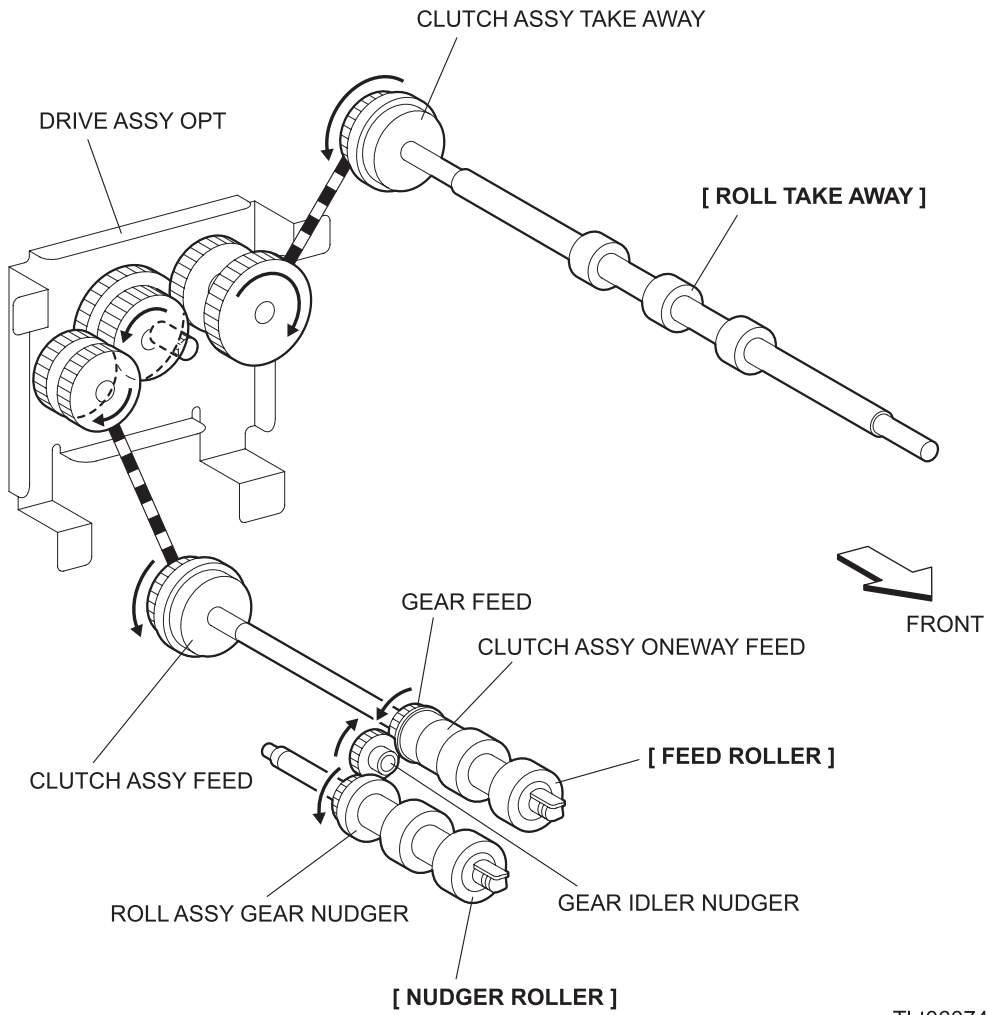

Tbt06074KA

Chapter 7 Wiring Diagrams and Signal Information CONTENTS

1. Connection Wiring Diagram..... 7 - 1

 1.1 Symbols in the General Connection Wiring Diagram..... 7 - 1

 1.2 General Wiring Diagram 7 - 2

2. Interconnection Wiring Diagram of Parts..... 7 - 3

 2.1 Notes on Using the Wiring Diagram between Parts..... 7 - 3

 2.2 Configuration of the Interconnection Wiring Diagram of Parts..... 7 - 5

 § 1 DC POWER SUPPLY 7 - 7

 § 2 FEEDER, MSI, REGI & DUPLEX 7 - 9

 § 3 DRIVE 7 - 11

 § 4 ROS 7 - 13

 § 5 XEROGRAPHIC 7 - 15

 § 6 HIGH VOLTAGE 7 - 17

 § 7 DEVELOPER 7 - 19

 § 8 FUSER & EXIT 7 - 21







 § 9 CONTROLLER 7 - 23

 § 10 OPTION 550 FEEDER & OPTION HIGH CAPACITY FEEDER (HCF)..... 7 - 25

1. Connection Wiring Diagram

1.1 Symbols in the General Connection Wiring Diagram

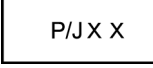
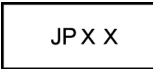
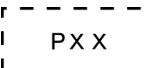
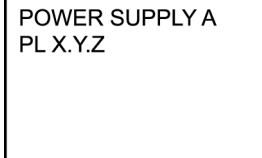
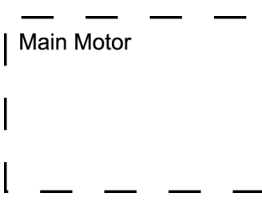
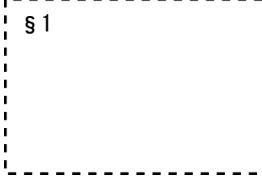
The symbols in the general connection wiring diagram are described below.

Symbol	Description
	Represents an interconnection between parts using wiring harness or wire.
	Represents an interconnection which differs according to the specifications.
	Represents an interconnection between parts using a conductive member such as a plate spring.
	Represents a connection between parts by tightening of a screw.
	Indicates a frame ground.
	Represents a connector. The connector No. is indicated inside the box.
	Represents a connection terminal with a plate spring on the printed circuit board. The connector (terminal) No. is indicated inside the box.
	Represents a connector directly connected to the printed circuit board. The connector No. is indicated inside the box.
	The box containing a part name represents a part. "PL X.Y.Z" indicates the item "Z" of the plate (PL) "X.Y" described in Chapter 5 "Parts List."
	Represents a functional part within a part, and indicates the name of the functional part.
	Represents a section in "2. Interconnection Wiring Diagram of Parts," and indicates its section No.
	Represents a screw for fixing wiring harness and a conductive member such as a plate spring.
	Represents a conductive member such as a plate spring.

1.2 General Wiring Diagram

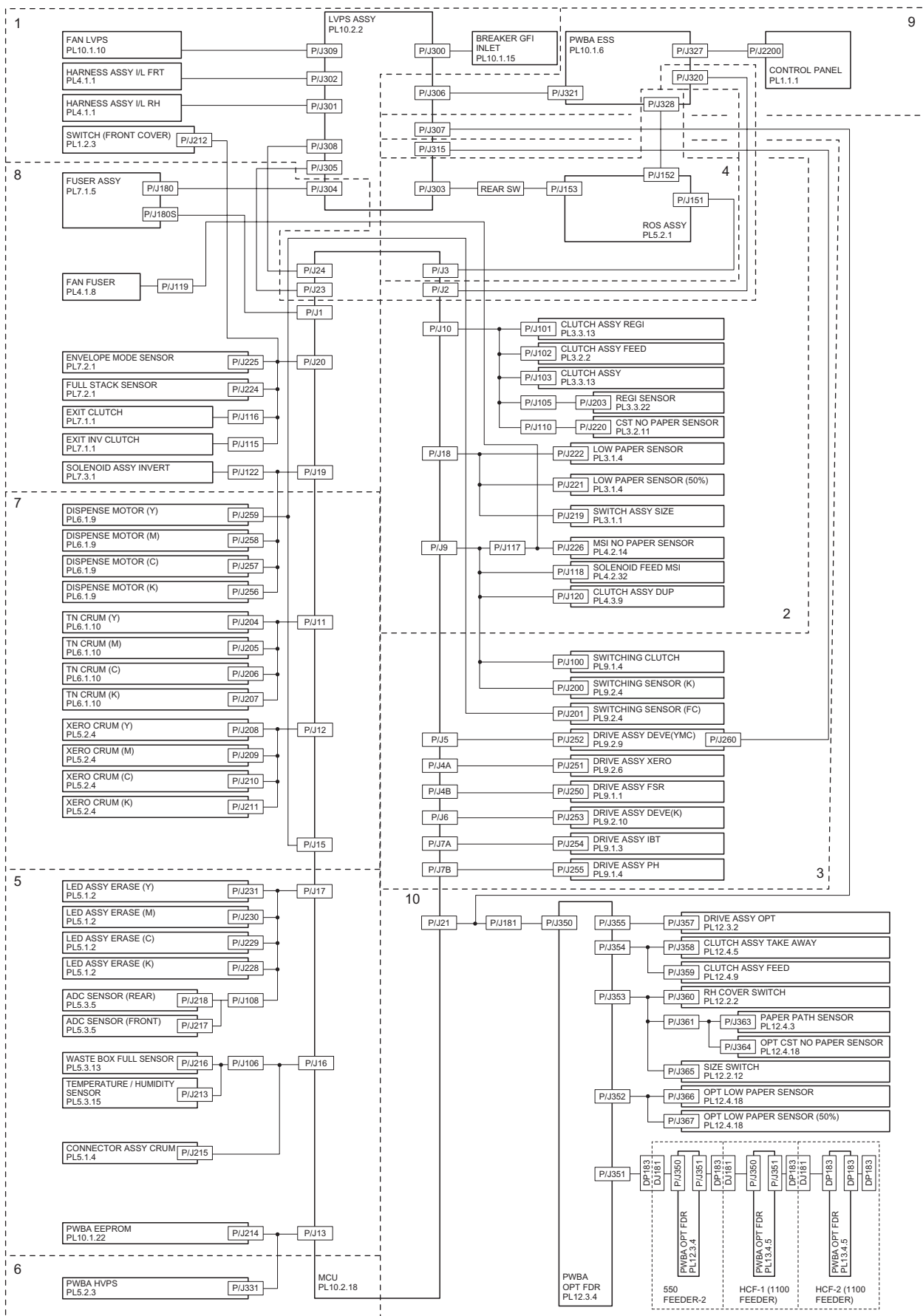



Tbt07001KB

2. Interconnection Wiring Diagram of Parts

2.1 Notes on Using the Wiring Diagram between Parts

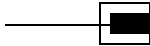
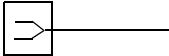
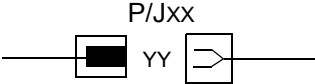
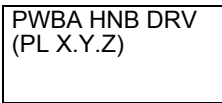
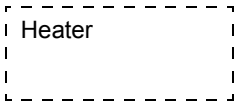
The following describes the legend of the wiring diagrams between parts shown on the following pages.

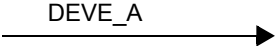
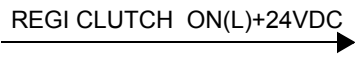
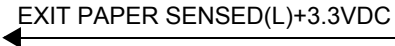
Symbols	Description
	Denotes a plug.
	Denotes a jack.
	Denotes Pin yy and Jack yy of the connector Pxx and Jxx.
	Denotes the parts. PL X.Y.Z implies the item "Z" of plate (PL) "X.Y" in Chapter 5. Parts List.
	Denotes functional parts attached with functional parts name.
	Denotes the control and its outline in PWB.
	Denotes a connection between parts with harnesses or wires, attached with signal name/contents.
	Denotes the function, and logic value of the signal to operate the function (Low: L, High: H). The given voltage is for signal in high status. The arrow indicates the direction of signal.
	Denotes the function, and logic value of the signal when the function operated (Low: L, High: H). The given voltage is for signal in high status. The arrow indicates the direction of signal.

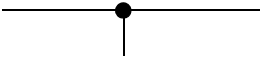
Symbols	Description
	Denotes a connection between wires.
I/L +24VDC	Denotes DC voltage when the interlock switch in HNB MCU WITH CPU turns on.
+5VDC +3.3VDC	Denotes DC voltage.
SG	Denotes signal ground.
AG	Denotes analog ground.
RTN	Denotes the return.

2.2 Configuration of the Interconnection Wiring Diagram of Parts

The interconnection wiring diagram is divided into 10 sections. § 1 to § 10 indicate details of the interconnections of parts.

§ 1 DC POWER SUPPLY

Connections of PWBA LVPS with PWBA MCU.
 Connections of BREAKER GFI INLET with PWBA LVPS.
 Connections of FAN LVPS with PWBA LVPS.
 Connections of HARNESS ASSY I/L RH with PWBA LVPS.
 Connections of HARNESS ASSY I/L FRT with PWBA LVPS.
 Connections of SWITCH (FRONT COVER) with PWBA MCU.

§ 2 FEEDER, MSI, REGI & DUPLEX

Connections of CLUTCH ASSY REGI with PWBA MCU.
 Connections of CLUTCH ASSY FEED with PWBA MCU.
 Connections of CLUTCH ASSY TAKE AWAY with PWBA MCU.
 Connections of REGI SENSOR with PWBA MCU.
 Connections of CST NO PAPER SENSOR with PWBA MCU.
 Connections of MSI NO PAPER SENSOR with PWBA MCU.
 Connections of SOLENOID FEED MSI with PWBA MCU.
 Connections of CLUTCH ASSY DUP with PWBA MCU.
 Connections of LOW PAPER SENSOR with PWBA MCU.
 Connections of LOW PAPER SENSOR (50%) with PWBA MCU.
 Connections of SWITCH ASSY SIZE with PWBA MCU.

§ 3 DRIVE

Connections of DRIVE ASSY DEVE (YMC) with PWBA MCU.
 Connections of DRIVE ASSY DEVE (YMC) with LVPS ASSY.
 Connections of DRIVE ASSY XERO with PWBA MCU.
 Connections of DRIVE ASSY FSR with PWBA MCU.
 Connections of DRIVE ASSY DEVE (K) with PWBA MCU.
 Connections of DRIVE ASSY IBT with PWBA MCU.
 Connections of DRIVE ASSY PH with PWBA MCU.
 Connections of SWITCHING CLUTCH with PWBA MCU.
 Connections of SWITCHING SENSOR (K) with PWBA MCU.
 Connections of SWITCHING SENSOR (FC) with PWBA MCU.

§ 4 ROS

Connections of ROS ASSY with PWBA MCU.

§ 5 XEROGRAPHIC

Connections of LED ASSY ERASE (Y) with PWBA MCU.
 Connections of LED ASSY ERASE (M) with PWBA MCU.
 Connections of LED ASSY ERASE (C) with PWBA MCU.
 Connections of LED ASSY ERASE (K) with PWBA MCU.
 Connections of ADC SENSOR (REAR) with PWBA MCU.
 Connections of ADC SENSOR (FRONT) with PWBA MCU.
 Connections of WASTE BOX FULL SENSOR with PWBA MCU.
 Connections of TEMPERATURE / HUMIDITY SENSOR with PWBA MCU.
 Connections of CONNECTOR ASSY CRUM with PWBA MCU.
 Connections of PWBA EEPROM with PWBA MCU.

§ 6 HIGH VOLTAGE

Connections of PWBA HVPS with PWBA MCU.

§ 7 DEVELOPER

Connections of DISPENSE MOTOR (Y) with PWBA MCU.
Connections of DISPENSE MOTOR (M) with PWBA MCU.
Connections of DISPENSE MOTOR (C) with PWBA MCU.
Connections of DISPENSE MOTOR (K) with PWBA MCU.
Connections of ZERO CRUM (Y) with PWBA MCU.
Connections of ZERO CRUM (M) with PWBA MCU.
Connections of ZERO CRUM (C) with PWBA MCU.
Connections of ZERO CRUM (K) with PWBA MCU.
Connections of TN CRUM (Y) with PWBA MCU.
Connections of TN CRUM (M) with PWBA MCU.
Connections of TN CRUM (C) with PWBA MCU.
Connections of TN CRUM (K) with PWBA MCU.

§ 8 FUSER & EXIT

Connections of FUSER FAN with PWBA MCU.
Connections of DRIVE ASSY EXIT with PWBA MCU.
Connections of CHUTE ASSY EXIT with PWBA MCU.
Connections of CHUTE ASSY INVERT with PWBA MCU.
Connections of FUSER ASSY with PWBA MCU.
Connections of FUSER ASSY with PWBA LVPS.

§ 9 CONTROLLER

Connections of PWBA ESS with PWBA MCU.
Connections of CONSOLE ASSY PANEL with PWBA ESS.
Connections of PWBA LVPS with PWBA ESS

§ 10 OPTION 550 FEEDER & OPTION HIGH CAPACITY FEEDER (HCF)

Connections of PWBA OPT FDR with PWBA MCU.
Connections of PWBA OPT FDR with PWBA LVPS.
Connections of DRIVE ASSY OPT with PWBA OPT FDR.
Connections of CLUTCH ASSY TAKE AWAY with PWBA OPT FDR.
Connections of CLUTCH ASSY FEED with PWBA OPT FDR.
Connections of RH COVER SWITCH with PWBA OPT FDR.
Connections of PAPER PATH SENSOR with PWBA OPT FDR.
Connections of NO PAPER SENSOR with PWBA OPT FDR.
Connections of SWITCH ASSY SIZE with PWBA OPT FDR.
Connections of LOW PAPER SENSOR with PWBA OPT FDR.
Connections of LOW PAPER SENSOR (50%) with PWBA OPT FDR.

§ 1 DC POWER SUPPLY

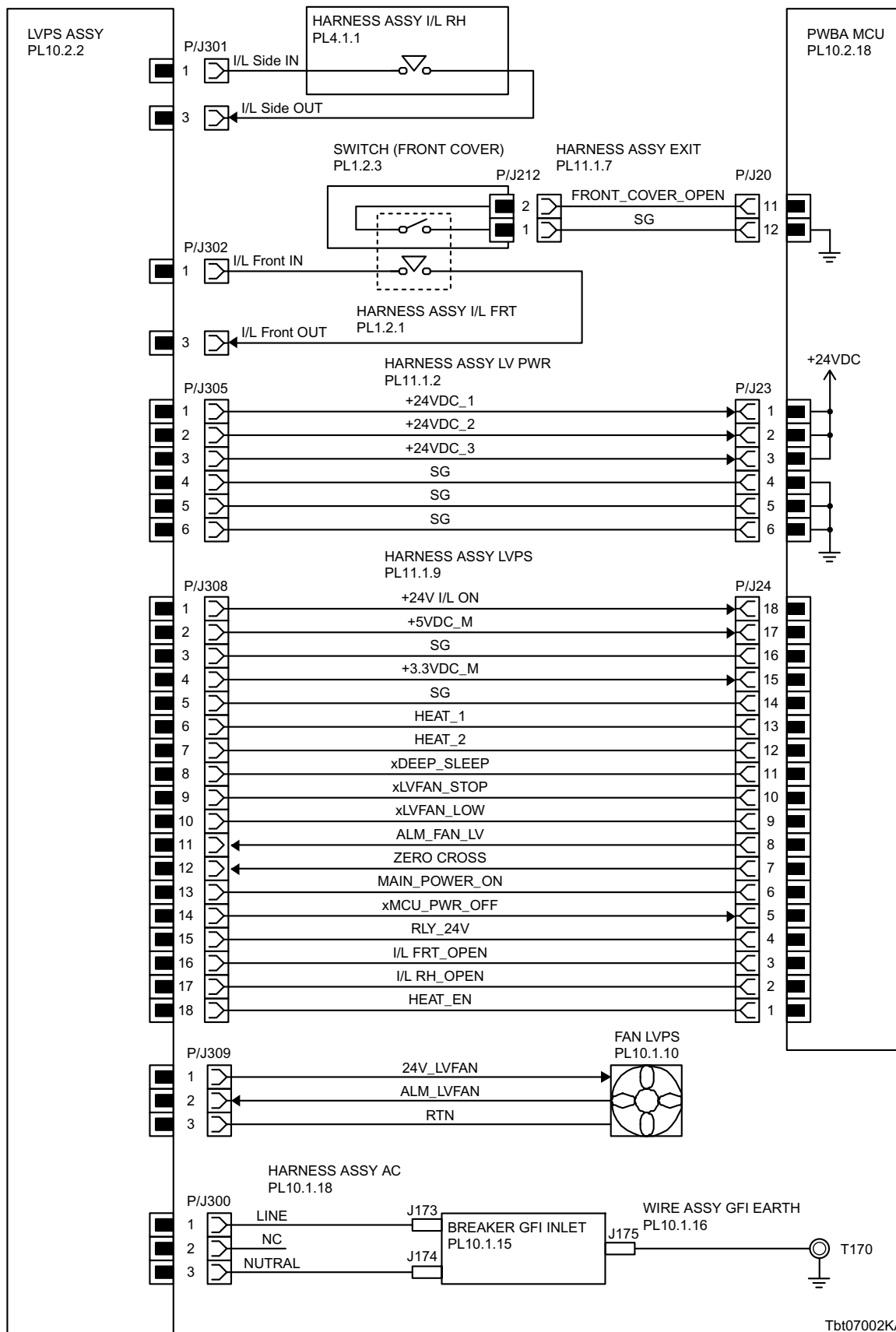

Tbt07002KA

Signal line name	Description
+24V I/L ON, +5VDC M, +3.3VDC M HEAT 1~3, HEAT EN I/L FRT OPEN, I/L RH OPEN DEEP SLEEP ZERO CROSS MAIN POWER ON MCU PWR OFF RLY 24V	Control signal of the LVPS
LVFAN STOP LVFAN LOW ALM FAN LV	Drive control signal of the SIDE FAN

- LVPS overcurrent protection circuit

This circuit stops all outputs, if the power supply voltage 24VDC, 5VDC, or 3.3VDC is shorted.

The circuit is reset, when after the cause of short was removed, the power is turned off, and then on again after certain time.

- LVPS overvoltage protection circuit

This circuit stops all outputs, if the power supply voltage 24VDC, 5VDC, or 3.3VDC exceeds the specified voltage respectively.

At this time, the operating point is 32VDC or less for 24VDC, 7VDC or less for 5VDC, or 4.4VDC or less for 3.3VDC.

The circuit is reset, when the power is turned off, and then on again after certain time.

- Sleep mode and deep sleep mode

The output of the following power supply are stopped according to the these signals.

Signal \ Output	+24VDC	+5VDC	+3.3VDC
Sleep	OFF	OFF	ON
Deep sleep	OFF	OFF	OFF

§ 2 FEEDER, MSI, REGI & DUPLEX

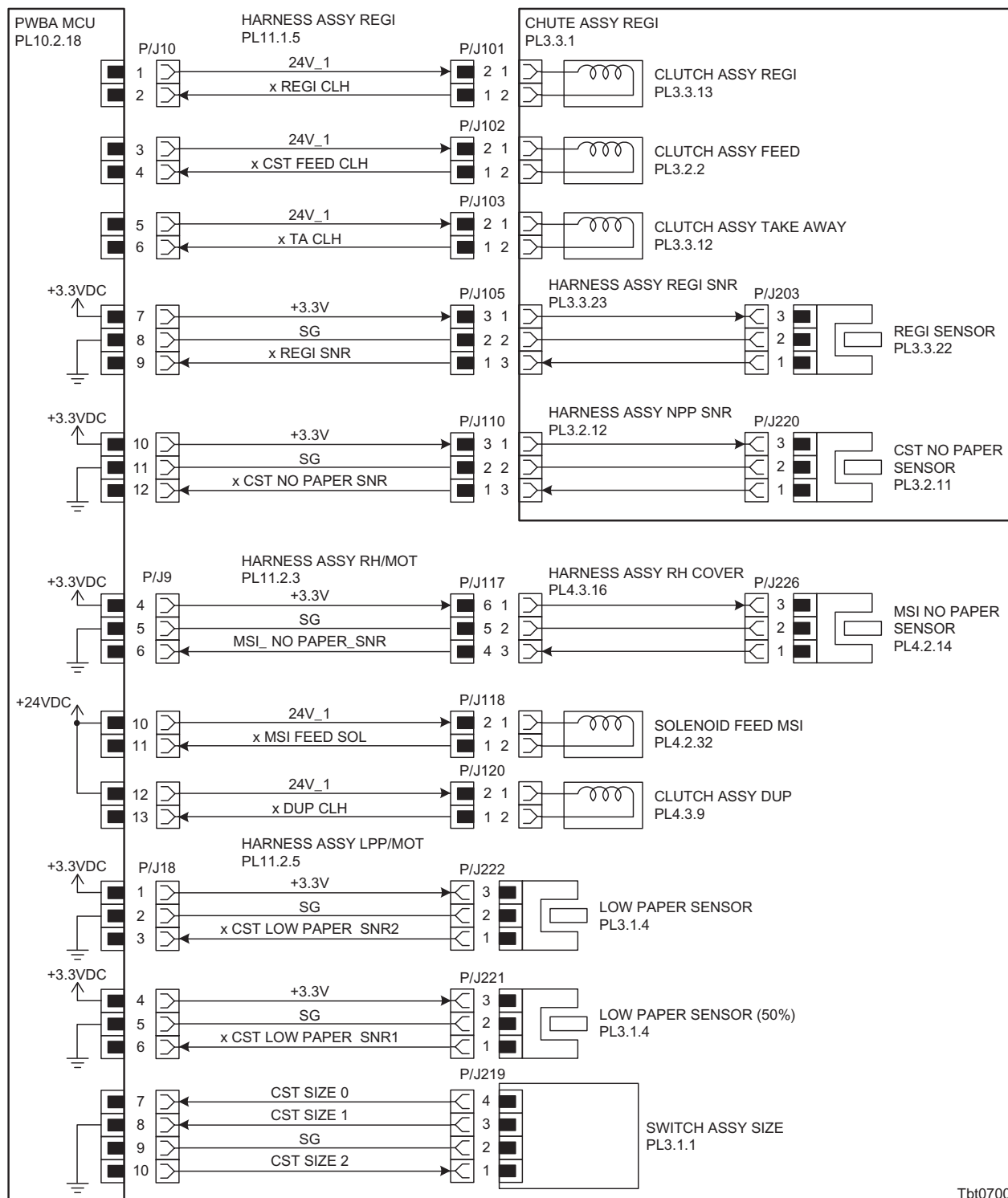

Tbt07003KA

Signal line name	Description
REGI CLH	ON/OFF signal of the REGI CLUTCH
CST FEED CLH	ON/OFF signal of the CST FEED CLUTCH
TA CLH	ON/OFF signal of the TAKE AWAY CLUTCH
REGI SNR	Paper detect signal of the Regi part by the Sensor Photo (REGI SENSOR)
CST NO PAPER SNR	Paper detect signal of the Paper Cassette by the Sensor Photo (CST NO PAPER SENSOR)
MSI NO PAPER SNR	Paper detect signal of the MSI by the Sensor Photo (MSI NO PAPER SENSOR)
MSI FEED SOL	ON/OFF signal of the MSI FEED SOLENOID
DUP CLH	ON/OFF signal of the DUPLEX CLUTCH
CST LOW PAPER SNR2	Paper detect signal of the Feeder by the Sensor Photo (LOW PAPER SENSOR-2)
CST LOW PAPER SNR1	Paper detect signal of the Feeder by the Sensor Photo (LOW PAPER SENSOR-1: 50%)
CST SIZE 0~2	ON/OFF signal of the SWITCH ASSY SIZE

- Outline of SWITCH ASSY SIZE

The paper size is determined by a combination of ON/OFF statuses of the SW 1, SW 2, and SW 3 switches of SWITCH ASSY SIZE.

Paper size	Switches		
	SW 1	SW 2	SW 3
LEGAL 14" (SEF)	ON	ON	ON
LEGAL 13" (SEF)	ON	ON	OFF
EXECUTIVE (SEF)	ON	OFF	ON
B5 (SEF)	ON	OFF	OFF
A4 (SEF)	OFF	ON	ON
LETTER (SEF)	OFF	OFF	ON
A5	OFF	ON	OFF
No cassette	OFF	OFF	OFF

ON: The actuator is pushing the size switch.

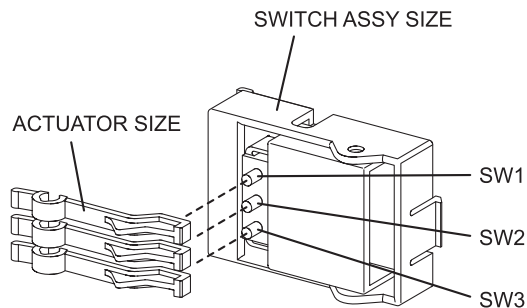

Tbt07100KA

§ 3 DRIVE

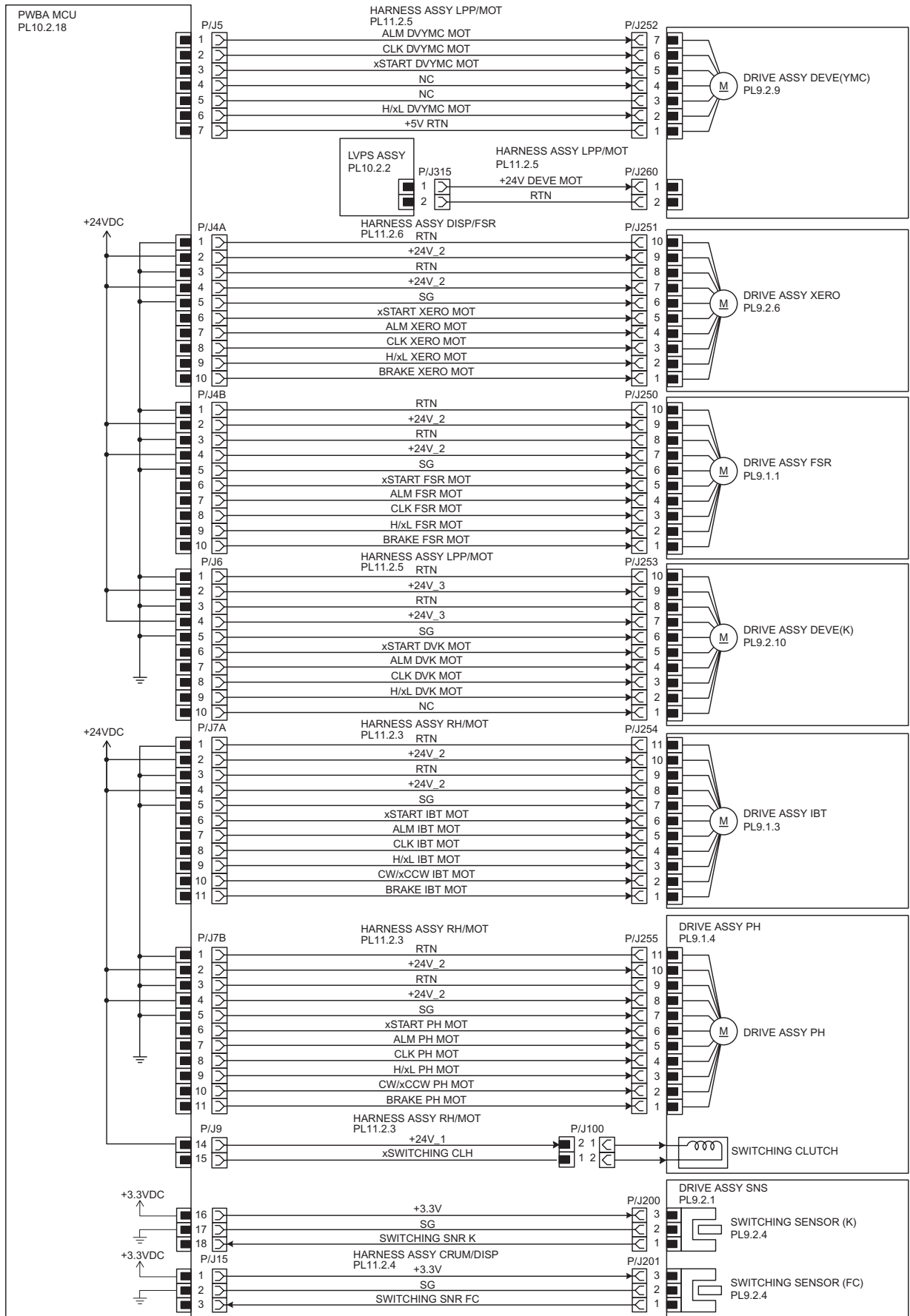

Tbt07004KA

Signal line name	Description
ALM DVYMC MOT CLK DVYMC MOT START DVYMC MOT H/xL DVYMC MOT	Drive control signal of the DEVE MOTOR (YMC)
START XERO MOT ALM XERO MOT CLK XERO MOT H/xL XERO MOT BRAKE XERO MOT	Drive control signal of the XERO MOTOR
START FSR MOT ALM FSR MOT CLK FSR MOT H/xL FSR MOT BRAKE FSR MOT	Drive control signal of the FUSER MOTOR
START DVK MOT ALM DVK MOT CLK DVK MOT H/xL DVK MOT	Drive control signal of the DEVE MOTOR (K)
START IBT MOT ALM IBT MOT CLK IBT MOT H/xL IBT MOT CW/xCCW IBT MOT BRAKE IBT MOT	Drive control signal of the IBT MOTOR
START PH MOT ALM PH MOT CLK PH MOT H/xL PH MOT CW/xCCW PH MOT BRAKE PH MOT	Drive control signal of the PH MOTOR
SWITCHING CLH	ON/OFF signal of the COLOR MODE SWITCHING CLUTCH
SWITCHING SNR K	K mode detect signal of the DRIVE ASSY PH by the Sensor Photo (COLOR MODE SWITCHING SENSOR K)
SWITCHING SNR FC	Color mode detect signal of the DRIVE ASSY PH by the Sensor Photo (COLOR MODE SWITCHING SENSOR FULL COLOR)

§ 4 ROS

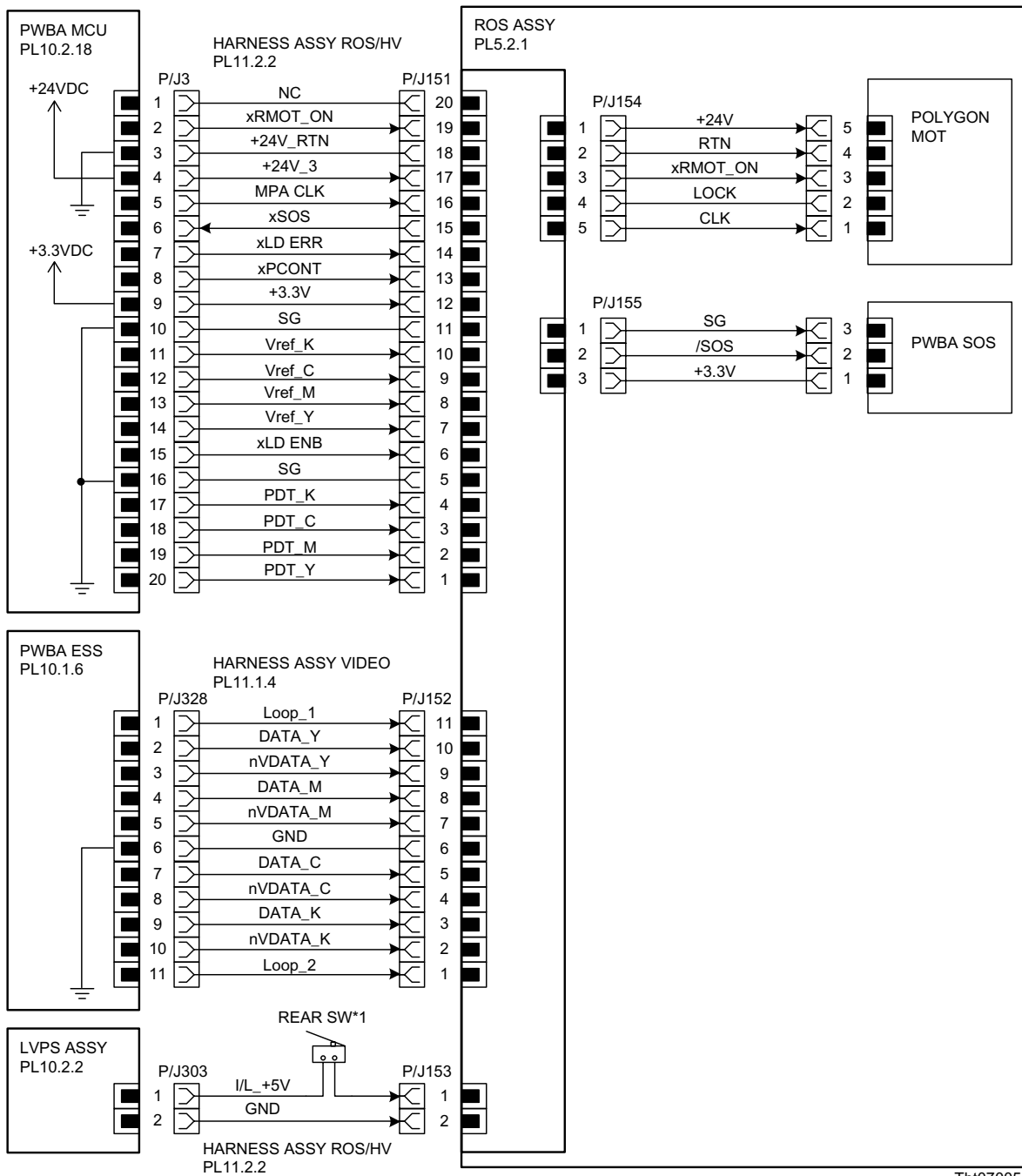

*1: The switch for Laser Safety.

Tbt07005K

Signal line name	Description
RMOT ON MPA CLK	Drive control signal of the POLYGON MOTOR
SOS	Reference signal for scan start of LASER
Vref K Vref C Vref M Vref Y	Emission control signal of the laser diode
LD ERR	Error signal of the laser diode
PCONT	Power control signal of the laser diode
PDT K PDT C PDT M PDT Y	Video signal of the laser diode

§ 5 XEROGRAPHIC

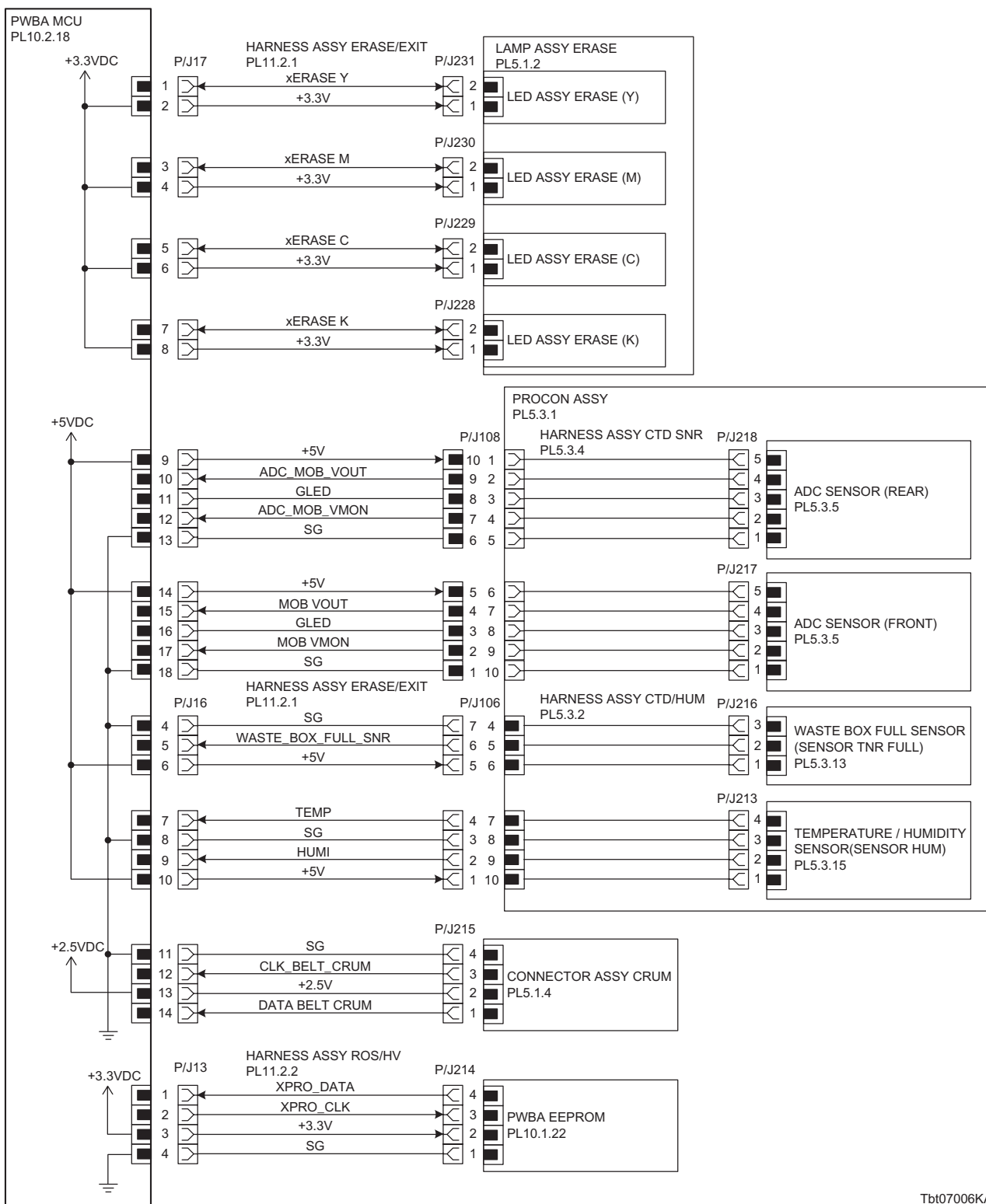

Tbt07006KA

Signal line name	Description
ERASE Y	ON/OFF signal of the LED Y ERASE
ERASE M	ON/OFF signal of the LED M ERASE
ERASE C	ON/OFF signal of the LED C ERASE
ERASE K	ON/OFF signal of the LED K ERASE
ADC MOB VOUT	Toner patch density data measured by the ADC SENSOR (REAR)
GLED	Remote signal of the LED of ADC SENSOR(REAR)
ADC MOB VMON	Control signal of the ADC SENSOR(REAR)
MOB VOUT	Toner patch density data measured by the ADC SENSOR (FRONT)
GLED	Remote signal of the LED of ADC SENSOR(FRONT)
MOB VMON	Control signal of the ADC SENSOR(FRONT)
WASTE BOX FULL SNR	Control signal of the WASTE BOX FULL SENSOR
TEMP	Temperature data in the printer by the TEMP. /HUM. SENSOR (Analog value)
HUMI	Humidity data in the printer by the TEMP. /HUM. SENSOR (Analog value)
CLK BELT CRUM DATA BELT CRUM	Control signal of the EEPROM BELT
XPRO DATA XPRO CLK	Control signal of the PWBA EEPROM

§ 6 HIGH VOLTAGE

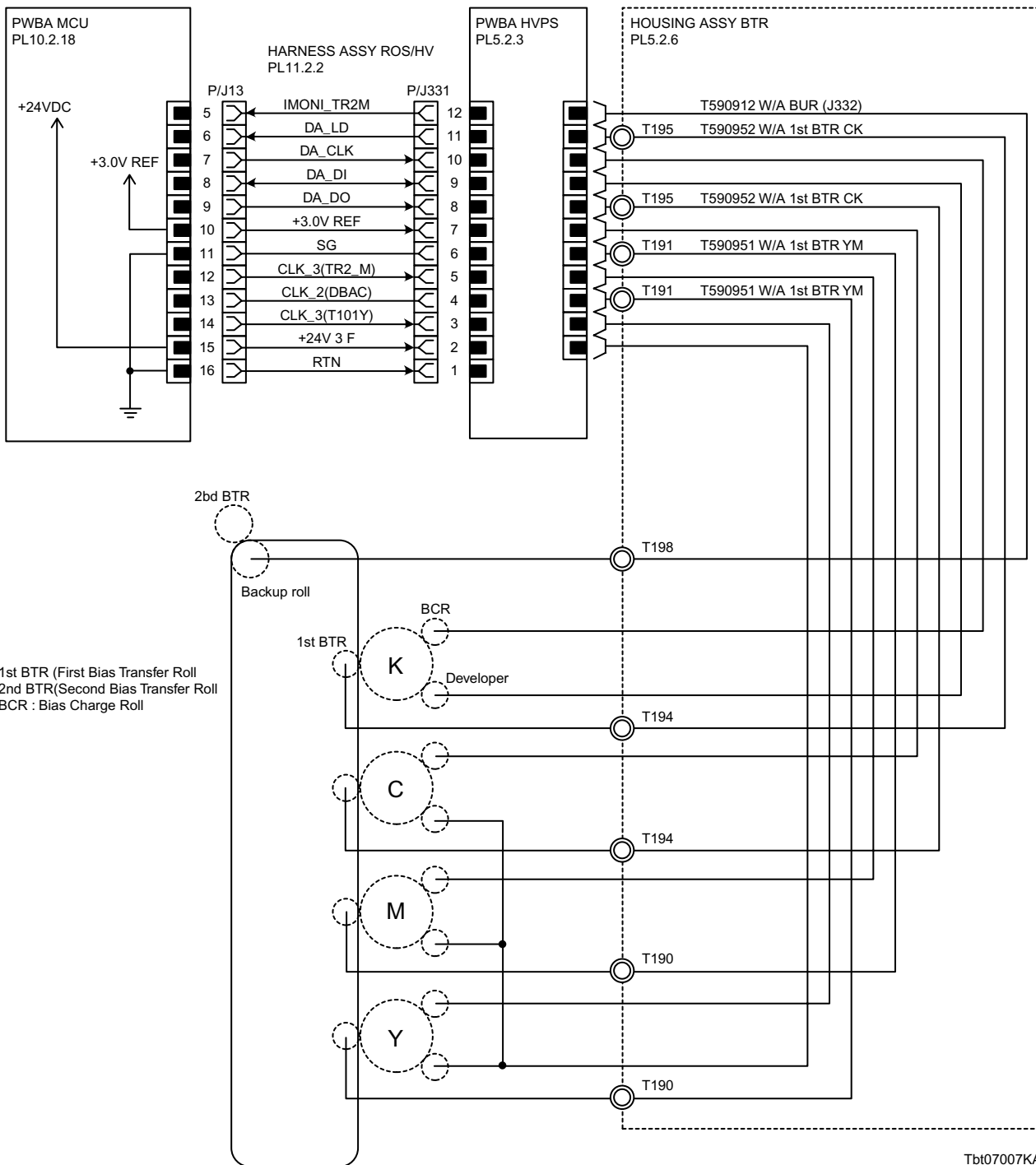

Signal line name	Description
IMONI TR2M DA LD DA CLK DA DI DA DO CLK 3(TR2_M) CLK 2(DBAC) CLK 3(T101Y)	Control signal of the HVPS

§ 7 DEVELOPER

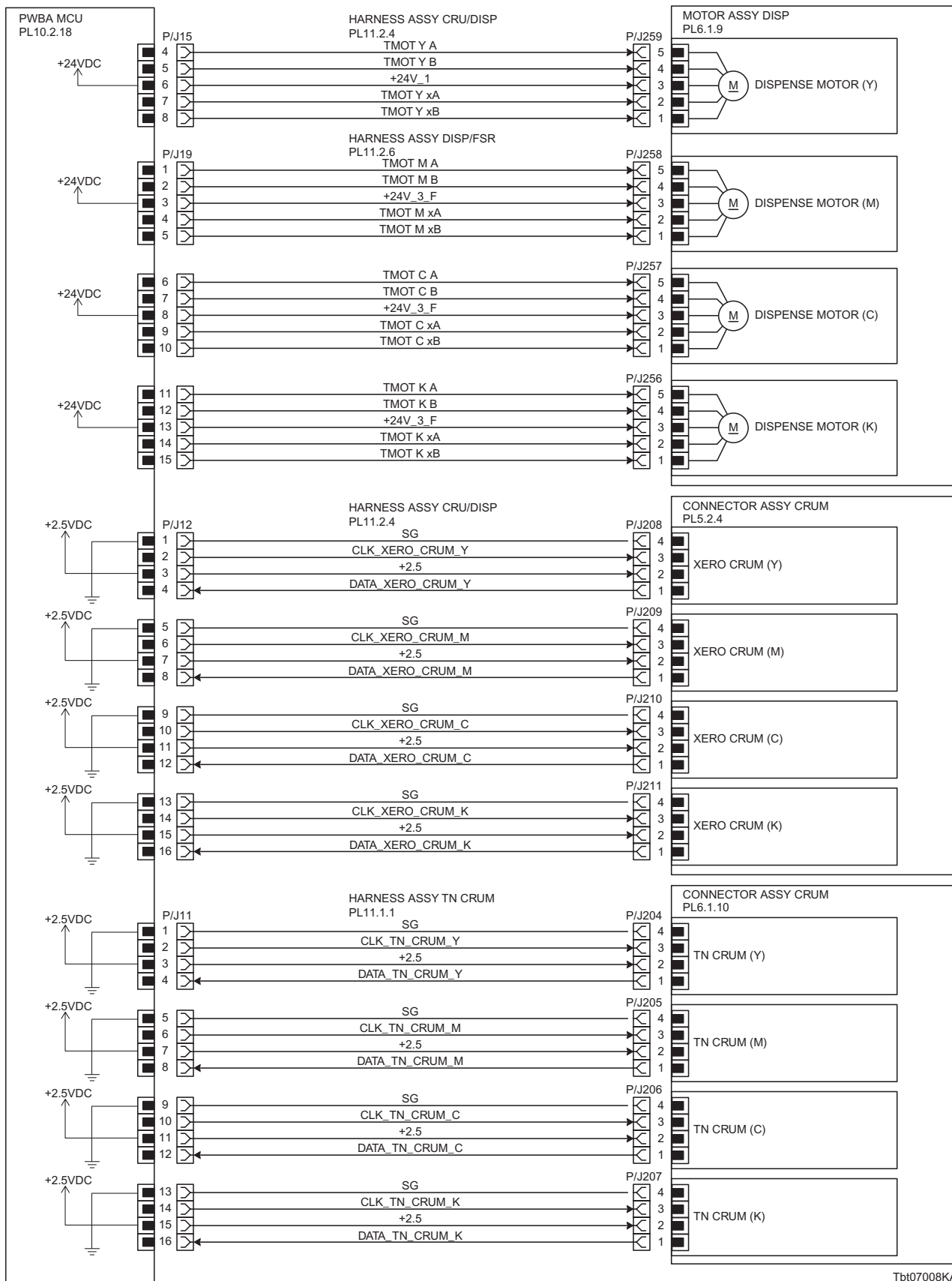

Tbt07008KA

Signal line name	Description
TMOT Y A	Drive control signal of the DISPENSE MOTOR (Y)
TMOT Y B	
TMOT Y xA	
TMOT Y xB	
TMOT M A	Drive control signal of the DISPENSE MOTOR (M)
TMOT MB	
TMOT M xA	
TMOT M xB	
TMOT C A	Drive control signal of the DISPENSE MOTOR (C)
TMOT C B	
TMOT C xA	
TMOT C xB	
TMOT K A	Drive control signal of the DISPENSE MOTOR (K)
TMOT K B	
TMOT K xA	
TMOT K xB	
CLK XERO CRUM Y	Detection signal of the XERO CRU SENSOR (Y)
DATA XERO CRUM Y	
CLK XERO CRUM M	Detection signal of the XERO CRU SENSOR (M)
DATA XERO CRUM M	
CLK XERO CRUM C	Detection signal of the XERO CRU SENSOR (C)
DATA XERO CRUM_C	
CLK XERO CRUM K	Detection signal of the XERO CRU SENSOR (K)
DATA XERO CRUM K	
CLK TN CRUM Y	Detection signal of the TONER CRU SENSOR (Y)
DATA TN CRUM Y	
CLK TN CRUM M	Detection signal of the TONER CRU SENSOR (M)
DATA TN CRUM M	
CLK TN CRUM C	Detection signal of the TONER CRU SENSOR (C)
DATA TN CRUM C	
CLK TN CRUM K	Detection signal of the TONER CRU SENSOR (K)
DATA TN CRUM K	

§ 8 FUSER & EXIT

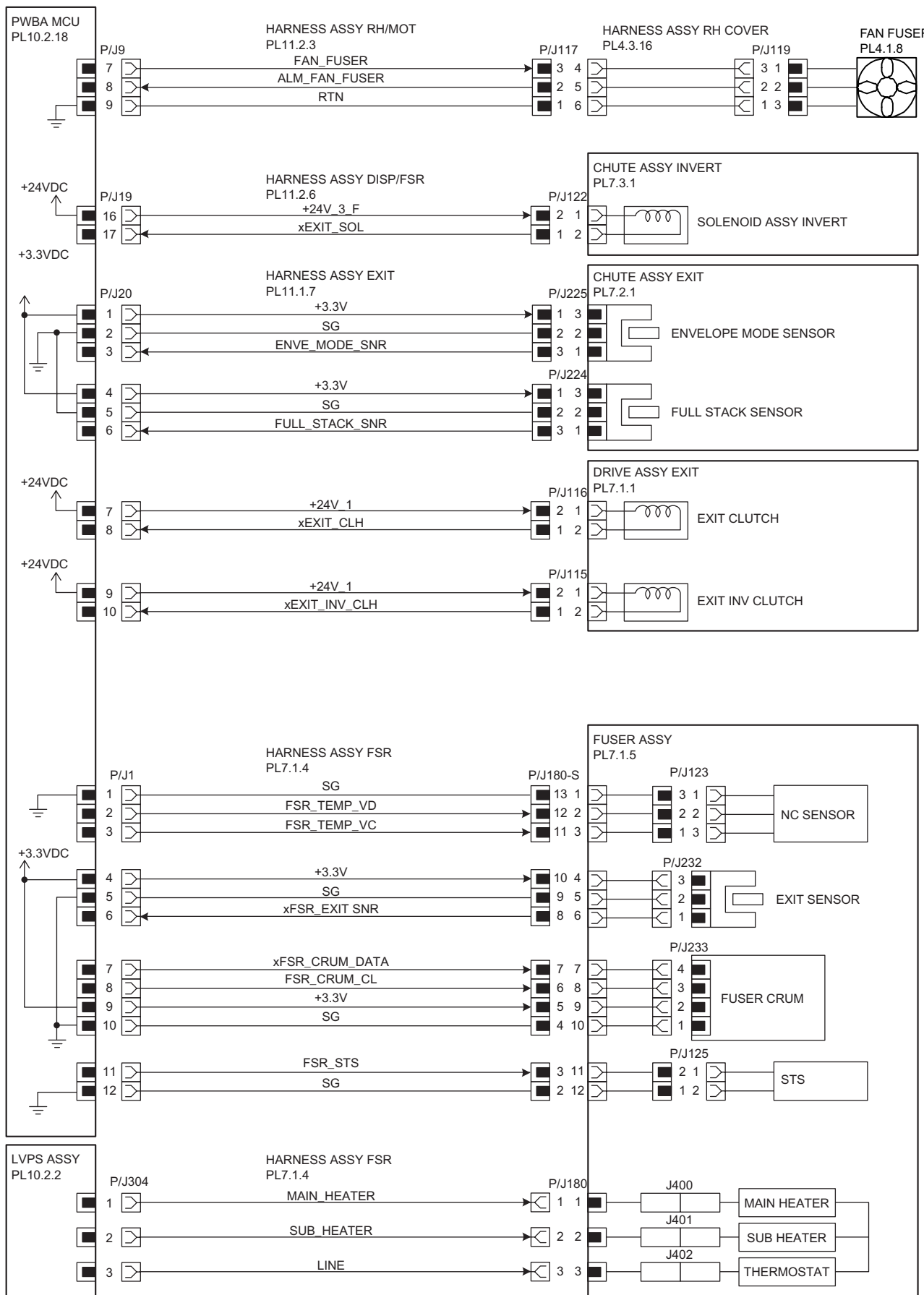

Tbt07009KA

Signal line name	Description
FAN FUSER ALM FAN FUSER	Drive control signal of the FUSER FAN
EXIT SOL	ON/OFF signal of the Exit Feed SOLENOID
ENVE MODE SNR	Envelope Mode detect signal of the Exit ASSY by the Sensor Photo (ENVE MODE SENSOR)
FULL STACK SNR	FULL STACK detect signal of the Exit ASSY by the Sensor Photo (FULL STACK SENSOR)
EXIT CLH	ON/OFF signal of the EXIT CLUTCH
EXIT INV CLH	ON/OFF signal of the EXIT INV CLUTCH
FSR TEMP VD FSR TEMP VC	Temperature data measured by Temp. Sensor for controlling temperature (analog value)
FSR EXIT SNR	Paper detect signal of the Fuser Exit by the Sensor Photo (EXIT SENSOR)
FSR CRUM DATA FSR CRUM CL	Control signal of the FUSER CRUM
FSR STS	Heat Roll surface temperature data measured by Temp. Sensor for detecting high temperature (analog value)

§ 9 CONTROLLER

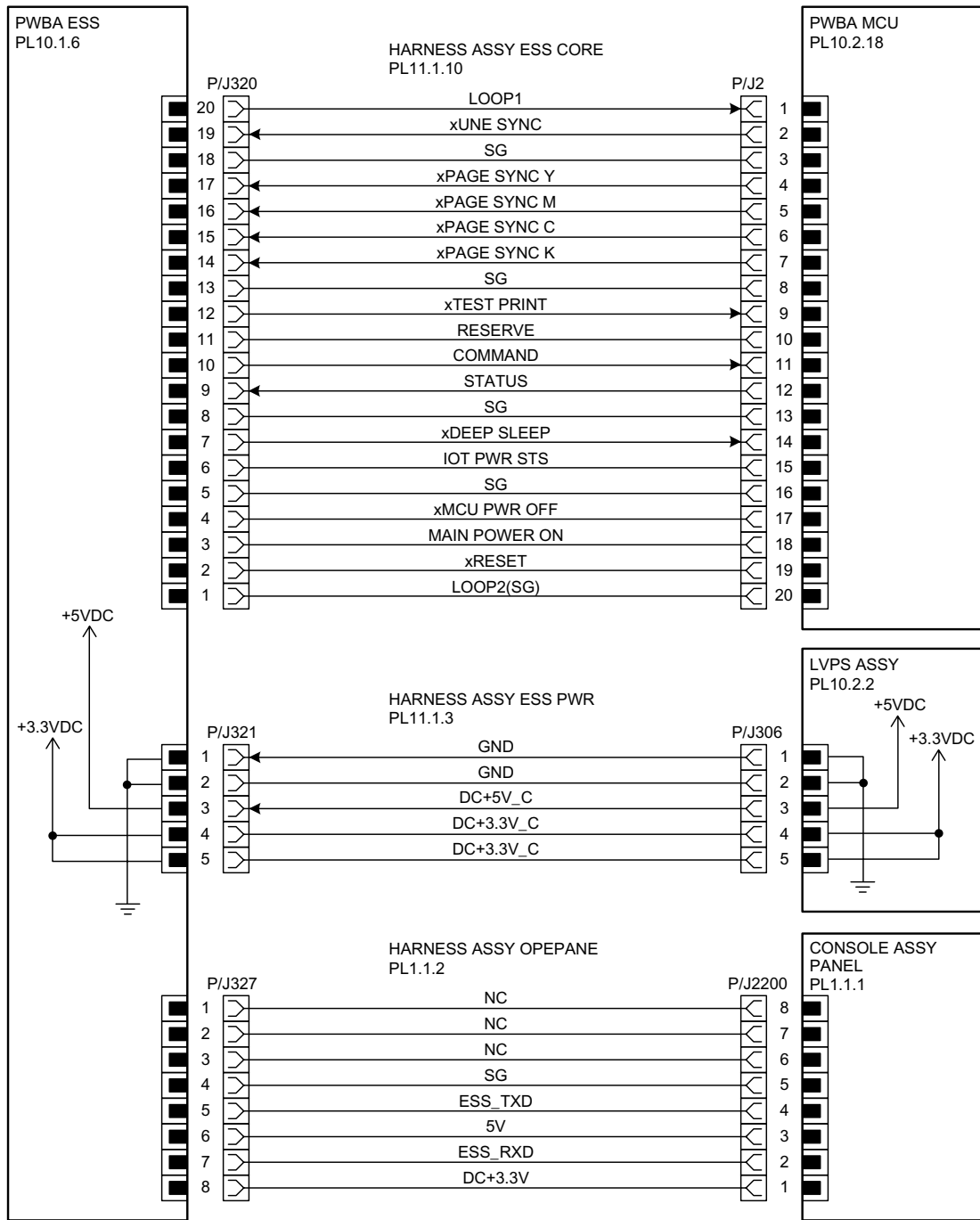

Tbt07010KB

Signal line name	Description
UNE SYNC	Signal for data
PAGE SYNC Y PAGE SYNC M PAGE SYNC C PAGE SYNC K	Signal for indicating registration position of each of images Y, M, C and K
TEST PRINT	Control signal for the TEST PRINT mode
COMMAND	Command signal transmitted from the PWBA ESS to the PWBA MCU
STATUS	Status signal transmitted fro the PWBA MCU to the PWBA ESS
DEEP SLEEP	Control signal for the DEEP SLEEP mode
-	Control signal of the CONTROL PANEL

§ 10 OPTION 550 FEEDER & OPTION HIGH CAPACITY FEEDER (HCF)

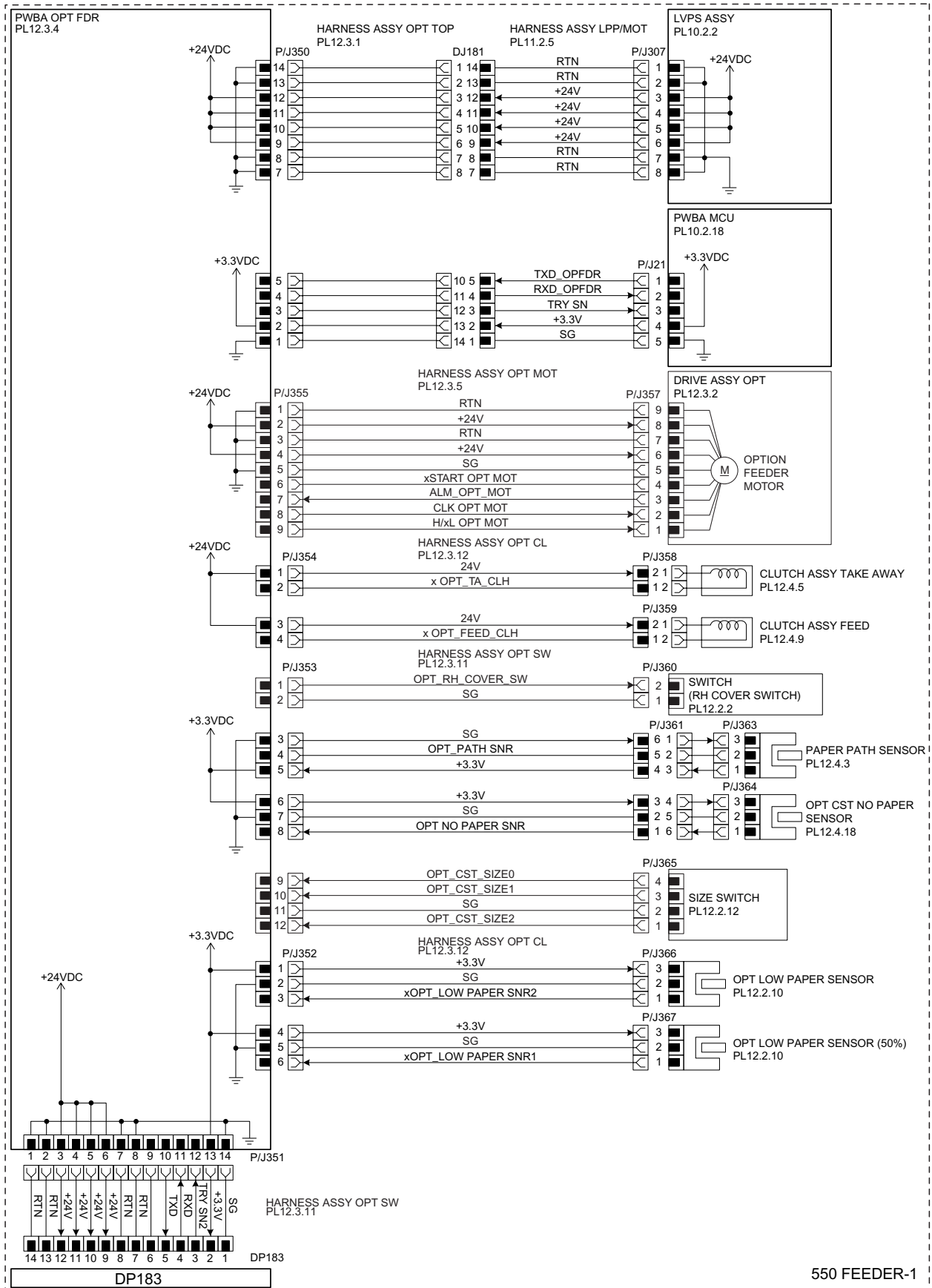

550 FEEDER-1

Tbt07011KA

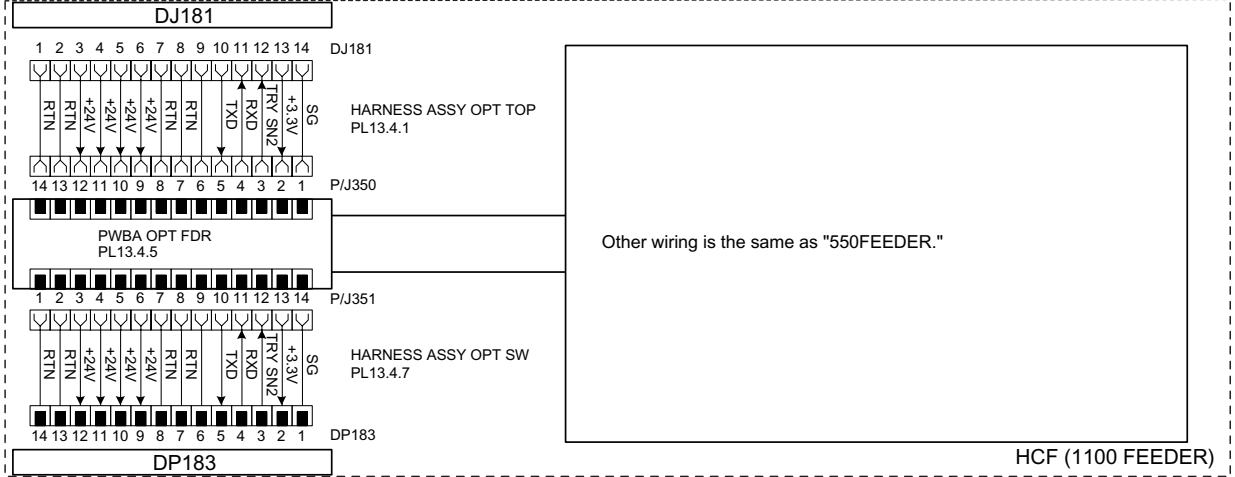
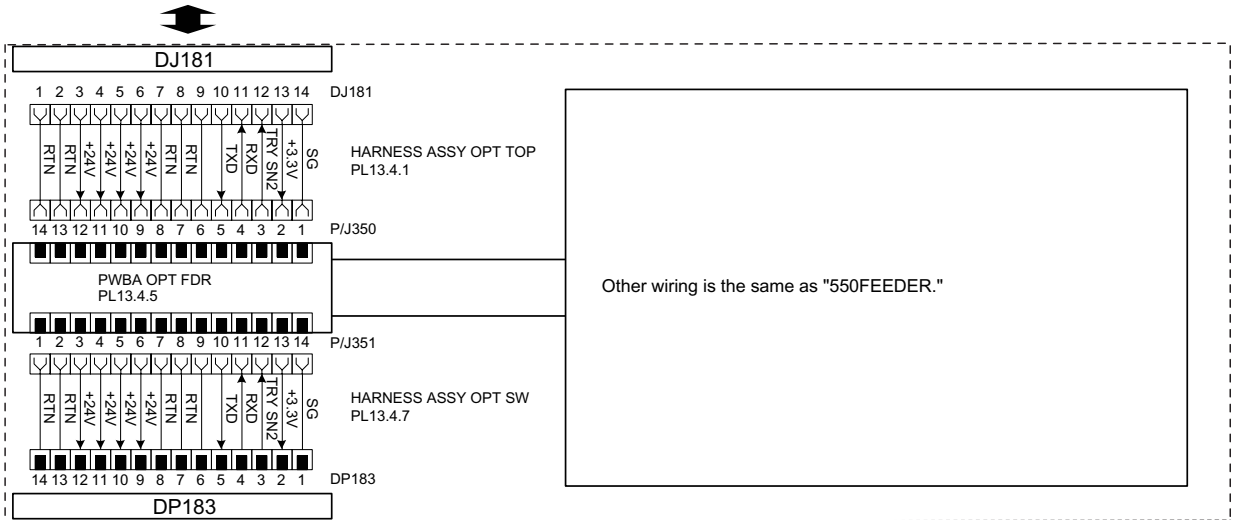
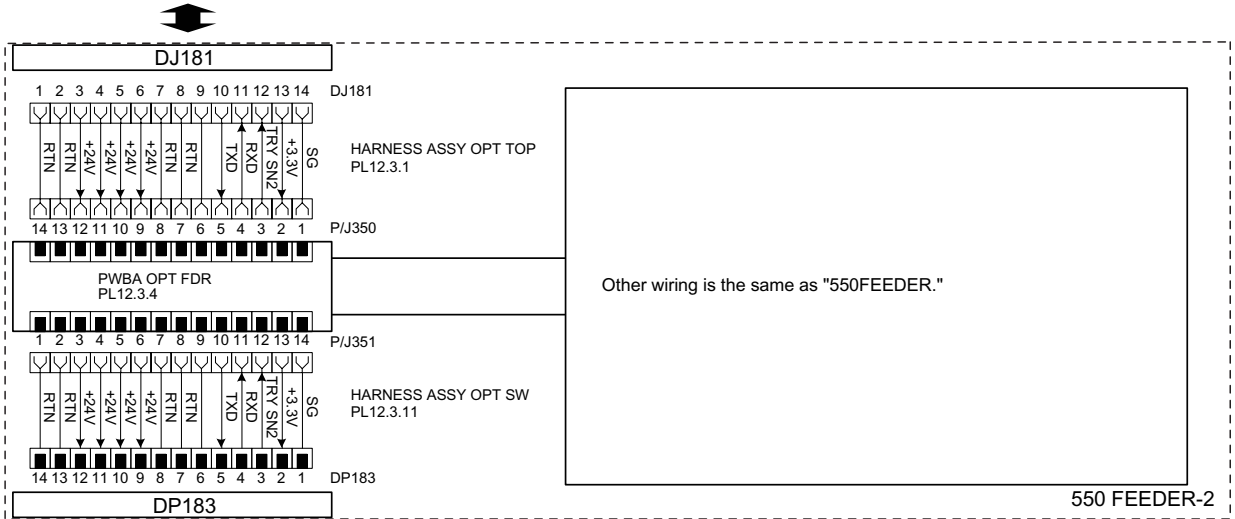

Tbi07012KA

Signal line name	Description
TXD OPFDR RXD OPFDR TRY SN	Control signal of the PWBA OPT FDR
START OPT MOT ALM OPT MOT CLK OPT MOT H/L OPT MOT	Drive control signal of the OPTION FEED MOTOR
TAKE AWAY CLUTCH	ON/OFF signal of the TAKE AWAY CLUTCH
CLUTCH ASSY FEED OPT	ON/OFF signal of the CLUTCH ASSY FEED
OPT NO PAPER SNR	Detect "No Paper signal" of the Feeder by the Sensor Photo (NO PAPER SENSOR)
OPT CST SIZE 0 OPT CST SIZE 1 OPT CST SIZE 2	ON/OFF signal of the SWITCH ASSY SIZE
OPT LOW PAPER SNR2	Detect "Low Paper signal" of the Feeder by the Sensor Photo (OPT LOW PAPER SENSOR 2)
OPT LOW PAPER SNR1	Detect "Low Paper signal" of the Feeder by the Sensor Photo (OPT LOW PAPER SENSOR 1)

- Outline of SWITCH ASSY SIZE

The paper size is determined by a combination of ON/OFF statuses of the SW 1, SW 2, and SW 3 switches of SWITCH ASSY SIZE.

Paper size	Switches		
	SW 1	SW 2	SW 3
LEGAL 14" (SEF)	ON	ON	ON
LEGAL 13" (SEF)	ON	ON	OFF
EXECUTIVE (SEF)	ON	OFF	ON
B5 (SEF)	ON	OFF	OFF
A4 (SEF)	OFF	ON	ON
LETTER (SEF)	OFF	OFF	ON
A5	OFF	ON	OFF
No cassette	OFF	OFF	OFF

ON: The actuator is pushing the size switch.

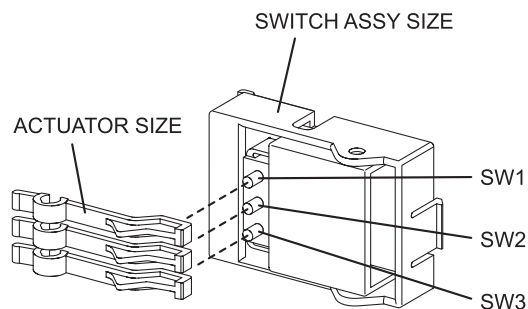

Tbt07100KA

MFG p/n	CRU or FRU	Quantity in a box	Dell #	Dell Description in RSL
TONER / INK				
675K 84590	CRU	1	R273N	YELLOW TONER CARTRIDGE 6K 5130CDN
675K 84720	CRU	1	T222N	YELLOW TONER CARTRIDGE 12K 5130CDN
675K 84600	CRU	1	P615N	MAGENTA TONER CARTRIDGE 6K 5130CDN
675K 84730	CRU	1	R272N	MAGENTA TONER CARTRIDGE 12K 5130CDN
675K 84610	CRU	1	X942N	CYAN TONER CARTRIDGE 6K 5130CDN
675K 84750	CRU	1	P614N	CYAN TONER CARTRIDGE 12K 5130CDN
675K 84620	CRU	1	U157N	BLACK TONER CARTRIDGE 6K 5130CDN
675K 84760	CRU	1	N848N	BLACK TONER CARTRIDGE 12K 5130CDN

DEVELOPERS				
848K 84580	CRU	1	X951N	YELLOW DRUM/DEVELOPER 5130CDN
848K 84690	CRU	1	T229N	MAGENTA DRUM/DEVELOPER 5130CDN
848K 84700	CRU	1	U163N	CYAN DRUM/DEVELOPER 5130CDN
848K 84710	CRU	1	P623N	BLACK DRUM/DEVELOPER 5130CDN

FUSER AND ACESSORIES				
675K 84630	CRU	1	N856N	FUSER 110V 5130CDN FOR AMERICAS
675K 84640	CRU	1	R279N	FUSER 220V 5130CDN FOR EMEA & AUSTRALIA & NEW ZEALAND

SERVICE KITS				
675K 84570	CRU	1	U164N	SERVICE KIT TRANSFER BELT 2ND TRANSFER BELT FEED ROLLER KIT 5130CDN
675K 84770	CRU	1	U162N	WASTE TONER CONTAINER

OPTIONS				
675K 84650	CRU	1	N854N	HARDDISK 80 GB 5130CDN (OPTION)
675K 84680	CRU	1	T226N	Memory, 1GB, DIMM,5130CDN (OPTION)
675K 84660	CRU	1	P624N	WIRELESS CARD, 5130CDN (OPTION)

DOCUMENTATION, DRIVERS AND APPLICATIONS				
675K 84870	CRU	1	D720R	DOCUMENT KIT IN ENGLISH, FRENCH, SPANISH FOR AMERICAS 5130CDN
675K 85610	CRU	1	H490R	DOCUMENT KIT FOR 110V TAA 5130CDN
	CRU	1	Y989P	DOCUMENT KIT FOR 220V TAA 5130CDN

TRANSFER BELT				
064K 93150	CRU	1	Y520R	MAIN TRANSFER BELT 5130CDN
059K 66361	CRU	1	R280N	2ND TRANSFER BELT 5130CDN

ROLLER				
019K10660 + 059K46040x2pcs + Instruction	CRU		D347T	FEEDER SEPARATOR ROLLER for all trays 5130CDN
019K 11140 + Instruction	CRU		G194T	MULTI-PAPER FEEDER SEPARATOR ROLLER on printer 5130CDN
059K 50731	FRU		P358C	MULTI-PAPER FEED ROLLER on printer 5130CDN

FEEDER, TRAY AND TRAY HOUSING				
050K 65090	CRU	1	H167T	DEFAULT PAPER TRAY 550 SHEET 5130CDN
848K 37991 with instruction	CRU	1	D526T	FDR,ASSY,CVR,MSI,5130CDN
059K66692 with instruction	CRU	1	D342T	OPTIONAL PAPER TRAY HOUSING 550 SHEET 5130CDN
050K 65100	CRU	1	K181T	OPTIONAL PAPER TRAY 550 SHEET 5130CDN
Feeder without tray with instruction	CRU	1	G193T	OPTIONAL PAPER TRAY HOUSING 1100 SHEET 5130CDN

PLASTICS				
848K 28740	FRU	1	C274T	FRONT COVER (PLASTIC) WITH INTERLOCK SWITCH AND CLEANER WAND 5130CDN
848K 28691	FRU	1	F162T	REAR COVER (PLASTIC) WITH ACTUATOR 5130CDN
032E 31780	CRU	1	51XMB	RIGHT HAND FRAME BOTTOM RIGHT CONNECTOR COVER 5130CDN
848K 37991 with instruction	CRU	1	D526T	MULTI-PAPER FEED (PLASTIC) 5130CDN
Without 2nd BTR	FRU	1	D352T	RIGHT COVER (PLASTIC) WITH RIGHT HAND FRAME WITH MULTI PAPER FEED(D526T) WITH DUPLEXOR MECHANISM WITH FUSER GUIDE WITH FUSER FAN 5130CDN
848E 36900	CRU	1	MM4H3	OUTPUT FINISHER TRAY BOTTOM COVER GUIDE 5130CDN
848E 38350	CRU	1	D44J3	OUTPUT FINISHER POWER CABLE ROUTING COVER 5130CDN
848E 36880	CRU	1	MNCPD	OUTPUT FINISHER DATA CABLE ROUTING COVER 5130CDN

ELECTRICAL / ELECTRONICS BOARDS AND CARDS				
105K 24050	FRU	1	H328T	HIGH VOLTAGE POWER BOARD 5130CDN
101K 55880	FRU	1	G133T	LOW VOLTAGE POWER BOARD 100V/115V 5130CDN FOR JAPAN & AMERICAS
101K 60370	FRU	1	Y357R	LOW VOLTAGE POWER BOARD 220V 5130CDN FOR EUROPE, AUS & NZ
960K 49970	FRU	1	Y358R	PRINTER MACHINE CONTROL UNIT BOARD 5130cdn
815K 00870	FRU	1	C398T	PRINTER ESS BOARD 5130CDN
960K 45390	FRU	1	J133T	OUTPUT FINISHER ESS BOARD 5130CDN
105E 19280	FRU	1	H222T	OUTPUT FINISHER LOW VOLTAGE POWER BOARD

FAN AND ACESSORIES				
101K 58770	FRU	1	F365T	FAN FOR LOW VOLTAGE POWER 5130CDN
127E 85810	FRU	1	Y910R	FAN FOR FUSER 5130CDN

MISCELLANOUS HARDWARE				
	FRU	1	G135T	OPERATOR DISPLAY PANEL FOR DAO 5130CDN
	FRU	1	VJT5J	OPERATOR DISPLAY PANEL FOR EMEA 5130CDN
110K 16170	FRU	1	C607T	INTERLOCK SWITCH WITH CABLE (FRONT FRAME LOCATION) 5130CDN
042K 93630	CRU	1	C608T	CLEANING WAND WITH 1 X PAD 5130CDN
110K 15830	FRU	1	F363T	PAPER SIZE SENSOR on Printer 5130CDN
019K 10650	FRU	1	K329T	PAPER LOW SENSOR on Printer 5130CDN
054K 42170	FRU	1	Y362R	MULTI-PAPER FEEDER SEPARATOR ROLLER on Printer 5130CDN
054K 40781	FRU	1	H223T	FEEDER WITH CHUTE ASSEMBLY MECHANISM 5130CDN
962K73670 + with screw driver	FRU	1	F448T	INTERLOCK SWITCH (RIGHT FRAME LOCATION) with screw driver 5130CDN
019E75770 + 120E31460 + 809E85570	FRU	1	Y545R	ACTUATOR (RIGHT FRAME LOCATION) 5130CDN
	FRU		J137T	SOLENOID, GEAR & CLUTCH (RIGHT FRAME LOCATION) 5130CDN
122K 94260	FRU	4	D529T	LED ERASE ASSEMBLY clears info on drum/developer 5130CDN
062K20920 + 019E 64450 + HW kit PPID: 897E 36840	FRU	1	C399T	ROS (Rastor Output Scanner) on Printer 5130CDN
130K 76651	FRU	4	F368T	MODULE CONTAINING ADC & HUMIDITY SENSOR WITH CABLE 5130CDN
019K 11160	FRU	4	H329T	TONER DISPENSOR CRUM on Printer 5130CDN
007K 15330	FRU	1	C626T	FUSER EXIT DRIVE MOTOR 5130CDN
	FRU	1	C631T	FUSER EXIT CHUTE WITH STACK SENSOR & ENVELOPE SENSOR 5130CDN
054K 40571	FRU	1	G319T	FUSER EXIT PAPER INVERTER CHUTE 5130CDN
801K42661 + 806E 28030x2pcs + 354W 24278 x 2pcs	FRU	1	H226T	FRONT INNER DOOR/COVER 5130CDN
007K 15360	FRU	1	H343T	FUSER DRIVE MOTOR 5130CDN
007K 15390	FRU	1	H345T	MAIN TRANSFER BELT MOTOR 5130CDN
007K 15350	FRU	1	Y928R	DRUM/DEVELOPER MOTOR 5130CDN ?
007K 15410	FRU	2	D540T	SWITCHING SENSOR FOR DRUM/DEVELOPER 5130CDN
007K 15370	FRU	1	H351T	CMY DRUM/DEVELOPER MOTOR 5130CDN
007K 15380	FRU	1	J252T	K DRUM/DEVELOPER MOTOR 5130CDN
	FRU	1	Y538R	DRUM/DEVELOPER ASSEMBLY LINK, XEROGRAPHY & RACK

	FRU	1	D349T	DRUM/DEVELOPER MOTOR GEAR 5130CDN
815K 02320	CRU	1	1M8DC	BACK METAL LOCKING PLATE FOR OPTIONAL 500 SHEET
826E 43840	CRU	1	CPGMY	SCREW FOR BACK METAL LOCKING PLATE FOR OPTIONAL 500 SHEET
	CRU	1	F243T	OUTPUT FINISHER MAIN ASSEMBLY MINUS TRAY STACKER & TRANSPORT ASSEMBLY 5130CDN
	CRU	1	H353T	OUTPUT FINISHER TRAY STACKER 5130CDN
826E 28960	CRU	2	JXWWY	OUTPUT FINISHER TRAY SCREWS 5130CDN
	CRU	1	K334T	OUTPUT FINISHER TRANSPORT ASSEMBLY TOP 5130CDN
	CRU	1	G321T	OUTPUT FINISHER TRANSPORT ASSEMBLY BOTTOM 5130CDN
848K 27270	FRU	1	C636T	OUTPUT FINISHER MAIN ASSEMBLY FRONT DOOR/COVER 5130CDN
019K 10370	FRU	1	Y934R	OUTPUT FINISHER MAIN ASSEMBLY STAPLER UNIT 5130CDN
050K 51250	CRU	1	5N2GY	OUTPUT FINISHER MAIN ASSEMBLY STAPLE CARTRIDGE HOLDER AND STAPLE CARTRIDGE 5130CDN
068K 64620	FRU	1	C638T	OUTPUT FINISHER MAIN ASSEMBLY DOOR/COVER INTERLOCK SWITCH 5130CDN

BASE UNIT				
999S Y353R	CRU	1	Y353R	PRINTER FOR SERVICE WHOLE UNIT EXCHANGE 110V AMERICAS 5130CN
999S C271T	CRU	1	C271T	PRINTER FOR SERVICE WHOLE UNIT EXCHANGE 220V EUROPE AUSTRALIA NEW ZEALAND 5130CN
999S C555T	CRU	1	C555T	PRINTER FOR SERVICE WHOLE UNIT EXCHANGE 110V TAA 5130CN
999S D227T	CRU	1	D227T	PRINTER FOR SERVICE WHOLE UNIT EXCHANGE 220V TAA 5130CN

Chapter 8 Printer Specifications CONTENTS

1. Configuration of Printer.....	8 - 1
1.1 Basic Configuration.....	8 - 1
1.2 Functional Configuration.....	8 - 1
2. Electrical Properties.....	8 - 2
2.1 Power Supply.....	8 - 2
2.2 Power Consumption.....	8 - 2
2.3 Inrush Current.....	8 - 2
3. Mechanical Properties.....	8 - 3
3.1 Dimensions/Mass.....	8 - 3
3.2 Dimensions/Mass of 550 Sheet Feeder.....	8 - 3
3.3 Dimensions/Mass of High Capacity Feeder (HCF).....	8 - 4
3.4 Dimensions/Mass of Consumables and CRUs.....	8 - 5
3.4.1 BELT ASSY IBT.....	8 - 5
3.4.2 FUSER.....	8 - 5
3.4.3 Black toner cartridge.....	8 - 5
3.4.4 Yellow toner cartridge.....	8 - 5
3.4.5 Magenta toner cartridge.....	8 - 5
3.4.6 Cyan toner cartridge.....	8 - 6
3.4.7 XERO DEVE CRU ASSY (Y).....	8 - 6
3.4.8 XERO DEVE CRU ASSY (M).....	8 - 6
3.4.9 XERO DEVE CRU ASSY (C).....	8 - 6
3.4.10 XERO DEVE CRU ASSY (K).....	8 - 6
3.4.11 WASTE TONER BOX.....	8 - 7
3.4.12 ROLL ASSY 2ND BTR.....	8 - 7
3.5 Installation Requirements.....	8 - 7
4. Functions.....	8 - 9
4.1 Printing System.....	8 - 9
4.2 Exposure System.....	8 - 9
4.3 Development System.....	8 - 9
4.4 Fixing System.....	8 - 9
4.5 Resolution.....	8 - 9
4.6 Operation Mode.....	8 - 10
4.7 Warm-up Time.....	8 - 10
4.8 FPOT (First Print Output Time).....	8 - 11
4.9 Average Print Speed.....	8 - 11
4.10 Input Properties.....	8 - 12
4.10.1 Feeding system.....	8 - 12
4.10.2 Paper capacity.....	8 - 12
4.11 Output Properties.....	8 - 13
4.11.1 Output system.....	8 - 13
4.11.2 Output capacity.....	8 - 13
4.11.3 Output paper size/weight.....	8 - 13
4.11.4 Full stack detection.....	8 - 13
4.11.5 Paper delivery capacity of Option Output Expander.....	8 - 13
4.12 Paper.....	8 - 14

Chapter 8 Printer Specifications CONTENTS

4.12.1 Paper type	8 - 14
4.12.2 Paper mass	8 - 14
4.12.3 Paper size	8 - 14
5. Consumables	8 - 15
5.1 Items of Consumables	8 - 15
5.2 Consumable Life	8 - 15
5.3 Periodic Replacing Parts (Reference)	8 - 15
6. Operating Environment	8 - 18
6.1 Installation Temperature / Humidity	8 - 18
6.2 Installation Altitude	8 - 18
6.3 Installation Horizontality	8 - 18
6.4 Ambient Lighting	8 - 18
6.5 Storage Temperature of a Toner Cartridge	8 - 18
7. Safety / Environment Conditions	8 - 19
7.1 Safety Standard	8 - 19
7.2 Laser Safety Standard	8 - 19
7.3 EMI	8 - 19
7.4 Noise	8 - 19
8. Print image Quality	8 - 20
8.1 Image Quality Guarantee Conditions	8 - 20
8.1.1 Environmental conditions	8 - 20
8.1.2 Guaranteed paper	8 - 20
8.1.3 Paper condition	8 - 20
8.1.4 Printer condition	8 - 20
8.1.5 Image quality guaranteed area	8 - 20
8.1.6 Criterion	8 - 20
9. Option	8 - 21
9.1 User-installable Options	8 - 21
10. ESS Specification	8 - 22
10.1 External Interface	8 - 22
10.1.1 USB	8 - 22
10.1.2 Ethernet	8 - 22
10.1.3 IEEE1284	8 - 22
10.1.4 Wireless	8 - 23
10.2 Network Protocol	8 - 24
10.2.1 Printing Protocol	8 - 24
10.2.2 Other Protocols	8 - 24
10.3 Decomposer	8 - 25
10.3.1 PDL/Emulation	8 - 25
10.3.2 Font	8 - 25
10.3.3 Form Overlay	8 - 25
10.3.4 Image Area	8 - 25
10.4 Job Control	8 - 26
10.4.1 Cancel Print	8 - 26

Chapter 8 Printer Specifications CONTENTS

10.4.2 Job Recovery	8 - 26
10.4.3 Job Time Out	8 - 26
10.4.4 Secure Print	8 - 26
10.4.5 Private MailBox Print.....	8 - 26
10.4.6 Public MailBox Print.....	8 - 26
10.4.7 Proof Print.....	8 - 26
10.4.8 IP Filter.....	8 - 26
10.4.9 Dell ColorTrack	8 - 26
10.5 Logging	8 - 27
10.5.1 Job Logging	8 - 27
10.5.2 Error Logging	8 - 27
10.5.3 Print Volume Counter.....	8 - 27
10.6 ID Print	8 - 27
10.7 Third Party Mode	8 - 28
10.8 Utility Print.....	8 - 29
10.8.1 Printer Settings List.....	8 - 29
10.8.2 Panel Settings List Print.....	8 - 29
10.8.3 Font List Print.....	8 - 29
10.8.4 Job History Report	8 - 30
10.8.5 Error History Report.....	8 - 30

Chapter 8 Printer Specifications CONTENTS

1. Configuration of Printer

1.1 Basic Configuration

The printer is basically configured as follows depending on the destination specifications.

- Print engine main unit (MSI and 550 feeder unit as the standard paper feeding)
- Consumables (CRU)

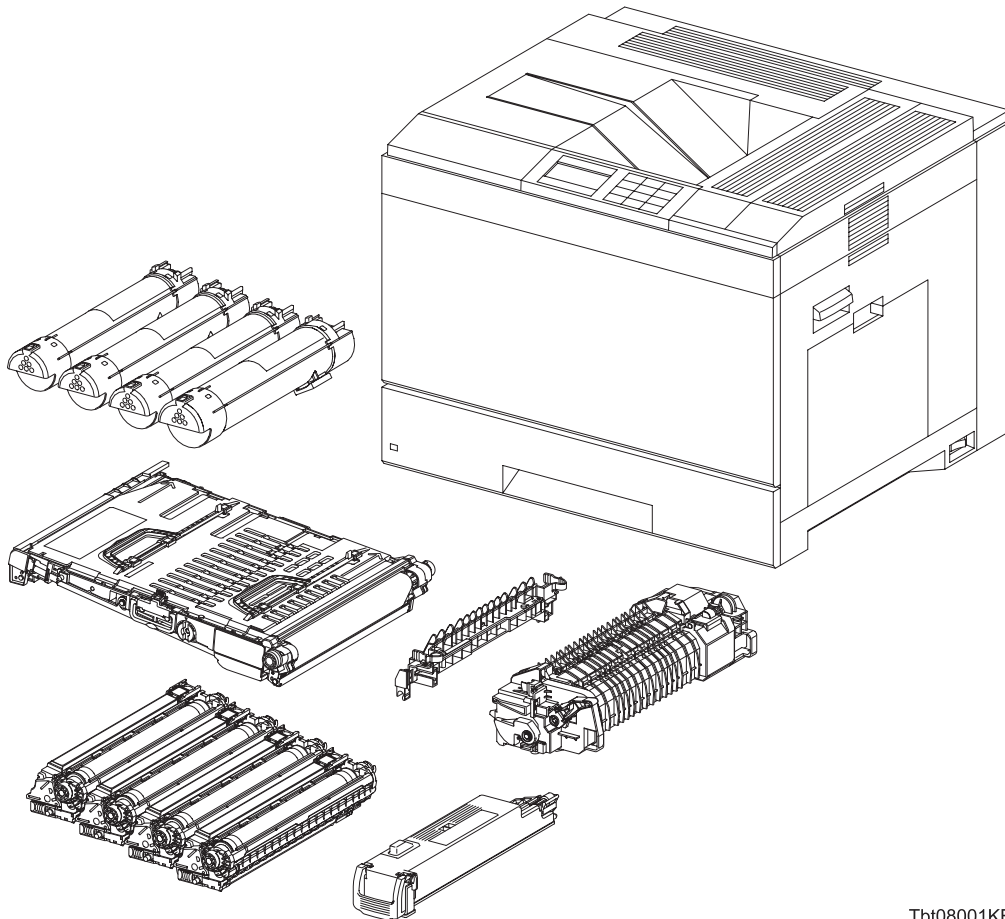

Tbt08001KB

1.2 Functional Configuration

Functional configuration of this printer is shown below.

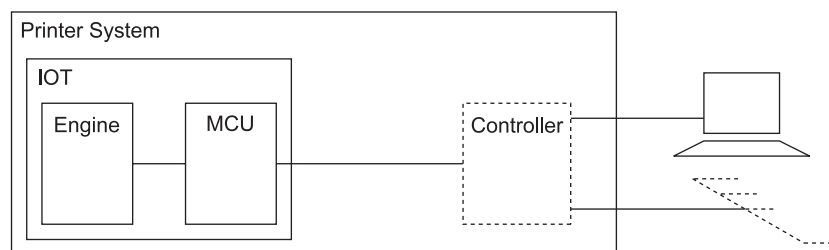

Tbt08002KA

2. Electrical Properties

2.1 Power Supply

The power supply is selected from the following two types depending on the specifications.

110/127V model: voltage 110-127 VAC \pm 10% (99-141 V), frequency 50/60 Hz \pm 3 Hz

220/240V model: voltage 220-240 VAC \pm 10% (198-264 V), frequency 50/60 Hz \pm 3 Hz

2.2 Power Consumption

Power consumption in each operation mode at rated voltage input is as follows:

Operation mode	Average (Wh/h)
Printing mode (F/C)	700 or less
Printing mode (B/W)	600 or less
Ready mode	130 or less
Sleep mode	75 or less
Deep sleep mode	7 or less

2.3 Inrush Current

When the printer is powered on, the maximum inrush current shall be 50 A (cold start)/135 A (hot start) within the first 2.5 msec period, and 80 A (120V/220V/240V)/85 A (100V) within the first 10 msec period.

3. Mechanical Properties

3.1 Dimensions/Mass

Width (mm)	Depth (mm)	Height (mm)	Mass (kg)
560 ^{*1}	505	431.6	41.2 ^{*2} or less

*1: The RH Cover Handle (10 mm) is not included.

*2: The Toner Cartridges (YMCK) are not included.

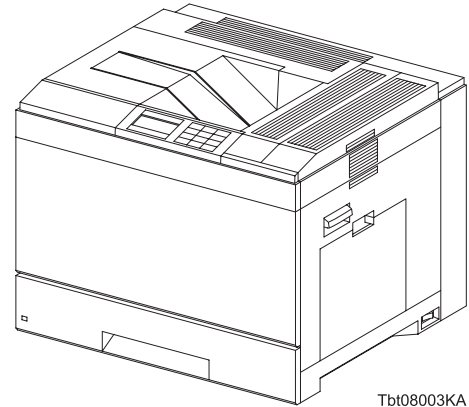

Tbt08003KA

3.2 Dimensions/Mass of 550 Sheet Feeder

Width (mm)	Depth (mm)	Height (mm)	Mass (kg)
560	505	134	10.8 or less

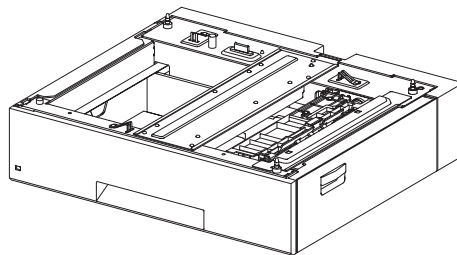

Tbt08004KA

3.3 Dimensions/Mass of High Capacity Feeder (HCF)

Width (mm)	Depth (mm)	Height (mm)	Mass (kg)
560	505	351	32 or less

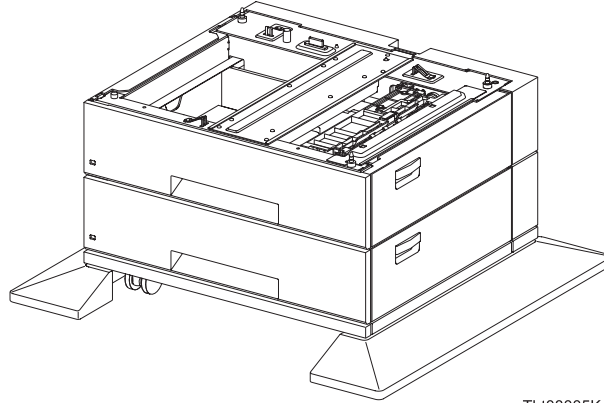

Tbt08005KA

3.4 Dimensions/Mass of Consumables and CRUs

3.4.1 BELT ASSY IBT

- Width: 400.9 mm
- Depth: 340.4 mm
- Height: 72.0 mm
- Mass: 2.0 kg

Reference: *The BELT ASSY IBT has CRUM (CRU memory) to record information.*

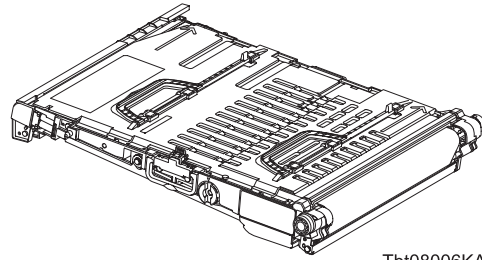

Tbt08006KA

3.4.2 FUSER

- Width: 153 mm
- Depth: 404 mm
- Height: 106 mm
- Mass: 1.8 kg

Reference: *The FUSER has CRUM (CRU memory) to record its information.*

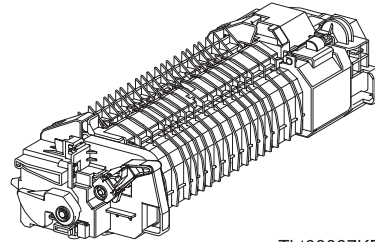

Tbt08007KB

3.4.3 Black toner cartridge

- Width: 67.4 mm
- Depth: 326.8 mm
- Height: 75.7 mm
- Mass: 0.5 kg

Reference: *The Black toner cartridge has CRUM (CRU memory) to record its information.*

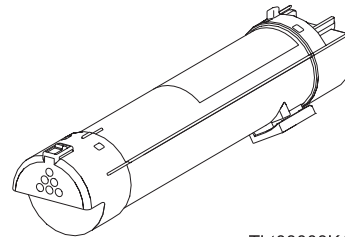

Tbt08008KA

3.4.4 Yellow toner cartridge

- Width: 61.6 mm
- Depth: 326.8 mm
- Height: 67.4 mm
- Mass: 0.4 kg

Reference: *The Yellow toner cartridge has CRUM (CRU memory) to record its information.*

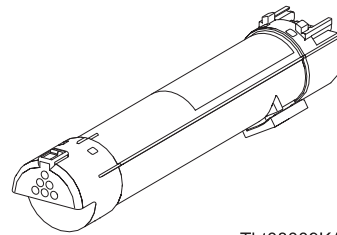

Tbt08009KA

3.4.5 Magenta toner cartridge

- Width: 61.6 mm
- Depth: 326.8 mm
- Height: 67.4 mm
- Mass: 0.4 kg

Reference: *The Magenta toner cartridge has CRUM (CRU memory) to record its information.*

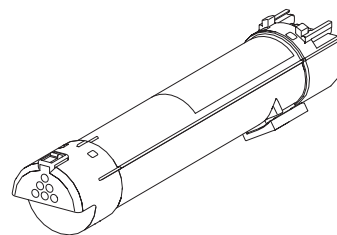

Tbt08009KA

3.4.6 Cyan toner cartridge

- Width: 61.6 mm
- Depth: 326.8 mm
- Height: 67.4 mm
- Mass: 0.4 kg

Reference: *The Cyan toner cartridge has CRUM (CRU memory) to record its information.*

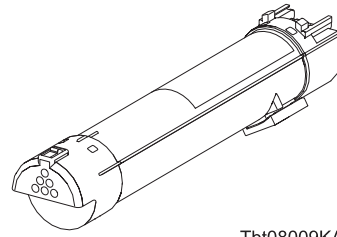

Tbt08009KA

3.4.7 XERO DEVE CRU ASSY (Y)

- Width: 82.2 mm
- Depth: 354.9 mm
- Height: 58.6 mm
- Mass: 1.05 kg

Reference: *The XERO DEVE CRU ASSY (Y) has CRUM (CRU memory) to record its information.*

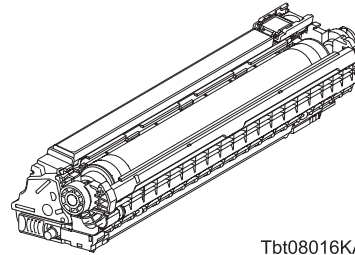

Tbt08016KA

3.4.8 XERO DEVE CRU ASSY (M)

- Width: 82.2 mm
- Depth: 354.9 mm
- Height: 58.6 mm
- Mass: 1.05 kg

Reference: *The XERO DEVE CRU ASSY (M) has CRUM (CRU memory) to record its information.*

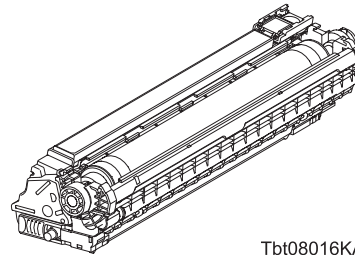

Tbt08016KA

3.4.9 XERO DEVE CRU ASSY (C)

- Width: 82.2 mm
- Depth: 354.9 mm
- Height: 58.6 mm
- Mass: 1.05 kg

Reference: *The XERO DEVE CRU ASSY (Y) has CRUM (CRU memory) to record its information.*

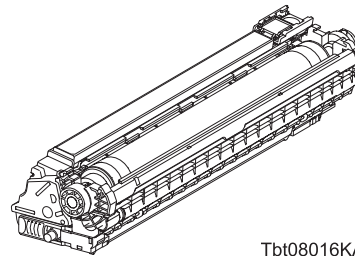

Tbt08016KA

3.4.10 XERO DEVE CRU ASSY (K)

- Width: 82.2 mm
- Depth: 354.9 mm
- Height: 58.6 mm
- Mass: 1.05 kg

Reference: *The XERO DEVE CRU ASSY (Y) has CRUM (CRU memory) to record its information.*

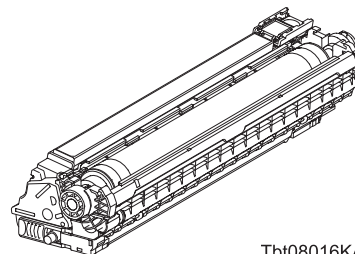

Tbt08016KA

3.4.11 WASTE TONER BOX

- Width: 74.8 mm
- Depth: 359.9 mm
- Height: 61.5 mm
- Mass: 0.165 kg

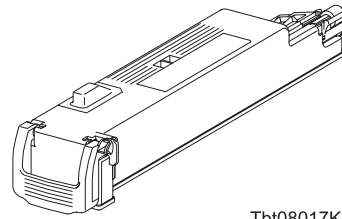

Tbt08017KA

3.4.12 ROLL ASSY 2ND BTR

- Width: 53.4 mm
- Depth: 299.6 mm
- Height: 75.6 mm
- Mass: 0.2 kg

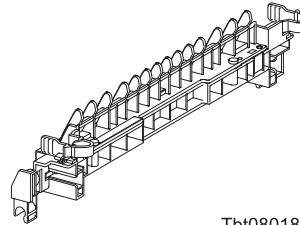

Tbt08018KA

3.5 Installation Requirements

The printer requires the minimum installation space shown below for typical operation.
(Space occupied by the operator is not included.)

Top view

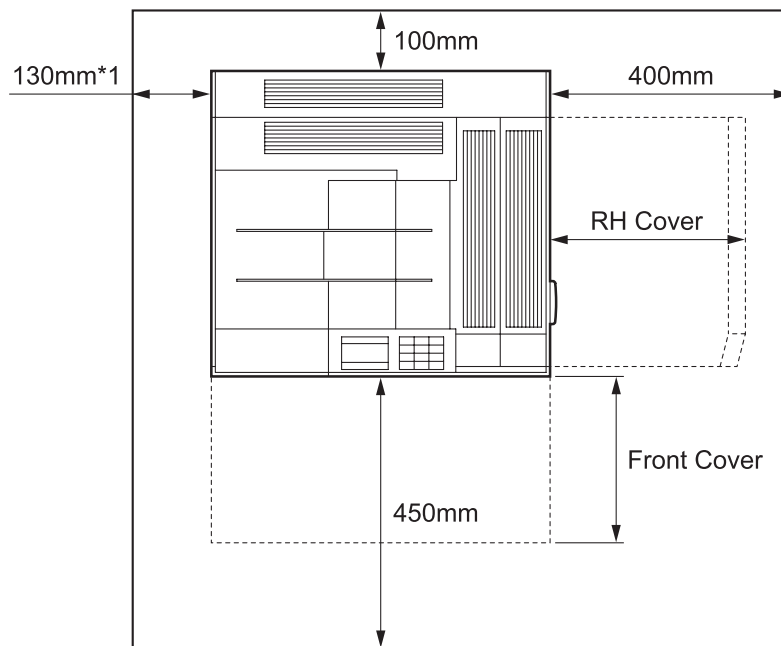

Tbt08010KA

*1: A minimum horizontal clearance of 500 mm is required when the optional Output Expander is installed.
(A minimum horizontal clearance of 60 mm is required adjacent to the edge of the Output Expander.)

Front view

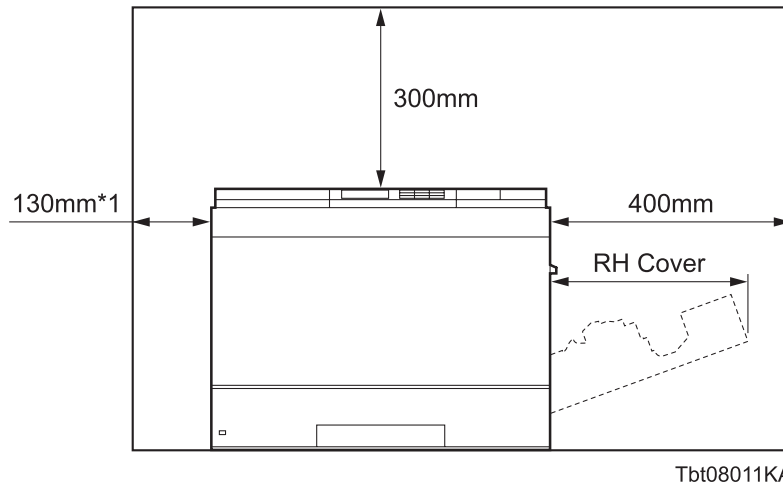

*1: A minimum horizontal clearance of 500 mm is required when the optional Output Expander is installed.
 (A minimum horizontal clearance of 60 mm is required adjacent to the edge of the Output Expander.)

Side view

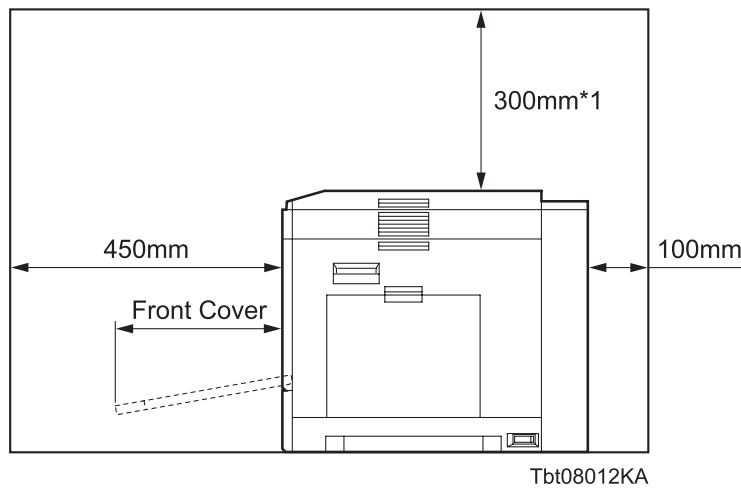

*1: A minimum horizontal clearance of 400 mm is required when the optional Output Expander is installed.

4. Functions

4.1 Printing System

Tandem electrophotographic system employing OPC drum and IBT.

4.2 Exposure System

Semiconductor laser beam scanning system

4.3 Development System

Development with dry type 2-component developer

4.4 Fixing System

Thermal fixing system by Free Belt Nip Fusing (FBNF)

4.5 Resolution

- Fast scanning direction: varies depending on printer controller
- Slow scanning direction: 600dpi in all speeds/1200dpi in half speeds

4.6 Operation Mode

The printer operates in the following four modes. The modes are switched over mainly by a command from the printer controller or a change of printer status.

The printer goes through a warm-up stage is required before shifting to the standby mode from a power-on, deep sleep mode, or sleep mode.

- Running mode

The printer is in an operating status such as running or recording.

Fixing system:	Kept at the operating temperature.
Exposure system:	Operating
Recording system:	Operating
Cooling fan:	Operating (High)

- Ready mode

The printer is ready for operation.

Fixing system:	Kept at the standby temperature.
Exposure system:	Resting
Recording system:	Resting
Cooling fan:	Operating (Low)

- Sleep mode

The printer is completely at rest. Compliant with Energy Star and BAM requirements.

Fixing system:	Kept at the sleep temperature
Exposure system:	Resting
Recording system:	Resting
Cooling fan:	Operating (Low)

- Deep sleep mode

A rest status after the sleep mode. Compliant with Energy Star and BAM requirements.

Fixing system:	Resting
Exposure system:	Resting
Recording system:	Resting
Cooling fan:	Resting

4.7 Warm-up Time

When a nominal voltage is applied, the printer goes to the standby mode at POWER-ON or within 30 seconds from a power-saving mode.

Reference: Measured at 22°C, 55% RH, rated voltage.

4.8 FPOT (First Print Output Time)

The FPOT (First Print Output Time) of the printer is shown in the table below.

The time required from print instruction to the output of the first sheet of paper is output is calculated on the following conditions (rounded to one decimal place).

- The printer is in the standby mode. (ROS MOTOR OFF, FUSER READY)
- The paper used is A4 short-edge feed.
- The time for process control is not included.*¹

*1: The process control refers to controls such as TC control, electric potential control, cleaning cycle, and registration control. While the printer executes these controls, the engine may stop feeding papers for a certain period of time.

Color Mode	FPOT(Sec.)						
	Standard Tray	MFP	OP FDR 1st Tray	OP FDR 2nd Tray	OP FDR 3rd Tray	OP FDR 4th Tray	OP Output Expander
B/W	8.5 sec or less	8.7 sec or less	9.1 sec or less	9.6 sec or less	10.0 sec or less	10.4 sec or less	13.4 sec or less
Color	10.0 sec or less	10.2 sec or less	10.6 sec or less	11.1 sec or less	11.5 sec or less	11.9 sec or less	14.9 sec or less

4.9 Average Print Speed

The average print speed is shown below.

OS	PDL	Color Mode	Paper Size	Paper Type	Input Tray	Simplex/Duplex	Throughput
XP	PCL 6	B/W	A4 SEF	Plain	Tray 1	Simplex	26.2 sec or less
		Color				Duplex	29.9 sec or less
						Simplex	27.7 sec or less
		Duplex				31.4 sec or less	
	PS	B/W				Simplex	38 sec or less
		Color				Duplex	42 sec or less
						Simplex	46 sec or less
		Duplex				50 sec or less	
OSX	PS	B/W	Simplex	190 sec or less			
		Duplex	200 sec or less				
	Color	Simplex	303 sec or less				
		Duplex	313 sec or less				

4.10 Input Properties

4.10.1 Feeding system

- Tray feed

The feeding system of this printer is ARRF.

- MSI feed

The feeding system of this printer is S-ARRF.

- Duplex feeder unit

A component that enables 2-sided printing. 2-sided printing can be selected via the controller.

4.10.2 Paper capacity

- Tray feed

550 sheet Paper Tray: Maximum 550 sheets or 59.4mm of standard paper

HCF Paper Tray: Same as 550 sheet Paper Tray.

- MPF feed

Maximum 150 sheets or 16.2mm of standard paper

4.11 Output Properties

4.11.1 Output system

The printer outputs prints in the following method.

- FACE DOWN output

4.11.2 Output capacity

- FACE DOWN output
500 sheets (Letter/A4 standard paper)

4.11.3 Output paper size/weight

- FACE DOWN output
All paper sizes supported by this printer

4.11.4 Full stack detection

Detected at the height of higher than 72mm

4.11.5 Paper delivery capacity of Option Output Expander

- FACE DOWN output
1000 sheets (Letter/A4 standard paper)

4.12 Paper

4.12.1 Paper type

The paper that can be used with this printer is grouped into "Standard Paper", "General Paper", and "Special Paper".

Standard Paper

The paper that is recommended for use with this printer. Its feed performance, reliability, and print quality satisfy the specifications.

Shown in the table below is the standard paper:

	B/W	F/C
For domestic market	P	C2
For overseas market	4200DP 20lb	X-pressions

General Paper

General paper is plain paper except for standard paper and special paper. Its feed performance and reliability satisfy the specifications, but the print quality does not.

Special Paper

Special paper except for plain paper. Its feed performance and reliability satisfy the specifications, but the print quality does not.

4.12.2 Paper mass

Paper feed from paper tray

"60 to 216 gsm" (16 lb to 57.6 lb)

Paper feed from MSI

"60 to 216 gsm" (16 lb to 57.6 lb)

4.12.3 Paper size

Paper size which can be set to each paper pick-up unit is shown in the table below.

Cassette	Paper size
550 Sheet Paper Tray	A5, B5, A4, Letter, Executive, Legal, Folio, Com-10 ^{*1} , Monarch ^{*1} , DL ^{*1} , C5 ^{*1} Minimum size Width 98.4mm (3.87 in) × Length 190.5mm (7.5 in) Maximum size Width 215.9mm (8.5 in) × Length 355.6mm (14 in)
MSI Tray	A5, B5, A4, Letter, Executive, Legal, Folio, Com-10, Monarch, DL, C5 Minimum size Width 76.2mm (3.0 in) × Length 127mm (5.0 in) Maximum size Width 215.9mm (8.5 in) × Length 355.6mm (14 in)

*1: The option cannot be used.

5. Consumables

Consumables are usually replaced by costumers. In the event of recovery of failure attributable to consumables or isolation of failure, you may replace them.

5.1 Items of Consumables

- Toner cartridge (YMCK)
Cartridge to supply yellow/magenta/cyan/black toner to the development unit.
Toner cartridge (YMCK) has CRUM (CRU memory) to record information.

- Drum cartridge (YMCK)
Drum cartridge which forms the visible image of toner (YMCK) on Drum.
Drum cartridges (YMCK) has CRUM (CRU memory) to record information.

- Waste toner box
BOX which collects Waste Toner.

5.2 Consumable Life

- Toner Cartridge (K) : 9kPV / 18kPV
- Toner Cartridge (YMC) : 6kPV / 12kPV
- Drum Cartridge (YMCK) : 50kPV
- Waste Toner Box : 25kPV

5.3 Periodic Replacing Parts (Reference)

- FUSER : 100kPV
- BELT ASSY IBT : 150kPV
- ROLL ASSY 2ND BTR : 150kPV
- ROLL ASSY FEED (550 Feeder, Option Feeder550/HCF 1100) : 150kPV
- HOLDER ASSY FEED (550 Feeder, Option Feeder550/HCF 1100) : 150kPV

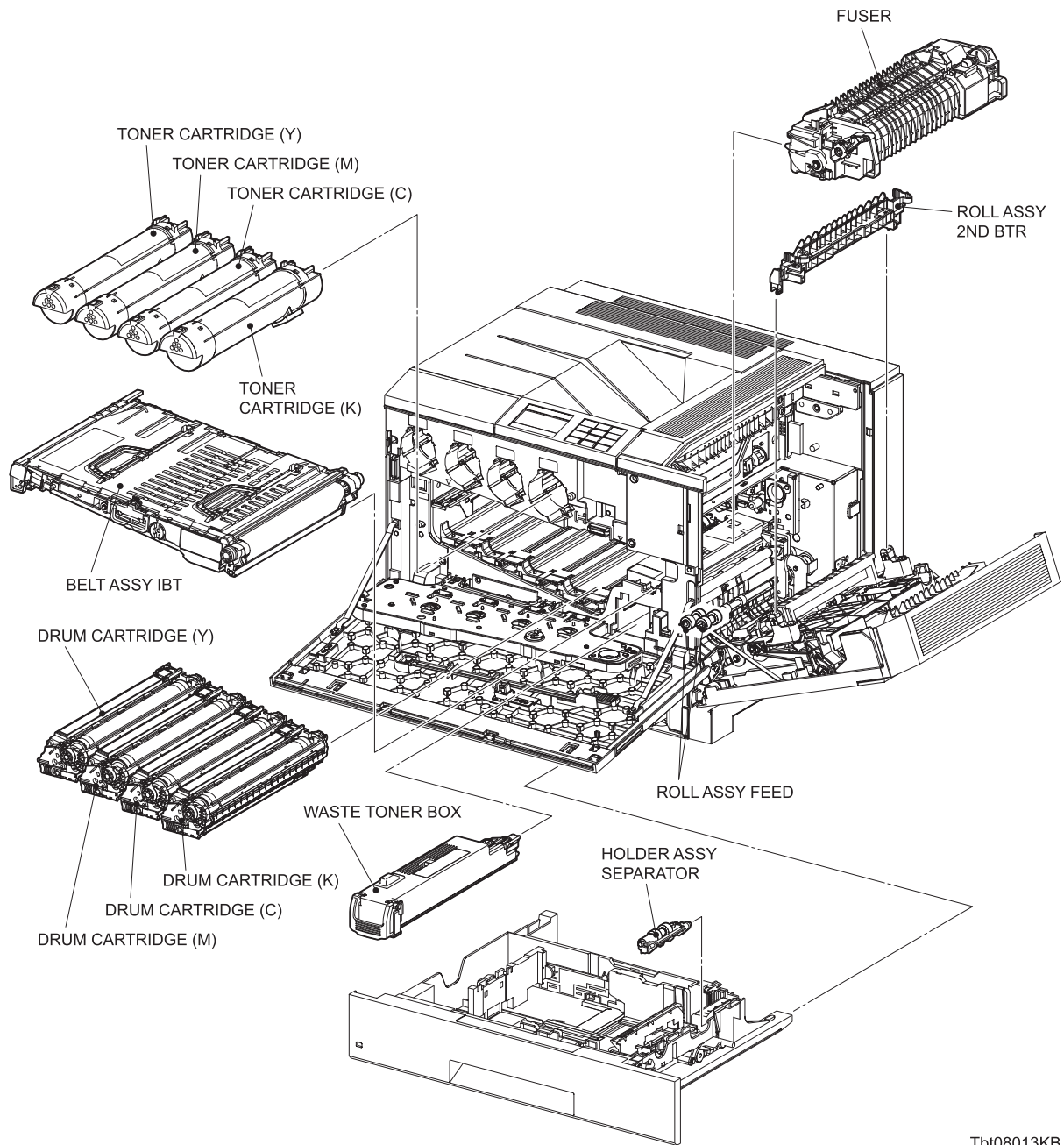

Tbt08013KB

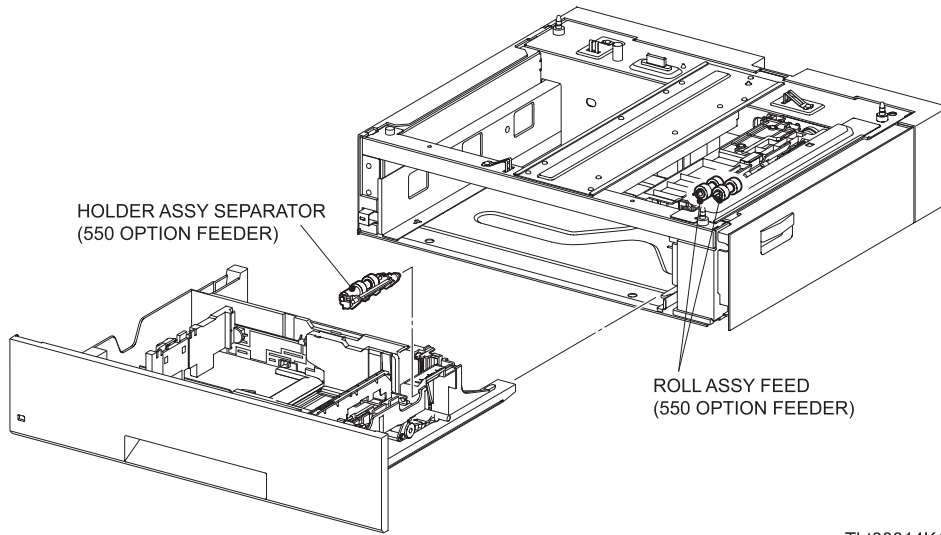

Tbt08014KA

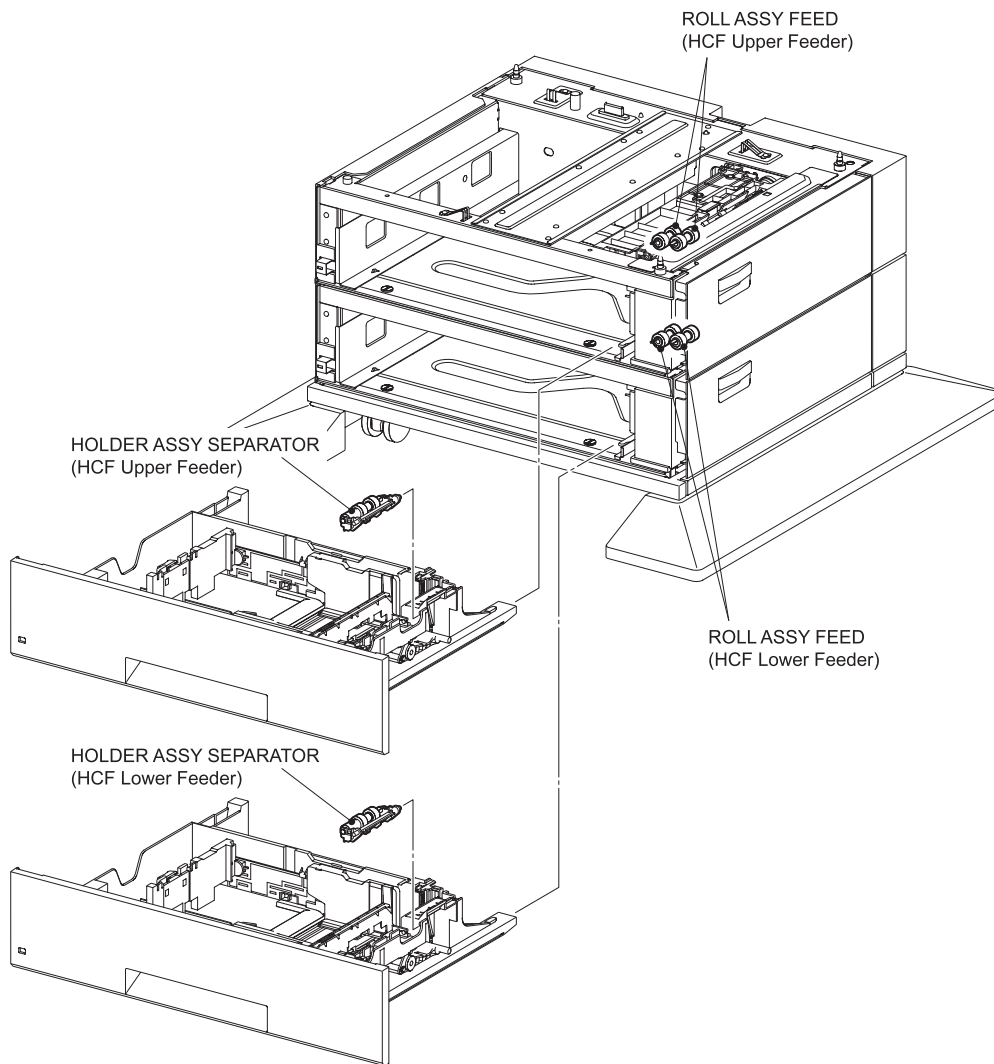

Tbt08015KA

6. Operating Environment

6.1 Installation Temperature / Humidity

Installation temperature and humidity on the condition without condensation is as follows.

At operating: 5-32 °C, 15-85%RH (No condensation)

At standby: minus 20-40 °C, 5-85%RH (No condensation)

6.2 Installation Altitude

0 to 3,100m (0 to 10170 ft).

6.3 Installation Horizontality

Longitudinal levelness of table surface on which the printer is installed:1 degree or less

Lateral levelness of table surface on which the printer is installed :1 degree or less

6.4 Ambient Lighting

3000 lux or less (without direct sun light)

6.5 Storage Temperature of a Toner Cartridge

The guaranteed period of a sealed print cartridge is as follows:

Normal conditions: 24 months under 0 to 35 °C, 15 to 80% RH.

Harsh conditions: Up to one month under -20 to 0 °C and 35 to 40 °C, 5 to 15% RH and 80 to 95% RH.

The storage altitude shall be 0 to 3,100 m. Can be extended to 0 to 15000 m when shipped by air.

(Provided that the cargo bay is pressurized to 70.9275 Kpa or more.)

7. Safety / Environment Conditions

7.1 Safety Standard

- 110V system
UL60950-1
CSA C22.2 No.60950
- 220V system
IEC60950 / EN60950

7.2 Laser Safety Standard

- 110V system
FDA21CFR Chapter 1, Subchapter J, Section 1010, 1040
- 220V system
IEC60825-1 Amendment 1 + Amendment 2 / EN60825-1 Amendment 11 + Amendment 2 Class 1
Laser Product

7.3 EMI

- 100V / 110V system (US)
FCC Part 15 Subpart B, Class B
- 220V system (EC)
EN55022 (2006), Class B

7.4 Noise

The operation noise level is as follows.

Printer	Sound power level	Sound pressure (by stander)
	LWAD	LpAm
During Printing	7.48 B	59.0dBA
During Standby	5.3 B	26.0dBA

8. Print image Quality

8.1 Image Quality Guarantee Conditions

The image quality is specified and guaranteed under the following conditions.

8.1.1 Environmental conditions

Environment condition for evaluating image quality

Temperature: 10-28 °C

Humidity: 15-85% RH (The humidity shall be at 28 °C using 26 °C Wet BULB)

8.1.2 Guaranteed paper

The print image quality specified here is guaranteed with standard paper fed from the paper tray.

Evaluation is performed with the maximum size of each standard paper.

Xerox 4200DP 20 lb letter (Black and White)

Xerox Digital Color Xpression 24 lb letter (Color)

8.1.3 Paper condition

The paper used is fresh paper immediately after unpacked, which has been left in the operating environment for 12 hours before unpacking.

8.1.4 Printer condition

The print image quality specified in this section is guaranteed with the printer in normal condition.

8.1.5 Image quality guaranteed area

The print image quality specified in this section is guaranteed in the guaranteed image quality area specified in this manual. (Refer to Chapter 1)

8.1.6 Criterion

The print image quality is guaranteed with the Spec. In rate = 90% ($\gamma = 90\%$).

9. Option

9.1 User-installable Options

Users can install the following units:

- 550 Sheet Feeder
- 1100 High Capacity Feeder (HCF)
- Output Expander
- Wireless Adapter
- Hard Disk
- Optional Memory (1GB)

10. ESS Specification

10.1 External Interface

10.1.1 USB

Item	Specification
Connector	Type-B x 1
Protocol	USB2.0, HighSpeed
Supported Client	Windows 2000, XP, Server 2003, Vista, Server 2008 MacOS X machine with USB Linux machine with USB

10.1.2 Ethernet

Item	Specification
Connection	RJ-45 x 1 connectr
Protocol	See "10.2 Network Protocol" for details
Supported Client	Windows 2000, XP, Server 2003, Vista, Server 2008, Mac OS X (10.3.x or higher) Mac OS 9 (TCP/IP only) Linux

10.1.3 IEEE1284

Item	Specification
Connection	Centronics 36pin x 1
Protocol	Standard, Nibble, ECP
Supported Client	Windows 2000, XP, Server 2003, Vista, Server 2008 Linux machine

10.1.4 Wireless

multi-protocol Card is required.

Item	Specification
Connectivity Technology	Wireless
Compliant Standards	IEEE802.11n/g/b
Band width	2.4GHz/5GHz
Data Transfer Rate	IEEE802.11n mode: 300, 100 Mbps IEEE802.11g mode: 54, 48, 36, 24, 18, 12, 9, 6 Mbps IEEE802.11b mode: 11, 5.5, 2, 1 Mbps
Protocol	See "10.2 Network Protocol" for details
Device Type	Wireless Adapter
Security Protocol	64(40-bit key)/128(104-bit key) WEP, WPA-PSK(TKIP,AES), WPA2-PSK(AES) WPA-Enterprise ^{*2} (TKIP, AES), WPA2-Enterprise ^{*2} (AES)
Supported Client	Windows 2000, XP, Server 2003, Vista, Server 2008, Mac OS X machine Linux machine ^{*1}

*1: Linux machine is supported only when connected in infrastructure mode and when Linux terminal is connected with Wired LAN connection.

*2: PEAPv0 only

10.2 Network Protocol

10.2.1 Printing Protocol

Protocol	Transport	Maximum Session	Remark
LPD	TCP/IP	1	
Port9100	TCP/IP	1	
IPP	TCP/IP	5	
SMB	TCP/IP	5	
	NetBEUI	5	
NetWare (P-Server)	NCP/IPX	1	
	TCP/IP		
WSD	TCP/IP	1	

10.2.2 Other Protocols

Protocol	Transport	Application / Usage
SNMP	UDP/IP	Driver, Installer
HTTP/HTTPS	TCP/IP	EWS
DHCP	UDP/IP	IP setup
BOOTP	UDP/IP	IP setup
RARP	TCP/IP	IP management
AutoIP	TCP/IP	Installer (Device discovery)
SMTP	TCP/IP	E-Mail Alert
Telnet	TCP/IP	
Bonjour(mDNS)	UDP/IP	
DDNS	TCP/IP	
FTP	TCP/IP	Firmware update
WINS	TCP/IP	
WSD	TCP/IP	

10.3 Decomposer

10.3.1 PDL/Emulation

The decomposer is PCL. Note that the printer can accept jobs generated by its own printer driver.

PDL	Interface port	Operating system
PCL 5c	IEEE1284, USB, TCP/IP	
PCL 6	IEEE1284, USB, TCP/IP	Windows 2000, XP, Server 2003, Vista, Server 2008, Windows 7 (Post RTS)
Post Scripts 3	IEEE1284, USB, TCP/IP	Windows 2000, XP, Server 2003, Vista, Server 2008, Windows 7 (Post RTS) Mac OS X (10.2.x or higher) Mac OS 9 (TCP/IP only) Linux, Unix
Host based (XPS)	IEEE1284, USB, TCP/IP	Windows Vista

10.3.2 Font

81 fonts and 36 Symbol Sets for PCL and 136 fonts for PS3 are available as built-in font.

10.3.3 Form Overlay

The function for writing PCL5 forms is supported.

10.3.4 Image Area

Usable Area Size	Maximum: 215.9mm (8.5 in.) x 355.6mm (14 in.)
Unprintable Area	4.1 mm each from four edges (left, right, top and bottom) of paper
	For DL LEF, 6.1mm from left and right edges, 4.1 mm from top and bottom edges are not printable
Printable Area	Maximum: 207.7mm (8.17 in.) x 347.4mm (13.67 in.)
Print Image Quality Guaranteed Area	Same as Printable Area

10.4 Job Control

10.4.1 Cancel Print

A print job in process can be cancelled via the operation panel.

10.4.2 Job Recovery

When a job fails due to a paper jam, the printer automatically restarts the job after the jammed paper is removed.

10.4.3 Job Time Out

When a job transmission is interrupted for a certain period of time (Time can be changed at the operation panel and unlimited time can be selected), the print data is deleted as an error.

10.4.4 Secure Print

You can store print jobs temporarily in printer memory to output at a specified time at the printer.

This feature can be used to print confidential documents.

A stored print job will be deleted after you print it, or after a designated period of time has elapsed.

Secure Print function is available when using the PCL or PS driver.

10.4.5 Private MailBox Print

You can store print jobs temporarily in printer memory to output at a more convenient time at the printer.

This feature can be used to print confidential documents.

The stored jobs remain in printer memory until you delete them on the operator panel.

Private MailBox Print function is available when using the PCL or PS driver.

10.4.6 Public MailBox Print

You can store print jobs temporarily in printer memory to output at a more convenient time at the printer. A print job is stored until you delete it from printer memory on the printer operator panel. You can not use the password function with this feature. This function does not require a password to print a stored job.

Public MailBox Print function is available when using the PCL or PS driver.

10.4.7 Proof Print

When you specify multiple copies for a collated job, this feature allows you to print only the first set for checking, before proceeding to print the remaining copies at the printer.

Proof Print function is available when using the PCL , PS or Linux driver.

10.4.8 IP Filter

The user can select to accept or reject jobs for the specified IP address. Up to 5 IP addresses can be specified.

IP filter is available only to LPD and Port9100.

10.4.9 Dell ColorTrack

Dell ColorTrack is a function to specify the availability of color print and to limit print volume per user.

Only administrators are allowed to make limitation settings from the EWS. User name and password is embedded in the print job in order to identify who the job is sent from. User name and password are entered by user via the printer driver.

10.5 Logging

10.5.1 Job Logging

The printer can retain up to 20 job logs. Job log can be printed upon the user's request or automatically when the number of the retained job logs has reached 20. Job log includes the following information:

- Job transmission date and time*
- Input interface (USB, Lpd etc.)
- Document name (File name)
- Output color
- User name/Host name*
- Number of printed pages (Color/B/W)
- Number of printed sides (Color/B/W)
- Paper size
- Result (Successful, Error, etc.)

10.5.2 Error Logging

The printer can retain up to 42 jam errors and up to 42 fatal errors.

The user can print error log by the panel operation.

Jam error log includes the following information:

- Date and time when error occurs.
- Name of jam

Fatal error log includes the following information:

- Date and time when error occurs.
- Error code

10.5.3 Print Volume Counter

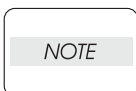

- Data can be stored or checked at multiple addresses within one IC.

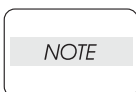

- IC can be transferred when the ESS is replaced. (IC is mounted on socket)

Counter	Description
Color Print Counter	Count the number of page printed in color (7 digits)
B/W Print Counter	Count the number of page printed in B/W (7 digits)
Total Print Counter	Count the total number of page printed in color and B/W (7 digits)

10.6 ID Print

User name can be printed. The printing position can be selected from upper right, upper left, lower right and lower left (Only for PCL6).

The user selects using the operation panel whether user name is printed or not and where it is printed.

10.7 Third Party Mode

When the life of the toner cartridge has ended, the printer stops accepting print request (life of toner cartridge is counted by the counter in CRUM). Taking into consideration that some users use refilled toner cartridges, the printer can accept print request via the control panel even if life of toner cartridge has ended. While in this mode, the printer displays a message on the operation panel to inform the user of the mode change. When the printer operates in this mode, print image quality is not guaranteed. Also, remaining toner level is not displayed (as CRUM data can not be guaranteed).

10.8 Utility Print

10.8.1 Printer Settings List

Printer Settings List can be printed upon the user's request.

Printer Settings List is printed in B/W in the automatically selected paper tray.

Printer Settings List includes the following information:

Items on the list are slightly different from below when wireless LAN option is installed.

[Title]

Product name (Logo)

[General]

Printer Name, Service Tag, Asset Tag Number, Total Impressions, Color Impressions, Black Impressions, Serial Number, Memory Capacity, Printer Language, Number of Fonts Available, Post Script Version, Post Script Serial Number, Firmware Version, Boot Version, Engine Version, Post Script CRD Version, Default Paper, Default Plain, Default Label, Default Language, Toner Level Status

[Network]

Firmware Version, MAC Address, Ethernet Settings, TCP/IP, IPv4, IPv6, Ipsec, LPD, Port9100, IPP, NetWare, WSD, FTP, SNMP, E-Mail Alert, EWS, Bonjour(mDNS), DNS, Telnet, HTTP_SSL/TSL, LDAP-SSL/TSL Communication, Verify Remote Server Certificate, IEEE 802.1x, Authentication System, Kerberos Server, LDAP Directory, IP Filter, WirelessSetting^{*1} (SSID, Network Type, Quality, Link Channel)

*1: Listed when wireless Printer Adapter is installed

[Printer Options]

Wireless Adapter, Hard Disk, Font USB Memory*2, Optional Tray, Output Expander, Stacker Tray

*2: Post RTS

[Print Volume]

Print volume for each paper size

10.8.2 Panel Settings List Print

Panel Settings List can be printed by the user's operation.

Panel Settings List is printed in B/W in the auto tray select mode.

10.8.3 Font List Print

PCL or PS Font List can be printed by the user's operation.

Font List is printed in the auto tray select mode.

10.8.4 Job History Report

The user can print Job History Report by requesting instant print or by setting auto print.
Job History Report in B/W on A4 size (Letter size for the US) in the automatically selected paper tray.

- Title: Printer Name (Logo)
- Date
- Time
- Input Port
- Host/User Name
- Document Name
- Output Color
- Page Size
- Pages
- Sheets
- Result

10.8.5 Error History Report

Error History Report can be printed according to the user's request.
Error History Report in B/W on A4 size (Letter size for the US) in the automatically selected paper tray.

- System Fail History:
 - Date
 - Time
 - Chain-Link (Error Code)
- Paper Jam History:
 - Date
 - Time
 - Chain-Link (Error Code)
 - Paper Jam Type

I

MFG p/n	CRU or FRU	Quantity in a box	Dell #	Dell Description in RSL
TONER / INK				
675K 84590	CRU	1	R273N	YELLOW TONER CARTRIDGE 6K 5130CDN
675K 84720	CRU	1	T222N	YELLOW TONER CARTRIDGE 12K 5130CDN
675K 84600	CRU	1	P615N	MAGENTA TONER CARTRIDGE 6K 5130CDN
675K 84730	CRU	1	R272N	MAGENTA TONER CARTRIDGE 12K 5130CDN
675K 84610	CRU	1	X942N	CYAN TONER CARTRIDGE 6K 5130CDN
675K 84750	CRU	1	P614N	CYAN TONER CARTRIDGE 12K 5130CDN
675K 84620	CRU	1	U157N	BLACK TONER CARTRIDGE 6K 5130CDN
675K 84760	CRU	1	N848N	BLACK TONER CARTRIDGE 12K 5130CDN

DEVELOPERS				
848K 84580	CRU	1	X951N	YELLOW DRUM/DEVELOPER 5130CDN
848K 84690	CRU	1	T229N	MAGENTA DRUM/DEVELOPER 5130CDN
848K 84700	CRU	1	U163N	CYAN DRUM/DEVELOPER 5130CDN
848K 84710	CRU	1	P623N	BLACK DRUM/DEVELOPER 5130CDN

FUSER AND ACESSORIES				
675K 84630	CRU	1	N856N	FUSER 110V 5130CDN FOR AMERICAS
675K 84640	CRU	1	R279N	FUSER 220V 5130CDN FOR EMEA & AUSTRALIA & NEW ZEALAND

SERVICE KITS				
675K 84570	CRU	1	U164N	SERVICE KIT TRANSFER BELT 2ND TRANSFER BELT FEED ROLLER KIT 5130CDN
675K 84770	CRU	1	U162N	WASTE TONER CONTAINER

OPTIONS				
675K 84650	CRU	1	N854N	HARDDISK 80 GB 5130CDN (OPTION)
675K 84680	CRU	1	T226N	Memory, 1GB, DIMM,5130CDN (OPTION)
675K 84660	CRU	1	P624N	WIRELESS CARD, 5130CDN (OPTION)

DOCUMENTATION, DRIVERS AND APPLICATIONS				
675K 84870	CRU	1	D720R	DOCUMENT KIT IN ENGLISH, FRENCH, SPANISH FOR AMERICAS 5130CDN
675K 85610	CRU	1	H490R	DOCUMENT KIT FOR 110V TAA 5130CDN
	CRU	1	Y989P	DOCUMENT KIT FOR 220V TAA 5130CDN

TRANSFER BELT				
064K 93150	CRU	1	Y520R	MAIN TRANSFER BELT 5130CDN
059K 66361	CRU	1	R280N	2ND TRANSFER BELT 5130CDN

ROLLER				
019K10660 + 059K46040x2pcs + Instruction	CRU		D347T	FEEDER SEPARATOR ROLLER for all trays 5130CDN
019K 11140 + Instruction	CRU		G194T	MULTI-PAPER FEEDER SEPARATOR ROLLER on printer 5130CDN
059K 50731	FRU		P358C	MULTI-PAPER FEED ROLLER on printer 5130CDN

FEEDER, TRAY AND TRAY HOUSING				
050K 65090	CRU	1	H167T	DEFAULT PAPER TRAY 550 SHEET 5130CDN
848K 37991 with instruction	CRU	1	D526T	FDR,ASSY,CVR,MSI,5130CDN
059K66692 with instruction	CRU	1	D342T	OPTIONAL PAPER TRAY HOUSING 550 SHEET 5130CDN
050K 65100	CRU	1	K181T	OPTIONAL PAPER TRAY 550 SHEET 5130CDN
Feeder without tray with instruction	CRU	1	G193T	OPTIONAL PAPER TRAY HOUSING 1100 SHEET 5130CDN

PLASTICS				
848K 28740	FRU	1	C274T	FRONT COVER (PLASTIC) WITH INTERLOCK SWITCH AND CLEANER WAND 5130CDN
848K 28691	FRU	1	F162T	REAR COVER (PLASTIC) WITH ACTUATOR 5130CDN
032E 31780	CRU	1	51XMB	RIGHT HAND FRAME BOTTOM RIGHT CONNECTOR COVER 5130CDN
848K 37991 with instruction	CRU	1	D526T	MULTI-PAPER FEED (PLASTIC) 5130CDN
Without 2nd BTR	FRU	1	D352T	RIGHT COVER (PLASTIC) WITH RIGHT HAND FRAME WITH MULTI PAPER FEED(D526T) WITH DUPLEXOR MECHANISM WITH FUSER GUIDE WITH FUSER FAN 5130CDN
848E 36900	CRU	1	MM4H3	OUTPUT FINISHER TRAY BOTTOM COVER GUIDE 5130CDN
848E 38350	CRU	1	D44J3	OUTPUT FINISHER POWER CABLE ROUTING COVER 5130CDN
848E 36880	CRU	1	MNCPD	OUTPUT FINISHER DATA CABLE ROUTING COVER 5130CDN

ELECTRICAL / ELECTRONICS BOARDS AND CARDS				
105K 24050	FRU	1	H328T	HIGH VOLTAGE POWER BOARD 5130CDN
101K 55880	FRU	1	G133T	LOW VOLTAGE POWER BOARD 100V/115V 5130CDN FOR JAPAN & AMERICAS
101K 60370	FRU	1	Y357R	LOW VOLTAGE POWER BOARD 220V 5130CDN FOR EUROPE, AUS & NZ
960K 49970	FRU	1	Y358R	PRINTER MACHINE CONTROL UNIT BOARD 5130cdn
815K 00870	FRU	1	C398T	PRINTER ESS BOARD 5130CDN
960K 45390	FRU	1	J133T	OUTPUT FINISHER ESS BOARD 5130CDN
105E 19280	FRU	1	H222T	OUTPUT FINISHER LOW VOLTAGE POWER BOARD

FAN AND ACESSORIES				
101K 58770	FRU	1	F365T	FAN FOR LOW VOLTAGE POWER 5130CDN
127E 85810	FRU	1	Y910R	FAN FOR FUSER 5130CDN

MISCELLANOUS HARDWARE				
	FRU	1	G135T	OPERATOR DISPLAY PANEL FOR DAO 5130CDN
	FRU	1	VJT5J	OPERATOR DISPLAY PANEL FOR EMEA 5130CDN
110K 16170	FRU	1	C607T	INTERLOCK SWITCH WITH CABLE (FRONT FRAME LOCATION) 5130CDN
042K 93630	CRU	1	C608T	CLEANING WAND WITH 1 X PAD 5130CDN
110K 15830	FRU	1	F363T	PAPER SIZE SENSOR on Printer 5130CDN
019K 10650	FRU	1	K329T	PAPER LOW SENSOR on Printer 5130CDN
054K 42170	FRU	1	Y362R	MULTI-PAPER FEEDER SEPARATOR ROLLER on Printer 5130CDN
054K 40781	FRU	1	H223T	FEEDER WITH CHUTE ASSEMBLY MECHANISM 5130CDN
962K73670 + with screw driver	FRU	1	F448T	INTERLOCK SWITCH (RIGHT FRAME LOCATION) with screw driver 5130CDN
019E75770 + 120E31460 + 809E85570	FRU	1	Y545R	ACTUATOR (RIGHT FRAME LOCATION) 5130CDN
	FRU		J137T	SOLENOID, GEAR & CLUTCH (RIGHT FRAME LOCATION) 5130CDN
122K 94260	FRU	4	D529T	LED ERASE ASSEMBLY clears info on drum/developer 5130CDN
062K20920 + 019E 64450 + HW kit PPID: 897E 36840	FRU	1	C399T	ROS (Rastor Output Scanner) on Printer 5130CDN
130K 76651	FRU	4	F368T	MODULE CONTAINING ADC & HUMIDITY SENSOR WITH CABLE 5130CDN
019K 11160	FRU	4	H329T	TONER DISPENSOR CRUM on Printer 5130CDN
007K 15330	FRU	1	C626T	FUSER EXIT DRIVE MOTOR 5130CDN
	FRU	1	C631T	FUSER EXIT CHUTE WITH STACK SENSOR & ENVELOPE SENSOR 5130CDN
054K 40571	FRU	1	G319T	FUSER EXIT PAPER INVERTER CHUTE 5130CDN
801K42661 + 806E 28030x2pcs + 354W 24278 x 2pcs	FRU	1	H226T	FRONT INNER DOOR/COVER 5130CDN
007K 15360	FRU	1	H343T	FUSER DRIVE MOTOR 5130CDN
007K 15390	FRU	1	H345T	MAIN TRANSFER BELT MOTOR 5130CDN
007K 15350	FRU	1	Y928R	DRUM/DEVELOPER MOTOR 5130CDN ?
007K 15410	FRU	2	D540T	SWITCHING SENSOR FOR DRUM/DEVELOPER 5130CDN
007K 15370	FRU	1	H351T	CMY DRUM/DEVELOPER MOTOR 5130CDN
007K 15380	FRU	1	J252T	K DRUM/DEVELOPER MOTOR 5130CDN
	FRU	1	Y538R	DRUM/DEVELOPER ASSEMBLY LINK, XEROGRAPHY & RACK

	FRU	1	D349T	DRUM/DEVELOPER MOTOR GEAR 5130CDN
815K 02320	CRU	1	1M8DC	BACK METAL LOCKING PLATE FOR OPTIONAL 500 SHEET
826E 43840	CRU	1	CPGMY	SCREW FOR BACK METAL LOCKING PLATE FOR OPTIONAL 500 SHEET
	CRU	1	F243T	OUTPUT FINISHER MAIN ASSEMBLY MINUS TRAY STACKER & TRANSPORT ASSEMBLY 5130CDN
	CRU	1	H353T	OUTPUT FINISHER TRAY STACKER 5130CDN
826E 28960	CRU	2	JXWWY	OUTPUT FINISHER TRAY SCREWS 5130CDN
	CRU	1	K334T	OUTPUT FINISHER TRANSPORT ASSEMBLY TOP 5130CDN
	CRU	1	G321T	OUTPUT FINISHER TRANSPORT ASSEMBLY BOTTOM 5130CDN
848K 27270	FRU	1	C636T	OUTPUT FINISHER MAIN ASSEMBLY FRONT DOOR/COVER 5130CDN
019K 10370	FRU	1	Y934R	OUTPUT FINISHER MAIN ASSEMBLY STAPLER UNIT 5130CDN
050K 51250	CRU	1	5N2GY	OUTPUT FINISHER MAIN ASSEMBLY STAPLE CARTRIDGE HOLDER AND STAPLE CARTRIDGE 5130CDN
068K 64620	FRU	1	C638T	OUTPUT FINISHER MAIN ASSEMBLY DOOR/COVER INTERLOCK SWITCH 5130CDN

BASE UNIT				
999S Y353R	CRU	1	Y353R	PRINTER FOR SERVICE WHOLE UNIT EXCHANGE 110V AMERICAS 5130CN
999S C271T	CRU	1	C271T	PRINTER FOR SERVICE WHOLE UNIT EXCHANGE 220V EUROPE AUSTRALIA NEW ZEALAND 5130CN
999S C555T	CRU	1	C555T	PRINTER FOR SERVICE WHOLE UNIT EXCHANGE 110V TAA 5130CN
999S D227T	CRU	1	D227T	PRINTER FOR SERVICE WHOLE UNIT EXCHANGE 220V TAA 5130CN

MFG p/n	CRU or FRU	Quantity in a box	Dell #	Dell Description in RSL
TONER / INK				
675K 84590	CRU	1	R273N	YELLOW TONER CARTRIDGE 6K 5130CDN
675K 84720	CRU	1	T222N	YELLOW TONER CARTRIDGE 12K 5130CDN
675K 84600	CRU	1	P615N	MAGENTA TONER CARTRIDGE 6K 5130CDN
675K 84730	CRU	1	R272N	MAGENTA TONER CARTRIDGE 12K 5130CDN
675K 84610	CRU	1	X942N	CYAN TONER CARTRIDGE 6K 5130CDN
675K 84750	CRU	1	P614N	CYAN TONER CARTRIDGE 12K 5130CDN
675K 84620	CRU	1	U157N	BLACK TONER CARTRIDGE 6K 5130CDN
675K 84760	CRU	1	N848N	BLACK TONER CARTRIDGE 12K 5130CDN

DEVELOPERS				
848K 84580	CRU	1	X951N	YELLOW DRUM/DEVELOPER 5130CDN
848K 84690	CRU	1	T229N	MAGENTA DRUM/DEVELOPER 5130CDN
848K 84700	CRU	1	U163N	CYAN DRUM/DEVELOPER 5130CDN
848K 84710	CRU	1	P623N	BLACK DRUM/DEVELOPER 5130CDN

FUSER AND ACESSORIES				
675K 84630	CRU	1	N856N	FUSER 110V 5130CDN FOR AMERICAS
675K 84640	CRU	1	R279N	FUSER 220V 5130CDN FOR EMEA & AUSTRALIA & NEW ZEALAND

SERVICE KITS				
675K 84570	CRU	1	U164N	SERVICE KIT TRANSFER BELT 2ND TRANSFER BELT FEED ROLLER KIT 5130CDN
675K 84770	CRU	1	U162N	WASTE TONER CONTAINER

OPTIONS				
675K 84650	CRU	1	N854N	HARDDISK 80 GB 5130CDN (OPTION)
675K 84680	CRU	1	T226N	Memory, 1GB, DIMM,5130CDN (OPTION)
675K 84660	CRU	1	P624N	WIRELESS CARD, 5130CDN (OPTION)

DOCUMENTATION, DRIVERS AND APPLICATIONS				
675K 84870	CRU	1	D720R	DOCUMENT KIT IN ENGLISH, FRENCH, SPANISH FOR AMERICAS 5130CDN
675K 85610	CRU	1	H490R	DOCUMENT KIT FOR 110V TAA 5130CDN
	CRU	1	Y989P	DOCUMENT KIT FOR 220V TAA 5130CDN

TRANSFER BELT				
064K 93150	CRU	1	Y520R	MAIN TRANSFER BELT 5130CDN
059K 66361	CRU	1	R280N	2ND TRANSFER BELT 5130CDN

ROLLER				
019K10660 + 059K46040x2pcs + Instruction	CRU		D347T	FEEDER SEPARATOR ROLLER for all trays 5130CDN
019K 11140 + Instruction	CRU		G194T	MULTI-PAPER FEEDER SEPARATOR ROLLER on printer 5130CDN
059K 50731	FRU		P358C	MULTI-PAPER FEED ROLLER on printer 5130CDN

FEEDER, TRAY AND TRAY HOUSING				
050K 65090	CRU	1	H167T	DEFAULT PAPER TRAY 550 SHEET 5130CDN
848K 37991 with instruction	CRU	1	D526T	FDR,ASSY,CVR,MSI,5130CDN
059K66692 with instruction	CRU	1	D342T	OPTIONAL PAPER TRAY HOUSING 550 SHEET 5130CDN
050K 65100	CRU	1	K181T	OPTIONAL PAPER TRAY 550 SHEET 5130CDN
Feeder without tray with instruction	CRU	1	G193T	OPTIONAL PAPER TRAY HOUSING 1100 SHEET 5130CDN

PLASTICS				
848K 28740	FRU	1	C274T	FRONT COVER (PLASTIC) WITH INTERLOCK SWITCH AND CLEANER WAND 5130CDN
848K 28691	FRU	1	F162T	REAR COVER (PLASTIC) WITH ACTUATOR 5130CDN
032E 31780	CRU	1	51XMB	RIGHT HAND FRAME BOTTOM RIGHT CONNECTOR COVER 5130CDN
848K 37991 with instruction	CRU	1	D526T	MULTI-PAPER FEED (PLASTIC) 5130CDN
Without 2nd BTR	FRU	1	D352T	RIGHT COVER (PLASTIC) WITH RIGHT HAND FRAME WITH MULTI PAPER FEED(D526T) WITH DUPLEXOR MECHANISM WITH FUSER GUIDE WITH FUSER FAN 5130CDN
848E 36900	CRU	1	MM4H3	OUTPUT FINISHER TRAY BOTTOM COVER GUIDE 5130CDN
848E 38350	CRU	1	D44J3	OUTPUT FINISHER POWER CABLE ROUTING COVER 5130CDN
848E 36880	CRU	1	MNCPD	OUTPUT FINISHER DATA CABLE ROUTING COVER 5130CDN

ELECTRICAL / ELECTRONICS BOARDS AND CARDS				
105K 24050	FRU	1	H328T	HIGH VOLTAGE POWER BOARD 5130CDN
101K 55880	FRU	1	G133T	LOW VOLTAGE POWER BOARD 100V/115V 5130CDN FOR JAPAN & AMERICAS
101K 60370	FRU	1	Y357R	LOW VOLTAGE POWER BOARD 220V 5130CDN FOR EUROPE, AUS & NZ
960K 49970	FRU	1	Y358R	PRINTER MACHINE CONTROL UNIT BOARD 5130cdn
815K 00870	FRU	1	C398T	PRINTER ESS BOARD 5130CDN
960K 45390	FRU	1	J133T	OUTPUT FINISHER ESS BOARD 5130CDN
105E 19280	FRU	1	H222T	OUTPUT FINISHER LOW VOLTAGE POWER BOARD

FAN AND ACESSORIES				
101K 58770	FRU	1	F365T	FAN FOR LOW VOLTAGE POWER 5130CDN
127E 85810	FRU	1	Y910R	FAN FOR FUSER 5130CDN

MISCELLANOUS HARDWARE				
	FRU	1	G135T	OPERATOR DISPLAY PANEL FOR DAO 5130CDN
	FRU	1	VJT5J	OPERATOR DISPLAY PANEL FOR EMEA 5130CDN
110K 16170	FRU	1	C607T	INTERLOCK SWITCH WITH CABLE (FRONT FRAME LOCATION) 5130CDN
042K 93630	CRU	1	C608T	CLEANING WAND WITH 1 X PAD 5130CDN
110K 15830	FRU	1	F363T	PAPER SIZE SENSOR on Printer 5130CDN
019K 10650	FRU	1	K329T	PAPER LOW SENSOR on Printer 5130CDN
054K 42170	FRU	1	Y362R	MULTI-PAPER FEEDER SEPARATOR ROLLER on Printer 5130CDN
054K 40781	FRU	1	H223T	FEEDER WITH CHUTE ASSEMBLY MECHANISM 5130CDN
962K73670 + with screw driver	FRU	1	F448T	INTERLOCK SWITCH (RIGHT FRAME LOCATION) with screw driver 5130CDN
019E75770 + 120E31460 + 809E85570	FRU	1	Y545R	ACTUATOR (RIGHT FRAME LOCATION) 5130CDN
	FRU		J137T	SOLENOID, GEAR & CLUTCH (RIGHT FRAME LOCATION) 5130CDN
122K 94260	FRU	4	D529T	LED ERASE ASSEMBLY clears info on drum/developer 5130CDN
062K20920 + 019E 64450 + HW kit PPID: 897E 36840	FRU	1	C399T	ROS (Rastor Output Scanner) on Printer 5130CDN
130K 76651	FRU	4	F368T	MODULE CONTAINING ADC & HUMIDITY SENSOR WITH CABLE 5130CDN
019K 11160	FRU	4	H329T	TONER DISPENSOR CRUM on Printer 5130CDN
007K 15330	FRU	1	C626T	FUSER EXIT DRIVE MOTOR 5130CDN
	FRU	1	C631T	FUSER EXIT CHUTE WITH STACK SENSOR & ENVELOPE SENSOR 5130CDN
054K 40571	FRU	1	G319T	FUSER EXIT PAPER INVERTER CHUTE 5130CDN
801K42661 + 806E 28030x2pcs + 354W 24278 x 2pcs	FRU	1	H226T	FRONT INNER DOOR/COVER 5130CDN
007K 15360	FRU	1	H343T	FUSER DRIVE MOTOR 5130CDN
007K 15390	FRU	1	H345T	MAIN TRANSFER BELT MOTOR 5130CDN
007K 15350	FRU	1	Y928R	DRUM/DEVELOPER MOTOR 5130CDN ?
007K 15410	FRU	2	D540T	SWITCHING SENSOR FOR DRUM/DEVELOPER 5130CDN
007K 15370	FRU	1	H351T	CMY DRUM/DEVELOPER MOTOR 5130CDN
007K 15380	FRU	1	J252T	K DRUM/DEVELOPER MOTOR 5130CDN
	FRU	1	Y538R	DRUM/DEVELOPER ASSEMBLY LINK, XEROGRAPHY & RACK

	FRU	1	D349T	DRUM/DEVELOPER MOTOR GEAR 5130CDN
815K 02320	CRU	1	1M8DC	BACK METAL LOCKING PLATE FOR OPTIONAL 500 SHEET
826E 43840	CRU	1	CPGMY	SCREW FOR BACK METAL LOCKING PLATE FOR OPTIONAL 500 SHEET
	CRU	1	F243T	OUTPUT FINISHER MAIN ASSEMBLY MINUS TRAY STACKER & TRANSPORT ASSEMBLY 5130CDN
	CRU	1	H353T	OUTPUT FINISHER TRAY STACKER 5130CDN
826E 28960	CRU	2	JXWWY	OUTPUT FINISHER TRAY SCREWS 5130CDN
	CRU	1	K334T	OUTPUT FINISHER TRANSPORT ASSEMBLY TOP 5130CDN
	CRU	1	G321T	OUTPUT FINISHER TRANSPORT ASSEMBLY BOTTOM 5130CDN
848K 27270	FRU	1	C636T	OUTPUT FINISHER MAIN ASSEMBLY FRONT DOOR/COVER 5130CDN
019K 10370	FRU	1	Y934R	OUTPUT FINISHER MAIN ASSEMBLY STAPLER UNIT 5130CDN
050K 51250	CRU	1	5N2GY	OUTPUT FINISHER MAIN ASSEMBLY STAPLE CARTRIDGE HOLDER AND STAPLE CARTRIDGE 5130CDN
068K 64620	FRU	1	C638T	OUTPUT FINISHER MAIN ASSEMBLY DOOR/COVER INTERLOCK SWITCH 5130CDN

BASE UNIT				
999S Y353R	CRU	1	Y353R	PRINTER FOR SERVICE WHOLE UNIT EXCHANGE 110V AMERICAS 5130CN
999S C271T	CRU	1	C271T	PRINTER FOR SERVICE WHOLE UNIT EXCHANGE 220V EUROPE AUSTRALIA NEW ZEALAND 5130CN
999S C555T	CRU	1	C555T	PRINTER FOR SERVICE WHOLE UNIT EXCHANGE 110V TAA 5130CN
999S D227T	CRU	1	D227T	PRINTER FOR SERVICE WHOLE UNIT EXCHANGE 220V TAA 5130CN

MFG p/n	CRU or FRU	Quantity in a box	Dell #	Dell Description in RSL
TONER / INK				
675K 84590	CRU	1	R273N	YELLOW TONER CARTRIDGE 6K 5130CDN
675K 84720	CRU	1	T222N	YELLOW TONER CARTRIDGE 12K 5130CDN
675K 84600	CRU	1	P615N	MAGENTA TONER CARTRIDGE 6K 5130CDN
675K 84730	CRU	1	R272N	MAGENTA TONER CARTRIDGE 12K 5130CDN
675K 84610	CRU	1	X942N	CYAN TONER CARTRIDGE 6K 5130CDN
675K 84750	CRU	1	P614N	CYAN TONER CARTRIDGE 12K 5130CDN
675K 84620	CRU	1	U157N	BLACK TONER CARTRIDGE 6K 5130CDN
675K 84760	CRU	1	N848N	BLACK TONER CARTRIDGE 12K 5130CDN

DEVELOPERS				
848K 84580	CRU	1	X951N	YELLOW DRUM/DEVELOPER 5130CDN
848K 84690	CRU	1	T229N	MAGENTA DRUM/DEVELOPER 5130CDN
848K 84700	CRU	1	U163N	CYAN DRUM/DEVELOPER 5130CDN
848K 84710	CRU	1	P623N	BLACK DRUM/DEVELOPER 5130CDN

FUSER AND ACESSORIES				
675K 84630	CRU	1	N856N	FUSER 110V 5130CDN FOR AMERICAS
675K 84640	CRU	1	R279N	FUSER 220V 5130CDN FOR EMEA & AUSTRALIA & NEW ZEALAND

SERVICE KITS				
675K 84570	CRU	1	U164N	SERVICE KIT TRANSFER BELT 2ND TRANSFER BELT FEED ROLLER KIT 5130CDN
675K 84770	CRU	1	U162N	WASTE TONER CONTAINER

OPTIONS				
675K 84650	CRU	1	N854N	HARDDISK 80 GB 5130CDN (OPTION)
675K 84680	CRU	1	T226N	Memory, 1GB, DIMM,5130CDN (OPTION)
675K 84660	CRU	1	P624N	WIRELESS CARD, 5130CDN (OPTION)

DOCUMENTATION, DRIVERS AND APPLICATIONS				
675K 84870	CRU	1	D720R	DOCUMENT KIT IN ENGLISH, FRENCH, SPANISH FOR AMERICAS 5130CDN
675K 85610	CRU	1	H490R	DOCUMENT KIT FOR 110V TAA 5130CDN
	CRU	1	Y989P	DOCUMENT KIT FOR 220V TAA 5130CDN

TRANSFER BELT				
064K 93150	CRU	1	Y520R	MAIN TRANSFER BELT 5130CDN
059K 66361	CRU	1	R280N	2ND TRANSFER BELT 5130CDN

ROLLER				
019K10660 + 059K46040x2pcs + Instruction	CRU		D347T	FEEDER SEPARATOR ROLLER for all trays 5130CDN
019K 11140 + Instruction	CRU		G194T	MULTI-PAPER FEEDER SEPARATOR ROLLER on printer 5130CDN
059K 50731	FRU		P358C	MULTI-PAPER FEED ROLLER on printer 5130CDN

FEEDER, TRAY AND TRAY HOUSING				
050K 65090	CRU	1	H167T	DEFAULT PAPER TRAY 550 SHEET 5130CDN
848K 37991 with instruction	CRU	1	D526T	FDR,ASSY,CVR,MSI,5130CDN
059K66692 with instruction	CRU	1	D342T	OPTIONAL PAPER TRAY HOUSING 550 SHEET 5130CDN
050K 65100	CRU	1	K181T	OPTIONAL PAPER TRAY 550 SHEET 5130CDN
Feeder without tray with instruction	CRU	1	G193T	OPTIONAL PAPER TRAY HOUSING 1100 SHEET 5130CDN

PLASTICS				
848K 28740	FRU	1	C274T	FRONT COVER (PLASTIC) WITH INTERLOCK SWITCH AND CLEANER WAND 5130CDN
848K 28691	FRU	1	F162T	REAR COVER (PLASTIC) WITH ACTUATOR 5130CDN
032E 31780	CRU	1	51XMB	RIGHT HAND FRAME BOTTOM RIGHT CONNECTOR COVER 5130CDN
848K 37991 with instruction	CRU	1	D526T	MULTI-PAPER FEED (PLASTIC) 5130CDN
Without 2nd BTR	FRU	1	D352T	RIGHT COVER (PLASTIC) WITH RIGHT HAND FRAME WITH MULTI PAPER FEED(D526T) WITH DUPLEXOR MECHANISM WITH FUSER GUIDE WITH FUSER FAN 5130CDN
848E 36900	CRU	1	MM4H3	OUTPUT FINISHER TRAY BOTTOM COVER GUIDE 5130CDN
848E 38350	CRU	1	D44J3	OUTPUT FINISHER POWER CABLE ROUTING COVER 5130CDN
848E 36880	CRU	1	MNCPD	OUTPUT FINISHER DATA CABLE ROUTING COVER 5130CDN

ELECTRICAL / ELECTRONICS BOARDS AND CARDS				
105K 24050	FRU	1	H328T	HIGH VOLTAGE POWER BOARD 5130CDN
101K 55880	FRU	1	G133T	LOW VOLTAGE POWER BOARD 100V/115V 5130CDN FOR JAPAN & AMERICAS
101K 60370	FRU	1	Y357R	LOW VOLTAGE POWER BOARD 220V 5130CDN FOR EUROPE, AUS & NZ
960K 49970	FRU	1	Y358R	PRINTER MACHINE CONTROL UNIT BOARD 5130cdn
815K 00870	FRU	1	C398T	PRINTER ESS BOARD 5130CDN
960K 45390	FRU	1	J133T	OUTPUT FINISHER ESS BOARD 5130CDN
105E 19280	FRU	1	H222T	OUTPUT FINISHER LOW VOLTAGE POWER BOARD

FAN AND ACESSORIES				
101K 58770	FRU	1	F365T	FAN FOR LOW VOLTAGE POWER 5130CDN
127E 85810	FRU	1	Y910R	FAN FOR FUSER 5130CDN

MISCELLANOUS HARDWARE				
	FRU	1	G135T	OPERATOR DISPLAY PANEL FOR DAO 5130CDN
	FRU	1	VJT5J	OPERATOR DISPLAY PANEL FOR EMEA 5130CDN
110K 16170	FRU	1	C607T	INTERLOCK SWITCH WITH CABLE (FRONT FRAME LOCATION) 5130CDN
042K 93630	CRU	1	C608T	CLEANING WAND WITH 1 X PAD 5130CDN
110K 15830	FRU	1	F363T	PAPER SIZE SENSOR on Printer 5130CDN
019K 10650	FRU	1	K329T	PAPER LOW SENSOR on Printer 5130CDN
054K 42170	FRU	1	Y362R	MULTI-PAPER FEEDER SEPARATOR ROLLER on Printer 5130CDN
054K 40781	FRU	1	H223T	FEEDER WITH CHUTE ASSEMBLY MECHANISM 5130CDN
962K73670 + with screw driver	FRU	1	F448T	INTERLOCK SWITCH (RIGHT FRAME LOCATION) with screw driver 5130CDN
019E75770 + 120E31460 + 809E85570	FRU	1	Y545R	ACTUATOR (RIGHT FRAME LOCATION) 5130CDN
	FRU		J137T	SOLENOID, GEAR & CLUTCH (RIGHT FRAME LOCATION) 5130CDN
122K 94260	FRU	4	D529T	LED ERASE ASSEMBLY clears info on drum/developer 5130CDN
062K20920 + 019E 64450 + HW kit PPID: 897E 36840	FRU	1	C399T	ROS (Rastor Output Scanner) on Printer 5130CDN
130K 76651	FRU	4	F368T	MODULE CONTAINING ADC & HUMIDITY SENSOR WITH CABLE 5130CDN
019K 11160	FRU	4	H329T	TONER DISPENSOR CRUM on Printer 5130CDN
007K 15330	FRU	1	C626T	FUSER EXIT DRIVE MOTOR 5130CDN
	FRU	1	C631T	FUSER EXIT CHUTE WITH STACK SENSOR & ENVELOPE SENSOR 5130CDN
054K 40571	FRU	1	G319T	FUSER EXIT PAPER INVERTER CHUTE 5130CDN
801K42661 + 806E 28030x2pcs + 354W 24278 x 2pcs	FRU	1	H226T	FRONT INNER DOOR/COVER 5130CDN
007K 15360	FRU	1	H343T	FUSER DRIVE MOTOR 5130CDN
007K 15390	FRU	1	H345T	MAIN TRANSFER BELT MOTOR 5130CDN
007K 15350	FRU	1	Y928R	DRUM/DEVELOPER MOTOR 5130CDN ?
007K 15410	FRU	2	D540T	SWITCHING SENSOR FOR DRUM/DEVELOPER 5130CDN
007K 15370	FRU	1	H351T	CMY DRUM/DEVELOPER MOTOR 5130CDN
007K 15380	FRU	1	J252T	K DRUM/DEVELOPER MOTOR 5130CDN
	FRU	1	Y538R	DRUM/DEVELOPER ASSEMBLY LINK, XEROGRAPHY & RACK

	FRU	1	D349T	DRUM/DEVELOPER MOTOR GEAR 5130CDN
815K 02320	CRU	1	1M8DC	BACK METAL LOCKING PLATE FOR OPTIONAL 500 SHEET
826E 43840	CRU	1	CPGMY	SCREW FOR BACK METAL LOCKING PLATE FOR OPTIONAL 500 SHEET
	CRU	1	F243T	OUTPUT FINISHER MAIN ASSEMBLY MINUS TRAY STACKER & TRANSPORT ASSEMBLY 5130CDN
	CRU	1	H353T	OUTPUT FINISHER TRAY STACKER 5130CDN
826E 28960	CRU	2	JXWWY	OUTPUT FINISHER TRAY SCREWS 5130CDN
	CRU	1	K334T	OUTPUT FINISHER TRANSPORT ASSEMBLY TOP 5130CDN
	CRU	1	G321T	OUTPUT FINISHER TRANSPORT ASSEMBLY BOTTOM 5130CDN
848K 27270	FRU	1	C636T	OUTPUT FINISHER MAIN ASSEMBLY FRONT DOOR/COVER 5130CDN
019K 10370	FRU	1	Y934R	OUTPUT FINISHER MAIN ASSEMBLY STAPLER UNIT 5130CDN
050K 51250	CRU	1	5N2GY	OUTPUT FINISHER MAIN ASSEMBLY STAPLE CARTRIDGE HOLDER AND STAPLE CARTRIDGE 5130CDN
068K 64620	FRU	1	C638T	OUTPUT FINISHER MAIN ASSEMBLY DOOR/COVER INTERLOCK SWITCH 5130CDN

BASE UNIT				
999S Y353R	CRU	1	Y353R	PRINTER FOR SERVICE WHOLE UNIT EXCHANGE 110V AMERICAS 5130CN
999S C271T	CRU	1	C271T	PRINTER FOR SERVICE WHOLE UNIT EXCHANGE 220V EUROPE AUSTRALIA NEW ZEALAND 5130CN
999S C555T	CRU	1	C555T	PRINTER FOR SERVICE WHOLE UNIT EXCHANGE 110V TAA 5130CN
999S D227T	CRU	1	D227T	PRINTER FOR SERVICE WHOLE UNIT EXCHANGE 220V TAA 5130CN

MFG p/n	CRU or FRU	Quantity in a box	Dell #	Dell Description in RSL
TONER / INK				
675K 84590	CRU	1	R273N	YELLOW TONER CARTRIDGE 6K 5130CDN
675K 84720	CRU	1	T222N	YELLOW TONER CARTRIDGE 12K 5130CDN
675K 84600	CRU	1	P615N	MAGENTA TONER CARTRIDGE 6K 5130CDN
675K 84730	CRU	1	R272N	MAGENTA TONER CARTRIDGE 12K 5130CDN
675K 84610	CRU	1	X942N	CYAN TONER CARTRIDGE 6K 5130CDN
675K 84750	CRU	1	P614N	CYAN TONER CARTRIDGE 12K 5130CDN
675K 84620	CRU	1	U157N	BLACK TONER CARTRIDGE 6K 5130CDN
675K 84760	CRU	1	N848N	BLACK TONER CARTRIDGE 12K 5130CDN

DEVELOPERS				
848K 84580	CRU	1	X951N	YELLOW DRUM/DEVELOPER 5130CDN
848K 84690	CRU	1	T229N	MAGENTA DRUM/DEVELOPER 5130CDN
848K 84700	CRU	1	U163N	CYAN DRUM/DEVELOPER 5130CDN
848K 84710	CRU	1	P623N	BLACK DRUM/DEVELOPER 5130CDN

FUSER AND ACESSORIES				
675K 84630	CRU	1	N856N	FUSER 110V 5130CDN FOR AMERICAS
675K 84640	CRU	1	R279N	FUSER 220V 5130CDN FOR EMEA & AUSTRALIA & NEW ZEALAND

SERVICE KITS				
675K 84570	CRU	1	U164N	SERVICE KIT TRANSFER BELT 2ND TRANSFER BELT FEED ROLLER KIT 5130CDN
675K 84770	CRU	1	U162N	WASTE TONER CONTAINER

OPTIONS				
675K 84650	CRU	1	N854N	HARDDISK 80 GB 5130CDN (OPTION)
675K 84680	CRU	1	T226N	Memory, 1GB, DIMM,5130CDN (OPTION)
675K 84660	CRU	1	P624N	WIRELESS CARD, 5130CDN (OPTION)

DOCUMENTATION, DRIVERS AND APPLICATIONS				
675K 84870	CRU	1	D720R	DOCUMENT KIT IN ENGLISH, FRENCH, SPANISH FOR AMERICAS 5130CDN
675K 85610	CRU	1	H490R	DOCUMENT KIT FOR 110V TAA 5130CDN
	CRU	1	Y989P	DOCUMENT KIT FOR 220V TAA 5130CDN

TRANSFER BELT				
064K 93150	CRU	1	Y520R	MAIN TRANSFER BELT 5130CDN
059K 66361	CRU	1	R280N	2ND TRANSFER BELT 5130CDN

ROLLER				
019K10660 + 059K46040x2pcs + Instruction	CRU		D347T	FEEDER SEPARATOR ROLLER for all trays 5130CDN
019K 11140 + Instruction	CRU		G194T	MULTI-PAPER FEEDER SEPARATOR ROLLER on printer 5130CDN
059K 50731	FRU		P358C	MULTI-PAPER FEED ROLLER on printer 5130CDN

FEEDER, TRAY AND TRAY HOUSING				
050K 65090	CRU	1	H167T	DEFAULT PAPER TRAY 550 SHEET 5130CDN
848K 37991 with instruction	CRU	1	D526T	FDR,ASSY,CVR,MSI,5130CDN
059K66692 with instruction	CRU	1	D342T	OPTIONAL PAPER TRAY HOUSING 550 SHEET 5130CDN
050K 65100	CRU	1	K181T	OPTIONAL PAPER TRAY 550 SHEET 5130CDN
Feeder without tray with instruction	CRU	1	G193T	OPTIONAL PAPER TRAY HOUSING 1100 SHEET 5130CDN

PLASTICS				
848K 28740	FRU	1	C274T	FRONT COVER (PLASTIC) WITH INTERLOCK SWITCH AND CLEANER WAND 5130CDN
848K 28691	FRU	1	F162T	REAR COVER (PLASTIC) WITH ACTUATOR 5130CDN
032E 31780	CRU	1	51XMB	RIGHT HAND FRAME BOTTOM RIGHT CONNECTOR COVER 5130CDN
848K 37991 with instruction	CRU	1	D526T	MULTI-PAPER FEED (PLASTIC) 5130CDN
Without 2nd BTR	FRU	1	D352T	RIGHT COVER (PLASTIC) WITH RIGHT HAND FRAME WITH MULTI PAPER FEED(D526T) WITH DUPLEXOR MECHANISM WITH FUSER GUIDE WITH FUSER FAN 5130CDN
848E 36900	CRU	1	MM4H3	OUTPUT FINISHER TRAY BOTTOM COVER GUIDE 5130CDN
848E 38350	CRU	1	D44J3	OUTPUT FINISHER POWER CABLE ROUTING COVER 5130CDN
848E 36880	CRU	1	MNCPD	OUTPUT FINISHER DATA CABLE ROUTING COVER 5130CDN

ELECTRICAL / ELECTRONICS BOARDS AND CARDS				
105K 24050	FRU	1	H328T	HIGH VOLTAGE POWER BOARD 5130CDN
101K 55880	FRU	1	G133T	LOW VOLTAGE POWER BOARD 100V/115V 5130CDN FOR JAPAN & AMERICAS
101K 60370	FRU	1	Y357R	LOW VOLTAGE POWER BOARD 220V 5130CDN FOR EUROPE, AUS & NZ
960K 49970	FRU	1	Y358R	PRINTER MACHINE CONTROL UNIT BOARD 5130cdn
815K 00870	FRU	1	C398T	PRINTER ESS BOARD 5130CDN
960K 45390	FRU	1	J133T	OUTPUT FINISHER ESS BOARD 5130CDN
105E 19280	FRU	1	H222T	OUTPUT FINISHER LOW VOLTAGE POWER BOARD

FAN AND ACESSORIES				
101K 58770	FRU	1	F365T	FAN FOR LOW VOLTAGE POWER 5130CDN
127E 85810	FRU	1	Y910R	FAN FOR FUSER 5130CDN

MISCELLANOUS HARDWARE				
	FRU	1	G135T	OPERATOR DISPLAY PANEL FOR DAO 5130CDN
	FRU	1	VJT5J	OPERATOR DISPLAY PANEL FOR EMEA 5130CDN
110K 16170	FRU	1	C607T	INTERLOCK SWITCH WITH CABLE (FRONT FRAME LOCATION) 5130CDN
042K 93630	CRU	1	C608T	CLEANING WAND WITH 1 X PAD 5130CDN
110K 15830	FRU	1	F363T	PAPER SIZE SENSOR on Printer 5130CDN
019K 10650	FRU	1	K329T	PAPER LOW SENSOR on Printer 5130CDN
054K 42170	FRU	1	Y362R	MULTI-PAPER FEEDER SEPARATOR ROLLER on Printer 5130CDN
054K 40781	FRU	1	H223T	FEEDER WITH CHUTE ASSEMBLY MECHANISM 5130CDN
962K73670 + with screw driver	FRU	1	F448T	INTERLOCK SWITCH (RIGHT FRAME LOCATION) with screw driver 5130CDN
019E75770 + 120E31460 + 809E85570	FRU	1	Y545R	ACTUATOR (RIGHT FRAME LOCATION) 5130CDN
	FRU		J137T	SOLENOID, GEAR & CLUTCH (RIGHT FRAME LOCATION) 5130CDN
122K 94260	FRU	4	D529T	LED ERASE ASSEMBLY clears info on drum/developer 5130CDN
062K20920 + 019E 64450 + HW kit PPID: 897E 36840	FRU	1	C399T	ROS (Rastor Output Scanner) on Printer 5130CDN
130K 76651	FRU	4	F368T	MODULE CONTAINING ADC & HUMIDITY SENSOR WITH CABLE 5130CDN
019K 11160	FRU	4	H329T	TONER DISPENSOR CRUM on Printer 5130CDN
007K 15330	FRU	1	C626T	FUSER EXIT DRIVE MOTOR 5130CDN
	FRU	1	C631T	FUSER EXIT CHUTE WITH STACK SENSOR & ENVELOPE SENSOR 5130CDN
054K 40571	FRU	1	G319T	FUSER EXIT PAPER INVERTER CHUTE 5130CDN
801K42661 + 806E 28030x2pcs + 354W 24278 x 2pcs	FRU	1	H226T	FRONT INNER DOOR/COVER 5130CDN
007K 15360	FRU	1	H343T	FUSER DRIVE MOTOR 5130CDN
007K 15390	FRU	1	H345T	MAIN TRANSFER BELT MOTOR 5130CDN
007K 15350	FRU	1	Y928R	DRUM/DEVELOPER MOTOR 5130CDN ?
007K 15410	FRU	2	D540T	SWITCHING SENSOR FOR DRUM/DEVELOPER 5130CDN
007K 15370	FRU	1	H351T	CMY DRUM/DEVELOPER MOTOR 5130CDN
007K 15380	FRU	1	J252T	K DRUM/DEVELOPER MOTOR 5130CDN
	FRU	1	Y538R	DRUM/DEVELOPER ASSEMBLY LINK, XEROGRAPHY & RACK

	FRU	1	D349T	DRUM/DEVELOPER MOTOR GEAR 5130CDN
815K 02320	CRU	1	1M8DC	BACK METAL LOCKING PLATE FOR OPTIONAL 500 SHEET
826E 43840	CRU	1	CPGMY	SCREW FOR BACK METAL LOCKING PLATE FOR OPTIONAL 500 SHEET
	CRU	1	F243T	OUTPUT FINISHER MAIN ASSEMBLY MINUS TRAY STACKER & TRANSPORT ASSEMBLY 5130CDN
	CRU	1	H353T	OUTPUT FINISHER TRAY STACKER 5130CDN
826E 28960	CRU	2	JXWWY	OUTPUT FINISHER TRAY SCREWS 5130CDN
	CRU	1	K334T	OUTPUT FINISHER TRANSPORT ASSEMBLY TOP 5130CDN
	CRU	1	G321T	OUTPUT FINISHER TRANSPORT ASSEMBLY BOTTOM 5130CDN
848K 27270	FRU	1	C636T	OUTPUT FINISHER MAIN ASSEMBLY FRONT DOOR/COVER 5130CDN
019K 10370	FRU	1	Y934R	OUTPUT FINISHER MAIN ASSEMBLY STAPLER UNIT 5130CDN
050K 51250	CRU	1	5N2GY	OUTPUT FINISHER MAIN ASSEMBLY STAPLE CARTRIDGE HOLDER AND STAPLE CARTRIDGE 5130CDN
068K 64620	FRU	1	C638T	OUTPUT FINISHER MAIN ASSEMBLY DOOR/COVER INTERLOCK SWITCH 5130CDN

BASE UNIT				
999S Y353R	CRU	1	Y353R	PRINTER FOR SERVICE WHOLE UNIT EXCHANGE 110V AMERICAS 5130CN
999S C271T	CRU	1	C271T	PRINTER FOR SERVICE WHOLE UNIT EXCHANGE 220V EUROPE AUSTRALIA NEW ZEALAND 5130CN
999S C555T	CRU	1	C555T	PRINTER FOR SERVICE WHOLE UNIT EXCHANGE 110V TAA 5130CN
999S D227T	CRU	1	D227T	PRINTER FOR SERVICE WHOLE UNIT EXCHANGE 220V TAA 5130CN

MFG p/n	CRU or FRU	Quantity in a box	Dell #	Dell Description in RSL
TONER / INK				
675K 84590	CRU	1	R273N	YELLOW TONER CARTRIDGE 6K 5130CDN
675K 84720	CRU	1	T222N	YELLOW TONER CARTRIDGE 12K 5130CDN
675K 84600	CRU	1	P615N	MAGENTA TONER CARTRIDGE 6K 5130CDN
675K 84730	CRU	1	R272N	MAGENTA TONER CARTRIDGE 12K 5130CDN
675K 84610	CRU	1	X942N	CYAN TONER CARTRIDGE 6K 5130CDN
675K 84750	CRU	1	P614N	CYAN TONER CARTRIDGE 12K 5130CDN
675K 84620	CRU	1	U157N	BLACK TONER CARTRIDGE 6K 5130CDN
675K 84760	CRU	1	N848N	BLACK TONER CARTRIDGE 12K 5130CDN

DEVELOPERS				
848K 84580	CRU	1	X951N	YELLOW DRUM/DEVELOPER 5130CDN
848K 84690	CRU	1	T229N	MAGENTA DRUM/DEVELOPER 5130CDN
848K 84700	CRU	1	U163N	CYAN DRUM/DEVELOPER 5130CDN
848K 84710	CRU	1	P623N	BLACK DRUM/DEVELOPER 5130CDN

FUSER AND ACESSORIES				
675K 84630	CRU	1	N856N	FUSER 110V 5130CDN FOR AMERICAS
675K 84640	CRU	1	R279N	FUSER 220V 5130CDN FOR EMEA & AUSTRALIA & NEW ZEALAND

SERVICE KITS				
675K 84570	CRU	1	U164N	SERVICE KIT TRANSFER BELT 2ND TRANSFER BELT FEED ROLLER KIT 5130CDN
675K 84770	CRU	1	U162N	WASTE TONER CONTAINER

OPTIONS				
675K 84650	CRU	1	N854N	HARDDISK 80 GB 5130CDN (OPTION)
675K 84680	CRU	1	T226N	Memory, 1GB, DIMM,5130CDN (OPTION)
675K 84660	CRU	1	P624N	WIRELESS CARD, 5130CDN (OPTION)

DOCUMENTATION, DRIVERS AND APPLICATIONS				
675K 84870	CRU	1	D720R	DOCUMENT KIT IN ENGLISH, FRENCH, SPANISH FOR AMERICAS 5130CDN
675K 85610	CRU	1	H490R	DOCUMENT KIT FOR 110V TAA 5130CDN
	CRU	1	Y989P	DOCUMENT KIT FOR 220V TAA 5130CDN

TRANSFER BELT				
064K 93150	CRU	1	Y520R	MAIN TRANSFER BELT 5130CDN
059K 66361	CRU	1	R280N	2ND TRANSFER BELT 5130CDN

ROLLER				
019K10660 + 059K46040x2pcs + Instruction	CRU		D347T	FEEDER SEPARATOR ROLLER for all trays 5130CDN
019K 11140 + Instruction	CRU		G194T	MULTI-PAPER FEEDER SEPARATOR ROLLER on printer 5130CDN
059K 50731	FRU		P358C	MULTI-PAPER FEED ROLLER on printer 5130CDN

FEEDER, TRAY AND TRAY HOUSING				
050K 65090	CRU	1	H167T	DEFAULT PAPER TRAY 550 SHEET 5130CDN
848K 37991 with instruction	CRU	1	D526T	FDR,ASSY,CVR,MSI,5130CDN
059K66692 with instruction	CRU	1	D342T	OPTIONAL PAPER TRAY HOUSING 550 SHEET 5130CDN
050K 65100	CRU	1	K181T	OPTIONAL PAPER TRAY 550 SHEET 5130CDN
Feeder without tray with instruction	CRU	1	G193T	OPTIONAL PAPER TRAY HOUSING 1100 SHEET 5130CDN

PLASTICS				
848K 28740	FRU	1	C274T	FRONT COVER (PLASTIC) WITH INTERLOCK SWITCH AND CLEANER WAND 5130CDN
848K 28691	FRU	1	F162T	REAR COVER (PLASTIC) WITH ACTUATOR 5130CDN
032E 31780	CRU	1	51XMB	RIGHT HAND FRAME BOTTOM RIGHT CONNECTOR COVER 5130CDN
848K 37991 with instruction	CRU	1	D526T	MULTI-PAPER FEED (PLASTIC) 5130CDN
Without 2nd BTR	FRU	1	D352T	RIGHT COVER (PLASTIC) WITH RIGHT HAND FRAME WITH MULTI PAPER FEED(D526T) WITH DUPLEXOR MECHANISM WITH FUSER GUIDE WITH FUSER FAN 5130CDN
848E 36900	CRU	1	MM4H3	OUTPUT FINISHER TRAY BOTTOM COVER GUIDE 5130CDN
848E 38350	CRU	1	D44J3	OUTPUT FINISHER POWER CABLE ROUTING COVER 5130CDN
848E 36880	CRU	1	MNCPD	OUTPUT FINISHER DATA CABLE ROUTING COVER 5130CDN

ELECTRICAL / ELECTRONICS BOARDS AND CARDS				
105K 24050	FRU	1	H328T	HIGH VOLTAGE POWER BOARD 5130CDN
101K 55880	FRU	1	G133T	LOW VOLTAGE POWER BOARD 100V/115V 5130CDN FOR JAPAN & AMERICAS
101K 60370	FRU	1	Y357R	LOW VOLTAGE POWER BOARD 220V 5130CDN FOR EUROPE, AUS & NZ
960K 49970	FRU	1	Y358R	PRINTER MACHINE CONTROL UNIT BOARD 5130cdn
815K 00870	FRU	1	C398T	PRINTER ESS BOARD 5130CDN
960K 45390	FRU	1	J133T	OUTPUT FINISHER ESS BOARD 5130CDN
105E 19280	FRU	1	H222T	OUTPUT FINISHER LOW VOLTAGE POWER BOARD

FAN AND ACESSORIES				
101K 58770	FRU	1	F365T	FAN FOR LOW VOLTAGE POWER 5130CDN
127E 85810	FRU	1	Y910R	FAN FOR FUSER 5130CDN

MISCELLANOUS HARDWARE				
	FRU	1	G135T	OPERATOR DISPLAY PANEL FOR DAO 5130CDN
	FRU	1	VJT5J	OPERATOR DISPLAY PANEL FOR EMEA 5130CDN
110K 16170	FRU	1	C607T	INTERLOCK SWITCH WITH CABLE (FRONT FRAME LOCATION) 5130CDN
042K 93630	CRU	1	C608T	CLEANING WAND WITH 1 X PAD 5130CDN
110K 15830	FRU	1	F363T	PAPER SIZE SENSOR on Printer 5130CDN
019K 10650	FRU	1	K329T	PAPER LOW SENSOR on Printer 5130CDN
054K 42170	FRU	1	Y362R	MULTI-PAPER FEEDER SEPARATOR ROLLER on Printer 5130CDN
054K 40781	FRU	1	H223T	FEEDER WITH CHUTE ASSEMBLY MECHANISM 5130CDN
962K73670 + with screw driver	FRU	1	F448T	INTERLOCK SWITCH (RIGHT FRAME LOCATION) with screw driver 5130CDN
019E75770 + 120E31460 + 809E85570	FRU	1	Y545R	ACTUATOR (RIGHT FRAME LOCATION) 5130CDN
	FRU		J137T	SOLENOID, GEAR & CLUTCH (RIGHT FRAME LOCATION) 5130CDN
122K 94260	FRU	4	D529T	LED ERASE ASSEMBLY clears info on drum/developer 5130CDN
062K20920 + 019E 64450 + HW kit PPID: 897E 36840	FRU	1	C399T	ROS (Rastor Output Scanner) on Printer 5130CDN
130K 76651	FRU	4	F368T	MODULE CONTAINING ADC & HUMIDITY SENSOR WITH CABLE 5130CDN
019K 11160	FRU	4	H329T	TONER DISPENSOR CRUM on Printer 5130CDN
007K 15330	FRU	1	C626T	FUSER EXIT DRIVE MOTOR 5130CDN
	FRU	1	C631T	FUSER EXIT CHUTE WITH STACK SENSOR & ENVELOPE SENSOR 5130CDN
054K 40571	FRU	1	G319T	FUSER EXIT PAPER INVERTER CHUTE 5130CDN
801K42661 + 806E 28030x2pcs + 354W 24278 x 2pcs	FRU	1	H226T	FRONT INNER DOOR/COVER 5130CDN
007K 15360	FRU	1	H343T	FUSER DRIVE MOTOR 5130CDN
007K 15390	FRU	1	H345T	MAIN TRANSFER BELT MOTOR 5130CDN
007K 15350	FRU	1	Y928R	DRUM/DEVELOPER MOTOR 5130CDN ?
007K 15410	FRU	2	D540T	SWITCHING SENSOR FOR DRUM/DEVELOPER 5130CDN
007K 15370	FRU	1	H351T	CMY DRUM/DEVELOPER MOTOR 5130CDN
007K 15380	FRU	1	J252T	K DRUM/DEVELOPER MOTOR 5130CDN
	FRU	1	Y538R	DRUM/DEVELOPER ASSEMBLY LINK, XEROGRAPHY & RACK

	FRU	1	D349T	DRUM/DEVELOPER MOTOR GEAR 5130CDN
815K 02320	CRU	1	1M8DC	BACK METAL LOCKING PLATE FOR OPTIONAL 500 SHEET
826E 43840	CRU	1	CPGMY	SCREW FOR BACK METAL LOCKING PLATE FOR OPTIONAL 500 SHEET
	CRU	1	F243T	OUTPUT FINISHER MAIN ASSEMBLY MINUS TRAY STACKER & TRANSPORT ASSEMBLY 5130CDN
	CRU	1	H353T	OUTPUT FINISHER TRAY STACKER 5130CDN
826E 28960	CRU	2	JXWWY	OUTPUT FINISHER TRAY SCREWS 5130CDN
	CRU	1	K334T	OUTPUT FINISHER TRANSPORT ASSEMBLY TOP 5130CDN
	CRU	1	G321T	OUTPUT FINISHER TRANSPORT ASSEMBLY BOTTOM 5130CDN
848K 27270	FRU	1	C636T	OUTPUT FINISHER MAIN ASSEMBLY FRONT DOOR/COVER 5130CDN
019K 10370	FRU	1	Y934R	OUTPUT FINISHER MAIN ASSEMBLY STAPLER UNIT 5130CDN
050K 51250	CRU	1	5N2GY	OUTPUT FINISHER MAIN ASSEMBLY STAPLE CARTRIDGE HOLDER AND STAPLE CARTRIDGE 5130CDN
068K 64620	FRU	1	C638T	OUTPUT FINISHER MAIN ASSEMBLY DOOR/COVER INTERLOCK SWITCH 5130CDN

BASE UNIT				
999S Y353R	CRU	1	Y353R	PRINTER FOR SERVICE WHOLE UNIT EXCHANGE 110V AMERICAS 5130CN
999S C271T	CRU	1	C271T	PRINTER FOR SERVICE WHOLE UNIT EXCHANGE 220V EUROPE AUSTRALIA NEW ZEALAND 5130CN
999S C555T	CRU	1	C555T	PRINTER FOR SERVICE WHOLE UNIT EXCHANGE 110V TAA 5130CN
999S D227T	CRU	1	D227T	PRINTER FOR SERVICE WHOLE UNIT EXCHANGE 220V TAA 5130CN



Dell 5130cn Finisher **Service Manual**

**Information in this document is subject to change without notice.
2010 Dell Inc. All rights reserved.**

Reproduction in any manner whatsoever without the written permission of Dell Inc. is strictly forbidden.
Trademarks used in this text: Dell and the DELL logo are trademarks of Dell Inc.

Other trademarks and trade names may be used in this document to refer to the entities claiming the marks and names of their products. Dell Inc. disclaims any proprietary interest in trademarks and trade names other than its own.

Version record

Refer to the portion indicated by change bar in each section.

Also refer to the reasons in table below.

Version	Issue date	Note
1 st	March 31, 2009	1 st issued
2 nd	June 10, 2009	2 nd issued Introduction - The illustration was reviewed by the externals change. - The illustration was changed or added. Chapter 3:RRP - The procedure of the RRP was reviewed according to the specification change. Chapter 4:Plug/Jack Connector Locations - The illustration was changed. Chapter 6:Principles of Operation - The illustration was reviewed by the externals change. - "3.3.2.3 Sheet/Envelope Select Lever" was added. Chapter 8:Printer Specifications - The printer specification was reviewed according to the specification change.

Introduction CONTENTS

Cautions.....	i
1. About this manual.....	ii
2. Marks giving caution.....	ii
3. Related documents.....	ii
4. Safety	iii
4.1 Power source	iii
4.2 Driving units	iv
4.3 Warning/caution labels.....	v
Unpacking the Finisher.....	vi

Cautions

Operation contents of this document may be subject to modification without notice.

Dell Inc. will not assume responsibility for accidental or incidental damages resulting from technical or editorial errors or omissions in this manual, the issue of this manual, the execution of descriptions in this manual, or the use of this manual.

This document is protected by copyright. Do not photocopy or duplicate any part of this document in any form without written permission from Dell Inc.

1. About this manual

This manual is a standard service manual of Dell Inc. containing information required for maintenance of this finisher.

2. Marks giving caution

Maintenance operations requiring special cautions or additional information regarding descriptions in this manual are presented as "Warning," "Caution," or "Note," depending on their nature.



If instructions are not observed, death or serious injury may result.



If instructions are not observed, injuries to workers or physical damage to assets (including this finisher) may result.

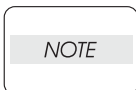

Essentials for procedures, steps, rules, and others.

Reference *Incidental information to descriptions.*

3. Related documents

- Instruction manuals (standard manuals)

Describe the operation and handling of this finisher.

- Performance specifications

Describe in detail various specifications of this finisher.

(In the event of a discrepancy between this manual and the performance specifications, the performance specifications take precedence.)

- Spare parts list

Information on maintenance parts (spare parts) for this finisher.

4. Safety

To prevent possible accidents during maintenance operation, you should observe strictly the "Warning" and "Caution" information in this manual.

Avoid dangerous operations and operations out of the scope of this manual.

Various processes not covered by this manual may be required in actual operations, and should be performed carefully, always giving attention to safety.

4.1 Power source

Keep the power plug disconnected during the maintenance operation to prevent electric shock, burns and other damages.

If the power supply should be kept connected to measure voltage or for other similar reasons, take sufficient care to prevent electric shock, by following the procedures in this manual.



While the printer is on, never touch live parts if not required.



Power is supplied to the power switch / inlet even while the printer is off. Never touch its live components.



Do not touch live parts unless otherwise specified.

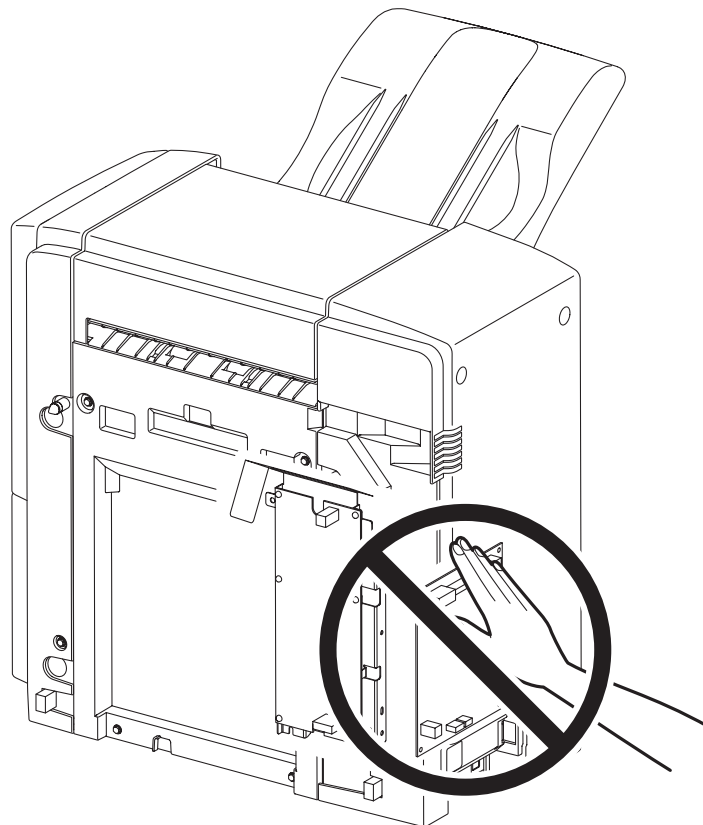

Tbt00502KB

4.2 Driving units

When servicing gears or other driving units, be sure to turn off the power switch and unplug the power cord. Drive them manually when required.



Do not do the print work removing the cover of the finisher to confirm the operation of driving part.

4.3 Warning/caution labels

Warning labels and caution labels are attached to this finisher to prevent accidents. Check those labels for their peeling or stains when servicing the finisher.

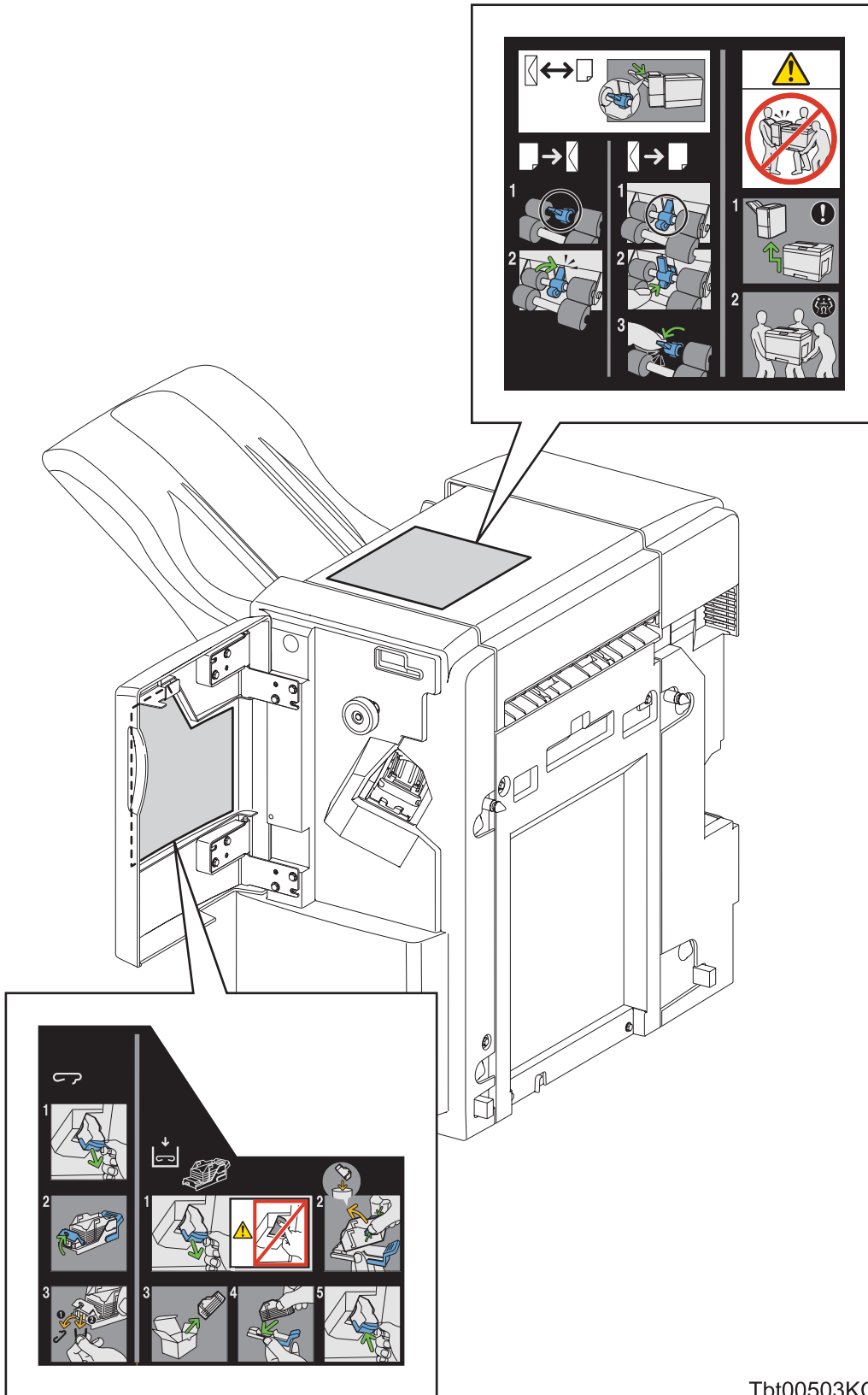

Tbt00503KC

Unpacking the Finisher



The finisher must be carried horizontally with three or more persons.



Take extreme care to avoid personal injuries.

Check visually the finisher for evidence of any damages.

Peel all tapes off the finisher.

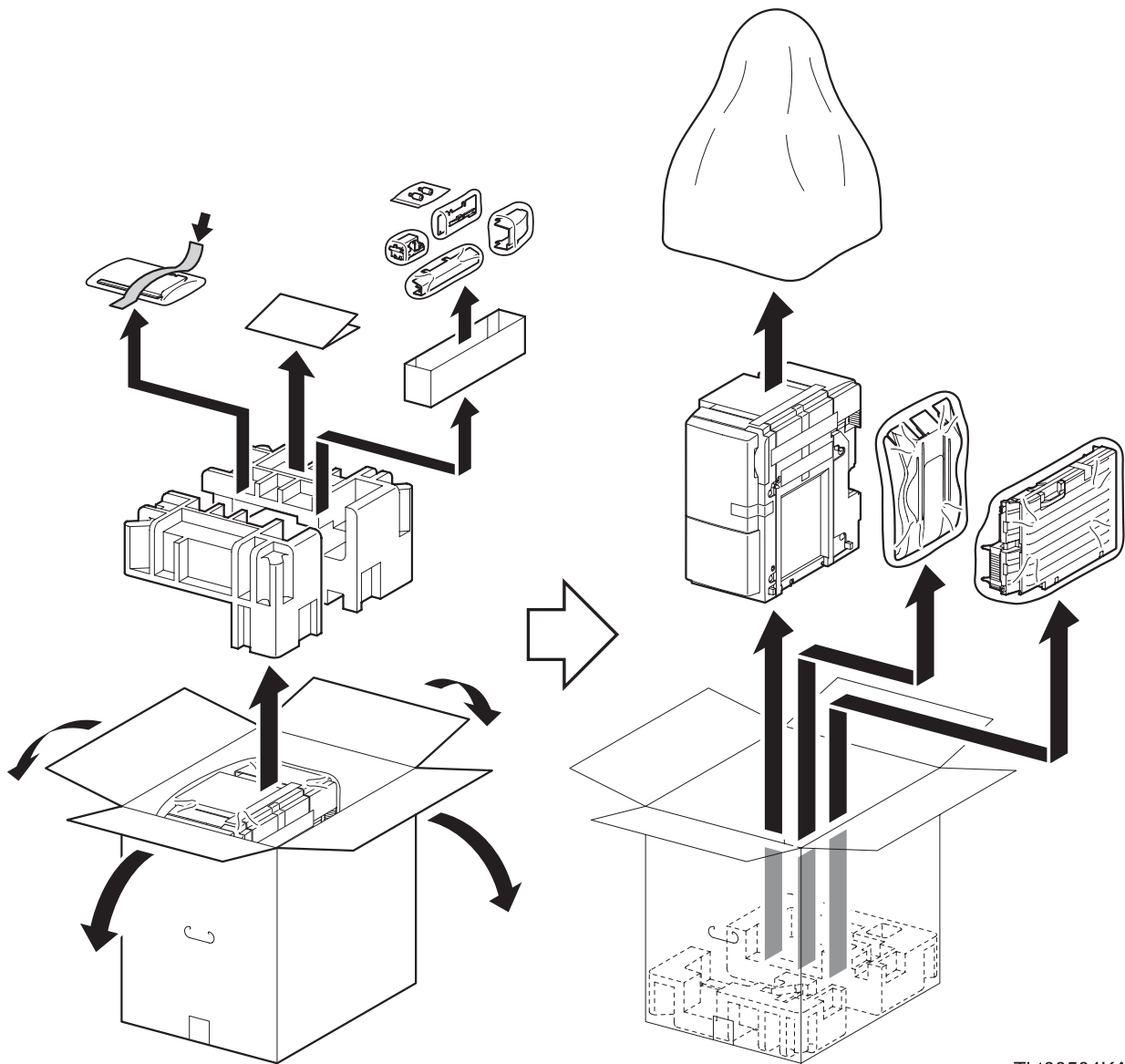

Tbt00504KA

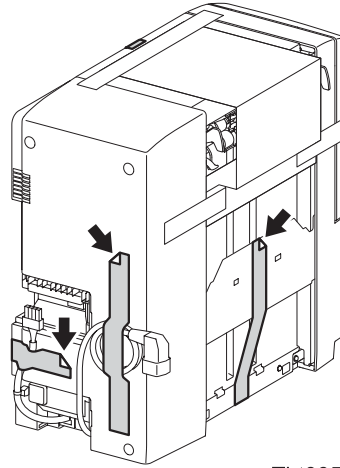
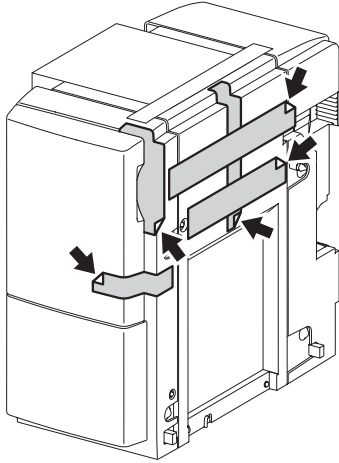
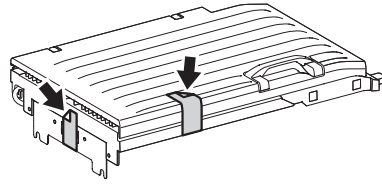

Tbt00505KA

TABLE OF CONTENTS

Chapter 1 Troubleshooting	1 - 1 (Dell 5130cn Service Manual)
Chapter 2 Operation of Diagnostic	2 - 1 (Dell 5130cn Service Manual)
Chapter 3 Removal and Replacement Procedures	3 - 1
Chapter 4 Plug/Jack(P/J) Connector Locations.....	4 - 1
Chapter 5 Parts List.....	5 - 1 (Dell 5130cn Service Manual)
Chapter 6 Principles of Operation	6 - 1
Chapter 7 Wiring Diagrams and Signal Information	7 - 1
Chapter 8 Printer Specifications	8 - 1

Chapter 3 Removal and Replacement Procedures (RRPs) CONTENTS

1. Removal and Replacement Procedures (RRPs)	3 - 1
1.1 Before Starting Service Procedure	3 - 1
1.2 General Notes	3 - 2
Removal Flows	3 - 3
Replacement Flows	3 - 4
2. Removal Steps	3 - 6
Removal 1 KIT TRAY STACKER (PL14.1.98)	3 - 6
Removal 2 KIT FINISHER ASSY (PL14.1.99)	3 - 8
Removal 3 TRANSPORT ASSY A4 (PL14.2.1)	3 - 12
Removal 4 KIT CHUTE ASSY LOWER H-TRA (PL14.2.98), KIT COVER ASSY TOP H-TRA (PL14.2.99)	3 - 14
Removal 5 COVER ASSY FRONT (PL14.3.5)	3 - 16
Removal 6 COVER FRONT (PL14.3.7)	3 - 19
Removal 7 HOLDER ASSY STAPLER A4 (PL14.8.19)	3 - 20
Removal 8 BRACKET ASSY INTERLOCK (PL14.10.1)	3 - 21
Removal 9 LVPS ASSY (PL14.10.10)	3 - 22
Removal 10 COVER REAR (PL14.3.3)	3 - 24
Removal 11 PWBA MAIN A4FIN (PL14.4.12)	3 - 25
Removal 12 HOLDER CARTRIDGE (PL14.8.21)	3 - 26
Removal 13 COVER ASSY FRONT DOOR (PL14.3.6)	3 - 27
4. Replacement Steps	3 - 28
Replacement 1 PWBA MAIN A4FIN (PL14.4.12)	3 - 28
Replacement 2 COVER REAR (PL14.3.3)	3 - 29
Replacement 3 LVPS ASSY (PL14.10.10)	3 - 30
Replacement 4 BRACKET ASSY INTERLOCK (PL14.10.1)	3 - 32
Replacement 5 HOLDER ASSY STAPLER A4 (PL14.8.19)	3 - 33
Replacement 6 COVER FRONT (PL14.3.7)	3 - 34
Replacement 7 COVER ASSY FRONT (PL14.3.5)	3 - 36
Replacement 8 KIT CHUTE ASSY LOWER H-TRA (PL14.2.98), KIT COVER ASSY TOP H-TRA (PL14.2.99)	3 - 39
Replacement 9 TRANSPORT ASSY A4 (PL14.2.1)	3 - 40
Replacement 10 KIT FINISHER ASSY (PL14.1.99)	3 - 42
Replacement 11 KIT TRAY STACKER (PL14.1.98)	3 - 46
Replacement 12 HOLDER CARTRIDGE (PL14.8.21)	3 - 47
Replacement 13 COVER ASSY FRONT DOOR (PL14.3.6)	3 - 48

Chapter 3 Removal and Replacement Procedures (RRPs) CONTENTS

1. Removal and Replacement Procedures (RRPs)

1.1 Before Starting Service Procedure

- Start the procedure after turning off the power, and removing the power cord from the outlet.
- Do not apply excessive force to parts to avoid functional damage.
- Since various types of screws are used, ensure that the right screws are used in their right positions. Use special caution not to confuse the screws for plastic and the ones for sheet metal, because using the wrong type of screw may result in damage to the screw threads or other troubles.

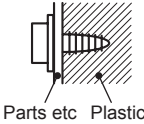
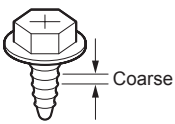
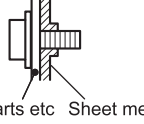
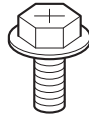
No.	Type	Application	Shape	How to Distinguish	Points to Be Noted	Major Location
1	<ul style="list-style-type: none"> • Screw for plastic • Silver, flanged, tapping 	<p>Plastic</p> 		<ul style="list-style-type: none"> • Silver-colored. • With flange. • Screw thread is coarser than that of the sheet metal type. • The thread is tapered toward the tip. 	<ul style="list-style-type: none"> • Oblique screwing damages the thread because this screw cuts female threads in the base material as it rotates. 	
2	<ul style="list-style-type: none"> • Screw for metal sheet • Silver, with a flange 	<p>Sheet metal</p> 		<ul style="list-style-type: none"> • Silver-colored • It has a flange. • Diameter of the thread section is uniform. 		

- Wear a wristband or the like wherever possible to remove electrostatic buildup from your body.

1.2 General Notes

- The string "(PL X.Y.Z)" appended to the part name in the procedure denotes that the part correto the plate (PL) "X.Y", item "Z" of the Engineering Parts list, and its shape and fitting position can be checked in the Engineering Parts list.
- Directional descriptions used in the procedures are defined as follows:
 - Front : Direction toward you when facing the front of the printer.
 - Rear : Direction opposite to the front when facing the front of the printer.
 - Left : Left-hand direction when facing the front of the printer.
 - Right : Right-hand direction when facing the front of the printer.

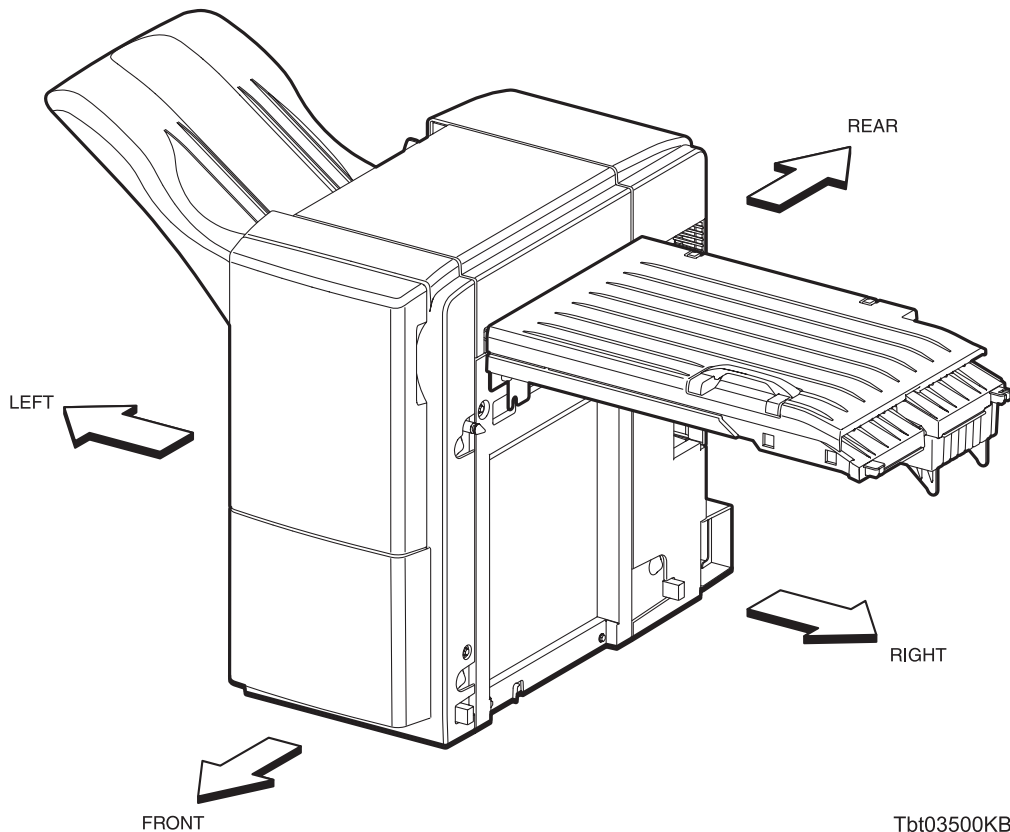

Tbt03500KB

Fig.: Directions Regarding the Printer

- The string "(RRP X.Y)" that appears in or at the end of the procedure denotes that the related service procedure is described in [RRP X.Y].
- Unless otherwise specified, use a Phillips-head screwdriver to remove the screws shown in the illus.
- Black arrows shown in the illustrations denote moving directions. The numbers assigned to these arrows refer to the order in the procedure.
- Refer to [Chapter 4 Plug/Jack (P/J) Connector Locations] for the positions of connectors (P/J).

Removal Flows

The components not connected with arrows in the flow below can be removed independently.

Finisher Removal Flow

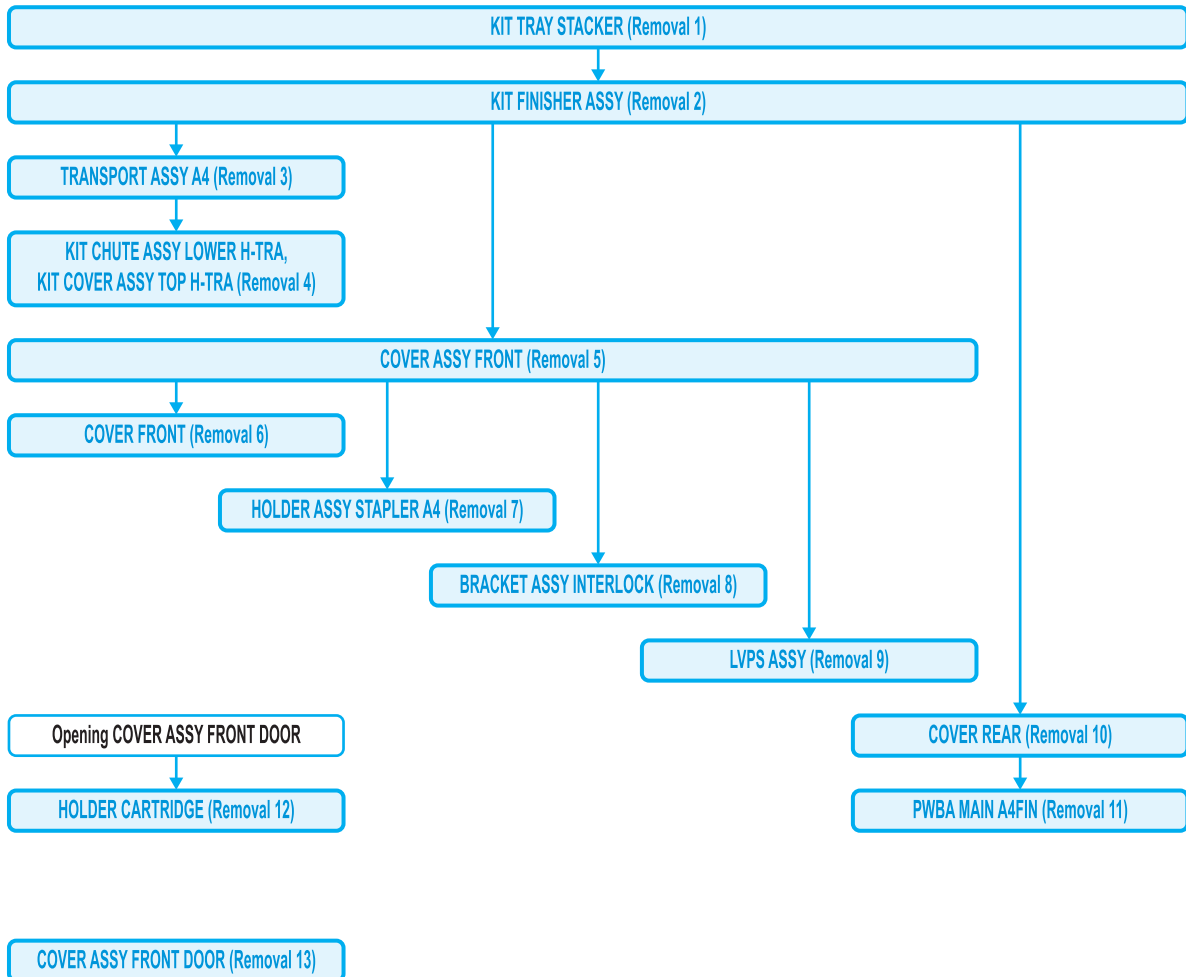

Replacement Flows

The components not connected with arrows in the flow below can be replaced independently.

Finisher Replacement Flow

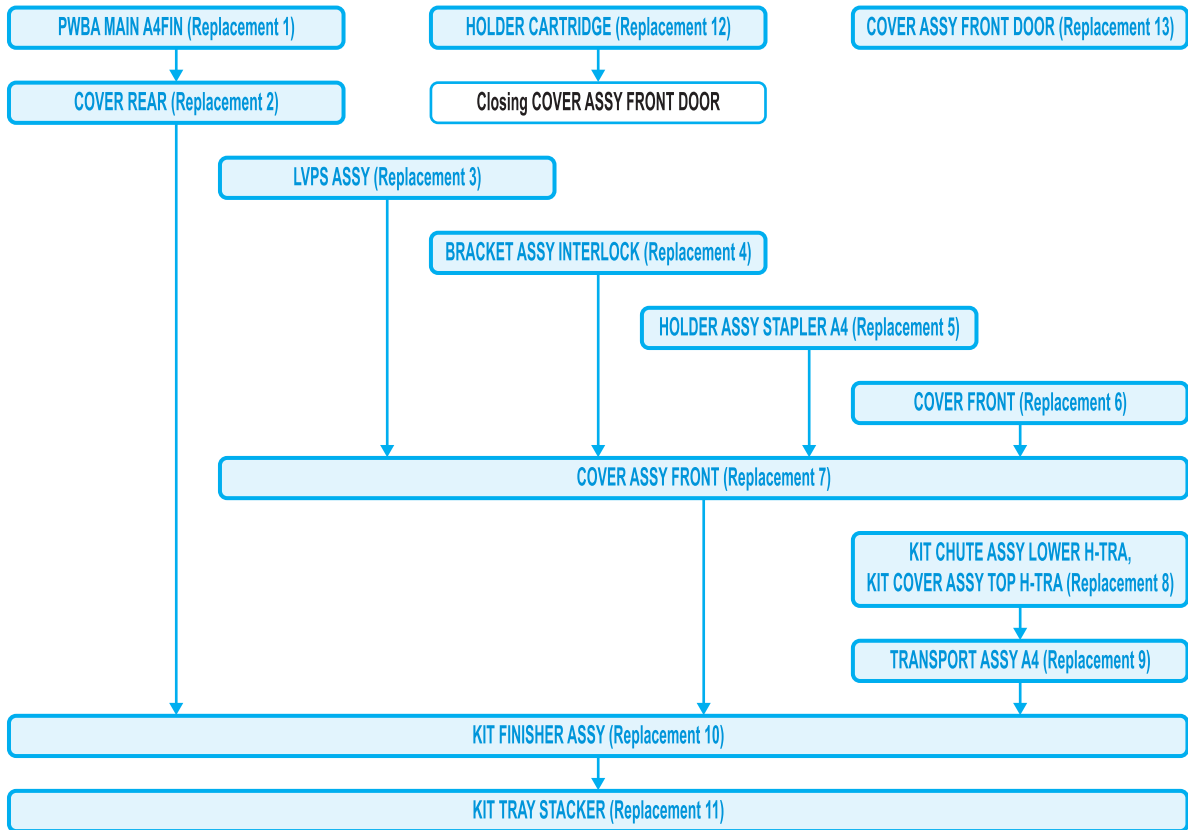

Blank Page

2. Removal Steps

Removal 1 KIT TRAY STACKER (PL14.1.98)

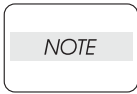

When performing the following step, use caution not to damage the GUIDE TAMPERs.

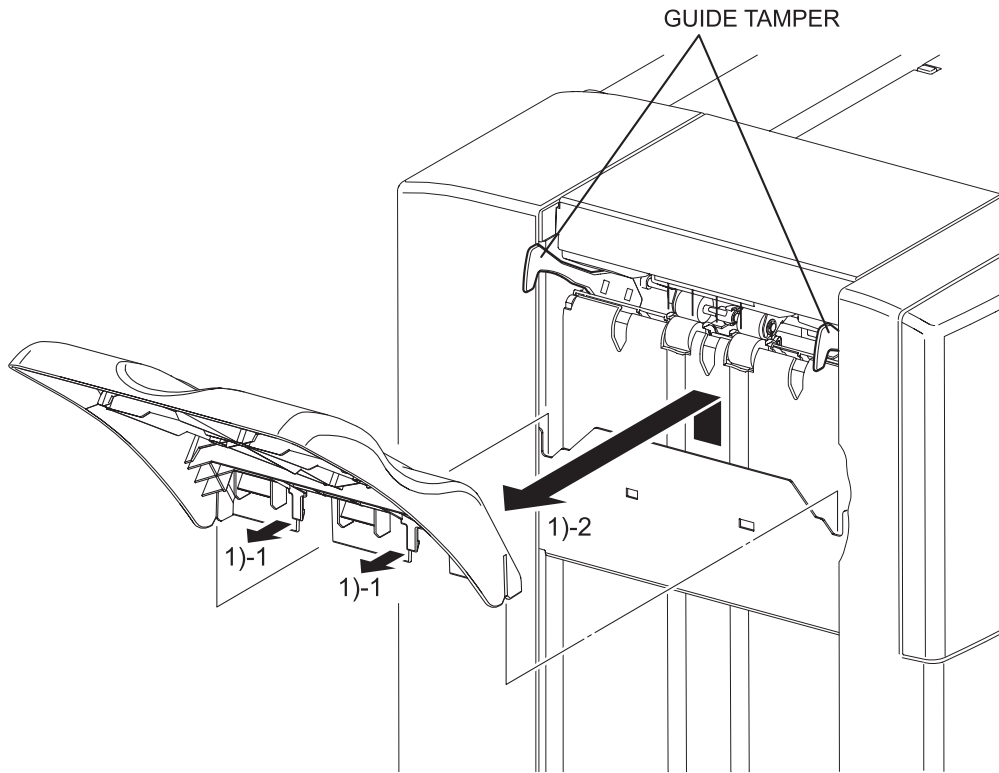

- 1) Remove the TRAY STACKER (PL14.1.2) from the FINISHER ASSY by releasing the two hooks of the TRAY STACKER.

Go to the next removal step:

Removal 2 KIT FINISHER ASSY (PL14.1.99)

Blank Page

Removal 2 KIT FINISHER ASSY (PL14.1.99)

In the following steps, the details of Step 1 are omitted because they are described earlier in this chapter.

Go to the step in parentheses to execute the necessary steps, and then go to Step 2 onward.

- 1) Remove the TRAY STACKER. (Removal 1)

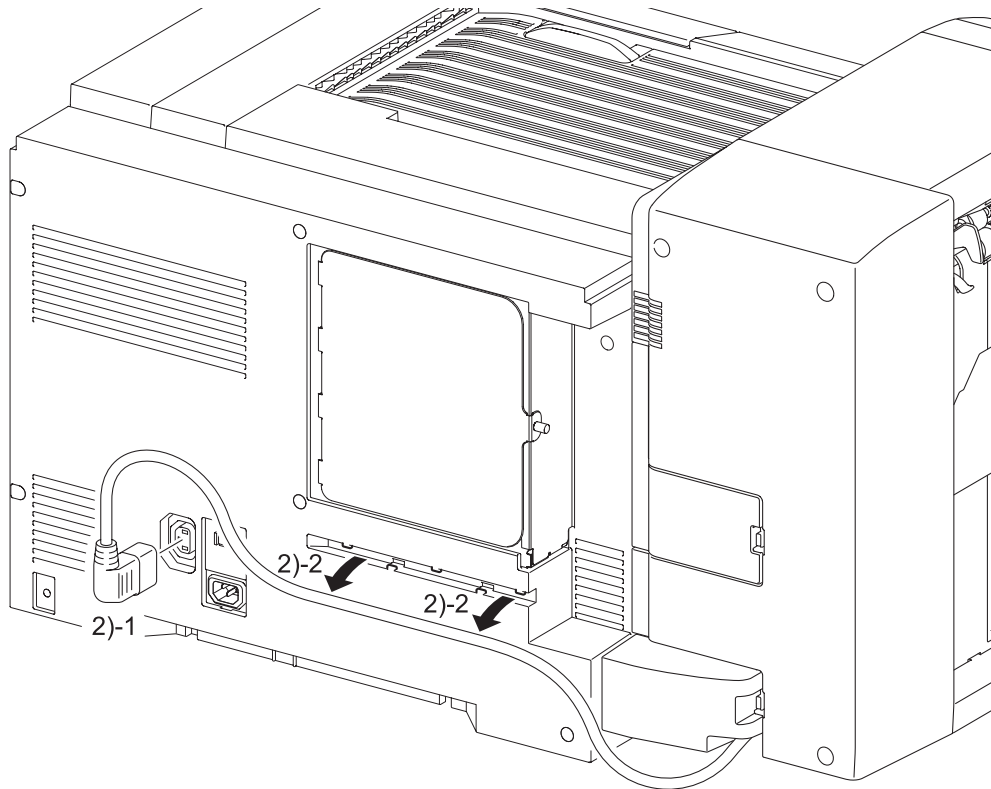

Tbt03537KA

- 2) Disengage the AC OUTLET of the CABLE ASSY POWER A4FIN (PL14.11.8) from the printer, and then release the CABLE ASSY POWER A4FIN from the harness guide on the printer.

Continues to the next page.

Removal 2 KIT FINISHER ASSY (PL14.1.99)

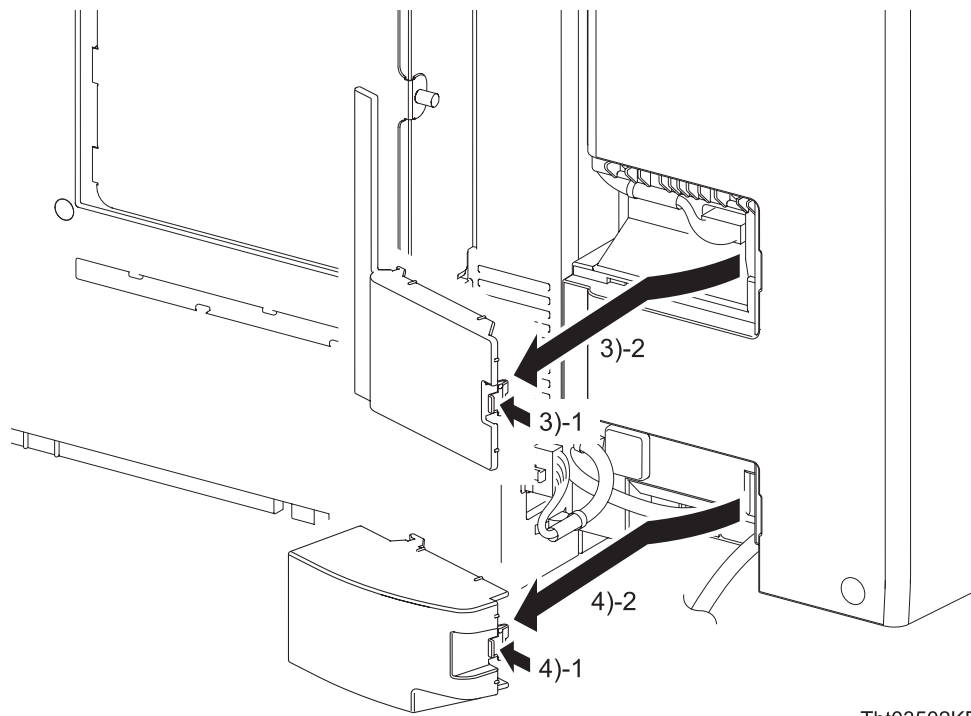

Tbt03502KB

- 3) Remove the COVER CONNECTOR (PL14.1.5) from the FINISHER ASSY by releasing the hook of the COVER CONNECTOR.
- 4) Remove the COVER CONNECTOR2 (PL14.1.4) from the FINISHER ASSY by releasing the hook of the COVER CONNECTOR2.

Continues to the next page.

Removal 2 KIT FINISHER ASSY (PL14.1.99)

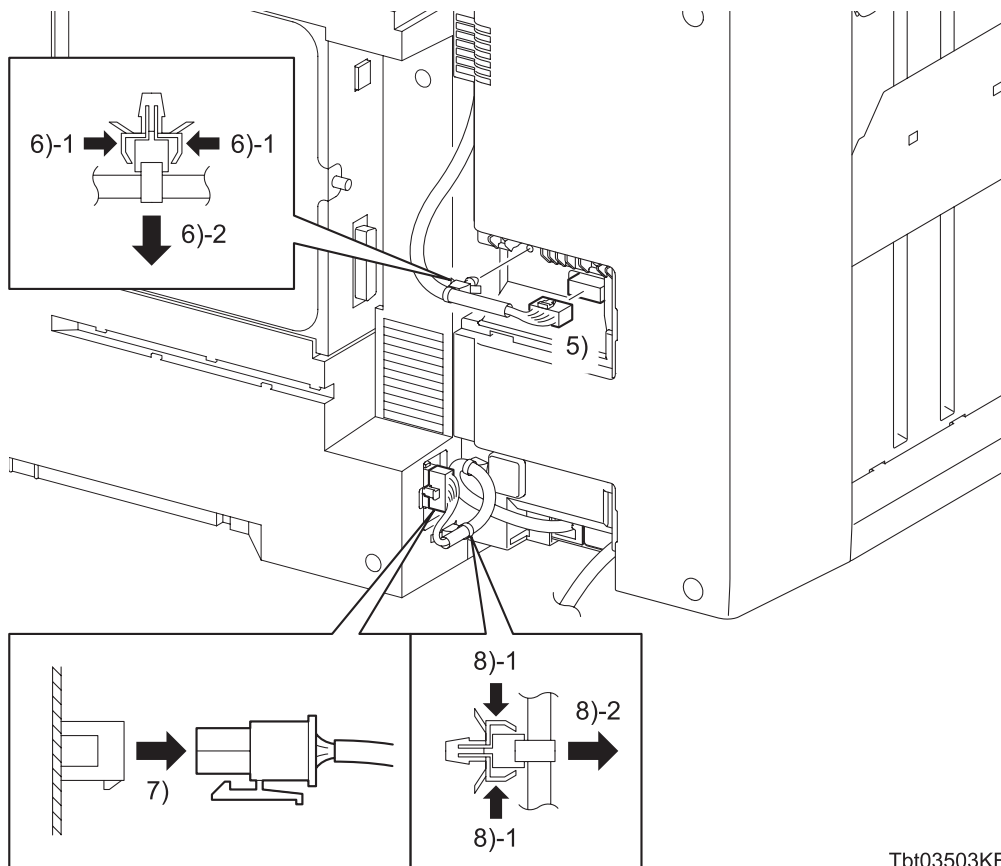

Tbt03503KB

- 5) Disengage the connectors (P/J8987) of the TRANSPORT ASSY A4 (PL14.2.1) from the FINISHER ASSY.
- 6) Remove the clamp that fixes the harness of the TRANSPORT ASSY A4 to the FINISHER ASSY.
- 7) Disengage the connectors (P121/CN4) of the HARNESS ASSY IF A4FIN (PL14.11.7) from the printer.
- 8) Remove the clamp that fixes the HARNESS ASSY IF A4FIN to the printer.

Continues to the next page.

Removal 2 KIT FINISHER ASSY (PL14.1.99)

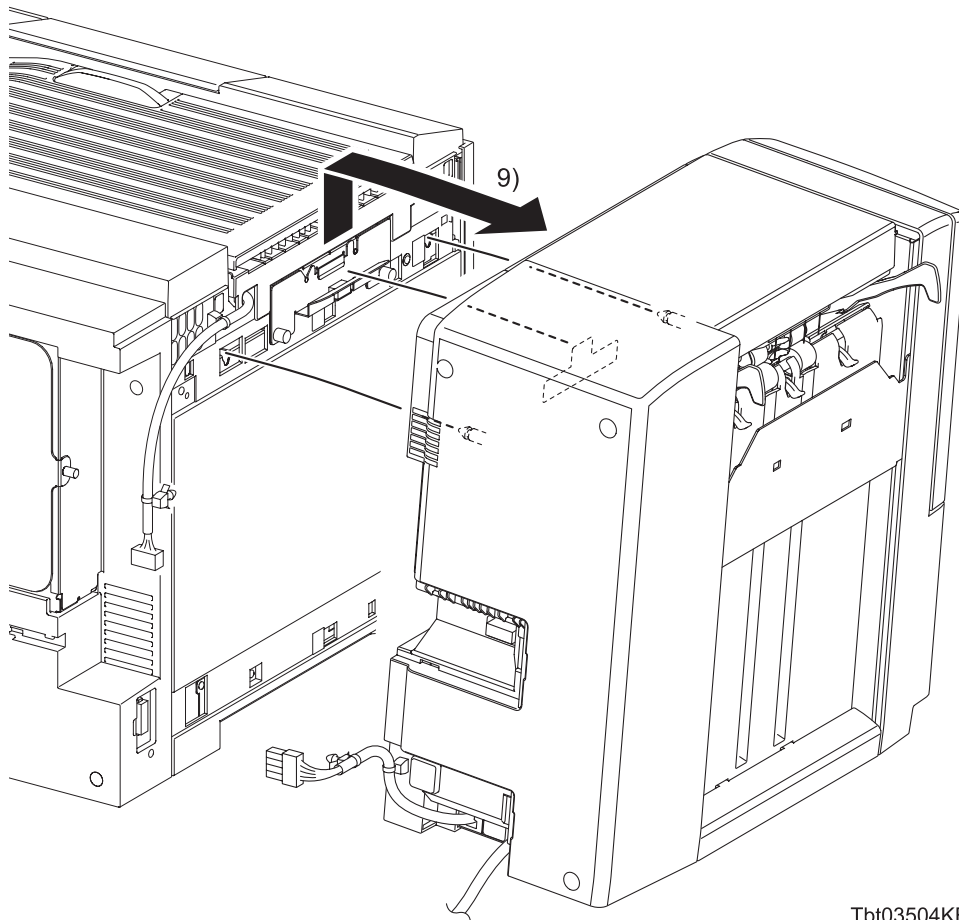

Tbt03504KB

- 9) Remove the FINISHER from the printer by lifting it slightly with one hand on the bottom of the COVER ASSY FRONT (PL 14.3.5) and the other hand on the handle.

Go to the next removal step:

- Removal 3 TRANSPORT ASSY A4 (PL14.2.1),
Removal 5 COVER ASSY FRONT (PL14.3.5),
Removal 10 COVER REAR (PL14.3.3)**

Removal 3 TRANSPORT ASSY A4 (PL14.2.1)

In the following steps, the details of Steps 1 and 2 are omitted because they are described earlier in this chapter. Go to the steps in parentheses to execute the necessary steps, and then go to Step 3 onward.

- 1) Remove the TRAY STACKER. (Removal 1)
- 2) Remove the FINISHER ASSY. (Removal 2)

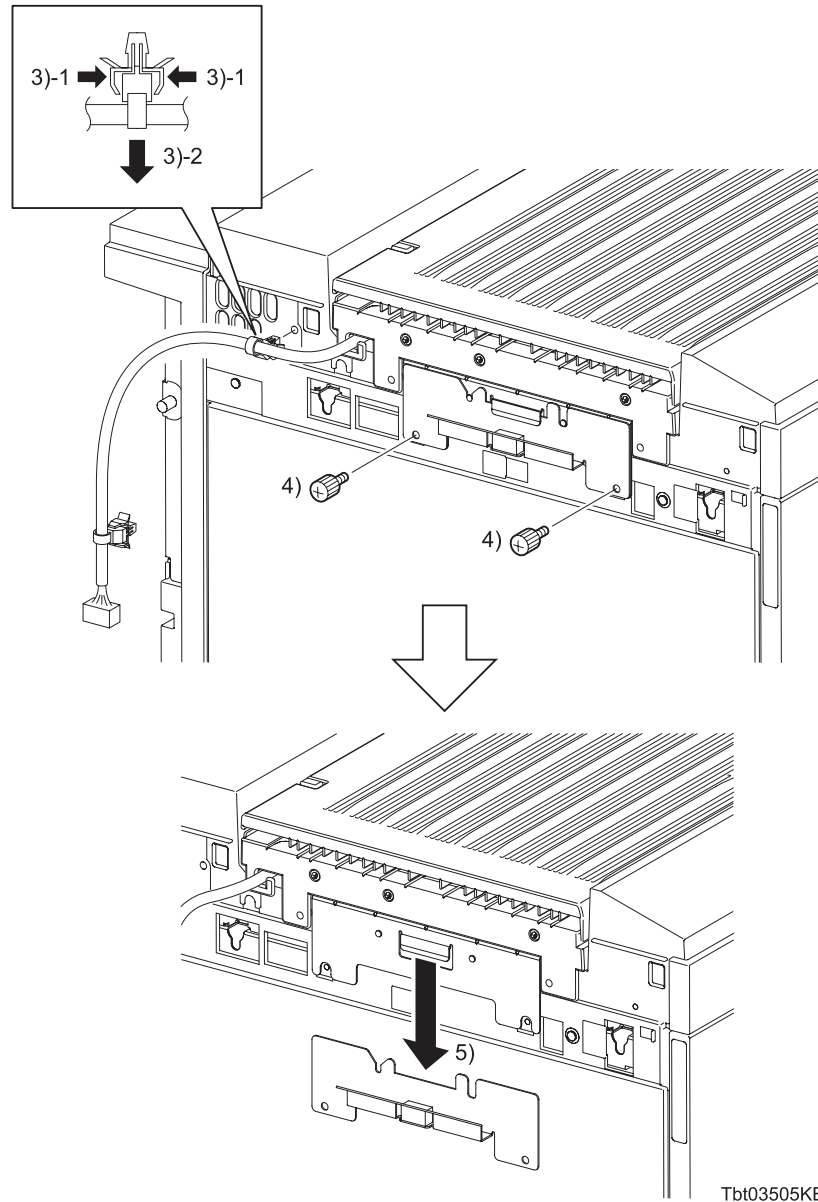

- 3) Remove the one clamp that fixes the harness of the TRANSPORT ASSY A4 (PL14.2.1) to the printer.

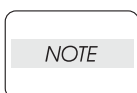

When performing the following step, use caution not to drop the BRACKET ASSY GUIDE ADD.

- 4) Remove the two SCREW M4 STEELS (PL14.1.8) while holding the BRACKET ASSY GUIDE ADD (PL14.1.9).
- 5) Remove the BRACKET ASSY GUIDE ADD.

Continues to the next page.

Removal 3 TRANSPORT ASSY A4 (PL14.2.1)

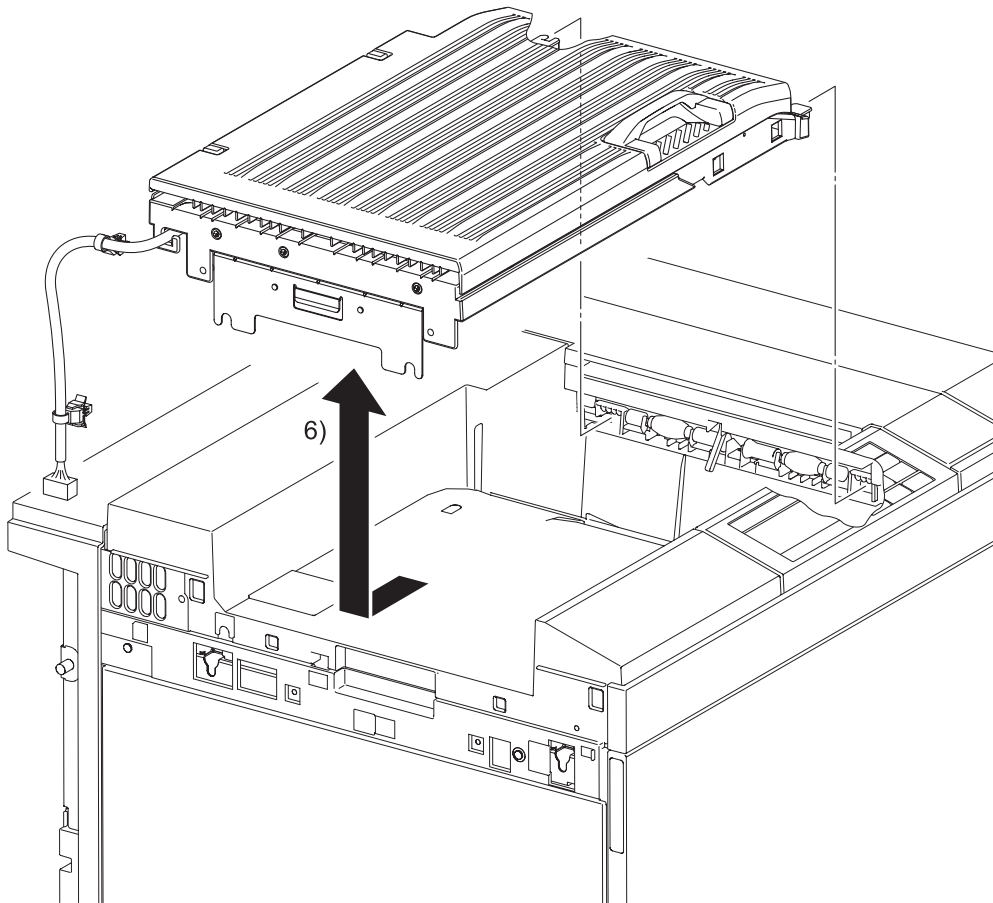

Tbt03506KB

- 6) Slide the TRANSPORT ASSY A4 toward the FINISHER ASSY until the two tabs on the TRANSPORT ASSY A4 are disengaged from the printer, and then remove the TRANSPORT ASSY upward from the printer.

Go to the next removal step:

Removal 4 KIT CHUTE ASSY LOWER H-TRA (PL14.2.98), KIT COVER ASSY TOP H-TRA (PL14.2.99)

Removal 4 KIT CHUTE ASSY LOWER H-TRA (PL14.2.98), KIT COVER ASSY TOP H-TRA (PL14.2.99)

In the following steps, the details of Steps 1 through 3 are omitted because they are described earlier in this chapter. Go to the steps in parentheses to execute the necessary steps, and then go to Step 4 onward.

- 1) Remove the TRAY STACKER. (Removal 1)
- 2) Remove the FINISHER ASSY. (Removal 2)
- 3) Remove the TRANSPORT ASSY A4. (Removal 3)

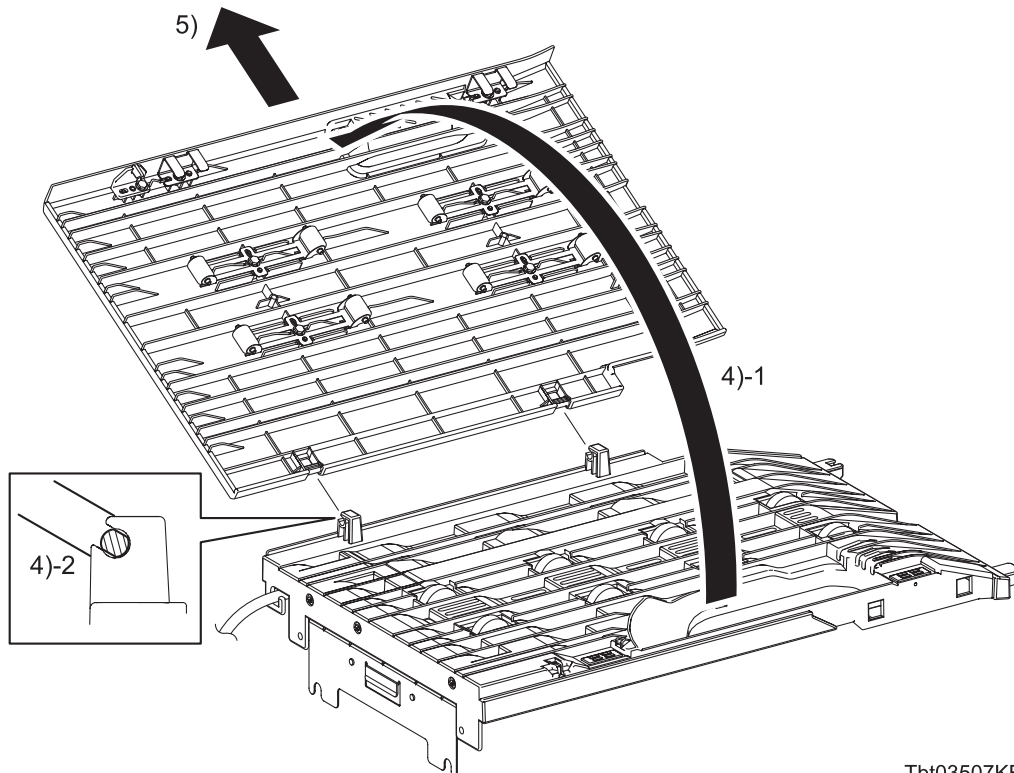

Tbt03507KB

- 4) Swing up the COVER ASSY TOP H-TRA (PL14.2.3) until the flat surfaces on the pivots of the COVER ASSY TOP H-TRA becomes parallel with the U-shaped notches on the CHUTE ASSY LOWER H-TRA (PL14.2.10).
- 5) Remove the COVER ASSY TOP H-TRA diagonally upward from the CHUTE ASSY LOWER H-TRA.

Blank Page

Removal 5 COVER ASSY FRONT (PL14.3.5)

In the following steps, the details of Steps 1 and 2 are omitted because they are described earlier in this chapter. Go to the steps in parentheses to execute the necessary steps, and then go to Step 3 onward.

- 1) Remove the TRAY STACKER. (Removal 1)
- 2) Remove the FINISHER ASSY. (Removal 2)

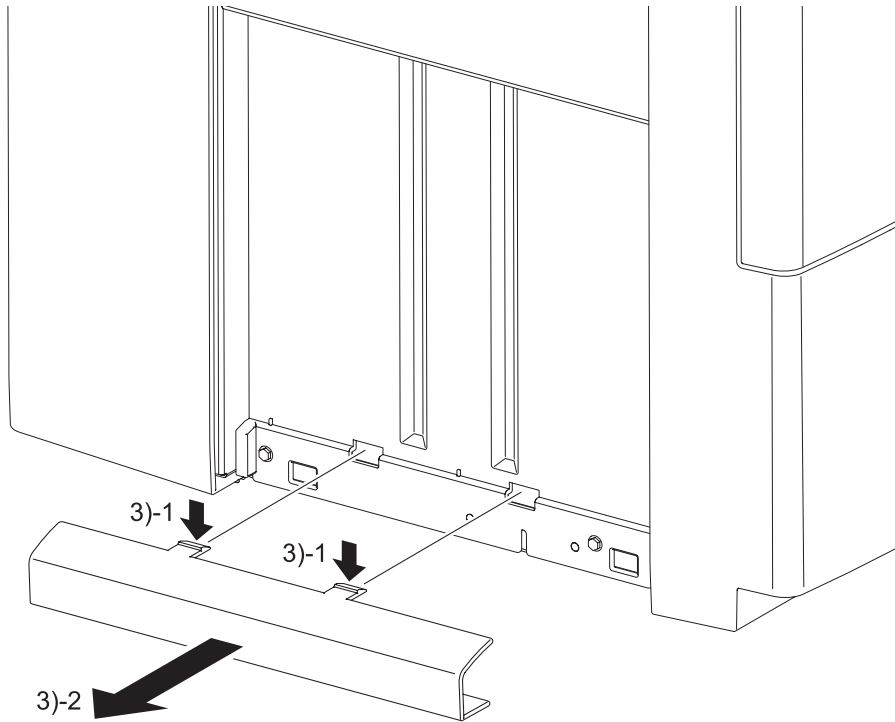

Tbt03508KB

- 3) Remove the COVER GUIDE TRAY (PL14.1.3) from FINISHER ASSY by releasing the two hooks on the COVER GUIDE TRAY.

Continues to the next page.

Removal 5 COVER ASSY FRONT (PL14.3.5)

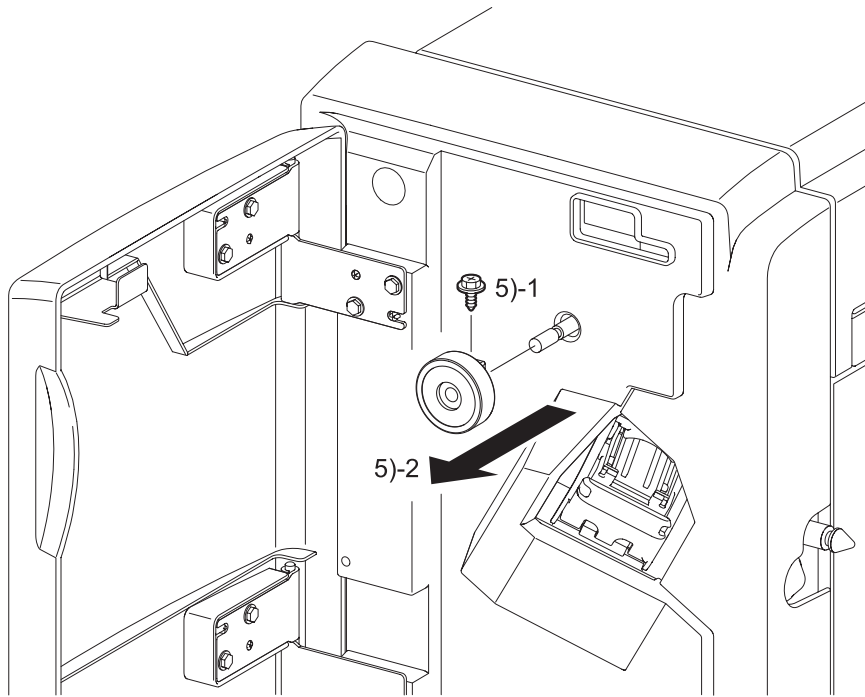

Tbt03509KA

- 4) Open the COVER ASSY FRONT DOOR (PL14.3.6).
- 5) Remove the KNOB ASSY EXIT from the ROLL ASSY DRIVE EXIT (PL14.7.12) by removing the one screw (sliver, flanged, tapping, 6mm).

Continues to the next page.

Removal 5 COVER ASSY FRONT (PL14.3.5)

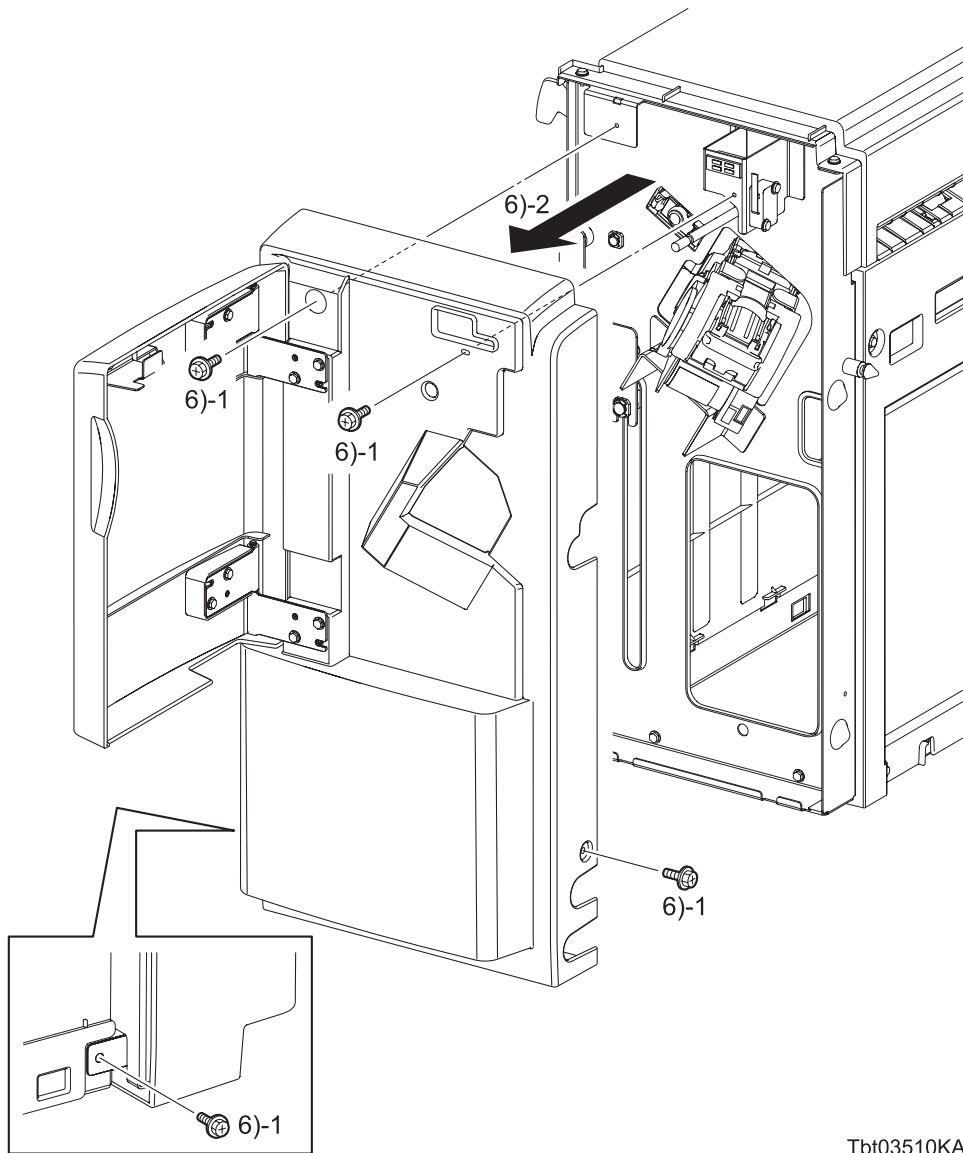

- 6) Remove the COVER ASSY FRONT from the FINISHER ASSY by removing the four screws (silver, flanged, 8mm).

Go to the next removal step:

- Removal 6 COVER FRONT (PL14.3.7),
Removal 7 HOLDER ASSY STAPLER A4 (PL14.8.19),
Removal 8 BRACKET ASSY INTERLOCK (PL14.10.1),
Removal 9 LVPS ASSY (PL14.10.10)**

Removal 6 COVER FRONT (PL14.3.7)

In the following steps, the details of Steps 1 through 3 are omitted because they are described earlier in this chapter. Go to the steps in parentheses to execute the necessary steps, and then go to Step 4 onward.

- 1) Remove the TRAY STACKER. (Removal 1)
- 2) Remove the FINISHER ASSY. (Removal 2)
- 3) Remove the COVER ASSY FRONT. (Removal 5)

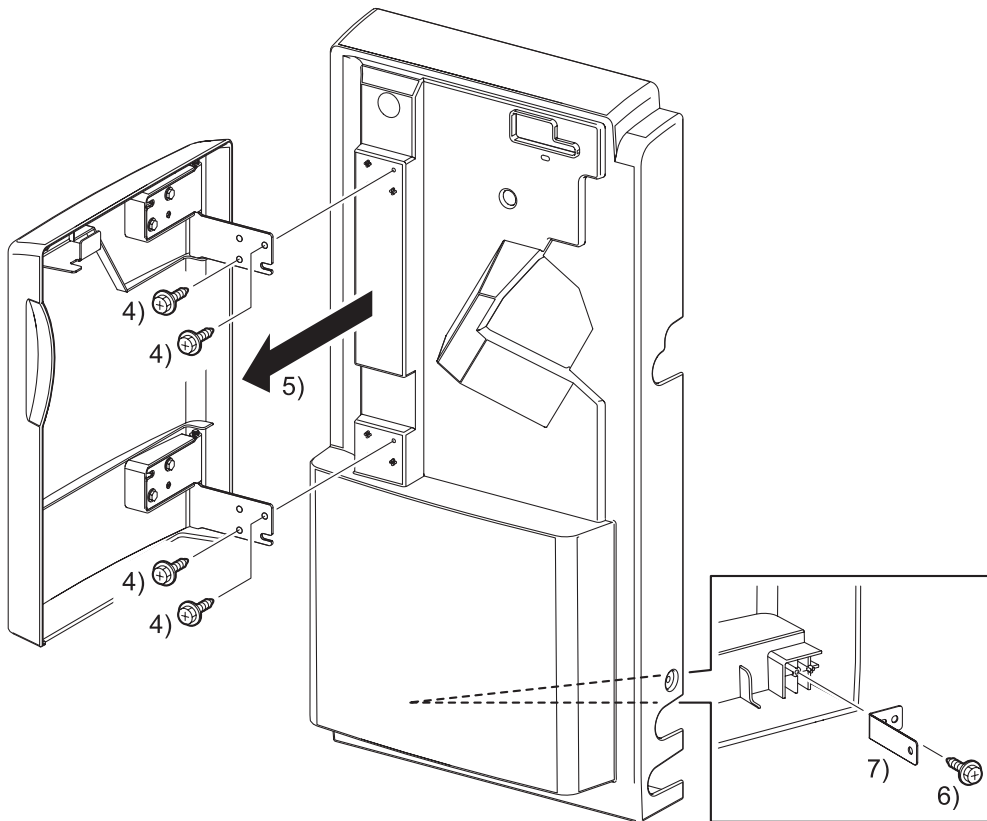

Tbt03511KA

- 4) Remove the four screws (silver, flanged, tapping, 8mm) that fix the COVER ASSY FRONT DOOR (PL14.3.6) to the COVER FRONT (PL14.3.7).
- 5) Remove the COVER ASSY FRONT DOOR from the COVER FRONT.
- 6) Remove the one screw (silver, flanged, tapping, 8mm) that fixes the BRACKET COVER FRONT (PL14.3.8) to the COVER FRONT.
- 7) Remove the BRACKET COVER FRONT from the COVER FRONT.

Removal 7 HOLDER ASSY STAPLER A4 (PL14.8.19)

In the following steps, the details of Steps 1 through 3 are omitted because they are described earlier in this chapter. Go to the steps in parentheses to execute the necessary steps, and then go to Step 4 onward.

- 1) Remove the TRAY STACKER. (Removal 1)
- 2) Remove the FINISHER ASSY. (Removal 2)
- 3) Remove the COVER ASSY FRONT. (Removal 5)

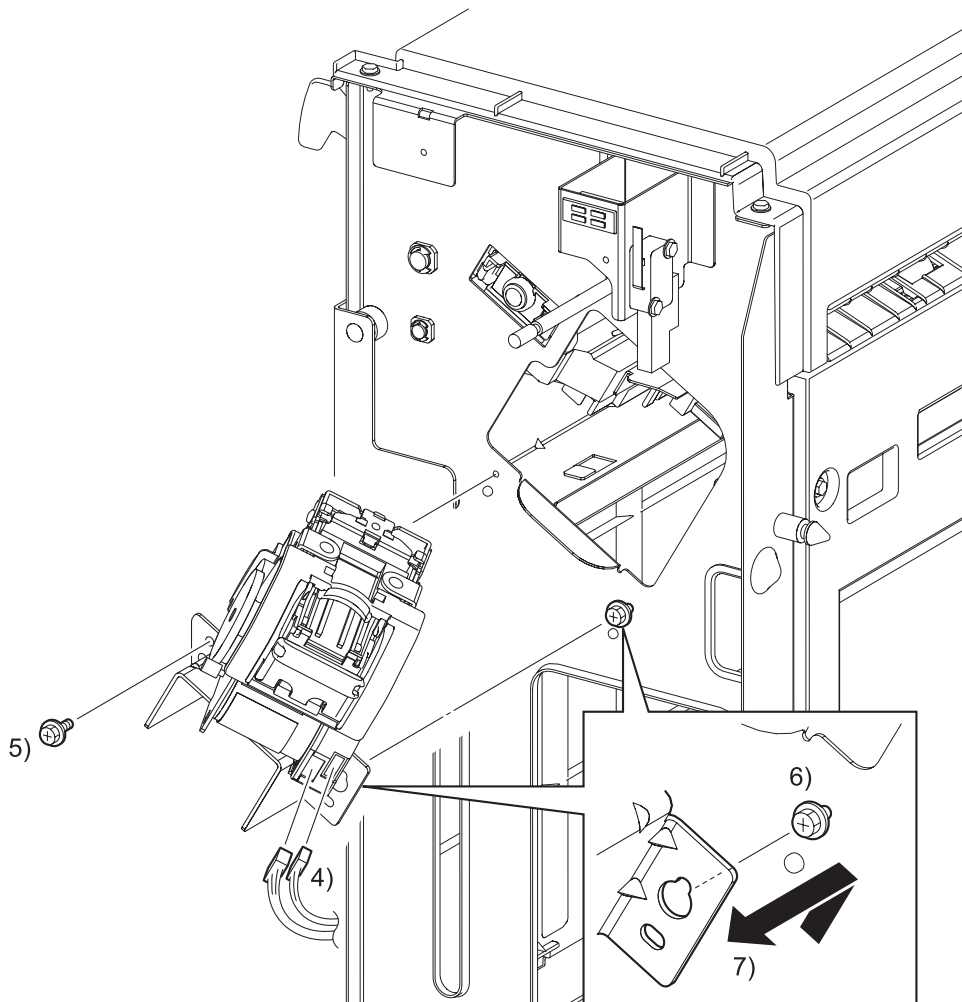

Tbt03512KB

- 4) Disengage the two sets of connectors (P/J8886, 8887) of the HOLDER ASSY STAPLER A4 (PL14.8.19).

NOTE

When performing the following step, use caution not to drop the HOLDER ASSY STAPLER A4.

- 5) Remove the one screw (silver, flanged, 6mm) that fixes the HOLDER ASSY STAPLER A4 to the FINISHER ASSY.
- 6) Loosen the one screw (silver, flanged, 6mm) that fixes the HOLDER ASSY STAPLER A4 to the FINISHER ASSY.
- 7) Release the notch of the HOLDER ASSY STAPLER A4 from the loosened screws by slightly lifting the HOLDER ASSY STAPLER A4. Then, remove the HOLDER ASSY STAPLER A4 from the FINISHER ASSY.

Removal 8 BRACKET ASSY INTERLOCK (PL14.10.1)

In the following steps, the details of Steps 1 through 3 are omitted because they are described earlier in this chapter. Go to the steps in parentheses to execute the necessary steps, and then go to Step 4 onward.

- 1) Remove the TRAY STACKER. (Removal 1)
- 2) Remove the FINISHER ASSY. (Removal 2)
- 3) Remove the COVER ASSY FRONT. (Removal 5)

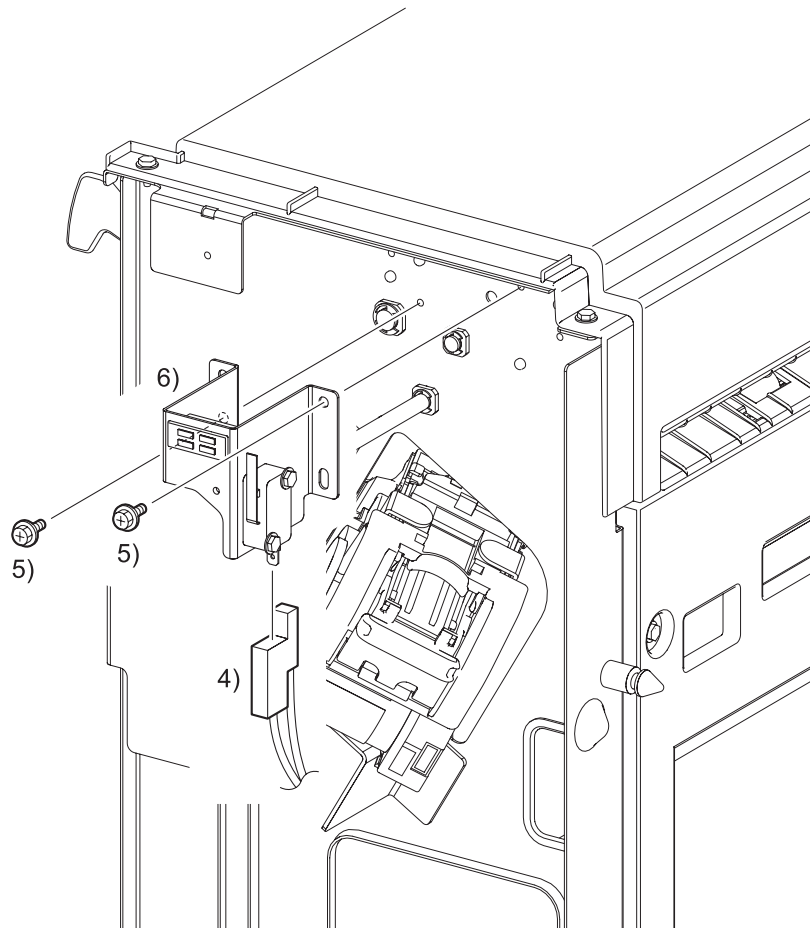

- 4) Disengage the connectors (P/J8889) of the SWITCH (PL14.10.13).
- 5) Remove the two screws (silver, flanged, 6mm) that fix the BRACKET ASSY INTERLOCK (PL14.10.1) to the FINISHER ASSY.
- 6) Remove the BRACKET ASSY INTERLOCK from the FINISHER ASSY.

Removal 9 LVPS ASSY (PL14.10.10)

NOTE

Use a wrist strap to protect the PWB from electrostatic damage.

In the following steps, the details of Steps 1 through 3 are omitted because they are described earlier in this chapter. Go to the steps in parentheses to execute the necessary steps, and then go to Step 4 onward.

- 1) Remove the TRAY STACKER. (Removal 1)
- 2) Remove the FINISHER ASSY. (Removal 2)
- 3) Remove the COVER ASSY FRONT. (Removal 5)

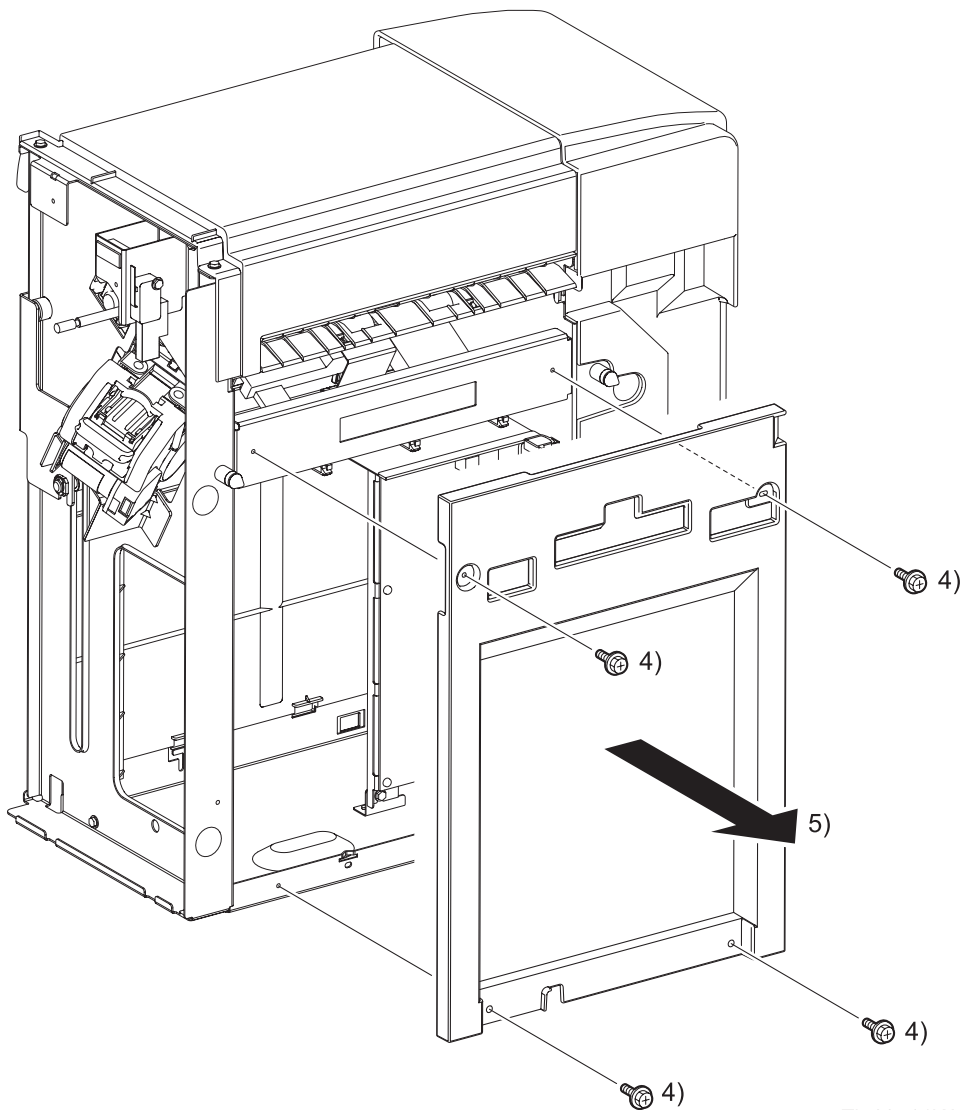

- 4) Remove the four screws (silver, flanged, 8mm) that fix the COVER RH (PL14.3.4) to the FINISHER ASSY.
- 5) Remove the COVER RH from the FINISHER ASSY.

Continues to the next page.

Removal 9 LVPS ASSY (PL14.10.10)

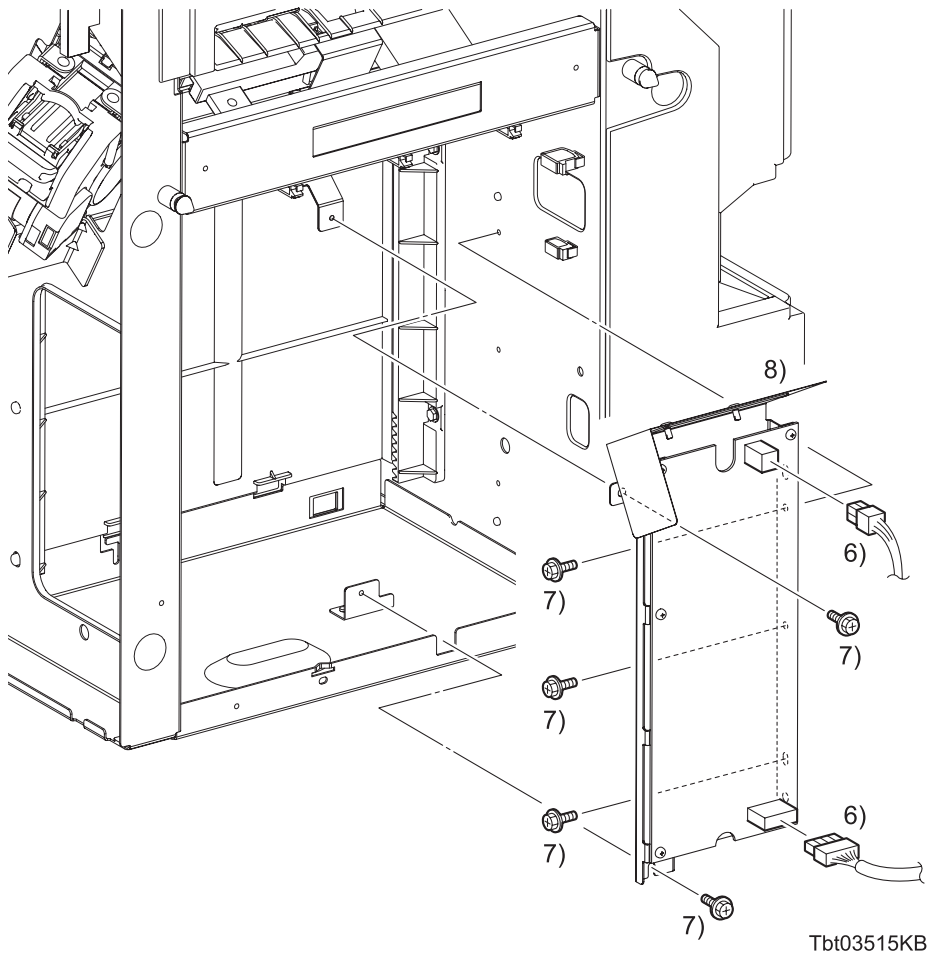

- 6) Disengage the two sets of connectors (P/J590, 591) of the LVPS ASSY (PL14.10.10).
- 7) Remove the five screws (silver, flanged, 6mm) that fix the LVPS ASSY to the FINISHER ASSY.
- 8) Remove the LVPS ASSY from the FINISHER ASSY.

Removal 10 COVER REAR (PL14.3.3)

In the following steps, the details of Steps 1 and 2 are omitted because they are described earlier in this chapter. Go to the steps in parentheses to execute the necessary steps, and then go to Step 3 onward.

- 1) Remove the TRAY STACKER. (Removal 1)
- 2) Remove the FINISHER ASSY. (Removal 2)

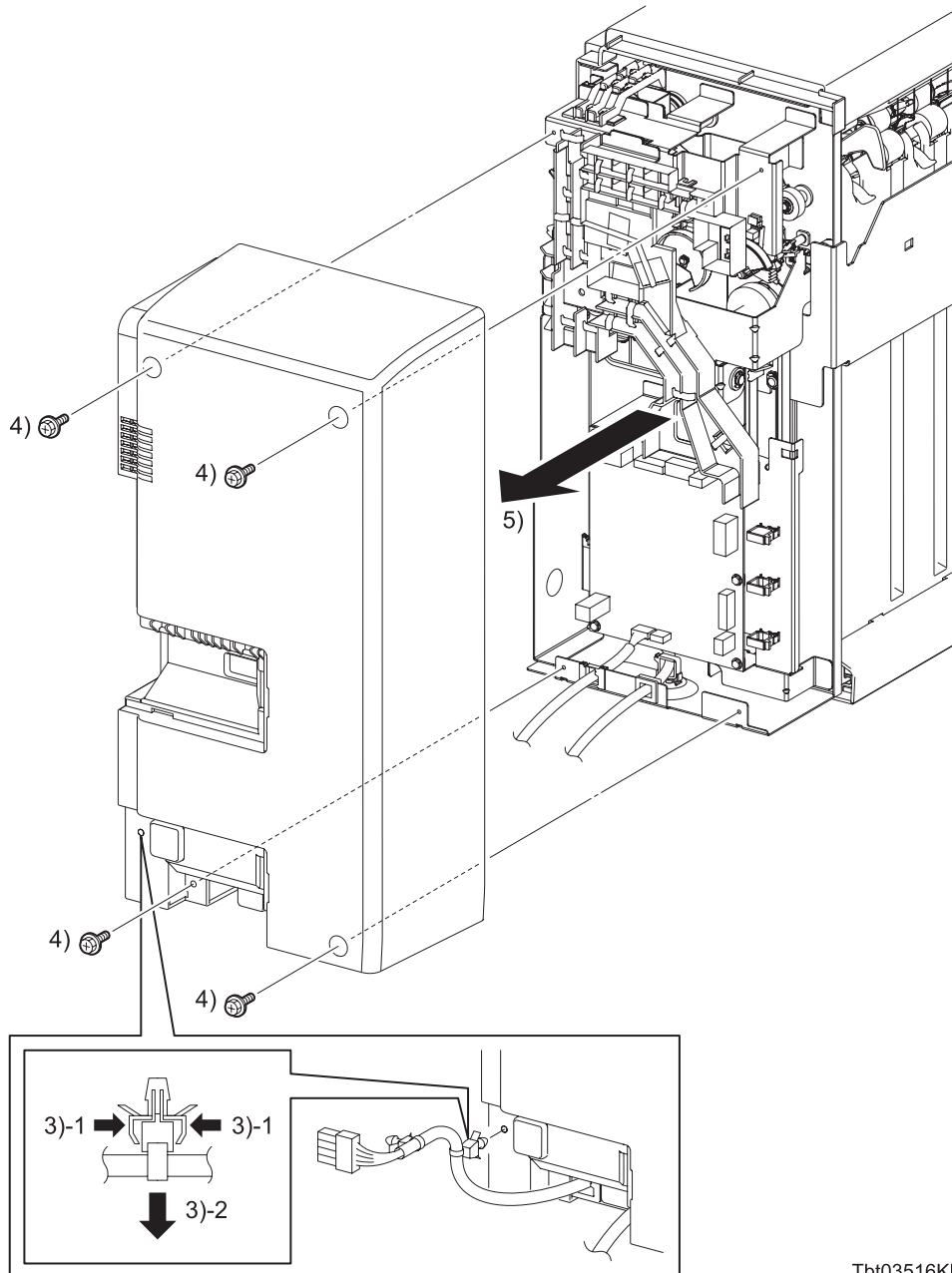

Tbt03516KB

- 3) Remove the clamp that fixes the HARNESS ASSY IF A4FIN (PL14.11.7) to the COVER REAR (PL14.3.3).
- 4) Remove the four screws (silver, flanged, 8mm) that fix the COVER REAR (PL14.3.3) to the FINISHER ASSY.
- 5) Remove the COVER REAR from the FINISHER ASSY.

Go to the next removal step:

Removal 11 PWBA MAIN A4FIN (PL14.4.12)

Removal 11 PWBA MAIN A4FIN (PL14.4.12)

NOTE

Use a wrist strap to protect the PWB from electrostatic damage.

In the following steps, the details of Steps 1 through 3 are omitted because they are described earlier in this chapter. Go to the steps in parentheses to execute the necessary steps, and then go to Step 4 onward.

- 1) Remove the TRAY STACKER. (Removal 1)
- 2) Remove the FINISHER ASSY. (Removal 2)
- 3) Remove the COVER REAR. (Removal 10)

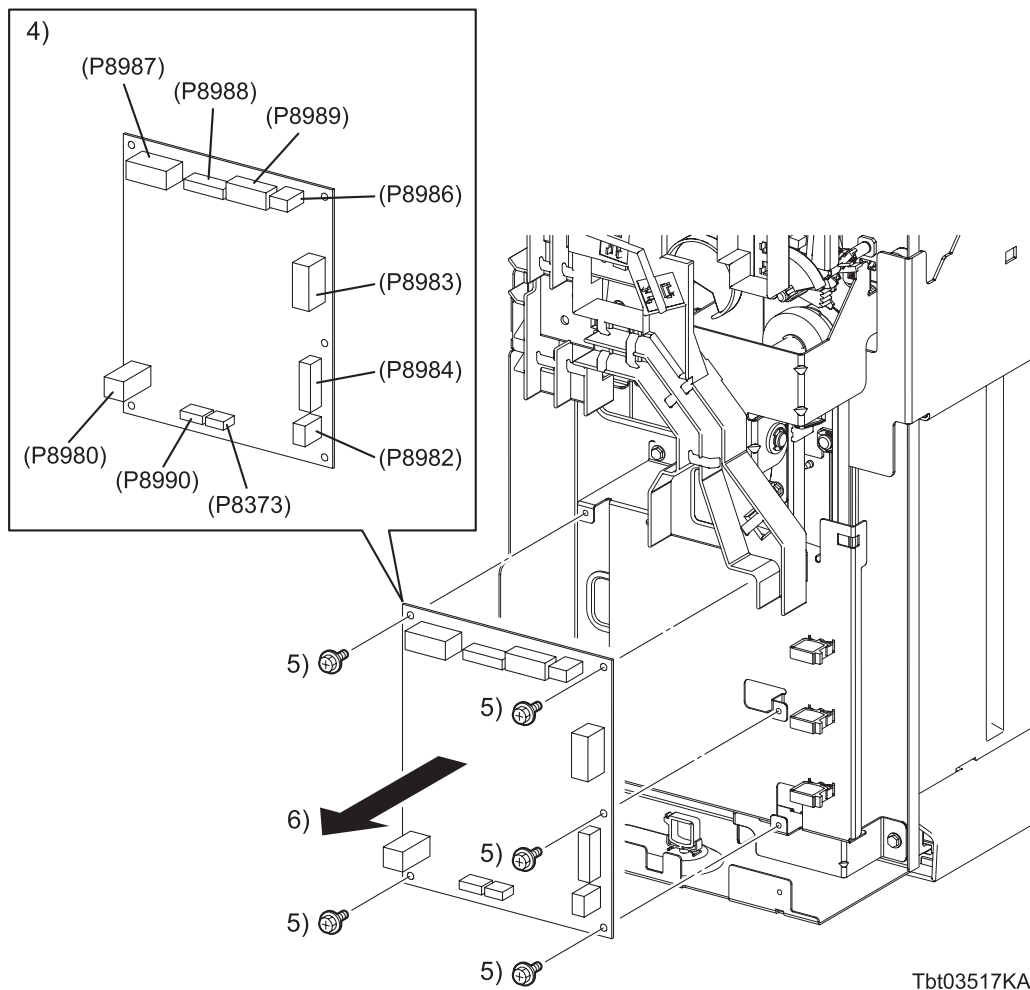

- 4) Disengage all the connectors of the PWBA MAIN A4FIN (PL14.4.12).
- 5) Remove the five screws (silver, flanged, 6mm) that fix the PWBA MAIN A4FIN to the FINISHER ASSY.
- 6) Remove the PWBA MAIN A4FIN from the FINISHER ASSY.

Removal 12 HOLDER CARTRIDGE (PL14.8.21)

- 1) Open the COVER ASSY FRONT DOOR (PL14.3.6).

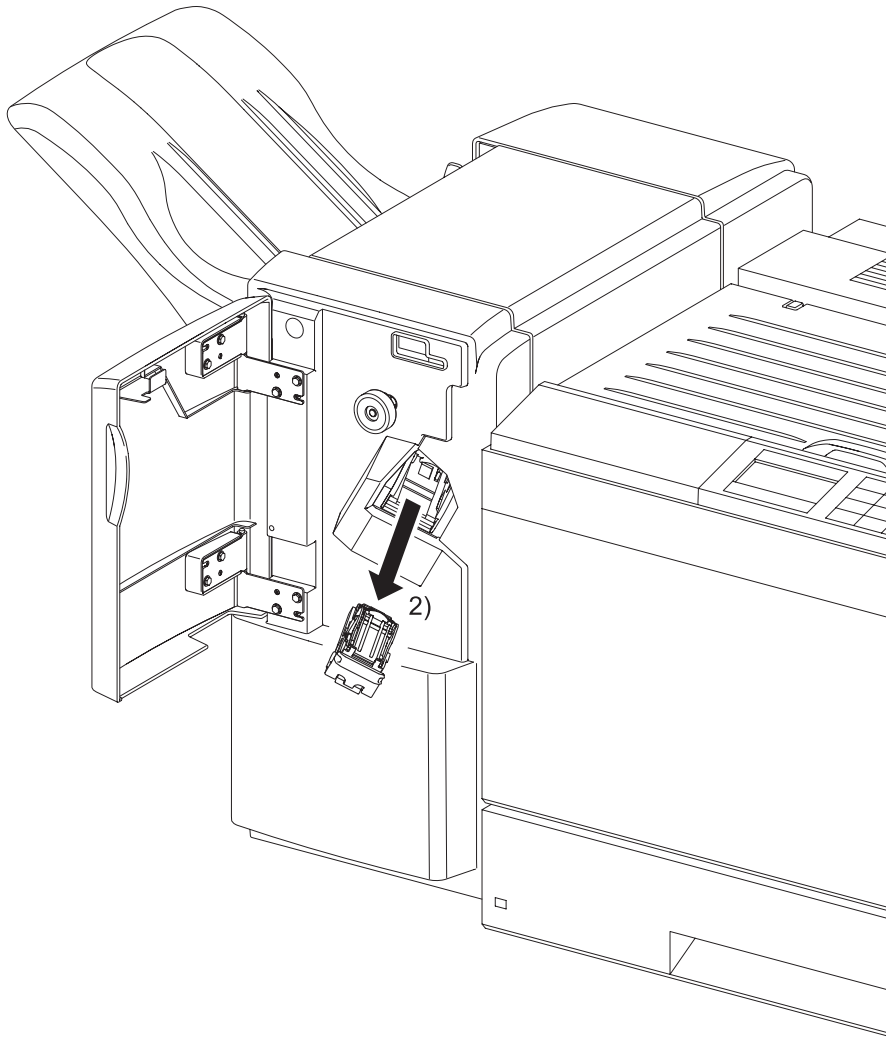

Tbt03518KA

- 2) Pull out the HOLDER CARTRIDGE (PL14.8.21) from the FINISHER ASSY.

Removal 13 COVER ASSY FRONT DOOR (PL14.3.6)

- 1) Open the COVER ASSY FRONT DOOR (PL14.3.6).

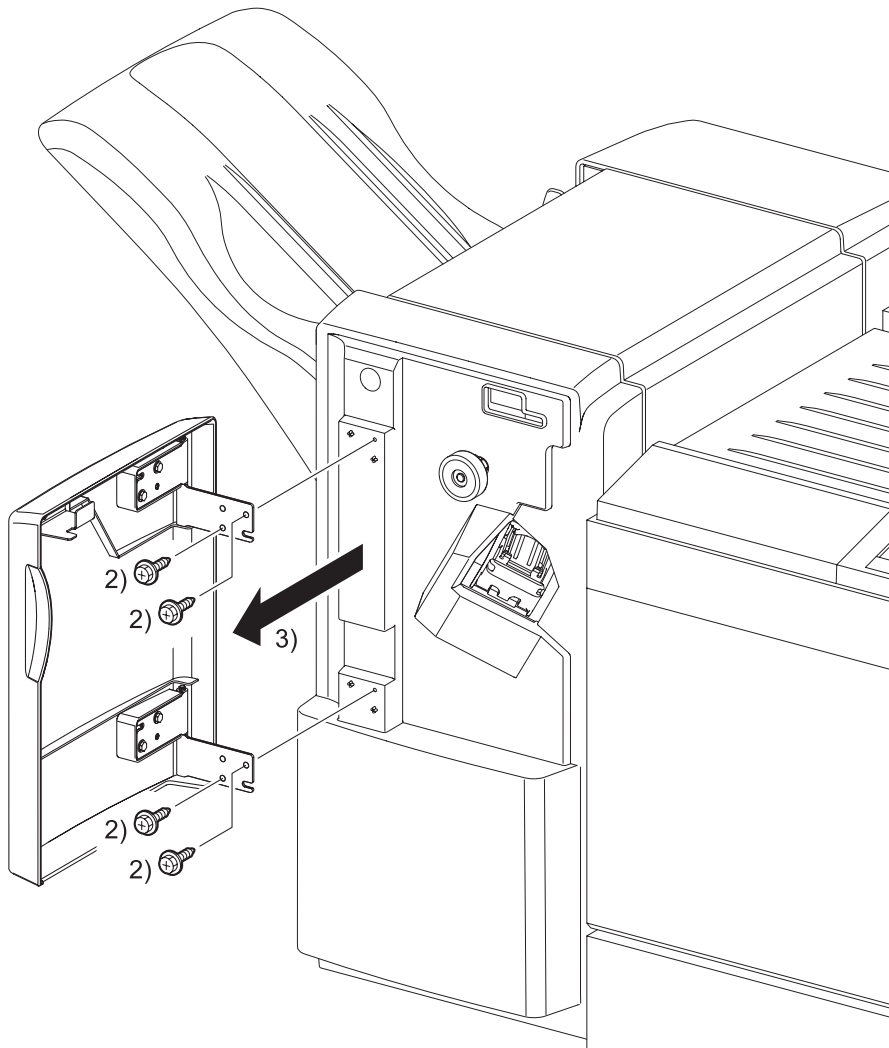

Tbt03538KA

- 2) Remove the four screws (silver, flanged, tapping, 8mm) that fix the COVER ASSY FRONT DOOR to the FINISHER ASSY.
- 3) Remove the COVER ASSY FRONT DOOR from the FINISHER ASSY.

4. Replacement Steps

Replacement 1 PWBA MAIN A4FIN (PL14.4.12)

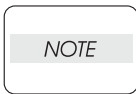

Use a wrist strap to protect the PWB from electrostatic damage.

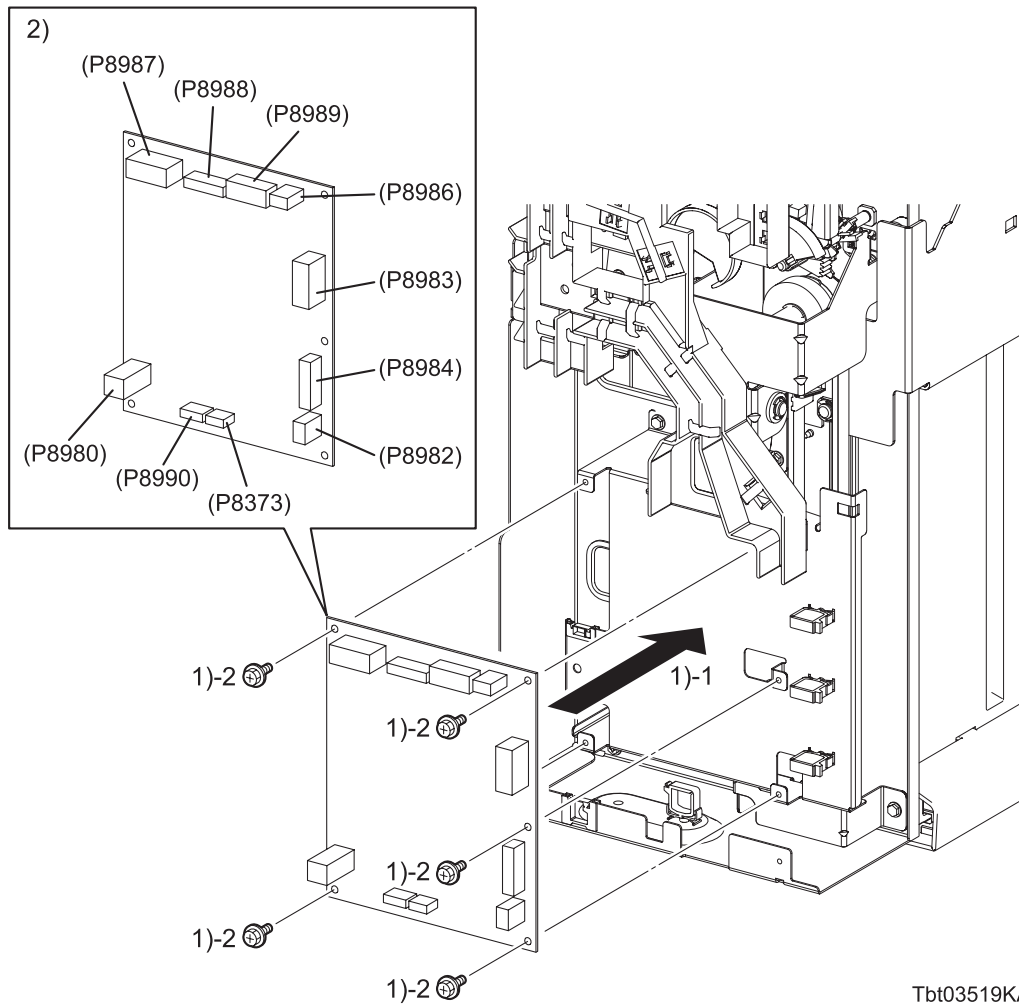

Tbt03519KA

- 1) Replace the PWBA MAIN A4FIN to the FINISHER ASSY, and then secure with the five screws (silver, flanged, 6mm).
- 2) Engage all the connectors of the PWBA MAIN A4FIN.

Go to the next replacement step:

Replacement 2 COVER REAR (PL14.3.3)

Replacement 2 COVER REAR (PL14.3.3)

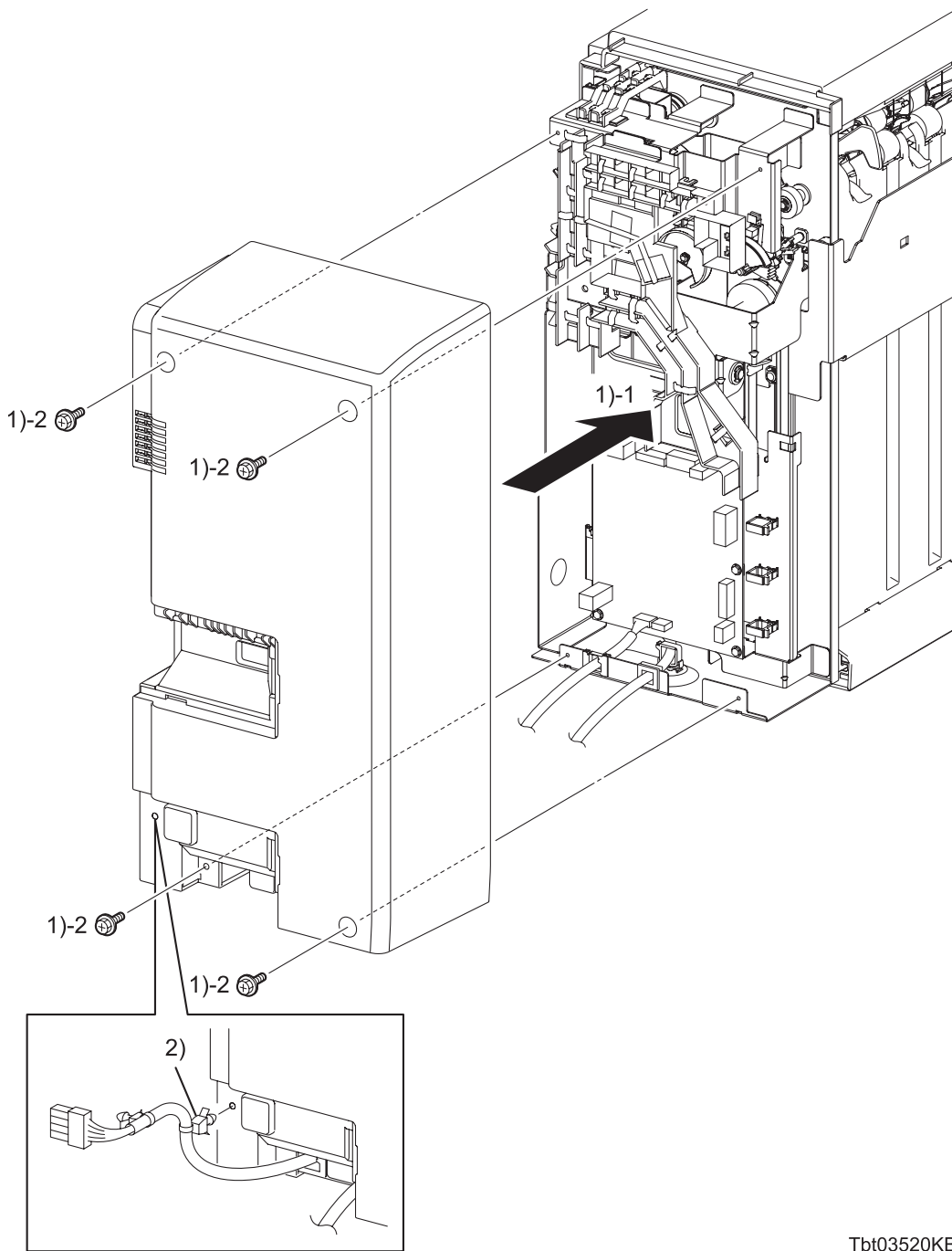

Tbt03520KB

- 1) Replace the COVER REAR to the FINISHER ASSY, and then secure with the four screws (silver, flanged, 8mm).
- 2) Secure the HARNESS ASSY IF A4FIN to the COVER REAR with the clamp.

Go to the next replacement step:

Replacement 10 KIT FINISHER ASSY (PL14.1.99)

Replacement 3 LVPS ASSY (PL14.10.10)

NOTE

Use a wrist strap to protect the PWB from electrostatic damage.

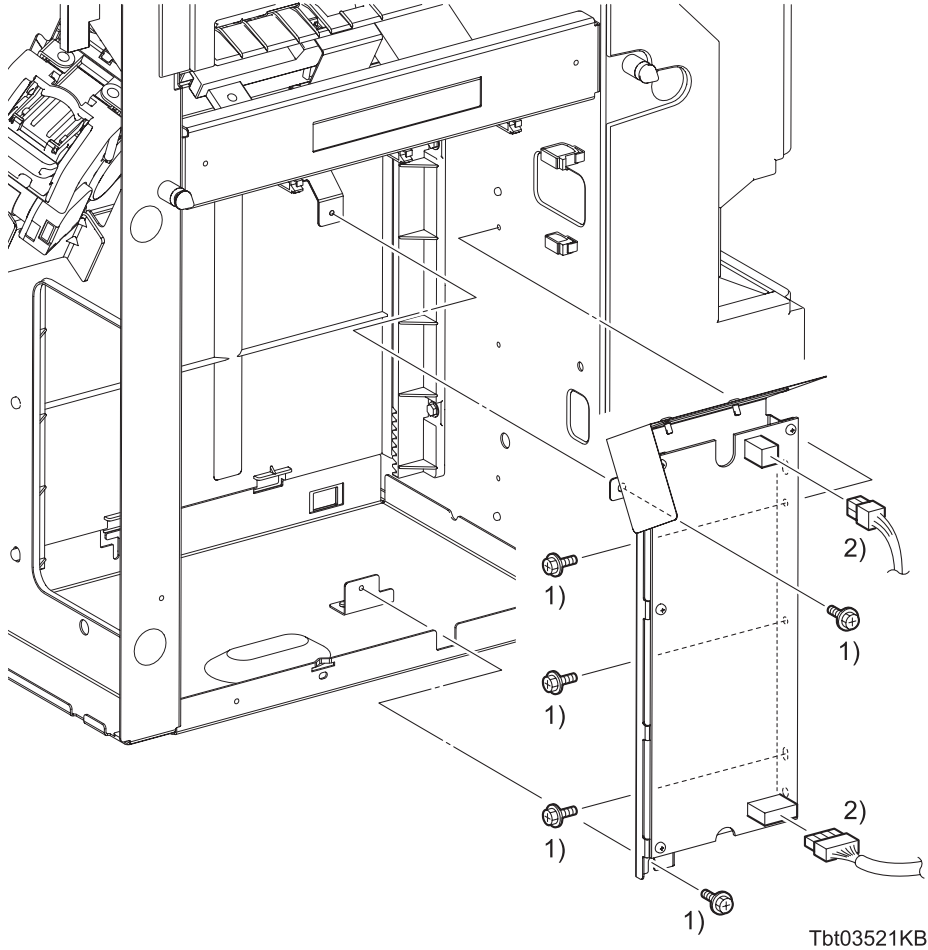

- 1) Replace the LVPS ASSY to the FINISHER ASSY, and then secure with the five screws (silver, flanged, 6mm).
- 2) Engage the two sets of connectors (P/J590, 591) of the LVPS ASSY.

Continues to the next page.

Replacement 3 LVPS ASSY (PL14.10.10)

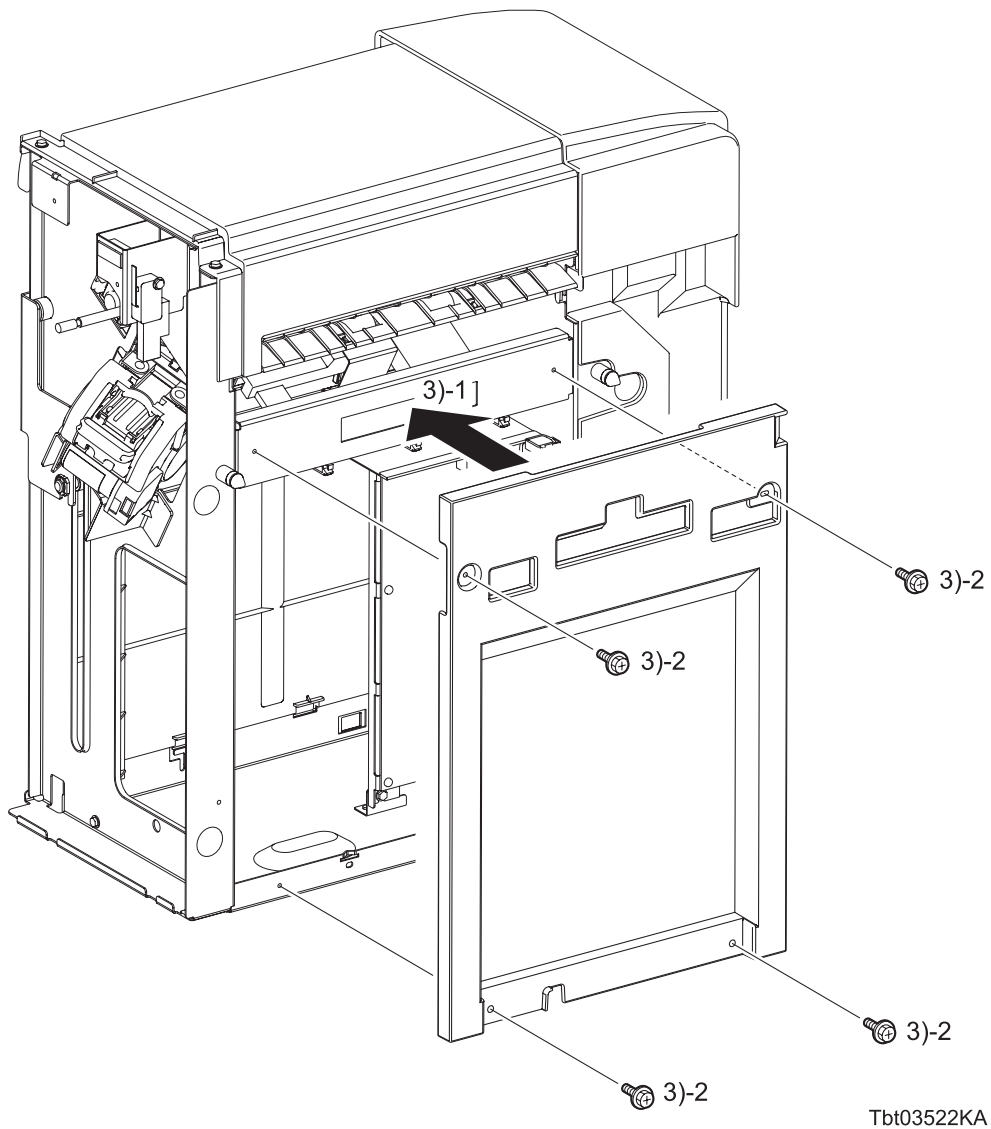

- 3) Replace the COVER RH to the FINISHER ASSY, and then secure with the four screws (silver, flanged, 8mm).

**Go to the next replacement step:
Replacement 7 COVER ASSY FRONT (PL14.3.5)**

Replacement 4 BRACKET ASSY INTERLOCK (PL14.10.1)

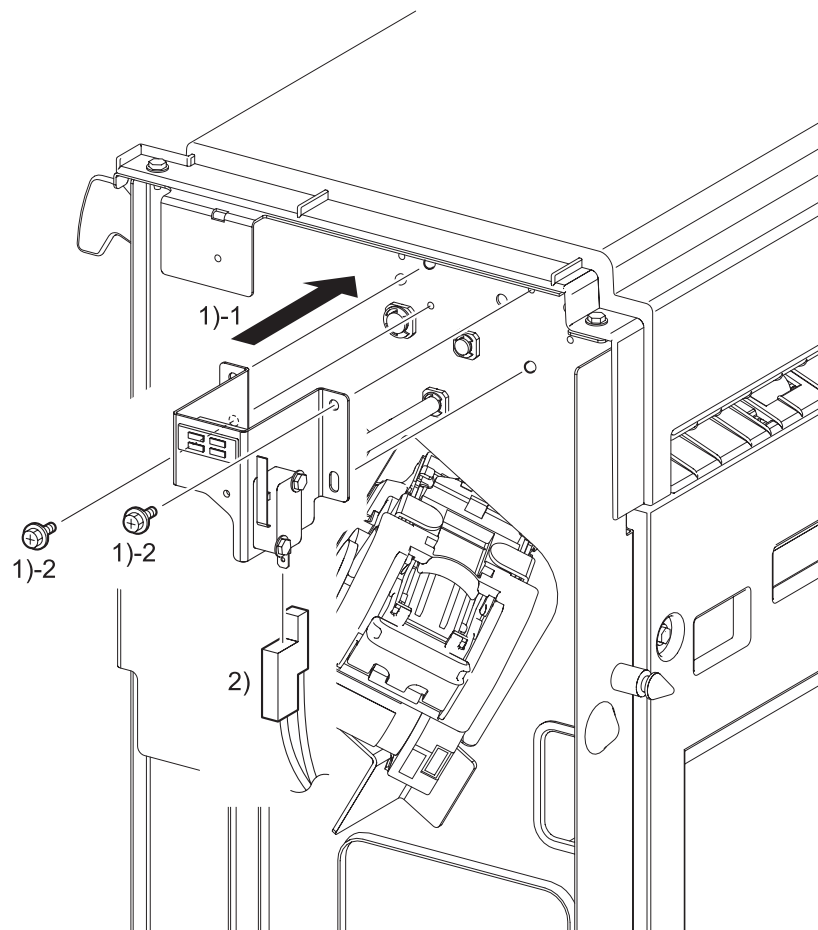

Tbt03523KA

- 1) Mate the two holes of the BRACKET ASSY INTERLOCK with the bosses of the FINISHER ASSY, and then secure with the two screws (silver, flanged, 6mm).
- 2) Engage the connectors (P/J8889) of the SWITCH.

Go to the next replacement step:

Replacement 7 COVER ASSY FRONT (PL14.3.5)

Replacement 5 HOLDER ASSY STAPLER A4 (PL14.8.19)

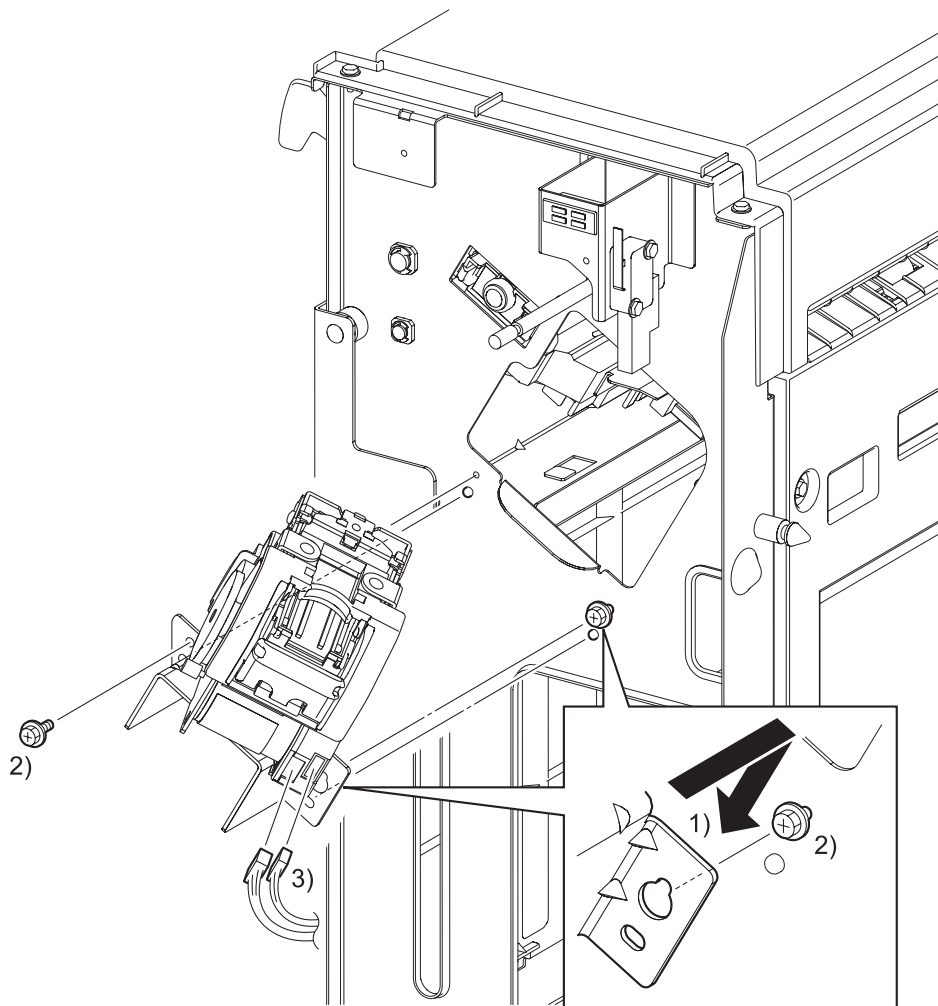

Tbt03524KB

NOTE

When performing the following steps, use caution not to drop the HOLDER ASSY STAPLER A4.

- 1) Fit the notch of the HOLDER ASSY STAPLER A4 with the loosened screws, and then mate the two holes of the HOLDER ASSY STAPLER A4 with the bosses of the FINISHER ASSY.
- 2) Secure the HOLDER ASSY STAPLER A4 to the FINISHER ASSY with the two screws (silver, flanged, 6mm).
- 3) Engage the two sets of connectors (P/J8886, 8887) of the HOLDER ASSY STAPLER A4.

Go to the next replacement step:

Replacement 7 COVER ASSY FRONT (PL14.3.5)

Replacement 6 COVER FRONT (PL14.3.7)

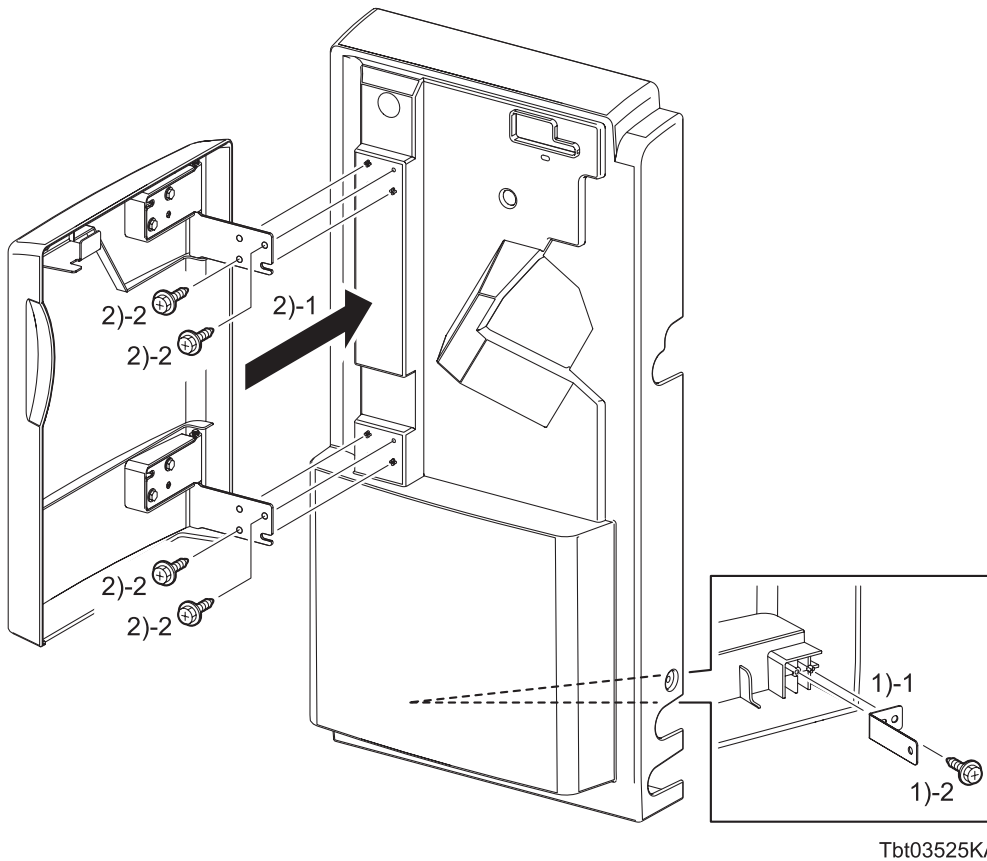

- 1) Mate the hole of the BRACKET COVER FRONT with the boss of the COVER FRONT, and then secure with the one screw (silver, flanged, tapping, 8mm).
- 2) Mate the four holes of the COVER ASSY FRONT DOOR with the bosses of the COVER FRONT, and then secure with the four screws (silver, flanged, tapping, 8mm).

Go to the next replacement step:

Replacement 7 COVER ASSY FRONT (PL14.3.5)

Blank Page

Replacement 7 COVER ASSY FRONT (PL14.3.5)

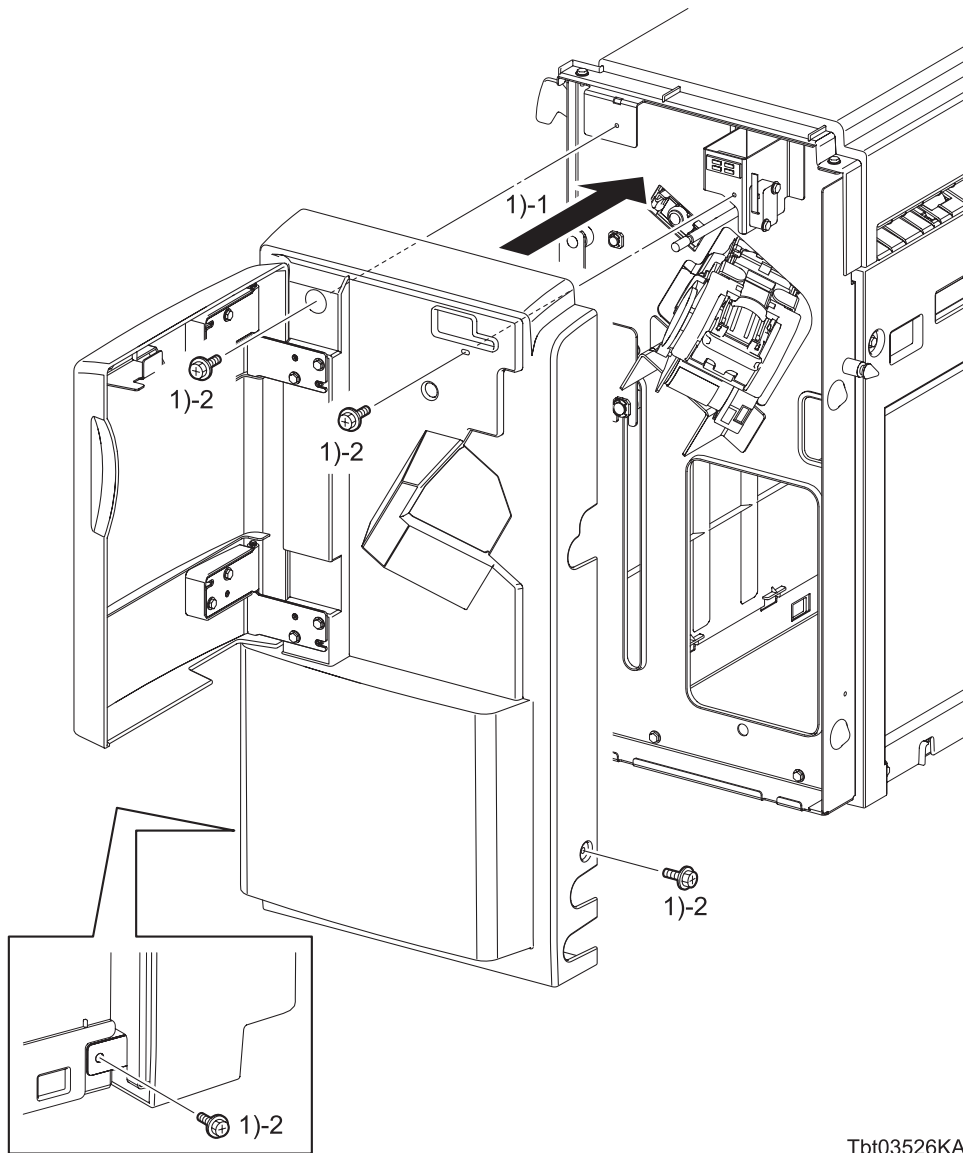

Tbt03526KA

- 1) Replace the COVER ASSY FRONT to the FINISHER ASSY, and then secure with the four screws (silver, flanged, 8mm).

Continues to the next page.

Replacement 7 COVER ASSY FRONT (PL14.3.5)

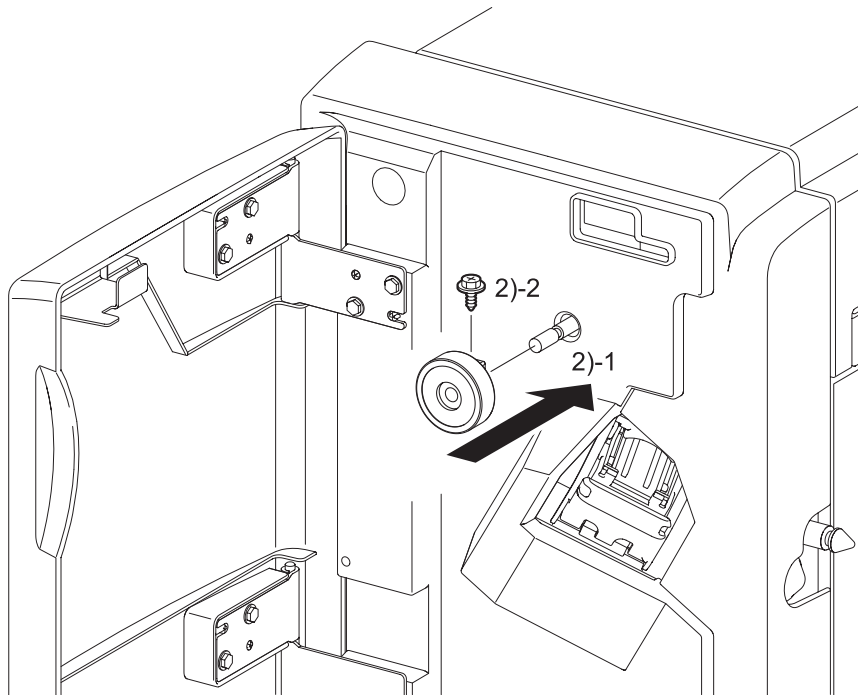

Tbt03527KA

- 2) Replace the KNOB ASSY EXIT to the ROLL ASSY DRIVE EXIT, and then secure with the one screw (sliver, flanged, tapping, 6mm).
- 3) Close the COVER ASSY FRONT DOOR.

Continues to the next page.

Replacement 7 COVER ASSY FRONT (PL14.3.5)

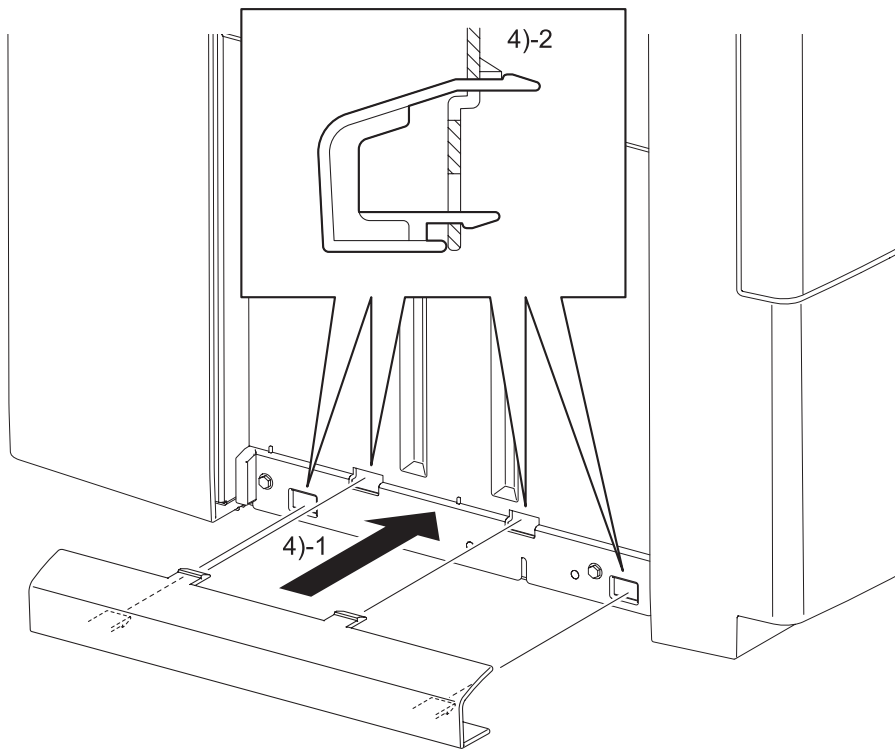

Tbt03528KB

- 4) Replace the COVER GUIDE TRAY to the FINISHER ASSY, and then secure with the two hooks.

Go to the next replacement step:

Replacement 10 KIT FINISHER ASSY (PL14.1.99)

Replacement 8 KIT CHUTE ASSY LOWER H-TRA (PL14.2.98), KIT COVER ASSY TOP H-TRA (PL14.2.99)

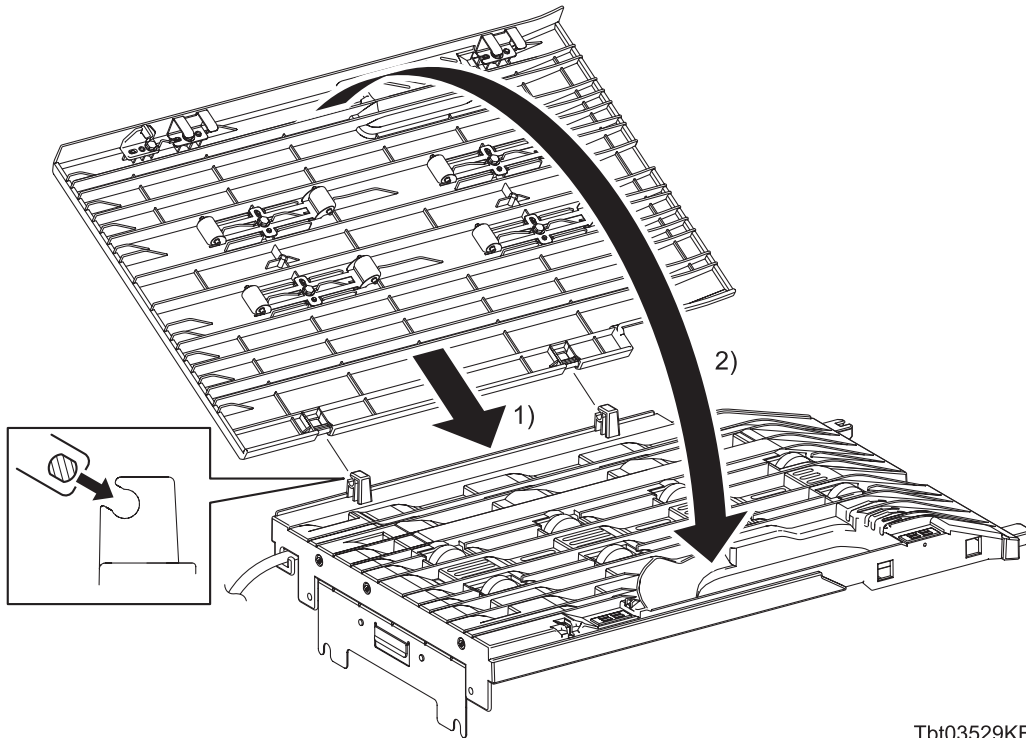

Tbt03529KB

- 1) Mate the pivots of the COVER ASSY TOP H-TRA into the U-shaped notches on the CHUTE ASSY LOWER H-TRA so that the flat surfaces of the pivots become parallel with the notches.
- 2) Swing down the COVER ASSY TOP H-TRA.

Go to the next replacement step:

Replacement 9 TRANSPORT ASSY A4 (PL14.2.1)

Replacement 9 TRANSPORT ASSY A4 (PL14.2.1)

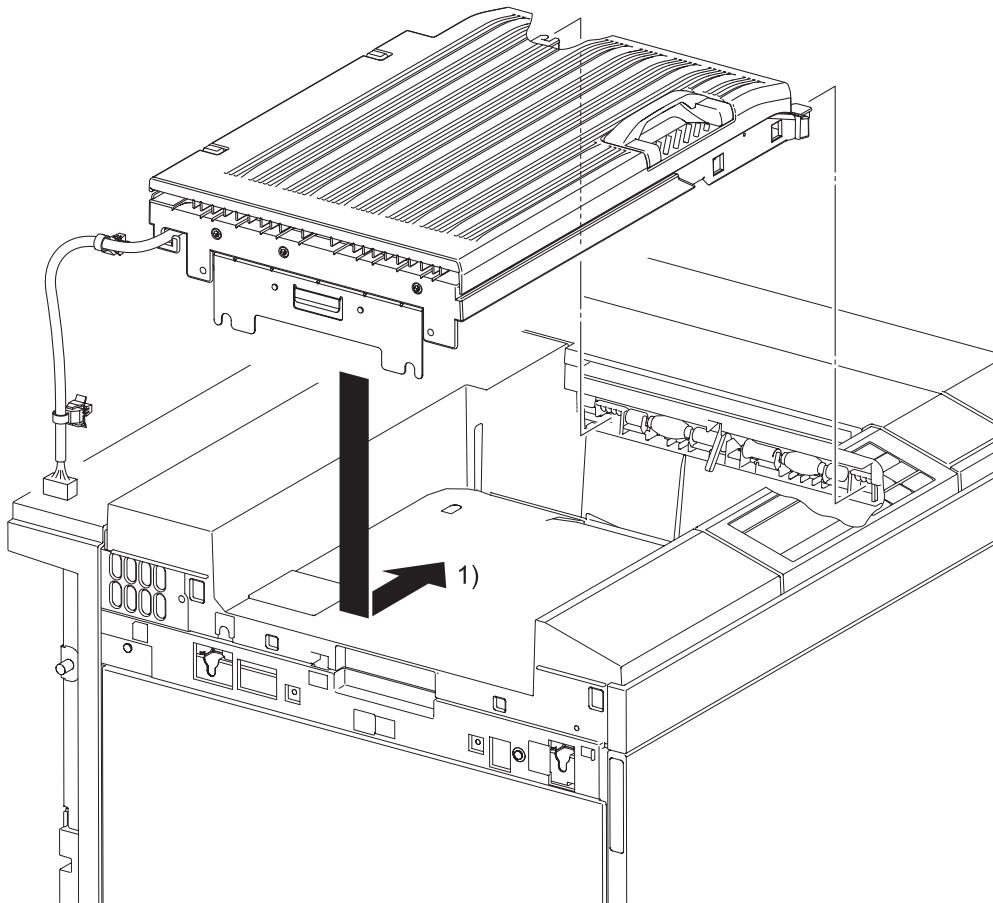

Tbt03530KB

- 1) Mate the two tabs on the TRANSPORT ASSY A4 with the holes on the printer.

Continues to the next page.

Replacement 9 TRANSPORT ASSY A4 (PL14.2.1)

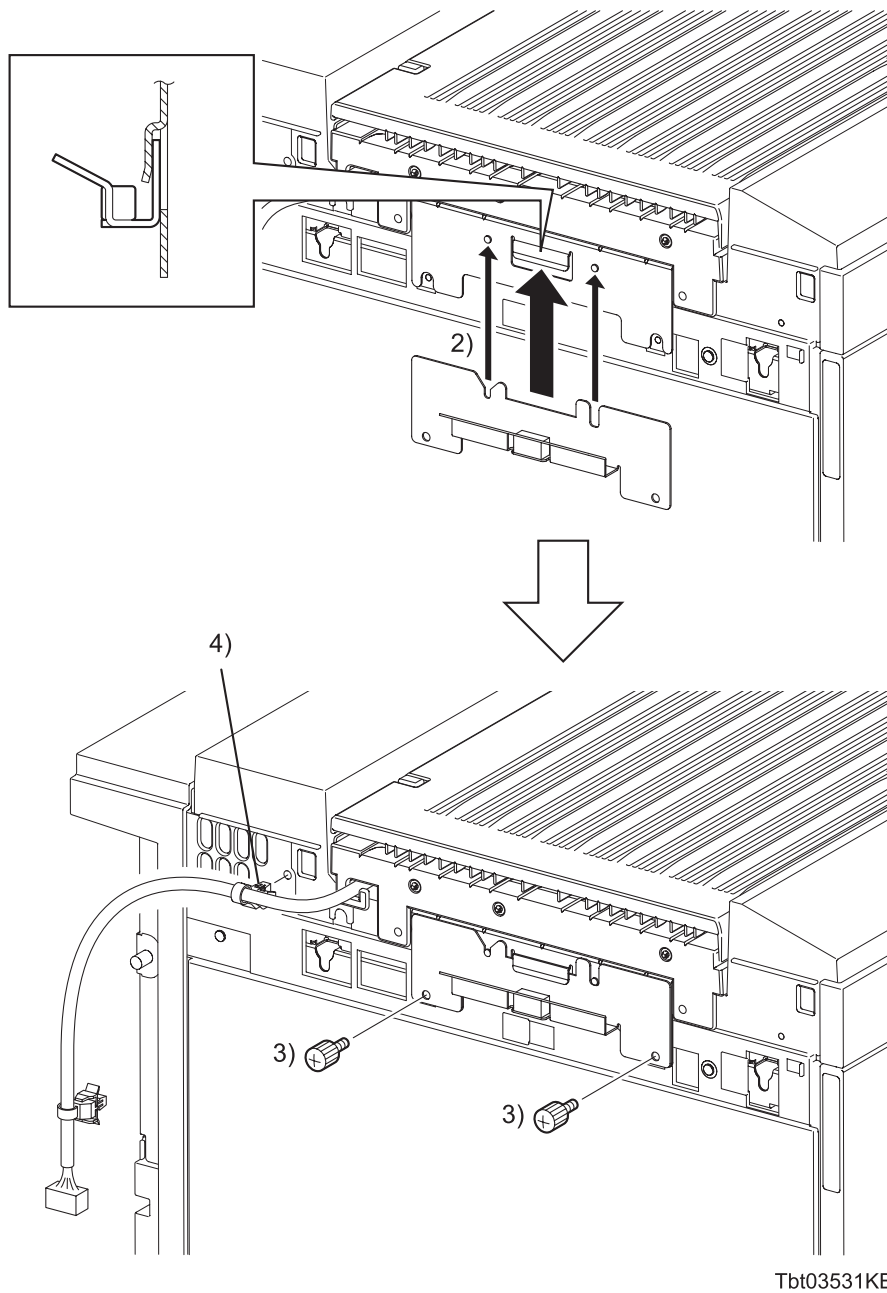

Tbt03531KB

- 2) Align the two notches on the BRACKET ASSY GUIDE ADD with the bosses on the TRANSPORT ASSY A4 and let the hooks of the TRANSPORT ASSY A4 catch the BRACKET ASSY GUIDE ADD.
- 3) Secure the TRANSPORT ASSY A4 with the two SCREW M4 STEELS while holding the BRACKET ASSY GUIDE ADD.
- 4) Secure the harness of the TRANSPORT ASSY A4 to the printer with the clamp.

Go to the next replacement step:

Replacement 10 KIT FINISHER ASSY (PL14.1.99)

Replacement 10 KIT FINISHER ASSY (PL14.1.99)

NOTE

When performing the following step, ensure that the two studs on the FINISHER ASSY are mated with the holes on the printer.

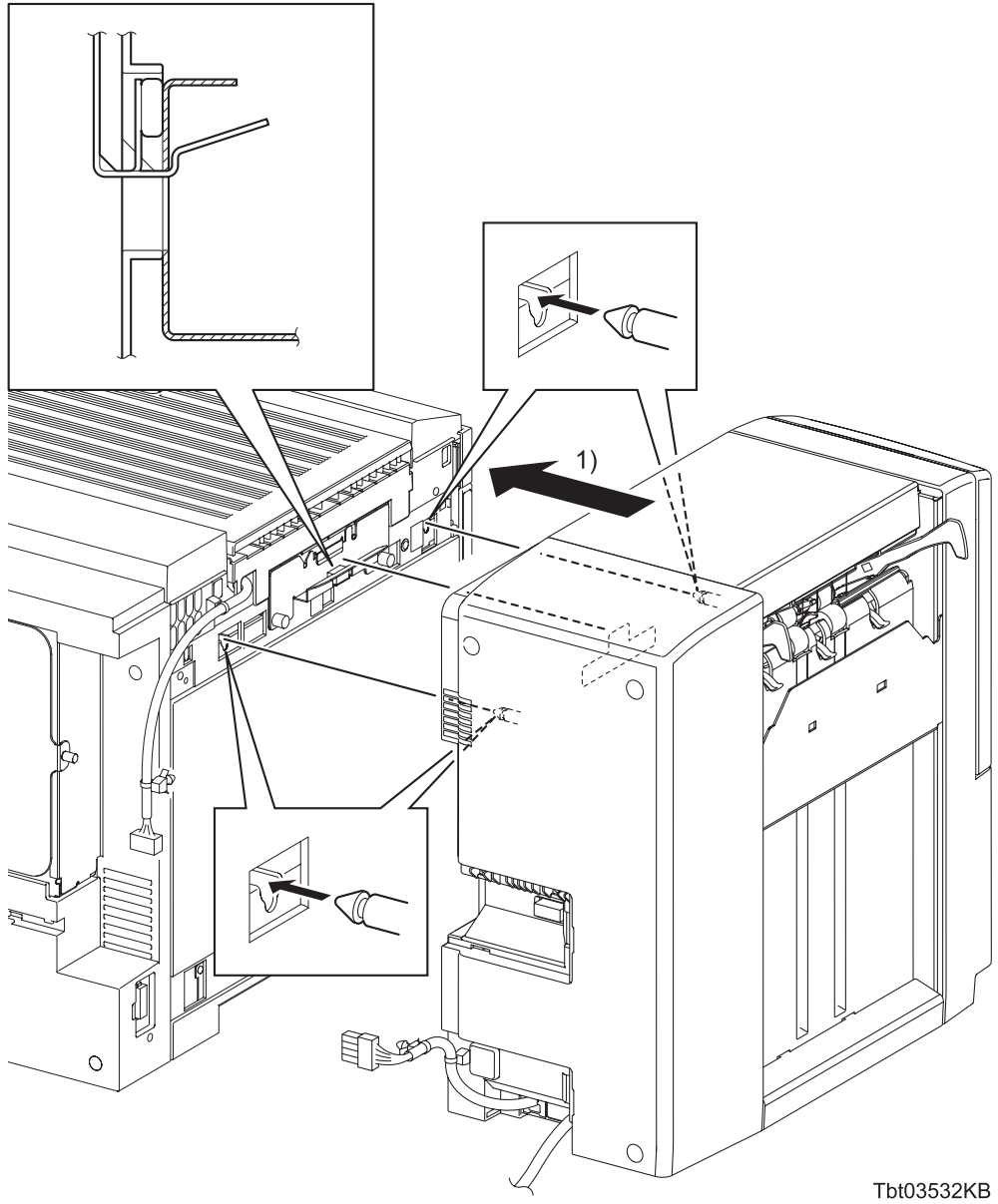

- 1) Replace the FINISHER ASSY to the printer by lifting it slightly with one hand on the bottom of the COVER ASSY FRONT and the other hand on the handle on the COVER REAR so that the right-hand notch on the FINISHER ASSY fits onto the BRACKET GUIDE on the TRANSPORT ASSY A4.

Continues to the next page.

Replacement 10 KIT FINISHER ASSY (PL14.1.99)

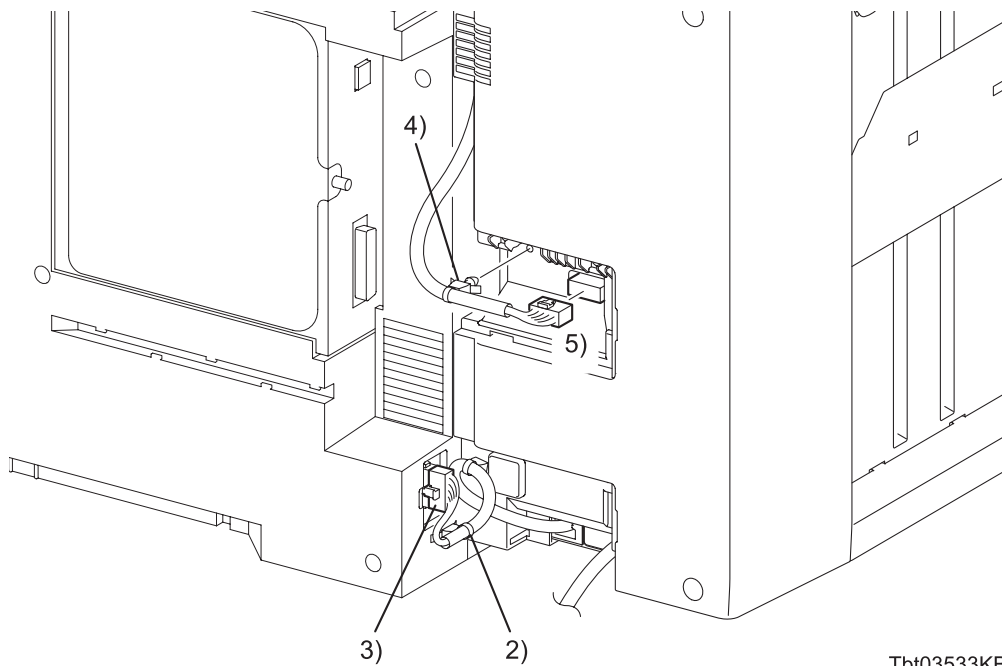

- 2) Secure the HARNESS ASSY IF A4FIN to the printer with the clamp.
- 3) Engage the connectors (P121/CN4) of the HARNESS ASSY IF A4FIN to the printer.
- 4) Secure the harness of the TRANSPORT ASSY A4 to the FINISHER ASSY with the clamp.
- 5) Engage the connectors (P/J8987) of the TRANSPORT ASSY A4 to the FINISHER ASSY.

Continues to the next page.

Replacement 10 KIT FINISHER ASSY (PL14.1.99)

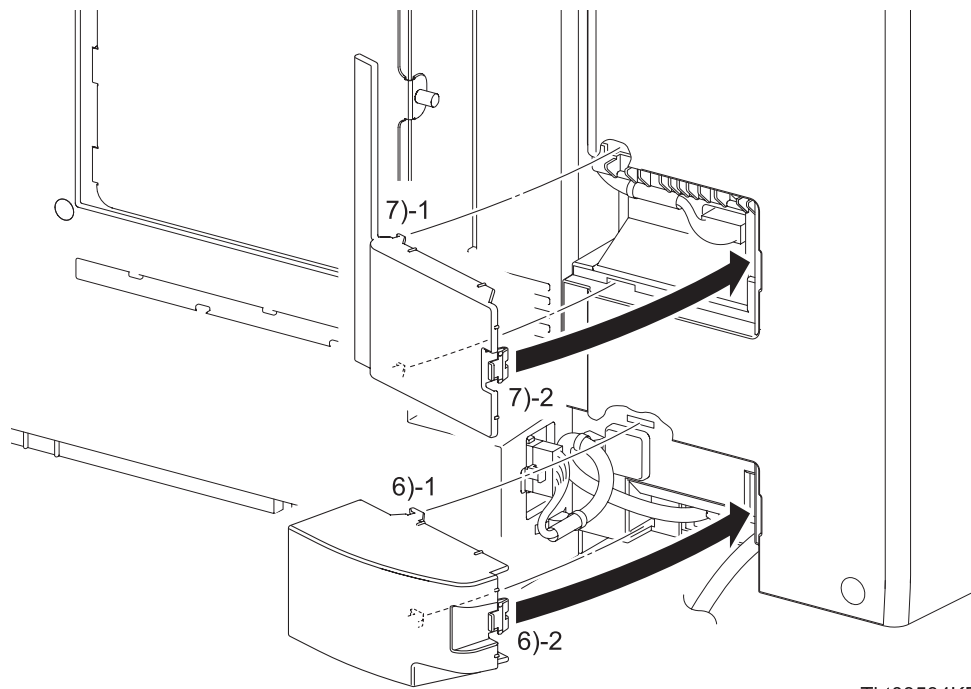

Tbt03534KB

- 6) Insert the two tabs on the COVER CONNECTOR2 into the COVER REAR, and then secure with the hook.
- 7) Insert the two tabs on the COVER CONNECTOR into the COVER REAR, and then secure with the hook.

Continues to the next page.

Replacement 10 KIT FINISHER ASSY (PL14.1.99)

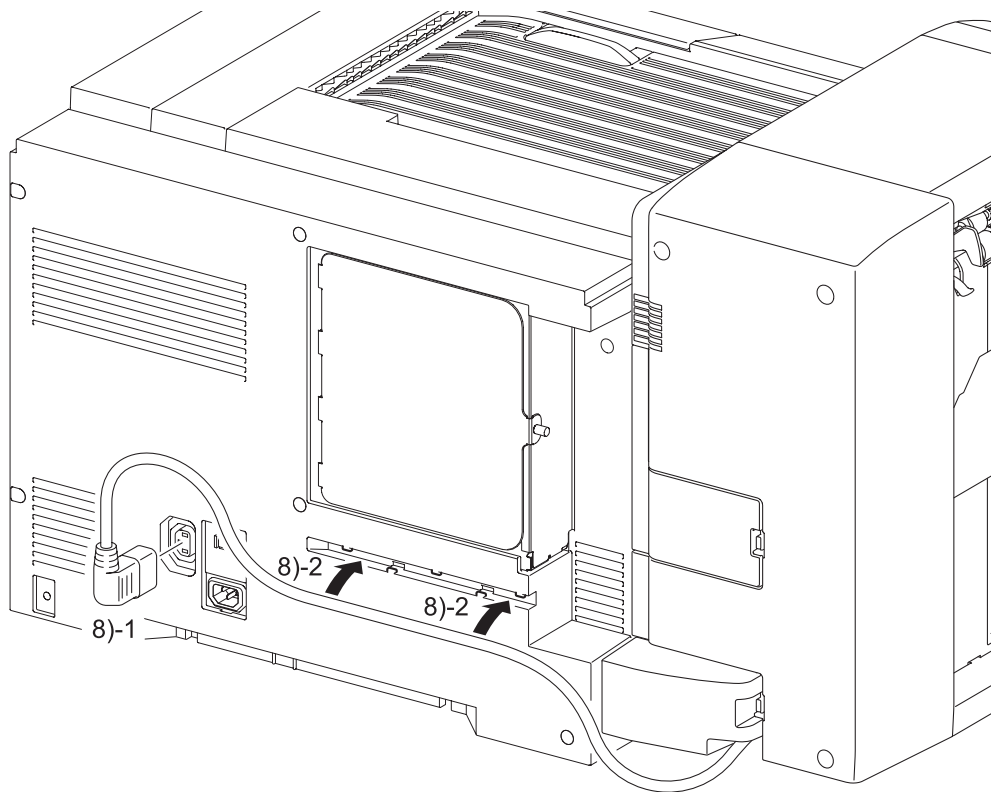

Tbt03539KA

- 8) Engage the AC OUTLET of the CABLE ASSY POWER A4FIN to the printer, and then route the CABLE ASSY POWER A4FIN along the harness guide of the printer.

Go to the next replacement step:

Replacement 11 KIT TRAY STACKER (PL14.1.98)

Replacement 11 KIT TRAY STACKER (PL14.1.98)

NOTE

When performing the following step, use caution not to damage the GUIDE TAMPERS.

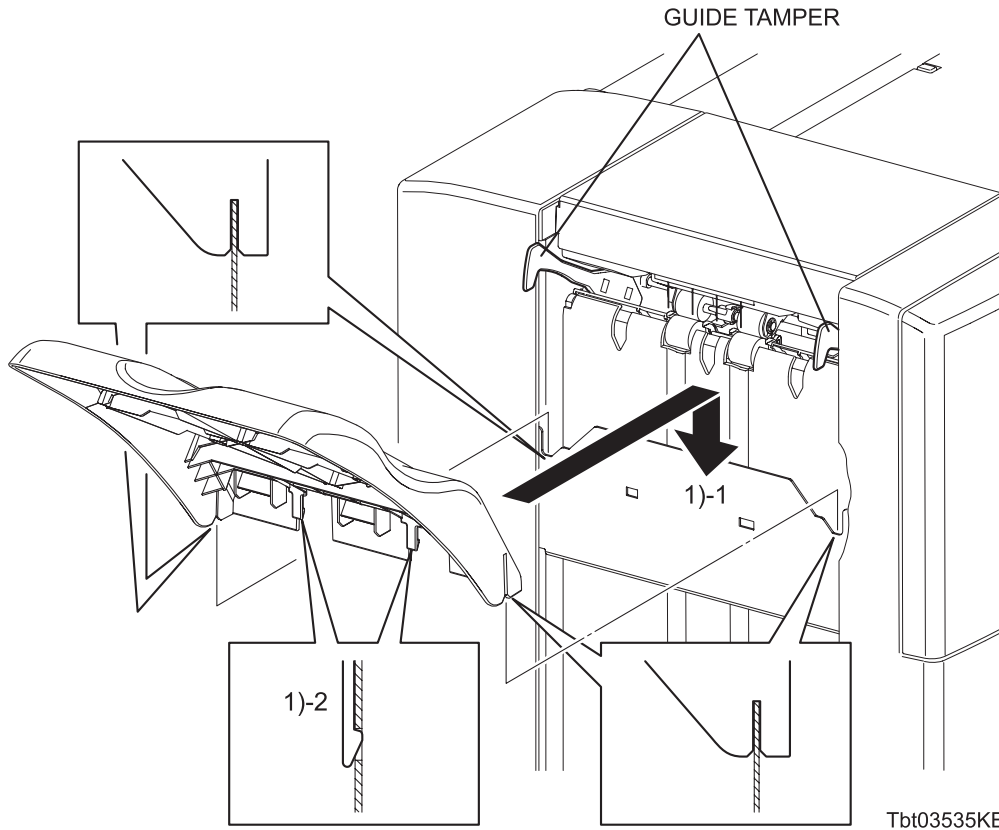

Tbt03535KB

- 1) Replace the TRAY STACKER to the CARRIAGE ASSY (PL14.9.16) on the FINISHER ASSY, and then secure with the two hooks.

Replacement 12 HOLDER CARTRIDGE (PL14.8.21)

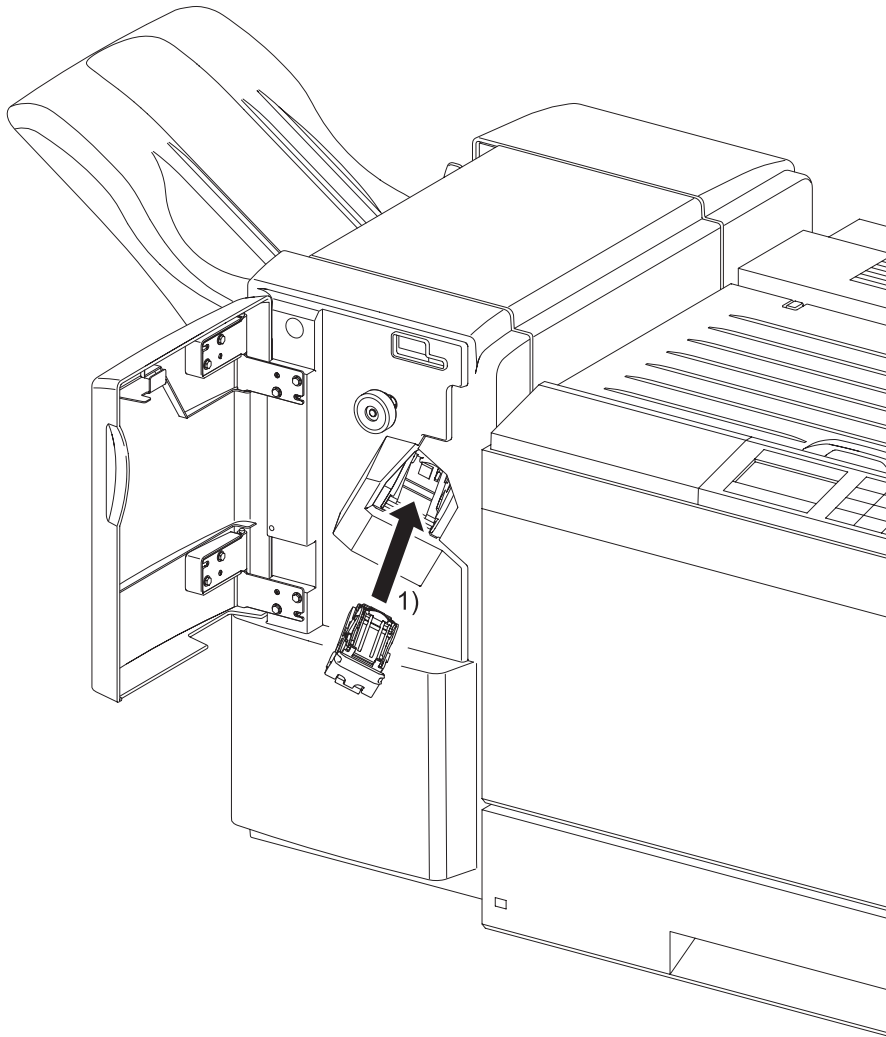

Tbt03536KA

- 1) Insert the HOLDER CARTRIDGE into the FINISHER ASSY.
- 2) Close the COVER ASSY FRONT DOOR.

Replacement 13 COVER ASSY FRONT DOOR (PL14.3.6)

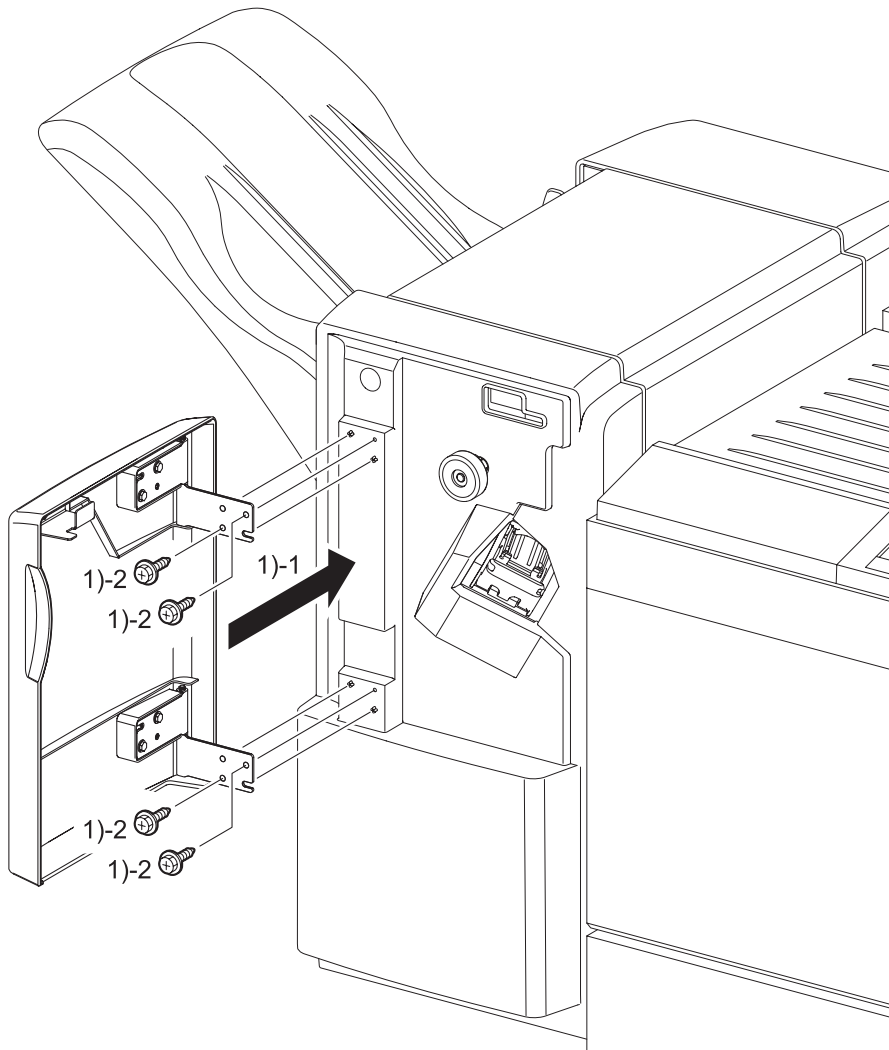

Tbt03540KA

- 1) Mate the four holes of the COVER ASSY FRONT DOOR with the bosses of the COVER FRONT, and then secure with the four screws (silver, flanged, tapping, 8mm).
- 2) Close the COVER ASSY FRONT DOOR.

Chapter 4 Plug/Jack(P/J) Connector Locations CONTENTS

- 1. Connector [P (plug) / J (jack)].....4 - 1
 - 1.1 List of P/J 4 - 1
 - 1.2 FINISHER P/J layout diagram 4 - 2

1. Connector [P (plug) / J (jack)]

1.1 List of P/J

Finisher

P/J	Coordinates	Remarks
590	G-126	Connects LVPS ASSY and CABLE ASSY POWER A4FIN
591	G-123	Connects LVPS ASSY and HARNESS ASSY LVPS A4FIN
8373	I-144	Not Connect
8863	I-108	Connects MOTOR ASSY PM HTU and HARNESS ASSY HTU A4FIN
8864	B-108	Connects H-TRA Top Cover Open Sensor and HARNESS ASSY HTU A4FIN
8869	E-133	Connects Compile Exit Sensor and HARNESS ASSY SNR2 A4FIN
8870	D-135	Connects Eject Clamp Home Sensor and HARNESS ASSY SNR2 A4FIN
8871	D-135	Connects Set Clamp Home Sensor and HARNESS ASSY SNR2 A4FIN
8872	E-136	Connects Stacker No Paper Sensor and HARNESS ASSY SNR2 A4FIN
8873	E-135	Connects Stack Height Sensor1 and HARNESS ASSY SNR2 A4FIN
8874	E-135	Connects Stack Height Sensor2 and HARNESS ASSY SNR2 A4FIN
8876	D-133	Connects Sub Paddle Solenoid and HARNESS ASSY MOT2 A4FIN
8877	C-134	Connects Set Clamp Clutch and HARNESS ASSY MOT2 A4FIN
8878	D-136	Connects Eject Motor and HARNESS ASSY MOT2 A4FIN
8879	C-135	Connects Transport Motor and HARNESS ASSY MOT2 A4FIN
8880	E-122	Connects Compile Tray No Paper Sensor and HARNESS ASSY SNR1 A4FIN
8881	D-122	Connects Front Tamper Home Sensor and HARNESS ASSY SNR1 A4FIN
8882	G-121	Connects Rear Tamper Home Sensor and HARNESS ASSY SNR1 A4FIN
8883	F-122	Connects Rear Tamper Motor and HARNESS ASSY MOT1 A4FIN
8884	G-122	Connects Front Tamper Motor and HARNESS ASSY MOT1 A4FIN
8885	E-137	Connects Stacker Motor and HARNESS ASSY MOT3 A4FIN
8886	E-124	Connects STAPLER ASSY and HARNESS ASSY SNR1 A4FIN
8887	D-124	Connects STAPLER ASSY and HARNESS ASSY MOT1 A4FIN
8889	G-132	Connects Finisher Front Door Switch and HARNESS ASSY INTL SW A4FIN
8980	H-143	Connects PWBA MAIN A4FIN and HARNESS ASSY LVPS A4FIN
8982	J-144	Connects PWBA MAIN A4FIN and HARNESS ASSY INTL SW A4FIN
8983	J-143	Connects PWBA MAIN A4FIN and HARNESS ASSY MOT1 A4FIN
8984	J-143	Connects PWBA MAIN A4FIN and HARNESS ASSY MOT2 A4FIN
8986	I-142	Connects PWBA MAIN A4FIN and HARNESS ASSY MOT3 A4FIN
8987	H-142	Connects PWBA MAIN A4FIN and Horizontal Transport (HARNESS ASSY HTU A4FIN)
8988	I-142	Connects PWBA MAIN A4FIN and HARNESS ASSY SNR1 A4FIN
8989	I-142	Connects PWBA MAIN A4FIN and HARNESS ASSY SNR2 A4FIN
8990	H-144	Connects PWBA MAIN A4FIN and HARNESS ASSY IF A4FIN
AC OUTLET	A-141	Connects CABLE ASSY POWER A4FIN and Printer (HARNESS ASSY FIN PWR)
CN4	A-139	Connects HARNESS ASSY IF A4FIN and Printer (HARNESS ASSY FIN)

1.2 FINISHER P/J layout diagram

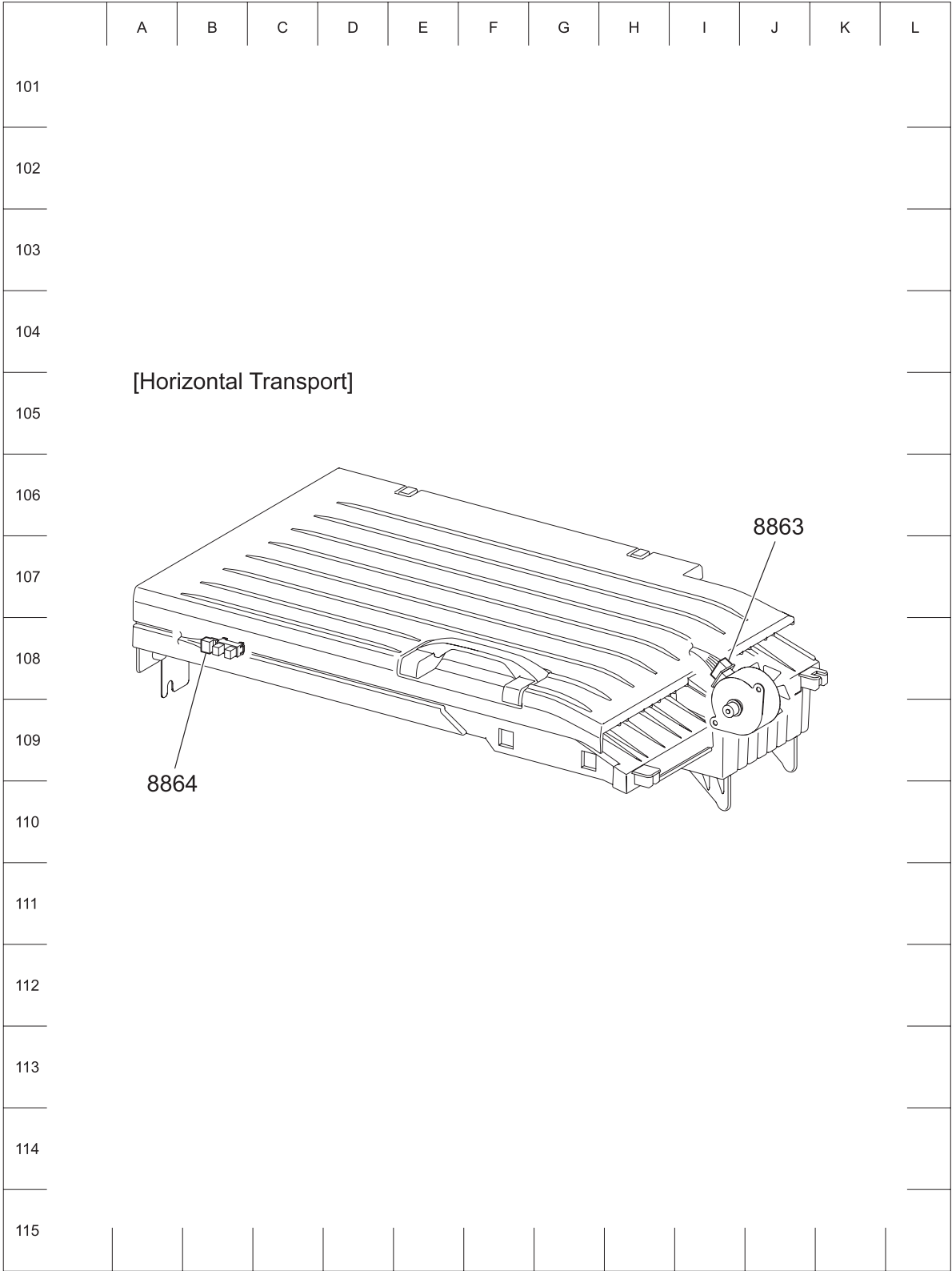

Tbt04100KA

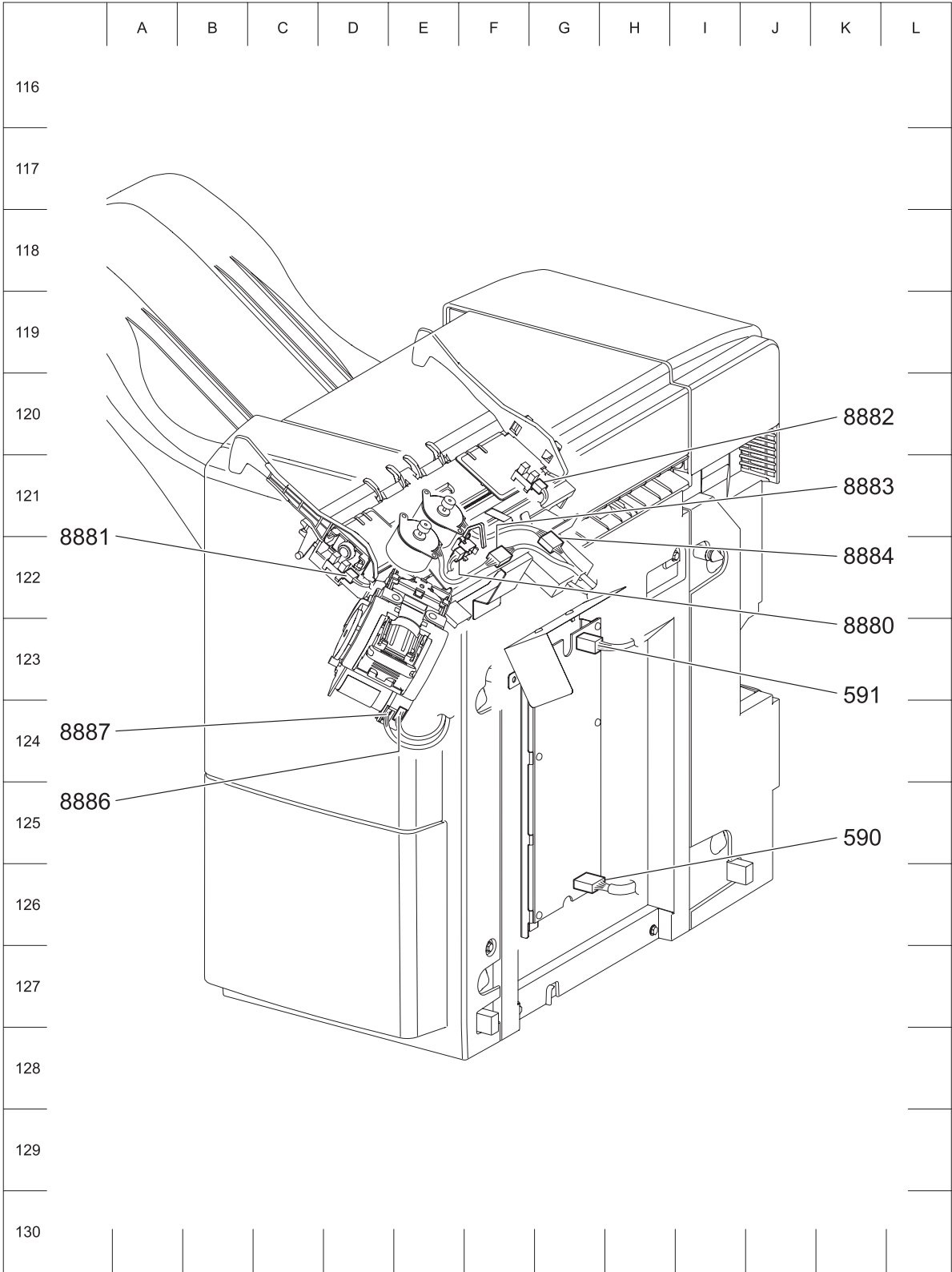

Tbt04101KB

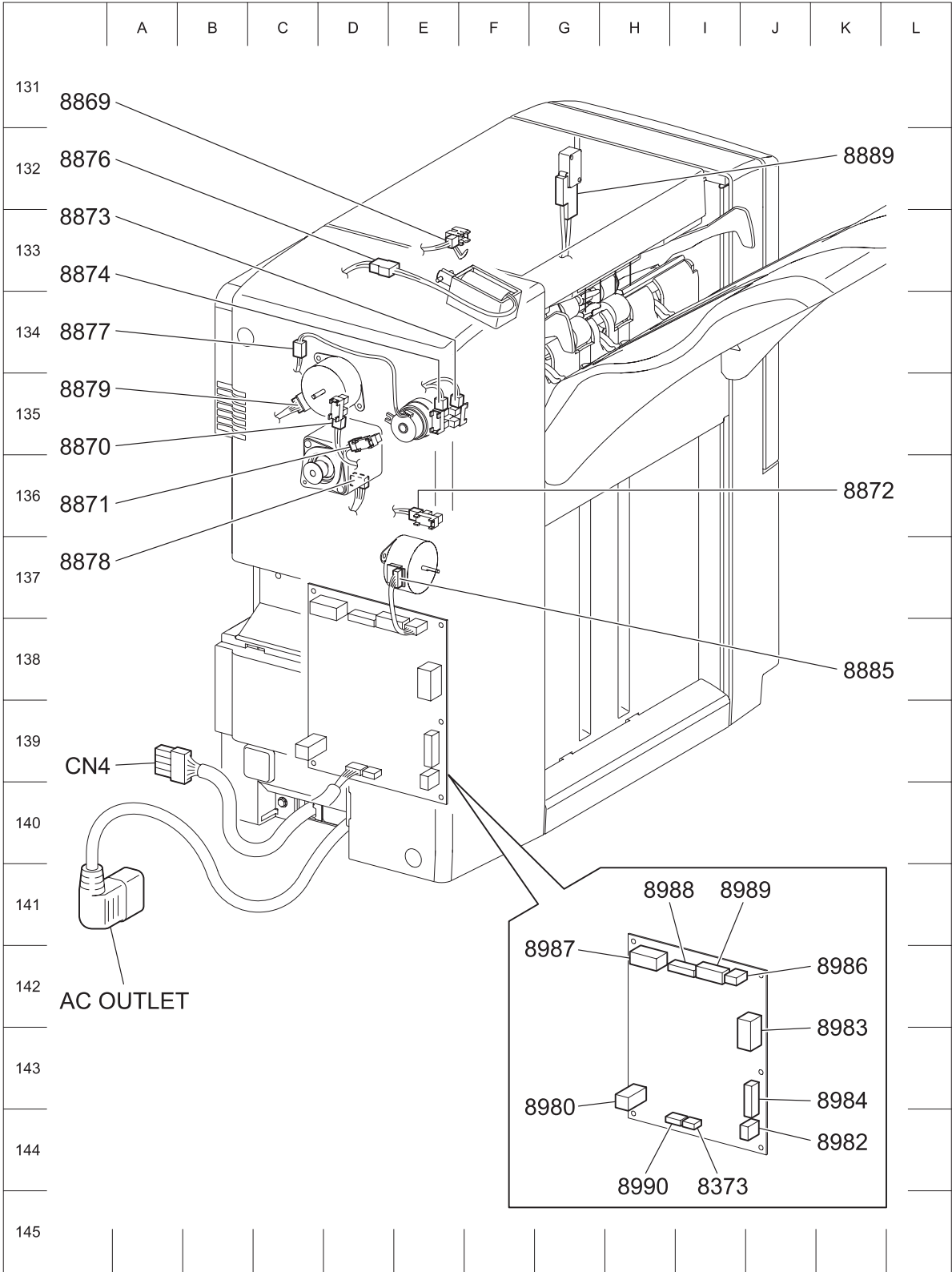

Tbt04102KB

Chapter 6 Principles of Operation CONTENTS

1. Overview.....	6 - 1
1.1 Configuration.....	6 - 1
2. Paper Feeding.....	6 - 2
2.1 Paper Path.....	6 - 2
2.2 Layout of Paper Path.....	6 - 3
2.3 Feeding in Horizontal Transport (H-TRA).....	6 - 4
2.4 Feeding in X' port.....	6 - 5
2.5 Feeding in Compile Tray.....	6 - 6
2.6 Ejection to Stacker Tray.....	6 - 7
3. Functions of Major Functional Components.....	6 - 8
3.1 H-TRA.....	6 - 8
3.1.1 Major Components and Their Functions.....	6 - 8
3.2 X' port.....	6 - 9
3.2.1 Major Components and Their Functions.....	6 - 9
3.3 Compile Tray.....	6 - 10
3.3.1 Major Components and Their Functions.....	6 - 10
3.3.2 Operations in Compile Tray.....	6 - 12
3.3.2.1 Tamping.....	6 - 12
3.3.2.2 Offset Stacking.....	6 - 13
3.3.2.3 Sheet/Envelope Select Lever.....	6 - 14
3.4 Stapler.....	6 - 16
3.4.1 Major Components and Their Functions.....	6 - 16
3.4.2 Stapling.....	6 - 21
3.4.2.1 Operation of Stapling.....	6 - 21
3.4.2.2 Stapling Position.....	6 - 22
3.5 Stacker Tray.....	6 - 23
3.5.1 Major Components and Their Functions.....	6 - 23
3.6 Electrical.....	6 - 28
3.6.1 Major Components and Their Functions.....	6 - 28
4. Torque Transmission Route.....	6 - 30
4.1 MOTOR ASSY PM HTU.....	6 - 30
4.2 DRIVE ASSY TRANS.....	6 - 32
4.3 MOTOR ASSY EJECT DRIVE.....	6 - 34
4.4 MOTOR ASSY EJECT DRIVE.....	6 - 36
4.5 MOTOR ASSY TAMPER.....	6 - 38
4.6 DRIVE ASSY STACKER.....	6 - 40

Chapter 6 Principles of Operation CONTENTS

1. Overview

The Finisher is a device that finishes the sheets ejected by the Printer with post-processing such as stapling, sorting, and stacking, and then deposits them in its Stacker Tray.

1.1 Configuration

The Finisher consists of the following blocks:

- Horizontal Transport (hereinafter, H-TRA)
Relays the sheets ejected from the Printer to the Finisher.
- Compile Tray
Aligns the sheets.
- Stapler
Staples the sheets in the specified position.
- Stacker Tray
Holds the sheets ejected.

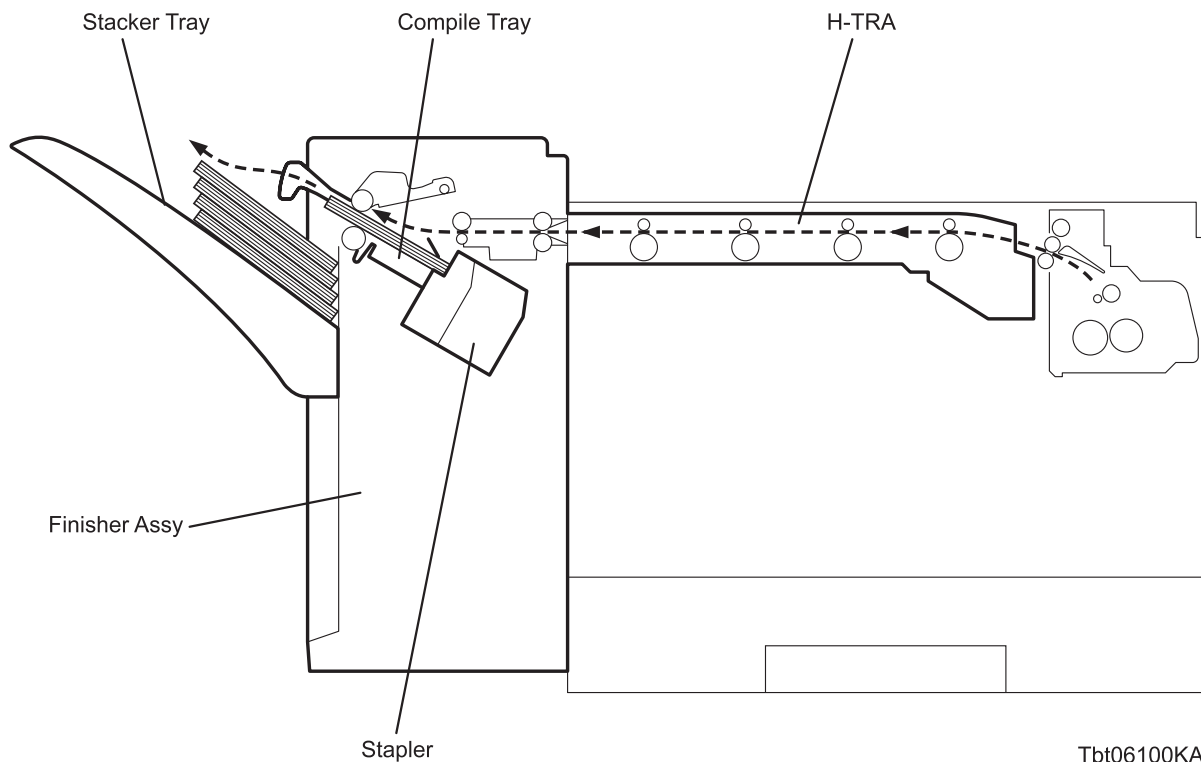

2. Paper Feeding

2.1 Paper Path

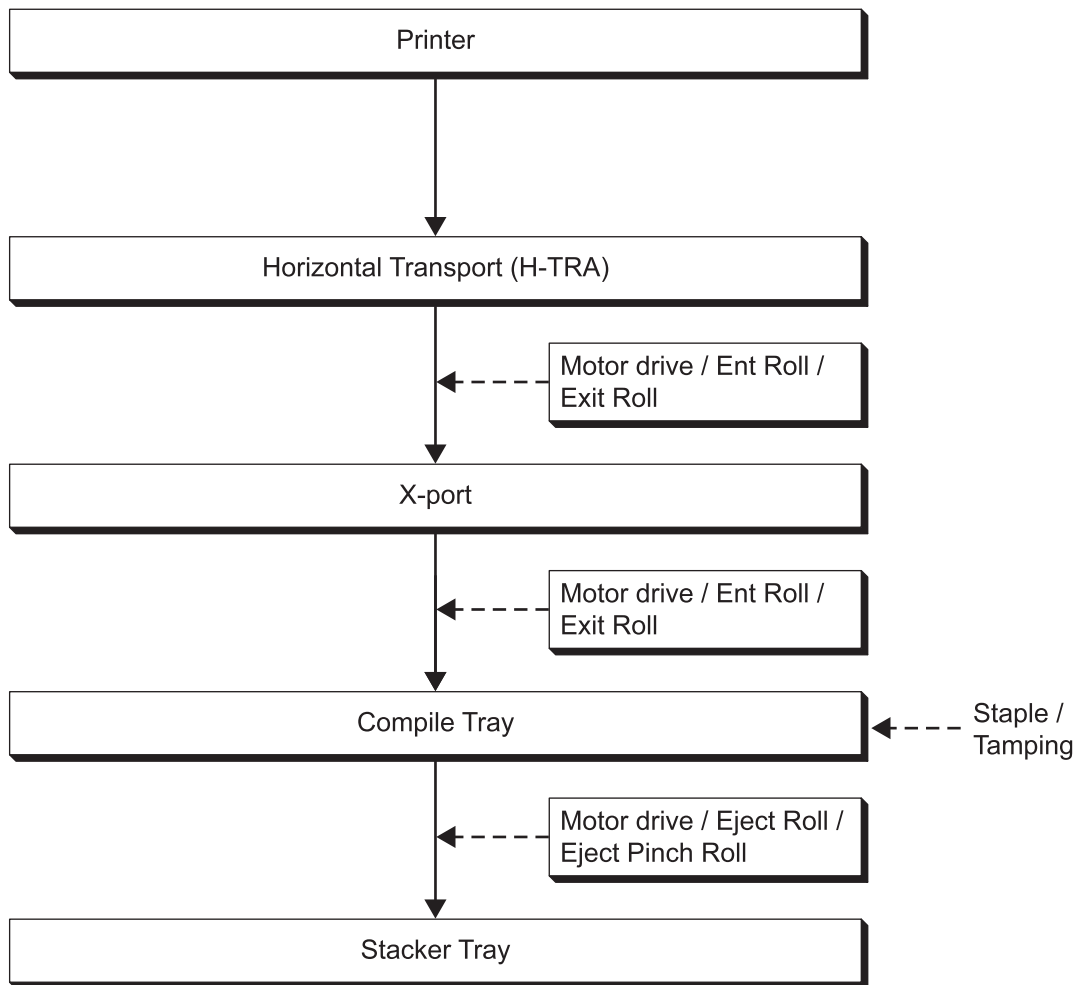

Tbt06101KA

2.2 Layout of Paper Path

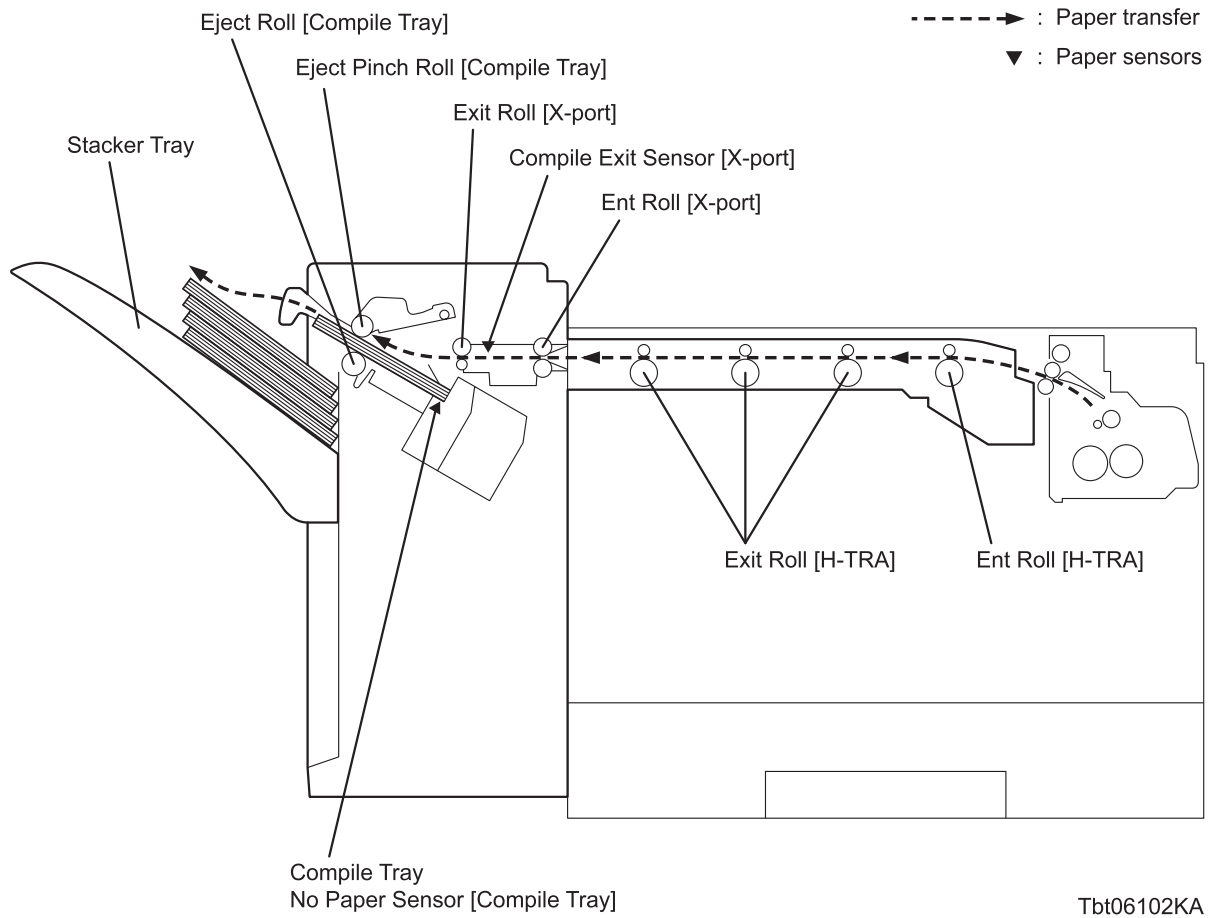

2.3 Feeding in Horizontal Transport (H-TRA)

The sheet coming in from the Exit section of the Printer is fed to the X' port by the ROLL ASSY ENT (PL 14.2.24) and the ROLL ASSY EXIT (PL 14.2.26) rotatably driven by the MOTOR ASSY PM HTU (PL 14.2.16) via the Belt.

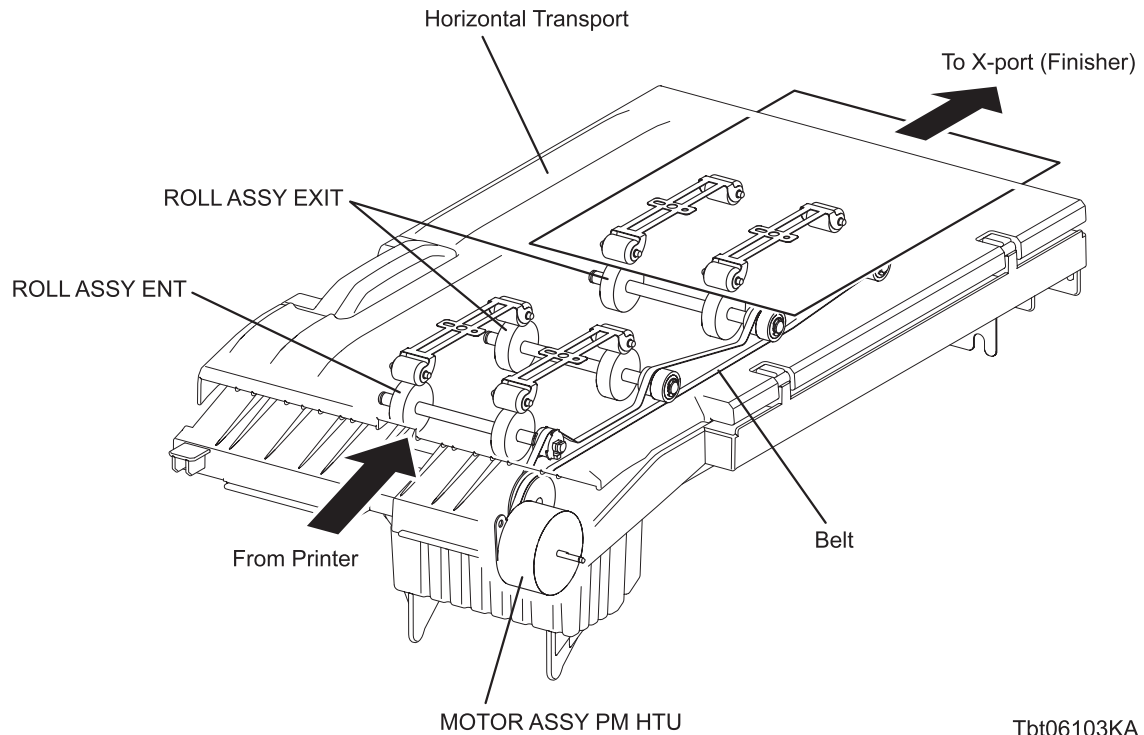

Tbt06103KA

2.4 Feeding in X' port

The sheet coming in from the H-TRA is fed to the Compile Tray by the ROLL ASSY DRIVE ENT (PL 14.7.11) and the ROLL ASSY DRIVE EXIT (PL 14.7.12) rotatably driven by the DRIVE ASSY TRANS (PL 14.7.16) via the Belt.

The passage of the sheet is detected by the COMPILE EXIT SENSOR (PL 14.7.9). (No paper: Sensor beam blocked. Refer to 3.2.1 Major Components and Their Functions.)

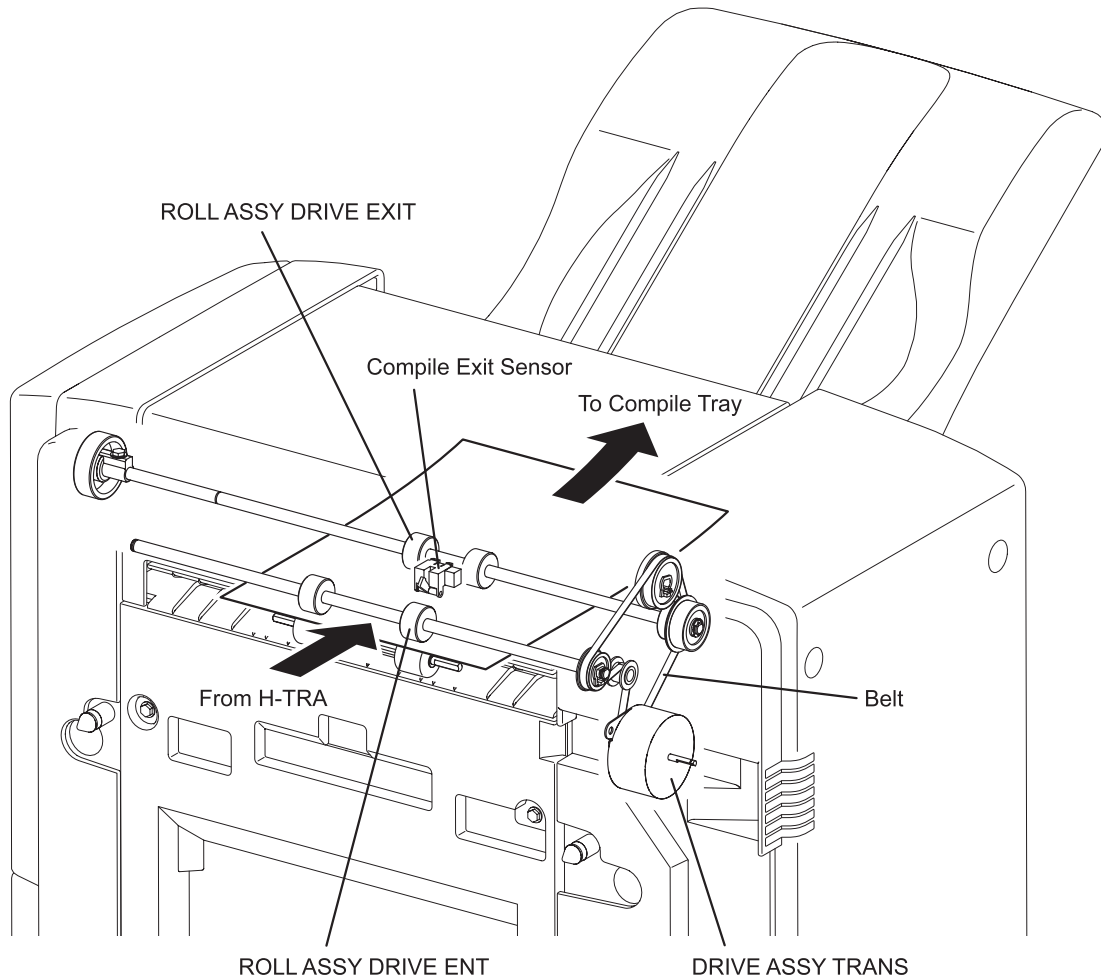

Tbt06104KA

2.5 Feeding in Compile Tray

While the GUIDE PAPER 240 (PL 14.5.38) slides out toward the Stacker Tray, driven by the MOTOR ASSY EJECT (PL 14.5.6), the ROLLER ASSY EJECT PINCH (PL 14.6.3) retracts upward to allow the sheet to come in from the X' port.

The sheet coming in from the X' port falls onto the Compile Tray.

When stapling or tamping is not specified, the ROLLER ASSY EJECT PINCH lowers to allow the sheet to exit to the Stacker Tray. (Refer to 2.6 Ejection to Stacker Tray.)

When stapling or tamping is specified, the ARM ASSY PADDLE (PL 14.6.4) lowered by the SOLENOID ASSY (PL 14.6.20), upon the falling of the sheet onto the Compile Tray.

Then, the PADDLE SUB (PL 14.6.8) of the ARM ASSY PADDLE and the Main Paddle of the SHAFT ASSY MAIN PADDLE (PL 14.7.13) rotate driven by the DRIVE ASSY TRANS (PL 14.7.6), to slide the sheet backward (reverse to the exit direction) until it stops against the flange of the Compile Tray.

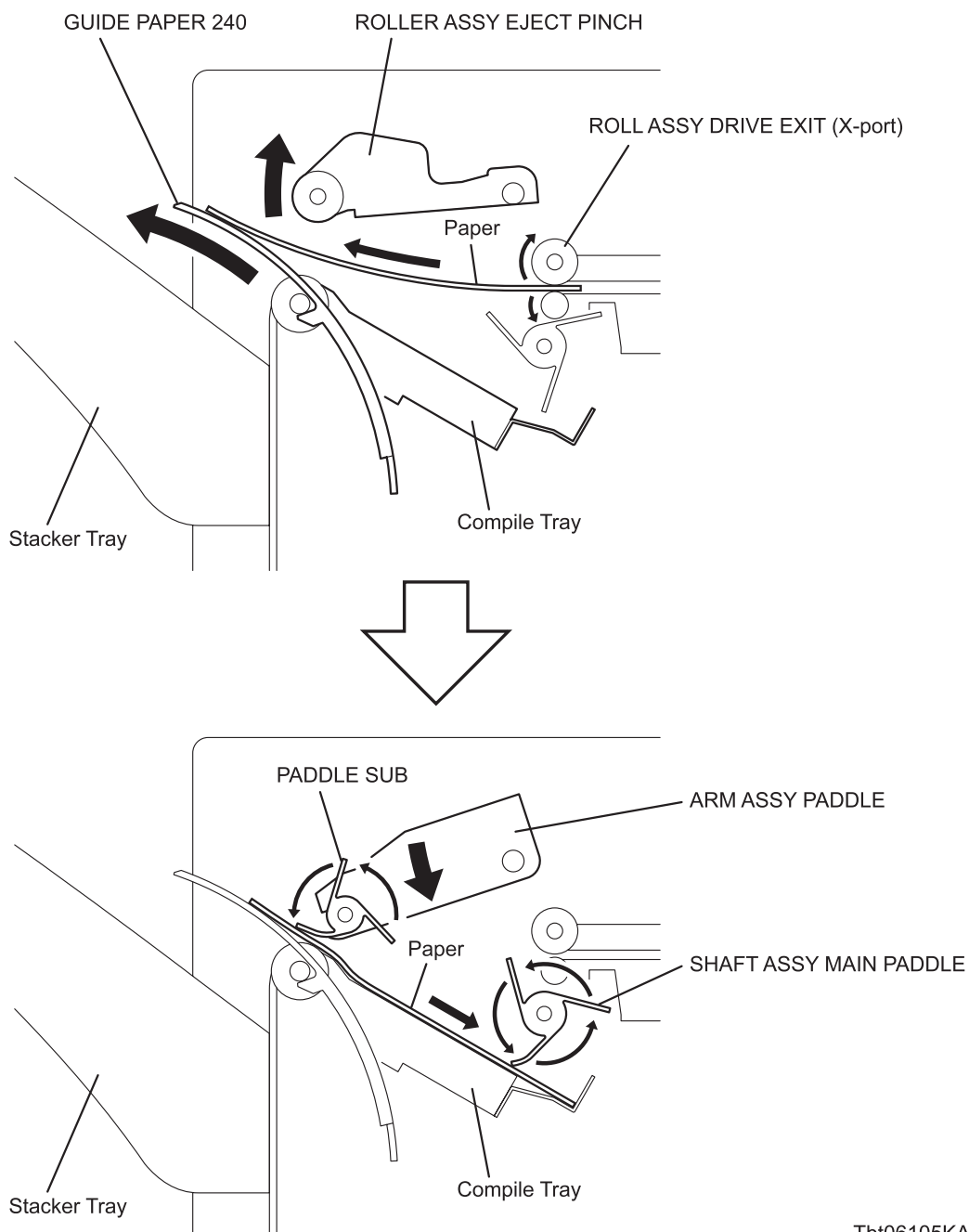

Tbt06105KA

2.6 Ejection to Stacker Tray

When the processing as stapling or tamping is completed in the Compile Tray, the ROLLER ASSY EJECT PINCH (PL 14.6.13) is lowered by the torque of the MOTOR ASSY EJECT (PL 14.5.6) and the spring pressure of the SPRING PINCH (PL 14.6.2) to guide the sheet to the point between the ROLLER EJECT PINCH (PL 14.6.16) and the ROLLER ASSY EJECT (PL 14.6.31).

Then, the sheet is ejected to the Stacker Tray by the ROLLER ASSY EJECT that rotates in the normal direction driven by the MOTOR ASSY EJECT and controlled by the GEAR ASSY SECTOR (PL 14.5.18).

During the ejection to the Stacker Tray, the GUIDE PAPER 240 (PL 14.5.38) slides back to its original position driven by the MOTOR ASSY EJECT so as not to obstruct the passage of the sheet.

Meanwhile, the CLUTCH Z34 (PL 14.5.25) transmits the torque of the MOTOR ASSY EJECT to the SHAFT ASSY SET CLAMP (PL 14.6.32), retracting the Holder of the SHAFT ASSY SET CLAMP inside the Finisher so as not to obstruct the passage of the sheet.

Upon completion of the sheet ejection, the Holder of the SHAFT ASSY SET CLAMP returns to its original position to hold down the sheet ejected.

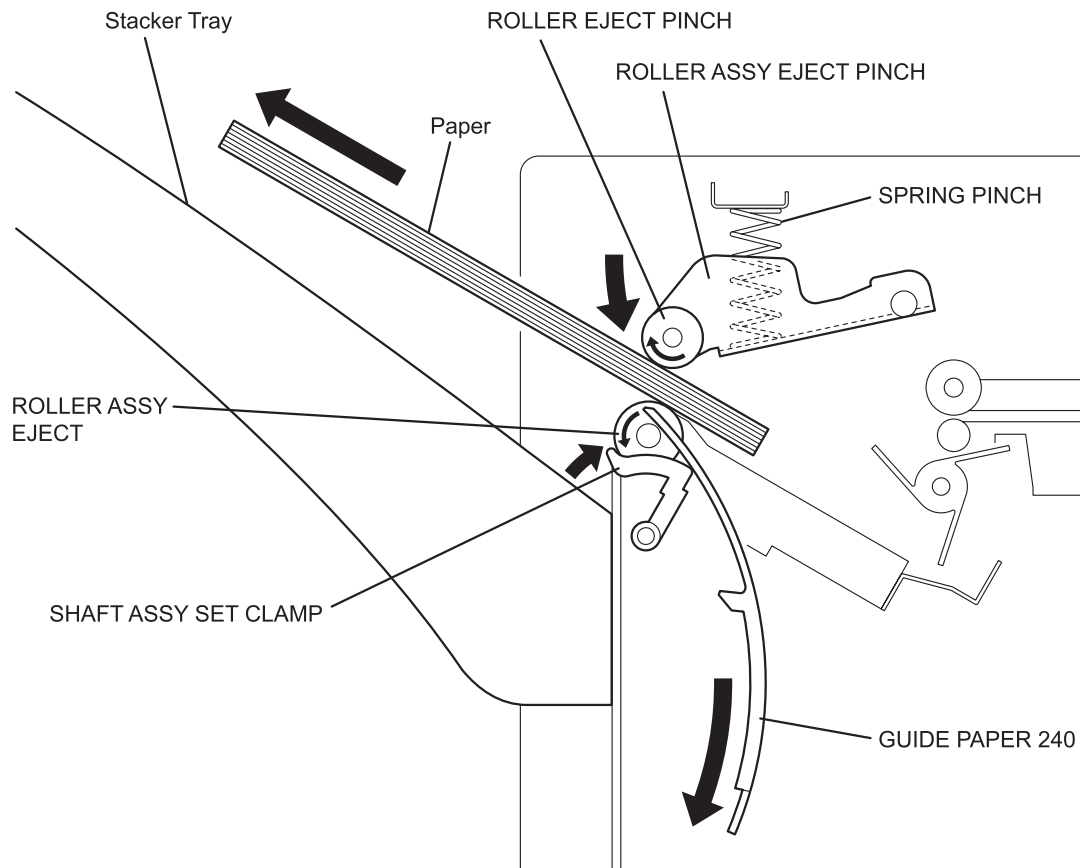

Tbt06106KA

3. Functions of Major Functional Components

3.1 H-TRA

3.1.1 Major Components and Their Functions

- HTU H-XPORT OPEN SENSOR (PL 14.2.36)

A sensor for detecting whether the COVER ASSY TOP of the H-TRA is open.
(COVER open: Sensor beam received)

- MOTOR ASSY PM HTU (PL 14.2.14)

A motor that drives the belt for paper feeding in the H-TRA. It is provided with the FAN A3 (PL14.2.15) for cooling down the motor in the H-Tra.

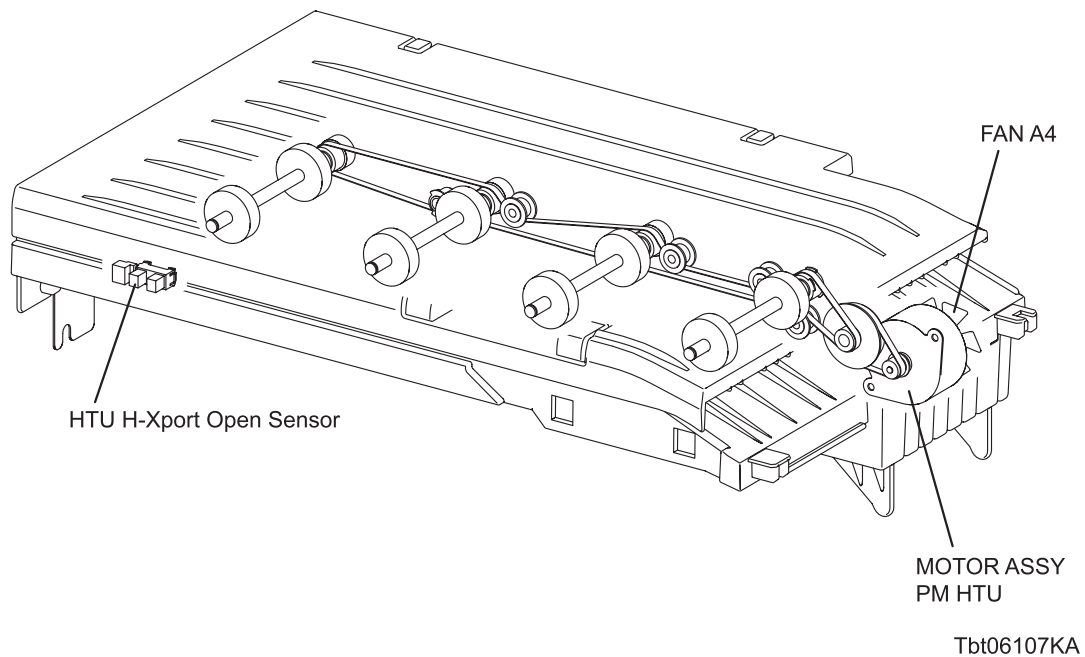

3.2 X' port

3.2.1 Major Components and Their Functions

- COMPILE EXIT SENSOR (PL 14.7.9)

A sensor for detecting the presence of the paper in the X' port based on the change of its actuator position.

(No paper: Sensor beam blocked)

- DRIVE ASSY TRANS (PL 14.7.16)

A motor that drives all feeding-related rollers in the X' port and Compile Tray.

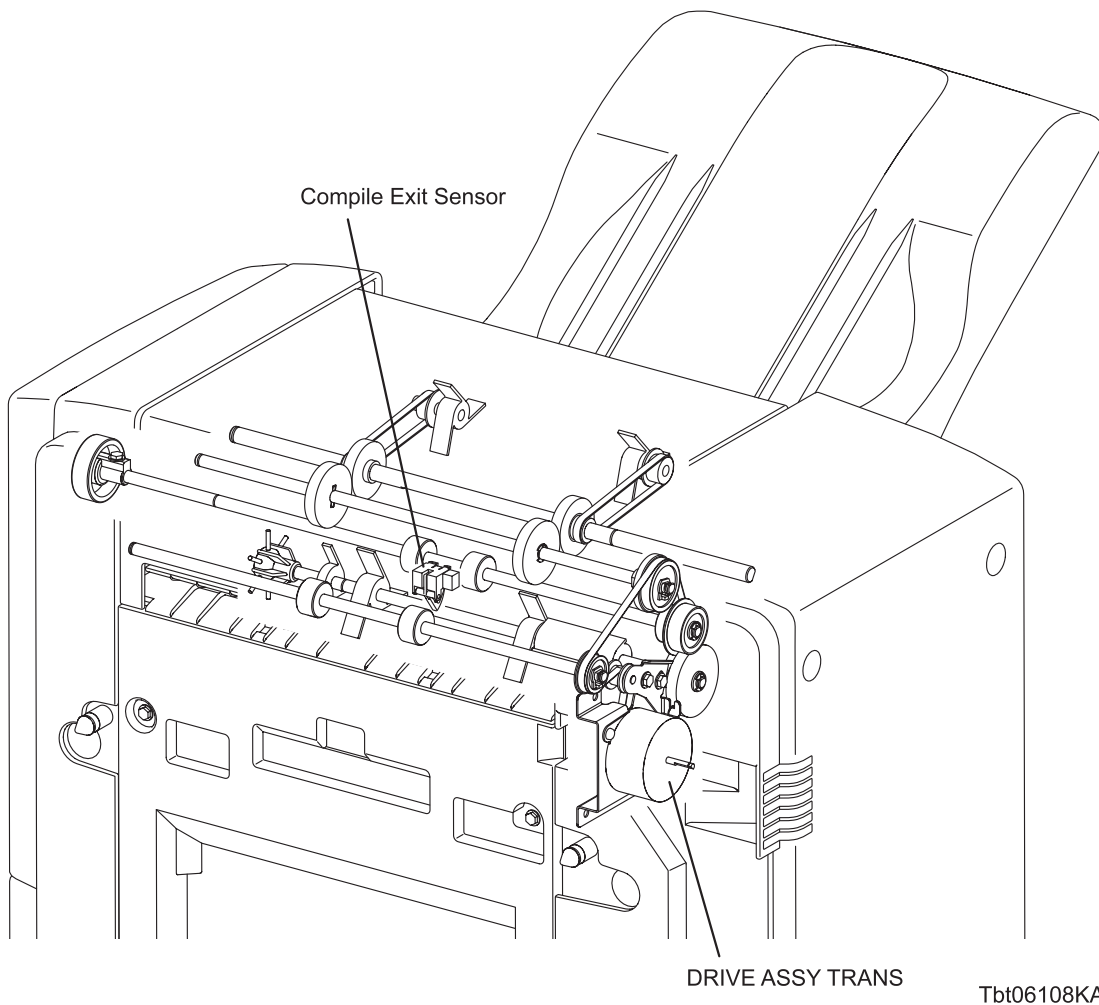

3.3 Compile Tray

3.3.1 Major Components and Their Functions

- SOLENOID ASSY (PL 14.6.20)

A solenoid that lowers the ARM ASSY PADDLE onto the sheet fed from the X' port, allowing the rotating PADDLE SUB to align the sheet to the flange of the Compile Tray.

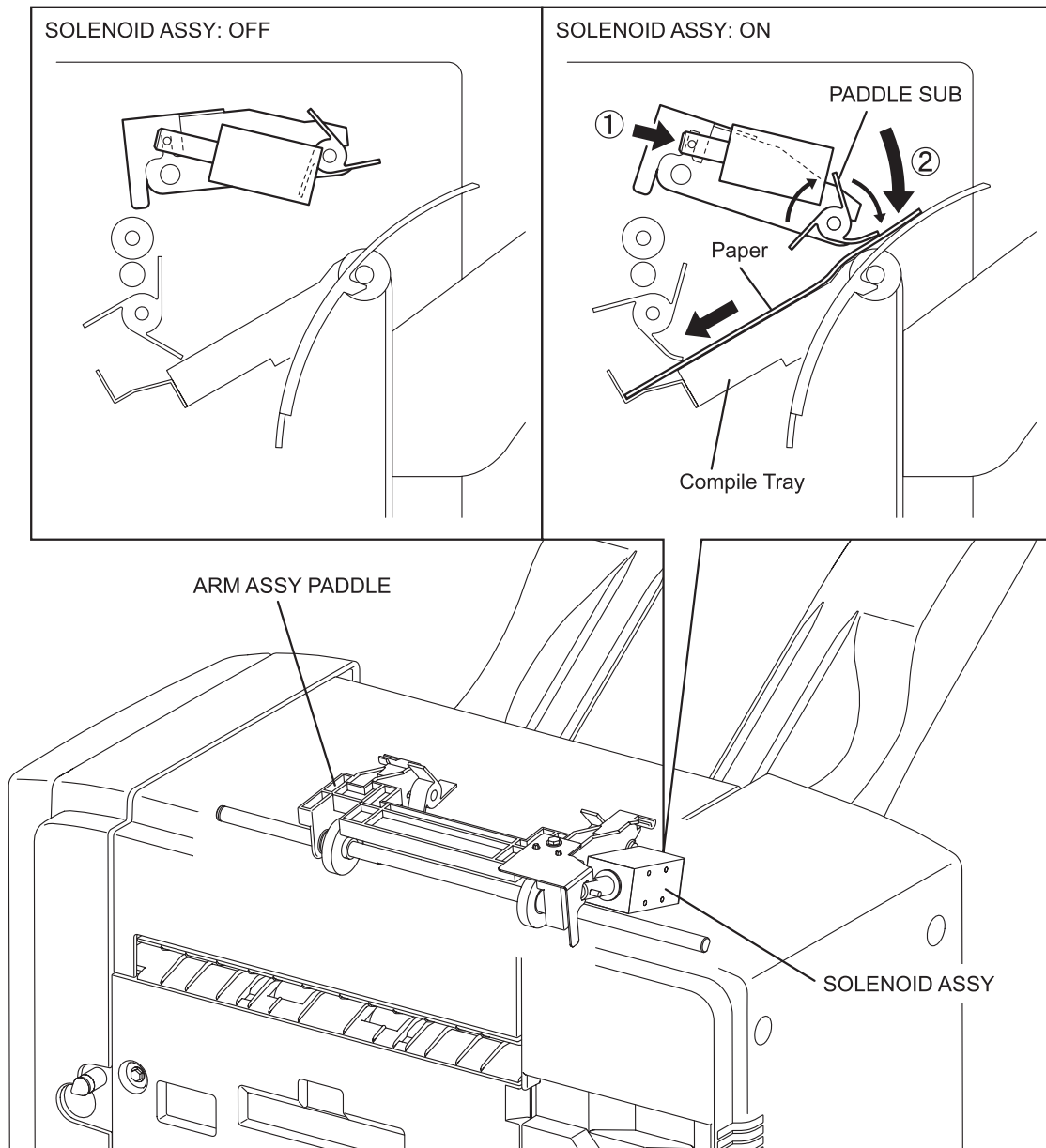

Tbt06109KA

- COMPILE TRAY NO PAPER SENSOR (PL 14.8.13)

Detects the presence of the paper in the Compile Tray based on the change of its actuator position.
(Paper present: Sensor beam received)

- FRONT TAMPER HOME SENSOR (PL 14.8.9)

A sensor for detecting that the GUIDE TAMPER FRONT A4 (PL 14.8.4) is at its home position.
(Home position: Sensor beam blocked).

- REAR TAMPER HOME SENSOR (PL 14.8.9)

A sensor for detecting that the GUIDE TAMPER REAR A4 (PL 14.8.5) is at its home position.
(Home position: Sensor beam blocked)

- MOTOR ASSY TAMPER (FRONT) (PL 14.8.18)

A motor that moves the GUIDE TAMPER FRONT A4 for tamping operation.

- MOTOR ASSY TAMPER (REAR) (PL 14.8.18)

A motor that moves the GUIDE TAMPER REAR A4 for tamping operation.

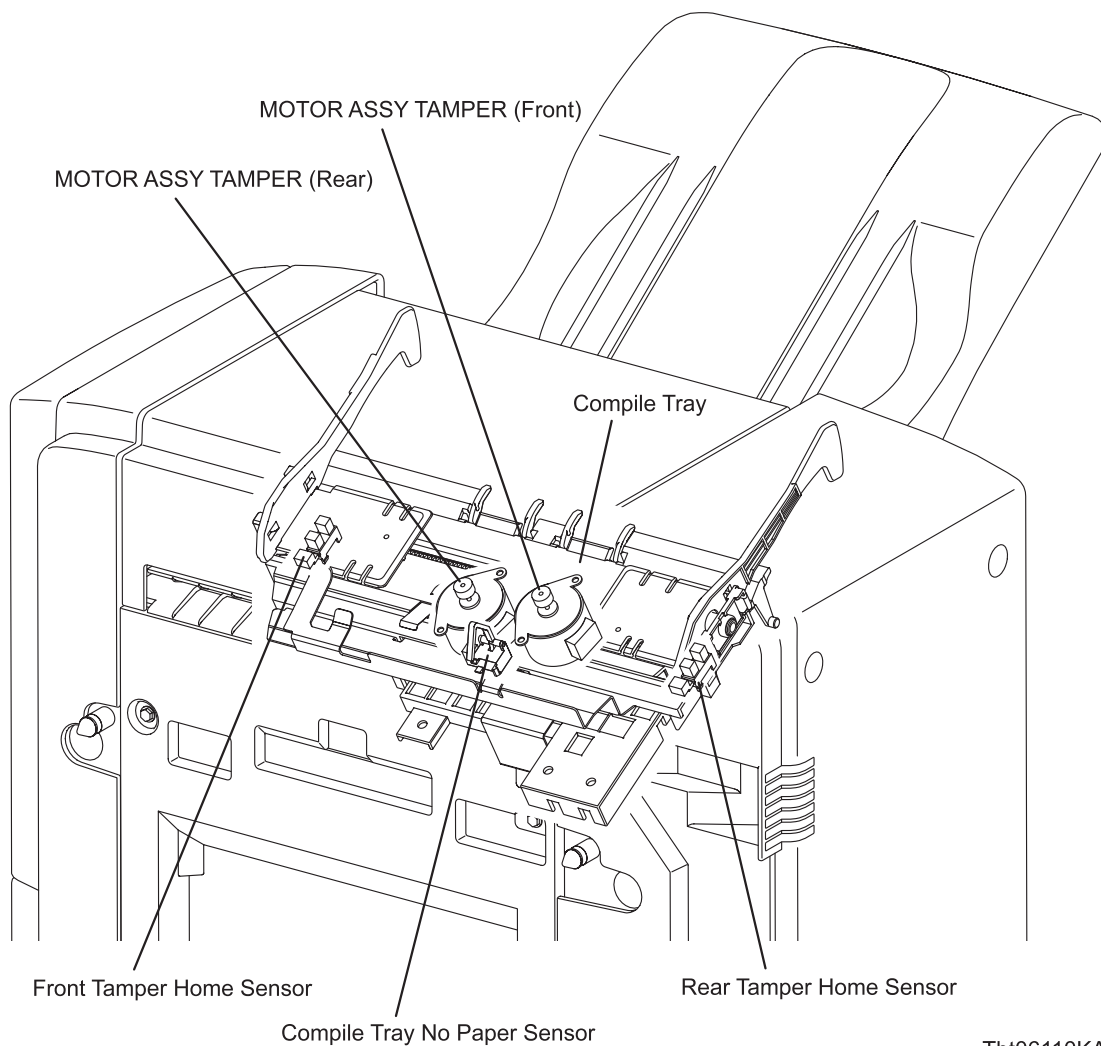

Tbt06110KA

3.3.2 Operations in Compile Tray

In the Compile Tray, the sheets fed from the X' port undergo the tamping operation for alignment with respect to width direction, and the offset stacking operation for placing the sets of sheets staggered in the Stacker Tray.

3.3.2.1 Tamping

The sheets fed from the X' port undergo the tamping operation in the Compile Tray for alignment with respect to width direction.

Tamping refers to the operation of aligning the sheet to the specified position by sliding the GUIDE TAMPER FRONT A4 (PL 14.8.4) and the GUIDE TAMPER REAR A4 (PL 14.8.5) until they contact the sheet edges by the torque from the respective motors (MOTOR ASSY TAMPER: PL 14.8.18).

This operation is executed when the specified time has elapsed after the trail edge of the sheet passed through the Compile Exit Sensor (PL14.7.9).

A tamping is executed for each incoming sheet. When stapling is specified, an additional tamping is executed after the tamping for the last sheet is completed.

Tamping includes the following two modes:

- Front Tamping
Activates the Rear Tamper only, with the Front Tamper locked.
- Rear Tamping
Activates the Front Tamper only, with the Rear Tamper locked.

3.3.2.2 Offset Stacking

Offset stacking staggers the position where the ejected sheets land on the Stacker Tray to help separate the stack of sheets into groups such as jobs or collated sets.

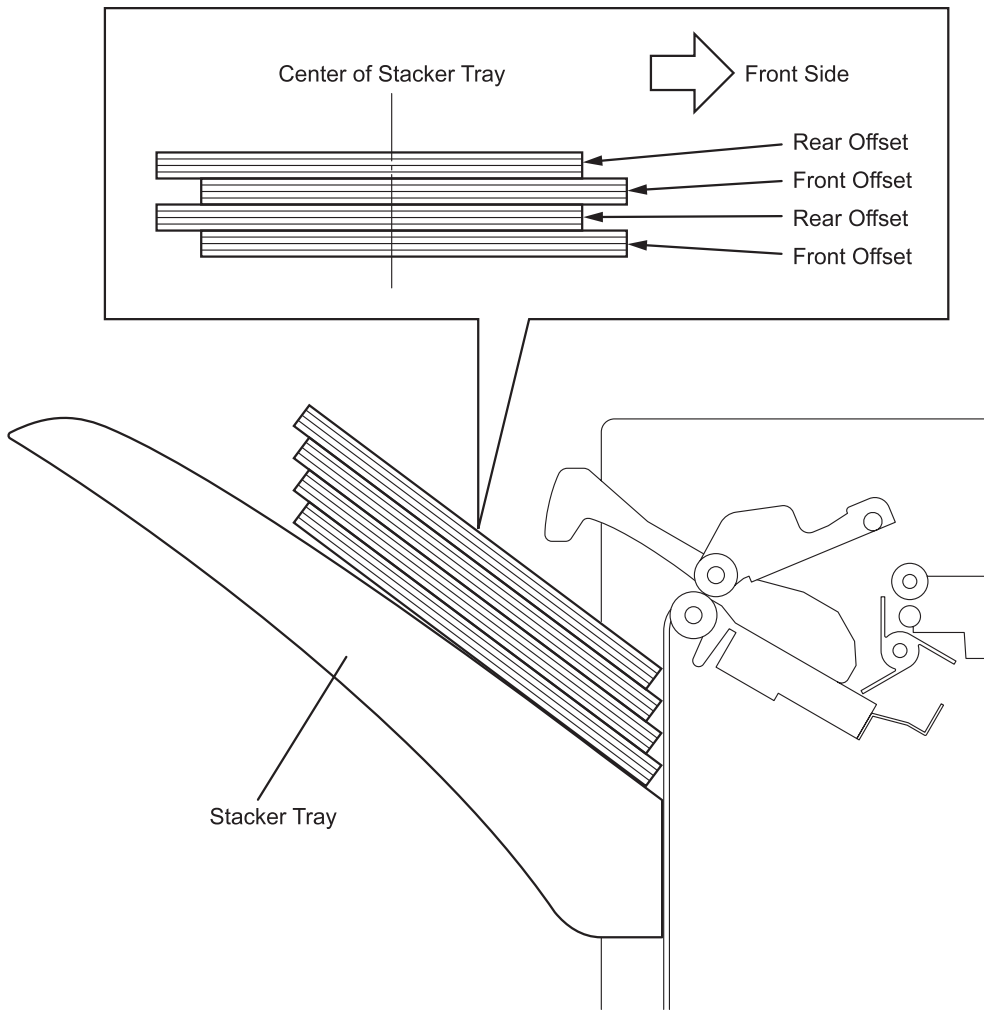

Tbt06111KA

3.3.2.3 Sheet/Envelope Select Lever

The Sheet/Envelope Select Lever can be switched to the "Sheet Mode" or "Envelope Mode" position depending on the print media to be used.

In the "Sheet Mode", the sheet exits to the Stacker Tray without contacting the Select Lever.

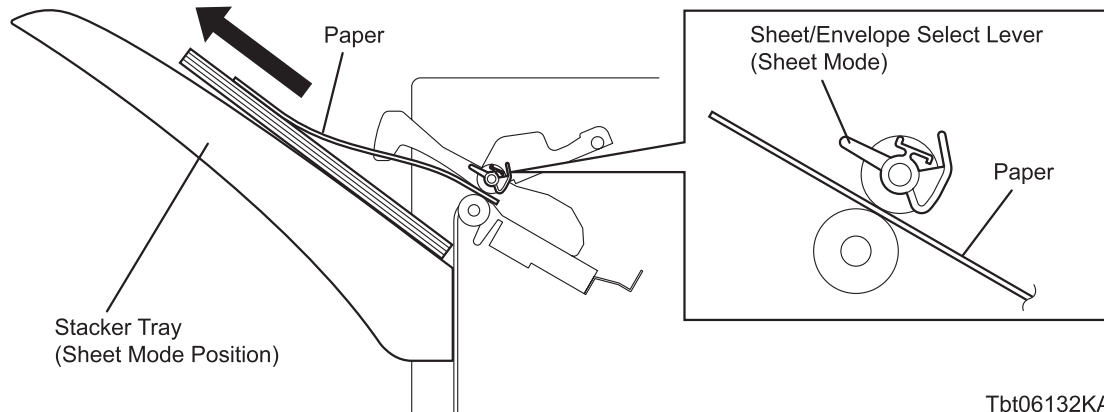

In the "Envelope Mode", the envelope is corrugated along the feeding direction by the projection from the Select Lever. This corrugation increases the rigidity of the envelope, thereby preventing the lead edge from slipping underneath the flap of the previous envelope.

Meanwhile, the Stacker Tray lowers slightly from the normal position to ensure that the envelopes are stacked up neatly.

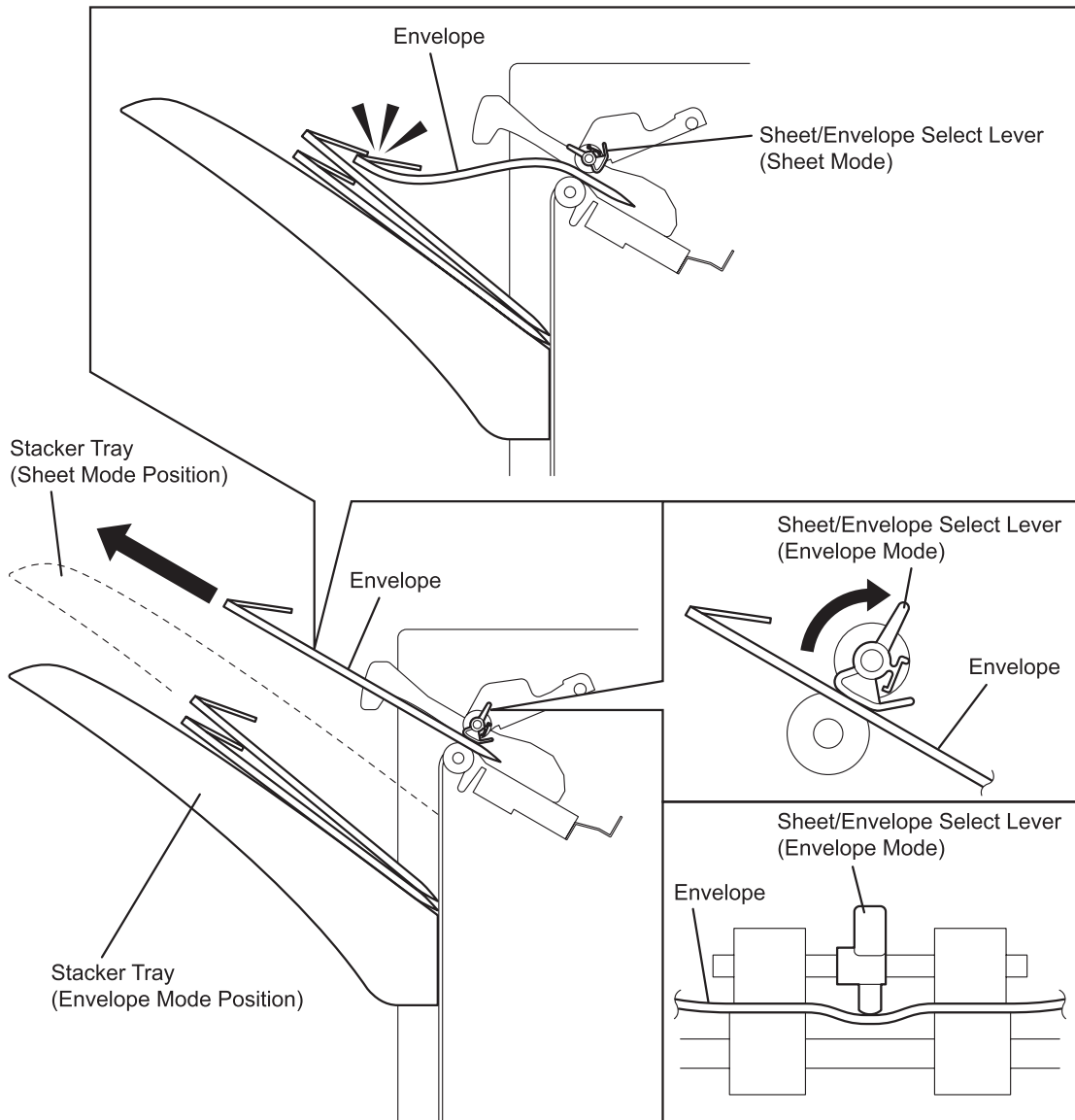

Tbt06133KA

3.4 Stapler

3.4.1 Major Components and Their Functions

- Low Staple Sensor

A photo-interrupter type sensor for detecting the remaining quantity of the staples. (Staples low: Sensor beam blocked)

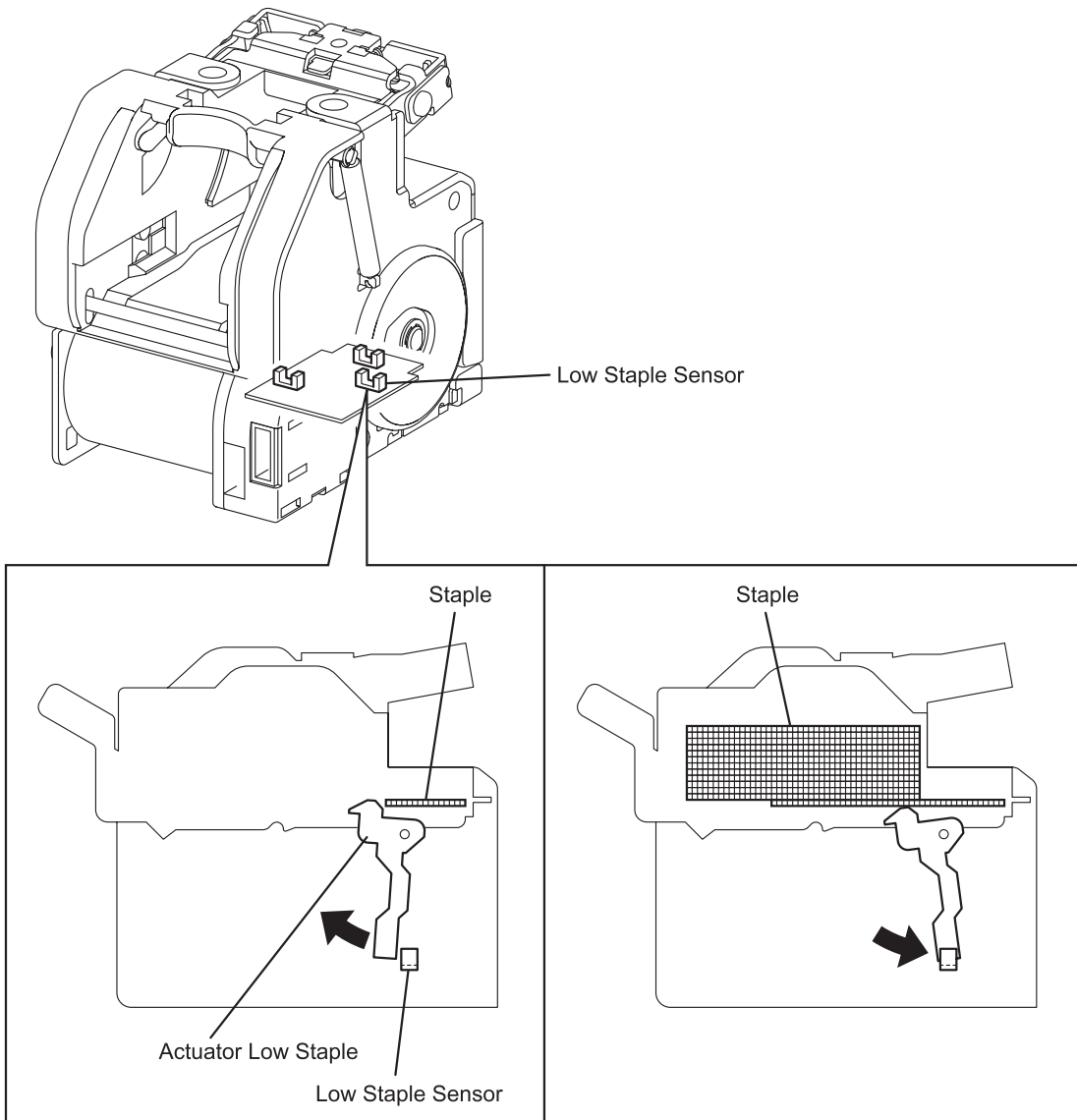

Tbt06134KA

- Self Priming Sensor

A photo-interrupter type sensor for detecting that the staple has reached the Stapler Head or that stapling has failed.

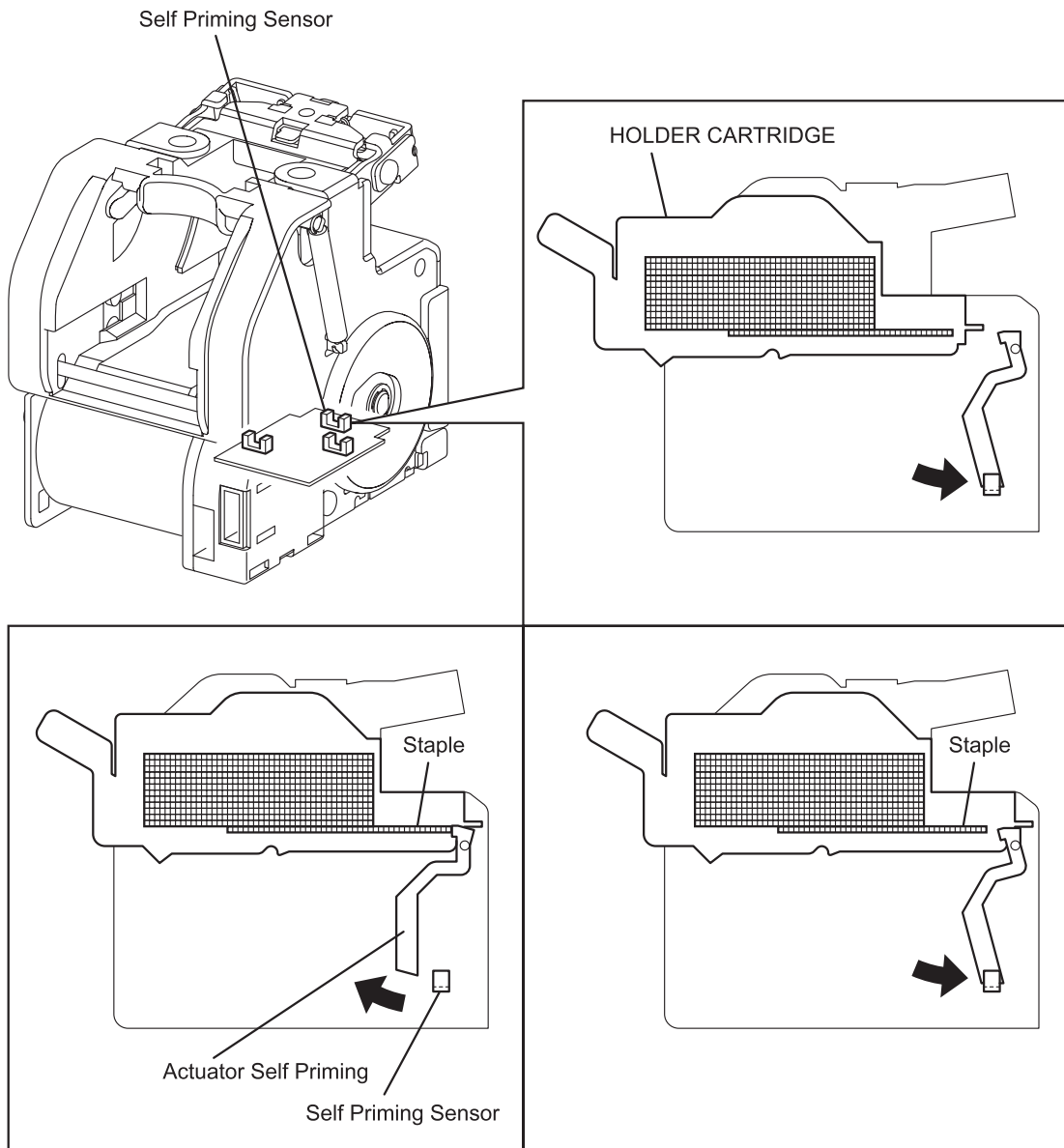

Tbt06135KA

- Staple Home Sensor

A photo-interrupter type sensor for detecting that the Stapler Head is at its home position or that stapling has failed. It also triggers the Staple Motor to stop. (Home position: Sensor beam blocked)

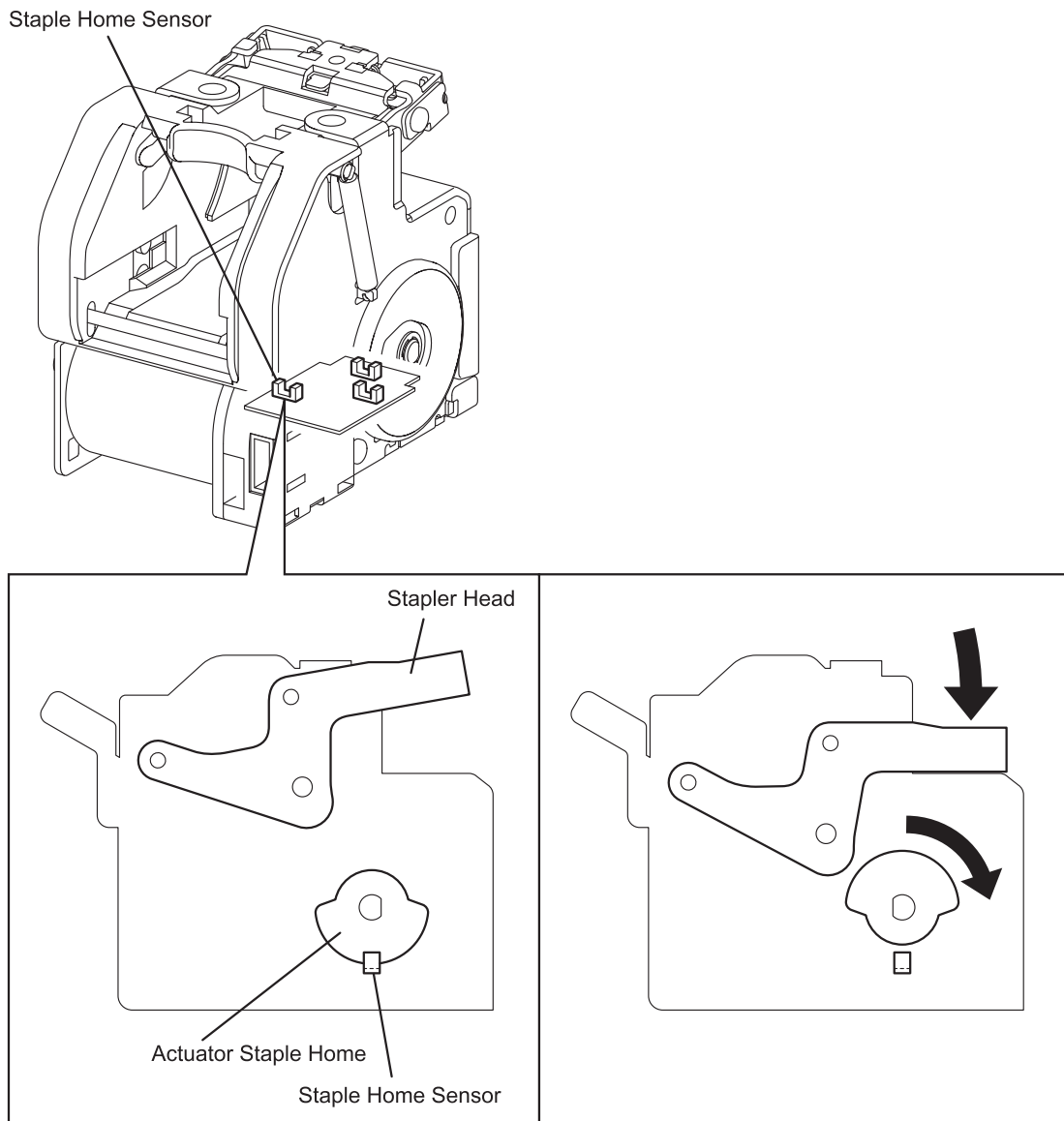

Tbt06136KA

- Staple Motor

A motor that drives the Stapler Head to execute stapling. Rotates clockwise to activate the Stapler Head, and counterclockwise to return it to its original position.

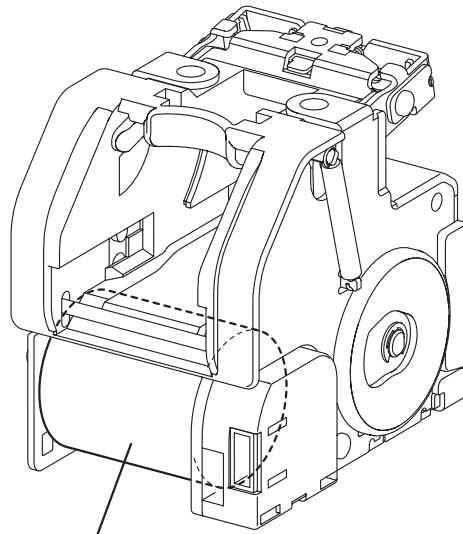

Staple Motor

Tbt06112KB

| Blank Page

3.4.2 Stapling

The sheets coming in from the X' port undergo tamping in the Compile Tray, and then are stapled in the position specified by the Printer. (Up to 50 sheets)

3.4.2.1 Operation of Stapling

Stapling starts when the number of sheets deposited in the Compile Tray has reached the number of sheets for one set. (Up to 50 sheets)

Stapling is executed by the Stapler Head that comes down to the sheets.

When the Staple Motor rotates in the normal direction (clockwise), the Stapler Head applies a staple onto the sheets and then returns to its home position. If stapling is not completed correctly, the Staple Motor rotates in the reverse direction (counterclockwise) to drive the Stapler Head back to its home position.

When staples are low, the Low Staple Sensor raises a warning message and suspends stapling. This warning message is also displayed when the Staple Cartridge is not installed.

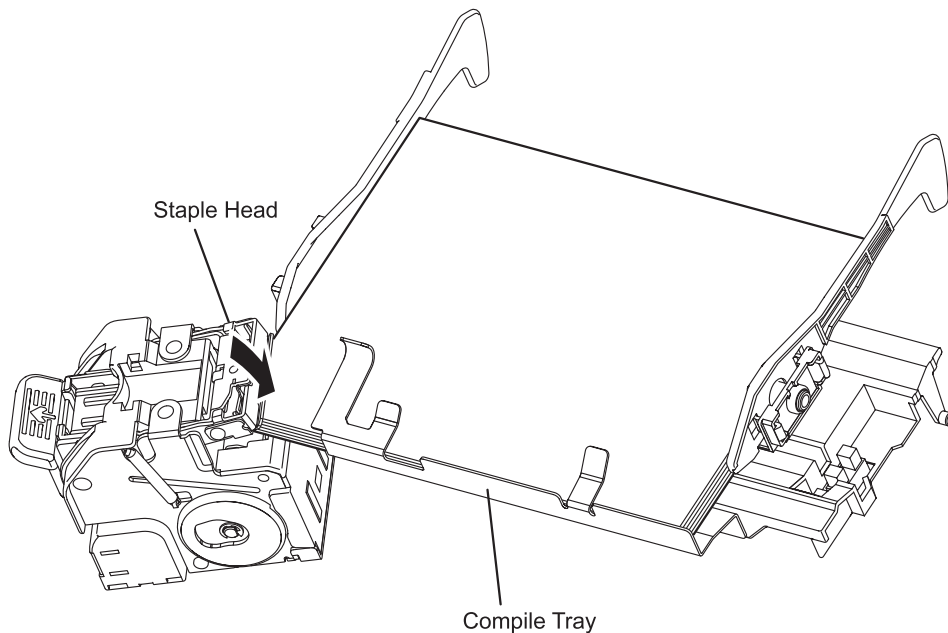

Tbt06113KA

3.4.2.2 Stapling Position

The staple is applied in the front corner at an angle of 25 degrees after the sheets are aligned to the front edge by the GUIDE TAMPER REAR A4 (PL 14.8.5).

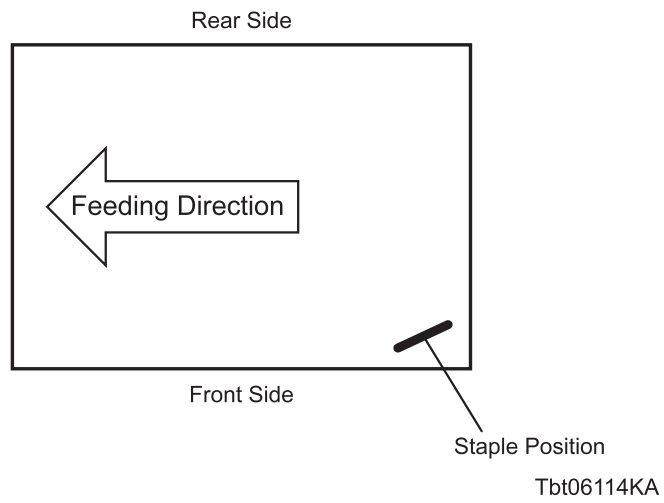

3.5 Stacker Tray

The Stacker Tray holds the sheets ejected from the Compile Tray by shifting to an appropriate position according to the height of the sheet stack.

3.5.1 Major Components and Their Functions

- STACKER HEIGHT SENSOR (PL 14.4.3)

* STACKER HEIGHT SENSOR 1/STACKER HEIGHT SENSOR 2

Detects the height of the sheet stack on the Stacker Tray based on the change of its actuator position.

The MOTOR ASSY STACKER (PL 14.9.7) moves up or down the Stacker Tray based on the detection results.

The following table shows the correspondence between the detection results and the moving direction of the Stacker Tray.

Sensor 1 Detection	Sensor 2 Detection	Stacker Tray Movement	Evaluation
Beam Blocked	Beam Received	Up	Too Low
Beam Blocked	Beam Blocked	As Is	Normal
Beam Received	Beam Blocked	Down	Too High

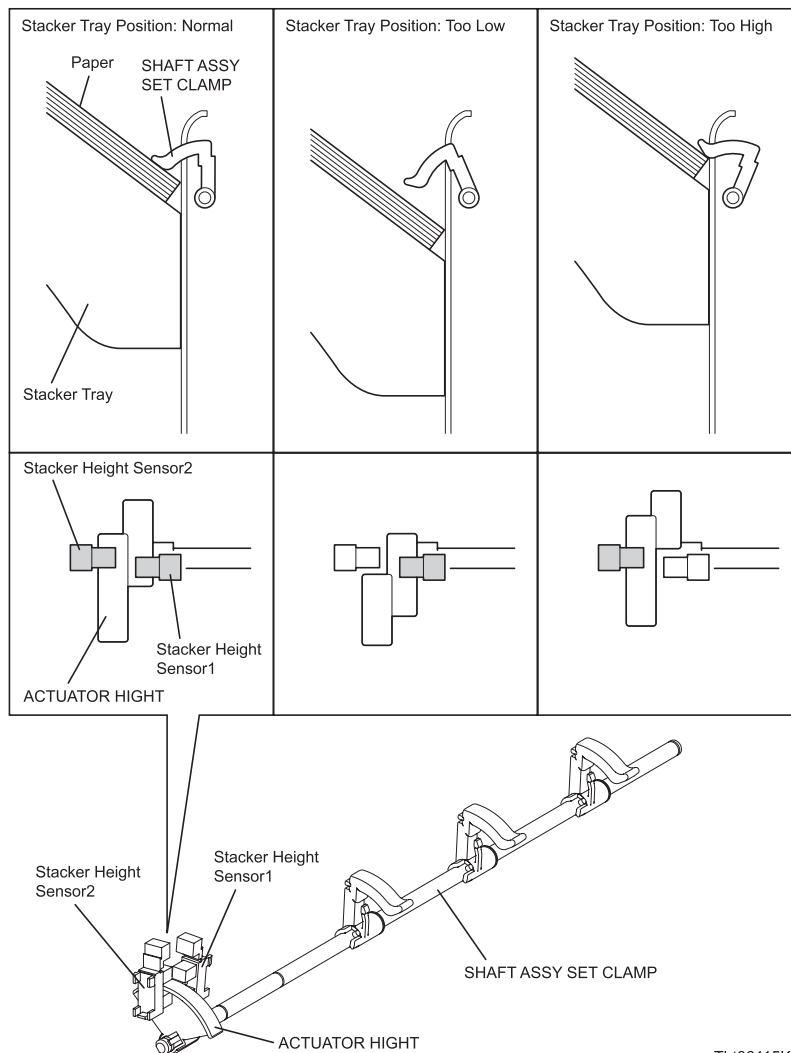

Tbt06115KA

- STACKER NO PAPER SENSOR (PL 14.9.10)
A sensor for detecting that the Stacker Tray is at the topmost position (home position). It also detects that the Stacker Tray has run out of paper.
(Home position: Sensor beam blocked)

- MOTOR ASSY STACKER (PL 14.4.7)
A motor that moves up or down the Stacker Tray.
Rotates clockwise to raise and counterclockwise to lower the Stacker Tray.

- MOTOR ASSY EJECT (PL 14.5.6)
A stepping motor that drives sheet-ejecting components such as the EJECT CLAMP and the SET CLAMP.

- EJECT CLAMP HOME SENSOR (PL 14.4.3)
A sensor for detecting that the EJECT CLAMP (ROLLER ASSY EJECT PINCH: PL 14.6.13) is at its home position. (Home position: Sensor beam received)

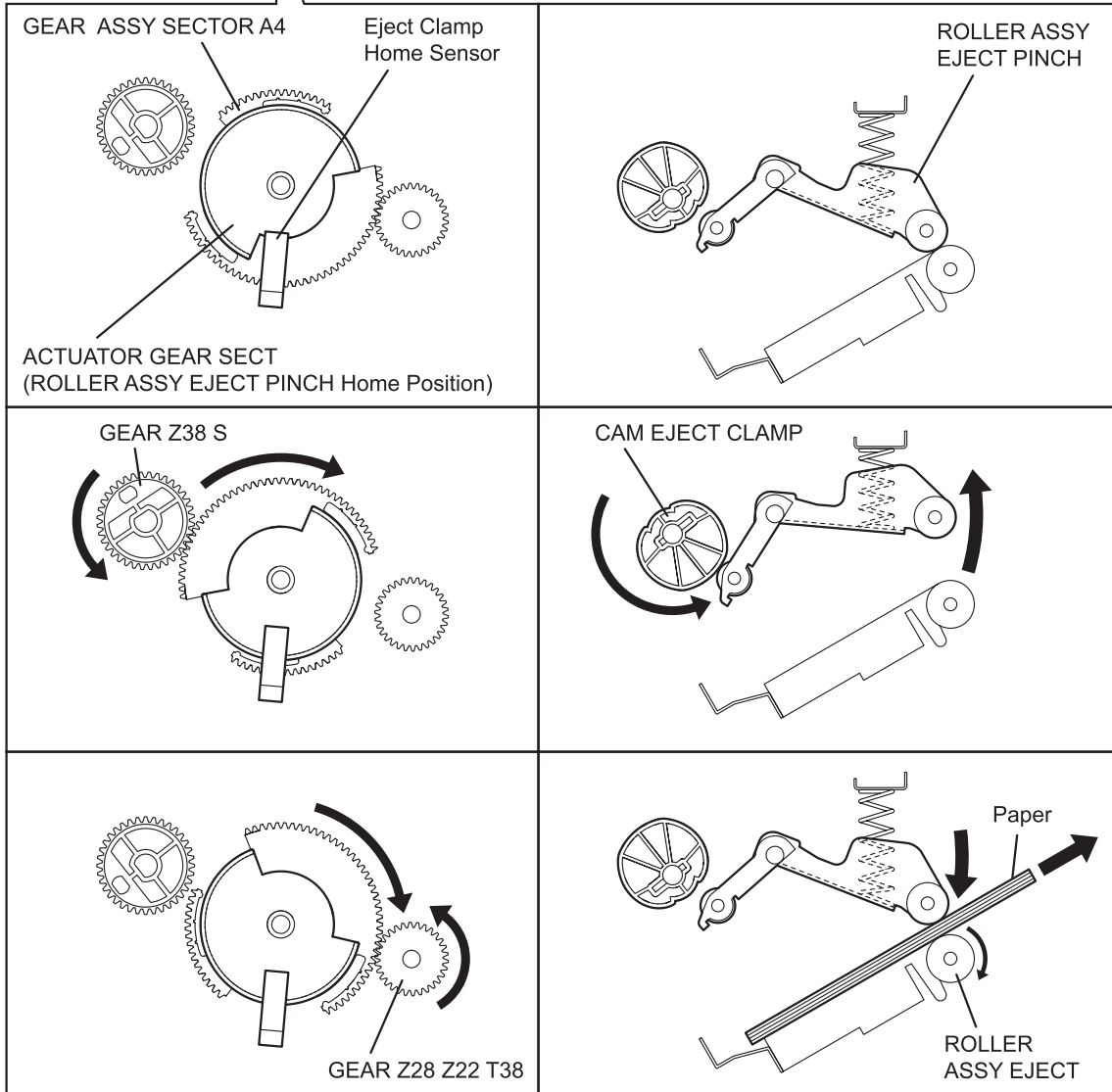
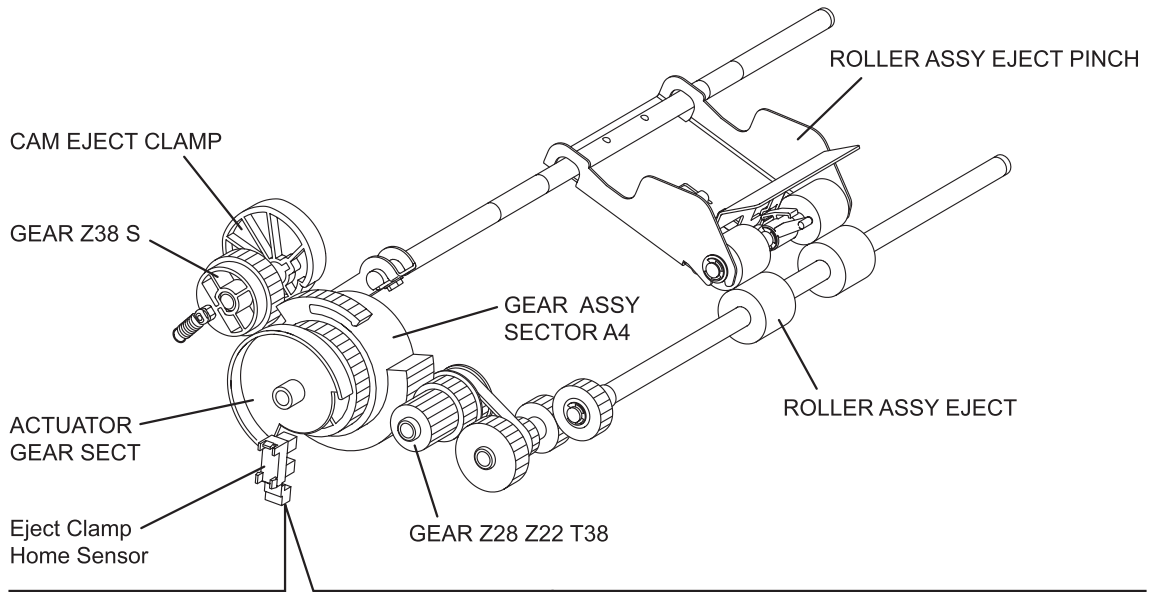

Tbt06116KA

- SET CLAMP HOME SENSOR (PL 14.4.3)

A sensor for detecting that the SET CLAMP (SHAFT ASSY SET CLAMP: PL 14.6.32) is at its home position. (Home position: Sensor beam received)

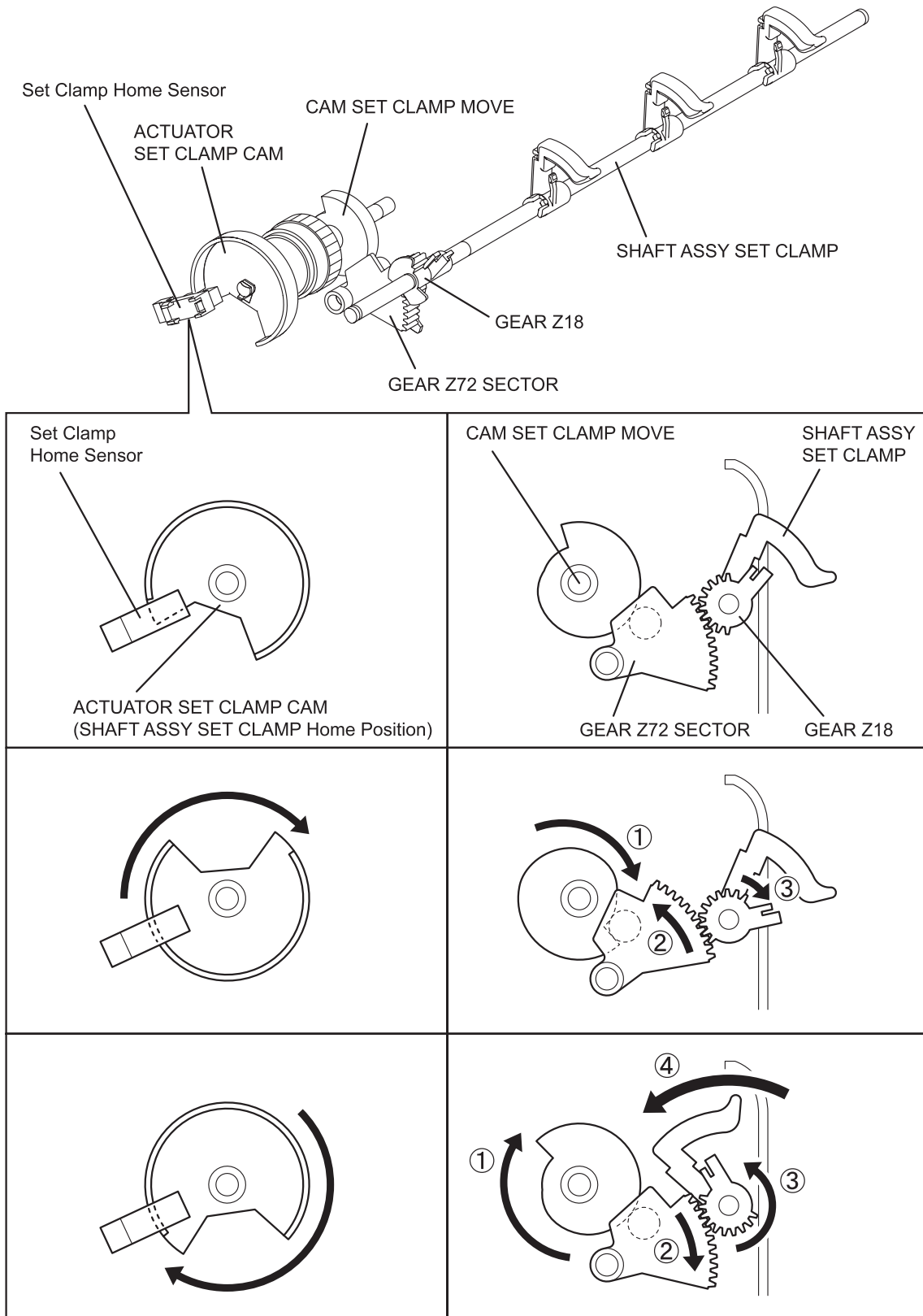

Tbt06117KA

- CLUTCH Z34 (PL 14.5.25)

A clutch that transmits the torque from the MOTOR ASSY EJECT to the SET CLAMP (SHAFT ASSY SET CLAMP: PL 14.6.32).

- GEAR ASSY SECTOR A4 (PL 14.5.18)

Controls the movement of the GUIDE PAPER 240 by changing the transmission route from the MOTOR ASSY EJECT. (Refer to 4. Torque Transmission Route.)

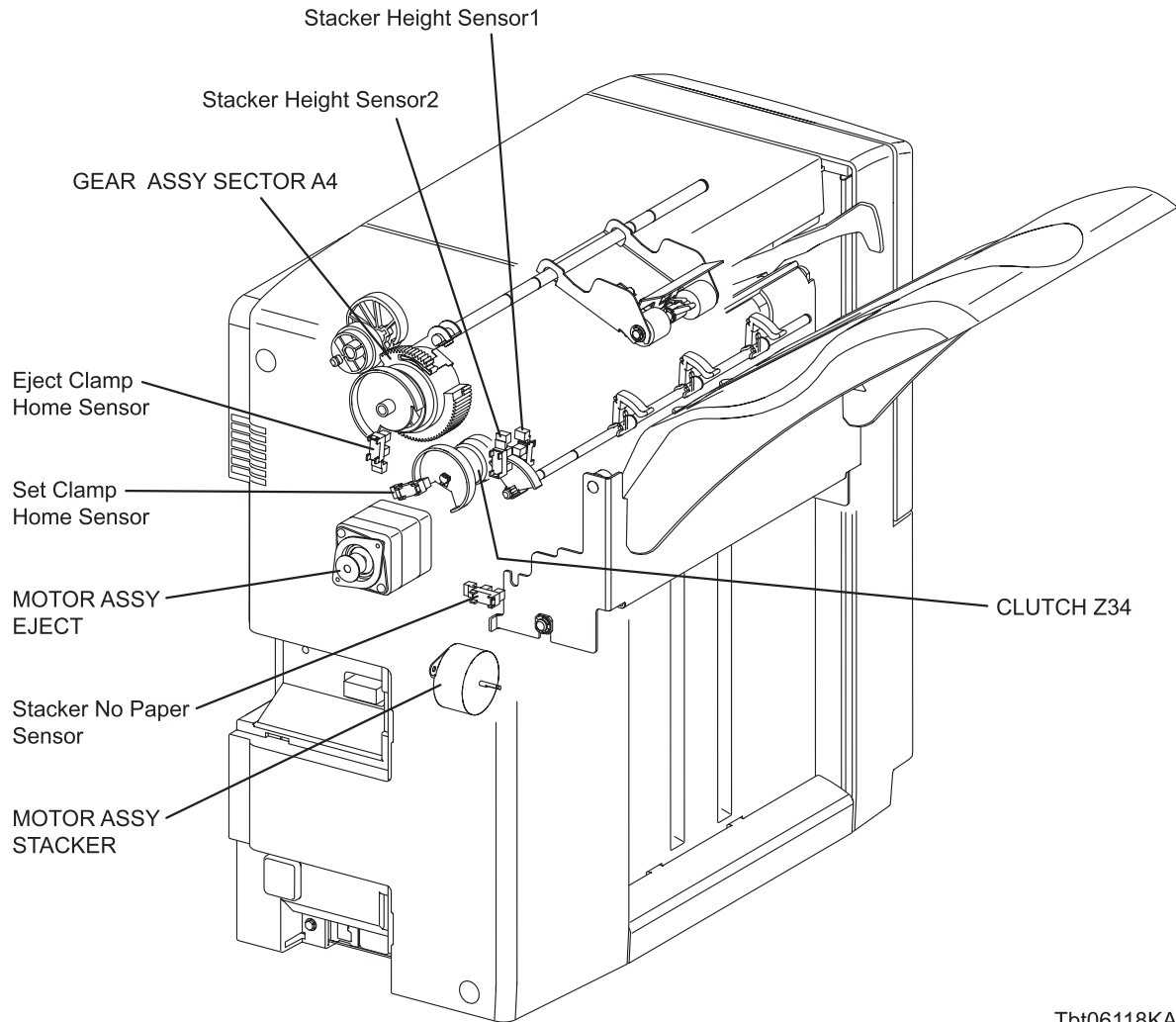

Tbt06118KA

3.6 Electrical

3.6.1 Major Components and Their Functions

- Switch

* FINISHER FRONT DOOR SWITCH (PL 14.10.3)

Detects whether the Front Cover is open. Interrupts the DC power to the components in the Finisher (+24VDC) when the Front Door is opened.

- PWBA

* PWBA MAIN A4FIN (PL 14.4.12Aj)

A board that controls the components in the Finisher.

* LVPS ASSY (PL 14.10.10)

Converts the AC power from the Printer into stable low voltage DC power to be used for such components as logic circuits in the Finisher.

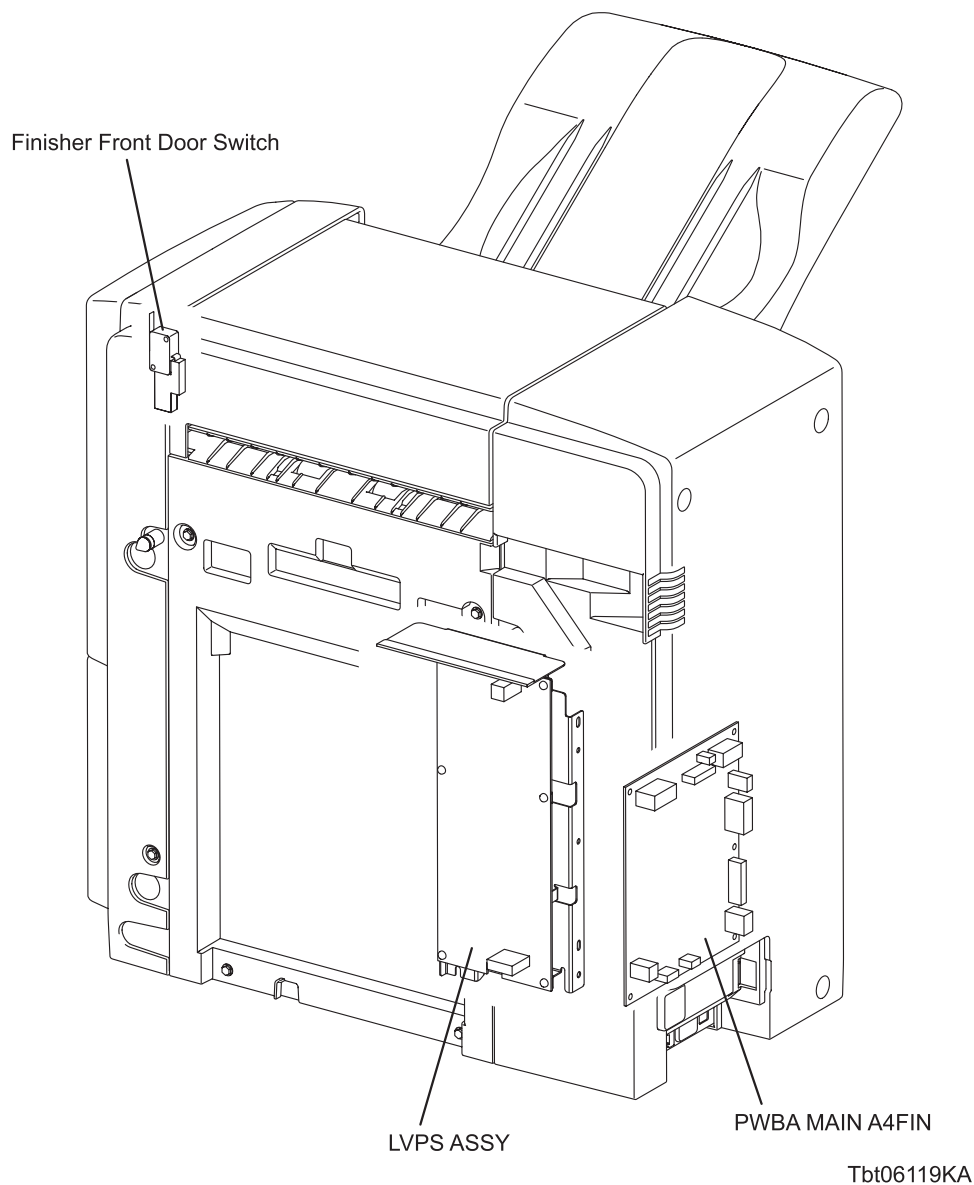

Blank Page

4. Torque Transmission Route

4.1 MOTOR ASSY PM HTU

The torque of the MOTOR ASSY PM HTU is transmitted through the route below.

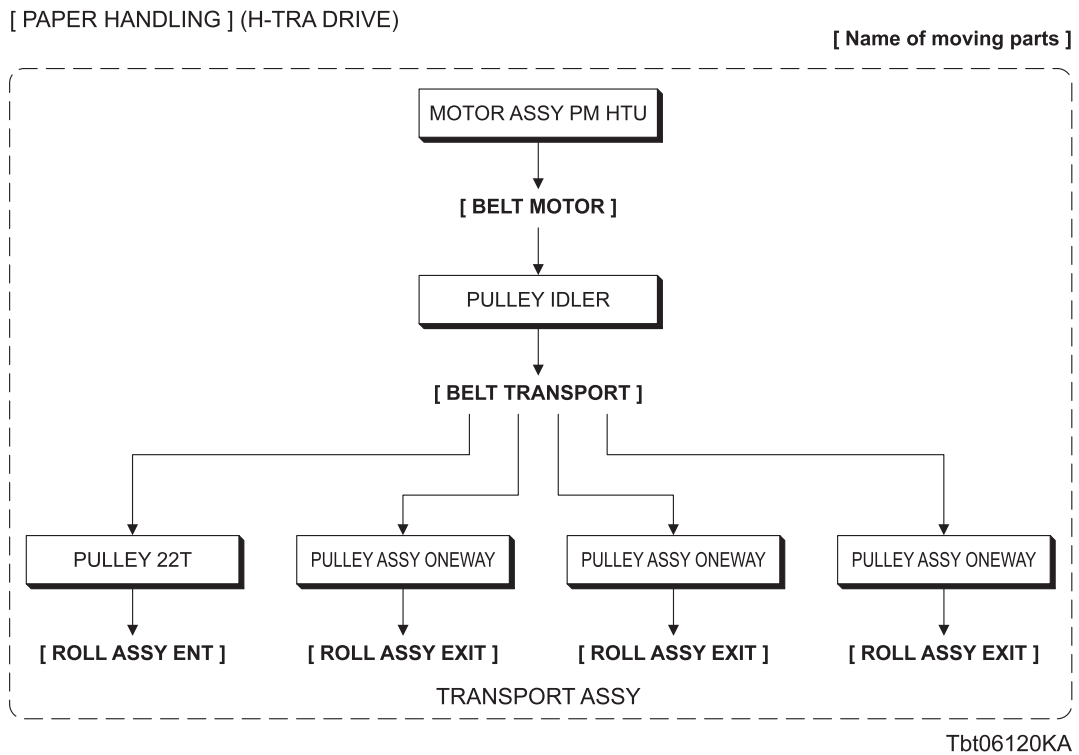

[PAPER HANDLING] (H-TRA DRIVE)

[Name of moving parts]

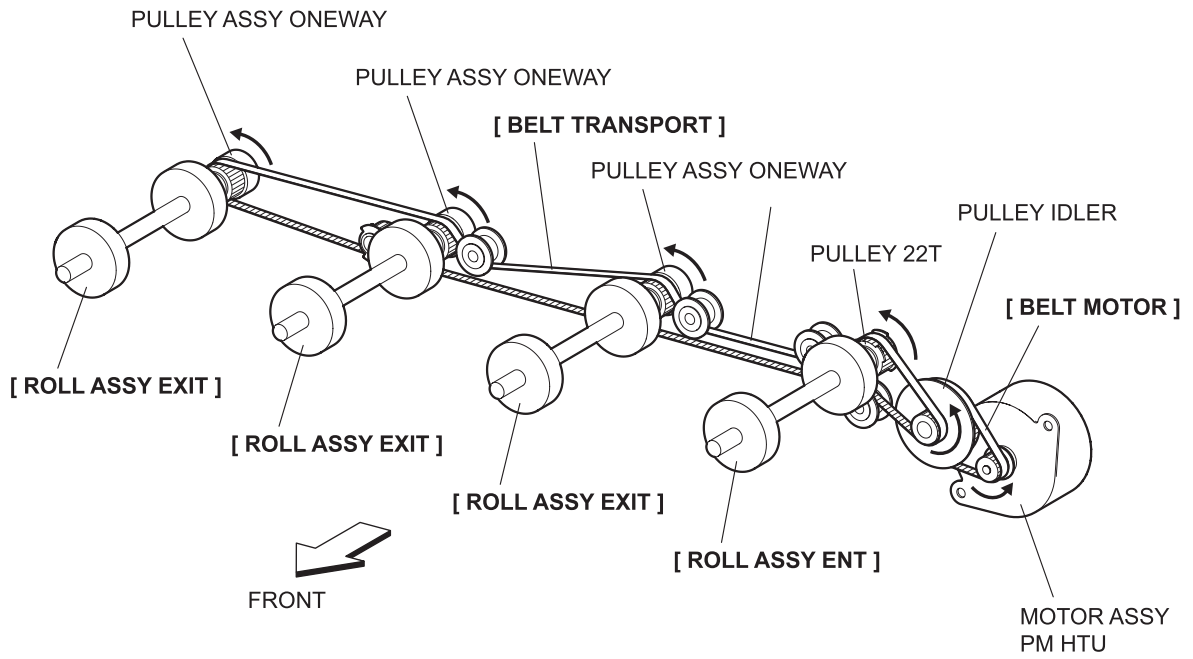

Tbt06121KA

4.2 DRIVE ASSY TRANS

The torque of the DRIVE ASSY TRANS is transmitted through the route below.

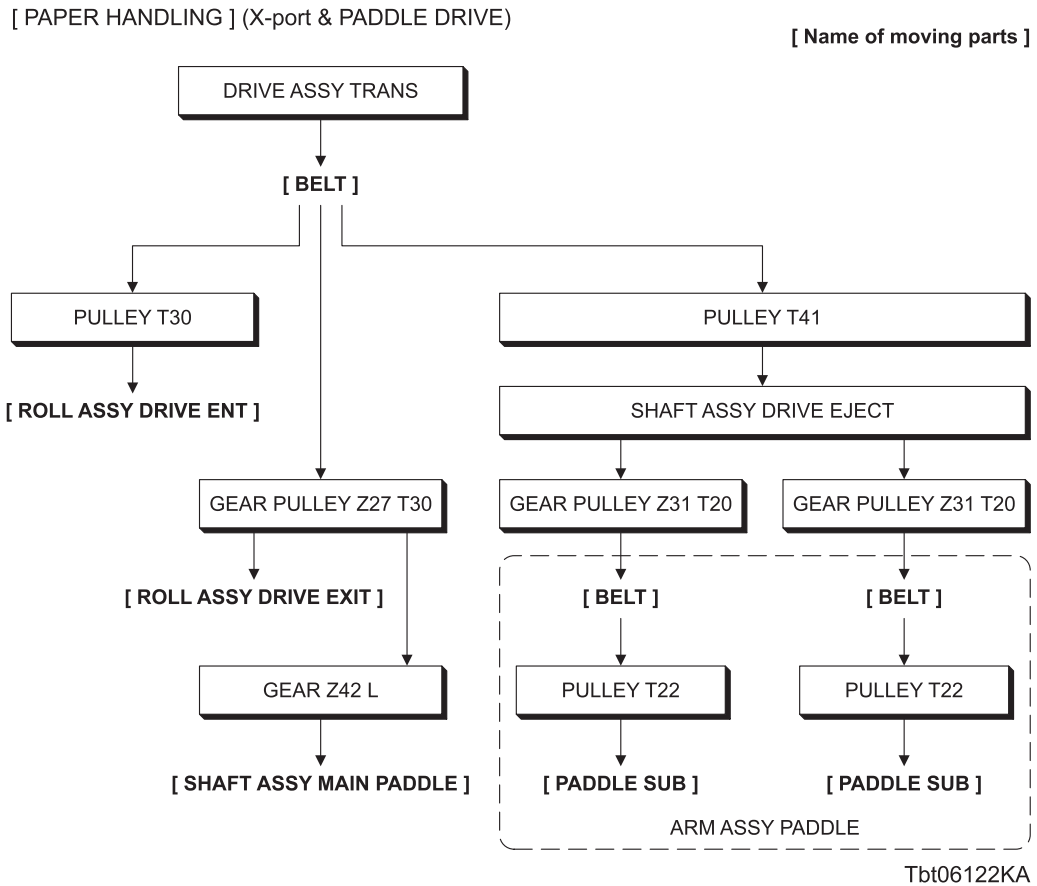

[PAPER HANDLING] (X-port & PADDLE DRIVE)

[Name of moving parts]

▬ : Indicates the engagement of gears.

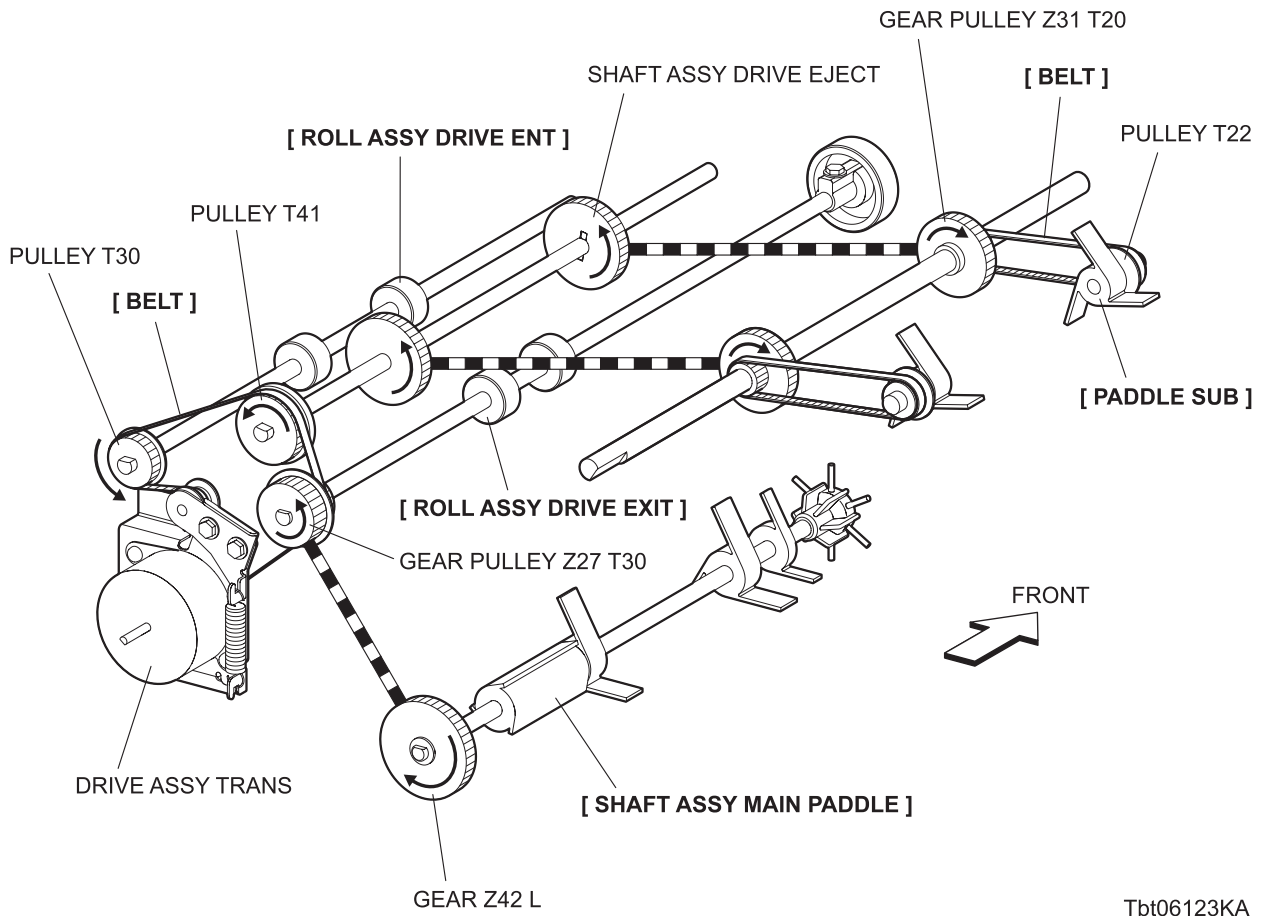

Tbt06123KA

4.3 MOTOR ASSY EJECT DRIVE

During sheet transfer from the X' port to the Compile Tray, the torque of the MOTOR ASSY EJECT DRIVE is transmitted through the route below.

[PAPER EJECT DRIVE] (From X-port)

[Name of moving parts]

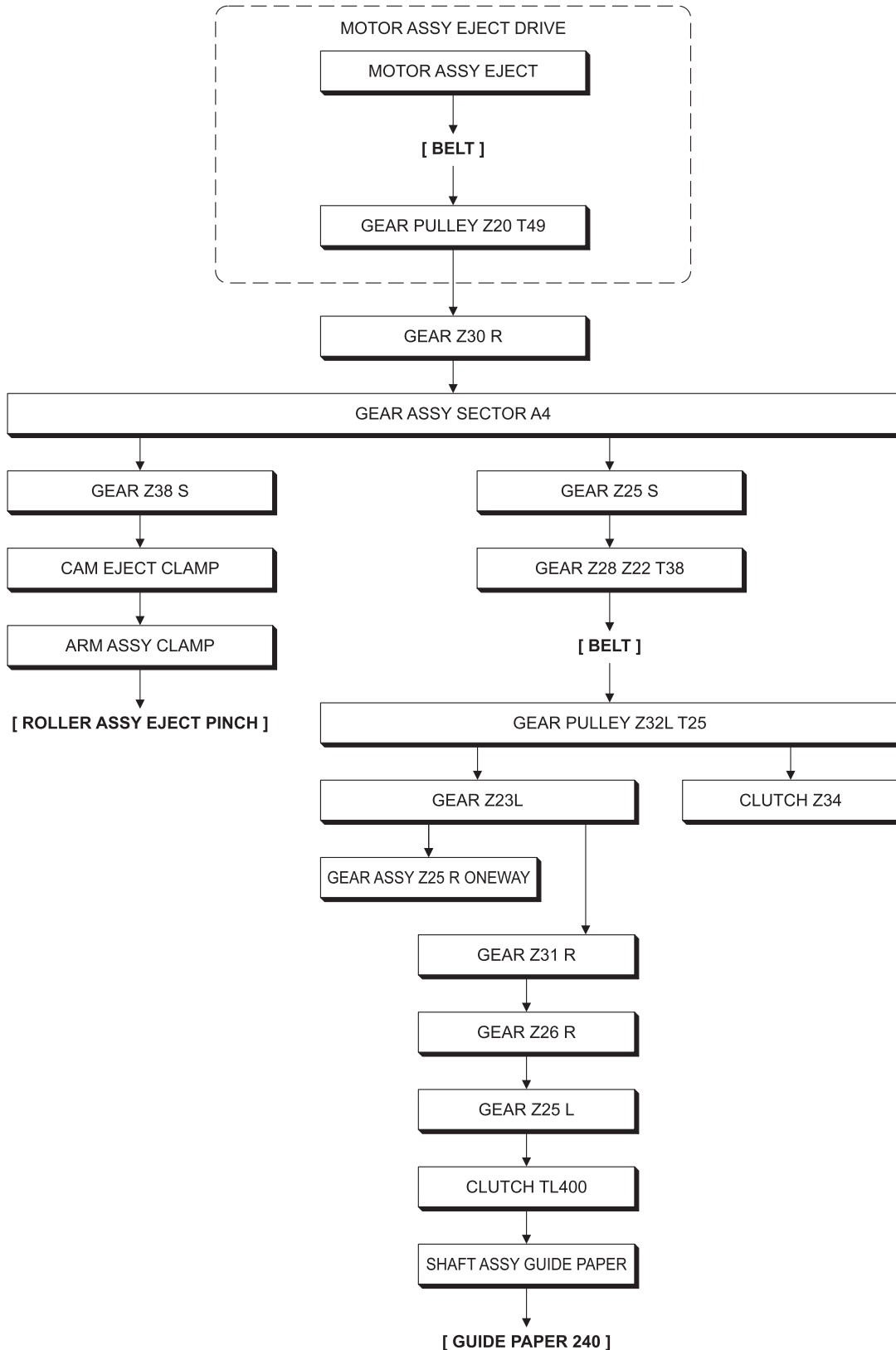

Tbt06124KA

4.4 MOTOR ASSY EJECT DRIVE

During sheet ejection from the Compile Tray to the Stacker Tray, the torque of the MOTOR ASSY EJECT DRIVE is transmitted through the route below.

[PAPER EJECT DRIVE] (To Stacker Tray)

[Name of moving parts]

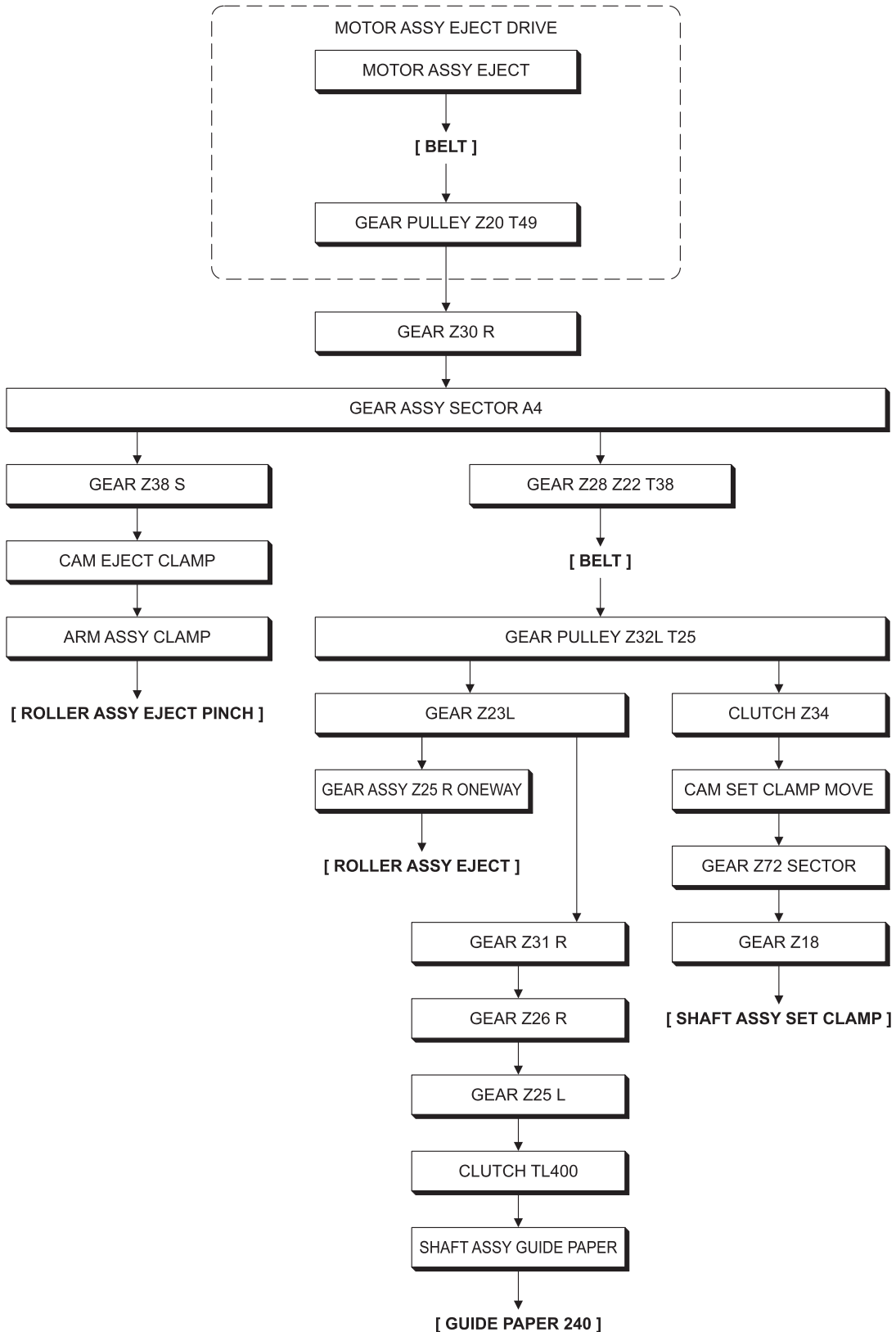

Tbt06126KA

[PAPER EJECT DRIVE] (To Stacker Tray)

[Name of moving parts]

▬ : Indicates the engagement of gears.

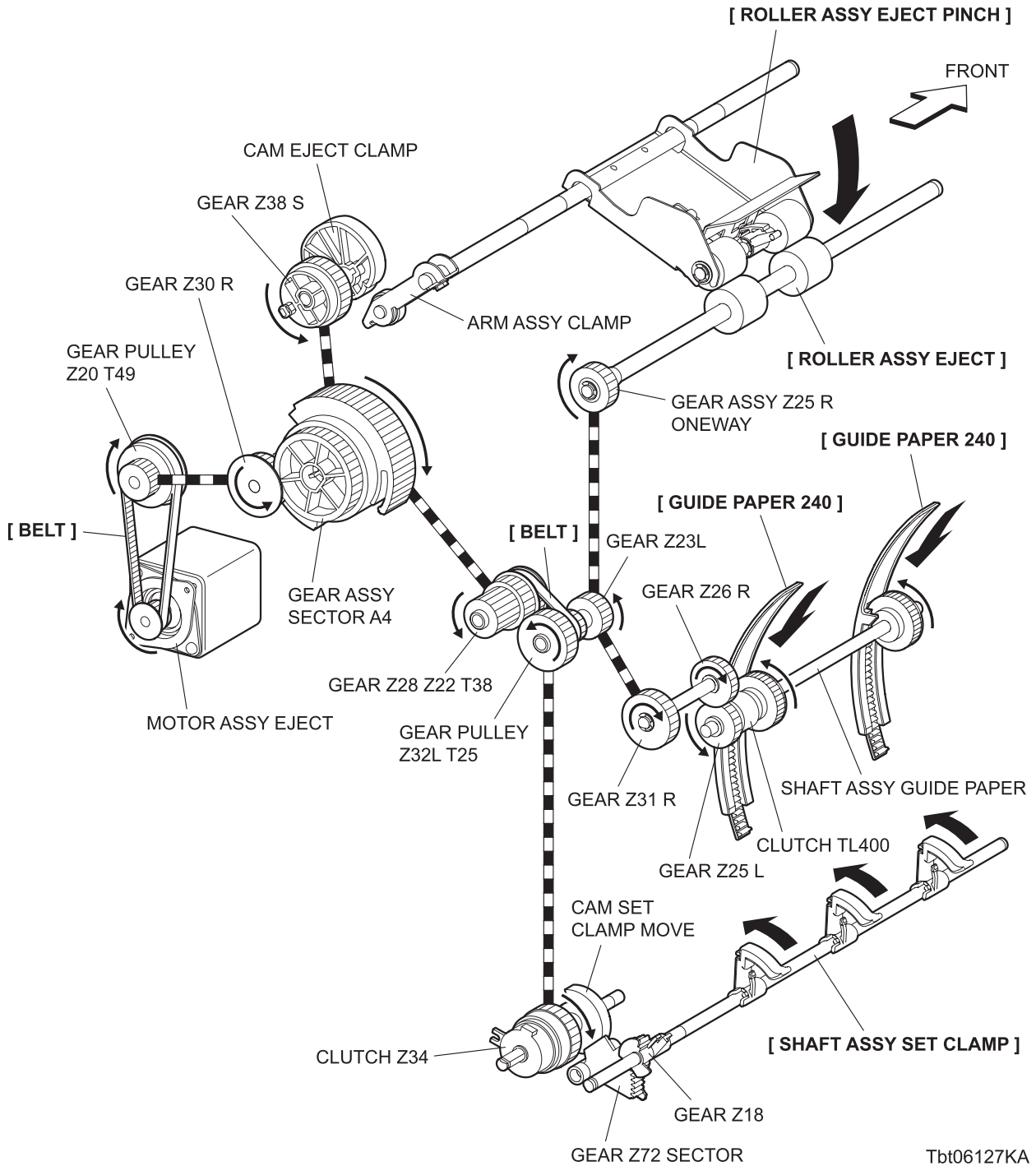

Tbt06127KA

4.5 MOTOR ASSY TAMPER

The torque of the MOTOR ASSY TAMPER is transmitted through the route below.

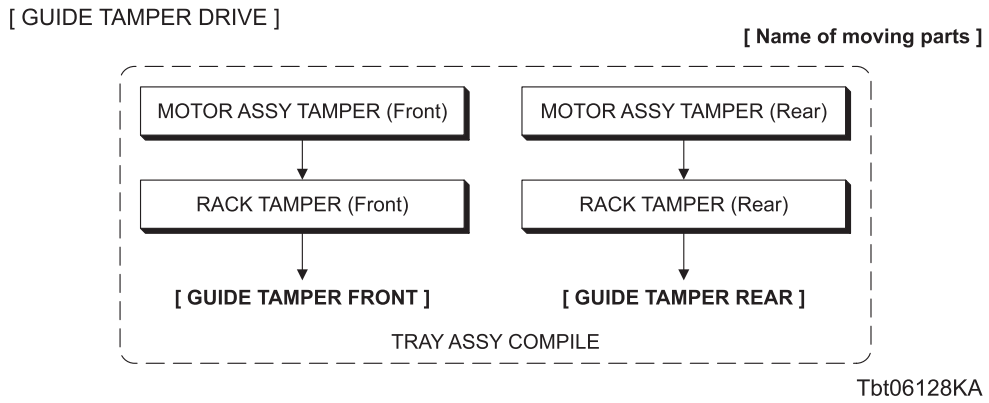

[GUIDE TAMPER DRIVE]

[Name of moving parts]

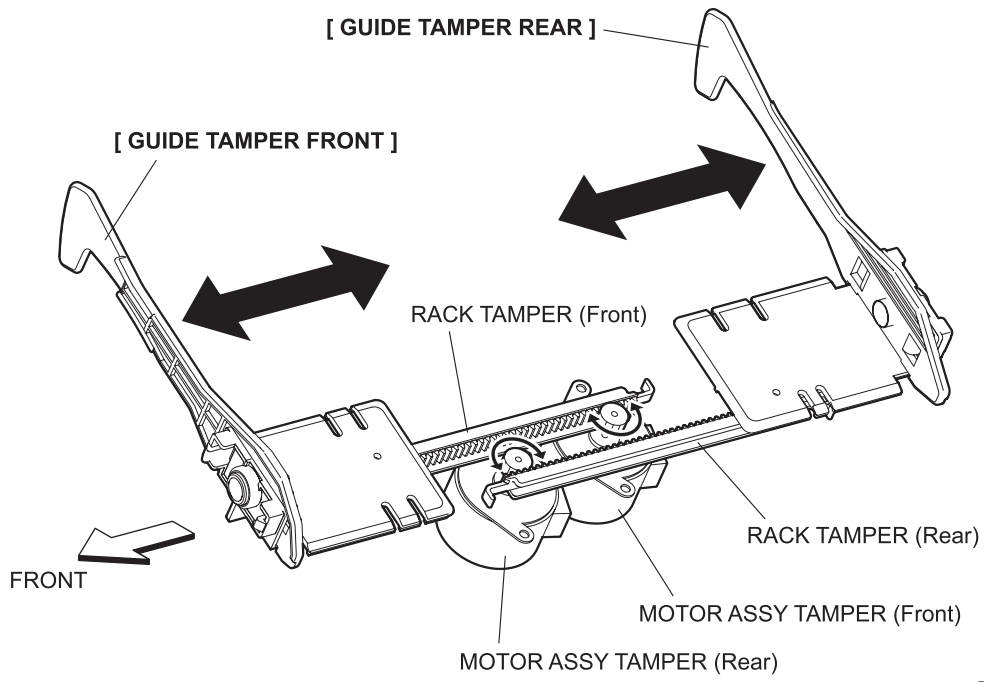

Tbt06129KA

4.6 DRIVE ASSY STACKER

The torque of the DRIVE ASSY STACKER is transmitted through the route below.

[TRAY STACKER DRIVE]

[Name of moving parts]

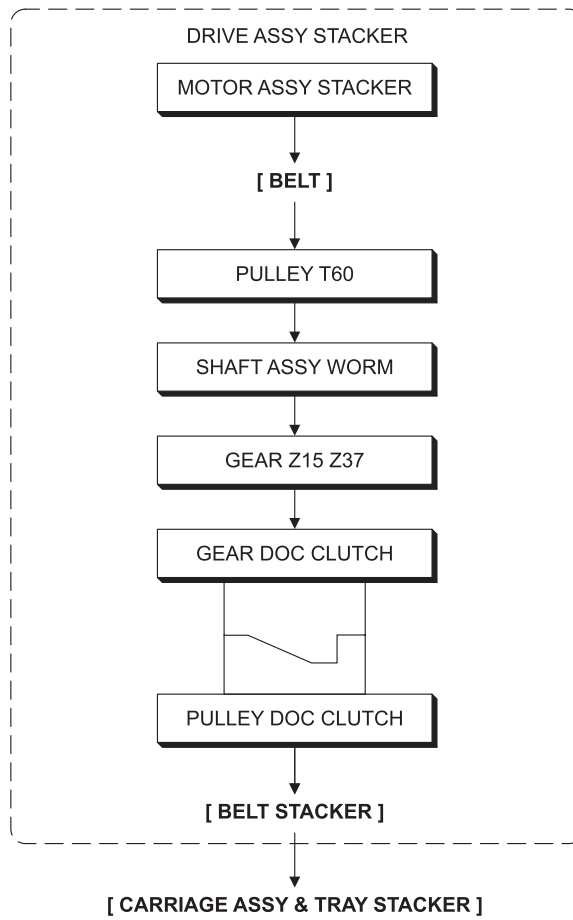

Tbt06130KA

[TRAY STACKER DRIVE]

[Name of moving parts]

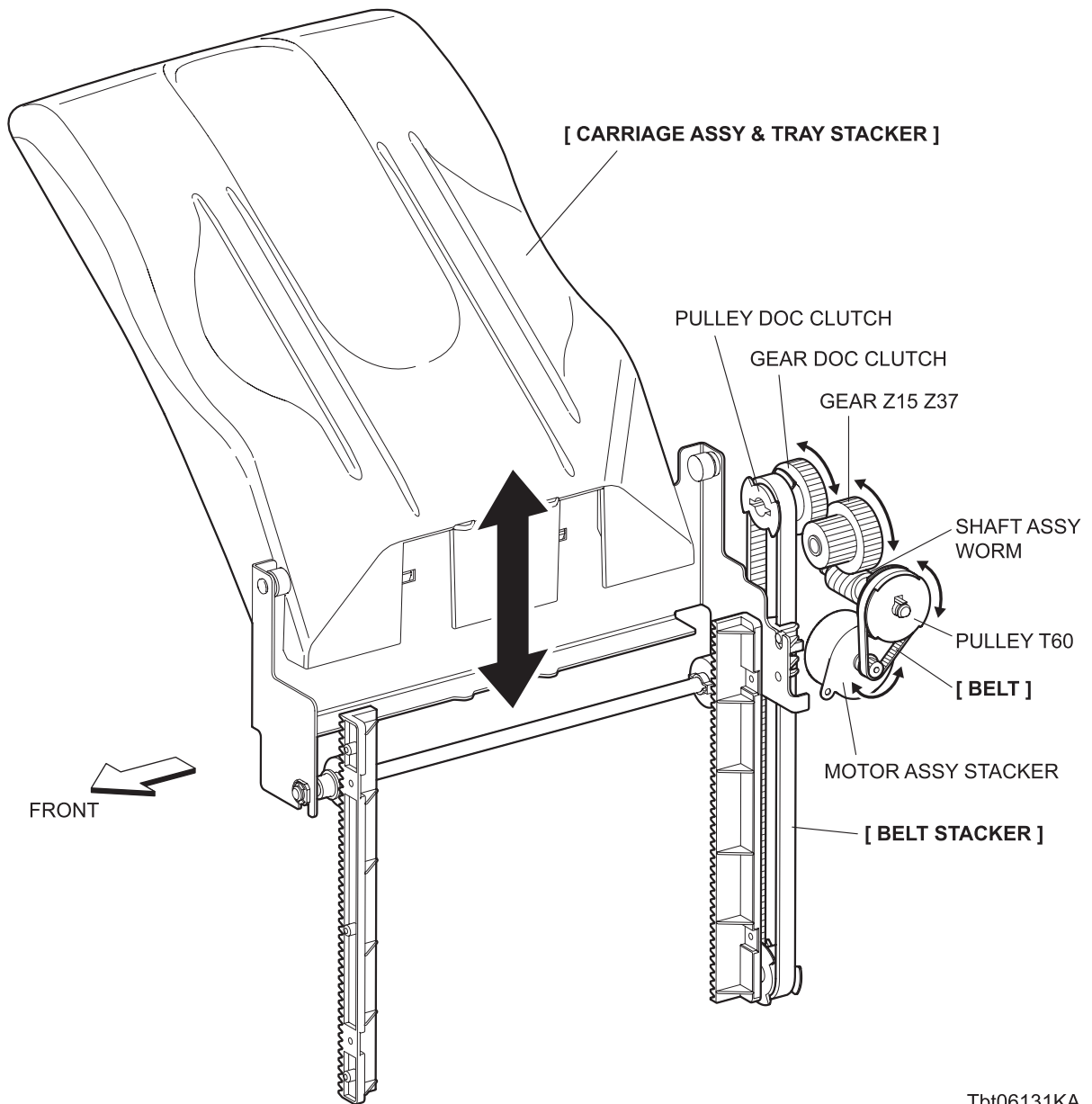

Tbt06131KA

Chapter 7 Wiring Diagrams and Signal Information CONTENTS

1. Connection Wiring Diagram..... 7 - 1

 1.1 Symbols in the General Connection Wiring Diagram..... 7 - 1

 1.2 General Wiring Diagram 7 - 2

2. Interconnection Wiring Diagram of Parts..... 7 - 3

 2.1 Notes on Using the Wiring Diagram between Parts..... 7 - 3

 2.2 Configuration of the Interconnection Wiring Diagram of Parts..... 7 - 5

 § 1 DC POWER SUPPLY & SWITCH 7 - 7

 § 2 H-TRANSPORT, X' PORT & COMPILER TRAY 7 - 9









 § 3 STACKER 7 - 11

 § 4 STAPLER..... 7 - 13

1. Connection Wiring Diagram

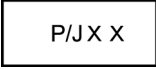
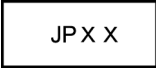
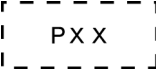
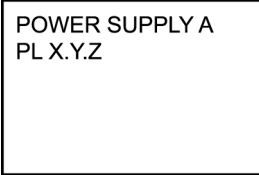
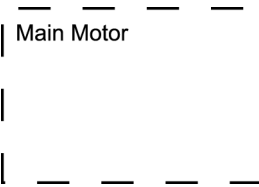
1.1 Symbols in the General Connection Wiring Diagram

The symbols in the general connection wiring diagram are described below.

Symbol	Description
	Represents an interconnection between parts using wiring harness or wire.
	Represents an interconnection which differs according to the specifications.
	Represents an interconnection between parts using a conductive member such as a plate spring.
	Represents a connection between parts by tightening of a screw.
	Indicates a frame ground.
	Represents a connector. The connector No. is indicated inside the box.
	Represents a connection terminal with a plate spring on the printed circuit board. The connector (terminal) No. is indicated inside the box.
	Represents a connector directly connected to the printed circuit board. The connector No. is indicated inside the box.
	The box containing a part name represents a part. "PL X.Y.Z" indicates the item "Z" of the plate (PL) "X.Y" described in Chapter 5 "Parts List."
	Represents a functional part within a part, and indicates the name of the functional part.
	Represents a section in "2. Interconnection Wiring Diagram of Parts," and indicates its section No.
	Represents a screw for fixing wiring harness and a conductive member such as a plate spring.
	Represents a conductive member such as a plate spring.

1.2 General Wiring Diagram

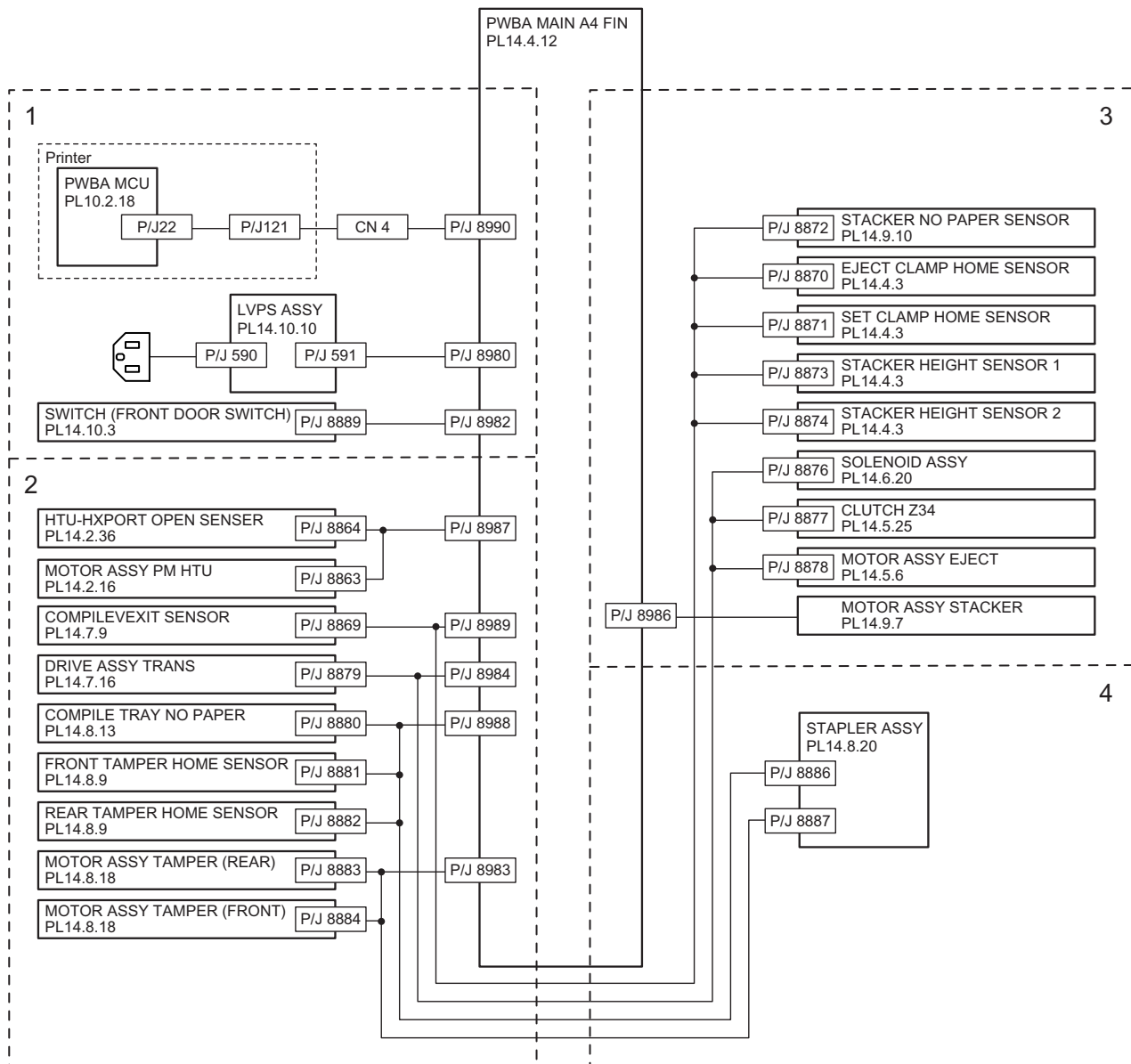



FIN07001KA

2. Interconnection Wiring Diagram of Parts

2.1 Notes on Using the Wiring Diagram between Parts

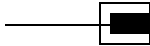
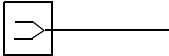
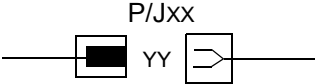
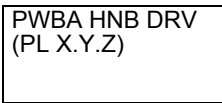
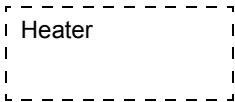
The following describes the legend of the wiring diagrams between parts shown on the following pages.

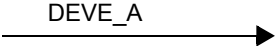
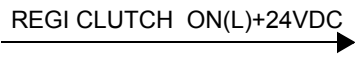
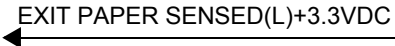
Symbols	Description
	Denotes a plug.
	Denotes a jack.
	Denotes Pin yy and Jack yy of the connector Pxx and Jxx.
	Denotes the parts. PL X.Y.Z implies the item "Z" of plate (PL) "X.Y" in Chapter 5. Parts List.
	Denotes functional parts attached with functional parts name.
	Denotes the control and its outline in PWB.
	Denotes a connection between parts with harnesses or wires, attached with signal name/contents.
	Denotes the function, and logic value of the signal to operate the function (Low: L, High: H). The given voltage is for signal in high status. The arrow indicates the direction of signal.
	Denotes the function, and logic value of the signal when the function operated (Low: L, High: H). The given voltage is for signal in high status. The arrow indicates the direction of signal.

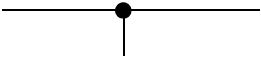
Symbols	Description
	Denotes a connection between wires.
I/L +24VDC	Denotes DC voltage when the interlock switch in HNB MCU WITH CPU turns on.
+5VDC +3.3VDC	Denotes DC voltage.
SG	Denotes signal ground.
AG	Denotes analog ground.
RTN	Denotes the return.

2.2 Configuration of the Interconnection Wiring Diagram of Parts

The interconnection wiring diagram is divided into 4 sections.

§ 1 to § 4 indicate details of the interconnections of parts.

§ 1 DC POWER SUPPLY & SWITCH

Connections of Printer with PWBA MAIN A4 FIN.

Connections of LVPS ASSY with PWBA MAIN A4 FIN.

Connections of SWITCH with PWBA MAIN A4 FIN.

§ 2 H-TRANSPORT, X' PORT & COMPILER

Connections of HTU-HXPORT OPEN SENSOR with PWBA MAIN A4 FIN.

Connections of MOTOR ASSY PM HTU with PWBA MAIN A4 FIN.

Connections of COMPILE EXIT SENSOR with PWBA MAIN A4 FIN.

Connections of DRIVE ASSY TRANS with PWBA MAIN A4 FIN.

Connections of COMPILE TRAY NO PAPER SENSOR with PWBA MAIN A4 FIN.

Connections of FRONT TAMPER HOME SENSOR with PWBA MAIN A4 FIN.

Connections of REAR TAMPER HOME SENSOR with PWBA MAIN A4 FIN.

Connections of MOTOR ASSY TAMPER (REAR) with PWBA MAIN A4 FIN.

Connections of MOTOR ASSY TAMPER (FRONT) with PWBA MAIN A4 FIN.

§ 3 STACKER

Connections of STACKER NO PAPER SENSOR with PWBA MAIN A4 FIN.

Connections of EJECT CLAMP HOME SENSOR with PWBA MAIN A4 FIN.

Connections of SET CLAMP HOME SENSOR with PWBA MAIN A4 FIN.

Connections of STACKER HEIGHT SENSOR 1 with PWBA MAIN A4 FIN.

Connections of STACKER HEIGHT SENSOR 2 with PWBA MAIN A4 FIN.

Connections of SOLENOID ASSY with PWBA MAIN A4 FIN.

Connections of CLUTCH Z34 with PWBA MAIN A4 FIN.

Connections of MOTOR ASSY EJECT with PWBA MAIN A4 FIN.

Connections of MOTOR ASSY STACKER with PWBA MAIN A4 FIN.

§ 4 STAPLER

Connections of STAPLER ASSY with PWBA MAIN A4 FIN.

BLANK PAGE

§ 1 DC POWER SUPPLY & SWITCH

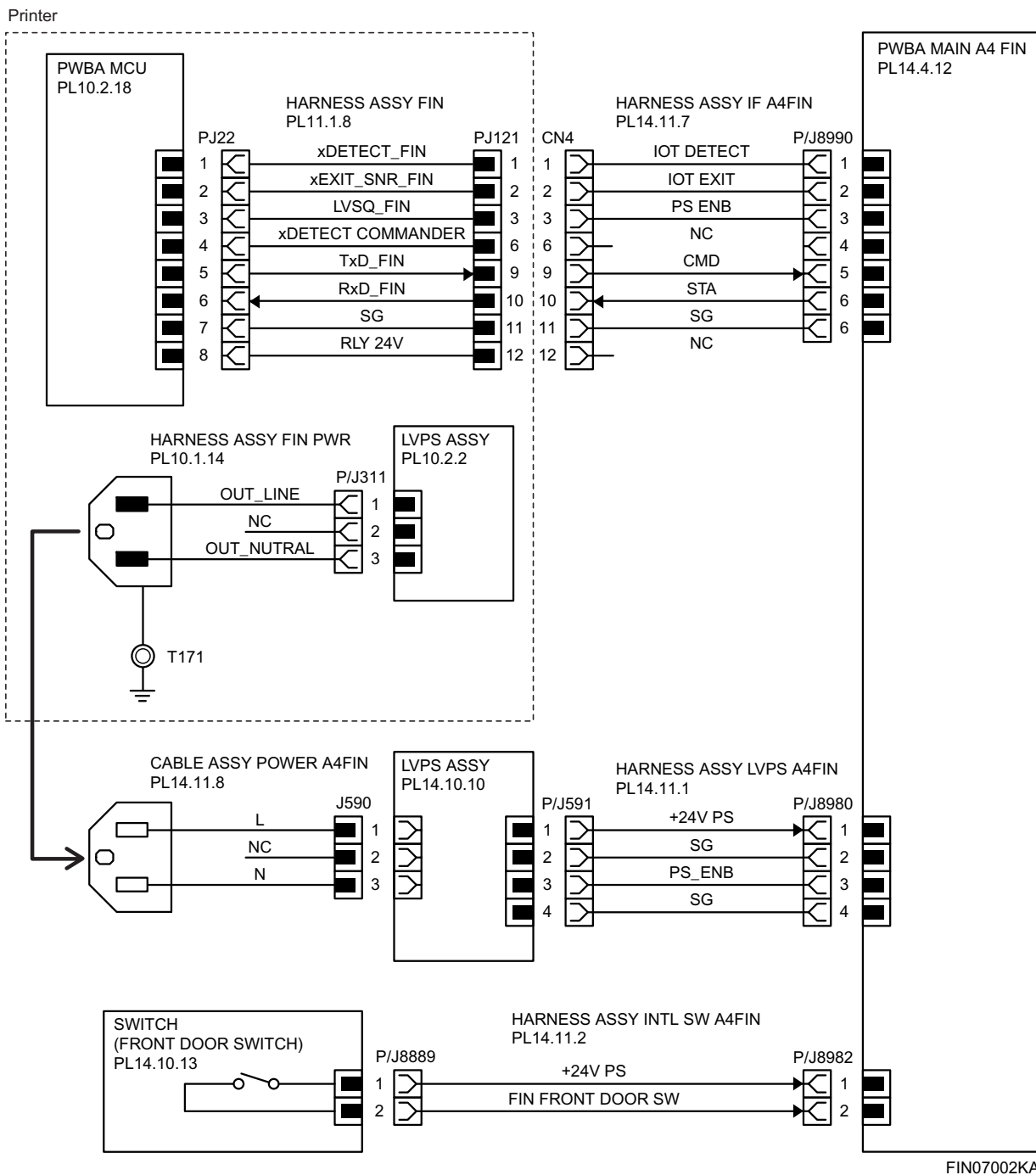

Signal line name	Description
xDETECT_FIN xEXIT_SNR_FIN LVSQ_FIN xDETECT COMMANDER TxD FIN RxD FIN	Communication signal of PWB A MCU (Engine) and PWB MAIN A4 FIN(Finisher)
PS_ENB	Control signal of the LVPS
FIN FRONT DOOR SW	Control signal of the Switch(Front Door)

§ 2 H-TRANSPORT, X' PORT & COMPILER TRAY

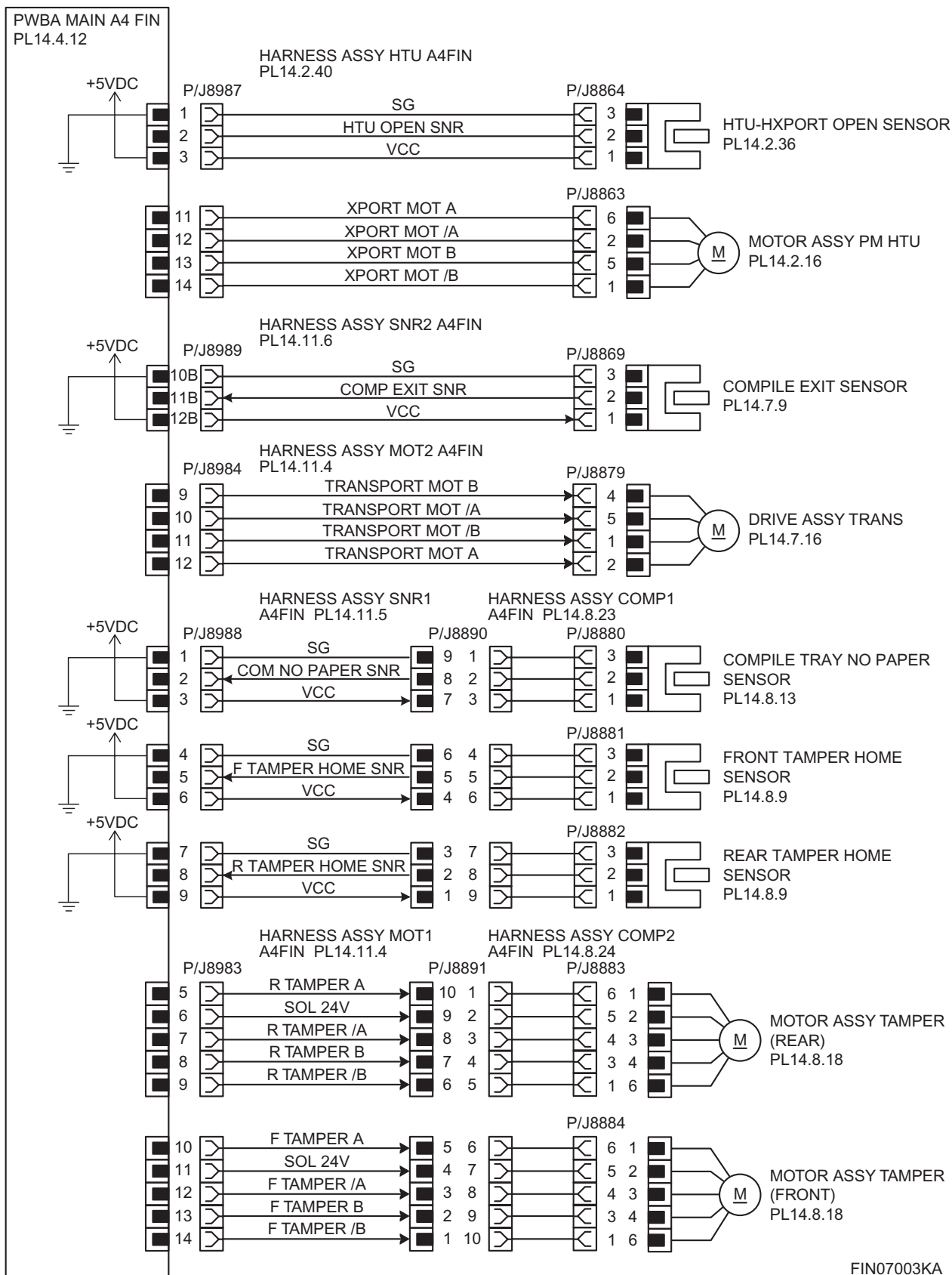

FIN07003KA

Signal line name	Description
HTU OPEN SNR	Opening/closing detection signal of "COVER TOP H-TRA"
XPORT MOT A XPORT MOT /A XPORT MOT B XPORT MOT /B	Drive control signal of the MOTOR ASSY PM HTU.
COMP EXIT SNR	Transport paper detection signal to Compile Tray by SENSOR (Compile Exit Sensor)
TRANSPORT MOT A TRANSPORT MOT /A TRANSPORT MOT B TRANSPORT MOT /B	Drive control signal of the DRIVE ASSY TRANS.
COM NO PAPER SNR	Paper detection signal in Compiler Tray by SENSOR(COMPILE TRAY NO PAPER)
F TAMPER HOME SNR	Front Tamper home position detection signal by SENSOR (FRONT TAMPER HOME SENSOR)
R TAMPER HOME SNR	Rear Tamper home position detection signal by SENSOR (REAR TAMPER HOME SENSOR)
R TAMPER A R TAMPER /A R TAMPER B R TAMPER /B	Drive control signal of the MOTOR ASSY TAMPER (REAR).
F TAMPER A F TAMPER /A F TAMPER B F TAMPER /B	Drive control signal of the MOTOR ASSY TAMPER (FRONT).

§ 3 STACKER

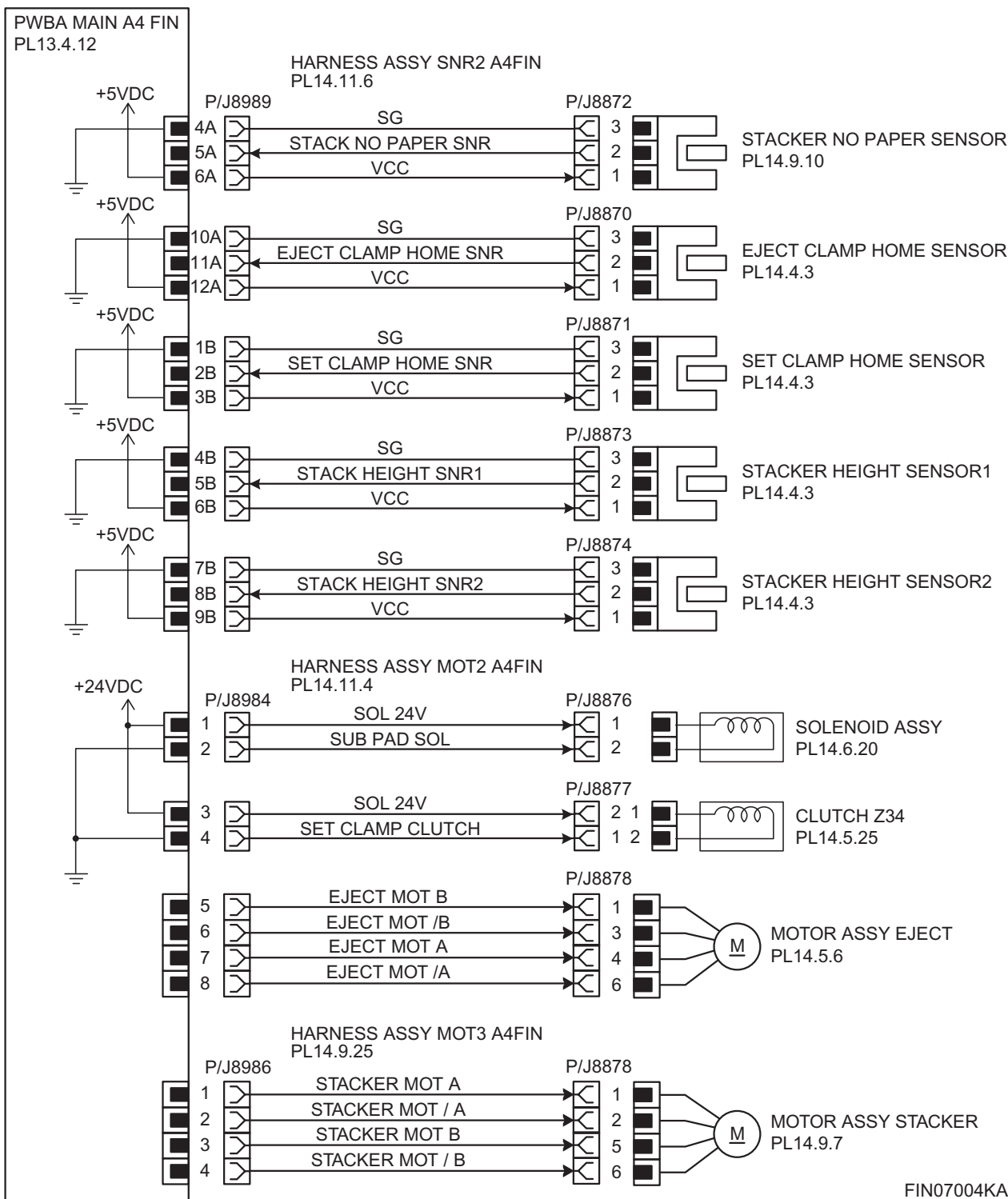

Signal line name	Description
STACK NO PAPER SNR	Paper detection signal in Stack Tray by SENSOR (STACKER NO PAPER SENSOR)
EJECT CLAMP HOME SNR	Eject Clamp home position detection signal by SENSOR (EJECT CLAMP HOME SENSOR)
SET CLAMP HOME SNR	Set Clamp home position detection signal by SENSOR (SET CLAMP HOME SENSOR)
STACK HEIGHT SNR1	Height detection signal of Stack Tray by SENSOR (STACKER HEIGHT SENSOR1)
STACK HEIGHT SNR2	Height detection signal of Stack Tray by SENSOR (STACKER HEIGHT SENSOR2)
SUB PAD SOL	SOLENOID ASSY(Sub Paddle Solenoid) ON/OFF control signal
SET CLAMP CLUTCH	CLUTCH Z34(Set Clamp Clutch) ON/OFF control signal
EJECT MOT A EJECT MOT /A EJECT MOT B EJECT MOT /B	Drive control signal of the MOTOR ASSY EJECT.
STACKER MOT A STACKER MOT /A STACKER MOT B STACKER MOT /B	Drive control signal of the D MOTOR ASSY STACKER.

§ 4 STAPLER

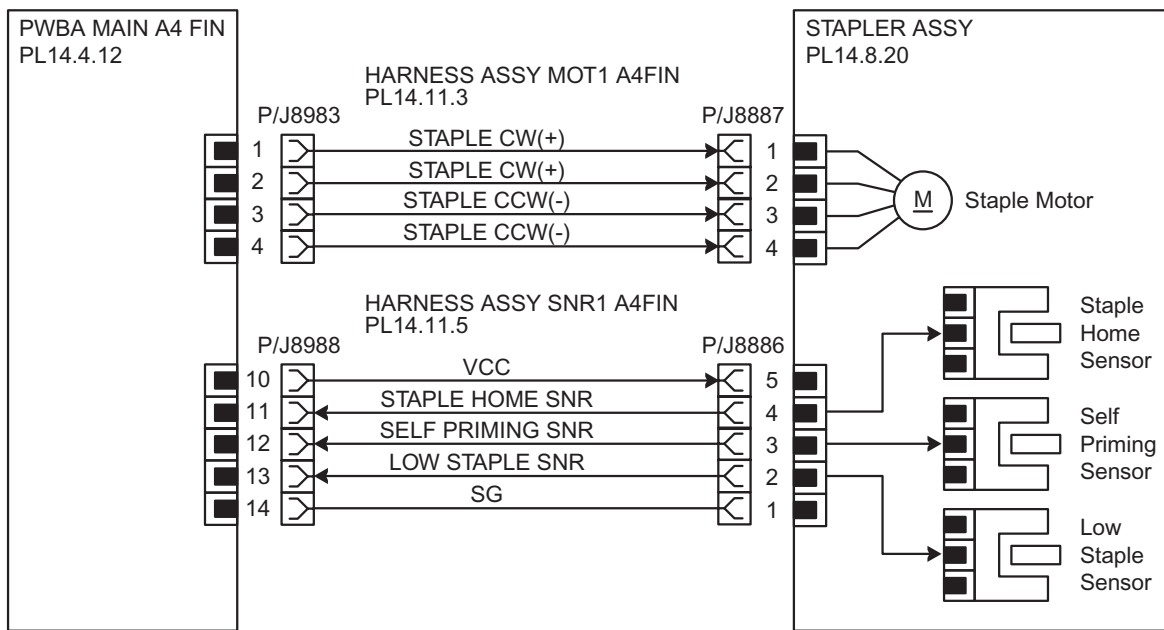

FIN07005KA

Signal line name	Description
STAPLE CW(+) STAPLE CCW(-)	Drive control signal of the Staple Motor.
STAPLE HOME SNR	Stapler Head home position detection signal by Staple Home Sensor in STAPLER ASSY
LOW STAPLE SNR	Detection signal of the needle of Stapler by Low Staple Sensor in STAPLER ASSY.

Chapter 8 Printer Specifications CONTENTS

1. Configuration of Finisher	8 - 1
1.1 Basic Configuration.....	8 - 1
2. Electrical Properties.....	8 - 2
2.1 Power Supply.....	8 - 2
2.2 Power Consumption.....	8 - 2
3. Mechanical Properties	8 - 3
3.1 Dimensions/Mass of Horizontal-Transport.....	8 - 3
3.2 Dimensions/Mass of Finisher.....	8 - 3
3.3 Installation Requirements	8 - 4
4. Functions	8 - 5
4.1 Stapling	8 - 5
4.2 Stacker Tray Ejection Mode.....	8 - 5
4.3 Paper Stack Capacity	8 - 5
4.4 Paper Size and Available Functions	8 - 5
4.5 Stapling Position	8 - 6
4.6 Processing Speed.....	8 - 6
5. Consumables.....	8 - 7
5.1 Items of Consumables	8 - 7
5.2 Consumable Life	8 - 7
6. Operating Environment.....	8 - 8
6.1 Ambient Temperature/Humidity	8 - 8
6.2 Installation Levelness.....	8 - 8
6.3 Ambient Lighting	8 - 8
7. Safety/Environment Conditions	8 - 9
7.1 Safety Standard	8 - 9
7.2 EMI.....	8 - 9

Chapter 8 Printer Specifications CONTENTS

1. Configuration of Finisher

1.1 Basic Configuration

The Finisher consists of "Horizontal-Transport", "Stacker Tray", and "Finisher Main Unit".
The Finisher functions only when installed to the printer.

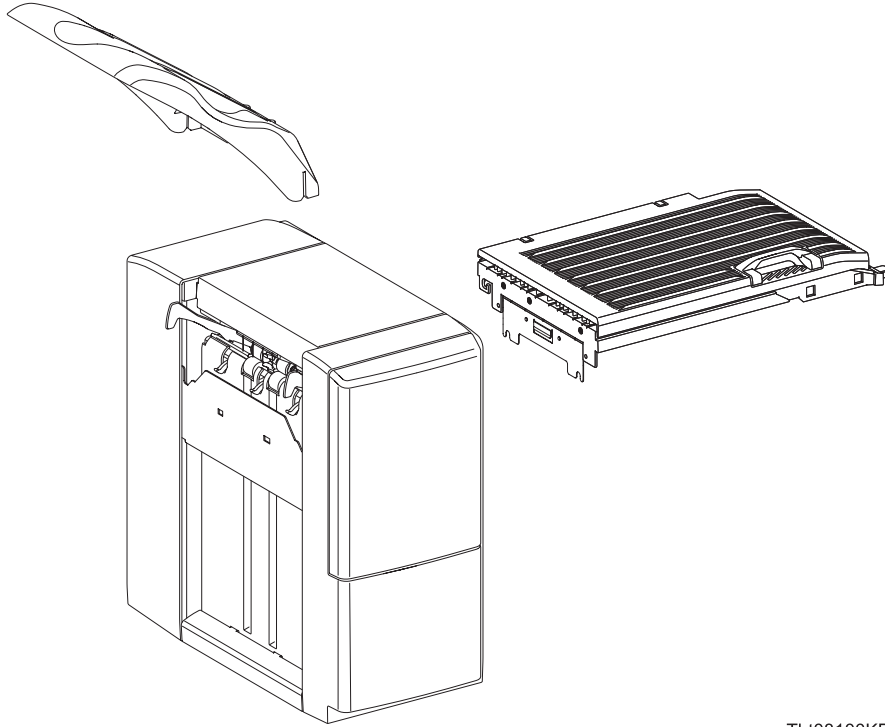

Tbt08100KB

2. Electrical Properties

2.1 Power Supply

The Finisher receives AC power from the printer it is connected to (100 to 240 VAC).

2.2 Power Consumption

65 VA or less

3. Mechanical Properties

3.1 Dimensions/Mass of Horizontal-Transport

Width (mm)	Depth (mm)	Height (mm)	Mass (kg)
429.8	256.3	115.8	1.7 or less

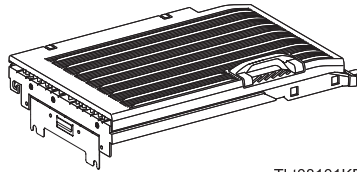

Tbt08101KB

3.2 Dimensions/Mass of Finisher

Width (mm)	Depth (mm)	Height (mm)	Mass (kg)
490.2	516	524.7	14.0 or less

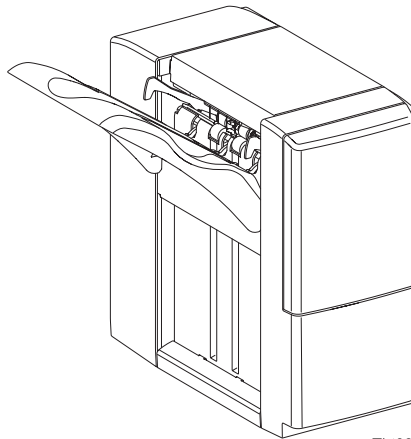

Tbt08102KB

3.3 Installation Requirements

The finisher requires the minimum installation space shown below for typical operation.
(Space occupied by the operator is not included.)

Top view

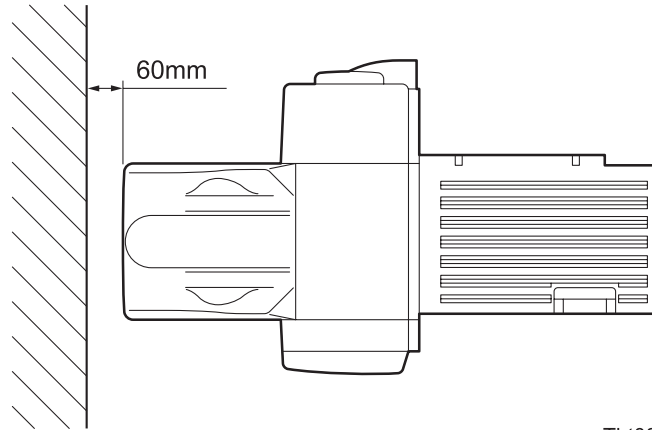

Tbt08103KA

4. Functions

4.1 Stapling

- Stapling Position: Front Corner
- Maximum Stapling Capacity: 50 sheets (90 g/m² or less)
- Staple Capacity: 5,000 or more

4.2 Stacker Tray Ejection Mode

The ejection mode is automatically selected from Set Mode and Sheet Mode depending on the paper size.

- Set Mode: The sheets are deposited in the Compile Tray, and then ejected to the Stacker Tray.
- Sheet Mode: The sheets are directly ejected to the Stacker Tray. Offset stacking and stapling cannot be used in this mode.

4.3 Paper Stack Capacity

Tray	Paper Size	Non-staple	Staple
Stacker Tray (Set Mode)	A4 B5 A5 Letter Executive C5	1,000 sheets	50 sets or 750 sheets
	Legal	750 sheets	50 sets or 500 sheets
Stacker Tray (Sheet Mode)	Other than those above	300 sheets	-

4.4 Paper Size and Available Functions

Paper Size	Stacker		Offset	Staple
	Set Mode	Sheet Mode		
A4 (210 x 297 mm)	Yes	Yes	Yes	Yes
A5 (148 x 210 mm)	No	Yes	No	No
B5 (182 x 257 mm)	Yes	Yes	Yes	Yes
Letter (8.5 x 11 in.)	Yes	Yes	Yes	Yes
Folio (8.5 x 13 in.)	Yes	No	Yes	Yes
Legal (8.5 x 14 in.)	Yes	Yes	Yes	Yes
Executive (7.25 x 10.5 in.)	Yes	Yes	Yes	Yes
Envelope #10 (4.125 x 9.5 in.)	No	Yes	No	No
Monarch (3.875 x 7.5 in.)	No	Yes	No	No

Yes: Supported No: Not Supported

4.5 Stapling Position

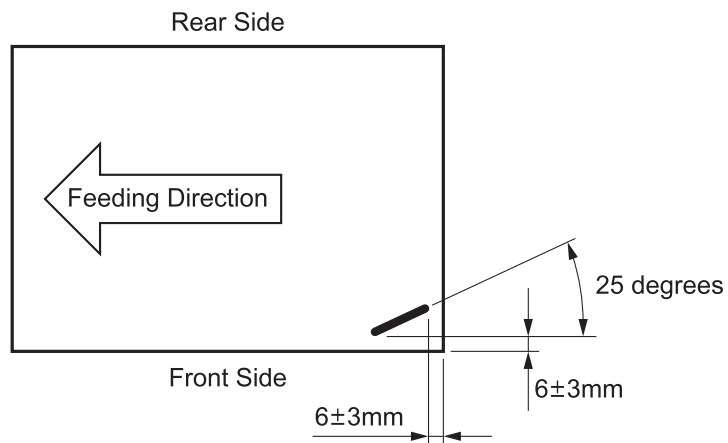

Tbt08105KA

4.6 Processing Speed

The processing speed of the Finisher depends on that of the Printer.

5. Consumables

5.1 Items of Consumables

- Staple cartridge

5.2 Consumable Life

- Staple cartridge: 5,000 staples

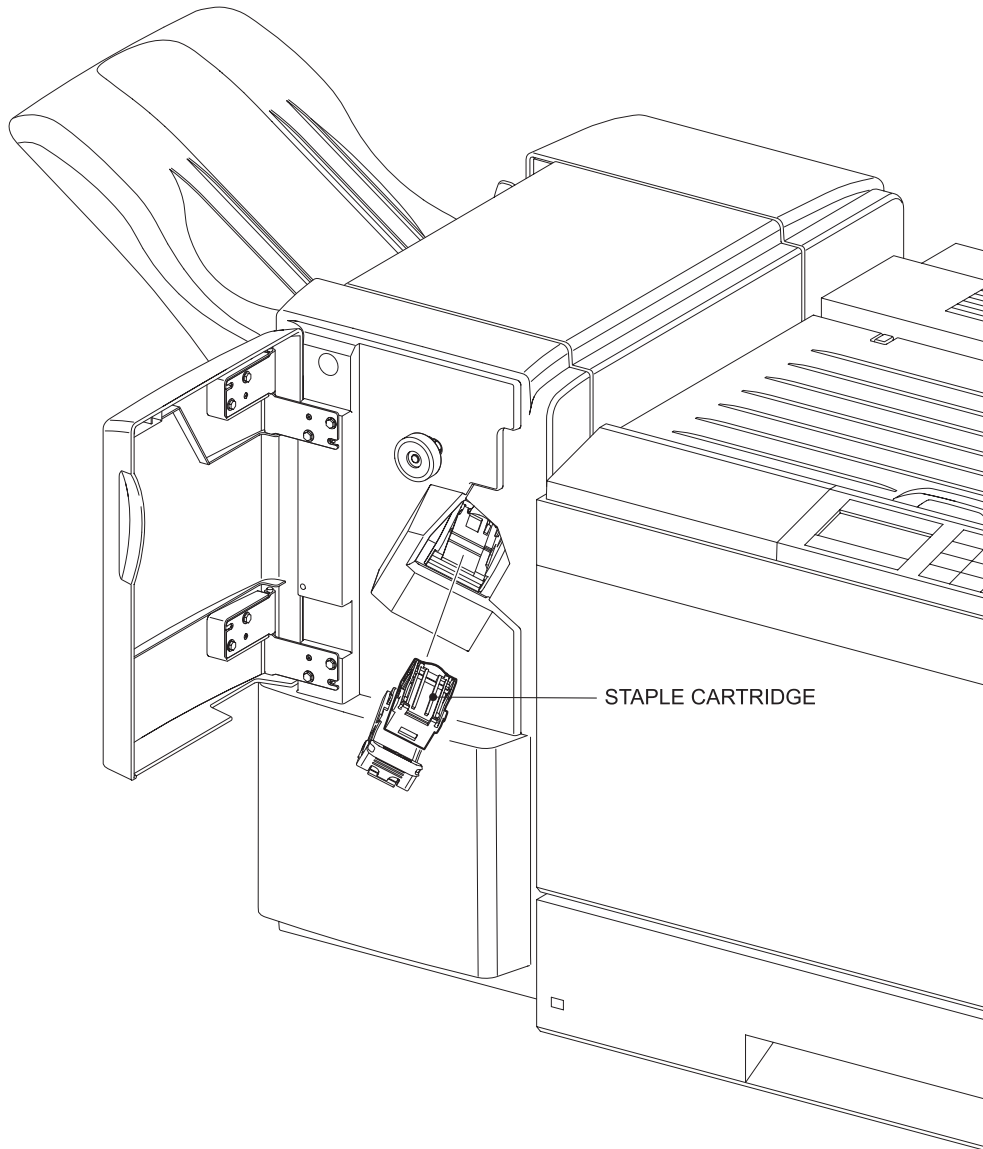

Tbt08106KA

6. Operating Environment

6.1 Ambient Temperature/Humidity

The ambient temperature and humidity of the installation site shall be as follows:

At operation: 10-32 °C, 15-85%RH (Non-condensing)

6.2 Installation Levelness

When secured to the Printer, the Finisher shall not malfunction at a tilt of 1° to the front, back, right, or left.

6.3 Ambient Lighting

3000 lux or less (without direct sunlight)

7. Safety/Environment Conditions

7.1 Safety Standard

- 100V system
 - UL60950-1
 - CSA C22.2 No.60950
- 220V system
 - IEC60950

7.2 EMI

- 100/110V system (US)
 - FCC Part 15, Subpart B, Class B
- 220V system (EC)
 - EN55022, Class B