



# Dell 5110cn **Service Manual**

**Information in this document is subject to change without notice.  
2010 Dell Inc. All rights reserved.**

Reproduction in any manner whatsoever without the written permission of Dell Inc. is strictly forbidden.  
Trademarks used in this text: Dell and the DELL logo are trademarks of Dell Inc.

Other trademarks and trade names may be used in this document to refer to the entities claiming the marks and names of their products. Dell Inc. disclaims any proprietary interest in trademarks and trade names other than its own.

# **Cautions for operation**

Contents of this document may be subjected to modification without previous notice.

Dell Inc. will not assume responsibility for accidental or incidental damages resulting from technical or editorial errors or omissions in this manual, the issue of this manual, the execution of descriptions in this manual, or the use of this manual.

This document is protected by copyright. Do not photocopy or duplicate any part of this document in any form without written permission from Dell Inc.

## 1. About this manual

This manual is a standard service manual of Dell Inc. containing information required for maintenance of this laser printer (standard specifications).

## 2. Marks giving caution

Maintenance operations requiring special cautions or additional information to descriptions of this manual are presented as "Warning", "Caution", or "Note", according to their nature.



***If instructions are not observed, death or serious injury may be caused.***



***If instructions are not observed, injuries of workers or physical damages to assets (including this laser printer) may result.***

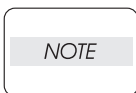

***Particularly important essentials for procedures, steps, rules, and others.***

***Reference*** *Incidental information to descriptions.*

## 3. Related documents

▼ Instruction manuals (standard manuals)

Describe operation and handling of this laser printer.

▼ Performance specifications

Describe in detail various specifications of this laser printer.

(In the event of discrepancy between this manual and the performance specifications, the performance specifications shall take preference.)

▼ Video interface specifications

Detailed video interface specifications for this laser printer

▼ Spare parts list

Information on maintenance parts (spare parts) for this laser printer

## 4. Safety

To prevent possible accidents during maintenance operation, you should observe strictly the "Warning" and "Caution" information in this manual.

Dangerous operations and operations out of range of this manual should be absolutely avoided.

Generally various processes not covered by this manual may be required in actual operation, which should be performed carefully always giving attention to safety.

### 4.1 Power source

Keep the power supply off during maintenance operation to prevent electric shock, burns and other damages. Keep the power plug disconnected during the maintenance operation.

If the power supply should be kept connected for measurement of voltage or other similar reasons, sufficient care should be given to prevent electric shock, by following the procedures of this manual.



***While the printer is ON, never touch live parts if not required absolutely.***



***Power is supplied to the power unit (Low Voltage Power Supply ASSY) even while the printer is off. Never touch its live components.***



***Do not touch live parts unless otherwise specified.***

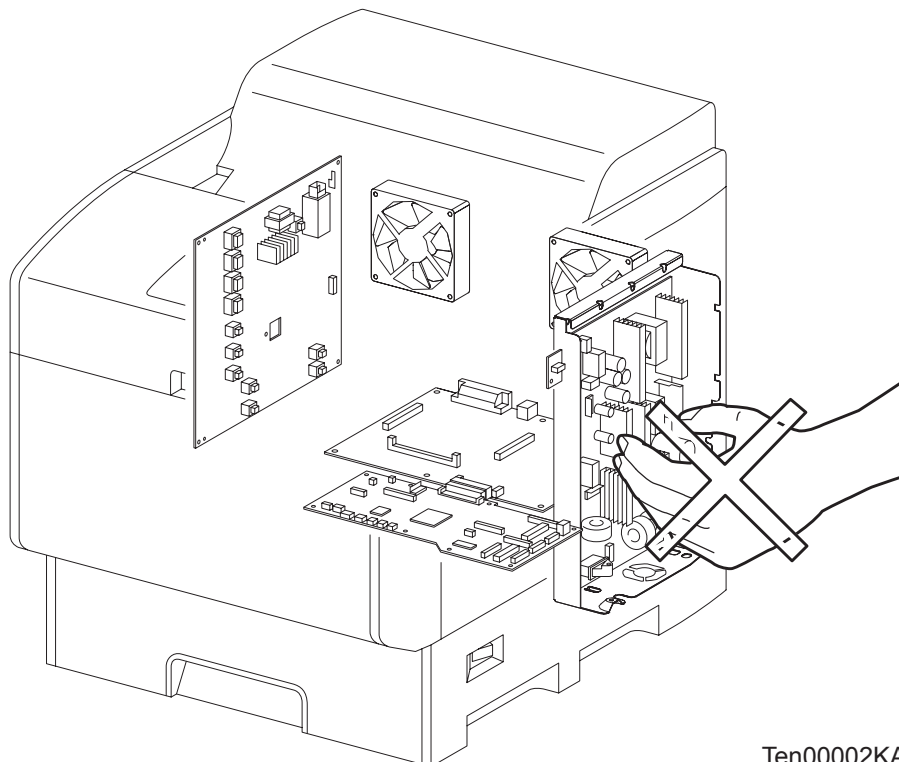

Ten00002KA

## 4.2 Driving units

When servicing gears or other driving units, be sure to turn them OFF and plug off. Drive them manually when required.



***Never touch the gears or other driving units while the printer is running.***

## 4.3 High-temperature units

When servicing high-temperature units (securing unit, etc.), be sure to turn them OFF to prevent burns, injuries and other troubles, remove the power plug and start service processes after they have cooled down enough.



***Immediately after completion of operation, they are still hot. Start services after more than 40 minutes.***

## 4.4 Laser beams



- *If your eyes are exposed to laser beams, you may lose your eyesight.*
- *Never open the cover if warning label for laser beams is attached there.*
- *Before disassembling and reassembling this laser printer, be sure to turn it OFF.*
- *When servicing this laser printer while it is running, be sure to follow the procedures specified in this manual.*
- *You should understand the features of the laser beams which are capable of having an injurious action on the human body, not to extend the danger over the workers as well as other people around the printer.*

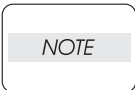

Laser beams have features as follows:

- **Frequencies are smaller in width than other beams (sun and electric bulbs) and phases are uniform so that high monochromatic and convergence performance can be obtained and thin beams of light can reach places at a long distance.**
- **Due to the high convergence, beams are concentrated in high density and high temperature, which is dangerous to human body.**

**Reference:** *Laser beams of this laser printer is invisible rays which you cannot see.*

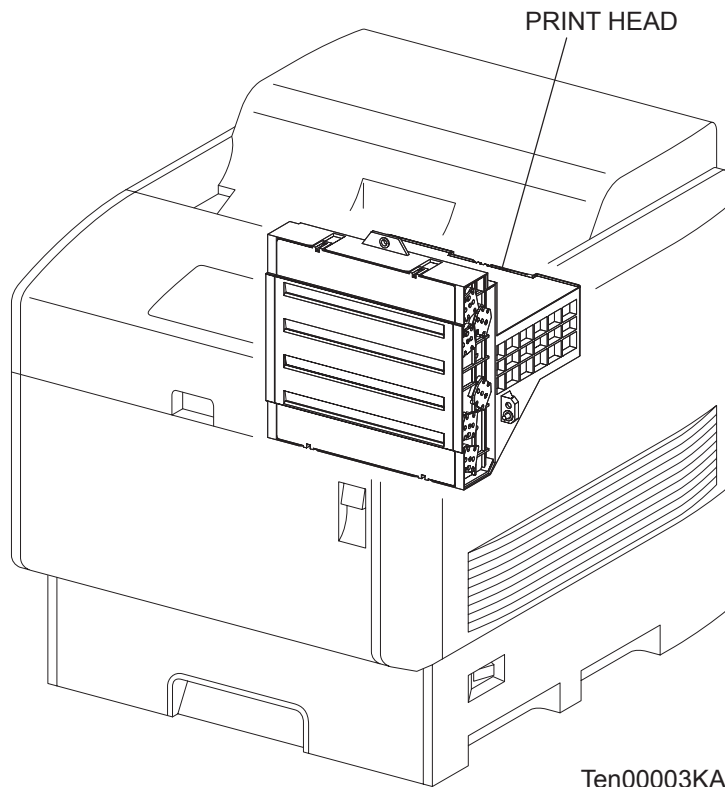

## 4.5 Warning/caution labels

Warning labels and caution labels are attached to this laser printer to prevent accidents. Check those labels for their peeling or stain when servicing the printer.

### 4.5.1 Caution label for high-temperature units

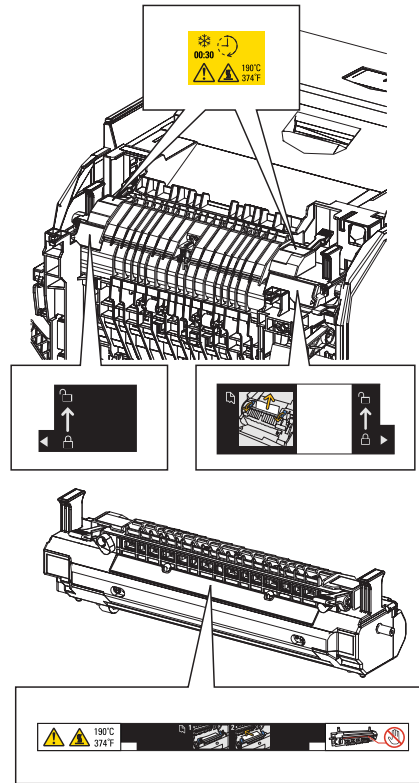

Ida\_Sec00\_010FA

### 4.5.2 Caution label regarding toner cartridge

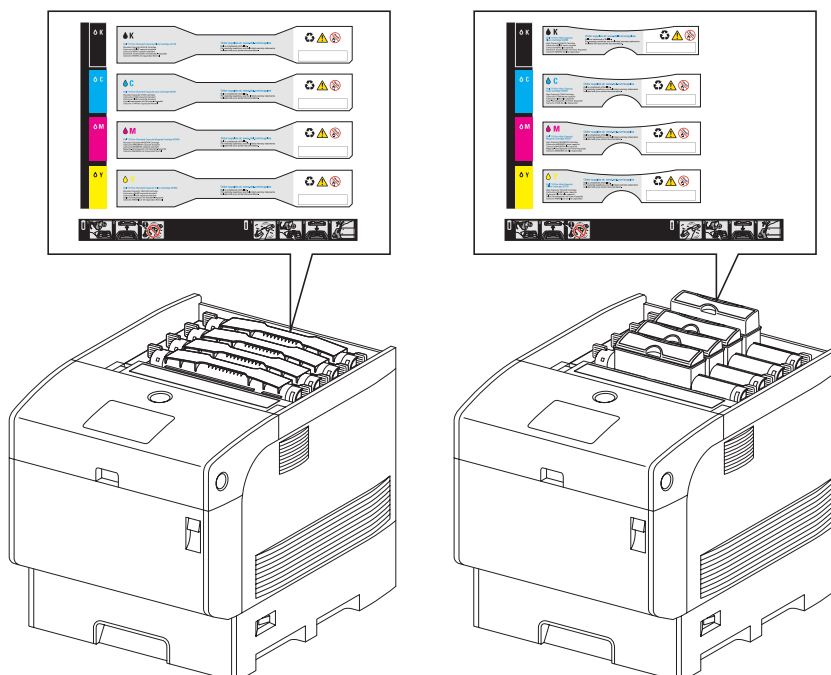

Ten00004KA



### 4.5.3 Caution label regarding Imaging Drum and Transfer Roller

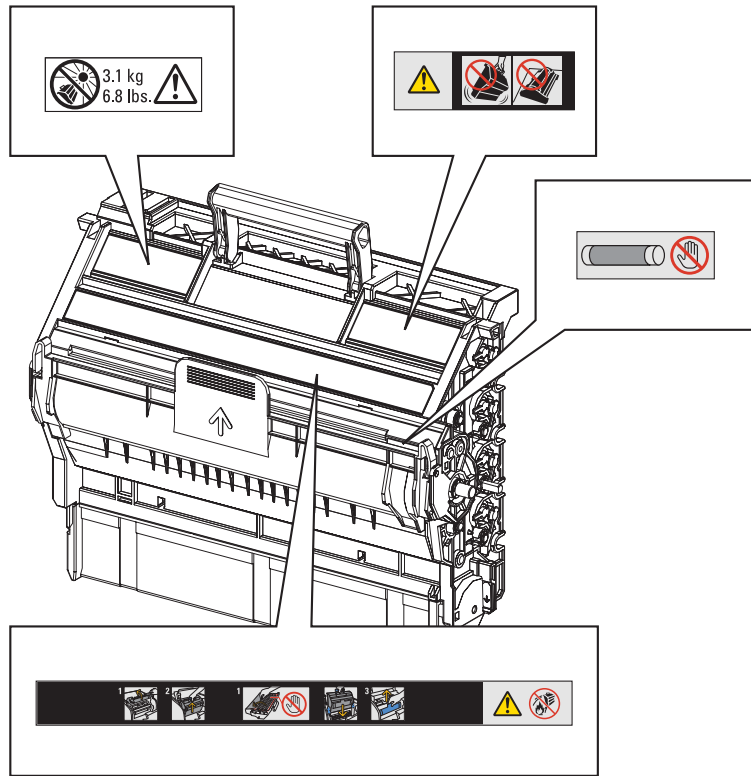

Ida\_Sec00\_005FA

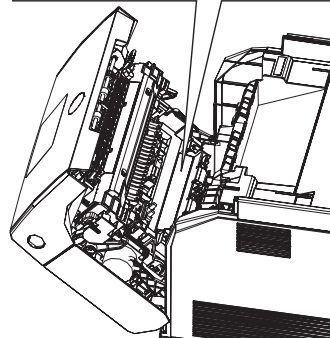
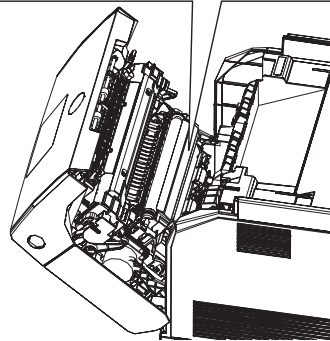
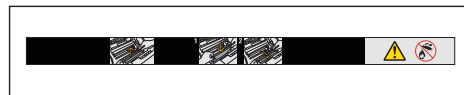

Ida\_Sec00\_009FA

#### 4.5.4 Caution label regarding MPF and paper tray

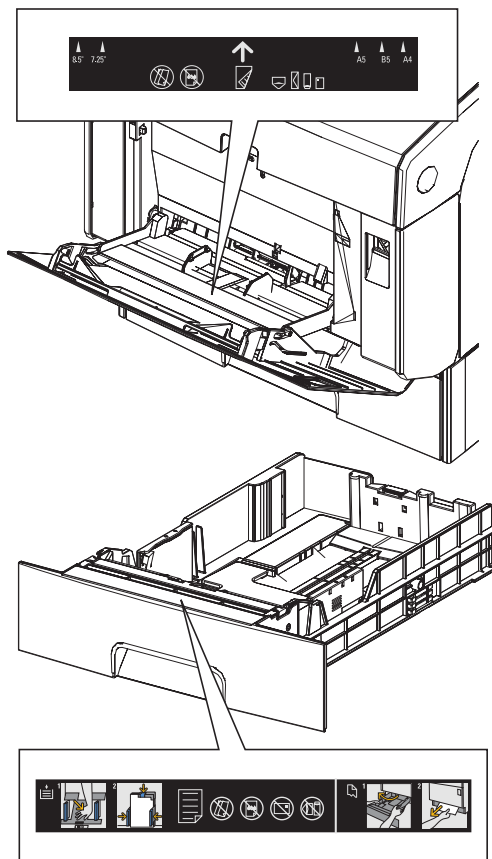

Ida\_Sec00\_006FA

#### 4.5.5 Caution label regarding Developer Frame

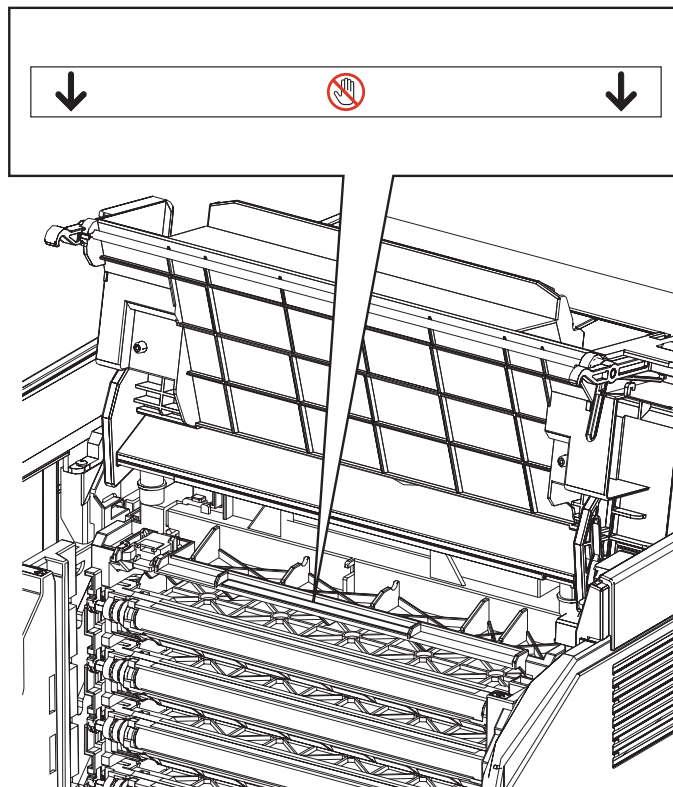

Ida\_Sec00\_007FA

#### 4.5.6 Caution label regarding Print Head

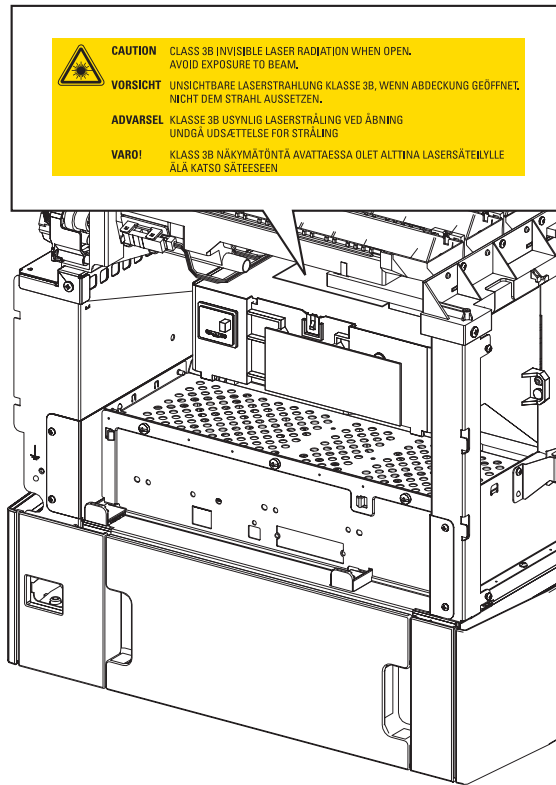

Ida\_Sec00\_008FA

# Unpacking the Printer



The printer must be carried horizontally with two or more persons.



Extreme care must be taken to avoid personal injuries.

Check the printer visually for evidence of any damage.

Peel all tapes off the printer.

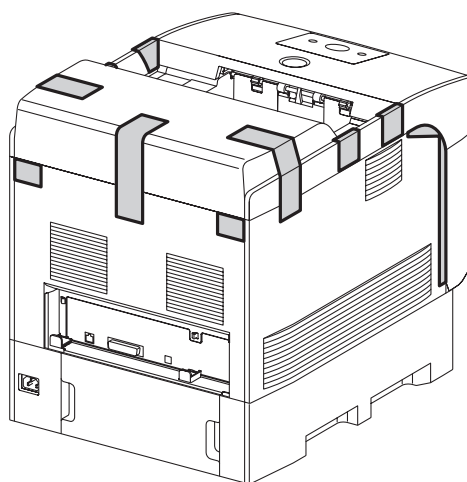
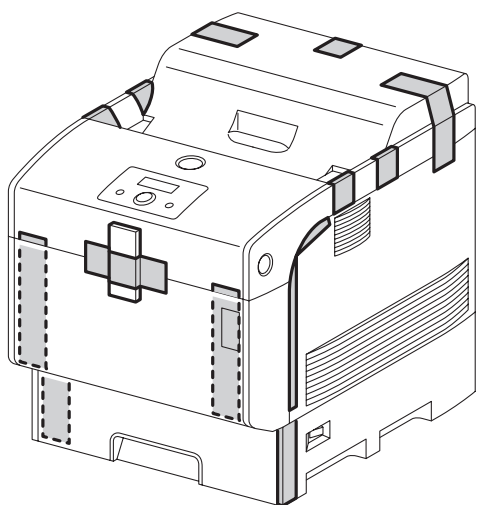

Ten00011KA

## TABLE OF CONTENTS

---

Cautions for operation .....	Intro-1
1. About this manual.....	Intro-2
2. Marks giving caution.....	Intro-2
3. Related documents.....	Intro-2
4. Safety .....	Intro-3
4.1 Power source.....	Intro-3
4.2 Driving unit.....	Intro-4
4.3 High-temperature units .....	Intro-4
4.4 Laser beams.....	Intro-5
4.5 Warning/caution labels .....	Intro-6
4.5.1 Caution label for high-temperature units .....	Intro-6
4.5.2 Caution label regarding toner cartridge .....	Intro-6
4.5.3 Caution label regarding PHD ASSY and BTR ASSY .....	Intro-7
4.5.4 Caution label regarding MSI and paper tray.....	Intro-8
4.5.5 Caution label regarding FRAME ASSY DEVE .....	Intro-8
4.5.6 Caution label regarding ROS ASSY .....	Intro-9
Unpacking the Printer.....	Intro-10
Chapter 1 Troubleshooting.....	1 - 1
Chapter 2 Operation of Diagnostic .....	2 - 1
Chapter 3 Removal and Replacement Procedures .....	3 - 1
Chapter 4 Plug/Jack(P/J) Connector Locations.....	4 - 1
Chapter 5 Parts List.....	5 - 1
Chapter 6 Principles of Operation .....	6 - 1
Chapter 7 Wiring Diagrams and Signal Information .....	7 - 1
Chapter 8 Printer Specifications .....	8 - 1

## Chapter 1 Troubleshooting CONTENTS

---

1. Progressing with the Troubleshooting .....	1 - 1
1.1 Flow of Troubleshooting.....	1 - 1
1.2 Preparatory Requirements.....	1 - 2
1.3 Cautions for Service Operations .....	1 - 3
1.4 Cautions for FIP Use.....	1 - 4
2. Level 1 FIP .....	1 - 6
2.1 Level 1 FIP .....	1 - 6
2.2 Flow of Level 1 FIP .....	1 - 6
3. Level 2 FIP .....	1 - 8
3.1 Level 2 FIP .....	1 - 8
3.2 Status Code List.....	1 - 9
3.3 LCD Display .....	1 - 15
3.4 Error Code FIP.....	1 - 25
FIP-1 001-360/001-363/001-364/001-366 Restart Printer .....	1 - 25
FIP-2 001-361/001-363/001-365/001-366 Restart Printer .....	1 - 26
FIP-3 001-362/001-364/001-365/001-366 Restart Printer .....	1 - 27
FIP-4 003-340/003-341/003-342/003-344/003-345/003-346/003-347/003-348/003-349/ 003-350/003-351 Restart Printer .....	1 - 28
FIP-5 003-343 Restart Printer.....	1 - 29
FIP-6 003-356 Restart Printer.....	1 - 31
FIP-7 004-310 Restart Printer.....	1 - 34
FIP-8 006-370/006-371/006-372/006-373/006-374/006-375/006-376/006-377/006-378/ 006-379/006-380/006-381/006-382/006-383/006-384 Restart Printer.....	1 - 35
FIP-9 007-342/007-345/007-346/007-348 Restart Printer .....	1 - 36
FIP-10 007-343/007-345/007-347/007-348 Restart Printer .....	1 - 37
FIP-11 007-344/007-346/007-347/007-348 Restart Printer .....	1 - 38
FIP-12 009-340/009-341 Restart Printer.....	1 - 39
FIP-13 009-360/009-361/009-362/009-363 Restart Printer .....	1 - 40
FIP-14 010-354 Restart Printer.....	1 - 41
FIP-15 010-378/010-379/010-380/010-381/010-382/010-383/010-384/010-385/010-386/ 010-387/010-388/010-389/010-390/010-391/010-392/010-393/010-394/010-395/ 010-396/010-397 Restart Printer .....	1 - 42
FIP-16 016-300/016-301/016-302/016-310/016-311/016-313/016-315/016-317/016-323/ 016-324/016-327/016-340/016-344/016-345/016-346 Restart Printer/ Erase Flash Err. 016-392/Write Flash Err. 016-393/Verify Error 016-394 .....	1 - 43
FIP-17 016-312 Restart Printer.....	1 - 44
FIP-18 016-316/016-318 Restart Printer.....	1 - 45
FIP-19 016-330/016-331/016-332/016-333/016-334/016-335/016-336/016-337 Restart Printer .....	1 - 46
FIP-20 016-338 Restart Printer.....	1 - 48
FIP-21 016-350 Restart Printer.....	1 - 49
FIP-22 016-360/016-361 Restart Printer.....	1 - 50
FIP-23 016-370 Restart Printer.....	1 - 51
FIP-24 Paper Jam 077-902.....	1 - 52
FIP-25 Paper Jam 077-900.....	1 - 53

## Chapter 1 Troubleshooting CONTENTS

---

FIP-26 Paper Jam 071-101.....	1 - 54
FIP-27 Paper Jam 077-907.....	1 - 60
FIP-28 Load Tray N 024-910/024-911/024-912/024-913/024-914 .....	1 - 61
FIP-29 Exit Tray Full 024-920 .....	1 - 62
FIP-30 Load MPF 024-969/Load Tray N 024-965/024-966/024-967/024-968/024-969.....	1 - 63
FIP-31 Tape On XXX Toner 093-919/093-920/093-921/093-922 .....	1 - 66
FIP-32 Insert TonerCart 093-970 .....	1 - 67
FIP-33 Insert TonerCart 093-971 .....	1 - 68
FIP-34 Insert TonerCart 093-972 .....	1 - 69
FIP-35 Insert TonerCart 093-973 .....	1 - 70
FIP-36 Replace Toner 093-930 .....	1 - 71
FIP-37 Replace Toner 093-931 .....	1 - 72
FIP-38 Replace Toner 093-932 .....	1 - 73
FIP-39 Replace Toner 093-933 .....	1 - 74
FIP-40 Ready to Print 093-423 .....	1 - 75
FIP-41 Ready to Print 093-424 .....	1 - 76
FIP-42 Ready to Print 093-425 .....	1 - 77
FIP-43 Ready to Print 093-426 .....	1 - 78
FIP-44 Toner Type 093-980/093-981/093-982/093-983/CRUM ID 093-960/093-961/ 093-962/093-963.....	1 - 79
FIP-45 Insert Drum 091-972 .....	1 - 81
FIP-46 Imaging Drum 091-935 .....	1 - 82
FIP-47 Ready to Print 094-402 .....	1 - 83
FIP-48 Imaging Drum 091-912/CRUM ID 093-965.....	1 - 84
FIP-49 Replace Fuser 010-351.....	1 - 85
FIP-50 Insert Fuser 010-317.....	1 - 86
FIP-51 Ready to Print 010-421 .....	1 - 87
FIP-52 Fuser Type 010-358/CRUM ID 093-964 .....	1 - 88
FIP-53 Transfer Roller 094-911 .....	1 - 89
FIP-54 Ready to Print 094-422 .....	1 - 90
FIP-55 BTR Not Detected 094-910.....	1 - 91
FIP-56 Load Tray N 077-912/077-913/077-914/Tray Detached 024-945/024-946/024-947/ 024-948/024-949.....	1 - 92
FIP-57 Close Front Door 077-300.....	1 - 93
FIP-58 CTD Sensor Dirty 092-310/Ready to Print 092-910.....	1 - 95
FIP-59 Out of Memory 016-700 .....	1 - 97
FIP-60 Disk Full 016-980 .....	1 - 98
FIP-61 PCL Request 016-720.....	1 - 100
FIP-62 Invalid Job 016-799.....	1 - 101
FIP-63 Ready to Print 193-700 .....	1 - 102
FIP-64 Invalid ID 016-383/Range Chk Error 016-384/Header Error 016-385/ Check Sum Error 016-386/Format Error 016-387.....	1 - 103
FIP-65 MPC Error 016-388/MPC Detached 016-389/MPC Com. Failed 016-390 .....	1 - 104
FIP-66 Invalid User 016-757/Disabled Func 016-758/Reached Limits 016-759.....	1 - 106
3.5 Image Quality Troubleshooting .....	1 - 107
3.5.1 Image Quality Specifications.....	1 - 109

## Chapter 1 Troubleshooting CONTENTS

---

P1 "Light (Undertoned) Prints" .....	1 - 113
P2 "Blank Prints" .....	1 - 116
P3 "Solid Prints" .....	1 - 118
P4 "Vertical deletion or blank line" .....	1 - 119
P5 "Horizontal deletion or blank line" .....	1 - 122
P6 "Black (color) spots" .....	1 - 125
P7 "Background or Foggy Print" .....	1 - 128
P8 "Skewed paper" .....	1 - 130
P9 "Paper Damage" .....	1 - 134
P10 "Unfused Image or Image Easily Rubs off of Page" .....	1 - 139
P11 "Vertical Dark Line" .....	1 - 140
P12 "Afterimage (Ghost)" .....	1 - 141
P13 "Partial Deletion" .....	1 - 142
P14 "Horizontal Line (Periodical)" .....	1 - 143
P15 "Fade Horizontal/Vertical" .....	1 - 145
P16 "Color Registration (Color Shift)" .....	1 - 147
3.6 Other FIP .....	1 - 150
FIP-No Power .....	1 - 150
FIP-Multiple Feed.....	1 - 151
<b>4. Abnormal Noise Trouble.....</b>	<b>1 - 152</b>
4.1 Entry Chart for Abnormal Noise Troubleshooting .....	1 - 152
4.2 Operation Mode Table .....	1 - 153
FIP-1.N1 When Power is Turned On .....	1 - 153
FIP-1.N2 During Standby.....	1 - 154
FIP-1.N3 During Printing.....	1 - 155



**Chapter 1 Troubleshooting CONTENTS**

---

NOTE

Troubleshooting in this manual assumes use of Diag. tools (maintenance tools). However, the troubleshooting allows for the case where the Diag tools are not used. You can correct troubles according to these troubleshooting procedures after understanding them well.

## 1. Progressing with the Troubleshooting

After making sure of actual condition of a trouble, proceed with the troubleshooting process efficiently making use of the Fault Isolation Procedure (FIP), Operation of Diag. tools (Chapter 2), Wire connecting diagram (Chapter 7), and Principle of operation (Chapter 6).

### 1.1 Flow of Troubleshooting

Flow of the troubleshooting is as follows:

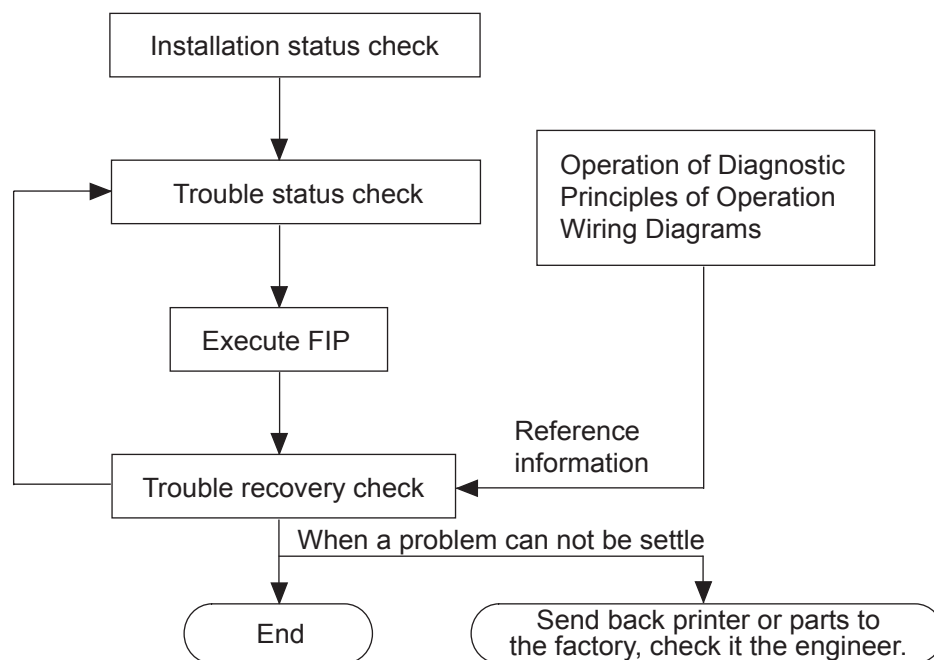

## 1.2 Preparatory Requirements

Be sure to check the following items before starting the troubleshooting procedures:

- 1) Voltage of the power supply is within the specifications (measure the voltage at the electric outlet).
- 2) Power cord is free from breakage, short-circuit, disconnected wire, or incorrect connection in the power cord.
- 3) The laser printer is properly grounded.
- 4) The laser printer is not installed at a place subjected to too high temperature, too high humidity, too low temperature, too low humidity or rapid change of temperature.
- 5) The laser printer is not installed close to water service, humidifier, heat generating unit, or fire, in very dusty place, or a place exposed to air flow from the air conditioning system.
- 6) The laser printer is not installed in a place where volatile gas or inflammable gas is generated.
- 7) The laser printer is not installed under direct sunbeams.
- 8) The laser printer is installed in a well-ventilated place.
- 9) The laser printer is installed on a stout and stable plane.
- 10) Paper used meets specifications (standard paper is recommendable).
- 11) The laser printer is handled properly.
- 12) Parts which should be periodically replaced are replaced each time when specified number of sheets have been printed.
- 13) Make the PHD ASSY and the FRAME ASSY DEVE reseated, and try some printing using the papers out of a newly opened package.

### 1.3 Cautions for Service Operations

- 1) Be sure to remove the power cord except when it is specifically required.



***If the printer is kept ON, never touch the conductive parts while it is not specifically required.***

***The power switch/inlet of LVPS is live even while the power supply is cut off. Never touch the live parts.***

- 2) When checking some parts with covers removed and with the interlock and safety and power switches ON, remove the connector (P/J151) on the ROS ASSY except when it is specifically required.



***When checking some parts with covers removed and with the interlock and safety and power switches ON, laser beams may be irradiated from the ROS ASSY. Since it is dangerous, be sure to remove the connector (P/J151) while it is not required.***

- 3) When checking some parts with the left cover removed and power ON, be sure to remove the connector (P/J141) on the HVPS while it is not required.



***When checking some parts with the left cover removed and power ON, high voltage may be applied by the HVPS. Be sure to remove the connector (P/J141) on the HVPS.***

***When connecting the connector (P/J141) on the HVPS according to the instructions of the FIP, never touch the HVPS and parts of high voltage.***

- 4) When using Diag. tools or other tools of high voltage, be sure to keep them covered except when otherwise specified.



***When using Diag.Tool or other tools of high voltage, never touch parts of high voltage.***

***When using Diag.Tool or other tools of high voltage, be sure to follow the procedure of this manual.***

- 5) When operating the driving units using the Diag or other tools, be sure to keep them covered unless otherwise specified.



***When operating the driving units using the Diag or other tools, never touch the driving units. When operating the driving units using Diag or other tools, be sure to observe the procedures in this manual.***

- 6) When touching hot parts, be careful not to get burnt.

- 7) Workers should wear a wrist band or the like to remove static electricity from their body, grounding their body while working.

## 1.4 Cautions for FIP Use

- 1) It is assumed in the FIP that the printer controller (CONTROLLER PWB) is normally functioning. If any trouble cannot be corrected by troubleshooting, replace the printer controller with a normal one and check for proper operation again.  
If the trouble is not still corrected, replace the major parts and then related parts in succession and confirm according to the procedure of the "Initial check" and "Major check parts".
- 2) When troubleshooting according to the FIP, normal MCU PWB, PHD ASSY or other parts may be necessary for isolation of failed parts. Prepare them in advance.
- 3) In the initial check according to the FIP, check only items which can be simply checked.
- 4) In the initial check according to the FIP, check the constitutive parts of the major check parts and related parts, as well as major check parts.
- 5) When working with the printer, Be sure to remove the power cord except when required specifically. Never touch live parts if not required, while the power cord is connected.
- 6) Connector condition is denoted as follows:  
[P/J12] → Connector (P/J12) is connected.  
[P12] → Plug side with the connector (P/J12) removed (except when attached directly to the board).  
[J12] → Jack side with the connector (P/J12) removed (except when attached directly to the board).
- 7) [P/J1-2PIN <=> P/J3-4PIN] in the FIP means measurement with the plus side of the measuring instrument connected to [P/J1] and the minus side to [4PIN] of [P/J3].
- 8) [P/J<=>P/12] in the FIP means measurement for all terminals corresponding between [P/J1] and [P/J2] referring to "Wire connecting diagram".
- 9) In [P/J1-2PIN <=> P/J3-4PIN] in the FIP where voltage is measured, [P/J3-4PIN] on the rear minus side is always at the AG (analog ground), SG (signal ground), or RTN (return).  
Therefore, after checking of proper conduction between AGs, SGs, or RTNs respectively, the rear minus side can be connected to the PIN of AG, SG or RTN instead of [P/J3-4PIN].  
However, care should be taken not to mistake since [AG], [SG], and [RTN] are not on the same level.
- 10) Measure the voltage of small connectors with the special tool. Handle the tool with care, as the leading edge of the tool is pointed.
- 11) When measuring the voltage, set the PDH ASSY, FUSER ASSY, BRT ASSY and paper tray, close the FRONT COVER ASSY and power ON if not required specifically.
- 12) Numerical values in the FIP are only for standard. If numerical values are approximate, they should be considered permissible.

- 13) Parts which are always removed to check as indicated in the FIP and procedures for that purpose are not specifically referred to here. They should be handled carefully.
- 14) "Replacement" in the FIP indicates replacement of parts which are considered to be the source of trouble to be checked after replacing those parts, assemblies containing them, or parts (HIGH ASSY).
- 15) In the FIP, the paper pick-up unit by means of the paper tray at the lower part of the printer is referred to as "try 1", the first level of the paper pick-up unit feeder unit as "try 2", and the second level as the "tray3".
- 16) In the FIP, existence and non-existence of Diag tools (maintenance tools,) are distinguished in some cases. Correct troubles according to the instructions in the FIP.
- 17) In the FIP, procedures are differentiated depending on specifications. Correct troubles according to the instructions in the FIP.
- 18) For optional parts, some troubleshooting procedure may follow the manual for those options, of which you should take note.  
Keep those manuals for the optional parts when required.

## 2. Level 1 FIP

### 2.1 Level 1 FIP

The level 1 FIP is the first step for trouble diagnosis. The level 1 FIP isolates the presence of various troubles including error codes, and the level 2 FIP provides a guide for proceeding of the troubleshooting.

### 2.2 Flow of Level 1 FIP

Before commencing Troubleshooting, verify or fix the following general matters first.

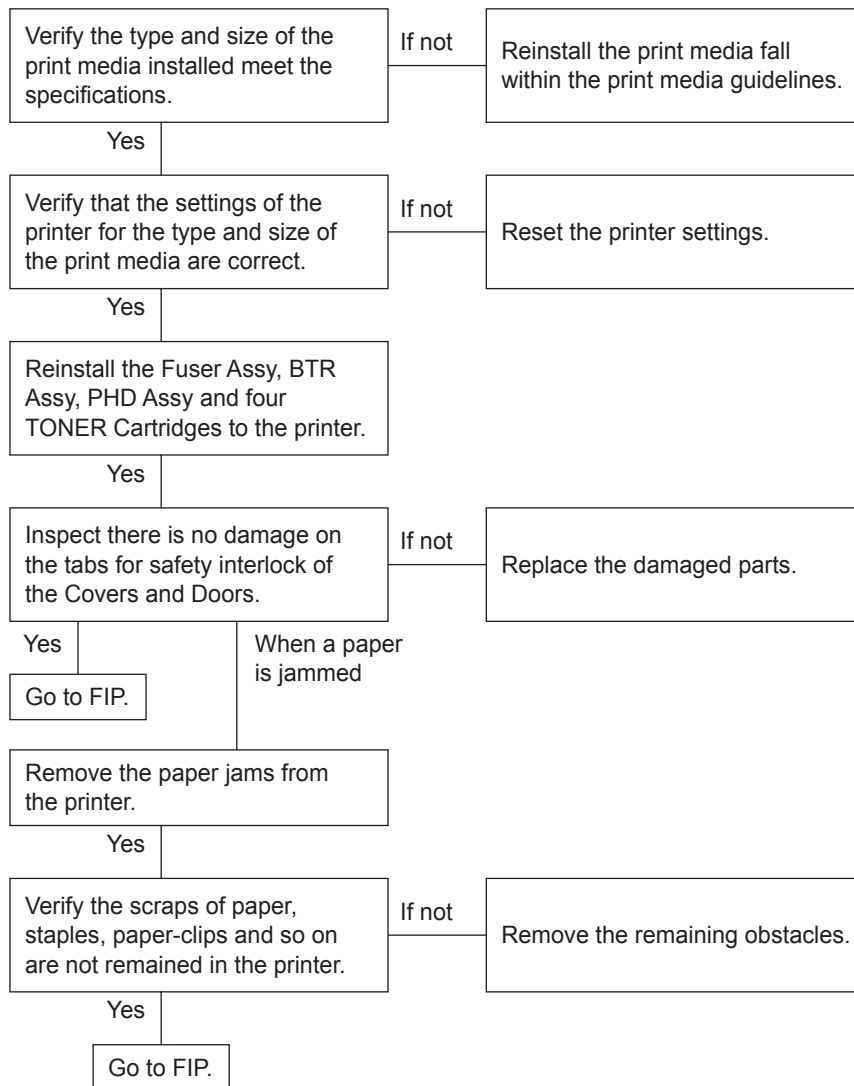

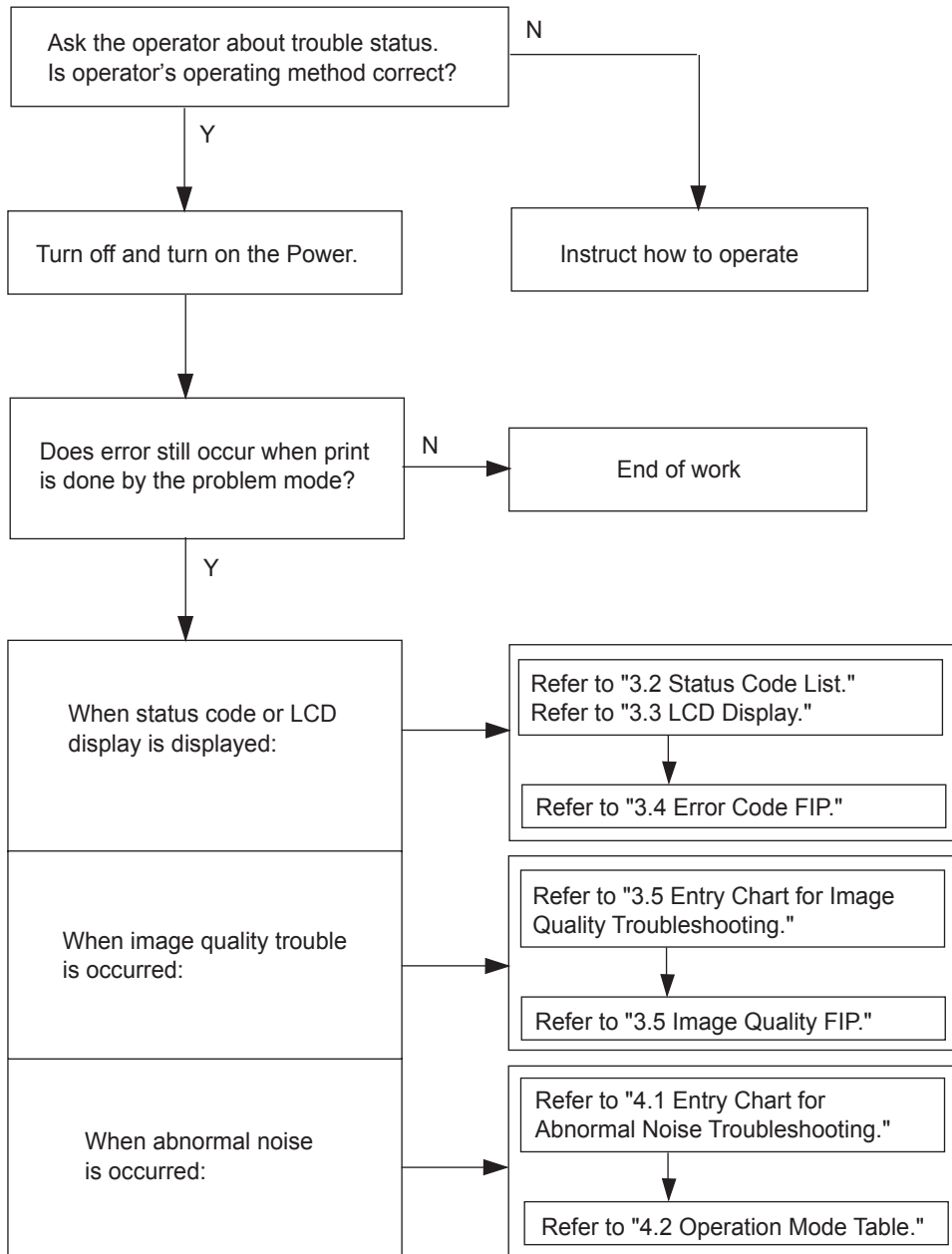



### **3. Level 2 FIP**

#### **3.1 Level 2 FIP**

The Level 2 FIP is the trouble diagnostic procedure to sort various troubles in addition to the error codes. In the troubleshooting, executing the steps given in the FIP or checking procedure allows you to find out a cause of trouble in a short time.

### 3.2 Status Code List

Error Message	Error Contents	FIP to be referred
001-360 Restart Printer ⇕ Flip Contact Support IfMessageReturns	<IOT Fan Motor 1 Failure> MCU detects an error upon receiving error signal from the Rear Fan.	FIP-1
001-361 Restart Printer ⇕ Flip Contact Support IfMessageReturns	<IOT Fan Motor 2 Failure> MCU detects an error upon receiving error signal from the Front Fan.	FIP-2
001-362 Restart Printer ⇕ Flip Contact Support IfMessageReturns	<IOT Fan Motor 3 Failure> MCU detects an error upon receiving error signal from the LV Fan.	FIP-3
001-363 Restart Printer ⇕ Flip Contact Support IfMessageReturns	<IOT Fan Motor 4 Failure> MCU detects an error upon receiving error signals from the Rear and Front Fans.	FIP-1 FIP-2
001-364 Restart Printer ⇕ Flip Contact Support IfMessageReturns	<IOT Fan Motor 5 Failure> MCU detects an error upon receiving error signals from the Rear and LV Fans.	FIP-1 FIP-3
001-365 Restart Printer ⇕ Flip Contact Support IfMessageReturns	<IOT Fan Motor 6 Failure> MCU detects an error upon receiving error signals from the Front and LV Fans.	FIP-2 FIP-3
001-366 Restart Printer ⇕ Flip Contact Support IfMessageReturns	<IOT Fan Motor 6 Failure> MCU detects an error upon receiving error signals from the Front, Rear and LV Fans.	FIP-1 FIP-2 FIP-3
003-340 to 003-342 Restart Printer ⇕ Flip Contact Support IfMessageReturns	<IOT Firmware Error> Firmware Error is detected.	FIP-4
003-343 Restart Printer ⇕ Flip Contact Support IfMessageReturns	<IOT Firmware Error> CRUM communication error is detected.	FIP-5

Error Message	Error Contents	FIP to be referred
003-344 to 003-351 Restart Printer ↕ Flip Contact Support IfMessageReturns	<IOT Firmware Error> Firmware Error is detected.	FIP-4
003-356 Restart Printer ↕ Flip Contact Support IfMessageReturns	<IOT NVRAM Error> NVRAM and CRUM errors are detected.	FIP-6
004-310 Restart Printer ↕ Flip Reseat Feeder Contact Support	<IOT Option Feeder Communication Error> Option Feeder Communication Error is detected. Communication error between the Option Feeder and the printer.	FIP-7
006-370 to 006-384 Restart Printer ↕ Flip Contact Support IfMessageReturns	<IOT ROS Motor Failure> The SOS signal does not come from the ROS ASSY.	FIP-8
007-342 Restart Printer ↕ Flip Contact Support IfMessageReturns	<IOT Motor Failure> Main Motor fail is detected. MCU detects an error upon receiving error signal from the Motor.	FIP-9
007-343 Restart Printer ↕ Flip Contact Support IfMessageReturns	<IOT Motor Failure> Deve Motor fail is detected. MCU detects an error upon receiving error signal from the Motor.	FIP-10
007-344 Restart Printer ↕ Flip Contact Support IfMessageReturns	<IOT Motor Failure> Fuser Motor fail is detected. MCU detects an error upon receiving error signal from the Motor.	FIP-11
007-345 Restart Printer ↕ Flip Contact Support IfMessageReturns	<IOT Motor Failure> Main and Deve Motor fails are detected. MCU detects an error upon receiving error signal from the Motors.	FIP-9 FIP-10
007-346 Restart Printer ↕ Flip Contact Support IfMessageReturns	<IOT Motor Failure> Main and Fuser Motor fails are detected. MCU detects an error upon receiving error signal from the Motors.	FIP-9 FIP-11
007-347 Restart Printer ↕ Flip Contact Support IfMessageReturns	<IOT Motor Failure> Deve and Fuser Motor fails are detected. MCU detects an error upon receiving error signal from the Motors.	FIP-10 FIP-11

Error Message	Error Contents	FIP to be referred
007-348 Restart Printer ↕ Flip Contact Support IfMessageReturns	<IOT Motor Failure> Main, Deve and Fuser Motor fails are detected. MCU detects an error upon receiving error signal from the Motors.	FIP-9 FIP-10 FIP-11
009-340/009-341 Restart Printer ↕ Flip Clean CTD Contact Support	<IOT CTD Sensor Error> CTD (ADC) Sensor Error is detected. CTD (ADC) Sensor error at calibrating.	FIP-12
009-360 Restart Printer ↕ Flip Reseat Y Toner Contact Support	<IOT (Y) Toner CRUM Error> Yellow Toner CRUM Communication Error is detected. Printer can not read the CRUM data of the yellow toner cartridge.	FIP-13
009-361 Restart Printer ↕ Flip Reseat M Toner Contact Support	<IOT (M) Toner CRUM Error> Magenta Toner CRUM Communication Error is detected. Printer can not read the CRUM data of the magenta toner cartridge.	FIP-13
009-362 Restart Printer ↕ Flip Reseat C Toner Contact Support	<IOT (C) Toner CRUM Error> Cyan Toner CRUM Communication Error is detected. Printer can not read the CRUM data of the cyan toner cartridge.	FIP-13
009-363 Restart Printer ↕ Flip Reseat K Toner Contact Support	<IOT (K) Toner CRUM Error> Black Toner CRUM Communication Error is detected. Printer can not read the CRUM data of the black toner cartridge.	FIP-13
010-354 Restart Printer ↕ Flip Contact Support IfMessageReturns	<IOT Environment Sensor Error> Temperature Sensor Error is detected. Temperature Sensor detected abnormal temperature.	FIP-14
010-378 to 010-397 Restart Printer ↕ Flip Reseat Fuser Contact Support	<IOT Fuser Fail> Fuser Error is detected.	FIP-15
016-300 Restart Printer ↕ Flip Contact Support IfMessageReturns	<ESS Data Cache Error> CPU data cache error	FIP-16
016-301 Restart Printer ↕ Flip Contact Support IfMessageReturns	<ESS Instruction Cache Error> CPU instruction cache error	FIP-16

Error Message	Error Contents	FIP to be referred
016-302 Restart Printer ↕ Flip Contact Support IfMessageReturns	<ESS Illegal Exception> CPU illegal exception	FIP-16
016-310 Restart Printer ↕ Flip Contact Support IfMessageReturns	<ESS FontROM SumCheckError (Main)> Checksum error in the built-in font ROM	FIP-16
016-311 Restart Printer ↕ Flip Contact Support IfMessageReturns	<ESS FontROM SumCheckErrorOption> Checksum error in the option font ROM	FIP-16
016-312 Restart Printer ↕ Flip Contact Support IfMessageReturns	<ESS HDD Error> The error is detected by HDD error.	FIP-17
016-313 Restart Printer ↕ Flip Contact Support IfMessageReturns	<ASIC Error> The error is detected by ASIC error.	FIP-16
016-315 Restart Printer ↕ Flip Contact Support IfMessageReturns	<ESS On Board RAM W/R Check Error> The error is detected by On board RAM W/R check during initialization.	FIP-16
016-316 Restart Printer ↕ Flip Reseat Memory Contact Support	<ESS DIMM Slot RAM W/R Check Error> The error is detected by DIMM slot RAM W/R check during initialization.	FIP-18
016-317 Restart Printer ↕ Flip Contact Support IfMessageReturns	<ESS ROM Check (Main) Error> Checksum error in the main program ROM	FIP-16
016-318 Restart Printer ↕ Flip Contact Support IfMessageReturns	<ESS DIMM Slot RAM Error> DIMM slot RAM (option) error occurs during the initialization.	FIP-18
016-323 Restart Printer ↕ Flip Contact Support IfMessageReturns	<ESS NVRAM1 W/R Check Error> The error is detected by master NVRAM W/R check.	FIP-16

Error Message	Error Contents	FIP to be referred
016-324 Restart Printer ↕ Flip Contact Support IfMessageReturns	<ESS NVRAM2 W/R Check Error> The error is detected by master NVRAM2 W/R check.	FIP-16
016-327 Restart Printer ↕ Flip Contact Support IfMessageReturns	<ESS NVRAM1 SIZE And ID Check Error> The error is detected by consistency check between the NVRAM size required by the system and its actual size, and by consistency check of the ID recorded when turning ON the power first.	FIP-16
016-330 Restart Printer ↕ Flip Contact Support IfMessageReturns	<MPC-ESS Communication Fail> Communication fail between MPC and ESS	FIP-19
016-331 Restart Printer ↕ Flip Reseat MPC Contact Support	<MPC Flash ROM Boot Module Checksum Error> Checksum error in the Flash ROM	FIP-19
016-332 Restart Printer ↕ Flip Reseat MPC Contact Support	<MPC RAM R/W Test Error> The error is detected by MPC RAM W/R check.	FIP-19
016-333 Restart Printer ↕ Flip Reseat MPC Contact Support	<MPC Flash ROM Application Module Checksum Error> Checksum error in the MPC Flash ROM	FIP-19
016-334 Restart Printer ↕ Flip Reseat MPC Contact Support	<MPC MAC Address Checksum Error> Checksum error in the MPC MAC address	FIP-19
016-335 Restart Printer ↕ Flip Reseat MPC Contact Support	<MPC Ethernet BIST Parity/RAM R/W Error> The error is detected by MPC Ethernet BIST parity RAM R/W check.	FIP-19
016-336 Restart Printer ↕ Flip Reseat MPC Contact Support	<MPC Internal Loopback Error> The error is detected by Loopback test.	FIP-19
016-337 Restart printer ↕ Flip Reseat MPC Contact Support	<MPC Fatal Error> The fatal error is detected by MPC check.	FIP-19

Error Message	Error Contents	FIP to be referred
016-338 Restart Printer ↕ Flip Reseat Wireless Contact Support	<Wireless Option Error> The error is detected by Wireless Option check.	FIP-20
016-340 Restart Printer ↕ Flip Contact Support IfMessageReturns	<ESS Network Communication Error> Communication error between CPU network and ESS firmware	FIP-16
016-344 Restart Printer ↕ Flip Contact Support IfMessageReturns	<ESS Network MAC Address Checksum Error> Checksum error in the Network MAC address	FIP-16
016-345 Restart Printer ↕ Flip Contact Support IfMessageReturns	<ESS Network Ethernet BIST parity/RAM R/W Error> The fail is detected by Network Ethernet parity RAM R/W check.	FIP-16
016-346 Restart Printer ↕ Flip Contact Support IfMessageReturns	<ESS Network Internal Loopback Error> The error is detected by On Board Network Internal Loopback check.	FIP-16
016-350 Restart Printer ↕ Flip Reseat Parallel Contact Support	<IEEE1284 Data Error> The error is detected by IEEE1284 controller.	FIP-21
016-360 Restart Printer ↕ Flip Reseat MPC Contact Support	<PCI Option#0 (MPC I/F Connector) Fail> Detection error of PCI option 0	FIP-22
016-361 Restart Printer ↕ Flip Reseat HDD Contact Support	<PCI Option#1 (HDD I/F Connector) Fail> Detection error of PCI option 1	FIP-22
016-370 Restart Printer ↕ Flip Reseat Parallel Contact Support	<MCU-ESS Communication Fail> Communication fail between MCU and ESS	FIP-23

## 3.3 LCD Display

Problem	Error Message	Error Contents	FIP to be referred
Paper Jam	Paper Jam 077-902 ↕ Flip Open Front Latch Remove Paper	<IOT Fuser Jam> 1. The exit sensor cannot detect passage of paper within specified time. 2. The exit sensor detected a paper while power is on or interlock is closed.	FIP-24
	Paper Jam 077-900 ↕ Flip Open Front Latch Remove Paper	<IOT Registration Jam> 1. The regi sensor cannot detect passage of paper within specified time. 2. The regi sensor detected a paper while power is on or interlock is closed.	FIP-25
	Paper Jam 071-101 ↕ Flip Open Tray Remove Paper ↕ Flip Open & close Front Latch	<IOT Feed Jam> The regi sensor cannot detect paper within specified time.	FIP-26
	Paper Jam 077-907 ↕ Flip Push Side Button Remove Paper	<IOT Duplex Jam> 1. The duplex jam sensor cannot detect passage of paper within specified time. 2. The duplex jam sensor detected a paper while power is on or interlock is closed.	FIP-27



Problem	Error Message	Error Contents	FIP to be referred
Paper Setting	Load Tray N 024-910, 024-911, 024-912, 024-913, 024-914 ⇕ Flip Load Tray N XXX ⇕ Flip Load Tray N YYY NOTE: N: Tray number XXX: Paper size YYY: Media type 024-910: Tray 1 024-911: Tray 2 024-912: Tray 3 024-913: Tray 4 024-914: MPF	<IOT Paper Size Mismatch> The paper size mismatch is detected.	FIP-28
	Exit Tray Full 024-920 ⇕ Flip Empty Exit Tray	<IOT Standard Stacker Full> The Exit tray full is detected. Printed paper on the Exit Tray exceeds the 250 sheets.	FIP-29
	Load MPF 024-969 ⇕ Flip Load MPF XXX ⇕ Flip Load MPF YYY NOTE: XXX: Paper size YYY: Media type	<Specified Tray Empty> When a tray is specified, the tray is empty. <No Suitable Paper>	FIP-30
	Load Tray N 024-965, 024-966, 024-967, 024-968, 024-969 ⇕ Flip Load Tray N XXX ⇕ Flip Load Tray N YYY NOTE: N: Tray number XXX: Paper size YYY: Media type 024-965: Tray 1 024-966: Tray 2 024-967: Tray 3 024-968: Tray 4 024-969: MPF	1. When the printer is waiting for a job or APS is specified, all the trays (including MPF) installed on the printer are empty. (All Tray Empty) 2. When APS is specified, a size of paper in all trays (including MPF) is mismatched. (All Tray Size Mismatch) 3. When a tray is specified, a size of paper in the specified tray (including MPF) is mismatched. (Specified Tray Size Mismatch)	

Problem	Error Message	Error Contents	FIP to be referred
Toner	Tape On XXX Toner 093-919, 093-920, 093-921, 093-922 ⇕ Flip Remove Tape From XXX Toner NOTE: XXX: Toner color 093-919: Yellow 093-920: Magenta 093-921: Cyan 093-922: Black	<IOT Toner Tape Staying> The toner tape staying is detected. When a new toner cartridge installed, the MCU does not detect the toner cartridge.	FIP-31
	Insert TonerCart 093-970, 093-971, 093-972, 093-973 ⇕ Flip Insert XXX Toner NOTE: XXX: Toner color 093-970: Yellow 093-971: Magenta 093-972: Cyan 093-973: Black	<IOT Toner Detached> The yellow, magenta, cyan or black toner cartridge detached is detected. Toner Cartridge Sensor on the BOX ASSY CRUM READER can not detect the toner cartridge.	FIP-32 (Y) FIP-33 (M) FIP-34 (C) FIP-35 (K)
	Replace Toner 093-930, 093-931, 093-932, 093-933 ⇕ Flip Replace XXX Toner NOTE: XXX: Toner color 093-930: Yellow 093-931: Magenta 093-932: Cyan 093-933: Black	<IOT Toner Empty> The toner empty is detected. The value of the Toner Cartridge counter has reached the replacement time. The No Toner Sensor on the DISPENSER ASSY HI detected the no toner.	FIP-36 (Y) FIP-37 (M) FIP-38 (C) FIP-39 (K)
	Ready to Print 093-423, 093-424, 093-425, 093-426 ⇕ Flip XXX Toner Is Low NOTE: XXX: Toner color 093-423: Yellow 093-424: Magenta 093-425: Cyan 093-426: Black	<IOT Toner Near Empty> Toner near empty is detected. The value of the Toner Cartridge counter is going to reach the replacement time.	FIP-40 (Y) FIP-41 (M) FIP-42 (C) FIP-43 (K)

Problem	Error Message	Error Contents	FIP to be referred
Toner	Toner Type 093-980, 093-981, 093-982, 093-983 ↕ Flip Reset XXX Toner NOTE: XXX: Toner color 093-980: Yellow 093-981: Magenta 093-982: Cyan 093-983: Black	<IOT Toner Type Error> The toner type error is detected. The CRUM data the CRUM Sensor read was the type of the other company.	FIP-44
	CRUM ID 093-960, 093-961, 093-962, 093-963 ↕ Flip Reset XXX Toner NOTE: XXX: Toner color 093-960: Yellow 093-961: Magenta 093-962: Cyan 093-963: Black	<IOT CRUM ID Error (Toner)> The toner CRUM ID error is detected. The toner cartridge CRUM ID read by the sensor is different from the one that was recorded.	FIP-44
PHD ASSY	Insert Drum 091-972 ↕ Flip Insert/Reset Imaging Drum	<IOT PHD Detached> The PHD detached is detected.	FIP-45
	Imaging Drum 091-935 ↕ Flip Replace Imaging Drum	<IOT PHD Life Over> The PHD life over is detected.	FIP-46
	Ready to Print 094-402 ↕ Flip Imaging Drum Replace Soon	<PHD Life Warning> The PHD life warning is detected. The value of the PHD counter has reached the replacement time.	FIP-47
	Imaging Drum 091-912 ↕ Flip Reset Imaging Drum	<IOT PHD Type Error> The PHD type error is detected. The CRUM data the MCU read was the type of the other company.	FIP-48
	CRUM ID 093-965 ↕ Flip Reset Imaging Drum	<IOT CRUM ID Error> The imaging drum CRUM ID error is detected. The toner cartridge CRUM ID read by the MCU is different from the one that was recorded.	FIP-48

Problem	Error Message	Error Contents	FIP to be referred
Fuser	Replace Fuser 010-351 ↕ Flip Replace Fuser	<IOT Fuser Life Over 2> The fuser life over is detected. The value of the Fuser counter has reached the replacement time.	FIP-49
	Insert Fuser 010-317 ↕ Flip Reseat Fuser	<IOT Fuser Detached> The fuser detached is detected.	FIP-50
	Ready to Print 010-421 ↕ Flip Replace Fuser Soon	<Fuser Life Warning> The fuser life warning is detected. The value of the Fuser counter is going to reach the replacement time.	FIP-51
	Fuser Type 010-358 ↕ Flip Reseat Fuser	<IOT Fuser Type Error> The fuser type error is detected. The CRUM data the MCU read was the type of the other company.	FIP-52
	CRUM ID 093-964 ↕ Flip Reseat Fuser	<IOT CRUM ID Error> The fuser CRUM ID error is detected. The Fuser CRUM ID read by the MCU is different from the one that was recorded.	FIP-52
BTR	Transfer Roller 094-911 ↕ Flip Replace Transfer Roller	<IOT BTR Life Over> The BTR life over is detected. The value of the BTR counter has reached the replacement time.	FIP-53
	Ready to Print 094-422 ↕ Flip Replace Transfer Roller Soon	<BTR Life Warning> The BTR life warning is detected. The value of the BTR counter is going to reach the replacement time.	FIP-54
	BTR Not Detected 094-910 ↕ Flip Insert/Reseat Transfer Roller	<IOT BTR Detached> The BTR detached is detected. The CTD (ADC) Sensor detected the BTR detached.	FIP-55

Problem	Error Message	Error Contents	FIP to be referred
	Load Tray N 077-912, 077-913, 077-914 ⇕ Flip Push In Tray N NOTE: N: Tray number 077-912: Tray 1 077-913: Tray 2 077-914: Tray 3	<Upper Cassette Detached> 1. When APS is specified, any trays located above the feedable tray are open. 2. When a tray is specified, any trays located above the specified tray are open. The Tray Size Switch detected the no tray.	
Tray	Tray Detached 024-945 ⇕ Flip Push in Tray	<Tray Detached> When the printer is waiting for a job or APS is specified, all the trays are detached. (All Tray Detached) The Tray Size Switch detected the no tray.	FIP-56
	Tray Detached 024-946, 024-947, 024-948, 024-949 ⇕ Flip Push in Tray N NOTE: N: Tray number 024-946: Tray 1 024-947: Tray 2 024-948: Tray 3 024-949: Tray 4	<Tray Detached> When a tray is specified, the tray is detached. (Specified Tray Detached) The Tray Size Switch detected the no tray.	

Problem	Error Message	Error Contents	FIP to be referred
Tray	<p>Load Tray N 024-965, 024-966, 024-967, 024-968</p> <p style="text-align: center;">↕ Flip</p> <p>Load Tray N XXX</p> <p style="text-align: center;">↕ Flip</p> <p>Load Tray N YYY</p> <p>NOTE: N: Tray number XXX: Paper size YYY: Media type 024-965: Tray 1 024-966: Tray 2 024-967: Tray 3 024-968: Tray 4</p> <hr/> <p>Load MPF 024-969</p> <p style="text-align: center;">↕ Flip</p> <p>Load MPF XXX</p> <p style="text-align: center;">↕ Flip</p> <p>Load MPF YYY</p> <p>NOTE: XXX: Paper size YYY: Media type</p>	<p>&lt;No Suitable Paper&gt;</p> <ol style="list-style-type: none"> <li>1. When the printer is waiting for a job or APS is specified, all the trays (including MPF) installed on the printer are empty. (All Tray Empty)</li> <li>2. When APS is specified, a size of paper in all trays (including MPF) is mismatched. (All Tray Size Mismatch)</li> <li>3. When a tray specified, the tray is empty. (Specified Tray Empty)</li> <li>4. When a tray is specified, a size of paper in the specified tray (including MPF) is mismatched. (Specified Tray Size Mismatch)</li> </ol>	FIP-30
Cover Open	<p>Close Front Door 077-300</p> <p style="text-align: center;">↕ Flip</p> <p>Front Door Is Open</p>	<p>&lt;IOT Cover Front Open&gt; The front cover is open.</p>	FIP-57

Problem	Error Message	Error Contents	FIP to be referred
Other	CTD Sensor Dirty 092-310 ↕ Flip Clean CTD Sensor	<IOT CTD Sensor Dustiness> The CTD (ADC) sensor dustiness is detected. The output signal of the CTD (ADC) sensor does not reach the specified value at sensing the toner patch on the BTR ASSY.	FIP-58
	Ready to Print 092-910 ↕ Flip Clean CTD Sensor	<IOT CTD Sensor Dustiness> The CTD (ADC) sensor dustiness is detected. The output signal of the CTD (ADC) sensor does not reach the specified value at sensing the toner patch on the BTR ASSY.	FIP-58
	Out of Memory 016-700 ↕ Flip Job too Large Press Set	<Out of Memory> Exceeds the memory capacity. The print data size exceeded the memory capacity of the printer.	FIP-59
	Disk Full 016-980 ↕ Flip Job too Large Press Set	<HDD full> Exceeds the memory or the Hard Disk capacity. The print data size exceeded the memory or the hard disk capacity of the printer.	FIP-60
	PCL Request 016-720 ↕ Flip Data Violation Press Set	<PDL Error> PCL error occurs. The print data cannot be processed by PCL.	FIP-61
	Invalid Job 016-799 ↕ Flip Data Violation Press Set	<Job Environment Violation> Detects violation data for the print condition. The print data specifies paper type/size not available for the printer.	FIP-62
	Ready to Print 193-700 ↕ Flip non-Dell Toner Installed	<Custom Toner Mode> The printer is in Custom Toner Mode.	FIP-63
	Invalid ID 016-383 ↕ Flip Data Violation Press set	<Download Error> The ID of the downloaded file is invalid.	FIP-64
	Range Chk Error 016-384 ↕ Flip Data Violation Press Set	<Download Error> The address of the write destination is invalid.	FIP-64
	Header Error 016-385 ↕ Flip Data Violation Press Set	<Download Error> The header information is invalid.	FIP-64

Problem	Error Message	Error Contents	FIP to be referred
Other	Check Sum Error 016-386 ↕ Flip Data Violation Press Set	<Download Error> The checksum is invalid.	FIP-64
	Format Error 016-387 ↕ Flip Data Violation Press Set	<Download Error> The format is invalid.	FIP-64
	MPC Error 016-388 ↕ Flip Reseat MPC Press Set	<MPC Download Error> Failed to start MPC download mode at MPC download.	FIP-65
	MPC Detached 016-389 ↕ Flip Reseat MPC Press Set	<MPC Download Error> MPC Download was attempted without MPC mounted.	FIP-65
	MPC Com. Failed 016-390 ↕ Flip Reseat MPC Press Set	<MPC Download Error> Communication error occurred between MPC and ESS during download.	FIP-65
	Erase Flash Err. 016-392 ↕ Flip Contact Support IfMessageReturns	<Download Error> An error occurred erasing the Flash.	FIP-16
	Write Flash Err. 016-393 ↕ Flip Contact Support IfMessageReturns	<Download Error> An error occurred writing to the Flash.	FIP-16
	Verify Error 016-394 ↕ Flip Contact Support IfMessageReturns	<Download Error> An error occurred verifying the Flash.	FIP-16
	Invalid User 016-757 ↕ Flip Account Denied Press Set	<Auditron Error> The user is not registered to any account.	FIP-66
	Disabled Func 016-758 ↕ Flip Denied Col print Press Set	<Auditron Error> An invalid account was detected.	FIP-66



<b>Problem</b>	<b>Error Message</b>	<b>Error Contents</b>	<b>FIP to be referred</b>
Other	Reached Limits 016-759 ↕ Flip Over your limits Press Set	<Auditron Error> The number of registered users exceeded its upper limit.	FIP-66

### 3.4 Error Code FIP

#### FIP-1 001-360/001-363/001-364/001-366 Restart Printer

Possible causative parts: FAN REAR (PL1.1.19)  
 LVPS (PL9.1.6)  
 PWBA MCU (PL9.1.16)

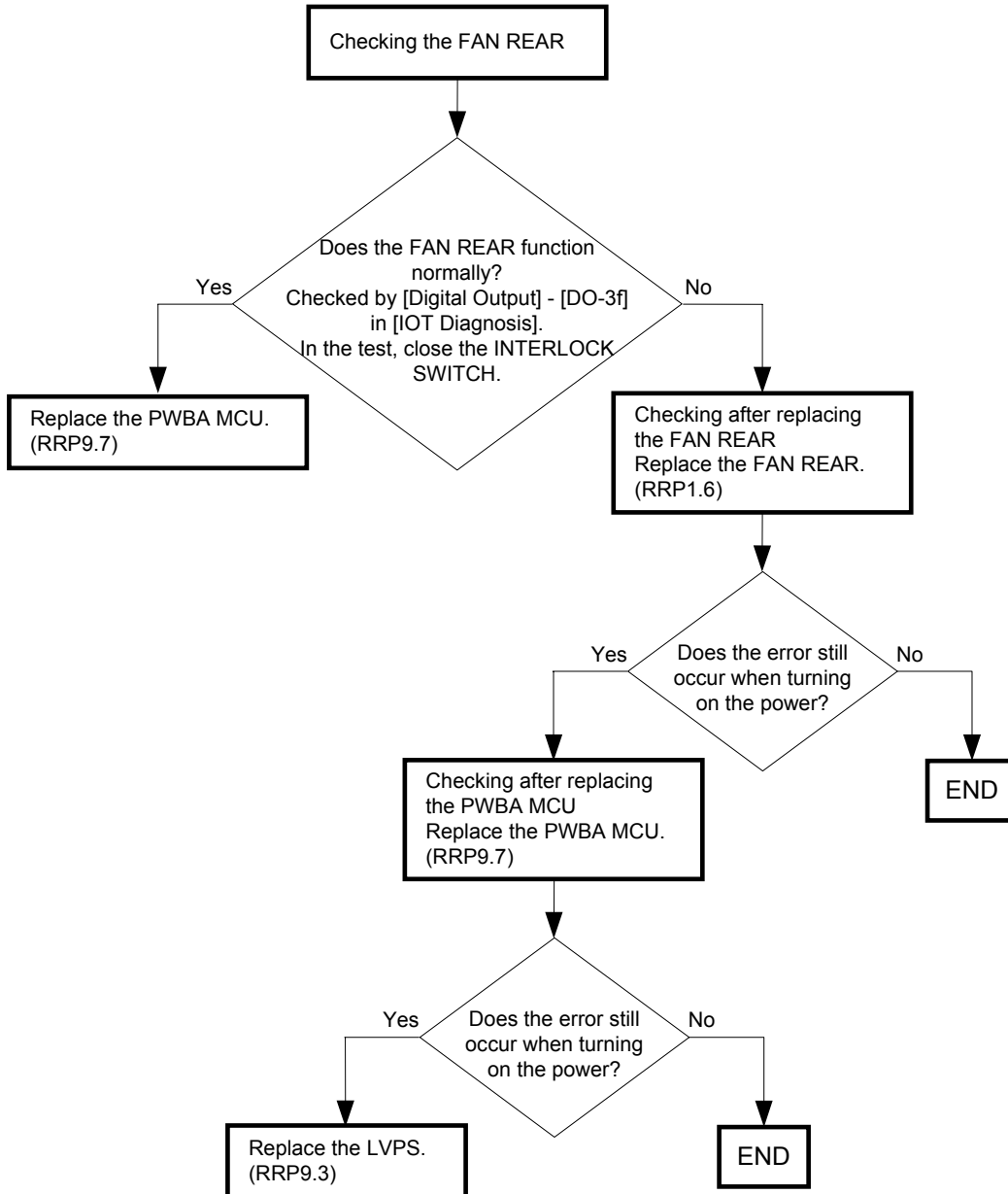

FIP-2 001-361/001-363/001-365/001-366 Restart Printer

Possible causative parts:FAN FRONT (PL5.3.31)  
PWBA MCU (PL9.1.16)

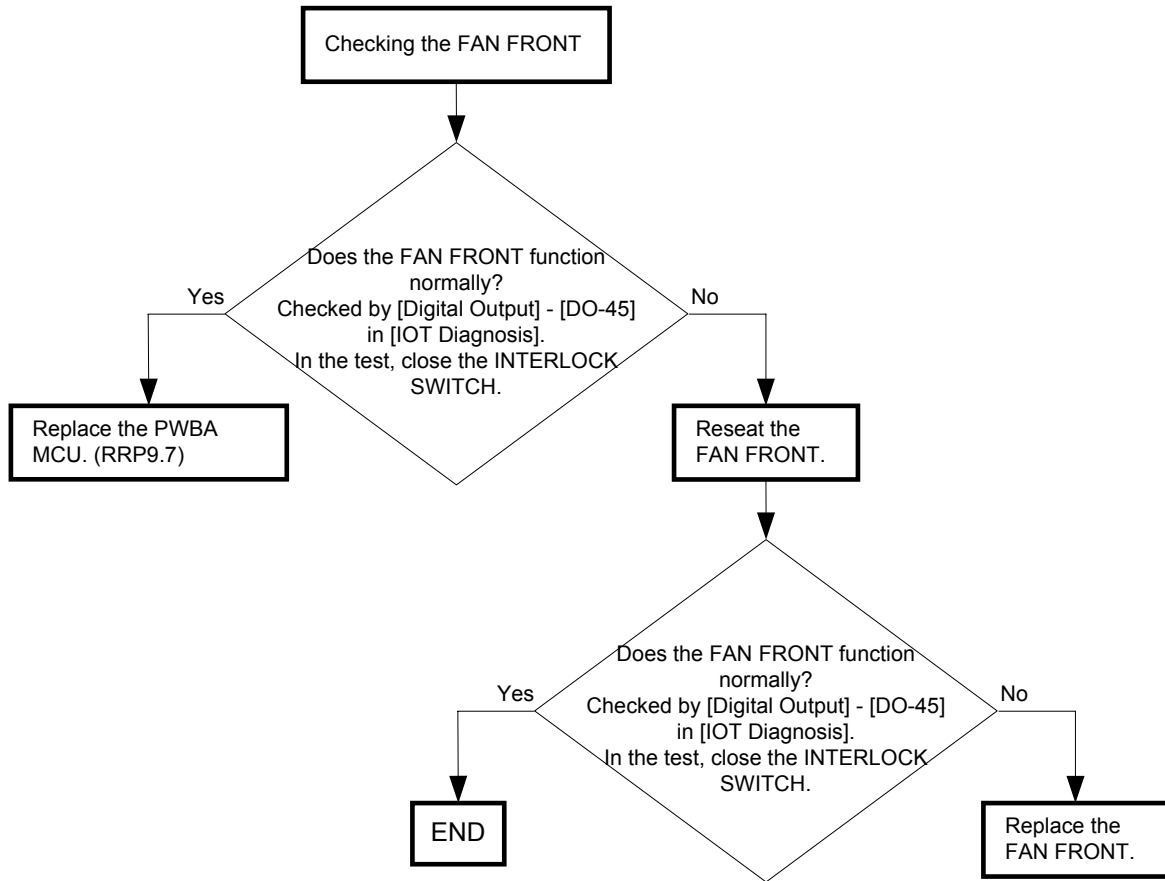

FIP-3 001-362/001-364/001-365/001-366 Restart Printer

Possible causative parts:FAN LV (PL1.1.33)  
 LVPS (PL9.1.6)  
 PWBA MCU (PL9.1.16)

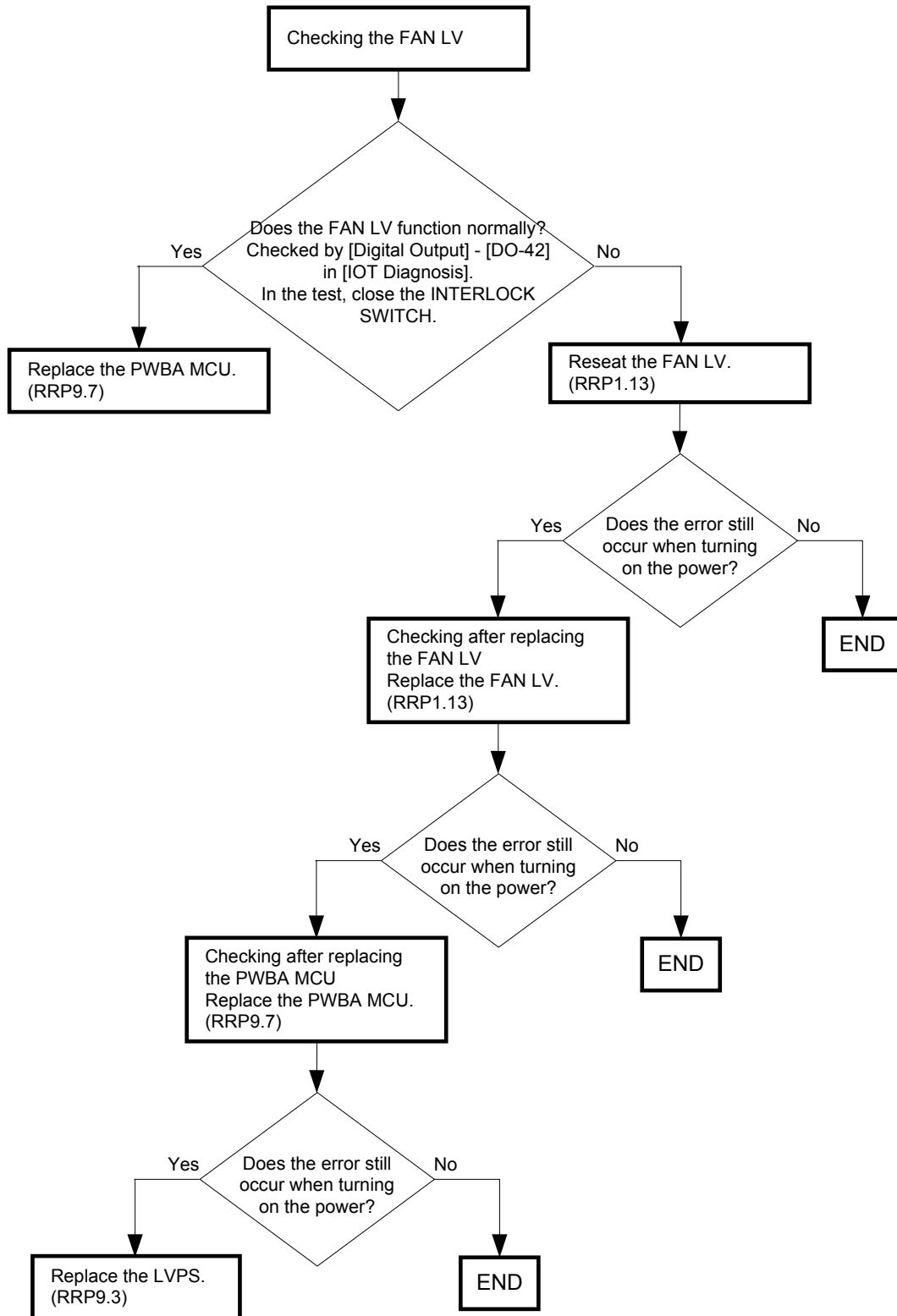

FIP-4 003-340/003-341/003-342/003-344/003-345/003-346/003-347/003-348/003-349/  
003-350/003-351 Restart Printer

*NOTE*

**If the error occurred after replacing the PWBA MCU, transfer the internal data of the old PWBA to the new PWBA.**

Possible causative parts:PWBA MCU (PL9.1.16)  
PWBA HVPS (9.1.21)

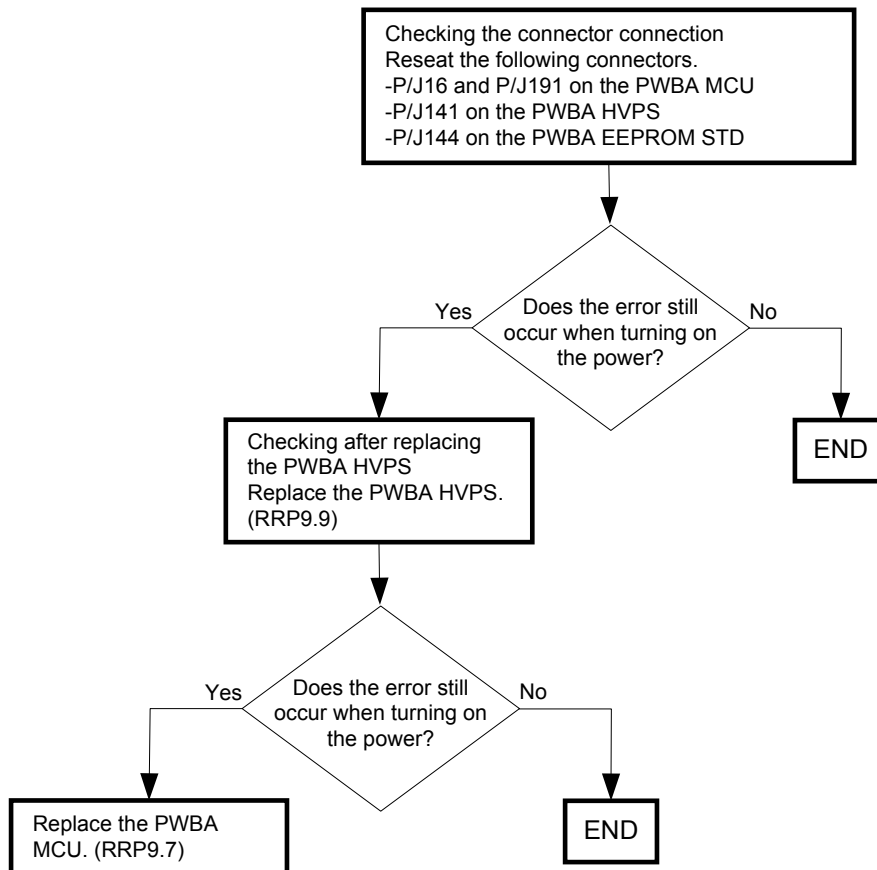

FIP-5 003-343 Restart Printer

Possible causative parts: FUSER ASSY (PL5.1.1)  
 PHD ASSY (PL6.1.1)  
 CRUM (PL7.1.4)  
 PWBA EEPROM STD (PL9.1.12)  
 PWBA MCU (PL9.1.16)  
 PWBA HVPS (PL9.1.21)

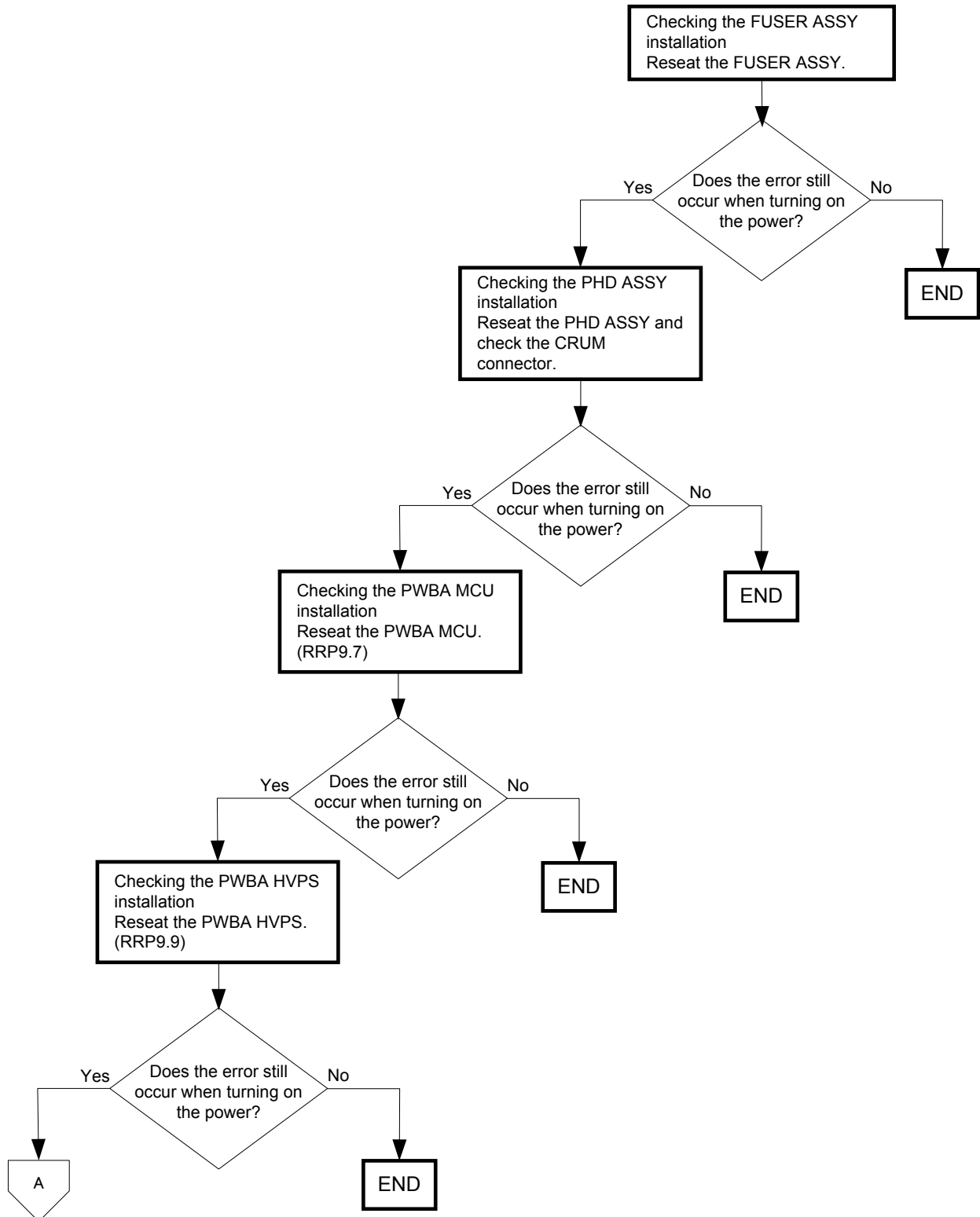

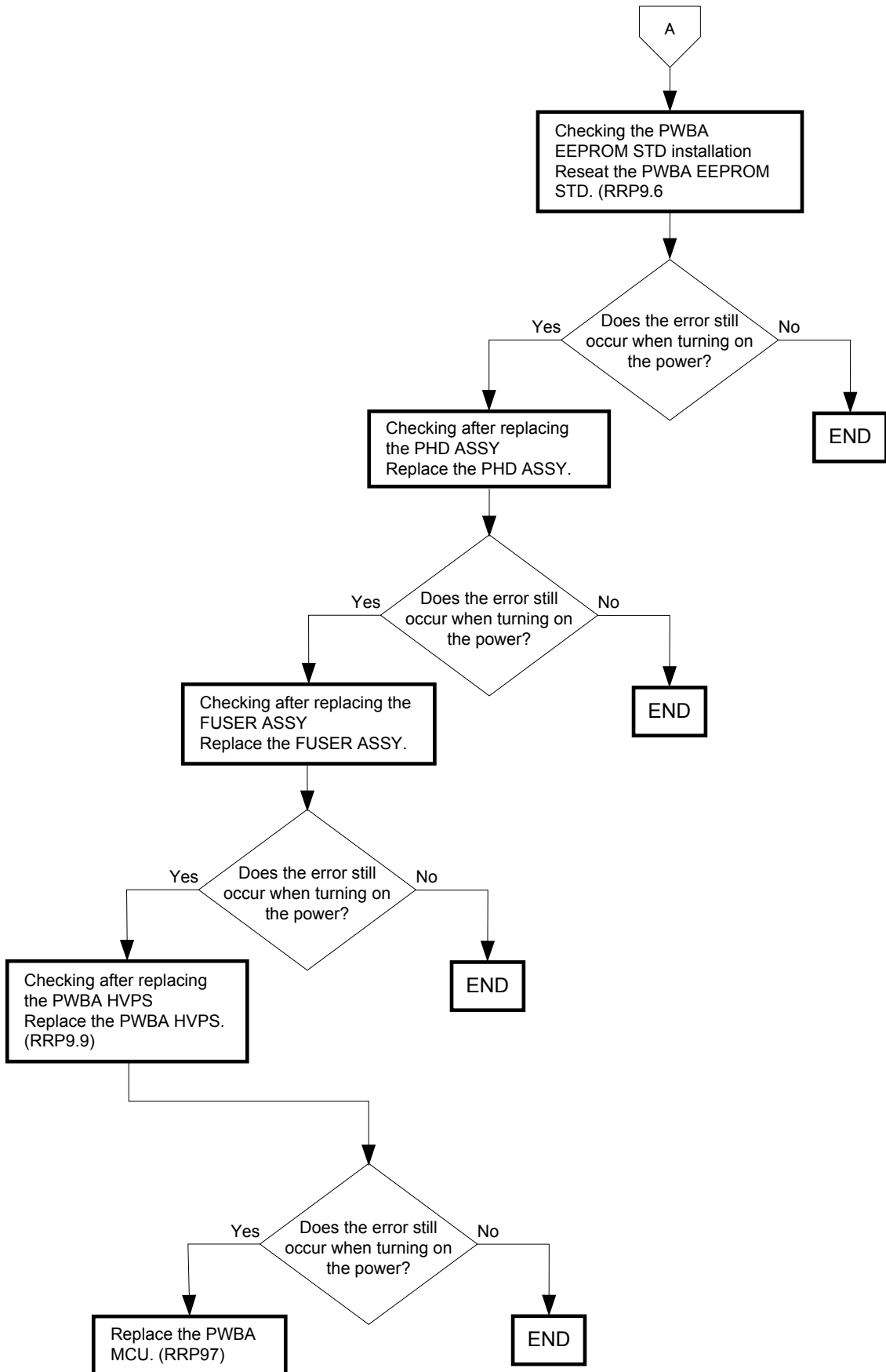

FIP-6 003-356 Restart Printer

Possible causative parts:FUSER ASSY (PL5.1.1)  
 PHD ASSY (PL6.1.1)  
 CRUM (PL7.1.4)  
 PWBA EEPROM STD (PL9.1.12)  
 PWBA MCU (PL9.1.16)  
 PWBA HVPS (PL9.1.21)

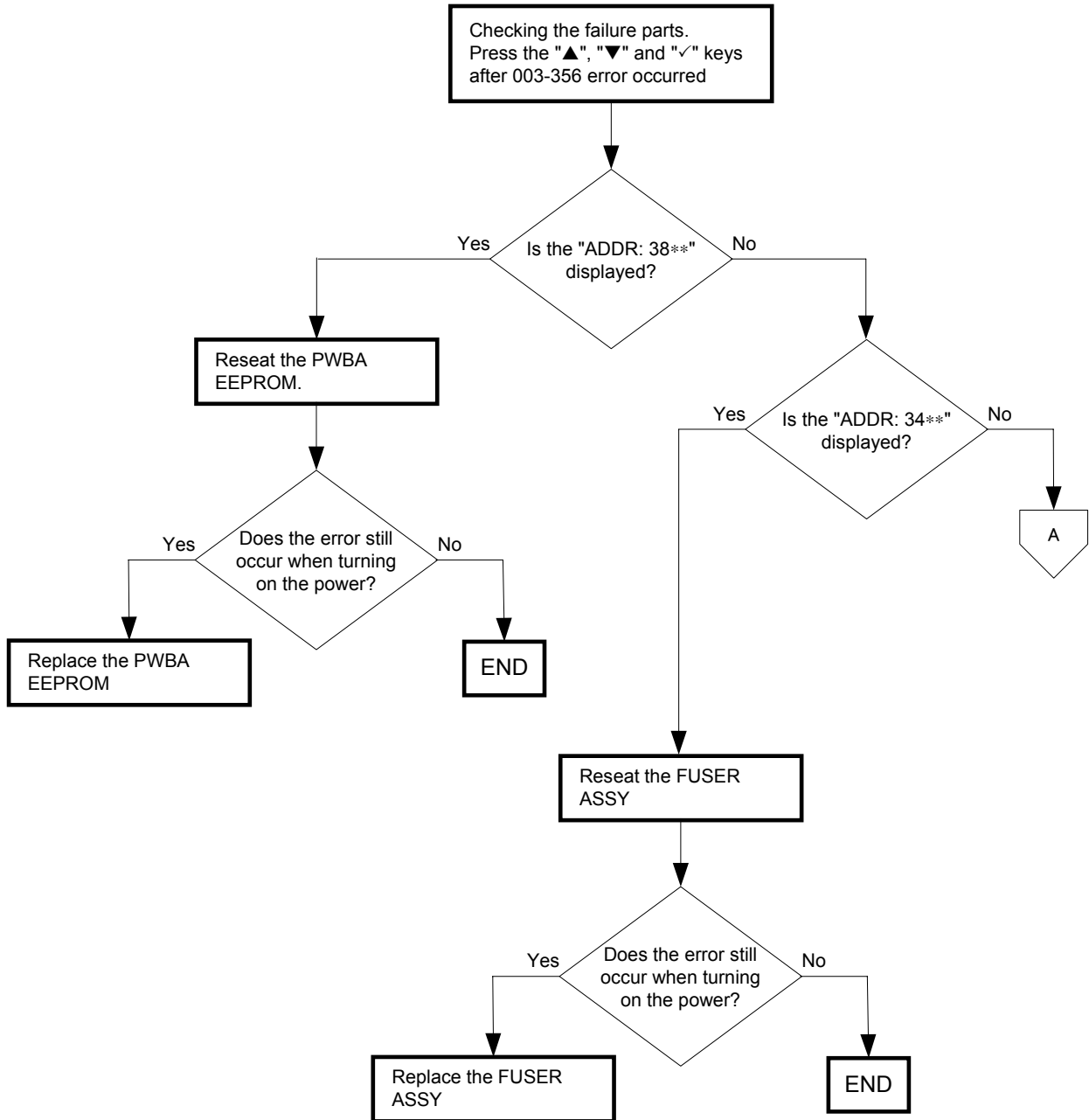



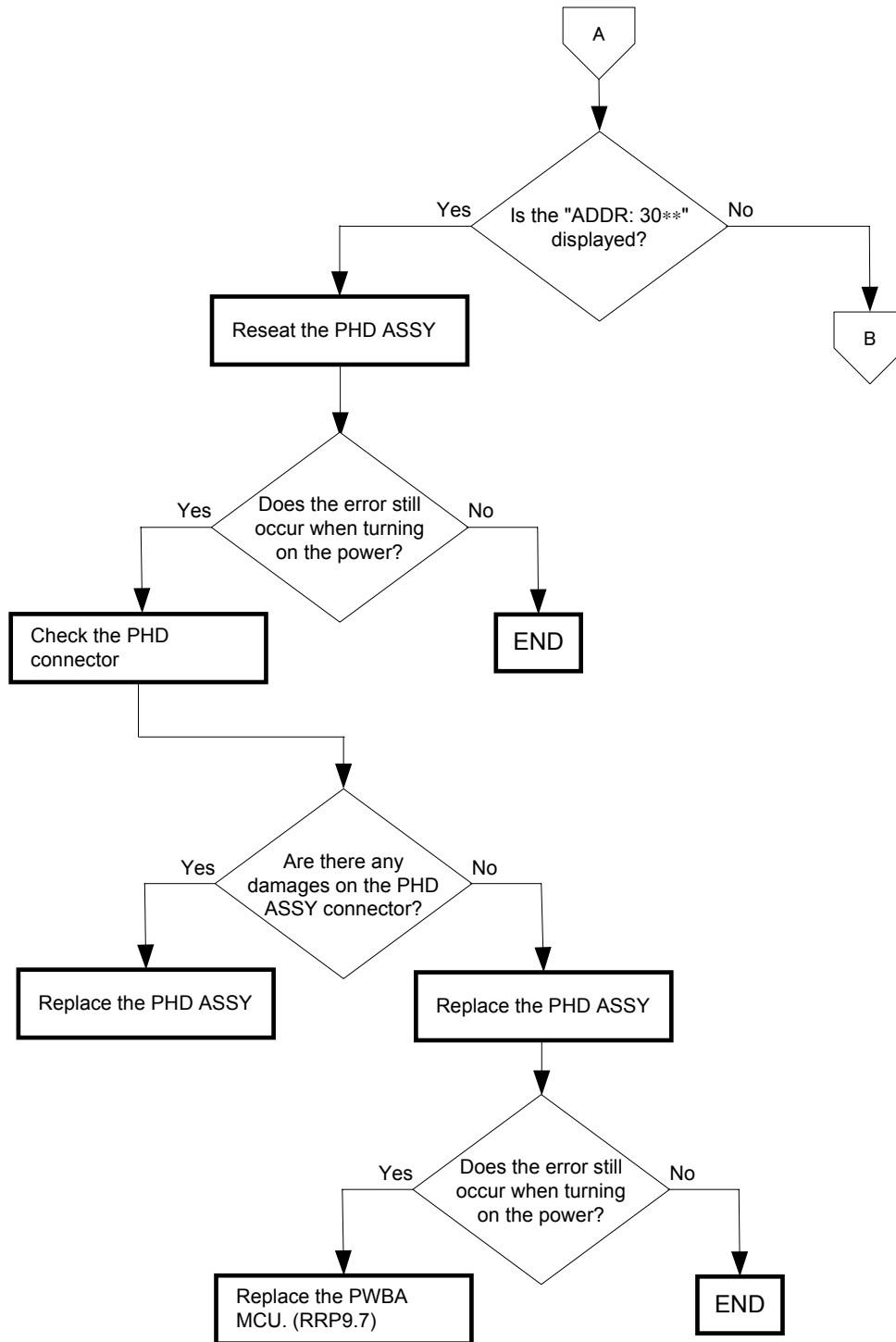

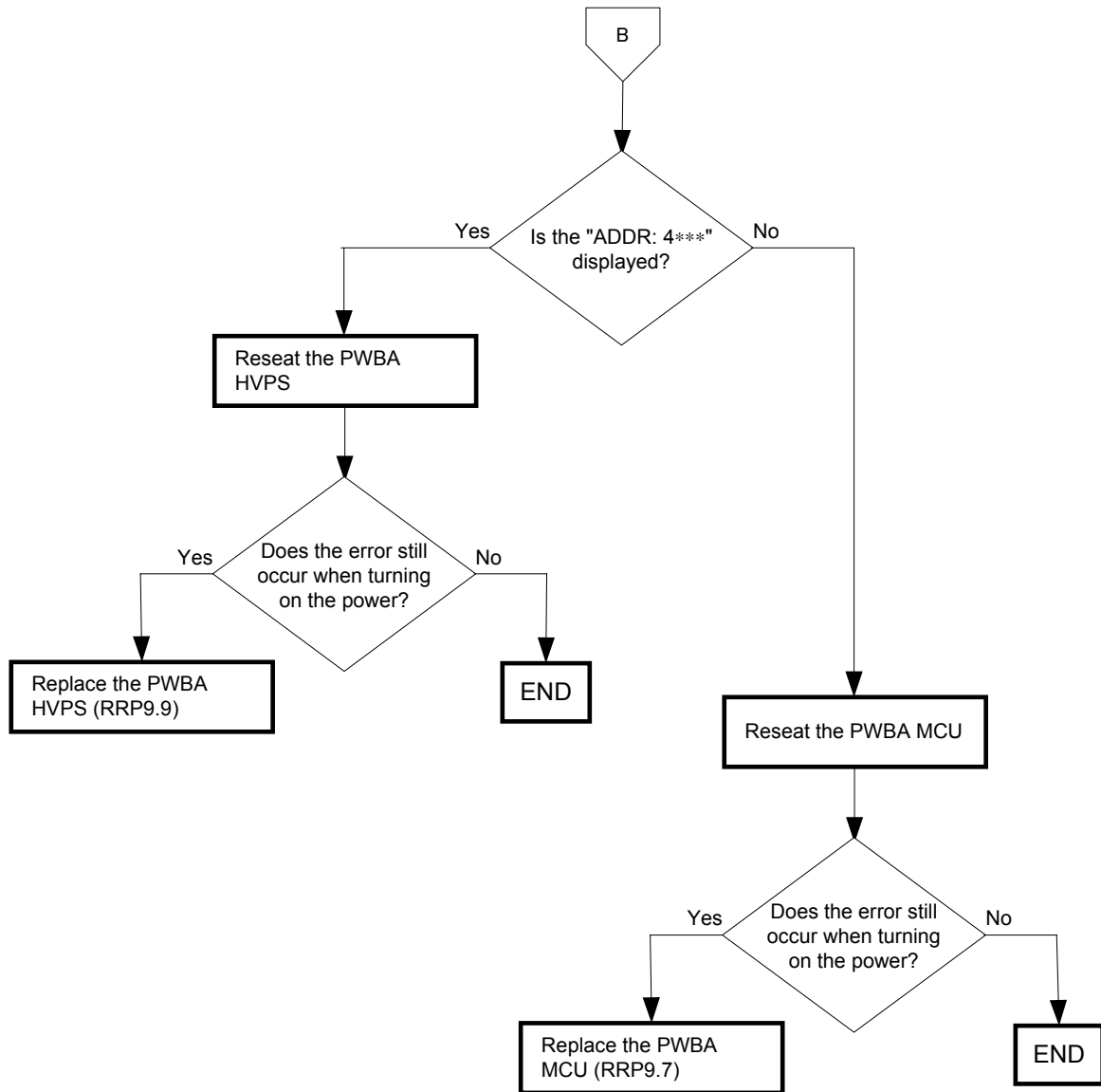

FIP-7 004-310 Restart Printer

Possible causative parts:PWBA MCU (PL9.1.16)  
1 TRAY OPTION FEEDER ASSY (PL11.1.1)  
2 TRAY OPTION FEEDER ASSY (PL12.1.1)

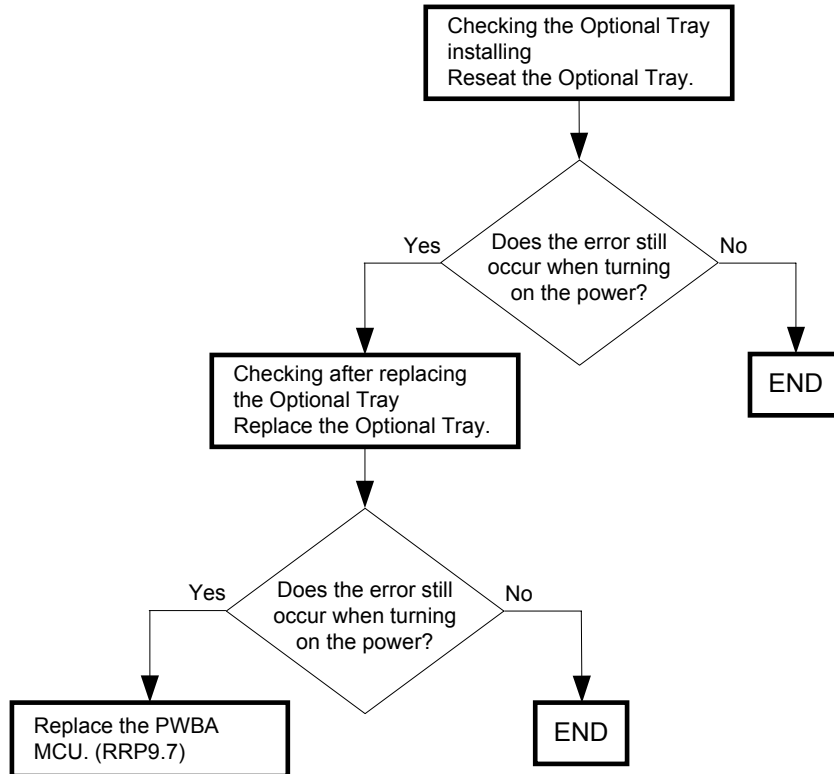

FIP-8 006-370/006-371/006-372/006-373/006-374/006-375/006-376/006-377/006-378/  
006-379/006-380/006-381/006-382/006-383/006-384 Restart Printer

Possible causative parts:ROS ASSY (PL6.1.2)  
PWBA MCU (PL9.1.16)

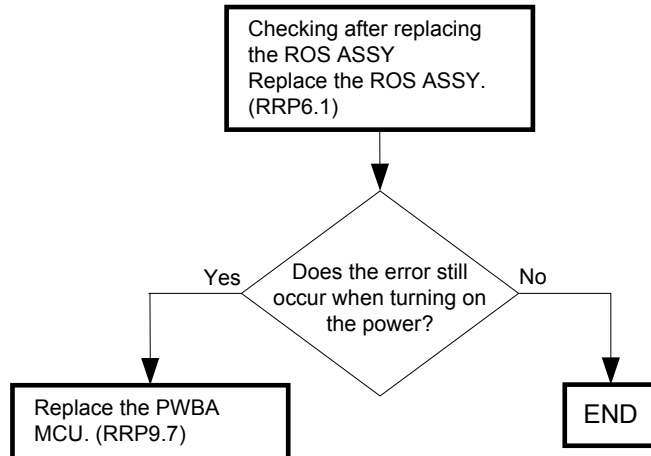

FIP-9 007-342/007-345/007-346/007-348 Restart Printer

Possible causative parts:DRIVE ASSY MAIN (PL8.1.2)  
PWBA MCU (PL9.1.16)

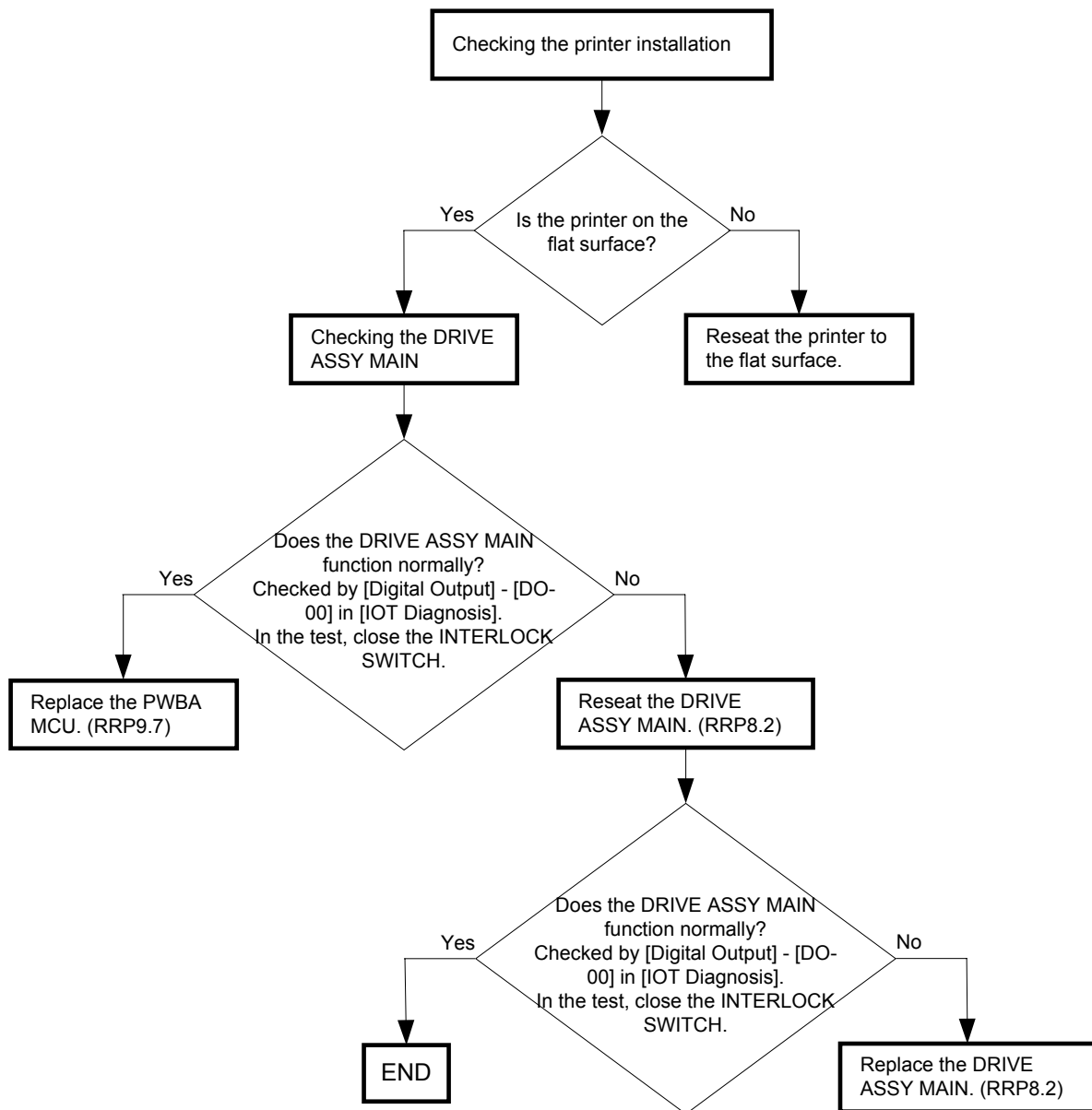

FIP-10 007-343/007-345/007-347/007-348 Restart Printer

Possible causative parts:DRIVE ASSY DEVE (PL8.1.1)  
PWBA MCU (PL9.1.16)

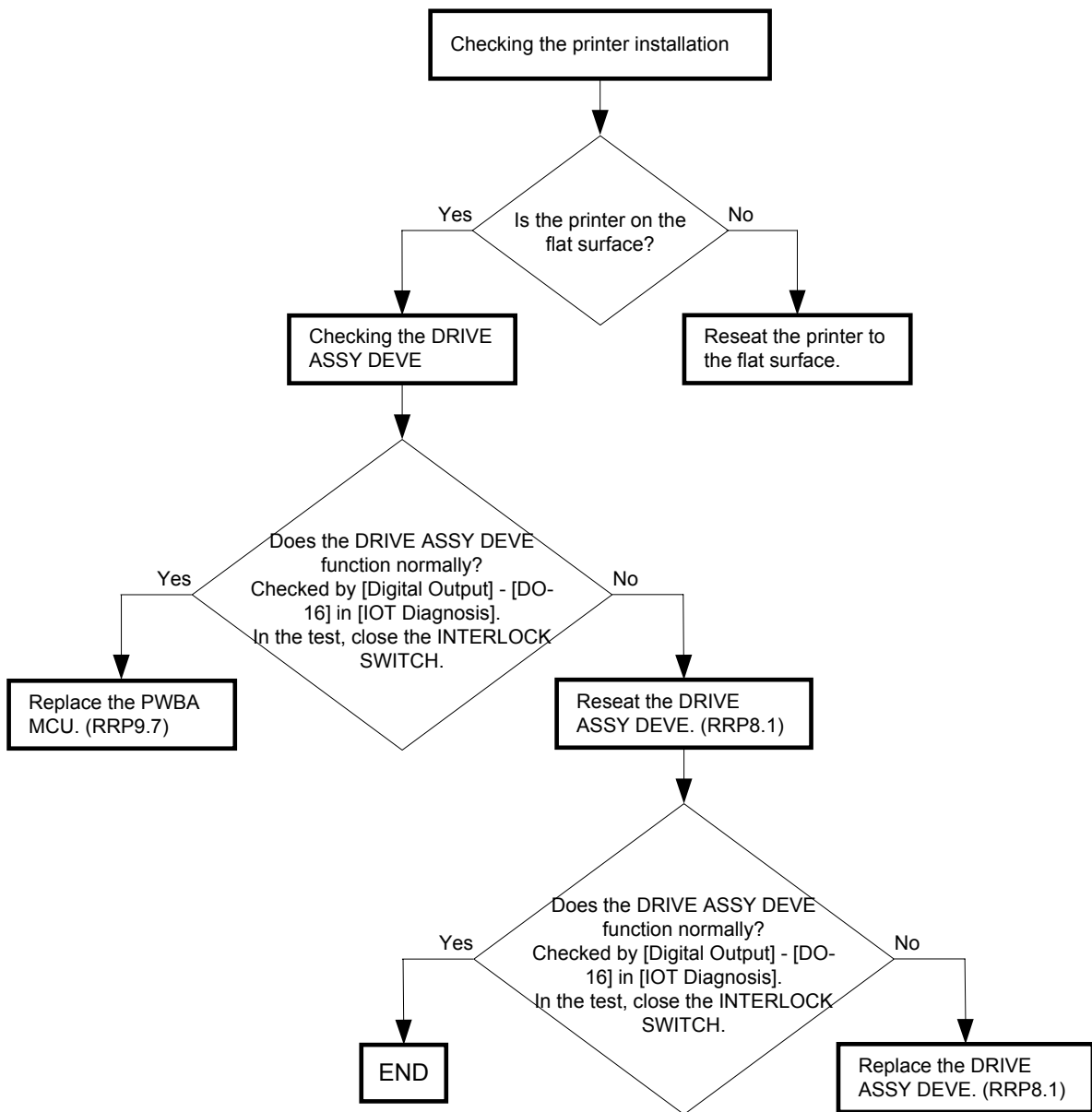

FIP-11 007-344/007-346/007-347/007-348 Restart Printer

Possible causative parts:DRIVE ASSY FUSER (PL5.2.25)  
PWBA MCU (PL9.1.16)

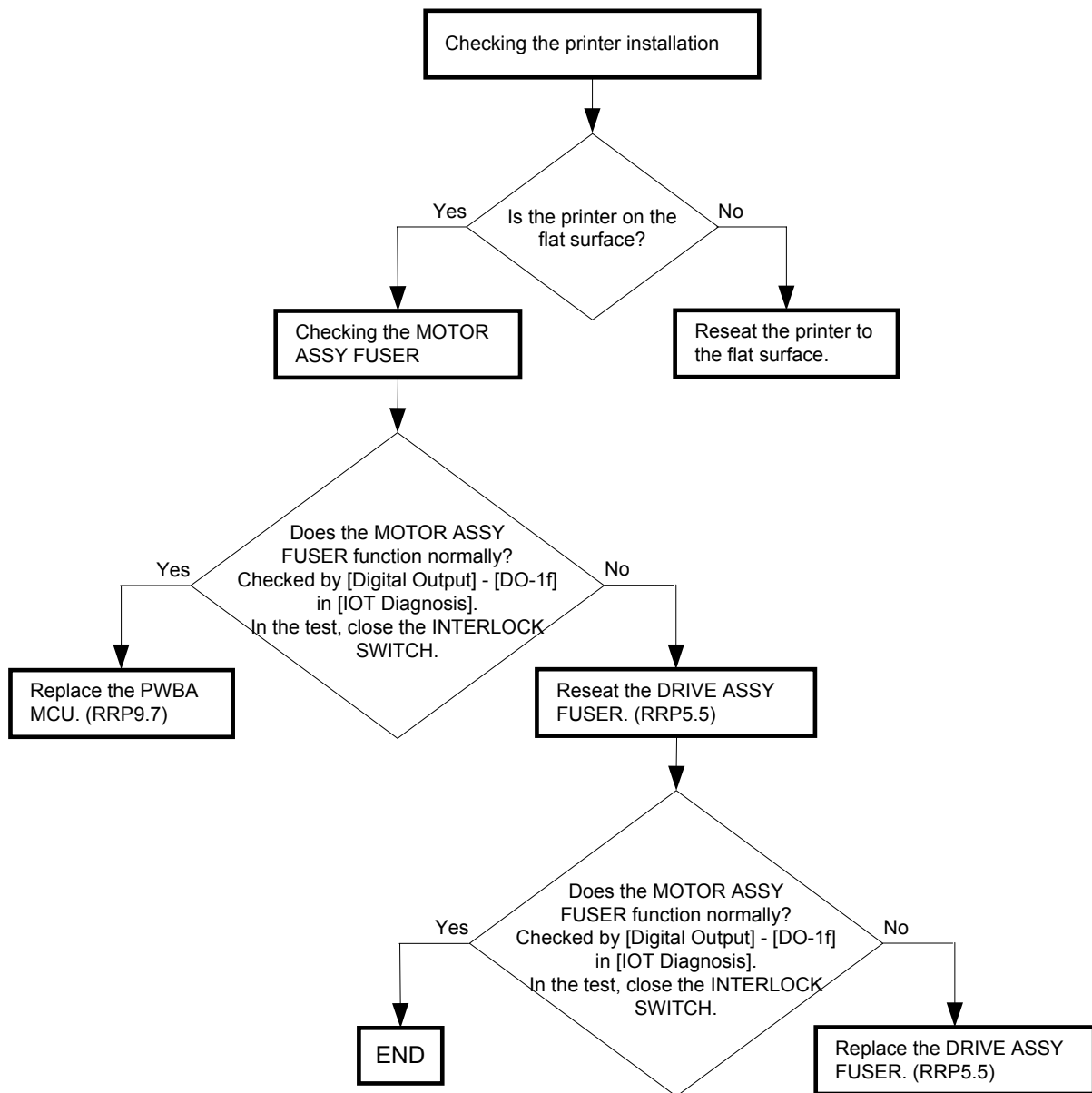

FIP-12 009-340/009-341 Restart Printer

Possible causative parts:HOLDER ASSY ADC (PL5.2.19)  
PWBA MCU (PL9.1.16)

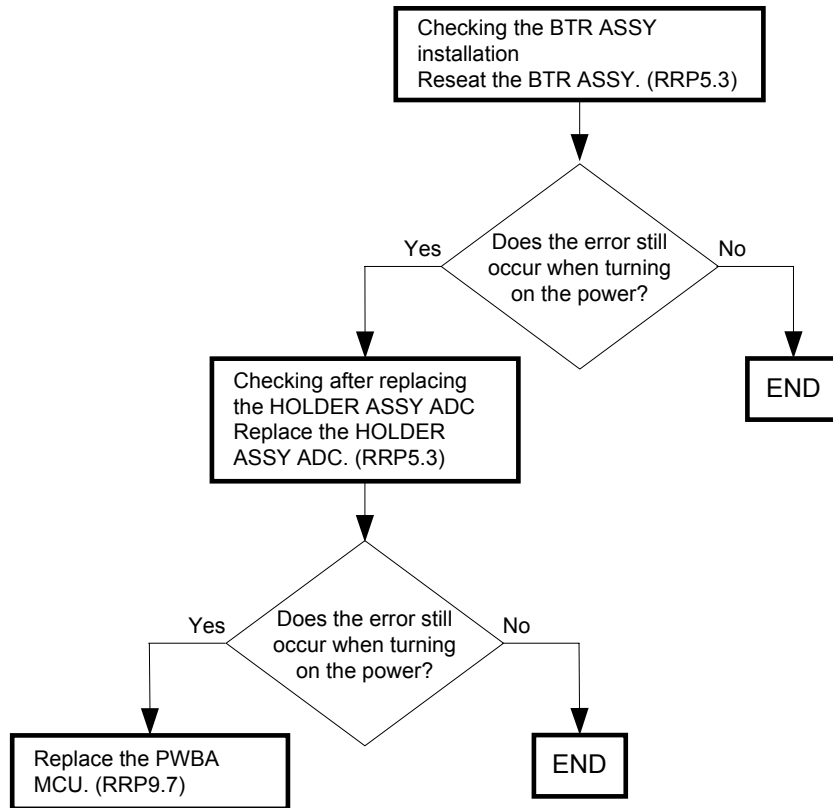



FIP-13 009-360/009-361/009-362/009-363 Restart Printer

Possible causative parts: TONER CARTRIDGE Y (PL7.2.8)  
 TONER CARTRIDGE M (PL7.2.9)  
 TONER CARTRIDGE C (PL7.2.10)  
 TONER CARTRIDGE K (PL7.2.11)  
 BOX ASSY CRUM READER (PL7.2.12)  
 PWBA MCU (PL9.1.16)

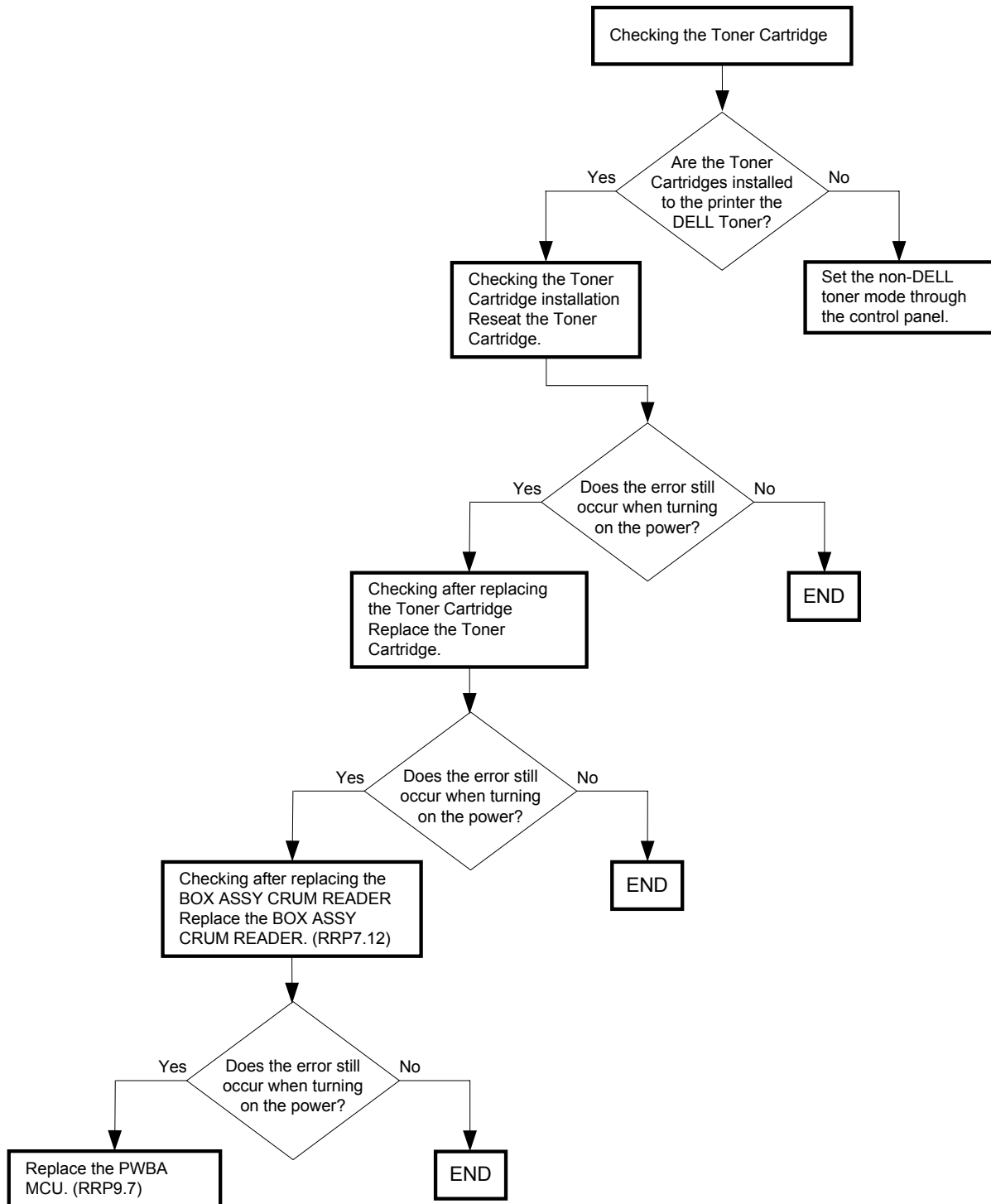

FIP-14 010-354 Restart Printer

Possible causative parts:PWBA MCU (PL9.1.16)

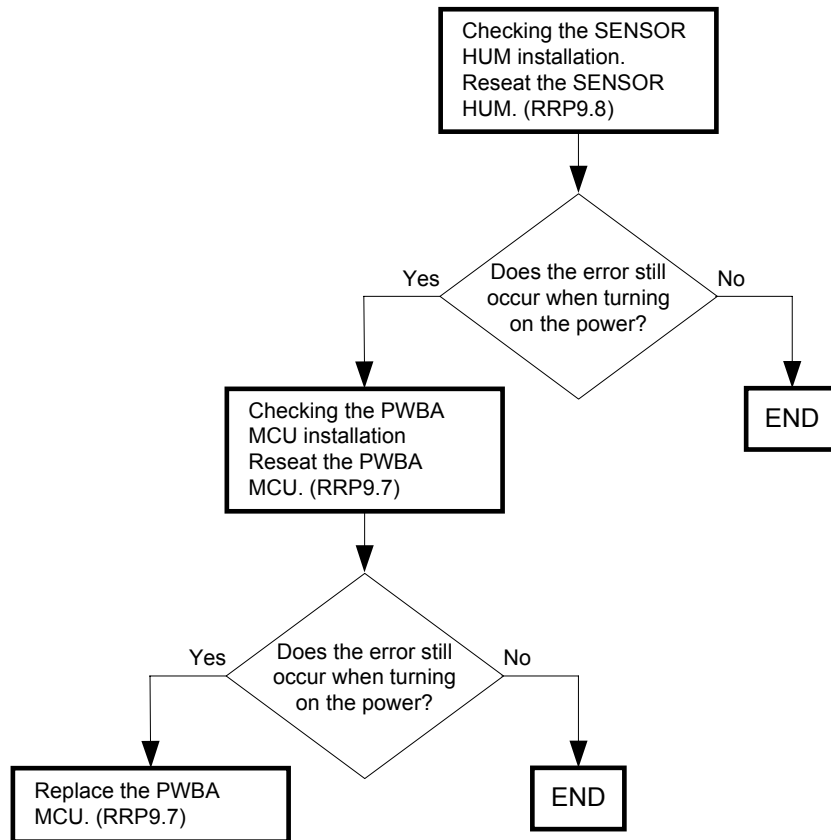

FIP-15 010-378/010-379/010-380/010-381/010-382/010-383/010-384/010-385/010-386/  
 010-387/010-388/010-389/010-390/010-391/010-392/010-393/010-394/010-395/  
 010-396/010-397 Restart Printer

Possible causative parts:FUSER ASSY (PL5.1.1)  
 LVPS (PL9.1.6)  
 PWBA MCU (PL9.1.16)

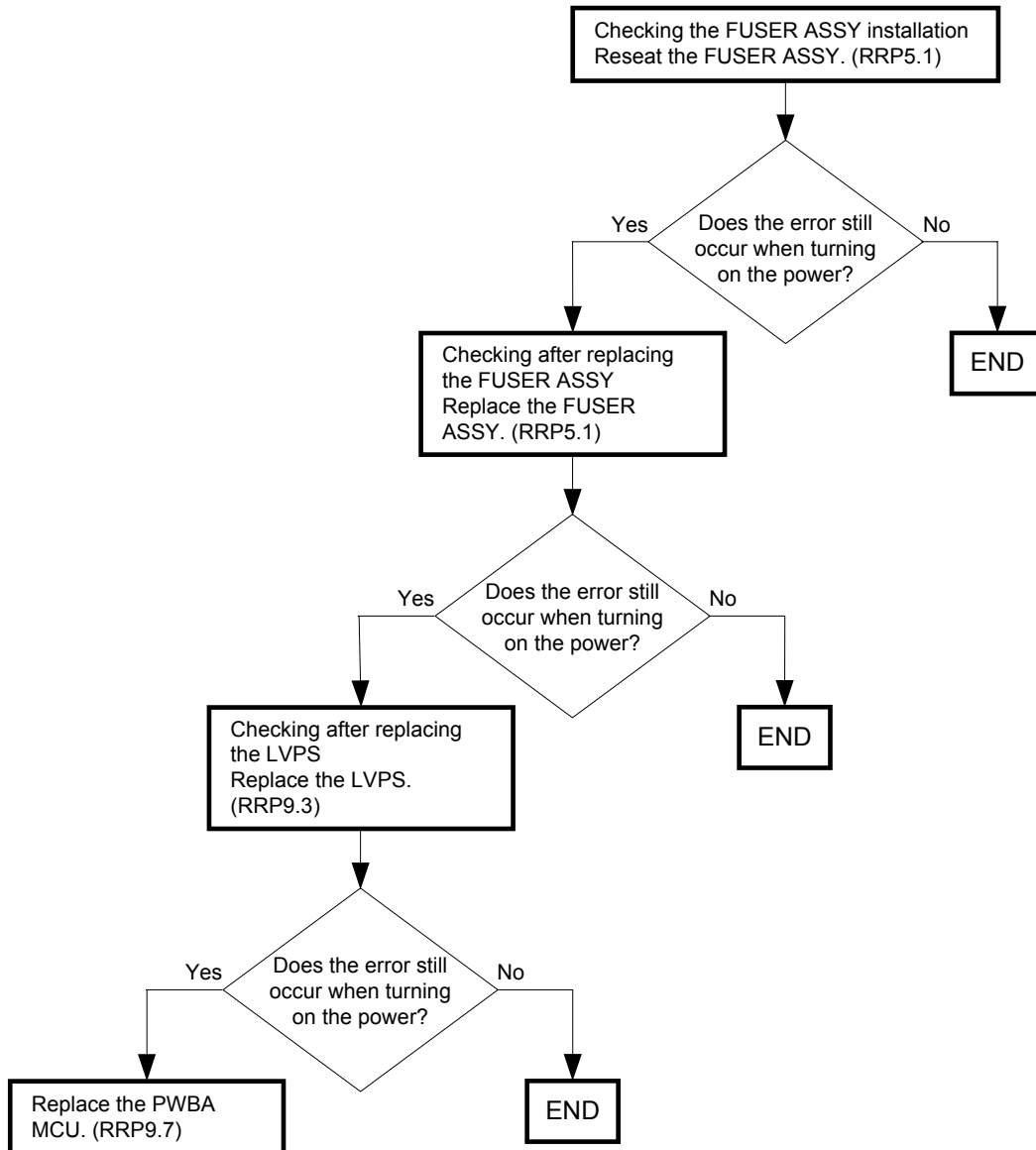

FIP-16 016-300/016-301/016-302/016-310/016-311/016-313/016-315/016-317/016-323/  
016-324/016-327/016-340/016-344/016-345/016-346 Restart Printer/  
Erase Flash Err. 016-392/Write Flash Err. 016-393/Verify Error 016-394

Possible causative parts:PWBA ESS (PL9.1.3)

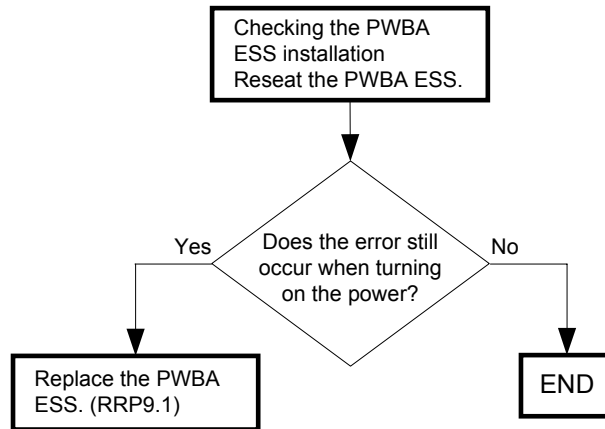

FIP-17 016-312 Restart Printer

Possible causative parts:PWBA ESS (PL9.1.3)  
HDD ASSY (PL9.1.25)

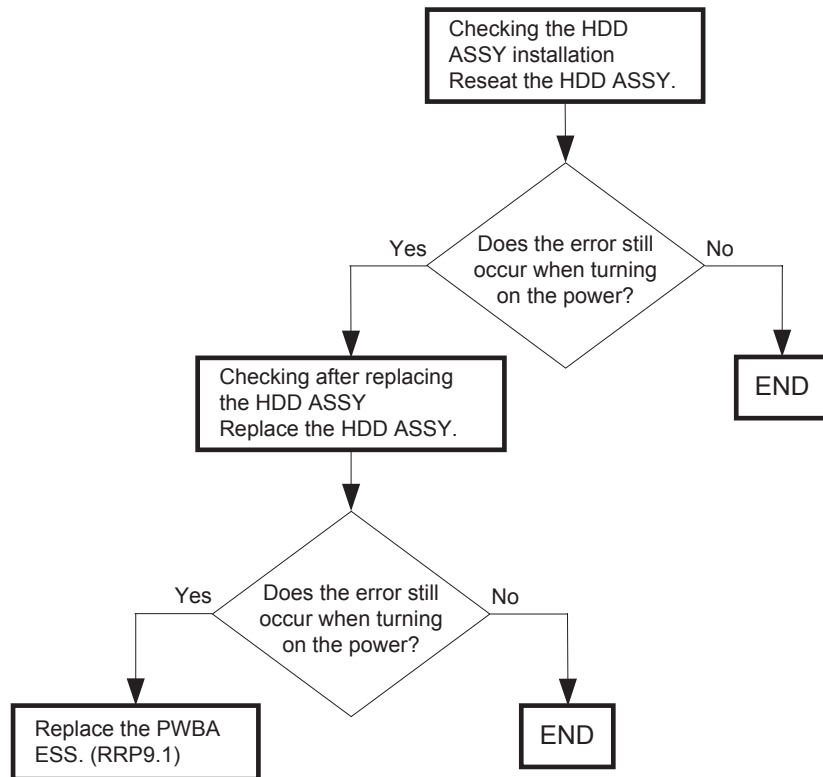

FIP-18 016-316/016-318 Restart Printer

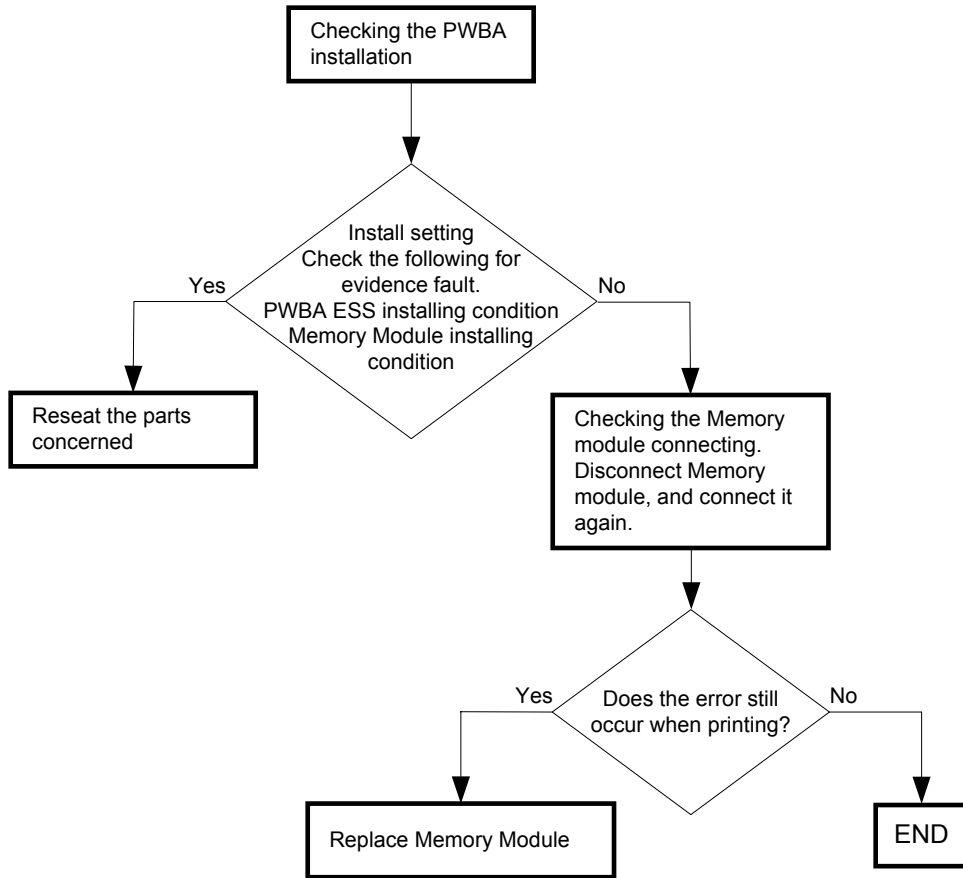

FIP-19 016-330/016-331/016-332/016-333/016-334/016-335/016-336/016-337

Restart Printer

Possible causative parts:PWBA ESS (PL9.1.3)  
OPTION NIC (MPC) ASSY (PL9.1.26)

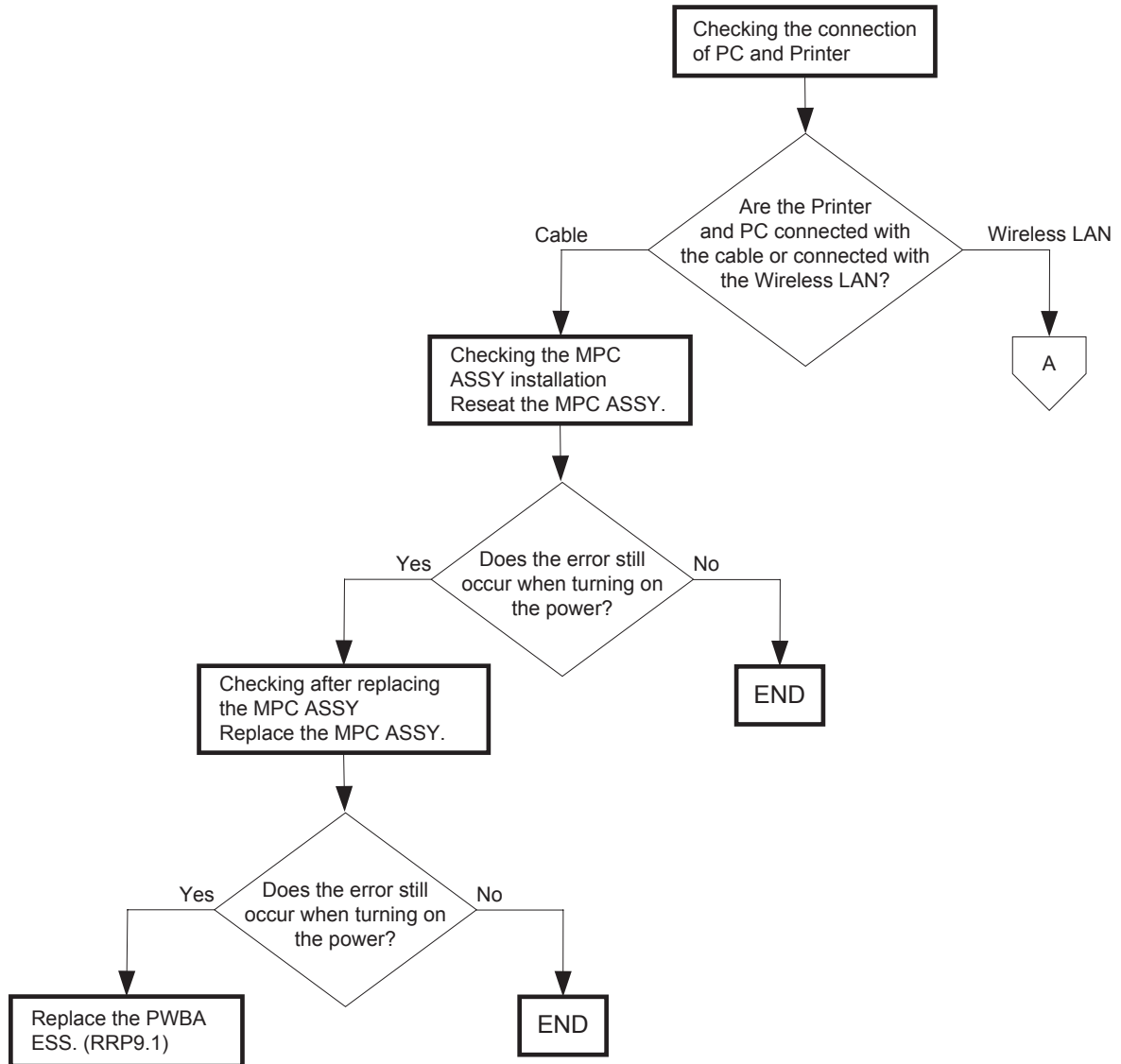

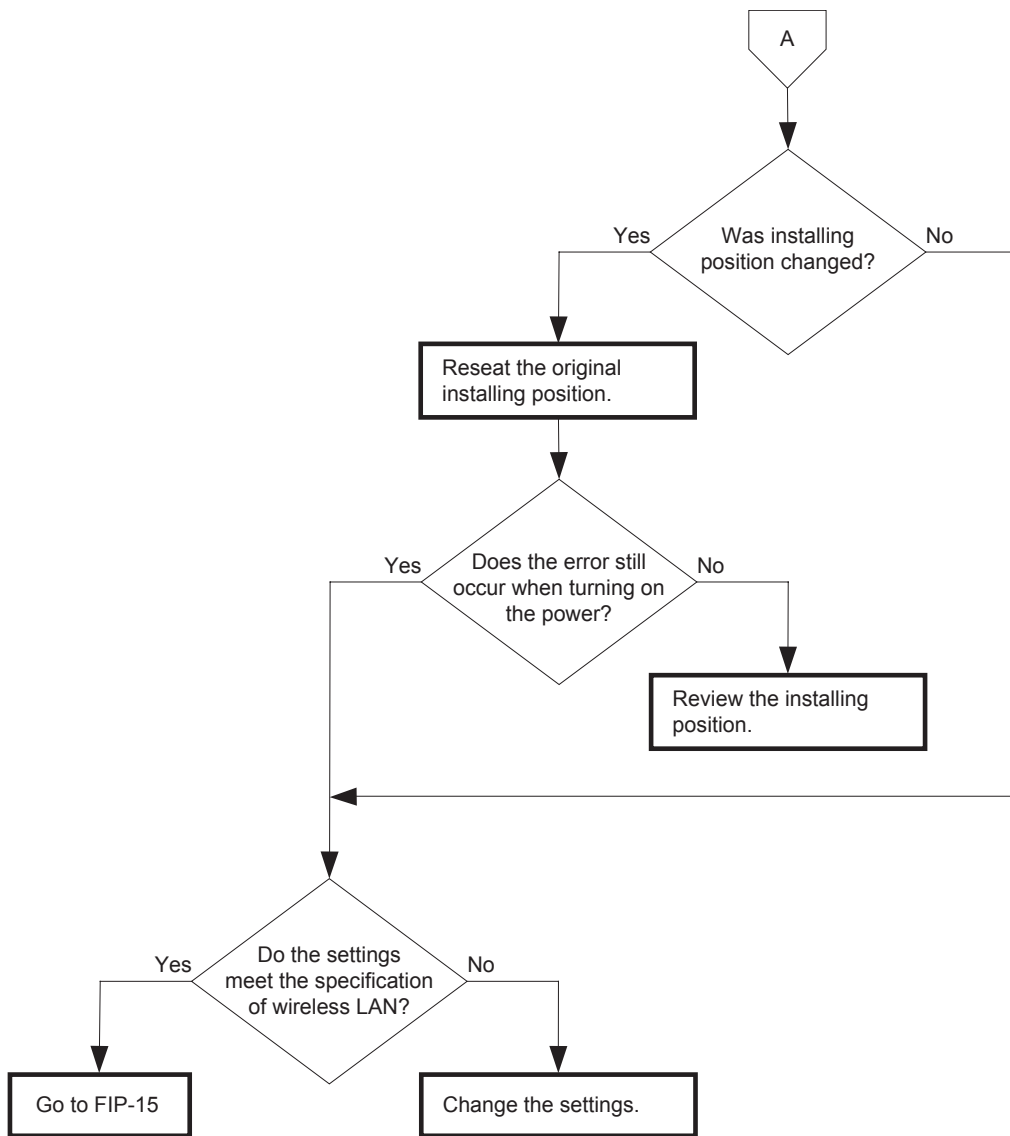



FIP-20 016-338 Restart Printer

Possible causative parts: Option Wireless Printer Adapter  
Option MPC Board

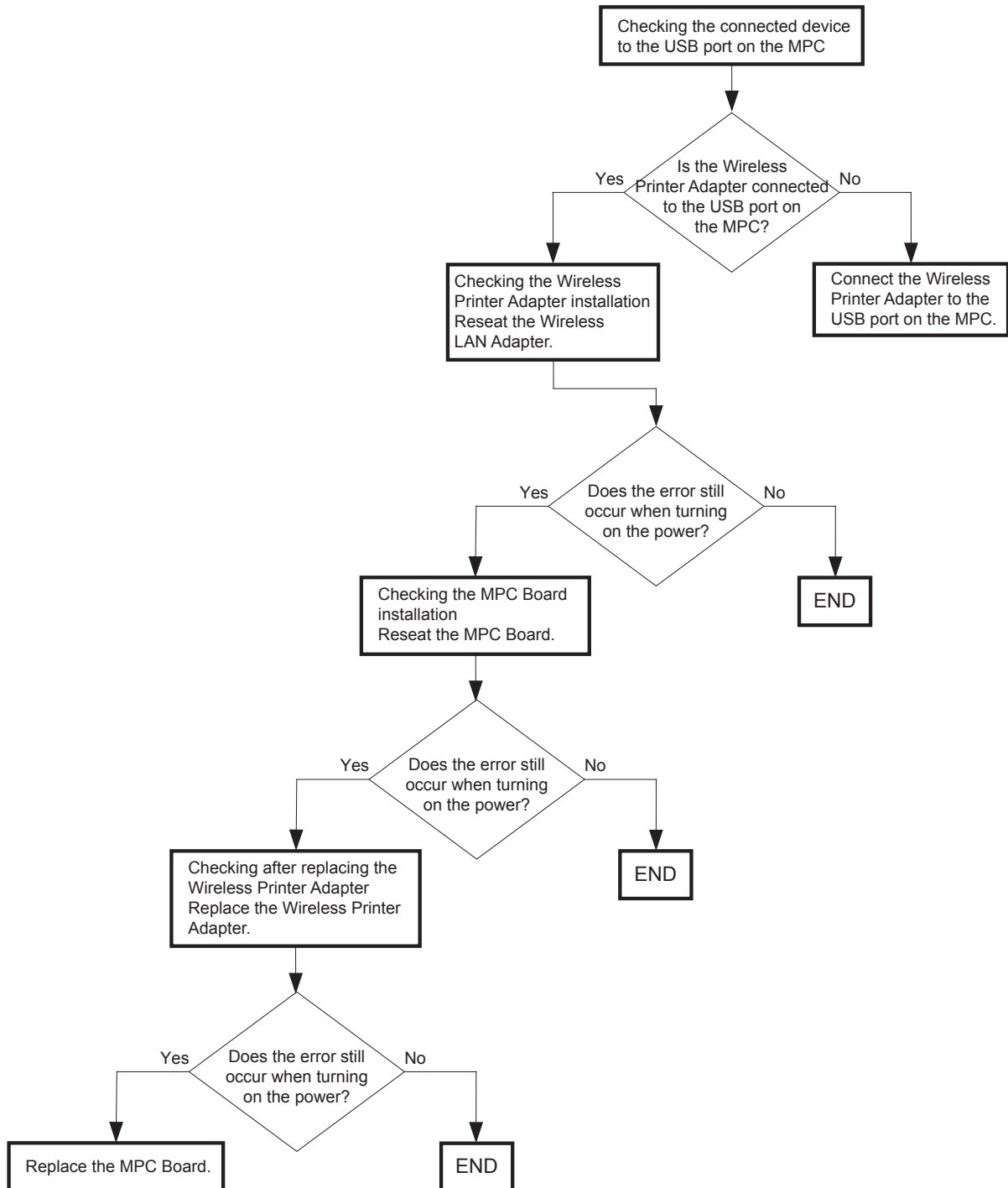

FIP-21 016-350 Restart Printer

Possible causative parts:PWBA ESS (PL9.1.3)  
IEEE 1284 Cable

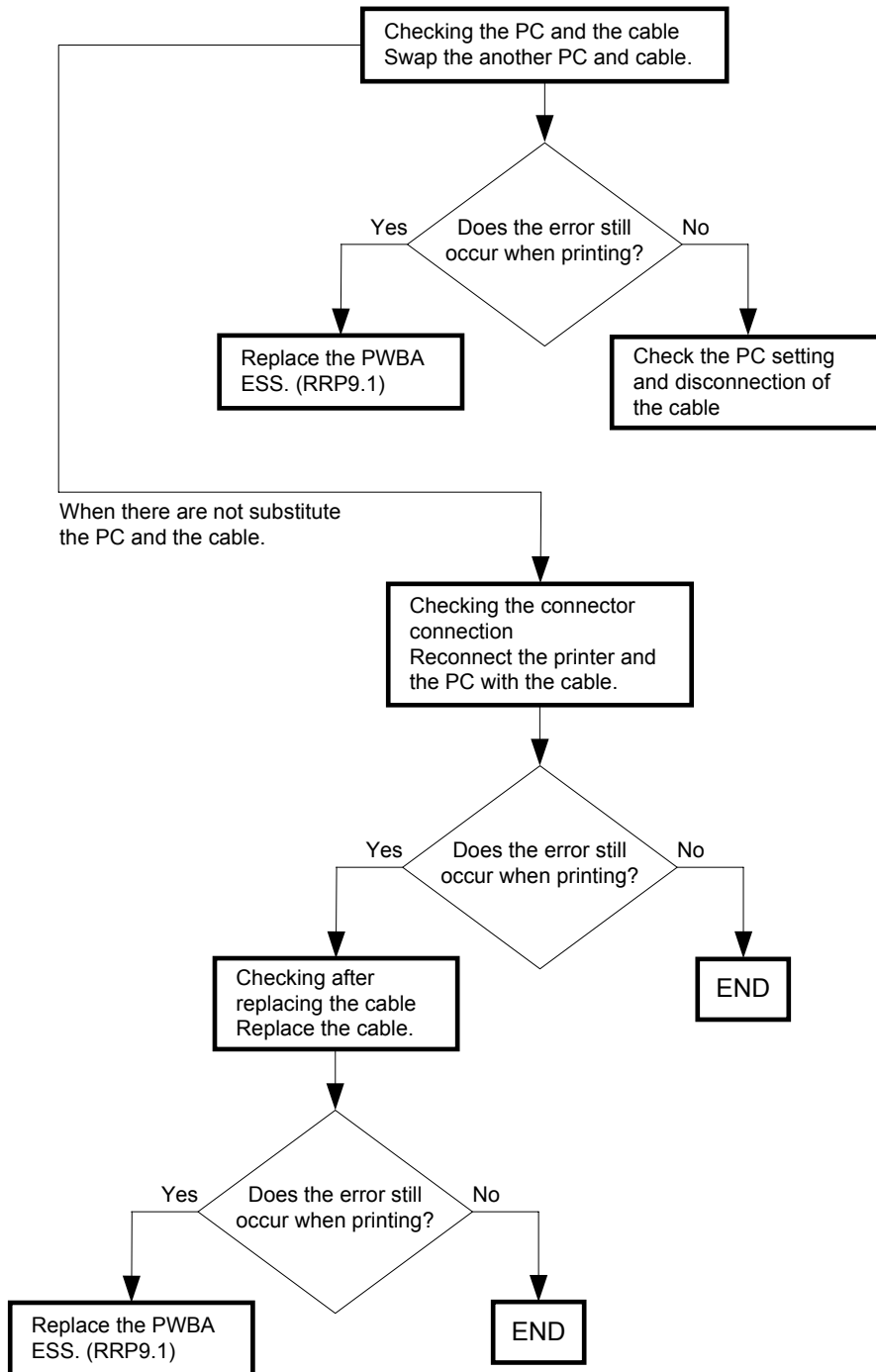

FIP-22 016-360/016-361 Restart Printer

Possible causative parts: PWBA ESS (PL9.1.3)  
 OPTION HDD ASSY (PL9.1.25)  
 OPTION NIC (MPC) ASSY (PL9.1.26)

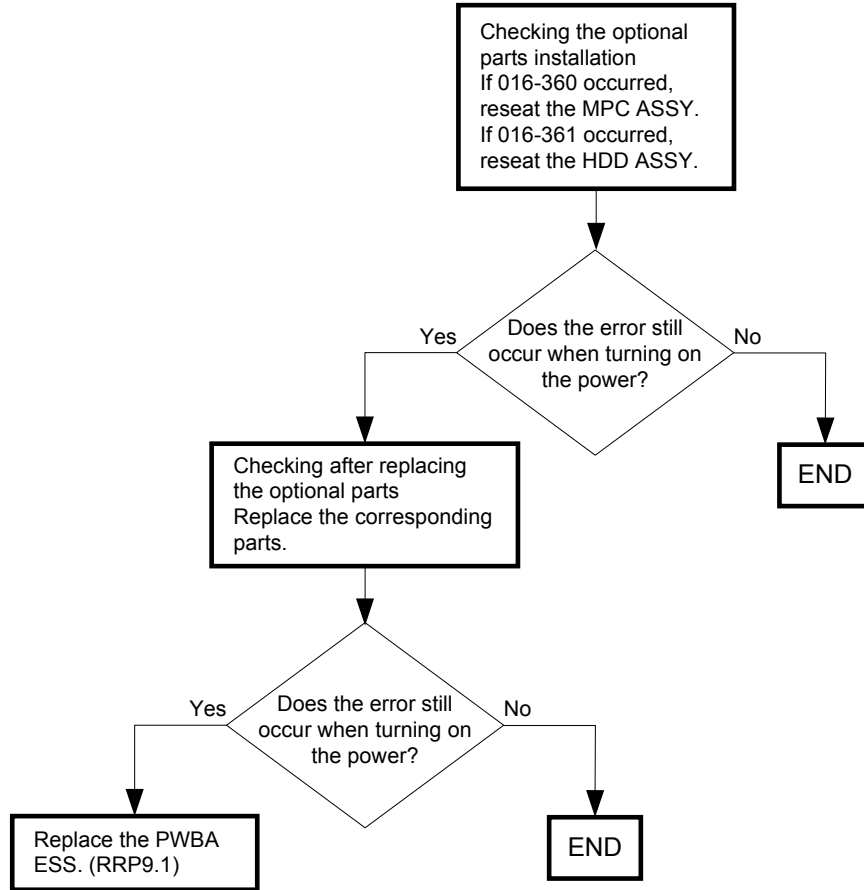

FIP-23 016-370 Restart Printer

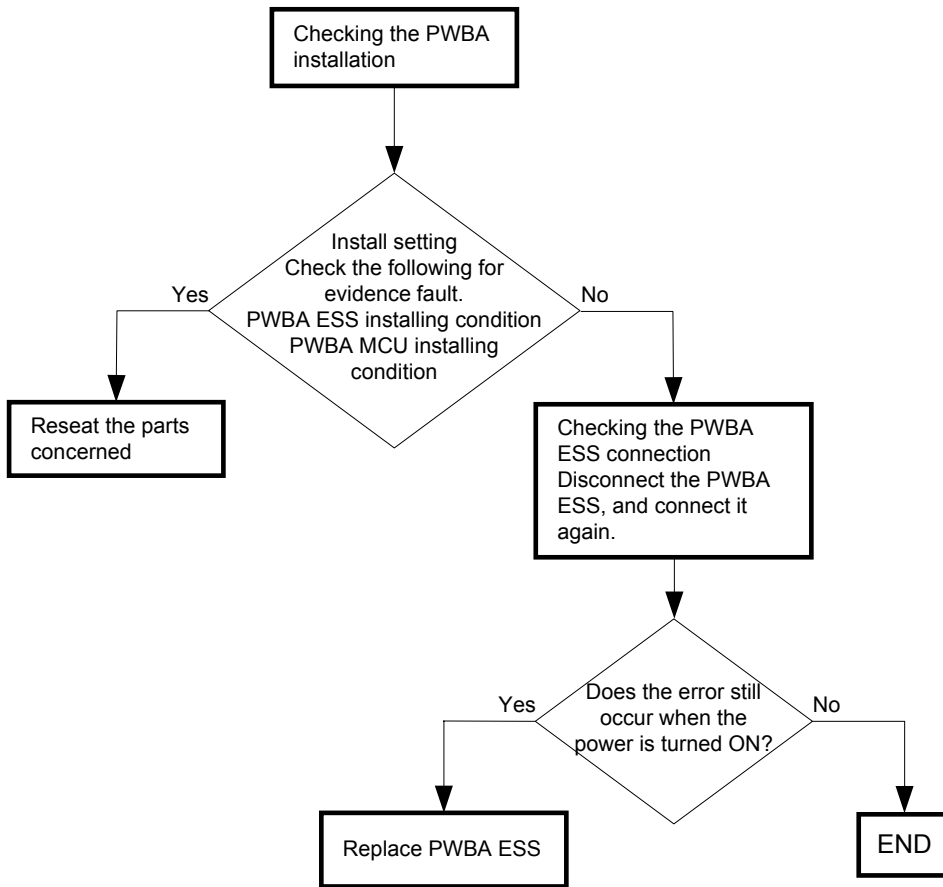

FIP-24 Paper Jam 077-902

Possible causative parts:FUSER ASSY (PL5.1.1)  
FRONT ASSY IN (PL5.2.1)

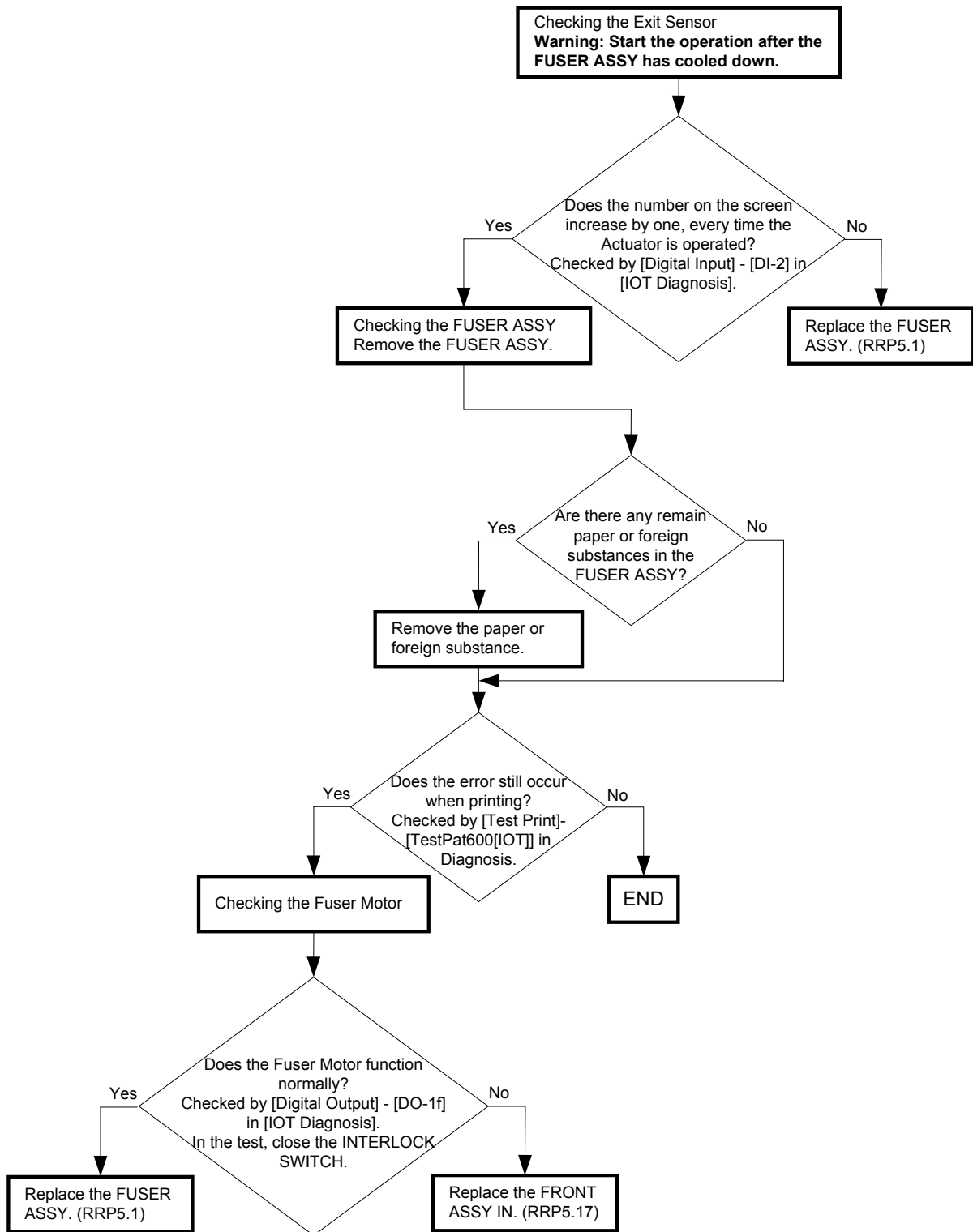

FIP-25 Paper Jam 077-900

Possible causative parts:CHUTE ASSY REGI IN (PL4.1.20)  
CHUTE ASSY REGI (PL4.2.1)

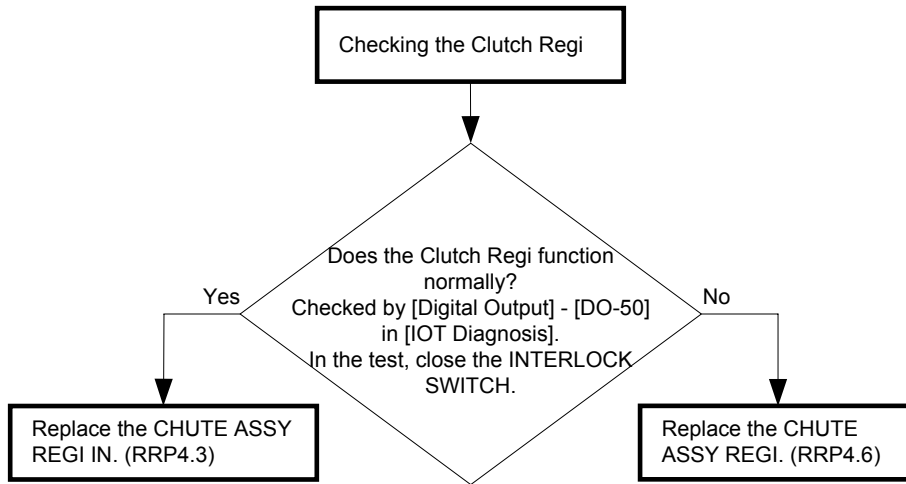

FIP-26 Paper Jam 071-101

**NOTE**

If the multiple feeding occurred, go to FIP-Multiple feed.

- Possible causative parts:
- PICK UP ASSY (PL3.3.1)
  - ROLL ASSY FEED (PL3.3.18)
  - CHUTE ASSY REGI IN (PL4.1.20)
  - CHUTE ASSYREGI (PL4.2.1)
  - CHUTE ASSY DUP OUT (PL5.3.1)
  - SOLENOID FEED MSI (PL5.3.9)
  - ROLL ASSY FEED (PL5.3.20)
  - PWBA MCU (PL9.1.16)

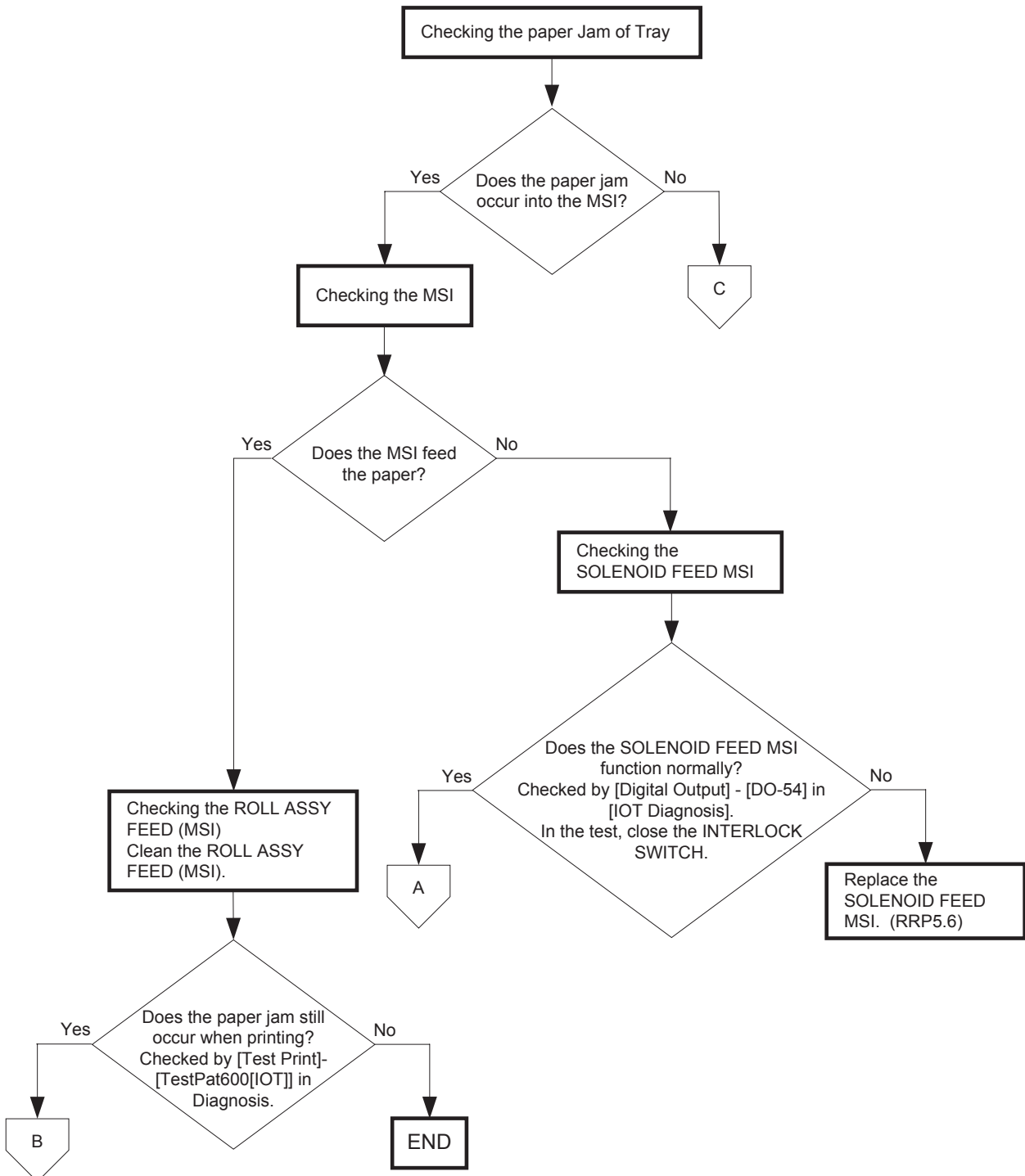

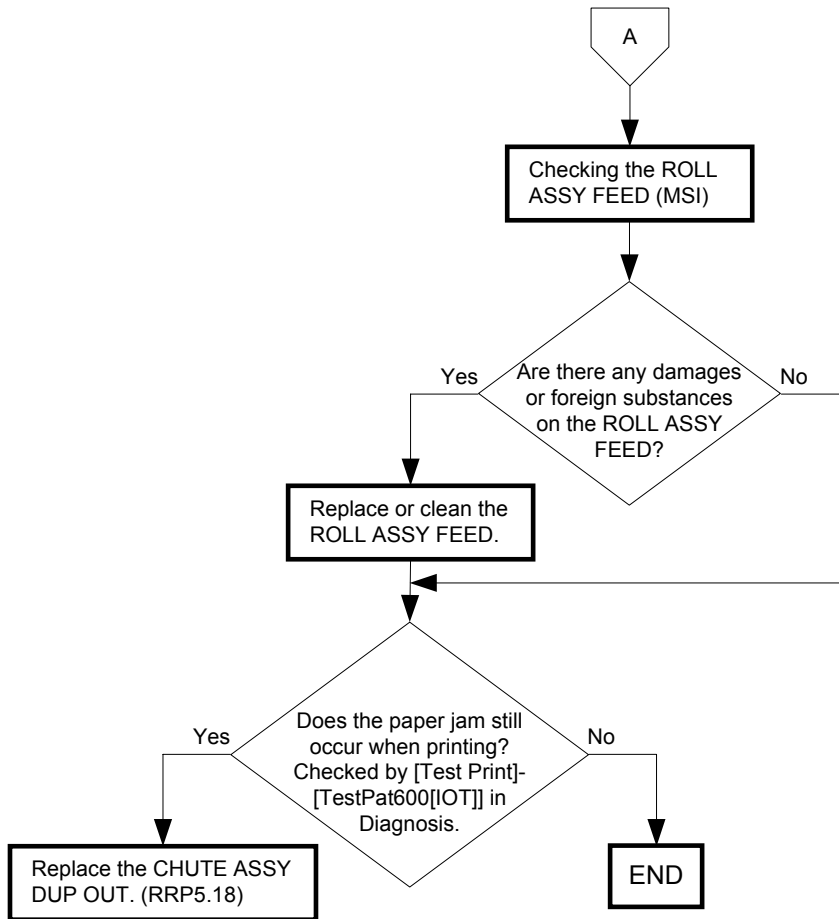



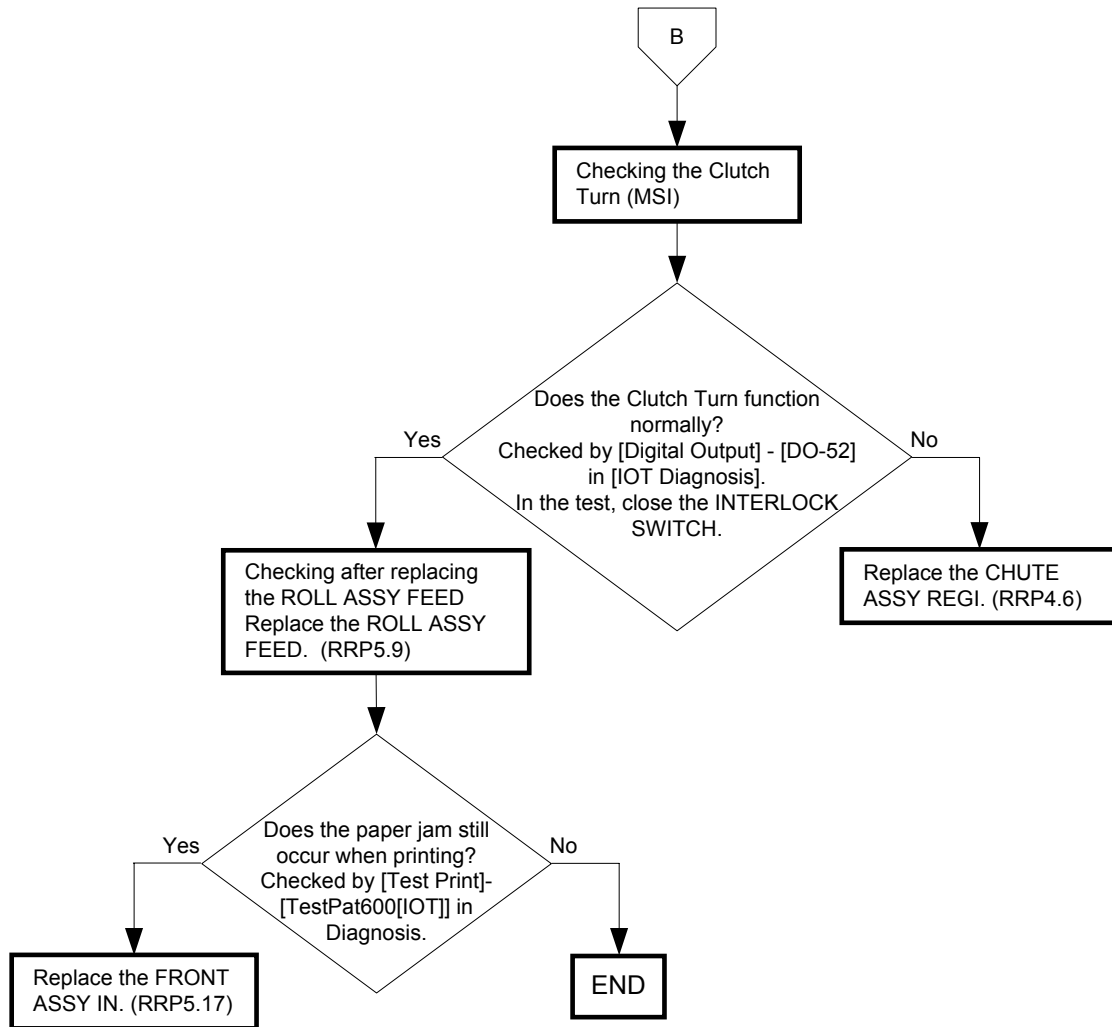

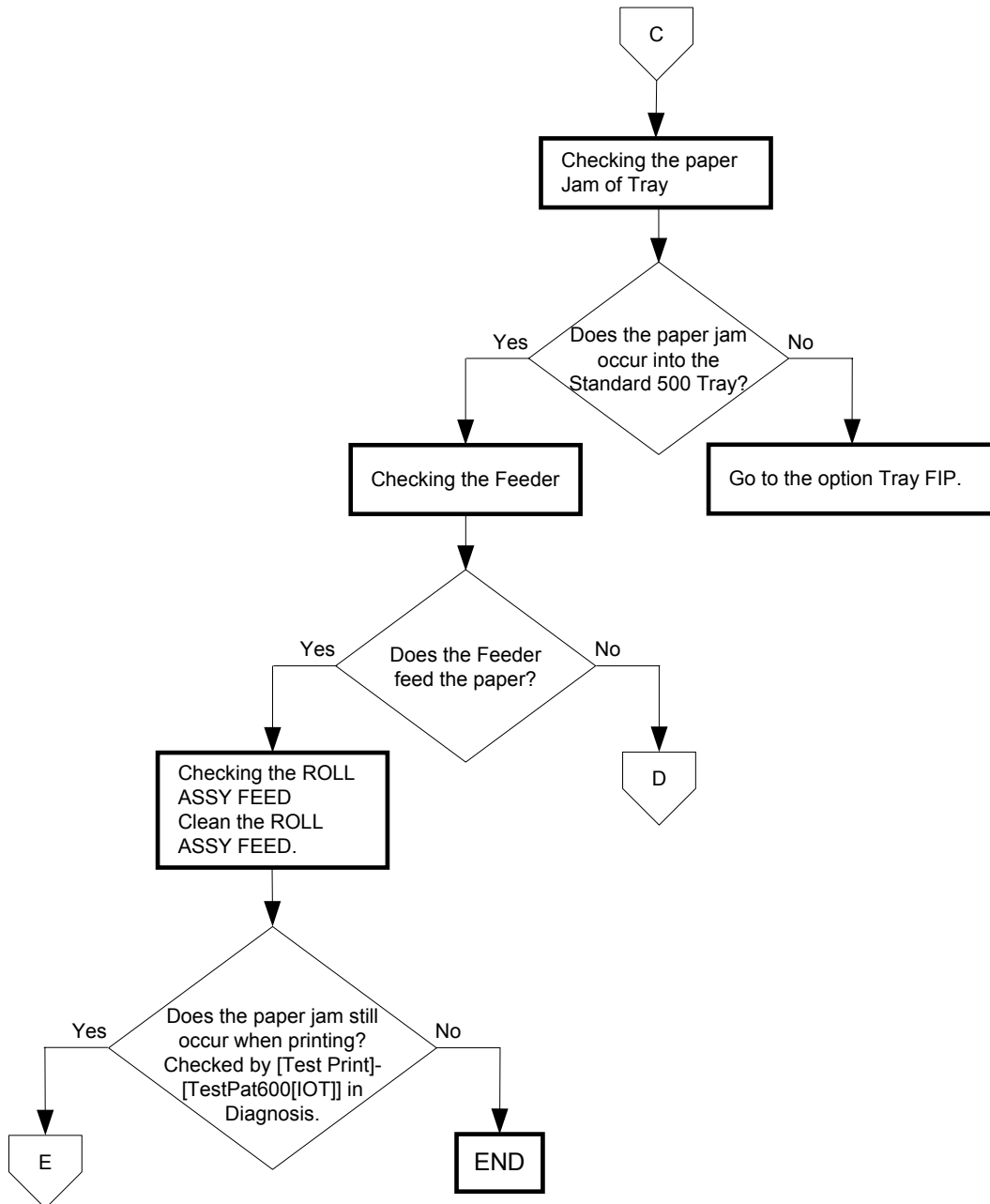

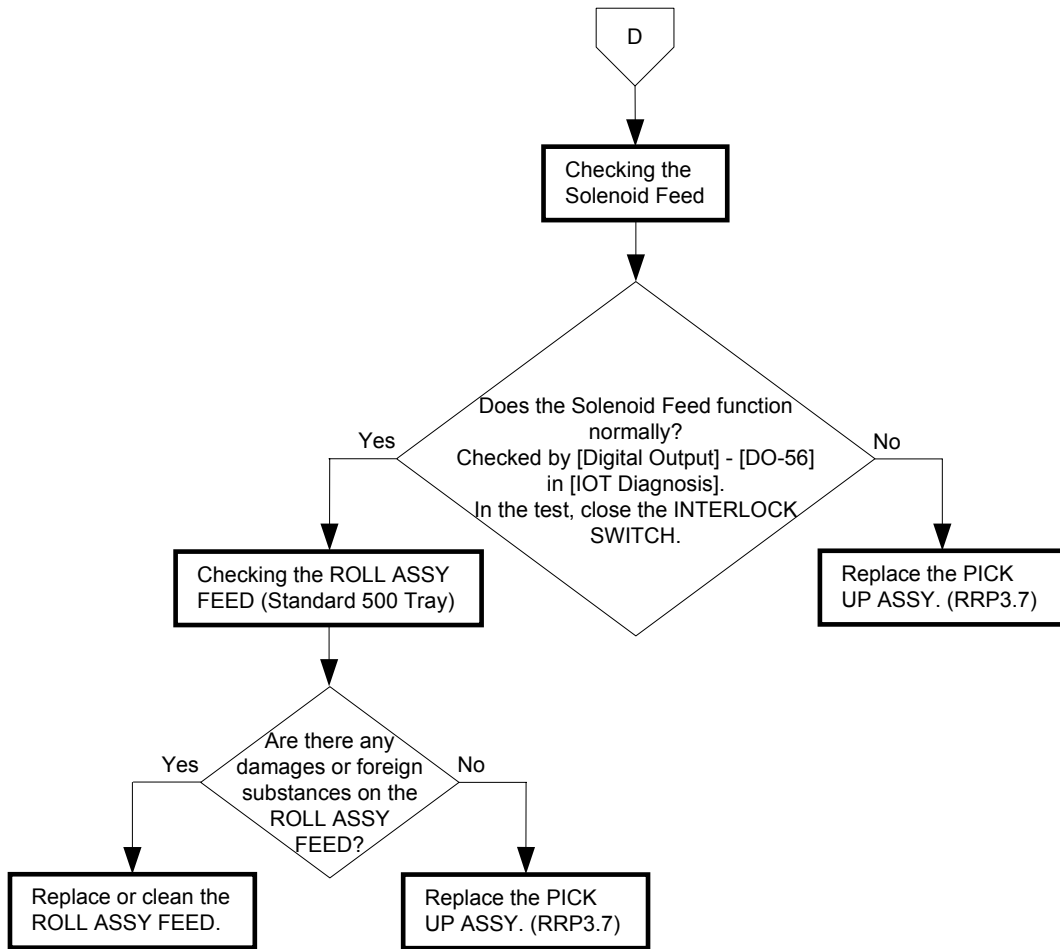

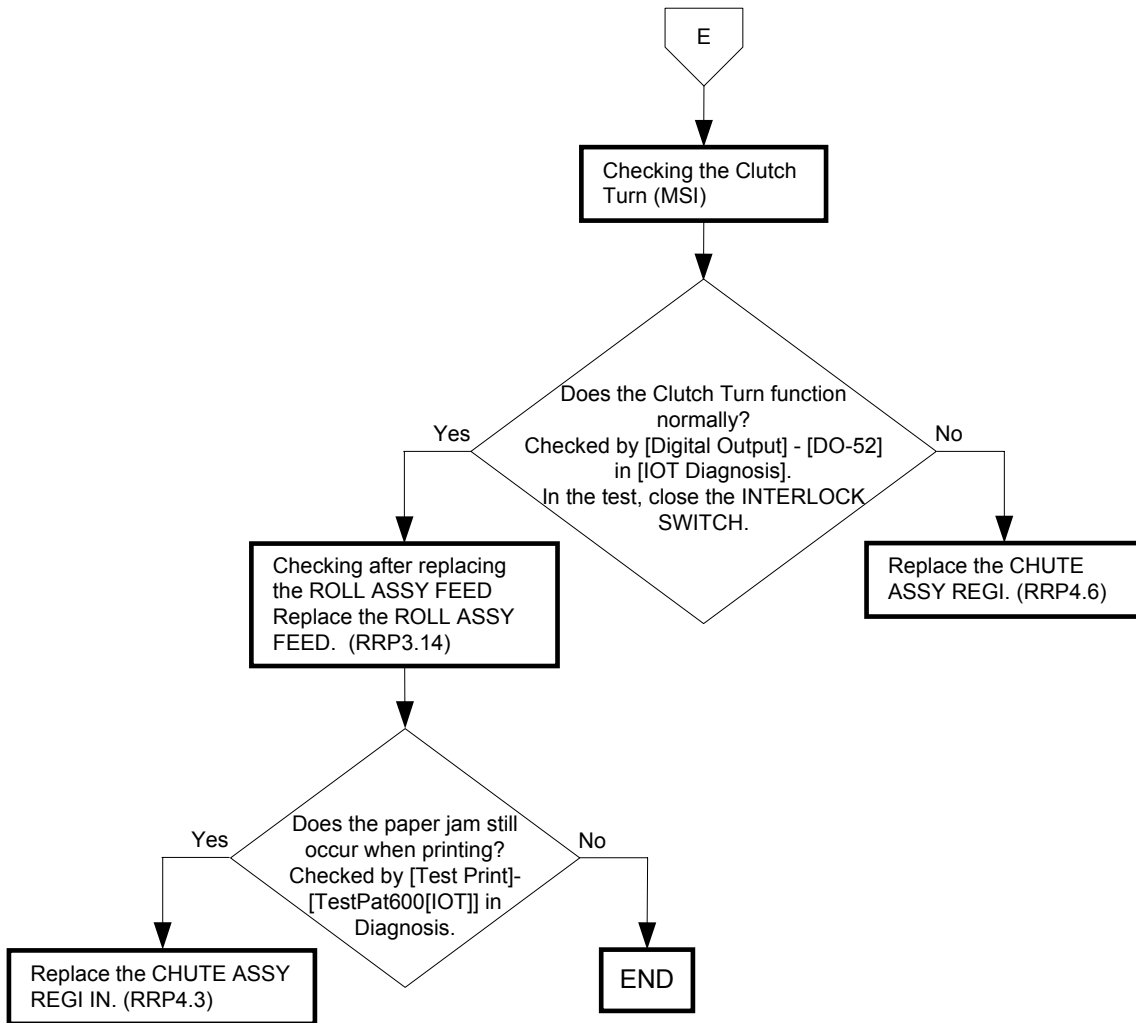

FIP-27 Paper Jam 077-907

Possible causative parts:CHUTE ASSY DUP OUT (PL5.3.1)  
MOTOR ASSY DUP (PL5.4.5)

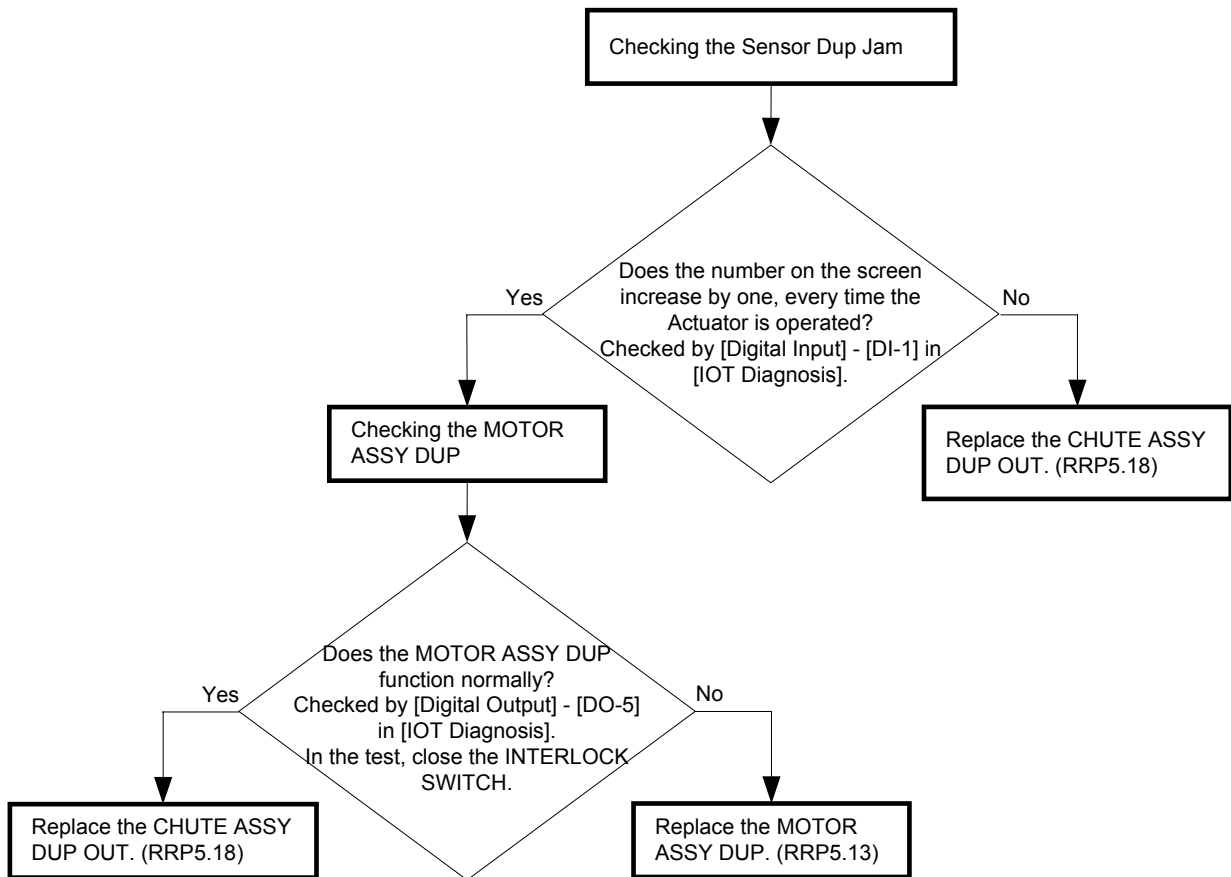

FIP-28 Load Tray N 024-910/024-911/024-912/024-913/024-914

Possible causative parts: CASSETTE ASSY 500 (PL2.1.1)  
PWBA MCU (PL9.1.16)

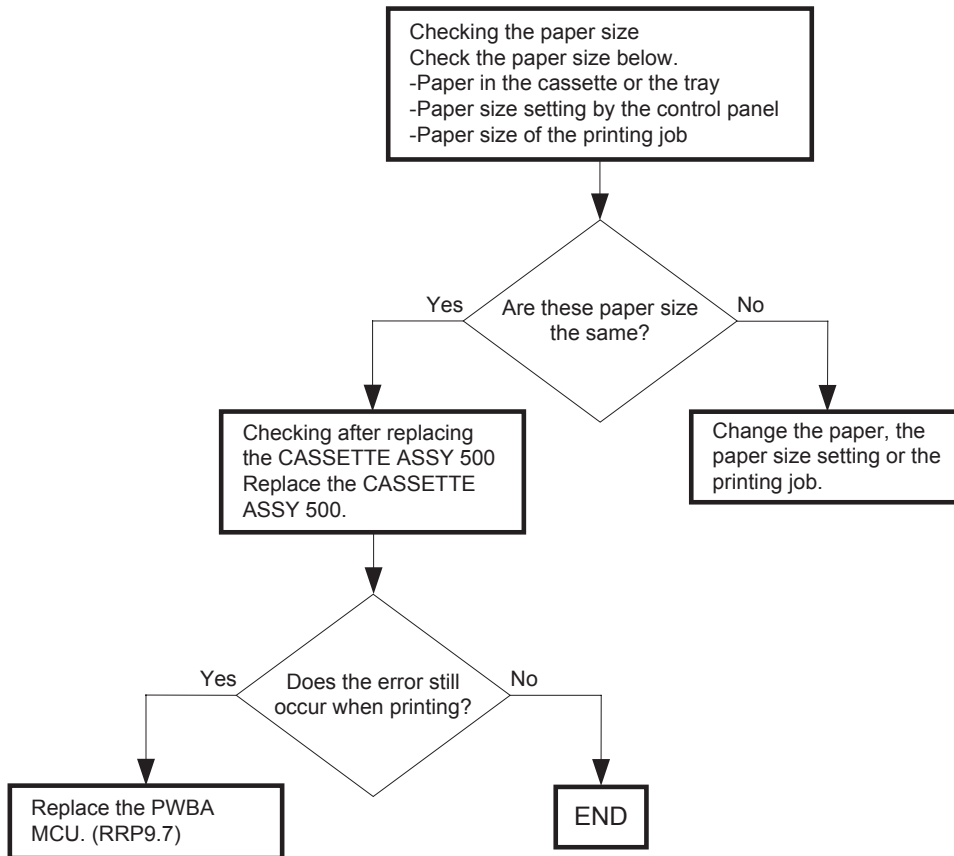

FIP-29 Exit Tray Full 024-920

Possible causative parts: SENSOR PHOTO (PL5.4.1)  
 ACTUATOR FULL STACK (PL5.4.2)  
 PWBA MCU (PL9.1.16)

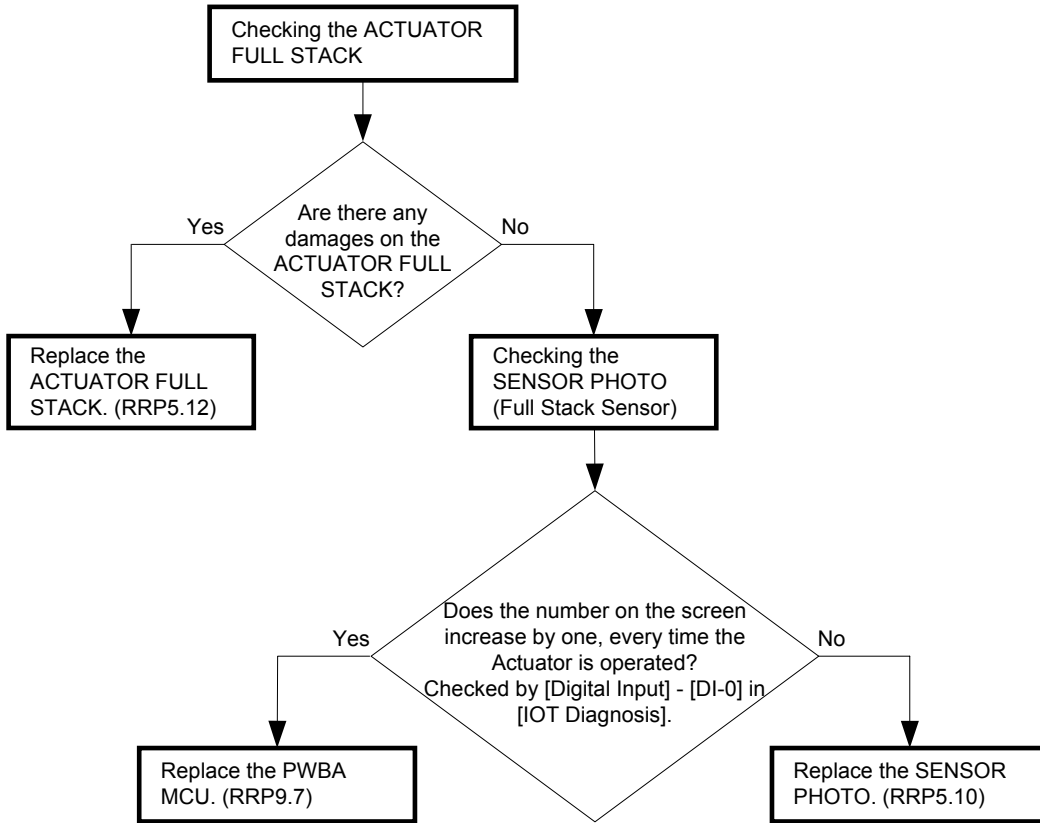

FIP-30 Load MPF 024-969/Load Tray N 024-965/024-966/024-967/024-968/024-969

Possible causative parts: PICK UP ASSY (PL3.3.1)  
 CHUTE ASSY DUP OUT (PL 5.3.1)  
 ACTUATOR NO PAPER MSI (PL5.3.15)  
 PWBA MCU (PL9.1.16)

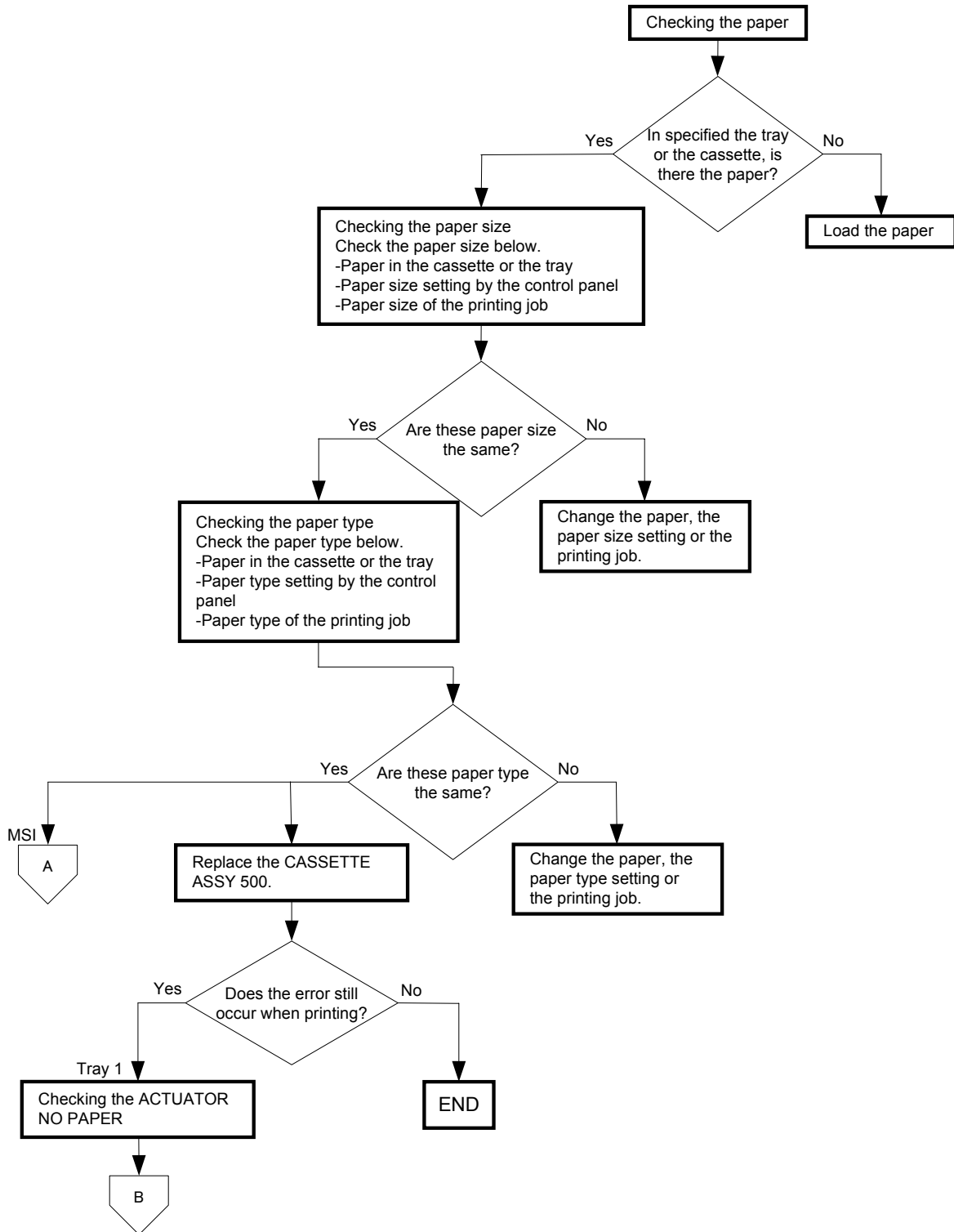



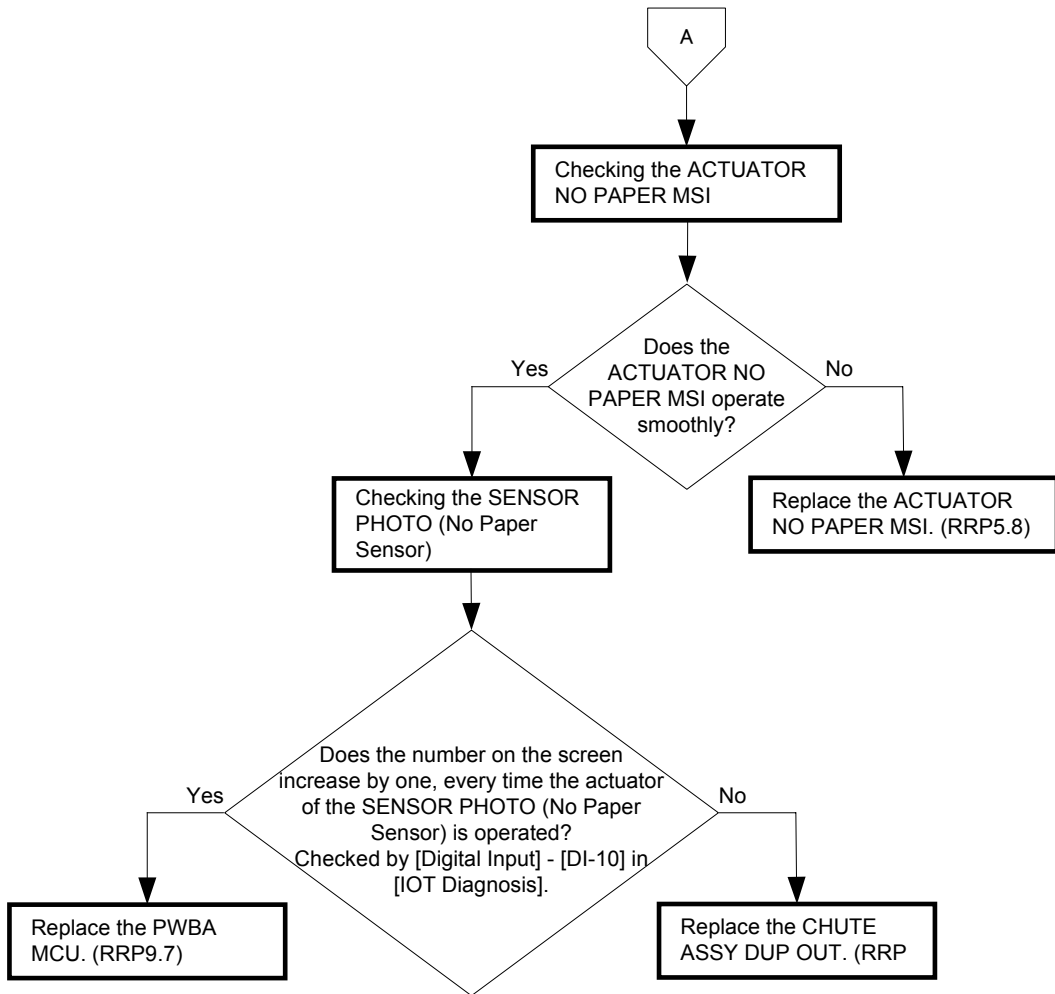

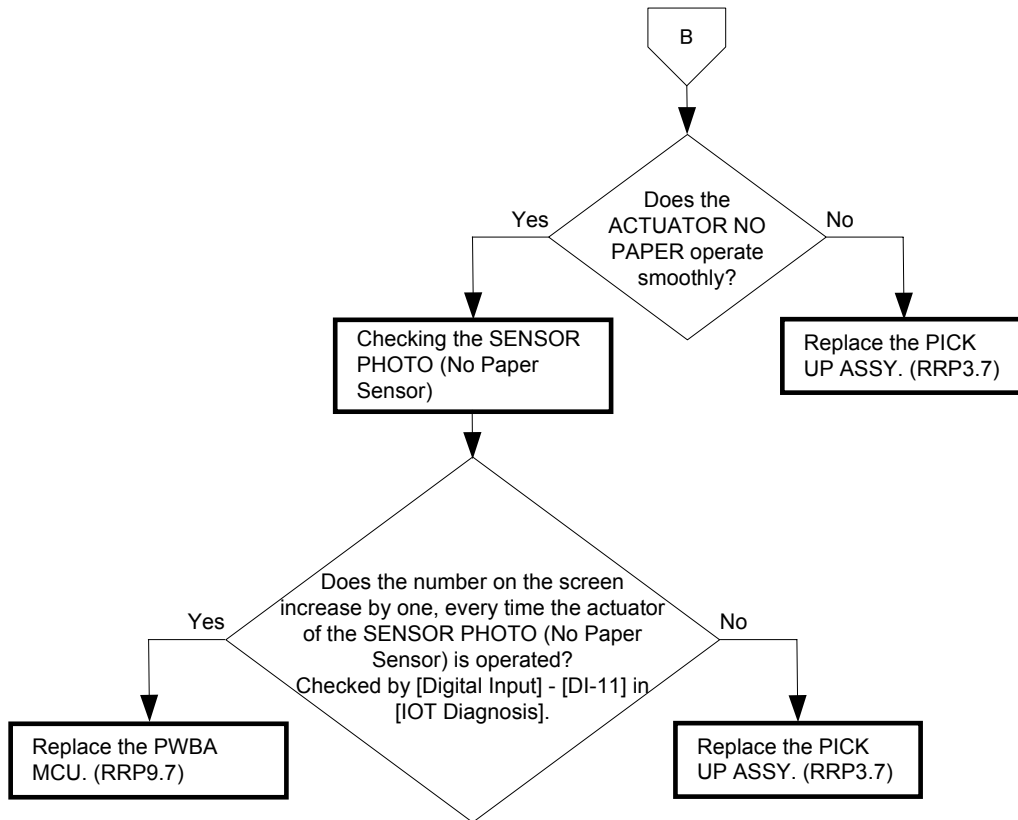

## FIP-31 Tape On XXX Toner 093-919/093-920/093-921/093-922

Possible causative parts: TONER CARTRIDGE Y (PL7.2.8)  
TONER CARTRIDGE M (PL7.2.9)  
TONER CARTRIDGE C (PL7.2.10)  
TONER CARTRIDGE K (PL7.2.11)

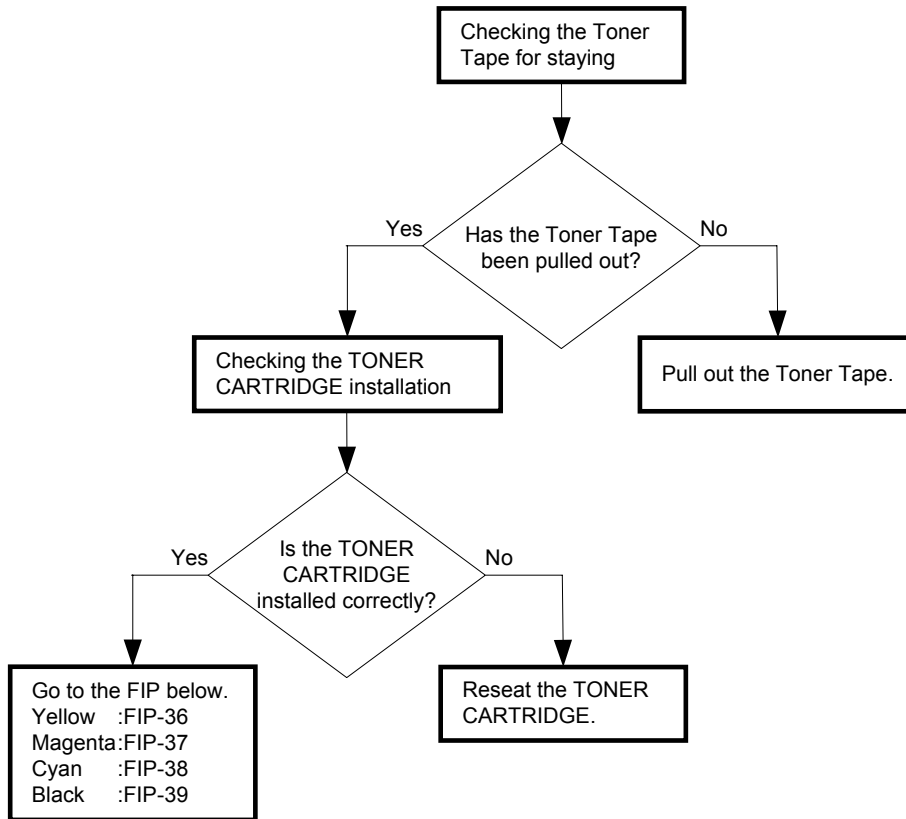

FIP-32 Insert TonerCart 093-970

Possible causative parts: TONER CARTRIDGE (Y) (PL7.2.8)  
 DISPENSER ASSY HI (PL7.2.22)  
 PWBA MCU (PL9.1.16)

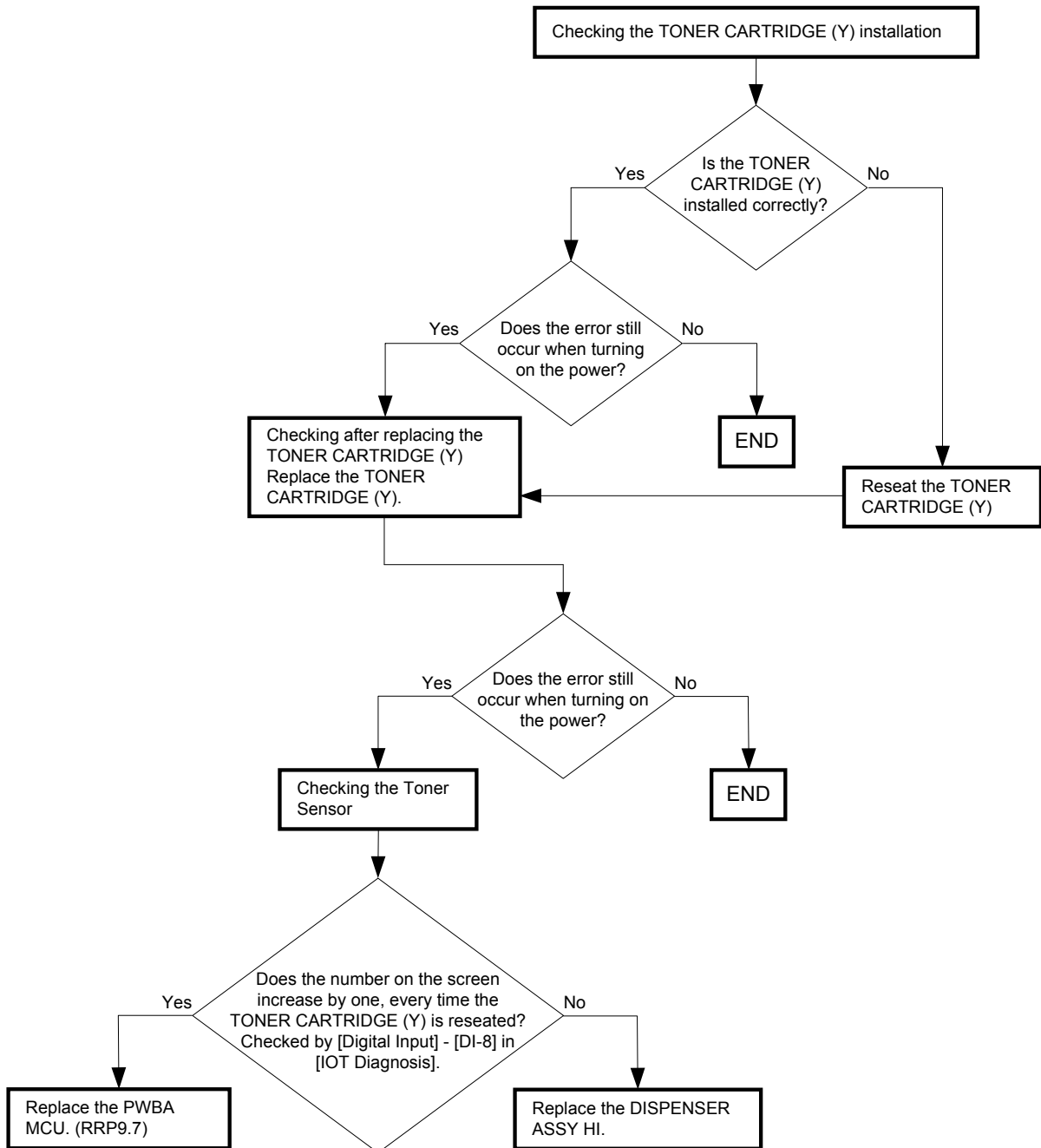

FIP-33 Insert TonerCart 093-971

Possible causative parts: TONER CARTRIDGE (M) (PL7.2.9)  
 DISPENSER ASSY HI (PL7.2.22)  
 PWBA MCU (PL9.1.16)

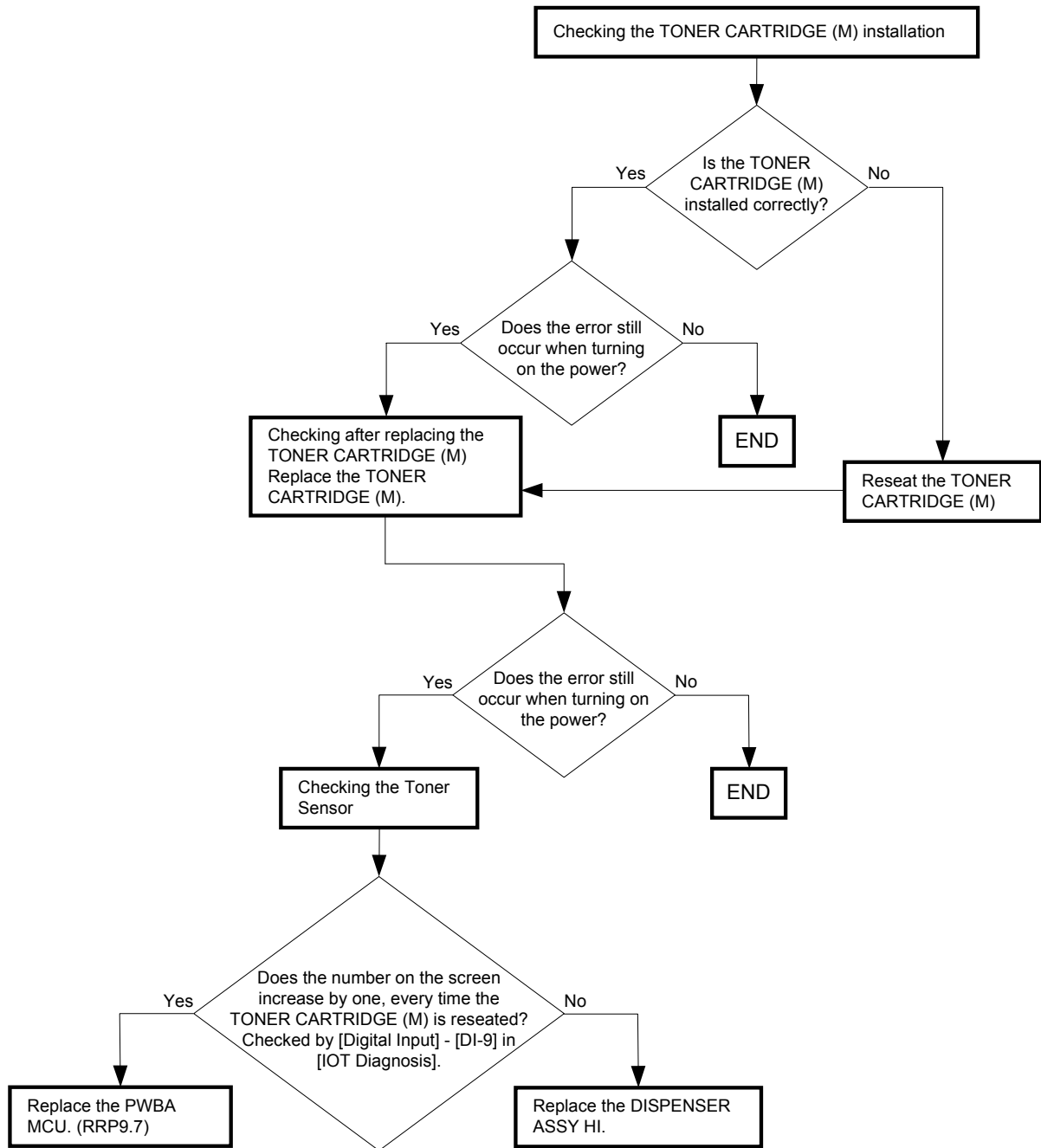

FIP-34 Insert TonerCart 093-972

Possible causative parts: TONER CARTRIDGE (C) (PL7.2.10)  
 DISPENSER ASSY HI (PL7.2.22)  
 PWBA MCU (PL9.1.16)

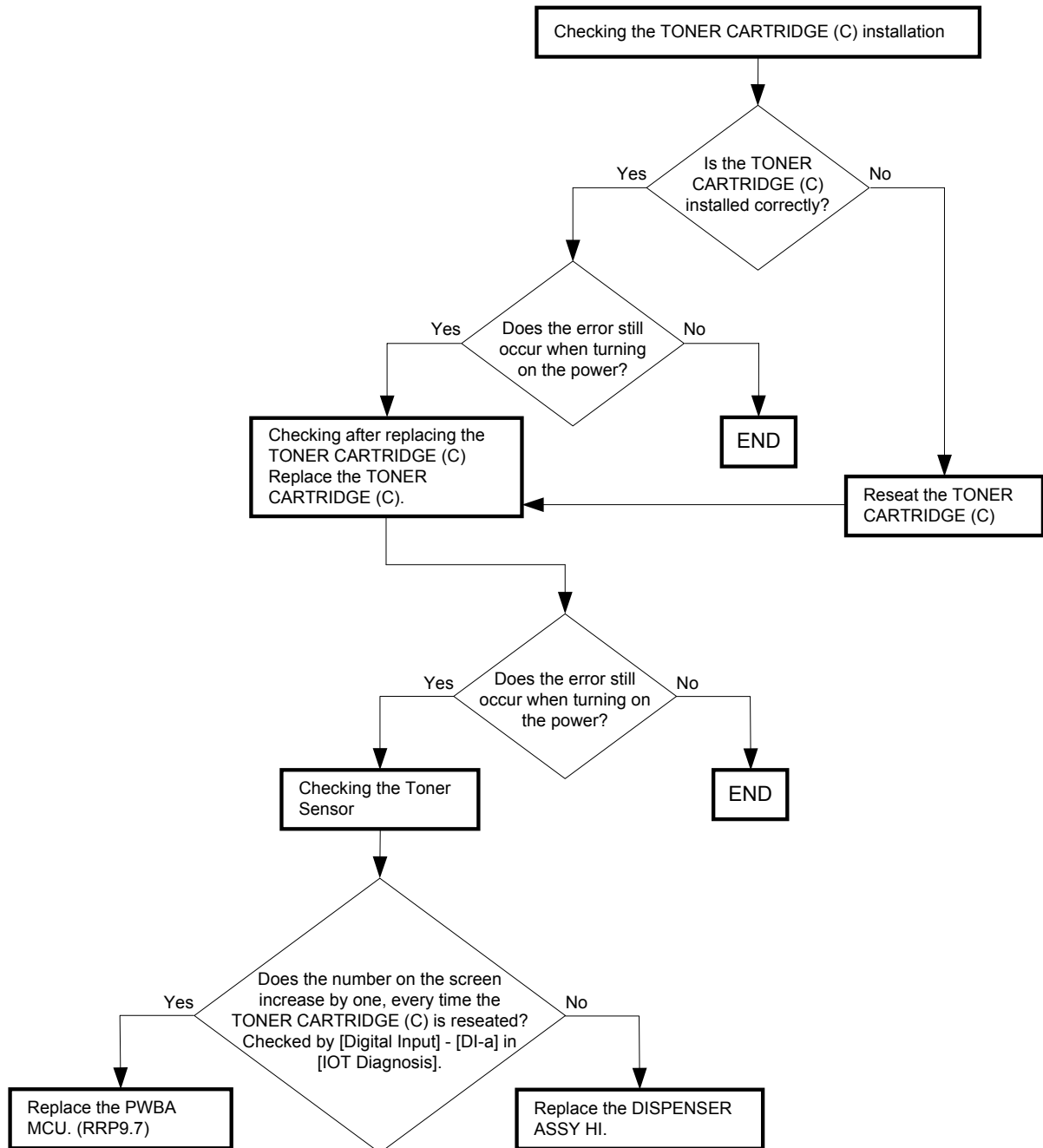

FIP-35 Insert TonerCart 093-973

Possible causative parts: TONER CARTRIDGE (K) (PL7.2.11)  
 DISPENSER ASSY HI (PL7.2.22)  
 PWBA MCU (PL9.1.16)

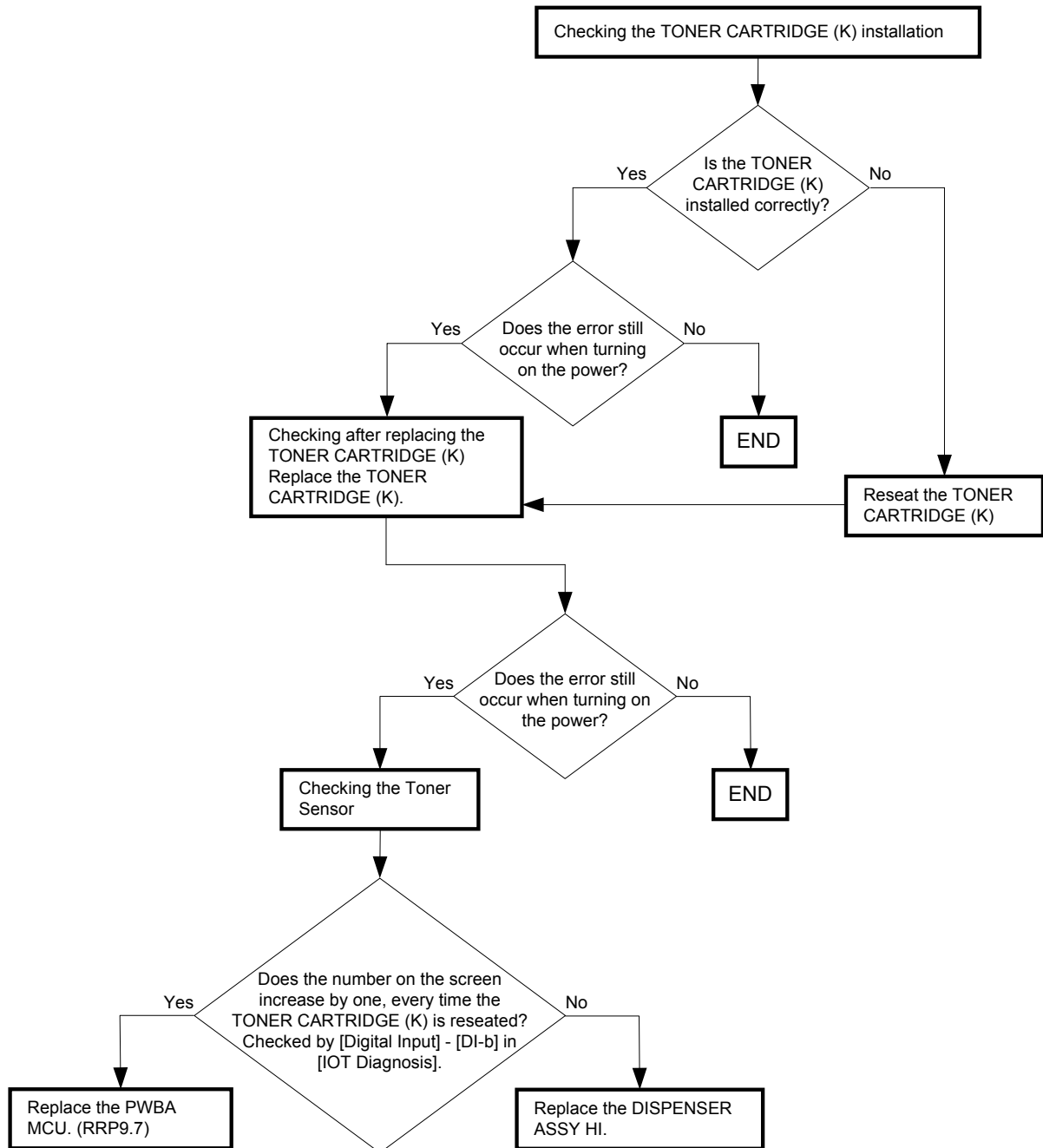

FIP-36 Replace Toner 093-930

Possible causative parts: TONER CARTRIDGE Y (PL7.2.8)  
 DISPENSER TONER HI (PL7.2.22)  
 PWBA MCU (PL9.1.16)

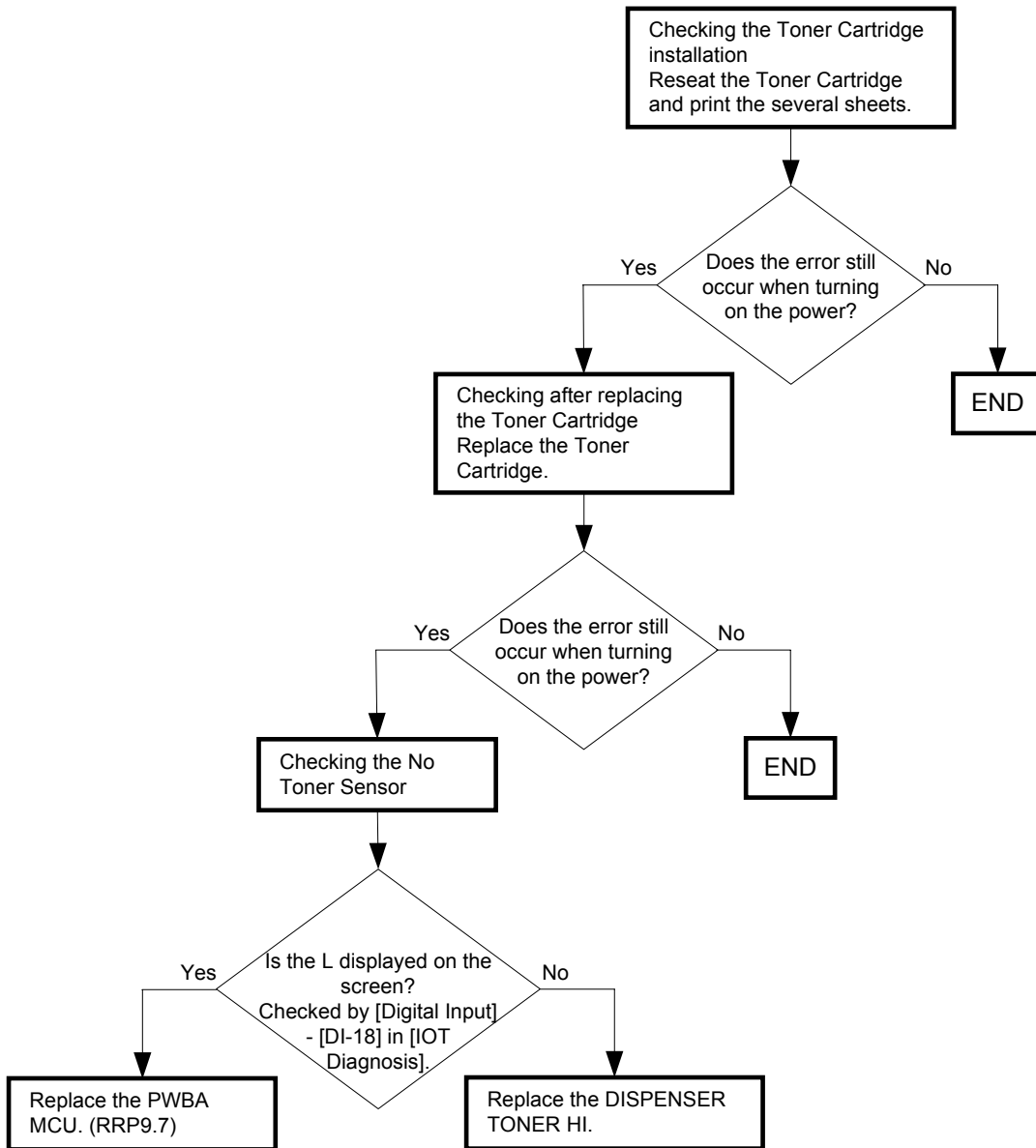



FIP-37 Replace Toner 093-931

Possible causative parts: TONER CARTRIDGE M (PL7.2.9)  
 DISPENSER TONER HI (PL7.2.22)  
 PWBA MCU (PL9.1.16)

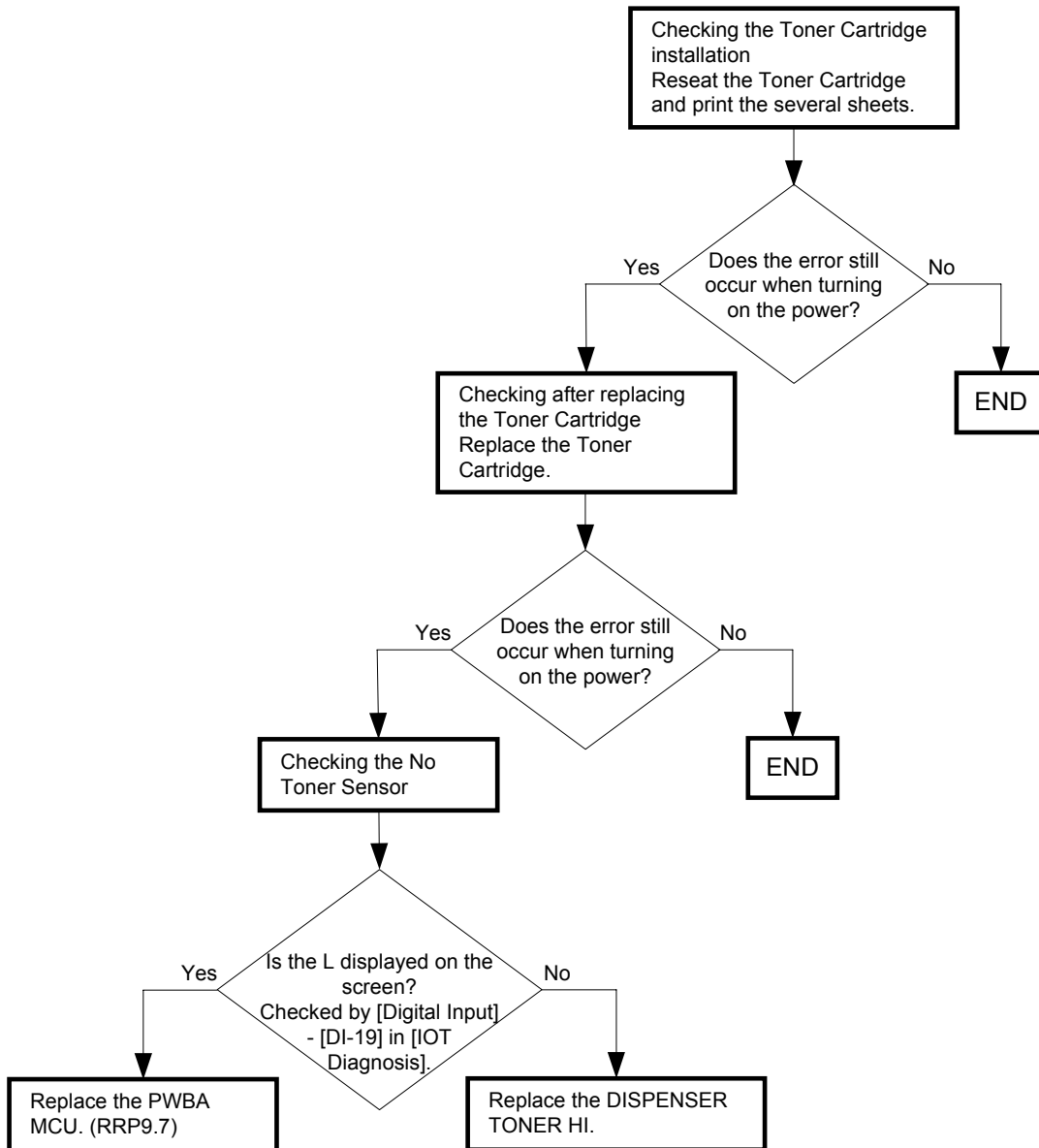

FIP-38 Replace Toner 093-932

Possible causative parts: TONER CARTRIDGE C (PL7.2.10)  
 DISPENSER TONER HI (PL7.2.22)  
 PWBA MCU (PL9.1.16)

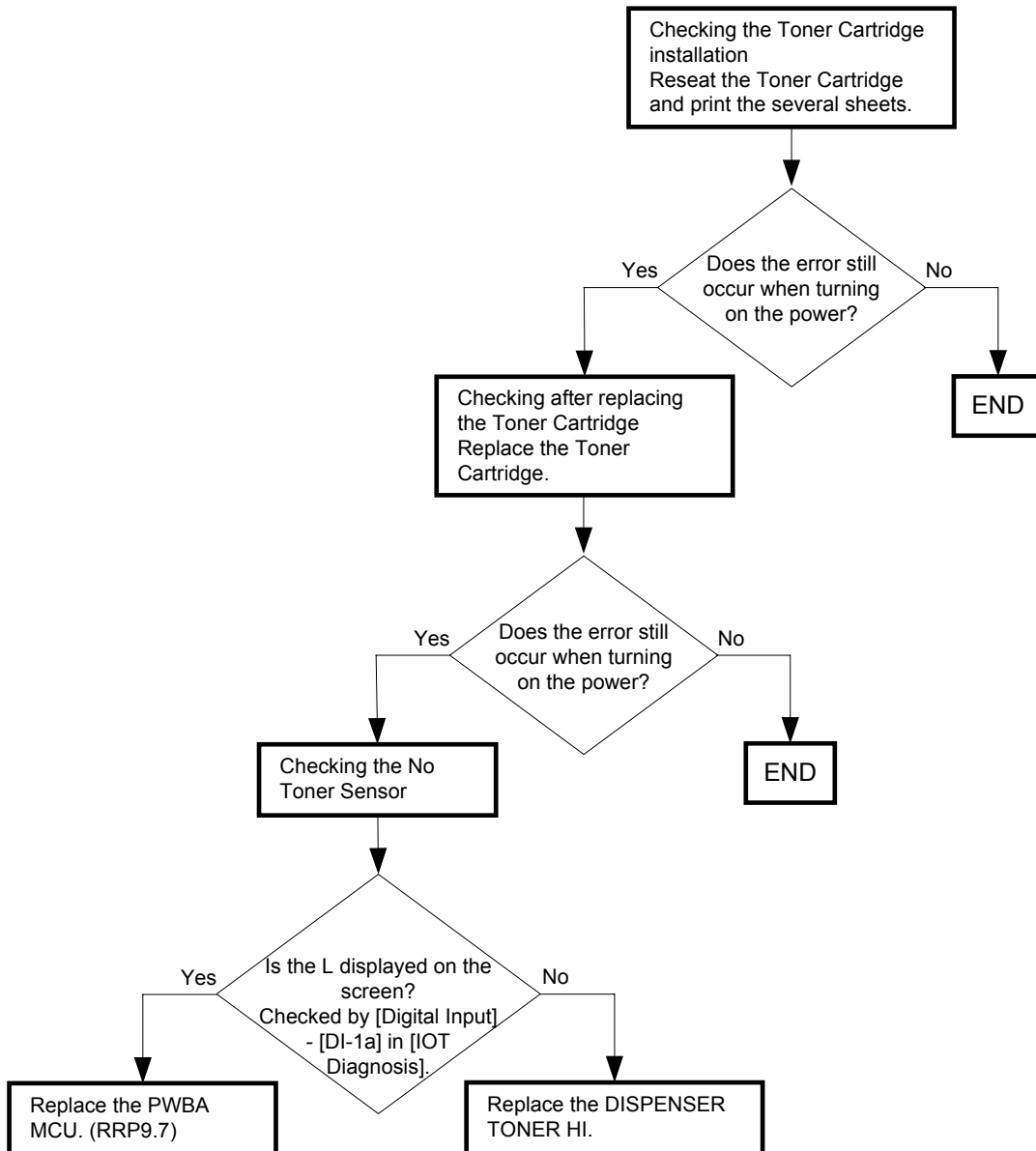

FIP-39 Replace Toner 093-933

Possible causative parts: TONER CARTRIDGE K (PL7.2.11)  
 DISPENSER TONER HI (PL7.2.22)  
 PWBA MCU (PL9.1.16)

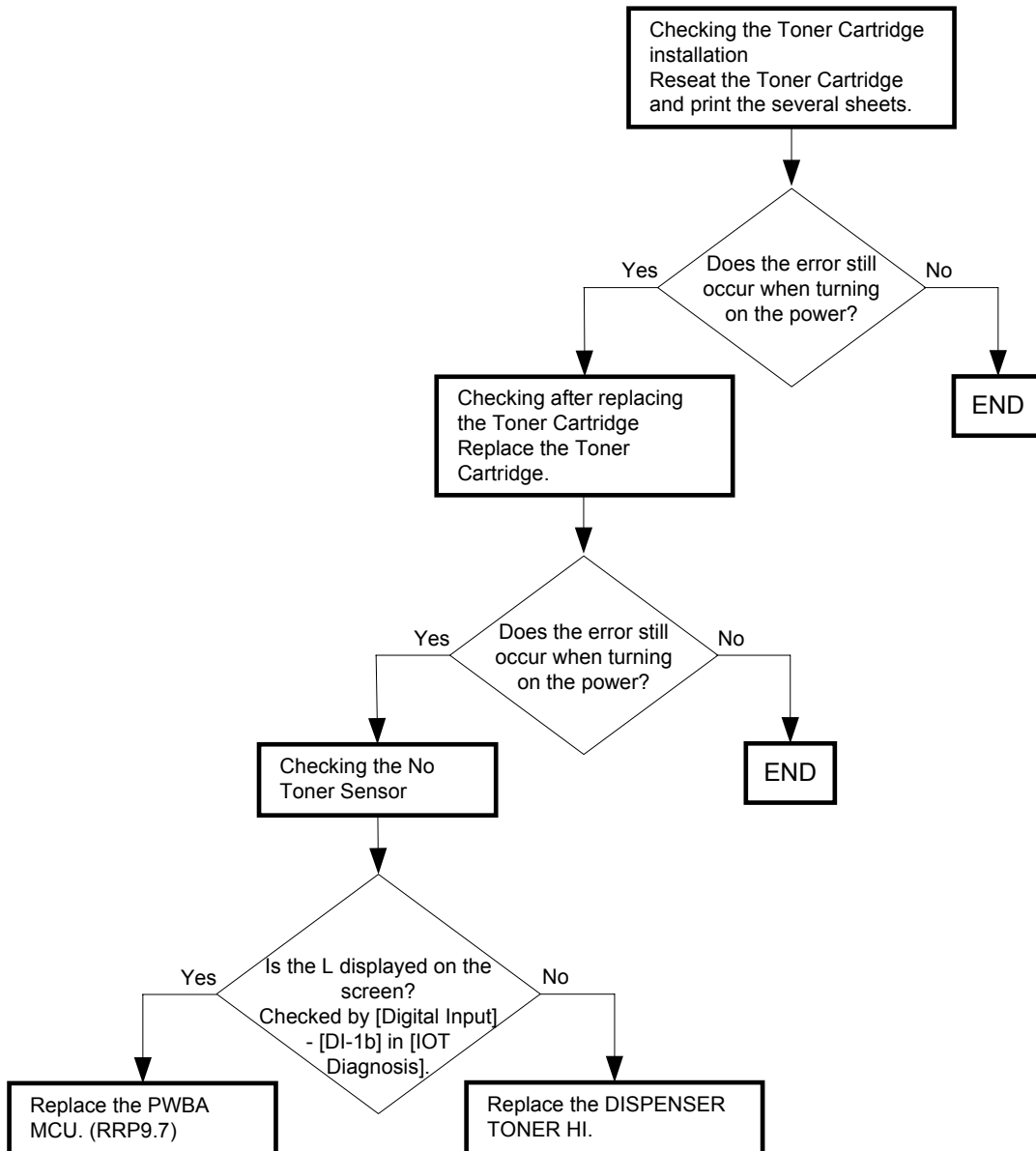

FIP-40 Ready to Print 093-423

Possible causative parts: TONER CARTRIDGE Y (PL7.2.8)  
PWBA MCU (PL9.1.16)

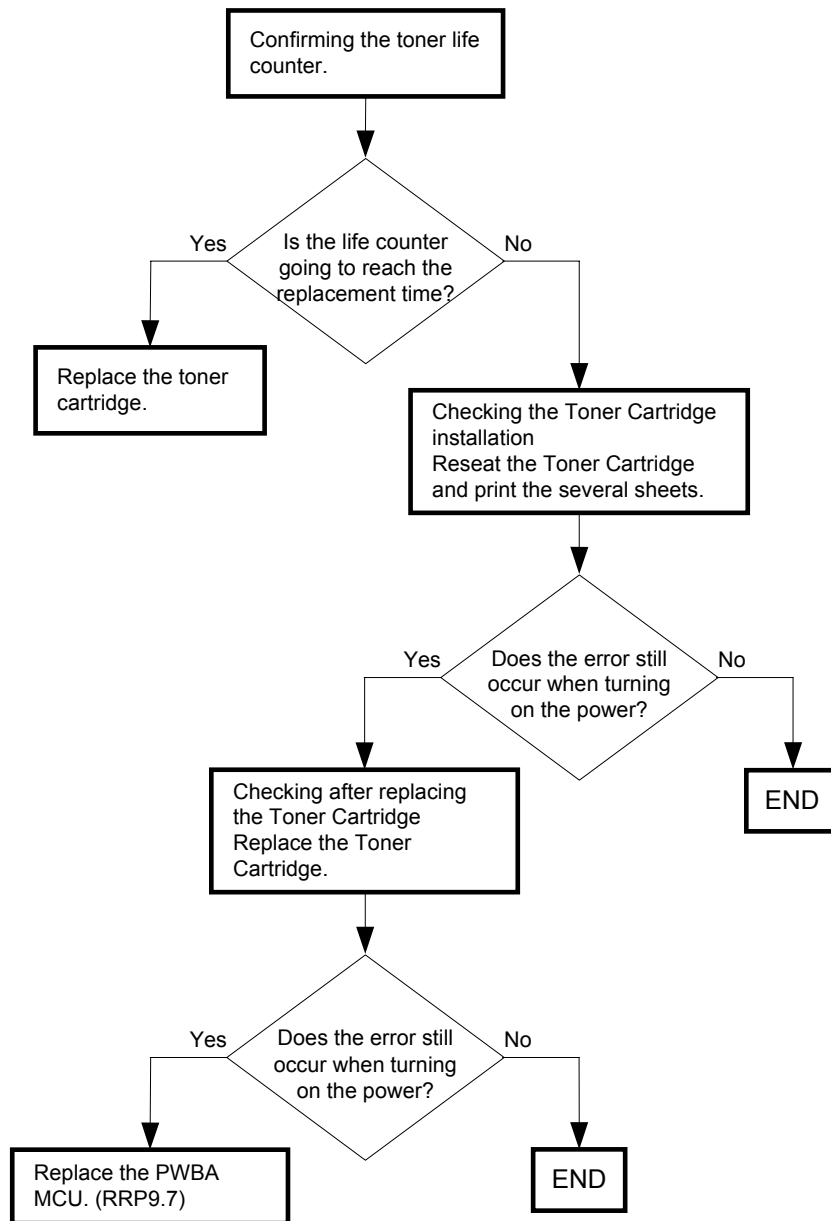

FIP-41 Ready to Print 093-424

Possible causative parts: TONER CARTRIDGE M (PL7.2.9)  
PWBA MCU (PL9.1.16)

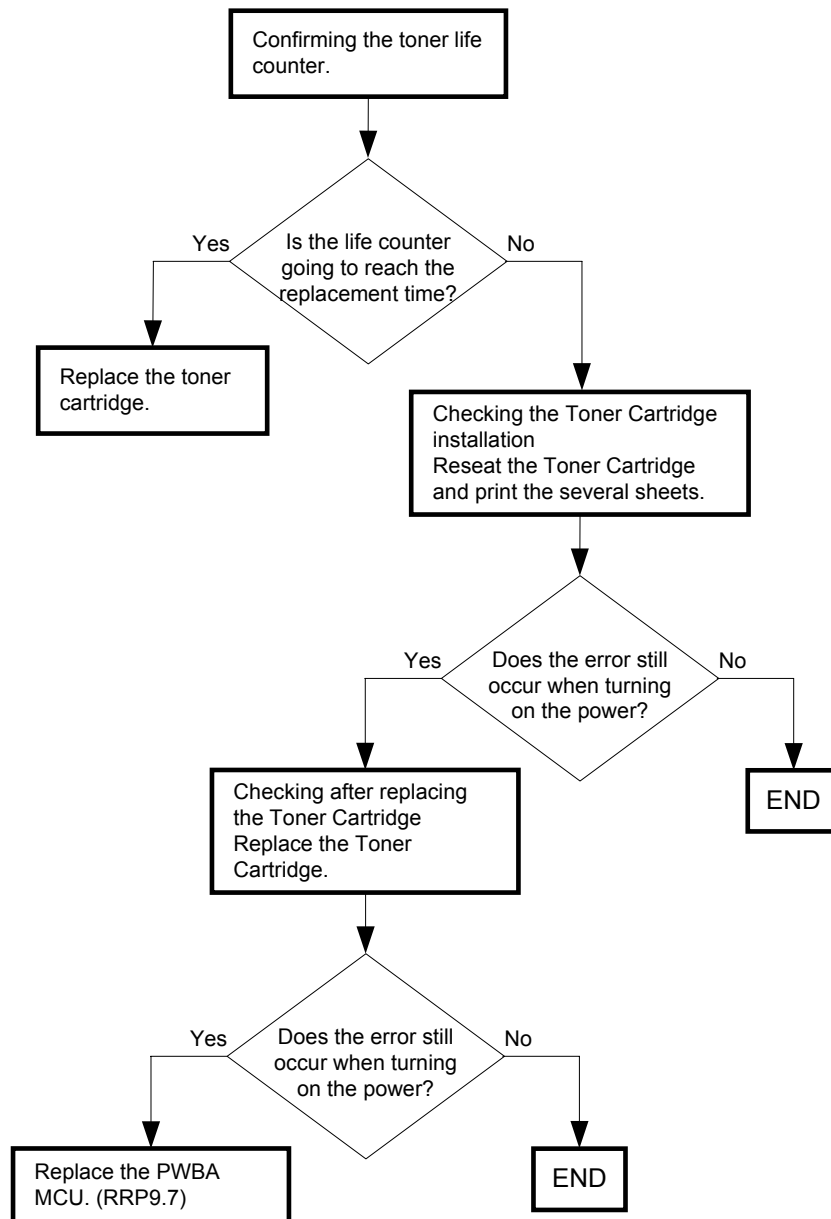

FIP-42 Ready to Print 093-425

Possible causative parts: TONER CARTRIDGE C (PL7.2.10)  
PWBA MCU (PL9.1.16)

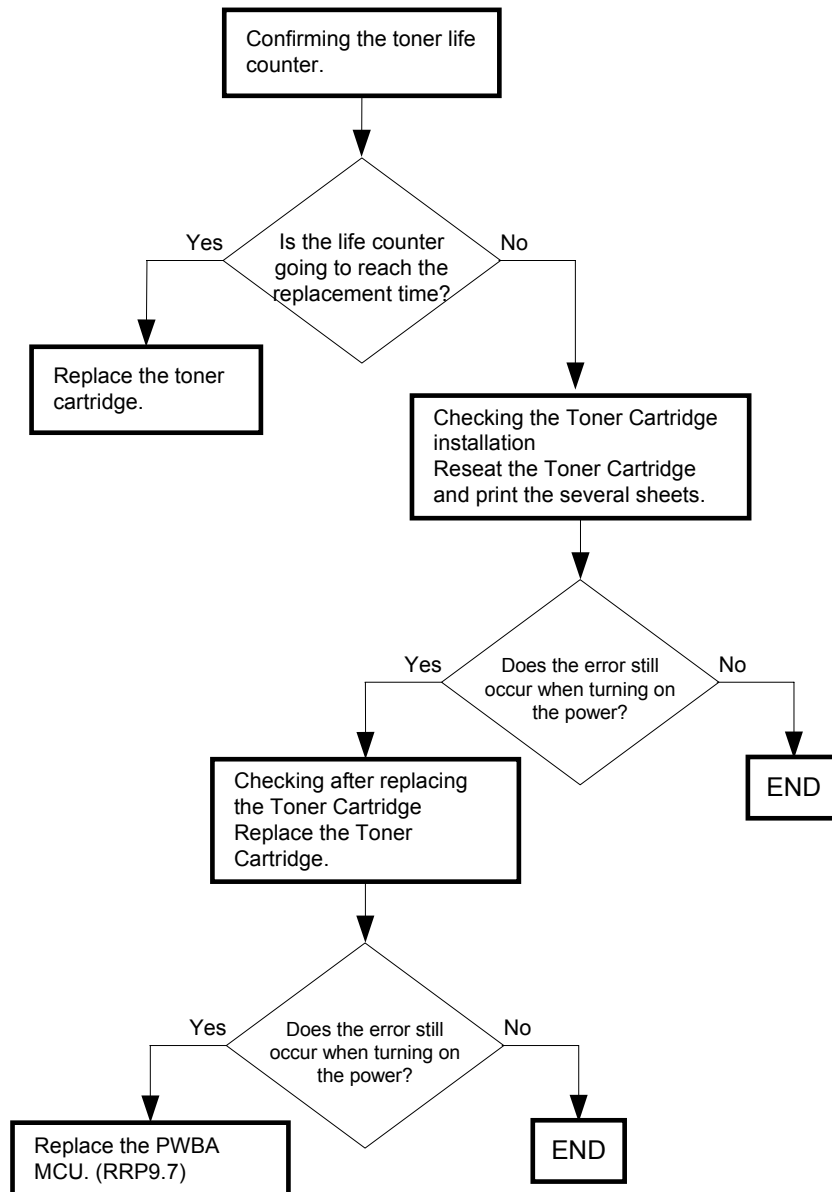

FIP-43 Ready to Print 093-426

Possible causative parts: TONER CARTRIDGE K (PL7.2.11)  
PWBA MCU (PL9.1.16)

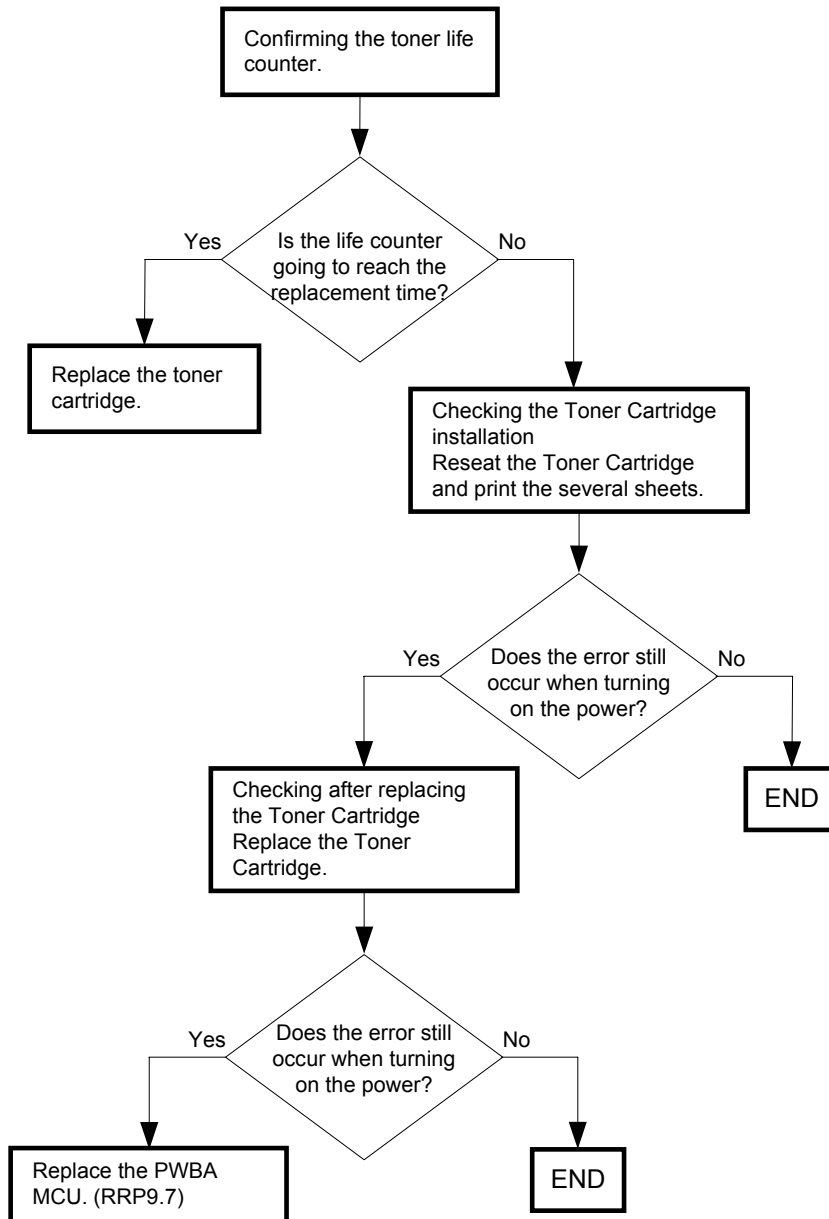

FIP-44 Toner Type 093-980/093-981/093-982/093-983/CRUM ID 093-960/093-961/  
093-962/093-963

Possible causative parts: TONER CARTRIDGE Y (PL7.2.8)  
TONER CARTRIDGE M (PL7.2.9)  
TONER CARTRIDGE C (PL7.2.10)  
TONER CARTRIDGE K (PL7.2.11)  
BOX ASSY CRUM READER (PL7.2.12)  
PWBA MCU (PL9.1.16)

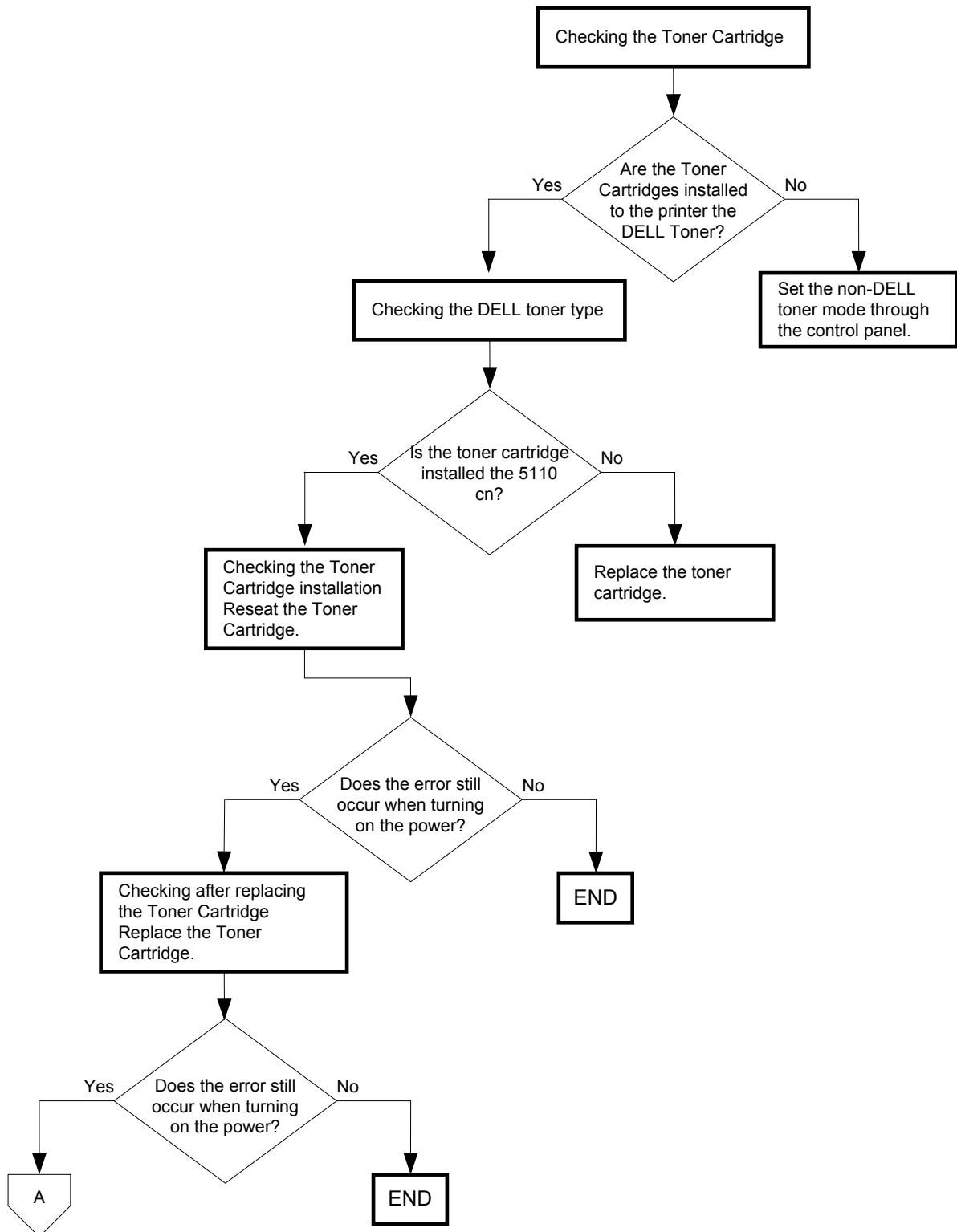



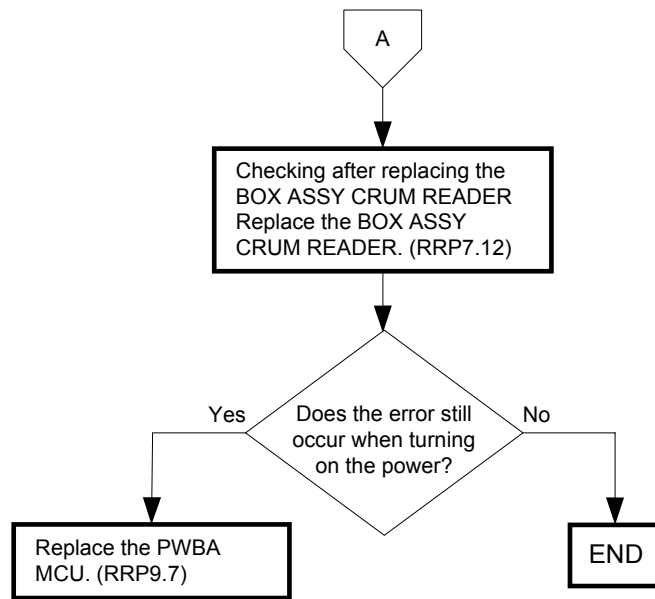

FIP-45 Insert Drum 091-972

Possible causative parts:PHD ASSY (PL6.1.1)  
PWBA MCU (PL9.1.16)

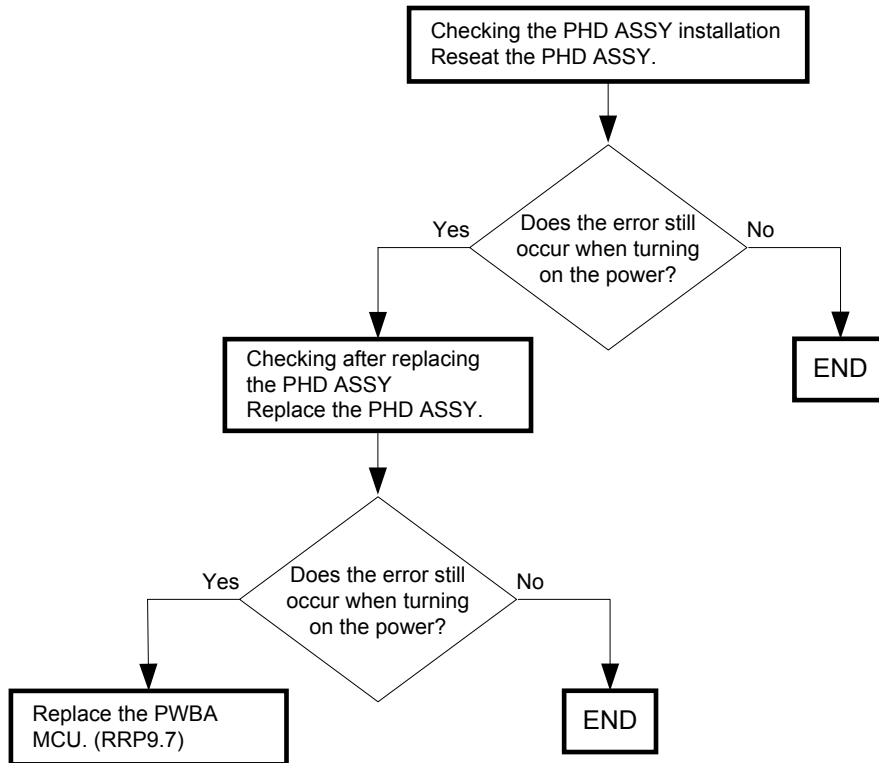

FIP-46 Imaging Drum 091-935

Possible causative parts:PHD ASSY (PL6.1.1)  
PWBA MCU (PL9.1.16)

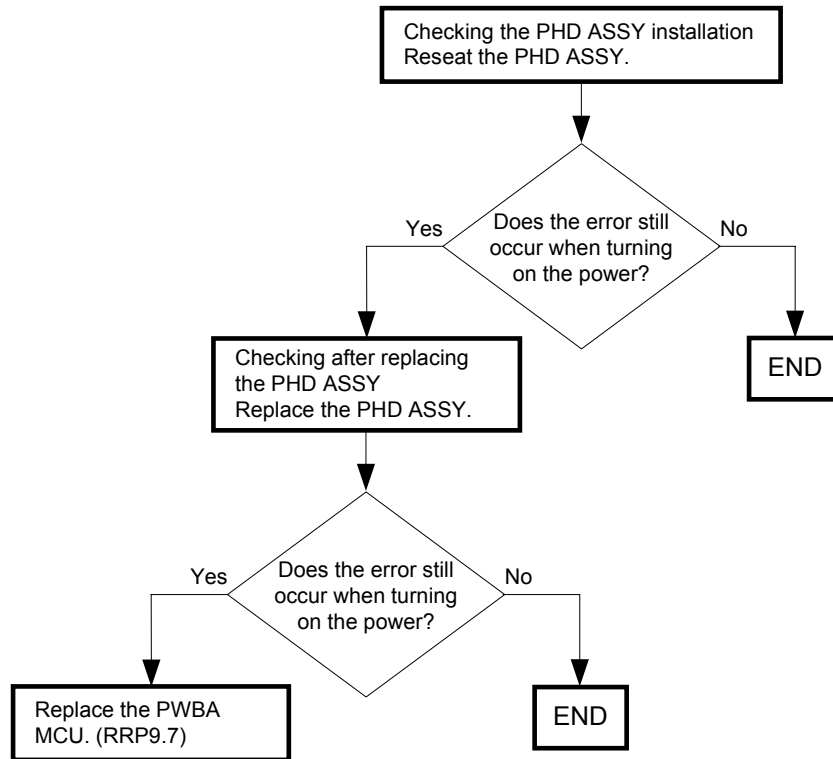

FIP-47 Ready to Print 094-402

Possible causative parts:PHD ASSY (PL6.1.1)  
PWBA MCU (PL9.1.16)

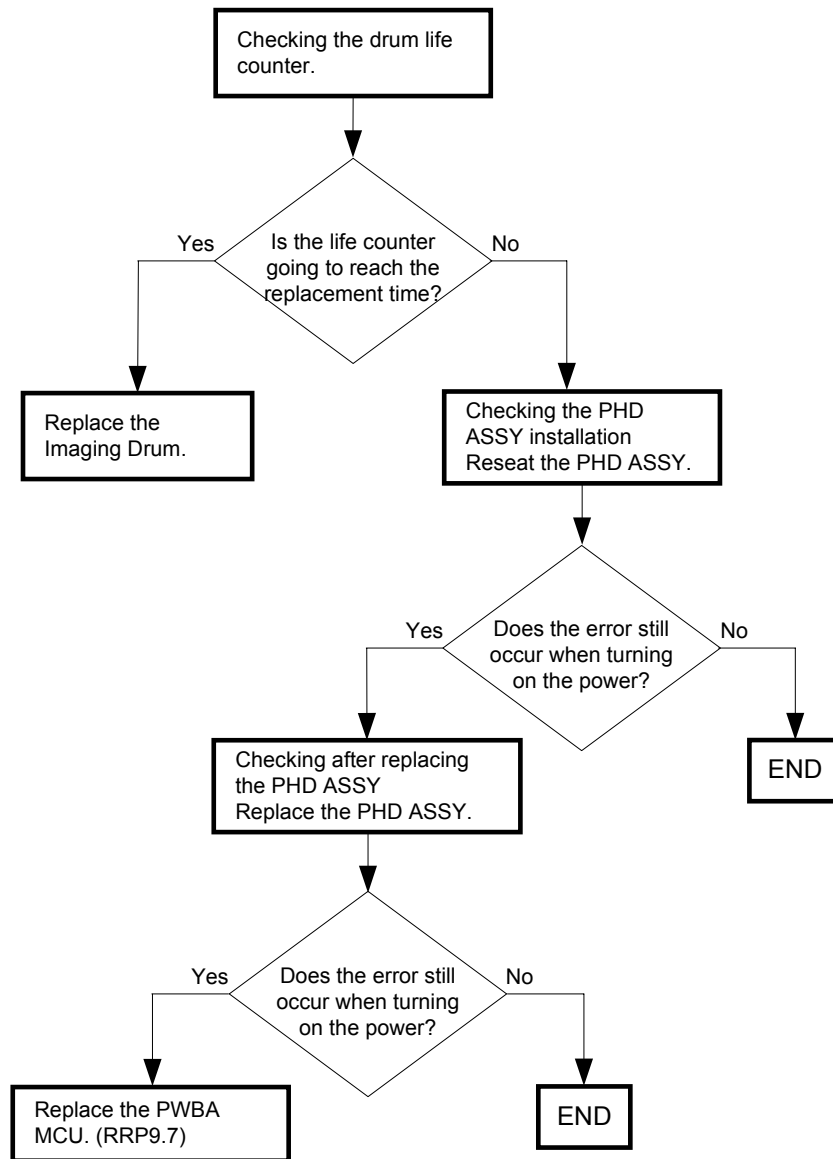

FIP-48 Imaging Drum 091-912/CRUM ID 093-965

Possible causative parts:PHD ASSY (PL6.1.1)  
PWBA MCU (PL9.1.16)

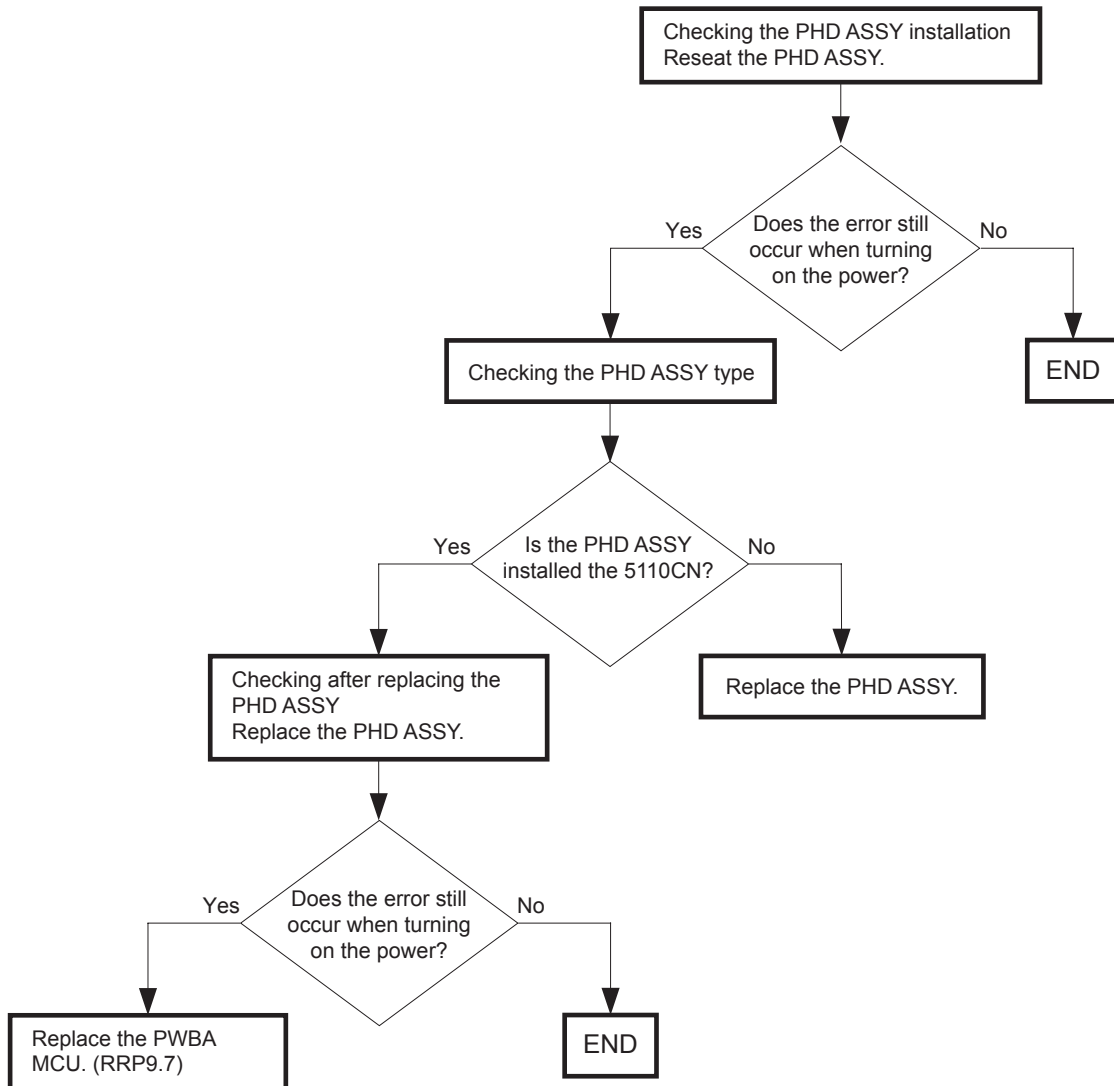

FIP-49 Replace Fuser 010-351

Possible causative parts:FUSER ASSY (PL5.1.1)  
PWBA MCU (PL9.1.16)

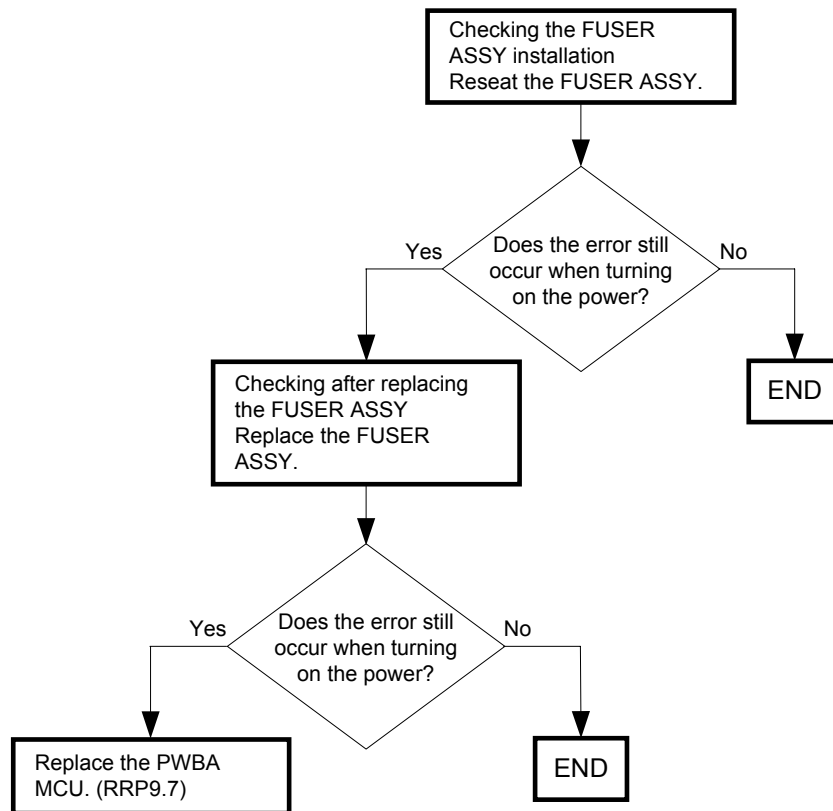

FIP-50 Insert Fuser 010-317

Possible causative parts:FUSER ASSY (PL5.1.1)  
PWBA MCU (PL9.1.16)

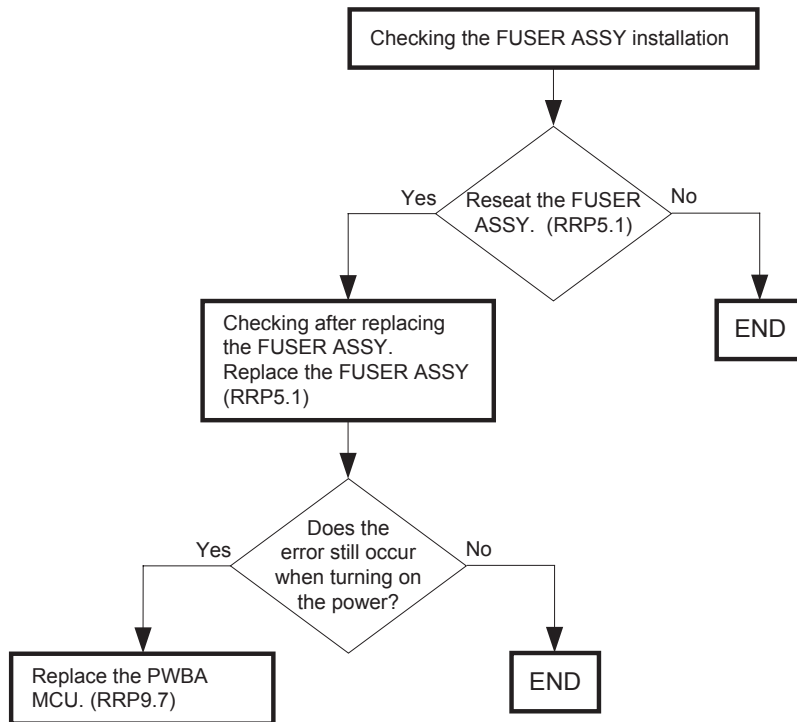

FIP-51 Ready to Print 010-421

Possible causative parts:FUSER ASSY (PL5.1.1)  
PWBA MCU (PL9.1.16)

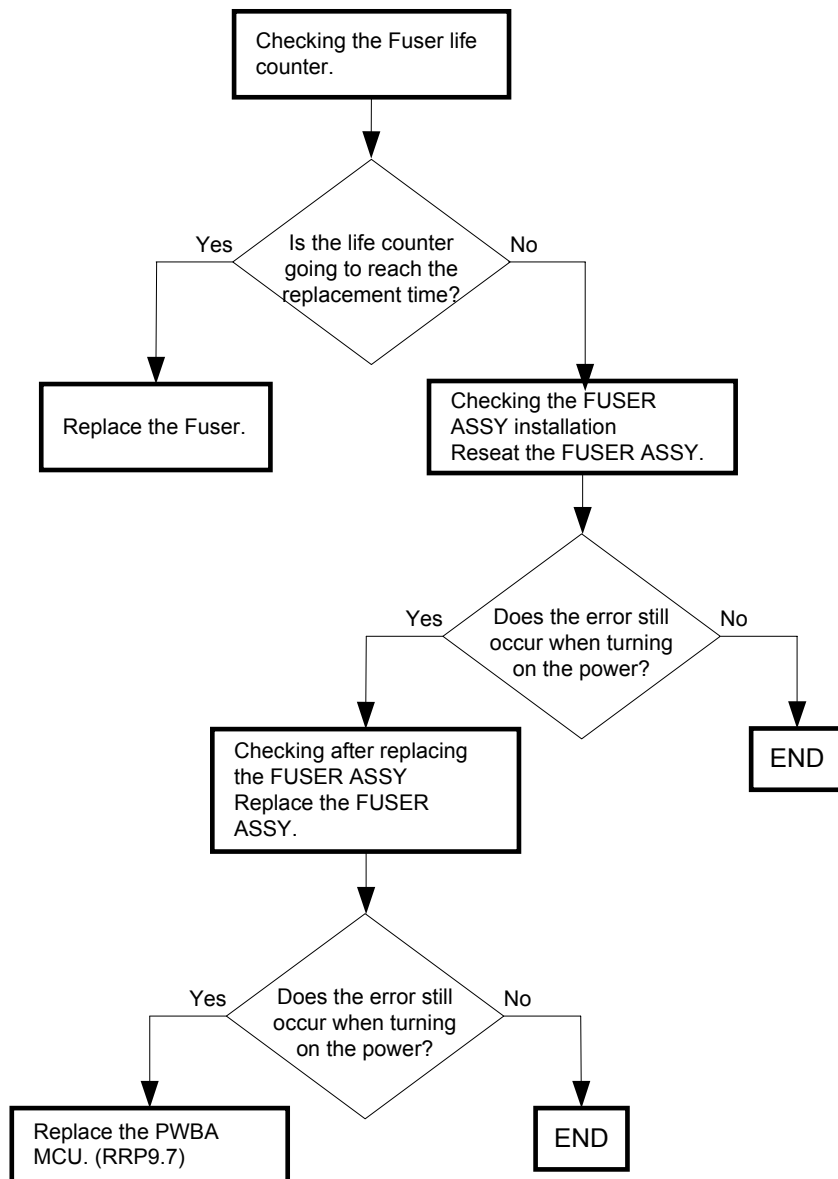



FIP-52 Fuser Type 010-358/CRUM ID 093-964

Possible causative parts:FUSER ASSY (PL5.1.1)  
PWBA MCU (PL9.1.16)

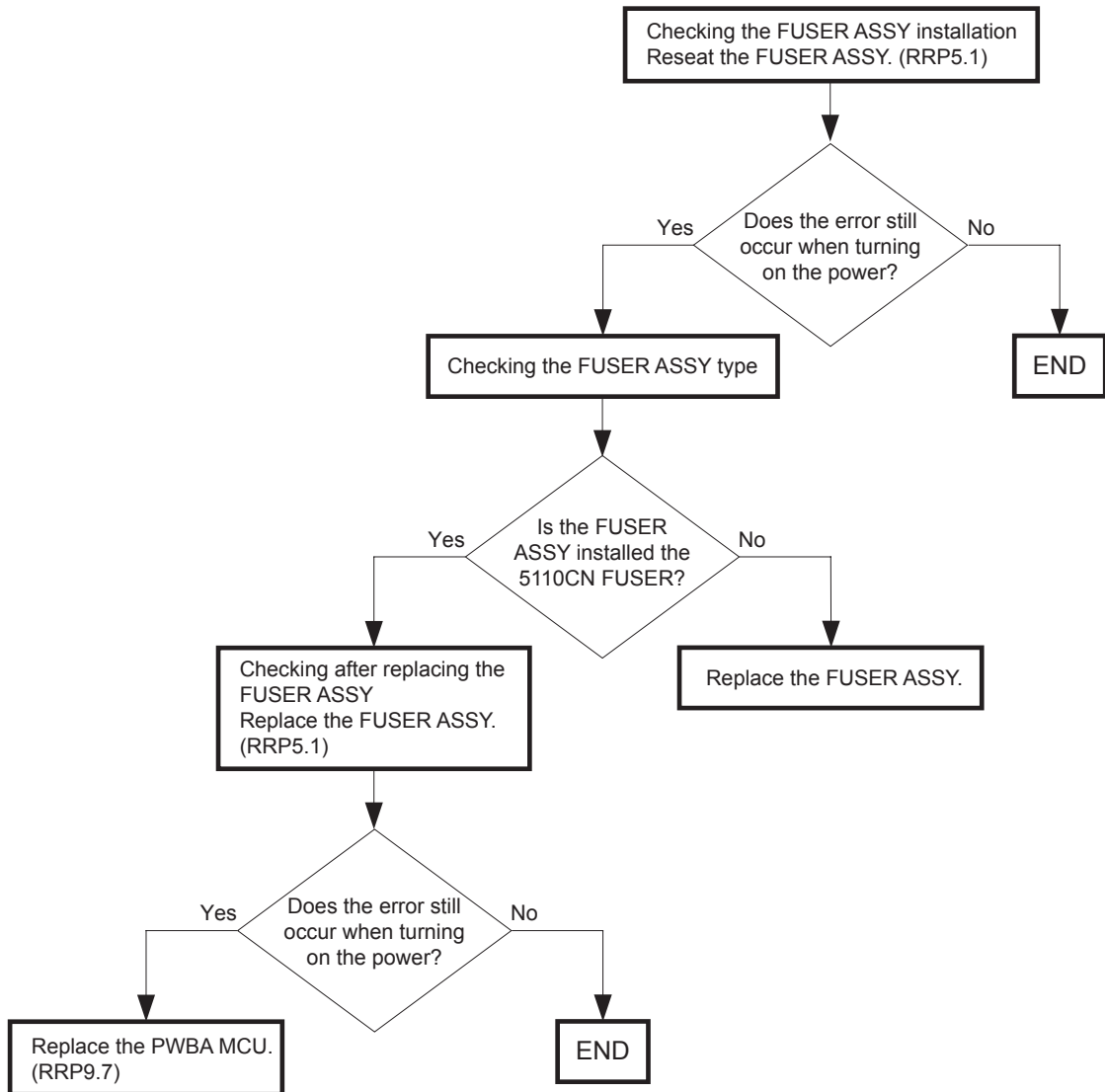

FIP-53 Transfer Roller 094-911

Possible causative parts: BTR ASSY (PL5.1.4)  
 SNR TNR FULL (PL5.2.20)  
 PWBA MCU (PL9.1.16)

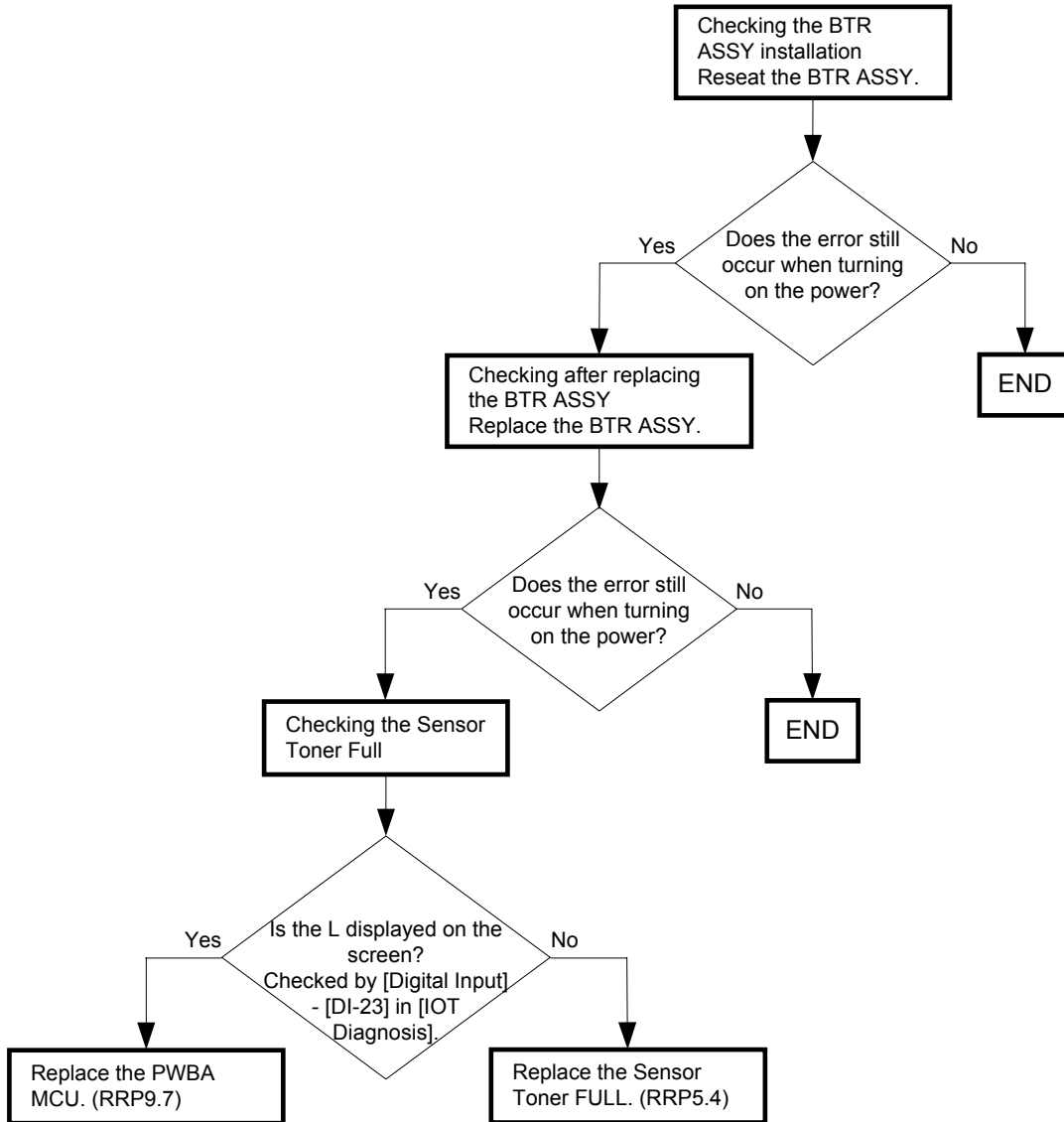

FIP-54 Ready to Print 094-422

Possible causative parts: BTR ASSY (PL5.1.4)  
 SNR TNR FULL (PL5.2.20)  
 PWBA MCU (PL9.1.16)

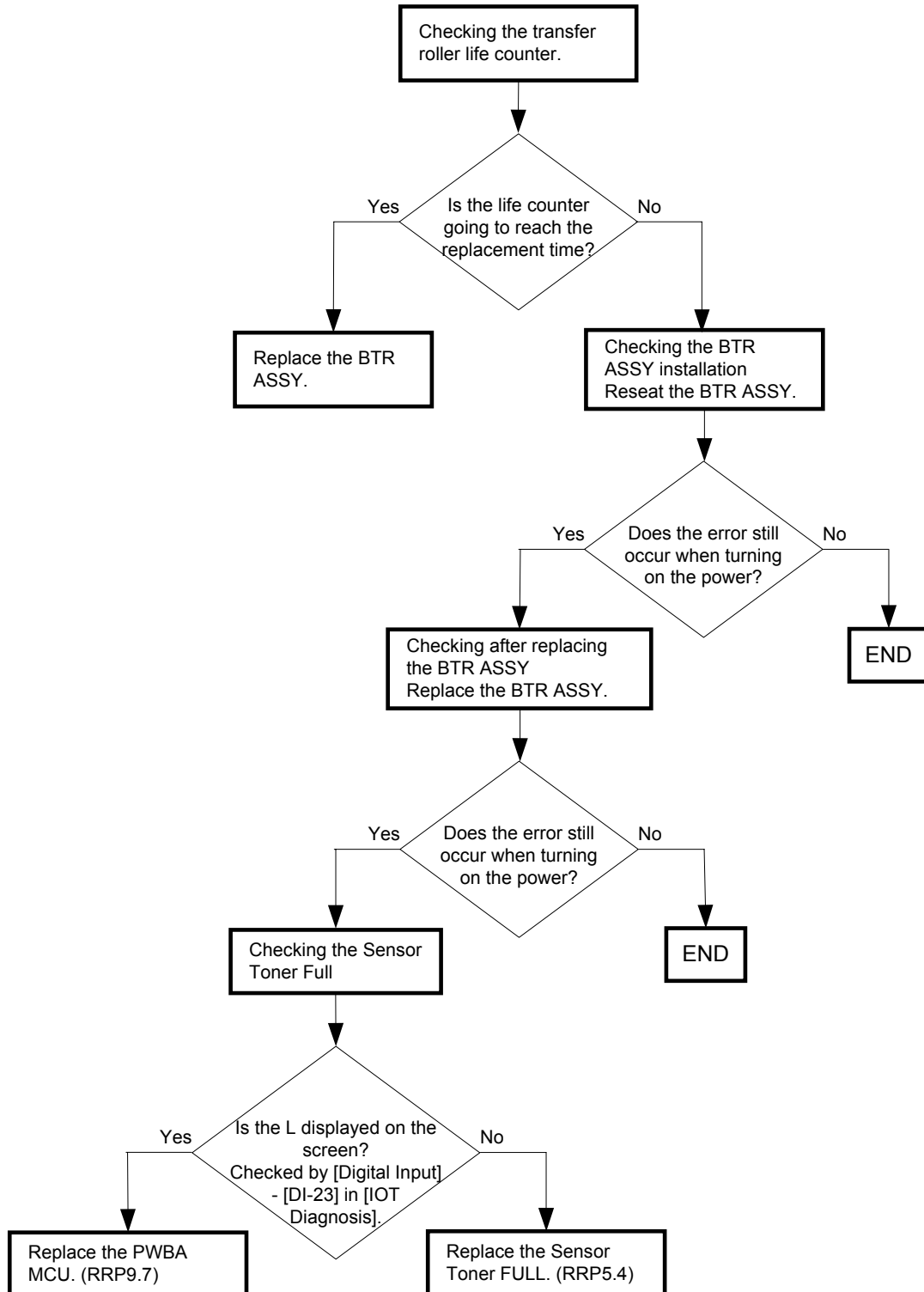

FIP-55 BTR Not Detected 094-910

Possible causative parts:HOLDER ASSY ADC (PL5.2.19)  
PWBA MCU (PL9.1.16)

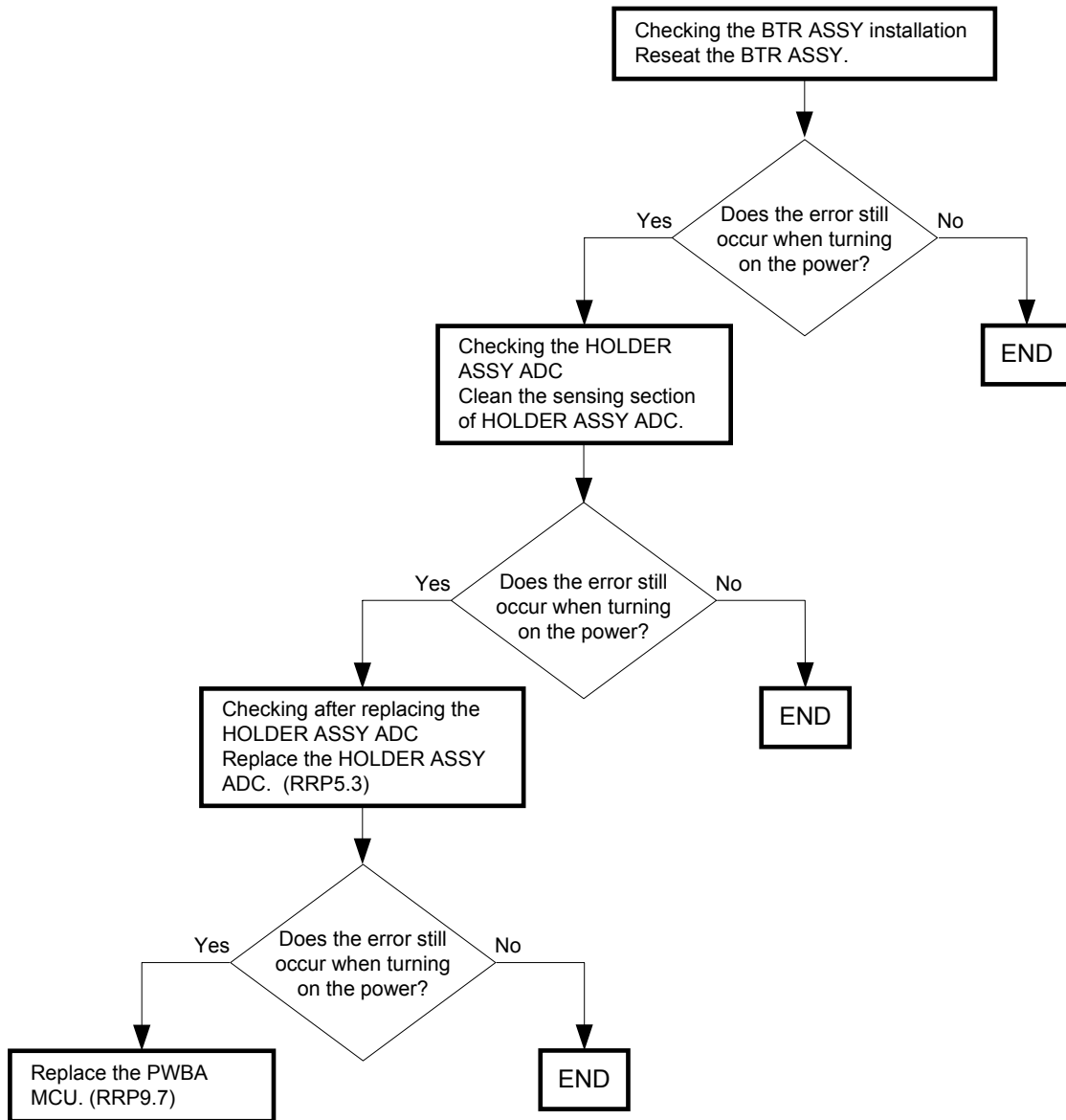

FIP-56 Load Tray N 077-912/077-913/077-914/Tray Detached 024-945/024-946/024-947/  
024-948/024-949

Possible causative parts: CASSETTE ASSY 500 (PL2.1.1)

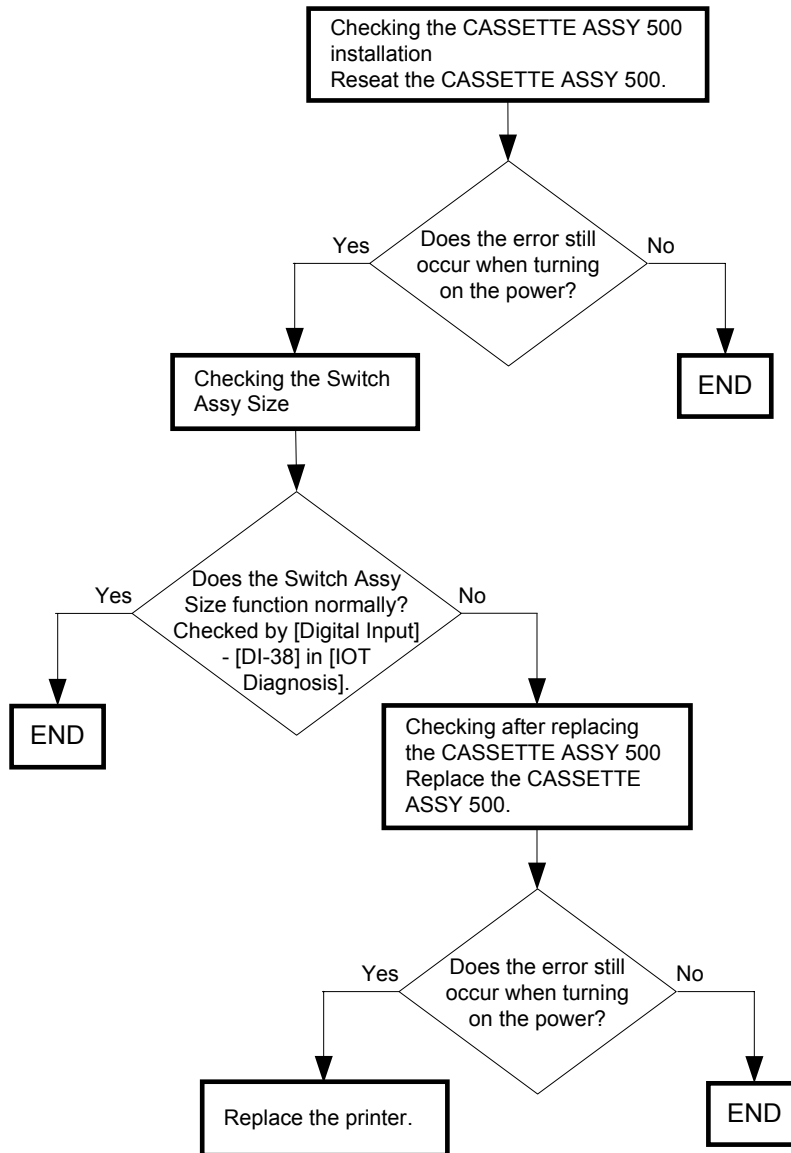

FIP-57 Close Front Door 077-300

Possible causative parts:COVER ASSY FRONT HEAD (PL1.1.6)  
 COVER ASSY TOP PHD (PL1.1.8)  
 LVPS (PL1.1.6)  
 HARNESS ASSY INTERLOCK (PL9.1.11)

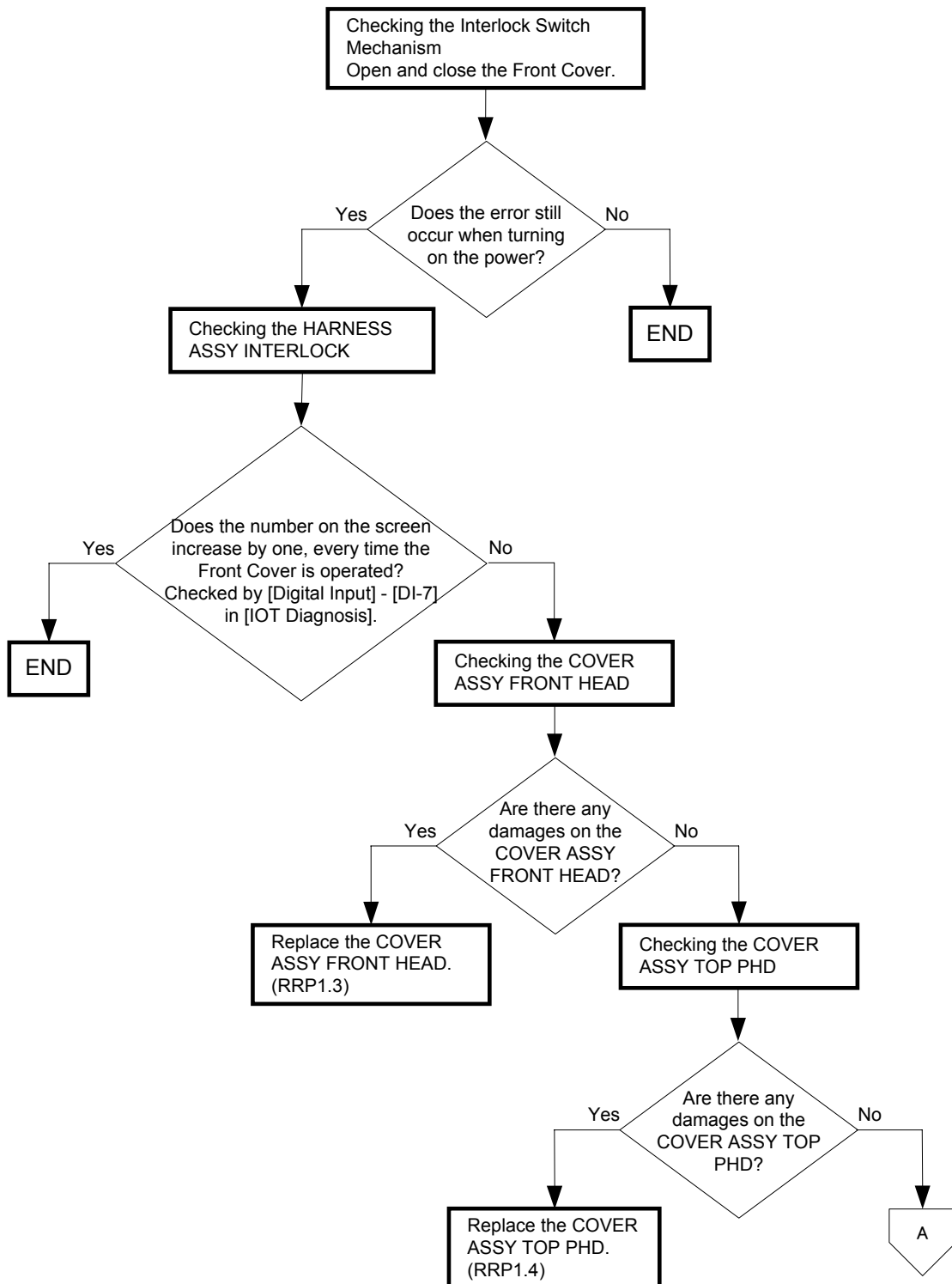

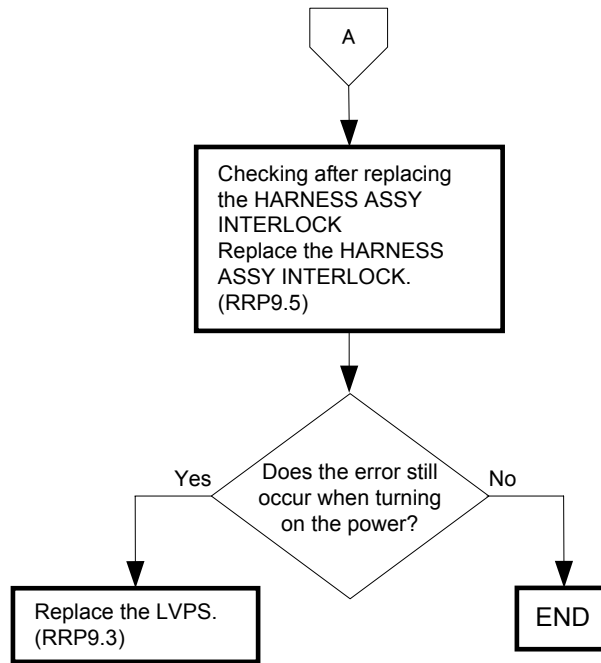

FIP-58 CTD Sensor Dirty 092-310/Ready to Print 092-910

Possible causative parts: BTR ASSY (PL5.1.4)  
 HOLDER ASSY ADC (PL5.2.19)  
 PWBA MCU (PL9.1.16)

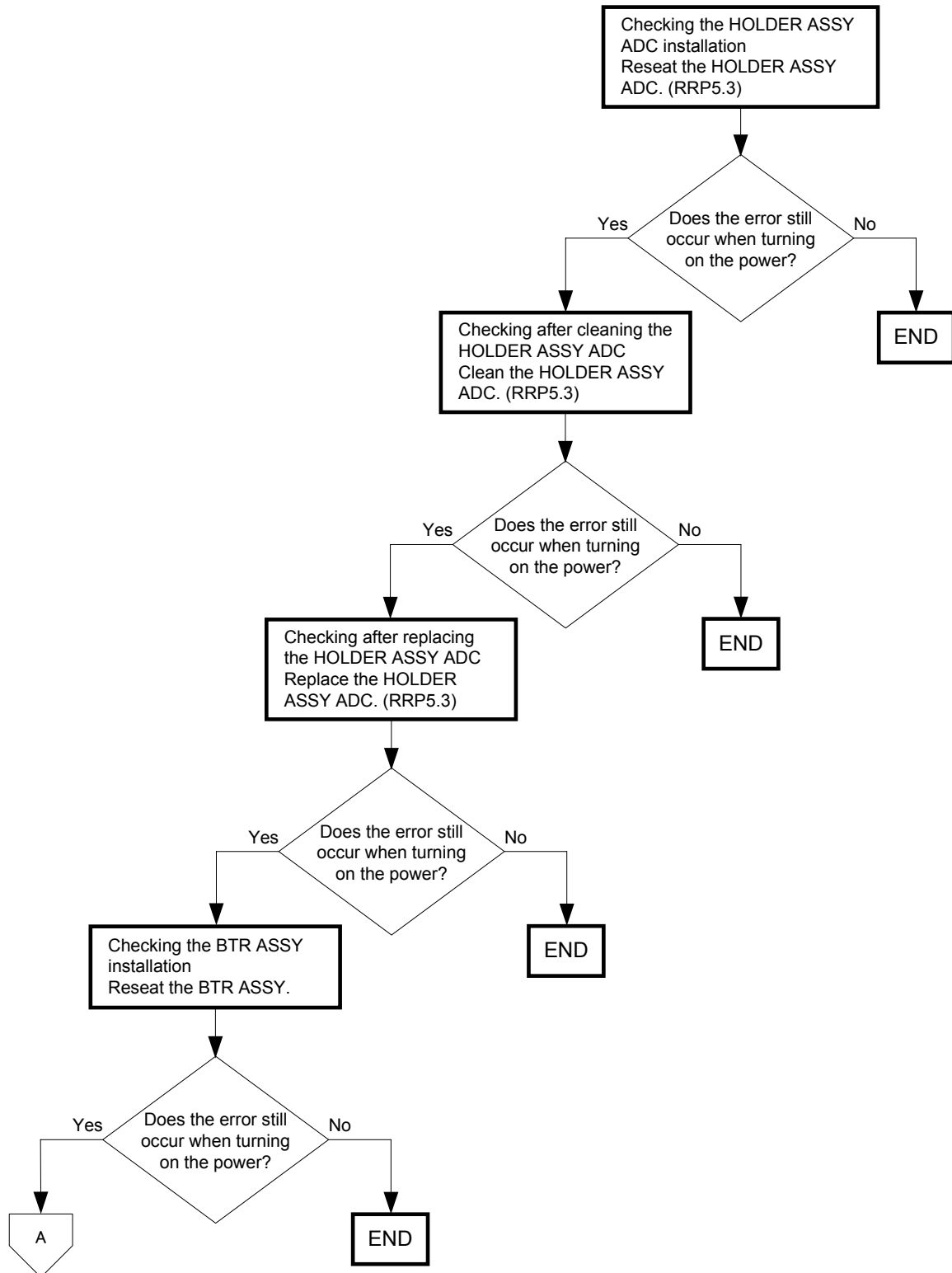



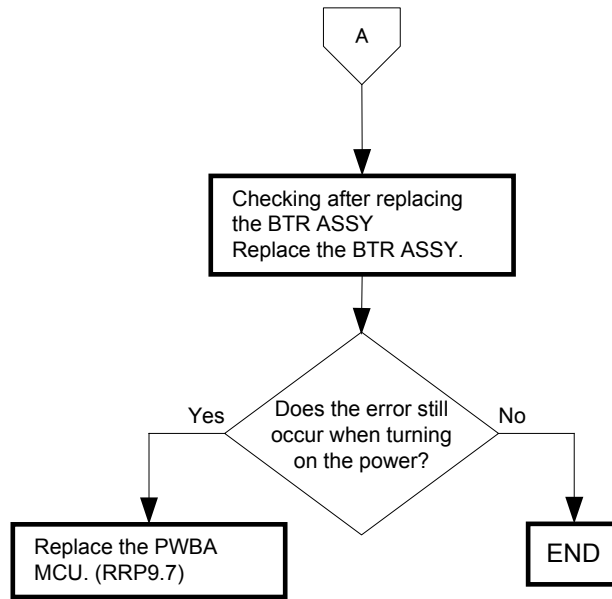

FIP-59 Out of Memory 016-700

Possible causative parts:PWBA ESS (PL9.1.3)  
OPTION SDRAM (PL9.1.27)

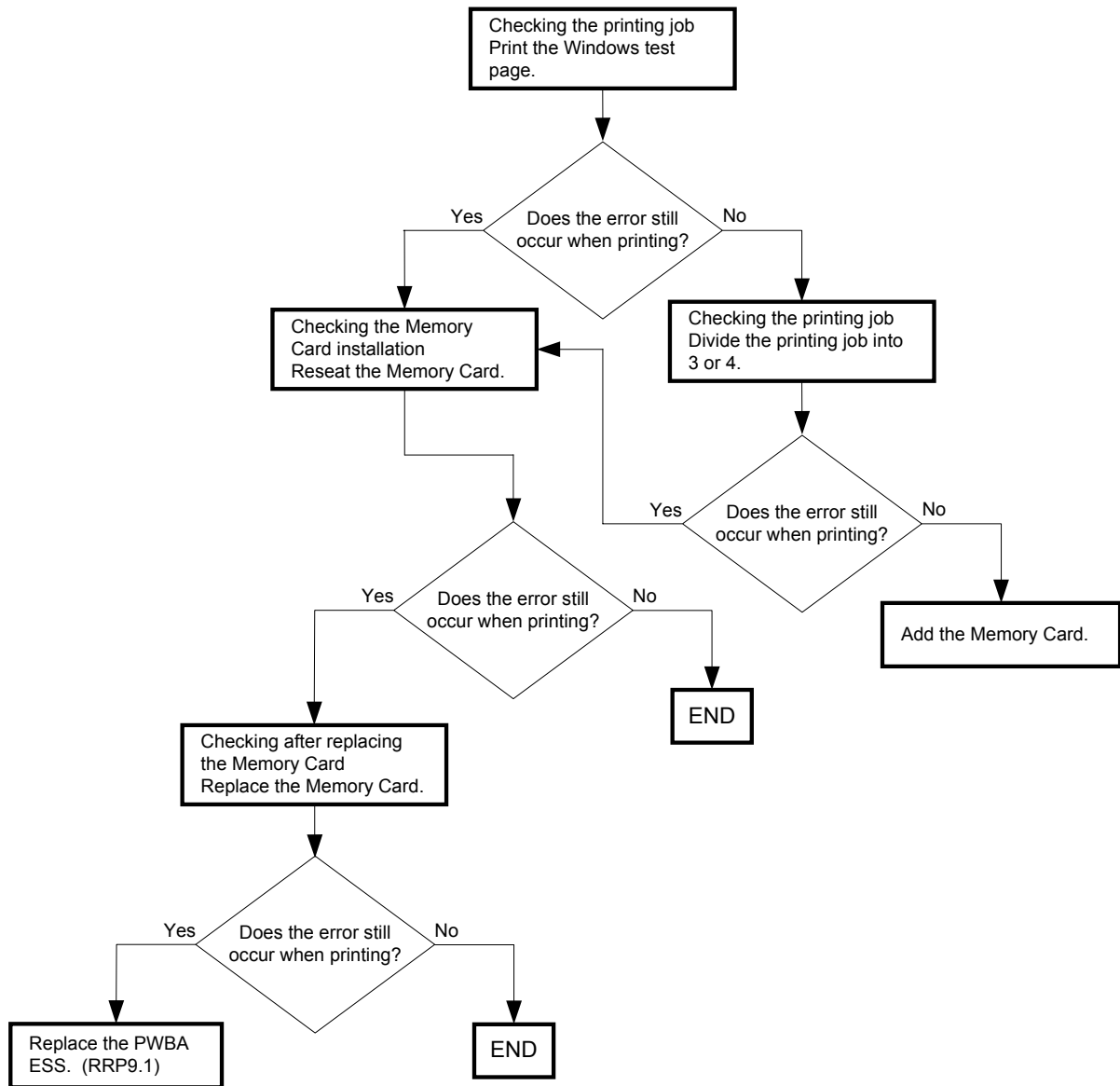

FIP-60 Disk Full 016-980

Possible causative parts: PWBA ESS (PL9.1.3)  
 OPTION HDD ASSY (PL9.1.25)  
 OPTION SDRAM (PL9.1.27)

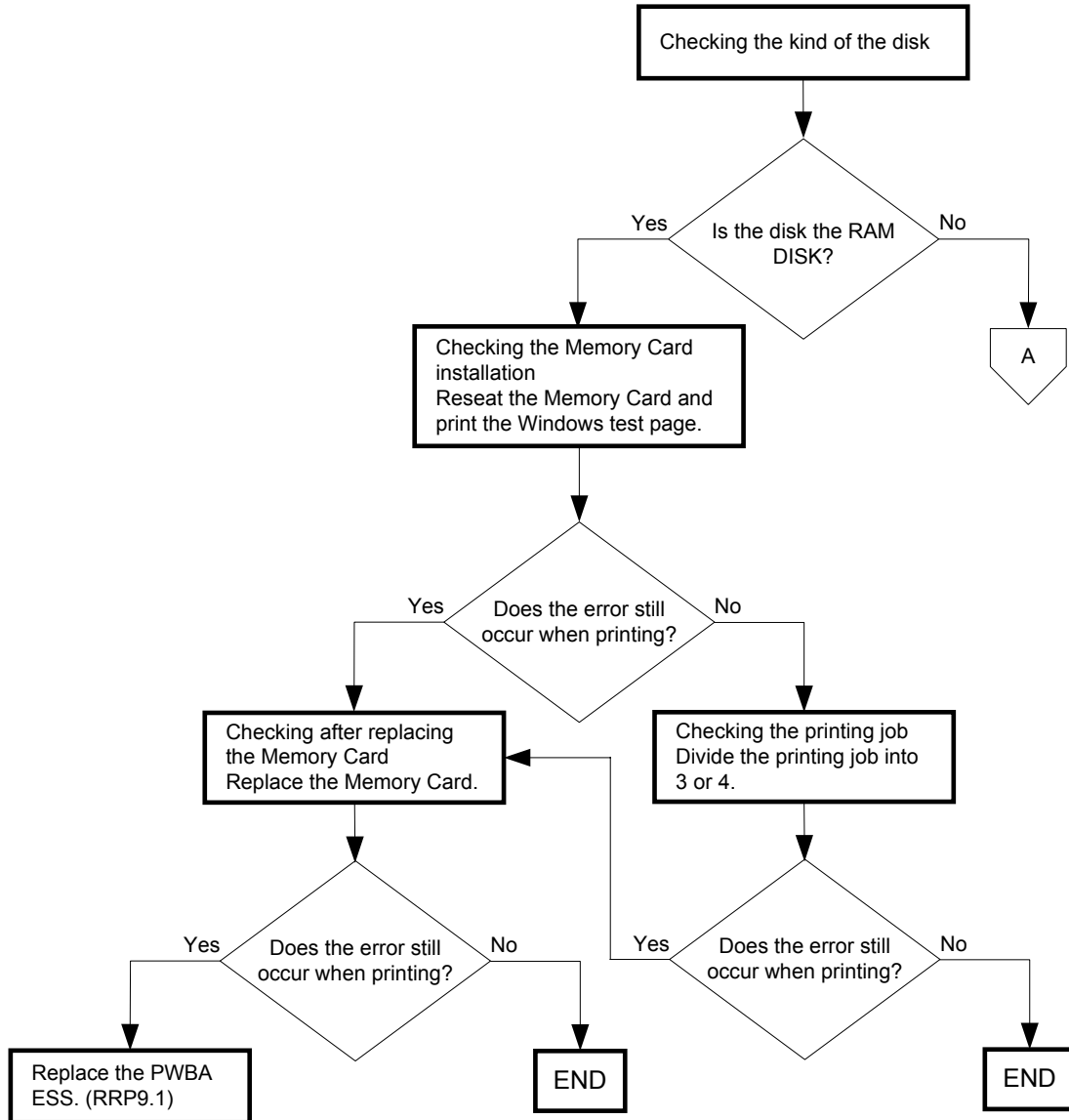

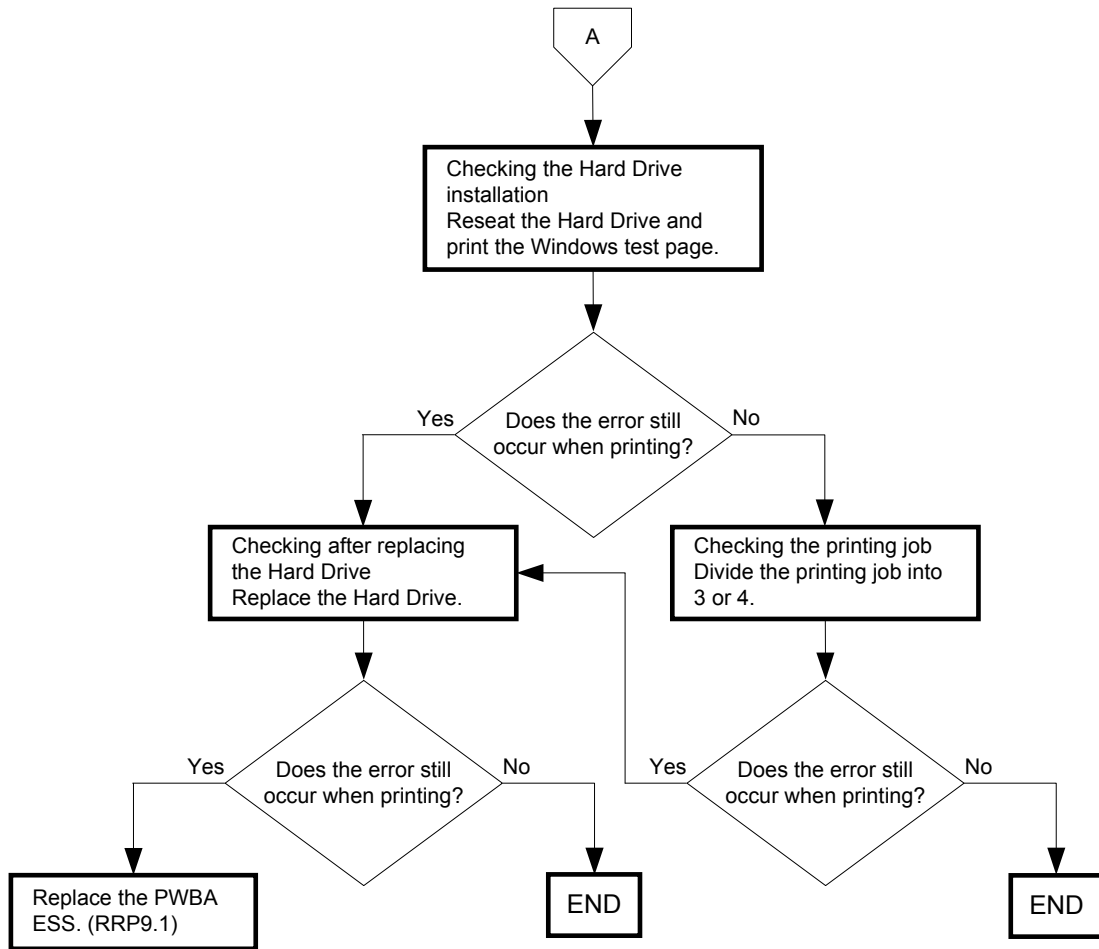

FIP-61 PCL Request 016-720

Possible causative parts:PWBA ESS (PL9.1.3)

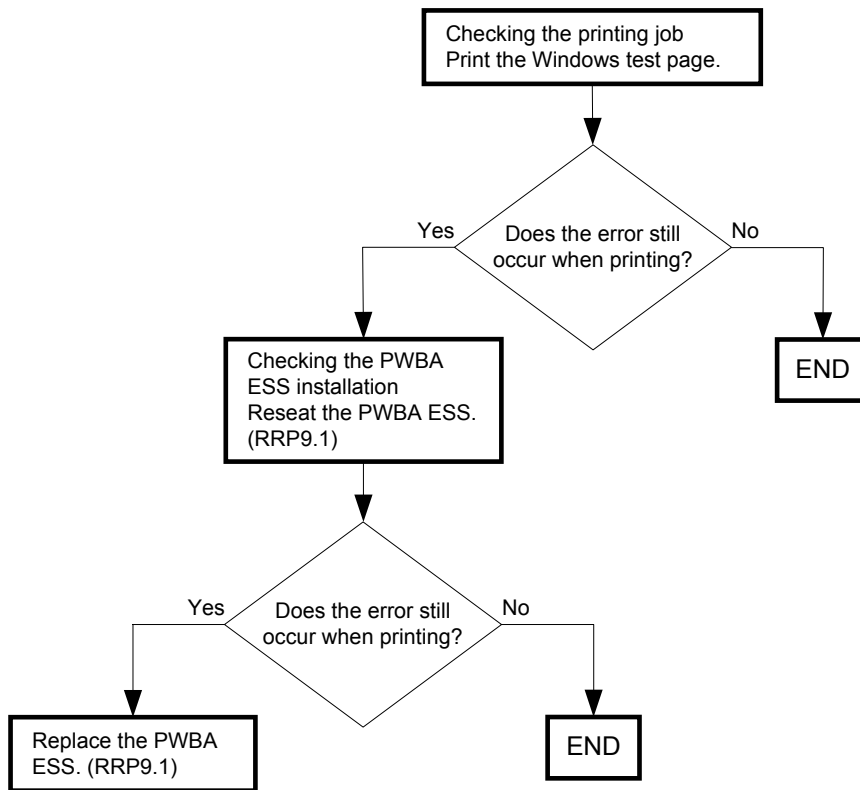

FIP-62 Invalid Job 016-799

Possible causative parts:PWBA ESS (PL9.1.3)

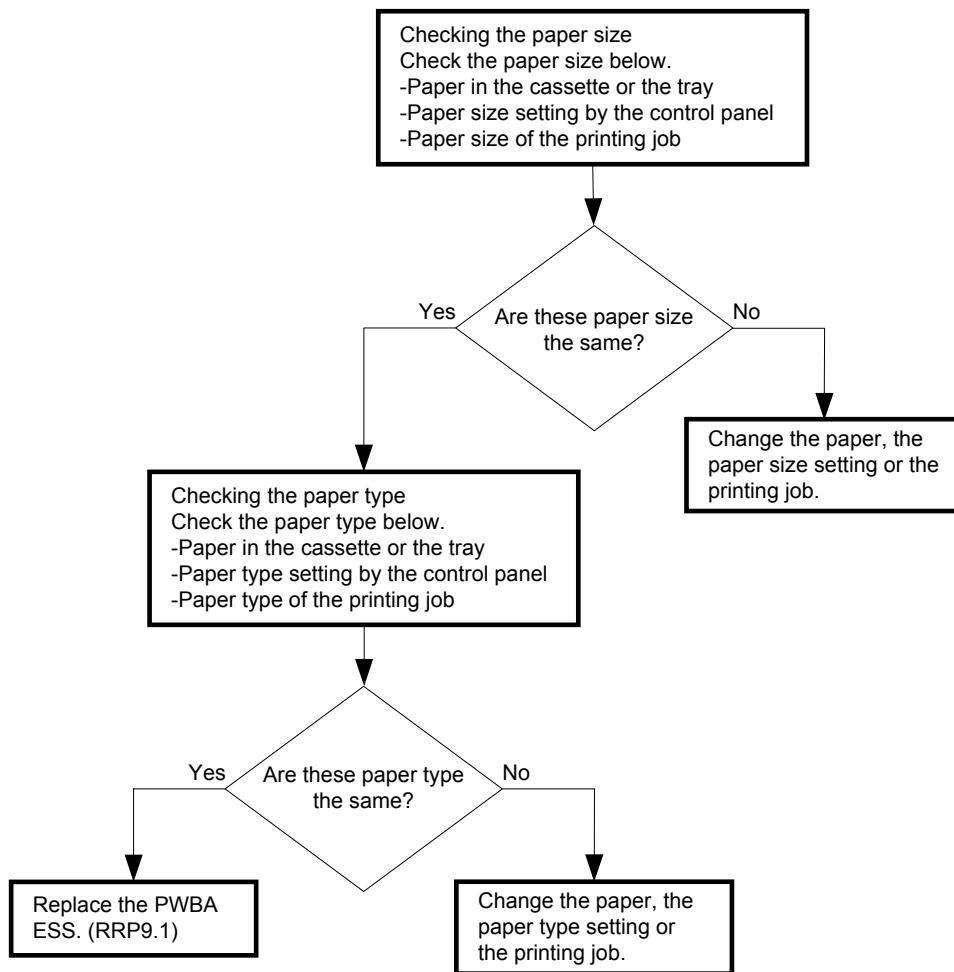

FIP-63 Ready to Print 193-700

Possible causative parts:PWBA ESS (PL9.1.3)

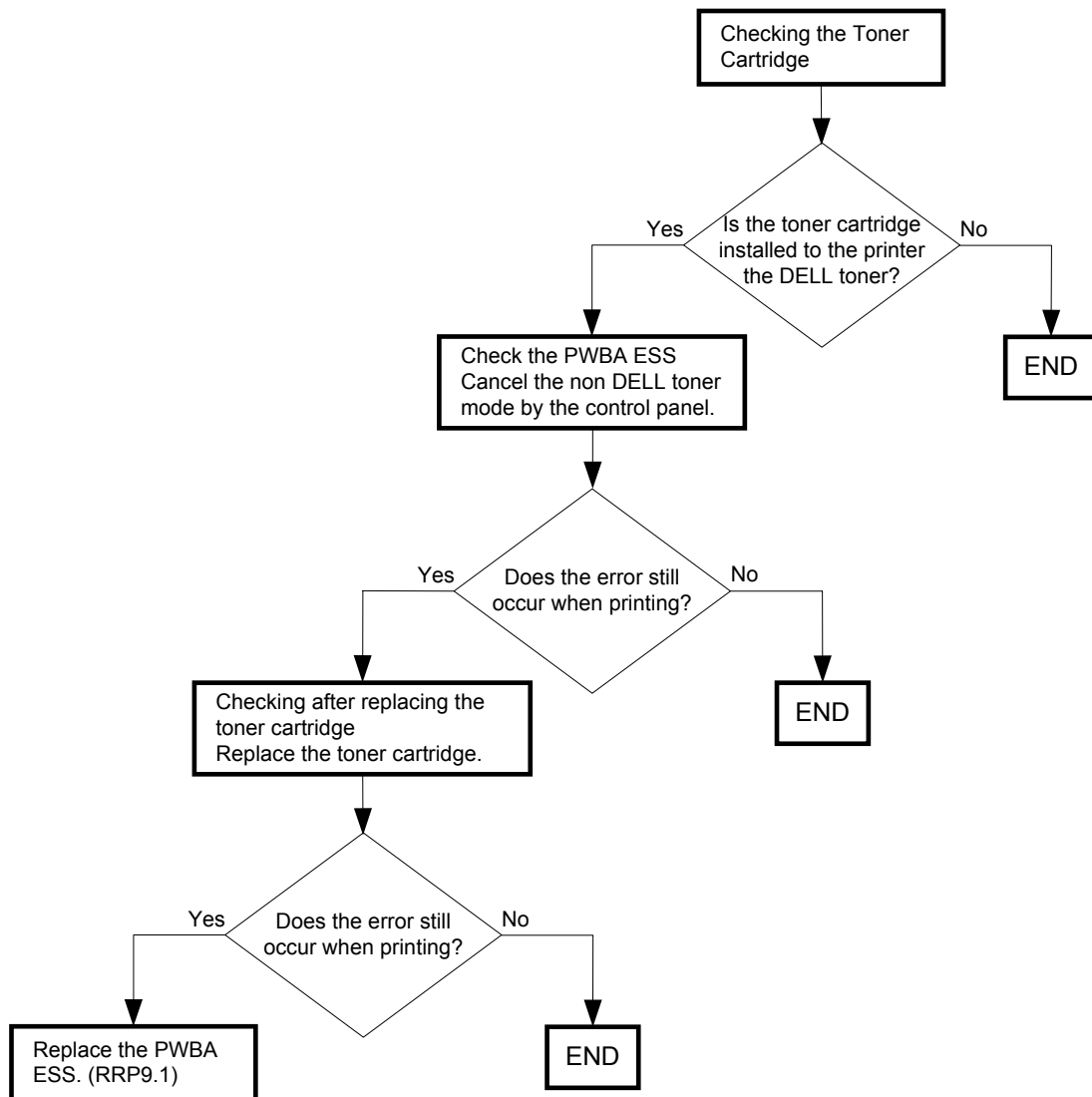

FIP-64 Invalid ID 016-383/Range Chk Error 016-384/Header Error 016-385/  
 Check Sum Error 016-386/Format Error 016-387

Possible causative parts:PWBA ESS (PL9.1.3)

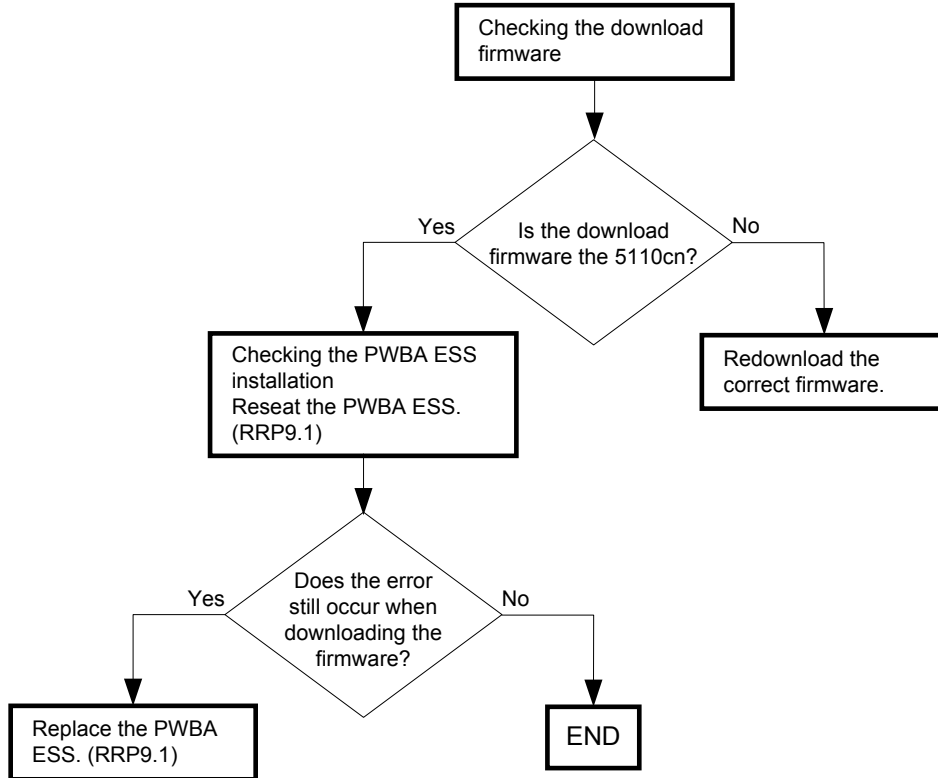



FIP-65 MPC Error 016-388/MPC Detached 016-389/MPC Com. Failed 016-390

Possible causative parts:PWBA ESS (PL9.1.3)  
MPC (PL9.1.26)

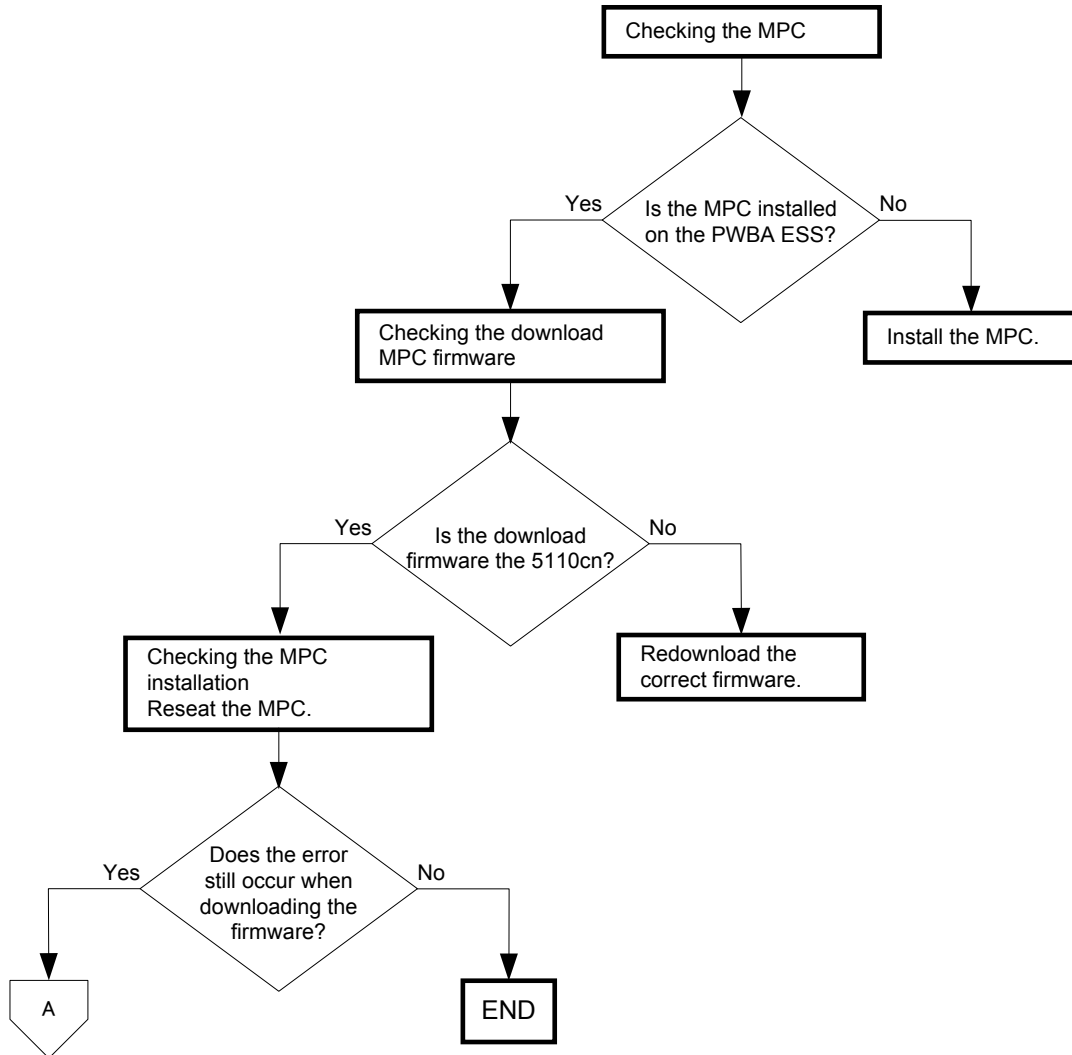

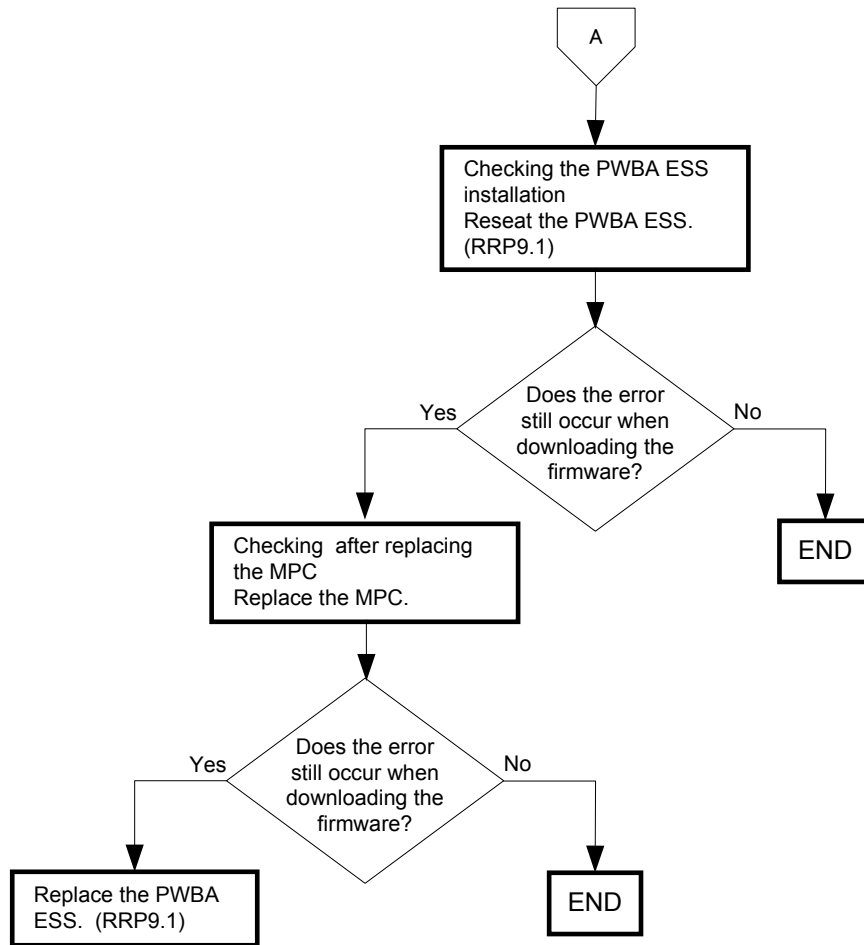

FIP-66 Invalid User 016-757/Disabled Func 016-758/Reached Limits 016-759

Possible causative parts:PWBA ESS (PL9.1.3)

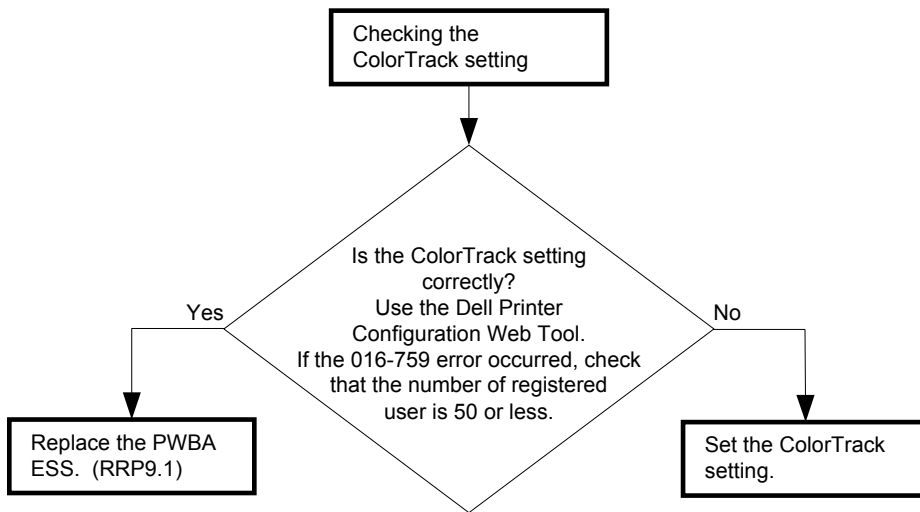

### 3.5 Image Quality Troubleshooting

Before commencing Image Troubleshooting, verify or fix the following general matters first.

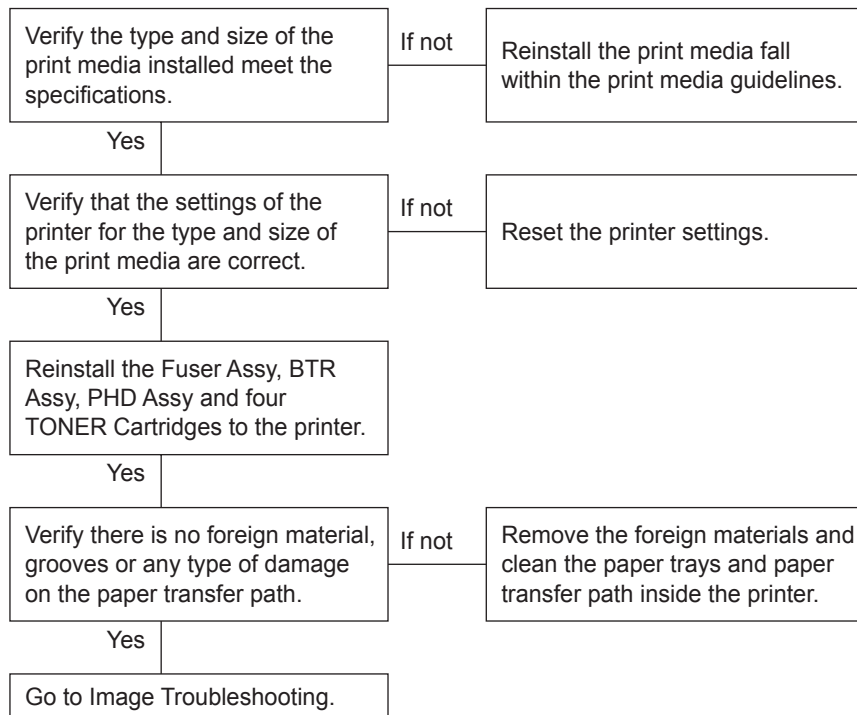

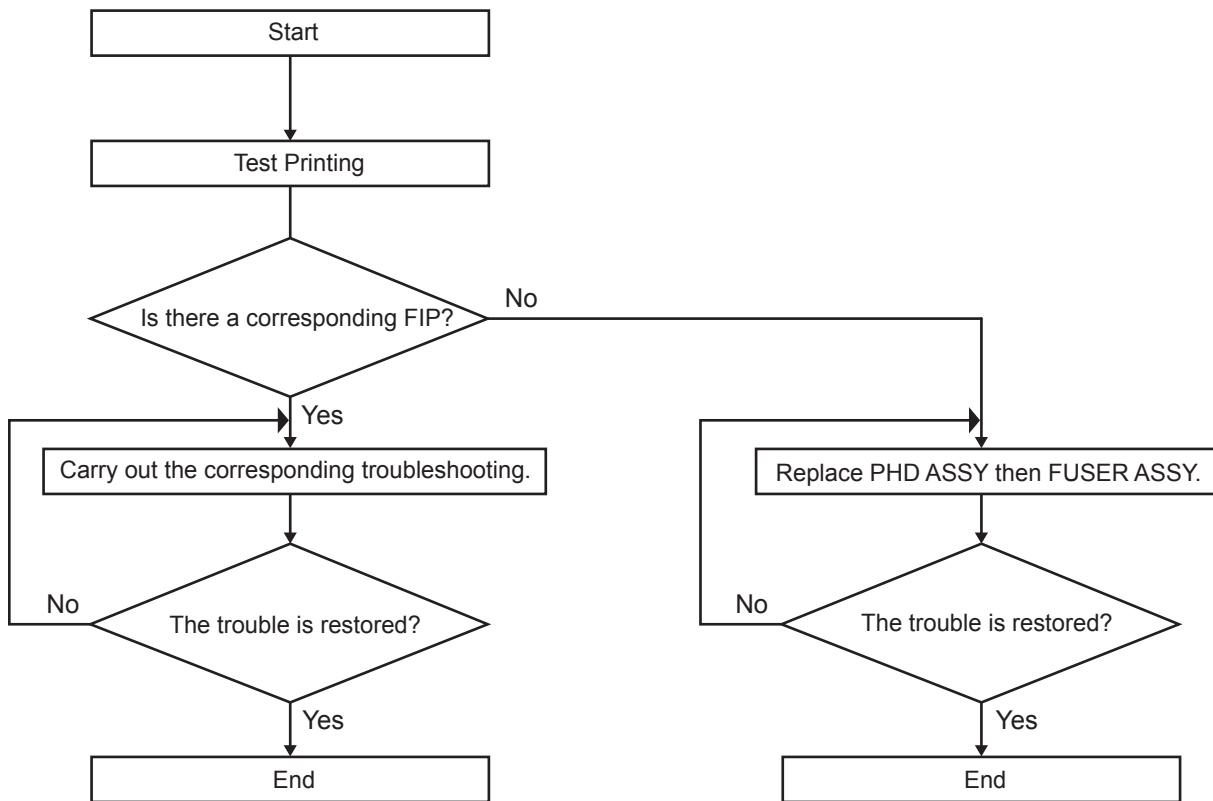

Leg\_Sec001\_001FA

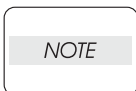

**Description below assumes that the printer controller is normal. By testing the printing operation for the engine only, conditions can be isolated simply to determine whether the trouble exists on the printer controller side or engine side.**

- When the test print with the engine only is correct, the printer controller is fault.
- When printing on the engine only is not correct, the engine is faulty.

**When trouble is considered to be on the printer controller side, replace the printer controller with proper one and check for proper operation again.**

**If the trouble persists even after the replacement, check the host side using the image troubleshooting for each condition as described below for effective troubleshooting.**

3.5.1 Image Quality Specifications

Test chart

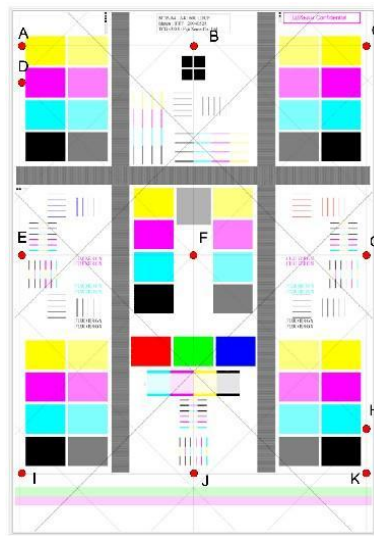

1) Parallelism

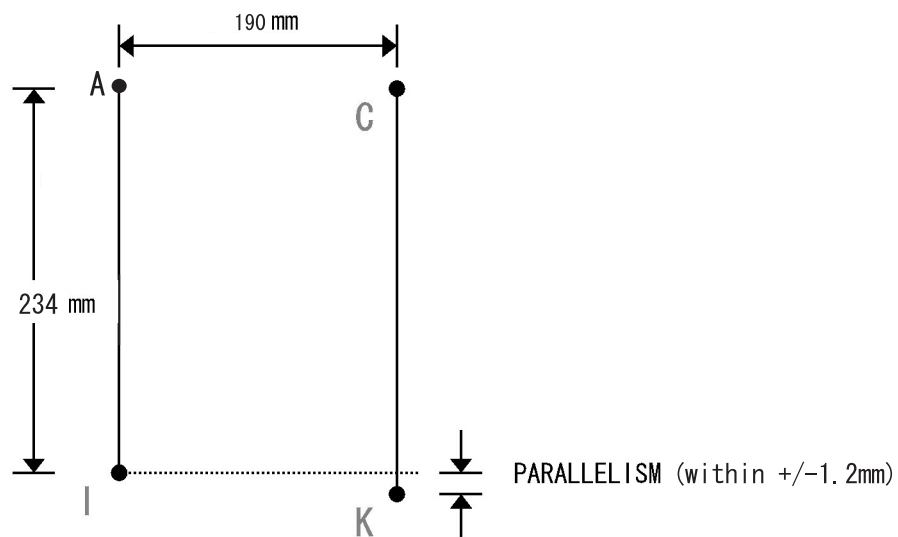

2) Perpendicularity

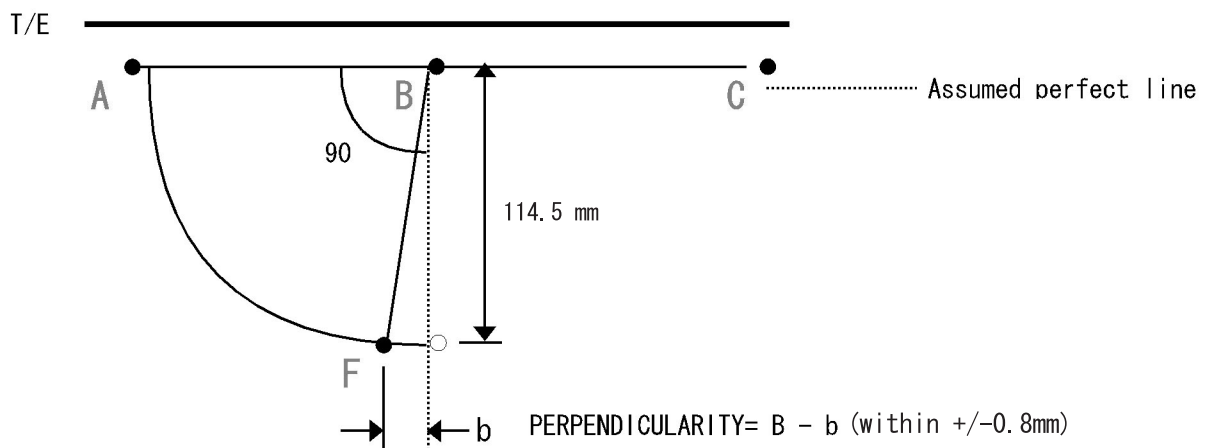

3) Skew

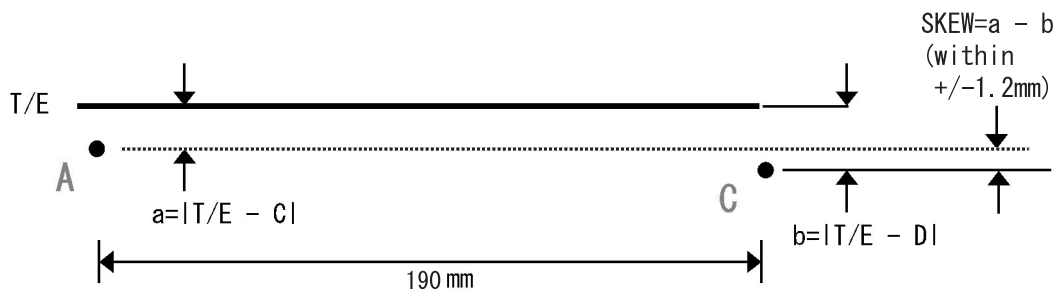

4) Linearity

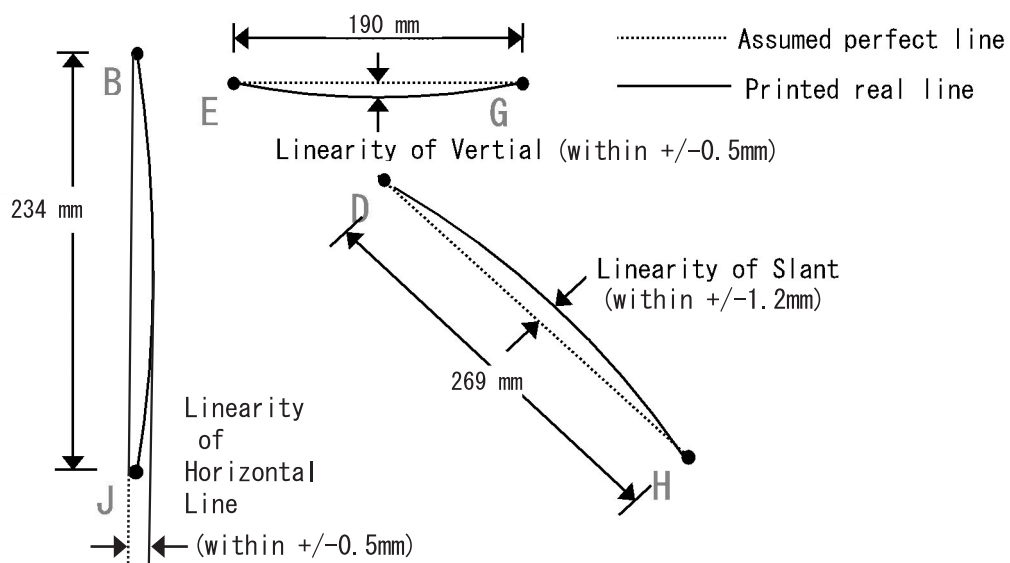

5) Magnification Error

Magnification = measured length  $\div$  Nominal

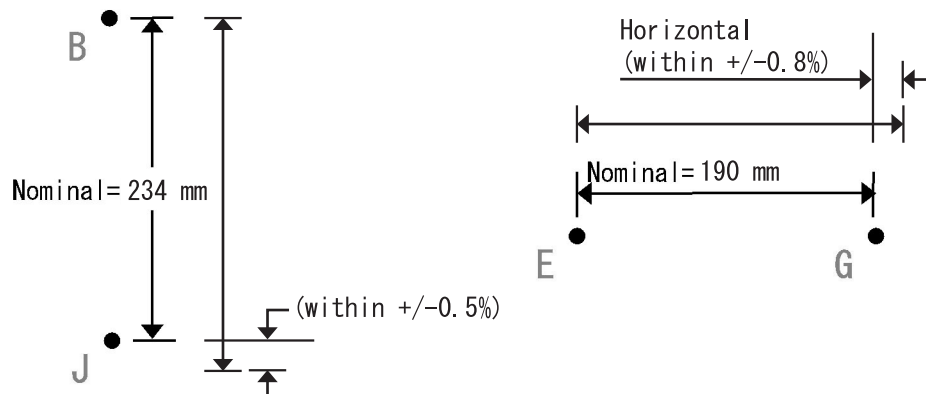

6) Registration

Registration-measured length - Nominal

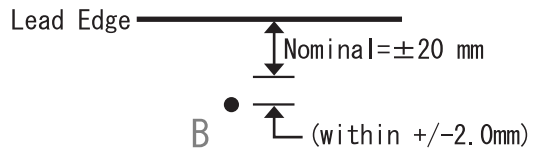

Side Edge (Left)

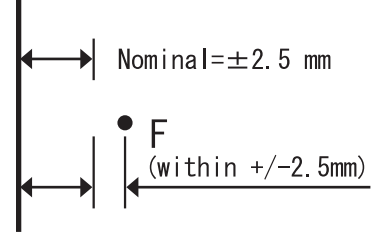

7) Printed Guaranteed Area

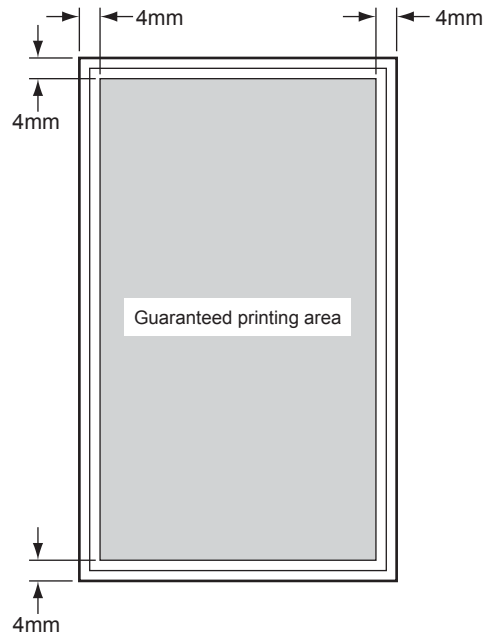

Kmy01001DA



If print image quality trouble occurs, print on paper of A3 or A4 size in order to judge and understand the trouble precisely and take proper remedy steps. Utilize the image quality troubleshooting correction table depending on the trouble for efficient troubleshooting.

If the trouble cannot be corrected according to the image quality troubleshooting, check the trouble after replacing the "Major check parts" specified for the "Initial check" in the image quality troubleshooting in succession making use of the Specifications in Chapter 6.

Image quality troubleshooting describes the representative image quality troubles as follows:

- P1 "Light (Undertoned) Prints"
- P2 "Blank Prints"
- P3 "Solid Prints"
- P4 "Vertical deletion or blank line"
- P5 "Horizontal deletion or blank line"
- P6 "Black (color) spots"
- P7 "Background or Foggy Print"
- P8 "Skewed paper"
- P9 "Paper Damage"
- P10 "Unfused Image or Image Easily Rubs off of Page"
- P11 "Vertical Dark Line"
- P12 "Afterimage (Ghost)"
- P13 "Partial Deletion"
- P14 "Horizontal Line (Periodical)"
- P15 "Fade Horizontal/Vertical"
- P16 "Color Registration (Color Shift)"

**Reference** *Rolls related with image quality troubles and interval appearing on prints are shown in the table below.*

Defect Parts	Replacement Parts	PL Number	Step
Magnet Roll	DEVE ASSY	7.1.17 to 7.1.20	34 mm
Drum	PHD ASSY	6.1.1	75 mm
RTC	PHD ASSY	6.1.1	32 mm
IDT 1	PHD ASSY	6.1.1	132 mm
IDT 2	PHD ASSY	6.1.1	132 mm
IDT 1 Cleaner	PHD ASSY	6.1.1	31 mm
IDT 2 Cleaner	PHD ASSY	6.1.1	56 mm
Refresher	PHD ASSY	6.1.1	66 mm
BTR	BTR ASSY	5.1.4	65 mm
Heat Roll	FUSER ASSY	5.1.1	98 mm
Belt	FUSER ASSY	5.1.1	95 mm

## P1 "Light (Undertoned) Prints"

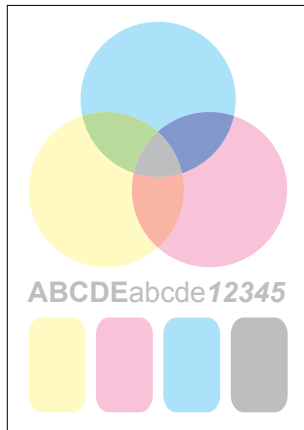
**Trouble substance**

The density of the image is entirely too faint.

**Possible causative parts**

- BTR ASSY (PL5.1.4)
- PHD ASSY (PL6.1.1)
- DEVE ASSY (Y) (PL7.1.17)
- DEVE ASSY (M) (PL7.1.18)
- DEVE ASSY (C) (PL7.1.19)
- DEVE ASSY (K) (PL7.1.20)
- DISPENSER ASSY HI (PL7.2.22)
- PWBA HVPS (PL9.1.21)

Before commencing troubleshooting, check the paper transfer path. Make sure there is no foreign materials on the transfer path, such as the staple, paper clip, scraps of paper and so on.

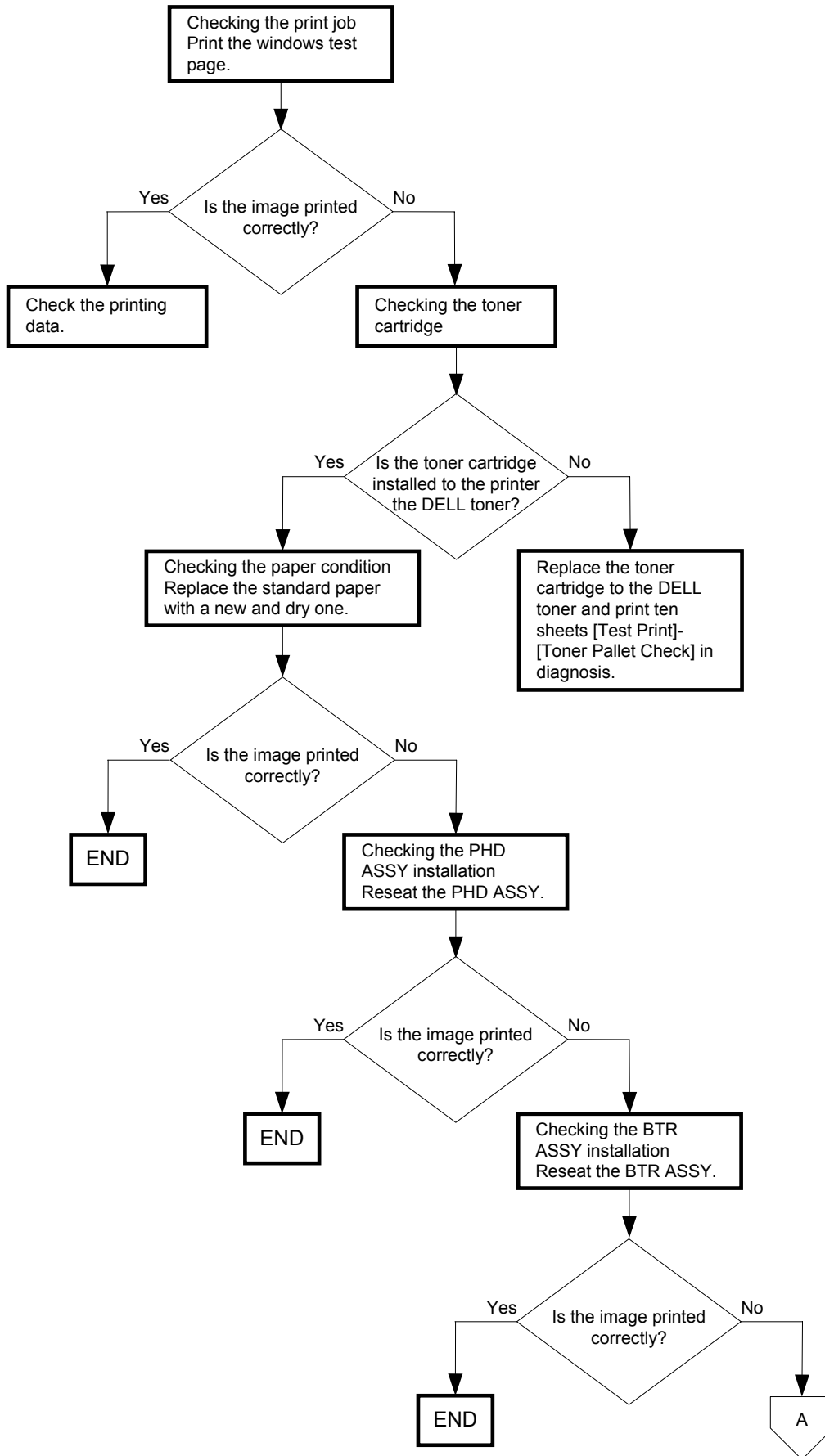

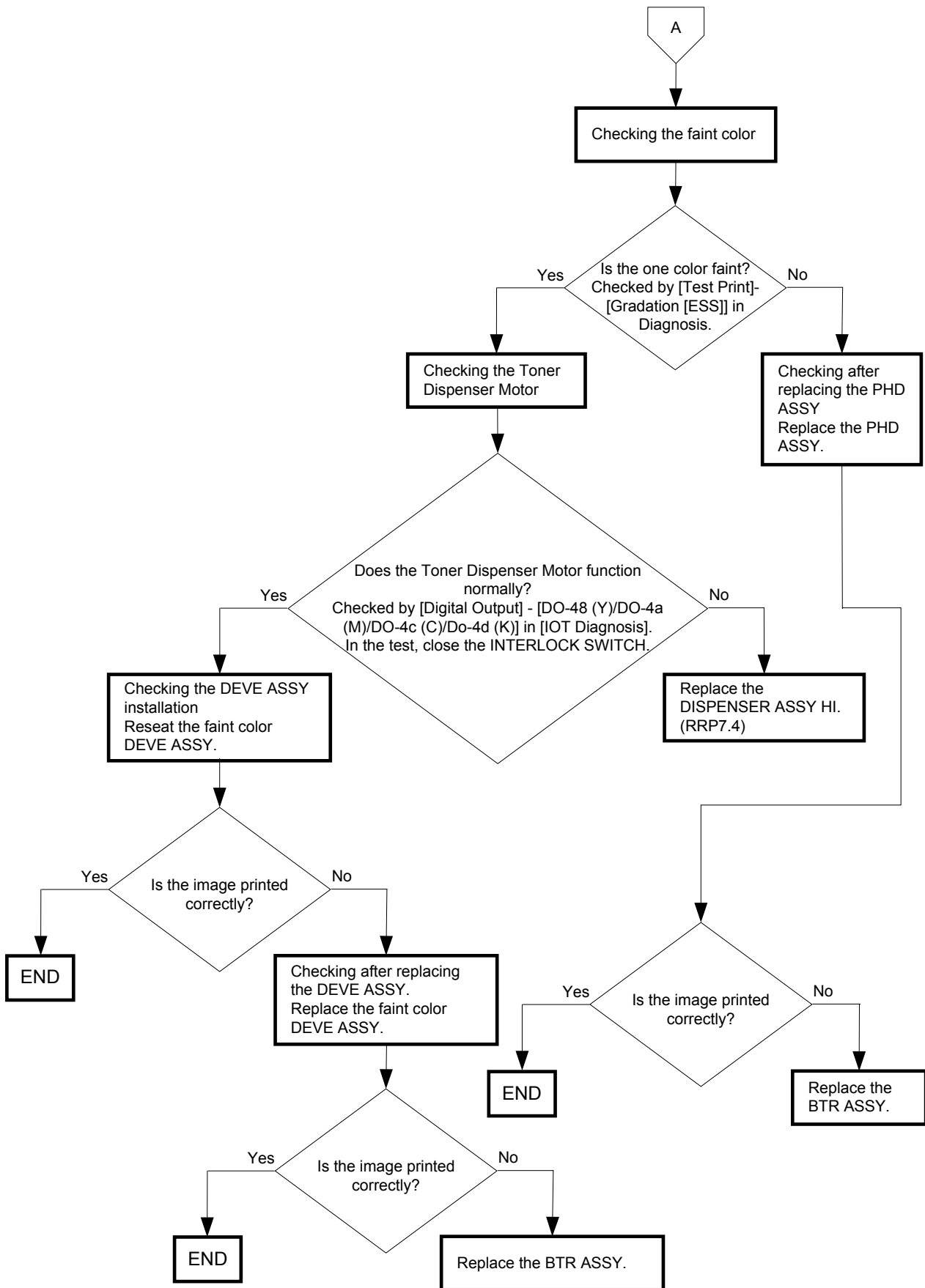

## P2 "Blank Prints"

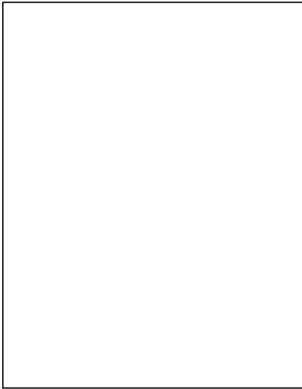

Leg\_Sec001\_003FA

### **Trouble substance**

The entire image area is blank.

### **Possible causative parts**

- BTR ASSY (PL5.1.4)
- PHD ASSY (PL6.1.1)
- PWBA ESS (PL9.1.3)
- PWBA HVPS (PL9.1.21)

Before commencing troubleshooting, check the paper transfer path. Make sure there is no foreign materials on the transfer path, such as the staple, paper clip, scraps of paper and so on.

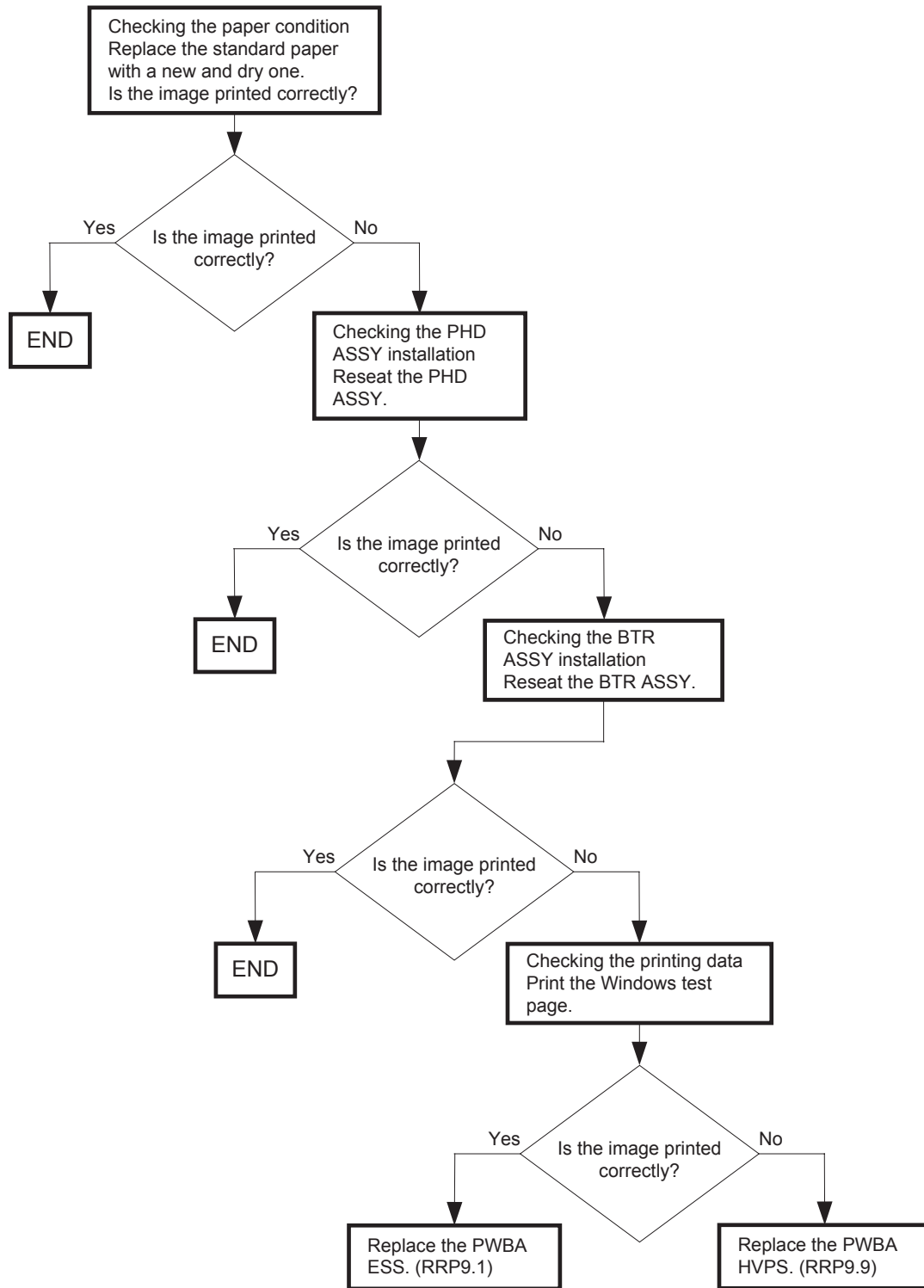

P3 "Solid Prints"



Leg\_Sec001\_004FA

**Trouble substance**  
The entire image area is black.

- Possible causative parts**
- PHD ASSY (PL6.1.1)
  - ROS ASSY (PL6.1.2)
  - PWBA HVPS (PL9.1.21)

Before commencing troubleshooting, check the paper transfer path. Make sure there is no foreign materials on the transfer path, such as the staple, paper clip, scraps of paper and so on.

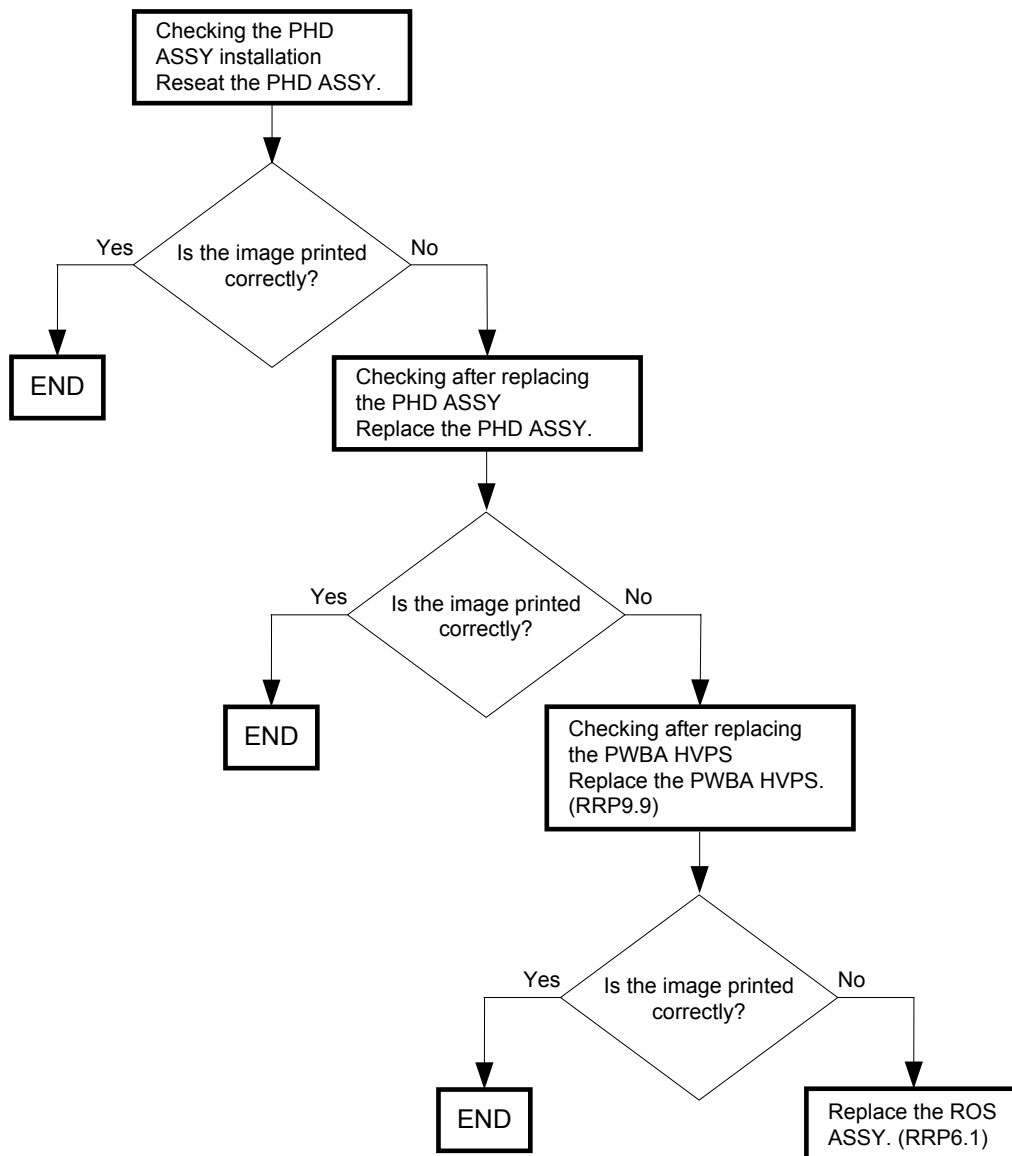

## P4 "Vertical deletion or blank line"

**Trouble substance**

There are some extremely faint or completely non-printed parts. Those non-printed parts cover a wide area vertically, along the paper feeding direction.

**ESS and possible causative parts**

- FUSER ASSY (PL5.1.1)
- BTR ASSY (PL5.1.4)
- PHD ASSY (PL6.1.1)
- DEVE ASSY (Y) (PL7.1.17)
- DEVE ASSY (M) (PL7.1.18)
- DEVE ASSY (C) (PL7.1.19)
- DEVE ASSY (K) (PL7.1.20)

Before commencing troubleshooting, check the paper transfer path. Make sure there is no foreign materials on the transfer path, such as the staple, paper clip, scraps of paper and so on.



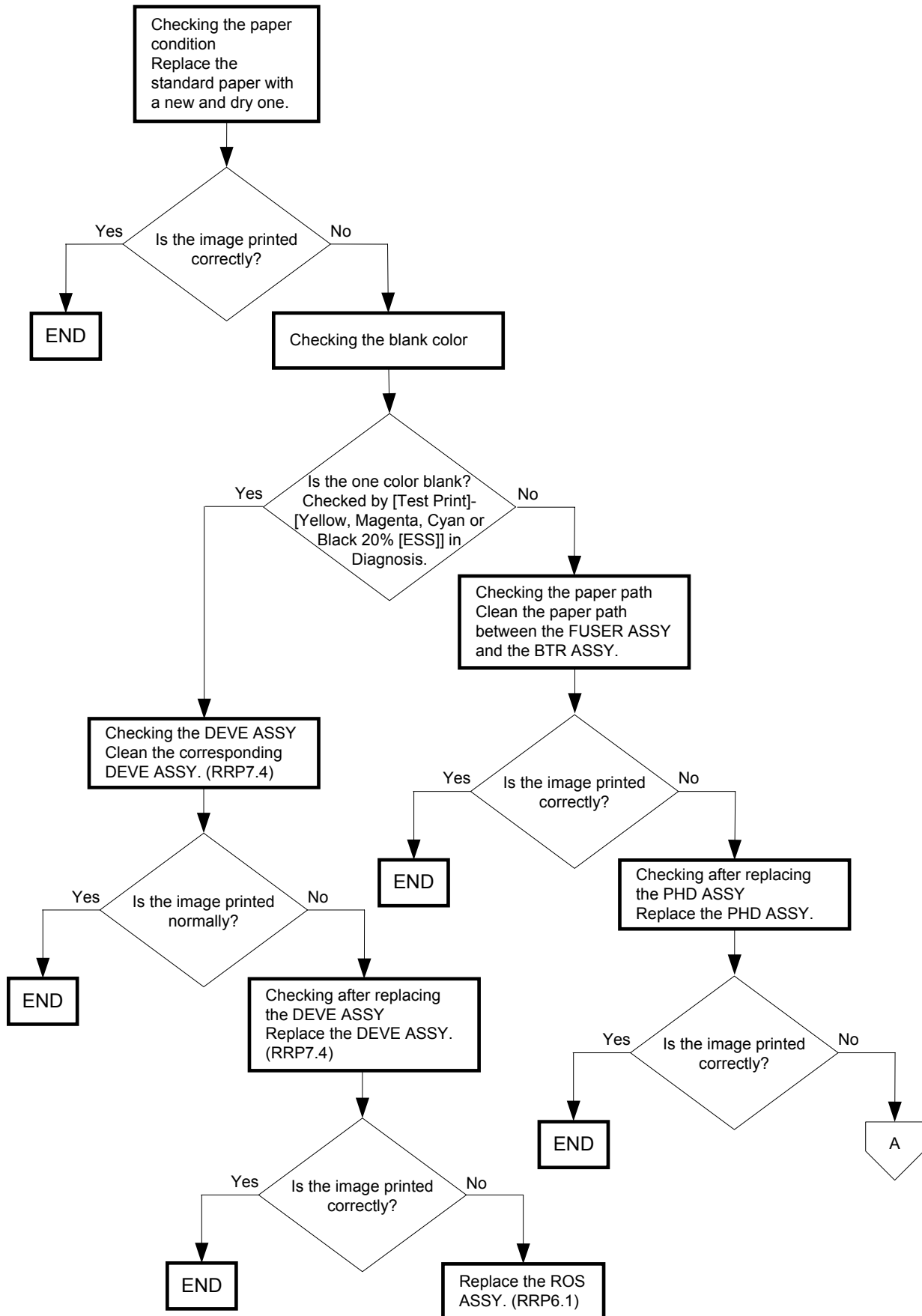

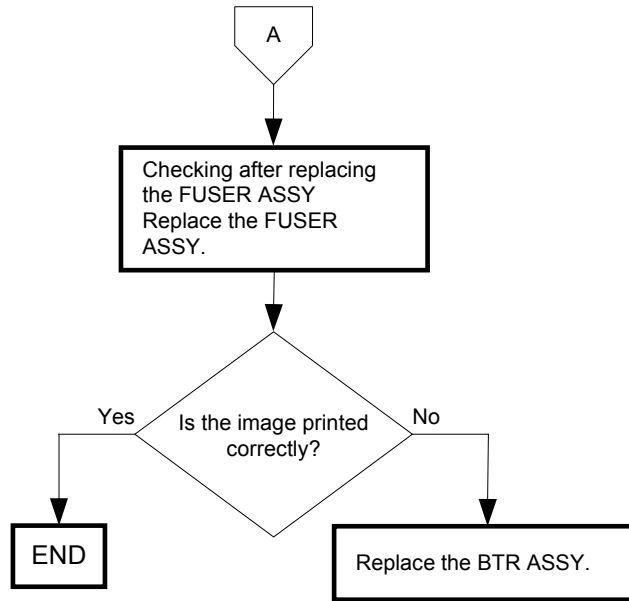

## P5 "Horizontal deletion or blank line"

**Trouble substance**

There are areas of the images that are extremely light or are missing entirely. These missing areas form wide bands that run horizontally across the page parallel with the paper feeding direction.

**Possible causative parts**

- BTR ASSY (PL5.1.4)
- PHD ASSY (PL6.1.1)
- DEVE ASSY (Y) (PL7.1.17)
- DEVE ASSY (M) (PL7.1.18)
- DEVE ASSY (C) (PL7.1.19)
- DEVE ASSY (K) (PL7.1.20)
- PWBA ESS (9.1.3)

Before commencing troubleshooting, check the paper transfer path. Make sure there is no foreign materials on the transfer path, such as the staple, paper clip, scraps of paper and so on.

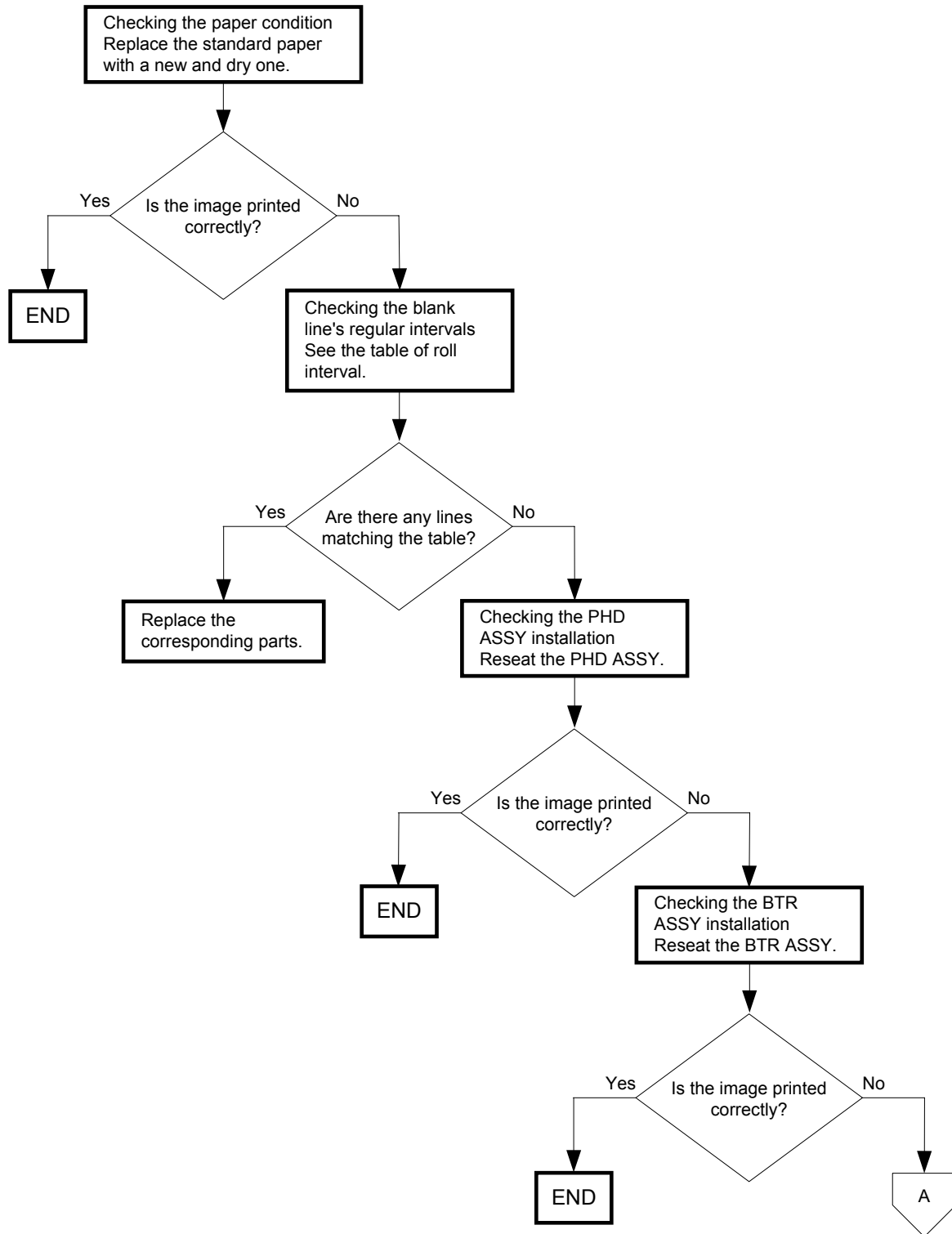

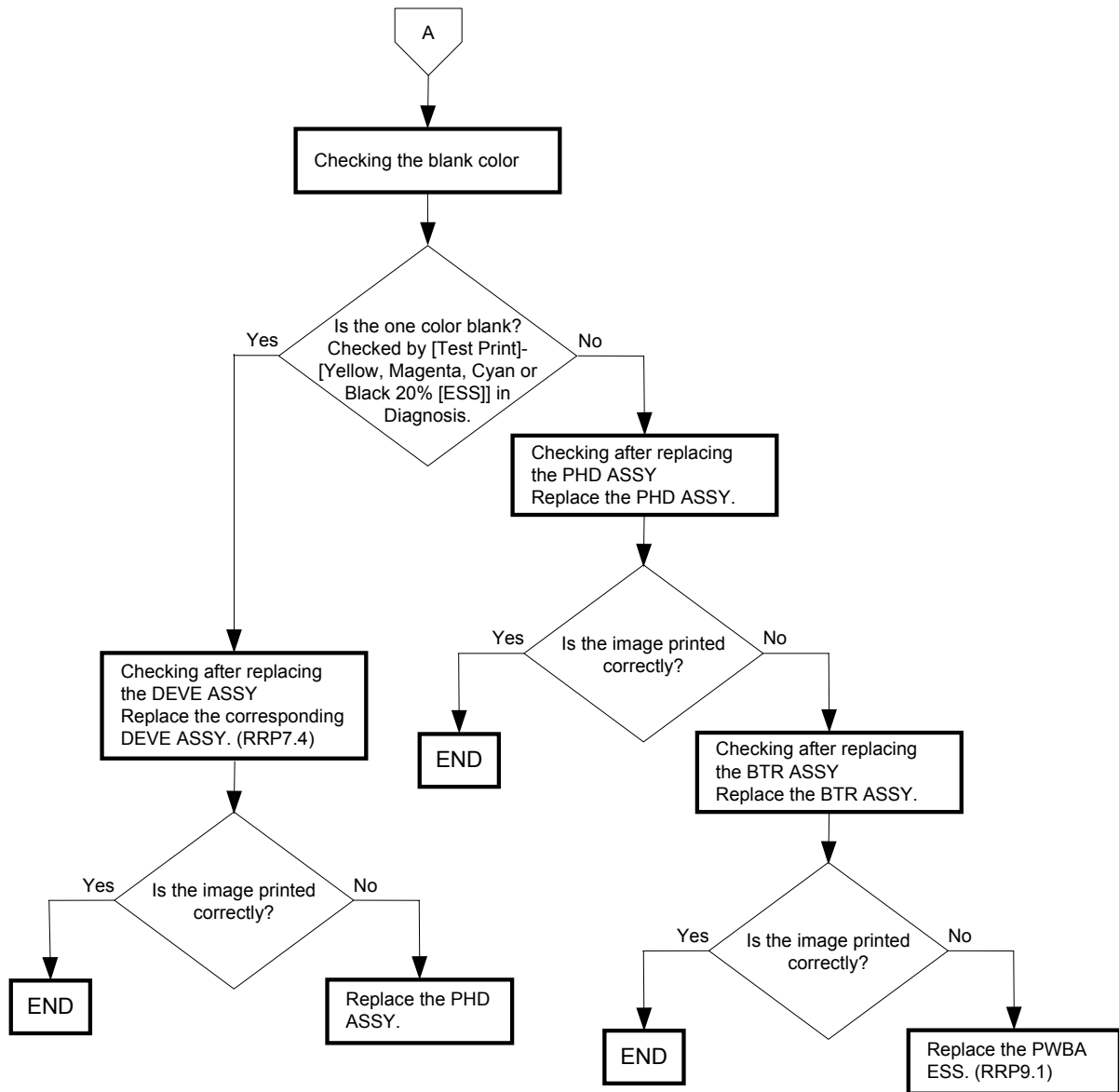

## P6 "Black (color) spots"

**Trouble substance**

There are toner spots all over the paper disorderedly.

**Possible causative parts**

- BTR ASSY (PL5.1.4)
- PHD ASSY (PL6.1.1)
- DEVE ASSY (Y) (PL7.1.17)
- DEVE ASSY (M) (PL7.1.18)
- DEVE ASSY (C) (PL7.1.19)
- DEVE ASSY (K) (PL7.1.20)

Before commencing troubleshooting, check the paper transfer path. Make sure there is no foreign materials on the transfer path, such as the staple, paper clip, scraps of paper and so on.

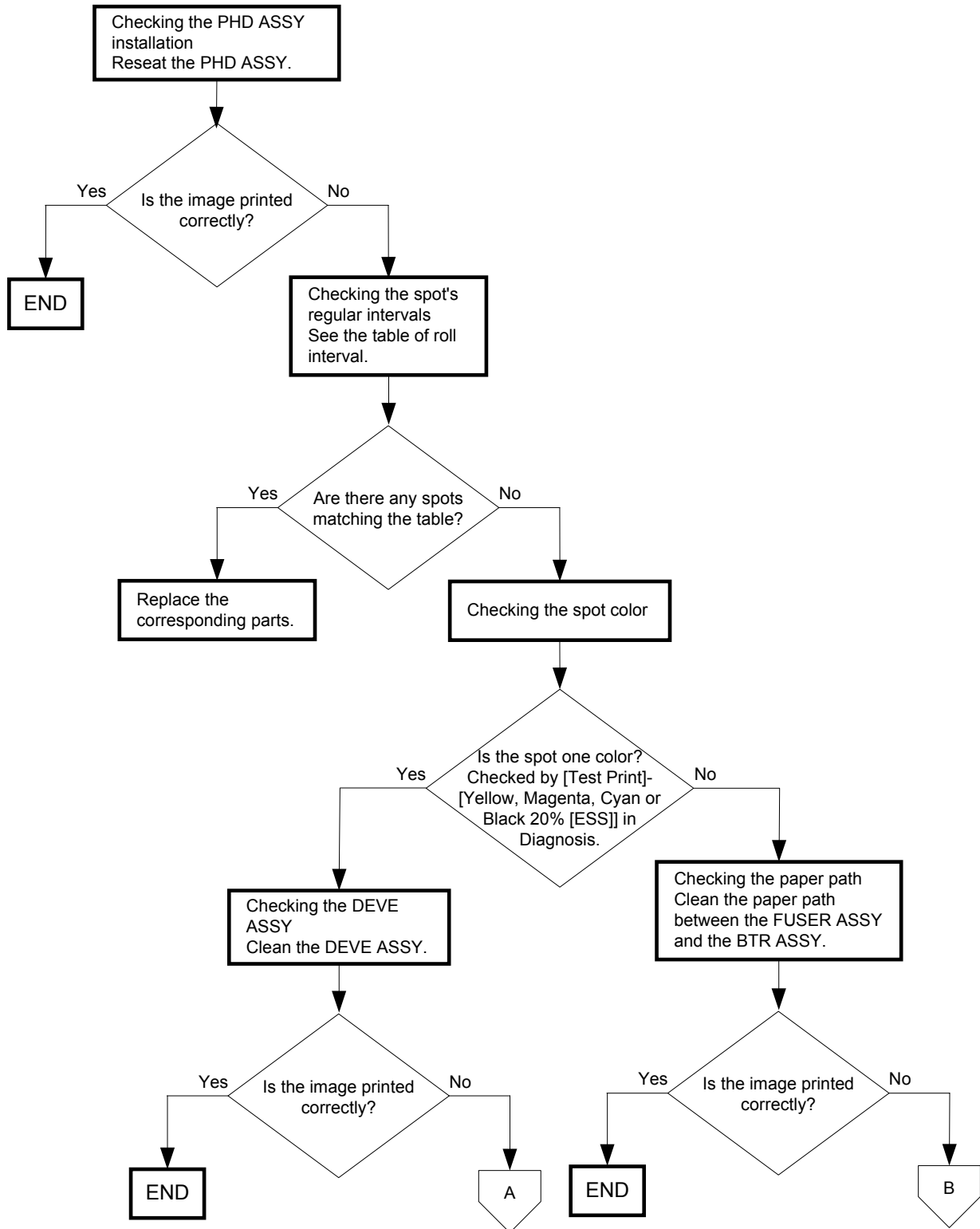

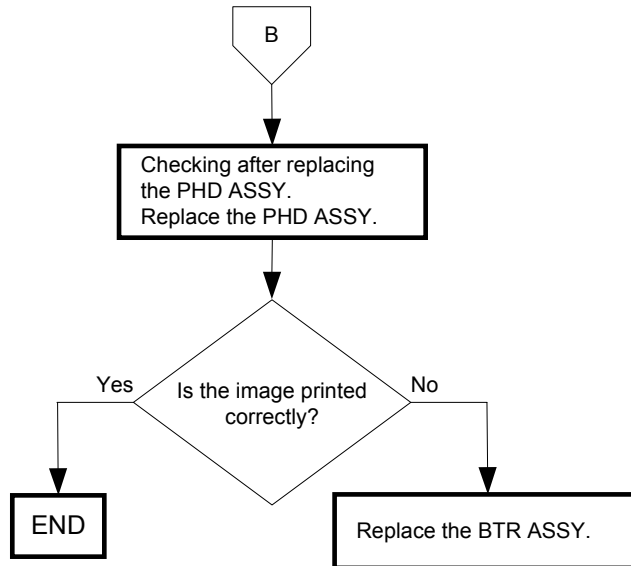
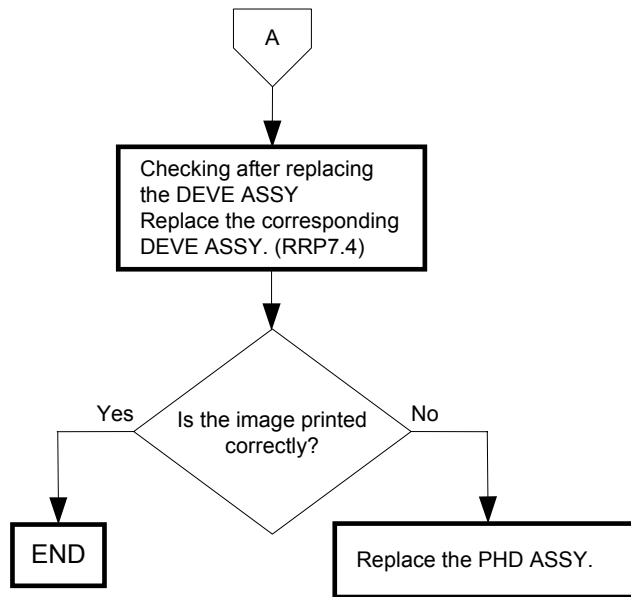



## 27 "Background or Foggy Print"



### Trouble substance

There is toner stain all over or a part of the page.

The stain appears as very bright gray or color stain.

### Possible causative parts

- BTR ASSY (PL5.1.4)
- PHD ASSY (PL6.1.1)
- DEVE ASSY (Y) (PL7.1.17)
- DEVE ASSY (M) (PL7.1.18)
- DEVE ASSY (C) (PL7.1.19)
- DEVE ASSY (K) (PL7.1.20)

Before commencing troubleshooting, check the paper transfer path. Make sure there is no foreign materials on the transfer path, such as the staple, paper clip, scraps of paper and so on.

Work before troubleshooting  
 Print the 10 sheets by the [Test Print]-[Gradation [ESS]] of Diagnosis.  
 Clean the HOLDER ASSY ADC.

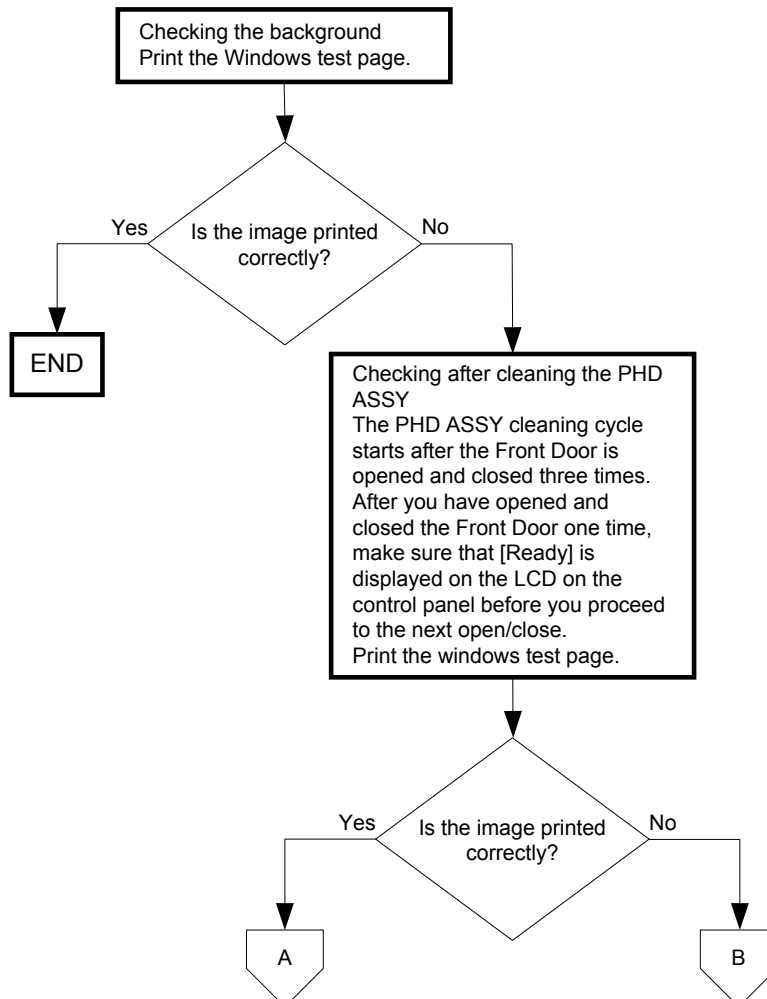

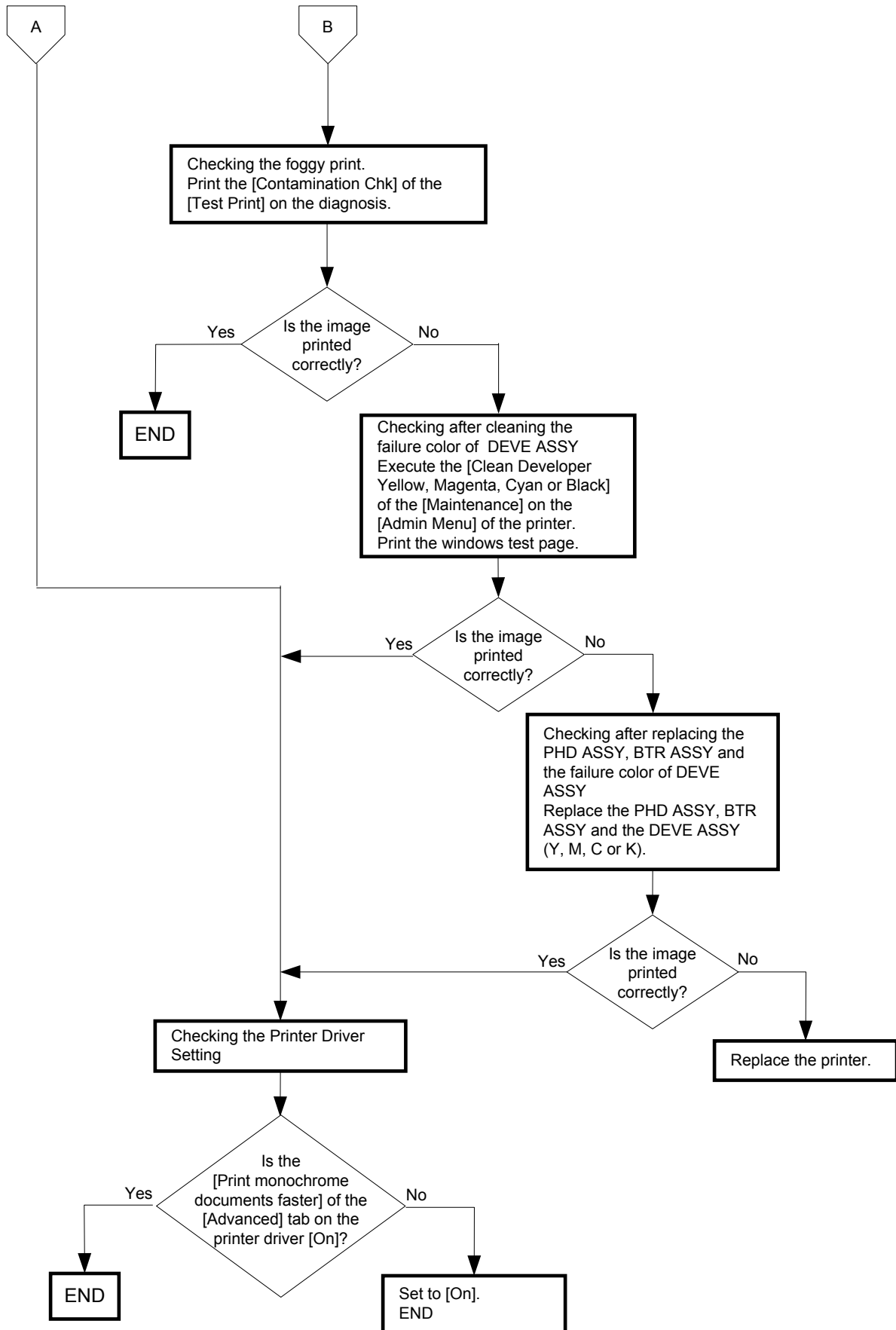

## P8 "Skewed paper"

**Trouble substance**

The paper is fed in skewed position.

**Possible causative parts**

- RETARD ASSY (PL2.1.12)
- CHUTE FEEDER ASSY (PL3.1.2)
- HOLDER ASSY RETARD (PL4.1.13)
- CHUTE ASSY REGI (PL4.2.1)
- BTR ASSY (PL5.1.4)
- CHUTE ASSY DUP OUT (PL5.3.1)

Before commencing troubleshooting, check the paper transfer path. Make sure there is no foreign materials on the transfer path, such as the staple, paper clip, scraps of paper and so on.

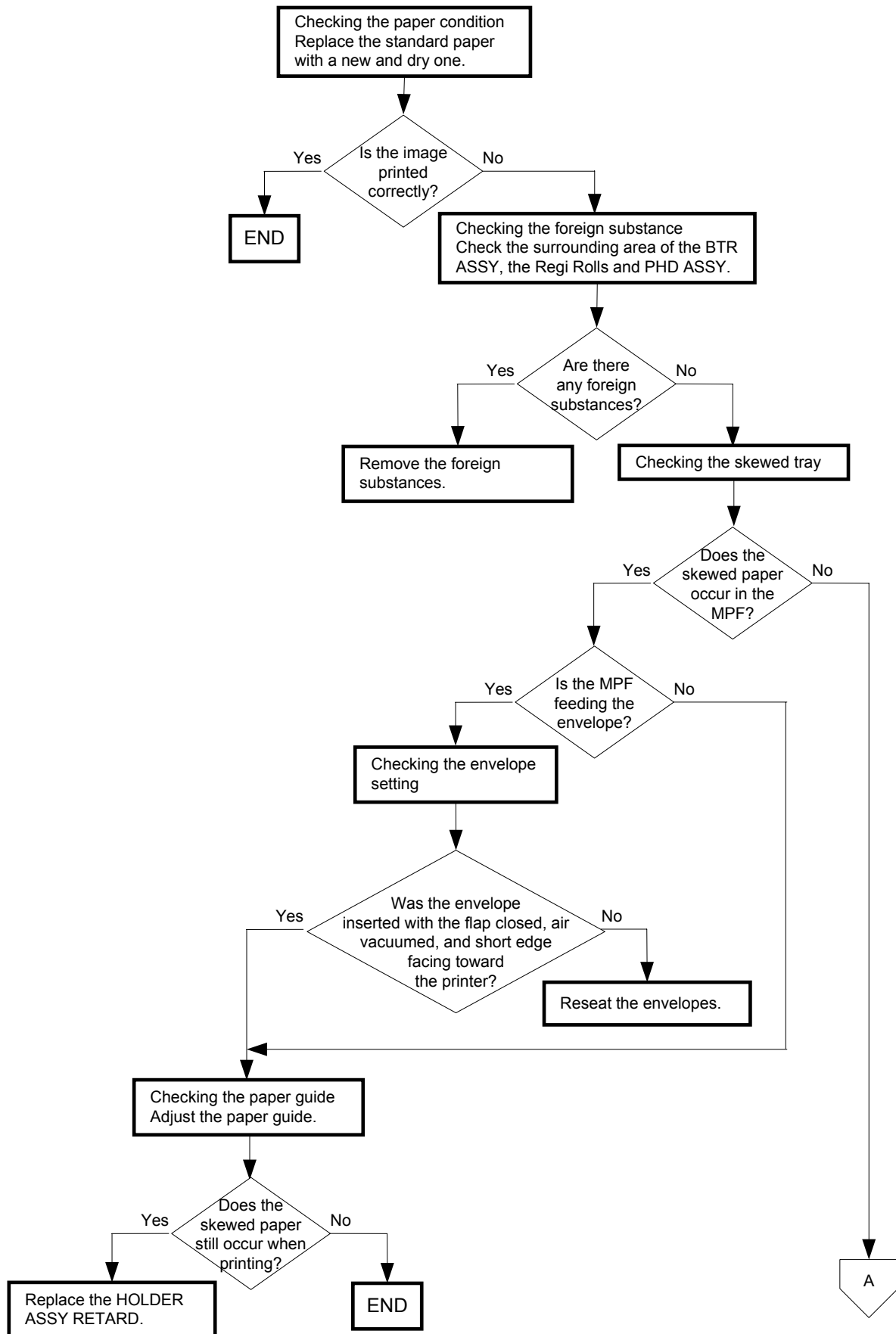

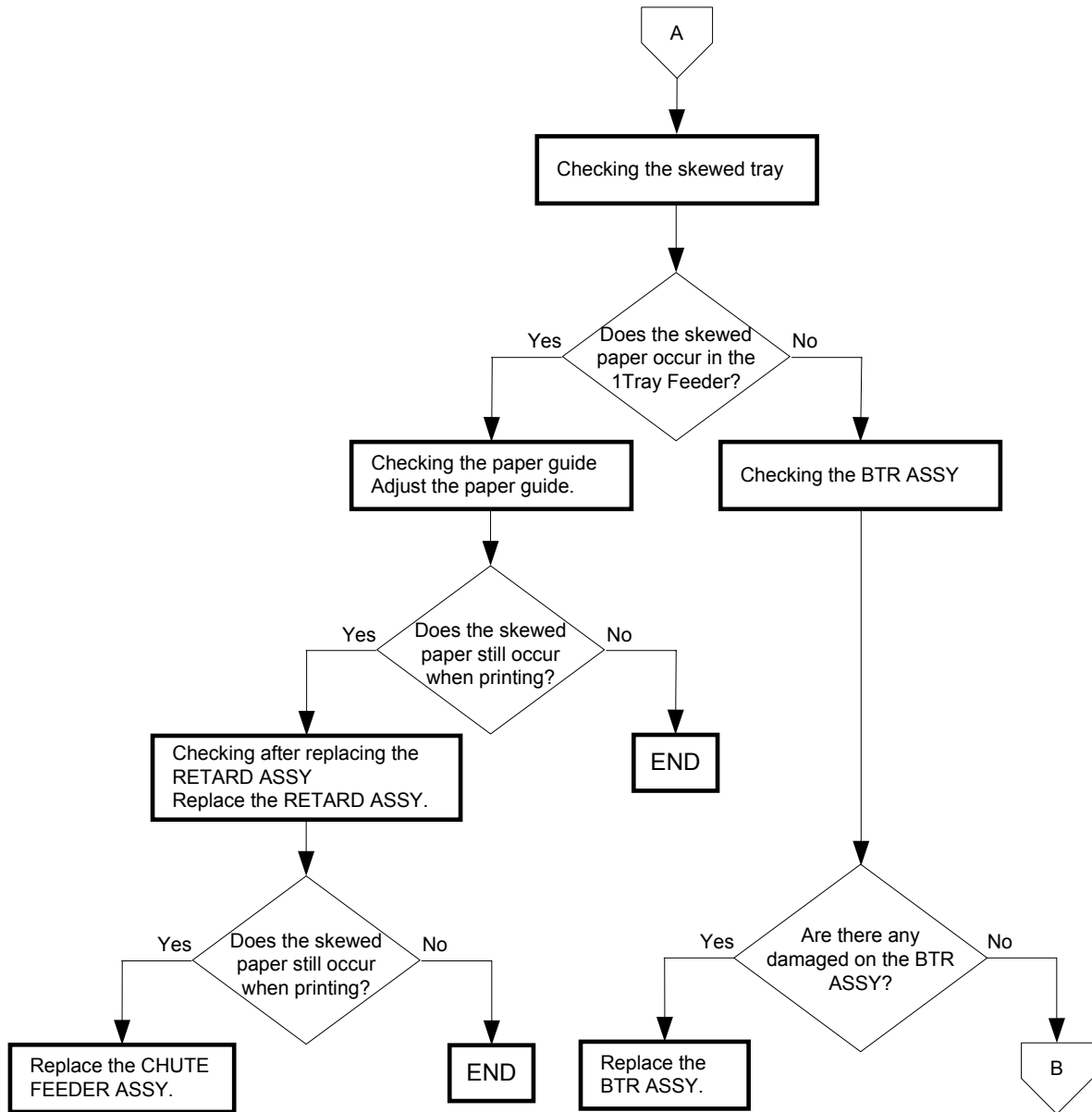

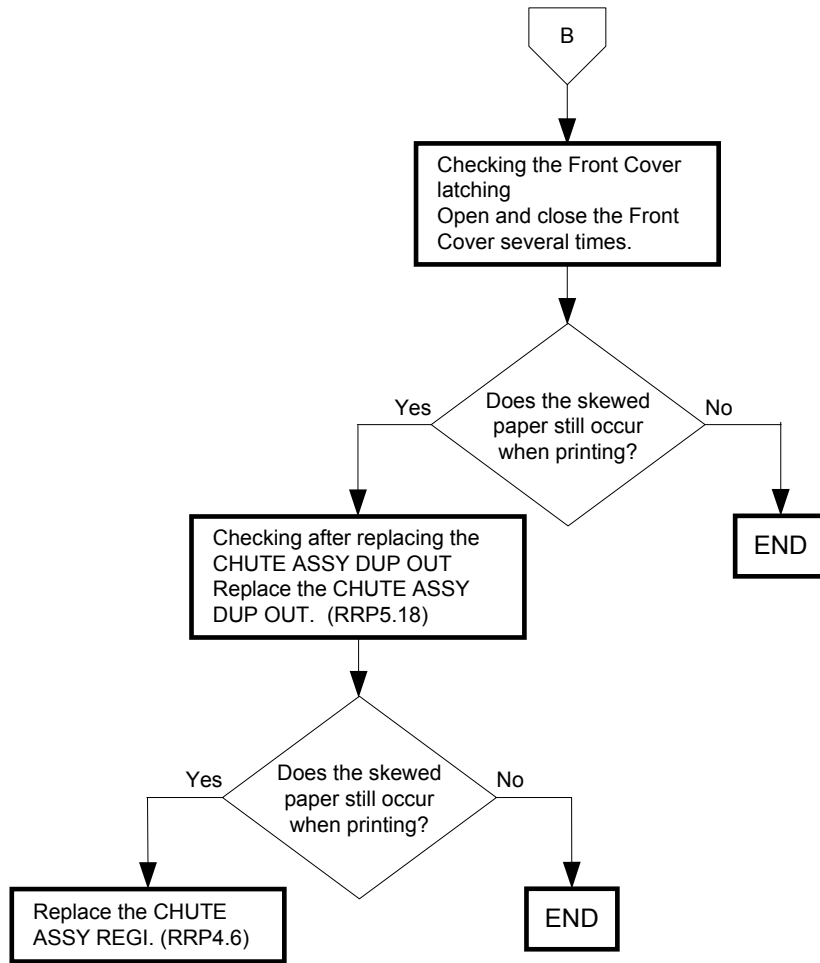

## P9 "Paper Damage"

**Trouble substance**

The paper comes out from the printer wrinkled, folded or worn-out.

**Possible causative parts**

- RETARD ASSY (PL2.1.12)
- CHUTE FEEDER ASSY (PL3.1.2)
- HOLDER ASSY RETARD (PL4.1.13)
- CHUTE ASSY REGI (PL4.2.1)
- FUSER ASSY (PL5.1.1)
- BTR ASSY (PL5.1.4)
- CHUTE ASSY DUP OUT (PL5.3.1)

Before commencing troubleshooting, check the paper transfer path. Make sure there is no foreign materials on the transfer path, such as the staple, paper clip, scraps of paper and so on.

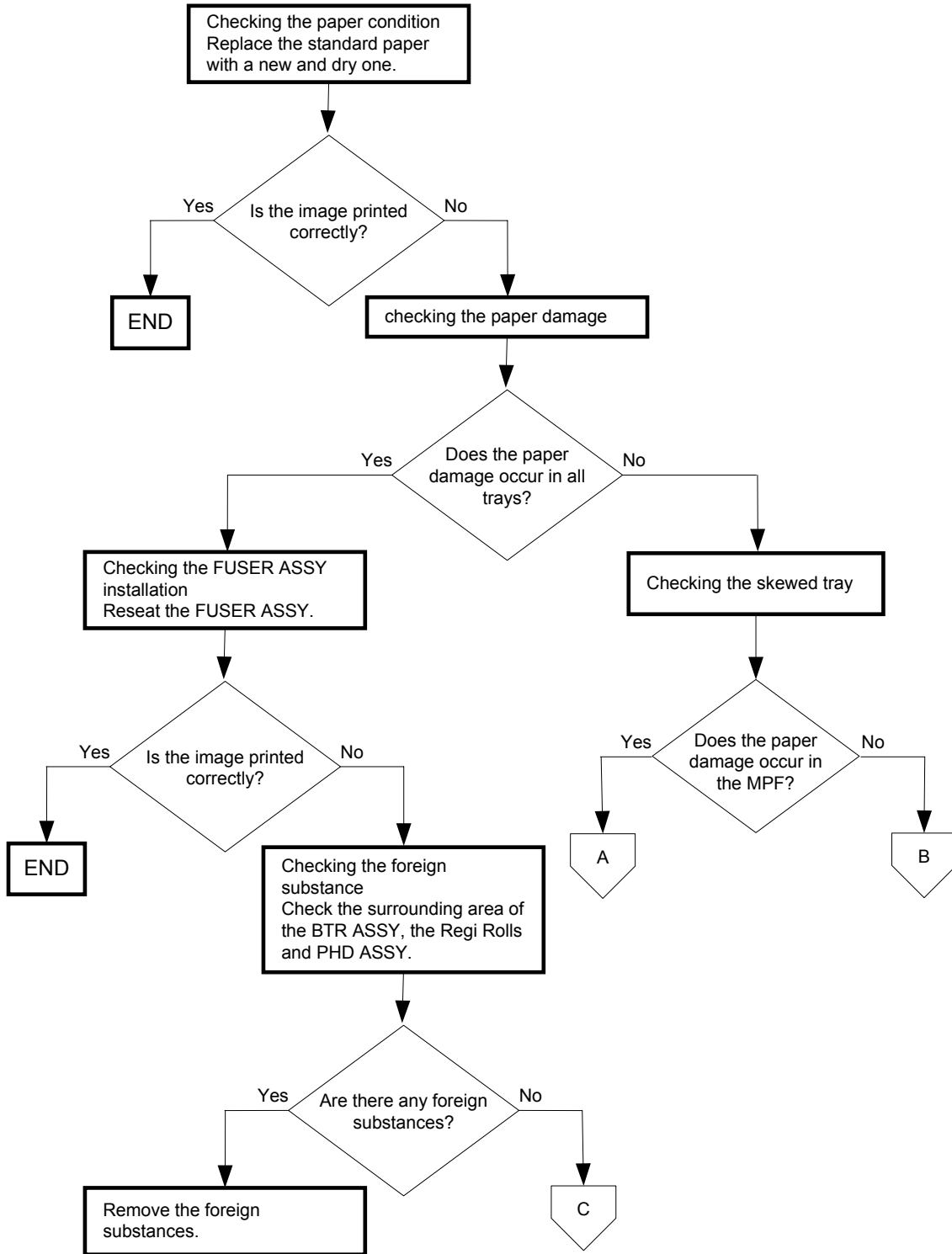



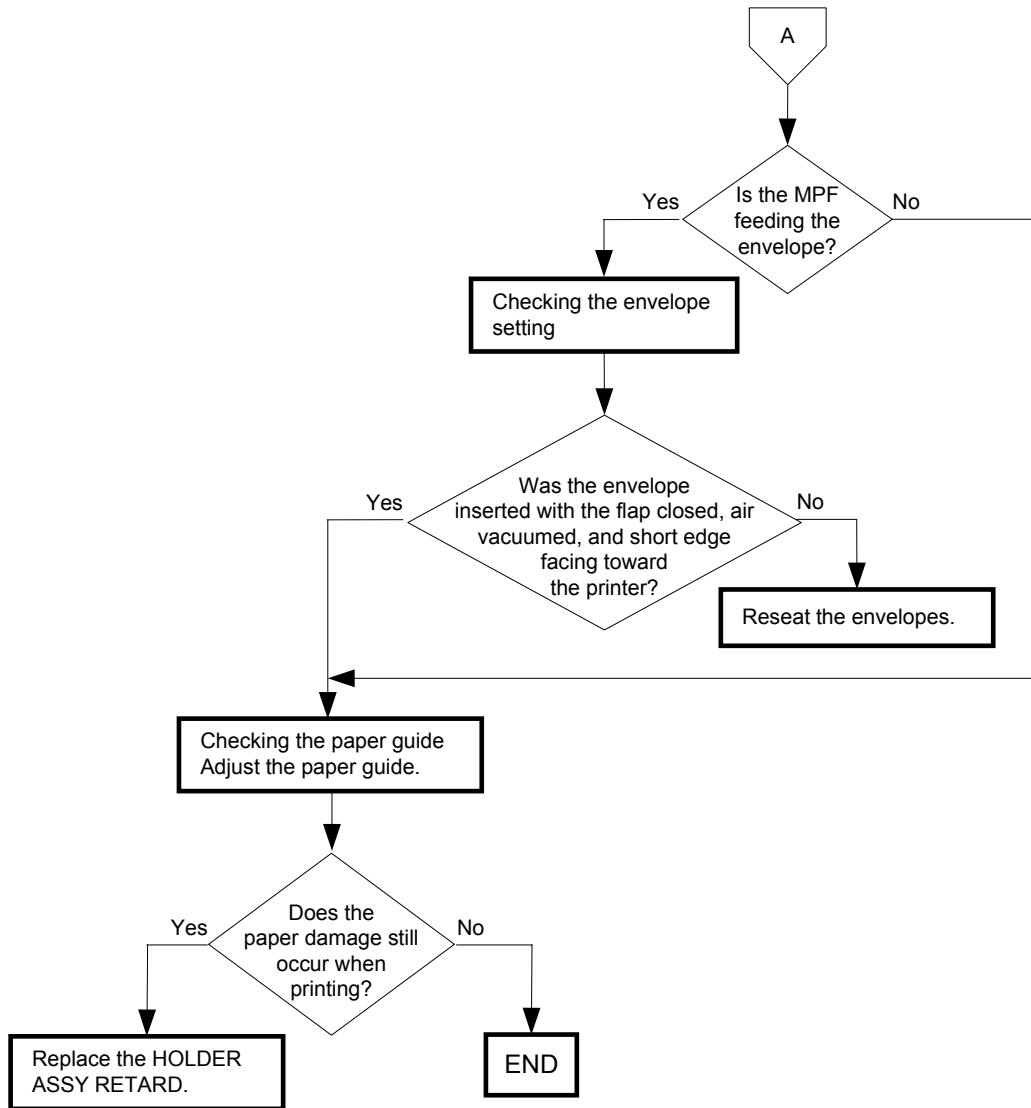

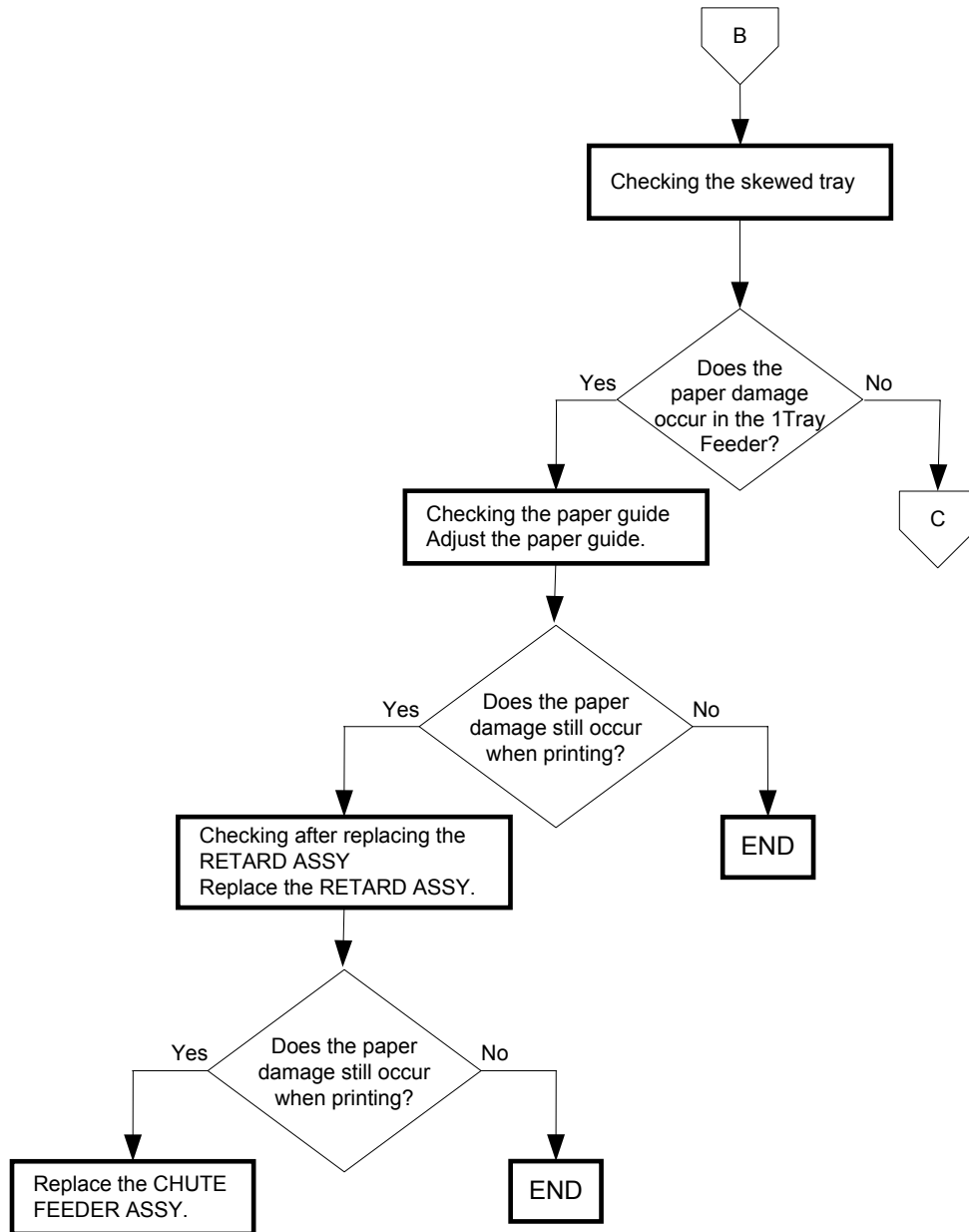

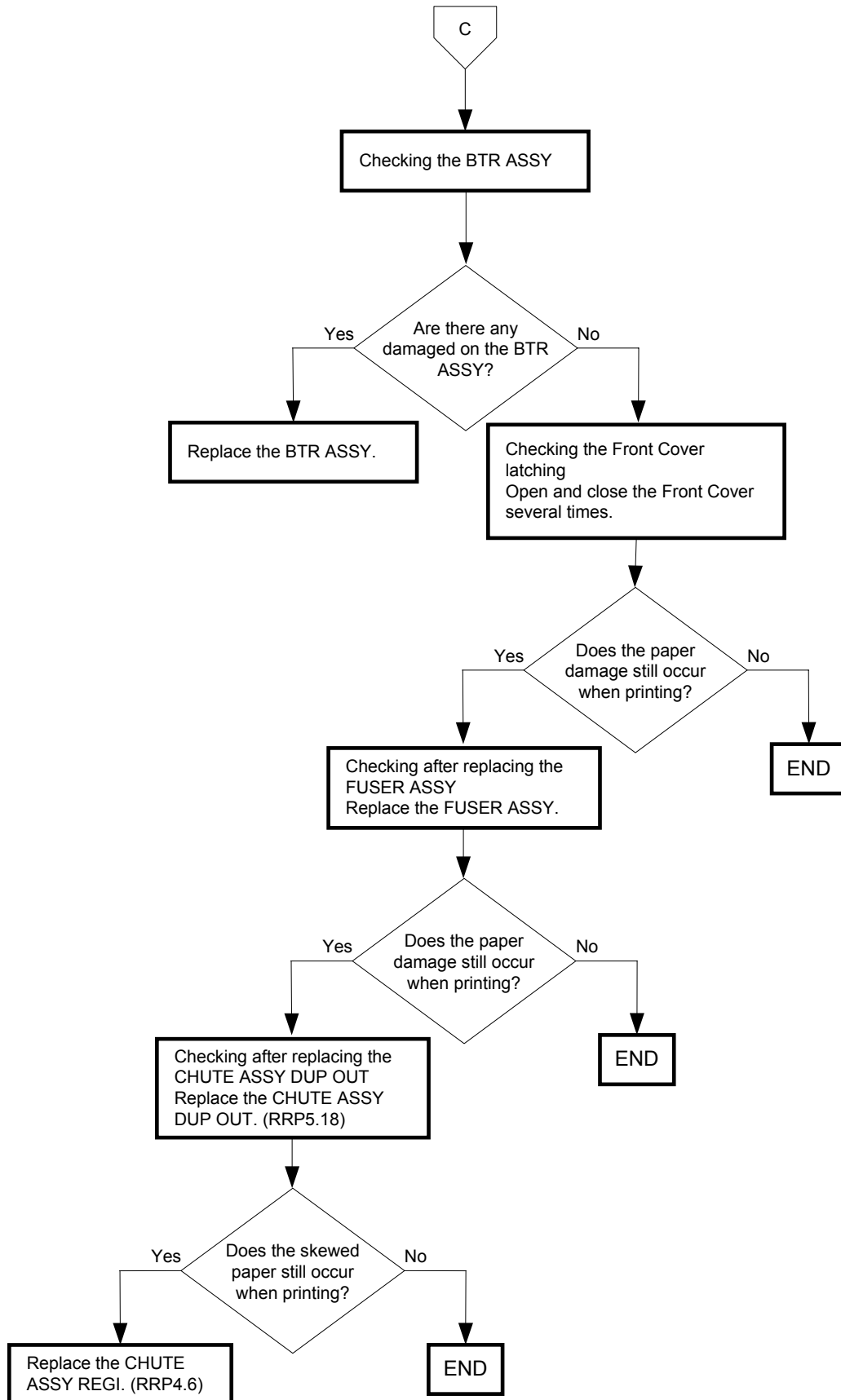

P10 "Unfused Image or Image Easily Rubs off of Page"



**Trouble substance**

The toner image is not completely fused to the paper.

**Possible causative parts**

- FUSER ASSY (PL5.1.1)

Before commencing troubleshooting, check the paper transfer path. Make sure there is no foreign materials on the transfer path, such as the staple, paper clip, scraps of paper and so on.

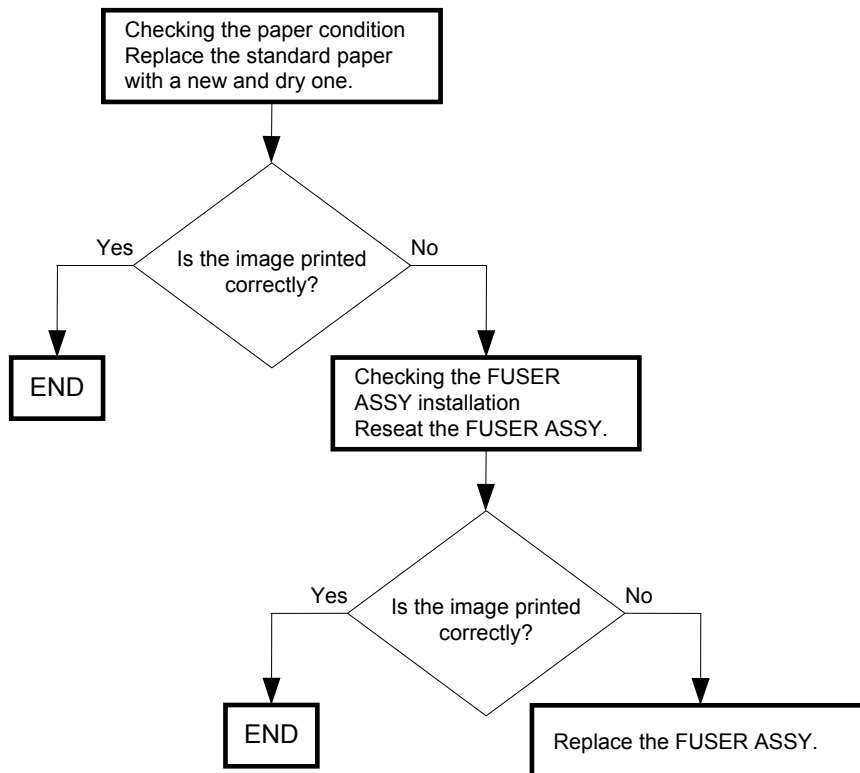

P11 "Vertical Dark Line"



**Trouble substance**

There are vertical black or color lines along the paper.

**Possible causative parts**

- PHD ASSY (PL6.1.1)
- FUSER ASSY (PL5.1.1)

Before commencing troubleshooting, check the paper transfer path. Make sure there is no foreign materials on the transfer path, such as the staple, paper clip, scraps of paper and so on.

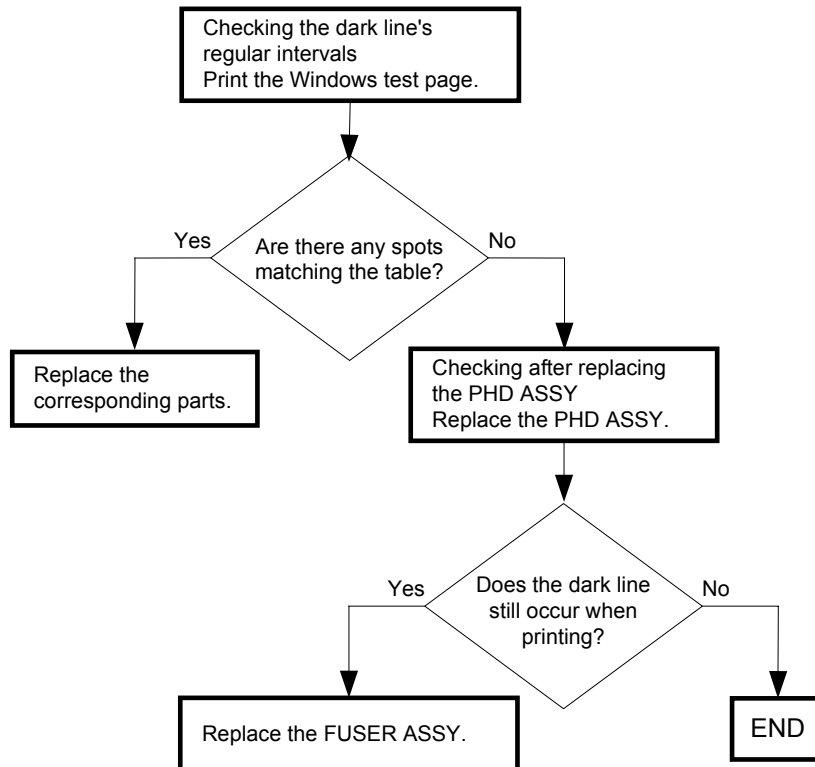

P12 "Afterimage (Ghost)"



**Trouble substance**  
The Ghost appears on the paper.

**Possible causative parts**  
- PHD ASSY (PL6.1.1)

Before commencing troubleshooting, check the paper transfer path. Make sure there is no foreign materials on the transfer path, such as the staple, paper clip, scraps of paper and so on.

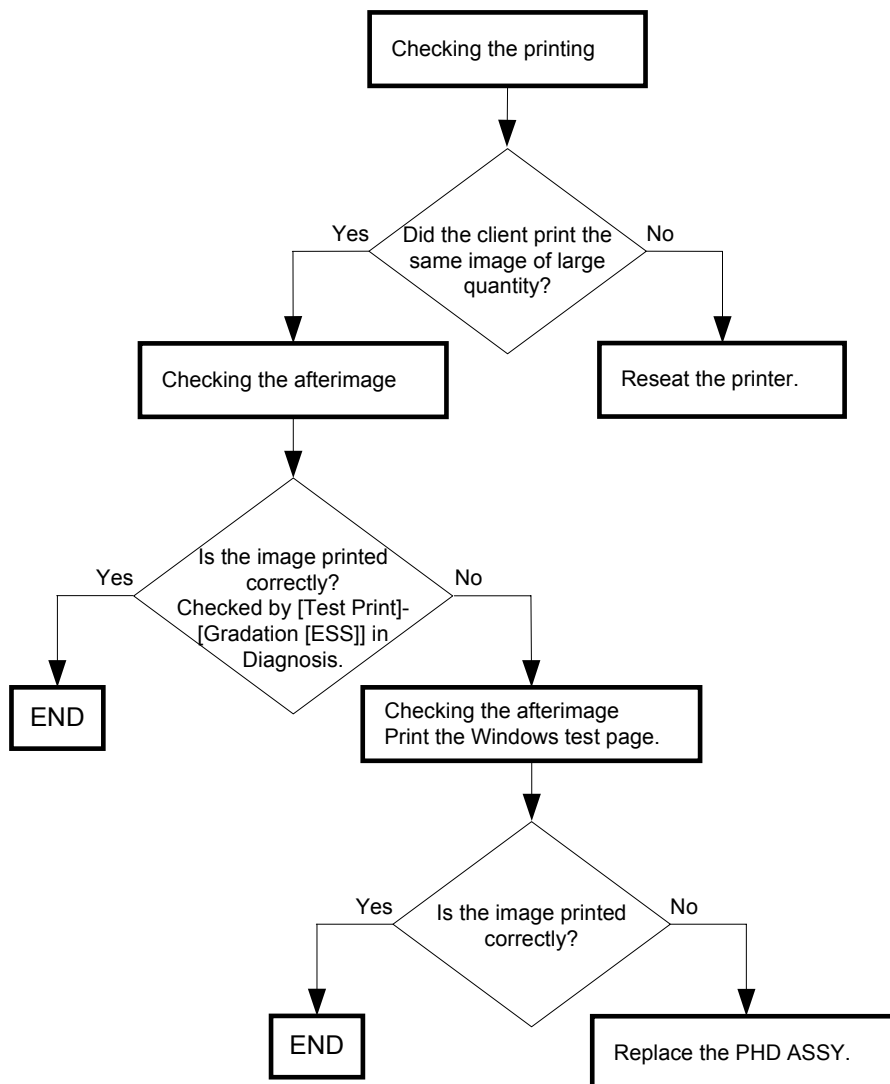

P13 "Partial Deletion"



**Trouble substance**

There are some extremely faint or completely missing parts in a limited area on the paper.

**Possible causative parts**

- BTR ASSY (PL5.1.4)
- PHD ASSY (PL6.1.1)

Before commencing troubleshooting, check the paper transfer path. Make sure there is no foreign materials on the transfer path, such as the staple, paper clip, scraps of paper and so on.

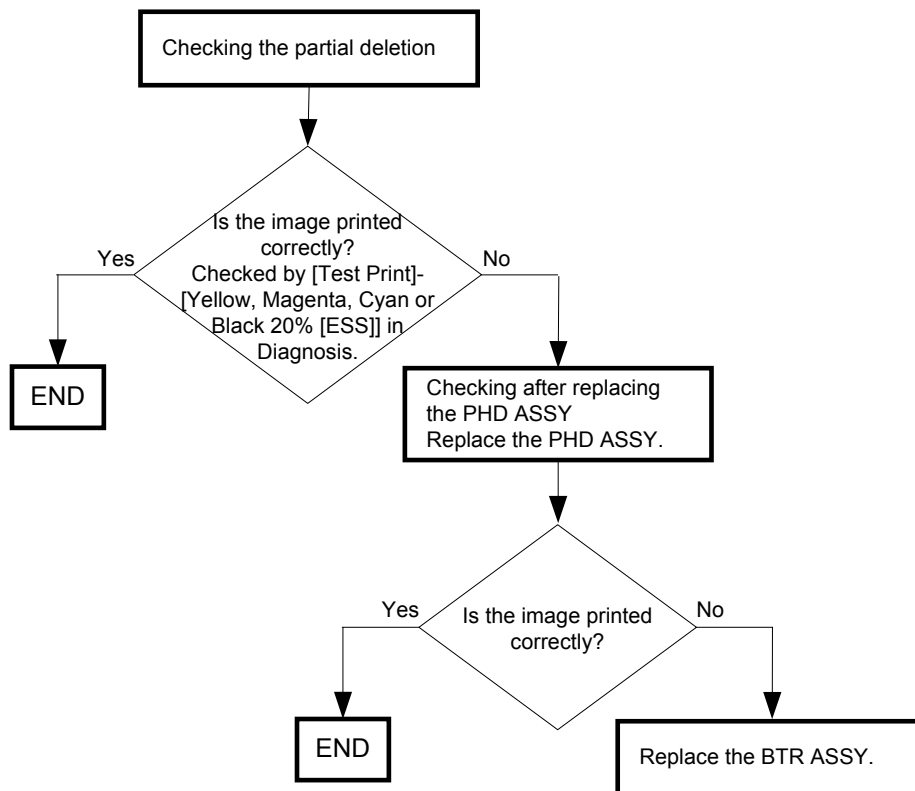

P14 "Horizontal Line (Periodical)"

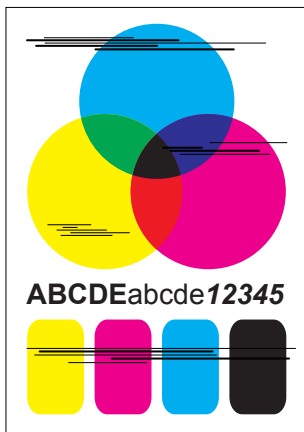

**Trouble substance**

There are horizontal black or color lines along the paper.

**Possible causative parts**

- BTR ASSY (PL5.1.4)
- PHD ASSY (PL6.1.1)
- DEVE ASSY (PL7.1.17 to 7.1.20)

Before commencing troubleshooting, check the paper transfer path. Make sure there is no foreign materials on the transfer path, such as the staple, paper clip, scraps of paper and so on.

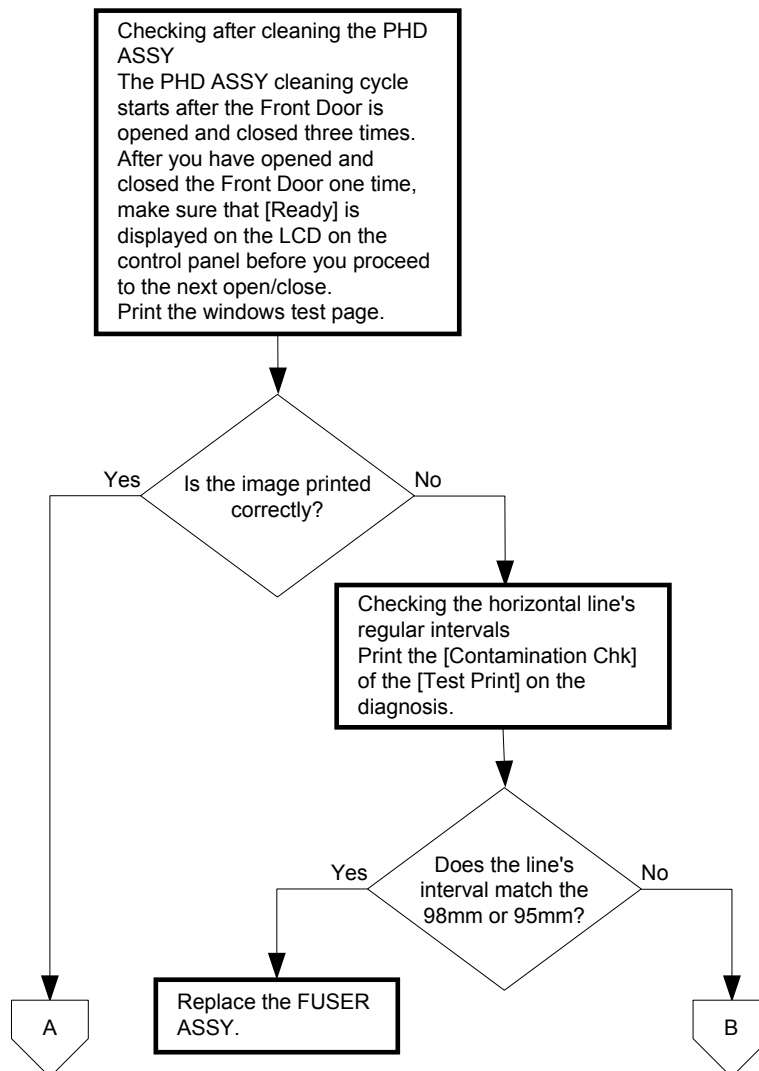



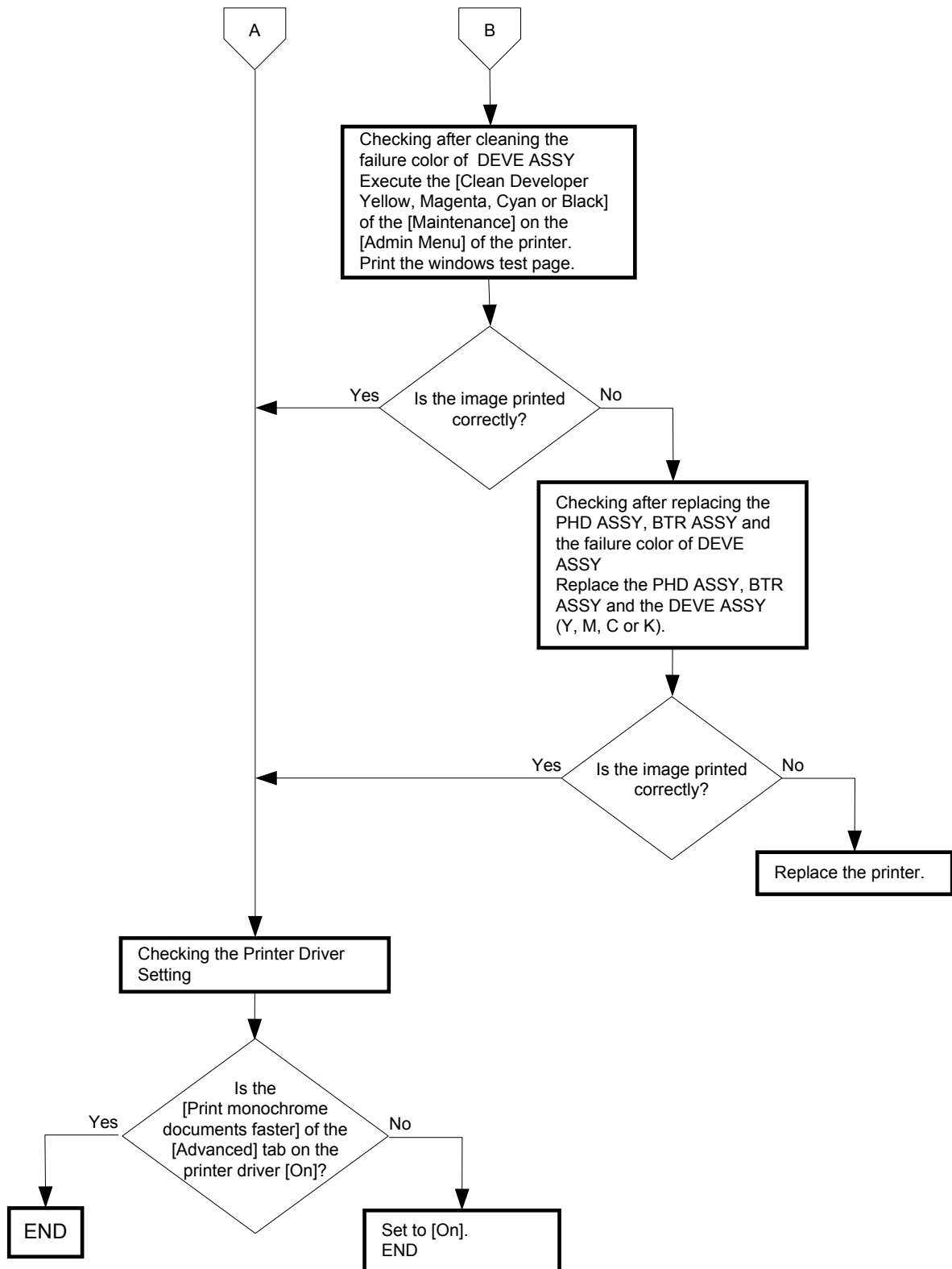

## P15 "Fade Horizontal/Vertical"

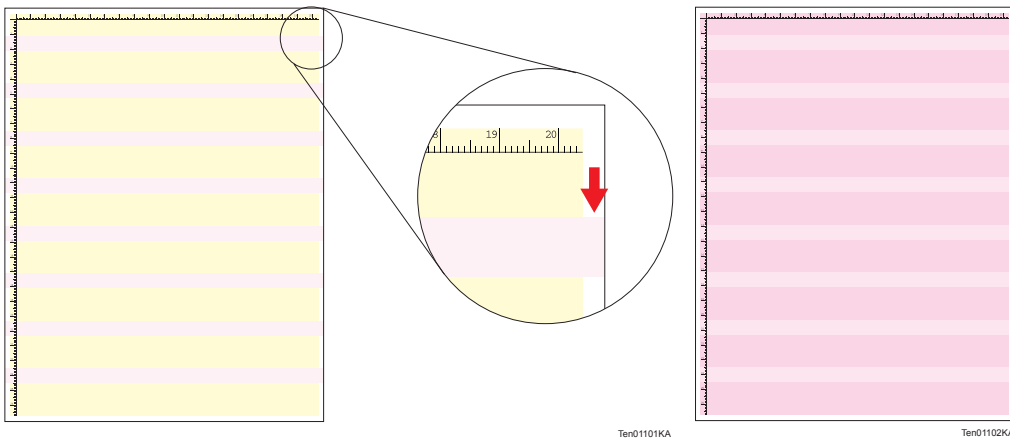

**Trouble substance**  
There are areas of the images that are extremely light or are missing entirely.

Before commencing troubleshooting, check the paper transfer path. Make sure there is no foreign materials on the transfer path, such as the staple, paper clip, scraps of paper and so on.

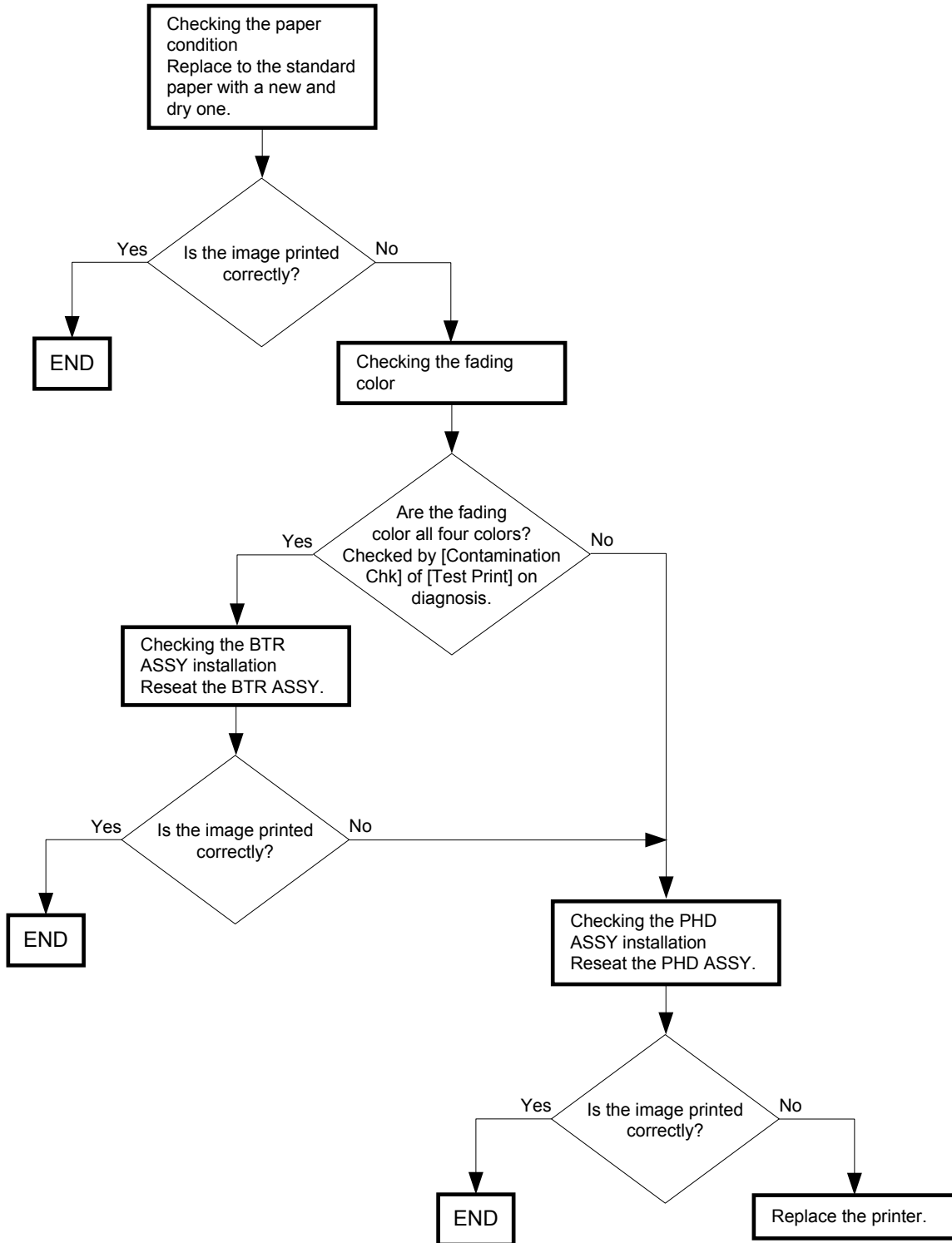

P16 "Color Registration (Color Shift)"



**Trouble substance**

A yellow or black image printed is not overlapped on a cyan or magenta image correctly.

**Possible causative parts**

- PHD ASSY (PL6.1.1)

Before commencing troubleshooting, check the paper transfer path. Make sure there is no foreign materials on the transfer path, such as the staple, paper clip, scraps of paper and so on.

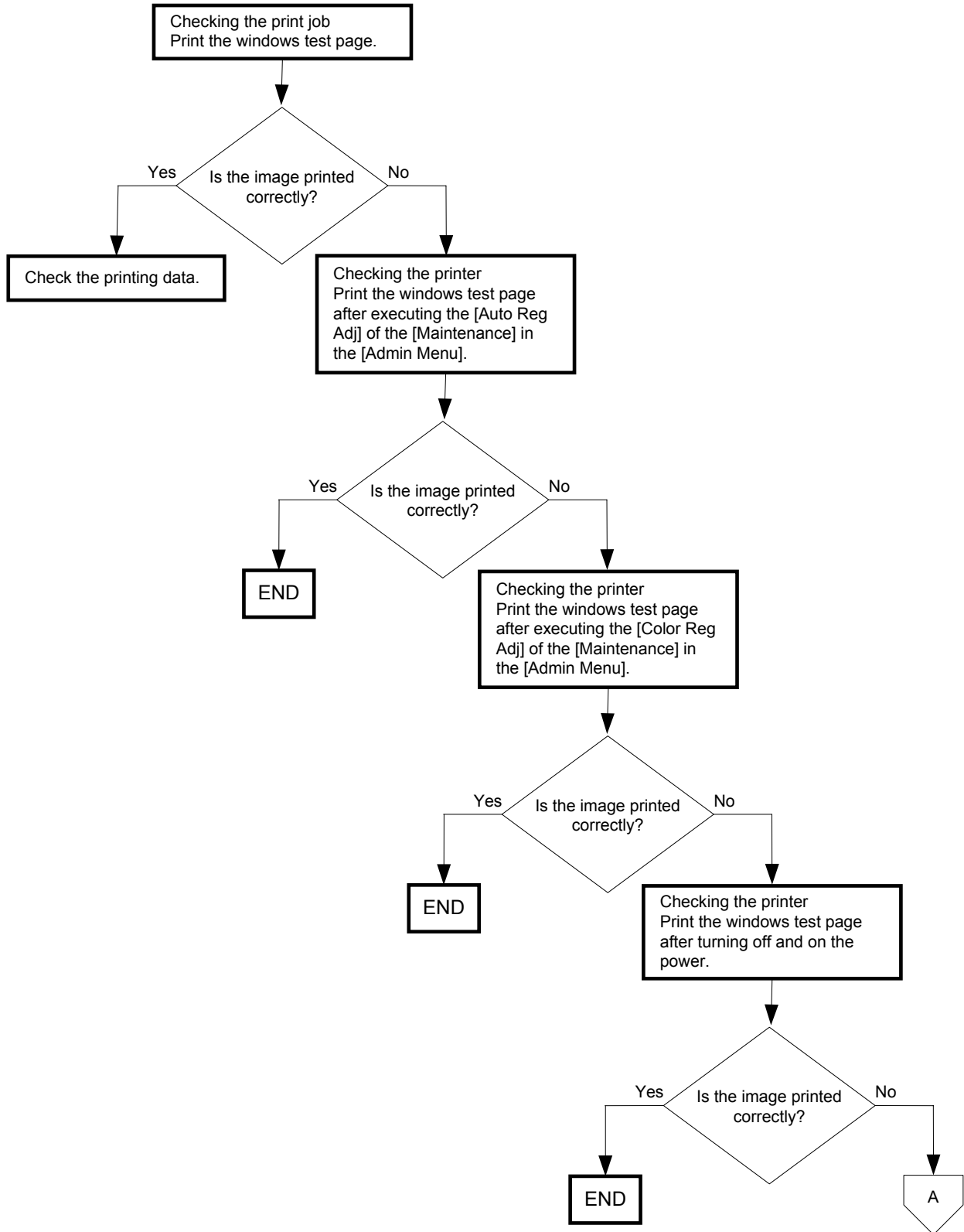

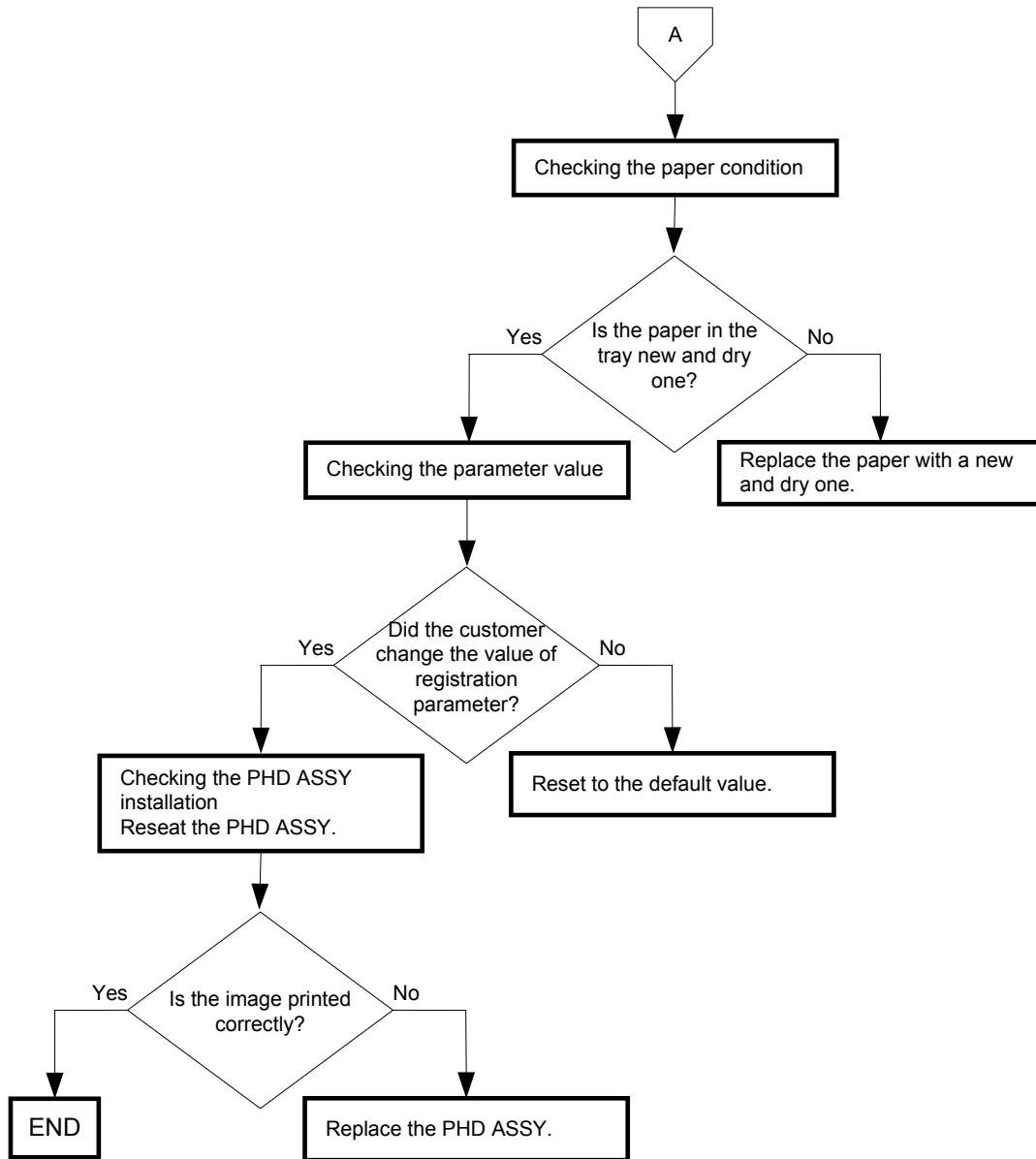

### 3.6 Other FIP

Other FIP covers the power supply trouble FIP, except error code FIP and image quality FIP.

#### FIP-No Power

Possible causative parts: CONSOLE PANEL (PL1.1.5)  
 PWBA ESS (PL9.1.3)  
 LVPS (PL9.1.6)  
 POWER CORD (PL9.1.23)

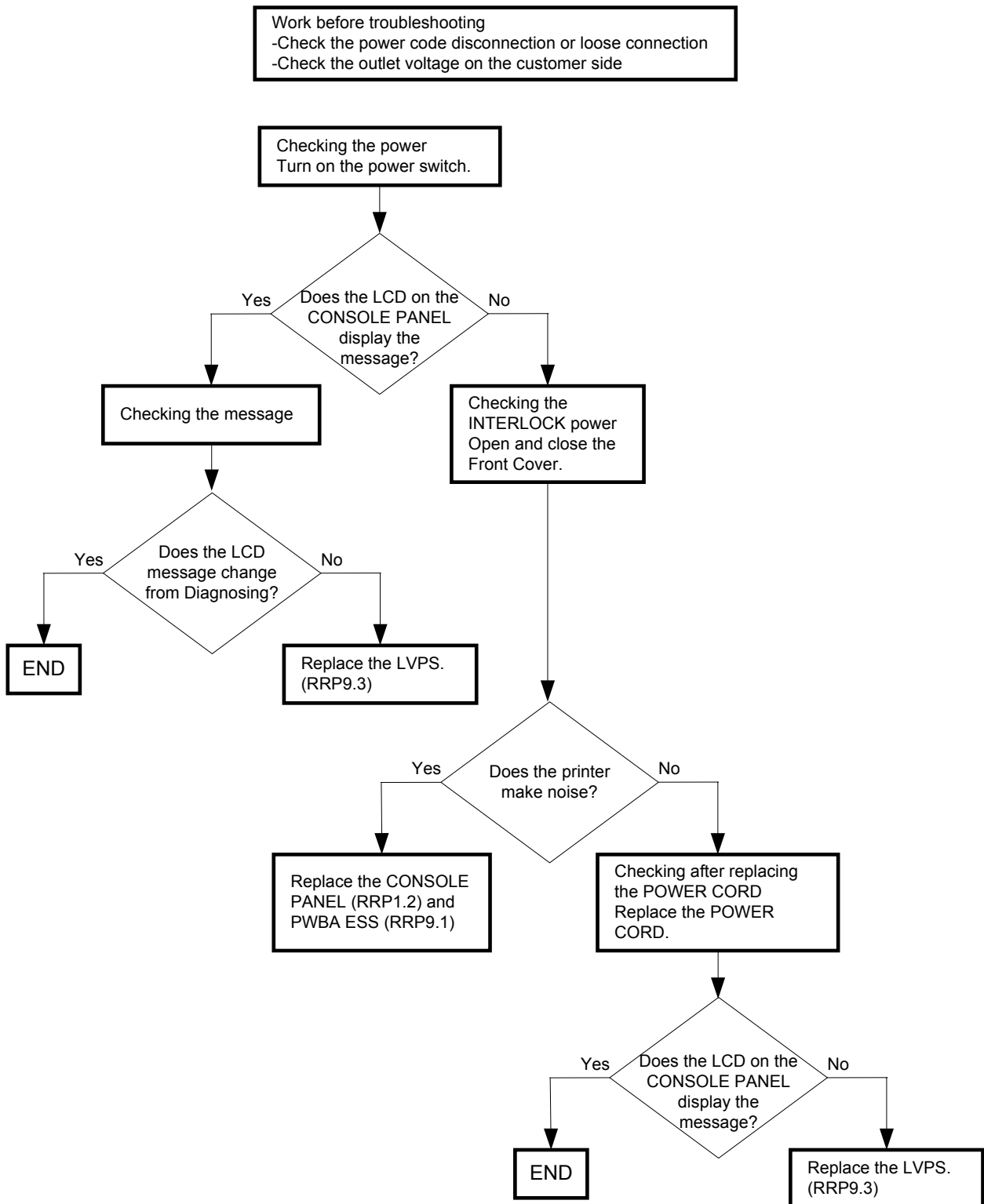

FIP-Multiple Feed

Possible causative parts:RETARD ASSY (PL2.1.12)  
 HOLDER ASSY RETARD (PL4.1.13)

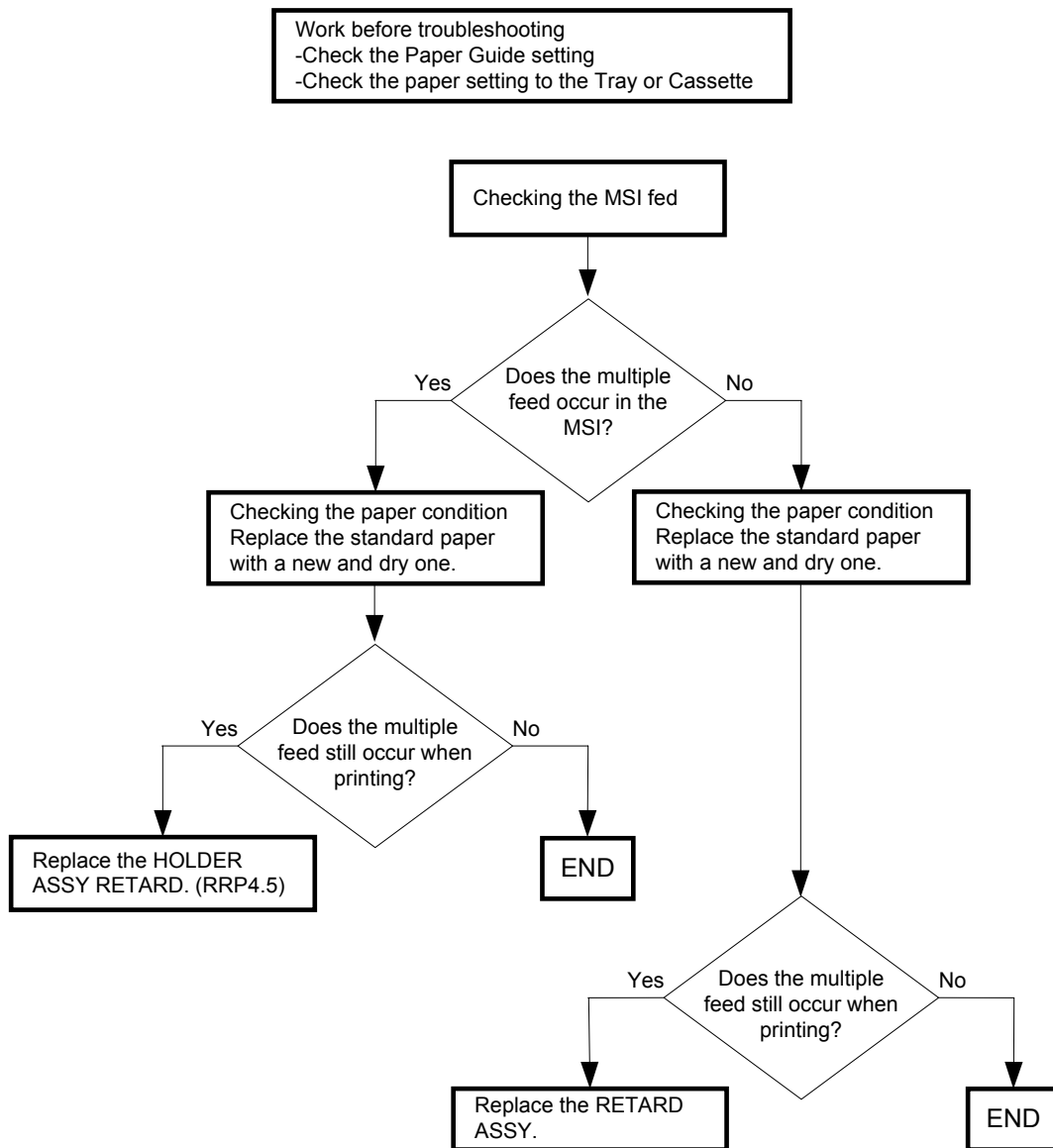



## 4. Abnormal Noise Trouble

### 4.1 Entry Chart for Abnormal Noise Troubleshooting

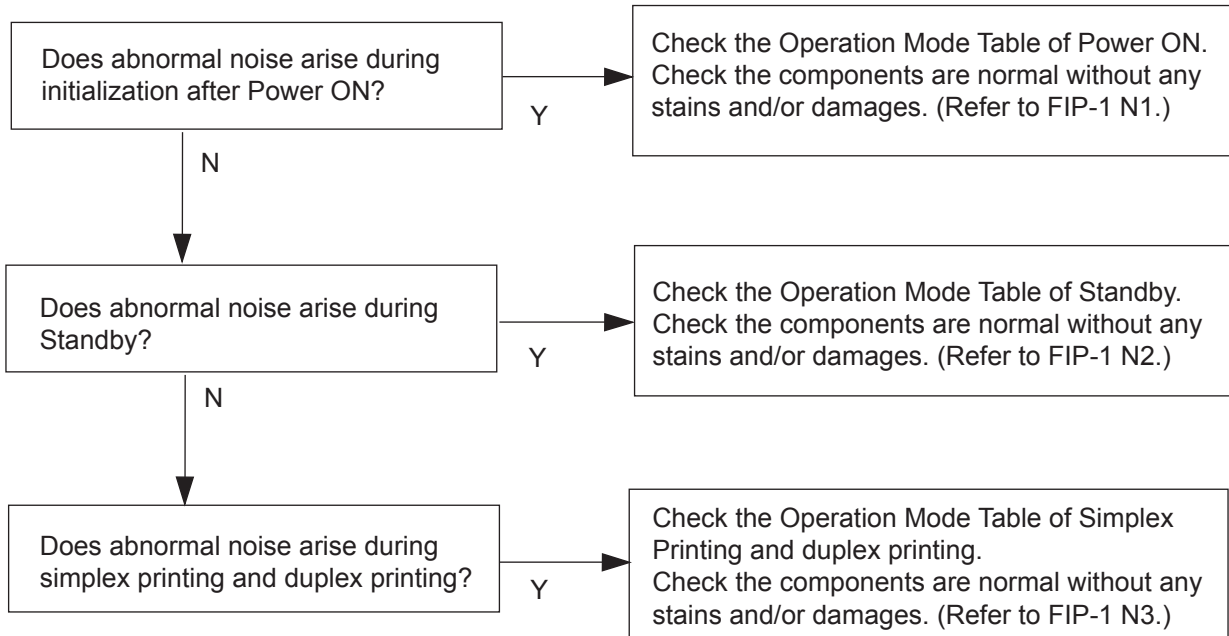

## 4.2 Operation Mode Table

### FIP-1.N1 When Power is Turned On

**NOTE**

If the noise occurred after installing printer, go to printing noise.

Possible causative parts: CHUTE ASSY REGI (PL4.2.1)  
 BTR ASSY (PL5.1.4)  
 PHD ASSY (PL6.1.1)

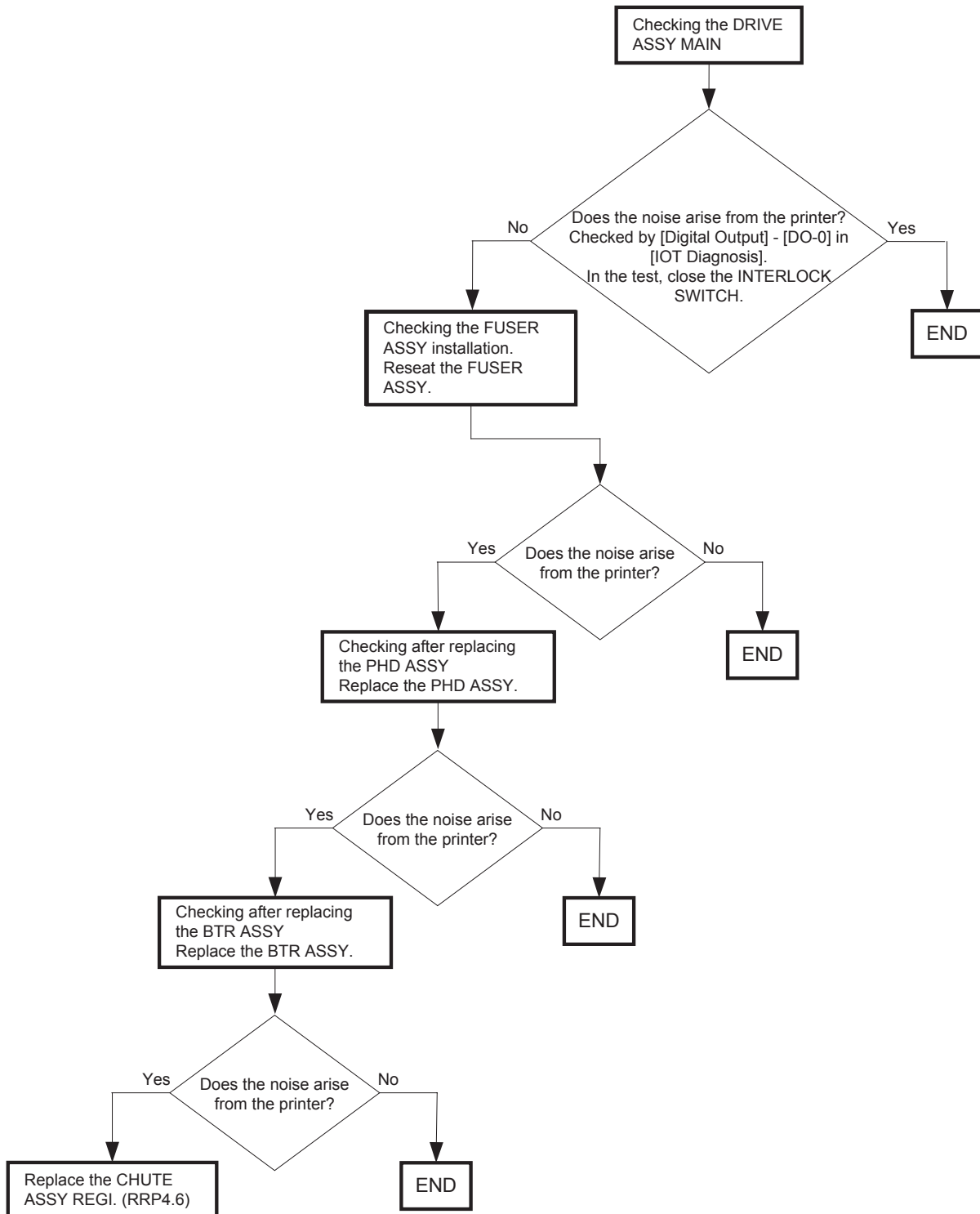

FIP-1.N2 During Standby

Possible causative parts:FAN REAR (PL1.1.19)  
 FAN LV (PL1.1.33)  
 FAN FRONT (PL5.3.31)  
 LVPS (PL9.1.6)

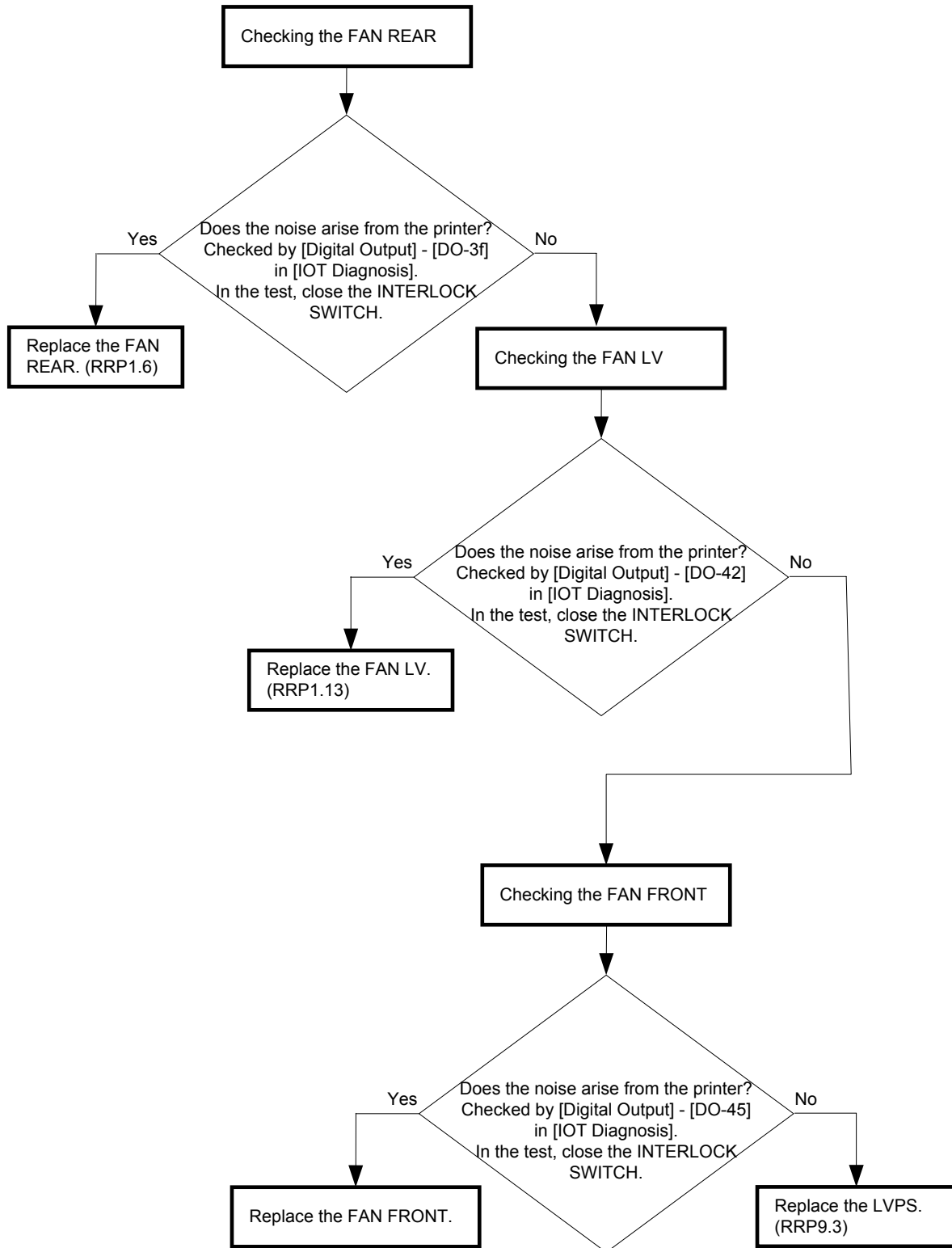

FIP-1.N3 During Printing

Possible causative parts:RETARD ASSY (PL2.1.12)  
 HOLDER ASSY RETARD (PL4.1.13)  
 CHUTE ASSY REGI (PL4.2.1)  
 FUSER ASSY (PL5.1.1)  
 BTR ASSY (PL5.1.4)  
 CHUTE ASSY DUP IN (PL5.2.1)  
 MOTOR ASSY DUP (PL5.4.5)  
 PHD ASSY (PL6.1.1)  
 ROS ASSY (PL6.1.2)  
 FRAME ASSY DEVE (PL7.1.1)  
 DISPENSER ASSY HI (PL7.2.22)  
 DRIVE ASSY DEVE (PL8.1.1)  
 DRIVE ASSY MAIN (PL8.1.2)

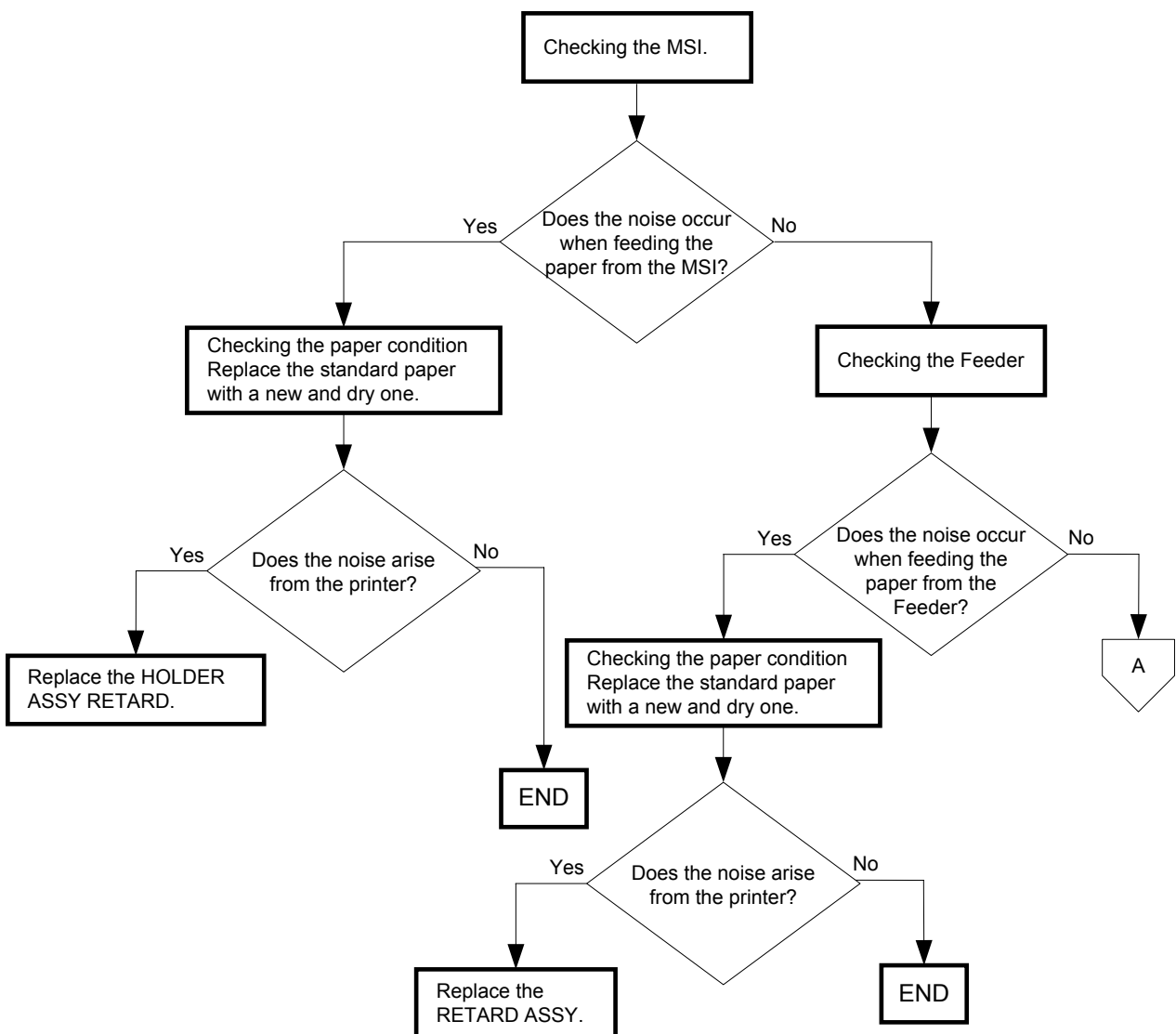

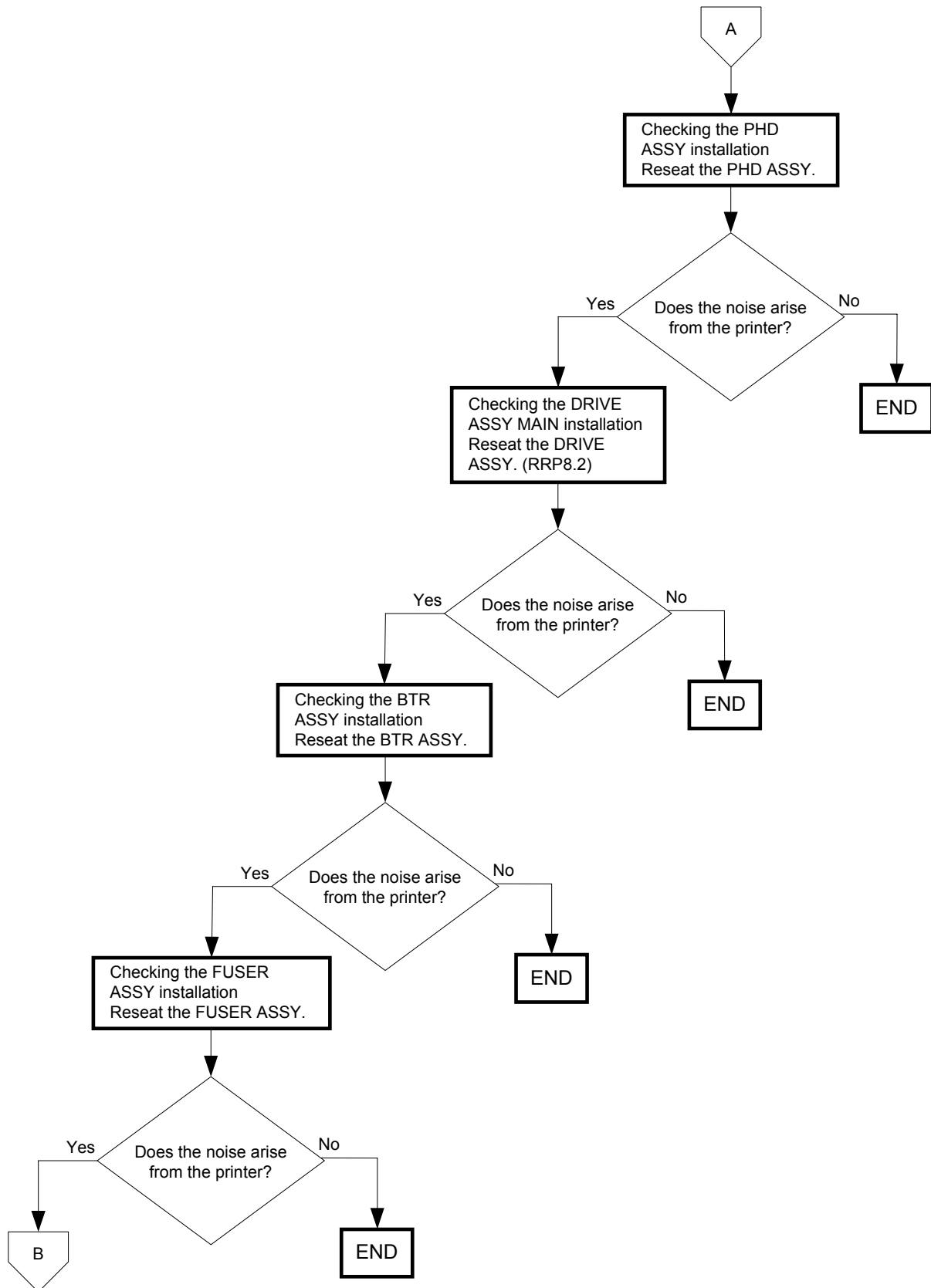

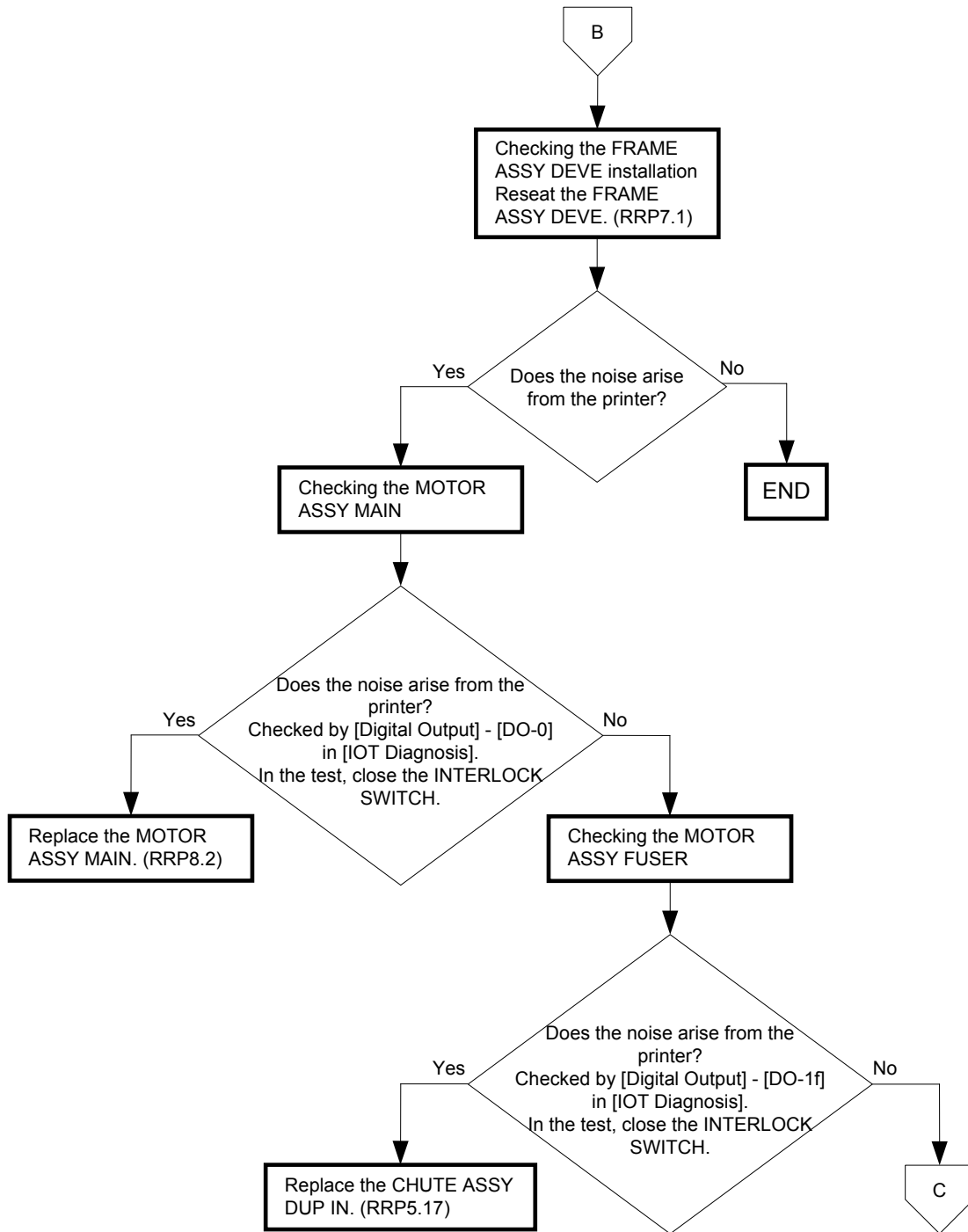

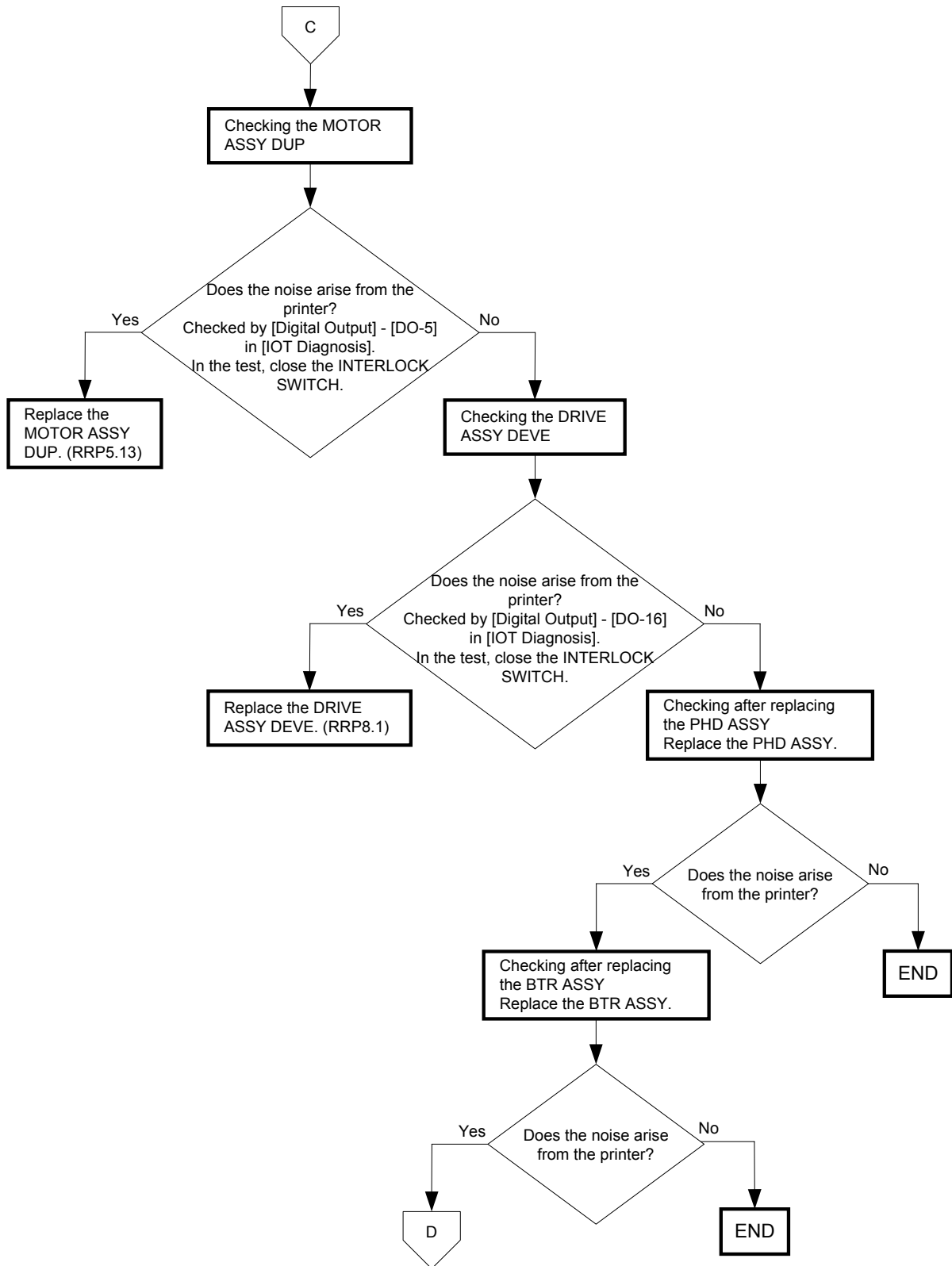

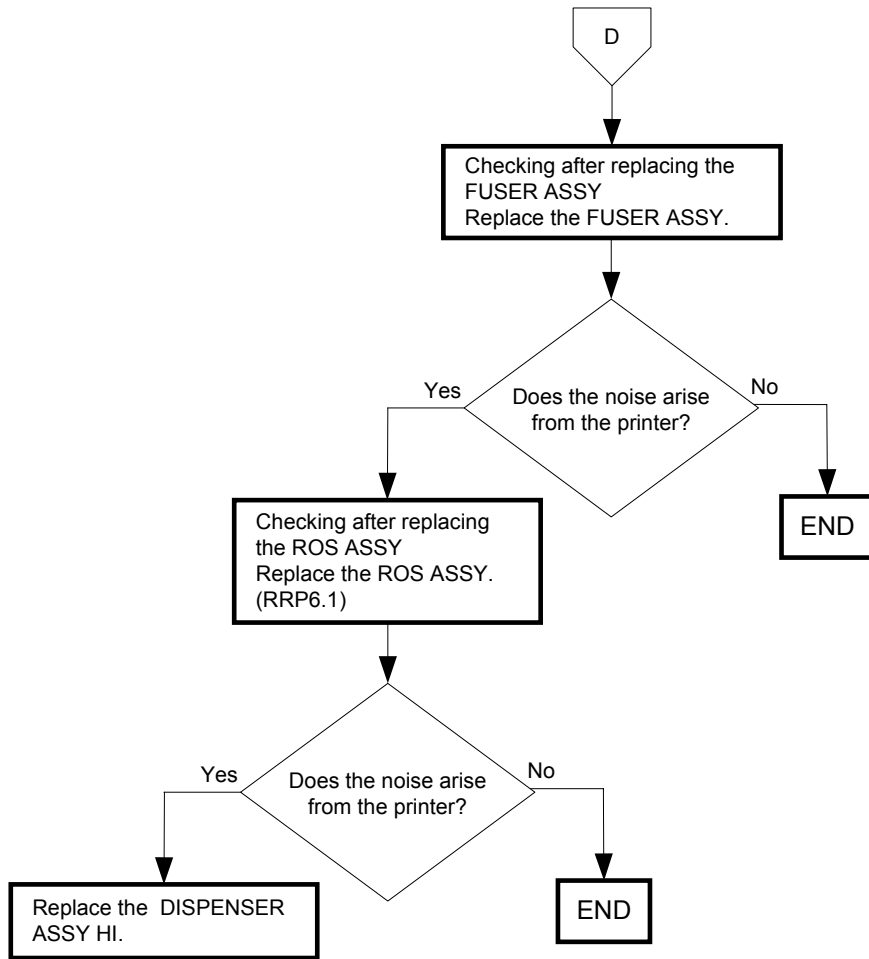



## Chapter 2 Operation of Diag. CONTENTS

1. Overview.....	2 - 1
1.1 Position of the Diag. in the Whole System.....	2 - 1
2. Configuration .....	2 - 2
3. How to use Diag. Customer Mode.....	2 - 3
3.1 Roles of the control panel in Diag. ....	2 - 3
3.2 Entering diag. Customer mode .....	2 - 4
3.3 Selecting Diag. item .....	2 - 4
3.4 Change method parameters value.....	2 - 4
3.5 Executing/Exiting Diag. mode .....	2 - 4
3.6 Diag. mode menu tree .....	2 - 5
4. The Kind of Diag. and Contents of a Test .....	2 - 7
4.1 Details of ESS diagnosis.....	2 - 11
4.1.1 Executing ESS diagnosis.....	2 - 11
4.1.2 All Test.....	2 - 11
4.1.3 CodeROM Test.....	2 - 11
4.1.4 FontROM Test .....	2 - 11
4.1.5 EEPROM Test .....	2 - 12
4.1.6 DRAM Test .....	2 - 12
4.1.7 MAC+PHY Test .....	2 - 13
4.1.8 ASIC Test.....	2 - 13
4.1.9 PANEL Test.....	2 - 13
4.1.10 IOT Test.....	2 - 13
4.1.11 HD Test.....	2 - 13
4.2 IOT Diag.....	2 - 14
4.2.1 Digital Input (DI) Test.....	2 - 14
4.2.2 Executing digital input (DI) test .....	2 - 14
4.2.3 Exiting digital input (DI) test .....	2 - 16
4.2.4 How to check sensors and switches .....	2 - 16
4.2.5 Digital Output (DO) Test .....	2 - 34
4.2.6 Executing digital output (DO) test .....	2 - 34
4.2.7 Exiting digital output (DO) test .....	2 - 38
4.2.8 How to check the motors, clutches and solenoids.....	2 - 38
4.3 Test Print.....	2 - 61
4.3.1 Executing test print .....	2 - 61
4.3.2 No Image [IOT] .....	2 - 61
4.3.3 Test Pattern 600[IOT] .....	2 - 61
4.3.4 Grid2 .....	2 - 62
4.3.5 20% Density Chart.....	2 - 62
4.3.6 Gradation .....	2 - 64
4.3.7 Toner Pallet Check .....	2 - 64
4.3.8 Contamination Check.....	2 - 65
4.4 Parameter Setting .....	2 - 66
4.4.1 Handling parameters.....	2 - 66
4.4.2 Printing the parameter list .....	2 - 68

Chapter 2 Operation of Diag. CONTENTS

---

## 1. Overview

### 1.1 Position of the Diag. in the Whole System

Major functions of this diag. are as follows:

- ESS diagnosis to locate a chip which causes a problem
- IOT Diag
- Setting of parameters for registration in paper feeding direction and so on.

## 2. Configuration

The diagnosis provides three modes that have their respective uses (purposes), target operators, and functions.

### Shippper Mode:

This mode intends to be used in the production line with the purpose to locate a chip that causes a problem.

Diagnosis time in the mode shall be as short as possible with consideration of production cost.

The mode shifts to the Developer mode (described later) after the ESS Diag.

This mode is protected password.

### Customer Mode:

This mode intends to be used by customer who handle problems in field with the purpose to locate a replaceable unit that causes a problem.

Sorting problems on the basis of parts that can be replaced by the customer support center.

This is the base of this mode design, and that is why so many features.

The mode allows the user to execute the ESS diagnosis, test prints, parameter settings and so on through the control panel.

### Developer/CE (Customer Engineer) Mode:

This mode is for debugging by developers or CEs. It intends to be partially used in the production line.

The mode allows the user to execute the ESS diagnosis, test prints, parameter settings and so on through the debug terminal.

The functions are activated by commands sent from the serial terminal. Special tool (FX internal debugging terminal) is required to operate Developer mode.

This mode is protected password.

### 3. How to use Diag. Customer Mode

#### 3.1 Roles of the control panel in Diag.

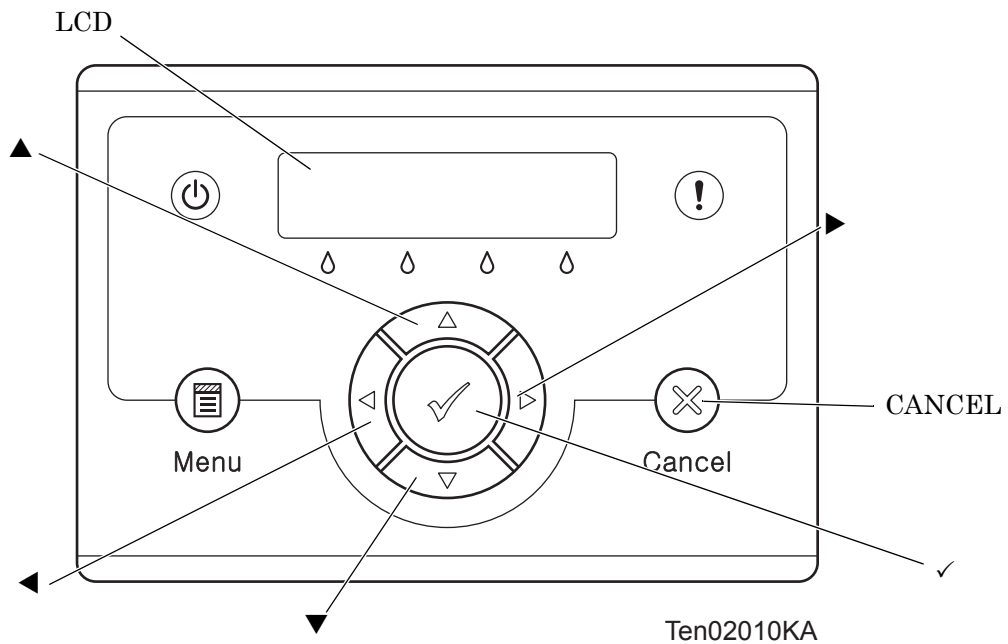

- [LCD]:        Displaying a diagnosis item and its result
- [▲], [▼]:    Selecting a diagnosis item/Selecting data at parameter setting
- [◀], [▶]:    Key moves the cursor to the left/right
- [✓]:         Determining a diagnosis item/Executing a diagnosis/Determining a parameter at parameter setting
- [CANCEL]:    Reseting a diagnosis item (Returning to the menu one level higher)  
Terminating each digital input/output

### 3.2 Entering diag. Customer mode

- 1) Turn off the power.
- 2) Turn on the power while holding down “▲” and “▼” keys.
- 3) Release the fingers from these keys when “Diagnosing...” is displayed.
- 4) The “Customer Mode” and “ESS Diag” are displayed. (Entered the Diag. mode.)

### 3.3 Selecting Diag. item

The diagnosis setting items are configured as menus, which can be operated with the control panel keys. Arrow keys select menu items and “✓” key activates functions.

### 3.4 Change method parameters value

For parameter setting, pressing “✓” key after selecting an item from the menu displays the current setting value of the item. Then a numeric value selected by “▼” and “▲” keys are written into the NVM by “✓” key.

### 3.5 Executing/Exiting Diag. mode

The diagnosis can be executed by as follows.

- 1) A test item is displayed. “✓” key fixed the test item.
- 2) The display prompts the user to start the test. Press “✓” key and start the test.

The diagnosis can be stopped by as follows.

- 1) During the diagnosis test, press “CANCEL” key.
- 2) The diagnosis is stopped, and the display indicates the one step higher menu.

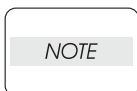

If an error occurs during the diag. sequence, the diagnosis displays the error and stops, leaving the remaining items unperformed.

Pressing “CANCEL” or “✓” key releases the error display, and then the menu items are displayed.

### 3.6 Diag. mode menu tree

Menu Tree of the Customer Mode is as follows

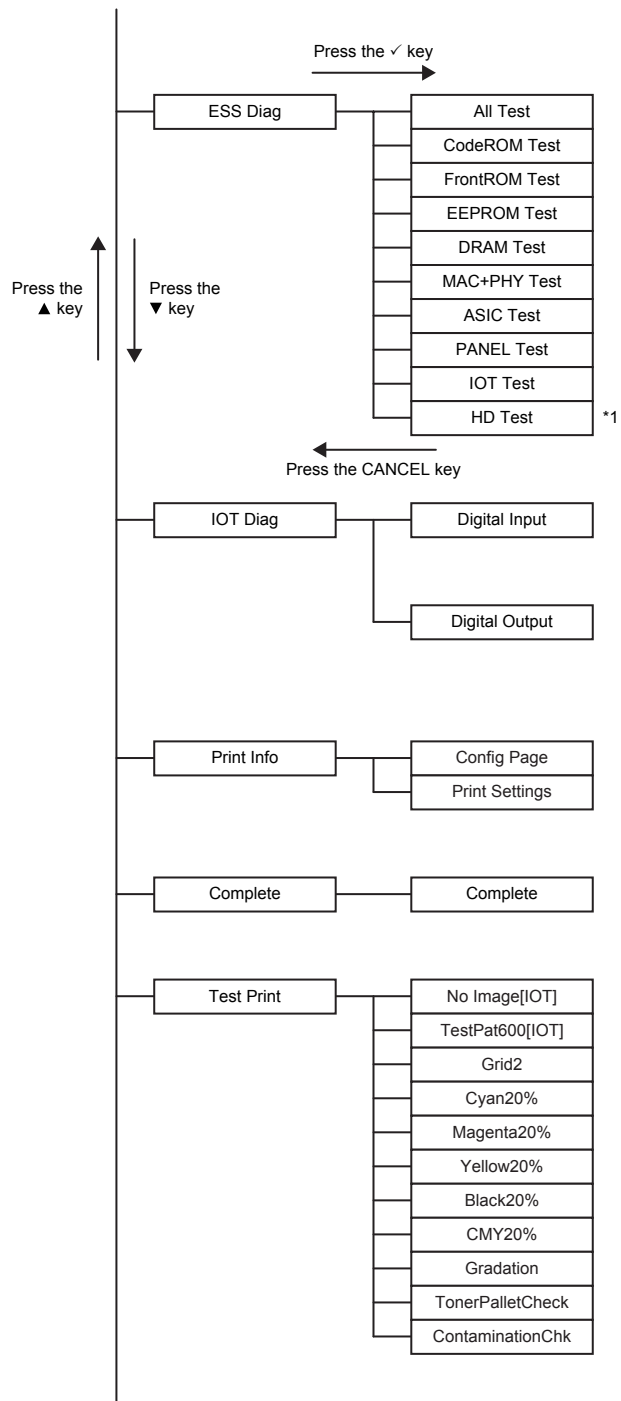

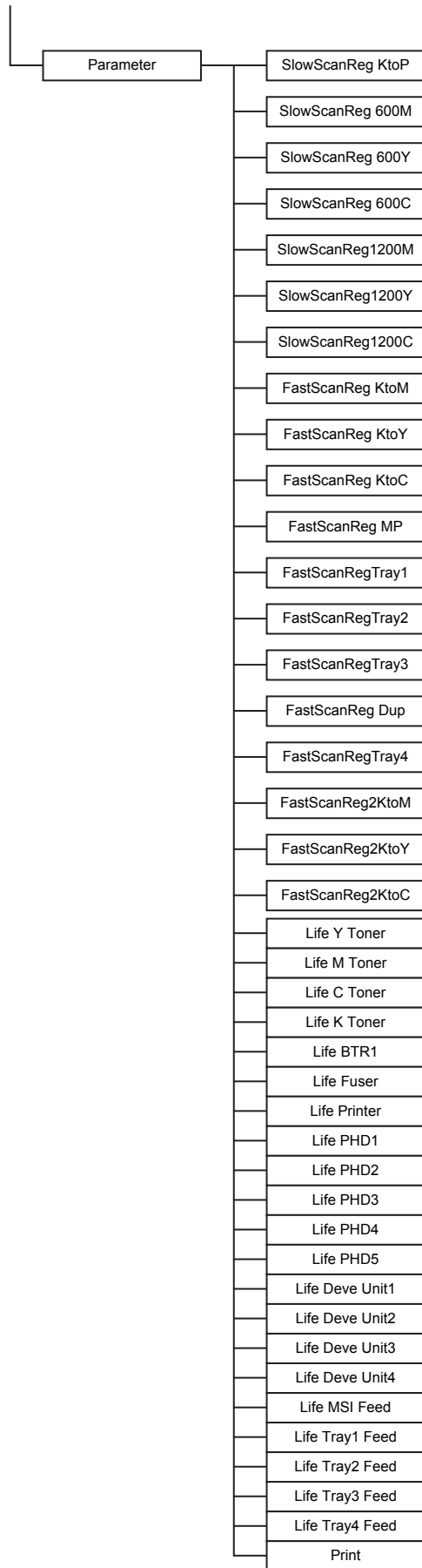

\*1: When not equipped with the HD option, it does not display.



## 4. The Kind of Diag. and Contents of a Test

The diagnosis/setting items which can be performed in the Customer mode are as follows.

menu	Function	Description
ESS Diag	ALL Test	Executes the ESS Diag except the following. MAC+PHY/Panel
	CodeROM Test	Calculates the ROM checksum and compares it with the value stored in the ROM. Executes this test when the 016-317 error occurred. Test result: NG (Go to FIP.) OK (Turn off/on the main power.)
	FontROM Test	Calculates the Font ROM checksum and compares it with the value stored in the FontROM. Executes this test when the 016-310 error occurred. Test result: NG (Go to FIP.) OK (Turn off/on the main power.)
	EEPROM Test	Performs write/read/verify on the diag. area of the EEPROM. Executes this test when the 016-327 and 016-323 errors occurred. Test result: NG (Go to each FIP.) OK (Turn off/on the main power.)
	DRAM Test	Tests OPEN/SHORT with the address line of the DRAM. Performs write/read/verify on the entire DRAM. Executes this test when the 016-315, 016-316, 016-318 and 016-332 errors occurred. Test result: NG (Go to each FIP.) OK (Turn off/on the main power.)
	MAC+PHY Test MAC: Media Access Control PHY: Physical Layer	PHY Internal loopback test Executes this test when the 016-334, 016-340, 016-344, 016-345 and 016-346 errors occurred. Test result: NG (Go to each FIP.) OK (Turn off/on the main power.)
	ASIC Test	Register check Executes this test when the 016-313 error occurred. Test result: NG (Go to FIP.) OK (Turn off/on the main power.)
	PANEL Test	Tests the LED, LCD, and buttons of the control panel.
	IOT Test	Communication test with the IOT Executes this test when the 016-370 error occurred. Test result: NG (Go to FIP.) OK (Turn off/on the main power.)
	HD Test	Test the optional hard disk. Executes this test when the 016-312 error occurred. Test result: NG (Go to FIP.) OK (Turn off/on the main power.)

menu	Function	Description
IOT Diag	Digital Input	Digital input component test When a paper jam is occurred, or an error message or code is displayed, execute this test to locate the damaged parts. The test will execute the DI Test codes of the components that are supposed to be faulty from the error details. (Refer to each FIP on Chapter 1.) Test result: NG (Go to each FIP or replace the parts.) OK (Turn off/on the main power.)
	Digital Output	Digital output component test When a paper jam or PQ problem is occurred, or an error message or code is displayed, this test enables to look for the broken or damaged parts. Test result: NG (Go to each FIP or replace the parts.) OK (Turn off/on the main power.)
Print Info	Config Page	The version of software of IOT and the printer configuration can be confirmed by executing this test.
	Print Settings	The service tag, printing count value and error count value can be confirmed by executing this test.
Complete	Complete	Completes the diagnosis operation and reboot the data.
Test Print	No Image[IOT]	Prints the blanked paper.
	Test Pattern 600[IOT]	Prints the IOT built-in 600dpi pattern. When the PQ problem occurred, this test enables to identify the problem as the printing process or the PWBA ESS related. Compare the sample chart (refer to 4.3.3) with the print. Check result: NG (Check the printing process.) OK (Check the PWBA ESS related.)
	Grid2	Prints the ESS built-in grid pattern. When the PQ problem occurred, this test enables to identify the problem as printer-related or otherwise. Compare the sample chart (refer to 4.3.4) with the print. Check result: NG (Check the printing process and PWBA ESS-related.) OK (Check the network, cable, PC and so on.)
	Cyan 20%	Outputs cyan 20% paint on the whole area of a A4 paper. When the PQ problem occurred, this test enables to identify the problem as the cyan toner or another color. Compare the sample chart (refer to 4.3.5) with the print. Check result: NG (Check the cyan toner-related.) OK (Check another toner.)
	Magenta 20%	Outputs magenta 20% paint on the whole area of a A4 paper. When the PQ problem occurred, this test enables to identify the problem as the magenta toner or another color. Compare the sample chart (refer to 4.3.5) with the print. Check result: NG (Check the magenta toner-related.) OK (Check another toner.)

menu	Function	Description
Test Print	Yellow 20%	Outputs yellow 20% paint on the whole area of a A4 paper. When the PQ problem occurred, this test enables to identify the problem as the yellow toner or another color. Compare the sample chart (refer to 4.3.5) with the print. Check result: NG (Check the yellow toner-related.) OK (Check another toner.)
	Black 20%	Outputs black 20% paint on the whole area of a A4 paper. When the PQ problem occurred, this test enables to identify the problem as the black toner or another color. Compare the sample chart (refer to 4.3.5) with the print. Check result: NG (Check the black toner-related.) OK (Check another toner.)
	CMY 20%	Outputs C/M/Y 20% paint on the whole area of a A4 paper. When the PQ problem occurred, this test enables to identify the problem as the balance of three color toners or otherwise. Compare the sample chart (refer to 4.3.5) with the print. Check result: NG (Check the C, M or Y toner-related.) OK (Check black toner.)
	Gradation	Outputs the tone pattern from 2% to 100% on a A4 paper for each of 4 colors. When the PQ problem occurred, this test enables to identify the problem as the printing process or PWBA ESS-related. Compare the sample chart (refer to 4.3.6) with the print. Check result: NG (Check the printing process.) OK (Check the PWBA ESS-related.)
	Toner Pallet Check	Outputs each 100% density color pattern of Y/M/C/K. When the PQ problem occurred in the picture or photo printing, this test enables to identify the problem as the toner or another. Compare the sample chart (refer to 4.3.7) with the print. Check result: NG (Check the problem toner-related.) OK (Check the print job or print data.)
	Contamination Check	Allows you to check the print for any regular lines or toner spots when encountering PQ problems. From the difference in the interval of regular lines or spots, you can determine the parts that have caused the trouble. Page 1 to 4: Prints the scale patterns in vertical and horizontal directions for evaluating regularity and intervals. (Refer to 4.3.8.) Page 5: Prints the list of intervals by component fault.

menu	Function	Description
Parameter	Registration adjustment in scanning direction	Adjusts the registration in laser beam scanning direction for each of Tray1, Tray2, Tray3, Tray4, Duplex, and MSI. The Registration Adjustment regulates the printing position of the image to be printed on a A4 paper. The Fast Scan regulates the ROS as to the printing start position of the image data, and the Slow Scan regulates the toner image transfer position in accordance with the feed timing of the paper.
	Life counter (Read only)	Reads and initializes the life counters of the Toner, BTR, Fuser, printer, PHD and DEVE. Allows you to check the current count reading of mandatory-replacement parts or consumables. By comparing the values on the Life Warning Table with the current count reading, you can check whether or not how soon you need to replace the parts.
	Printing	Prints the parameters and life counts having IOT.

## 4.1 Details of ESS diagnosis

This section describes how to perform each test of the ESS Diag in detail.

### 4.1.1 Executing ESS diagnosis

- 1) Turn off the power.
- 2) Turn on the power while holding down “▲” and “▼” keys.
- 3) Release the fingers from these keys when “Diagnosing...” is displayed.
- 4) The “Customer Mode” and “ESS Diag” are displayed. (Entered the Diag. mode.)
- 5) Press “✓” key.
- 6) Press “▲” or “▼” key to select the test item.
- 7) Press “✓” key twice to execute the test.

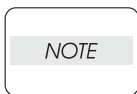

To exit the test or to returning to one step higher menu, press “CANCEL” key.

### 4.1.2 All Test

This test executes the all tests of the ESS diagnostic except the MAC+PHY test and PANEL test.

Normal	Error
CHECK OK	*** ERROR

\*\*\*:Displays the test name that became error.

(CodeROM/FontROM/EEPROM/DRAM/ASIC/IOT/HD)

### 4.1.3 CodeROM Test

This test calculates the checksum of the each ROM, and compares it with the valid checksum value stored in the corresponding chip beforehand. When the checksum is identical to the stored value, this test judges the chip is normal.

Normal	Error
CHECK OK	CodeROM #* ERROR S=xxxx V=yyyy (xxxx:calculated value yyyy:ROM stored value *:0,1)

### 4.1.4 FontROM Test

This test calculates the checksum of the each FontROM, and compares it with the valid checksum value stored in the corresponding chip beforehand. When the checksum is identical to the stored value, this test judges the chip is normal.

Normal	Error
CHECK OK	FontROM ERROR S=xxxx V=yyyy (xxxx:calculated value yyyy:ROM stored value)

## 4.1.5 EEPROM Test

The test performs read/write/verify of the test patterns (0xff,0xaa, 0x55 and 0x00) on one byte at every 0x400 from the first address of EEPROM.

Normal	Error
CHECK OK	EEPROM ID* ERROR (ID*:1,2)

## 4.1.6 DRAM Test

When the optional DRAM SIMM is checked and found, it checks the optional memory area.

First, the test performs read/write/verify of the increment data for the whole tested area by the word. Then, it performs read/write/verify of the test patterns (0xffffffff, 0xaaaaaaaa, 0x55555555, 0x00000000) for the whole tested area by the word.

Normal	Error
CHECK OK	DRAM slot* ERROR (* : 0,1)

## 4.1.7 MAC+PHY Test

PHY Internal loopback test

Normal	Error
CHECK OK	MAC+PHY ERROR

## 4.1.8 ASIC Test

ASIC register check.

Normal	Error
CHECK OK	ERROR

## 4.1.9 PANEL Test

This test checks input and output of the control panel. When buttons are pressed in the manner shown in the following table, the test displays the corresponding contents on the LED and LCD.

Button	LED	LCD
▲	■ ■	Displays " UP " on the LCD.
▼	■ ■	Displays " DOWN " on the LCD.
◀	■ □	Displays " LEFT " on the LCD.
▶	■ □	Displays " RIGHT " on the LCD.
✓	□ ■	Displays " SET " on the LCD.
MENU	□ ■	Displays " MENU " on the LCD.
CANCEL	□ □	Displays " CANCEL " on the LCD.
▲ ▼ pressed at the same time	- (The test is completed)	Displays " Start " on the LCD.

□□ Indicates left side square is the Ready LED (Green) and right side square is the Alarm LED (Amber). □Not lighting ■Lighting

## 4.1.10 IOT Test

This test checks communication with the IOT. Then it reads the status register of the IOT to check whether commands can be exchanged with the IOT.

It sends the following command to read the status register, and checks whether the appropriate response returns.

Read ROM Revision No

Normal	Error
CHECK OK	IOT ERROR

## 4.1.11 HD Test

When the optional hard disk is checked and found, it checks the optional hard disk. The test performs read/write/verify on the hard disk.

Normal	Error
CHECK OK	HD ERROR

## 4.2 IOT Diag.

### 4.2.1 Digital Input (DI) Test

This function checks whether the DI components operate normally or not.

The DI test is performed for all the DI components.

Exit operation of the DI test makes the control panel display the Customer diag. function menu.

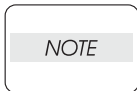

During the DI test, other Customer diag. functions can not be performed simultaneously. Therefore, the printer does not accept any operation except operations for the DI components and exit operation of the DI test.

At the start of the DI test, number “0” is displayed on the control panel. This number is counted up when a DI component is turned on from off, therefore it allows the user to know the component is active.

### 4.2.2 Executing digital input (DI) test

- 1) Turn off the power.
- 2) Turn on the power while holding down “▲” and “▼” keys.
- 3) Release the fingers from these keys when “Diagnosing...” is displayed.
- 4) The “Customer Mode” and “ESS Diag” are displayed. (Entered the Diag. mode.)
- 5) Press “▼” to select “IOT Diag”, and then press “✓” key.
- 6) Press “▼” key to select “Digital Input”, and then press “✓” key.
- 7) Press “▲” or “▼” key to select the test item.
- 8) Press “✓” key twice to execute the test.

Parameters for the Digital Input Test are as follows.

Code(HEX)	Code_DI	Menu No.
00	FULL STACK SENSOR	DI-0
01	DUP JAM SENSOR	DI-1
02	EXIT SENSOR	DI-2
03	REGI SENSOR	DI-3
04	ROS READY (Internal signal)	DI-4
05	FUSER READY (Internal signal)	DI-5
07	INTERLOCK OPEN	DI-7
08	TONER CARTRIDGE SENSOR Y	DI-8
09	TONER CARTRIDGE SENSOR M	DI-9
0A	TONER CARTRIDGE SENSOR C	DI-a
0B	TONER CARTRIDGE SENSOR K	DI-b
0C	NO TONER Y (Internal signal)	DI-c
0D	NO TONER M (Internal signal)	DI-d
0E	NO TONER C (Internal signal)	DI-e
0F	NO TONER K (Internal signal)	DI-f
10	MSI NO PAPER	DI-10
11	TRAY1 NO PAPER	DI-11
12	TRAY2 NO PAPER	DI-12
13	TRAY3 NO PAPER	DI-13
15	TRAY1 LOW PAPER (not use)	DI-15



Code(HEX)	Code_DI	Menu No.	
16	TRAY2 LOW PAPER (not use)	DI-16	
17	TRAY3 LOW PAPER (not use)	DI-17	
18	TONER SENSOR Y	DI-18	*1
19	TONER SENSOR M	DI-19	*1
1A	TONER SENSOR C	DI-1a	*1
1B	TONER SENSOR K	DI-1b	*1
1E	TRAY4 NO PAPER	DI-1e	
1F	TRAY4 LOW PAPER (not use)	DI-1f	
22	NO PHD (Internal signal)	DI-22	
23	BTR TONER FULL	DI-23	
24	FAN REAR ALARM (Internal signal)	DI-24	
25	NO OPTION FEEDER1 (Internal signal)	DI-25	
26	NO OPTION FEEDER2 (Internal signal)	DI-26	
27	NO OPTION FEEDER3 (Internal signal)	DI-27	
28	FAN FRONT ALARM (Internal signal)	DI-28	
29	FAN FUSER RIGHT ALARM (Internal signal)	DI-29	
2A	FAN REAR2 ALARM (Internal signal)	DI-2a	
30	MAIN MOTOR ALARM (Internal signal)	DI-30	
31	FUSER MOTOR ALARM (Internal signal)	DI-31	
32	DEVE MOTOR ALARM (Internal signal)	DI-32	
38	CASSETTE1 SIZE	DI-38	
40	CASSETTE2 SIZE	DI-40	
48	CASSETTE3 SIZE	DI-48	
50	CASSETTE4 SIZE	DI-50	

\*1: These code check the operation of each No Toner Sensor.

### 4.2.3 Exiting digital input (DI) test

- 1) Press “CANCEL” key to stop the DI Test.
- 2) Press “MENU” key to exit the DI Test mode. (“IOT Diag” and “Digital Input” are displayed after that “Please Wait” was displayed.)
- 3) Press “CANCEL” key, “IOT Diag” is displayed.

To shift the mode from Diag. mode to the normal mode, perform as follows.

- 4) Press “▼” key to select “Complete”.
- 5) Press “✓” key three times to exit the “Diag. Mode.”

### 4.2.4 How to check sensors and switches

- Parts Location

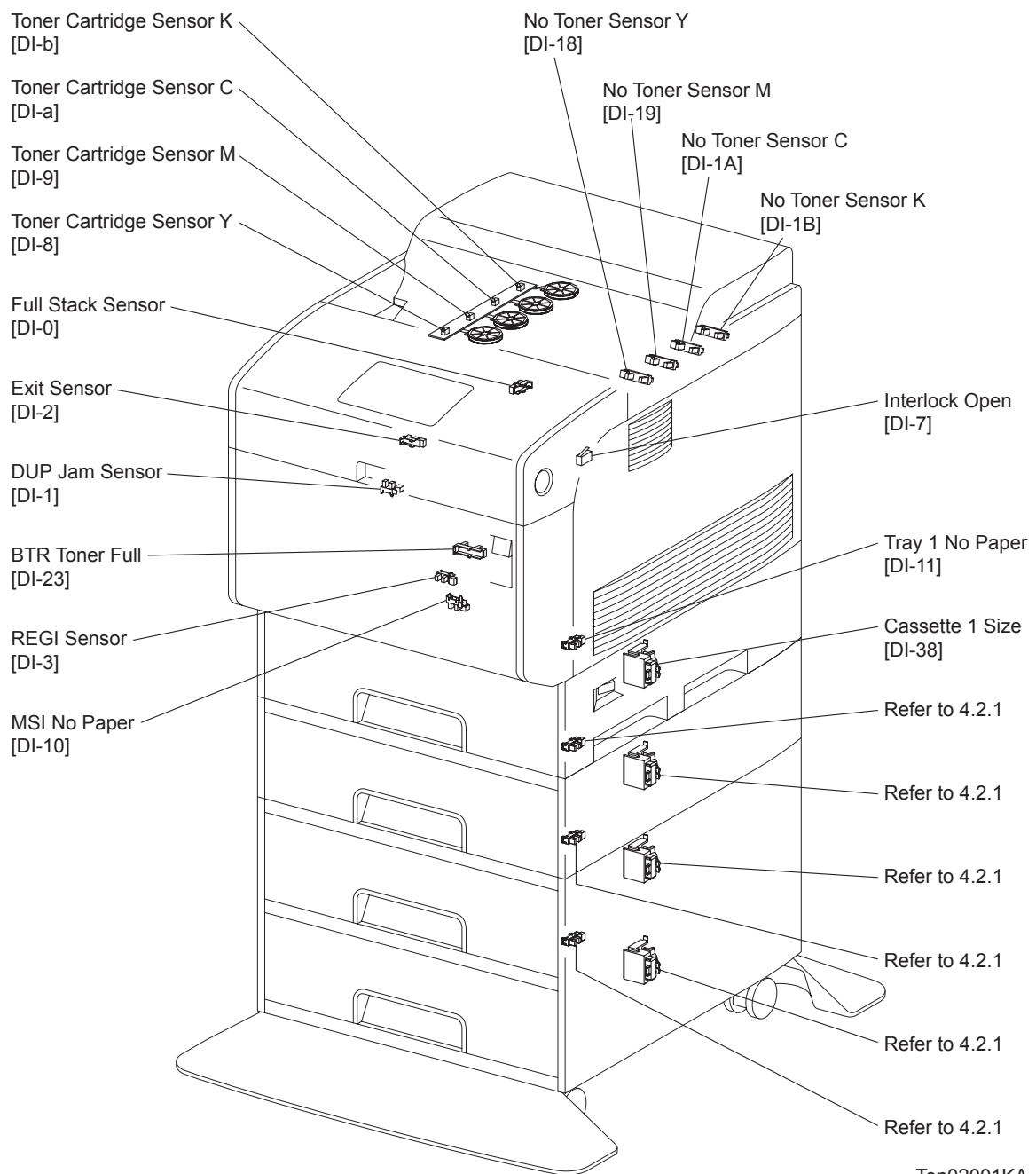

- About Sensor

There are two types of the sensor in the printer, one is reflective type, and another is transmissive type.

A reflective type sensor detects, on the basis of whether or not the light is reflected by the sheet, the paper absence/presence or the sheet such as OHP transparency or others.

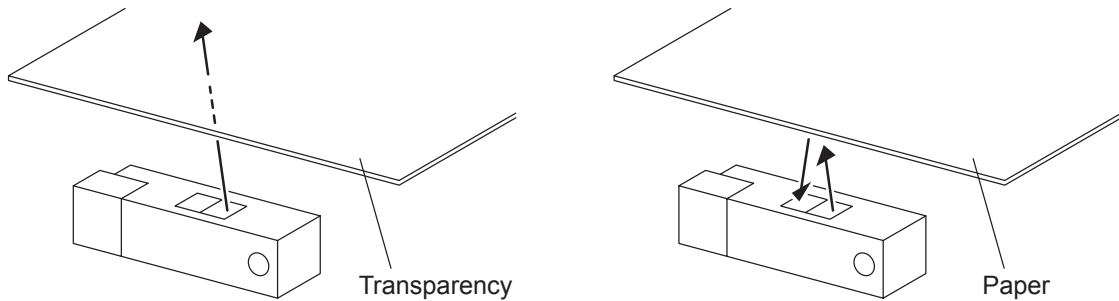

Leg\_Sec02\_015FA

A transmissive type sensor is composed of the light-emitting side and the light-receiving side that are placed opposite to each other allowing the light to pass from the former to the latter. On the basis of whether or not the light path is blocked due to the actuator, etc., the sensor detects the paper absence/presence or the moving part position such as at the home position or elsewhere.

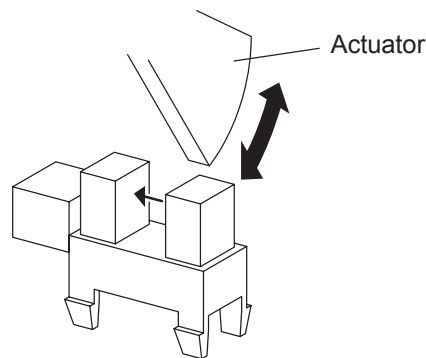

Leg\_Sec02\_016FA

The following table shows the correspondence between the sensors and the types.

Reflective type (Diag. Code)	Transmissive type (Diag. Code)
	Full Stack Sensor (DI-0)
	DUP Jam Sensor (DI-1)
	Exit Sensor (DI-2)
	REGI Sensor (DI-3)
	MSI No Paper Sensor (DI-10)
	Tray 1 No Paper Sensor (DI-11)
	Tray 2 No Paper Sensor (DI-12)
	Tray 3 No Paper Sensor (DI-13)
	Tray 4 No Paper Sensor (DI-1e)
	BTR Toner Full Sensor (DI-23)
	No Toner Sensor Y (DI-18) (Internal signal)
	No Toner Sensor M (DI-19) (Internal signal)
	No Toner Sensor C (DI-1a) (Internal signal)
	No Toner Sensor K (DI-1b) (Internal signal)

- About Switch

There are two types of the switch in the printer, one is the push-switch detecting close/open of the door or cover, and another is the micro-switch using for safety interlock to safeguard the user.

A push-switch closes the internal contacts via the plunger that is pushed down by the actuator of the cover or door that is being closed.

When the door or cover has been opened, the plunger is pushed up by the spring in the switch allowing the internal contacts to open.

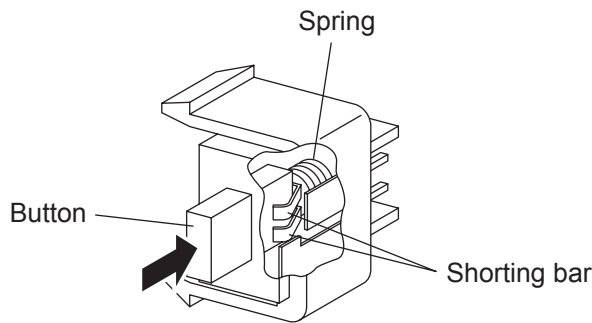

Leg\_Sec02\_017FA

A micro-switch closes the internal contacts via the button which is pushed down under the provided leaf spring which is held down by the actuator of the cover or door that is being closed.

When the door or cover has being opened, the leaf spring returns to its original position and the button is pushed up by the spring in the switch, allowing the internal contacts to open.

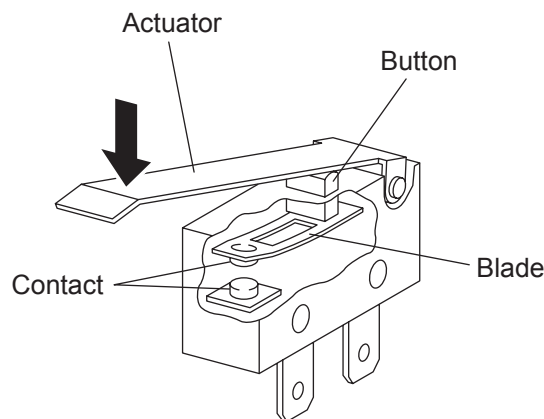

Leg\_Sec02\_018FA

The following table shows the correspondence between the push switches and the types.

Push switch (Diag. Code)	Micro switch (Diag. Code)
Toner Cartridge Switch Y (DI-8)	Interlock Switch (DI-7)
Toner Cartridge Switch M (DI-9)	
Toner Cartridge Switch C (DI-a)	
Toner Cartridge Switch K (DI-b)	
Cassette 1 Size Switch (DI-38)	
Cassette 2 Size Switch (DI-40)	
Cassette 3 Size Switch (DI-48)	
Cassette 4 Size Switch (DI-50)	

## - About Diag. Matrix

The diagnosis number differs depending on the composition of the Optional Feeder(s) that was installed to the printer. Refer to Diag Matrix table below.

Diag Matrix for Tray 1/2/3/4 No Paper Sensor (DI-11/-12/-13/-1e)

Printer	Paper Tray Composition			
	Standard Only	One Tray Opt. Feeder	Two Tray Opt. Feeder	One Tray + Two Tray Opt. Feeders
1. Standard	DI-11	DI-11	DI-11	DI-11
2. 500 Sheets (One Tray Opt. Feeder)	--	DI-12	--	DI-12
3. 500 Sheets	--	--	DI-12	DI-13
4. 500 Sheets (Two Tray Opt. Feeder)	--	--	DI-13	DI-1e

Diag Matrix for Cassette 1/2/3/4 Size Sensor (DI-38/-40/-48/-50)

Printer	Paper Tray Composition			
	Standard Only	One Tray Opt. Feeder	Two Tray Opt. Feeder	One Tray + Two Tray Opt. Feeders
1. Standard	DI-38	DI-38	DI-38	DI-38
2. 500 Sheets (One Tray Opt. Feeder)	--	DI-40	--	DI-40
3. 500 Sheets	--	--	DI-40	DI-48
4. 500 Sheets (Two Tray Opt. Feeder)	--	--	DI-48	DI-50

-Checking the Sensor and Switch

Sensor name (Diag. Code)	Confirmation procedures
<p>Full Stack Sensor (DI-0)</p>	<ol style="list-style-type: none"> <li>1) Turn on the power and enter the Diagnostic Mode.</li> <li>2) Execute the DI-0.</li> <li>3) Move the Output Tray Actuator to check the sensor. Check the number on the control panel is counted up.</li> </ol> <div data-bbox="783 439 1265 972" style="text-align: center;"> <p>The diagram shows a close-up of the actuator being moved up and down, labeled '3)'. Below it, the operator panel display shows 'Digital Input DI-0 L 0' changing to 'Digital Input DI-0 L 1' after a downward arrow. A larger diagram below shows the printer's output tray with the actuator mechanism.</p> <p style="text-align: right; font-size: small;">Ida_Sec02_006FA</p> </div> <ol style="list-style-type: none"> <li>4) Press the "CANCEL" key to stop the test.</li> </ol>
<p>DUP Jam Sensor (DI-1)</p>	<ol style="list-style-type: none"> <li>1) Turn on the power and enter the Diagnostic Mode.</li> <li>2) Execute the DI-1.</li> <li>3) Push the Side Button to open the Front Cover.</li> <li>4) Move the Actuator Dup to check the sensor. Check the number on the control panel is counted up.</li> </ol> <div data-bbox="754 1252 1294 1973" style="text-align: center;"> <p>The diagram shows the front cover being opened, labeled '3)-2'. A side button is labeled '3)-1'. A close-up shows the dup actuator being moved up and down, labeled '4)'. Below it, the operator panel display shows 'Digital Input DI-1 L 0' changing to 'Digital Input DI-1 L 1' after a downward arrow. A larger diagram below shows the printer's front cover and dup mechanism.</p> <p style="text-align: right; font-size: small;">Ida_Sec02_007FA</p> </div> <ol style="list-style-type: none"> <li>5) Press the "CANCEL" key to stop the test.</li> <li>6) Close the Front Cover.</li> </ol>

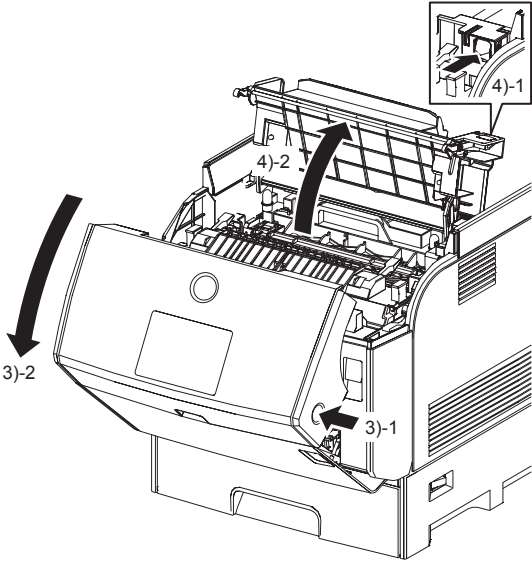
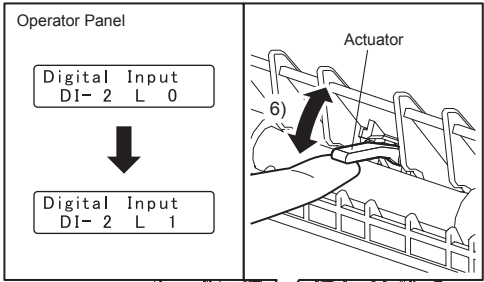
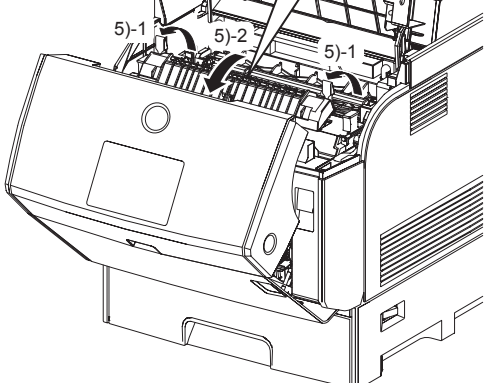
Sensor name (Diag. Code)	Confirmation procedures
Exit Sensor (DI-2)	<p><b>CAUTION:</b> The Fuser is very hot. Take extremely care not to get burned when carrying the followings.</p> <ol style="list-style-type: none"> <li>1) Turn on the power and enter the Diagnostic Mode.</li> <li>2) Execute the DI-2.</li> <li>3) Push the Side Button to open the Front Cover.</li> <li>4) Push the button and lift the Output Tray Cover and push it toward the back of the printer. (Caution: Fuser is very hot. Do not touch the inside of the Fuser.)</li> </ol>  <p style="text-align: right; font-size: small;">Ida_Sec02_008FA</p> <ol style="list-style-type: none"> <li>5) Lift up the levers on both ends of the Fuser.</li> <li>6) Move the Actuator on the Fuser to check the sensor. Check the number on the control panel is counted up.</li> </ol>   <p style="text-align: right; font-size: small;">Ida_Sec02_009FA</p> <ol style="list-style-type: none"> <li>7) Press the "CANCEL" key to stop the test.</li> <li>8) Reseat the Fuser, and close the Output Tray Cover and Front Cover.</li> </ol>

Sensor name (Diag. Code)	Confirmation procedures
REGI Sensor (DI-3)	<p>NOTE: Prepare the small size slip of paper (20mm x 50mm).</p> <ol style="list-style-type: none"> <li>1) Turn on the power and enter the Diagnostic Mode.</li> <li>2) Execute the DI-3.</li> <li>3) Push up the Front Latch to open the Front Cover.</li> <li>4) Move the Actuator REGI to check the sensor by the paper. Check the number on the control panel is counted up.</li> </ol> <div style="text-align: center;"> <p>The diagram illustrates the steps for testing the REGI sensor. At the top, the Operator Panel shows the 'Digital Input' changing from 'DI-3 L 0' to 'DI-3 L 1' after a paper slip is inserted. Below this, a cross-sectional view of the 'Actuator' shows a paper slip being fed through, with an arrow labeled '4)' indicating the direction of movement. A larger view shows the front cover being opened, with an arrow labeled '3)-2' pointing to the cover. A detailed inset labeled '3)-1' shows the front latch mechanism.</p> </div> <ol style="list-style-type: none"> <li>5) Press the "CANCEL" key to stop the test.</li> <li>6) Close the Front Cover.</li> </ol> <p style="text-align: right; font-size: small;">Ida_Sec02_010FA</p>



Sensor name (Diag. Code)	Confirmation procedures
<p>Interlock Open (DI-7)</p>	<ol style="list-style-type: none"> <li>1) Turn on the power and enter the Diagnostic Mode.</li> <li>2) Execute the DI-7.</li> <li>3) Push the Side Button to open and close the Front Cover. Check the number on the control panel is counted up.</li> </ol> <div data-bbox="778 371 1299 981" style="text-align: center;"> <p style="text-align: right; font-size: small;">Ida_Sec02_011FA</p> </div> <ol style="list-style-type: none"> <li>4) Close the Front Cover.</li> <li>5) Press the “CANCEL” key to stop the test.</li> </ol>
<p>Toner Cartridge Sensor Y (DI-8)</p>	<ol style="list-style-type: none"> <li>1) Turn on the power and enter the Diagnostic Mode.</li> <li>2) Remove the Top Cover.</li> <li>3) Execute the DI-8.</li> <li>4) Move the levers on both ends of the Yellow Toner backward to release the lock. Check the number on the control panel is counted up.</li> </ol> <div data-bbox="766 1303 1286 1778" style="text-align: center;"> <p style="text-align: right; font-size: small;">Ida_Sec02_012FA</p> </div> <ol style="list-style-type: none"> <li>5) Press the “CANCEL” key to stop the test.</li> <li>6) Rotate the levers of the Yellow Toner forward until it locks firmly. (You may hear a click when the Toner Cartridge seats properly.)</li> <li>7) Reseat the Top Cover.</li> </ol>

Sensor name (Diag. Code)	Confirmation procedures
<p>Toner Cartridge Sensor M (DI-9)</p>	<ol style="list-style-type: none"> <li>1) Turn on the power and enter the Diagnostic Mode.</li> <li>2) Remove the Top Cover.</li> <li>3) Execute the DI-9.</li> <li>4) Move the levers on both ends of the Magenta Toner backward to release the lock. Check the number on the control panel is counted up.</li> </ol> <div data-bbox="767 439 1283 875" style="text-align: center;"> <p style="text-align: right; font-size: small;">Ida_Sec02_013FA</p> </div> <ol style="list-style-type: none"> <li>5) Press the “CANCEL” key to stop the test.</li> <li>6) Rotate the levers of the Magenta Toner forward until it locks firmly. (You may hear a click when the Toner Cartridge seats properly.)</li> <li>7) Reseat the Top Cover.</li> </ol>
<p>Toner Cartridge Sensor C (DI-a)</p>	<ol style="list-style-type: none"> <li>1) Turn on the power and enter the Diagnostic Mode.</li> <li>2) Remove the Top Cover.</li> <li>3) Execute the DI-a.</li> <li>4) Move the levers on both ends of the Cyan Toner backward to release the lock. Check the number on the control panel is counted up.</li> </ol> <div data-bbox="767 1335 1283 1771" style="text-align: center;"> <p style="text-align: right; font-size: small;">Ida_Sec02_014FA</p> </div> <ol style="list-style-type: none"> <li>5) Press the “CANCEL” key to stop the test.</li> <li>6) Rotate the levers of the Cyan Toner forward until it locks firmly. (You may hear a click when the Toner Cartridge seats properly.)</li> <li>7) Reseat the Top Cover.</li> </ol>

Sensor name (Diag. Code)	Confirmation procedures
<p>Toner Cartridge Sensor K (DI-b)</p>	<ol style="list-style-type: none"> <li>1) Turn on the power and enter the Diagnostic Mode.</li> <li>2) Remove the Top Cover.</li> <li>3) Execute the DI-b.</li> <li>4) Move the levers on both ends of the Black Toner backward to release the lock. Check the number on the control panel is counted up.</li> </ol> <div data-bbox="767 439 1283 909" style="text-align: center;"> <p style="text-align: right; font-size: small;">Ida_Sec02_015FA</p> </div> <ol style="list-style-type: none"> <li>5) Press the “CANCEL” key to stop the test.</li> <li>6) Rotate the levers of the Black Toner forward until it locks firmly. (You may hear a click when the Toner Cartridge seats properly.)</li> <li>7) Reseat the Top Cover.</li> </ol>
<p>MSI No Paper (DI-10)</p>	<ol style="list-style-type: none"> <li>1) Turn on the power and enter the Diagnostic Mode.</li> <li>2) Remove the paper on the Multipurpose Feeder (MPF) Tray or open the Multipurpose Feeder (MPF) Cover.</li> <li>3) Execute the DI-10.</li> <li>4) Move the Actuator No Paper MSI to check the sensor by finger. Check the number on the control panel is counted up.</li> </ol> <div data-bbox="783 1368 1267 2002" style="text-align: center;"> <p style="text-align: right; font-size: small;">Ida_Sec02_016FA</p> </div> <ol style="list-style-type: none"> <li>5) Press the “CANCEL” key to stop the test.</li> </ol>

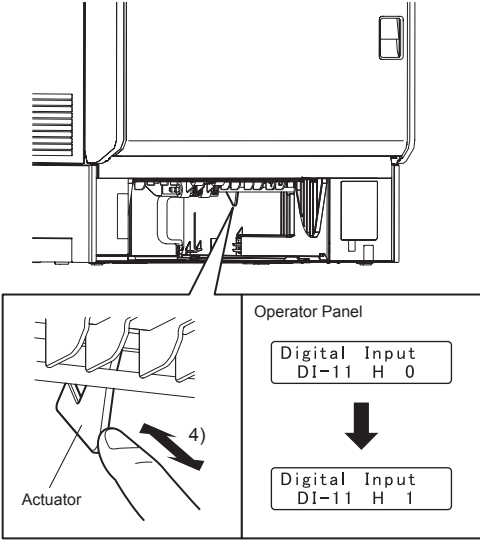
Sensor name (Diag. Code)	Confirmation procedures
<p>Tray 1 No Paper (DI-11)</p>	<ol style="list-style-type: none"> <li>1) Remove the Tray 1.</li> <li>2) Turn on the power and enter the Diagnostic Mode.</li> <li>3) Execute the DI-11.</li> <li>4) Move the Actuator No Paper on the Paper Pickup Assembly to check the sensor by finger. Check the number on the control panel is counted up.</li> </ol>  <p style="text-align: right; font-size: small;">Ida_Sec02_017FA</p> <ol style="list-style-type: none"> <li>5) Press the “CANCEL” key to stop the test.</li> <li>6) Reseat the Tray 1.</li> </ol>

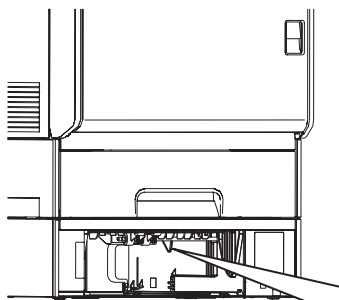
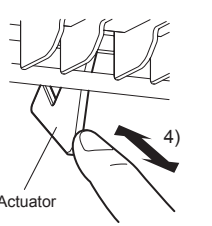
Sensor name (Diag. Code)	Confirmation procedures
<p>Tray 2 No Paper (DI-12)</p>	<ol style="list-style-type: none"> <li>1) Remove the Tray 2.</li> <li>2) Turn on the power and enter the Diagnostic Mode.</li> <li>3) Execute the DI-12.</li> <li>4) Move the Actuator No Paper on the Paper Pickup Assembly of Tray 2 to check the sensor by finger. Check the number on the control panel is counted up.</li> </ol> <div style="display: flex; justify-content: space-around; align-items: center;">  <div style="border: 1px solid black; padding: 5px; width: 150px;"> <p>Operator Panel</p> <p>Digital Input DI-12 H 0</p> <p style="text-align: center;">↓</p> <p>Digital Input DI-12 H 1</p> </div> </div> <p style="text-align: right; font-size: small;">Ida_Sec02_018FA</p> <div style="display: flex; justify-content: space-around; align-items: center;">  <div style="border: 1px solid black; padding: 5px; width: 150px;"> <p>Operator Panel</p> <p>Digital Input DI-12 H 0</p> <p style="text-align: center;">↓</p> <p>Digital Input DI-12 H 1</p> </div> </div> <p style="text-align: right; font-size: small;">Ida_Sec02_019FA</p> <ol style="list-style-type: none"> <li>5) Press the "CANCEL" key to stop the test.</li> <li>6) Reseat the Tray 2.</li> </ol>

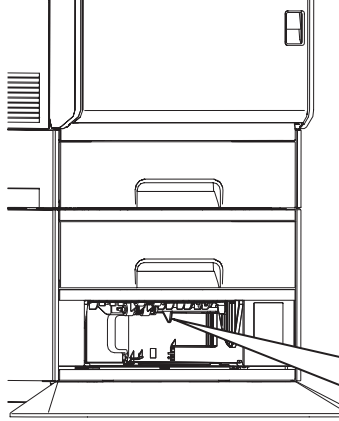
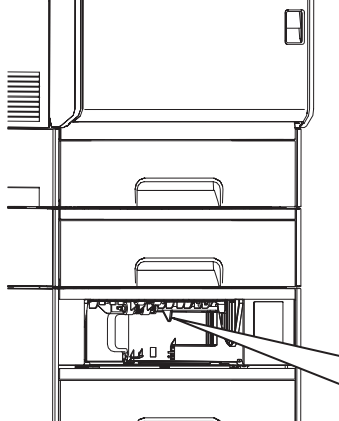
Sensor name (Diag. Code)	Confirmation procedures
<p>Tray 3 No Paper (DI-13)</p>	<ol style="list-style-type: none"> <li>1) Remove the Tray 3.</li> <li>2) Turn on the power and enter the Diagnostic Mode.</li> <li>3) Execute the DI-13.</li> <li>4) Move the Actuator No Paper on the Paper Pickup Assembly of Tray 3 to check the sensor by finger. Check the number on the control panel is counted up.</li> </ol> <div style="display: flex; justify-content: space-around; align-items: flex-start;"> <div style="text-align: center;">  <p>Actuator</p> </div> <div style="border: 1px solid black; padding: 5px;"> <p>Operator Panel</p> <div style="border: 1px solid black; padding: 2px; margin-bottom: 5px;">Digital Input DI-13 H 0</div> <p style="text-align: center;">↓</p> <div style="border: 1px solid black; padding: 2px;">Digital Input DI-13 H 1</div> </div> </div> <p style="text-align: right; font-size: small;">Ida_Sec02_020FA</p> <div style="display: flex; justify-content: space-around; align-items: flex-start;"> <div style="text-align: center;">  <p>Actuator</p> </div> <div style="border: 1px solid black; padding: 5px;"> <p>Operator Panel</p> <div style="border: 1px solid black; padding: 2px; margin-bottom: 5px;">Digital Input DI-13 H 0</div> <p style="text-align: center;">↓</p> <div style="border: 1px solid black; padding: 2px;">Digital Input DI-13 H 1</div> </div> </div> <p style="text-align: right; font-size: small;">Ida_Sec02_021FA</p> <ol style="list-style-type: none"> <li>5) Press the "CANCEL" key to stop the test.</li> <li>6) Reseat the Tray 3.</li> </ol>

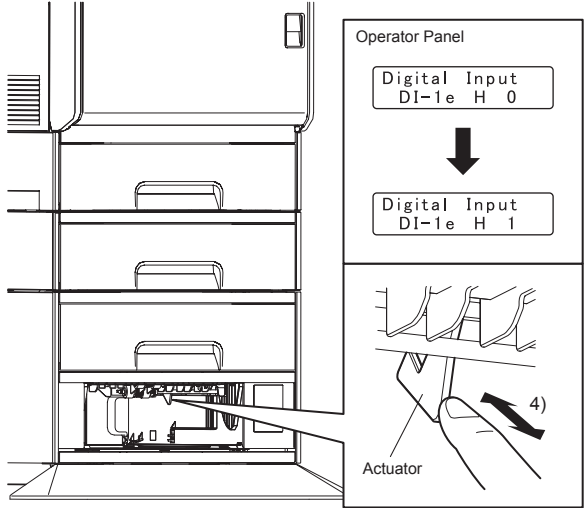
Sensor name (Diag. Code)	Confirmation procedures
<p>Tray 4 No Paper (DI-1e)</p>	<ol style="list-style-type: none"> <li>1) Remove the Tray 4.</li> <li>2) Turn on the power and enter the Diagnostic Mode.</li> <li>3) Execute the DI-1e.</li> <li>4) Move the Actuator No Paper on the Paper Pickup Assembly of Tray 4 to check the sensor by finger. Check the number on the control panel is counted up.</li> </ol>  <p style="text-align: right; font-size: small;">Ida_Sec02_022FA</p> <ol style="list-style-type: none"> <li>5) Press the "CANCEL" key to stop the test.</li> <li>6) Reseat the Tray 4.</li> </ol>
<p>Toner Sensor Y/M/C/K (DI-18/19/1a/1b)</p>	<p>NOTE: Very difficult to check.</p>

Sensor name (Diag. Code)	Confirmation procedures
BTR Toner Full (DI-23)	<p>CAUTION: The Fuser is very hot. Take extremely care not to get burned when carrying the followings.</p> <p>NOTE: Prepare the small size slip of paper (10mm x 50mm).</p> <ol style="list-style-type: none"> <li>1) Turn on the power and enter the Diagnostic Mode.</li> <li>2) Execute the DI-23.</li> <li>3) Push up the Front Latch to open the Front Cover.</li> <li>4) Pinch the tabs on both end of the Transfer Roller, and then remove the Transfer Roller.</li> <li>5) Taking out and putting a small size slip of paper into the gap of the Toner Full Sensor. Check the number on the control panel is counted up.</li> </ol> <ol style="list-style-type: none"> <li>6) Press the "CANCEL" key to stop the test.</li> <li>7) Turn off the power.</li> <li>8) Reinstall the Transfer Roller into position by pushing down on the tabs until you hear a click. (You may hear a click when the Transfer Roller seats properly.)</li> <li>9) Close the Front Cover.</li> </ol>

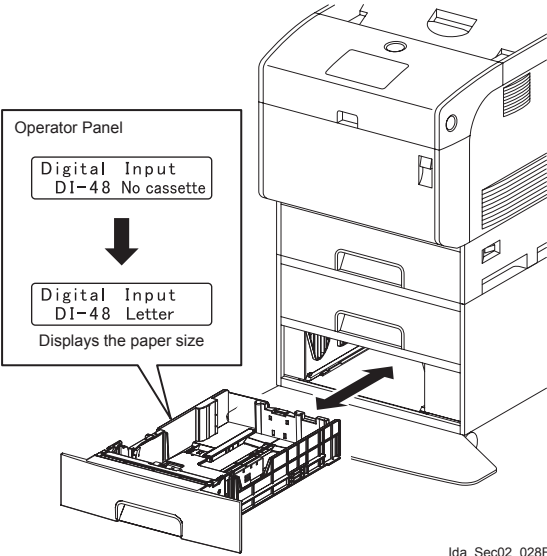
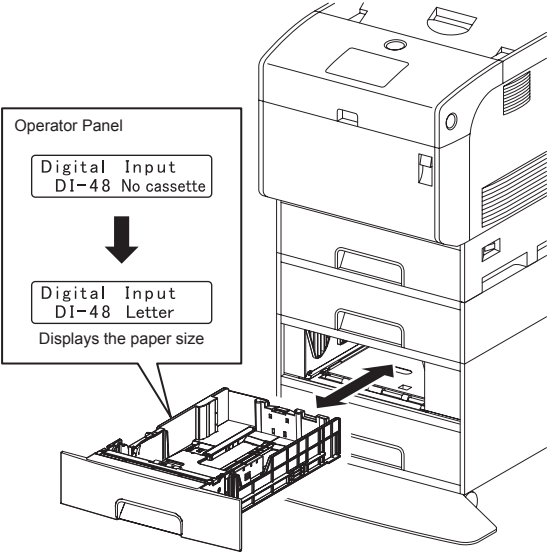

Sensor name (Diag. Code)	Confirmation procedures
Cassette 1 Size (DI-38)	<p>1) Turn on the power and enter the Diagnostic Mode.                      2) Execute the DI-38.                      3) Push and pull the tray 1, and check the message.</p> <div data-bbox="746 338 1295 779" style="text-align: center;"> <p>The diagram shows the operator panel with two message boxes. The top box says 'Digital Input DI-38 No cassette'. An arrow points down to a second box that says 'Digital Input DI-38 Letter' and 'Displays the paper size'. To the right, a printer is shown with tray 1 open. An arrow indicates the tray is pushed in, and another arrow indicates it is pulled out.</p> <p style="text-align: right; font-size: small;">Ida_Sec02_025FA</p> </div> <p>4) Press the "CANCEL" key to stop the test.</p>
Cassette 2 Size (DI-40)	<p>1) Turn on the power and enter the Diagnostic Mode.                      2) Execute the DI-40.                      3) Push and pull the tray 2, and check the message.</p> <div data-bbox="746 981 1295 1473" style="text-align: center;"> <p>The diagram shows the operator panel with two message boxes. The top box says 'Digital Input DI-40 No cassette'. An arrow points down to a second box that says 'Digital Input DI-40 Letter' and 'Displays the paper size'. To the right, a printer is shown with tray 2 open. An arrow indicates the tray is pushed in, and another arrow indicates it is pulled out.</p> <p style="text-align: right; font-size: small;">Ida_Sec02_026FA</p> </div> <div data-bbox="746 1503 1295 1995" style="text-align: center;"> <p>The diagram shows the operator panel with two message boxes. The top box says 'Digital Input DI-40 No cassette'. An arrow points down to a second box that says 'Digital Input DI-40 Letter' and 'Displays the paper size'. To the right, a printer is shown with tray 2 open. An arrow indicates the tray is pushed in, and another arrow indicates it is pulled out.</p> <p style="text-align: right; font-size: small;">Ida_Sec02_027FA</p> </div> <p>4) Press the "CANCEL" key to stop the test.</p>

Sensor name (Diag. Code)	Confirmation procedures
<p>Cassette 3 Size (DI-48)</p>	<ol style="list-style-type: none"> <li>1) Turn on the power and enter the Diagnostic Mode.</li> <li>2) Execute the DI-48.</li> <li>3) Push and pull the tray 3, and check the message.</li> </ol> <div style="text-align: center;">  <p style="text-align: right; font-size: small;">Ida_Sec02_028FA</p> </div> <div style="text-align: center;">  <p style="text-align: right; font-size: small;">Ida_Sec02_029FA</p> </div> <ol style="list-style-type: none"> <li>4) Press the "CANCEL" key to stop the test.</li> </ol>

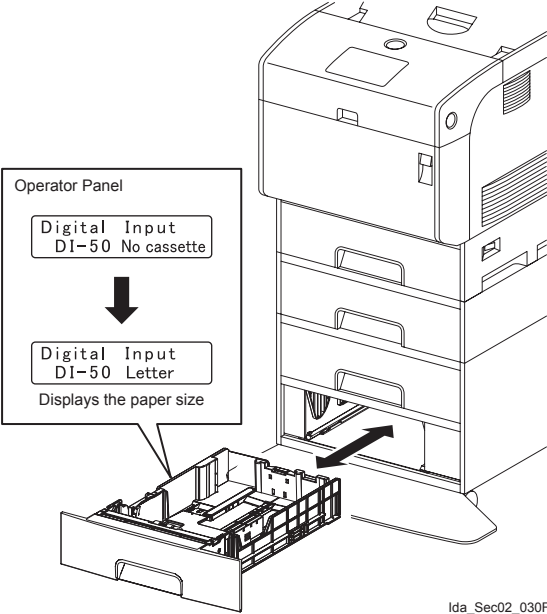
Sensor name (Diag. Code)	Confirmation procedures
<p>Cassette 4 Size (DI-50)</p>	<ol style="list-style-type: none"> <li>1) Turn on the power and enter the Diagnostic Mode.</li> <li>2) Execute the DI-50.</li> <li>3) Push and pull the tray 4, and check the message.</li> </ol> <div style="text-align: center;">  <p style="text-align: right; font-size: small;">Ida_Sec02_030FA</p> </div> <ol style="list-style-type: none"> <li>4) Press the "CANCEL" key to stop the test.</li> </ol>

#### 4.2.5 Digital Output (DO) Test

This function checks whether the DO components operate.

When the interlock is opened while the DO test is performed, each component ends to operate.

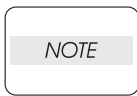

In this Test Mode, each DO component can be turned individually. Therefore it allows the customer to check a component's operation from outside, and judge whether the component is normal or not.

When all the diag. functions are stopped, all the DO components can be turned off. DO test can make each of the DO components operate simultaneously.

#### 4.2.6 Executing digital output (DO) test

- 1) Turn off the power.
- 2) Turn on the power while holding down “▲” and “▼” keys.
- 3) Release the fingers from these keys when “Diagnosing...” is displayed.
- 4) The “Customer Mode” and “ESS Diag” are displayed. (Entered the Diag. mode.)
- 5) Press “▼” key to select “IOT Diag”, and then press “✓” key.
- 6) Press “▼” key to select “Digital Output”, and then press “✓” key.
- 7) Press “▲” or “▼” key to select test item.
- 8) Press “✓” key to execute the test.

Parameters for the Digital Output Test are as follows.

Code(HEX)	Code_DO	Menu No.
00	MAIN MOTOR (FULL1 FORWARD)	DO-0
01	MAIN MOTOR (FULL2 FORWARD)	DO-1
02	MAIN MOTOR (HALF FORWARD)	DO-2
03	MAIN MOTOR (SLOW FORWARD)	DO-3
05	DUPLEX MOTOR (FULL1 FORWARD)	DO-5
06	DUPLEX MOTOR (FULL2 FORWARD)	DO-6
07	DUPLEX MOTOR (HALF FORWARD)	DO-7
08	DUPLEX MOTOR (SLOW FORWARD)	DO-8
09	DUPLEX MOTOR (FULL1 FORWARD-DOUBLE)	DO-9
0A	DUPLEX MOTOR (FULL2 FORWARD-DOUBLE)	DO-a
0B	DUPLEX MOTOR (HALF FORWARD-DOUBLE)	DO-b
0C	DUPLEX MOTOR (SLOW FORWARD-DOUBLE)	DO-c
0D	DUPLEX MOTOR (FULL1 REVERSE)	DO-d

Code(HEX)	Code_DO	Menu No.
0E	DUPLEX MOTOR (FULL2 REVERSE)	DO-e
0F	DUPLEX MOTOR (HALF REVERSE)	DO-f
10	DUPLEX MOTOR (SLOW REVERSE)	DO-10
11	DUPLEX MOTOR (FULL1 REVERSE-DOUBLE)	DO-11
12	DUPLEX MOTOR (FULL2 REVERSE-DOUBLE)	DO-12
13	DUPLEX MOTOR (HALF REVERSE-DOUBLE)	DO-13
14	DUPLEX MOTOR (SLOW REVERSE-DOUBLE)	DO-14
16	DEVE MOTOR (FULL1 FORWARD)	DO-16
17	DEVE MOTOR (FULL2 FORWARD)	DO-17
18	DEVE MOTOR (HALF FORWARD)	DO-18
19	DEVE MOTOR (SLOW FORWARD)	DO-19
1A	DEVE MOTOR (FULL1 REVERSE)	DO-1a
1B	DEVE MOTOR (FULL2 REVERSE)	DO-1b
1C	DEVE MOTOR (HALF REVERSE)	DO-1c
1D	DEVE MOTOR (SLOW REVERSE)	DO-1d
1F	FUSER MOTOR (FULL1 FORWARD)	DO-1f
20	FUSER MOTOR (FULL2 FORWARD)	DO-20
21	FUSER MOTOR (HALF FORWARD)	DO-21
22	FUSER MOTOR (SLOW FORWARD)	DO-22
24	OPTION FEED MOTOR 1 (FULL1 FORWARD)	DO-24
25	OPTION FEED MOTOR 1 (FULL2 FORWARD)	DO-25
26	OPTION FEED MOTOR 1 (HALF FORWARD)	DO-26
27	OPTION FEED MOTOR 1 (SLOW FORWARD)	DO-27
28	OPTION FEED MOTOR 1 (FULL1 FORWARD-DOUBLE)	DO-28
29	OPTION FEED MOTOR 1 (FULL2 FORWARD-DOUBLE)	DO-29
2A	OPTION FEED MOTOR 1 (HALF FORWARD-DOUBLE)	DO-2a

Code(HEX)	Code_DO	Menu No.
2B	OPTION FEED MOTOR 1 (SLOW FORWARD-DOUBLE)	DO-2b
2D	OPTION FEED MOTOR 2 (FULL1 FORWARD)	DO-2d
2E	OPTION FEED MOTOR 2 (FULL2 FORWARD)	DO-2e
2F	OPTION FEED MOTOR 2 (HALF FORWARD)	DO-2f
30	OPTION FEED MOTOR 2 (SLOW FORWARD)	DO-30
31	OPTION FEED MOTOR 2 (FULL1 FORWARD-DOUBLE)	DO-31
32	OPTION FEED MOTOR 2 (FULL2 FORWARD-DOUBLE)	DO-32
33	OPTION FEED MOTOR 2 (HALF FORWARD-DOUBLE)	DO-33
34	OPTION FEED MOTOR 2 (SLOW FORWARD-DOUBLE)	DO-34
36	OPTION FEED MOTOR 3 (not use) (FULL1 FORWARD)	DO-36
37	OPTION FEED MOTOR 3 (not use) (FULL2 FORWARD)	DO-37
38	OPTION FEED MOTOR 3 (not use) (HALF FORWARD)	DO-38
39	OPTION FEED MOTOR 3 (not use) (SLOW FORWARD)	DO-39
3A	OPTION3 MOTOR (not use) (FULL1 FORWARD-DOUBLE)	DO-3a
3B	OPTION3 MOTOR (not use) (FULL2 FORWARD-DOUBLE)	DO-3b
3C	OPTION3 MOTOR (not use) (HALF FORWARD-DOUBLE)	DO-3c
3D	OPTION3 MOTOR (not use) (SLOW FORWARD-DOUBLE)	DO-3d
3F	REAR FAN MOTOR (HIGH)	DO-3f
40	REAR FAN MOTOR (LOW)	DO-40
42	REAR FAN 2 MOTOR (HIGH)	DO-42
43	REAR FAN 2 MOTOR (HIGH)	DO-43
45	FRONT FAN MOTOR (HIGH)	DO-45
46	FRONT FAN MOTOR (LOW)	DO-46
48	TONER MOTOR Y	DO-48
4A	TONER MOTOR M	DO-4a
4C	TONER MOTOR C	DO-4c
4E	TONER MOTOR K	DO-4e
50	REGI CLUTCH	DO-50
52	MSI TURN CLUTCH	DO-52
54	MSI FEED SOLENOID	DO-54
56	CASSETTE1 FEED SOLENOID	DO-56
58	CASSETTE2 TURN CLUTCH	DO-58
5A	CASSETTE2 FEED SOLENOID	DO-5a

Code(HEX)	Code_DO	Menu No.
5C	CASSETTE3 TURN CLUTCH	DO-5c
5E	CASSETTE3 FEED SOLENOID	DO-5e
60	CASSETTE4 TURN CLUTCH	DO-60
62	CASSETTE4 FEED SOLENOID	DO-62
64	CTD (ADC) SENSOR (not use)	DO-64
66	MEDIA SENSOR-1 (not use)	DO-66

#### 4.2.7 Exiting digital output (DO) test

- 1) Press "CANCEL" key to stop the DO Test.
- 2) Press "MENU" key to exit the DO Test mode. ("IOT Diag" and "Digital Output" are displayed after that "Please Wait" was displayed.)
- 3) Press "CANCEL" key, "IOT Diag" is displayed.

To shift the mode from Diag. mode to the normal mode, perform as follows.

- 4) Press "▼" key to select "Complete".
- 5) Press "✓" key three times to exit the "Diag. Mode."

#### 4.2.8 How to check the motors, clutches and solenoids

- Parts Location

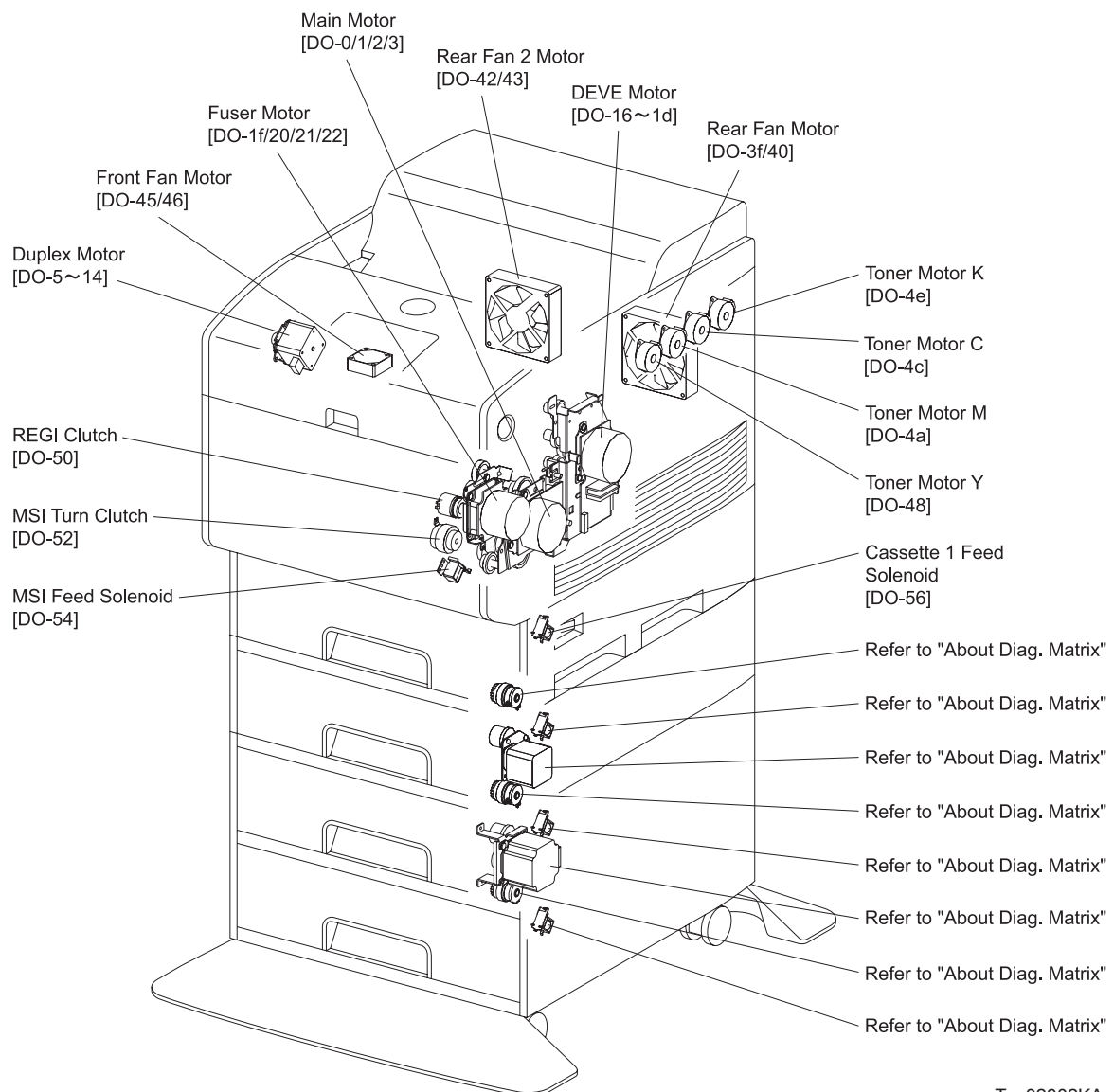

Ten02002KA



- About Clutch

The electromagnetic clutch in the printer controls the rotation of the roller by transferring or cutting the torque from the motor to the roller.

The electromagnetic clutch becomes an electromagnet by the passage of electric current through the coil inside the case and attracts the armature and gear to the rotating rotor, thereby rotating the gear.

Upon the loss of power to the coil, electromagnetic force is lost and the armature comes off the rotor, and the gear comes to rest.

The clutch makes so soft noises that you must be close the component to audibly confirm the operation of the component.

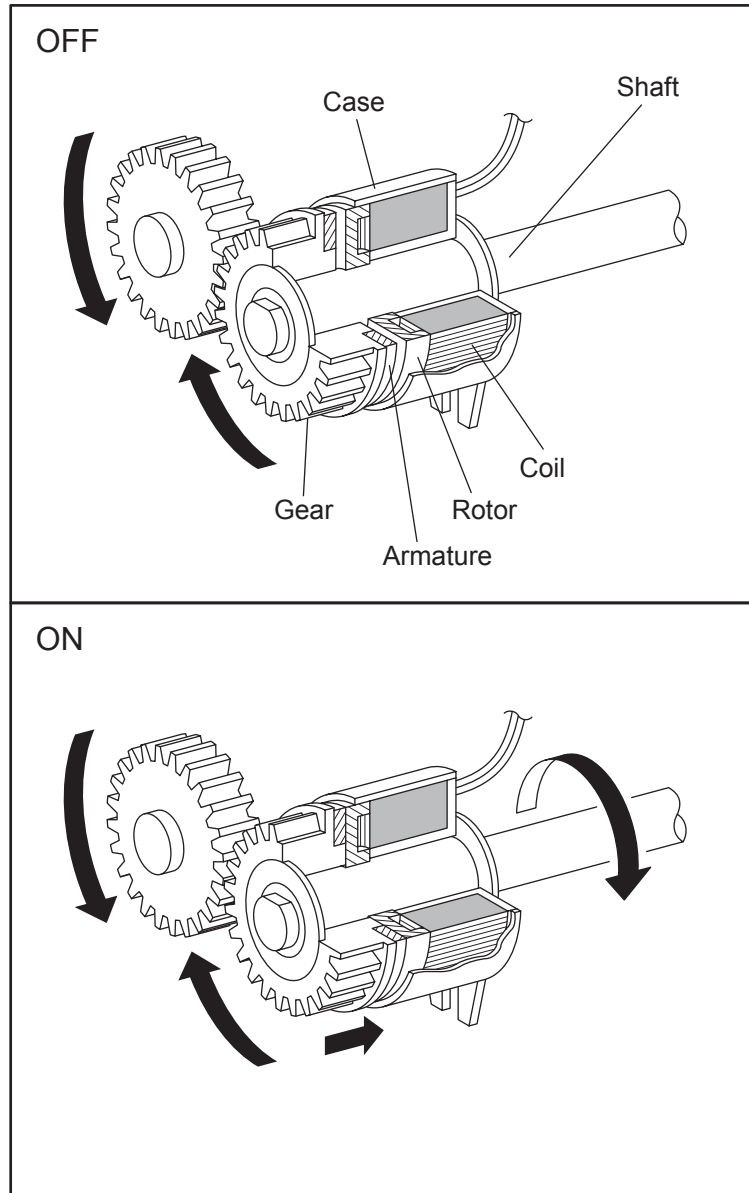

Leg\_Sec02\_050FA

- About Solenoid

The solenoid in the printer opens/closes the shutter or controls the position of the gear for transferring the torque of the motor to the roller.

A solenoid becomes an electromagnet by the passage of electric current through the coil inside the case and attracts the plunger.

Upon the loss of power to the coil, electromagnetic force is lost and the plunger is returned to its original position by spring action, thereby allowing the shutter to operate or the gear to move to the predefined position.

Unlike a clutch, a solenoid generates a loud operation noise.

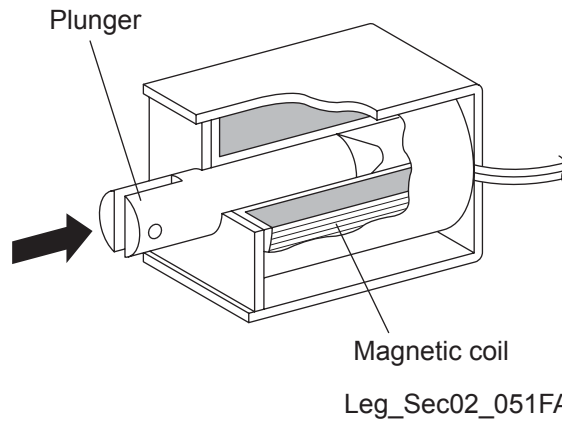

## - About Diag. Matrix

The diagnosis number differs depending on the composition of the Optional Feeder(s) that was installed to the printer. Refer to Diag Matrix table below.

Diag Matrix for Option Feed Motor 1/2 (Forward) (DO-24/-25/-26/-27/-2d/-2e/2f/-30)

Printer	Paper Tray Composition			
	Standard Only	One Tray Opt. Feeder	Two Tray Opt. Feeder	One Tray + Two Tray Opt. Feeders
1. Standard	--	--	--	--
2. 500 Sheets (One Tray Opt. Feeder)	--	DO-24/-25/ -26/27	--	DO-24/-25/ -26/27
3. 500 Sheets 4. 500 Sheets (Two Tray Opt. Feeder)	--	--	DO-24/-25/ -26/27	DO-2d/-2e/ -2f/30

Diag Matrix for Option Feed Motor 1/2 (Forward-Double) (DO-28/-29/-2a/-2b/-31/-32/33/-34)

Printer	Paper Tray Composition			
	Standard Only	One Tray Opt. Feeder	Two Tray Opt. Feeder	One Tray + Two Tray Opt. Feeders
1. Standard	--	--	--	--
2. 500 Sheets (One Tray Opt. Feeder)	--	DO-28/-29/ -2a/-2b	--	DO-28/-29/ -2a/-2b
3. 500 Sheets 4. 500 Sheets (Two Tray Opt. Feeder)	--	--	DO-28/-29/ -2a/-2b	DO-31/-32/ -33/-34

Diag Matrix for Cassette 2/3/4 Turn Clutch (DO-58/-5c/-60)

Printer	Paper Tray Composition			
	Standard Only	One Tray Opt. Feeder	Two Tray Opt. Feeder	One Tray + Two Tray Opt. Feeders
1. Standard	--	--	--	--
2. 500 Sheets (One Tray Opt. Feeder)	--	DO-58	--	DO-58
3. 500 Sheets 4. 500 Sheets (Two Tray Opt. Feeder)	--	--	DO-58	DO-5c
	--	--	DO-5c	DO-60

Diag Matrix for Cassette 2/3/4 Feed Solenoid (DO-5a/-5e/-62)

Printer	Paper Tray Composition			
	Standard Only	One Tray Opt. Feeder	Two Tray Opt. Feeder	One Tray + Two Tray Opt. Feeders
1. Standard	--	--	--	--
2. 500 Sheets (One Tray Opt. Feeder)	--	DO-5a	--	DO-5a
3. 500 Sheets 4. 500 Sheets (Two Tray Opt. Feeder)	--	--	DO-5a	DO-5e
	--	--	DO-5e	DO-62

- Checking Motor, Clutch and Solenoid

**NOTE**

Before executing the DO test, close all covers and doors.

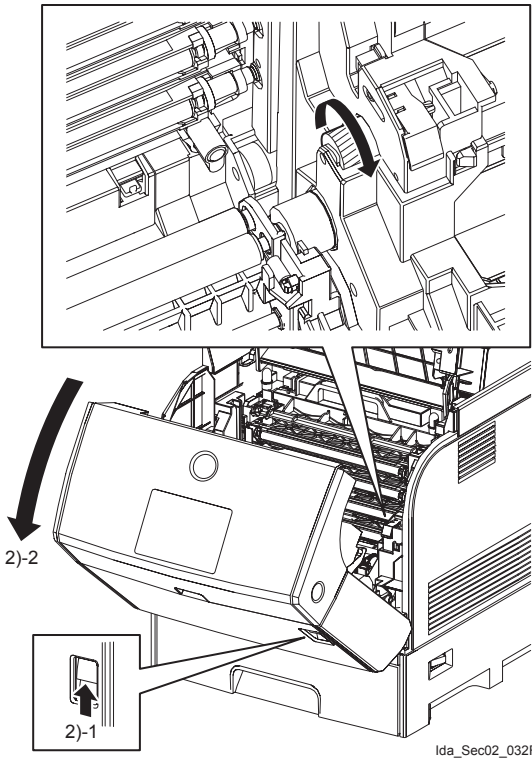
Motor, Clutch and Solenoid name (Diag. Code)	Confirmation procedures
<p>Main Motor (Full 1 Forward) (DO-0)                      Main Motor (Full 2 Forward) (DO-1)                      Main Motor (Half Forward) (DO-2)                      Main Motor (Slow Forward) (DO-3)</p>	<p>NOTE: The following procedures are for the technical staff. The customer check is procedures 2, 3 and 4.</p> <ol style="list-style-type: none"> <li>1) Turn on the power and enter the Diagnostic Mode.</li> <li>2) Push up the Front Latch to open the Front Cover.</li> <li>3) Cheat the safety Interlock System.</li> <li>4) Execute the DO-0, DO-1, DO-2 or DO-3. Confirm the rotation of the gear on the Main Motor. (The customer can confirm the motor noise only.)                      The rotational speed of the motor is as follows.                      DO-3 (slow speed) &lt; DO-2 &lt; DO-1 &lt; DO-0 (high speed)</li> </ol>  <p style="text-align: right; font-size: small;">Ida_Sec02_032FA</p> <ol style="list-style-type: none"> <li>5) Press the "CANCEL" key to stop the test.</li> <li>6) Remove the cheater.</li> <li>7) Close the Front Cover.</li> </ol>

Motor, Clutch and Solenoid name (Diag. Code)	Confirmation procedures
<p>Duplex Motor (Full 1 Forward) (DO-5)  Duplex Motor (Full 2 Forward) (DO-6)  Duplex Motor (Half Forward) (DO-7)  Duplex Motor (Slow Forward) (DO-8)</p> <p>Duplex Motor (Full 1 Forward-Double) (DO-9)  Duplex Motor (Full 2 Forward-Double) (DO-a)  Duplex Motor (Half Forward-Double) (DO-b)  Duplex Motor (Slow Forward-Double) (DO-c)</p> <p>Duplex Motor (Full 1 Reverse) (DO-d)  Duplex Motor (Full 2 Reverse) (DO-e)  Duplex Motor (Half Reverse) (DO-f)  Duplex Motor (Slow Reverse) (DO-10)</p> <p>Duplex Motor (Full 1 Reverse-Double) (DO-11)  Duplex Motor (Full 2 Reverse-Double) (DO-12)  Duplex Motor (Half Reverse-Double) (DO-13)  Duplex Motor (Slow Reverse-Double) (DO-14)</p>	<p>NOTE: The following procedures are for the technical staff. The customer check is procedures 1, 4 and 5.</p> <ol style="list-style-type: none"> <li>1) Turn on the power and enter the Diagnostic Mode.</li> <li>2) Push the Side Button to open the Front Cover.</li> <li>3) Cheat the safety Interlock System.</li> <li>4) For DO-5/-6/-7/-8 diagnosis  Execute the DO-5, DO-6, DO-7 or DO-8. Confirm the gear on the Front Cover rotates in clockwise direction viewing from the left side of the printer. (The customer can confirm the motor noise only.)  The rotational speed of the motor is as follows.  DO-8 (slow speed) &lt; DO-7 &lt; DO-6 &lt; DO-5 (high speed)</li> </ol> <p>For DO-9/-a/-b/-c diagnosis  Execute the DO-9, DO-a, DO-b or DO-c. Confirm the gear on the Front Cover rotates in clockwise direction viewing from the left side of the printer. (The customer can confirm the motor noise only.)  The rotational speed of the motor is as follows.  DO-c (slow speed) &lt; DO-b &lt; DO-a &lt; DO-9 (high speed)</p> <p>For DO-d/-e/-f/-10 diagnosis  Execute the DO-d, DO-e, DO-f or DO-10. Confirm the gear on the Front Cover rotates in counterclockwise direction viewing from the left side of the printer. (The customer can confirm the motor noise only.)  The rotational speed of the motor is as follows.  DO-10 (slow speed) &lt; DO-f &lt; DO-e &lt; DO-d (high speed)</p> <p>For DO-11/-12/-13/-14 diagnosis  Execute the DO-11, DO-12, DO-13 or DO-14. Confirm the gear on the Front Cover rotates in counterclockwise direction viewing from the left side of the printer. (The customer can confirm the motor noise only.)  The rotational speed of the motor is as follows.  DO-14 (slow speed) &lt; DO-13 &lt; DO-12 &lt; DO-11 (high speed)</p> <div data-bbox="780 1294 1267 1951" style="text-align: center;"> </div> <p style="text-align: right; font-size: small;">Ida_Sec02_033FA</p> <ol style="list-style-type: none"> <li>5) Press the "CANCEL" key to stop the test.</li> <li>6) Remove the cheater.</li> <li>7) Close the Front Cover.</li> </ol>

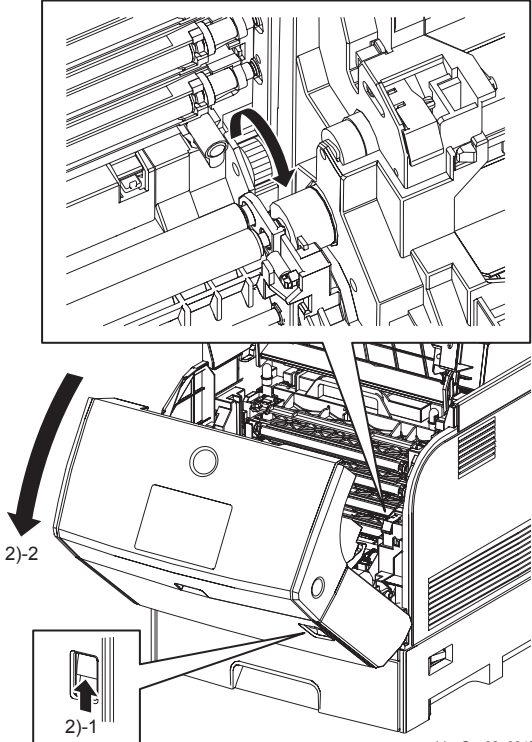
Motor, Clutch and Solenoid name (Diag. Code)	Confirmation procedures
<p>DEVE Motor (Full 1 Forward) (DO-16)                      DEVE Motor (Full 2 Forward) (DO-17)                      DEVE Motor (Half Forward) (DO-18)                      DEVE Motor (Slow Forward) (DO-19)</p> <p>DEVE Motor (Full 1 Reverse) (DO-1a)                      DEVE Motor (Full 2 Reverse) (DO-1b)                      DEVE Motor (Half Reverse) (DO-1c)                      DEVE Motor (Slow Reverse) (DO-1d)</p>	<p>NOTE: The following procedures are for the technical staff. The customer check is procedures 2, 3 and 4.</p> <ol style="list-style-type: none"> <li>1) Turn on the power and enter the Diagnostic Mode.</li> <li>2) Push up the Front Latch to open the Front Cover.</li> <li>3) Push the Button to open the Imaging Drum Cover, and open it backward.</li> <li>4) Remove the Imaging Drum.</li> <li>5) Cheat the safety Interlock System.</li> <li>6) For DO-16/-17/-18/-19 diagnosis                      Execute the DO-16, DO-17, DO-18 or DO-19. Confirm the gear on the DEVE motor rotates in the frontward direction viewing from the top of the printer. (The customer can confirm the motor noise only.)                      The rotational speed of the motor is as follows.                      DO-19 (slow speed) &lt; DO-18 &lt; DO-17 &lt; DO-16 (high speed)</li> <li>For DO-1a/-1b/-1c/-1d diagnosis                      Execute the DO-1a, DO-1b, DO-1c or DO-1d. Confirm the gear on the DEVE motor rotates in the backward direction viewing from the top of the printer. (The customer can confirm the motor noise only.)                      The rotational speed of the motor is as follows.                      DO-1d (slow speed) &lt; DO-1c &lt; DO-1b &lt; DO-1a (high speed)</li> </ol> <div style="text-align: center;">  </div> <ol style="list-style-type: none"> <li>7) Press the "CANCEL" key to stop the test.                      NOTE: Press the "CANCEL" key within 5 seconds after executing the test.</li> <li>8) Remove the cheater.</li> <li>9) Reinstall the Imaging Drum, and close the Imaging Drum Cover.</li> <li>10) Close the Front Cover.</li> </ol>

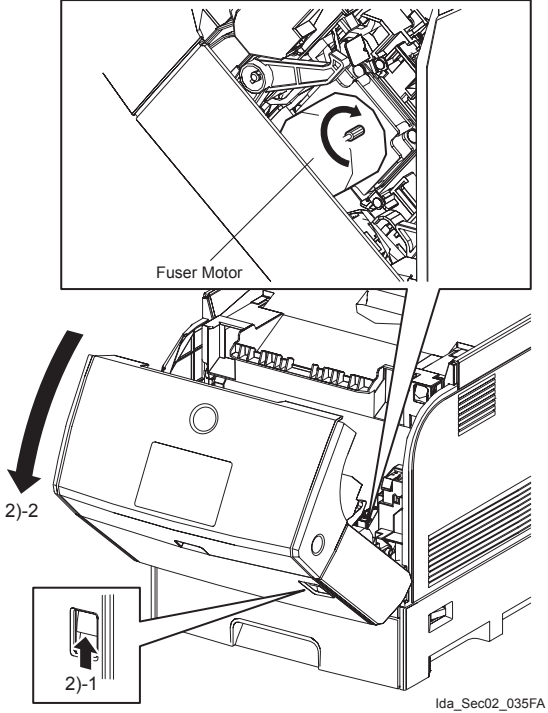
Motor, Clutch and Solenoid name (Diag. Code)	Confirmation procedures
<p>Fuser Motor (Full 1 Forward) (DO-1f)  Fuser Motor (Full 2 Forward) (DO-20)  Fuser Motor (Half Forward) (DO-21)  Fuser Motor (Slow Forward) (DO-22)</p>	<p>NOTE: The following procedures are for the technical staff. The customer check is procedures 1, 4 and 5.</p> <ol style="list-style-type: none"> <li>1) Turn on the power and enter the Diagnostic Mode.</li> <li>2) Push up the Front Latch to open the Front Cover.</li> <li>3) Cheat the safety Interlock System.</li> <li>4) Execute the DO-1f, DO-20, DO-21 or DO-22. Confirm the rotation of the motor. (The customer can confirm the motor noise only.)  The rotational speed of the motor is as follows.  DO-22 (slow speed) &lt; DO-21 &lt; DO-20 &lt; DO-1f (high speed)</li> </ol>  <p style="text-align: right; font-size: small;">Ida_Sec02_035FA</p> <ol style="list-style-type: none"> <li>5) Press the "CANCEL" key to stop the test.</li> <li>6) Remove the cheater.</li> <li>7) Close the Front Cover.</li> </ol>

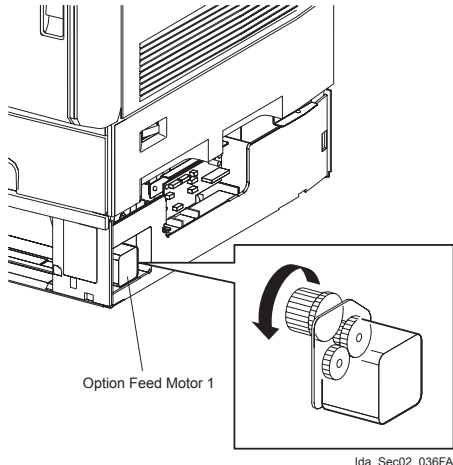
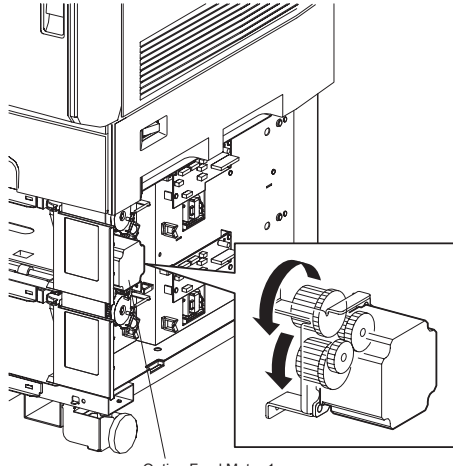
Motor, Clutch and Solenoid name (Diag. Code)	Confirmation procedures
<p>Option Feed Motor 1 (Full 1 Forward) (DO-24)                      Option Feed Motor 1 (Full 2 Forward) (DO-25)                      Option Feed Motor 1 (Half Forward) (DO-26)                      Option Feed Motor 1 (Slow Forward) (DO-27)</p> <p>Option Feed Motor 1 (Full 1 Forward-Double) (DO-28)                      Option Feed Motor 1 (Full 2 Forward-Double) (DO-29)                      Option Feed Motor 1 (Half Forward-Double) (DO-2a)                      Option Feed Motor 1 (Slow Forward-Double) (DO-2b)</p>	<p><b>NOTE:</b> The following procedures are for the technical staff. The customer check is procedures 2, 3 and 4.</p> <ol style="list-style-type: none"> <li>1) Remove the Cover Right on One Tray Option Feeder or 2 Tray Feeder Right Cover on Two Tray Option Feeder. (Refer to RRP.)</li> <li>2) Turn on the power and enter the Diagnostic Mode.</li> <li>3) For DO-24/-25/-26/-27 diagnosis                      Execute the DO-24, DO-25, DO-26 or DO-27. Confirm the gear attached to the Drive Motor rotates in counterclockwise direction viewing from the right side of the feeder. (The customer can confirm the motor noise only.)                      The rotational speed of the motor is as follows.                      DO-27 (slow speed) &lt; DO-26 &lt; DO-25 &lt; DO-24 (high speed)</li>                       For DO-28/-29/-2a/-2b diagnosis                      Execute the DO-28, DO-29, DO-2a or DO-2b. Confirm the gear attached to the Drive Motor rotates in counterclockwise direction viewing from the right side of the feeder. (The customer can confirm the motor noise only.)                      The rotational speed of the motor is as follows.                      DO-2b (slow speed) &lt; DO-2a &lt; DO-29 &lt; DO-28 (high speed) </ol> <div style="text-align: center;">  <p>Option Feed Motor 1</p> <p><small>Ida_Sec02_036FA</small></p> </div> <div style="text-align: center;">  <p>Option Feed Motor 1</p> <p><small>Ida_Sec02_037FA</small></p> </div> <ol style="list-style-type: none"> <li>4) Press the "CANCEL" key to stop the test.</li> <li>5) Turn off the power.</li> <li>6) Reinstall the Cover Right or 2 Tray Feeder Right Cover. (Refer to RRP.)</li> </ol>

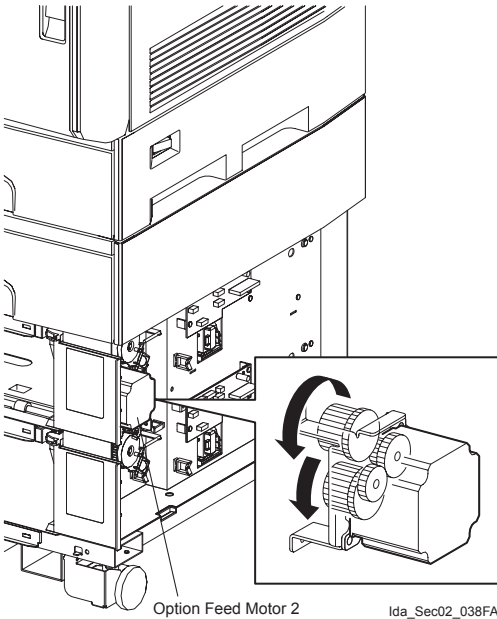

Motor, Clutch and Solenoid name (Diag. Code)	Confirmation procedures
<p>Option Feed Motor 2 (Full 1 Forward) (DO-2d)  Option Feed Motor 2 (Full 2 Forward) (DO-2e)  Option Feed Motor 2 (Half Forward) (DO-2f)  Option Feed Motor 2 (Slow Forward) (DO-30)</p> <p>Option Feed Motor 2 (Full 1 Forward-Double) (DO-31)  Option Feed Motor 2 (Full 2 Forward-Double) (DO-32)  Option Feed Motor 2 (Half Forward-Double) (DO-33)  Option Feed Motor 2 (Slow Forward-Double) (DO-34)</p>	<p>NOTE: The following procedures are for the technical staff. The customer check is procedures 2, 3 and 4.</p> <ol style="list-style-type: none"> <li>1) Remove the 2 Tray Feeder Right Cover from the Two Tray Option Feeder. (Refer to RRP.)</li> <li>2) Turn on the power and enter the Diagnostic Mode.</li> <li>3) For DO-2d/-2e/-2f/-30 diagnosis  Execute the DO-2d, DO-2e, DO-2f or DO-30. Confirm the gear attached to the Drive Motor rotates in counterclockwise direction viewing from the right side of the feeder. (The customer can confirm the motor noise only.)  The rotational speed of the motor is as follows.  DO-30 (slow speed) &lt; DO-2f &lt; DO-2e &lt; DO-2d (high speed)</li>   For DO-31/-32/-33/-34 diagnosis  Execute the DO-31, DO-32, DO-33 or DO-34. Confirm the gear attached to the Drive Motor rotates in counterclockwise direction viewing from the right side of the feeder. (The customer can confirm the motor noise only.)  The rotational speed of the motor is as follows.  DO-34 (slow speed) &lt; DO-33 &lt; DO-32 &lt; DO-31 (high speed) </ol>  <ol style="list-style-type: none"> <li>4) Press the "CANCEL" key to stop the test.</li> <li>5) Turn off the power.</li> <li>6) Reinstall the 2 Tray Feeder Right Cover. (Refer to RRP.)</li> </ol>

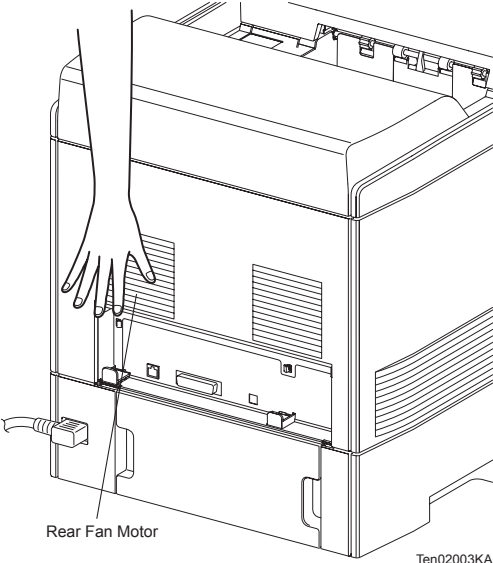
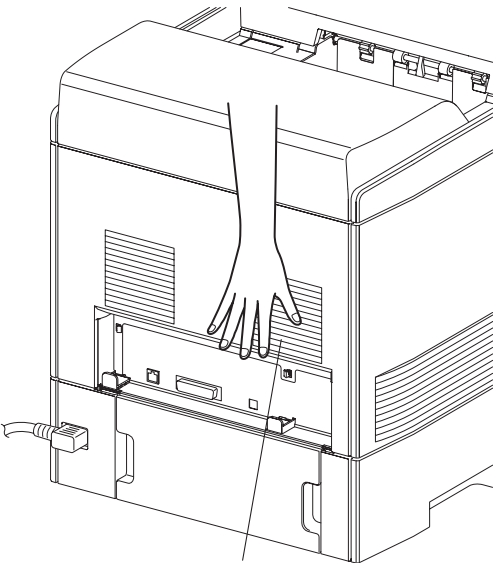
Motor, Clutch and Solenoid name (Diag. Code)	Confirmation procedures
<p>Rear Fan Motor (High) (DO-3f) Rear Fan Motor (Low) (DO-40)</p>	<ol style="list-style-type: none"> <li>1) Turn on the power and enter the Diagnostic Mode.</li> <li>2) Execute the DO-3f or DO-40. Put the hand to the left side ventilation holes on the Rear Cover viewing from the back, and confirm the air is inhaled into the printer. The rotational speed of the rear fan motor is as follows. DO-40 (slow speed) &lt; DO-3f (high speed)</li> <li>3) Press the "CANCEL" key to stop the test.</li> </ol> 
<p>Rear Fan 2 Motor (High) (DO-42) Rear Fan 2 Motor (High) (DO-43)</p>	<ol style="list-style-type: none"> <li>1) Turn on the power and enter the Diagnostic Mode.</li> <li>2) Execute the DO-42 or DO-43. Put the hand to the right side ventilation holes on the Rear Cover viewing from the back, and confirm the air is inhaled into the printer.</li> <li>3) Press the "CANCEL" key to stop the test.</li> </ol> 

Motor, Clutch and Solenoid name (Diag. Code)	Confirmation procedures
<p>Front Fan Motor (High) (DO-45) Front Fan Motor (Low) (DO-46)</p>	<p>NOTE: The following procedures are for the technical staff. The customer check is procedures 1, 4 and 5.</p> <ol style="list-style-type: none"> <li>1) Turn on the power and enter the Diagnostic Mode.</li> <li>2) Push the Side Button to open the Front Cover.</li> <li>3) Cheat the safety Interlock System.</li> <li>4) Execute the DO-45 or DO-46. Put the hand into inside of the Front Cover, and confirm the air blows from the Front Fan. (The customer can confirm the motor noise only.) The rotational speed of the Front Fan Motor is as follows. DO-46 (slow speed) &lt; DO-45 (high speed)</li> </ol> <div data-bbox="756 595 1294 1323" style="text-align: center;"> </div> <p style="text-align: right; font-size: small;">Ida_Sec02_040FA</p> <ol style="list-style-type: none"> <li>5) Press the "CANCEL" key to stop the test.</li> <li>6) Remove the cheater.</li> <li>7) Close the Front Cover.</li> </ol>

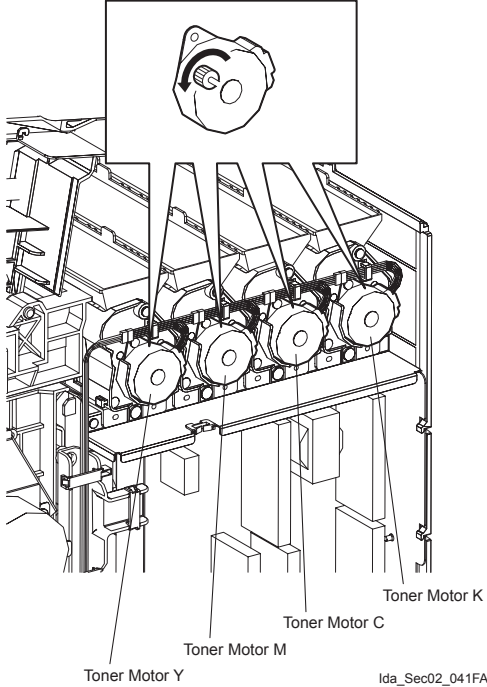
Motor, Clutch and Solenoid name (Diag. Code)	Confirmation procedures
<p>Toner Motor Y (DO-48)  Toner Motor M (DO-4a)  Toner Motor C (DO-4c)  Toner Motor K (DO-4e)</p>	<p>NOTE: Be sure to install the Toner Cartridges to the printer at this confirmation.</p> <p>NOTE: The following procedures are for the technical staff. The customer check is procedures 2, 3 and 4.</p> <ol style="list-style-type: none"> <li>1) Remove the Right Side Cover. (Refer to RRP.)</li> <li>2) Turn on the power and enter the Diagnostic Mode.</li> <li>3) Execute the DO-48, DO-4a, DO-4c or DO-4e. Confirm the rotation of the gear attached to the toner motor. (The customer can confirm the motor noise only.)</li> </ol> <div style="text-align: center;">  <p style="text-align: center;">Toner Motor Y      Toner Motor M      Toner Motor C      Toner Motor K</p> <p style="text-align: right;">Ida_Sec02_041FA</p> </div> <ol style="list-style-type: none"> <li>4) Press the "CANCEL" key to stop the test.</li> <li>5) Turn off the power.</li> <li>6) Reinstall the Right Side Cover. (Refer to RRP.)</li> </ol>

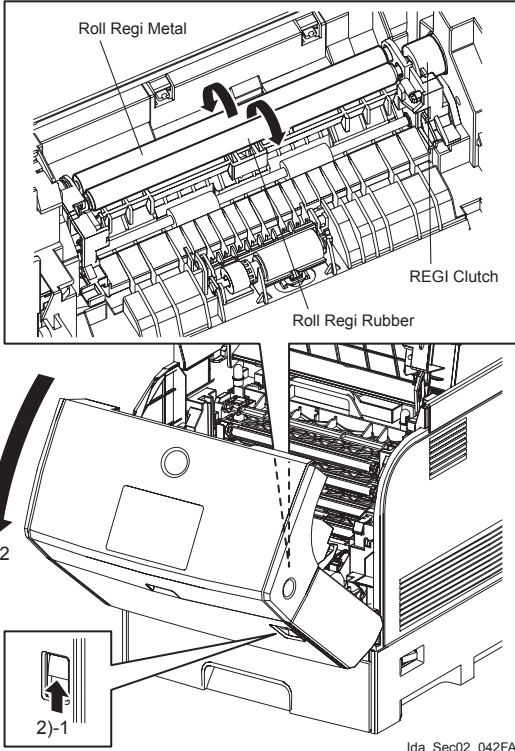
Motor, Clutch and Solenoid name (Diag. Code)	Confirmation procedures
REGI Clutch (DO-50)	<ol style="list-style-type: none"> <li>1) Turn on the power and enter the Diagnostic Mode.</li> <li>2) Execute the DO-50. Upon pressing the “✓” key, confirm the operation noise of the clutch is heard.</li> <li>3) Press the “CANCEL” key to stop the test.</li> </ol> <p>Combination test is as follows.  <b>NOTE:</b> The Regi Roll rotates when the DO-0 and DO-50 are executed. The following procedures are for the technical staff.</p> <ol style="list-style-type: none"> <li>1) Turn on the power and enter the Diagnostic Mode.</li> <li>2) Push up the Front Latch to open the Front Cover.</li> <li>3) Cheat the safety Interlock System.</li> <li>4) Execute the DO-0 and DO-50. Confirm the rotation of the Roll Regi Metal and Roll Regi Rubber on the Retard and Regi Assy.</li> </ol> <div style="text-align: center;">  <p style="text-align: right; font-size: small;">Ida_Sec02_042FA</p> </div> <ol style="list-style-type: none"> <li>5) Press the “CANCEL” key to stop the REGI Clutch test (DO-50 test).</li> <li>6) Press the “▼” key to display the DO-0.</li> <li>7) Press the “CANCEL” key to stop the Main Motor (DO-0 test).</li> <li>8) Remove the cheater.</li> <li>9) Close the Front Cover.</li> </ol>

Motor, Clutch and Solenoid name (Diag. Code)	Confirmation procedures
MSI Turn Clutch (DO-52)	<p>1) Turn on the power and enter the Diagnostic Mode.</p> <p>2) Execute the DO-52. Upon pressing the “✓” key, confirm the operation noise of the clutch is heard.</p> <p>3) Press the “CANCEL” key to stop the test.</p> <p>Combination test is as follows.  <b>NOTE:</b> The Roll Turn MSI rotates when the DO-0 and DO-52 are executed. The following procedures are for the technical staff.</p> <p>1) Turn on the power and enter the Diagnostic Mode.</p> <p>2) Push up the Front Latch to open the Front Cover.</p> <p>3) Cheat the safety Interlock System.</p> <p>4) Execute the DO-0 and DO-52. Confirm the rotation of the Roll Turn MSI on the Retard and Regi Assy.</p> <div data-bbox="778 703 1295 1451" style="text-align: center;"> <p style="text-align: right; margin-right: 50px;">Roll Turn MSI</p> <p style="text-align: right;">Ida_Sec02_043FA</p> </div> <p>5) Press the “CANCEL” key to stop the MSI Turn Clutch test (DO-52 test).</p> <p>6) Press the “▼” key to display the DO-0.</p> <p>7) Press the “CANCEL” key to stop the Main Motor (DO-0 test).</p> <p>8) Remove the cheater.</p> <p>9) Close the Front Cover.</p>

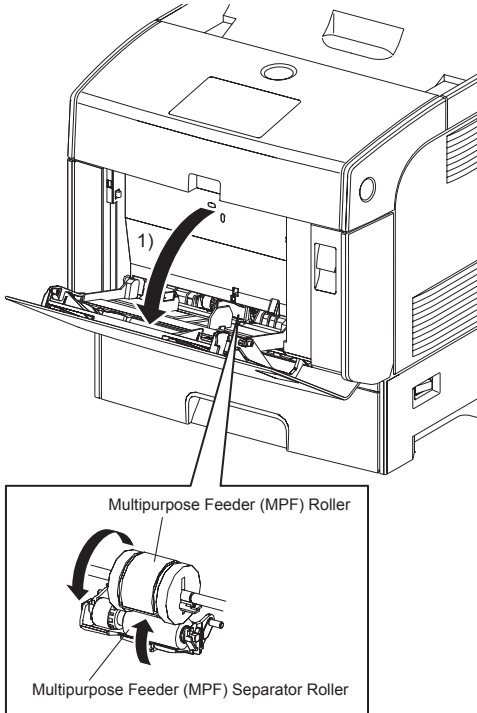
Motor, Clutch and Solenoid name (Diag. Code)	Confirmation procedures
MSI Feed Solenoid (DO-54)	<p>1) Turn on the power and enter the Diagnostic Mode.</p> <p>2) Execute the DO-54. Upon pressing the “✓” key, confirm the operation noise of the solenoid is heard.</p> <p>3) Press the “CANCEL” key to stop the test.</p> <p>Combination test is as follows.  <b>NOTE:</b> The Multipurpose Feeder (MPF) Separator Roller rotates when the DO-0 and DO-54 are executed. The following procedures are for the technical staff.</p> <p>1) Open the Multipurpose Feeder (MPF) Tray.</p> <p>2) Turn on the power and enter the Diagnostic Mode.</p> <p>3) Execute the DO-0 and DO-54. Confirm the rotation of the Multipurpose Feeder (MPF) Separator Roller.</p>  <p>The diagram consists of two parts. The upper part is a perspective view of a printer's Multipurpose Feeder (MPF) tray, which is shown open. A curved arrow labeled '1)' indicates the rotation of the Multipurpose Feeder (MPF) Separator Roller. The lower part is a detailed cross-sectional view of the roller assembly, with two arrows indicating the rotation of the Multipurpose Feeder (MPF) Roller and the Multipurpose Feeder (MPF) Separator Roller.</p> <p style="text-align: right; font-size: small;">Ida_Sec02_044FA</p> <p>4) Press the “CANCEL” key to stop the MSI Feed Solenoid test (DO-54 test).</p> <p>5) Press the “▼” key to display the DO-0.</p> <p>6) Press the “CANCEL” key to stop the Main Motor (DO-0 test).</p> <p>7) Close the Multipurpose Feeder (MPF) Tray.</p>

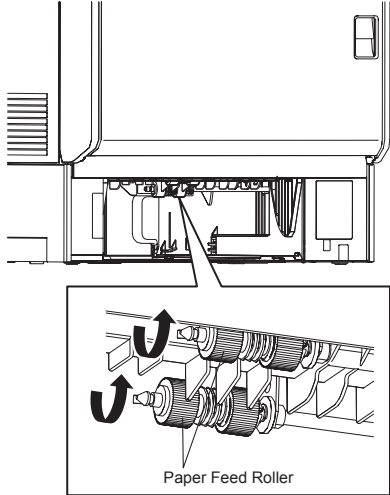
Motor, Clutch and Solenoid name (Diag. Code)	Confirmation procedures
Cassette 1 Feed Solenoid (DO-56)	<p>1) Turn on the power and enter the Diagnostic Mode.</p> <p>2) Execute DO-56.</p> <p>3) Press the “CANCEL” key to stop the test. Upon pressing the “CANCEL” key, confirm the operation noise of the solenoid is heard.</p> <p>Combination test is as follows.  <b>NOTE:</b> The Paper Feed Roller of Tray 1 rotates when the DO-0 and DO-56 are executed. The following procedures are for the technical staff.</p> <p>1) Remove the 500 Sheet Paper Tray of Tray 1.</p> <p>2) Turn on the power and enter the Diagnostic Mode.</p> <p>3) Execute the DO-0 and DO-56. Confirm the rotation of the Paper Feed Rollers viewing from the removed Paper Tray portion.</p> <div data-bbox="826 763 1219 1256" style="text-align: center;">  <p>The diagram consists of two parts. The upper part is a cross-sectional view of the paper tray area, showing the internal rollers and drive mechanism. A line points from this view to a more detailed, exploded view of the Paper Feed Roller assembly below. This detailed view shows two rollers with arrows indicating their rotation direction. The label 'Paper Feed Roller' is centered below this detailed view.</p> </div> <p style="text-align: right; font-size: small;">Ida_Sec02_045FA</p> <p>4) Press the “CANCEL” key to stop the Cassette 1 Feed Solenoid test (DO-56 test).</p> <p>5) Press the “▼” key to display the DO-0.</p> <p>6) Press the “CANCEL” key to stop the Main Motor (DO-0 test).</p> <p>7) Reseat the 500 Sheet Paper Tray.</p>

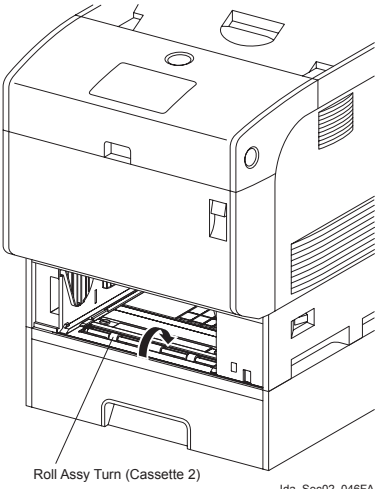
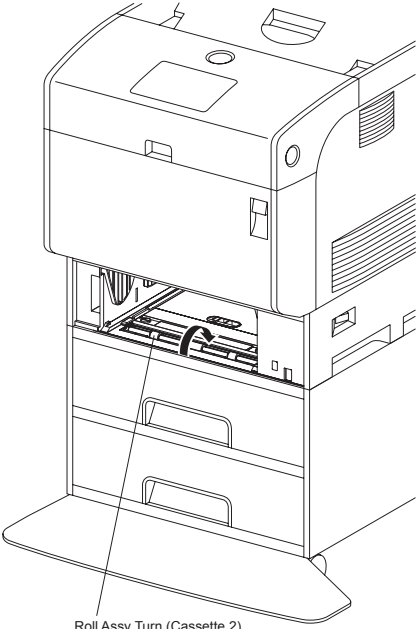

Motor, Clutch and Solenoid name (Diag. Code)	Confirmation procedures
<p>Cassette 2 Turn Clutch (DO-58)</p>	<ol style="list-style-type: none"> <li>1) Turn on the power and enter the Diagnostic Mode.</li> <li>2) Execute DO-58. Upon pressing the “✓” key, confirm the operation noise of the clutch is heard.</li> <li>3) Press the “CANCEL” key to stop the test.</li> </ol> <p>Combination test is as follows.  <b>NOTE:</b> The Roll Assy Turn of Tray 2 rotates when the DO-24 and DO-58 are executed. The following procedures are for the technical staff.</p> <ol style="list-style-type: none"> <li>1) Remove the 500 Sheet Paper Tray of Tray 1. (Remove the upper Paper Tray on the cassette number. For example: when the cassette number is 2, remove the Paper Tray of Tray 1.)</li> <li>2) Turn on the power and enter the Diagnostic Mode.</li> <li>3) Execute the DO-24 and DO-58. Confirm the rotation of the Roll Assy Turn viewing from the removed Paper Tray portion.</li> </ol> <div style="display: flex; justify-content: space-around; align-items: center;"> <div style="text-align: center;">  <p>Roll Assy Turn (Cassette 2) Ida_Sec02_046FA</p> </div> <div style="text-align: center;">  <p>Roll Assy Turn (Cassette 2) Ida_Sec02_047FA</p> </div> </div> <ol style="list-style-type: none"> <li>4) Press the “CANCEL” key to stop the Cassette 2 Turn Clutch test (DO-58 test).</li> <li>5) Press the “▼” key to display the DO-24.</li> <li>6) Press the “CANCEL” key to stop the Option Feed Motor 1 (DO-24 test).</li> <li>7) Reseat the 500 Sheet Paper Tray.</li> </ol>

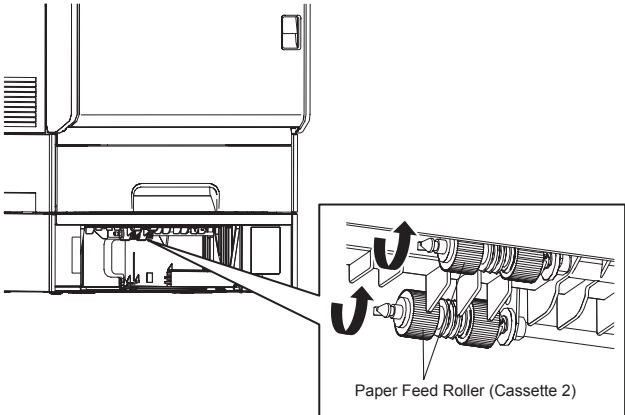
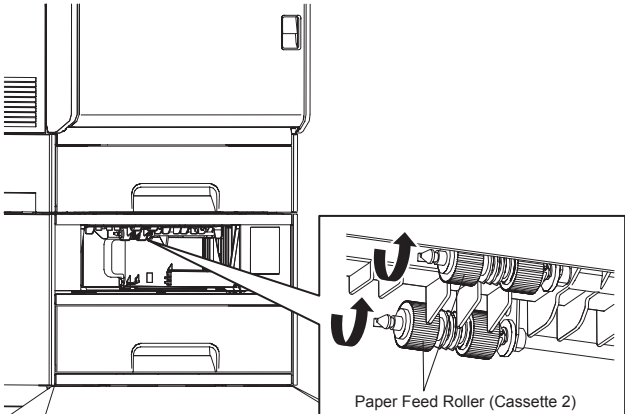
Motor, Clutch and Solenoid name (Diag. Code)	Confirmation procedures
<p>Cassette 2 Feed Solenoid (DO-5a)</p>	<ol style="list-style-type: none"> <li>1) Turn on the power and enter the Diagnostic Mode.</li> <li>2) Execute DO-5a.</li> <li>3) Press the "CANCEL" key to stop the test. Upon pressing the "CANCEL" key, confirm the operation noise of the solenoid is heard.</li> </ol> <p>Combination test is as follows.  NOTE: The Paper Feed Roller of Tray 2 rotates when the DO-24 and DO-5a are executed. The following procedures are for the technical staff.</p> <ol style="list-style-type: none"> <li>1) Remove the 500 Sheet Paper Tray of Tray 2.</li> <li>2) Turn on the power and enter the Diagnostic Mode.</li> <li>3) Execute the DO-24 and DO-5a. Confirm the rotation of the Paper Feed Rollers of Tray 2 viewing from the removed Paper Tray portion.</li> </ol> <div style="text-align: center;">  <p style="text-align: center;">Paper Feed Roller (Cassette 2)</p> <p style="text-align: right; font-size: small;">Ida_Sec02_048FA</p> </div> <div style="text-align: center;">  <p style="text-align: center;">Paper Feed Roller (Cassette 2)</p> <p style="text-align: right; font-size: small;">Ida_Sec02_049FA</p> </div> <ol style="list-style-type: none"> <li>4) Press the "CANCEL" key to stop the Cassette 2 Feed Solenoid test (DO-5a test).</li> <li>5) Press the "▼" key to display the DO-24.</li> <li>6) Press the "CANCEL" key to stop the Option Feed Motor 1 (DO-24 test).</li> <li>7) Reseat the 500 Sheet Paper Tray.</li> </ol>

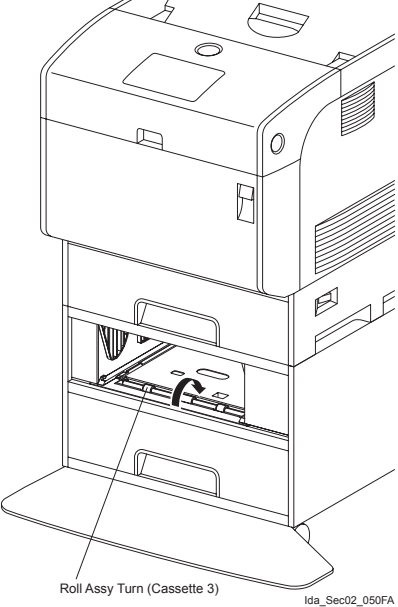
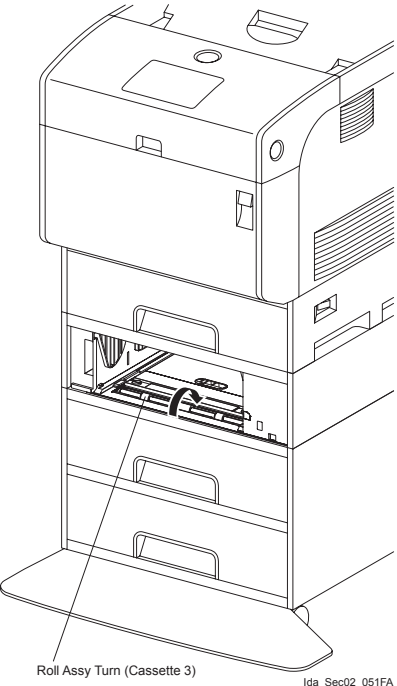
Motor, Clutch and Solenoid name (Diag. Code)	Confirmation procedures
<p>Cassette 3 Turn Clutch (DO-5c)</p>	<ol style="list-style-type: none"> <li>1) Turn on the power and enter the Diagnostic Mode.</li> <li>2) Execute DO-5c. Upon pressing the “✓” key, confirm the operation noise of the clutch is heard.</li> <li>3) Press the “CANCEL” key to stop the test.</li> </ol> <p>Combination test is as follows.  <b>NOTE:</b> The Roll Assy Turn of Tray 3 rotates when the DO-2d and DO-5c are executed. The following procedures are for the technical staff.</p> <ol style="list-style-type: none"> <li>1) Remove the 500 Sheet Paper Tray of Tray 2. (Remove the upper Paper Tray on the cassette number. For example: when the cassette number is 3, remove the Paper Tray of Tray 2.)</li> <li>2) Turn on the power and enter the Diagnostic Mode.</li> <li>3) Execute the DO-2d and DO-5c. Confirm the rotation of the Roll Assy Turn viewing from the removed Paper Tray portion.</li> </ol> <div style="display: flex; justify-content: space-around; align-items: center;"> <div style="text-align: center;">  <p>Roll Assy Turn (Cassette 3) Ida_Sec02_050FA</p> </div> <div style="text-align: center;">  <p>Roll Assy Turn (Cassette 3) Ida_Sec02_051FA</p> </div> </div> <ol style="list-style-type: none"> <li>4) Press the “CANCEL” key to stop the Cassette 3 Turn Clutch test (DO-5c test).</li> <li>5) Press the “▼” key to display the DO-2d.</li> <li>6) Press the “CANCEL” key to stop the Option Feed Motor 2 (DO-2d test).</li> <li>7) Reseat the 500 Sheet Paper Tray.</li> </ol>

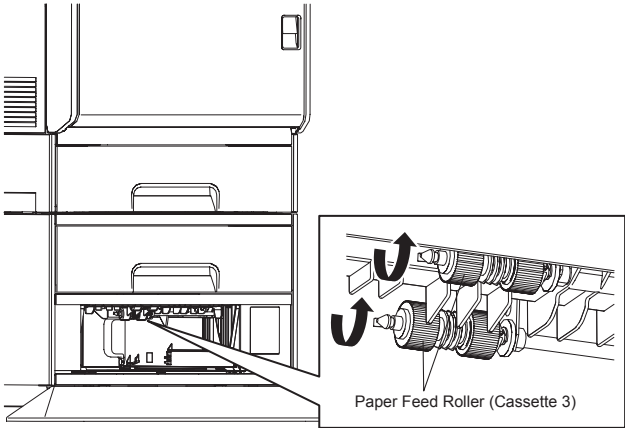
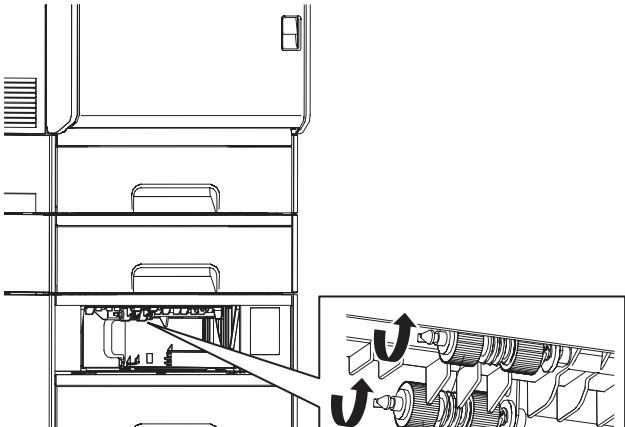
Motor, Clutch and Solenoid name (Diag. Code)	Confirmation procedures
<p>Cassette 3 Feed Solenoid (DO-5e)</p>	<ol style="list-style-type: none"> <li>1) Turn on the power and enter the Diagnostic Mode.</li> <li>2) Execute DO-5e.</li> <li>3) Press the "CANCEL" key to stop the test. Upon pressing the "CANCEL" key, confirm the operation noise of the solenoid is heard.</li> </ol> <p>Combination test is as follows.  NOTE: The Paper Feed Roller of Tray 3 rotates when the DO-2d and DO-5e are executed. The following procedures are for the technical staff.</p> <ol style="list-style-type: none"> <li>1) Remove the 500 Sheet Paper Tray of Tray 3.</li> <li>2) Turn on the power and enter the Diagnostic Mode.</li> <li>3) Execute the DO-2d and DO-5e. Confirm the rotation of the Paper Feed Rollers of Tray 3 viewing from the removed Paper Tray portion.</li> </ol> <div style="text-align: center;">  <p style="text-align: right; font-size: small;">Ida_Sec02_052FA</p> </div> <div style="text-align: center;">  <p style="text-align: right; font-size: small;">Ida_Sec02_053FA</p> </div> <ol style="list-style-type: none"> <li>4) Press the "CANCEL" key to stop the Cassette 3 Feed Solenoid test (DO-5e test).</li> <li>5) Press the "▼" key to display the DO-2d.</li> <li>6) Press the "CANCEL" key to stop the Option Feed Motor 2 (DO-2d test).</li> <li>7) Reseat the 500 Sheet Paper Tray.</li> </ol>

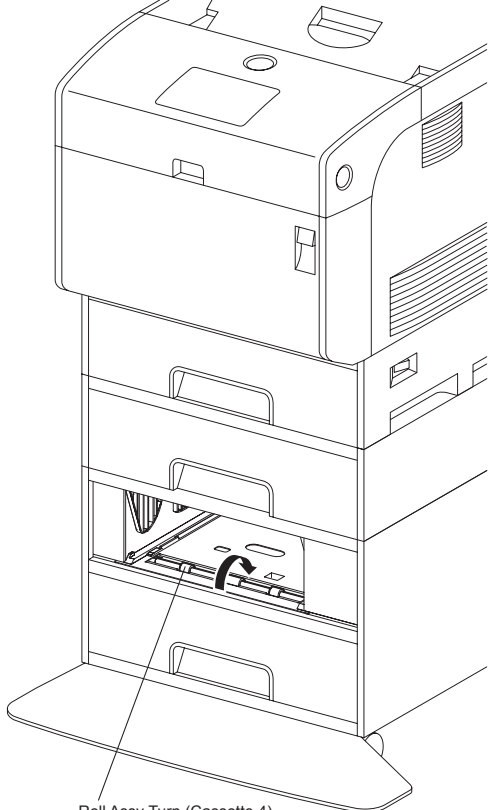
Motor, Clutch and Solenoid name (Diag. Code)	Confirmation procedures
Cassette 4 Turn Clutch (DO-60)	<p>1) Turn on the power and enter the Diagnostic Mode.</p> <p>2) Execute DO-60. Upon pressing the “✓” key, confirm the operation noise of the clutch is heard.</p> <p>3) Press the “CANCEL” key to stop the test.</p> <p>Combination test is as follows.  NOTE: The Roll Assy Turn of Tray 4 rotates when the DO-2d and DO-60 are executed. The following procedures are for the technical staff.</p> <p>1) Remove the 500 Sheet Paper Tray of Tray 3. (Remove the upper Paper Tray on the cassette number. For example: when the cassette number is 4, remove the Paper Tray of Tray 3.)</p> <p>2) Turn on the power and enter the Diagnostic Mode.</p> <p>3) Execute the DO-2d and DO-60. Confirm the rotation of the Roll Assy Turn viewing from the removed Paper Tray portion.</p>  <p>Roll Assy Turn (Cassette 4) <span style="float: right;">Ida_Sec02_054FA</span></p> <p>4) Press the “CANCEL” key to stop the Cassette 4 Turn Clutch test (DO-60 test).</p> <p>5) Press the “▼” key to display the DO-2d.</p> <p>6) Press the “CANCEL” key to stop the Option Feed Motor 2 (DO-2d test).</p> <p>7) Reseat the 500 Sheet Paper Tray.</p>

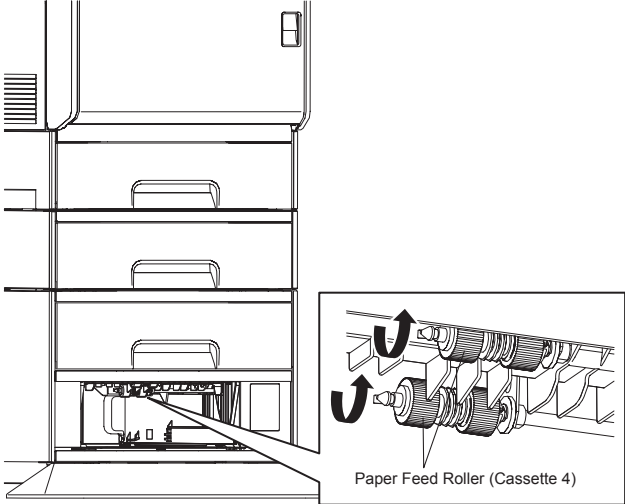
Motor, Clutch and Solenoid name (Diag. Code)	Confirmation procedures
Cassette 4 Feed Solenoid (DO-62)	<ol style="list-style-type: none"> <li>1) Turn on the power and enter the Diagnostic Mode.</li> <li>2) Execute DO-62.</li> <li>3) Press the "CANCEL" key to stop the test. Upon pressing the "CANCEL" key, confirm the operation noise of the solenoid is heard.</li> </ol> <p>Combination test is as follows.  <b>NOTE:</b> The Paper Feed Roller of Tray 4 rotates when the DO-2d and DO-62 are executed. The following procedures are for the technical staff.</p> <ol style="list-style-type: none"> <li>1) Remove the 500 Sheet Paper Tray of Tray 4.</li> <li>2) Turn on the power and enter the Diagnostic Mode.</li> <li>3) Execute the DO-2d and DO-62. Confirm the rotation of the Paper Feed Rollers of Tray 4 viewing from the removed Paper Tray portion.</li> </ol> <div style="text-align: center;">  <p style="text-align: right; font-size: small;">Ida_Sec02_055FA</p> </div> <ol style="list-style-type: none"> <li>4) Press the "CANCEL" key to stop the Cassette 4 Feed Solenoid test (DO-62 test).</li> <li>5) Press the "▼" key to display the DO-2d.</li> <li>6) Press the "CANCEL" key to stop the Option Feed Motor 2 (DO-2d test).</li> <li>7) Reseat the 500 Sheet Paper Tray.</li> </ol>

## 4.3 Test Print

Print an internal test pattern of the printer. If paper jam or paper empty occurs during the print, the test waits until they are resolved.

### 4.3.1 Executing test print

- 1) Turn off the power.
- 2) Turn on the power while holding down “▲” and “▼” keys.
- 3) Release the fingers from these keys when “Diagnosing...” is displayed.
- 4) The “Customer Mode” and “ESS Diag” are displayed. (Entered the Diag. mode.)
- 5) Press “▼” key to select “Test Print”, and then press “✓” key.
- 6) Press “▲” or “▼” key to select the test item.
- 7) Press “✓” key twice to execute the test.

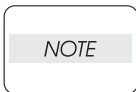

To exit the test or to returning to one step higher menu, press “CANCEL” key.

### 4.3.2 No Image [IOT]

This function feeds the paper without printing.

### 4.3.3 Test Pattern 600[IOT]

This function prints the MCU PWB built-in 600 dpi pattern. It checks the print function of the IOT.

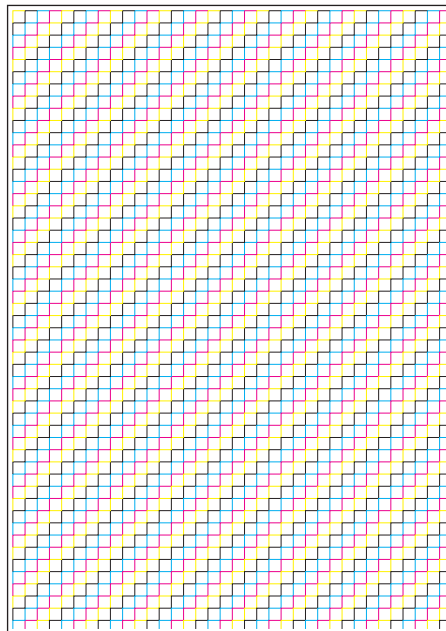

Ida\_Sec02\_002FA

#### 4.3.4 Grid2

This function prints the ESS PWB built-in grid pattern.



Leg\_Sec02\_004FA

#### 4.3.5 20% Density Chart

This function prints a 20% density paint pattern for each of cyan, magenta, yellow, black and mixed CMY on the whole area of the sheet.

Cyan 20%

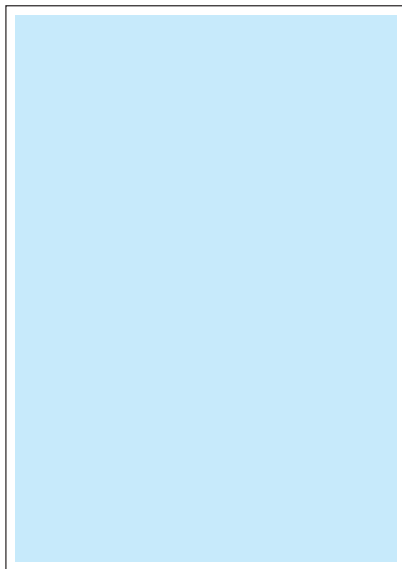

Leg\_Sec02\_005FA

Magenta 20%

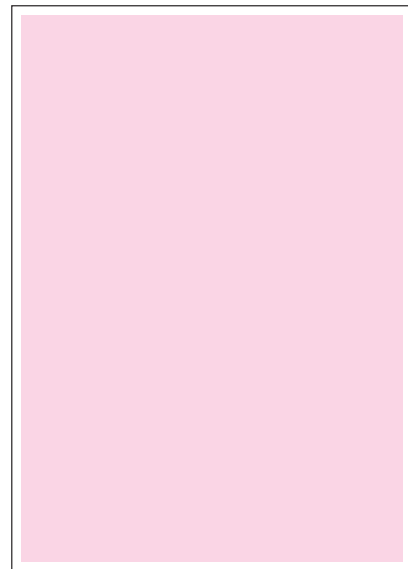

Leg\_Sec02\_006FA



Yellow 20%

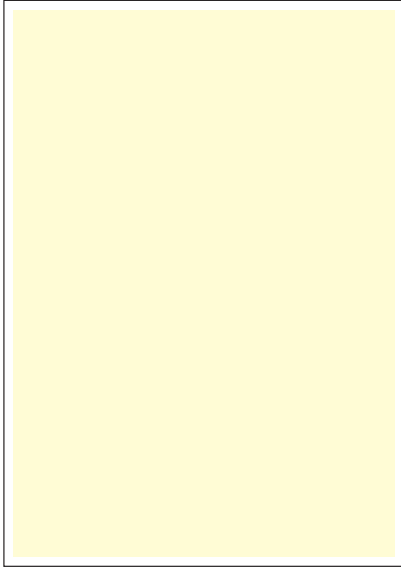

Leg\_Sec02\_007FA

Black 20%

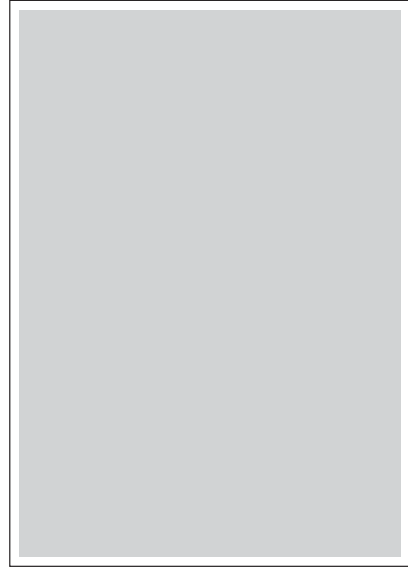

Leg\_Sec02\_008FA

YMC 20%

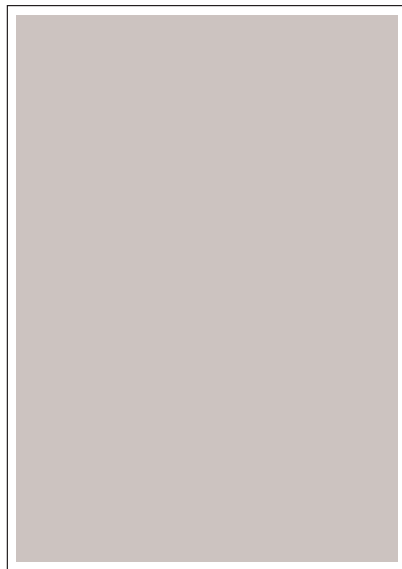

Leg\_Sec02\_009FA

#### 4.3.6 Gradation

This function prints a pattern in which the density of each of cyan, magenta, yellow, or black is varied from 2 to 100%.

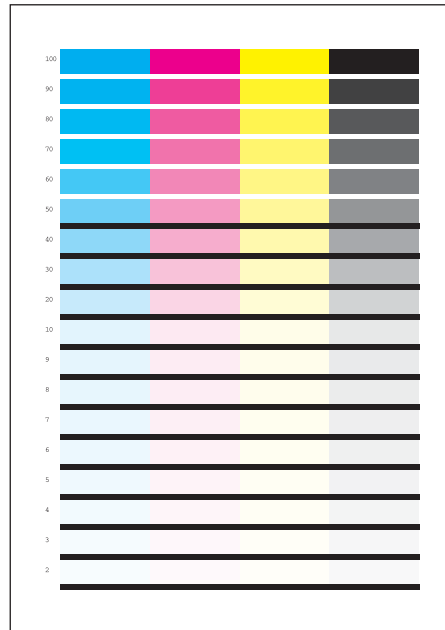

Leg\_Sec02\_010FA

#### 4.3.7 Toner Pallet Check

This function prints each 100% density pattern of cyan, magenta, yellow and black on a sheet. This function uses the density confirmation of each toner cartridge.

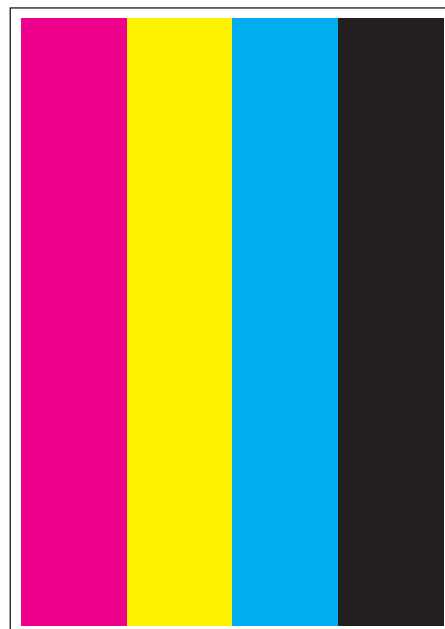

Leg\_Sec02\_011FA

4.3.8 Contamination Check

Print five sheets of paper.

Page 1 to 4: Prints the scale patterns in vertical and horizontal directions for evaluating regularity and intervals.

Page 5: Prints the list of intervals by component fault.

Page 1

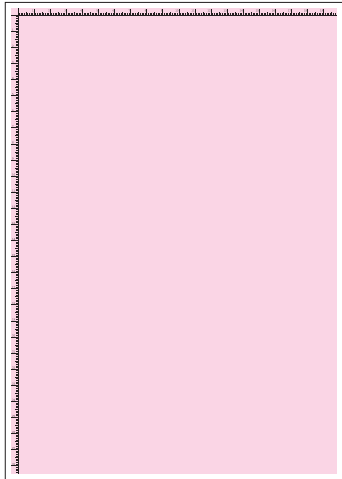

Leg\_Sec02\_012FA

Page 2

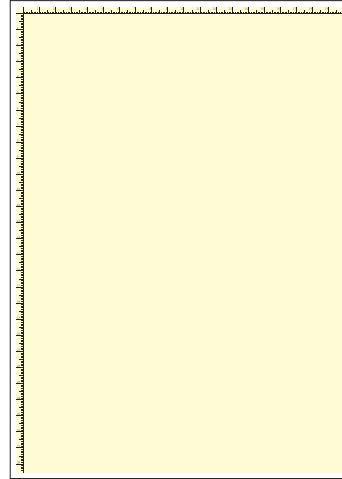

Leg\_Sec02\_071FA

Page 3

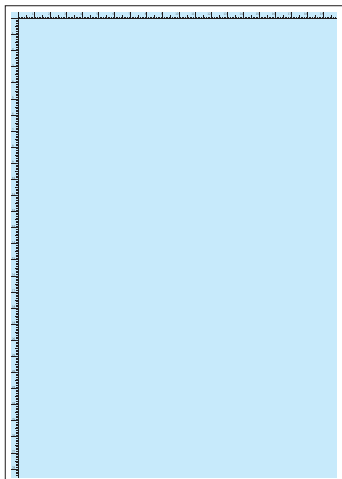

Leg\_Sec02\_072FA

Page 4

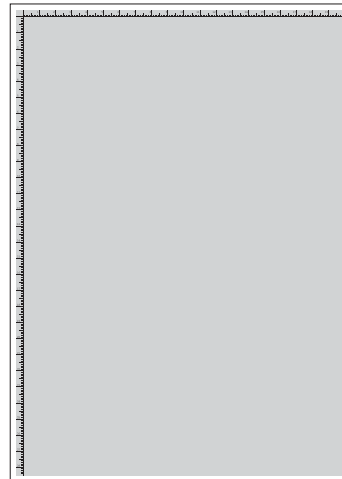

Leg\_Sec02\_073FA

Page 5

Color Laser Printer Components/CRU

Pitch (interval)	Dell Component Name
34mm	Developer Assembly
65mm	Transfer Roller
75mm	Imaging Drum
32mm	Imaging Drum
132mm	Imaging Drum
31mm	Imaging Drum
56mm	Imaging Drum
66mm	Imaging Drum
98mm	Fuser
95mm	Fuser

## 4.4 Parameter Setting

### 4.4.1 Handling parameters

This function reads/writes the following parameters stored in the IOT.

Item	Range	Description
Registration in the paper feeding direction	-128 to 127	Sets the registration in the paper feeding direction.
Registration in the scanning direction	-30 to 30	Sets the registration in the scanning direction for each of Tray 1, Tray 2, Tray 3, Tray 4, MSI, and Dup.
Life counter	-	Reads the life counters and the printer.

**NOTE**

Print the parameter list using the Print function of Parameter Menu in diagnosis before changing the value of the registration.

Parameter	Function	Default	Adjustable range
Slow Scan Reg K to P (Shifts 0.17mm/1count)	Black registration adjustment	--	-128 to 127
Slow Scan Reg 600 M,Y,C (Shifts 0.042mm/1count)	Color registration adjustment (600 and 1200 dpi)	--	-60 to 60
Slow Scan Reg1200 M,Y,C (Shifts 0.021mm/1count)			
Fast Scan Reg K to M, Y or C (Shifts 0.042mm/1count)	Color registration adjustment Calculation of adjustment is shown below. (exp. Yellow) (Value of Fast Scan Reg K to Y + Value of Fast Scan Reg2 K to Y)/4	--	-30 to 30
Fast Scan Reg2 K to M, C or Y (Shifts 0.01mm/1count)		--	-1 to 2
Fast Scan Reg MP, Tray1, Tray2, Tray3 or Tray4 (Shifts 0.042mm/1count)	Black registration adjustment at side 1 print	--	-30 to 30
Fast Scan Reg Dup (Shifts 0.17mm/1count)	Black registration adjustment at side 2 print	--	-30 to 30

**NOTE**

The default values are different in each printer.

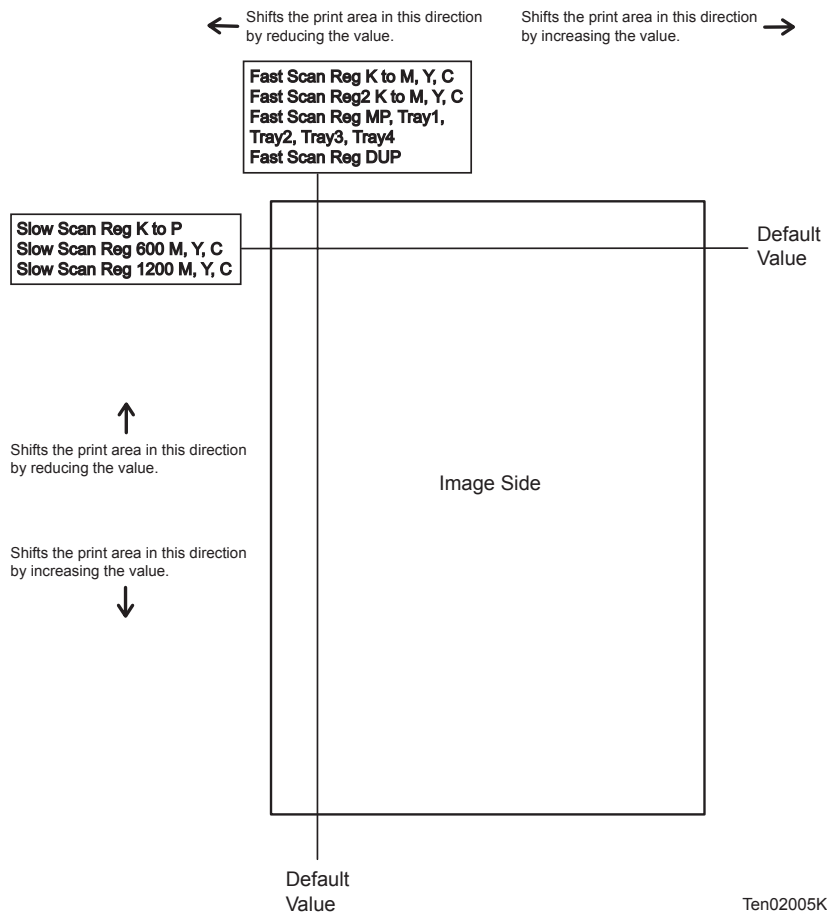

## Reference Counter Values

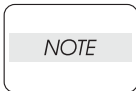

These counter values are reference only. Do not use as the official value.

Counter Name	Value of life warning
Life Y Toner	1365 (TBD)
Life M Toner	1487 (TBD)
Life C Toner	1404 (TBD)
Life K Toner	1698 (TBD)
Life BTR (Transfer Roller) 1	33200 (TBD)
Life Fuser	80000 (TBD)
Life Printer	-
Life PHD (Imaging Drum) 1 (Print volume)	28000 (TBD)
Life PHD (Imaging Drum) 2 (Round time)	160000 (TBD)
Life PHD (Imaging Drum) 3 (Dispense time)	132174 (Value of replacement) (TBD)
Life PHD (Imaging Drum) 4 (Toner cartridge exchange)	450 (TBD)
Life PHD (Imaging Drum) 5 (Dispense time, after Life PHD 4 reached life limit)	8492 (Value of replacement) (TBD)
Life Deve Unit 1 (Yellow)	1072401 (TBD)
Life Deve Unit 2 (Magenta)	1072401 (TBD)
Life Deve Unit 3 (Cyan)	1072401 (TBD)
Life Deve Unit 4 (Black)	1072401 (TBD)
Life MSI Feed	-
Life Tray 1 Feed	-
Life Tray 2 Feed	-
Life Tray 3 Feed	-
Life Tray 4 Feed	-

## 4.4.2 Printing the parameter list

This function prints the parameter values and life counter values stored in the IOT.

## Chapter 3 Removal and Replacement Procedures (RRPs) CONTENTS

1. Removal and Replacement Procedures (RRPs) .....	3 - 1
1.1 Before starting service work.....	3 - 1
1.2 Description of procedure.....	3 - 4
2. Removal and Replacement Flows.....	3 - 6
RRP1. COVER .....	3 - 14
RRP1.1 TOP COVER FRAME (PL1.1.4).....	3 - 14
RRP1.2 OPERATOR PANEL (PL1.1.5).....	3 - 16
RRP1.3 FRONT COVER (PL1.1.6) .....	3 - 18
RRP1.4 IMAGING DRUM COVER (PL1.1.8), IMAGING DRUM COVER HINGE PIN (PL1.1.21) .....	3 - 20
RRP1.5 COVER ASSY REAR (PL1.1.17) .....	3 - 22
RRP1.6 REAR FAN (PL1.1.19) .....	3 - 24
RRP1.7 RIGHT SIDE COVER (PL1.1.20) .....	3 - 26
RRP1.8 RIGHT FRONT COVER (PL1.1.22) .....	3 - 28
RRP1.9 MULTIPURPOSE FEEDER (MPF) TRAY (PL1.1.23) .....	3 - 30
RRP1.10 MULTIPURPOSE FEEDER (MPF) COVER (PL1.1.25).....	3 - 32
RRP1.11 LEFT FRONT COVER (PL1.1.28).....	3 - 34
RRP1.12 LEFT SIDE COVER (PL1.1.30).....	3 - 36
RRP1.13 FAN LV (PL1.1.33) .....	3 - 38
RRP1.14 REAR COVER (PL1.1.18).....	3 - 40
RRP2. PAPER CASSETTE .....	3 - 42
RRP2.1 SEPARATOR ROLLER. (PL2.1.13), SEPARATOR ROLLER CLUTCH (PL2.1.14) .....	3 - 42
RRP2.2 RETARD ASSY (PL2.1.12) .....	3 - 44
RRP3. PAPER FEEDER .....	3 - 46
RRP3.1 PAPER FEEDER CHUTE. (PL3.1.2) .....	3 - 46
RRP3.2 PAPER TRAY COVER (PL3.1.3).....	3 - 48
RRP3.3 PAPER FEEDER (PL3.1.7).....	3 - 50
RRP3.4 SWITCH ASSY SIZE (PL3.2.5).....	3 - 54
RRP3.5 SWITCH (PL3.2.10) .....	3 - 56
RRP3.6 HARNESS ASSY OPFPLG (PL3.2.11) .....	3 - 58
RRP3.7 PAPER PICKUP ASSEMBLY (PL3.3.1).....	3 - 60
RRP3.8 ROLL ASSY TURN (PL3.3.2).....	3 - 62
RRP3.9 SENSOR PHOTO: NO PAPER (PL3.3.7) .....	3 - 64
RRP3.10 Blank Page .....	3 - 66
RRP3.11 SOLENOID FEED (PL3.3.11) .....	3 - 68
RRP3.12 Blank Page .....	3 - 70
RRP3.13 CHUTE UPPER (REFERENCE ONLY) .....	3 - 72
RRP3.14 PAPER FEED ROLLER (PL3.3.18) .....	3 - 74
RRP3.15 ACTUATOR NO PAPER (PL3.3.20) .....	3 - 76
RRP4. RETARD & REGI ASSY .....	3 - 78
RRP4.1 ACTUATOR REGI (PL4.1.1) .....	3 - 78
RRP4.2 REGISTRATION SENSOR (PL.4.1.3) .....	3 - 80
RRP4.3 REGISTRATION CHUTE ASSEMBLY (PL4.1.20).....	3 - 82
RRP4.4 Blank Page .....	3 - 84
RRP4.5 MULTIPURPOSE FEEDER (MPF) SEPARATOR ASSEMBLY (PL4.1.13), MULTIPURPOSE FEEDER (MPF) SEPARATOR ROLLER (PL4.1.16) .....	3 - 86

## Chapter 3 Removal and Replacement Procedures (RRPs) CONTENTS

RRP4.6 REGISTRATION ASSEMBLY (PL4.2.1) .....	3 - 88
RRP4.7 ROLL REGI METAL. (PL4.2.3) .....	3 - 90
RRP4.8 ROLL REGI RUBBER. (PL4.2.4) .....	3 - 92
RRP4.9 CLUTCH REGI. (PL4.2.7) .....	3 - 94
RRP4.10 CLUTCH TURN. (PL4.2.9) .....	3 - 96
RRP4.11 ROLL TURN MSI. (PL4.2.10).....	3 - 98
<b>RRP5. CHUTE ASSY IN &amp; OUT .....</b>	<b>3 - 100</b>
RRP5.1 FUSER. (PL5.1.1) .....	3 - 100
RRP5.2 TRANSFER ROLLER. (PL5.1.4).....	3 - 102
RRP5.3 AUTOMATIC DENSITY CONTROL (ADC) SENSOR. (PL5.2.19) .....	3 - 104
RRP5.4 TONER FULL SENSOR (PL5.2.20) .....	3 - 106
RRP5.5 DRIVE ASSY FUSER (PL5.2.25).....	3 - 108
RRP5.6 MULTIPURPOSE FEEDER (MPF) SOLENOID. (PL5.3.9) .....	3 - 112
RRP5.7 MULTIPURPOSE FEEDER (MPF) PAPER SENSOR (PL5.3.14) .....	3 - 116
RRP5.8 MULTIPURPOSE FEEDER (MPF) ACTUATOR (PL5.3.15).....	3 - 118
RRP5.9 MULTIPURPOSE FEEDER (MPF) ROLLER (PL5.3.20) .....	3 - 120
RRP5.10 OUTPUT TRAY FULL SENSOR (PL5.4.1) .....	3 - 124
RRP5.11 SENSOR PHOTO: JAM (PL5.4.1) .....	3 - 126
RRP5.12 OUTPUT TRAY ACTUATOR (PL5.4.2) .....	3 - 130
RRP5.13 DUPLEX DRIVE MOTOR (PL5.4.5).....	3 - 132
RRP5.14 ACTUATOR DUP (PL5.4.13) .....	3 - 134
RRP5.15 ROLL DUP (PL5.4.15).....	3 - 136
RRP5.16 ROLL EXIT (PL5.4.16) .....	3 - 138
RRP5.17 INNER DUPLEX ASSEMBLY (PL5.2.1), DUPLEX HINGE LINK SPRING (PL5.1.6), DUPLEX HINGE LINK (PL5.1.7) .....	3 - 140
RRP5.18 OUTER DUPLEX ASSEMBLY (PL5.3.1), DUPLEX RETAINING STRAP (PL5.1.5) .....	3 - 144
RRP5.19 FAN FRONT (PL5.3.31) .....	3 - 148
<b>RRP6. XEROGRAPHICS .....</b>	<b>3 - 150</b>
RRP6.1 PRINT HEAD (PL6.1.2).....	3 - 150
RRP6.2 HSG ASSY BIAS (PL6.1.7) .....	3 - 152
<b>RRP7. DEVELOPMENT .....</b>	<b>3 - 154</b>
RRP7.1 DEVELOPER FRAME (PL7.1.1) .....	3 - 154
RRP7.2 CRUM (PL7.1.4).....	3 - 156
RRP7.3 DEVELOPER ASSEMBLY (Y), (M), (C), (K) (PL7.1.17~20) .....	3 - 158
RRP7.4 TONER DISPENSER ASSEMBLY (PL7.2.22) .....	3 - 160
RRP7.5 DISPENSER ASSY (Y) (PL7.2.1) .....	3 - 164
RRP7.6 DISPENSER ASSY (M) (PL7.2.2).....	3 - 166
RRP7.7 DISPENSER ASSY (C) (PL7.2.3) .....	3 - 168
RRP7.8 DISPENSER ASSY (K) (PL7.2.4) .....	3 - 170
RRP7.9 SENSOR NO TONER (Y), (M), (C) (PL7.2.5) .....	3 - 172
RRP7.10 SENSOR NO TONER (K) (PL7.2.5).....	3 - 174
RRP7.11 ACTUATOR SENSOR 2 (PL7.2.7).....	3 - 176
RRP7.12 TONER CARTRIDGE SENSOR (PL7.2.12).....	3 - 178
RRP7.13 DUCT LV (PL7.2.23) .....	3 - 180



Chapter 3 Removal and Replacement Procedures (RRPs) CONTENTS

---

<b>RRP8. DRIVE</b> .....	<b>3 - 182</b>
RRP8.1 DEVELOPER DRIVE ASSEMBLY (PL8.1.1) .....	3 - 182
RRP8.2 MAIN DRIVE ASSEMBLY (PL8.1.2) .....	3 - 186
<b>RRP9. ELECTRICAL</b> .....	<b>3 - 188</b>
RRP9.1 CONTROLLER CARD (PL9.1.3) .....	3 - 188
RRP9.2 LVPS ASSY (REFERENCE ONLY) .....	3 - 192
RRP9.3 LOW VOLTAGE POWER SUPPLY (LVPS) (PL9.1.6) .....	3 - 194
RRP9.4 HARNESS ASSY AC INLET (PL9.1.7) .....	3 - 196
RRP9.5 HARNESS ASSY INTERLOCK (PL9.1.11) .....	3 - 198
RRP9.6 PWBA EEPROM STD (PL9.1.12) .....	3 - 200
RRP9.7 MACHINE CONTROL UNIT (MCU) (PL9.1.16) .....	3 - 202
RRP9.8 SENSOR HUM (PL9.1.20) .....	3 - 208
RRP9.9 HIGH VOLTAGE POWER SUPPLY (HVPS) (PL9.1.21) .....	3 - 210
RRP9.10 OPTION HDD ASSY (PL9.1.25) .....	3 - 212
RRP9.11 OPTION MULTI PROTOCOL (PL9.1.26) .....	3 - 214

Chapter 3 Removal and Replacement Procedures (RRPs) CONTENTS

---

# 1. Removal and Replacement Procedures (RRPs)

Parts removal and replacement procedures are described in major 9 items which correspond to classification of parts list.

- \*RRP 1 COVER
- \*RRP 2 PAPER CASSETTE
- \*RRP 3 PAPER FEEDER
- \*RRP 4 RETARD & REGI ASSY
- \*RRP 5 CHUTE ASSY IN & OUT
- \*RRP 6 XEROGRAPHICS
- \*RRP 7 DEVELOPMENT
- \*RRP 8 DRIVE
- \*RRP 9 ELECTRICAL

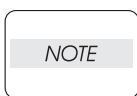

Parts are controlled as spare parts. When servicing for parts for which no procedures are described, observe their assembling condition before starting the service.

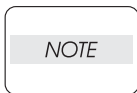

For optional parts, refer to the manual for them.

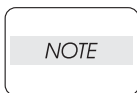

Though the optional parts are assumed to be removed, they may not be removed if not required for the purpose of service operation.

## 1.1 Before starting service work

- ◆ Start the work after turning off the power and removing the power cord from the outlet.
- ◆ Disassemble the device after removing INNER DUPLEX ASSEMBLY (PL5.2.1), OUTER DUPLEX ASSEMBLY (PL5.3.1) and IMAGING DRUM (PL6.1.1).
- ◆ When carrying out the work around FUSER, temperature of FUSER and surrounding area should have cooled sufficiently.
- ◆ Pay sufficient attention to the parts during work because they may be broken or may not perform their functions properly if unreasonable force is applied to the parts.
- ◆ Various kinds of screws are used, so be sure to use the screw at the correct positions. Pay attention in distinguishing the screws for plastic and for sheet metal. Incorrect use of the screw type may cause in damaging the screw threads or other troubles.

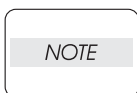

If or the screw installation locations on the frame where the character "TAP" is stamped, use the screws for plastic.

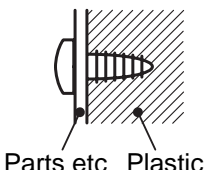
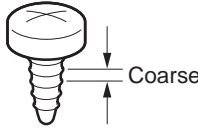
No.	Type	Application	Shape	How to distinguish	Pointed to be noted.	Major installation locations
1	Screw for plastic Silver, tap	Plastic  Parts etc Plastic	 Coarse	<ul style="list-style-type: none"> <li>•Silver colored</li> <li>•Screw thread is coarse comparing to the sheet metal type.</li> <li>•Screw tip is thin.</li> </ul>	As it has a function to cut the thread by itself, if the screw is inserted in an angle and tightened, the screw thread will be damaged.	

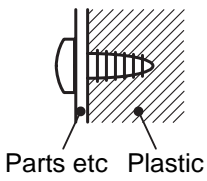
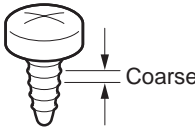
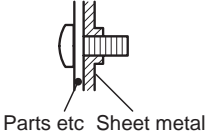
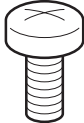
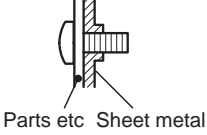
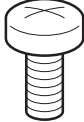
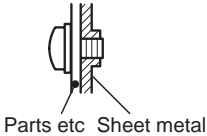
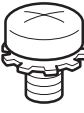
No.	Type	Application	Shape	How to distinguish	Pointed to be noted.	Major installation locations
2	Screw for plastic Black, tap	Plastic  Parts etc Plastic	 Coarse	<ul style="list-style-type: none"> <li>•Black colored</li> <li>•Screw thread is coarse comparing to the sheet metal type.</li> <li>•Screw tip is thin.</li> </ul>	As it has a function to cut the thread by itself, if the screw is inserted in an angle and tightened, the screw thread will be damaged.	
3	Screw for metal sheet Silver	Sheet metal  Parts etc Sheet metal		<ul style="list-style-type: none"> <li>•Silver colored</li> <li>•Diameter of the screw section is uniform.</li> </ul>		
4	Screw for metal sheet Gold	Sheet metal  Parts etc Sheet metal		<ul style="list-style-type: none"> <li>•Gold colored</li> <li>•Diameter of the screw section is uniform.</li> </ul>		
5	Screw for metal sheet Silver, with an external tooth washer	Sheet metal  Parts etc Sheet metal		<ul style="list-style-type: none"> <li>•Silver colored</li> <li>•It has an external tooth washer.</li> <li>•Diameter of the screw section is uniform.</li> </ul>		<ul style="list-style-type: none"> <li>•Each section of the ground wire.</li> </ul>

◆ Wear a wrist band or the like as far as possible to remove static electricity of the human body.

- ◆ Remove the TOP COVER, IMAGING DRUM, TONER CARTRIDGE, and 500 SHEET PAPER TRAY (RRP. 6.2) to place them at another place where they do not interrupt the job. (Note that service operation can be done with those parts remained in place according to the location of disassembly/assembly.)

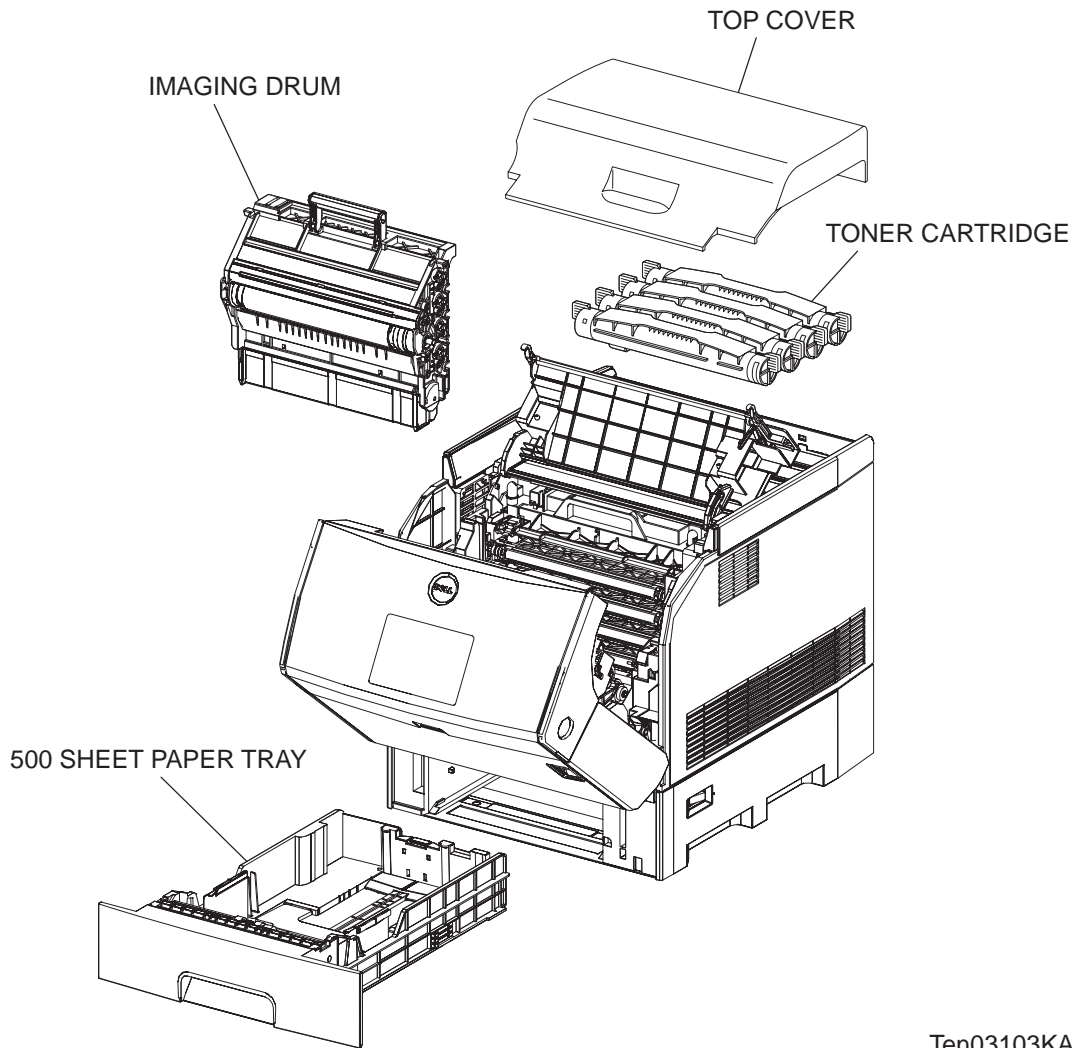

Ten03103KA

## 1.2 Description of procedure

- ❑ [RRP X.Y “AAAAA”] attached at the front of the procedure shows that the name of parts to be assembled/disassembled is “AAAAA”.
- ❑ “(PL X.Y.Z)” attached at the end of parts name in the procedure shows that the parts corresponds to the plate (PL) “X.Y”, item “Z” of [Chapter 5 Parts list], and their shape and fitting position can be checked in [Chapter 5 parts list].
- ❑ Description of direction shown below is used in the procedure.
  - ▼Front : Front direction when facing the front of device.
  - ▼Rear : Rear direction when facing the front of device.
  - ▼Left : Left direction when facing the front of device.
  - ▼right : Right direction when facing the front of device.

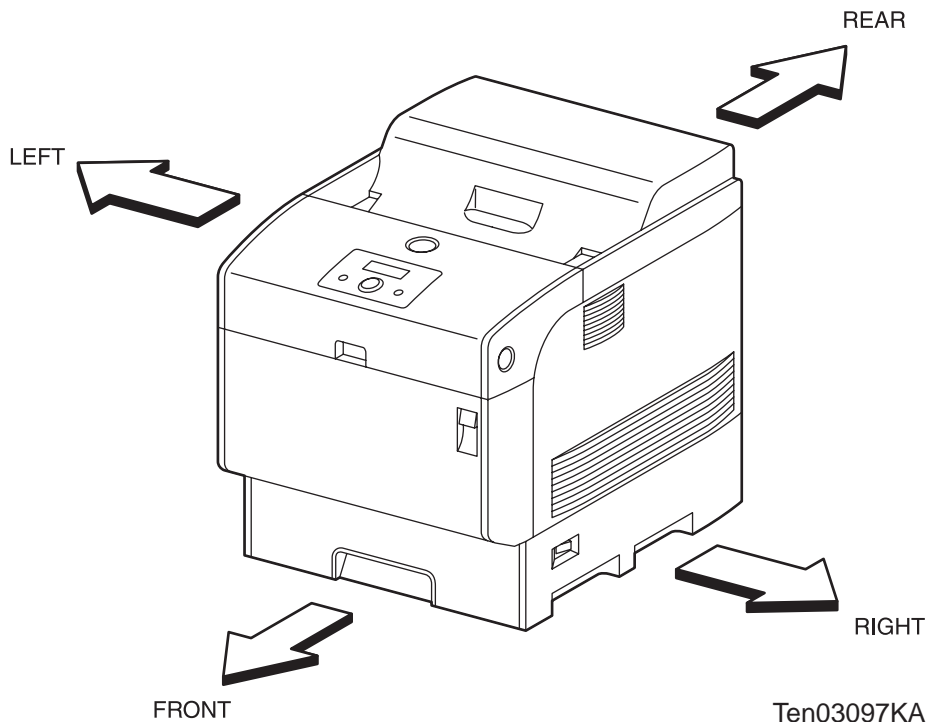

Figure: Definition of Printer Orientation

- ❑ Description of “◆[In the case of specification \*\*\*]” in the procedure shows that the work is performed only on the device with relevant specification. (no work is performed on device with irrelevant specification.)
- ❑ “(RRP X.Y) used in or at the end of sentences in the procedure shows that related work procedure is described in [RRP X.Y].
- ❑ Screws in a diagram are supposed to be loosened and removed using a plus (+ screw driver), unless otherwise specified.
- ❑ Black arrow in a diagram shows the moving direction. Moreover, the order number attached to the black arrows shows the order of movement.
- ❑ Refer to [Chapter 4 Plug/Jack (P/J) Connector Locations] for the position of connector (P/J).

Blank Page

## 2. Removal and Replacement Flows

### PRINTER RRP FLOW

This flow shows the removing procedures of the following parts.

**(COVER Reration)**  
**TOP COVER FRAME, OPERATOR PANEL, FRONT COVER**  
**IMAGING DRUM COVER, IMAGING DRUM COVER HINGE PIN**  
**COVER ASSY REAR, REAR COVER, REAR FAN, FAN LV**  
**RIGHT FRONT COVER, RIGHT SIDE COVER, LEFT FRONT COVER, LEFT SIDE COVER**  
**MULTIPURPOSE FEEDER (MPF) COVER, MULTIPURPOSE FEEDER (MPF) TRAY**

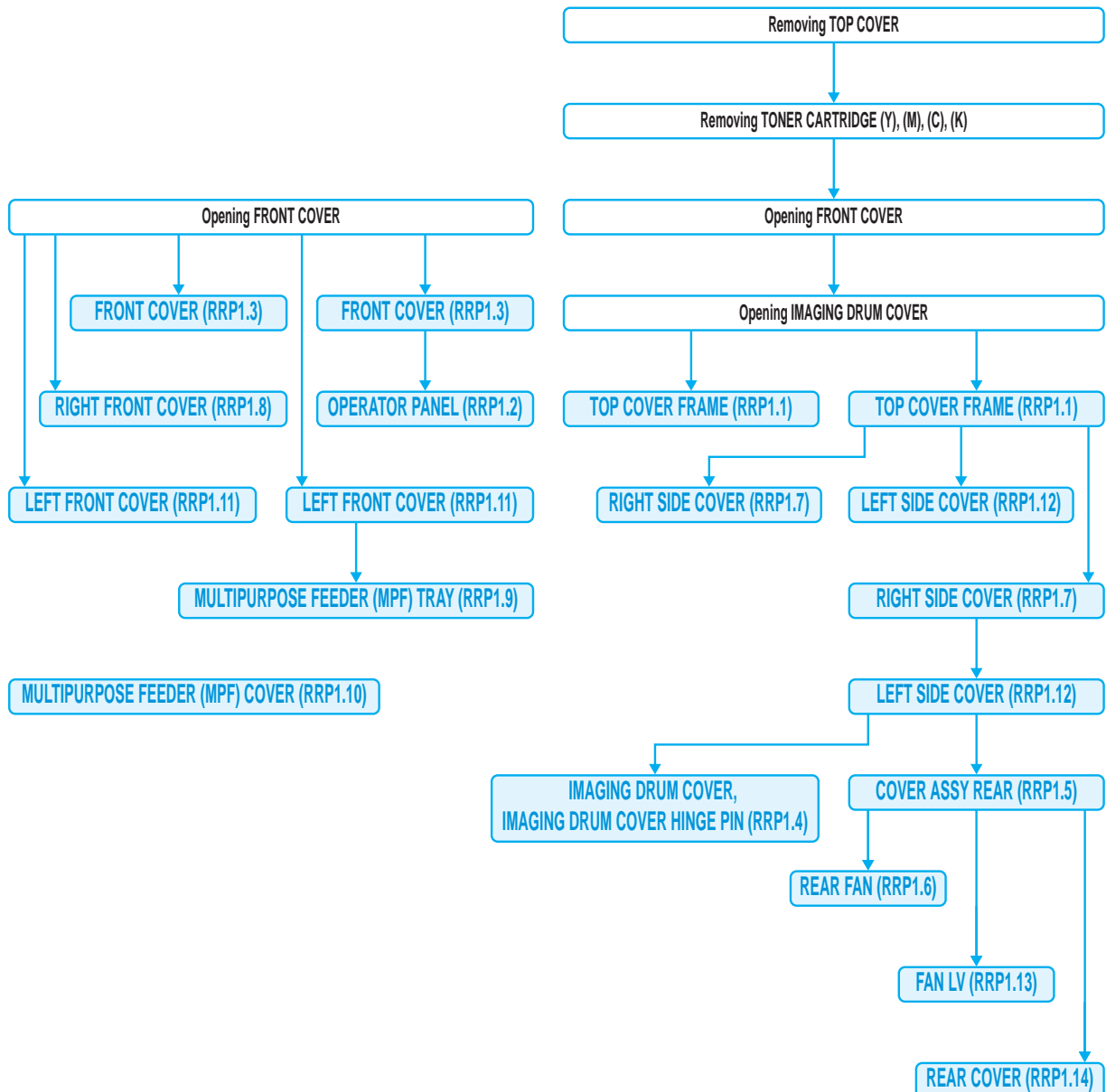



**PRINTER RRP FLOW**

This flow shows the removing procedures of the following parts.

**(500 SHEET PAPER TRAY Reration)  
RETARD ASSY, SEPARATOR ROLLER, SEPARATOR ROLLER CLUTCH  
(PAPER FEEDER Reration)  
PAPER FEEDER CHUTE, PAPER TRAY COVER, PAPER FEEDER  
PAPER PICKUP ASSEMBLY, PAPER FEED ROLLER**

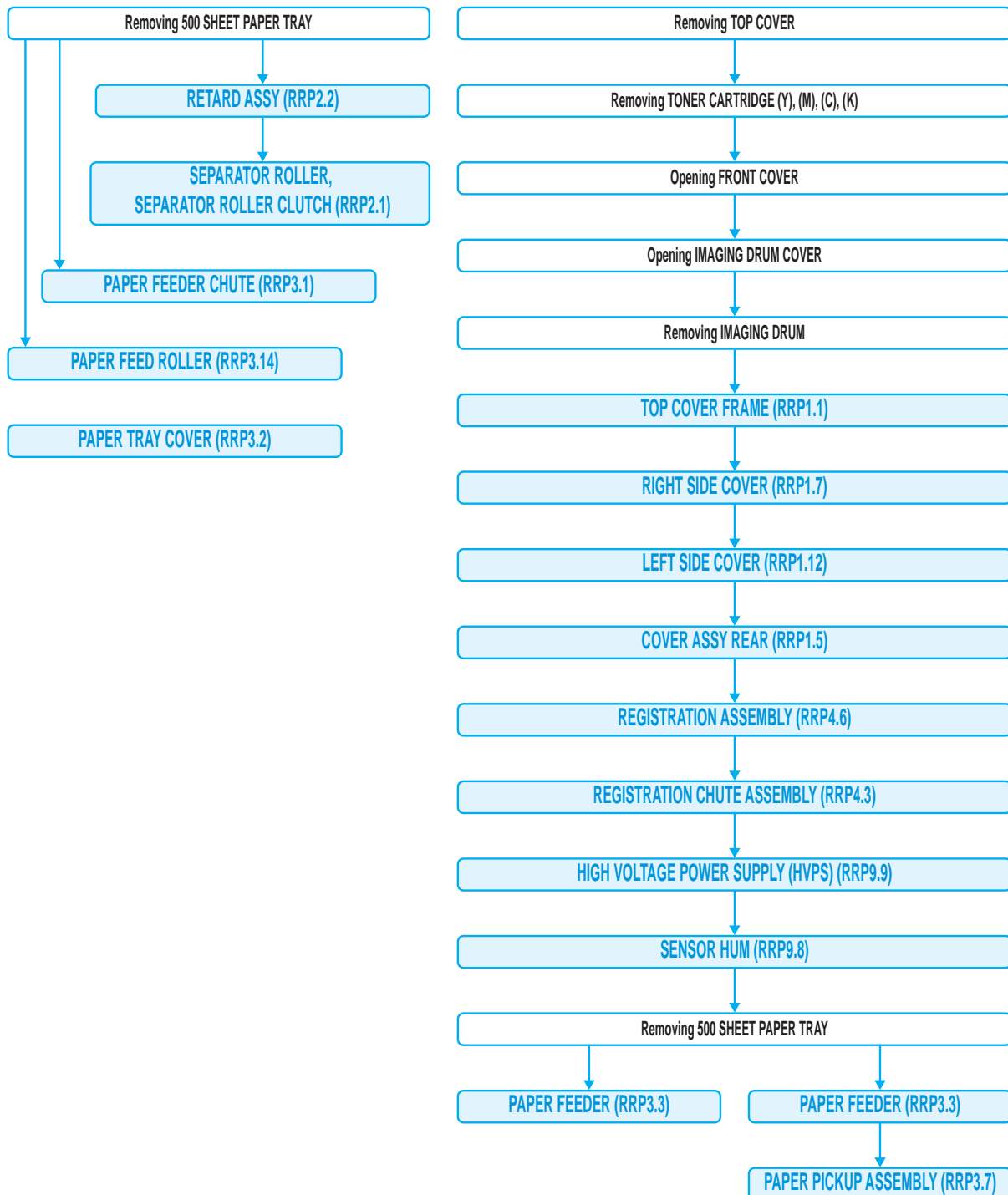

### PRINTER RRP FLOW

This flow shows the removing procedures of the following parts.

**(REGISTRATION Reration)**  
**REGISTRATION ASSEMBLY, REGISTRATION CHUTE ASSEMBLY, REGISTRATION SENSOR**  
**MULTIPURPOSE FEEDER (MPF) SEPARATOR ASSEMBLY**  
**MULTIPURPOSE FEEDER (MPF) SEPARATOR ROLLER**

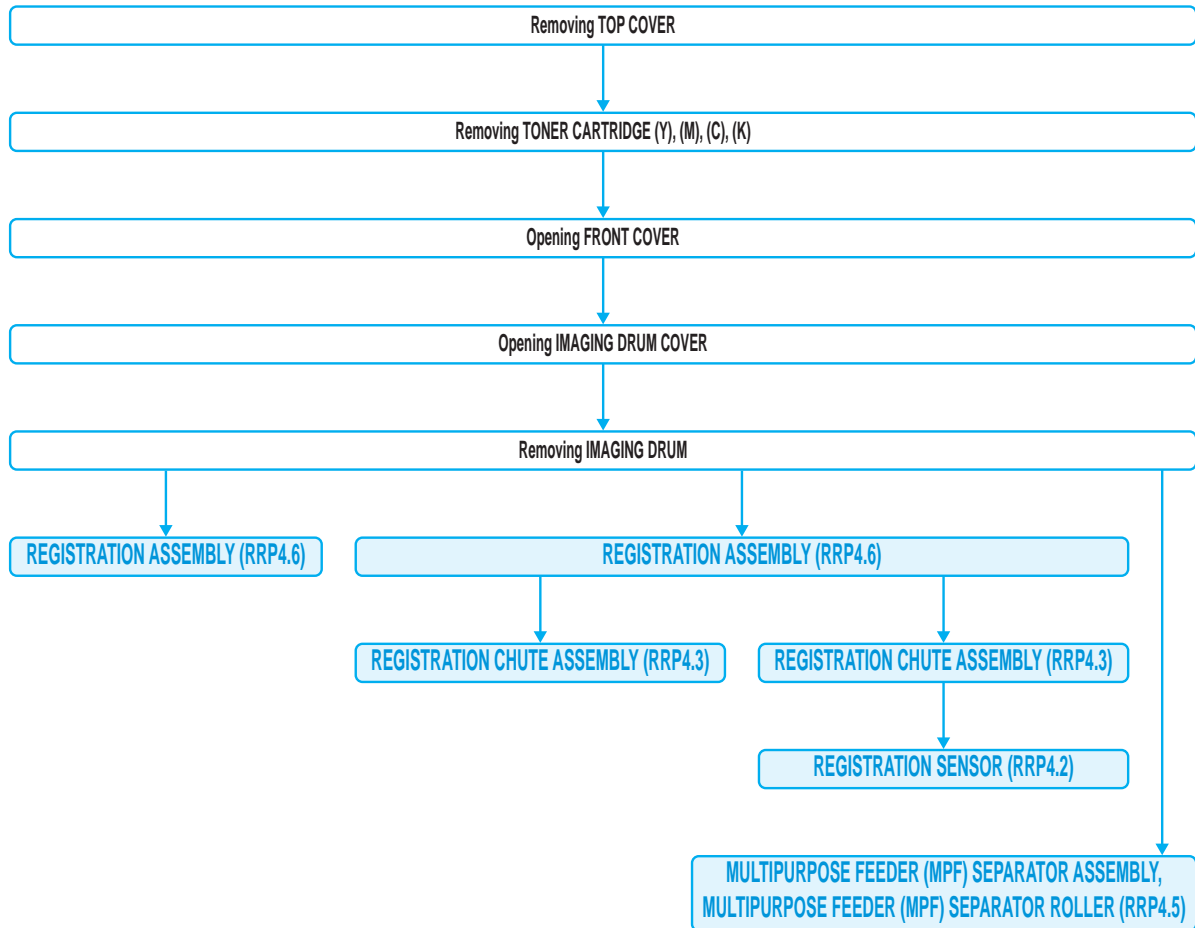

**PRINTER RRP FLOW**

This flow shows the removing procedures of the following parts.

**(OUTER DUPLEX ASSEMBLY Reration)  
 OUTER DUPLEX ASSEMBLY, DUPLEX RETAINING STRAP  
 MULTIPURPOSE FEEDER (MPF) ROLLER, MULTIPURPOSE FEEDER (MPF) SOLENOID  
 MULTIPURPOSE FEEDER (MPF) ACTUATOR, MULTIPURPOSE FEEDER (MPF) PAPER SENSOR  
 OUTPUT TRAY ACTUATOR, OUTPUT TRAY FULL SENSOR  
 DUPLEX DRIVE MOTOR, FAN FRONT**

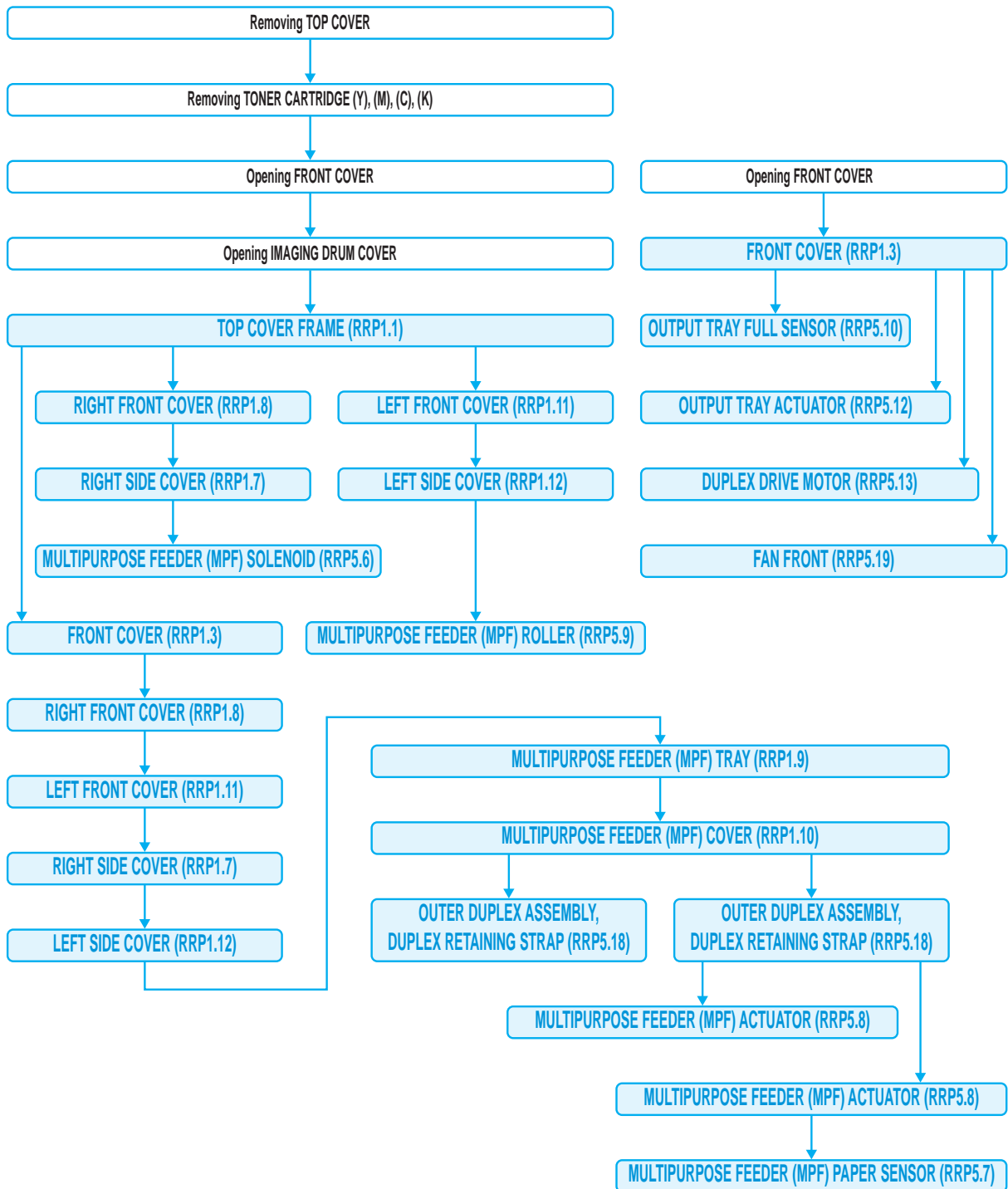

**PRINTER RRP FLOW**

This flow shows the removing procedures of the following parts.

**(INNER DUPLEX ASSEMBLY Reration)  
FUSER, TRANSFER ROLLER  
INNER DUPLEX ASSEMBLY, DUPLEX HINGE LINK SPRING, DUPLEX HINGE LINK  
AUTOMATIC DENSITY CONTROL (ADC) SENSOR, TONER FULL SENSOR**

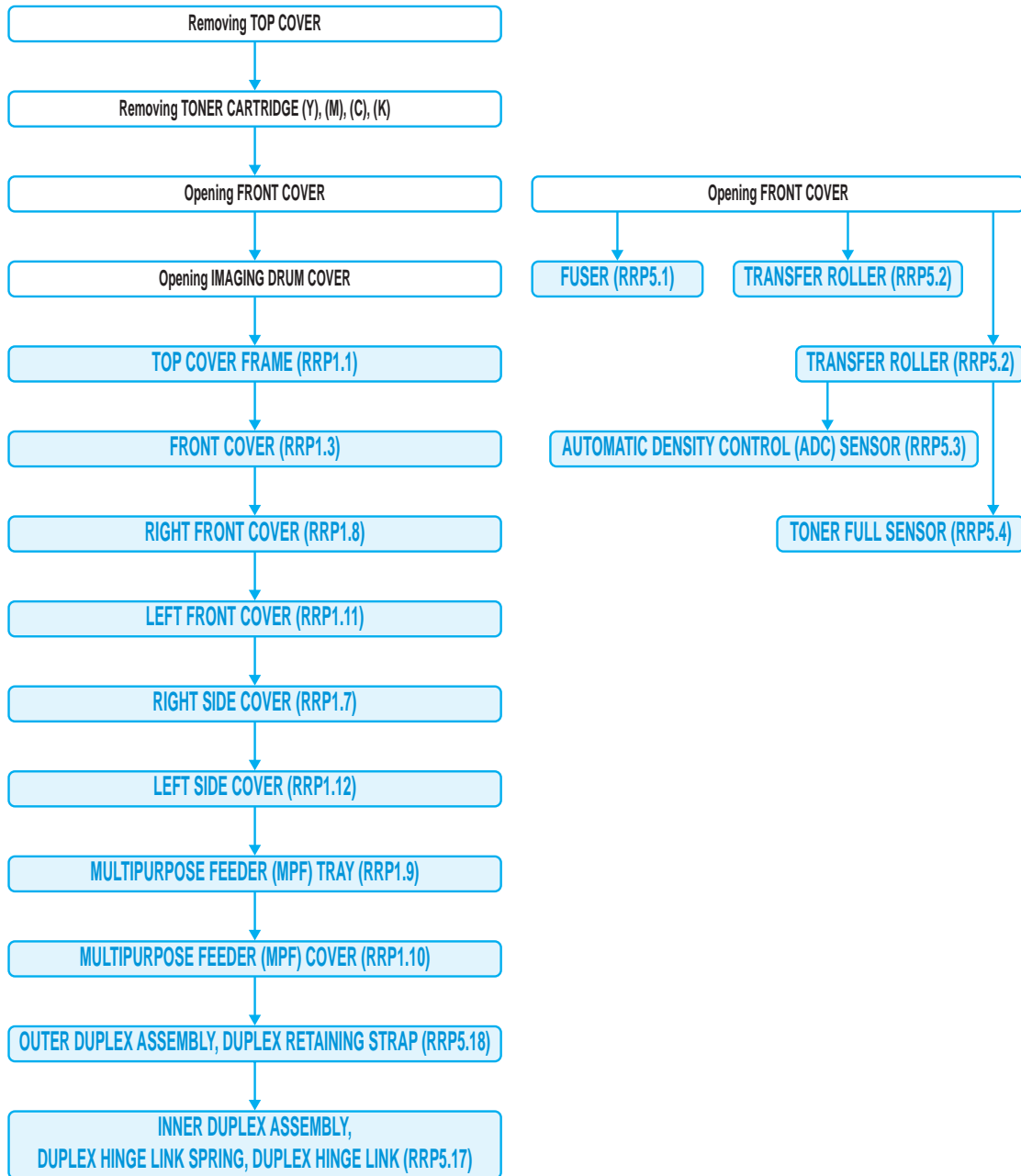

**PRINTER RRP FLOW**

This flow shows the removing procedures of the following parts.

- (PRINT HEAD Reration)**
- PRINT HEAD**
- (DEVELOPER Reration)**
- DEVELOPER FRAME, DEVELOPER ASSEMBLY (Y), (M), (C), (K)**
- TONER DISPENSER ASSEMBLY, DISPENSER ASSY (Y), (M), (C), (K)**
- TONER CARTRIDGE SENSOR, DUCT LV**

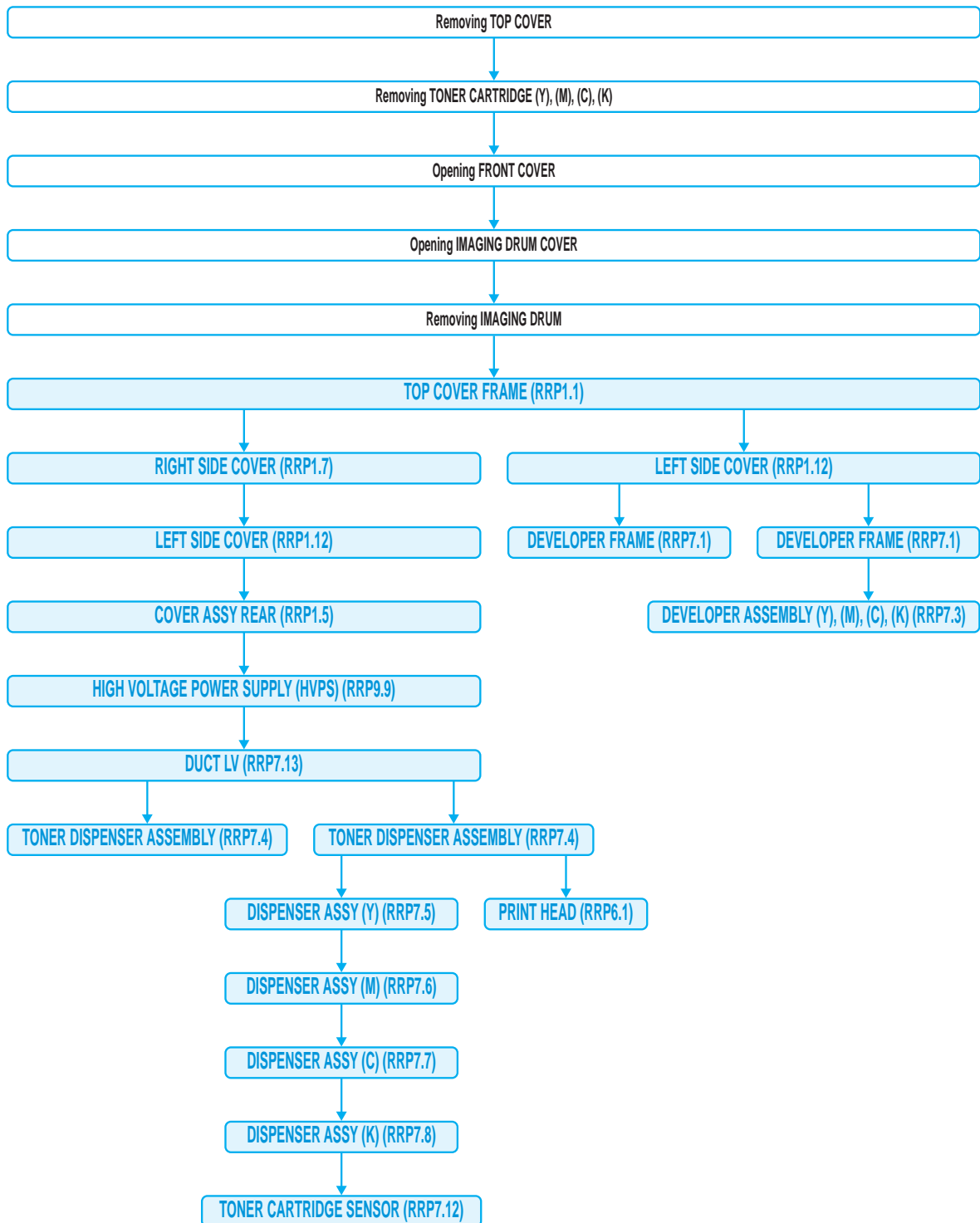

**PRINTER RRP FLOW**

This flow shows the removing procedures of the following parts.

**(DRIVE Reration)**  
**MAIN DRIVE ASSEMBLY, DEVELOPER DRIVE ASSEMBLY**  
**(ELECTRICAL Reration)**  
**MACHINE CONTROL UNIT (MCU), HIGH VOLTAGE POWER SUPPLY (HVPS)**  
**LVPS ASSY, HARNESS ASSY AC INLET, LOW VOLTAGE POWER SUPPLY (LVPS)**  
**CONTROLLER CARD, OPTION HDD ASSY, OPTION MULTI PROTOCOL CARD**  
**HARNESS ASSY INTERLOCK**

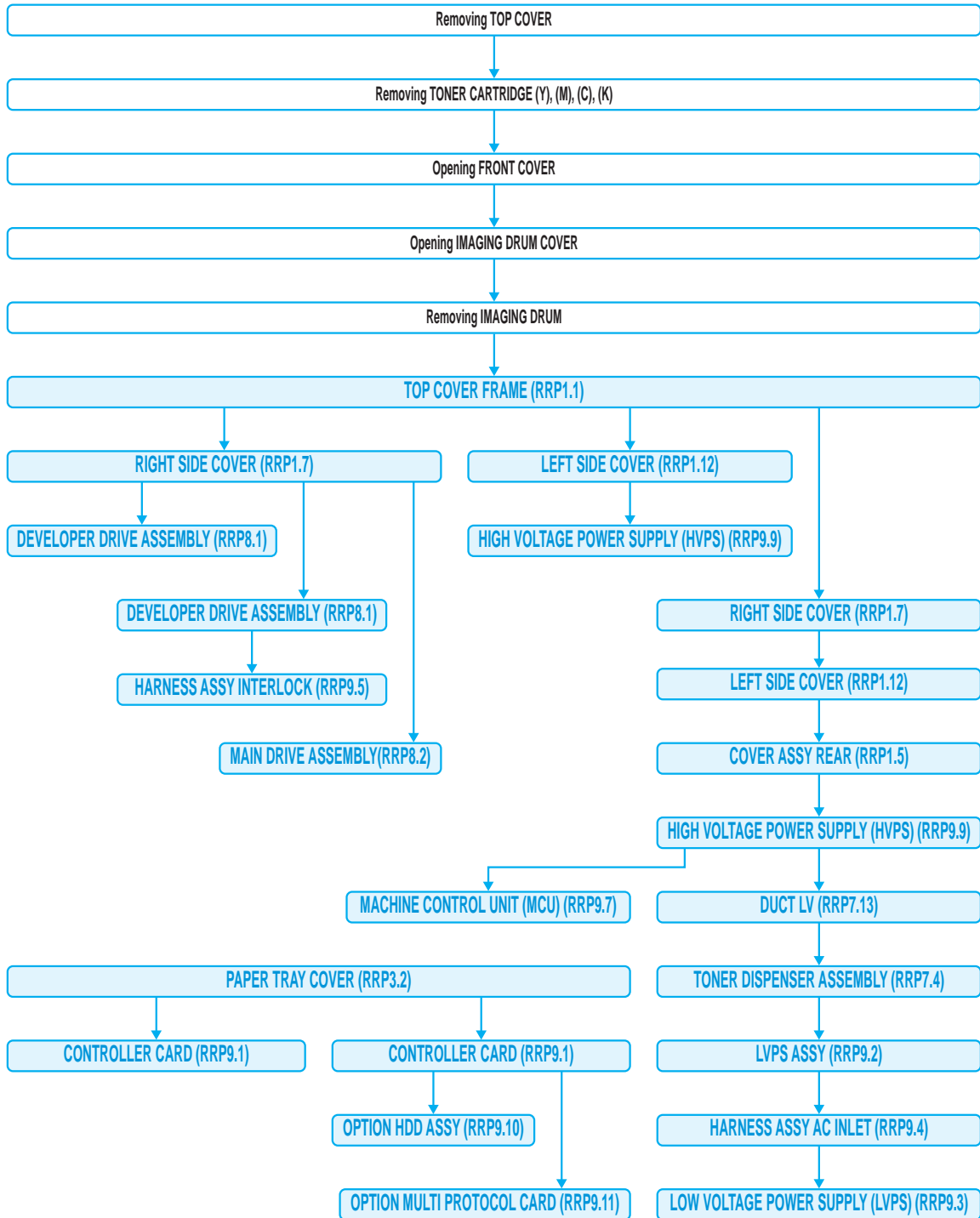

Blank Page

## RRP1. COVER

### RRP1.1 TOP COVER FRAME (PL1.1.4)

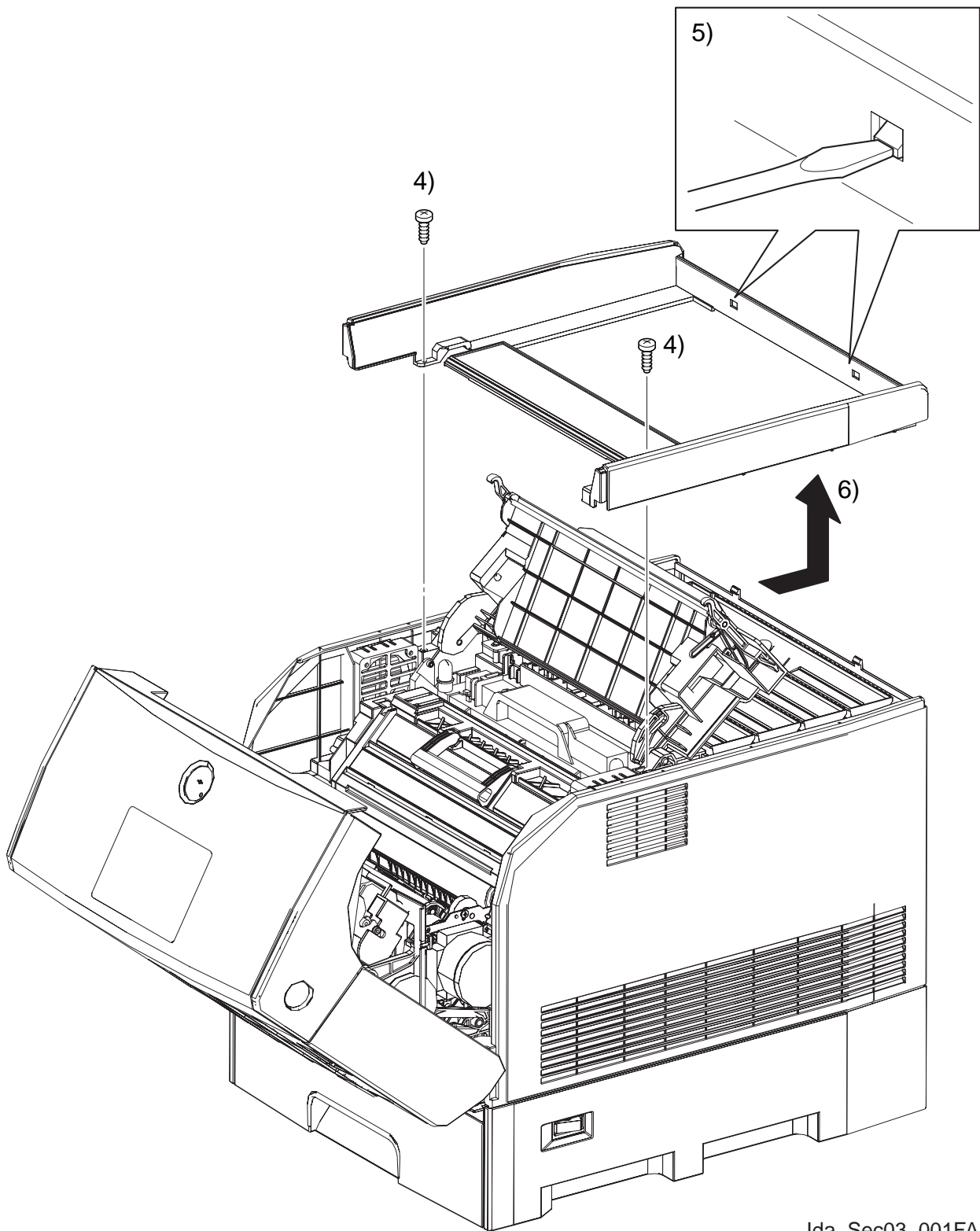

Ida\_Sec03\_001FA



## RRP1.1 TOP COVER FRAME (PL1.1.4)

### [Removal]

- 1) Remove TOP COVER (PL1.1.1).
- 2) Release the latch and open OUTER DUPLEX ASSEMBLY (PL5.3.1).
- 3) Open IMAGING DRUM COVER (PL1.1.8).
- 4) Remove two screws (silver, tap, 10 mm) that fix TOP COVER FRAME (PL1.1.4).
- 5) Release the hooks at two locations fixing the rear of TOP COVER FRAME.
- 6) Pull out and remove TOP COVER FRAME backward with IMAGING DRUM COVER a little opened.

### [Replacement]

- 1) Insert TOP COVER FRAME from the rear with IMAGING DRUM COVER a little opened.
- 2) Fix the hooks at two locations fixing the rear of TOP COVER FRAME.
- 3) Attach TOP COVER FRAME using two screws (silver, tap, 10mm).
- 4) Close IMAGING DRUM COVER.
- 5) Close OUTER DUPLEX ASSEMBLY.
- 6) Attach TOP COVER.

RRP1.2 OPERATOR PANEL (PL1.1.5)

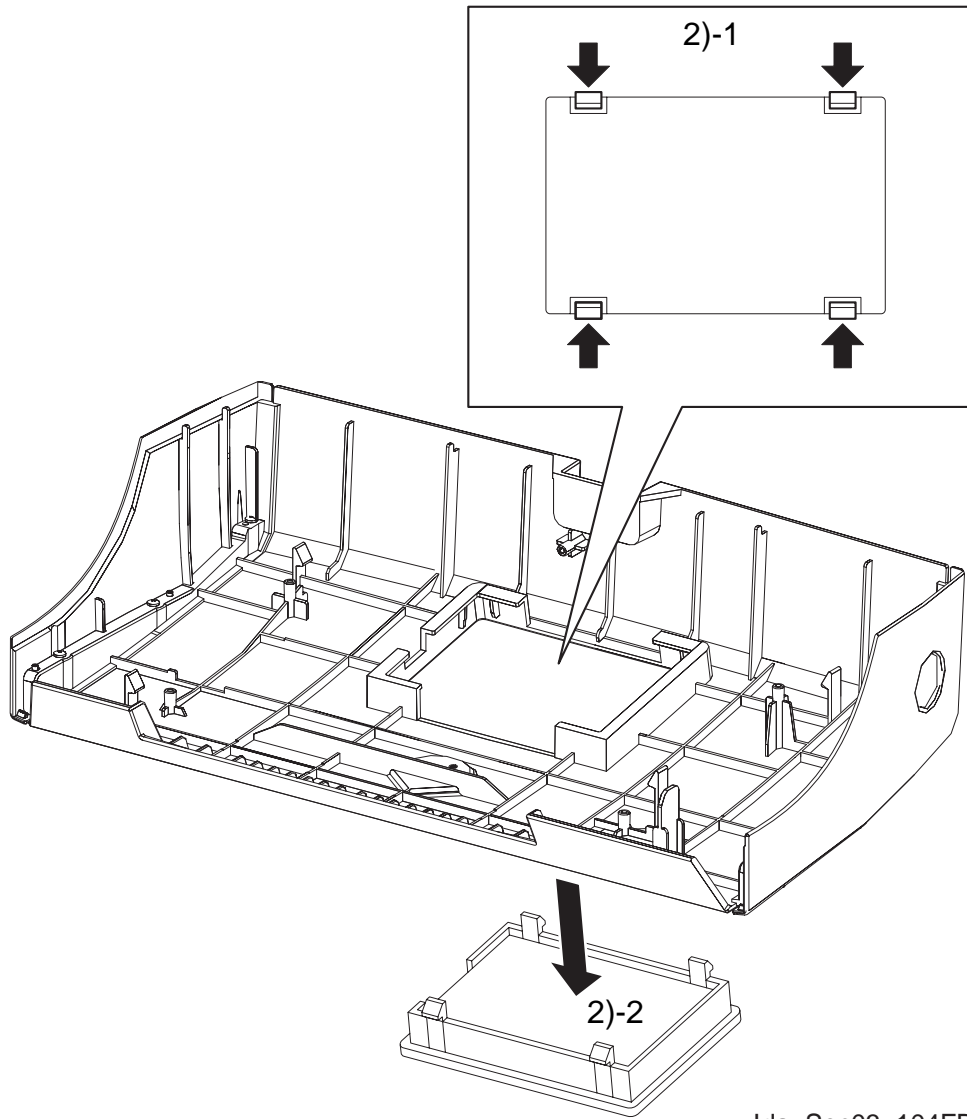

Ida\_Sec03\_104FB

| RRP1.2 OPERATOR PANEL (PL1.1.5)

[Removal]

- |
- 1) Remove FRONT COVER. (RRP1.3)
  - 2) Release the hooks at four locations fixing OPERATOR PANEL on FRONT COVER and remove OPERATOR PANEL.

[Replacement]

- |
- 1) Insert OPERATOR PANEL into FRONT COVER and fix with the four hooks.
  - 2) Attach FRONT COVER. (RRP1.3)

RRP1.3 FRONT COVER (PL1.1.6)

NOTE

Procedure No. with [ ] included in Fig. shows the procedure at attachment.

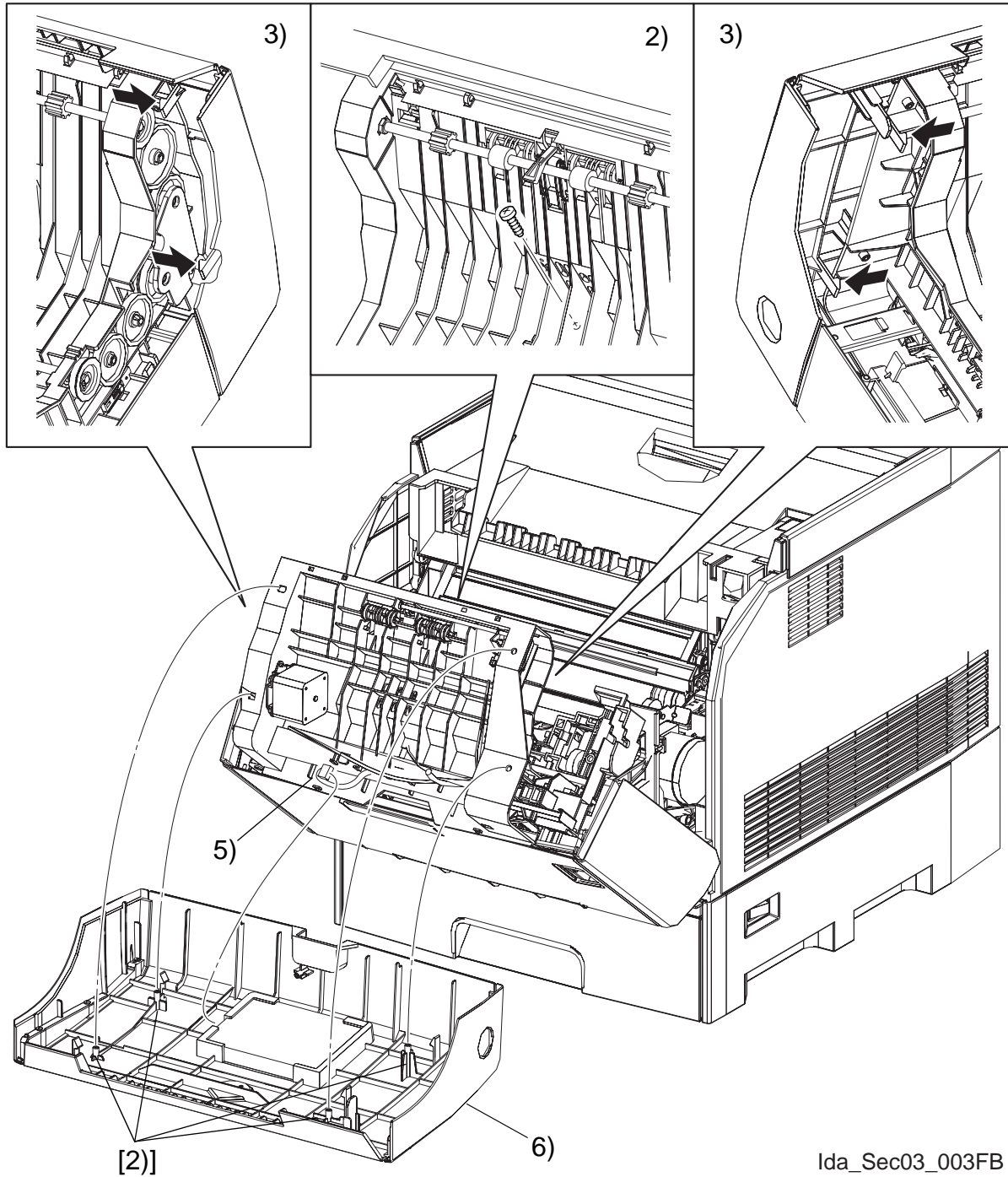

Ida\_Sec03\_003FB

### RRP1.3 FRONT COVER (PL1.1.6)

#### [Removal]

- 1) Release the latch and open OUTER DUPLEX ASSEMBLY (PL5.3.1).
- 2) Remove a screw (silver, tap, 10mm) that fixes FRONT COVER.
- 3) Release the hooks at four locations fixing FRONT COVER to OUTER DUPLEX ASSEMBLY.

**NOTE**

OUTER DUPLEX ASSEMBLY is connected to FRONT COVER with connector, so they should not be set far apart when carrying out the work shown below.

- 4) Move FRONT COVER a little from OUTER DUPLEX ASSEMBLY.
- 5) Remove the connector (P/J220) on OPERATOR PANEL (PL1.1.5).
- 6) Remove FRONT COVER from OUTER DUPLEX ASSEMBLY.

#### [Replacement]

- 1) Attach the connector (P/J220) to CONSOL PANEL IDATEN.
- 2) Match the bosses at four locations on FRONT COVER to hole of OUTER DUPLEX ASSEMBLY, push FRONT COVER and attach it.
- 3) Attach FRONT COVER using a screw (silver, tap, 10mm).
- 4) Close OUTER DUPLEX ASSEMBLY.

RRP1.4 IMAGING DRUM COVER (PL1.1.8), IMAGING DRUM COVER HINGE PIN (PL1.1.21)

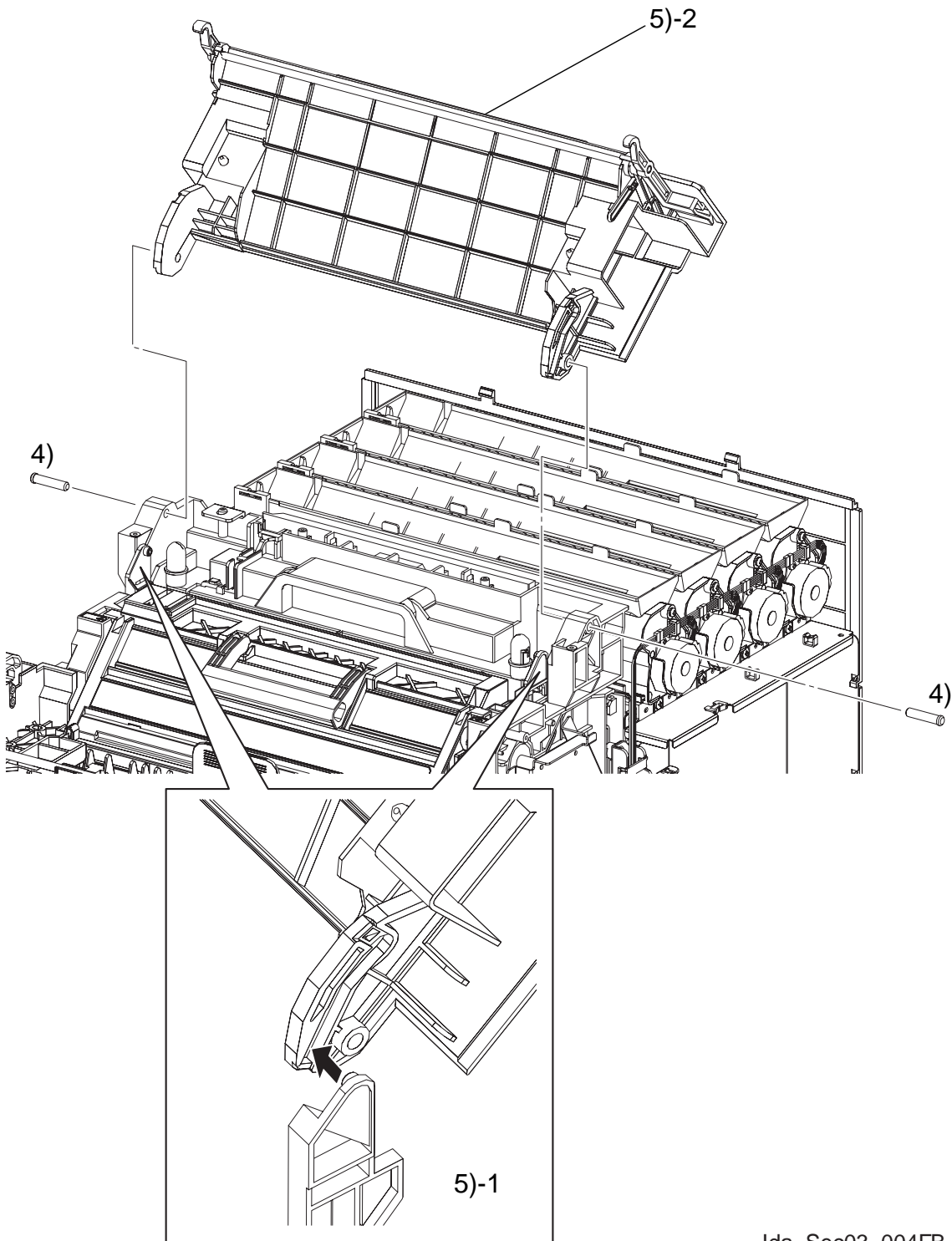

Ida\_Sec03\_004FB

RRP1.4 IMAGING DRUM COVER (PL1.1.8), IMAGING DRUM COVER HINGE PIN  
(PL1.1.21)

[Removal]

- 1) Remove TOP COVER FRAME. (RRP1.1)
- 2) Remove RIGHT SIDE COVER. (RRP1.7)
- 3) Remove LEFT SIDE COVER. (RRP1.12)
- 4) Pull out two IMAGING DRUM COVER HINGE PIN (PL1.1.21) to the left and right, that fix IMAGING DRUM COVER to the printer.
- 5) Move bosses of the GUIDE FRAME DEVE L (PL7.1.21) and GUIDE FRAME DEVE R (PL.7.1.22) that are fitted in the left and right grooves of IMAGING DRUM COVER, and remove IMAGING DRUM COVER.

[Replacement]

- 1) Attach bosses of GUIDE FRAME DEVE L and GUIDE FRAME DEVE R in the left and right grooves in IMAGING DRUM COVER.
- 2) Match two holes in IMAGING DRUM COVER with the holes in the printer, insert two IMAGING DRUM COVER HINGE PIN into those holes to attach IMAGING DRUM COVER on the printer.
- 3) Attach LEFT SIDE COVER. (RRP1.12)
- 4) Attach RIGHT SIDE COVER. (RRP1.7)
- 5) Attach TOP COVER FRAME. (RRP1.1)

RRP1.5 COVER ASSY REAR (PL1.1.17)

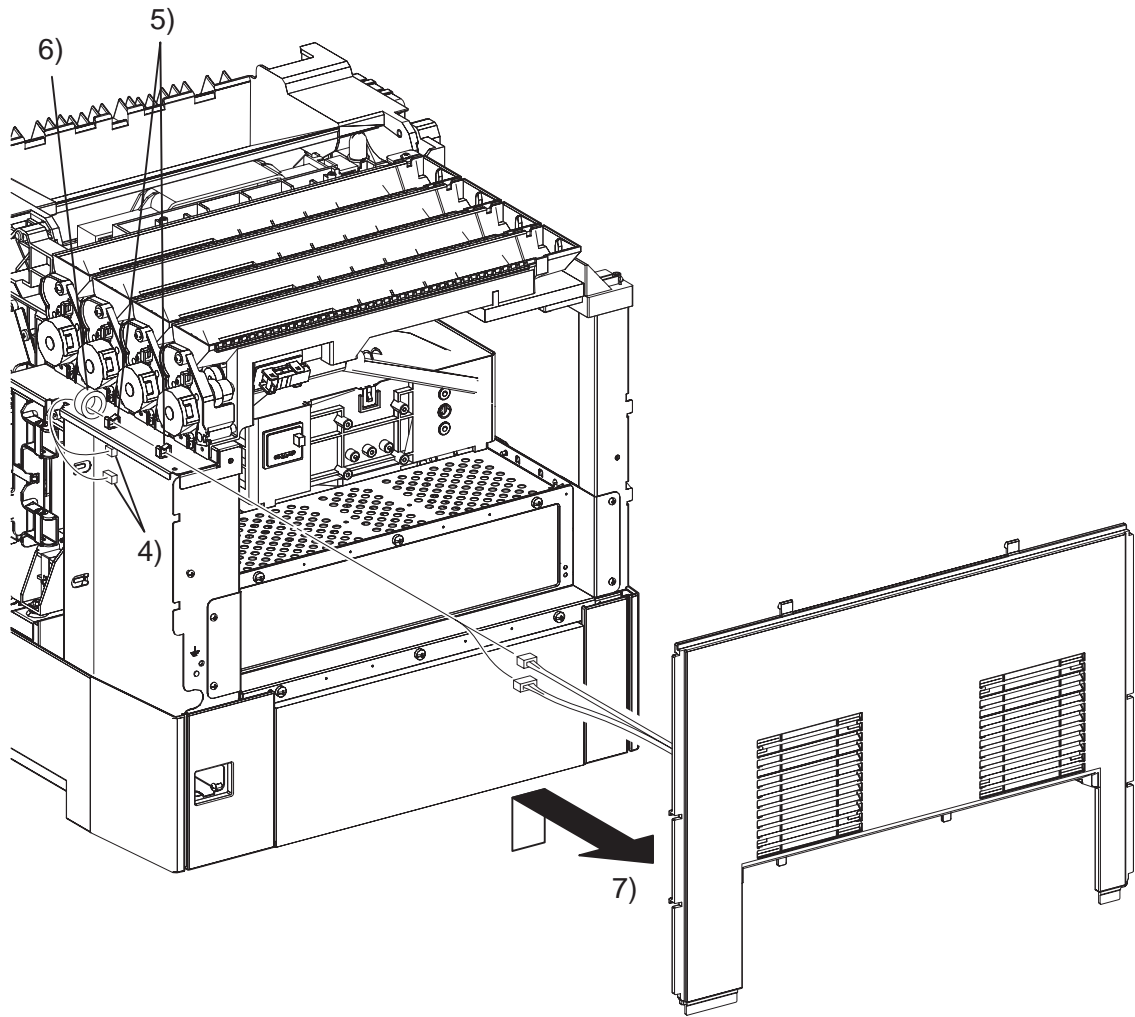

Ten03005KA



## RRP1.5 COVER ASSY REAR (PL1.1.17)

### [Removal]

- 1) Remove TOP COVER FRAME. (RRP1.1)
- 2) Remove RIGHT SIDE COVER. (RRP1.7)
- 3) Remove LEFT SIDE COVER. (RRP1.12)
- 4) Remove the connector (P/J166,167) on LOW VOLTAGE POWER SUPPLY (LVPS) (PL9.1.6).
- 5) Release the clamp to remove the harness.
- 6) Remove the CORE (PL1.1.34) from the harness of the FAN.
- 7) A little lifting up COVER ASSY REAR, remove it backward.

### [Replacement]

- 1) Attach the hook located at seven locations on COVER ASSY REAR to the printer.
- 2) Pass the harness of the FAN through the CORE.
- 3) Put the harness through the clamp.
- 4) Attach the connector (P/J166,167) to LOW VOLTAGE POWER SUPPLY (LVPS).
- 5) Attach LEFT SIDE COVER. (RRP1.12)
- 6) Attach RIGHT SIDE COVER. (RRP1.7)
- 7) Attach TOP COVER FRAME. (RRP1.1)

RRP1.6 REAR FAN (PL1.1.19)

NOTE

Procedure No. with [ ] included in Fig. shows the procedure at attachment.

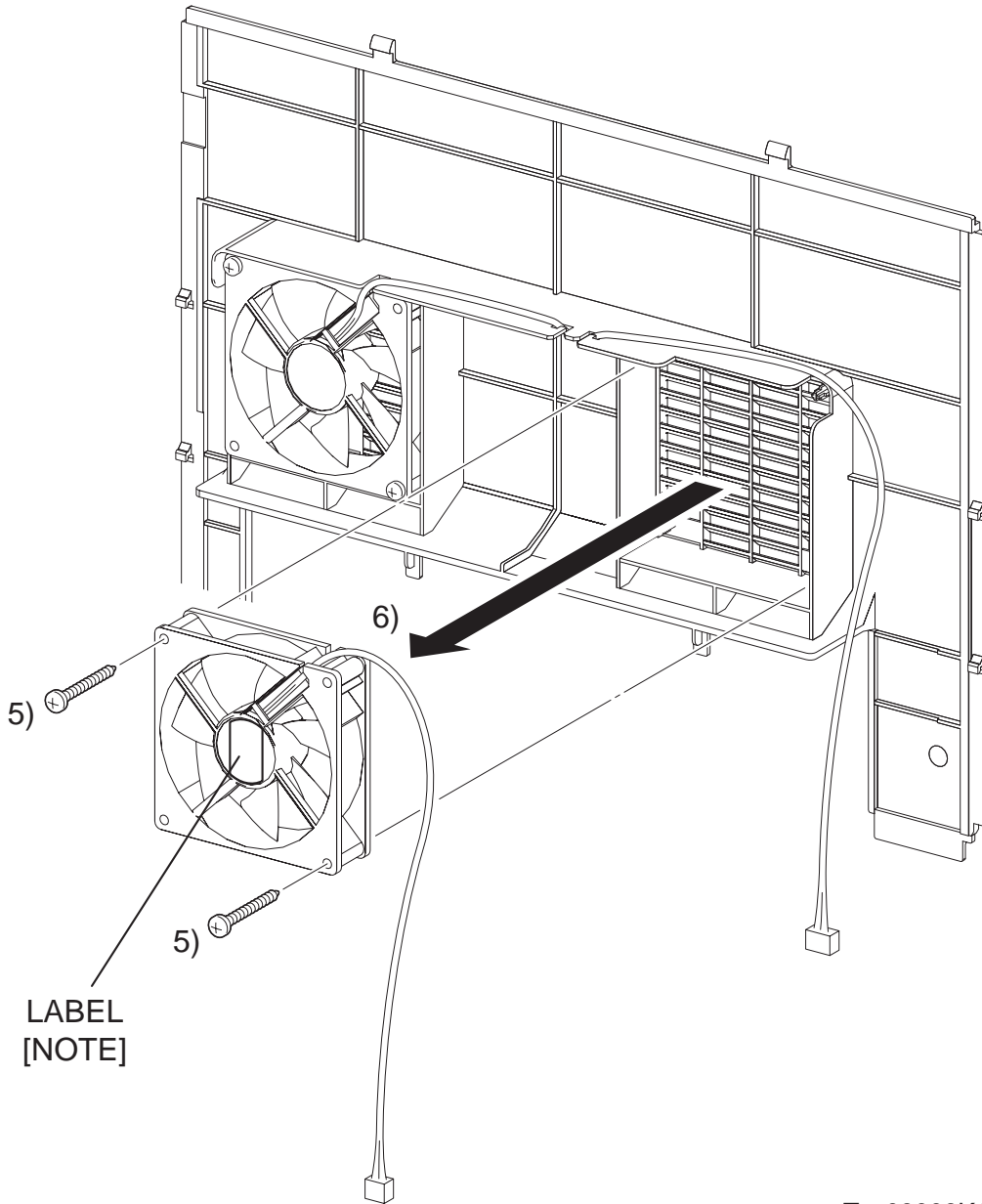

Ten03006KA

## RRP1.6 REAR FAN (PL1.1.19)

### [Removal]

- 1) Remove TOP COVER FRAME. (RRP1.1)
- 2) Remove RIGHT SIDE COVER. (RRP1.7)
- 3) Remove LEFT SIDE COVER. (RRP1.12)
- 4) Remove COVER ASSY REAR. (RRP1.5)
- 5) Remove two screws (black, tap, 35mm) that fix REAR FAN.
- 6) Remove REAR FAN.

### [Replacement]

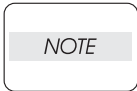

Be sure to check the orientation of the FAN before attaching it.

(Attach the FAN so that its labeled surface comes inside.)

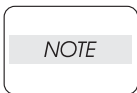

When attaching the FAN REAR (PL1.1.19) and the FAN LV (PL1.1.33), take care not to attach the FANS to wrong position.

(The length of harness of the FAN LV is longer than the harness of the FAN REAR.)

- 1) Attach REAR FAN with two screws (black, tap, 35 mm) with its labeled surface comes inside.
- 2) Attach COVER ASSY REAR. (RRP1.5)
- 3) Attach LEFT SIDE COVER. (RRP1.12)
- 4) Attach RIGHT SIDE COVER. (RRP1.7)
- 5) Attach TOP COVER FRAME. (RRP1.1)

RRP1.7 RIGHT SIDE COVER (PL1.1.20)

NOTE

Procedure No. with [ ] included in Fig. shows the procedure at attachment.

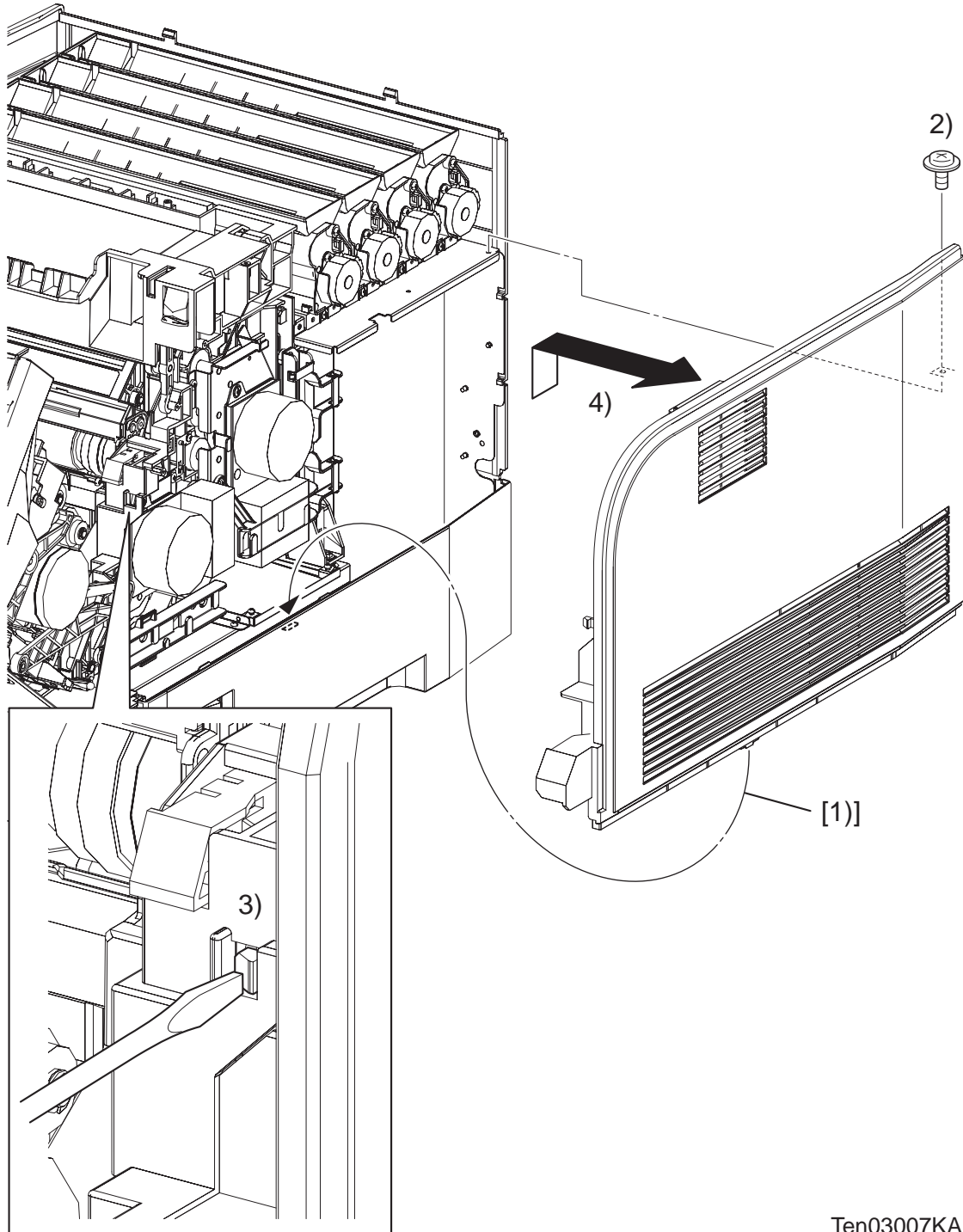

Ten03007KA

| RRP1.7 RIGHT SIDE COVER (PL1.1.20)

[Removal]

- 1) Remove TOP COVER FRAME. (RRP1.1)
- 2) Remove a screw (silver, with flange, 8mm) that fixes RIGHT SIDE COVER.
- 3) Release a hook at the front side that fix RIGHT SIDE COVER.
- 4) Remove RIGHT SIDE COVER from the printer.

[Replacement]

- 1) Fit the projection located on the lower part of RIGHT SIDE COVER in the groove on the printer.
- 2) Fix a hook located on the front side of RIGHT SIDE COVER to the printer.
- 3) Attach RIGHT SIDE COVER using a screw (silver, with flange, 8mm).
- 4) Attach TOP COVER FRAME. (RRP1.1)

RRP1.8 RIGHT FRONT COVER (PL1.1.22)

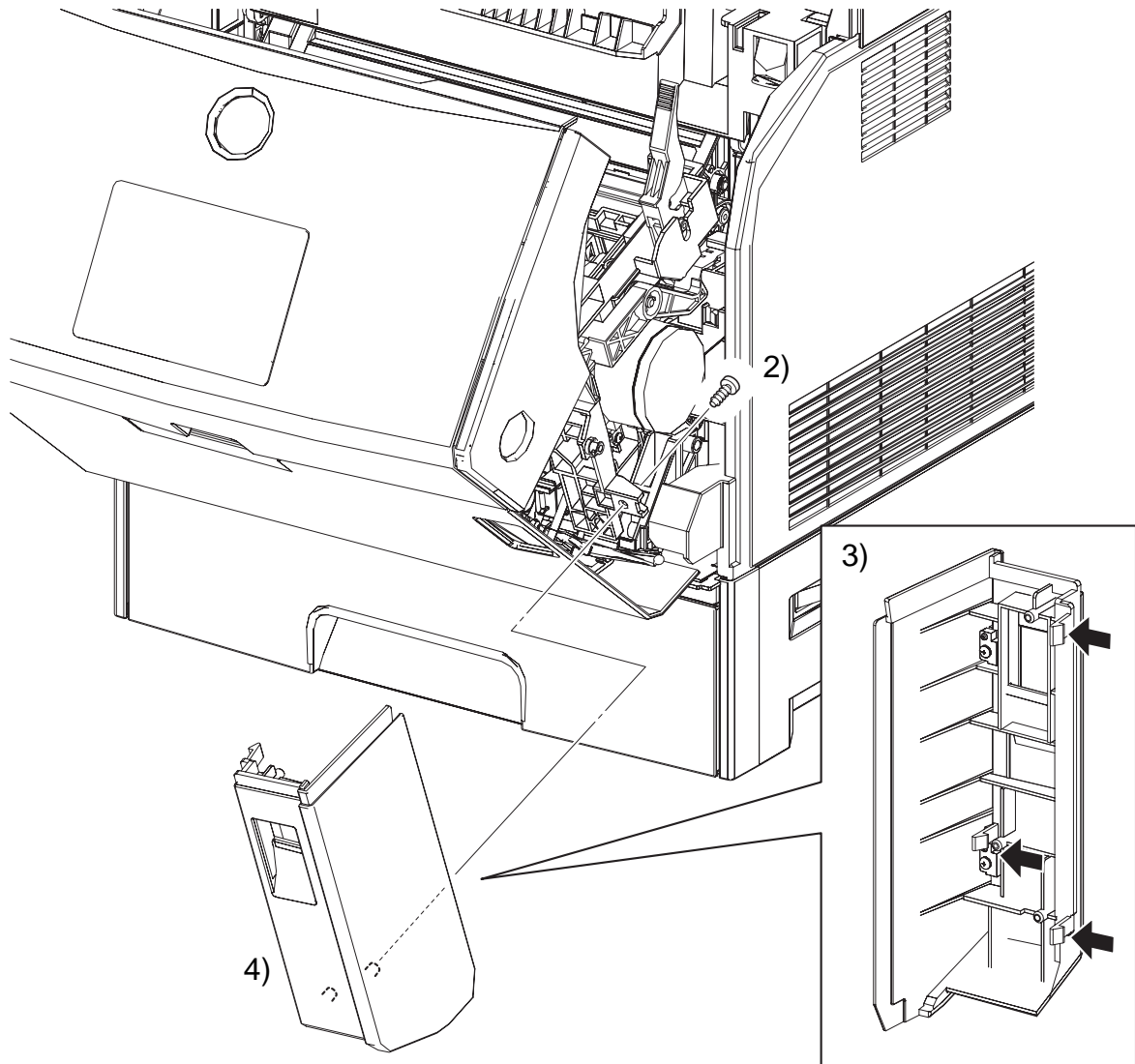

Ida\_Sec03\_008FB

## RRP1.8 RIGHT FRONT COVER (PL1.1.22)

### [Removal]

- 1) Release the latch and open OUTER DUPLEX ASSEMBLY (PL5.3.1) together with INNER DUPLEX ASSEMBLY (PL5.2.1).
- 2) Remove a screw (silver, tap, 10mm) that fixes RIGHT FRONT COVER.
- 3) Release the hooks fixing RIGHT FRONT COVER at three locations.
- 4) Release the latch. Remove RIGHT FRONT COVER with OUTER DUPLEX ASSEMBLY fully open state and with INNER DUPLEX ASSEMBLY half-open state.

### [Replacement]

- 1) Release the latch and open OUTER DUPLEX ASSEMBLY.
- 2) Match the bosses at three locations on RIGHT FRONT COVER to the holes of INNER DUPLEX ASSEMBLY and push COVER FRONT ASSY. Insert the bosses into the holes and fix the hooks at three locations.
- 3) Attach RIGHT FRONT COVER using a screw (silver, tap, 10mm).
- 4) Close OUTER DUPLEX ASSEMBLY.

RRP1.9 MULTIPURPOSE FEEDER (MPF) TRAY (PL1.1.23)

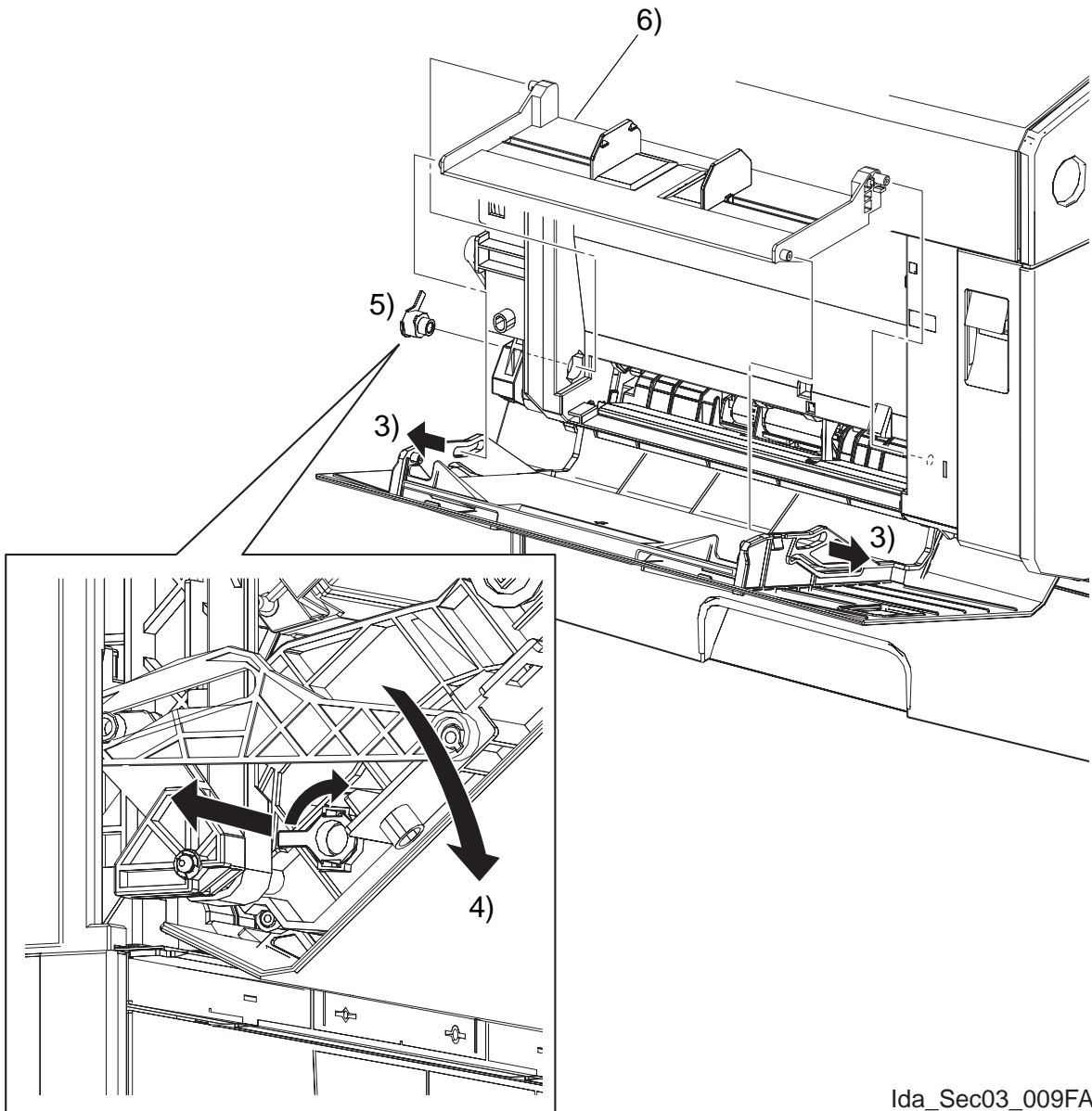

Ida\_Sec03\_009FA



RRP1.9 MULTIPURPOSE FEEDER (MPF) TRAY (PL1.1.23)

[Removal]

- 1) Remove LEFT FRONT COVER. (RRP1.11)
- 2) Open MULTIPURPOSE FEEDER (MPF) COVER (PL1.1.25).
- 3) Opening the left and right slots of MULTIPURPOSE FEEDER (MPF) COVER outward, pull out the right and left bosses of MULTIPURPOSE FEEDER (MPF) TRAY.
- 4) Release the latch and open OUTER DUPLEX ASSEMBLY (PL5.3.1).
- 5) Turn HOLDER TRAY L (PL1.1.29) located at the left base of OUTER DUPLEX ASSEMBLY clockwise to remove it.
- 6) Remove the left side boss of MULTIPURPOSE FEEDER (MPF) TRAY, pull out and remove the right side boss.

[Replacement]

- 1) Insert the right side boss of MULTIPURPOSE FEEDER (MPF) TRAY into HOLDER TRAY R (PL1.1.24).
- 2) Insert HOLDER TRAY L into the left base of OUTER DUPLEX ASSEMBLY and fix the left side boss of MULTIPURPOSE FEEDER (MPF) TRAY.
- 3) Attach HOLDER TRAY L by turning it counterclockwise.
- 4) Close OUTER DUPLEX ASSEMBLY.
- 5) Opening the left and right slots of MULTIPURPOSE FEEDER (MPF) COVER outward, fix the left and right bosses of TRAY MSI BASE.
- 6) Attach LEFT FRONT COVER. (RRP1.11)

RRP1.10 MULTIPURPOSE FEEDER (MPF) COVER (PL1.1.25)

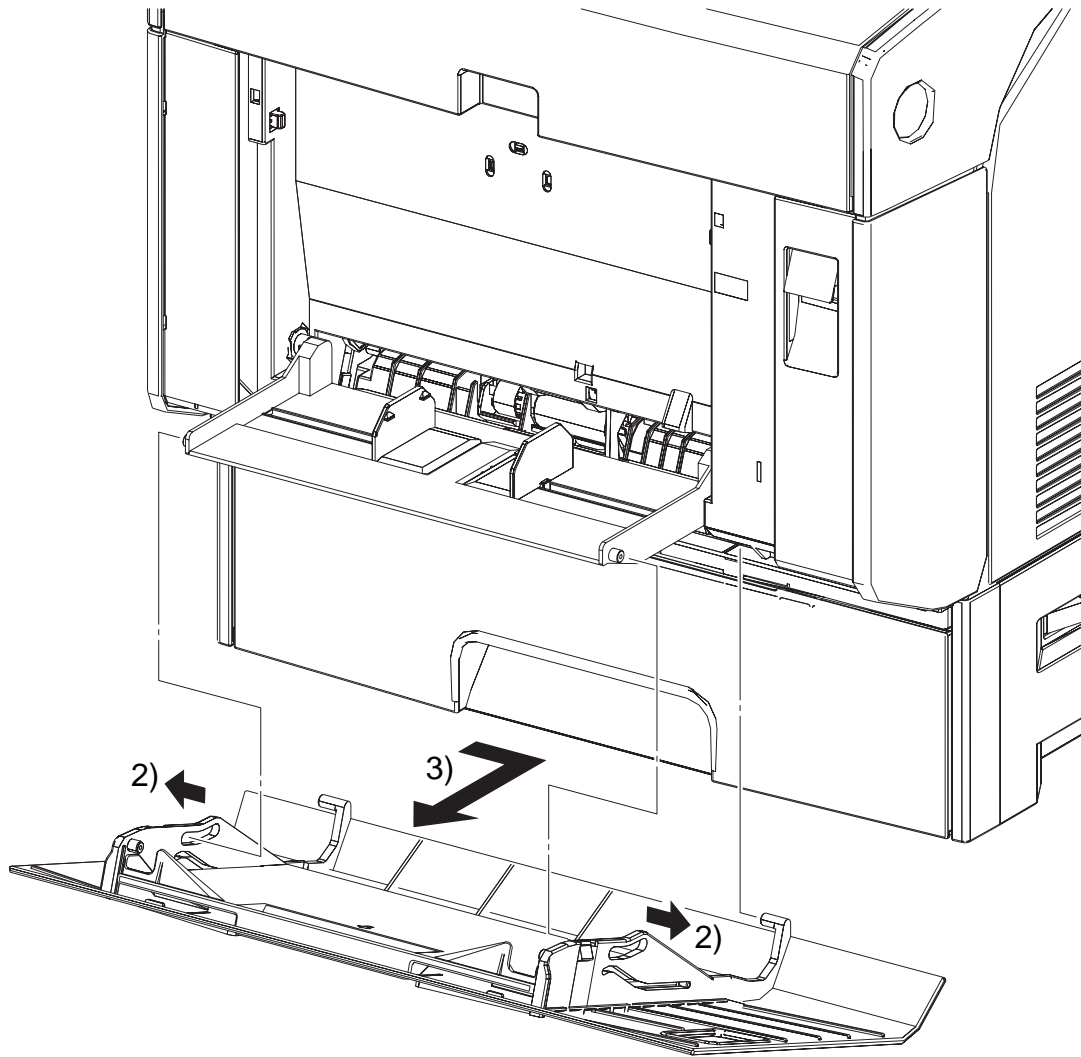

Ida\_Sec03\_010FB

RRP1.10 MULTIPURPOSE FEEDER (MPF) COVER (PL1.1.25)

[Removal]

- 1) Open MULTIPURPOSE FEEDER (MPF) COVER.
- 2) Opening the right and left slots of MULTIPURPOSE FEEDER (MPF) COVER outward, pull out the left and right bosses of MULTIPURPOSE FEEDER (MPF) TRAY (PL1.1.23).
- 3) Pull out and remove the bosses at two locations of MULTIPURPOSE FEEDER (MPF) COVER to the right.

[Replacement]

- 1) Match the bosses at two locations of MULTIPURPOSE FEEDER (MPF) COVER with holes in the lower part of OUTER DUPLEX ASSEMBLY (PL5.3.1), insert the bosses to the left so that they are placed in the holes.
- 2) Opening the left and right slots of MULTIPURPOSE FEEDER (MPF) COVER outward, fix the left and right bosses of MULTIPURPOSE FEEDER (MPF) TRAY.
- 3) Close MULTIPURPOSE FEEDER (MPF) COVER.

RRP1.11 LEFT FRONT COVER (PL1.1.28)

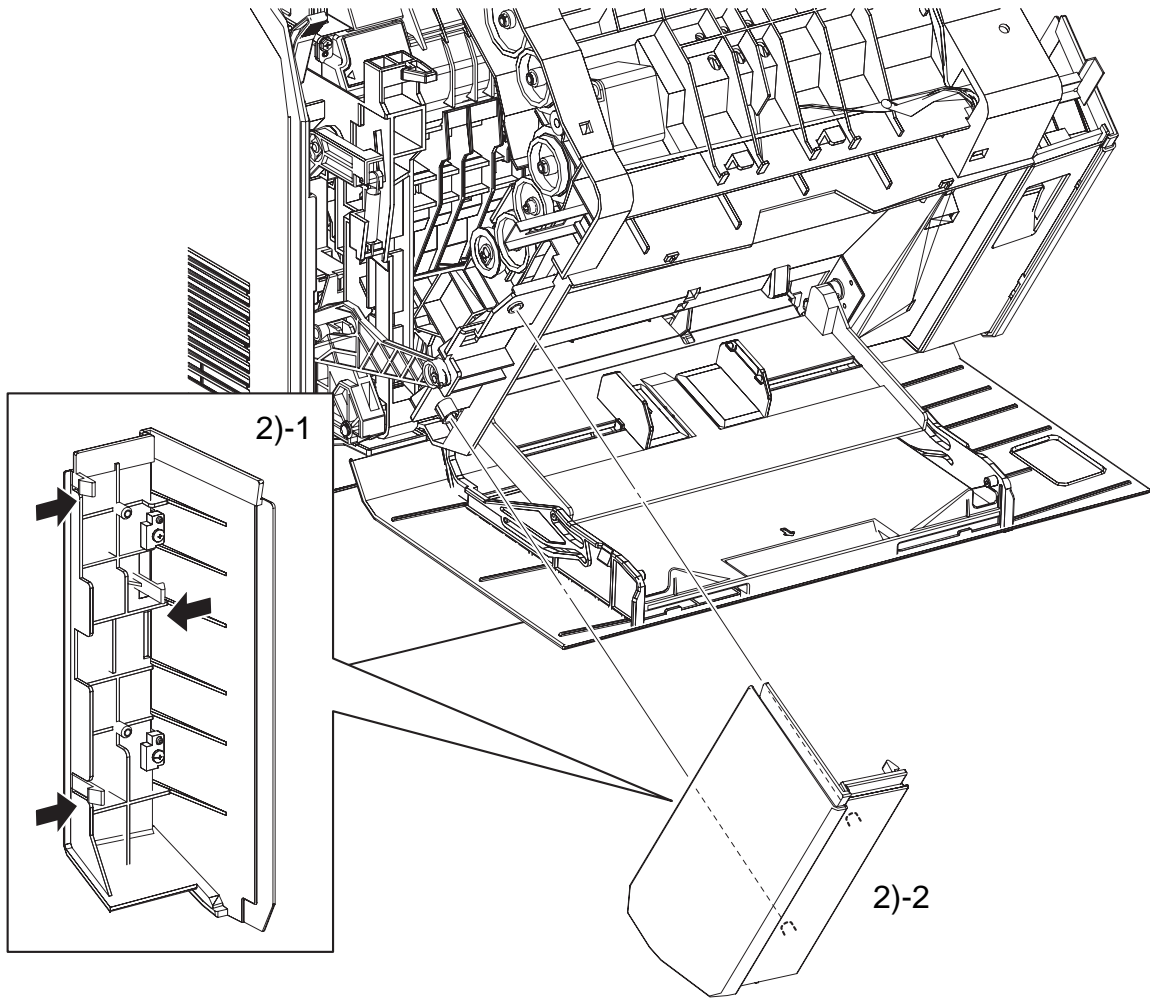

Ida\_Sec03\_011FA

RRP1.11 LEFT FRONT COVER (PL1.1.28)

[Removal]

- 1) Release the latch and open OUTER DUPLEX ASSEMBLY (PL5.3.1).
- 2) Release the hooks at three locations fixing the rear of LEFT FRONT COVER to remove LEFT FRONT COVER..

[Replacement]

- 1) Release the latch and open OUTER DUPLEX ASSEMBLY.
- 2) Match the bosses at two locations of LEFT FRONT COVER with the holes in OUTER DUPLEX ASSEMBLY, insert the bosses into the holes and fix the hooks at three locations.
- 3) Close OUTER DUPLEX ASSEMBLY.

RRP1.12 LEFT SIDE COVER (PL1.1.30)

NOTE

Procedure No. with [ ] included in Fig. shows the procedure at attachment.

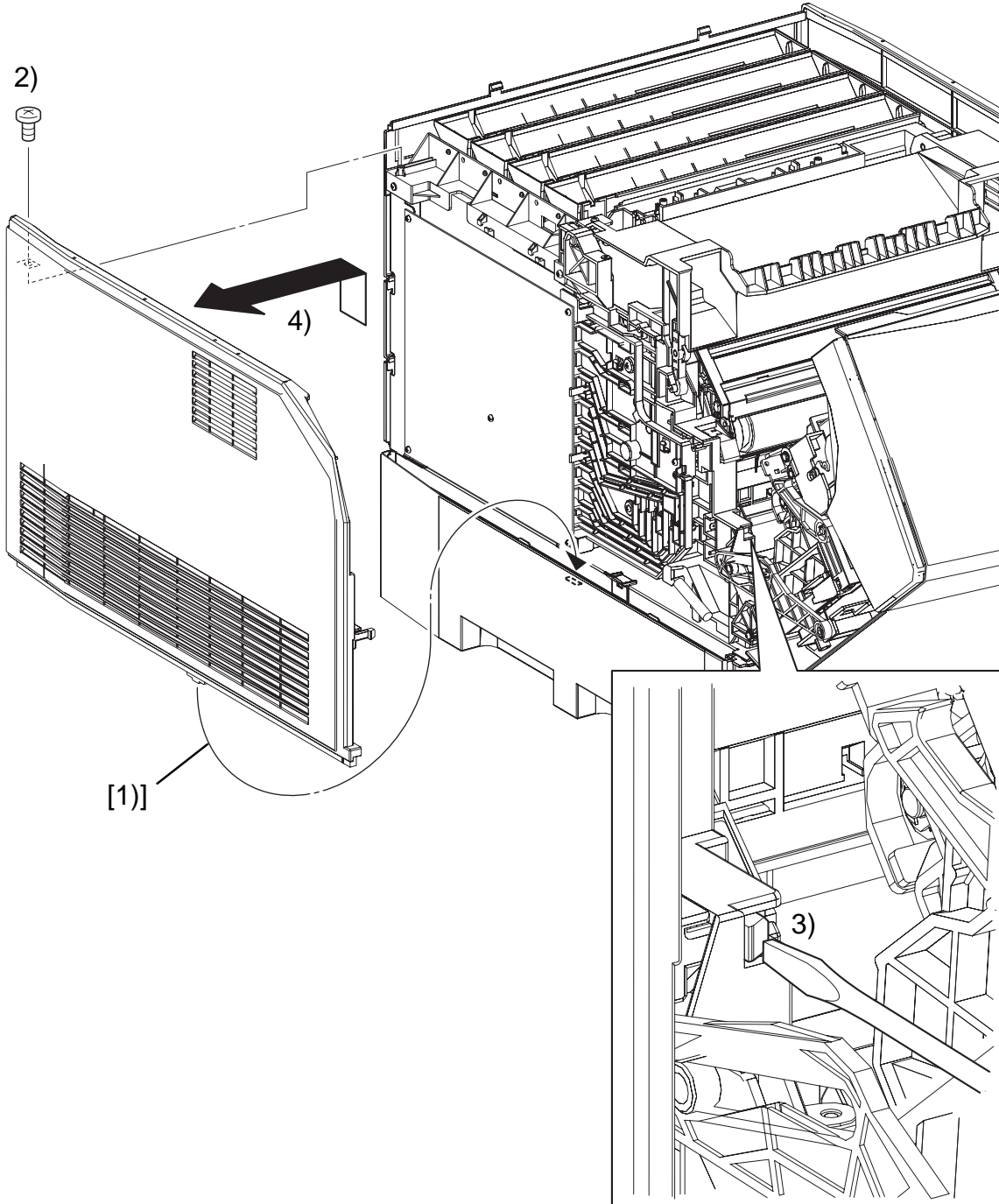

Ida\_Sec03\_012FB

RRP1.12 LEFT SIDE COVER (PL1.1.30)

[Removal]

- 1) Remove TOP COVER FRAME. (RRP1.1)
- 2) Remove a screw (silver, 6mm) that fixes LEFT SIDE COVER.
- 3) Release a hook on the front side that fix LEFT SIDE COVER.
- 4) Remove LEFT SIDE COVER to the printer.

[Replacement]

- 1) Put the projection on the lower part of LEFT SIDE COVER in the groove on the printer.
- 2) Fix a hook on the front side of LEFT SIDE COVER to the printer.
- 3) Attach that fixes LEFT SIDE COVER using a screw (silver, 6mm).
- 4) Attach TOP COVER FRAME. (RRP1.1)

RRP1.13 FAN LV (PL1.1.33)

NOTE

Procedure No. with [ ] included in Fig. shows the procedure at attachment.

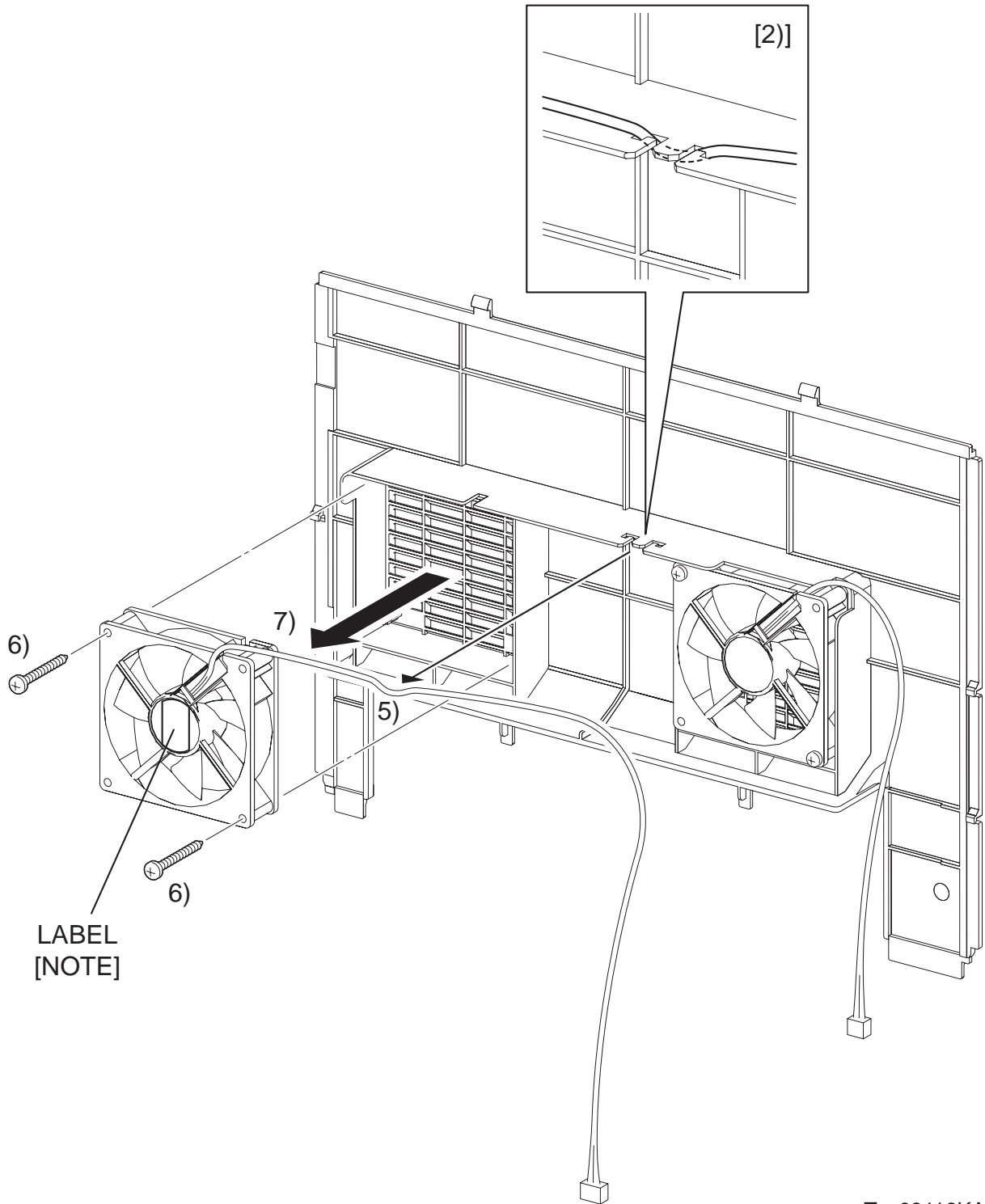

Ten03116KA



### RRP1.13 FAN LV (PL1.1.33)

#### [Removal]

- 1) Remove TOP COVER FRAME. (RRP1.1)
- 2) Remove RIGHT SIDE COVER. (RRP1.7)
- 3) Remove LEFT SIDE COVER. (RRP1.12)
- 4) Remove COVER ASSY REAR. (RRP1.5)
- 5) Release the harness of the FAN LV from the hook of the COVER REAR.
- 6) Remove two screws (black, tap, 35mm) that fix FAN LV.
- 7) Remove FAN LV.

#### [Replacement]

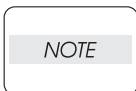

Be sure to check the orientation of the FAN before attaching it.  
(Attach the FAN so that its labeled surface comes inside.)

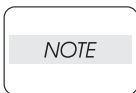

When attaching the FAN REAR (PL1.1.19) and the FAN LV (PL1.1.33), take care not to attach the FANS to wrong position.  
(The length of harness of the FAN LV is longer than the harness of the FAN REAR.)

- 1) Attach FAN LV with two screws (black, tap, 35 mm) with its labeled surface comes inside.
- 2) Pass the harness of the FAN LV through the hook of the COVER REAR.
- 3) Attach COVER ASSY REAR. (RRP1.5)
- 4) Attach LEFT SIDE COVER. (RRP1.12)
- 5) Attach RIGHT SIDE COVER. (RRP1.7)
- 6) Attach TOP COVER FRAME. (RRP1.1)

RRP1.14 REAR COVER (PL1.1.18)

NOTE

Procedure No. with [ ] included in Fig. shows the procedure at attachment.

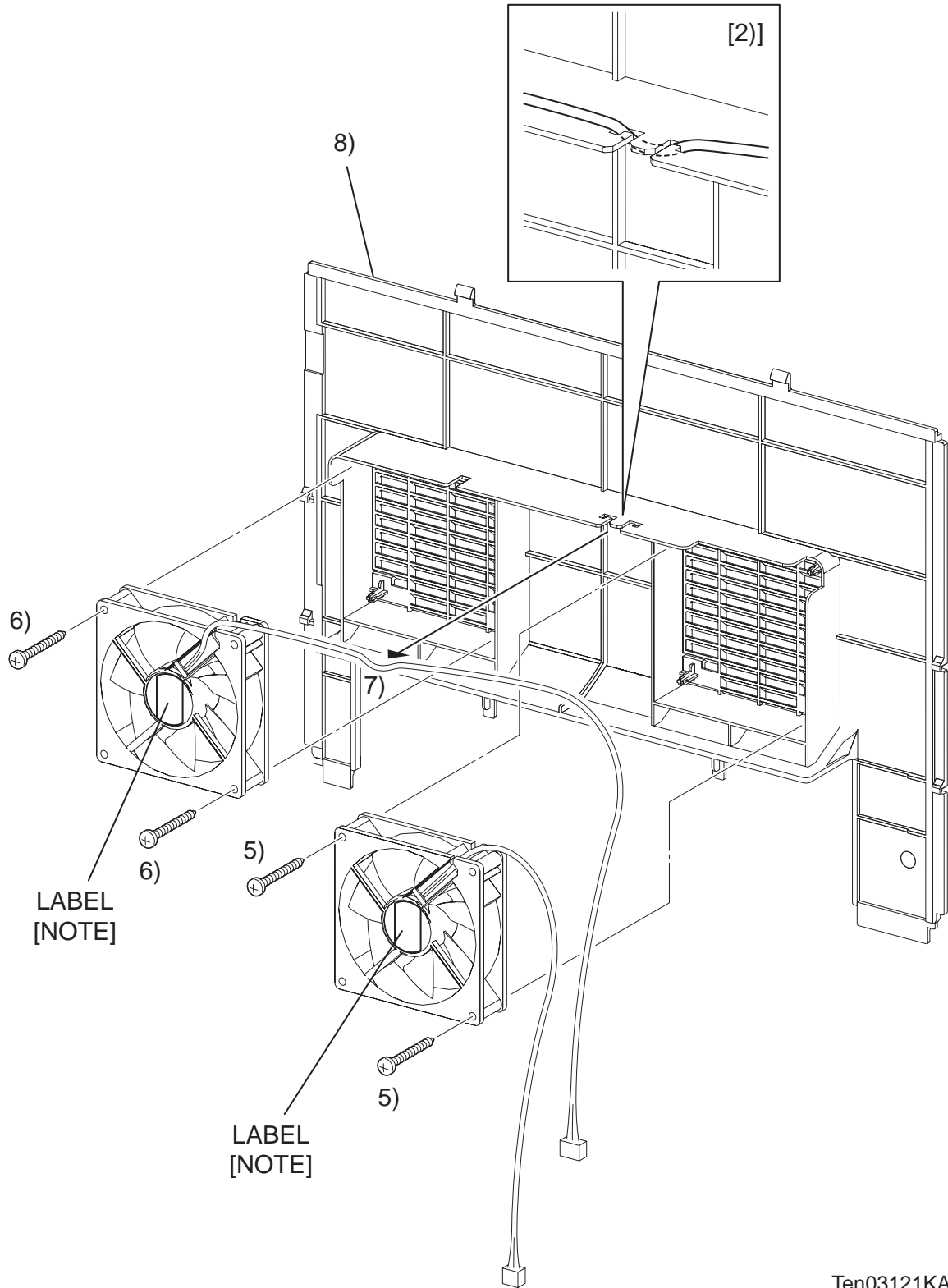

Ten03121KA

## RRP1.14 REAR COVER (PL1.1.18)

## [Removal]

- 1) Remove TOP COVER FRAME. (RRP1.1)
- 2) Remove RIGHT SIDE COVER. (RRP1.7)
- 3) Remove LEFT SIDE COVER. (RRP1.12)
- 4) Remove COVER ASSY REAR. (RRP1.5)
- 5) Remove two screws (black, tap, 35mm) that fix REAR FAN.
- 6) Remove two screws (black, tap, 35mm) that fix FAN LV.
- 7) Release the harness of the FAN LV from the hook of the REAR COVER.
- 8) Remove the REAR FAN and the FAN LV from the REAR COVER, remove the REAR COVER.

## [Replacement]

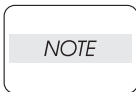

Be sure to check the orientation of the FAN before attaching it.  
(Attach the FAN so that its labeled surface comes inside.)

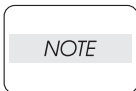

When attaching the FAN REAR (PL1.1.19) and the FAN LV (PL1.1.33), take care not to attach the FANS to wrong position.  
(The length of harness of the FAN LV is longer than the harness of the FAN REAR.)

- 1) Attach FAN LV with two screws (black, tap, 35mm) with its labeled surface comes inside.
- 2) Pass the harness of the FAN LV through the hook of the REAR COVER.
- 3) Attach REAR FAN with two screws (black, tap, 35 mm) with its labeled surface comes inside.
- 4) Attach COVER ASSY REAR. (RRP1.5)
- 5) Attach LEFT SIDE COVER. (RRP1.12)
- 6) Attach RIGHT SIDE COVER. (RRP1.7)
- 7) Attach TOP COVER FRAME. (RRP1.1)

## RRP2. PAPER CASSETTE

### RRP2.1 SEPARATOR ROLLER. (PL2.1.13), SEPARATOR ROLLER CLUTCH (PL2.1.14)

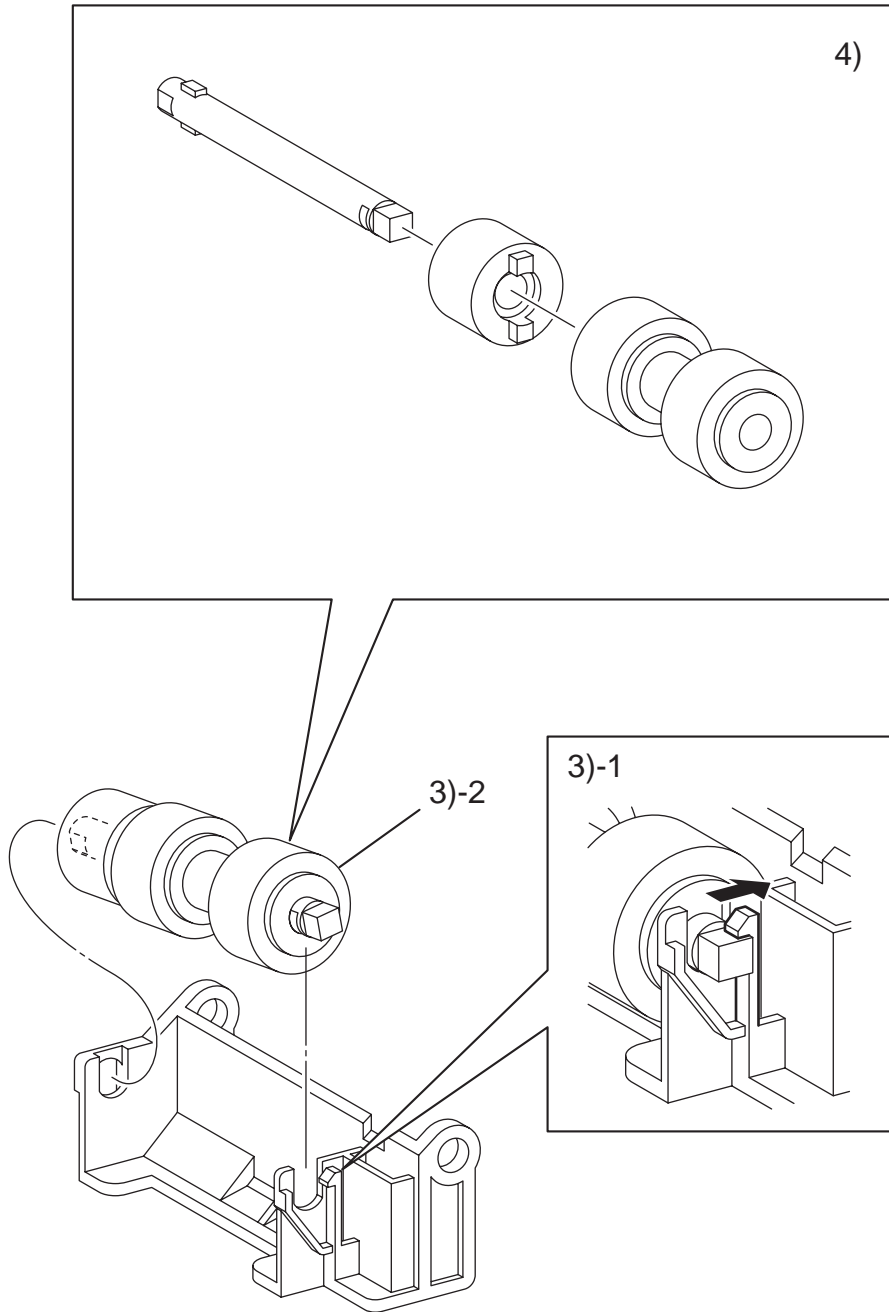

Ten03122KA

RRP2.1 SEPARATOR ROLLER. (PL2.1.13), SEPARATOR ROLLER CLUTCH  
(PL2.1.14)

[Removal]

- 1) Pull out 500 SHEET PAPER TRAY from the printer.
- 2) Remove the RETARD ASSY. (RRP2.2)
- 3) Remove the hook which fixes SHAFT ASSY RETARD to HOLDER RETARD, and remove SEPARATOR ROLLER and SEPARATOR ROLLER CLUTCH.
- 4) Pull out the SEPARATOR ROLLER and SEPARATOR ROLLER CLUTCH from the SHAFT RETARD and remove.

[Replacement]

- 1) Insert the SEPARATOR ROLLER CLUTCH into the SHAFT RETARD.
- 2) Insert the SEPARATOR ROLLER into the SHAFT ASSY RETARD to engage with the SEPARATOR ROLLER CLUTCH.
- 3) Attach the SHAFT ASSY RETARD together with the SEPARATOR ROLLER and the SEPARATOR ROLLER CLUTCH to the HOLDER RETARD, fix them using the hook.
- 4) Attach the RETARD ASSY. (RRP2.2)
- 5) Insert 500 SHEET PAPER TRAY into the printer.

RRP2.2 RETARD ASSY (PL2.1.12)

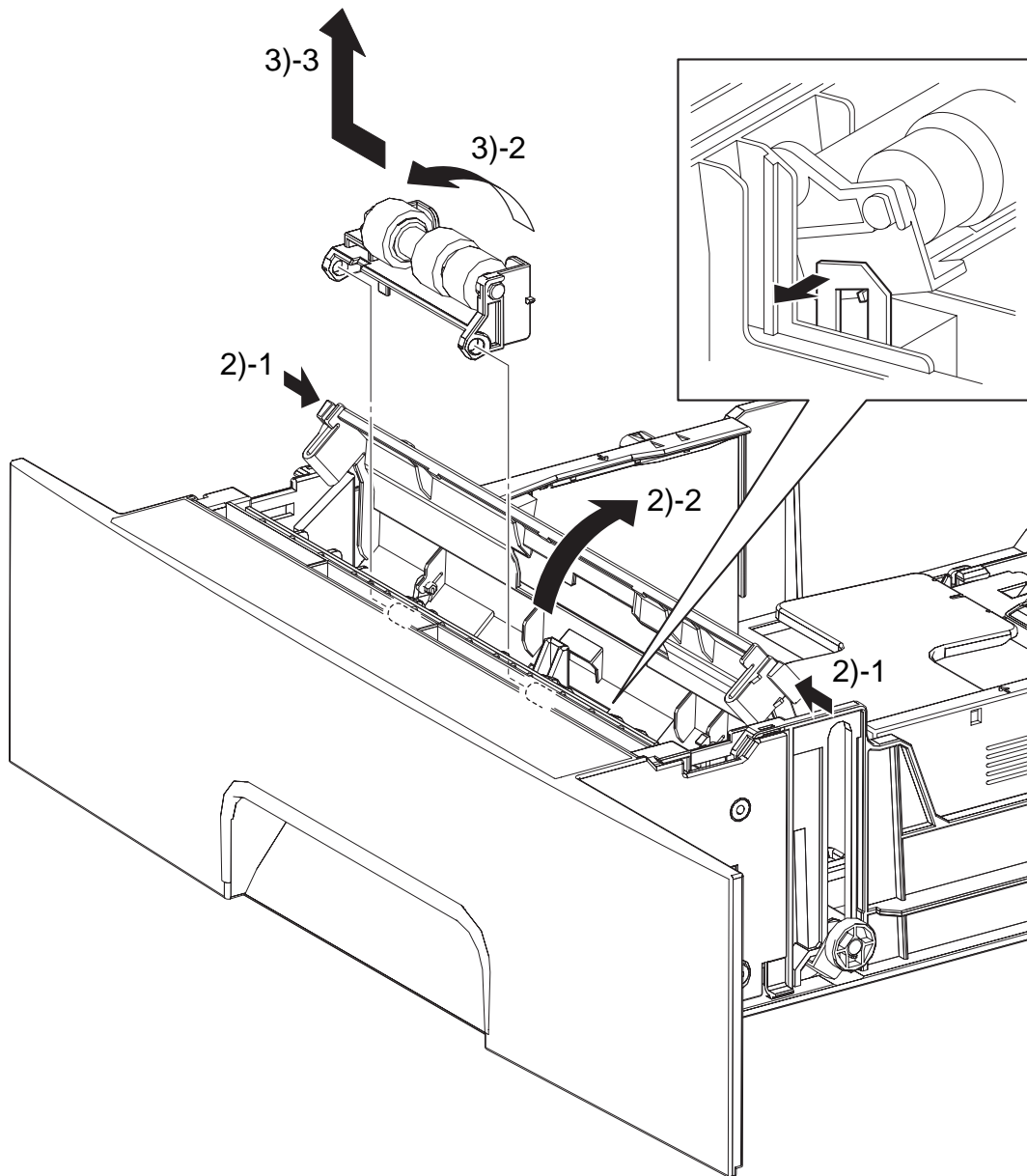

Ida\_Sec03\_015FB

## RRP2.2 RETARD ASSY (PL2.1.12)

### [Removal]

- 1) Pull out 500 SHEET PAPER TRAY from the printer.
- 2) Push the right and left bosses of PAPER TRAY TURN CHUTE (PL2.1.11) inward and release it, open PAPER TRAY TURN CHUTE.
- 3) Release the hook which fixes RETARD ASSY to 500 SHEET PAPER TRAY, rotate RETARD ASSY upward, then shift RETARD ASSY to the left and remove it.

### [Replacement]

- 1) Match the two holes of RETARD ASSY to the boss of 500 SHEET PAPER TRAY and attach it using the hook.
- 2) Close PAPER TRAY TURN CHUTE.
- 3) Insert 500 SHEET PAPER TRAY into the printer.

## RRP3. PAPER FEEDER

### RRP3.1 PAPER FEEDER CHUTE. (PL3.1.2)

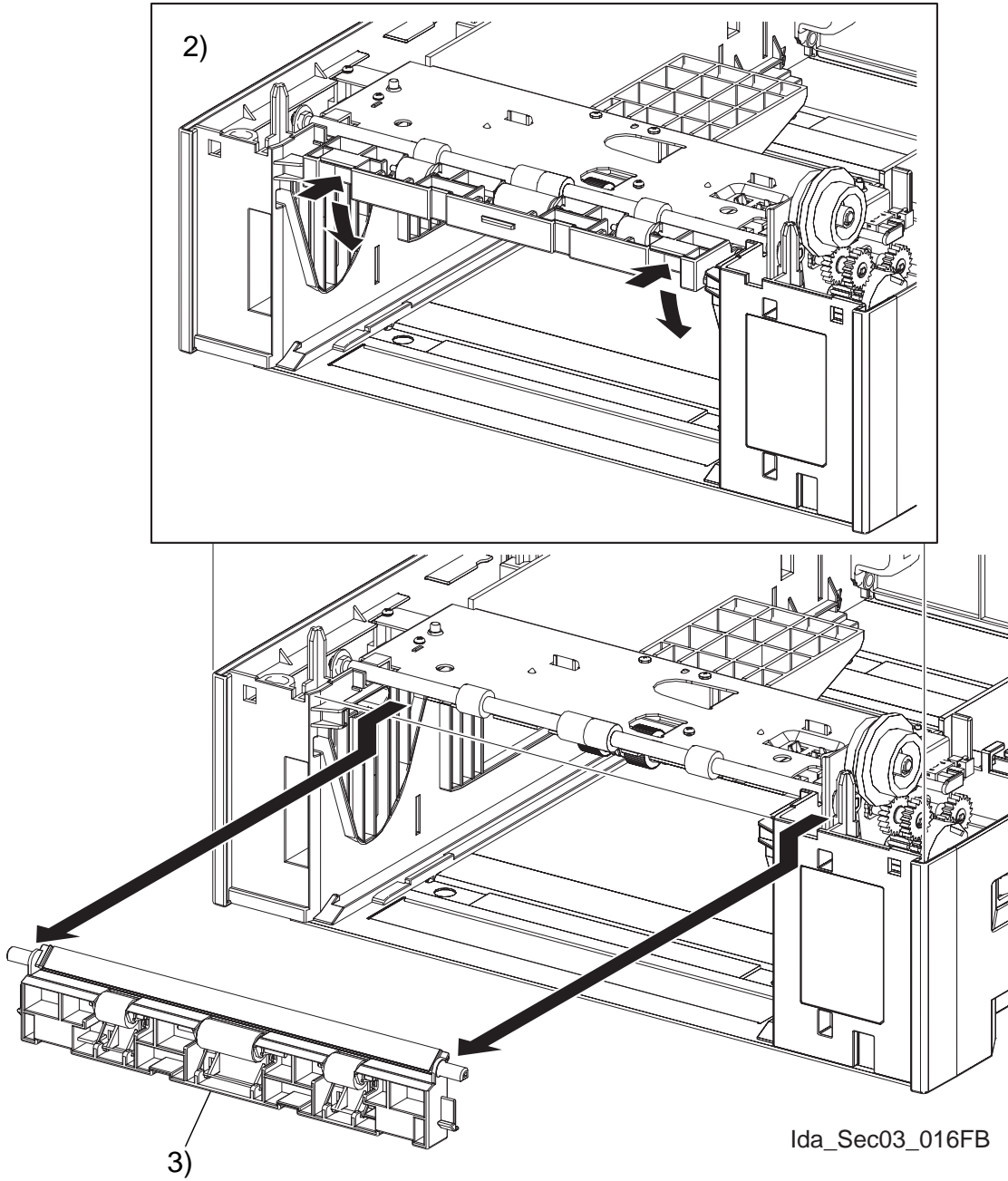



RRP3.1 PAPER FEEDER CHUTE. (PL3.1.2)

[Removal]

- 1) Pull out 500 SHEET PAPER TRAY from the printer.
- 2) Push down concaved section at the left and the right sides of PAPER FEEDER CHUTE and swing PAPER FEEDER CHUTE downward.
- 3) Pull PAPER FEEDER CHUTE once toward you and remove it downward.

[Replacement]

- 1) Insert the left and right bosses of PAPER FEEDER CHUTE into FEEDER of the printer from the lower part and push them backward.
- 2) Swing PAPER FEEDER CHUTE upward and lock it.
- 3) Insert 500 SHEET PAPER TRAY into the printer.

RRP3.2 PAPER TRAY COVER (PL3.1.3)

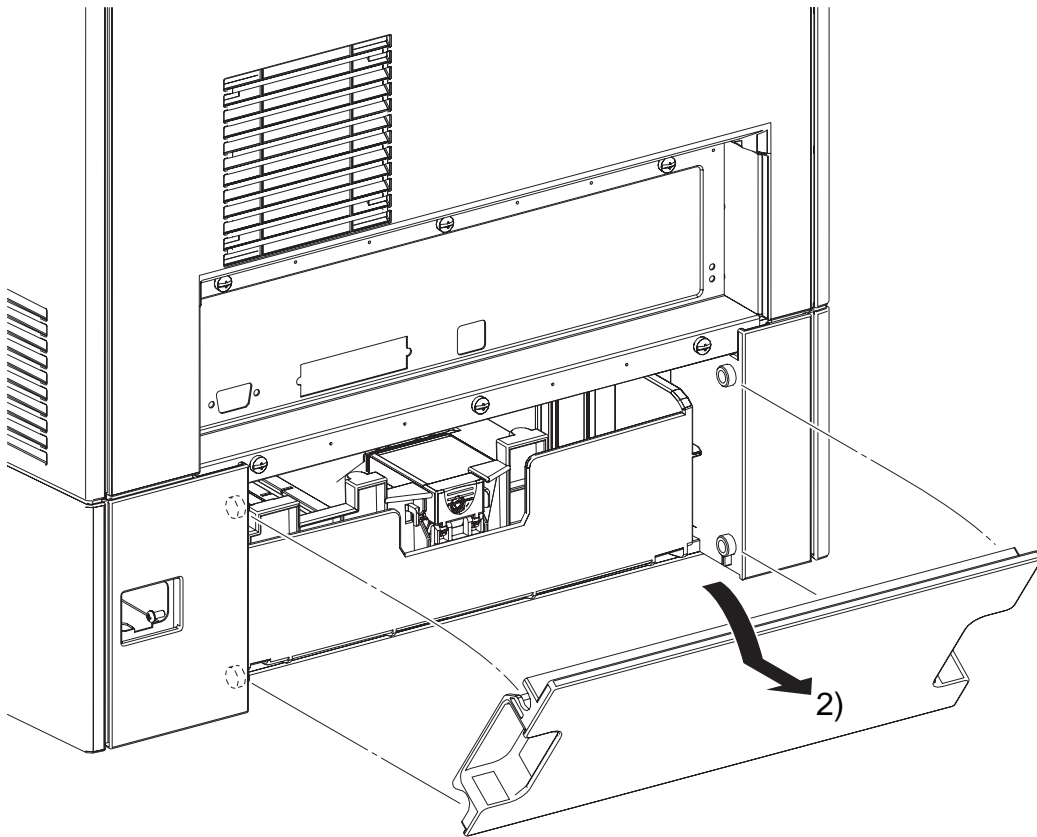

Ida\_Sec03\_017FA

RRP3.2 PAPER TRAY COVER (PL3.1.3)

[Removal]

- 1) Pull the upper side of PAPER TRAY COVER toward you to remove it from the mounting part on the upper side of PAPER FEEDER.
- 2) Remove PAPER TRAY COVER from the mounting part on the lower side of PAPER FEEDER.

[Replacement]

- 1) Put PAPER TRAY COVER on the mounting part on the lower side of PAPER FEEDER.
- 2) Push the upper side of PAPER TRAY COVER to the mounting part on the upper side of PAPER FEEDER and attach it.

RRP3.3 PAPER FEEDER (PL3.1.7)

Procedure No. with [ ] included in Fig. shows the procedure at attachment.

NOTE

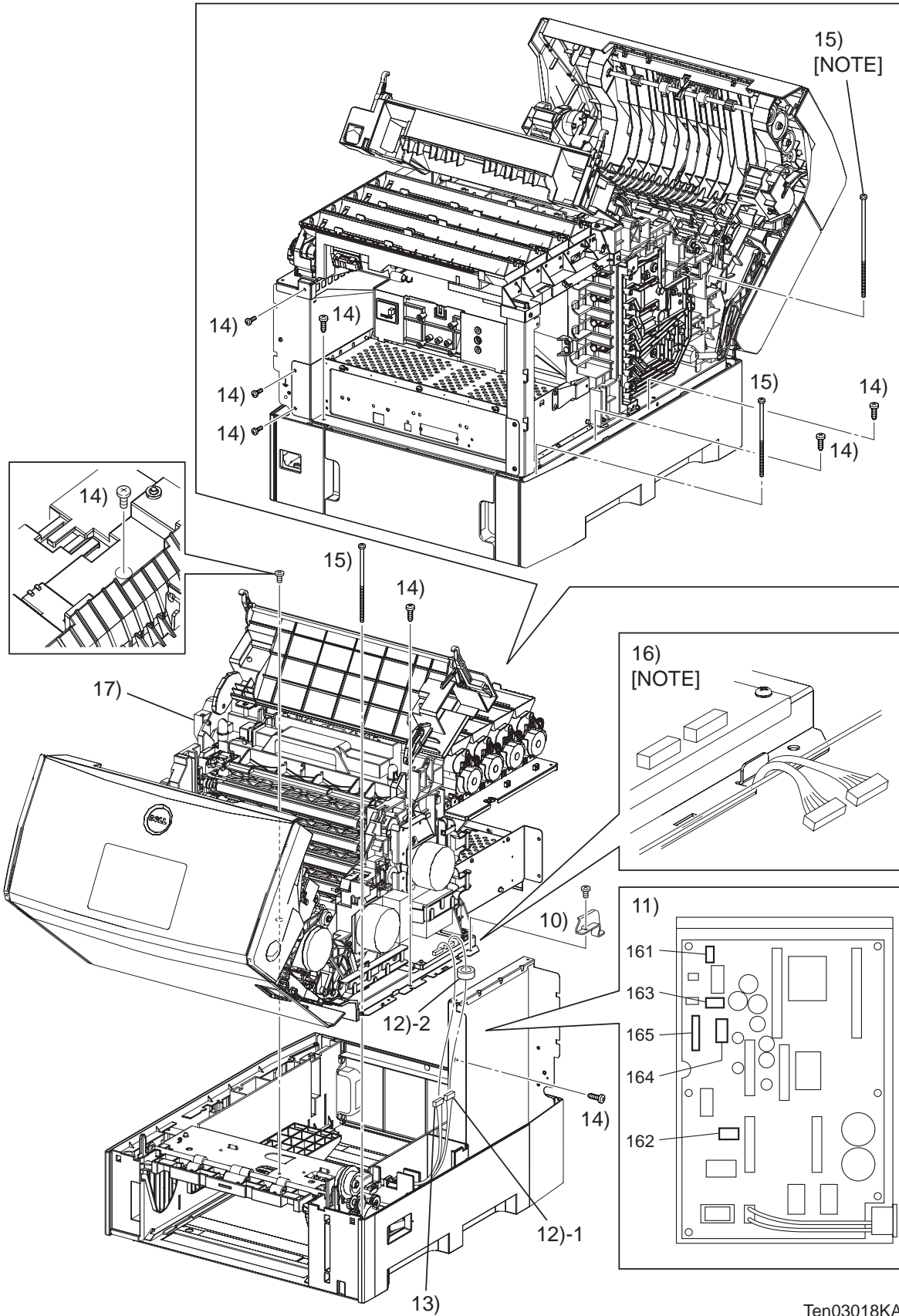

Ten03018KA

## RRP3.3 PAPER FEEDER (PL3.1.7)

[Removal]

- 1) Pull out 500 SHEET PAPER TRAY from the printer.
- 2) Remove TOP COVER FRAME. (PL1.1.4). (RRP1.1)
- 3) Remove RIGHT SIDE COVER. (PL1.1.20). (RRP1.7)
- 4) Remove LEFT SIDE COVER. (PL1.1.30). (RRP1.12)
- 5) Remove COVER ASSY REAR. (PL1.1.17). (RRP1.5)
- 6) Remove REGISTRATION ASSEMBLY. (RRP4.6)
- 7) Remove REGISTRATION CHUTE ASSEMBLY (RRP4.3)
- 8) Remove HIGH VOLTAGE POWER SUPPLY (HVPS). (RRP9.9)
- 9) Remove BRACKET TEMP. (PL9.1.19). (RRP9.8)
- 10) Remove a screw (silver, 6mm) that fixes SUPPORT LINK SW (PL3.1.6) and remove SUPPORT LINK SW.
- 11) Remove the all connectors on LOW VOLTAGE POWER SUPPLY (LVPS).
- 12) Disconnect the connector (P/J17) of the MACHINE CONTROL UNIT (MCU) (PL9.1.16) that is connecting to the PAPER FEEDER, remove the CORE (PL3.2.12) from the harness.
- 13) Remove connector (P/J47) that is connected from PAPER FEEDER to MACHINE CONTROL UNIT (MCU) (PL9.1.16) on the printer.
- 14) Remove five screws (silver, 6 mm) and four screws (silver, tap, 10 mm) that fixes PAPER FEEDER on the printer.

NOTE

One of the long screws to be removed following the steps of procedure described below is especially long. Take care to remove it without fail.

- 15) Remove three long screws (gold) that fixes PAPER FEEDER on the printer.
- 16) Loosen two harnesses of connectors (P/J17) and (P/J47) from the slit in the bottom plate at the lower part of printer toward FEEDER.

NOTE

When lifting up the printer, be sure to do it by two people.

NOTE

When removing the upper unit of printer from PAPER FEEDER, take care not to drop or damage the upper part unit of printer.

- 17) Lift up the upper unit of printer and separate it from PAPER FEEDER.

### RRP3.3 PAPER FEEDER (PL3.1.7s)

[Replacement]

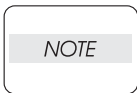

When placing the upper unit of printer on the PAPER FEEDER, take care not to catch the harness of the PAPER FEEDER between them.

- 1) Place the upper unit of printer on the PAPER FEEDER.
- 2) Attach the upper unit of printer using three long screws (gold).
- 3) Fix the upper unit of printer with five screws (silver, 6 mm) and four screws (silver, tap, 10 mm).
- 4) Attach the connector (P/J47) of PAPER FEEDER to MACHINE CONTROL UNIT (MCU) of the printer.
- 5) Attach the CORE to the harness of the connector (P/J17), connect the connector to the MACHINE CONTROL UNIT (MCU).
- 6) Attach the all connectors on LOW VOLTAGE POWER SUPPLY (LVPS).
- 7) Attach SUPPORT LINK SW using a screw (silver, 6mm).
- 8) Attach BRACKET TEMP (PL9.1.19). (RRP9.8)
- 9) Attach HIGH VOLTAGE POWER SUPPLY (HVPS). (RRP9.9)
- 10) Attach REGISTRATION CHUTE ASSEMBLY (RRP4.3)
- 11) Attach REGISTRATION ASSEMBLY. (RRP4.6)
- 12) Attach COVER ASSY REAR (PL1.1.17). (RRP1.5)
- 13) Attach LEFT SIDE COVER (PL1.1.30). (RRP1.12)
- 14) Attach RIGHT SIDE COVER (PL1.1.20). (RRP1.7)
- 15) Attach TOP COVER FRAME (PL1.1.4). (RRP1.1)
- 16) Insert 500 SHEET PAPER TRAY into the printer.

Blank Page

RRP3.4 SWITCH ASSY SIZE (PL3.2.5)

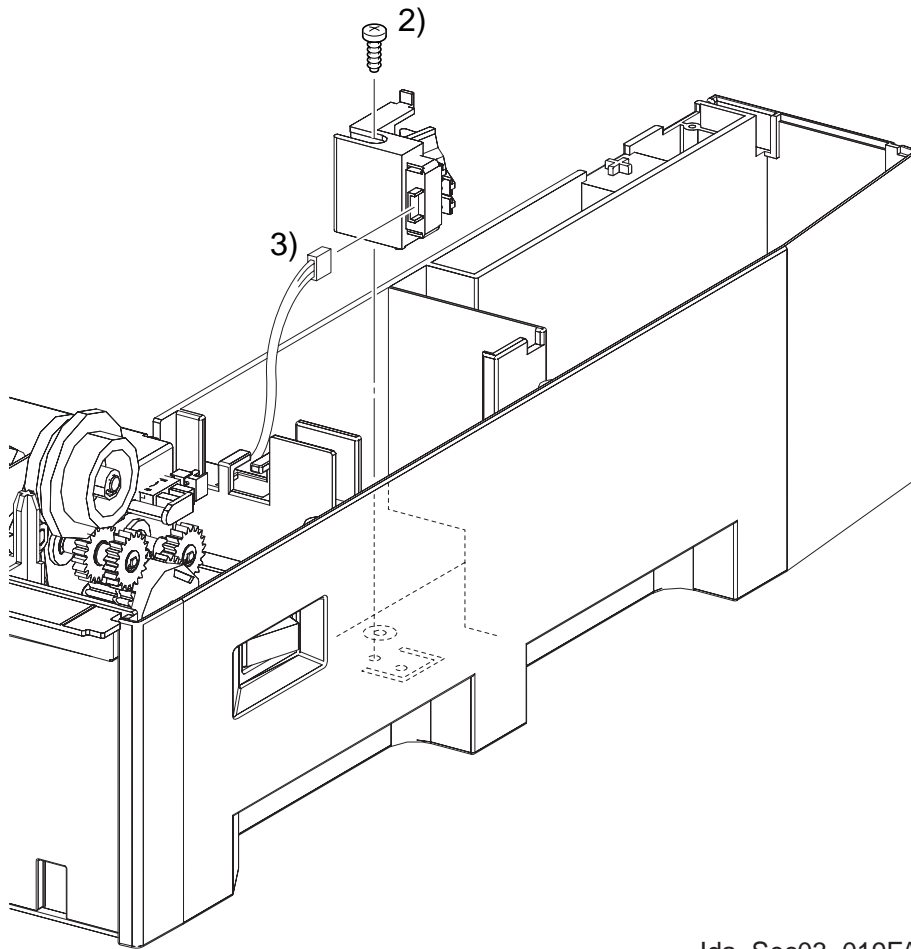

Ida\_Sec03\_019FA



### RRP3.4 SWITCH ASSY SIZE (PL3.2.5)

[Removal]

- 1) Remove PAPER FEEDER. (RRP3.3)
- 2) Remove a screw (silver, tap, 10mm) that fixes SWITCH ASSY SIZE to FEEDER R (PL3.2.6).
- 3) Remove the connector (P/J471) on SWITCH ASSY SIZE, and remove SWITCH ASSY SIZE.

[Replacement]

- 1) Attach the connector (P/J471) to SWITCH ASSY SIZE.
- 2) Match bosses at two locations of SWITCH ASSY SIZE to the holes on FEEDER R, and fix it using a screw (silver, tap, 10mm).
- 3) Attach PAPER FEEDER. (RRP3.3)

RRP3.5 SWITCH (PL3.2.10)

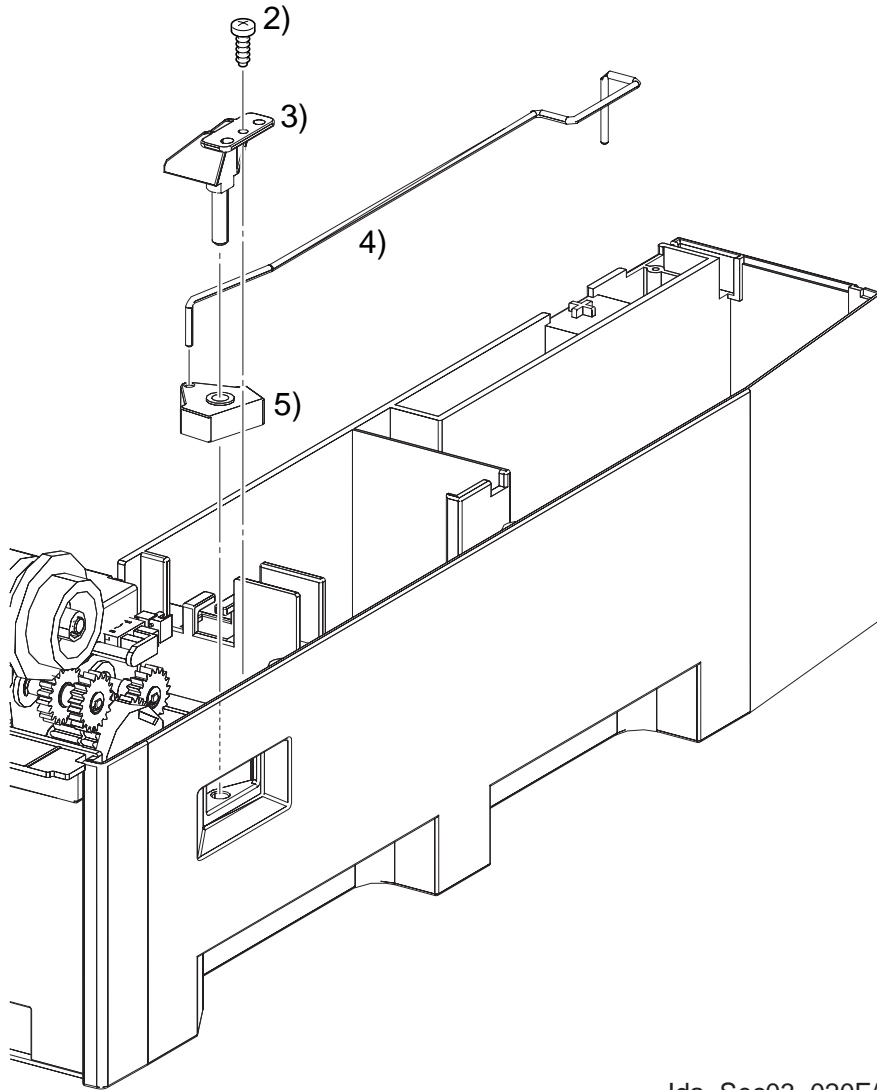

Ida\_Sec03\_020FA

### RRP3.5 SWITCH (PL3.2.10)

#### [Removal]

- 1) Remove PAPER FEEDER. (RRP3.3)
- 2) Remove a screw (silver, tap, 10mm) that fixes S/W HOLDER (PL3.2.7).

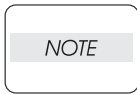

When removing S/W HOLDER, take care not to drop SWITCH and SHAFT LINK S/W.

- 3) Remove S/W HOLDER.
- 4) Remove SHAFT LINK S/W.
- 5) Remove SWITCH.

#### [Replacement]

- 1) Attach SHAFT LINK S/W in the hole of SWITCH.
- 2) Attach SWITCH to the shaft of S/W HOLDER.
- 3) Attach S/W HOLDER to PAPER FEEDER using a screw (silver, tap, 10 mm).
- 4) Attach PAPER FEEDER. (RRP3.3)

RRP3.6 HARNESS ASSY OPFPLG (PL3.2.11)

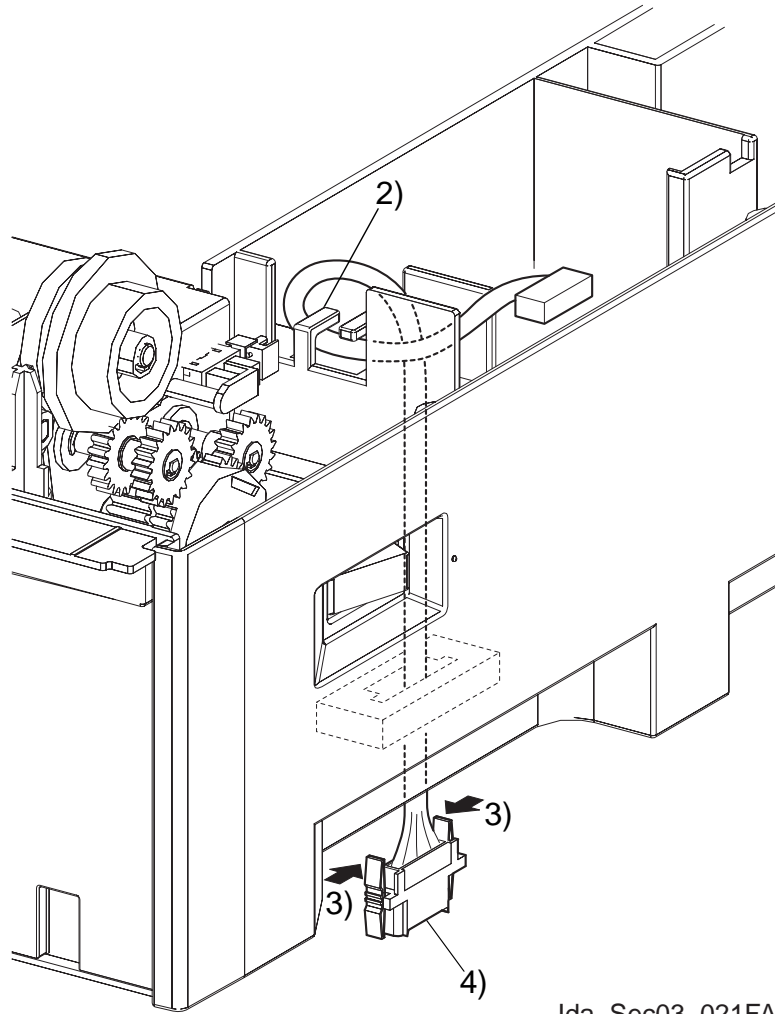

Ida\_Sec03\_021FA

### RRP3.6 HARNESS ASSY OPFPLG (PL3.2.11)

#### [Removal]

- 1) Remove PAPER FEEDER. (RRP3.3)
- 2) Loosen the harness of HARNESS ASSY OPFPLG from the harness guide of FEEDER R (FL3.2.6).
- 3) Release the hooks at two locations that fix HARNESS ASSY OPFPLG to FEEDER R.
- 4) Pull out HARNESS ASSY OPFPLG from FEEDER R downward.

#### [Replacement]

- 1) Insert HARNESS ASSY OPFPLG into the lower side of FEEDER R.
- 2) Attach the hooks at the two locations on HARNESS ASSY OPFPLG by locking them.
- 3) Put the harness of HARNESS ASSY OPFPLG into the harness guide of FEEDER R.
- 4) Attach FEEDER ASSY UNIT. (RRP3.3)

RRP3.7 PAPER PICKUP ASSEMBLY (PL3.3.1)

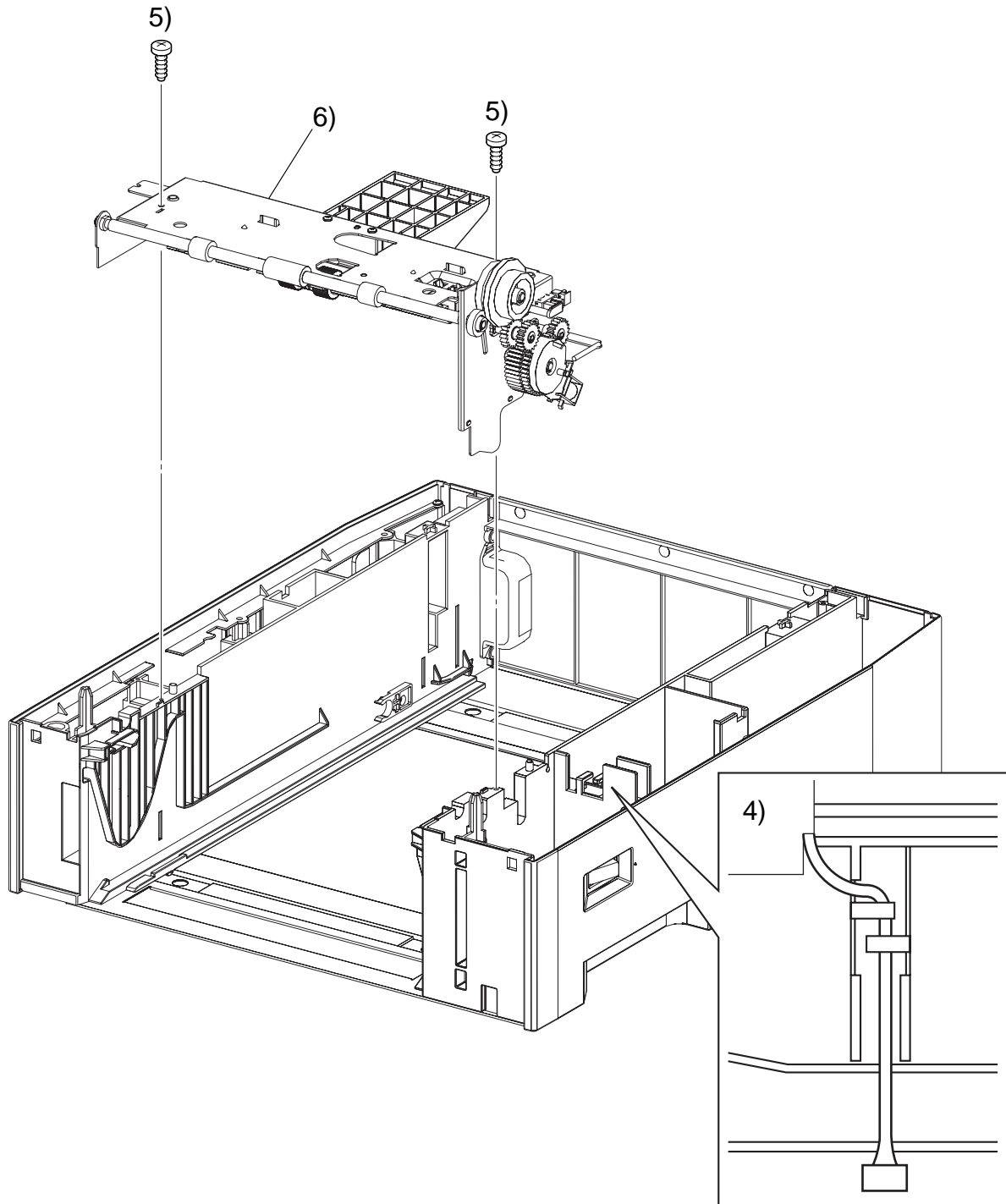

Ida\_Sec03\_022FB

### RRP3.7 PAPER PICKUP ASSEMBLY (PL3.3.1)

#### [Removal]

- 1) Remove PAPER FEEDER. (RRP3.3)
- 2) Remove PAPER FEEDER CHUTE. (RRP3.1)
- 3) Remove SWITCH ASSY SIZE. (RRP3.4)
- 4) Loosen the harness of PAPER PICKUP ASSEMBLY from the harness guide of FEEDER R (PL3.2.6).
- 5) Remove two screws (silver, tap, 10mm) that fixes PAPER PICKUP ASSEMBLY to PAPER FEEDER.
- 6) Lift up PAPER PICKUP ASSEMBLY from PAPER FEEDER and remove it.

#### [Replacement]

- 1) Match the hole of PAPER PICKUP ASSEMBLY to the bosses located at the left and right of PAPER FEEDER, and attach it.
- 2) Attach PAPER PICKUP ASSEMBLY to PAPER FEEDER using two screws (silver, tap, 10mm).
- 3) Put the harness of PAPER PICKUP ASSEMBLY into the harness guide of FEEDER R.
- 4) Attach SWITCH ASSY SIZE. (RRP3.4)
- 5) Attach PAPER FEEDER CHUTE. (RRP3.1)
- 6) Attach PAPER FEEDER. (RRP3.3)

RRP3.8 ROLL ASSY TURN (PL3.3.2)

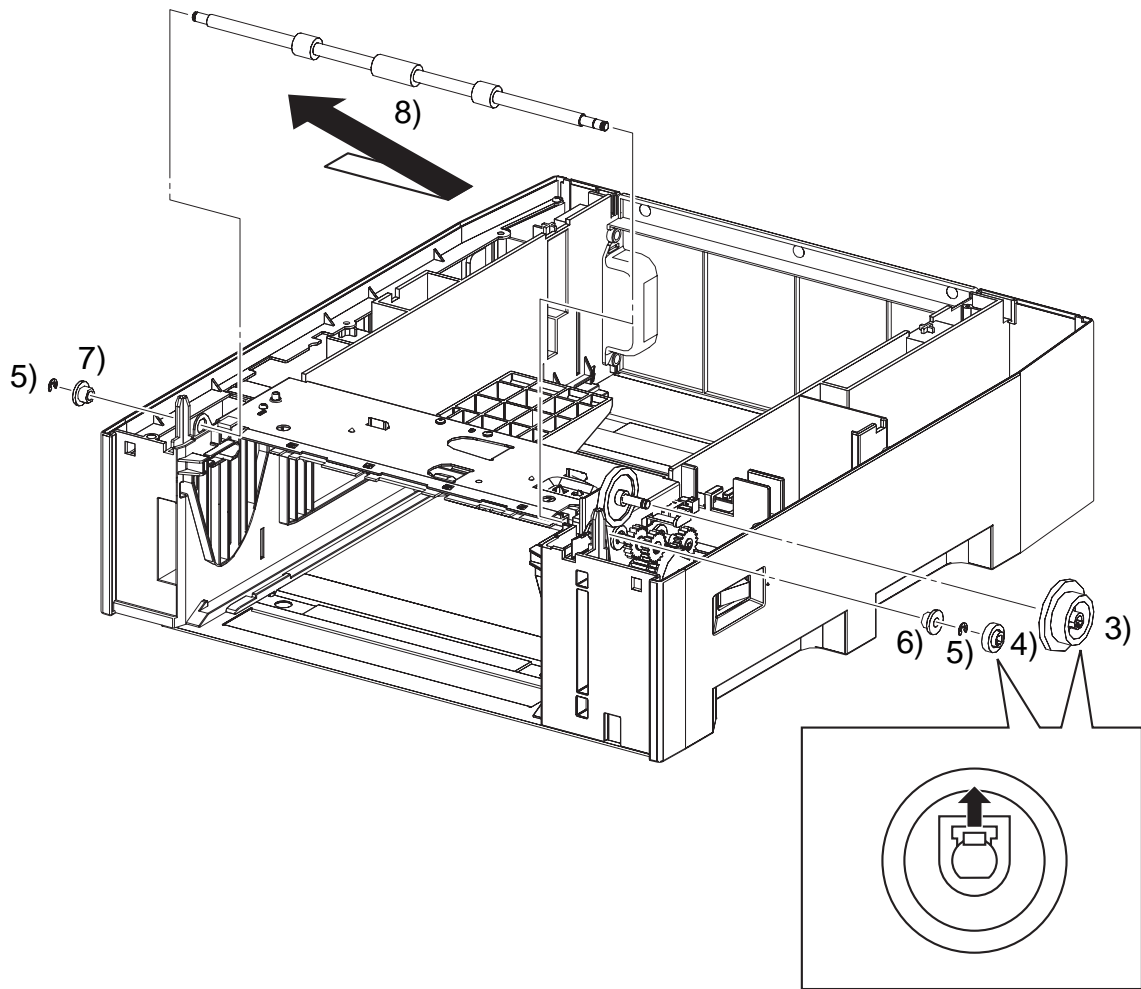

Ida\_Sec03\_023FB



### RRP3.8 ROLL ASSY TURN (PL3.3.2)

#### [Removal]

- 1) Remove PAPER FEEDER. (RRP3.3)
- 2) Remove PAPER FEEDER CHUTE. (RRP3.1)
- 3) Release the hook that fixes GEAR IDLER IN on the right side of PAPER FEEDER, pull out GEAR IDLER IN.
- 4) Release the hook that fixes GEAR TURN (PL3.3.4) on the shaft of ROLL ASSY TURN, pull out GEAR TURN.
- 5) Remove the right side E-ring and the left side E-ring that fixes ROLL ASSY TURN on PAPER PICKUP ASSEMBLY.
- 6) Remove BEARING (METAL) at the right that fixes ROLL ASSY TURN on PAPER PICKUP ASSEMBLY.
- 7) Remove BEARING (BLACK) at the left that fixes ROLL ASSY TURN on PAPER PICKUP ASSEMBLY.
- 8) Slide ROLL ASSY TURN once to the right from PAPER PICKUP ASSEMBLY and pull out the left end of ROLL ASSY TURN from the bearing. Then, pull out ROLL ASSY TURN to the upper left and remove it.

#### [Replacement]

- 1) Insert the right end of ROLL ASSY TURN into the bearing at the right side of PAPER PICKUP ASSEMBLY, slide ROLL ASSY TURN to the left, and insert the left end of ROLL ASSY TURN into the bearing at the left side of PAPER PICKUP ASSEMBLY.
- 2) Fix BEARING (BLACK) on the left side of ROLL ASSY TURN using an E-ring.
- 3) Fix BEARING (METAL) on the right side of ROLL ASSY TURN using an E-ring.
- 4) Attach GEAR TURN to the shaft at the right side of ROLL ASSY TURN.
- 5) Attach GEAR IDLER IN to the shaft at the right side of PAPER FEEDER.
- 6) Attach PAPER FEEDER CHUTE. (RRP3.1)
- 7) Attach PAPER FEEDER. (RRP3.3)

RRP3.9 SENSOR PHOTO: NO PAPER (PL3.3.7)

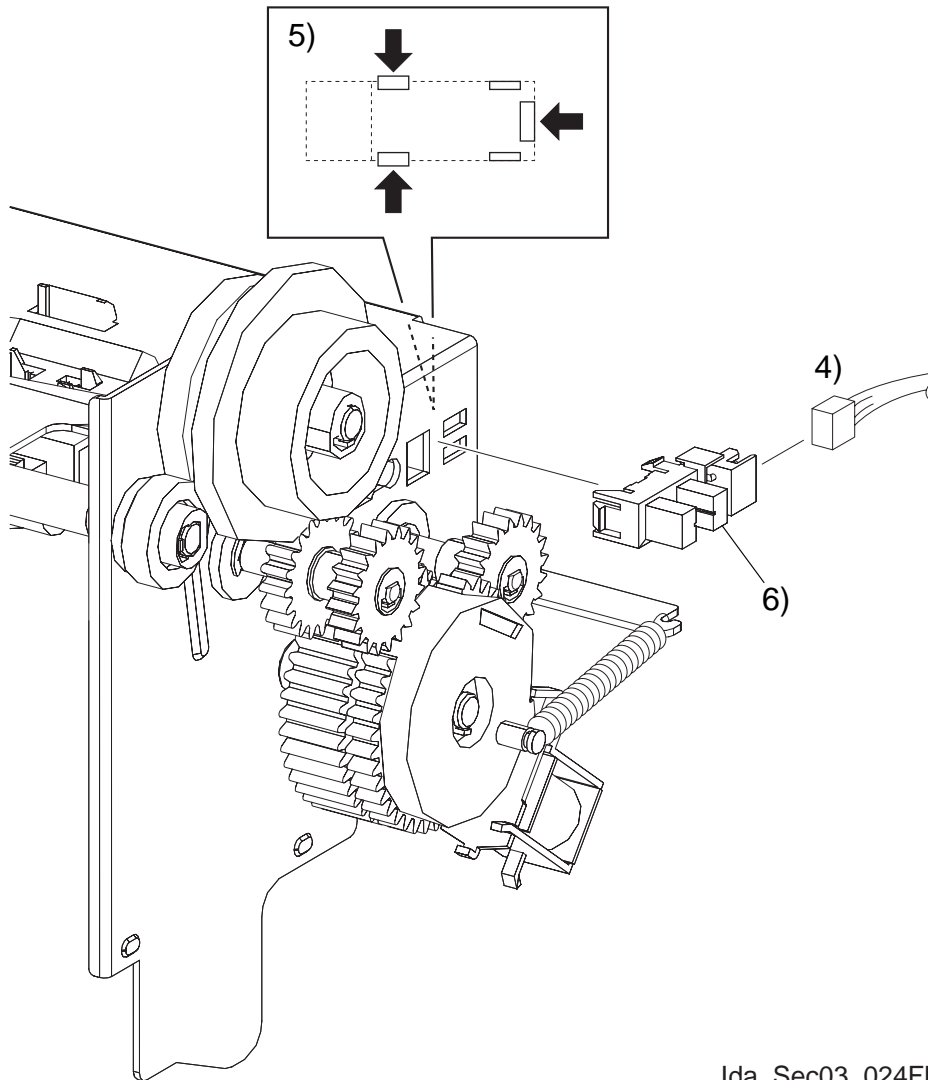

Ida\_Sec03\_024FB

### RRP3.9 SENSOR PHOTO: NO PAPER (PL3.3.7)

#### [Removal]

- 1) Remove PAPER FEEDER. (RRP3.3)
- 2) Remove PAPER PICKUP ASSEMBLY. (RRP3.7)
- 3) Remove ACTUATOR NO PAPER. (RRP3.15)
- 4) Remove the connector (P/J472) that is connected to SENSOR PHOTO: NO PAPER.
- 5) Release the three hooks that fix SENSOR PHOTO: NO PAPER to PAPER PICKUP ASSEMBLY.
- 6) Remove SENSOR PHOTO: NO PAPER from PAPER PICKUP ASSEMBLY.

#### [Replacement]

- 1) Attach SENSOR PHOTO: NO PAPER to PAPER PICKUP ASSEMBLY by locking the hooks at three locations of SENSOR PHOTO: NO PAPER.
- 2) Attach the connector (P/J472) to SENSOR PHOTO: NO PAPER.
- 3) Attach ACTUATOR NO PAPER. (RRP3.15)
- 4) Attach PAPER PICKUP ASSEMBLY. (RRP3.7)
- 5) Attach PAPER FEEDER. (RRP3.3)

RRP3.10 Blank Page

RRP3.10 Blank Page

RRP3.11 SOLENOID FEED (PL3.3.11)

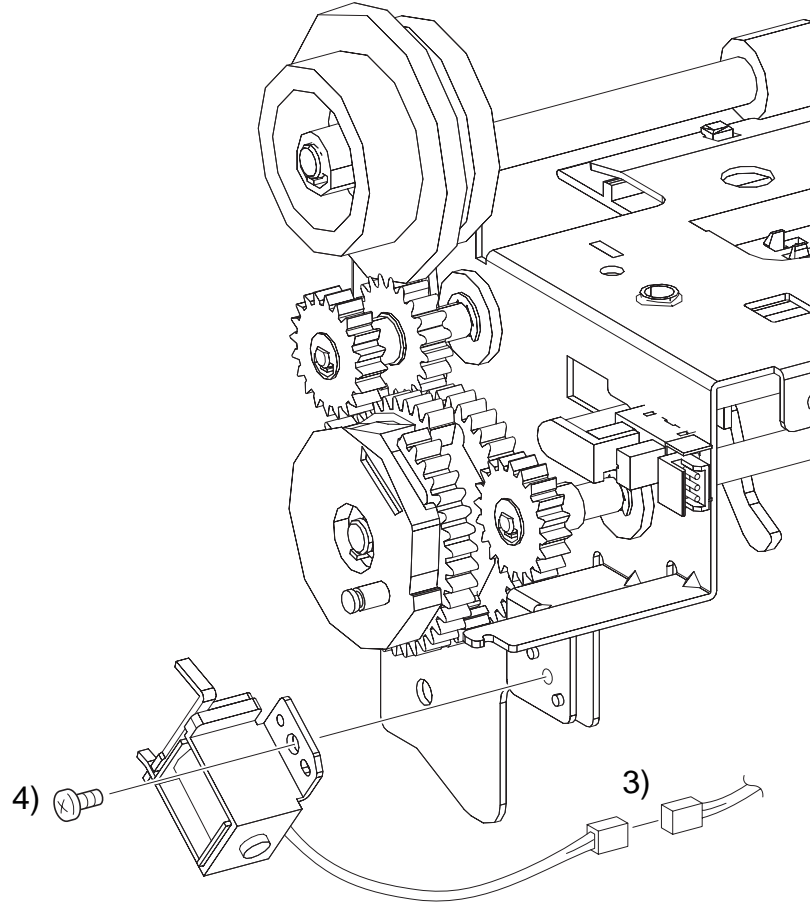

Ida\_Sec03\_026FA

### RRP3.11 SOLENOID FEED (PL3.3.11)

#### [Removal]

- 1) Remove PAPER FEEDER. (RRP3.3)
- 2) Remove PAPER PICKUP ASSEMBLY. (RRP3.7)
- 3) Remove the connector (P/J474) of the harness that is connected to SOLENOID FEED.
- 4) Remove a screw (silver, 6mm) that fixes SOLENOID FEED to PAPER PICKUP ASSEMBLY, and remove SOLENOID FEED.

#### [Replacement]

- 1) Match the holes of SOLENOID FEED with the bosses mounted at two locations on PAPER PICKUP ASSEMBLY, attach SOLENOID FEED to PAPER PICKUP ASSEMBLY using a screw (silver, 6 mm).
- 2) Attach the connector (P/J474) of the harness that is connected to SOLENOID FEED.
- 3) Attach PAPER PICKUP ASSEMBLY. (RRP3.7)
- 4) Attach PAPER FEEDER. (RRP3.3)

RRP3.12 Blank Page



RRP3.12 Blank Page

### RRP3.13 CHUTE UPPER (REFERENCE ONLY)

NOTE

Procedure No. with [ ] included in Fig. shows the procedure at attachment.

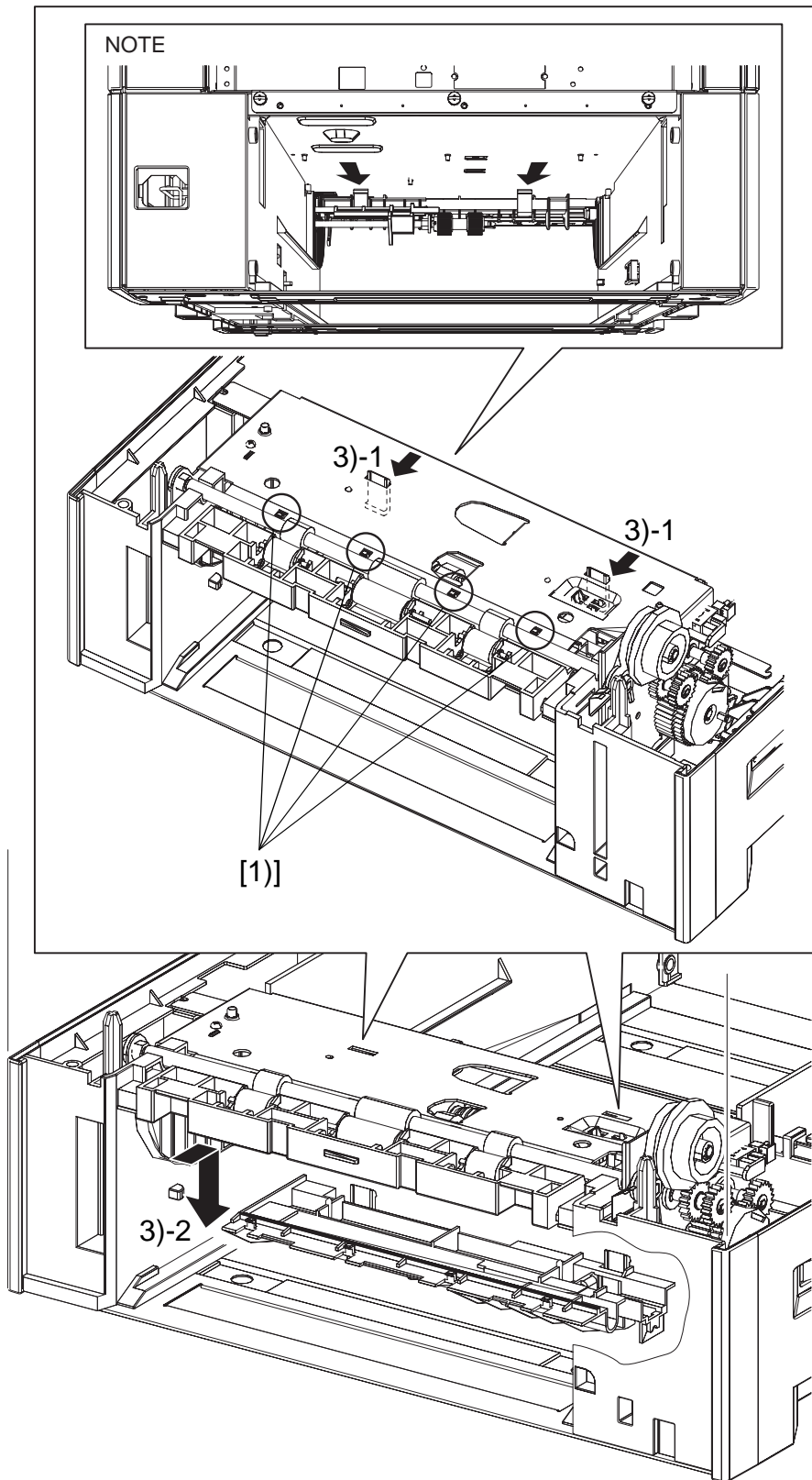

Ida\_Sec03\_028FB

### RRP3.13 CHUTE UPPER (REFERENCE ONLY)

[Removal]

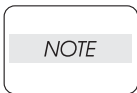

The hooks at two locations of CHUTE UPPER are positioned on the top surface of PAPER PICKUP ASSEMBLY when looking from the rear side with 500 SHEET PAPER TRAY and COVER 500 SHEET PAPER TRAY removed.

- 1) Pull out 500 SHEET PAPER TRAY from the printer.
- 2) Remove PAPER TRAY COVER. (RRP3.2)
- 3) Release the hooks at two locations that fix CHUTE UPPER to PAPER PICKUP ASSEMBLY, slide CHUTE UPPER to the back first, release four hooks, then remove CHUTE UPPER downward.

[Replacement]

- 1) Engage four hooks of PAPER PICKUP ASSEMBLY to four holes of PAPER PICKUP ASSEMBLY, fix the hooks at two locations to attach PAPER PICKUP ASSEMBLY.
- 2) Attach PAPER TRAY COVER. (RRP3.2)
- 3) Insert 500 SHEET PAPER TRAY into the printer.

RRP3.14 PAPER FEED ROLLER (PL3.3.18)

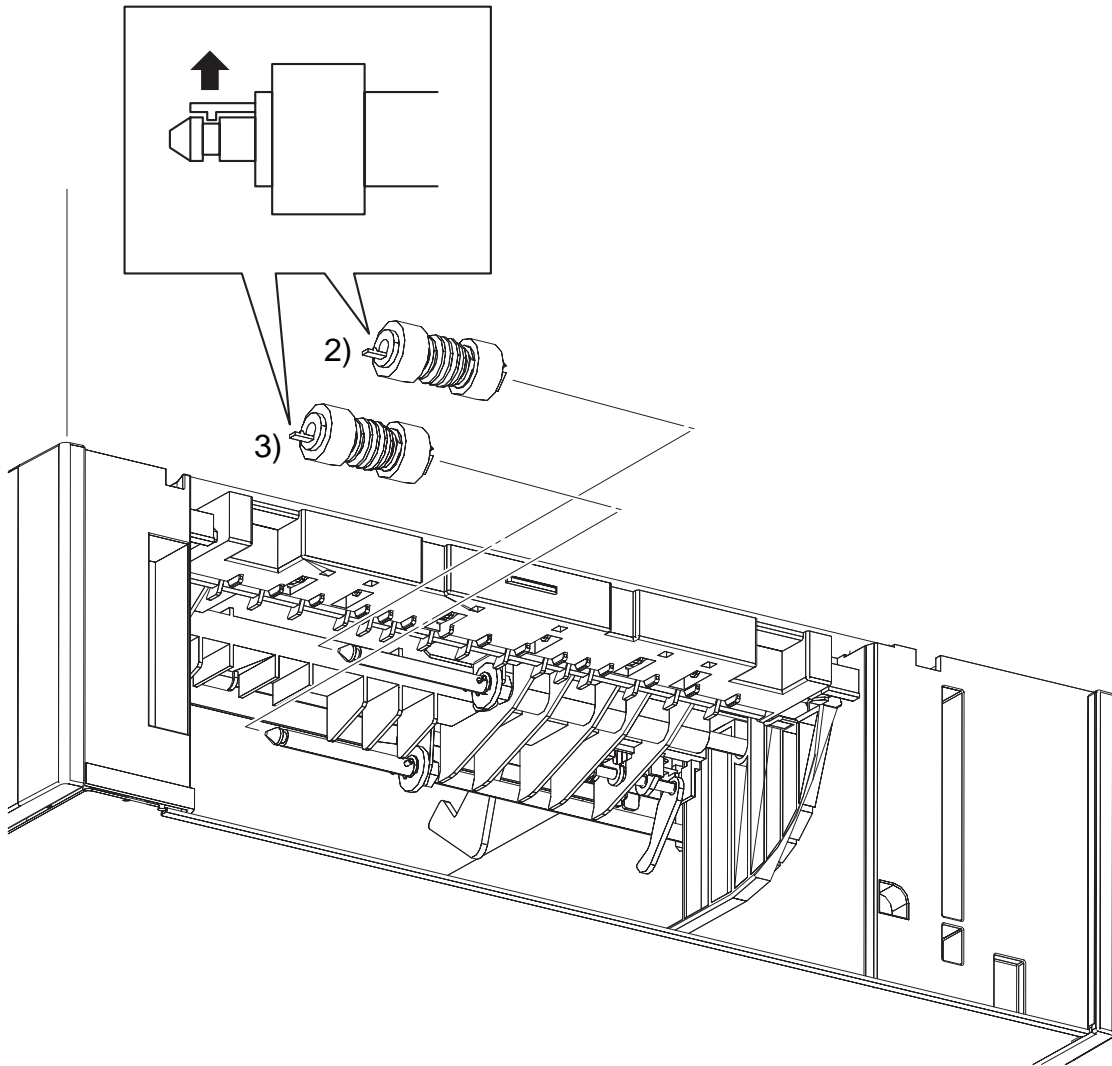

Ida\_Sec03\_029FA

RRP3.14 PAPER FEED ROLLER (PL3.3.18)

[Removal]

- 1) Pull out 500 SHEET PAPER TRAY from the printer.
- 2) Release the lock that fixes PAPER FEED ROLLER to SHAFT ASSY FEED (PL3.3.17), then pull out PAPER FEED ROLLER and remove it.
- 3) Release the lock that fixes PAPER FEED ROLLER to SHAFT ASSY NUDGER (PL3.3.19), then pull out PAPER FEED ROLLER and remove it.

[Replacement]

- 1) Insert PAPER FEED ROLLER into SHAFT ASSY NUDGER, and lock it to attach.
- 2) Insert PAPER FEED ROLLER into SHAFT ASSY FEED, and lock it to attach.
- 3) Insert 500 SHEET PAPER TRAY into the printer.

RRP3.15 ACTUATOR NO PAPER (PL3.3.20)

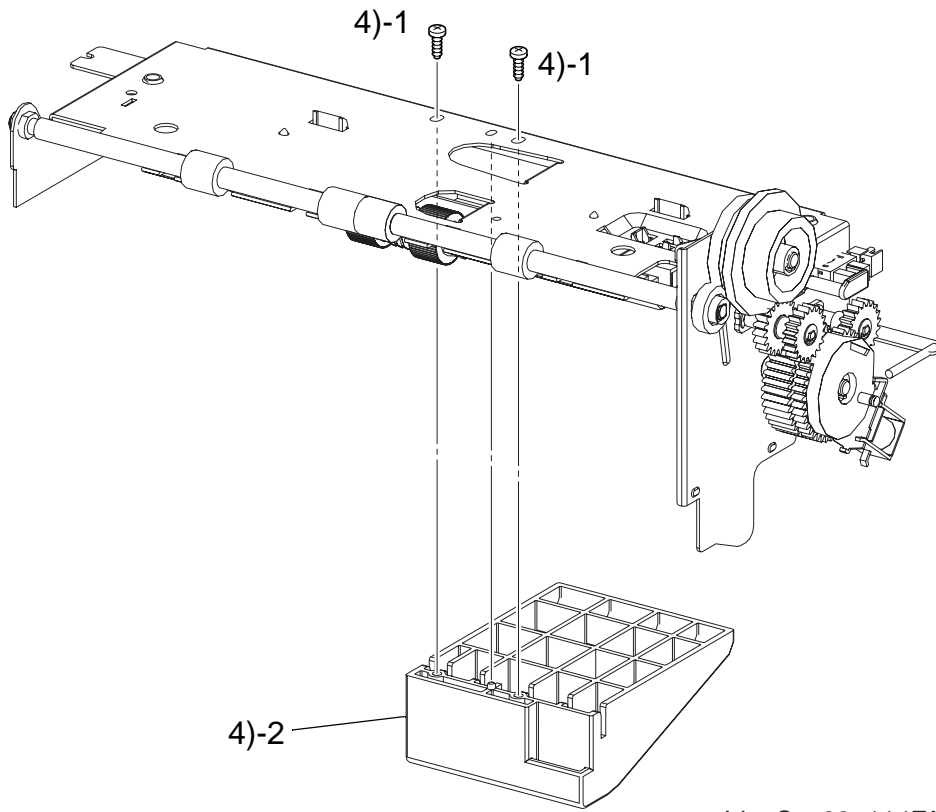

Ida\_Sec03\_114FA

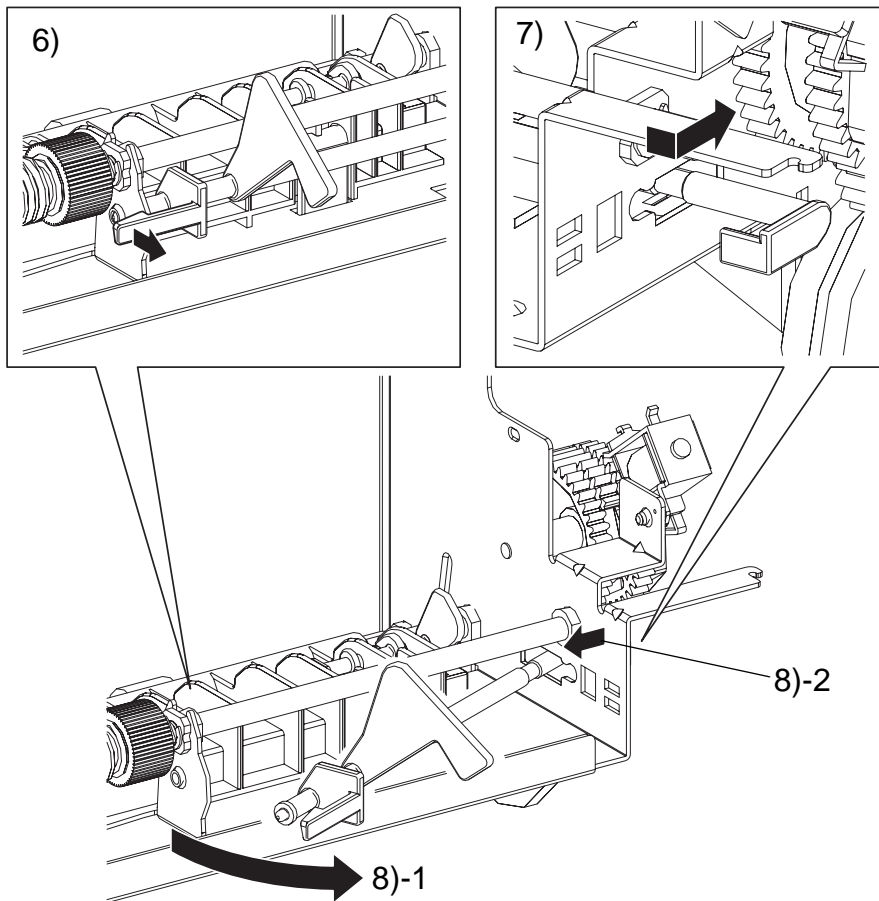

Ida\_Sec03\_030FB

### RRP3.15 ACTUATOR NO PAPER (PL3.3.20)

#### [Removal]

- 1) Remove PAPER FEEDER. (RRP3.3)
- 2) Remove PAPER FEEDER CHUTE. (RRP3.1)
- 3) Remove PAPER PICKUP ASSEMBLY. (RRP3.7)
- 4) Remove the two screws (silver, tap, 8mm) that fix GUIDE PAPER to PAPER PICKUP ASSEMBLY.
- 5) Turn over PAPER PICKUP ASSEMBLY.
- 6) Release the hook that fixes ACTUATOR NO PAPER to PAPER PICKUP ASSEMBLY.
- 7) Pull out ACTUATOR NO PAPER a little, then shift the thin section of the shaft from the hole to the slot side.
- 8) Remove ACTUATOR NO PAPER out of the slot of PAPER PICKUP ASSEMBLY while moving the hook side of ACTUATOR NO PAPER forward.

#### [Replacement]

- 1) Insert ACTUATOR NO PAPER into the slot of PAPER PICKUP ASSEMBLY.
- 2) Shift the thin section of the shaft of ACTUATOR NO PAPER from the slot of PAPER PICKUP ASSEMBLY to the installation hole of ACTUATOR NO PAPER.
- 3) Insert the boss of ACTUATOR NO PAPER into the hole of PAPER PICKUP ASSEMBLY, then fix the hook and attach it.
- 4) Match the boss of ACTUATOR NO PAPER to the hole of PAPER PICKUP ASSEMBLY, fix GUIDE PAPER using the screw (silver, tap, 8mm)
- 5) Attach PAPER PICKUP ASSEMBLY. (RRP3.7)
- 6) Attach PAPER FEEDER CHUTE. (RRP3.1)
- 7) Attach PAPER FEEDER. (RRP3.3)

## RRP4. RETARD & REGI ASSY

### RRP4.1 ACTUATOR REGI (PL4.1.1)

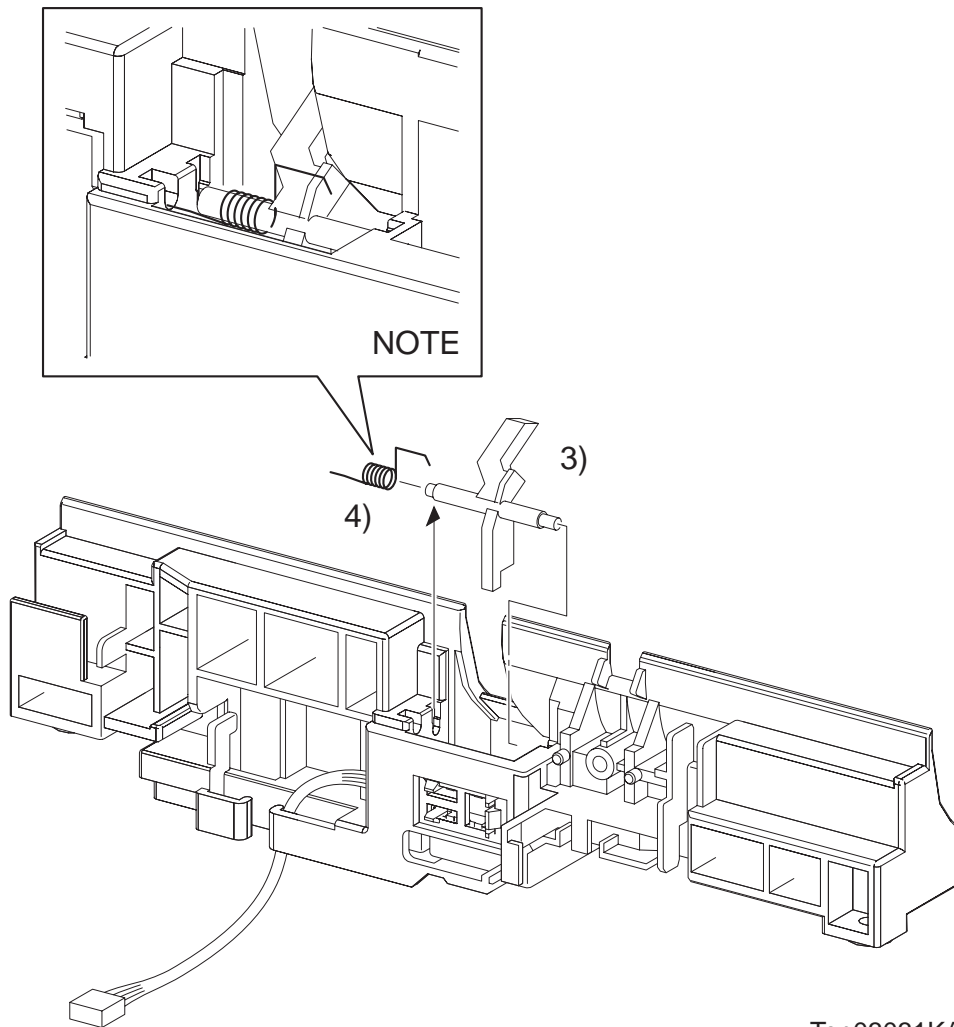

Ten03031KA



## RRP4.1 ACTUATOR REGI (PL4.1.1)

### [Removal]

- 1) Remove REGISTRATION ASSEMBLY. (RRP4.6)
- 2) Remove REGISTRATION CHUTE ASSEMBLY (RRP4.3)
- 3) Lift up the shaft at the right side of ACTUATOR REGI, pull out the left side shaft section through the mounting hole and remove.
- 4) Remove SPRING SENSOR REGI. (PL4.1.2)

### [Replacement]

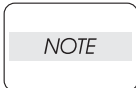

- Check to be sure that the direction of replacement of the SPRING is correct.
- Be sure to put the SPRING in place without fail.

- 1) Attach SPRING SENSOR REGI to ACTUATOR REGI.
- 2) Put one end of SPRING SENSOR REGI on ACTUATOR REGI and the other end on REGISTRATION CHUTE ASSEMBLY
- 3) Attach ACTUATOR REGI to REGISTRATION CHUTE ASSEMBLY
- 4) Attach REGISTRATION CHUTE ASSEMBLY (RRP4.3)
- 5) Attach REGISTRATION ASSEMBLY. (RRP4.6)

RRP4.2 REGISTRATION SENSOR (PL.4.1.3)

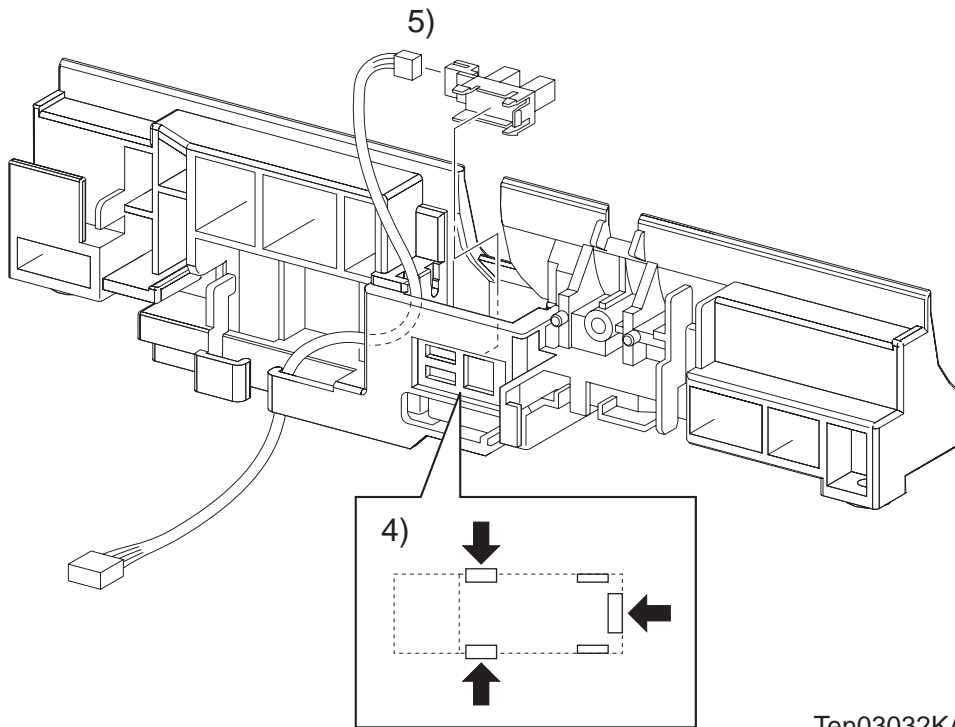

Ten03032KA

RRP4.2 REGISTRATION SENSOR (PL.4.1.3)

[Removal]

- 1) Remove REGISTRATION ASSEMBLY. (RRP4.6)
- 2) Remove REGISTRATION CHUTE ASSEMBLY (RRP4.3)
- 3) Remove ACTUATOR REGI. (RRP4.1)
- 4) Release the hooks at three locations that fix REGISTRATION SENSOR to REGISTRATION CHUTE ASSEMBLY and remove REGISTRATION SENSOR.
- 5) Remove the connector (P/J181) that is connected to REGISTRATION SENSOR.

[Replacement]

- 1) Attach the connector (P/J181) to REGISTRATION SENSOR.
- 2) Attach REGISTRATION SENSOR on REGISTRATION CHUTE ASSEMBLY by locking the hooks at three locations.
- 3) Attach ACTUATOR REGI. (RRP4.1)
- 4) Attach REGISTRATION CHUTE ASSEMBLY (RRP4.3)
- 5) Attach REGISTRATION ASSEMBLY. (RRP4.6)

RRP4.3 REGISTRATION CHUTE ASSEMBLY (PL4.1.20)

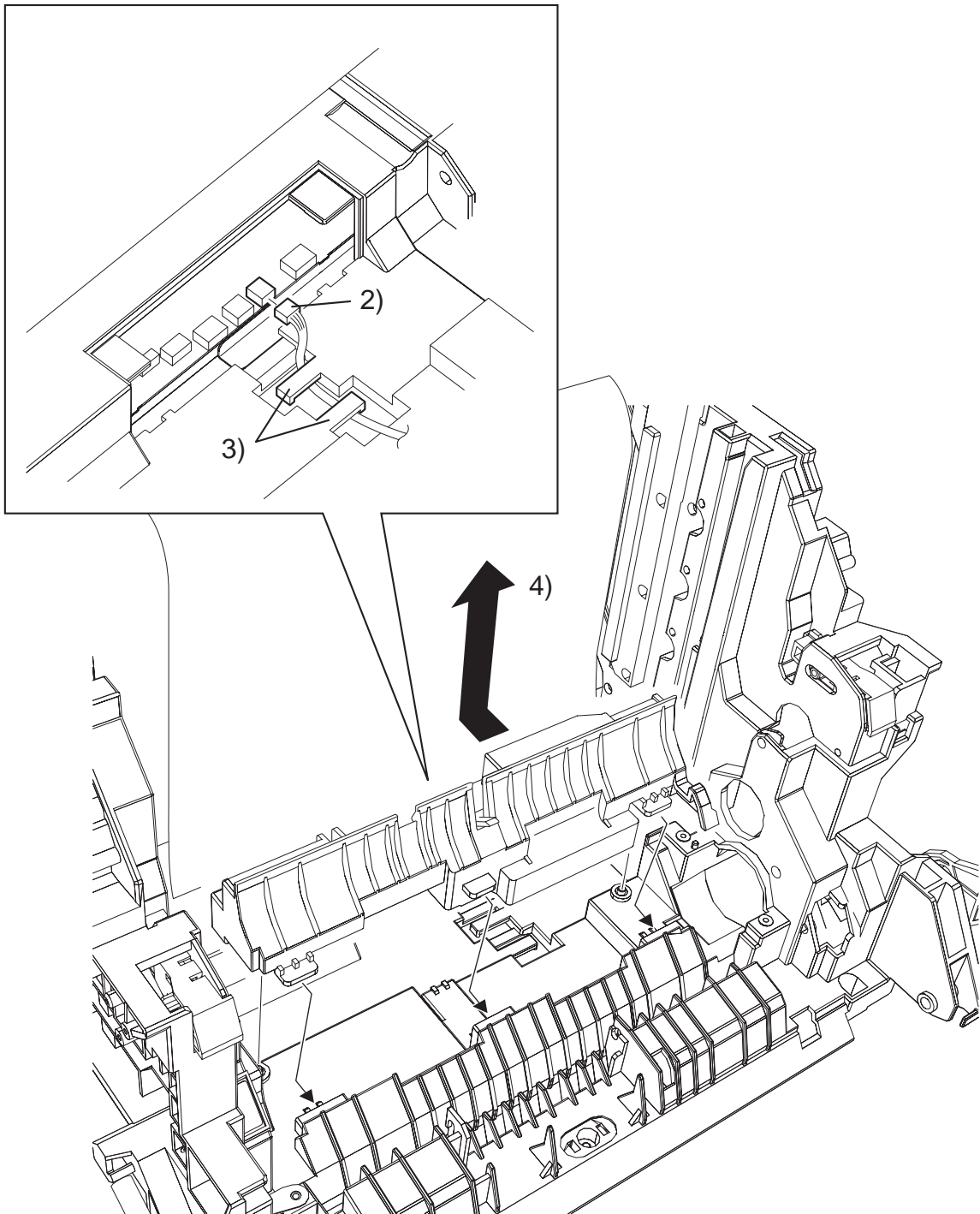

Ten03034KA

### RRP4.3 REGISTRATION CHUTE ASSEMBLY (PL4.1.20)

#### [Removal]

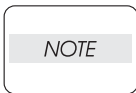

Before starting the following work, cover the entire DEVELOPER ASSEMBLY with paper or the like so as to prevent toner in DEVELOPER ASSEMBLY from adhering on your clothing.

- 1) Remove REGISTRATION ASSEMBLY. (RRP4.6)
- 2) Disconnect the connector (P/J18) of the MACHINE CONTROL UNIT (MCU) (PL9.1.16).
- 3) Remove the harness of the HARNESS ASSY REGISNS (PL4.1.4) from the harness guide of the printer.
- 4) A little lift up the rear part of REGISTRATION CHUTE ASSEMBLY and pull it out backward and remove.

#### [Replacement]

- 1) Put the three hooks of front part of REGISTRATION CHUTE ASSEMBLY into the holes at three locations in the printer frame, thrust the projections at two locations on the rear part of REGISTRATION CHUTE ASSEMBLY into the mounting holes at two locations and attach it.
- 2) Lay the harness of the HARNESS ASSY REGISNS to the harness guide of the printer.
- 3) Connect the connector (P/J18) of the MACHINE CONTROL UNIT (MCU).

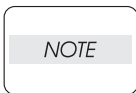

Be sure to remove the paper covering DEVELOPER ASSEMBLY.

- 4) Attach REGISTRATION ASSEMBLY. (RRP4.6)

RRP4.4 Blank Page

RRP4.4 Blank Page

RRP4.5 MULTIPURPOSE FEEDER (MPF) SEPARATOR ASSEMBLY (PL4.1.13),  
MULTIPURPOSE FEEDER (MPF) SEPARATOR ROLLER (PL4.1.16)

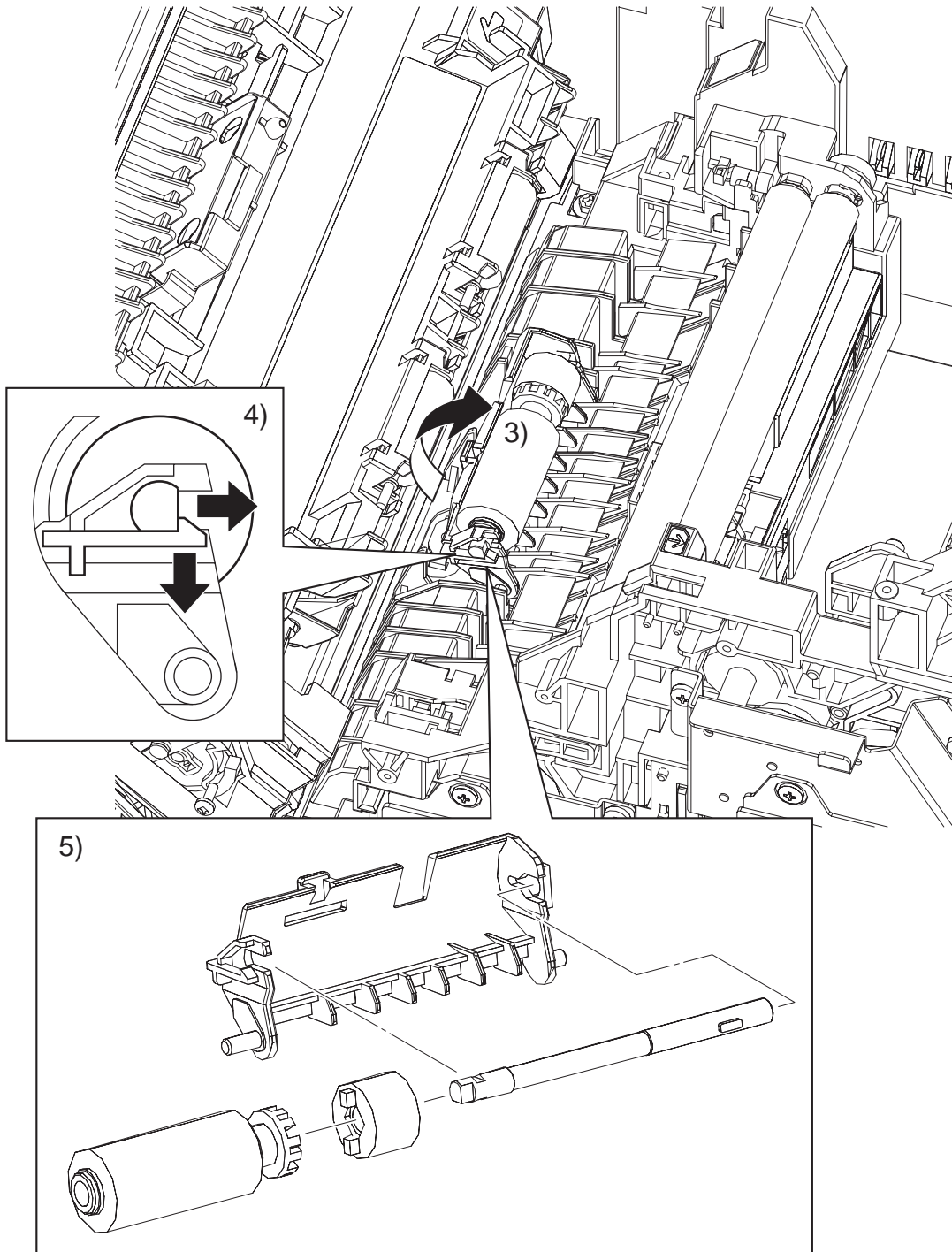

Ida\_Sec03\_036FB



RRP4.5 MULTIPURPOSE FEEDER (MPF) SEPARATOR ASSEMBLY (PL4.1.13),  
MULTIPURPOSE FEEDER (MPF) SEPARATOR ROLLER (PL4.1.16)

[Removal]

- 1) Release the latch and open INNER DUPLEX ASSEMBLY (PL5.2.1).
- 2) Remove TRANSFER ROLLER. (RRP5.2)

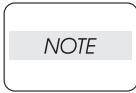

Before starting the following work, cover the entire DEVELOPER ASSEMBLY with paper or the like so as to prevent toner in DEVELOPER ASSEMBLY from adhering on your clothing.

- 3) Turn MULTIPURPOSE FEEDER (MPF) SEPARATOR ASSEMBLY upward.
- 4) Release the hook that fixes SHAFT RETARD to HOLDER RETARD, remove SHAFT RETARD with MULTIPURPOSE FEEDER (MPF) SEPARATOR ROLLER attached.
- 5) Pull out MULTIPURPOSE FEEDER (MPF) SEPARATOR ROLLER and CLUTCH ASSY FRICTION from SHAFT RETARD and remove.

[Replacement]

- 1) Insert CLUTCH ASSY FRICTION into SHAFT RETARD.
- 2) Insert ROLL ASSY FRICTION into SHAFT RETARD to engage with CLUTCH ASSY FRICTION.
- 3) Attach SHAFT RETARD to HOLDER RETARD by locking the hook.
- 4) Turn MULTIPURPOSE FEEDER (MPF) SEPARATOR ASSEMBLY forward.

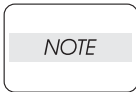

Be sure to remove the paper covering DEVELOPER ASSEMBLY.

- 5) Attach TRANSFER ROLLER. (RRP5.2)
- 6) Close INNER DUPLEX ASSEMBLY.

RRP4.6 REGISTRATION ASSEMBLY (PL4.2.1)

Procedure No. with [ ] included in Fig. shows the procedure at attachment.

NOTE

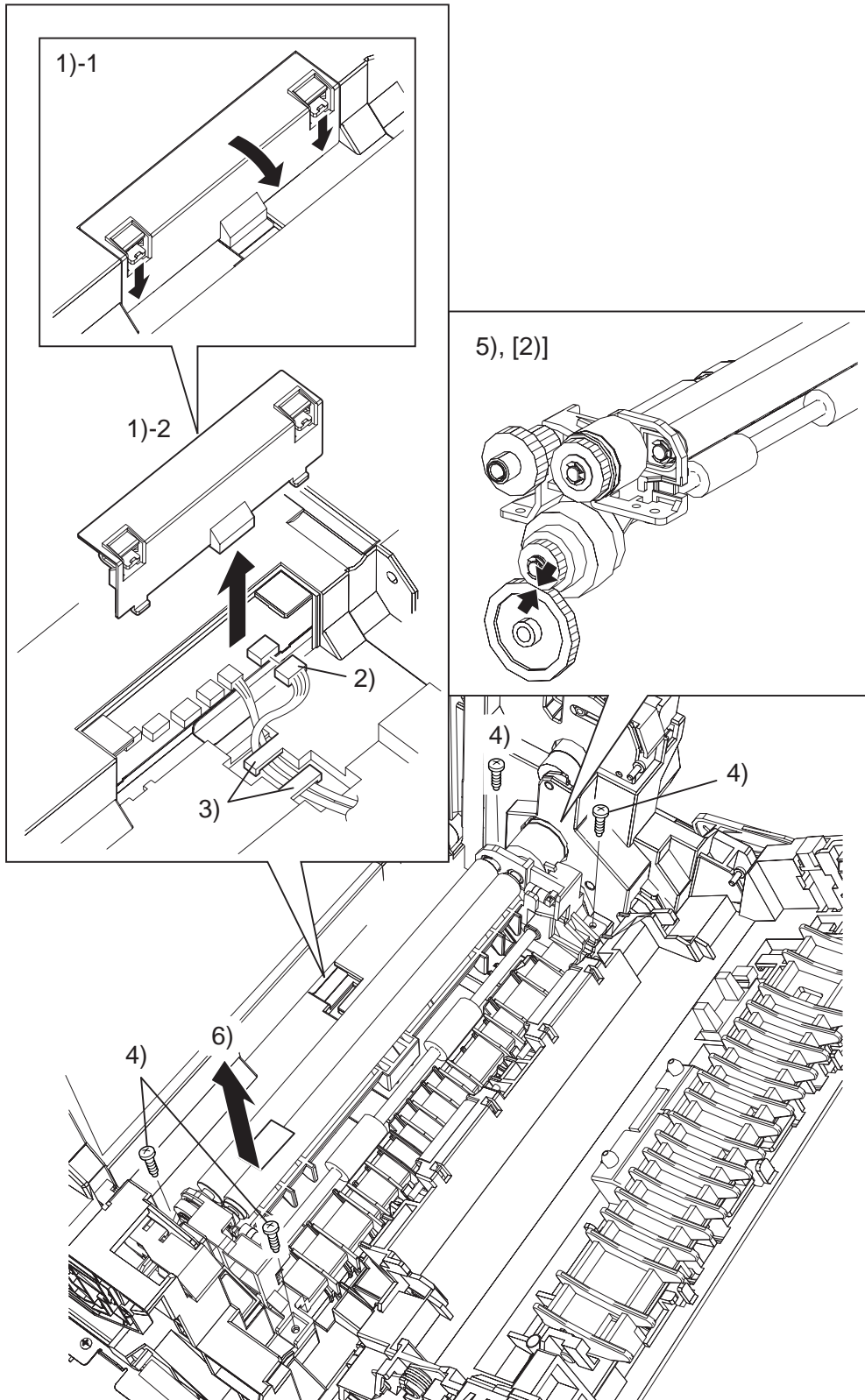

Ten03037KA

## RRP4.6 REGISTRATION ASSEMBLY (PL4.2.1)

## [Removal]

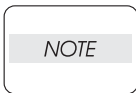

Before starting the following work, cover the entire DEVELOPER ASSEMBLY with paper or the like so as to prevent toner in DEVELOPER ASSEMBLY from adhering on your clothing.

- 1) Release the two hooks of the COVER ELEC (PL9.1.18), remove the COVER ELEC.
- 2) Disconnect the connector (P/J19) of the MACHINE CONTROL UNIT (MCU) (PL9.1.16).
- 3) Remove the harness of the HARNESS ASSY FRONTCLH (PL4.2.17) from the harness guide of the printer.
- 4) Remove four screws (silver, tap, 10mm) that fix REGISTRATION ASSEMBLY to the printer.
- 5) Lift the gear of CLUTCH at the right side of REGISTRATION ASSEMBLY by approximately 5 mm to disengage the gear.
- 6) Move REGISTRATION ASSEMBLY to the left side and lift it up to remove.

## [Replacement]

- 1) Insert the gear of CLUTCH at the right side of REGISTRATION ASSEMBLY into the hole of the printer to engage the gear.
- 2) Match the bosses at two locations on the printer with the holes of CLUTCH ASSY REGI, insert it into the holes.
- 3) Attach REGISTRATION ASSEMBLY using four screws (silver, tap, 10mm).
- 4) Lay the harness of the HARNESS ASSY FRONTCLH to the harness guide of the printer.
- 5) Connect the connector (P/J19) of the MACHINE CONTROL UNIT (MCU).
- 6) Attach the COVER ELEC using the two hooks of the COVER ELEC.

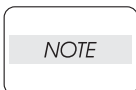

Be sure to remove the paper covering DEVELOPER ASSEMBLY.

RRP4.7 ROLL REGI METAL. (PL4.2.3)

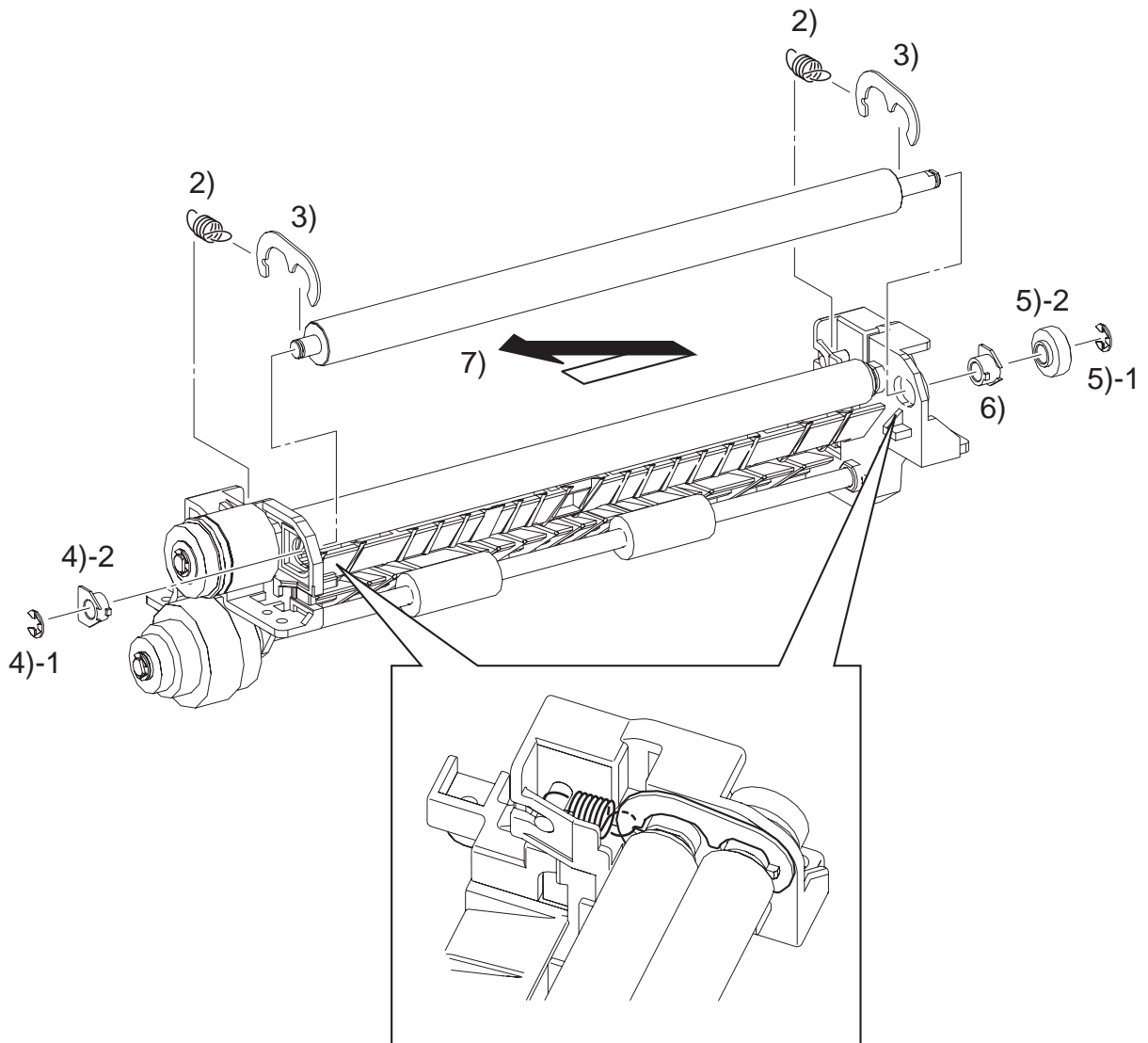

Ten03038KA

## RRP4.7 ROLL REGI METAL. (PL4.2.3)

### [Removal]

- 1) Remove REGISTRATION ASSEMBLY. (RRP4.6)
- 2) Remove the two SPRING REGI from the left and right sides of the PLATE REGI.
- 3) Remove the left and right sides of the PLATE REGI.
- 4) Remove the E-ring that fixes the right side shaft of ROLL REGI METAL to CHUTE REGI, remove BEARING METAL R.
- 5) Remove the E-ring that fixes GEAR REGI METAL to ROLL REGI METAL, remove GEAR REGI METAL.
- 6) Remove BEARING METAL L that fixes the left side shaft of ROLL REGI METAL to CHUTE REGI.
- 7) Shift ROLL REGI METAL from CHUTE REGI to the left, remove it upward.

### [Replacement]

- 1) Attach ROLL REGI METAL to CHUTE REGI.
- 2) Insert BEARING METAL L into the left side shaft of ROLL REGI METAL.
- 3) Insert GEAR REGI METAL into the left side shaft of ROLL REGI METAL and fix it using the E-ring.
- 4) Insert ROLL REGI METAL into the right side shaft of ROLL REGI METAL and fix it using the E-ring.

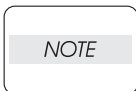

Pay attention to fitting direction of the PLATE REGI and the SPRING REGI.

- 5) Attach the PLATE REGI to the left and right sides of the BEARING METAL L,R.
- 6) Hang the SPRING REGI on the left and right sides of the PLATE REGI, fix the PLATE REGI.
- 7) Attach REGISTRATION ASSEMBLY. (RRP4.6)

RRP4.8 ROLL REGI RUBBER. (PL4.2.4)

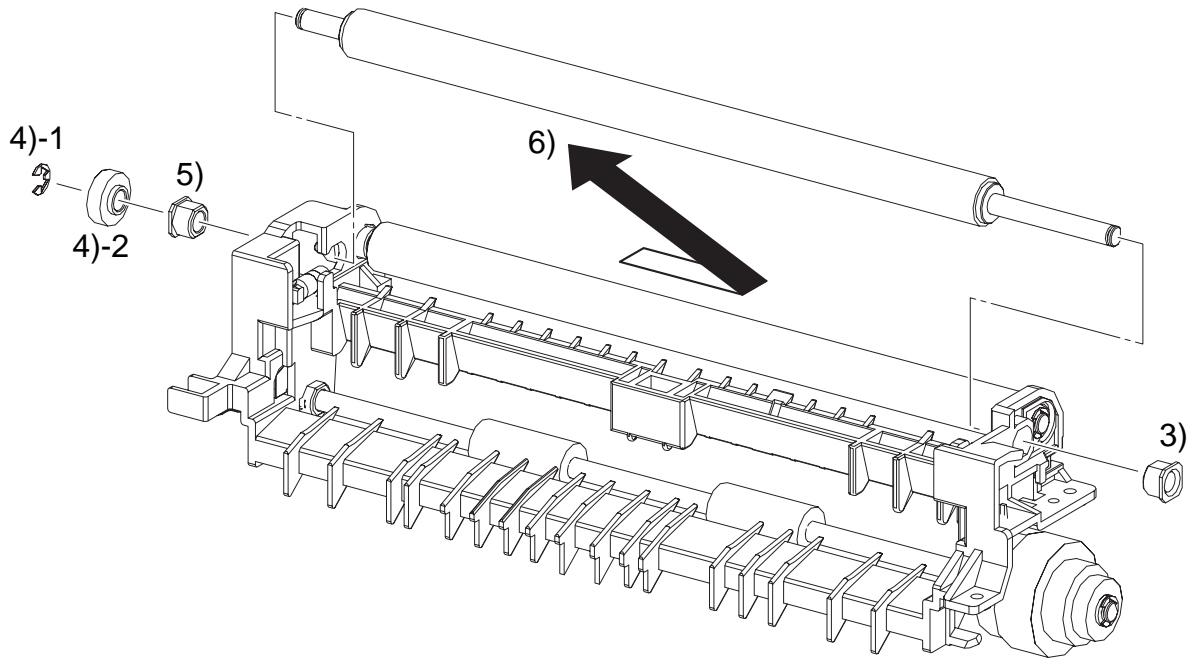

Ida\_Sec03\_039FB

#### RRP4.8 ROLL REGI RUBBER. (PL4.2.4)

[Removal]

- 1) Remove REGISTRATION ASSEMBLY. (RRP4.6)
- 2) Remove CLUTCH REGI. (RRP4.9)
- 3) Remove BEARING that fixes the right side shaft of ROLL REGI RUBBER to CHUTE REGI.
- 4) Remove the E-ring that fixes GEAR REGI RUBBER to ROLL REGI RUBBER, remove GEAR REGI RUBBER.
- 5) Remove BEARING EARTH that fixes the left side shaft of ROLL REGI RUBBER to CHUTE REGI.
- 6) Shift ROLL REGI RUBBER from CHUTE REGI to the right, remove it upward.

[Replacement]

- 1) Attach ROLL REGI RUBBER to CHUTE REGI.
- 2) Insert BEARING EARTH into the left-side shaft of ROLL REGI RUBBER.
- 3) Insert GEAR REGI RUBBER into the left side shaft of ROLL REGI RUBBER and fix it using the E-ring.
- 4) Insert BEARING into the right side shaft of ROLL REGI RUBBER.
- 5) Attach CLUTCH RREGI. (RRP4.9)
- 6) Attach REGISTRATION ASSEMBLY. (RRP4.6)

RRP4.9 CLUTCH REGI. (PL4.2.7)

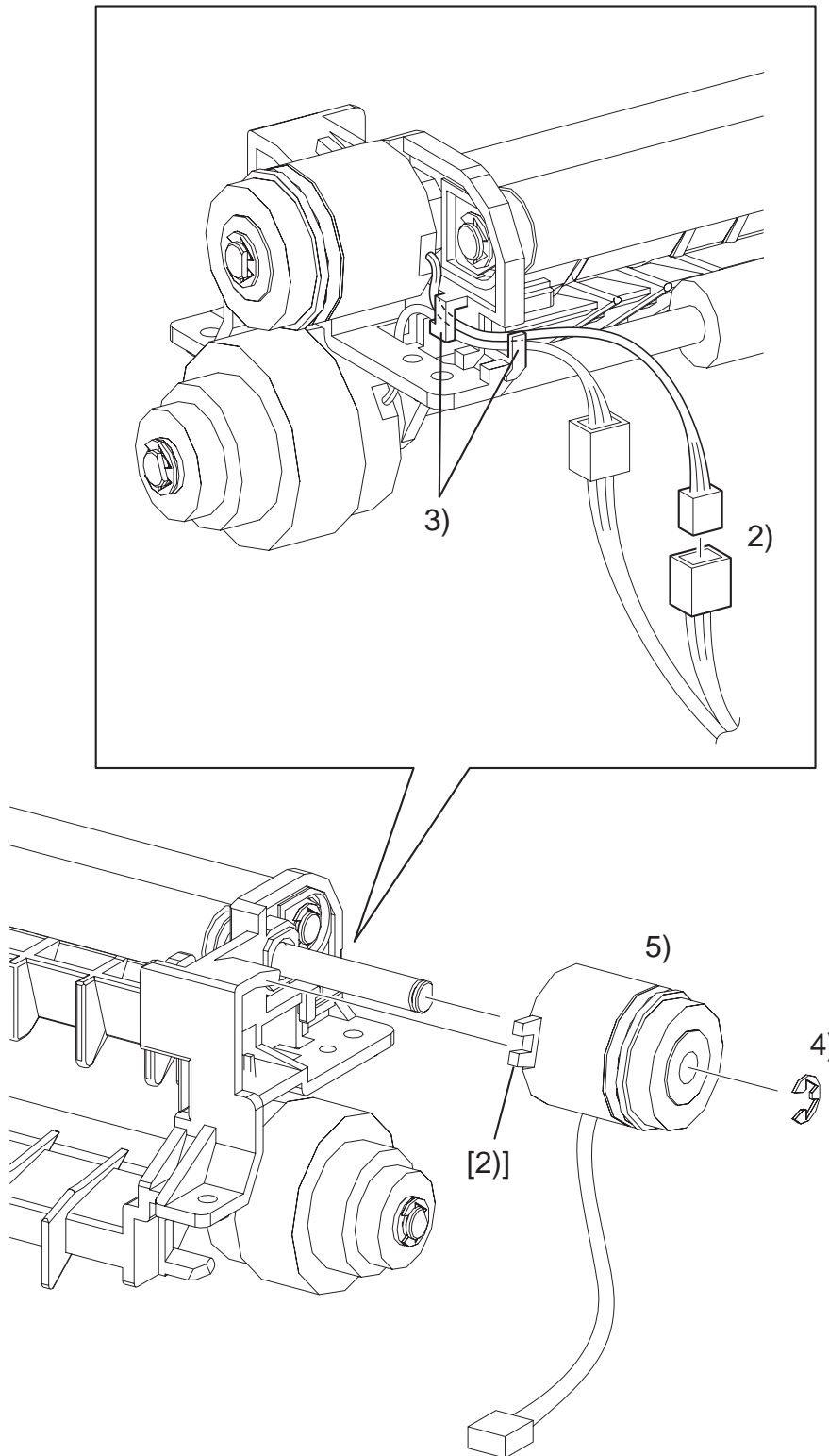

Ten03040KA



## RRP4.9 CLUTCH REGI. (PL4.2.7)

### [Removal]

- 1) Remove REGISTRATION ASSEMBLY. (RRP4.6)
- 2) Disconnect the connector (P/J192) of the CLUTCH REGI (PL4.2.7) from the HARNESS ASSY FRONTCLH (PL4.2.17).
- 3) Release the harness of the CLUTCH REGI from the hook of the REGISTRATION ASSEMBLY.
- 4) Remove the E-ring that fixes CLUTCH REGI to ROLL REGI RUBBER.
- 5) Pull out CLUTCH REGI from ROLL REGI RUBBER, then remove it.

### [Replacement]

- 1) Insert CLUTCH REGI into the shaft of ROLL REGI RUBBER.
- 2) Fit CLUTCH REGI fixing groove over CLUTCH fixing section of CHUTE REGI.
- 3) Attach the E-ring to ROLL REGI RUBBER.
- 4) Attach the harness of the CLUTCH REGI to the hook of the REGISTRATION ASSEMBLY.
- 5) Connect the connector (P/J192) of the CLUTCH REGI with the HARNESS ASSY FRONTCLH.
- 6) Attach REGISTRATION ASSEMBLY. (RRP4.6)

RRP4.10 CLUTCH TURN. (PL4.2.9)

NOTE

Procedure No. with [ ] included in Fig. shows the procedure at attachment.

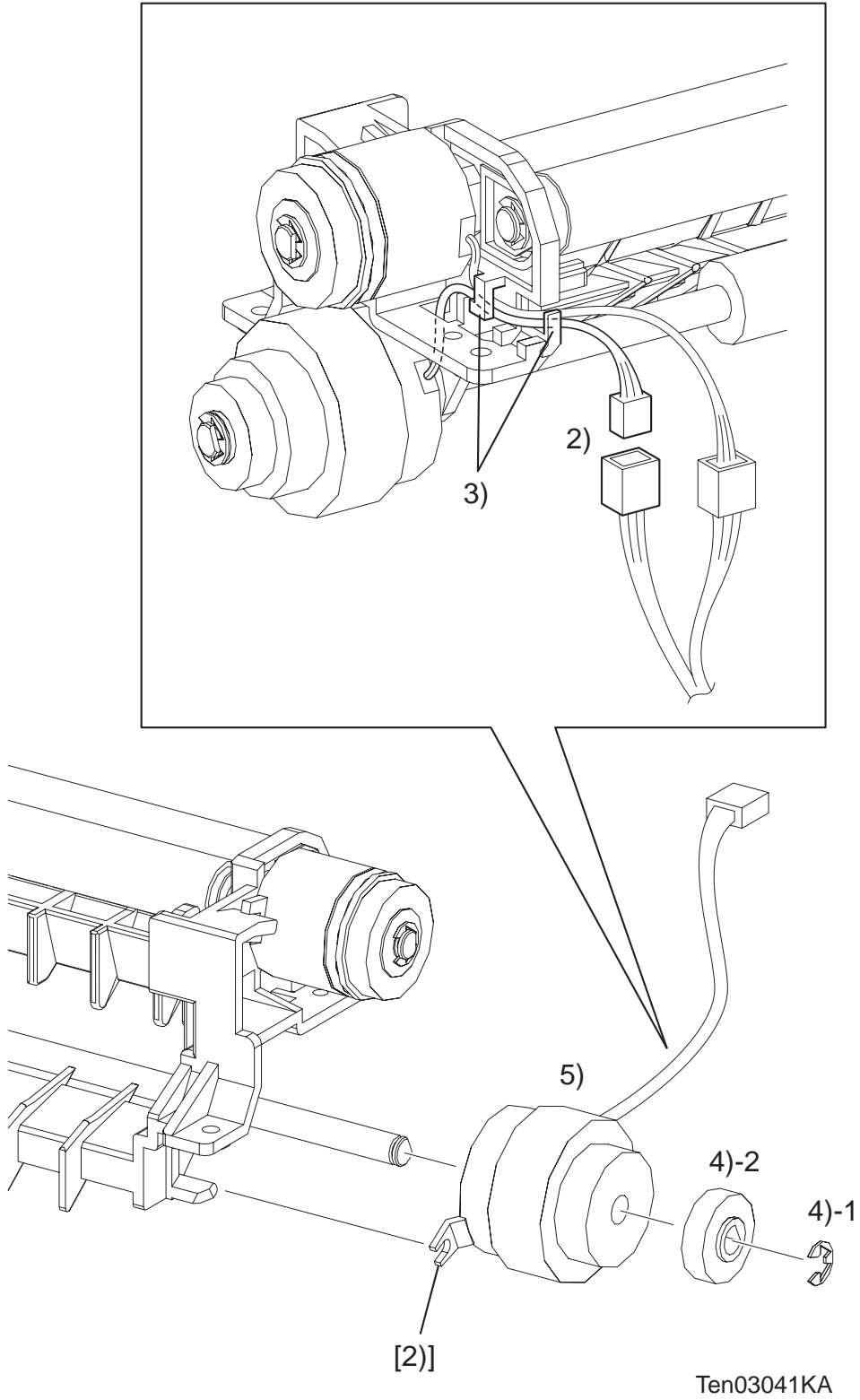

## RRP4.10 CLUTCH TURN. (PL4.2.9)

### [Removal]

- 1) Remove REGISTRATION ASSEMBLY. (RRP4.6)
- 2) Disconnect the connector (P/J190) of the CLUTCH TURN (PL4.2.9) from the HARNESS ASSY FRONTCLH (PL4.2.17).
- 3) Release the harness of the CLUTCH TURN from the hook of the REGISTRATION ASSEMBLY.
- 4) Remove the E-ring that fixes GEAR P1 to ROLL TURN MSI, remove GEAR P1.
- 5) Pull out CLUTCH TURN from ROLL TURN MSI, then remove it.

### [Replacement]

- 1) Insert CLUTCH TURN into the shaft of ROLL TURN MSI.
- 2) Fit CLUTCH TURN fixing groove over CLUTCH fixing section of CHUTE REGI.
- 3) Insert GEAR P1 into the shaft of ROLL TURN MSI and fix it using the E-ring.
- 4) Attach the harness of the CLUTCH TURN to the hook of the REGISTRATION ASSEMBLY.
- 5) Connect the connector (P/J190) of the CLUTCH TURN with the HARNESS ASSY FRONTCLH.
- 6) Attach REGISTRATION ASSEMBLY. (RRP4.6)

RRP4.11 ROLL TURN MSI. (PL4.2.10)

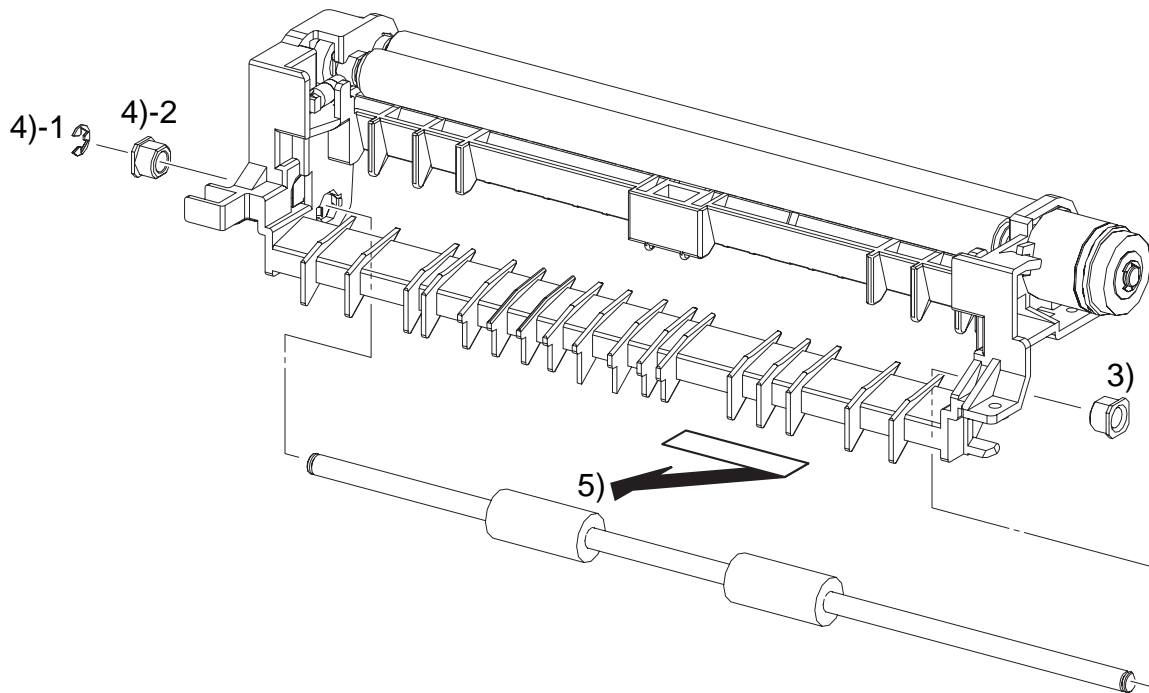

Ida\_Sec03\_042FB

### RRP4.11 ROLL TURN MSI. (PL4.2.10)

#### [Removal]

- 1) Remove REGISTRATION ASSEMBLY. (RRP4.6)
- 2) Remove CLUTCH TURN. (RRP4.10)
- 3) Remove BEARING that fixes the right side shaft of ROLL TURN MSI to CHUTE REGI.
- 4) Remove the E-ring that fixes the left side shaft of ROLL TURN MSI to CHUTE REGI, remove BEARING EARTH.
- 5) Shift ROLL TURN MSI from CHUTE REGI to the right, remove it downward.

#### [Replacement]

- 1) Attach ROLL TURN MSI to CHUTE REGI.
- 2) Insert BEARING EARTH into the left side shaft of ROLL TURN MSI and fix it using the E-ring.
- 3) Insert BEARING into the right side shaft of ROLL TURN MSI.
- 4) Attach CLUTCH TURN. (RRP4.10)
- 5) Attach CLUTCH ASSY REGI. (RRP4.6)

## RRP5. CHUTE ASSY IN & OUT

### RRP5.1 FUSER. (PL5.1.1)

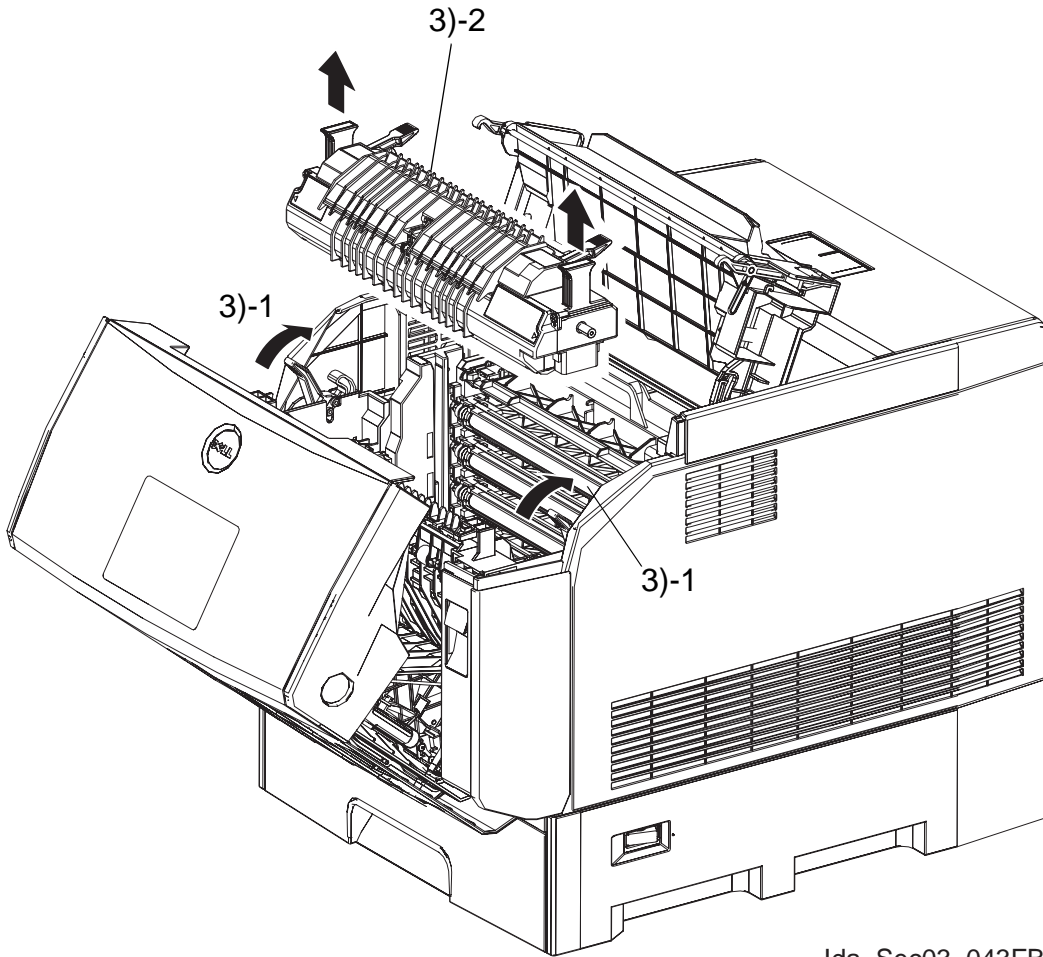

Ida\_Sec03\_043FB

## RRP5.1 FUSER. (PL5.1.1)

### [Removal]

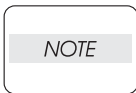

The FUSER part is very hot. Take added care not to get burned when carrying out service operation.

- 1) Release the latch and open OUTER DUPLEX ASSEMBLY (PL5.3.1).
- 2) Open IMAGING DRUM COVER (PL1.1.8).
- 3) Pull LEVER FUSER (PL5.2.2), remove FUSER holding the left and right handles by hands.

### [Replacement]

- 1) Hold the left and right handles of FUSER, attach FUSER on INNER DUPLEX ASSEMBLY with the boss and connector mounted underside of FUSER aligned with the hole in INNER DUPLEX ASSEMBLY (PL5.2.1)
- 2) Push LEVER FUSER, fix FUSER.
- 3) Close IMAGING DRUM COVER.
- 4) Close OUTER DUPLEX ASSEMBLY.

RRP5.2 TRANSFER ROLLER. (PL5.1.4)

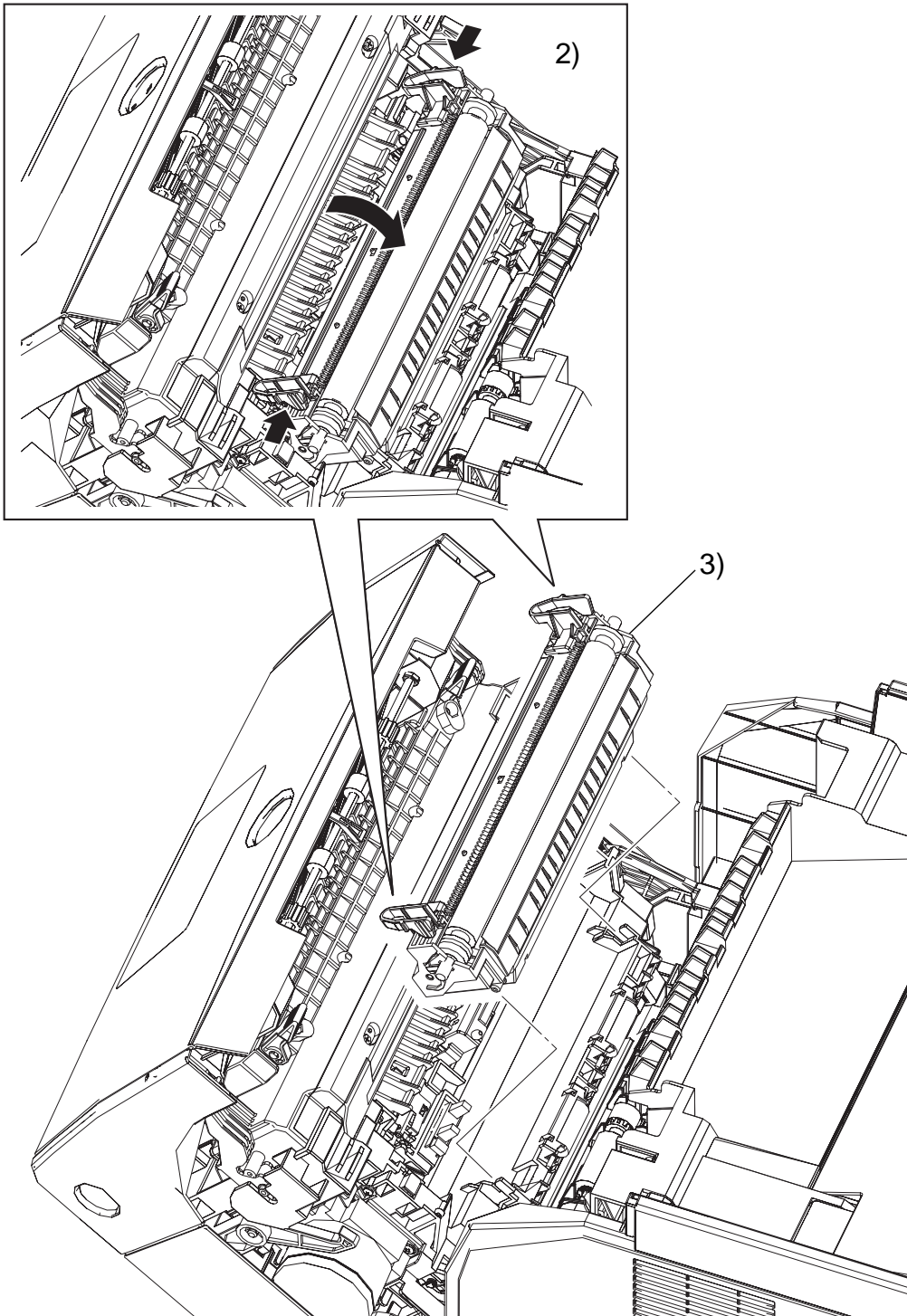

Ida\_Sec03\_044FB



## RRP5.2 TRANSFER ROLLER. (PL5.1.4)

### [Removal]

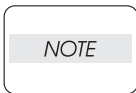

The FUSER part is very hot. Take added care not to get burned when carrying out service operation.

- 1) Release the latch and open INNER DUPLEX ASSEMBLY (PL5.2.1).
- 2) Pinch the left and right knobs that fixes TRANSFER ROLLER on INNER DUPLEX ASSEMBLY to unlock them. Turn TRANSFER ROLLER backward.
- 3) Remove TRANSFER ROLLER upward from INNER DUPLEX ASSEMBLY.

### [Replacement]

- 1) Match the projections at the left and the right on TRANSFER ROLLER and the groove of INNER DUPLEX ASSEMBLY, put it.
- 2) Pinch the left and right knobs of TRANSFER ROLLER to turn it forward, then lock the knob and attach TRANSFER ROLLER.
- 3) Close INNER DUPLEX ASSEMBLY.

RRP5.3 AUTOMATIC DENSITY CONTROL (ADC) SENSOR. (PL5.2.19)

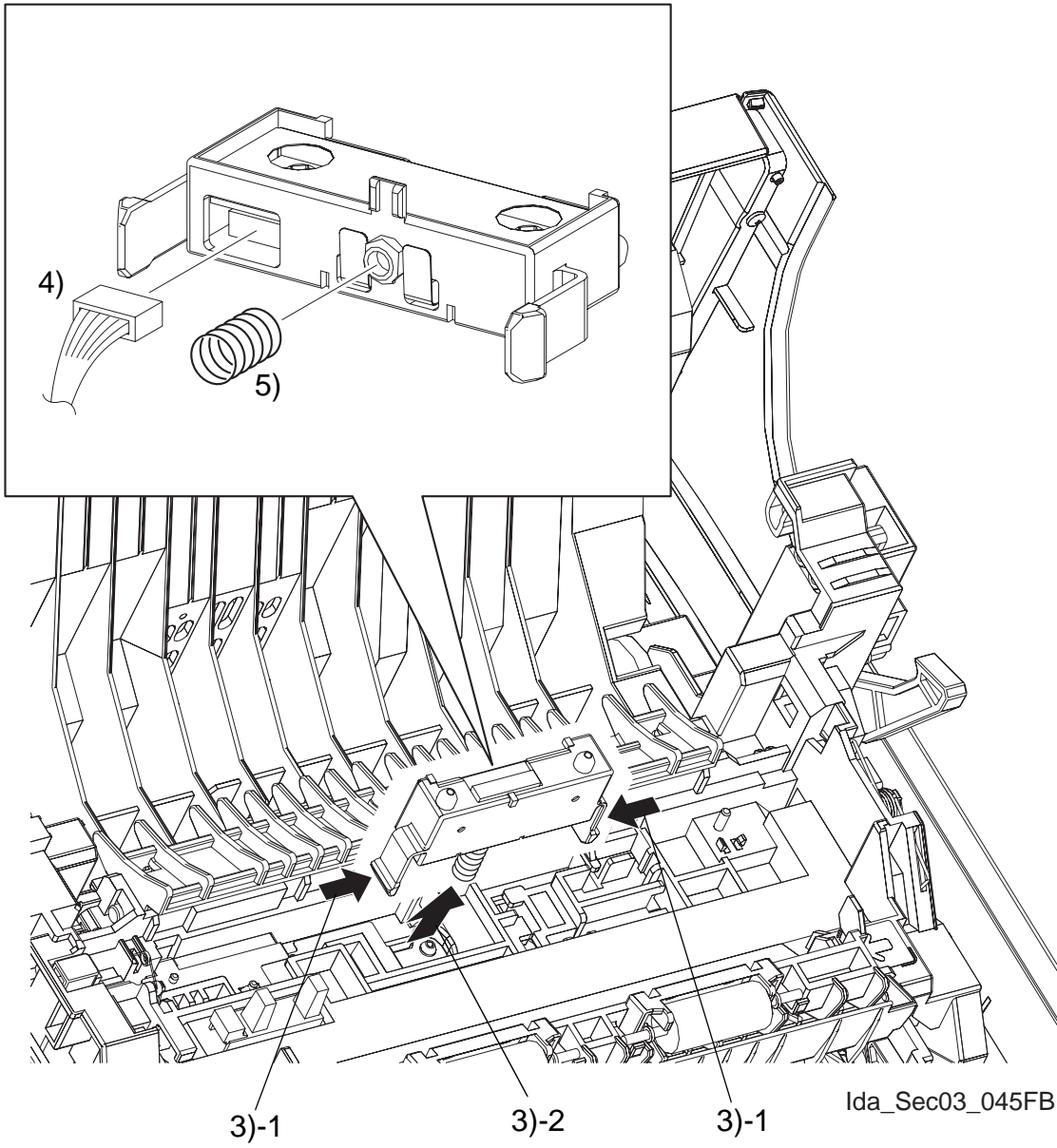

RRP5.3 AUTOMATIC DENSITY CONTROL (ADC) SENSOR. (PL5.2.19)

[Removal]

- 1) Release the latch and open INNER DUPLEX ASSEMBLY (PL5.2.1).
- 2) Remove TRANSFER ROLLER (PL5.1.4). (RRP5.2)
- 3) Pinch the hooks at two locations that fixes AUTOMATIC DENSITY CONTROL (ADC) SENSOR on INNER DUPLEX ASSEMBLY (PL5.2.1) to unlock them, remove AUTOMATIC DENSITY CONTROL (ADC) SENSOR.
- 4) Remove the connector (P/J136) that is connected to AUTOMATIC DENSITY CONTROL (ADC) SENSOR, remove AUTOMATIC DENSITY CONTROL (ADC) SENSOR.
- 5) Remove SPRING ADC (PL5.2.18) from AUTOMATIC DENSITY CONTROL (ADC) SENSOR.

[Replacement]

- 1) Attach SPRING ADC to AUTOMATIC DENSITY CONTROL (ADC) SENSOR.
- 2) Attach the connector (P/J136) to AUTOMATIC DENSITY CONTROL (ADC) SENSOR.
- 3) Put the harness on the connector (P/J136) through the harness guide located under AUTOMATIC DENSITY CONTROL (ADC) SENSOR.
- 4) Pinching the hooks at two locations on AUTOMATIC DENSITY CONTROL (ADC) SENSOR, insert AUTOMATIC DENSITY CONTROL (ADC) SENSOR into the mounting holes in INNER DUPLEX ASSEMBLY and lock the hooks.
- 5) Attach TRANSFER ROLLER. (RRP5.2)
- 6) Close INNER DUPLEX ASSEMBLY.

RRP5.4 TONER FULL SENSOR (PL5.2.20)

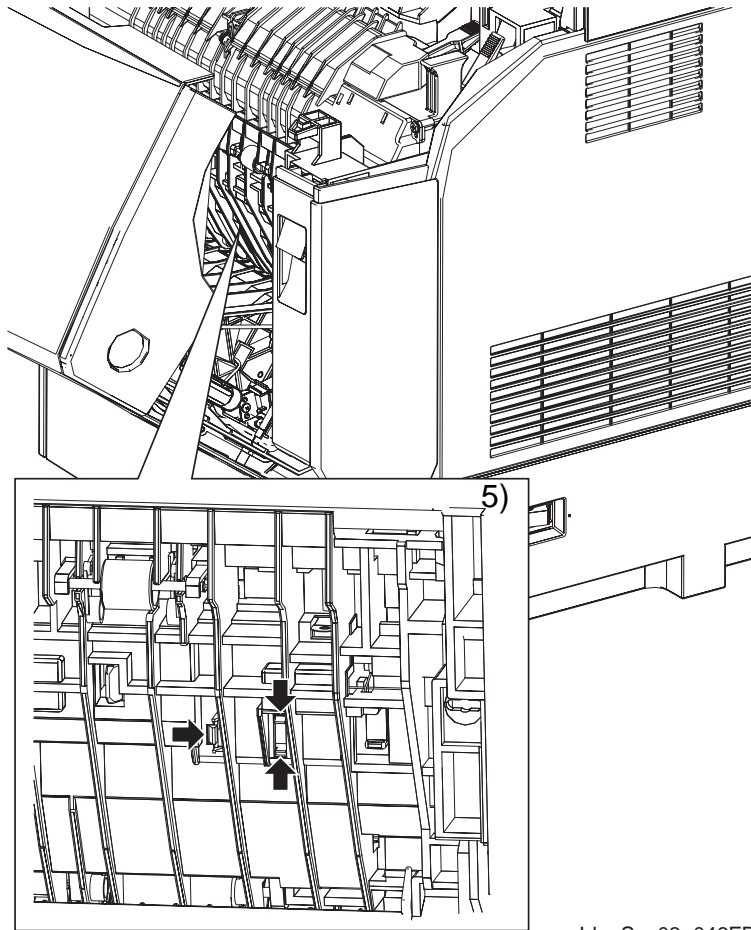

Ida\_Sec03\_046FB

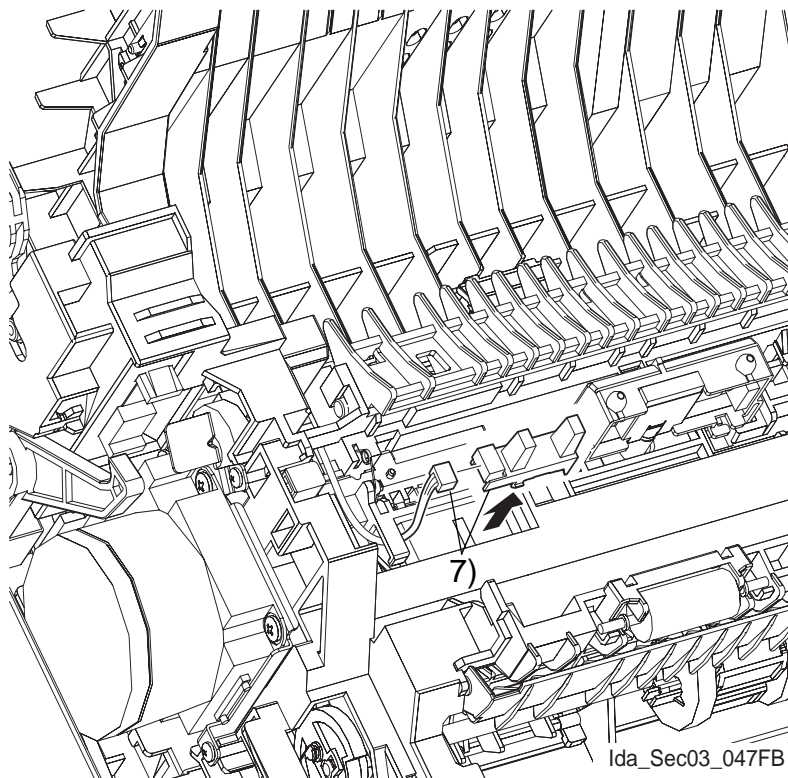

Ida\_Sec03\_047FB

## RRP5.4 TONER FULL SENSOR (PL5.2.20)

### [Removal]

- 1) Release the latch and open INNER DUPLEX ASSEMBLY (PL5.2.1).
- 2) Remove TRANSFER ROLLER (PL5.1.4). (RRP5.2)
- 3) Close INNER DUPLEX ASSEMBLY.
- 4) Release the latch and open OUTER DUPLEX ASSEMBLY (PL5.3.1).
- 5) Remove the hooks at three locations that fixes SENSOR TONER PULL to INNER DUPLEX ASSEMBLY, remove TONER FULL SENSOR.
- 6) Release the latch and open INNER DUPLEX ASSEMBLY.
- 7) Remove the connector (P/J142) that is connected to TONER FULL SENSOR, and remove TONER FULL SENSOR.

### [Replacement]

- 1) Attach the connector (P/J142) to TONER FULL SENSOR.
- 2) Thrust the hooks of TONER FULL SENSOR into the mounting holes in INNER DUPLEX ASSEMBLY and lock the hooks to attach TONER FULL SENSOR on INNER DUPLEX ASSEMBLY.
- 3) Attach TRANSFER ROLLER. (RRP5.2)
- 4) Close INNER DUPLEX ASSEMBLY.

RRP5.5 DRIVE ASSY FUSER (PL5.2.25)

Procedure No. with [ ] included in Fig. shows the procedure at attachment.

NOTE

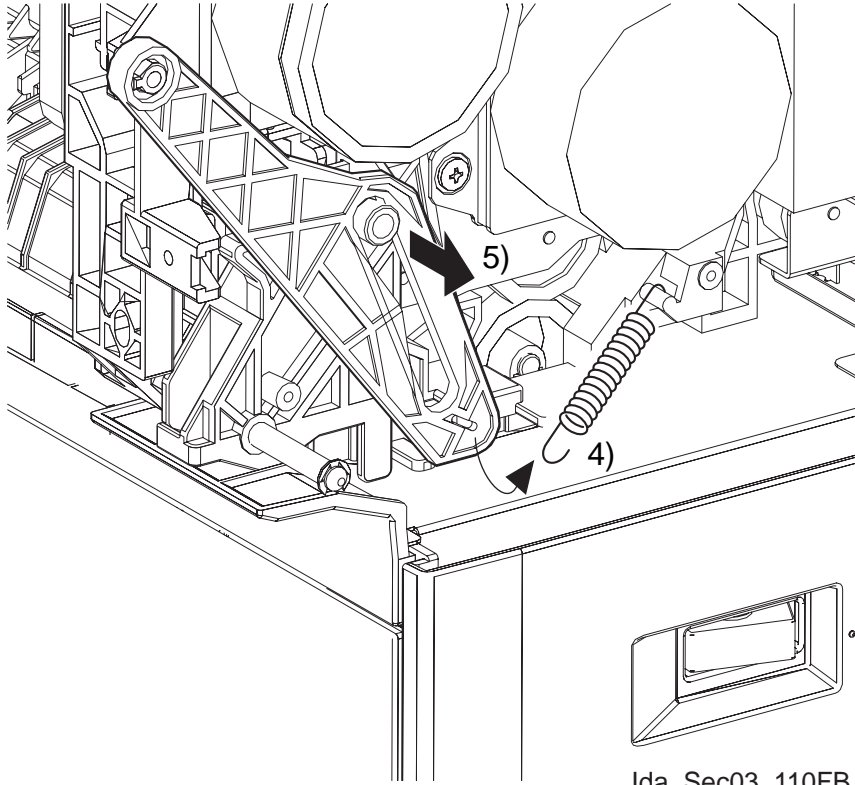

RRP5.5 DRIVE ASSY FUSER (PL5.2.25)

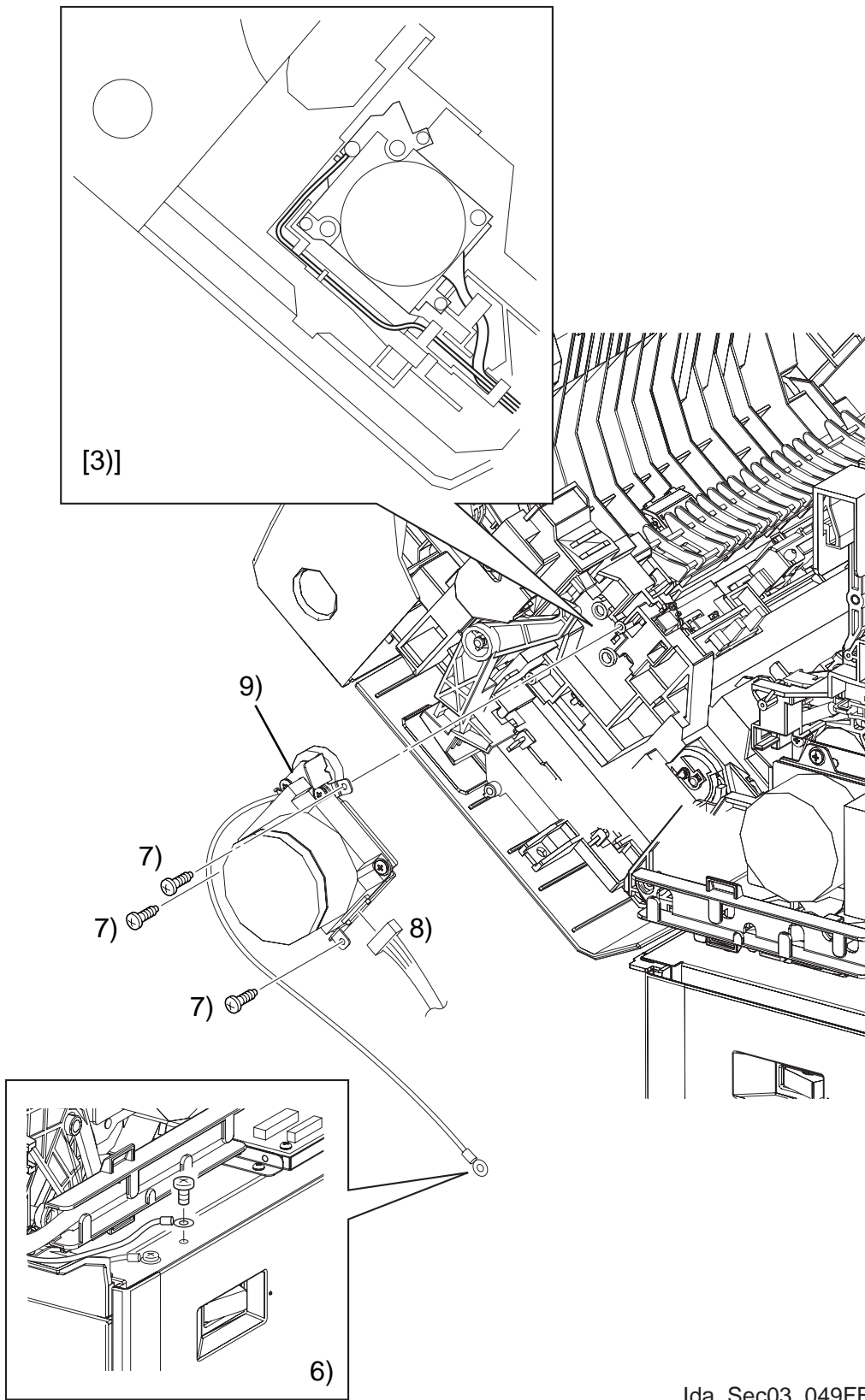

Ida\_Sec03\_049FB

## RRP5.5 DRIVE ASSY FUSER (PL5.2.25)

## [Removal]

- 1) Remove TOP COVER FRAME. (RRP1.1)
- 2) Remove RIGHT FRONT COVER. (RRP1.8)
- 3) Remove RIGHT SIDE COVER. (RRP1.7)
- 4) Remove DUPLEX HINGE LINK SPRING (PL5.1.6) on the right side of the printer.
- 5) Remove the hole at the center of DUPLEX HINGE LINK (PL5.1.7) on the right side of the printer from the boss.
- 6) Remove the one screw (silver, provided with outer-teeth washer, 5mm) securing the ground wire on the bottom plate of the printer. Take out the ground wire.
- 7) Remove three screws (silver, tap, 10mm) which fix DRIVE ASSY FUSER to INNER DUPLEX ASSEMBLY (PL5.2.1).
- 8) Remove the connector (P/J521) on DRIVE ASSY FUSER.
- 9) Remove the harness and ground wire coming from the DRIVE ASSY FUSER from the respective harness guide. Remove the DRIVE ASSY FUSER.

## [Replacement]

- 1) Connect the connector (P/J521) on DRIVE ASSY FUSER.
- 2) Fix DRIVE ASSY FUSER to INNER DUPLEX ASSEMBLY using three screws (silver, tap, 10 mm).
- 3) Pass the harness and ground wire coming from the DRIVE ASSY FUSER through the respective harness guides.
- 4) Insert the boss on the right side of the printer into the hole on DUPLEX HINGE LINK.
- 5) Attach DUPLEX HINGE LINK SPRING to DUPLEX HINGE LINK at the right side of the printer.
- 6) Fix the ground wire on the bottom plate of the printer with one screw (silver, provided with outer-teeth washer, 5 mm).
- 7) Attach RIGHT SIDE COVER. (RRP1.7)
- 8) Attach COVER FRONT R. (RRP1.8)
- 9) Attach COVER TOP MAIN. (RRP1.1)



Blank Page

RRP5.6 MULTIPURPOSE FEEDER (MPF) SOLENOID. (PL5.3.9)

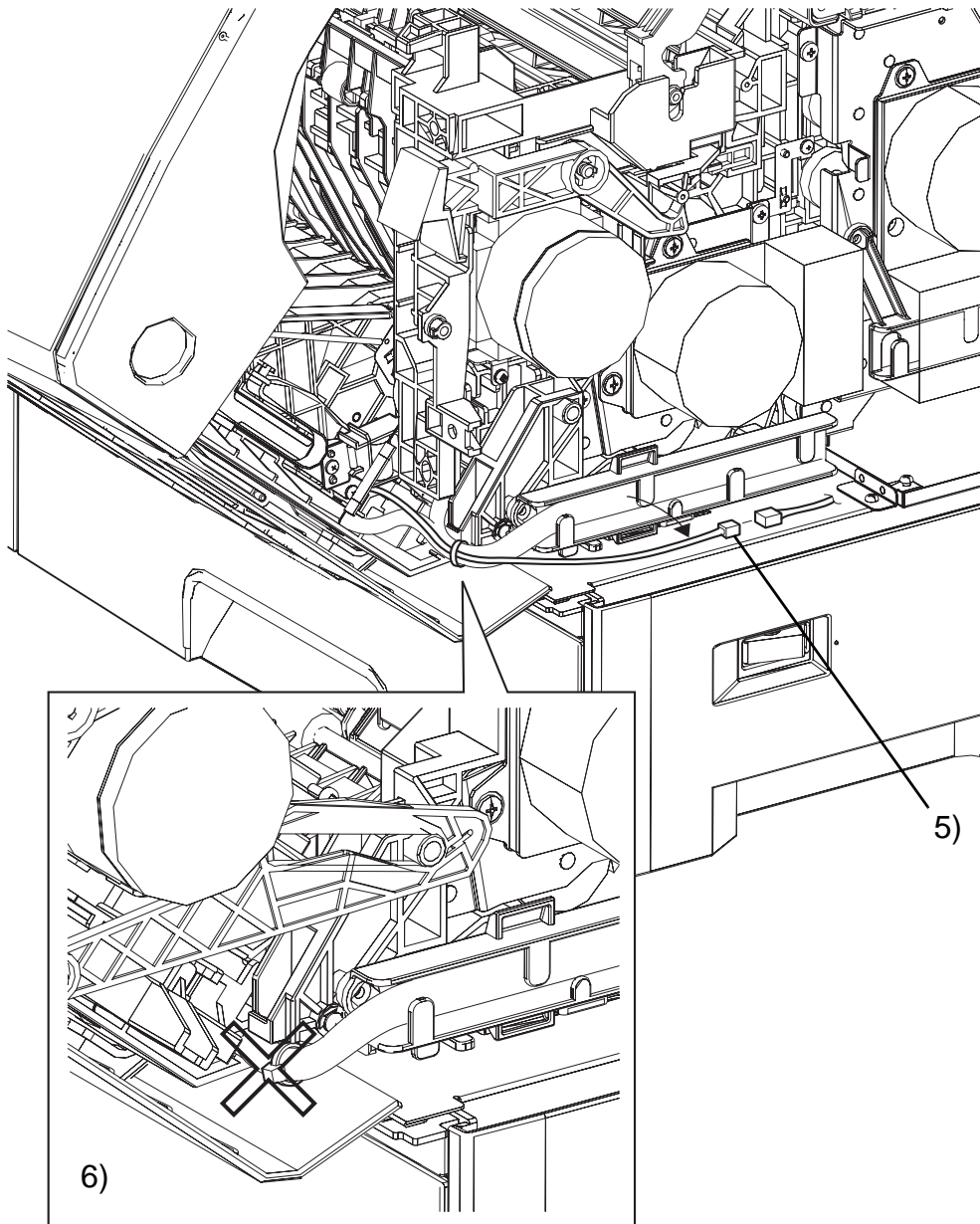

Ida\_Sec03\_050FA

RRP5.6 MULTIPURPOSE FEEDER (MPF) SOLENOID. (PL5.3.9)

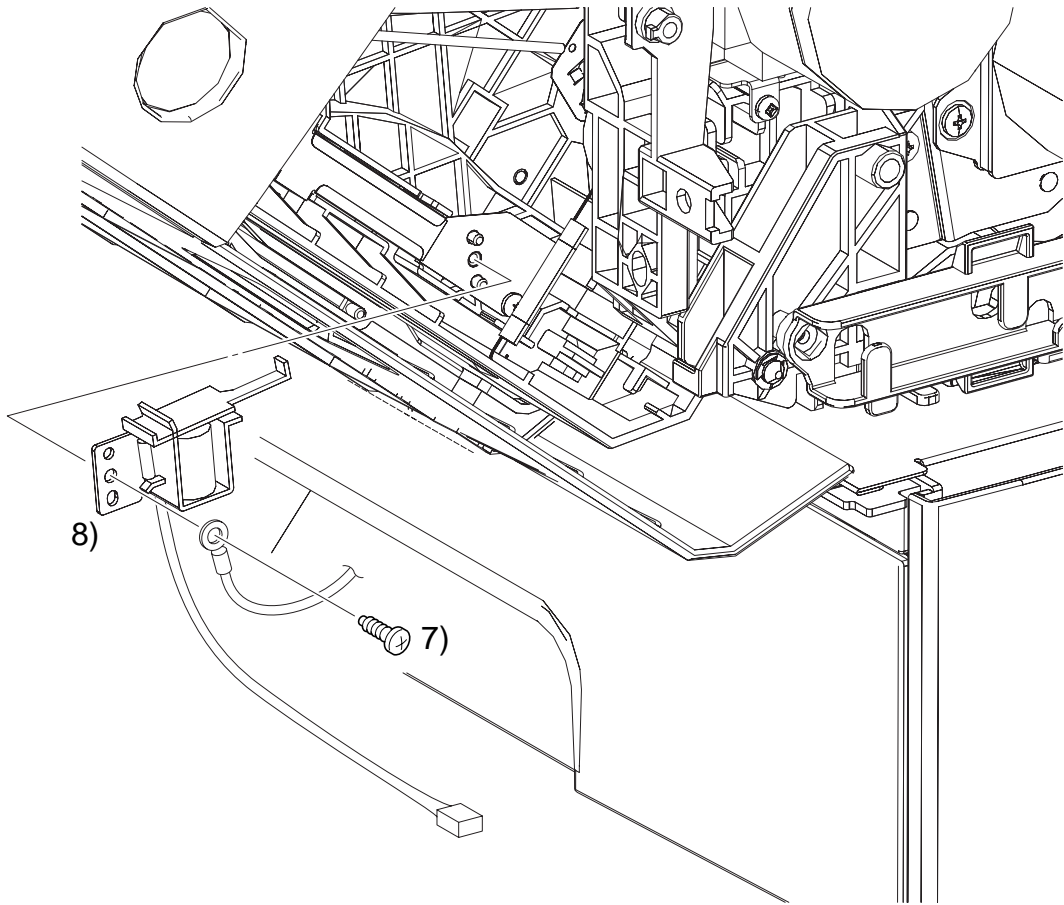

Ida\_Sec03\_051FA

## RRP5.6 MULTIPURPOSE FEEDER (MPF) SOLENOID. (PL5.3.9)

### [Removal]

- 1) Remove TOP COVER FRAME. (RRP1.1)
- 2) Remove RIGHT FRONT COVER. (RRP1.8)
- 3) Remove RIGHT SIDE COVER. (RRP1.7)
- 4) Release the latch and open OUTER DUPLEX ASSEMBLY (PL5.3.1).
- 5) Remove the harness, that is connected to MULTIPURPOSE FEEDER (MPF) SOLENOID, from GUIDE HARNESS F (PL9.1.15) on the right side of the printer. Remove the connector (P/J132).

**NOTE**

Take care not to damage other harnesses when cutting the cable tie following the steps of procedure described below.

- 6) Cut out the cable tie binding the harnesses at the right front side of the printer.
- 7) Remove one screw (silver, tap, 8mm) which fixes MULTIPURPOSE FEEDER (MPF) SOLENOID and WIRE ASSY DUP EARTH (PL5.3.29) together onto OUTER DUPLEX ASSEMBLY.
- 8) Remove MULTIPURPOSE FEEDER (MPF) SOLENOID.

### [Replacement]

- 1) Match the positioning holes of MULTIPURPOSE FEEDER (MPF) SOLENOID to the bosses at two locations on the right side of OUTER DUPLEX ASSEMBLY, and attach together with WIRE ASSY DUP EARTH using one screw (silver, tap, 8mm).
- 2) Put the harness into GUIDE HARNESS F and attach the connector (P/J132).
- 3) Bind the harnesses located at the right front side of the printer, fix them using the cable tie.
- 4) Attach RIGHT SIDE COVER. (RRP1.7)
- 5) Attach RIGHT FRONT COVER. (RRP1.8)
- 6) Attach TOP COVER FRAME. (RRP1.1)

Blank Page

RRP5.7 MULTIPURPOSE FEEDER (MPF) PAPER SENSOR (PL5.3.14)

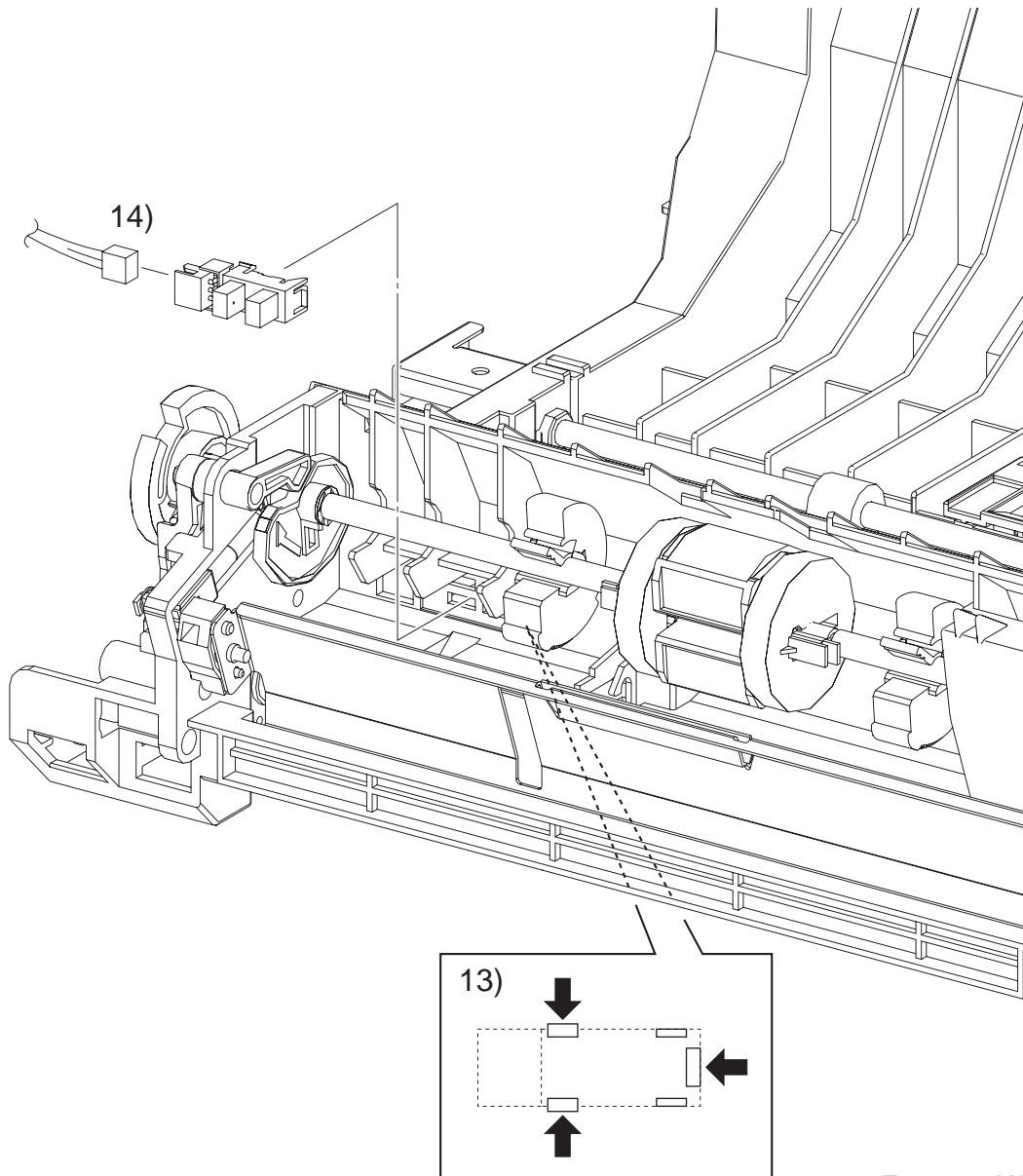

Ten03052KA

## RRP5.7 MULTIPURPOSE FEEDER (MPF) PAPER SENSOR (PL5.3.14)

### [Removal]

- 1) Remove FUSER. (RRP5.1)
- 2) Remove TRANSFER ROLLER. (RRP5.2)
- 3) Remove TOP COVER FRAME. (RRP1.1)
- 4) Remove FRONT COVER. (RRP1.3)
- 5) Remove RIGHT FRONT COVER. (RRP1.8)
- 6) Remove LEFT FRONT COVER. (RRP1.11)
- 7) Remove RIGHT SIDE COVER. (RRP1.7)
- 8) Remove LEFT SIDE COVER. (RRP1.12)
- 9) Remove COVER ASSY REAR. (RRP1.5)
- 10) Remove MULTIPURPOSE FEEDER (MPF) TRAY. (RRP1.9)
- 11) Remove OUTER DUPLEX ASSEMBLY. (RRP5.18)
- 12) Remove MULTIPURPOSE FEEDER (MPF) ACTUATOR. (RRP5.8)
- 13) Release the hook that fixes MULTIPURPOSE FEEDER (MPF) PAPER SENSOR to OUTER DUPLEX ASSEMBLY, remove MULTIPURPOSE FEEDER (MPF) PAPER SENSOR with the harness.
- 14) Remove the connector (P/J135) from MULTIPURPOSE FEEDER (MPF) PAPER SENSOR, remove MULTIPURPOSE FEEDER (MPF) PAPER SENSOR.

### [Replacement]

- 1) Attach the connector (P/J135) to MULTIPURPOSE FEEDER (MPF) PAPER SENSOR.
- 2) Attach MULTIPURPOSE FEEDER (MPF) PAPER SENSOR to OUTER DUPLEX ASSEMBLY.
- 3) Attach MULTIPURPOSE FEEDER (MPF) ACTUATOR. (RRP5.8)
- 4) Attach OUTER DUPLEX ASSEMBLY. (RRP5.18)
- 5) Attach MULTIPURPOSE FEEDER (MPF) COVER. (RRP1.10)
- 6) Attach MULTIPURPOSE FEEDER (MPF) TRAY. (RRP1.9)
- 7) Attach COVER ASSY REAR. (RRP1.5)
- 8) Attach LEFT SIDE COVER. (RRP1.12)
- 9) Attach RIGHT SIDE COVER. (RRP1.7)
- 10) Attach LEFT FRONT COVER. (RRP1.11)
- 11) Attach RIGHT FRONT COVER. (RRP1.8)
- 12) Attach FRONT COVER. (RRP1.3)
- 13) Attach TOP COVER FRAME. (RRP1.1)
- 14) Attach TRANSFER ROLLER. (RRP5.2)
- 15) Attach FUSER. (RRP5.1)

RRP5.8 MULTIPURPOSE FEEDER (MPF) ACTUATOR (PL.5.3.15)

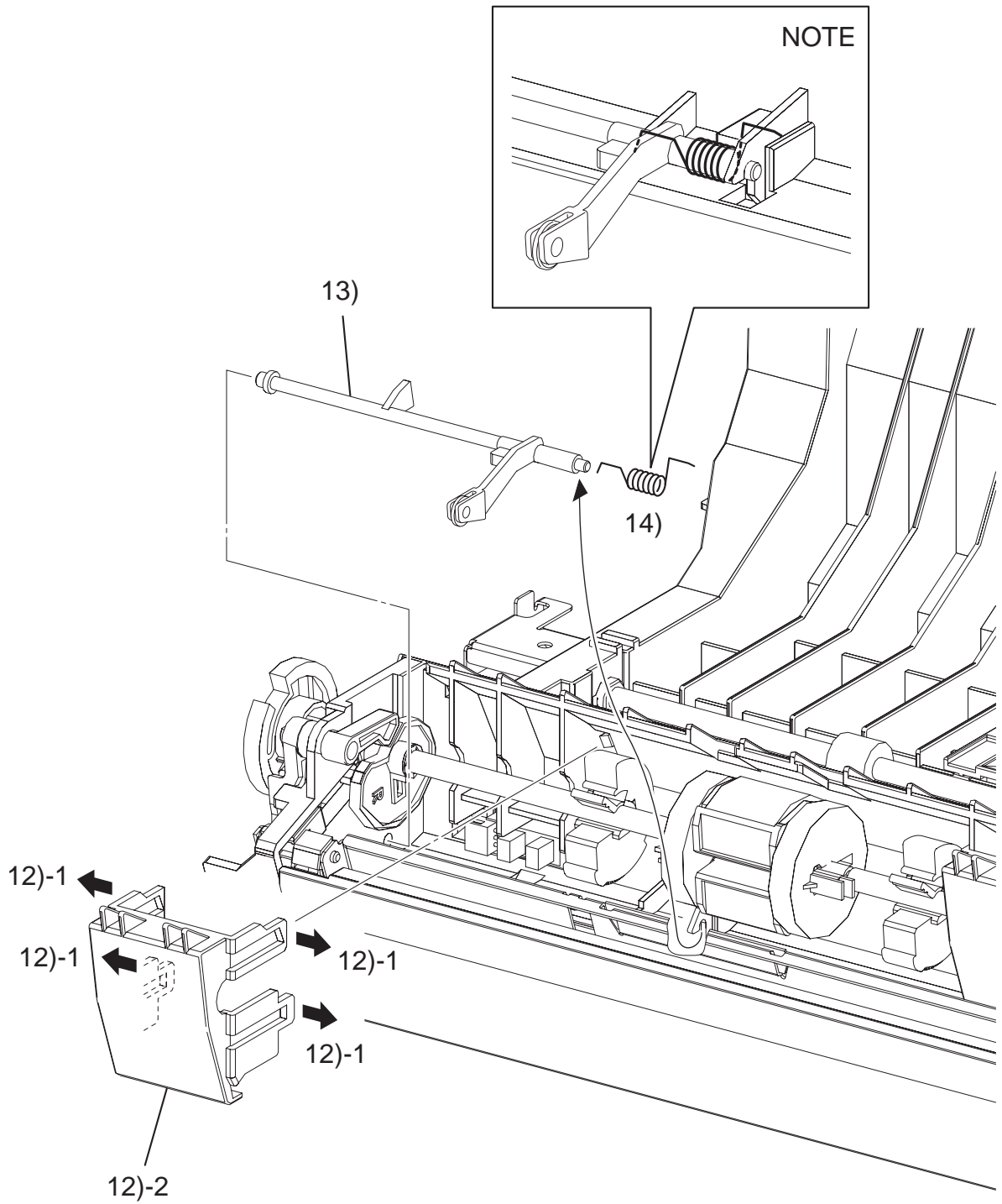

Ten03053KA



## RRP5.8 MULTIPURPOSE FEEDER (MPF) ACTUATOR (PL.5.3.15)

## [Removal]

- 1) Remove FUSER. (RRP5.1)
- 2) Remove TRANSFER ROLLER. (RRP5.2)
- 3) Remove TOP COVER FRAME. (RRP1.1)
- 4) Remove FRONT COVER. (RRP1.3)
- 5) Remove RIGHT FRONT COVER. (RRP1.8)
- 6) Remove LEFT FRONT COVER. (RRP1.11)
- 7) Remove RIGHT SIDE COVER. (RRP1.7)
- 8) Remove LEFT SIDE COVER. (RRP1.12)
- 9) Remove COVER ASSY REAR. (RRP1.5)
- 10) Remove MULTIPURPOSE FEEDER (MPF) TRAY. (RRP1.9)
- 11) Remove OUTER DUPLEX ASSEMBLY. (RRP5.18)
- 12) Release the four hooks that fix CHUTE FEED UP to OUTER DUPLEX ASSEMBLY, remove CHUTE FEED UP.
- 13) Remove ACTUAOR NO PAPER MSI from the notch of the hole which fixes MULTIPURPOSE FEEDER (MPF) ACTUATOR to OUTER DUPLEX ASSEMBLY, and pull out MULTIPURPOSE FEEDER (MPF) ACTUATOR from the other attaching hole to remove together with SPRING NO PAPER MSI.
- 14) Remove SPRING NO PAPER MSI from ACTUAOR NO PAPER MSI.

## [Replacement]

## NOTE

- There shall be no mistake in attaching orientation of SPRING.
- SPRING shall be securely hooked without fail.

- 1) Attach SPRING NO PAPER MSI to MULTIPURPOSE FEEDER (MPF) ACTUATOR.
- 2) Insert one end the MULTIPURPOSE FEEDER (MPF) ACTUATOR into the hole on the side face of the OUTER DUPLEX ASSEMBLY. Insert the other end of the MULTIPURPOSE FEEDER (MPF) ACTUATOR into the other notch and attach it.
- 3) Hook one end of SPRING NO PAPER MSI to MULTIPURPOSE FEEDER (MPF) ACTUATOR and the other end to OUTER DUPLEX ASSEMBLY.
- 4) Attach CHUTE FEED UP to OUTER DUPLEX ASSEMBLY, fix it using the four hooks.
- 5) Attach OUTER DUPLEX ASSEMBLY. (RRP5.18)
- 6) Attach MULTIPURPOSE FEEDER (MPF) COVER. (RRP1.10)
- 7) Attach MULTIPURPOSE FEEDER (MPF) TRAY. (RRP1.9)
- 8) Attach COVER ASSY REAR. (RRP1.5)
- 9) Attach LEFT SIDE COVER. (RRP1.12)
- 10) Attach RIGHT SIDE COVER. (RRP1.7)
- 11) Attach LEFT FRONT COVER. (RRP1.11)
- 12) Attach RIGHT FRONT COVER. (RRP1.8)
- 13) Attach FRONT COVER. (RRP1.3)
- 14) Attach TOP COVER FRAME. (RRP1.1)
- 15) Attach TRANSFER ROLLER. (RRP5.2)
- 16) Attach FUSER. (RRP5.1)

RRP5.9 MULTIPURPOSE FEEDER (MPF) ROLLER (PL.5.3.20)

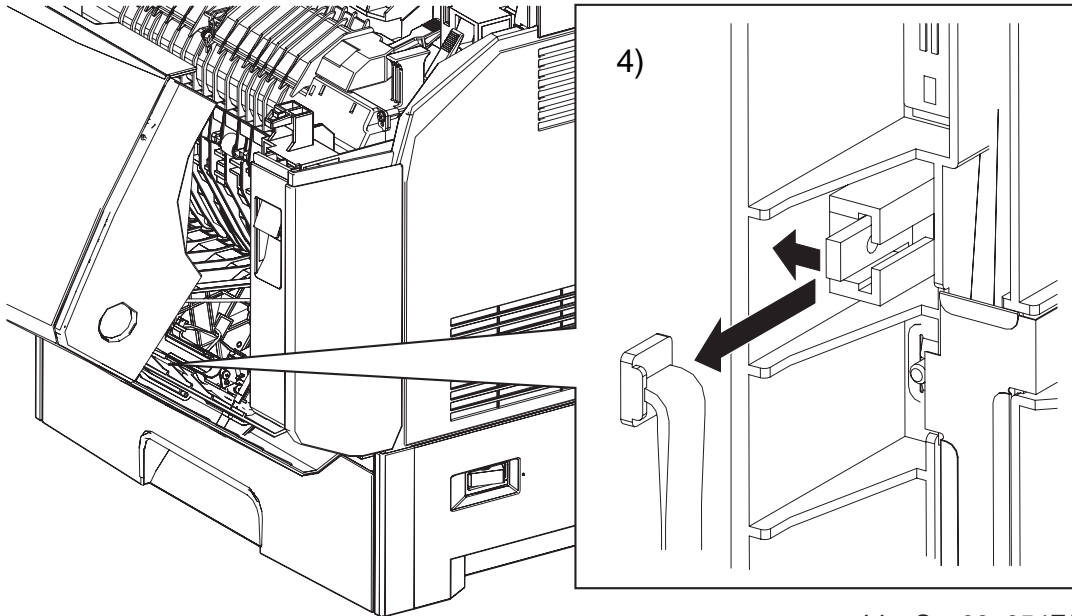

Ida\_Sec03\_054FA

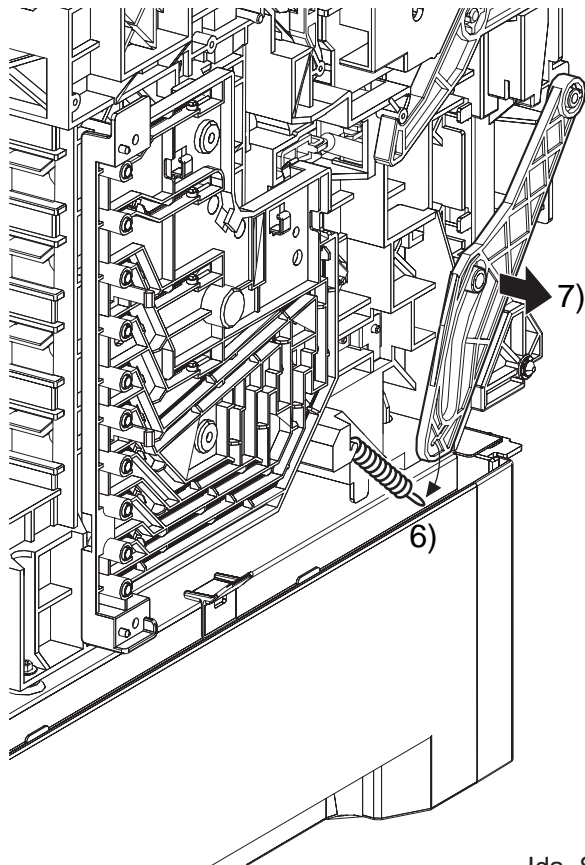

Ida\_Sec03\_101FB

RRP5.9 MULTIPURPOSE FEEDER (MPF) ROLLER (PL.5.3.20)

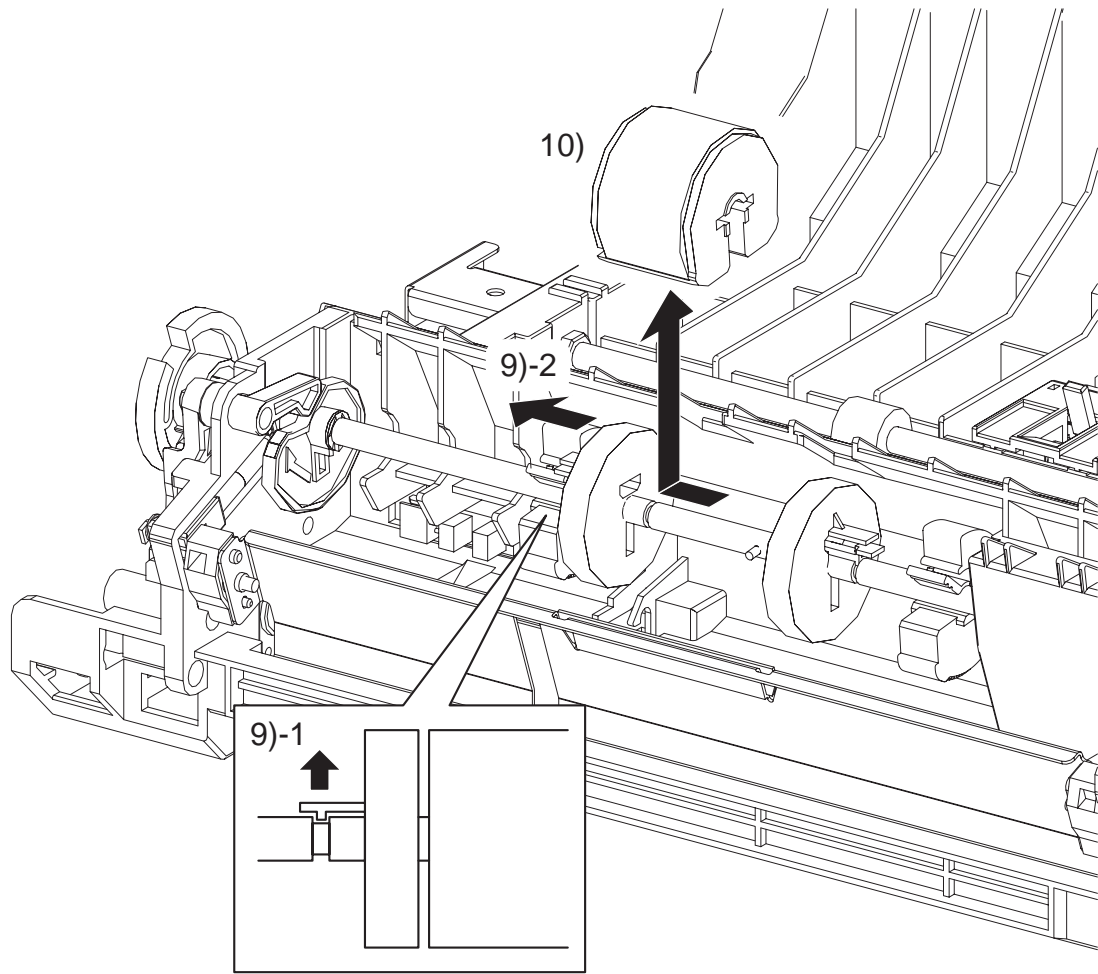

Ten03102KA

**RRP5.9 MULTIPURPOSE FEEDER (MPF) ROLLER (PL.5.3.20)****[Removal]**

- 1) Remove LEFT FRONT COVER. (RRP1.11)
- 2) Remove LEFT SIDE COVER. (RRP1.12)
- 3) Release the latch and open OUTER DUPLEX ASSEMBLY (PL5.3.1).
- 4) Release the hook to remove DUPLEX RETAINING DUPLEX HINGE LINK SPRING (PL5.1.5) from OUTER DUPLEX ASSEMBLY.
- 5) Close OUTER DUPLEX ASSEMBLY.
- 6) Remove DUPLEX HINGE LINK SPRING (PL5.1.6) that is hooked on DUPLEX HINGE LINK (PL5.1.7) of the left frame of the printer.

**NOTE**

Be aware that tilting OUTER DUPLEX ASSEMBLY suddenly can break it when removing LINK following the steps of procedure described below.

- 7) Remove DUPLEX HINGE LINK from the boss of the left frame of the printer.
- 8) Fully open OUTER DUPLEX ASSEMBLY.
- 9) Release the hook that fixes ROLL CORE MSI (PL5.3.19) on SHAFT MSI (PL5.3.18), move ROLL CORE MSI crosswise.
- 10) Move MULTIPURPOSE FEEDER (MPF) ROLLER crosswise until the PIN on SHAFT MSI appears. Now, remove MULTIPURPOSE FEEDER (MPF) ROLLER.

**[Replacement]**

- 1) Attach MULTIPURPOSE FEEDER (MPF) ROLLER so that the pin on SHAFT MSI fits in the groove of MULTIPURPOSE FEEDER (MPF) ROLLER.
- 2) Move ROLL CORE MSI crosswise to attach it with the hook locked.
- 3) Close OUTER DUPLEX ASSEMBLY.
- 4) Attach DUPLEX HINGE LINK to the boss of the left frame of the printer.
- 5) Hook DUPLEX HINGE LINK SPRING on DUPLEX HINGE LINK of the left frame of the printer.
- 6) Attach DUPLEX RETAINING DUPLEX HINGE LINK SPRING to OUTER DUPLEX ASSEMBLY.
- 7) Attach LEFT SIDE COVER. (RRP1.12)
- 8) Attach LEFT FRONT COVER. (RRP1.11)

Blank Page

RRP5.10 OUTPUT TRAY FULL SENSOR (PL5.4.1)

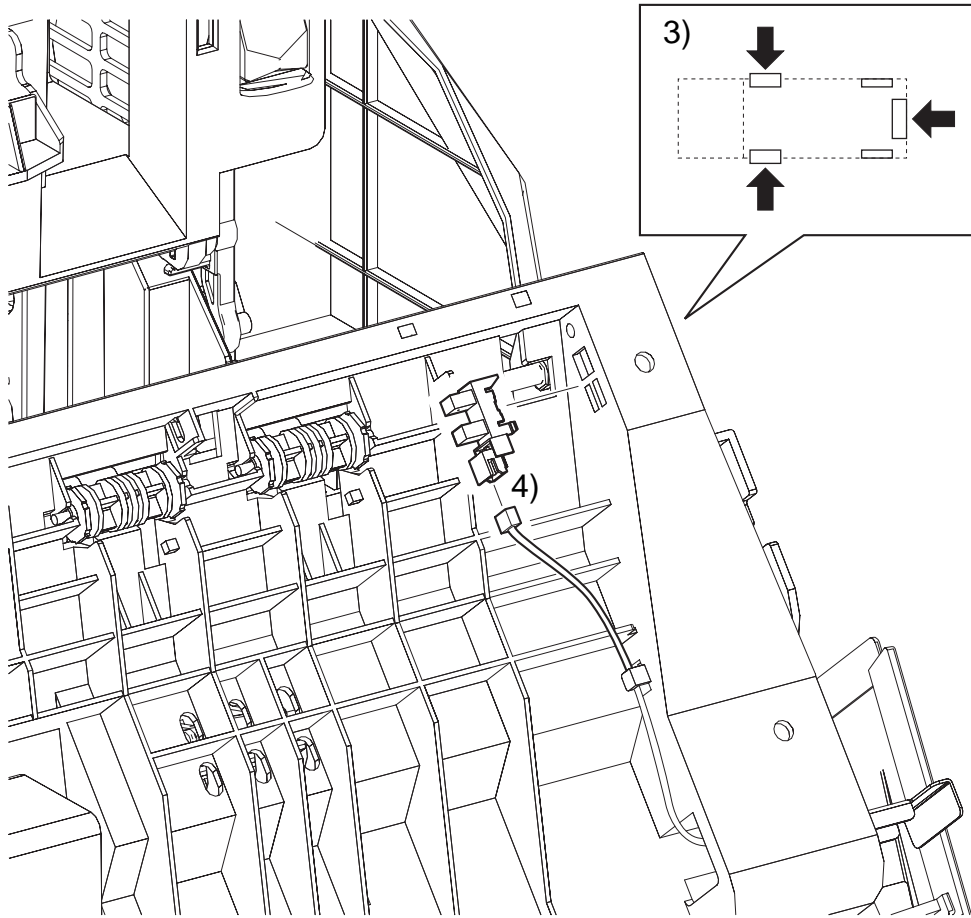

Ida\_Sec03\_055FA

## RRP5.10 OUTPUT TRAY FULL SENSOR (PL5.4.1)

### [Removal]

- 1) Remove FRONT COVER. (RRP1.3)
- 2) Remove OUTPUT TRAY ACTUATOR. (RRP5.12)
- 3) Remove the hooks at three locations that fix OUTPUT TRAY FULL SENSOR to OUTER DUPLEX ASSEMBLY (PL5.3.1).
- 4) Remove the connector (P/J134) from OUTPUT TRAY FULL SENSOR, remove OUTPUT TRAY FULL SENSOR.

### [Replacement]

- 1) Attach the connector (P/J134) to SENSOR PHOTO:FULL STACK.
- 2) Match the hooks at three locations of OUTPUT TRAY FULL SENSOR with the holes in OUTER DUPLEX ASSEMBLY, attach OUTPUT TRAY FULL SENSOR to OUTER DUPLEX ASSEMBLY by locking the hooks.
- 3) Attach OUTPUT TRAY ACTUATOR. (RRP5.12)
- 4) Attach FRONT COVER. (RRP1.3)

RRP5.11 SENSOR PHOTO: JAM (PL5.4.1)

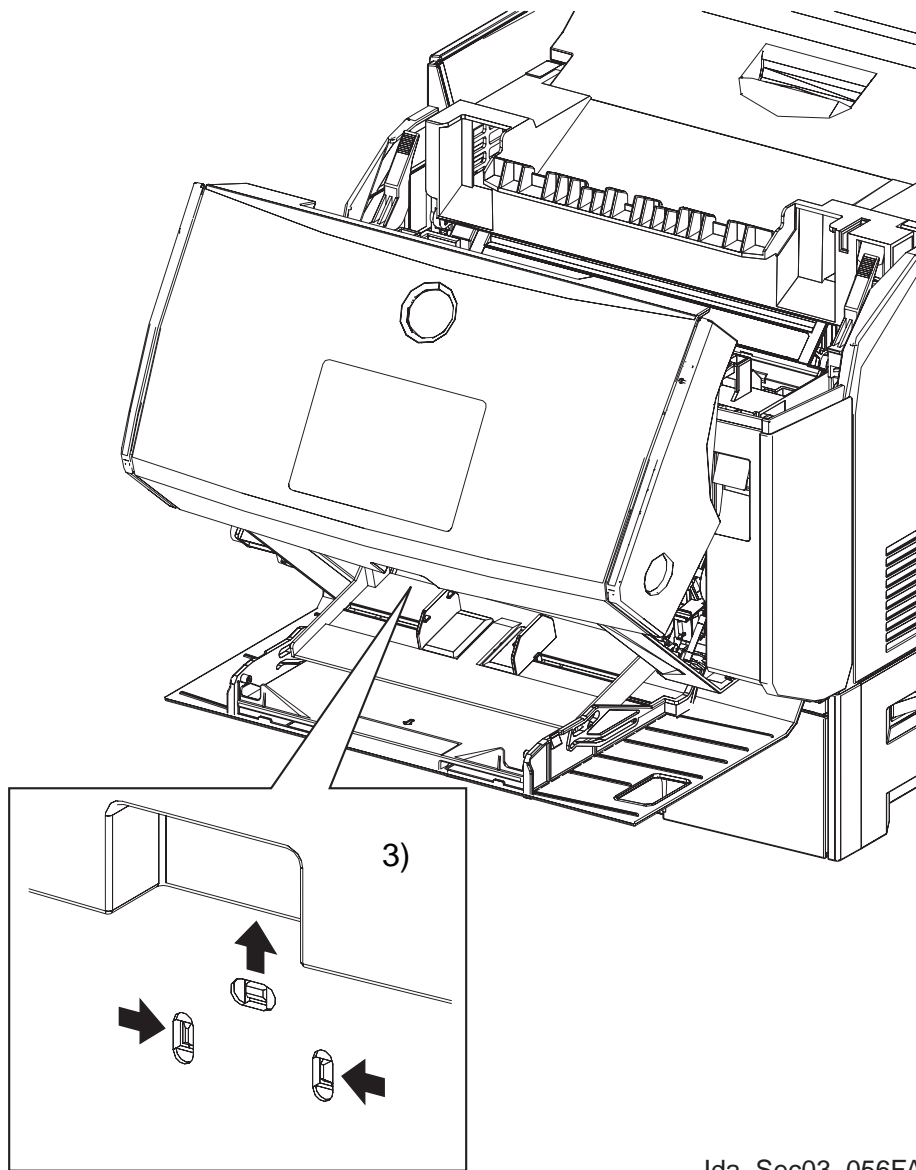

Ida\_Sec03\_056FA



RRP5.11 SENSOR PHOTO: JAM (PL5.4.1)

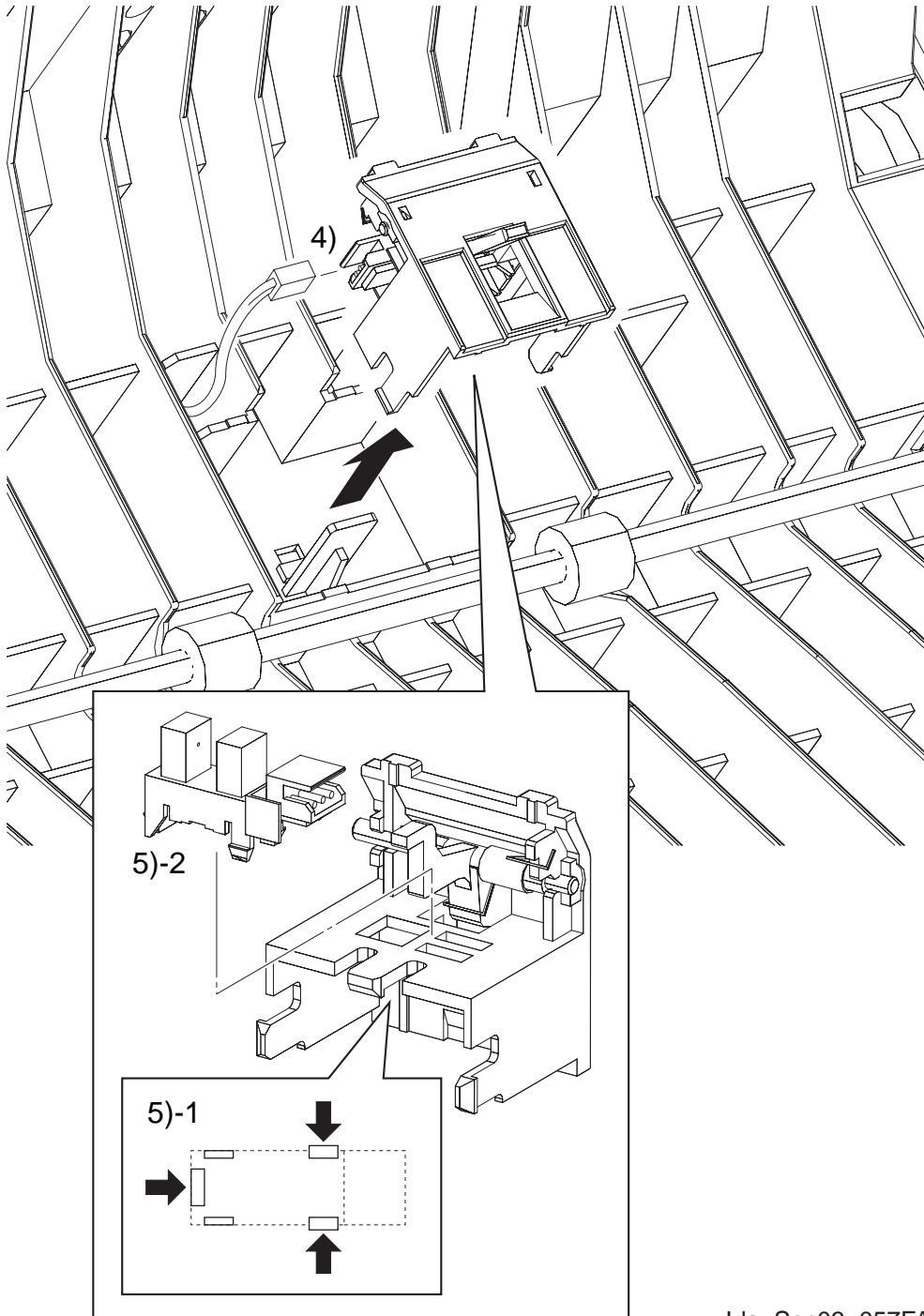

Ida\_Sec03\_057FA

## RRP5.11 SENSOR PHOTO: JAM (PL5.4.1)

### [Removal]

- 1) Open MULTIPURPOSE FEEDER (MPF) COVER. (PL1.1.25)
- 2) Release the latch and open OUTER DUPLEX ASSEMBLY (PL5.3.1).
- 3) Release the hooks at three locations that fix HOLDER SENSOR DUP (PL5.4.12) to OUTER DUPLEX ASSEMBLY.
- 4) Remove the connector (P/J133) that is connected to SENSOR PHOTO:JAM.
- 5) Release the hooks at three locations that fix SENSOR PHOTO: JAM to HOLDER SENSOR DUP, and remove SENSOR PHOTO: JAM.

### [Replacement]

- 1) Match the hooks at three locations of SENSOR PHOTO: JAM with the holes in HOLDER SENSOR DUP, and attach SENSOR PHOTO: JAM on HOLDER SENSOR DUP
- 2) Attach the connector (P/J133) to SENSOR PHOTO:JAM.
- 3) Match the hooks at three locations of HOLDER SENSOR DUP with the holes in OUTER DUPLEX ASSEMBLY, attach HOLDER SENSOR DUP on OUTER DUPLEX ASSEMBLY.
- 4) Close OUTER DUPLEX ASSEMBLY.
- 5) Close MULTIPURPOSE FEEDER (MPF) COVER.

Blank Page

RRP5.12 OUTPUT TRAY ACTUATOR (PL5.4.2)

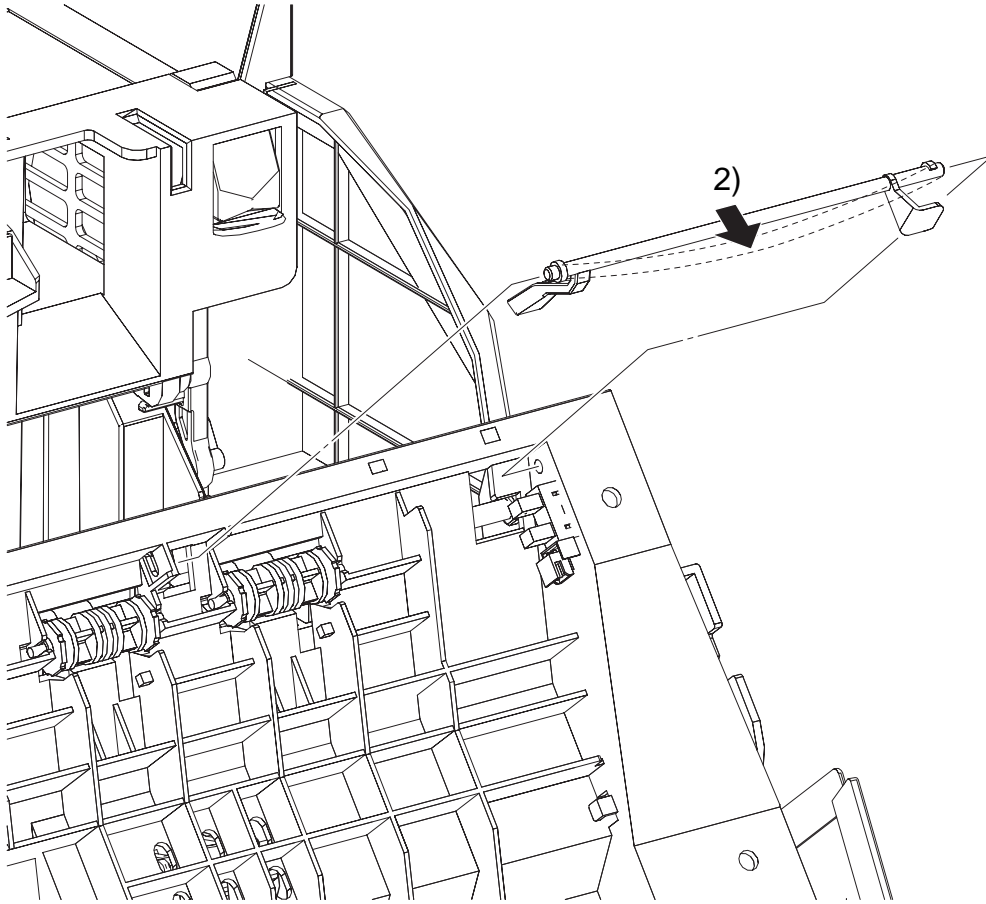

Ida\_Sec03\_058FA

| RRP5.12 OUTPUT TRAY ACTUATOR (PL5.4.2)

[Removal]

- |
- 1) Remove FRONT COVER. (RRP1.3)
  - 2) Sag the midsection of OUTPUT TRAY ACTUATOR, remove the left and right shafts through the mounting holes.

[Replacement]

- |
- 1) Sag the midsection of OUTPUT TRAY ACTUATOR, fit the left and right shafts through the mounting holes.
  - 2) Attach FRONT COVER. (RRP1.3)
- |

RRP5.13 DUPLEX DRIVE MOTOR (PL5.4.5)

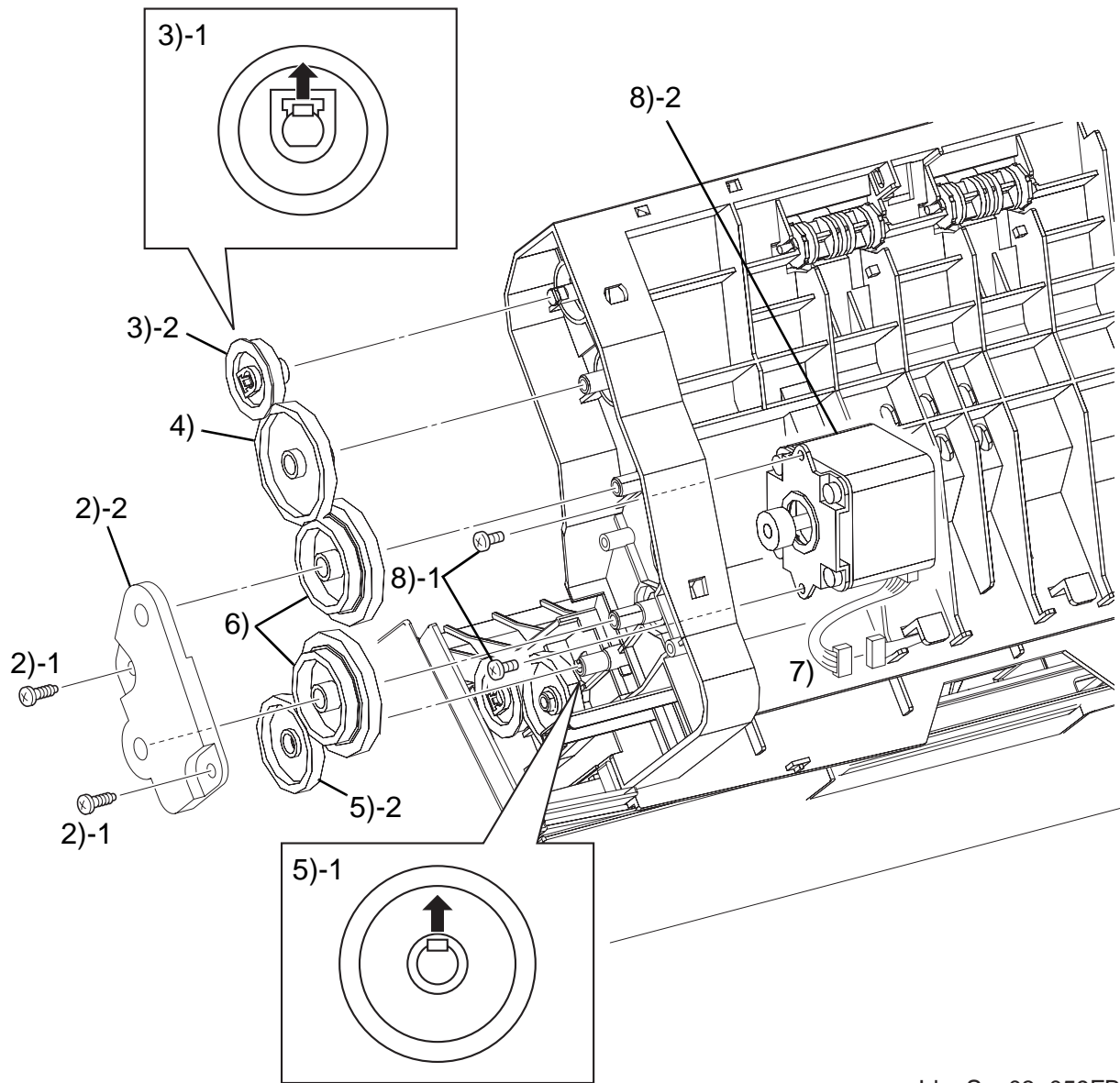

Ida\_Sec03\_059FB

### RRP5.13 DUPLEX DRIVE MOTOR (PL5.4.5)

#### [Removal]

- 1) Remove FRONT COVER. (RRP1.3)
- 2) Remove two screws (silver, 10mm) that fixes COVER GEAR DUPOUT to OUTER DUPLEX ASSEMBLY and remove DUPLEX DRIVE MOTOR.
- 3) Release the hook of GEAR EXIT/DUP that fixes OUTER DUPLEX ASSEMBLY, and remove it.
- 4) Remove GEAR 52 that fixes OUTER DUPLEX ASSEMBLY.
- 5) Release the hook of GEAR 41 that fixes OUTER DUPLEX ASSEMBLY, and remove it.
- 6) Remove GEARS 40/66H, which are engaged with the gears of DUPLEX DRIVE MOTOR, from two locations.
- 7) Remove the connector (P/J501) from the harness of MOTOR ASSY.
- 8) Remove two screws (silver, 6mm) that fixes DUPLEX DRIVE MOTOR to OUTER DUPLEX ASSEMBLY and remove DUPLEX DRIVE MOTOR.

#### [Replacement]

- 1) Attach DUPLEX DRIVE MOTOR on OUTER DUPLEX ASSEMBLY using two screws (silver, 6mm).
- 2) Attach the connector (P/J501) on the harness that is connected to DUPLEX DRIVE MOTOR.
- 3) Attach GEARS 40/66H to the two locations on the gears mounted on both sides of the gears of DUPLEX DRIVE MOTOR.
- 4) Attach GEAR 41 to OUTER DUPLEX ASSEMBLY by locking the hook.
- 5) Attach GEAR 52 to OUTER DUPLEX ASSEMBLY.
- 6) Attach GEAR EXIT DUP to OUTER DUPLEX ASSEMBLY by locking the hook.
- 7) Attach COVER GEAR DUPOUT on OUTER DUPLEX ASSEMBLY using two screws (silver, 10mm).
- 8) Attach FRONT COVER. (RRP1.3)

RRP5.14 ACTUATOR DUP (PL5.4.13)

NOTE

Procedure No. with [ ] included in Fig. shows the procedure at attachment.

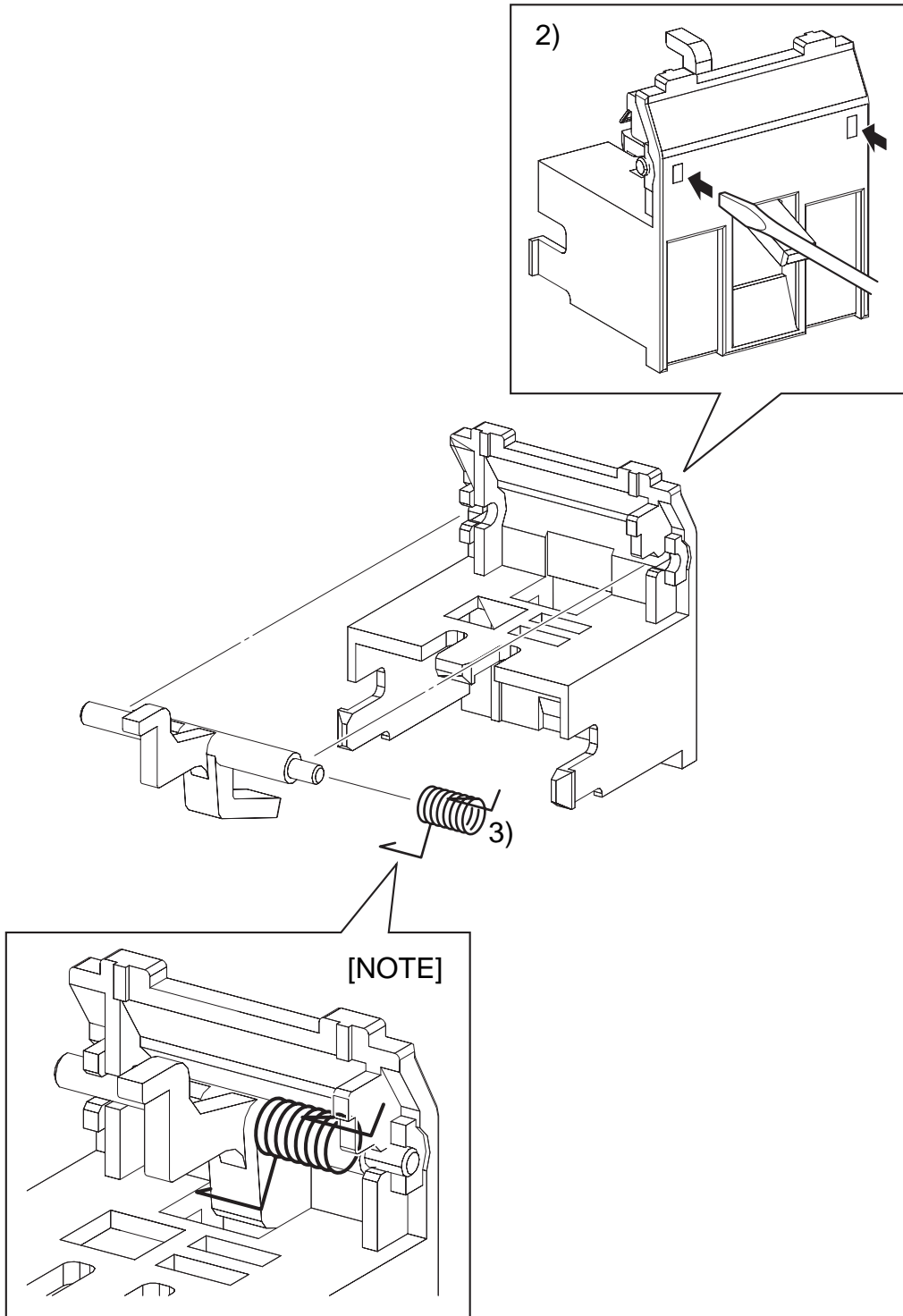

Ida\_Sec03\_060FA



### RRP5.14 ACTUATOR DUP (PL5.4.13)

[Removal]

- 1) Remove SENSOR PHOTO: JAM. (RRP5.11)
- 2) Press the shaft of ACTUATOR DUP through the holes at two locations of HOLDER SENSOR DUP (PL5.4.12) with a miniature screwdriver or the like to remove ACTUATOR DUP.
- 3) Remove SPRING SENSOR DUP from ACTUATOR DUP.

[Replacement]

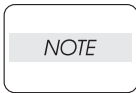

- Check to be sure that the direction of replacement of SPRING is correct.
- Be sure to hook SPRING without fail.

- 1) Attach SPRING SENSOR DUP to ACTUATOR DUP.
- 2) Put one end of SPRING SENSOR DUP to ACTUATOR DUP and the other end to HOLDER SENSOR DUP.
- 3) Attach ACTUATOR DUP in the groove on HOLDER SENSOR.
- 4) Attach SENSOR PHOTO: JAM. (RRP5.11)

RRP5.15 ROLL DUP (PL5.4.15)

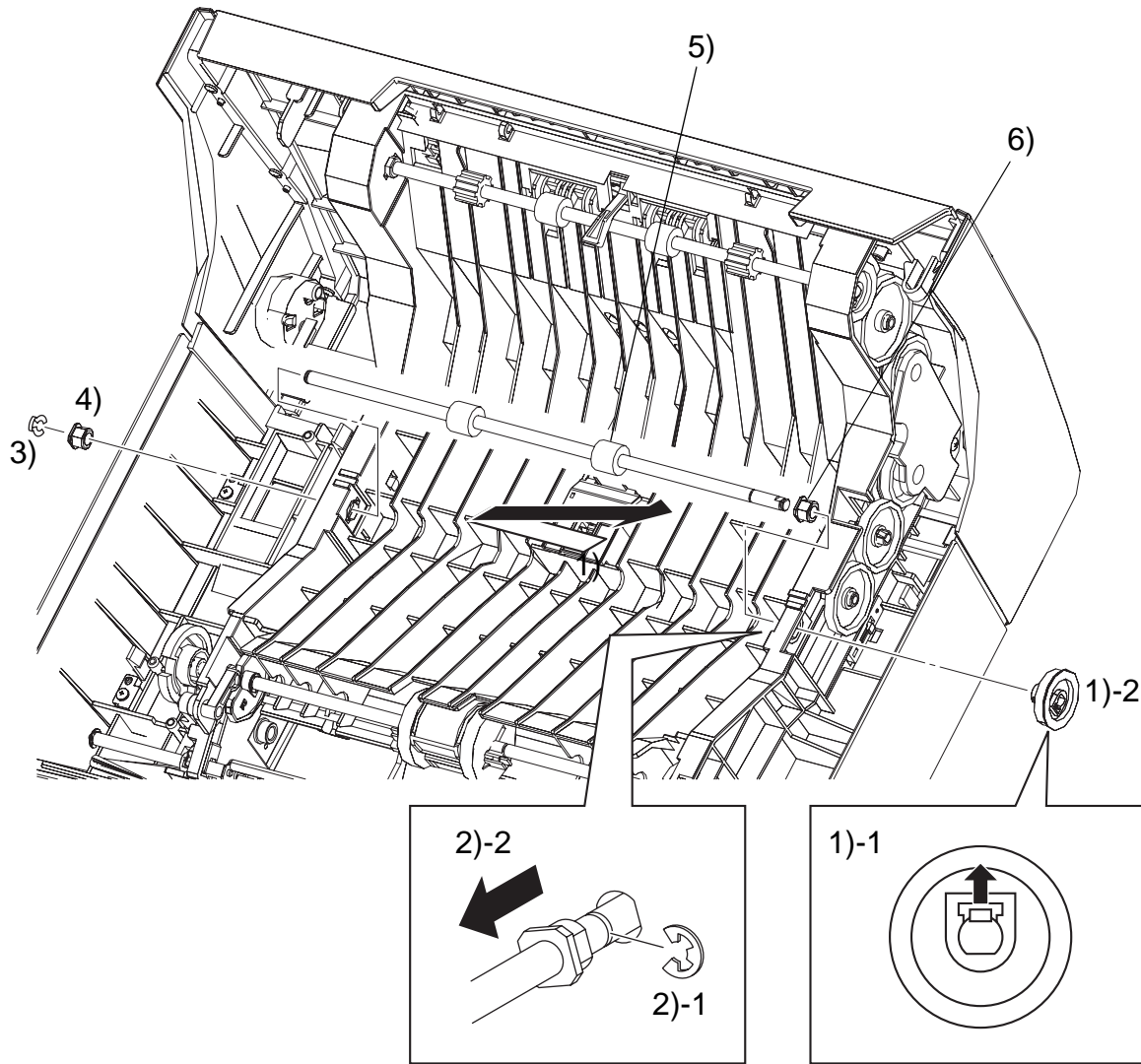

Ida\_Sec03\_061FB

### RRP5.15 ROLL DUP (PL5.4.15)

#### [Removal]

- 1) Release the hook of GEAR EXIT/DUP (PL5.4.9), that is fixed on ROLL DUP shaft, to remove GEAR EXIT/DUP from OUTER DUPLEX ASSEMBLY (PL5.3.1).
- 2) Remove the E ring which fixes BEARING (PL5.4.8) to OUTER DUPLEX ASSEMBLY, and shift BEARING to the right.
- 3) Remove the KL-ring that fixes the right side shaft of ROLL DUP to OUTER DUPLEX ASSEMBLY.
- 4) Pull out BEARING EARTH (PL5.4.19) that fixed the shaft of the right side of ROLL DUP to OUTER DUPLEX ASSEMBLY.
- 5) First, shift ROLL DUP from OUTER DUPLEX ASSEMBLY to the right and pull out ROLL DUP from the left bearing of OUTER DUPLEX ASSEMBLY, then pull it in the left upward direction to remove it together with BEARING.
- 6) Remove BEARING from ROLL DUP.

#### [Replacement]

- 1) Attach BEARING to the shaft of ROLL DUP having a D cut face.
- 2) Insert the shaft of ROLL DUP having a D cut face into the left side bearing of OUTER DUPLEX ASSEMBLY, and insert the shaft on the right side of ROLL DUP into the right side bearing of OUTER DUPLEX ASSEMBLY, and attach ROLL DUP together with BEARING.
- 3) Insert BEARING EARTH into the right side shaft of ROLL DUP.
- 4) Fix the shaft on the right side of ROLL DUP using the KL-ring.
- 5) Insert the left side shaft of ROLL DUP into BEARING, and fix it using an E ring.
- 6) Attach GEAR EXIT/DUP to the shaft on the left side of ROLL DUP by locking the hook.

RRP5.16 ROLL EXIT (PL5.4.16)

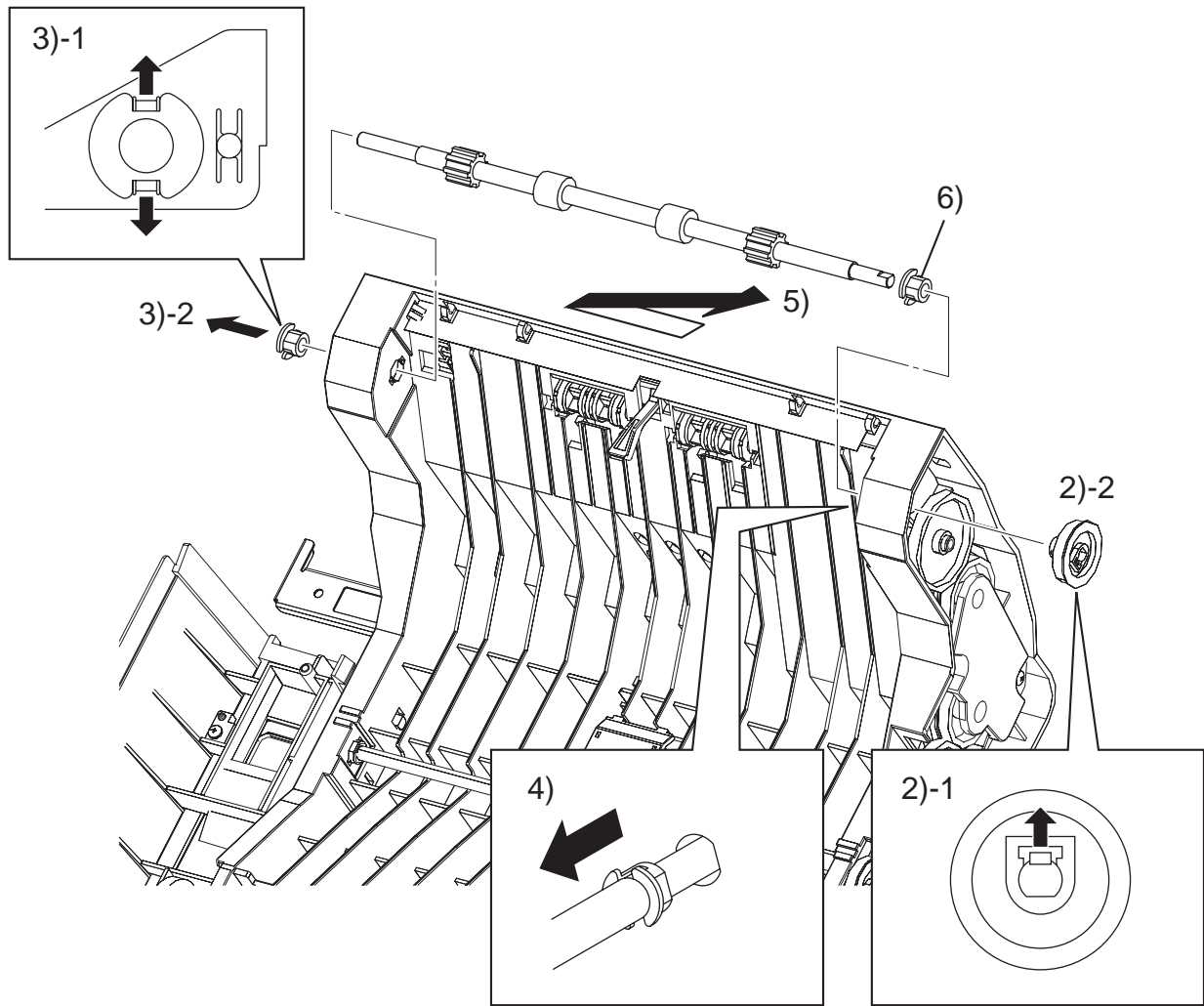

Ten03062KA

## RRP5.16 ROLL EXIT (PL5.4.16)

### [Removal]

- 1) Remove FRONT COVER. (RRP1.3)
- 2) Release the hook of GEAR EXIT/DUP (PL5.4.9), that is fixed to ROLL EXIT shaft, remove GEAR EXIT/DUP from OUTER DUPLEX ASSEMBLY (PL5.3.1).
- 3) Remove the BEARING EXIT by vertically expanding the boss of the PLATE EARTH located at the fitting position of the BEARING EXIT that fixes the right shaft of the ROLL EXIT to the CHUTE ASSY DUP OUT.
- 4) Move the BEARING EXIT to left side that fixes the left side shaft of the ROLL EXIT to the CHUTE ASSY DUP OUT.
- 5) Move the ROLL EXIT to the right side once, pull out the ROLL EXIT from the left side shaft of the CHUTE ASSY DUP OUT and then remove the ROLL EXIT together with the BEARING EXIT.
- 6) Remove the BEARING EXIT from the ROLL EXIT.

### [Replacement]

- 1) Attach BEARING EXIT to the shaft of ROLL EXIT having a D cut face.
- 2) Insert the shaft of ROLL EXIT having a D cut face into the left side bearing of OUTER DUPLEX ASSEMBLY, and insert the shaft on the right side of ROLL EXIT into the right side bearing of OUTER DUPLEX ASSEMBLY, and attach ROLL EXIT together with BEARING EXIT.
- 3) Insert the BEARING EXIT into the left side bearing of the CHUTE ASSY DUP OUT.
- 4) Insert the BEARING EXIT into the right side bearing of the CHUTE ASSY DUP OUT, fix it at the convex of the PLATE EARTH.
- 5) Attach GEAR EXIT/DUP to the shaft on the left side of ROLL EXIT by locking the hook.
- 6) Attach FRONT COVER. (RRP1.3)

RRP5.17 INNER DUPLEX ASSEMBLY (PL5.2.1), DUPLEX HINGE LINK SPRING (PL5.1.6), DUPLEX HINGE LINK (PL5.1.7)

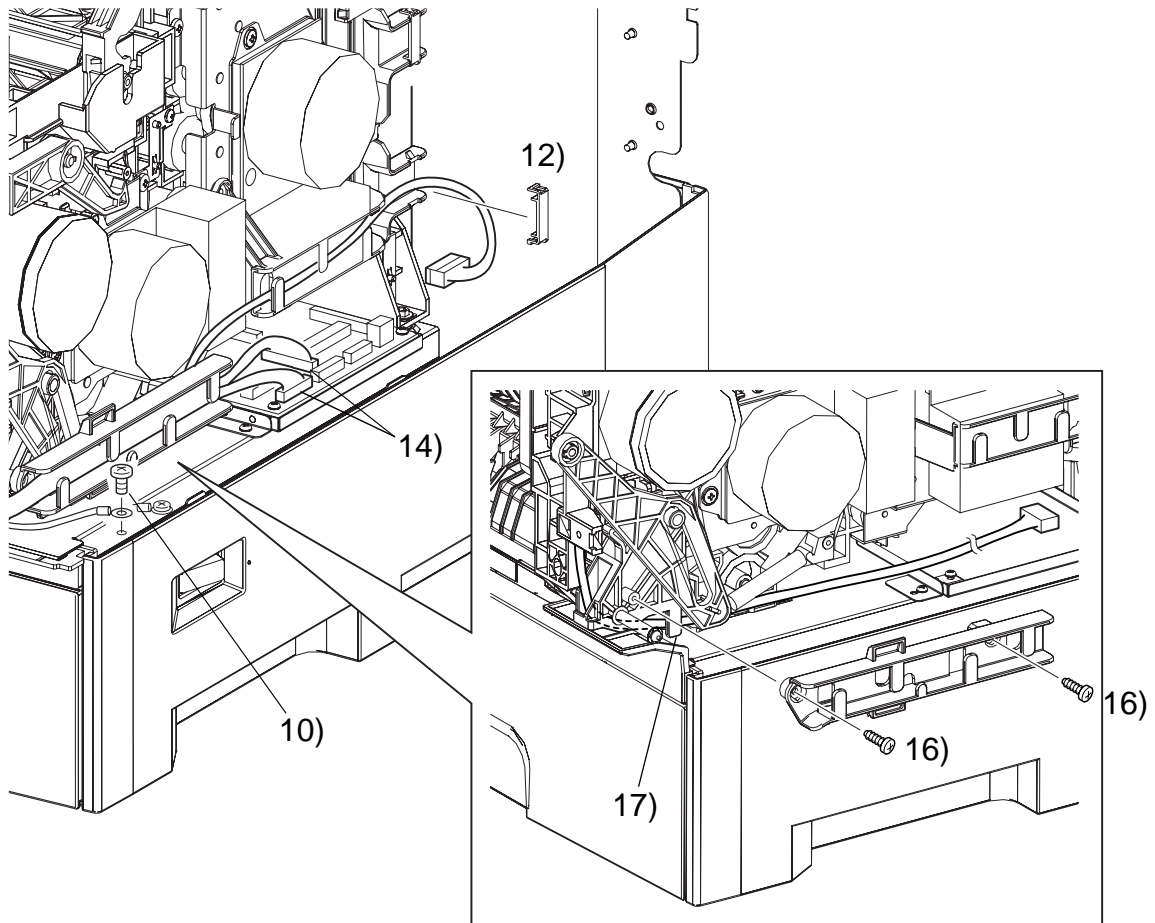

Ida\_Sec03\_109FA

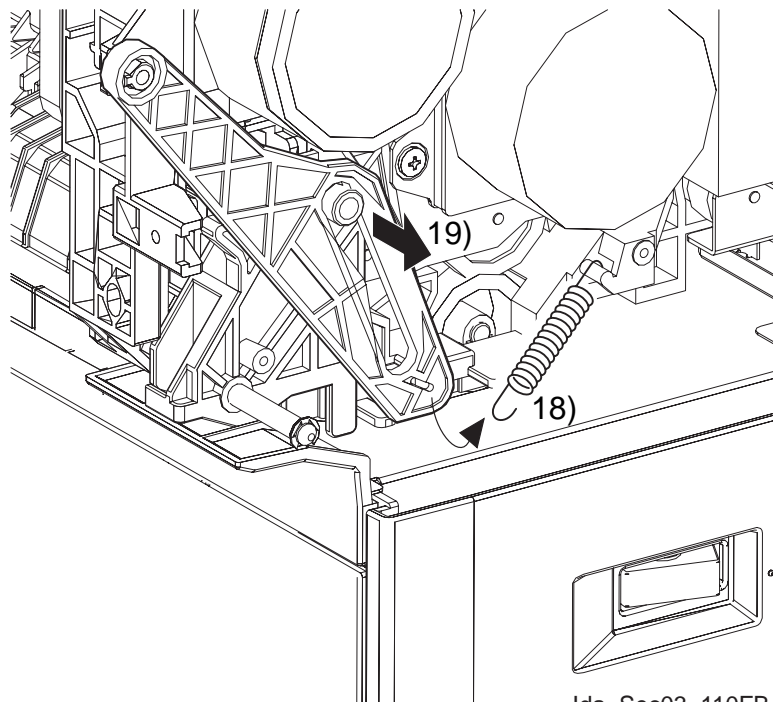

Ida\_Sec03\_110FB

RRP5.17 INNER DUPLEX ASSEMBLY (PL5.2.1), DUPLEX HINGE LINK SPRING (PL5.1.6), DUPLEX HINGE LINK (PL5.1.7)

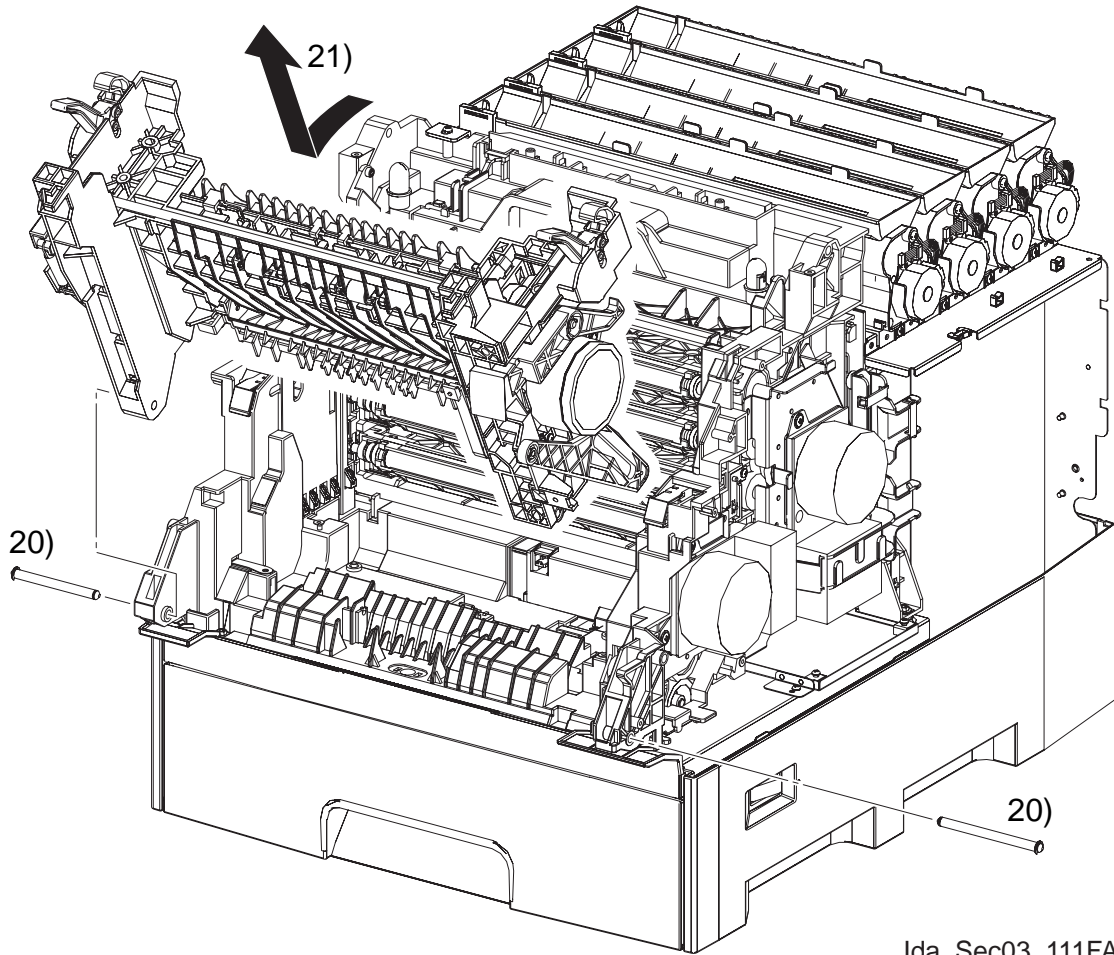

Ida\_Sec03\_111FA

## RRP5.17 INNER DUPLEX ASSEMBLY (PL5.2.1), DUPLEX HINGE LINK SPRING (PL5.1.6), DUPLEX HINGE LINK (PL5.1.7)

### [Removal]

- 1) Remove TOP COVER FRAME. (RRP1.1)
- 2) Remove FRONT COVER. (RRP1.3)
- 3) Remove RIGHT FRONT COVER. (RRP1.8)
- 4) Remove LEFT FRONT COVER. (RRP1.11)
- 5) Remove RIGHT SIDE COVER. (RRP1.7)
- 6) Remove LEFT SIDE COVER. (RRP1.12)
- 7) Remove MULTIPURPOSE FEEDER (MPF) TRAY. (RRP1.9)
- 8) Remove MULTIPURPOSE FEEDER (MPF) COVER. (RRP1.10)
- 9) Remove OUTER DUPLEX ASSEMBLY. (RRP5.18)
- 10) Remove a screw (silver, provided with external tooth washer, 5 mm) that fixes the ground wire on the right side of the bottom plate, remove the ground wire.
- 11) Remove connector (P/J162) that is connected to LOW VOLTAGE POWER SUPPLY (LVPS) from INNER DUPLEX ASSEMBLY.
- 12) Remove one CLAMP GUIDE HARNESS from GUIDE HARNESS R (PL.9.1.14) on the right side of the printer.
- 13) Remove the harness from GUIDE HARNESS R on the right side of the printer.
- 14) Remove the connector (P/J36, P/J52) that is connected to MACHINE CONTROL UNIT (MCU) from INNER DUPLEX ASSEMBLY.
- 15) Remove the harness from GUIDE HARNESS F on the right side of the printer.
- 16) Remove two screws (silver, tap, 10 mm) that fixes GUIDE HARNESS F to the right side of the printer, remove GUIDE HARNESS F.
- 17) Remove the harness from the harness guide mounted in the clearance between the right side of the printer and the bottom plate.
- 18) Remove DUPLEX HINGE LINK SPRING (PL5.1.6) from the right side of the printer.
- 19) Remove the boss from the hole in the center of the DUPLEX HINGE LINK (PL5.1.7) on the right side of the printer.

**NOTE**

Take care not to drop or break INNER DUPLEX ASSEMBLY when pulling out SHAFT PIVOT following the steps of procedure described below.

- 20) Holding INNER DUPLEX ASSEMBLY, pull out SHAFT PIVOT R and SHAFT PIVOT L.
- 21) Release the latch of INNER DUPLEX ASSEMBLY, then remove INNER DUPLEX ASSEMBLY.



RRP5.17 INNER DUPLEX ASSEMBLY (PL5.2.1), DUPLEX HINGE LINK SPRING  
(PL5.1.6), DUPLEX HINGE LINK (PL5.1.7)

[Replacement]

- 1) Holding INNER DUPLEX ASSEMBLY, insert SHAFT PIVOT R and SHAFT PIVOT L up to the half of the respective shafts.
- 2) Put the hole in DUPLEX HINGE LINK over the boss into the right side of the printer.
- 3) Attach DUPLEX HINGE LINK SPRING to DUPLEX HINGE LINK on the right side of the printer.
- 4) Pass the harness through the harness guide located in the clearance between the right side of the printer and the bottom plate.
- 5) Attach GUIDE HARNESS F to the right side of the printer using two screws (silver, tap, 10mm).
- 6) Pass the harness through GUIDE HARNESS F to the right side of the printer.
- 7) Attach the connector (P/J36, P/J52) to MACHINE CONTROL UNIT (MCU).
- 8) Pass the harness through GUIDE HARNESS R to the right side of the printer.
- 9) Attach CLAMP GUIDE HARNESS to GUIDE HARNESS R on the right side of the printer.
- 10) Attach the connector (P/J162) to LOW VOLTAGE POWER SUPPLY (LVPS).
- 11) Attach the ground wire to the right side of the bottom plate using a screw (silver, provided with external tooth washer, 5 mm).
- 12) Attach OUTER DUPLEX ASSEMBLY. (RRP5.18)
- 13) Attach MULTIPURPOSE FEEDER (MPF) COVER. (RRP1.10)
- 14) Attach MULTIPURPOSE FEEDER (MPF) TRAY. (RRP1.9)
- 15) Attach LEFT SIDE COVER. (RRP1.12)
- 16) Attach RIGHT SIDE COVER. (RRP1.7)
- 17) Attach LEFT FRONT COVER. (RRP1.11)
- 18) Attach RIGHT FRONT COVER. (RRP1.8)
- 19) Attach FRONT COVER. (RRP1.3)
- 20) Attach TOP COVER FRAME. (RRP1.1)

RRP5.18 OUTER DUPLEX ASSEMBLY (PL5.3.1), DUPLEX RETAINING STRAP  
(PL5.1.5)

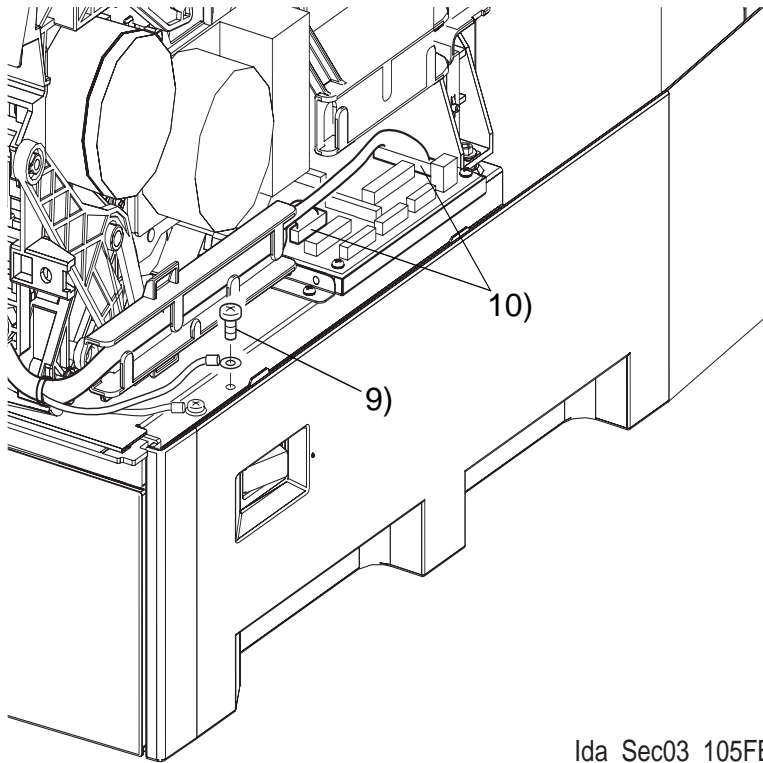

Ida\_Sec03\_105FB

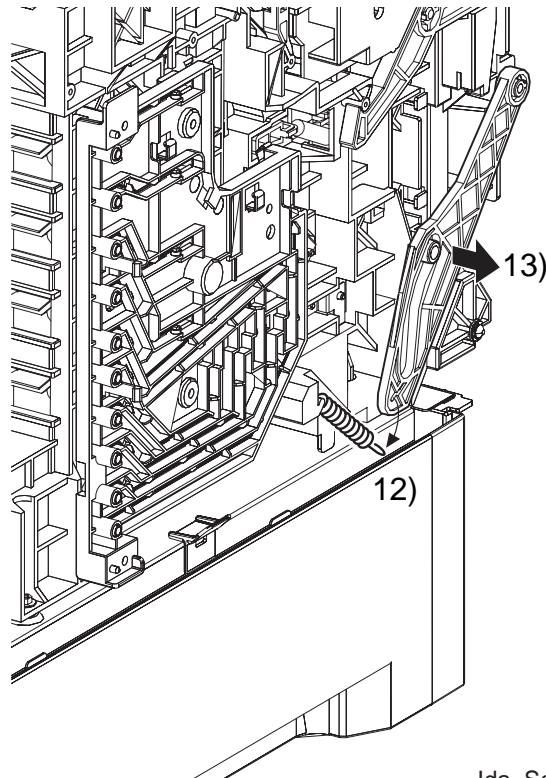

Ida\_Sec03\_101FB

RRP5.18 OUTER DUPLEX ASSEMBLY (PL5.3.1), DUPLEX RETAINING STRAP  
(PL5.1.5)

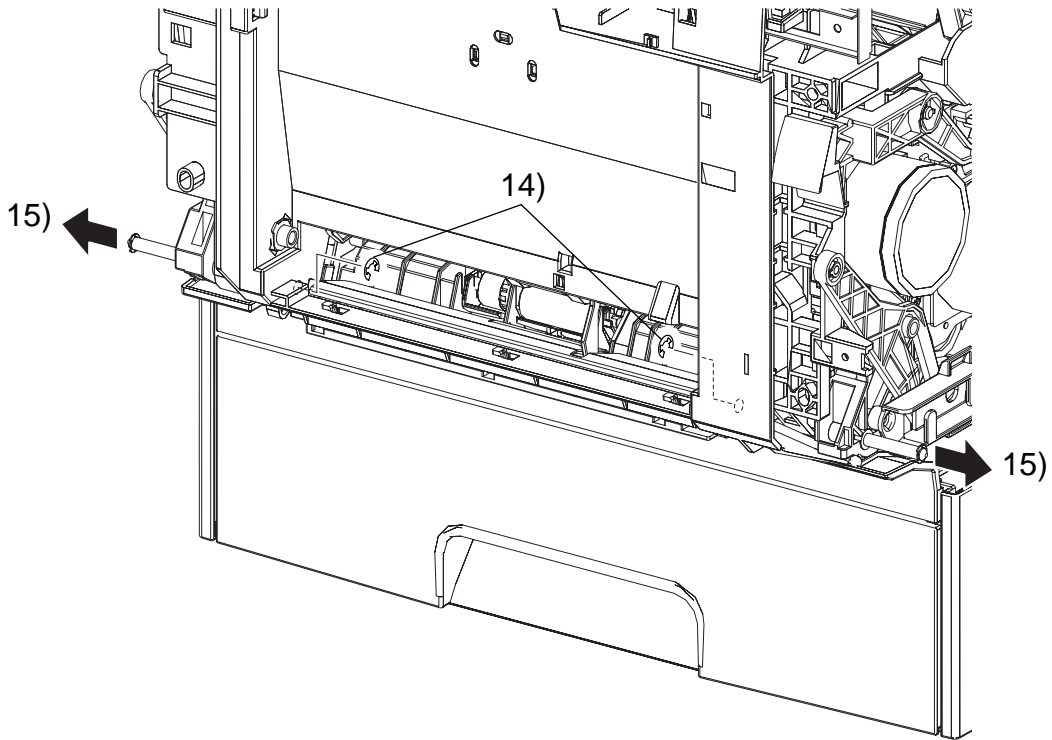

Ida\_Sec03\_107FA

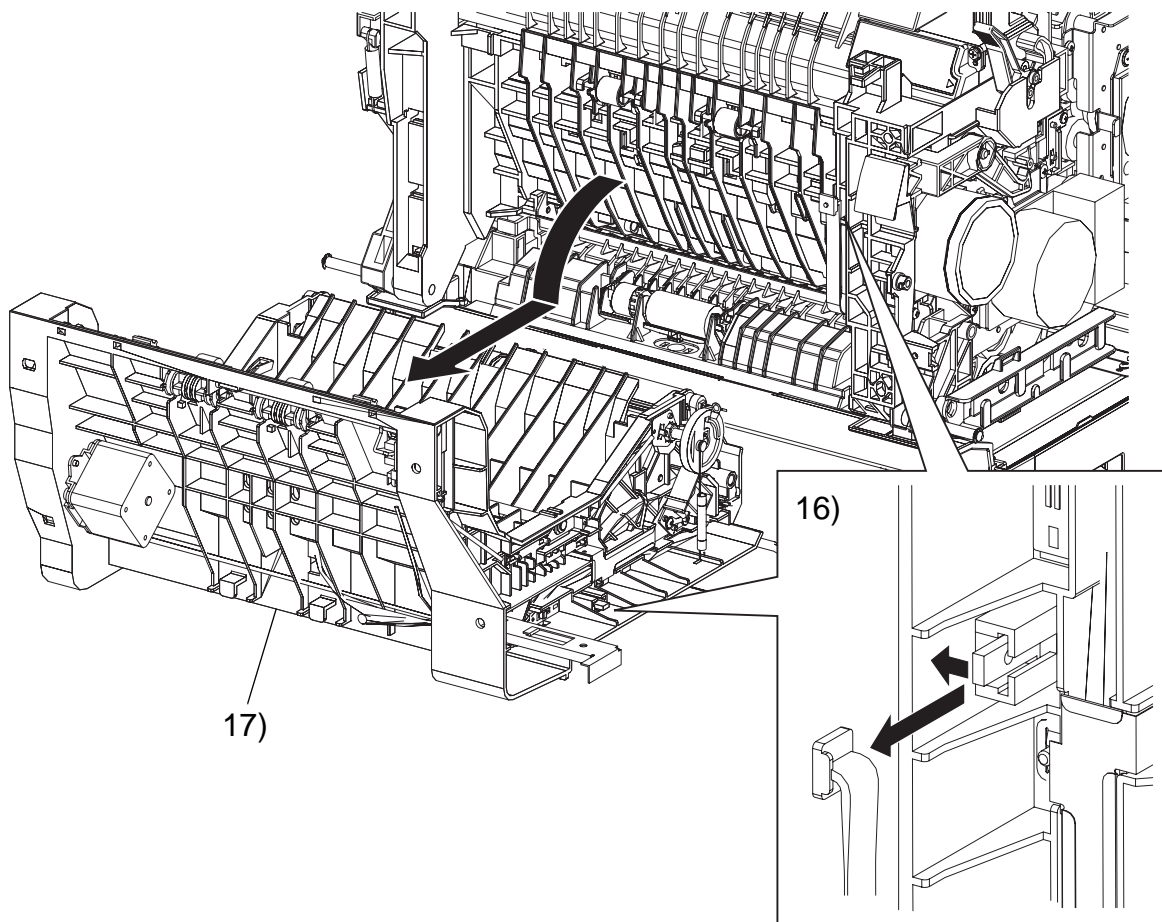

Ida\_Sec03\_108FA

## RRP5.18 OUTER DUPLEX ASSEMBLY (PL5.3.1), DUPLEX RETAINING STRAP (PL5.1.5)

### [Removal]

- 1) Remove TOP COVER FRAME. (RRP1.1)
  - 2) Remove FRONT COVER. (RRP1.3)
  - 3) Remove RIGHT FRONT COVER. (RRP1.8)
  - 4) Remove LEFT FRONT COVER. (RRP1.11)
  - 5) Remove RIGHT SIDE COVER. (RRP1.7)
  - 6) Remove LEFT SIDE COVER. (RRP1.12)
  - 7) Remove MULTIPURPOSE FEEDER (MPF) TRAY. (RRP1.9)
  - 8) Remove MULTIPURPOSE FEEDER (MPF) COVER. (RRP1.10)
  - 9) Remove a screw (silver, provided with external tooth washer, 5 mm) that fixes the ground wire to the right side of the bottom plate, remove the ground wire.
  - 10) Remove connector (P/J13, P/J22) that is connected to MACHINE CONTROL UNIT (MCU) of the printer from OUTER DUPLEX ASSEMBLY.
  - 11) Remove the harness of GUIDE HARNESS F (PL9.1.15) on the right side of the printer.
  - 12) Remove DUPLEX HINGE LINK SPRING (PL5.1.6) from the left side face of the printer.
  - 13) Remove the boss from the hole of the center of DUPLEX HINGE LINK (PL5.1.7) on the left side of the printer.
  - 14) Remove two E-rings that fix SHAFT PIVOT R (PL5.1.8) and SHAFT PIVOT L (PL5.1.9) from underside of OUTER DUPLEX ASSEMBLY.
- NOTE*
- Take care not to drop or break OUTER DUPLEX ASSEMBLY when pulling SHAFT PIVOT and removing DUPLEX RETAINING DUPLEX HINGE LINK SPRING following the steps of procedure described below.
- 15) Holding OUTER DUPLEX ASSEMBLY, pull out SHAFT PIVOT R and SHAFT PIVOT L respectively by approximately half of shaft length.
  - 16) Release the latch of OUTER DUPLEX ASSEMBLY. Release the hook that fixes DUPLEX RETAINING DUPLEX HINGE LINK SPRING (PL5.1.5). Remove DUPLEX RETAINING DUPLEX HINGE LINK SPRING.
  - 17) Remove OUTER DUPLEX ASSEMBLY.

RRP5.18 OUTER DUPLEX ASSEMBLY (PL5.3.1), DUPLEX RETAINING STRAP  
(PL5.1.5)

[Replacement]

- 1) Holding OUTER DUPLEX ASSEMBLY, insert SHAFT PIVOT R and SHAFT PIVOT L.
- 2) Attach DUPLEX RETAINING DUPLEX HINGE LINK SPRING to OUTER DUPLEX ASSEMBLY.
- 3) Attach the two E-rings to SHAFT PIVOT R and SHAFT PIVOT L located under OUTER DUPLEX ASSEMBLY.
- 4) Fit the hole in DUPLEX HINGE LINK over the boss on the left side of the printer.
- 5) Attach DUPLEX HINGE LINK SPRING to the DUPLEX HINGE LINK on the left side of the printer.
- 6) Pass the harness through GUIDE HANRNESS F to the right side of the printer.
- 7) Attach the ground wire to the right side of the bottom plate with a screw (silver, provided with external tooth washer, 5 mm).
- 8) Attach the connector (P/J13, P/J22) to MACHINE CONTROL UNIT (MCU).
- 9) Attach MULTIPURPOSE FEEDER (MPF) COVER. (RRP1.10)
- 10) Attach MULTIPURPOSE FEEDER (MPF) TRAY. (RRP1.9)
- 11) Attach LEFT SIDE COVER. (RRP1.12)
- 12) Attach RIGHT SIDE COVER. (RRP1.7)
- 13) Attach LEFT FRONT COVER. (RRP1.11)
- 14) Attach RIGHT FRONT COVER. (RRP1.8)
- 15) Attach FRONT COVER. (RRP1.3)
- 16) Attach TOP COVER FRAME. (RRP1.1)

RRP5.19 FAN FRONT (PL5.3.31)

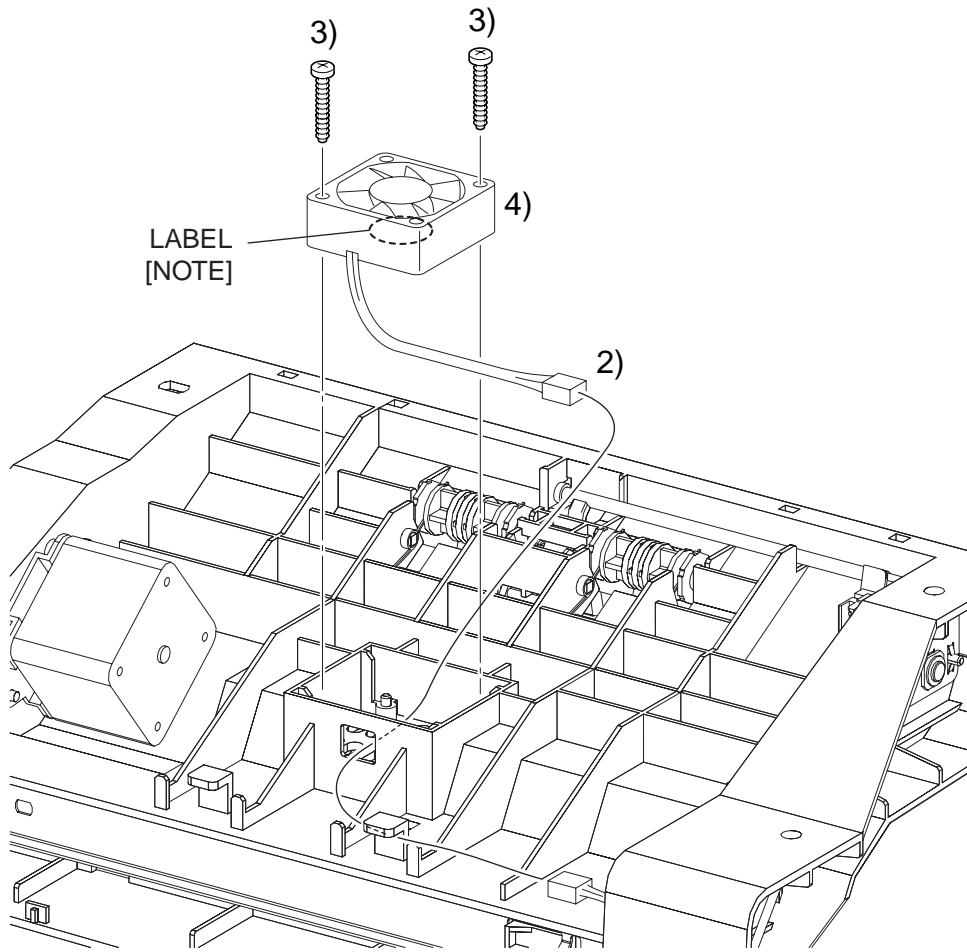

Ida\_Sec03\_113FA

RRP5.19 FAN FRONT (PL5.3.31)

[Removal]

- 1) Remove FRONT COVER. (RRP1.3)
- 2) Remove the connector (P/J482) on the harness that is connected from FAN FRONT, remove the harness from the harness guide.
- 3) Remove two screws (black, tap, 20 mm) which are used to secure the FAN FRONT to the FAN mounting seat at the OUTER DUPLEX ASSEMBLY.
- 4) Lifting the FAN FRONT, draw out the harness from the front hole in the FAN mounting seat.

[Replacement]

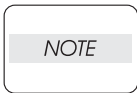

Be sure to check the orientation of the FAN before attaching it.  
(Attach the FAN so that its labeled surface comes down side.)

- 1) Pass the FAN FRONT harness through the front hole in the FAN mounting seat from inside toward outside.
- 2) Attach FAN FRONT with two screws (black, tap, 20 mm) with its labeled surface comes down side.
- 3) Pass the FAN FRONT harness through the harness guide. Connect the connector (P/J482) properly.
- 4) Attach FRONT COVER. (RRP1.3)

## RRP6. XEROGRAPHICS

### RRP6.1 PRINT HEAD (PL6.1.2)

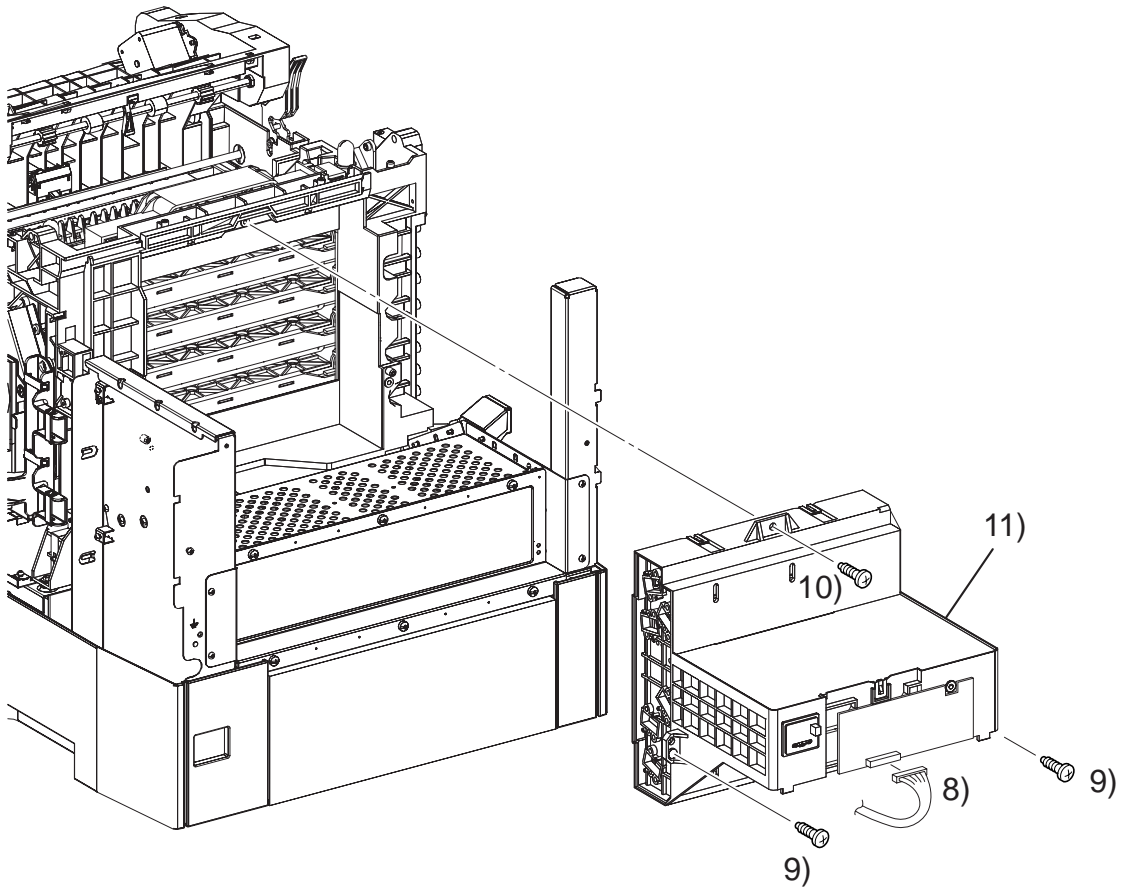

Ten03063KA



## RRP6.1 PRINT HEAD (PL6.1.2)

## [Removal]

- 1) Remove TOP COVER FRAME. (RRP1.1)
- 2) Remove RIGHT SIDE COVER. (RRP1.7)
- 3) Remove LEFT SIDE COVER. (RRP1.12)
- 4) Remove COVER ASSY REAR. (RRP1.5)
- 5) Remove HIGH VOLTAGE POWER SUPPLY (HVPS). (RRP9.9)
- 6) Remove DUCT LV. (RRP7.13)
- 7) Remove TONER DISPENSER ASSEMBLY. (RRP7.4)
- 8) Remove connector (P/J151) that is connected to PRINT HEAD from the printer.

## NOTE

Take care not to drop or break PRINT HEAD when removing it following the steps of procedure described below.

- 9) Remove two screws (silver, tap, 10mm) that fix PRINT HEAD of the left and right from the printer.
- 10) Holding PRINT HEAD, remove a upper screw (silver, tap, 10 mm).
- 11) Pull out PRINT HEAD backward and remove it.

## [Replacement]

- 1) Matching the right and left holes in PRINT HEAD with the bosses at the two locations on the printer, insert PRINT HEAD from backward in the printer.
- 2) Fix PRINT HEAD with the upper screw (silver, tap, 10 mm).
- 3) Fix PRINT HEAD with two screws (silver, tap, 10 mm) on the left and right.
- 4) Attach the connector (P/J151) to the PRINT HEAD.
- 5) Attach TONER DISPENSER ASSEMBLY. (RRP7.4)
- 6) Attach DUCT LV.(RRP7.13)
- 7) Attach HIGH VOLTAGE POWER SUPPLY (HVPS). (RRP9.9)
- 8) Attach COVER ASSY REAR. (RRP1.5)
- 9) Attach LEFT SIDE COVER. (RRP1.12)
- 10) Attach RIGHT SIDE COVER. (RRP1.7)
- 11) Attach TOP COVER FRAME. (RRP1.1)

RRP6.2 HSG ASSY BIAS (PL6.1.7)

NOTE

Procedure No. with [ ] included in Fig. shows the procedure at attachment.

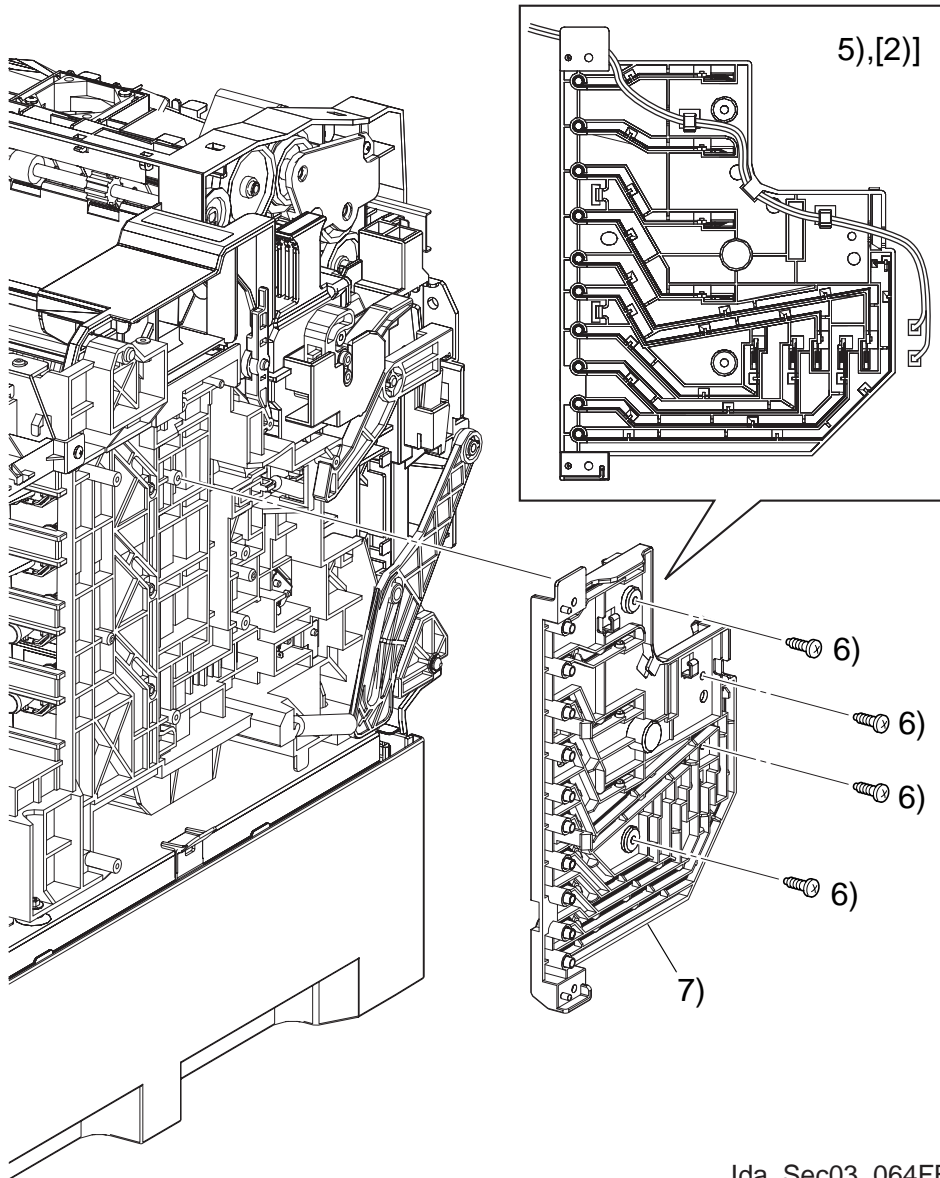

Ida\_Sec03\_064FB

## RRP6.2 HSG ASSY BIAS (PL6.1.7)

### [Removal]

- 1) Remove TOP COVER FRAME. (RRP1.1)
- 2) Remove LEFT FRONT COVER. (RRP1.11)
- 3) Remove LEFT SIDE COVER. (RRP1.12)
- 4) Remove PWBA HVRS. (RRP9.9)
- 5) Remove two wires from the harness guide on HSG ASSY BIAS.
- 6) Remove four screws (silver, tap, 10 mm) that fix HSG ASSY BIAS from the printer.
- 7) Remove HSG ASSY BIAS from the printer.

### [Replacement]

- 1) Attach HSG ASSY BIAS to the printer using the four screws (silver, tap, 10mm).
- 2) Pass the two wires through the harness guide to HSG ASSY BIAS.
- 3) Attach HIGH VOLTAGE POWER SUPPLY (HVPS). (RRP9.9)
- 4) Attach LEFT SIDE COVER. (RRP1.12)
- 5) Attach LEFT FRONT COVER. (RRP1.11)
- 6) Attach TOP COVER FRAME. (RRP1.1)

## RRP7. DEVELOPMENT

### RRP7.1 DEVELOPER FRAME (PL7.1.1)

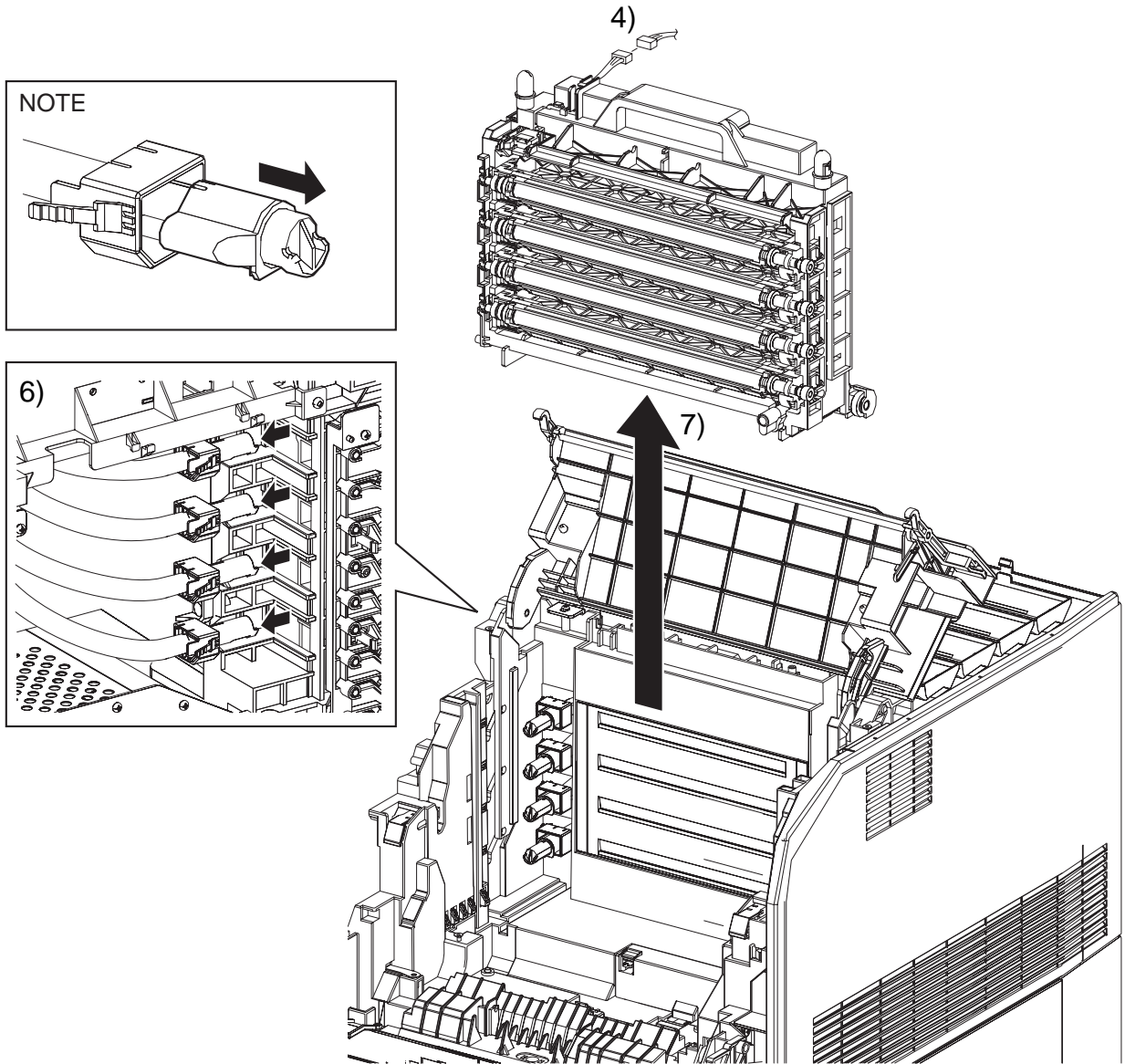

Ida\_Sec03\_065FB

## RRP7.1 DEVELOPER FRAME (PL7.1.1)

## [Removal]

- 1) Remove TOP COVER FRAME. (RRP1.1)
- 2) Remove LEFT SIDE COVER. (RRP1.12)
- 3) Remove HIGH VOLTAGE POWER SUPPLY (HVPS). (RRP9.9)

## NOTE

Cover the entire DEVELOPER ASSEMBLY with paper or the like so as to prevent toner in DEVELOPER ASSEMBLY from adhering on your clothing, when taking out DEVELOPER FRAME.

## NOTE

Take care not to allow toner to scatter when taking out DEVELOPER FRAME.

## NOTE

Be sure to store DEVELOPER FRAME removed on a flat table with its handle placed upward.

- 4) Remove the connector (P.J484) on the harness that is connected to CRUM of DEVELOPER FRAME.
- 5) Open IMAGING DRUM COVER.
- 6) Release the hooks to remove four toner nozzle, which are connected to DEVELOPER FRAME, from DISPENSER ASSY (Y), (M), (C) and (K).

## NOTE

Be sure to check that the shutter of the toner nozzle is closed. If the shutter is opened, close it.

- 7) Holding the handle of DEVELOPER FRAME, remove it upward.

## [Replacement]

## NOTE

Take care not to catch your hand between the printer and the DEVELOPER FRAME.

- 1) Holding the handle of DEVELOPER FRAME, fit the groove of DEVELOPER FRAME to the sliding projections of GUIDE FRAME DEVE R and GUIDE FRAME DEVE L from the upper side, attach it slowly.

## NOTE

Be sure to attach the four toner nozzle (Y), (M), (C) and (K) to each corresponding DEVELOPER ASSEMBLY while carefully matching the color.

- 2) Attach the four toner nozzle to DEVELOPER FRAME by locking the hooks.
- 3) Close IMAGING DRUM COVER.
- 4) Attach the connector (P.J484) on the harness that is connected to CRUM of DEVELOPER FRAME.

## NOTE

Be sure to remove the paper covering DEVELOPER ASSEMBLY.

- 5) Attach HIGH VOLTAGE POWER SUPPLY (HVPS). (RRP9.9)
- 6) Attach LEFT SIDE COVER. (RRP1.12)
- 7) Attach TOP COVER FRAME. (RRP1.1)

RRP7.2 CRUM (PL7.1.4)

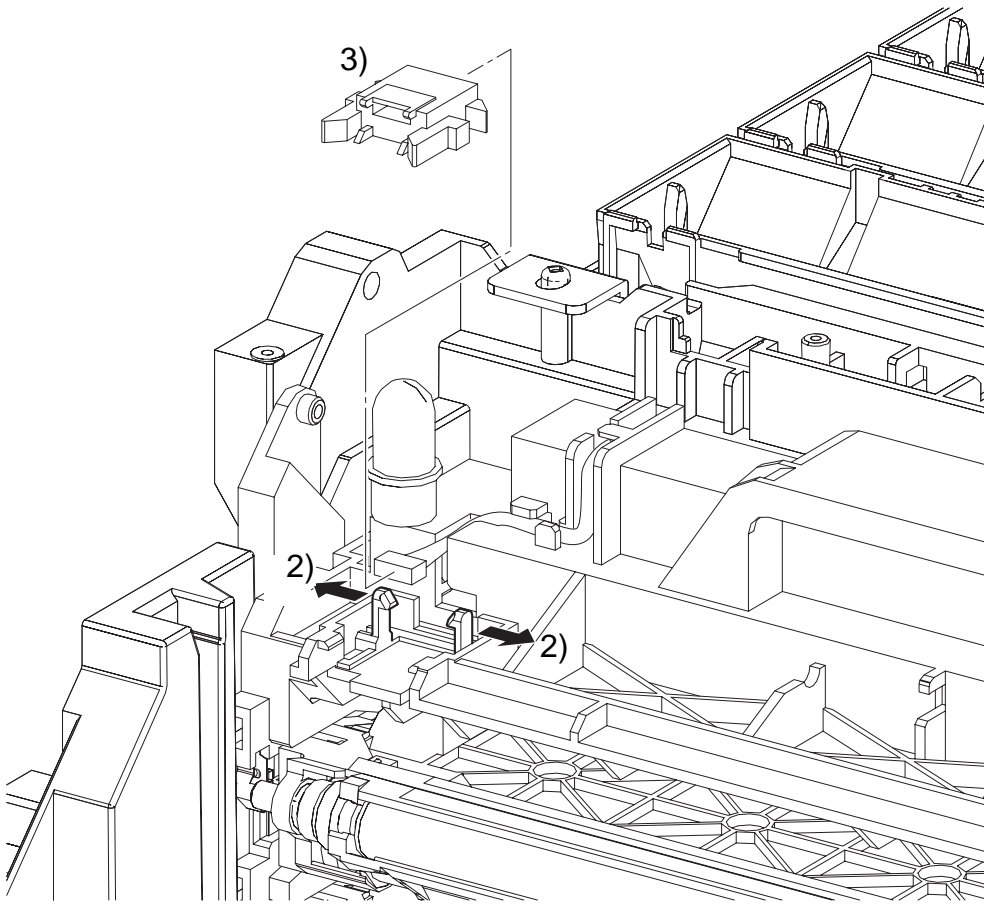

Ida\_Sec03\_067FB

## RRP7.2 CRUM (PL7.1.4)

### [Removal]

- 1) Release the latch and open INNER DUPLEX ASSEMBLY (PL5.2.1).
- 2) Open the hook that fix CRUM to the upper left section of DEVELOPER FRAME, remove the CRUM.
- 3) Remove the connector (P/J710) from the CRUM, remove the CRUM.

### [Replacement]

- 1) Attach the connector (P/J710) to the CRUM.
- 2) Attach CRUM on DEVELOPER FRAME by fixing with hook located at the upper left section of DEVELOPER FRAME.
- 3) Close INNER DUPLEX ASSEMBLY.

RRP7.3 DEVELOPER ASSEMBLY (Y), (M), (C), (K) (PL7.1.17~20)

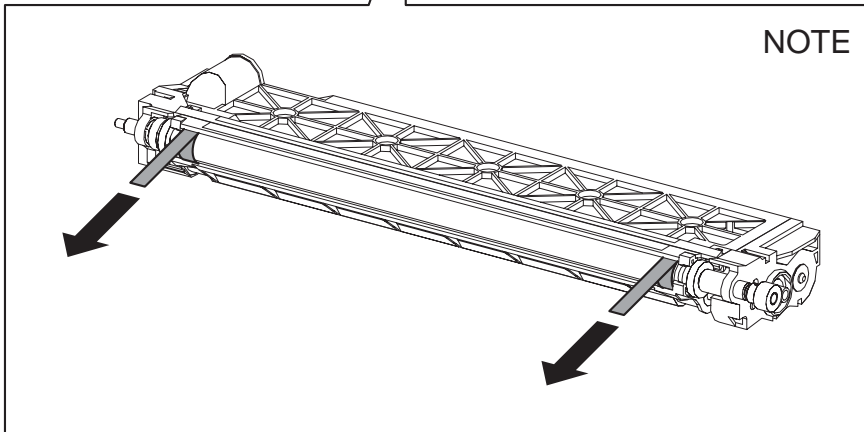
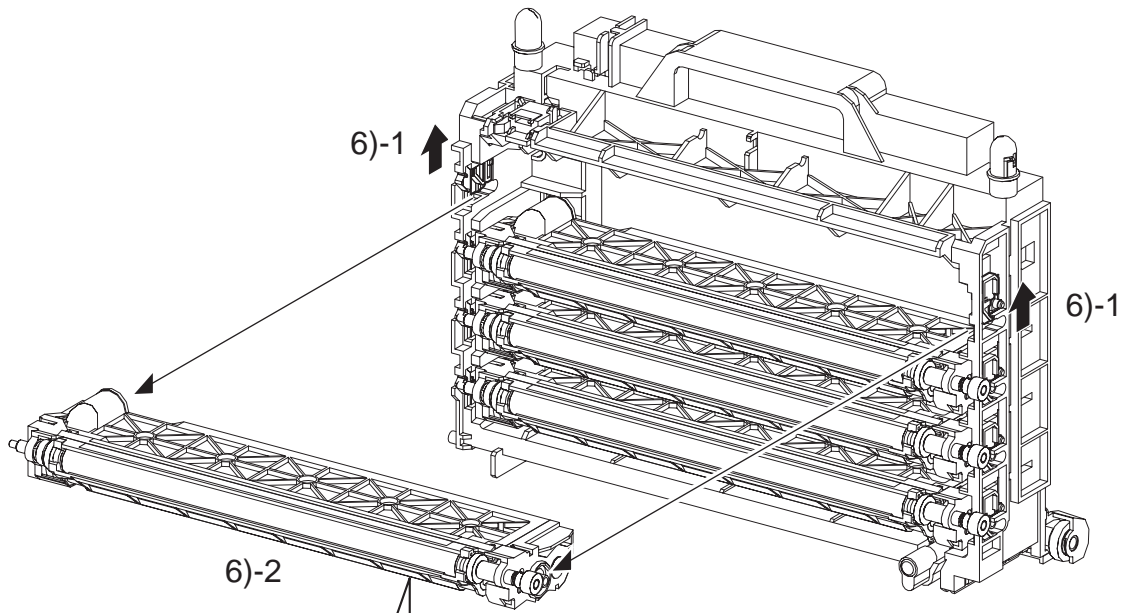

Ten03068KA



## RRP7.3 DEVELOPER ASSEMBLY (Y), (M), (C), (K) (PL7.1.17~20)

NOTE

Since DEVELOPER ASSEMBLY (Y), (M), (C) and (K) are to be removed in the same manner, the removal procedure is described for one of them only.

## [Removal]

- 1) Remove TOP COVER FRAME. (RRP1.1)
- 2) Remove LEFT FRONT COVER. (RRP1.11)
- 3) Remove LEFT SIDE COVER. (RRP1.12)
- 4) Remove HIGH VOLTAGE POWER SUPPLY (HVPS). (RRP9.9)
- 5) Remove DEVELOPER FRAME. (RRP7.1)

NOTE

Take care not to allow toner to scatter when taking out DEVELOPER ASSEMBLY.

- 6) Release STOPPER DEVE R and STOPPER DEVE L located on the left and right side of DEVELOPER FRAME, pull out DEVELOPER ASSEMBLY forward.

## [Replacement]

NOTE

When attaching the new DEVELOPER ASSEMBLY to the printer, peel the SEAL MAG SIDE L and the SEAL MAG SIDE R from the DEVELOPER ASSEMBLY.

NOTE

Take care not to attach the DEVELOPER ASSEMBLY of each color to the DEVELOPER FRAME on the wrong position.

- 1) Insert DEVELOPER ASSEMBLY into DEVELOPER FRAME and lock STOPPER DEVE R and STOPPER DEVE L to attach DEVELOPER ASSEMBLY.
- 2) Attach DEVELOPER FRAME. (RRP7.1)
- 3) Attach HIGH VOLTAGE POWER SUPPLY (HVPS). (RRP9.9)
- 4) Attach LEFT SIDE COVER. (RRP1.12)
- 5) Attach LEFT FRONT COVER. (RRP1.11)
- 6) Attach TOP COVER FRAME. (RRP1.1)

RRP7.4 TONER DISPENSER ASSEMBLY (PL7.2.22)

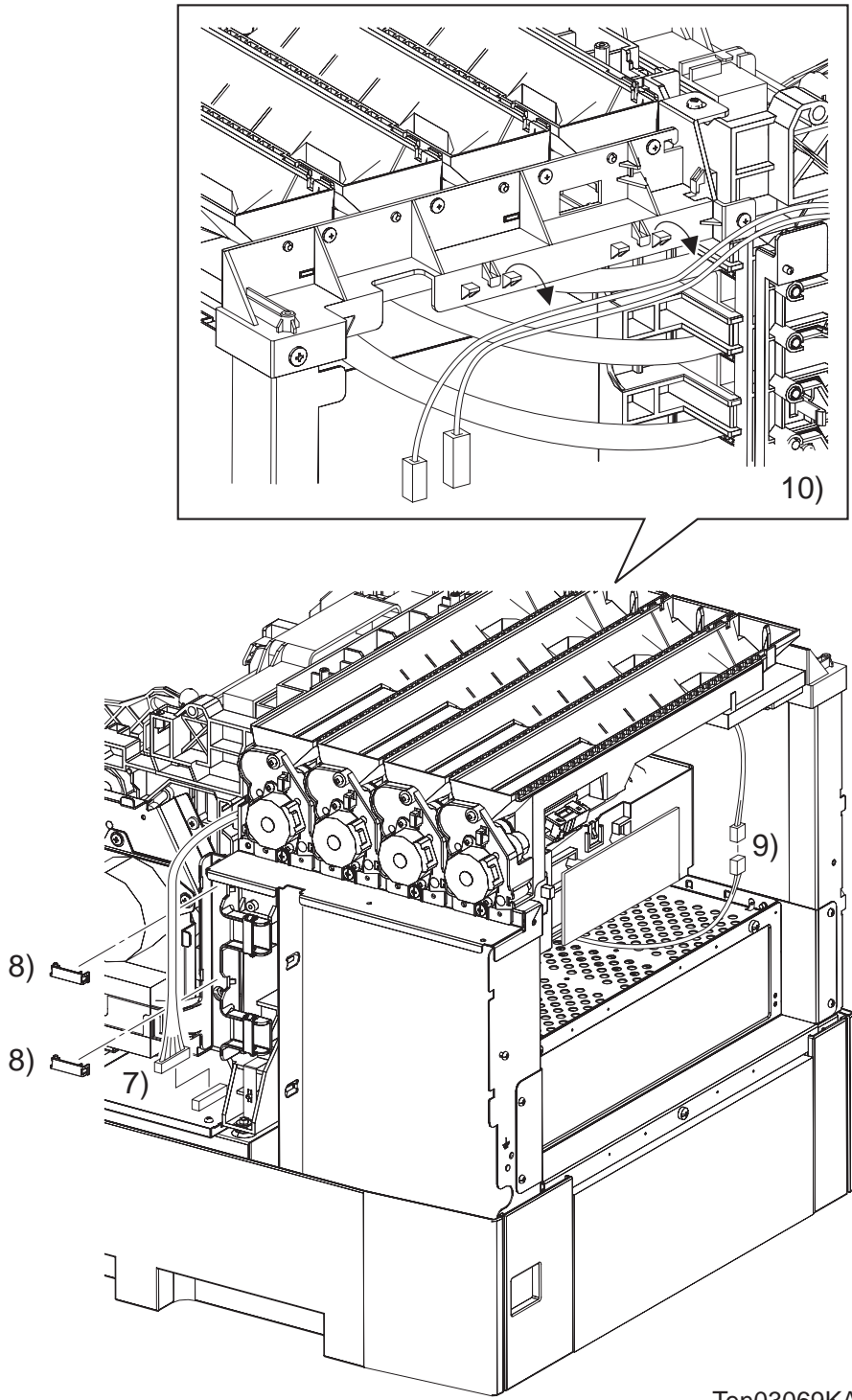

Ten03069KA

RRP7.4 TONER DISPENSER ASSEMBLY (PL7.2.22)

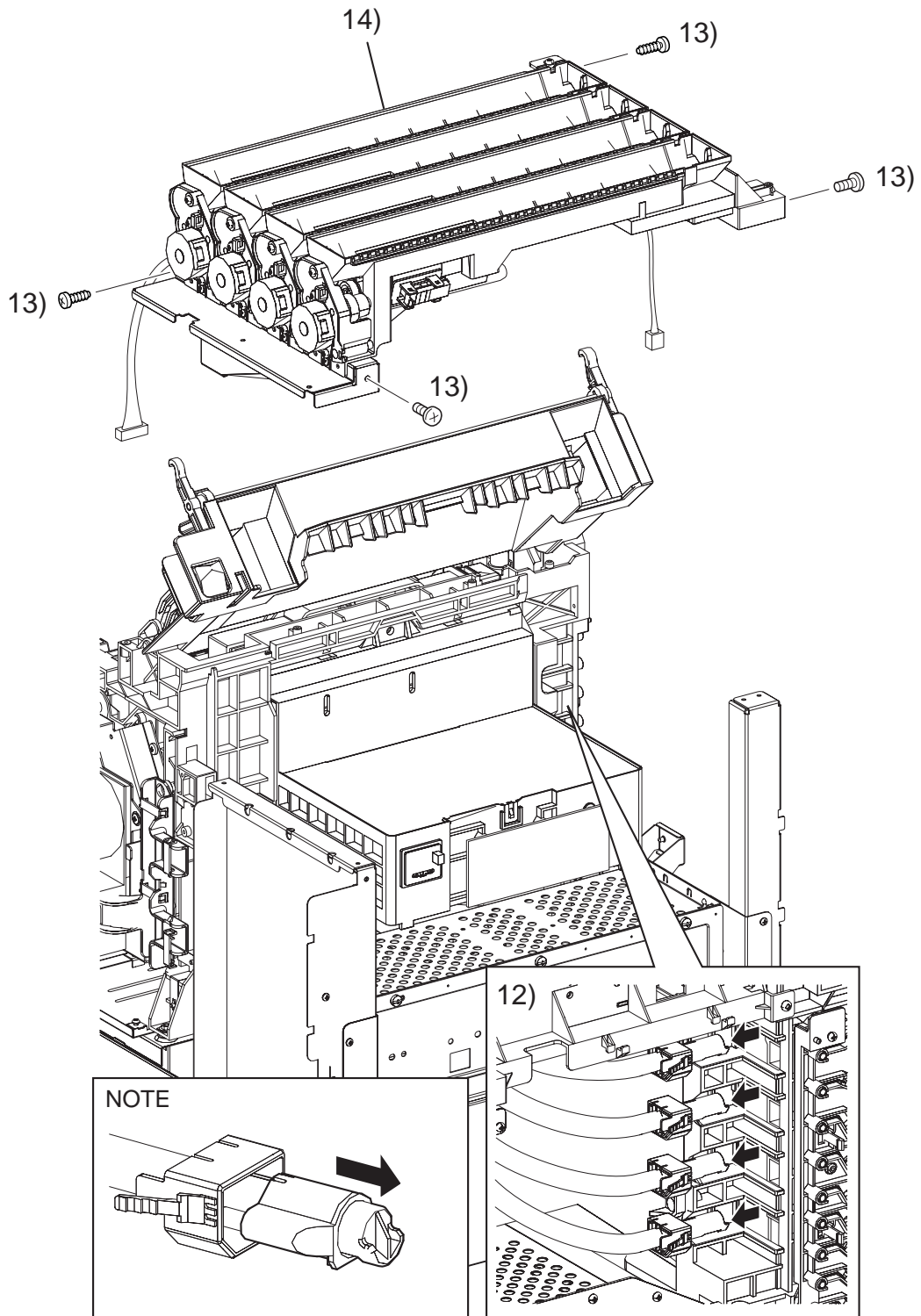

Ten03070KA

## RRP7.4 TONER DISPENSER ASSEMBLY (PL7.2.22)

[Removal]



**Do not absorb the toner with a general-purpose vacuum cleaner to avoid the risk of flashing off.**

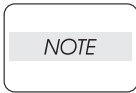

When removing TONER DISPENSER ASSEMBLY, be sure to start the removal work after absorbing the remaining toner on HOLDER ASSY TONER HBN with a vacuuming device such as a vacuum cleaner.

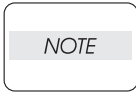

When absorbing the remaining toner on HOLDER ASSY TONER HBN with a vacuuming device such as a vacuum cleaner, be sure to attach an earth cable at the top of the vacuuming device so as to discharge static electricity.

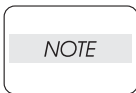

When absorbing the remaining toner on HOLDER ASSY TONER HBN with a vacuuming device such as a vacuum cleaner, take care not to allow the toner to fly off to adhere, by static electricity, on each sensor section on HOLDER ASSY TONER HBN.

- 1) Remove TOP COVER FRAME. (RRP1.1)
- 2) Remove RIGHT SIDE COVER. (RRP1.7)
- 3) Remove LEFT SIDE COVER. (RRP1.12)
- 4) Remove COVER ASSY REAR. (RRP1.5)
- 5) Remove HIGH VOLTAGE POWER SUPPLY (HVPS). (RRP9.9)
- 6) Remove DUCT LV.(RRP7.13)
- 7) Remove the connector (P/J51) on MACHINE CONTROL UNIT (MCU) (PL9.1.16) from the right side of the printer.
- 8) Remove CLAMP on GUIDE HARNESS R (PL9.1.14) from the right side of the printer, remove the harness that is connected to the connector (P/J51).
- 9) Remove the connector (P/J3411) on the harness that is connected to COIL ASSY CRUM READER from the rear of the printer.
- 10) Remove two wires (red) from the harness guide that is mounted on HSG BASE CRUM on the left side of the printer.
- 11) Open COVER IMAGING DRUM.
- 12) Release the hooks to remove the four toner nozzle, that are connected to the DEVELOPER FRAME, from DISPENSER ASSY (Y), (M), (C) and (K).

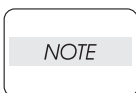

Be sure to check that the shutter of the toner nozzle is closed. If the shutter is opened, close it.

- 13) Remove two screws (silver, 6 mm) and two screws (silver, tap, 10mm) that fix TONER DISPENSER ASSEMBLY from the printer.
- 14) Remove TONER DISPENSER ASSEMBLY and FRAME HOLDER DSP, in the assembled state, from the printer.

## RRP7.4 TONER DISPENSER ASSEMBLY (PL7.2.22)

[Replacement]

- 1) Put the TONER DISPENSER ASSEMBLY and FRAME HOLDER DSP, in the assembled state, on the printer.
- 2) Attach GUIDE HARNESS F to the printer using five screws (silver, 6mm) and a screw (silver, tap, 10mm).

*NOTE*

Be sure to attach the four toner nozzle (Y), (M), (C) and (K) to each corresponding DEVELOPER ASSEMBLY while carefully matching the color.

- 3) Attach the four toner nozzle to DISPENSER ASSY (Y), (M), (C) and (K).
- 4) Pass the two wires (red) through the harness guide mounted on HSG BASE CRUM on the left side of the printer.
- 5) Attach the connector (P/J3411) on the harness that is connected to COIL ASSY CRUM READER from the rear side of the printer.
- 6) Pass the harness through GUIDE HARNESS R on the right side of the printer and fix it with CLAMP.
- 7) Attach the connector (P/J51) to MACHINE CONTROL UNIT (MCU) on the right side of the printer.
- 8) Attach DUCT LV. (RRP7.13)
- 9) Attach HIGH VOLTAGE POWER SUPPLY (HVPS). (RRP9.9)
- 10) Attach COVER ASSY REAR. (RRP1.5)
- 11) Attach LEFT SIDE COVER. (RRP1.12)
- 12) Attach RIGHT SIDE COVER. (RRP1.7)
- 13) Attach TOP COVER FRAME. (RRP1.1)

RRP7.5 DISPENSER ASSY (Y) (PL7.2.1)

NOTE

Procedure No. with [ ] included in Fig. shows the procedure at attachment.

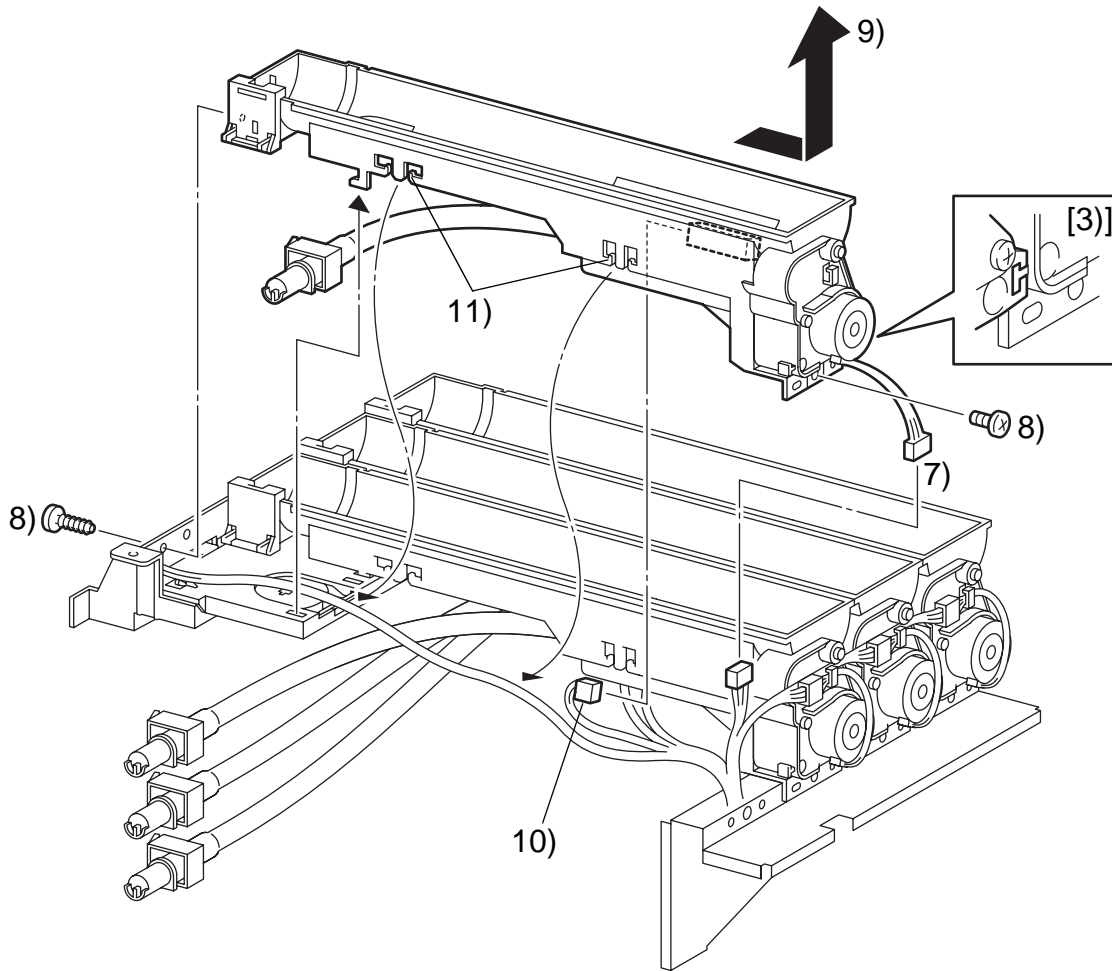

Ida\_Sec03\_071FA

## RRP7.5 DISPENSER ASSY (Y) (PL7.2.1)

## [Removal]

- 1) Remove TOP COVER FRAME. (RRP1.1)
- 2) Remove RIGHT SIDE COVER. (RRP1.7)
- 3) Remove LEFT SIDE COVER. (RRP1.12)
- 4) Remove COVER ASSY REAR. (RRP1.5)
- 5) Remove HIGH VOLTAGE POWER SUPPLY (HVPS). (RRP9.9)
- 6) Remove TONER DISPENSER ASSEMBLY. (RRP7.4)
- 7) Remove the connector (P/J511) of the motor from the right side of DISPENSER ASSY (Y).  
Remove the harness from the clamp mounted directly above the motor.

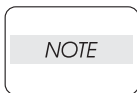

Do not separate TONER DISPENSER ASSEMBLY and DISPENSER ASSY (Y) too far in the following process since they are connected with a harness.

- 8) Remove a screw (silver, 6 mm) that fixes DISPENSER ASSY (Y) on the right, and a screw (silver, tap, 10mm) on the left from the printer.
- 9) Slide DISPENSER ASSY (Y) to the right and a little lift it upward.
- 10) Remove the connector (P/J701) from SENSOR NO TONER on DISPENSER ASSY (Y).
- 11) Release the harness from the hook mounted on the lower section of DISPENSER ASSY (Y), remove DISPENSER ASSY (Y).

## [Replacement]

- 1) Pass the harness through the hook mounted on the lower section of DISPENSER ASSY (Y).
- 2) Attach the connector (P/J701) to SENSOR NO TONER on DISPENSER ASSY (Y).
- 3) Fit the hook located on the lower left section of the DISPENSER ASSY (Y) in the groove of COVER HOLDER CRUM and slide it to the left.
- 4) Attach DISPENSER ASSY (Y) in place by fixing a screw (silver, 6 mm) on its right side and another screw (silver, tap, 10 mm) on its left side.
- 5) Attach the connector (P/J511) of the motor of HLDER TCRU ASSY (Y), pass the harness through the clamp mounted directly above the motor.
- 6) Attach TONER DISPENSER ASSEMBLY. (RRP7.4)
- 7) Attach HIGH VOLTAGE POWER SUPPLY (HVPS). (RRP9.9)
- 8) Attach COVER ASSY REAR. (RRP1.5)
- 9) Attach LEFT SIDE COVER. (RRP1.12)
- 10) Attach RIGHT SIDE COVER. (RRP1.7)
- 11) Attach TOP COVER FRAME. (RRP1.1)

RRP7.6 DISPENSER ASSY (M) (PL7.2.2)

Procedure No. with [ ] included in Fig. shows the procedure at attachment.

NOTE

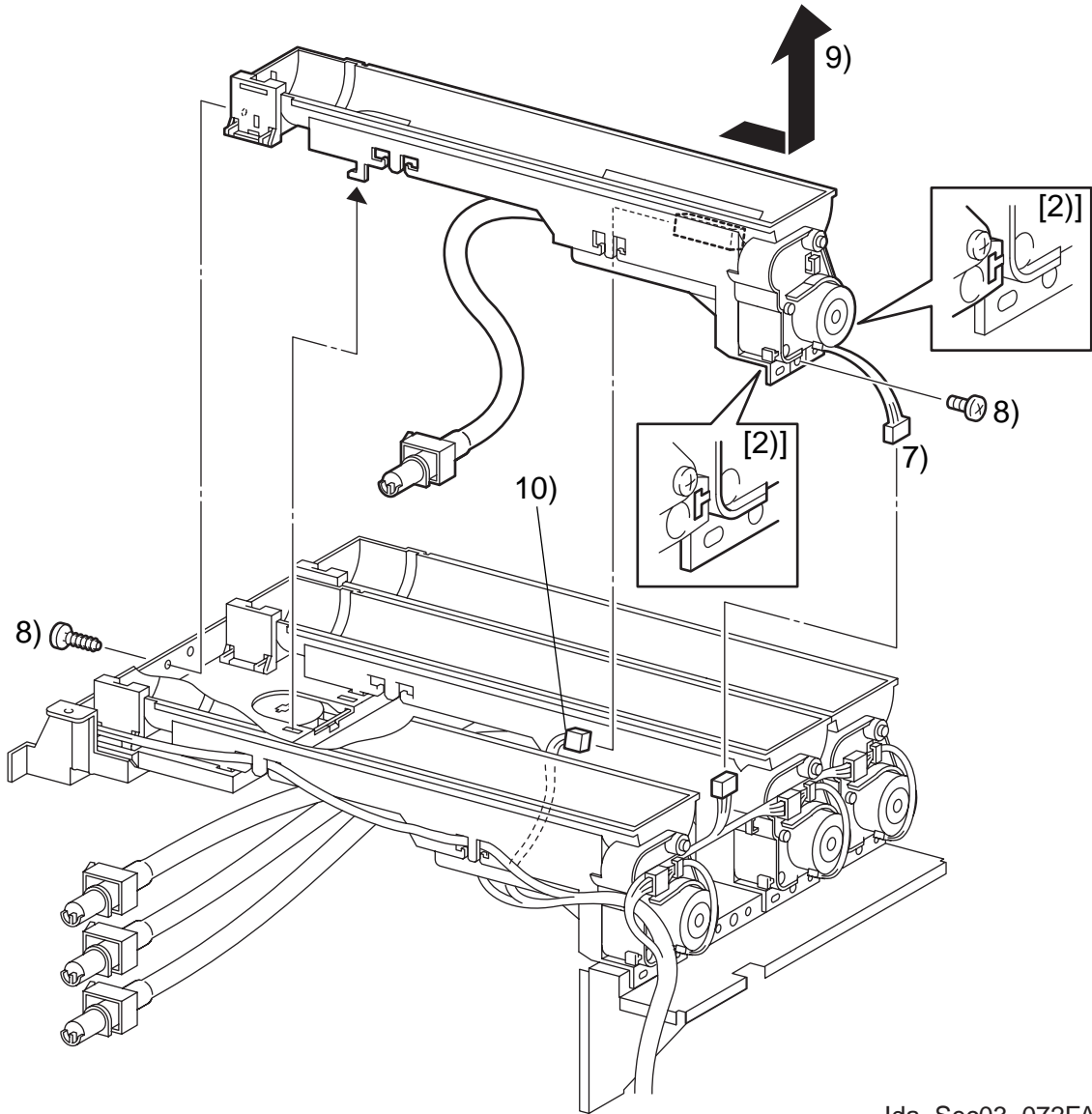

Ida\_Sec03\_072FA



## RRP7.6 DISPENSER ASSY (M) (PL7.2.2)

## [Removal]

- 1) Remove TOP COVER FRAME. (RRP1.1)
- 2) Remove RIGHT SIDE COVER. (RRP1.7)
- 3) Remove LEFT SIDE COVER. (RRP1.12)
- 4) Remove COVER ASSY REAR. (RRP1.5)
- 5) Remove HIGH VOLTAGE POWER SUPPLY (HVPS). (RRP9.9)
- 6) Remove TONER DISPENSER ASSEMBLY. (RRP7.4)
- 7) Remove the connector (P/J512) of the motor from the right side of DISPENSER ASSY (M).  
Remove the harness from the clamp mounted directly above the motor.

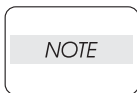

Do not separate TONER DISPENSER ASSEMBLY and DISPENSER ASSY (M) too far in the following process since they are connected with a harness.

- 8) Remove a screw (silver, 6 mm) that fixes DISPENSER ASSY (M) on the right, and a screw (silver, taptgg, 10mm) on the left from the printer.
- 9) Slide DISPENSER ASSY (M) to the right and a little lift it upward.
- 10) Remove the connector (P/J702) from SENSOR NO TONER on DISPENSER ASSY (M).
- 11) Remove DISPENSER ASSY (M).

## [Replacement]

- 1) Attach the connector (P/J702) to SENSOR NO TONER on DISPENSER ASSY (M).
- 2) Fit the hook located on the lower left section of DISPENSER ASSY (M) in the groove of COVER HOLDER CRUM and slide it to the left.
- 3) Attach DISPENSER ASSY (M) in place by fixing one screw (silver, 6 mm) on its right side and another screw (silver, tap, 10 mm) on its left side.
- 4) Attach the connector (P/J512) of the motor of HLDER TCRU ASSY (M), pass the harness through the clamp mounted directly above the motor.
- 5) Attach TONER DISPENSER ASSEMBLY. (RRP7.4)
- 6) Attach HIGH VOLTAGE POWER SUPPLY (HVPS). (RRP9.9)
- 7) Attach COVER ASSY REAR. (RRP1.5)
- 8) Attach LEFT SIDE COVER. (RRP1.12)
- 9) Attach RIGHT SIDE COVER. (RRP1.7)
- 10) Attach TOP COVER FRAME. (RRP1.1)

RRP7.7 DISPENSER ASSY (C) (PL7.2.3)

Procedure No. with [ ] included in Fig. shows the procedure at attachment.

NOTE

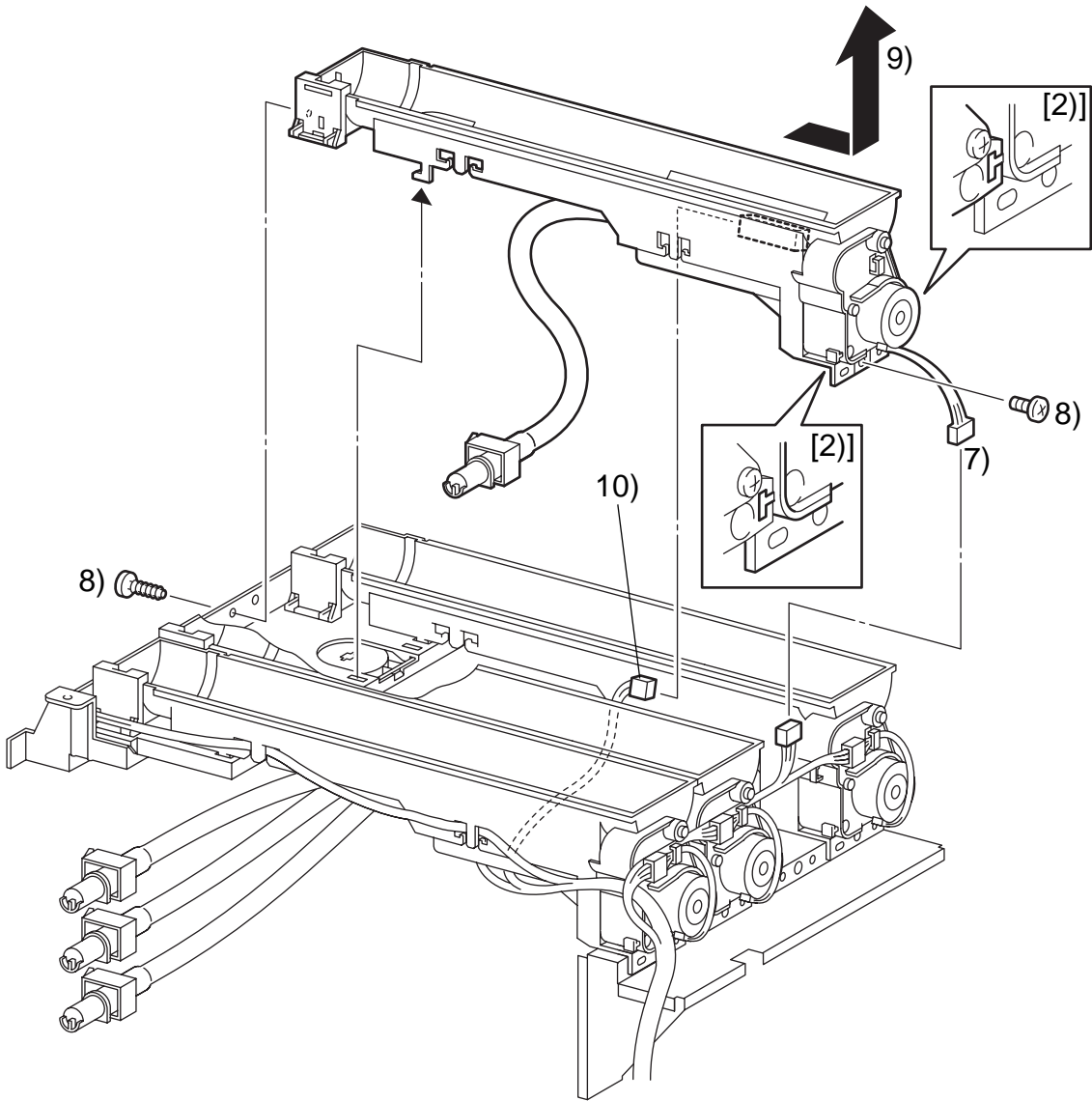

Ida\_Sec03\_073FA

## RRP7.7 DISPENSER ASSY (C) (PL7.2.3)

## [Removal]

- 1) Remove TOP COVER FRAME. (RRP1.1)
- 2) Remove RIGHT SIDE COVER. (RRP1.7)
- 3) Remove LEFT SIDE COVER. (RRP1.12)
- 4) Remove COVER ASSY REAR. (RRP1.5)
- 5) Remove HIGH VOLTAGE POWER SUPPLY (HVPS). (RRP9.9)
- 6) Remove TONER DISPENSER ASSEMBLY. (RRP7.4)
- 7) Remove the connector (P/J513) of the motor from the right side of DISPENSER ASSY (C).  
Remove the harness from the clamp mounted directly above the motor.

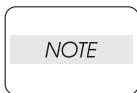

Do not separate TONER DISPENSER ASSEMBLY and DISPENSER ASSY (C) too far in the following process since they are connected with a harness.

- 8) Remove a screw (silver, 6 mm) that fixes DISPENSER ASSY (C) on the right, and a screw (silver, taptgg, 10mm) on the left from the printer.
- 9) Slide DISPENSER ASSY (C) to the right and a little lift it upward.
- 10) Remove the connector (P/J703) from SENSOR NO TONER on DISPENSER ASSY (C).
- 11) Remove DISPENSER ASSY (C).

## [Replacement]

- 1) Attach the connector (P/J703) to the SENSOR NO TONER on the DISPENSER ASSY (C).
- 2) Fit the hook located on the lower left section of DISPENSER ASSY (C) in the groove of COVER HOLDER CRUM and slide it to the left.
- 3) Attach DISPENSER ASSY (C) in place by fixing one screw (silver, 6 mm) on its right side and another screw (silver, tap, 10 mm) on its left side.
- 4) Attach the connector (P/J513) of the motor of HLDER TCRU ASSY (C), pass the harness through the clamp mounted directly above the motor.
- 5) Attach TONER DISPENSER ASSEMBLY. (RRP7.4)
- 6) Attach HIGH VOLTAGE POWER SUPPLY (HVPS). (RRP9.9)
- 7) Attach COVER ASSY REAR. (RRP1.5)
- 8) Attach LEFT SIDE COVER. (RRP1.12)
- 9) Attach RIGHT SIDE COVER. (RRP1.7)
- 10) Attach TOP COVER FRAME. (RRP1.1)

RRP7.8 DISPENSER ASSY (K) (PL7.2.4)

Procedure No. with [ ] included in Fig. shows the procedure at attachment.

NOTE

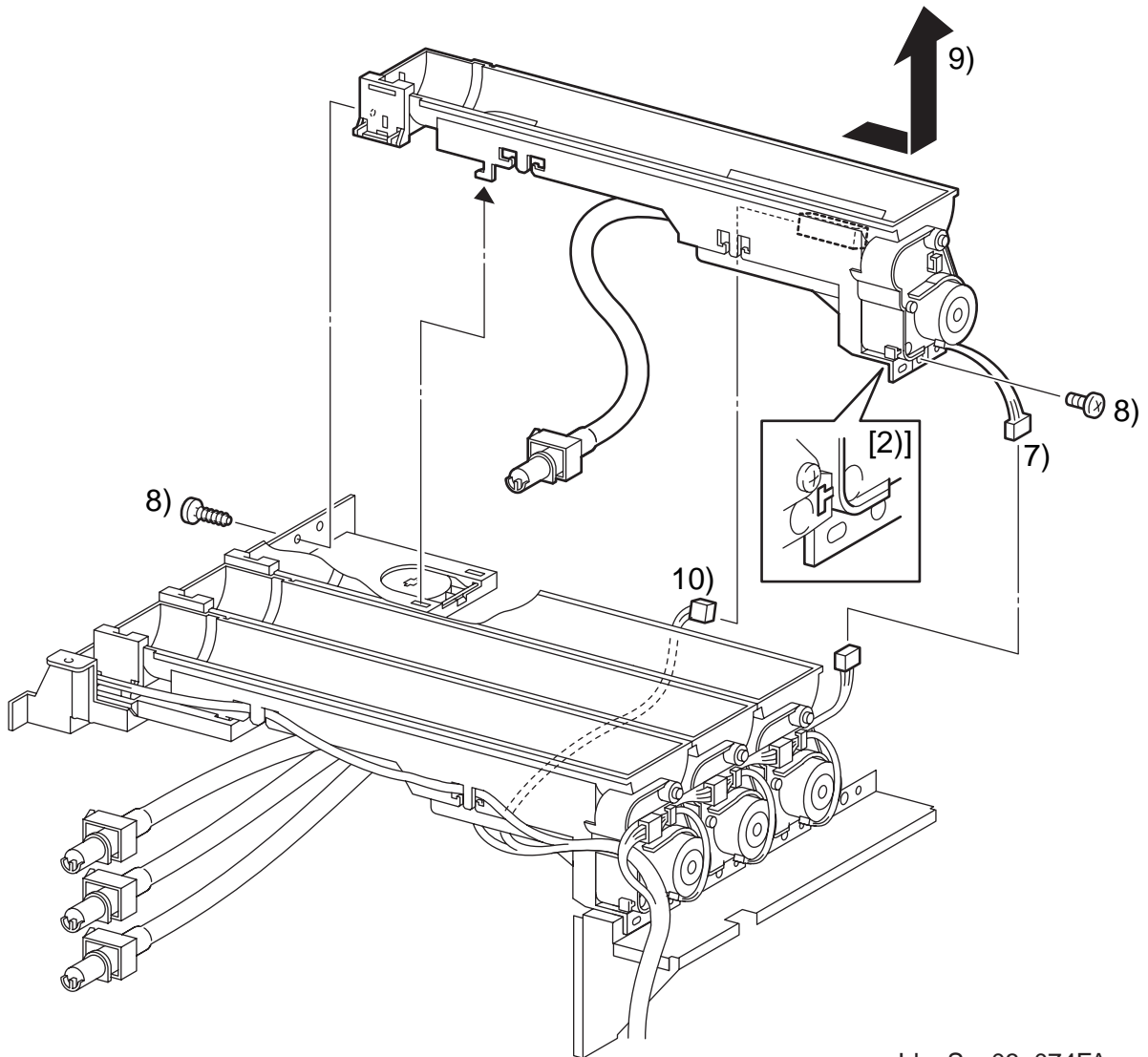

Ida\_Sec03\_074FA

## RRP7.8 DISPENSER ASSY (K) (PL7.2.4)

## [Removal]

- 1) Remove TOP COVER FRAME. (RRP1.1)
- 2) Remove RIGHT SIDE COVER. (RRP1.7)
- 3) Remove LEFT SIDE COVER. (RRP1.12)
- 4) Remove COVER ASSY REAR. (RRP1.5)
- 5) Remove HIGH VOLTAGE POWER SUPPLY (HVPS). (RRP9.9)
- 6) Remove TONER DISPENSER ASSEMBLY. (RRP7.4)
- 7) Remove the connector (P/J514) of the motor from the right side of DISPENSER ASSY (K).  
Remove the harness from the clamp mounted directly above the motor.

## NOTE

Do not separate TONER DISPENSER ASSEMBLY and DISPENSER ASSY (K) too far in the following process since they are connected with a harness.

- 8) Remove a screw (silver, 6 mm) that fixes DISPENSER ASSY (K) on the right, and a screw (silver, taptgg, 10mm) on the left from the printer.
- 9) Slide DISPENSER ASSY (K) to the right and a little lift it upward.
- 10) Remove the connector (P/J704) from SENSOR NO TONER on DISPENSER ASSY (K).
- 11) Remove DISPENSER ASSY (K).

## [Replacement]

- 1) Attach the connector (P/J704) to SENSOR NO TONER on DISPENSER ASSY (K).
- 2) Fit the hook located on the lower left section of DISPENSER ASSY (K) in the groove of COVER HOLDER CRUM and slide it to the left.
- 3) Attach DISPENSER ASSY (K) in place by fixing one screw (silver, 6 mm) on its right side and another screw (silver, tap, 10 mm) on its left side.
- 4) Attach the connector (P/J514) of the motor of DISPENSER ASSY (K), pass the harness through the clamp mounted directly above the motor.
- 5) Attach TONER DISPENSER ASSEMBLY. (RRP7.4)
- 6) Attach HIGH VOLTAGE POWER SUPPLY (HVPS). (RRP9.9)
- 7) Attach COVER ASSY REAR. (RRP1.5)
- 8) Attach LEFT SIDE COVER. (RRP1.12)
- 9) Attach RIGHT SIDE COVER. (RRP1.7)
- 10) Attach TOP COVER FRAME. (RRP1.1)

RRP7.9 SENSOR NO TONER (Y), (M), (C) (PL7.2.5)

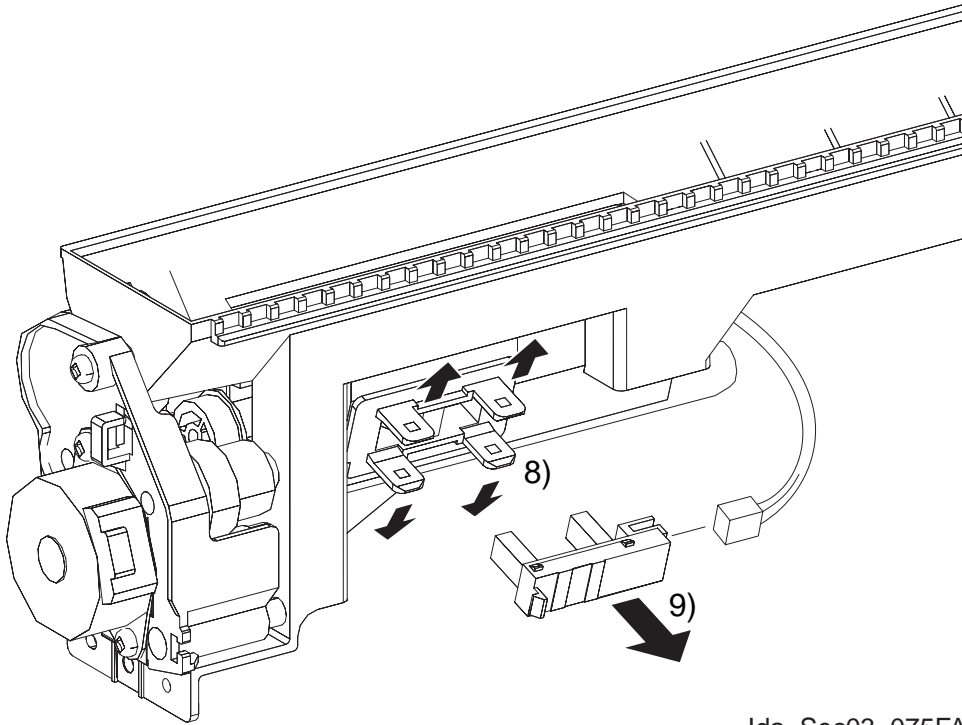

Ida\_Sec03\_075FA

### RRP7.9 SENSOR NO TONER (Y), (M), (C) (PL7.2.5)

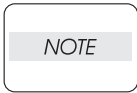

Since SENSOR NO TONER (Y), (M) and (C) are to be removed in the same manner, the removal procedure is described for one of them only.

#### [Removal]

- 1) Remove TOP COVER FRAME. (RRP1.1)
- 2) Remove RIGHT SIDE COVER. (RRP1.7)
- 3) Remove LEFT SIDE COVER. (RRP1.12)
- 4) Remove COVER ASSY REAR. (RRP1.5)
- 5) Remove HIGH VOLTAGE POWER SUPPLY (HVPS). (RRP9.9)
- 6) Remove TONER DISPENSER ASSEMBLY. (RRP7.4)
- 7) Remove DISPENSER ASSY. (RRP7.5, 7.6 or 7.7)
- 8) Release the hooks at four locations that fix DISPENSER ASSY to SENSOR NO TONER.
- 9) Remove SENSOR NO TONER from DISPENSER ASSY.

#### [Replacement]

- 1) Attach SENSOR NO TONER to DISPENSER ASSY and fix with the hooks at four locations.
- 2) Attach DISPENSER ASSY. (RRP7.5, 7.6 or 7.7)
- 3) Attach TONER DISPENSER ASSEMBLY. (RRP7.4)
- 4) Attach HIGH VOLTAGE POWER SUPPLY (HVPS). (RRP9.9)
- 5) Attach COVER ASSY REAR. (RRP1.5)
- 6) Attach LEFT SIDE COVER. (RRP1.12)
- 7) Attach RIGHT SIDE COVER. (RRP1.7)
- 8) Attach TOP COVER FRAME. (RRP1.1)

RRP7.10 SENSOR NO TONER (K) (PL7.2.5)

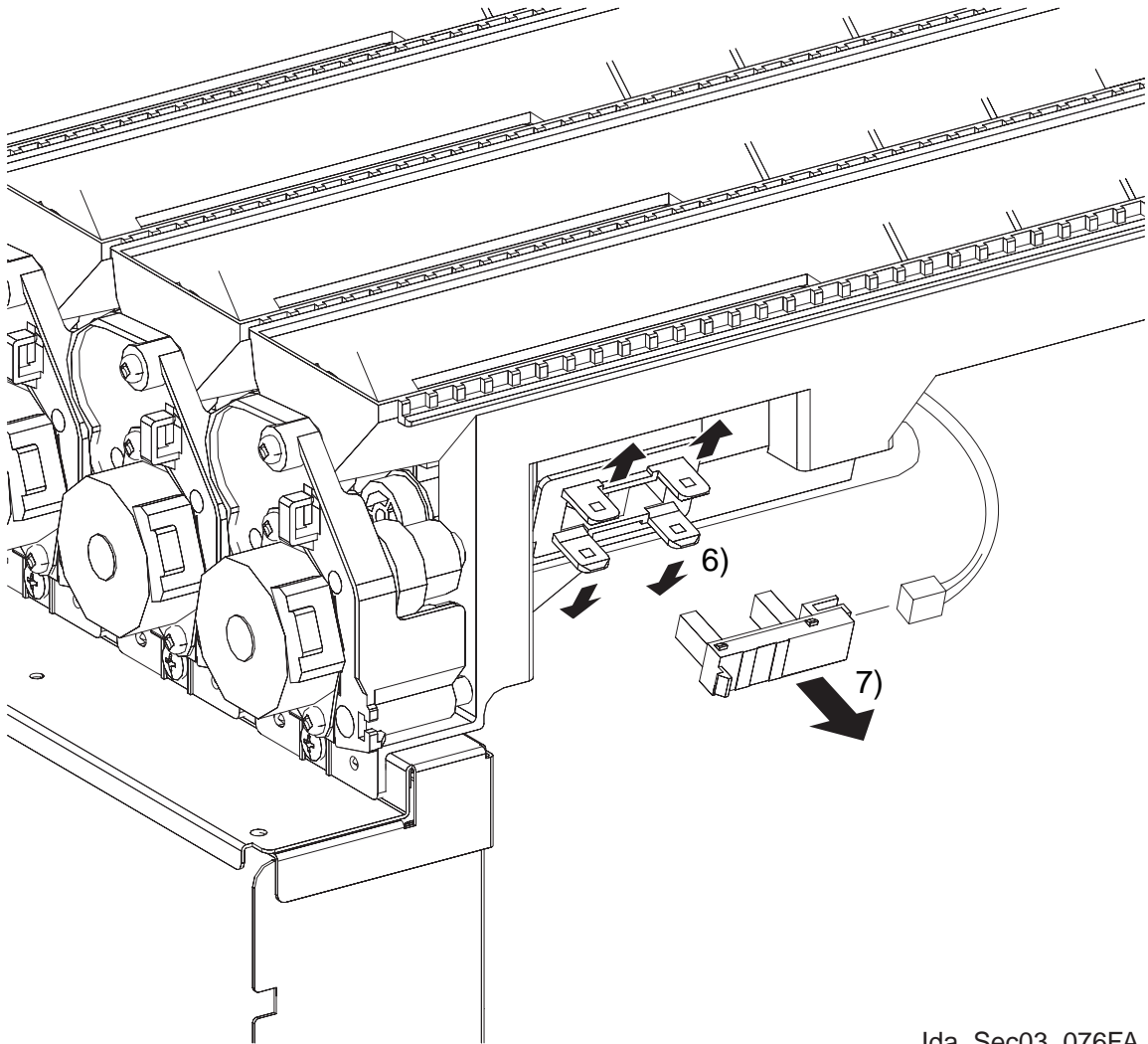

Ida\_Sec03\_076FA



RRP7.10 SENSOR NO TONER (K) (PL7.2.5)

[Removal]

- 1) Remove TOP COVER FRAME. (RRP1.1)
- 2) Remove RIGHT SIDE COVER. (RRP1.7)
- 3) Remove LEFT SIDE COVER. (RRP1.12)
- 4) Remove COVER ASSY REAR. (RRP1.5)
- 5) Remove the connector (P/J704) from SENSOR NO TONER on DISPENSER ASSY (K).
- 6) Remove the hooks at four locations that fix DISPENSER ASSY (K) to SENSOR NO TONER.
- 7) Remove SENSOR NO TONER from DISPENSER ASSY (K).

[Replacement]

- 1) Attach SENSOR NO TONER to DISPENSER ASSY (K) and fix with the hooks at four locations.
- 2) Attach the connector (P/J704) to SENSOR NO PAPER.
- 3) Attach COVER ASSY REAR. (RRP1.5)
- 4) Attach LEFT SIDE COVER. (RRP1.12)
- 5) Attach RIGHT SIDE COVER. (RRP1.7)
- 6) Attach TOP COVER FRAME. (RRP1.1)

RRP7.11 ACTUATOR SENSOR 2 (PL7.2.7)

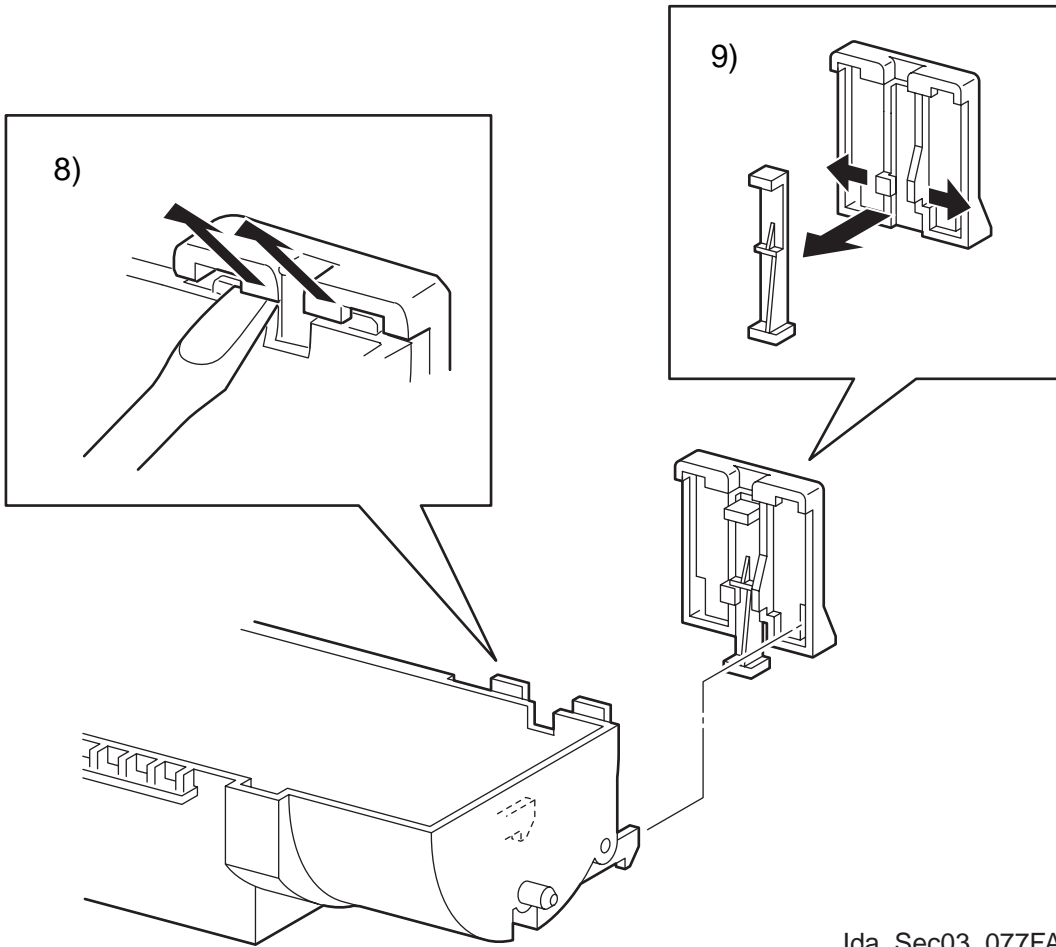

Ida\_Sec03\_077FA

## RRP7.11 ACTUATOR SENSOR 2 (PL7.2.7)

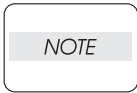

Since the four ACTUATOR SENSORS 2 are to be removed in the same manner, the removal procedure is described for one of them only.

## [Removal]

- 1) Remove TOP COVER FRAME. (RRP1.1)
- 2) Remove RIGHT SIDE COVER. (RRP1.7)
- 3) Remove LEFT SIDE COVER. (RRP1.12)
- 4) Remove COVER ASSY REAR. (RRP1.5)
- 5) Remove HIGH VOLTAGE POWER SUPPLY (HVPS). (RRP9.9)
- 6) Remove TONER DISPENSER ASSEMBLY. (RRP7.4)
- 7) Remove DISPENSER ASSY. (RRP7.5, 7.6, 7.7 or 7.8)
- 8) Release the hooks, at two locations, fixing BRACKET SENSOR 2 to DISPENSER ASSY with a miniature screwdriver, remove the BRACKET SENSOR 2
- 9) Opening the hooks of BRACKET SENSOR 2, remove the ACTUATOR SENSOR 2.

## [Replacement]

- 1) Attach ACTUATOR SENSOR 2 to BEACKET SENSOR 2.
- 2) Attach BRACKET SENSOR 2 to DISPENSER ASSY.
- 3) Attach DISPENSER ASSY. (RRP7.5, 7.6, 7.7 or 7.8)
- 4) Attach TONER DISPENSER ASSEMBLY. (RRP7.4)
- 5) Attach HIGH VOLTAGE POWER SUPPLY (HVPS). (RRP9.9)
- 6) Attach COVER ASSY REAR. (RRP1.5)
- 7) Attach LEFT SIDE COVER. (RRP1.12)
- 8) Attach RIGHT SIDE COVER. (RRP1.7)
- 9) Attach TOP COVER FRAME. (RRP1.1)

RRP7.12 TONER CARTRIDGE SENSOR (PL7.2.12)

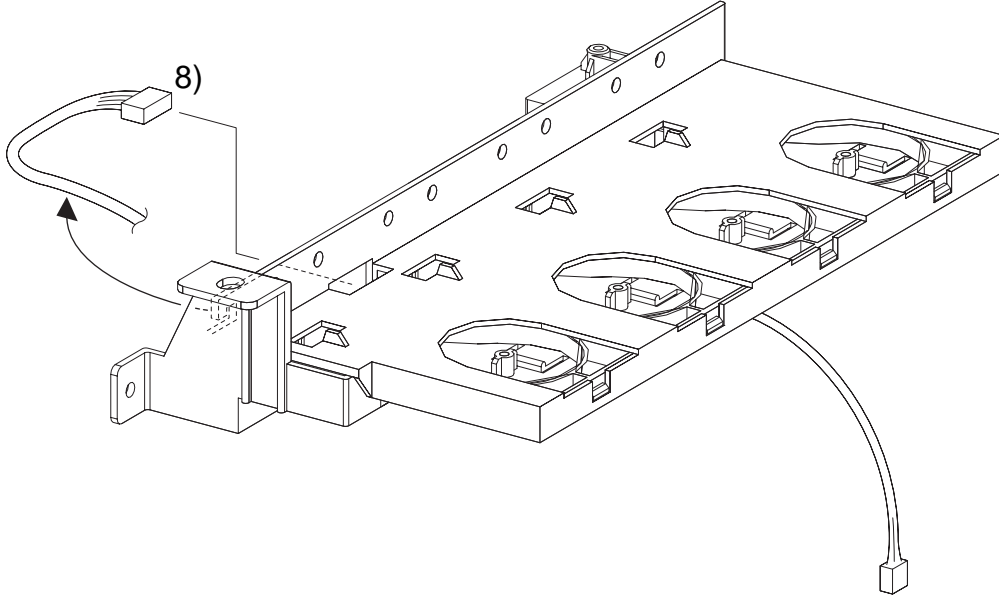

Ida\_Sec03\_078FA

## RRP7.12 TONER CARTRIDGE SENSOR (PL7.2.12)

### [Removal]

- 1) Remove TOP COVER FRAME. (RRP1.1)
- 2) Remove RIGHT SIDE COVER. (RRP1.7)
- 3) Remove LEFT SIDE COVER. (RRP1.12)
- 4) Remove COVER ASSY REAR. (RRP1.5)
- 5) Remove HIGH VOLTAGE POWER SUPPLY (HVPS). (RRP9.9)
- 6) Remove TONER DISPENSER ASSEMBLY. (RRP7.4)
- 7) Remove DISPENSER ASSY (Y), (M), (C), (K). (RRP7.5, 7.6, 7.7 or 7.8)
- 8) Remove the connector (P/J342) from COIL ASSY CRUM READER (PL7.2.14). Remove the harness from the harness guide on HSG BASE CRUM (PL7.2.15).

### [Replacement]

- 1) Attach the connector (P/J342) to COIL ASSY CRUM READER. Pass the harness through the harness guide on HSG BASE CRUM.
- 2) Attach DISPENSER ASSY (Y), (M), (C), (K). (RRP7.5, 7.6, 7.7 or 7.8)
- 3) Attach TONER DISPENSER ASSEMBLY. (RRP7.4)
- 4) Attach HIGH VOLTAGE POWER SUPPLY (HVPS). (RRP9.9)
- 5) Attach COVER ASSY REAR. (RRP1.5)
- 6) Attach LEFT SIDE COVER. (RRP1.12)
- 7) Attach RIGHT SIDE COVER. (RRP1.7)
- 8) Attach TOP COVER FRAME. (RRP1.1)

RRP7.13 DUCT LV (PL7.2.23)

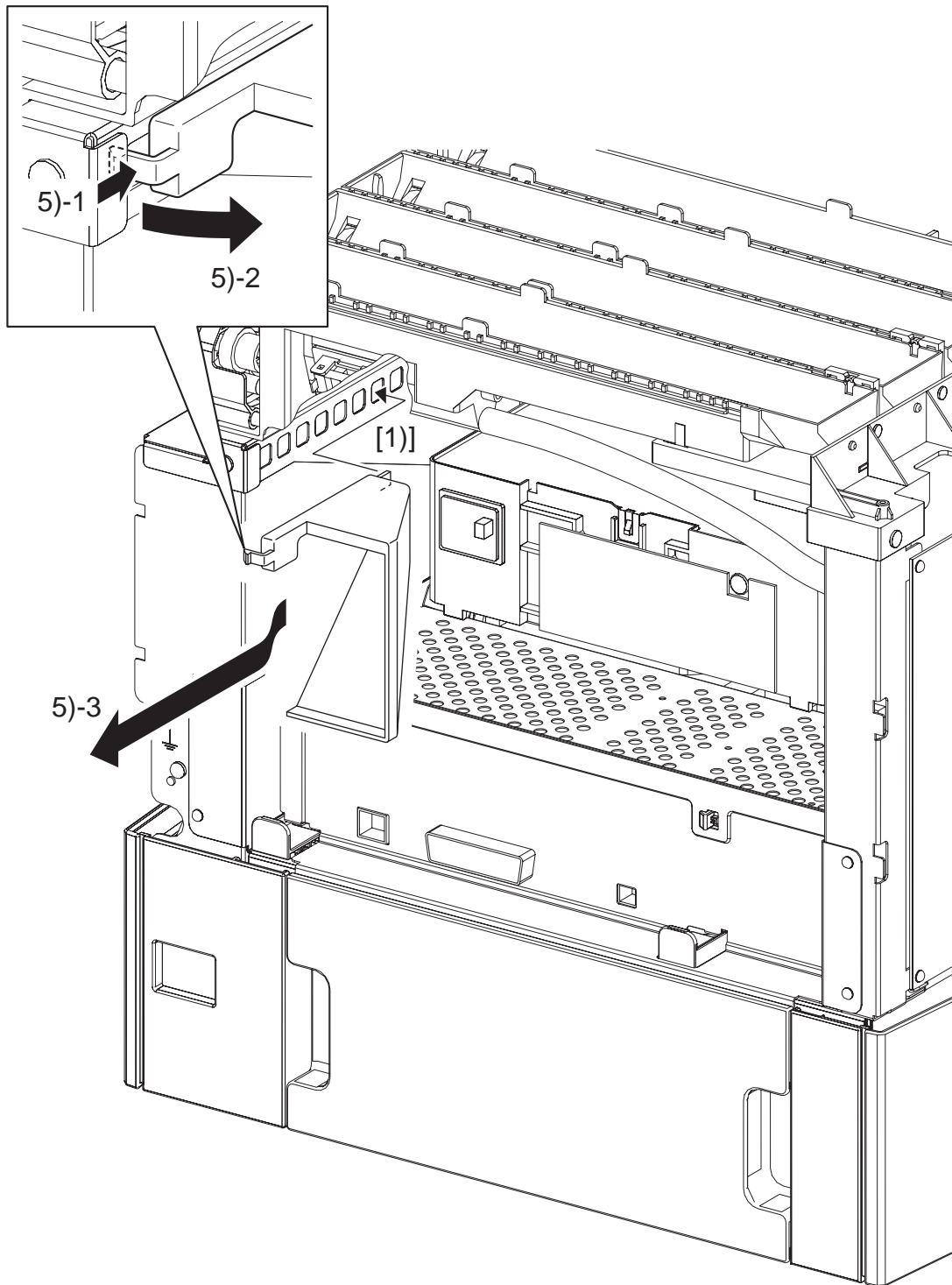

Ten03118KA

### RRP7.13 DUCT LV (PL7.2.23)

[Removal]

- 1) Remove TOP COVER FRAME. (RRP1.1)
- 2) Remove RIGHT SIDE COVER. (RRP1.7)
- 3) Remove LEFT SIDE COVER. (RRP1.12)
- 4) Remove COVER ASSY REAR. (RRP1.5)
- 5) Release a hook that fixes the DUCT LV to the BRACKET HOLDER DSP, remove the DUCT LV.

[Replacement]

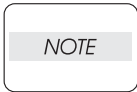

Pay attention to fitting position of the DUCT LV.

- 1) Insert the convex of the DUCT LV into the seventh hole from the rear side at the BRACKET HOLDER DSP.
- 2) Attach COVER ASSY REAR. (RRP1.5)
- 3) Attach LEFT SIDE COVER. (RRP1.12)
- 4) Attach RIGHT SIDE COVER. (RRP1.7)
- 5) Attach TOP COVER FRAME. (RRP1.1)

## RRP8. DRIVE

### RRP8.1 DEVELOPER DRIVE ASSEMBLY (PL8.1.1)

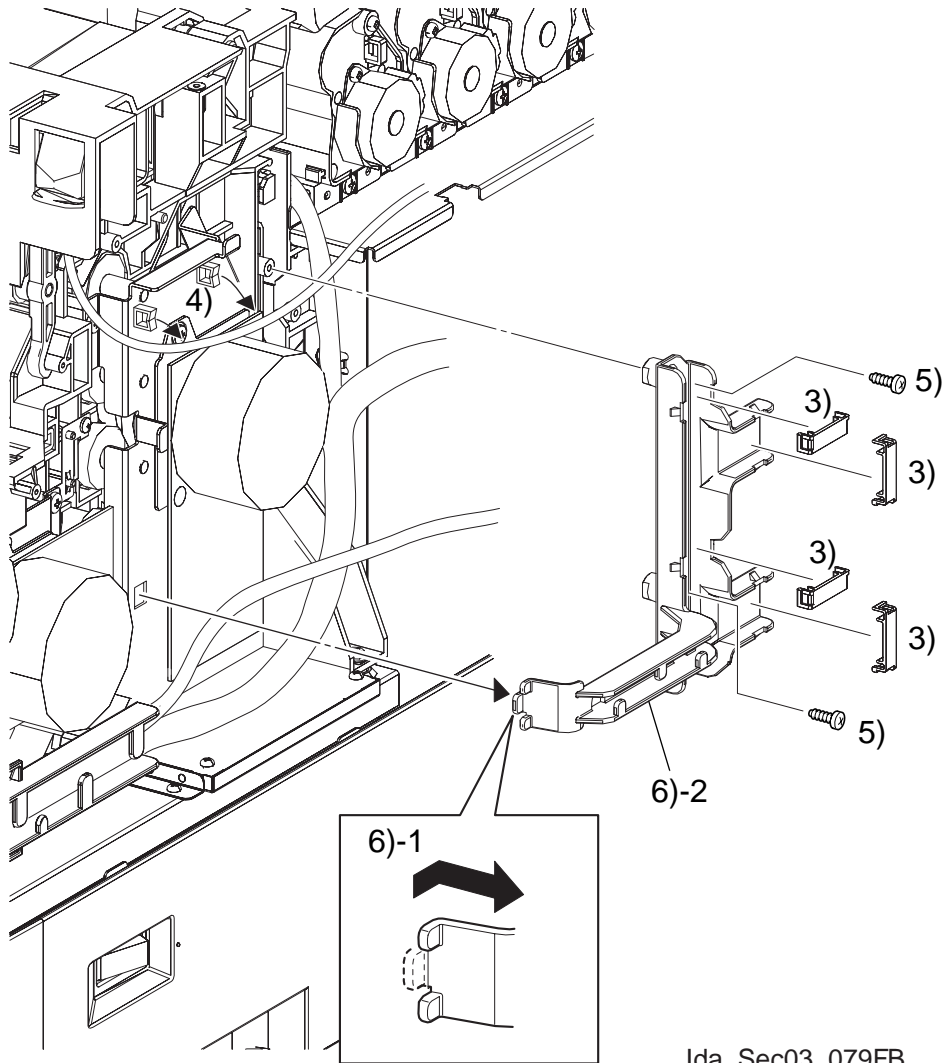

Ida\_Sec03\_079FB



RRP8.1 DEVELOPER DRIVE ASSEMBLY (PL8.1.1)

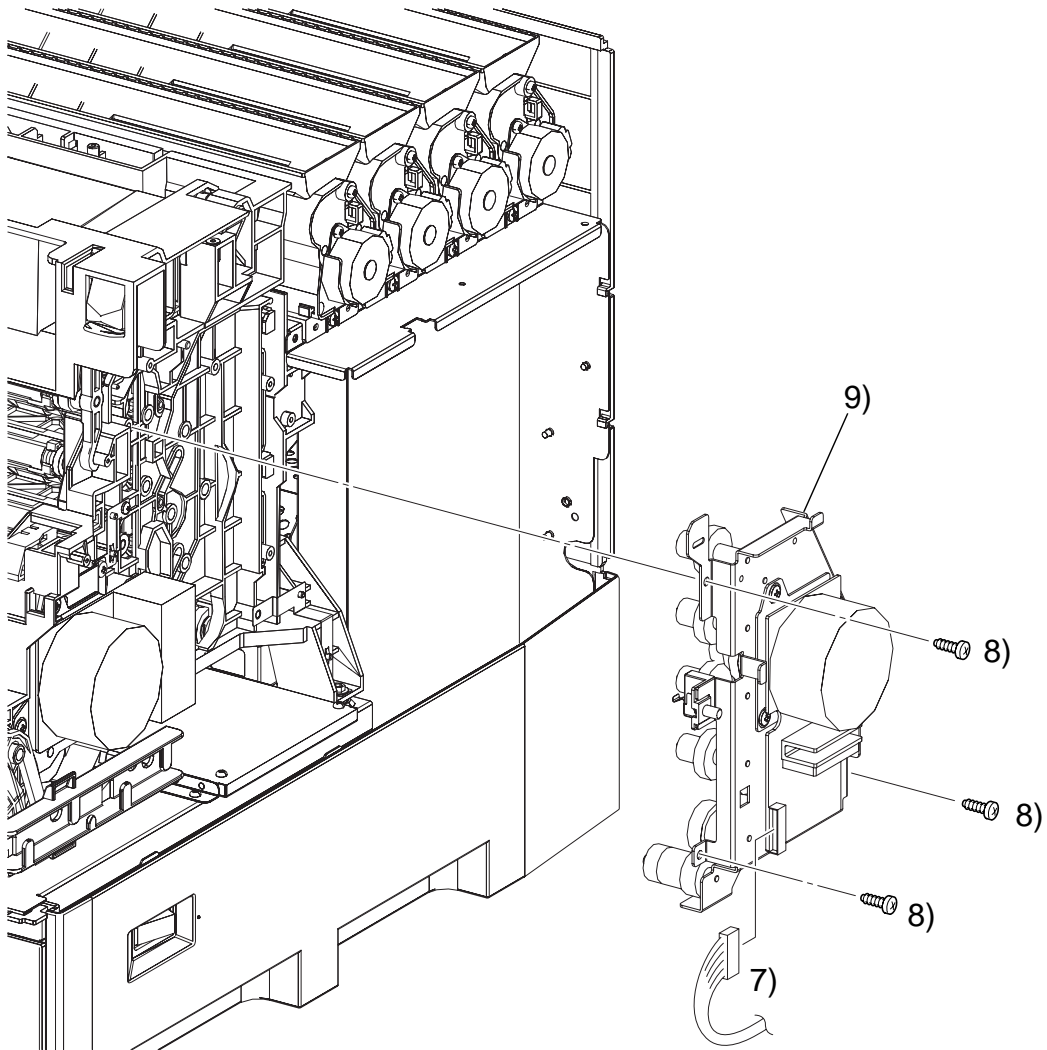

Ida\_Sec03\_080FB

## RRP8.1 DEVELOPER DRIVE ASSEMBLY (PL8.1.1)

## [Removal]

- 1) Remove TOP COVER FRAME. (RRP1.1)
- 2) Remove RIGHT SIDE COVER. (RRP1.7)
- 3) Remove CLAMP GUIDES HARNESES (PL9.1.13), at the four locations, from GUIDE HARNESS R (PL9.1.14). Then, remove the harness.
- 4) Release the clamp on DEVELOPER DRIVE ASSEMBLY to remove the harness.
- 5) Remove two screws (silver, tap 10 mm) fixing GUIDE HARNESS R on the printer.
- 6) Release the hook on the front side of GUIDE HARNESS R from the hole of DEVELOPER DRIVE ASSEMBLY and remove GUIDE HARNESS R.
- 7) Remove the connector (P/J491) on DEVELOPER DRIVE ASSEMBLY.
- 8) Remove three screws (silver, tap, 10 mm) fixing DEVELOPER DRIVE ASSEMBLY from the printer.
- 9) Remove DEVELOPER DRIVE ASSEMBLY from the printer.

## [Replacement]

- 1) Attach DEVELOPER DRIVE ASSEMBLY to the printer using three screws (silver, tap, 10mm).
- 2) Attach the connector (P/J491) on DEVELOPER DRIVE ASSEMBLY.
- 3) Engage the hook on the front side of GUIDE HARNESS R to the hole of DEVELOPER DRIVE ASSEMBLY and attach GUIDE HARNESS R.
- 4) Attach GUIDE HARNESS R to the printer using two screws (silver, tap 10mm).

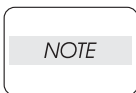

Check to be sure that the gear of DEVELOPER DRIVE ASSEMBLY is engaged with the gear on the printer side.

- 5) Attach the harness to the clamp on DEVELOPER DRIVE ASSEMBLY.
- 6) Pass the harness through GUIDE HARNESS R, attach CLAMP GUIDE HARNESES at the four locations.
- 7) Attach RIGHT SIDE COVER. (RRP1.7)
- 8) Attach TOP COVER FRAME. (RRP1.1)

Blank Page

RRP8.2 MAIN DRIVE ASSEMBLY (PL8.1.2)

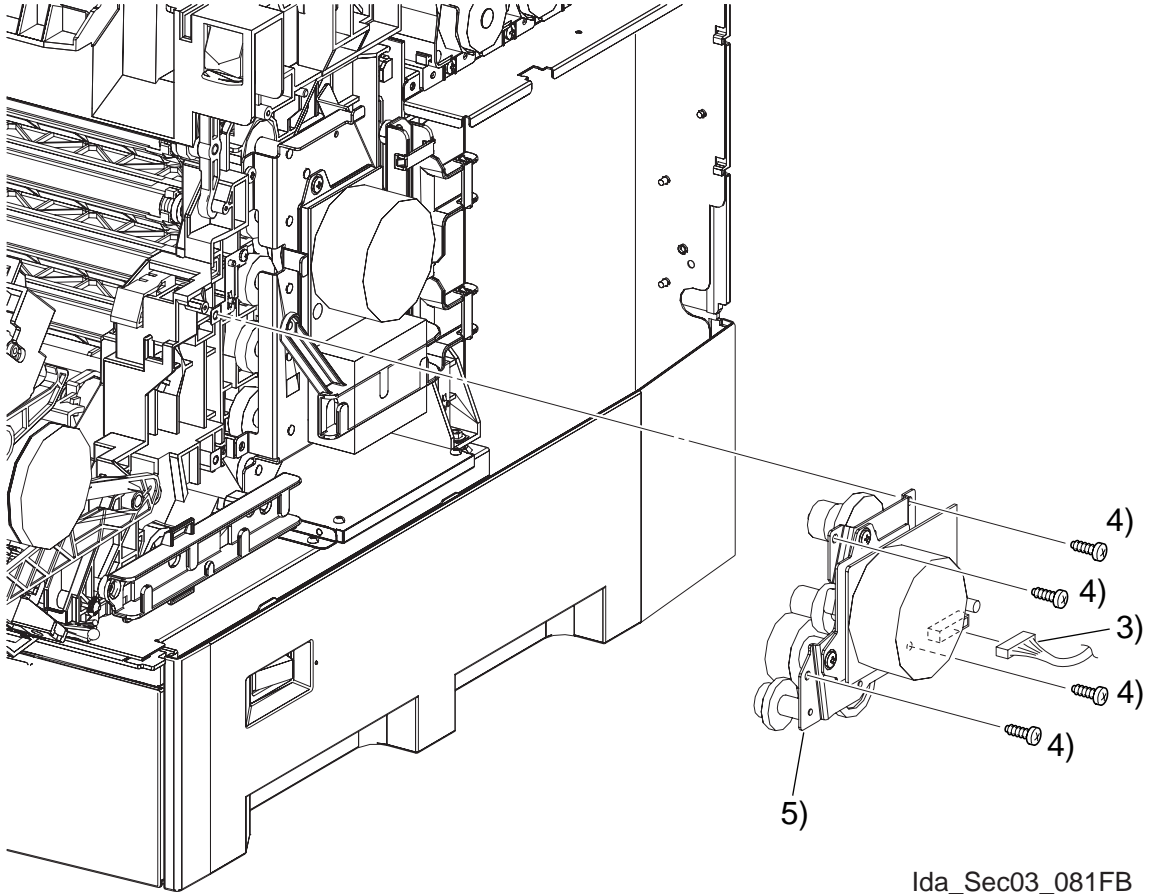

Ida\_Sec03\_081FB

## RRP8.2 MAIN DRIVE ASSEMBLY (PL8.1.2)

### [Removal]

- 1) Remove TOP COVER FRAME. (RRP1.1)
- 2) Remove RIGHT SIDE COVER. (RRP1.7)
- 3) Remove the connector (P/J481) on MAIN DRIVE ASSEMBLY.
- 4) Remove four screws (silver, tap, 10 mm) fixing MAIN DRIVE ASSEMBLY from the printer.
- 5) Remove MAIN DRIVE ASSEMBLY from the printer.

### [Replacement]

- 1) Attach MAIN DRIVE ASSEMBLY to the printer using four screws (silver, tap, 10mm).

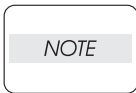

Check to be sure that the gear of DEVELOPER DRIVE ASSEMBLY is engaged with the gear on the printer side.

- 2) Attach the connector (P/J481) on MAIN DRIVE ASSEMBLY.
- 3) Attach RIGHT SIDE COVER. (RRP1.7)
- 4) Attach TOP COVER FRAME. (RRP1.1)

# RRP9. ELECTRICAL

## RRP9.1 CONTROLLER CARD (PL9.1.3)

**NOTE**

Procedure No. with [ ] included in Fig. shows the procedure at attachment.

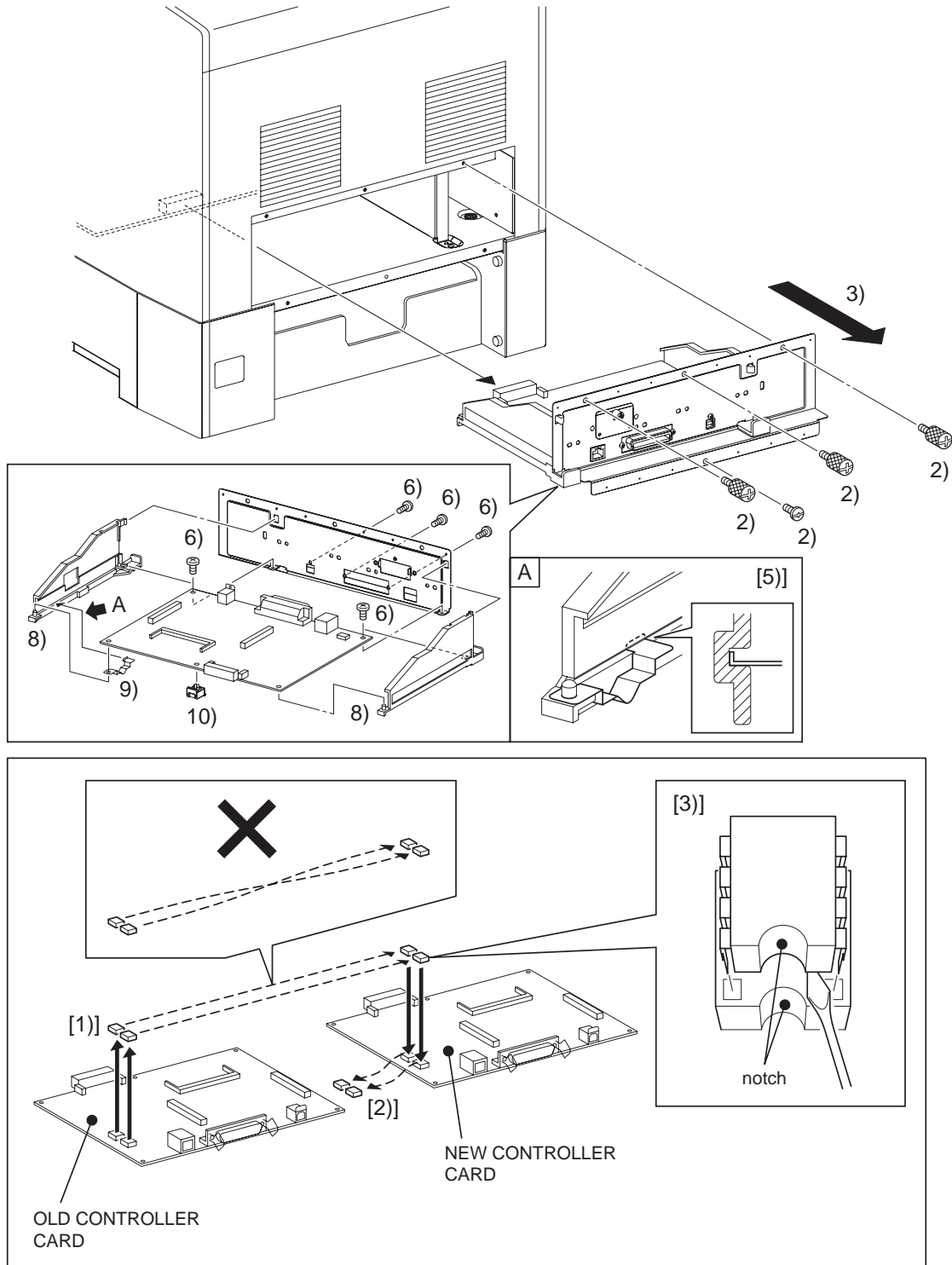

Ten03082KA

## RRP9.1 CONTROLLER CARD (PL9.1.3)

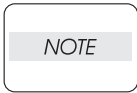

Use the wrist strap to protect the PWB from the electrostatic.

## [Removal]

- 1) Remove PAPER TRAY COVER. (RRP3.2)
- 2) Remove three SCREW KNURLING (PL9.1.32) and a screw (silver, 6mm) that fix ESS ASSY to the printer.
- 3) Holding two handles of the ESS ASSY, draw it out.
- 4) If there is the OPTION HDD ASSY in the printer, remove the OPTION HDD ASSY. (RRP9.10)
- 5) If there is the OPTION MULTI PROTOCOL CARD in the printer, remove the OPTION MULTI PROTOCOL CARD. (RRP9.11)
- 6) Remove two screws (silver, 6 mm) that fix CONTROLLER CARD to PLATE ASSY REAR (PL9.1.2) and three screws fixing the interface.
- 7) Removing CONTROLLER CARD interface connector from the hole in PLATE ASSY REAR, remove CONTROLLER CARD together with PWB BRACKET R (PL9.1.30) and PWB BRACKET L (PL.9. 1 . 29).
- 8) Remove CONTROLLER CARD from the front projections of PWB BRACKET R and PWB BRACKET L.
- 9) Remove SPRING EARTH ESS (PL9.1.37) from PWB BRACKET L.
- 10) Remove BLOCK PWBA (PL9.1.36) from CONTROLLER CARD.

## RRP9.1 CONTROLLER CARD (PL9.1.3)

## [Replacement]

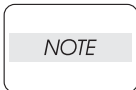

The replacement steps of procedure 1) to 3) are to be required for changing the PWB ESS. Those steps are not required for only removing it.

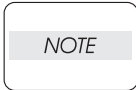

There are two NVM ROM on the PWB, do not attach the NVM ROM to the wrong position.

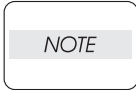

Do not press the PWB when removing the NVM ROM.

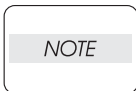

Take care not to bend the terminal section of NVM when carrying out the job described below.

- 1) Remove NVM, using a miniature screwdriver or the like, from the IC socket on old CONTROLLER CARD that was removed from the printer.
- 2) Remove NVM from IC socket on new CONTROLLER CARD using a miniature screwdriver or the like.

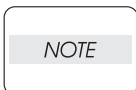

Do not use NVM removed from new CONTROLLER CARD.

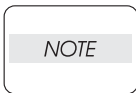

Carefully check the correct orientation of NVM when carrying out the following job.

- 3) Attach NVM that was removed from old CONTROLLER CARD on IC socket of new CONTROLLER CARD with its notch aligned with the notch in IC socket.
- 4) Attach BLOCK PWBA to CONTROLLER CARD.
- 5) Insert the bent part of the SPRING EARTH ESS to the groove of the PWB BRACKET L, attach the SPRING EARTH ESS to the PWB BRACKET L.
- 6) Attach PWB BRACKET R and PWB BRACKET L on CONTROLLER CARD with their front projections aligned.
- 7) Inserting the interface connector mounted on CONTROLLER CARD into the hole in PLATE ASSY REAR, install CONTROLLER CARD in place together with PWB BRACKET R and PWB BRACKET L.
- 8) Attach CONTROLLER CARD on PLATE ASSY REAR with the two screws (silver, 6 mm) and the three screws which are also used to fix the interface connector.
- 9) Attach the OPTION MULTI PROTOCOL CARD. (RRP9.11)
- 10) Attach the OPTION HDD ASSY. (RRP9.10)
- 11) Insert ESS ASSY into the printer, attach the connectors of CONTROLLER CARD and MACHINE CONTROL UNIT (MCU).
- 12) Attach CONTROLLER CARD to the printer using two SCREW KNURLING and a screw (silver, 6mm).
- 13) Attach PAPER TRAY COVER. (RRP3.2)



RRP9.1 Blank Page

RRP9.2 LVPS ASSY (REFERENCE ONLY)

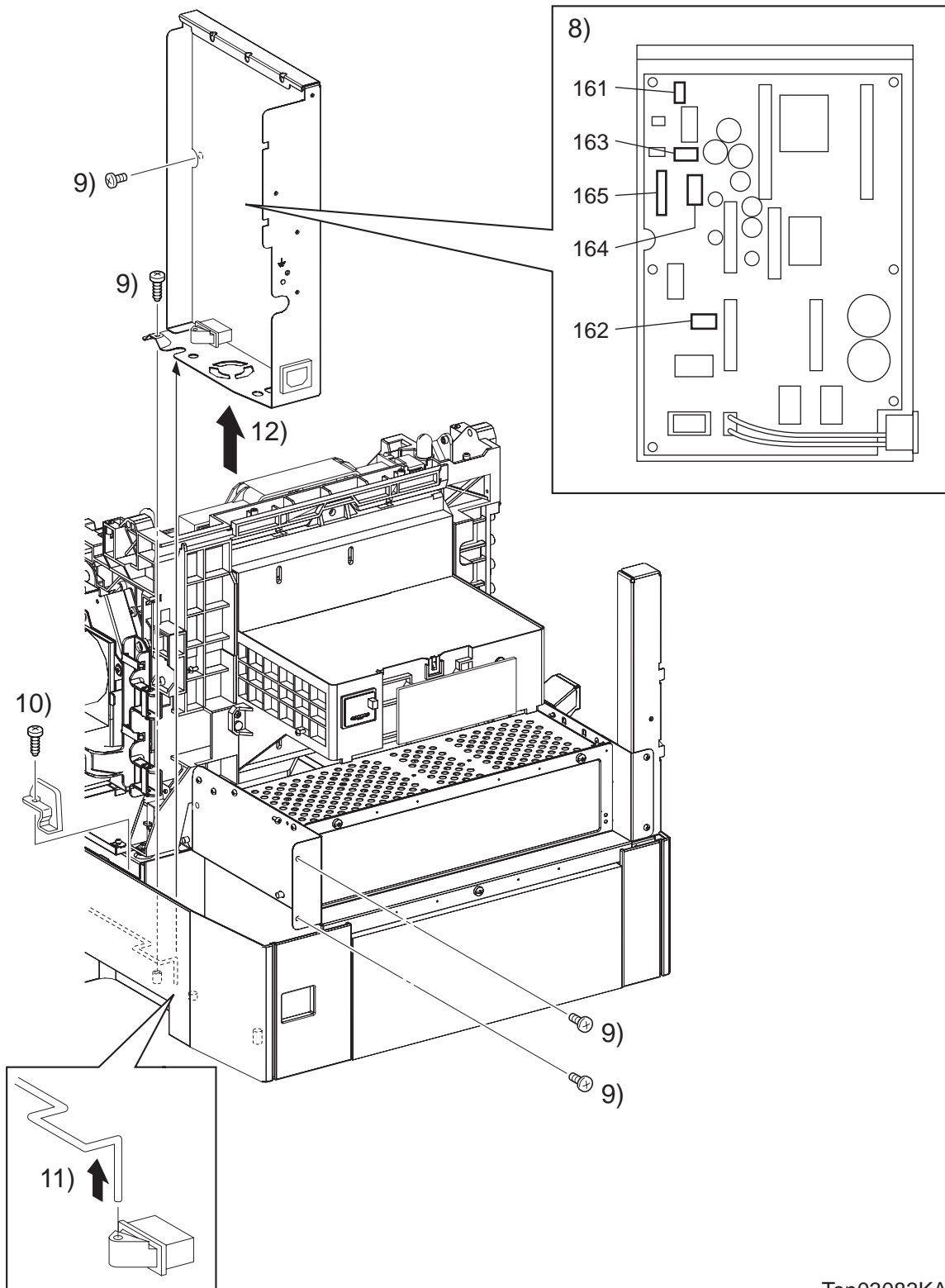

Ten03083KA

## RRP9.2 LVPS ASSY (REFERENCE ONLY)

## [Removal]

- 1) Remove TOP COVER FRAME. (RRP1.1)
- 2) Remove RIGHT SIDE COVER. (RRP1.7)
- 3) Remove LEFT SIDE COVER. (RRP1.12)
- 4) Remove COVER ASSY REAR. (RRP1.5)
- 5) Remove HIGH VOLTAGE POWER SUPPLY (HVPS). (RRP9.9)
- 6) Remove DUCT LV. (RRP7.13)
- 7) Remove TONER DISPENSER ASSEMBLY. (RRP7.4)
- 8) Remove the connector (P/J161, 162, 163, 164, 165) on LOW VOLTAGE POWER SUPPLY (LVPS).
- 9) Remove two screws (silver, 6 mm) fixing LVPS ASSY on the rear face of the printer and a screw (silver, tap, 10 mm) on the underside of the printer.
- 10) Remove the screw (silver, tap, 10mm) fixing SUPPORT LINK SW (PL3.1.6) and remove SUPPORT LINK SW.
- 11) Remove SHAFT LINK S/W (PL3.2.8) from the switch on LOW VOLTAGE POWER SUPPLY (LVPS).
- 12) Releasing SHAFT LINK S/W from the notch in LVPS ASSY, lift up and remove LOW VOLTAGE POWER SUPPLY (LVPS).

## [Replacement]

- 1) Pass SHAFT LINK S/W through the notch of LVPS ASSY. Match the holes of LVPS ASSY with the bosses at the two location on the lower section of the printer, fit the holes over the bosses.
- 2) Insert SHAFT LINK S/W into the switch on LOW VOLTAGE POWER SUPPLY (LVPS).
- 3) Attach SUPPORT LINK SW to the printer using a screw (silver, tap, 10mm).
- 4) Attach LVPS ASSY to the printer by tightening two screws (silver, 6mm) on its rear face side and a screw (silver, tap, 10mm) on its under side.
- 5) Attach the connector (P/J161, 162, 163, 164, and 165) to LOW VOLTAGE POWER SUPPLY (LVPS).
- 6) Attach TONER DISPENSER ASSEMBLY. (RRP7.4)
- 7) Attach DUCT LV. (RRP7.13)
- 8) Attach HIGH VOLTAGE POWER SUPPLY (HVPS). (RRP9.9)
- 9) Attach COVER ASSY REAR. (RRP1.5)
- 10) Attach LEFT SIDE COVER. (RRP1.12)
- 11) Attach RIGHT SIDE COVER. (RRP1.7)
- 12) Attach TOP COVER FRAME. (RRP1.1)

RRP9.3 LOW VOLTAGE POWER SUPPLY (LVPS) (PL9.1.6)

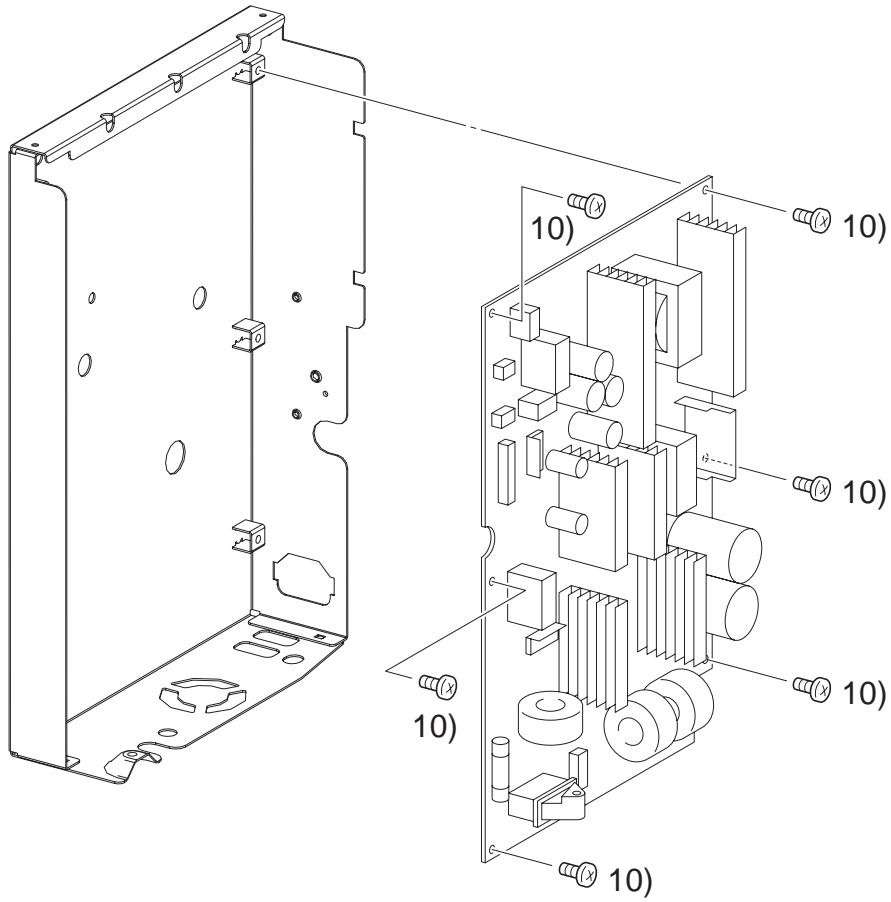

Ten03084KA

RRP9.3 LOW VOLTAGE POWER SUPPLY (LVPS) (PL9.1.6)

[Removal]

- 1) Remove TOP COVER FRAME. (RRP1.1)
- 2) Remove RIGHT SIDE COVER. (RRP1.7)
- 3) Remove LEFT SIDE COVER. (RRP1.12)
- 4) Remove COVER ASSY REAR. (RRP1.5)
- 5) Remove HIGH VOLTAGE POWER SUPPLY (HVPS). (RRP9.9)
- 6) Remove DUCT LV. (RRP7.13)
- 7) Remove TONER DISPENSER ASSEMBLY. (RRP7.4)
- 8) Remove LVPS ASSY. (RRP9.2)
- 9) Remove HARNESS ASSY AC INLET. (RRP9.4)
- 10) Remove six screws (silver, 6 mm) that fix LOW VOLTAGE POWER SUPPLY (LVPS) to BOX ASSY LVPS (PL9.1.4), remove LOW VOLTAGE POWER SUPPLY (LVPS).

[Replacement]

- 1) Attach LOW VOLTAGE POWER SUPPLY (LVPS) to BOX ASSY LVPS using six screws (silver, 6mm).
- 2) Attach HARNESS ASSY AC INLET. (RRP9.4)
- 3) Attach LVPS ASSY. (RRP9.2)
- 4) Attach TONER DISPENSER ASSEMBLY. (RRP7.4)
- 5) Attach DUCT LV. (RRP7.13)
- 6) Attach HIGH VOLTAGE POWER SUPPLY (HVPS). (RRP9.9)
- 7) Attach COVER ASSY REAR. (RRP1.5)
- 8) Attach LEFT SIDE COVER. (RRP1.12)
- 9) Attach RIGHT SIDE COVER. (RRP1.7)
- 10) Attach TOP COVER FRAME. (RRP1.1)

RRP9.4 HARNESS ASSY AC INLET (PL9.1.7)

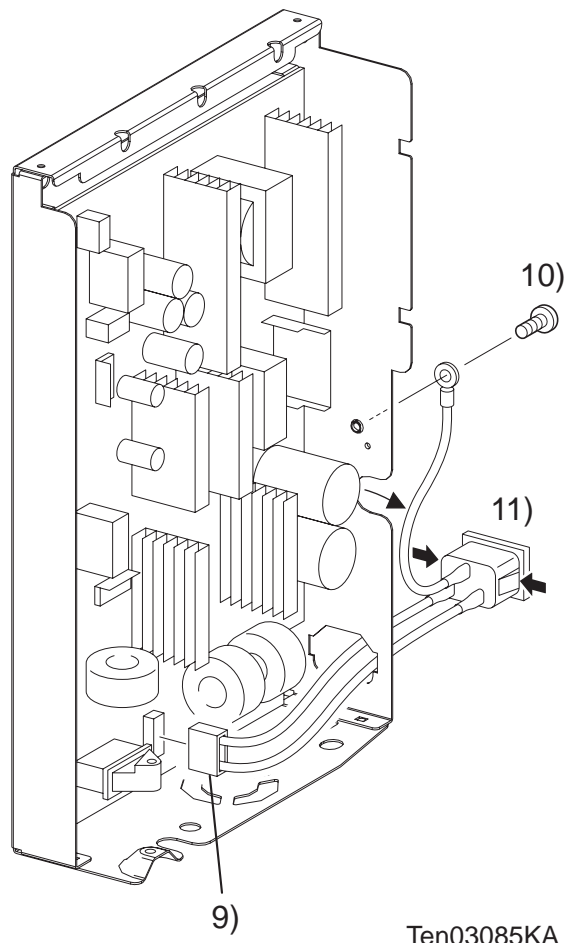

## RRP9.4 HARNESS ASSY AC INLET (PL9.1.7)

### [Removal]

- 1) Remove TOP COVER FRAME. (RRP1.1)
- 2) Remove RIGHT SIDE COVER. (RRP1.7)
- 3) Remove LEFT SIDE COVER. (RRP1.12)
- 4) Remove COVER ASSY REAR. (RRP1.5)
- 5) Remove HIGH VOLTAGE POWER SUPPLY (HVPS). (RRP9.9)
- 6) Remove DUCT LV. (RRP7.13)
- 7) Remove TONER DISPENSER ASSEMBLY. (RRP7.4)
- 8) Remove LVPS ASSY. (RRP9.2)
- 9) Remove the connector (P/J160) on LOW VOLTAGE POWER SUPPLY (LVPS).
- 10) Remove a screw (silver, 6 mm) that fix the ground wire to BOX ASSY LVPS (PL9.1.4).
- 11) Release the hooks at two locations on HARNESS ASSY AC INLET, remove HARNESS ASSY AC INLET through the hole of BOX ASSY LVPS.

### [Replacement]

- 1) Insert HARNESS ASSY AC INLET into the mounting hole of BOX ASSY LVPS.
- 2) Attach the ground wire to BOX ASSY LVPS using a screw (silver, 6 mm).
- 3) Attach the connector (P/J160) on LOW VOLTAGE POWER SUPPLY (LVPS).
- 4) Attach LVPS ASSY. (RRP9.2)
- 5) Attach TONER DISPENSER ASSEMBLY. (RRP7.4)
- 6) Attach DUCT LV. (RRP7.13)
- 7) Attach HIGH VOLTAGE POWER SUPPLY (HVPS). (RRP9.9)
- 8) Attach COVER ASSY REAR. (RRP1.5)
- 9) Attach LEFT SIDE COVER. (RRP1.12)
- 10) Attach RIGHT SIDE COVER. (RRP1.7)
- 11) Attach TOP COVER FRAME. (RRP1.1)

RRP9.5 HARNESS ASSY INTERLOCK (PL9.1.11)

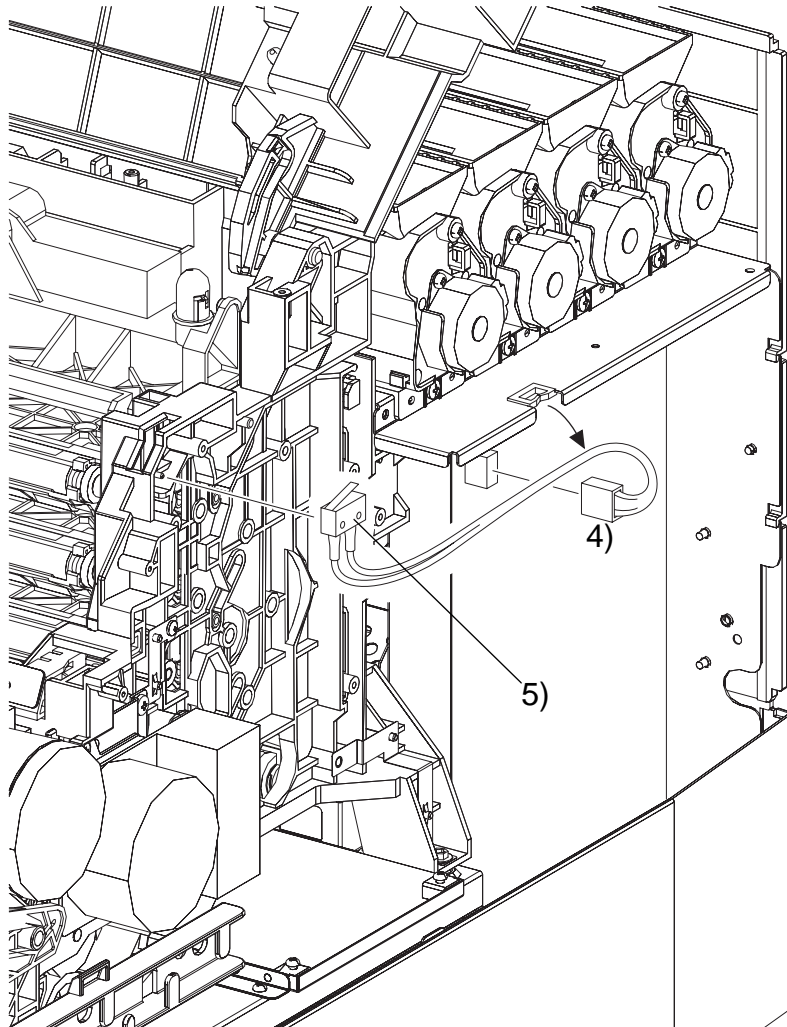

Ida\_Sec03\_089FB



## RRP9.5 HARNESS ASSY INTERLOCK (PL9.1.11)

### [Removal]

- 1) Remove TOP COVER FRAME. (RRP1.1)
- 2) Remove RIGHT SIDE COVER. (RRP1.7)
- 3) Remove DEVELOPER DRIVE ASSEMBLY. (RRP8.1)
- 4) Remove the connector (P/J161), that is connected to LOW VOLTAGE POWER SUPPLY (LVPS), from HARNESS ASSY INTERLOCK
- 5) Remove HARNESS ASSY INTERLOCK from the printer.

### [Replacement]

- 1) Attach HARNESS ASSY INTERLOCK to the printer.
- 2) Attach DEVELOPER DRIVE ASSEMBLY. (RRP8.1)
- 3) Pass the harness on HARNESS ASSY INTERLOCK through the clamp on DEVELOPER DRIVE ASSEMBLY.
- 4) Attach the connector (P/J161), to be connected to the harness on HARNESS ASSY INTERLOCK, to LOW VOLTAGE POWER SUPPLY (LVPS).
- 5) Attach RIGHT SIDE COVER. (RRP1.7)
- 6) Attach TOP COVER FRAME. (RRP1.1)

RRP9.6 PWBA EEPROM STD (PL9.1.12)

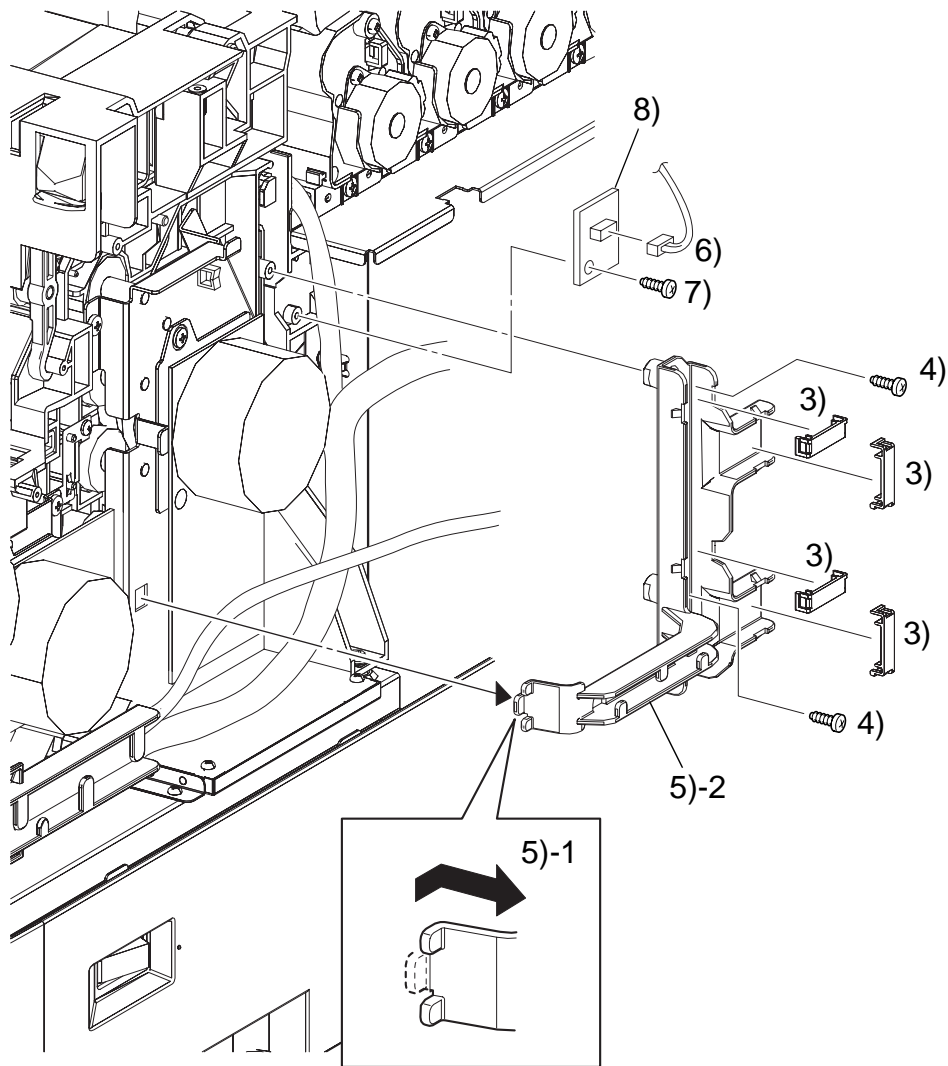

Ida\_Sec03\_090FB

## RRP9.6 PWBA EEPROM STD (PL9.1.12)

### [Removal]

- 1) Remove TOP COVER FRAME. (RRP1.1)
- 2) Remove RIGHT SIDE COVER. (RRP1.7)
- 3) Remove four CLAMP GUIDE HARNESSSES that fix the harness to GUIDE HARNESS R, remove the harness.
- 4) Remove two screws (silver, tap, 10mm) fixing GUIDE HARNESS R.
- 5) Release the hook on the front side of GUIDE HARNESS R from the hole of DEVELOPER DRIVE ASSEMBLY and remove GUIDE HARNESS R.
- 6) Remove the connector (P/J144), that is connected to PWBA EEPROM STD.
- 7) Remove a screw (silver, tap, 10mm) that fix PWBA EEPROM STD to the printer.
- 8) Remove PWBA EEPROM STD from the printer.

### [Replacement]

- 1) Attach PWBA EEPROM to the printer using a screw (silver, tap, 10mm).
- 2) Attach the connector (P/J144) to PWBA EEPROM.
- 3) Engage the hook on the front side of GUIDE HARNESS R to the hole of DEVELOPER DRIVE ASSEMBLY and attach GUIDE HARNESS R.
- 4) Fix GUIDE HARNESS R using two screws (silver, tap, 10mm).
- 5) Pass the harness through GUIDE HARNESS R and fix it using the four CLAMP GUIDE HARNESSSES.
- 6) Attach RIGHT SIDE COVER. (RRP1.7)
- 7) Attach TOP COVER FRAME. (RRP1.1)

RRP9.7 MACHINE CONTROL UNIT (MCU) (PL9.1.16)

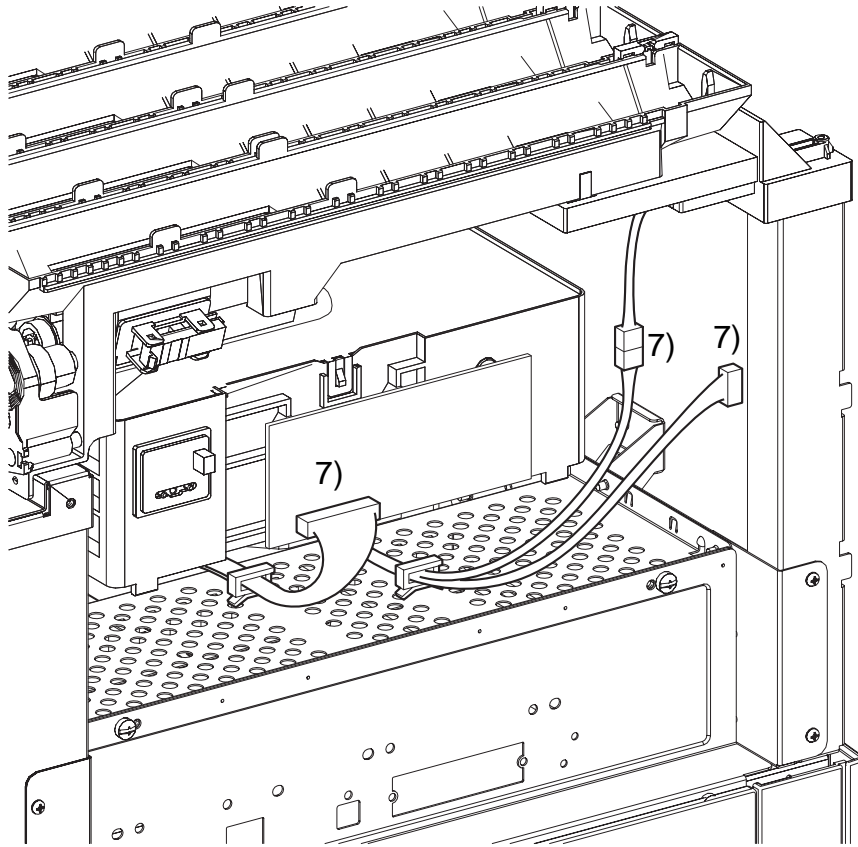

Ida\_Sec03\_112FB

RRP9.7 MACHINE CONTROL UNIT (MCU) (PL9.1.16)

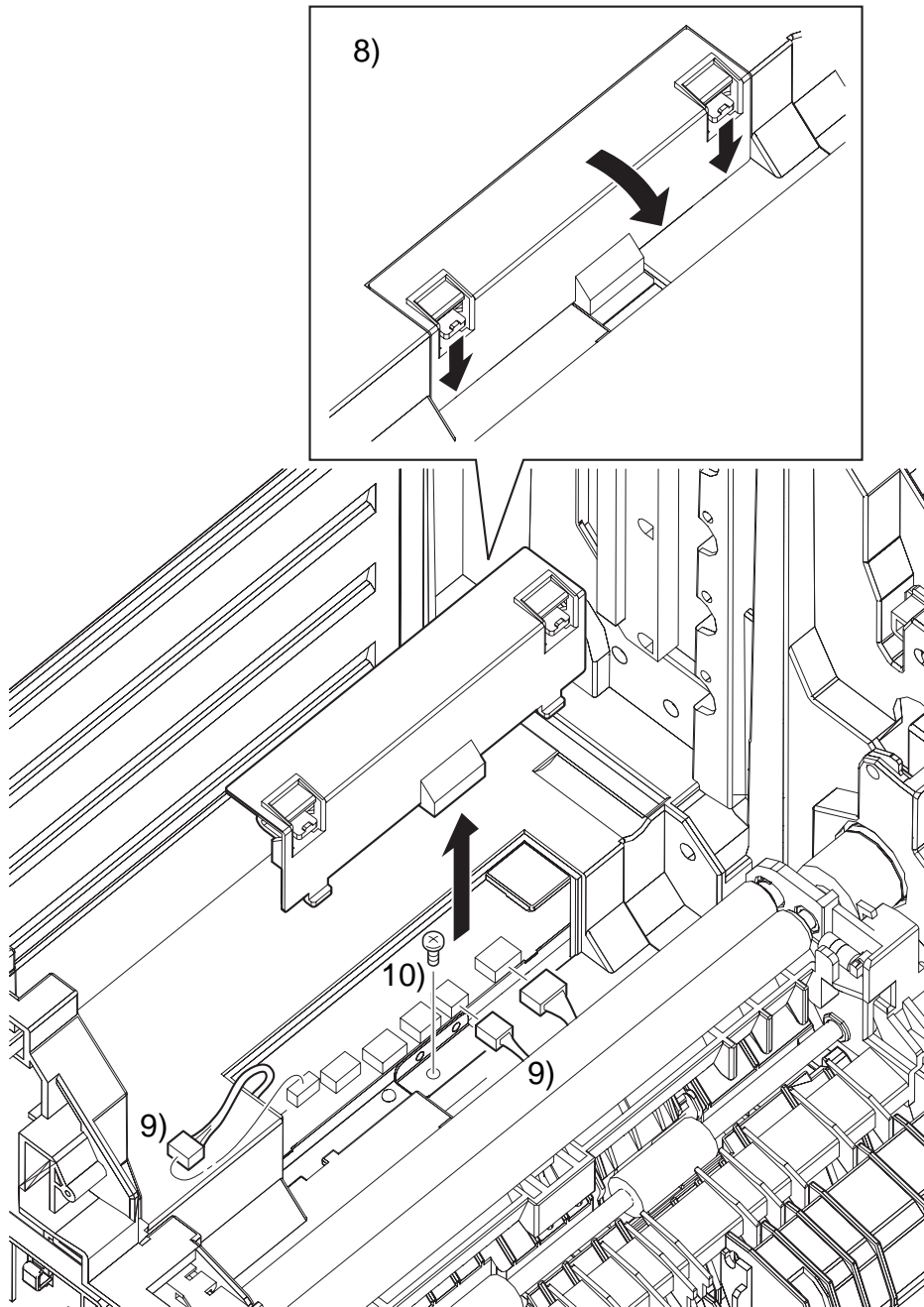

Ida\_Sec03\_091FB

RRP9.7 MACHINE CONTROL UNIT (MCU) (PL9.1.16)

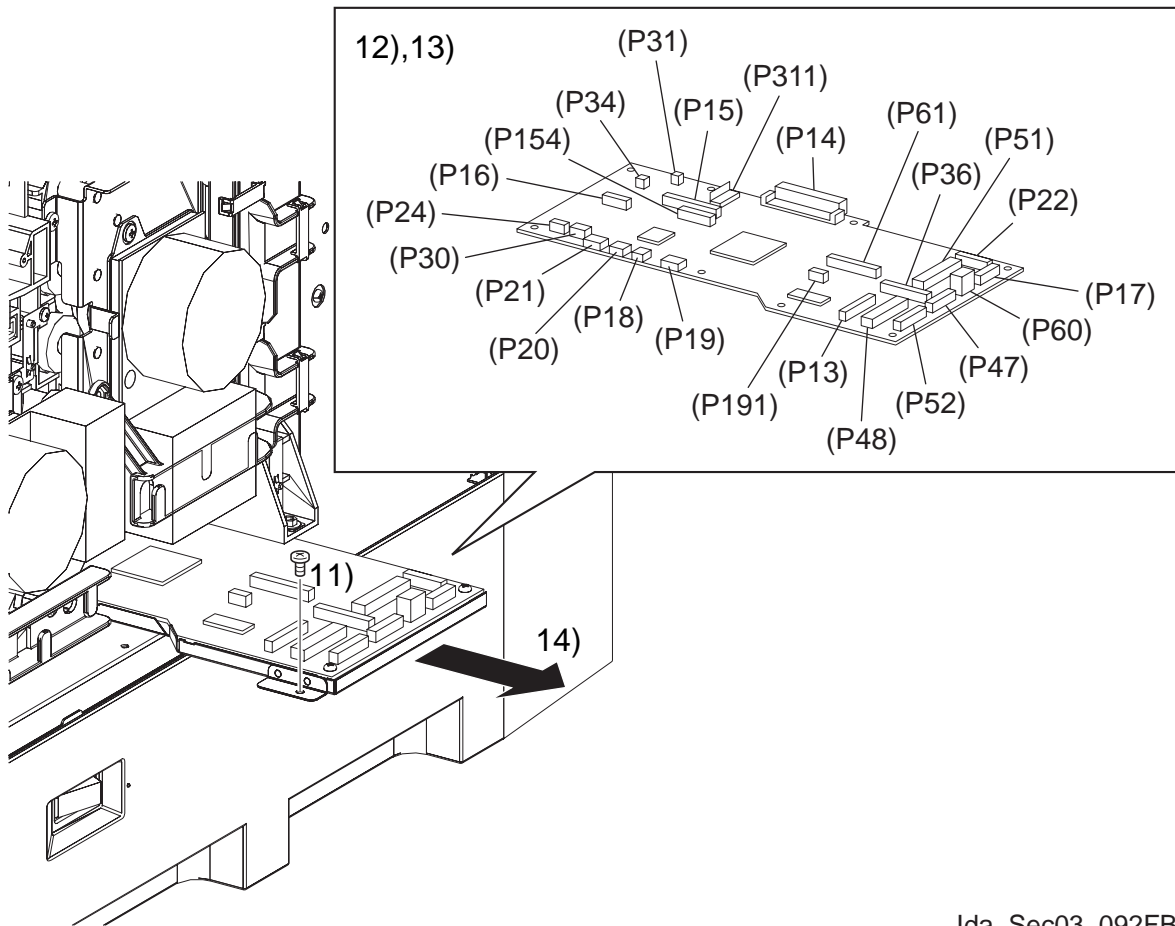

Ida\_Sec03\_092FB

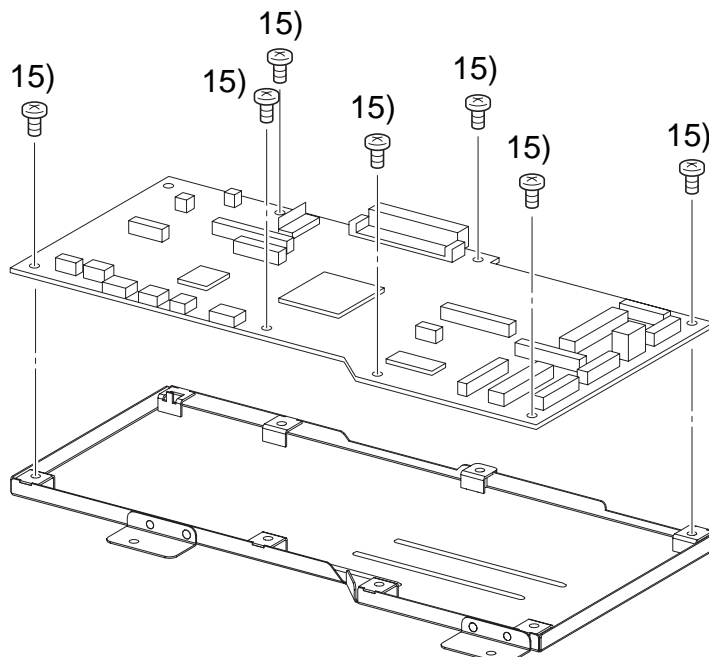

Ida\_Sec03\_094FB

## RRP9.7 MACHINE CONTROL UNIT (MCU) (PL9.1.16)

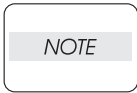

Use the wrist strap to protect the PWB from the electrostatic.

## [Removal]

- 1) Turn the power switch off. Remove the power cord from the wall outlet.
- 2) Remove TOP COVER FRAME. (RRP1.1)
- 3) Remove RIGHT SIDE COVER. (RRP1.7)
- 4) Remove LEFT SIDE COVER. (RRP1.12)
- 5) Remove COVER ASSY REAR. (RRP1.5)
- 6) Remove HIGH VOLTAGE POWER SUPPLY (HVPS). (RRP9.9)
- 7) Disconnect the three connectors (P/J151, P/J141, P/J3411) of the rear side of the printer, release the harness of the connectors from the clamp.
- 8) Release the hooks at two locations, of COVER ELEC (PL9.1.18), and remove hooks.

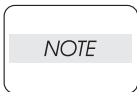

Take care not to allow the removed connectors to be drawn inside the printer.

- 9) Remove all connectors inside COVER ELEC.
- 10) Remove a screw (silver, 6 mm) that fixes BRACKET ASSY MCU inside COVER ELEC of the printer.
- 11) Remove a screw (silver, 6 mm) that fixes BRACKET ASSY MCU to the right side of the printer.
- 12) A little draw out BRACKET ASSY MCU from the right side of the printer. Remove all connectors that appear above MACHINE CONTROL UNIT (MCU).

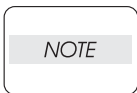

Take care not to allow the removed connectors to be drawn inside the printer.

- 13) Further draw out BRACKET ASSY MCU, remove all connectors on MACHINE CONTROL UNIT (MCU).
- 14) Remove BRACKET ASSY MCU from the printer.
- 15) Remove seven screws (silver, 6mm) that fix MACHINE CONTROL UNIT (MCU) to BRACKET ASSY MCU and remove MACHINE CONTROL UNIT (MCU).

**RRP9.7 MACHINE CONTROL UNIT (MCU) (PL9.1.16)****[Replacement]**

- 1) Attach BRACKET ASSY MCU to MACHINE CONTROL UNIT (MCU) using seven screws (silver, 6mm).
- 2) Attach the connectors, coming from inside the printer, to MACHINE CONTROL UNIT (MCU).

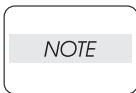

When attaching MCU, thrust MCU PWB while confirming that the harness is correctly routed.

- 3) Insert BRACKET ASSY MCU into the right side of the printer, attach all connectors.
- 4) Attach the connector (P/J24) coming from inside COVER ELEC of the printer to MACHINE CONTROL UNIT (MCU), attach all other connectors.
- 5) Attach BRACKET ASSY MCU to the printer using two screws.
- 6) Attach COVER ELEC by locking the hooks at the two locations.
- 7) Connect the three connectors (P/J151, P/J141, P/J3411) of the rear side of the printer, fix the harness of the connectors using the clamp.
- 8) Attach HIGH VOLTAGE POWER SUPPLY (HVPS). (RRP9.9)
- 9) Attach COVER ASSY REAR. (RRP1.5)
- 10) Attach LEFT SIDE COVER. (RRP1.12)
- 11) Attach RIGHT SIDE COVER. (RRP1.7)
- 12) Attach TOP COVER FRAME. (RRP1.1)
- 13) Insert the power cord into the wall outlet. Turn the power switch on.



RRP9.7 Blank Page

RRP9.8 SENSOR HUM (PL9.1.20)

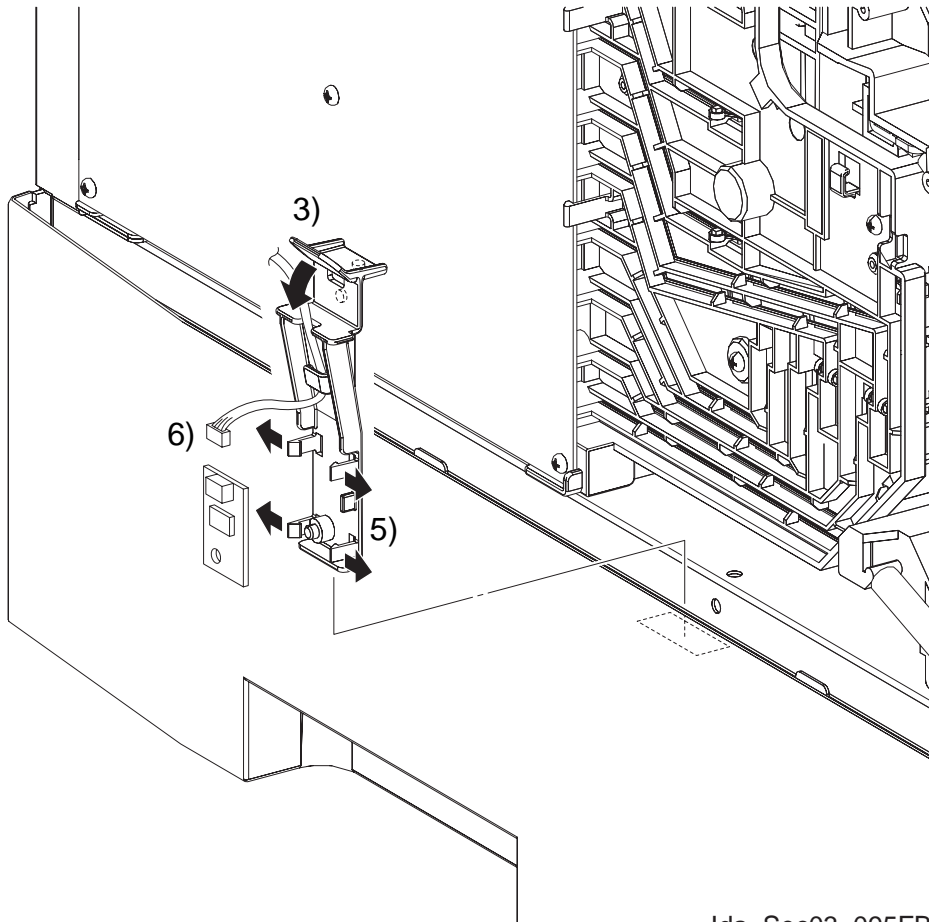

Ida\_Sec03\_095FB

## RRP9.8 SENSOR HUM (PL9.1.20)

### [Removal]

- 1) Remove TOP COVER FRAME. (RRP1.1)
- 2) Remove LEFT SIDE COVER. (RRP1.12)
- 3) Holding the knob of BRACKET TEMP (PL9.1.19) mounted on the left side of the printer, press down the knob to release the boss.
- 4) Lift up BRACKET TEMP.
- 5) Release the hooks, at four locations, that fix SENSOR HUM to BRACKET TEMP, remove SENSOR HUM.
- 6) Remove the connector (P/J231) that is connected to SENSOR HUM, and remove SENSOR HUM.

### [Replacement]

- 1) Attach the connector (P/J231) to SENSOR HUM.
- 2) Attach SENSOR HUM to BRACKET TEMP.
- 3) Insert BRACKET TEMP in the notch in the bottom plate on the left side of the printer.
- 4) Holding the knob of BRACKET TEMP, insert the bosses, at two locations, into the holes and lock them.
- 5) Attach LEFT SIDE COVER. (RRP1.12)
- 6) Attach TOP COVER FRAME. (RRP1.1)

RRP9.9 HIGH VOLTAGE POWER SUPPLY (HVPS) (PL9.1.21)

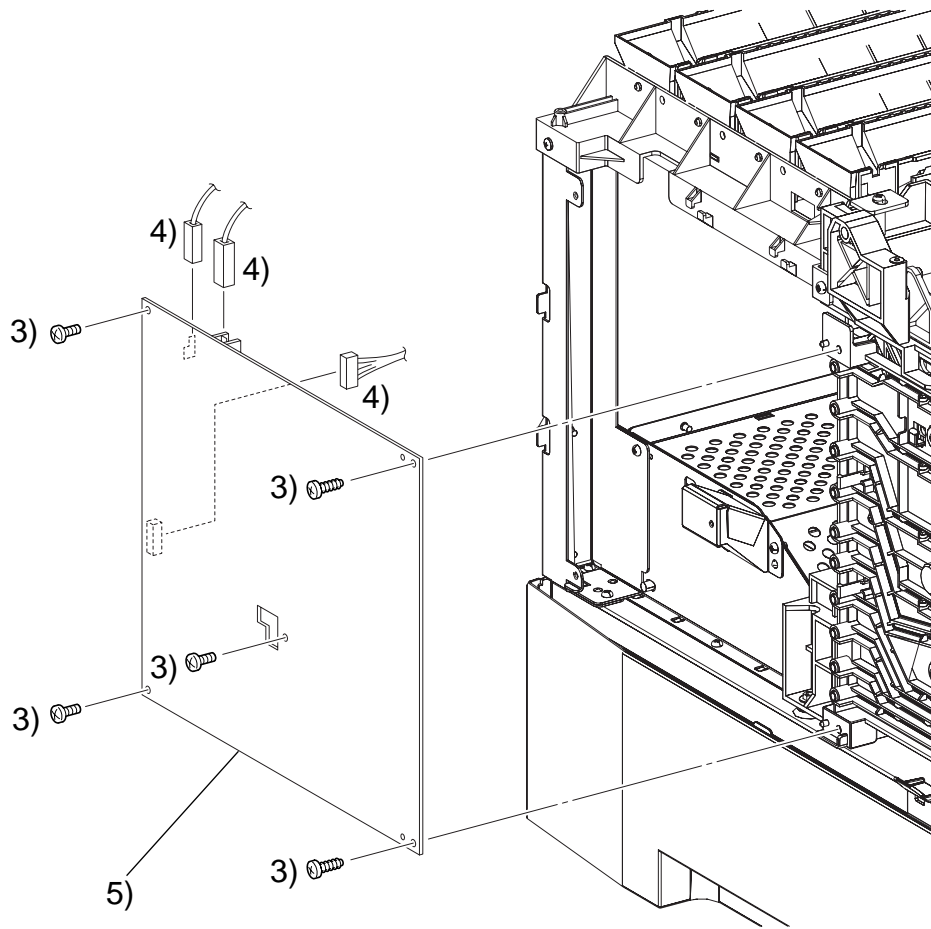

Ida\_Sec03\_096FB

RRP9.9 HIGH VOLTAGE POWER SUPPLY (HVPS) (PL9.1.21)

[Removal]

- 1) Remove TOP COVER FRAME. (RRP1.1)
- 2) Remove LEFT SIDE COVER. (RRP1.12)
- 3) Remove two screws (silver, tap, 10mm) and three screws (silver, 6mm) fixing HIGH VOLTAGE POWER SUPPLY (HVPS) from the left side of the printer.
- 4) Separate the HIGH VOLTAGE POWER SUPPLY (HVPS) a little from the left face side of the printer and remove the connector (P/J141), WIRE ASSY BTR and WIRE ASSY REGI.
- 5) Remove HIGH VOLTAGE POWER SUPPLY (HVPS) from the left side of the printer.

[Replacement]

- 1) Connect the connector (P/J141), WIRE ASSY BTR and WIRE ASSY REGI to the HIGH VOLTAGE POWER SUPPLY (HVPS).
- 2) Match the holes in HIGH VOLTAGE POWER SUPPLY (HVPS) with the bosses at two locations on the left side of the printer.
- 3) Attach HIGH VOLTAGE POWER SUPPLY (HVPS) with two screws (silver, tap, 10mm) and three screws (silver, 6mm) on the left face side of the printer.
- 4) Attach LEFT SIDE COVER. (RRP1.12)
- 5) Attach TOP COVER FRAME. (RRP1.1)

RRP9.10 OPTION HDD ASSY (PL9.1.25)

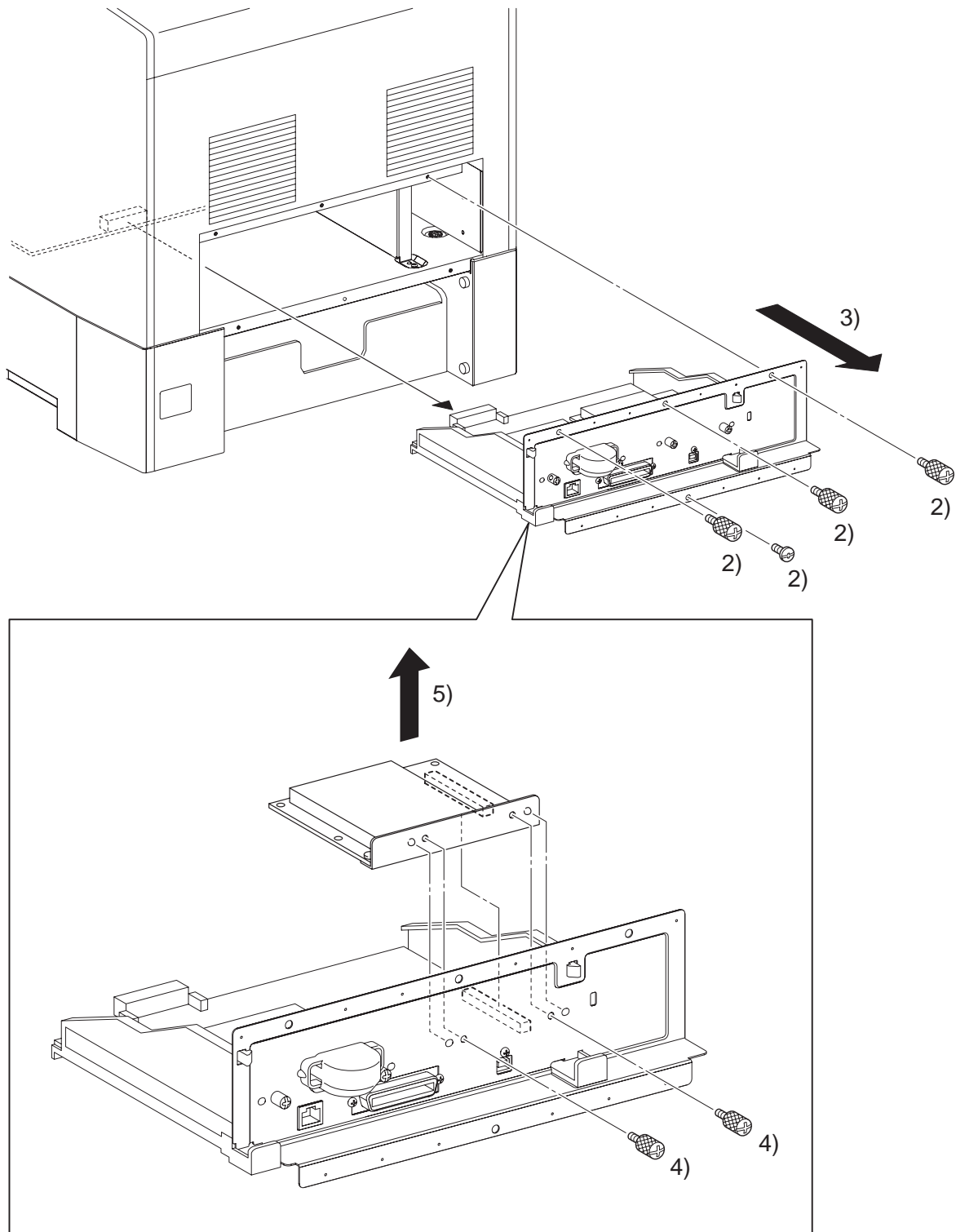

Ten03119KA

## RRP9.10 OPTION HDD ASSY (PL9.1.25)

### [Removal]

- 1) Remove PAPER TRAY COVER. (RRP3.2)
- 2) Remove three SCREW KNURLING (PL9.1.32) and a screw (silver, 6mm) that fix ESS ASSY to the printer.
- 3) Holding two handles of the ESS ASSY, draw it out.
- 4) Remove the two SCREW KNURLING that fix the OPTION HDD ASSY (PL9.1.25) to the ESS ASSY.
- 5) Lift up the OPTION HDD ASSY to disconnect the connector, remove the OPTION HDD ASSY from the ESS ASSY.

### [Replacement]

- 1) Match the two bosses of the OPTION HDD ASSY with the holes of the PLATE ASSY REAR (PL9.1.2), connect the connector of the CONTROLLER CARD (PL9.1.3) and the connector of the OPTION HDD ASSY.
- 2) Attach the OPTION HDD ASSY to the ESS ASSY using the two SCREW KNURLING.
- 3) Insert ESS ASSY into the printer, attach the connectors of CONTROLLER CARD and MACHINE CONTROL UNIT (MCU). (PL9.1.16)
- 4) Attach CONTROLLER CARD to the printer using two SCREW KNURLING and a screw (silver, 6mm).
- 5) Attach PAPER TRAY COVER. (RRP3.2)

RRP9.11 OPTION MULTI PROTOCOL (PL9.1.26)

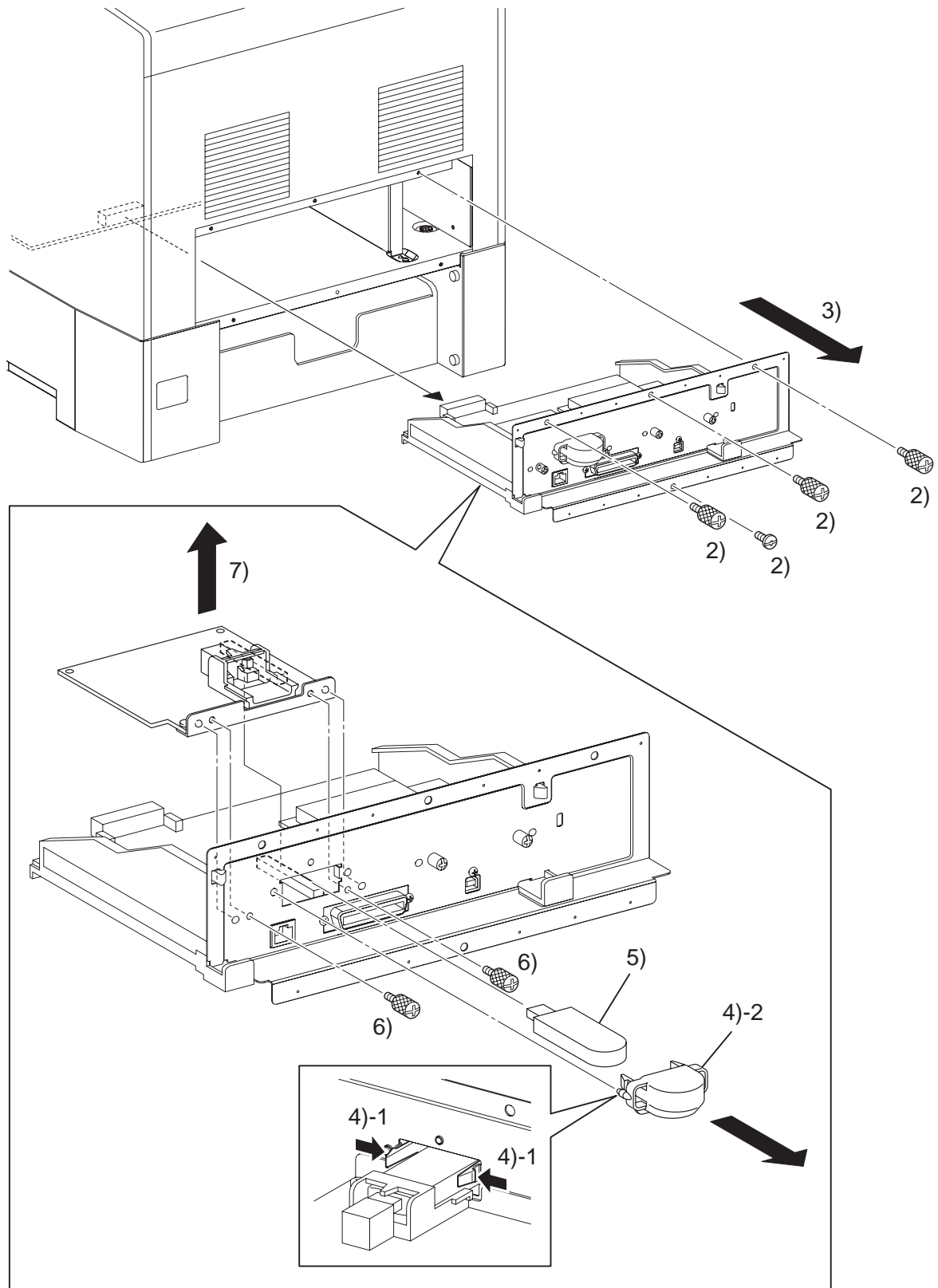

Ten03120KA



## RRP9.11 OPTION MULTI PROTOCOL (PL9.1.26)

### [Removal]

- 1) Remove PAPER TRAY COVER. (RRP3.2)
- 2) Remove three SCREW KNURLING (PL9.1.32) and a screw (silver, 6mm) that fix ESS ASSY to the printer.
- 3) Holding two handles of the ESS ASSY, draw it out.
- 4) Release the two hooks of the OPTION COVER USB (PL9.1.34), remove it from the ESS ASSY.
- 5) Remove the OPTION WIRELESS LAN ADAPTER (PL9.1.33) from the OPTION MULTI PROTOCOL CARD (PL9.1.26).
- 6) Remove the two SCREW KNURLING that fix the OPTION MULTI PROTOCOL CARD to the ESS ASSY.
- 7) Lift up the OPTION MULTI PROTOCOL CARD to disconnect the connector, remove the OPTION MULTI PROTOCOL CARD from the ESS ASSY.

### [Replacement]

- 1) Match the two bosses of the OPTION MULTI PROTOCOL CARD with the holes of the PLATE ASSY REAR (PL9.1.2), connect the connector of the CONTROLLER CARD (PL9.1.3) and the connector of the OPTION MULTI PROTOCOL CARD.
- 2) Attach the OPTION MULTI PROTOCOL CARD to the ESS ASSY using the two SCREW KNURLING.
- 3) Attach the OPTION WIRELESS LAN ADAPTER to the OPTION MULTI PROTOCOL CARD.
- 4) Attach the OPTION COVER USB to the ESS ASSY, fix it using the two hooks.
- 5) Insert ESS ASSY into the printer, attach the connectors of CONTROLLER CARD and MACHINE CONTROL UNIT (MCU). (PL9.1.16)
- 6) Attach CONTROLLER CARD to the printer using two SCREW KNURLING and a screw (silver, 6mm).
- 7) Attach PAPER TRAY COVER. (RRP3.2)

**Chapter 4 Plug/Jack(P/J) Connector Locations CONTENTS**

---

- 1. Connector [P (plug) / J (jack)].....4 - 1
  - 1.1 List of P/J ..... 4 - 1
  - 1.2 IOT P/J layout diagram ..... 4 - 3

**Chapter 4 Plug/Jack(P/J) Connector Locations CONTENTS**

---

## 1. Connector [P (plug) / J (jack)]

### 1.1 List of P/J

P/J	Coordinates	Remarks
13	H-143	Connects PWBA MCU and FRONT/DUP Harness Assembly
14	G-142	Connects PWBA MCU and PWBA ESS
15	F-142	Connects PWBA MCU and ROS Harness Assembly
16	F-142	Connects PWBA MCU and HVPS Harness Assembly
17	I-143	Connects PWBA MCU and OPFPLG Harness Assembly
18	F-143	Connects PWBA MCU and REGI SNS Harness Assembly
19	F-143	Connects PWBA MCU and FRONTCLH Harness Assembly
20	F-143	Not Connects
21	E-142	Not Connects
22	I-143	Connects PWBA MCU and OPEPANE2 Harness Assembly
24	E-142	Connects PWBA MCU and TMP Harness Assembly
30	E-142	Flash Write
31	F-142	Test Print
34	F-142	Connects PWBA MCU and RFID Harness Assembly
36	H-143	Connects PWBA MCU and FSR/ADC Harness Assembly
47	H-143	Connects PWBA MCU and FDR Harness Assembly
48	H-143	Connects PWBA MCU and HAN/PHD/MOT Harness Assembly
51	H-143	Connects PWBA MCU and TNR Harness Assembly
52	H-143	Connects PWBA MCU and TNR FULL/FSR Harness Assembly
60	I-143	Connects PWBA MCU and 24V Harness Assembly
61	H-143	Connects PWBA MCU and LV Harness Assembly
132	H-109	Connects MSI Feed Solenoid and FRONT/DUP Harness Assembly
133	D-108	Connects Dup Jam Sensor and FRONT/DUP Harness Assembly
134	F-106	Connects Full Stack Sensor and FRONT/DUP Harness Assembly
135	E-109	Connects MSI No Paper Sensor and FRONT/DUP Harness Assembly
136	D-122	Connects ADC Sensor and FSR/ADC Harness Assembly
141	E-135	Connects PWBA HVPS and HVPS Harness Assembly
142	E-122	Connects Toner sensor and TNR FULL/FSR Harness Assembly
144	H-121	Connects EEPROM and EEPROM Harness Assembly
151	H-120	Connects Ros and ROS Harness Assembly
160	I-128	Connects PWBA LVPS and A.C Inlet
161	I-126	Connects PWBA LVPS and Interlock Switch
162	I-128	Connects PWBA LVPS and FSR/ADC Harness Assembly
163	I-126	Connects PWBA LVPS and 24V Harness Assembly
164	I-127	Connects PWBA LVPS and LV PRG Harness Assembly
165	I-127	Connects PWBA LVPS and LV Harness Assembly
166	I-126	Connects PWBA LVPS and Rear Fan
167	I-126	Connects PWBA LVPS and LV Fan
171	G-154	Connects Option Feeder and OPFPLG Harness Assembly
181	E-138	Connects REGI Sensor and REGI SNS Harness Assembly
190	F-138	Connects MSI Turn Clutch and FRONTCLH Harness Assembly
191	G-143	Connects PWBA MCU and EEPROM Harness Assembly
192	F138	Connects REGI Clutch and FRONTCLH Harness Assembly
220	C-106	Connects Opepane and OPEPANE Harness Assembly
231	B-153	Connects HUM Sensor and TMP Harness Assembly
311	G-142	Connects PWBA MCU and LV RPG Harness Assembly
341	E-105	Connects Antenna and RFID2 Harness Assembly

<b>P/J</b>	<b>Coordiates</b>	<b>Remarks</b>
342	E-105	Connects Antenna and TNR Harness Assembly
361	F-122	Connects Fuser Assy and FSR/ADC Harness Assembly
471	H-154	Connects Size Switch and FDR Harness Assembly
472	G-153	Connects No Paper Sensor and FDR Harness Assembly
474	G-153	Connects Feed Solenoid and FDR Harness Assembly
481	G-123	Connects Main Motor and FAN/PHD/MOT Harness Assembly
482	E-107	Connects Front Fan and FAN/PHD/MOT Harness Assembly
484	E-119	Connects PHD2 Harness Assembly and FAN/PHD/MOT Harness Assembly
491	H-123	Connects DEVE Motor and FAN/PHD/MOT Harness Assembly
501	C-107	Connects Dup Motor and FRONT/DUP Harness Assembly
511	H-106	Connects Toner Motor (Y) and TNR Harness Assembly
512	I-106	Connects Toner Motor (M) and TNR Harness Assembly
513	I-106	Connects Toner Motor (C) and TNR Harness Assembly
514	J-106	Connects Toner Motor (K) and TNR Harness Assembly
521	F-123	Connects Fuser Motor and TNR FULL/FSR Harness Assembly
701	G-106	Connects No Toner Sensor (Y) and TNR Harness Assembly
702	H-106	Connects No Toner Sensor (M) and TNR Harness Assembly
703	H-106	Connects No Toner Sensor (C) and TNR Harness Assembly
704	I-105	Connects No Toner Sensor (K) and TNR Harness Assembly
710	D-119	Connects Crum and PHD2 Harness Assembly
3411	F-106	Connects RFID2 Harness Assembly and RFID Harness Assembly

1.2 IOT P/J layout diagram

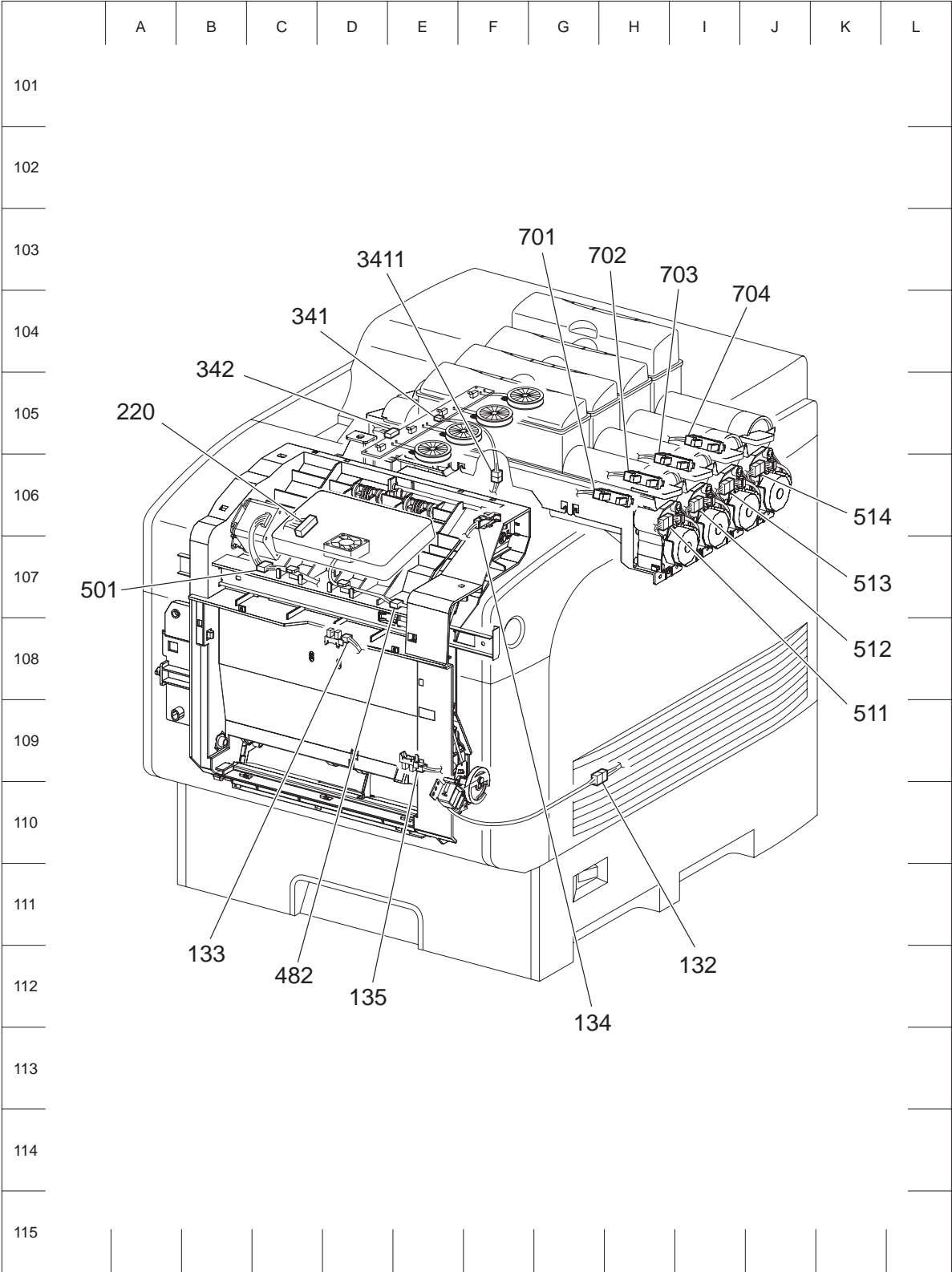

Ten04001KA

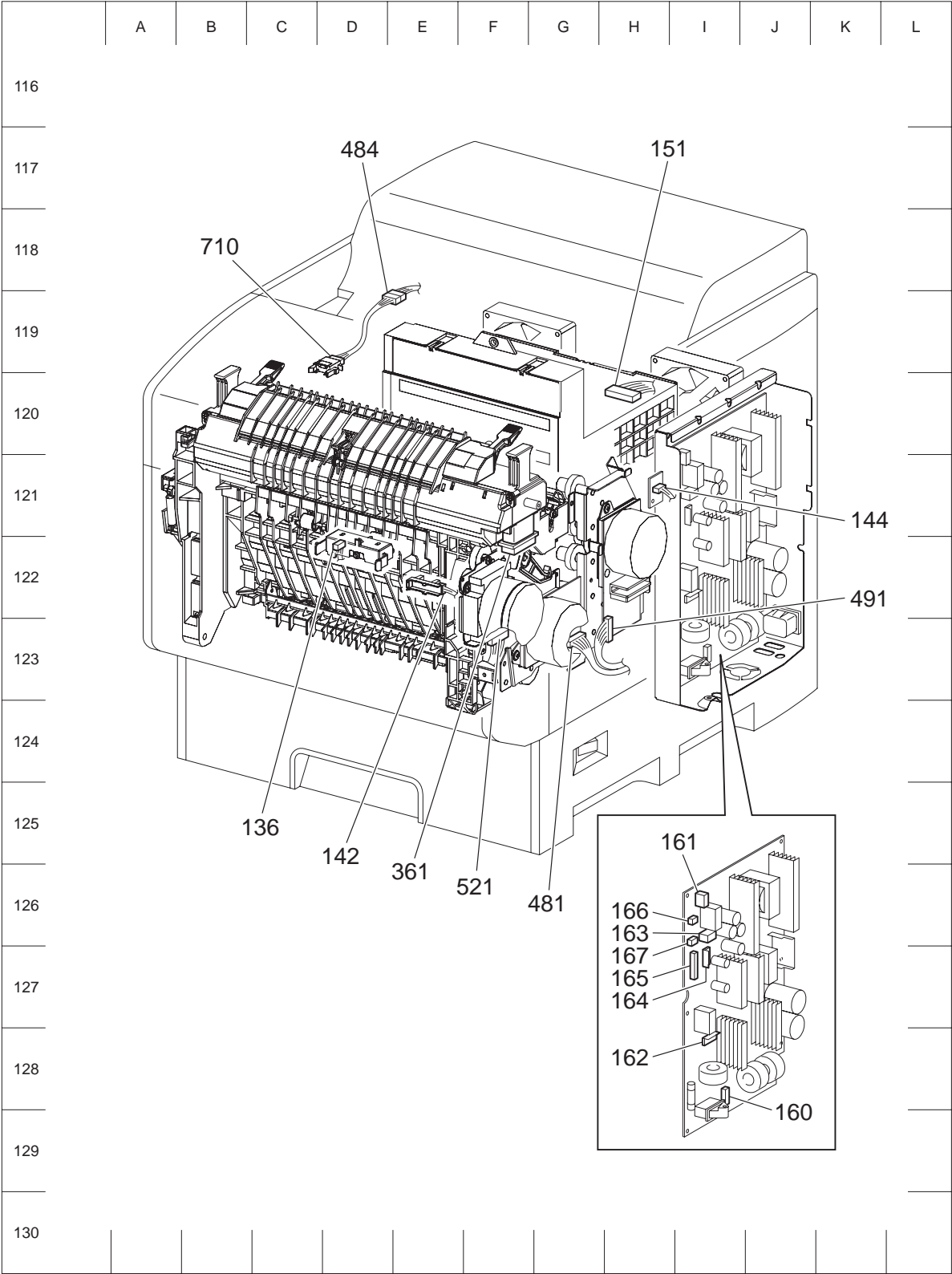

Ten04002KA

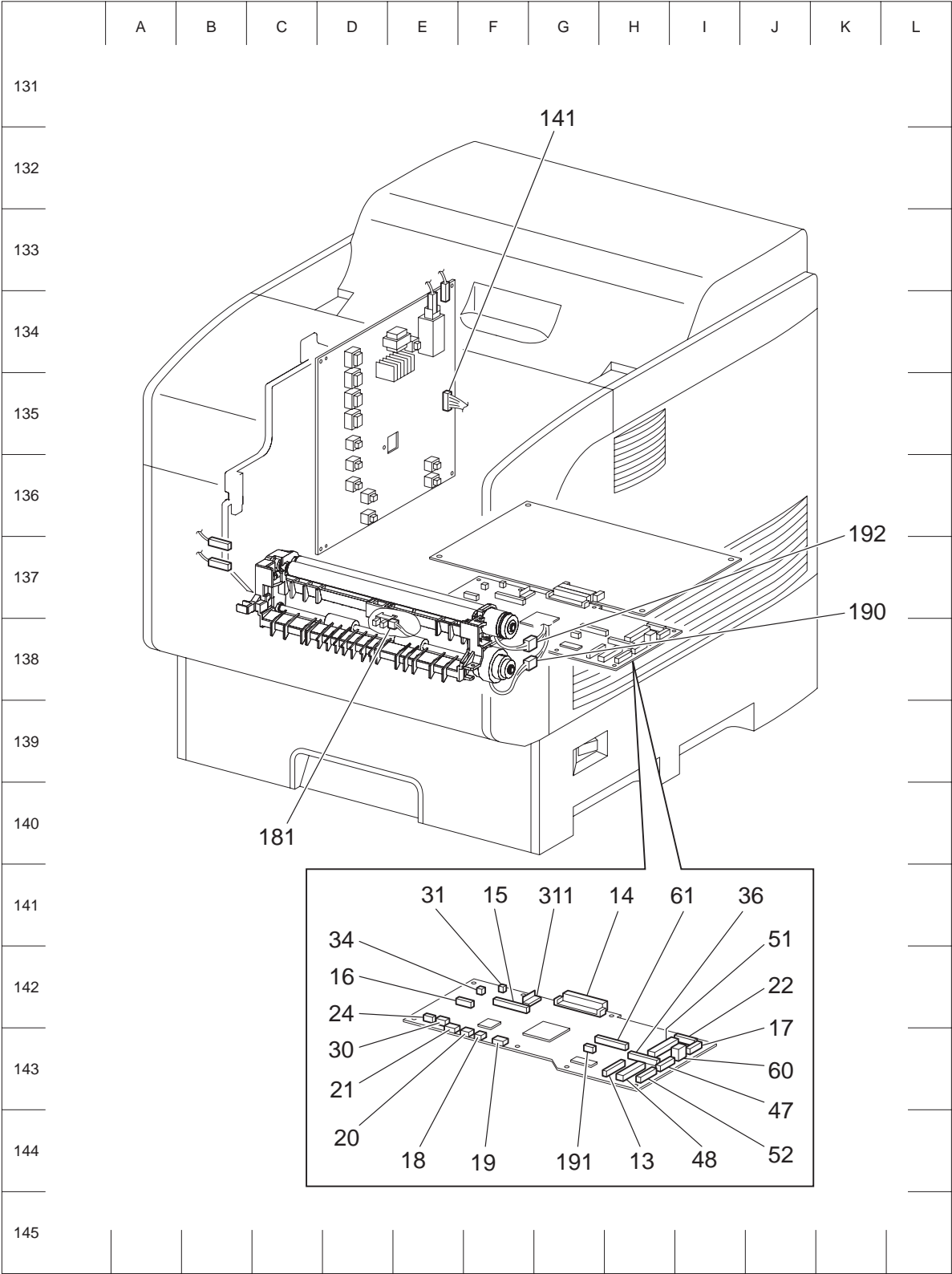

Ten04003KA



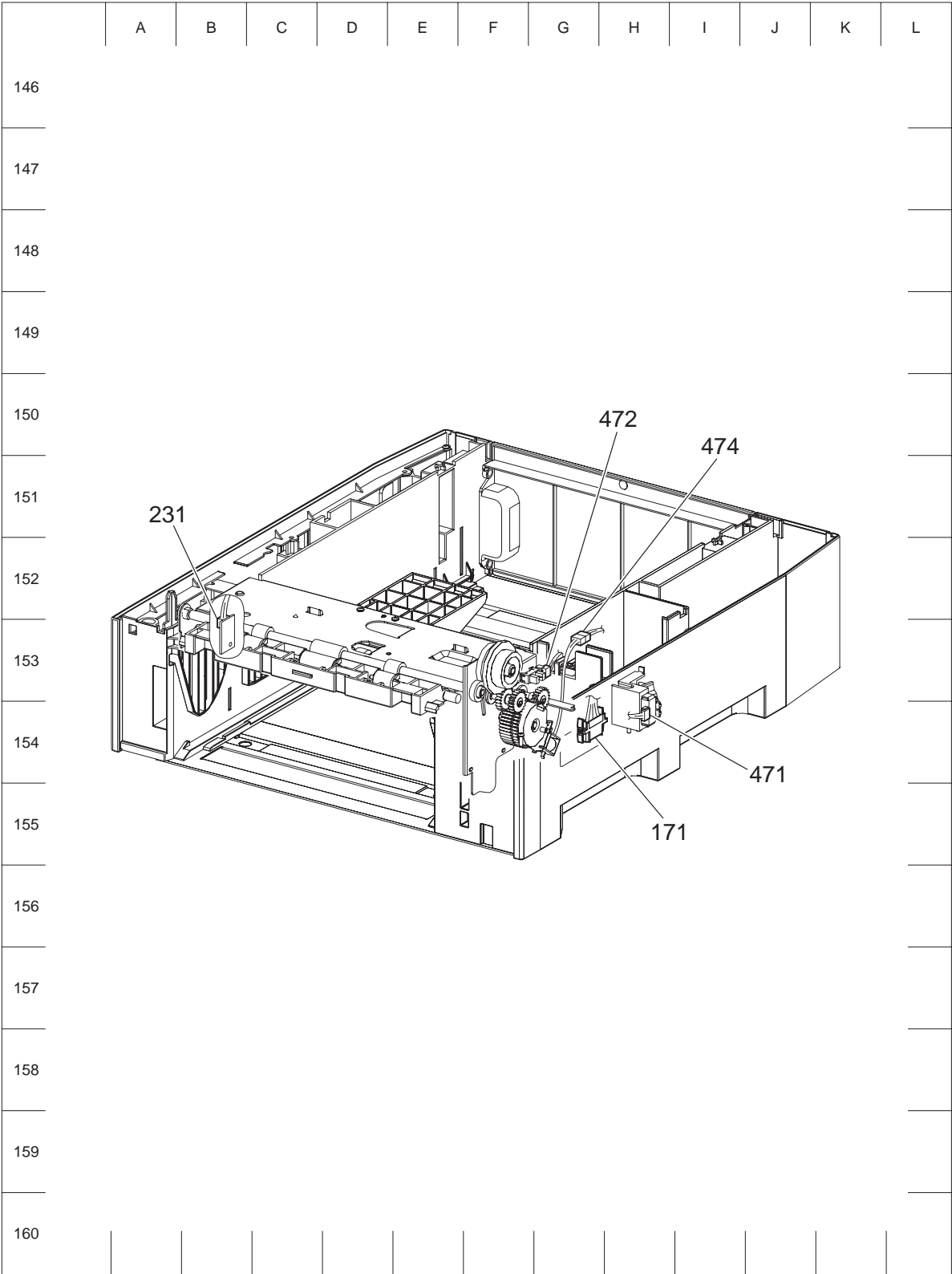

Ida\_Sec04\_004FA

## Chapter 5 Parts List CONTENTS

---

1. Parts List.....	5 - 1
1.1 Caution for use of parts list .....	5 - 1
1.2 Caution for use of engineering parts list .....	5 - 1
Spare parts illustration.....	5 - 2
Engineering parts list.....	5 - 8
PL1.1 Cover [Illustration].....	5 - 8
PL1.1 Cover [List] .....	5 - 9
PL2.1 Paper Cassette [Illustration] .....	5 - 10
PL2.1 Paper Cassette [List] .....	5 - 11
PL3.1 Paper Feeder (1/3) [Illustration].....	5 - 12
PL3.1 Paper Feeder (1/3) [List].....	5 - 13
PL3.2 Paper Feeder (2/3) [Illustration].....	5 - 14
PL3.2 Paper Feeder (2/3) [List].....	5 - 15
PL3.3 Paper Feeder (3/3) [Illustration].....	5 - 16
PL3.3 Paper Feeder (3/3) [List].....	5 - 17
PL4.1 Retard & Regi assy (1/2) [Illustration].....	5 - 18
PL4.1 Retard & Regi assy (1/2) [List].....	5 - 19
PL4.2 Retard & Regi assy (2/2) [Illustration].....	5 - 20
PL4.2 Retard & Regi assy (2/2) [List].....	5 - 21
PL5.1 Chute Assy In & Out (1/4) [Illustration] .....	5 - 22
PL5.1 Chute Assy In & Out (1/4) [List] .....	5 - 23
PL5.2 Chute Assy In & Out (2/4) [Illustration] .....	5 - 24
PL5.2 Chute Assy In & Out (2/4) [List] .....	5 - 25
PL5.3 Chute Assy In & Out (3/4) [Illustration] .....	5 - 26
PL5.3 Chute Assy In & Out (3/4) [List] .....	5 - 27
PL5.4 Chute Assy In & Out (4/4) [Illustration] .....	5 - 28
PL5.4 Chute Assy In & Out (4/4) [List] .....	5 - 29
PL6.1 Xerographics [Illustration].....	5 - 30
PL6.1 Xerographics [List].....	5 - 31
PL7.1 Development (1/2) [Illustration].....	5 - 32
PL7.1 Development (1/2) [List] .....	5 - 33
PL7.2 Development (2/2) [Illustration].....	5 - 34
PL7.2 Development (2/2) [List] .....	5 - 35
PL8.1 Drive [Illustration].....	5 - 36
PL8.1 Drive [List].....	5 - 37
PL9.1 Electrical [Illustration].....	5 - 38
PL9.1 Electrical [List] .....	5 - 39
PL10.1 Harness [Illustration].....	5 - 40
PL10.1 Harness [List].....	5 - 41

**Chapter 5 Parts List CONTENTS**

---

## 1. Parts List

### 1.1 Caution for use of parts list

- ◆ Available spare parts are shown in the illustration by name.
- ◆ [Ref PL X.Y.Z] shown below the part name denotes the item is "Z" in the plate "PL X.Y" of the engineering part list.
- ◆ For the detailed composition of the KIT parts, check with the engineering part list.

### 1.2 Caution for use of engineering parts list

- ◆ The figures indicating the illustrations are the item No. in the list and present correspondence between the illustrations and parts.
- ◆ The notation of PL "X.Y.Z" is composed of the plate (PL), item "X.Y", and parts "Z".
- ◆ The alphabet characters in the illustrations represent screws and clips as follows:  
"S": screw, "E": E-ring, "KL": KL clip, "C": C-ring, and "N": nut
- ◆ "q" mark in the illustrations are attached to items indicating assembly parts in the illustrations.
- ◆ Encircled alphabetical figures in the illustrations indicate interrupted leader lines. Same characters in the illustrations represent lines to be connected.
- ◆ The mark "(with 2-5)" attached to assembly parts on the illustrations and lists represents that the items "2, 3, 4, and 5" of that plate are contained and the mark "(with 2-5, PL6.1.1)" represent that the item "2, 3, 4, and 5" of that plate and the item "1" of the plate "6.1" are contained.
- ◆ The mark "[Ref PLX.Y.Z]" attached to parts in the illustrations and lists represents that the parts is the same as the parts of the item "Z" of the plate "X.Y".
- ◆ The mark "\*" attached to parts in the list represents "Note" or "Reference" about that parts is contained in the same page.

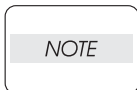

**For spare parts, refer to the "Spare parts list" which is issued separately.**

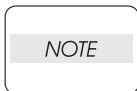

**For the connector (P/J), parts such as harness, wire, etc. in the list, refer to "Chapter 7, Electric wiring"**

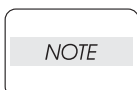

**It should be noted that configuration of parts may be different or some parts are not used depending on specifications of OEM.**

Spare parts illustration

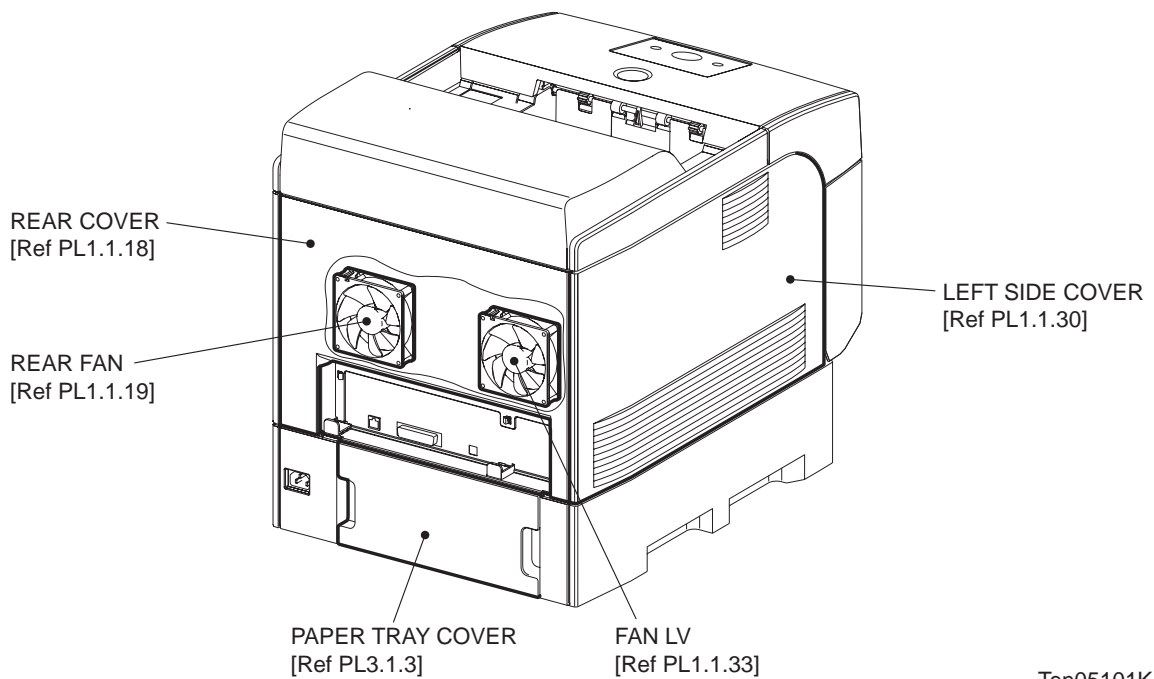
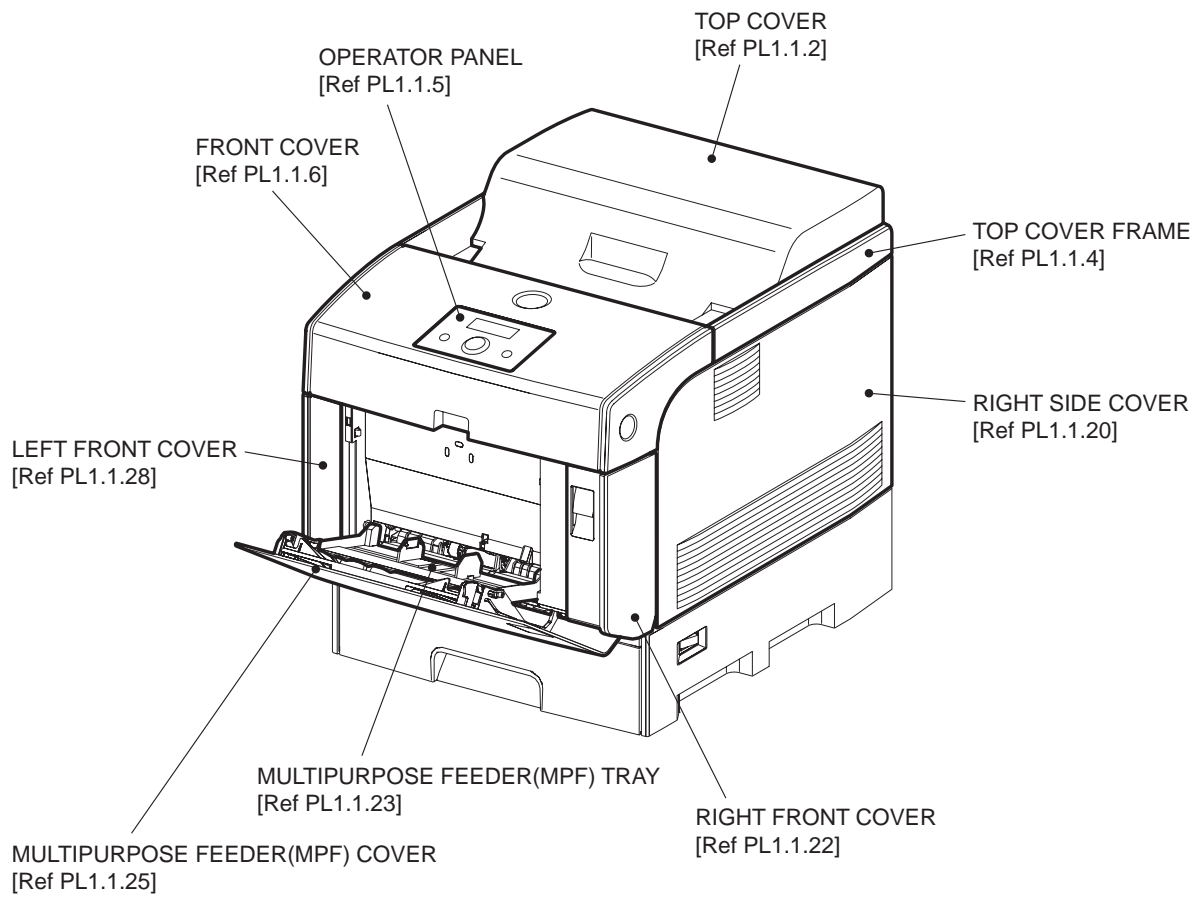

Ten05101KA

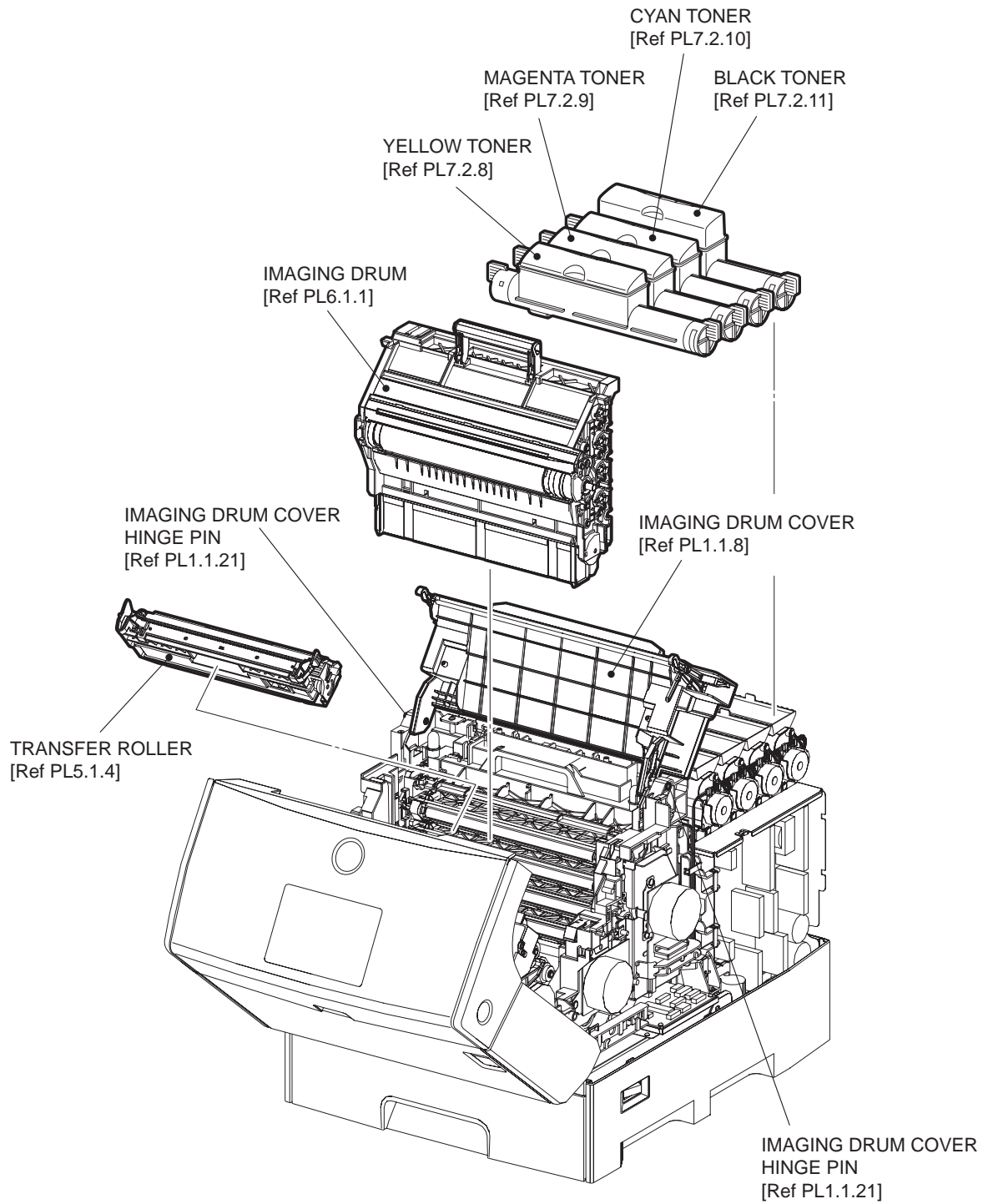

Ten05102KA

PAPER FEEDER [Ref PL3.1.7]

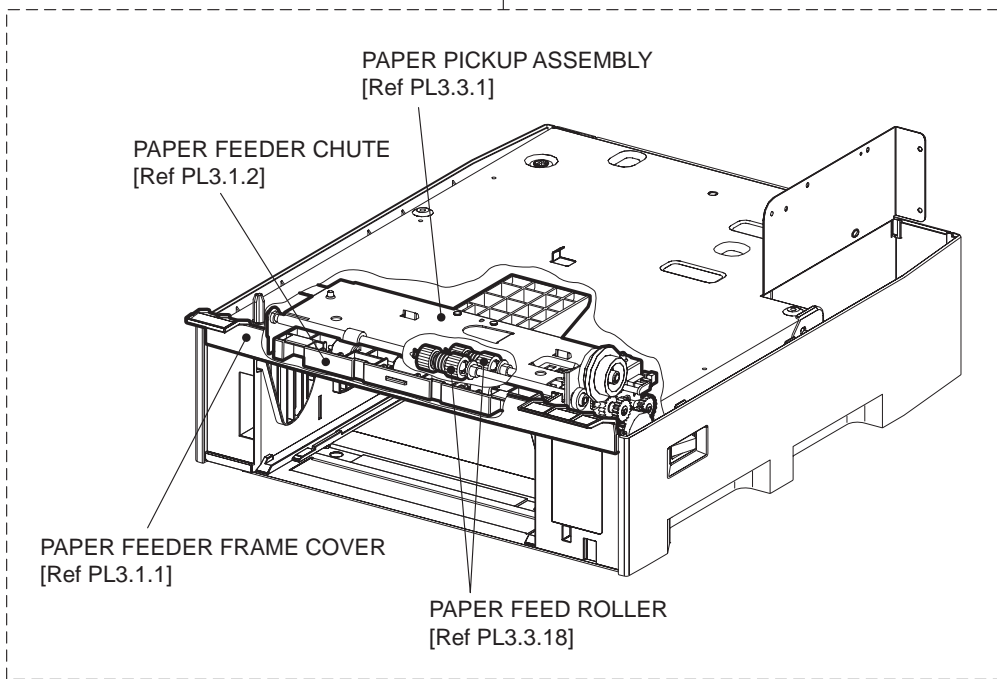

500 SHEET PAPER TRAY [Ref PL2.1.1]

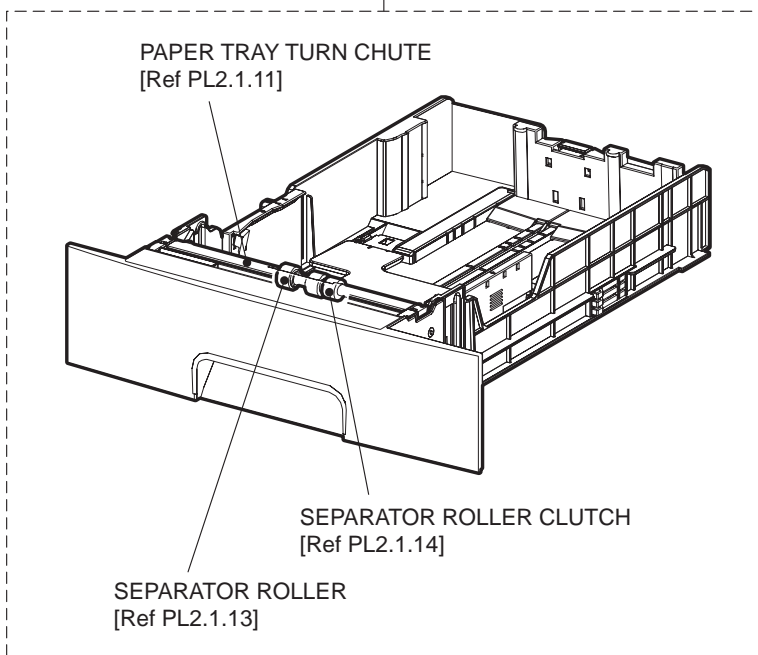

Ten05103KA

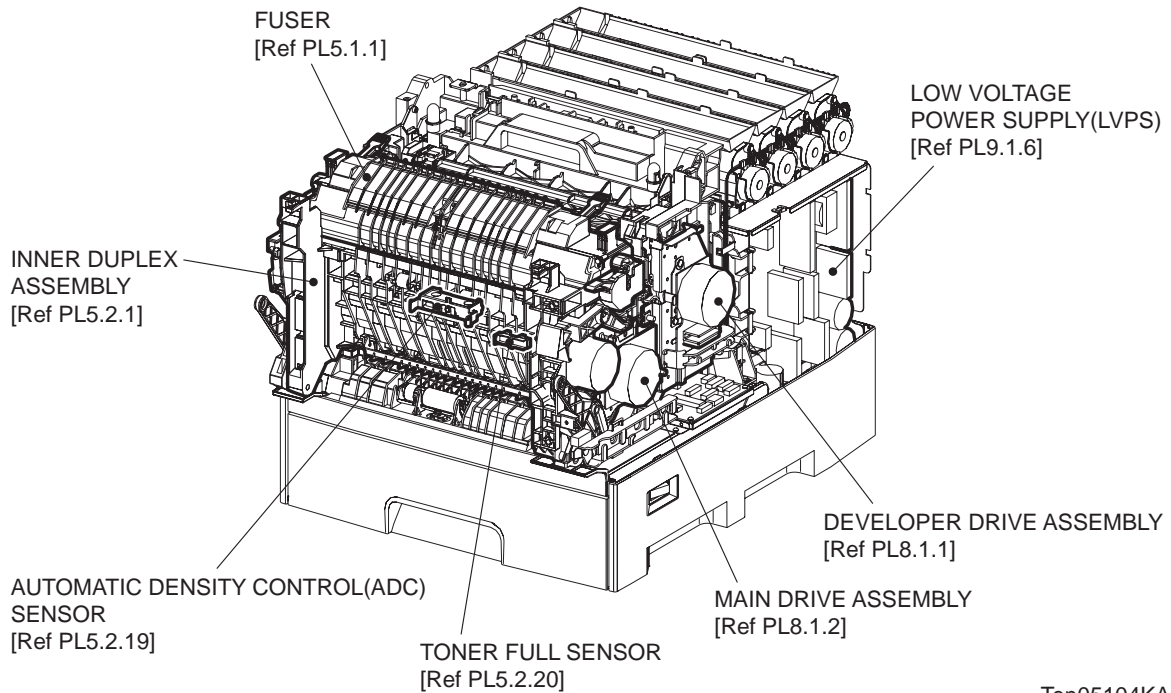
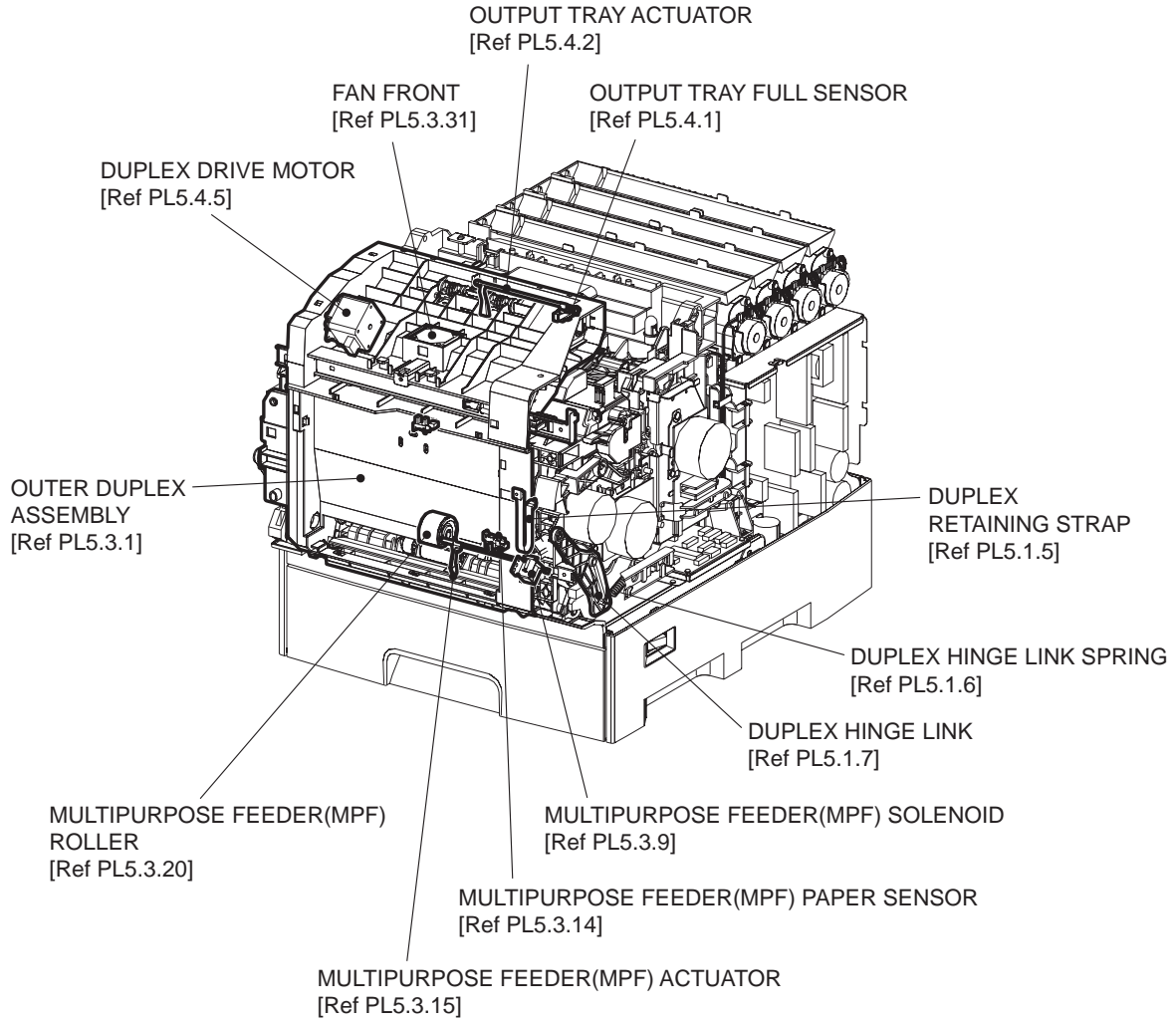

Ten05104KA



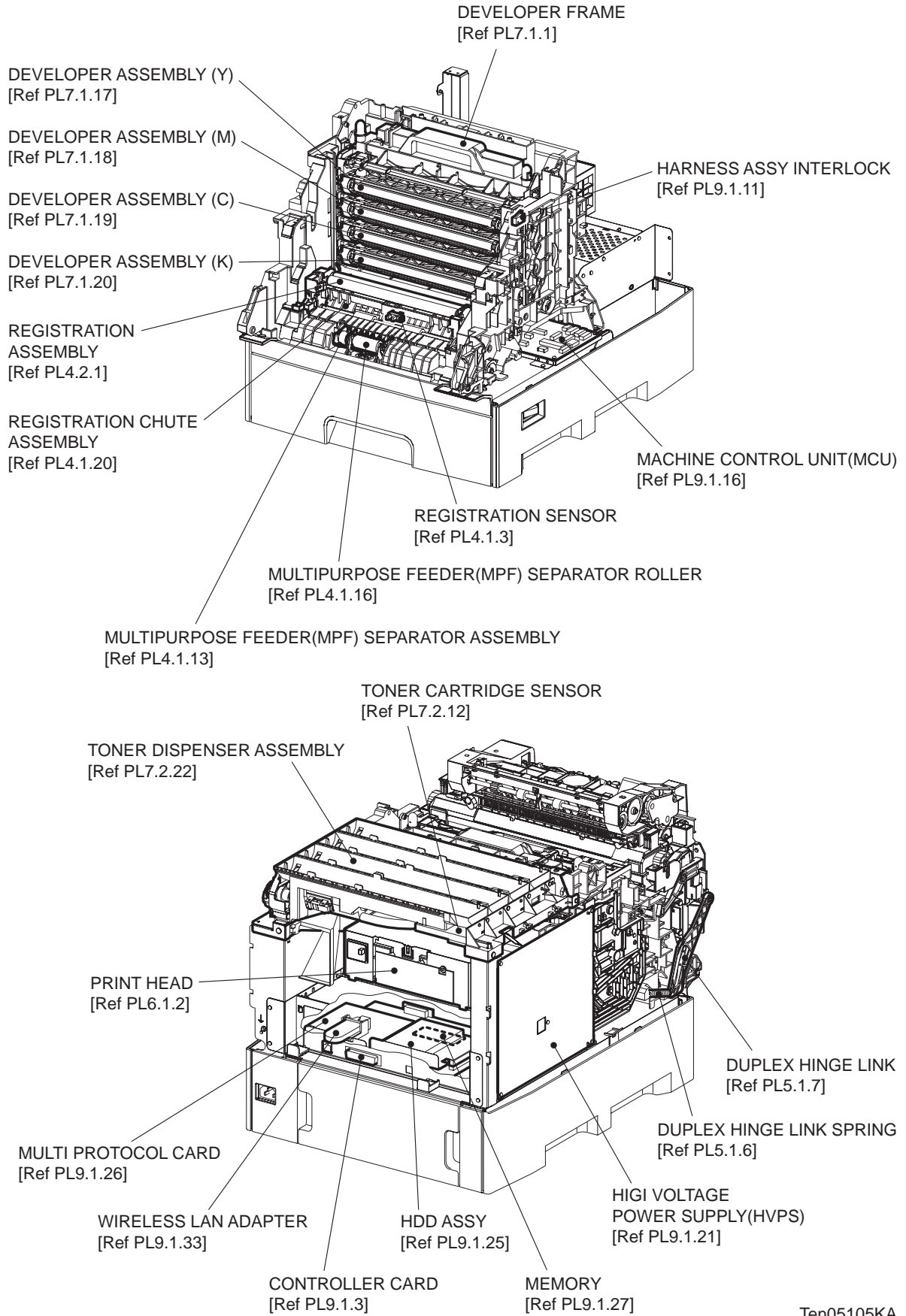

Blank Page

**Engineering parts list**

PL1.1 Cover [Illustration]

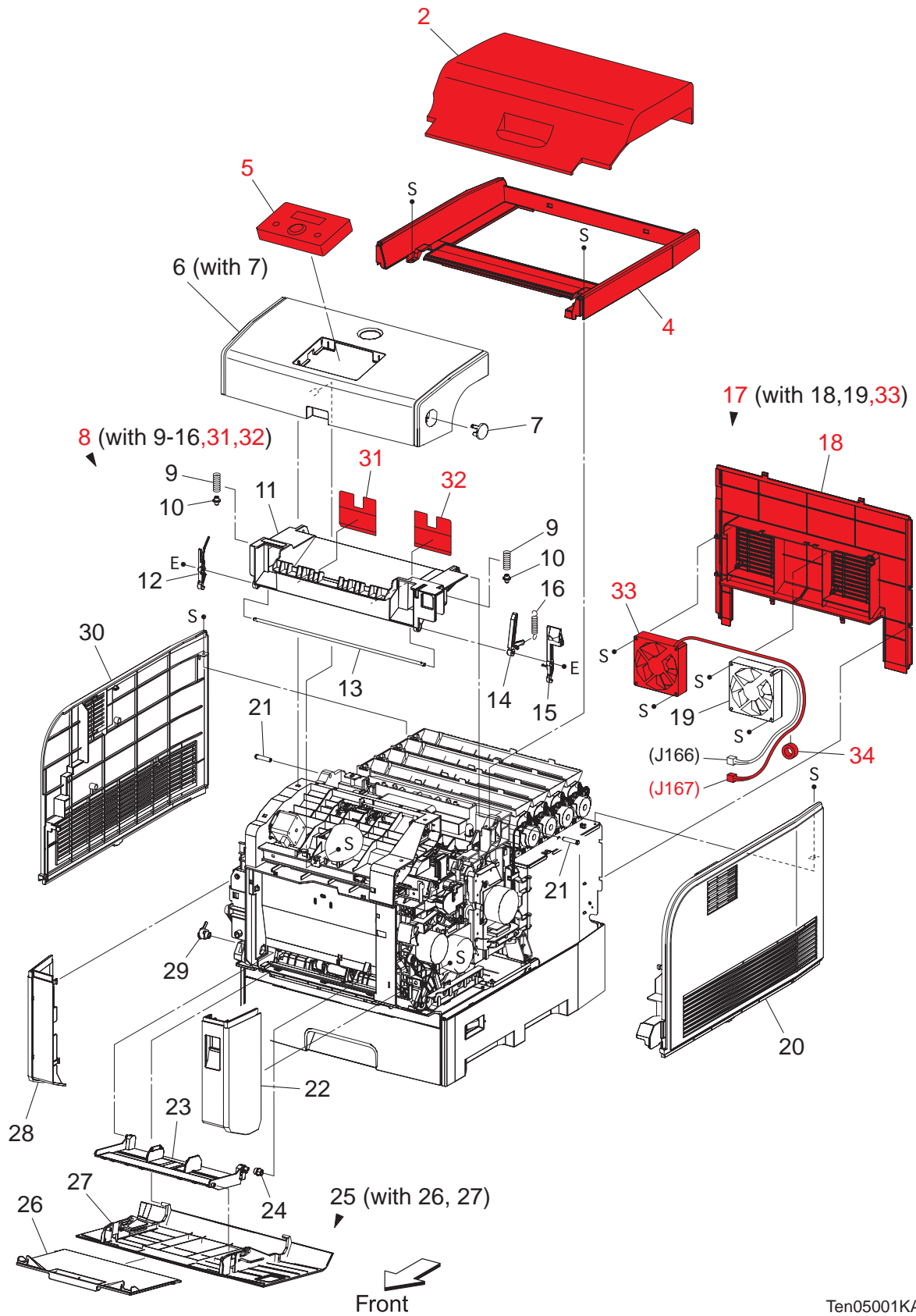

Ten05001KA

## PL1.1 Cover [List]

Item	Parts name
1	--
2	COVER TOP
3	--
4	COVER TOP MAIN ASSY
5	CONSOLE PANEL
6	COVER ASSY FRONT HEAD (with 7)
7	LEVER OUT
8	COVER ASSY TOP PHD (with 9-16,31,32)
9	SPRING L/R
10	PLUNGER
11	COVER TOP PHD
12	LATCH TOP L
13	SHAFT LATCH
14	LATCH TOP IR R
15	LATCH TOP R
16	SPRING STOPPER BOTTOM
17	COVER ASSY REAR (with 18,19,33)
18	COVER REAR
19	FAN REAR
20	COVER SIDE R
21	STUD TOP
22	COVER FRONT R ASSY
23	TRAY ASSY MSI BASE
24	HOLDER TRAY R
25	COVER ASSY MSI (with 26,27)
26	TRAY MSI SLIDE
27	COVER MSI
28	COVER FRONT L ASSY
29	HOLDER TRAY L
30	COVER SIDE L
31	SHUTTER EXIT L
32	SHUTTER EXIT R
33	FAN LV
34	CORE

PL2.1 Paper Cassette [Illustration]

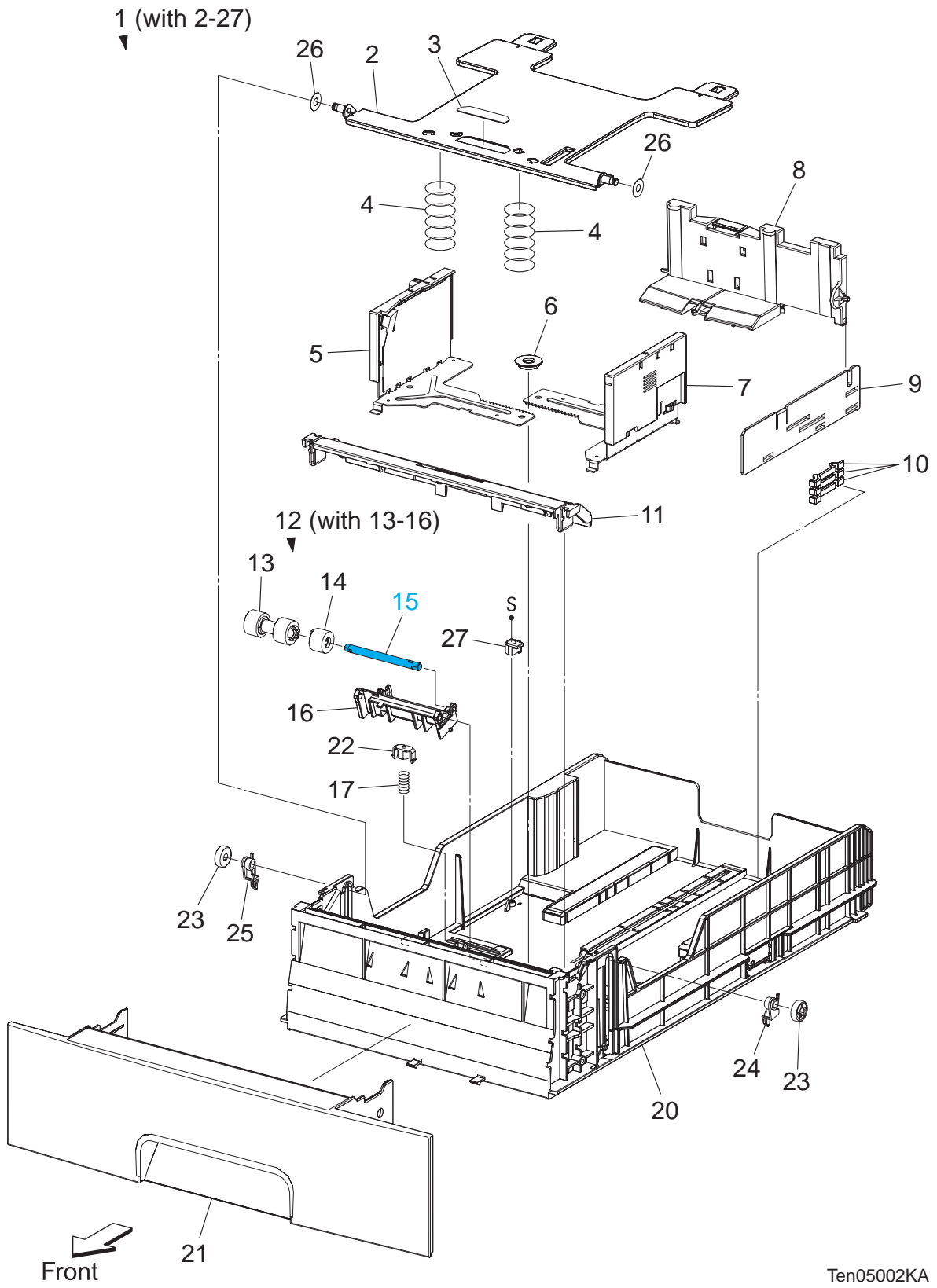

Ten05002KA

## PL2.1 Paper Cassette [List]

Item	Parts name
1	CASSETTE ASSY 500 (with 2-27)
2	PLATE ASSY BTM
3	PAD BOTTOM
4	SPRING N/F
5	GUIDE ASSY SIDE L
6	GEAR MANUAL
7	GUIDE ASSY SIDE R
8	GUIDE ASSY END
9	ACTUATOR GUIDE END
10	ACTUATOR SIZE
11	CHUTE TURN CST
12	RETARD ASSY (with 13-16)
13	ROLL ASSY RETARD
14	CLUTCH ASSY FRICTION
15	SHAFT ASSY RETARD
16	HOLDER RETARD
17	SPRING RETARD
18	--
19	--
20	HOUSING CST 500
21	HANDLE CST
22	HOLDER SPRING RETARD
23	ROLL PB
24	STOPPER LINK PB R
25	STOPPER LINK PB L
26	SPACER PLATE BTM
27	STOPPER BLOCK

PL3.1 Paper Feeder (1/3) [Illustration]

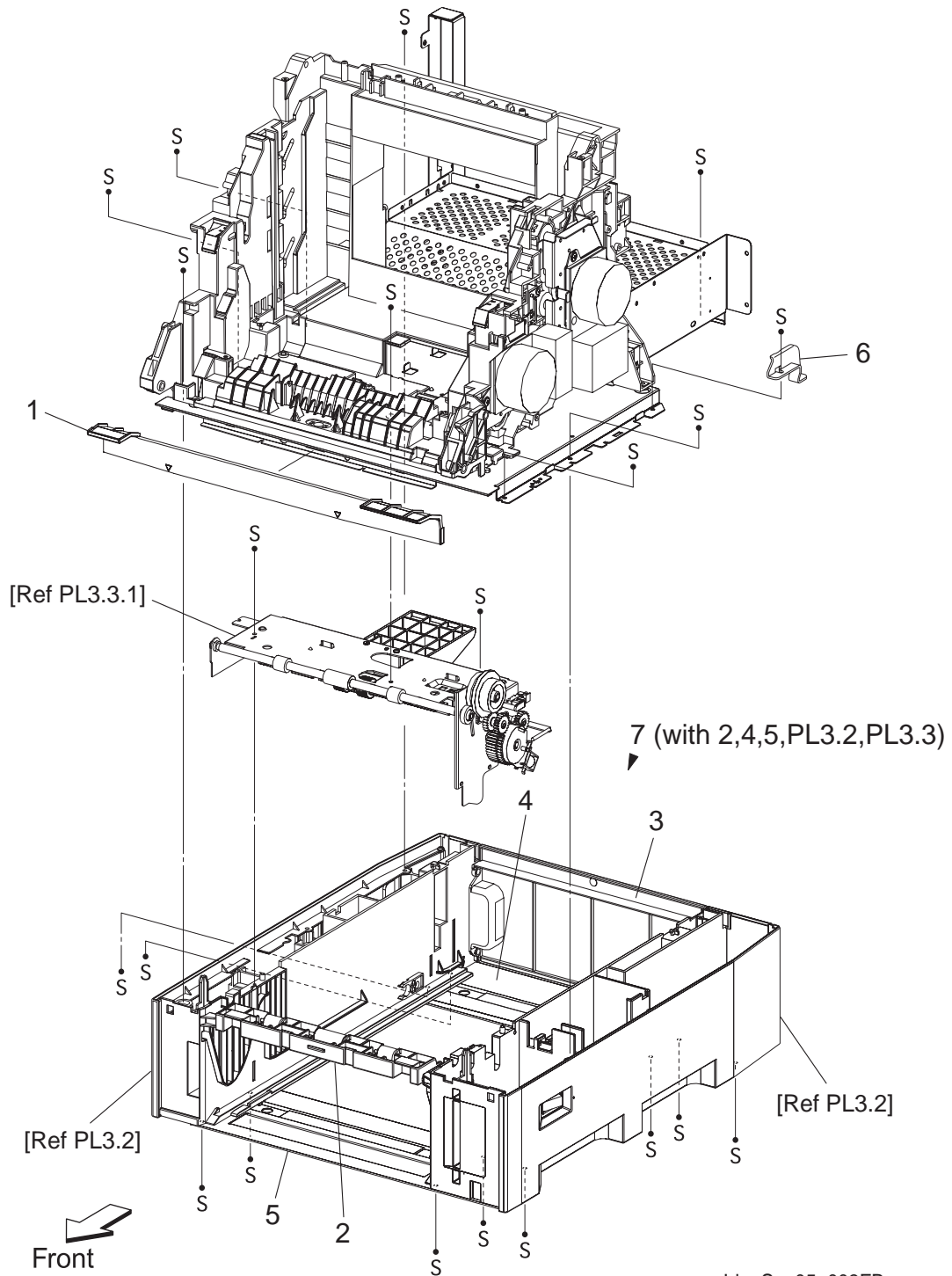

Ida\_Sec05\_003FB

## PL3.1 Paper Feeder (1/3) [List]

Item	Parts name
1	FRAME FEEDER F
2	CHUTE FEEDER ASSY
3	COVER CASSETTE
4	FRAME FEEDER BOTTOM REAR
5	FRAME FEEDER BOTTOM FRONT
6	SUPPORT LINK SW
7	FEEDER ASSY (with 2,4,5,PL3.2,PL3.3)



PL3.2 Paper Feeder (2/3) [Illustration]

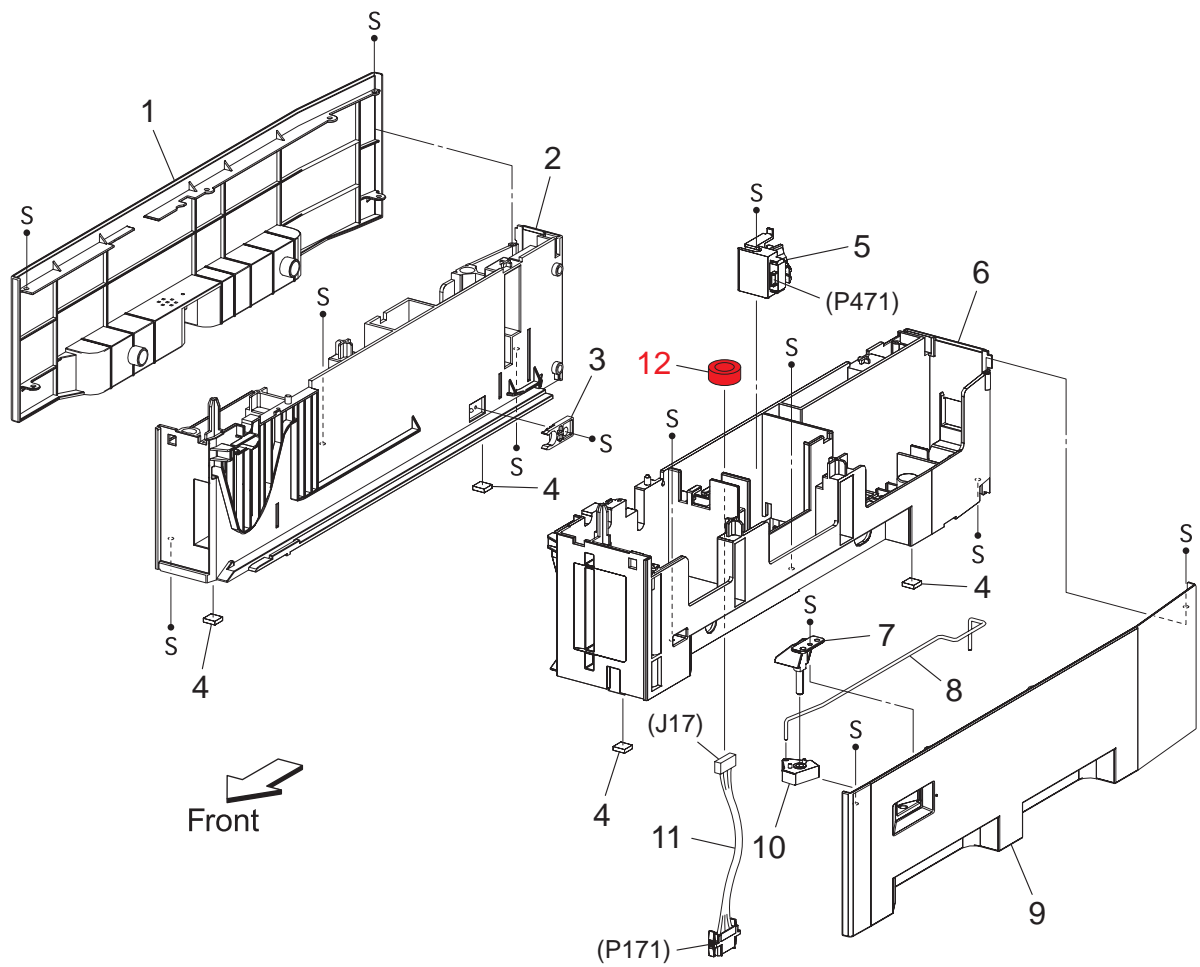

Ten05004KA

## PL3.2 Paper Feeder (2/3) [List]

Item	Parts name
1	COVER L
2	FEEDER L
3	STOPPER CST
4	FOOT
5	SWITCH ASSY SIZE
6	FEEDER R
7	S/W HOLDER
8	SHAFT LINK S/W
9	COVER R
10	SWITCH
11	HARNESS ASSY OPFPLG(J17-P171)
12	CORE

PL3.3 Paper Feeder (3/3) [Illustration]

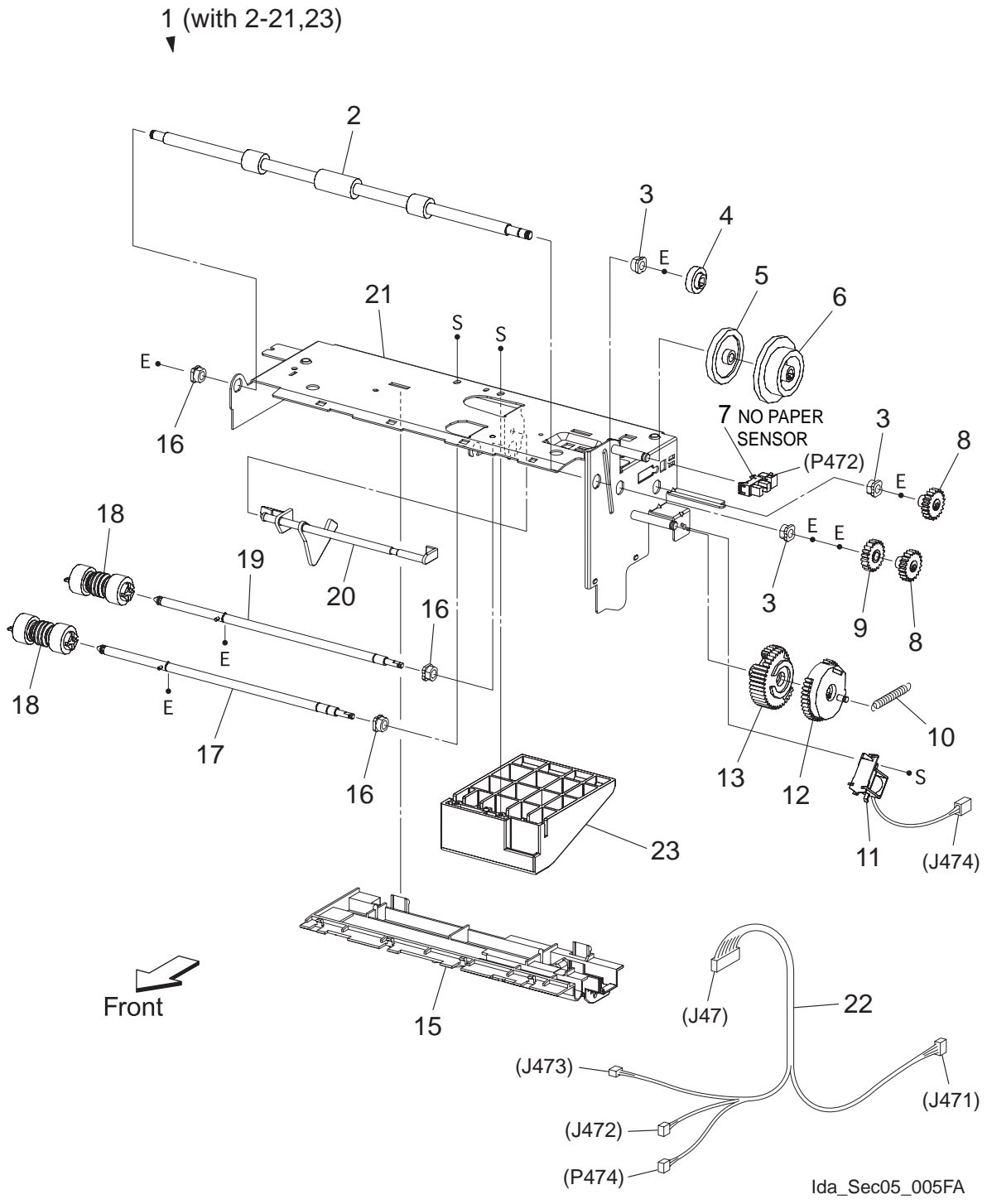

## PL3.3 Paper Feeder (3/3) [List]

Item	Parts name
1	PICK UP ASSY (WITH 2-21,23)
2	ROLL ASSY TURN
3	BEARING( 6xL8)/METAL
4	GEAR TURN
5	GEAR IDLER TURN
6	GEAR IDLER IN
7	SENSOR PHOTO
8	GEAR FEED 2
9	GEAR IDLER FEED
10	SPRING FEED H
11	SOLENOID FEED
12	GEAR FEED H2
13	GEAR FEED H1
14	- -
15	CHUTE UPPER
16	BEARING( 6xL8)/BLACK
17	SHAFT ASSY FEED
18	ROLL ASSY FEED
19	SHAFT ASSY NUDGER
20	ACTUATOR NO PAPER
21	FRAME ASSY DRIVE
22	HARNESS ASSY FDR(J47-J471,J472,J473,P474)
23	GUIDE PAPER

PL4.1 Retard & Regi assy (1/2) [Illustration]

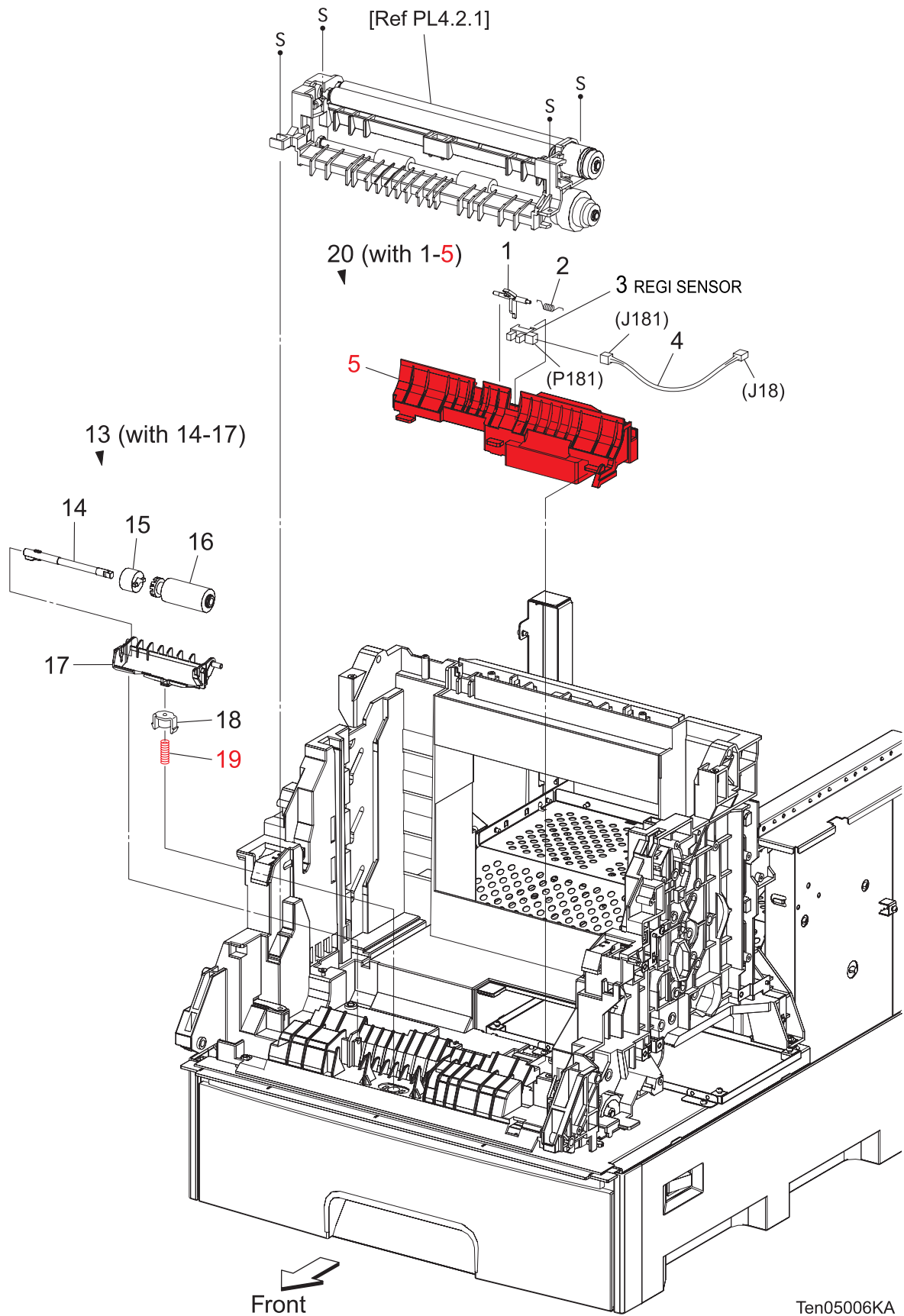

## PL4.1 Retard &amp; Regi assy (1/2) [List]

Item	Parts name
1	ACTUATOR REGI
2	SPRING REGI
3	SENSOR PHOTO
4	HARNESS ASSY REGISNS(J18-J181)
5	CHUTE REGI IN
6	--
7	--
8	--
9	--
10	--
11	--
12	--
13	HOLDER ASSY RETARD (with 14-17)
14	SHAFT RETARD
15	CLUTCH ASSY FRICTION
16	ROLL ASSY RETARD
17	HOLDER RETARD
18	HOLDER SPRING RETARD
19	SPRING RETARD
20	CHUTE ASSY REGI IN (with 1-5)
21	--
22	--
23	--
24	--
25	--
26	--

PL4.2 Retard & Regi assy (2/2) [Illustration]

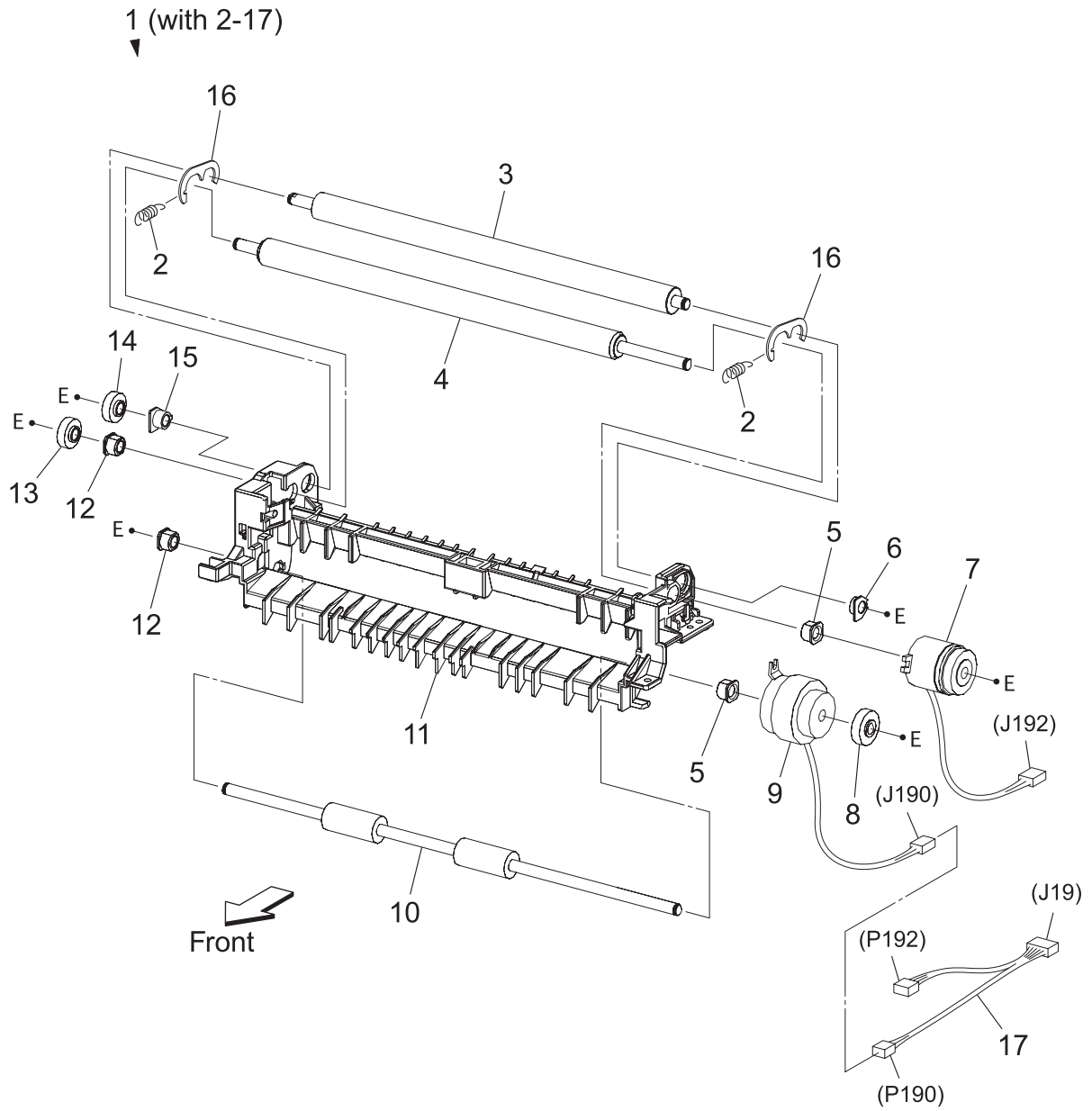

Ida\_Sec05\_007FA

## PL4.2 Retard &amp; Regi assy (2/2) [List]

Item	Parts name
1	CHUTE ASSY REGI (with 2-17)
2	SPRING REGI
3	ROLL REGI METAL
4	ROLL REGI RUBBER
5	BEARING
6	BEARING METAL R
7	CLUTCH REGI
8	GEAR P1
9	CLUTCH TURN
10	ROLL TURN MSI
11	CHUTE REGI
12	BEARING EARTH
13	GEAR REGI RUBBER
14	GEAR REGI METAL
15	BEARING METAL L
16	PLATE REGI
17	HARNES ASSY FRONTCLH (J19-P190,P192)



PL5.1 Chute Assy In & Out (1/4) [Illustration]

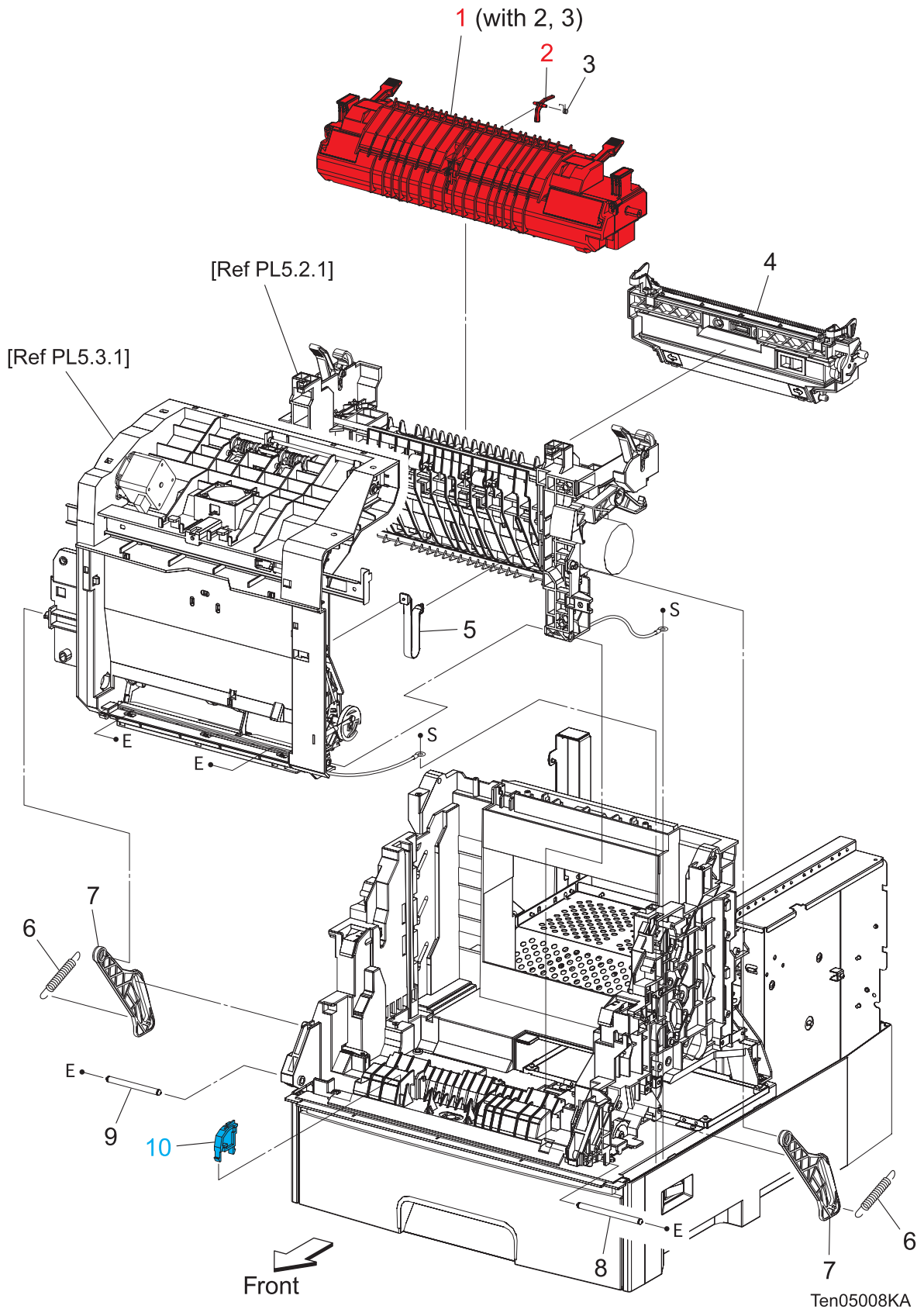

## PL5.1 Chute Assy In &amp; Out (1/4) [List]

Item	Parts name
1	FUSER ASSY (with 2,3)
2	ACTUATOR EXIT
3	SPRING ACTUATOR
4	BTR ASSY
5	STRAP
6	SPRING LINK
7	LINK
8	SHAFT PIVOT R
9	SHAFT PIVOT L
10	GUIDE CHASSIS

PL5.2 Chute Assy In & Out (2/4) [Illustration]

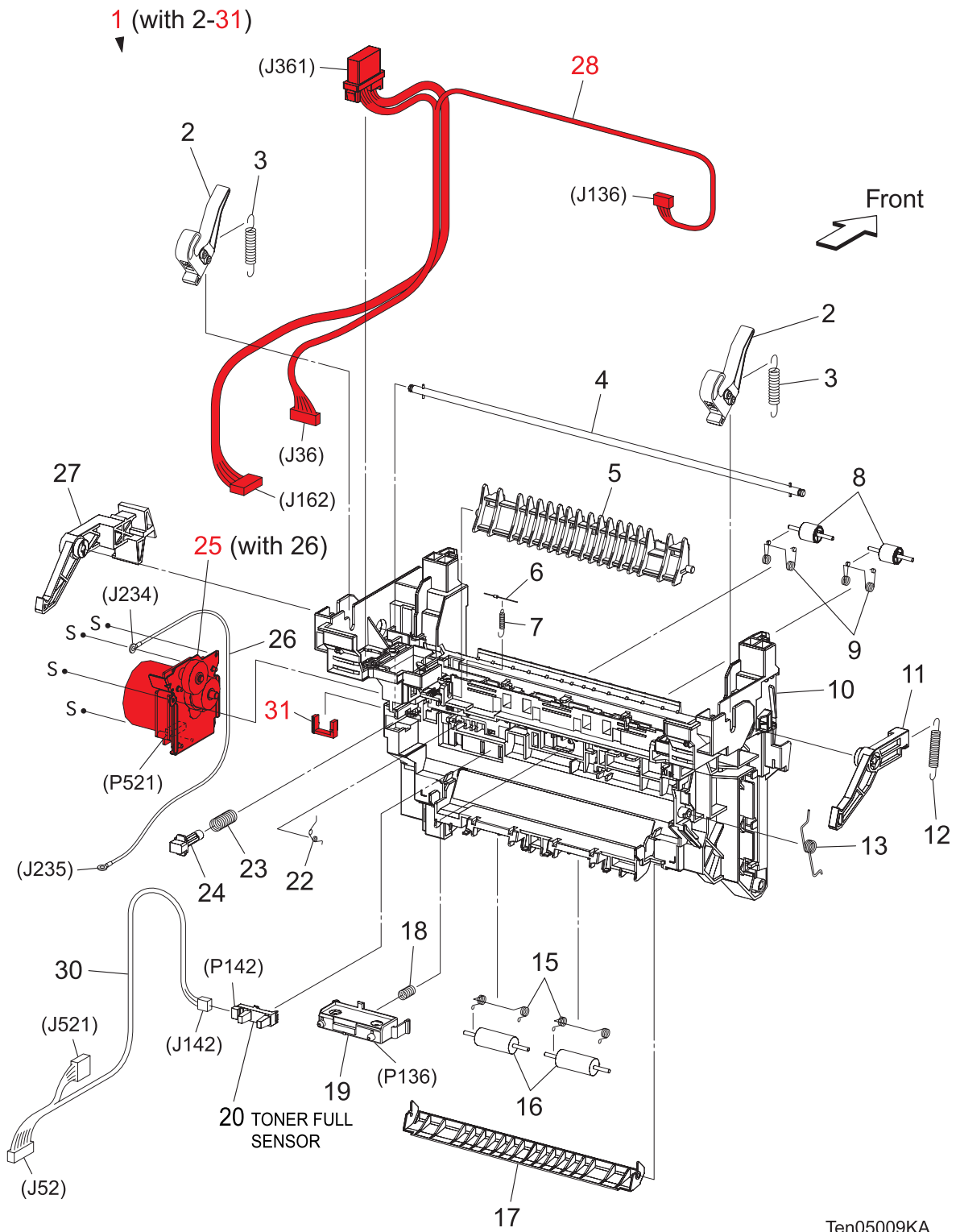

Ten05009KA

## PL5.2 Chute Assy In &amp; Out (2/4) [List]

Item	Parts name
1	FRONT ASSY IN (with 2-31)
2	LEVER FUSER
3	SPRING LEVER
4	SHAFT LATCH
5	CHUTE FSR IN
6	DIODE F
7	SPRING DIODE F
8	ROLL PINCH DUP
9	SPRING PINCH DUP
10	CHUTE DUP IN
11	LATCH L
12	SPRING LATCH
13	SPRING BTR L
14	--
15	SPRING PINCH T
16	ROLL PINCH TURN
17	CHUTE TURN IN
18	SPRING ADC
19	HOLDER ASSY ADC
20	SNR TNR FULL
21	--
22	SPRING BIAS DTC
23	SPRING BTR R
24	STOPPER BTR R
25	MOTOR ASSY FUSER (with 26)
26	WIRE ASSY FSR EARTH
27	LATCH R
28	HARNESS ASSY FSR/ADC(J36-J136,J162,J361)
29	--
30	HARNESS ASSY TNRFULL/FSR(J52-J142,J521)
31	CLAMP

PL5.3 Chute Assy In & Out (3/4) [Illustration]

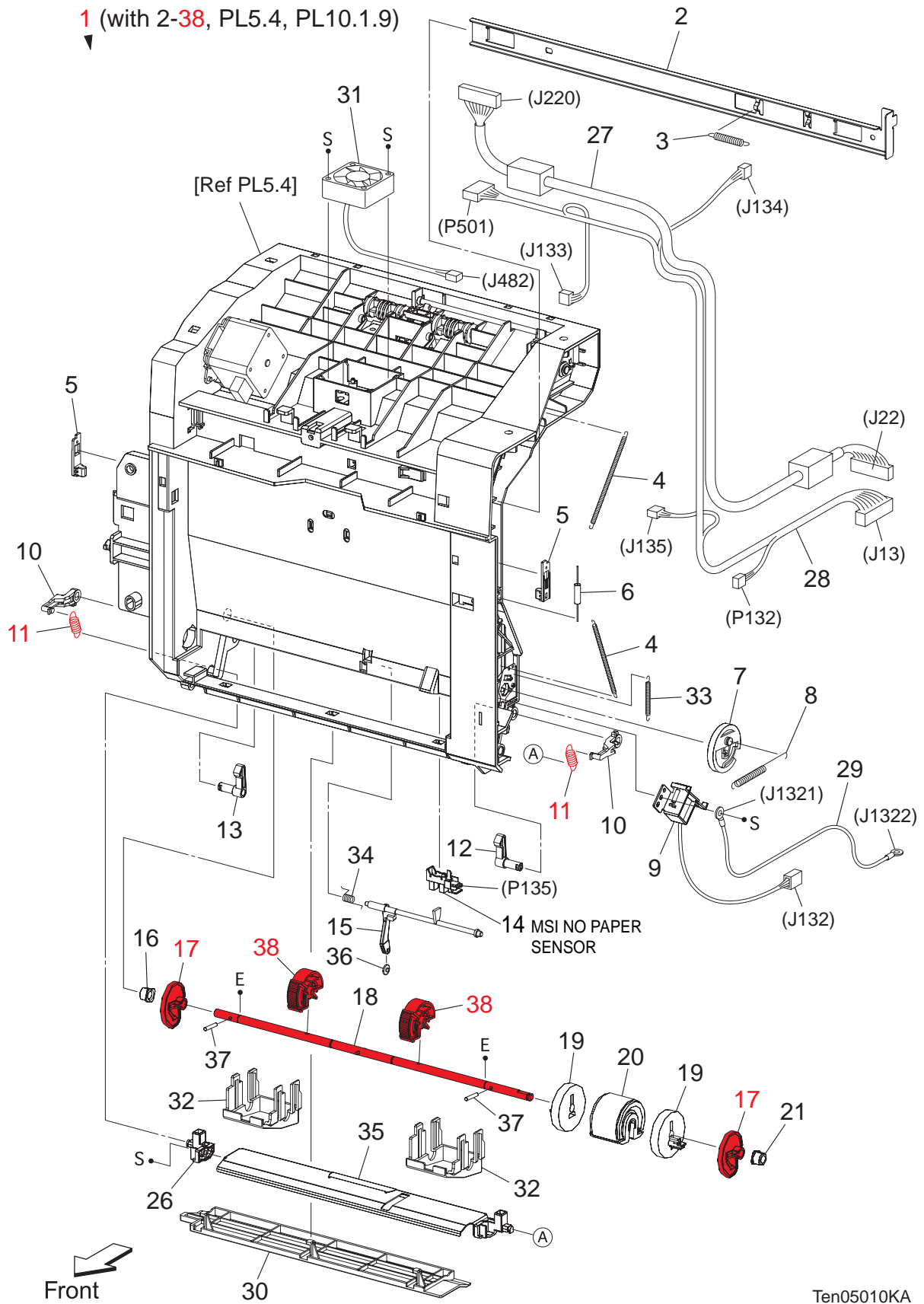

## PL5.3 Chute Assy In &amp; Out (3/4) [List]

Item	Parts name
1	CHUTE ASSY DUP OUT (with 2-38,PL5.4,PL10.1.9)
2	PLATE LATCH
3	SPRING LATCH OUT
4	SPRING BIAS IDT1-L
5	LATCH MSI
6	RESISTOR GS1 200M
7	GEAR MSI
8	SPRING FEED MSI
9	SOLENOID FEED MSI
10	ARM MSI
11	SPRING N/F MSI
12	FOLLOWER R
13	FOLLOWER L
14	SENSOR PHOTO
15	ACTUATOR NO PAPER MSI
16	BEARING
17	CAM MSI
18	SHAFT MSI
19	ROLL CORE MSI
20	ROLL ASSY FEED
21	BEARING EARTH
22	--
23	--
24	--
25	--
26	HOLDER MSI L
27	HARNESS ASSY OPEPANE2(J22-J220)
28	HARNESS ASSY FRONT/DUP(J13-P132,J133,J134,J135,P501)
29	WIRE ASSY DUP EARTH(J1321-J1322)
30	COVER LOWER OUT
31	FAN FRONT
32	CHUTE FEED UP
33	SPRING EARTH OUT2
34	SPRING NO PAPER MSI
35	PLATE ASSY BOTTOM
36	ROLL ACTUATOR NO PAPER
37	PIN MSI
38	ROLL ASSY ENV

PL5.4 Chute Assy In & Out (4/4) [Illustration]

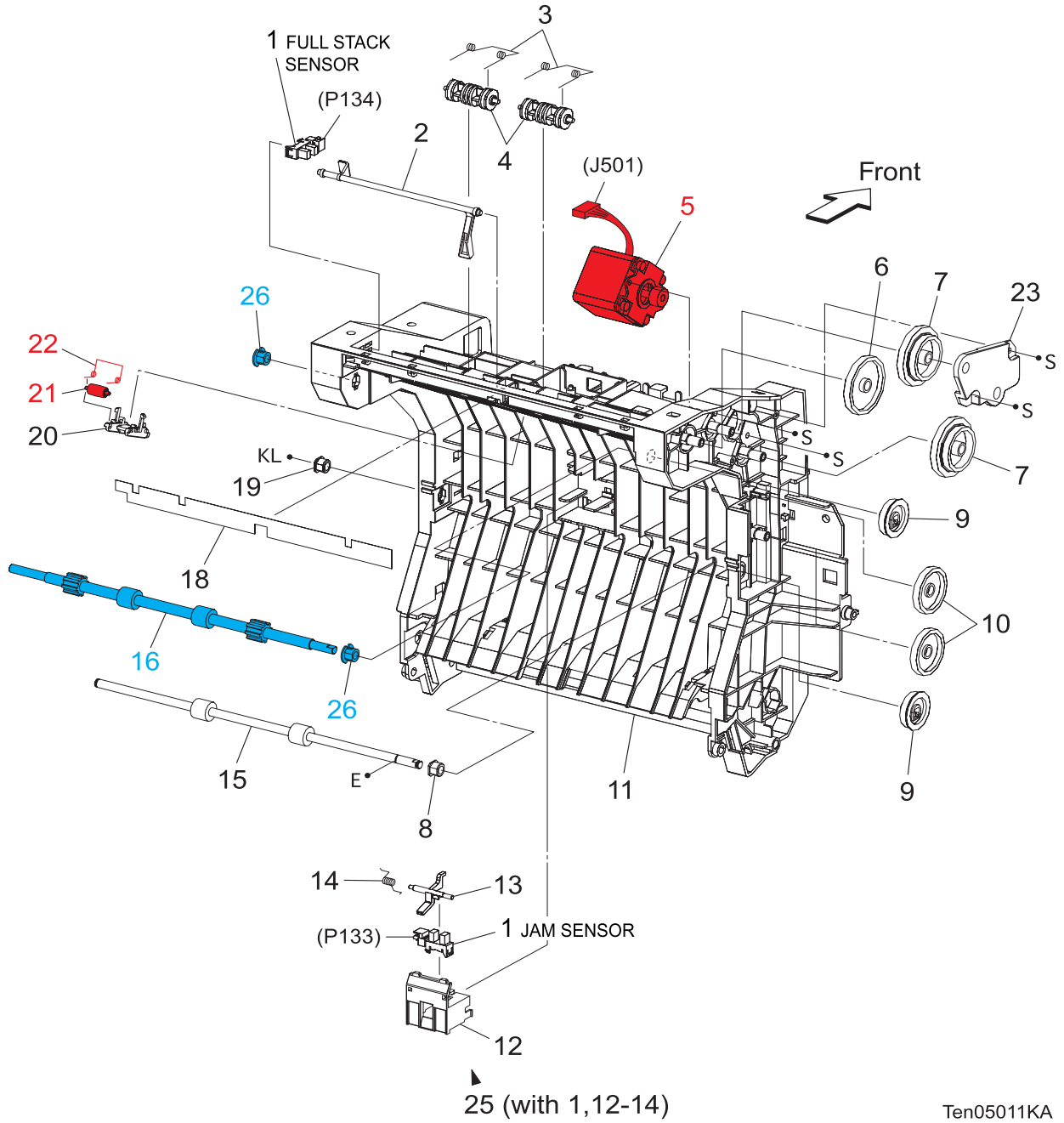

Ten05011KA

## PL5.4 Chute Assy In &amp; Out (4/4) [List]

Item	Parts name
1	SENSOR PHOTO
2	ACTUATOR FULL STACK
3	SPRING PINCH EXIT
4	ROLL PINCH EXIT
5	MOTOR ASSY DUP 17PM
6	GEAR 52
7	GEAR 40/66H
8	BEARING
9	GEAR EXIT/DUP
10	GEAR 41
11	CHUTE DUP OUT
12	HOLDER SENSOR DUP
13	ACTUATOR DUP
14	SPRING SENSOR DUP
15	ROLL DUP
16	ROLL EXIT
17	--
18	ELIMINATOR EXIT
19	BEARING EARTH
20	HOLDER ROLL
21	ROLL CORRUGATE
22	SPRING CORRUGATE
23	COVER GEAR DUPOUT
24	--
25	HOLDER ASSY DUP SENSOR (with 1,12-14)
26	BEARING EXIT



PL6.1 Xerographics [Illustration]

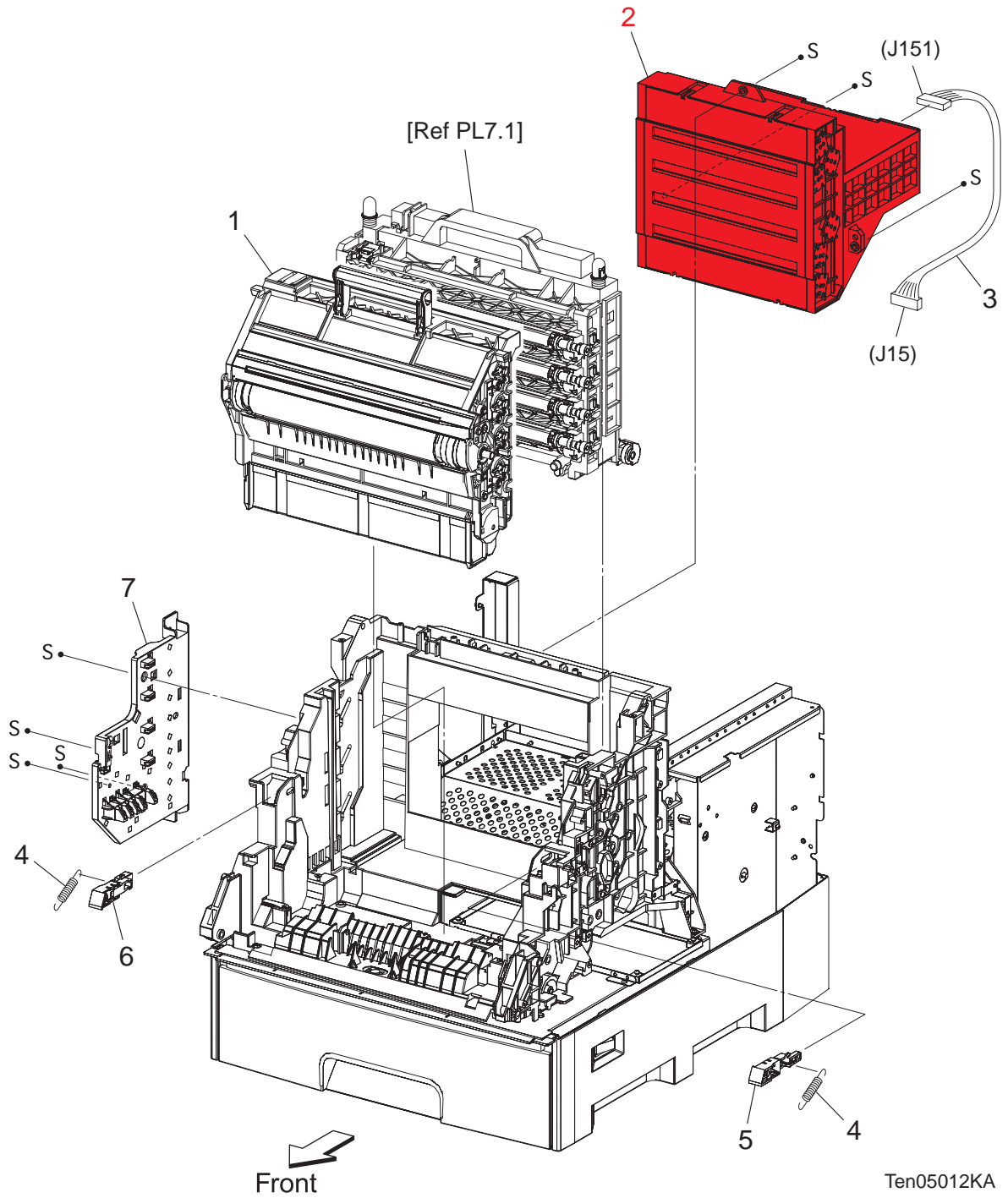

## PL6.1 Xerographics [List]

Item	Parts name
1	PHD ASSY
2	ROS ASSY
3	HARNES ASSY ROS (J15-J151)
4	SPRING RELEASE
5	LEVER STOPPER R
6	LEVER STOPPER L
7	HSG ASSY BIAS

PL7.1 Development (1/2) [Illustration]

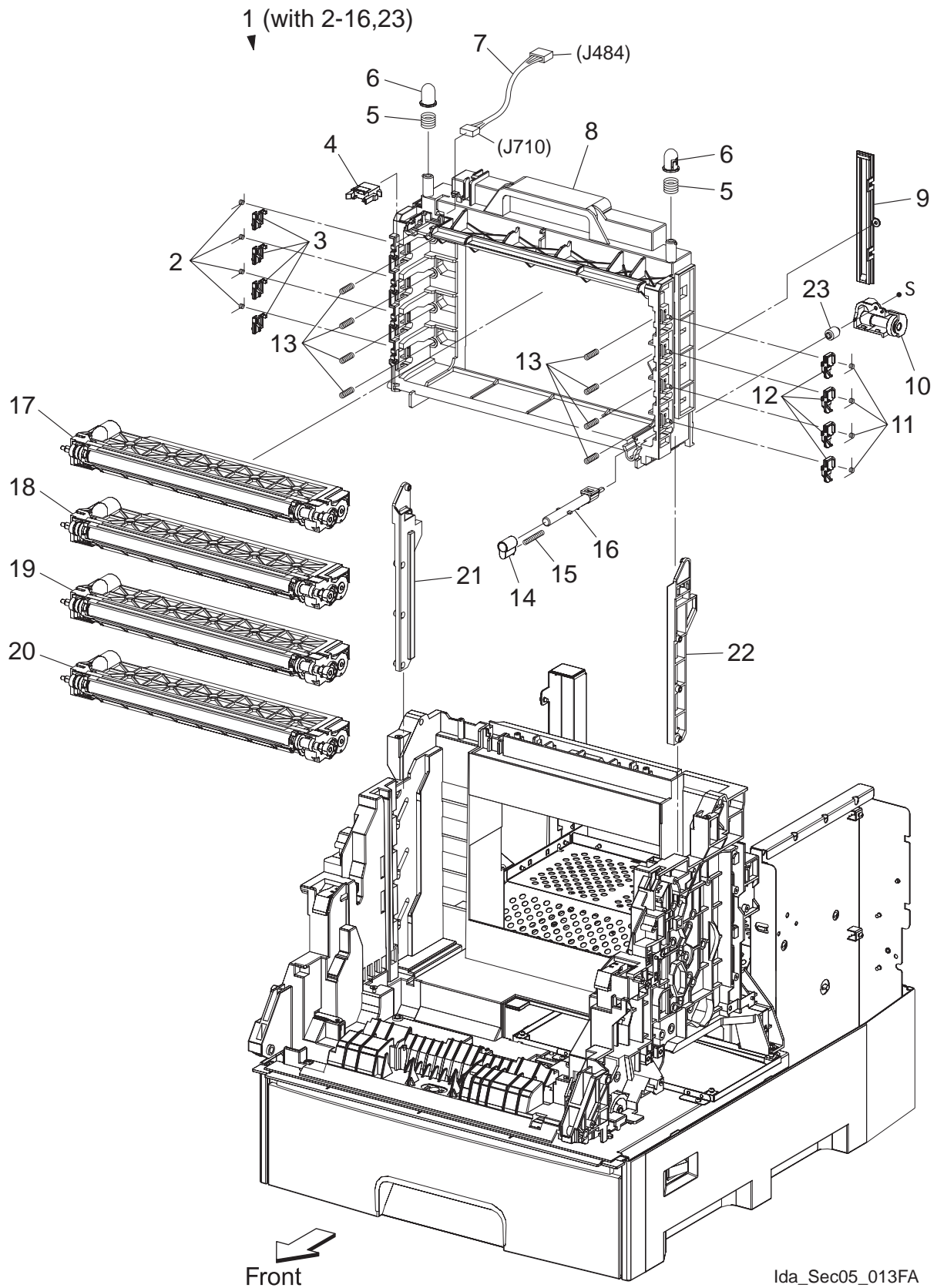

## PL7.1 Development (1/2) [List]

Item	Parts name
1	FRAME ASSY DEVE (with 2-16,23)
2	SPRING L
3	STOPPER DEVE L
4	CRUM
5	SPRING PLUNGER
6	PLUNGER FRAME
7	HARNASS ASSY PHD2 (J484-J710)
8	FRAME DEVE
9	COVER ASSY FRAME
10	GEAR ASSY DUCT
11	SPRING R
12	STOPPER DEVE R
13	SPRING TRACKING
14	SHUTTER DUCT
15	SPRING SHUTTER DUCT
16	NOZZLE ASSY DUCT
17	DEVE ASSY (Y)
18	DEVE ASSY (M)
19	DEVE ASSY (C)
20	DEVE ASSY (K)
21	GUIDE FRAME DEVE L
22	GUIDE FRAME DEVE R
23	GEAR

PL7.2 Development (2/2) [Illustration]

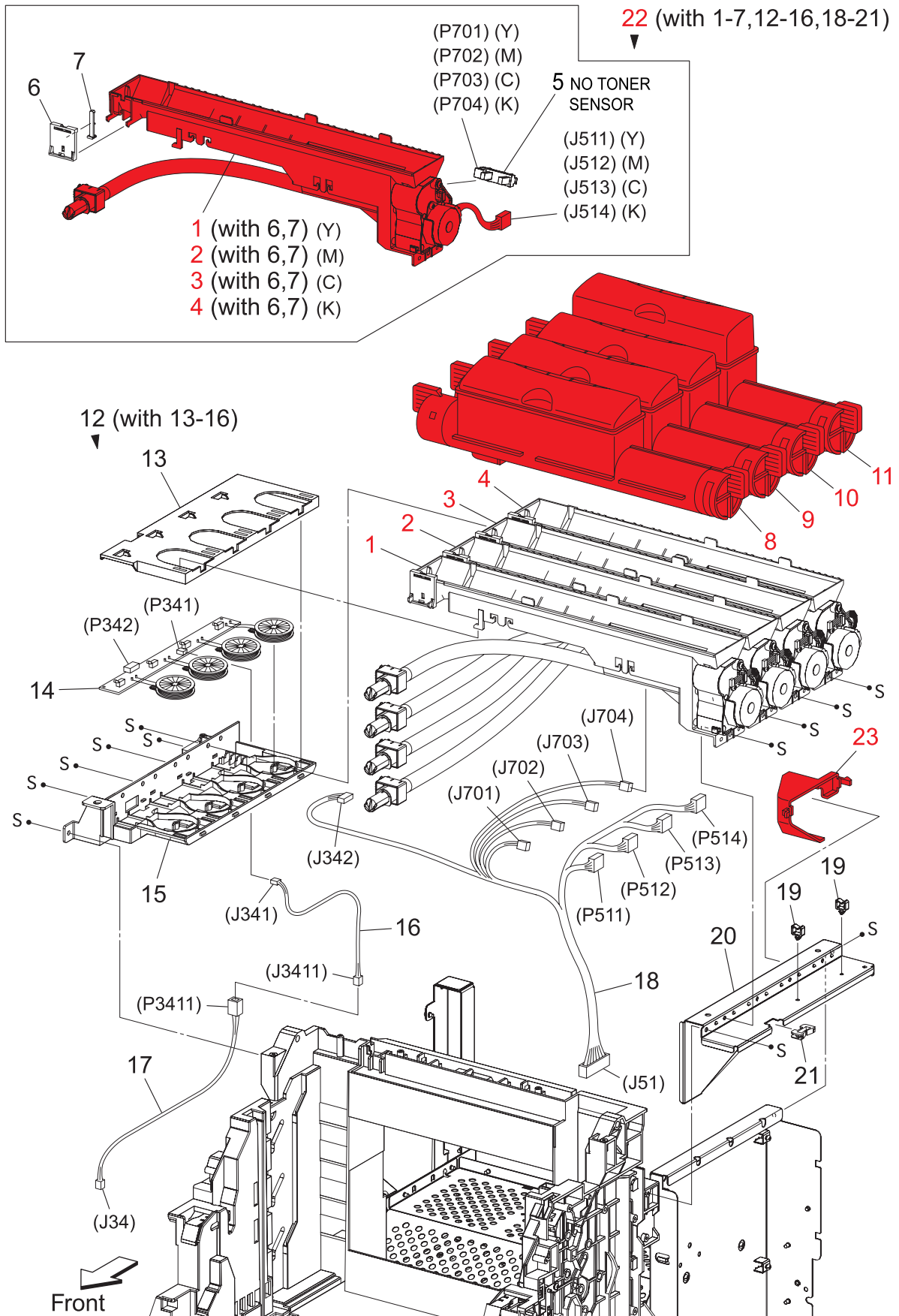

## PL7.2 Development (2/2) [List]

Item	Parts name
1	DISPENSER ASSY (Y) (with 6,7)
2	DISPENSER ASSY (M) (with 6,7)
3	DISPENSER ASSY (C) (with 6,7)
4	DISPENSER ASSY (K) (with 6,7)
5	SENSOR NO TONER
6	BRACKET SENSOR 2
7	ACTUATOR SENSOR 2
8	TONER CARTRIDGE (Y)
9	TONER CARTRIDGE (M)
10	TONER CARTRIDGE (C)
11	TONER CARTRIDGE (K)
12	BOX ASSY CRUM READER (with 13-16)
13	COVER HOLDER CRUM
14	COIL ASSY CRUM READER
15	HSG BASE CRUM
16	HARNESS ASSY RFID2 (J341-J3411)
17	HARNESS ASSY RFID (J34-P3411)
18	HARNESS ASSY TNR (J51-J342,P511,P512,P513,P514,J701,J702,J703,J704)
19	CLAMP MINI-SDL
20	BRACKET HOLDER DSP
21	SADDLE BUSH
22	DISPENSER ASSY HI (with 1-7,12-16,18-21)
23	DUCT LV

PL8.1 Drive [Illustration]

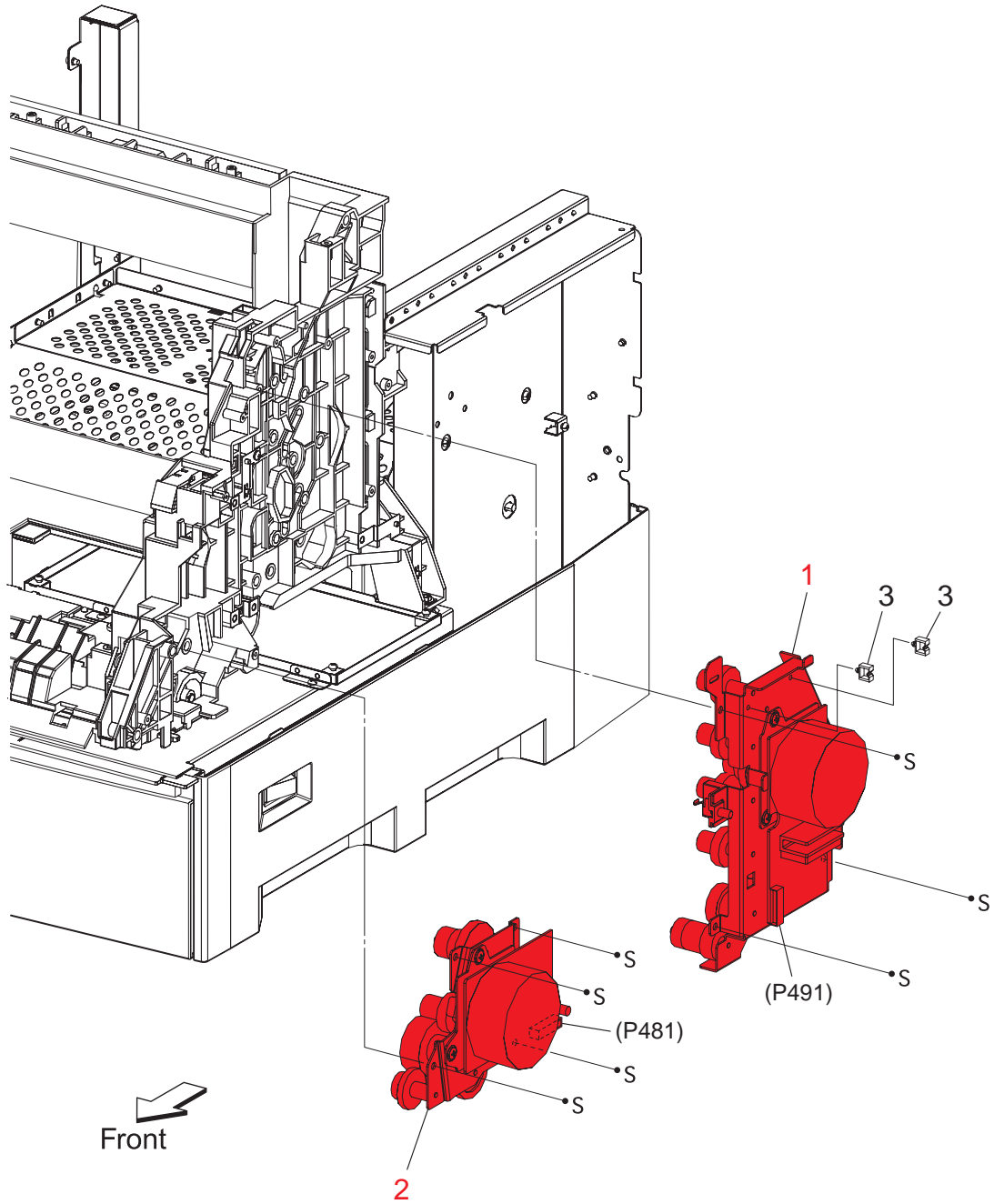

Ten05015KA

## PL8.1 Drive [List]

Item	Parts name
1	DRIVE ASSY DEVE
2	DRIVE ASSY MAIN
3	CLAMP



PL9.1 Electrical [Illustration]

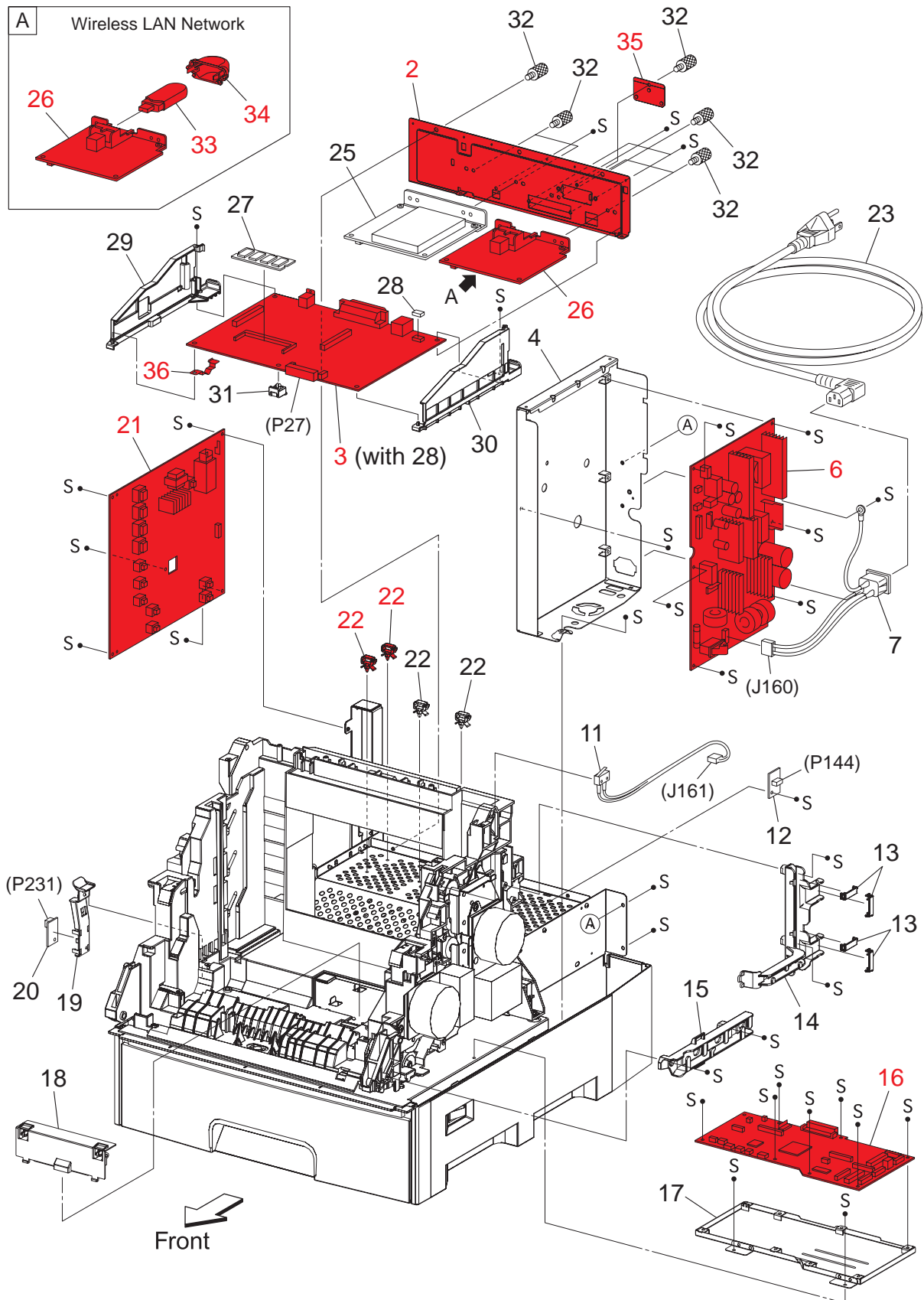

Ten05016KA

## PL9.1 Electrical [List]

Item	Parts name
1	--
2	PLATE ASSY REAR
3	ESS (with 28)
4	BOX ASSY LVPS
5	--
6	LVPS 100/120 LVPS 230V
7	HARNESS ASSY AC INLET
8	--
9	--
10	--
11	HARNESS ASSY INTERLOCK
12	PWBA EEPROM STD
13	CLAMP GUIDE HARNESS
14	GUIDE HARNESS R
15	GUIDE HARNESS F
16	PWBA MCU
17	BRACKET ASSY MCU
18	COVER ELEC
19	BRACKET TEMP
20	SENSOR HUM
21	PWBA HVPS
22	CLAMP
23	POWER CORD
24	--
25	OPTION HDD ASSY
26	OPTION MULTI PROTOCOL CARD (WIRELESS LAN NETWORK)
27	OPTION SDRAM 256MB OPTION SDRAM 512MB OPTION SDRAM 1024MB
28	NVM
29	PWB BRACKET L
30	PWB BRACKET R
31	BLOCK PWB
32	SCREW KNURLING
33	OPTION WIRELESS LAN ADAPTER (Installs to the MPC)
34	OPTION COVER USB
35	PANEL EXCOPRO
36	SPRING EARTH ESS

PL10.1 Harness [Illustration]

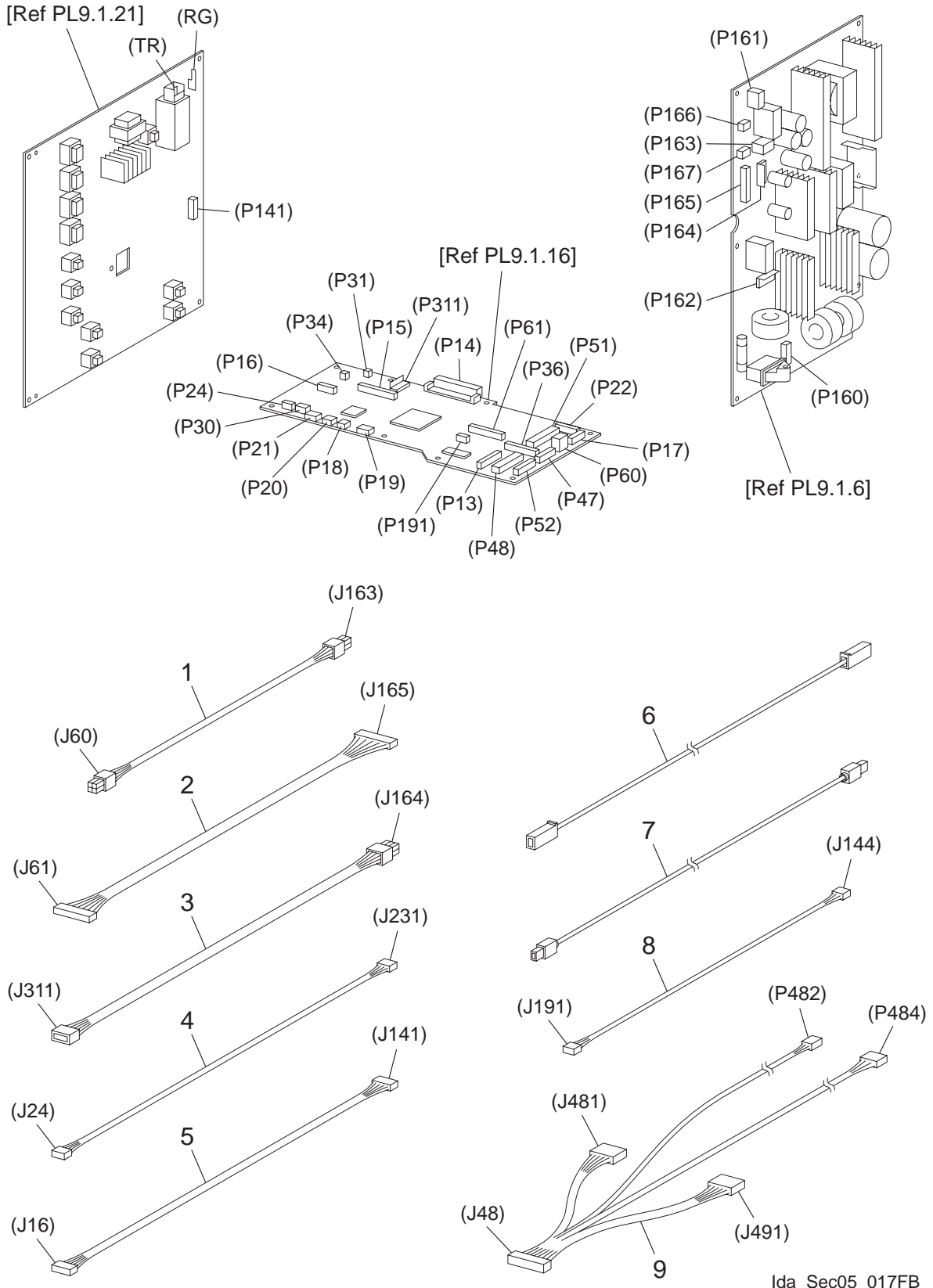

Ida\_Sec05\_017FB

## PL10.1 Harness [List]

Item	Parts name
1	HARNESS ASSY 24V (J60-J163)
2	HARNESS ASSY LV (J61-J165)
3	HARNESS ASSY LV RPG (J164-J311)
4	HARNESS ASSY TMP (J24-J231)
5	HARNESS ASSY HVPS (J16-J141)
6	WIRE ASSY BTR
7	WIRE ASSY REGI
8	HARNESS ASSY EEPROM (J191-J144)
9	HARNESS ASSY FAN/PHD/MOT (J48-J481,P482,P484,J491)

Blank Page

## Chapter 6 Principles of Operation CONTENTS

---

1. Printing Process .....	6 - 1
1.1 Summary of Printing Process .....	6 - 1
1.2 Schematic Diagram for Printing Processes .....	6 - 2
1.3 Description of Printing Process Techniques .....	6 - 3
1.3.1 Charging with electricity .....	6 - 3
1.3.2 Exposure.....	6 - 4
1.3.3 Development.....	6 - 6
1.3.4 Trickle .....	6 - 8
1.3.5 Primary transfer (drum -> IDT 1).....	6 - 10
1.3.6 Secondary transfer (IDT 1 -> IDT 2) .....	6 - 12
1.3.7 Cleaning (IDT 1).....	6 - 12
1.3.8 Tertiary transfer (IDT 2 - paper).....	6 - 14
1.3.9 Cleaning (IDT 2).....	6 - 14
1.3.10 Static elimination.....	6 - 14
1.3.11 Fixing .....	6 - 15
1.3.12 Cleaning (general) .....	6 - 16
2. Paper Transfer.....	6 - 18
2.1 Paper Transfer Route (without option).....	6 - 18
2.2 Layout of Paper Transfer Route.....	6 - 19
3. Functions of Major Functional Components .....	6 - 20
3.1 Paper Cassette .....	6 - 20
3.1.1 Major functions.....	6 - 20
3.1.2 Reference diagram .....	6 - 21
3.1.3 Multiple sheet feed prevention .....	6 - 22
3.2 Paper Feeder .....	6 - 24
3.2.1 Major functions.....	6 - 24
3.2.2 Reference diagram .....	6 - 25
3.3 Separator & Registration Assembly .....	6 - 26
3.3.1 Major functions.....	6 - 26
3.3.2 Reference diagram .....	6 - 27
3.3.3 Multiple sheet feed prevention.....	6 - 28
3.3.4 Lead edge registration .....	6 - 29
3.4 Inner Duplex Assembly .....	6 - 30
3.4.1 Major functions.....	6 - 30
3.4.2 Reference diagram .....	6 - 31
3.5 Outer Duplex Assembly .....	6 - 32
3.5.1 Major functions.....	6 - 32
3.5.2 Reference diagram .....	6 - 33
3.6 Transfer Roller & Fuser.....	6 - 34
3.6.1 Major functions.....	6 - 34
3.6.2 Reference diagram .....	6 - 35
3.7 Xerographics.....	6 - 36
3.7.1 Major functions.....	6 - 36
3.7.2 Reference diagram .....	6 - 37
3.8 Toner Dispenser Assembly.....	6 - 38

3.8.1 Major functions.....	6 - 38
3.8.2 Reference diagram .....	6 - 39
3.9 Frame & Drive.....	6 - 40
3.9.1 Major functions.....	6 - 40
3.9.2 Reference diagram .....	6 - 41
3.10 Electrical .....	6 - 42
3.10.1 Major functions.....	6 - 42
3.10.2 Reference diagram .....	6 - 43
3.10.3 Data Flow.....	6 - 44
<b>4. MODES .....</b>	<b>6 - 45</b>
4.1 Print Mode.....	6 - 45
4.2 Operation Modes .....	6 - 45
<b>5. Control .....</b>	<b>6 - 46</b>
5.1 Control of Paper Size.....	6 - 46
5.2 Selective Control on Paper Cassette .....	6 - 46
5.3 PRINT HEAD Light Quantity Control .....	6 - 46
5.4 Process Control .....	6 - 47
5.4.1 Potential Control .....	6 - 47
5.4.2 Toner Density Control .....	6 - 48
5.4.3 High Area Coverage Mode .....	6 - 49
5.4.4 Admix Mode.....	6 - 49
5.4.5 LED Light Quantity Control of AUTOMATIC DENSITY CONTROL SENSOR.....	6 - 49
5.5 Color Registration Control.....	6 - 50
5.6 Transfer Roller Control.....	6 - 51
5.6.1 Detecting the Installation of Transfer Roller.....	6 - 51
5.6.2 Detecting the Life of Transfer Roller .....	6 - 51
5.7 Toner Control .....	6 - 52
5.7.1 SENSOR NO TONER.....	6 - 52
5.7.2 Toner presence control .....	6 - 52
5.8 Fuser Control .....	6 - 53
5.8.1 Fuser temperature control.....	6 - 53
5.8.2 Cool down .....	6 - 53
5.8.3 Sensor Warm-up.....	6 - 53
<b>6. Drive Transmission Route and Gear Layout .....</b>	<b>6 - 54</b>
6.1 MAIN DRIVE ASSEMBLY.....	6 - 54
6.2 DEVELOPER DRIVE ASSEMBLY.....	6 - 56
6.3 TONER DISPENSER ASSEMBLY (Y, M, C, K) .....	6 - 58
6.4 DRIVE ASSY FUSER .....	6 - 59
6.5 MOTOR ASSY DUP .....	6 - 60

# 1. Printing Process

## 1.1 Summary of Printing Process

This printer is a "Full-color laser printer" which applies the principal of an electrophotographic recording system. The tandem system comprising a drum and developing unit respectively for each color of yellow, magenta, cyan and black (Y, M, C and K) places toner image of each color on paper producing full-color prints finally through 3 intermediate transfer units (IDT 1: 2, IDT 2: 1).

Printing processes of this printer is composed of the basic steps as follows.

- (1) Charging with electricity: Drum surface is charged with electricity.
- (2) Exposure: ..... Image unit is exposed to laser beams.
- (3) Development: ..... Image is developed with toner.
- (4) Primary transfer: ..... Toner image is transferred to the intermediate transfer unit (IDT 1).
- (5) Secondary transfer: ..... Toner image on the intermediate transfer unit (IDT 1) is transferred to the intermediate transfer unit (IDT 2).
- (6) Cleaning: ..... The intermediate transfer unit (IDT 1) is cleaned.
- (7) Tertiary transfer: ..... Four-color finished toner image on the intermediate transfer unit (IDT 2) is transferred onto the paper.
- (8) Cleaning: ..... Intermediate transfer unit (IDT 2) is cleaned.
- (9) Static elimination: ..... Electric charge of the paper is eliminated.
- (10) Fixing: ..... Toner on the paper is fixed by heat and pressure.
- (11) Cleaning: ..... Remaining toner on the drum and intermediate transfer units are collected.

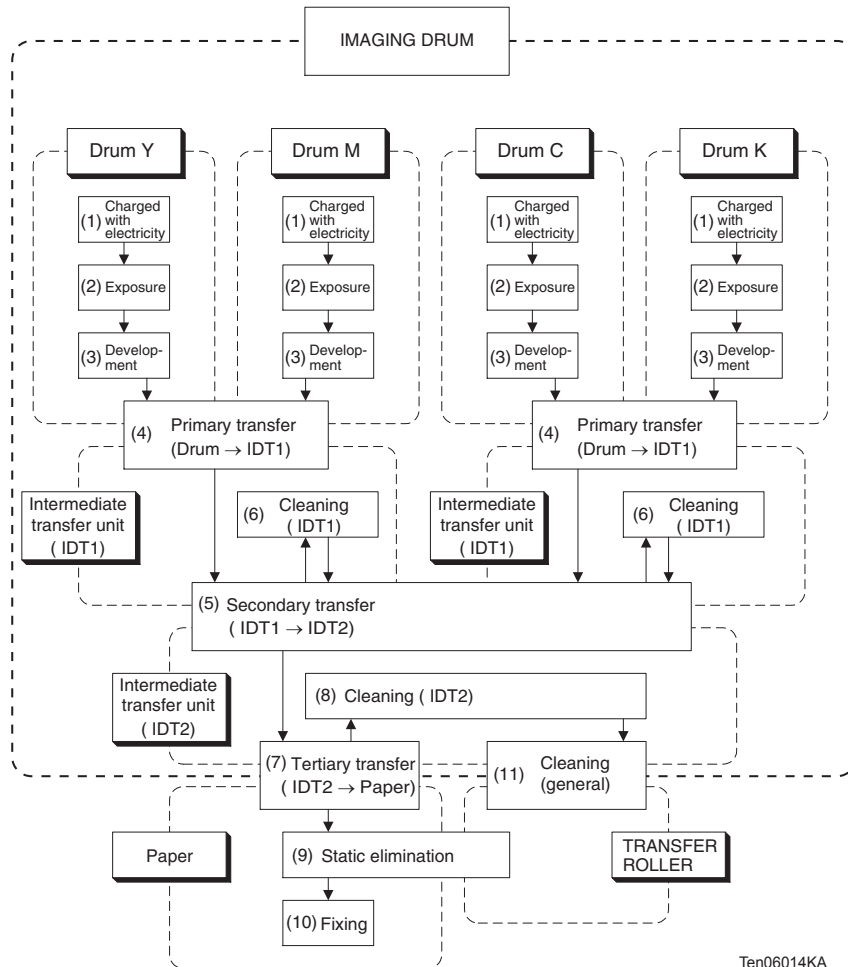

Ten06014KA



## 1.2 Schematic Diagram for Printing Processes

Outline of printing processes is shown in the figures below.

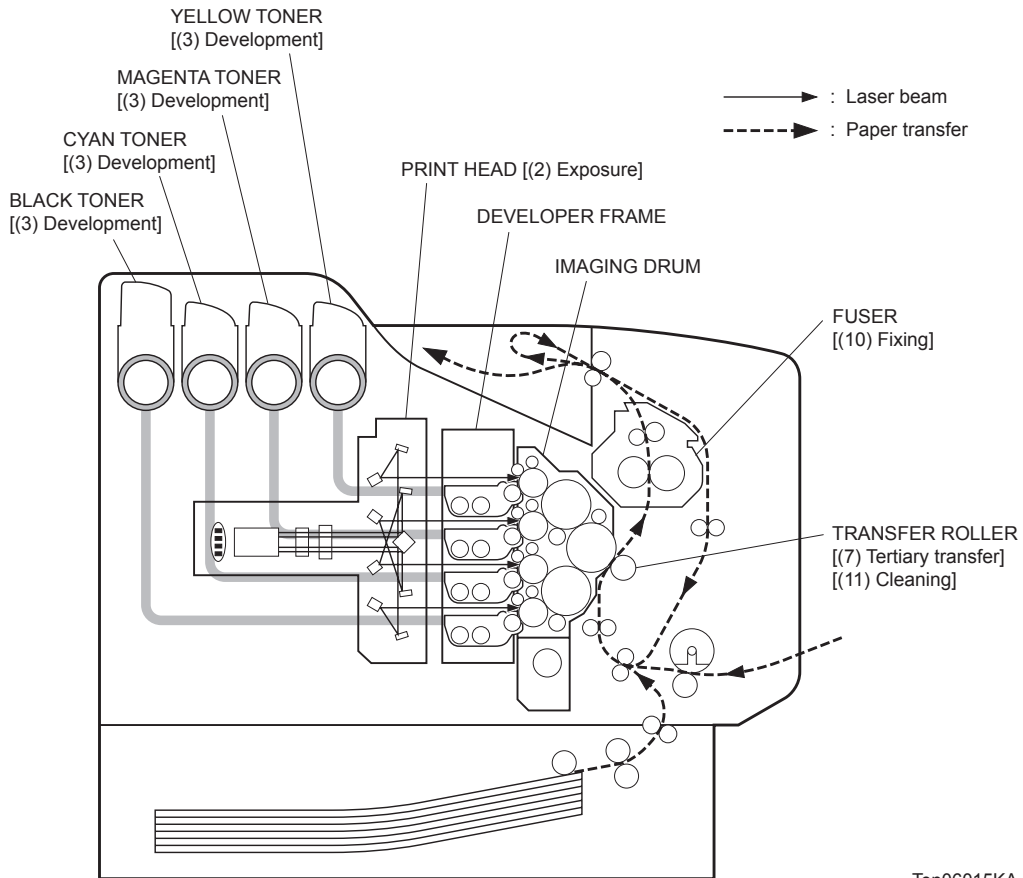

Ten06015KA

IMAGING DRUM and DEVELOPER FRAME is integrated major units of printing processes. It is composed as follows.

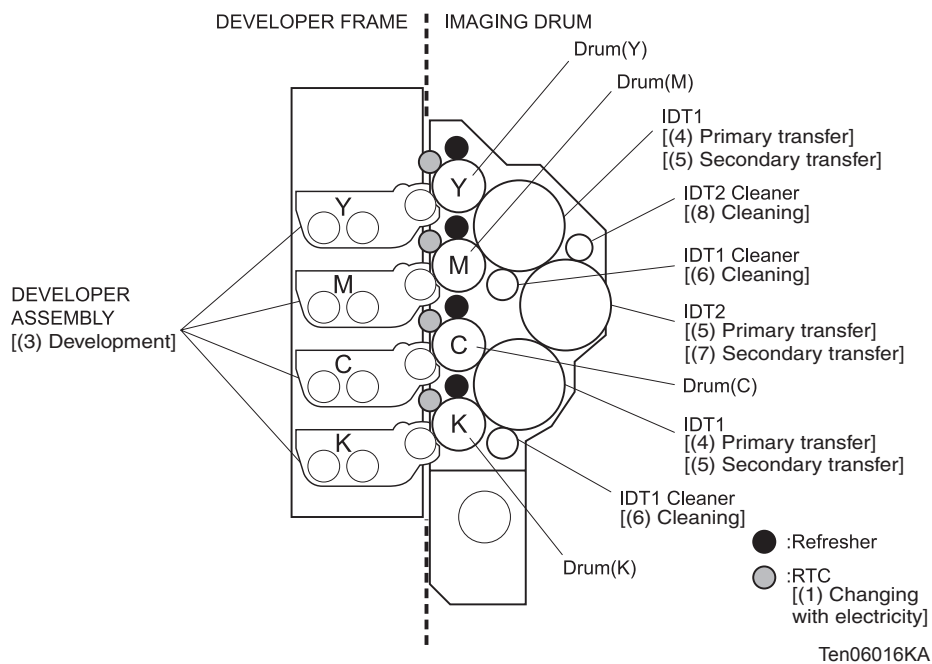

Ten06016KA

### 1.3 Description of Printing Process Techniques

#### 1.3.1 Charging with electricity

In the charging process, the drum surface rotating at a constant speed is charged uniformly with negative electricity by discharging of RTC (Rubber Tube Charge: Charged film).

This process is performed in parallel for yellow, magenta, cyan and black colors.

- The RTC is kept in contact with the drum and rotates following the rotations of the drum. RTC is a conductive roll, receives discharge voltage from HIGH VOLTAGE POWER SUPPLY (HVPS) and discharges at minus DC voltage.
- The drum surface is uniformly and negatively charged with DC bias voltage. The drum surface is optical conductor (which is insulator in a dark place and conductor when receiving light) and the drum inside is composed of conductor.
- The Refresher is a conductive brush, and it receives negative DC voltage from the HIGH VOLTAGE POWER SUPPLY (HVPS) to catch the toner of reverse polarity returned to the drum via IDT. Also, it removes discharge products.

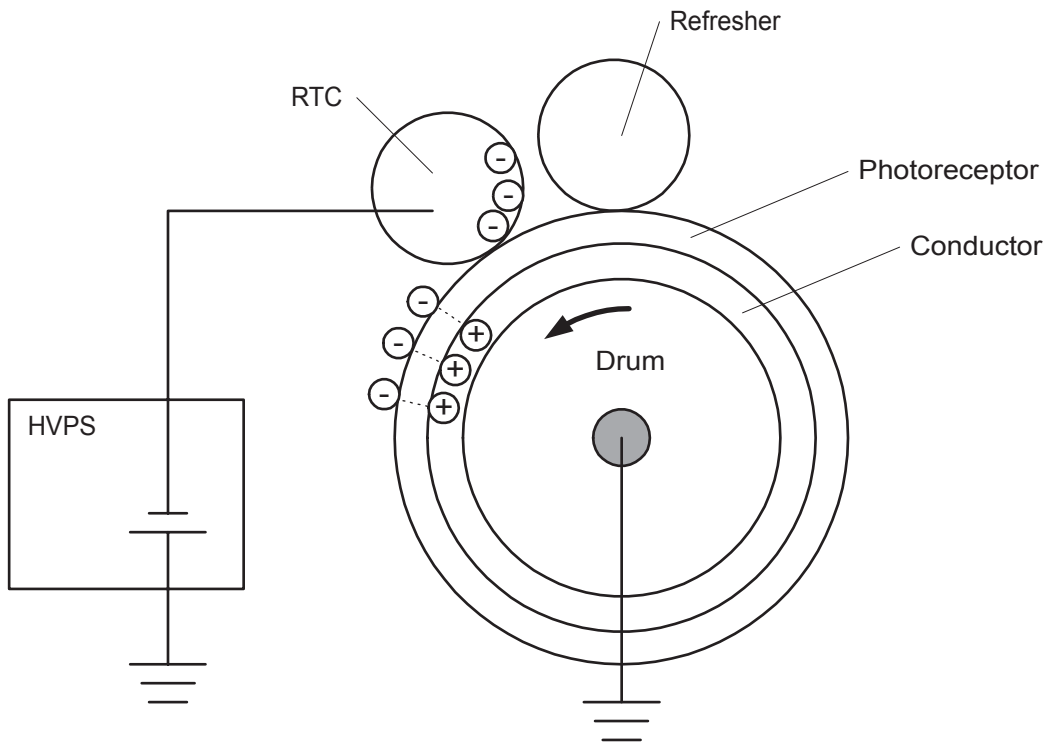

Ten06039KA

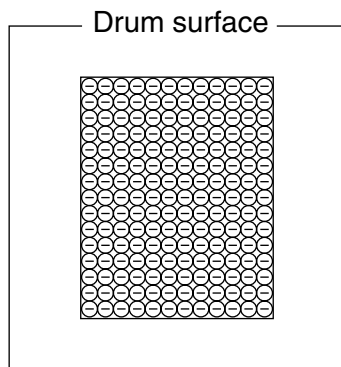

engine principle0005FA

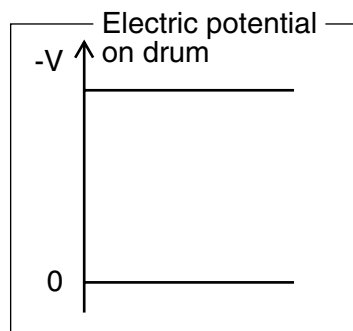

engine principle0006FA

### 1.3.2 Exposure

In the exposure process, the drum surface charged negatively is scanned by laser beams to form invisible electrostatic latent image on the drum surface.

This process is performed in parallel for yellow, magenta, cyan and black colors.

- Laser beams are emitted from the laser diode in the PRINT HEAD. By the rotating polygon mirror, fixed mirror and lens attached to the Scanner Motor Assy of the PRINT HEAD, each color of drum surface is scanned from end to end in the axial direction.

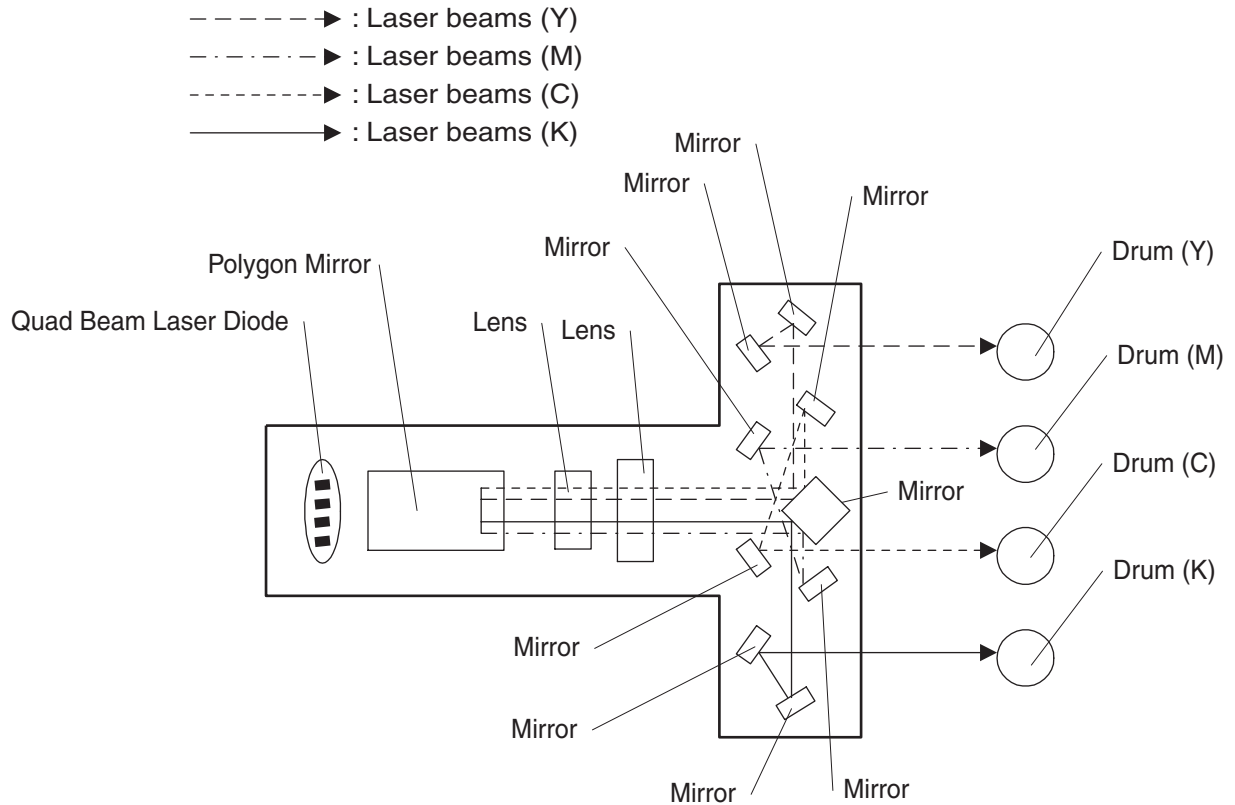

engine principle0007FA

- The laser beam is radiated according to the printing data (image data) output from the printer controller. The laser beam is output only when printing data is pixels (micro points composing characters or pictures). (The laser diode lights up for parts to be developed by toner, and not for parts that are not to be developed.)

The drum surface radiated by the laser beam becomes a conductor, and the negative charge on the drum surface flows to the positive side and the charges negate each other so that the potential on the drum surface drops. The part on the surface where potential drops becomes the electrostatic latent image.

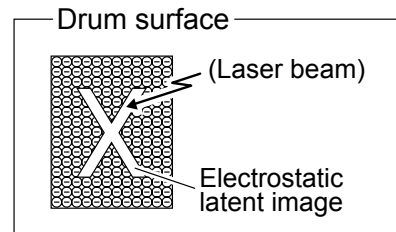
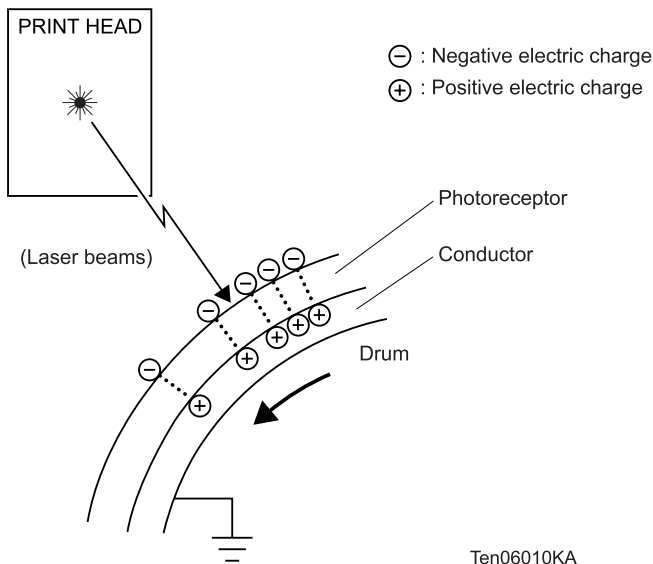

Leg\_Sec06\_011FA

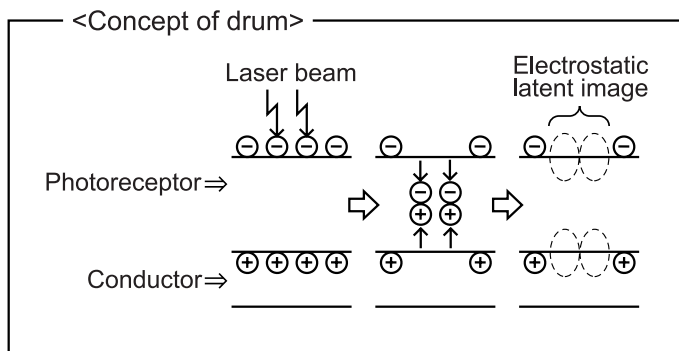

Ten06011KA

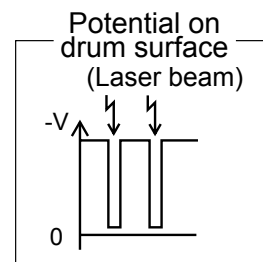

Leg\_Sec06\_012FA

### 1.3.3 Development

In the development process, toner is electrically attached to the invisible electrostatic latent image on the drum surface to form visible toner image on the drum.

This process is performed in parallel for yellow, magenta, cyan and black color respectively.

- The toner in the toner cartridge is agitated by the Agitator in the toner cartridge and fed into the TONER DISPENSER ASSEMBLY. Further, the toner is fed to the developer by the Auger in the TONER DISPENSER ASSEMBLY and the Auger in the tube that connects the TONER DISPENSER ASSEMBLY and the developer. The Agitator and Auger are spiral agitating components and they are driven by the toner motor provided on the rear of toner cartridge. The toner to be consumed according to the print count is calculated and fed into the developer. This is called "toner dispensation", which is controlled by two types of control, "PCDC" and "ADC". For the PCDC and ADC, refer to "5.4 Process Control" in this chapter.
- The toner fed into the developer and the carrier in the developer are agitated by the Auger, and supplied to the Magnet Roll arranged in the vicinity of the drum surface. The toner and carrier are charged by friction due to the agitation (toner in negative, carrier in positive), and they are absorbed each other electrically. As the carrier is a magnetic substance, it is attracted to the Magnet Roll having a magnetic force and a homogeneous layer is formed by the Trimmer Rod and the Paddle.
- The magnet roll is covered by a thin semi-conductive sleeve over the surface. DB (Developing Bias) voltage is supplied to this semiconductor sleeve from HIGH VOLTAGE POWER SUPPLY (HVPS). DB voltage is negative DC voltage combined with AC voltage. The magnet roll is kept at constant negative voltage against the optical conducting layer of the drum by DC voltage. Therefore, at the area on the drum surface where the negative electric charge does not decrease, potential is lower than the magnet roll, while the potential is higher than the magnet roll at the area where the negative charge on the drum surface decreases. The AC voltage shakes the developer on the magnet roll surface pressing the toner to fly to the drum. Thus, the toner charged negatively is attracted only by the area where the minus charge has decreased on the drum surface from the magnet roll (electrostatic latent image) and the toner image is formed on the drum. When the toner is attached, minus charge at that portion increases, potential decreases, and force to attract the toner decreases.

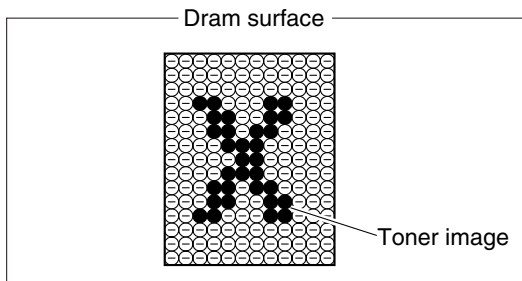
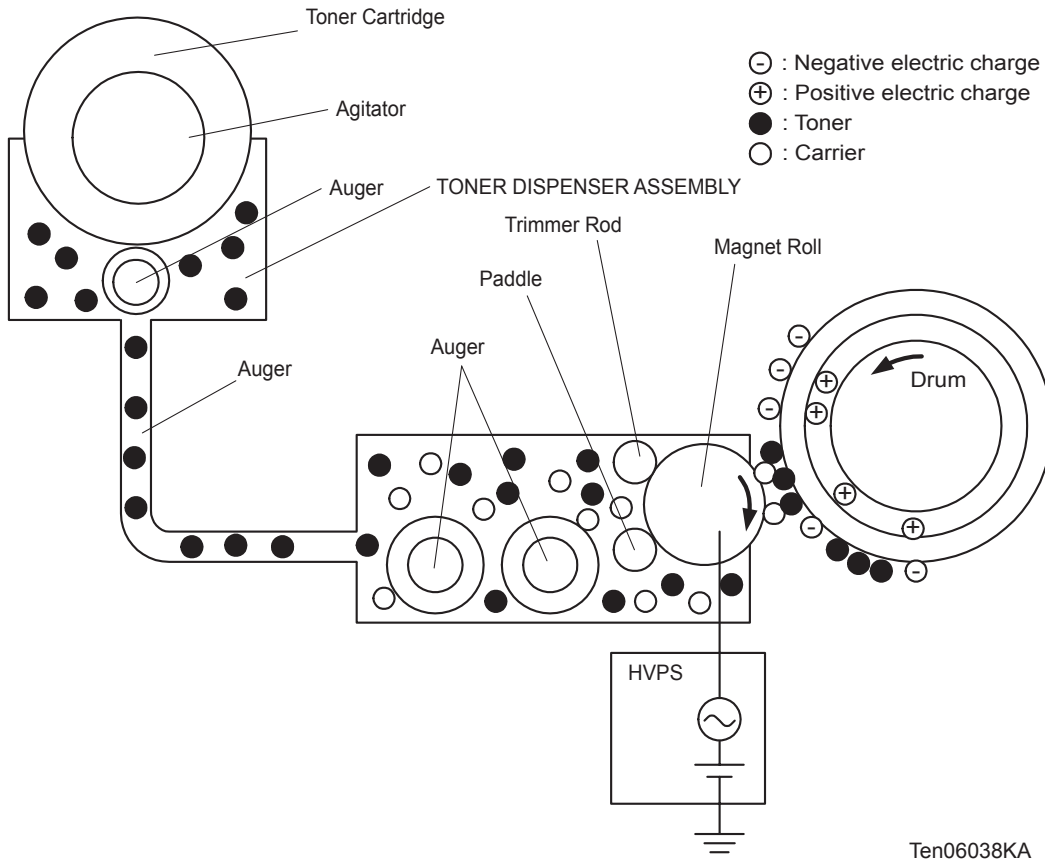

engine principle0013FA

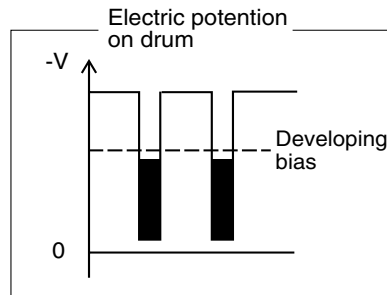

engine principle0014FA

### 1.3.4 Trickle

The carrier suffers deterioration in electrostatic characteristics due to surface contamination by toner or scratches by agitation.

In order to maintain electrostatic characteristics, a slight amount of carrier is mixed with the toner in the toner cartridge.

While the toner and the carrier are supplied to the Developer Assembly when the toner is dispensed, the deteriorated carrier in the Developer Assembly is collected to a separate chamber in the IMAGING DRUM.

This is called "trickle development method". The trickle development is enabled by the rotation of the Auger in the Developer Assembly.

Described below is the mechanism of trickle development.

- 1) The toner and the carrier are agitated in the arrow's direction by the two Augers in the Developer Assembly.
- 2) A portion of the carrier that reached the section A of the AUGER DEVE REAR is carried to and dropped from the carrier chute.
- 3) The dropped carrier is carried toward the IMAGING DRUM by the NOZZLE mounted on DEVELOPER FRAME.
- 4) The carrier collected to the box in the IMAGING DRUM is carried by the Auger therein to the center area of the box.

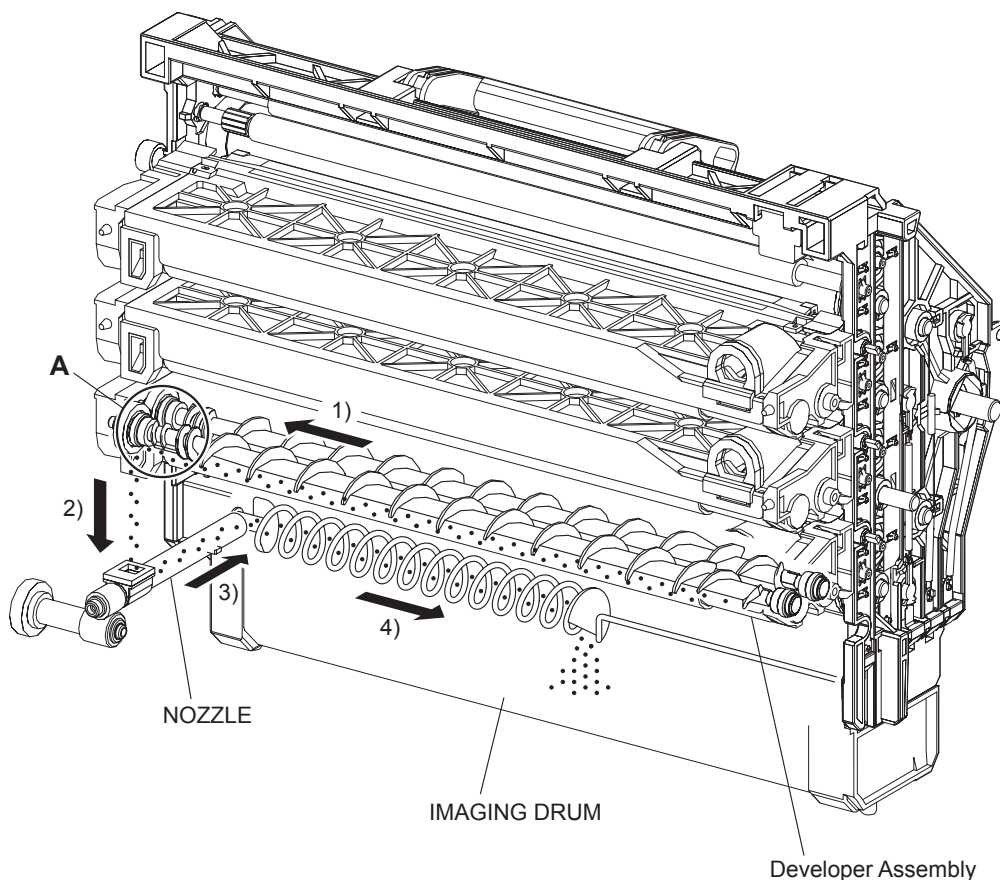

Ten06005KA

Blank Page



**1.3.5 Primary transfer (drum -> IDT 1)**

In the primary transfer process, toner image formed on the drum surface is transferred onto the surface of the IDT 1 (Intermediate Drum Transfer 1).

Two IDT 1 are provided: yellow and magenta, and cyan and black are respectively transferred to their IDT 1.

- IDT 1 is a conductive roll and receives supply of high positive voltage from HIGH VOLTAGE POWER SUPPLY (HVPS).

The toner image (negatively charged) on the drum is attracted to the IDT1 positively charged, and transferred from the drum to the IDT1 surface.

At this time, electric charge of the drum surface is neutralized by the IDT1

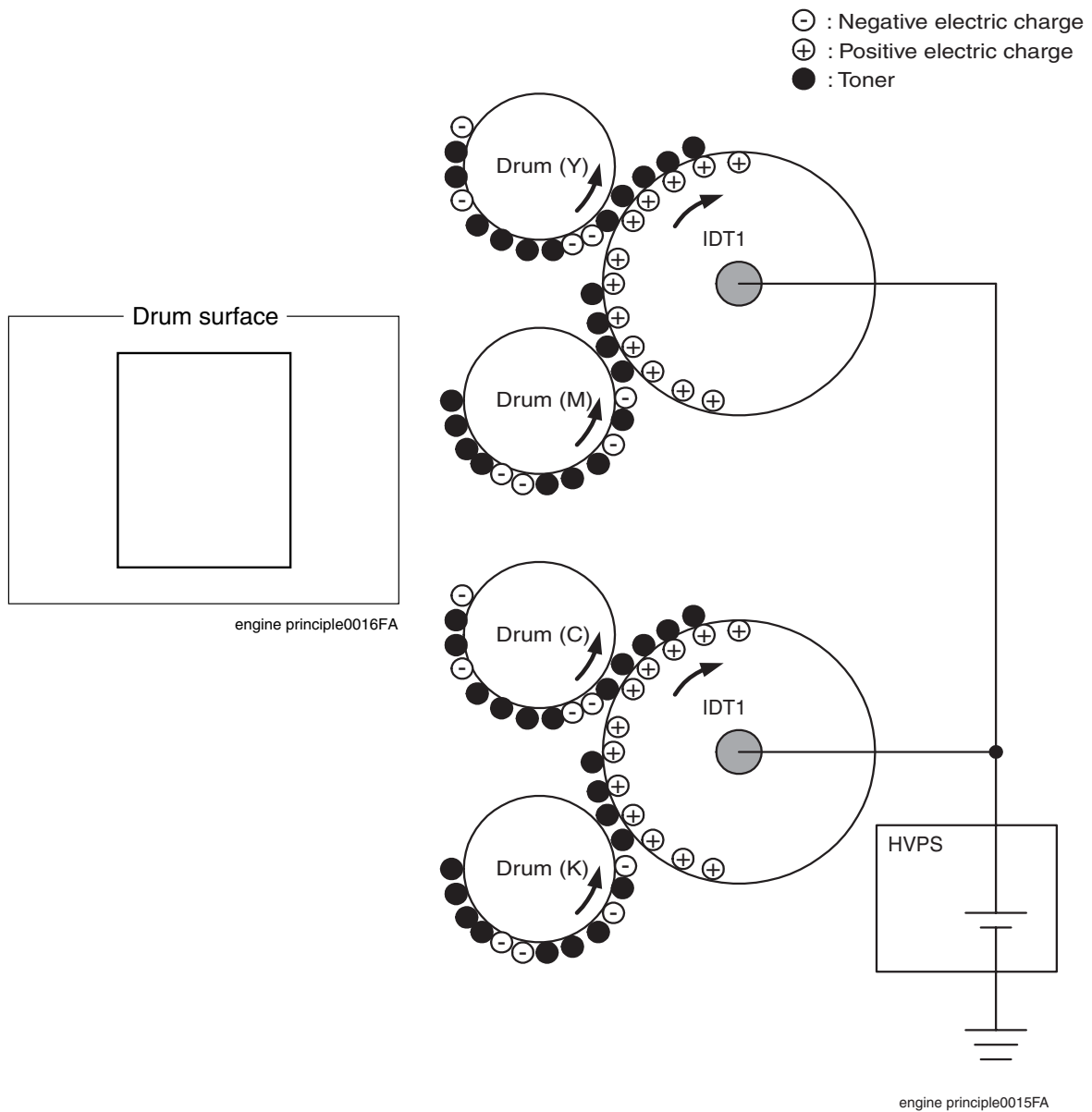

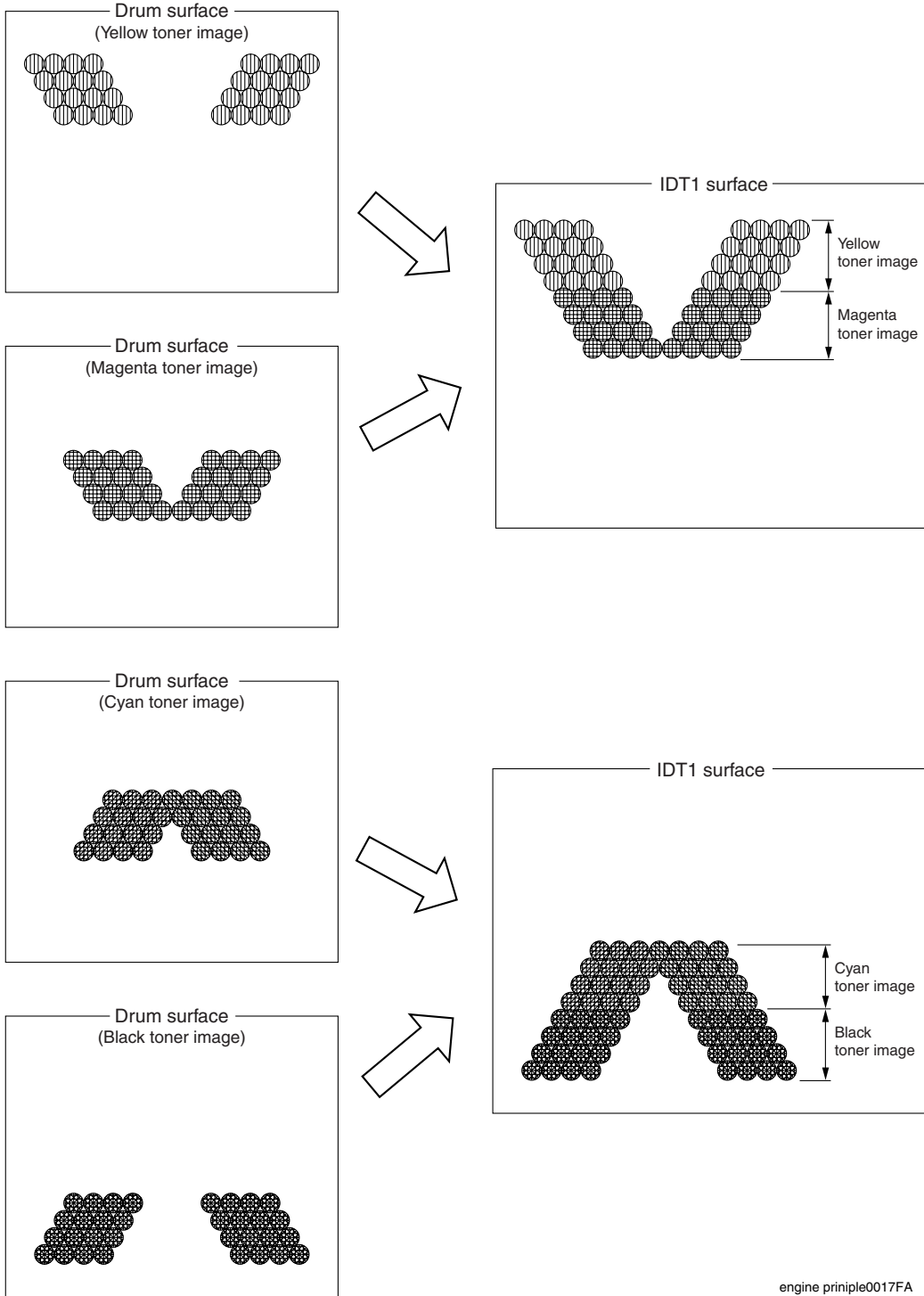

engine priniple0017FA

### 1.3.6 Secondary transfer (IDT 1 -> IDT 2)

In the secondary transfer process, the toner image formed on the IDT 1 surface is transferred onto the surface of the IDT 2 (Intermediate Drum Transfer 2).

Two color toner image transferred onto the 2 IDT 1 is transferred to the IDT 2. Thus, 4 color toner image are compiled on the IDT 2 as finished toner image.

- IDT 2 is a conductive roll and receives supply of positive high voltage from HIGH VOLTAGE POWER SUPPLY (HVPS).  
Both the IDT 1 and IDT 2 are positively charged. Voltage is higher on the IDT 2 and toner image is attracted to the IDT 2 surface and transferred onto the IDT 2.

### 1.3.7 Cleaning (IDT 1)

In the cleaning process (IDT 1), toner remaining on the IDT 1 after the toner image is transferred to the IDT 2 is temporarily stored in the IDT 1 cleaner.

- The IDT 1 cleaner receives positive high voltage from the HIGH VOLTAGE POWER SUPPLY (HVPS) with a conductive roll brush.  
The IDT 1 cleaner is placed in contact with the IDT 1 at the position through which it passes after the toner image having been transferred from the drum is transferred to the IDT2. Toner remaining on the IDT 1 is electrically absorbed and stored.  
The toner stored is collected upon completion of printing or at the time of cleaning cycle. (Refer to "1.3.12 Cleaning (general)".)

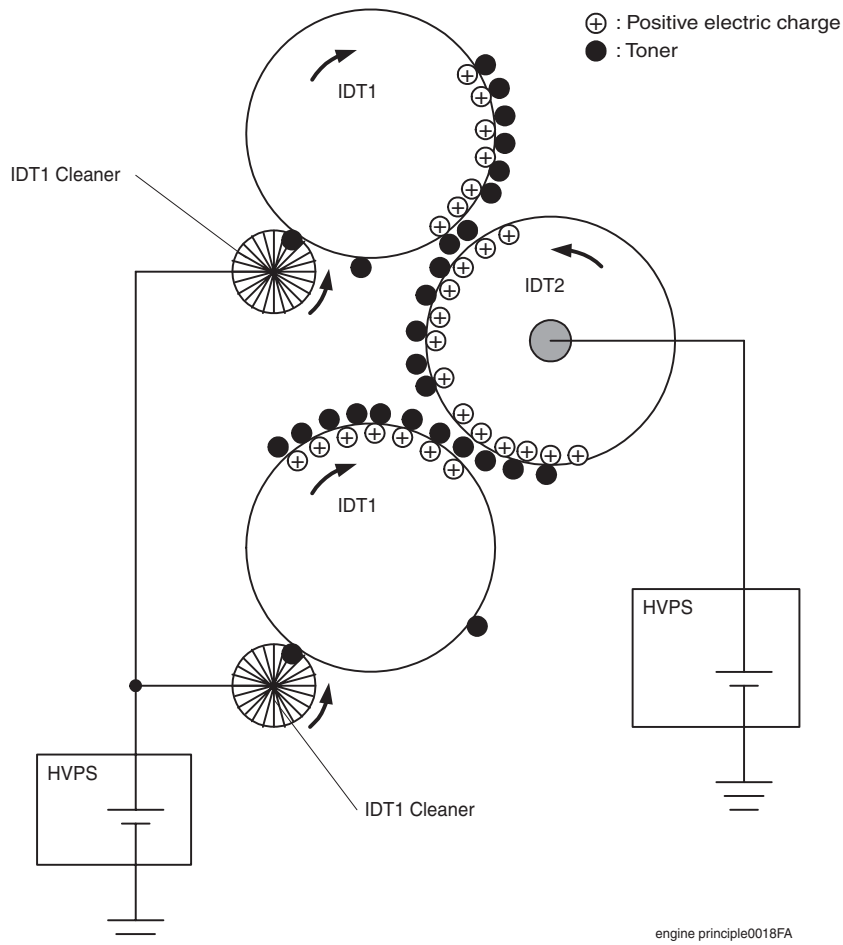

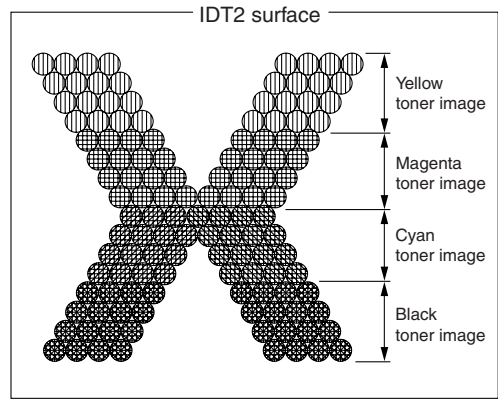
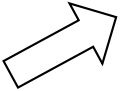
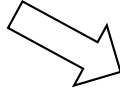
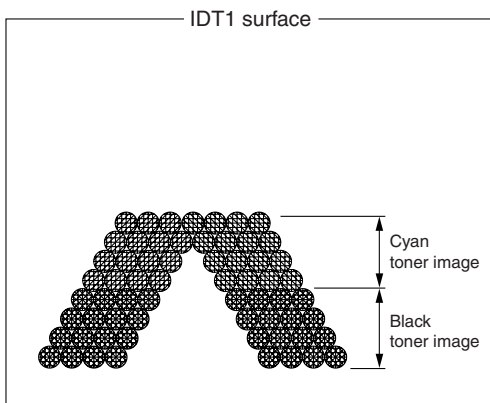
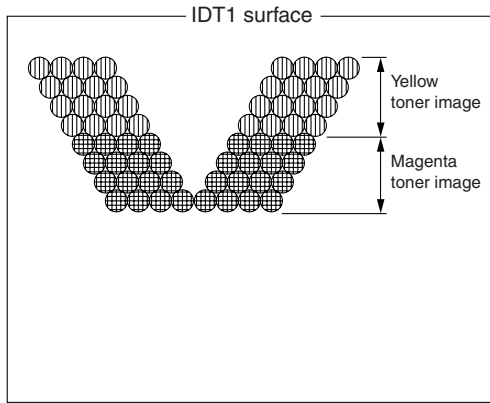

engine principle0019FA

### 1.3.8 Tertiary transfer (IDT 2 - paper)

In the tertiary transfer process, finished toner image formed on the IDT 2 surface is transferred onto the paper under the voltage supplied to the BTR (Bias Transfer Roll).

- BTR is composed in the Transfer Roller.

BTR is a conductive roll and receives positive high current from HIGH VOLTAGE POWER SUPPLY (HVPS).

When paper passes through between IDT2 and BTR, plus potential is given to the back side of the paper so that the toner on the IDT 2 is transferred onto the paper. At this time, potential on the BTR is higher than that on the IDT 2.

### 1.3.9 Cleaning (IDT 2)

In the cleaning process, toner remaining on the IDT 2 after the toner image is transferred onto the paper is temporarily held at the IDT 2 cleaner.

- The IDT 2 cleaner is a conductive roll brush and receives positive high voltage from HIGH VOLTAGE POWER SUPPLY (HVPS).

The IDT 2 cleaner is placed in contact with the IDT 2 at a position through which it passes after the toner image having been transferred from IDT 1 is transferred onto the paper. Remaining toner on the IDT 2 is electrically scraped and held at the IDT 2 cleaner.

The toner held is collected upon completion of printing or at the cleaning cycle. (Refer to "1.3.12 Cleaning (general)".)

### 1.3.10 Static elimination

In the static elimination process, negative DC voltage is given to the back side of the paper from the Detack Saw (static elimination board) to neutralize and eliminate the charge of paper.

- The Detack Saw is held at a constant voltage by the varistor.

The positive charge caused in the tertiary transfer process generates image quality troubles by scattering toner. Static electricity of the paper is eliminated by discharge of the Detack Saw preventing those image quality troubles.

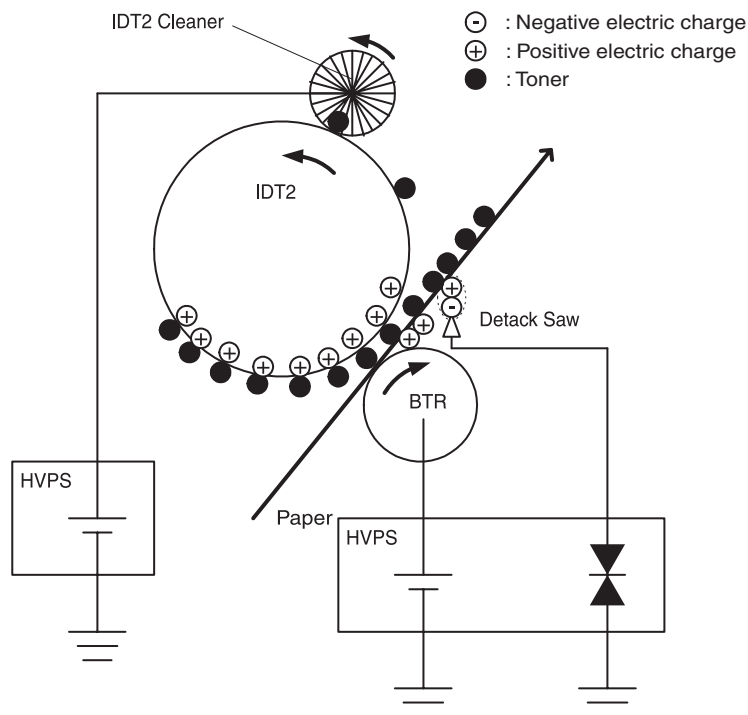

Ida\_Sec06\_017FA

**1.3.11 Fixing**

In the fixing process, toner is fixed on the paper by heat and pressure.

- Finished toner image transferred from the belt is easily broken only by touching it with fingers. The toner image is fixed on the paper with the FUSER (fixing unit). The toner melts by heat of the HEAT ROLL with the Heater lamp as the heat source and is deposited on the paper under pressure given by the belt opposed against the heat roll.

Conditions to be met to light up the Heater Lamp

	Warm up	Stand by	Printing
Main Heater Lamp	ON	Auxiliary lighting (ON)	Main lighting (ON)
Sub Heater Lamp	ON	Main lighting (ON)	Auxiliary lighting (ON)

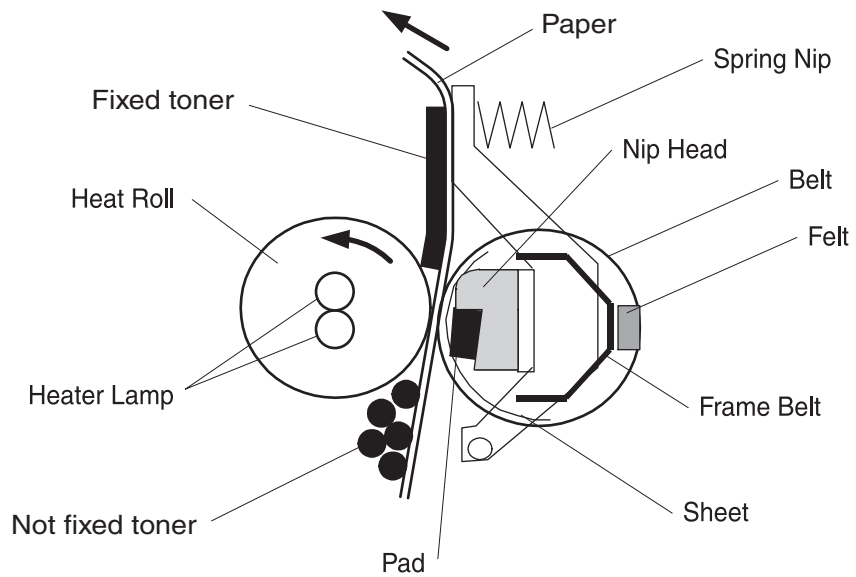

Ida\_Sec06\_018FA

**1.3.12 Cleaning (general)**

In the cleaning (general) process, toner stored in the IDT 1 cleaner and IDT 2 cleaner after the finished toner image is transferred onto the paper and the toner remaining on the BTR are removed.

- The toner not completely transferred in the "secondary transfer" and "tertiary transfer" processes is held temporarily in the IDT1 Cleaner and IDT2 Cleaner. Also, the toner of which polarity is reversed and returned to the drum is held in the Refresher. Further, the toner that passes the Refresher may stick to the RTC. These toners are cleaned at the completion of the printing. The recovery method is different between the toner held in the IDT1 Cleaner and IDT2 Cleaner and the toner held in the Refresher and RTC.

(1) IDT1 Cleaner and IDT2 Cleaner

High voltage equivalent to the voltage at the printing transfer is applied to the IDT1, IDT2, and BTR. The toner (negative polarity) remaining in the IDT1 Cleaner and IDT2 Cleaner are moved to the IDT1 and IDT2 electrically by transforming the IDT1 Cleaner and IDT2 Cleaner to 0V. Then, in the same manner as in the printing transfer, the residual toner is collected to the BTR surface by potential difference between IDT1, IDT2, and BTR.

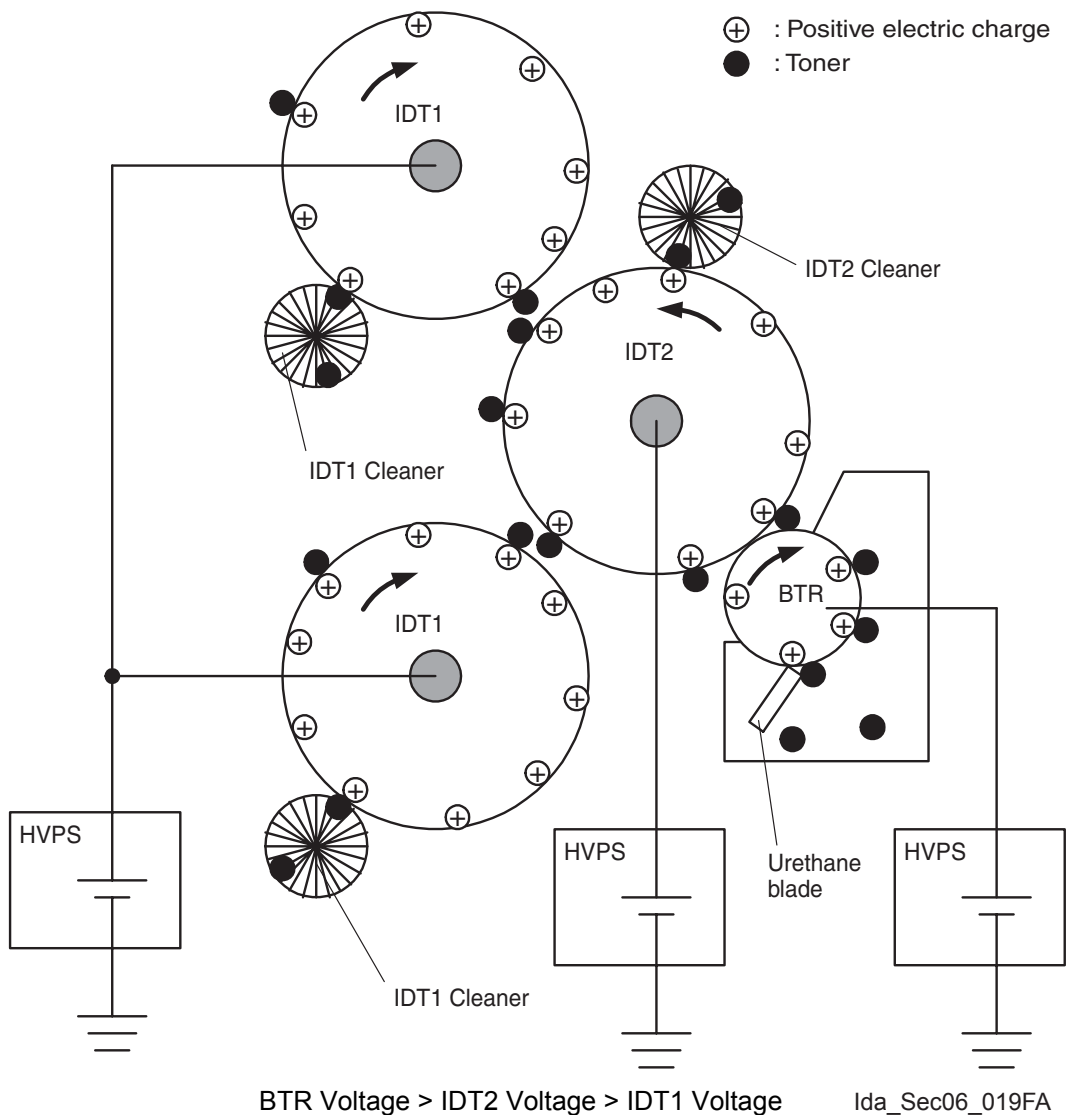

(2) Refresher and RTC

High voltage of the polarity (negative) reverse to that at the printing transfer is applied to the IDT1, IDT2, and BTR. At this time, the drum surface is charged negatively by negative voltage of the IDT1. The toner (positive polarity) remaining in the Refresher and RTC are move to the drum electrically by transforming the Refresher and HTC to 0V. Then, in the same manner as in the printing transfer, the residual toner is collected to the BTR surface by potential difference between IDT1, IDT2, and BTR.

- Toner attached to the surface of BTR is urethane blade off with the BTR cleaner which is in contact with the BTR and collected into the collection space in the Transfer Roller.

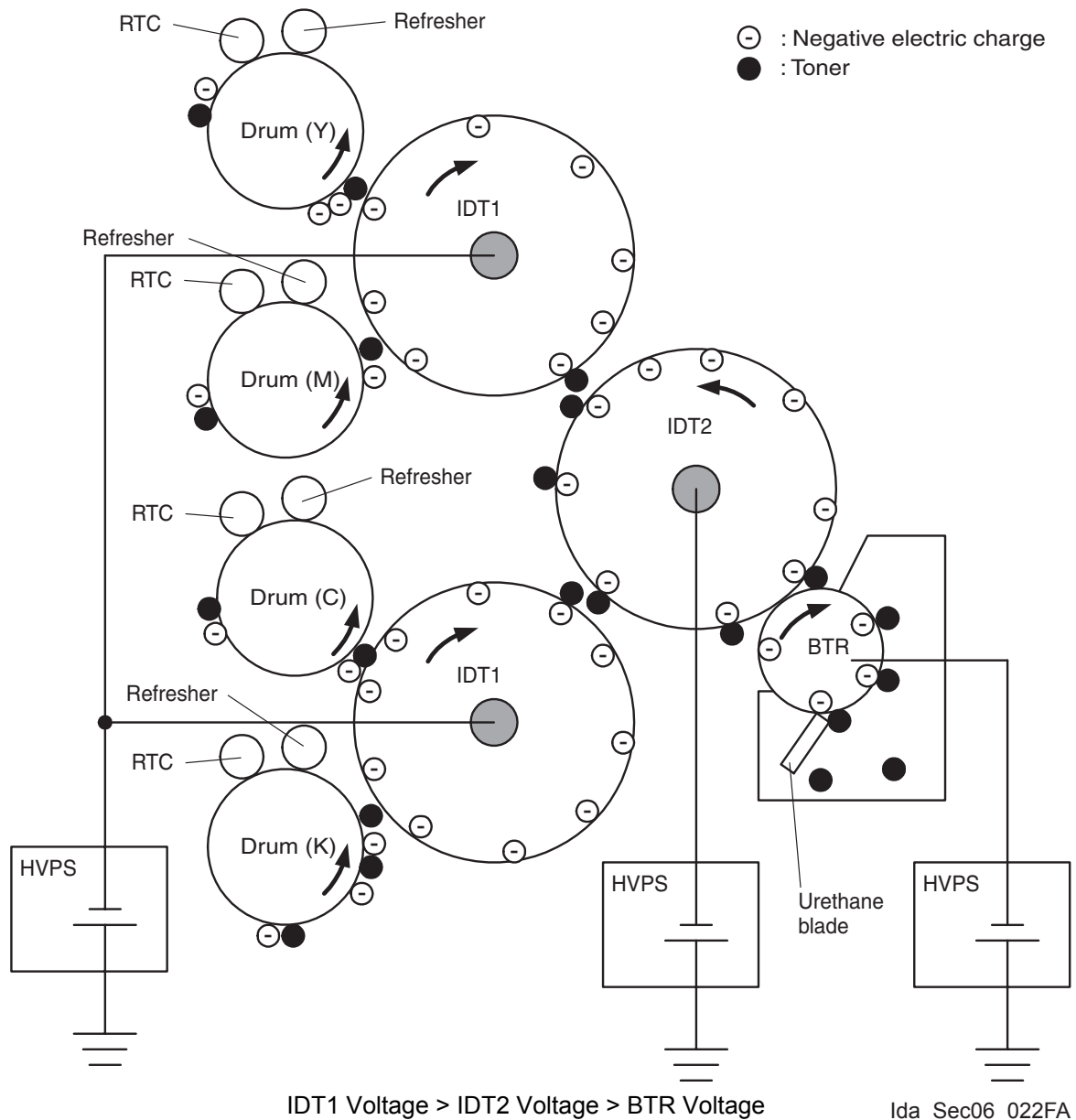



## 2. Paper Transfer

### 2.1 Paper Transfer Route (without option)

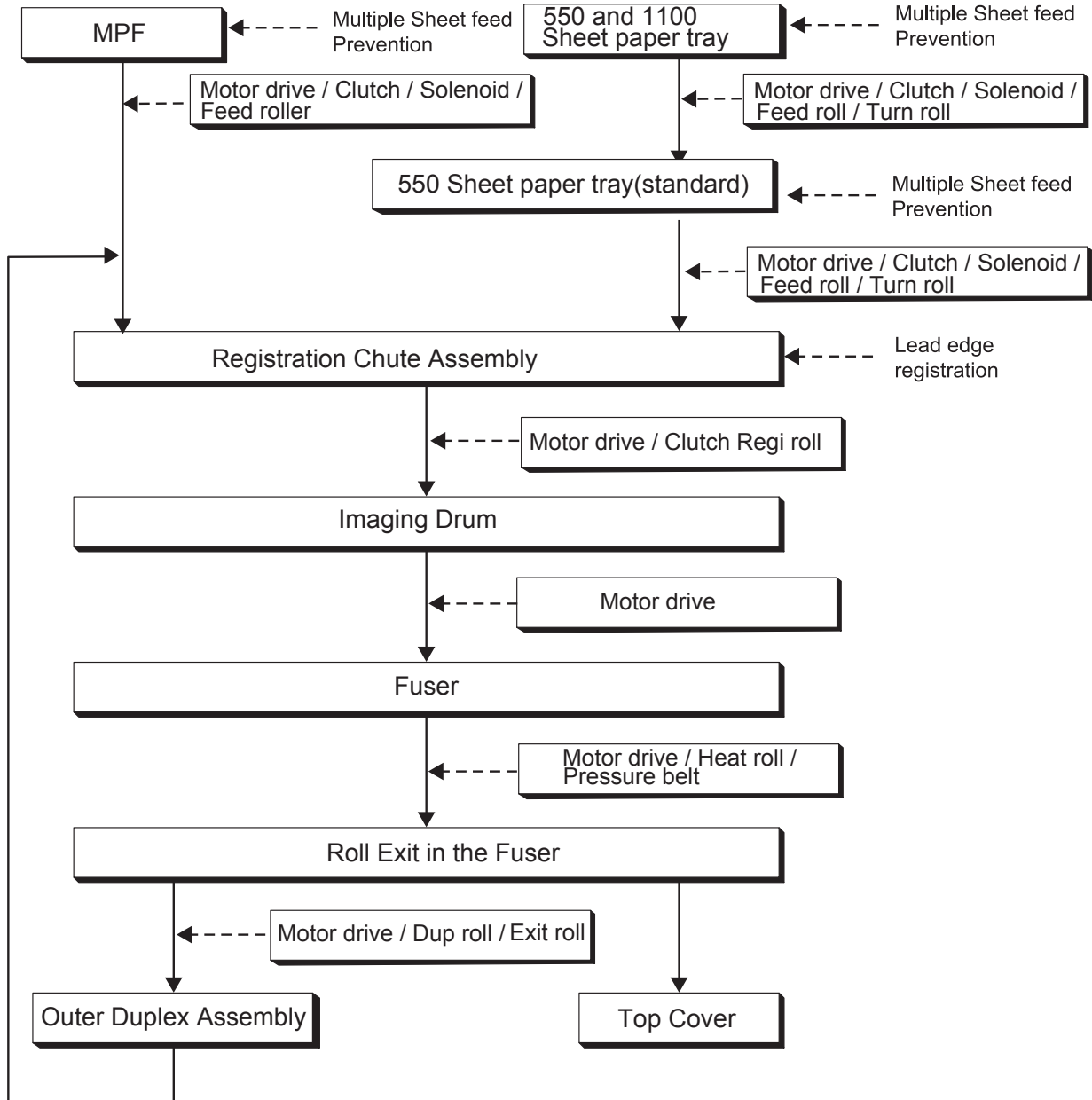

Ten06041KA

## 2.2 Layout of Paper Transfer Route

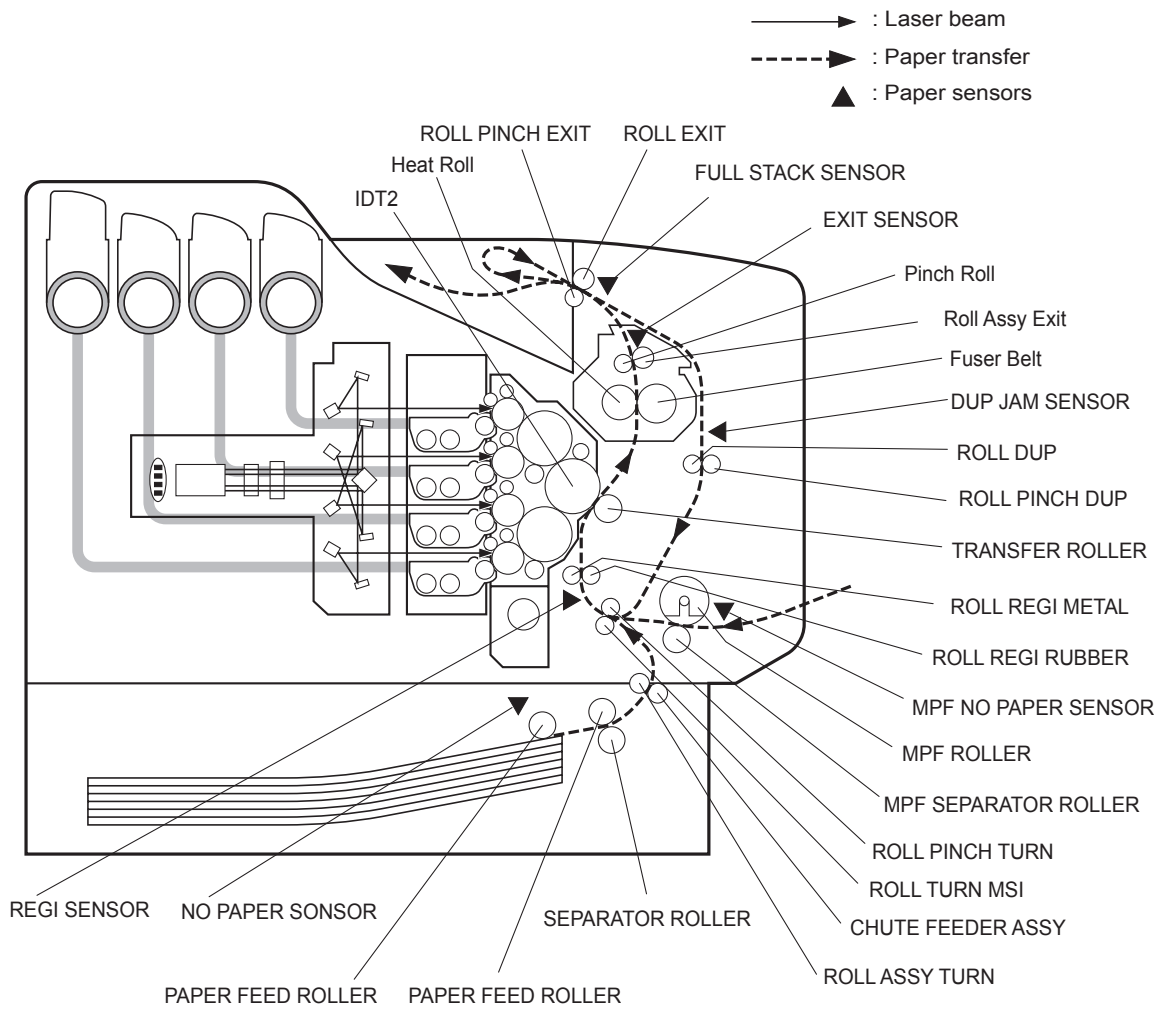

Ten06028KA

### 3. Functions of Major Functional Components

Major functional components comprising the printer are described below referring to their illustrations. Those components are classified into the following blocks based on the configuration of the printer.

- Paper Cassette
- Paper Feeder
- Separator & Registration Assembly
- Inner Duplex Assembly
- Outer Duplex Assembly
- Transfer Roller & Fuser
- Xerographics
- Toner Dispenser Assembly
- Frame & Drive
- Electrical

#### 3.1 Paper Cassette

##### 3.1.1 Major functions

- Guide Side (R/L)  
The Guide Side Assy (R/L) can move at right angle to the paper transfer direction to align the paper width.
  
- End Guide  
The Guide End Assy can move in the paper transfer direction to determine the paper size. The ON/OFF of SWITCH ASSY SIZE (refer to "3.2 Paper Feeder") varies according to the Guide End Assy position to detect the paper size.
  
- SEPARATOR ROLLER  
The SEPARATOR ROLLER and the PAPER FEED ROLLER (refer to "3.2 Paper Feeder") pinch the paper to feed.

3.1.2 Reference diagram

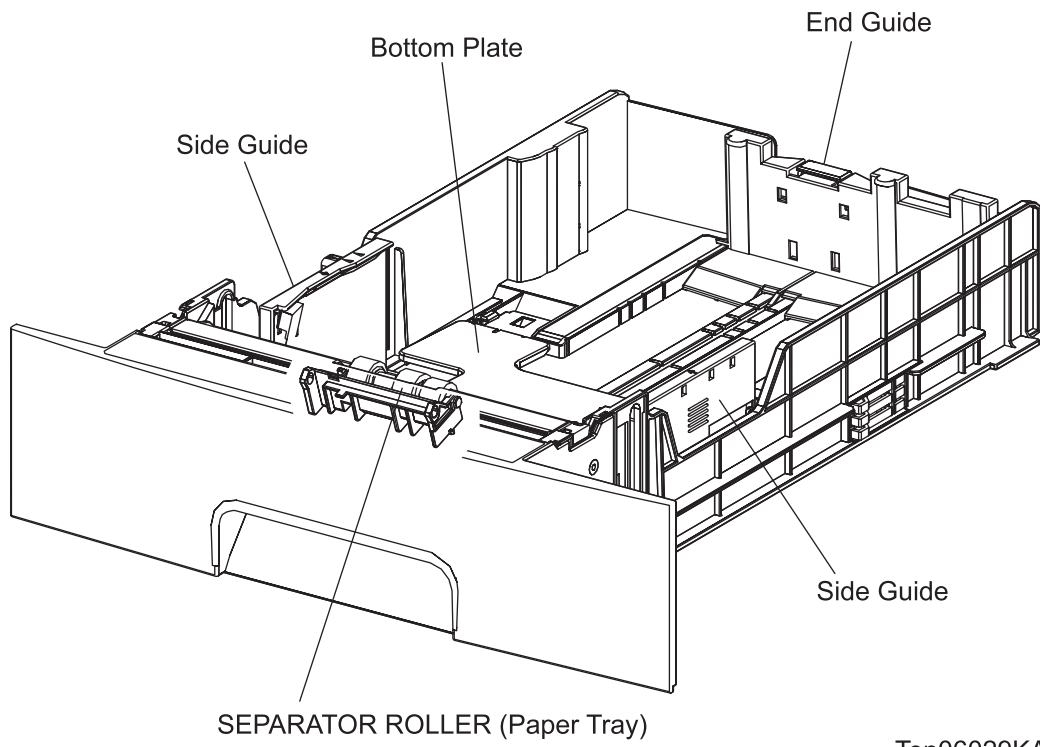

Ten06029KA

### 3.1.3 Multiple sheet feed prevention

The sheets set in a tray or a cassette may be stuck together at the edge due to microscope curl-up along the cutting plane caused by the guillotine, etc. The stuck sheets cause a multiple sheet feed or a jam.

The mechanism for separating these stuck sheets is called "ARRF (Active Retard Roll Feeder) method".

The sheets are carried by the Paper Feed Roller to the position between the Paper Feed Roller and the Separator Roller. The Separator Roller is being pushed toward the Paper Feed Roller by a spring tension.

When two sheets are carried concurrently, the top sheet is separated from the bottom sheet by the friction between the Separator Roller allowing only the top sheet to be fed.

When only one sheet is carried, two kinds of friction are concurrently generated between the Paper Feed Roller and the sheet (carrying force), and between the Separator Roller and the sheet (retaining force). However, the friction by the Separator Roller is released because the Separator Roller turns free by the torque limiter (CLUTCH ASSY FRICTION) provided on its shaft.

The release of the Retard Roll friction allows the sheet to be fed by the Paper Feed Roller.

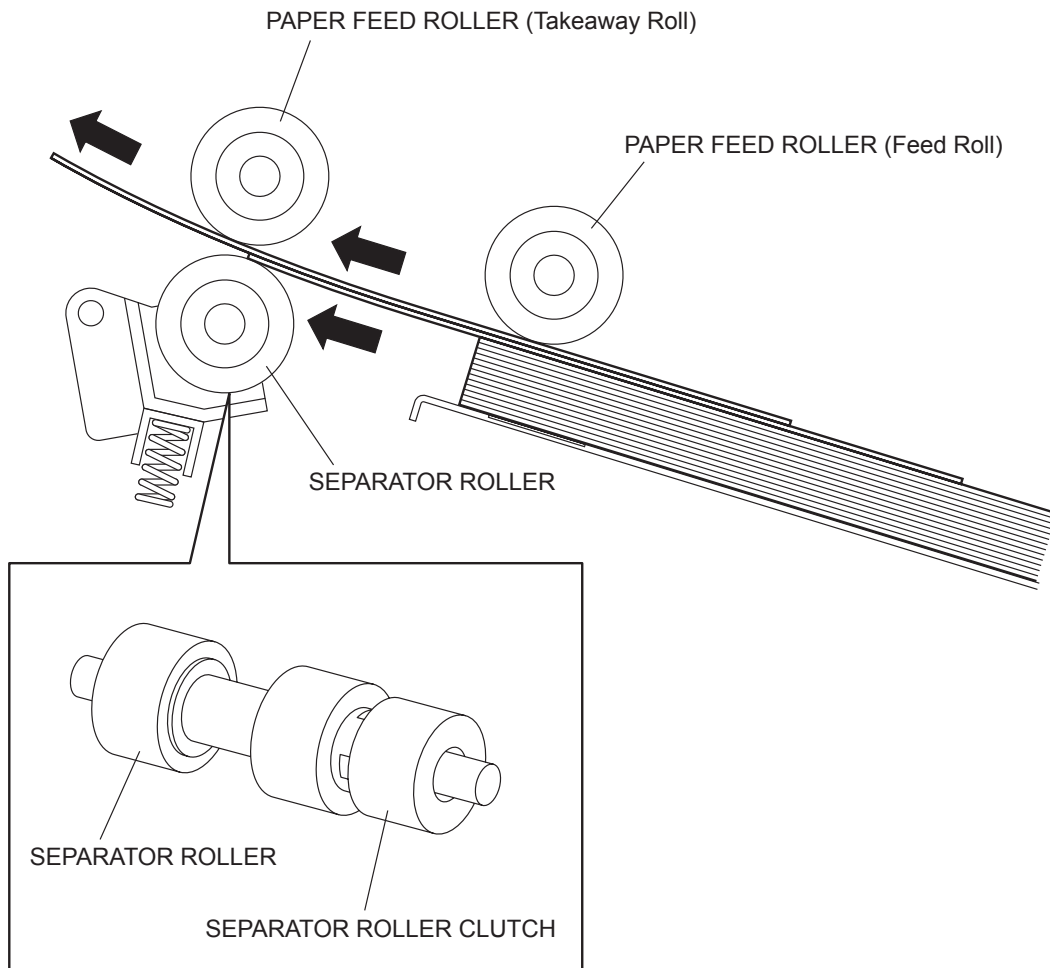

Ten06007KA

Blank Page

## 3.2 Paper Feeder

### 3.2.1 Major functions

- SWITCH ASSY SIZE

SWITCH ASSY SIZE detects paper size and existence or non existence of the paper tray.

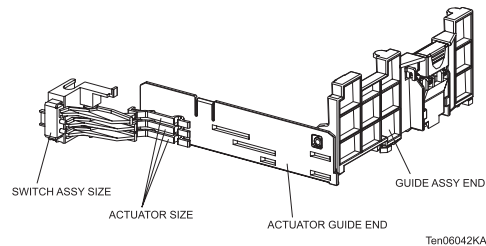

- SENSOR PHOTO (No Paper Sensor)

Detects existence or non existence of paper in the paper tray based on the position of ACTUATOR NO PAPER. (No paper: Sensor beam is intercepted)

- SOLENOID FEED

Controls operation (rotation/stop) of PAPER FEED ROLLER by controlling the rotations of the GEAR FEED.

- CLUTCH ASSY TURN

Transmits the drive from the MAIN DRIVE ASSEMBLY to ROLL ASSY TURN.

- PAPER FEED ROLLER

When the SOLENOID FEED operates, the GEAR FEED and GEAR IDLER FEED are engaged by the force of the SPRING FEED. Under the drive from the MAIN DRIVE ASSEMBLY, the PAPER FEED ROLLER starts rotating and the ROLL ASSY (PICK UP ASSY) sends paper. After having rotated one turn, the GEAR FEED and GEAR IDLER FEED are disengaged at the notch of the GEAR FEED, no drive is transmitted any more, and the PAPER FEED ROLLER stops rotating. Thus sheets of paper is sent out one by one.

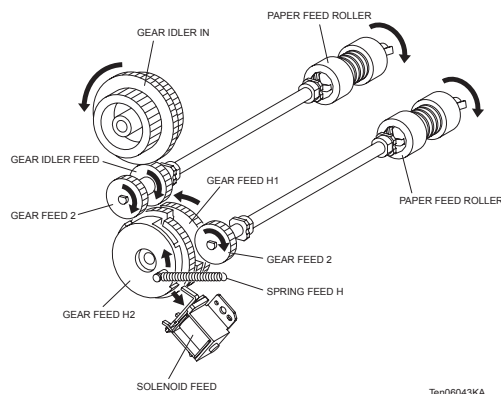

- ROLL ASSY TURN

The ROLL ASSY TURN rotates by the drive from the MAIN DRIVE ASSEMBLY through the CLUTCH ASSY TURN to feed the paper from the paper tray to CHUTE ASSY REGI (Regi Roll) (refer to "3.7 Xerographics").

- SENSOR HUM TEMP

Detects temperature and humidity in the printer.

The printer corrects the charging voltage, the voltage supplied to the transfer rolls, and the developing bias based on the detected temperature and humidity.

3.2.2 Reference diagram

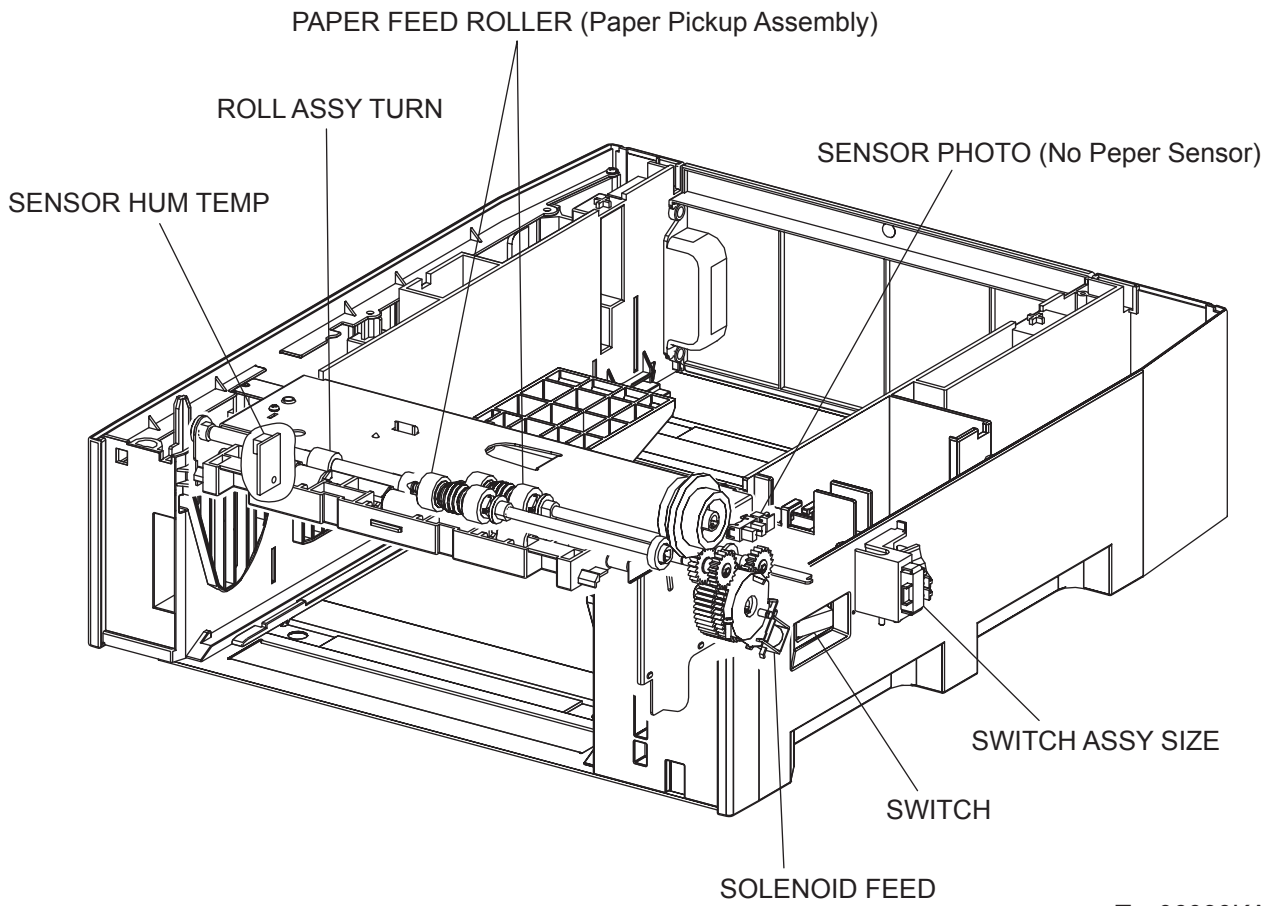

Ten06030KA



### 3.3 Separator & Registration Assembly

#### 3.3.1 Major functions

- CLUTCH TURN (MSI)  
Transmits the drive from the MAIN DRIVE ASSEMBLY to the ROLL TURN MSI.
  
- ROLL TURN MSI  
The ROLL TURN MSI is rotated by the drive from the MAIN DRIVE ASSEMBLY through the CLUTCH TURN (MSI) to feed the paper from the manual feed tray to the CHUTE ASSY REGI(Regi Roll) (refer to "3.7 Xerographics").
  
- SENSOR PHOTO (Regi Sensor)  
It detects when the paper front end reaches the CHUTE ASSY REGI.
  
- CLUTCH REGI  
CLUTCH REGI transfers the driving power from the MAIN DRIVE ASSEMBLY to ROLL REGI RUBBER, and transports the paper from the tray, MSI and duplex path toward IMAGING DRUM direction.  
The timing of sheet feed from the Regi Assy is adjusted by the duration of the CLUTCH REGI operation so that the toner image on the IDT2 can be transferred to the appropriate position on the sheet.

3.3.2 Reference diagram

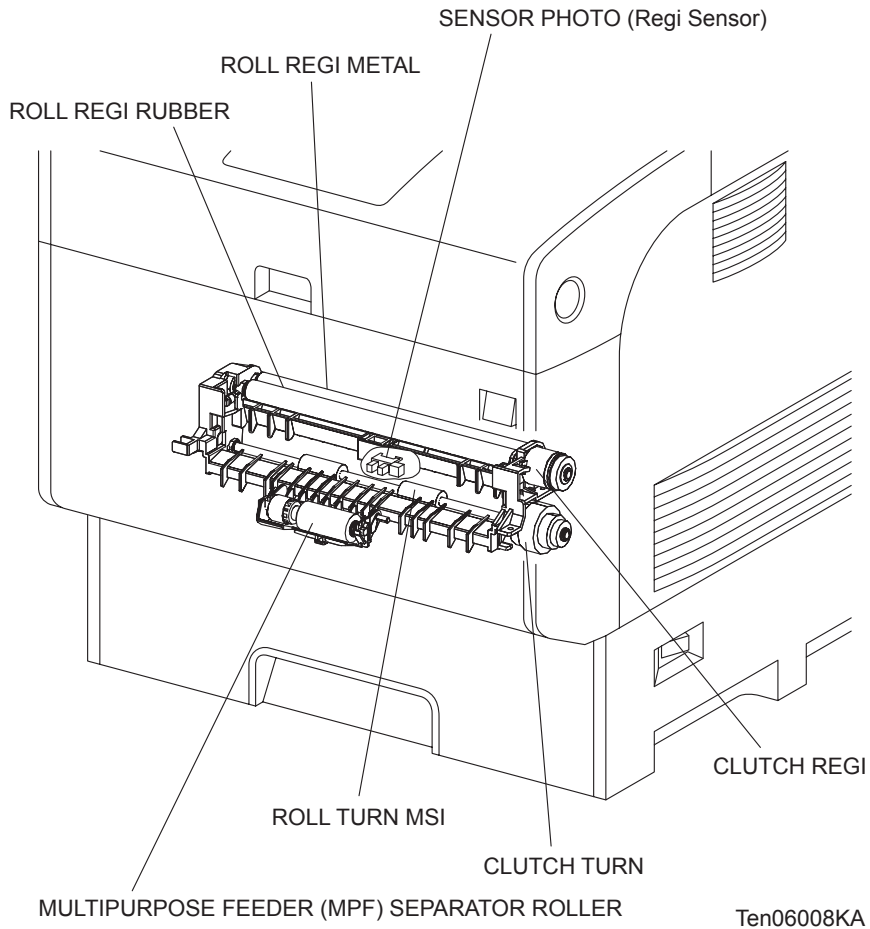

### 3.3.3 Multiple sheet feed prevention

The sheets set in a tray or a cassette may be stuck together at the edge due to microscopic curl-up along the cutting plane caused by the guillotine, etc. The stuck sheets cause a multiple sheet feed or a jam. The mechanism for separating these stuck sheets is called "ARRF (Active Separator Roller Feeder) method". The Separator Roller is being pushed toward the MPF Roller by a spring tension. The Separator Roller is coupled with the torque limiter (CLUTCH ASSY FRICTION), which prevents the Separator Roller from being rotated by a torque below a certain level. When two sheets are fed concurrently, the top sheet is separated from the bottom sheet by the friction between the Separator Roller locked by the torque limiter thereby allowing only the top sheet to be fed. When only one sheet is fed, two kinds of friction are concurrently generated between the MPF Roller and the sheet (feeding force), and between the Separator Roller and the sheet (retaining force). However, the friction by the Separator Roller is released because the Separator Roller rotates by the torque of the MPF Roller. The release of the Separator Roller friction allows the sheet to be fed by the MPF Roller.

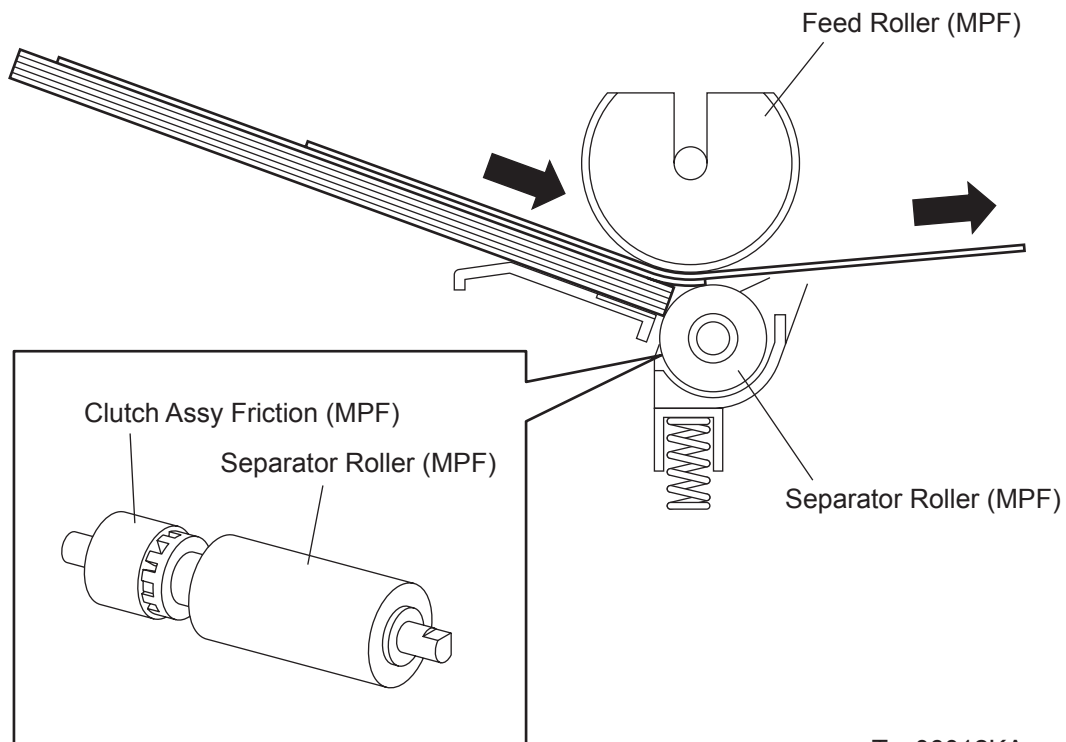

Ten06012KA

### 3.3.4 Lead edge registration

When paper is set in a tray or a cassette, and a sheet is carried to the toner transfer position, the toner transfer may not be performed in the appropriate position.

The "Roll Loop" method of the Regi part enables the paper top positions to be aligned before the sheets are carried to the toner transfer position.

The "Roll Loop" method thrusts a sheet coming out of the ROLL TURN MSI against the ROLL REGE that is at rest to make a loop out of the sheet.

When the REGI ROLL rotates with the sheet looped, the sheets are carried out of the REGI ROLL with the paper tops aligned.

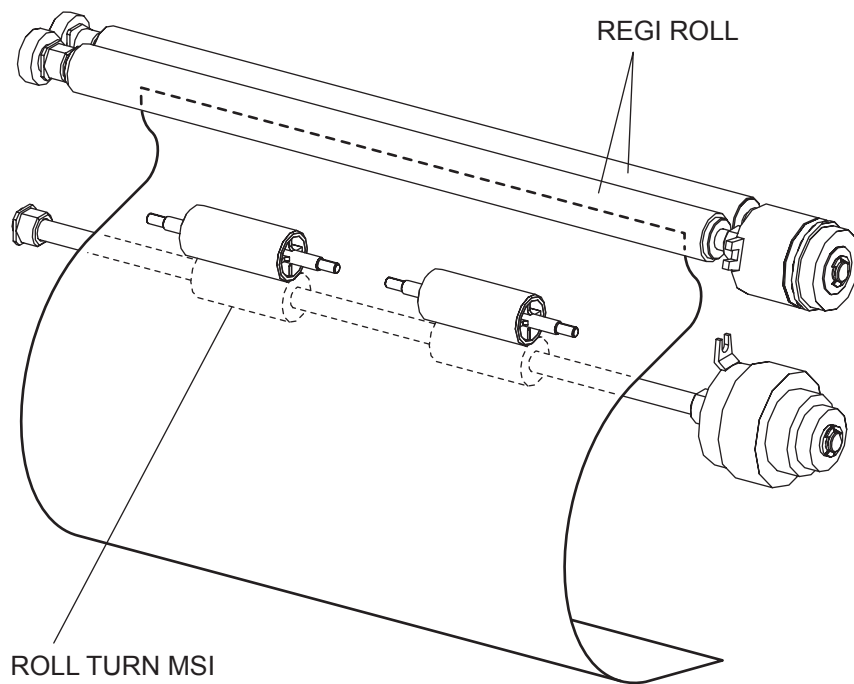

Ten06006KA

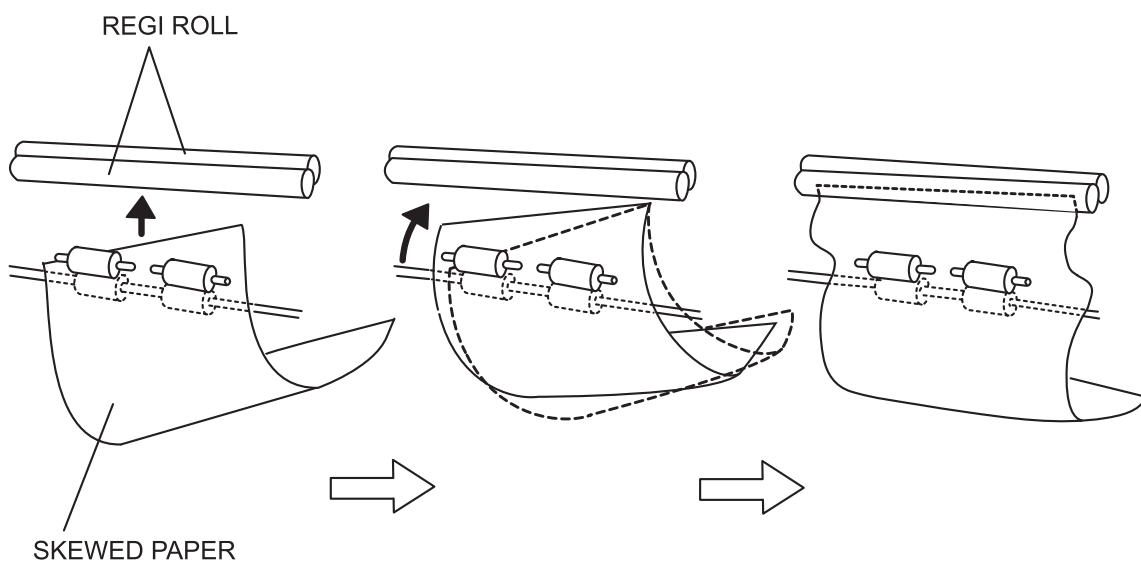

Ten06040KA

### **3.4 Inner Duplex Assembly**

#### **3.4.1 Major functions**

- **AUTOMATIC DENSITY CONTROL (ADC) SENSOR**  
Reads the density of the toner image prepared on the surface of BTR in the TRANSFER ROLLER (refer to "3.6 Transfer Roller & Fuser") and feeds it back to the process control (refer to "5.4 Process Control").
  
- **SENSOR TONER FULL**  
Detects that the toner collect space in the TRANSFER ROLLER (refer to "3.6 Transfer Roller & Fuser") has become full of waste toner to be collected.
  
- **DRIVE ASSY FUSER**  
Supplies the drive to the FUSER (refer to "3.6 Transfer Roller & Fuser").

3.4.2 Reference diagram

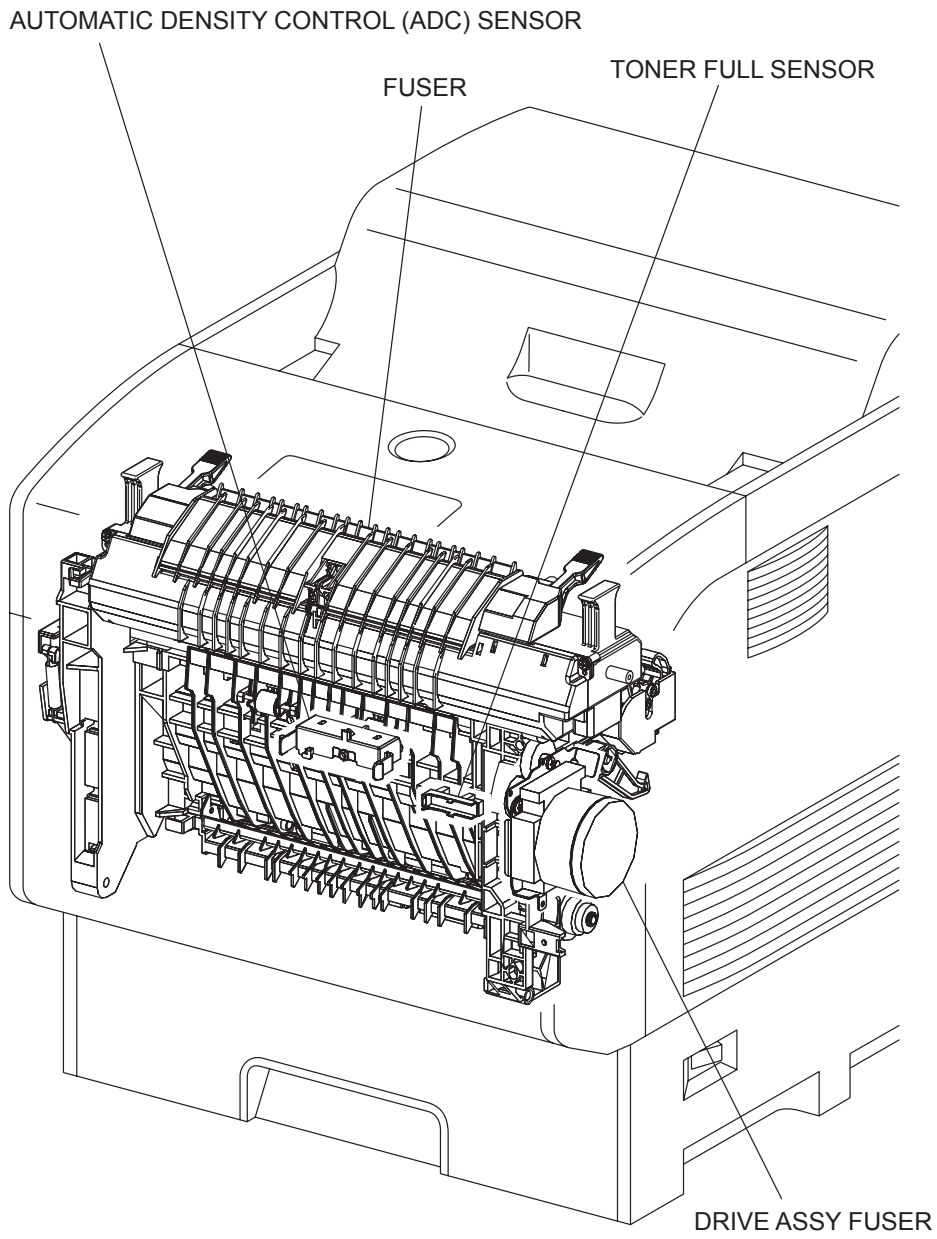

Ten06031KA

### 3.5 Outer Duplex Assembly

#### 3.5.1 Major functions

- SENSOR PHOTO (Full Stack Sensor)  
Detects that the prints discharged onto the top cover have accumulated more than specified number of sheets based on the change of position of the actuator.  
(Full stack: Sensor beam is received)
  
- SENSOR PHOTO (Dup Jam Sensor)  
Detects that paper has reached and passed through the ROLL DUP based on the change of position of the actuator.  
(Paper present: Sensor beam is received)
  
- SENSOR PHOTO (MSI No Paper Sensor)  
Detects existence or non existence of paper on the manual feed tray based on the change of position of the actuator.  
(No paper: Sensor beam is intercepted)
  
- MULTIPURPOSE FEEDER (MPF) SOLENOID  
Controls the operation (rotation/stop) of MULTIPURPOSE FEEDER (MPF) ROLLER by controlling the rotations of the GEAR MSI.
  
- MULTIPURPOSE FEEDER (MPF) ROLLER  
When the MULTIPURPOSE FEEDER (MPF) SOLENOID operates, the GEAR MSI and Gear IDLER are engaged by the force of the SPRING FEED H, the MULTIPURPOSE FEEDER (MPF) ROLLER starts rotating under the drive from the MAIN DRIVE ASSEMBLY, and feeds paper from the manual feed tray.  
After having rotated one turn, the GEAR MSI and Gear IDLER are disengaged at the notch of the GEAR MSI, drive is not transmitted any more, and the MULTIPURPOSE FEEDER (MPF) ROLLER stops rotating. Thus sheets of paper are fed one by one.
  
- ROLL DUP  
The ROLL DUP rotates under the drive from the MOTOR ASSY DUP and feeds paper printed on simplex returned from the CHUTE ASSY EXIT to the ROLL TURN.
  
- MOTOR ASSY DUP 17PM  
It supplies the driving power to ROLL EXIT and ROLL DUP.
  
- ROLL EXIT  
ROLL EXIT receives the driving power from MOTOR ASSY DUP 17PM and rotates, and transports the printed paper after fixing onto the top cover.  
Furthermore, it rotates reversely, in the case of duplex mode, to transport the printed paper after fixing of one side toward REGI direction.

3.5.2 Reference diagram

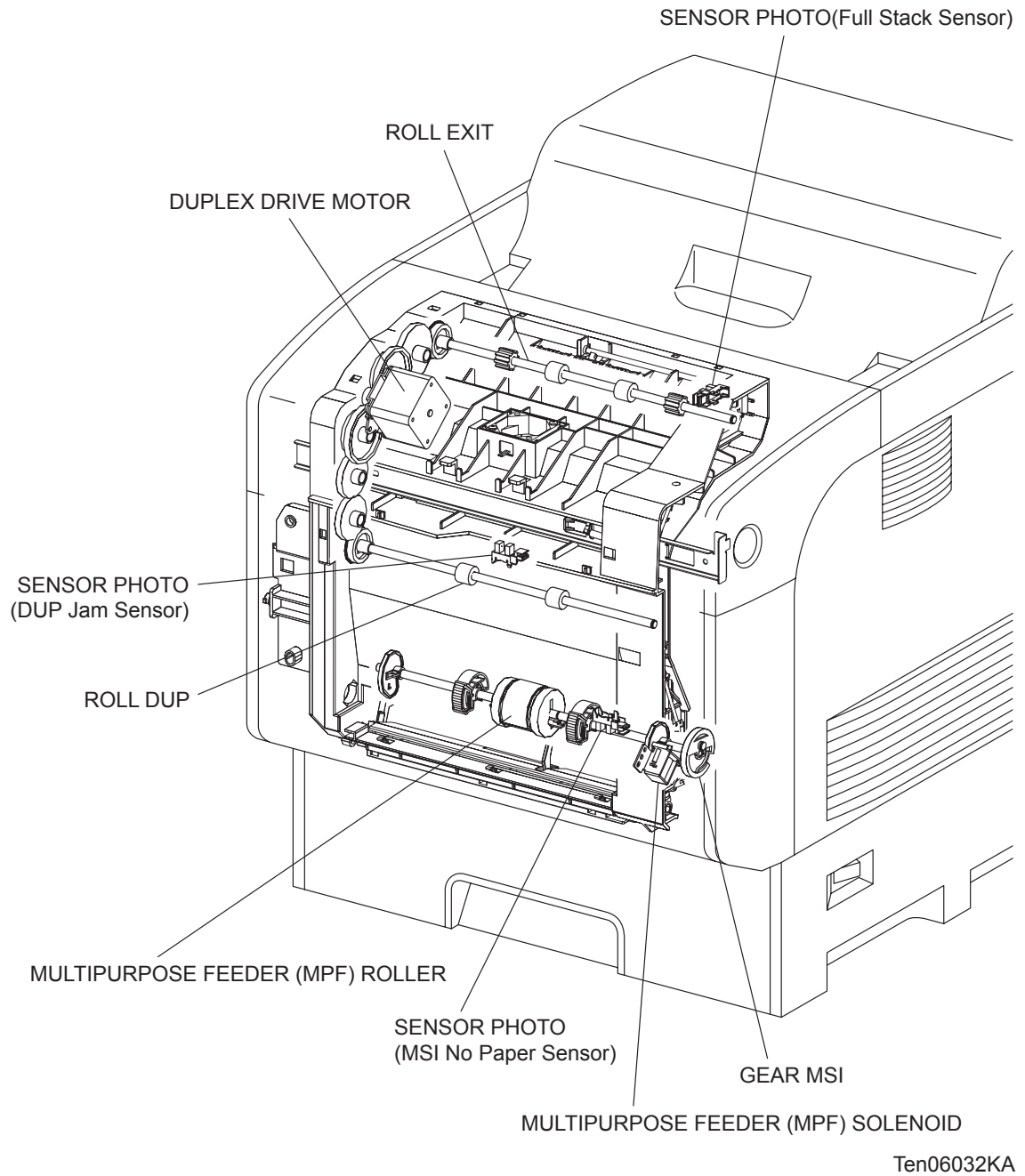



## 3.6 Transfer Roller & Fuser

### 3.6.1 Major functions

#### - FUSER

The FUSER fixes toner which was transferred onto the paper but not fixed by the heat and pressure and feeds paper before and after being fixed.

The FUSER mainly consists of the following parts:

- Heat Roll
- Heater Lamp (MAIN/SUB)
- Thermostat
- Thermistor
- Fuser NCS
- CHUTE
- Belt Unit
- Roll Assy Exit
- Exit Sensor
- STS

#### - Exit Sensor

Detects passage of print after fixed based on the change of position of the actuator.

#### - TRANSFER ROLLER

The TRANSFER ROLLER consists of a BTR (Bias Transfer Roll) and a waste toner recovery system.

The BTR (Bias Transfer Roll) is opposed to the IDT 2 in the IMAGING DRUM and transfer the toner image on the IDT 2 onto the paper.

#### - FAN FRONT

The cooling fan of FUSER EXIT SENSOR.

3.6.2 Reference diagram

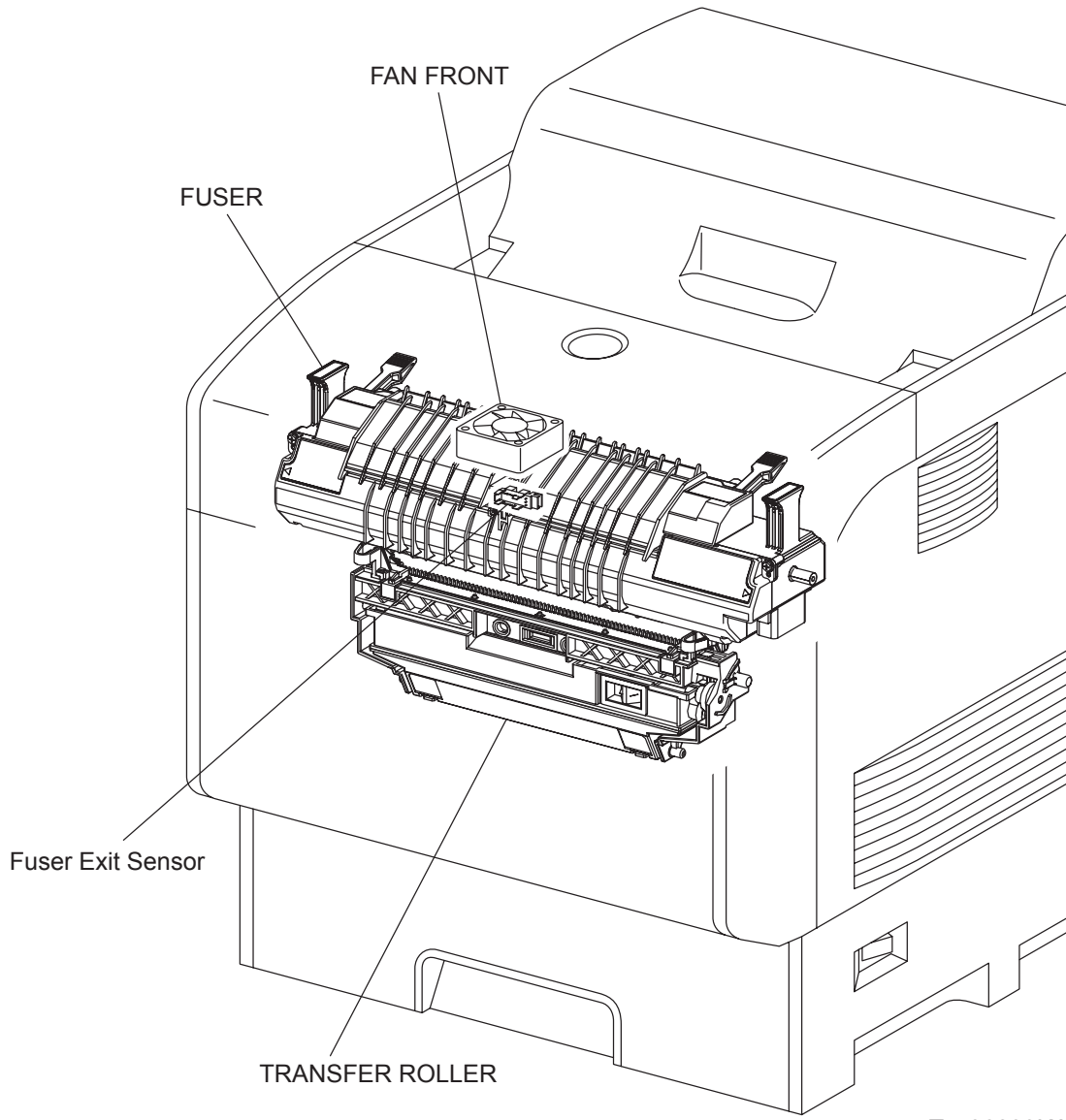

Ten06033KA

## 3.7 Xerographics

### 3.7.1 Major functions

#### - PRINT HEAD

PRINT HEAD (Raster Output Scanner Assembly) is an exposure unit to generate laser beams to form electrostatic latent image on the drum surface.

In this manual, the PRINT HEAD is referred to as PRINT HEAD.

The PRINT HEAD mainly consists of the following parts:

- LD ASSY
- Scanner ASSY
- SOS PWB
- Lens
- Mirror
- Window

#### - IMAGING DRUM

IMAGING DRUM carries out a series of operation in the print process such as charging, and transfer.

IMAGING DRUM mainly consists of the following parts.

- |                     |                 |
|---------------------|-----------------|
| - Drum (Y)          | - Refresher (Y) |
| - Drum (M)          | - Refresher (M) |
| - Drum (C)          | - Refresher (C) |
| - Drum (K)          | - Refresher (K) |
| - RTC (Y)           | - IDT 2         |
| - RTC (M)           | - IDT 2 Cleaner |
| - RTC (C)           | - Tricle        |
| - RTC (K)           |                 |
| - IDT 1 (2)         |                 |
| - IDT 1 cleaner (2) |                 |

#### - DEVELOPER FRAME

DEVELOPER FRAME is an equipment which develops images in the print process.

DEVELOPER FRAME consists of the components as listed below.

- Developer (Y)
- Developer (M)
- Developer (C)
- Developer (K)

3.7.2 Reference diagram

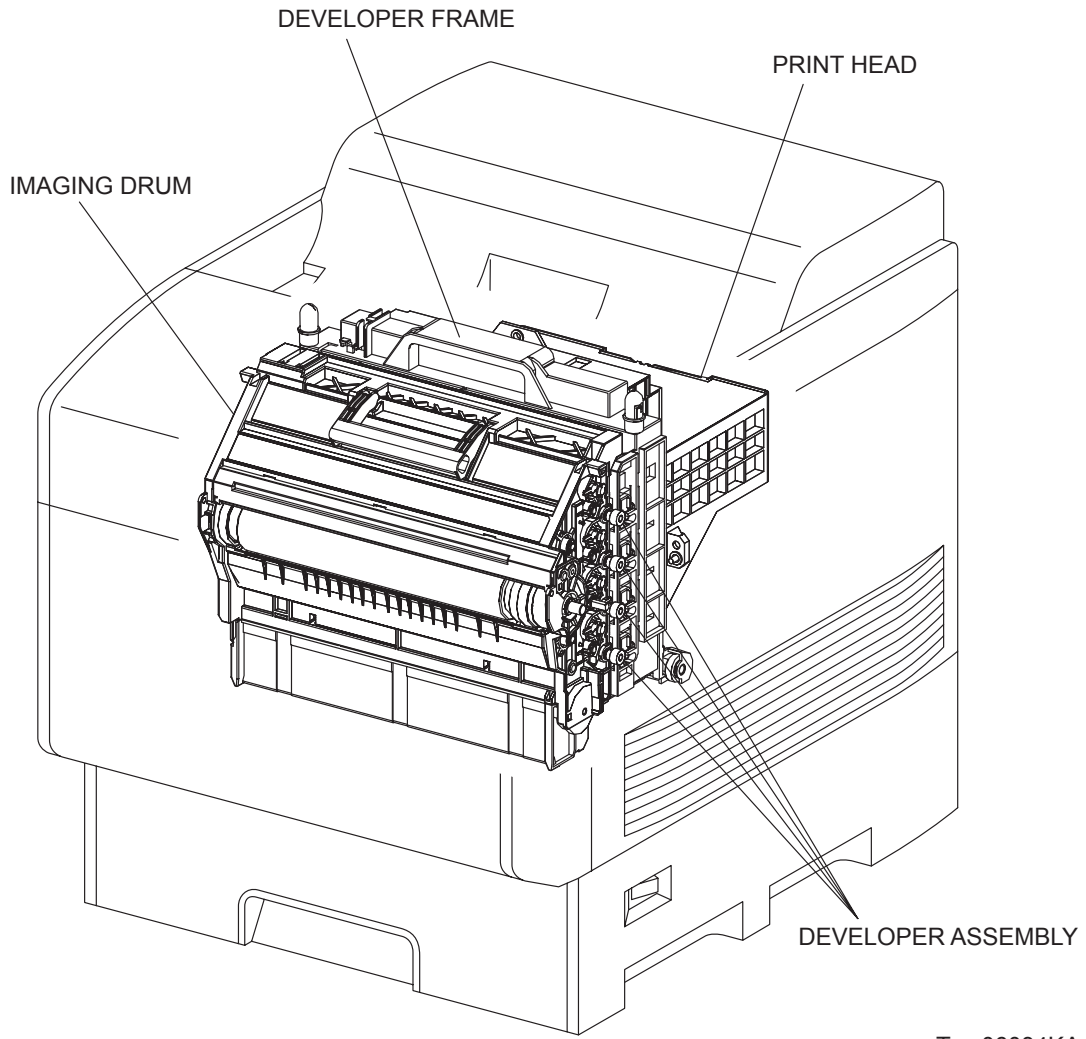

Tem06034KA

## 3.8 Toner Dispenser Assembly

### 3.8.1 Major functions

- COIL ASSY CRUM READER

The PWB consists of each color toner bottle switch and CRUM.

Toner bottle switch:

Detects whether Toner Cartridge of each color is installed or not.

CRUM:

Printer specific information is stored.

- SENSOR NO TONER (Y)
- SENSOR NO TONER (M)
- SENSOR NO TONER (C)
- SENSOR NO TONER (K)

Detects residual toner of each color.

- DISPENSER ASSY (Y) (Toner Motor: Y)
- DISPENSER ASSY (M) (Toner Motor: M)
- DISPENSER ASSY (C) (Toner Motor: C)
- DISPENSER ASSY (K) (Toner Motor: K)

The toner motor incorporated in the DISPENSER ASSY of each color supplies the drive to the Agitator in the Toner Cartridge of each color and to Auger in the DISPENSER ASSY and supplies toner to the developer incorporated in the DEVELOPER FRAME.

- YELLOW TONER
- MAGENTA TONER
- CYAN TONER
- BLACK TONER

Toner bottle containing toner of each color.

3.8.2 Reference diagram

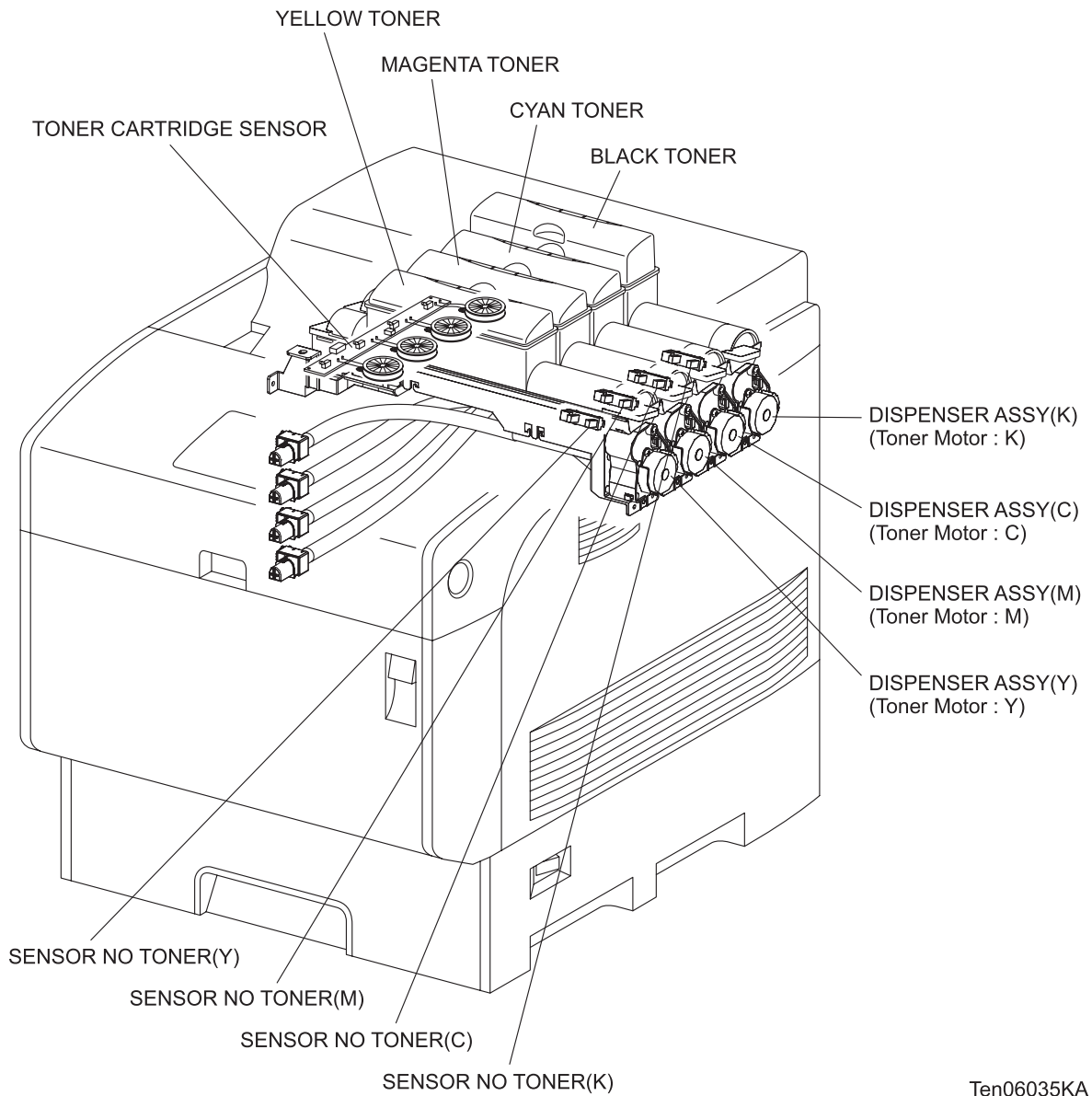

Ten06035KA

### **3.9 Frame & Drive**

#### **3.9.1 Major functions**

- MAIN DRIVE ASSEMBLY

Supplies the drive to parts as follows.

- PICK UP ASSY
  - HOUSING ASSY RETARD
  - OUTER DUPLEX ASSEMBLY (MSI position)
  - CHUTE ASSY REGI
  - IMAGING DRUM (IDT 2, IDT 1, Drum)
  - TRANSFER ROLLER
- 
- DEVELOPER DRIVE ASSEMBLY

Supplies the drive to parts as follows.

- DEVELOPER FRAME (Developer)

3.9.2 Reference diagram

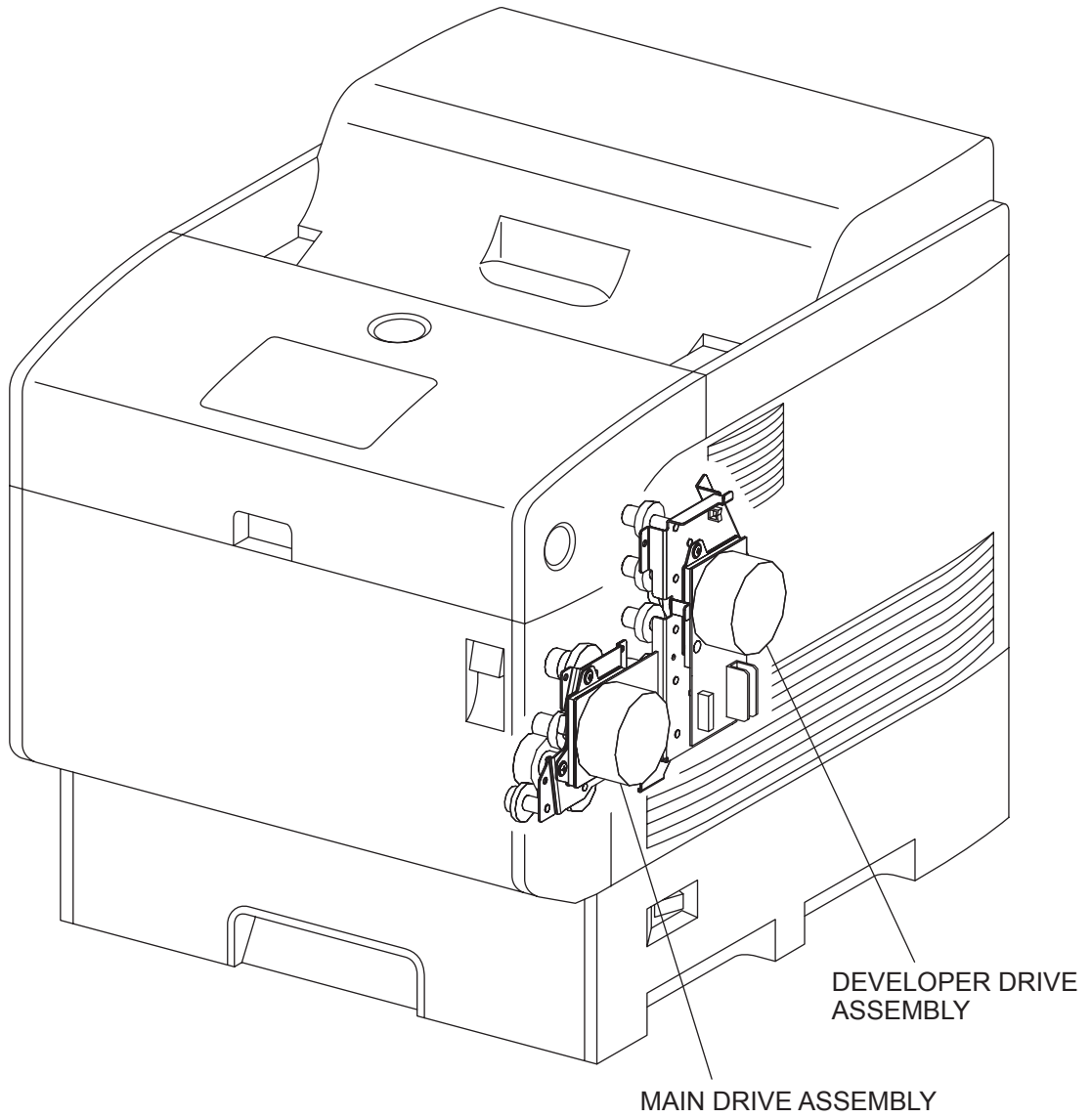

Ten06036KA



## 3.10 Electrical

### 3.10.1 Major functions

- REAR FAN/LV FAN  
Discharges heat out of the printer to prevent too high temperature in the printer.
  
- SWITCH  
SWITCH operates the main switches LVPS.
  
- LOW VOLTAGE POWER SUPPLY (LVPS)  
The LVPS is provided with two types, 100/120V and 230V.  
Supplies AC power from the power source to the FUSER heater and generates and supplies stable low voltage DC power used for the logic circuit, etc.  
LVPS contains control circuit for the heater of the FUSER, in addition to the power circuit.
  
- MACHINE CONTROL UNIT (MCU)  
Controls printing operation based on the communication with the print controller and information from the sensor/switch.  
Major functions are as follows:
  - Communication with the printer controller.
  - Receive of information from the sensors or switches.
  - Control of Toner Motor in MAIN DRIVE ASSEMBLY, DEVELOPER DRIVE ASSEMBLY, DRIVE ASSY FUSER, MOTOR ASSY DUP, and TONER DISPENSER ASSEMBLY.
  - Distributing low voltage DC power outputted from LVPS to each component
  - Control of PRINT HEAD
  
- HIGH VOLTAGE POWER SUPPLY (HVPS)  
Supplies high voltage to parts in the DEVELOPER FRAME and IMAGING DRUM to perform charging, development, primary transfer and secondary transfer of the print process to the following parts in the IMAGING DRUM.
  - RTC
  - Refresher
  - Developer
  - IDT 1
  - IDT2
  - IDT 1 Cleaner
  - IDT 2 Cleaner
  
- PWBA EEPROM STD  
Information unique to the printer is stored.
  
- CONTROLLER CARD  
The CONTROLLER CARD connected to the MCU controls the entire system.

3.10.2 Reference diagram

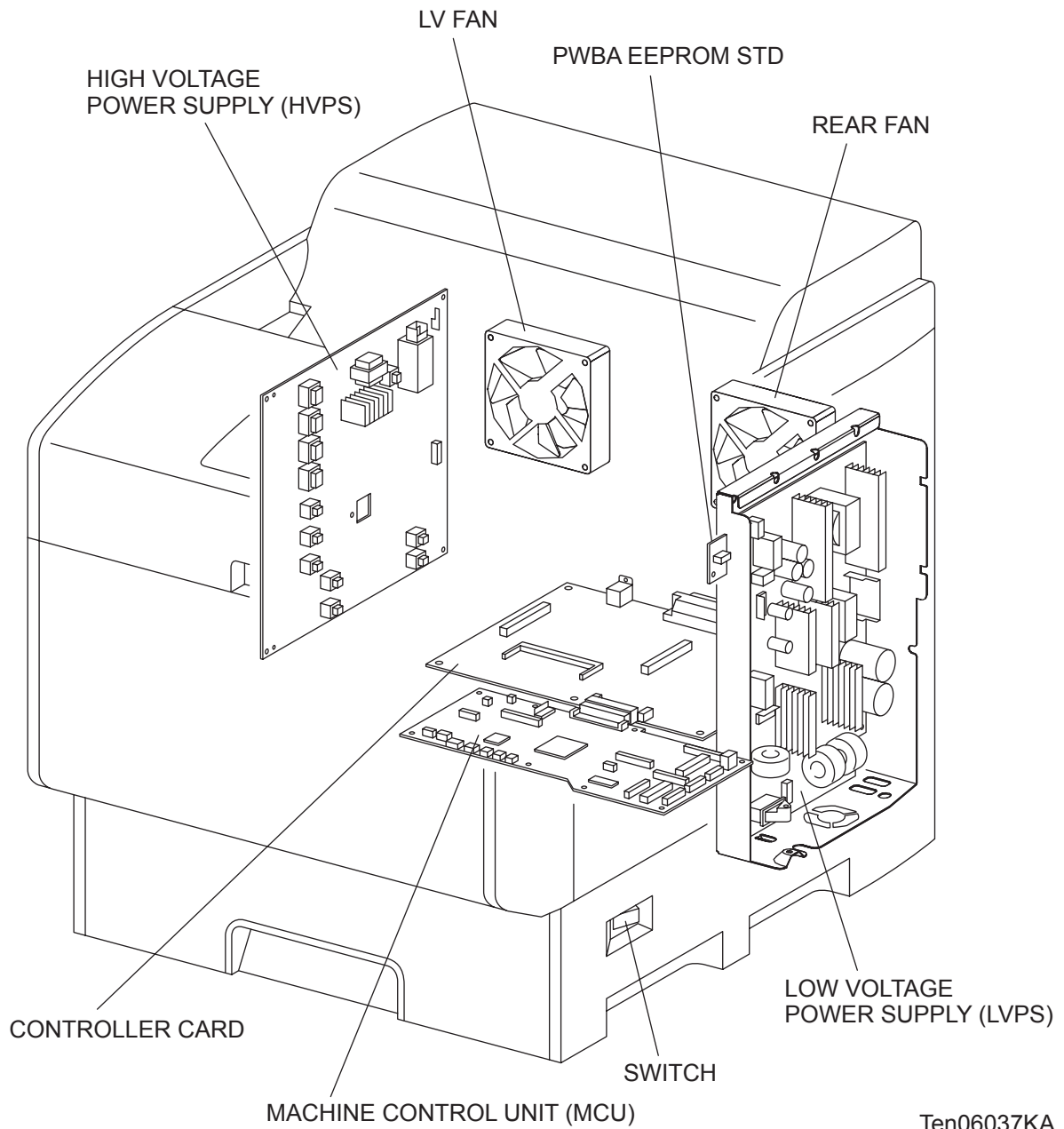

Ten06037KA

**3.10.3 Data Flow**

Print data (electric signal) from the printer controller flows as shown below to turn to the print image finally.

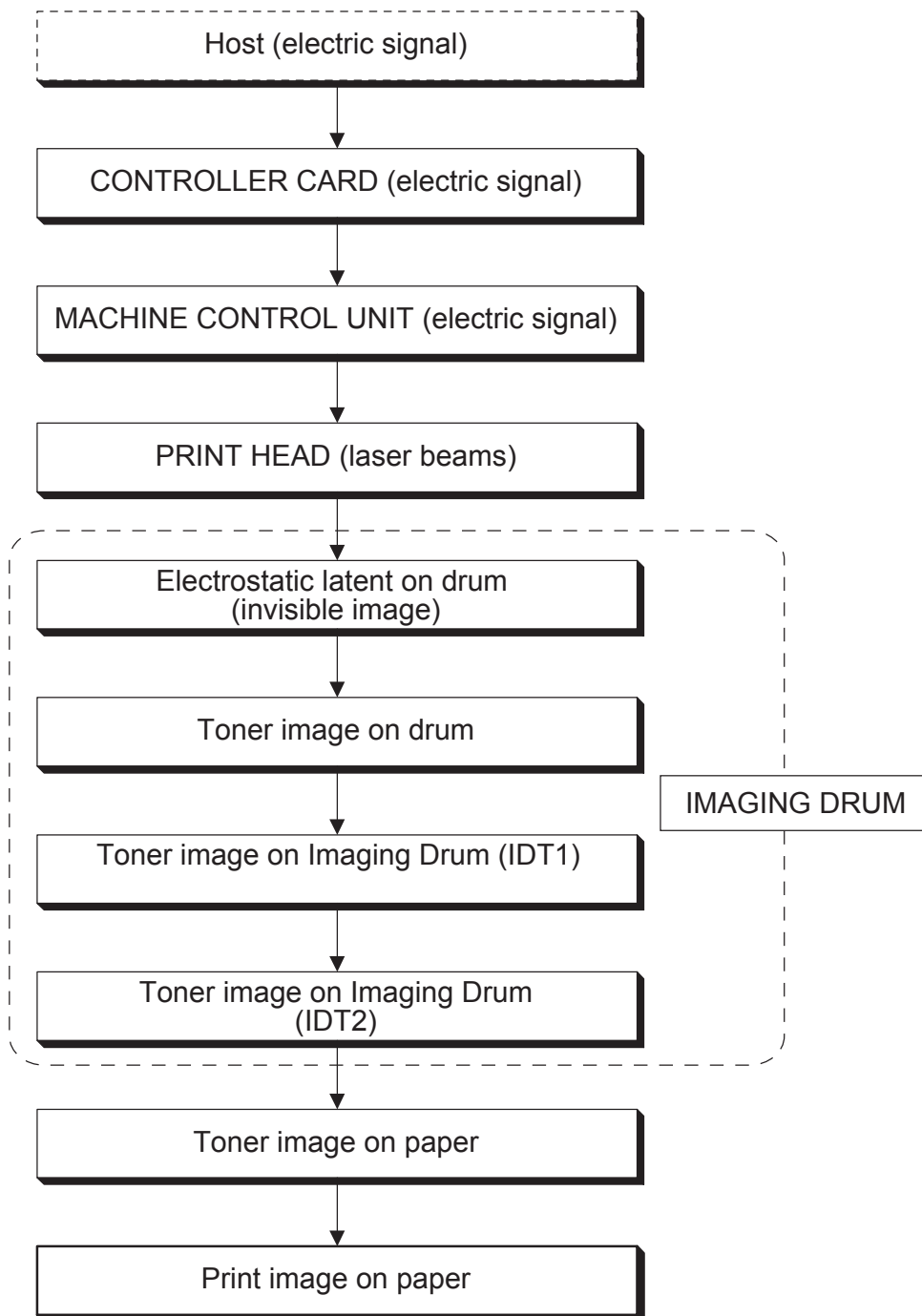

Ten06017KA

## 4. MODES

### 4.1 Print Mode

The equipment has 3 different print modes, BW full speed (264mm/s), Color full speed (225mm/s), and BW/Color low speed (88mm/s). Switching to each mode is accomplished by the instruction from the controller.

- (1) BW full speed mode, Color full speed mode : used for printing with resolution 600dpi
- (2) BW mid speed mode : thick paper and special paper
- (3) BW low speed mode, Color low speed mode : thick paper and special paper

Relation between the resolution, process speed, print mode and paper mode is shown in the table below.

Paper mode		Resolution/Process speed			
		BW		Color	
	Print mode	600dpi	1200dpi	600dpi	1200dpi
Plain paper	BW full speed	264mm/s	-	-	-
	Color full speed	-	-	225mm/s	-
	Color/BW mid speed	132mm/s	-	-	-
Thick paper, special paper *1, *2	Color/BW mid speed	132mm/s	-	-	-
	Color/BW low speed	88mm/s	-	88mm/s	-

\*1: Thick paper-L, Thick paper-H.

\*2: Label-L, Label-H, OHP, Envelope, Postcard

### 4.2 Operation Modes

For the operation of the printer, the following five modes are provided.

- DIAG TEST mode  
The printer is ready for receiving diagnostic commands, or the printer diagnostic function is operating.
- WAIT mode  
The printer is under the adjustment of print quality.
- READY mode  
The printer is ready for printing.
- PRINTING mode  
The printer is under printing.
- ERROR mode  
Any error was detected in the printer.
- Initializing mode  
New parts have been just set to the printer (initializing with a new Deve Unit).
- Checking Unit mode  
Printer is under checking consumable units.

## 5. Control

### 5.1 Control of Paper Size

"ON/OFF of Paper Size Switch of SWITCH ASSY SIZE" and "Diag Tool indication data" are shown in the table below.

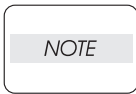

**Paper Size Switches are indicated as SW1, SW2, and SW3 from the above one.**

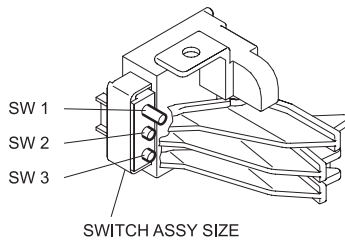

Paper Size	Paper Size Switch			Diag indication data
	SW1	SW2	SW3	
LEGAL14" (SEF)	ON	ON	ON	00
LEGAL13" (SEF)	ON	ON	OFF	01
EXECUTIVE (SEF)	ON	OFF	ON	02
B5 (SEF)	ON	OFF	OFF	03
A4 (SEF)	OFF	ON	ON	04
LETTER (SEF)	OFF	OFF	ON	06
A5	OFF	ON	OFF	05
No cassette	OFF	OFF	OFF	07

ON : The actuator is pushing the switch.

### 5.2 Selective Control on Paper Cassette

The preferred paper cassette selected after powering on can be changed via the printer settings. The default is Tray 1 (TBD)..

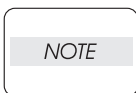

**The paper feeder by the paper tray under the printer is called "Tray 1", and the first tray and the second tray in optional TRAY UNIT are called "Tray 2" , "Tray 3" and "Tray 4" respectively.**

### 5.3 PRINT HEAD Light Quantity Control

The image data are entered to the laser diodes in the PRINT HEAD as electric signals (data are expressed with high and low voltage values), and the laser diodes convert the image data from electric signals to optical signals (data are expressed with blinking laser beams).

Variations in light quantity of laser beams or variations in optical system (such as lenses) or drum sensitivity cannot attain proper electrostatic image, and accordingly the laser diodes monitor the light quantity of laser beams to control the light quantity so as to attain stable and proper electrostatic image. The PRINT HEAD in this printer has four laser diodes for yellow, magenta, cyan, and black respectively, and the light quantity is automatically adjusted for each color.

## 5.4 Process Control

For a stable printing, the parameters related to the image forming must be corrected as necessary. The control of entire printing process including parameter correction control is called "process control".

Mainly, the following two controls are made:

- Potential control
- Toner density control

To supplement these two controls, the following controls are provided:

- High Area Coverage Mode
- Admix Mode
- AUTOMATIC DENSITY CONTROL SENSOR LED light quantity setting

### 5.4.1 Potential Control

To attain stable printing image density, the drum charging voltage and the developing DC voltage are adjusted according to the developing capability of each color carrier that varies momentarily. The adjusted drum charging voltage and the developing DC voltage are fed back to keep the printing image density constant.

The potential control is made immediately before the start of printing, if either of the following conditions is satisfied:

- At the first printing after the power on
- When cumulative print count after the power on exceeds 25
- When a cleaning cycle is executed during continuous printing

The outline of control is as follows.

- 1) The AUTOMATIC DENSITY CONTROL SENSOR (temperature and humidity sensor) detects the temperature and humidity, and sets target values of drum charging voltage and developing DC voltage.
- 2) The patches of respective colors (yellow, magenta, cyan, and black) for the potential control are generated and transferred on the BTR. (For the shape of patches, see the following figure.)

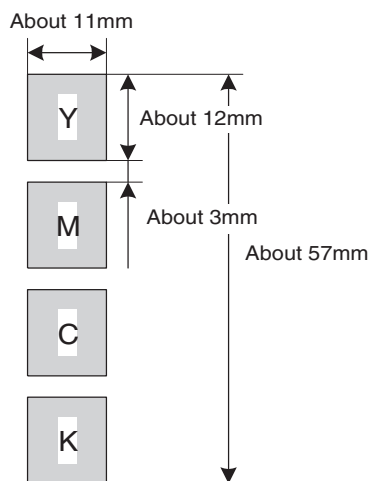

engine principle0046FA

- 3) The AUTOMATIC DENSITY CONTROL SENSOR (density sensor) detects the density of the area on BTR where no toner is present and the density of patches.
- 4) The density measured in step 3) is compared with target value set in step 1) to change the drum charging voltage and the developing DC voltage for each color according to a difference.

### 5.4.2 Toner Density Control

The toner density must be kept constant to attain stable printing image. To keep the toner density constant, the toner should be dispensed exactly by the quantity consumed for the printing. This system is the PCDC. However, the system with only the PCDC generates a difference from target toner density, thus requiring the system to correct this error. This is the toner density control by the AUTOMATIC DENSITY CONTROL SENSOR. These two control systems are altogether called the toner density control.

#### 1) PCDC (Pixel Count Dispense Control)

The toner quantity consumed in the developing process is calculated by counting the video signals entered to the PRINT HEAD. The video signal counting is made by the charging and discharging of the capacitor in the CR circuit arranged in parallel to the video signal line. The consumed toner quantity is calculated by the toner dispense time. The Toner Motor in the TONER DISPENSER ASSEMBLY is driven by the amount of calculated toner dispense time to supply the toner into the developer.

#### 2) ADC (Auto Density Control)

The patches of respective colors (yellow, magenta, cyan, and black) for the toner density control are generated under specified potential condition, and transferred on the BTR. The AUTOMATIC DENSITY CONTROL SENSOR measures this density. The measured value is compared with reference value, and if the toner density is low, the toner dispense quantity is increased at the next printing, or if the toner density is high, the toner dispense quantity is reduced at the next printing. The toner dispense quantity is calculated by the toner dispense time. This calculation is made for each color.

ADC is made after the completion of printing, if either of the following conditions is satisfied:

- When cumulative print count after the power on exceeds 25
- When a cleaning cycle is executed during continuous printing

#### 3) Example of toner dispensation

The Toner Motor revolves for the duration of the specified time per 1-time dispensation. The toner dispense time in 1) and 2) above is calculated with the number of revolutions of Toner Motor. In the following description, this is called the dispense count.

The dispense count calculated by the ADC is cancelled in the subsequent 8 prints.

If 16 dispense counts were calculated as a lack of toner by the ADC, the toner is dispensed additionally to the dispense count calculated by the PCDC by 2 counts ( $16/8=2$ ) in the subsequent 8 prints.

Or, if 16 dispense counts were calculated as an excess of toner by the ADC, the toner is dispensed by subtracting from the dispense count calculated by the PCDC in the subsequent 8 prints. If the excess amount cannot be subtracted in 8 prints, the remainder is subtracted in 9 and subsequent prints.

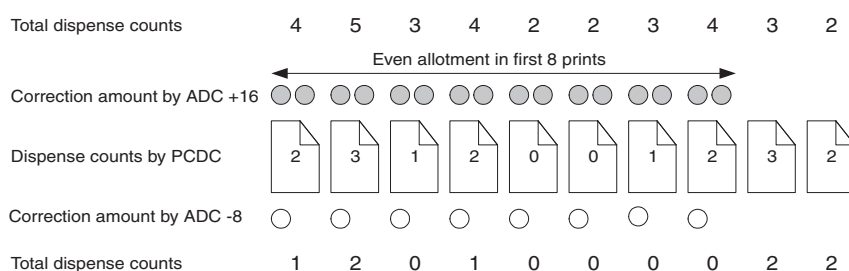

engine principle0044FA

### 5.4.3 High Area Coverage Mode

A continuous printing of the image of area coverage exceeding the toner dispense capability causes the toner density in the developer to be lowered.

The High Area Coverage Mode extends the next page feed and dispenses the toner during this time, if the toner dispense time reached the specified value during a continuous printing.

### 5.4.4 Admix Mode

Even the High Area Coverage Mode may not be able to cope with the reduction of toner density in the developer. Also, if the machine used in high humidity environment is relocated to the place in low humidity environment, the reference value of toner density is different in respective environments, thus causing large discrepancy between measured value by AUTOMATIC DENSITY CONTROL SENSOR and reference value of toner density.

The Admix Mode dispenses the toner immediately to prevent the reduction of toner density, if the patch density result measured by the AUTOMATIC DENSITY CONTROL SENSOR is far lower than the reference value when the patches for toner density control are generated.

### 5.4.5 LED Light Quantity Control of AUTOMATIC DENSITY CONTROL SENSOR

The AUTOMATIC DENSITY CONTROL SENSOR is a reflection type density sensor that radiates the light to an objective from the LED in the sensor and detects the reflected light from the objective to output electric signal according to the light quantity. For exact density measurement, the sensor output value (reflected light quantity) must be the specified value when no toner is put on the BTR as an objective. The reflected light quantity varies depending on the BTR surface condition or dirty condition of AUTOMATIC DENSITY CONTROL SENSOR surface. The light quantity emitted from the LED is controlled so that the reflected light quantity satisfies the specified value.

This control is made in two ways; one to set the light quantity so that the reflected light quantity satisfies the specified value, and one to adjust the subsequent light quantity to be within the tolerance.

#### 1) Light quantity setting

The reflected light quantity may vary largely, if the Transfer Roller was replaced or the AUTOMATIC DENSITY CONTROL SENSOR was cleaned. Assuming this fact, the light quantity is set when the power is turned on, or the front cover is opened and closed.

The light quantity of LED is increased gradually, and the set value is fixed when the output of AUTOMATIC DENSITY CONTROL SENSOR exceeds the specified value. At this time, if the output of AUTOMATIC DENSITY CONTROL SENSOR does not reach the specified value even though the light quantity is increased to the upper limit, the controller judges the sensor as dirty. Also, the controller judges the sensor as faulty in the event of extremely high output.

#### 2) Light quantity adjustment

At the execution of ADC, the light quantity adjustment is made immediately before the patches for toner density control are generated.

The light is emitted from the LED with current setting of light quantity to check if the output value of the AUTOMATIC DENSITY CONTROL SENSOR is within the specified range. If the output value is low, the light quantity is increased by the specified amount at the next ADC, or if high, the light quantity is reduced at the next ADC.

At this time, if the output value is less than the first lower limit, the controller judges the sensor as dirty and outputs the warning. Further, if less than the second lower limit, the controller judges the sensor as faulty and stops the printing.



## 5.5 Color Registration Control

The printer uses a tandem system where the drums and developers exclusively for yellow, magenta, cyan, and black are arranged respectively. The images are formed on the drums of respective colors and they are overlapped to form one image, and in this case a color shift may occur. The color registration control calculates how much the registration is shifted, and adjusts the PRINT HEAD write timing.

The lateral registration control adjusts all of four colors in lateral directions.

The color registration control is made from a change in inside temperature and the print count at the execution of the process control.

The control is outlined below:

- 1) With no toner put on the BTR, the output value of AUTOMATIC DENSITY CONTROL SENSOR is measured to determine the threshold value.
- 2) The patches for color registration control are generated on the BTR. These patches are composed of 10mm lines of K, C, K, M, K, and Y in this order by the amount of four dispense counts, led by a black trigger.

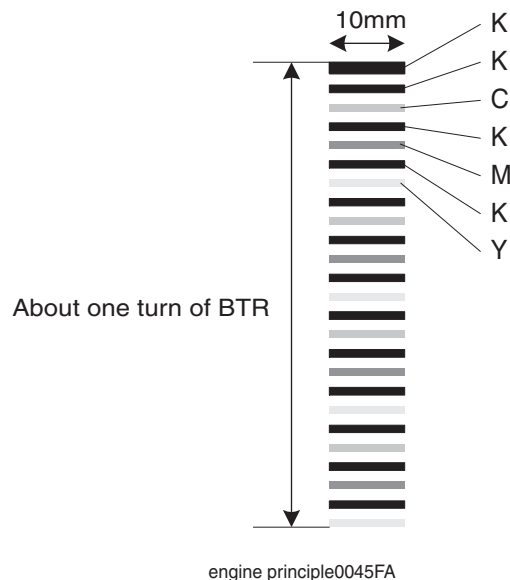

- 3) The density of patches generated by the AUTOMATIC DENSITY CONTROL SENSOR is read.
- 4) The adjusting amount of registration shift is calculated from the threshold value determined in 1) and the patch density measured in 3).
- 5) The PRINT HEAD write timing is changed from the adjusting amount of registration shift.

## 5.6 Transfer Roller Control

### 5.6.1 Detecting the Installation of Transfer Roller

Whether the Transfer Roller is installed is detected when the power is turned on, or the front cover is opened and closed. The sensor for detecting the installation is not provided, but judgment is made from the output of the AUTOMATIC DENSITY CONTROL SENSOR.

The light is emitted from the LED of AUTOMATIC DENSITY CONTROL SENSOR with the specified light quantity, and if the output of the AUTOMATIC DENSITY CONTROL SENSOR is larger than the specified value, the controller judges as installation. If the operation stops by a jam, the toner image could be put on the BTR and in such a case, the sensor output is reduced, causing the controller to judge as uninstallation. To prevent this wrong detection, the BTR is rotated by a half turn if the output is less than the specified value. Then, when the output of the AUTOMATIC DENSITY CONTROL SENSOR is larger than the specified value, the controller judges as installation, or if less than the specified value, the controller judges as uninstallation.

### 5.6.2 Detecting the Life of Transfer Roller

The Transfer Roller consists of a BTR and a waste toner recovery system. The life of the Transfer Roller is detected when the toner recovery space has become full.

The full toner recovery space is detected by the SENSOR TONER FULL.

1) Check timing of full waste toner recovery space

- When the power is turned on, or the front cover is opened and closed
- When paper is outputted

2) Output of "BTR Life Warning"

The "BTR Life Warning" is outputted when the SENSOR TONER FULL detects the full toner recovery space.

3) Output of "BTR Life Error"

After the output of "BTR Life Warning", the print count and the toner dispense time are counted up, and if total counts exceed the specified value, the "BTR Life Error" is outputted.

4) Reset of "BTR Life Warning"/"BTR Life Error"

The "BTR Life Warning" and "BTR Life Error" are reset, if the SENSOR TONER FULL does not detect the full toner recovery space when the power is turned on, or the front cover is opened and closed.

## 5.7 Toner Control

Whether the toner bottle is installed is detected by the toner bottle switch in COIL ASSY CRUM READER, and the presence of toner in the toner bottle is detected by the SENSOR NO TONER. These switches and sensors are provided for respective colors, and detection is made for each color.

### 5.7.1 SENSOR NO TONER

The SENSOR NO TONER is provided for each color.

The SENSOR NO TONER is attached to the TONER DISPENSER ASSEMBLY, and it detects the presence of toner dispensed by the Toner Motor from the toner bottle into the TONER DISPENSER ASSEMBLY.

Also, the SENSOR NO TONER could make a wrong detection if the toner sticks to the sensor surface. To prevent this, the film attached in the vicinity of the Auger in the TONER DISPENSER ASSEMBLY cleans the sensor surface when the toner is dispensed. This film rotates together with the Auger at the toner dispensation to scrape the toner off the SENSOR NO TONER surface. However, the sensor may detect the toner even if the toner is not present or may not detect the toner even if the toner is present, depending on the film position when the Toner Motor stopped. This is avoided by the printer internal control.

### 5.7.2 Toner presence control

The control is outlined below.

- 1) Check timing
  - When the power is turned on, or the front cover is opened and closed
  - Printing
- 2) Output of "Toner Empty Warning"
 

Output "Toner Empty Warning" based on the counter on the Toner Cartridge.
- 3) Output of "Toner Empty Error"
 

Output "Toner Empty Error" when the SENSOR NO TONER properly detects TONER EMPTY.
- 4) Reset of "Toner Empty Warning"/"Toner Empty Error"
 

When a new Toner Bottle is installed ("Toner Empty Error" not being generated), the machine executes Toner Dispense for 1.7 seconds to detect Toner. If SENSOR NO TONER detects Toner Full on checking "Toner Full"/"Uncontrolled Execution", "Toner Empty Warning/Toner Empty Error" will be disabled.

However, the Unit inside still recognizes "Toner Empty" at this stage. The Unit recognizes "Toner Full" when the SENSOR NO TONER has detected "Toner Full" more than three times consecutively by executing Toner Dispense.
- 5) Outputting "Toner Tape not Removed Error"
 

When the new Toner Bottle is installed ("Toner Empty Error" not being generated), the machine executes Toner Dispense for 1.7 seconds to detect Toner. If Toner Full is not detected, Toner Dispense will be executed for 1.7 sec again 5 seconds later. If Toner Full is not detected after executing Toner Dispense three times, and if Toner Bottle Dispense Time shows 0, "Tape not Removed Error" will be output. In addition, in the case where the toner sensor detects absence of toner during printing, the "tape remaining error" is output.

## 5.8 Fuser Control

### 5.8.1 Fuser temperature control

As for the fuser temperature control, the target temperature is set, then the Heat Roll surface temperature is controlled so as to be the target temperature by turning on/off the Heater Lamp.

Temperature of individual area of the Heat Roll is detected by the Fuser Non-Contact Sensor (NCS) in the middle of the Heat Roll and the Temp Sensor at the edge of it. NCS checks the temperature every 10ms. When the temperature detected higher than the target, the Heater Lamp will be turned OFF. When the result shows a lower figure, the Heater Lamp will be turned ON.

The target temperature set up varies depending on the time of Warm-up, Printing, or Process Control. The target temperature will be changed based on the interior temperature detected by the Sensor Hum Temp, the difference of temperature between the center and edge areas of the Heat Roll, Printing Mode, or the Input Power Voltage.

### 5.8.2 Cool down

As the printing continues, the distribution of temperature in the Heat Roll becomes uneven both in the paper feed and non-paper feed areas. Cooling Down is to provide a certain period of time without feeding paper so that the Heat Roll temperature can be distributed evenly.

When the edge of Heat Roll temperature is high, cool down does the control to lower to target temperature.

### 5.8.3 Sensor Warm-up

The Fuser NCS (Non Contact Sensor) at the center of the Heat Roll will be lose accuracy of detect temperature when the temperature of the Sensor itself is below  $-5^{\circ}\text{C}$ . Therefore, the Sensor will be warmed up when the temperature is below  $-5^{\circ}\text{C}$ . This action is called Sensor Warm-up.

## 6. Drive Transmission Route and Gear Layout

### 6.1 MAIN DRIVE ASSEMBLY

Rotary power of the MAIN DRIVE ASSEMBLY is transmitted through the route below.

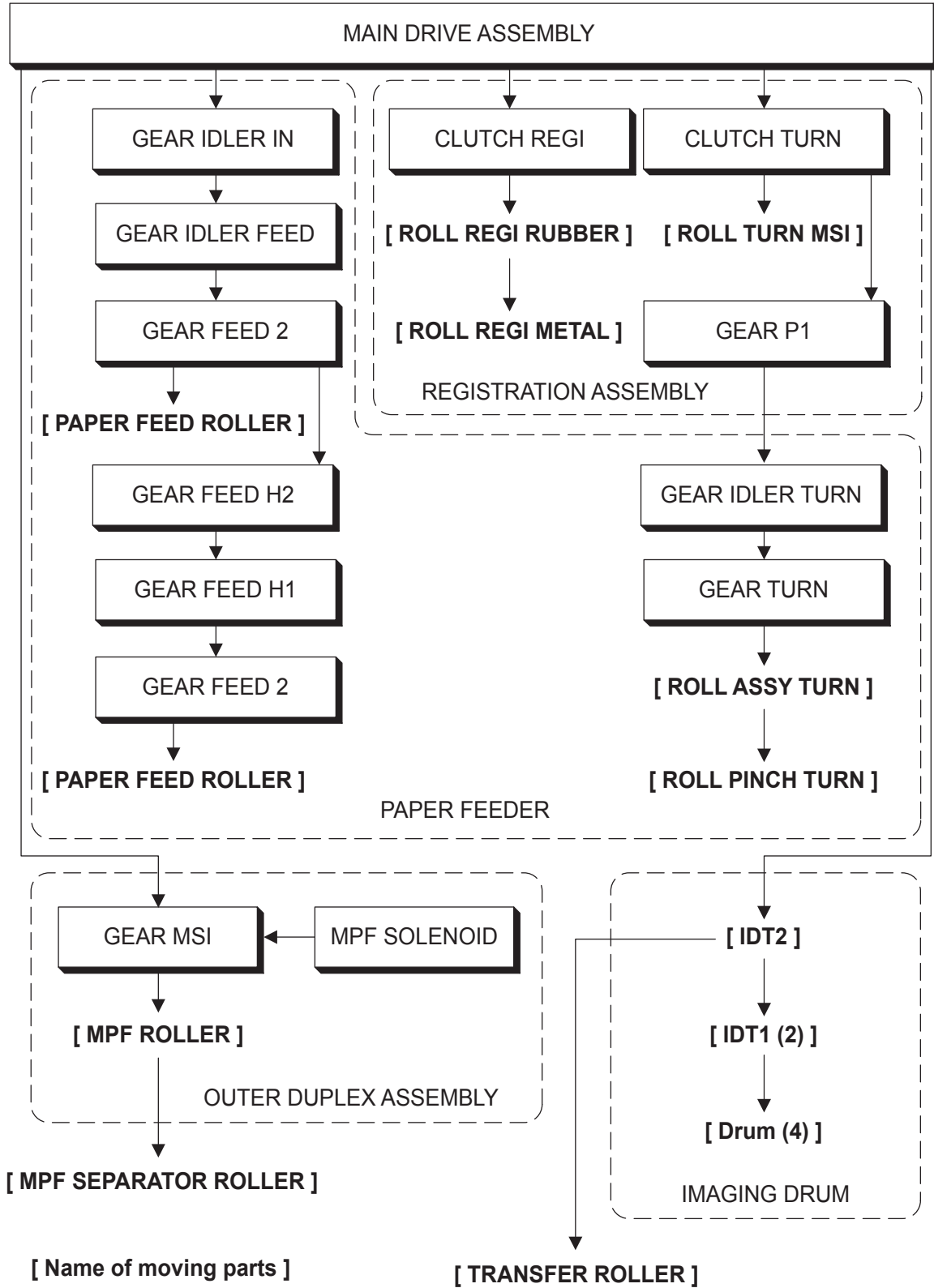

Ten06018KA

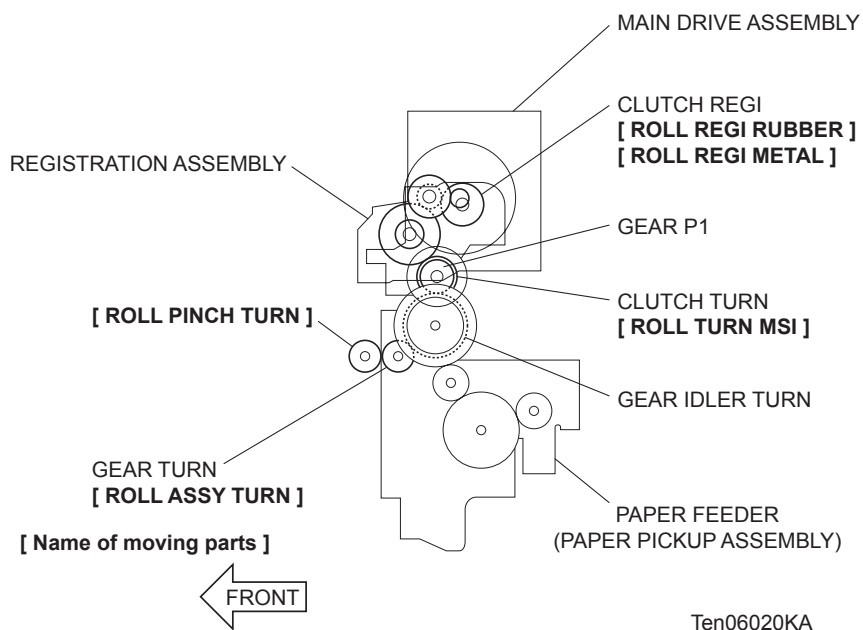
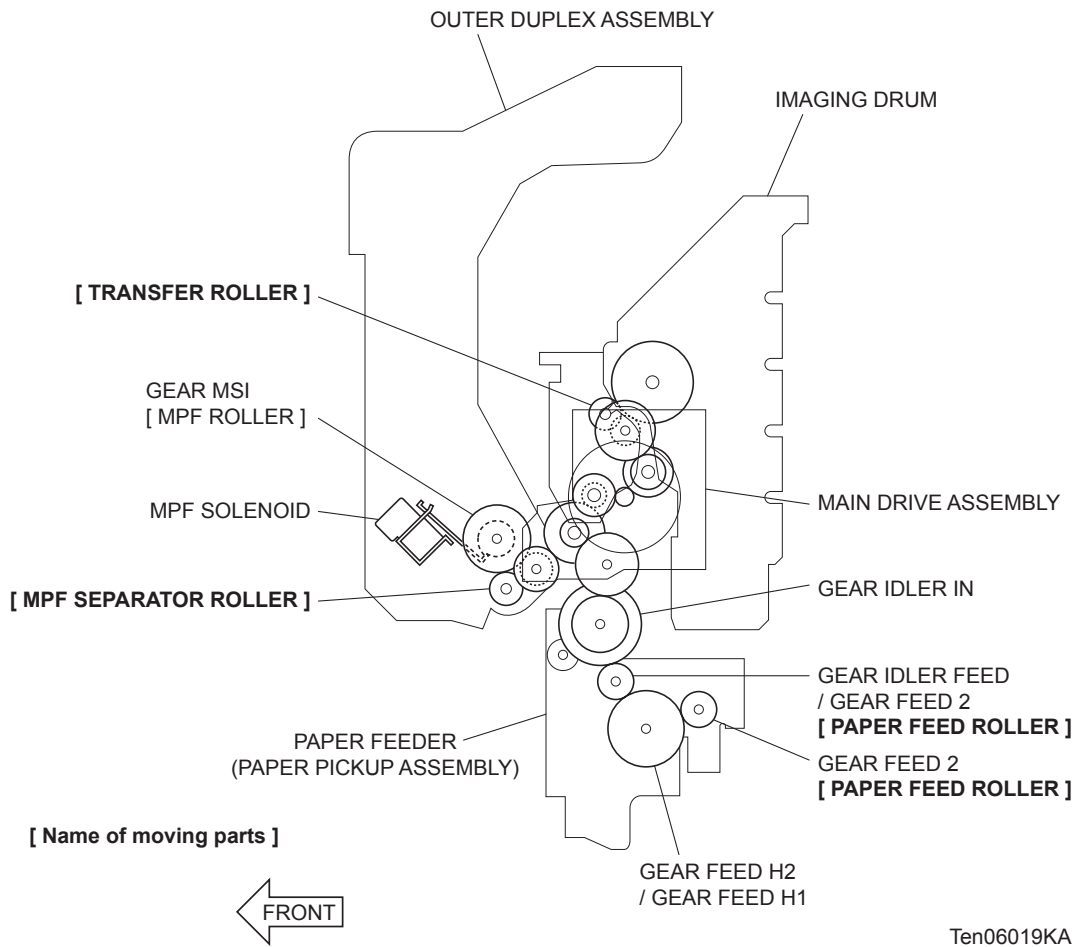

## 6.2 DEVELOPER DRIVE ASSEMBLY

The rotary power of the DEVELOPER DRIVE ASSEMBLY drives the developers of 4 colors in the DEVELOPER FRAME.

<BLACK and WHITE MODE>

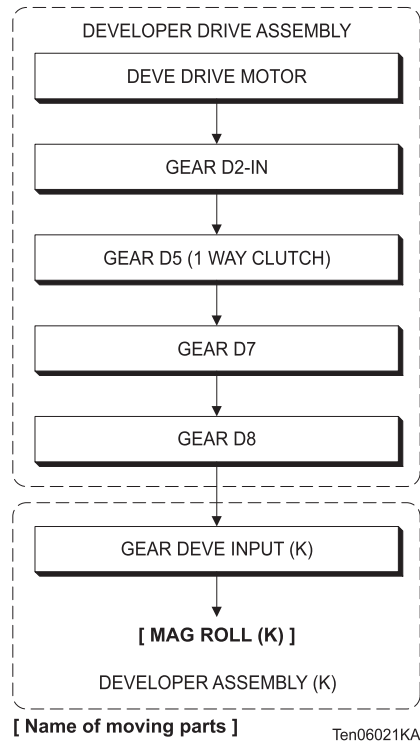

BLACK and WHITE MODE

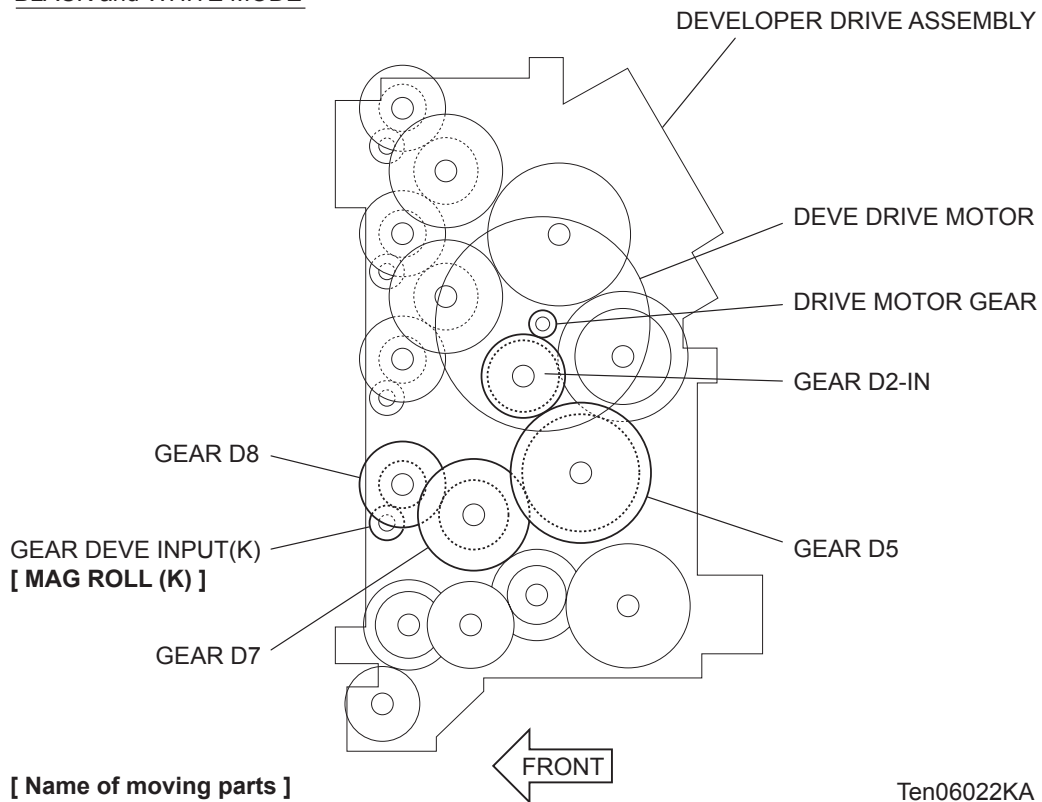

<FULL COLOR MODE>

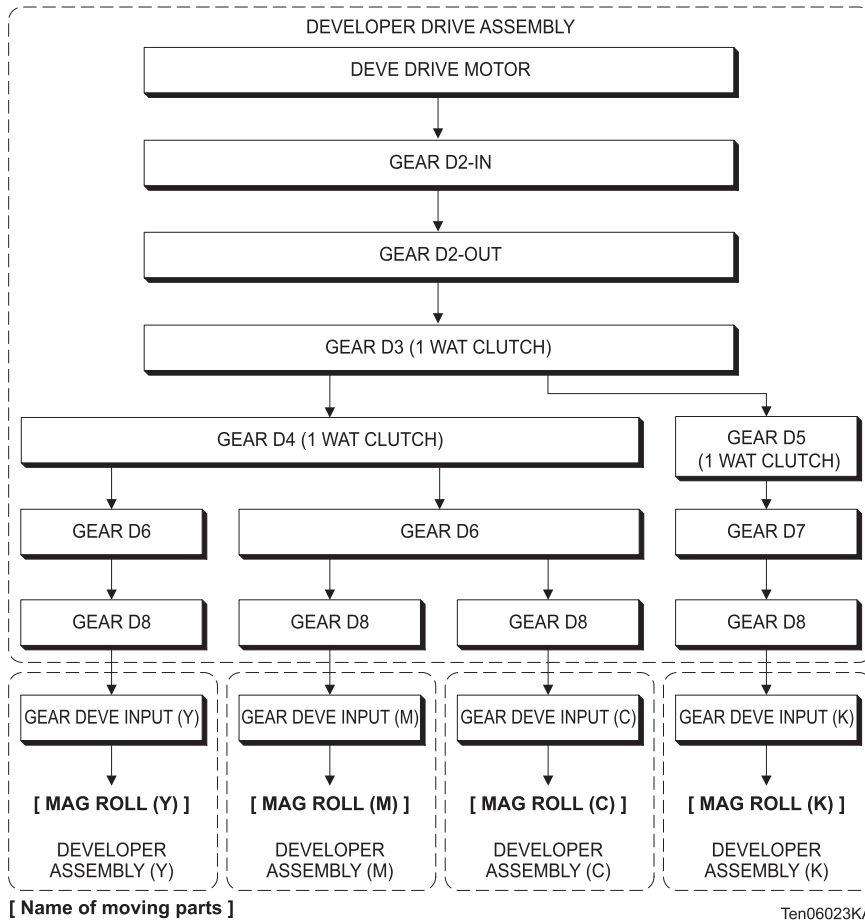

FULL COLOR MODE

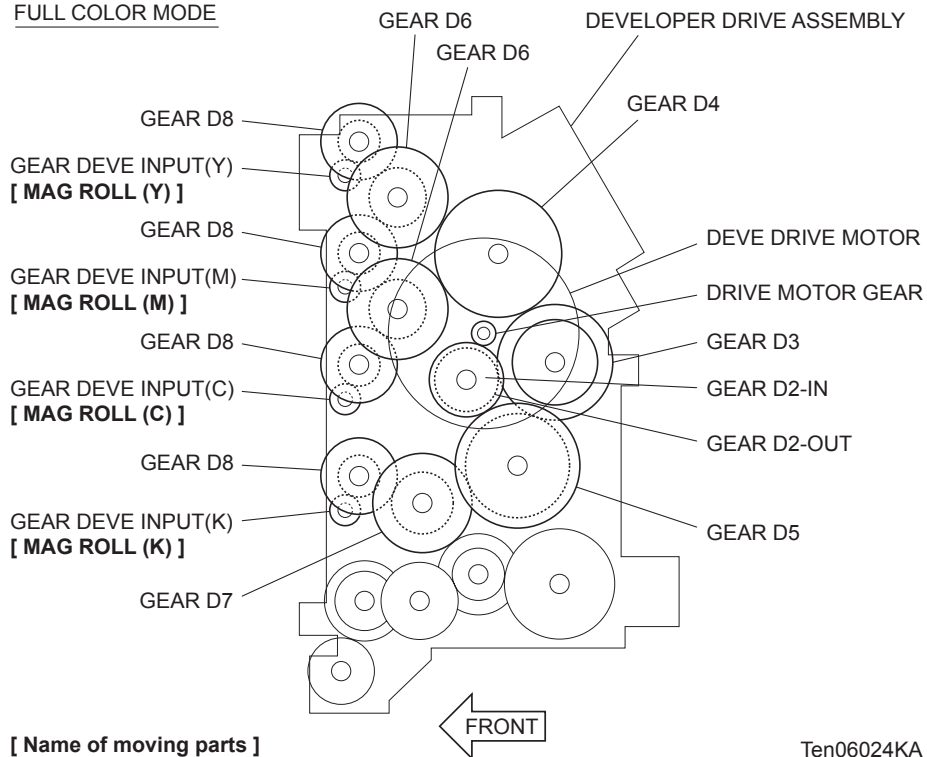



### 6.3 TONER DISPENSER ASSEMBLY (Y, M, C, K)

Rotary power of the toner motor in the TONER DISPENSER ASSEMBLY drives the agitator in the TONER DISPENSER ASSEMBLY (to supply toner from the TONER DISPENSER ASSEMBLY to TONER DISPENSER ASSEMBLY) and auger in the TONER DISPENSER ASSEMBLY (to supply toner to developer in the DEVELOPER FRAME).

Four TONER DISPENSER ASSEMBLY, Y, M, C and K, operate respectively in the same way.

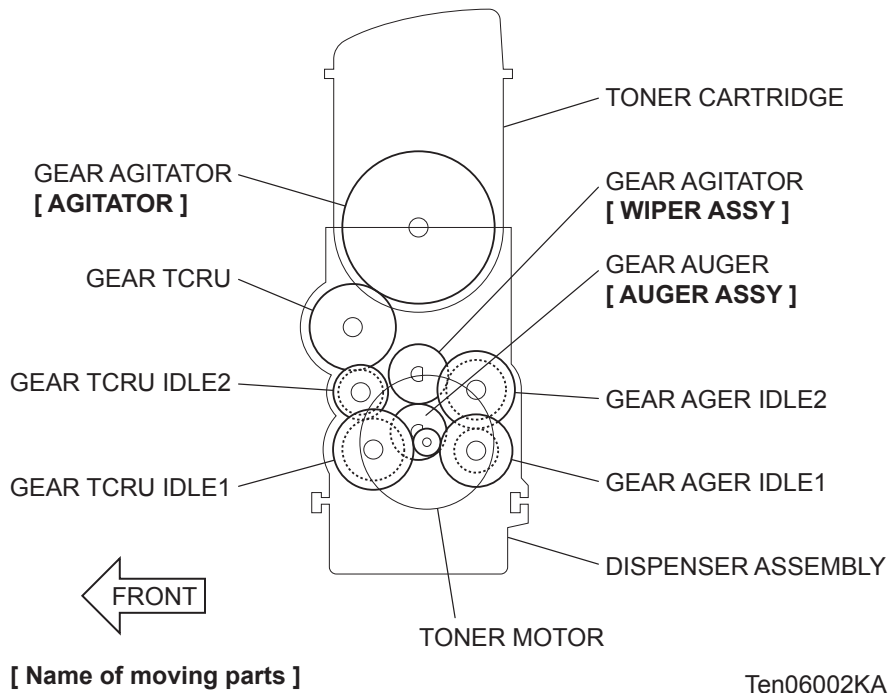
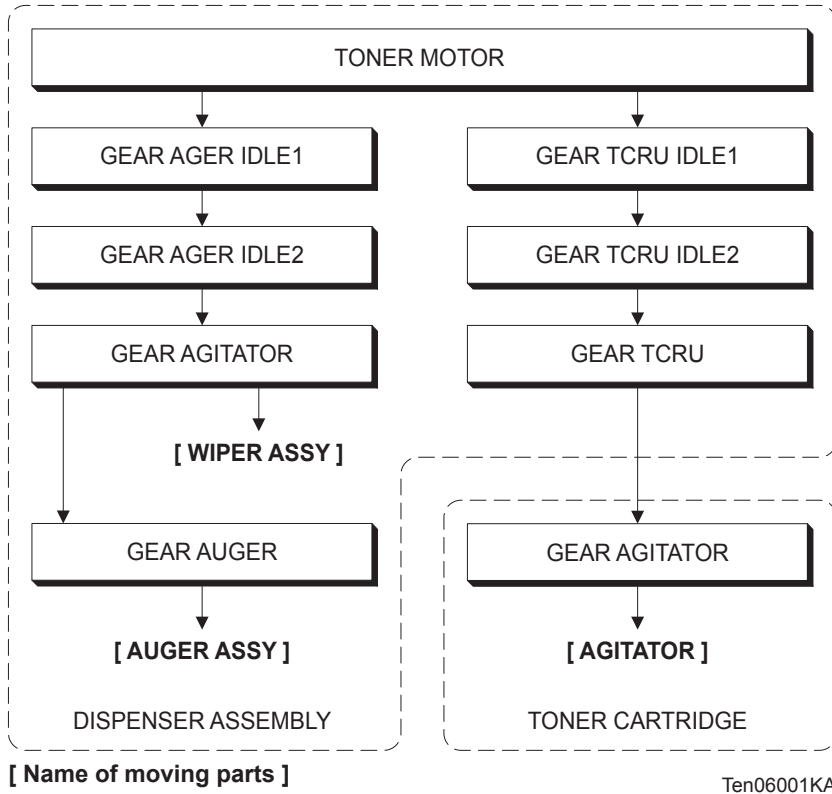

### 6.4 DRIVE ASSY FUSER

Rotary power of the DRIVE ASSY FUSER drives the FUSER.

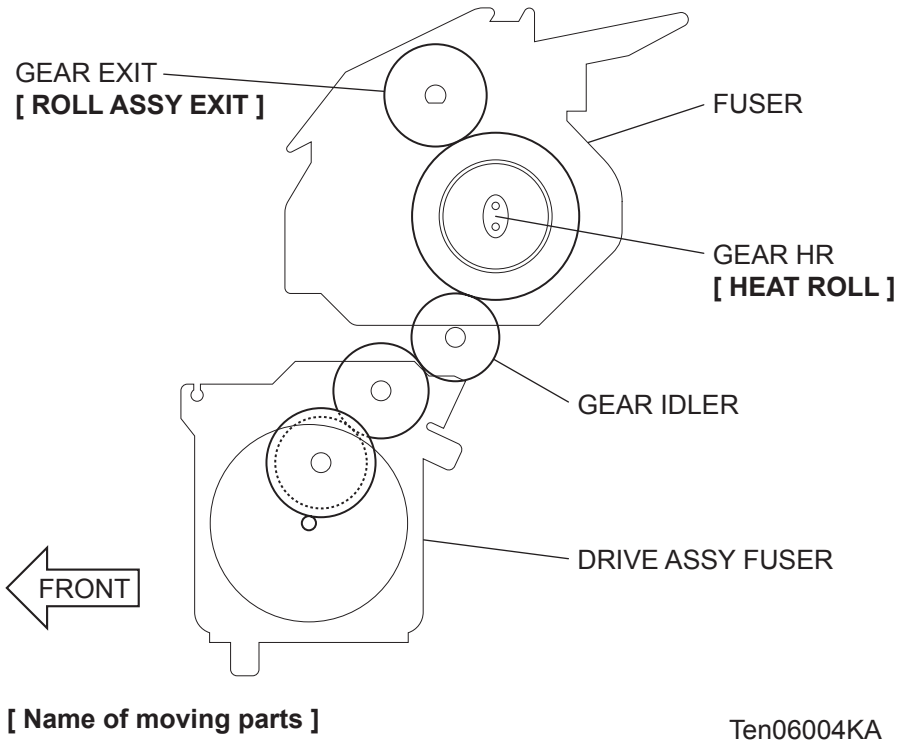
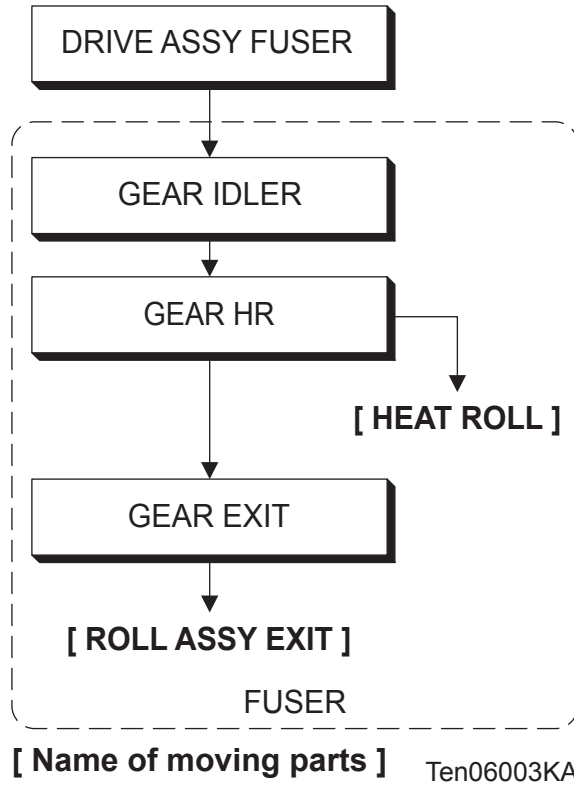

### 6.5 MOTOR ASSY DUP

Rotary power of the MOTOR ASSY DUP is transmitted through the route below.

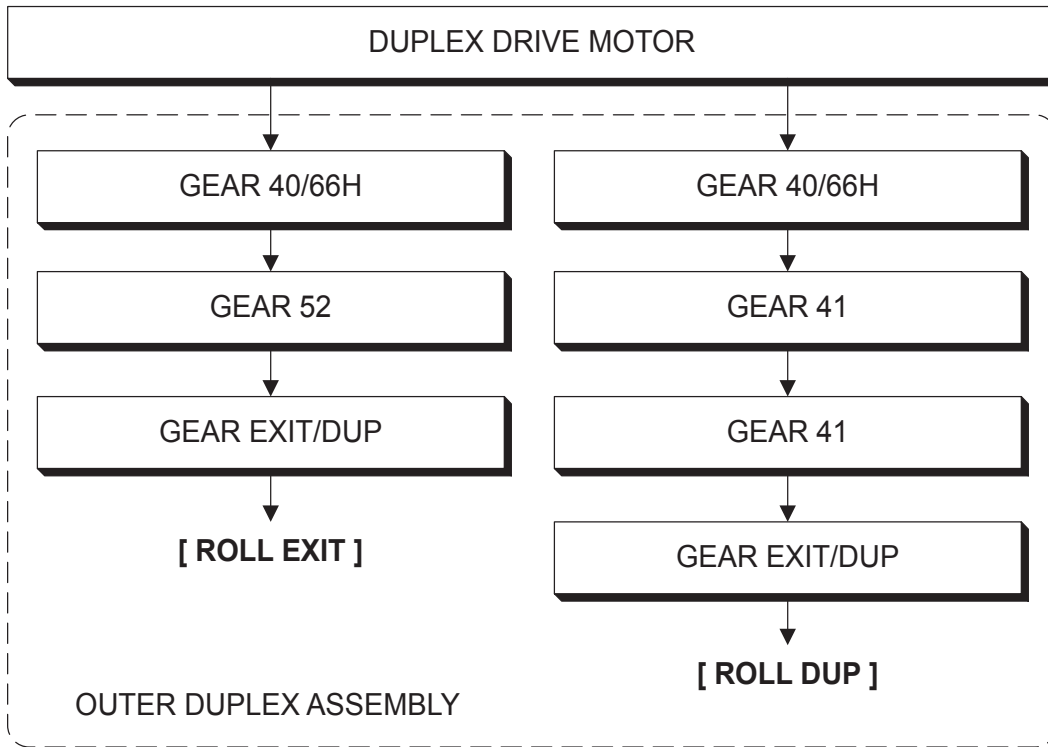

[ Name of moving parts ]

Ten06025KA

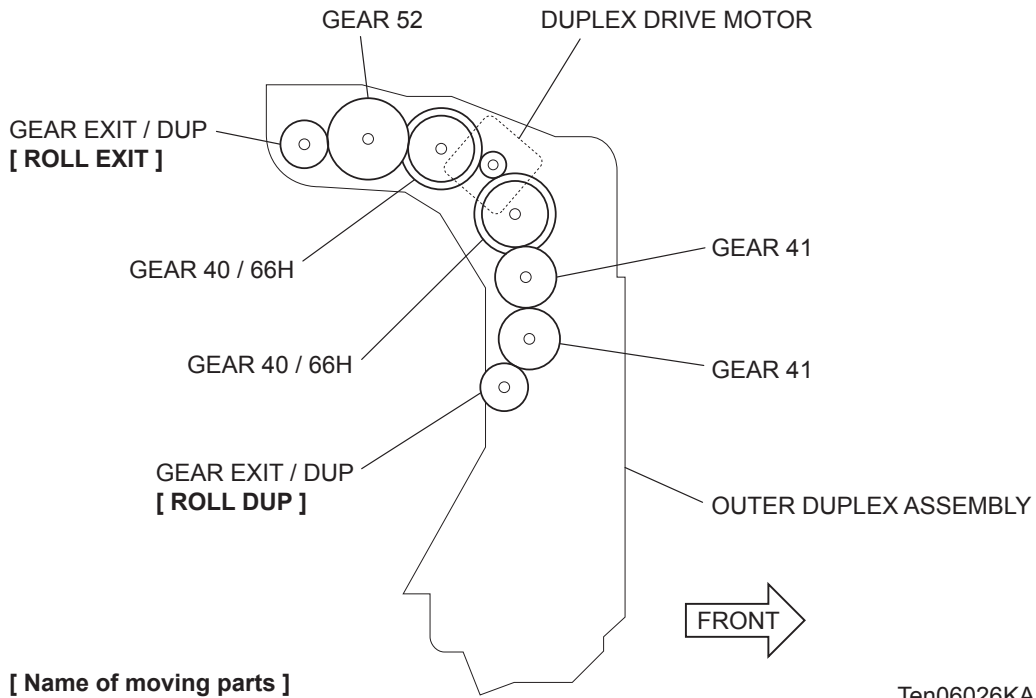

[ Name of moving parts ]

Ten06026KA

**Chapter 7 Wiring Diagrams and Signal Information CONTENTS**

---

1. General Wiring Diagram ..... 7 - 1

2. Wiring Diagram between Parts ..... 7 - 3

    2.1 Configuration ..... 7 - 3

    2.2 Notes on Using the Wiring Diagram between Parts ..... 7 - 5

        § 1 Power supply section ..... 7 - 8

        § 2 Cassette section ..... 7 - 10

        § 3 Drive section ..... 7 - 12

        § 4 Developer section 1 ..... 7 - 14

        § 5 Developer section 2 ..... 7 - 16

        § 6 Fuser section ..... 7 - 18

        § 7 ROS section ..... 7 - 20

        § 8 Xerographics 1 ..... 7 - 22

        § 9 Xerographics 2 ..... 7 - 24

        § 10 Paper feed section ..... 7 - 26



        § 11 Controller section ..... 7 - 28

**Chapter 7 Wiring Diagrams and Signal Information CONTENTS**

---

## 1. General Wiring Diagram

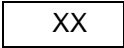
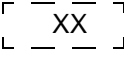
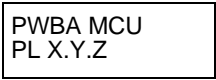
The following describes the legend of the general wiring diagram shown on the next page.

Symbols	Description
	Denotes a connection between parts with harnesses and wires.
	A frame not having parts name inside denotes the connector (P/J). Numeric value inside implies the connector number.
	A frame of broken line denotes the connector (P/J) written in several places separately. Numeric value inside implies the connector number.
	A frame having parts name inside denotes the parts. PL X.Y.Z implies the item "Z" of plate (PL) "X.Y" in Chapter 5. Parts List.
	A frame of dotted line denotes the section in "2. Wiring Diagram between Parts", and numeric value implies the section number.

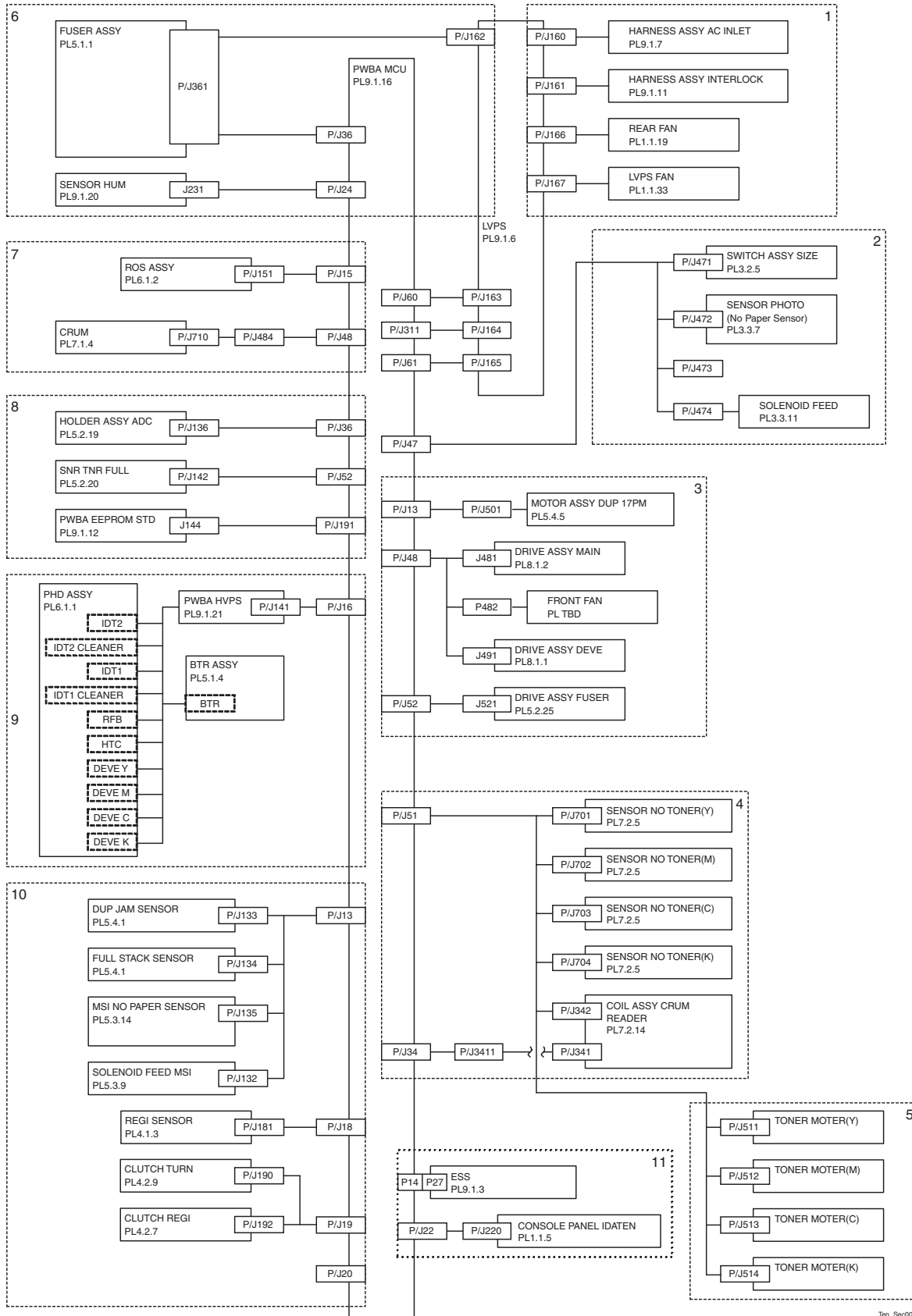

## 2. Wiring Diagram between Parts

### 2.1 Configuration

The wiring diagram is separated into 11 sections to show detailed connection between parts.

#### § 1 Power supply section

Connection between PWBA MCU and LVPS  
 Connection between LVPS and FAN REAR  
 Connection between LVPS and HARNESS ASSY AC INLET  
 Connection between LVPS and HARNESS ASSY INTERLOCK  
 Connection between LVPS and LVPS FAN

#### § 2 Cassette section

Connection between PWBA MCU and SWITCH ASSY SIZE  
 Connection between PWBA MCU and SENSOR PHOTO (No Paper Sensor)  
 Connection between PWBA MCU and SOLENOID FEED (Tray 1)

#### § 3 Drive section

Connection between PWBA MCU and DRIVE ASSY MAIN  
 Connection between PWBA MCU and DRIVE ASSY DEVE  
 Connection between PWBA MCU and DRIVE ASSY FUSER  
 Connection between PWBA MCU and MOTOR ASSY DUP 17 PM  
 Connection between PWBA MCU and FAN FUSER

#### § 4 Developer section 1

Connection between PWBA MCU and COIL ASSY CRUM READER  
 Connection between PWBA MCU and SENSOR NO TONER (Y)  
 Connection between PWBA MCU and SENSOR NO TONER (M)  
 Connection between PWBA MCU and SENSOR NO TONER (C)  
 Connection between PWBA MCU and SENSOR NO TONER (K)

#### § 5 Developer section 2

Connection between PWBA MCU and HOLDER TCRU ASSY (Y) (Toner Motor:Y)  
 Connection between PWBA MCU and HOLDER TCRU ASSY (M) (Toner Motor:M)  
 Connection between PWBA MCU and HOLDER TCRU ASSY (C) (Toner Motor:C)  
 Connection between PWBA MCU and HOLDER TCRU ASSY (K) (Toner Motor:K)

#### § 6 Fuser section

Connection between LVPS and FUSER ASSY  
 Connection between PWBA MCU and FUSER ASSY  
 Connection between FUSER ASSY and SENSOR HUM

#### § 7 ROS section

Connection between PWBA MCU and ROS ASSY  
 Connection between PWBA MCU and CRUM



§ 8 Xerographics section 1

Connection between PWBA MCU and SNR TNR FULL  
Connection between PWBA MCU and PWBA EEPROM STD  
Connection between PWBA MCU and HOLDER ASSY ADC

§ 9 Xerographics section 2

Connection between PWBA MCU , HVPS , PHD ASSY and BTR ASSY

§ 10 Paper feed section



Connection between PWBA MCU and SENSOR PHOTO (Dup Jam Sensor)  
Connection between PWBA MCU and SENSOR PHOTO (Full Stack Sensor)  
Connection between PWBA MCU and SENSOR PHOTO (MSI No Paper Sensor)  
Connection between PWBA MCU and SOLENOID FEED MSI  
Connection between PWBA MCU and SENSOR PHOTO (Regi Sensor)  
Connection between PWBA MCU and CLUTCH REGI  
Connection between PWBA MCU and CHUTE TURN (MSI)

§ 11 Controller section

Connection between PWBA MCU and ESS  
Connection between PWBA MCU and CONSOLE PANEL IDATEN

## 2.2 Notes on Using the Wiring Diagram between Parts

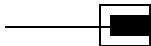
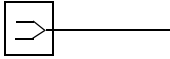
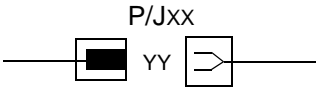
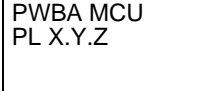
The following describes the legend of the wiring diagrams between parts shown on the following pages.

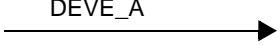
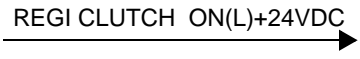
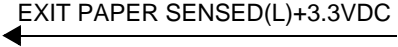
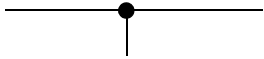
Symbols	Description
	Denotes a plug.
	Denotes a jack.
	Denotes Pin yy and Jack yy of the connector Pxx and Jxx.
	Denotes the parts. PL X.Y.Z implies the item "Z" of plate (PL) "X.Y" in Chapter 5. Parts List.
	Denotes functional parts attached with functional parts name.
	Denotes the control and its outline in PWB.
	Denotes a connection between parts with harnesses or wires, attached with signal name/contents.
	Denotes the function, and logic value of the signal to operate the function (Low: L, High: H). The given voltage is for signal in high status. The arrow indicates the direction of signal.
	Denotes the function, and logic value of the signal when the function operated (Low: L, High: H). The given voltage is for signal in high status. The arrow indicates the direction of signal.
	Denotes a connection between wires.

<b>Symbols</b>	<b>Description</b>
I/L +24VDC	Denotes DC voltage when the interlock switch in PWBA MCU turns on.
+5VDC +3.3VDC	Denotes DC voltage.
SG	Denotes signal ground.

Blank Page

§ 1 Power supply section

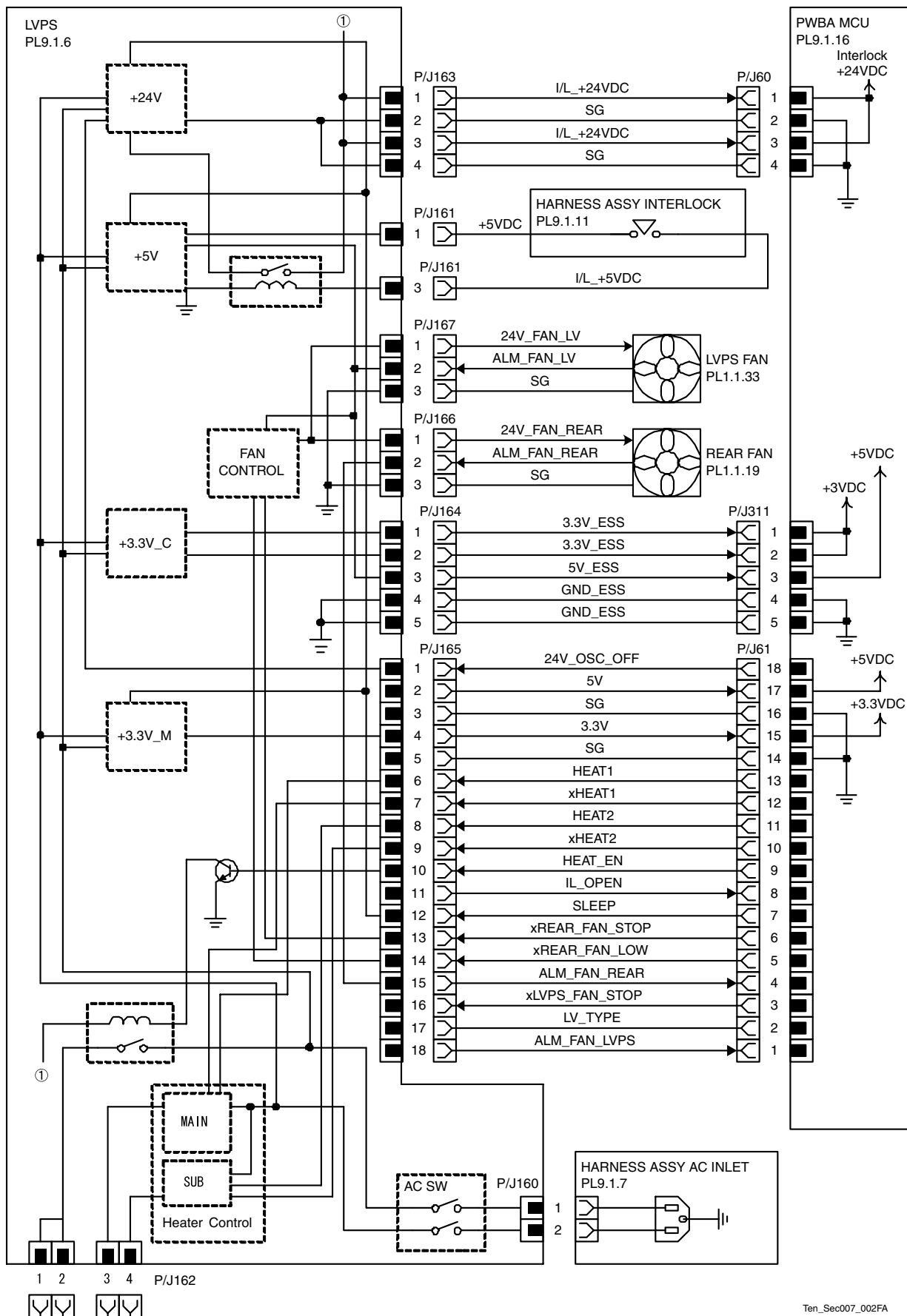

Ten\_Sec007\_002FA

Signal line name	Description
24V OSC OFF	Control signal for +24 VDC output (High: Output is stopped)
HEAT1	Control signal of Main Lamp placed in FUSER ASSY (LAMP lights up at "High: HEAT1" and "Low:xHEAT1")
xHEAT1	
HEAT2	Control signal of Sub Lamp placed in FUSER ASSY (LAMP lights up at "High: HEAT1" and "Low:xHEAT1")
xHEAT2	
HEAT EN	Control signal for AC power supply for Main Lamp and Sub Lamp placed in FUSER ASSY (High: AC power supply is output)
IL OPEN	Signal for opening/closing INTERLOCK SWITCH (High: Switch opens)
SLEEP	Control signal for Sleep Mode (High: Output is stopped at +24 VDC, +5 VDC and +3VDC)
xREAR FAN STOP	Control signal for REAR FAN (High: Fan rotates)
xREAR FAN LOW	Control signal for REAR FAN (High: Fan rotates at high speed/ Low: Fan rotates at low speed)
ALM FAN REAR	Alarm signal for REAR FAN (High: Fan fails)
xLVPS FAN STOP	Control signal for LVPS FAN (High: Fan rotates)
LV TYPE	Identifying signal for LVPS
ALM FAN LVPS	Alarm signal for LVPS FAN (High: Fan fails)

◆ LVPS overcurrent protection circuit

This circuit stops all outputs, if the power supply voltage 24VDC, 5VDC, or 3.3VDC is shorted. The circuit is reset, when after the cause of short was removed, the power is turned off, and then on again after certain time.

\* Note that the 5 V power supplies for the ESS and operation panel are excluded. The 5 VDC power supplies cannot be restored since they use a fuse.

◆ LVPS overvoltage protection circuit

This circuit stops all outputs, if the power supply voltage 24VDC, 5VDC, or 3.3VDC exceeds the specified voltage respectively.

At this time, the operating point is 32VDC or less for 24VDC, 7VDC or less for 5VDC, or 4.4V or less for 3.3VDC.

The circuit is reset, when the power is turned off, and then on again after certain time.

◆ REAR FAN output circuit

For the xFAN REAR ON (H) signal, the output voltage varies depending on the status of FAN LOW signal and FAN STOP signal.

FAN LOW	FAN STOP	FAN REAR ON(H)
High	High	24V
Low	High	15V
High	Low	0V
Low	Low	0V

LVPS FAN is controlled by FAN STOP signal only.

◆ Output stop by I/L Switch

Output is stopped by I/L Switch. +24VDC output from LVPS is stopped by turning off the I/L Switch connected to LVPS.

§ 2 Cassette section

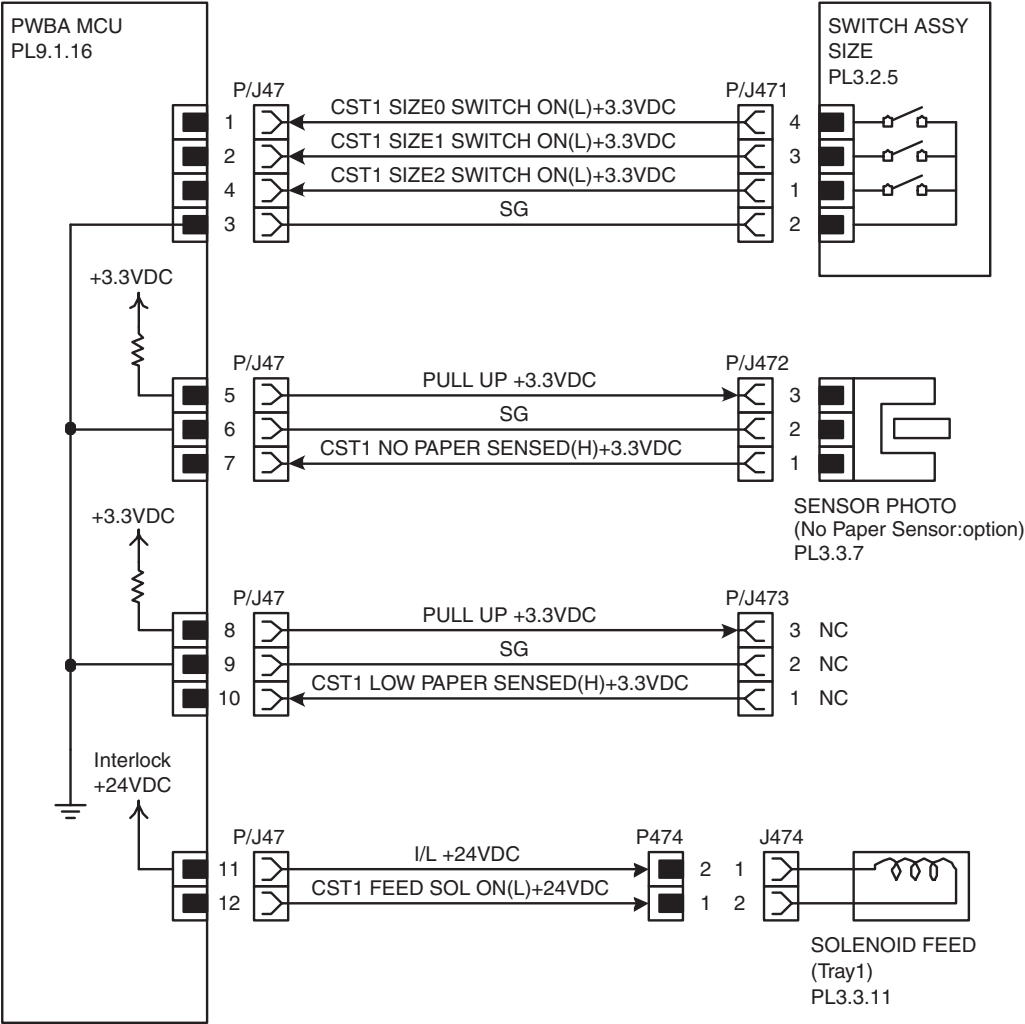

Ten\_Sec007\_003FA

Signal line name	Description
CST1 SIZE0 SWITCH ON(L)+3.3VDC	ON/OFF detection signal of SWITCH ASSY SIZE upper SW
CST1 SIZE1 SWITCH ON(L)+3.3VDC	ON/OFF detection signal of SWITCH ASSY SIZE middle SW
CST1 SIZE2 SWITCH ON(L)+3.3VDC	ON/OFF detection signal of SWITCH ASSY SIZE lower SW
CST1 NO PAPER SENSED(H)+3.3VDC	Cassette paper detection signal by SENSOR PHOTO (No Paper Sensor) (High:no paper)
CST1 FEED SOL ON(L)+24VDC	ON/OFF control signal of SOLENOID FEED (Tray 1)
CST1 TURN CL ON(L)+24VDC	ON/OFF control signal of CLUTCH ASSY TURN (Tray 1)

◆ Outline of SWITCH ASSY SIZE

The paper size is determined by a combination of ON/OFF statuses of the upper, middle, and lower switches of SWITCH ASSY SIZE.

Paper size	Switches		
	Upper	Middle	Lower
LEGAL14" (SEF)	ON	ON	ON
LEGAL13" (SEF)	ON	ON	OFF
EXECUTIVE (SEF)	ON	OFF	ON
B5 (SEF)	ON	OFF	OFF
A4 (SEF)	OFF	ON	ON
LETTER (SEF)	OFF	OFF	ON
A5	OFF	ON	OFF
No cassette	OFF	OFF	OFF

ON: The actuator is pushing the switch.



§ 3 Drive section

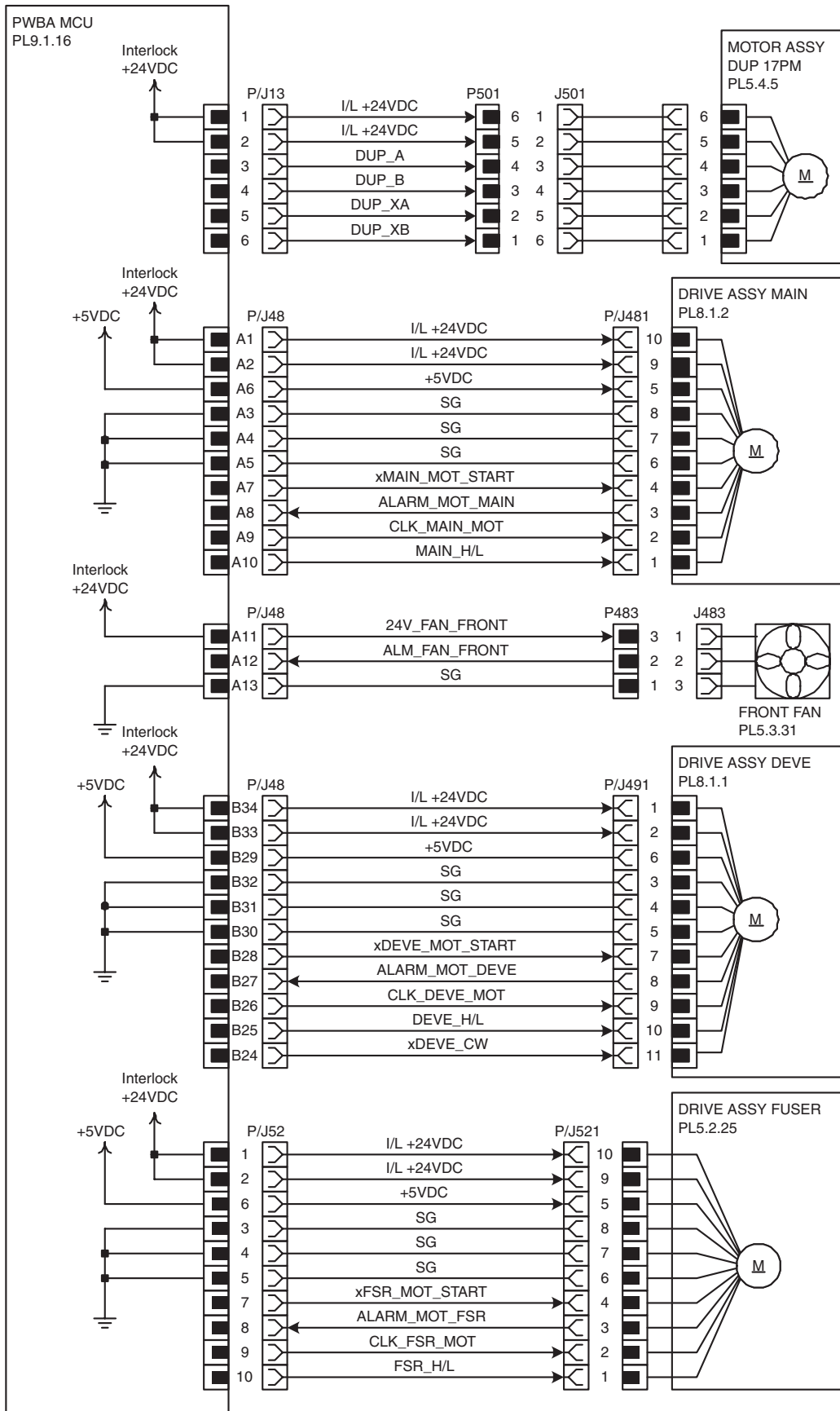

Ten\_Sec007\_004FA

Signal line name	Description
xMAIN MOT START	Control signal for MAIN MOTOR (High:MOTOR stops)
ALARM MOT MAIN	Control signal for MAIN MOTOR (High:MOTOR error)
CLK MAIN MOT	Control signal for MAIN MOTOR
MAIN H/L	Control signal for MAIN MOTOR (High:MOTOR rotates at high speed/Low:MOTOR rotates at low speed)
ALM FAN FRONT	Control signal for FRONT FAN (High: Fan fails)
xDEVE MOT START	Control signal for DEVE MOTOR (High:MOTOR stops)
ALARM MOT DEVE	Control signal for DEVE MOTOR (High: MOTOR error)
CLK DEVE MOTO	Control signal for DEVE MOTOR
DEVE H/L	Control signal for DEVE MOTOR (High:MOTOR rotates at high speed/Low: MOTOR rotates at low speed)
xDEVE CW	Control signal for DEVE MOTOR (High:MOTOR rotates counter-clockwise)
xFSR MOT START	Control signal for FUSER MOTOR (High:MOTOR stops)
ALARM MOT FSR	Control signal for FUSER MOTOR (High:MOTOR error)
CLK FSR MOT	Control signal for FUSER MOTOR
FSR H/L	Control signal for FUSER MOTOR (High:MOTOR rotates at low speed)

◆ Outline of MOTOR ASSY DUP Motor type: Hybrid stepping motor

- ◆ Stepping angle: 1.8°
- ◆ Winding resistance: 3.3Ω ± 10% / phase (25°C)
- ◆ Exciting sequence: (\*: Exciting)

Phase	Step (2 phases)							
	1	2	3	4	5	6	7	8
DUP_A					*	*	*	
DUP_XA			*	*	*			
DUP_B	*	*	*					
DUP_XB	*						*	*

§ 4 Developer section 1

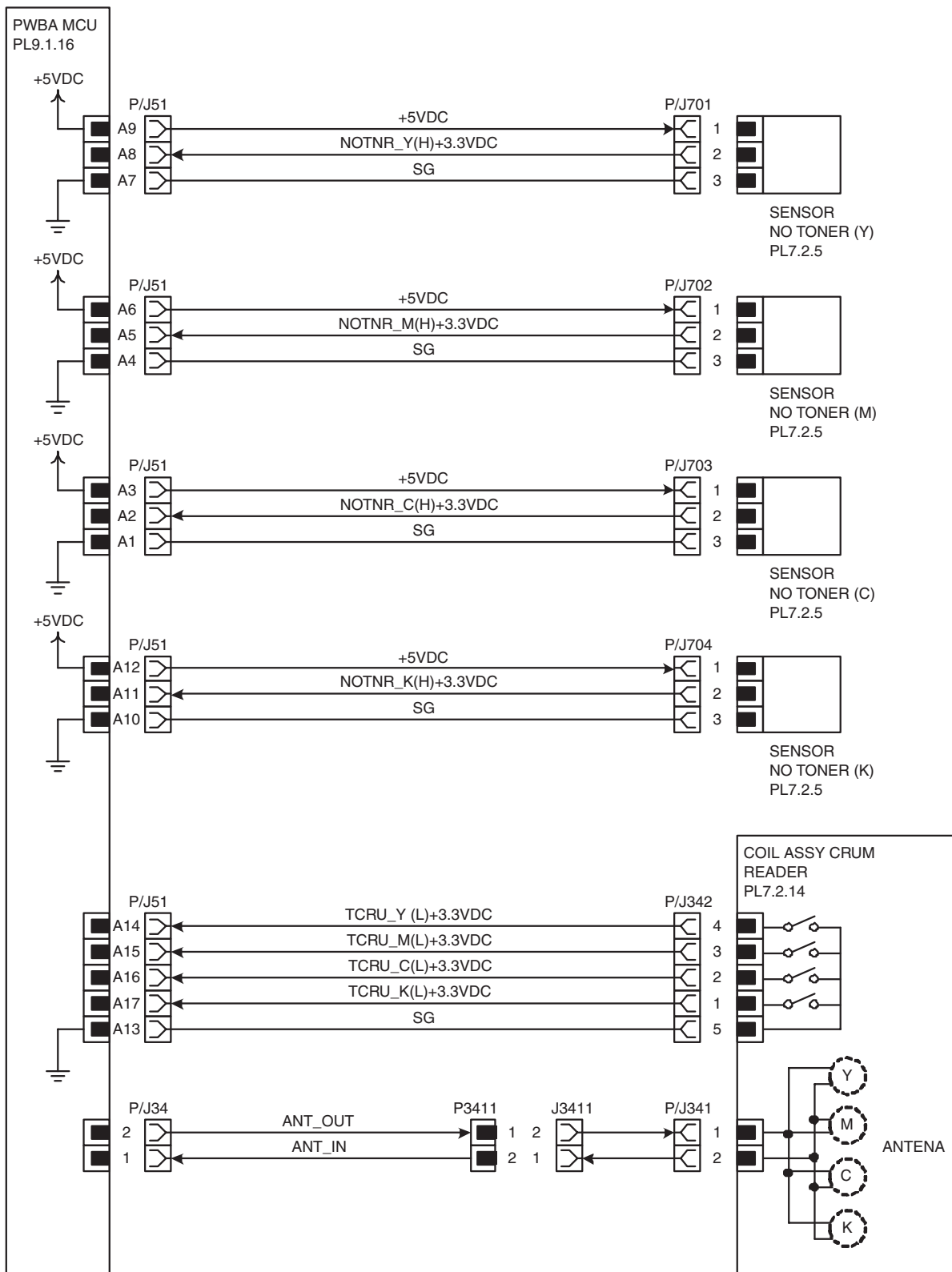

Ten\_Sec007\_005FA

Signal line name	Description
NOTNR(Y)(H)+3.3VDC	Residual toner detection signal by SENSOR TONER LOW (Y) (High: No Toner, Low:Toner present)
NOTNR(M)(H)+3.3VDC	Residual toner detection signal by SENSOR TONER LOW (M) (High: No Toner, Low:Toner present)
NOTNR(C)(H)+3.3VDC	Residual toner detection signal by SENSOR TONER LOW (C) (High: No Toner, Low:Toner present)
NOTNR(K)(H)+3.3VDC	Residual toner detection signal by SENSOR TONER LOW (K) (High: No Toner, Low:Toner present)
TCRU_Y SENSED(L)+3.3VDC	TCRU ASSY Y (toner bottle) detection signal (Low:Toner bottle present)
TCRU_M SENSED(L)+3.3VDC	TCRU ASSY M (toner bottle) detection signal (Low:Toner bottle present)
TCRU_C SENSED(L)+3.3VDC	TCRU ASSY C (toner bottle) detection signal (Low:Toner bottle present)
TCRU_K SENSED(L)+3.3VDC	TCRU ASSY K (toner bottle) detection signal (Low:Toner bottle present)
ANT_OUT	PWBA MCU and COIL ASSY CRUM READER communication signal (PWBA MCU output)
ANT_IN	PWBA MCU and COIL ASSY CRUM READER communication signal (COIL ASSY CRUM READER output)

§ 5 Developer section 2

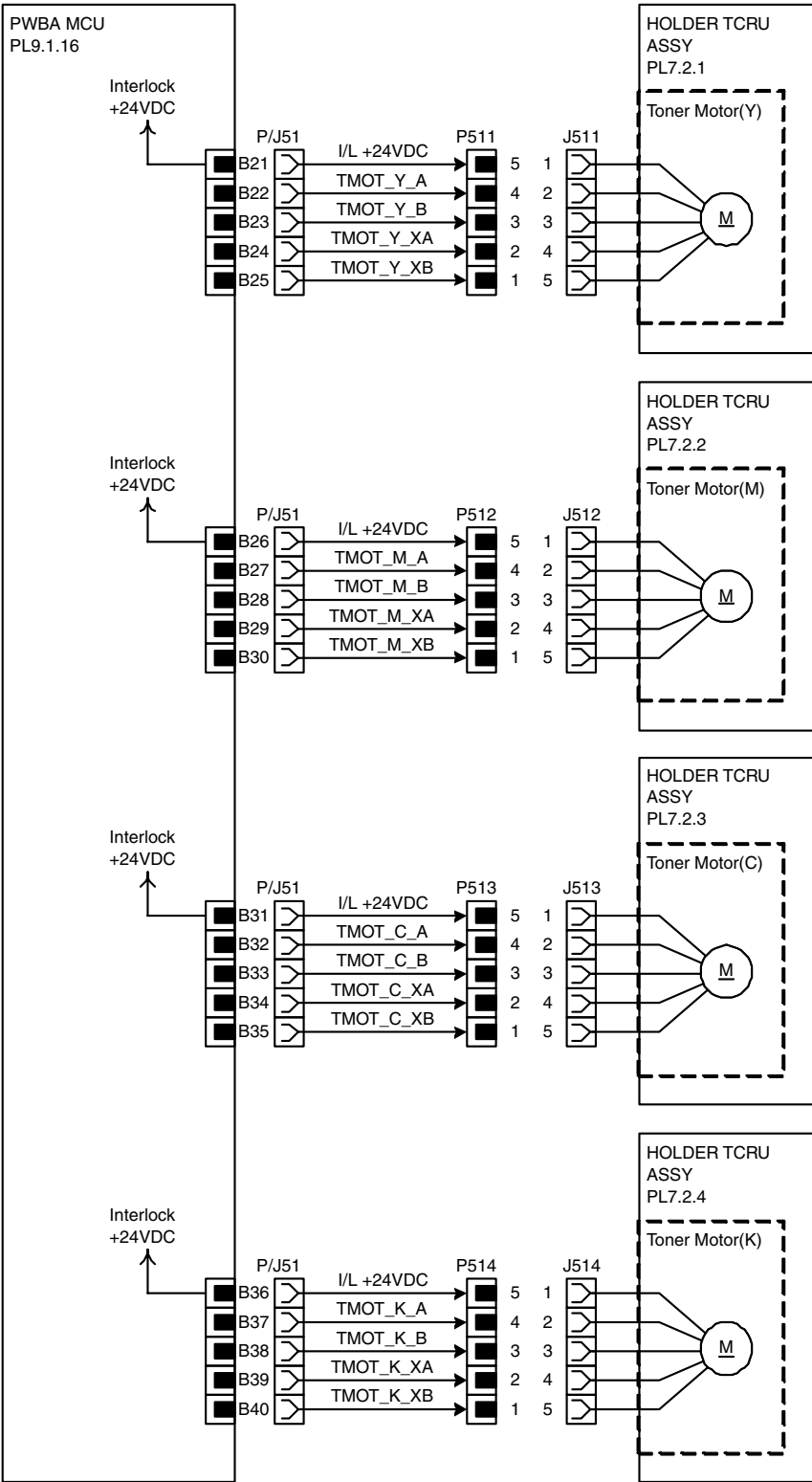

Ten\_Sec007\_006FA

◆ Outline of Toner Motor

- ◆ Motor type: PM stepping motor
- ◆ Stepping angle:  $7.5^\circ \pm 0.5^\circ$
- ◆ Winding resistance:  $80\Omega \pm 10\%$  / phase (20°C)
- ◆ Exciting sequence: (\*: Exciting)

Phase	Step (2 phases)							
	1	2	3	4	5	6	7	8
A	*			*	*			*
B			*	*			*	*
XA		*	*			*	*	
XB	*	*			*	*		

§ 6 Fuser section

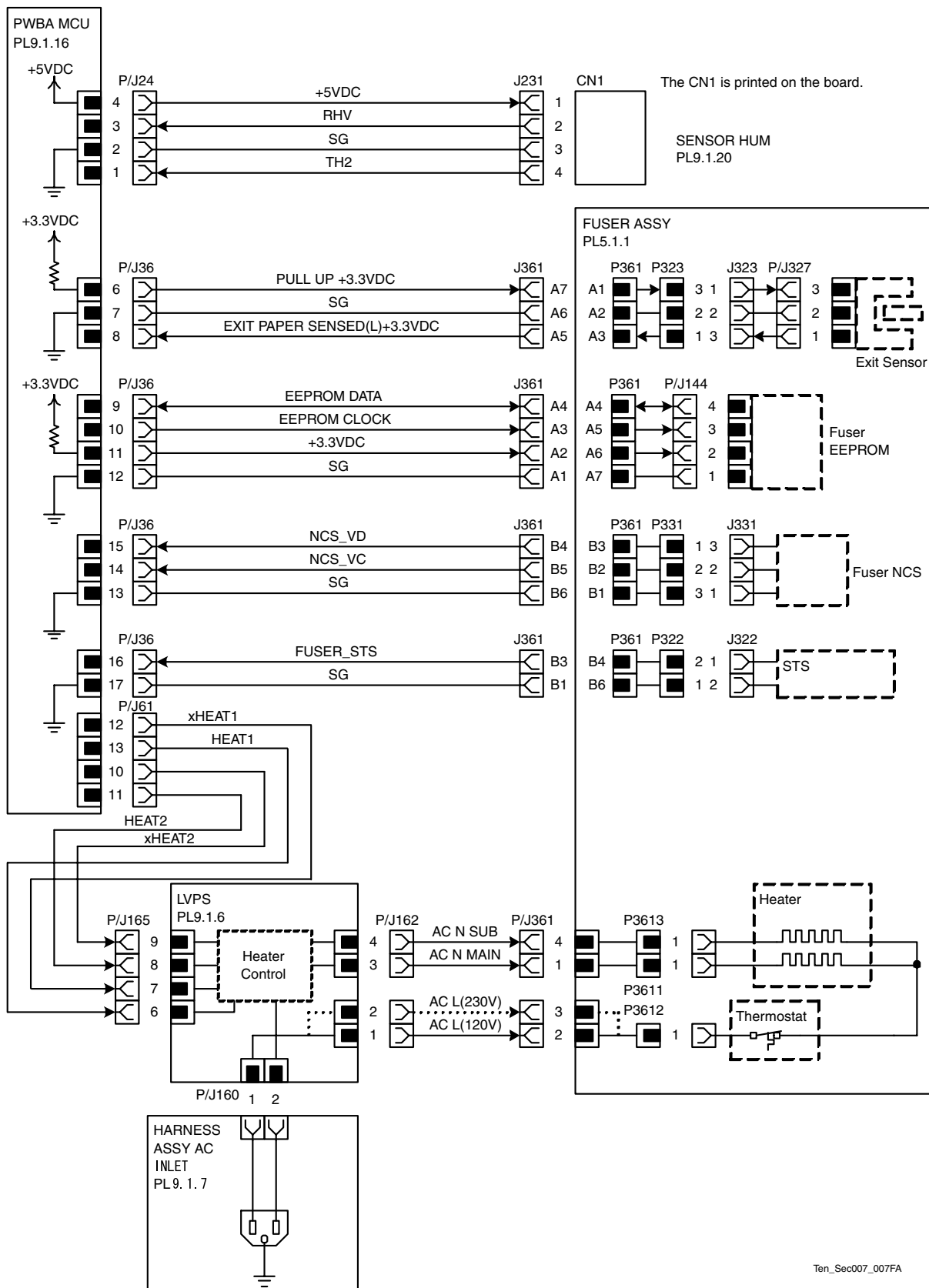

Ten\_Sec007\_007FA

Signal line name	Description
RHV	Data on humidity inside the device (analog value)
TH2	Data on temperature inside the device (analog value)
EEPROM DATA	Control signal of EEPROM
EEPROM CLOCK	Control signal of EEPROM
NSC VD	Data on temperature of the temperature control sensor (analog value)
NSC VC	Data on temperature of the temperature control sensor (analog value)
FUSER STS	Data on temperature of the high temperature detection sensor (analog value)
HEAT1	Control signal for Main Lamp placed in FUSER ASSY (LAMP lights up at "High:HEAT1 and "Low:xHEAT1")
xHEAT1	
HEAT2	Control signal for Sub Lamp placed in FUSER ASSY (LAMP lights up at "High:HEAT1 and "Low:xHEAT1")
xHEAT2	

◆ Heater rated power:

MAIN:550 ± 27.5W (120VAC/230VAC)

SUB :330 ± 15.0W (120VAC/230VAC)

◆ Thermostat contact open temperature: 180 ± 5°C



§ 7 ROS section

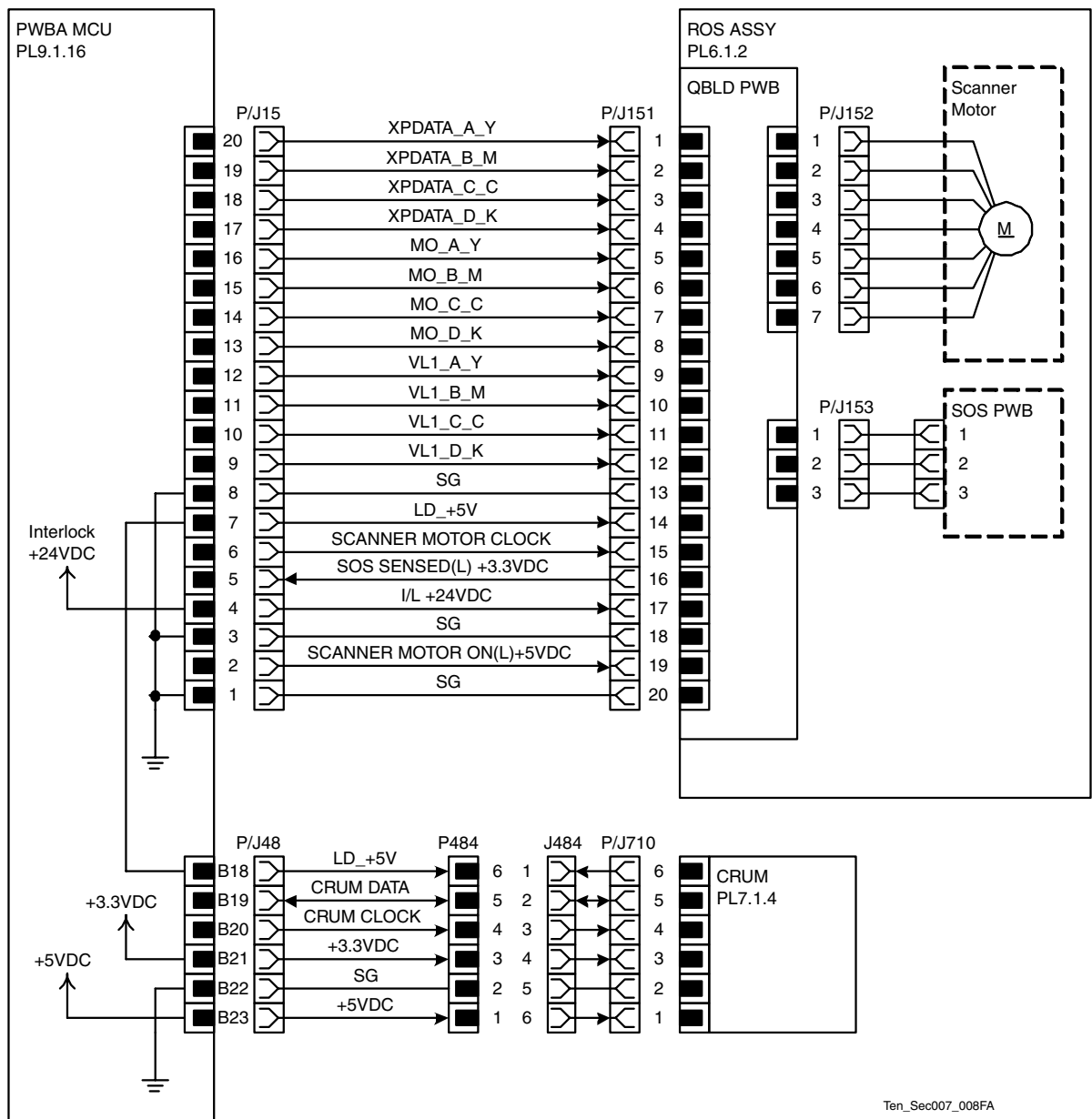

Ten\_Sec007\_008FA

Signal line name	Description
XPDATA_A_Y,XPDATA_B_M,XPDATA_C_C,XPDATA_D_K	Pixel data signals to make Quad Beam Laser Diodes (laser diodes for 4 colors) in ROS ASSY emit the light
MO_A_Y,MO_B_M,MO_C_C,MO_D_K	Light quantity control signals for each color LD (laser diode)
VL1_A_Y,VL1_B_M,VL1_C_C,VL1_D_K	Voltages for adjusting light quantity of each color LD
LD_+5VDC	Line to provide ROS ASSY with +5VDC through from PWBA MCU to PHD ASSY.
SOS SENSED(L) +3.3VDC	Scanning start reference signal based on the input of laser beam to the SOS Sensor in SOS PWB
SCANNER MOTOR ON(L)+5VDC	Scanner Motor ON/OFF control signal in ROS ASSY
CRUM DATA	Write/read data to CRU
CRUM CLOCK	Clock signal to CRU

§ 8 Xerographics 1

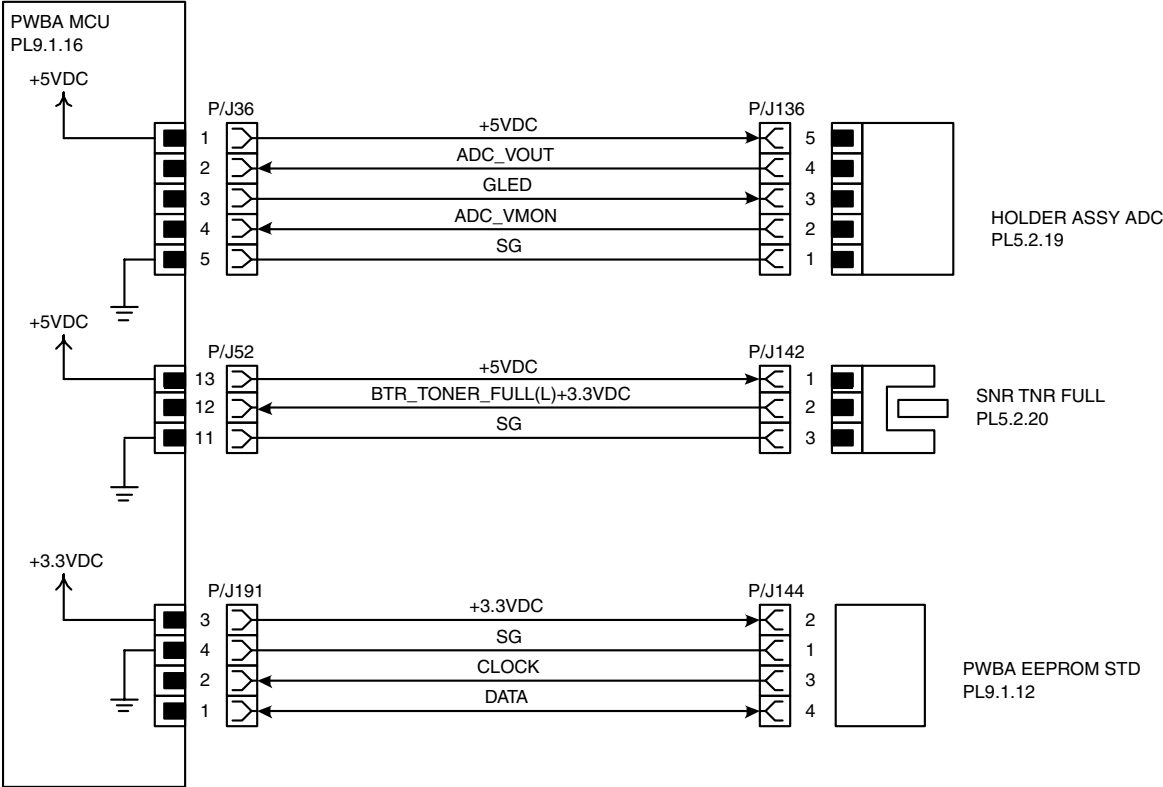

Ten\_Sec007\_009FA

<b>Signal line name</b>	<b>Description</b>
BTR_TONER_FULL(L)+3.3VDC	Waste toner recovery bottle full detection signal by SNR TNR FULL
ADC VOUT	Measured data (analog value) by ADC Sensor in HOLDER ASSY ADC
ADC MONITOR	Monitor output signal by ADC Sensor in HOLDER ASSY ADC
GLED	LED control signal (analog value) in HOLDER ASSY ADC
CLOCK	Clock signal to PWBA EEPROM STD
DATA	Data to be written on/read from PWBA EEPROM STD

§ 9 Xerographics 2

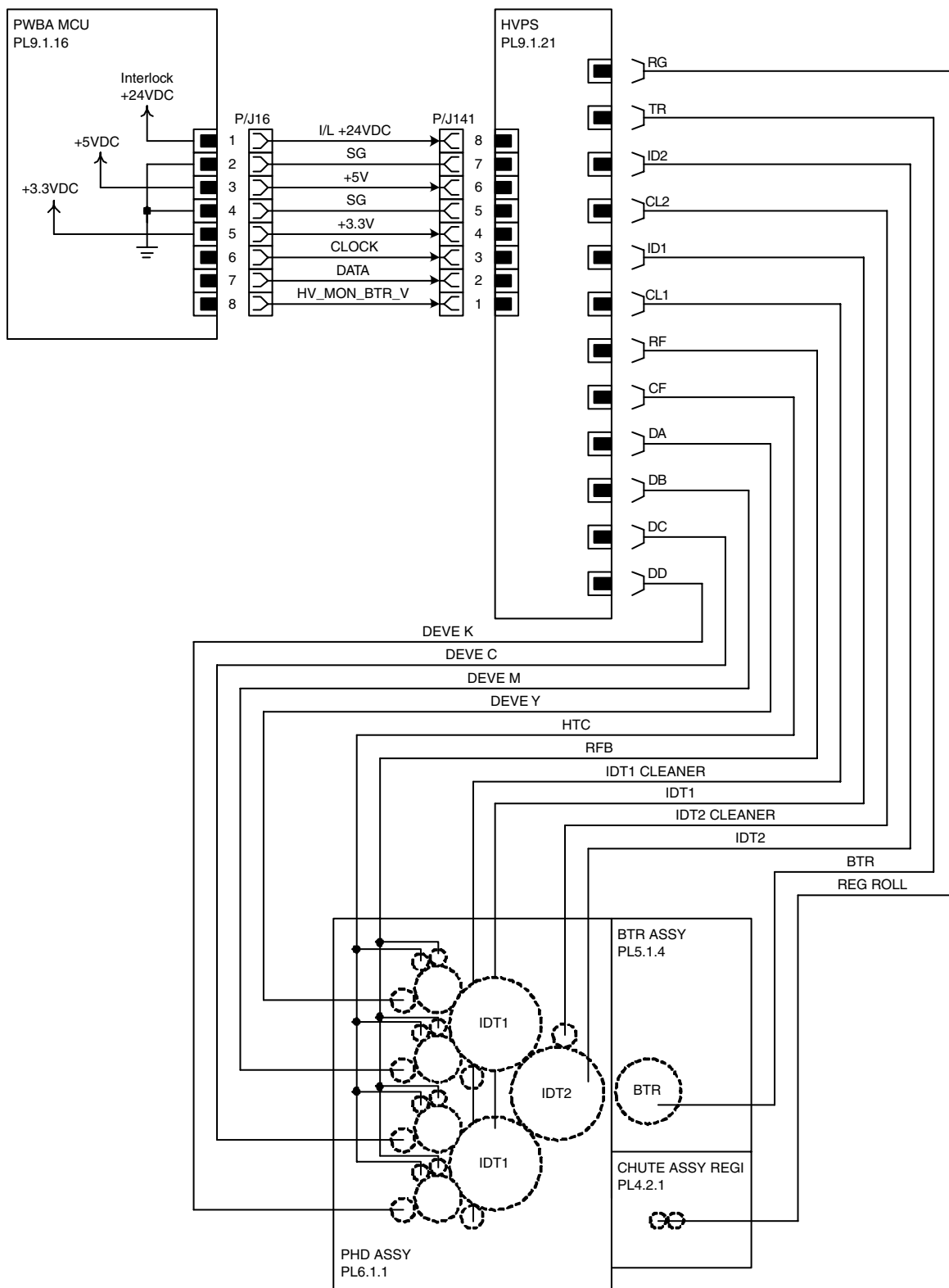

Ten\_Sec007\_010FA

Signal line name	Description
CLOCK	Control signal for capturing data sent from PWBA MCU in HVPS.
DATA	Control signal for output value and output timing for HVPS.
HV_MONI_BTR_V	Voltage monitor signal of BTR output (analog value)
IDT2	Secondary transfer output from HVPS in PWBA MCU to IDT2
IDT2CLEANER	Output from HVPS in PWBA MCU to IDT2 Cleaner
IDT1	Primary transfer output from HVPS in PWBA MCU to IDT1
IDT1 CLEANER	Output from HVPS in PWBA MCU to IDT1 Cleaner
RFB	Output from HVPS in PWBA MCU to Refresher
HTC	Charging output from HVPS in PWBA MCU to HTC
DEVE Y	Output from HVPS in PWBA MCU to Developer Y(Magnet Roll)
DEVE M	Output from HVPS in PWBA MCU to Developer M(Magnet Roll)
DEVE C	Output from HVPS in PWBA MCU to Developer C(Magnet Roll)
DEVE K	Output from HVPS in PWBA MCU to Developer K(Magnet Roll)
BTR	Third transfer output from HVPS to BTR in BTR ASSY
REGI ROLL	Third transfer output from HVPS to REGI ROLL

§ 10 Paper feed section

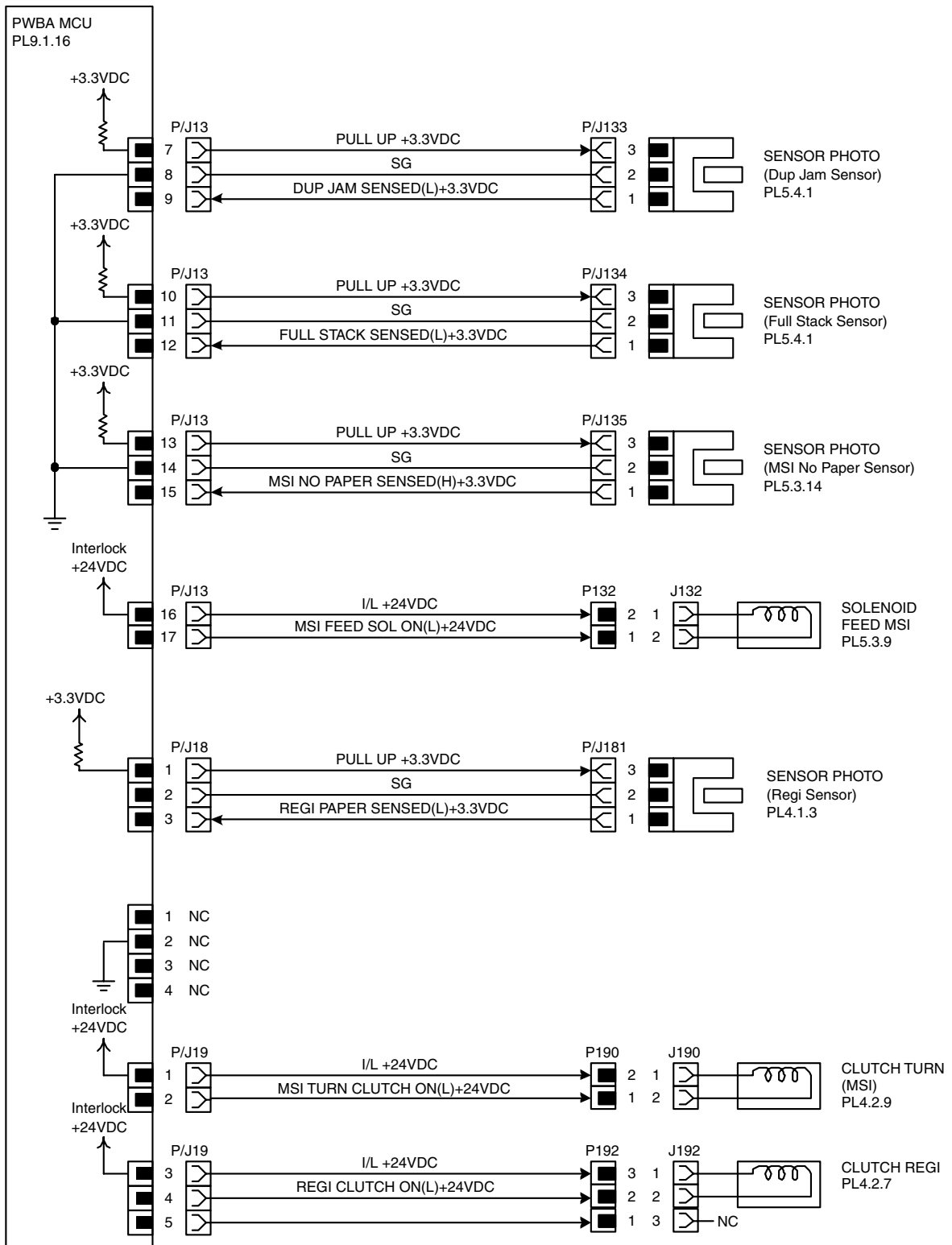

Ten\_Sec007\_011FA

Signal line name	Description
DUP JAM SENSED(H)+3.3VDC	Paper detection signal in Duplex section by SENSOR PHOTO (Dup Jam Sensor) (High:paper present)
FULL STACK SENSED(L)+3.3VDC	Full Stack detection signal in paper output tray by SENSOR PHOTO (Full Stack Sensor) (LOW:full)
MSI NO PAPER SENSED(H)+3.3VDC	Paper detection signal in MSI by SENSOR PHOTO (MSI No Sensor) (High:no paper)
MSI FEED SOL ON(L)+24VDC	SOLENOID FEED MSI ON/OFF control signal
REGI PAPER SENSED(L)+3.3VDC	Paper detection signal in Regi section by SENSOR PHOTO (Regi Sensor)
REGI CLUTCH ON(L)+24VDC	ON/OFF control signal of Regi Clutch in CHUTE REGI ASSY
MSI TURN CLUTCH ON(L)+24VDC	CLUTCH TURN (MSI) ON/OFF control signal



§ 11 Controller section

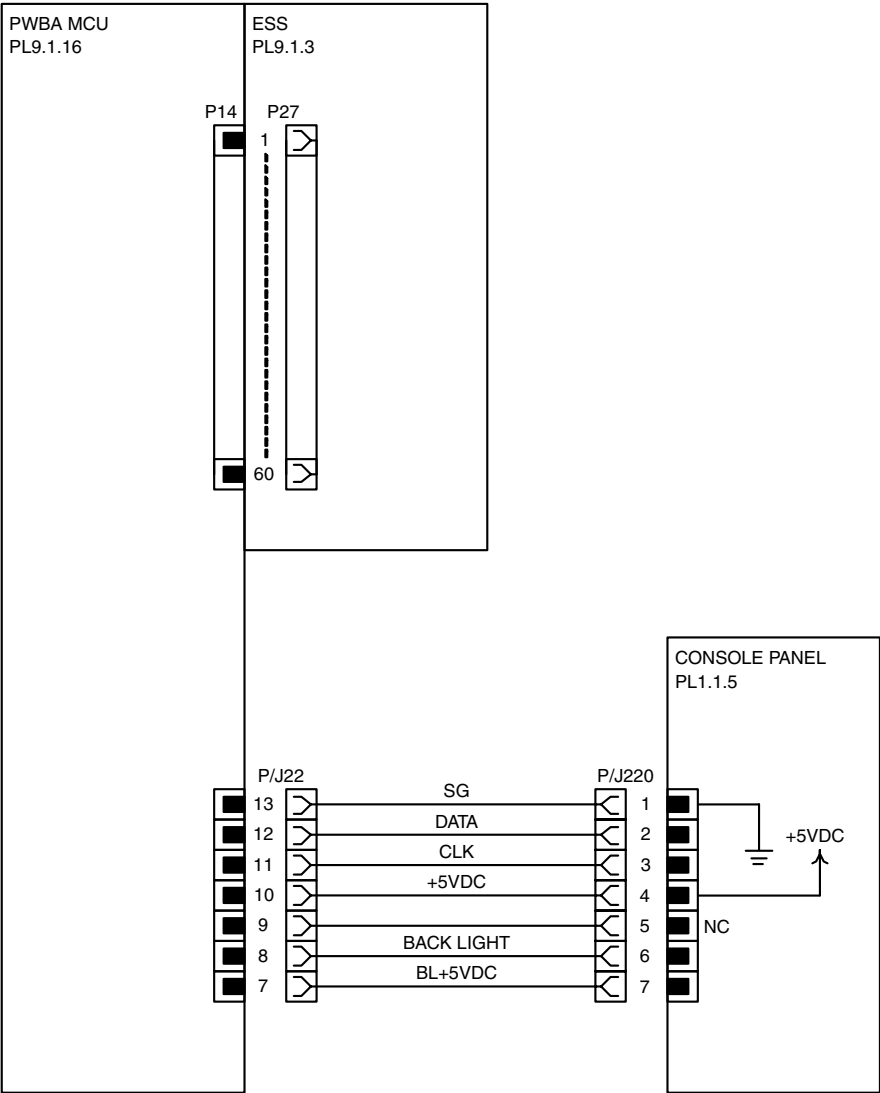

Ten\_Sec007\_012FA

<b>Signal line name</b>	<b>Description</b>
DATA	Data signal
CLK	Signal for allowing control panel to capture transmitted data
BACK LITE	LCD backlight power save signal
BL +5VDC	Power source for backlight

## Chapter 8 Printer Specifications CONTENTS

---

1. Configuration of Printer.....	8 - 1
1.1 Basic Configuration.....	8 - 1
1.2 Functional Configuration.....	8 - 1
2. Electrical Properties.....	8 - 2
2.1 Power Source.....	8 - 2
2.2 Power Consumption.....	8 - 2
3. Mechanical Properties.....	8 - 3
3.1 Dimensions/Mass of Printer.....	8 - 3
3.2 Dimensions/Mass of Universal Paper Tray (standard paper supply - 500 sheets).....	8 - 3
3.3 Dimensions/Mass of Consumables (CRU).....	8 - 4
3.3.1 Imaging Drum (PHD) cartridge.....	8 - 4
3.3.2 Transfer roll (BTR) cartridge.....	8 - 4
3.3.3 Black toner cartridge.....	8 - 4
3.3.4 Yellow toner cartridge.....	8 - 4
3.3.5 Magenta toner cartridge.....	8 - 4
3.3.6 Cyan toner cartridge.....	8 - 5
3.3.7 Black toner high yield cartridge.....	8 - 5
3.3.8 Yellow toner high yield cartridge.....	8 - 5
3.3.9 Magenta toner high yield cartridge.....	8 - 5
3.3.10 Cyan toner high yield cartridge.....	8 - 5
3.4 Installation Space (min. installation space).....	8 - 6
4. Functions.....	8 - 7
4.1 Recording System.....	8 - 7
4.2 Exposure System.....	8 - 7
4.3 Development System.....	8 - 7
4.4 Fixing System.....	8 - 7
4.5 Resolution.....	8 - 7
4.6 Operation Mode.....	8 - 7
4.7 Process Speed.....	8 - 8
4.8 Print Mode.....	8 - 8
4.9 Paper Mode.....	8 - 9
4.10 Warm-up Time.....	8 - 9
4.11 FPOT (First Print Output Time).....	8 - 10
4.12 Continuous Printing Speed.....	8 - 11
4.13 Printing Area.....	8 - 12
4.13.1 Usable paper size.....	8 - 12
4.13.2 Maximum printable area.....	8 - 12
4.13.3 Guaranteed printing area.....	8 - 12
4.14 Input Properties.....	8 - 13
4.14.1 Paper pick-up system.....	8 - 13
4.14.2 Paper pick-up capacity.....	8 - 13
4.15 Output Properties.....	8 - 14
4.15.1 Paper delivery system.....	8 - 14
4.15.2 Paper delivery capacity.....	8 - 14
4.15.3 Delivery paper size/mass.....	8 - 14

## Chapter 8 Printer Specifications CONTENTS

---

4.15.4 Full stack detection .....	8 - 14
4.16 Paper .....	8 - 15
4.16.1 Paper type .....	8 - 15
4.16.2 Paper mass .....	8 - 15
4.16.3 Paper size .....	8 - 15
5. Consumables.....	8 - 16
5.1 Items of Consumables .....	8 - 16
5.2 Consumable Life .....	8 - 16
6. Operating Environment.....	8 - 17
6.1 Installation Temperature / Humidity .....	8 - 17
6.2 Installation Altitude .....	8 - 17
6.3 Installation Horizontality .....	8 - 17
6.4 Ambient Lighting .....	8 - 17
7. Safety / Environment Conditions .....	8 - 18
7.1 Safety Standard .....	8 - 18
7.2 Laser Safety Standard .....	8 - 18
7.3 EMI.....	8 - 18
7.4 Noise.....	8 - 18
8. Print image Quality .....	8 - 19
8.1 Image Quality Guarantee Conditions.....	8 - 19
8.1.1 Environmental conditions.....	8 - 19
8.1.2 Guaranteed paper.....	8 - 19
8.1.3 Paper condition .....	8 - 19
8.1.4 Printer condition.....	8 - 19
8.1.5 Image quality guaranteed area .....	8 - 19
8.1.6 Criterion .....	8 - 19
8.1.7 Print mode and resolution.....	8 - 19
9. Option .....	8 - 20
9.1 Options to be Installed by Users .....	8 - 20
10. Controller Specifications.....	8 - 21
10.1 External Interface .....	8 - 21
10.2 Network Protocol.....	8 - 22
10.3 Decomposer.....	8 - 24
10.4 Job Control.....	8 - 25
10.5 Log Function .....	8 - 26
10.6 ID Print .....	8 - 27
10.7 Non-Genuine Mode.....	8 - 27
10.8 Maintenance .....	8 - 27
10.9 Power Saver .....	8 - 28
10.10 Utility Print.....	8 - 29
10.11 EWS.....	8 - 30
10.12 Status Messenger .....	8 - 30

## 1. Configuration of Printer

### 1.1 Basic Configuration

This printer basically consists of the print engine main unit, consumables (CRU), and standard universal paper tray (500 sheets).

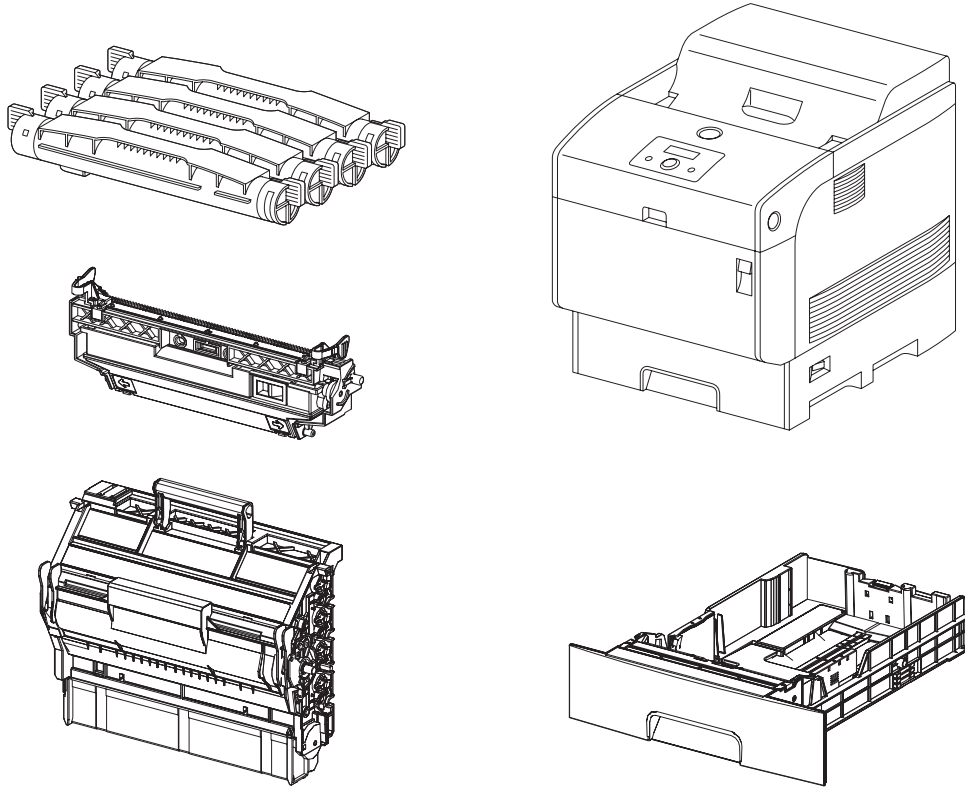

Ten08001KA

### 1.2 Functional Configuration

Functional configuration of this printer is shown below.

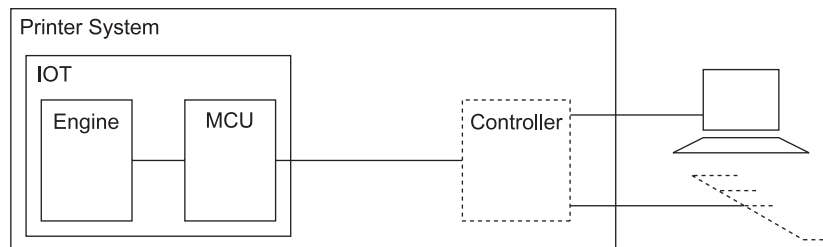

Ten08014KA

## 2. Electrical Properties

### 2.1 Power Source

Two types of power source as follows are available for this printer, which are selected according to the specifications.

- ◆ 100V/127V printer: ..... Voltage: 100-127VAC  $\pm 10\%$  (90 ~ 140V), frequency: 50/60Hz  $\pm 3$ Hz
- ◆ 220/240V printer: ..... voltage: 220-240VAC  $\pm 10\%$  (198 ~ 264V), frequency: 50/60Hz  $\pm 3$ Hz

### 2.2 Power Consumption

Power consumption in each operation mode at rated voltage input

Operation mode	Power Consumption
Printing mode	600 W or less (B&W) 550 W or less (Full Color)
READY mode	120 W or less
Power Save mode *1	45 W or less

\*1 Energy Star support mode (Ros and Fan are placed in the stop mode)

### 3. Mechanical Properties

#### 3.1 Dimensions/Mass of Printer

- Width: 429mm  $\pm$  1%
- Depth: 580mm  $\pm$  1%
- Height: 497mm  $\pm$  1%
- Mass: 34.6kg or less (except paper)

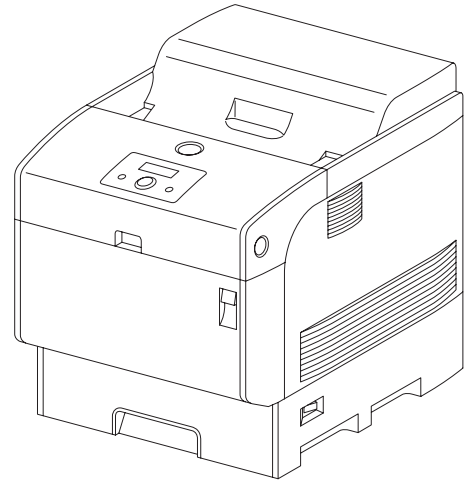

Ten08003KA

#### 3.2 Dimensions/Mass of Universal Paper Tray (standard paper supply - 500 sheets)

- Width: 429mm  $\pm$  1%
- Depth: 509mm  $\pm$  1%
- Height: 127mm  $\pm$  1%
- Mass: 6.3kg or less (except paper)

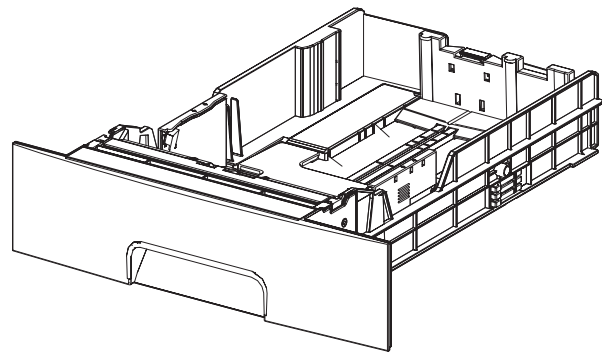

Ida\_Sec08\_004FA

### 3.3 Dimensions/Mass of Consumables (CRU)

#### 3.3.1 Imaging Drum (PHD) cartridge

Width: 328mm ± 3mm  
 Depth: 113mm ± 3mm  
 Height: 244mm ± 3mm  
 Mass: 3.2kg ± 0.1kg

**Reference:** *The Imaging Drum cartridge has CRUM (CRU memory) to record information.*

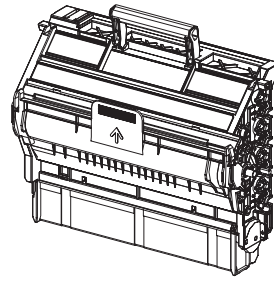

Ida\_Sec08\_005FA

#### 3.3.2 Transfer roll (BTR) cartridge

Width: 290mm ± 3mm  
 Depth: 54mm ± 3mm  
 Height: 97mm ± 3mm  
 Mass: 0.52kg ± 0.01kg

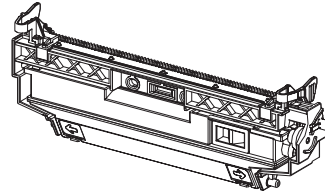

Ida\_Sec08\_006FA

#### 3.3.3 Black toner cartridge

Width: 355mm ± 3mm  
 Depth: 51mm ± 3mm  
 Height: 55mm ± 3mm  
 Mass: 0.38kg ± 0.01kg

**Reference:** *The black toner cartridge has CRUM (CRU memory) to record information.*

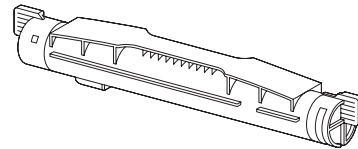

Ida\_Sec08\_007FA

#### 3.3.4 Yellow toner cartridge

Width: 355mm ± 3mm  
 Depth: 51mm ± 3mm  
 Height: 55mm ± 3mm  
 Mass: 0.35kg ± 0.01kg

**Reference:** *The yellow toner cartridge has CRUM (CRU memory) to record information.*

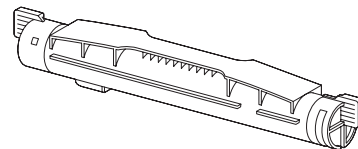

Ida\_Sec08\_007FA

#### 3.3.5 Magenta toner cartridge

Width: 355mm ± 3mm  
 Depth: 51mm ± 3mm  
 Height: 55mm ± 3mm  
 Mass: 0.36kg ± 0.01kg

**Reference:** *The magenta toner cartridge has CRUM (CRU memory) to record information.*

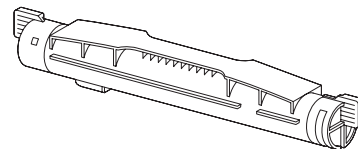

Ida\_Sec08\_007FA



**3.3.6 Cyan toner cartridge**

Width: 355mm ± 3mm  
 Depth: 51mm ± 3mm  
 Height: 55mm ± 3mm  
 Mass: 0.36kg ± 0.01kg

**Reference:** *The cyan toner cartridge has CRUM (CRU memory) to record information.*

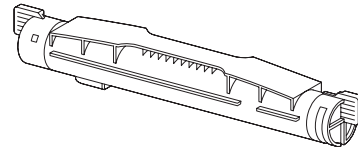

Ida\_Sec08\_007FA

**3.3.7 Black toner high yield cartridge**

Width: 355mm ± 3mm  
 Depth: 51mm ± 3mm  
 Height: 109.5mm ± 3mm  
 Mass: 0.485kg ± 0.01kg

**Reference:** *The black toner high yield cartridge has CRUM (CRU memory) to record information.*

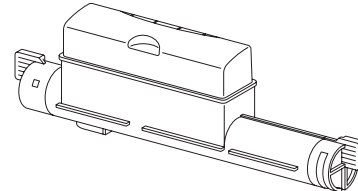

Ten08013KA

**3.3.8 Yellow toner high yield cartridge**

Width: 355mm ± 3mm  
 Depth: 51mm ± 3mm  
 Height: 93.5mm ± 3mm  
 Mass: 0.3522kg ± 0.01kg

**Reference:** *The yellow toner high yield cartridge has CRUM (CRU memory) to record information.*

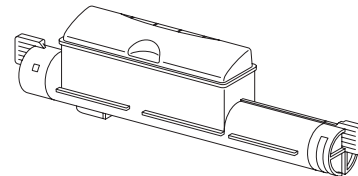

Ten08012KA

**3.3.9 Magenta toner high yield cartridge**

Width: 355mm ± 3mm  
 Depth: 51mm ± 3mm  
 Height: 93.5mm ± 3mm  
 Mass: 0.3995kg ± 0.01kg

**Reference:** *The magenta toner high yield cartridge has CRUM (CRU memory) to record information.*

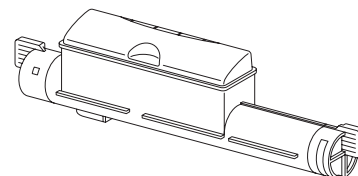

Ten08012KA

**3.3.10 Cyan toner high yield cartridge**

Width: 355mm ± 3mm  
 Depth: 51mm ± 3mm  
 Height: 93.5mm ± 3mm  
 Mass: 0.3905kg ± 0.01kg

**Reference:** *The cyan toner high yield cartridge has CRUM (CRU memory) to record information.*

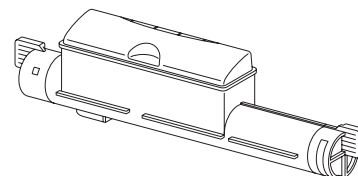

Ten08012KA

### 3.4 Installation Space (min. installation space)

Minimum space as shown below is required to install the printer when it is used for normal objects.  
 (Space occupied by the operator is not included.)

#### Top view

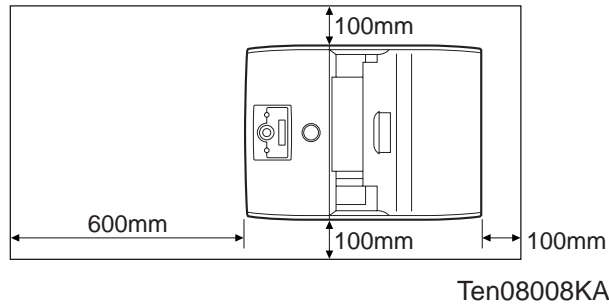

#### Front view

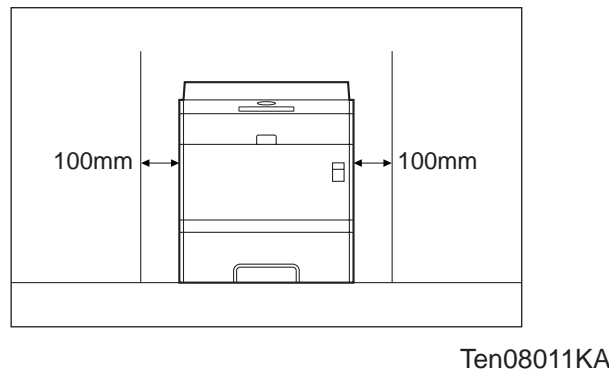

#### Side view

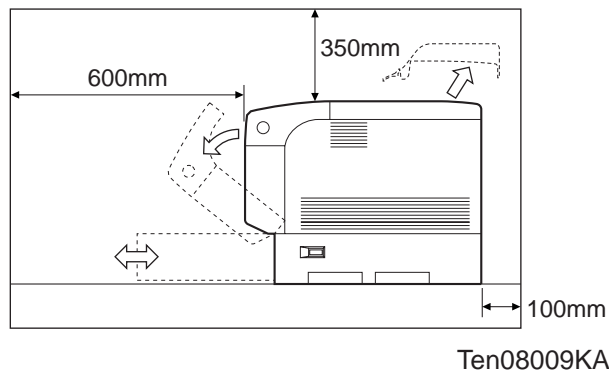

## 4. Functions

### 4.1 Recording System

4-tandem cartridges , electro-photographic system using intermediate transfer rolls

### 4.2 Exposure System

Semiconductor laser, simultaneous scanning by 4 beams

### 4.3 Development System

Development with dry type 2-component developer

### 4.4 Fixing System

Heat fusing of the free belt nip system

### 4.5 Resolution

Two types of resolutions can be switched. Printing speed is halved at sub scanning direction

- ◆ Main scanning direction: Resolution is determined by the video signal coming from the controller.
- ◆ Sub scanning direction: 600 dots/25.4mm (fixed) (B/W full speed / Color full speed / Medium speed / Low speed)

### 4.6 Operation Mode

The printer can be operated in either of 2 operation modes. The modes are switched over by command from the printer controller or change of printer operation, etc.

#### ◆ Running mode

State in running or recording operation

Fixing system: Held at operating temperature.

Exposure system: Operating status

Recording system: Operating status

Front fan: Operating status

Rear fan: Operating status

#### ◆ Ready mode

Ready state

Fixing system: Pause status \*1

Exposure system: Pause status \*2

Recording system: Pause status

Front fan: Pause status/Operating status

Rear fan: Pause status/Operating status \*3

\*1: It can be changed to ready temperature status by a command from a controller.

(However, it needs to be back in a stop status within 1 hour.)

\*2: It can be changed to the operating status by a command from a controller.

\*3: Fan status is changed depending on the state (temperature, etc.) of the fixing system.

## 4.7 Process Speed

The printer prints by switching four levels, B/W full speed (264mm/s), Color full speed (225mm/s), Color / B/W medium speed (132mm/s), and Color/B/W low speed (88mm/s).The controller cannot instruct to change the process speed.

## 4.8 Print Mode

The printer has the following six different print modes.

< B/W >

- (1) B/W full speed mode : Under the mode, the printer prints out data at the highest processing speed prepared for black and white printing. This mode is employed for printing on plain paper of less than 105 gsm.
- (2) B/W medium speed mode : The mode is employed for printing on plain paper, heavy-weight paper and special-purpose paper of more than 64gsm (17lb) and equal to or less than 163gsm.
- (3) B/W low speed mode : The mode is employed for printing on heavy-weight paper and special-purpose paper of more than 106gsm (28lb).

< F/C >

- (4) Color full speed mode : Under the mode, the printer prints out data at the highest processing speed prepared for color printing. This mode is employed for printing on plain paper of less than 105 gsm.
- (5) Color medium speed mode : The mode is employed for printing on plain paper, heavy-weight paper and special-purpose paper of more than 64 gsm (17lb) and equal to or less than 163 gsm.
- (6) Color low speed mode : The mode is employed for printing on heavy-weight paper and special-purpose paper of more than 106gsm (28lb).

## 4.9 Paper Mode

8 paper modes are available for this printer. Modes are switched over under the instruction from the controller.

Classification of paper mode

- (1) Plain paper-L mode : Plain paper such as FX-P, R, J/JD (for Japanese) whose thickness is 60-80 gsm.
- (2) Plain paper-H mode : Plain paper such as XC-4200 20lb, 24lbs RX-80, 90 (for overseas) whose thickness is 65-105 gsm.
- (3) Plain paper-H' mode : Plain paper such as XC-4200 20lb, 24lbs RX-80, 90 (for overseas) whose thickness is 24lb-28lb.
- (4) Thick paper-L mode : it is selected to run on the papers whose thickness is 106-163 gsm.
- (5) Thick paper-H mode : It is selected to run on the papers whose thickness is 164-216 gsm.
- (6) Label-L mode : It is mainly selected to run on Japanese labels (V860 etc.).
- (7) Label-H mode : It is mainly selected to run on labels (3R4469 etc.).
- (8) OHP mode : It is selected to run on OHPs (V516 etc).
- (9) Envelop mode : It is selected to run on envelopes.
- (10) Postcard mode : It is selected to run on postcards.
- (11) Coated paper-L mode : It is selected to run on the coated papers whose thickness is 60-105 gsm.
- (12) Coated paper-H mode : It is selected to run on the coated papers whose thickness is 106-163 gsm.
- (13) Coated paper-H' mode : It is selected to run on the coated papers whose thickness is 164-216 gsm.

Relation between the resolution, process speed, print mode and paper mode is shown in the table below.

Correspondence media mode		Process direction resolution/ Process speed	
		B/W	Color
	Print mode	600dpi	600dpi
Plain paper (1)	B/W full speed mode	264mm/s	-
	Color full speed mode	-	225mm/s
	Color / B/W medium speed mode	132mm/s	132mm/s
Thick/Special paper (2) - (13)	Color / B/W low speed mode	88mm/s	88mm/s

## 4.10 Warm-up Time

When the nominal voltage (100 V, 120 V or 220 V) is applied, the FUSER standby temperature should be reached within the time stated below.

- From the moment of POWER ON to the start of Standby mode: 10 seconds or less
- When a mode change command is received from IOT during the Power Save mode: 35 seconds or less

**Reference:** *Excluding the period of time required to adjust the color registration.*

#### 4.11 FPOT (First Print Output Time)

FPOT of the printer is shown in the table below.

The time required for the first sheet of paper to be delivered after the START command is given is calculated on the following conditions (rounded to one decimal place).

- IOT performance that the controller does not have IOT wait.
- IOT is in the two Standby modes
  - ROS Motor Ready (at operating) and Fuser Ready temperature: ROS RDY mode
  - ROS Motor Off (at stopping) and Fuser Ready temperature: ROS OFF mode
- Paper is A4/Letter SEF.
- Except when process control is operating

##### Simplex Printing

Process speed	FPOT (sec)			
	MPF		Tray 1 (Standard)	
	ROS RDY	ROS OFF	ROS RDY	ROS OFF
B/W full speed mode	5.1	9.6	5.4	9.9
Color full speed mode	5.7	10.2	6.0	10.5
Medium speed mode	8.7	14.5	9.2	15.0
Low speed mode	12.5	18.8	13.2	19.5

Process speed	FPOT (sec)					
	Tray 2 (Option Feeder)		Tray 3 (Option Feeder)		Tray 4 (Option Feeder)	
	ROS RDY	ROS OFF	ROS RDY	ROS OFF	ROS RDY	ROS OFF
B/W full speed mode	5.9	10.4	6.4	10.9	6.9	11.4
Color full speed mode	6.6	11.1	7.2	11.7	7.8	12.3
Medium speed mode	10.2	16.0	11.2	17.0	12.2	18.0
Low speed mode	14.7	21.0	16.2	22.5	17.6	23.9

##### Duplex Printing

Process speed	FPOT (sec)			
	MPF		Tray 1 (Standard)	
	ROS RDY	ROS OFF	ROS RDY	ROS OFF
B/W full speed mode	8.5	13.0	8.8	13.3
Color full speed mode	9.7	14.2	10.0	14.5
Medium speed mode	14.7	21.5	15.2	22.0
Low speed mode	21.0	29.3	21.7	30.0

Process speed	FPOT (sec)					
	Tray 2 (Option Feeder)		Tray 3 (Option Feeder)		Tray 4 (Option Feeder)	
	ROS RDY	ROS OFF	ROS RDY	ROS OFF	ROS RDY	ROS OFF
B/W full speed mode	9.3	13.8	9.8	14.3	10.3	14.8
Color full speed mode	10.6	15.1	11.2	15.7	11.8	16.3
Medium speed mode	16.2	23.0	17.2	24.0	18.2	25.0
Low speed mode	23.2	31.5	24.7	33.0	26.1	34.4

## 4.12 Continuous Printing Speed

Assuming the time until the trailing end of the 11th sheet is discharged after the trail end of the 1st sheet is discharged as  $t$  seconds, number of printed sheets for a minute given by the equation  $[60/t \times 10]$  is shown in the table below, excluding, however, the time for which the process control is working is not contained.

NOTE

This performance capability is provided as an IOT performance which works in the case where the controller did not keep IOT waiting.

In addition, all of the Tray 1 feeder, MSI feeder, optional single 500-sheet feeder and optional double 500-sheet feeder satisfy the following performance values.

**Reference:** Unit "PPM" stands for "prints per minute" indicating number of prints per minute.

"ipm" is abbreviation of "Impression Per Min", and indicates "number of printed sides per minute" for Duplex.

Print mode		Letter SEF *1		A4 SEF	
		Simplex	Duplex	Simplex	Duplex
		(ppm)	(ipm)*2	(ppm)	(ipm)*2
B/W	Full speed mode	42.0	24.5	40.0	24.0
	Medium speed mode	21.0	13.5	20.0	13.1
	Low speed mode	14.0	9.2	13.3	8.9
Color	Full speed mode	36.6	21.3	35.0	20.8
	Medium speed mode	21.0	13.5	20.0	13.1
	Low speed mode	14.0	9.2	13.3	8.9

\*1 Depending on paper size (small size), print speed might slow down.

\*2 ipm (impression per minutes): For Duplex printing, ipm is determined with print speed at each side.

## 4.13 Printing Area

### 4.13.1 Usable paper size

Minimum and maximum paper size usable for this printer are as follows:

Minimum usable paper size: Width 88.9mm (3.5inch) × length 139.7mm (5.5 inch)  
(when using MSI)

Maximum usable paper size: Width 220mm (8.66 inch) × length 355.6mm (14 inch)  
(when using MSI).

### 4.13.2 Maximum printable area

For each printable size of paper, this printer masks 2.5mm within the left edge and right edge, 2.0mm from within edge and back edge as unprintable area, in order to prevent from that images exceed the size of printable area.

Maximum area where image can be printed is as follows:

Width: 210.9mm (8.3 inch) × length: 351.6mm (13.8 inch)

### 4.13.3 Guaranteed printing area

Area for which the image quality is guaranteed as follows:

Area except for 4mm (0.1575 inch) from edges of the paper.

Maximum area for which the image quality is guaranteed as follows:

Width: 207.9mm (8.2 inch) × length: 347.6mm (13.7 inch)

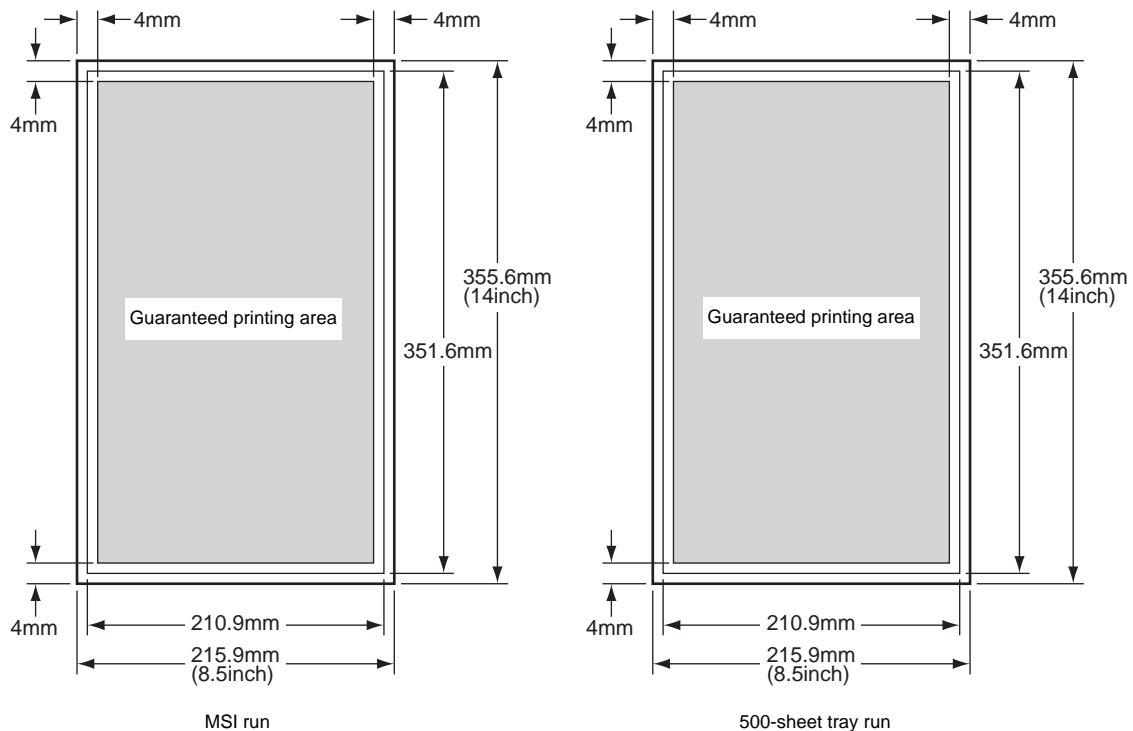

Ten08015KA



## 4.14 Input Properties

### 4.14.1 Paper pick-up system

- ◆ Paper pick-up with paper tray  
Feeding method of this printer is ARRF method.
  
- ◆ MSI paper pick-up  
The MSI (Multi Sheet Inserter) is equipped as standard. Selection of MSI is designated from the controller.
  
- ◆ Duplex paper feeder unit  
This unit is equipped as standard to enable the printing on duplex of paper. Selection of Duplex Feeder Unit is designated from the controller.

### 4.14.2 Paper pick-up capacity

- ◆ Paper pick-up with paper tray  
500 sheets or below 61mm of standard paper
  
- ◆ MSI paper pick-up  
150 sheets or below 15mm of standard paper

## **4.15 Output Properties**

### **4.15.1 Paper delivery system**

Paper can be delivered by the following method.

- ◆ FACE DOWN delivery

### **4.15.2 Paper delivery capacity**

- ◆ FACE DOWN delivery  
250 sheets (Letter/A4 standard paper)

### **4.15.3 Delivery paper size/mass**

- ◆ FACE DOWN delivery  
All paper sizes applicable to this printer

### **4.15.4 Full stack detection**

- ◆ Height of paper to be fed  
Detect when the height reached about 36mm.

## 4.16 Paper

### 4.16.1 Paper type

Paper which can be used with this printer is classified into standard paper, general paper and special paper.

◆ Standard paper

Using this type of paper is recommended. Reliability, operability and print image quality are the application range of the specifications.

Following paper is the standard paper.

- \* Xerox 4200 DP 20lb
- \* Xerox premier 80gsm

◆ General paper

General paper is plain paper except standard paper and special paper, and its reliability and running performance are within the specification, but the print image quality is out of the specification.

◆ Special paper

Special paper except for standard paper and general paper. Reliability and operability are the applicable range of specifications but the print image quality is out of the applicable range of specifications.

### 4.16.2 Paper mass

- ◆ Paper feed from paper tray  
"60 to 163 gsm" (16 - 43 lb)
- ◆ Paper feed from MSI  
"60 to 216 gsm" (16 - 58 lb)

### 4.16.3 Paper size

Paper size which can be set to each paper pick-up unit is shown in the table below.

Cassette	Paper size
500 Sheet Paper Universal Tray	A4-SEF B5(JIS)-SEF A5-SEF EXECUTIVE-SEF LETTER-SEF LEGAL(13")-SEF LEGAL(14")-SEF
MSI Tray	Minimum size Width 88.9mm(3.5inch)×Length139.7mm(5.5inch) Maximum size Width 220mm(8.66inch)×Length 355.6mm(14inch)

## 5. Consumables

Consumables are usually replaced by costumers. In the event of recovery of failure attributable to consumables or isolation of failure, you may replace them.

### 5.1 Items of Consumables

- ◆ Imaging Drum (PHD) cartridge  
Composed of photosensitive medium, intermediate transfer roll, etc.
- ◆ Transfer roll (BTR) cartridge  
Composed of BTR, waste toner collection box, etc.
- ◆ Black toner cartridge  
Cartridge to supply black toner to the development unit.
- ◆ Yellow toner cartridge  
Cartridge to supply yellow toner to the development unit.
- ◆ Magenta toner cartridge  
Cartridge to supply magenta toner to the development unit.
- ◆ Cyan toner cartridge  
Cartridge to supply cyan toner to the development unit.

### 5.2 Consumable Life

- ◆ Imaging Drum (PHD) cartridge: equivalent to about 35,000 prints
- ◆ Transfer roll (BTR) cartridge: equivalent to about 35,000 prints
- ◆ Black toner cartridge: equivalent to about 9,000 prints
- ◆ Yellow toner cartridge: equivalent to about 8,000 prints
- ◆ Magenta toner cartridge: equivalent to about 8,000 prints
- ◆ Cyan toner cartridge: equivalent to about 8,000 prints

## **6. Operating Environment**

### **6.1 Installation Temperature / Humidity**

Installation temperature and humidity on the condition without condensation is as follows.

At operating: from 5 to 32 °C, 15-85%RH

At stopping: minus from -20 to 40 °C, 5-85%RH

### **6.2 Installation Altitude**

0 to 3,100m

### **6.3 Installation Horizontality**

Longitudinal levelness of table surface on which the printer is installed: 10 mm or less

Lateral levelness of table surface on which the printer is installed: 5 mm or less

### **6.4 Ambient Lighting**

3000 Lux or less (without no direct sun beams)

## 7. Safety / Environment Conditions

### 7.1 Safety Standard

- ◆ 100V / 127V system
  - UL60950-1 1st Edition
  - CSA C22.2 No.60950-1-03 1st Edition
- ◆ 220V / 240V system
  - IEC60950-1 :2001
  - UL60950-1 :2001

### 7.2 Laser Safety Standard

- ◆ 100V / 127V system
  - FDA21CFR Chapter 1, Subchapter J, Section 1010, 1040
- ◆ 220V / 240V system
  - IEC60825-1 2 Class1 Laser Product

### 7.3 EMI

- ◆ 100V system (JPN)
  - VCCI Class B
- ◆ 120V system (US)
  - FCC Part 15, Subpart B, Class B (ANSI C63.4)
- ◆ 220V / 240V system (EC)
  - EN55022 (CISPR Publication 22), Class B

### 7.4 Noise

Noise of printing is as follows.

<Printer (Simplex/Duplex)>

Print mode	Noise level (B)	Impulsive Noise level (B)
Standby	≤ 5.0	-
B/W full speed mode	≤ 6.65	≤ 5.5
Color full speed mode	≤ 6.65	≤ 5.5
Medium speed mode	≤ 6.35	≤ 5.1
Low speed mode	≤ 6.25	≤ 5.1

<Printe, One Tray Feeder and Two Tray Feeder>

Print mode	Noise level (B)	Impulsive Noise level (B)
Standby	≤ 5.0	-
B/W full speed mode	≤ 7.35	≤ 5.6
Color full speed mode	≤ 7.35	≤ 5.6
Medium speed mode	≤ 7.30	≤ 5.4
Low speed mode	≤ 7.30	≤ 5.4

## 8. Print image Quality

### 8.1 Image Quality Guarantee Conditions

The image quality is specified and guaranteed under the following conditions.

#### 8.1.1 Environmental conditions

Environment condition for general office

Temperature: 15-28 °C

Humidity: 20-70%RH

#### 8.1.2 Guaranteed paper

The print image quality specified here is guaranteed with standard paper fed from the paper tray.

The evaluation is performed with paper.

Color print: 4200 DP

B/W print: 4200 DP

#### 8.1.3 Paper condition

The paper used is fresh paper immediately after unpacked, which has been left in the operating environment for 12 hours before unpacking.

#### 8.1.4 Printer condition

The print image quality specified in this section is guaranteed with the printer in normal condition.

#### 8.1.5 Image quality guaranteed area

The print image quality specified in this section is guaranteed in the guaranteed image quality area specified in this manual.

#### 8.1.6 Criterion

The print image quality is guaranteed with the Spec. In rate = 90% ( $\gamma = 90\%$ ).

#### 8.1.7 Print mode and resolution

The print image quality specified here is guaranteed with full speed print mode and 600dpi.

## 9. Option

### 9.1 Options to be Installed by Users

Users can install the following 2 types of units.

- ◆ 1000 sheet Tray Module  
500 sheets × 2 feeder units (with 500 sheet universal cassette × 2)
- ◆ 500 sheet Tray Module  
500 sheets × 1 feeder unit (with 500 sheet universal cassette × 1)
- ◆ Hard Disk Unit
- ◆ Expansion Memory  
256 MB Memory
- ◆ Expansion Memory  
512 MB Memory
- ◆ Expansion Memory  
1024 MB Memory
- ◆ Multi-protocol Card
- ◆ Wireless LAN Adapter  
Multi-protocol Card is required when installing a wireless LAN adapter.



## 10. Controller Specifications

### 10.1 External Interface

#### 1) USB

Item	Specifications
Connector	Type-B x 1
Protocol	USB 2.0 High Speed
Support Client	Windows NT4.0/2000/XP/x64XP/2003 Server/x64Server 2003 PC with USB Mac OS X, PC with USB Linux PC with USB

\*1: Supports after Windows98SE

#### 2) IEEE1284

Item	Specifications
Connector	Centronics 36pin x 1
Protocol	Standard, Nibble, ECP
Support Client	Windows NT4.0/2000/XP/x64XP/Server 2003/x64Server 2003 PC Linux PC

#### 3) Ethernet

Item	Specifications
Connection	10Base-T/100Base-TX
Protocol	Refer to 10.2 Network Protocol for details
Support Client	Windows NT4.0/2000/XP/x64XP/Server 2003/x64 Server 2003 PC Mac OS X Linux/Unix PC

#### 4) Wireless

When Wireless LAN Adapter is installed, the Multi-protocol Card is required.

Item	Specifications
Connection	802.11b/802.11g
Protocol	Refer to 10.2 Network Protocol for details
Support Client	Windows NT4.0/2000/XP/x64XP/Server 2003/x64 Server 2003 PC Windows XP/x64XP: Support in Ad-hoc mode Mac OS X Linux PC

## 10.2 Network Protocol

### 1) Printing Protocol

The Printing Protocol is shown below.

Protocol	Transport	Maximum Session	Supported Client
LPD	TCP/IP	1	Windows NT4.0/2000/XP/x64XP/Server 2003/x64Server 2003 Linux <sup>*4</sup> Unix <sup>*4</sup>
Port9100	TCP/IP	1	Windows NT4.0/2000/XP/x64XP/Server 2003/x64Server 2003 Linux <sup>*4</sup>
IPP <sup>*1</sup>	TCP/IP	5	Windows NT4.0/2000/XP/x64XP/Server 2003/x64Server 2003 Mac OS X 10.3
SMB <sup>*1</sup>	TCP/IP	5	Windows NT4.0/2000/XP/x64XP/Server 2003/x64Server 2003
	NetBEUI	5	Windows NT4.0/2000
NetWare (P-Server) <sup>*1</sup>	NCP/IPX	1	NetWare3.12, 3.2(NDS unsupported) NetWare4.1, 4.11, 4.2, 5, 6, 6.5 <sup>*3</sup>
	TCP/IP <sup>*5</sup>		
EtherTalk <sup>*1</sup>	ATP/DDP	1	Mac OS X
FTP	TCP/IP	1	Windows NT4.0/2000/XP/x64XP/Server 2003/x64Server 2003 Unix

\*1: Optional multi-protocol card is required.

\*2: Maximum session is defined as the number of print request acceptable at the same time.

\*3: NetWare 6.5 is required to apply Support Pack 1.1 or later provided by Novell.

\*4: Supported if a driver provided by FXPS is used.

\*5: Available for versions later than NetWare5.

## 2) Other Protocol

Protocol	Transport	Support
SNMP	UDP/IP	[Supported MIB] MIB-II (RFC1213) HostResources MIB (RFC1514) Printer MIB (RFC1759) XCMI2.4
	IPX	
HTTP	TCP/IP	[Client] (Windows NT4.0/2000/XP) Netscape Communicator 7.x or later Internet Explorer 6.0 or later (Mac OS X 10.2 or later) Safari 1.0 or later
DHCP	UDP/IP	[Supported OS] Windows NT4.0 Server/2000 Server/Server 2003/ x64Server 2003, Linux, Unix
BootTP	UDP/IP	[Supported OS] Windows NT4.0 Server/2000 Server/Server 2003/x64 Server 2003, Unix
RARP	TCP/IP	[Supported OS] Unix
AutoIP	TCP/IP	[Software] Installer
WINS* <sup>1</sup>	TCP/IP	[Supported OS] Windows NT4.0 Server/2000 Server/Server 2003/x64 Server 2003
SMTP	TCP/IP	E-mail Alert [Supported Mail Server] LotusNotes, MS-Exchange, Eudora
FTP	TCP/IP	Firmware Update
Bonjour (mDNS)* <sup>1</sup>	UDP/IP	[Supported OS] Mac OS x 10.2 or later
DDNS* <sup>1</sup>	TCP/IP	[Supported OS] Windows 2000 Server/Server 2003/x64 Server 2003, Unix

\*1: Optional multiprotocol card is required.

### 10.3 Decomposer

1) PDL/Emulation

The PDL and emulation functions are shown in the table below.

Interface/Protocol	PDL/Emulation		
	PCL5c	PCL6	PS3
USB	available	available	available
IEEE1284	available	available	available
Lpd	available	available	available
Port9100	available	available	available
IPP	available	available	available
SMB	available	available	available
NetWare (P-server)	available	available	available
EtherTalk (A-PAP)	not available	not available	available
FTP	not available	not available	available

2) Font

81 fonts/36 symbol sets for PCL and 136 fonts for PS3 are available as built-in font.

3) Form Overlay

The function for writing PCL5 forms is supported.

4) Image Area

<b>Usage Area Size</b>	Maximum: 215.9mm x 355.6mm
<b>Unprintable Area</b>	4.1mm each from four edges (left, right, top, bottom) of paper For DL LEF, 6.1mm from left and right edges, 4.1mm from top and bottom edges are not printable.
<b>Printable Area</b>	Maximum: 207.9mm x 347.6mm
<b>Print Image Quality Guaranteed Area</b>	Same as Printable Area

## 10.4 Job Control

1) Cancel Print

A job in process can be canceled at the operation panel.

2) Job Recovery

When a job fails due to a paper jam, the printer automatically restarts the job after the jammed paper is removed.

3) Job Time Out

When job transmission is interrupted for a certain period of time (time can be changed at the operation panel and unlimited time can be selected), the print data is deleted as an error.

4) Secure Print (/Store Print)

When memory is expanded (256MB or more) or HDD is installed, the printer holds the print data, including a user password (12 digits) specified in the printer driver, user name and document name, in memory. The data is not printed until the same password, user name and document name are specified at the printer UI. The user can select whether the data is cleared or not after being printed. The data remains in the printer as long as it is not cleared. The data on the memory is cleared when the printer is turned off. The data on the HDD is not cleared even the printer is turned off. The user can omit entering a password (this is called Store Print).

\* This function is not available for Mac OS X 10.2.8.

5) Proof Print

When memory is expanded (256MB or more) or HDD is installed, proof print can be selected only when multiple sets of prints are specified in the printer driver. The printer prints only the first set of the print data including a user name and document name specified in the printer driver. Then the user can select whether the remaining sets are printed or not (the remaining data is cleared) when the same user name and document name are entered at the printer UI. The data remains in the printer as long as it is not cleared. The data on the memory is cleared when the printer is turned off. The data on the HDD is not cleared even the printer is turned off.

\* This function is not available for Mac OS x 10.2.8 and Linux.

6) IP Filter

The user can select to accept or reject jobs for the specified IP address. Up to 5 IP addresses can be specified.

IP filter is available only to LPD and Port9100.

## 10.5 Log Function

### 1) Job Log Function

The printer can retain up to 22 job logs.

The job log can be printed instantly according to the user's request or automatically printed when the number of the retained job logs has reached 22.

Log details are as follows:

- Job Received Data/Time
- Input interface (USB, Lpd, etc)
- Document Name (File Name)
- Output Color
- User Name/Host Name
- Number of printed pages (Color/B/W)
- Number of printed impressions (Color/B/W)
- Paper Size
- Result (Successful, Error, etc)

### 2) Error Log Function

The printer can retain up to 42 jam errors history and up to 42 fatal errors history.

The user can print error log by the panel operation.

The jam error log includes the following information:

- Total PV when jam has occurred.
- Name of Jam

The fatal error log includes the following information:

- Total PV when error has occurred.
- Error Code

### 3) Print Counter Function

The counter counts the number of completed prints (+1 for 1 Sided prints (including N-Up) and +2 for 2 Sided prints (including N-Up)). +1 if an error occurs during a 2 Sided print after one side has been printed.

Special Notes:

- Carries out data storage or data check (checksum etc.) in more than one address within the same IC.
- The IC can be moved and changed when the ESS is being replaced (the IC socket is mounted).

Counter Type	Counter Details
Color Print Counter	Counts the number of sheets for Color Print (7 digits)
B/W Print Counter	Counts the number of sheets for B/W Print (7 digits)
Total Print Counter	Counts the total number of sheets for Color Print and B/W print (7 digits)

## 10.6 ID Print

The user name can be printed. The printing position can be selected from upper right, upper left, lower right and lower left (only for PCL6).

## 10.7 Non-Genuine Mode

When life of toner cartridge has ended, the printer stops accepting request (life of toner cartridge is counted by the counter in CRUM).

Taking into consideration that same users use refilled toner cartridge they get from re-manufacturers, the printer can accept print request by the user's panel operation even if life of the toner cartridge has ended.

Setting of toner cartridge can be made separately (setting of toner cartridge can not be made by color). When the mode has changes so that the printer does not stop even after life of toner cartridge ends, the printer displays a message on the operation panel to inform the user of the mode change.

When the printer operates in this mode, print image quality is not guaranteed. Also, remaining toner level is not displayed (as CRUM data can not be guaranteed).

## 10.8 Maintenance

### 1) Firmware Update

The ESS and MPC firmware can be updated by the user.

Firmware can be updated using Windows PC with the dedicated utility.

Updated Firmware	Windows		
	via USB	via 1284	via Network (port9100)
ESS	Available	Available	Available
MPC	Available	Available	Available
MCU*1	Available	Available	Available

\*1: MCU can not be updated when ROM starts to be used for MCU.

### 2) Diagnostic Function

There are 2 types of diagnostic function as follows.

#### 1) Auto Diagnostic: The printer is checked when it is turned on.

It is checked whether hardware (ROM, RAM, ASIC etc) operates properly.

#### 2) Manual Diagnostic: Diagnosis is conducted using the operation panel.

The user can select the test items, such as Code ROM Test, Font ROM Test, EEPROM Test, and Operation Panel Test, on the operation panel individually.

## 10.9 Power Saver

### 1) Power Saver Modes

The printer has 2 Power Saver modes to reduce power consumption when it is left idle. When no print data is received for a period of time, the printer will enter the Power Saver mode.

The switch to Low Power mode cannot be prohibited. (Cannot be disabled)

The switch to Sleep mode can be enabled or disabled.

\* The function is the same when installing the optional Network Expansion Card.

Mode	Power Saver Details	Default
Low Power mode	Fusing: Paused, Exposure: Paused, Recording: Paused, Fan: Paused	Enabled only
Sleep mode	Fusing: Paused, Exposure: Paused, Recording: Paused, Fan: Paused	Enabled

### 2) Power Saver Mode Timer

The time between Standby mode and Low Power mode and the time between Lower Power mode and Sleep mode can be specified.

Mode	Specifying Switch Time	Default
Standby mode to Low Power mode	Specify between 1-60min in increments of 1min	3min
Low Power mode to Sleep mode	Specify between 5-120min in increments of 1mind	5min

### 3) Resume from Power Saver mode

Printer returns to Normal mode when a print job is received or any button on the operation panel is pressed in Low Power mode.

Printer returns to Normal mode when a print job is received or the Power Saver button on the operation panel is pressed in Sleep mode.



## 10.10 Utility Print

### 1) Printer Settings List

Printer Settings can be printed at user's command.

Printer Settings List is printed in B/W in the automatically selected paper tray.

Printer Setting List includes the following information:

Items on the list are slightly different from blow when the Wireless Lan Adapter is installed.

[Title]

Product Name (Logo)

[General]

Printer Name, Service tag, Asset Number,

Memory Capacity, ESS Version, IOT Version, Boot Version, Color Print Volume, B/W Print

Volume, PDL Name and Version, Default Paper Size, Default Paper Type for Plain Paper,

Default Paper Type for Label, Printer Language, Number of Font, Default Language

[Network]

NIC Version, MAC Address, Ethernet Setting (10 or 100base and half or full)

TCP/IP: TCP/IP Settings, IP Address, Subnet Mask, Gateway Address

IPX/SPX: Frame Type, Network Address

IP Filter: Address, Mask, Mode

Other Supported Protocols

[Wireless]

Wireless Setting\* (SSID, Network Type, Encryption, Link Quality, Link Channel)

\* Listed when wireless Lan Adapter is installed.

[Printer Options]

Multi-protocol Card: Yes or No (If available, version)

Available Paper Tray (Tray 1, Tray 2, Tray 3, Tray 4, MPF)

Hard Disk: Yes or No

[Print Volume]

Print Volume for each paper size

### 2) Printing the Panel Settings List

The Settings List can be printed by the user's operation. The Panel Settings List is printed in B/W on A4 size paper in the automatically selected paper tray.

### 3) Printing Font List

The PCL or PS Font and Color Bar (for color check) can be printed by the user's operation.

Font List is printed in color on A4 size paper (Letter size paper for the US) in the automatically selected paper tray.

### 4) Printing the Job Log

The user can print the Jog Log by requesting instant print or by setting auto print.

The Job Log is printed in B/W on A4 size paper (Letter size paper for the US) in the automatically selected paper tray.

### 5) Printing the Error Log

The Error Log can be printed by the user's operation.

The Jam error and fatal error log are printed in B/W on A4 size paper (Letter size paper for the US) in the automatically selected paper tray.

6) Printing Stored Document List

The list of documents stored in the printer by Secure Print/Proof Print can be printed by the user's operation.

The list is printed in B/W on A4 size paper (Letter size paper for the US) in the automatically selected paper tray.

## 10.11 EWS

General web browsers enable the user to access the website in the network card. In the website, the following items are displayed and the user can make setting of some items.

Items include Printer Status display, Job History display, Network Parameter settings/display functions.

## 10.12 Status Messenger

The printer has a function that sends a notification E-mail to the preset address to inform of any phenomenon that has occurred. "Contact" and "Installation place" are also included in the E-mail.

The notification to be sent can be chosen from Warning/Caution/Others.

The printer status can also be acquired.