

Chapter 1 Troubleshooting CONTENTS

1. Troubleshooting Overview	1 - 1
1.1 Flow of Troubleshooting.....	1 - 1
1.2 Check Installation Status	1 - 2
1.3 Cautions on Service Operations	1 - 3
1.4 Cautions on Using FIP	1 - 4
1.5 Items To Be Confirmed Before Going To FIP Troubleshooting	1 - 6
2. FIP	1 - 12
2.1 FIP	1 - 12
2.2 Flow of FIP	1 - 12
2.3 Status Code List.....	1 - 13
3. Error Code FIP	1 - 36
3.1 Troubleshooting for the call center.....	1 - 36
Flows 1 001-360-01 Restart Printer	1 - 36
Flows 2 001-360-02 Restart Printer	1 - 37
Flows 3 003-340-01/003-340-02/003-340-03/003-340-04/003-340-05/003-340-07/003-340-08/ 003-340-0A/003-340-0B/003-340-14 Restart Printer	1 - 38
Flows 4 003-340-09 Restart Printer	1 - 39
Flows 5 003-356 Restart Printer	1 - 40
Flows 6 004-310 Restart Printer	1 - 41
Flows 7 004-311 Restart Printer	1 - 42
Flows 8 006-370 Restart Printer	1 - 43
Flows 9 007-340-00 Restart Printer	1 - 44
Flows 10 007-340-01 Restart Printer	1 - 45
Flows 12 007-340-03 Restart Printer	1 - 46
Flows 13 007-340-04 Restart Printer	1 - 47
Flows 14 007-371 Restart Printer	1 - 48
Flows 15 009-360 Restart Printer	1 - 49
Flows 16 009-361 Restart Printer	1 - 50
Flows 17 009-362 Restart Printer	1 - 51
Flows 18 009-363 Restart Printer	1 - 52
Flows 19 009-654-01 Restart Printer	1 - 53
Flows 20 009-654-02 Restart Printer	1 - 55
Flows 21 010-317 Restart Printer	1 - 57
Flows 22 010-351 Restart Printer	1 - 58
Flows 23 010-354 Restart Printer	1 - 59
Flows 24 010-377 Restart Printer	1 - 60
Flows 25 016-300/016-301/016-302/016-310/016-313/016-315/016-317/016-323/016-327/016-344/ 016-345/016-346/016-347 Restart / Erase Flash Err. 016-392 / Write Flash Err. 016-393 / Verify Error 016-394.....	1 - 61
Flows 25-1 016-340 Restart Printer	1 - 62
Flows 26 016-312/016-361 Restart Printer	1 - 64
Flows 27 016-316/016-318 Restart Printer	1 - 65
Flows 28 016-338 Restart Printer	1 - 66
Flows 29 016-350 Restart Printer	1 - 67
Flows 30 016-365 Restart Printer	1 - 68
Flows 31 016-370 Restart Printer	1 - 69
Flows 32 093-964 Restart Printer	1 - 71
Flows 33 Paper Jam 071-100	1 - 72
Flows 34 Paper Jam 072-100	1 - 74
Flows 35 Paper Jam 075-100	1 - 77
Flows 36 Paper Jam 077-100/077-101	1 - 79
Flows 37 Paper Jam 077-102/077-103	1 - 80
Flows 38 Paper Jam 077-104/077-107	1 - 81

Chapter 1 Troubleshooting CONTENTS

Flows 39 Paper Jam 077-105/077-106	1 - 83
Flows 40 Paper Jam 077-900/077-901	1 - 85
Flows 41 Paper Jam 077-903	1 - 89
Flows 42 Paper Jam 077-907	1 - 90
Flows 43 Load Tray N or MPF 024-910/024-911/024-914	1 - 93
Flows 44 Load Tray N or MPF 024-965/024-966/024-969	1 - 95
Flows 45 CRUM ID 009-367/009-368/009-369/009-370	1 - 98
Flows 46 Error Y Cart 093-919	1 - 99
Flows 47 Error M Cart 093-920	1 - 100
Flows 48 Error C Cart 093-921	1 - 101
Flows 49 Error K Cart 093-922	1 - 102
Flows 50 093-950 Yellow Toner / 093-951 Magenta Toner / 093-952 Cyan Toner / 093-953 Black Toner	1 - 103
Flows 51 Replace Cart 093-930/093-931/093-932/093-933	1 - 104
Flows 52 Ready to Print 093-423/093-424/093-425/093-426	1 - 105
Flows 53 Insert Print Cart 093-970	1 - 106
Flows 54 Insert Print Cart 093-971	1 - 107
Flows 55 Insert Print Cart 093-972	1 - 108
Flows 56 Insert Print Cart 093-973	1 - 109
Flows 57 CRUM ID 009-371	1 - 110
Flows 58 Ready to Print 094-422	1 - 111
Flows 59 Insert Belt Unit 094-910	1 - 112
Flows 60 Belt Unit 094-911	1 - 113
Flows 61 010-359 Restart Printer	1 - 114
Flows 62 Ready to Print 010-421	1 - 115
Flows 63 Tray Detached 024-946/007-912	1 - 116
Flows 64 Load Tray 024-947	1 - 117
Flows 65 Close Front Cover 077-300	1 - 118
Flows 66 Invalid ID 016-383 / Range Chk Error 016-384 / Header Error 016-385 / Check Sum Error 016-386 / Format Error 016-387	1 - 119
Flows 67 Out of Memory 016-700	1 - 120
Flows 68 Disc Full 016-980	1 - 121
Flows 69 Collate Full 016-981	1 - 122
Flows 70 016-720 PDL Error	1 - 124
Flows 71 Invalid User 016-757	1 - 125
Flows 72 Disabled Func 016-758	1 - 126
Flows 73 Reached Limits 016-759	1 - 127
Flows 74 Invalid Job 016-799	1 - 128
Flows 75 Ready to Print 193-700	1 - 129
Flows 76 Over Heat 042-700 / Ready to Print 142-700	1 - 130
Flows 77 Electrical Noise	1 - 131
Flows 78 Faint print (Low contrast)	1 - 132
Flows 79 Blank print (No print)	1 - 134
Flows 80 Solid black	1 - 135
Flows 81 Vertical blank lines (White stripes in paper transport direction)	1 - 136
Flows 82 Horizontal band cross out (White stripes in the horizontal direction)	1 - 138
Flows 83 Vertical stripes	1 - 140
Flows 84 Horizontal stripes	1 - 142
Flows 85 Partial Deletion	1 - 144
Flows 86 Spots	1 - 147
Flows 87 Afterimage (Ghost)	1 - 149
Flows 88 Grey Background	1 - 151
Flows 89 Skew	1 - 153
Flows 90 Paper damage	1 - 156
Flows 91 Unfusing	1 - 160
Flows 92 Color Registration (Color Shift)	1 - 161
Flows 93 Noise: When Power is Turned On	1 - 165

Chapter 1 Troubleshooting CONTENTS

Flows 94 Noise: During Standby.....	1 - 167
Flows 95 Noise: During Printing.....	1 - 168
Flows 96 AC.....	1 - 172
Flows 97 DC	1 - 173
Flows 98 Multiple feed	1 - 174
Flows 99 Control Panel Freezes.....	1 - 175
3.2 Troubleshooting for the repair center.....	1 - 177
FIP1.1 001-360-01 Restart Printer.....	1 - 177
FIP1.2 001-360-02 Restart Printer.....	1 - 178
FIP1.3 003-340-01/003-340-02/003-340-03/003-340-04/003-340-05/003-340-07/003-340-08/003-340-0A/ 003-340-0B/003-340-0C/003-340-0D/003-340-0E/003-340-0F/003-340-10/003-340-11/ 003-340-12/003-340-13/003-340-14 Restart Printer	1 - 179
FIP1.4 003-340-09 Restart Printer.....	1 - 180
FIP1.5 003-356 Restart Printer	1 - 181
FIP1.6 004-310 Restart Printer	1 - 182
FIP1.7 004-311 Restart Printer	1 - 183
FIP1.8 006-370 Restart Printer	1 - 184
FIP1.9 007-340-00 Restart Printer.....	1 - 185
FIP1.10 007-340-01 Restart Printer.....	1 - 187
FIP1.12 007-340-03 Restart Printer.....	1 - 188
FIP1.13 007-340-04 Restart Printer.....	1 - 189
FIP1.14 007-371 Restart Printer	1 - 191
FIP1.15 009-360 Restart Printer	1 - 193
FIP1.16 009-361 Restart Printer	1 - 194
FIP1.17 009-362 Restart Printer	1 - 195
FIP1.18 009-363 Restart Printer.....	1 - 196
FIP1.19 009-654-01 Restart Printer.....	1 - 197
FIP1.20 009-654-02 Restart Printer.....	1 - 199
FIP1.21 010-317 Restart Printer	1 - 201
FIP1.22 010-351 Restart Printer	1 - 202
FIP1.23 010-354 Restart Printer	1 - 203
FIP1.24 010-377 Restart Printer	1 - 204
FIP1.25 016-300/016-301/016-302/016-310/016-313/016-315/016-317/016-323/016-327/016-340/ 016-344/016-345/016-346/016-347 Restart / Erase Flash Err. 016-392 / Write Flash Err. 016-393 / Verify Error 016-394	1 - 205
FIP1.26 016-312/016-361 Restart Printer.....	1 - 206
FIP1.27 016-316/016-318 Restart Printer.....	1 - 207
FIP1.28 016-338 Restart Printer	1 - 208
FIP1.29 016-350 Restart Printer	1 - 209
FIP1.30 016-365 Restart Printer	1 - 210
FIP1.31 016-370 Restart Printer	1 - 211
FIP1.32 093-964 Restart Printer	1 - 212
FIP1.33 Paper Jam 071-100.....	1 - 213
FIP1.34 Paper Jam 072-100.....	1 - 215
FIP1.35 Paper Jam 075-100.....	1 - 219
FIP1.36 Paper Jam 077-100/077-101.....	1 - 222
FIP1.37 Paper Jam 077-102/077-103.....	1 - 223

Chapter 1 Troubleshooting CONTENTS

FIP1.38 Paper Jam 077-104/077-107.....	1 - 224
FIP1.39 Paper Jam 077-105/077-106.....	1 - 228
FIP1.40 Paper Jam 077-900/077-901.....	1 - 231
FIP1.41 Paper Jam 077-903.....	1 - 235
FIP1.42 Paper Jam 077-907.....	1 - 236
FIP1.43 Load Tray N or MPF 024-910/024-911/024-914.....	1 - 239
FIP1.44 Load Tray N or MPF 024-965/024-966/024-969.....	1 - 241
FIP1.45 CRUM ID 009-367/009-368/009-369/009-370.....	1 - 245
FIP1.46 Error Y Cart 093-919.....	1 - 246
FIP1.47 Error M Cart 093-920.....	1 - 247
FIP1.48 Error C Cart 093-921.....	1 - 248
FIP1.49 Error K Cart 093-922.....	1 - 249
FIP1.50 093-950 Yellow Toner/093-951 Magenta Toner/093-952 Cyan Toner/093-953 Black Toner	1 - 250
FIP1.51 Replace Cart 093-930/093-931/093-932/093-933.....	1 - 251
FIP1.52 Ready to Print 093-423/093-424/093-425/093-426.....	1 - 252
FIP1.53 Insert Print Cart 093-970.....	1 - 253
FIP1.54 Insert Print Cart 093-971.....	1 - 254
FIP1.55 Insert Print Cart 093-972.....	1 - 255
FIP1.56 Insert Print Cart 093-973.....	1 - 256
FIP1.57 CRUM ID 009-371.....	1 - 257
FIP1.58 Ready to Print 094-422.....	1 - 258
FIP1.59 Insert Belt Unit 094-910.....	1 - 259
FIP1.60 Belt Unit 094-911.....	1 - 260
FIP1.61 010-359 Restart Printer.....	1 - 261
FIP1.62 Ready to Print 010-421.....	1 - 262
FIP1.63 Tray Detached 024-946/007-912.....	1 - 263
FIP1.64 Load Tray 024-947.....	1 - 264
FIP1.65 Close Front Cover 077-300.....	1 - 265
FIP1.66 Invalid ID 016-383 / Range Chk Error 016-384 / Header Error 016-385 / Check Sum Error 016-386 / Format Error 016-387.....	1 - 266
FIP1.67 Out of Memory 016-700 / Disc Full 016-980 / Collate Full 016-981.....	1 - 267
FIP1.68 016-720 PDL Error.....	1 - 268
FIP1.69 Invalid User 016-757 / Disabled Func 016-758 / Reached Limits 016-759.....	1 - 269
FIP1.70 Invalid Job 016-799.....	1 - 270
FIP1.71 Ready to Print 193-700.....	1 - 271
FIP1.72 Over Heat 042-700/Ready to Print 142-700.....	1 - 272
FIP1.73 Electrical Noise.....	1 - 273
4. Image Quality Trouble.....	1 - 274
4.1 Entry Chart for Image Quality Troubleshooting.....	1 - 274
4.2 Diagnosis Test Chart.....	1 - 278
4.3 Items to be Confirmed Before Image Quality Troubleshooting.....	1 - 283
4.4 Print Image Quality Specification.....	1 - 285
4.5 Image Quality FIP.....	1 - 288
FIP-1.P1 Faint print (Low contrast).....	1 - 288
FIP-1.P2 Blank print (No print).....	1 - 290

Chapter 1 Troubleshooting CONTENTS

FIP-1.P3 Solid black	1 - 292
FIP-1.P4 Vertical blank lines (White stripes in paper transport direction)	1 - 294
FIP-1.P5 Horizontal band cross out (White stripes in the horizontal direction)	1 - 296
FIP-1.P6 Vertical stripes.....	1 - 298
FIP-1.P7 Horizontal stripes.....	1 - 300
FIP-1.P8 Partial Deletion.....	1 - 302
FIP-1.P9 Spots.....	1 - 304
FIP-1.P10 Afterimage (Ghost).....	1 - 306
FIP-1.P11 Grey Background	1 - 308
FIP-1.P12 Skew	1 - 309
FIP-1.P13 Paper damage.....	1 - 311
FIP-1.P14 Unfusing.....	1 - 313
FIP-1.P15 Color Registration (Color Shift).....	1 - 314
5. Abnormal Noise Trouble.....	1 - 317
5.1 Entry Chart for Abnormal Noise Troubleshooting	1 - 317
5.2 Operation Mode Table	1 - 318
FIP-1.N1 When Power is Turned On.....	1 - 318
FIP-1.N2 During Standby.....	1 - 320
FIP-1.N3 During Printing.....	1 - 321
6. Other FIP	1 - 323
FIP-AC.....	1 - 323
FIP-DC.....	1 - 324
FIP-Multiple feed.....	1 - 325
FIP-Control Panel Freezes.....	1 - 326

Chapter 1 Troubleshooting CONTENTS

Blank Page

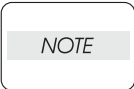

The troubleshooting procedures described herein assume the use of the Diag Tool. However, the procedures can be performed without the Diag Tool as long as they are carefully followed.

1. Troubleshooting Overview

To increase the efficiency of troubleshooting, ensure that preliminary checks should be made to confirm the trouble status before proceeding to the Fault Isolation Procedure (FIP), Operation of Diagnostic (Chapter 2), Wiring Diagrams (Chapter 7), and Principles of Operation (Chapter 6).

1.1 Flow of Troubleshooting

Flow of the troubleshooting is as follows:

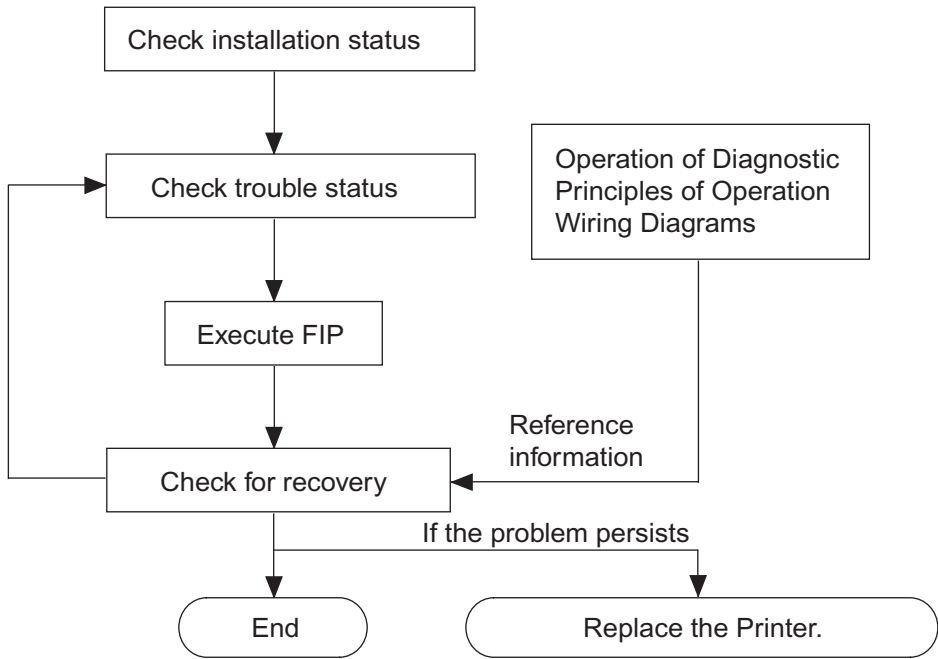

1.2 Check Installation Status

Be sure to check the following items before starting the troubleshooting procedures

- 1) The power supply voltage is within the specifications (measure the voltage at the wall outlet).
- 2) The power cord is free from breakage, short-circuit, open wire, or internal miswiring.
- 3) The printer is properly grounded.
- 4) The printer is not installed at a place subjected to high/low temperature, humidity, and sudden temperature changes.
- 5) The printer is not installed at or near water facilities, humidifier, heating appliance, fire, dust, or in airflow from air conditioner.
- 6) The printer is not installed in a place subjected to volatile or inflammable gas.
- 7) The printer is not installed under direct sunlight.
- 8) The printer is installed in a well-ventilated place.
- 9) The printer is installed on a firm and stable surface.
- 10) The paper meets the specifications (standard paper is recommended).
- 11) The printer is handled properly.
- 12) The high frequency service items are replaced at the recommended print count intervals.

1.3 Cautions on Service Operations

- 1) Be sure to remove the power cord unless otherwise required.



While the printer is powered ON, never touch the conductive parts unless otherwise required.

Never touch the conductive parts of the power switch and inlet of the LVPS, because they are live even while the printer is powered off.

- 2) When checking some parts with covers removed and with the interlock, safety, and power switches ON, remove the connector (P/J151) on the ROS ASSY unless otherwise required.



When checking some parts with covers removed and with the interlock, safety, and switches ON, laser beams may be irradiated from the ROS ASSY. For your safety, be sure to remove the connector (P/J151) unless otherwise required.

- 3) When checking some parts with the Front Cover removed and the printer powered ON, be sure to remove the connector (P/J16) on the PWBA MCU unless otherwise required.



When checking some parts with the Front Cover removed and the printer powered ON, be sure to remove the connector (P/J16) on the MCU. Otherwise, a high voltage may be output from the HVPS.

When connecting the connector (P/J16) on the MCU according to the instructions in the FIP, never touch the HVPS and high voltage parts.

- 4) When outputting a high voltage using the Diag Tool, etc., keep all the covers on unless otherwise required.



When outputting a high voltage using the Diag Tool, etc., ensure that:

- The high voltage carrying parts must never be touched.***
- The instructions in this manual must be followed.***

- 5) When operating the drive unit using the Diag Tool, etc., keep all the covers on unless otherwise required.



When operating the drive unit using the Diag Tool, etc., ensure that:

- The drive unit must never be touched.***
- The instructions in this manual must be followed.***

- 6) When touching hot parts, be careful not to get burnt.

- 7) While working, be sure to wear a wrist band or the like to dissipate static charges from your body.

1.4 Cautions on Using FIP

- 1) When troubleshooting according to the FIP, have on hand a normal MCU, LVPS, HVPS, FUSER ASSY, BELT ASSY, etc., for possible fault isolation.
- 2) In the initial check according to the FIP, check only items which can be simply checked.
- 3) In the initial check according to the FIP, check the constitutive parts of the major check parts and related parts, as well as major check parts.
- 4) When working with the printer, be sure to remove the power cord unless otherwise required. Never touch live parts if not required, while the power cord is connected.
- 5) Connector condition is denoted as follows:
 - [P/J12] → Connector (P/J12) is connected.
 - [P12] → Plug side with the connector (P/J12) removed (except when attached directly to the board).
 - [J12] → Jack side with the connector (P/J12) removed (except when attached directly to the board).
- 6) [P/J1-2PIN <=> P/J3-4PIN] in the FIP means measurement with the positive side of the measuring instrument connected to [2PIN] of [P/J1] and the negative side to [4PIN] of [P/J3].
- 7) [P/J1<=> P/J2] in the FIP means measurement for all terminals corresponding between [P/J1] and [P/J2] based on "Wiring Diagrams".
- 8) In [P/J1-2PIN <=> P/J3-4PIN] in the FIP where voltage is measured, [P/J3-4PIN] on the rear negative side is always at the AG (analog ground), SG (signal ground), or RTN (return). Therefore, after checking of proper conductivity between AGs, SGs, or RTNs respectively, the rear negative side can be connected to the PIN of AG, SG or RTN instead of [P/J3-4PIN]. However, care should be taken not to confuse [AG], [SG], and [RTN] because they are not on the same level.
- 9) When measuring the voltage at small connectors, use the dedicated tool. Handle the tool with care because its business end is pointed.
- 10) When measuring the voltage, set the BELT ASSY, print cartridge and paper cassette, close the COVERs and power ON unless otherwise required.
- 11) Numerical values in the FIP are only for guideline. Approximate values are acceptable.
- 12) In each step of the FIP, parts removal and other procedures implicitly required for the step are omitted.
- 13) In the FIP, "Replacement" means the replacement of the parts that are considered to be the cause of the trouble. Replacement of those parts means the replacement of the assembly part (HIGH ASSY) that contain them.

- 14) In the FIP, the paper cassette immediately below the printer main body is called "Tray 1", and the cassette below it is called "Tray 2".
- 15) Some of the instructions in the FIP are branched off depending on the specifications. Follow the applicable instruction.
- 16) For some optional components, you may have to refer to the manual of the relevant component for troubleshooting. Have the relevant manual at hand as needed.

1.5 Items To Be Confirmed Before Going To FIP Troubleshooting

Basic Printer Problems

Some printer problems can be easy to resolve. If a problem occurs with your printer, check each the following:

- 1) If a message is displayed on the LCD of operator panel, see "2.3 Status Code List".
- 2) The printer power cable is plugged into the printer and a properly grounded electrical outlet.
- 3) The printer power is powered ON.
- 4) The electrical outlet is not turned off by any switch or breaker.
- 5) Other electrical equipment plugged into the outlet is working.
- 6) All options are properly installed.
- 7) If you have checked all of the above and still have a problem, turn off the printer, wait for 10 seconds, and then turn on the printer. This often solves the problem.

Display Problems

- 1) If the operator panel displays only diamonds or is blank, check and try the action below. If the problem persists even after checking and executing the items below, execute Flow 96, Flow 97, or "FIP-AC" and "FIP-DC" in "6. Other FIP".
 - a) Turn off the printer, wait for 10 seconds, and turn on the printer.
 - b) Self Test Message appears on the operator panel. When the test is completed, "Ready to Print" is displayed.
- 2) If menu settings changed from the operator panel have no effect, check and try the actions below.

Settings in the software program, the printer driver, or the printer utilities are overriding the settings made on the operator panel.

 - a) Change the menu settings from the printer driver, the printer utilities, or the software program instead of the operator panel.
 - b) Disable the settings in the printer driver, the printer utilities, or the software program so you can change settings on the operator panel.

Printing Problems

- 1) If a job did not print correct or incorrect characters were printed, check and try the actions below.
 - a) Make sure "Ready to Print" appears on the operator panel before sending a job to print. Press **Menu** to return to "Ready to Print".
 - b) Make sure print media is loaded in the printer. Press **Menu** to return to "Ready to Print".
 - c) Verify that you are using the correct printer driver.
 - d) Make sure you are using the correct Ethernet or USB cables and it securely connected at the back of the printer.
 - e) Verify that the correct print media size is selected.
 - f) If using a print spooler, verify that the spooler has not stalled.
 - g) Check the printer interface from the "Configure" menu. Determine the host interface you are using. Print a Panel Setting page to verify that the current interfaces settings are correct.
 - h) Output fonts will not print correctly using the PCL driver in its default mode. To correct this problem, use PostScript driver when using the PCL driver.

- 2) If secure print is not available or not printing, refer to the requirements below.
 - a) Minimum 256 MB is required.
 - b) RAM Disk must be enabled using the operation panel.
 - c) The number of secure print jobs your printer can store is dependent on the job size including number of pages, graphics, color attributes, and the amount of memory installed. To increase this number, add additional memory.
- 3) If print media misfeeds or multiple feeds occur, check and try the actions below.
 - a) Make sure the print media you are using meets the specifications for your printer. Refer to **Print Media Guidelines** of this section.
 - b) Flex print media before loading it in any of the sources.
 - c) Make sure the print media is loaded correctly.
 - d) Make sure the width and length guides on the print media sources are adjusted correctly.
 - e) If the print media are overfilled in sources, reduce the amount of media.
 - f) Load the recommended print side correctly for the type of print media you are using.
 - g) Turn the print media over or around and try printing again to see if feeding improves.
 - h) Check the print media type loaded in the source, and refill only one type of print media, if print media types are mixed.
 - i) Refill a new ream of print media, if some reams are mixed.
 - j) Remove the top and bottom sheets of a ream before loading the print media.
 - k) Do not reload print media until the print media source is empty.
- 4) If envelope misfeeds or multiple feeds occur, check and try the action below.
 - a) Remove the stack of envelopes from the multiple purpose feeder (MPF).
- 5) If page breaks in unexpected places, check and try the action below.
 - a) Check the "Job Timeout" in the Basic Settings menu and increase the value.
- 6) If a job prints from the wrong source or on the wrong print media, check and try the action below.
 - a) Check the "Paper Size" and "Paper Type" in the Tray Settings menu on the printer operator panel and in the printer driver.
- 7) If print media does not stack neatly in the output tray, check and try the action below.
 - a) Turn the print media stack over in the tray or multipurpose feeder.

Print Media Guidelines

Print media is paper, transparencies, labels, envelopes, coated paper among others. Your printer provides high-quality printing on a variety of print media. Selecting the appropriate print media for your printer helps avoid printing troubles. This section describes how to select print media, how to care for print media, and how to load the print media in the optional 250-sheet tray module or 550-sheet tray module.

Paper

For the best print quality in color, use 75 g/m² (20 lb.) xerographic, grain long paper. For the best print quality in black and white, use 90 g/m² (24 lb.) xerographic, grain long paper. Before buying large quantities of any print media, Dell recommends trying a sample first.

When loading paper, identify the recommended print side on the paper package, and load the paper accordingly. See "Loading Print Media in Optional Trays" and "Loading the Multipurpose Feeder" for detailed loading instructions.

Paper Characteristics

The following paper characteristics affect print quality and reliability. Dell recommends that you follow these guidelines when evaluating new paper stock.

Weight

The tray automatically feeds paper weights from 60 to 216 g/m² (16 to 57.6 lb. bond) grain long. The multipurpose feeder automatically feeds paper weights from 60 to 216 g/m² (16 to 56 lb. bond) grain long. Paper lighter than 60 g/m² (16 lb.) might not be stiff enough to feed properly, and could cause paper jams. For best performance, use 75 g/m² (20 lb. bond) grain long paper.

Curl

Curl is the tendency of print media to curve at its edges. Excessive curl can cause paper feeding problems. Curl usually occurs after the paper passes through the printer, where it is exposed to high temperatures. Storing paper unwrapped in humid conditions, even in the paper tray, can contribute to paper curling prior to printing and cause feeding problems.

Smoothness

The degree of paper smoothness directly affects print quality. If the paper is too rough, the toner does not fuse to the paper properly, resulting in poor print quality. If the paper is too smooth, it can cause paper feeding problems. Smoothness between 150 and 250 Sheffield points produces the best print quality.

Moisture Content

The amount of moisture in the paper affects both print quality and the ability of the printer to feed the paper properly. Leave the paper in its original packaging until you are ready to use it. This limits the exposure of the paper to moisture changes that can degrade its performance.

Grain Direction

Grain refers to the alignment of the paper fibers in a sheet of paper. Grain is either grain long, running the length of the paper, or grain short, running the width of the paper. For 60 to 135 g/m² (16 to 36 lb. bond) paper, grain long fibers are recommended. For papers heavier than 135 g/m² (36 lb. bond), grain short is preferred.

Fiber Content

Most high-quality xerographic paper is made from 100% chemically pulped wood. Paper containing fibers such as cotton possess characteristics that can result in degraded paper handling.

Recommended Paper

To ensure the best print quality and feed reliability, use 75 g/m² (20 lb.) xerographic paper. Business papers designed for general business use also provide acceptable print quality.

Always print several samples before buying large quantities of any type of print media. When choosing any print media, you should consider the weight, fiber content, and color.

The laser printing process heats paper to high temperatures of 225°C (437°F) for Magnetic Ink Character Recognition (MICR) applications, and 205°C (401°F) for non-MICR applications. Only use paper able to withstand these temperatures without discoloring, bleeding, or releasing hazardous emissions. Check with the manufacturer or vendor to determine whether the paper you have chosen is acceptable for laser printers.

Unacceptable Paper

The following paper types are not recommended for use with the printer:

- 1) Chemically treated papers used to make copies without carbon paper, also known as carbonless papers, carbonless copy paper (CCP), or no carbon required (NCR) paper
- 2) Preprinted papers with chemicals that may contaminate the printer
- 3) Preprinted papers that can be affected by the temperature in the printer fuser

- 4) Preprinted papers that require a registration (the precise print location on the page) greater than ± 0.09 in., such as optical character recognition (OCR) forms
In some cases, you can adjust registration with your software program to successfully print on these forms.
- 5) Coated papers (erasable bond), synthetic papers, thermal papers
- 6) Rough-edged, rough or heavily textured surface papers or curled papers
- 7) Recycled papers containing more than 25% post-consumer waste that do not meet DIN 19 309
- 8) Multiple-part forms or documents
- 9) Label paper with Cut

Selecting Paper

Proper paper selection helps prevent jams and ensures trouble-free printing.

To help avoid jams or poor print quality:

1. Always use new, undamaged paper.
2. Before loading the paper, identify the recommended print side of the paper. This information is usually indicated on the paper package.
3. Do not use paper that you have cut or trimmed yourself.
4. Do not mix print media sizes, weights, or types in the same source. This may result in a paper jam.
5. Do not remove trays while a job is printing or Printing is displayed on the operator panel.
6. Make sure the Paper Type and Paper Size settings are correct.
7. Make sure the paper is properly loaded in the tray.
8. Flex paper back and forth, and then fan them. Straighten the edges of the stack on a level surface.
9. When curl is excessive, with plain paper, turn it over and reset it.

Identifying Print Media Sources and Specifications

The following tables provide information on standard and optional print media sources.

Print Media Sizes and Support Y: Yes N: No

	Multipurpose Feeder	250-sheet Tray	Optional 550-sheet Tray
A4	Y	Y	Y
A5	Y	Y	Y
B5	Y	Y	Y
Letter	Y	Y	Y
Folio (8.5 x 13 in.)	Y	Y	Y
Legal (8.5 x 14 in.)	Y	Y	Y
Executive	Y	Y	Y
COM-10 envelope	Y	N	N
Monarch	Y	N	N
C5	Y	N	N
DL	Y	N	N
User-specified print media	Y	N	N
Yokei size 2	Y	N	N
Yokei size 3	Y	N	N
Yokei size 4	Y	N	N
Yochokei size 3	Y	N	N
Chokey size 3	Y	N	N

	Multipurpose Feeder	250-sheet Tray	Optional 550-sheet Tray
Japanese Post Card	Y	N	N

Print Media Supported

Y: Yes N: No

	Multipurpose Feeder	250-sheet Tray	Optional 550-sheet Tray
Plain Paper Light (60-76gsm)	Y	Y	Y
Plain Paper Normal (80gms)	Y	Y	Y
Plain Paper Thick (82-98gms)	Y	Y	Y
Covers Normal (106-163gms)	Y	Y	Y
Covers Thick (164-216gms)	Y	Y	Y
Transparency	Y	N	N
Labels	Y	Y	Y
Coated Normal (106-163gms)	Y	Y	Y
Coated Thick (164-216gms)	Y	Y	Y
Envelope	Y	N	N
Recycled Paper	Y	Y	Y
Japanese Coated Paper	Y	Y	Y
Japanese Post Card	Y	N	N

About indication of near life and Life over for consumables life

The table below gives details on how the near life (Near Empty) and Life over for consumables life are to be indicated.

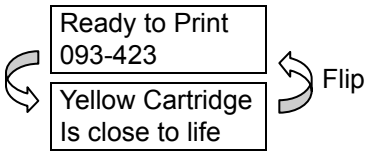
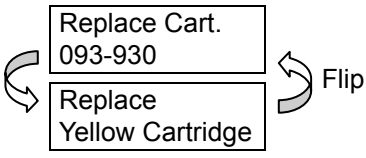
Consumables	Near Life Indication	Life over Indication
Print Cartridge (Y/M/C/K)	<p>When the remaining life of the Print Cartridge reaches approximately 25%, the following messages are displayed.</p> <p>Example) Print Cartridge for Yellow</p> <p><Panel></p>  <p><Status Window> The Yellow Cartridge needs to be replaced soon.</p> <p>093-423</p> <p>NOTE: The message displayed varies depending on the color of the Print Cartridge.</p>	<p>When the Print Cartridge reaches its end of life, the following messages are displayed.</p> <p>Example) Print Cartridge for Yellow</p> <p><Panel></p>  <p><Status Window> The XXX Cartridge need to be replaced now. Open the Front Cover. Then remove the used Yellow Cartridge and install a new one. Please click the Show Me How Button for details.</p> <p>093-930</p> <p>NOTE: The message displayed varies depending on the color of the Print Cartridge.</p>

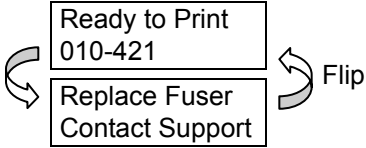
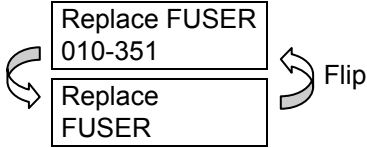
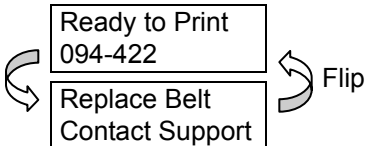
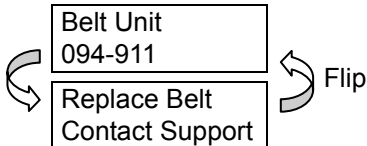
Consumables	Near Life Indication	Life over Indication
FUSER	<p>When the remaining life of the FUSER reaches approximately 20%, the following messages are displayed.</p> <p><Panel></p>  <p><Status Window> Contact customer support if this failure is repeated.</p> <p>010-421</p>	<p>When the FUSER reaches its end of life, the following messages are displayed.</p> <p><Panel></p>  <p><Status Window> The Fuser needs to be replaced now. Remove the used Fuser and install a new one. Please click the Show Me How Button for details.</p> <p>010-351</p>
Belt Unit	<p>When the remaining life of the Belt Unit reaches approximately 20%, the following messages are displayed.</p> <p><Panel></p>  <p><Status Window> Contact customer support if this failure is repeated.</p> <p>094-422</p>	<p>When the Belt Unit reaches its end of life, the following messages are displayed.</p> <p><Panel></p>  <p><Status Window> The Belt Unit needs to be replaced now. Remove the used Belt Unit and install a new one. Please click the Show Me How Button for details.</p> <p>094-911</p>

NOTE

The remaining amounts given in this table are for reference only.

2. FIP

2.1 FIP

The FIP is the first step for trouble diagnosis. The FIP isolates the presence of various troubles including error codes, and guides the troubleshooting procedure.

2.2 Flow of FIP

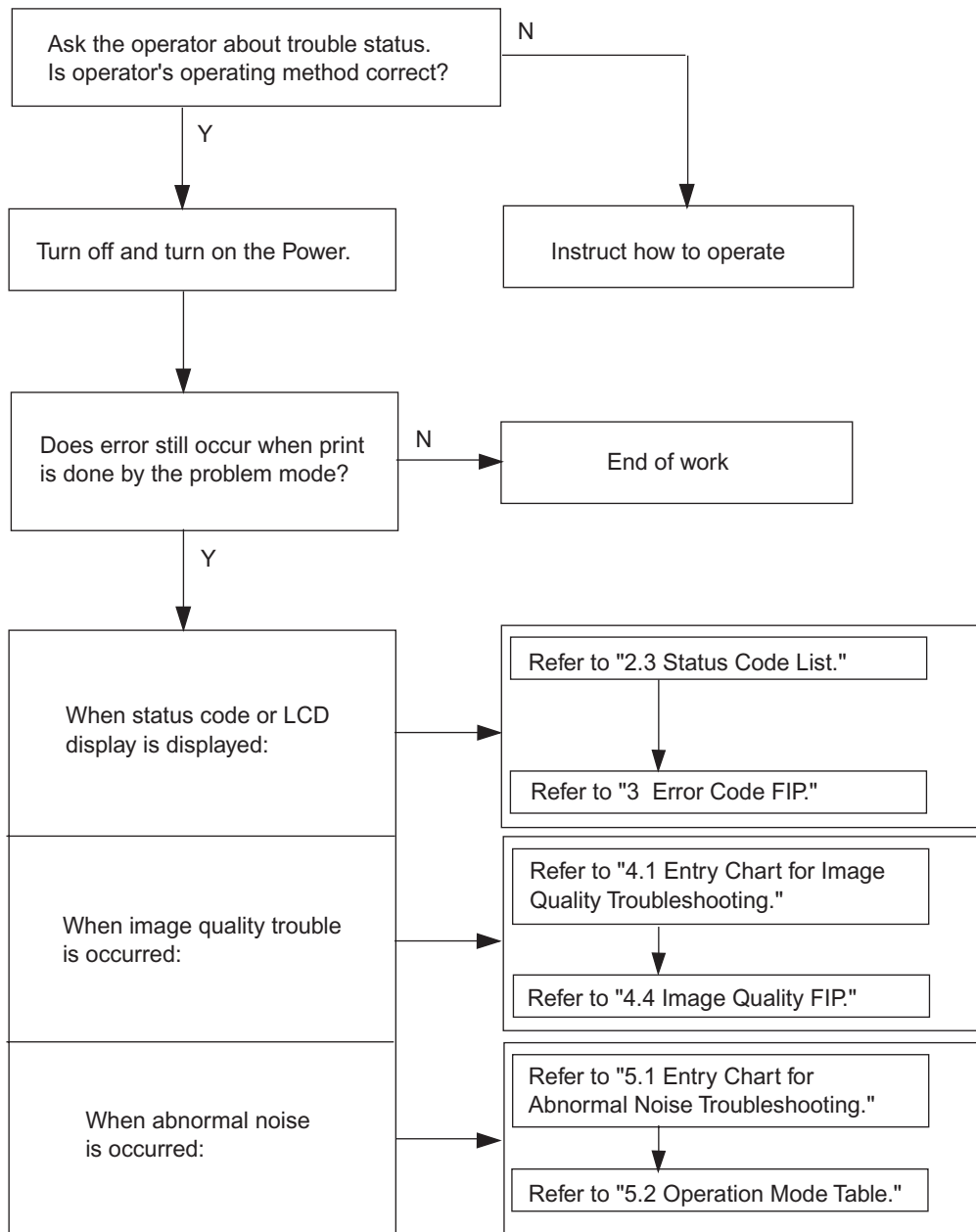

2.3 Status Code List

Error Message		Error Contents	FIP to be referred
LCD	Status Window		
001-360 Restart Printer ⇕ Flip Contact Support IfMessageReturns	Printer error. Turn off the printer, and turn it on again. Contact customer support if this failure is repeated. 001-360-01(or 02)*1	<IOT Fan Motor Failure> MCU detects an error upon receiving error signal from the Rear Fan or Duplexer Fan. Pressing three keys (<↓> + <↑> + <✓>) shows detail error code. Line1 001-360 Line2 Code:01(or 02)*	Flows 1: Rear Fan Flows 2: Duplexer Fan FIP1.1: Rear Fan FIP1.2: Duplexer Fan
	*1: The error code number varies depending on the error contents. 01: "Rear Fan Motor error" 02: "Duplex Fan Motor error"		
003-340 Restart Printer ⇕ Flip Contact Support IfMessageReturns	Printer error. Turn off the printer, and turn it on again. Contact customer support if this failure is repeated. 003-340-01(or 02 to 14)*1	<IOT Firmware Error> MCU firmware error occurs. Pressing three keys (<↓> + <↑> + <✓>) shows detail error code. Line1 003-340 Line2 Code:01(or 02 to 14)*1	Flows 3: Other than Code 09 Flows 4: Code 09 FIP1.3: Other than Code 09 FIP1.4: Code 09
	*1: The error code number varies depending on the error contents. 01-02,04-05,0B-14: "Unexpected firmware trap error" 03: "I2C retry error" 07: "Master fail 1 error" 08: "Master fail 2 error" 09: "NVM illegal data error" 0A: "Over dispense error"		
003-356 Restart Printer ⇕ Flip Contact Support IfMessageReturns	Printer error. Turn off the printer, and turn it on again. Contact customer support if this failure is repeated. 003-356-0000XXXX	<IOT NVRAM Error> The error is detected by MCU NVRAM check. Pressing three keys (<↓> + <↑> + <✓>) shows detail error code. Line1 003-356 Line2 Code:1000-1FFF (or 3100-3CFF)*1	Flows 5 FIP1.5
	*1: The error code number varies depending on the error contents. 1000-1FFF: EEPROM of PWBA MCU 3100-31FF: HVPS 3800-38FF: PWBA EEPROM XPRO 3A00-3AFF: Belt CRUM 3C00-3CFF: Fuser CRUM		
004-310 Restart Printer ⇕ Flip Reseat Feeder Contact Support	Printer error. Turn off the printer. Confirm Feeder is correctly installed. Turn on the printer. Contact customer support if this failure is repeated. 004-310	<IOT Option Feeder Failure> The error is detected by Option Feeder communication check.	Flows 6 FIP1.6

Error Message		Error Contents	FIP to be referred
LCD	Status Window		
004-311 Restart Printer ↕ Flip Reseat Duplexer Contact Support	Printer error. Turn off the printer. Confirm Duplex is correctly installed. Turn on the printer. Contact customer support if this failure is repeated. 004-311	<IOT Option Duplexer Failure> The error is detected by Option Duplexer check.	Flows 7 FIP1.7
006-370 Restart Printer ↕ Flip Contact Support IfMessageReturns	Printer error. Turn off the printer, and turn it on again. Contact customer support if this failure is repeated. 006-370-01(or 02 to 0F)* ¹	<IOT ROS Failure> The rotational error is detected by ROS Motor check. Pressing three keys (<↓> + <↑> + <✓>) shows detail error code. Line1 006-370 Line2 Code:01(or 02 to 0F)* ¹	Flows 8 FIP1.8
	*1: The error code number varies depending on the error contents. 01 to 0F: "IOT ROS Failure error"		
007-340 Restart Printer ↕ Flip Contact Support IfMessageReturns	Printer error. Turn off the printer, and turn it on again. Contact customer support if this failure is repeated. 007-340-01(or 02 to 04)* ¹	<IOT Motor Failure> Motor failure is detected. Pressing three keys (<↓> + <↑> + <✓>) shows detail error code. Line1 007-340 Line2 Code:01(or 02 to 04)* ¹	Flows 9: Main Motor Flows 10: Sub Motor Flows 12: PH Motor Flows 13: Option Feeder Motor FIP1.9: Main Motor FIP1.10: Sub Motor FIP1.12: PH Motor FIP1.13: Option Feeder Motor
	*1: The error code number varies depending on the error contents. 00: "Main Motor error" 01: "Sub Motor error" 02: Not Used 03: "PH Motor error" 04: "Option Feeder Motor error"		
007-371 Restart Printer ↕ Flip Contact Support IfMessageReturns	Printer error. Turn off the printer, and turn it on again. Contact customer support if this failure is repeated. 007-371	<IOT K Mode Solenoid Error> K Mode Solenoid (Color Mode Switching Solenoid) error is detected.	Flows 14 FIP1.14
009-360 Restart Printer ↕ Flip Reseat Y Cart. Contact Support	Printer error. Turn off the printer. Confirm toner is correctly installed. Turn on the printer. Contact customer support if this failure is repeated. 009-360	<IOT (Y) Toner CRUM Error> Yellow Toner CRUM communication error is detected.	Flows 15 FIP1.15

Error Message		Error Contents	FIP to be referred
LCD	Status Window		
009-361 Restart Printer ↕ Flip Reseat M Cart. Contact Support	Printer error. Turn off the printer. Confirm toner is correctly installed. Turn on the printer. Contact customer support if this failure is repeated. 009-361	<IOT (M) Toner CRUM Error> Magenta Toner CRUM communication error is detected.	Flows 16 FIP1.16
009-362 Restart Printer ↕ Flip Reseat C Cart. Contact Support	Printer error. Turn off the printer. Confirm toner is correctly installed. Turn on the printer. Contact customer support if this failure is repeated. 009-362	<IOT (C) Toner CRUM Error> Cyan Toner CRUM communication error is detected.	Flows 17 FIP1.17
009-363 Restart Printer ↕ Flip Reseat K Cart. Contact Support	Printer error. Turn off the printer. Confirm toner is correctly installed. Turn on the printer. Contact customer support if this failure is repeated. 009-363	<IOT (K) Toner CRUM Error> Black Toner CRUM communication error is detected.	Flows 18 FIP1.18
009-654 Restart Printer ↕ Flip Contact Support IfMessageReturns	Printer error. Turn off the printer, and turn it on again. Contact customer support if this failure is repeated. 009-654-01(or 02)* ¹	<IOT ADC Sensor Error> ADC sensor sensed the high density or low density. Pressing three keys (<↓> + <↑> + <✓>) shows detail error code. Line1 009-654 Line2 Code:01(or 02)* ¹	Flows 19: ADC fail 1 (high) Flows 20: ADC fail 2 (low) FIP1.19: ADC fail 1 (high) FIP1.20: ADC fail 2 (low)
010-317 Restart Printer ↕ Flip Reseat Fuser Contact Support	Printer error. Turn off the printer, and turn it on again. Contact customer support if this failure is repeated. 010-317	<IOT Fuser Detached> Fuser detached is detected.	Flows 21 FIP1.21
010-351 Replace Fuser ↕ Flip Replace Fuser	Printer error. Turn off the printer, and turn it on again. Contact customer support if this failure is repeated. 010-351	<IOT Fuser Life Over> The value of Fuser counter has reached the replacement time.	Flows 22 FIP1.22

Error Message		Error Contents	FIP to be referred
LCD	Status Window		
010-354 Restart Printer ↕ Flip Contact Support IfMessageReturns	Printer error. Turn off the printer, and turn it on again. Contact customer support if this failure is repeated. 010-354	<IOT environment Sensor Error> Temperature Sensor Error is detected.	Flows 23 FIP1.23
010-377 Restart Printer ↕ Flip Reseat Fuser Contact Support	Printer error. Turn off the printer. Confirm Fuser is correctly installed. Turn on the printer. Contact customer support if this failure is repeated. 010-377-01(or 02 to 13)*1	<IOT Fuser Failure> The NC sensor circuit is defective in the MCU. NC: No Contact Pressing three keys (<↓> + <↑> + <✓>) shows detail error code. Line1 010-377 Line2 Code:01(or 02 to 13)*1	Flows 24 FIP1.24
	*1: The error code number varies depending on the error contents. 01: "NC circuit fail error" 02: "NCD snap out error" 03: "NCD fail error" 04: "NCC snap out error" 05: "NC comp fail error" 06: "NC-STs temp over error" 07: "STs-NC temp over error" 08: "NC comp fail error" 09: "NC overheat error" 0A: "STs snap out error" 0B: "STs overheat error" 0C: "Low temp1 error" 0D: "Low temp2 error" 0E: "Timeout 1 error" 0F: "Timeout 2 error" 10: "Timeout 3 error" 11: "Relay cutoff 1 error" 12: "Relay cutoff 2 error" 13: "Relay cutoff 3 error"		
016-300 Restart Printer ↕ Flip Contact Support IfMessageReturns	Printer error. Turn off the printer, and turn it on again. Contact customer support if this failure is repeated. 016-300	<ESS Data Cache Error> CPU data cache error.	Flows 25 FIP1.25
016-301 Restart Printer ↕ Flip Contact Support IfMessageReturns	Printer error. Turn off the printer, and turn it on again. Contact customer support if this failure is repeated. 016-301	<ESS Instruction Cache Error> CPU instruction cache error.	Flows 25 FIP1.25

Error Message		Error Contents	FIP to be referred
LCD	Status Window		
016-302 Restart Printer ↕ Flip Contact Support IfMessageReturns	Printer error. Turn off the printer, and turn it on again. Contact customer support if this failure is repeated. 016-302	<ESS Illegal Exception> CPU illegal exception.	Flows 25 FIP1.25
016-310 Restart Printer ↕ Flip Contact Support IfMessageReturns	Printer error. Turn off the printer, and turn it on again. Contact customer support if this failure is repeated. 016-310	<ESS FontROM Error (Main)> Checksum error in the built-in font ROM.	Flows 25 FIP1.25
016-312 Restart Printer ↕ Flip Contact Support IfMessageReturns	Printer error. Turn off the printer, and turn it on again. Contact customer support if this failure is repeated. 016-312	<ESS HDD Fail> HDD error is detected.	Flows 26 FIP1.26
016-313 Restart Printer ↕ Flip Contact Support IfMessageReturns	Printer error. Turn off the printer, and turn it on again. Contact customer support if this failure is repeated. 016-313	<ESS ASIC Fail> The error is detected by ASIC error.	Flows 25 FIP1.25
016-315 Restart Printer ↕ Flip Contact Support IfMessageReturns	Printer error. Turn off the printer, and turn it on again. Contact customer support if this failure is repeated. 016-315	<ESS On Board RAM R/W Check Fail> The error is detected by on board RAM R/W check during initialization.	Flows 25 FIP1.25
016-316 Restart Printer ↕ Flip Reseat Memory Contact Support	Printer error. Turn off the printer. Confirm Memory is correctly installed. Turn on the printer. Contact customer support if this failure is repeated. 016-316	<ESS DIMM Slot RAM R/W Check Fail> The error is detected by DIMM slot RAM R/W check during initialization.	Flows 27 FIP1.27
016-317 Restart Printer ↕ Flip Contact Support IfMessageReturns	Printer error. Turn off the printer, and turn it on again. Contact customer support if this failure is repeated. 016-317	<ESS ROM Check (Main) Fail> Checksum error in the main program ROM.	Flows 25 FIP1.25

Error Message		Error Contents	FIP to be referred
LCD	Status Window		
016-318 Restart Printer ↕ Flip Reseat Memory Contact Support	Printer error. Turn off the printer, and turn it on again. Contact customer support if this failure is repeated. 016-318	<ESS DIMM Slot RAM Error> Power-on initialization detected that unsupported DIMM was installed.	Flows 27 FIP1.27
016-323 Restart Printer ↕ Flip Contact Support IfMessageReturns	Printer error. Turn off the printer, and turn it on again. Contact customer support if this failure is repeated. 016-323	<ESS NVRAM 1 R/W Check Fail> The fail is detected by NVRAM 1 R/W check during initialization.	Flows 25 FIP1.25
016-327 Restart Printer ↕ Flip Contact Support IfMessageReturns	Printer error. Turn off the printer, and turn it on again. Contact customer support if this failure is repeated. 016-327	<ESS NVRAM 1 SIZE And ID Check Fail> The error is detected by consistency check between the NVRAM size required by the system and its actual size, and by consistency check of the ID recorded when turning ON the power.	Flows 25 FIP1.25
016-338 Restart Printer ↕ Flip Reseat Wireless Contact Support	Printer error. Turn off the printer, and turn it on again. Contact customer support if this failure is repeated. 016-338	<Wireless Option Error> The error is detected by Wireless option check.	Flows 28 FIP1.28
016-340 Restart Printer ↕ Flip Contact Support IfMessageReturns	Printer error. Turn off the printer, and turn it on again. Contact customer support if this failure is repeated. 016-340	<ESS Network Communication Fail> Communication error between CPU network and ESS F/W.	Flows 25-1 FIP1.25
016-344 Restart Printer ↕ Flip Contact Support IfMessageReturns	Printer error. Turn off the printer, and turn it on again. Contact customer support if this failure is repeated. 016-344	<ESS Network MAC Address Checksum Error> Checksum error in the Network MAC address.	Flows 25 FIP1.25
016-345 Restart Printer ↕ Flip Contact Support IfMessageReturns	Printer error. Turn off the printer, and turn it on again. Contact customer support if this failure is repeated. 016-345	<ESS Network Ethernet BIST parity/ RAM R/W Error> The error is detected by network Ethernet parity RAM R/W check.	Flows 25 FIP1.25

Error Message		Error Contents	FIP to be referred
LCD	Status Window		
016-346 Restart Printer ↕ Flip Contact Support IfMessageReturns	Printer error. Turn off the printer, and turn it on again. Contact customer support if this failure is repeated. 016-346	<ESS Network Internal Loopback Error> The error is detected by on board Network Internal Loopback check.	Flows 25 FIP1.25
016-347 Restart Printer ↕ Flip Contact Support IfMessageReturns	Printer error. Turn off the printer, and turn it on again. Contact customer support if this failure is repeated. 016-347	<ESS Network Fatal Error> The fatal error is detected by On Board Network check.	Flows 25 FIP1.25
016-350 Restart Printer ↕ Flip Reseat Parallel Contact Support	Printer error. Turn off the printer, and turn it on again. Contact customer support if this failure is repeated. 016-350	<IEEE1284 Data Error> The error is detected by IEEE1284 controller of ESS.	Flows 29 FIP1.29
016-361 Restart Printer ↕ Flip Reseat HDD Contact Support	Printer error. Turn off the printer, and turn it on again. Contact customer support if this failure is repeated. 016-361	<ESS PCI Option #0 Fail> Detection error of PCI option 0.	Flows 26 FIP1.26
016-365 Restart Printer ↕ Flip Reseat NPA Contact Support	Printer error. Turn off the printer, and turn it on again. Contact customer support if this failure is repeated. 016-365	<HW Key Option Fatal Error> Network Adapter error is detected when it is connected to the printer.	Flows 30 FIP1.30
016-370 Restart Printer ↕ Flip Contact Support IfMessageReturns	Printer error. Turn off the printer, and turn it on again. Contact customer support if this failure is repeated. 016-370	<MCU-ESS Communication Fail> Communication fail between MCU and ESS.	Flows 31 FIP1.31
093-964 Restart Printer ↕ Flip Reseat Fuser Contact Support	Printer error. Turn off the printer, and turn it on again. Contact customer support if this failure is repeated. 093-964	<IOT Fuser CRUM ID Error> Fuser CRUM communication error is detected.	Flows 32 FIP1.32

Problem	Error Message		Error Contents	FIP to be referred
	LCD	Status Window		
Paper Jam	Paper Jam 071-100 ⇕ Flip Open Tray1 Remove Paper ⇕ Flip Open & close Front Cover	Paper Jam has occurred at the Tray 1. Clear the paper path. Please click the Show Me How Button for details. 071-100	<IOT 250 Feeder Misfeed JAM> The Regi sensor is not turned ON within the specified time.	Flows 33 FIP1.33
	Paper Jam 072-100 ⇕ Flip Open Tray2 Remove Paper ⇕ Flip Open & close Front Cover	Paper Jam has occurred at the Tray 2. Clear the paper path. Please click the Show Me How Button for details. 072-100	<IOT Option Feeder Misfeed JAM> The Regi sensor is not turned ON within the specified time.	Flows 34 FIP1.34
	Paper Jam 075-100 ⇕ Flip Check MPF Remove Paper ⇕ Flip Open & close Front Cover	Paper Jam has occurred at the MPF. Clear the paper path. Please click the Show Me How Button for details. 075-100	<IOT MPF Misfeed JAM> The Regi sensor is not turned ON within the specified time.	Flows 35 FIP1.35
	Paper Jam 077-100 ⇕ Flip Open Front Cover Remove Paper	Paper Jam has occurred at the Print Cartridge. Push the Side Button to open the Front Cover and remove the jammed paper. 077-100	<IOT Reg1 JAM> Fuser Exit Senor does not turn ON after a paper is detected by Registra- tion Sensor.	Flows 36 FIP1.36
	Paper Jam 077-101 ⇕ Flip Open Front Cover Remove Paper	Paper Jam has occurred at the Print Cartridge. Push the Side Button to open the Front Cover and remove the jammed paper. 077-101	<IOT Reg2 JAM> Registration Senor does not turn OFF after a paper is detected by Registra- tion Sensor.	Flows 36 FIP1.36
	Paper Jam 077-102 ⇕ Flip Open Front Cover Remove Paper	Paper Jam has occurred at the Print Cartridge. Push the Side Button to open the Front Cover and remove the jammed paper. 077-102	<IOT Exit1 JAM> Fuser Exit Senor does not turn OFF after a paper is detected by Fuser Exit Sensor.	Flows 37 FIP1.37

Problem	Error Message		Error Contents	FIP to be referred
	LCD	Status Window		
Paper Jam	Paper Jam 077-103 ↕ Flip Open Front Cover Remove Paper	Paper Jam has occurred at the Print Cartridge. Push the Side Button to open the Front Cover and remove the jammed paper. 077-103	<IOT Exit2 JAM> Fuser Exit Senor detect turn OFF too early after a paper is detected by Fuser Exit Sensor.	Flows 37 FIP1.37
	Paper Jam 077-104 ↕ Flip Open Front Cover & Belt Unit Remove Paper	Paper Jam has occurred at the Duplexer. Push the Side Button to open the Front Cover and the Belt Unit. Then remove the jammed paper. 077-104	<IOT Duplexer1 JAM> Registration Senor detects turn ON too early after a paper is detected by Duplexer JAM Sensor.	Flows 38 FIP1.38
	Paper Jam 077-105 ↕ Flip Open Front Cover & Belt Unit Remove Paper	Paper Jam has occurred at the Duplexer. Push the Side Button to open the Front Cover and the Belt Unit. Then remove the jammed paper. 077-105	<IOT Duplexer2 JAM> Duplexer Senor does not turn ON after switching back a paper.	Flows 39 FIP1.39
	Paper Jam 077-106 ↕ Flip Open Front Cover & Belt Unit Remove Paper	Paper Jam has occurred at the Duplexer. Push the Side Button to open the Front Cover and the Belt Unit. Then remove the jammed paper. 077-106	<IOT Duplexer3 JAM> Duplexer Senor does not turn OFF after a paper is detected by Duplexer JAM Sensor.	Flows 39 FIP1.39
	Paper Jam 077-107 ↕ Flip Open Front Cover & Belt Unit Remove Paper	Paper Jam has occurred at the Duplexer. Push the Side Button to open the Front Cover and the Belt Unit. Then remove the jammed paper. 077-107	<IOT Duplexer4 JAM> Registration Senor does not turn ON after a paper is detected by Duplexer JAM Sensor.	Flows 38 FIP1.38

Problem	Error Message		Error Contents	FIP to be referred
	LCD	Status Window		
Paper Jam	Paper Jam 077-900 ↕ Flip Open Front Cover Remove Paper	Paper Jam has occurred at the Print Cartridge. Push the Side Button to open the Front Cover and remove the jammed paper. 077-900	<IOT Remain Paper JAM> -The remain paper at the Exit Sensor. -The paper does not reach the Exit Sensor within the specified time. -The paper passed Exit Sensor earlier than the specified times.	Flows 40 FIP1.40
	Paper Jam 077-901 ↕ Flip Open Front Cover Remove Paper	Paper Jam has occurred at the Print Cartridge. Push the Side Button to open the Front Cover and remove the jammed paper. 077-901	<IOT Remain Paper JAM> -The remain paper at the Regi Sensor. -The paper does not reach the Exit Sensor within the specified time after the Regi Sensor is ON. -The paper does not pass through the Regi Sensor within the specified time.	Flows 40 FIP1.40
	Paper Jam 077-903 ↕ Flip Open Tray1 Remove Paper ↕ Flip Open & close Front Cover	Paper Jam has occurred at the Tray 1. Clear the paper path. Please click the Show Me How Button for details. 077-903	<IOT Feed JAM> The arrival time of the regi sensor is early than the specified time.	Flows 41 FIP1.41
	Paper Jam 077-907 ↕ Flip Open Front Cover & Belt Unit ↕ Flip Remove Paper	Paper Jam has occurred at the Duplexer. Push the Side Button to open the Front Cover and the Belt Unit. Then remove the jammed paper. 077-907	<IOT Duplexer Remain Paper JAM> -The remain paper at the Dup Jam Sensor. -The paper reached Dup Jam Sensor earlier than the specified time. -The paper passed Dup Jam Sensor earlier than the specified time. -The paper does not pass through the Dup Jam Sensor within the specified time. -The paper does not reach the Regi Sensor within the specified time, after the Dup Jam Sensor is ON.	Flows 42 FIP1.42

Problem	Error Message		Error Contents	FIP to be referred
	LCD	Status Window		
Paper Setting	Load Tray 1 024-910 ↕ Flip Load Tray 1 A4(Paper Size) ↕ Flip Load Tray 1 Plain(Paper Type)	Actual paper size in tray and specified paper size are different. Load the specified paper in Tray 1. Paper Size: A4 Paper Type: Plain 024-910	<IOT Paper Size Mismatch> The paper size mismatch is detected	Flows 43 FIP1.43
	Load Tray 2 024-911 ↕ Flip Load Tray 2 A4(Paper Size) ↕ Flip Load Tray 2 Plain(Paper Type)	Actual paper size in tray and specified paper size are different. Load the specified paper in Tray 2. Paper Size: A4 Paper Type: Plain 024-911		
	Load Tray MPF 024-914 ↕ Flip Load MPF A4(Paper Size) ↕ Flip Load MPF Plain(Paper Type)	Actual paper size in tray and specified paper size are different. Load the specified paper in MPF. Paper Size: A4 Paper Type: Plain 024-914		
	Load Tray 1 024-965 ↕ Flip Load Tray 1 A4(Paper Size) ↕ Flip Load Tray 1 Plain(Paper Type)	No paper detected. Load the specified paper in Tray 1. Paper Size: A4 Paper Type: Plain 024-965	<IOT No Suitable Paper> The specified tray is paper empty, size mismatch or type mismatch.	Flows 44 FIP1.44
	Load Tray 2 024-966 ↕ Flip Load Tray 2 A4(Paper Size) ↕ Flip Load Tray 2 Plain(Paper Type)	No paper detected. Load the specified paper in Tray 2. Paper Size: A4 Paper Type: Plain 024-966		
	Load Tray MPF 024-969 ↕ Flip Load MPF A4(Paper Size) ↕ Flip Load MPF Plain(Paper Type)	No paper detected. Load the specified paper in MPF. Paper Size: A4 Paper Type: Plain 024-969		

Problem	Error Message		Error Contents	FIP to be referred
	LCD	Status Window		
Toner	CRUM ID 009-367 ⇕ Flip Reseat Cyan Cartridge	An unsupported Cyan Cartridge is installed. Open the Front Cover. Remove the unsupported Cyan Cartridge and install a supported one. Please click the Show Me How Button for details. 009-367	<IOT Print Cartridge ID Error> The toner CRUM ID error is detected.	Flows 45 FIP1.45
	CRUM ID 009-368 ⇕ Flip Reseat Magenta Cartridge	An unsupported Magenta Cartridge is installed. Open the Front Cover. Remove the unsupported Magenta Cartridge and install a supported one. Please click the Show Me How Button for details. 009-368		
	CRUM ID 009-369 ⇕ Flip Reseat Yellow Cartridge	An unsupported Yellow Cartridge is installed. Open the Front Cover. Remove the unsupported Yellow Cartridge and install a supported one. Please click the Show Me How Button for details. 009-369		
	CRUM ID 009-370 ⇕ Flip Reseat Black Cartridge	An unsupported Black Cartridge is installed. Open the Front Cover. Remove the unsupported Black Cartridge and install a supported one. Please click the Show Me How Button for details. 009-370		

Problem	Error Message		Error Contents	FIP to be referred
	LCD	Status Window		
Toner	Error Yellow Cart 093-919 ⇕ Flip Remove Tape from Yellow Cart	The sealing tape is still on the Yellow Cartridge. Open the Front Cover. Pull the toner seal straight up to remove it. Please click the Show Me How Button for details. 093-919	<IOT Toner Seal Staying : on the default Print Cartridge> The toner seal staying is detected. When a new print cartridge is installed, the ADC sensor checks that the density of the toner patch on the transfer belt does not reach the spec- ified value.	Flows 46 Y Flows 47 M Flows 48 C Flows 49 K FIP1.46 Y FIP1.47 M FIP1.48 C FIP1.49 K
	Error Magenta Cart 093-920 ⇕ Flip Remove Tape from Magenta Cart	The sealing tape is still on the Magenta Car- tridge. Open the Front Cover. Pull the toner seal straight up to remove it. Please click the Show Me How Button for details. 093-920		
	Error Cyan Cart 093-921 ⇕ Flip Remove Tape from Cyan Cart	The sealing tape is still on the Cyan Cartridge. Open the Front Cover. Pull the toner seal straight up to remove it. Please click the Show Me How Button for details. 093-921		
	Error Black Cart 093-922 ⇕ Flip Remove Tape from Black Cart	The sealing tape is still on the Black Cartridge. Open the Front Cover. Pull the toner seal straight up to remove it. Please click the Show Me How Button for details. 093-922		

Problem	Error Message		Error Contents	FIP to be referred
	LCD	Status Window		
Toner	Error Yellow Cart 093-950 ⇕ Flip Remove Sheet from Yellow Cart	The protection cover is still on the Yellow Cartridge. Open the Front Cover. Remove the protection cover. Please click the Show Me How Button for details. 093-950	<IOT CRU Cover Staying : on the reordered Print Cartridge> The CRU Cover staying is detected. When a new print cartridge is installed, the ADC sensor checks that the density of the toner patch on the transfer belt does not reach the specified value.	Flows 50 FIP1.50
	Error Magenta Cart 093-951 ⇕ Flip Remove Sheet from Magenta Cart	The protection cover is still on the Magenta Cartridge. Open the Front Cover. Remove the protection cover. Please click the Show Me How Button for details. 093-951		
	Error Cyan Cart 093-952 ⇕ Flip Remove Sheet from Cyan Cart	The protection cover is still on the Cyan Cartridge. Open the Front Cover. Remove the protection cover. Please click the Show Me How Button for details. 093-952		
	Error Black Cart 093-953 ⇕ Flip Remove Sheet from Black Cart	The protection cover is still on the Black Cartridge. Open the Front Cover. Remove the protection cover. Please click the Show Me How Button for details. 093-953		

Problem	Error Message		Error Contents	FIP to be referred
	LCD	Status Window		
Toner	Replace Cart. 093-930 ⇕ Flip Reseat Yellow Cartridge	The Yellow Cartridge need to be replaced now. Open the Front Cover. Then remove the used Yellow Cartridge and install a new one. Please click the Show Me How Button for details. 093-930	<IOT Print Cartridge Life Over> The value of print cartridge counter has reached the replacement time. When all print cartridges have reached their replacement timing at the same time, a warning is indicated on the LCD panel in the following order: 1)Black → 2)Cyan → 3)Magenta → 4)Yellow	Flows 51 FIP1.51
	Replace Cart. 093-931 ⇕ Flip Reseat Magenta Cartridge	The Magenta Cartridge need to be replaced now. Open the Front Cover. Then remove the used Magenta Cartridge and install a new one. Please click the Show Me How Button for details. 093-931		
	Replace Cart. 093-932 ⇕ Flip Reseat Cyan Cartridge	The Cyan Cartridge need to be replaced now. Open the Front Cover. Then remove the used Cyan Cartridge and install a new one. Please click the Show Me How Button for details. 093-932		
	Replace Cart. 093-933 ⇕ Flip Reseat Black Cartridge	The Black Cartridge need to be replaced now. Open the Front Cover. Then remove the used Black Cartridge and install a new one. Please click the Show Me How Button for details. 093-933		

Problem	Error Message		Error Contents	FIP to be referred
	LCD	Status Window		
Toner	Ready to Print 093-423 ↕ Flip Yellow Cartridge Is close to Life	The Yellow Cartridge need to be replaced soon. 093-423	<IOT Print Cartridge Near Empty> The value of print cartridge counter is going to reach the replacement time. When all print cartridges are near their replacement timing at the same time, a warning is indicated on the LCD panel in the following order: 1)Black → 2)Cyan → 3)Magenta → 4)Yellow	Flows 52 FIP1.52
	Ready to Print 093-424 ↕ Flip Magenta Cartridge Is close to Life	The Magenta Cartridge need to be replaced soon. 093-424		
	Ready to Print 093-425 ↕ Flip Cyan Cartridge Is close to Life	The Cyan Cartridge need to be replaced soon. 093-425		
	Ready to Print 093-426 ↕ Flip Black Cartridge Is close to Life	The Black Cartridge need to be replaced soon. 093-426		

Problem	Error Message		Error Contents	FIP to be referred
	LCD	Status Window		
Toner	Insert PrintCart 093-970 ⇕ Flip Insert Yellow Cartridge	The Yellow Cartridge is either missing or not fully inserted into the printer. Open the Front Cover and make sure that the Yellow Cartridge have been fully installed. Please click the Show Me How Button for details. 093-970	<IOT Print Cartridge Detached> The yellow, magenta, cyan or black Print Cartridge detached is detected. The print cartridge sensor detected the cartridge detached. When no print cartridges are installed, a warning is indicated on the LCD panel in the following order: 1)Black → 2)Cyan → 3)Magenta → 4)Yellow	Flows 53 Y Flows 54 M Flows 55 C Flows 56 K FIP1.53 Y FIP1.54 M FIP1.55 C FIP1.56 K
	Insert PrintCart 093-971 ⇕ Flip Insert Magenta Cartridge	The Magenta Cartridge is either missing or not fully inserted into the printer. Open the Front Cover and make sure that the Magenta Cartridge have been fully installed. Please click the Show Me How Button for details. 093-971		
	Insert PrintCart 093-972 ⇕ Flip Insert Cyan Cartridge	The Cyan Cartridge is either missing or not fully inserted into the printer. Open the Front Cover and make sure that the Cyan Cartridge have been fully installed. Please click the Show Me How Button for details. 093-972		
	Insert PrintCart 093-973 ⇕ Flip Insert Black Cartridge	The Black Cartridge is either missing or not fully inserted into the printer. Open the Front Cover and make sure that the Black Cartridge have been fully installed. Please click the Show Me How Button for details. 093-973		

Problem	Error Message		Error Contents	FIP to be referred
	LCD	Status Window		
Belt	CRUM ID 009-371 ↕ Flip Reseat Belt Unit	An unsupported Belt Unit is installed. Open the Front Cover. Remove the unsupported Belt Unit and install a supported one. Please click the Show Me How Button for details. 009-371	<IOT Belt Unit CRUM ID Error> The Belt Unit CRUM ID error is detected. The Belt Unit CRUM ID read by the sensor is different from the one that was recorded.	Flows 57 FIP1.57
	Ready to Print 094-422 ↕ Flip Replace Belt Contact Support	Contact customer support if this failure is repeated. 094-422	<IOT Belt Unit Life Warning> The Belt Unit Counter is going to reach the replacement time.	Flows 58 FIP1.58
	Insert Belt Unit 094-910 ↕ Flip Insert Belt Unit	The Belt Unit is either missing or not fully inserted into the printer. Open the Front Cover and make sure that the Belt Unit have been fully installed. Please click the Show Me How Button for details. 094-910	<IOT Belt Unit Detached> The Belt Unit Detached is detected.	Flows 59 FIP1.59
	Belt Unit 094-911 ↕ Flip Replace Belt Contact Support	The Belt Unit needs to be replaced now. Remove the used Belt Unit and install a new one. Please click the Show Me How Button for details. 094-911	<IOT Belt Unit Life Over> The Belt Unit Counter has reached the replacement time.	Flows 60 FIP1.60

Problem	Error Message		Error Contents	FIP to be referred
	LCD	Status Window		
Fuser	010-351 Restart Printer ↕ Flip Reseat Fuser Contact Support	The Fuser needs to be replaced now. Remove the used Fuser and install a new one. Please click the Show Me How Button for details. 010-351	<IOT Fuser Life Over> The Fuser Counter has reached the replacement time.	Flows 22 FIP1.22
	010-359 Restart Printer ↕ Flip Reseat Fuser Contact Support	An unsupported Fuser is installed. Open the Front Cover. Remove the unsupported Fuser and install a supported one. Please click the Show Me How Button for details. 010-359	<IOT Fuser CRUM ID Error> The Fuser CRUM ID error is detected. The Fuser CRUM ID read by the sensor is different from the one that was recorded.	Flows 61 FIP1.61
	Ready to Print 010-421 ↕ Flip Replace Fuser Contact Support	Contact customer support if this failure is repeated. 010-421	<IOT Fuser Life Warning> The Fuser Counter is going to reach the replacement time.	Flows 62 FIP1.62
Tray	Tray Detached 024-946 ↕ Flip Push In Tray 1	No Message.	<IOT Tray Detached> The paper cassette(Tray1) is detached. The Tray Size Switch detected the no tray.	Flows 63 FIP1.63
	Tray Detached 024-947 ↕ Flip Push In Tray 2	No Message.	<IOT Tray Detached> The paper cassette(Tray2) is detached. The Tray Size Switch detected the no tray.	Flows 64 FIP1.64
	Load Tray 1 077-912 ↕ Flip Push In Tray 1	Insert Tray 1. Tray cannot be detected. 077-912	<Upper Cassette Detached> The Tray 1 paper cassette is detached when the tray 2 is selected. The Tray Size Switch detected the no tray.	Flows 63 FIP1.63
Cover Open	Close FrontCover 077-300 ↕ Flip Front Cover Is Open	The Front Cover is open. Close the Front Cover. 077-300	<IOT Cover Front Open> The Front Cover is open.	Flows 65 FIP1.65

Problem	Error Message		Error Contents	FIP to be referred
	LCD	Status Window		
Other	Invalid ID 016-383 ↕ Flip Data Violation Press ✓	Firmware download ID error has occurred. Press the Set Button. Contact customer support if this failure is repeated. 016-383	<Download Error> An error occurred because an invalid firmware is installed.	Flows 66 FIP1.66
	Range Chk Error 016-384 ↕ Flip Data Violation Press ✓	Firmware download range error has occurred. Press the Set Button. Contact customer support if this failure is repeated. 016-384	<Download Error> The address of the write destination is invalid.	Flows 66 FIP1.66
	Header Error 016-385 ↕ Flip Data Violation Press ✓	Firmware download header checksum error has occurred. Press the Set Button. Contact customer support if this failure is repeated. 016-385	<Download Error> The header information is invalid.	Flows 66 FIP1.66
	Check Sum Error 016-386 ↕ Flip Data Violation Press ✓	Firmware download checksum error has occurred. Press the Set Button. Contact customer support if this failure is repeated. 016-386	<Download Error> The checksum is invalid.	Flows 66 FIP1.66
	Format Error 016-387 ↕ Flip Data Violation Press ✓	Firmware download format error has occurred. Press the Set Button. Contact customer support if this failure is repeated. 016-387	<Download Error> The format is invalid.	Flows 66 FIP1.66

Problem	Error Message		Error Contents	FIP to be referred
	LCD	Status Window		
Other	Erase Flash Err. 016-392 ↕ Flip Contact Support IfMessageReturns	Firmware download delete error has occurred. Contact customer support if this failure is repeated. 016-392	<Download Error> An error occurred erasing the Flash.	Flows 25 FIP1.25
	Write Flash Err. 016-393 ↕ Flip Contact Support IfMessageReturns	Firmware download write error has occurred. Contact customer support if this failure is repeated. 016-393	<Download Error> An error occurred writing the Flash.	Flows 25 FIP1.25
	Verify Error 016-394 ↕ Flip Contact Support IfMessageReturns	Firmware download verify error has occurred. Contact customer support if this failure is repeated. 016-394	<Download Error> An error occurred verifying the Flash.	Flows 25 FIP1.25
	Out of Memory 016-700 ↕ Flip Job too Large Press ✓	The printer memory is full and cannot continue processing the current print job. Press Set Button to clear the message, cancel the current print job. Please click the Show Me How Button for details. 016-700	<Memory Over flow> The printer memory is full and cannot continue processing the current print job.	Flows 67 FIP1.67
	Disk Full 016-980 ↕ Flip Job too Large Press ✓	Disk space is insufficient and cannot continue processing the current print job. Press Set Button to clear the message, cancel the current print job. Please click the Show Me How Button for details. 016-980	<Memory Over flow> RAM disk memory or hard disk is full and cannot continue processing the current print job.	Flows 68 FIP1.67

Problem	Error Message		Error Contents	FIP to be referred
	LCD	Status Window		
Other	Collate Full 016-981 ↕ Flip Job too Large Press ✓	Disk space is insufficient and cannot continue processing the current print job. Press Set Button to clear the message, cancel the current print job. Please click the Show Me How Button for details. 016-981	<Memory Over flow> Exceeds the memory capacity.	Flows 69 FIP1.67
	PDL Error 016-720 ↕ Flip Data Violation Press ✓	Error relating to PDL emulation problems occurs. Press Set Button to clear the message, cancel the current print job. Please click the Show Me How Button for details. 016-720	<PDL Error> PDL error occurs. The print data cannot be processed by PDL.	Flows 70 FIP1.68
	Invalid User 016-757 ↕ Flip Account Denied Press ✓	Authentication error has occurred. The account is not registered. Please inquire of the system administrator. 016-757	<Auditron Error> An error occurred because the user's account settings did not match those of the Administrator.	Flows 71 FIP1.69
	Disabled Func 016-758 ↕ Flip Denied Col print Press ✓	Function unavailable. It is a function that cannot be used. Please inquire of the system administrator. 016-758	<Auditron Error> An error occurred because a user authorized only for B&W print attempted to execute color printing.	Flows 72 FIP1.69
	Reached Limits 016-759 ↕ Flip Over your limits Press ✓	Printable page limit reached. Printable page limit reached, cannot print. Please inquire of the system administrator. 016-759	<Auditron Error> An attempt was made to print more copies than the print count limit.	Flows 73 FIP1.69

Problem	Error Message		Error Contents	FIP to be referred
	LCD	Status Window		
Other	Invalid Job 016-799 ↕ Flip Data Violation Press ✓	The configuration of the printer on the printer driver does not conform to the printer. Press the Cancel button to cancel the print job. Make sure that the configuration of the printer on the printer driver conforms to the printer. 016-799	<Job Environment Violation> Detects violation data for the print condition. The print data specifies paper type/size not available for the printer.	Flows 74 FIP1.70
	Ready to Print 193-700 ↕ Flip non-DELL Toner Installed	No Message.	<Custom Toner Mode> The printer is in custom toner mode.	Flows 75 FIP1.71
	Over Heat 042-700 ↕ Flip cooling down Please Wait...	An internal temperature of the printer became a high temperature. Please wait for a while until falling in temperature. 042-700	<IOT Over Heat Stop> The temp. sensor sensed high temperature.	Flows 76 FIP1.72
	Ready to Print 142-700 ↕ Flip Over Heat Turned Halfmode	No Message.	<IOT Over Heat Warning> The printing mode becomes half speed mode, by the high temperature. The temp. sensor sensed high temperature.	Flows 76 FIP1.72

3. Error Code FIP

3.1 Troubleshooting for the call center

Flows 1 001-360-01 Restart Printer

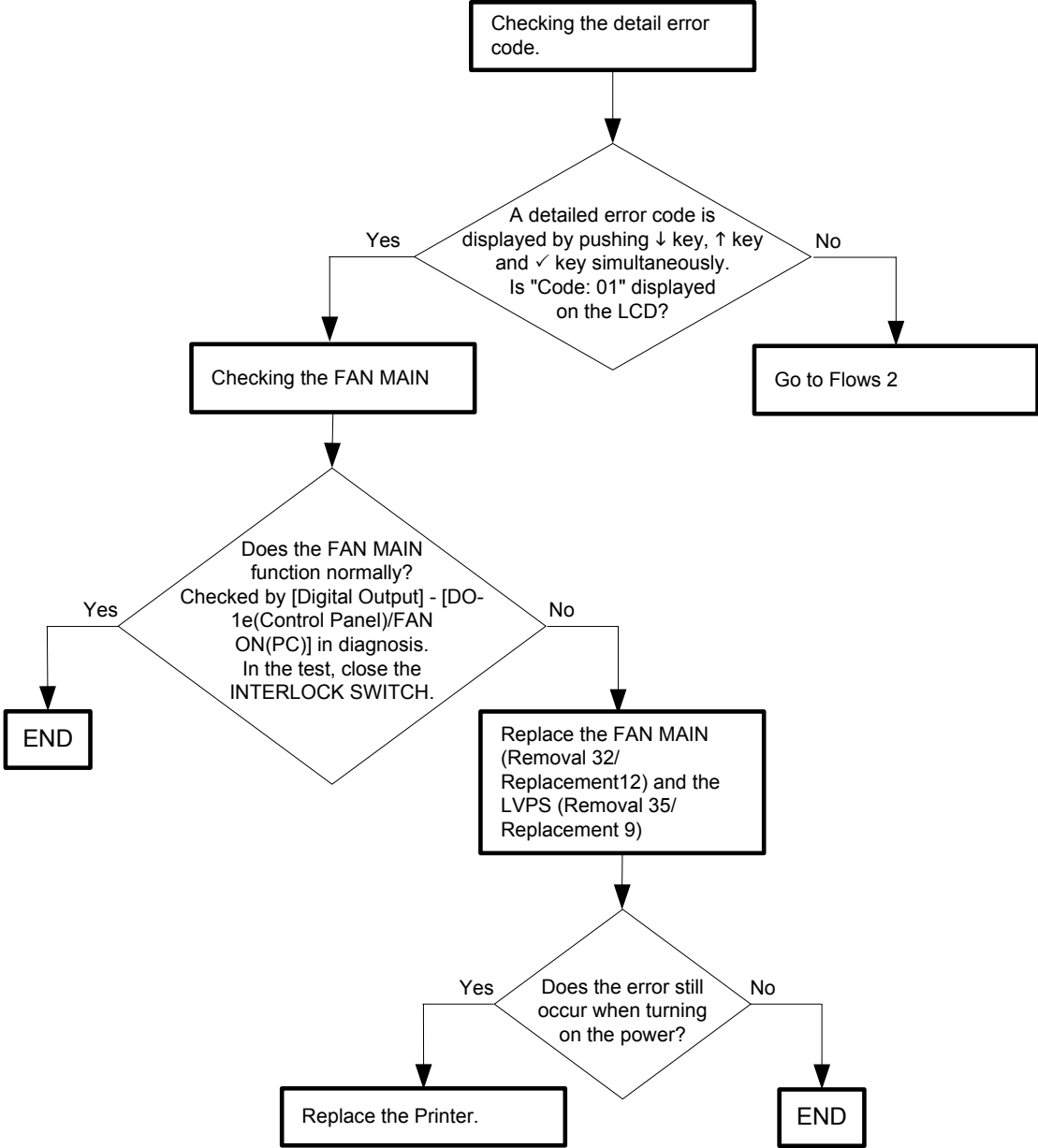

Flows 2 001-360-02 Restart Printer

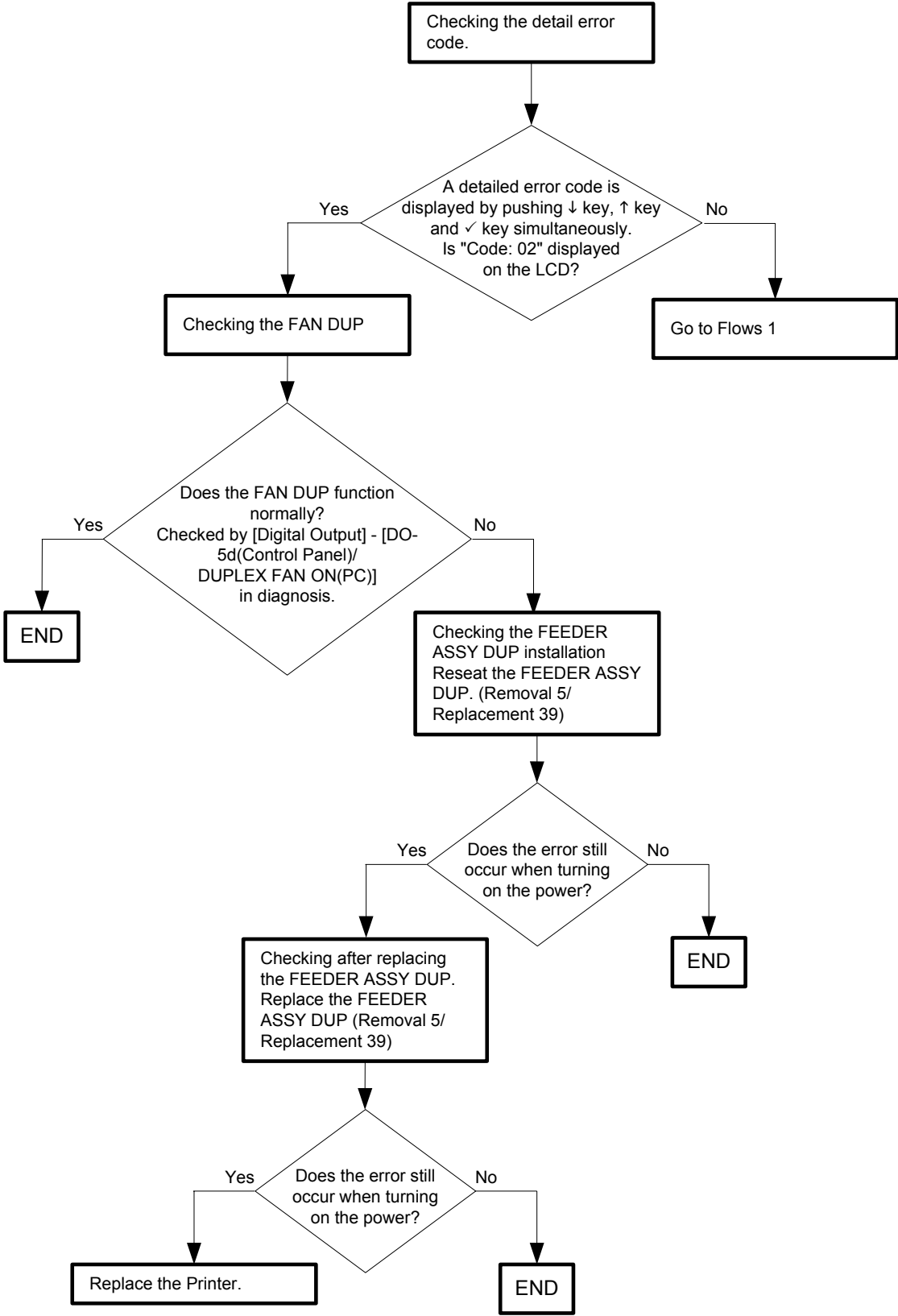

Flows 3 003-340-01/003-340-02/003-340-03/003-340-04/003-340-05/003-340-07/003-340-08/003-340-0A/003-340-0B/003-340-14 Restart Printer

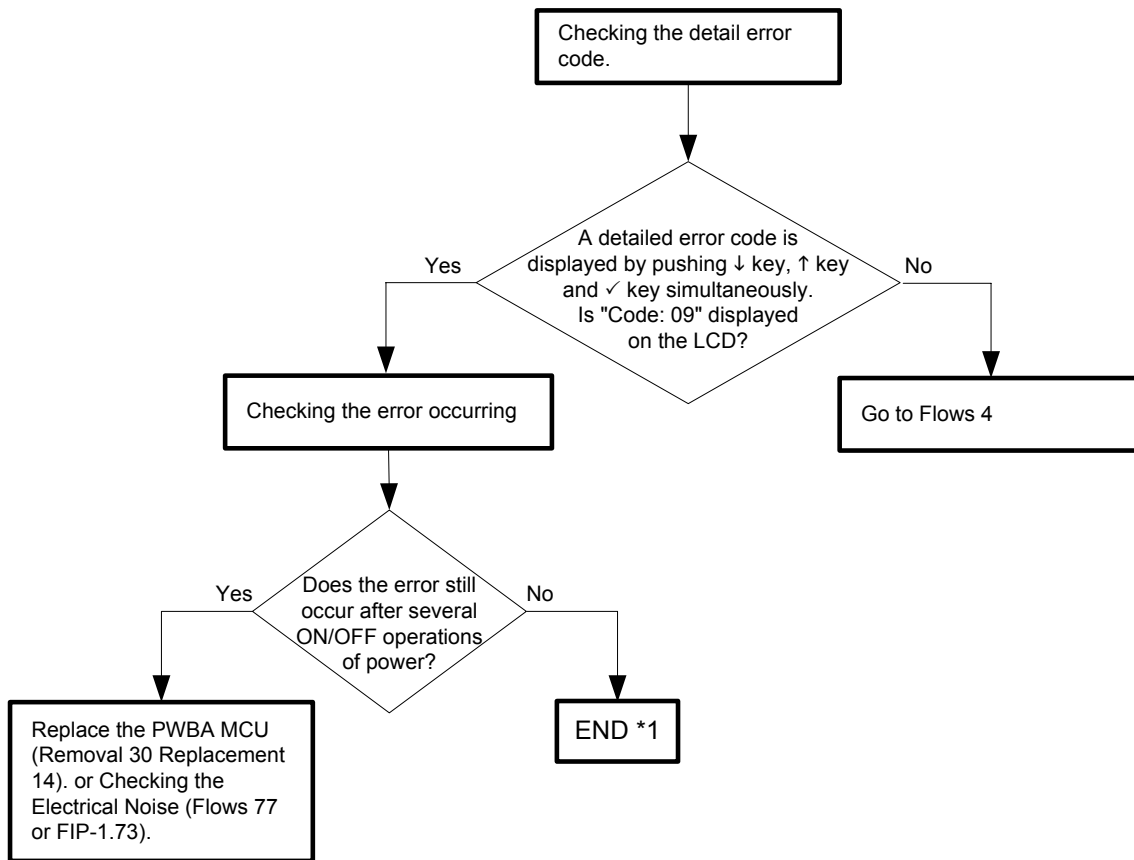

*1: Though some kind of external noise would be possible cause, go to [FIP1.73 Electrical Noise] and check, to make sure.

Flows 4 003-340-09 Restart Printer

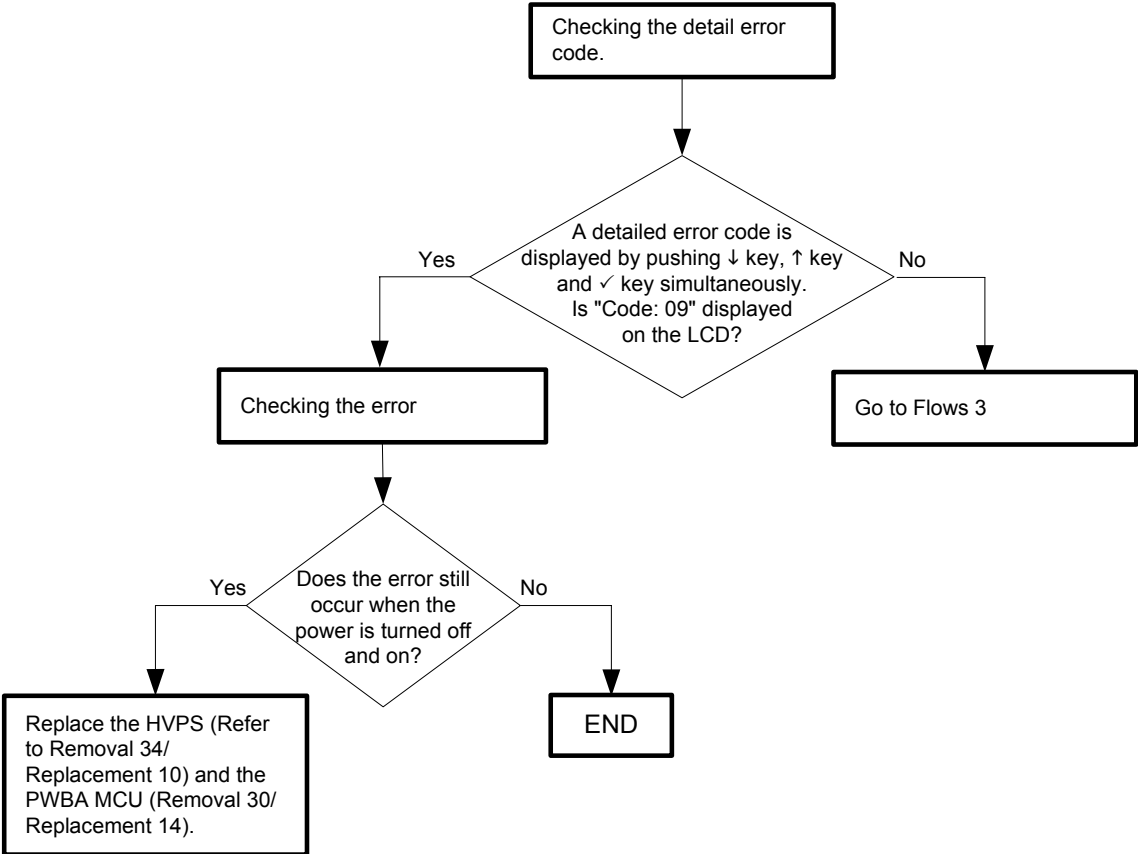

Flows 5 003-356 Restart Printer

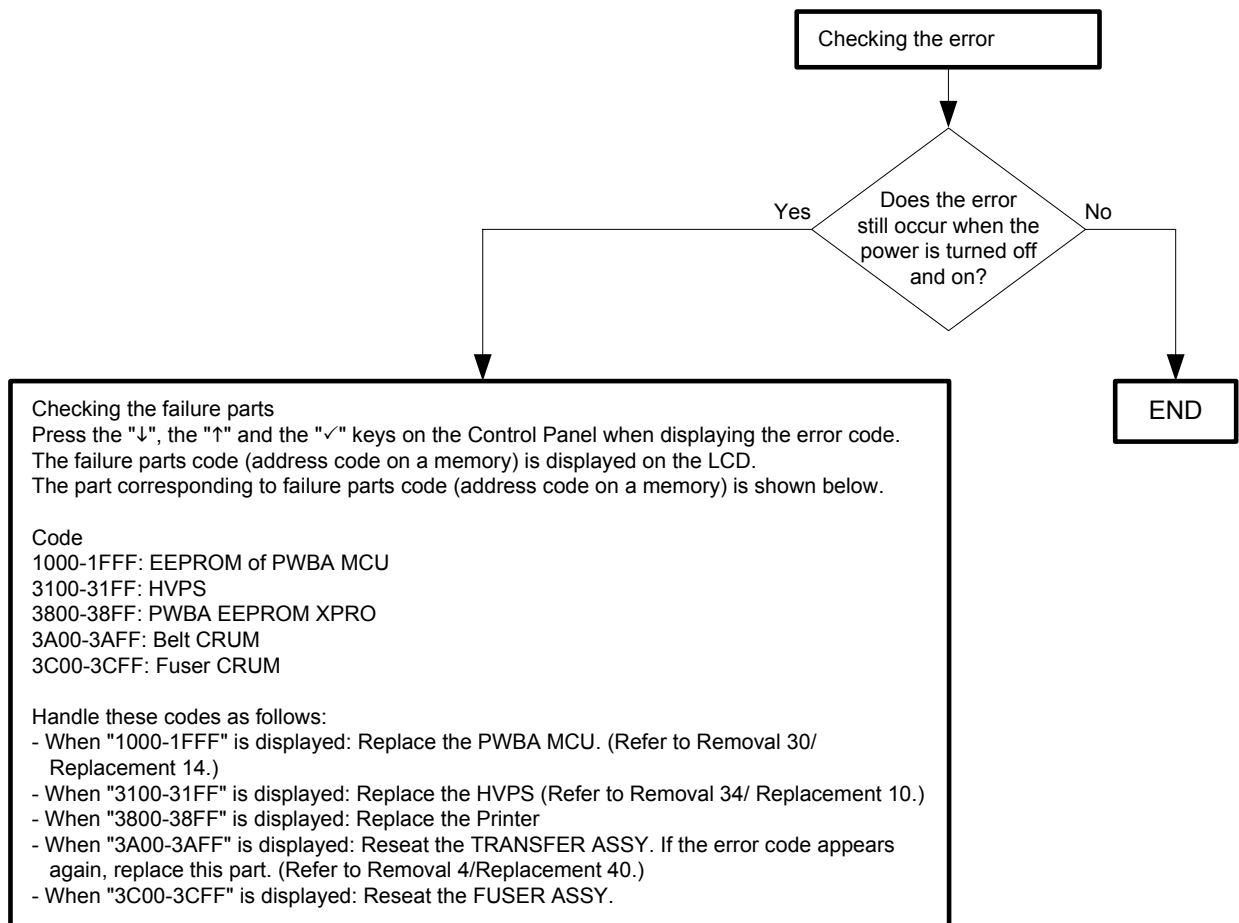

Flows 6 004-310 Restart Printer

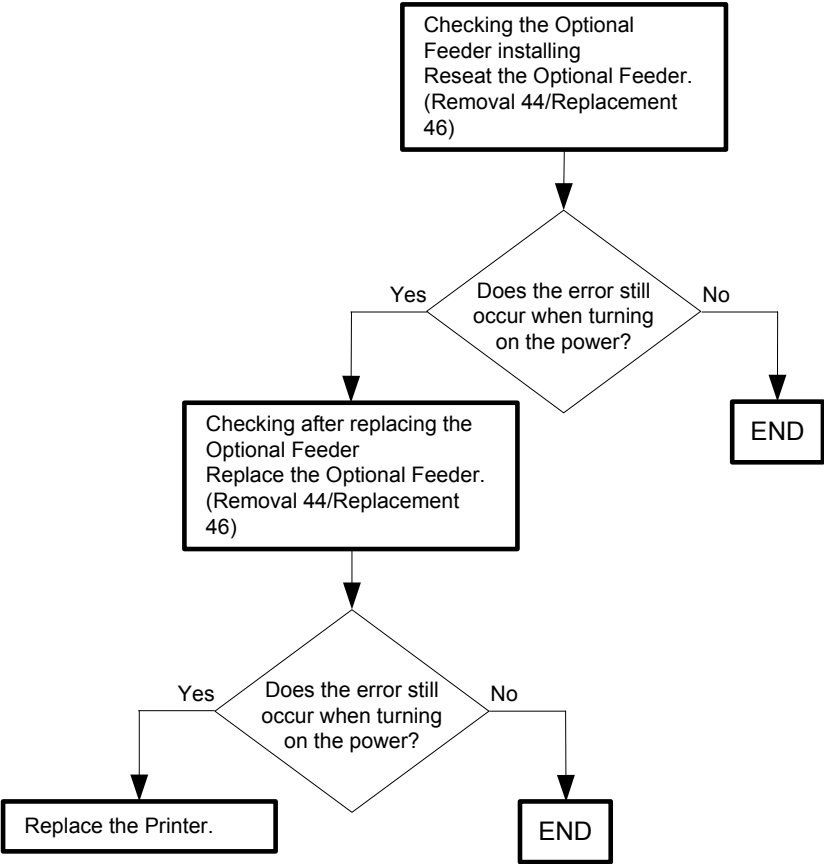

Flows 7 004-311 Restart Printer

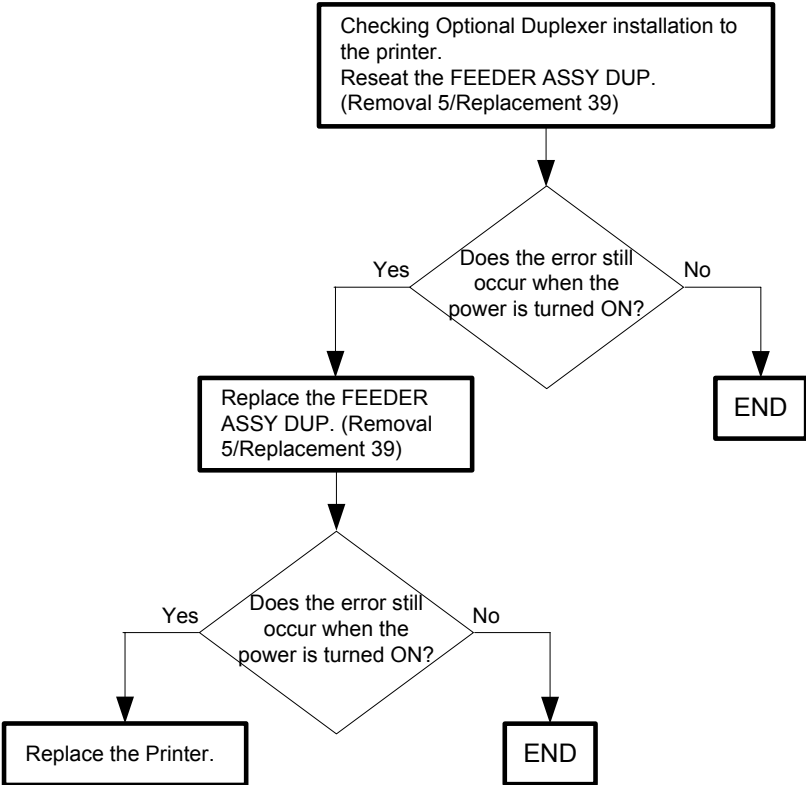

Flows 8 006-370 Restart Printer

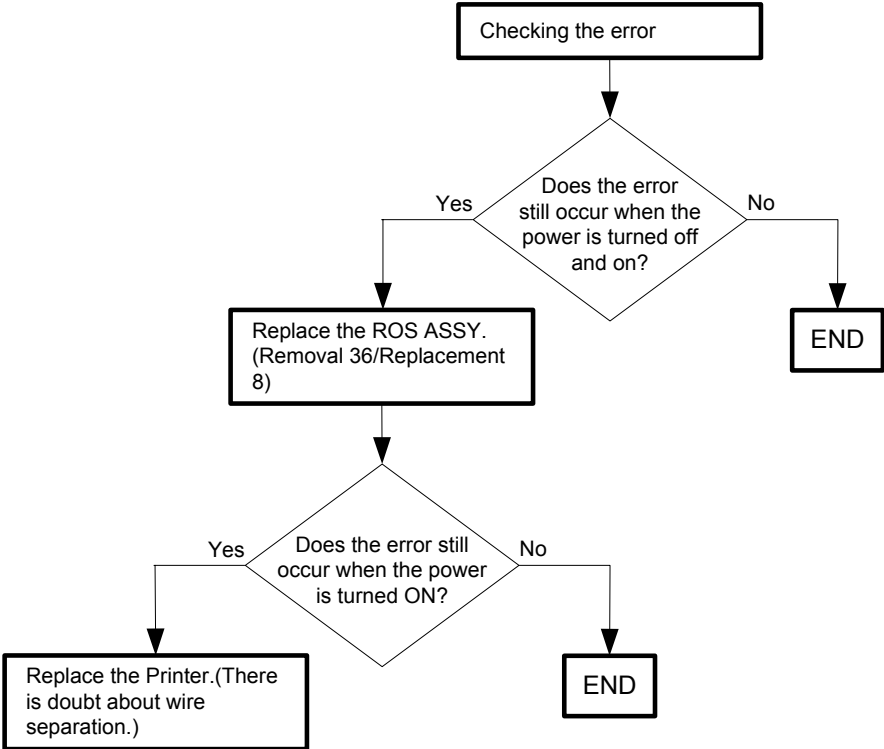

Flows 9 007-340-00 Restart Printer

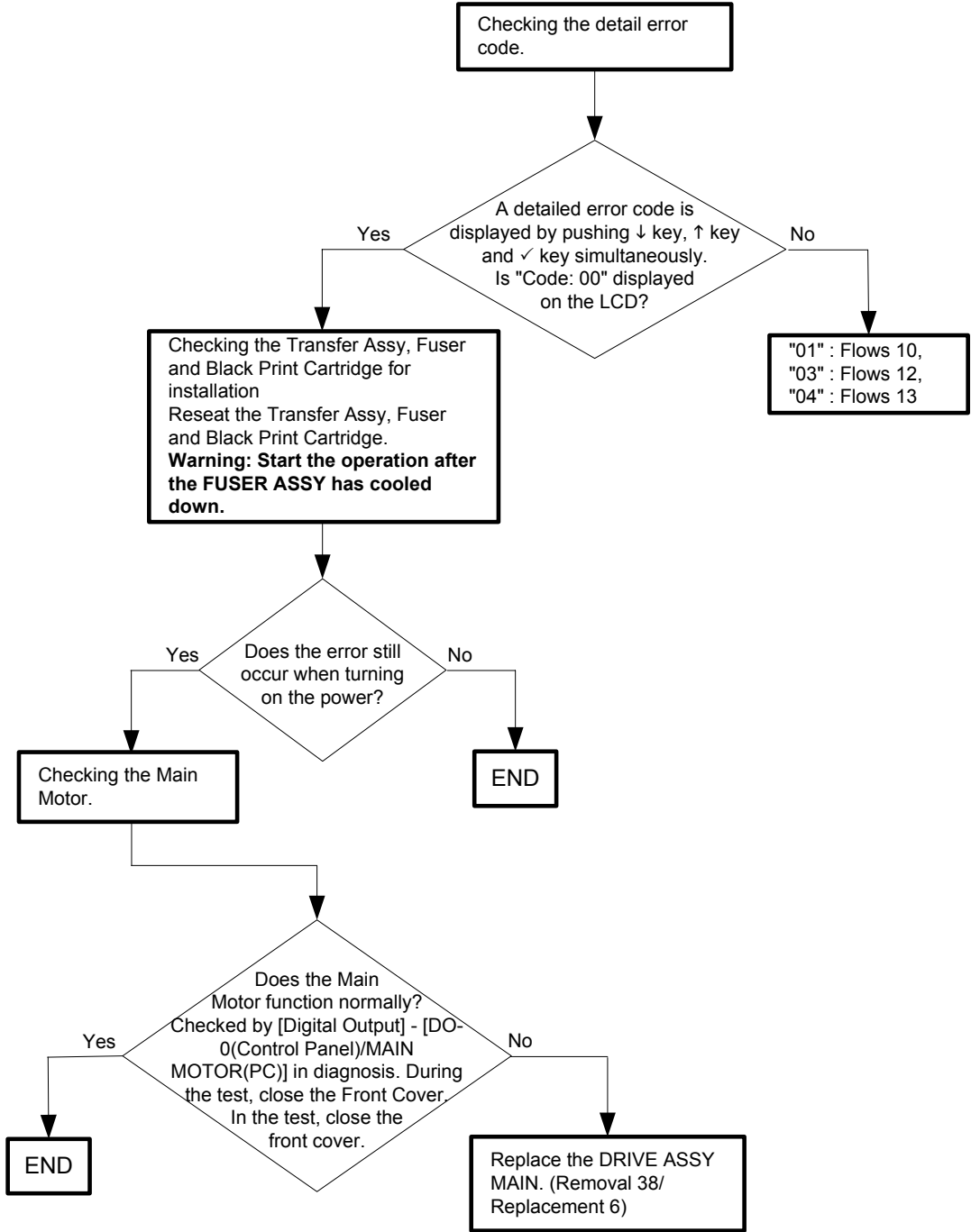

Flows 10 007-340-01 Restart Printer

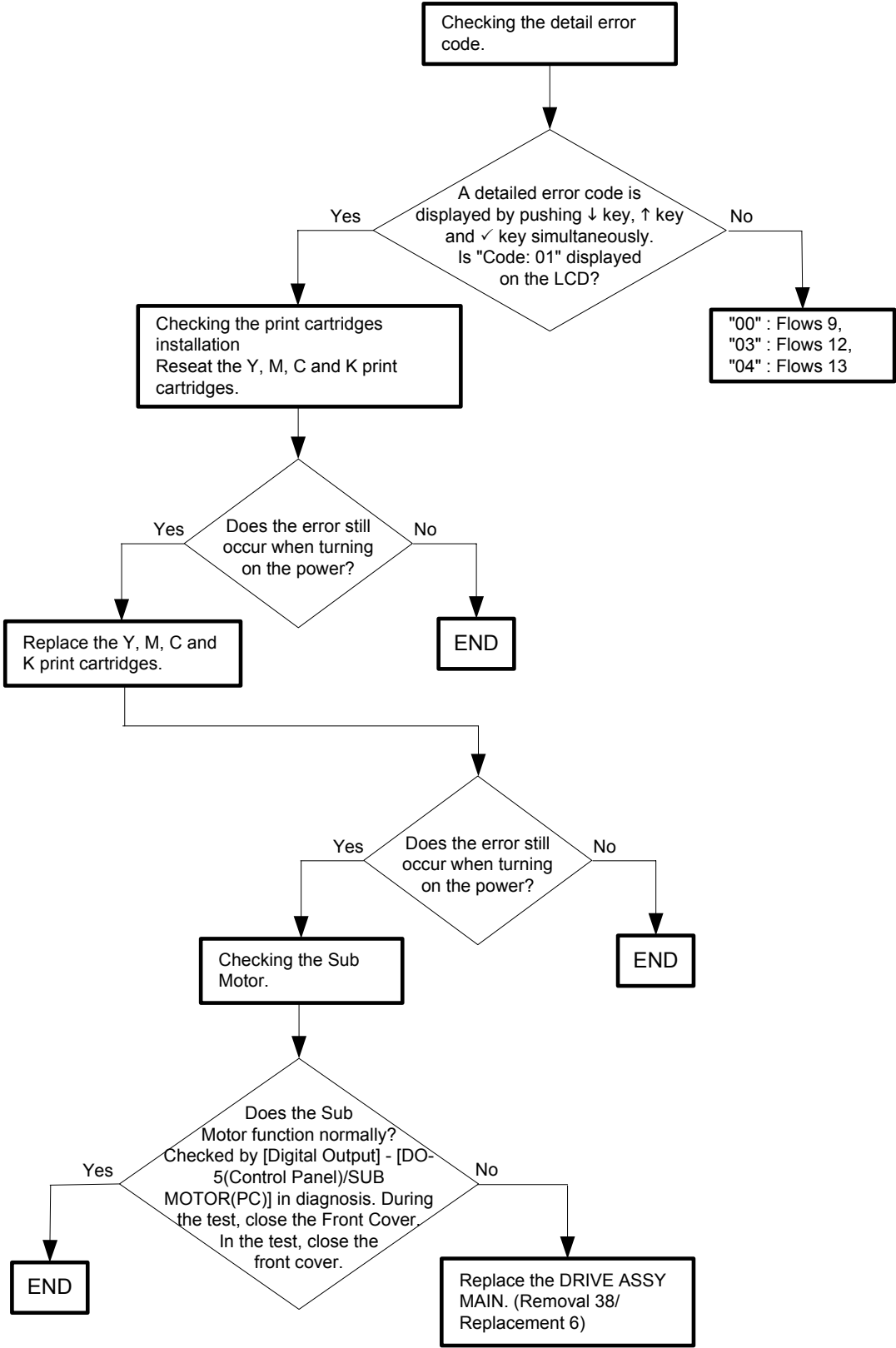

Flows 12 007-340-03 Restart Printer

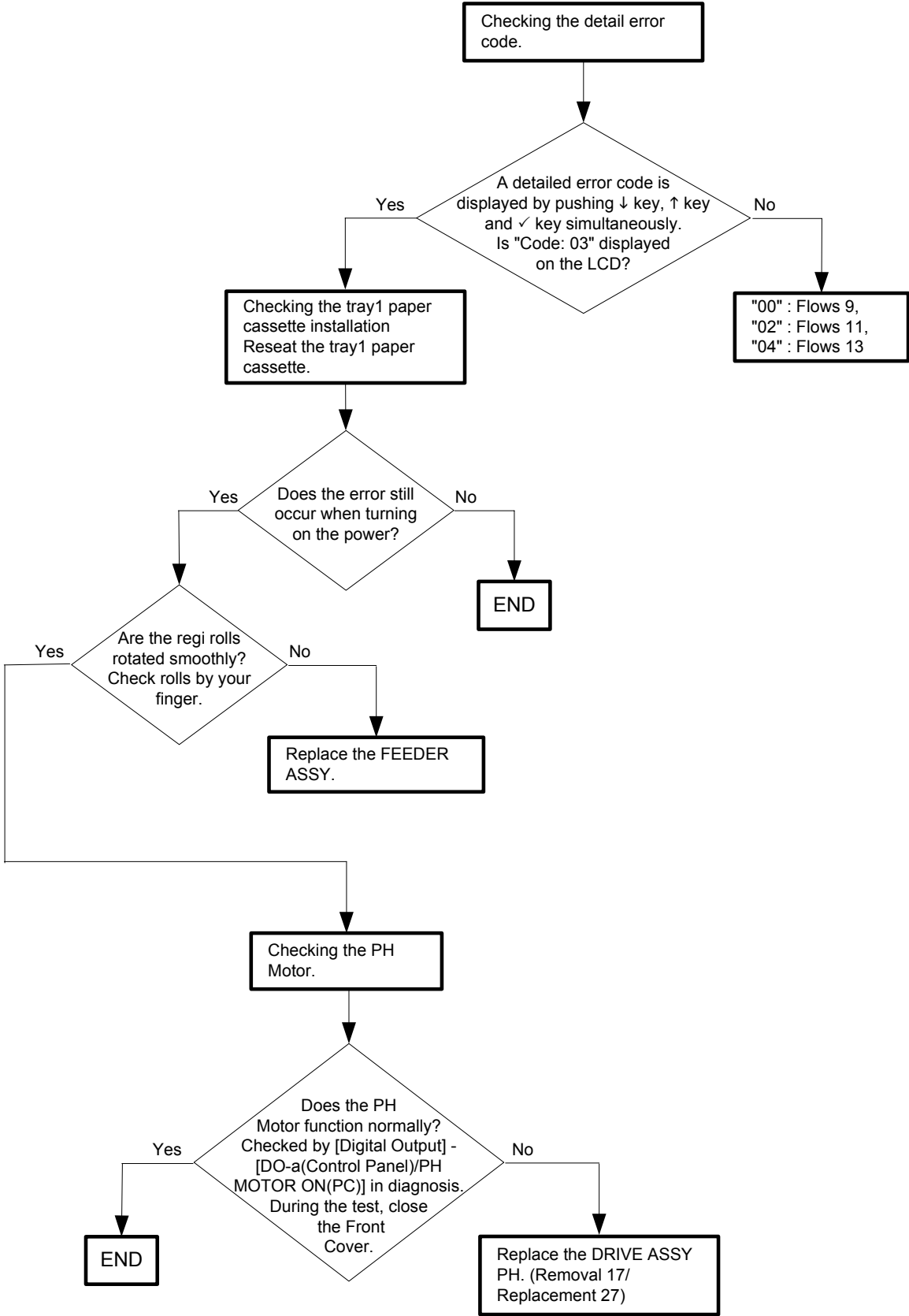

Flows 13 007-340-04 Restart Printer

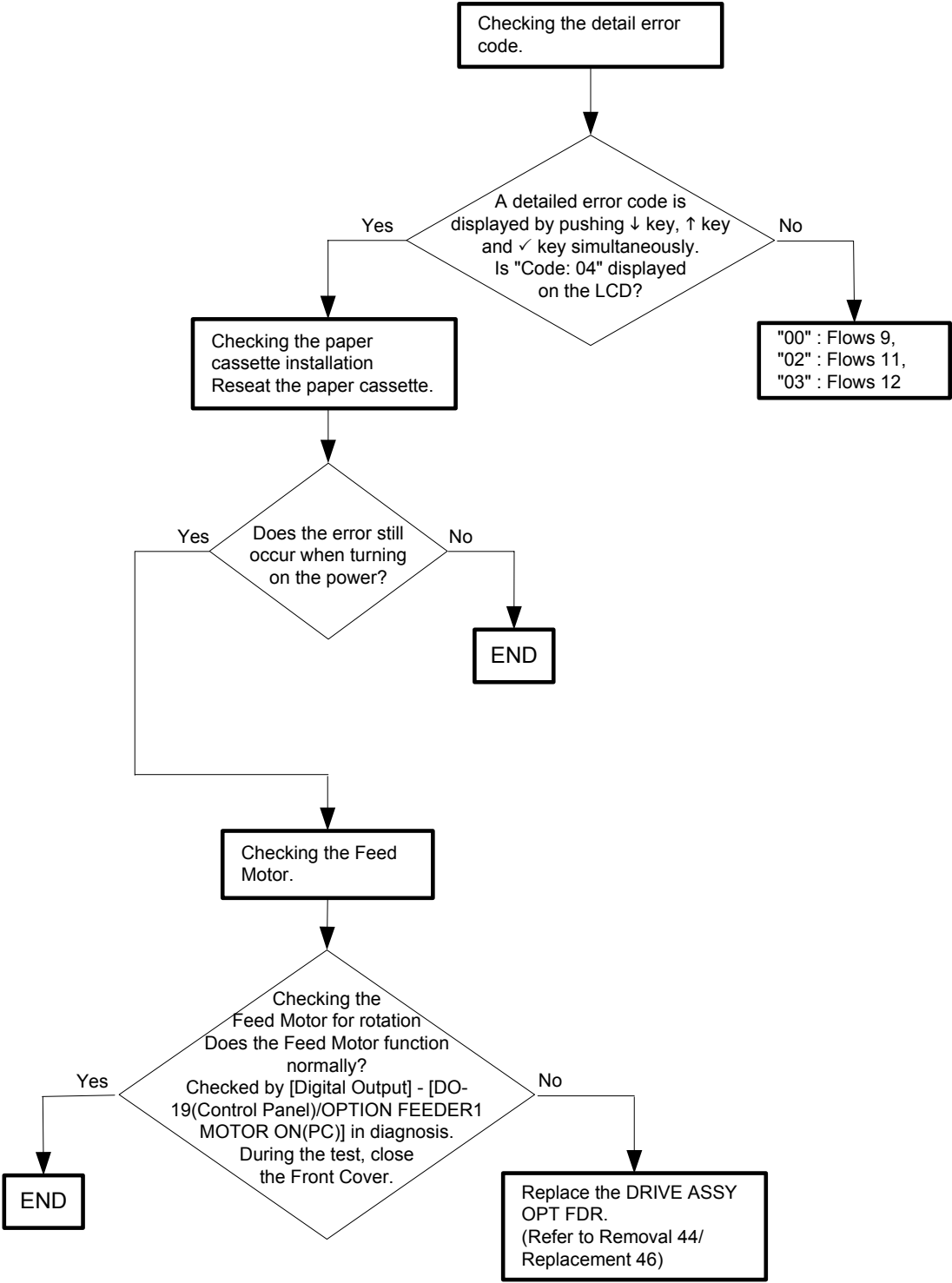

Flows 14 007-371 Restart Printer

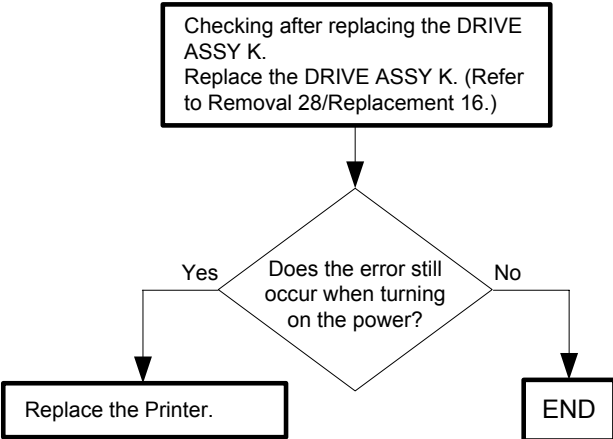

Flows 15 009-360 Restart Printer

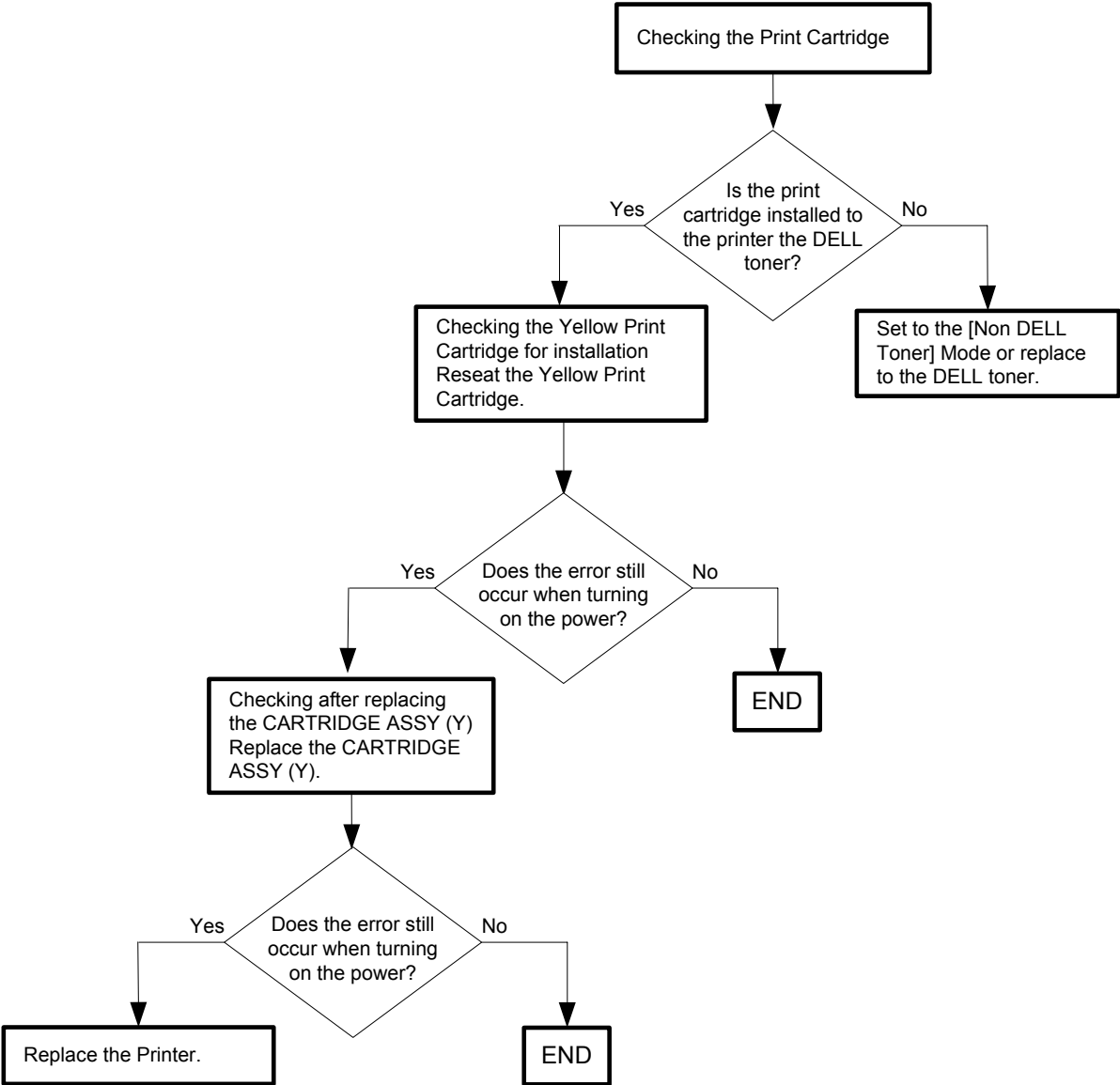

Flows 16 009-361 Restart Printer

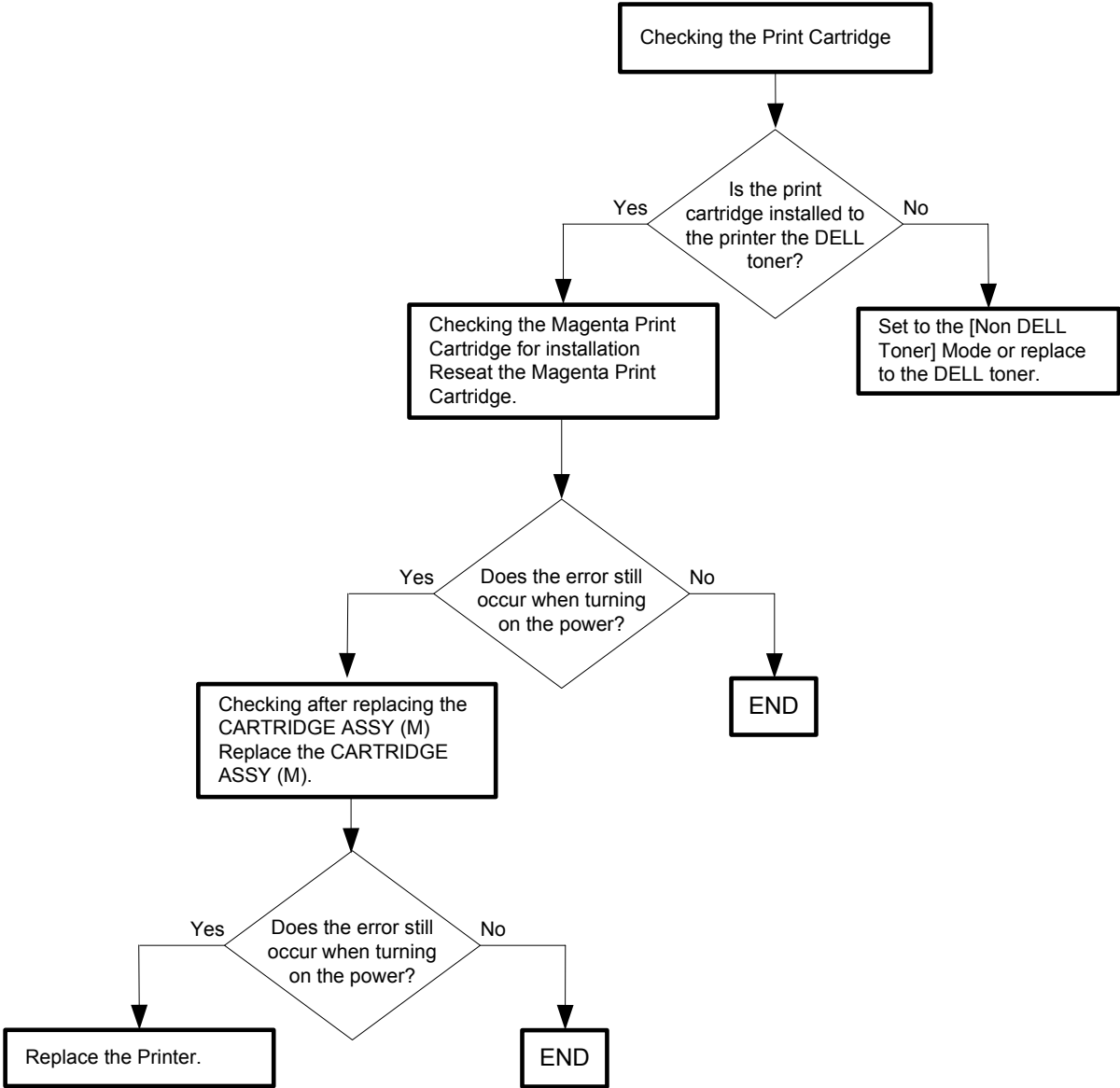

Flows 17 009-362 Restart Printer

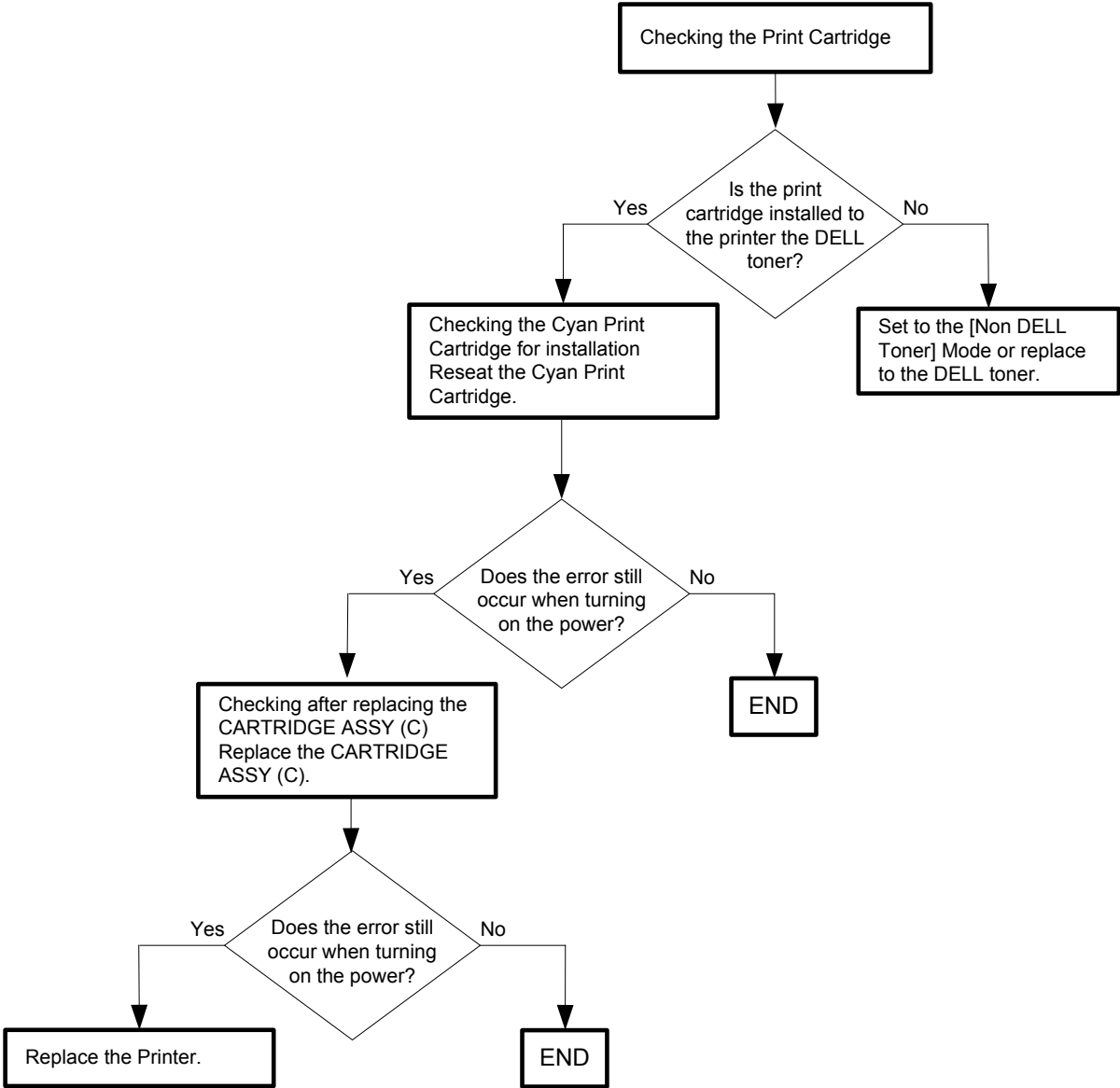

Flows 18 009-363 Restart Printer

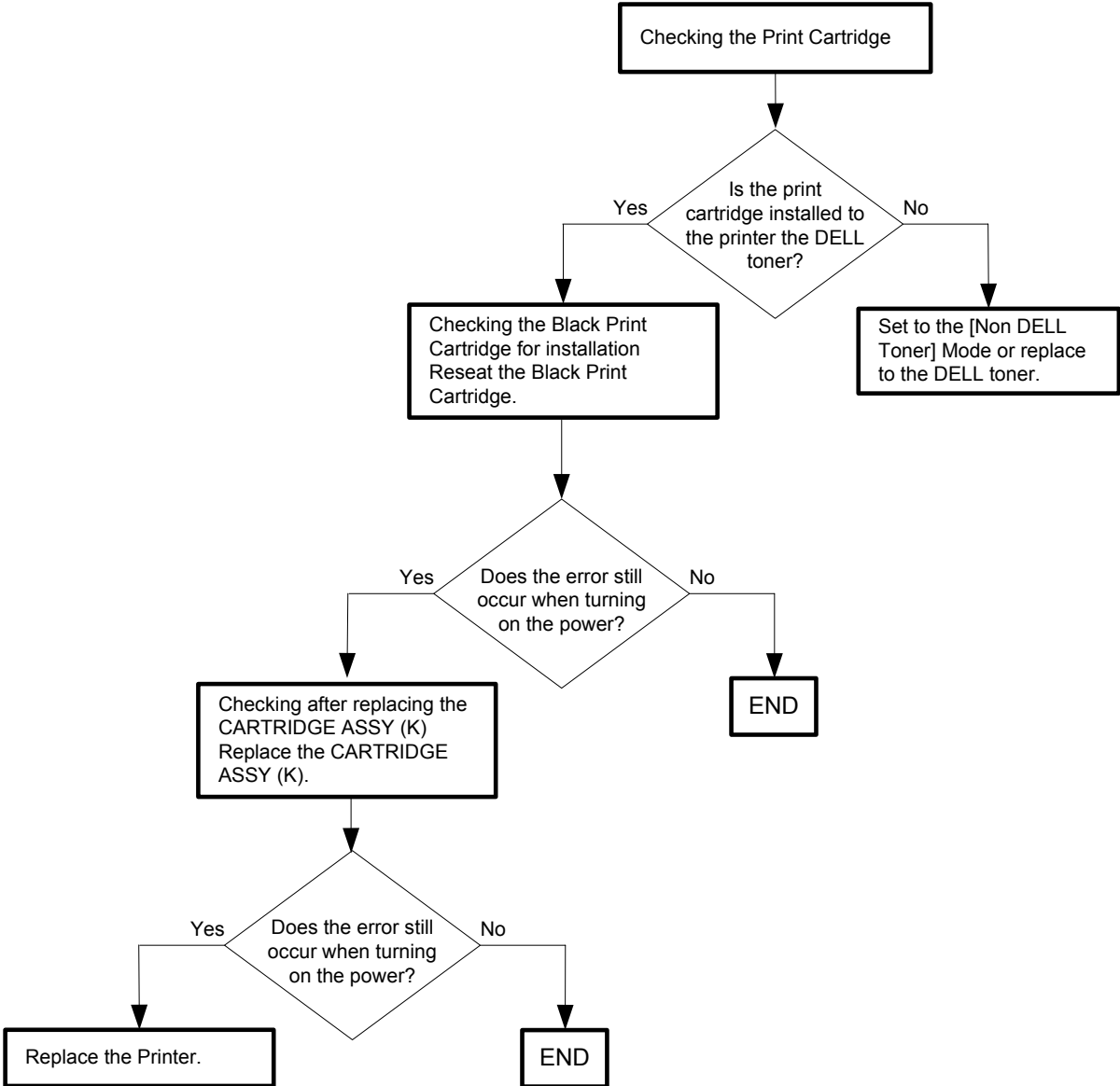

Flows 19 009-654-01 Restart Printer

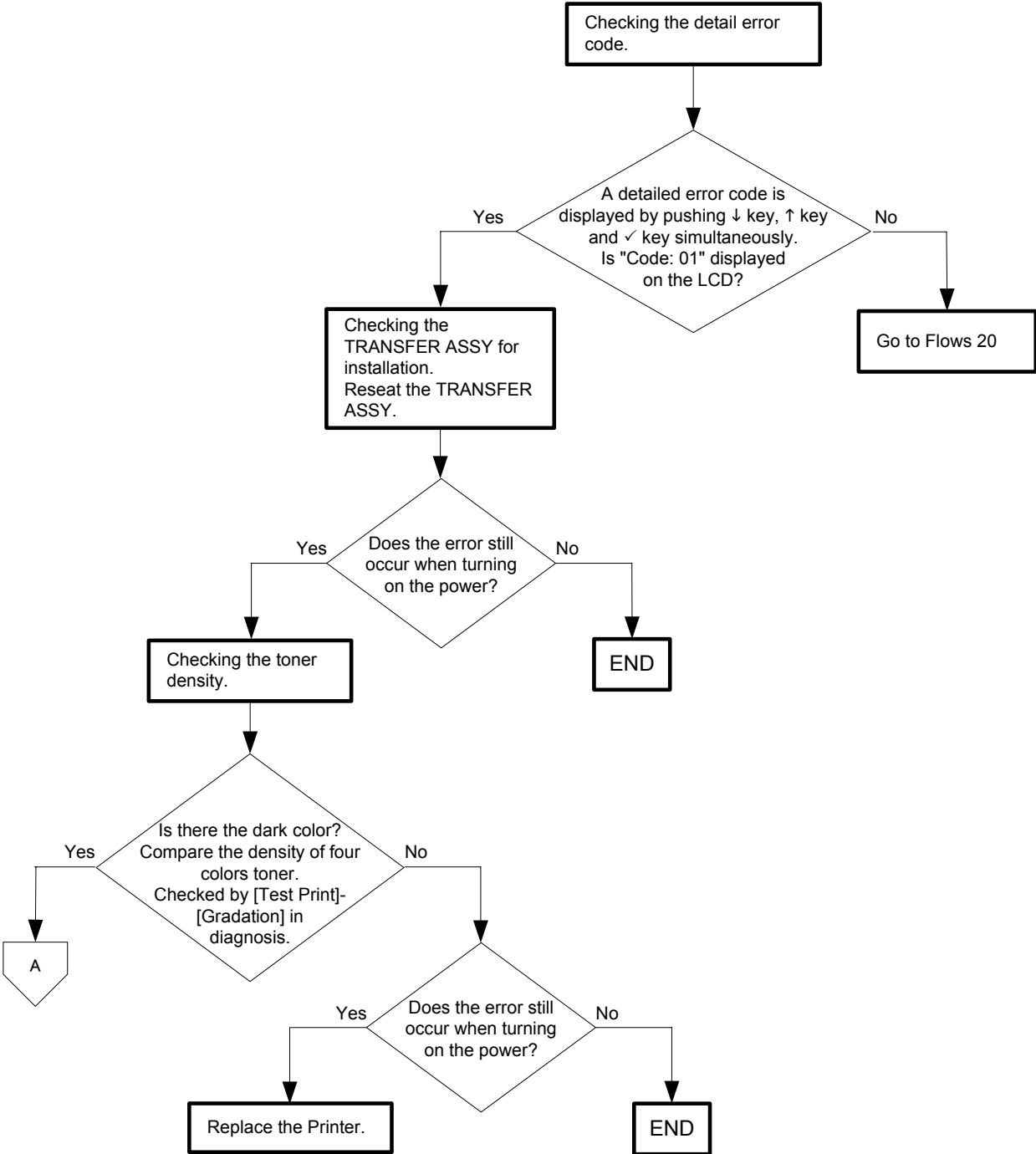

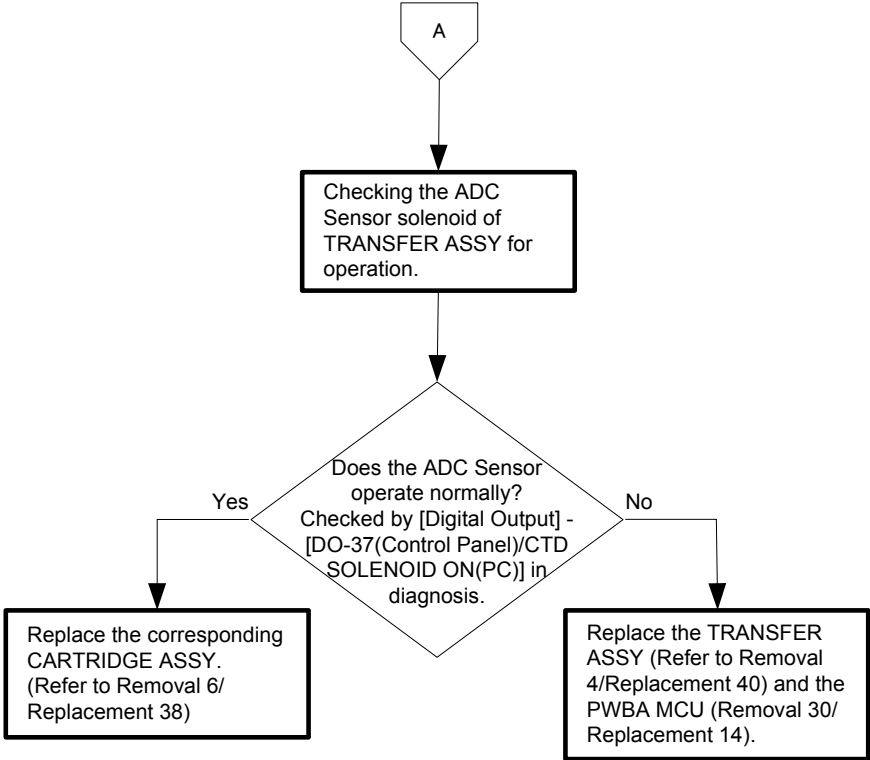

Flows 20 009-654-02 Restart Printer

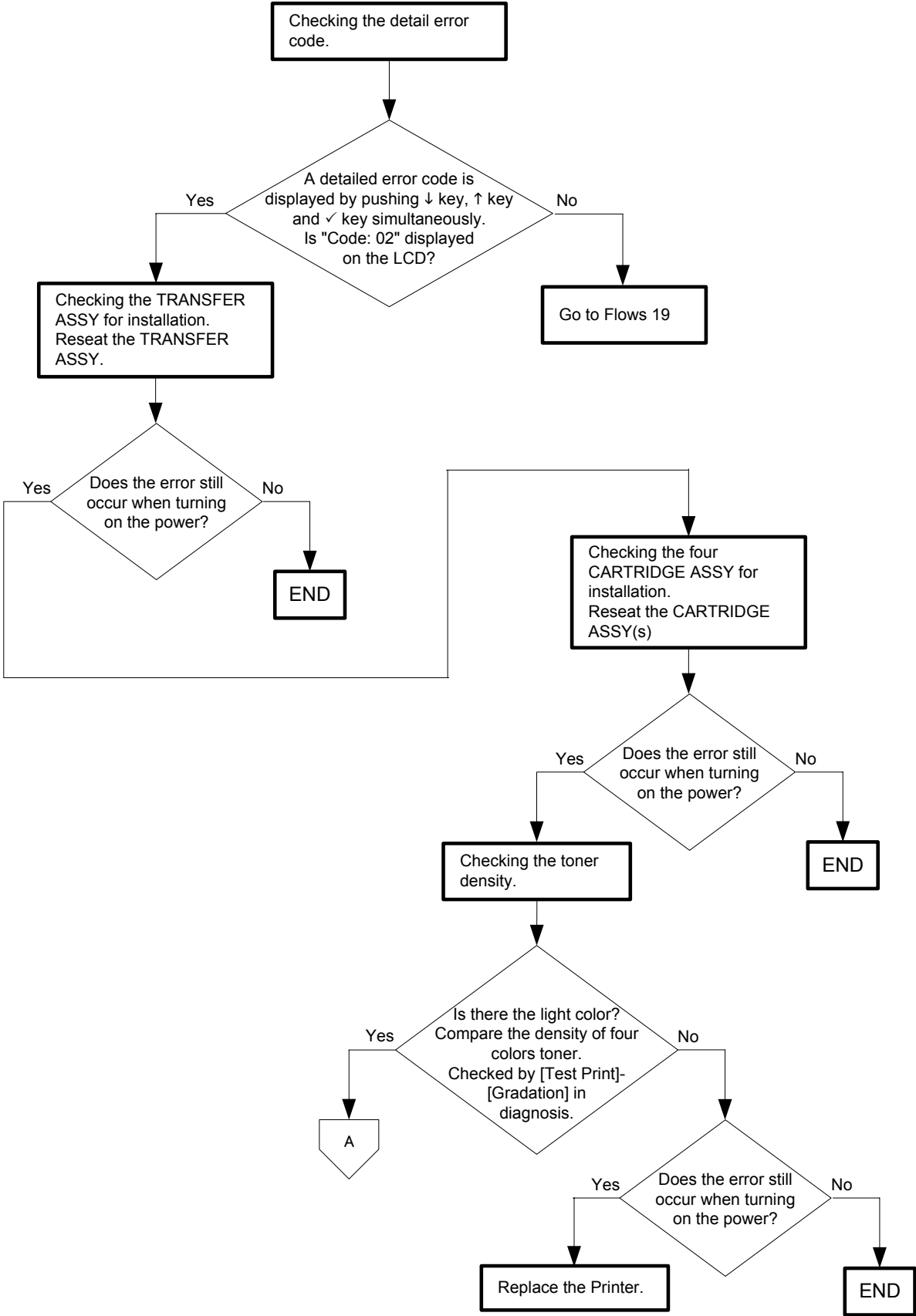

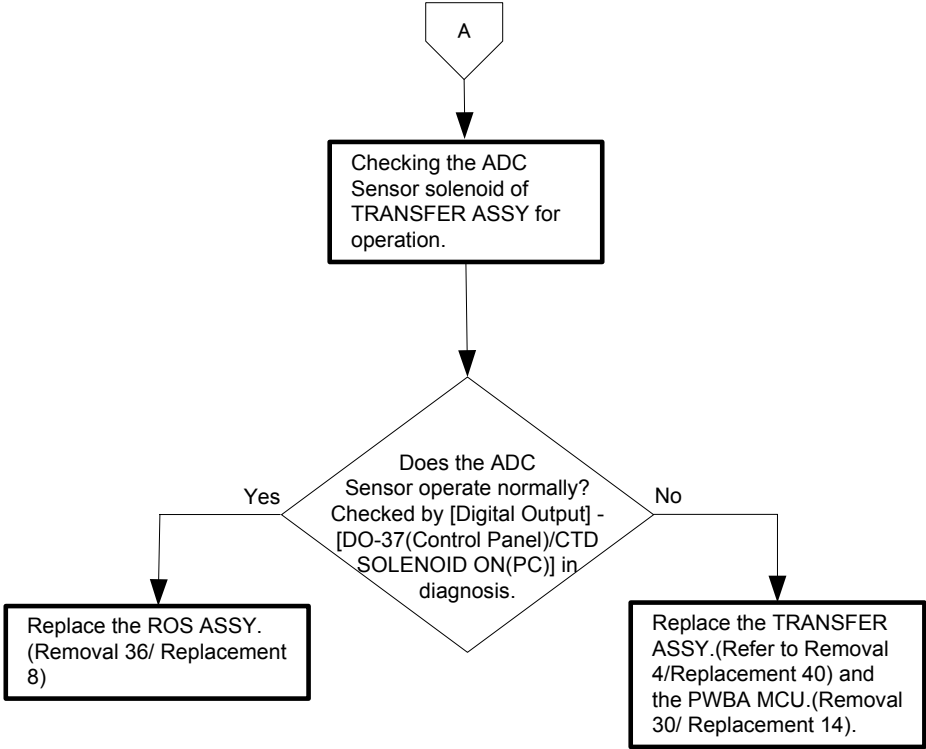

Flows 21 010-317 Restart Printer

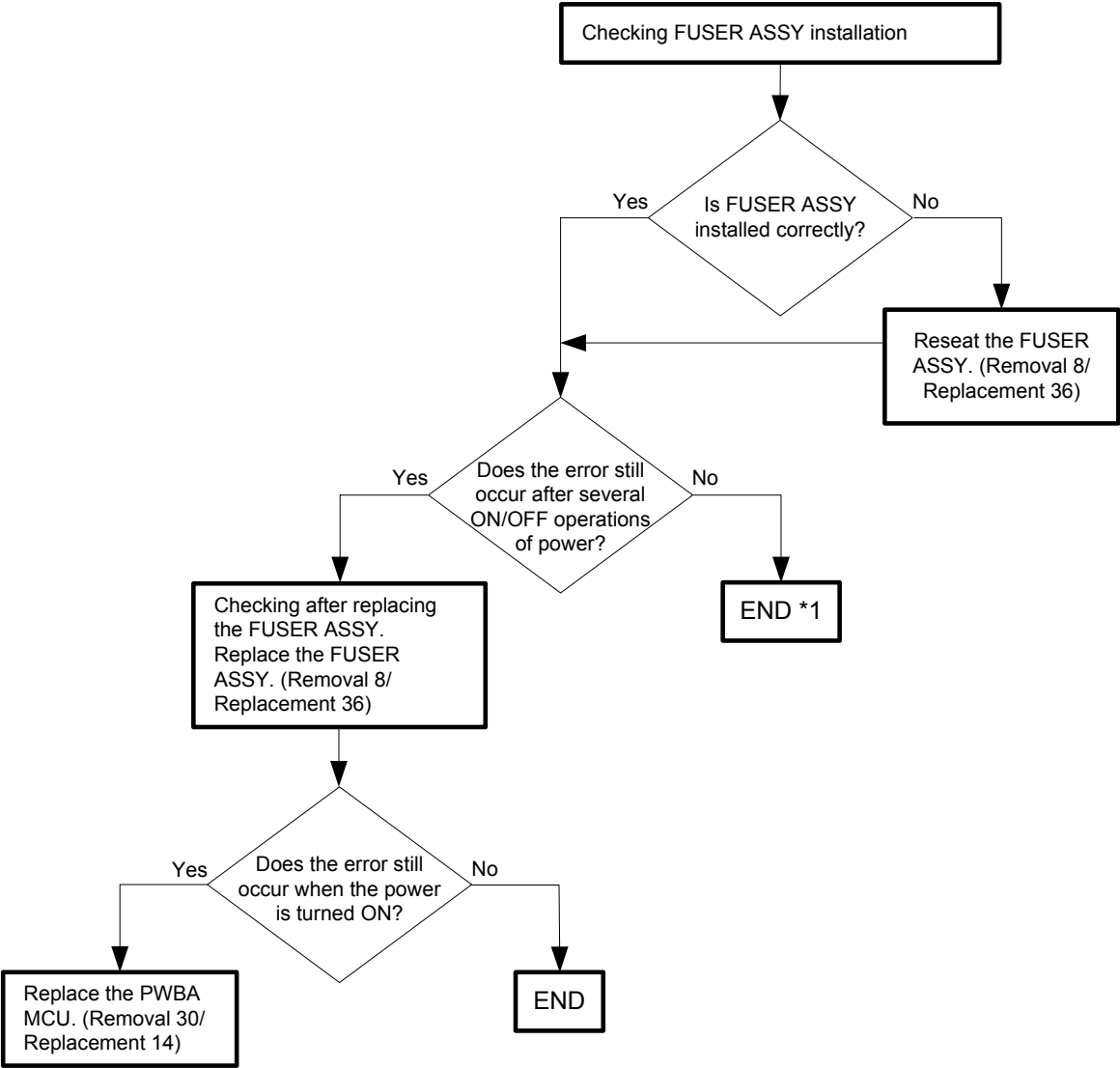

*1: Though some kind of external noise would be possible cause, go to [FIP1.73 Electrical Noise] and check, to make sure.

Flows 22 010-351 Restart Printer

NOTE

This error code is displayed when the Fuser ASSY has reached its end of life and needs replacing.

Immediately replace the Fuser ASSY with a new one.

If this error code is displayed although the Fuser ASSY has been replaced only recently, follow the following flow.

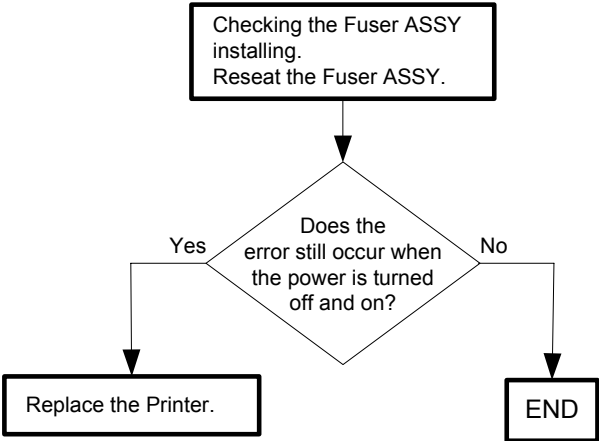

Flows 23 010-354 Restart Printer

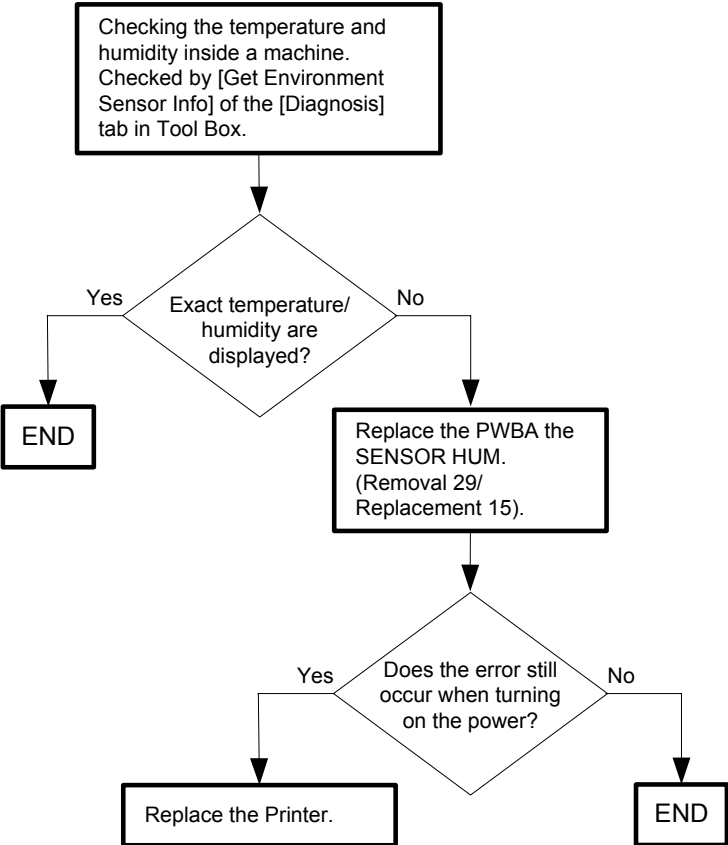

Flows 24 010-377 Restart Printer

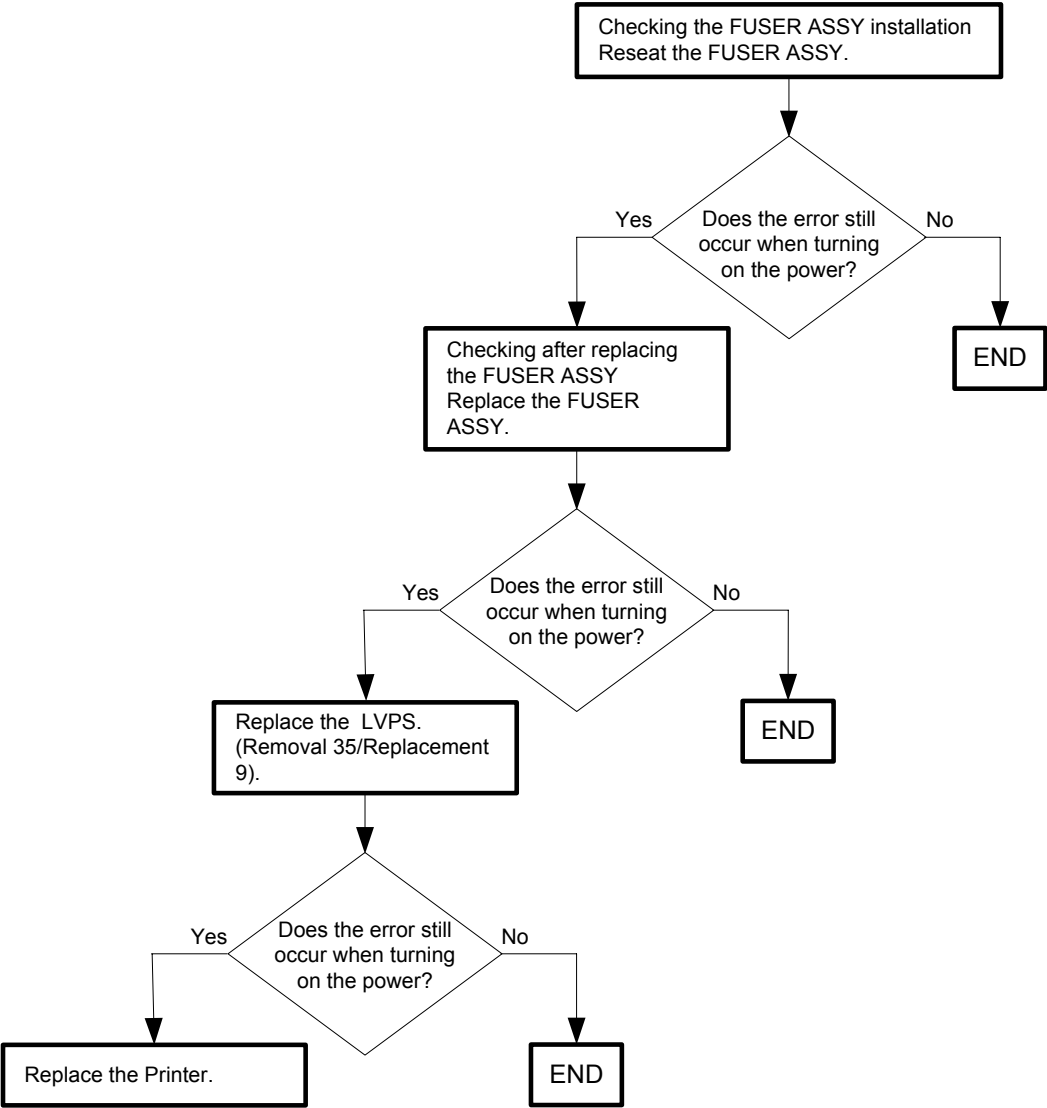

Flows 25 016-300/016-301/016-302/016-310/016-313/016-315/016-317/016-323/016-327/016-344/016-345/016-346/016-347 Restart / Erase Flash Err. 016-392 / Write Flash Err. 016-393 / Verify Error 016-394

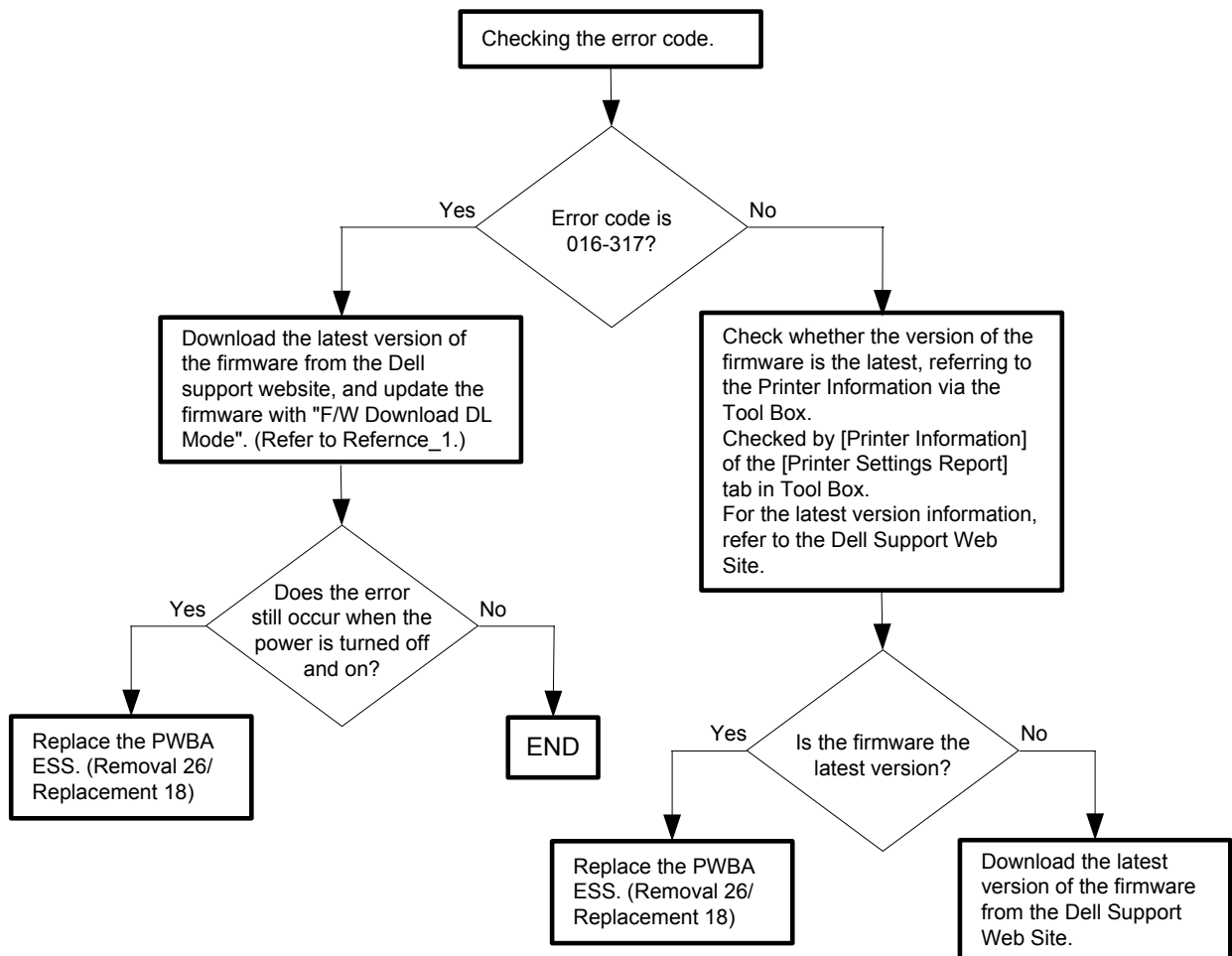

Reference_1:

1. Make sure that the printer is connected to the computer via USB port or Parallel port (remove the network cable). Then, try downloading as follows:
 - 1) Power on the printer while pressing the <X Cancel> and <✓> buttons.
 - 2) Press <▼> button to select "F/W Download DL Mode Parallel" or "F/W Download DL Mode USB", and then press <✓> button.
 - 3) The printer goes into the Download Mode with a message "Download Mode Ready. Then, activate firmware update tool and follow the instruction displayed.

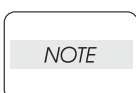

While the firmware download is being executed, the printer displays a message "Writing..... F/W", and the computer displays a progress bar and may be restarted during the downloading process. Never power off the printer or the computer until the downloading process completes, and never interrupt the downloading process.

Flows 25-1 016-340 Restart Printer

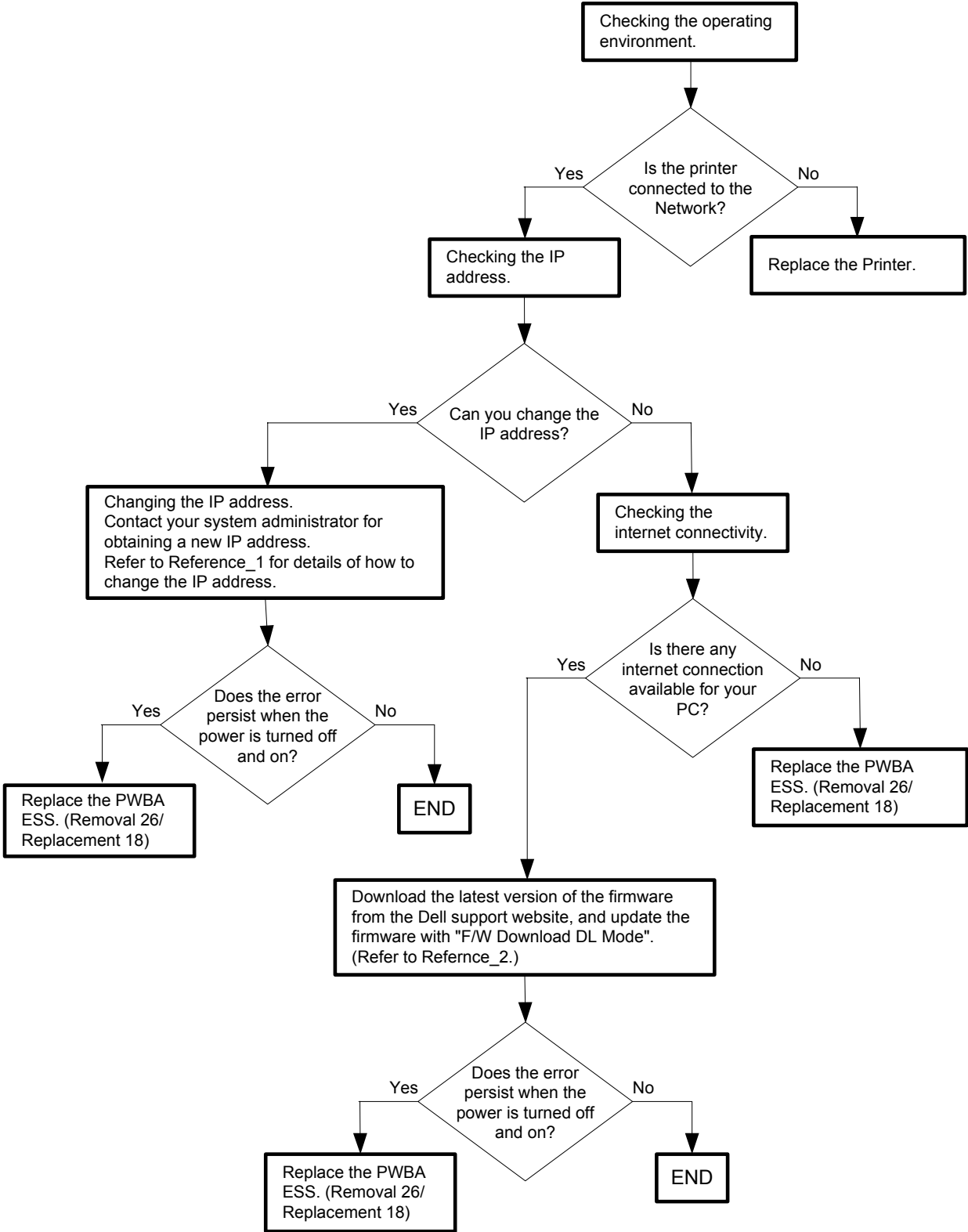

Reference_1: Changing the IP address

- 1) Remove the network cable, and power off the printer and then on
- 2) Change the IP address on the Control Panel.
- 3) Plug the network cable back into the printer, and then turn the power on.
- 4) On the Control Panel, open [Admin] > [Network] > [TCP/IP], and confirm that the IP address has been changed.

Reference_2:

1. Make sure that the printer is connected to the computer via USB port or Parallel port (remove the network cable). Then, try downloading as follows:
 - 1) Power on the printer while pressing the <X Cancel> and <✓> buttons.
 - 2) Press <▼> button to select "F/W Download DL Mode Parallel" or "F/W Download DL Mode USB", and then press <✓> button.
 - 3) The printer goes into the Download Mode with a message "Download Mode Ready". Then, activate firmware update tool and follow the instruction displayed.

NOTE

While the firmware download is being executed, the printer displays a message "Writing..... F/W", and the computer displays a progress bar and may be restarted during the downloading process. Never power off the printer or the computer until the downloading process completes, and never interrupt the downloading process.

Flows 26 016-312/016-361 Restart Printer

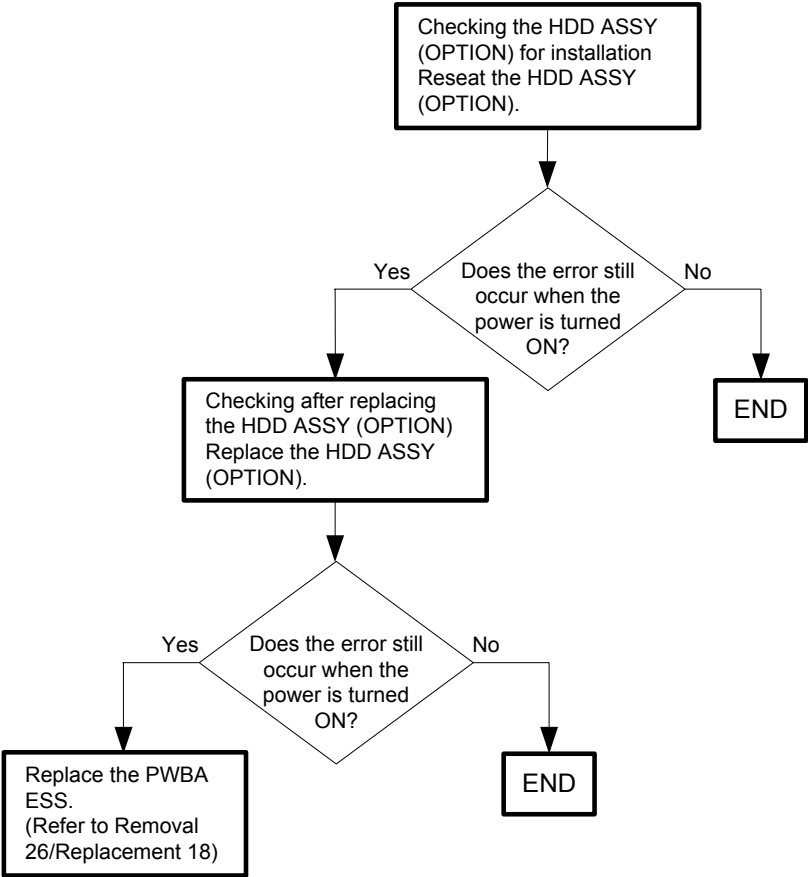

Flows 27 016-316/016-318 Restart Printer

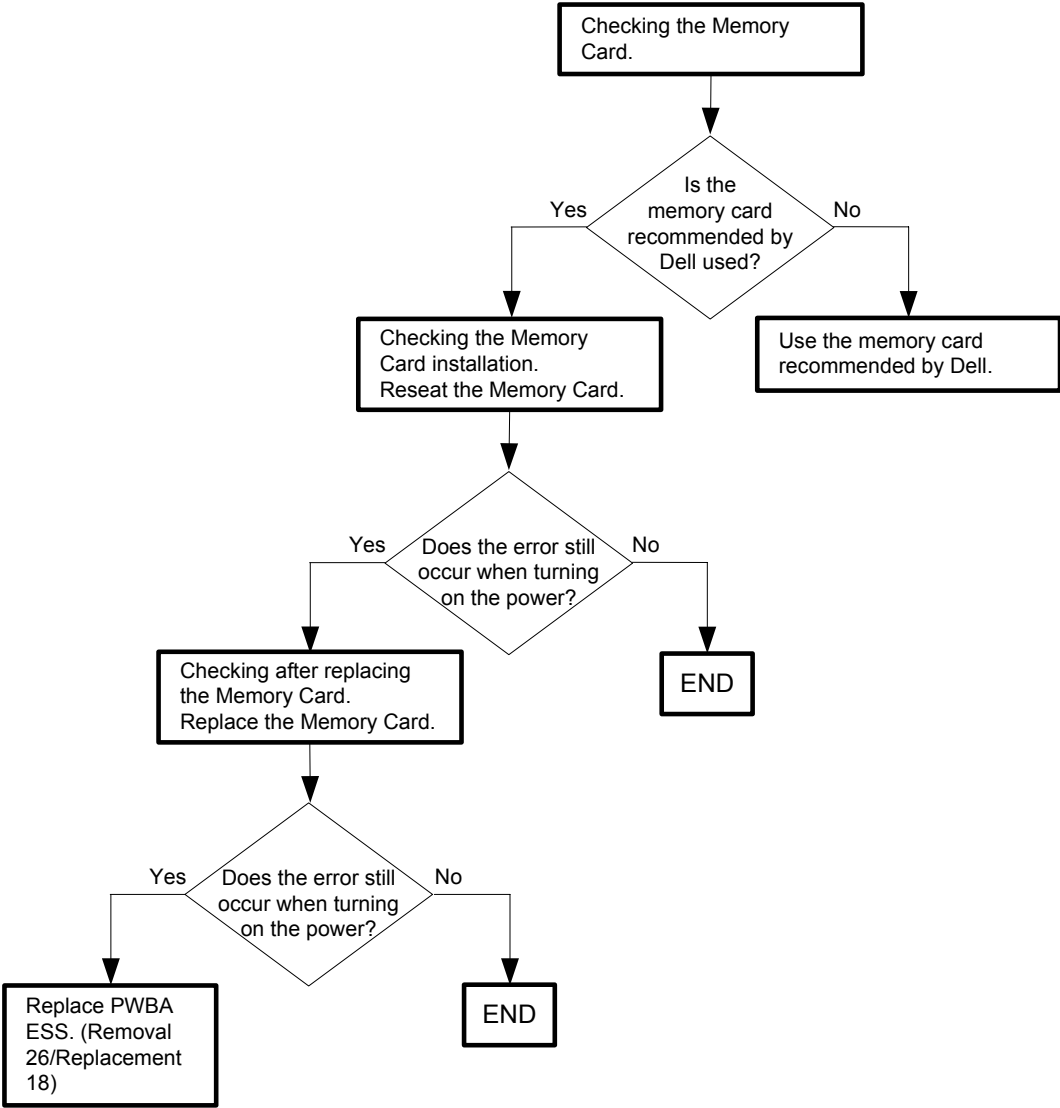

Flows 28 016-338 Restart Printer

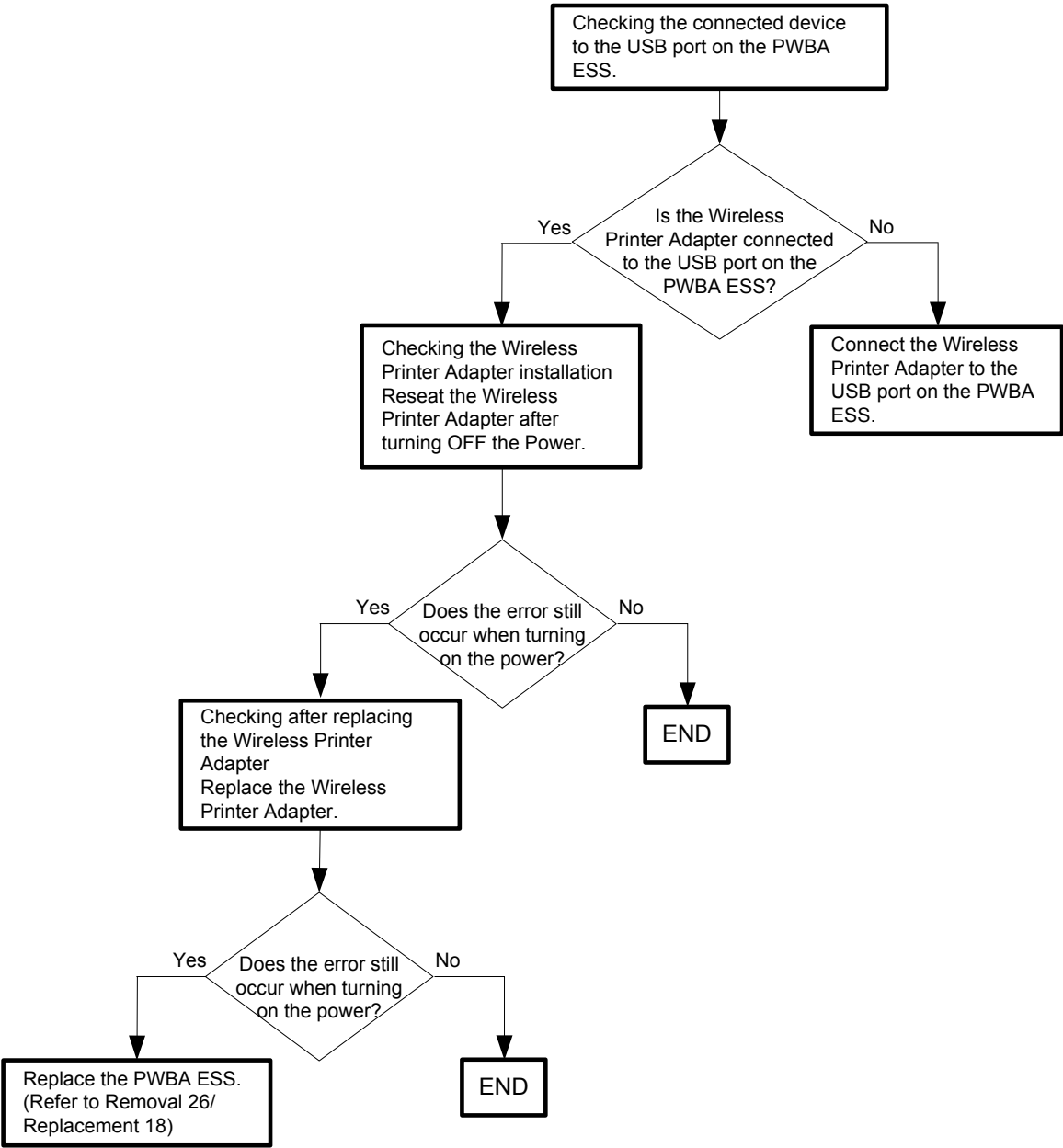

Flows 29 016-350 Restart Printer

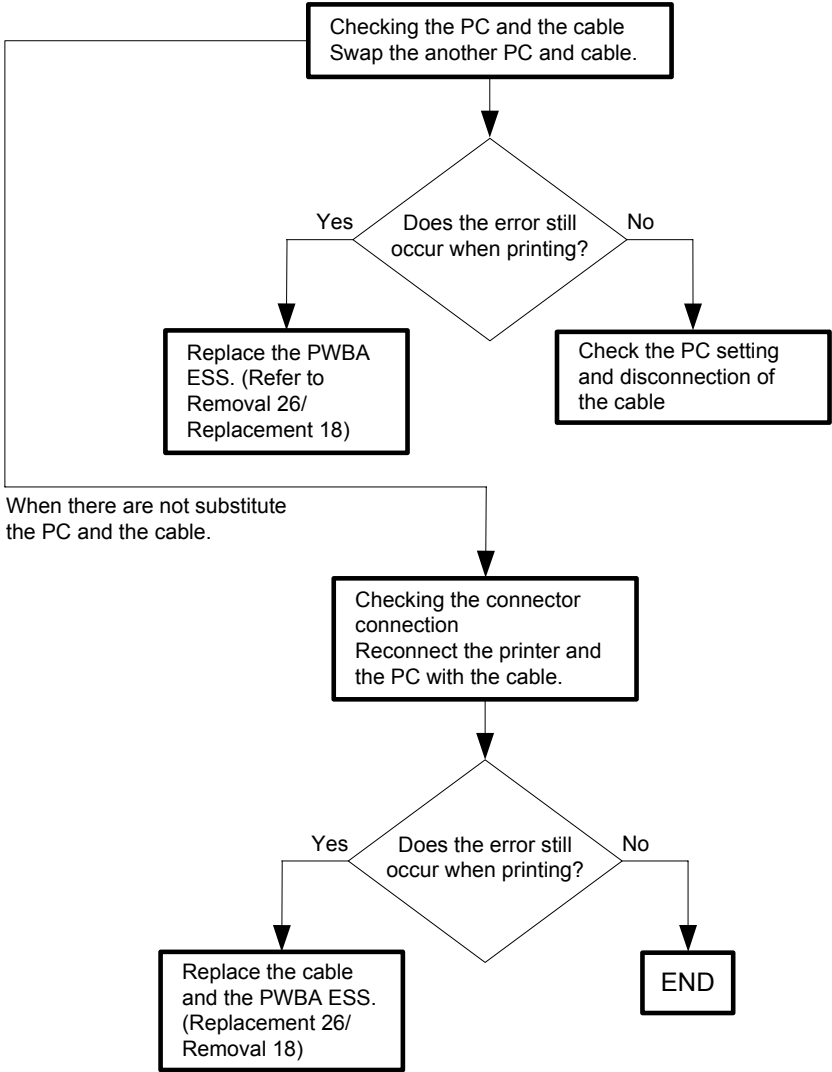

Flows 30 016-365 Restart Printer

NOTE

If Network Adapter is missing you cannot print to the protocols it supports over the network (wired or wireless).

To use the printer without the Network Adapter, you need to clear the Wireless LAN settings. Refer to the User Guide for how to clear the Wireless LAN settings.

To keep the printer connected to your wireless network, replace the Network Adapter with a new one.

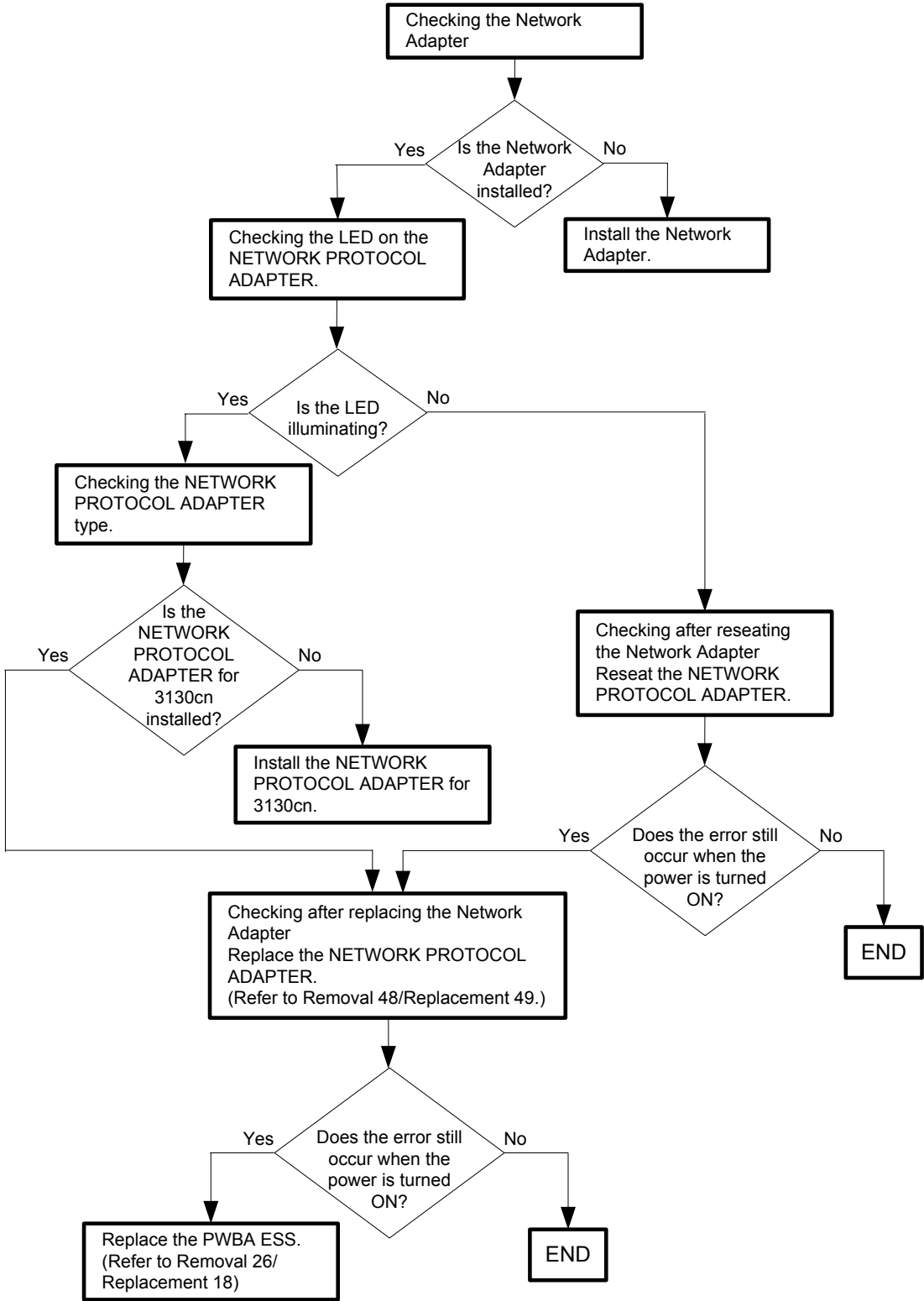

Flows 31 016-370 Restart Printer

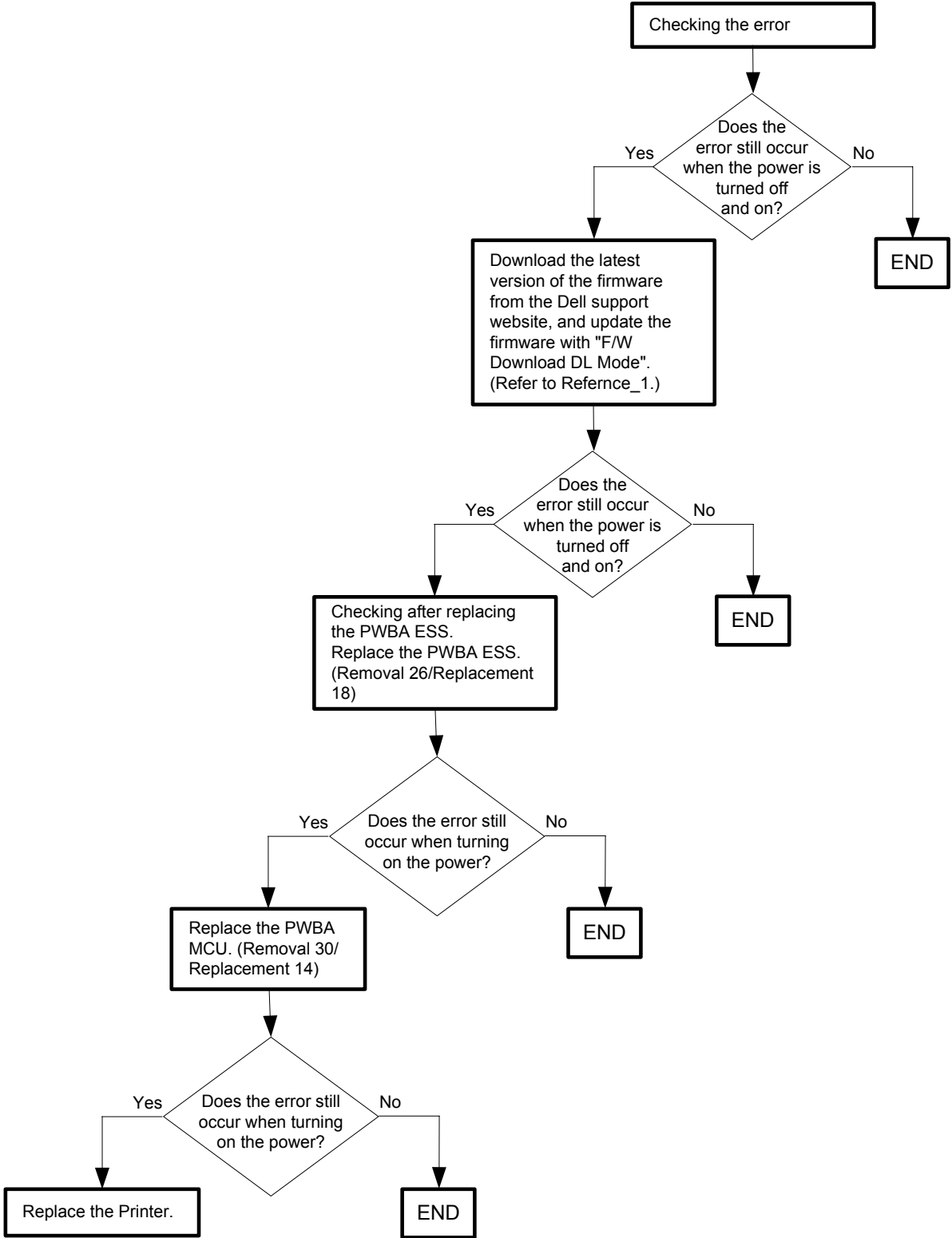

Reference_1:

1. Make sure that the printer is connected to the computer via USB port or Parallel port (remove the network cable). Then, try downloading as follows:
 - 1) Power on the printer while pressing the <X Cancel> and <✓> buttons.
 - 2) Press <▼> button to select "F/W Download DL Mode Parallel" or "F/W Download DL Mode USB", and then press <✓> button.
 - 3) The printer goes into the Download Mode with a message "Download Mode Ready. Then, activate firmware update tool and follow the instruction displayed.

NOTE

While the firmware download is being executed, the printer displays a message "Writing..... F/W", and the computer displays a progress bar and may be restarted during the downloading process. Never power off the printer or the computer until the downloading process completes, and never interrupt the downloading process.

Flows 32 093-964 Restart Printer

NOTE

For the PPID, refer to the label on the FUSER.

Example) FUSER for 100V
XX-0M507D-XXXXX-XXX-XXXX

↑
PPID No.

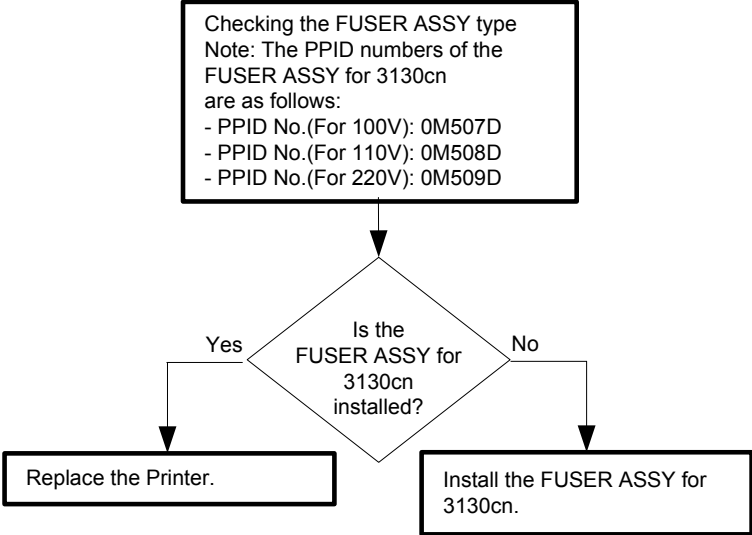

Flows 33 Paper Jam 071-100

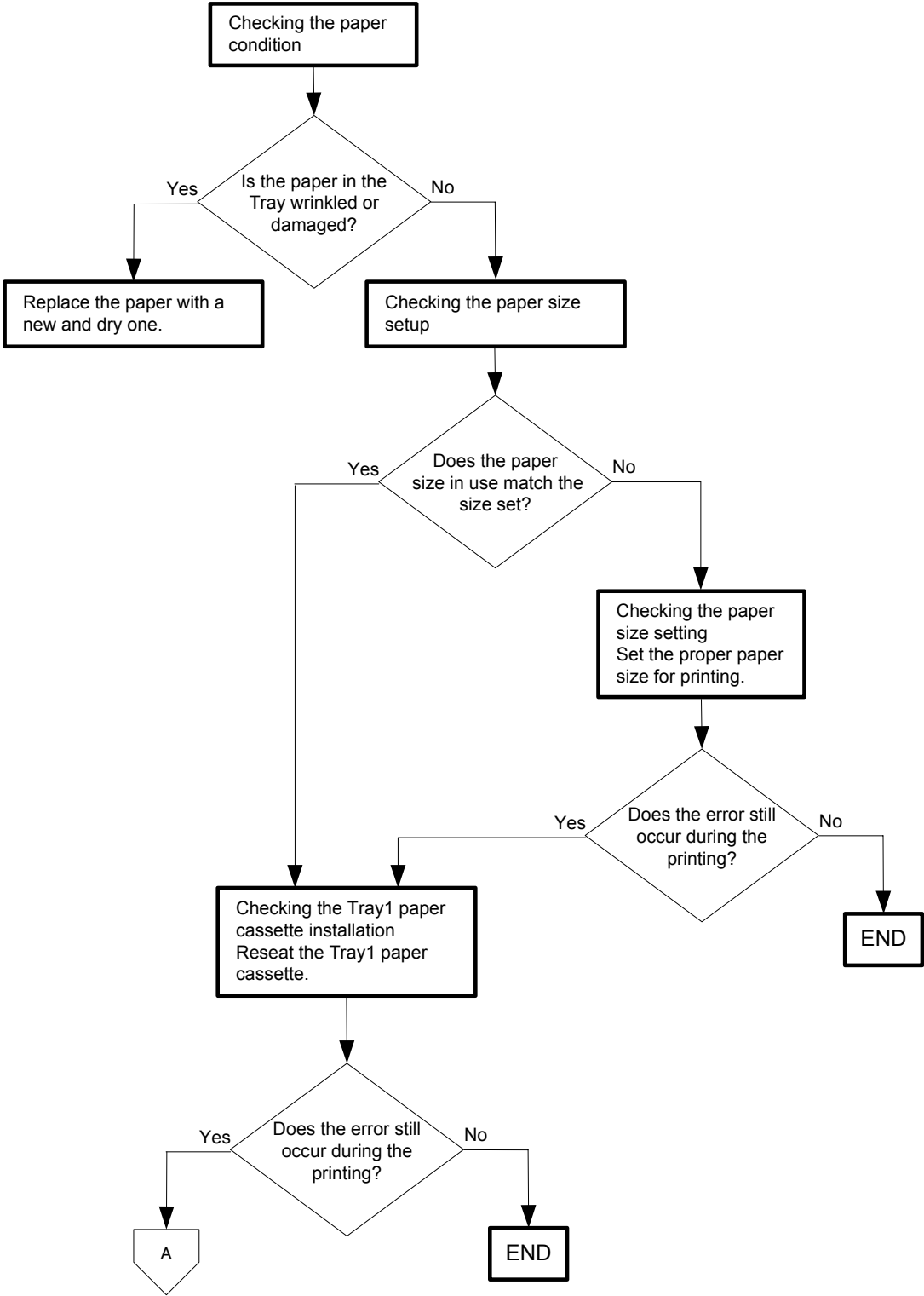

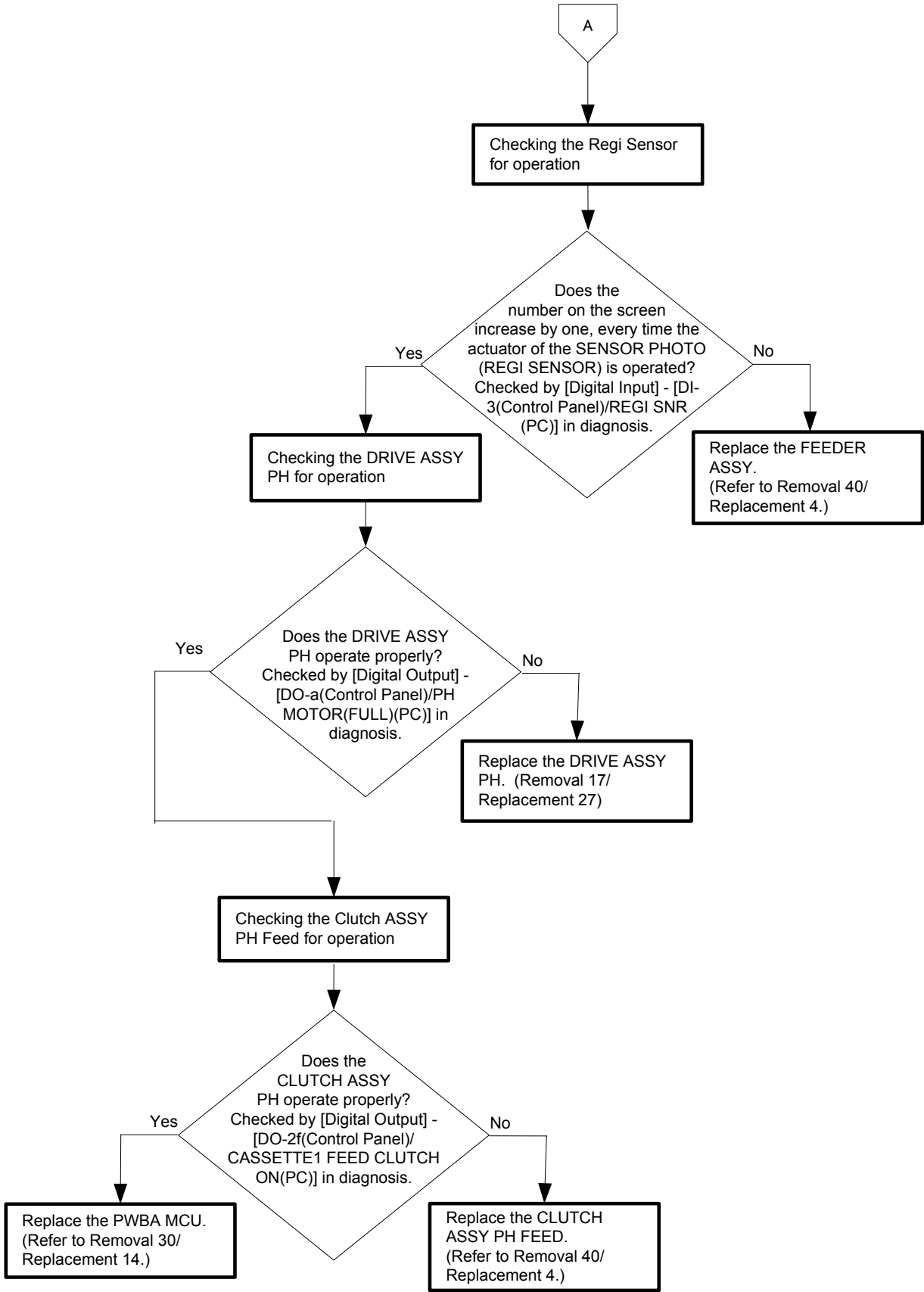

Flows 34 Paper Jam 072-100

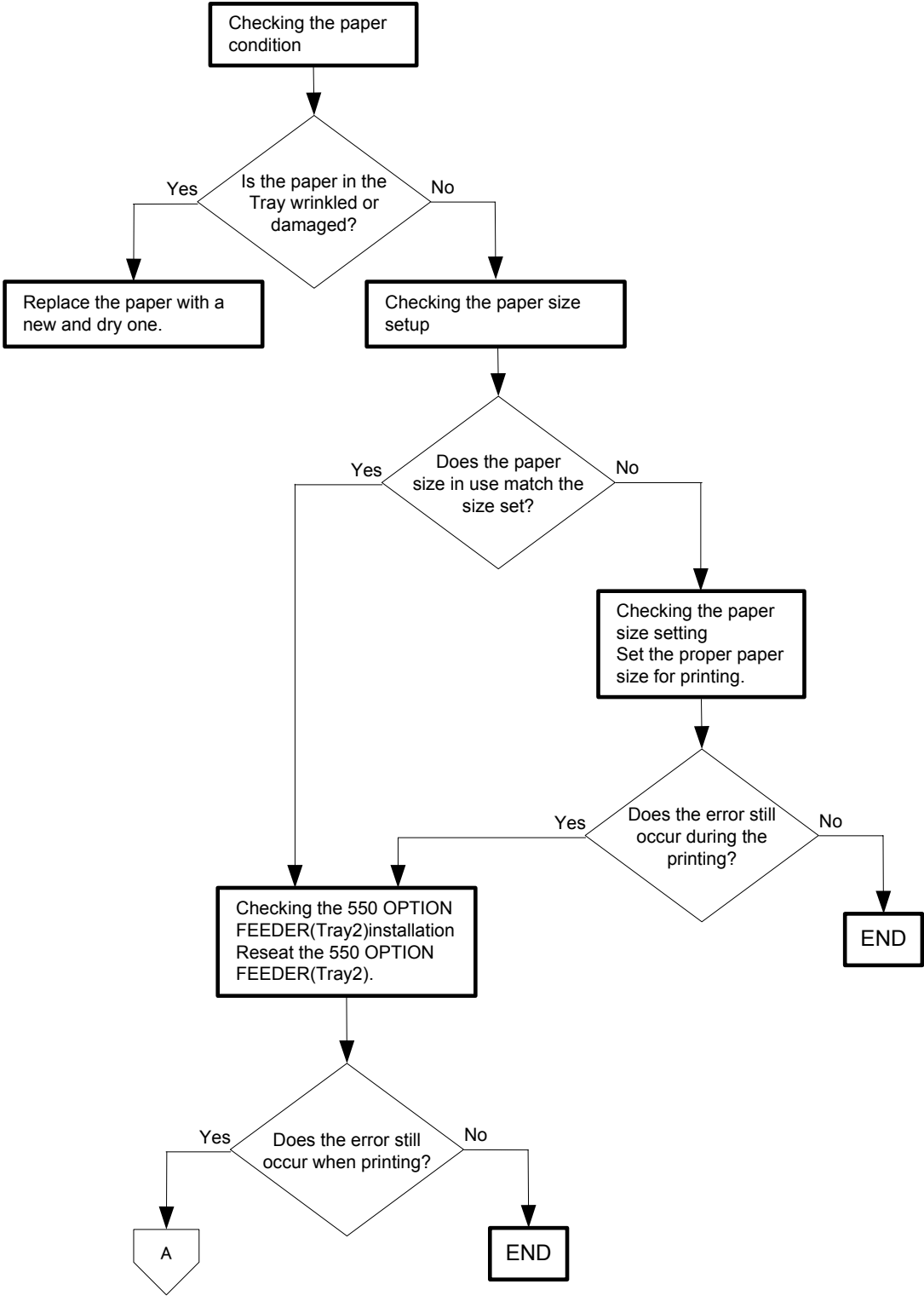

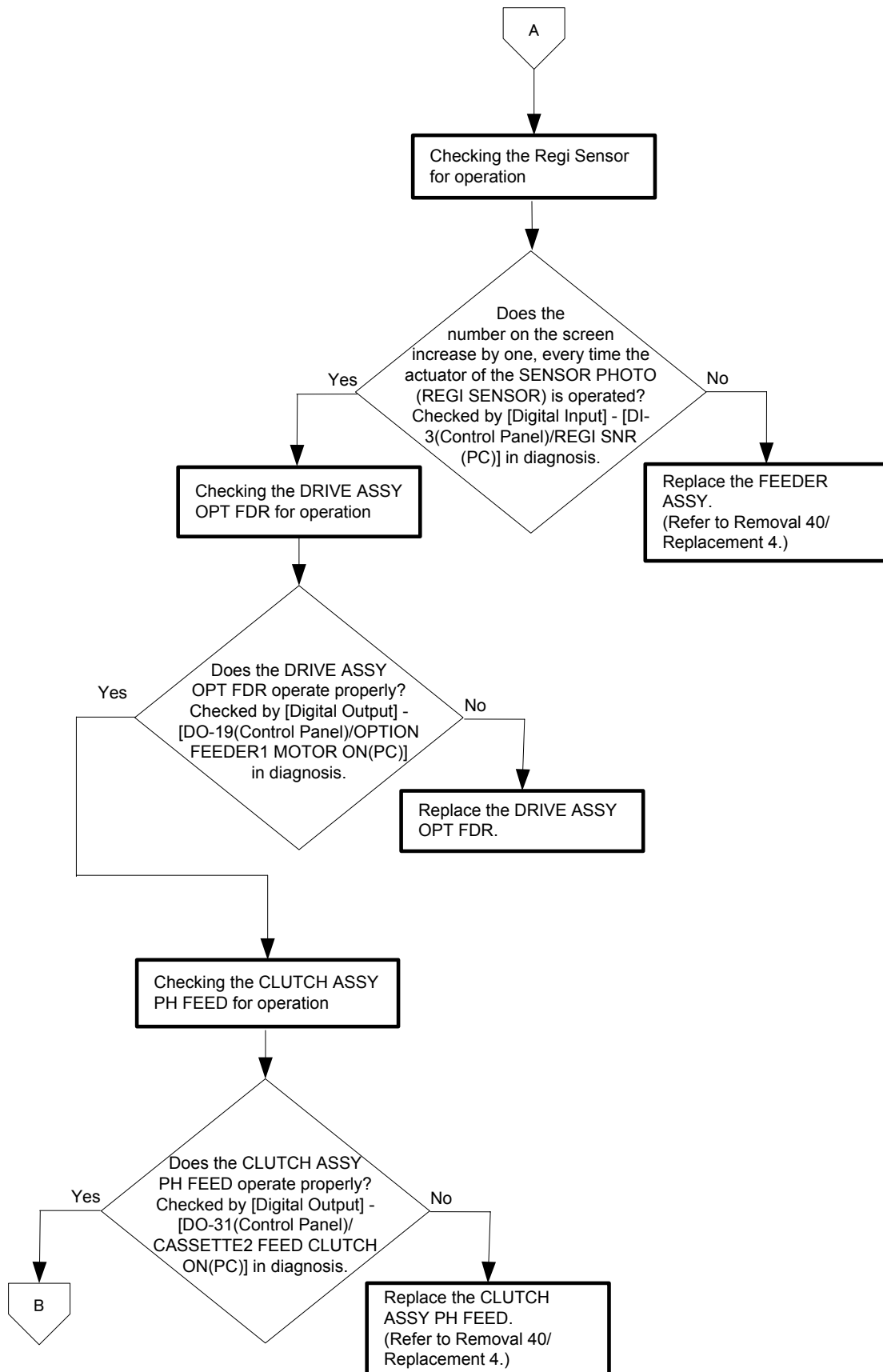

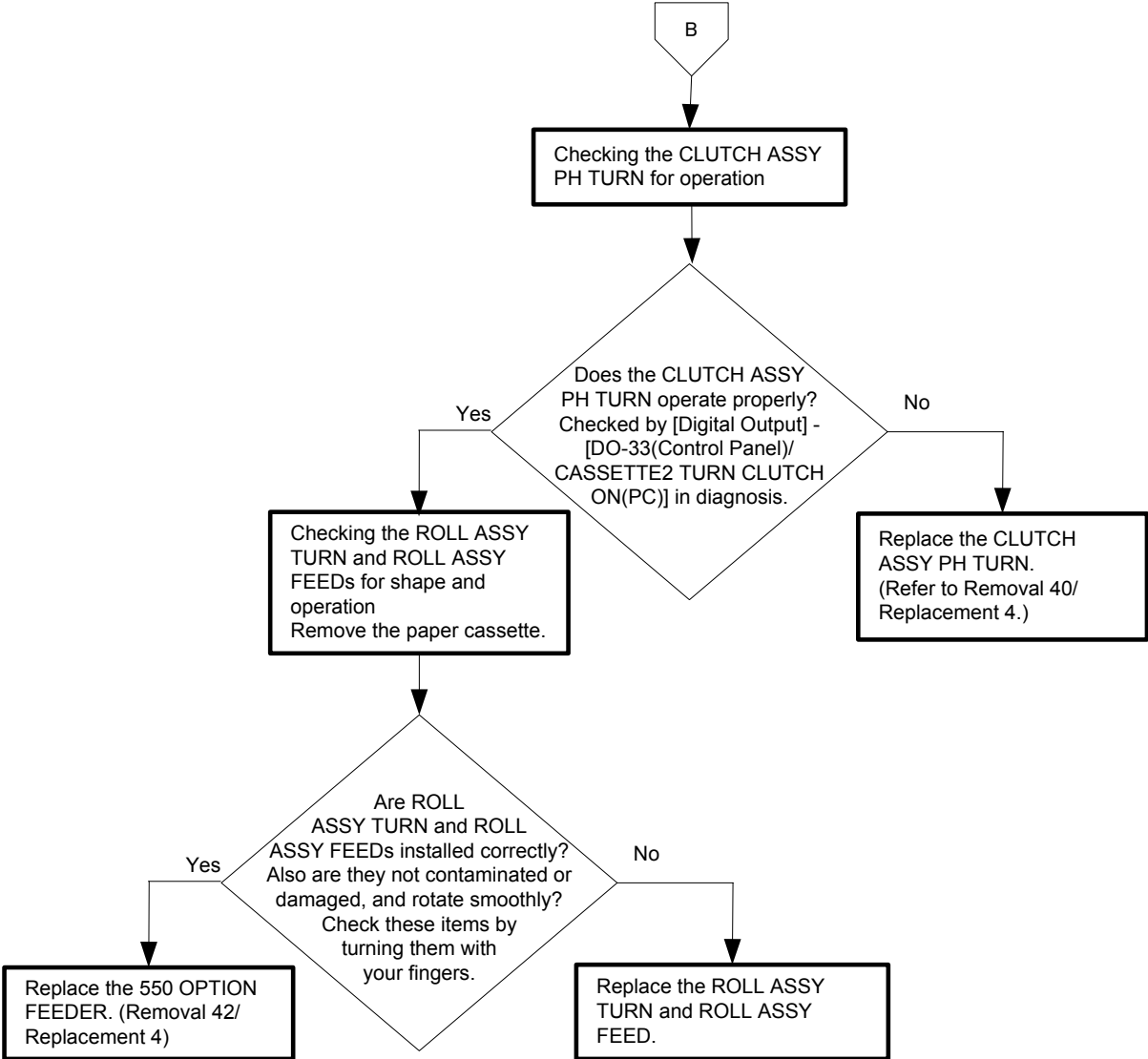

Flows 35 Paper Jam 075-100

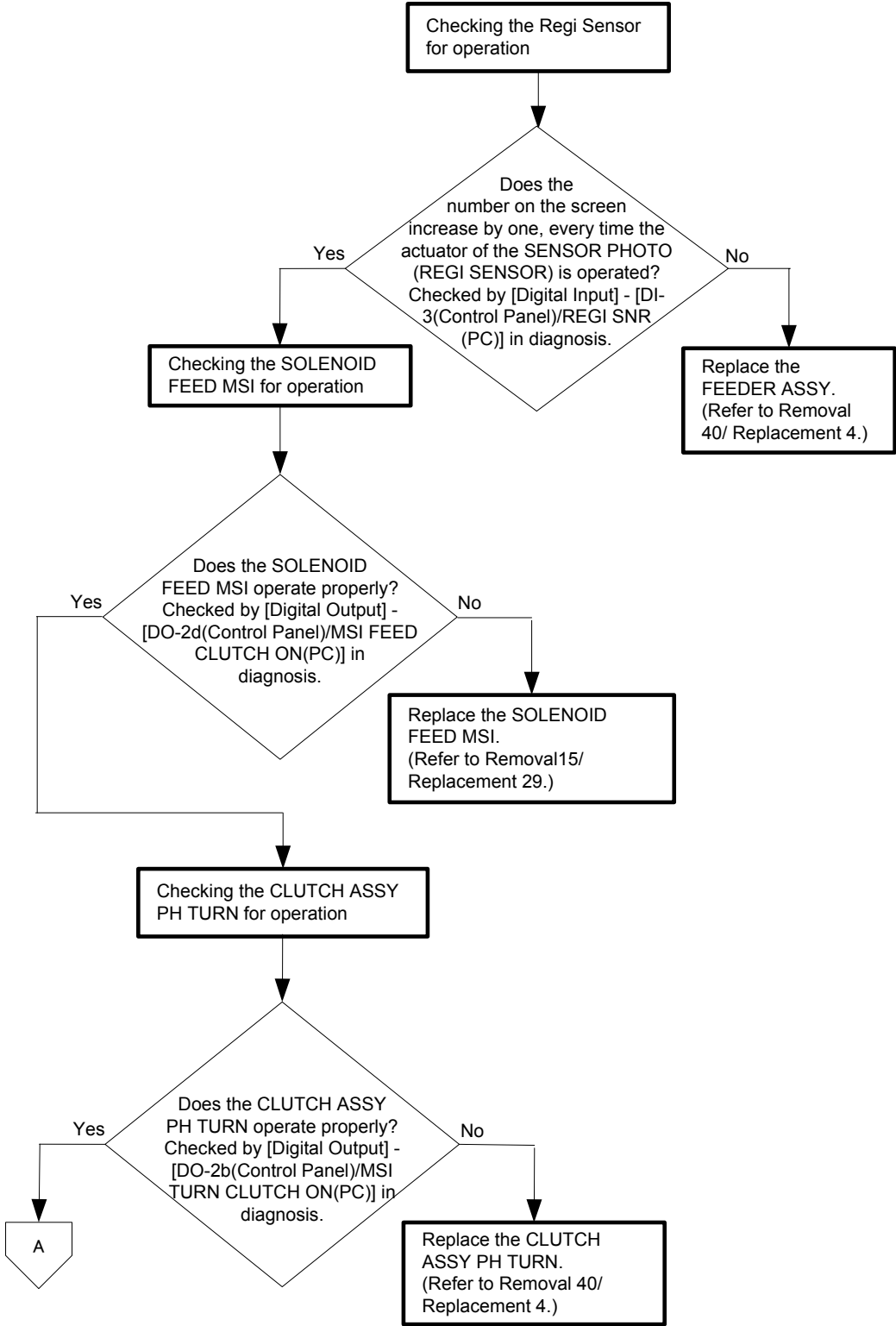

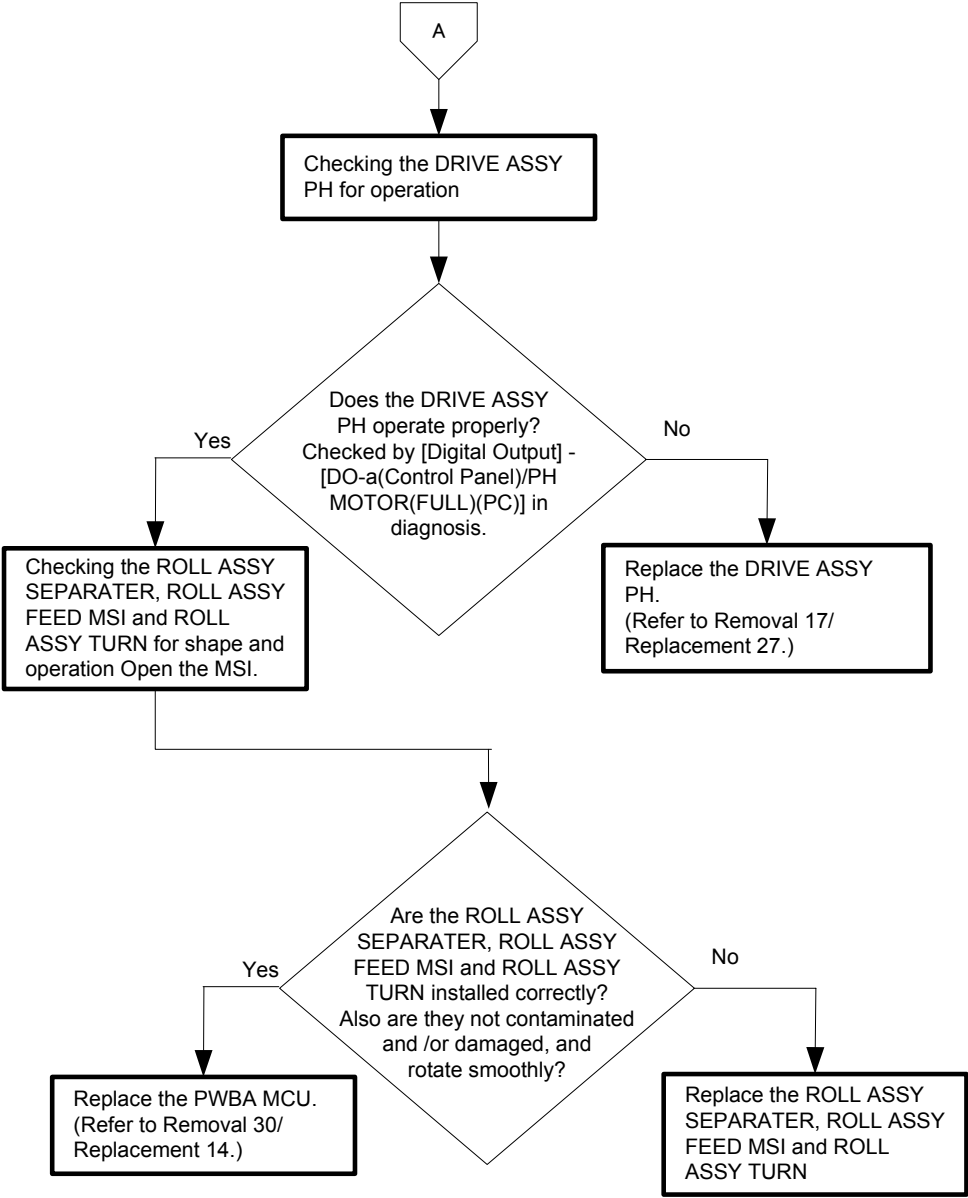

Flows 36 Paper Jam 077-100/077-101

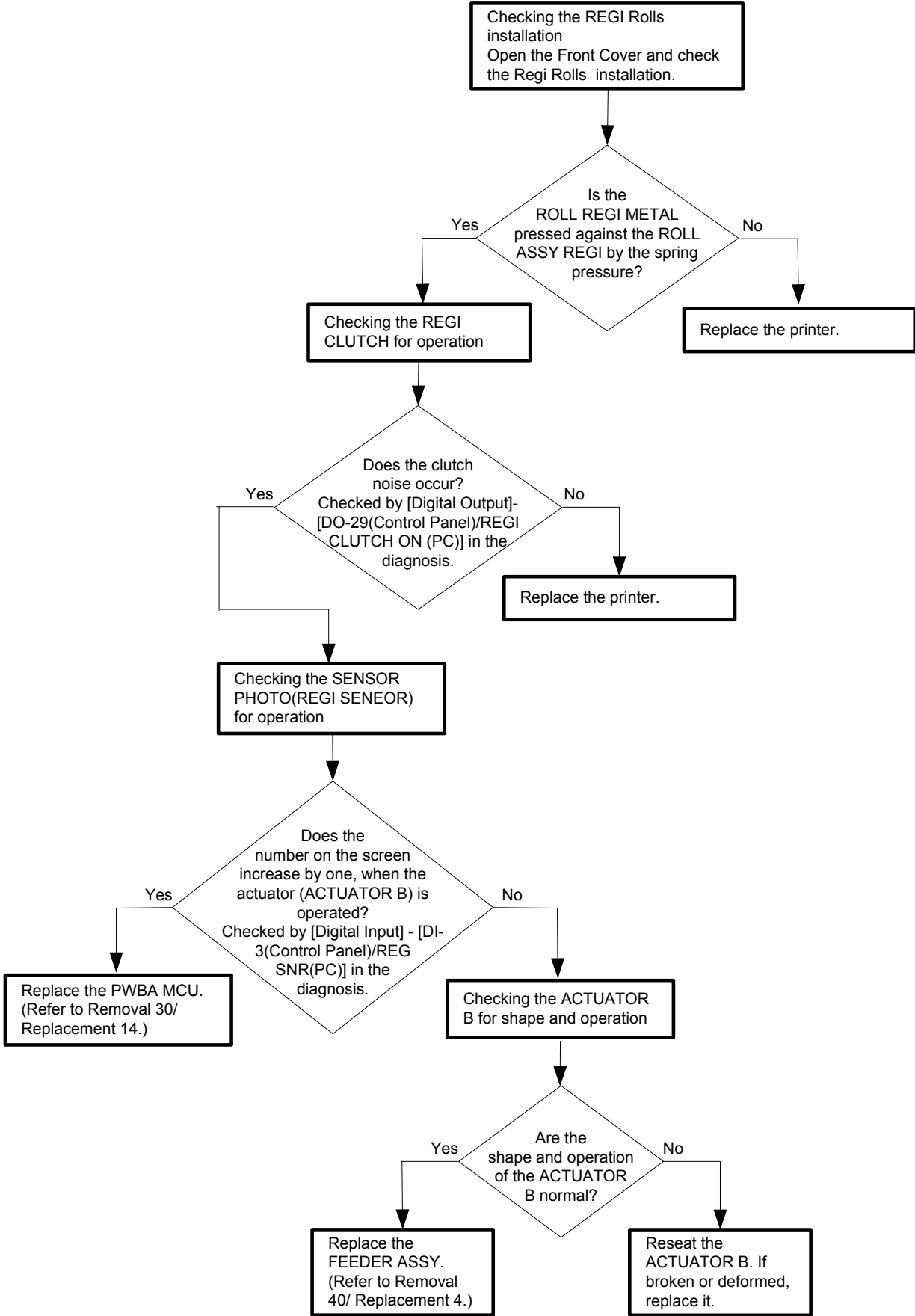

Flows 37 Paper Jam 077-102/077-103

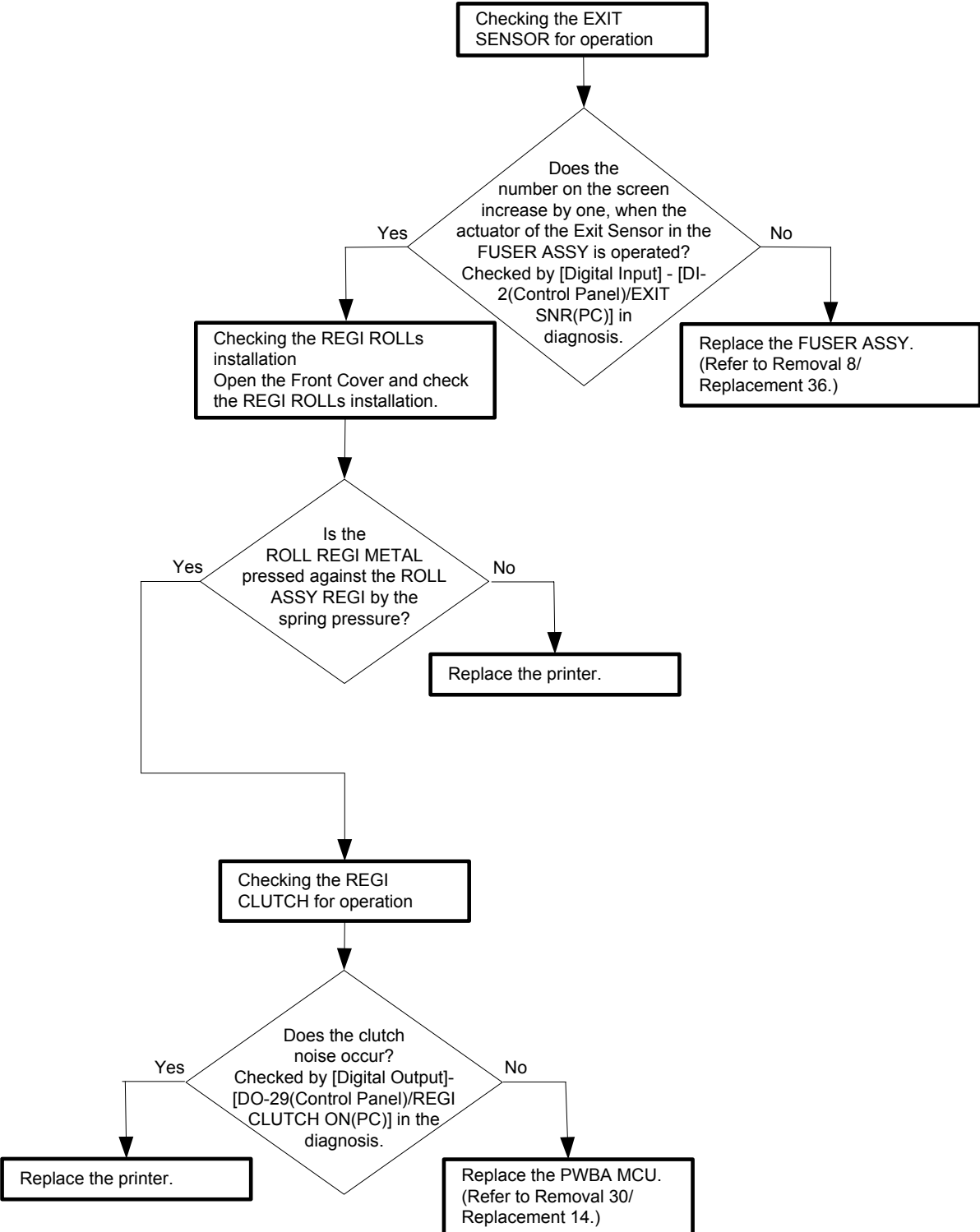

Flows 38 Paper Jam 077-104/077-107

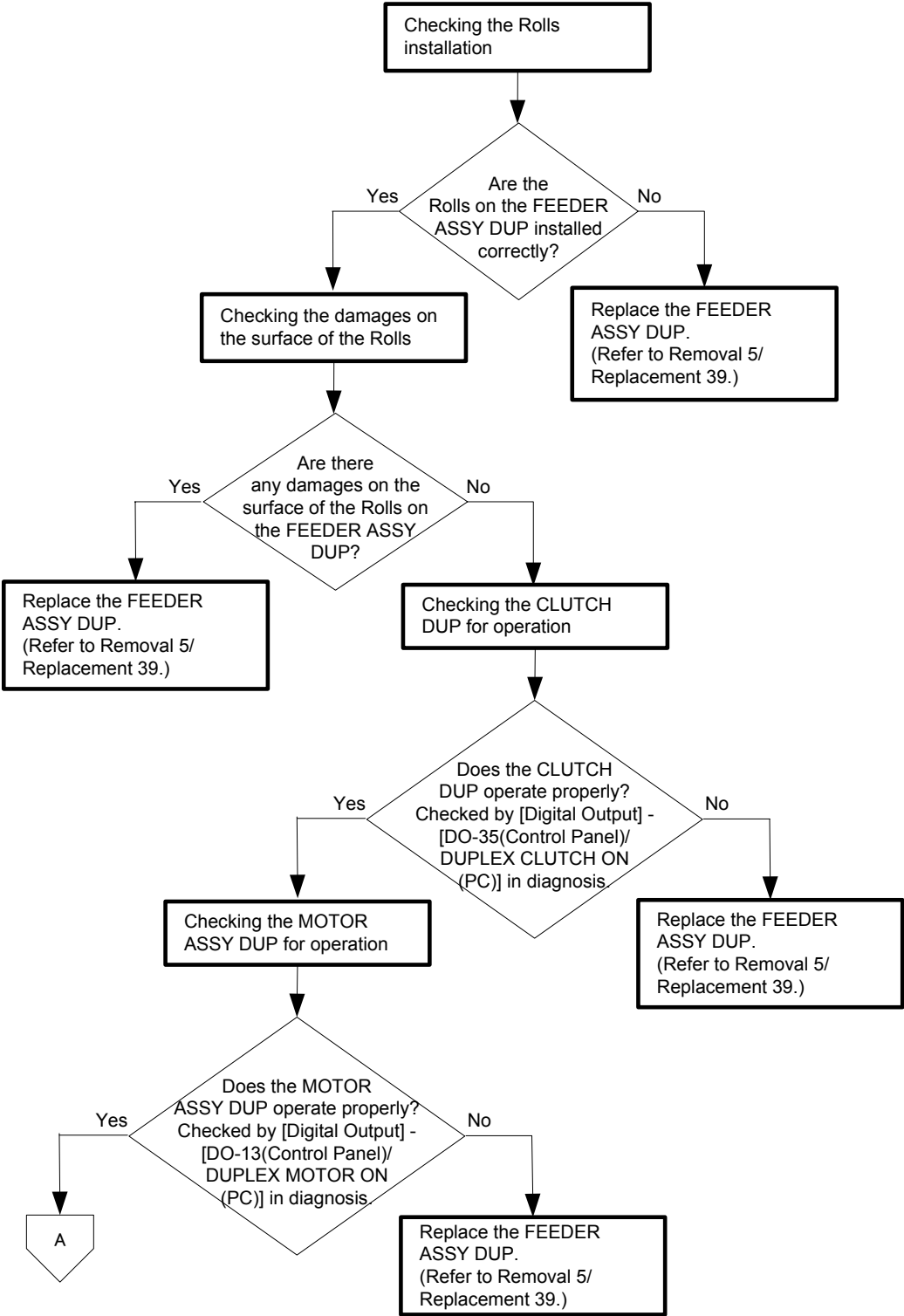

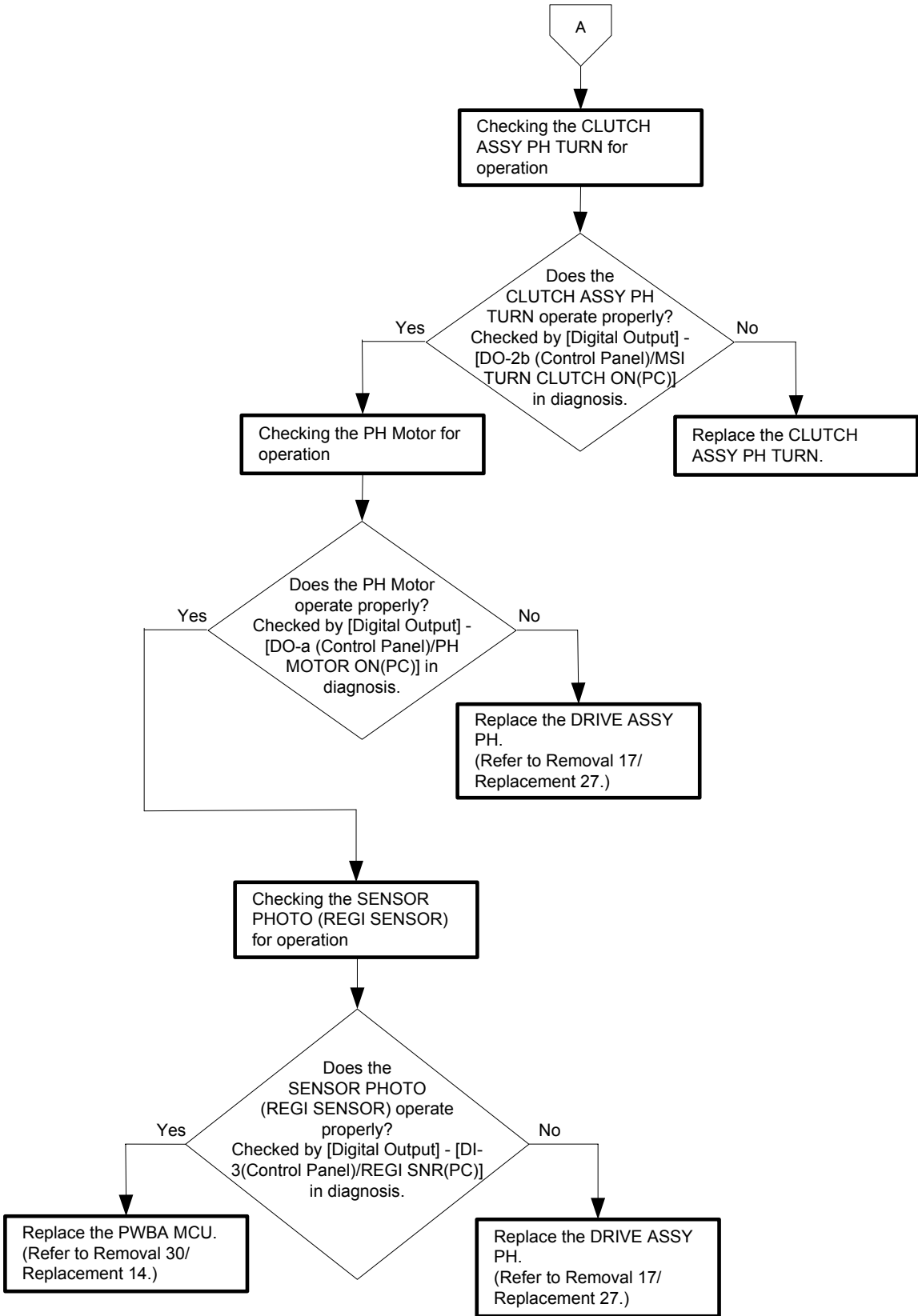

Flows 39 Paper Jam 077-105/077-106

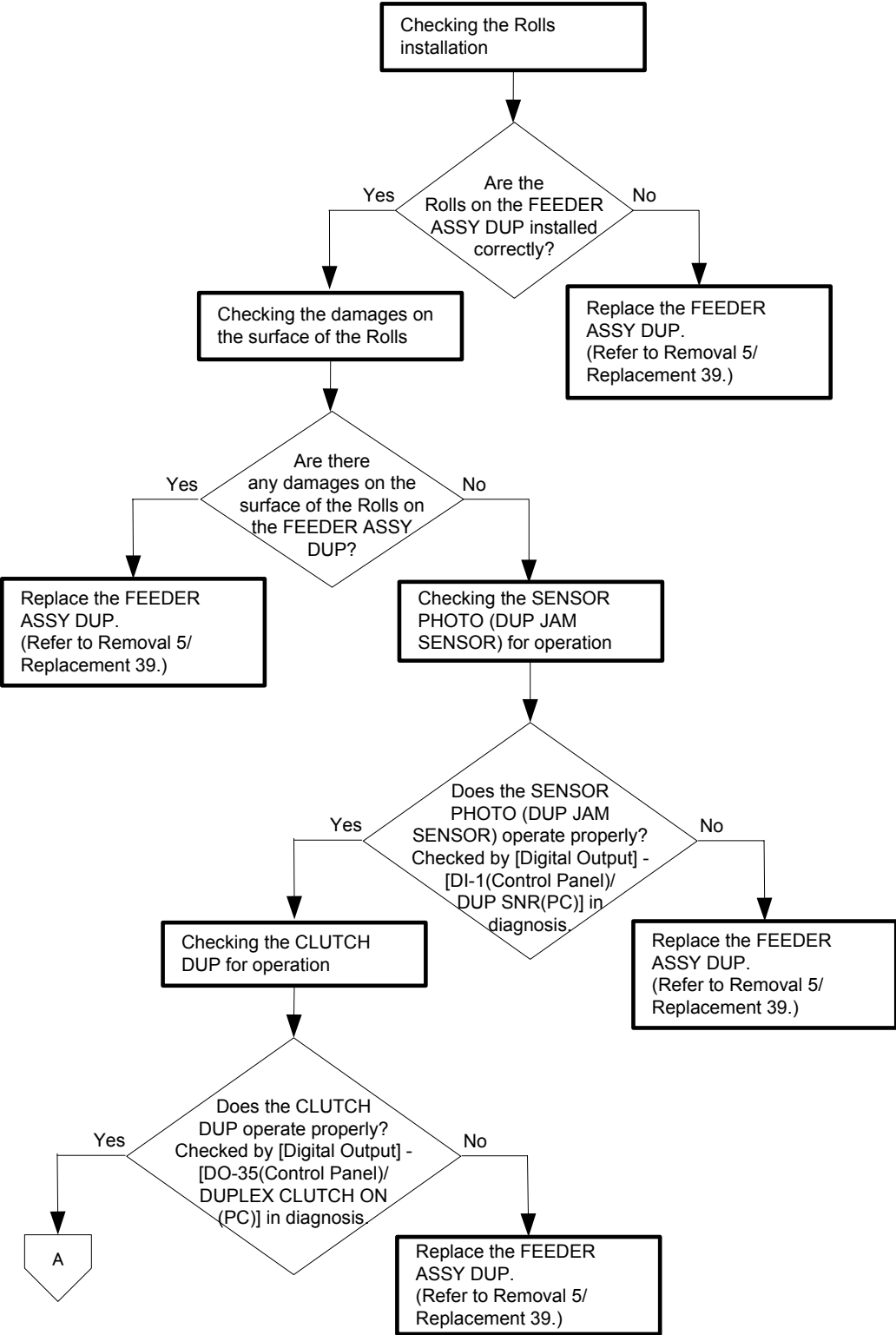

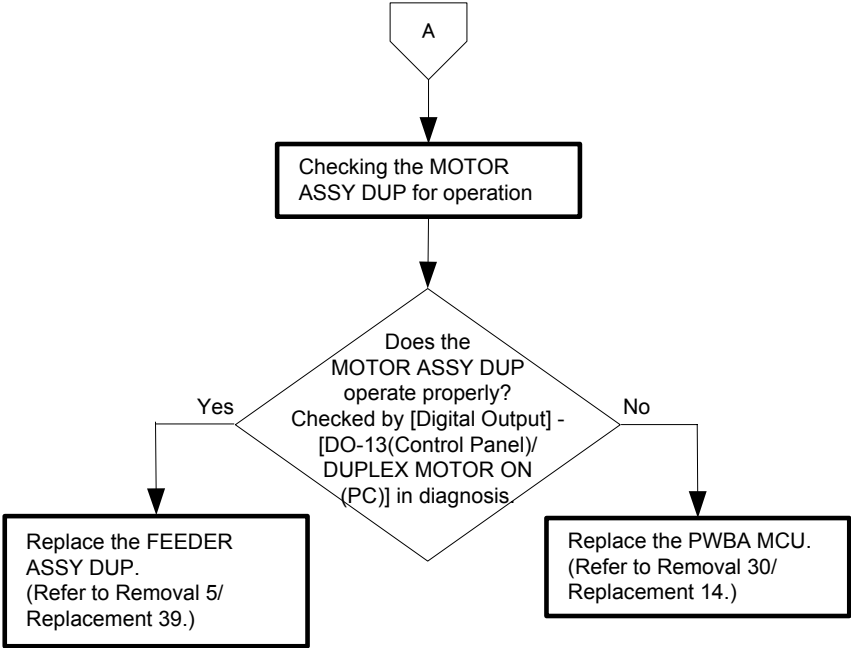

Flows 40 Paper Jam 077-900/077-901

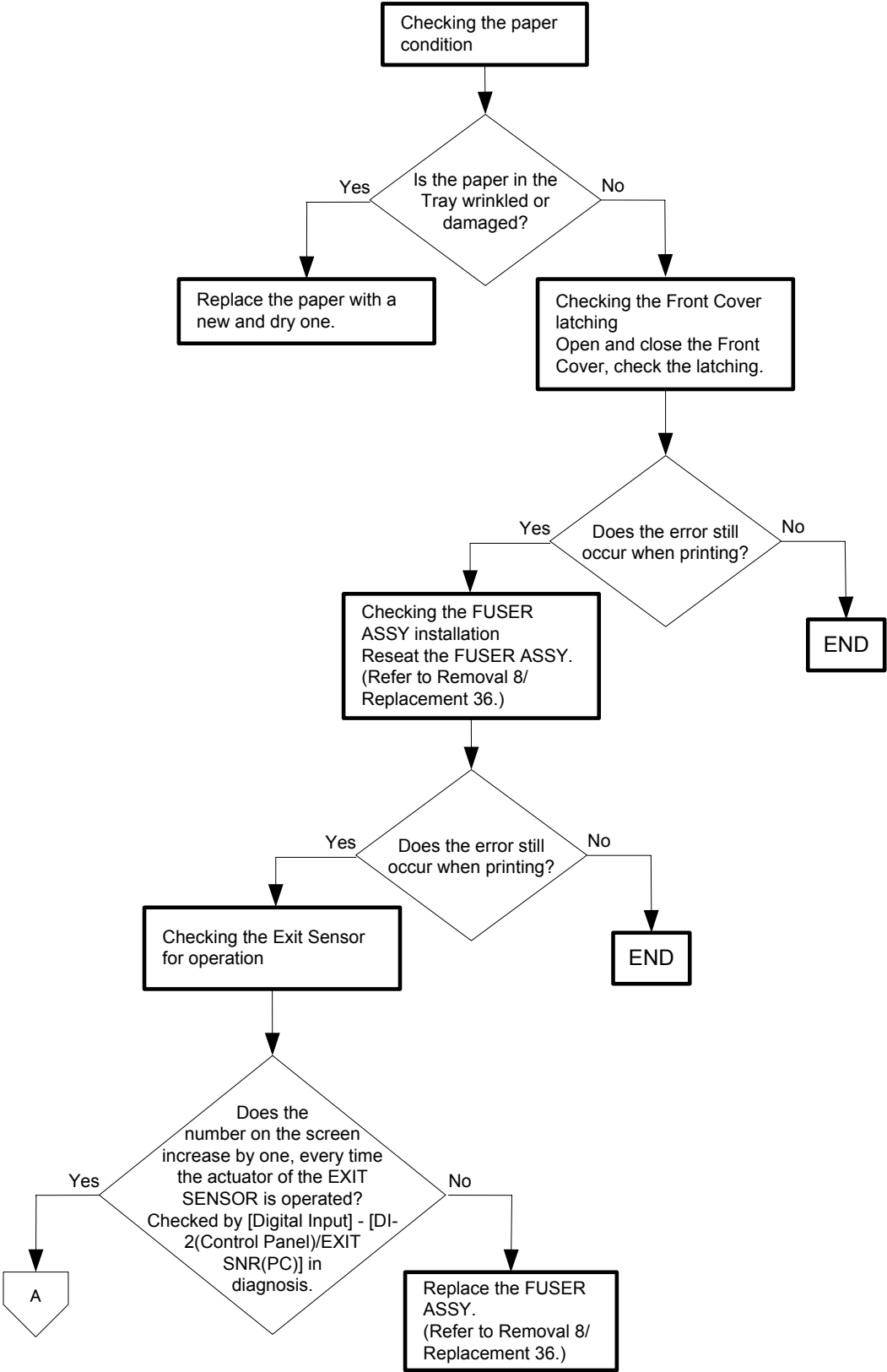

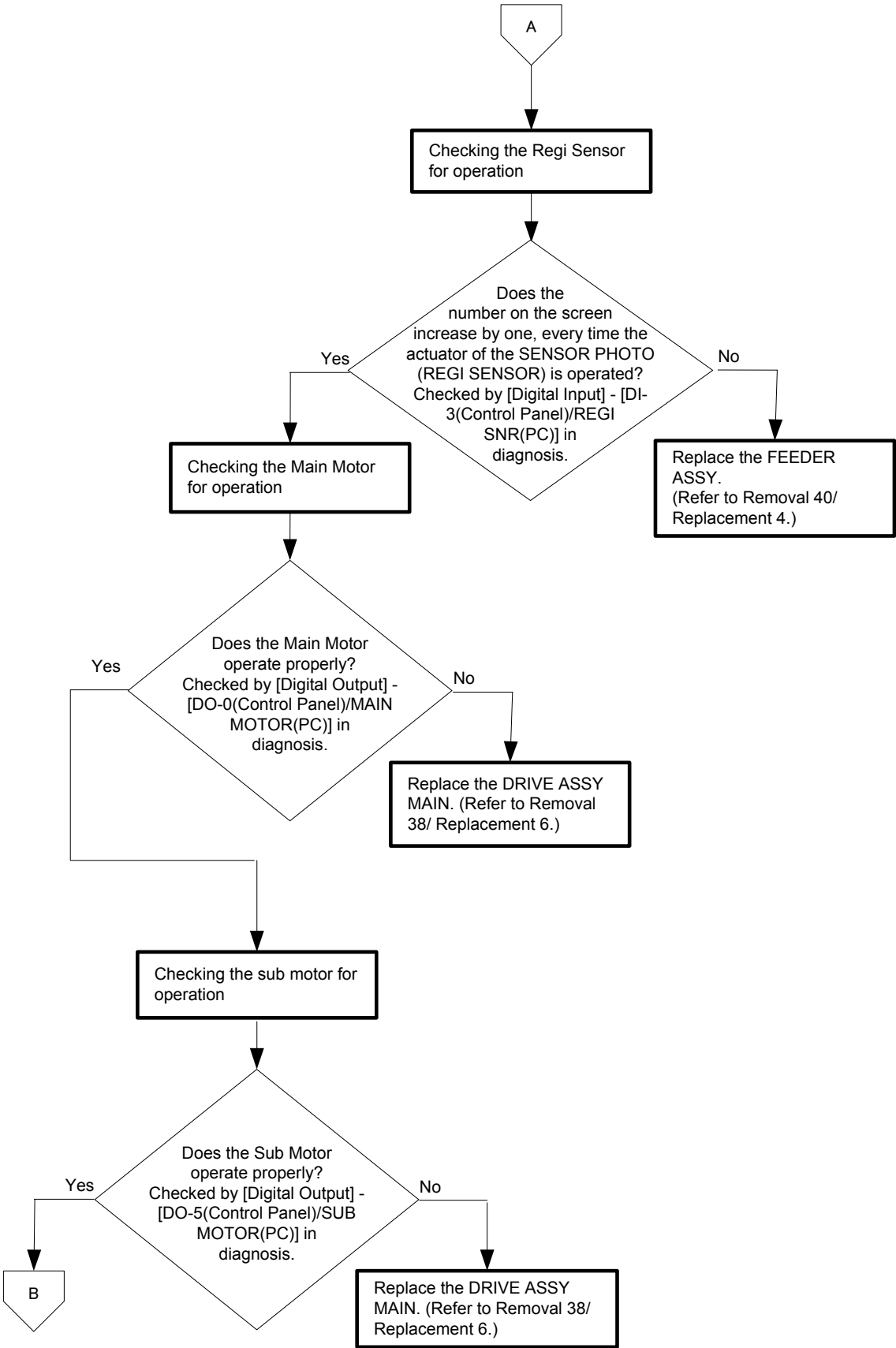

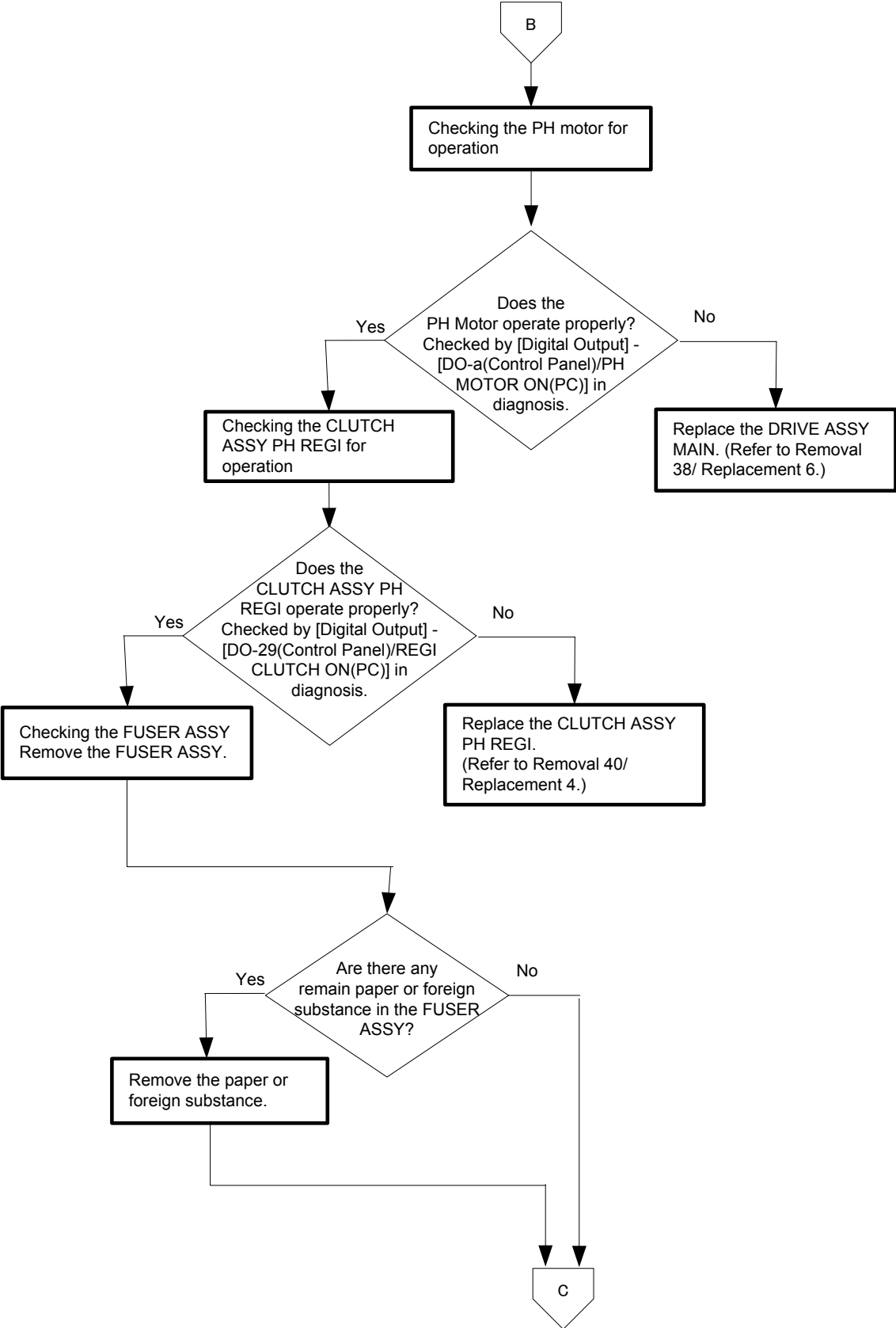

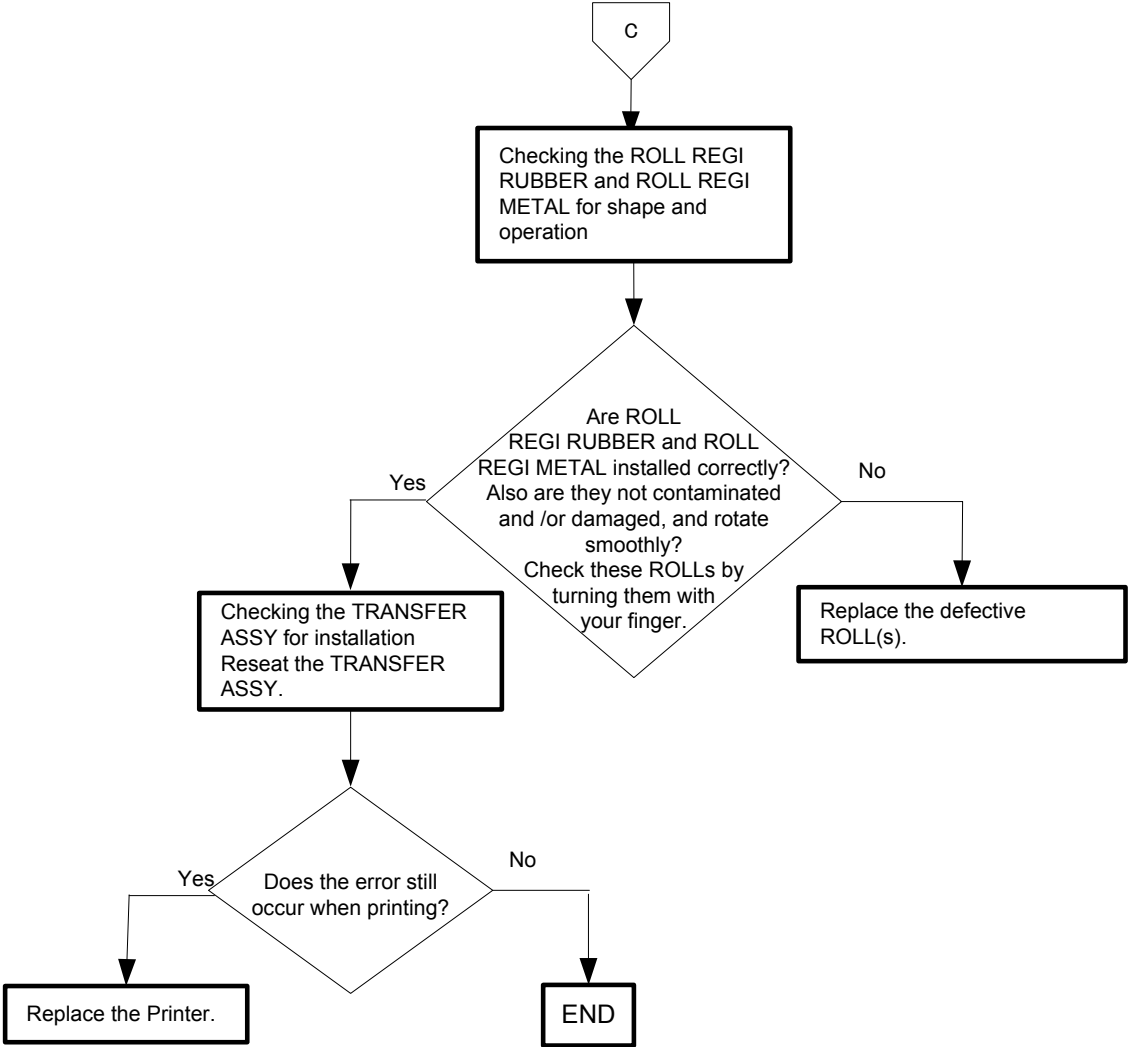

Flows 41 Paper Jam 077-903

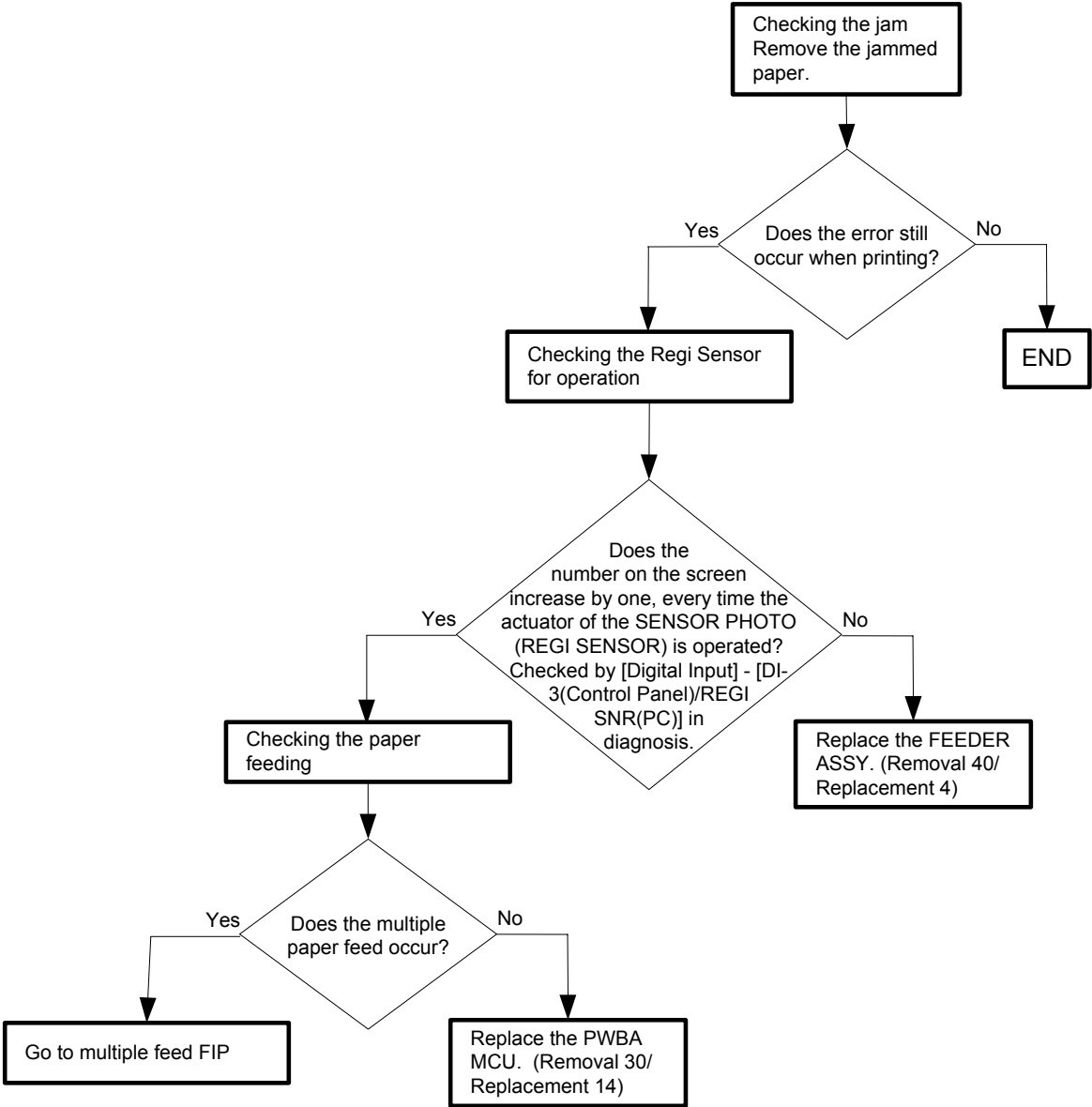

Flows 42 Paper Jam 077-907

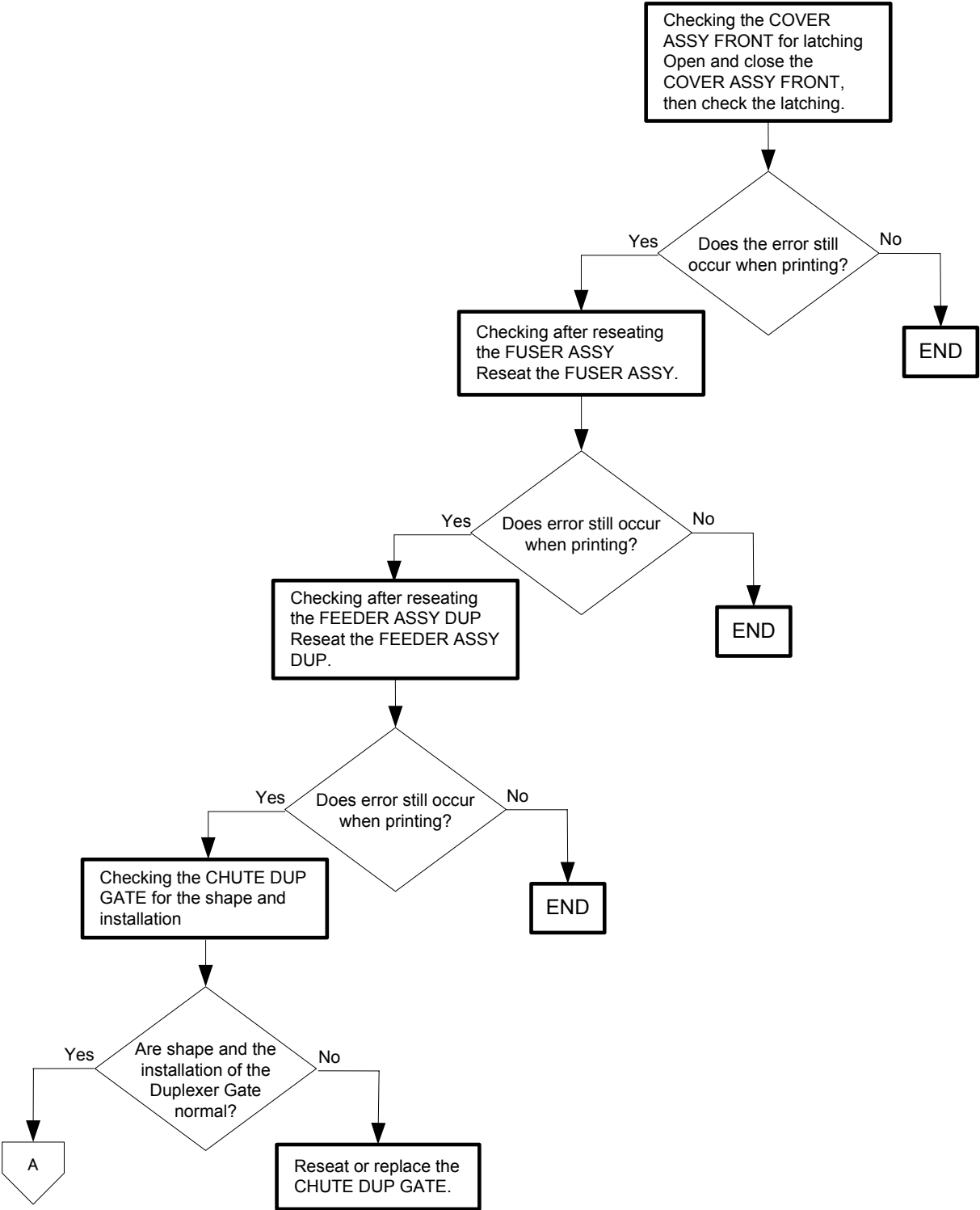

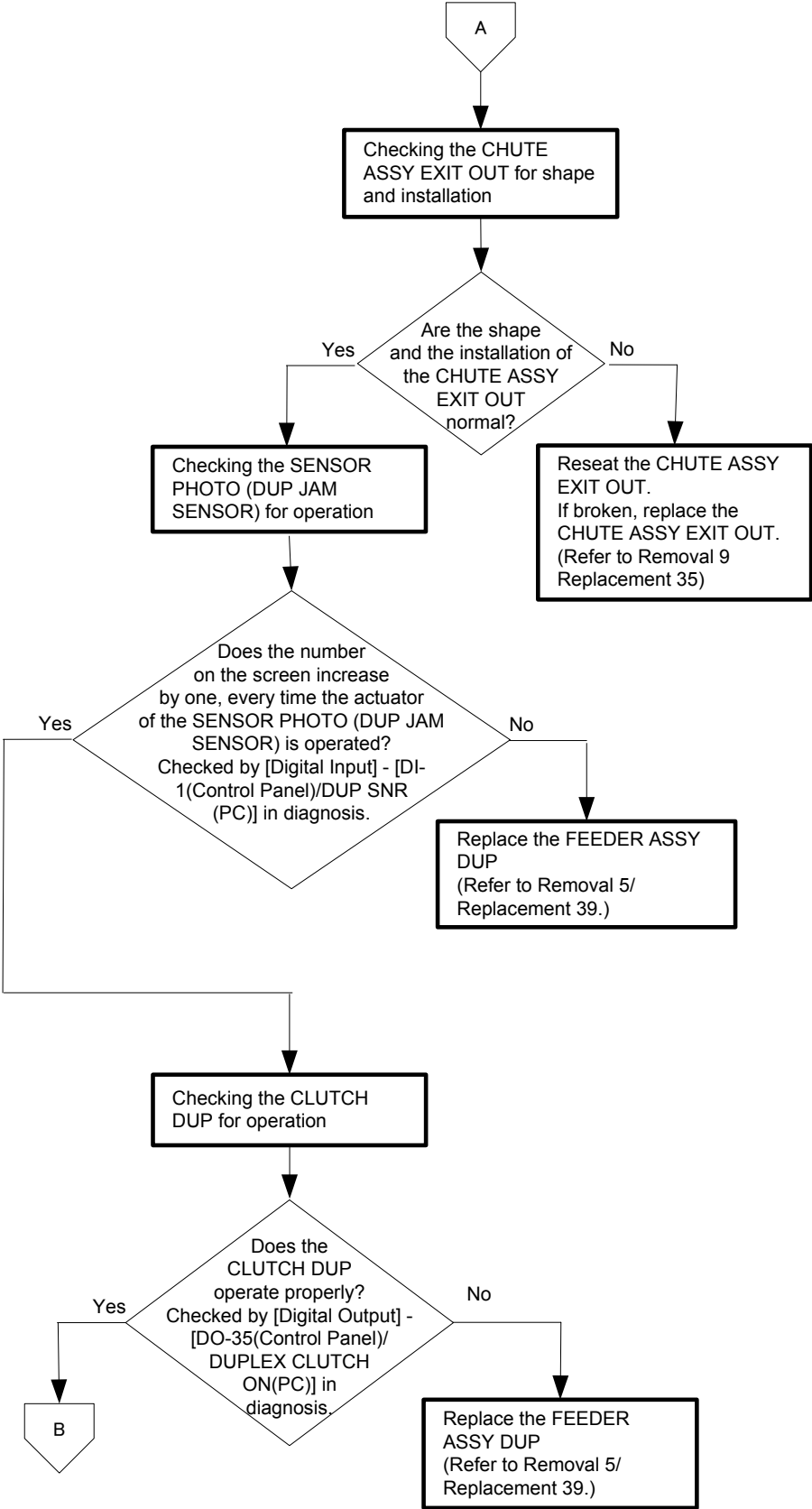

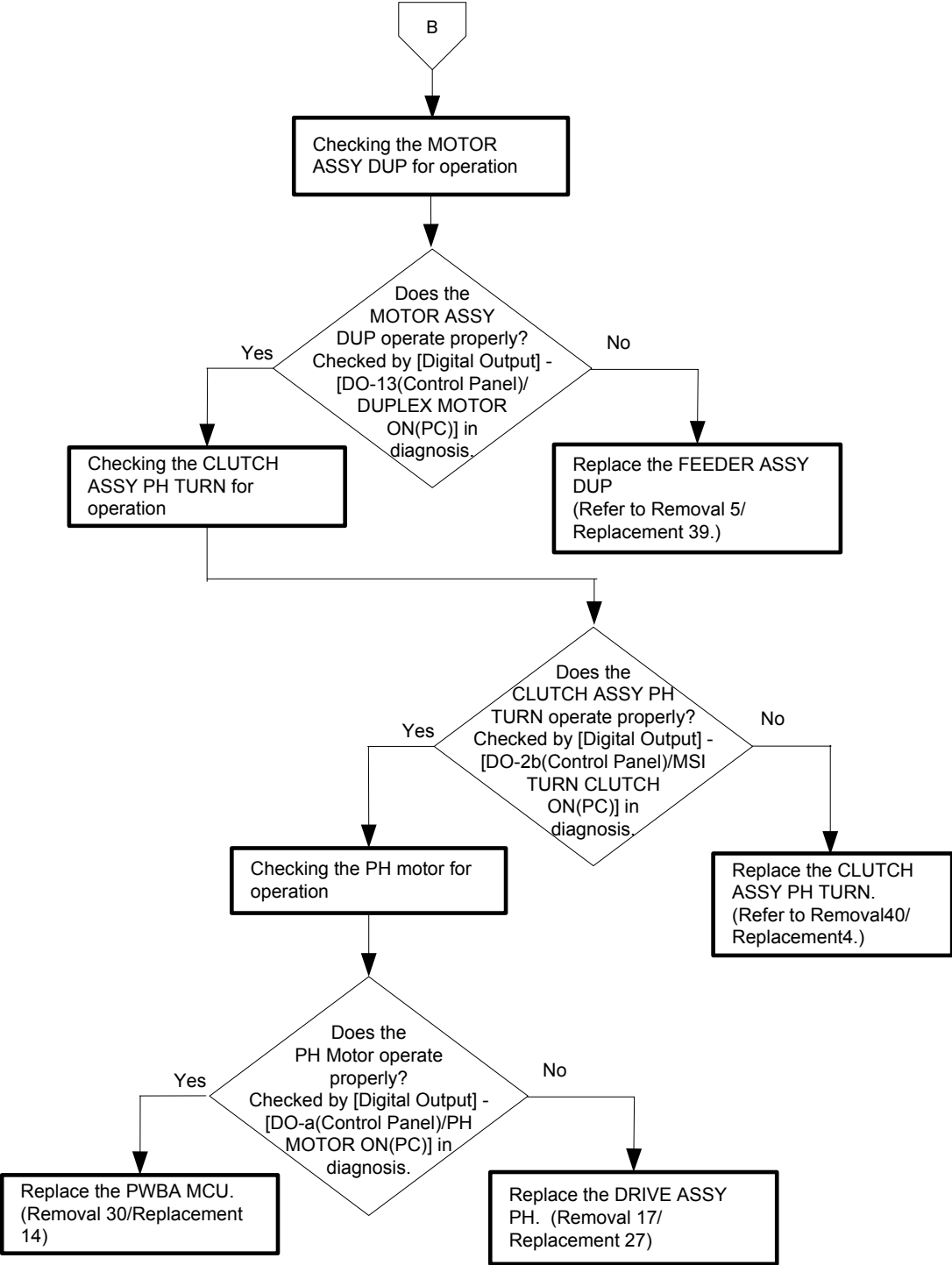

Flows 43 Load Tray N or MPF 024-910/024-911/024-914

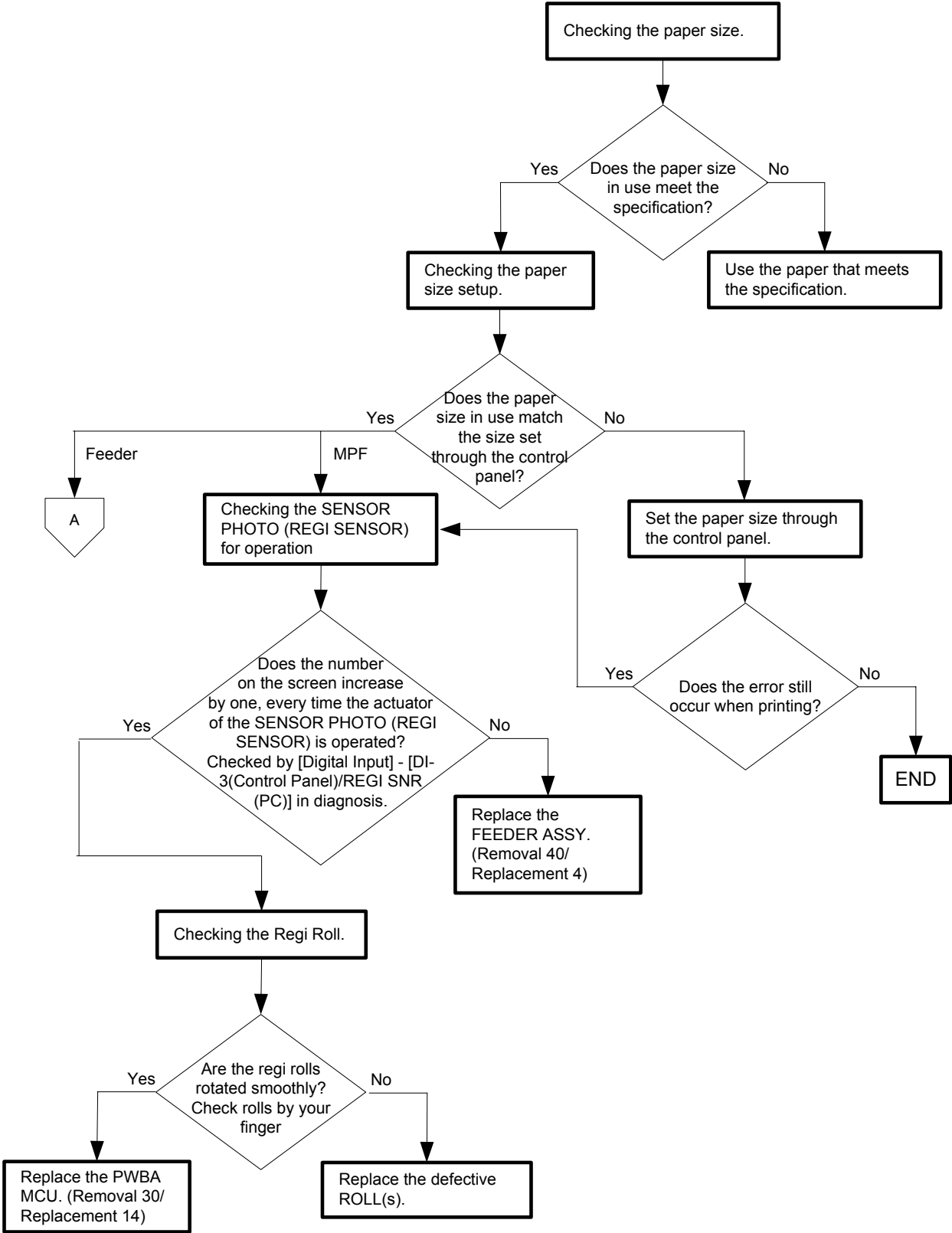

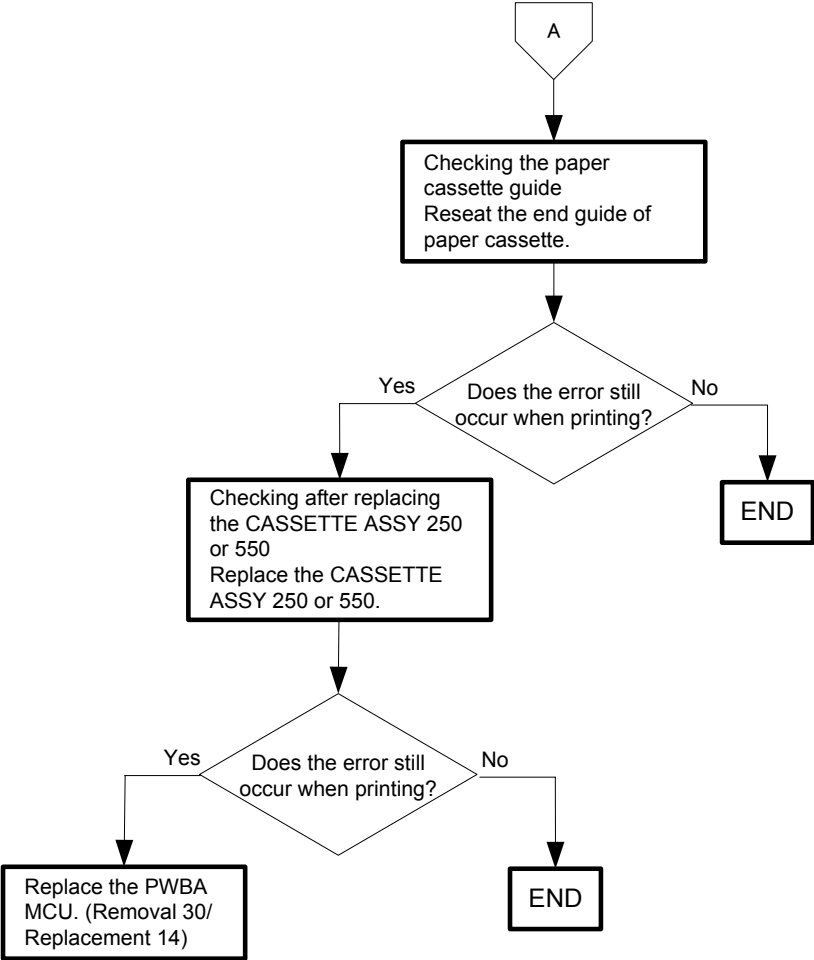

Flows 44 Load Tray N or MPF 024-965/024-966/024-969

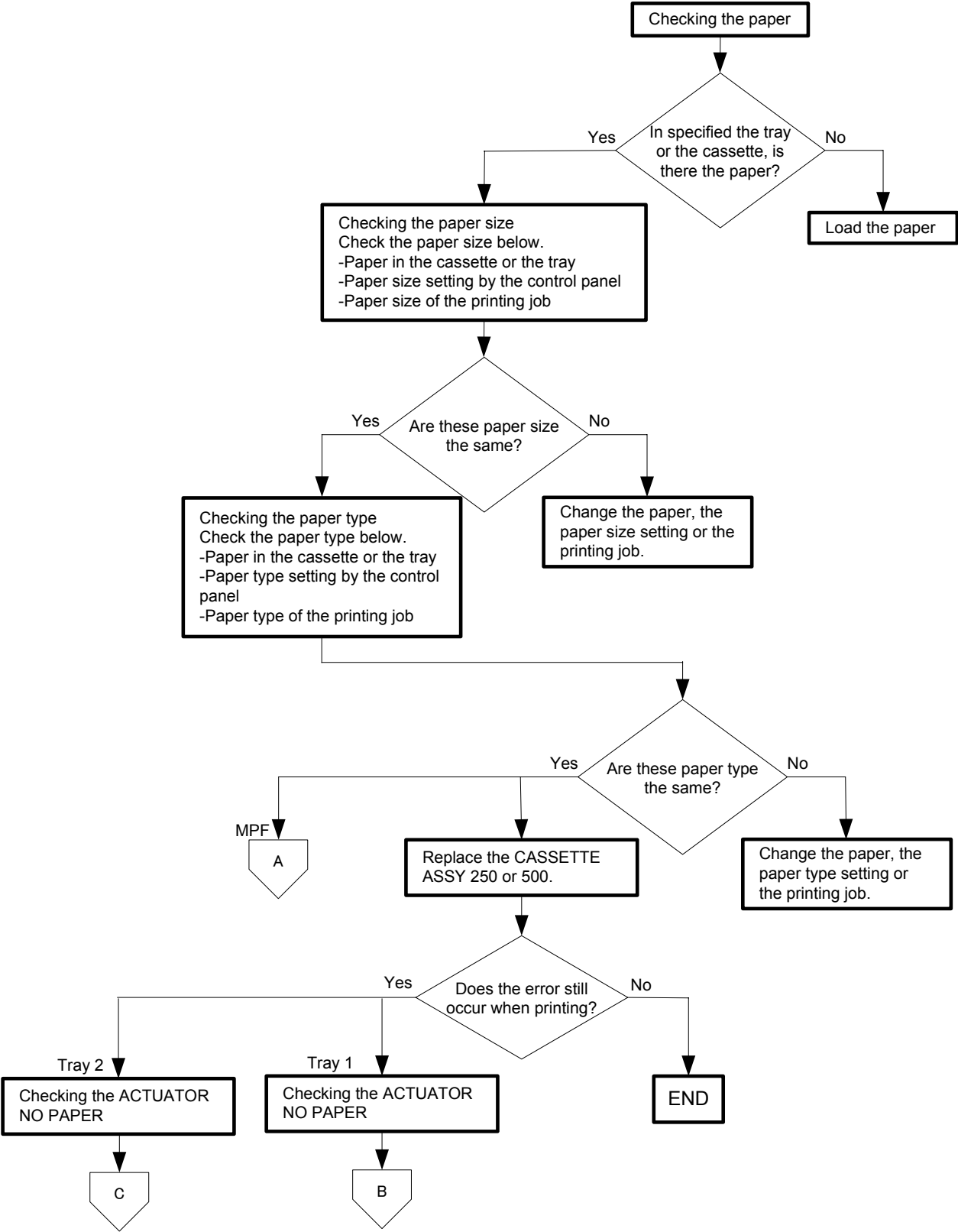

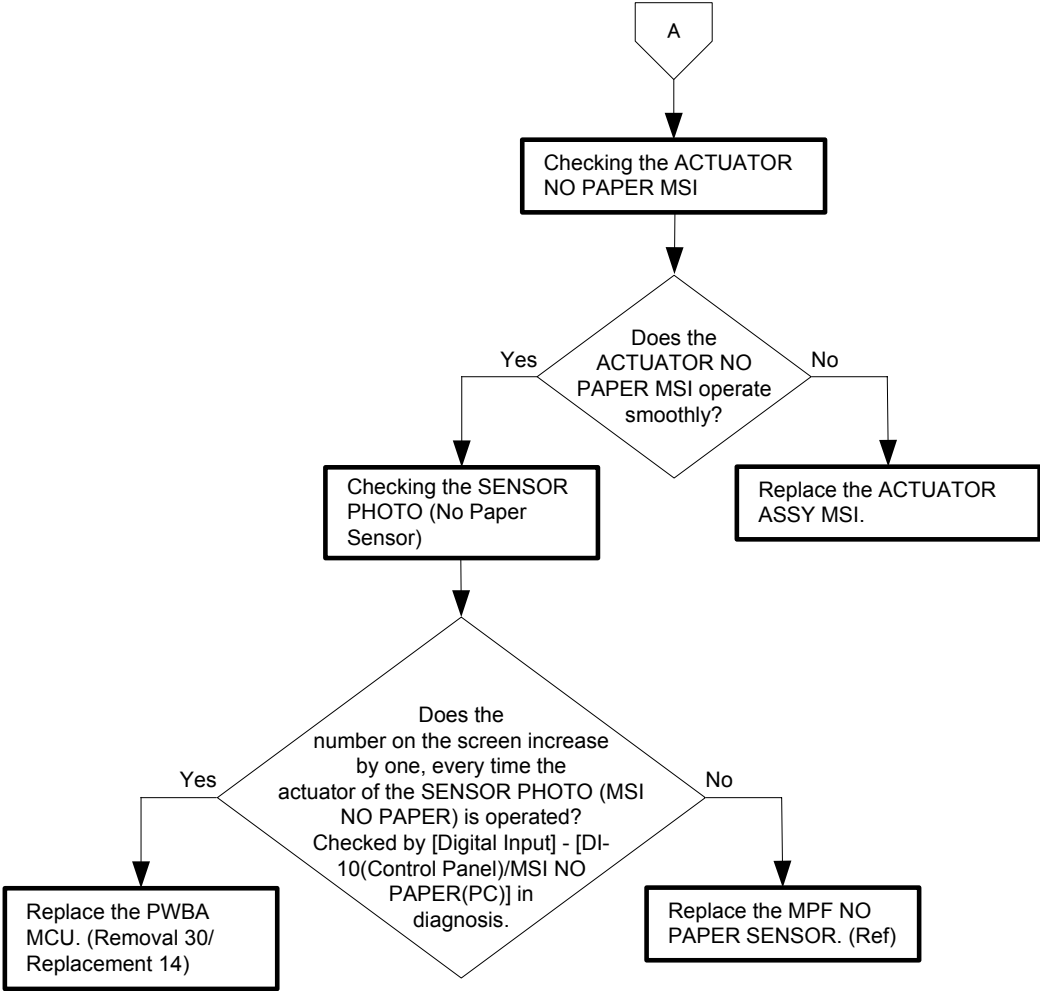

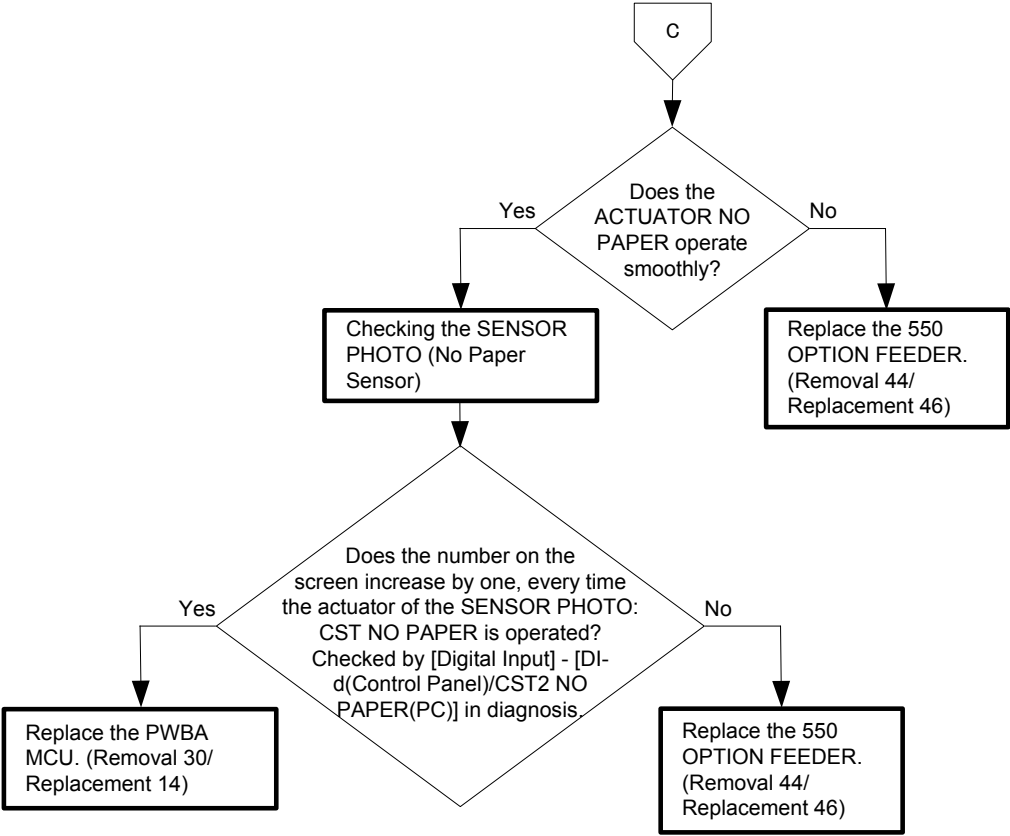
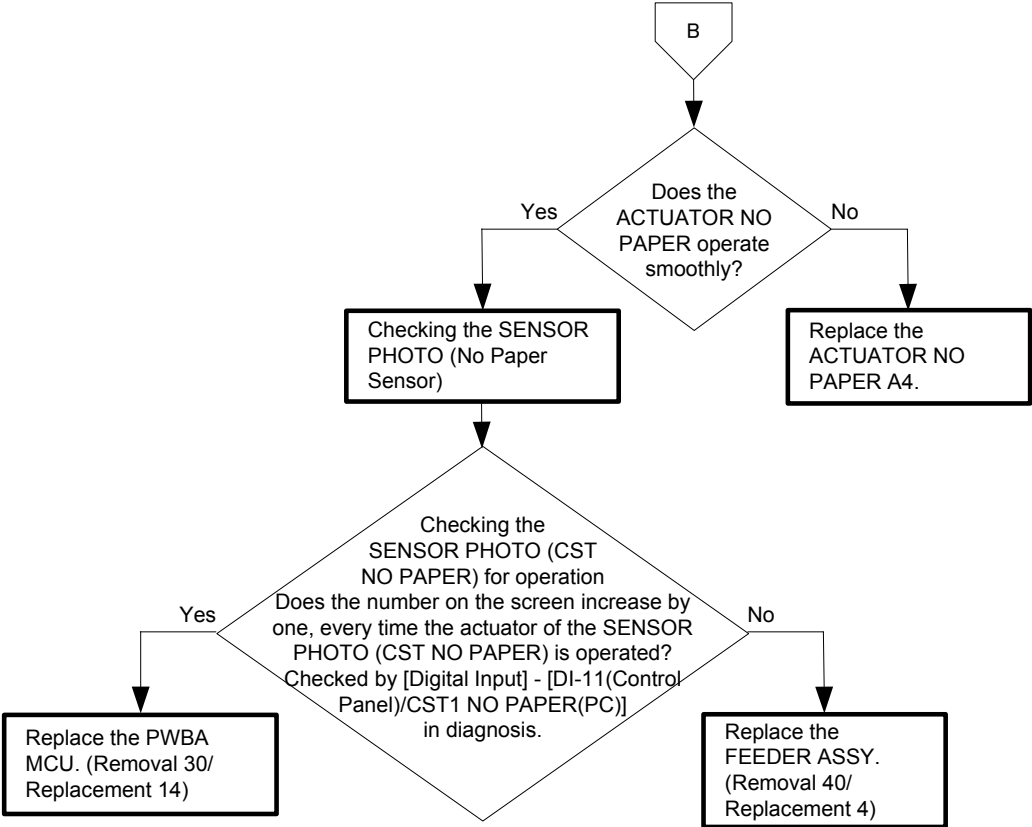

Flows 45 CRUM ID 009-367/009-368/009-369/009-370

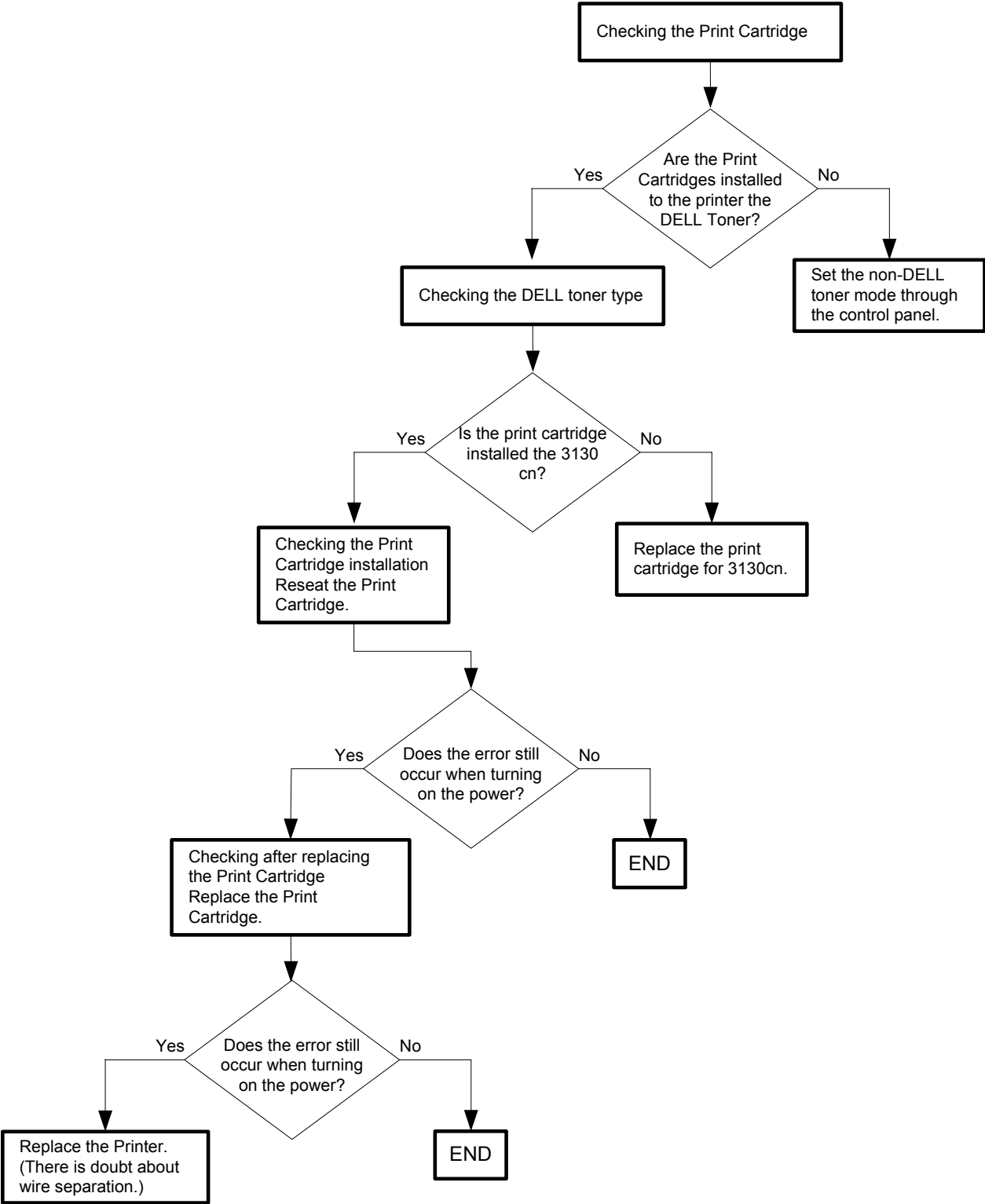

Flows 46 Error Y Cart 093-919

NOTE

Every unused Print Cartridge originally installed in the printer is covered with a Toner Tape that protects the drum from intense light. This error is displayed when the printer is operated without removing the Toner Tape.

Open the Front Cover to check if the Toner Tape is affixed on the Print Cartridge (Y).

Remove the Toner Tape if present.

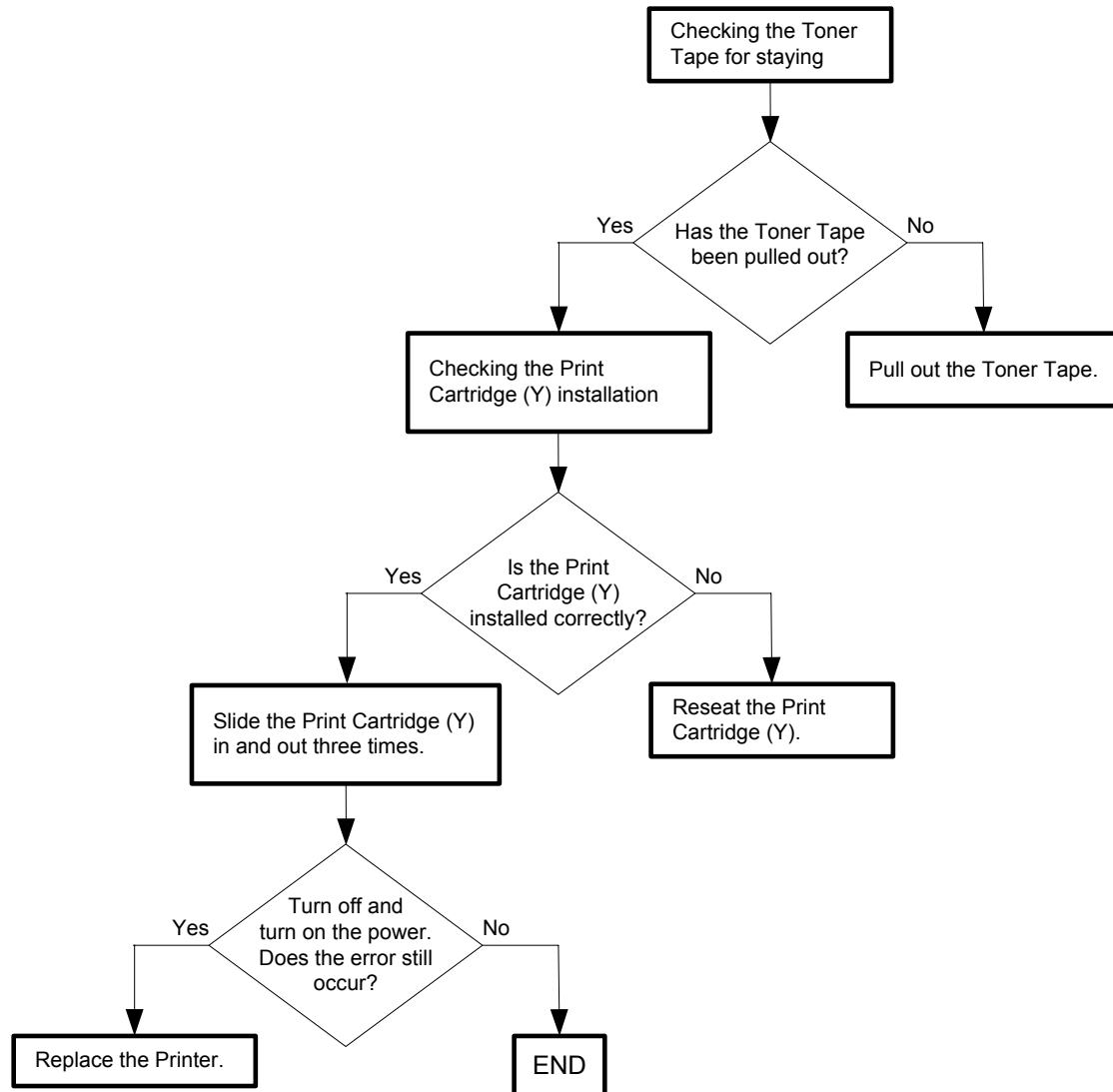

Flows 47 Error M Cart 093-920

NOTE

Every unused Print Cartridge originally installed in the printer is covered with a Toner Tape that protects the drum from intense light. This error is displayed when the printer is operated without removing the Toner Tape.

Open the Front Cover to check if the Toner Tape is affixed on the Print Cartridge (M).

Remove the Toner Tape if present.

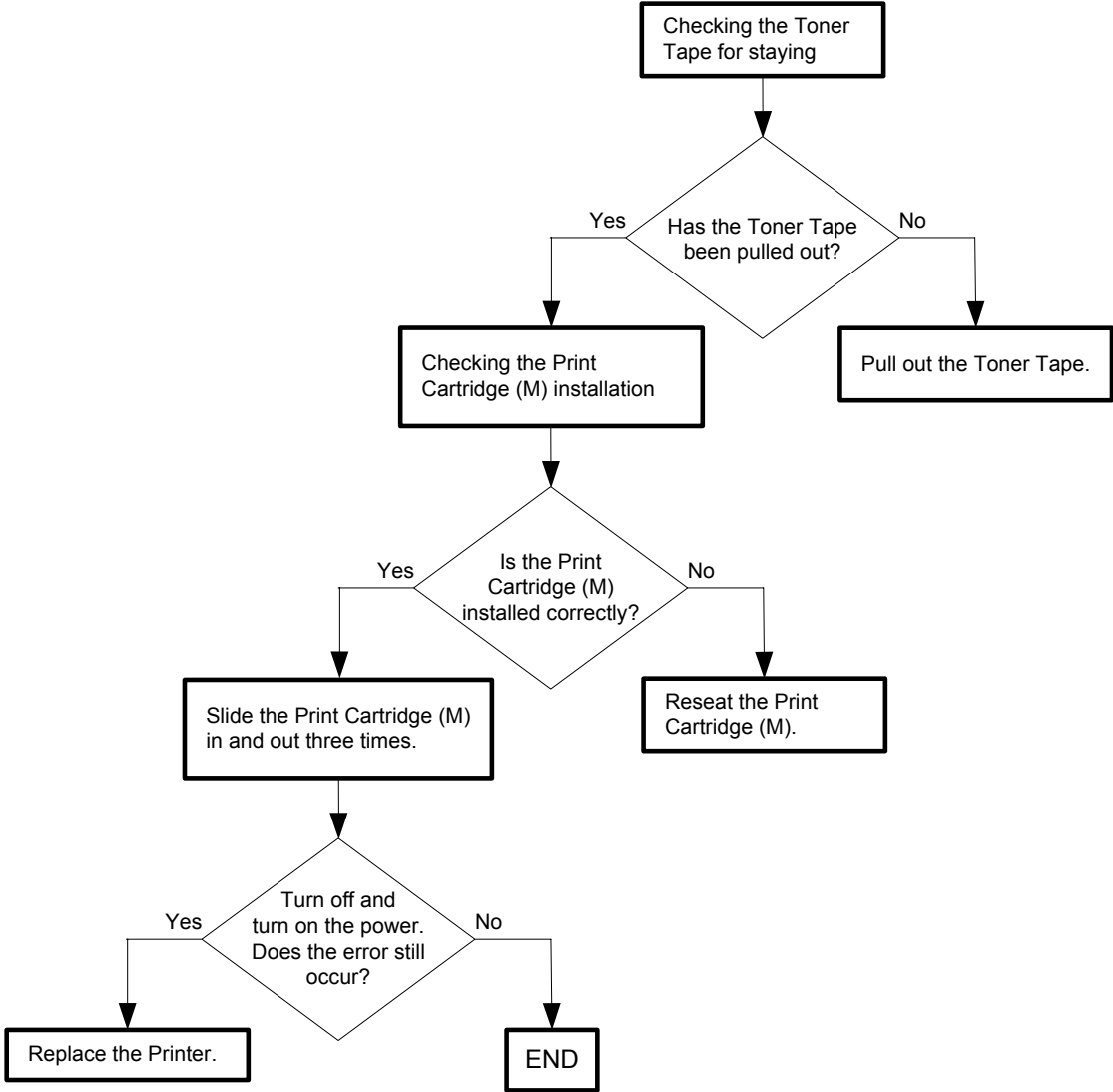

Flows 48 Error C Cart 093-921

NOTE

Every unused Print Cartridge originally installed in the printer is covered with a Toner Tape that protects the drum from intense light. This error is displayed when the printer is operated without removing the Toner Tape.

Open the Front Cover to check if the Toner Tape is affixed on the Print Cartridge (C).

Remove the Toner Tape if present.

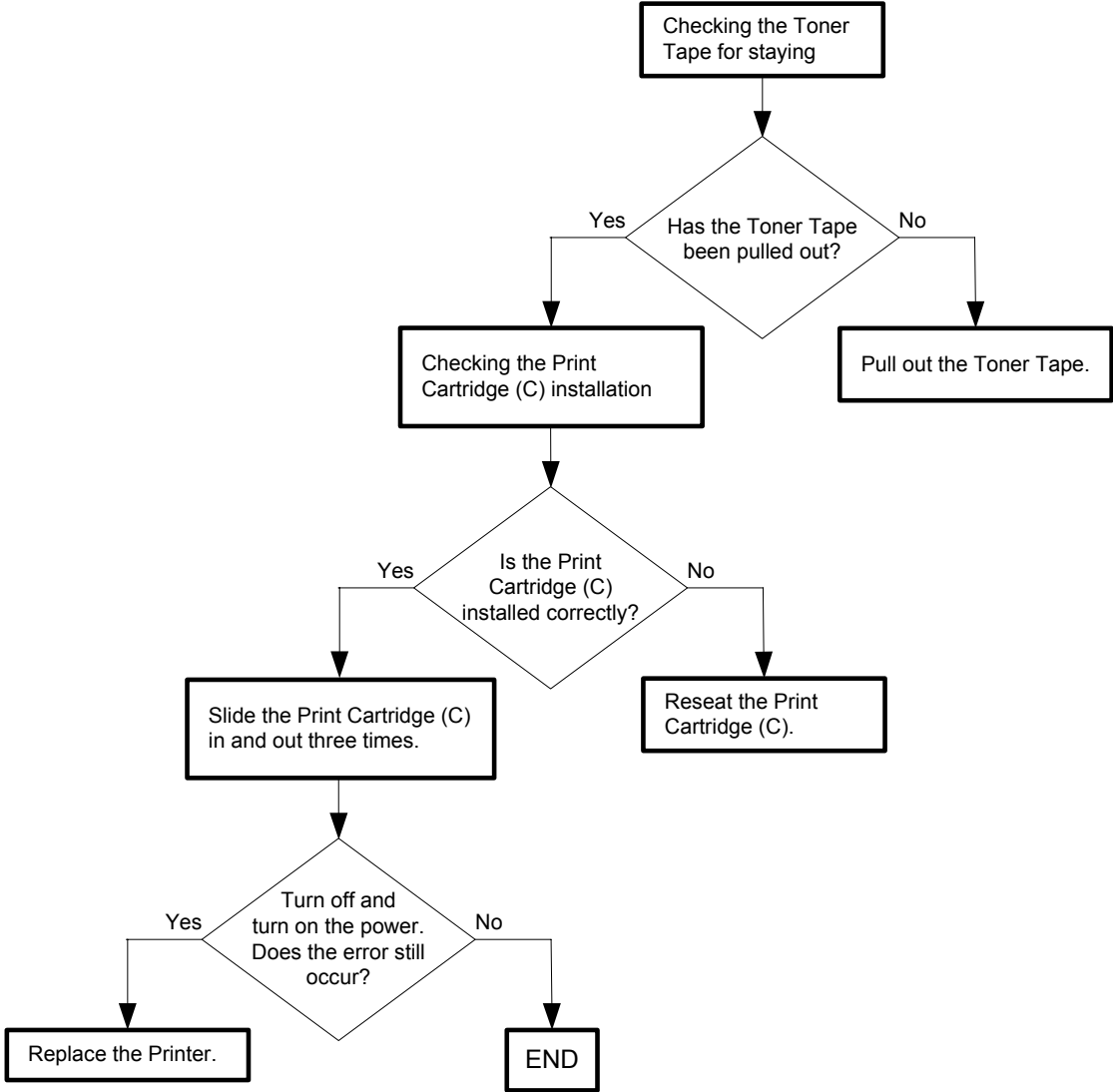

Flows 49 Error K Cart 093-922

NOTE

Every unused Print Cartridge originally installed in the printer is covered with a Toner Tape that protects the drum from intense light. This error is displayed when the printer is operated without removing the Toner Tape.

Open the Front Cover to check if the Toner Tape is affixed on the Print Cartridge (K).

Remove the Toner Tape if present.

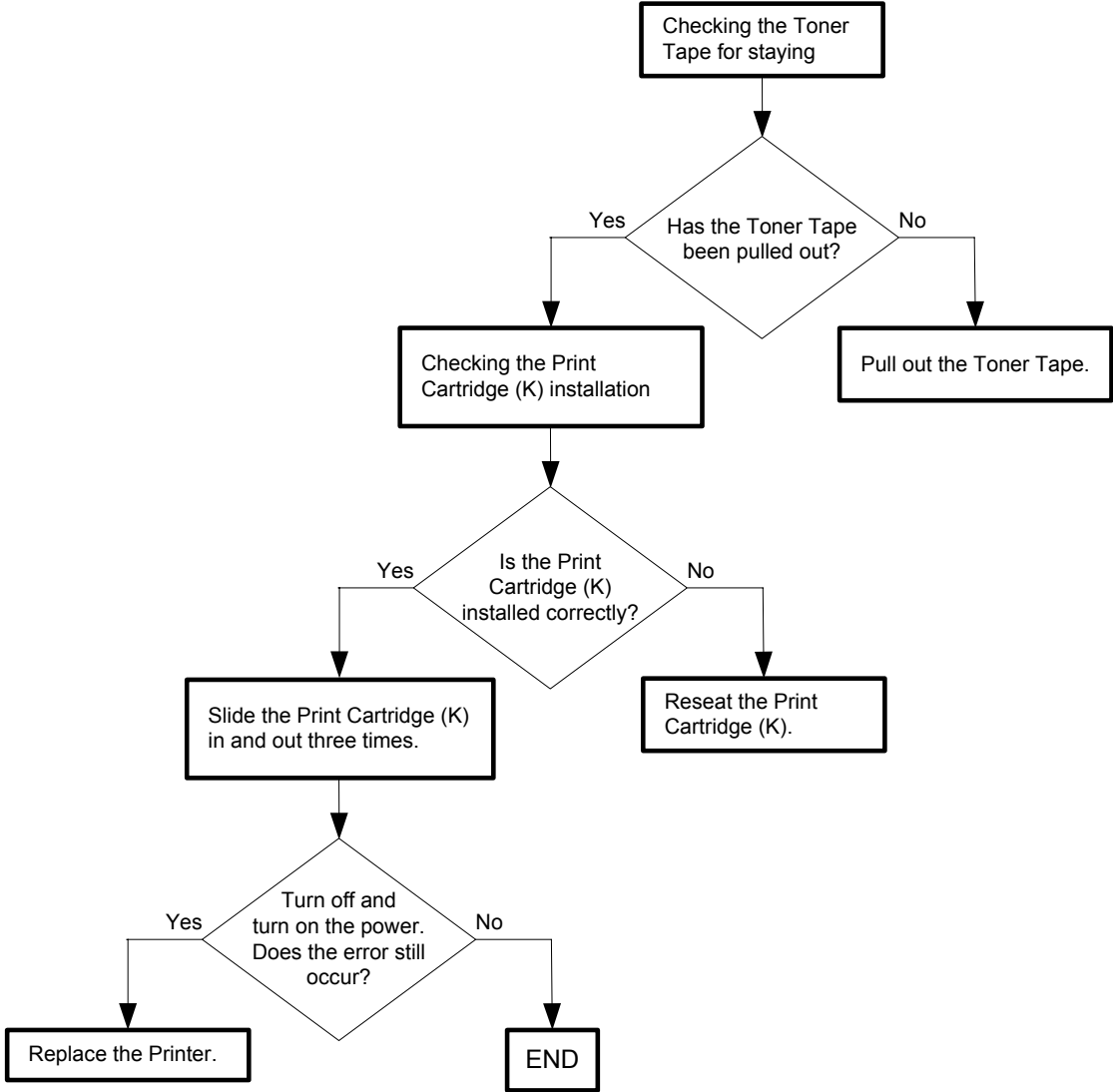

Flows 50 093-950 Yellow Toner / 093-951 Magenta Toner / 093-952 Cyan Toner / 093-953 Black Toner

NOTE

Every reorder Print Cartridge is covered with an orange Protect Cover (At the time of printer purchase, it is Protect Paper.)that protects the drum from intense light. This error is displayed when the printer is operated without removing the Protect Cover(or Protect Paper).

Open the Front Cover and check if the Protect Cover(or Protect Paper) is affixed on the Print Cartridges (Y, M, C, or K).

Remove the Protect Cover(or Protect Paper) if present.

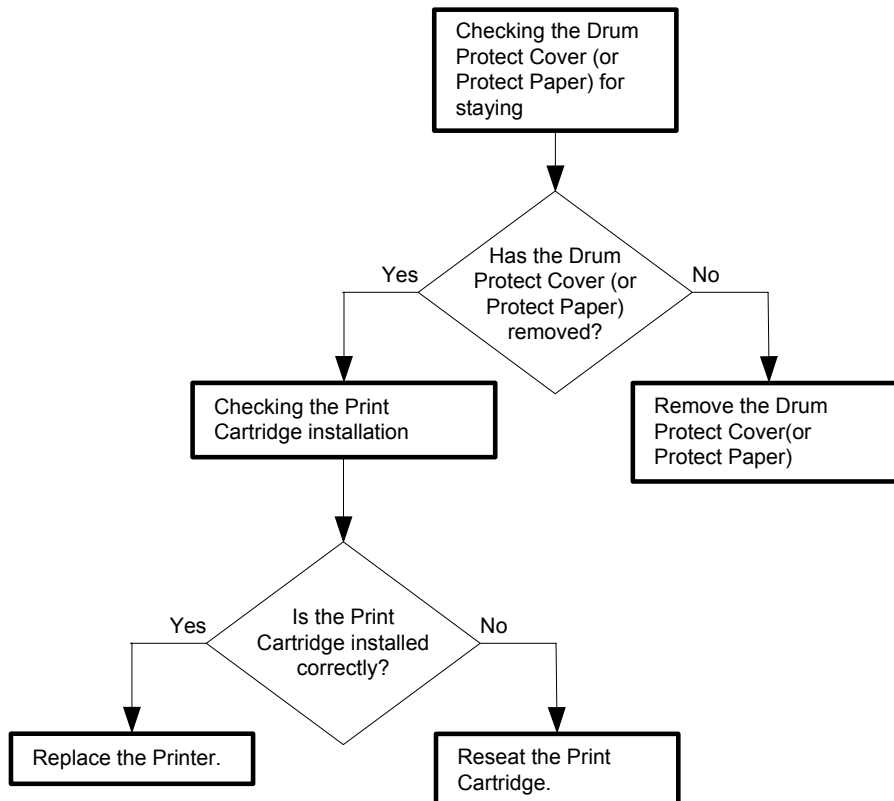

Flows 51 Replace Cart 093-930/093-931/093-932/093-933

NOTE

This error code is displayed when the Print Cartridge (Y, M, C, or K) has reached its end of life and needs replacing.

Immediately replace the Print Cartridge (Y, M, C, or K) with a new one.

If this error code is displayed although the Print Cartridge (Y, M, C, or K) has been replaced only recently, follow the following flow.

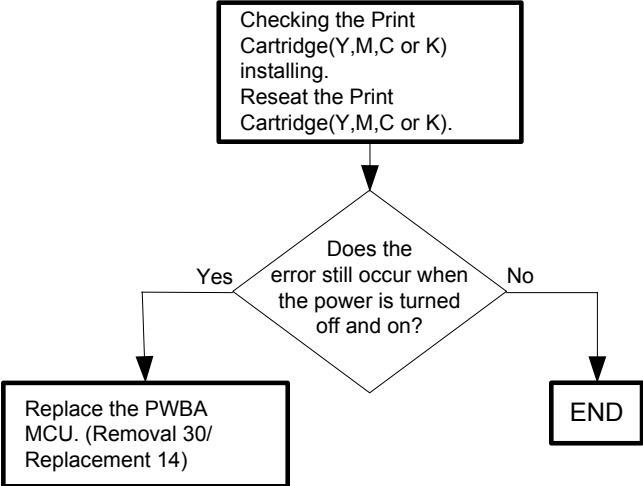

Flows 52 Ready to Print 093-423/093-424/093-425/093-426

NOTE

This error code is not a fault warning and only denotes that the Print Cartridge (Y, M, C, or K) is approaching but has not reached its end of life. Immediately prepare a new Print Cartridge (Y, M, C, or K). If this error code is displayed although the Print Cartridge (Y, M, C, or K) has been replaced only recently, follow the following flow.

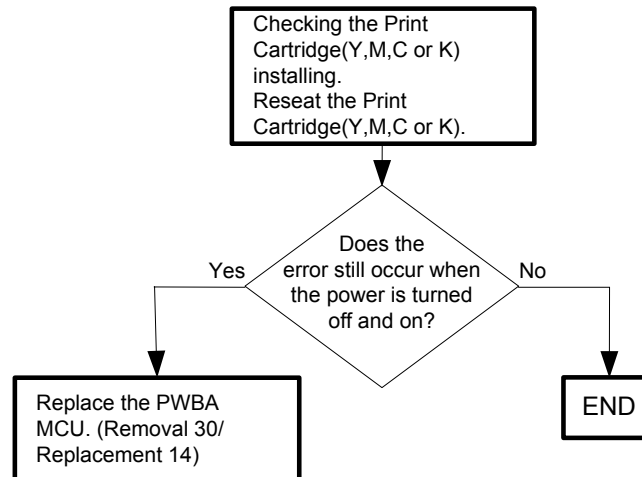

Flows 53 Insert Print Cart 093-970

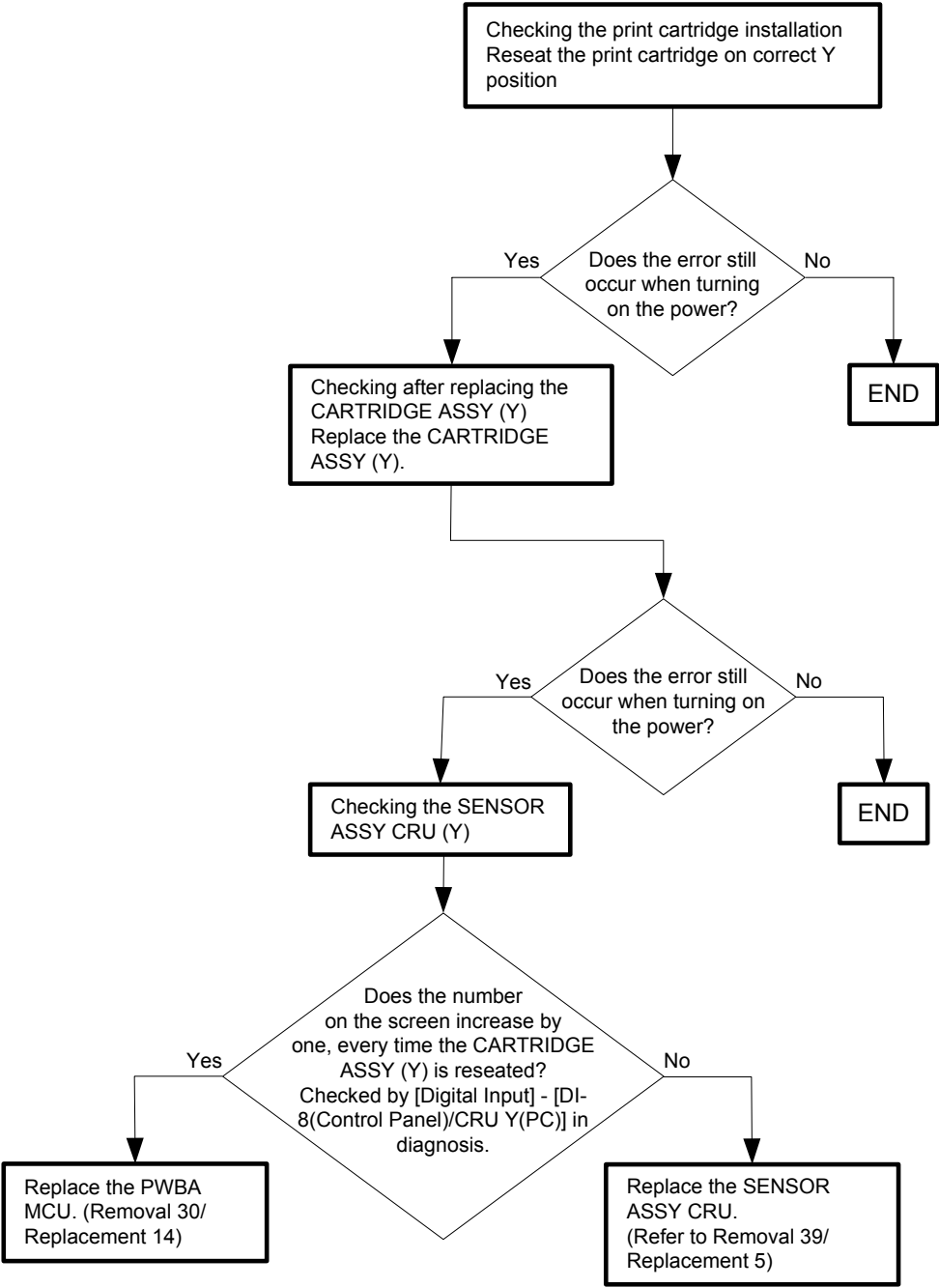

Flows 54 Insert Print Cart 093-971

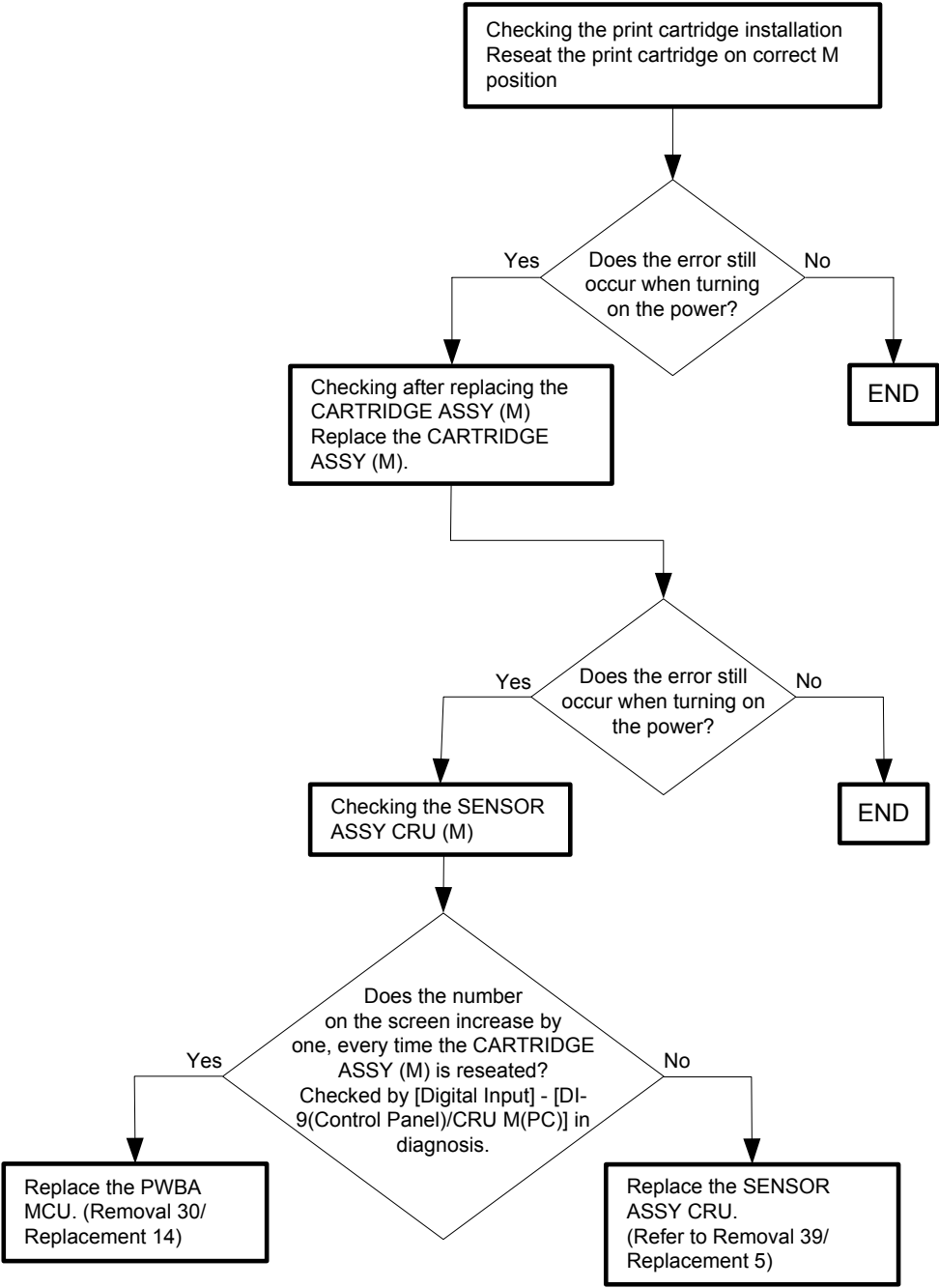

Flows 55 Insert Print Cart 093-972

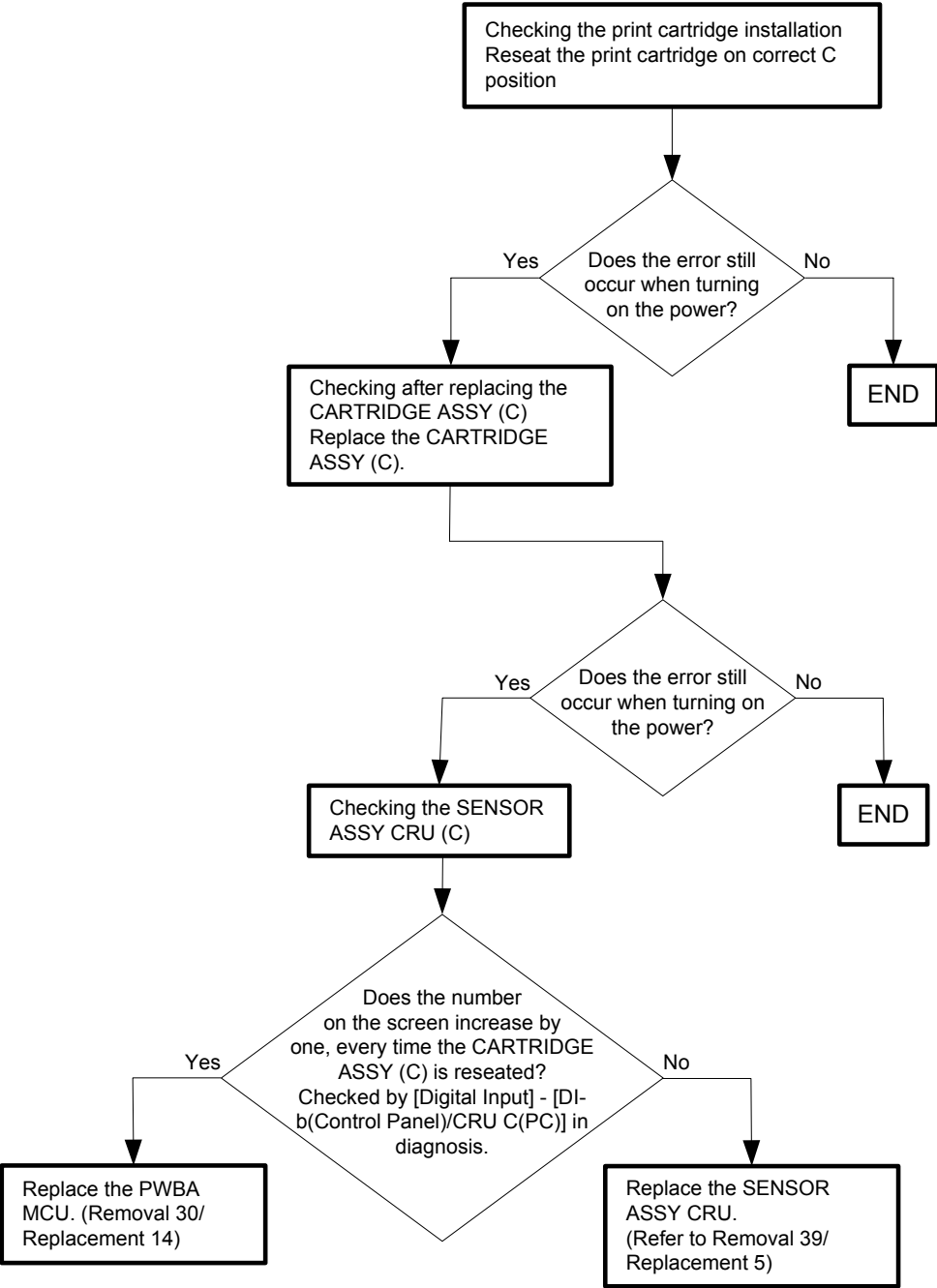

Flows 56 Insert Print Cart 093-973

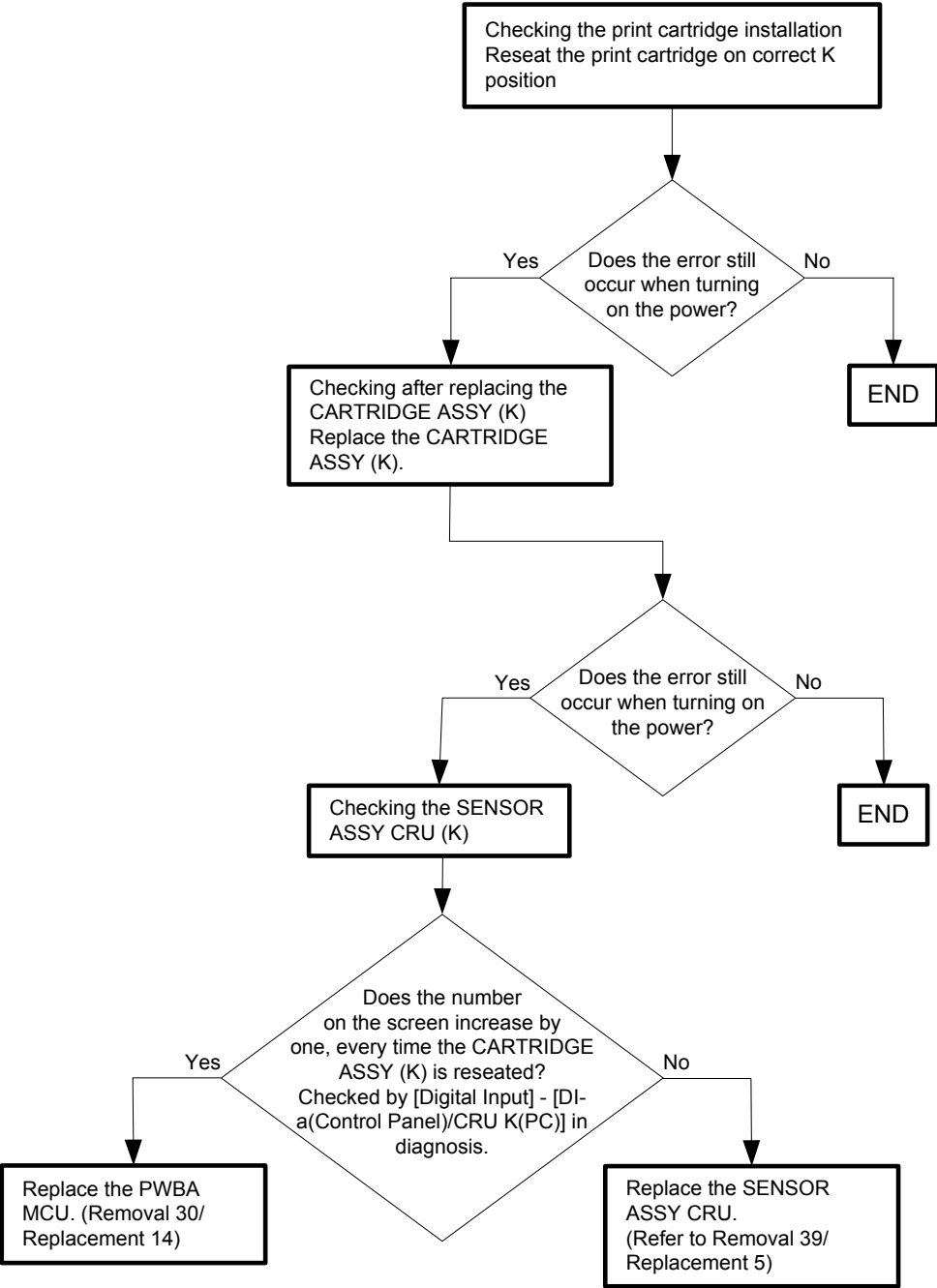

Flows 57 CRUM ID 009-371

NOTE

For the PPID, refer to the label on the TRANSFER ASSY.

XX-0R298D-XXXXX-XXX-XXXX

↑
PPID No.

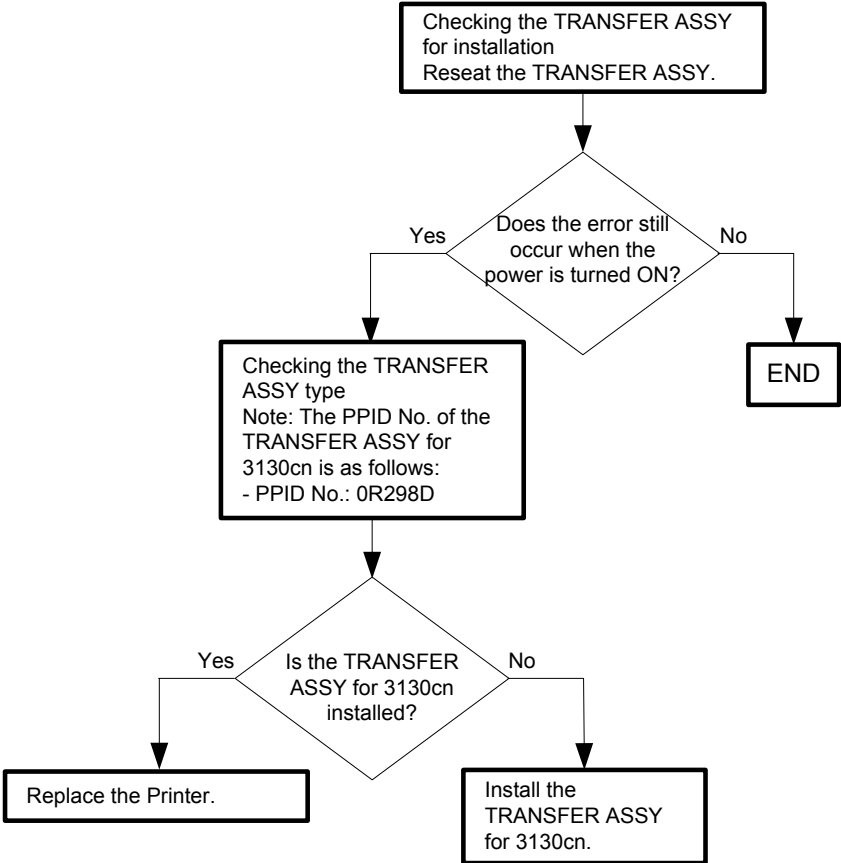

Flows 58 Ready to Print 094-422

NOTE

This error code is not a fault warning and only denotes that the Transfer ASSY (Belt Unit) is approaching but has not reached its end of life. Immediately prepare a new Transfer ASSY (Belt Unit). If this error code is displayed although the Transfer ASSY (Belt Unit) has been replaced only recently, follow the following flow.

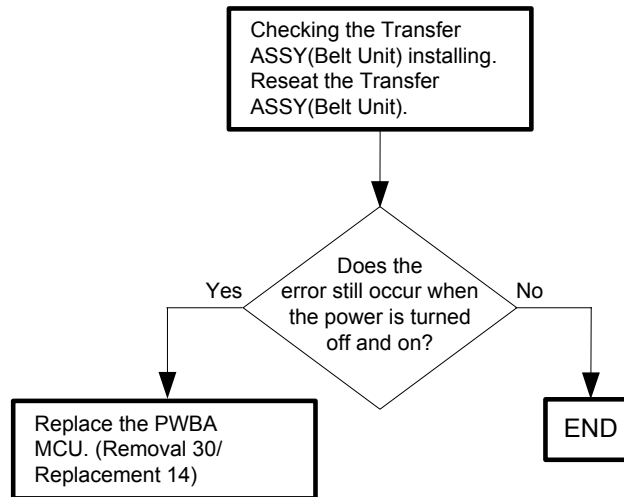

Flows 59 Insert Belt Unit 094-910

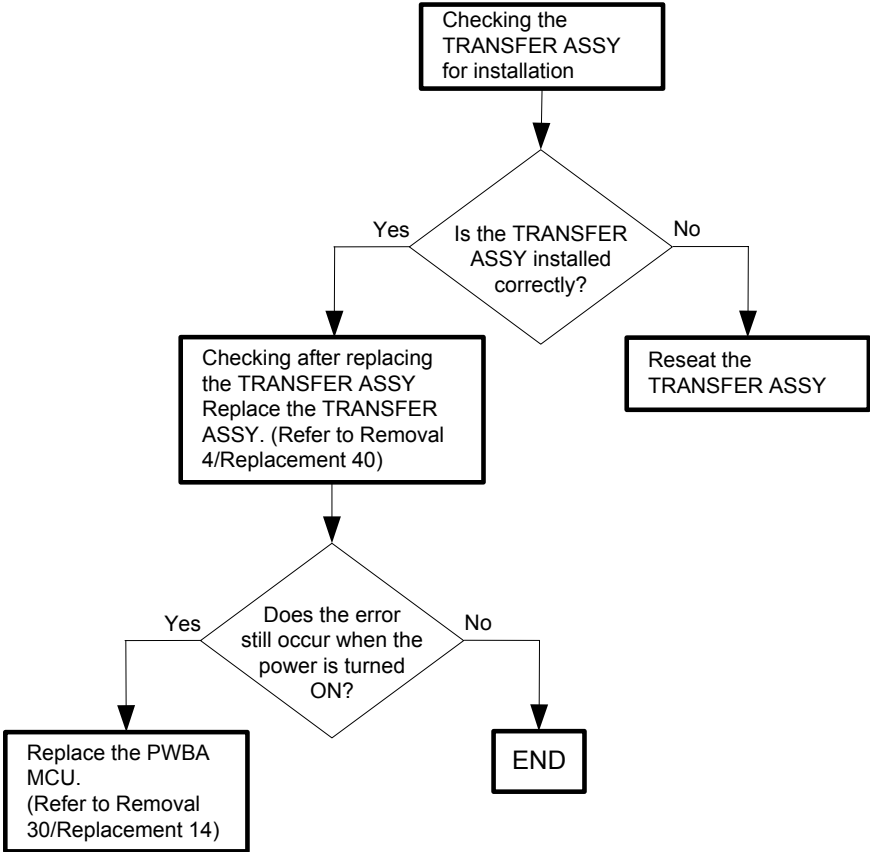

Flows 60 Belt Unit 094-911

NOTE

This error code denotes that the Transfer ASSY (Belt Unit) has reached its end of life and needs replacing.

Immediately replace the Transfer ASSY (Belt Unit) with a new one.

If this error code is displayed although the Transfer ASSY (Belt Unit) has been replaced only recently, follow the following flow.

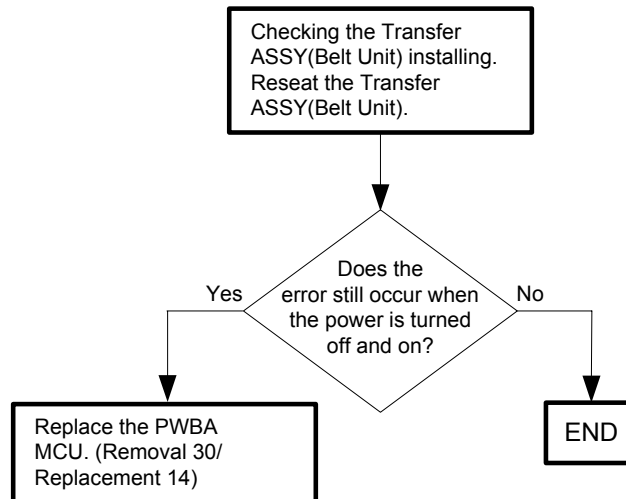

Flows 61 010-359 Restart Printer

NOTE

For the PPID, refer to the label on the FUSER.

Example) FUSER for 100V
XX-0M507D-XXXXX-XXX-XXXX

↑
PPID No.

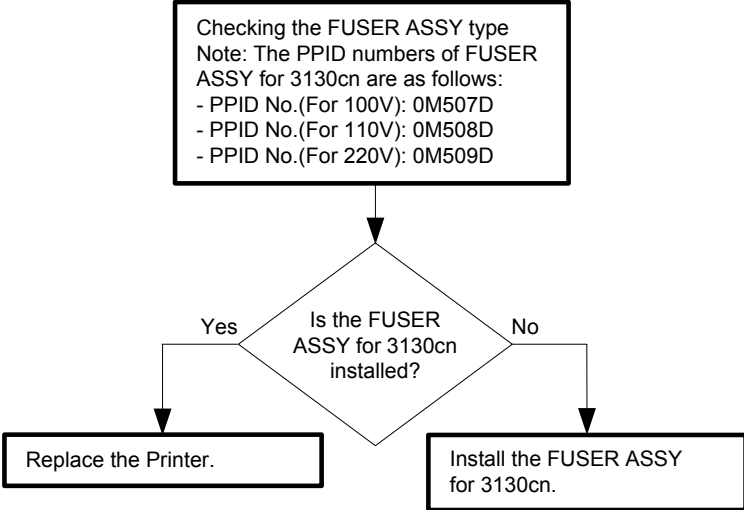

Flows 62 Ready to Print 010-421

NOTE

This error code is not a fault warning and only denotes that the Fuser ASSY is approaching but has not reached its end of life.

Immediately prepare a new Fuser ASSY.

If this error code is displayed although the Fuser ASSY has been replaced only recently, follow the following flow.

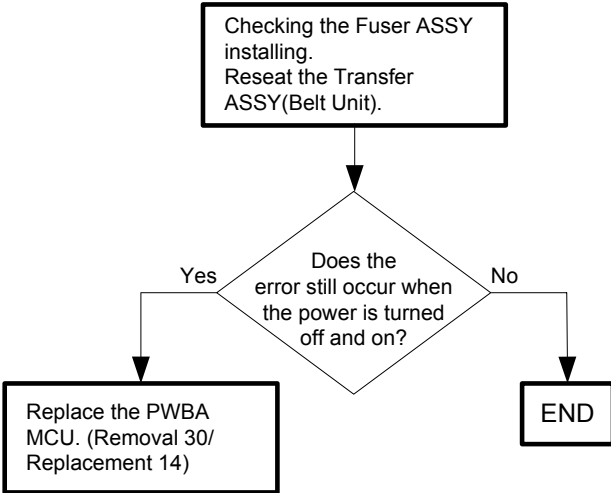

Flows 63 Tray Detached 024-946/007-912

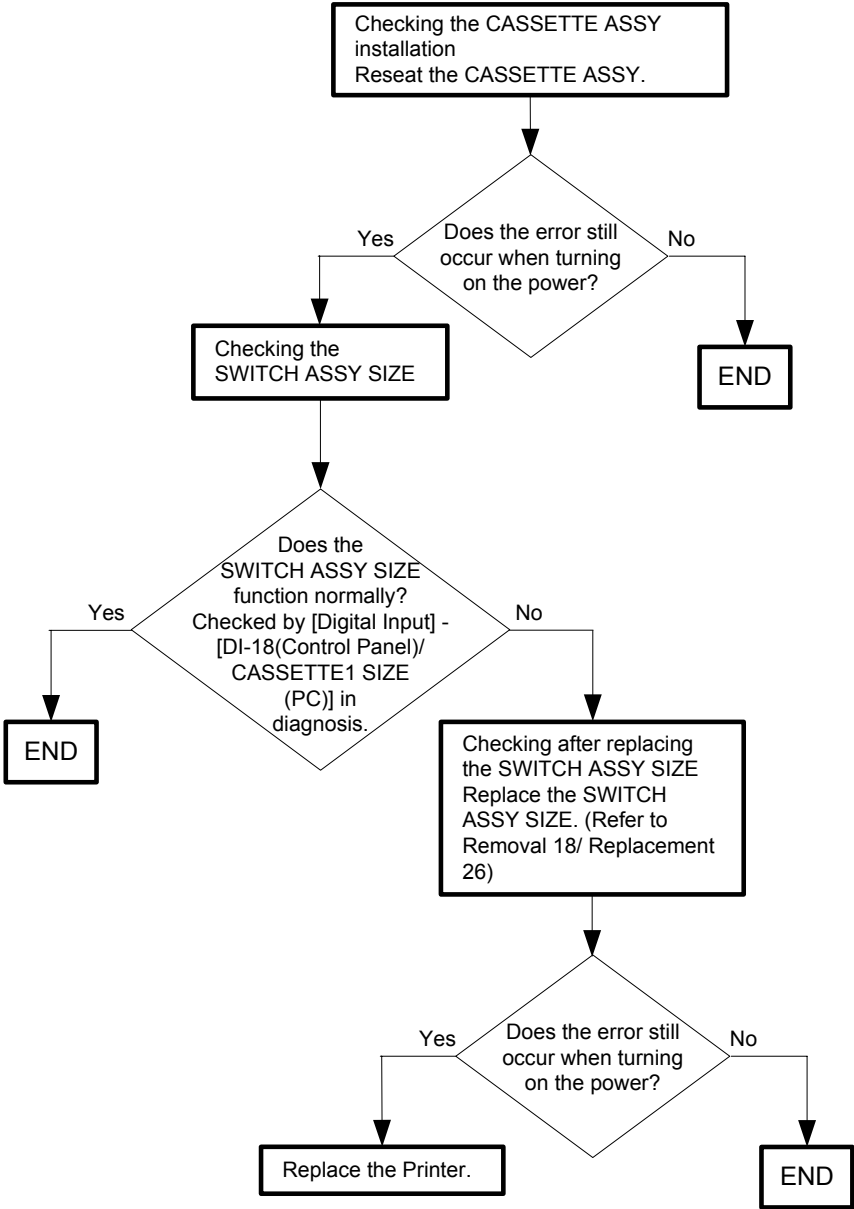

Flows 64 Load Tray 024-947

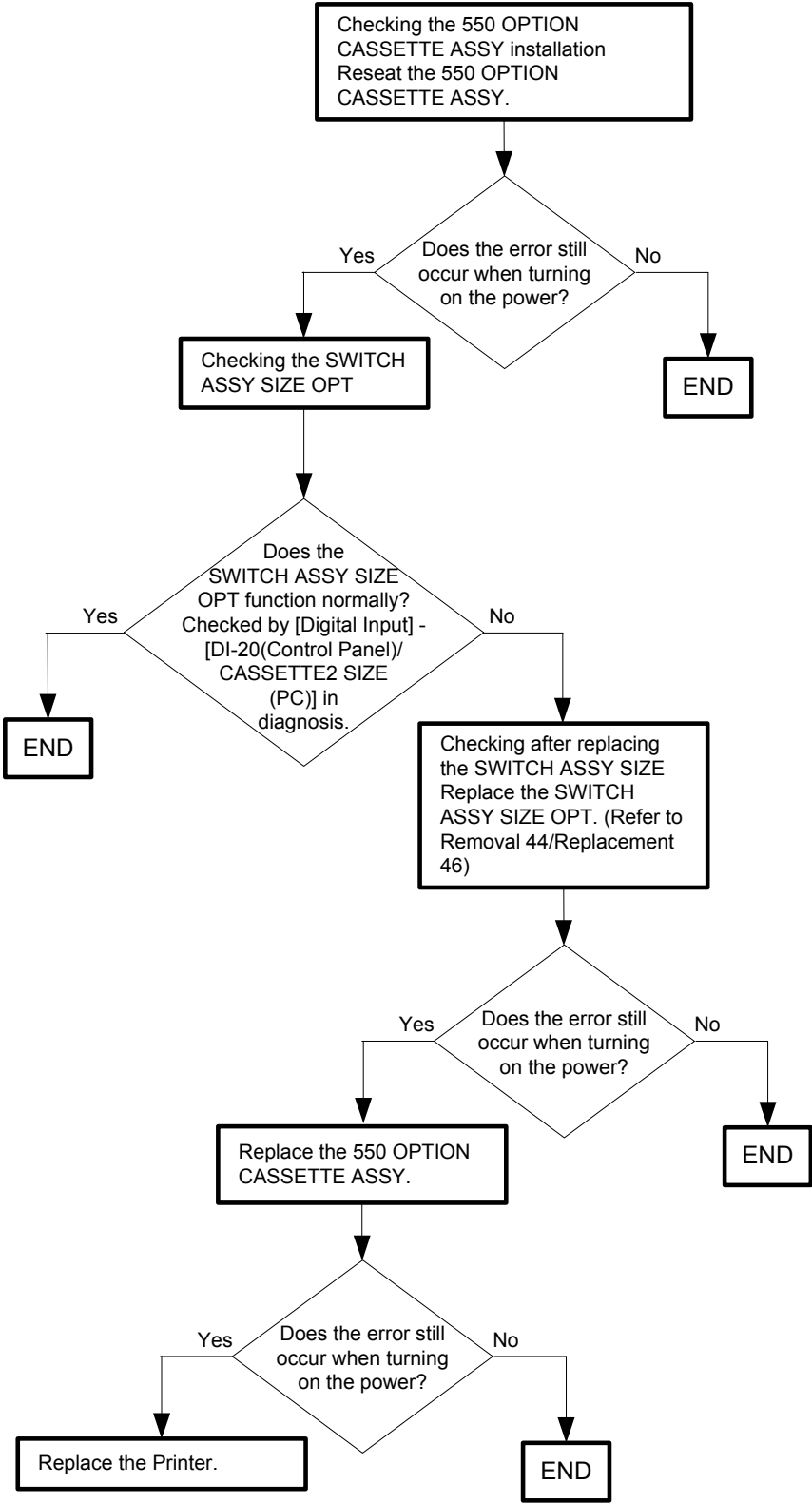

Flows 65 Close Front Cover 077-300

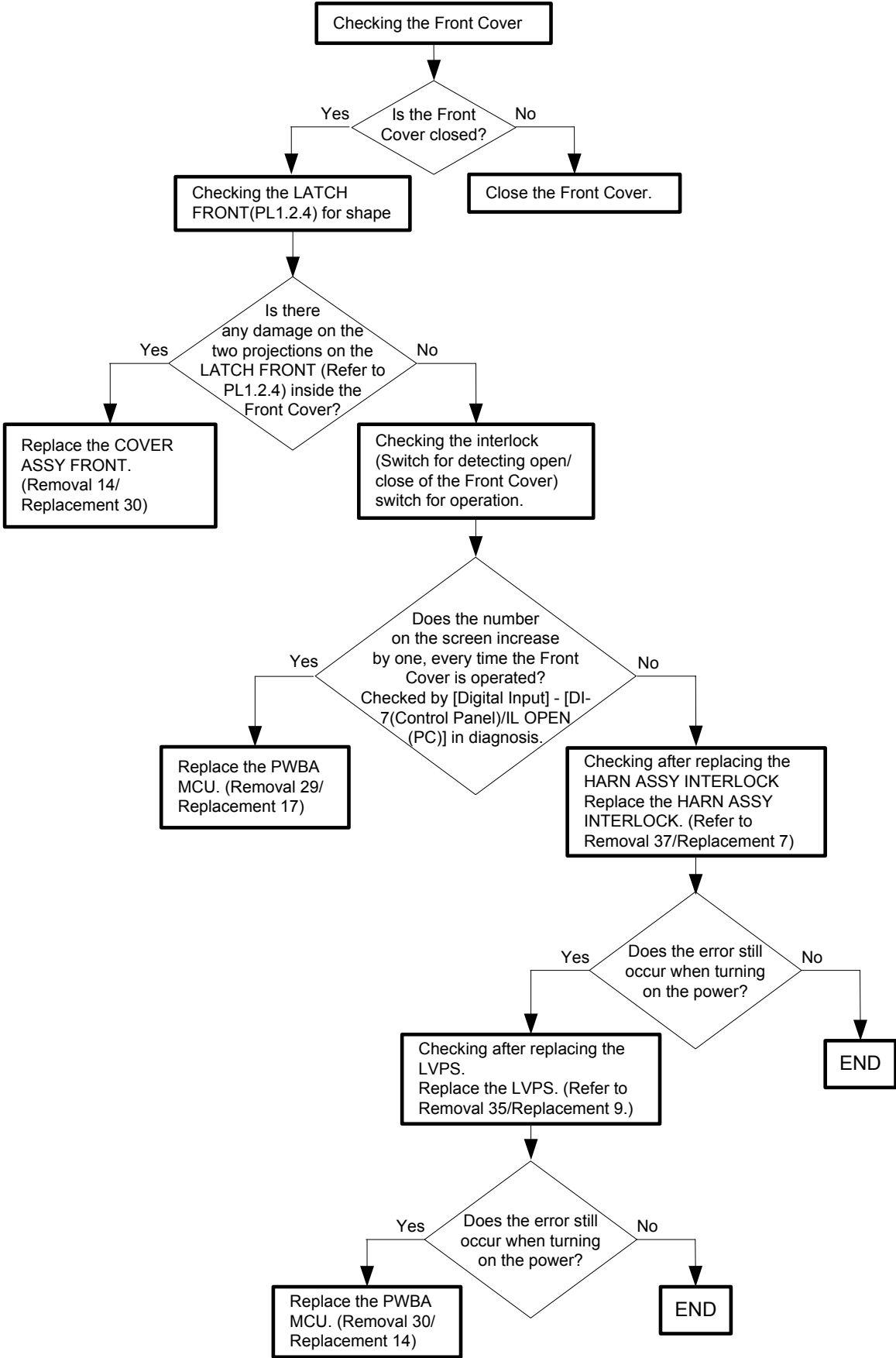

Flows 66 Invalid ID 016-383 / Range Chk Error 016-384 / Header Error 016-385 / Check Sum Error 016-386 / Format Error 016-387

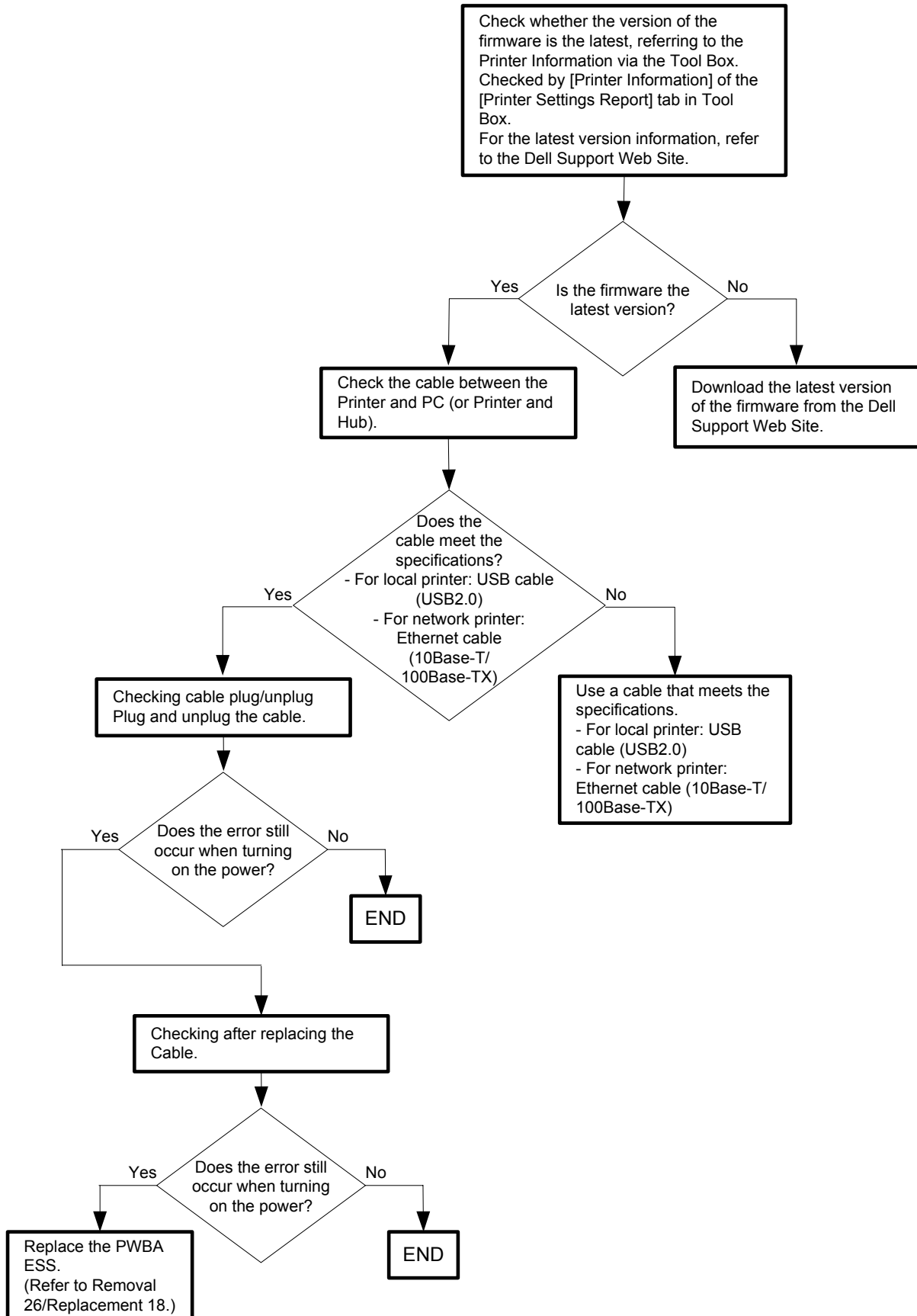

Flows 67 Out of Memory 016-700

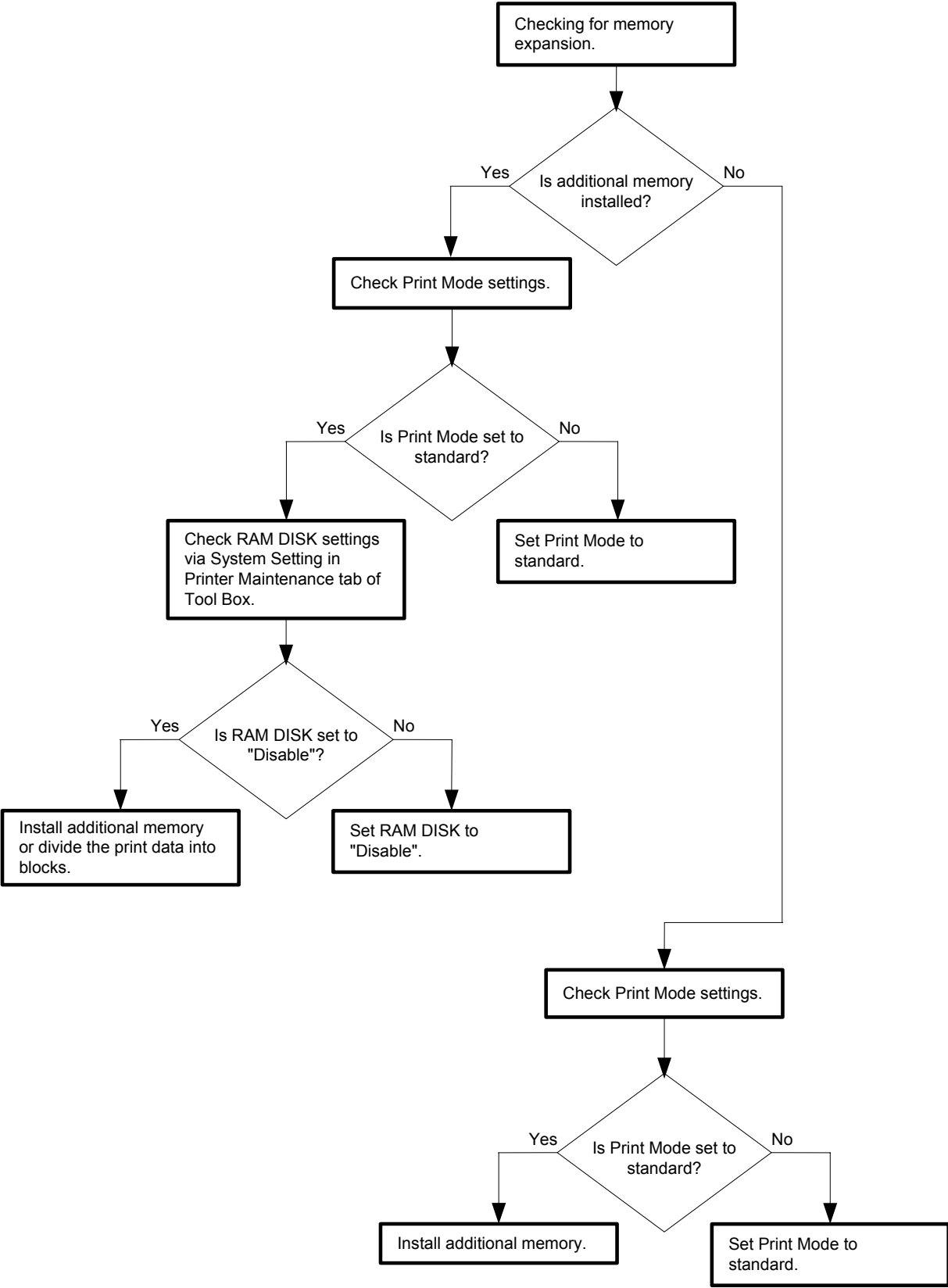

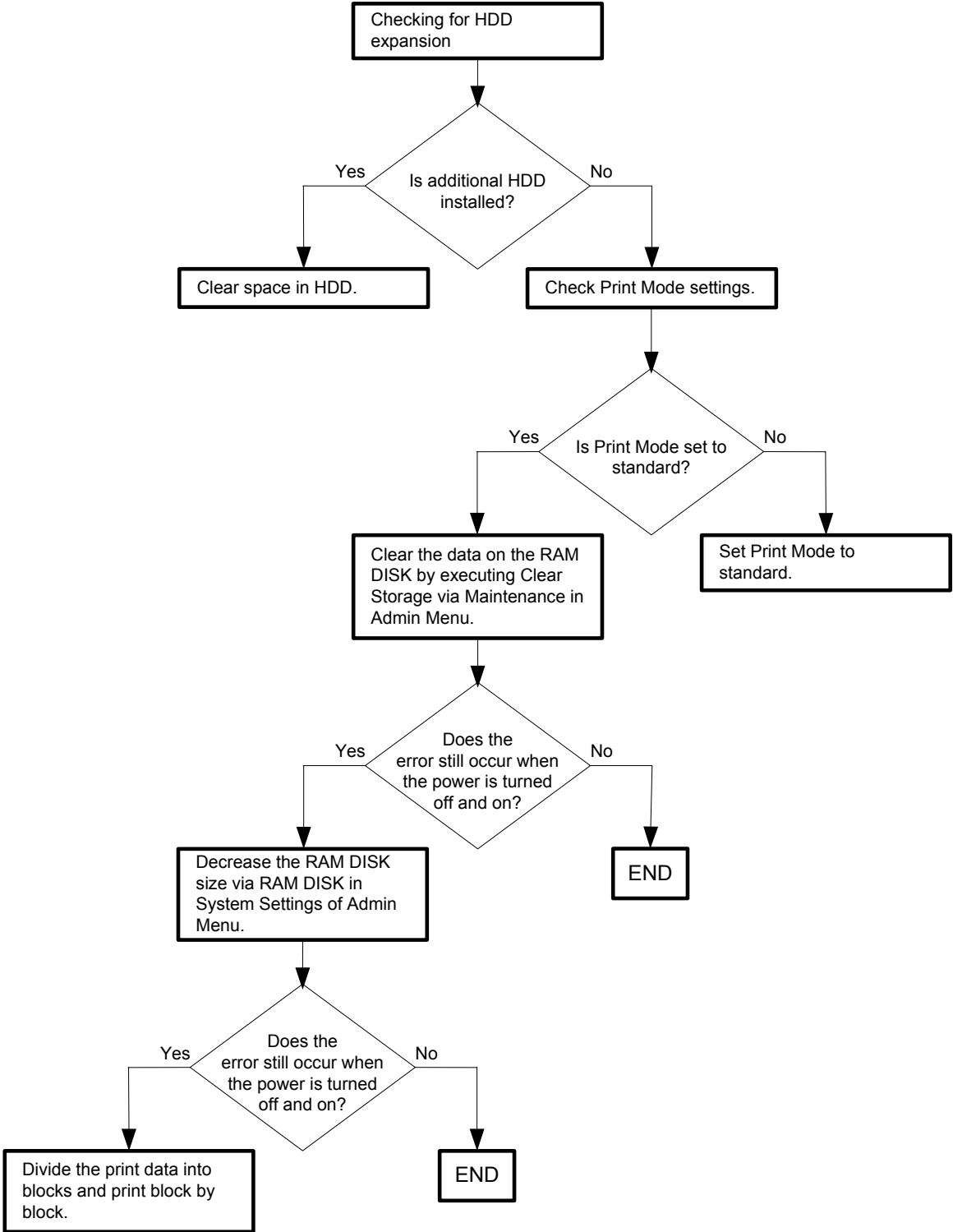

Flows 69 Collate Full 016-981

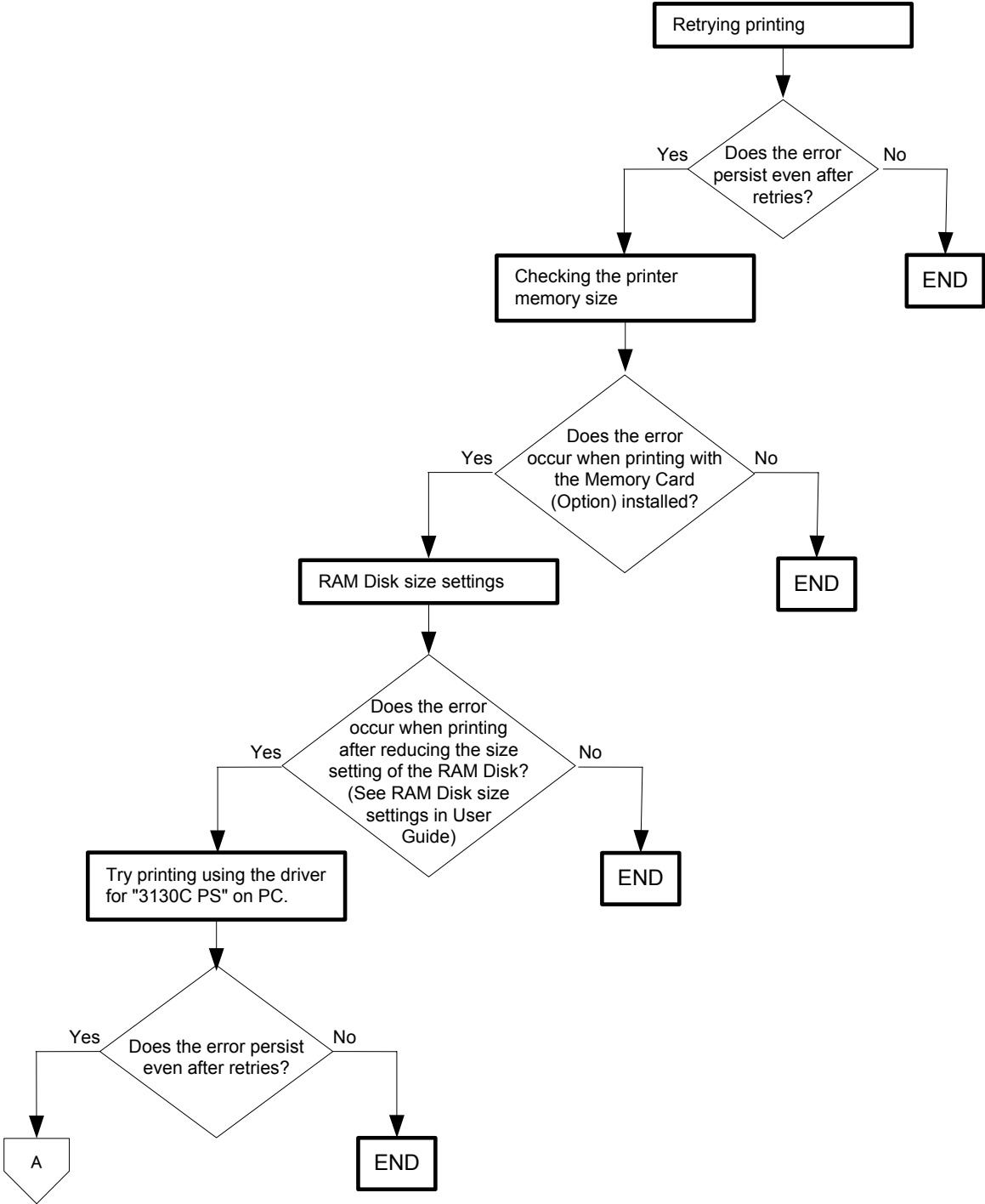

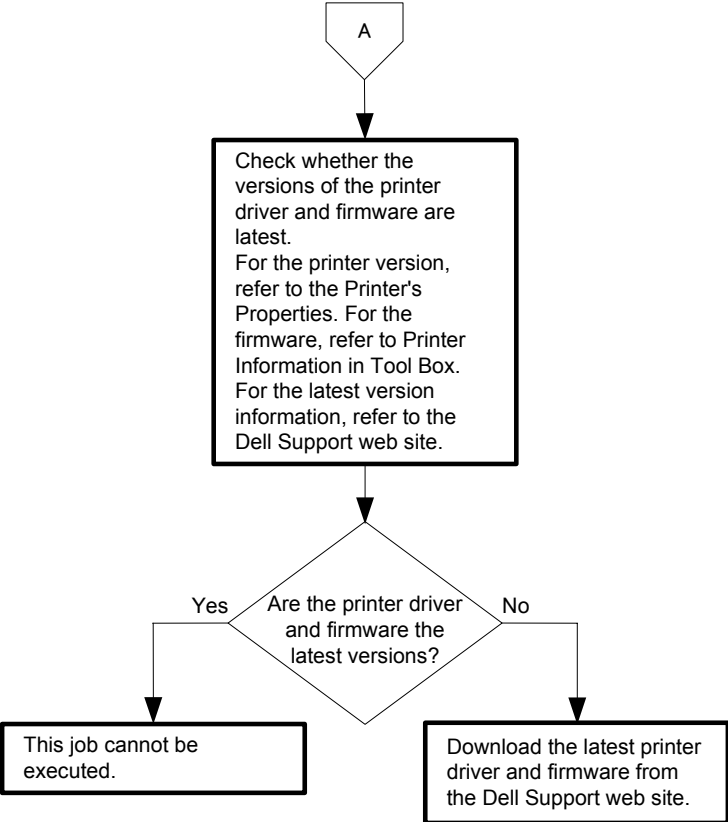

Flows 70 016-720 PDL Error

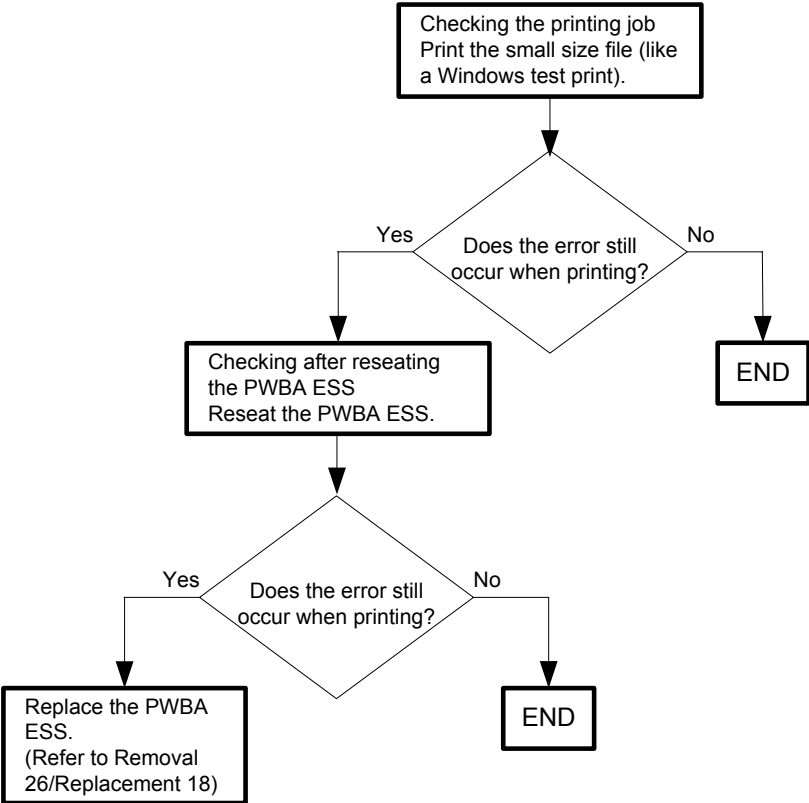

Flows 71 Invalid User 016-757

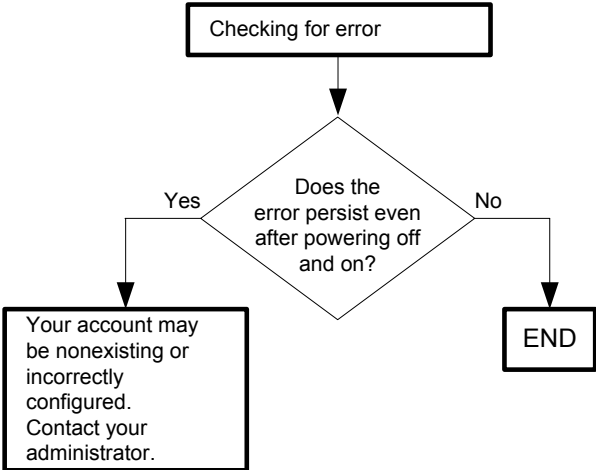

Flows 72 Disabled Func 016-758

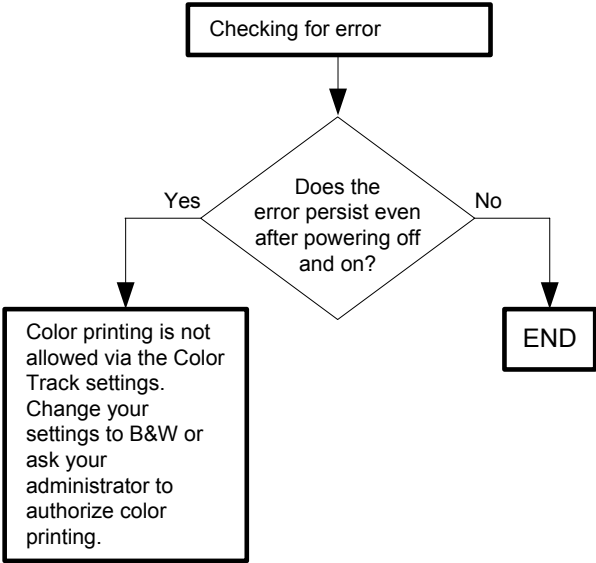

Flows 73 Reached Limits 016-759

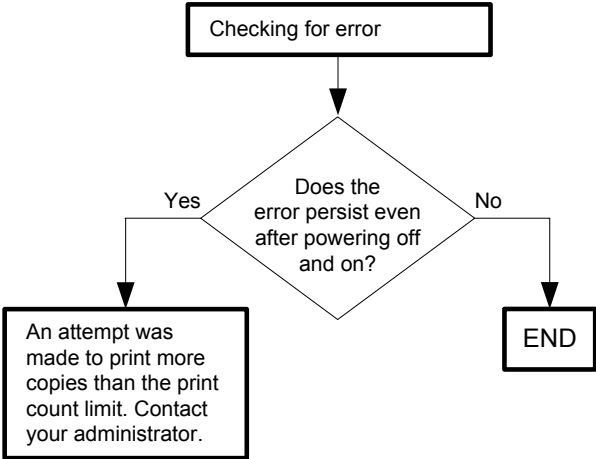

Flows 74 Invalid Job 016-799

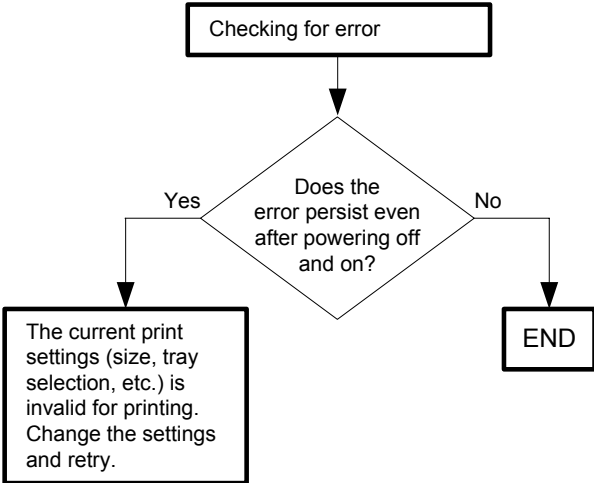

Flows 75 Ready to Print 193-700

NOTE

- This message appears when [Non-Dell Toner] setting of [Maintenance] on [Admin Menu] is turned to [ON] for using non-Dell toner cartridge.

Printing is available while this message is displayed.

Use of a non-Dell print cartridge may result in some of the printer's functions to be unavailable, a reduction in print quality, or deterioration of printer's reliability. Use of a new Dell brand print cartridge is recommended for your printer.

- When you use Dell toner cartridge, you can turn off the message by turning the [Non-DELL Toner] setting to [OFF].

- Use of a non-Dell print cartridge may result in some of the printer's functions to be unavailable, a reduction in print quality, or deterioration of printer's reliability. Use of a new Dell brand print cartridge is recommended for your printer.

The Dell warranty does not cover any problems caused by the use of any accessory, part, or component that is not supplied by Dell.

If this error code is displayed although the [Non-Dell Toner] setting is [OFF], follow the following flow.

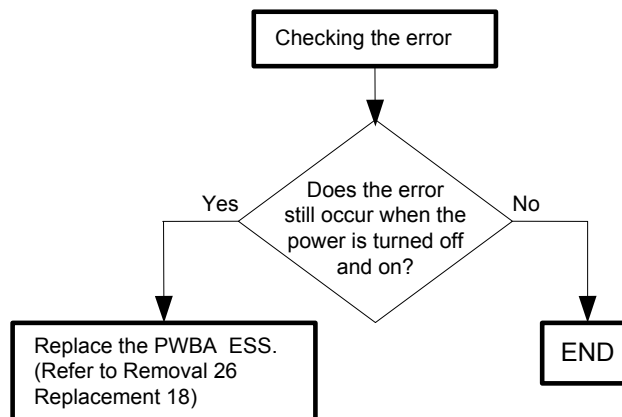

Flows 76 Over Heat 042-700 / Ready to Print 142-700

NOTE

- The error code "042-700" is displayed when the internal temperature of the printer has risen to somewhere near the predetermined value due to a large volume 2-sided printing. Wait a while with the printer on until the error disappears.

When performing a large volume of 2-sided printing, make the printing interval as long as possible.

If this error code is displayed although you have not performed any large volume 2-sided printing, follow the following flow.

- The error code "142-700" is displayed when the internal temperature of the printer has risen due to a large volume printing. Do not start another print job until the warning disappears.

If this error code is displayed although you have not performed any large volume printing, follow the following flow.

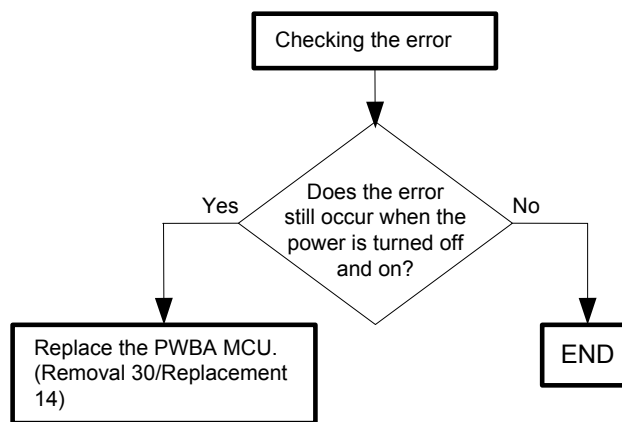

Flows 77 Electrical Noise

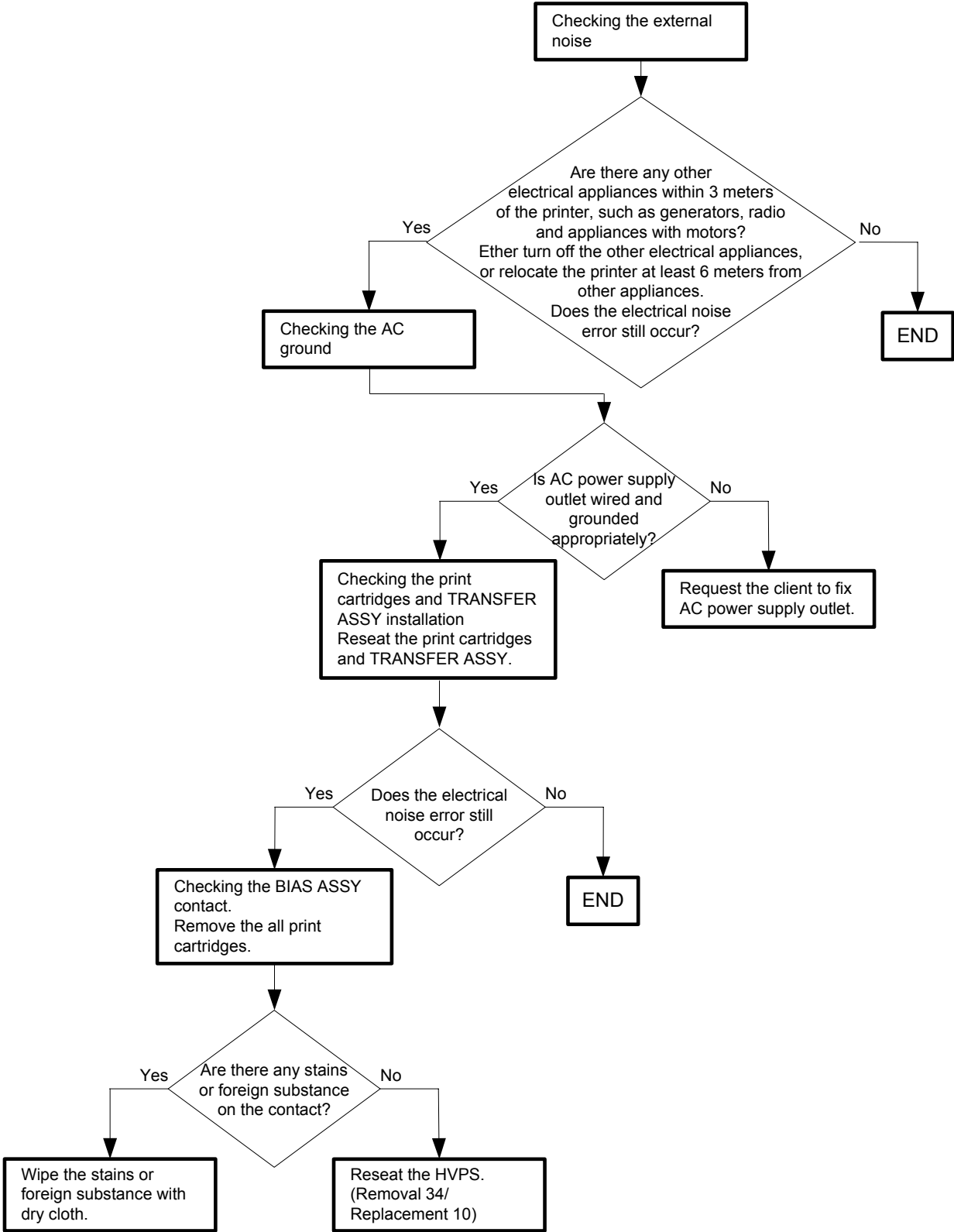

Flows 78 Faint print (Low contrast)

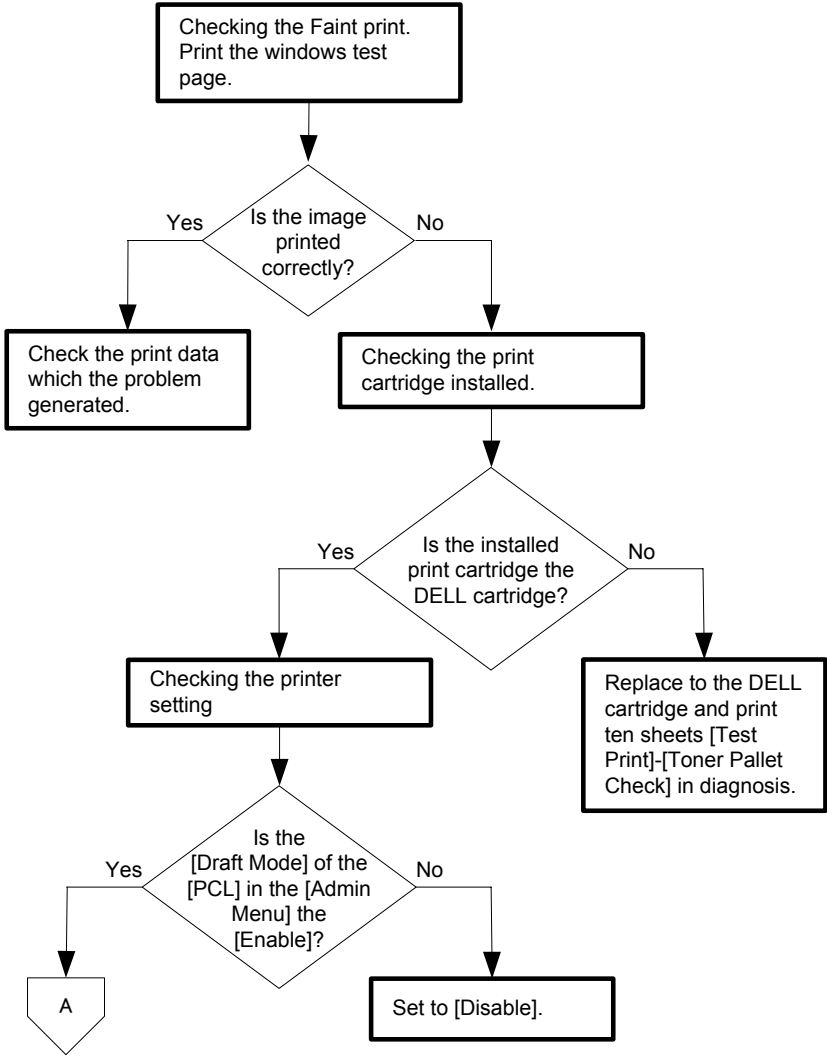
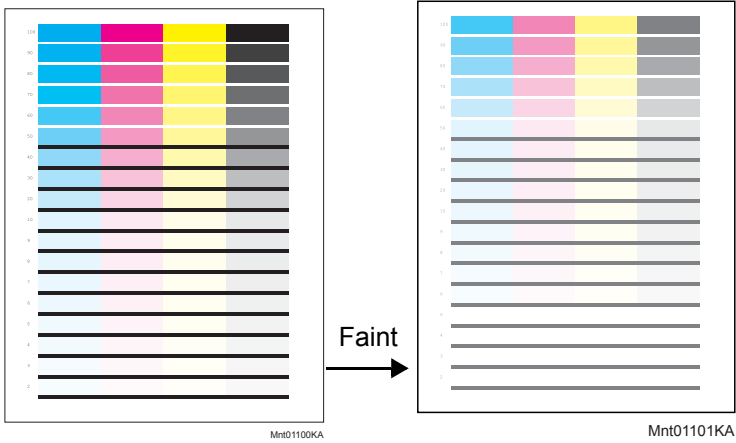

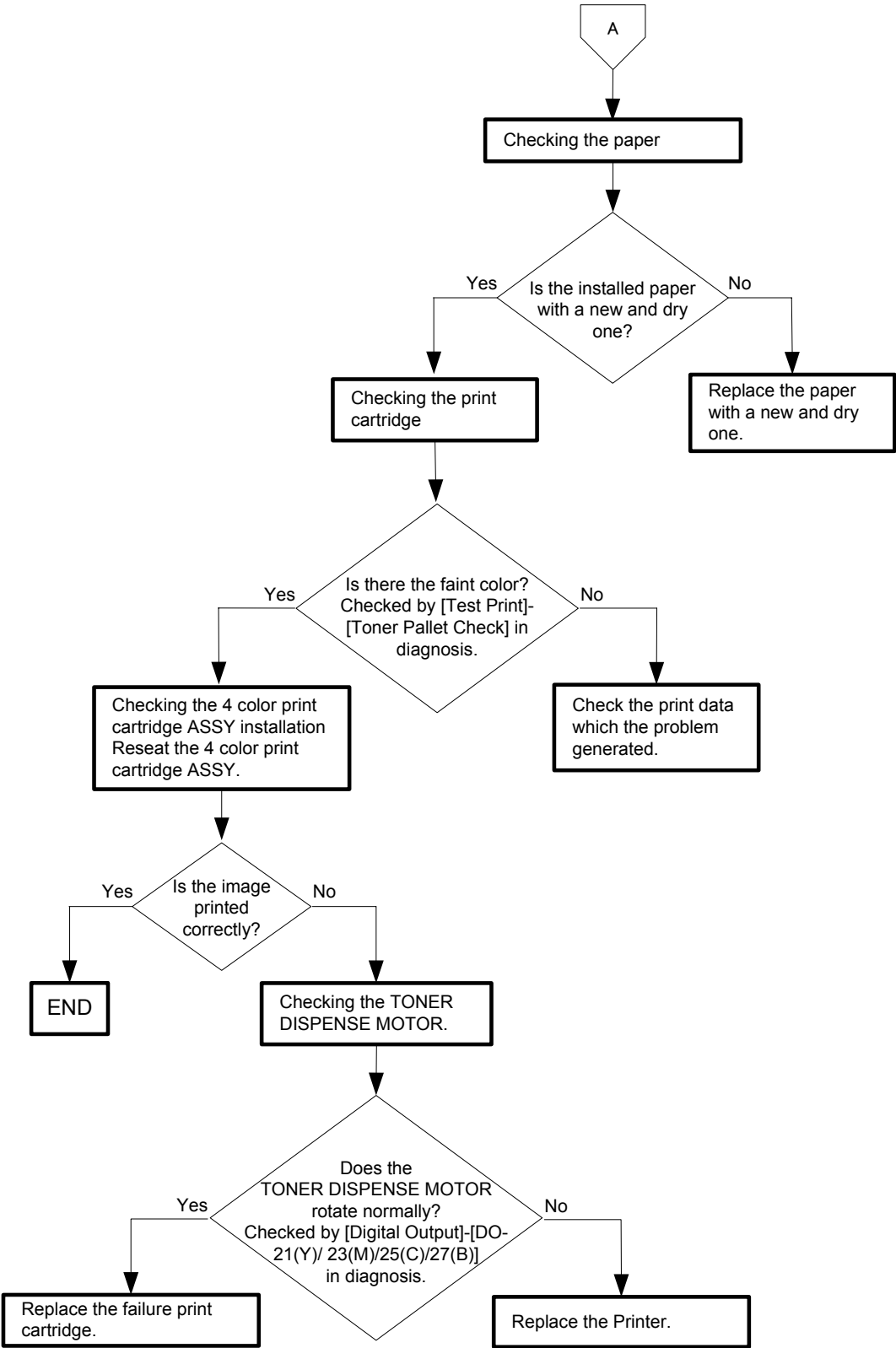

Flows 79 Blank print (No print)

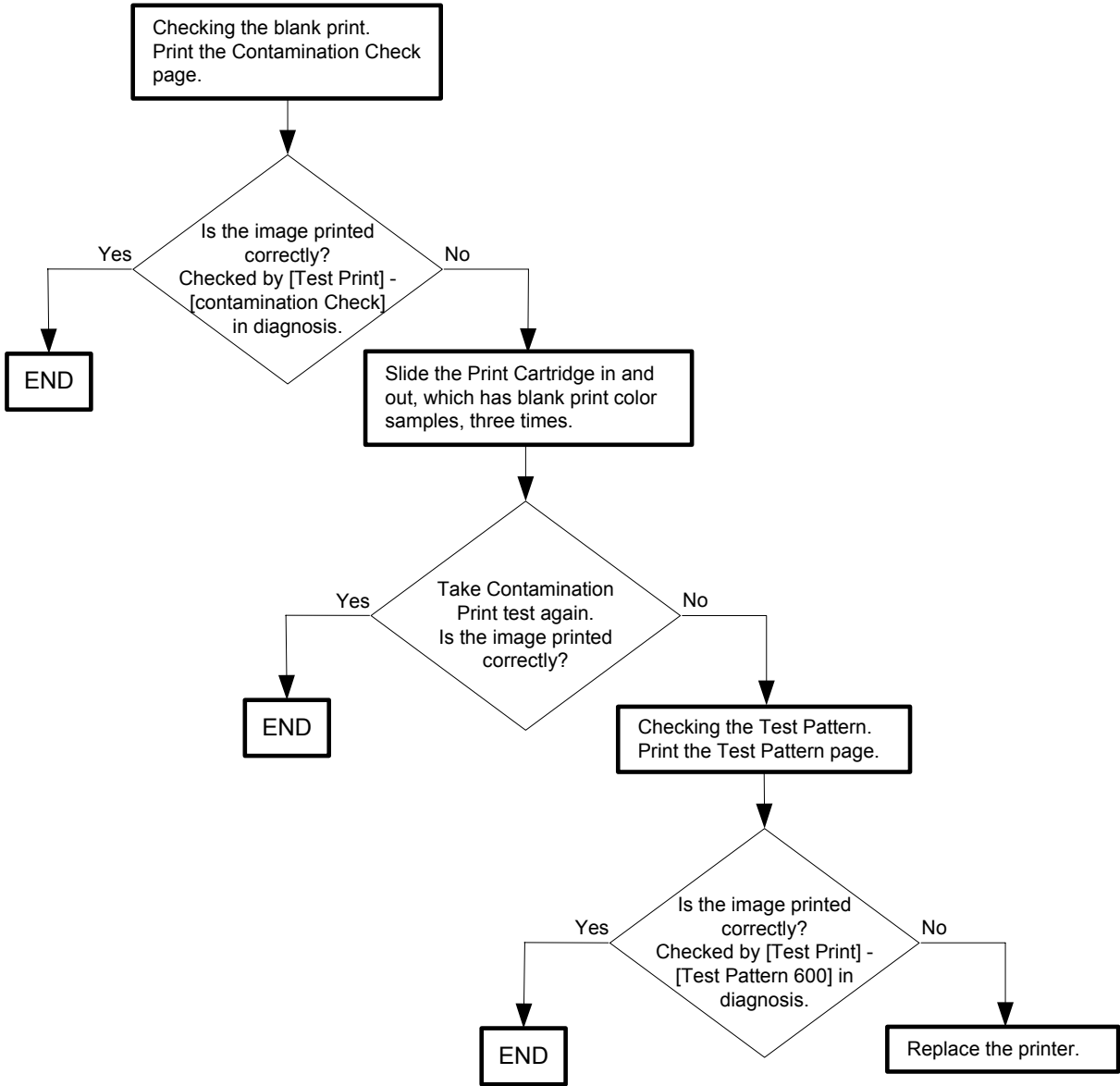
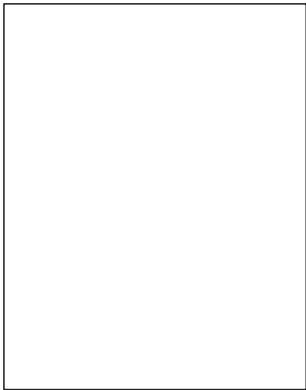

Flows 80 Solid black

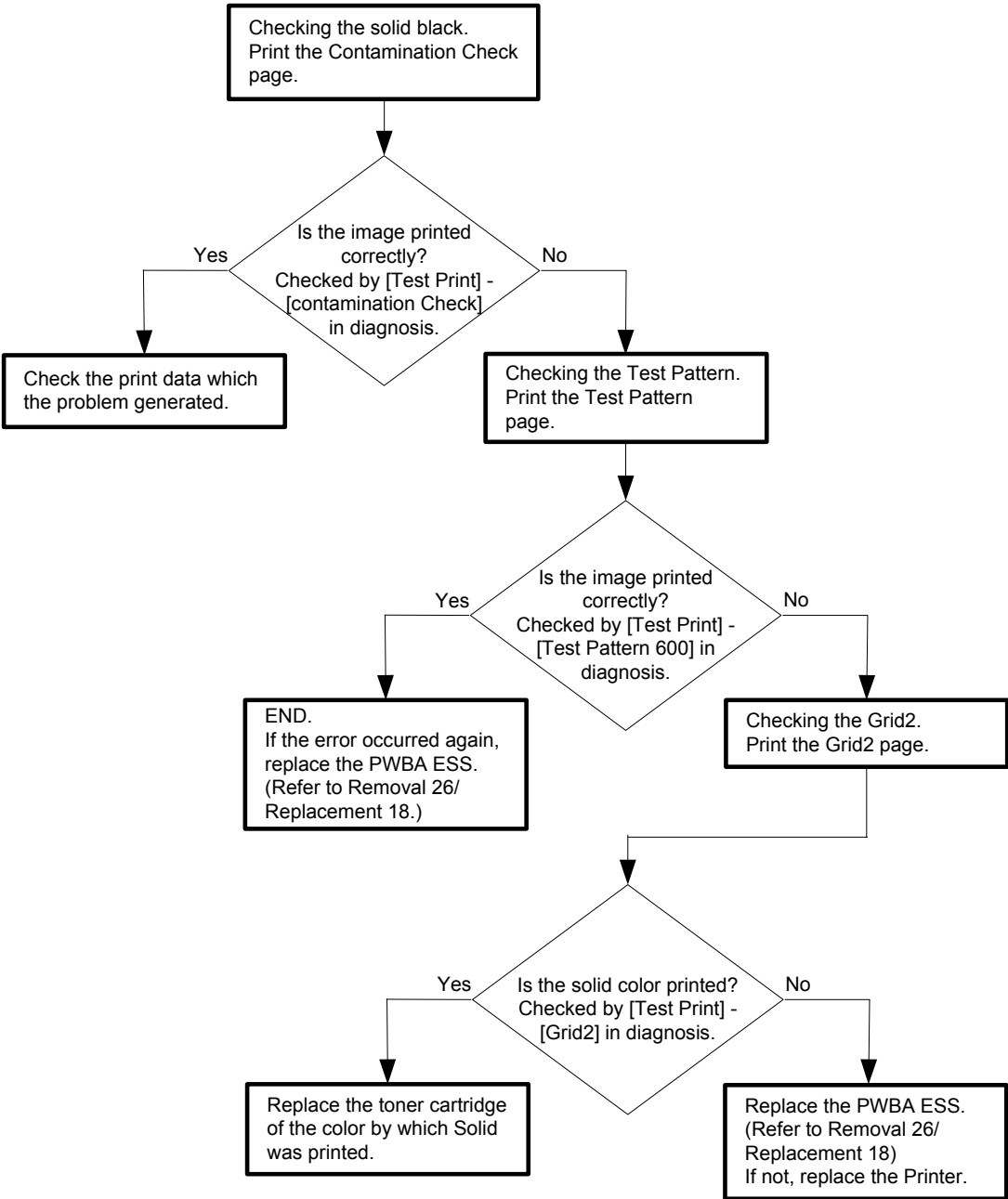
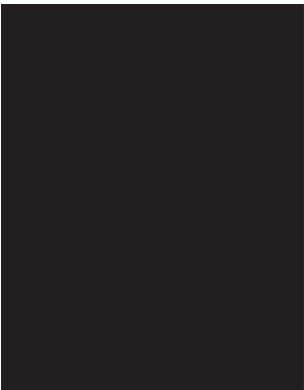

Flows 81 Vertical blank lines (White stripes in paper transport direction)

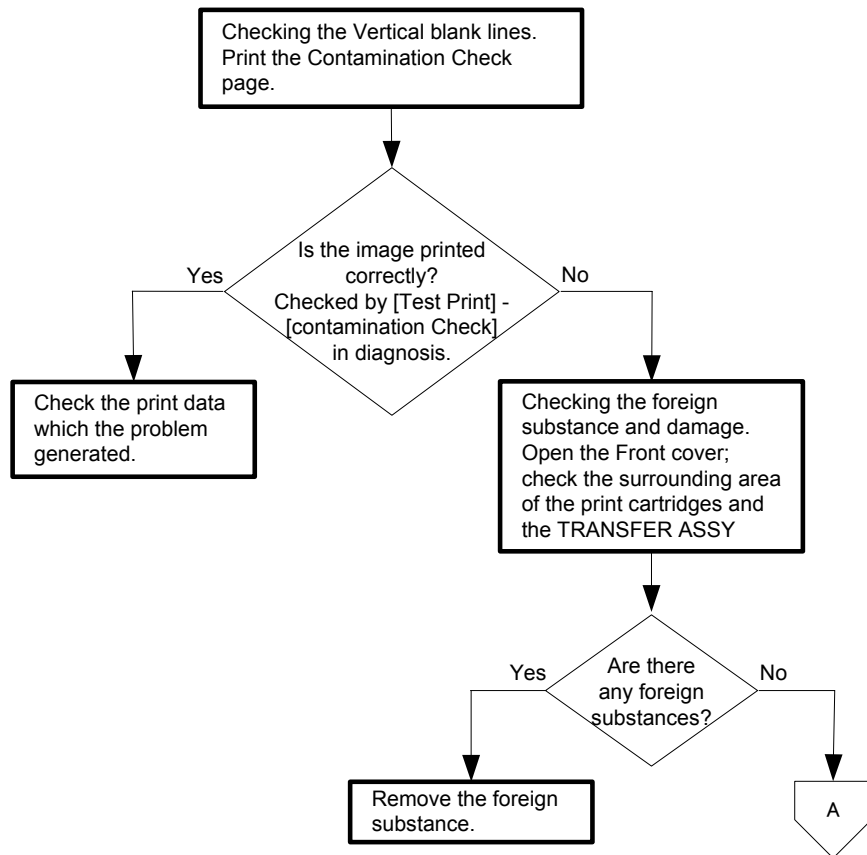
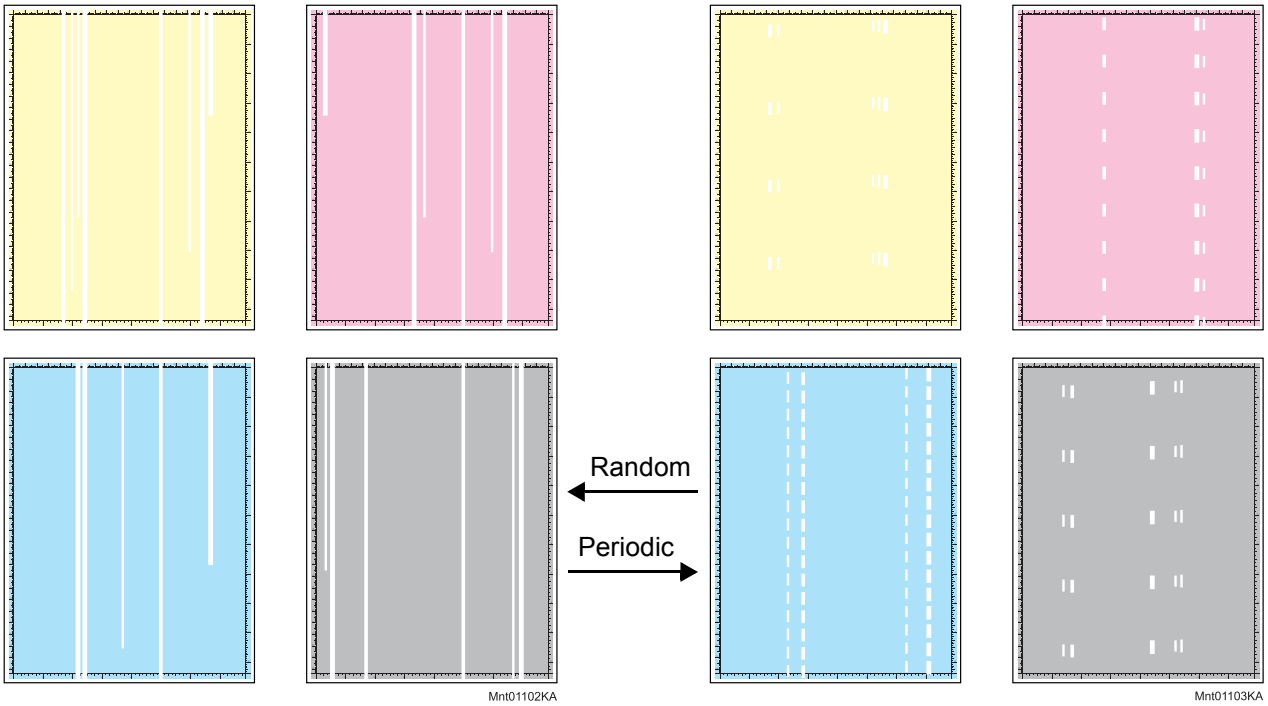

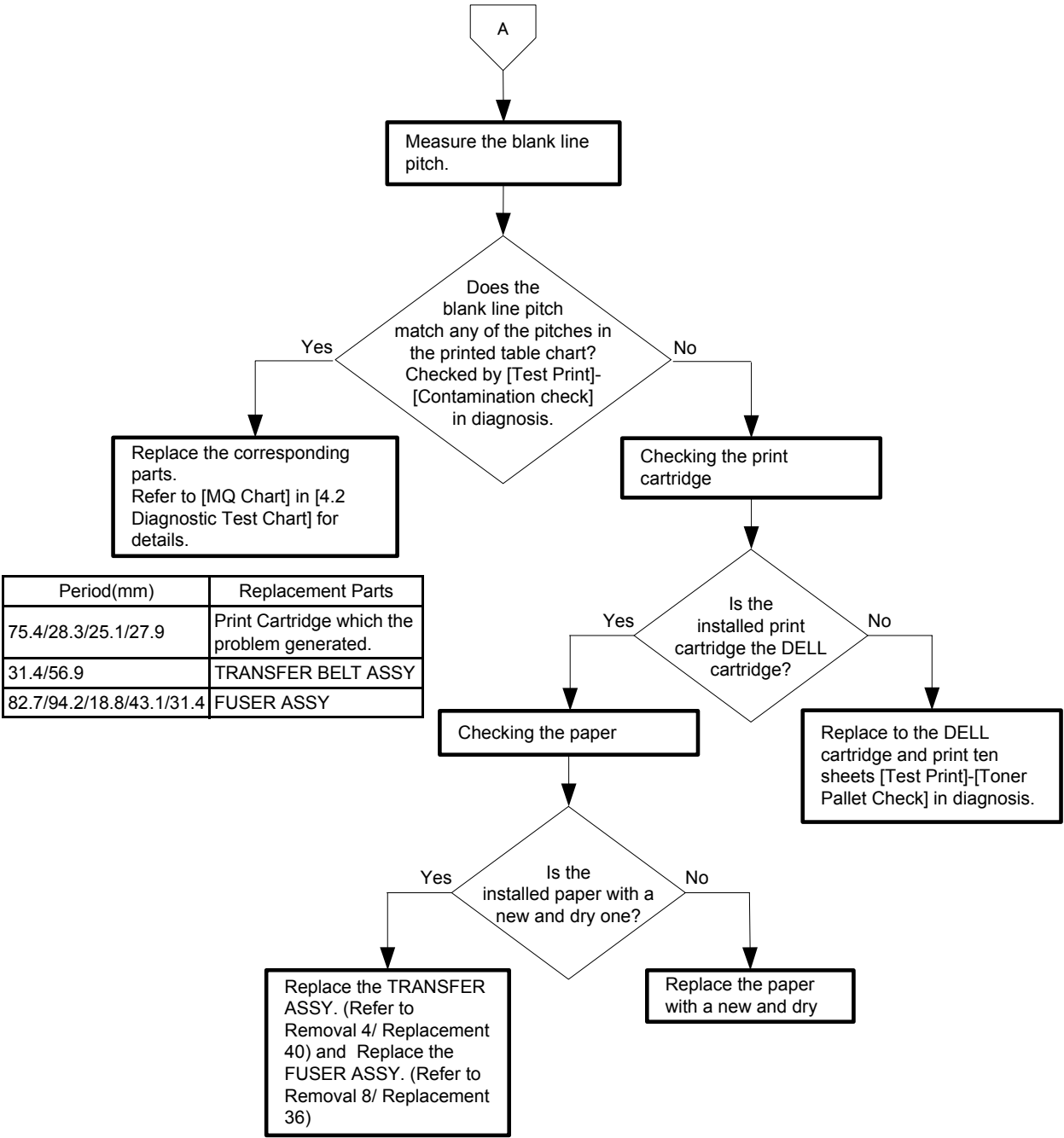

Flows 82 Horizontal band cross out (White stripes in the horizontal direction)

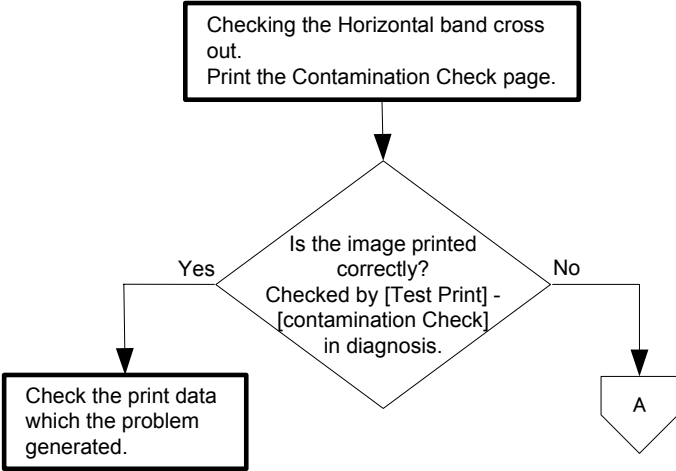
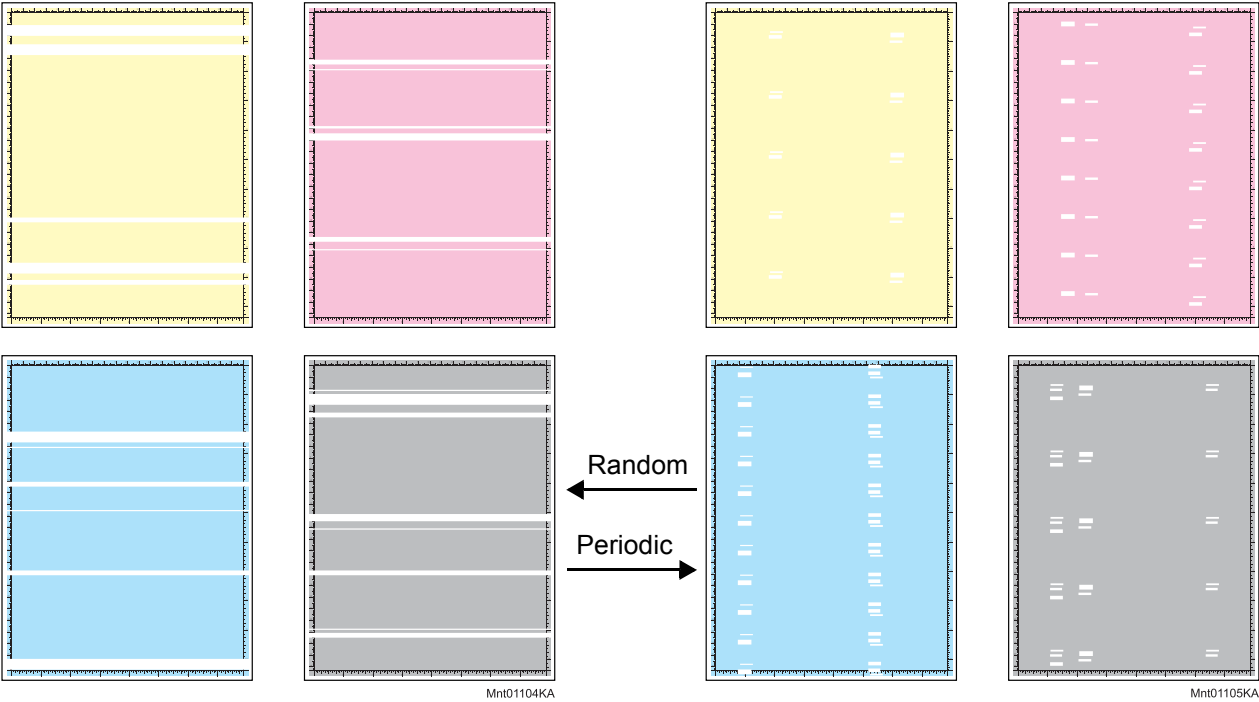

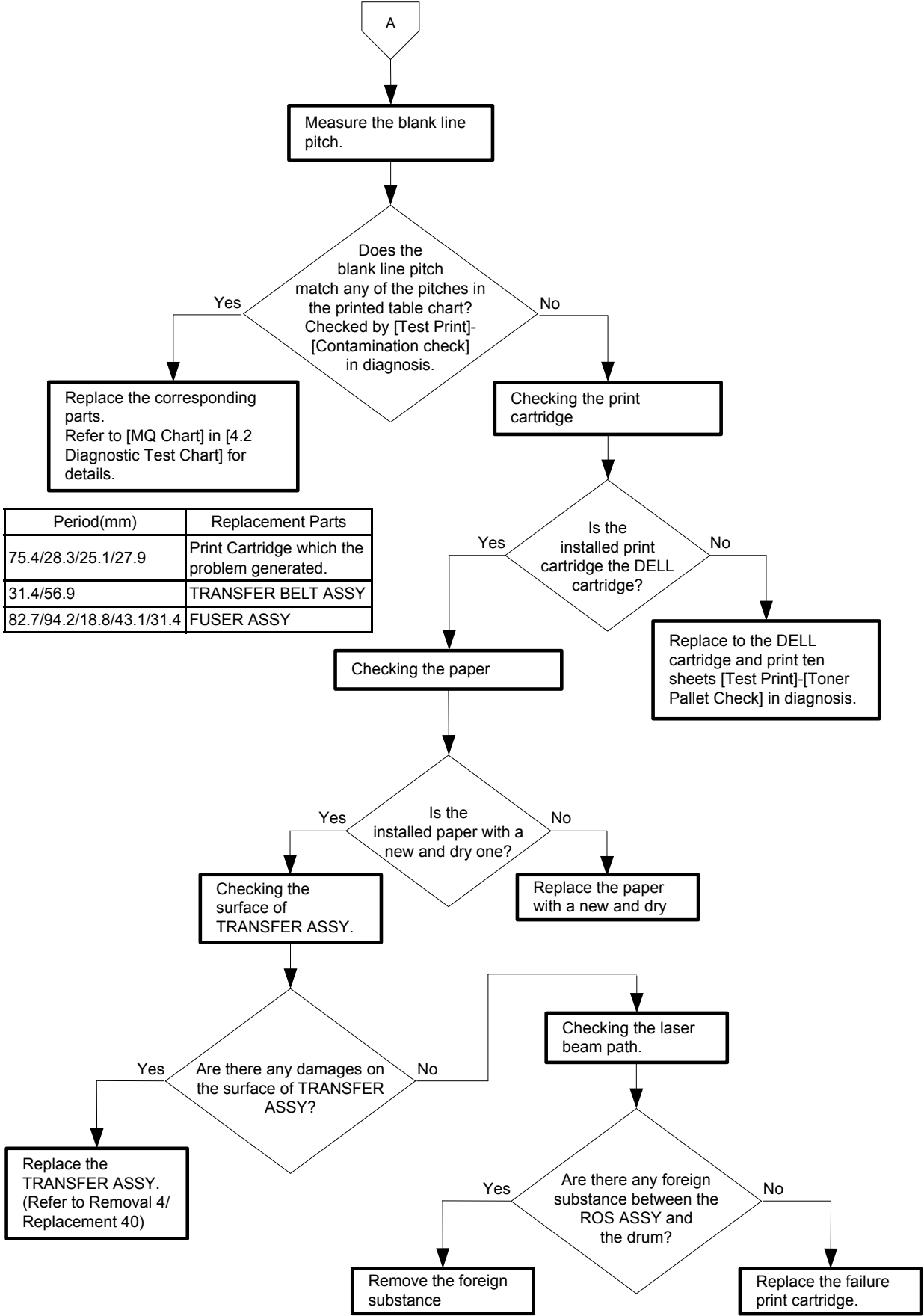

Flows 83 Vertical stripes

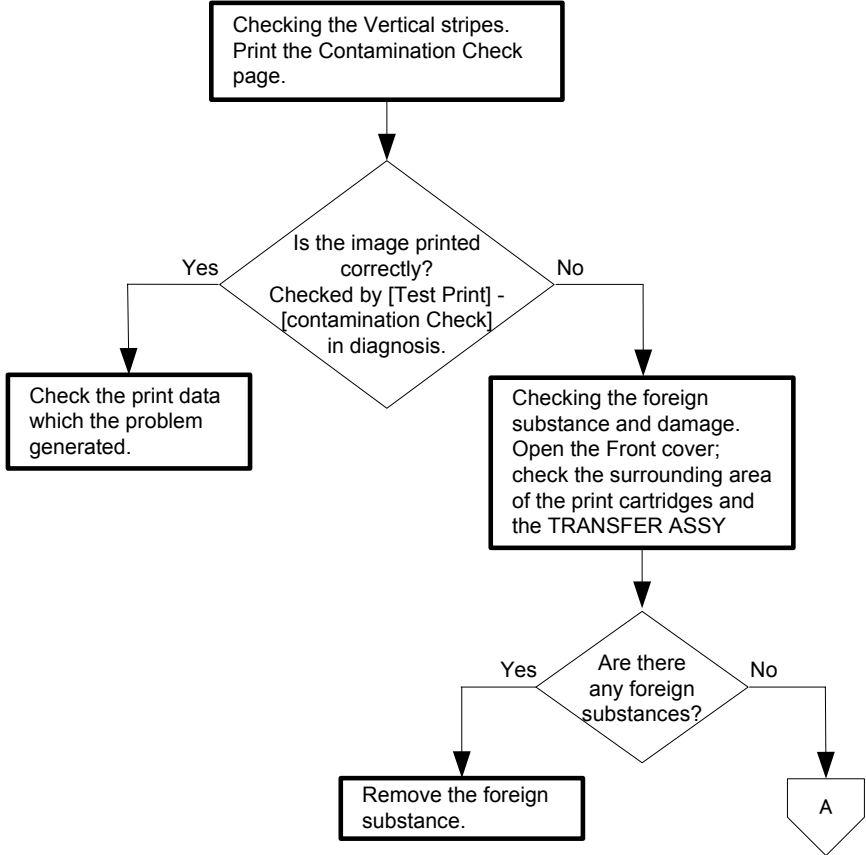
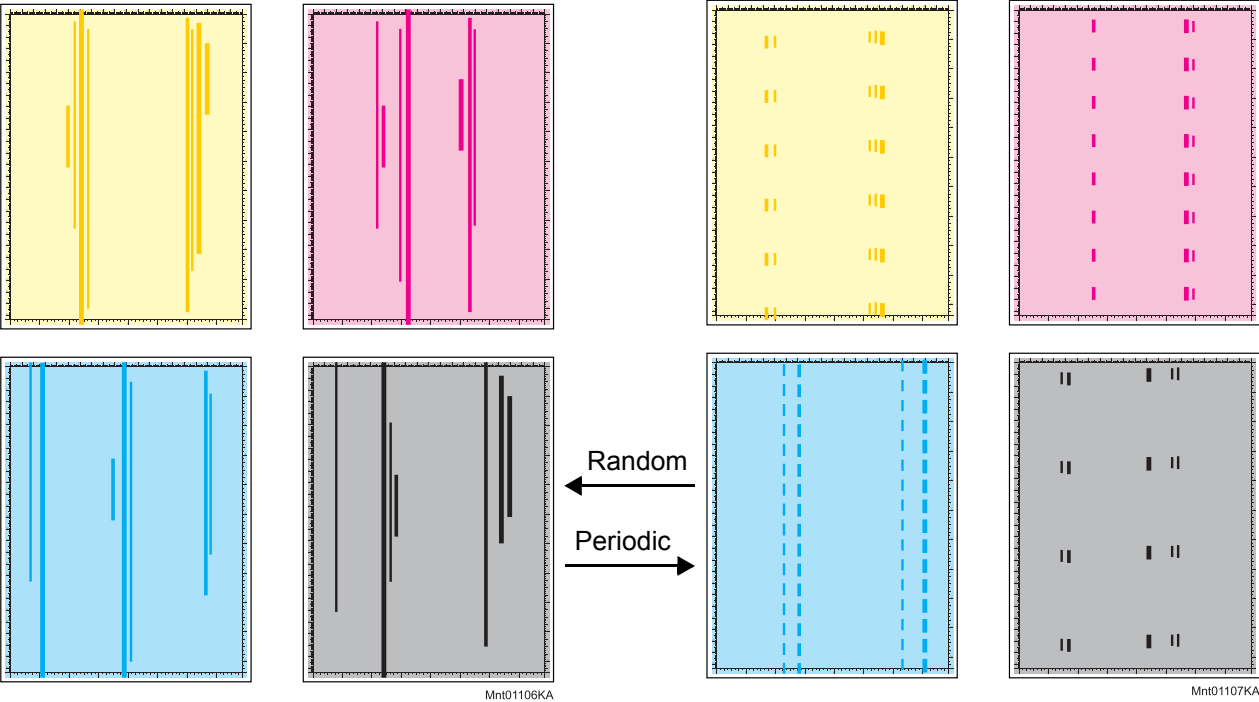

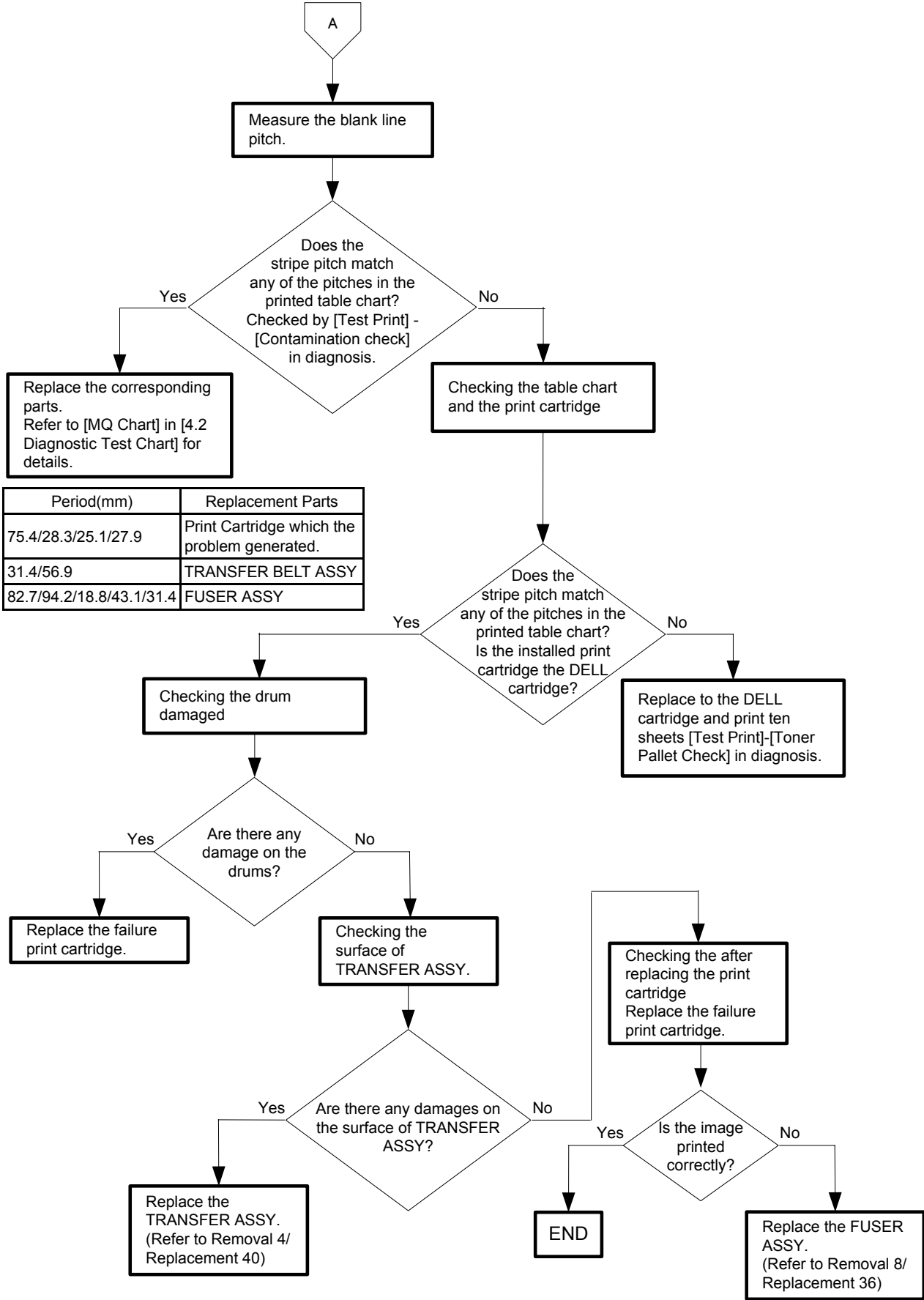

Period(mm)	Replacement Parts
75.4/28.3/25.1/27.9	Print Cartridge which the problem generated.
31.4/56.9	TRANSFER BELT ASSY
82.7/94.2/18.8/43.1/31.4	FUSER ASSY

Flows 84 Horizontal stripes

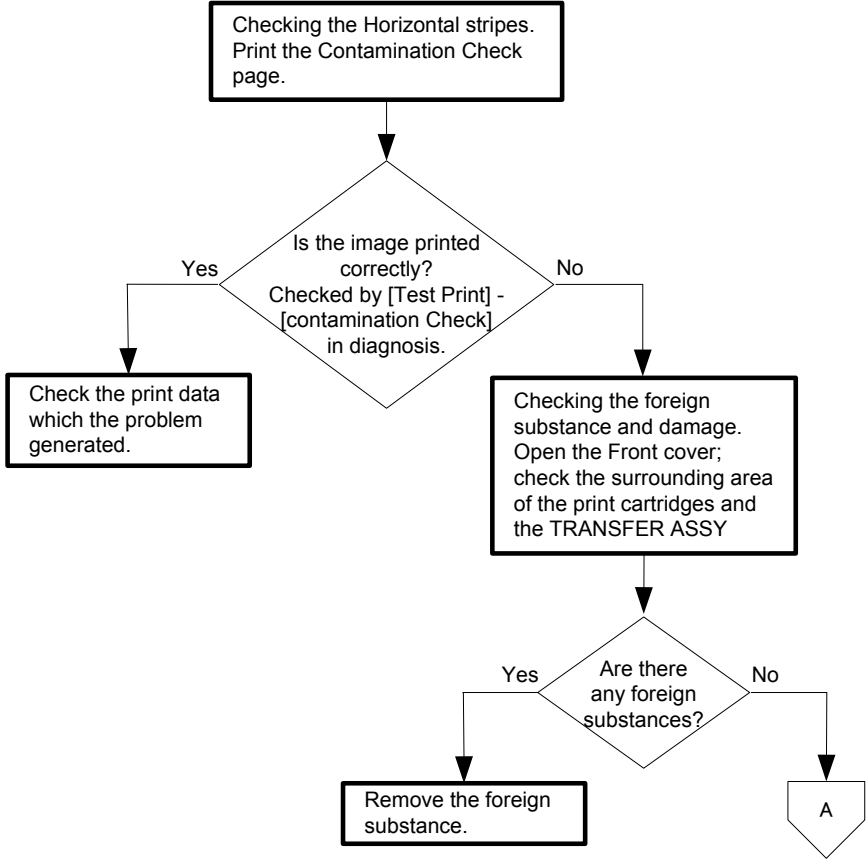
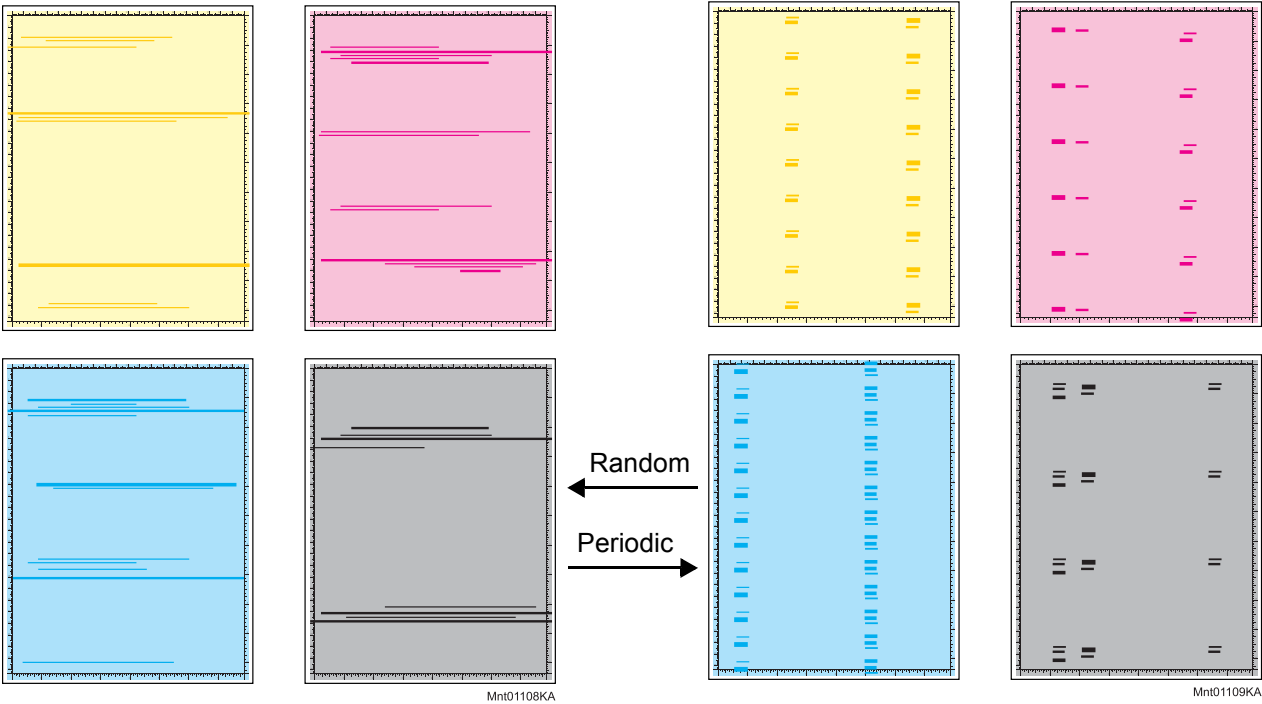

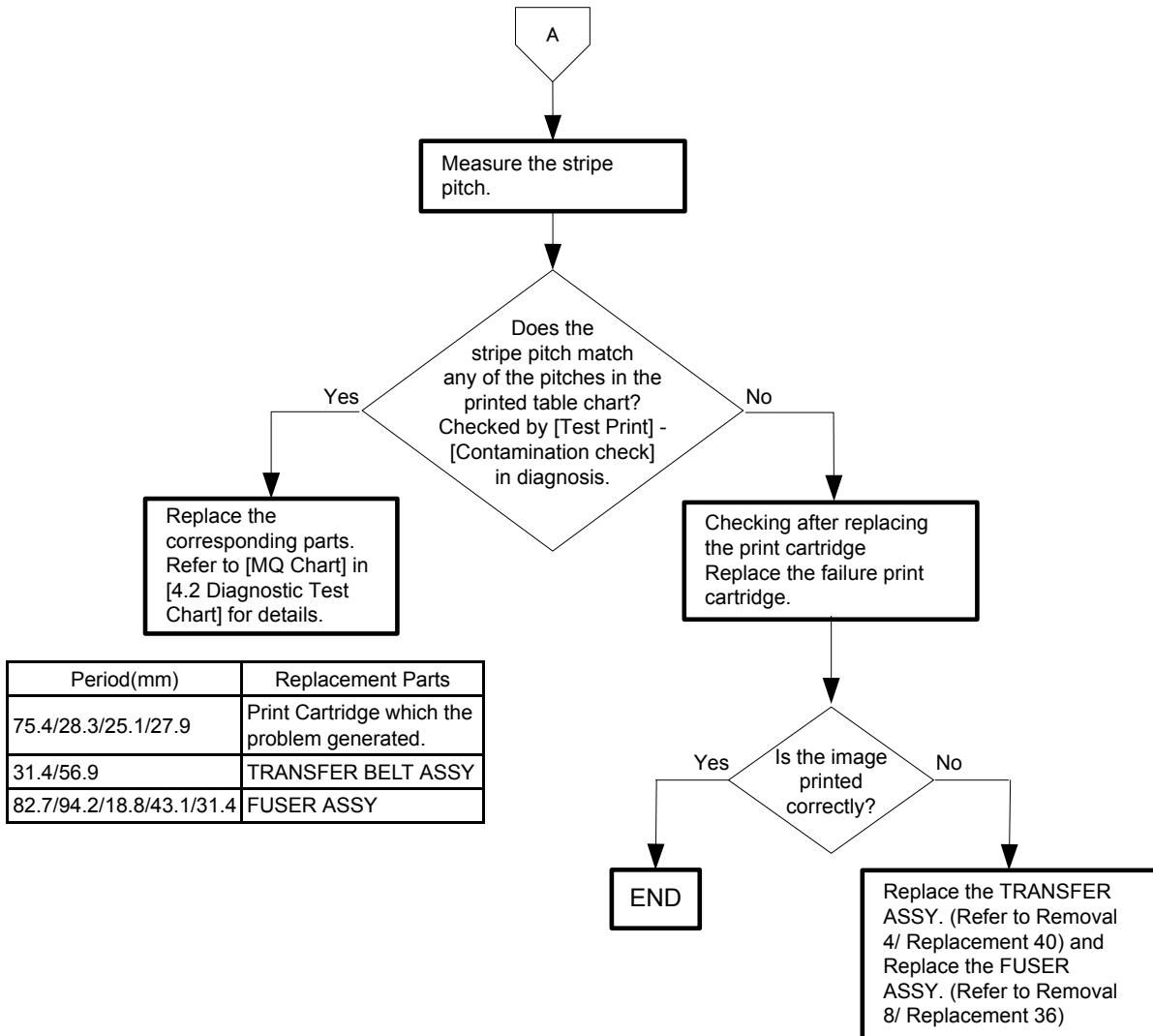

Flows 85 Partial Deletion

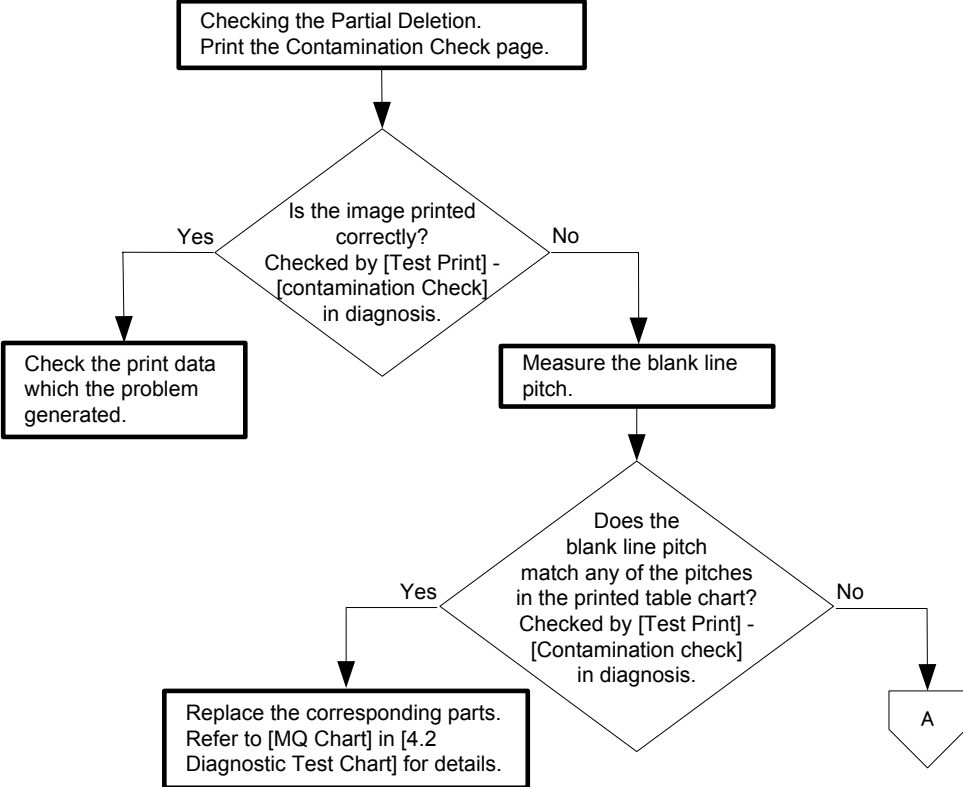
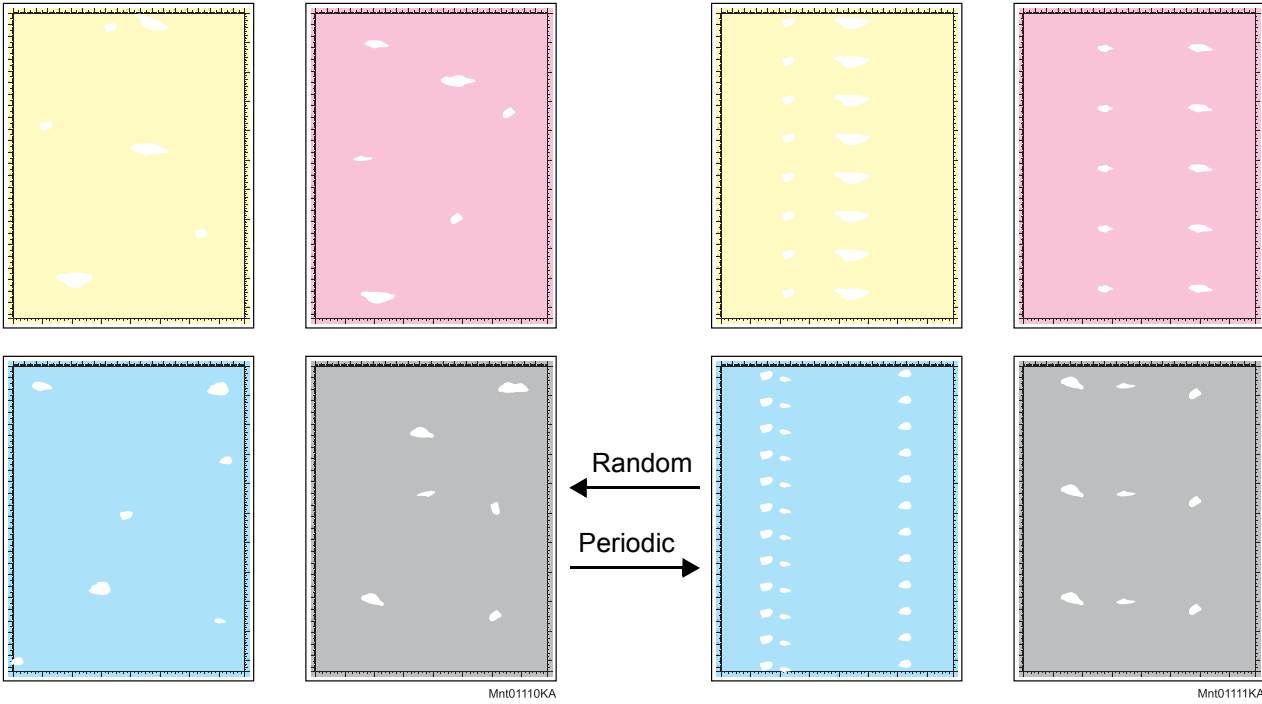

Period(mm)	Replacement Parts
75.4/28.3/25.1/27.9	Print Cartridge which the problem generated.
31.4/56.9	TRANSFER BELT ASSY
82.7/94.2/18.8/43.1/31.4	FUSER ASSY

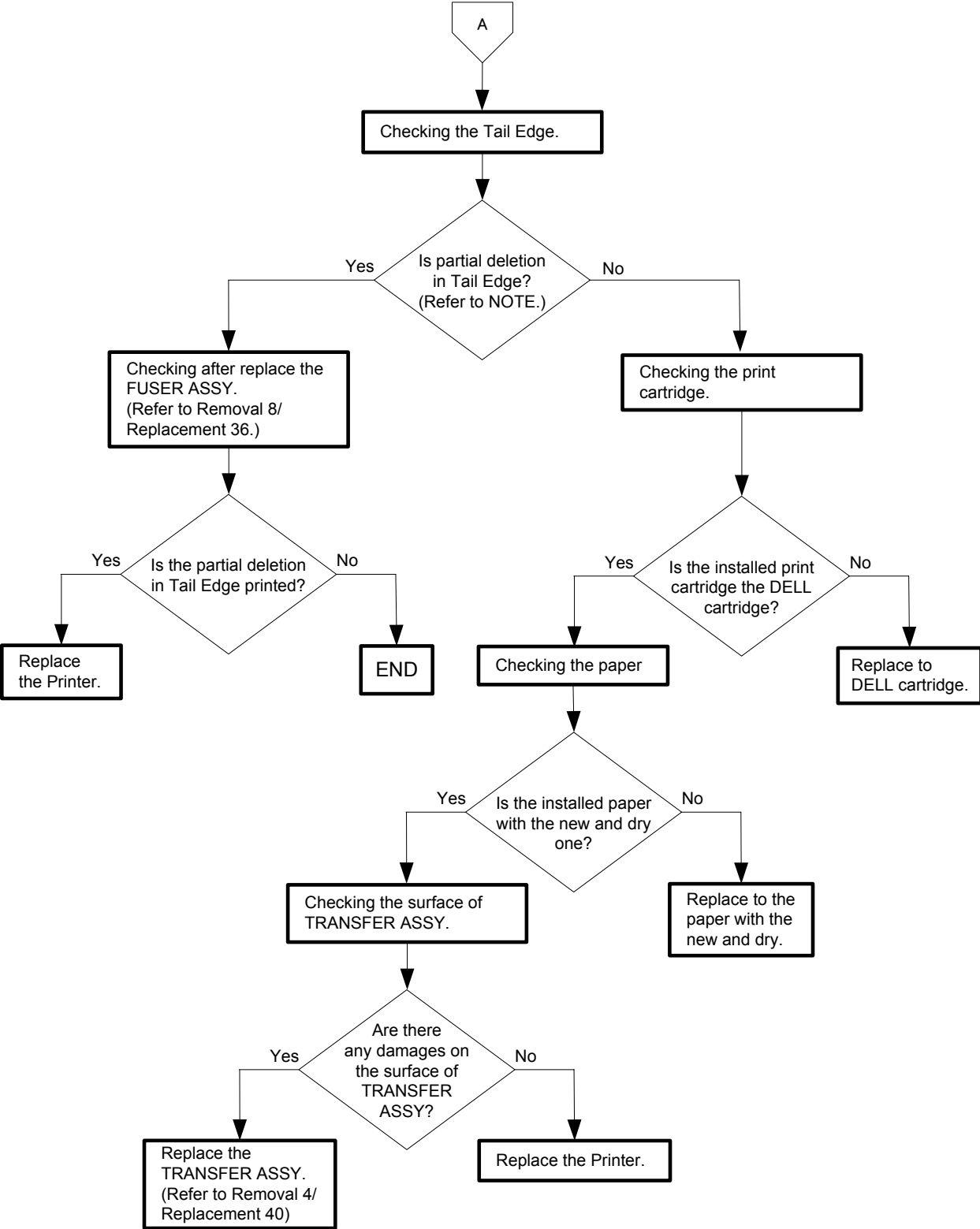

NOTE

This partial deletion is called as "smudge". Can be seen A4 size and half tone print. The partial deletion sample of Tail Edge is shown below.

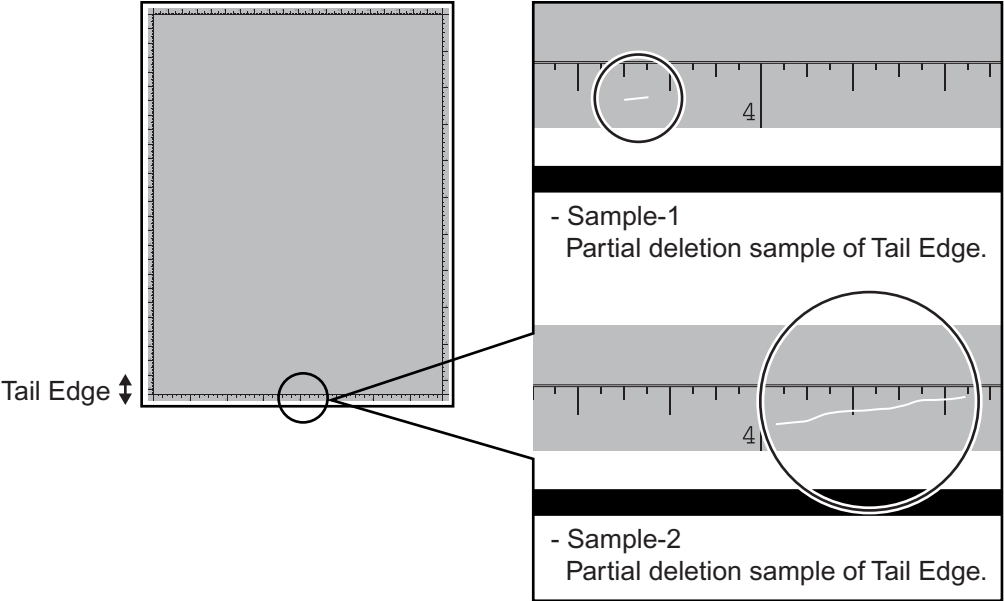

Zna0500KA

Flows 86 Spots

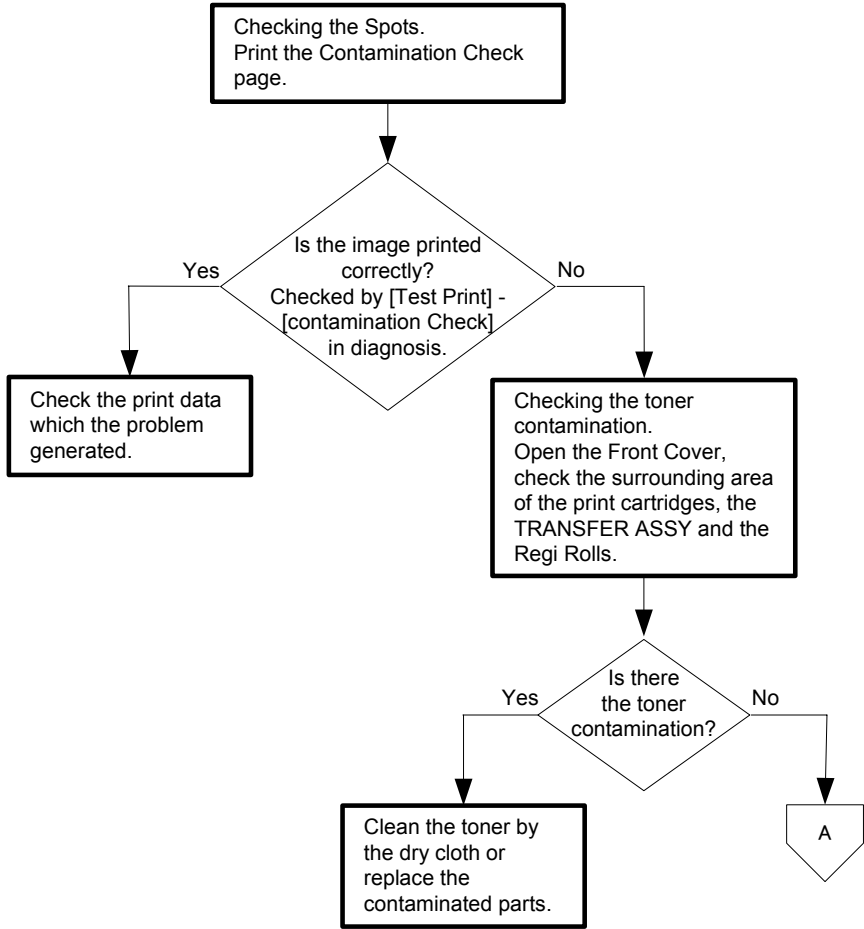
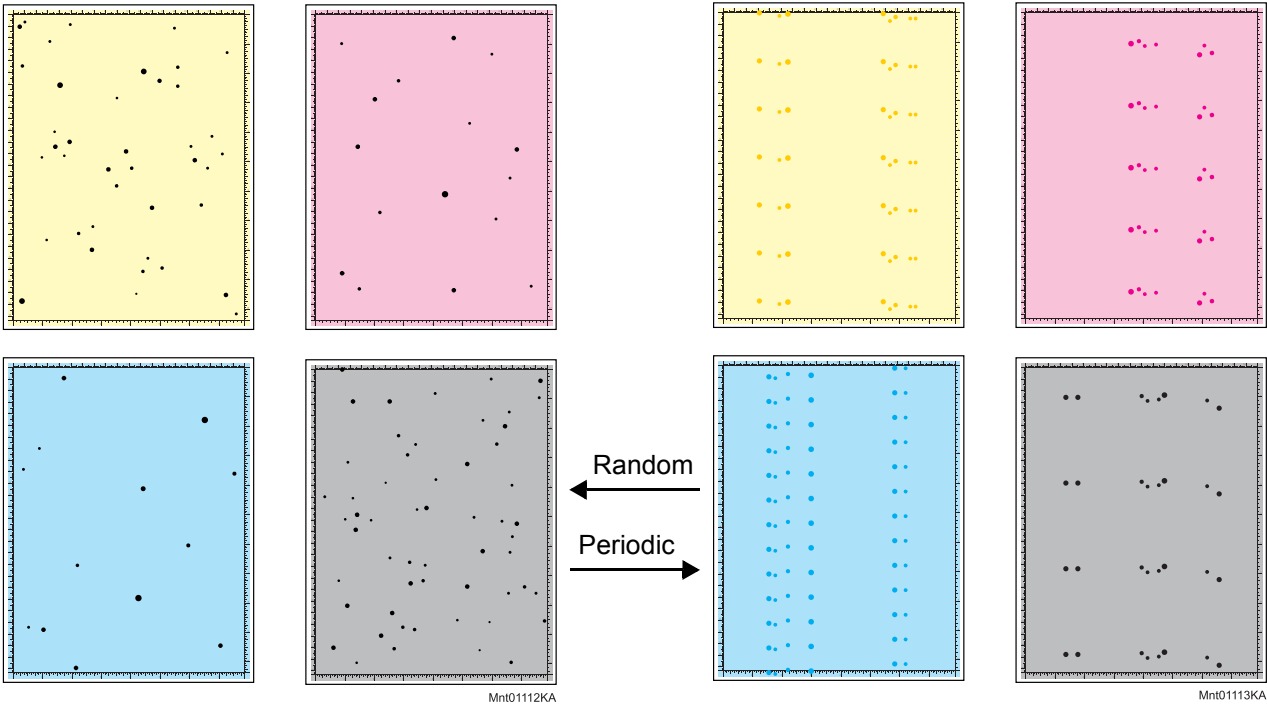

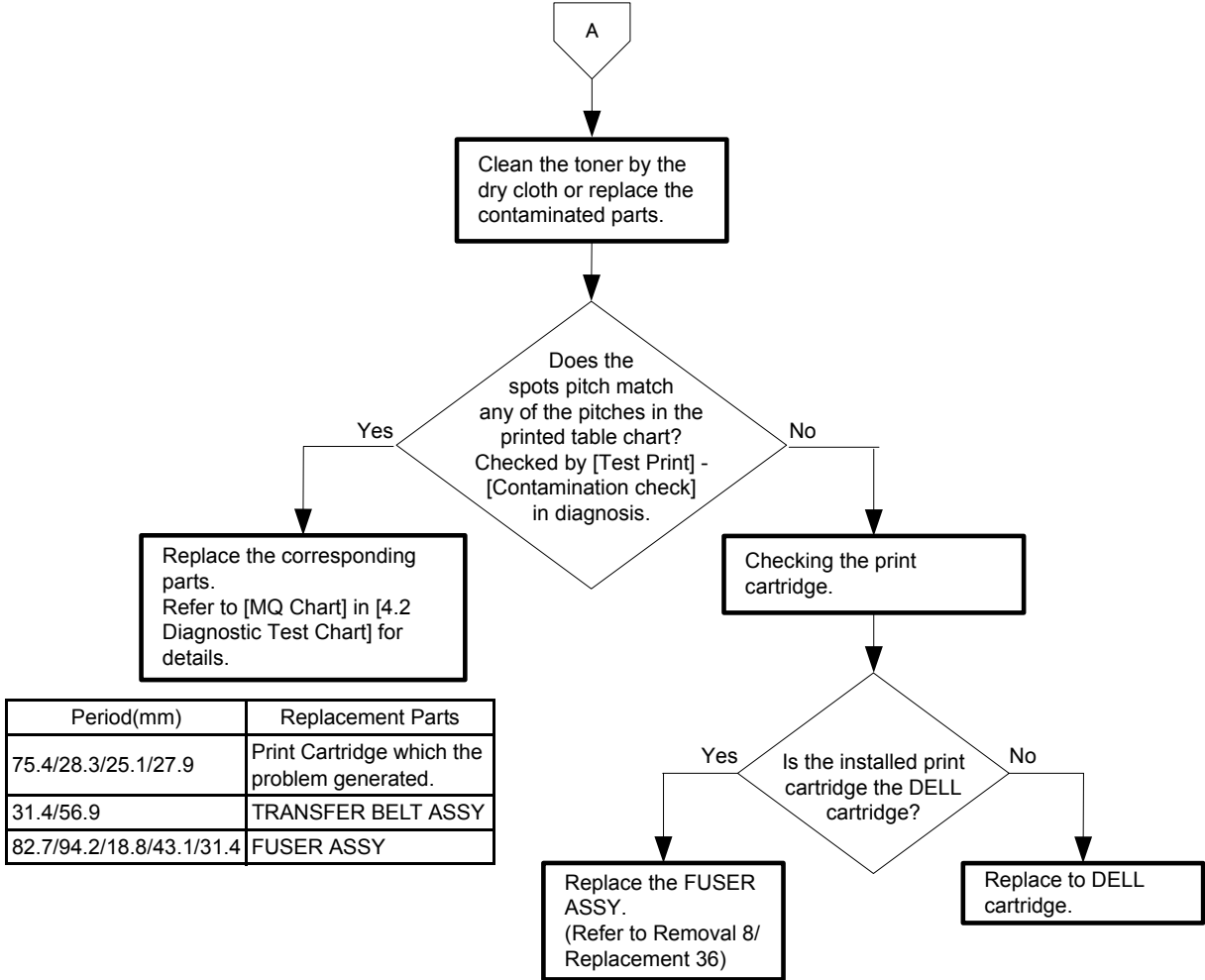

Period(mm)	Replacement Parts
75.4/28.3/25.1/27.9	Print Cartridge which the problem generated.
31.4/56.9	TRANSFER BELT ASSY
82.7/94.2/18.8/43.1/31.4	FUSER ASSY

Flows 87 Afterimage (Ghost)

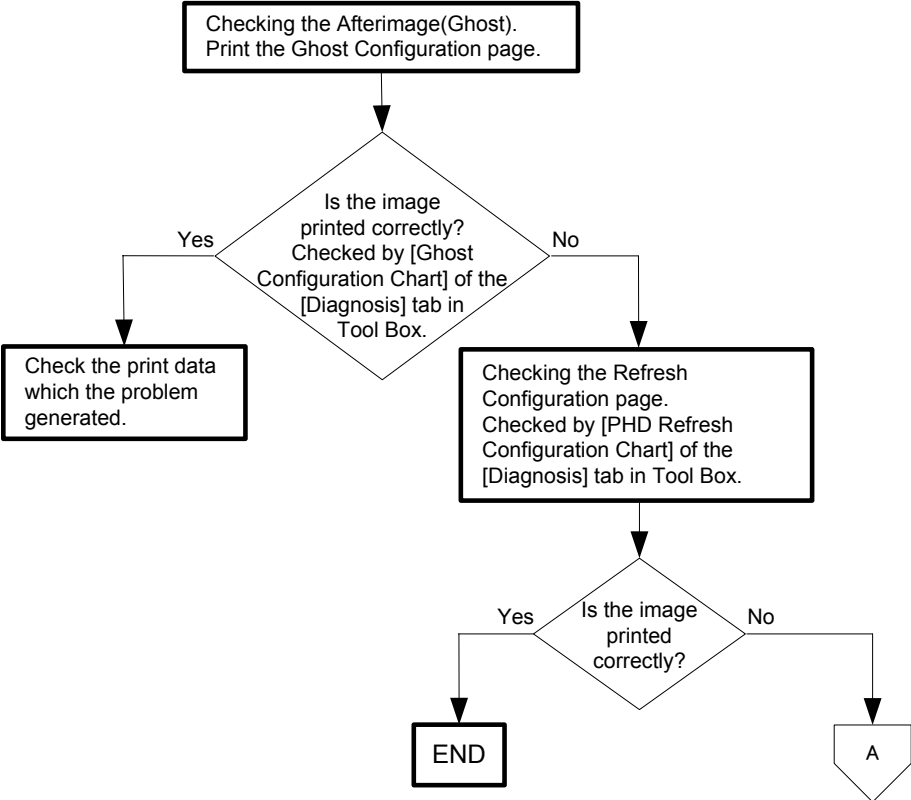
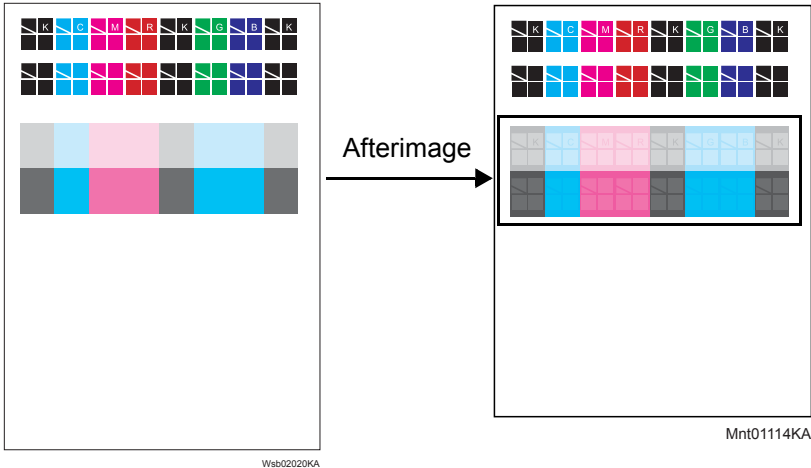

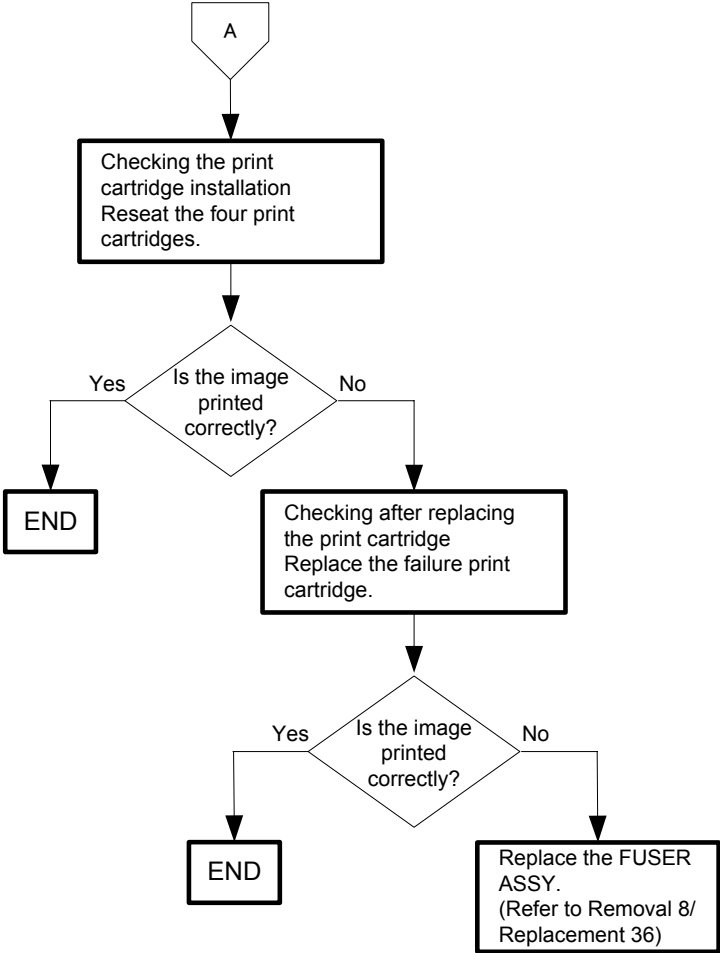

Flows 88 Grey Background

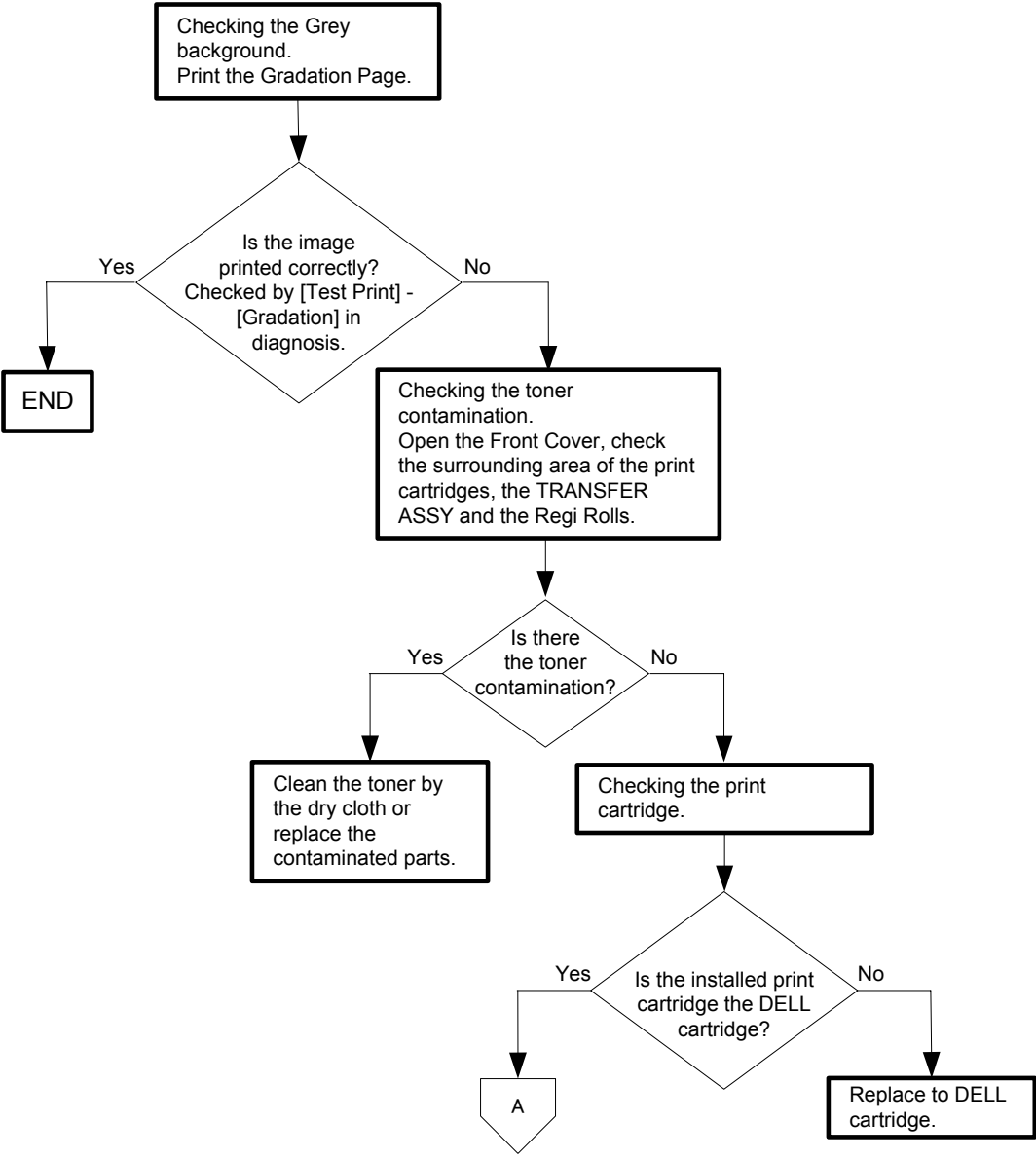
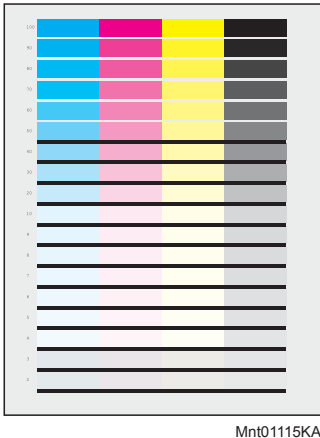

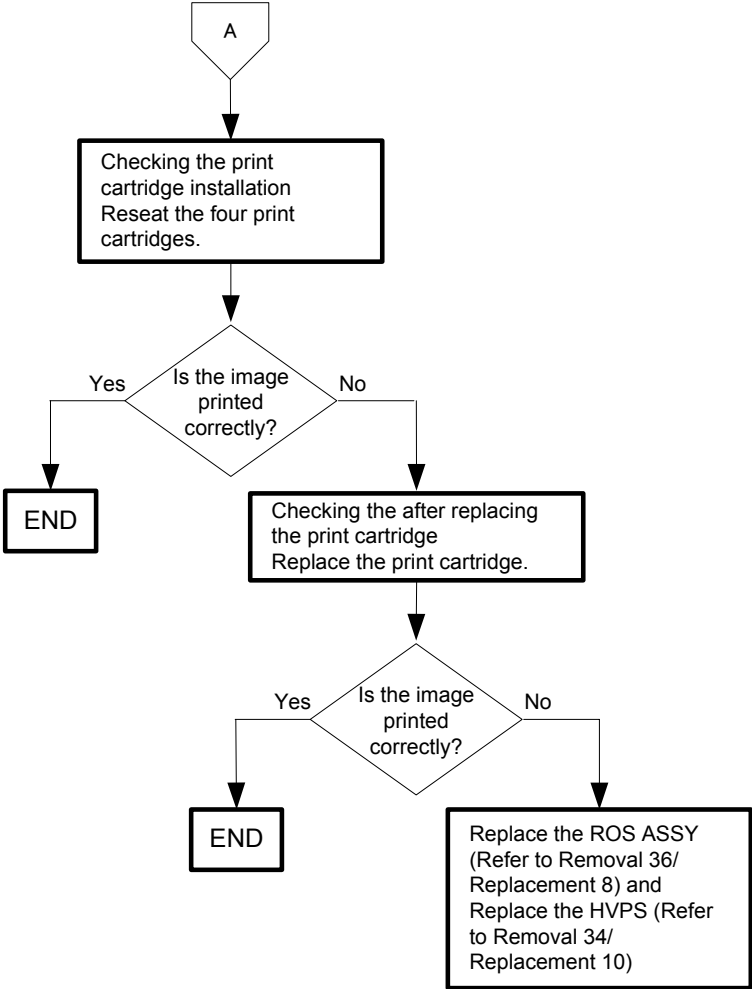

Flows 89 Skew

NOTE

Tray is recommended for paper feeding because sheets fed via SSF is prone to skew depending on how the sheet is placed of SSF.

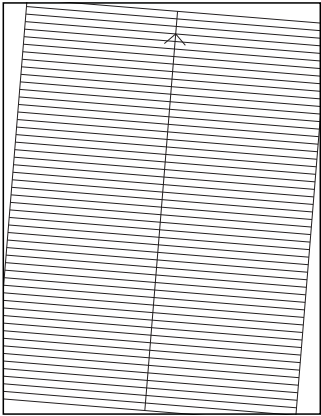

Mnt01116KA

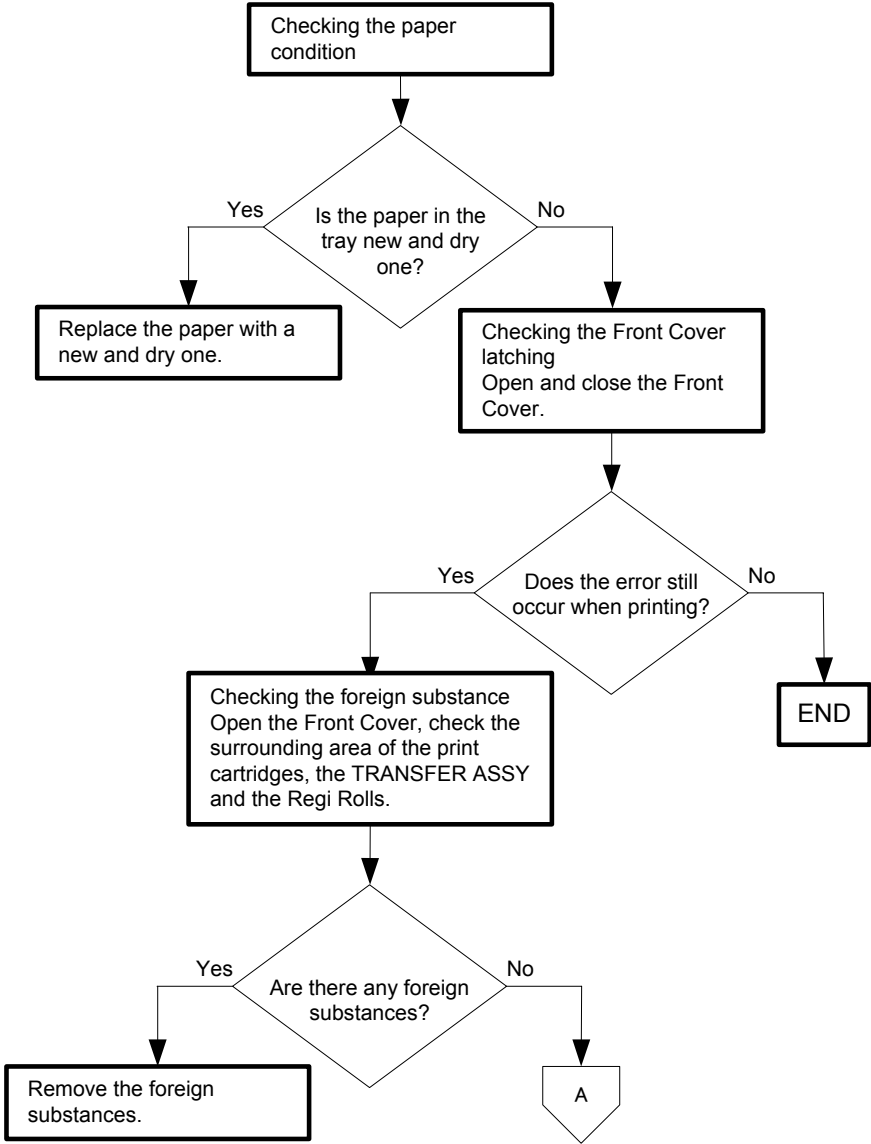

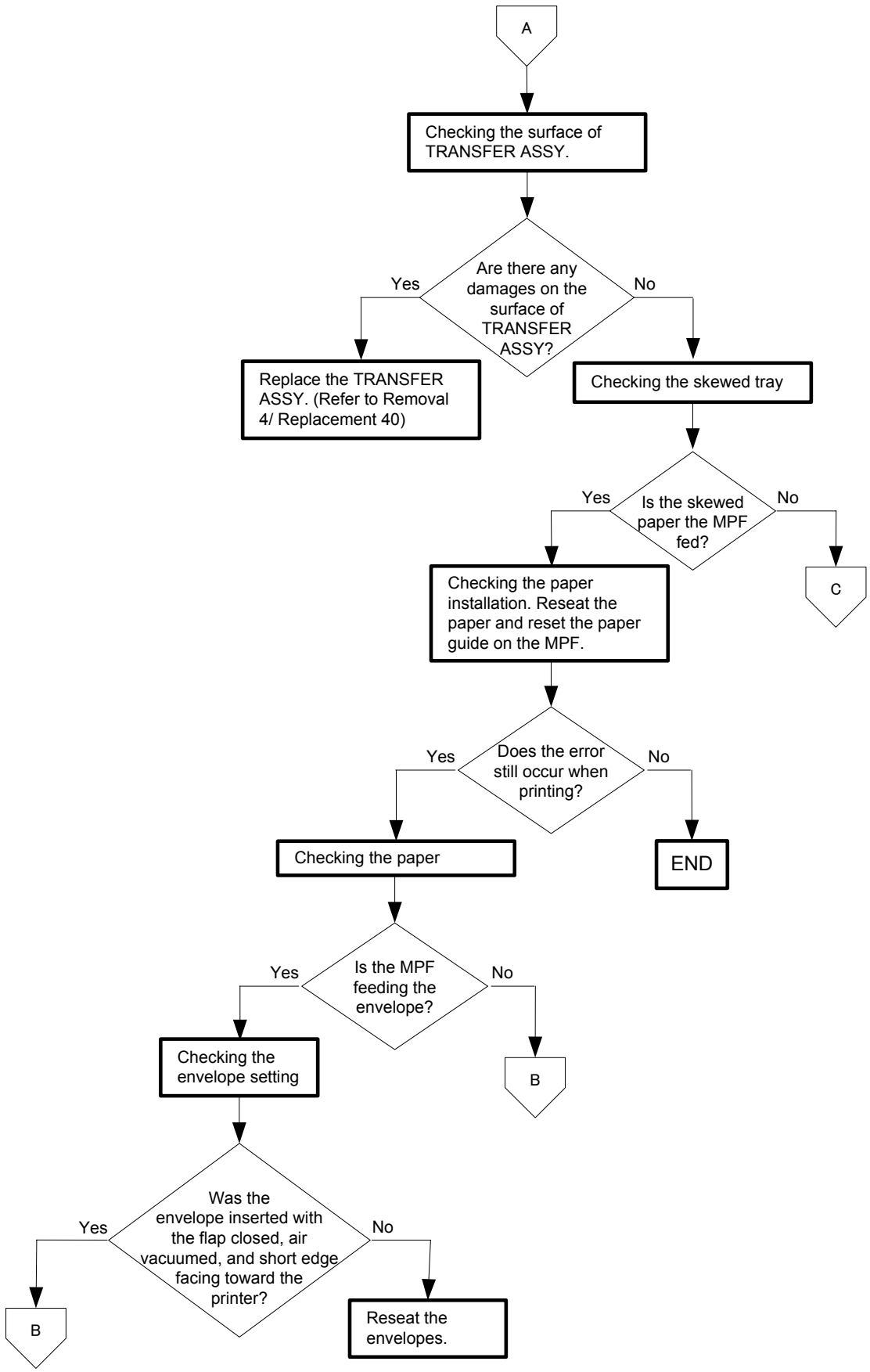

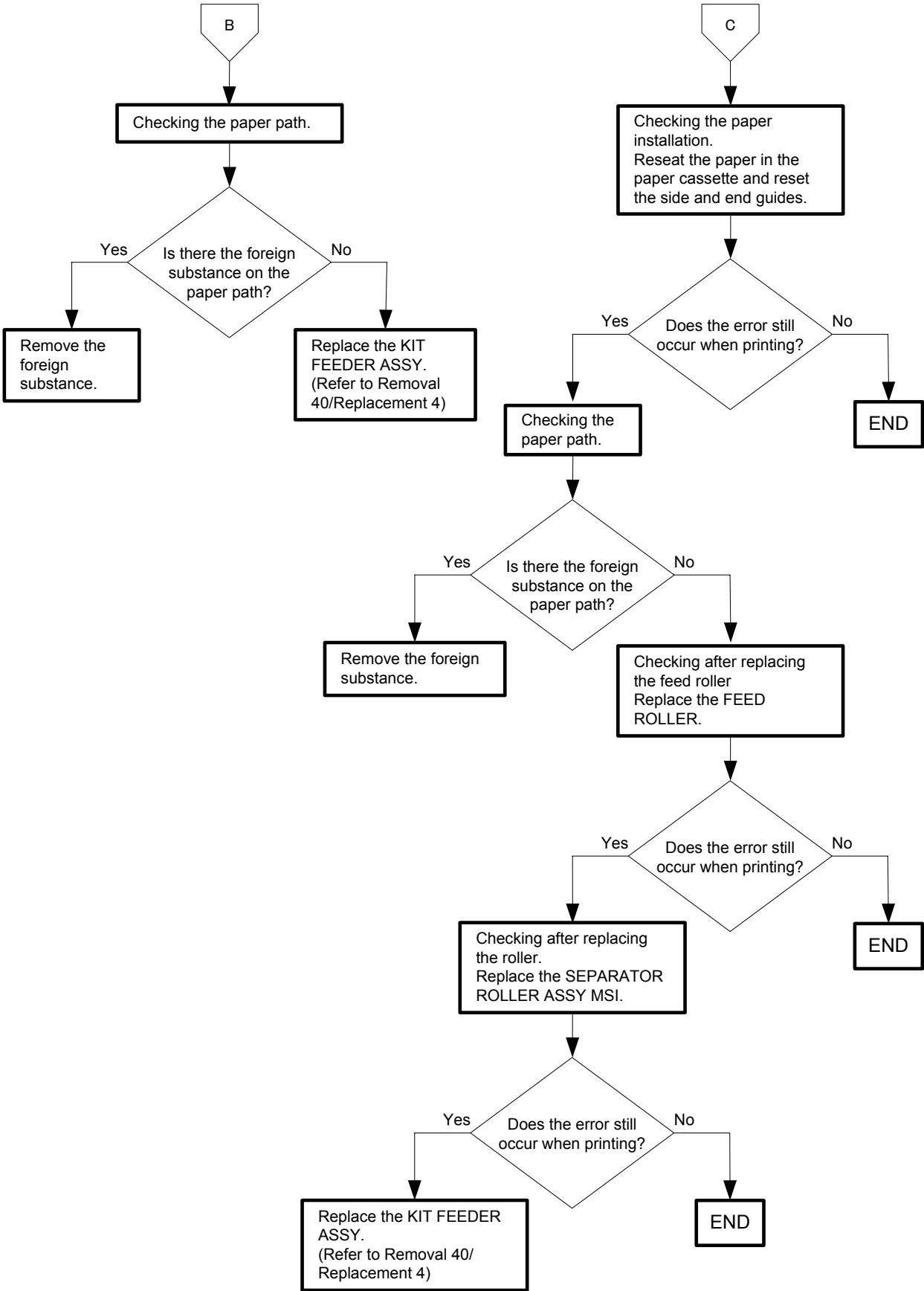

Flows 90 Paper damage

NOTE

Tray is recommended for paper feeding because sheets fed via SSF is prone to skew depending on how the sheet is placed on SSF.

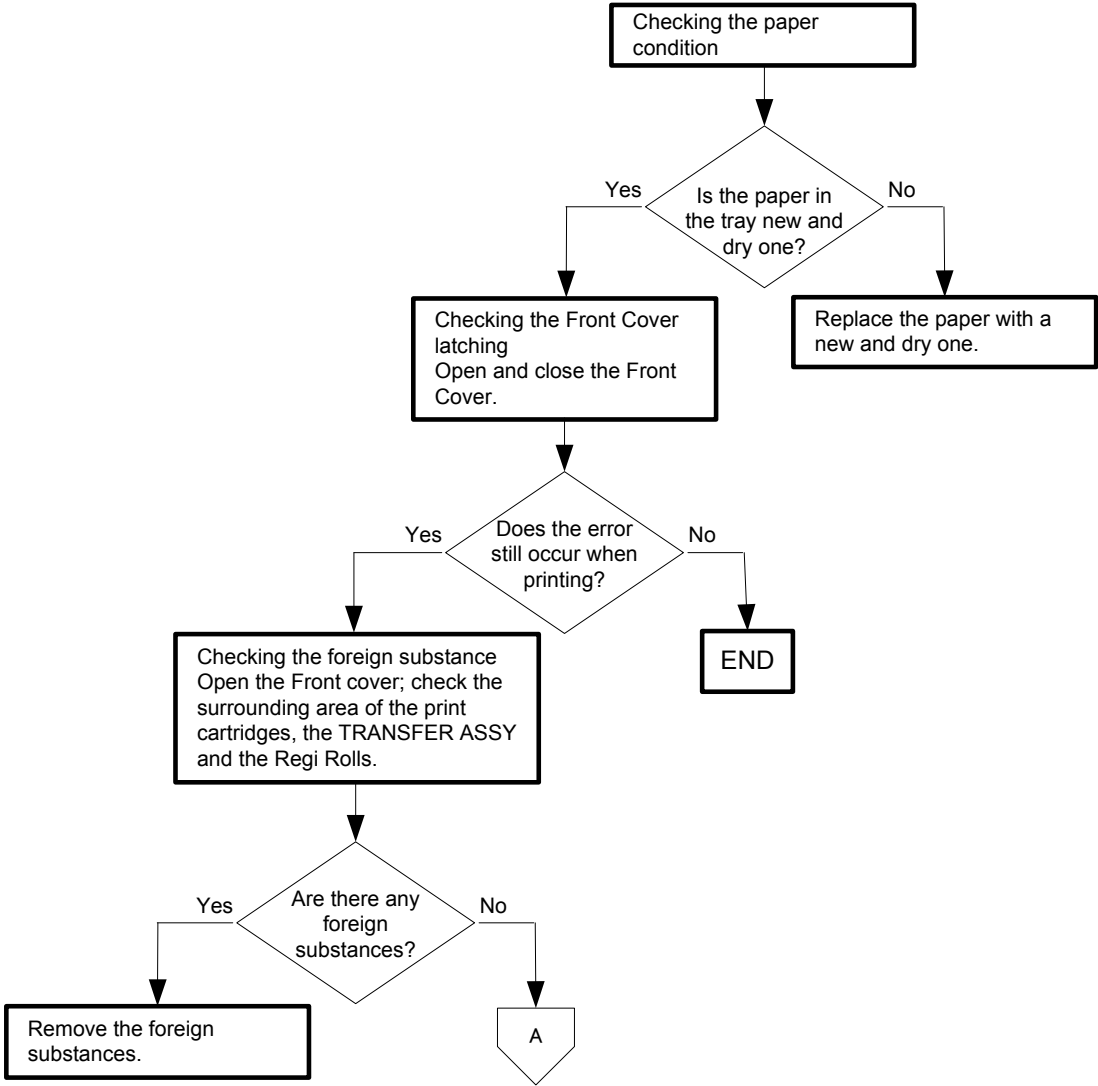
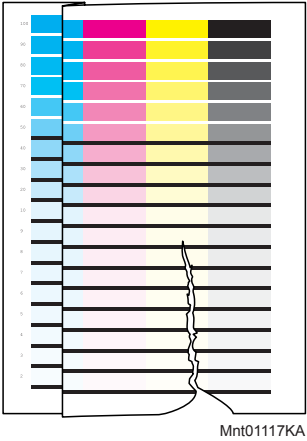

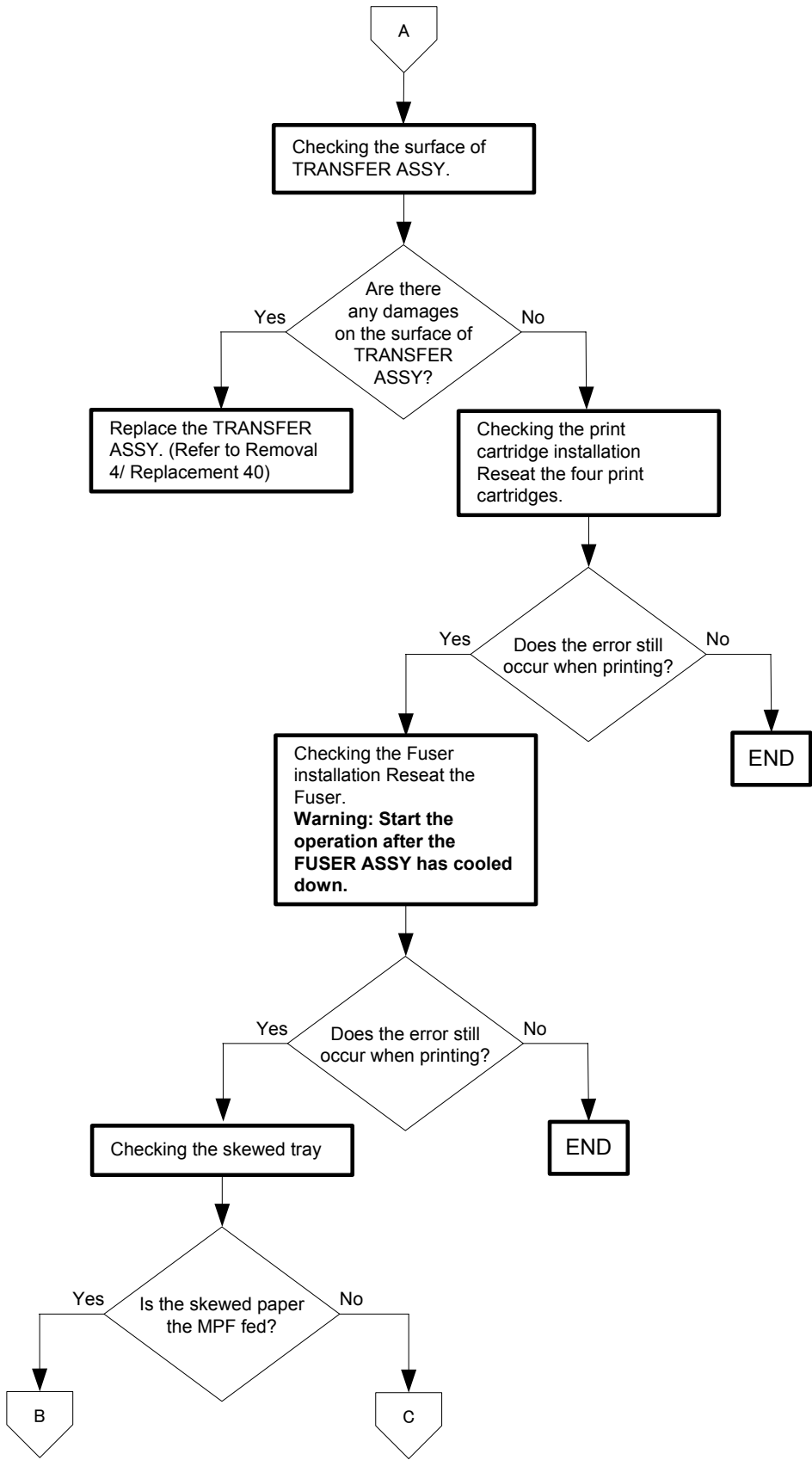

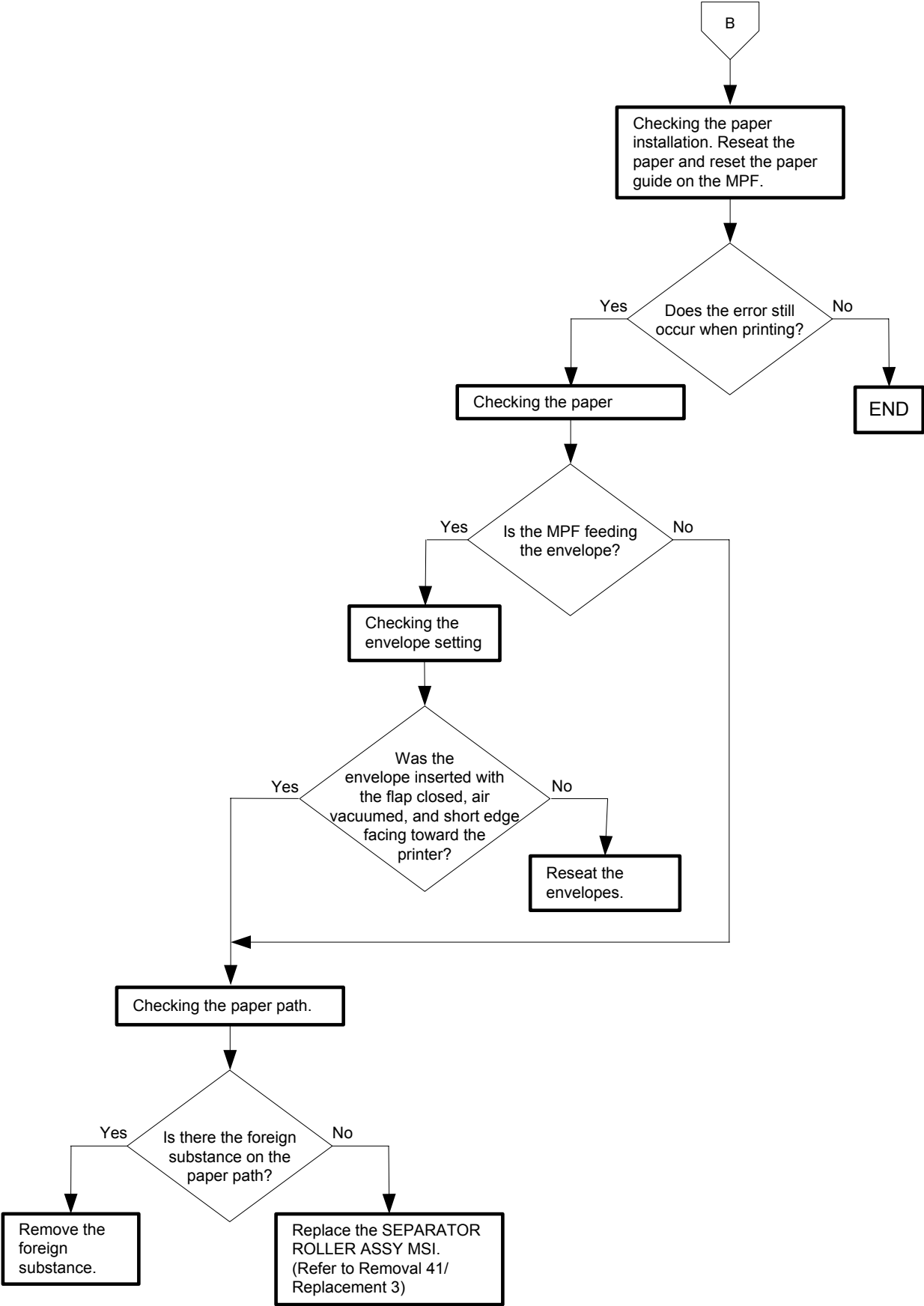

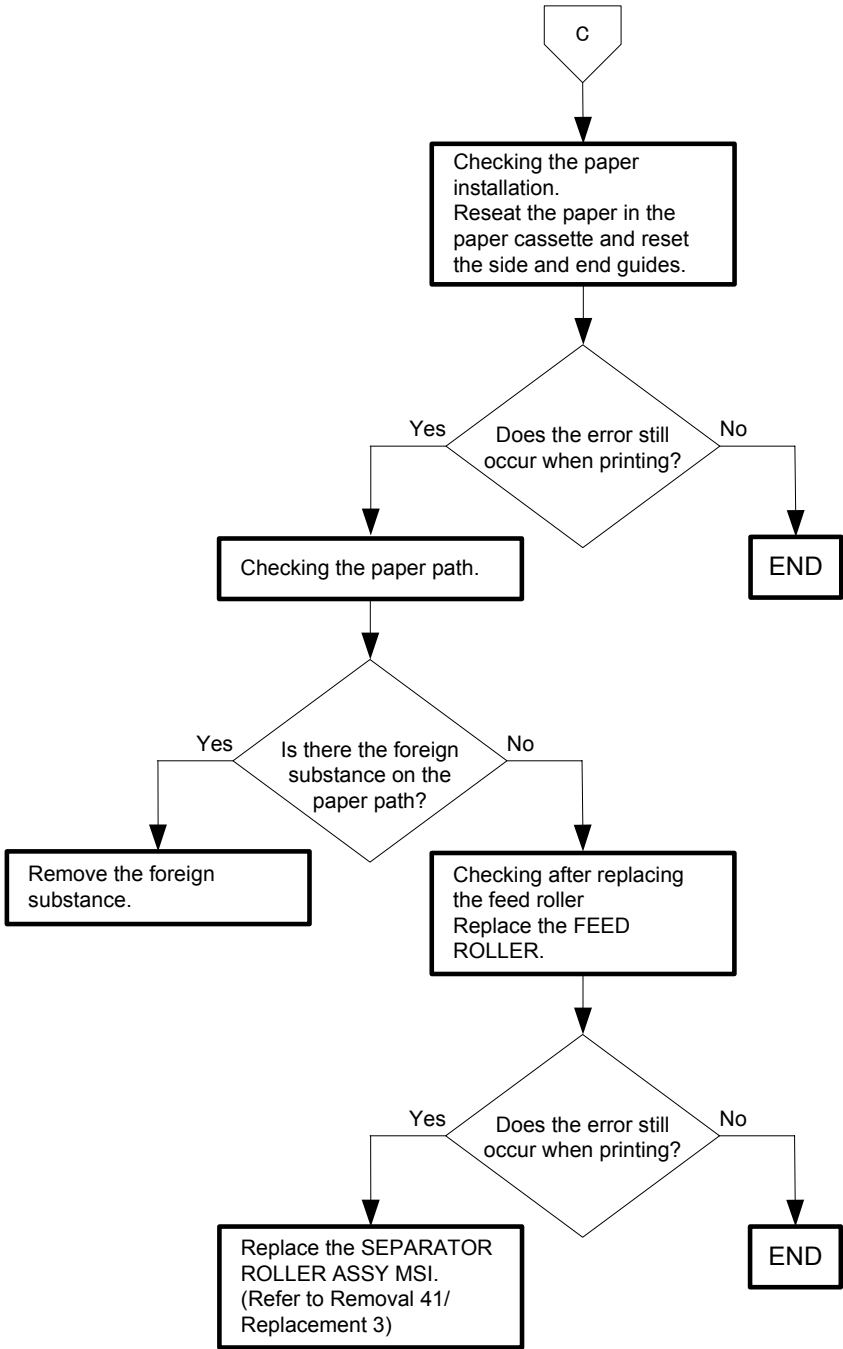

Flows 91 Unfusing

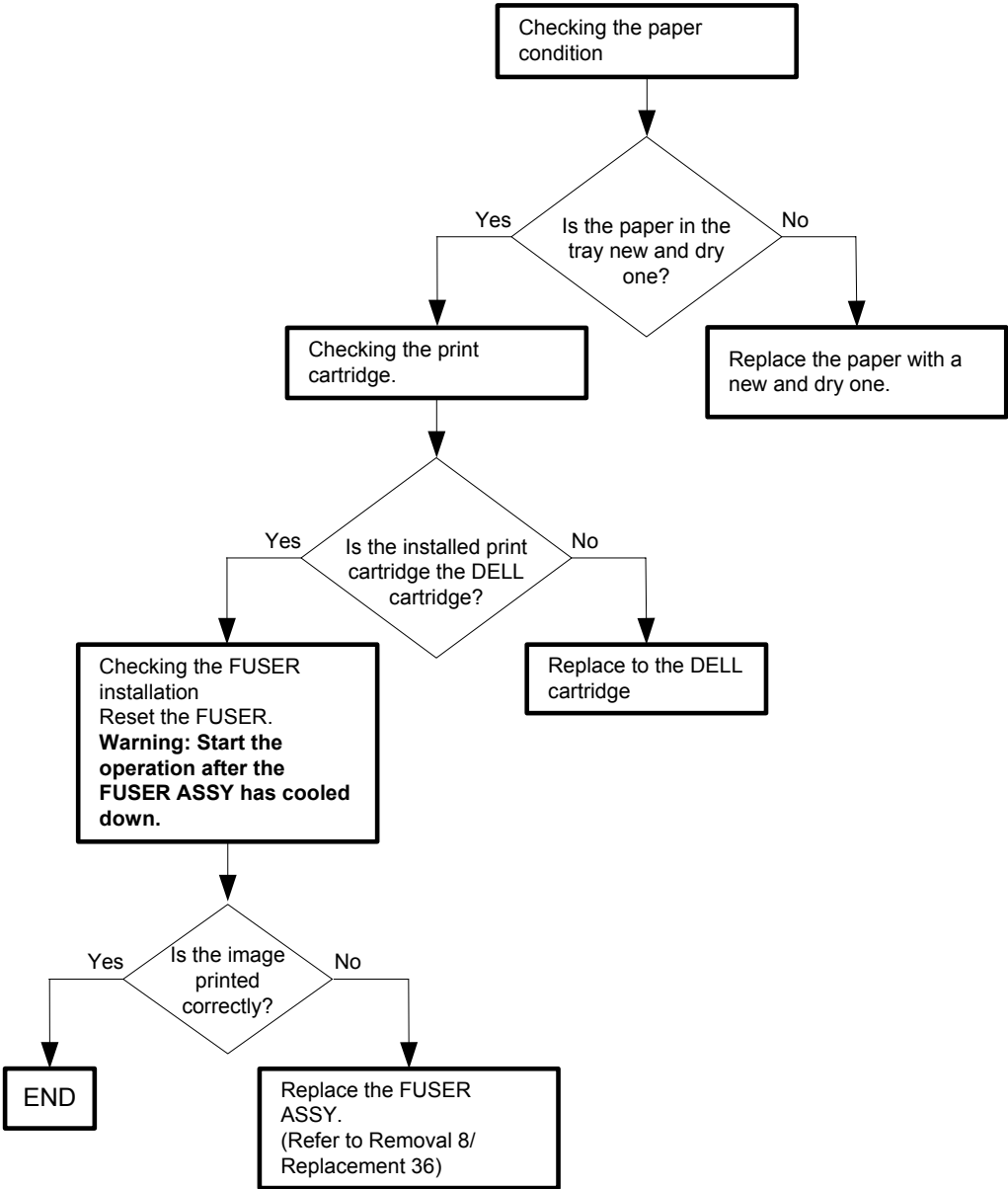
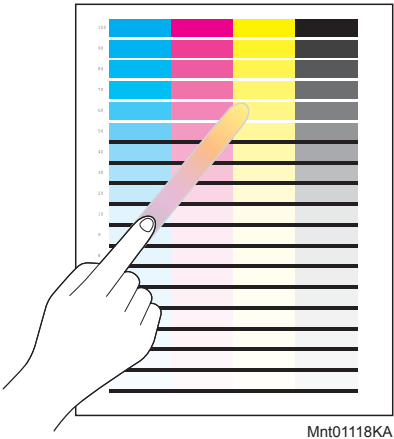

Flows 92 Color Registration (Color Shift)

- Troubleshooting of a control system

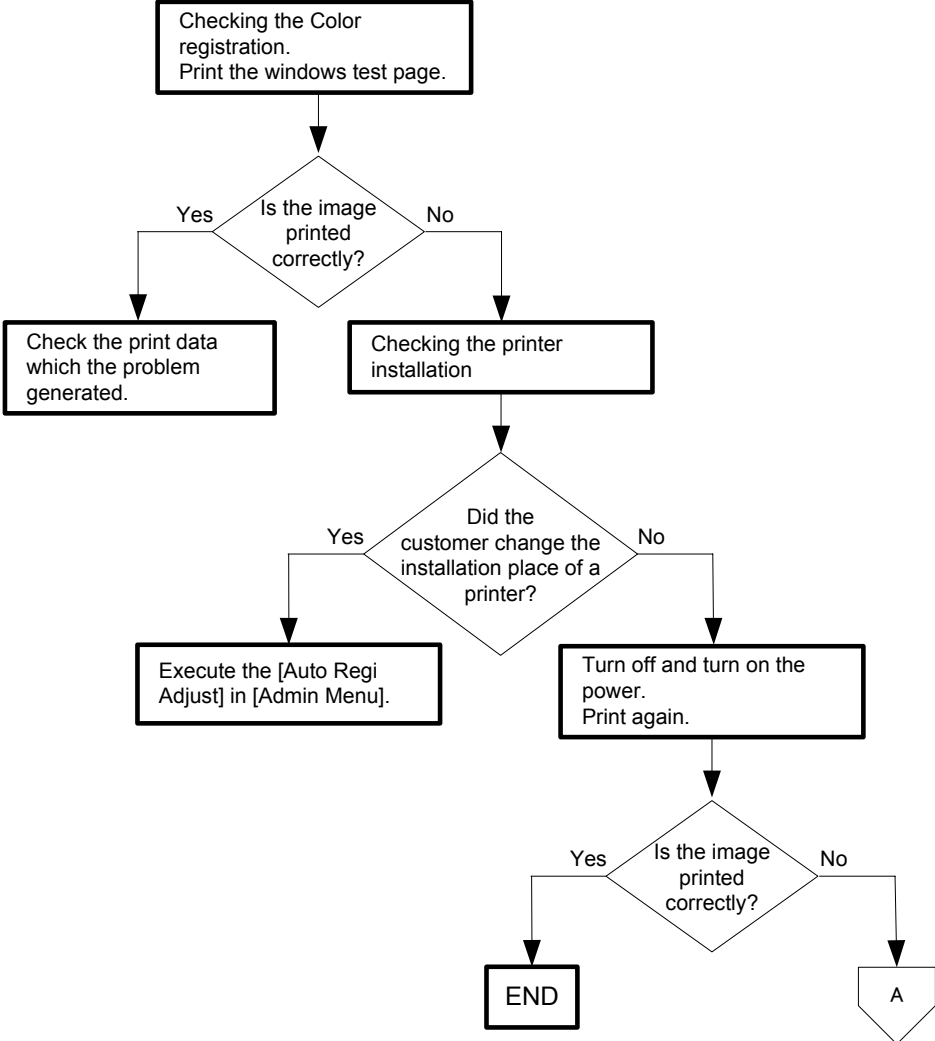

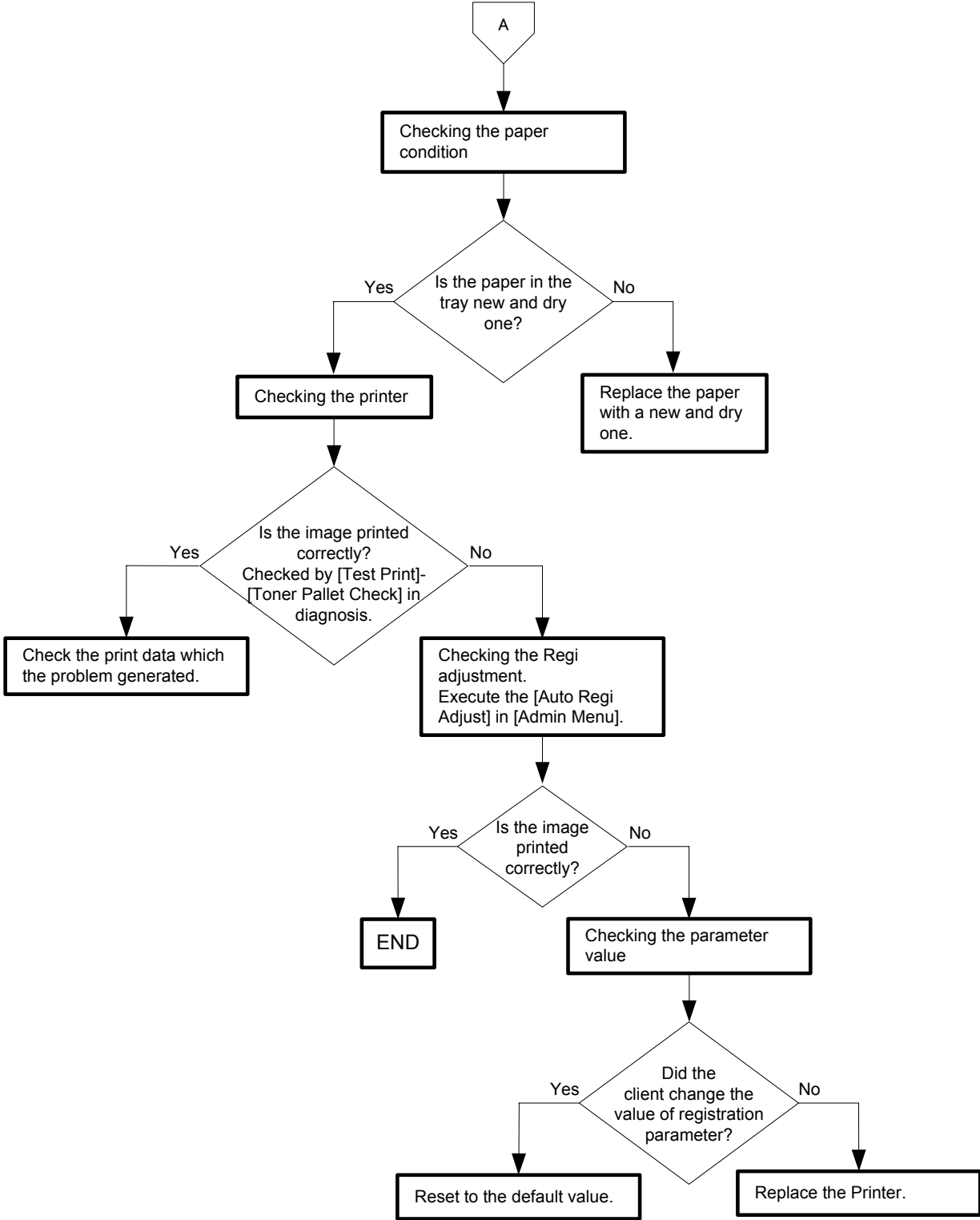

- Troubleshooting of a paper feeding system

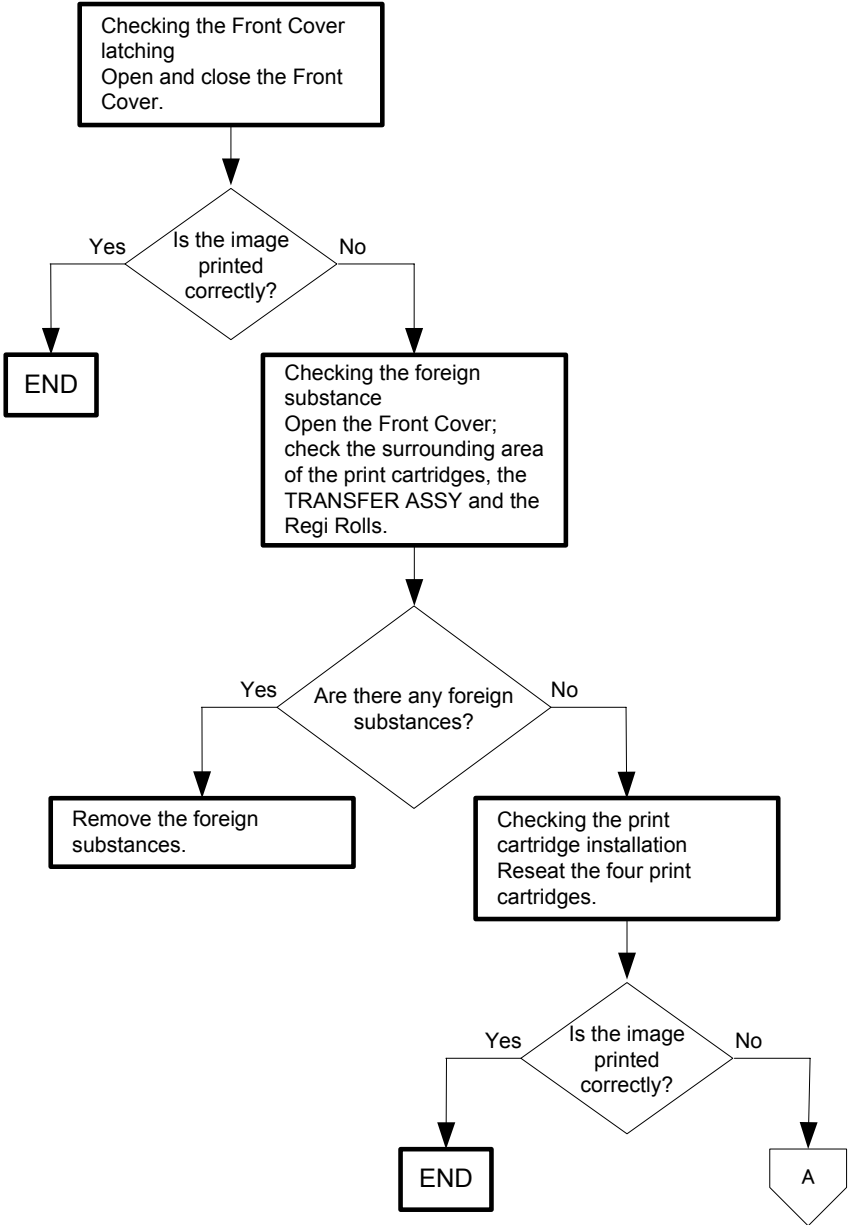
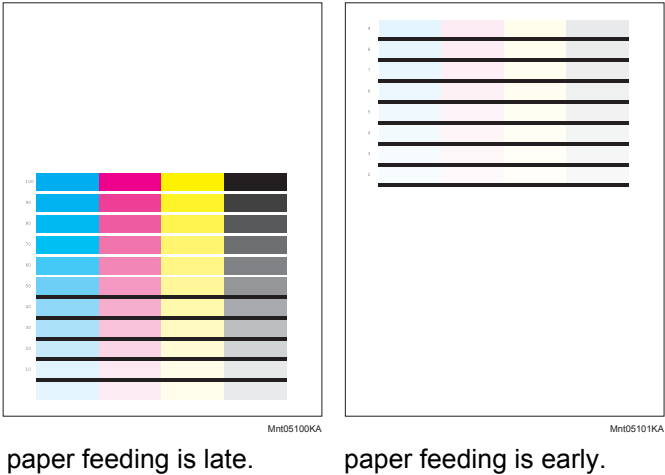

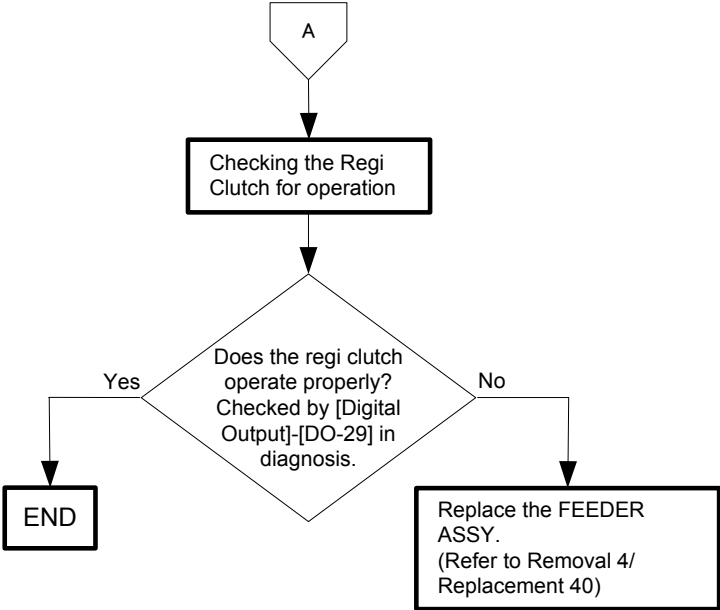

Flows 93 Noise: When Power is Turned On

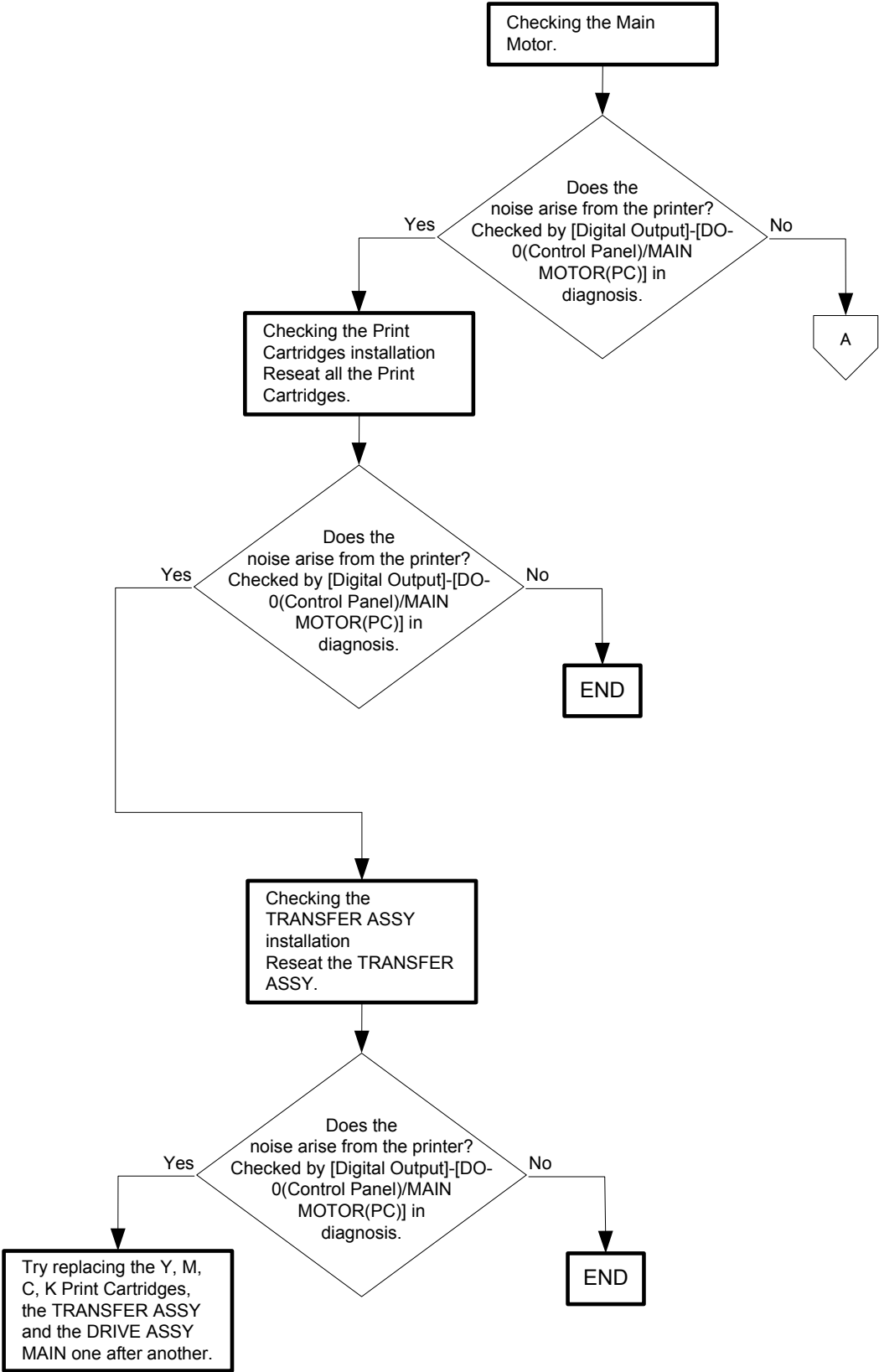

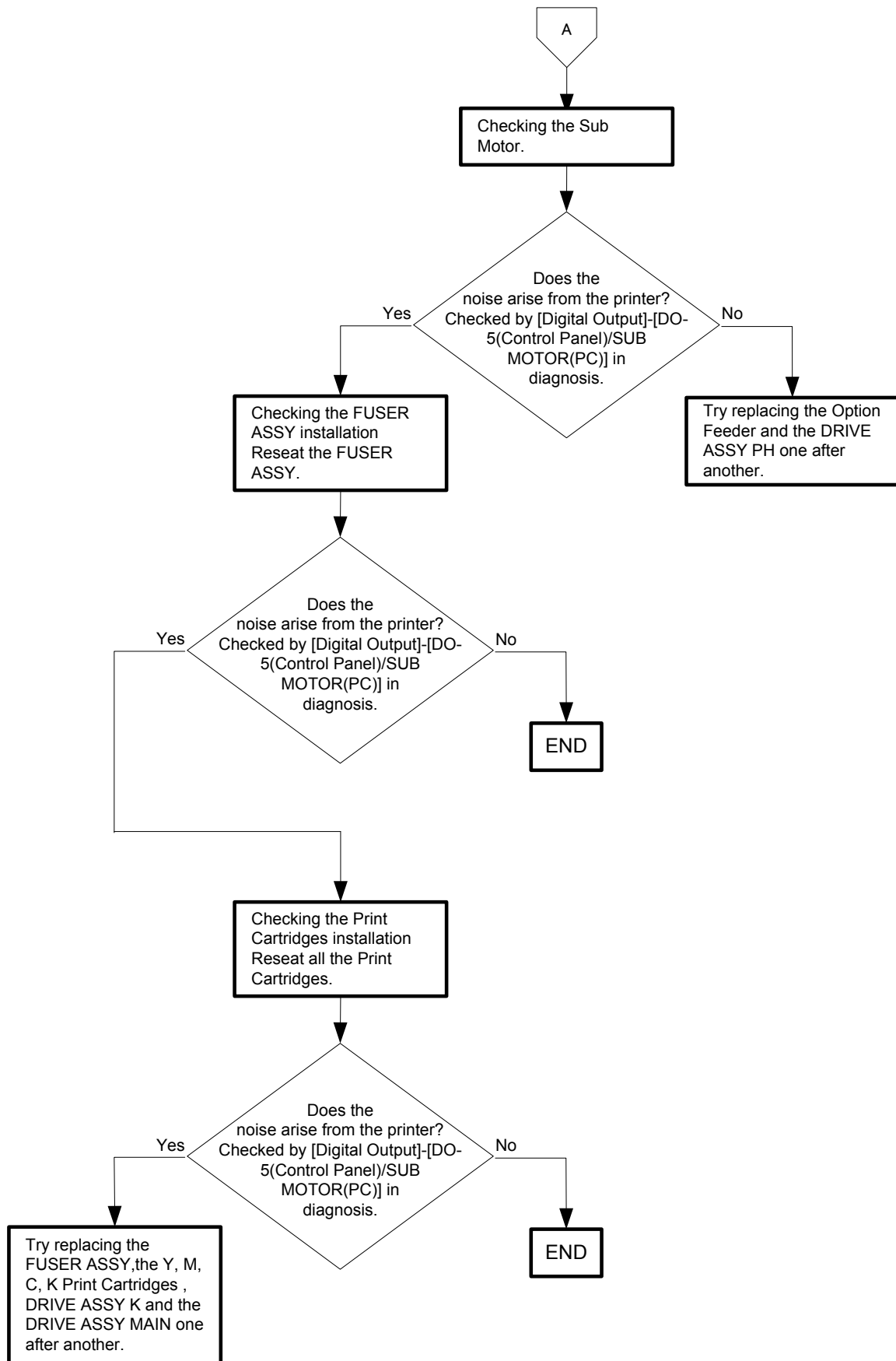

Flows 94 Noise: During Standby

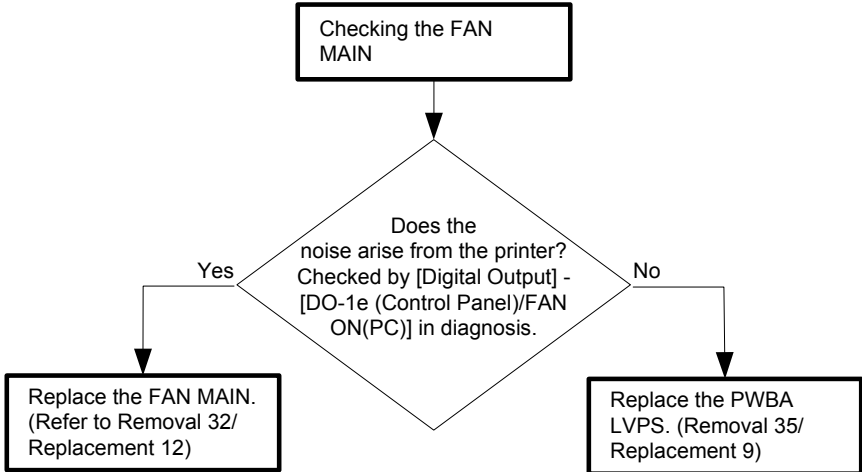

Flows 95 Noise: During Printing

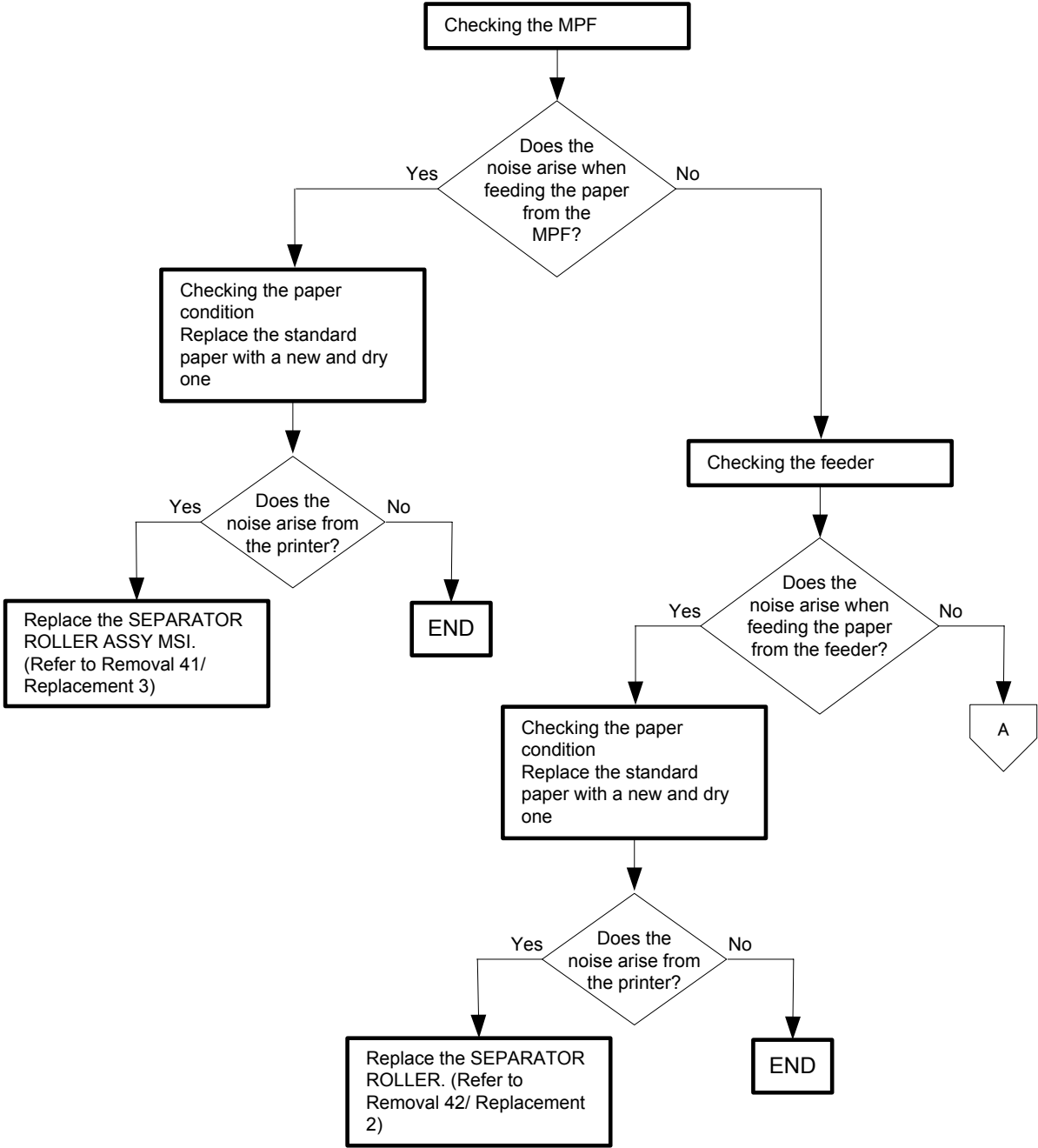

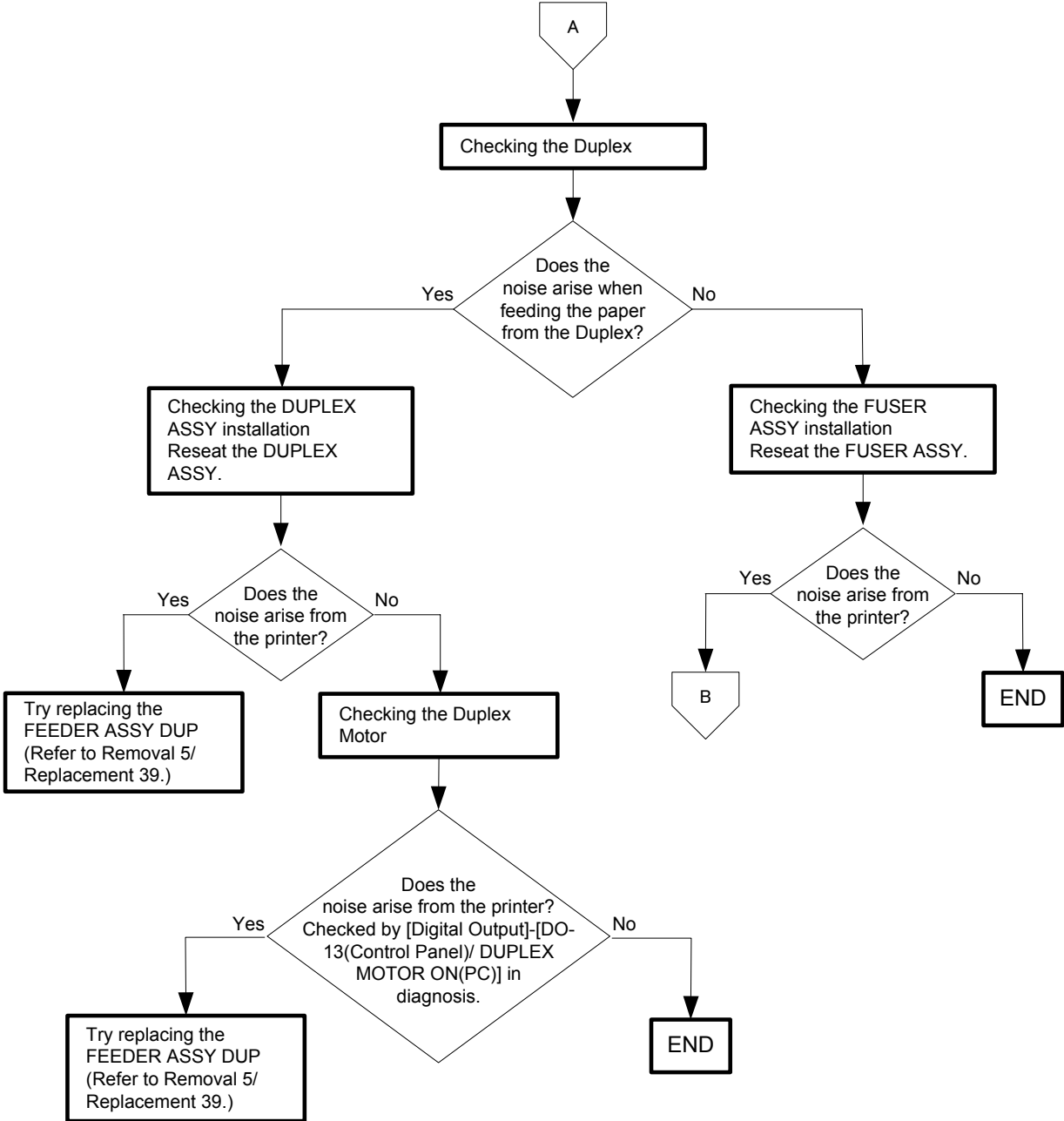

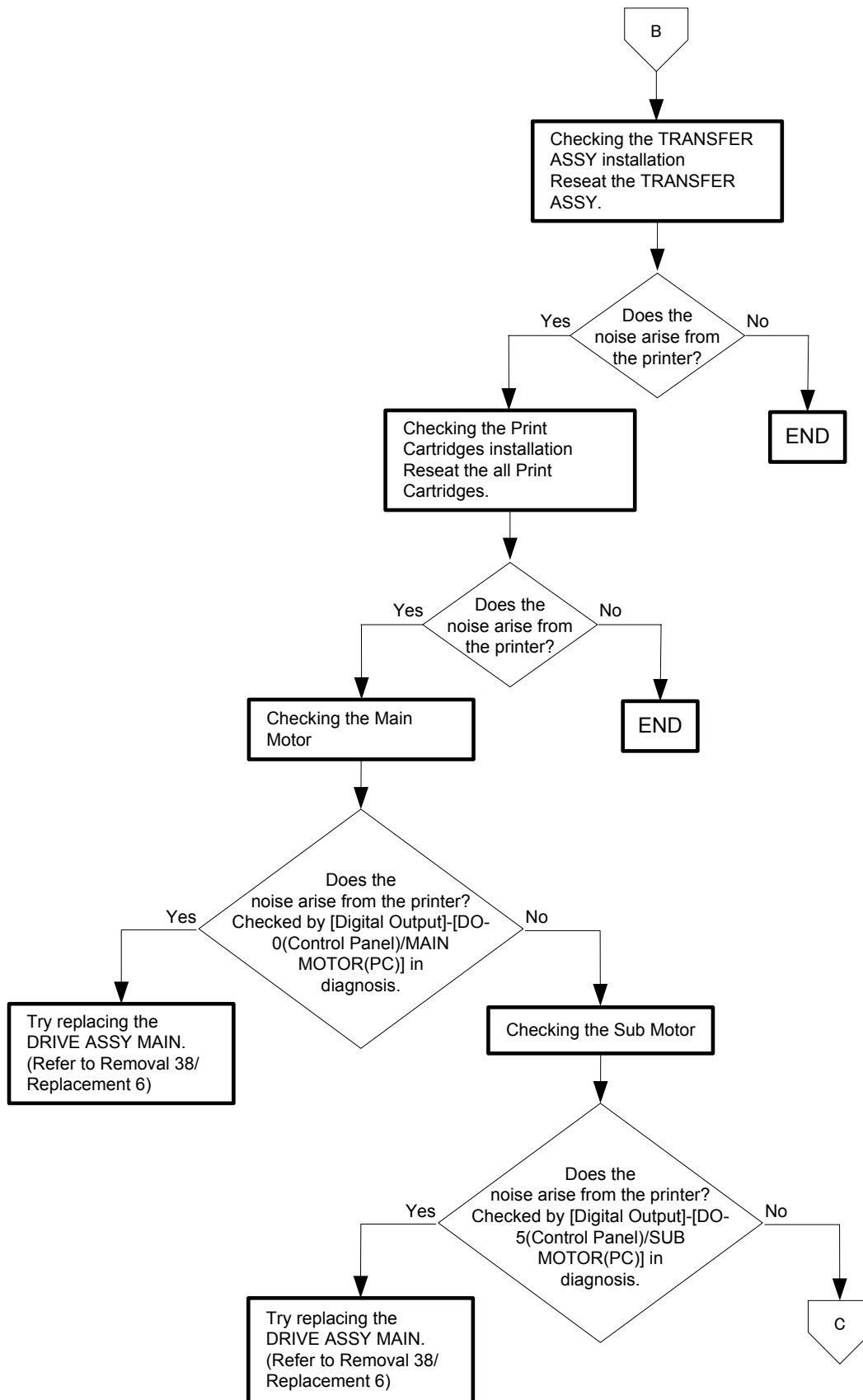

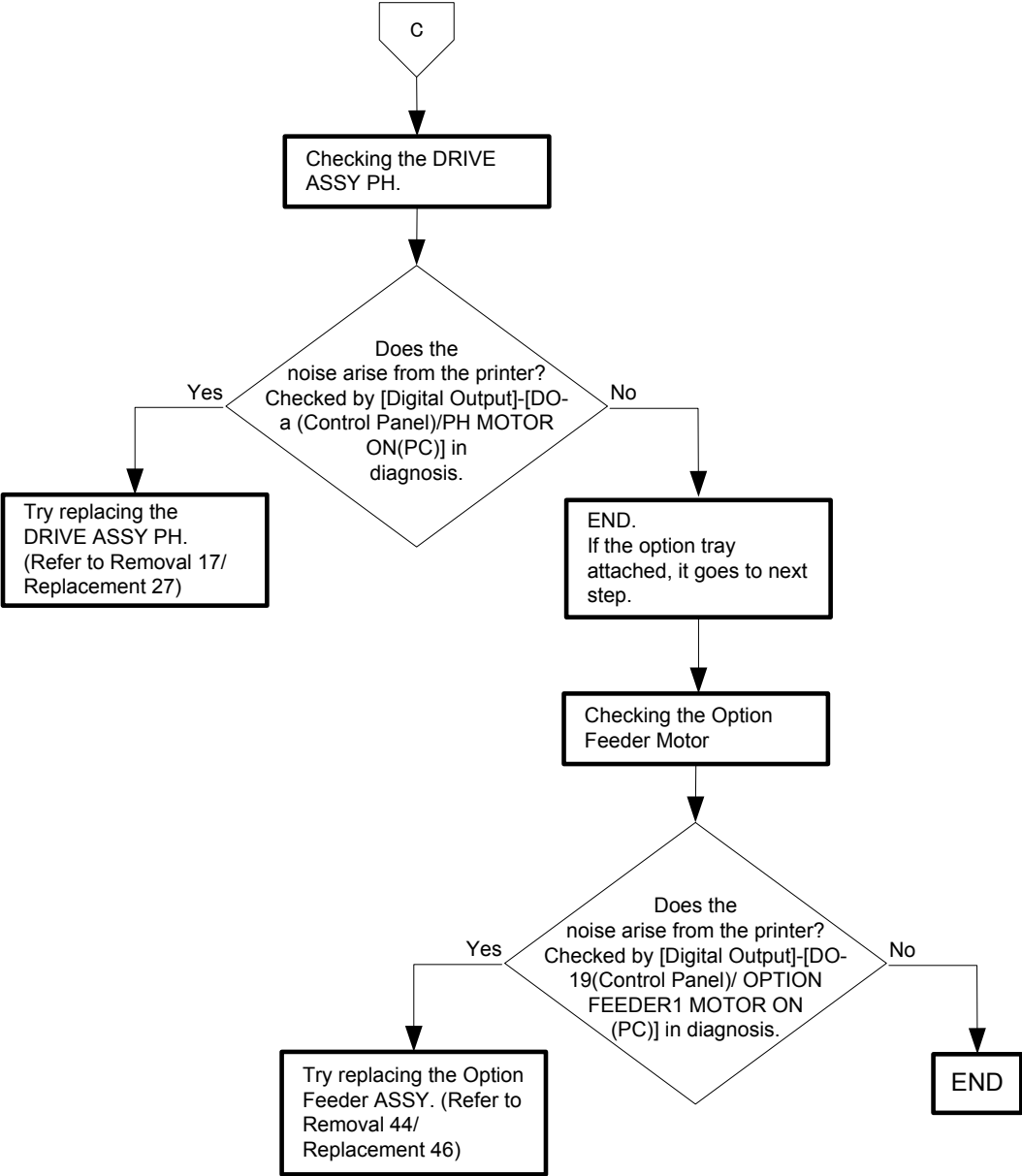

Flows 96 AC

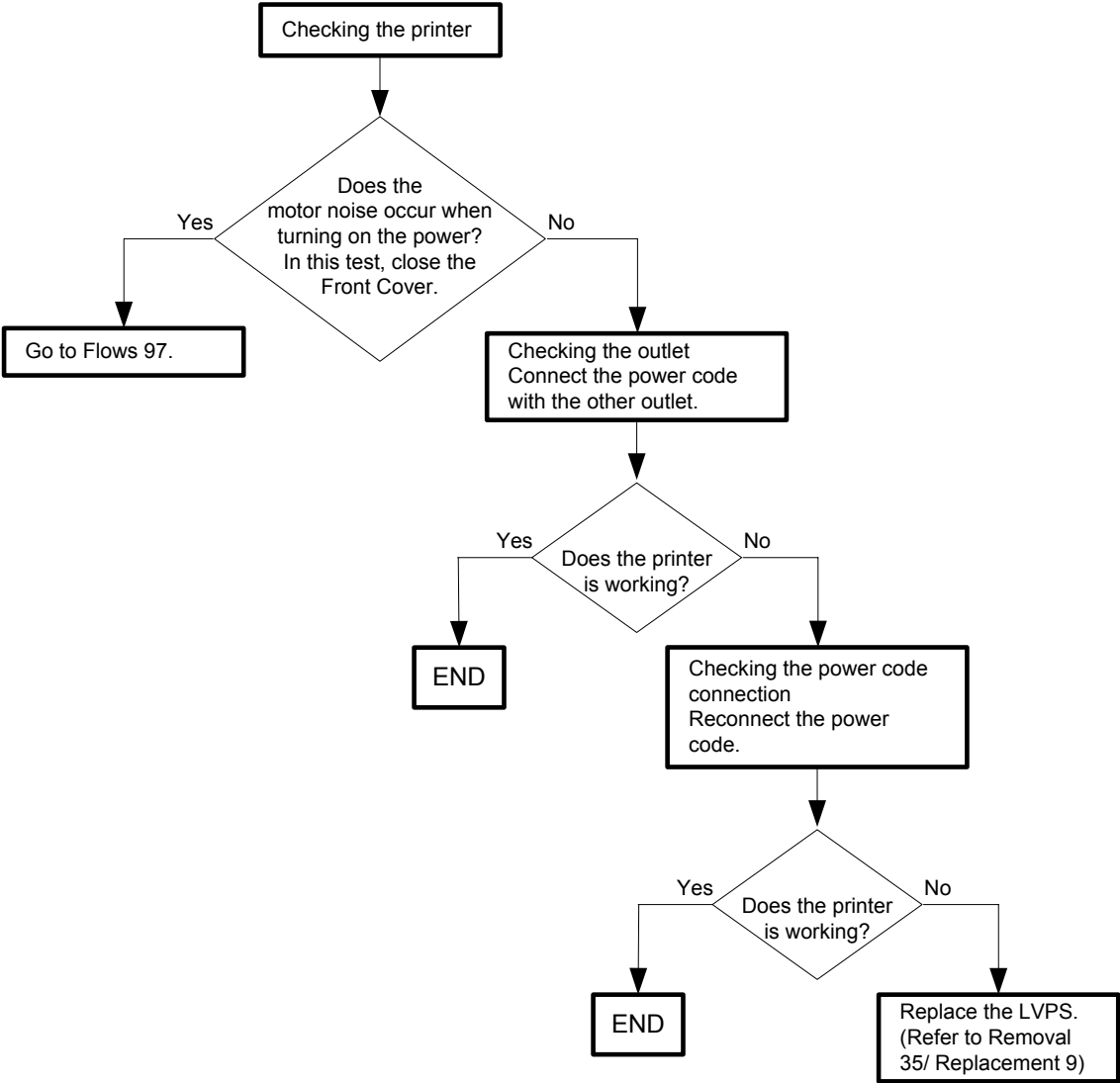

Flows 97 DC

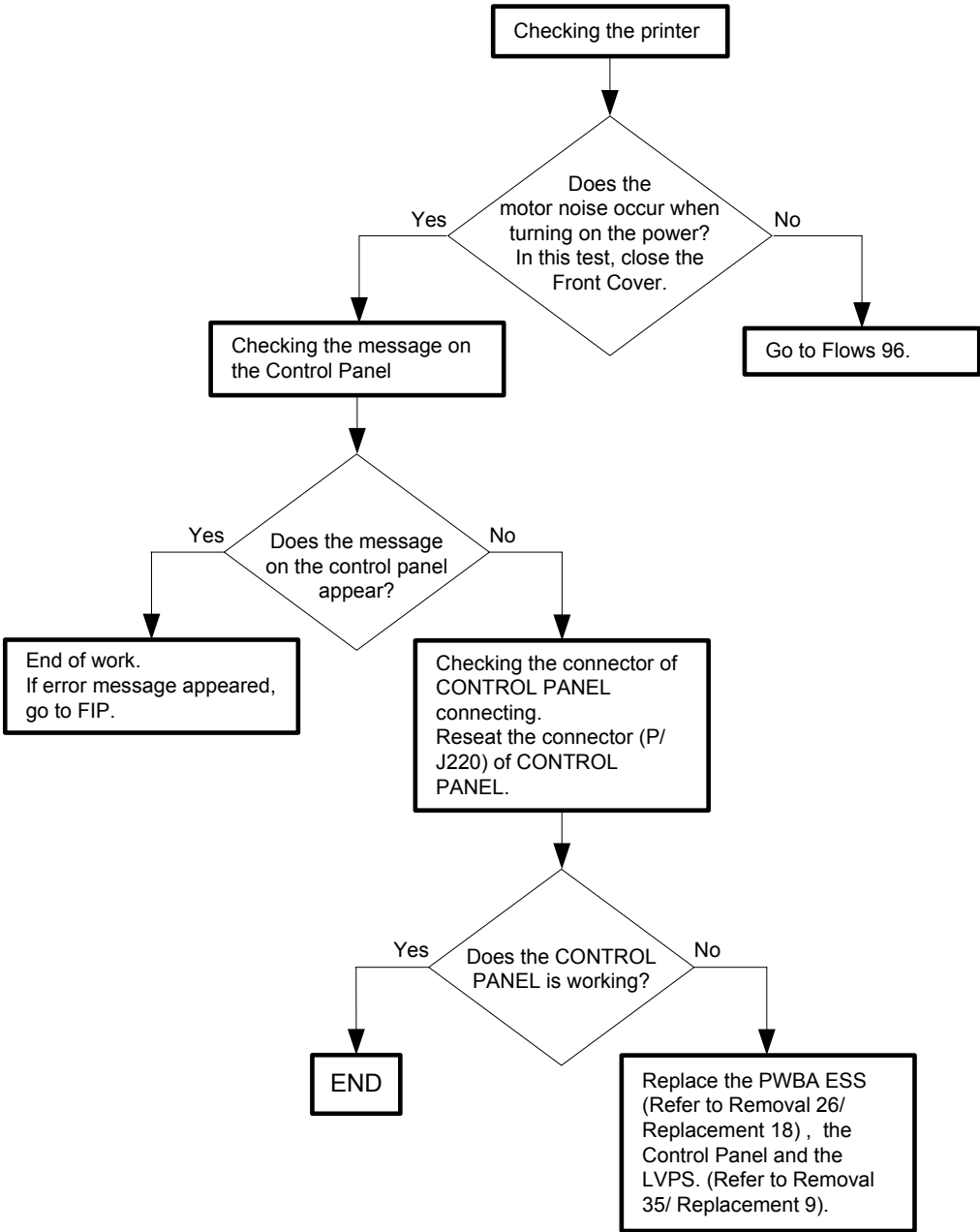

Flows 98 Multiple feed

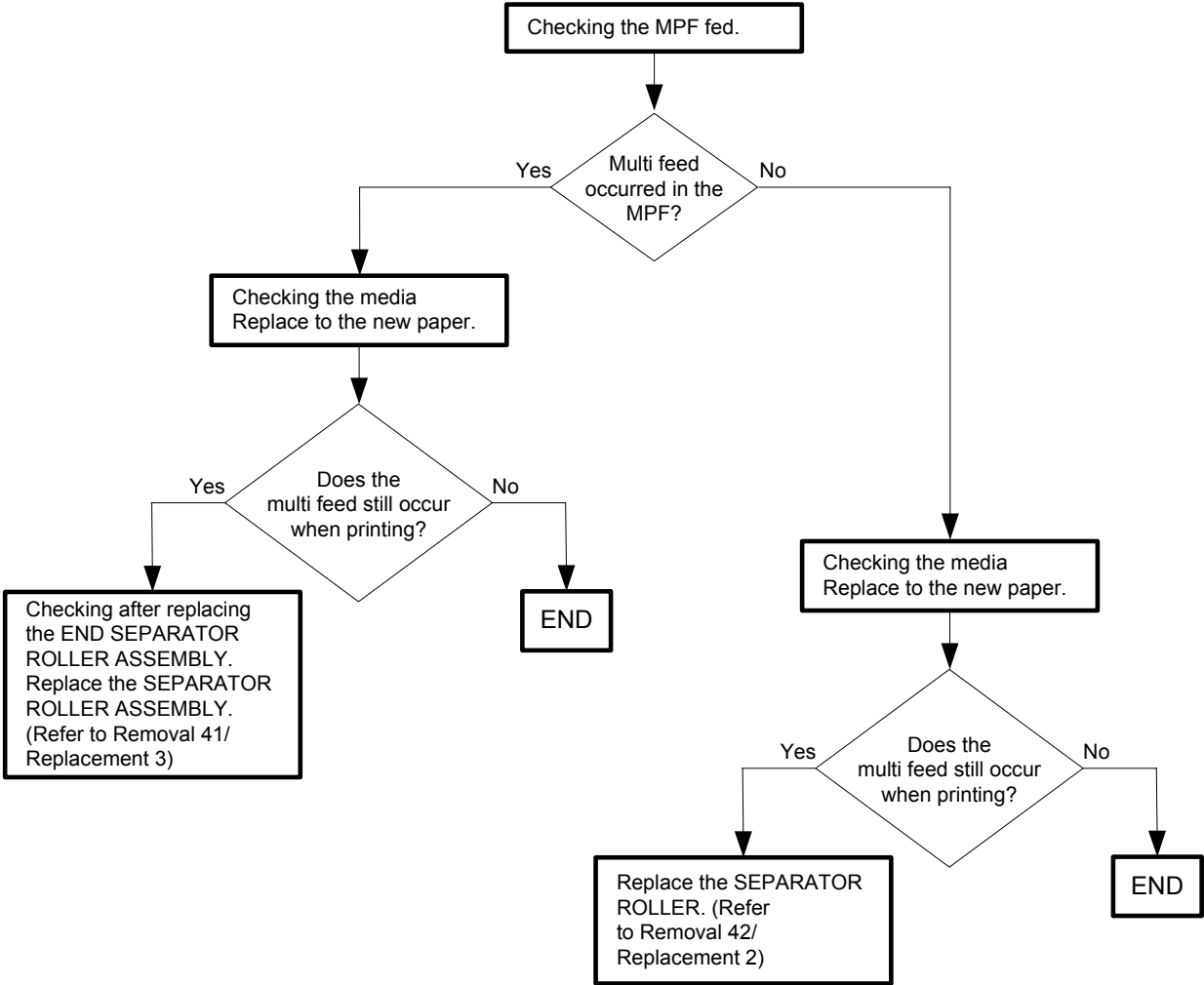

Flows 99 Control Panel Freezes

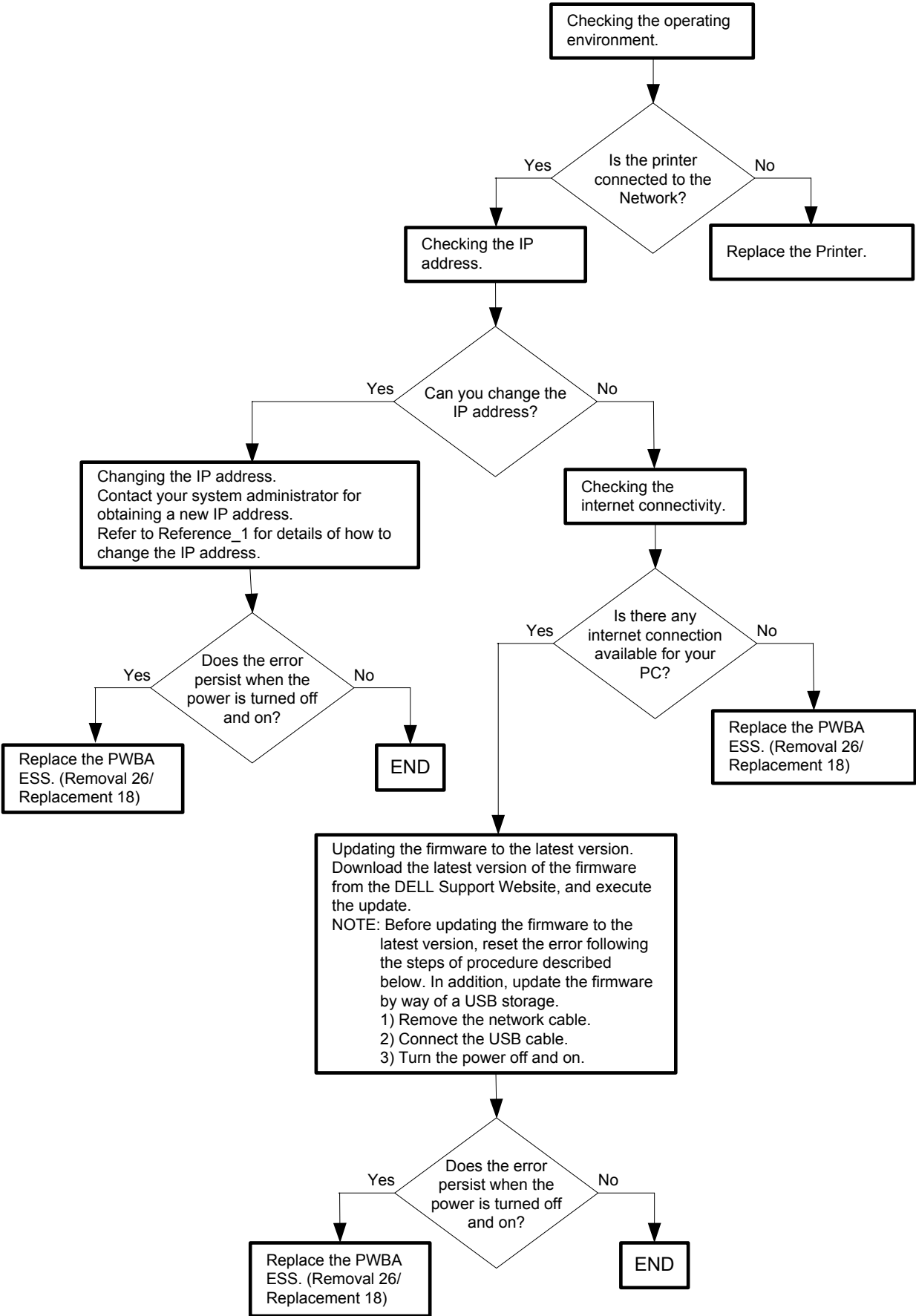

Reference_1: Changing the IP address

- 1) Remove the network cable, and power off the printer and then on
- 2) Change the IP address on the Control Panel.
- 3) Plug the network cable back into the printer, and then turn the power on.
- 4) On the Control Panel, open [Admin] > [Network] > [TCP/IP], and confirm that the IP address has been changed.

3.2 Troubleshooting for the repair center

FIP1.1 001-360-01 Restart Printer

Step	Check	Yes	No
	Possible causative parts: FAN MAIN (PL9.1.10) HARN ASSY LV TOP (PL10.1.16) LVPS (PL9.1.4) PWBA MCU (PL9.1.20)		
1	Checking the detail error code. A detailed error code is displayed by pushing ↓ key, ↑ key and ✓ key simultaneously. Is "Code:01" displayed on the LCD?	Go to step 2.	Go to FIP1.2.
2	Checking the connectors for connection Check the connections between the FAN MAIN and LVPS. Is P/J503 connected surely?	Go to step 3.	Reconnect the connector P/J503 surely, then go to step 3.
3	Does the error still occur when the power is turned ON?	Go to step 4.	End of work
4	Checking the FAN MAIN for rotation Does the FAN MAIN function normally? Checked by [Digital Output] - [DO-1e(Control Panel)/FAN ON(PC)] in diagnosis.	Replace the PWBA MCU. (Refer to Removal 30/Replacement 14)	Go to step 5.
5	Checking the HARN ASSY LV TOP for continuity Disconnect P/J501 from the LVPS. Disconnect P/J13 from the PWBA MCU. Is each cable of P/J501 <=> P/J13 continuous?	Go to step 6.	Replace the HARN ASSY LV TOP.
6	Checking the output power of LVPS Disconnect P/J503 on the LVPS. Is the voltage across ground <=> J503-1pin on the LVPS, about +24 VDC when the interlock switch (HARN ASSY INTERLOCK) is pushed?	Go to step 7.	Replace the LVPS. (Refer to Removal 35/Replacement 9)
7	Checking after replacing FAN MAIN. Replace the FAN MAIN. Does the error still occur when the power is turned ON?	Replace the PWBA MCU. (Refer to Removal 30/Replacement 14)	End of work

FIP1.2 001-360-02 Restart Printer

Step	Check	Yes	No
	Possible causative parts: FAN DUP (PL11.1.25) HARN ASSY DUP UNIT (PL11.1.18) HARNESS ASSY FRONT COVER (PL1.2.11) HARN ASSY R SIDE (PL10.1.15) PWBA MCU (PL9.1.20) PWBA DUP-H (PL11.1.15)		
1	Checking the detail error code. A detailed error code is displayed by pushing ↓ key, ↑ key and ✓ key simultaneously. Is "Code:02" displayed on the LCD?	Go to step 2.	Go to FIP1.1.
2	Checking the connectors for connection Check the connections between the FAN DUP and PWBA DUP. Is P/J427 connected surely?	Go to step 3.	Reconnect the connector P/J427 surely, then go to step 3.
3	Does the error still occur when the power is turned ON?	Go to step 4.	End of work
4	Checking the FAN DUP for rotation Does the FAN DUP function normally? Checked by [Digital Output] - [DO-5d(Control Panel)/DUPLICATE FAN ON(PC)] in diagnosis.	Replace the PWBA MCU. (Refer to Removal 30/Replacement 14).	Go to step 5.
5	Checking the connectors of the PWBA DUP and PWBA MCU for connection Check the connections between the PWBA DUP and PWBA MCU. Are P/J428, P/J2720, P/J272 and P/J27 connected surely?	Go to step 6.	Reconnect the connector(s) P/J428, P/J2720, P/J272 and/or P/J27 surely.
6	Checking the HARN ASSY DUP UNIT for continuity Disconnect P/J428 from the PWBA DUP. Disconnect P/J2720 from the HARNESS ASSY FRONT COVER. Is each cable of P/J428 <=> P/J2720 continuous?	Go to step 7.	Replace the HARN ASSY DUP UNIT.
7	Checking the HARNESS ASSY FRONT COVER for continuity Disconnect P/J2720 from the HARNESS ASSY DUP UNIT. Disconnect P/J272 from the HARN ASSY R SIDE. Is each cable of P/J2720 <=> P/J272 continuous?	Go to step 8.	Replace the HARNESS ASSY FRONT COVER.
8	Checking the HARN ASSY R SIDE for continuity Disconnect P/J272 from the HARNESS ASSY FRONT COVER. Disconnect P/J27 from the PWBA MCU. Is each cable of P/J272 <=> P/J27 continuous?	Go to step 9.	Replace the HARN ASSY R SIDE.
9	Checking the power to the PWBA DUP Disconnect P/J27 on the PWBA MCU. Are the voltages across ground <=> J27-17pin and J27-18pin on the PWBA MCU, about +24 VDC when the interlock switch (HARN ASSY INTERLOCK) is pushed?	Replace the FEEDER ASSY DUP. (Refer to Removal 5/Replacement 39)	Replace the PWBA MCU. (Refer to Removal 30/Replacement 14)

FIP1.3 003-340-01/003-340-02/003-340-03/003-340-04/003-340-05/003-340-07/003-340-08/003-340-0A/003-340-0B/003-340-0C/003-340-0D/003-340-0E/003-340-0F/003-340-10/003-340-11/003-340-12/003-340-13/003-340-14 Restart Printer

Step	Check	Yes	No
	Possible causative parts: PWBA MCU (PL9.1.20)		
1	Checking the detail error code. A detailed error code is displayed by pushing ↓ key, ↑ key and ✓ key simultaneously. Is "Code:09" displayed on the LCD?	Go to FIP1.4.	Go to step 2.
2	Does Error still occur after several ON/OFF procedures of the power?	Go to step 3.	End of work *1
3	Checking the firmware version Does the firmware is the latest version?	Go to step 4.	Upgrade the firm-ware version, then go to step 4.
4	Checking after reseating the PWBA MCU Reseat the PWBA MCU. Does Error still occur when the power is turned ON?	Go to step 5.	End of work *1
5	Checking after replacing the PWBA MCU Replace the PWBA MCU. (Refer to Removal 30/Replacement 14) Does Error still occur when the power is turned ON?	Go to Electrical noise.	End of work

*1: Though some kind of foreign noise would be possible cause, go to FIP1.73 Electrical Noise in Other FIP and check, to make sure.

FIP1.4 003-340-09 Restart Printer

NOTE

If the error occurred after replacing the PWBA MCU, transfer the internal data of the old PWBA to a new PWBA.

Step	Check	Yes	No
	Possible causative parts: PWBA MCU (PL9.1.20) HVPS (PL5.1.17)		
1	Checking the detail error code. A detailed error code is displayed by pushing ↓ key, ↑ key and ✓ key simultaneously. Is "Code:09" displayed on the LCD?	Go to step 2.	Go to FIP1.3.
2	Checking the connectors for connection Are the following connectors connected correctly? - P/J16 and P/J28 on the PWBA MCU - P/J144 on the PWBA EEPROM	Go to step 4.	Reconnect the connector(s) P/J16, P/J28 and/or P/J144 surely, then go to step 3.
3	Does the error still occur when the power is turned ON?	Go to step 4.	End of work
4	Checking after replacing the HVPS Replace the HVPS. (Refer to Removal 34/Replacement 10) Does the error still occur when the power is turned ON?	Replace the PWBA MCU. (Refer to Removal 30/Replacement 14)	End of work

FIP1.5 003-356 Restart Printer

Step	Check	Yes	No
	Possible causative parts: HARN ASSY R SIDE (PL10.1.15) PWBA EEPROM (PL9.1.1) PWBA MCU (PL9.1.20)		
1	Does Error still occur after several ON/OFF procedures of the power?	Go to step 2.	End of work *1
2	Checking the firmware version Does the firmware is the latest version?	Go to step 3.	Upgrade the firm-ware version, then go to step 3.
3	Checking after reseating the PWBA MCU Reseat the PWBA MCU. Does Error still occur when the power is turned ON?	Go to step 4.	End of work *1
4	Checking the connectors for connection Check the connections between the PWBA EEPROM and PWBA MCU. Are P/J28 and P/J144 connected surely?	Go to step 6.	Reconnect the connector(s) P/J28 and/or P/J144 surely, then go to step 5.
5	Does the error still occur when the power is turned ON?	Go to step 6.	End of work
6	Checking the HARN ASSY R SIDE for continuity Disconnect P/J28 form the PWBA MCU. Disconnect P/J144 from the PWBA EEPROM. Is each cable of P/J28 <=> P/J144 continuous?	Go to step 7.	Replace the HARN ASSY R SIDE.
7	Checking the power to PWBA EEPROM Disconnect P/J28 on the PWBA MCU. Is the voltage across ground <=> J28-16pin on the PWBA MCU, about +3.3 VDC?	Replace the PWBA MCU.	Go to step 8.
8	Checking after replacing the PWBA MCU Replace the PWBA MCU. (Refer to Removal 30/Replacement 14) Does Error still occur when the power is turned ON?	Go to Electrical noise.	End of work

*1: Though some kind of foreign noise would be possible cause, go to FIP1.73 Electrical Noise in Other FIP and check, to make sure.

FIP1.6 004-310 Restart Printer

Step	Check	Yes	No
	Possible causative parts: HARN ASSY FDR UNIT (PL12.2.3) HARN ASSY R SIDE (PL10.1.15) PWBA OPT FDR (PL12.2.6) 550 OPTION FEEDER (PL12.1.1) PWBA MCU (PL9.1.20)		
1	Checking the Optional Feeder for installation Is the Optional Feeder installed correctly?	Go to step 3.	Reseat the Optional Feeder, then go to step 2.
2	Does the error still occur when the power is turned ON?	Go to step 3.	End of work
3	Checking the connectors for connection Check the connections between the PWBA OPT FDR and PWBA MCU. Are P/J28, P/J281, and P/J419 connected surely?	Go to step 5.	Reconnect the connector(s) P/J28, P/J281 and/or P/J419 surely, then go to step 4.
4	Does the error still occur when the power is turned ON?	Go to step 5.	End of work
5	Checking the HARN ASSY FDR UNIT for continuity Disconnect P/J419 from the PWBA OPT FDR. Disconnect P/J281 from the HARN ASSY R SIDE. Is each cable of P/J419 <=> P/J281 continuous?	Go to step 6.	Replace the HARN ASSY FDR UNIT.
6	Checking the HARN ASSY R SIDE for continuity Disconnect P/J28 from the PWBA MCU. Disconnect P/J281 from the HARNESS ASSY FDR UNIT. Is each cable of P/J28 <=> P/J281 continuous?	Go to step 7.	Replace the HARN ASSY R SIDE.
7	Checking after replacing the PWBA OPT FDR Replace the PWBA OPT FDR. (Refer to Removal 44/ Replacement 46) Does the error still occur when the power is turned ON?	Go to step 8.	End of work
8	Checking after replacing the 550 OPTION FEEDER Replace the 550 OPTION FEEDER. (Refer to Removal 44/ Replacement 46) Does the error still occur when the power is turned ON?	Replace the PWBA MCU. (Refer to Removal 30/Replacement 14)	End of work

FIP1.7 004-311 Restart Printer

Step	Check	Yes	No
	Possible causative parts: HARNESS ASSY DUP UNIT (PL11.1.18) HARNESS ASSY FRONT COVER (PL1.2.11) HARN ASSY R SIDE (PL10.1.15) PWBA DUP-H (PL11.1.15) PWBA MCU (PL9.1.20)		
1	Checking the Option Duplex for installation Is the Option Duplex installed correctly?	Go to step 3.	Reseat the Option Duplex, then go to step 2.
2	Does the error still occur when the power is turned ON?	Go to step 3.	End of work
3	Checking the connectors for connection Check the connections between the PWBA DUP-H and PWBA MCU. Are P/J27, P/J272, P/J2720 and P/J 428 connected surely?	Go to step 5.	Reconnect the connector(s) P/J27, P/J272, P/J2720 and/or P/J 428 surely, then go to step 4.
4	Does the error still occur when the power is turned ON?	Go to step 5.	End of work
5	Checking the HARN ASSY DUP UNIT for continuity Disconnect P/J428 from the PWBA DUP-H. Disconnect P/J2720 from the HARNESS ASSY FRONT COVER. Is each cable of P/J428 <=> P/J2720 continuous?	Go to step 6.	Replace the HARN ASSY DUP UNIT.
6	Checking the HARNESS ASSY FRONT COVER for continuity Disconnect P/J272 from the HARN ASSY R SIDE. Disconnect P/J 2720 from the HARNESS ASSY DUP UNIT. Is each cable of P/J272 <=> P/J2720 continuous?	Go to step 7.	Replace the HARNESS ASSY FRONT COVER.
7	Checking the HARN ASSY R SIDE for continuity Disconnect P/J272 from the HARNESS ASSY FRONT COVER. Disconnect P/J27 from the PWBA MCU. Is each cable of P/J272 <=> P/J27 continuous?	Go to step 8.	Replace the HARN ASSY R SIDE.
8	Checking after replacing the FEEDER ASSY DUP Replace the FEEDER ASSY DUP. (Refer to Removal 5/ Replacement 39) Does the error still occur when the power is turned ON?	Replace the PWBA MCU. (Refer to Removal 30/Replacement 14)	End of work

FIP1.8 006-370 Restart Printer

Step	Check	Yes	No
	Possible causative parts: ROS ASSY (PL13.3.12) PWBA MCU (PL13.5.13)		
1	Checking the ROS ASSY for installation Is the ROS ASSY installed correctly?	Go to step 3.	Reseat the ROS ASSY, then go to step 2.
2	Does the error still occur when the power is turned ON?	Go to step 3.	End of work
3	Checking the connector for connection Check the connection the PWBA MCU. Are P/J12 and P/J151 connected surely?	Go to step 5.	Reconnect the connector(s) P/J12 and/or P/J151 surely, then go to step 4.
4	Does the error still occur when the power is turned ON?	Go to step 5.	End of work
5	Checking the PWBA MCU for installation Is the PWBA MCU installed correctly?	Go to step 7.	Reseat the PWBA MCU, then go to step 6.
6	Does the error still occur when the power is turned ON?	Go to step 7.	End of work
7	Checking after replacing the ROS ASSY Replace the ROS ASSY. (Refer to Removal 36/Replacement 8) Does the error still occur when the power is turned ON?	Replace the PWBA MCU. (Refer to Removal 30/Replacement 14)	End of work

FIP1.9 007-340-00 Restart Printer

Step	Check	Yes	No
	Possible causative parts: PWBA MCU (PL9.1.20) HARN ASSY R SIDE (PL10.1.15) DRIVE ASSY MAIN (PL8.1.2)		
1	Checking the detail error code. A detailed error code is displayed by pushing ↓ key, ↑ key and ✓ key simultaneously. Is "Code:00" displayed on the LCD?	Go to step 2.	"01":Go to FIP1.10. "03":Go to FIP1.12. "04":Go to FIP1.13.
2	Checking the Transfer Assy, Fuser and Black Print Cartridge for installation Are the Transfer Assy, Fuser and Black Print Cartridge installed correctly?	Go to step 4.	Reseat the Transfer Assy, Fuser and/or Black Print Cartridge, then go to step 3.
3	Does the error still occur when the power is turned ON?	Go to step 4.	End of work
4	Checking the connectors for connection Check the connections between the PWBA MCU and DRIVE ASSY MAIN. Are P/J22 and P/J222 connected surely?	Go to step 6.	Reconnect the connector(s) P/J22 and/or P/J222 surely, then go to step 5.
5	Does the error still occur when the power is turned ON?	Go to step 6.	End of work
6	Checking the Main Motor in the DRIVE ASSY MAIN for rotation Does the Main Motor function normally? Checked by [Digital Output] - [DO-0(Control Panel)/MAIN MOTOR(PC)] in diagnosis. During the test, close the Front Cover.	Replace the PWBA MCU. (Refer to Removal 30/Replacement 14)	Go to step 7.
7	Checking the DRIVE ASSY MAIN for installation Is the DRIVE ASSY MAIN installed correctly?	Go to step 8.	Reseat the DRIVE ASSY MAIN, then go to step 8.
8	Does the error still occur when the power is turned ON?	Go to step 9.	End of work
9	Checking the connectors of the Main Motor on the DRIVE ASSY MAIN for connection Check the connections between the PWBA MCU and DRIVE ASSY MAIN. Are P/J22 and P/J222 connected surely?	Go to step 10.	Reconnect the connector(s) P/J22 and/or P/J222 surely.
10	Checking the HARN ASSY R SIDE for continuity Disconnect P/J22 from the PWBA MCU. Disconnect P/J222 from the DRIVE ASSY MAIN. Is each cable of P/J22 <=> P/J222 continuous?	Go to step 11.	Replace the HARN ASSY R SIDE.

Step	Check	Yes	No
11	Checking the power to DRIVE ASSY MAIN Disconnect the connector of P/J22 on the PWBA MCU. Are the voltages across ground \Leftrightarrow J22-B2pin/J21-B4pin on the PWBA MCU, about +24 VDC when the interlock switch (HARN ASSY INTERLOCK) is pushed?	Replace the DRIVE ASSY MAIN. (Refer to Removal 38/Replacement 6)	Replace the PWBA MCU. (Refer to Removal 30/Replacement 14)

FIP1.10 007-340-01 Restart Printer

Step	Check	Yes	No
	Possible causative parts: PWBA MCU (PL9.1.20) HARN ASSY R SIDE (PL10.1.15) DRIVE ASSY MAIN (PL8.1.2)		
1	Checking the detail error code. A detailed error code is displayed by pushing ↓ key, ↑ key and ✓ key simultaneously. Is "Code:01" displayed on the LCD?	Go to step 2.	"00":Go to FIP1.9. "03":Go to FIP1.12. "04":Go to FIP1.13.
2	Checking the print cartridges for installation Are the Y, M, C and K print cartridges installed correctly?	Go to step 4.	Reseat the print cartridge(s), then go to step 3.
3	Does the error still occur when the power is turned ON?	Go to step 4.	End of work
4	Checking the connectors for connection Check the connections between the PWBA MCU and DRIVE ASSY MAIN. Are P/J22 and P/J221 connected surely?	Go to step 5.	Reconnect the connector(s) P/J22 and/or P/J221 surely, then go to step 5.
5	Checking the Sub Motor in the DRIVE ASSY MAIN for rotation Does the Sub Motor function normally? Checked by [Digital Output] - [DO-5(Control Panel)/SUB MOTOR(PC)] in diagnosis. During the test, close the Front Cover.	Replace the PWBA MCU. (Refer to Removal 30/Replacement 14)	Go to step 6.
6	Checking the DRIVE ASSY MAIN for installation Is the DRIVE ASSY MAIN installed correctly?	Go to step 7.	Reseat the DRIVE ASSY MAIN, then go to step 7.
7	Does the error still occur when the power is turned ON?	Go to step 8.	End of work
8	Checking the connectors of the Sub Motor on the DRIVE ASSY MAIN for connection Check the connections between the PWBA MCU and DRIVE ASSY MAIN. Are P/J22 and P/J221 connected surely?	Go to step 9.	Reconnect the connector(s) P/J22 and/or P/J221 surely.
9	Checking the HARN ASSY R SIDE for continuity Disconnect P/J22 from the PWBA MCU. Disconnect P/J221 from the DRIVE ASSY MAIN. Is each cable of P/J22 <=> P/J221 continuous?	Go to step 10.	Replace the HARN ASSY R SIDE.
10	Checking the power to DRIVE ASSY MAIN Disconnect the connector of P/J22 on the PWBA MCU. Are the voltages across ground <=> J22-A2pin/J22-A4pin on the PWBA MCU, about +24 VDC when the interlock switch (HARN ASSY INTERLOCK) is pushed?	Replace the DRIVE ASSY MAIN. (Refer to Removal 38/Replacement 6)	Replace the PWBA MCU. (Refer to Removal 30/Replacement 14)

FIP1.12 007-340-03 Restart Printer

Step	Check	Yes	No
	Possible causative parts: FEEDER ASSY (PL3.2.1) PWBA MCU (PL9.1.20) HARN ASSY R SIDE (PL10.1.15) DRIVE ASSY PH (PL8.1.7)		
1	Checking the detail error code. A detailed error code is displayed by pushing ↓ key, ↑ key and ✓ key simultaneously. Is "Code:03" displayed on the LCD?	Go to step 2.	"00":Go to FIP1.9. "01":Go to FIP1.10. "04":Go to FIP1.13.
2	Checking the ROLL REGI RUBBER for rotation Does the ROLL REGI RUBBER rotate smoothly? Check the rotation of the ROLL REGI RUBBER with a finger.	Go to step 3.	Replace the FEEDER ASSY.
3	Checking the connectors for connection Check the connections between the PWBA MCU and DRIVE ASSY PH. Are P/J25 and P/J251 connected surely?	Go to step 4.	Reconnect the connector(s) P/J25 and/or P/J251 surely, then go to step 4.
4	Checking the PH Motor for rotation Does the PH Motor function normally? Checked by [Digital Output] - [DO-a(Control Panel)/PH MOTOR ON(PC)] in diagnosis. During the test, close the Front Cover.	Replace the PWBA MCU. (Refer to Removal 30/Replacement 14)	Go to step 5.
5	Checking the DRIVE ASSY PH for installation Is the DRIVE ASSY PH installed correctly?	Go to step 6.	Reseat the DRIVE ASSY PH, then go to step 6.
6	Does the error still occur when the power is turned ON?	Go to step 7.	End of work
7	Checking the connectors of the DRIVE ASSY PH for connection Check the connections between the PWBA MCU and DRIVE ASSY PH. Are P/J25 and P/J251 connected surely?	Go to step 8.	Reconnect the connector(s) P/J25 and/or P/J251 surely.
8	Checking the HARN ASSY R SIDE for continuity Disconnect P/J25 from the PWBA MCU. Disconnect P/J251 from the DRIVE ASSY PH. Is each cable of P/J25 <=> P/J251 continuous?	Go to step 9.	Replace the HARN ASSY R SIDE.
9	Checking the power to DRIVE ASSY PH Disconnect the connector of P/J25 on the PWBA MCU. Are the voltages across ground <=> J25-1pin/J25-2pin on the PWBA MCU, about +24 VDC when the interlock switch (HARN ASSY INTERLOCK) is pushed?	Replace the DRIVE ASSY PH. (Refer to Removal 17/Replacement 27)	Replace the PWBA MCU. (Refer to Removal 30/Replacement 14)

FIP1.13 007-340-04 Restart Printer

Step	Check	Yes	No
	Possible causative parts: SEPARATOR ROLLER (PL12.5.17) ROLL ASSY FEED (PL12.3.29) PWBA MCU (PL9.1.20) DRIVE ASSY OPT FDR (PL12.2.10) HARN ASSY C2 MOT (PL12.2.9) HARN ASSY FDR UNIT (PL12.2.3) HARN ASSY R SIDE (PL10.1.15) PWBA OPT FDR (PL12.2.6)		
1	Checking the detail error code. A detailed error code is displayed by pushing ↓ key, ↑ key and ✓ key simultaneously. Is "Code:04" displayed on the LCD?	Go to step 2.	"00":Go to FIP1.9. "01":Go to FIP1.10. "03":Go to FIP1.12.
2	Checking the paper cassette for installation Is the paper cassette installed correctly?	Go to step 4.	Reseat the paper cassette, then go to step 3.
3	Does the error still occur when the power is turned ON?	Go to step 4.	End of work
4	Checking the ROLL ASSY FEEDS and SEPARATOR ROLLER for rotation Do these ROLLS rotate smoothly? Check the rotation of the ROLLS with a finger.	Go to step 5.	Replace the defective ROLL(s).
5	Checking the connectors for connection Check the connections between the PWBA OPT FDR and DRIVE ASSY OPT FDR. Are P/J422, P/J4221 and P/J4222 connected surely?	Go to step 6.	Reconnect the connector(s) P/J422, P/J 4221 and/or P/J4222 surely, then go to step 6.
6	Checking the Feed Motor for rotation Does the Feed Motor function normally? Checked by [Digital Output] - [DO-19(Control Panel)/OPTION FEEDER1 MOTOR ON(PC)] in diagnosis. During the test, close the Front Cover.	Replace the PWBA MCU. (Refer to Removal 30/Replacement 14)	Go to step 7.
7	Checking the DRIVE ASSY OPT FDR for installation Is the DRIVE ASSY OPT FDR installed correctly?	Go to step 8.	Reseat the DRIVE ASSY OPT FDR, then go to step 8.
8	Does the error still occur when the power is turned ON?	Go to step 9.	End of work
9	Checking the connectors of the DRIVE ASSY OPT FDR for connection Check the connections between the PWBA OPT FDR and DRIVE ASSY OPT FDR. Are P/J422 and P/J4222 connected surely?	Go to step 10.	Reconnect the connector(s) P/J422 and/or P/J4222 surely.

Step	Check	Yes	No
10	Checking the HARN ASSY C2 MOT for continuity Disconnect P/J422 from the PWBA OPT FDR. Disconnect P/J4222 from the DRIVE ASSY OPT FDR. Is each cable of P/J422 <=> P/J4222 continuous?	Go to step 11.	Replace the HARN ASSY C2 MOT.
11	Checking the power to DRIVE ASSY OPT FDR Disconnect the connector of P/J422 on the PWBA OPT FDR. Is the voltage across ground <=> J422-6pin on the PWBA OPT FDR, about +24 VDC when the interlock switch (HARN ASSY INTERLOCK) is pushed?	Replace the DRIVE ASSY OPT FDR. (Refer to Removal 44/Replacement 46)	Go to step 5.
12	Checking the connectors of the PWBA OPT FDR and PWBA MCU for connection Check the connections between the PWBA OPT FDR and PWBA MCU. Are P/J419, P/J281 and P/J28 connected surely?	Go to step 13.	Reconnect the connector(s) P/J419, P/J281 and/or P/J28 surely.
13	Checking the HARN ASSY FDR UNIT for continuity Disconnect P/J419 from the PWBA OPT FDR. Disconnect P/J281 from the HARN ASSY R SIDE. Is each cable of P/J419 <=> P/J281 continuous?	Go to step 14.	Replace the HARN ASSY FDR UNIT.
14	Checking the HARN ASSY R SIDE for continuity Disconnect P/J281 from the HARNESS ASSY FDR UNIT. Disconnect P/J28 from the PWBA MCU. Is each cable of P/J281 <=> P/J28 continuous?	Go to step 15.	Replace the HARN ASSY R SIDE.
15	Checking the power to the PWBA OPT FDR Disconnect the connector of P/J28 on the PWBA MCU. Is the voltage across ground <=> J28-4pin/J28-5pin on the PWBA MCU, about +24 VDC when the interlock switch (HARN ASSY INTERLOCK) is pushed?	Replace the PWBA OPT FDR. (Refer to Removal 44/Replacement 46)	Replace the PWBA MCU. (Refer to Removal 30/Replacement 14)

FIP1.14 007-371 Restart Printer

Step	Check	Yes	No
	Possible causative parts: DRIVE ASSY K (PL8.1.10) PWBA MCU (PL.1.20) DRIVE ASSY K(HARN ASSY KSNR REGCL) (PL8.1.10)		
1	Checking the K Mode Solenoid (Color Mode Switching Solenoid) for operation Does the K Mode Solenoid function normally? Checked by [Digital Output] - [DO-61(Control Panel)/K MODE CLUTCH ON(PC)] in diagnosis. During this check, close the COVER ASSY FRONT. Does the K Mode Solenoid click sound arise from the DRIVE ASSY K, when the K Mode Solenoid check is performed?	Go to step 2.	Go to step 3.
2	Checking after reseating the DRIVE ASSY K Reseat the DRIVE ASSY K. Does the error still occur when the power is turned ON?	Go to step 7.	End of work
3	Checking the connectors for connection Check the connections between the PWBA MCU and K Mode Solenoid. Are P/J24 and P/J241 connected surely?	Go to step 4.	Reconnect the connector(s) P/J24 and/o P/J241 surely, then go to step 4.
4	Does the error still occur when the power is turned ON?	Go to step 5.	End of work
5	Checking the power to the K Mode Solenoid Disconnect J24 from the PWBA MCU. Is the voltage across P24-1pin <=> ground on the PWBA MCU, about +24 VDC when the Interlock Switch (HARN ASSY INTERLOCK) is pushed?	Go to step 6.	Replace the PWBA MCU. (Refer to Removal 30/ Replacement 14.)?
6	Checking the K Mode Solenoid for resistance Disconnect P/J24 from the PWBA MCU. Is the resistance across J24-1 and J24-2 about 80 to 110-ohm?	Replace the PWBA MCU. (Refer to Removal 30/ Replacement 14.)	Replace the DRIVE ASSY K. (Refer to Removal 28/ Replacement 16.)
7	Checking the connectors of the K Mode Sensor in the DRIVE ASSY K for connection Check the connections between the PWBA MCU and K Mode Sensor. Are P/J20 and P/J201 connected correctly?	Go to step 8.	Reconnect the connector(s) P/J20 and/o P/J201 surely, then go to step 8.
8	Does the error still occur when the power is turned ON?	Go to step 9.	End of work
9	Checking the HARN ASSY KSNR REGCL for continuity Disconnect J20 from the PWBA MCU. Disconnect J201 from the K Mode Sensor. Is each cable of J20 <=> J201 continuous?	Go to step 10.	Replace the HARN ASSY KSNR REGCL.
10	Checking the power to the K Mode Sensor Disconnect J20 from the PWBA MCU. Is the voltage across P20-1pin <=> ground on the PWBA MCU, about +3.3 VDC?	Go to step 11.	Replace the PWBA MCU. (Refer to Removal 30/ Replacement 14.)

Step	Check	Yes	No
11	Checking the K Mode Sensor for operation Remove the DRIVE ASSY K from the printer once, but P/J201 and P/J24 should be connected. Enter the [Digital Input] - [DI-0(Control Panel)/K MODE SNR (PC)] in diagnosis. During this check, close the COVER ASSY FRONT. Does the voltage change, when a piece of paper is inserted into the gap of the K Mode Sensor?	Replace the PWBA MCU. (Refer to Removal 30/ Replacement 14.)	Replace the DRIVE ASSY K. (Refer to Removal 28/ Replacement 16.)

FIP1.15 009-360 Restart Printer

Step	Check	Yes	No
	Possible causative parts: CARTRIDGE ASSY (Y) (PL5.1.21) CONNECTOR CRUM (PL5.1.3) HARN ASSY CRUM (PL10.1.13) PWBA MCU (PL9.1.20)		
1	Checking the CARTRIDGE ASSY (Y) for installation Is the CARTRIDGE ASSY (Y) installed correctly?	Go to step 3.	Reseat the CARTRIDGE ASSY (Y), then go to step 2.
2	Does the error still occur when the power is turned ON?	Go to step 3.	End of work
3	Checking the CONNECTOR CRUM for installation Is the CONNECTOR CRUM installed correctly?	Go to step 4.	Reseat the CONNECTOR CRUM, then go to step 4.
4	Checking the connectors for connection Check the connections between the PWBA MCU and CONNECTOR CRUM. Are P/J31 and P/J311 connected surely?	Go to step 5.	Reconnect the connector(s) P/J31 and/or P/J311 surely, then go to step 5.
5	Checking the HARN ASSY CRUM for continuity Disconnect P/J31 from the PWBA MCU. Disconnect P/J311 from the CONNECTOR CRUM. Is each cable of P/J31 <=> P/J311 continuous?	Go to step 6.	Replace the HARN ASSY CRUM.
6	Checking the CONNECTOR CRUM for shape Is there any damage on the CONNECTOR CRUM?	Replace the CONNECTOR CRUM.	Go to step 7.
7	Checking after replacing the CONNECTOR CRUM Replace the CONNECTOR CRUM. Does the error still occur when the power is turned ON?	Go to step 8.	End of work
8	Checking after replacing the CARTRIDGE ASSY (Y) Replace the CARTRIDGE ASSY (Y). Does the error still occur when the power is turned ON?	Replace the PWBA MCU. (Refer to Removal 30/Replacement 14)	End of work

FIP1.16 009-361 Restart Printer

Step	Check	Yes	No
	Possible causative parts: CARTRIDGE ASSY (M) (PL5.1.20) HARN ASSY CRUM (PL10.1.13) CONNECTOR CRUM (PL5.1.3) PWBA MCU (PL9.1.20)		
1	Checking the CARTRIDGE ASSY (M) for installation Is the CARTRIDGE ASSY (M) installed correctly?	Go to step 3.	Reseat the CARTRIDGE ASSY (M), then go to step 2.
2	Does the error still occur when the power is turned ON?	Go to step 3.	End of work
3	Checking the CONNECTOR CRUM for installation Is the CONNECTOR CRUM installed correctly?	Go to step 4.	Reseat the CONNECTOR CRUM, then go to step 4.
4	Checking the connectors for connection Check the connections between the PWBA MCU and CONNECTOR CRUM. Are P/J31 and P/J 312 connected surely?	Go to step 5.	Reconnect the connector(s) P/J31 and/or P/J 312 surely, then go to step 5.
5	Checking the HARN ASSY CRUM for continuity Disconnect P/J31 from the PWBA MCU. Disconnect P/J312 from the CONNECTOR CRUM. Is each cable of P/J31 <=> P/J 312 continuous?	Go to step 6.	Replace the HARN ASSY CRUM.
6	Checking the CONNECTOR CRUM for shape Is there any damage on the CONNECTOR CRUM?	Replace the CONNECTOR CRUM.	Go to step 7.
7	Checking after replacing the CONNECTOR CRUM Replace the CONNECTOR CRUM. Does the error still occur when the power is turned ON?	Go to step 8.	End of work
8	Checking after replacing the CARTRIDGE ASSY (M) Replace the CARTRIDGE ASSY (M). Does the error still occur when the power is turned ON?	Replace the PWBA MCU. (Refer to Removal 30/Replacement 14)	End of work

FIP1.17 009-362 Restart Printer

Step	Check	Yes	No
	Possible causative parts: CARTRIDGE ASSY (C) (PL5.1.19) HARN ASSY CRUM (PL10.1.13) CONNECTOR CRUM (PL5.1.3) PWBA MCU (PL9.1.20)		
1	Checking the CARTRIDGE ASSY (C) for installation Is the CARTRIDGE ASSY (C) installed correctly?	Go to step 3.	Reseat the CARTRIDGE ASSY (C), then go to step 2.
2	Does the error still occur when the power is turned ON?	Go to step 3.	End of work
3	Checking the CONNECTOR CRUM for installation Is the CONNECTOR CRUM installed correctly?	Go to step 4.	Reseat the CONNECTOR CRUM, then go to step 4.
4	Checking the connectors for connection Check the connections between the PWBA MCU and CONNECTOR CRUM. Are P/J31 and P/J 313 connected surely?	Go to step 5.	Reconnect the connector(s) P/J31 and/or P/J 313 surely, then go to step 5.
5	Checking the HARN ASSY CRUM for continuity Disconnect P/J31 from the PWBA MCU. Disconnect P/J313 from the CONNECTOR CRUM. Is each cable of P/J31 <=> P/J313 continuous?	Go to step 6.	Replace the HARN ASSY CRUM.
6	Checking the CONNECTOR CRUM for shape Is there any damage on the CONNECTOR CRUM?	Replace the CONNECTOR CRUM.	Go to step 7.
7	Checking after replacing the CONNECTOR CRUM Replace the CONNECTOR CRUM. Does the error still occur when the power is turned ON?	Go to step 8.	End of work
8	Checking after replacing the CARTRIDGE ASSY (C) Replace the CARTRIDGE ASSY (C). Does the error still occur when the power is turned ON?	Replace the PWBA MCU. (Refer to Removal 30/Replacement 14)	End of work

FIP1.18 009-363 Restart Printer

Step	Check	Yes	No
	Possible causative parts: CARTRIDGE ASSY (K) (PL5.1.18) HARN ASSY CRUM (PL10.1.13) CONNECTOR CRUM (PL5.1.3) PWBA MCU (PL9.1.20)		
1	Checking the CARTRIDGE ASSY (K) for installation Is the CARTRIDGE ASSY (K) installed correctly?	Go to step 3.	Reseat the CARTRIDGE ASSY (K), then go to step 2.
2	Does the error still occur when the power is turned ON?	Go to step 3.	End of work
3	Checking the CONNECTOR CRUM for installation Is the CONNECTOR CRUM installed correctly?	Go to step 4.	Reseat the CONNECTOR CRUM, then go to step 4.
4	Checking the connectors for connection Check the connections between the PWBA MCU and CONNECTOR CRUM. Are P/J31 and P/J314 connected surely?	Go to step 5.	Re-connect the connector(s) P/J31 and/or P/J314 surely, then go to step 5.
5	Checking the HARN ASSY CRUM for continuity Disconnect P/J31 from the PWBA MCU. Disconnect P/J314 from the CONNECTOR CRUM. Is each cable of P/J31 <=> P/J314 continuous?	Go to step 6.	Replace the HARN ASSY CRUM.
6	Checking the CONNECTOR CRUM for shape Is there any damage on the CONNECTOR CRUM?	Replace the CONNECTOR CRUM.	Go to step 7.
7	Checking after replacing the CONNECTOR CRUM Replace the CONNECTOR CRUM. Does the error still occur when the power is turned ON?	Go to step 8.	End of work
8	Checking after replacing the CARTRIDGE ASSY (K) Replace the CARTRIDGE ASSY (K). Does the error still occur when the power is turned ON?	Replace the PWBA MCU. (Refer to Removal 30/Replacement 14)	End of work

FIP1.19 009-654-01 Restart Printer

Step	Check	Yes	No
	Possible causative parts: TRANSFER ASSY (PL4.1.1) CARTRIDGE ASSY (K) (PL5.1.18) CARTRIDGE ASSY (C) (PL5.1.19) CARTRIDGE ASSY (M) (PL5.1.20) CARTRIDGE ASSY (Y) (PL5.1.21) HARNESS ASSY FRONT COVER (PL13.2.1) HARN ASSY R SIDE (PL10.1.15) PWBA MCU (PL9.1.20)		
1	Checking the detail error code. A detailed error code is displayed by pushing ↓ key, ↑ key and ✓ key simultaneously. Is "Code:01" displayed on the LCD?	Go to step 2.	Go to FIP1.20.
2	Checking the TRANSFER ASSY for installation Is the TRANSFER ASSY installed correctly?	Go to step 4.	Reseat the TRANSFER ASSY, then go to step 3.
3	Does the error still occur when the power is turned ON?	Go to step 4.	End of work
4	Checking the toner density Is there the dark color? Compare the density of four colors toner. Checked by [Test Print] - [Gradation] in diagnosis.	Go to step 5.	Replace the PWBA MCU. (Refer to Removal 30/Replacement 14)
5	Checking the solenoid in the TRANSFER ASSY for operation Does the ADC Sensor operate normally? Checked by [Digital Output] - [DO-37(Control Panel)/CTD SOLENOID ON(PC)] in diagnosis.	Replace the corresponding CARTRIDGE ASSY. (Refer to Removal 6/Replacement 38)	Go to step 6.
6	Checking the connectors for connection Check the connections between the PWBA MCU and TRANSFER ASSY. Are P/J27, P/J272 and P/J2721 connected surely?	Go to step 7.	Reconnect the connector(s) P/J27, P/J272 and/or P/J2721 surely, then go to step 7.
7	Checking the HARNESS ASSY FRONT COVER for continuity Disconnect P/J2721 from the TRANSFER ASSY. Disconnect P/J272 from the HARN ASSY R SIDE. Is each cable of P/J2721 <=> P/J272 continuous?	Go to step 8.	Replace the HARNESS ASSY FRONT COVER.
8	Checking the HARN ASSY R SIDE for continuity Disconnect P/J27 from the PWBA MCU. Disconnect P/J272 from the HARNESS ASSY FRONT COVER. Is each cable of P/J27 <=> P/J272 continuous?	Go to step 9.	Replace the HARN ASSY R SIDE.

Step	Check	Yes	No
9	Checking the power to ADC SENSOR Disconnect P/J27 on PWBA MCU. Is the voltage across ground \Leftrightarrow J27-7pin on the PWBA MCU, about +5 VDC?	Replace the TRANSFER ASSY. (Refer to Removal 4/ Replacement 40)	Replace the PWBA MCU. (Refer to Removal 30/Replacement 14)

FIP1.20 009-654-02 Restart Printer

Step	Check	Yes	No
	Possible causative parts: TRANSFER ASSY (PL4.1.1) CARTRIDGE ASSY (K) (PL5.1.18) CARTRIDGE ASSY (C) (PL5.1.19) CARTRIDGE ASSY (M) (PL5.1.20) CARTRIDGE ASSY (Y) (PL5.1.21) DRIVE ASSY MAIN (PL8.1.2) ROS ASSY (PL5.1.12) HARNESS ASSY FRONT COVER (PL1.2.11) HARN ASSY R SIDE (PL10.1.15) PWBA MCU (PL9.1.20)		
1	Checking the detail error code. A detailed error code is displayed by pushing ↓ key, ↑ key and ✓ key simultaneously. Is "Code:02" displayed on the LCD?	Go to step 2.	Go to FIP1.19.
2	Checking the TRANSFER ASSY for installation Is the TRANSFER ASSY installed correctly?	Go to step 4.	Reseat the TRANSFER ASSY, then go to step 3.
3	Does the error still occur when the power is turned ON?	Go to step 4.	End of work
4	Checking the four CARTRIDGE ASSY for installation Are the CARTRIDGE ASSYs installed correctly?	Go to step 6.	Reseat the CARTRIDGE ASSY(s), then go to step 5.
5	Does the error still occur when the power is turned ON?	Go to step 6.	End of work
6	Checking the toner density Is there the light color? Compare the density of four colors toner. Checked by [Test Print] - [Gradation] in diagnosis.	Go to step 7.	Replace the PWBA MCU. (Refer to Removal 30/Replacement 14)
7	Checking the solenoid in the TRANSFER ASSY for operation Does the ADC Sensor operate normally? Checked by [Digital Output] - [DO-37(Control Panel)/CTD SOLENOID ON(PC)] in diagnosis.	Go to step 12.	Go to step 8.
8	Checking the connectors for connection Check the connections between the PWBA MCU and TRANSFER ASSY. Are P/J27, P/J272 and P/J2721 connected surely?	Go to step 9.	Reconnect the connector(s) P/J27, P/J272 and/or P/J2721 surely, then go to step 9.
9	Checking the HARNESS ASSY FRONT COVER for continuity Disconnect P/J2721 from the TRANSFER ASSY. Disconnect P/J272 from the HARN ASSY R SIDE. Is each cable of P/J2721 <=> P/J272 continuous?	Go to step 10.	Replace the HARNESS ASSY FRONT COVER.

Step	Check	Yes	No
10	Checking the HARN ASSY R SIDE for continuity Disconnect P/J27 from the PWBA MCU. Disconnect P/J272 from the HARNESS ASSY FRONT COVER. Is each cable of P/J27 <=> P/J272 continuous?	Go to step 11.	Replace the HARN ASSY R SIDE.
11	Checking the power to ADC SENSOR Disconnect the connector of P/J27 on PWBA MCU. Is the voltage across ground <=> J27-7pin on the PWBA MCU, about +5 VDC?	Replace the TRANSFER ASSY. (Refer to Removal 4/ Replacement 40)	Replace the PWBA MCU. (Refer to Removal 30/Replacement 14)
12	Checking after replacing the corresponding CARTRIDGE ASSY Replace the CARTRIDGE ASSY. (Refer to Removal 6/ Replacement 38) Does the error still occur when the power is turned ON?	Replace the ROS ASSY. (Refer to Removal 36/ Replacement 8)	End of work

FIP1.21 010-317 Restart Printer

Step	Check	Yes	No
	Possible causative parts: FUSER ASSY (PL6.1.10) PWBA MCU (PL9.1.20) HARN ASSY FUSER (PL6.1.11) HARN ASSY LV TOP (PL10.1.16)		
1	Checking the FUSER ASSY for installation Is the FUSER ASSY installed correctly?	Go to step 2.	Reseat the FUSER ASSY, then go to step2.
2	Does the error still occur when the power is turned ON?	Go to step 3.	End of work *1
3	Checking the connectors for connection Remove the FUSER ASSY. Check the connections between the PWBA MCU and FUSER ASSY. Warning: Start the operation after the FUSER ASSY has cooled down. Are P/J17, P/J171 connected surely?	Go to step 4.	Reconnect the connector(s) P/J17 and/or P/J171 surely, then go to step 4.
4	Checking the HARN ASSY FUSER for continuity Remove the FUSER ASSY. Warning: Start the operation after the FUSER ASSY has cooled down. Disconnect P/J17 from the PWBA MCU. Disconnect P/J171 from the FUSER ASSY. Is each cable of P/J17 <=> P/J171 continuous?	Go to step 5.	Replace the HARN ASSY FUSER.
5	Checking after replacing the FUSER ASSY Replace the FUSER ASSY. (Refer to Removal 8/ Replacement 36.) Warning: Start the operation after the FUSER ASSY has cooled down. Does the error still occur when the power is turned ON?	Replace the PWBA MCU. (Refer to Removal 30/ Replacement 14.)	End of work

*1: Though some kind of foreign noise would be possible cause, go to FIP1.73 Electrical Noise in Other FIP and check, to make sure.

FIP1.22 010-351 Restart Printer

Step	Check	Yes	No
	Possible causative parts: FUSER ASSY (PL6.1.10) PWBA MCU (PL9.1.20)		
1	Checking the life counter value of the FUSER ASSY. Does the life counter value show the near of the end?	Replace the FUSER ASSY. (Refer to Removal 8/ Replacement 36.) After replacement, be sure to clear the life counter value.	Go to step 2.
2	Checking the FUSER ASSY for installation Is the FUSER ASSY installed correctly? Warning: Start the operation after the FUSER ASSY has cooled down.	Go to step 4.	Reseat the FUSER ASSY, then go to step 3.
3	Does the error still occur when the power is turned ON?	Go to step 4.	End of work
4	Checking after replacing the FUSER ASSY Replace the FUSER ASSY. (Refer to Removal 8/ Replacement 36.) Warning: Start the operation after the FUSER ASSY has cooled down. Does the error still occur when the power is turned ON?	Replace the PWBA MCU. (Refer to Removal 30/ Replacement 14.)	End of work

FIP1.23 010-354 Restart Printer

Step	Check	Yes	No
	Possible causative parts: SENSOR HUM (PL9.1.19) HARN ASSY HUM (PL10.1.4) PWBA MCU (PL9.1.20)		
1	Checking the SENSOR HUM for installation Is the SENSOR HUM installed correctly?	Go to step 2.	Reseat the SENSOR HUM, then go to step 2.
2	Does the error still occur when the power is turned ON?	Go to step 3.	End of work
3	Checking the connectors for connection Check the connections between the PWBA MCU and SENSOR HUM. Are P/J26 and P/J261 connected surely?	Go to step 4.	Reconnect the connector(s) P/J26 and/or P/J261 surely, then go to step 4.
4	Checking the HARN ASSY HUM for continuity Disconnect P/J26 from the PWBA MCU. Disconnect P/J261 from the SENSOR HUM. Is each cable of P/J26 <=> P/J261 continuous?	Go to step 5.	Replace the HARN ASSY HUM.
5	Checking the power to SENSOR HUM Disconnect the connector of P/J26 on PWBA MCU. Is the voltage across ground <=> J26-4pin on the PWBA MCU, about +5 VDC?	Replace the SENSOR HUM. (Refer to Removal 29/Replacement 15)	Replace the PWBA MCU. (Refer to Removal 30/Replacement 14)

FIP1.24 010-377 Restart Printer

Step	Check	Yes	No
	Possible causative parts: FUSER ASSY (PL6.1.10) HARN ASSY FUSER (PL6.1.11) HARN ASSY LV TOP (PL10.1.16) LVPS (PL9.1.4) PWBA MCU (PL9.1.20)		
1	Checking the FUSER ASSY for installation Is the FUSER ASSY installed correctly?	Go to step 2.	Reseat the FUSER ASSY, then go to step 2.
2	Does the error still occur when the power is turned ON?	Go to step 3.	End of work
3	Checking the connectors for connection Remove the FUSER ASSY. Check the connections between the PWBA MCU and FUSER ASSY. Warning: Start the operation after the FUSER ASSY has cooled down. Check the connections between the FUSER ASSY and LVPS. Check the connections between the LVPS and PWBA MCU. Are P/J17, P/J171, P/J47, P/J501 and P/J13 connected surely?	Go to step 4.	Reconnect the connector(s) P/J17, P/J171, P/J47, P/J501 and/or P/J13 surely, then go to step 4.
4	Checking the HARN ASSY FUSER for continuity Remove the FUSER ASSY. Warning: Start the operation after the FUSER ASSY has cooled down. Disconnect P/J17 from the PWBA MCU. Disconnect P/J171 from the FUSER ASSY. Is each cable of P/J17 <=> P/J171 continuous?	Go to step 5.	Replace the HARN ASSY FUSER.
5	Checking the HARN ASSY LV TOP for continuity Disconnect P/J171 from the FUSER ASSY. Disconnect P/J47 and 501 from the LVPS. Disconnect P/J13 from the PWBA MCU. Is each cable of P/J47 <=> P/J171 continuous? Is each cable of P/J501 <=> P/J13 continuous?	Go to step 6.	Replace the HARN ASSY LV TOP.
6	Checking after replacing the FUSER ASSY Replace the FUSER ASSY. (Refer to Removal 8/Replacement 36) Warning: Start the operation after the FUSER ASSY has cooled down. Does the error still occur when the power is turned ON?	Go to step 7	End of work
7	Checking after replacing the LVPS Replace the LVPS. (Refer to Removal 35/Replacement 9) Does the error still occur when the power is turned ON?	Replace the PWBA MCU. (Refer to Removal 30/Replacement 14)	End of work

FIP1.25 016-300/016-301/016-302/016-310/016-313/016-315/016-317/016-323/016-327/
016-340/016-344/016-345/016-346/016-347 Restart / Erase Flash Err. 016-392 /
Write Flash Err. 016-393 / Verify Error 016-394

Step	Check	Yes	No
	Possible causative parts: PWBA ESS (PL9.1.27)		
1	Checking the error code. Error code is 016-317 or 016-340?	Go to step 2.	Go to step 3.
2	Download the latest version of the firmware from the Dell support website, and update the firmware with "F/W Download DL Mode". (Refer to Reference_1.) Does the error still occur when the power is turned off and on?	Replace the PWBA ESS. (Removal 26/ Replacement 18)	End of work
3	Check whether the version of the firmware is the latest, referring to the Printer Information via the Tool Box. Checked by [Printer Information] of the [Printer Settings Report] tab in Tool Box. For the latest version information, refer to the Dell Support Web Site. Is the firmware the latest version?	Replace the PWBA ESS. (Removal 26/ Replacement 18)	Download the latest version of the firmware from the Dell Support Web Site.

Reference_1:

1. Make sure that the printer is connected to the computer via USB port or Parallel port (remove the network cable). Then, try downloading as follows:
 - 1) Power on the printer while pressing the <X Cancel> and <✓> buttons.
 - 2) Press <▼> button to select "F/W Download DL Mode Parallel" or "F/W Download DL Mode USB", and then press <✓> button.
 - 3) The printer goes into the Download Mode with a message "Download Mode Ready. Then, activate firmware update tool and follow the instruction displayed.

NOTE

While the firmware download is being executed, the printer displays a message "Writing..... F/W", and the computer displays a progress bar and may be restarted during the downloading process. Never power off the printer or the computer until the downloading process completes, and never interrupt the downloading process.

FIP1.26 016-312/016-361 Restart Printer

Step	Check	Yes	No
	Possible causative parts: PWBA ESS (PL9.1.27) HDD ASSY (OPTION) (PL9.1.47)		
1	Checking the HDD ASSY (OPTION) for installation Reseat the HDD ASSY (OPTION). Does the error still occur when the power is turned ON?	Go to step 2.	End of work
2	Checking after replacing the HDD ASSY (OPTION) Replace the HDD ASSY (OPTION). Does the error still occur when the power is turned ON?	Replace the PWBA ESS. (Refer to Removal 26/Replacement 18)	End of work

FIP1.27 016-316/016-318 Restart Printer

Step	Check	Yes	No
	Possible causative parts: MEMORY CARD (OPTION) (PL9.1.30) PWBA ESS (PL9.1.27)		
1	Checking the MEMORY CARD for installation Reseat the MEMORY CARD. Does the error still occur when the power is turned ON?	Got to step 2.	End of work
2	Checking after replacing the MEMORY CARD Replace the MEMORY CARD. Does the error still occur when the power is turned ON?	Replace the PWBA ESS. (Refer to Removal 26/Replacement 18)	End of work

FIP1.28 016-338 Restart Printer

Step	Check	Yes	No
	Possible causative parts: PWBA ESS (OPTION) (PL9.1.27) WIRELESS PRINTER ADAPTER (OPTION) (PL9.1.32)		
1	Checking the connected device to the USB port on the PWBA ESS Is the WIRELESS PRINTER ADAPTER connected to the USB port on the PWBA ESS?	Go to step 2.	Connect the WIRELESS PRINTER ADAPTER to the USB port on the PWBA ESS.
2	Checking the WIRELESS PRINTER ADAPTER for installation Reseat the WIRELESS PRINTER ADAPTER. Does the error still occur when the power is turned ON?	Go to step 3.	End of work
3	Checking the PWBA ESS for installation Reseat the PWBA ESS. Does the error still occur when the power is turned ON?	Go to step 4.	End of work
4	Checking after replacing the WIRELESS PRINTER ADAPTER Replace the WIRELESS PRINTER ADAPTER. Does the error still occur when the power is turned ON?	Replace the PWBA ESS. (Refer to Removal 26/Replacement 18)	End of work

FIP1.29 016-350 Restart Printer

Step	Check	Yes	No
	Possible causative parts: IEEE1284 Cable PWBA ESS (PL9.1.27)		
1	Checking the PC and cable for connection Swap another PC and cable. (If there are not substitute PC and cable, go to step 2.) Does the error still occur when printing?	Replace the PWBA ESS. (Refer to Removal 26/Replacement 18)	Check the PC set- ting and discon- nection of the cable, then go to step 2.
2	Checking the connection Reconnect the printer and PC with the cable. Does the error still occur when printing?	Go to step 3.	End of work
3	Checking after replacing the cable Replace the cable. Does the error still occur when printing?	Replace the PWBA ESS. (Refer to Removal 26/Replacement 18)	End of work

FIP1.30 016-365 Restart Printer

Step	Check	Yes	No
	Possible causative parts: PWBA ESS (PL9.1.27) NETWORK PROTOCOL ADAPTER (OPTION) (PL9.1.46)		
1	Checking after reseating the Network Adapter Reseat the NETWORK PROTOCOL ADAPTER. Does the error still occur when the power is turned ON?	Go to step 2.	End of work
2	Checking after replacing the Network Adapter Replace the NETWORK PROTOCOL ADAPTER. (Refer to Removal 48/Replacement 49.) Does the error still occur when the power is turned ON?	Replace the PWBA ESS. (Refer to Removal 26/ Replacement 18.)	End of work

FIP1.31 016-370 Restart Printer

Step	Check	Yes	No
	Possible causative parts: PWBA ESS (PL9.1.27) PWBA MCU (PL9.1.20)		
1	Download the latest version of the firmware from the Dell support website, and update the firmware with "F/W Download DL Mode". (Refer to Reference_1.) Does the error still occur when the power is turned off and on?	Go to step 2.	End of work
2	Checking after replacing the PWBA ESS Replace the PWBA ESS. Does the error still occur when the power is turned off and on?	Go to step 3.	End of work
3	Checking after replacing the PWBA MCU. Replace the PWBA MCU. Does the error still occur when the power is turned off and on?	Replace the Printer.	End of work

Reference_1:

1. Make sure that the printer is connected to the computer via USB port or Parallel port (remove the network cable). Then, try downloading as follows:
 - 1) Power on the printer while pressing the <X Cancel> and <✓> buttons.
 - 2) Press <▼> button to select "F/W Download DL Mode Parallel" or "F/W Download DL Mode USB", and then press <✓> button.
 - 3) The printer goes into the Download Mode with a message "Download Mode Ready. Then, activate firmware update tool and follow the instruction displayed.

NOTE

While the firmware download is being executed, the printer displays a message "Writing..... F/W", and the computer displays a progress bar and may be restarted during the downloading process. Never power off the printer or the computer until the downloading process completes, and never interrupt the downloading process.

FIP1.32 093-964 Restart Printer

Step	Check	Yes	No
	Possible causative parts: FUSER ASSY (PL6.1.10) PWBA MCU (PL9.1.20)		
1	Checking the FUSER ASSY for installation Is the FUSER ASSY installed correctly?	Go to step 2.	Reseat the FUSER ASSY, then go to step 2.
2	Does the error still occur when the power is turned ON?	Go to step 3.	End of work
3	Checking the FUSER ASSY type Remove the FUSER ASSY. Is the FUSER ASSY installed the 3130cn FUSER?	Go to step 4.	End of work
4	Checking after replacing the FUSER ASSY Replace the FUSER ASSY. (Refer to Removal 8/ Replacement 36.) Does the error still occur when the power is turned ON?	Replace the PWBA MCU. (Refer to Removal 30/ Replacement 14.)	End of work

FIP1.33 Paper Jam 071-100

Step	Check	Yes	No
	Possible causative parts: HARN ASSY REGI SNR (PL3.2.37) HARN ASSY R SIDE (PL10.1.15) SENSOR PHOTO (REGI SENSOR) (PL3.2.30) PWBA MCU (PL9.1.20) CLUTCH ASSY PH FEED (PL3.2.24) DRIVE ASSY PH (PL8.1.7)		
1	Checking the paper condition Is the paper in the Tray wrinkled or damaged?	Replace the paper with a new and dry one, then go to step 2.	Go to step 2.
2	Checking the paper size setup Does the paper size in use match the size setup set through the control panel?	Go to step 3.	Correct the paper size through the control panel, then go to step 3.
3	Does the error still occur when printing?	Go to step 4.	End of work
4	Checking after reseating the Paper Cassette Reseat the Paper Cassette. Does the error still occur when printing?	Go to step 5.	End of work
5	Checking the paper transfer path Check if there are any stains or obstacles on the paper transfer path. Are there any obstacles on the paper transfer path?	Remove the obstacles or stains from the paper transfer path.	Go to step 6.
6	Checking the SENSOR PHOTO (REGI SENSOR) for operation Does the number on the screen increase by one, every time the actuator of the SENSOR PHOTO (REGI SENSOR) is operated? Checked by [Digital Input] - [DI-3(Control Panel)/REGI SNR(PC)] in diagnosis.	Go to step 7.	Go to step 9.
7	Checking the DRIVE ASSY PH for operation Does the DRIVE ASSY PH operate properly? Checked by [Digital Output] - [DO-a(Control Panel)/PH MOTOR(FULL)(PC)] in diagnosis.	Go to step 8.	Go to step 14.
8	Checking the CLUTCH ASSY PH FEED for operation Does the CLUTCH ASSY PH operate properly? Checked by [Digital Output] - [DO-2f(Control Panel)/CASSETTE1 FEED CLUTCH ON(PC)] in diagnosis.	Replace the PWBA MCU. (Refer to Removal 30/Replacement 14)	Go to step 17.
9	Checking the connectors of the SENSOR PHOTO (REGI SENSOR) for connection Check the connections between the PWBA MCU and REGI SENSOR. Are P/J29, P/J292 and P/J2922 connected surely?	Go to step 10.	Reconnect the connector(s) P/J29, P/J292 and/or P/J2922 surely.

Step	Check	Yes	No
10	Checking the HARN ASSY REGI SNR for continuity Disconnect P/J2922 from the REGI SENSOR. Disconnect P/J292 from the HARN ASSY R SIDE. Is each cable of P/J2922 <=> P/J292 continuous?	Go to step 11.	Replace the HARN ASSY REGI SNR.
11	Checking the HARN ASSY R SIDE for continuity Disconnect P/J29 from the PWBA MCU. Disconnect P/J292 from the HARNESS ASSY REGI SNR. Is each cable of P/J29 <=> P/J292 continuous?	Go to step 12.	Replace the HARN ASSY R SIDE.
12	Checking the power to REGI SENSOR Disconnect the connector of P/J29 on the PWBA MCU. Is the voltage across ground <=> J29-8pin on the PWBA MCU, about +3.3 VDC?	Go to step 13.	Replace the PWBA MCU. (Refer to Removal 30/ Replacement 14.)
13	Checking the REGI SENSOR for operation Measure the voltage across ground <=> J29-10pin on the PWBA MCU. Does the voltage change, every time the actuator of the REGI SENSOR is operated?	Replace the PWBA MCU. (Refer to Removal 30/ Replacement 14.)	Replace the SENSOR PHOTO (REGI SENSOR).
14	Checking the connectors of the DRIVE ASSY PH for connection Check the connections between the PWBA MCU and DRIVE ASSY PH. Are P/J25 and P/J251 connected surely?	Go to step 15.	Reconnect the connector(s) P/J25 and/or P/J251 surely.
15	Checking the HARN ASSY R SIDE for continuity Disconnect P/J25 from the PWBA MCU. Disconnect P/J251 from the DRIVE ASSY PH. Is each cable of P/J25 <=> P/J251 continuous?	Go to step 16.	Replace the HARN ASSY R SIDE.
16	Checking the power to DRIVE ASSY PH Disconnect the connector of P/J25 on the PWBA MCU. Are the voltages across ground <=> J25-1pin/J25-2pin on the PWBA MCU, about +24 VDC when the interlock switch (HARN ASSY INTERLOCK) is pushed?	Replace the DRIVE ASSY PH. (Refer to Removal 17/ Replacement 27.)	Replace the PWBA MCU. (Refer to Removal 30/ Replacement 14.)
17	Checking the connectors of the CLUTCH ASSY PH FEED for connection Check the connections between the PWBA MCU and CLUTCH ASSY PH FEED. Are P/J23 and P/J233 connected surely?	Go to step 18.	Reconnect the connector(s) P/J23 and/or P/J233 surely.
18	Checking the HARN ASSY R SIDE for continuity Disconnect P/J23 from the PWBA MCU. Disconnect P/J233 from the CLUTCH ASSY PH FEED. Is each cable of P/J23 <=> P/J233 continuous?	Go to step 19.	Replace the HARN ASSY R SIDE.
19	Checking the power to CLUTCH ASSY PH FEED Disconnect the connector of P/J23 on the PWBA MCU. Is the voltage across ground <=> J23-5pin on the PWBA MCU, about +24 VDC when the interlock switch (HARN ASSY INTERLOCK) is pushed?	Replace the CLUTCH ASSY PH FEED. (Refer to Removal 40/ Replacement 4.)	Replace the PWBA MCU. (Refer to Removal 30/ Replacement 14.)

FIP1.34 Paper Jam 072-100

Step	Check	Yes	No
	Possible causative parts: ROLL ASSY TURN (PL12.3.4) ROLL ASSY FFEED (Feed Roll) (PL12.3.29) ROLL ASSY FEED (Nudger Roll) (PL12.3.29) 550 OPTION FEEDER (PL12.1.1) SENSOR PHOTO (REGI SENSOR) (PL3.2.30) CLUTCH ASSY FEED OPT (PL12.1.6) CLUTCH ASSY TURN OPT (PL12.1.5) HARN ASSY REGI SNR (PL3.2.37) HARN ASSY R SIDE (PL10.1.15) HARN ASSY C2 MOT (PL12.2.9) HARN ASSY FDR UNIT (PL12.2.3) HARN ASSY C2 CHUTE(PL12.2.7) HARN ASSY C2 TURN(PL12.2.8) PWBA OPT FDR (PL12.2.6) PWBA MCU (PL9.1.20) DRIVE ASSY OPT FDR(PL12.2.10)		
1	Checking the paper condition Is the paper in the Tray wrinkled or damaged?	Replace the paper with a new and dry one, then go to step 2.	Go to step 2.
2	Checking the paper size setup Does the paper size in use match the size setup set through the control panel?	Go to step 3.	Correct the paper size through the control panel, then go to step 3.
3	Does the error still occur when printing?	Go to step 4.	End of work
4	Checking after reseating the CASSETTE ASSY 550 OPT Reseat the CASSETTE ASSY 550 OPT. Does the error still occur when printing?	Go to step 5.	End of work
5	Checking the SENSOR PHOTO (REGI SENSOR) for operation Does the number on the screen increase by one, every time the actuator of the SENSOR PHOTO (REGI SENSOR) is operated? Checked by [Digital Input] - [DI-3(Control Panel)/REGI SNR(PC)] in diagnosis.	Go to step 6.	Go to step 11.
6	Checking the DRIVE ASSY OPT FDR for operation Does the DRIVE ASSY OPT FDR operate properly? Checked by [Digital Output] - [DO-19(Control Panel)/OPTION FEEDER1 MOTOR ON(PC)] in diagnosis.	Go to step 7.	Go to step 16.
7	Checking the CLUTCH ASSY PH FEED for operation Does the CLUTCH ASSY PH FEED operate properly? Checked by [Digital Output] - [DO-31(Control Panel)/CASSETTE2 FEED CLUTCH ON(PC)] in diagnosis.	Go to step 8.	Go to step 23.
8	Checking the CLUTCH ASSY PH TURN for operation Does the CLUTCH ASSY PH TURN operate properly? Checked by [Digital Output] - [DO-33(Control Panel)/CASSETTE2 TURN CLUTCH ON(PC)] in diagnosis.	Go to step 9.	Go to step 30.

Step	Check	Yes	No
9	Checking the ROLL ASSY TURN and ROLL ASSY FEEDs for shape and operation Remove the paper cassette. Are ROLL ASSY TURN and ROLL ASSY FEEDs installed correctly? Also are they not contaminated and /or damaged, and rotate smoothly? Check these items by turning them with your finger.	Go to step 10.	Replace the defective ROLL(s).
10	Checking after replacing the 550 OPTION FEEDER Replace the 550 OPTION FEEDER. (Refer to Removal 44/Replacement 46) Does the error still occur when printing?	Replace the PWBA MCU. (Refer to Removal 30/Replacement 14)	End of work
11	Checking the connectors of the SENSOR PHOTO (REGI SENSOR) for connection Check the connections between the PWBA MCU and REGI SENSOR. Are P/J29, P/J292 and P/J2922 connected surely?	Go to step 12.	Reconnect the connector(s) P/J29, P/J292 and/or P/J2922 surely.
12	Checking the HARN ASSY REGI SNR for continuity Disconnect P/J2922 from the REGI SENSOR. Disconnect P/J292 from the HARN ASSY R SIDE. Is each cable of P/J2922 <=> P/J292 continuous?	Go to step 13.	Replace the HARN ASSY REGI SNR.
13	Checking the HARN ASSY R SIDE for continuity Disconnect P/J29 from the PWBA MCU. Disconnect P/J292 from the HARN ASSY REGI SNR. Is each cable of P/J29 <=> P/J292 continuous?	Go to step 14.	Replace the HARN ASSY R SIDE.
14	Checking the power to REGI SENSOR Disconnect the connector of P/J29 on the PWBA MCU. Is the voltage across ground <=> J29-8pin on the PWBA MCU, about +3.3 VDC?	Go to step 15.	Replace the PWBA MCU. (Refer to Removal 30/ Replacement 14.)
15	Checking the REGI SENSOR for operation Measure the voltage across ground <=> J29-10pin on the PWBA MCU. Does the voltage change, every time the actuator of the REGI SENSOR is operated?	Replace the PWBA MCU. (Refer to Removal 30/ Replacement 14.)	Replace the SENSOR PHOTO (REGI SENSOR).
16	Checking the connectors of the DRIVE ASSY OPT FDR for connection Check the connections between the PWBA OPT FDR and DRIVE ASSY OPT FDR. Are P/J422 and P/J4222 connected surely?	Go to step 17.	Reconnect the connector(s) P/J422 and/or P/J4222 surely.
17	Checking the HARNESS ASSY C2 MOT for continuity Disconnect P/J422 from the PWBA OPT FDR. Disconnect P/J4222 from the DRIVE ASSY OPT FDR. Is each cable of P/J422 <=> P/J4222 continuous?	Go to step 18.	Replace the HARN ASSY C2 MOT.

Step	Check	Yes	No
18	Checking the power to DRIVE ASSY OPT FDR Disconnect the connector of P/J422 on the PWBA OPT FDR. Is the voltage across ground \Leftrightarrow J422-6pin on the PWBA OPT FDR, about +24 VDC when the interlock switch (HARN ASSY INTERLOCK) is pushed?	Replace the DRIVE ASSY OPT FDR.	Go to step 19.
19	Checking the connectors of the PWBA OPT FDR and PWBA MCU for connection Check the connections between the PWBA OPT FDR and PWBA MCU. Are P/J419, P/J281 and P/J28 connected surely?	Go to step 20.	Reconnect the connector(s) P/J419, P/J281 and/or P/J28 surely.
20	Checking the HARN ASSY FDR UNIT for continuity Disconnect P/J419 from the PWBA OPT FDR. Disconnect P/J281 from the HARN ASSY R SIDE. Is each cable of P/J419 \Leftrightarrow P/J281 continuous?	Go to step 21.	Replace the HARN ASSY FDR UNIT.
21	Checking the HARN ASSY R SIDE for continuity Disconnect P/J281 from the HARN ASSY FDR UNIT. Disconnect P/J28 from the PWBA MCU. Is each cable of P/J281 \Leftrightarrow P/J28 continuous?	Go to step 22.	Replace the HARN ASSY R SIDE.
22	Checking the power to the PWBA OPT FDR Disconnect the connector of P/J28 on the PWBA MCU. Is the voltage across ground \Leftrightarrow J28-4pin/J28-5pin on the PWBA MCU, about +24 VDC when the interlock switch (HARN ASSY INTERLOCK) is pushed?	Replace the PWBA OPT FDR.	Replace the PWBA MCU. (Refer to Removal 30/ Replacement 14.)
23	Checking the connectors of the CLUTCH ASSY FEED OPT for connection Check the connections between the PWBA OPT FDR and CLUTCH ASSY FEED OPT. Are P/J421 and P/J4213 connected surely?	Go to step 24.	Reconnect the connector(s) P/J421 and/or P/J4213 surely.
24	Checking the HARN ASSY C2 CHUTE for continuity Disconnect P/J421 from the PWBA OPT FDR. Disconnect P/J4213 from the CLUTCH ASSY PH FEED. Is each cable of P/J421 \Leftrightarrow P/J4213 continuous?	Go to step 25.	Replace the HARN ASSY C2 CHUTE.
25	Checking the power to CLUTCH ASSY FEED OPT Disconnect the connector of P/J421 on the PWBA OPT FDR. Is the voltage across ground \Leftrightarrow J421-1pin on the PWBA OPT FDR, about +24 VDC when the interlock switch (HARN ASSY INTERLOCK) is pushed?	Replace the CLUTCH ASSY PH FEED. (Refer to Removal 40/ Replacement 4.)	Go to step 26.
26	Checking the connectors of the PWBA OPT FDR and PWBA MCU for connection Check the connections between the PWBA OPT FDR and PWBA MCU. Are P/J419, P/J281 and P/J28 connected surely?	Go to step 27.	Reconnect the connector(s) P/J419, P/J281 and/or P/J28 surely.
27	Checking the HARN ASSY FDR UNIT for continuity Disconnect P/J419 from the PWBA OPT FDR. Disconnect P/J281 from the HARN ASSY R SIDE. Is each cable of P/J419 \Leftrightarrow P/J281 continuous?	Go to step 28.	Replace the HARN ASSY FDR UNIT.

Step	Check	Yes	No
28	Checking the HARN ASSY R SIDE for continuity Disconnect P/J281 from the HARN ASSY FDR UNIT. Disconnect P/J28 from the PWBA MCU. Is each cable of P/J281 <=> P/J28 continuous?	Go to step 29.	Replace the HARN ASSY R SIDE.
29	Checking the power to the PWBA OPT FDR Disconnect the connector of P/J28 on the PWBA MCU. Is the voltage across ground <=> J28-4pin/J28-5pin on the PWBA MCU, about +24 VDC when the interlock switch (HARN ASSY INTERLOCK) is pushed?	Replace the PWBA OPT FDR.	Replace the PWBA MCU. (Refer to Removal 30/ Replacement 14.)
30	Checking the connectors of the CLUTCH ASSY TURN OPT for connection Check the connections between the PWBA OPT FDR and CLUTCH ASSY TURN OPT. Are P/J420 and P/J4201 connected surely?	Go to step 31.	Reconnect the connector(s) P/J420 and/or P/J4201 surely.
31	Checking the HARN ASSY C2 TURN for continuity Disconnect P/J420 from the PWBA OPT FDR. Disconnect P/J4201 from the CLUTCH ASSY TURN OPT. Is each cable of P/J420 <=> P/J4201 continuous?	Go to step 32.	Replace the HARN ASSY C2 TURN.
32	Checking the power to CLUTCH ASSY TURN OPT Disconnect the connector of P/J420 on the PWBA OPT FDR. Is the voltage across ground <=> J420-1pin on the PWBA OPT FDR, about +24 VDC when the interlock switch (HARN ASSY INTERLOCK) is pushed?	Replace the CLUTCH ASSY PH TURN. (Refer to Removal 40/ Replacement 4.)	Go to step 33.
33	Checking the connectors of the PWBA OPT FDR and PWBA MCU for connection Check the connections between the PWBA OPT FDR and PWBA MCU. Are P/J419, P/J281 and P/J28 connected surely?	Go to step 34.	Reconnect the connector(s) P/J419, P/J281 and/or P/J28 surely.
34	Checking the HARN ASSY FDR UNIT for continuity Disconnect P/J419 from the PWBA OPT FDR. Disconnect P/J281 from the HARN ASSY R SIDE. Is each cable of P/J419 <=> P/J281 continuous?	Go to step 35.	Replace the HARN ASSY FDR UNIT.
35	Checking the HARN ASSY R SIDE for continuity Disconnect P/J281 from the HARN ASSY FDR UNIT. Disconnect P/J28 from the PWBA MCU. Is each cable of P/J281 <=> P/J28 continuous?	Go to step 36.	Replace the HARN ASSY R SIDE.
36	Checking the power to the PWBA OPT FDR Disconnect the connector of P/J28 on the PWBA MCU. Is the voltage across ground <=> J28-4pin/J28-5pin on the PWBA MCU, about +24 VDC when the interlock switch (HARN ASSY INTERLOCK) is pushed?	Replace the PWBA OPT FDR.	Replace the PWBA MCU. (Refer to Removal 30/ Replacement 14.)

FIP1.35 Paper Jam 075-100

Step	Check	Yes	No
	Possible causative parts: ROLL ASSY FFEED MSI (PL3.1.10) ROLL ASSY TURN (PL3.2.32) SENSOR PHOTO (REGI SENSOR) (PL3.2.30) SOLENOID FEED MSI (PL3.1.3) CLUTCH ASSY PH TURN (PL3.2.25) DRIVE ASSY PH (PL8.1.7) HARN ASSY R SIDE (PL10.1.15) HARN ASSY REGI SNR (PL3.2.37) PWBA MCU (PL9.1.20)		
1	Checking the paper condition Is the paper on the MPT wrinkled or damaged?	Replace the paper with a new and dry one, then go to step 2.	Go to step 2.
2	Checking the paper size setup Does the paper size in use match the size setup set through the control panel?	Go to step 3.	Correct the paper size through the control panel, then go to step 3.
3	Does the error still occur when printing?	Go to step 4.	End of work
4	Checking after reseating the side guides of the MPT Reseat the side guides. Does the error still occur when printing?	Go to step 5.	End of work
5	Checking the SENSOR PHOTO (REGI SENSOR) for operation Does the number on the screen increase by one, every time the actuator of the SENSOR PHOTO (REGI SENSOR) is operated? Checked by [Digital Input] - [DI-3(Control Panel)/REGI SNR(PC)] in diagnosis.	Go to step 6.	Go to step 10.
6	Checking the SOLENOID FEED MSI for operation Does the SOLENOID FEED MSI operate properly? Checked by [Digital Output] - [DO-2d(Control Panel)/MSI FEED CLUTCH ON(PC)] in diagnosis.	Go to step 7.	Go to step 15.
7	Checking the CLUTCH ASSY PH TURN for operation Does the CLUTCH ASSY PH TURN operate properly? Checked by [Digital Output] - [DO-2b(Control Panel)/MSI TURN CLUTCH ON(PC)] in diagnosis.	Go to step 8.	Go to step 18.
8	Checking the DRIVE ASSY PH for operation Does the DRIVE ASSY PH operate properly? Checked by [Digital Output] - [DO-a(Control Panel)/PH MOTOR(FULL)(PC)] in diagnosis.	Go to step 9.	Go to step 21.

Step	Check	Yes	No
9	<p>Checking the ROLL ASSY SEPARATER, ROLL ASSY FEED MSI and ROLL ASSY TURN for shape and operation Open the MSI. Are the ROLL ASSY SEPARATER, ROLL ASSY FEED MSI and ROLL ASSY TURN installed correctly? Also are they not contaminated and /or damaged, and rotate smoothly? Check these ROLLS by turning them with your finger.</p>	<p>Replace the PWBA MCU. (Refer to Removal 30/Replacement 14)</p>	<p>Replace the troubled ROLL(s).</p>
10	<p>Checking the connectors of the SENSOR PHOTO (REGI SENSOR) for connection Check the connections between the PWBA MCU and REGI SENSOR. Are P/J29, P/J292 and P/J2922 connected surely?</p>	<p>Go to step 11.</p>	<p>Reconnect the connector(s) P/J29, P/J292 and/or P/J2922 surely.</p>
11	<p>Checking the HARN ASSY REGI SNR for continuity Disconnect P/J2922 from the REGI SENSOR. Disconnect P/J292 from the HARN ASSY R SIDE. Is each cable of P/J2922 <=> P/J292 continuous?</p>	<p>Go to step 12.</p>	<p>Replace the HARN ASSY REGI SNR.</p>
12	<p>Checking the HARN ASSY R SIDE for continuity Disconnect P/J29 from the PWBA MCU. Disconnect P/J292 from the HARN ASSY REGI SNR. Is each cable of P/J29 <=> P/J292 continuous?</p>	<p>Go to step 13.</p>	<p>Replace the HARN ASSY R SIDE.</p>
13	<p>Checking the power to REGI SENSOR Disconnect the connector of P/J29 on the PWBA MCU. Is the voltage across ground <=> J29-8pin on the PWBA MCU, about +3.3 VDC?</p>	<p>Go to step 14.</p>	<p>Replace the PWBA MCU. (Refer to Removal 30/ Replacement 14.)</p>
14	<p>Checking the REGI SENSOR for operation Measure the voltage across ground <=> J29-10pin on the PWBA MCU. Does the voltage change, every time the actuator of the REGI SENSOR is operated?</p>	<p>Replace the PWBA MCU. (Refer to Removal 30/ Replacement 14.)</p>	<p>Replace the SENSOR PHOTO (REGI SENSOR).</p>
15	<p>Checking the connectors of the SOLENOID FEED MSI for connection Check the connections between the PWBA MCU and SOLENOID FEED MSI. Are P/J29 and P/J234 connected surely?</p>	<p>Go to step 16.</p>	<p>Reconnect the connector(s) P/J29 and/or P/J234 surely.</p>
16	<p>Checking the HARN ASSY R SIDE for continuity Disconnect P/J29 from the PWBA MCU. Disconnect P/J234 from the SOLENOID FEED MSI. Is each cable of P/J29 <=> P/J234 continuous?</p>	<p>Go to step 17.</p>	<p>Replace the HARN ASSY R SIDE.</p>
17	<p>Checking the power to SOLENOID FEED MSI Disconnect the connector of P/J29 on the PWBA MCU. Is the voltage across ground <=> J29-7pin on the PWBA MCU, about +24 VDC when the interlock switch (HARN ASSY INTERLOCK) is pushed?</p>	<p>Replace the SOLENOID FEED MSI. (Refer to Removal 15/ Replacement 29.)</p>	<p>Replace the PWBA MCU. (Refer to Removal 30/ Replacement 14.)</p>

Step	Check	Yes	No
18	Checking the connectors of the CLUTCH ASSY PH TURN for connection Check the connections between the PWBA MCU and CLUTCH ASSY PH TURN. Are P/J23 and P/J232 connected surely?	Go to step 19.	Reconnect the connector(s) P/J23 and/or P/J232 surely.
19	Checking the HARN ASSY R SIDE for continuity Disconnect P/J23 from the PWBA MCU. Disconnect P/J232 from the CLUTCH ASSY PH TURN. Is each cable of P/J23 <=> P/J232 continuous?	Go to step 20.	Replace the HARN ASSY R SIDE.
20	Checking the power to CLUTCH ASSY PH TURN Disconnect the connector of P/J23 on the PWBA MCU. Is the voltage across ground <=> J23-3pin on the PWBA MCU, about +24 VDC when the interlock switch (HARN ASSY INTERLOCK) is pushed?	Replace the CLUTCH ASSY PH TURN. (Refer to Removal 40/ Replacement 4.)	Replace the PWBA MCU. (Refer to Removal 30/ Replacement 14.)
21	Checking the connectors of the DRIVE ASSY PH for connection Check the connections between the PWBA MCU and DRIVE ASSY PH. Are P/J25 and P/J251 connected surely?	Go to step 22.	Reconnect the connector(s) P/J25 and/or P/J251 surely.
22	Checking the HARN ASSY R SIDE for continuity Disconnect P/J25 from the PWBA MCU. Disconnect P/J251 from the DRIVE ASSY PH. Is each cable of P/J25 <=> P/J251 continuous?	Go to step 23.	Replace the HARN ASSY R SIDE.
23	Checking the power to DRIVE ASSY PH Disconnect the connector of P/J25 on the PWBA MCU. Are the voltages across ground <=> J25-1pin/J25-2pin on the PWBA MCU, about +24 VDC when the interlock switch (HARN ASSY INTERLOCK) is pushed?	Replace the DRIVE ASSY PH. (Refer to Removal 17/ Replacement 27.)	Replace the PWBA MCU. (Refer to Removal 30/ Replacement 14.)

FIP1.36 Paper Jam 077-100/077-101

Step	Check	Yes	No
	Possible causative parts: ACTUATOR B (PL3.2.15) SENSOR PHOTO(REGI SENEOR) (PL3.2.30) HARN ASSY R SIDE (PL10.1.15) PWBA MCU(PL9.1.20)		
1	Checking the error Replace to known good paper. Does the error still occur when printing?	Go to step 2.	End of work
2	Checking the REGI Rolls installation Open the Front Cover and check the Regi Rolls installation. Is the ROLL REGI METAL pressed against the ROLL ASSY REGI by the spring pressure?	Go to step 3.	Replace the printer.
3	Checking the REGI CLUTCH for operation Does the clutch noise occur? Checked by [Digital Output]-[DO-29(Control Panel)/REGI CLUTCH ON (PC)] in the diagnosis.	Go to step 4.	Replace the printer.
4	Checking the SENSOR PHOTO(REGI SENEOR) for operation Does the number on the screen increase by one, when the actuator (ACTUATOR B) is operated? Checked by [Digital Input] - [DI-3(Control Panel)/REG SNR(PC)] in the diagnosis.	Replace the PWBA MCU. (Refer to Removal 30/ Replacement 14.)	Go to step 5.
5	Checking the ACTUATOR B for shape and operation Are the shape and operation of the ACTUATOR B normal?	Go to step 6.	Reseat the ACTUATOR B. If broken or deformed, replace it.
6	Checking the connectors of the SENSOR PHOTO (REGI SENEOR)) for connection Check the connections between the PWBA MCU and SENSOR PHOTO (REGI SENEOR)). Are P/J29 and P/J292 connected correctly?	Go to step 7.	Reconnect the connector(s) P/J29 and/or P/J292 correctly.
7	Checking the HARN ASSY R SIDE for continuity Disconnect J29 from the PWBA MCU. Disconnect J292 from the SENSOR PHOTO. Is each cable of J29 <=> J292 continuous?	Go to step 8.	Replace the HARN ASSY R SIDE.
8	Checking the power to the SENSOR PHOTO(REGI SENEOR) Disconnect J29 from the PWBA MCU. Is the voltage across P29-8pin <=> ground on the PWBA MCU, about +3.3 VDC?	Go to step 9.	Replace the PWBA MCU. (Refer to Removal 30/ Replacement 14.)
9	Checking the SENSOR PHOTO(REGI SENEOR) for operation Check the voltage across J29-10pin <=> ground on the PWBA MCU. Does the voltage change, when the actuator (ACTUATOR REGI IN) is operated?	Replace the PWBA MCU. (Refer to Removal 30/ Replacement 14.)	Replace the SENSOR PHOTO (REGI SENEOR).

FIP1.37 Paper Jam 077-102/077-103

Step	Check	Yes	No
	Possible causative parts: FUSER ASSY (PL6.1.10) PWBA MCU (PL9.1.20) HARN ASSY FUSER (PL6.1.11)		
1	Checking the error Replace to known good paper. Does the error still occur when printing?	Go to step 2.	End of work
2	Checking the EXIT SENSOR for operation Does the number on the screen increase by one, when the actuator of the Exit Sensor in the FUSER ASSY is operated? Checked by [Digital Input] - [DI-2(Control Panel)/EXIT SNR(PC)] in diagnosis. Warning: Start the operation after the FUSER ASSY has cooled down.	Go to step 7.	Go to step 3.
3	Checking the connectors of the SENSOR PHOTO(EXIT SENSOR) in the FUSER ASSY for connection Check the connections between the PWBA MCU and FUSER ASSY. Are P/J17 and P/J171 connected correctly?	Go to step 4.	Reconnect the connector(s) P/ J17 and/or P/J171 correctly.
4	Checking the HARN ASSY FUSER for continuity Remove the FUSER ASSY. Disconnect J17 from the PWBA MCU. Is each cable of J17 <=> P171 continuous?	Go to step 5.	Replace the HARN ASSY FUSER.
5	Checking the power to the SENSOR PHOTO(EXIT SENSOR) in the FUSER ASSY Disconnect the connector of J17 on the PWBA MCU. Is the voltage across J17-1pin <=> ground on the PWBA MCU, about +3.3 VDC?	Go to step 6.	Replace the PWBA MCU. (Refer to Removal 30/ Replacement 14.)
6	Checking the SENSOR PHOTO(EXIT SENSOR) for operation Check the voltage across J17-3pin <=> ground on the PWBA MCU. Does the voltage change, when the actuator of the Exit Sensor is operated?	Replace the PWBA MCU. (Refer to Removal 30/ Replacement 14.)	Replace the FUSER ASSY.
7	Checking the REGI ROLLs installation Open the Front Cover and check the REGI ROLLs installation. Is the ROLL REGI METAL pressed against the ROLL ASSY REGI by the spring pressure?	Go to step 8.	Replace the printer.
8	Checking the REGI CLUTCH for operation Does the clutch noise occur? Checked by [Digital Output]-[DO-29(Control Panel)/REGI CLUTCH ON(PC)] in the diagnosis.	Replace the printer.	Replace the PWBA MCU. (Refer to Removal 30/ Replacement 14.)

FIP1.38 Paper Jam 077-104/077-107

Step	Check	Yes	No
	Possible causative parts: CLUTCH DUP (PL11.2.10) MOTOR ASSY DUP (PL11.2.23) ROLL ASSY DUP1 (PL11.2.14) ROLL ASSY DUP2 (PL11.2.15) ROLL ASSY TURN (PL3.2.32) CLUTCH ASSY PH TURN (PL3.2.25) DRIVE ASSY PH (PL8.1.7) REGI SENSOR (PL3.2.30) PWBA DUP-H (PL11.1.15) PWBA MCU (PL9.1.20) HARN ASSY DUP UNIT(PL11.1.18) HARNESS ASSY FRONT COVER(PL1.2.11) HARN ASSY R SIDE(PL10.1.15) HARN ASSY REGI SNR(PL3.2.37)		
1	Checking the paper path Are there any contaminations of the toner on the paper path?	Clean the paper path.	Go to step 2.
2	Checking the Rolls installation Are the Rolls on the FEEDER ASSY DUP installed correctly?	Go to step 3.	Reinstall the Rolls.
3	Are there any damages on the surface of the Rolls on the FEEDER ASSY DUP?	Replace the FEEDER ASSY DUP. (Refer to Removal 5/ Replacement 39.)	Go to step 4.
4	Checking the CLUTCH DUP for operation Does the CLUTCH DUP operate properly? Checked by [Digital Output] - [DO-35(Control Panel)/ DUPLEX CLUTCH ON(PC)] in diagnosis.	Go to step 5.	Go to step 9.
5	Checking the MOTOR ASSY DUP for operation Does the MOTOR ASSY DUP operate properly? Checked by [Digital Output] - [DO-13(Control Panel)/ DUPLEX MOTOR ON(PC)] in diagnosis.	Go to step 6.	Go to step 16.
6	Checking the CLUTCH ASSY PH TURN for operation Does the CLUTCH ASSY PH TURN operate properly? Checked by [Digital Output] - [DO-2b (Control Panel)/MSI TURN CLUTCH ON(PC)] in diagnosis.	Go to step 7.	Go to step 18.
7	Checking the PH Motor for operation Does the PH Motor operate properly? Checked by [Digital Output] - [DO-a (Control Panel)/PH MOTOR ON(PC)] in diagnosis.	Go to step 8.	Go to step 21.
8	Checking the SENSOR PHOTO (REGI SENSOR) for operation Does the SENSOR PHOTO (REGI SENSOR) operate properly? Checked by [Digital Output] - [DI-3(Control Panel)/REGI SNR(PC)] in diagnosis.	Replace the PWBA MCU. (Refer to Removal 30/ Replacement 14.)	Go to step 24.

Step	Check	Yes	No
9	Checking the connectors of the PWBA DUP-H and CLUTCH DUP for connection Check the connections between the PWBA DUP-H and CLUTCH DUP. Are P/J431 connected surely?	Go to step 10.	Reconnect the connector(s) P/J431 surely.
10	Checking the power to the CLUTCH DUP Disconnect the connector of P/J431 on the PWBA DUP. Is the voltage across ground \Leftrightarrow J431-1pin on the PWBA DUP, about +24 VDC?	Replace the FEEDER ASSY DUP (Refer to Removal 5/ Replacement 39.)	Go to step 11.
11	Checking the connectors of the PWBA DUP-H and PWBA MCU for connection Check the connections between the PWBA DUP-H and PWBA MCU. Are P/J428, P/J2720, P/J272 and P/J27 connected surely?	Go to step 12.	Reconnect the connector(s) P/J428, P/J2720, P/J272 and/or P/J27 surely.
12	Checking the HARNESS ASSY DUP UNIT for continuity Disconnect P/J428 from the PWBA DUP-H. Disconnect P/J2720 from the HARN ASSY FRONT COVER. Is each cable of P/J428 \Leftrightarrow P/J2720 continuous?	Go to step 13.	Replace the HARNESS ASSY DUP UNIT.
13	Checking the HARNESS ASSY FRONT COVER for continuity Disconnect P/J2720 from the HARNESS ASSY DUP UNIT. Disconnect P/J272 from the HARN ASSY R SIDE. Is each cable of P/J2720 \Leftrightarrow P/J272 continuous?	Go to step 14.	Replace the HARNESS ASSY FRONT COVER.
14	Checking the HARN ASSY R SIDE for continuity Disconnect P/J272 from the HARNESS ASSY FRONT COVER. Disconnect P/J27 from the PWBA MCU. Is each cable of P/J272 \Leftrightarrow P/J27 continuous?	Go to step 15.	Replace the HARN ASSY R SIDE.
15	Checking the power to the PWBA DUP-H Disconnect the connector of P/J27 on the PWBA MCU. Is the voltage across ground \Leftrightarrow J27-15pin on the PWBA MCU, about +3.3 VDC?	Replace the FEEDER ASSY DUP (Refer to Removal 5/ Replacement 39.)	Replace the PWBA MCU. (Refer to Removal 30/ Replacement 14.)
16	Checking the connectors of the PWBA DUP-H and MOTOR ASSY DUP for connection Check the connections between the PWBA DUP-H and MOTOR ASSY DUP. Are P/J429 connected surely?	Go to step 17.	Reconnect the connector(s) P/J429 surely.
17	Checking the power to the MOTOR ASSY DUP Disconnect the connector of P/J429 on the PWBA DUP. Is the voltage across ground \Leftrightarrow J429-2pin on the PWBA DUP, about +24 VDC?	Replace the FEEDER ASSY DUP (Refer to Removal 5/ Replacement 39.)	Go to step 11.

Step	Check	Yes	No
18	Checking the connectors of the CLUTCH ASSY PH TURN for connection Check the connections between the PWBA MCU and CLUTCH ASSY PH TURN. Are P/J23 and P/J232 connected surely?	Go to step 19.	Reconnect the connector(s) P/J23 and/or P/J232 surely.
19	Checking the HARN ASSY R SIDE for continuity Disconnect P/J23 from the PWBA MCU. Disconnect P/J232 from the CLUTCH ASSY PH TURN. Is each cable of P/J23 <=> P/J232 continuous?	Go to step 20.	Replace the HARN ASSY R SIDE.
20	Checking the power to CLUTCH ASSY PH TURN Disconnect the connector of P/J23 on the PWBA MCU. Is the voltage across ground <=> J23-3pin on the PWBA MCU, about +24 VDC?	Replace the CLUTCH ASSY PH TURN.	Replace the PWBA MCU. (Refer to Removal 30/ Replacement 14.)
21	Checking the connectors of the DRIVE ASSY PH for connection Check the connections between the PWBA MCU and DRIVE ASSY PH. Are P/J25 and P/J251 connected surely?	Go to step 22.	Reconnect the connector(s) P/J25 and/or P/J251 surely.
22	Checking the HARN ASSY R SIDE for continuity Disconnect P/J25 from the PWBA MCU. Disconnect P/J251 from the DRIVE ASSY PH. Is each cable of P/J25 <=> P/J251 continuous?	Go to step 23.	Replace the HARN ASSY R SIDE.
23	Checking the power to DRIVE ASSY PH Disconnect the connector of P/J25 on the PWBA MCU. Are the voltages across ground <=> J25-1pin/J25-2pin on the PWBA MCU, about +24 VDC?	Replace the DRIVE ASSY PH. (Refer to Removal 17/ Replacement 27.)	Replace the PWBA MCU. (Refer to Removal 30/ Replacement 14.)
24	Checking the connectors of the SENSOR PHOTO (REGI SENSOR) for connection Check the connections between the PWBA MCU and REGI SENSOR. Are P/J29, P/J292 and P/J2922 connected surely?	Go to step 25.	Reconnect the connector(s) P/J29, P/J292 and/or P/J2922 surely.
25	Checking the HARNESS ASSY REGI SNR for continuity Disconnect P/J2922 from the REGI SENSOR. Disconnect P/J292 from the HARN ASSY R SIDE. Is each cable of P/J2922 <=> P/J292 continuous?	Go to step 26.	Replace the HARNESS ASSY REGI SNR.
26	Checking the HARN ASSY R SIDE for continuity Disconnect P/J29 from the PWBA MCU. Disconnect P/J292 from the HARN ASSY REGI SNR. Is each cable of P/J29 <=> P/J292 continuous?	Go to step 27.	Replace the HARN ASSY R SIDE.
27	Checking the power to REGI SENSOR Disconnect the connector of P/J29 on the PWBA MCU. Is the voltage across ground <=> J29-8pin on the PWBA MCU, about +3.3 VDC?	Go to step 28.	Replace the PWBA MCU. (Refer to Removal 30/ Replacement 14.)

Step	Check	Yes	No
28	Checking the SENSOR PHOTO (REGI SENSOR) for operation Disconnect the connector of P/J29 on the PWBA MCU. Is the voltage across ground \leftrightarrow J29-10pin on the PWBA MCU Does the voltage change, every time the actuator of the REGI SENSOR is operated?	Replace the PWBA MCU. (Refer to Removal 30/ Replacement 14.)	Replace the SENSOR PHOTO (REGI SENSOR).

FIP1.39 Paper Jam 077-105/077-106

Step	Check	Yes	No
	Possible causative parts: DUP JAM SENSOR (PL11.1.12) CLUTCH DUP (PL11.2.10) MOTOR ASSY DUP (PL11.2.23) ROLL ASSY DUP1 (PL11.2.14) ROLL ASSY DUP2 (PL11.2.15) PWBA DUP (PL11.1.15) PWBA MCU (PL9.1.20) HARN ASSY DUP UNIT(PL11.1.18) HARNESS ASSY FRONT COVER(PL1.2.11) HARN ASSY R SIDE(PL10.1.15) HARN ASSY DUP SNR(PL11.1.13)		
1	Checking the paper path Are there any contaminations of the toner on the paper path?	Clean the paper path.	Go to step 2.
2	Checking the Rolls installation Are the Rolls on the FEEDER ASSY DUP installed correctly?	Go to step 3.	Reinstall the Rolls.
3	Are there any damages on the surface of the Rolls on the FEEDER ASSY DUP?	Replace the FEEDER ASSY DUP (Refer to Removal 5/ Replacement 39.)	Go to step 4.
4	Checking the SENSOR PHOTO (DUP JAM SENSOR) for operation Does the SENSOR PHOTO (DUP JAM SENSOR) operate properly? Checked by [Digital Output] - [DI-1(Control Panel)/DUP SNR(PC)] in diagnosis.	Go to step 5.	Go to step 7.
5	Checking the CLUTCH DUP for operation Does the CLUTCH DUP operate properly? Checked by [Digital Output] - [DO-35(Control Panel)/DUPLEX CLUTCH ON(PC)] in diagnosis.	Go to step 6.	Go to step 16.
6	Checking the MOTOR ASSY DUP for operation Does the MOTOR ASSY DUP operate properly? Checked by [Digital Output] - [DO-13(Control Panel)/DUPLEX MOTOR ON(PC)] in diagnosis.	Replace the FEEDER ASSY DUP (Refer to Removal 5/ Replacement 39.)	Go to step 23.
7	Checking the connectors of the PWBA DUP-H and SENSOR PHOTO (DUP JAM SENSOR) for connection Check the connections between the PWBA DUP-H and SENSOR PHOTO (DUP JAM SENSOR). Are P/J430 and P/J4301 connected surely?	Go to step 8.	Reconnect the connector(s) P/J430 and/or P/J4301 surely.
8	Checking the HARNESS ASSY DUP SNR for continuity Disconnect P/J4301 from the REGI SENSOR. Disconnect P/J430 from the PWBA DUP-H. Is each cable of P/J430 <=> P/J4301 continuous?	Go to step 9.	Replace the HARNESS ASSY DUP SNR.

Step	Check	Yes	No
9	Checking the power to the DUP JAM SENSOR Disconnect the connector of P/J430 on the PWBA DUP-H. Is the voltage across ground \Leftrightarrow J430-1pin on the PWBA DUP, about +3.3 VDC?	Go to step 10.	Go to step 11.
10	Checking the SENSOR PHOTO (DUP JAM SENSOR) for operation Disconnect the connector of P/J430 on the PWBA DUP-H. Is the voltage across ground \Leftrightarrow J430-3pin on the PWBA MCU Does the voltage change, every time the actuator of the DUP JAM SENSOR is operated?	Go to step 11.	Replace the FEEDER ASSY DUP. (Refer to Removal 5/ Replacement 39.)
11	Checking the connectors of the PWBA DUP-H and PWBA MCU for connection Check the connections between the PWBA DUP-H and PWBA MCU. Are P/J428, P/J2720, P/J272 and P/J27 connected surely?	Go to step 12.	Reconnect the connector(s) P/J428, P/J2720, P/J272 and/or P/J27 surely.
12	Checking the HARNESS ASSY DUP UNIT for continuity Disconnect P/J428 from the PWBA DUP-H. Disconnect P/J2720 from the HARNESS ASSY FRONT COVER. Is each cable of P/J428 \Leftrightarrow P/J2720 continuous?	Go to step 13.	Replace the HARNESS ASSY DUP UNIT.
13	Checking the HARNESS ASSY FRONT COVER for continuity Disconnect P/J2720 from the HARNESS ASSY DUP UNIT. Disconnect P/J272 from the HARN ASSY R SIDE. Is each cable of P/J2720 \Leftrightarrow P/J272 continuous?	Go to step 14.	Replace the HARNESS ASSY FRONT COVER.
14	Checking the HARN ASSY R SIDE for continuity Disconnect P/J272 from the HARNESS ASSY FRONT COVER. Disconnect P/J27 from the PWBA MCU. Is each cable of P/J272 \Leftrightarrow P/J27 continuous?	Go to step 15.	Replace the HARN ASSY R SIDE.
15	Checking the power to the PWBA DUP-H Disconnect the connector of P/J27 on the PWBA MCU. Is the voltage across ground \Leftrightarrow J27-17pin / J27-18pin on the PWBA MCU, about +24 VDC?	Replace the FEEDER ASSY DUP (Refer to Removal 5/ Replacement 39.)	Replace the PWBA MCU. (Refer to Removal 30/ Replacement 14.)
16	Checking the connectors of the PWBA DUP-H and CLUTCH DUP for connection Check the connections between the PWBA DUP-H and CLUTCH DUP. Are P/J431 connected surely?	Go to step 17.	Reconnect the connector(s) P/J431 surely.
17	Checking the power to the CLUTCH DUP Disconnect the connector of P/J431 on the PWBA DUP. Is the voltage across ground \Leftrightarrow J431-1pin on the PWBA DUP, about +24 VDC?	Replace the FEEDER ASSY DUP (Refer to Removal 5/ Replacement 39.)	Go to step 18.

Step	Check	Yes	No
18	Checking the connectors of the PWBA DUP-H and PWBA MCU for connection Check the connections between the PWBA DUP-H and PWBA MCU. Are P/J428, P/J2720, P/J272 and P/J27 connected surely?	Go to step 19.	Reconnect the connector(s) P/J428, P/J2720, P/J272 and/or P/J27 surely.
19	Checking the HARNESS ASSY DUP UNIT for continuity Disconnect P/J428 from the PWBA DUP-H. Disconnect P/J2720 from the HARN ASSY FRONT COVER. Is each cable of P/J428 <=> P/J2720 continuous?	Go to step 20.	Replace the HARNESS ASSY DUP UNIT.
20	Checking the HARNESS ASSY FRONT COVER for continuity Disconnect P/J2720 from the HARNESS ASSY DUP UNIT. Disconnect P/J272 from the HARN ASSY R SIDE. Is each cable of P/J2720 <=> P/J272 continuous?	Go to step 21.	Replace the HARNESS ASSY FRONT COVER.
21	Checking the HARN ASSY R SIDE for continuity Disconnect P/J272 from the HARNESS ASSY FRONT COVER. Disconnect P/J27 from the PWBA MCU. Is each cable of P/J272 <=> P/J27 continuous?	Go to step 22.	Replace the HARN ASSY R SIDE.
22	Checking the power to the PWBA DUP-H Disconnect the connector of P/J27 on the PWBA MCU. Is the voltage across ground <=> J27-15pin on the PWBA MCU, about +3.3 VDC?	Replace the FEEDER ASSY DUP (Refer to Removal 5/ Replacement 39.)	Replace the PWBA MCU. (Refer to Removal 30/ Replacement 14.)
23	Checking the connectors of the PWBA DUP-H and MOTOR ASSY DUP for connection Check the connections between the PWBA DUP-H and MOTOR ASSY DUP. Are P/J429 connected surely?	Go to step 24.	Reconnect the connector(s) P/J429 surely.
24	Checking the power to the MOTOR ASSY DUP Disconnect the connector of P/J429 on the PWBA DUP. Is the voltage across ground <=> J429-2pin on the PWBA DUP, about +24 VDC?	Replace the FEEDER ASSY DUP (Refer to Removal 5/ Replacement 39.)	Go to step 18.

FIP1.40 Paper Jam 077-900/077-901

Step	Check	Yes	No
	Possible causative parts: ROLL REGI RUBBER (PL3.2.7) SENSOR PHOTO (REGI SENSOR) (PL3.2.30) CLUTCH ASSY PH REGI (PL3.2.23) DRIVE ASSY PH (PL8.1.7) DRIVE ASSY MAIN (PL8.1.2) HARN ASSY REGI SNR (PL3.2.37) HARN ASSY FUSER (PL6.1.11) HARN ASSY R SIDE (PL10.1.15) PWBA MCU (PL9.1.20)		
1	Checking the paper condition Is the paper in the Tray wrinkled or damaged?	Replace the paper with a new and dry one, then go to step 2.	Go to step 2.
2	Checking the COVER ASSY FRONT for latching Open and close the COVER ASSY FRONT, then check the latching. Does the error still occur when printing?	Go to step 3.	End of work
3	Checking after reseating the FUSER ASSY Reseat the FUSER ASSY. Warning: Start the operation after the FUSER ASSY has cooled down. Does the error still occur when printing?	Go to step 4.	End of work
4	Checking the EXIT SENSOR for operation Does the number on the screen increase by one, every time the actuator of the EXIT SENSOR is operated? Checked by [Digital Input] - [DI-2(Control Panel)/EXIT SNR(PC)] in diagnosis. Warning: Start the operation after the FUSER ASSY has cooled down.	Go to step 5.	Go to step 13.
5	Checking the SENSOR PHOTO (REGI SENSOR) for operation Does the number on the screen increase by one, every time the actuator of the SENSOR PHOTO (REGI SENSOR) is operated? Checked by [Digital Input] - [DI-3(Control Panel)/REGI SNR(PC)] in diagnosis.	Go to step 6.	Go to step 17.
6	Checking the Main Motor for operation Does the Main Motor operate properly? Checked by [Digital Output] - [DO-0(Control Panel)/MAIN MOTOR(PC)] in diagnosis.	Go to step 7.	Go to step 22.
7	Checking the Sub Motor for operation Does the Sub Motor operate properly? Checked by [Digital Output] - [DO-5(Control Panel)/SUB MOTOR(PC)] in diagnosis.	Go to step 8.	Go to step 25.
8	Checking the PH Motor for operation Does the PH Motor operate properly? Checked by [Digital Output] - [DO-a(Control Panel)/PH MOTOR ON(PC)] in diagnosis.	Go to step 9.	Go to step 28.

Step	Check	Yes	No
9	Checking the CLUTCH ASSY PH REGI for operation Does the CLUTCH ASSY PH REGI operate properly? Checked by [Digital Output] - [DO-29(Control Panel)/REGI CLUTCH ON(PC)] in diagnosis.	Go to step 10.	Go to step 31.
10	Checking the FUSER Are there any remaining paper and/or foreign substance in the FUSER ASSY? Warning: Start the operation after the FUSER ASSY has cooled down.	Remove the paper and/or substance, then go to step 11.	Go to step 11.
11	Checking the ROLL REGI RUBBER and ROLL REGI METAL for shape and operation Are ROLL REGI RUBBER and ROLL REGI METAL installed correctly? Also are they not contaminated and /or damaged, and rotate smoothly? Check these ROLLS by turning them with your finger.	Go to step 12.	Replace the defective ROLL(s).
12	Checking the TRANSFER ASSY for installation Reseat the TRANSFER ASSY. Does the error still occur when printing?	Replace the PWBA MCU. (Refer to Removal 30/Replacement 14)	End of work
13	Checking the connectors of the Exit Sensor on the FUSER ASSY for connection Check the connections between the PWBA MCU and FUSER ASSY. Are P/J17 and P/J171 connected surely?	Go to step 14.	Reconnect the connector(s) P/J17 and/or P/J171 surely.
14	Checking the HARN ASSY FUSER for continuity Disconnect P/J17 from the PWBA MCU. Disconnect P/J171 from the FUSER. Is each cable of P/J17 <=> P/J171 continuous?	Go to step 15.	Replace the HARN ASSY FUSER.
15	Checking the power to Exit Sensor on the FUSER ASSY Disconnect the connector of P/J17 on the PWBA MCU. Is the voltage across ground <=> J17-1pin on the PWBA MCU, about +3.3 VDC?	Go to step 16.	Replace the PWBA MCU. (Refer to Removal 30/Replacement 14.)
16	Checking the Exit Sensor for operation Measure the voltage across ground <=> P/J17-3pin on the PWBA MCU. Does the voltage change, every time the actuator of the Exit Sensor is operated?	Replace the PWBA MCU. (Refer to Removal 30/Replacement 14.)	Replace the FUSER ASSY. (Refer to Removal 8/Replacement 36.)
17	Checking the connectors of the SENSOR PHOTO (REGI SENSOR) for connection Check the connections between the PWBA MCU and REGI SENSOR. Are P/J29, P/J292 and P/J2922 connected surely?	Go to step 18.	Reconnect the connector(s) P/J29, P/J292 and/or P/J2922 surely.
18	Checking the HARN ASSY REGI SNR for continuity Disconnect P/J2922 from the REGI SENSOR. Disconnect P/J292 from the HARN ASSY R SIDE. Is each cable of P/J2922 <=> P/J292 continuous?	Go to step 19.	Replace the HARN ASSY REGI SNR.

Step	Check	Yes	No
19	Checking the HARN ASSY R SIDE for continuity Disconnect P/J29 from the PWBA MCU. Disconnect P/J292 from the HARN ASSY REGI SNR. Is each cable of P/J29 <=> P/J292 continuous?	Go to step 20.	Replace the HARN ASSY R SIDE.
20	Checking the power to REGI SENSOR Disconnect the connector of P/J29 on the PWBA MCU. Is the voltage across ground <=> J29-8pin on the PWBA MCU, about +3.3 VDC?	Go to step 21.	Replace the PWBA MCU. (Refer to Removal 30/Replacement 14.)
21	Checking the REGI SENSOR for operation Measure the voltage across ground <=> J29-10pin on the PWBA MCU. Does the voltage change, every time the actuator of the REGI SENSOR is operated?	Replace the PWBA MCU. (Refer to Removal 30/Replacement 14.)	Replace the SENSOR PHOTO (REGI SENSOR).
22	Checking the connectors of the Main Motor on the DRIVE ASSY MAIN for connection Check the connections between the PWBA MCU and DRIVE ASSY MAIN. Are P/J22 and P/J222 connected surely?	Go to step 23.	Reconnect the connector(s) P/J22 and/or P/J222 surely.
23	Checking the HARN ASSY R SIDE for continuity Disconnect P/J22 from the PWBA MCU. Disconnect P/J222 from the DRIVE ASSY MAIN. Is each cable of P/J22 <=> P/J222 continuous?	Go to step 24.	Replace the HARN ASSY R SIDE.
24	Checking the power to DRIVE ASSY MAIN Disconnect the connector of P/J22 on the PWBA MCU. Are the voltages across ground <=> J22-B2pin/J22-B4pin on the PWBA MCU, about +24 VDC when the interlock switch (HARN ASSY INTERLOCK) is pushed?	Replace the DRIVE ASSY MAIN. (Refer to Removal 38/Replacement 6.)	Replace the PWBA MCU. (Refer to Removal 30/Replacement 14.)
25	Checking the connectors of the Sub Motor on the DRIVE ASSY MAIN for connection Check the connections between the PWBA MCU and DRIVE ASSY MAIN. Are P/J22 and P/J221 connected surely?	Go to step 26.	Reconnect the connector(s) P/J22 and/or P/J221 surely.
26	Checking the HARN ASSY R SIDE for continuity Disconnect P/J22 from the PWBA MCU. Disconnect P/J221 from the DRIVE ASSY MAIN. Is each cable of P/J22 <=> P/J221 continuous?	Go to step 27.	Replace the HARN ASSY R SIDE.
27	Checking the power to DRIVE ASSY MAIN Disconnect the connector of P/J22 on the PWBA MCU. Are the voltages across ground <=> J22-A2pin/J22-A4pin on the PWBA MCU, about +24 VDC when the interlock switch (HARN ASSY INTERLOCK) is pushed?	Replace the DRIVE ASSY MAIN. (Refer to Removal 38/Replacement 6.)	Replace the PWBA MCU. (Refer to Removal 30/Replacement 14.)
28	Checking the connectors of the DRIVE ASSY PH for connection Check the connections between the PWBA MCU and DRIVE ASSY PH. Are P/J25 and P/J251 connected surely?	Go to step 22.	Reconnect the connector(s) P/J25 and/or P/J251 surely.

Step	Check	Yes	No
29	Checking the HARN ASSY R SIDE for continuity Disconnect P/J25 from the PWBA MCU. Disconnect P/J251 from the DRIVE ASSY PH. Is each cable of P/J25 <=> P/J251 continuous?	Go to step 23.	Replace the HARN ASSY R SIDE.
30	Checking the power to DRIVE ASSY PH Disconnect the connector of P/J25 on the PWBA MCU. Are the voltages across ground <=> J25-1pin/J25-2pin on the PWBA MCU, about +24 VDC when the interlock switch (HARN ASSY INTERLOCK) is pushed?	Replace the DRIVE ASSY PH. (Refer to Removal 17/Replacement 27.)	Replace the PWBA MCU. (Refer to Removal 30/Replacement 14.)
31	Checking the connectors of the CLUTCH ASSY PH REGI for connection Check the connections between the PWBA MCU and CLUTCH ASSY PH REGI. Are P/J23 and P/J231 connected surely?	Go to step 32.	Reconnect the connector(s) P/J23 and/or P/J231 surely.
32	Checking the HARN ASSY R SIDE for continuity Disconnect P/J23 from the PWBA MCU. Disconnect P/J231 from the CLUTCH ASSY PH REGI. Is each cable of P/J23 <=> P/J231 continuous?	Go to step 33.	Replace the HARN ASSY R SIDE.
33	Checking the power to CLUTCH ASSY PH REGI Disconnect the connector of P/J23 on the PWBA MCU. Is the voltage across ground <=> J23-1pin on the PWBA MCU, about +24 VDC when the interlock switch (HARN ASSY INTERLOCK) is pushed?	Replace the CLUTCH ASSY PH REGI. (Refer to Removal 40/Replacement 4.)	Replace the PWBA MCU. (Refer to Removal 30/Replacement 14.)

FIP1.41 Paper Jam 077-903

Step	Check	Yes	No
	Possible causative parts: HARN ASSY REGI SNR (PL3.2.37) HARN ASSY R SIDE (PL10.1.15) SENSOR PHOTO (REGI SENSOR) (PL3.2.30) PWBA MCU (PL9.1.20)		
1	Checking the jam Remove the jammed paper. Does the error still occur when printing?	Go to step 2.	End of work
2	Checking the SENSOR PHOTO (REGI SENSOR) for operation Does the number on the screen increase by one, every time the actuator of the SENSOR PHOTO (REGI SENSOR) is operated? Checked by [Digital Input] - [DI-3(Control Panel)/REGI SNR(PC)] in diagnosis.	Go to step 3.	Go to step 4.
3	Checking the paper feed Does the multiple paper feed occur?	Go to Multiple Feed in Other FIP.	Replace the PWBA MCU. (Refer to Removal 30/Replacement 14)
4	Checking the connectors of the SENSOR PHOTO (REGI SENSOR) for connection Check the connections between the PWBA MCU and REGI SENSOR. Are P/J29, P/J292 and P/J2922 connected surely?	Go to step 5.	Reconnect the connector(s) P/J29, P/J292 and/or P/J2922 surely.
5	Checking the HARNESS ASSY REGI SNR for continuity Disconnect P/J2922 from the REGI SENSOR. Disconnect P/J292 from the HARN ASSY R SIDE. Is each cable of P/J2922 <=> P/J292 continuous?	Go to step 6.	Replace the HARN ASSY REGI SNR.
6	Checking the HARN ASSY R SIDE for continuity Disconnect P/J29 from the PWBA MCU. Disconnect P/J292 from the HARN ASSY REGI SNR. Is each cable of P/J29 <=> P/J292 continuous?	Go to step 7.	Replace the HARN ASSY R SIDE.
7	Checking the power to REGI SENSOR Disconnect the connector of P/J29 on the PWBA MCU. Is the voltage across ground <=> J29-8pin on the PWBA MCU, about +3.3 VDC?	Go to step 8.	Replace the PWBA MCU. (Refer to Removal 30/Replacement 14.)
8	Checking the REGI SENSOR for operation Measure the voltage across ground <=> J29-10pin on the PWBA MCU. Does the voltage change, every time the actuator of the REGI SENSOR is operated?	Replace the PWBA MCU. (Refer to Removal 30/Replacement 14.)	Replace the SENSOR PHOTO (REGI SENSOR).

FIP1.42 Paper Jam 077-907

Step	Check	Yes	No
	Possible causative parts: CHUTE ASSY EXIT OUT (PL6.1.1) CHUTE DUP GATE (PL6.1.13) FEEDER ASSY DUP (PL11.1.1) DRIVE ASSY PH (PL8.1.7) CLUTCH ASSY PH TURN (PL3.2.25) HARN ASSY R SIDE (PL10.1.15) HARN ASSY DUP UNIT (PL11.1.18) HARNESS ASSY FRONT COVER (PL1.2.11) PWBA DUP-H (PL11.1.15) PWBA MCU (PL9.1.20)		
1	Checking the COVER ASSY FRONT for latching Open and close the COVER ASSY FRONT, then check the latching. Does the error still occur when printing?	Go to step 2.	End of work
2	Checking after reseating the FUSER ASSY Reseat the FUSER ASSY. Warning: Start the operation after the FUSER ASSY has cooled down. Does the error still occur when printing?	Go to step 3.	End of work
3	Checking after reseating the FEEDER ASSY DUP Reseat the FEEDER ASSY DUP. Does the error still occur when printing?	Go to step 4.	End of work
4	Checking the CHUTE DUP GATE for the shape and installation Are the shape and the installation of the CHUTE DUP GATE normal?	Go to step 5.	Reseat or replace the CHUTE DUP GATE.
5	Checking the CHUTE ASSY EXIT OUT for shape and installation Are the shape and the installation of the CHUTE ASSY EXIT OUT normal?	Go to step 6.	Reseat the CHUTE ASSY EXIT OUT. If broken, replace the CHUTE ASSY EXIT OUT. (Refer to Removal 9/Replacement 35)
6	Checking the SENSOR PHOTO (DUP JAM SENSOR) for operation Does the number on the screen increase by one, every time the actuator of the SENSOR PHOTO (DUP JAM SENSOR) is operated? Checked by [Digital Input] - [DI-1(Control Panel)/DUP SNR(PC)] in diagnosis.	Go to step 7.	Go to step 11.
7	Checking the CLUTCH DUP for operation Does the CLUTCH DUP operate properly? Checked by [Digital Output] - [DO-35(Control Panel)/DUPLEX CLUTCH ON(PC)] in diagnosis.	Go to step 8.	Go to step 11.

Step	Check	Yes	No
8	Checking the MOTOR ASSY DUP for operation Does the MOTOR ASSY DUP operate properly? Checked by [Digital Output] - [DO-13(Control Panel)/DUPLEX MOTOR ON(PC)] in diagnosis.	Go to step 9.	Go to step 11.
9	Checking the CLUTCH ASSY PH TURN for operation Does the CLUTCH ASSY PH TURN operate properly? Checked by [Digital Output] - [DO-2b(Control Panel)/MSI TURN CLUTCH ON(PC)] in diagnosis.	Go to step 10.	Go to step 17.
10	Checking the PH Motor for operation Does the PH Motor operate properly? Checked by [Digital Output] - [DO-a(Control Panel)/PH MOTOR ON(PC)] in diagnosis.	Replace the PWBA MCU. (Refer to Removal 30/Replacement 14)	Go to step 20.
11	Checking the connectors of the PWBA DUP-H and PWBA MCU for connection Check the connections between the PWBA DUP-H and PWBA MCU. Are P/J428, P/J2720, P/J272 and P/J27 connected surely?	Go to step 12.	Reconnect the connector(s) P/J428, P/J2720, P/J272 and/or P/J27 surely.
12	Checking the HARN ASSY DUP UNIT for continuity Disconnect P/J428 from the PWBA DUP. Disconnect P/J2720 from the HARN ASSY FRONT COVER. Is each cable of P/J428 <=> P/J2720 continuous?	Go to step 13.	Replace the HARN ASSY DUP UNIT.
13	Checking the HARNESS ASSY FRONT COVER for continuity Disconnect P/J2720 from the HARNESS ASSY DUP UNIT. Disconnect P/J272 from the HARN ASSY R SIDE. Is each cable of P/J2720 <=> P/J272 continuous?	Go to step 14.	Replace the HARNESS ASSY FRONT COVER.
14	Checking the HARN ASSY R SIDE for continuity Disconnect P/J272 from the HARNESS ASSY FRONT COVER. Disconnect P/J27 from the PWBA MCU. Is each cable of P/J272 <=> P/J27 continuous?	Go to step 15.	Replace the HARN ASSY R SIDE.
15	Checking the power to the PWBA DUP-H <The check of DUP JAM SENSOR> Disconnect the connector of P/J27 on the PWBA MCU. Is the voltage across ground <=> J27-15pin on the PWBA MCU, about +3.3 VDC? <The check of CLUTCH DUP/MOTOR ASSY DUP > Disconnect the connector of P/J27 on the PWBA MCU. Is the voltage across ground <=> J27-17,18pin on the PWBA MCU, about +24 VDC?	Go to step 16.	Replace the PWBA MCU. (Refer to Removal 30/Replacement 14.)
16	Checking after replacing the PWBA DUP-H Replace the PWBA DUP-H. Does the error still occur when the power is turned ON?	End of work	Replace the FEEDER ASSY DUP (Refer to Removal 5/Replacement 39.)

Step	Check	Yes	No
17	Checking the connectors of the CLUTCH ASSY PH TURN for connection Check the connections between the PWBA MCU and CLUTCH ASSY PH TURN. Are P/J23 and P/J232 connected surely?	Go to step 18.	Reconnect the connector(s) P/J23 and/or P/J232 surely.
18	Checking the HARN ASSY R SIDE for continuity Disconnect P/J23 from the PWBA MCU. Disconnect P/J232 from the CLUTCH ASSY PH TURN. Is each cable of P/J23 <=> P/J232 continuous?	Go to step 19.	Replace the HARN ASSY R SIDE.
19	Checking the power to CLUTCH ASSY PH TURN Disconnect the connector of P/J23 on the PWBA MCU. Is the voltage across ground <=> J23-3pin on the PWBA MCU, about +24 VDC when the interlock switch (HARN ASSY INTERLOCK) is pushed?	Replace the CLUTCH ASSY PH TURN. (Refer to Removal 40/Replacement 4.)	Replace the PWBA MCU. (Refer to Removal 30/Replacement 14.)
20	Checking the connectors of the DRIVE ASSY PH for connection Check the connections between the PWBA MCU and DRIVE ASSY PH. Are P/J25 and P/J251 connected surely?	Go to step 21.	Reconnect the connector(s) P/J25 and/or P/J251 surely.
21	Checking the HARN ASSY R SIDE for continuity Disconnect P/J25 from the PWBA MCU. Disconnect P/J251 from the DRIVE ASSY PH. Is each cable of P/J25 <=> P/J251 continuous?	Go to step 22.	Replace the HARN ASSY R SIDE.
22	Checking the power to DRIVE ASSY PH Disconnect the connector of P/J25 on the PWBA MCU. Are the voltages across ground <=> J25-1pin/J25-2pin on the PWBA MCU, about +24 VDC when the interlock switch (HARN ASSY INTERLOCK) is pushed?	Replace the DRIVE ASSY PH. (Refer to Removal 17/Replacement 27.)	Replace the PWBA MCU. (Refer to Removal 30/Replacement 14.)

FIP1.43 Load Tray N or MPF 024-910/024-911/024-914

Step	Check	Yes	No
	Possible causative parts: CASSETTE ASSY 250 (PL2.1.1) CASSETTE ASSY 550 OPT (PL12.4.1) SWITCH ASSY SIZE (PL7.1.18) SWITCH ASSY SIZE OPT (PL12.2.5) HARN ASSY REGI SNR (PL3.2.37) HARN ASSY R SIDE (PL10.1.15) SENSOR PHOTO (REGI SENSOR) (PL3.2.30) PWBA MCU (PL9.1.20)		
1	Checking the paper size Does the paper size in use meet the specification?	Go to step 2.	Use the paper that meets the specification.
2	Checking the paper for size setup Does the paper size in use match the size set through the control panel?	For Tray1 and Tray2: Go to step 4. For MPF: Go to step 6.	Set the paper size through the control panel, then go to step 3.
3	Does the error still occur when printing?	For Tray1 and Tray2: Go to step 4. For MPF: Go to step 6.	End of work
4	Checking after reseating the Paper Cassette Guide Reseat the end guide of the Paper Cassette. Does the error still occur when printing?	Go to step 5.	End of work
5	Checking after replacing the CASSETTE ASSY 250 or 550 Replace the CASSETTE ASSY 250 or 550. Does the error still occur when printing?	Go to step 7.	End of work
6	Checking the SENSOR PHOTO (REGI SENSOR) for operation Does the number on the screen increase by one, every time the actuator of the SENSOR PHOTO (REGI SENSOR) is operated? Checked by [Digital Input] - [DI-3(Control Panel)/REGI SNR(PC)] in diagnosis.	Replace the PWBA MCU. (Refer to Removal 30/Replacement 14).	Go to step 10.
7	Checking the SWITCH ASSY SIZE of Tray 1 for operation Does the SWITCH ASSY SIZE operate properly? Checked by [Digital Input] - [DI-18(Control Panel)/CASSETTE1 SIZE(PC)] in diagnosis.	Go to step 8.	Replace the SWITCH ASSY SIZE. (Refer to Removal 18/Replacement 26)
8	Checking the SWITCH ASSY SIZE of Tray 2 for operation Does the SWITCH ASSY SIZE OPT operate properly? Checked by [Digital Input] - [DI-20(Control Panel)/CASSETTE2 SIZE(PC)] in diagnosis.	Go to step 9.	Replace the SWITCH ASSY SIZE OPT. (Refer to Removal 44/Replacement 46)

Step	Check	Yes	No
9	Checking the ROLLS for rotation Do the ROLLS rotate smoothly? Check the rotation with your finger.	Replace the PWBA MCU. (Refer to Removal 30/Replacement 14)	Replace the defective ROLL(s).
10	Checking the connectors of the SENSOR PHOTO (REGI SENSOR) for connection Check the connections between the PWBA MCU and REGI SENSOR. Are P/J29, P/J292 and P/J2922 connected surely?	Go to step 5.	Reconnect the connector(s) P/J29, P/J292 and/or P/J2922 surely.
11	Checking the HARN ASSY REGI SNR for continuity Disconnect P/J2922 from the REGI SENSOR. Disconnect P/J292 from the HARN ASSY R SIDE. Is each cable of P/J2922 <=> P/J292 continuous?	Go to step 6.	Replace the HARN ASSY REGI SNR.
12	Checking the HARN ASSY R SIDE for continuity Disconnect P/J29 from the PWBA MCU. Disconnect P/J292 from the HARN ASSY REGI SNR. Is each cable of P/J29 <=> P/J292 continuous?	Go to step 7.	Replace the HARN ASSY R SIDE.
13	Checking the power to REGI SENSOR Disconnect the connector of P/J29 on the PWBA MCU. Is the voltage across ground <=> J29-8pin on the PWBA MCU, about +3.3 VDC?	Go to step 8.	Replace the PWBA MCU. (Refer to Removal 30/Replacement 14.)
14	Checking the REGI SENSOR for operation Measure the voltage across ground <=> J29-10pin on the PWBA MCU. Does the voltage change, every time the actuator of the REGI SENSOR is operated?	Replace the PWBA MCU. (Refer to Removal 30/Replacement 14.)	Replace the SENSOR PHOTO (REGI SENSOR).

FIP1.44 Load Tray N or MPF 024-965/024-966/024-969

Step	Check	Yes	No
	Possible causative parts: HARN ASSY R SIDE (PL10.1.15) HARN ASSY REGI SNR (PL3.2.37) HARN ASSY C2 CHUTE (PL12.2.7) HARN ASSY C2 NO PAPER (PL12.3.30) HARN ASSY FDR UNIT (PL12.2.3) HARN ASSY MSI NPP (PL3.1.17) SENSOR PHOTO (CST NO PAPER SENSOR) (PL3.2.30) SENSOR PHOTO (CST NO PAPER SENSOR) (PL12.3.14) SENSOR PHOTO (MSI NO PAPER SENSOR) (PL3.1.15) PWBA OPT FDR (PL12.2.6) PWBA MCU (PL9.1.20)		
1	Checking the paper Is there the paper in the specified tray or the cassette?	Go to step 2.	Load the paper.
2	Checking the paper size Check the paper size below. - Paper in the cassette or the tray - Paper size setting through the control panel - Paper size of the printing job Are these paper sizes the same?	Go to step 3.	Change the paper, paper size setting or printing job.
3	Checking the paper type Check the paper type below. - Paper in the cassette or the tray - Paper type setting through the control panel - Paper type of the printing job Are these paper types the same?	For Tray; Go to step 4. For MPF: Go to step 9.	Change the paper, paper type setting or printing job.
4	Checking after reseating the CASSETTE ASSY 250 or 550 Reseat the CASSETTE ASSY 250 or 550. Does the error still occur when printing?	For Tray 1: Go to step 5. For Tray 2: Go to step 7.	End of work
5	Checking the ACTUATOR NO PAPER A4 for operation Does the ACTUATOR NO PAPER A4 operate smoothly?	Go to step 6.	Replace the ACTUATOR NO PAPER A4.
6	Checking the SENSOR PHOTO (CST NO PAPER) for operation Does the number on the screen increase by one, every time the actuator of the SENSOR PHOTO (CST NO PAPER) is operated? Checked by [Digital Input] - [DI-11(Control Panel)/CST1 NO PAPER(PC)] in diagnosis.	Replace the PWBA MCU. (Refer to Removal 30/Replacement 14)	Go to step 11.
7	Checking the ACTUATOR NO PAPER A4 for operation Does the ACTUATOR NO PAPER A4 operate smoothly?	Go to step 8.	Replace the ACTUATOR NO PAPER A4.

Step	Check	Yes	No
8	Checking the SENSOR PHOTO (CST NO PAPER) for operation Does the number on the screen increase by one, every time the actuator of the SENSOR PHOTO: CST NO PAPER is operated? Checked by [Digital Input] - [DI-d(Control Panel)/CST2 NO PAPER(PC)] in diagnosis.	Replace the PWBA MCU. (Refer to Removal 30/Replacement 14)	Go to step 16.
9	Checking the ACTUATOR ASSY MSI for operation Does the ACTUATOR ASSY MSI operate smoothly?	Go to step 10.	Replace the ACTUATOR ASSY MSI.
10	Checking the SENSOR PHOTO (MPF NO PAPER) for operation Does the number on the screen increase by one, every time the actuator of the SENSOR PHOTO (MSI NO PAPER) is operated? Checked by [Digital Input] - [DI-10(Control Panel)/MSI NO PAPER(PC)] in diagnosis.	Replace the PWBA MCU. (Refer to Removal 30/Replacement 14)	Go to step 26.
11	Checking the connectors of the SENSOR PHOTO (CST NO PAPER SENSOR) for connection Check the connections between the PWBA MCU and SENSOR PHOTO (CST NO PAPER SENSOR). Are P/J29, P/J292 and P/J2921 connected surely?	Go to step 12.	Reconnect the connector(s) P/J29, P/J292 and/or P/J2921 surely.
12	Checking the HARN ASSY R SIDE for continuity Disconnect P/J29 from the PWBA MCU. Disconnect P/J292 from the HARN ASSY REGI SNR. Is each cable of P/J29 <=> P/J292 continuous?	Go to step 13.	Replace the HARN ASSY R SIDE.
13	Checking the HARNESS ASSY REGI SNR for continuity Disconnect P/J292 from the HARN ASSY R SIDE. Disconnect P/J2921 from the SENSOR PHOTO (CST NO PAPER SENSOR). Is each cable of P/J292 <=> P/J2921 continuous?	Go to step 14.	Replace the HARN ASSY REGI SNR.
14	Checking the power to SENSOR PHOTO (CST NO PAPER SENSOR) Disconnect P/J29 on the PWBA MCU. Is the voltage across ground <=> J29-5pin on the PWBA MCU, about +3.3 VDC?	Go to step 15.	Replace the PWBA MCU. (Refer to Removal 30/Replacement 14.)
15	Checking the SENSOR PHOTO (CST NO PAPER SENSOR) for operation Measure the voltage across ground <=> J29-7pin on the PWBA MCU. Does the voltage change, every time the ACTUATOR NO PAPER A4 of the SENSOR PHOTO (CST NO PAPER SENSOR) is operated?	Replace the PWBA MCU. (Refer to Removal 30/Replacement 14.)	Replace the SENSOR PHOTO (CST NO PAPER SENSOR).
16	Checking the connectors of the SENSOR PHOTO (CST NO PAPER SENSOR) for connection Check the connections between the PWBA OPT FDR and SENSOR PHOTO (CST NO PAPER SENSOR). Are P/J421, P/J4212 and P/J42121 connected surely?	Go to step 17.	Reconnect the connector(s) P/J421, P/J4212 and/or P/J42121 surely.

Step	Check	Yes	No
17	Checking the HARNESS ASSY C2 CHUTE for continuity Disconnect P/J421 from the PWBA OPT FDR. Disconnect P/J4212 from the HARN ASSY C2 NO PAPER. Is each cable of P/J421 <=> P/J4212 continuous?	Go to step 18.	Replace the HARN ASSY C2 CHUTE.
18	Checking the HARNESS ASSY C2 NO PAPER for continuity Disconnect P/J4212 from the HARN ASSY C2 CHUTE. Disconnect P/J42121 from the SENSOR PHOTO (CST NO PAPER SENSOR). Is each cable of P/J4212 <=> P/J42121 continuous?	Go to step 19.	Replace the HARN ASSY C2 NO PAPER.
19	Checking the power to the SENSOR PHOTO (CST NO PAPER SENSOR) Disconnect P/J421 on the PWBA OPT FDR. Is the voltage across ground <=> J421-3pin on the PWBA OPT FDR, about +3.3 VDC?	Go to step 20.	Go to step 22.
20	Checking the SENSOR PHOTO (CST NO PAPER SENSOR) for operation Measure the voltage across ground <=> J421-5pin on the PWBA OPT FDR. Does the voltage change, every time the ACTUATOR NO PAPER A4 of the SENSOR PHOTO (CST NO PAPER SENSOR) is operated?	Go to step 21.	Replace the SENSOR PHOTO (CST NO PAPER SENSOR).
21	Checking after replacing the PWBA OPT FDR Replace the PWBA OPT FDR. Does the error still occur when the power is turned ON?	End of work	Replace the PWBA MCU. (Refer to Removal 30/Replacement 14.)
22	Checking the connectors of the PWBA OPT FDR and PWBA MCU for connection Check the connections between the PWBA OPT FDR and PWBA MCU. Are P/J419, P/J281 and P/J28 connected surely?	Go to step 23.	Reconnect the connector(s) P/J419, P/J281 and/or P/J28 surely.
23	Checking the HARNESS ASSY FDR UNIT for continuity Disconnect P/J419 from the PWBA OPT FDR. Disconnect P/J281 from the HARN ASSY R SIDE. Is each cable of P/J419 <=> P/J281 continuous?	Go to step 24.	Replace the HARN ASSY FDR UNIT.
24	Checking the HARN ASSY R SIDE for continuity Disconnect P/J281 from the HARN ASSY FDR UNIT. Disconnect P/J28 from the PWBA MCU. Is each cable of P/J281 <=> P/J28 continuous?	Go to step 25.	Replace the HARN ASSY R SIDE.
25	Checking the power to the PWBA OPT FDR Disconnect P/J28 on the PWBA MCU. Is the voltage across ground <=> J28-7pin on the PWBA MCU, about +3.3 VDC?	Replace the PWBA OPT FDR.	Replace the PWBA MCU. (Refer to Removal 30/Replacement 14.)
26	Checking the connectors of the SENSOR PHOTO (MSI NO PAPER SENSOR) for connection Check the connections between the PWBA MCU and SENSOR PHOTO (MSI NO PAPER SENSOR). Are P/J28, P/J282 and P/J2821 connected surely?	Go to step 27.	Reconnect the connector(s) P/J28, P/J282 and/or P/J2821 surely.

Step	Check	Yes	No
27	Checking the HARN ASSY R SIDE for continuity Disconnect P/J28 from the PWBA MCU. Disconnect P/J282 from the HARN ASSY MSI NPP. Is each cable of P/J28 <=> P/J282 continuous?	Go to step 28.	Replace the HARN ASSY R SIDE.
28	Checking the HARNESS ASSY MSI NPP for continuity Disconnect P/J282 from the HARN ASSY R SIDE. Disconnect P/J2821 from the SENSOR PHOTO (MSI NO PAPER SENSOR). Is each cable of P/J282 <=> P/J2821 continuous?	Go to step 29.	Replace the HARN ASSY MSI NPP.
29	Checking the power to SENSOR PHOTO (MSI NO PAPER SENSOR) Disconnect P/J28 on the PWBA MCU. Is the voltage across ground <=> J28-B11pin on the PWBA MCU, about +3.3 VDC?	Go to step 30.	Replace the PWBA MCU. (Refer to Removal 30/Replacement 14.)
30	Checking the SENSOR PHOTO (MSI NO PAPER SENSOR) for operation Measure the voltage across ground <=> J28-B13pin on the PWBA MCU. Does the voltage change, every time the ACTUATOR NO PAPER MSI of the SENSOR PHOTO (MSI NO PAPER SENSOR) is operated?	Replace the PWBA MCU. (Refer to Removal 30/Replacement 14.)	Replace the SENSOR PHOTO (MSI NO PAPER SENSOR).

FIP1.45 CRUM ID 009-367/009-368/009-369/009-370

Step	Check	Yes	No
	Possible causative parts: CARTRIDGE ASSY (K) (PL5.1.18) CARTRIDGE ASSY (C) (PL5.1.19) CARTRIDGE ASSY (M) (PL5.1.20) CARTRIDGE ASSY (Y) (PL5.1.21) PWBA MCU (PL9.1.20)		
1	Checking the Print Cartridge Are the Print Cartridges installed to the printer the DELL Toner?	Go to step 2.	Set the non-DELL toner mode through the control panel.
2	Checking the DELL toner type Is the print cartridge installed the 3130cn?	Go to step 3.	Replace the print cartridge.
3	Checking the Print Cartridge installation Reseat the Print Cartridge. Does the error still occur when the power is turned ON?	Go to step 4.	End of work
4	Checking after replacing the Print Cartridge Replace the Print Cartridge. Does the error still occur when the power is turned ON?	Replace the PWBA MCU. (Refer to Removal 30/Replacement 14.)	End of work

FIP1.46 Error Y Cart 093-919

Step	Check	Yes	No
	Possible causative parts: CARTRIDGE ASSY (Y) (PL5.1.21) DISPENSER ASSY (PL5.1.12) HARN ASSY LV TOP (PL10.1.16) PWBA MCU (PL9.1.20)		
1	Checking the Toner Tape for staying Has the Toner Tape been pulled out?	Go to step 2.	Pull the Toner Tape out, then go to step 2.
2	Does the error still occur when the power is turned ON?	Go to step 3.	End of work
3	Checking after replacing the CARTRIDGE ASSY (Y) Replace the CARTRIDGE ASSY (Y). Does the error still occur when the power is turned ON?	Go to step 4.	End of work
4	Checking the Dispenser Motor for rotation Does the Dispense Motor function normally? Checked by [Digital Output] - [DO-21(Control Panel)/ TONER MOTOR Y ON(PC)] in diagnosis. During the test, close the interlock switch (HARN ASSY INTERLOCK).	Check the gear of the Auger is not damaged. If the gear is damaged, replace the DISPENSER ASSY (Y). (Refer to Removal 24/Replacement 20) Replace the PWBA MCU. (Refer to Removal 30/Replacement 14)	Go to step 5.
5	Checking the connector for connection Check the connectors between the PWBA MCU and DISPENSER ASSY. Are P/J18 and P/J181 connected surely?	Go to step 6.	Reconnect the connector(s) P/J18 and/or P/J181 surly, then go to step 6.
6	Does the error still occur when the power is turned ON?	Go to step 7.	End of work
7	Checking the HARN ASSY LV TOP for continuity Disconnect P/J18 from the PWBA MCU. Disconnect P/J181 from the DISPENSER ASSY. Is each cable of P/J18 <=> P/J181 continuous?	Go to step 8.	Replace the HARN ASSY LV TOP.
8	Checking the power to DISPENSER ASSY Disconnect P/J18 on the PWBA MCU. Are the voltages across ground <= >J18-A1pin/A2pin on PWBA MCU, about +24 VDC when the interlock switch (HARN ASSY INTERLOCK) is pushed.	Replace the DISPENSER ASSY. (Refer to Removal 24/Replacement 20)	Replace the PWBA MCU. (Refer to Removal 30/Replacement 14)

FIP1.47 Error M Cart 093-920

Step	Check	Yes	No
	Possible causative parts: CARTRIDGE ASSY (M) (PL5.1.20) DISPENSER ASSY (PL5.1.12) HARN ASSY LV TOP (PL10.1.16) PWBA MCU (PL9.1.20)		
1	Checking the Toner Tape for staying Has the Toner Tape been pulled out?	Go to step 2.	Pull the Toner Tape out, then go to step 2.
2	Does the error still occur when the power is turned ON?	Go to step 3.	End of work
3	Checking after replacing the CARTRIDGE ASSY (M) Replace the CARTRIDGE ASSY (M). Does the error still occur when the power is turned ON?	Go to step 4.	End of work
4	Checking the Dispenser Motor for rotation Does the Dispense Motor function normally? Checked by [Digital Output] - [DO-23(Control Panel)/ TONER MOTOR M ON(PC)] in diagnosis. During the test, close the interlock switch (HARN ASSY INTERLOCK).	Check the gear of the Auger is not damaged. If the gear is damaged, replace the DISPENSER ASSY. (Refer to Removal 24/Replacement 20) Replace the PWBA MCU. (Refer to Removal 30/Replacement 14)	Go to step 5.
5	Checking the connector for connection Check the connectors between the PWBA MCU and DISPENSER ASSY. Are P/J18 and P/J182 connected surely?	Go to step 6.	Reconnect the connector(s) P/J18 and/or P/J182 surly, then go to step 6.
6	Does the error still occur when the power is turned ON?	Go to step 7.	End of work
7	Checking the HARN ASSY LV TOP for continuity Disconnect P/J18 from the PWBA MCU. Disconnect P/J182 from the DISPENSER ASSY. Is each cable of P/J18 <=> P/J182 continuous?	Go to step 8.	Replace the HARN ASSY LV TOP.
8	Checking the power to DISPENSER ASSY Disconnect P/J18 on the PWBA MCU. Are the voltages across ground <= >J18-A7pin/A8pin on PWBA MCU, about +24 VDC when the interlock switch (HARN ASSY INTERLOCK) is pushed?	Replace the DISPENSER ASSY. (Refer to Removal 24/Replacement 20)	Replace the PWBA MCU. (Refer to Removal 30/Replacement 14)

FIP1.48 Error C Cart 093-921

Step	Check	Yes	No
	Possible causative parts: CARTRIDGE ASSY (C) (PL5.1.19) DISPENSER ASSY (PL5.1.12) HARN ASSY LV TOP (PL10.1.16) PWBA MCU (PL9.1.20)		
1	Checking the Toner Tape for staying Has the Toner Tape been pulled out?	Go to step 2.	Pull the Toner Tape out, then go to step 2.
2	Does the error still occur when the power is turned ON?	Go to step 3.	End of work
3	Checking after replacing the CARTRIDGE ASSY (C) Replace the CARTRIDGE ASSY (C). Does the error still occur when the power is turned ON?	Go to step 4.	End of work
4	Checking the Dispenser Motor for rotation Does the Dispense Motor function normally? Checked by [Digital Output] - [DO-25(Control Panel)/ TONER MOTOR C ON(PC)] in diagnosis. During the test, close the interlock switch (HARN ASSY INTERLOCK).	Check the gear of the Auger is not damaged. If the gear is damaged, replace the DISPENSER ASSY. (Refer to Removal 24/Replacement 20). Replace the PWBA MCU. (Refer to Removal 30/Replacement 14).	Go to step 5.
5	Checking the connector for connection Check the connectors between the PWBA MCU and DISPENSER ASSY. Are P/J18 and P/J184 connected surely?	Go to step 6.	Reconnect the connector(s) P/J18 and/or P/J184 surly, then go to step 6.
6	Does the error still occur when the power is turned ON?	Go to step 7.	End of work
7	Checking the HARN ASSY LV TOP for continuity Disconnect P/J18 from the PWBA MCU. Disconnect P/J184 from the DISPENSER ASSY. Is each cable of P/J18 <=> P/J184 continuous?	Go to step 8.	Replace the HARN ASSY LV TOP.
8	Checking the power to DISPENSER ASSY Disconnect P/J18 on the PWBA MCU. Are the voltages across ground <=> J18-B7pin/B8pin on PWBA MCU, about +24 VDC when the interlock switch (HARN ASSY INTERLOCK) is pushed?	Replace the DISPENSER ASSY. (Refer to Removal 24/Replacement 20).	Replace the PWBA MCU. (Refer to Removal 30/Replacement 14).

FIP1.49 Error K Cart 093-922

Step	Check	Yes	No
	Possible causative parts: CARTRIDGE ASSY (K) (PL5.1.18) DISPENSER ASSY (PL5.1.12) HARN ASSY LV TOP (PL10.1.16) PWBA MCU (PL9.1.20)		
1	Checking the Toner Tape for staying Has the Toner Tape been pulled out?	Go to step 2.	Pull the Toner Tape out, then go to step 2.
2	Does the error still occur when the power is turned ON?	Go to step 3.	End of work
3	Checking after replacing the CARTRIDGE ASSY (K) Replace the CARTRIDGE ASSY (K). Does the error still occur when the power is turned ON?	Go to step 4.	End of work
4	Checking the Dispenser Motor for rotation Does the Dispense Motor function normally? Checked by [Digital Output] - [DO-27(Control Panel)/ TONER MOTOR K ON(PC)] in diagnosis. During the test, close the interlock switch (HARN ASSY INTERLOCK).	Check the gear of the Auger is not damaged. If the gear is damaged, replace the DISPENSER ASSY. (Refer to Removal 24/Replacement 20). Replace the PWBA MCU. (Refer to Removal 30/Replacement 14).	Go to step 5.
5	Checking the connector for connection Check the connectors between the PWBA MCU and DISPENSER ASSY. Are P/J18 and P/J183 connected surely?	Go to step 6.	Reconnect the connector(s) P/J18 and/or P/J183 surly, then go to step 6.
6	Does the error still occur when the power is turned ON?	Go to step 7.	End of work
7	Checking the HARN ASSY LV TOP for continuity Disconnect P/J18 from the PWBA MCU. Disconnect P/J183 from the DISPENSER ASSY. Is each cable of P/J18 <=> P/J183 continuous?	Go to step 8.	Replace the HARN ASSY LV TOP.
8	Checking the power to DISPENSER ASSY Disconnect P/J18 on the PWBA MCU. Are the voltages across ground <= >J18-B1pin/B2pin on PWBA MCU, about +24 VDC when the interlock switch (HARN ASSY INTERLOCK) is pushed?	Replace the DISPENSER ASSY. (Refer to Removal 24/Replacement 20).	Replace the PWBA MCU. (Refer to Removal 30/Replacement 14)

FIP1.50 093-950 Yellow Toner/093-951 Magenta Toner/093-952 Cyan Toner/093-953
Black Toner

Step	Check	Yes	No
	Possible causative parts: CARTRIDGE ASSY (K) (PL5.1.18) CARTRIDGE ASSY (C) (PL5.1.19) CARTRIDGE ASSY (M) (PL5.1.20) CARTRIDGE ASSY (Y) (PL5.1.21)		
1	Checking the Drum Protect Cover for staying Has the Drum Protect Cover removed?	Go to step 2.	Remove the Drum Protect Cover
2	Checking the Print Cartridge installation Is the Print Cartridge installed correctly?	Go to the FIP below. Yellow :FIP1.53 Magenta:FIP1.54 Cyan :FIP1.55 Black :FIP1.56	Reseat the Print Cartridge.

FIP1.51 Replace Cart 093-930/093-931/093-932/093-933

Step	Check	Yes	No
	Possible causative parts: CARTRIDGE ASSY (K) (PL5.1.18) CARTRIDGE ASSY (C) (PL5.1.19) CARTRIDGE ASSY (M) (PL5.1.20) CARTRIDGE ASSY (Y) (PL5.1.21) PWBA MCU (PL13.5.13)		
1	Checking the CARTRIDGE ASSY for installation Are the CARTRIDGE ASSYs installed correctly?	Go to step 3.	Reseat the CARTRIDGE ASSY, then go step 2.
2	Does the error still occur when the power is turned ON?	Go to step 3.	End of work
3	Checking after replacing the CARTRIDGE ASSY Replace the CARTRIDGE ASSY. (Refer to Removal 6/ Replacement 38) Does the error still occur when the power is turned ON?	Replace the PWBA MCU. (Refer to Removal 30/Replacement 14)	End of work

FIP1.52 Ready to Print 093-423/093-424/093-425/093-426

Step	Check	Yes	No
	Possible causative parts: CARTRIDGE ASSY (K) (PL5.1.18) CARTRIDGE ASSY (C) (PL5.1.19) CARTRIDGE ASSY (M) (PL5.1.20) CARTRIDGE ASSY (Y) (PL5.1.21) PWBA MCU (PL13.5.13)		
1	Checking the CARTRIDGE ASSY for installation Are the CARTRIDGE ASSYs installed correctly?	Go to step 3.	Reseat the CARTRIDGE ASSY, then go step 2.
2	Does the error still occur when the power is turned ON?	Go to step 3.	End of work
3	Checking after replacing the CARTRIDGE ASSY Replace the CARTRIDGE ASSY. (Refer to Removal 6/ Replacement 38) Does the error still occur when the power is turned ON?	Replace the PWBA MCU. (Refer to Removal 30/Replacement 14)	End of work

FIP1.53 Insert Print Cart 093-970

Step	Check	Yes	No
	Possible causative parts: CARTRIDGE ASSY (Y) (PL5.1.21) SENSOR ASSY CRU (PL5.1.4) HARN ASSY CRU SNR (PL10.1.9) PWBA MCU (PL9.1.20)		
1	Checking the CARTRIDGE ASSY (Y) for installation Is the CARTRIDGE ASSY (Y) installed correctly?	Go to step 3.	Reseat the CARTRIDGE ASSY (Y), then go step 2.
2	Does the error still occur when the power is turned ON?	Go to step 3.	End of work
3	Checking after replacing the CARTRIDGE ASSY (Y) Replace the CARTRIDGE ASSY (Y). Does the error still occur when the power is turned ON?	Go to step 4.	End of work
4	Checking the SENSOR ASSY CRU (Y) Does the number on the screen increase by one, every time the CARTRIDGE ASSY (Y) is reseated? Checked by [Digital Input] - [DI-8(Control Panel)/CRU Y(PC)] in diagnosis.	Replace the PWBA MCU. (Refer to Removal 30/Replacement 14)	Go to step 5.
5	Checking the connector for connection Check the connectors between the PWBA MCU and SENSOR ASSY CRU (Y). Are P/J19 and P/J191 connected surely?	Go to step 6.	Reconnect the connector(s) P/J19 and/or P/J191 surly, then go to step 6.
6	Does the error still occur when the power is turned ON?	Go to step 7.	End of work
7	Checking the HARN ASSY CRU SNR for continuity Disconnect P/J19 from the PWBA MCU. Disconnect P/J191 from the SENSOR ASSY CRU. Is each cable of P/J19 <=> P/J191 continuous?	Go to step 8.	Replace the HARN ASSY CRU SNR.
8	Checking the power to SENSOR ASSY CRU Disconnect P/J19 on the PWBA MCU. Are the voltage J19-1pin <=> J19-2pin, about +3.3 VDC?	Go to step 9.	Replace the PWBA MCU. (Refer to Removal 30/Replacement 14)
9	Checking the SENSOR ASSY CRU for operation Measure the voltage across ground <=> P/J19-3pin. Check that the voltage changes when the paper is inserted into the sensor detecting point.	Replace the PWBA MCU. (Refer to Removal 30/Replacement 14)	Replace the SENSOR ASSY CRU. (Refer to Removal 39/Replacement 5)

FIP1.54 Insert Print Cart 093-971

Step	Check	Yes	No
	Possible causative parts: CARTRIDGE ASSY (M) (PL5.1.20) SENSOR ASSY CRU (PL5.1.4) HARN ASSY CRU SNR (PL10.1.9) PWBA MCU (PL9.1.20)		
1	Checking the CARTRIDGE ASSY (M) for installation Is the CARTRIDGE ASSY (M) installed correctly?	Go to step 3.	Reseat the CARTRIDGE ASSY (M), then go step 2.
2	Does the error still occur when the power is turned ON?	Go to step 3.	End of work
3	Checking after replacing the CARTRIDGE ASSY (M) Replace the CARTRIDGE ASSY (M). Does the error still occur when the power is turned ON?	Go to step 4.	End of work
4	Checking the SENSOR ASSY CRU (M) Does the number on the screen increase by one, every time the CARTRIDGE ASSY (M) is reseated? Checked by [Digital Input] - [DI-9(Control Panel)/CRU M(PC)] in diagnosis.	Replace the PWBA MCU. (Refer to Removal 30/Replacement 14)	Go to step 5.
5	Checking the connector for connection Check the connectors between the PWBA MCU and SENSOR ASSY CRU (M). Are P/J19 and P/J192 connected surely?	Go to step 6.	Reconnect the connector(s) P/J19 and/or P/J192 surly, then go to step 6.
6	Does the error still occur when the power is turned ON?	Go to step 7.	End of work
7	Checking the HARN ASSY CRU SNR for continuity Disconnect P/J19 from the PWBA MCU. Disconnect P/J192 from the SENSOR ASSY CRU. Is each cable of P/J19 <=> P/J192 continuous?	Go to step 8.	Replace the HARN ASSY CRU SNR.
8	Checking the power to SENSOR ASSY CRU Disconnect P/J19 on the PWBA MCU. Are the voltage J19-4pin <=> J19-5pin, about +3.3 VDC?	Go to step 9.	Replace the PWBA MCU. (Refer to Removal 30/Replacement 14)
9	Checking the SENSOR ASSY CRU for operation Measure the voltage across ground <=> P/J19-6pin. Check that the voltage changes when the paper is inserted into the sensor detecting point.	Replace the PWBA MCU. (Refer to Removal 30/Replacement 14)	Replace the SENSOR ASSY CRU. (Refer to Removal 39/Replacement 5)

FIP1.55 Insert Print Cart 093-972

Step	Check	Yes	No
	Possible causative parts: CARTRIDGE ASSY (C) (PL5.1.19) SENSOR ASSY CRU (PL5.1.4) HARN ASSY CRU SNR (PL10.1.9) PWBA MCU (PL9.1.20)		
1	Checking the CARTRIDGE ASSY (C) for installation Is the CARTRIDGE ASSY (C) installed correctly?	Go to step 3.	Reseat the CARTRIDGE ASSY (C), then go step 2.
2	Does the error still occur when the power is turned ON?	Go to step 3.	End of work
3	Checking after replacing the CARTRIDGE ASSY (C) Replace the CARTRIDGE ASSY (C). Does the error still occur when the power is turned ON?	Go to step 4.	End of work
4	Checking the SENSOR ASSY CRU (C) Does the number on the screen increase by one, every time the CARTRIDGE ASSY (C) is reseated? Checked by [Digital Input] - [DI-b(Control Panel)/CRU C(PC)] in diagnosis.	Replace the PWBA MCU. (Refer to Removal 30/Replacement 14)	Go to step 5.
5	Checking the connector for connection Check the connectors between the PWBA MCU and SENSOR ASSY CRU (C). Are P/J19 and P/J194 connected surely?	Go to step 6.	Reconnect the connector(s) P/J19 and/or P/J194 surly, then go to step 6.
6	Does the error still occur when the power is turned ON?	Go to step 7.	End of work
7	Checking the HARN ASSY CRU SNR for continuity Disconnect P/J19 from the PWBA MCU. Disconnect P/J194 from the SENSOR ASSY CRU. Is each cable of P/J19 <=> P/J194 continuous?	Go to step 8.	Replace the HARN ASSY CRU SNR.
8	Checking the power to SENSOR ASSY CRU Disconnect P/J19 on the PWBA MCU. Are the voltage J19-10pin <=> J19-11pin, about +3.3 VDC?	Go to step 9.	Replace the PWBA MCU. (Refer to Removal 30/Replacement 14)
9	Checking the SENSOR ASSY CRU for operation Measure the voltage across ground <=> P/J19-12pin. Check that the voltage changes when the paper is inserted into the sensor detecting point.	Replace the PWBA MCU. (Refer to Removal 30/Replacement 14)	Replace the SENSOR ASSY CRU. (Refer to Removal 39/Replacement 5)

FIP1.56 Insert Print Cart 093-973

Step	Check	Yes	No
	Possible causative parts: CARTRIDGE ASSY (K) (PL5.1.18) SENSOR ASSY CRU (PL5.1.4) HARN ASSY CRU SNR (PL10.1.9) PWBA MCU (PL9.1.20)		
1	Checking the CARTRIDGE ASSY (K) for installation Is the CARTRIDGE ASSY (K) installed correctly?	Go to step 3.	Reseat the CARTRIDGE ASSY (K), then go step 2.
2	Does the error still occur when the power is turned ON?	Go to step 3.	End of work
3	Checking after replacing the CARTRIDGE ASSY (K) Replace the CARTRIDGE ASSY (K). Does the error still occur when the power is turned ON?	Go to step 4.	End of work
4	Checking the SENSOR ASSY CRU (K) Does the number on the screen increase by one, every time the CARTRIDGE ASSY (K) is reseated? Checked by [Digital Input] - [DI-a(Control Panel)/CRU K(PC)] in diagnosis.	Replace the PWBA MCU. (Refer to Removal 30/Replacement 14)	Go to step 5.
5	Checking the connector for connection Check the connectors between the PWBA MCU and SENSOR ASSY CRU (K). Are P/J19 and P/J193 connected surely?	Go to step 6.	Reconnect the connector(s) P/J19 and/or P/J193 surly, then go to step 6.
6	Does the error still occur when the power is turned ON?	Go to step 7.	End of work
7	Checking the HARN ASSY CRU SNR for continuity Disconnect P/J19 from the PWBA MCU. Disconnect P/J193 from the SENSOR ASSY CRU. Is each cable of P/J19 <=> P/J193 continuous?	Go to step 8.	Replace the HARN ASSY CRU SNR.
8	Checking the power to SENSOR ASSY CRU Disconnect P/J19 on the PWBA MCU. Are the voltage J19-7pin <=> J19-8pin, about +3.3 VDC?	Go to step 9.	Replace the PWBA MCU. (Refer to Removal 30/Replacement 14)
9	Checking the SENSOR ASSY CRU for operation Measure the voltage across ground <=> P/J19-9pin. Check that the voltage changes when the paper is inserted into the sensor detecting point.	Replace the PWBA MCU. (Refer to Removal 30/Replacement 14)	Replace the SENSOR ASSY CRU. (Refer to Removal 39/Replacement 5)

FIP1.57 CRUM ID 009-371

Step	Check	Yes	No
	Possible causative parts: TRANSFER ASSY (PL4.1.1) PWBA MCU (PL9.1.20)		
1	Checking the TRANSFER ASSY for installation Is the TRANSFER ASSY installed correctly? Does the error still occur when the power is turned ON?	Go to step 2.	End of work
2	Checking the TRANSFER ASSY model Is the TRANSFER ASSY installed the 3130cn?	Go to step 3.	Replace the TRANSFER ASSY.
3	Checking after replacing the TRANSFER ASSY Replace the TRANSFER ASSY. (Refer to Removal 4/ Replacement 40.) Does the error still occur when the power is turned ON?	Replace the PWBA MCU. (Refer to Removal 30/Replacement 14.)	End of work

FIP1.58 Ready to Print 094-422

Step	Check	Yes	No
	Possible causative parts: TRANSFER ASSY (PL4.1.1) PWBA MCU (PL9.1.20)		
1	Checking the life counter value of the TRANSFER ASSY. Does the life counter value show the near of the end?	Replace the TRANSFER ASSY. (Refer to Removal 4/ Replacement 40.) After replacement, be sure to clear the life counter value.	Go to step 2.
2	Checking after replacing the TRANSFER ASSY Replace the TRANSFER ASSY. (Refer to Removal 4/ Replacement 40) Does the error still occur when the power is turned ON?	Replace the PWBA MCU. (Refer to Removal 30/Replacement 14)	End of work

FIP1.59 Insert Belt Unit 094-910

Step	Check	Yes	No
	Possible causative parts: TRANSFER ASSY (PL4.1.1) HARN ASSY R SIDE (PL10.1.15) HARNESS ASSY FRONT COVER (PL1.2.11) PWBA MCU (PL9.1.20)		
1	Checking the TRANSFER ASSY for installation Is the TRANSFER ASSY installed correctly?	Go to step 3.	Reseat the TRANSFER ASSY, then go step 2.
2	Does the error still occur when the power is turned ON?	Go to step 3.	End of work
3	Checking the connector for connection Check the connectors between the PWBA MCU and TRANSFER ASSY. Are P/J27, P/J272 and P/J2721 connected surely?	Go to step 4.	Reconnect the connector(s) P/J27, P/J272 and P/J2721 surly, then go to step 4.
4	Checking the HARN ASSY R SIDE for continuity Disconnect P/J27 from the PWBA MCU. Disconnect P/J272 from the HARNESS ASSY FRONT COVER. Is each cable of P/J27 <=> P/J272 continuous?	Go to step 5.	Replace the HARN ASSY R SIDE.
5	Checking the HARNESS ASSY FRONT COVER for continuity Disconnect P/J272 from the HARN ASSY R SIDE. Disconnect P/J2721 from the TRANSFER ASSY. Is each cable of P/J272 <=> P/J2721 continuous?	Go to step 6.	Replace the HARNESS ASSY FRONT COVER .
6	Checking after replacing the TRANSFER ASSY Replace the TRANSFER ASSY. (Refer to Removal 4/ Replacement 40) Does the error still occur when the power is turned ON?	Replace the PWBA MCU. (Refer to Removal 30/Replacement 14)	End of work

FIP1.60 Belt Unit 094-911

Step	Check	Yes	No
	Possible causative parts: TRANSFER ASSY (PL4.1.1) PWBA MCU (PL9.1.20)		
1	Checking the life counter value of the TRANSFER ASSY. Does the life counter value show the near of the end?	Replace the TRANSFER ASSY. (Refer to Removal 4/ Replacement 40.) After replacement, be sure to clear the life counter value.	Go to step 2.
2	Checking after replacing the TRANSFER ASSY Replace the TRANSFER ASSY. (Refer to Removal 4/ Replacement 40) Does the error still occur when the power is turned ON?	Replace the PWBA MCU. (Refer to Removal 30/Replacement 14)	End of work

FIP1.61 010-359 Restart Printer

Step	Check	Yes	No
	Possible causative parts: FUSER ASSY (PL6.1.10) PWBA MCU (PL9.1.20)		
1	Checking the FUSER ASSY for installation Is the FUSER ASSY installed correctly? Warning: Start the operation after the FUSER ASSY has cooled down. Does the error still occur when the power is turned ON?	Go to step 2.	End of work
2	Checking the FUSER ASSY type Is the FUSER ASSY installed the 3130cn FUSER?	Go to step 3.	Replace the FUSER ASSY.
3	Checking after replacing the FUSER ASSY Replace the FUSER ASSY. (Refer to Removal 8/ Replacement 36.) Warning: Start the operation after the FUSER ASSY has cooled down. Does the error still occur when the power is turned ON?	Replace the PWBA MCU. (Refer to Removal 30/Replacement 14.)	End of work

FIP1.62 Ready to Print 010-421

Step	Check	Yes	No
	Possible causative parts: FUSER ASSY (PL6.1.10) PWBA MCU (PL9.1.20)		
1	Checking the life counter value of the FUSER ASSY. Does the life counter value show the near of the end?	Replace the FUSER ASSY. (Refer to Removal 8/ Replacement 36.) After replacement, be sure to clear the life counter value.	Go to step 2.
2	Checking the FUSER ASSY for installation Is the FUSER ASSY installed correctly? Warning: Start the operation after the FUSER ASSY has cooled down.	Go to step 4.	Reseat the FUSER ASSY, then go step 3.
3	Does the error still occur when the power is turned ON?	Go to step 4.	End of work
4	Checking after replacing the FUSER ASSY Replace the FUSER ASSY. (Refer to Removal 8/Replacement 36) Warning: Start the operation after the FUSER ASSY has cooled down. Does the error still occur when the power is turned ON?	Replace the PWBA MCU. (Refer to Removal 30/Replacement 14)	End of work

FIP1.63 Tray Detached 024-946/007-912

Step	Check	Yes	No
	Possible causative parts: HARN ASSY R SIDE (PL10.1.15) SWITCH ASSY SIZE (PL7.1.18) PWBA MCU (PL9.1.20)		
1	Checking the cassette assy installation Is the cassette assy installed correctly?	Go to step 3.	Reseat the cassette assy, then go to step 2.
2	Does the error still occur when the power is turned ON?	Go to step 3.	End of work
3	Checking the SWITCH ASSY SIZE Does the SWITCH ASSY SIZE function normally? Checked by [Digital Input] - [DI-18(Control Panel)/CASSETTE1 SIZE(PC)] in diagnosis.	End of work	Go to step 4.
4	Checking the HARN ASSY R SIDE for continuity Disconnect P/J29 from the PWBA MCU. Disconnect P/J291 from the SWITCH ASSY SIZE. Is each cable of P/J29 <=> P/J291 continuous?	Go to step 5.	Replace the HARN ASSY R SIDE.
5	Checking after replacing the SWITCH ASSY SIZE Replace the SWITCH ASSY SIZE. (Refer to Removal 18/Replacement 26) Does the error still occur when the power is turned ON?	Replace the PWBA MCU. (Refer to Removal 30/Replacement 14)	End of work

FIP1.64 Load Tray 024-947

Step	Check	Yes	No
	Possible causative parts: HARN ASSY C2 CHUTE (PL12.2.7) SWITCH ASSY SIZE OPT (PL12.2.5) PWBA MCU (PL9.1.20)		
1	Checking the cassette assy installation Is the cassette assy installed correctly?	Go to step 3.	Reseat the cassette assy, then go to step 2.
2	Does the error still occur when the power is turned ON?	Go to step 3.	End of work
3	Checking the SWITCH ASSY SIZE OPT Does the SWITCH ASSY SIZE OPT function normally? Checked by [Digital Input] - [DI-20(Control Panel)/CASSETTE2 SIZE(PC)] in diagnosis.	End of work	Go to step 4.
4	Checking the HARN ASSY C2 CHUTE for continuity Disconnect P/J421 from the PWBA MCU. Disconnect P/J4211 from the SWITCH ASSY SIZE OPT. Is each cable of P/J421 <=> P/J4211 continuous?	Go to step 5.	Replace the HARN ASSY C2 CHUTE.
5	Checking after replacing the SWITCH ASSY SIZE Replace the SWITCH ASSY SIZE OPT. (Refer to Removal 44/Replacement 46) Does the error still occur when the power is turned ON?	Replace the PWBA MCU. (Refer to Removal 30/Replacement 14)	End of work

FIP1.65 Close Front Cover 077-300

Step	Check	Yes	No
	Possible causative parts: COVER ASSY FRONT (PL1.2.98) HARN ASSY INTERLOCK (PL9.1.3) LVPS (PL9.1.4) PWBA MCU (PL9.1.20)		
1	Checking the COVER ASSY FRONT for shape Are there any damages on the COVER ASSY FRONT?	Replace the COVER ASSY FRONT. (Refer to Removal 14/ Replacement 30)	Go to step 2.
2	Checking the interlock switch for operation Does the number on the screen increase by one, every time the Front Cover is operated? Checked by [Digital Input] - [DI-7(Control Panel)/IL OPEN(PC)] in diagnosis.	Replace the PWBA MCU. (Refer to Removal 30/Replacement 14)	Go to step 3.
3	Checking after replacing the HARN ASSY INTERLOCK Replace the HARN ASSY INTERLOCK. (Refer to Removal 37/Replacement 7) Does the error still occur when the power is turned ON?	Go to step 4.	End of work
4	Checking after replacing the LVPS. Replace the LVPS. (Refer to Removal 35/Replacement 9.) Does the error still occur when the power is turned ON?	Replace the PWBA MCU. (Refer to Removal 30/Replacement 14.)	End of work

FIP1.66 Invalid ID 016-383 / Range Chk Error 016-384 / Header Error 016-385 / Check Sum Error 016-386 / Format Error 016-387

Step	Check	Yes	No
	Possible causative parts: PWBA ESS (PL9.1.27)		
1	Checking the download firmware Is the download firmware the 3130cn?	Go to step 2.	Redownload the correct firmware.
2	Checking the PWBA ESS for installation Does the error still occur when downloading the firmware?	Replace the PWBA ESS. (Refer to Removal 26/Replacement 18.)	End of work

FIP1.67 Out of Memory 016-700 / Disc Full 016-980 / Collate Full 016-981

Step	Check	Yes	No
	Possible causative parts: PWBA ESS (PL9.1.27) MEMORY CARD (OPTION) (PL9.1.30)		
1	Checking the memory capacity for print Print the small size file (like a Windows test print). Does the error still occur when printing?	Go to step 2.	Add the MEM- ORY CARD or divide the printing job.
2	Checking after reseating the MEMORY CARD Reseat the MEMORY CARD. Does the error still occur when printing?	Go to step 3.	End of work
3	Checking the memory card capacity Is the memory capacity recognized normally? Checked by [Information Page] - [Configuration] in [Setup].	Go to step 4.	Replace the PWBA ESS. (Refer to Removal 26/Replacement 18)
4	Checking after replacing the MEMORY CARD Replace the MEMORY CARD. Does the error still occur when printing?	Replace the PWBA ESS. (Refer to Removal 26/Replacement 18)	End of work

FIP1.68 016-720 PDL Error

Step	Check	Yes	No
	Possible causative parts: PWBA ESS (PL9.1.27)		
1	Checking the printing job Print the small size file (like a Windows test print). Does the error still occur when printing?	Go to step 2.	End of work
2	Checking after reseating the PWBA ESS Reseat the PWBA ESS. Does the error still occur when printing?	Replace the PWBA ESS. (Refer to Removal 26/Replacement 18)	End of work

FIP1.69 Invalid User 016-757 / Disabled Func 016-758 / Reached Limits 016-759

Step	Check	Yes	No
	Possible causative parts: PWBA ESS (PL9.1.27)		
1	Checking the Color Track setting Is the Color Track setting correctly? Use the Dell Printer Configuration Web Tool.	Replace the PWBA ESS. (Refer to Removal 26/Replacement 18.)	Set the Color Track setting.

FIP1.70 Invalid Job 016-799

Step	Check	Yes	No
	Possible causative parts: PWBA ESS (PL9.1.27)		
1	Checking the paper size Does the paper size in use meet the specification?	Go to step 2.	Use the paper that meets the specification.
2	Checking the paper size setup Does the paper size in use match the size set through the control panel?	Go to step 4.	Go to step 3.
3	Set the paper size through the control panel. Does the error still occur when printing?	Replace the PWBA ESS. (Refer to Removal 26/Replacement 18)	End of work
4	Does the error still occur when printing?	Go to step 5.	End of work
5	Checking the printing job Does the error still occur when printing the windows test print?	Replace the PWBA ESS. (Refer to Removal 26/Replacement 18)	End of work

FIP1.71 Ready to Print 193-700

Step	Check	Yes	No
	Possible causative parts: PWBA ESS (PL9.1.27)		
1	Checking the Print Cartridge. Is the installed print cartridge to the printer the DELL toner?	Go to step 2.	End of work
2	Checking the PWBA ESS. Cancel the non DELL toner mode by the control panel. Does the message on the LCD turn off the non DELL toner?	End of work	Go to step 3.
3	Checking after replacing the print cartridge. Replace the print cartridge. Does the error still occur when printing?	Replace the PWBA ESS. (Refer to Removal 26/Replacement 18.)	End of work

FIP1.72 Over Heat 042-700/Ready to Print 142-700

Step	Check	Yes	No
	Possible causative parts: KIT FEEDER ASSY (PL3.2.99) PWBA MCU (PL9.1.20)		
1	Checking the room temperature Is the room temp. Over 32 degrees C?	Change the room or cool down the room	Go to step 2.
2	Checking the printing Did the client print the large volume of printing?	Go to step 3.	Go to step 4.
3	Checking the printing after cool down of five minutes. Does the error still occur when printing?	Go to step 4.	End of work
4	Checking the PWBA MCU Reseat the PWBA MCU. Does the error still occur when printing?	Go to step 5.	End of work
5	Checking after replacing the PWBA MCU Replace the PWBA Does the error still occur when printing?	Replace the KIT FEEDER ASSY. (Refer to Removal 40/Replacement 4)	End of work

FIP1.73 Electrical Noise

Step	Check	Yes	No
1	Checking the external noise Are there any other electrical appliances within 3 meters of the printer, such as generators, radio and appliances with motors? Either turn off the other electrical appliances, or relocate the printer at least 6 meters from other appliances. Does the electrical noise error still occur?	Go to step 2.	End of work
2	Checking the AC ground Is AC power supply outlet wired and grounded appropriately?	Go to step 3.	Request the client to fix AC power supply outlet.
3	Checking the print cartridges and TRANSFER ASSY installation Reseat the print cartridges and TRANSFER ASSY. Does the electrical noise error still occur?	Go to step 4.	End of work
4	Checking the BIAS ASSY contact. Remove the all print cartridges. Are there any stains or foreign substance on the contact?	Wipe the stains or foreign substance with dry cloth.	Reseat the HVPS. (Refer to Removal 34/Replacement 10)

4. Image Quality Trouble

4.1 Entry Chart for Image Quality Troubleshooting

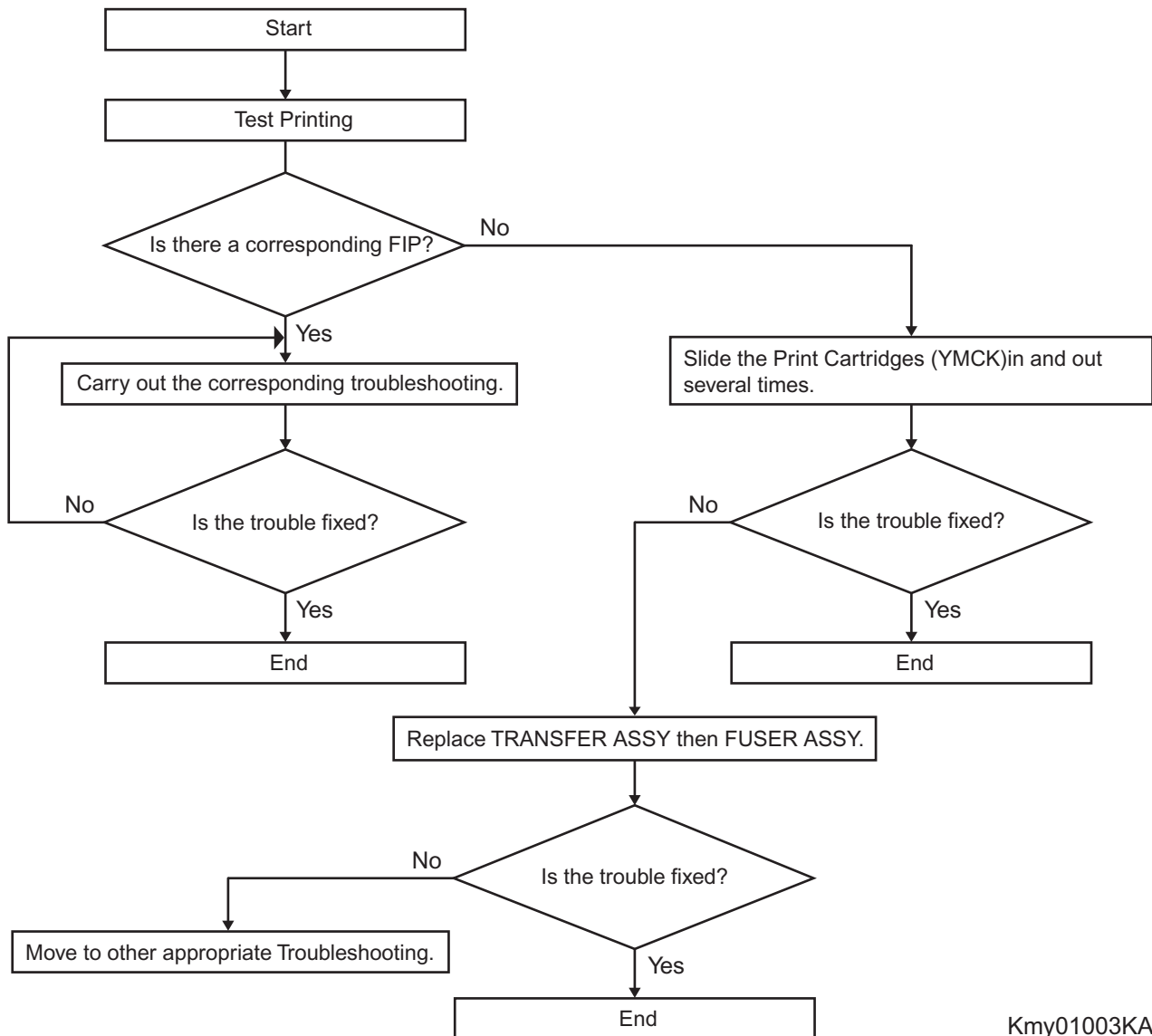

Kmy01003KA

NOTE

By performing a test print with the engine only, you can determine if the failure is Printer Controller-caused or engine-caused, except for phenomena that cannot be determined by test print.

- Test print result with the engine only is normal. ---> Malfunction on Printer Controller side

- Test print result with the engine only is also abnormal. ---> Malfunction on the engine side

When Printer-Controller-caused is more likely, replace with normal Printer Controller and normal Interface Cable, and then confirm the operation. When the trouble persists even after replacement, check the host, and then operate Troubleshooting efficiently, using the following image quality FIP for each phenomenon.

When the image quality trouble of print occurs, get a print to judge, understand and treat the trouble substance precisely and appropriately, and then troubleshoot efficiently, using the image quality FIP table according to each phenomenon.

When trouble restoration with image quality FIP is not possible, check again with the image quality FIP, and then replace [ESS and possible causative parts] in order and check, and operate Troubleshooting, using [Chapter 2 Diagnostic].

Image quality FIP states regarding the typical image quality trouble, as follows.

- FIP-1.P1 Faint print (Low contrast)
- FIP-1.P2 Blank print
- FIP-1.P3 Solid black
- FIP-1.P4 Vertical blank lines (White stripes in paper transport direction)
- FIP-1.P5 Horizontal band cross out (White stripes in the horizontal direction)
- FIP-1.P6 Vertical stripes
- FIP-1.P7 Horizontal stripes
- FIP-1.P8 Partial lack
- FIP-1.P9 Spots
- FIP-1.P10 Afterimage
- FIP-1.P11 Background (Fog)
- FIP-1.P12 Skew
- FIP-1.P13 Paper damage
- FIP-1.P14 No fix
- FIP-1.P15 Color Registration (Color Shift)

NOTE

When horizontal lines and/or spot occur periodically, it is possibly caused by the trouble of a particular roll. In this case, measure the trouble interval on the test print, and check the relation to the roll in the table below. The interval does not necessarily match circumference of the roll. The trouble may be solved easily by the check.

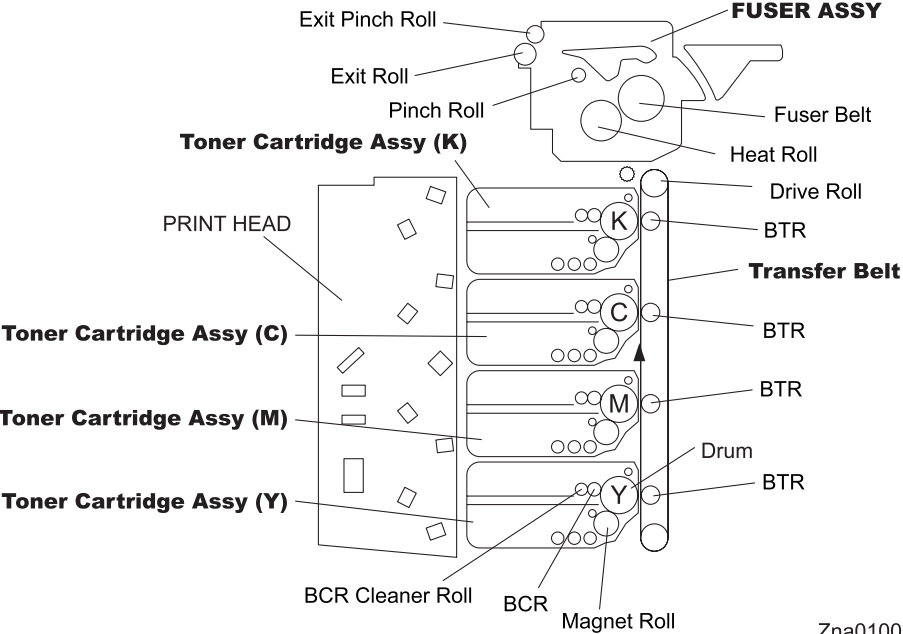

Zna01002KA

-Pitch Chart

The chart is printed [Pitch Configuration Chart] in the [Diagnosis] tab of the [Tool Box].

Page 1

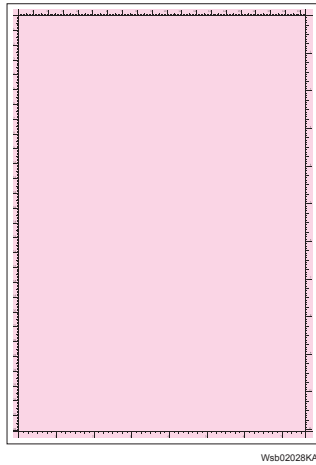

Wsb02028KA

Page 2

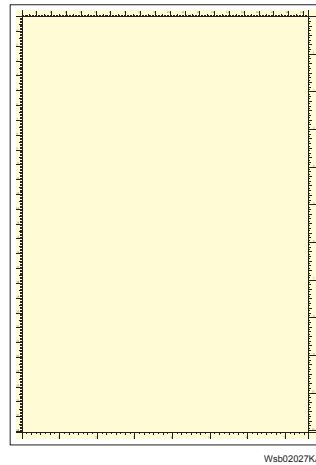

Wsb02027KA

Page 3

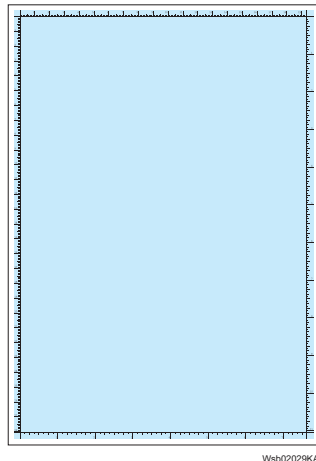

Wsb02029KA

Page 4



Wsb02030KA

Page 5

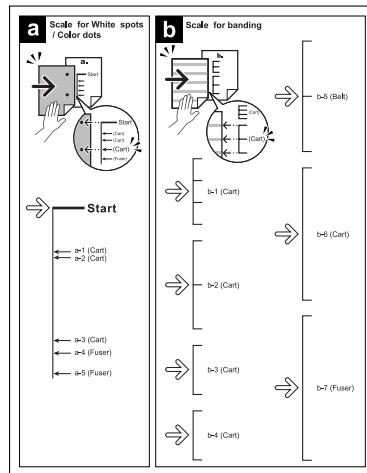

Zna02119KA

4.2 Diagnosis Test Chart

The test charts to improve a defective image quality or to specify the cause of generation when a defective image was generated are in [Diagnosis] tab in [Tool Box].

Use the following test charts properly by the state of a defective image quality.

-Drum Refresh

When the result of [Contamination Check] corresponds to b-6 (Drum) of the pitch chart, performing this test print may improve image quality.

This chart is printed the [Drum Refresh Configuration Chart] of the [Diagnosis] tab in [Tool Box].

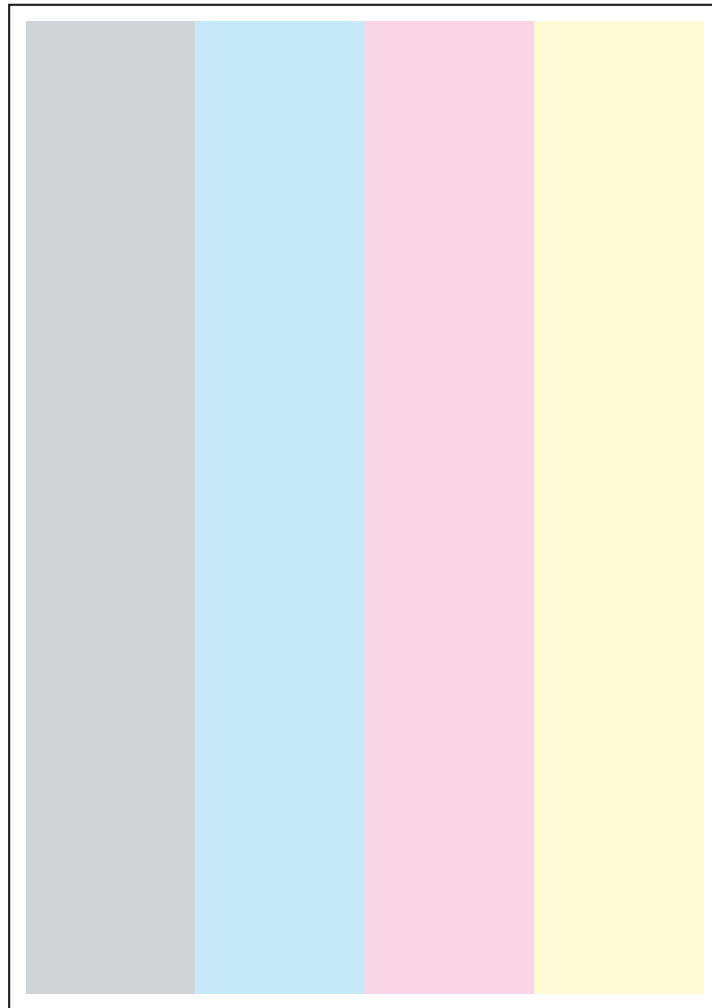

Wsb02021KA

-MQ Chart

This chart allows you to check for a banding if any occurs.

This chart is printed the [MQ Chart] of the [Diagnosis] tab in [Tool Box].

When the image quality is normal, the waves of Y, M, and C are confined within the frame. When the image quality is abnormal, the wave runs out the frame. Compare the pitch of the wave with the pitch chart of second page.

No	Roll Parts	Period (mm)	Replaceable parts
Drum	Toner Cartridge ASSY	75.4	TONER CARTRIDGE ASSY
BCR	Toner Cartridge ASSY	28.3	TONER CARTRIDGE ASSY
BCR Cleaner Roll	Toner Cartridge ASSY	25.1	TONER CARTRIDGE ASSY
Sleeve (K)	Toner Cartridge ASSY	27.9	TONER CARTRIDGE ASSY
Sleeve (Y,M,C)	Toner Cartridge ASSY	27.9	TONER CARTRIDGE ASSY
1stBTR	Transfer Belt	31.4	TRANSFER BELT ASSY
Drive Roll	Transfer Belt	56.9	TRANSFER BELT ASSY
Fuser Roll	FUSER ASSY	82.7	FUSER ASSY
Fuser Belt	FUSER ASSY	94.2	FUSER ASSY
Pinch Roll	FUSER ASSY	18.8	FUSER ASSY
Exit Roll	FUSER ASSY	43.1	FUSER ASSY
Exit Pinch Roll	FUSER ASSY	31.4	FUSER ASSY

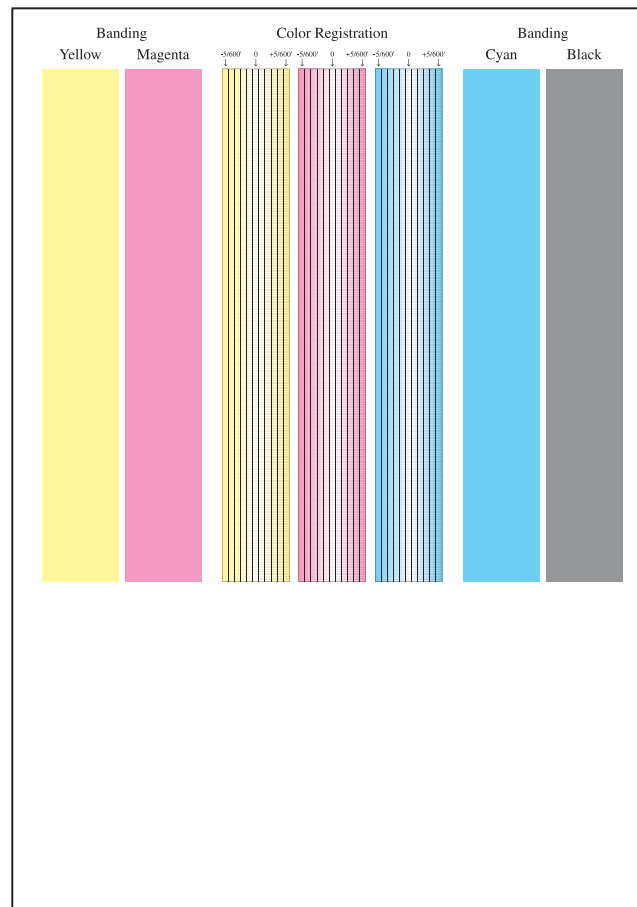

Wsb02024KA

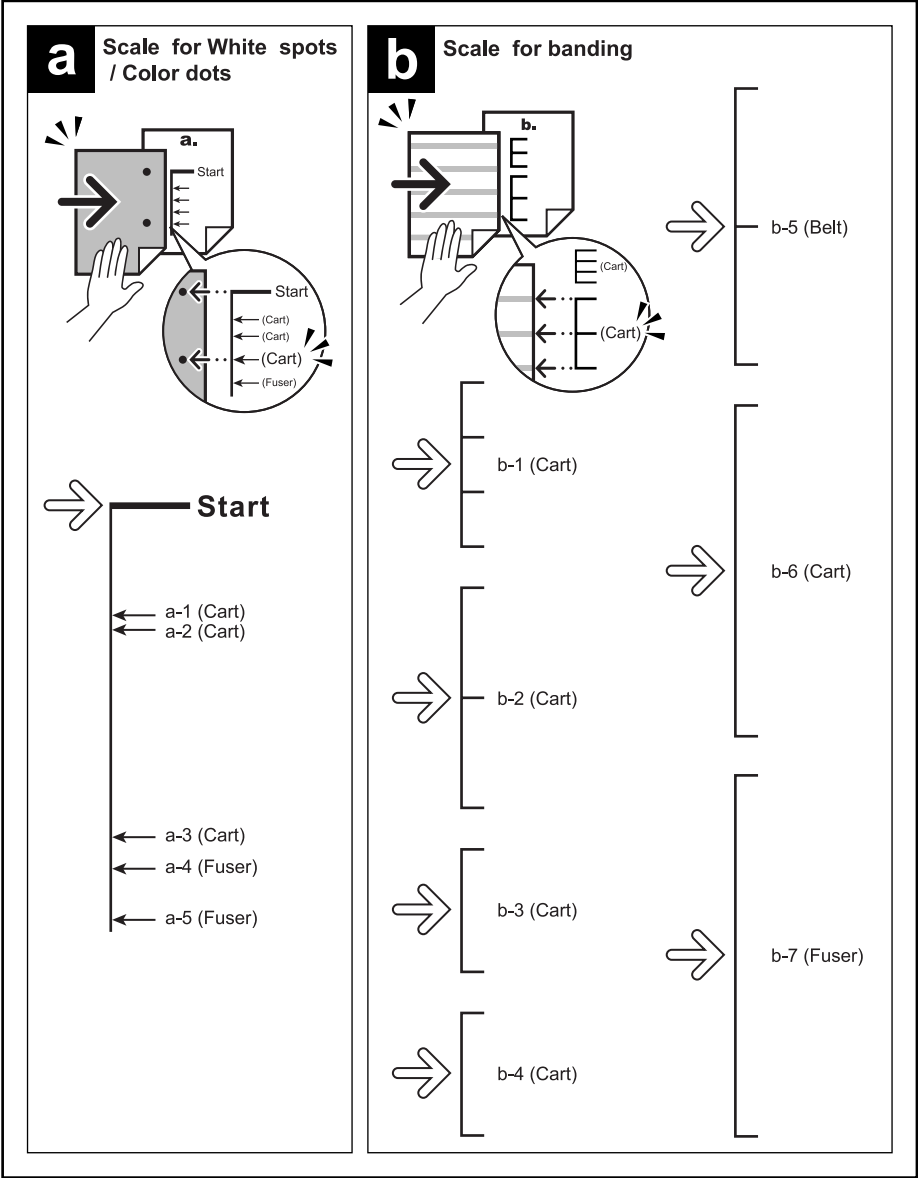

Zna02119KA

-Alignment Chart

This chart allows you to check for the skewed paper if any occurs.
This chart is printed the [Alignment Chart] of the [Diagnosis] tab in [Tool Box].

When the sheet is fed normally, the vertical and horizontal lines are aligned parallel to the edges of the sheet. When there is a problem, this alignment is skewed.

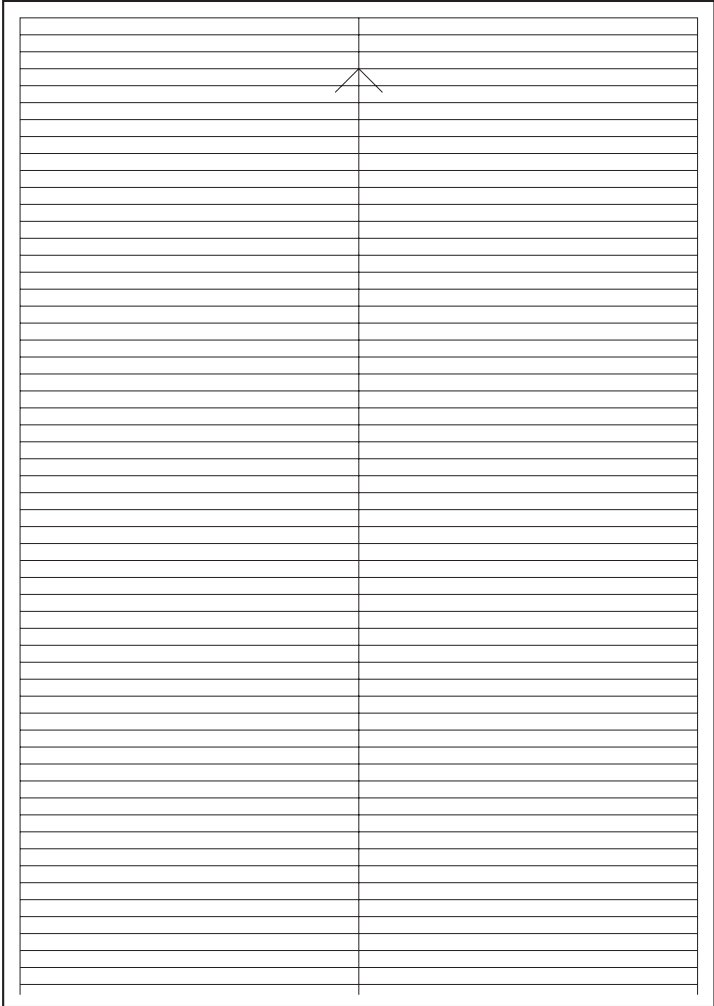

Wsb02022KA

-Ghost Chart

This chart allows you to check for a ghost if any occurs.

This chart is printed the [Ghost Configuration Chart] of the [Diagnosis] tab in [Tool Box].

When a ghost occurs, the patches with open cross and character K/B/G/R/M/C appear on the light-colored patches K/C/M in the lower half of the chart, and the patches with open cross only appears on the dark-colored patches K/C/M below the light-colored patches.

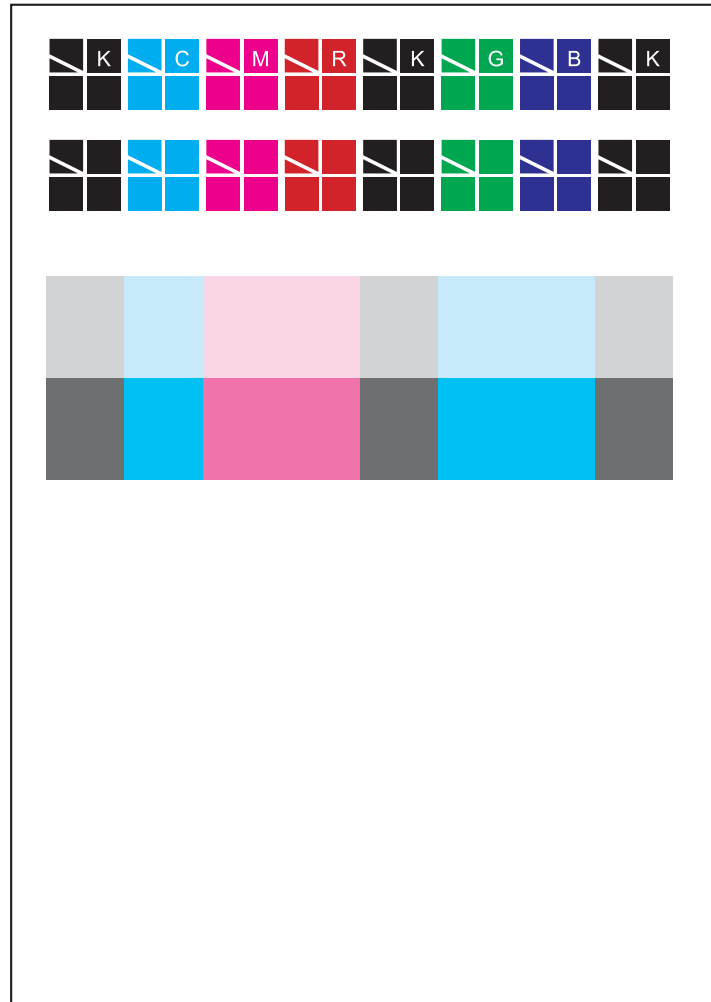

Wsb02020KA

4.3 Items to be Confirmed Before Image Quality Troubleshooting

Print Quality Problems

Customers may need your help determining the cause of print quality issues such as streaking, fading, or dropouts. Here are some questions that may help you determine why your customer's printer is not printing optionally. First, confirm the following items to understand customer's operating condition.

1. Does your customer's print media fall within the Printer Media Guidelines? (Go to 1.5 of this chapter and refer to "**Printer Media Guidelines**").
2. Is there enough toner?
3. Has the printer been cleaned recently?

Checking printer condition

Toner

Low toner can cause print quality problems such as fading, streaking, white lines, or dropouts.

Have your customer print a small document from a different application to replicate the problem and verify the amount of toner available for printing. When your customers print a document, the Laser Printer Status Monitor should display a dialog box that estimates the amount of toner left in the cartridge.

If the toner is low, your customers can something extend the cartridge life by removing the cartridge from the 3130cn, gently shaking it from side-to-side, and replacing it (Rocking the print cartridge from side-to-side loosens toner that may get stuck).

Cleaning

Paper, toner, and dust particles can accumulate inside the 3130cn printer and cause print quality problems, such as smearing or toner specks. Clean inside the 3130cn to prevent these problems.

Prior checks before troubleshooting

Check the following items if any print quality problems occur before going to each troubleshooting.

Those actions may solve problems easily and simply.

If the any problems below have occurred, check and take actions described in each item.

- 1) Color is out of alignment:
 - a) Clean inside of the printer.
 - b) If you install a new black print cartridge and a Print Head cleaning has not been done, this problem will happen. Clean inside of the printer.
- 2) Print is too light:
 - a) The toner may be low. Confirm the amount of the toner and change the print cartridges if necessary.
 - b) Set the **Draft Mode** check box to off in the Advanced in the printer driver.
 - c) If you are printing on an uneven print surface, change the Paper Type settings in the Tray Settings menu.
 - d) Verify that the correct print media is being used.
 - e) The print cartridge may need to be replaced. Change the print cartridge.
- 3) Toner smears or print comes off page:
 - a) If you are printing on an uneven print surface, change the Paper Type settings in the Tray Settings menu.
 - b) Verify that the print media is within the printer specifications. (Go to 1.5 of this chapter and refer to "**Printer Media Guidelines**").

- 4) Toner spots appear on the page/printing is blurred:
 - a) Check the print cartridge to make sure it is installed correctly.
 - b) Change the print cartridge.
- 5) Entire page is white:
 - a) Make sure the packaging material is removed from the print cartridge.
 - b) Check the print cartridge to make sure it is installed correctly.
 - c) The toner may be low. Change the print cartridge.
- 6) Streaks appear on the page:
 - a) The toner may be low. Change the print cartridge.
 - b) If you are using preprinted forms, make sure the toner can withstand temperatures of 0°C to 35°C.
- 7) Characters have jagged or uneven edges:
 - a) Change the **Print Mode** in the **Graphics** tab (or **Advanced** dialog box) to **Standard** in the printer driver.
 - b) If you are using downloaded fonts, verify that the fonts are supported by the printer, the host computer, and the software program.
- 8) Part or all of the page prints in black:
 - a) Check the print cartridge to make sure it is installed correctly.
- 9) The job prints, but the top and side margins are incorrect:
 - a) Make sure the Paper Size setting in the Tray Settings is correct.
 - b) Make sure the margins are set correctly in your software program.
- 10) Printing on both ends of the transparencies is faded:
 - a) This occurs when the printer is operating in a location where relative humidity reaches 85% or more. Adjust the humidity or relocate the printer to an appropriate environment.

4.4 Print Image Quality Specification

Image Quality Guarantee Conditions

The image quality is specified and guaranteed under the following conditions.

1) Environmental Condition

Temperature: 10°C - 32°C

Humidity: 15% RH - 85% RH (85% RH at 28°C)

Note that defect may occur due to condensation after around 30 minutes if the printer is turned on in an critical environment such as 85% at 10°C.

2) Guaranteed Paper

The print image quality specified in this chapter should be guaranteed when the standard paper is fed from the paper tray. The print image quality is evaluated on the maximum size of each standard paper.

Color print quality: X-Pression paper

Black and White quality: 4200 paper

3) Paper condition

The paper used is fresh paper immediately after unpacked, which has been left in the operating environment for 12 hours before unpacking.

4) Printer condition

The print image quality specified in this chapter is guaranteed with the printer in normal condition.

6) Criterion for judgment

The print image quality is guaranteed with Spec. In rate = 95% ($\gamma = 90\%$).

5) For **Color chart**, **Parallelism**, **Perpendicularity**, **Skew**, **Linearity**, **Magnification Error**, **Registration** and **Printed Guaranteed Area**, refer to each chart below.

Chart

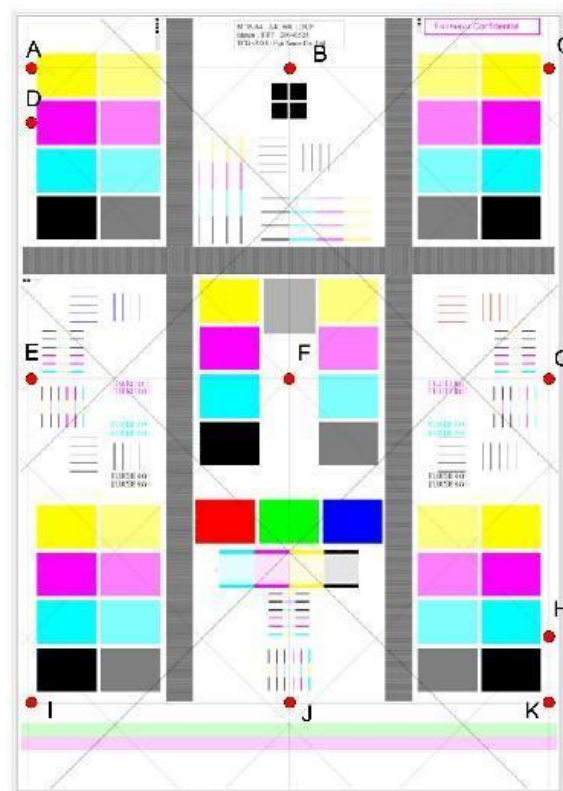

Parallelism

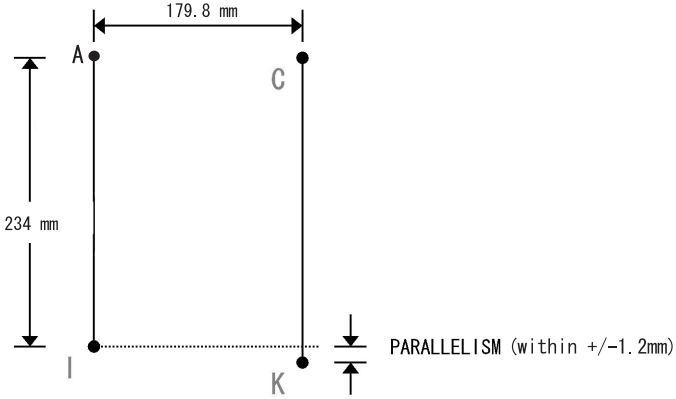

Perpendicularity

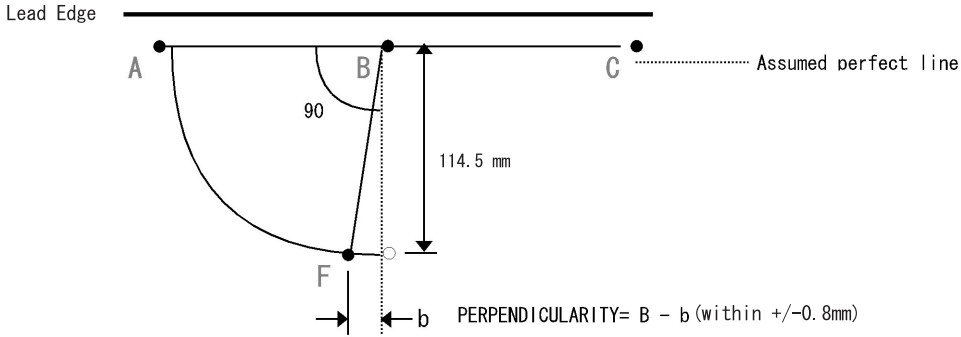

Skew

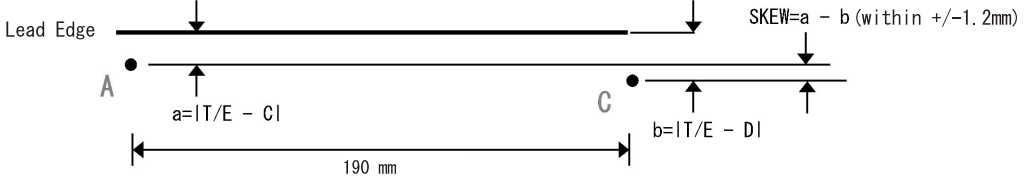

Linearity

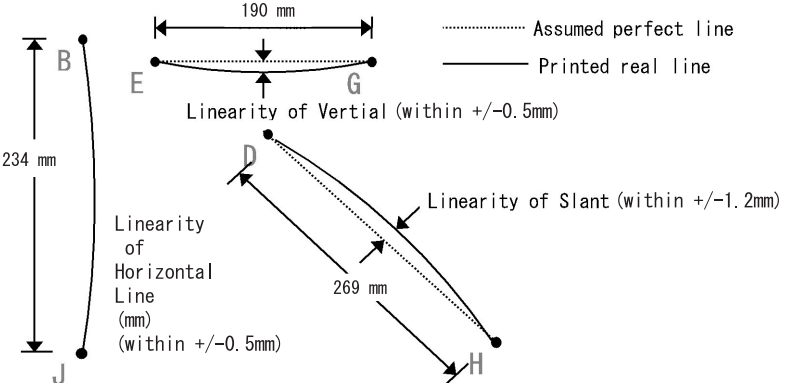

Magnification Error

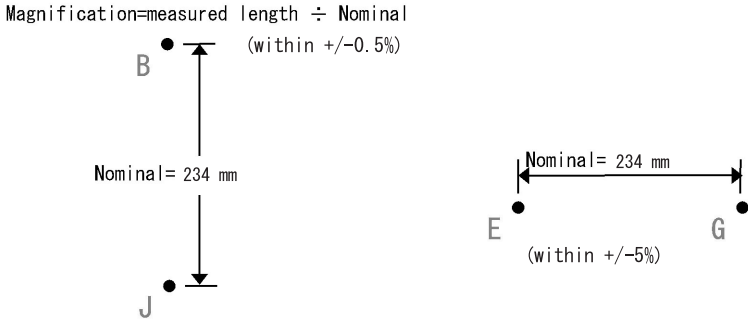

Registration

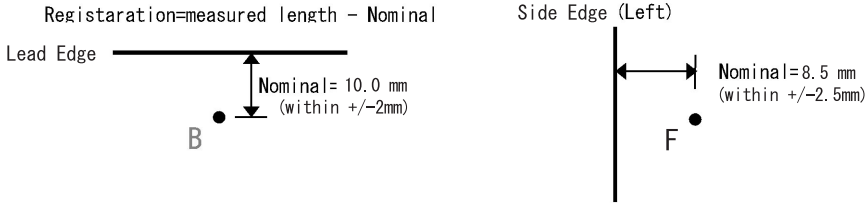

Printed Guaranteed Area

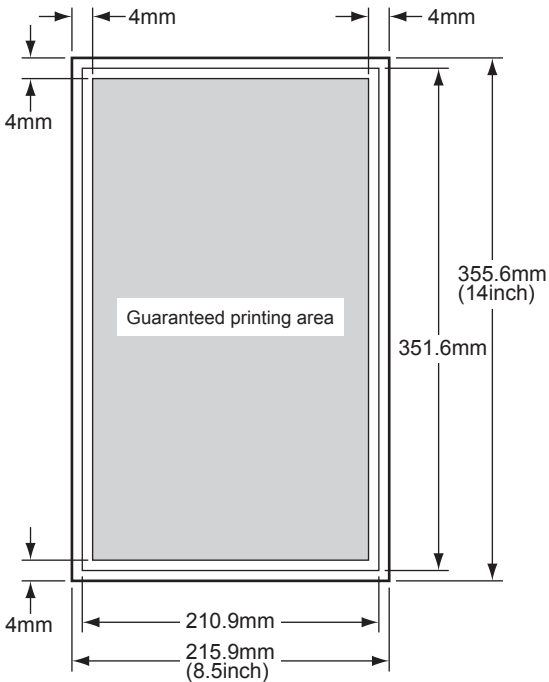

Kmy01001KA

4.5 Image Quality FIP

FIP-1.P1 Faint print (Low contrast)

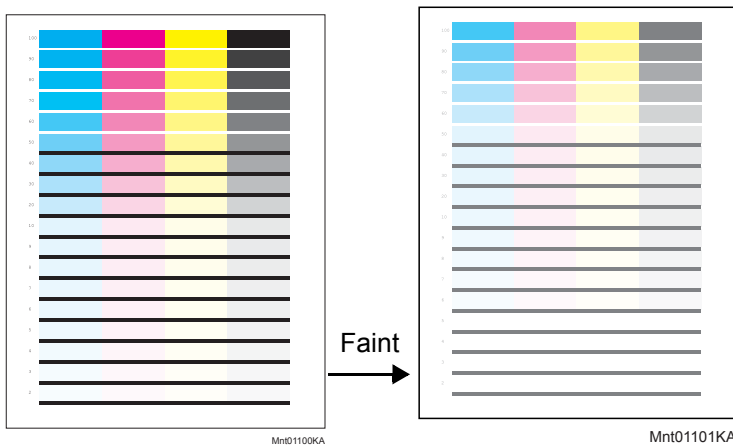

Trouble substance

The density of the image is entirely too faint.

Possible causative parts

- TRANSFER ASSY (PL4.1.1)
- DISPENSER ASSY (PL5.1.12)
- CARTRIDGE ASSY (PL5.1.18(K)/
PL5.1.19 (C)/PL5.1.20 (M)/PL5.1.21 (Y))
- PWBA MCU (PL9.1.20)

Before commencing troubleshooting, check the paper transfer path. Make sure there is no foreign materials on the transfer path, such as staples, paper clips, scraps of paper and so on.

Step	Check	Yes	No
1	Checking the Faint print. Print the windows test page. Is the image printed correctly?	Check the print data which the problem generated.	Go to step 2.
2	Checking the print cartridge installation. Is the installed print cartridge the DELL cartridge?	Go to step 3.	Replace to the DELL cartridge and print ten sheets [Test Print]-[Toner Pallet Check] in diagnosis.
3	Checking the sealing tape staying Remove the print cartridge from the printer. Is there the sealing tape on the right side of the print cartridge? (The drum side is the front.)	Pull the tape out.	Go to step 4.
4	Checking the printer setting Is the [Draft Mode] of the [PCL] in the [Admin Menu] the [Enable]?	Go to step 5.	Set to [Disable].
5	Checking the paper Is the installed paper with a new and dry one?	Go to step 6.	Replace the paper with a new and dry one.
6	Checking the print cartridge Is there the faint toner? Checked by [Test Print]- [Toner Pallet Check] in diagnosis.	Go to step 7.	Check the print data which the problem generated.

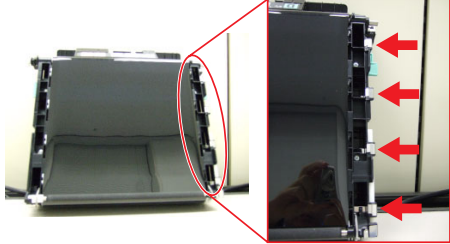
Step	Check	Yes	No
7	Checking the PLATE EARTH CRU(Drum Terminal). Are the PLATE EARTH CRU clean?	Go to step 8.	Clean up the PLATE EARTH CRU.
8	Checking the PLATE EARTH CRU ground Is PLATE EARTH CRU grounded appropriately?	Go to step 9.	Replace the printer.
9	<p>Checking the high voltage terminal of the TRANSFER ASSY. Open the Front Cover, check the terminals.</p>  <p>Are the terminals clean?</p>	Go to step 10.	Clean up the terminals.
10	Checking the TRANSFER ASSY installation Reseat the TRANSFER ASSY. Is the image printed correctly?	End of work.	Go to step 11.
11	Checking the TONER DISPENSE MOTOR. Does the TONER DISPENSE MOTOR rotate normally? Checked by [Digital Output]-[DO-21(Control Panel)/ TONER MOTOR Y ON(PC)/ 23(Control Panel)/TONER MOTOR M ON(PC)/25(Control Panel)/TONER MOTOR C ON(PC)/27(Control Panel)/TONER MOTOR K ON(PC)] in diagnosis.	Replace the failure print cartridge.	<p>Replace the PWBA MCU. (Refer to Removal 30/Replacement 14)</p> <p>If not, replace the TONER DISPENSE MOTOR. (Refer to Removal 24/Replacement 20)</p>

FIP-1.P2 Blank print (No print)

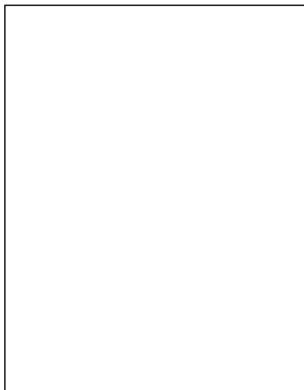
**Trouble substance**

The entire paper is printed pure white.

Possible causative parts

- TRANSFER ASSY (PL4.1.1)
- DISPENSER ASSY (PL5.1.12)
- HVPS (PL5.1.17)
- CARTRIDGE ASSY (PL5.1.18(K)/PL5.1.19 (C)/PL5.1.20 (M)/PL5.1.21 (Y))
- KIT ROS ASSY (PL5.1.99)
- PWBA MCU (PL9.1.20)
- PWBA ESS (PL9.1.27)

Before commencing troubleshooting, check the paper transfer path. Make sure there is no foreign materials on the transfer path, such as staples, paper clips, scraps of paper and so on.

Step	Check	Yes	No
1	Checking the blank print. Print the Contamination Check page. Is the image printed correctly?	Check the print data which the problem generated.	Go to step 2.
2	Checking the print cartridge installation. Is the installed print cartridge the DELL cartridge?	Go to step 3.	Replace to the DELL cartridge and print ten sheets [Test Print]-[Toner Pal-let Check] in diagnosis.
3	Checking the paper Is the installed paper with a new and dry one?	Go to step 4.	Replace the paper with a new and dry.
4	Checking the Test Pattern. Is the image printed correctly? Checked by [Test Print] - [Test Pattern 600] in diagnosis.	Replace the PWBA ESS. (Refer to Removal 26/Replacement 18)	Go to step 5.
5	Checking the laser beam path. Are there any foreign substance between the ROS ASSY and the drum?	Remove the foreign substance	Go to step 6.
6	Checking the connection of the ROS ASSY. Reseat the connector (P/J 151) of the ROS ASSY. Is the image printed correctly?	End of work.	Go to step 7.
7	Checking the TRANSFER ASSY installation Reseat the TRANSFER ASSY. Is the image printed correctly?	End of work.	Go to step 8.

Step	Check	Yes	No
8	Checking the TONER DISPENSE MOTOR. Does the TONER DISPENSE MOTOR rotate normally? Checked by [Digital Output]-[DO-21(Control Panel)/ TONER MOTOR Y ON(PC)/ 23(Control Panel)/TONER MOTOR M ON(PC)/25(Control Panel)/TONER MOTOR C ON(PC)/27(Control Panel)/TONER MOTOR K ON(PC)] in diagnosis.	Go to step 9.	Replace the PWBA MCU. (Refer to Removal 30/Replacement 14) If not, replace the TONER DIS- PENSE MOTOR (Refer to Removal 24/Replacement 20) and print ten sheets [Test Print]-[Toner Pal- let Check] in diag- nosis.
9	Checking the PWBA MCU installation Reseat the PWBA MCU. (Refer to Removal 30/Replace- ment 14) Is the image printed correctly?	End of work.	Go to step 10.
10	Checking the PWBA ESS installation Reseat the PWBA ESS. (Refer to Removal 26/Replace- ment 18) Is the image printed correctly?	End of work.	Go to step 11.
11	Checking the HVPS installation Reseat the HVPS. Is the image printed correctly?	End of work.	Go to step 12.
12	Checking after replacing the ROS ASSY Replace the ROS ASSY. (Refer to Removal 36/Replace- ment 8) Is the image printed correctly?	End of work.	Replace the PWBA ESS. (Refer to Removal 26/ Replacement 18)

FIP-1.P3 Solid black

**Trouble substance**

The entire paper is printed jet-black.

Possible causative parts

- HVPS (PL5.1.17)
- CARTRIDGE ASSY (PL5.1.18(K)/PL5.1.19(C)/PL5.1.20 (M)/PL5.1.21 (Y))
- KIT ROS ASSY (PL5.1.99)
- PWBA MCU (PL9.1.20)
- PWBA ESS (PL9.1.27)

Before commencing troubleshooting, check the paper transfer path. Make sure there is no foreign materials on the transfer path, such as staples, paper clips, scraps of paper and so on.

Step	Check	Yes	No
1	Checking the solid black. Print the Contamination Check page. Is the image printed correctly?	Check the print data which the problem generated.	Go to step 2.
2	Checking the print cartridge installation. Is the installed print cartridge the DELL cartridge?	Go to step 3.	Replace to the DELL cartridge and print ten sheets [Test Print]-[Toner Pal-let Check] in diagnosis.
3	Checking the paper Is the installed paper with a new and dry one?	Go to step 4.	Replace the paper with a new and dry.
4	Checking the Test Pattern. Print the Test Pattern page. Is the image printed correctly? Checked by [Test Print] - [Test Pattern 600] in diagnosis.	Replace the PWBA ESS. (Refer to Removal 26/Replacement 18)	Go to step 5.
5	Checking the Grid2. Print the Grid2 page. Is the solid color printed? Checked by [Test Print] - [Grid2] in diagnosis.	Replace the toner cartridge of the color by which Solid was printed.	Go to step 6.
6	Checking the PWBA MCU installation Reseat the PWBA MCU. (Refer to Removal 30/Replacement 14.) Is the image printed correctly?	End of work.	Go to step 7.

Step	Check	Yes	No
7	Checking the PWBA ESS installation Reseat the PWBA ESS. (Refer to Removal 26/Replacement 18.) Is the image printed correctly?	End of work.	Go to step 8.
8	Checking the HVPS installation Reseat the HVPS. (Refer to Removal 34/Replacement 10.) Is the image printed correctly?	End of work.	Replace the PWBA ESS. (Refer to Removal 26/Replacement 18) If not, replace the PWBA MCU. (Refer to Removal 30/Replacement 14)

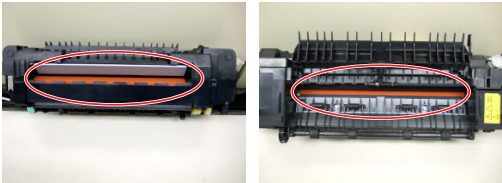
Step	Check	Yes	No
3	Measure the blank line pitch. Does the blank line pitch match any of the pitches in the printed table chart? Checked by [Test Print]- [Contamination check] in diagnosis.	Replace the corresponding parts. See [MQ Chart] of [4.2 Diagnosis Test Chart].	Go to step 4.
4	Checking the print cartridge Is the installed print cartridge the DELL cartridge?	Go to step 5.	Replace to the DELL cartridge and print ten sheets [Test Print]-[Toner Pallet Check] in diagnosis.
5	Checking the paper Is the installed paper with a new and dry one?	Go to step 6.	Replace the paper with a new and dry.
6	Checking the surface of TRANSFER ASSY. Are there any damages on the surface of TRANSFER ASSY?	Replace the TRANSFER ASSY. (Refer to Removal 4/ Replacement 40)	Go to step 7.
7	Checking the foreign substance. Remove the Fuser. Warning: Start the operation after the FUSER ASSY has cooled down. Check the heat roll surface.  Are there any foreign substances?	Replace the FUSER ASSY. (Refer to Removal 8/Replacement 36)	Replace the printer.

FIP-1.P5 Horizontal band cross out (White stripes in the horizontal direction)

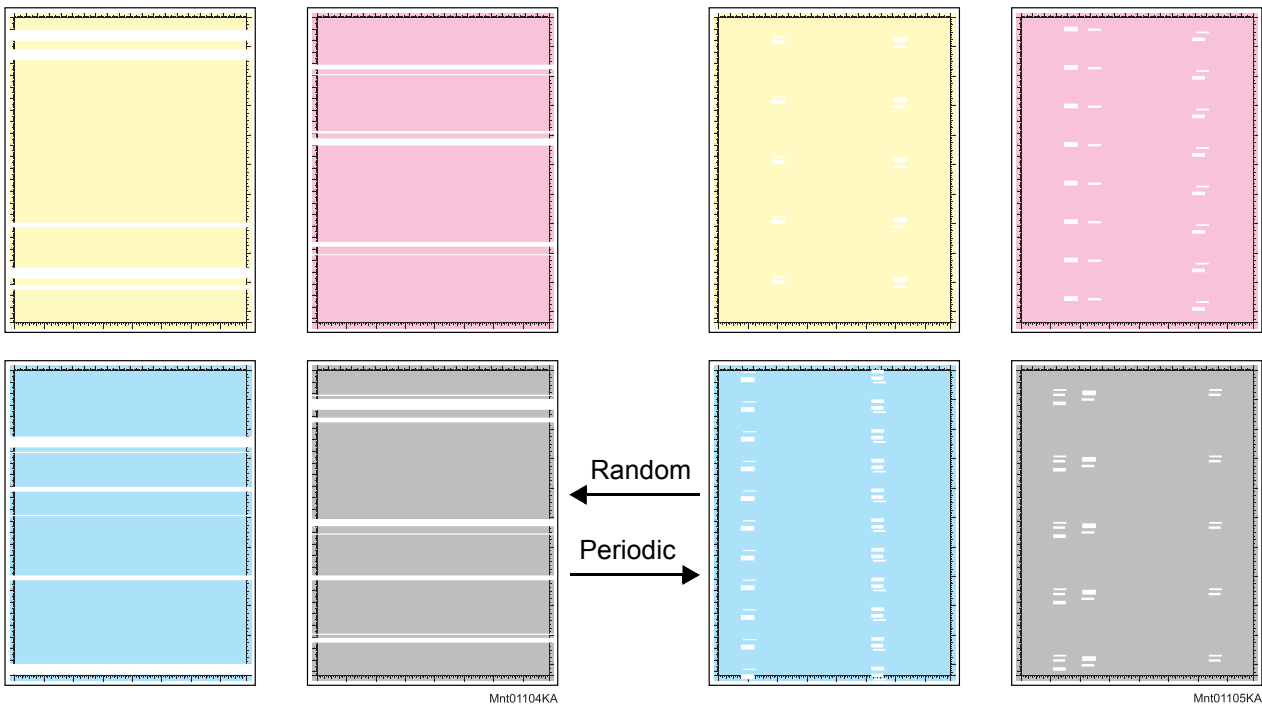

Trouble substance

There are some extremely faint or completely non-printed parts. Those non-printed parts cover a wide area horizontally, perpendicular to the paper feeding direction.

Possible causative parts

- TRANSFER ASSY (PL4.1.1)
- CARTRIDGE ASSY (PL5.1.18(K)/PL5.1.19(C)/PL5.1.20 (M)/PL5.1.21 (Y))
- FUSER ASSY (PL6.1.10)

Before commencing troubleshooting, check the paper transfer path. Make sure there is no foreign materials on the transfer path, such as staples, paper clips, scraps of paper and so on.

Step	Check	Yes	No
1	Checking the Horizontal band cross out. Print the Contamination Check page. Is the image printed correctly? Checked by [Test Print] - [contamination Check] in diagnosis.	Check the print data which the problem generated.	Go to step 2.
2	Measure the blank line pitch. Does the blank line pitch match any of the pitches in the printed table chart? Checked by [Test Print]- [Contamination check] in diagnosis.	Replace the corresponding parts. See [MQ Chart] of [4.2 Diagnosis Test Chart].	Go to step 3.

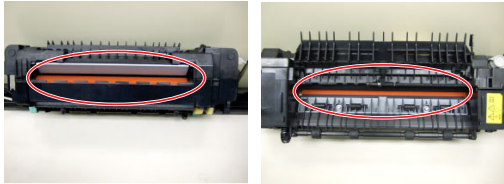
Step	Check	Yes	No
3	Checking the print cartridge Is the installed print cartridge the DELL cartridge?	Go to step 4.	Replace to the DELL cartridge and print ten sheets [Test Print]-[Toner Pallet Check] in diagnosis.
4	Checking the paper Is the installed paper with a new and dry one?	Go to step 5.	Replace the paper with a new and dry.
5	Checking the surface of TRANSFER ASSY. Are there any damages on the surface of TRANSFER ASSY?	Replace the TRANSFER ASSY. (Refer to Removal 4/ Replacement 40)	Go to step 6.
6	Checking the foreign substance. Remove the Fuser. Warning: Start the operation after the FUSER ASSY has cooled down. Check the heat roll surface.  Are there any foreign substances?	Replace the FUSER ASSY. (Refer to Removal 8/Replacement 36)	Go to step 7.
7	Checking the laser beam path. Are there any foreign substance between the ROS ASSY and the drum?	Remove the foreign substance	Replace the failure print cartridge.

FIP-1.P6 Vertical stripes

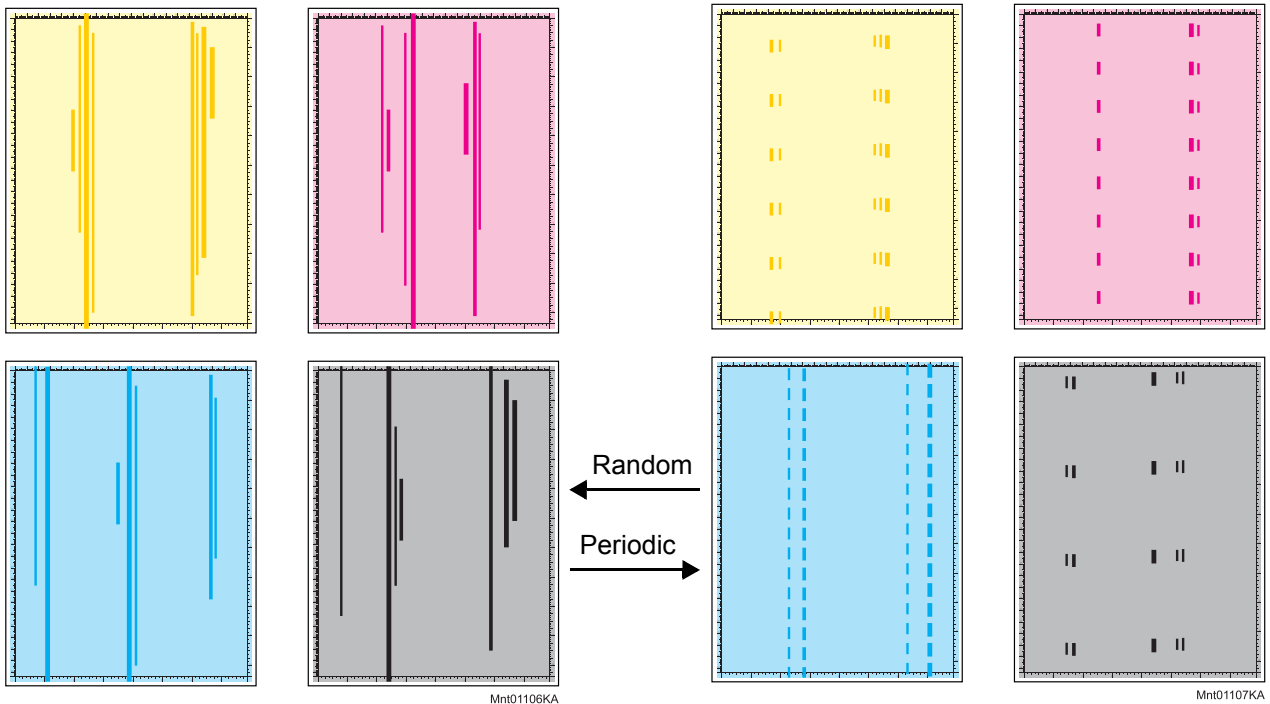

Trouble substance

There are vertical black stripes along the paper.

Possible causative parts

- TRANSFER ASSY (PL4.1.1)
- CARTRIDGE ASSY (PL5.1.18(K)/PL5.1.19(C)/PL5.1.20 (M)/PL5.1.21 (Y))
- FUSER ASSY (PL6.1.10)

NOTE

If the stripes at the top or back of the paper, replace the IBT ASSY only.

Before commencing troubleshooting, check the paper transfer path. Make sure there is no foreign materials on the transfer path, such as staples, paper clips, scraps of paper and so on.

Step	Check	Yes	No
1	Checking the Vertical stripes. Print the Contamination Check page. Is the image printed correctly? Checked by [Test Print] - [contamination Check] in diagnosis.	Check the print data which the problem generated.	Go to step 2.
2	Checking the foreign substance and damage. Open the Front cover; check the surrounding area of the print cartridges and the TRANSFER ASSY. Are there any foreign substances?	Remove the foreign substance.	Go to step 3.

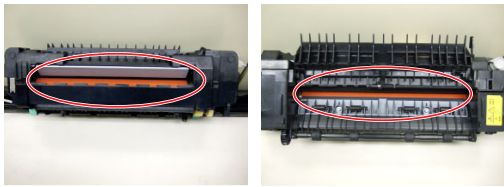
Step	Check	Yes	No
3	Measure the blank line pitch. Does the stripe pitch match any of the pitches in the printed table chart? Checked by [Test Print] - [Contamination check] in diagnosis.	Replace the corresponding parts. See [MQ Chart] of [4.2 Diagnosis Test Chart].	Go to step 4.
4	Does the stripe pitch match any of the pitches in the printed table chart? Is the installed print cartridge the DELL cartridge?	Go to step 5.	Replace to the DELL cartridge and print ten sheets [Test Print]-[Toner Pallet Check] in diagnosis.
5	Checking the drum damaged Are there any damage on the drums?	Replace the failure print cartridge.	Go to step 6.
6	Checking the surface of TRANSFER ASSY. Are there any damages on the surface of TRANSFER ASSY?	Replace the TRANSFER ASSY. (Refer to Removal 4/ Replacement 40)	Go to step 7.
7	Checking the foreign substance. Remove the Fuser. Warning: Start the operation after the FUSER ASSY has cooled down. Check the heat roll surface.  Are there any foreign substances?	Replace the FUSER ASSY. (Refer to Removal 8/Replacement 36)	Go to step 8.
8	Checking the after replacing the print cartridge Replace the failure print cartridge. Is the image printed correctly?	End of work.	Replace the FUSER ASSY.

FIP-1.P7 Horizontal stripes

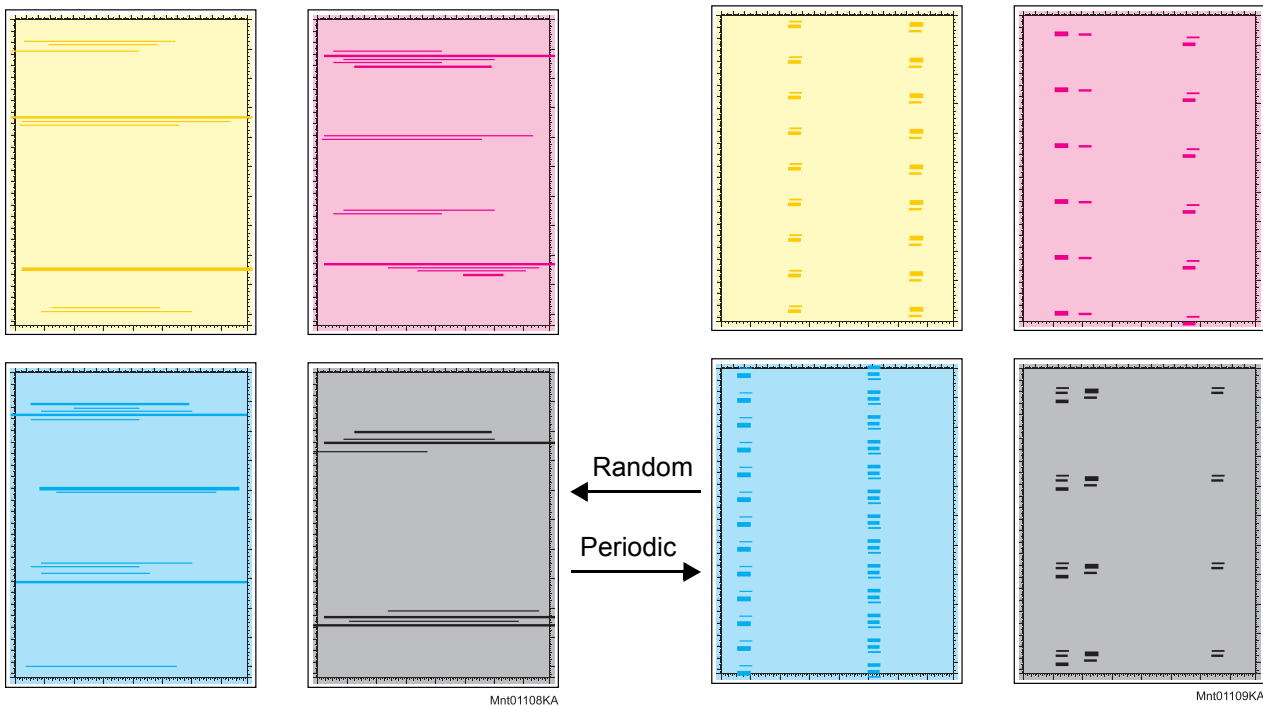

Trouble substance

There are horizontal black stripes (perpendicular to the paper path direction) along the paper.

Possible causative parts

- TRANSFER ASSY (PL4.1.1)
- CARTRIDGE ASSY (PL5.1.18(K)/PL5.1.19(C)/PL5.1.20 (M)/PL5.1.21 (Y))
- FUSER ASSY (PL6.1.10)

Before commencing troubleshooting, check the paper transfer path. Make sure there is no foreign materials on the transfer path, such as staples, paper clips, scraps of paper and so on.

Step	Check	Yes	No
1	Checking the Horizontal stripes. Print the Contamination Check page. Is the image printed correctly? Checked by [Test Print] - [contamination Check] in diagnosis.	Check the print data which the problem generated.	Go to step 2.
2	Checking the foreign substance and damage. Open the Front cover; check the surrounding area of the print cartridges and the TRANSFER ASSY. Are there any foreign substances?	Remove the foreign substance.	Go to step 3.
3	Measure the stripe pitch. Does the stripe pitch match any of the pitches in the printed table chart? Checked by [Test Print] - [Contamination check] in diagnosis.	Replace the corresponding parts. See [MQ Chart] of [4.2 Diagnosis Test Chart].	Go to step 4.

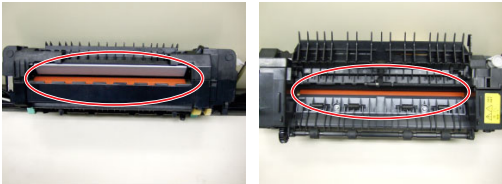
Step	Check	Yes	No
4	Checking after replacing the print cartridge Replace the failure print cartridge. Is the image printed correctly?	End of work.	Go to step 5.
5	Checking the surface of TRANSFER ASSY. Are there any damages on the surface of TRANSFER ASSY?	Replace the TRANSFER ASSY. (Refer to Removal 4/Replacement 40)	Go to step 6.
6	Checking the foreign substance. Remove the Fuser. Warning: Start the operation after the FUSER ASSY has cooled down. Check the heat roll surface.  Are there any foreign substances?	Replace the FUSER ASSY. (Refer to Removal 8/Replacement 36)	Replace the printer.

FIP-1.P8 Partial Deletion

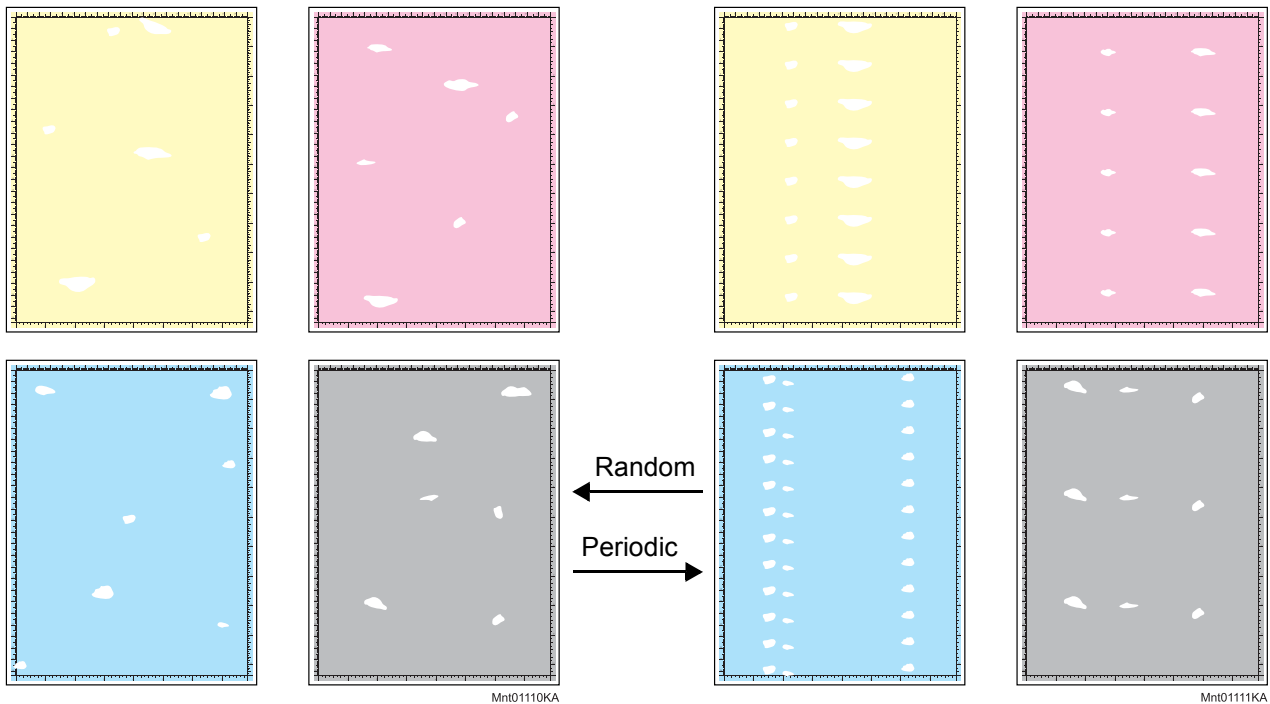
**Trouble substance**

There are some extremely faint or completely missing parts in a limited area on the paper.

Possible causative parts

- TRANSFER ASSY (PL4.1.1)
- CARTRIDGE ASSY (PL5.1.18(K)/PL5.1.19(C)/PL5.1.20 (M)/PL5.1.21 (Y))

Before commencing troubleshooting, check the paper transfer path. Make sure there is no foreign materials on the transfer path, such as staples, paper clips, scraps of paper and so on.

Step	Check	Yes	No
1	Checking the Partial Deletion. Print the Contamination Check page. Is the image printed correctly? Checked by [Test Print] - [contamination Check] in diagnosis.	Check the print data which the problem generated.	Go to step 2.
2	Measure the blank line pitch. Does the blank line pitch match any of the pitches in the printed table chart? Checked by [Test Print] - [Contamination check] in diagnosis.	Replace the corresponding parts. See [MQ Chart] of [4.2 Diagnosis Test Chart].	Go to step 3.
3	Checking the Tail Edge. Is partial deletion in Tail Edge? (Refer to NOTE.)	Go to step 4.	Go to step 5.

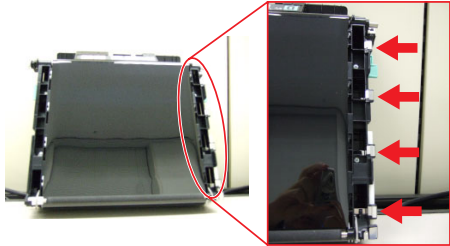
Step	Check	Yes	No
4	Checking after replace the FUSER ASSY. (Refer to Removal 8/Replacement 36.) Is the partial deletion in Tail Edge printed?	Replace the Printer.	End of work.
5	Checking the print cartridge. Is the installed print cartridge the DELL cartridge?	Go to step 6.	Replace to DELL cartridge.
6	Checking the paper Is the installed paper with the new and dry one?	Go to step 7.	Replace to the paper with the new and dry.
7	Checking the surface of TRANSFER ASSY. Are there any damages on the surface of TRANSFER ASSY?	Replace the TRANSFER ASSY. (Refer to Removal 4/Replacement 40)	Go to step 8.
8	Checking the high voltage terminal of the TRANSFER ASSY. Open the Front Cover, check the terminals.  Are the terminals clean?	Replace the printer.	Clean up the terminals.

NOTE

This partial deletion is called as "smudge". Can be seen A4 size and half tone print. The partial deletion sample of Tail Edge is shown below.

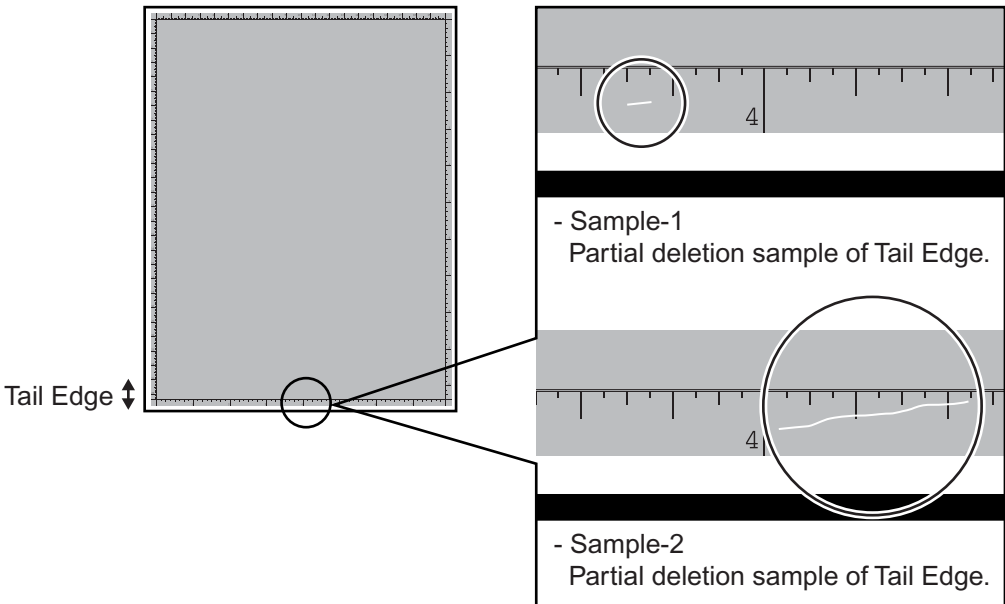

Zna05000KA

FIP-1.P9 Spots

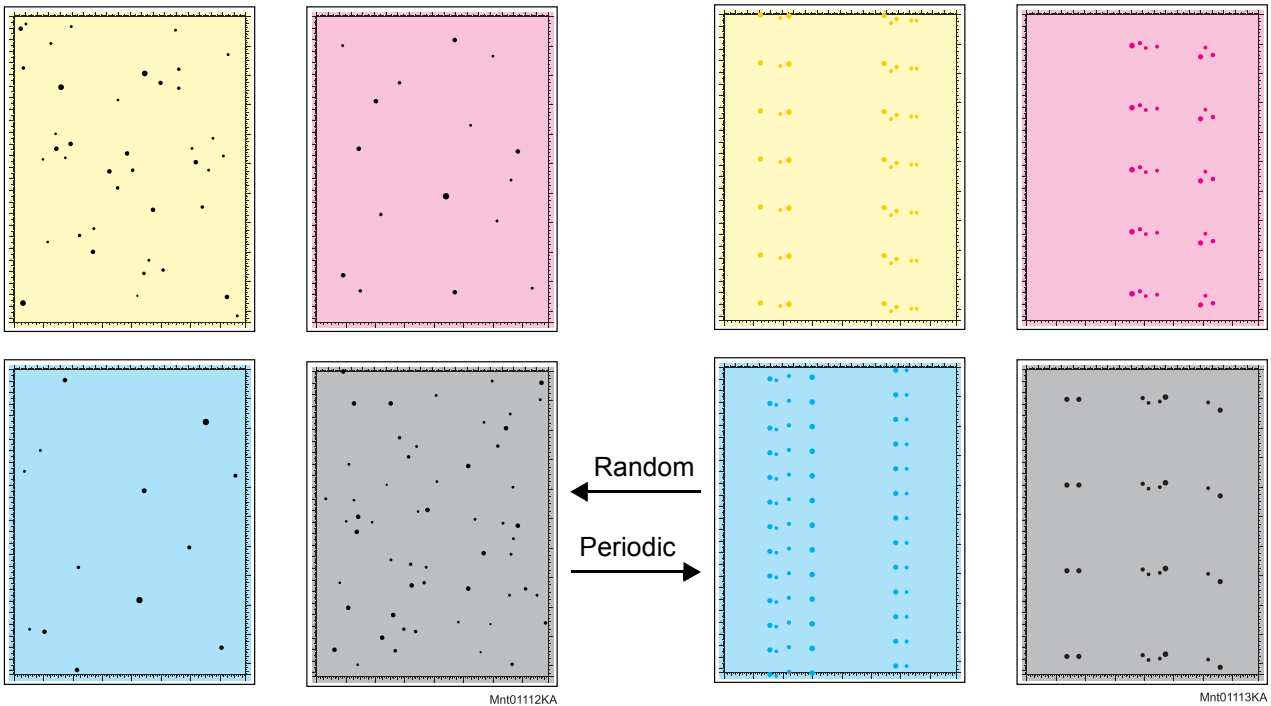

Trouble substance

There are toner spots all over the paper disorderedly.

Possible causative parts

- TRANSFER ASSY (PL4.1.1)
- CARTRIDGE ASSY (PL5.1.18(K)/PL5.1.19(C)/PL5.1.20 (M)/PL5.1.21 (Y))
- FUSER ASSY (PL61.1.10)

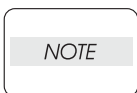

If the toner spot at the top or back of the paper, replace the IBT ASSY only.

Before commencing troubleshooting, check the paper transfer path. Make sure there is no foreign materials on the transfer path, such as staples, paper clips, scraps of paper and so on.

Step	Check	Yes	No
1	Checking the Spots. Print the Contamination Check page. Is the image printed correctly? Checked by [Test Print] - [contamination Check] in diagnosis.	Check the print data which the problem generated.	Go to step 2.
2	Checking the toner contamination. Open the Front Cover, check the surrounding area of the print cartridges, the TRANSFER ASSY and the Regi Rolls. Is there the toner contamination?	Clean the toner by the dry cloth or replace the contaminated parts.	Go to step 3.

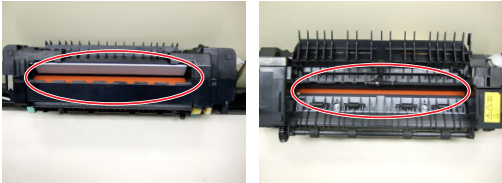
Step	Check	Yes	No
3	Clean the toner by the dry cloth or replace the contaminated parts. Does the spots pitch match any of the pitches in the printed table chart? Checked by [Test Print] - [Contamination check] in diagnosis.	Replace the corresponding parts. See [MQ Chart] of [4.2 Diagnosis Test Chart].	Go to step 4.
4	Checking the print cartridge. Is the installed print cartridge the DELL cartridge?	Go to step 5.	Replace to DELL cartridge.
5	Checking the foreign substance. Remove the Fuser. Warning: Start the operation after the FUSER ASSY has cooled down. Check the heat roll surface.  Are there any foreign substances?	Replace the FUSER ASSY. (Refer to Removal 8/Replacement 36)	Go to step 6.
6	Checking the paper path. Is there the contamination of the toner on the paper path?	Clean the paper path.	Replace the FUSER ASSY. (Refer to Removal 8/Replacement 36)

FIP-1.P10 Afterimage (Ghost)

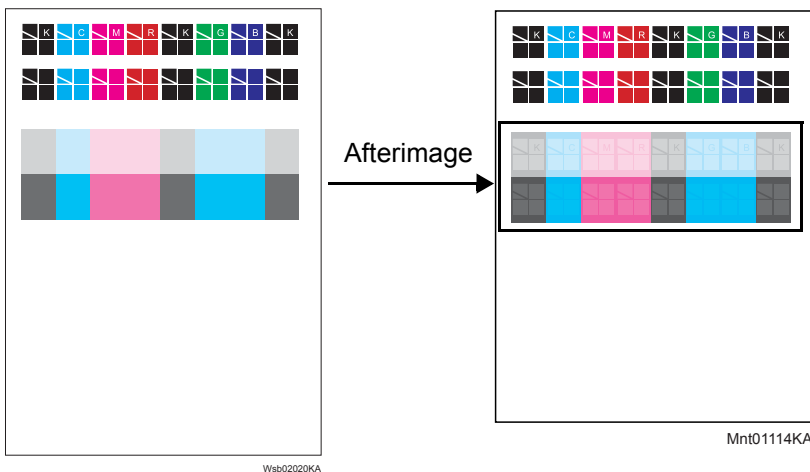
**Trouble substance**

The ghost appears on the paper. The ghost may be the image of the previous page, or a part of the page currently printing.

Possible causative parts

- TRANSFER ASSY (PL4.1.1)
- CARTRIDGE ASSY (PL5.1.18(K)/PL5.1.19(C)/PL5.1.20 (M)/PL5.1.21 (Y))
- FUSER ASSY (PL6.1.10)

Before commencing troubleshooting, check the paper transfer path. Make sure there is no foreign materials on the transfer path, such as staples, paper clips, scraps of paper and so on.

Step	Check	Yes	No
1	Checking the paper condition Is the paper dry and recommended paper?	Go to step 3.	Replace the paper with a new dry and recommended one, then go to step 2.
2	Is the image printed correctly?	End of work.	Go to step 3.
3	Checking the Afterimage(Ghost). Print the Ghost Configuration Page. Is the image printed correctly? Checked by [Ghost Configuration Chart] of the [Diagnosis] tab in Tool Box.	Check the print data which the problem generated.	Go to step 4.
4	Checking the Refresh Configuration page. Checked by [PHD Refresh Configuration Chart] of the [Diagnosis] tab in Tool Box. Is the image printed correctly?	End of work.	Go to step 5.
5	Checking the surface of the TRANSFER ASSY Are there any damages on the surface of the TRANSFER ASSY?	Replace the TRANSFER ASSY. (Refer to Removal 4/ Replacement 40)	Go to step 6.
6	Checking the TRANSFER ASSY for installation Reseat the TRANSFER ASSY. Is the image printed correctly?	End of work.	Go to step 7.

Step	Check	Yes	No
7	Checking the print cartridge installation Reseat the four print cartridges. Is the image printed correctly?	End of work.	Go to step 8.
8	Checking after replacing the print cartridge Replace the failure print cartridge. Is the image printed correctly?	End of work.	Replace the FUSER ASSY. (Refer to Removal 8/Replacement 36)

FIP-1.P11 Grey Background

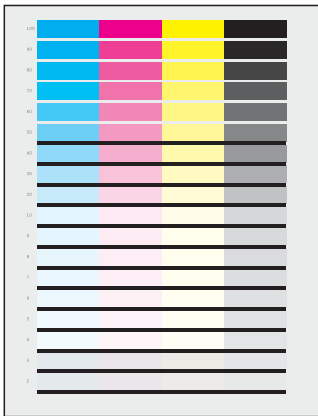

Mnt01115KA

Trouble substance

There is toner stain all over or a part of the page. The stain appears as very bright color (Y, M, C, K or etc.) stain.

Possible causative parts

- ROS ASSY (PL5.1.2)
- CARTRIDGE ASSY (PL5.1.18(K)/PL5.1.19(C)/PL5.1.20 (M)/PL5.1.21 (Y))

Before commencing troubleshooting, check the paper transfer path. Make sure there is no foreign materials on the transfer path, such as staples, paper clips, scraps of paper and so on.

Step	Check	Yes	No
1	Checking the Grey background. Print the Gradation Page. Is the image printed correctly? Checked by [Test Print] - [Gradation] in diagnosis.	End of work.	Go to step 2.
2	Checking the toner contamination. Open the Front Cover, check the surrounding area of the print cartridges, the TRANSFER ASSY and the Regi Rolls. Is there the toner contamination?	Clean the toner by the dry cloth or replace the contaminated parts.	Go to step 3.
3	Checking the print cartridge. Is the installed print cartridge the DELL cartridge?	Go to step 4.	Replace to DELL cartridge.
4	Checking the print cartridge installation Reseat the four print cartridges. Is the image printed correctly?	End of work.	Go to step 5.
5	Checking the after replacing the print cartridge Replace the print cartridge. Is the image printed correctly?	End of work.	Replace the ROS ASSY (Refer to Removal 36/Replacement 8) and Replace the HVPS (Refer to Removal 34/Replacement 10)

FIP-1.P12 Skew

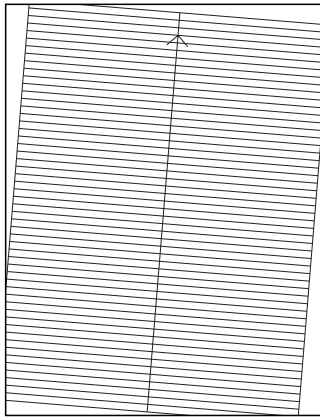

Mnt01116KA

Trouble substance

The printed image is not paralleled with both sides of the paper.

Possible causative parts

- SEPARATOR ROLLER ASSY MSI (PL2.1.3)
- KIT SEPARATOR and FEED ROLLER (PL2.2.99)
- ROLL ASSY FEED MSI (PL3.1.10)
- KIT FEEDER ASSY (PL3.2.99)
- TRANSFER ASSY (PL4.1.1)
- FEEDER ASSY DUP (PL11.1.1)
- KIT SEPARATOR and FEED ROLLER (PL12.3.99)

Before commencing troubleshooting, check the paper transfer path. Make sure there is no foreign materials on the transfer path, such as staples, paper clips, scraps of paper and so on.

Step	Check	Yes	No
1	Checking the paper condition Is the paper in the tray new and dry one?	Replace the paper with a new and dry one.	Go to step 2.
2	Checking the Front Cover latching Open and close the Front Cover. Does the error still occur when printing?	Go to step 3.	End of work.
3	Checking the foreign substance Open the Front Cover, check the surrounding area of the print cartridges, the TRANSFER ASSY and the Regi Rolls. Are there any foreign substances?	Remove the foreign substances.	Go to step 4.
4	Checking the surface of TRANSFER ASSY. Are there any damages on the surface of TRANSFER ASSY?	Replace the TRANSFER ASSY. (Refer to Removal 4/ Replacement 40)	Go to step 5.
5	Checking the skewed tray Is the skewed paper the MPF fed?	Go to step 6.	Go to step 12.
6	Checking the paper installation. Reseat the paper and reset the paper guide on the MPF. Does the error still occur when printing?	Go to step 7.	End of work.
7	Checking the paper Is the MPF feeding the envelope?	Go to step 8.	Go to step 9.
8	Checking the envelope setting Was the envelope inserted with the flap closed, air vacuumed, and short edge facing toward the printer?	Go to step 9.	Reseat the envelopes.
9	Checking the paper path. Is there the foreign substance on the paper path?	Remove the foreign substance.	Go to step 10.

Step	Check	Yes	No
10	Checking after replacing the feed roller Replace the ROLL ASSY FEED MSI. Does the error still occur when printing?	Go to step 11.	End of work.
11	Checking after replacing the roller Replace the SEPARATOR ROLLER ASSY MSI. (Refer to Removal 41/ Replacement 3) Does the error still occur when printing?	Replace the KIT FEEDER ASSY. (Refer to Removal 40/Replacement 4)	End of work.
12	Checking the skewed mode Is the skewed paper the duplex fed?	Go to step 13.	Go to step 15.
13	Checking the FEEDER ASSY DUP installation Reseat the CHUTE ASSY DUP. Does the error still occur when printing?	Go to step 14.	End of work.
14	Checking the paper path. Is there the foreign substance on the paper path?	Remove the foreign substance.	Replace the FEEDER ASSY DUP (Refer to Removal 5/Replacement 39.)
15	Checking the paper installation Reseat the paper in the paper cassette and reset the side and end guides. Does the error still occur when printing?	Go to step 16.	End of work.
16	Checking the paper path. Is there the foreign substance on the paper path?	Remove the foreign substance.	Go to step 17.
17	Checking after replacing the feed roller Replace the FEED ROLLER. Does the error still occur when printing?	Go to step 18.	End of work.
18	Checking after replacing the roller. Replace the SEPARATOR ROLLER ASSY MSI. Does the error still occur when printing?	Replace the KIT FEEDER ASSY. (Refer to Removal 40/Replacement 4)	End of work.

FIP-1.P13 Paper damage

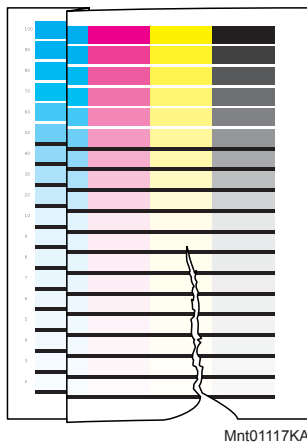
**Trouble substance**

The paper comes out from the printer wrinkled, folded or worn-out.

Possible causative parts

- SEPARATOR ROLLER ASSY MSI (PL2.1.3)
- KIT SEPARATOR and FEED ROLLER (PL2.2.99)
- ROLL ASSY FEED MSI (PL3.1.10)
- TRANSFER ASSY (PL4.1.1)
- FUSER ASSY (PL6.1.10)
- FEEDER ASSY DUP (PL11.1.1)
- KIT SEPARATOR and FEED ROLLER (PL12.3.99)

Before commencing troubleshooting, check the paper transfer path. Make sure there is no foreign materials on the transfer path, such as staples, paper clips, scraps of paper and so on.

Step	Check	Yes	No
1	Checking the paper condition Is the paper in the tray new and dry one?	Go to step 2.	Replace the paper with a new and dry one.
2	Checking the Front Cover latching Open and close the Front Cover. Does the error still occur when printing?	Go to step 3.	End of work.
3	Checking the foreign substance Open the Front cover; check the surrounding area of the print cartridges, the TRANSFER ASSY and the Regi Rolls. Are there any foreign substances?	Remove the foreign substances.	Go to step 4.
4	Checking the surface of TRANSFER ASSY. Are there any damages on the surface of TRANSFER ASSY?	Replace the TRANSFER ASSY. (Refer to Removal 4/ Replacement 40)	Go to step 5.
5	Checking the print cartridge installation Reseat the four print cartridges. Does the error still occur when printing?	Go to step 6.	End of work.
6	Checking the Fuser installation Reseat the Fuser. Does the error still occur when printing?	Go to step 7.	End of work.
7	Checking the skewed tray Is the skewed paper the MPF fed?	Go to step 8.	Go to step 13.
8	Checking the paper installation. Reseat the paper and reset the paper guide on the MPF. Does the error still occur when printing?	Go to step 9.	End of work.
9	Checking the paper Is the MPF feeding the envelope?	Go to step 10.	Go to step 11.

Step	Check	Yes	No
10	Checking the envelope setting Was the envelope inserted with the flap closed, air vacuumed, and short edge facing toward the printer?	Go to step 11.	Reseat the envelopes.
11	Checking the paper path. Is there the foreign substance on the paper path?	Remove the foreign substance.	Go to step 12.
12	Checking after replacing the feed roller Replace the ROLL ASSY FEED MSI. Does the error still occur when printing?	Replace the SEPARATOR ROLLER ASSY MSI. (Refer to Removal 41/Replacement 3)	End of work.
13	Checking the damaged mode Is the damaged paper the duplex fed?	Go to step 14.	Go to step 16.
14	Checking the FEEDER ASSY DUP installation Reseat the FEEDER ASSY DUP. Does the error still occur when printing?	Go to step 15.	End of work.
15	Checking the paper path. Is there the foreign substance on the paper path?	Remove the foreign substance.	Replace the FEEDER ASSY DUP (Refer to Removal 5/Replacement 39.)
16	Checking the paper installation Reseat the paper in the paper cassette and reset the side and end guides. Does the error still occur when printing?	Go to step 17.	End of work.
17	Checking the paper path. Is there the foreign substance on the paper path?	Remove the foreign substance.	Go to step 18.
18	Checking after replacing the feed roller Replace the FEED ROLLER. Does the error still occur when printing?	Replace the SEPARATOR ROLLER ASSY MSI. (Refer to Removal 41/Replacement 3)	End of work.

FIP-1.P14 Unfusing

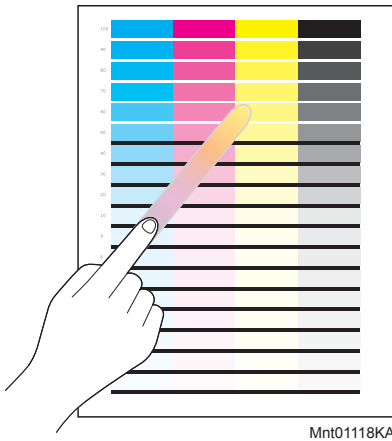
**Trouble substance**

The printed image is not fixed on the paper properly. The image easily comes off when rubbed.

Possible causative parts

- CARTRIDGE ASSY (PL5.1.18(K)/PL5.1.19(C)/PL5.1.20 (M)/PL5.1.21 (Y))
- FUSER ASSY (PL6.1.10)

Before commencing troubleshooting, check the paper transfer path. Make sure there is no foreign materials on the transfer path, such as staples, paper clips, scraps of paper and so on.

Step	Check	Yes	No
1	Checking the paper condition Is the paper in the tray new and dry one?	Go to step 2.	Replace the paper with a new and dry one.
2	Checking the print cartridge. Is the installed print cartridge the DELL cartridge?	Go to step 3.	Replace to the DELL cartridge.
3	Checking the FUSER installation Reset the FUSER. Is the image printed correctly?	End of work.	Replace the FUSER. (Refer to Removal 8/ Replacement 36)

FIP-1.P15 Color Registration (Color Shift)

- Troubleshooting of a control system

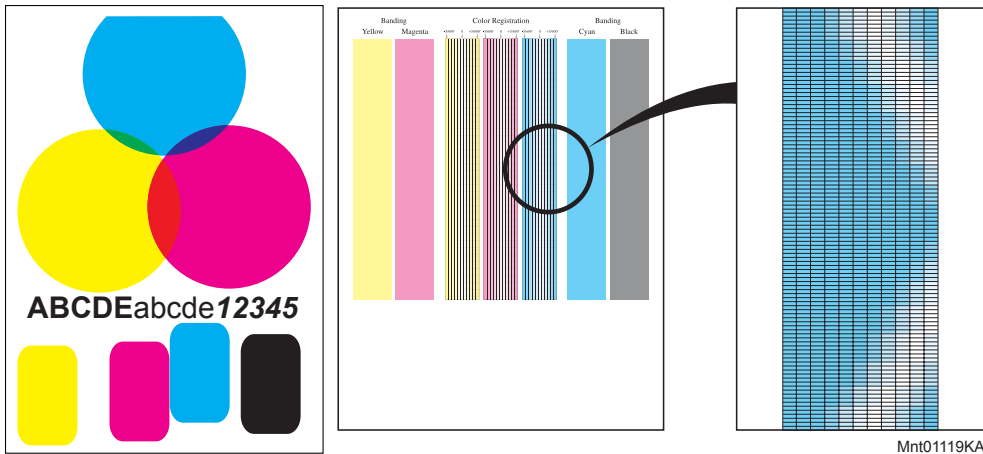
**Trouble substance**

A yellow or black image printed is not overlapped on a cyan or magenta image correctly.

Possible causative parts

- PWBA MCU (PL9.1.20)

Before commencing troubleshooting, check the paper transfer path. Make sure there is no foreign materials on the transfer path, such as staples, paper clips, scraps of paper and so on.

Step	Check	Yes	No
1	Checking the Color registration. Print the windows test page. Is the image printed correctly?	Check the print data which the problem generated.	Go to step 2.
2	Checking the printer installation Did the customer change the installation place of a printer?	Execute the [Auto Regi Adjust] in [Admin Menu].	Go to step 3.
3	Turn off and turn on the power. Print again. Is the image printed correctly?	End of work.	Go to step 4.
4	Checking the paper condition Is the paper in the tray new and dry one?	Go to step 5.	Replace the paper with a new and dry one.
5	Checking the printer Is the image printed correctly? Checked by [Test Print]- [Toner Pallet Check] in diagnosis.	Check the print data which the problem generated.	Go to step 6.
6	Checking the Regi adjustment. Execute the [Auto Regi Adjust] in [Admin Menu]. Is the image printed correctly?	End of work.	Go to step 7.

Step	Check	Yes	No
7	Checking the parameter value Did the client change the value of registration parameter?	Reset to the default value.	Replace the Printer.

- Troubleshooting of a paper feeding system

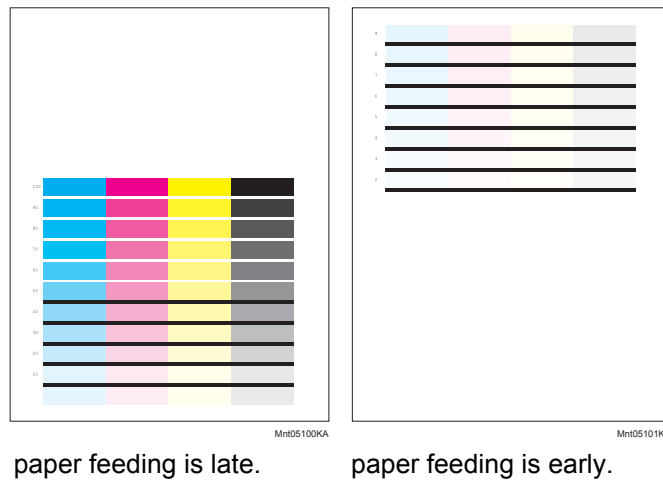
**Trouble substance**

A yellow or black image printed is not overlapped on a cyan or magenta image correctly.

Possible causative parts

- FEEDER ASSY (PL3.2.1)

Before commencing troubleshooting, check the paper transfer path. Make sure there is no foreign materials on the transfer path, such as staples, paper clips, scraps of paper and so on.

Step	Check	Yes	No
1	Checking the Front Cover latching Open and close the Front Cover. Is the image printed correctly?	End of work.	Go to step 2.
2	Checking the foreign substance Open the Front Cover; check the surrounding area of the print cartridges, the TRANSFER ASSY and the Regi Rolls. Are there any foreign substances?	Remove the foreign substances.	Go to step 3.
3	Checking the print cartridge installation Reseat the four print cartridges. Is the image printed correctly?	End of work.	Go to step 4.
4	Checking the Regi Clutch for operation Does the regi clutch operate properly? Checked by [Digital Output]-[DO-29(Control Panel)/REGI CLUTCH ON(PC)] in diagnosis.	End of work.	Replace the FEEDER ASSY. (Refer to Removal 4/Replacement 40)

5. Abnormal Noise Trouble

5.1 Entry Chart for Abnormal Noise Troubleshooting

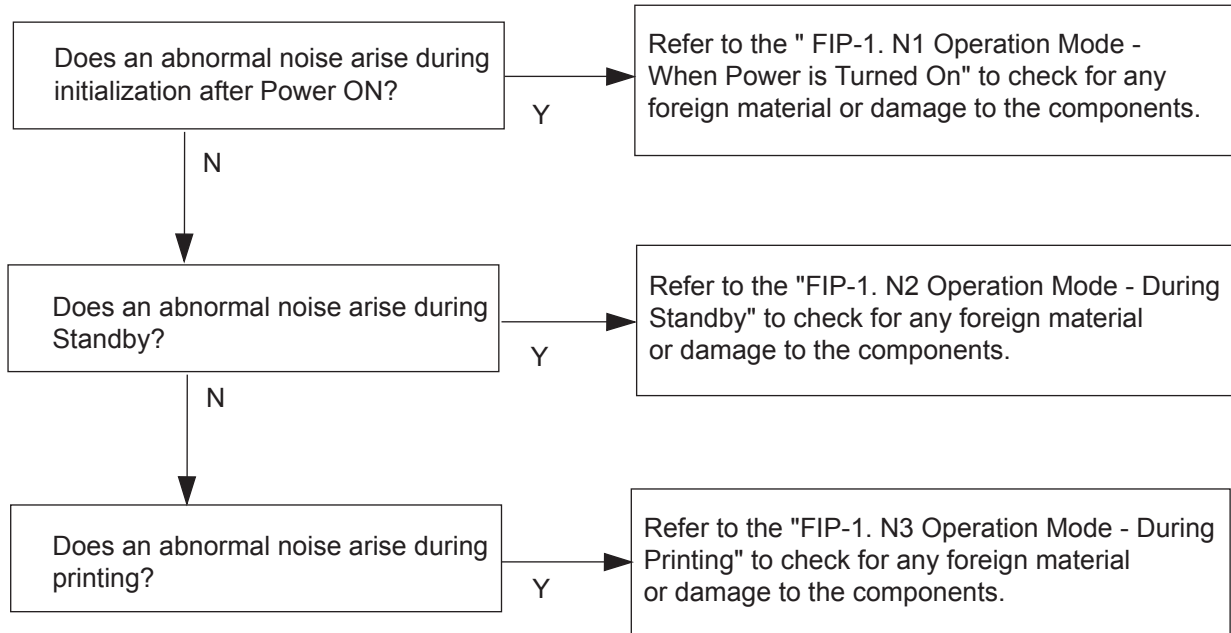

5.2 Operation Mode Table

FIP-1.N1 When Power is Turned On

Step	Check	Yes	No
	Possible causative parts: TRANSFER ASSY (PL4.1.1) CARTRIDGE ASSY (PL5.1.18 (K)/PL5.1.19 (C)/PL5.1.20 (M)/PL5.1.21 (Y)) FUSER ASSY (PL6.1.10) DRIVE ASSY MAIN (PL8.1.2) DRIVE ASSY PH (PL8.1.7) 500 OPTION FEEDER (PL12.1.1)		
1	Checking the Main Motor. Does the noise arise from the printer? Checked by [Digital Output]-[DO-0(Control Panel)/MAIN MOTOR(PC)] in diagnosis.	Go to step 2.	Go to step 5.
2	Checking the Print Cartridges installation Reseat all the Print Cartridges. Does the noise arise from the printer? Checked by [Digital Output]-[DO-0(Control Panel)/MAIN MOTOR(PC)] in diagnosis.	Go to step 3.	End of work.
3	Checking the TRANSFER ASSY installation Reseat the TRANSFER ASSY. Does the noise arise from the printer? Checked by [Digital Output]-[DO-0(Control Panel)/MAIN MOTOR(PC)] in diagnosis.	Go to step 4.	End of work.
4	Checking the DRIVE ASSY MAIN installation Reseat the DRIVE ASSY MAIN. (Refer to Removal 38/ Replacement 6) Does the noise arise from the printer? Checked by [Digital Output]-[DO-0(Control Panel)/MAIN MOTOR(PC)] in diagnosis.	Try replacing the Yellow, Magenta, Cyan, Black Print Cartridges, the TRANSFER ASSY and the DRIVE ASSY MAIN one after another.	End of work.
5	Checking the Sub Motor. Does the noise arise from the printer? Checked by [Digital Output]-[DO-5(Control Panel)/SUB MOTOR(PC)] in diagnosis.	Go to step 6.	Go to step 10.
6	Checking the FUSER ASSY installation Reseat the FUSER ASSY. Does the noise arise from the printer? Checked by [Digital Output]-[DO-5(Control Panel)/SUB MOTOR(PC)] in diagnosis.	Go to step 7.	End of work.
7	Checking the Print Cartridges installation Reseat all the Print Cartridges. Does the noise arise from the printer? Checked by [Digital Output]-[DO-5(Control Panel)/SUB MOTOR(PC)] in diagnosis.	Go to step 8.	End of work.

Step	Check	Yes	No
8	Checking the DRIVE ASSY K installation Reseat all the DRIVE ASSY K. Does the noise arise from the printer? Checked by [Digital Output]-[DO-5(Control Panel)/SUB MOTOR(PC)] in diagnosis.	Go to step 9.	End of work.
9	Checking the DRIVE ASSY MAIN installation Reseat the DRIVE ASSY MAIN. (Refer to Removal 38/ Replacement 6) Does the noise arise from the printer? Checked by [Digital Output]-[DO-5(Control Panel)/SUB MOTOR(PC)] in diagnosis.	Try replacing the FUSER ASSY,the Yellow, Magenta, Cyan, Black Print Cartridges , DRIVE ASSY K and the DRIVE ASSY MAIN one after another.	End of work.
10	Checking the DRIVE ASSY K. Does the noise arise from the printer? Checked by [Digital Output]-[DO-0 (Control Panel)/ MAIN MOTOR (PC)] and [Digital Output]-[DO-61 (Control Panel)/ K MODE SNR (PC)]in diagnosis.	Go to step 11.	Go to step 12.
11	Checking the DRIVE ASSY K installation Reseat the DRIVE ASSY K. Does the noise arise from the printer? Checked by [Digital Output]-[DO-0 (Control Panel)/ MAIN MOTOR (PC)] and [Digital Output]-[DO-61 (Control Panel)/ K MODE SNR (PC)]in diagnosis.	Try replacing the DRIVE ASSY K. (Refer to Removal 28/ Replacement 16)	End of work.
12	Checking the DRIVE ASSY PH. Does the noise arise from the printer? Checked by [Digital Output]-[DO-a (Control Panel)/PH MOTOR ON(PC)] in diagnosis.	Go to step 14.	End of work. If the option tray attached, it goes to step 13.
13	Checking the Option Feeder Motor Does the noise arise from the printer? Checked by [Digital Output]-[DO-19(Control Panel)/ OPTION FEEDER1 MOTOR ON(PC)] in diagnosis.	Try replacing the Option Feeder ASSY. (Refer to Removal 44/ Replacement 46)	End of work.
14	Checking the DRIVE ASSY PH installation Reseat the DRIVE ASSY PH. (Refer to Removal 17/ Replacement 27) Does the noise arise from the printer? Checked by [Digital Output]-[DO-a (Control Panel)/PH MOTOR ON(PC)] in diagnosis.	Try replacing the DRIVE ASSY PH. (Refer to Removal 17/ Replacement 27)	End of work.

FIP-1.N2 During Standby

Step	Check	Yes	No
	Possible causative parts: FAN MAIN (PL9.1.10) LVPS (PL9.1.40)		
1	Checking the FAN MAIN Does the noise arise from the printer? Checked by [Digital Output] - [DO-1e (Control Panel)/FAN ON(PC)] in diagnosis.	Replace the FAN MAIN. (Refer to Removal 32/Replacement 12)	Replace the PWBA LVPS. (Removal 35/Replacement 9)

FIP-1.N3 During Printing

Step	Check	Yes	No
	Possible causative parts: KIT SEPARATOR ROLLER ASSY MSI (PL2.1.99) KIT SEPARATOR AND FEED ROLLER (PL2.2.99) TRANSFER ASSY (PL4.1.1) CARTRIDGE ASSY (PL5.1.18/PL5.1.19/PL5.1.20/ PL5.1.21) FUSER ASSY (PL6.1.10) DRIVE ASSY MAIN (PL8.1.2) DRIVE ASSY PH (PL8.1.7) FEEDER ASSY DUP (PL11.1.1) 550 OPTION FEEDER (PL12.1.1)		
1	Checking the MPF Does the noise arise when feeding the paper from the MPF?	Go to step 2.	Go to step 3.
2	Checking the paper condition Replace the standard paper with a new and dry one Does the noise arise from the printer?	Replace the SEP- ARATOR ROLLER ASSY MSI. (Refer to Removal 41/ Replacement 3)	End of work.
3	Checking the feeder Does the noise arise when feeding the paper from the feeder?	Go to step 4.	Go to step 5.
4	Checking the paper condition Replace the standard paper with a new and dry one Does the noise arise from the printer?	Replace the SEP- ARATOR ROLLER. (Refer to Removal 42/ Replacement 2)	End of work.
5	Checking the Duplex Does the noise arise when feeding the paper from the Duplex?	Go to step 6.	Go to step 8.
6	Checking the DUPLEX ASSY installation Reseat the DUPLEX ASSY. Does the noise arise from the printer?	Try replacing the FEEDER ASSY DUP (Refer to Removal 5/Replacement 39.)	Go to step 7.
7	Checking the Duplex Motor Does the noise arise from the printer? Checked by [Digital Output]-[DO-13(Control Panel)/ DUPLEX MOTOR ON(PC)] in diagnosis.	Try replacing the FEEDER ASSY DUP (Refer to Removal 5/Replacement 39.)	End of work.
8	Checking the FUSER ASSY installation Reseat the FUSER ASSY. Does the noise arise from the printer?	Go to step 9.	End of work.

Step	Check	Yes	No
9	Checking the TRANSFER ASSY installation Reseat the TRANSFER ASSY. Does the noise arise from the printer?	Go to step 10.	End of work.
10	Checking the Print Cartridges installation Reseat the all Print Cartridges. Does the noise arise from the printer?	Go to step 11.	End of work.
11	Checking the DRIVE ASSY MAIN installation Reseat the DRIVE ASSY MAIN. (Refer to Removal 38/ Replacement 6) Does the noise arise from the printer?	Go to step 12.	End of work.
12	Checking the DRIVE ASSY PH installation Reseat the DRIVE ASSY PH. (Refer to Removal 17/ Replacement 27) Does the noise arise from the printer?	Go to step 13.	End of work.
13	Checking the Main Motor Does the noise arise from the printer? Checked by [Digital Output]-[DO-0(Control Panel)/MAIN MOTOR(PC)] in diagnosis.	Try replacing the DRIVE ASSY MAIN. (Refer to Removal 38/ Replacement 6)	Go to step 14.
14	Checking the Sub Motor Does the noise arise from the printer? Checked by [Digital Output]-[DO-5(Control Panel)/SUB MOTOR(PC)] in diagnosis.	Try replacing the DRIVE ASSY MAIN. (Refer to Removal 38/ Replacement 6)	Go to step 15.
15	Checking the DRIVE ASSY PH. Does the noise arise from the printer? Checked by [Digital Output]-[DO-a (Control Panel)/PH MOTOR ON(PC)] in diagnosis.	Try replacing the DRIVE ASSY PH. (Refer to Removal 17/ Replacement 27)	End of work. If the option tray attached, it goes to step 16.
16	Checking the Option Feeder Motor Does the noise arise from the printer? Checked by [Digital Output]-[DO-19(Control Panel)/ OPTION FEEDER1 MOTOR ON(PC)] in diagnosis.	Try replacing the Option Feeder ASSY. (Refer to Removal 44/ Replacement 46)	End of work.

6. Other FIP

Other FIP covers the power supply trouble FIP, except error code FIP, Noise FIP and image quality FIP.

FIP-AC

Step	Check	Yes	No
1	Checking the printer Does the motor noise occur when turning on the power? In this test, close the Front Cover.	Go to DC.	Go to step 2.
2	Checking the outlet Connect the power code with the other outlet. Does the printer is working?	End of work.	Go to step 3.
3	Checking the power code connection Reconnect the power code. Does the printer is working?	End of work.	Go to step 4.
4	Checking the connector of LVPS connecting Disconnect the power code and wait for one minute. Reseat the all connectors of LVPS. Does the printer is working?	End of work.	Go to step 5.
5	Checking the connector of MAIN SWITCH connecting Disconnect the power code and wait for one minute. Reseat the connector of MAIN SWITCH. Does the printer is working?	End of work.	Replace the LVPS. (Refer to Removal 35/ Replacement 9)

FIP-DC

Step	Check	Yes	No
1	Checking the printer Does the motor noise occur when turning on the power? In this test, close the Front Cover.	Go to step 2.	Go to step 5.
2	Checking the message on the Control Panel Does the message on the control panel appear?	End of work. If error message appeared, go to FIP.	Go to step 3.
3	Checking the connector of CONTROL PANEL connecting. Reseat the connector (P/ J220) of CONTROL PANEL. Does the CONTROL PANEL is working?	End of work.	Go to step 4.
4	Checking the PWBA ESS installation Reseat the PWBA ESS. (Refer to Removal 26/ Replacement 18) Does the message on the control panel appear?	End of work.	Replace the PWBA ESS and the Control Panel.
5	Go to FIP-AC. If not Checking the PWBA MCU installation Reseat the PWBA MCU. (Refer to Removal 30/ Replacement 14) Does the printer is working?	End of work.	Replace the LVPS. (Refer to Removal 35/ Replacement 9)

FIP-Multiple feed

Step	Check	Yes	No
1	Checking the MPF fed. Multi feed occurred in the MPF?	Go to step 2.	Go to step 3.
2	Checking the media Replace to the new paper. Does the multi feed still occur when printing?	Checking after replacing the END SEPARATOR ROLLER ASSEMBLY. Replace the SEPARATOR ROLLER ASSEMBLY. (Refer to Removal 41/ Replacement 3)	End of work.
3	Checking the media Replace to the new paper. Does the multi feed still occur when printing?	Replace the SEPARATOR ROLLER. (Refer to Removal 42/ Replacement 2)	End of work.

FIP-Control Panel Freezes

Step	Check	Remedy	
		Yes	No
	Possible causative parts PWBA ESS (PL9.1.27)		
1	Checking the operating environment. Is the printer connected to the Network?	Go to step 2.	Replace the Printer.
2	Checking the IP address. Can you change the IP address?	Go to step 5.	Go to step 3.
3	Checking the internet connectivity. Is there any internet connection available for your PC?	Go to step 4.	Replace the PWBA ESS. (Removal 26/ Replacement 18)
4	Updating the firmware to the latest version. Download the latest version of the firmware from the DELL Support Website, and execute the update. NOTE: Before updating the firmware to the latest version, reset the error following the steps of procedure described below. In addition, update the firmware by way of a USB storage. 1) Remove the network cable. 2) Connect the USB cable. 3) Turn the power off and on. Does the error persist when the power is turned off and on?	Replace the PWBA ESS. (Removal 26/ Replacement 18)	End of work.
5	Changing the IP address. Contact your system administrator for obtaining a new IP address. Refer to Reference_1 for details of how to change the IP address. Does the error persist when the power is turned off and on?	Replace the PWBA ESS. (Removal 26/ Replacement 18)	End of work.

Reference_1: Changing the IP address

- 1) Remove the network cable, and power off the printer and then on
- 2) Change the IP address on the Control Panel.
- 3) Plug the network cable back into the printer, and then turn the power on.
- 4) On the Control Panel, open [Admin] > [Network] > [TCP/IP], and confirm that the IP address has been changed.