

## Chapter 6 Principles of Operation CONTENTS

---

1. Printing Process .....	6 - 1
1.1 Summary of Printing Process .....	6 - 1
1.2 Schematic Diagram for Printing Processes .....	6 - 2
1.3 Description of Printing Process Techniques .....	6 - 3
1.3.1 Charging with electricity .....	6 - 3
1.3.2 Exposure.....	6 - 4
1.3.3 Development.....	6 - 6
1.3.4 Transfer (Drum -> Paper) .....	6 - 8
1.3.5 Cleaning (TONER CARTRIDGE).....	6 - 10
1.3.6 Fusing .....	6 - 11
2. Paper Path.....	6 - 12
2.1 Paper Path .....	6 - 12
2.2 Layout of Paper Path .....	6 - 13
3. Functions of Major Functional Components .....	6 - 14
3.1 Paper Cassette .....	6 - 14
3.1.1 Major functions.....	6 - 14
3.1.2 Reference diagram .....	6 - 15
3.1.3 Multiple Sheet Feed Prevention.....	6 - 16
3.1.4 Reference diagram .....	6 - 16
3.1.5 Bottom Plate Moving.....	6 - 17
3.2 Paper Feeder .....	6 - 18
3.2.1 Major functions.....	6 - 18
3.2.2 Reference diagram .....	6 - 19
3.3 MPF & Regi Assy.....	6 - 20
3.3.1 Major functions.....	6 - 20
3.3.2 Reference diagram .....	6 - 21
3.3.3 Multiple Sheet Feed Prevention.....	6 - 22
3.3.4 Reference diagram .....	6 - 22
3.3.5 Lead-edge Registration.....	6 - 23
3.3.6 Reference diagram .....	6 - 23
3.3.7 Paper detection by the Regi Sensor .....	6 - 24
3.3.8 Reference diagram .....	6 - 24
3.4 Transfer Belt & Fuser.....	6 - 26
3.4.1 Major functions.....	6 - 26
3.4.2 Reference diagram .....	6 - 27
3.5 PRINTHEAD .....	6 - 28
3.5.1 Major functions.....	6 - 28
3.5.2 Reference diagram .....	6 - 29
3.6 TONER CARTRIDGE .....	6 - 30
3.6.1 Major functions.....	6 - 30
3.6.2 Reference diagram .....	6 - 31
3.7 Drive.....	6 - 32
3.7.1 Major functions.....	6 - 32
3.7.2 Reference diagram .....	6 - 34
3.8 Electrical .....	6 - 36

## Chapter 6 Principles of Operation CONTENTS

---

3.8.1 Major functions.....	6 - 36
3.8.2 Reference diagram .....	6 - 37
3.8.3 Data Flow.....	6 - 38
3.9 Duplex.....	6 - 40
3.9.1 Major functions.....	6 - 40
3.9.2 Reference diagram .....	6 - 41
3.10 550 Paper Feeder .....	6 - 42
3.10.1 Major functions (Paper Cassette) .....	6 - 42
3.10.2 Reference diagram .....	6 - 42
3.10.3 Multiple paper feed prevention.....	6 - 43
3.10.4 Reference diagram .....	6 - 43
3.10.5 Bottom Plate Moving.....	6 - 44
3.10.6 Major functions (Feeder).....	6 - 46
3.10.7 Reference diagram .....	6 - 47
4. MODES .....	6 - 48
4.1 Operation Modes .....	6 - 48
5. Control .....	6 - 49
5.1 Control of Paper Size.....	6 - 49
5.2 Selective Control on Paper Cassette.....	6 - 49
5.3 PRINTHEAD Light Quantity Control .....	6 - 49
5.4 Process Control .....	6 - 50
5.4.1 Potential Control .....	6 - 50
5.4.2 Toner Density Control.....	6 - 51
5.4.3 High Area Coverage Mode .....	6 - 51
5.4.4 Admix Mode.....	6 - 51
5.4.5 ADC Sensor Adjustment.....	6 - 51
5.5 Color Registration Control.....	6 - 52
5.6 Fuser Control .....	6 - 53
5.6.1 Fuser temperature control.....	6 - 53
5.6.2 Cooling down .....	6 - 53
5.6.3 Sensor Warm-up.....	6 - 53
6. Drive Transmission Route .....	6 - 54
6.1 PHOTOCONDUCTOR (PC)/DEVELOPER (DEV) DRIVE.....	6 - 54
6.2 TONER DISPENSER (Y, M, C, K).....	6 - 60
6.3 FEED DRIVE ASSEMBLY .....	6 - 62
6.4 DRIVE ASSY DUP .....	6 - 64
6.5 DRIVE ASSY OPT FDR.....	6 - 66

# 1. Printing Process

## 1.1 Summary of Printing Process

This printer is a "Full-color laser printer" which applies the principle of an electrophotographic recording system. The tandem system comprising the four color TONER CARTRIDGES of yellow, magenta, cyan and black (Y, M, C and K) creates the toner image.

Printing processes of this printer is composed of the basic steps as follows.

- (1) Charge: ..... Drum surface is charged with electricity.
- (2) Exposure: ..... Image unit is exposed to laser beams.
- (3) Development: ..... Image is developed with toner.
- (4) Transfer: ..... Four-color finished toner image on the Drum is transferred onto the paper.
- (5) Cleaning: ..... Remaining toner on the drum is collected.
- (6) Fusing: ..... Toner on the paper is fixed by heat and pressure.
- (7) Cleaning: ..... Remaining toner on the belt is collected.

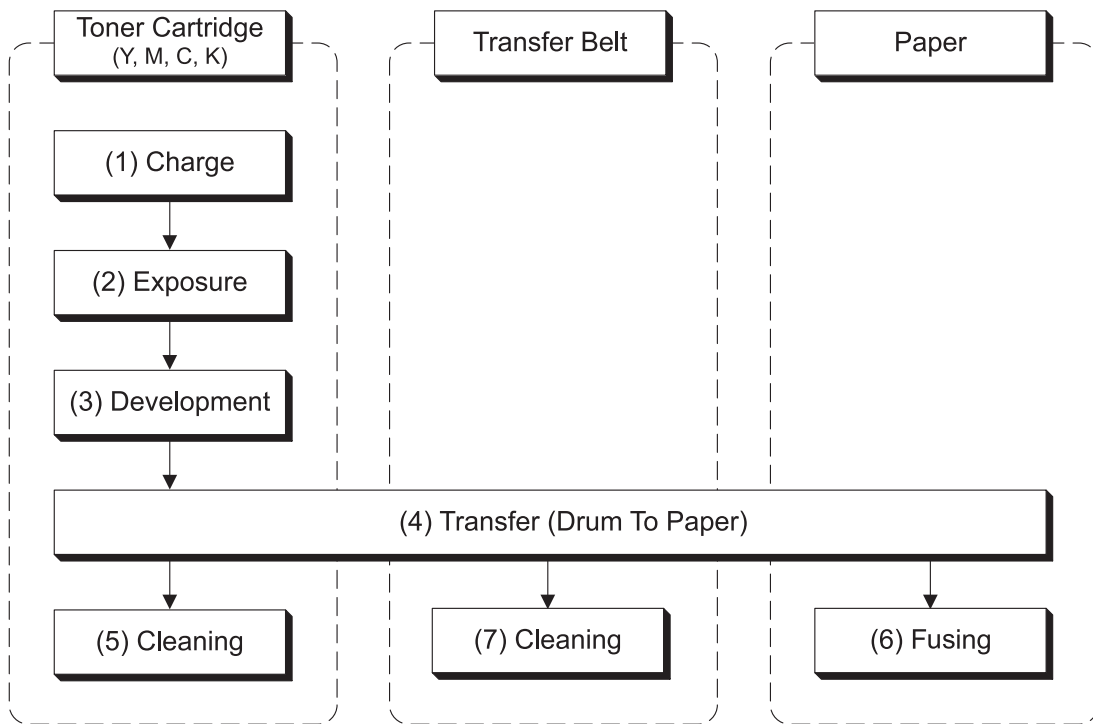

Zna06001KA

## 1.2 Schematic Diagram for Printing Processes

Outline of printing processes is shown in the figure below.

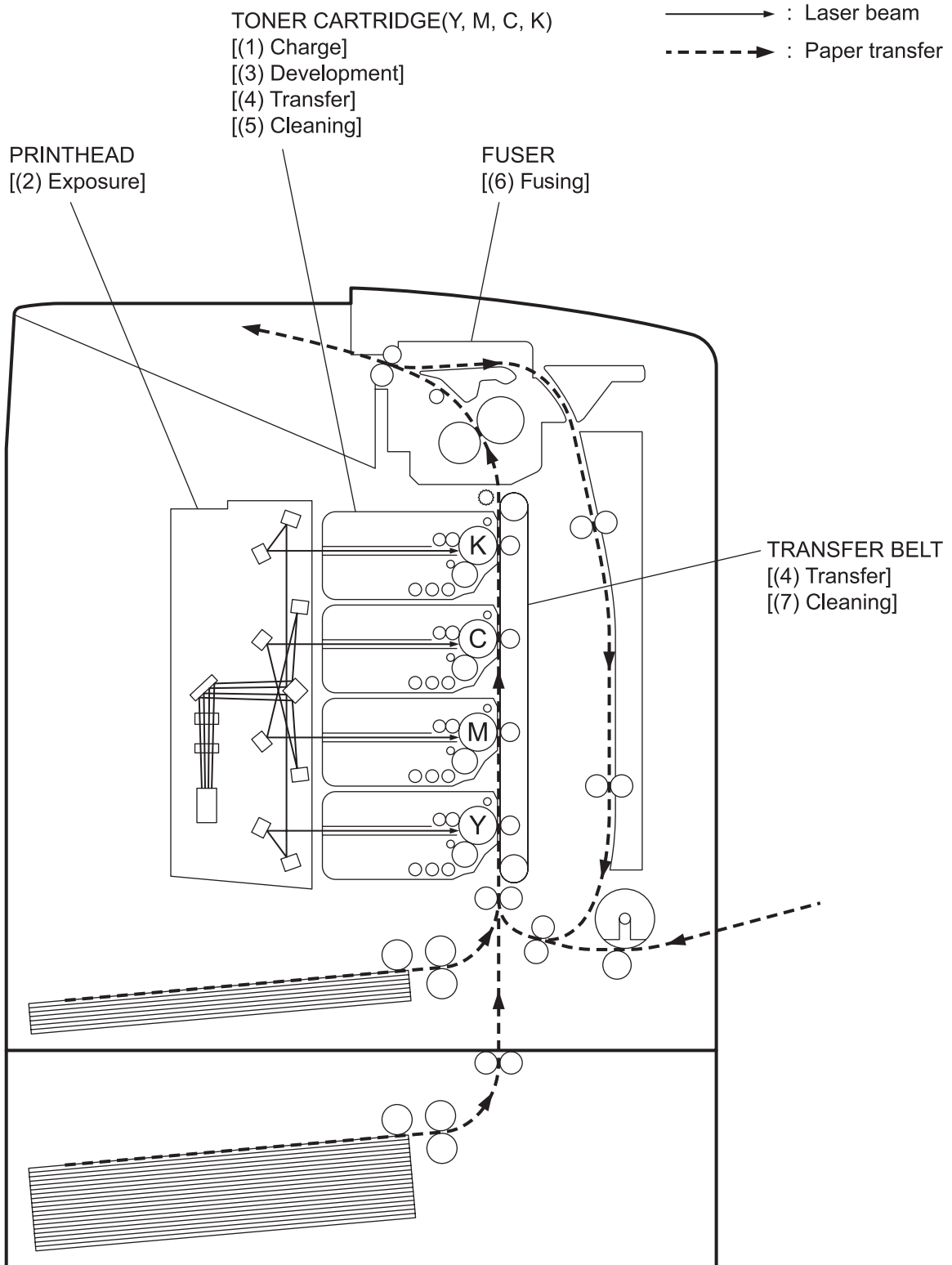

Zna06002KB

### 1.3 Description of Printing Process Techniques

#### 1.3.1 Charging with electricity

In the charging process, the drum surface rotating at a constant speed is charged uniformly with negative electricity by the discharge from BCR (Bias Charge Roll).

This process is performed in parallel for yellow, magenta, cyan and black colors.

- The BCR is kept in contact with the drum and rotates following the rotations of the drum. BCR is a conductive roll, receives discharge voltage from the High Voltage Power Supply (HVPS) and discharges a negative DC voltage.
- The drum surface is uniformly and negatively charged with DC bias voltage. The drum surface is a photoreceptor (which is an insulator in the dark and a conductor in the light) and the drum inside is composed of a conductor.
- The Cleaning Roll is a sponge, which contacts with the BCR to catch the toner.

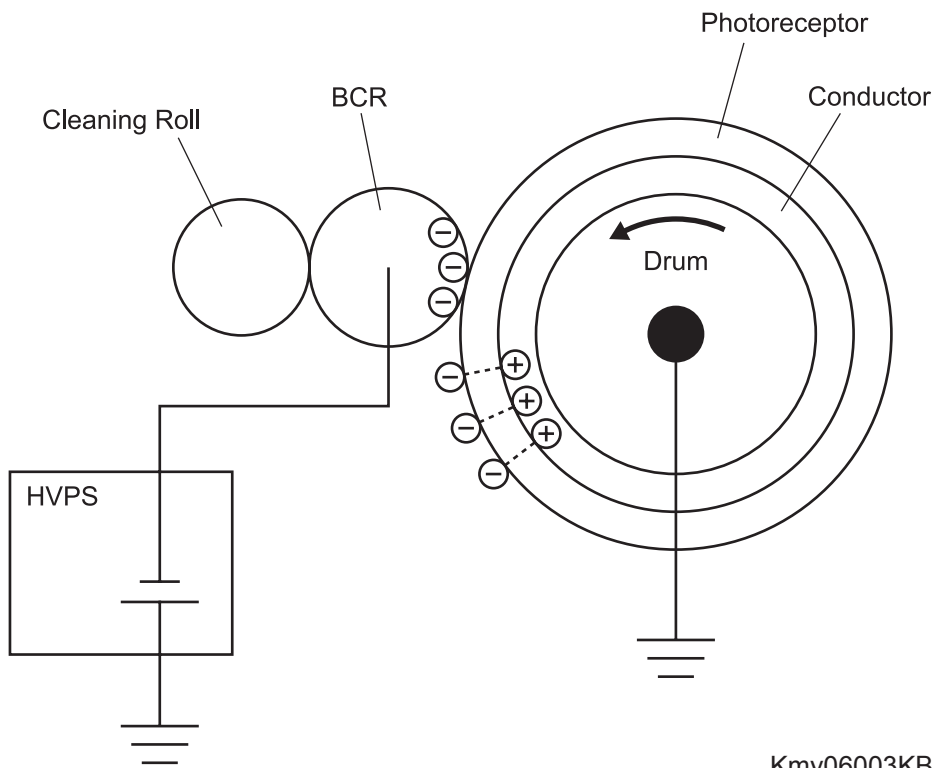

Kmy06003KB

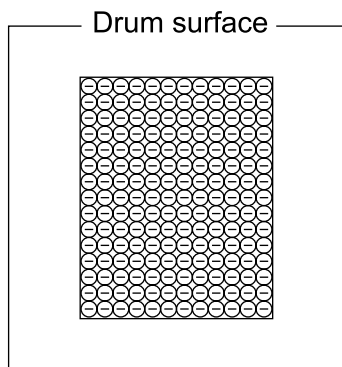

engine principle0005FA

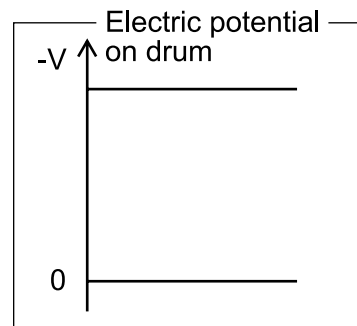

engine principle0006FA

**1.3.2 Exposure**

In the exposure process, the drum surface charged negatively is scanned by laser beams to form invisible electrostatic latent image on the drum surface.

This process is performed in parallel for yellow, magenta, cyan and black colors.

- Laser beams are emitted from the laser diode in the PRINTHEAD. By the rotating polygon mirror, fixed mirror and lens attached to the Scanner Motor Assy of the PRINTHEAD, the surface of each color drum is scanned from end to end in the axial direction.

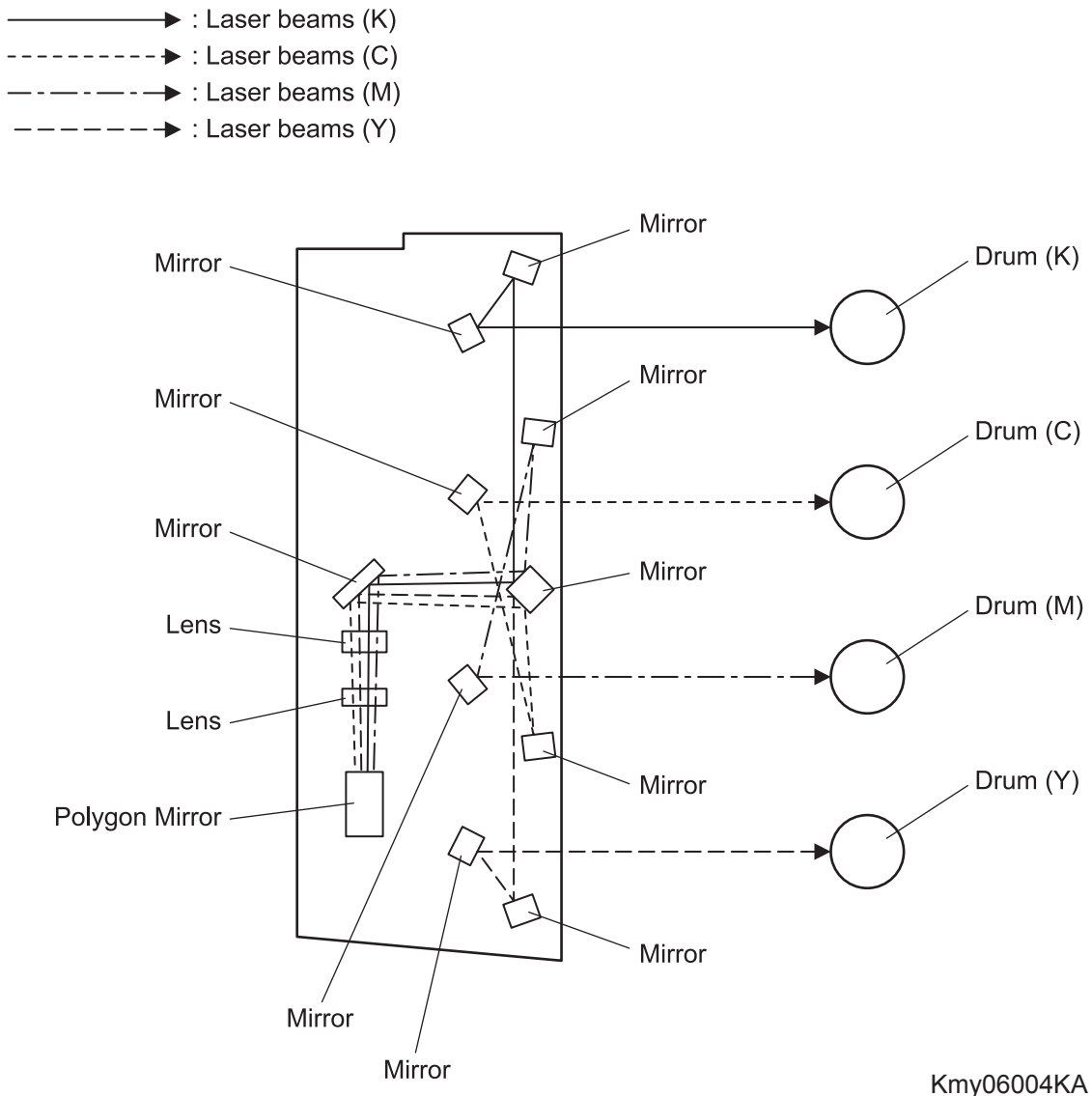

- The laser beam is irradiated according to the printing data (image data) output from the printer controller. The laser beam is output only when printing data is pixels (micro points composing characters or pictures). (The laser diode lights up for parts to be developed by toner, and not for parts that are not to be developed.)

The drum surface irradiated by the laser beam becomes a conductor, and the negative charge on the drum surface flows to the positive side and the charges cancel each other out so that the potential on the drum surface drops. The part on the surface where potential drops becomes the electrostatic latent image.

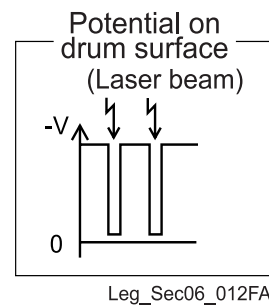
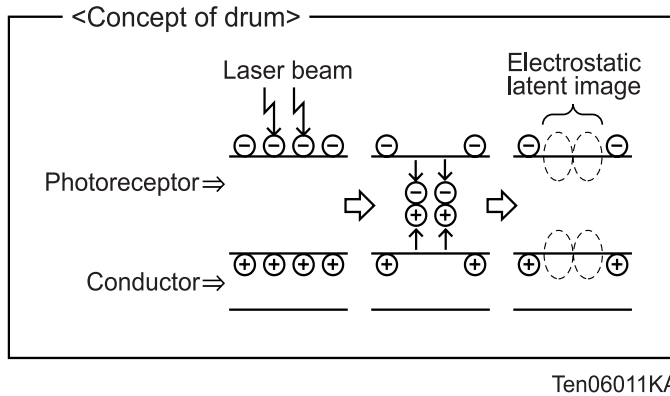
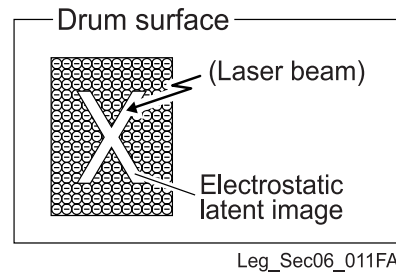
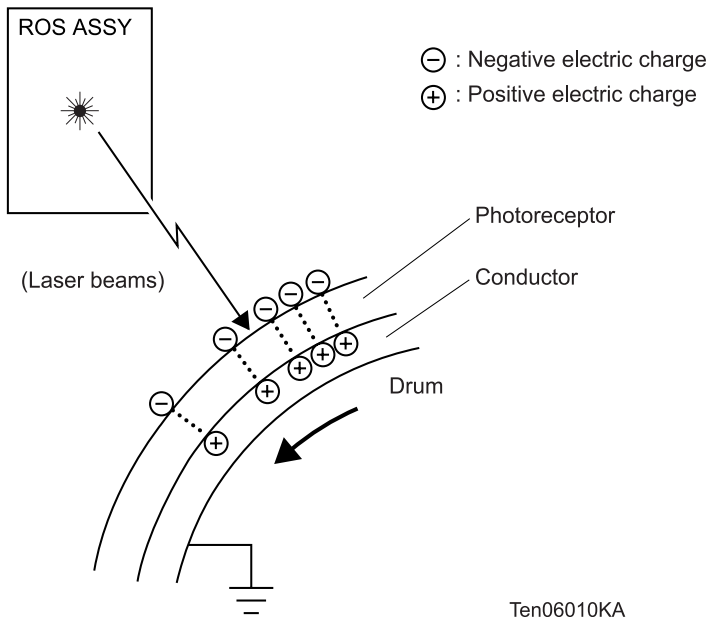

### 1.3.3 Development

In the development process, toner is electrically attached to the invisible electrostatic latent image on the drum surface to form visible toner image on the drum.

This process is performed in parallel for yellow, magenta, cyan and black color independently.

- The toner in the toner cartridge part is agitated by the built-in Agitator and fed into the developer part. The Auger is driven by the toner motor and the deve motor in the PHOTOCONDUCTOR (PC)/DEVELOPER (DEV) DRIVE. The amount of toner to be consumed according to the print count is calculated and that amount is fed into the developer. This is called "toner dispensation", which is controlled by two types of control, "PCDC" and "ADC". ([Refer to 5.4.2 Toner Density Control](#))
- The toner fed into the developer part and the carrier in the developer part are agitated by the Auger, and supplied to the Magnet Roll arranged in the vicinity of the drum surface. The toner and carrier are charged by friction due to the agitation (toner in negative, carrier in positive), and they are attracted to one another electrically. As the carrier is a magnetic substance, it is attracted to the Magnet Roll having a magnetic force and a homogeneous layer is formed by the Trimmer Bar.
- The magnet roll is covered by a thin semi-conductive sleeve over the surface. DB (Developing Bias) voltage is supplied to this semiconductor sleeve from the High Voltage Power Supply (HVPS). DB voltage is negative DC voltage combined with AC voltage. The magnet roll is kept at a constant negative voltage against the photoreceptor layer of the drum by DC voltage. Therefore, at the area surface where the negative electric charge on the drum does not decrease, potential is lower than the magnet roll, while the potential is higher than the magnet roll at the area where the negative charge on the drum surface decreases. The AC voltage shakes the developer on the magnet roll surface Stimulating the toner to fly to the drum.  
Thus, the toner charged negatively is attracted only to the drum surface area where the negative charge has decreased below that of the magnet roll (electrostatic latent image) and the toner image is formed on the drum.  
Once the toner is adhered on the drum, the negative charge of the toner-bearing portion increases, which decreases the potential and the toner-attracting force of that portion.



- ⊖ : Negative electric charge
- ⊕ : Positive electric charge
- : Toner
- : Carrier

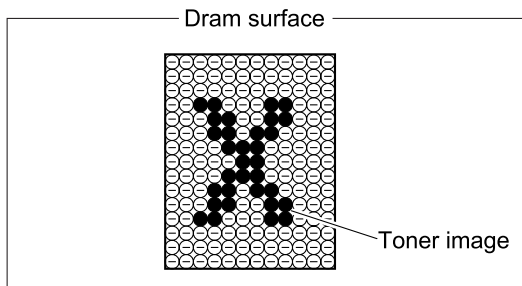
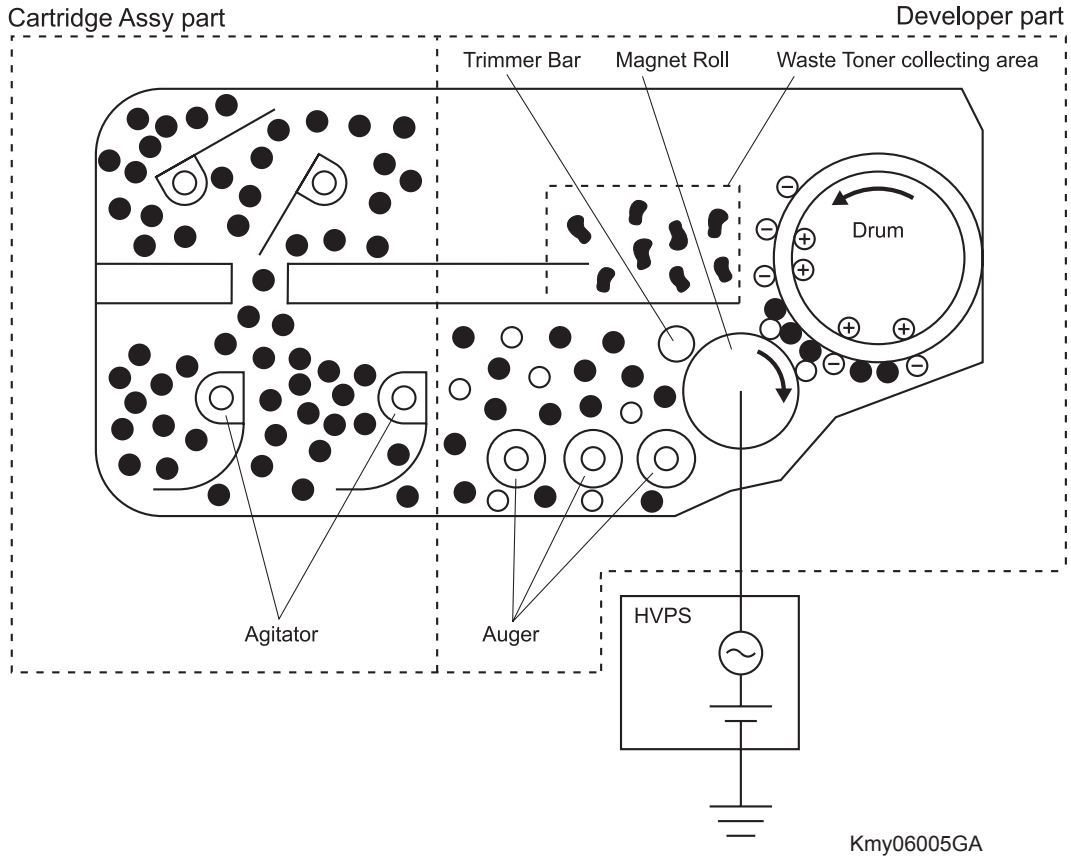

engine principle0013FA

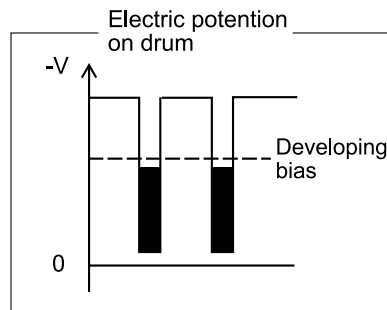

engine principle0014FA

### 1.3.4 Transfer (Drum -> Paper)

In the transfer process, toner image formed on the drum surface is transferred onto the surface of the paper. The toner is transferred onto the paper in the order of Y, M, C, and K.

#### - BTR

The BTR (Bias Transfer Roll) is a conductive roll, to which the positive voltage is applied from the High Voltage Power Supply (HVPS). The BTR contacts the rear side of the Belt and applies the positive voltage to the Belt.

#### - Belt

The Belt is a conductive belt, to which the positive voltage is applied from the BTR. After the negatively charged toner image on the drum surface is drawn by the positive charge on the belt, it is transferred from the drum to the paper. The Belt feeds the paper to the direction of FUSER.

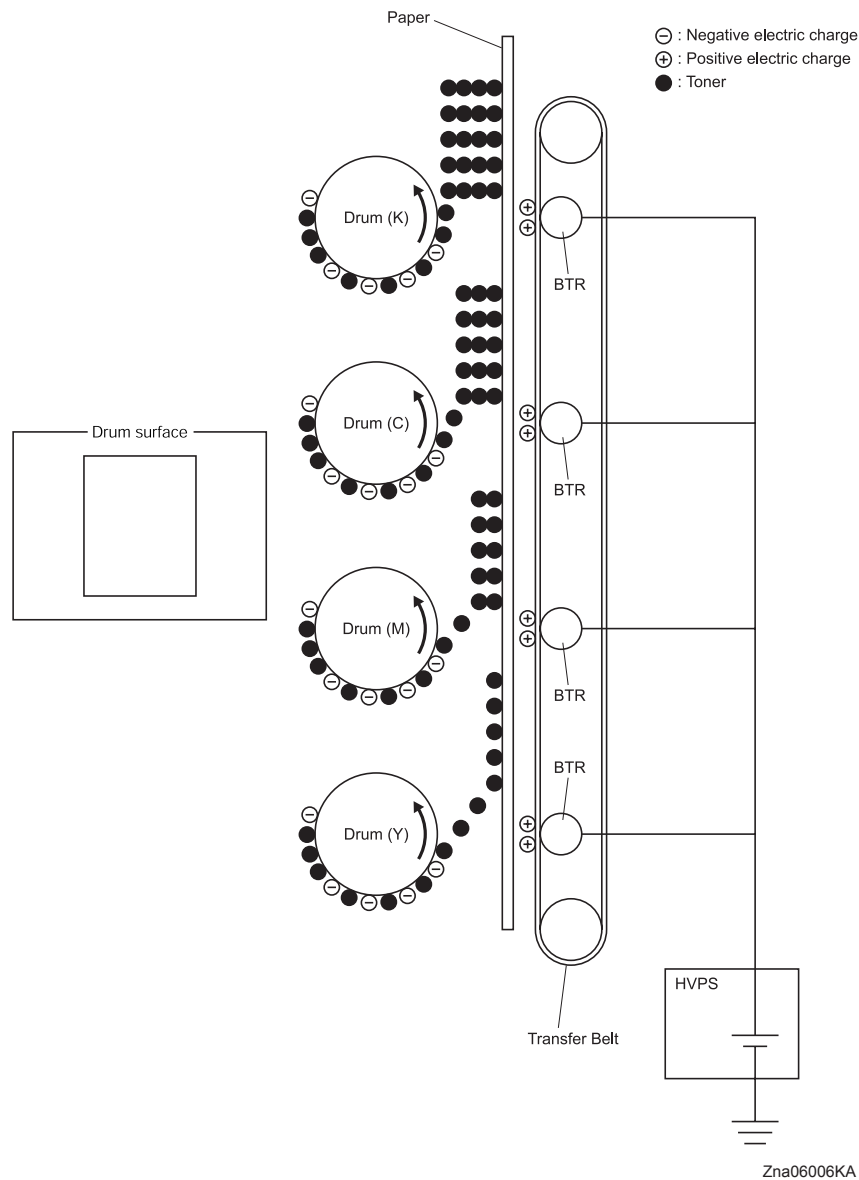

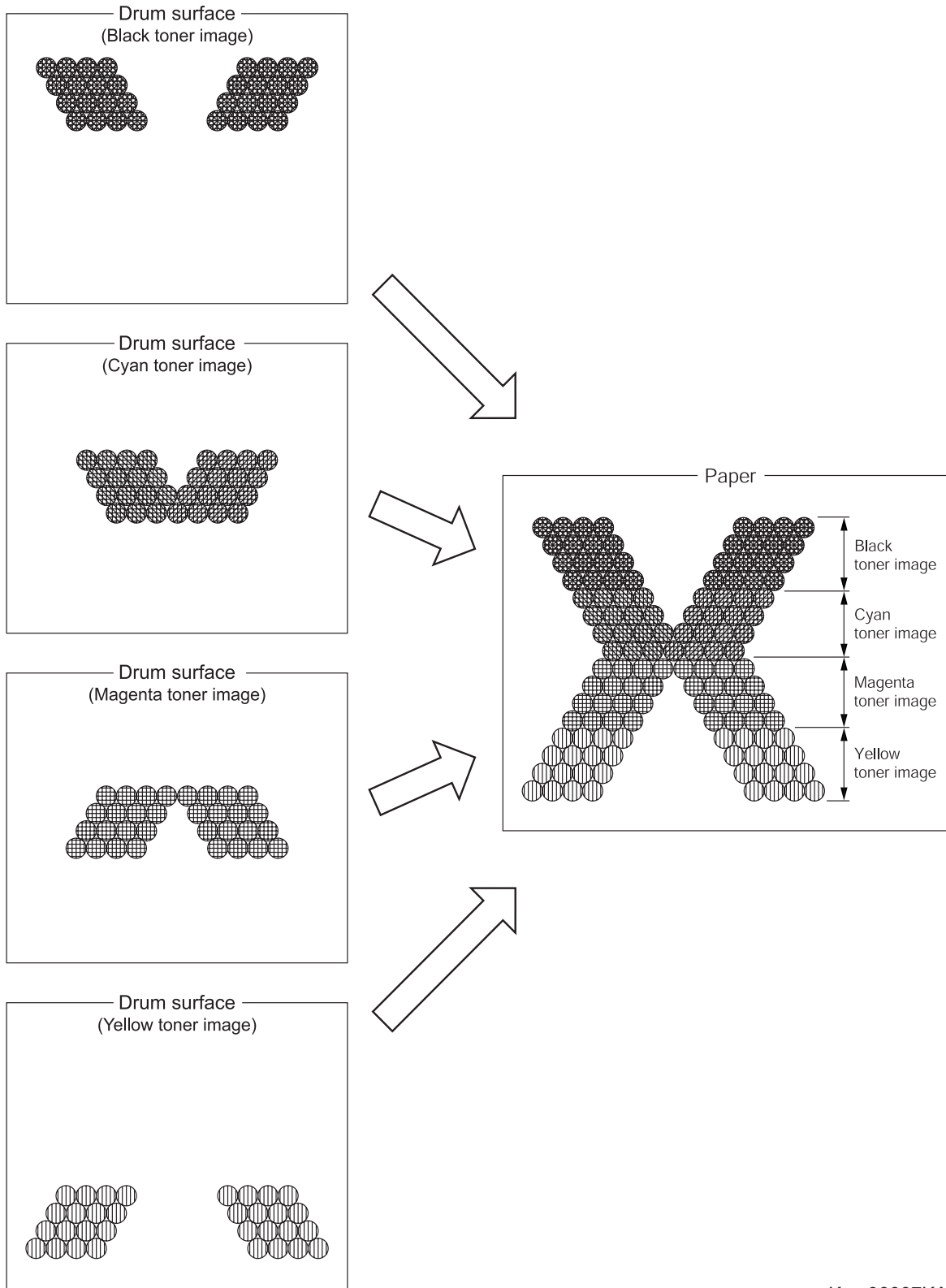

Kmy06007KA

### 1.3.5 Cleaning (TONER CARTRIDGE)

In the cleaning (TONER CARTRIDGE) process, excess toner is removed from the drum and BCR surfaces, while excess charge is also eliminated from the drum surface.

- Drum cleaning  
The cleaning blade contacts the surface of the drum collecting the excess toner by scraping.
- Cleaning Roll  
The Cleaning Roll contacts the surface of the BCR collecting the excess toner by scraping.
- Charge cleaning  
When the drum is charged by BCR, any excess charge hinders the drum surface from being uniformly charged, which may lead to print quality problems.  
The excess charge on the surface of the drum is eliminated by irradiating the light of the Erase Lamp (LED ASSEMBLY).

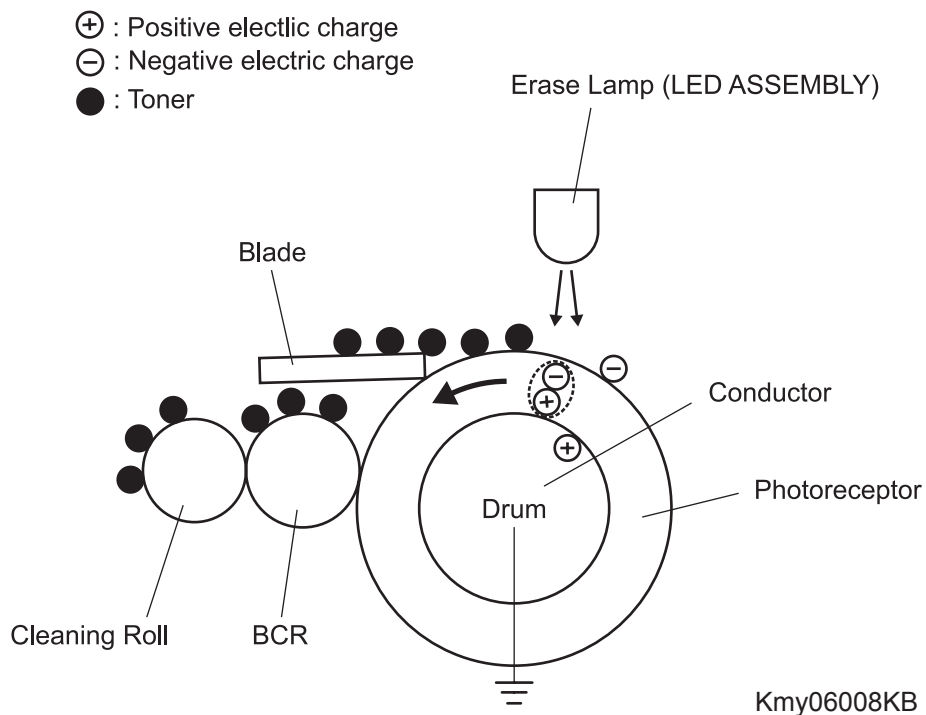

I

**1.3.6 Fusing**

In the fusing process, toner is fixed on the paper by heat and pressure.

- Since the finished toner image transferred from the belt can be easily broken by a finger touch, the toner image must be fixed on the paper with the FUSER (fusing unit). The toner particles are melted by the HEAT ROLL heated by the Heater lamp and is deposited on the paper under pressure given by the belt opposed against the heat roll.

Conditions to be met to light up the Heater Lamp

	<b>Warm up</b>	<b>Stand by</b>	<b>Printing</b>
Main Heater Lamp	ON	ON/OFF	ON/OFF

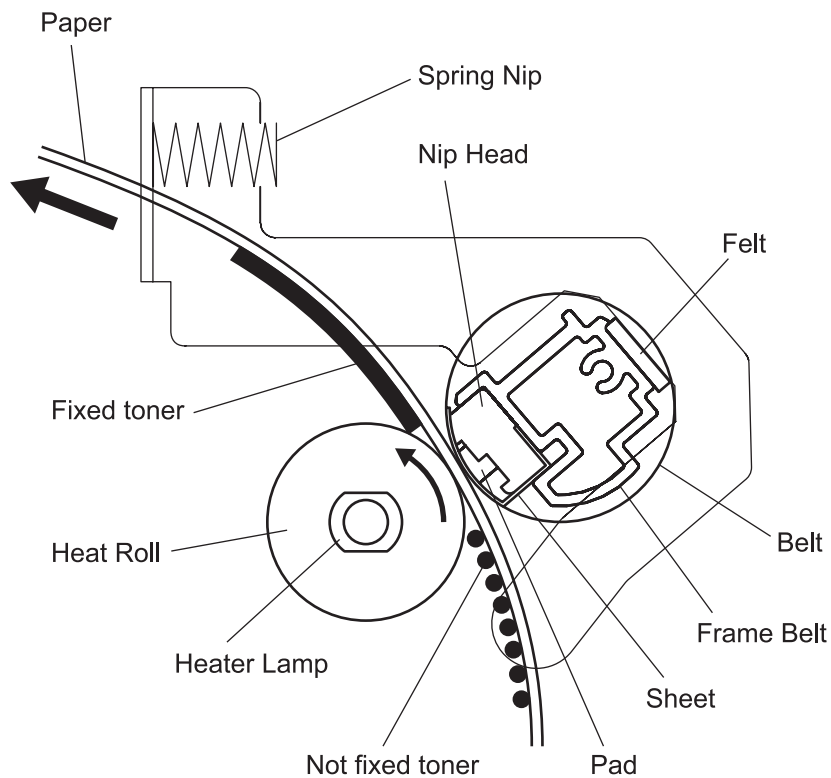

Kmy06010KA

## 2. Paper Path

### 2.1 Paper Path

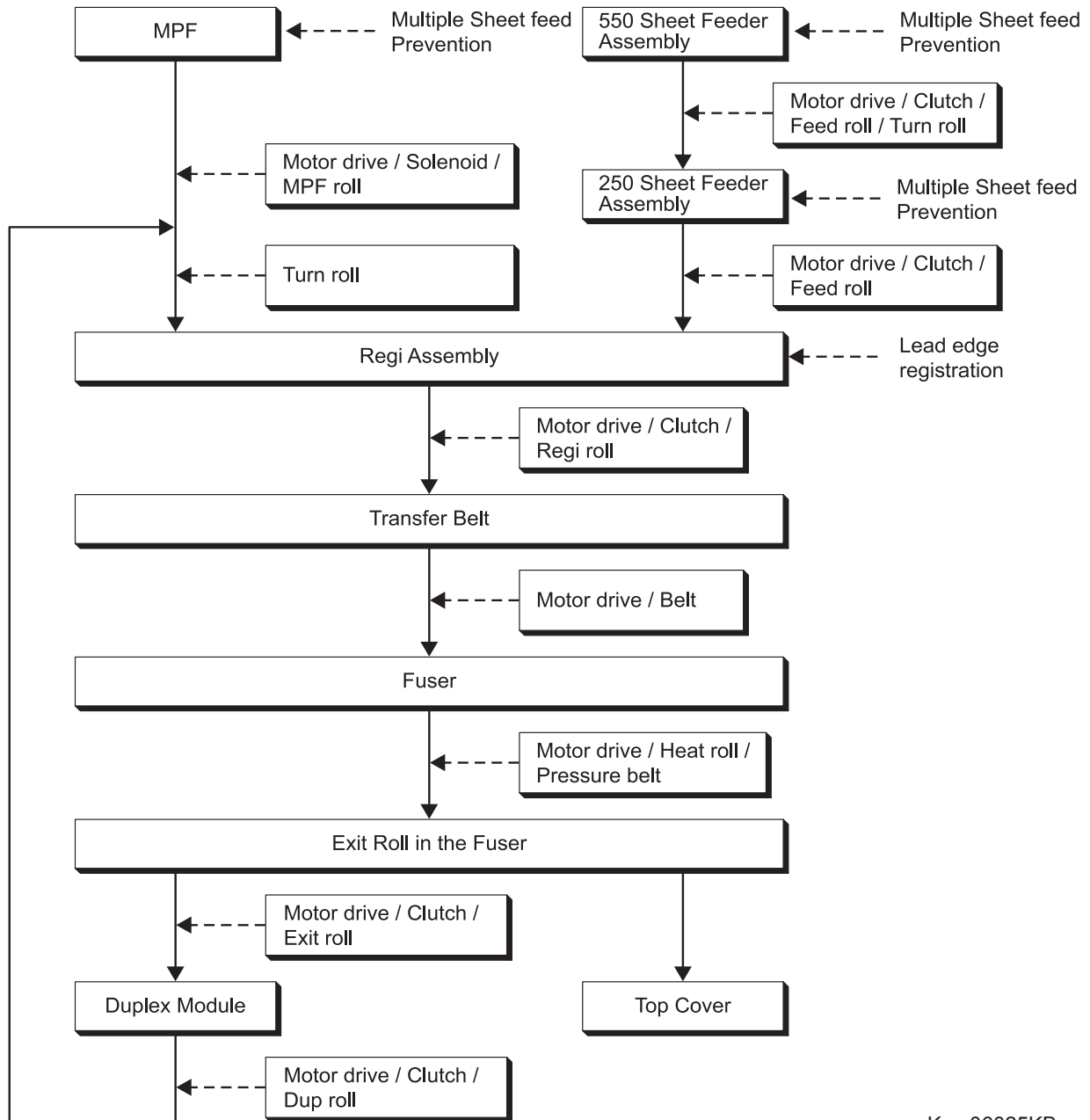

Kmy06025KB

## 2.2 Layout of Paper Path

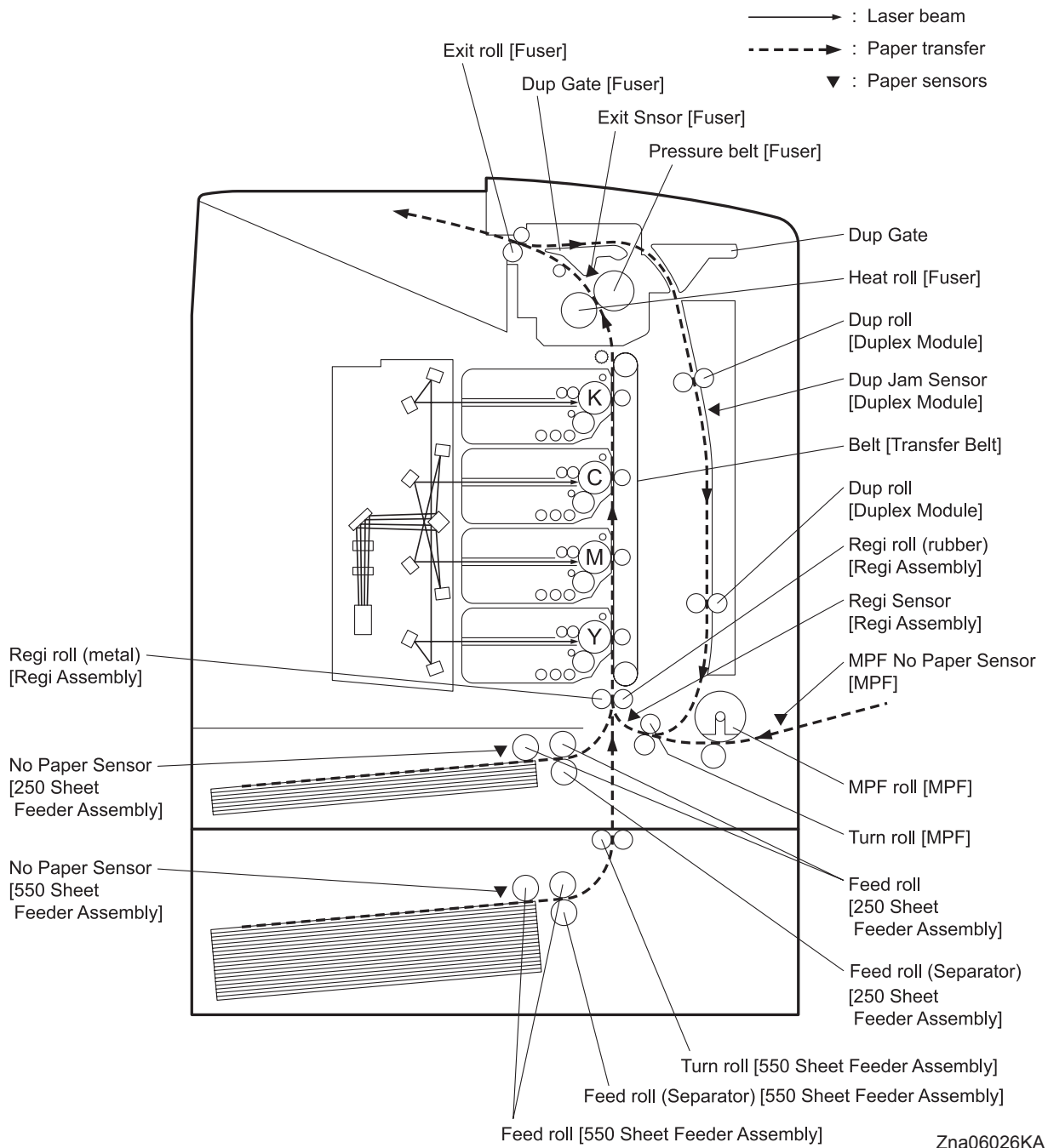

### 3. Functions of Major Functional Components

Major functional components of the printer are described below with illustrations.

These components are classified into the following blocks based on the configuration of the printer.

- Paper Cassette
- Paper Feeder
- MPF & Regi Assy
- Transfer Belt & Fuser
- PRINTHEAD
- TONER CARTRIDGE
- Drive
- Electrical
- Duplex
- 550 Paper Feeder

#### 3.1 Paper Cassette

##### 3.1.1 Major functions

- Guide Side (R/L)  
The Guide Side Assy (R/L) can move at a right angle to the paper transfer direction to align the paper width.
  
- End Guide  
The Guide End Assy can move in the paper transfer direction to determine the paper size. The ON/OFF of SIZE SWITCH ASSEMBLY ([Refer to 5.1 Control of Paper Size](#)) varies according to the Guide End Assy position to detect the paper size.
  
- FEED ROLLER (SEPARATOR)  
The FEED ROLLER (SEPARATOR) and the FEED ROLLER pinch the paper to prevent multiple sheet feed.
  
- Bottom Plate  
Bottom plate is locked to the bottom side when paper cassette is pulled out from the paper feeder and unlocked when paper cassette is installed to the paper feeder. Pushes the paper against the feed roll using a spring tension.



3.1.2 Reference diagram

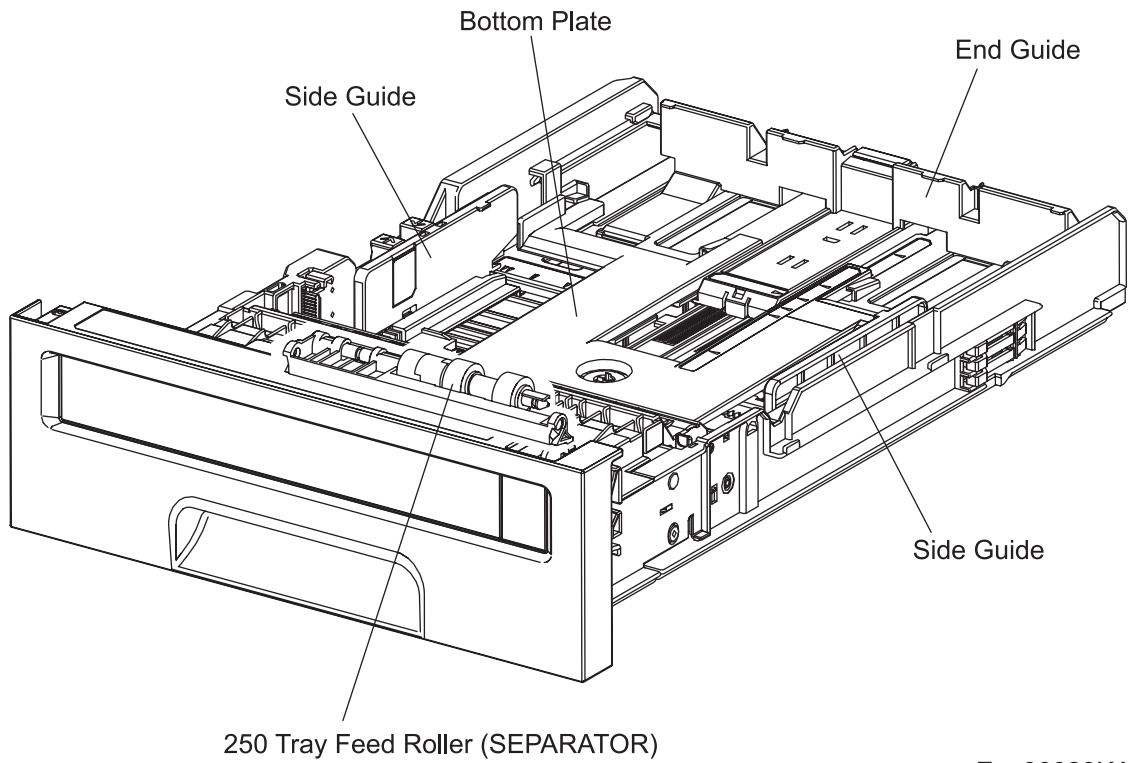

Zna06029KA

### 3.1.3 Multiple Sheet Feed Prevention

The sheets set in a tray or cassette are occasionally stuck together along the edges. The stuck sheets cause a multiple sheet feed or a jam. The sheets are fed by the Nudger Roll to a position between the Feed Roll and the Separator Roll. Normally, when only one sheet is fed, both the Feed Roll and Separator Roll rotate to allow the sheet to pass. However, when two sheets are fed concurrently, only the Feed Roll rotates and the Separator Roll is locked thereby allowing the upper sheet to pass by being separated from the lower sheet that is stopped by the friction with the Separator Roll at rest.

The Separator Roll is being pushed toward the Feed Roll by spring pressure, and controlled by the torque limiter (Clutch Assy Friction) with which it is coupled.

### 3.1.4 Reference diagram

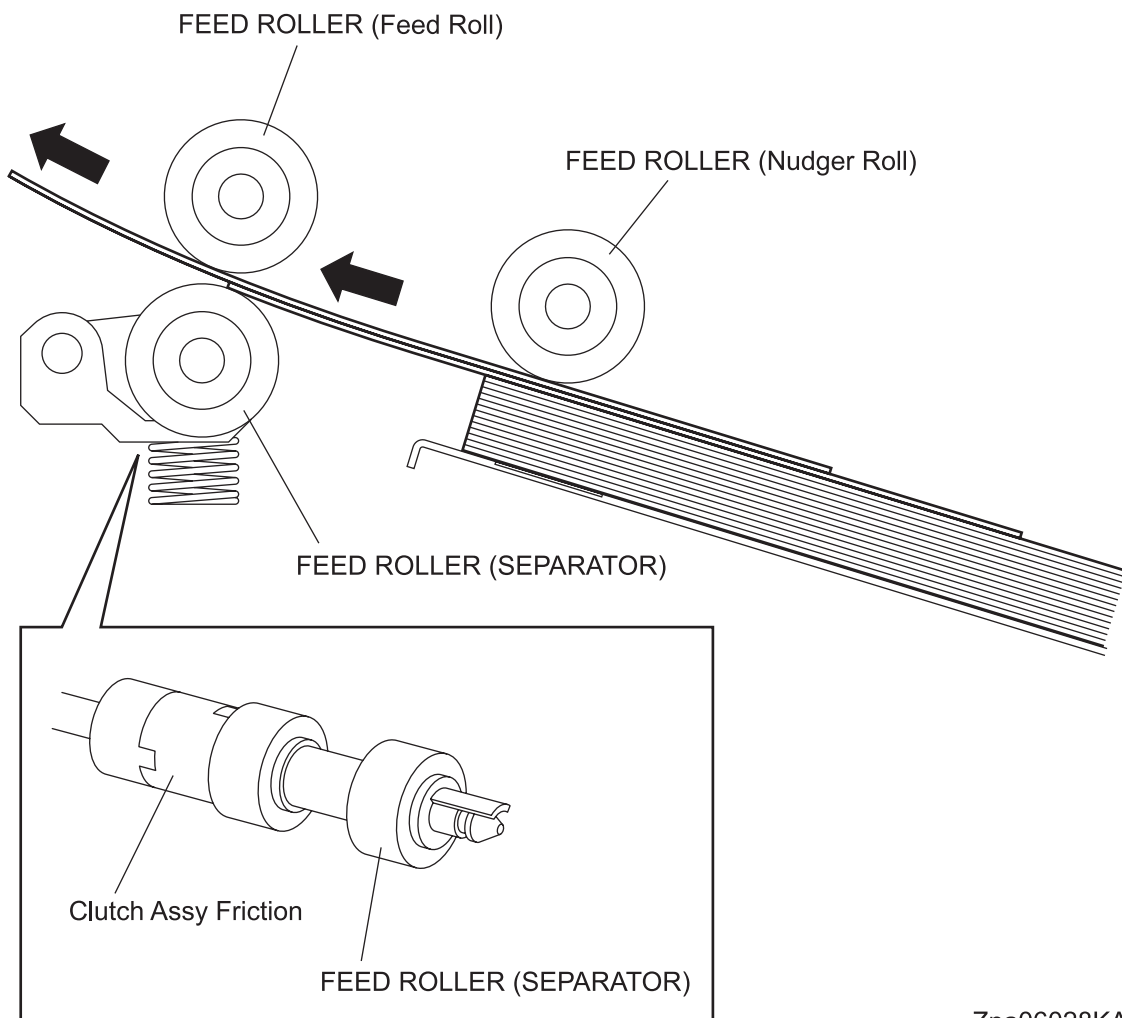

Zna06028KA

### 3.1.5 Bottom Plate Moving

Inserting the paper tray into the feeder section unlocks the GEAR BTM LOCK ONEWAY. When the paper tray is pushed in until it stops, the gear teeth of the RACK BTM LOCK and GEAR BTM LOCK ONEWAY are out of engagement allowing the PLATE ASSY BTM to rise by the spring pressure of the SPRING BTM UP.

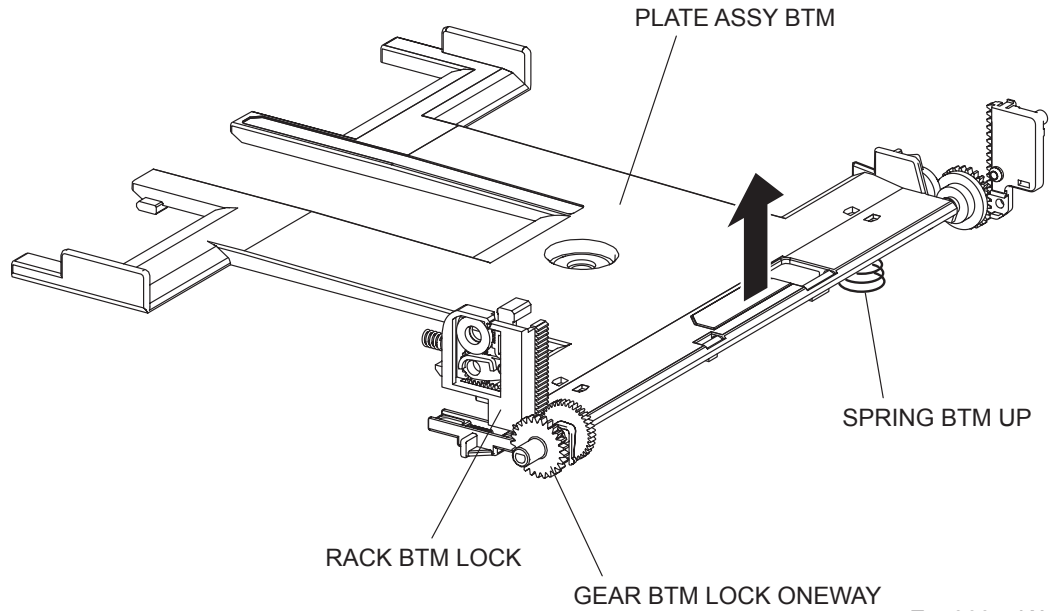

## 3.2 Paper Feeder

### 3.2.1 Major functions

#### - SIZE SWITCH ASSEMBLY

SIZE SWITCH ASSEMBLY detects paper size and the presence/absence of the paper tray.

(Refer to 5.1 Control of Paper Size for the combination of switches.)

The paper size is decided at the position of the END GUIDE.

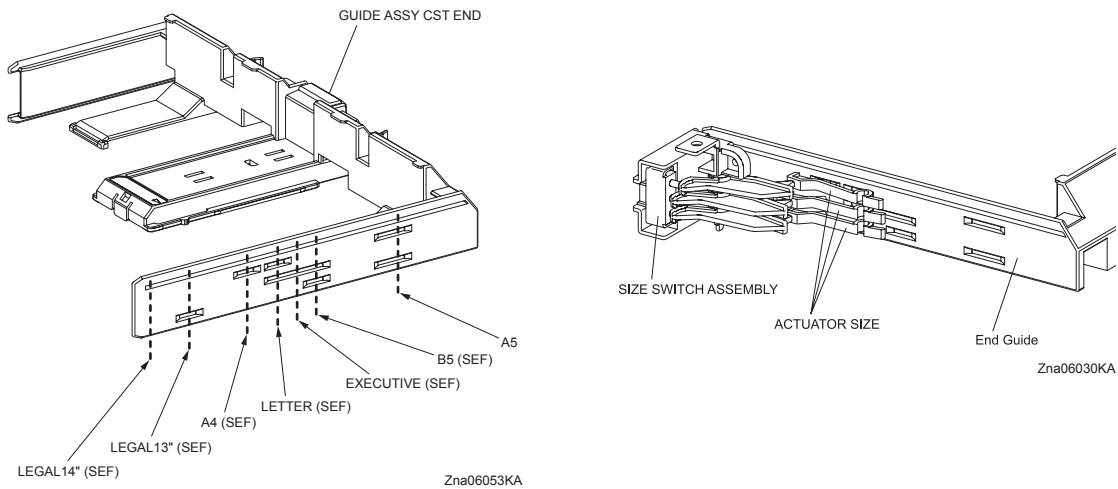

#### - SENSOR PHOTO (No Paper Sensor)

Detects the presence/absence of paper in the paper tray based on the position of ACTUATOR NO PAPER. (No paper: Sensor beam is intercepted)

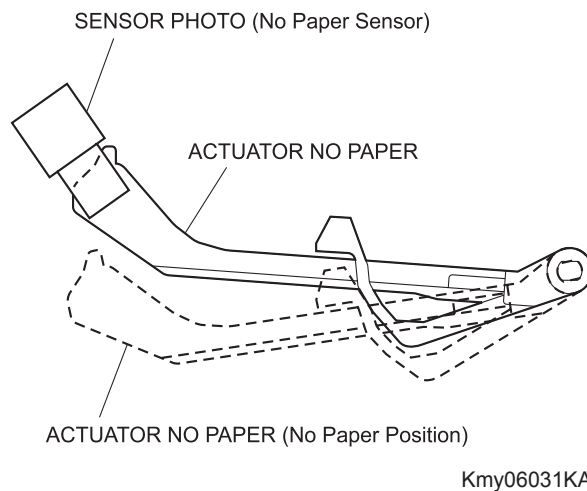

#### - CLUTCH ASSY FEED

Transmits the drive from the FEED DRIVE ASSEMBLY to FEED ROLLER. (Refer to 6.3 FEED DRIVE ASSEMBLY)

#### - FEED ROLLER

When the CLUTCH ASSY FEED operates, the FEED ROLLER starts rotating and the FEED ROLLER feeds the paper. (Refer to 6.3 FEED DRIVE ASSEMBLY)

3.2.2 Reference diagram

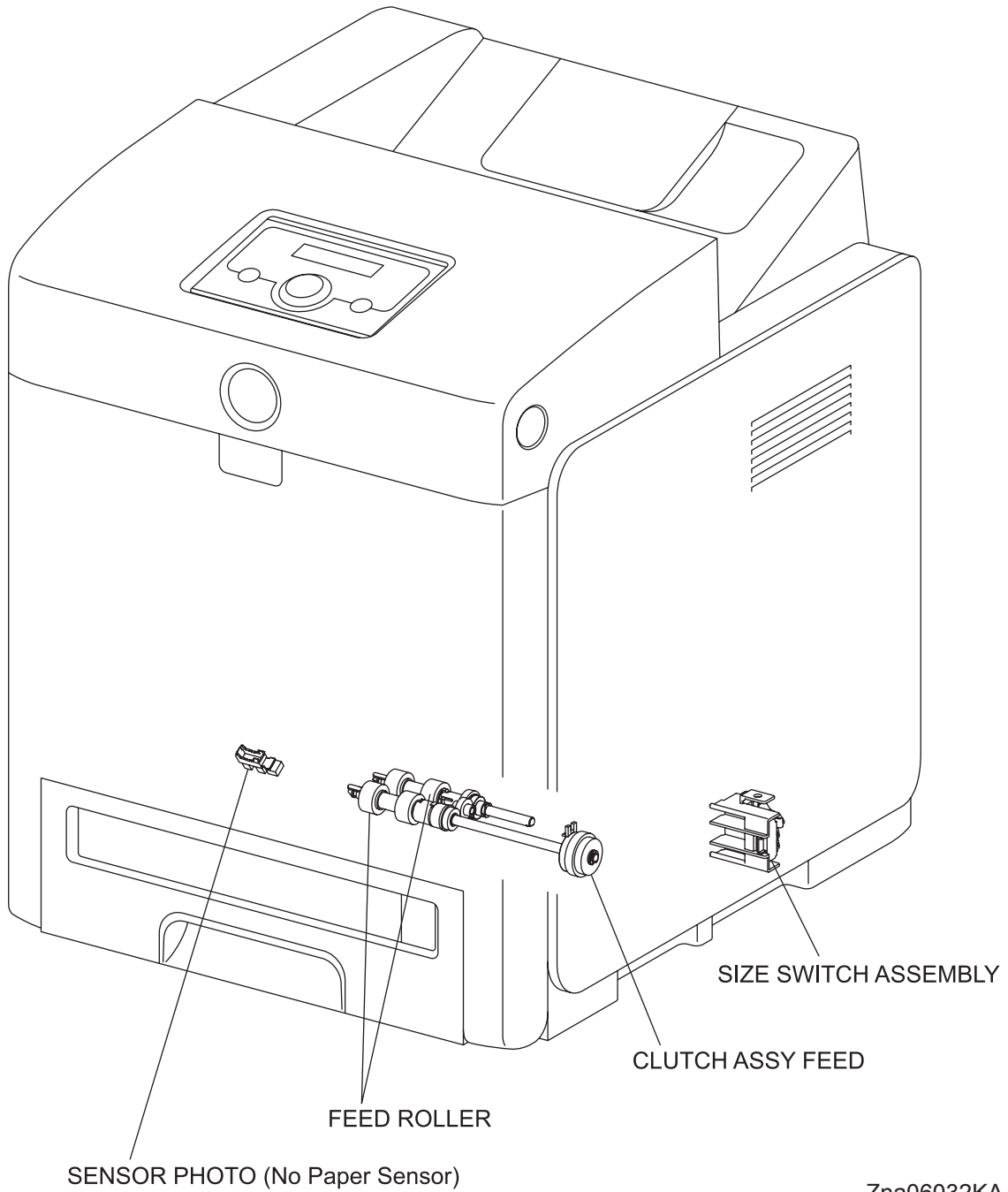

Zna06032KA

### 3.3 MPF & Regi Assy

#### 3.3.1 Major functions

- MPF FEED SOLENOID  
Controls the drive from the FEED DRIVE ASSEMBLY to the MPF ROLLER. (Refer to 6.3 FEED DRIVE ASSEMBLY)

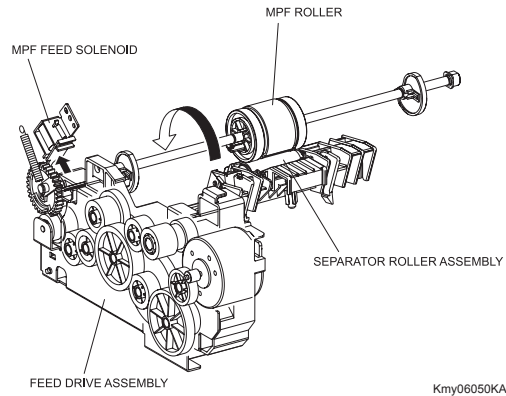

- CLUTCH ASSY TURN  
Transmits the drive from the FEED DRIVE ASSEMBLY to the ROLL ASSY TURN. (Refer to 6.3 FEED DRIVE ASSEMBLY)
- ROLL ASSY TURN  
The ROLL ASSY TURN is rotated by the drive from the FEED DRIVE ASSEMBLY through the CLUTCH ASSY TURN to feed the paper from the MPF or Duplex to the CHUTE ASSY REGI. (Refer to 6.3 FEED DRIVE ASSEMBLY)
- SENSOR PHOTO (MPF No Paper Sensor)  
Detects presence/absence of paper in the MPF tray by the change in actuator position.

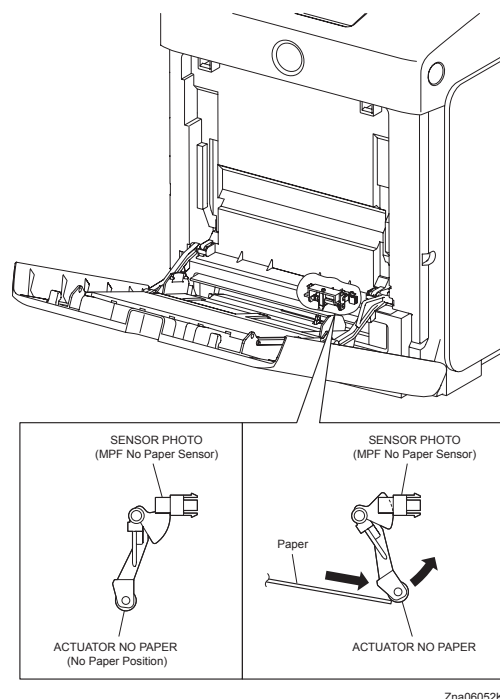

- SENSOR PHOTO (Regi Sensor)

It detects when the paper front end reaches the CHUTE ASSY REGI.

When the paper feeds from the MPF, Regi Sensor is measuring the paper length (size).

The ON time of Regi Sensor is converted into the paper length.

ON: The paper activates the actuator.

- CLUTCH ASSY REGI

CLUTCH ASSY REGI transmits the driving power from the PHOTOCOnductor (PC)/ DEVELOPER (DEV) DRIVE to ROLL REGI RUBBER, and transports the paper from the tray, MPF and duplex path toward the toner cartridge direction. (Refer to 6.3 FEED DRIVE ASSEMBLY)

The timing of sheet feed from the Regi Assy is adjusted by the duration of the CLUTCH ASSY REGI operation so that the toner image on the drum can be transferred to the appropriate position on the sheet.

3.3.2 Reference diagram

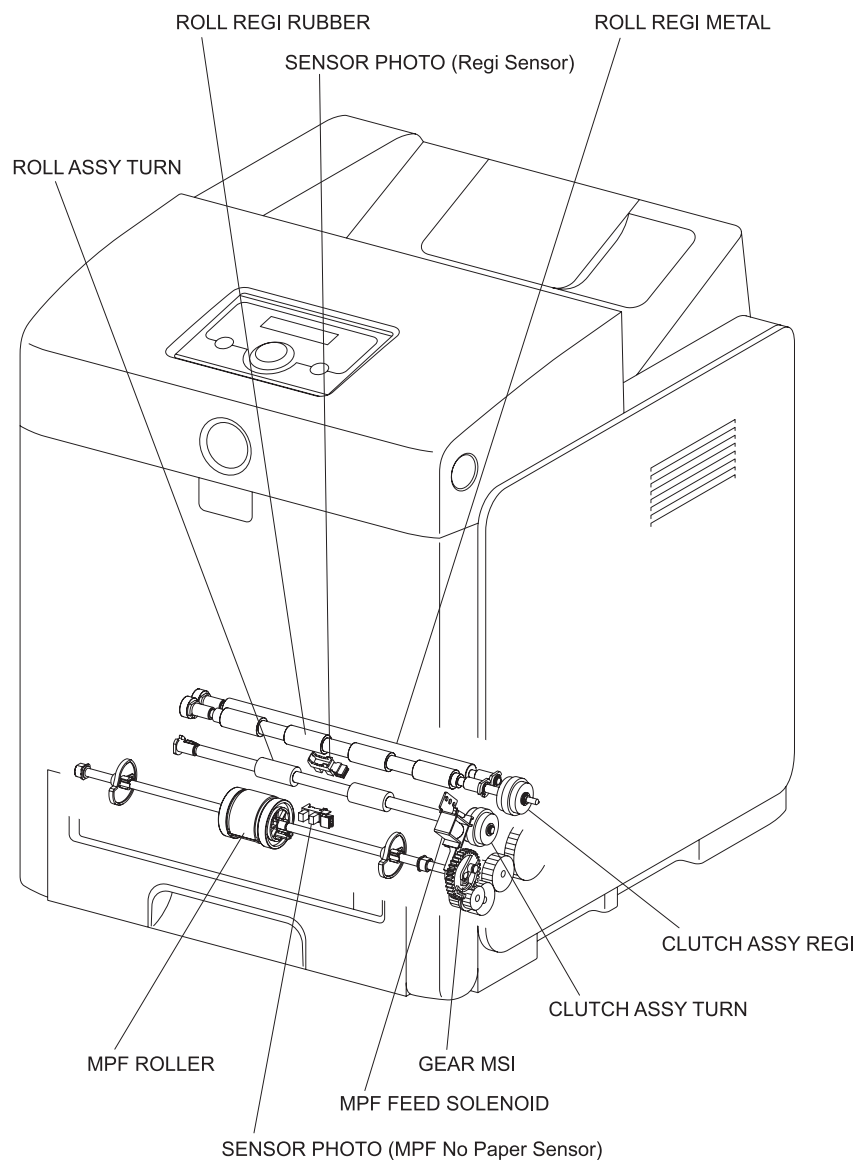

Zna06033KA

### 3.3.3 Multiple Sheet Feed Prevention

The sheets set in the MPF are occasionally stuck together at the edges. The stuck sheets cause a multiple sheet feed or a jam. Normally, when only one sheet is fed, both the MPF ROLLER and SEPARATOR ROLLER rotate to allow the sheet to pass. However, when two sheets are fed concurrently, only the MPF ROLLER rotates and the SEPARATOR ROLLER is locked thereby allowing the upper sheet to pass by being separated from the lower sheet that is stopped by the friction with the SEPARATOR ROLLER at rest.

The SEPARATOR ROLLER is being pushed toward the MPF ROLLER by spring pressure, and controlled by the torque limiter with which it is coupled..

### 3.3.4 Reference diagram

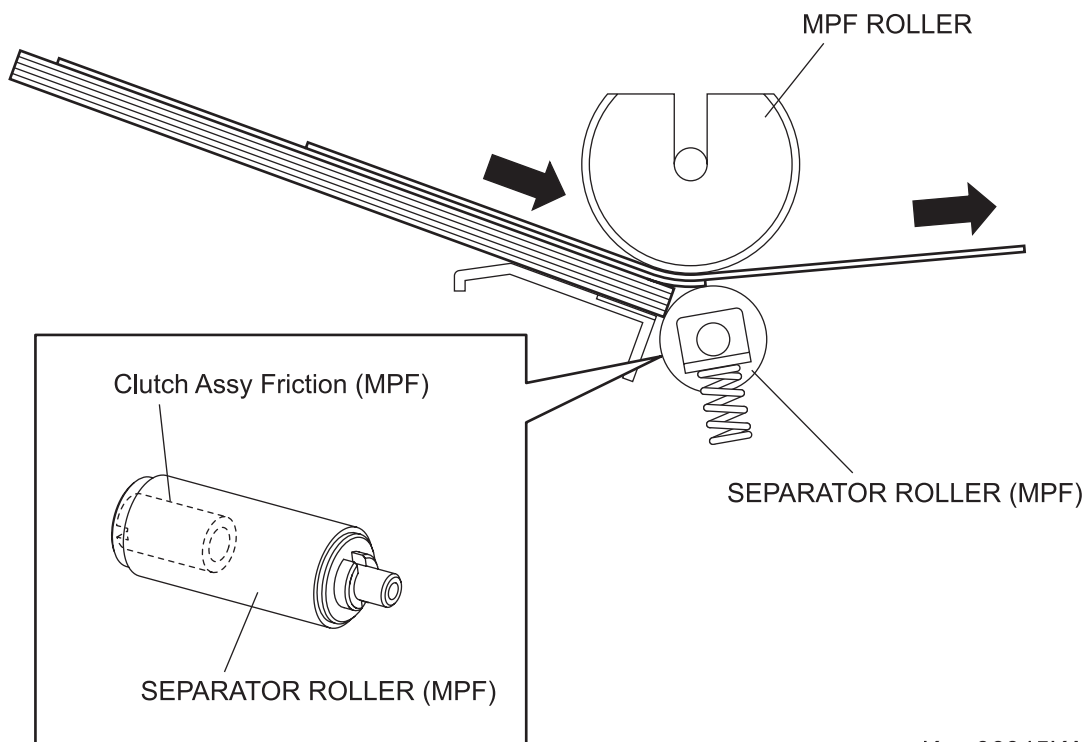

Kmy06045KA



### 3.3.5 Lead-edge Registration

When a sheet is fed from the MPF or Tray to the toner transfer position, the registration of the sheet may not be correctly maintained due to such troubles as misalignment of lead edges in the tray/cassette. To avoid this trouble, the lead edge position needs to be aligned at the Regi part before the sheet is fed to the toner transfer position.

By thrusting the edge of the sheet coming out of the MPF or Tray against the REGI ROLL that is at rest, the lead edge of the sheet is registered.

### 3.3.6 Reference diagram

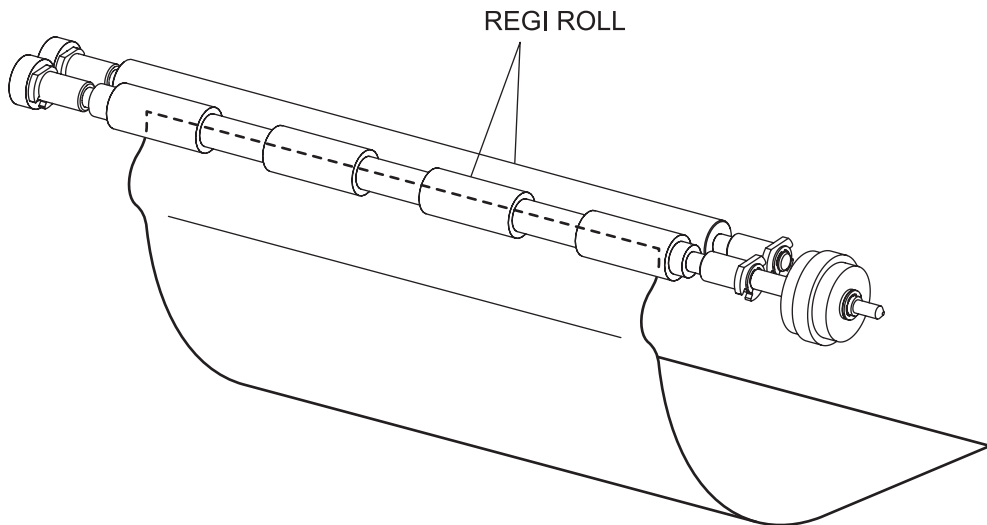

Kmy06034KA

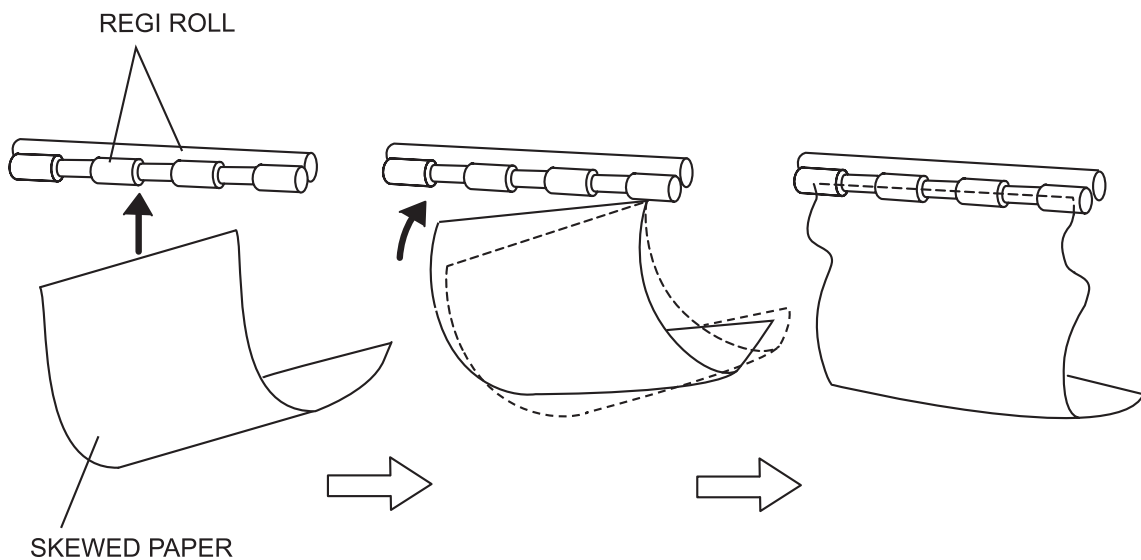

Kmy06049KA

### 3.3.7 Paper detection by the Regi Sensor

Since the paper path from the MPF/Duplex to the Regi Sensor and that from the Paper Tray to the Regi Sensor are different, the Regi Sensor is provided with the Actuator A and Actuator B.

The Actuator A detects the sheet fed from the MPF/Duplex.

The Actuator B detects the sheet fed from the Paper Tray.

However, the movement of the Actuator A does not affect the Actuator B.

### 3.3.8 Reference diagram

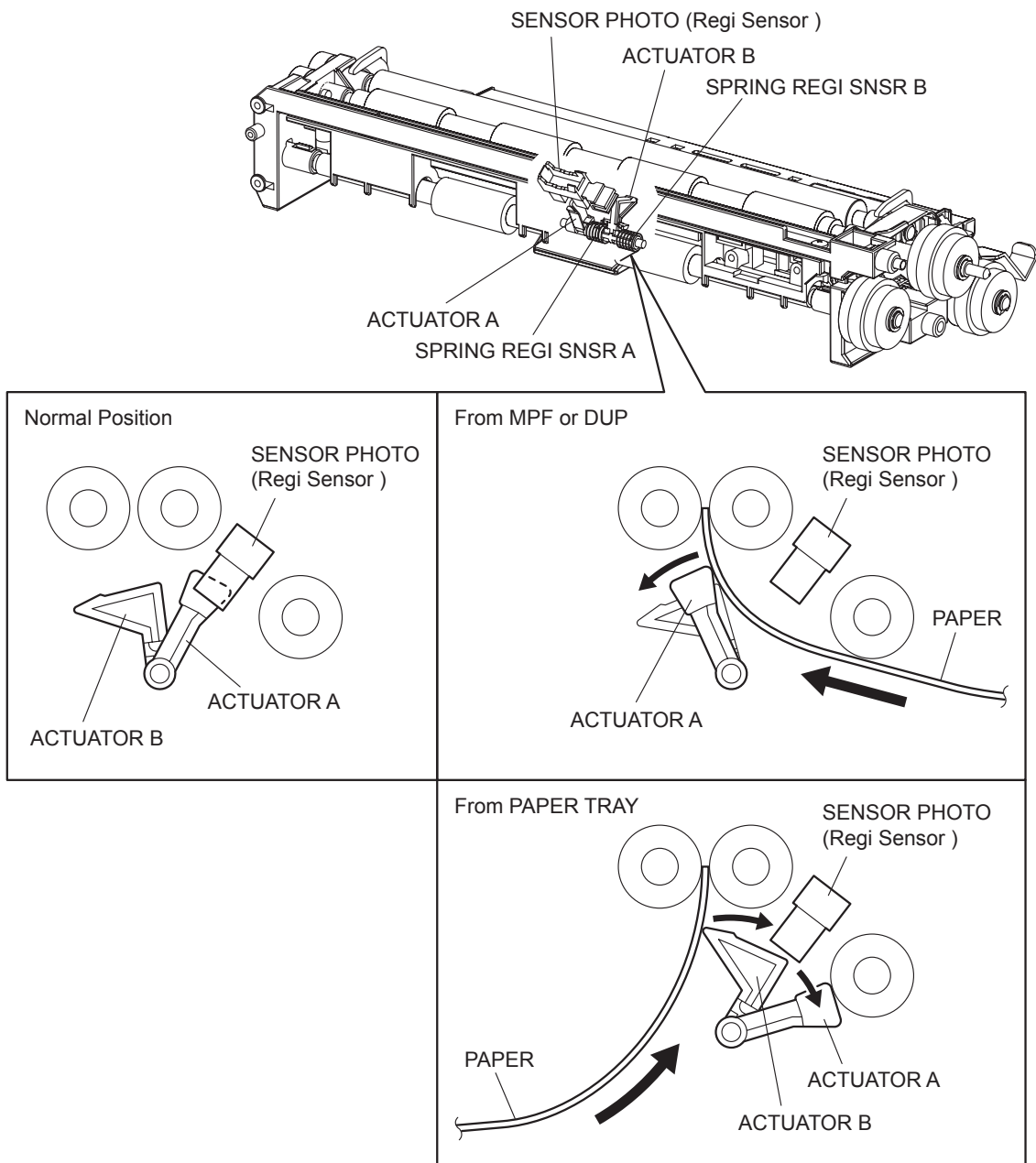

Kmy06057KA

Blank Page

### 3.4 Transfer Belt & Fuser

#### 3.4.1 Major functions

##### - FUSER

The FUSER fixes toner which was transferred onto the paper but not fixed by the heat and pressure and feeds paper before and after being fixed.

The FUSER mainly consists of the following parts:

- Heat Roll
- Heater Lamp
- Thermostat
- Temp. Sensor
- Pressure Belt
- Roll Assy Exit
- Exit Sensor

##### - Exit Sensor

Detects passage of print after fixed based on the change of position of the actuator.

##### - Transfer Belt

###### • Belt

Belt feeds the paper to the direction of FUSER

###### • SENSOR ADC

SENSOR ADC reads the toner patch on the BELT, and converts it to voltage value. Voltage value is used to control the density of toner. (Refer to 5.4.1 Potential Control)

###### • ADC Solenoid

When turned on, the ADC Solenoid activates the PAD ADC to wipe the ADC Sensor surface clean of contaminants. To activate the PAD ADC, the ADC Solenoid must be turned on for a fixed duration before the ADC Sensor starts reading the toner patches.

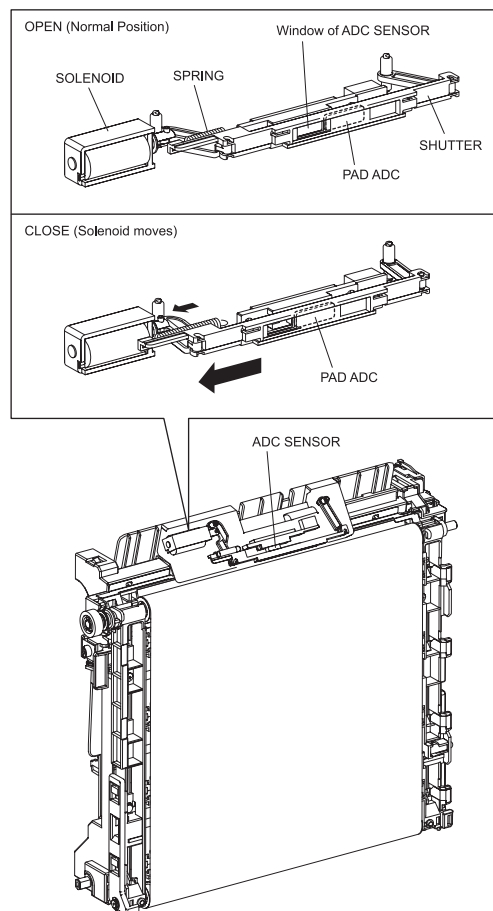

Zna06048KA

3.4.2 Reference diagram

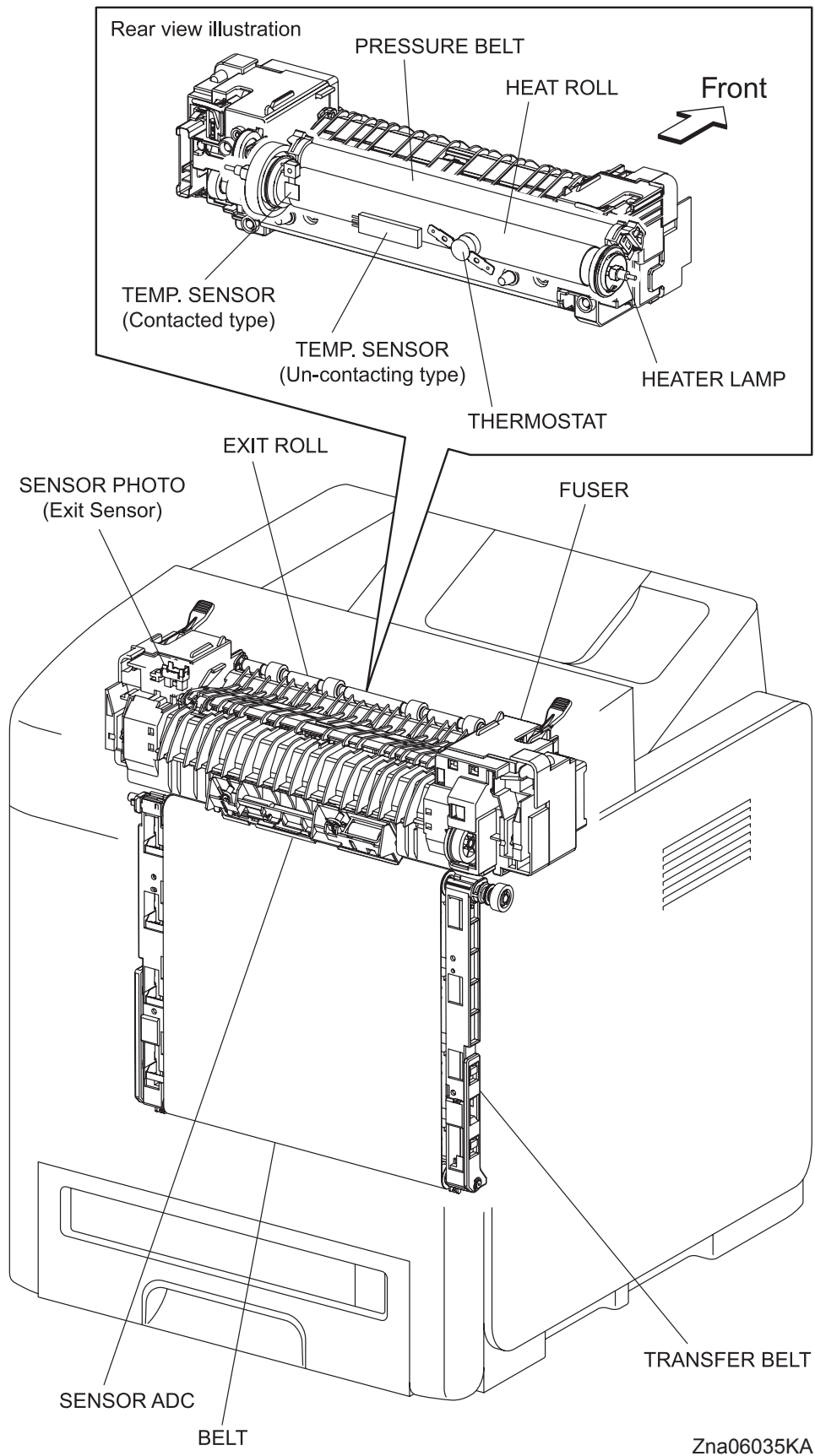

## 3.5 PRINTHEAD

### 3.5.1 Major functions

#### - PRINTHEAD

PRINTHEAD is an exposure unit that generates laser beams to form electrostatic latent image on the drum surface.

In this manual, the PRINTHEAD is referred to as PRINTHEAD.

The PRINTHEAD mainly consists of the following parts:

- LD PWB
- Scanner ASSY
- SOS PWB
- Lens
- Mirror
- Window

#### \* LD PWB

The LD PWB is comprised of four LDs (laser diodes) corresponding to Y, M, C, and K.

Each LD converts the electric signals of incoming image data into laser wave or pulse. In order to stabilize the laser light quantity during formation of an electrostatic latent image, the PWBA LD always monitors the laser light quantity to adjust it to the appropriate level. This is called "APC (auto power control)".

#### \* Scanner Assy

The Scanner Assy is comprised of the Scanner Motor that rotates at a constant speed and the Polygon Mirror that is mounted on the motor shaft.

The laser light output from the LD is irradiated onto the Polygon Mirror via the Mirror.

The Polygon Mirror, provided with twelve reflecting mirror faces, changes the reflection angle of the laser light as it rotates by the Scanner Motor, thereby allowing the laser light to scan the drum along its axial direction. Scanning is performed using one reflecting mirror face for each line.

#### \* Mirror

#### \* Window

#### \* Lens

The laser light reflected from the Polygon Mirror reaches the drum surface via the Lens, Mirror, and Window. The Lens corrects aberration, the Mirror secures an optical path, and the Window prevents foreign matters from entering the ROS.

#### \* SOS PWB

The SOS sensor on the SOS (start of scan) PWB converts an incoming laser beam, upon detection, to an electric signal as the reference signal for starting scanning and transmits this signal to the PWBA MCU.

The SOS sensor signals are used to synchronize the starting point of the laser-beam scanning with the starting point of the image writing.

3.5.2 Reference diagram

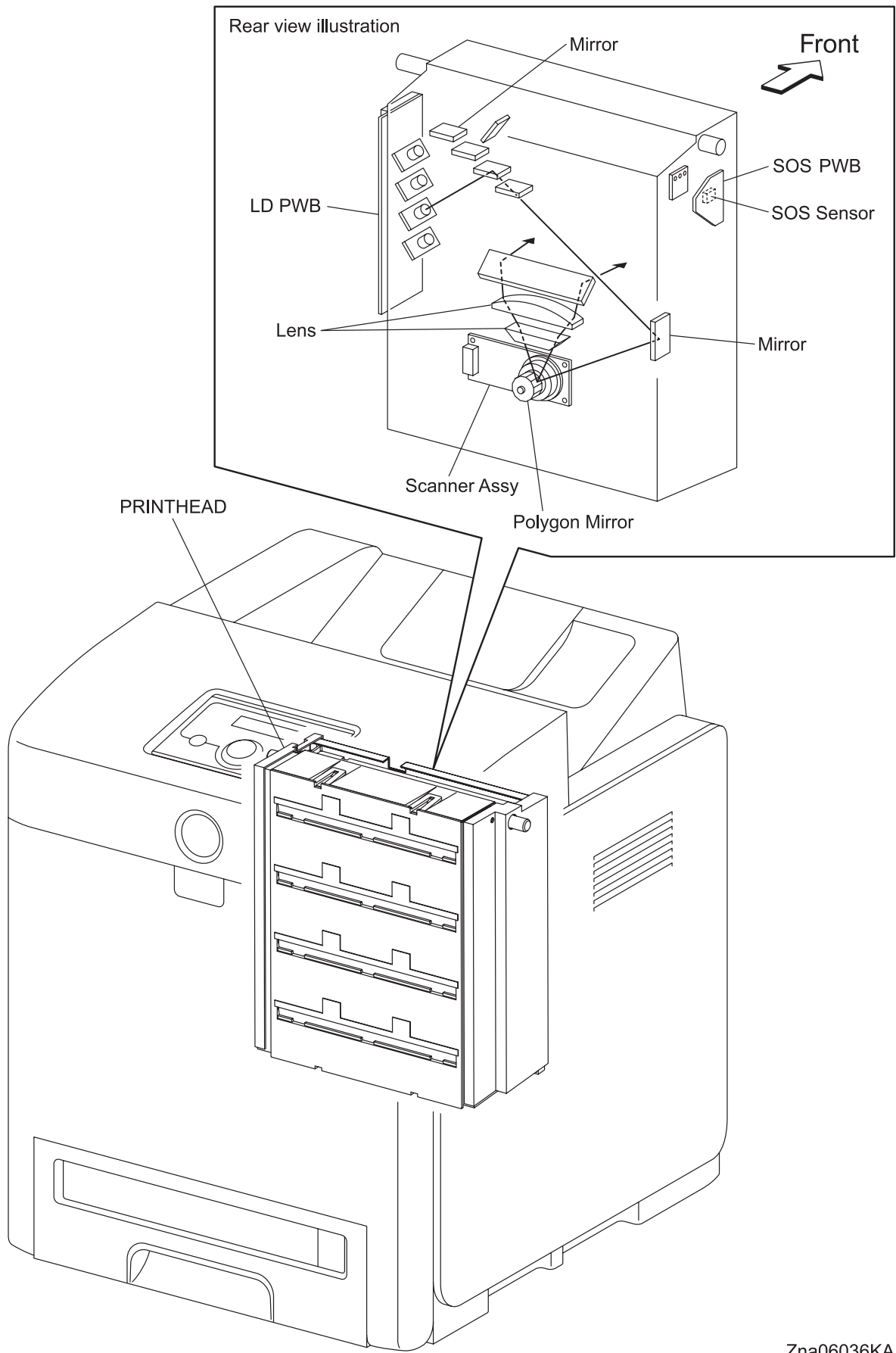

Zna06036KA

## 3.6 TONER CARTRIDGE

### 3.6.1 Major functions

- CRUM (Customer Replaceable Unit Memory) SENSOR  
The CRUM SENSOR reads and writes the data of the CRUM.  
Printer specific information is stored.
  
- SENSOR PHOTO (TONER CARTRIDGE Sensor Y/M/C/K)  
Detects presence/absence of the TONER CARTRIDGE.

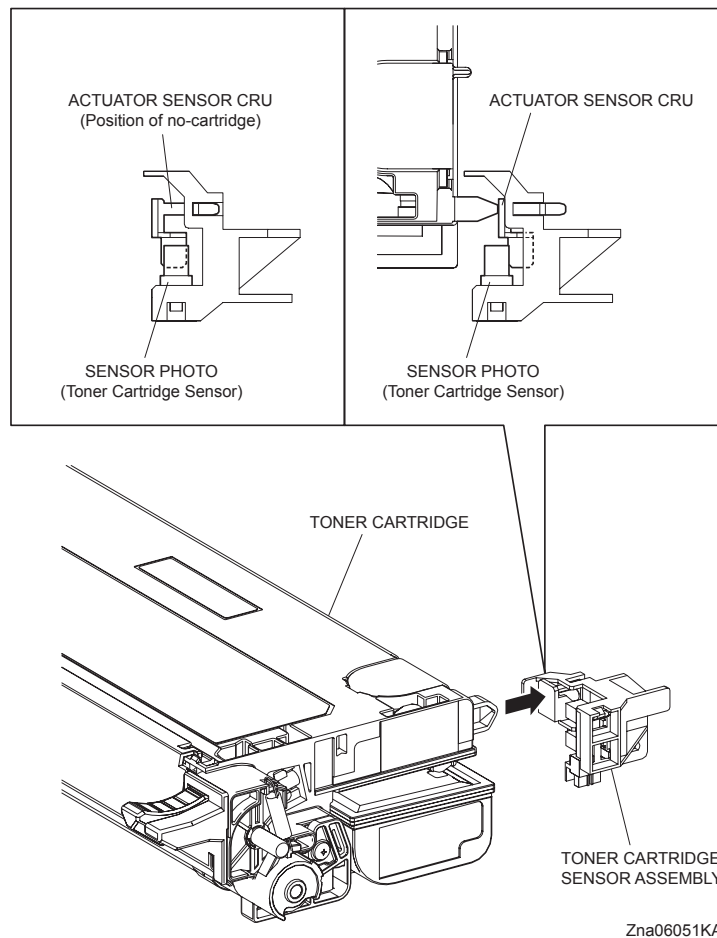

- DISPENSE MOTOR (Y/M/C/K)  
The dispense motor supplies the drive to the Agitator and Auger in the TONER CARTRIDGE, and supplies toner to the developer part in the TONER CARTRIDGE.
  
- TONER CARTRIDGE (Y)
- TONER CARTRIDGE (M)
- TONER CARTRIDGE (C)
- TONER CARTRIDGE (K)  
The TONER CARTRIDGE is constituted from the toner cartridge, developer and the drum.
  
- Erase Lamp (LED ASSEMBLY)  
The light of the LED passes through the lens of the TONER CARTRIDGE, and irradiates the drum.  
The light of the LED eliminates the charge on the drum.



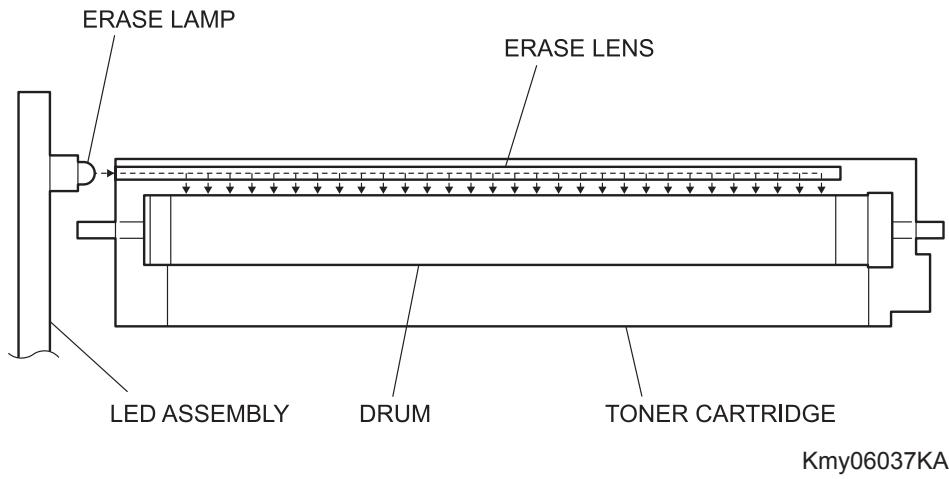

3.6.2 Reference diagram

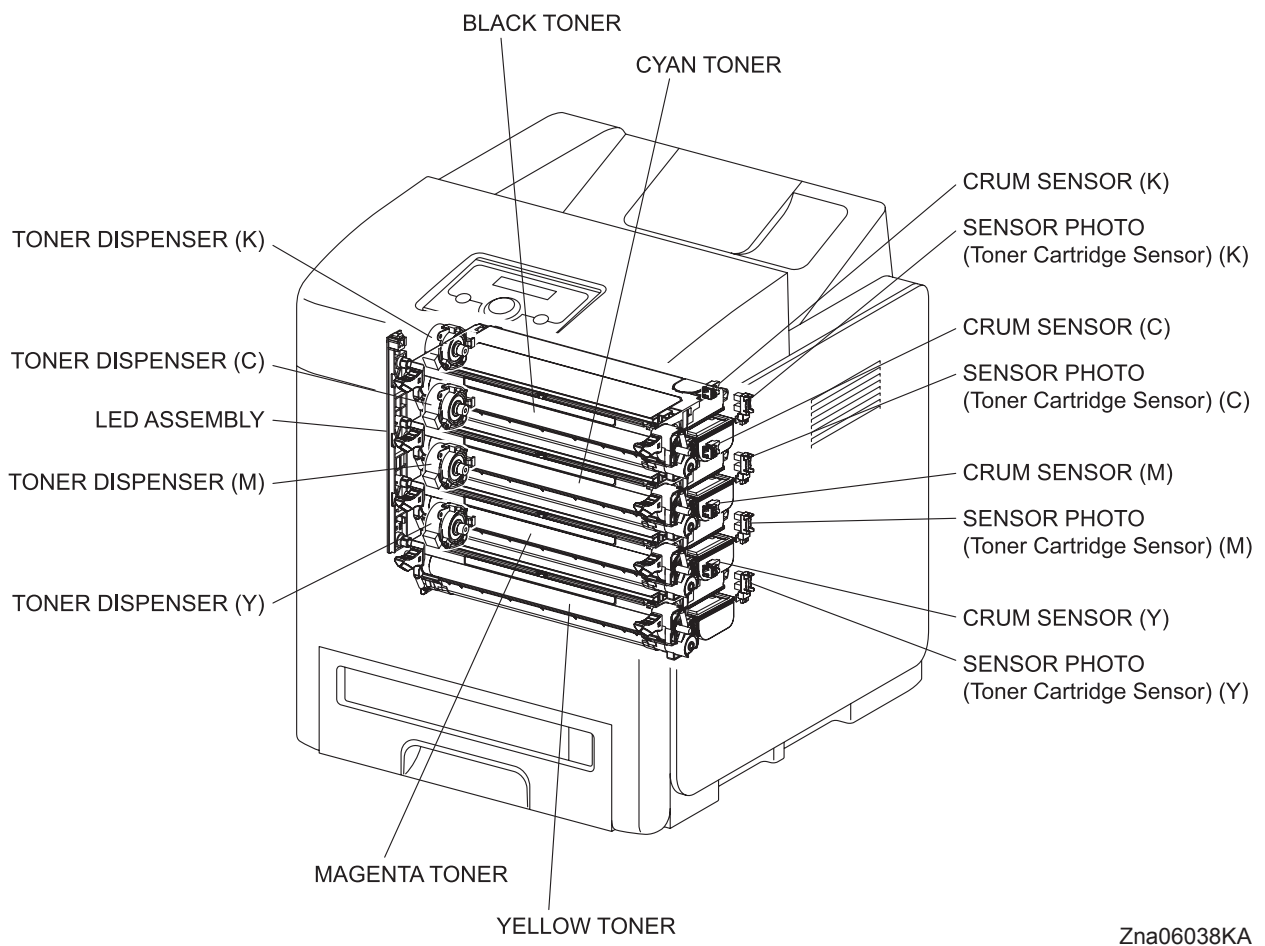

### 3.7 Drive

#### 3.7.1 Major functions

- PHOTOCONDUCTOR (PC)/DEVELOPER (DEV) DRIVE (Refer to 6.1 PHOTOCONDUCTOR (PC)/DEVELOPER (DEV) DRIVE)

Supplies the drive to parts as follows.

- Main Motor
  - Yellow, Magenta, Cyan and Black Drum
  - Transfer Belt
- Sub Motor
  - Fuser
  - Yellow, Magenta, Cyan and Black Developer

- DRIVE ASSY K

The transmission channel is changed by the COLOR MODE SWITCHING SOLENOID in the DRIVE ASSY K to allow the driving force of the SUB MOTOR to reach the C/M/Y Developer only.

This is performed to ensure that the Yellow, Magenta, and Cyan Developers cannot be rotated by the DRIVE ASSY SUB during B/W printing.

The COLOR MODE SWITCHING SENSOR detects the status of the transmission route (whether it is set for B/W or full color).

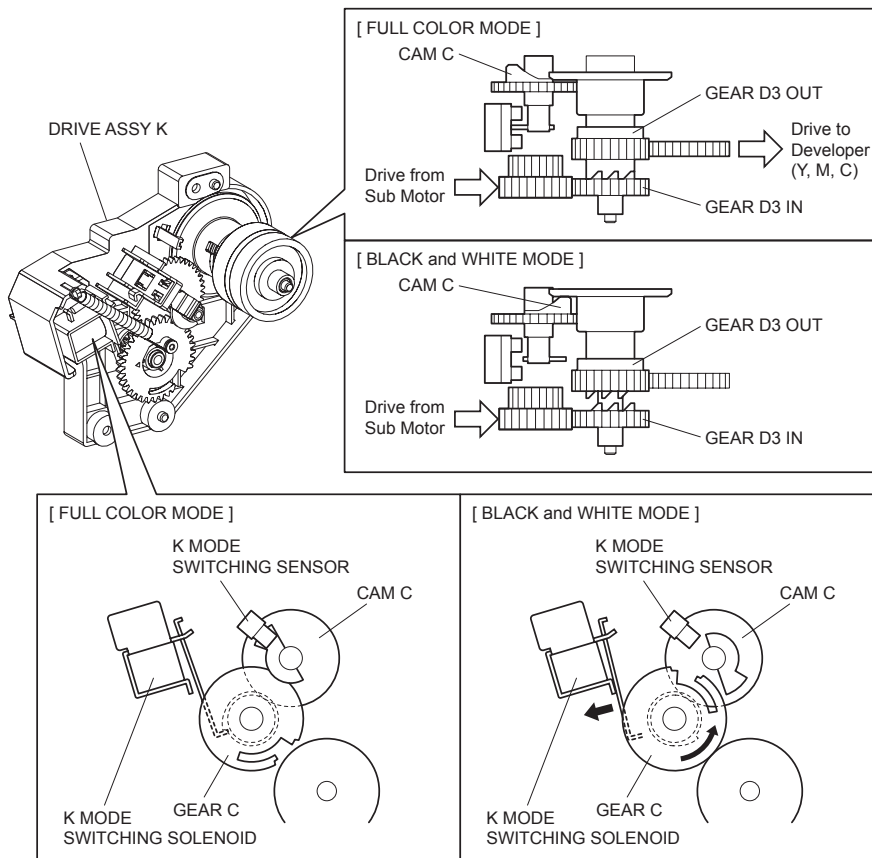

Zna06100KA

- Clutch Assy Exit

Transmits the drive from the Sub Motor to the Roll Assy Exit in the FUSER.

In the backside printing, the exit clutch stops.

Exit Roll is driven by Duplex Motor. (Refer to 6.1 PHOTOCONDUCTOR (PC)/DEVELOPER (DEV) DRIVE [SIMPLEX MODE] and 6.4 DRIVE ASSY DUP)

- FEED DRIVE ASSEMBLY

- Standard Cassette
- MPF
- Regi Assy

3.7.2 Reference diagram

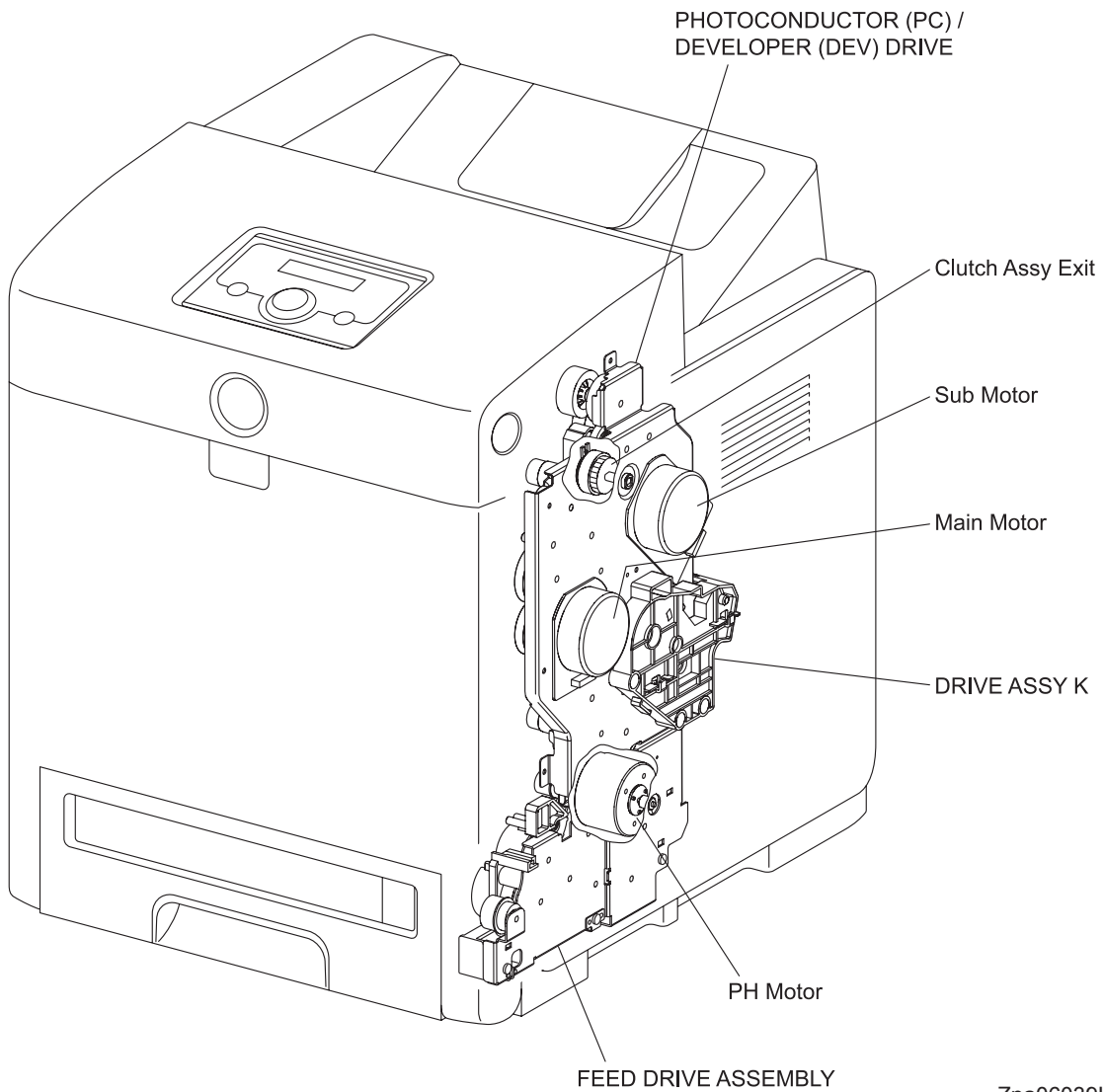

Zna06039KB

Blank Page

## 3.8 Electrical

### 3.8.1 Major functions

- FAN  
Dissipates heat out of the printer to prevent the printer from overheating.
- SWITCH  
The SWITCH turns ON/OFF the AC power supply of the printer.
- Low Voltage Power Supply (LVPS)  
The LVPS is provided in two types, 100/120V and 230V.  
Supplies AC power from the power source to the FUSER heater and generates and supplies stable low voltage DC power used for the logic circuit, etc.  
LVPS contains control circuit for the heater of the FUSER, in addition to the power circuit.
- Machine Control Unit (MCU)  
Controls printing operation based on the communication with the print controller and information from the sensor/switch.  
Major functions are as follows:
  - Communication with the ESS.
  - Receive of information from the sensors or switches.
  - Control of Motor in PHOTOCODUCTOR (PC)/DEVELOPER (DEV) DRIVE and FEED DRIVE ASSEMBLY.
  - Distributing low voltage DC power output from LVPS to each component
  - Control of PRINTHEAD
- High Voltage Power Supply (HVPS)  
Supplies high voltage to the following parts in the Transfer Belt and TONER CARTRIDGE to perform charging, development, and primary transfer.
  - BCR
  - BTR
  - Developer
  - ESA
- PWBA EEPROM  
Information unique to the printer is stored.
- Electronic Sub System (ESS)  
The ESS connected to the MCU controls the entire system (Diagnostic, Interface and Image processing).
- HUMIDITY SENSOR  
HUMIDITY SENSOR reads the temperature/humidity within the printer and converts the values to voltage values.

- OPERATOR PANEL  
OPERATOR PANEL displays the state of the printer using LCD or LED, operates the printer using the switch.
- INTERLOCK SWITCH  
INTERLOCK SWITCH is a switch that cuts the +24VDC power supply to the HVPS or Motor, etc. upon the opening of the Front Cover.

### 3.8.2 Reference diagram

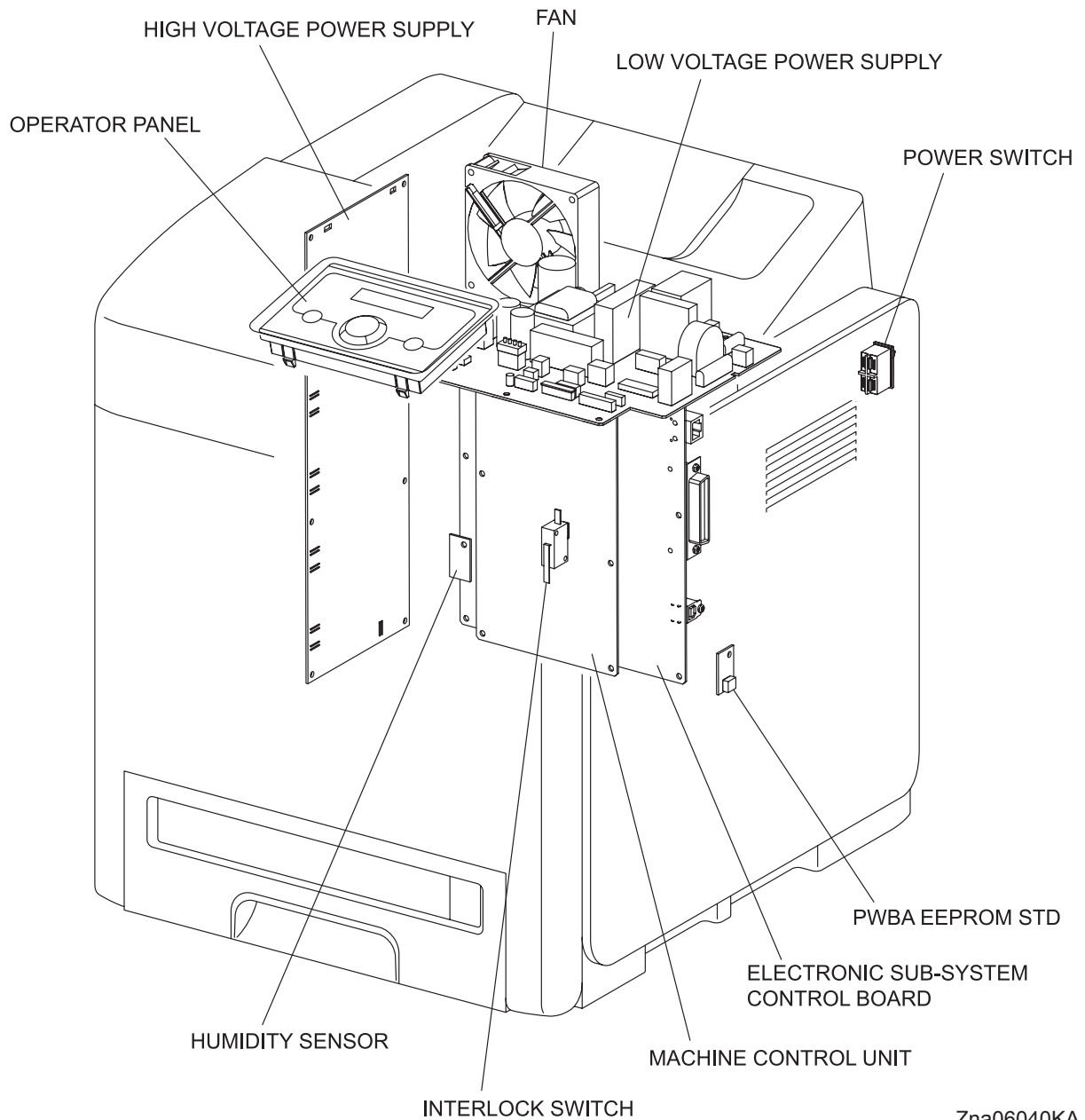

Zna06040KA

**3.8.3 Data Flow**

Print data (electric signal) from the printer controller flows as shown below until it is turned into a print.

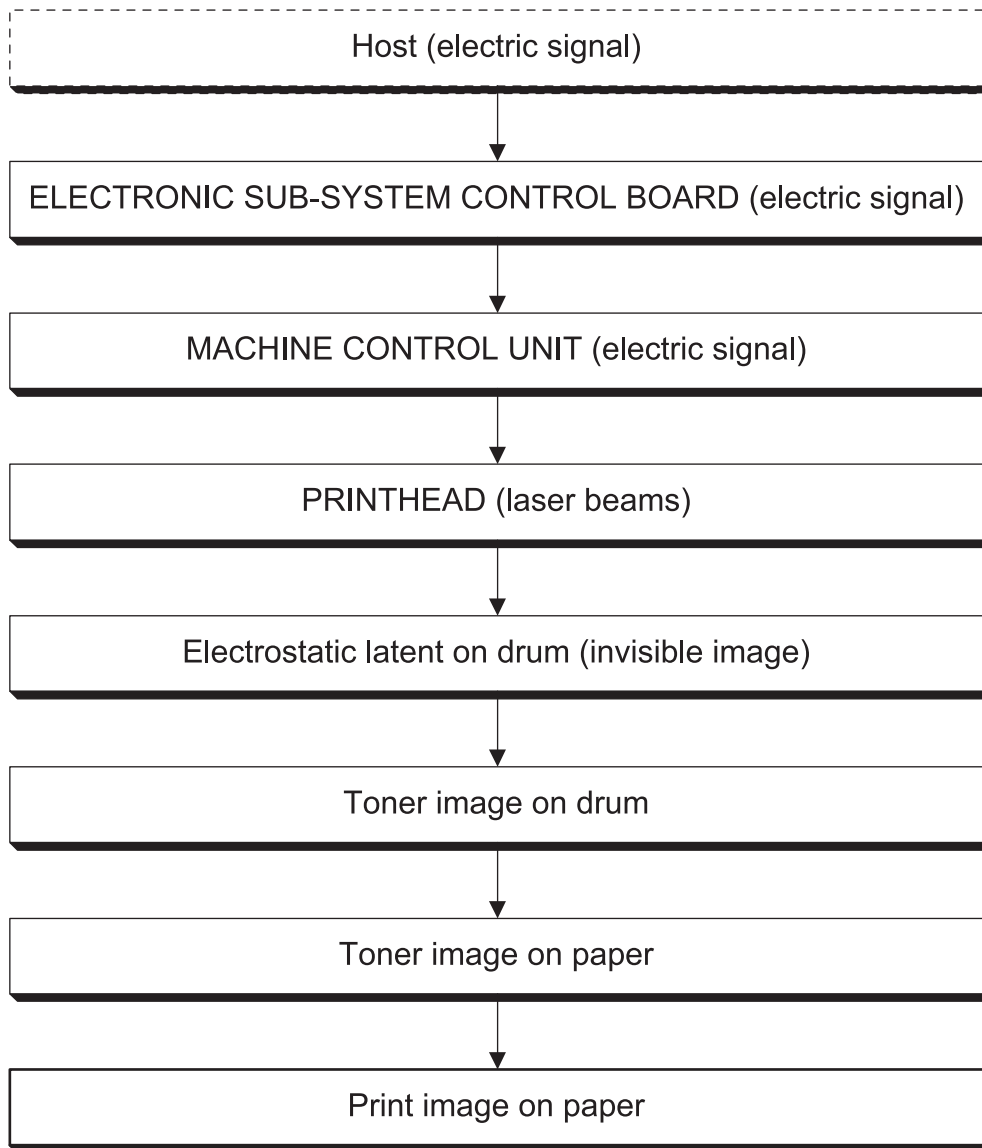

Kmy06011KA



Blank Page

## 3.9 Duplex

### 3.9.1 Major functions

- SENSOR PHOTO (DUP Jam Sensor)  
The DUP Jam SENSOR detects that the paper is carried to duplex part.
  
- CLUTCH DUP  
Transmits the drive from the MOTOR DUP to Roll Assy Exit in the FUSER.  
When the clutch operates, the Roll Assy Exit rotates in the reverse direction.  
The clutch is stopped when the paper reached the Duplex.
  
- DRIVE ASSY DUP  
The DRIVE ASSY DUP supplies the driving power to the Lower Roll (ROLL ASSY DUP2), Upper Roll (ROLL ASSY DUP1) and Roll Assy Exit of Fuser. ([Refer to 6.4 DRIVE ASSY DUP](#))
  
- PWBA DUP  
The PWBA DUP controls motor, sensor and clutch.
  
- FAN DUP  
The FAN DUP is cooling inside of printer.

3.9.2 Reference diagram

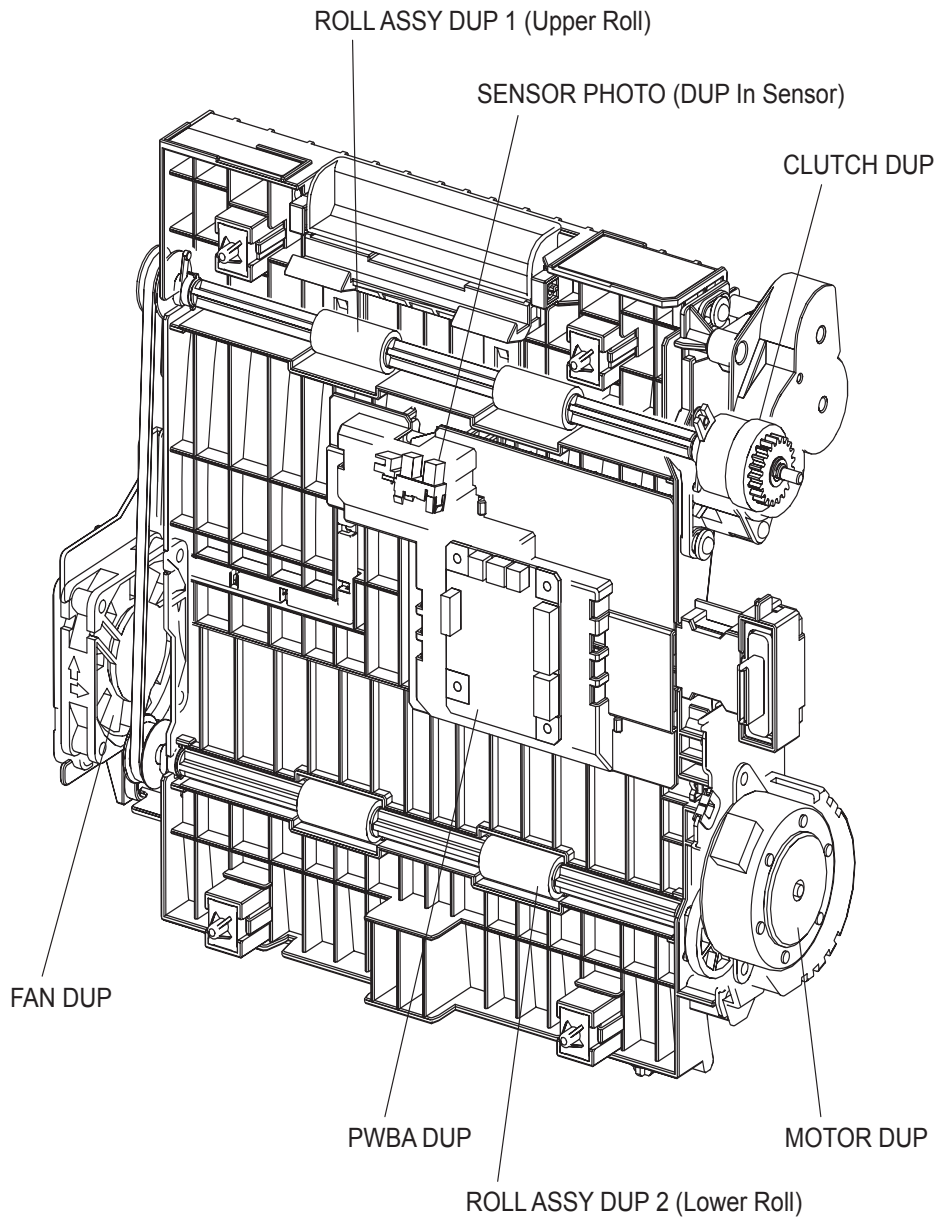

Kmy06041KA

### 3.10 550 Paper Feeder

#### 3.10.1 Major functions (Paper Cassette)

- Side Guide (R/L)  
The Guide Side Assy (R/L) can move at a right angle to the paper transfer direction to align the paper width.
  
- End Guide  
The Guide End Assy can move in the paper transfer direction to determine the paper size. The ON/OFF of SIZE SWITCH ASSEMBLY (Refer to 5.1 Control of Paper Size) varies according to the Guide End Assy position to detect the paper size.
  
- FEED ROLLER (SEPARATOR)  
The FEED ROLLER (SEPARATOR) and the FEED ROLLER (PICK UP ASSY) pinch the paper to feed.
  
- Bottom Plate  
Bottom plate is locked to bottom side when paper cassette is pulled out from the paper feeder and unlocked when the paper cassette is installed to the paper feeder. Pushes the paper against the feed roll using a spring tension.

#### 3.10.2 Reference diagram

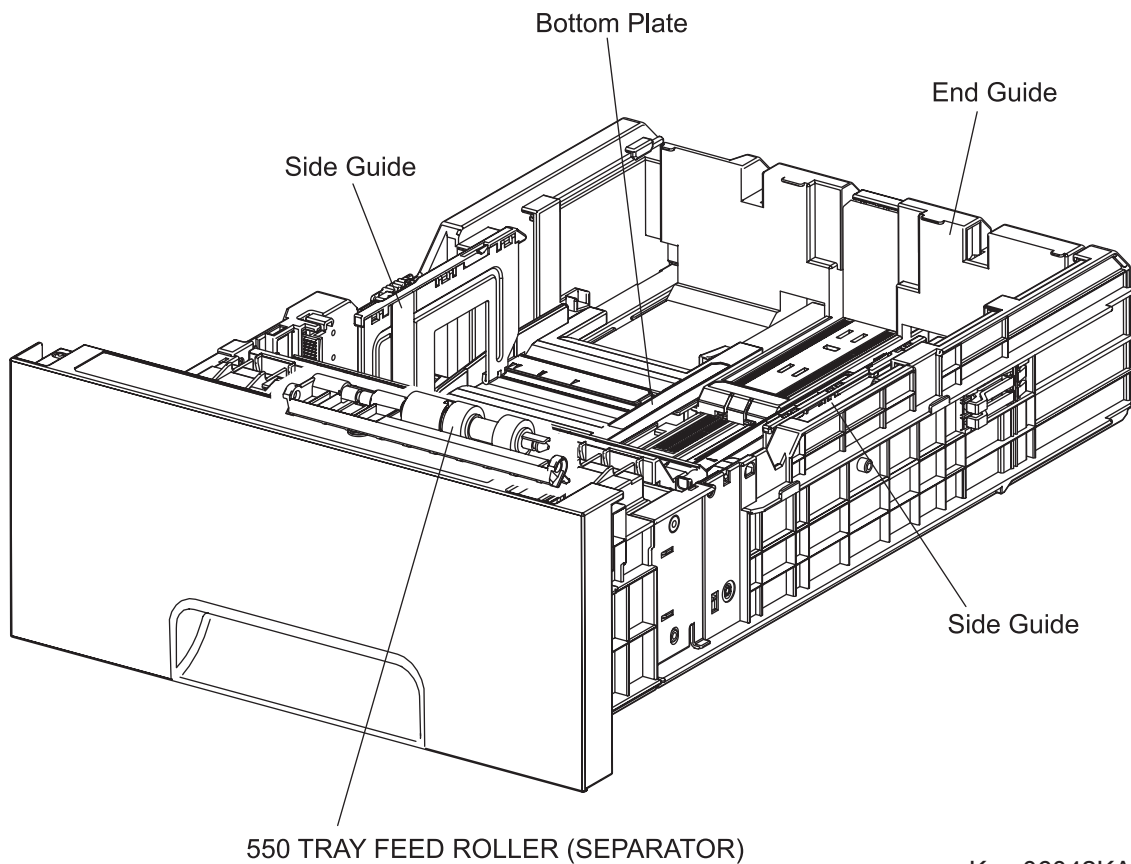

Kmy06042KA

### 3.10.3 Multiple paper feed prevention

The sheets set in a tray or cassette are occasionally stuck together along the edges. The stuck sheets cause a multiple sheet feed or a jam. The sheets are fed by the Nudger Roll to a position between the Feed Roll and the Separator Roll. Normally, when only one sheet is fed, both the Feed Roll and Separator Roll rotate to allow the sheet to pass. However, when two sheets are fed concurrently, only the Feed Roll rotates and the Separator Roll is locked thereby allowing the upper sheet to pass by being separated from the lower sheet that is stopped by the friction with the Separator Roll at rest.

The Separator Roll is being pushed toward the Feed Roll by spring pressure, and controlled by the torque limiter (Clutch Assy Friction) with which it is coupled.

### 3.10.4 Reference diagram

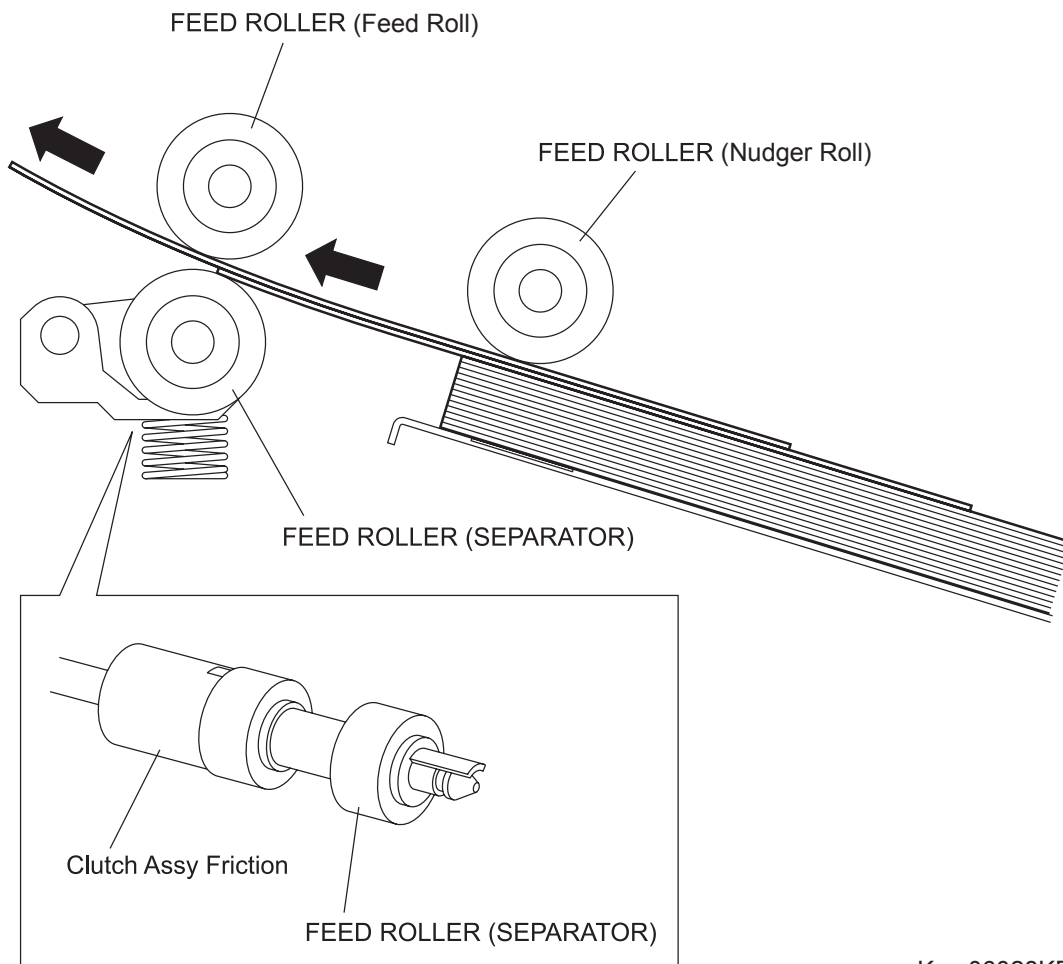

Kmy06028KB

### 3.10.5 Bottom Plate Moving

Inserting the paper tray into the feeder section unlocks the GEAR BTM LOCK ONEWAY. When the paper tray is pushed in until it stops, the gear teeth of the RACK BTM LOCK and GEAR BTM LOCK ONEWAY are out of engagement allowing the PLATE ASSY BTM to rise by the spring pressure of the SPRING BTM UP.

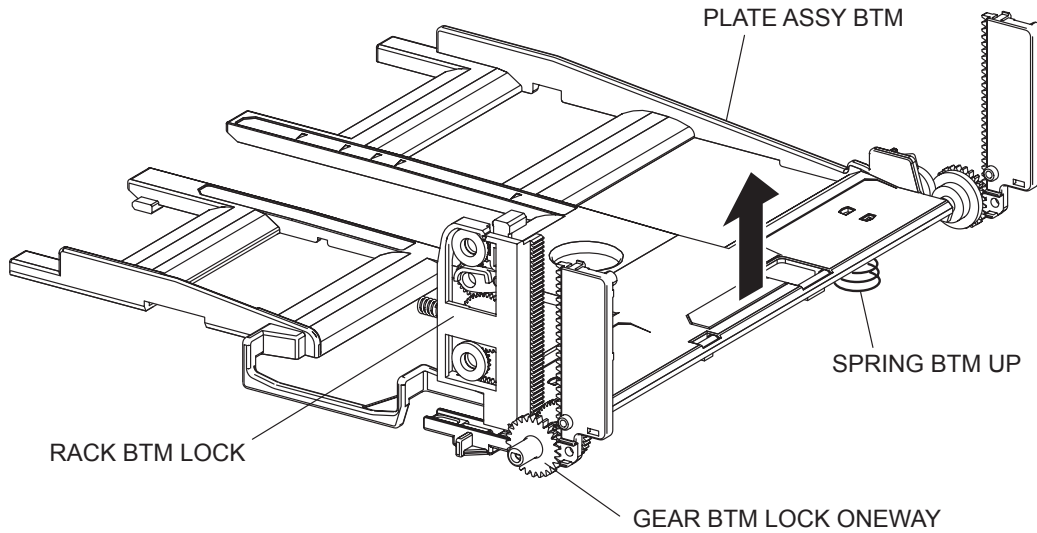

Kmy06023EA

Blank Page

### 3.10.6 Major functions (Feeder)

#### - SIZE SWITCH ASSEMBLY

SIZE SWITCH ASSEMBLY detects the paper size and presence/absence of the paper tray.

(Refer to 5.1 Control of Paper Size for the combination of switches.)

The paper size is decided at the position of the END GUIDE.

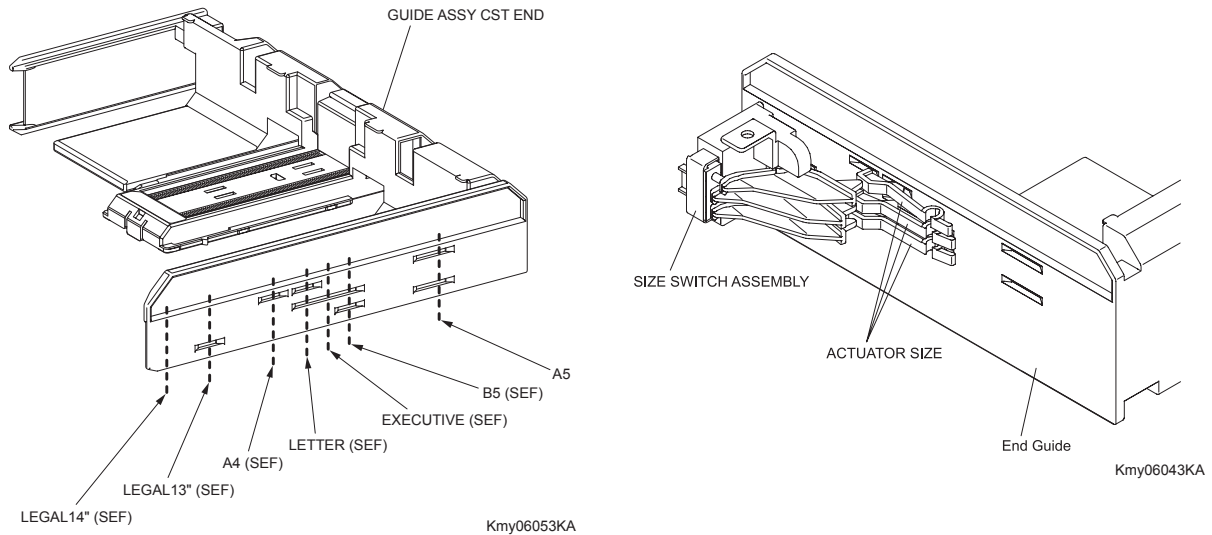

#### - SENSOR PHOTO (No Paper Sensor)

Detects the presence/absence of paper in the paper tray based on the position of ACTUATOR NO PAPER. (No paper: Sensor beam is intercepted)

#### - CLUTCH ASSY FEED

Transmits the drive from the DRIVE ASSY OPTION FEEDER to FEED ROLLER. (PICK UP ASSY)  
(Refer to 6.5 DRIVE ASSY OPT FDR)

#### - FEED ROLLER

When the CLUTCH ASSY FEED operates, the FEED ROLLER starts rotating and the FEED ROLLER feeds the paper. (Refer to 6.5 DRIVE ASSY OPT FDR)

#### - CLUTCH ASSY TURN

Transmits the drive from the DRIVE ASSY OPTION FEEDER to ROLL ASSY TURN.

#### - ROLL ASSY TURN

The ROLL ASSY TURN rotates by the drive from DRIVE ASSY OPTION FEEDER through the CLUTCH ASSY TURN to feed the paper from the paper tray to the printer.

#### - DRIVE ASSY OPTION FEEDER

The MOTOR OPTION FEEDER is driving the rolls of the option feeder. (Refer to 6.5 DRIVE ASSY OPT FDR)

#### - PWBA OPTION FEEDER

The PWBA OPTION FEEDER controls motor, sensor and clutch.



3.10.7 Reference diagram

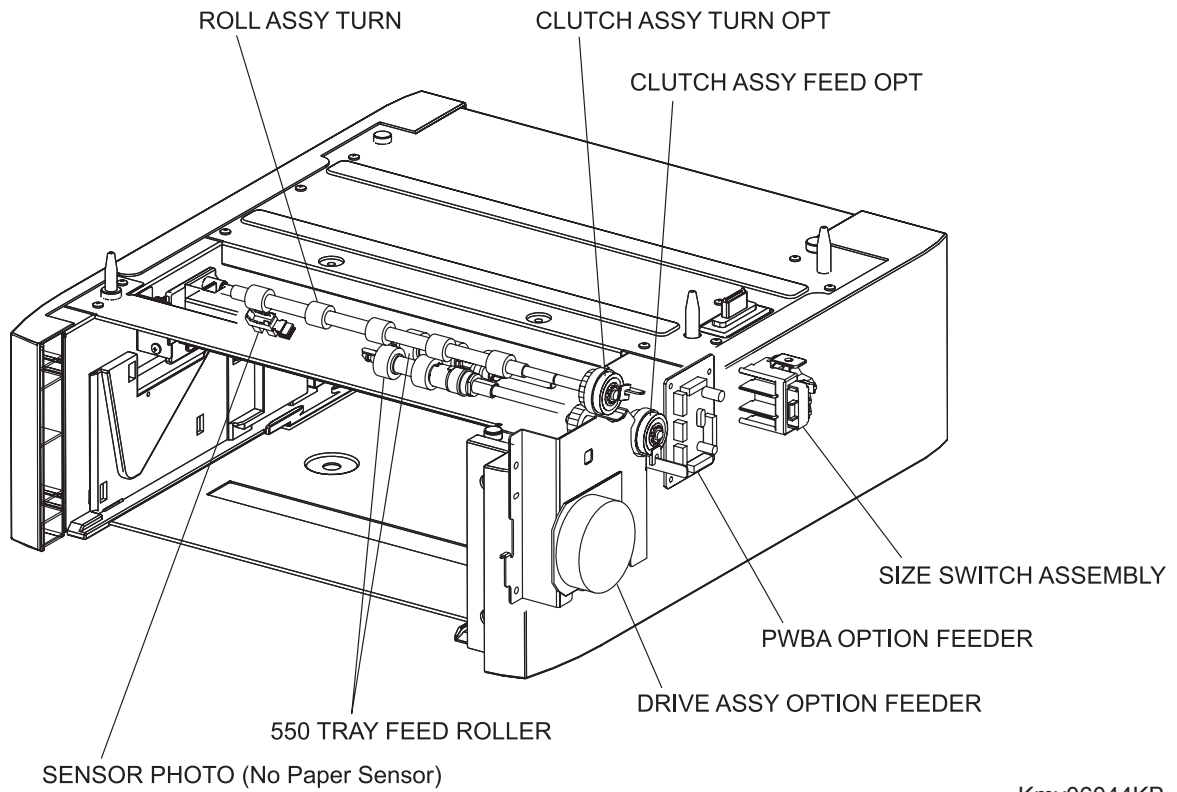

## 4. MODES

### 4.1 Operation Modes

For the operation of the printer, the following five modes are provided.

- DIAG TEST mode  
The printer is ready for receiving diagnostic commands, or the printer diagnostic function is operating.
- WAIT mode  
The printer is under the adjustment of print quality.
- READY mode  
The printer is ready for printing.
- PRINTING mode  
The printer is under printing.
- ERROR mode  
Any error was detected in the printer.
- Initializing mode  
New parts have been just set to the printer (initializing with a new Deve Unit).
- Checking Unit mode  
Printer is under checking consumable units.

## 5. Control

### 5.1 Control of Paper Size

"ON/OFF of Paper Size Switch of SIZE SWITCH ASSEMBLY" and "Diag Tool indication data" are shown in the table below.

NOTE

Paper Size Switches are indicated as SW1, SW2, and SW3 from the above one.

Paper Size	Paper Size Switch			Diag indication data
	SW1	SW2	SW3	
LEGAL14" (SEF)	ON	ON	ON	00
LEGAL13" (SEF)	ON	ON	OFF	01
EXECUTIVE (SEF)	ON	OFF	ON	02
B5 (SEF)	ON	OFF	OFF	03
A4 (SEF)	OFF	ON	ON	04
LETTER (SEF)	OFF	OFF	ON	06
A5	OFF	ON	OFF	05
No cassette	OFF	OFF	OFF	07

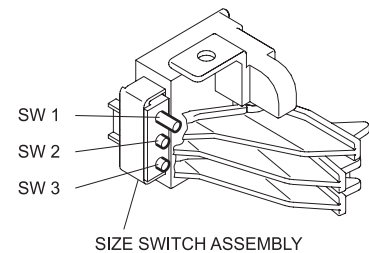

ON: The actuator is pushing the size switch.

### 5.2 Selective Control on Paper Cassette

The preferred paper cassette selected after powering on can be changed via the printer settings. The default is Tray1 (TBD).

NOTE

The paper feeder by the paper tray under the printer is called "Tray 1", and the optional TRAY is called "Tray 2".

### 5.3 PRINTHEAD Light Quantity Control

The image data are entered to the laser diodes in the PRINTHEAD as electric signals (data are expressed with high and low voltage values), and the laser diodes convert the image data from electric signals to optical signals (data are expressed with blinking laser beams).

Variations in light quantity of laser beams or variations in optical system (such as lenses) or drum sensitivity cannot attain a proper electrostatic image, therefore, the laser beam light quantity is monitored and controlled by the laser diodes.

The PRINTHEAD in this printer has four laser diodes for yellow, magenta, cyan, and black respectively, and the light quantity is automatically adjusted for each color.

## 5.4 Process Control

For a stable printing, the parameters related to the image forming must be corrected as necessary. The control of the entire printing process including parameter correction control is called "process control". Mainly, the process control is performed in the following two methods, both of which are performed after every 30 cumulative prints upon termination of a print run or during a continuous run.:

- Potential control
- Toner density control

To supplement these two controls, the following controls are provided:

- High Area Coverage Mode
- Admix Mode

### 5.4.1 Potential Control

To attain stable printing image density, the drum charging voltage, the developing DC voltage and the PRINT HEAD light amount are adjusted according to the developing capability of each color carrier that varies momentarily. The adjusted drum charging voltage, the developing DC voltage and the PRINT HEAD light amount are fed back to keep the printing image density constant.

The outline of control is as follows.

- 1) The HUMIDITY SENSOR (temperature and humidity sensor) detects the temperature and humidity.
- 2) The patches of respective colors (yellow, magenta, cyan, and black) for the potential control are generated and transferred on the Belt.
- 3) The ADC Sensor (density sensor) detects the density of the patch on Belt.
- 4) The drum charging voltage, the developing DC voltage and the PRINT HEAD light amount are adjusted for each color according to the detected patch density.

### 5.4.2 Toner Density Control

The toner density must be kept constant to attain stable printing image. The control system for this purpose is called toner density control.

1) PCDC (Pixel Count Dispense Control)

The quantity of the toner to be consumed in the developing process is calculated by counting the video signals entered to the PRINthead. The quantity of the toner to be consumed is calculated by the toner dispensing time. The toner motor is driven based on the calculated toner dispensing time when supplying the toner to the developer.

2) ADC (Auto Density Control)

The patches of respective colors (yellow, magenta, cyan, and black) for the toner density control are generated under specified potential condition, and transferred on the Belt. The ADC Sensor measures this density. The measured value is compared with the reference value. If the toner density is lower, the toner dispense quantity is increased at the next printing, or if the toner density is higher, the toner dispense quantity is reduced at the next printing. The toner dispense quantity is calculated by the toner dispense time. This calculation is made for each color.

### 5.4.3 High Area Coverage Mode

A continuous printing of any image of area coverage exceeding extra toner dispense capability causes the toner density in the developer to be lowered.

The High Area Coverage Mode postpones the next page feed and dispenses the toner during this time, if the toner dispense time reached the specified value during a continuous printing.

### 5.4.4 Admix Mode

This mode prevents the toner density from being lowered, whenever the value of the toner density control patch measured by the ADC Sensor falls far below the standard value, by performing extra toner dispensation. If the toner density level cannot be recovered even after this operation, it is judged that the toner has run out.

### 5.4.5 ADC Sensor Adjustment

The ADC Sensor is a reflection type sensor that irradiates the light from its LED onto the target and detects the reflected light at its photoreceptor and outputs electric signals responsive to the amount of the detected light. To ensure an accurate patch density measurement, the surfaces of the ADC Sensor is cleaned to remove soil due to toner, etc., and the light amount adjustment is made so that the reflected light amount satisfies the prescribed value, when creating the patch for potential control and toner density control.

## 5.5 Color Registration Control

The printer uses a tandem system where the drums and developers are arranged respectively for each of yellow, magenta, cyan, and black colors. Since the images are formed on the drum of each color to be overlaid one another, a color shift may occur. The color registration control calculates how much the registration is shifted, and adjusts the PRINTHEAD write timing.

The lateral registration control adjusts all of four colors in lateral directions.

The color registration control is made from a change in inside temperature and the print count at the execution of the process control.

The control is outlined below:

- 1) With no toner on the Belt, the output value of ADC Sensor is measured to determine the threshold value.
- 2) The patches for color registration control are generated on the Belt. These patches are composed of 10mm lines of K, C, K, M, K, and Y in this order.

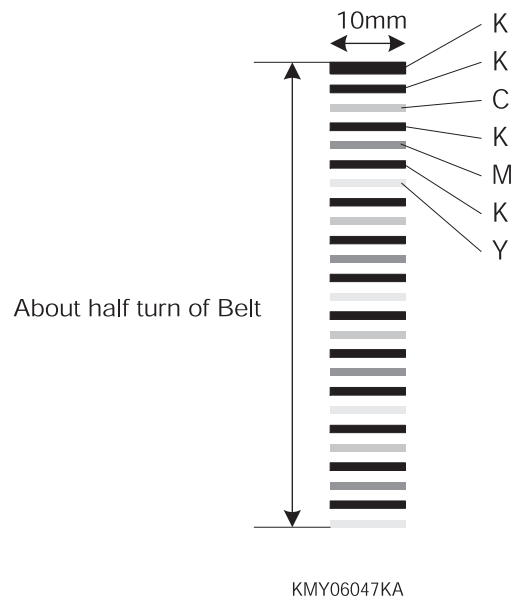

- 3) The density of patches generated by the ADC Sensor is read.
- 4) The shift correction amount is calculated from the threshold value determined in 1) and the patch density measured in 3).
- 5) The PRINTHEAD write timing is changed according to the shift correction amount.

## 5.6 Fuser Control

### 5.6.1 Fuser temperature control

As for the fuser temperature control, the target temperature is set, then the Heat Roll surface temperature is controlled so that it can meet the target value by turning on/off the Heater Lamp.

Temperature of individual area of the Heat Roll is detected by the Fuser Non-Contact Sensor (NCS) in the middle of the Heat Roll and the Temp Sensor at the edge of it. When the temperature detected is higher than the target value, the Heater Lamp will be turned OFF. When the temperature is below the target value, the Heater Lamp will be turned ON.

The target temperature setting varies depending on the time of Warm-up, Printing, or Process Control. The target temperature varies according to such environmental factors as the interior temperature detected by the Sensor Hum Temp.

### 5.6.2 Cooling down

As the printing continues, the temperature distribution in the Heat Roll becomes uneven both in the paper feed and non-paper feed areas. Cooling Down suspends paper feeding for a certain period of time so that the Heat Roll temperature distribution can be uniform.

When the temperature of the Heat Roll edge is high, cooling down is performed to lower the temperature to the target value.

### 5.6.3 Sensor Warm-up

The Fuser NCS (Non Contact Sensor) at the center of the Heat Roll will lose its accuracy of detecting temperature when the temperature of the Sensor itself is below  $-5^{\circ}\text{C}$ . Therefore, the Sensor will be warmed up when the temperature is below  $-5^{\circ}\text{C}$ . This action is called Sensor Warm-up.

## 6. Drive Transmission Route

### 6.1 PHOTOCONDUCTOR (PC)/DEVELOPER (DEV) DRIVE

Rotation power of the PHOTOCONDUCTOR (PC)/DEVELOPER (DEV) DRIVE is transmitted through the route below.

[ BLACK and WHITE MODE ]

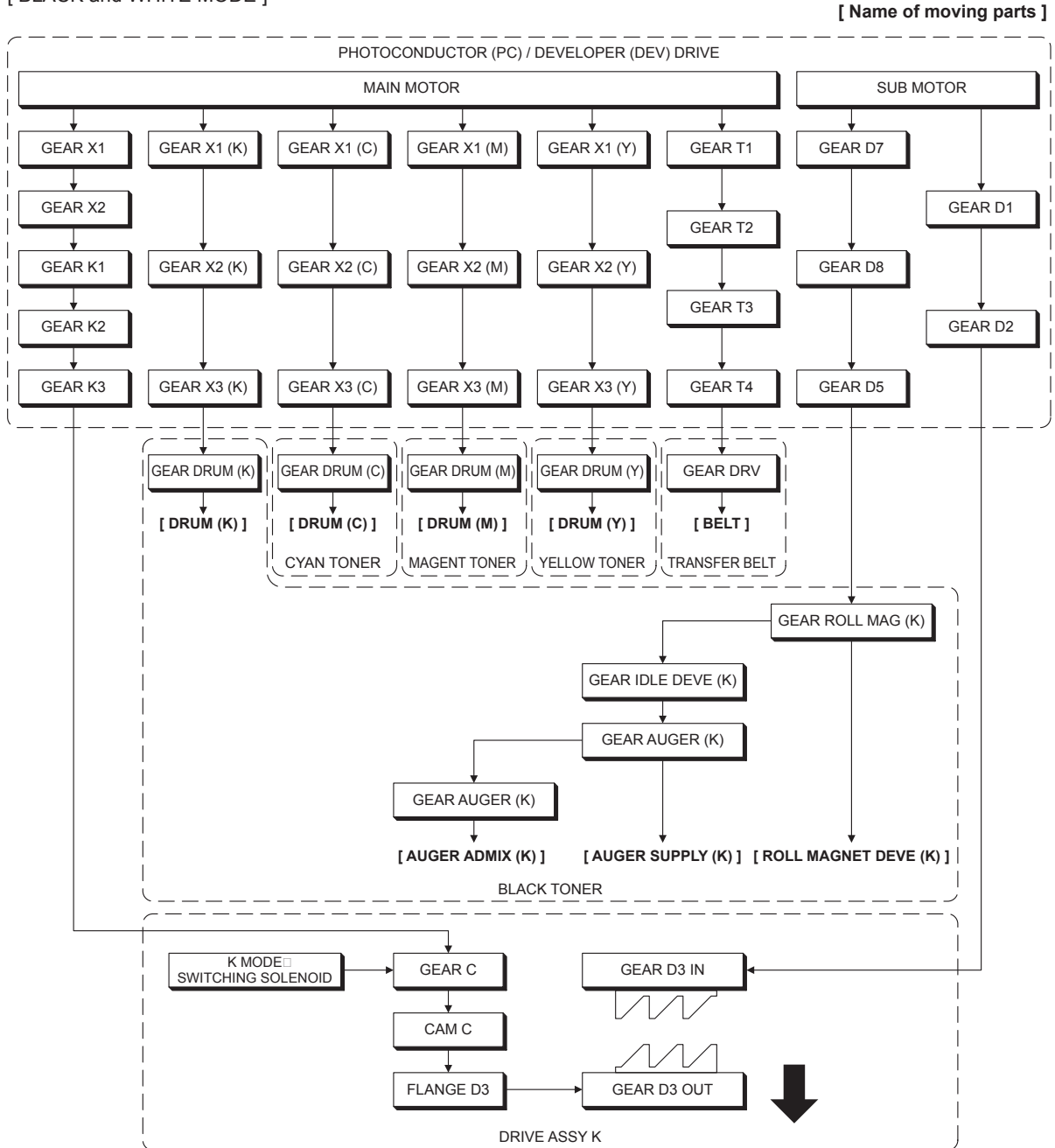

Zna06012KA



[ BLACK and WHITE MODE ]

[ Name of moving parts ]

▬ : Indicates the engagement of gears.

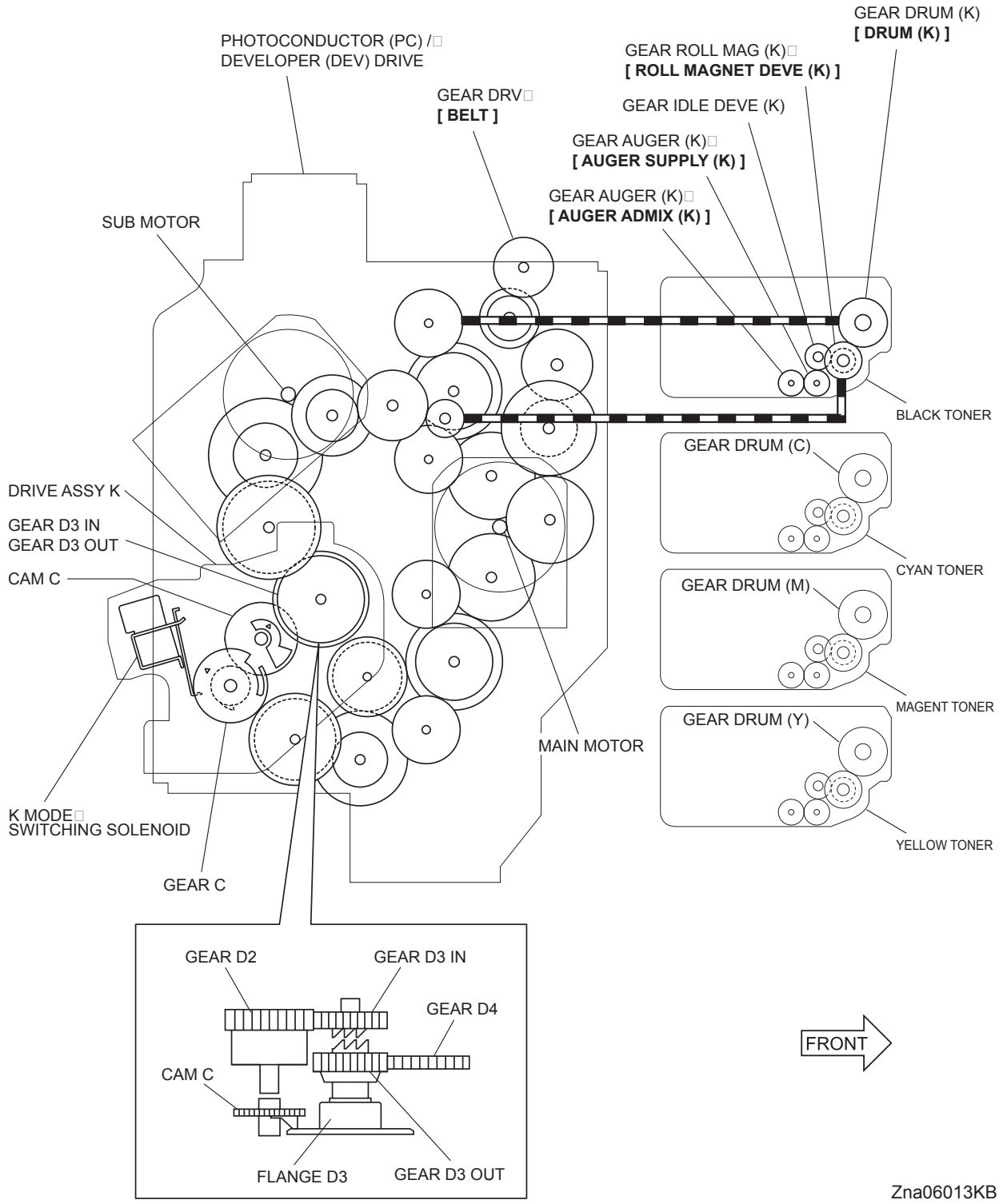

[ FULL COLOR MODE ]

[ Name of moving parts ]

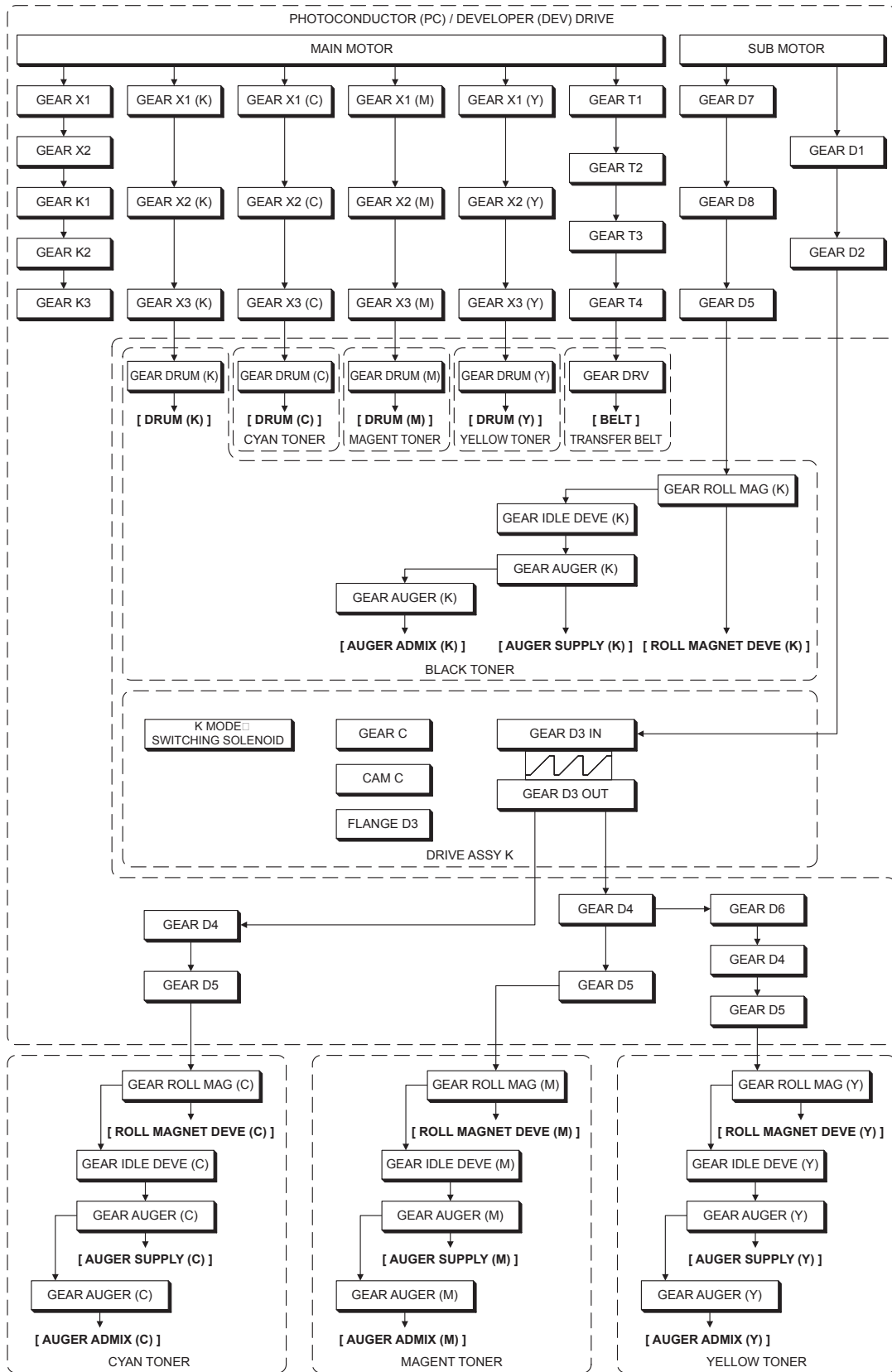

Zna06014KB

[ BLACK and WHITE MODE ]

[ Name of moving parts ]

▬ : Indicates the engagement of gears.

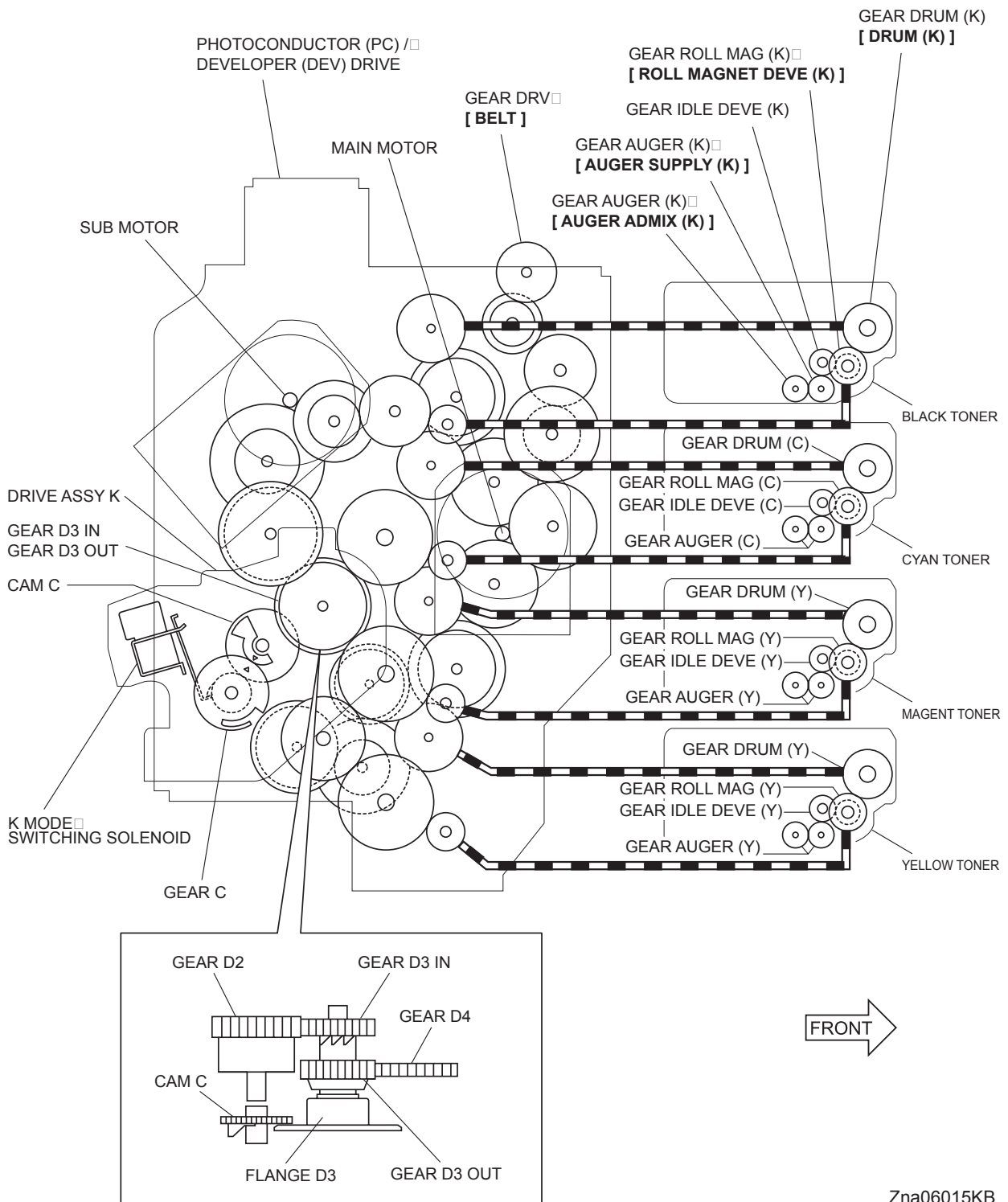

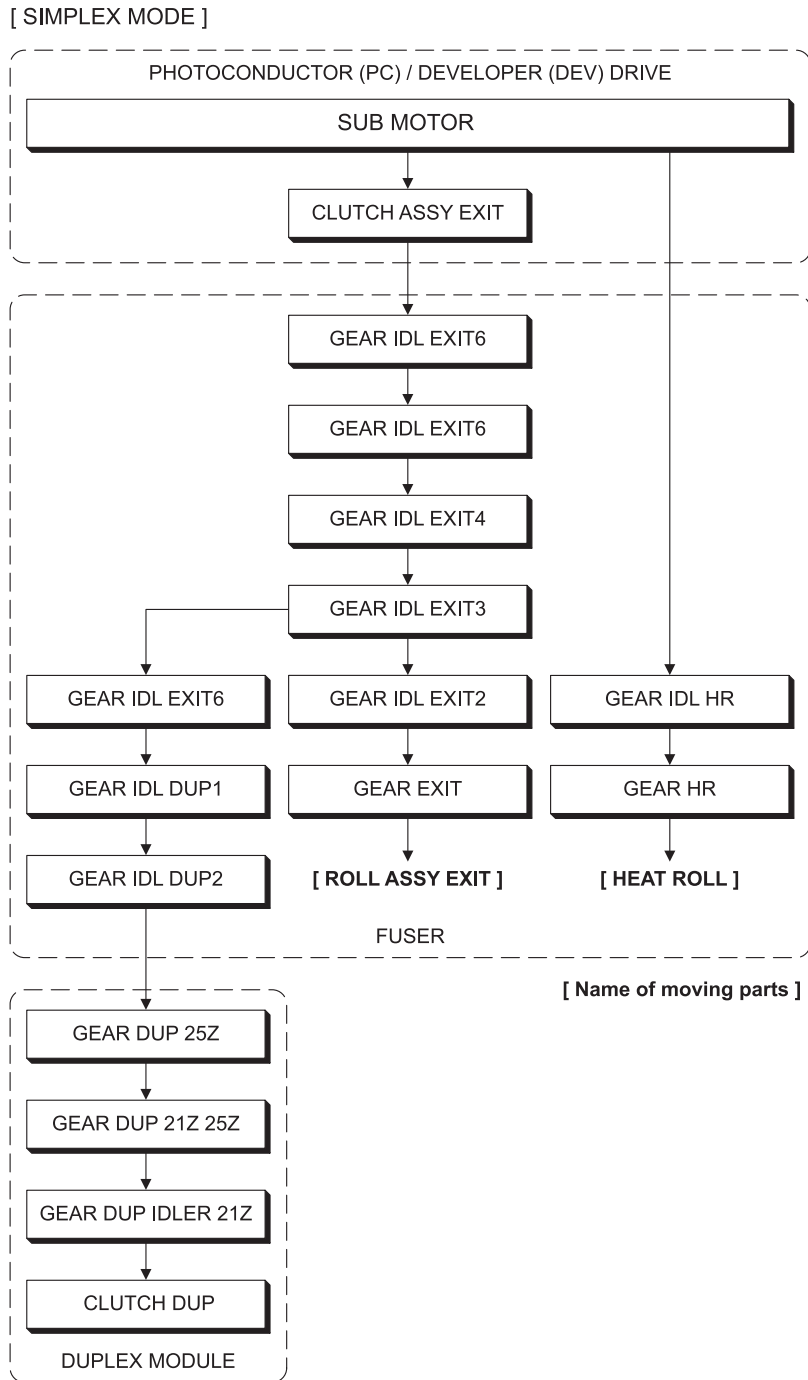

Zna06016KB

[ SIMPEX MODE ]

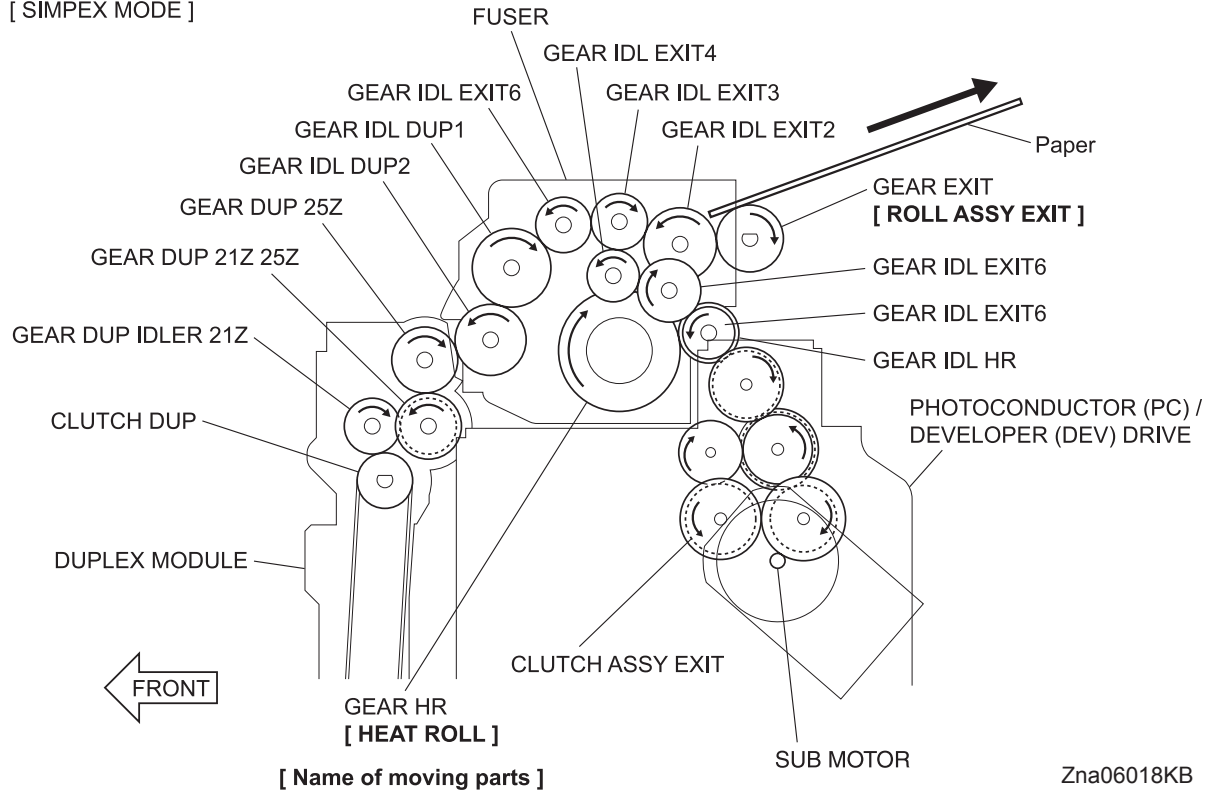

Zna06018KB

## 6.2 TONER DISPENSER (Y, M, C, K)

Rotation power of the TONER DISPENSER drives the agitator and the auger in the TONER CARTRIDGE.

The operation is common among the TONER DISPENSER Y, M, C and K.

[TONER CARTRIDGE]

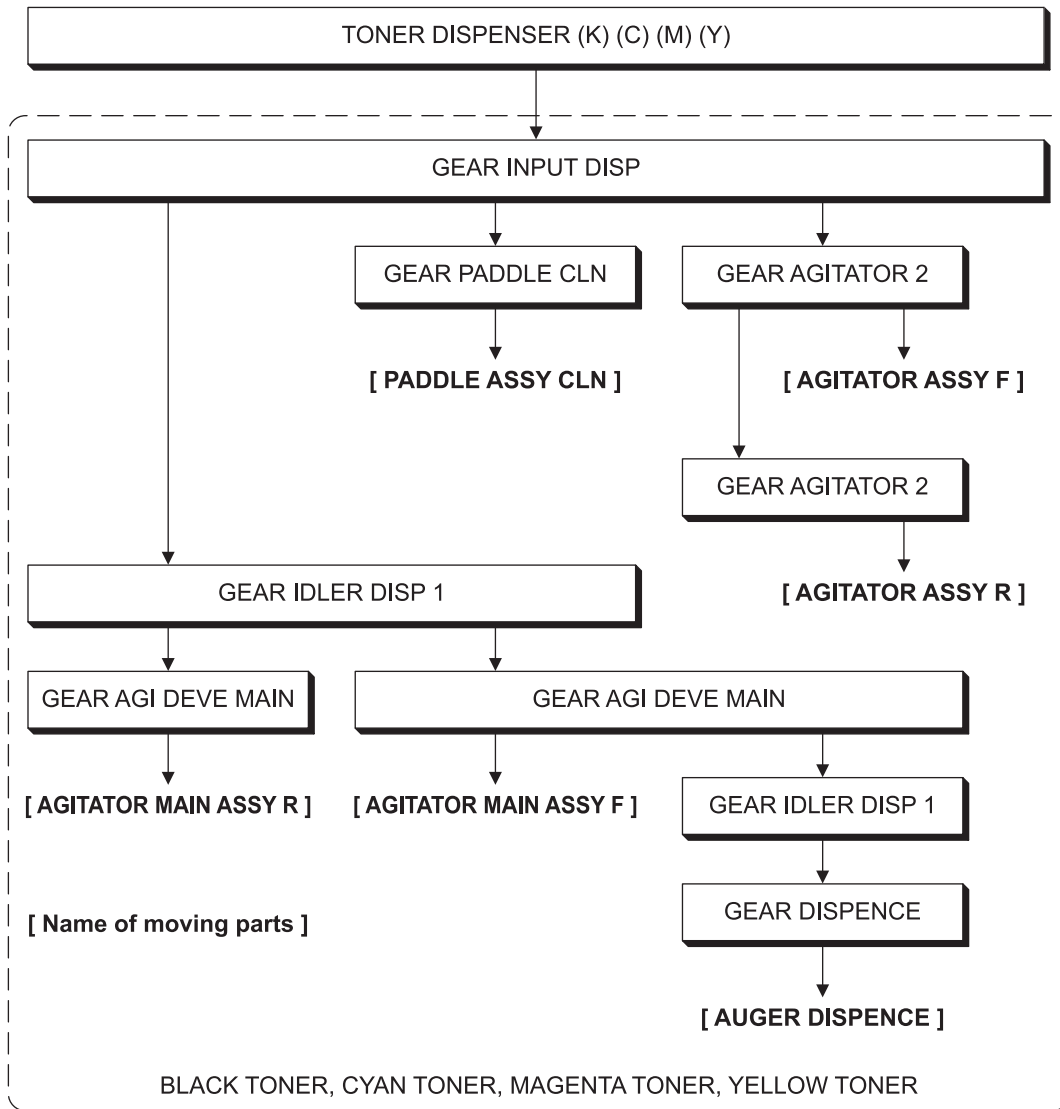

Kmy06021KA

[TONER CARTRIDGE]

GEAR AGITATOR 2  
[ AGITATOR ASSY R ]

GEAR AGITATOR 2  
[ AGITATOR ASSY F ]

TONER DISPENSER (K) (C) (M) (Y)

GEAR PADDLE CLN  
[ PADDLE ASSY CLN ]

[ Name of moving parts ]

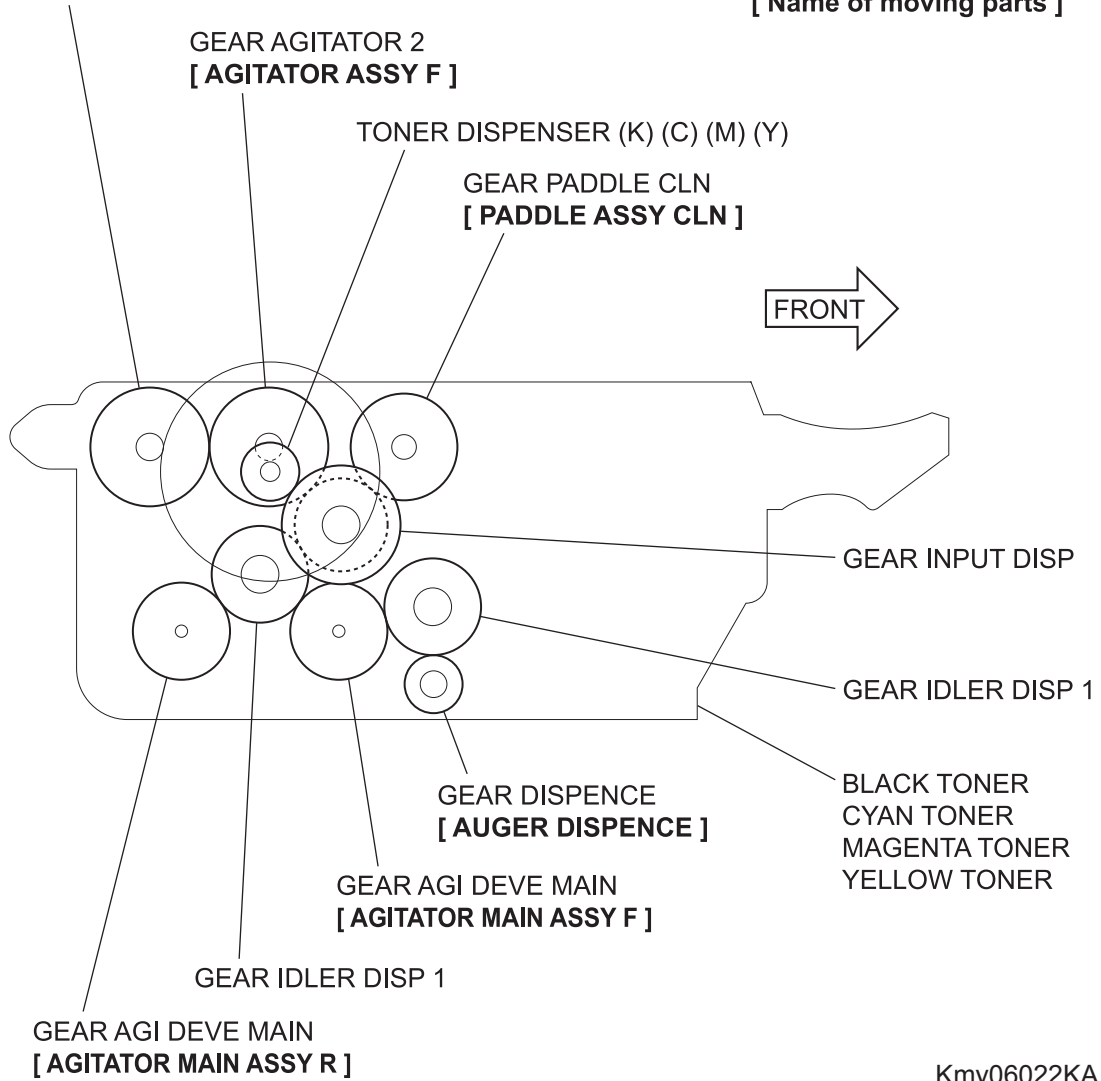

GEAR INPUT DISP

GEAR IDLER DISP 1

BLACK TONER  
CYAN TONER  
MAGENTA TONER  
YELLOW TONER

GEAR DISPENCE  
[ AUGER DISPENCE ]

GEAR AGI DEVE MAIN  
[ AGITATOR MAIN ASSY F ]

GEAR IDLER DISP 1

GEAR AGI DEVE MAIN  
[ AGITATOR MAIN ASSY R ]

Kmy06022KA

### 6.3 FEED DRIVE ASSEMBLY

Rotation power of the FEED DRIVE ASSEMBLY is transmitted through the route below.

[PAPER HANDLING]

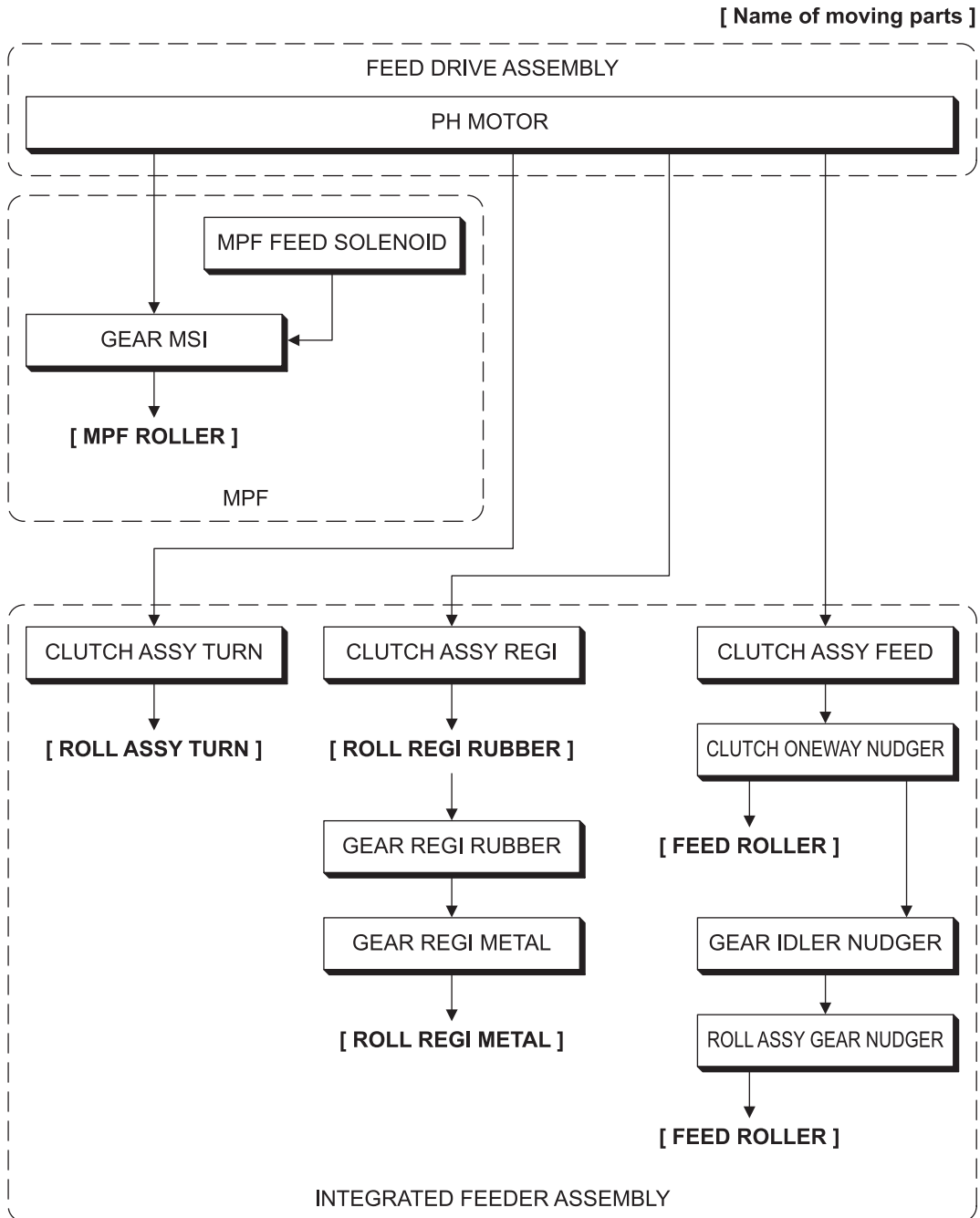

Kmy06019KA



[PAPER HANDLING]

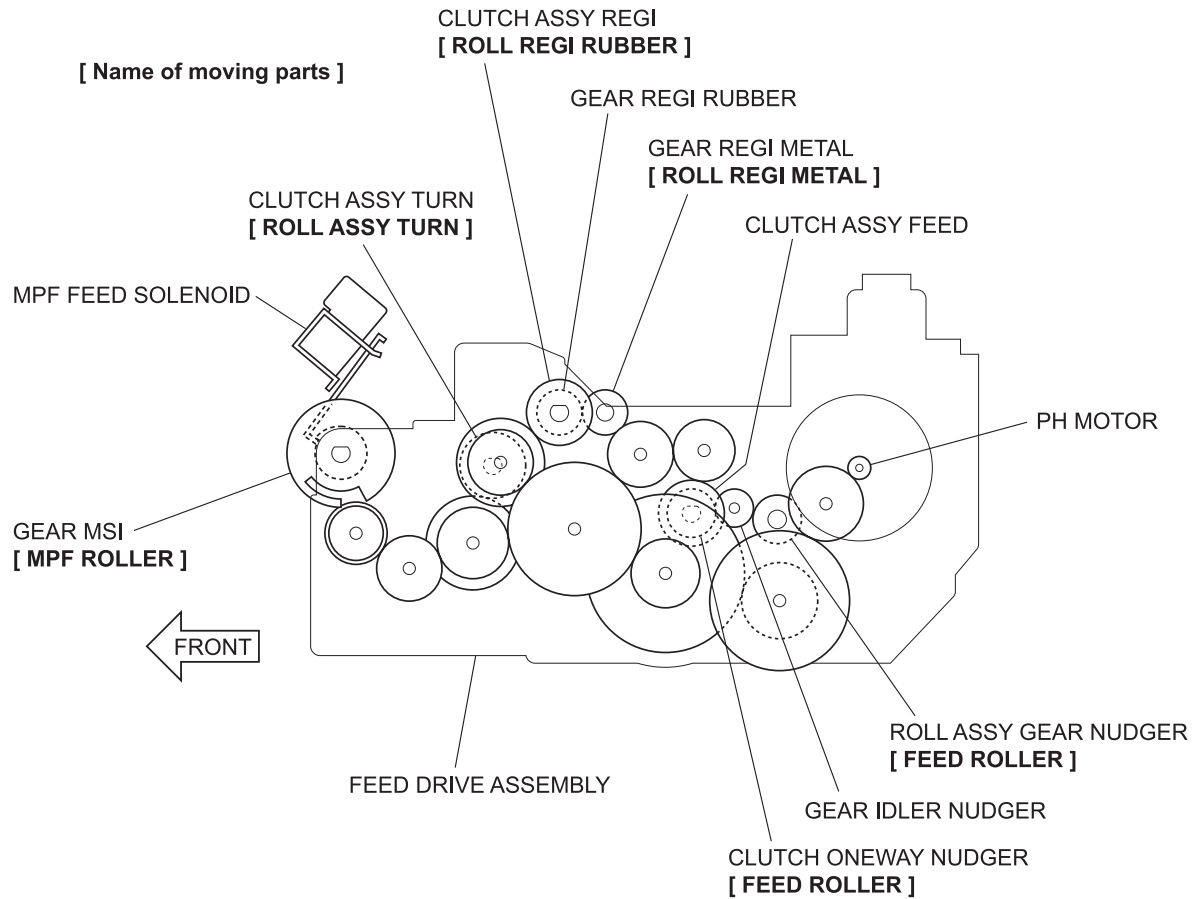

Kmy06020KA

### 6.4 DRIVE ASSY DUP

Rotation power of the DRIVE ASSY DUP is transmitted through the route below.

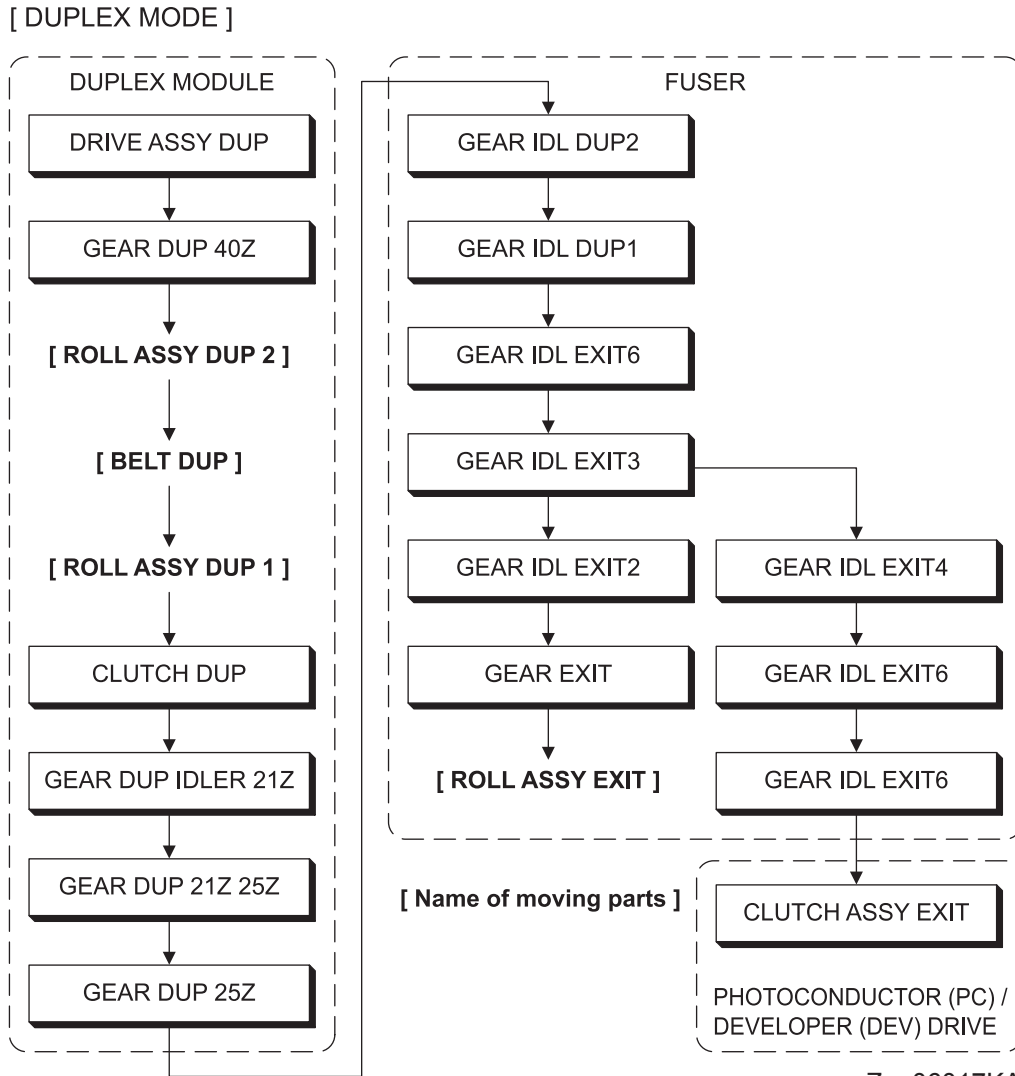

Zna06017KA

[ DUPLEX MODE ]

[ Name of moving parts ]

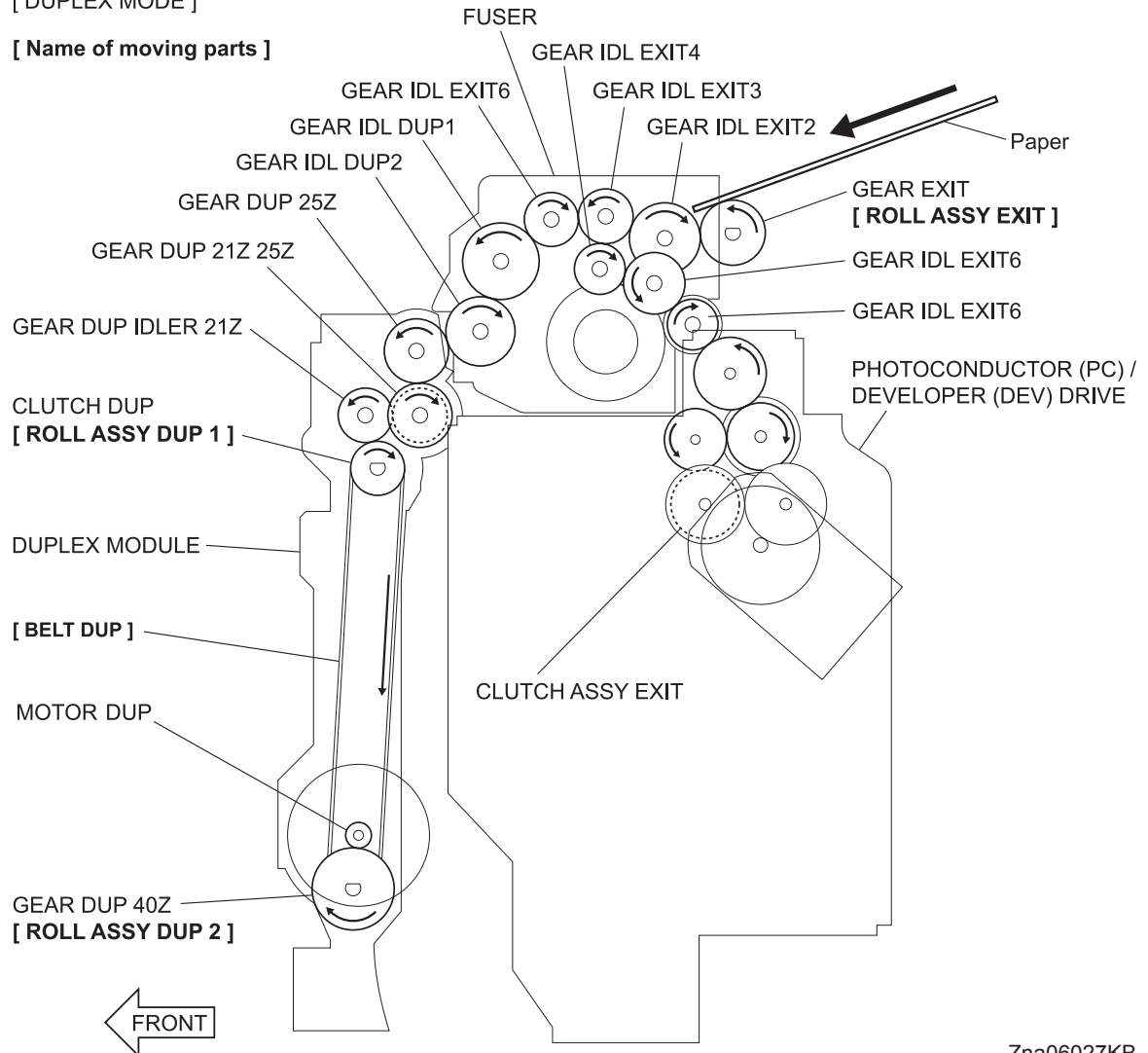

Zna06027KB

### 6.5 DRIVE ASSY OPT FDR

Rotation power of the DRIVE ASSY OPT FDR is transmitted through the route below.

[550 OPTION FEEDER]

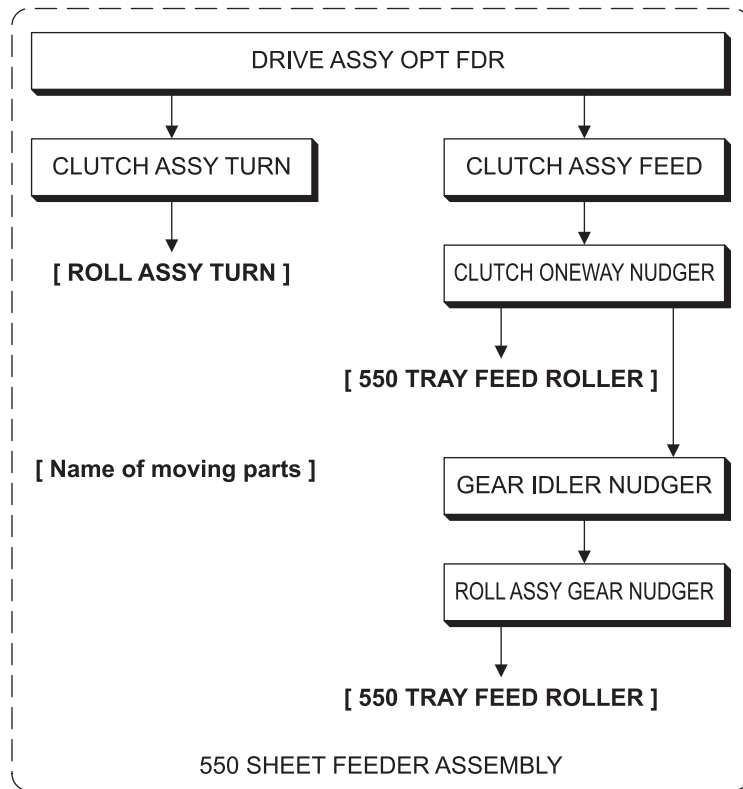

Kmy06023KA

[550 OPTION FEEDER]

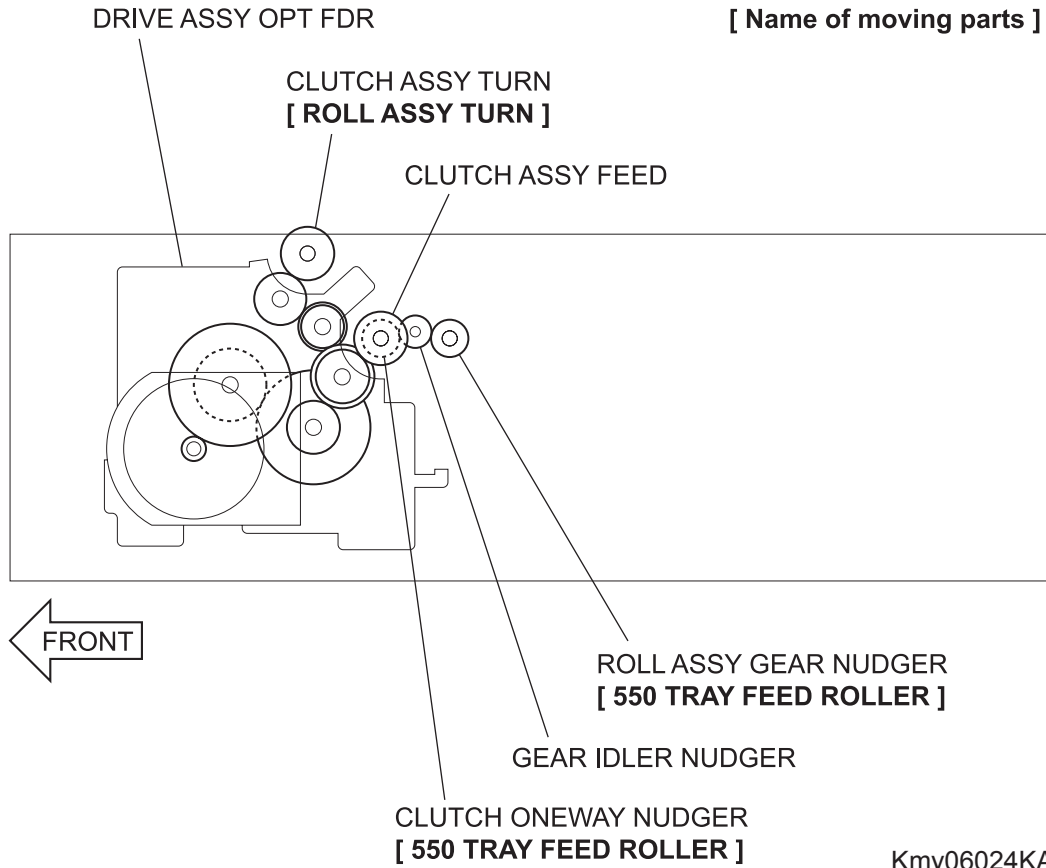

Kmy06024KA