







Chapter 7 Wiring Diagrams and Signal Information CONTENTS

| | |
|---|--------|
| 1. Connection Wiring Diagram..... | 7 - 1 |
| 1.1 Symbols in the General Connection Wiring Diagram..... | 7 - 1 |
| 1.2 General Wiring Diagram | 7 - 2 |
| 2. Interconnection Wiring Diagram of Parts..... | 7 - 3 |
| 2.1 Notes on Using the Wiring Diagram between Parts..... | 7 - 3 |
| 2.2 Configuration of the Interconnection Wiring Diagram of Parts..... | 7 - 5 |
| § 1 DC POWER SUPPLY | 7 - 7 |
| § 2 FEEDER, SSI & REGI | 7 - 9 |
| § 3 DRIVE | 7 - 11 |
| § 4 ROS | 7 - 13 |
| § 5 XEROGRAPHIC | 7 - 15 |
| § 6 HIGH VOLTAGE..... | 7 - 17 |
| § 7 DEVELOPER | 7 - 19 |
| § 8 FUSER..... | 7 - 21 |
| § 9 CONTROLLER | 7 - 23 |
| § 10 250 FEEDER | 7 - 25 |
| § 11 DUPLEX..... | 7 - 27 |

1. Connection Wiring Diagram

1.1 Symbols in the General Connection Wiring Diagram

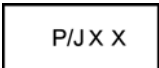
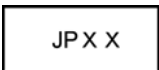
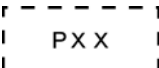
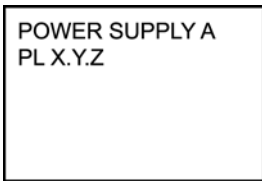
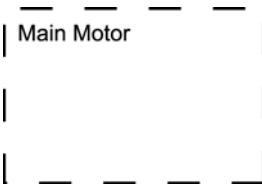
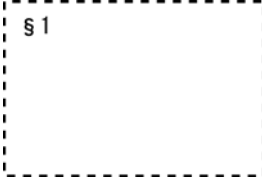
The symbols in the general connection wiring diagram are described below.

| Symbol | Description |
|---|---|
|  | Represents an interconnection between parts using wiring harness or wire. |
|  | Represents an interconnection which differs according to the specifications. |
|  | Represents an interconnection between parts using a conductive member such as a plate spring. |
|  | Represents a connection between parts by tightening of a screw. |
|  | Indicates a frame ground. |
|  | Represents a connector. The connector No. is indicated inside the box. |
|  | Represents a connection terminal with a plate spring on the printed circuit board. The connector (terminal) No. is indicated inside the box. |
|  | Represents a connector directly connected to the printed circuit board. The connector No. is indicated inside the box. |
|  | The box containing a part name represents a part. "PL X.Y.Z" indicates the item "Z" of the plate (PL) "X.Y" described in Chapter 5 "Parts List." |
|  | Represents a functional part within a part, and indicates the name of the functional part. |
|  | Represents a section in "2. Interconnection Wiring Diagram of Parts," and indicates its section No. |
|  | Represents a screw for fixing wiring harness and a conductive member such as a plate spring. |
|  | Represents a conductive member such as a plate spring. |

1.2 General Wiring Diagram

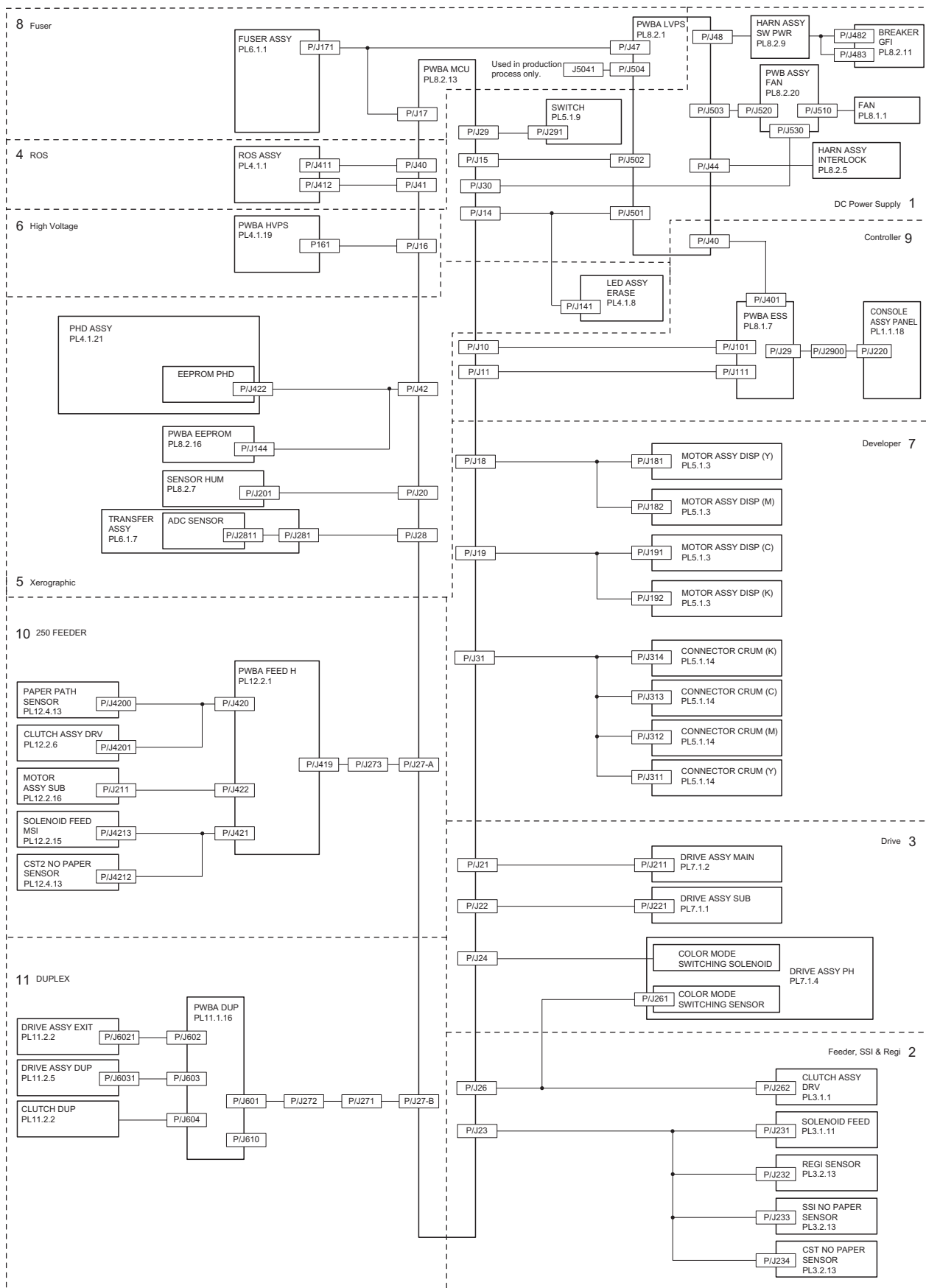



RIO07001KA

2. Interconnection Wiring Diagram of Parts

2.1 Notes on Using the Wiring Diagram between Parts

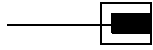
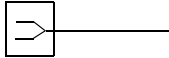
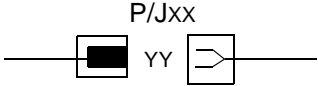
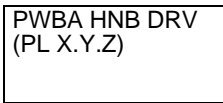
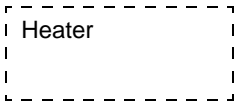
The following describes the legend of the wiring diagrams between parts shown on the following pages.

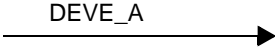
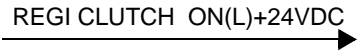
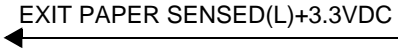
| Symbols | Description |
|---|--|
|  | Denotes a plug. |
|  | Denotes a jack. |
|  | Denotes Pin yy and Jack yy of the connector Pxx and Jxx. |
|  | Denotes the parts. PL X.Y.Z implies the item "Z" of plate (PL) "X.Y" in Chapter 5. Parts List. |
|  | Denotes functional parts attached with functional parts name. |
|  | Denotes the control and its outline in PWB. |
|  | Denotes a connection between parts with harnesses or wires, attached with signal name/contents. |
|  | Denotes the function, and logic value of the signal to operate the function (Low: L, High: H). The given voltage is for signal in high status. The arrow indicates the direction of signal. |
|  | Denotes the function, and logic value of the signal when the function operated (Low: L, High: H). The given voltage is for signal in high status. The arrow indicates the direction of signal. |

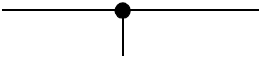
| Symbols | Description |
|---|--|
|  | Denotes a connection between wires. |
| I/L +24VDC | Denotes DC voltage when the interlock switch in HNB MCU WITH CPU turns on. |
| +5VDC +3.3VDC | Denotes DC voltage. |
| SG | Denotes signal ground. |
| AG | Denotes analog ground. |
| RTN | Denotes the return. |

2.2 Configuration of the Interconnection Wiring Diagram of Parts

The interconnection wiring diagram is divided into 11 sections.

§ 1 to § 11 indicate details of the interconnections of parts.

§ 1 DC POWER SUPPLY

Connections of PWBA LVPS with PWBA MCU.

Connections of HARN ASSY SW PWR with PWBA LVPS.

Connections of BREAKER GFI with HARN ASSY SW PWR.

Connections of FAN with PWBA HAN.

Connections of PWBA LVPS with PWBA HAN.

Connections of HARN ASSY INTERLOCK with PWBA LVPS.

Connections of SWITCH with PWBA MCU.

§ 2 FEEDER, SSI & REGI

Connections of SOLENOID FEED with PWBA MCU.

Connections of REGI SENSOR with PWBA MCU.

Connections of SSI NO PAPER SENSOR with PWBA MCU.

Connections of CST NO PAPER SENSOR with PWBA MCU.

Connections of CLUTCH ASSY DRV with PWBA MCU.

§ 3 DRIVE

Connections of DRIVE ASSY PH with PWBA MCU.

Connections of DRIVE ASSY MAIN with PWBA MCU.

Connections of DRIVE ASSY SUB with PWBA MCU.

§ 4 ROS

Connections of ROS ASSY with PWBA MCU.

§ 5 XEROGRAPHIC

Connections of PWBA EEPROM with PWBA MCU.

Connections of PHD ASSY with PWBA MCU.

Connections of SENSOR HUM with PWBA MCU.

Connections of LED ASSY ERASE with PWBA MCU.

Connections of TRANSFER ASSY with PWBA MCU.

§ 6 HIGH VOLTAGE

Connections of PWBA HVPS with PWBA MCU.

§ 7 DEVELOPER

Connections of DISPENSE MOTOR (Y) with PWBA MCU.
Connections of DISPENSE MOTOR (M) with PWBA MCU.
Connections of DISPENSE MOTOR (C) with PWBA MCU.
Connections of DISPENSE MOTOR (K) with PWBA MCU.
Connections of CONNECTOR CRUM (Y) with PWBA MCU.
Connections of CONNECTOR CRUM (M) with PWBA MCU.
Connections of CONNECTOR CRUM (C) with PWBA MCU.
Connections of CONNECTOR CRUM (K) with PWBA MCU.

§ 8 FUSER

Connections of FUSER ASSY with PWBA MCU.
Connections of FUSER ASSY with PWBA LVPS.
Connections of PWBA MCU with PWBA LVPS.

§ 9 CONTROLLER

Connections of PWBA ESS with PWBA MCU.
Connections of CONSOLE ASSY PANEL with PWBA ESS.
Connections of PWBA LVPS with PWBA ESS.

§ 10 250 FEEDER

Connections of PWBA FEEDER H with PWBA MCU.
Connections of PWBA FEEDER H with CLUTCH ASSY PH TURN.
Connections of PWBA FEEDER H with PATH SENSOR.
Connections of PWBA FEEDER H with SOLENOID FEED.
Connections of PWBA FEEDER H with CST NO PAPER SENSOR.
Connections of PWBA FEEDER H with DRIVE ASSY OPTION.

§ 11 DUPLEX

Connections of PWBA DUP with PWBA MCU.
Connections of PWBA DUP with MOTOR ASSY DUP-UP.
Connections of PWBA DUP with MOTOR ASSY DUP-DN.
Connections of PWBA DUP with CLUTCH DUP.

§ 1 DC POWER SUPPLY

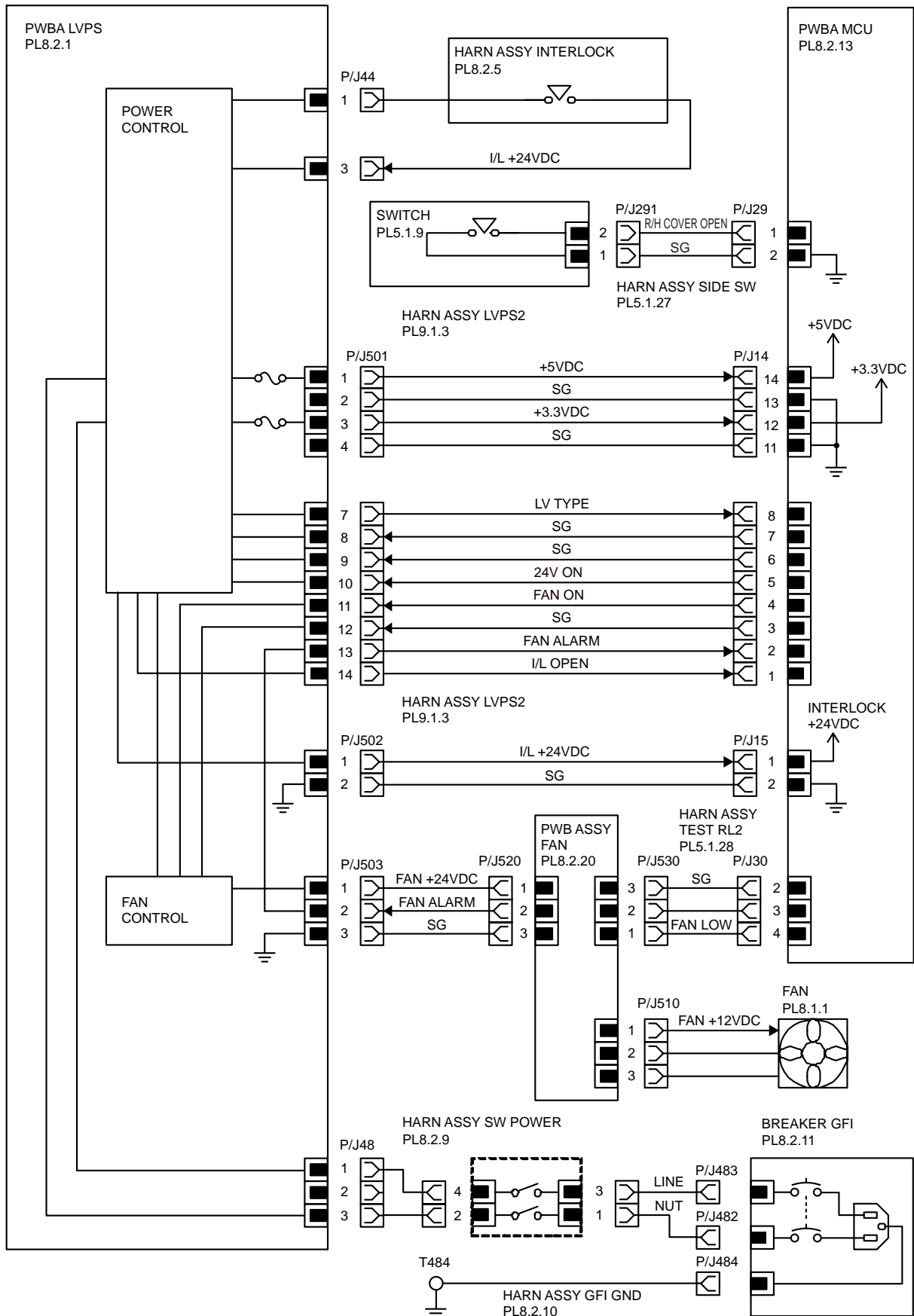

RIO07002KB

I

| Signal line name | Description |
|---------------------|--------------------------------------|
| LV TYPE 24V ON | Control signal of the LVPS |
| FAN ON FAN ALARM | Drive control signal of the SIDE FAN |

- LVPS overcurrent protection circuit

This circuit stops all outputs, if the power supply voltage 24VDC, 5VDC, or 3.3VDC is shorted.

- LVPS overvoltage protection circuit

This circuit stops all outputs, if the power supply voltage 24VDC, 5VDC, or 3.3VDC exceeds the specified voltage respectively.

At this time, the operating point is 36VDC or less for 24VDC, 7VDC or less for 5VDC and 3.3VDC.

§ 2 FEEDER, SSI & REGI

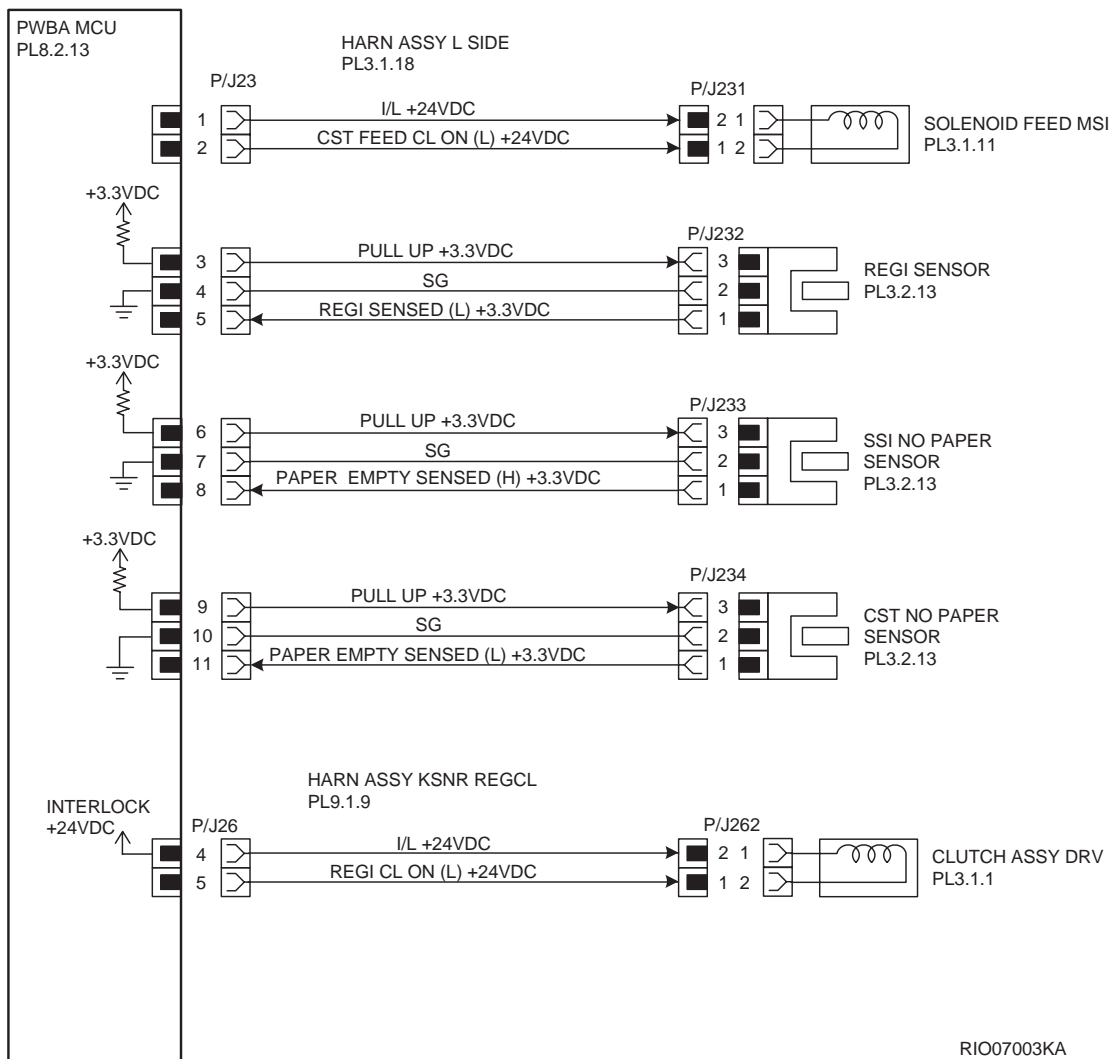

RIO07003KA

| Signal line name | Description |
|-----------------------------------|--|
| CST FEED CL ON (L) +24VDC | ON/OFF signal of the SOLENOID FEED |
| REGI SENSED (L) +3.3VDC | Paper detect signal of the Regi part by the Sensor Photo (REGI SENSOR) |
| PAPER EMPTY SENSED (H) +3.3VDC | Paper detect signal of the SSI by the Sensor Photo (SSI NO PAPER SENSOR) |
| PAPER EMPTY SENSED (L) +3.3VDC | Paper detect signal of the Paper Cassette by the Sensor Photo (CST NO PAPER SENSOR) |
| REGI CL ON (L) +24VDC | ON/OFF signal of the CLUTCH ASSY DRV |

§ 3 DRIVE

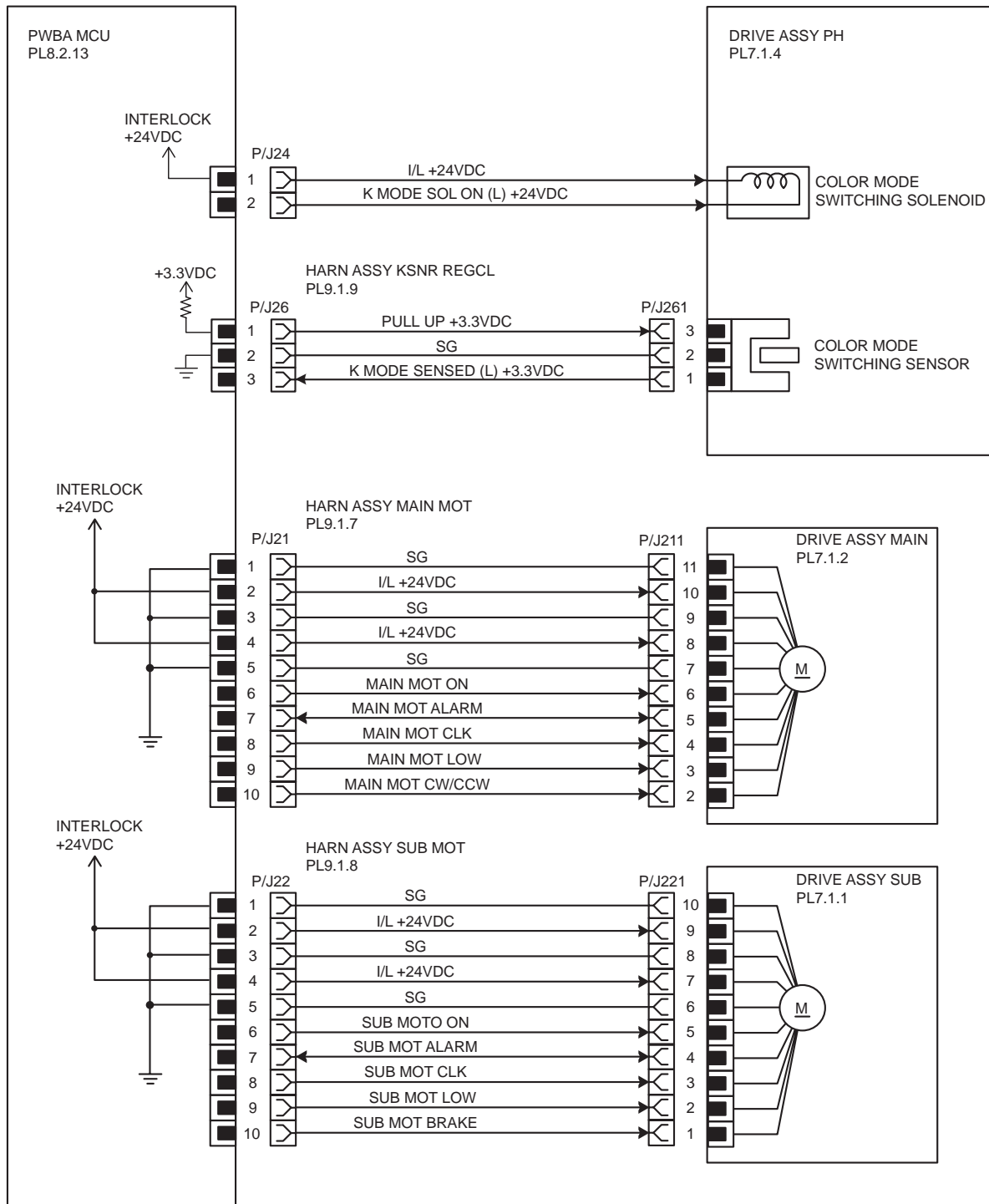

WSB07004KC

| Signal line name | Description |
|--|---|
| K MODE SOL ON (L) +24VDC | ON/OFF signal of the COLOR MODE SWITCHING SOLENOID |
| K MODE SENSED (L) +3.3VDC | Color mode detect signal of the DRIVE ASSY PH by the Sensor Photo (COLOR MODE SWITCHING SENSOR) |
| MAIN MOT ON MAIN MOT ALARM MAIN MOT CLK MAIN MOT LOW MAIN MOT CW/CCW | Drive control signal of the DRIVE ASSY MAIN |
| SUB MOT ON SUB MOT ALARM SUB MOT CLK SUB MOT LOW SUB MOT BRAKE | Drive control signal of the DRIVE ASSY SUB |

§ 4 ROS

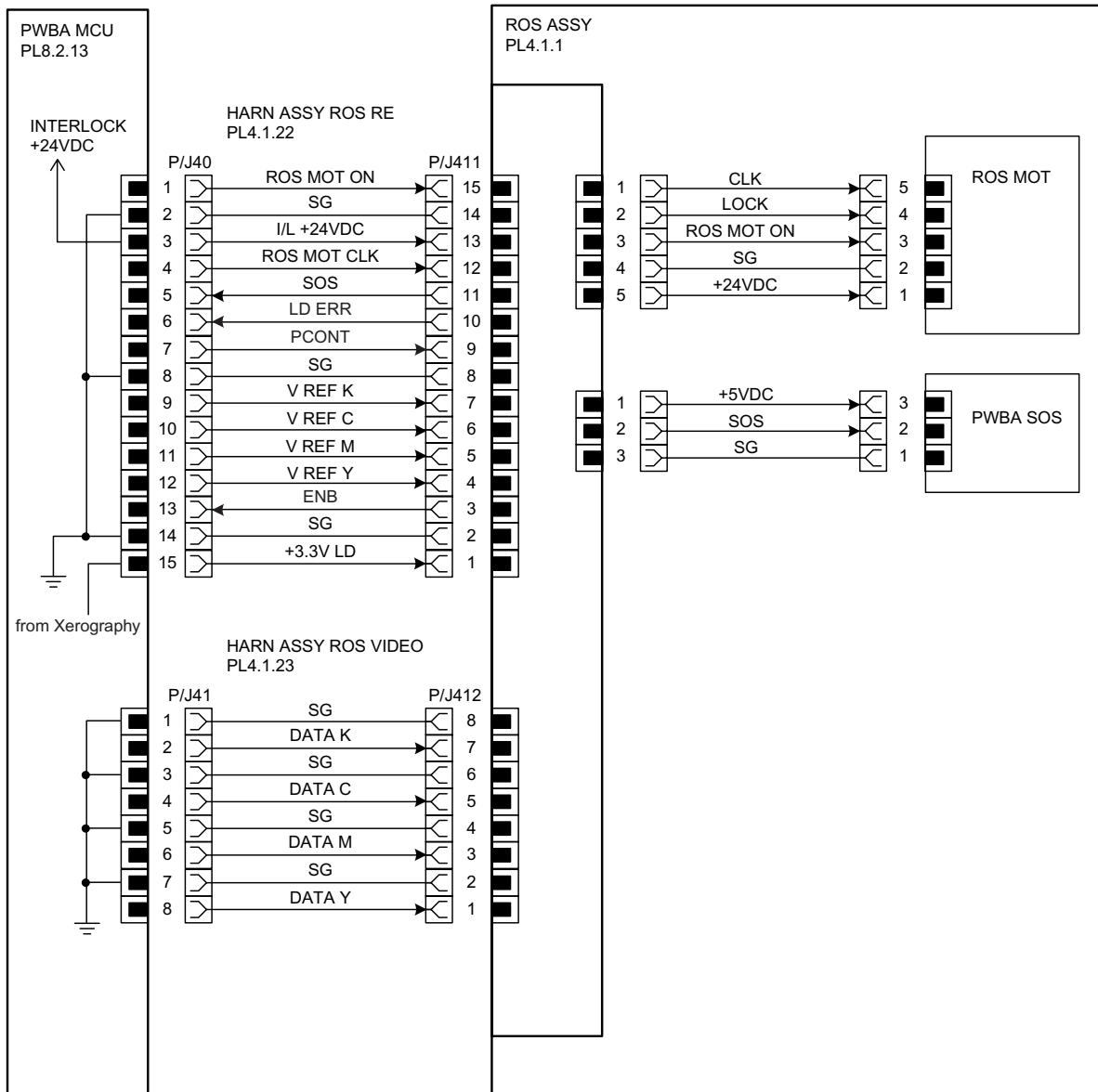

RIO07006KA

| Signal line name | Description |
|--|--|
| ROS MOT ON ROS MOT CLK | Drive control signal of the ROS MOTOR |
| SOS | Reference signal for scan start of LASER |
| V REF K V REF C V REF M V REF Y | Emission control signal of the laser diode |
| LD ERR | Error signal of the laser diode |
| PCONT | Power control signal of the laser diode |
| DATA K DATA C DATA M DATA Y | Video signal of the laser diode |

§ 5 XEROGRAPHIC

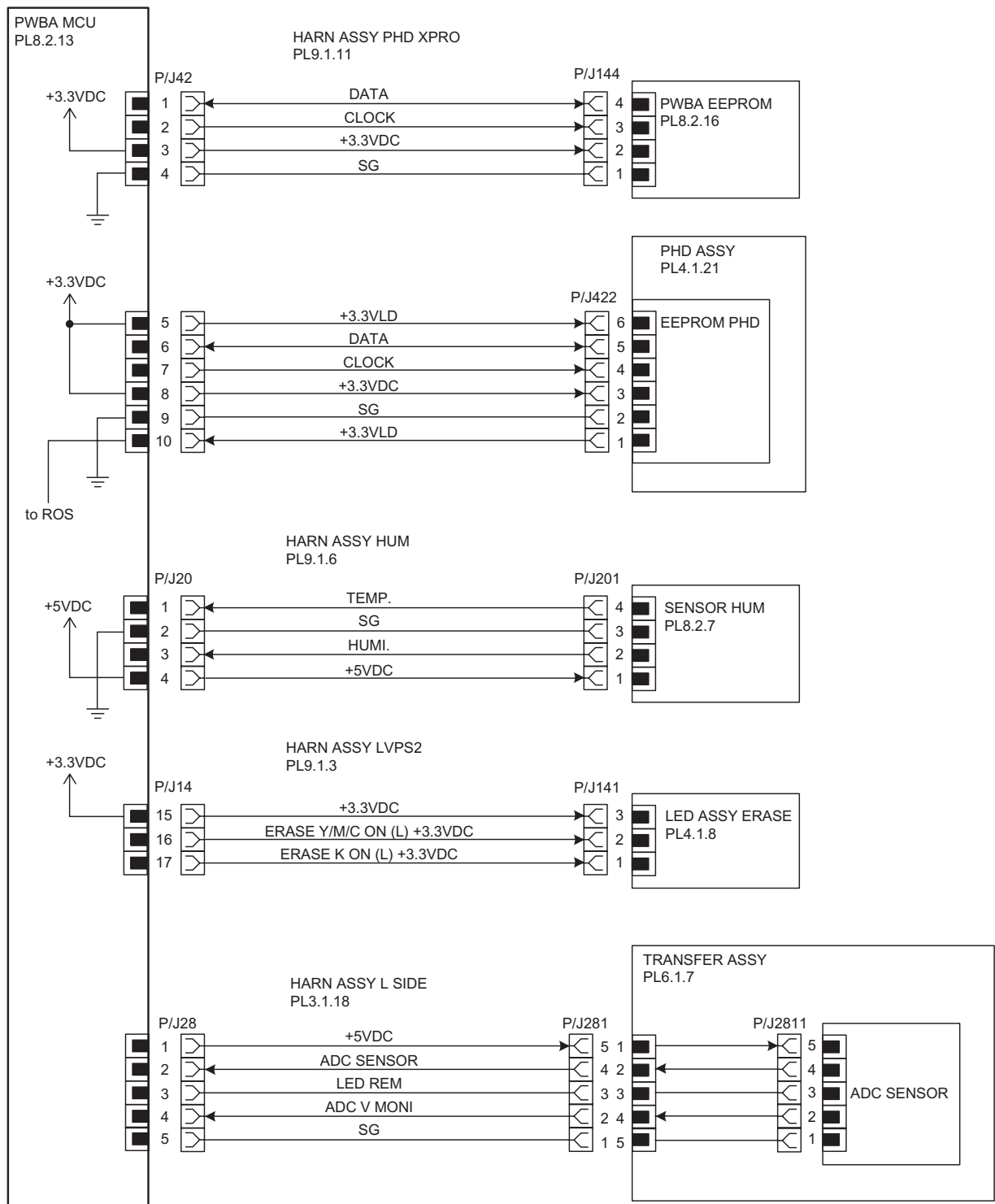

RIO07007KA

| Signal line name | Description |
|--|---|
| CLOCK DATA | Control signal of the PWBA EEPROM |
| CLOCK DATA | Control signal of the EEPROM PHD |
| TEMP. | Temperature data in the printer by the SENSOR HUM (Analog value) |
| HUMI. | Humidity data in the printer by the SENSOR HUM (Analog value) |
| ERASE K ON (L) +3.3VDC ERASE Y/M/C ON (L) +3.3VDC | ON/OFF signal of the LED ASSY ERASE |
| ADC SENSOR | Toner patch density data measured by the ADC SENSOR (Analog value) |
| LED REM | Remote signal of the LED of ADC SENSOR |
| ADC V MONI | Control signal of the ADC SENSOR |

§ 6 HIGH VOLTAGE

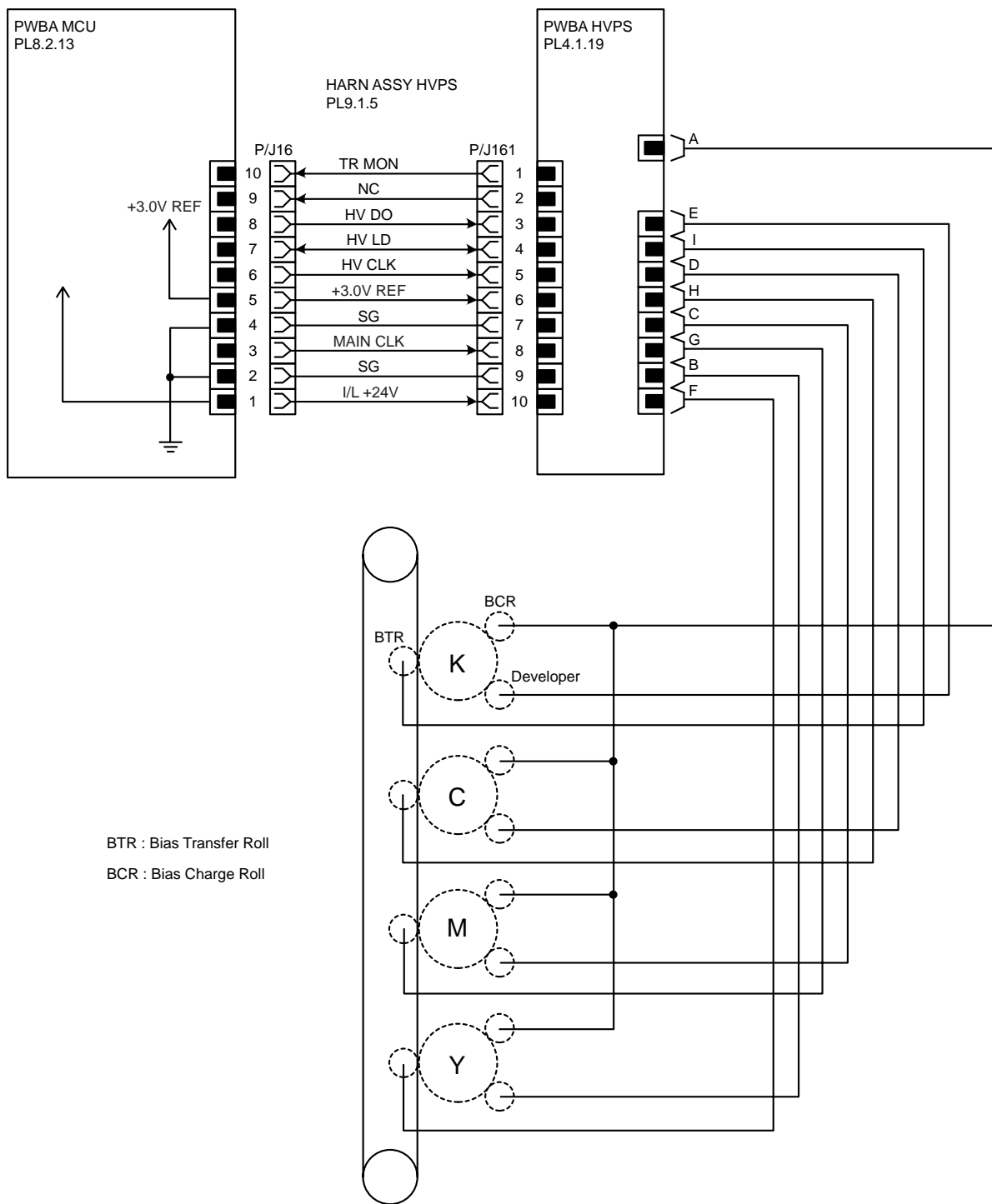

RIO07008KA

| Signal line name | Description |
|--|----------------------------|
| TR MON HV DO HV LD HV CLK MAIN CLK | Control signal of the HVPS |

§ 7 DEVELOPER

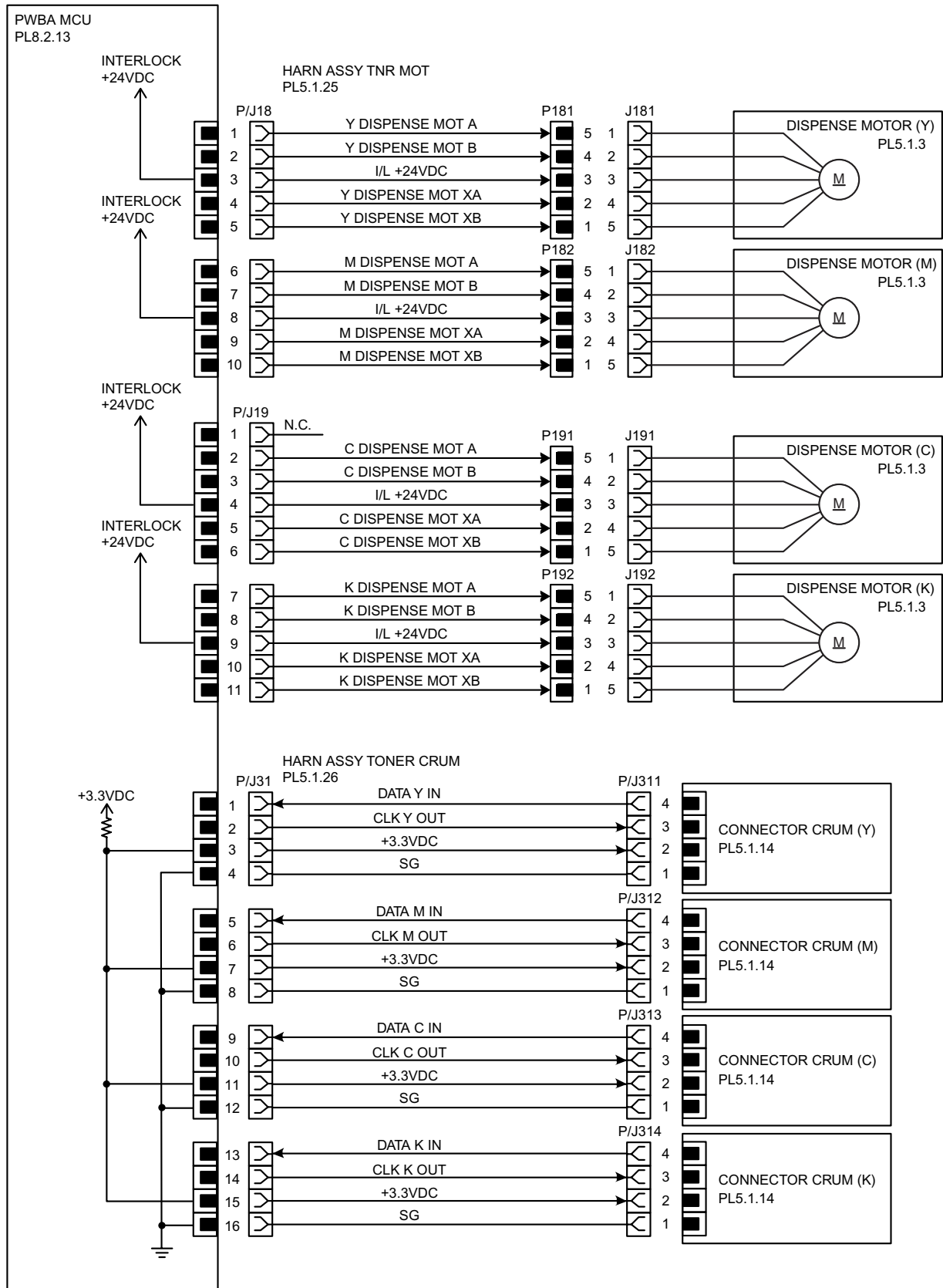

RIO07009KA

| Signal line name | Description |
|--|--|
| Y DISPENSE MOT A Y DISPENSE MOT B Y DISPENSE MOT XA Y DISPENSE MOT XB | Drive control signal of the DISPENSE MOTOR (Y) |
| M DISPENSE MOT A M DISPENSE MOT B M DISPENSE MOT XA M DISPENSE MOT XB | Drive control signal of the DISPENSE MOTOR (M) |
| C DISPENSE MOT A C DISPENSE MOT B C DISPENSE MOT XA C DISPENSE MOT XB | Drive control signal of the DISPENSE MOTOR (C) |
| K DISPENSE MOT A K DISPENSE MOT B K DISPENSE MOT XA K DISPENSE MOT XB | Drive control signal of the DISPENSE MOTOR (K) |
| DATA Y IN CLK Y OUT | Control signal of the CONNECTOR CRUM (Y) |
| DATA M IN CLK M OUT | Control signal of the CONNECTOR CRUM (M) |
| DATA C IN CLK C OUT | Control signal of the CONNECTOR CRUM (C) |
| DATA K IN CLK K OUT | Control signal of the CONNECTOR CRUM (K) |

§ 8 FUSER

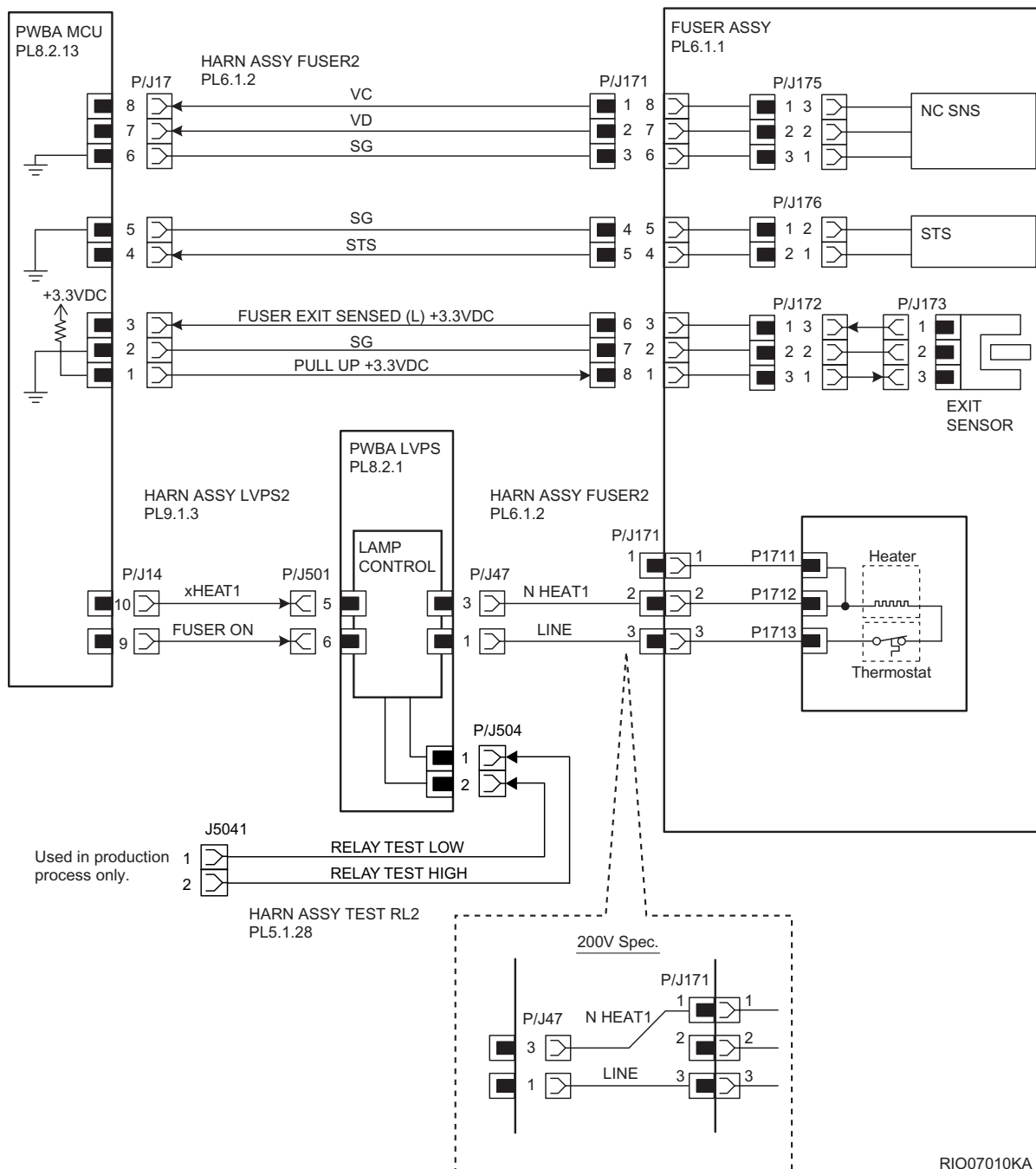

RIO07010KA

| Signal line name | Description |
|-----------------------------------|---|
| VC VD | Temperature data measured by Temp. Sensor for controlling temperature (analog value) |
| STS | Heat Roll surface temperature data measured by Temp. Sensor for detecting high temperature (analog value) |
| FUSER EXIT SENSED (L) +3.3VDC | Paper detect signal of the Fuser Exit by the Sensor Photo (EXIT SENSOR) |
| FUSER ON | Lighting signal of Fuser Lamp |
| RELAY TEST LOW RELAY TEST HIGH | Test signal of the LVPS (Used in production process only) |

§ 9 CONTROLLER

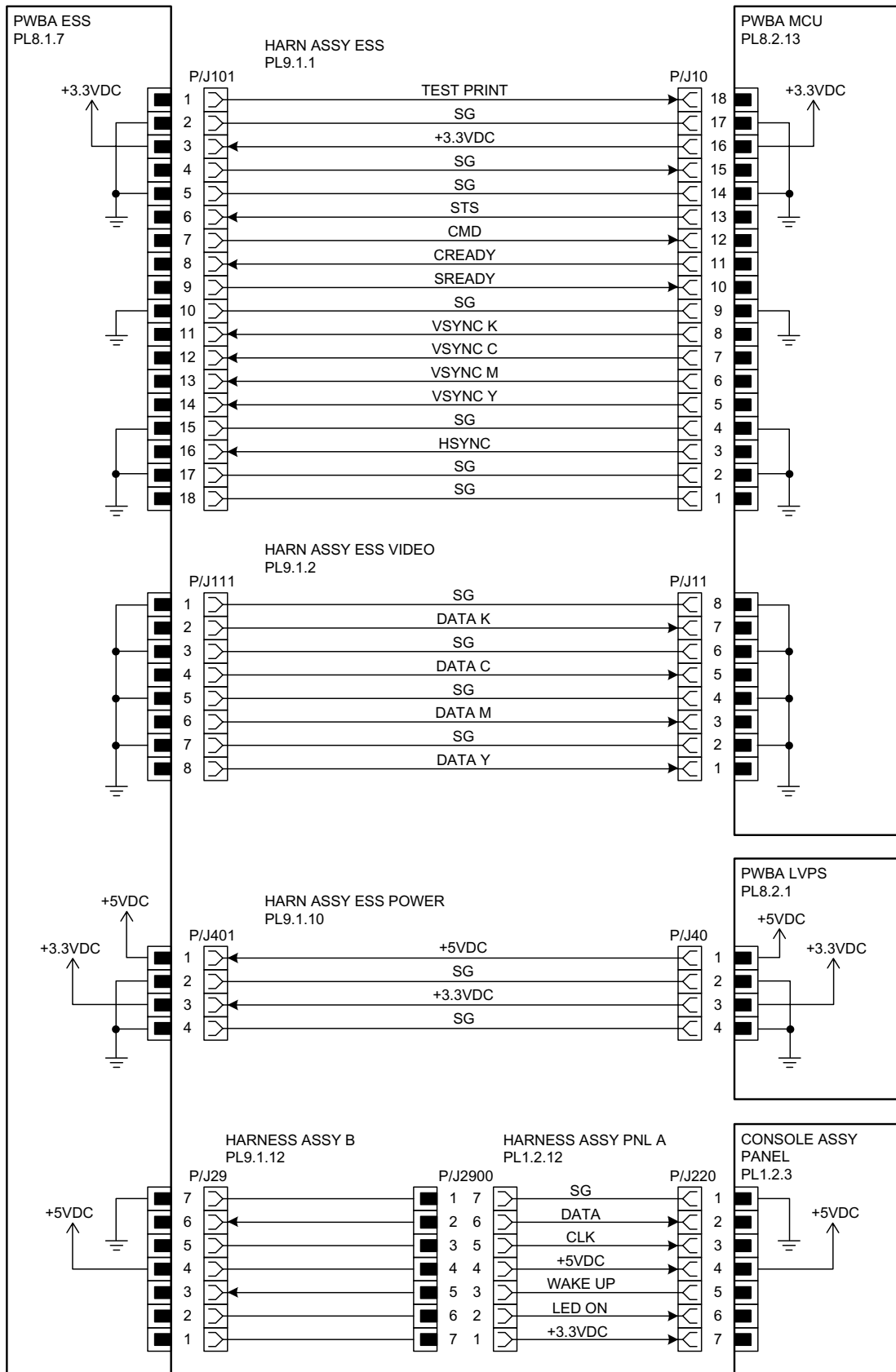

RIO07011KA

| Signal line name | Description |
|--|--|
| TEST PRINT | Control signal for the TEST PRINT mode |
| STS | Status signal transmitted from the PWBA MCU to the PWBA ESS |
| CMD | Command signal transmitted from the PWBA ESS to the PWBA MCU |
| CREADY SREADY | Signal for indicating whether or not the printer is ready for receiving command signal |
| VSYNC K VSYNC C VSYNC M VSYNC Y | Signal for indicating registration position of each of images Y, M, C and K |
| HSYNC | Signal for data |
| DATA K DATA C DATA M DATA Y | Video data of four colors |
| DATA CLK WAKE UP LED ON | Control signal of the CONSOLE ASSY |

§ 10 250 FEEDER

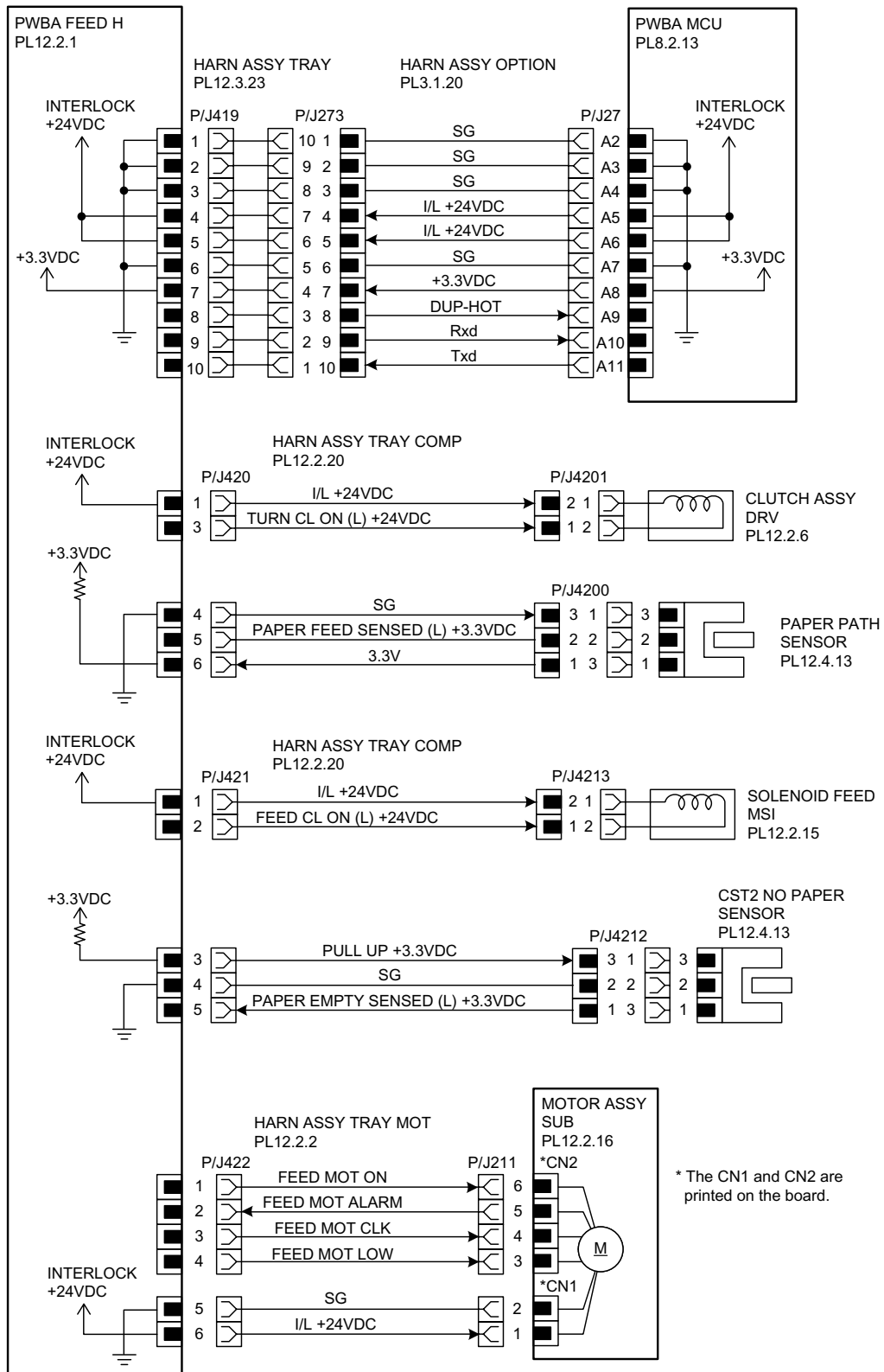

RIO07012KA

| Signal line name | Description |
|---|--|
| DUP-HOT Rxd Txd | Control signal of the PWBA FEEDER |
| TURN CL ON (L) +24VDC | ON/OFF signal of the TURN CLUTCH |
| FEED CL ON (L) +24VDC | ON/OFF signal of the FEED CLUTCH |
| PAPER EMPTY SENSED (L) +3.3VDC | Paper detect signal of the Feeder by the Sensor Photo (NO PAPER SENSOR) |
| FEED MOT ON FEED MOT ALARM FEED MOT CLK FEED MOT LOW | Drive control signal of the FEED MOTOR |

§ 11 DUPLEX

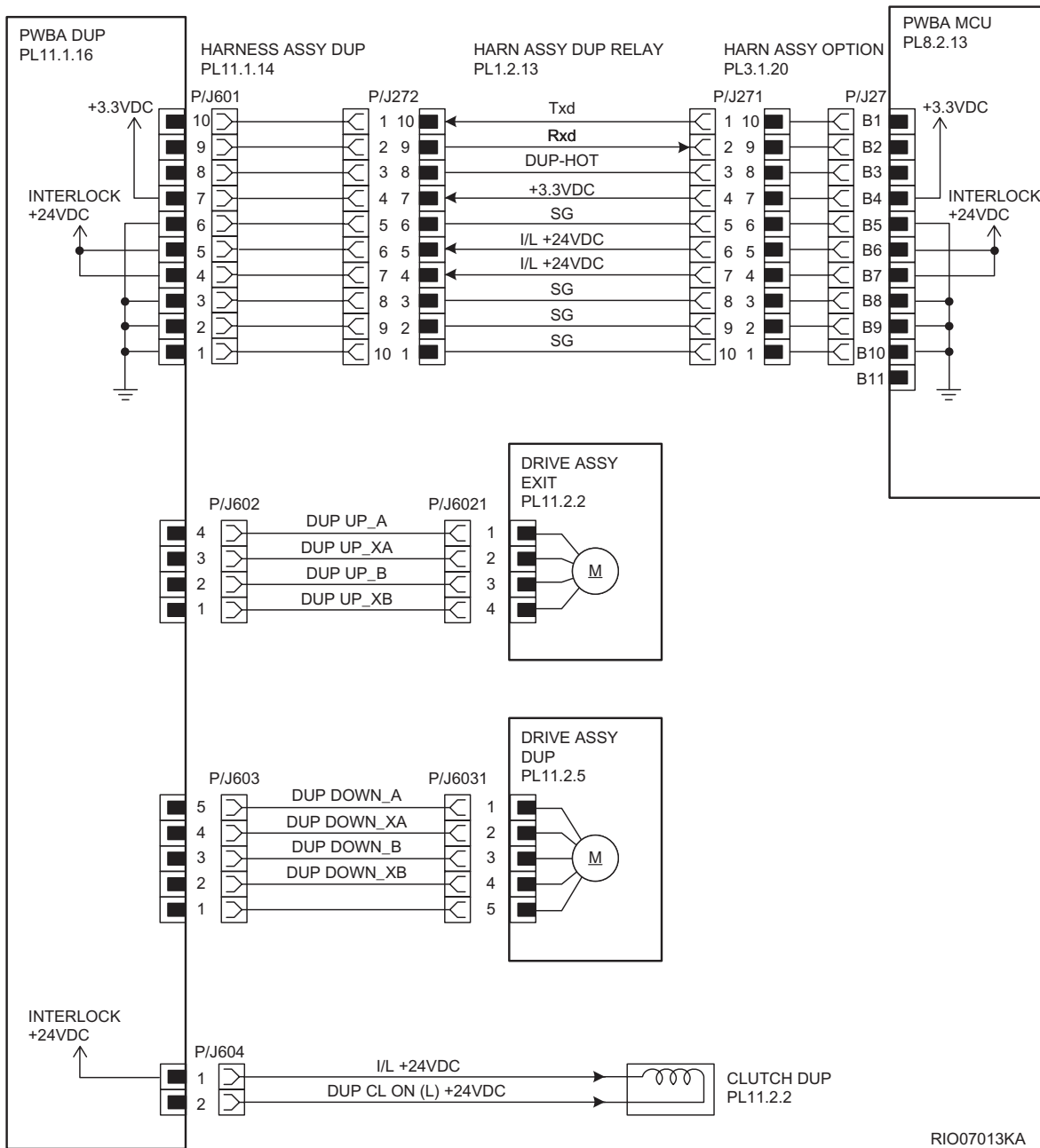

RIO07013KA

| Signal line name | Description |
|--|--|
| Txd Rxd | Control signal of the PWBA DUP |
| DUP UP_A DUP UP_XA DUP UP_B DUP UP_XB | Drive control signal of the DUP MOTOR UP |
| DUP DOWN_A DUP DOWN_XA DUP DOWN_B DUP DOWN_XB | Drive control signal of the DUP MOTOR DOWN |
| DUP CL ON (L) +24VDC | ON/OFF signal of the DUP CLUTCH |
| FAN +24VDC FAN ALARM | Drive control signal of the DUP FAN |