

Chapter 1 Troubleshooting CONTENTS

1. Troubleshooting Overview	1 - 1
1.1 Flow of Troubleshooting.....	1 - 1
1.2 Check Installation Status	1 - 2
1.3 Cautions on Service Operations	1 - 3
1.4 Cautions on Using FIP	1 - 4
1.5 Items to Be Confirmed Before Going to FIP Troubleshooting.....	1 - 5
2. FIP	1 - 10
2.1 FIP	1 - 10
2.2 Flow of FIP	1 - 10
2.3 Status Code List.....	1 - 11
3. ERROR CODE FIP.....	1 - 32
3.1 Troubleshooting for the call center.....	1 - 32
Flows 1 001-360 Restart Printer	1 - 32
Flows 2 003-340 Restart Printer	1 - 33
Flows 3 003-356 Restart Printer	1 - 34
Flows 4 004-310 Restart Printer	1 - 35
Flows 5 004-311 Restart Printer	1 - 36
Flows 6 006-370 Restart Printer	1 - 37
Flows 7 007-340 Restart Printer	1 - 38
Flows 8 007-341 Restart Printer	1 - 39
Flows 9 007-371/007-372 Restart Printer	1 - 40
Flows 10 009-340 Restart Printer (Yellow Toner).....	1 - 41
Flows 11 009-340 Restart Printer (Magenta Toner)	1 - 43
Flows 12 009-340 Restart Printer (Cyan Toner)	1 - 45
Flows 13 009-340 Restart Printer (Black Toner).....	1 - 47
Flows 14 010-317 Restart Printer	1 - 49
Flows 15 010-351 Restart Printer	1 - 50
Flows 16 010-354 Restart Printer	1 - 51
Flows 17 010-377 Restart Printer	1 - 52
Flows 18 Ready to Print 010-421.....	1 - 53
Flows 19 016-300/016-301/016-302/016-313/016-315/016-317/016-323/016-327/ 016-344/016-345/016-346/016-347 Restart Printer.....	1 - 54
Flows 19-1 016-340 Restart Printer	1 - 55
Flows 20 016-316/016-318 Restart Printer	1 - 57
Flows 21 016-338 Restart Printer	1 - 58
Flows 22 016-365 Restart Printer	1 - 59
Flows 23 016-370 Restart Printer	1 - 61
Flows 24 Invalid ID 016-383 / Range Chk Error 016-384 / Header Error 016-385 / Check Sum Error 016-386 / Protection Error 016-391 / Erase Flash Err. 016-392 / Write Flash Err. 016-393 / Verify Error 016-394	1 - 62
Flows 25 Out of Memory 016-700.....	1 - 63
Flows 26 PDL Request 016-720	1 - 64
Flows 27 Invalid User 016-757	1 - 65
Flows 28 Disabled Func 016-758	1 - 66
Flows 29 Reached Limit 016-759	1 - 67

Chapter 1 Troubleshooting CONTENTS

Flows 30 Invalid Job 016-799	1 - 68
Flows 31 Disk Full 016-980.....	1 - 69
Flows 32 Collate Full 016-981	1 - 70
Flows 33 MCU Flash Error 024-360	1 - 71
Flows 34 024-362 Restart Printer	1 - 72
Flows 35 Check Paper Size 024-910.....	1 - 73
Flows 36 Check Paper Size 024-911.....	1 - 74
Flows 37 Check Paper Size 024-914.....	1 - 75
Flows 38 Load Tray 1 024-965	1 - 76
Flows 39 Load Tray 2 024-966	1 - 77
Flows 40 Load SSF 024-969 / Pause Feed SSF 024-985 / Check SSF 075-923	1 - 78
Flows 41 Over Heat 042-700	1 - 79
Flows 42 Paper Jam 071-100	1 - 80
Flows 43 Paper Jam 072-100 / Paper Jam 072-908	1 - 82
Flows 44 Paper Jam 072-101	1 - 84
Flows 45 Paper Jam 075-101	1 - 86
Flows 46 Paper Jam 075-102	1 - 87
Flows 47 Check SSF 075-922	1 - 88
Flows 48 Paper Jam 077-100/077-101.....	1 - 89
Flows 49 Paper Jam 077-102	1 - 90
Flows 50 Paper Jam 077-103/077-104/077-105.....	1 - 91
Flows 51 Paper Jam 077-107	1 - 93
Flows 52 Paper Jam 077-108	1 - 95
Flows 53 Close FrontCover 077-300	1 - 97
Flows 54 Close Side Cover 077-301	1 - 98
Flows 55 Paper Jam 077-900	1 - 99
Flows 56 Paper Jam 077-901	1 - 100
Flows 57 Paper Jam 077-907	1 - 102
Flows 58 Ready to Print 091-402 / Replace PHD 091-935.....	1 - 104
Flows 59 PHD 091-912.....	1 - 105
Flows 60 Insert PHD 091-972.....	1 - 106
Flows 61 CTD Sensor Dirty 092-310 / Ready to Print 092-410	1 - 107
Flows 62 Ready to Print 093-423 / Replace Cart. 093-930	1 - 108
Flows 63 Ready to Print 093-424 / Replace Cart. 093-931	1 - 109
Flows 64 Ready to Print 093-425 / Replace Cart. 093-932	1 - 110
Flows 65 Ready to Print 093-426 / Replace Cart. 093-933	1 - 111
Flows 66 Shake Cartridge 093-919	1 - 112
Flows 67 Shake Cartridge 093-920	1 - 114
Flows 68 Shake Cartridge 093-921	1 - 116
Flows 69 Shake Cartridge 093-922	1 - 118
Flows 70 Replace Cart. 093-934	1 - 120
Flows 71 Replace Cart. 093-935	1 - 121
Flows 72 Replace Cart. 093-936	1 - 122
Flows 73 Replace Cart. 093-937	1 - 123
Flows 74 CRUM ID 093-960	1 - 124
Flows 75 CRUM ID 093-961	1 - 125

Chapter 1 Troubleshooting CONTENTS

Flows 76 CRUM ID 093-962	1 - 126
Flows 77 CRUM ID 093-963	1 - 127
Flows 78 CRUM ID 093-965	1 - 128
Flows 79 Insert PrintCart 093-970	1 - 129
Flows 80 Insert PrintCart 093-971	1 - 130
Flows 81 Insert PrintCart 093-972	1 - 131
Flows 82 Insert PrintCart 093-973	1 - 132
Flows 83 Ready to Print 094-422 / 094-911 Contact Support	1 - 133
Flows 84 Ready to Print 193-700.....	1 - 134
Flows 85 Faint print (Low contrast).....	1 - 135
Flows 86 Blank print (No print).....	1 - 137
Flows 87 Solid black	1 - 138
Flows 88 Vertical blank line (White stripes in paper transport direction)	1 - 139
Flows 89 Horizontal band cross out (White stripe in horizontal direction.....	1 - 140
Flows 90 Vertical stripes	1 - 142
Flows 91 Horizontal stripes.....	1 - 144
Flows 92 Partial Deletion	1 - 146
Flows 93 Spots	1 - 148
Flows 94 Afterimage (Ghost)	1 - 150
Flows 95 Grey Background.....	1 - 151
Flows 96 Skew	1 - 152
Flows 97 Paper damage	1 - 153
Flows 98 Unfusing	1 - 155
Flows 99 Color registration (Color shift).....	1 - 156
Flows 100 Noise :When power is turned on.	1 - 159
Flows 101 Noise During standby	1 - 160
Flows 102 Noise During printing	1 - 161
Flows 103 Electrical Noise.....	1 - 162
Flows 104 AC.....	1 - 163
Flows 105 DC	1 - 164
Flows 106 Multiple Feed	1 - 165
Flows 107 Control Panel Freezes.....	1 - 166
3.2 Troubleshooting for the repair center.....	1 - 168
FIP-1. 1 001-360 Restart Printer.....	1 - 168
FIP-1. 2 003-340 Restart Printer.....	1 - 170
FIP-1. 3 003-356 Restart Printer.....	1 - 171
FIP-1. 4 004-310 Restart Printer.....	1 - 173
FIP-1. 5 004-311 Restart Printer.....	1 - 174
FIP-1. 6 006-370 Restart Printer.....	1 - 175
FIP-1. 7 007-340 Restart Printer.....	1 - 176
FIP-1. 8 007-341 Restart Printer.....	1 - 177
FIP-1. 9 007-371/007-372 Restart Printer.....	1 - 178
FIP-1. 10 009-340 Restart Printer (Yellow Toner)	1 - 180
FIP-1. 11 009-340 Restart Printer (Magenta Toner).....	1 - 183
FIP-1. 12 009-340 Restart Printer (Cyan Toner).....	1 - 186
FIP-1. 13 009-340 Restart Printer (Black Toner)	1 - 189

Chapter 1 Troubleshooting CONTENTS

FIP-1. 14 010-317 Restart Printer	1 - 192
FIP-1. 15 010-351 Restart Printer	1 - 194
FIP-1. 16 010-354 Restart Printer	1 - 195
FIP-1. 17 010-377 Restart Printer	1 - 196
FIP-1. 18 Ready to Print 010-421	1 - 198
FIP-1. 19 016-300/016-301/016-302/016-313/016-315/016-317/016-323/016-327/016-340/016-344/ 016-345/016-346/016-347 Restart Printer	1 - 199
FIP-1. 20 016-316/016-318 Restart Printer	1 - 200
FIP-1. 21 016-338 Restart Printer	1 - 201
FIP-1. 22 016-365 Restart Printer	1 - 202
FIP-1. 23 016-370 Restart Printer	1 - 203
FIP-1. 24 Invalid ID 016-383 / Range Chk Error 016-384 / Header Error 016-385 / Check Sum Error 016-386 / Protection Error 016-391 / Erase Flash Err. 016-392 / Write Flash Err. 016-393 / Verify Error 016-394	1 - 205
FIP-1. 25 Out of Memory 016-700	1 - 206
FIP-1. 26 PDL Request 016-720	1 - 207
FIP-1. 27 Invalid User 016-757	1 - 208
FIP-1. 28 Disabled Func 016-758	1 - 209
FIP-1. 29 Reached Limit 016-759	1 - 210
FIP-1. 30 Invalid Job 016-799	1 - 211
FIP-1. 31 Disk Full 016-980	1 - 212
FIP-1. 32 Collate Full 016-981	1 - 213
FIP-1. 33 MCU Flash Error 024-360	1 - 214
FIP-1. 34 024-362 Restart Printer	1 - 215
FIP-1. 35 Check Paper Size 024-910	1 - 216
FIP-1. 36 Check Paper Size 024-911	1 - 217
FIP-1. 37 Check Paper Size 024-914	1 - 218
FIP-1. 38 Load Tray 1 024-965	1 - 219
FIP-1. 39 Load Tray 2 024-966	1 - 221
FIP-1. 40 Load SSF 024-969 / Pause Feed SSF 024-985 / Check SSF 075-923	1 - 223
FIP-1. 41 Over Heat 042-700	1 - 225
FIP-1. 42 Paper Jam 071-100	1 - 226
FIP-1. 43 Paper Jam 072-100 / Paper Jam 072-908	1 - 231
FIP-1. 44 Paper Jam 072-101	1 - 234
FIP-1. 45 Paper Jam 075-101	1 - 239
FIP-1. 46 Paper Jam 075-102	1 - 240
FIP-1. 47 Check SSF 075-922	1 - 242
FIP-1. 48 Paper Jam 077-100/077-101	1 - 246
FIP-1. 49 Paper Jam 077-102	1 - 248
FIP-1. 50 Paper Jam 077-103/077-104/077-105	1 - 252
FIP-1. 51 Paper Jam 077-107	1 - 253
FIP-1. 52 Paper Jam 077-108	1 - 255
FIP-1. 53 Close FrontCover 077-300	1 - 257
FIP-1. 54 Close Side Cover 077-301	1 - 259
FIP-1. 55 Paper Jam 077-900	1 - 260
FIP-1. 56 Paper Jam 077-901	1 - 262

Chapter 1 Troubleshooting CONTENTS

FIP-1. 57 Paper Jam 077-907.....	1 - 266
FIP-1. 58 Ready to Print 091-402 / Replace PHD 091-935.....	1 - 268
FIP-1. 59 PHD 091-912.....	1 - 269
FIP-1. 60 Insert PHD 091-972.....	1 - 270
FIP-1. 61 CTD Sensor Dirty 092-310 / Ready to Print 092-410.....	1 - 271
FIP-1. 62 Ready to Print 093-423 / Replace Cart. 093-930.....	1 - 272
FIP-1. 63 Ready to Print 093-424 / Replace Cart. 093-931.....	1 - 273
FIP-1. 64 Ready to Print 093-425 / Replace Cart. 093-932.....	1 - 274
FIP-1. 65 Ready to Print 093-426 / Replace Cart. 093-933.....	1 - 275
FIP-1. 66 Shake Cartridge 093-919.....	1 - 276
FIP-1. 67 Shake Cartridge 093-920.....	1 - 279
FIP-1. 68 Shake Cartridge 093-921.....	1 - 282
FIP-1. 69 Shake Cartridge 093-922.....	1 - 285
FIP-1. 70 Replace Cart. 093-934.....	1 - 288
FIP-1. 71 Replace Cart. 093-935.....	1 - 289
FIP-1. 72 Replace Cart. 093-936.....	1 - 290
FIP-1. 73 Replace Cart. 093-937.....	1 - 291
FIP-1. 74 CRUM ID 093-960.....	1 - 292
FIP-1. 75 CRUM ID 093-961.....	1 - 293
FIP-1. 76 CRUM ID 093-962.....	1 - 294
FIP-1. 77 CRUM ID 093-963.....	1 - 295
FIP-1. 78 CRUM ID 093-965.....	1 - 296
FIP-1. 79 Insert PrintCart 093-970.....	1 - 297
FIP-1. 80 Insert PrintCart 093-971.....	1 - 298
FIP-1. 81 Insert PrintCart 093-972.....	1 - 299
FIP-1. 82 Insert PrintCart 093-973.....	1 - 300
FIP-1. 83 Ready to Print 094-422 / 094-911 Contact Support.....	1 - 301
FIP-1. 84 Ready to Print 193-700.....	1 - 302
4. Image Quality Trouble.....	1 - 303
4.1 Entry Chart for Image Quality Troubleshooting.....	1 - 303
4.2 Diagnosis Test Chart.....	1 - 307
4.3 Items to Be Confirmed Before Image Quality Troubleshooting.....	1 - 312
4.4 Print Image Quality Specifications.....	1 - 314
4.5 Image Quality FIP.....	1 - 318
FIP-1.P1 Faint print (Low contrast).....	1 - 318
FIP-1.P2 Blank print (No print).....	1 - 322
FIP-1.P3 Solid black.....	1 - 326
FIP-1.P4 Vertical blank lines (White stripes in paper transport direction).....	1 - 328
FIP-1.P5 Horizontal band cross out (White stripes in horizontal direction).....	1 - 332
FIP-1.P6 Vertical stripes.....	1 - 336
FIP-1.P7 Horizontal stripes.....	1 - 339
FIP-1.P8 Partial Deletion.....	1 - 343
FIP-1.P9 Spots.....	1 - 346
FIP-1.P10 Afterimage (Ghost).....	1 - 350
FIP-1.P11 Grey Background.....	1 - 353

Chapter 1 Troubleshooting CONTENTS

FIP-1.P12 Skew	1 - 357
FIP-1.P13 Paper damage	1 - 360
FIP-1.P14 Unfusing.....	1 - 363
FIP-1.P15 Color registration (Color shift).....	1 - 364
5. Abnormal Noise Trouble.....	1 - 367
5.1 Entry Chart for Abnormal Noise Troubleshooting	1 - 367
5.2 Operation Mode Table	1 - 368
FIP-1.N1 When Power is Turned On	1 - 368
FIP-1.N2 During Standby.....	1 - 370
FIP-1.N3 During Printing.....	1 - 371
6. Other FIP.....	1 - 374
FIP-Electrical Noise	1 - 374
FIP-AC	1 - 375
FIP-DC	1 - 376
FIP-Multiple Feed.....	1 - 377
FIP-Control Panel Freezes	1 - 378

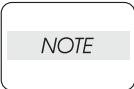

The troubleshooting procedures described herein assume the use of the Diag Tool. However, the procedures can be performed without the Diag Tool as long as they are carefully followed.

1. Troubleshooting Overview

To increase the efficiency of troubleshooting, ensure that preliminary checks should be made to confirm the trouble status before proceeding to the Fault Isolation Procedure (FIP), Operation of Diagnostic (Chapter 2), Wiring Diagrams (Chapter 7), and Principles of Operation (Chapter 6).

1.1 Flow of Troubleshooting

Flow of the troubleshooting is as follows:

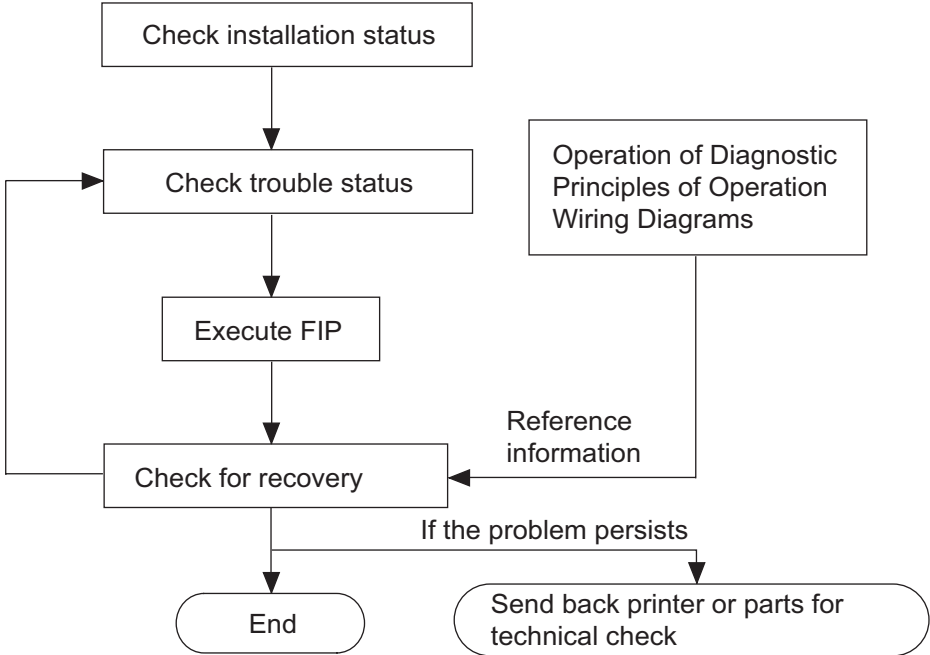

1.2 Check Installation Status

Be sure to check the following items before starting the troubleshooting procedures.

- 1) The power supply voltage is within the specifications (measure the voltage at the wall outlet).
- 2) The power cord is free from breakage, short-circuit, open wire, or internal miswiring.
- 3) The printer is properly grounded.
- 4) The printer is not installed at a place subjected to high/low temperature, humidity, and sudden temperature changes.
- 5) The printer is not installed at or near water facilities, humidifier, heating appliance, fire, dust, or in airflow from air conditioner.
- 6) The printer is not installed in a place subjected to volatile or inflammable gas.
- 7) The printer is not installed under direct sunlight.
- 8) The printer is installed in a well-ventilated place.
- 9) The laser printer is installed on a firm and stable surface.
- 10) The paper meets the specifications (standard paper is recommended).
- 11) The printer is handled properly.
- 12) The high frequency service items are replaced at the recommended print count intervals.

1.3 Cautions on Service Operations

- 1) Be sure to remove the power cord unless otherwise required.



**While the printer is powered ON, never touch the conductive parts unless otherwise required.
Never touch the conductive parts of the power switch and inlet of the LVPS, because they are live even while the printer is powered off.**

- 2) When checking some parts with covers removed and with the interlock, safety, and power switches ON, disconnect the connectors (P/J411 and P/J412) on the ROS ASSY except unless otherwise required.



When checking some parts with covers removed and with the interlock, safety, and power switches ON, laser beams may be irradiated from the ROS ASSY. For your safety, be sure to disconnect the connectors (P/J411 and P/J 412) unless otherwise required.

- 3) When checking some parts with the Front Cover removed and the printer powered ON, be sure to disconnect the connector (P/J16) on the PWBA MCU unless otherwise required.



**When checking some parts with the Front Cover removed and the printer powered ON, be sure to remove the connector (P/J15) on the MCU. Otherwise, a high voltage may be output from the HVPS.
When connecting the connector (P/J15) on the MCU according to the instructions in the FIP, never touch the HVPS and high voltage parts.**

- 4) When outputting a high voltage using the Diag Tool, etc., keep all the covers on unless otherwise required.



When outputting a high voltage using the Diag Tool, etc., ensure that:
- The high voltage carrying parts must never be touched.
- The instructions in this manual must be followed.

- 5) When operating the drive unit using the Diag Tool, etc., keep all the covers on unless otherwise required.



When operating the drive unit using the Diag Tool, etc., ensure that:
- The drive unit must never be touched.
- The instructions in this manual must be followed.

- 6) When touching hot parts, be careful not to get burnt.

- 7) While working, be sure to wear a wrist band or the like to dissipate static charges from your body.

1.4 Cautions on Using FIP

- 1) When troubleshooting according to the FIP, have on hand a normal MCU, LVPS, HVPS, FUSER ASSY, BELT ASSY, etc., for possible fault isolation.
- 2) In the initial check according to the FIP, check only items which can be simply checked.
- 3) In the initial check according to the FIP, check the constitutive parts of the major check parts and related parts, as well as major check parts.
- 4) When working with the printer, be sure to remove the power cord unless otherwise required. Never touch live parts if not required, while the power cord is connected.
- 5) Connector condition is denoted as follows:
 - [P/J12] → Connector (P/J12) is connected.
 - [P12] → Plug side with the connector (P/J12) removed (except when attached directly to the board).
 - [J12] → Jack side with the connector (P/J12) removed (except when attached directly to the board).
- 6) [P/J1-2PIN <=> P/J3-4PIN] in the FIP means measurement with the positive side of the measuring instrument connected to [2PIN] of [P/J1] and the negative side to [4PIN] of [P/J3].
- 7) [P/J1<=> P/J2] in the FIP means measurement for all terminals corresponding between [P/J1] and [P/J2] based on "Wiring Diagrams".
- 8) In [P/J1-2PIN <=> P/J3-4PIN] in the FIP where voltage is measured, [P/J3-4PIN] on the rear negative side is always at the AG (analog ground), SG (signal ground), or RTN (return).

Therefore, after checking of proper conductivity between AGs, SGs, or RTNs respectively, the rear negative side can be connected to the PIN of AG, SG or RTN instead of [P/J3-4PIN].

However, care should be taken not to confuse [AG], [SG], and [RTN] because they are not on the same level.
- 9) When measuring the voltage at small connectors, use the dedicated tool. Handle the tool with care because its business end is pointed.
- 10) When measuring the voltage, set the BELT ASSY, toner cartridge and paper cassette, close the COVERS and power ON unless otherwise required.
- 11) Numerical values in the FIP are only for guideline. Approximate values are acceptable.
- 12) In each step of the FIP, parts removal and other procedures implicitly required for the step are omitted.
- 13) In the FIP, "Replacement" means the replacement of the parts that are considered to be the cause of the trouble. Replacement of those parts means the replacement of the assembly part (HIGH ASSY) that contain them.
- 14) In the FIP, the paper cassette immediately below the printer main body is called "Tray 1", and the cassette below it is called "Tray 2".
- 15) Some of the instructions in the FIP are branched off depending on the specifications. Follow the applicable instruction.
- 16) For some optional components, you may have to refer to the manual of the relevant component for troubleshooting. Have the relevant manual at hand as needed.

1.5 Items to Be Confirmed Before Going to FIP Troubleshooting

Basic Printer Problems

Some printer problems can be easy to resolve. If a problem occurs with your printer, check each the following:

- 1) If a message is displayed on the LCD of operator panel, see “2.3 Status Code List”.
- 2) The printer power cable is plugged into the printer and a properly grounded electrical outlet.
- 3) The printer power is powered ON.
- 4) The electrical outlet is not turned off by any switch or breaker.
- 5) Other electrical equipment plugged into the outlet is working.
- 6) All options are properly installed.
- 7) If you have checked all of the above and still have a problem, turn off the printer, wait for 10 seconds, and then turn on the printer. This often solves the problem.

Display Problems

- 1) If the operator panel displays only diamonds or is blank, check and try the action below. If the problem persists even after checking and executing the items below, execute Flow 104, Flow 105, or “FIP-AC” and “FIP-DC” in “6. Other FIP”.
 - a) Turn off the printer, wait for 10 seconds, and turn on the printer.
 - b) Self Test Message appears on the operator panel. When the test is completed, “Ready to Print” is displayed.
- 2) If menu settings changed from the operator panel have no effect, check and try the actions below.

Settings in the software program, the printer driver, or the printer utilities are overriding the settings made on the operator panel.

 - a) Change the menu settings from the printer driver, the printer utilities, or the software program instead of the operator panel.
 - b) Disable the settings in the printer driver, the printer utilities, or the software program so you can change settings on the operator panel.

Printing Problems

- 1) If a job did not print correct or incorrect characters were printed, check and try the actions below.
 - a) Make sure “Ready to Print” appears on the operator panel before sending a job to print. Press **Menu** to return to “Ready to Print”.
 - b) Make sure print media is loaded in the printer. Press **Menu** to return to “Ready to Print”.
 - c) Verify that you are using the correct printer driver.
 - d) Make sure you are using the correct Ethernet or USB cables and it securely connected at the back of the printer.
 - e) Verify that the correct print media size is selected.
 - f) If using a print spooler, verify that the spooler has not stalled.
 - g) Check the printer interface from the “Configure” menu. Determine the host interface you are using. Print a Panel Setting page to verify that the current interfaces settings are correct.
 - h) Output fonts will not print correctly using the PCL driver in its default mode. To correct this problem, use PostScript driver when using the PCL driver.

- 2) If secure print is not available or not printing, refer to the requirements below.
 - a) Minimum 256 MB is required.
 - b) RAM Disk must be enabled using the operation panel.
 - c) The number of secure print jobs your printer can store is dependent on the job size including number of pages, graphics, color attributes, and the amount of memory installed. To increase this number, add additional memory.
- 3) If print media misfeeds or multiple feeds occur, check and try the actions below.
 - a) Make sure the print media you are using meets the specifications for your printer. Refer to **Print Media Guidelines** of this section.
 - b) Flex print media before loading it in any of the sources.
 - c) Make sure the print media is loaded correctly.
 - d) Make sure the width and length guides on the print media sources are adjusted correctly.
 - e) If the print media are overfilled in sources, reduce the amount of media.
 - f) Load the recommended print side correctly for the type of print media you are using.
 - g) Turn the print media over or around and try printing again to see if feeding improves.
 - h) Check the print media type loaded in the source, and refill only one type of print media, if print media types are mixed.
 - i) Refill a new ream of print media, if some reams are mixed.
 - j) Remove the top and bottom sheets of a ream before loading the print media.
 - k) Do not reload print media until the print media source is empty.
- 4) If envelope misfeeds or multiple feeds occur, check and try the action below.
 - a) Remove the stack of envelopes from the multiple purpose feeder (MPF).
- 5) If page breaks in unexpected places, check and try the action below.
 - a) Check the "Job Timeout" in the Basic Settings menu and increase the value.
- 6) If a job prints from the wrong source or on the wrong print media, check and try the action below.
 - a) Check the "Paper Size" and "Paper Type" in the Tray Settings menu on the printer operator panel and in the printer driver.
- 7) If print media does not stack neatly in the output tray, check and try the action below.
 - a) Turn the print media stack over in the tray or multipurpose feeder.

Print Media Guidelines

Print media is paper, transparencies, labels, envelopes, coated paper among others. Your printer provides high-quality printing on a variety of print media. Selecting the appropriate print media for your printer helps avoid printing troubles. This section describes how to select print media, how to care for print media, and how to load the print media in the optional 250-sheet tray module or 550-sheet tray module.

Paper

For the best print quality in color, use 75 g/m² (20 lb.) xerographic, grain long paper. For the best print quality in black and white, use 90 g/m² (24 lb.) xerographic, grain long paper. Before buying large quantities of any print media, Dell recommends trying a sample first.

When loading paper, identify the recommended print side on the paper package, and load the paper accordingly. See "Loading Print Media in Optional Trays" and "Loading the Multipurpose Feeder" for detailed loading instructions.

Paper Characteristics

The following paper characteristics affect print quality and reliability. Dell recommends that you follow these guidelines when evaluating new paper stock.

Weight

The tray automatically feeds paper weights from 60 to 216 g/m² (16 to 57.6 lb. bond) grain long. The multipurpose feeder automatically feeds paper weights from 60 to 216 g/m² (16 to 56 lb. bond) grain long. Paper lighter than 60 g/m² (16 lb.) might not be stiff enough to feed properly, and could cause paper jams. For best performance, use 75 g/m² (20 lb. bond) grain long paper.

Curl

Curl is the tendency of print media to curve at its edges. Excessive curl can cause paper feeding problems. Curl usually occurs after the paper passes through the printer, where it is exposed to high temperatures. Storing paper unwrapped in humid conditions, even in the paper tray, can contribute to paper curling prior to printing and cause feeding problems.

Smoothness

The degree of paper smoothness directly affects print quality. If the paper is too rough, the toner does not fuse to the paper properly, resulting in poor print quality. If the paper is too smooth, it can cause paper feeding problems. Smoothness between 150 and 250 Sheffield points produces the best print quality.

Moisture Content

The amount of moisture in the paper affects both print quality and the ability of the printer to feed the paper properly. Leave the paper in its original packaging until you are ready to use it. This limits the exposure of the paper to moisture changes that can degrade its performance.

Grain Direction

Grain refers to the alignment of the paper fibers in a sheet of paper. Grain is either grain long, running the length of the paper, or grain short, running the width of the paper. For 60 to 135 g/m² (16 to 36 lb. bond) paper, grain long fibers are recommended. For papers heavier than 135 g/m² (36 lb. bond), grain short is preferred.

Fiber Content

Most high-quality xerographic paper is made from 100% chemically pulped wood. Paper containing fibers such as cotton possess characteristics that can result in degraded paper handling.

Recommended Paper

To ensure the best print quality and feed reliability, use 75 g/m² (20 lb.) xerographic paper. Business papers designed for general business use also provide acceptable print quality.

Always print several samples before buying large quantities of any type of print media. When choosing any print media, you should consider the weight, fiber content, and color.

The laser printing process heats paper to high temperatures of 225°C (437°F) for Magnetic Ink Character Recognition (MICR) applications, and 205°C (401°F) for non-MICR applications. Only use paper able to withstand these temperatures without discoloring, bleeding, or releasing hazardous emissions. Check with the manufacturer or vendor to determine whether the paper you have chosen is acceptable for laser printers.

Unacceptable Paper

The following paper types are not recommended for use with the printer:

- 1) Chemically treated papers used to make copies without carbon paper, also known as carbonless papers, carbonless copy paper (CCP), or no carbon required (NCR) paper
- 2) Preprinted papers with chemicals that may contaminate the printer
- 3) Preprinted papers that can be affected by the temperature in the printer fuser

- 4) Preprinted papers that require a registration (the precise print location on the page) greater than ± 0.09 in., such as optical character recognition (OCR) forms
In some cases, you can adjust registration with your software program to successfully print on these forms.
- 5) Coated papers (erasable bond), synthetic papers, thermal papers
- 6) Rough-edged, rough or heavily textured surface papers or curled papers
- 7) Recycled papers containing more than 25% post-consumer waste that do not meet DIN 19 309
- 8) Multiple-part forms or documents
- 9) Label paper with Cut

Selecting Paper

Proper paper selection helps prevent jams and ensures trouble-free printing.

To help avoid jams or poor print quality:

1. Always use new, undamaged paper.
2. Before loading the paper, identify the recommended print side of the paper. This information is usually indicated on the paper package.
3. Do not use paper that you have cut or trimmed yourself.
4. Do not mix print media sizes, weights, or types in the same source. This may result in a paper jam.
5. Do not remove trays while a job is printing or Printing is displayed on the operator panel.
6. Make sure the Paper Type and Paper Size settings are correct.
7. Make sure the paper is properly loaded in the tray.
8. Flex paper back and forth, and then fan them. Straighten the edges of the stack on a level surface.
9. When curl is excessive, with plain paper, turn it over and reset it.

Identifying Print Media Sources and Specifications

The following tables provide information on standard and optional print media sources.

Print Media Sizes and Support		Y: Yes N: No
	250-sheet Tray	
A4	Y	
A5	Y	
B5	Y	
Letter	Y	
Executive	Y	
Folio (8.5" x13")	Y	
Legal (8.5" x14")	Y	
Com-10	Y	
Monarch	Y	
DL	Y	
C5	Y	
User-specified print media	Y	

Print Media Supported		Y: Yes N: No
		250-sheet Tray
Plain Paper (60-90gsm)		Y
Plain Paper Thick (80/90-105gsm)		Y
Labels		Y
Covers Normal (106-163gsm)		Y
Covers Thick (164-216gsm)		Y
Envelope		Y
Coated Normal (106-163gsm)		Y
Coated Thick (164-216gsm)		Y

Consumables life display.

The following tables provide information on status display of consumables life.

Consumables	Pre Warning	Warning
CRU	<p><Near Life> When the remainder reaches 25%, the following messages are displayed.</p> <div style="display: flex; align-items: center; justify-content: center;"> <div style="border: 1px solid black; padding: 5px; text-align: center; width: 150px;">Ready to Print 093-XXX</div> <div style="margin: 0 10px;">↻</div> <div style="margin: 0 10px;">↻</div> <div style="border: 1px solid black; padding: 5px; text-align: center; width: 150px;">YYY Cartridge Is close to life</div> <div style="margin: 0 10px;">↻</div> <div style="margin-left: 10px;">Alternation</div> </div> <p>XXX: 423, 424, 425, 426 YYY: Yellow, Magenta, Cyan, Black</p>	<p><Life Over> When the remainder reaches 0%, the following messages are displayed.</p> <div style="display: flex; align-items: center; justify-content: center;"> <div style="border: 1px solid black; padding: 5px; text-align: center; width: 150px;">Replace Cart. 093-930</div> <div style="margin: 0 10px;">↻</div> <div style="margin: 0 10px;">↻</div> <div style="border: 1px solid black; padding: 5px; text-align: center; width: 150px;">Replace YYY Cartridge</div> <div style="margin: 0 10px;">↻</div> <div style="margin-left: 10px;">Alternation</div> </div> <p>YYY: Yellow, Magenta, Cyan, Black</p>
PHD	<p><Near Life> When the remainder reaches 30%(12K), the following messages are displayed.</p> <div style="display: flex; align-items: center; justify-content: center;"> <div style="border: 1px solid black; padding: 5px; text-align: center; width: 150px;">Ready to Print 091-402</div> <div style="margin: 0 10px;">↻</div> <div style="margin: 0 10px;">↻</div> <div style="border: 1px solid black; padding: 5px; text-align: center; width: 150px;">Ready to Print Contact Support</div> <div style="margin: 0 10px;">↻</div> <div style="margin-left: 10px;">Alternation</div> </div>	<p><Life Over> When the remainder reaches 0%, the following messages are displayed.</p> <div style="display: flex; align-items: center; justify-content: center;"> <div style="border: 1px solid black; padding: 5px; text-align: center; width: 150px;">Replace PHD. 091-935</div> <div style="margin: 0 10px;">↻</div> <div style="margin: 0 10px;">↻</div> <div style="border: 1px solid black; padding: 5px; text-align: center; width: 150px;">Replace PHD Contact Support</div> <div style="margin: 0 10px;">↻</div> <div style="margin-left: 10px;">Alternation</div> </div>
FUSER	<p><Near Life> When the remainder reaches 30%(50Kpv), the following messages are displayed.</p> <div style="display: flex; align-items: center; justify-content: center;"> <div style="border: 1px solid black; padding: 5px; text-align: center; width: 150px;">Ready to Print 010-421</div> <div style="margin: 0 10px;">↻</div> <div style="margin: 0 10px;">↻</div> <div style="border: 1px solid black; padding: 5px; text-align: center; width: 150px;">Ready to Print Contact Support</div> <div style="margin: 0 10px;">↻</div> <div style="margin-left: 10px;">Alternation</div> </div>	<p><Life Over> When the remainder reaches 0%, the following messages are displayed.</p> <div style="display: flex; align-items: center; justify-content: center;"> <div style="border: 1px solid black; padding: 5px; text-align: center; width: 150px;">Replace FUSER. 010-351</div> <div style="margin: 0 10px;">↻</div> <div style="margin: 0 10px;">↻</div> <div style="border: 1px solid black; padding: 5px; text-align: center; width: 150px;">Replace FUSER Contact Support</div> <div style="margin: 0 10px;">↻</div> <div style="margin-left: 10px;">Alternation</div> </div>
Transfer Belt	<p><Near Life> When the remainder reaches 30%(100Kpv), the following messages are displayed.</p> <div style="display: flex; align-items: center; justify-content: center;"> <div style="border: 1px solid black; padding: 5px; text-align: center; width: 150px;">Ready to Print 094-422</div> <div style="margin: 0 10px;">↻</div> <div style="margin: 0 10px;">↻</div> <div style="border: 1px solid black; padding: 5px; text-align: center; width: 150px;">Contact Support IfMessageReturns</div> <div style="margin: 0 10px;">↻</div> <div style="margin-left: 10px;">Alternation</div> </div>	<p><Life Over> When the remainder reaches 0%, the following messages are displayed.</p> <div style="display: flex; align-items: center; justify-content: center;"> <div style="border: 1px solid black; padding: 5px; text-align: center; width: 150px;">094-911 Contact Support</div> <div style="margin: 0 10px;">↻</div> <div style="margin: 0 10px;">↻</div> <div style="border: 1px solid black; padding: 5px; text-align: center; width: 150px;">094-911 IfMessageReturns</div> <div style="margin: 0 10px;">↻</div> <div style="margin-left: 10px;">Alternation</div> </div>

2. FIP

2.1 FIP

The FIP is the first step for trouble diagnosis. The FIP isolates the presence of various troubles including error codes, and guides the troubleshooting procedure.

2.2 Flow of FIP

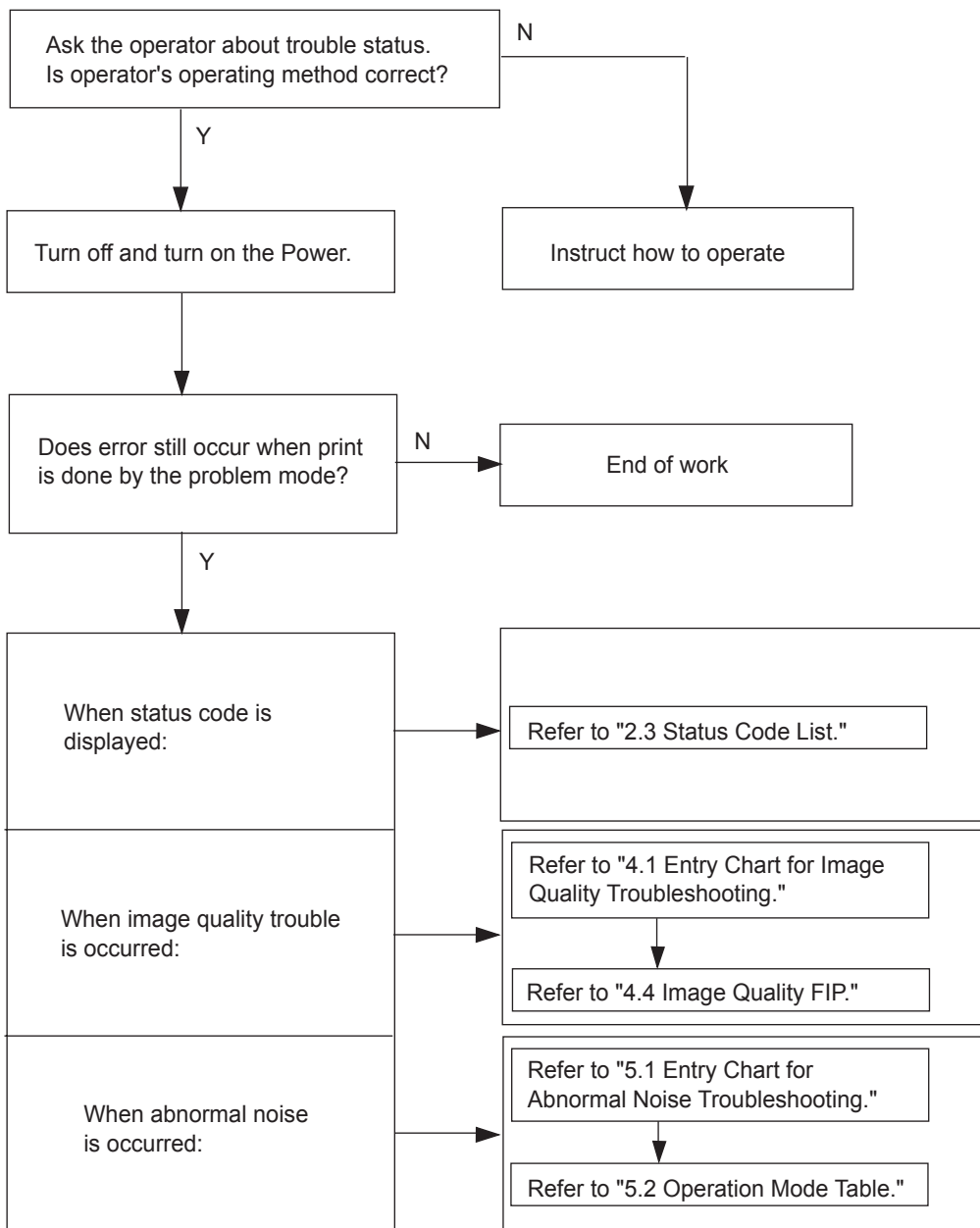

2.3 Status Code List

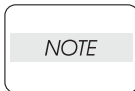

The error messages for the errors which automatically reset themselves will not appear on the "Status Window".

Error Message		Error Contents	FIP to be referred
Panel Message	Status Window		
001-360 Restart Printer ⇕ Flip Contact Support IfMessageReturns	Printer error. Turn off the printer, and turn it on again. Contact customer support if this failure is repeated. 001-360	<IOT Fan Motor Failure> Fan Motor failure is detected.	Flows 1 FIP-1. 1
003-340 Restart Printer ⇕ Flip Contact Support IfMessageReturns	Printer error. Turn off the printer, and turn it on again. Contact customer support if this failure is repeated. 003-340-000000XX	<IOT Firmware Error> MCU firmware error occurred. Pressing three keys (<↓> + <↑> + <✓>) shows detail error code. Line1 003-340 Line2 Code:XX 01: Unexpected firmware trap 02: Unexpected firmware trap 03: I2C retry error 04: Unexpected firmware trap 05: Unexpected firmware trap 07: Master fail 1 08: Master fail 2 09: NVM illegal data 0A: Over dispense 0B: Unexpected firmware trap 0C: Unexpected firmware trap 0D: Unexpected firmware trap 0E: Unexpected firmware trap 0F: Unexpected firmware trap 10: Unexpected firmware trap 11: Unexpected firmware trap 12: Unexpected firmware trap 13: Unexpected firmware trap 14: Unexpected firmware trap	Flows 2 FIP-1. 2
003-356 Restart Printer ⇕ Flip Contact Support IfMessageReturns	Printer error. Turn off the printer, and turn it on again. Contact customer support if this failure is repeated. 003-356-0000XXXX	<IOT NVRAM Error> The error is detected at MCU NVRAM check. Pressing three keys (<↓> + <↑> + <✓>) shows detail address and data. Line1 003-356 Line2 Code: XXXX 1000-17FF: PWBA MCU NVM 3000-30FF: PHD CRUM 3100-31FF: Y Toner CRUM 3200-32FF: M Toner CRUM 3300-33FF: C Toner CRUM 3400-34FF: K Toner CRUM 3800-38FF: PWBA EEPROM	Flows 3 FIP-1. 3

Error Message		Error Contents	FIP to be referred
Panel Message	Status Window		
004-310 Restart Printer ↕ Flip Reseat Feeder Contact Support	Printer error. Turn off the printer. Confirm Feeder is correctly installed. Turn on the printer. Contact customer support if this failure is repeated. 004-310	<IOT Option Feeder Failure> The error is detected by Option Feeder communication check.	Flows 4 FIP-1. 4
004-311 Restart Printer ↕ Flip Reseat Duplexer Contact Support	Printer error. Turn off the printer. Confirm Duplex is correctly installed. Turn on the printer. Contact customer support if this failure is repeated. 004-311	<IOT Option Duplexer Failure> The error is detected by Option Duplexer communication check.	Flows 5 FIP-1. 5
006-370 Restart Printer ↕ Flip Contact Support IfMessageReturns	Printer error. Turn off the printer, and turn it on again. Contact customer support if this failure is repeated. 006-370-000000XX	<IOT ROS Failure> The ROS failure is detected. Pressing three keys (<↓> + <↑> + <→>) shows detail error code. Line1 006-370 Line2 Code: XX 01: SOS Rotating up defect 02: SOS Interval defect 03: LD defect	Flows 6 FIP-1. 6
007-340 Restart Printer ↕ Flip Contact Support IfMessageReturns	Printer error. Turn off the printer, and turn it on again. Contact customer support if this failure is repeated. 007-340	<IOT Motor Failure> Main Motor failure is detected.	Flows 7 FIP-1. 7
007-341 Restart Printer ↕ Flip Contact Support IfMessageReturns	Printer error. Turn off the printer, and turn it on again. Contact customer support if this failure is repeated. 007-341	<IOT Motor Failure> Sub Motor failure is detected.	Flows 8 FIP-1. 8
007-371 Restart Printer ↕ Flip Contact Support IfMessageReturns	Printer error. Turn off the printer, and turn it on again. Contact customer support if this failure is repeated. 007-371	<IOT K Mode Solenoid Error> The error is generated when K Mode Solenoid (Color Mode Switching Solenoid) does not operate in specified time.	Flows 9 FIP-1. 9

Error Message		Error Contents	FIP to be referred
Panel Message	Status Window		
007-372 Restart Printer ↕ Flip Contact Support IfMessageReturns	Printer error. Turn off the printer, and turn it on again. Contact customer support if this failure is repeated. 007-372	<IOT K Mode Solenoid Error 2> The error is generated when the gear which operates by K Mode Solenoid (Color Mode Switching Solenoid) rotates two times.	Flows 9 FIP-1. 9
009-340 Restart Printer ↕ Flip Contact Support IfMessageReturns	Printer error. Contact customer support if this failure is repeated. 009-340-000000XX	<IOT CTD (ADC) Sensor Error> CTD (ADC) sensor error is detected. Pressing three keys (<↓> + <↑> + <✓>) shows detail address and data. Line1 009-340 Line2 Code: XX 01 or 10: Y Toner Patch Error 02 or 20: M Toner Patch Error 03 or 30: Y and M Toner Patch Error 04 or 40: C Toner Patch Error 05 or 50: Y and C Toner Patch Error 06 or 60: M and C Toner Patch Error 07 or 70: Y, M and C Toner Patch Error 08 or 80: K Toner Patch Error 09 or 90: Y and K toner Patch Error 0A or A0: M and K Toner Patch Error 0B or B0: Y, M and K Toner Patch Error 0C or C0: C and K Toner Patch Error 0D or D0: Y, C and K Toner Patch Error 0E or E0: M, C and K Toner Patch Error 0F or F0: Y, M, C and K Toner Patch Error	Flows 10 (Y) Flows 11 (M) Flows 12 (C) Flows 13 (K) FIP-1. 10 (Y) FIP-1. 11 (M) FIP-1. 12 (C) FIP-1. 13 (K)
010-317 Restart Printer ↕ Flip Reseat Fuser Contact Support	The Fuser is either missing or not fully inserted into the printer. CAUTION: Turn off the printer and wait for 30 minutes. Open the Front Cover and make sure that the Fuser have been fully installed. Please click the Show Me How Button for details. 010-317	<IOT Fuser Detached> Fuser detached is detected.	Flows 14 FIP-1. 14
010-351 Restart Printer ↕ Flip Replace Fuser Now ↕ Flip Contact Support	Replace Fuser Now. Contact customer support. Please click the Show Me How Button to show details. 010-351	<IOT Fuser Life Over> Fuser has reached the replacement time.	Flows 15 FIP-1. 15

Error Message		Error Contents	FIP to be referred
Panel Message	Status Window		
010-354 Restart Printer ↕ Flip Contact Support IfMessageReturns	Printer error. Turn off the printer, and turn it on again. Contact customer support if this failure is repeated. 010-354-000000XX	<IOT Environment Sensor Error> Environment sensor error is detected. Pressing three keys (<↓> + <↑> + <✓>) shows detail address and data. Line1 010-354 Line2 Code: XX 01: Humid Sensor Error 02: Temp. Sensor Error	Flows 16 FIP-1. 16
010-377 Restart Printer ↕ Flip Reseat Fuser Contact Support	Printer error. Turn off the printer. Confirm Fuser is correctly installed. Turn on the printer. Contact customer support if this failure is repeated. 010-377-000000XX	<IOT Fuser Failure> The Fuser failure is detected. Pressing three keys (<↓> + <↑> + <✓>) shows detail error code. Line1 010-377 Line2 Code:XX 01: NC circuit fail 02: NCD snap out 03: NCD fail 04: NCC snap out 05: NC comp fail 06: NC-STs temp over 07: STS-NC temp over 08: NC comp fail 09: NC overheat 0A: STS snap out 0B: STS overheat 0C: Low temp1 0D: Low temp2 0E: Timeout 1 0F: Timeout 2 10: Timeout 3 11: Relay cutoff 1 12: Relay cutoff 2 13: Relay cutoff 3	Flows 17 FIP-1. 17
Ready to Print 010-421 ↕ Flip Replace Fuser Now ↕ Flip Contact Support	Replace Fuser Now. Contact customer support. Please click the Show Me How Button for details. 010-421	<IOT Fuser Life Pre Warning> Fuser is going to reach the replacement time.	Flows 18 FIP-1. 18
016-300 Restart Printer ↕ Flip Contact Support IfMessageReturns	Printer error. Turn off the printer, and turn it on again. Contact customer support if this failure is repeated. 016-300	<ESS Data Cache Error> CPU data cache error is detected.	Flows 19 FIP-1. 19

Error Message		Error Contents	FIP to be referred
Panel Message	Status Window		
016-301 Restart Printer ↕ Flip Contact Support IfMessageReturns	Printer error. Turn off the printer, and turn it on again. Contact customer support if this failure is repeated. 016-301	<ESS Instruction Cache Error> CPU instruction cache error is detected.	Flows 19 FIP-1. 19
016-302 Restart Printer ↕ Flip Contact Support IfMessageReturns	Printer error. Turn off the printer, and turn it on again. Contact customer support if this failure is repeated. 016-302	<ESS Illegal Exception> CPU illegal exception is detected.	Flows 19 FIP-1. 19
016-313 Restart Printer ↕ Flip Contact Support IfMessageReturns	Printer error. Turn off the printer, and turn it on again. Contact customer support if this failure is repeated. 016-313	<ESS ASIC Fail> The error is detected by ASIC error.	Flows 19 FIP-1. 19
016-315 Restart Printer ↕ Flip Contact Support IfMessageReturns	Printer error. Turn off the printer, and turn it on again. Contact customer support if this failure is repeated. 016-315	<ESS On Board RAM R/W Check Fail> The error is detected by on board RAM R/W check during initialization.	Flows 19 FIP-1. 19
016-316 Restart Printer ↕ Flip Reseat Memory Contact Support	Printer error. Turn off the printer. Remove the additional memory module from the slot, and then reattach it firmly. Turn on the printer. Contact customer support if this failure is repeated. 016-316	<ESS DIMM Slot RAM R/W Check Fail> The error is detected by DIMM slot RAM R/W check.	Flows 20 FIP-1. 20
016-317 Restart Printer ↕ Flip Contact Support IfMessageReturns	Printer error. Turn off the printer, and turn it on again. Contact customer support if this failure is repeated. 016-317	<ESS ROM Check (Main) Fail> Checksum error in main program ROM is detected.	Flows 19 FIP-1. 19

Error Message		Error Contents	FIP to be referred
Panel Message	Status Window		
016-318 Restart Printer ↕ Flip Reseat Memory Contact Support	Printer error. Remove the unsupported additional memory module. Contact customer support if this failure is repeated. 016-318	<ESS DIMM Slot RAM Error> The error is detected by DIMM slot RAM power on initial check.	Flows 20 FIP-1. 20
016-323 Restart Printer ↕ Flip Contact Support IfMessageReturns	Printer error. Turn off the printer, and turn it on again. Contact customer support if this failure is repeated. 016-323	<ESS NVRAM1 R/W Check Fail> The failure is detected by NVRAM 1 R/W check during initialization.	Flows 19 FIP-1. 19
016-327 Restart Printer ↕ Flip Contact Support IfMessageReturns	Printer error. Turn off the printer, and turn it on again. Contact customer support if this failure is repeated. 016-327	<ESS NVRAM1 SIZE And ID Check Fail> The error is detected by consistency check between NVRAM size required by the system and its actual size, and by consistency check of ID recorded when turning ON the power.	Flows 19 FIP-1. 19
016-338 Restart Printer ↕ Flip Reseat Wireless Contact Support	Printer error. Turn off the printer, and turn it on again. Contact customer support if this failure is repeated. 016-338	<Wireless Option Error> The error is detected by Wireless option check.	Flows 21 FIP-1. 21
016-340 Restart Printer ↕ Flip Contact Support IfMessageReturns	Printer error. Turn off the printer, and turn it on again. Contact customer support if this failure is repeated. 016-340	<On Board Network Communication Fail> Communication error between CPU network and ESS firmware.	Flows 19-1 FIP-1. 19
016-344 Restart Printer ↕ Flip Contact Support IfMessageReturns	Printer error. Turn off the printer, and turn it on again. Contact customer support if this failure is repeated. 016-344	<On Board Network MAC Address Checksum Error> Checksum error in Network MAC address is detected. MAC: Media Access Control	Flows 19 FIP-1. 19
016-345 Restart Printer ↕ Flip Contact Support IfMessageReturns	Printer error. Turn off the printer, and turn it on again. Contact customer support if this failure is repeated. 016-345	<On Board Network Ethernet BIST parity/RAM R/W Error> The error is detected by Network Ethernet parity RAM R/W check.	Flows 19 FIP-1. 19

Error Message		Error Contents	FIP to be referred
Panel Message	Status Window		
016-346 Restart Printer ↕ Flip Contact Support IfMessageReturns	Printer error. Turn off the printer, and turn it on again. Contact customer support if this failure is repeated. 016-346	<On Board Network Internal Loop back Error> The error is detected by on board Network Internal Loopback check.	Flows 19 FIP-1. 19
016-347 Restart Printer ↕ Flip Contact Support IfMessageReturns	Printer error. Turn off the printer, and turn it on again. Contact customer support if this failure is repeated. 016-347	<On Board Network Fatal Error> The fatal error is detected by on board Network check.	Flows 19 FIP-1. 19
016-365 Restart Printer ↕ Flip Reseat NPA ContactSupport	Printer error. Turn off the printer, and turn it on again. Contact customer support if this failure is repeated. 016-365	<HW Key Option Fatal Error> Network Protocol Adapter error is detected when it is connected to the printer.	Flows 22 FIP-1. 22
016-370 Restart Printer ↕ Flip Contact Support IfMessageReturns	Printer error. Turn off the printer, and turn it on again. Contact customer support if this failure is repeated. 016-370	<IOT-ESS Communication Fail> Communication failure between IOT and ESS is detected.	Flows 23 FIP-1. 23
Invalid ID 016-383 ↕ Flip Data Violation Press set	Firmware download ID error has occurred. Press Set Button. Contact customer support if this failure is repeated. 016-383	<Download ID Error> The download file of other models (different ID) is detected.	Flows 24 FIP-1. 24
Range Chk Error 016-384 ↕ Flip Data Violation Press Set	Firmware download range error has occurred. Press Set Button. Contact customer support if this failure is repeated. 016-384	<Download Range Error> Due to the wrong data downloaded, writing was attempted to the non-modifiable area.	Flows 24 FIP-1. 24

Error Message		Error Contents	FIP to be referred
Panel Message	Status Window		
Header Error 016-385 ↕ Flip Data Violation Press Set	Firmware download header checksum error has occurred. Press Set Button. Contact customer support if this failure is repeated. 016-385	<Download Header Error> The download file is broken, or communication error is detected.	Flows 24 FIP-1. 24
Check Sum Error 016-386 ↕ Flip Data Violation Press Set	Firmware download checksum error has occurred. Press Set Button. Contact customer support if this failure is repeated. 016-386	<Download Checksum Error> The download file is broken, or communication error is detected.	Flows 24 FIP-1. 24
Protection Error 016-391 ↕ Flip Data Violation Press Set	Firmware download protect error has occurred. Press Set Button. Contact customer support if this failure is repeated. 016-391	<Download Protect Error> Download was attempted under the condition where it is prohibited.	Flows 24 FIP-1. 24
Erase Flash Err. 016-392 ↕ Flip Contact Support IfMessageReturns	Firmware download delete error has occurred. Contact customer support if this failure is repeated. 016-392	<Download Delete Error> An error was detected at Flash memory erasing.	Flows 24 FIP-1. 24
Write Flash Err. 016-393 ↕ Flip Contact Support IfMessageReturns	Firmware download write error has occurred. Contact customer support if this failure is repeated. 016-393	<Download Write Error> An error was detected at Flash memory writing.	Flows 24 FIP-1. 24
Verify Error 016-394 ↕ Flip Contact Support IfMessageReturns	Firmware download verify error has occurred. Contact customer support if this failure is repeated. 016-394	<Download Verify Error> An error was detected at Flash memory verifying.	Flows 24 FIP-1. 24

Error Message		Error Contents	FIP to be referred
Panel Message	Status Window		
Out of Memory 016-700 ⇕ Flip Job too Large Press Set	The printer memory is full and cannot continue processing the current print job. Press Set Button to clear the message and cancel the current print job. Please click the Show Me How Button for details. 016-700	<Memory Overflow> The amount of data in the print job exceeded the memory capacity of the printer.	Flows 25 FIP-1. 25
PDL Request 016-720 ⇕ Flip Data Violation Press Set	Error relating to PDL emulation problems occurs. Press Set Button to clear the message and cancel the current print job. Please click the Show Me How Button for details. 016-720	<PDL Error> PDL error occurs.	Flows 26 FIP-1. 26
Invalid User 016-757 ⇕ Flip Account Denied Press Set	Authentication error has occurred. The account is not registered. Please inquire of the system administrator. 016-757	<Auditron - Invalid User> Account error occurs.	Flows 27 FIP-1. 27
Disabled Func 016-758 ⇕ Flip Denied Col print Press Set	Function unavailable. It is a function that cannot be used. Please inquire of the system administrator. 016-758	<Auditron - Disabled Function> Disabled function is selected.	Flows 28 FIP-1. 28
Reached Limit 016-759 ⇕ Flip Over your limits Press Set	Printable page limit reached. Printable page limit reached, cannot print. Please inquire of the system administrator. 016-759	<Auditron - Reached Limit> Detects the reached limit.	Flows 29 FIP-1. 29

Error Message		Error Contents	FIP to be referred
Panel Message	Status Window		
Invalid Job 016-799 ↕ Flip Data Violation Press Set	The configuration of the printer on the printer driver does not conform to the printer. Press the Set Button to clear the message and cancel the current print job. Make sure that the configuration of the printer on the printer driver conforms to the printer. 016-799	<Job Environment Violation> There are some prohibition in the setting contents of a print job.	Flows 30 FIP-1. 30
Disk Full 016-980 ↕ Flip Job too Large Press Set	Disk space is insufficient and cannot continue processing the current print job. Press Set Button to clear the message and cancel the current print job. Please click the Show Me How Button for details. 016-980	<Memory Over flow> RAM disk memory or hard disk is full and cannot continue processing the current print job.	Flows 31 FIP-1. 31
Collate Full 016-981 ↕ Flip Job too Large Press Set	Disk space is insufficient and cannot continue processing the current print job. Press Set Button to clear the message and cancel the current print job. Please click the Show Me How Button for details. 016-981	<Collate Full> Collate Full error occurred.	Flows 32 FIP-1. 32
MCU Flash Error 024-360 ↕ Flip Contact Support IfMessageReturns	Printer error. Turn off the printer, and turn it on again. Contact customer support if this failure is repeated. 024-360	<MCU Down Load Error> Download failure of MCU firmware.	Flows 33 FIP-1. 33
024-362 Restart Printer ↕ Flip Contact Support IfMessageReturns	Printer error. Turn off the printer, and turn it on again. Contact customer support if this failure is repeated. 024-362	<PAGEC Timeout Error> The PAGEC timeout error is detected.	Flows 34 FIP-1. 34

Error Message		Error Contents	FIP to be referred
Panel Message	Status Window		
Check Paper Size 024-910 ↓ Flip Load Tray 1 XX ↓ Flip Load Tray 1 YY XX: Paper Size YY: Paper Type	Actual paper size in tray and specified paper size are different. Load the specified paper in Tray 1. Paper Size: XX Paper Type: YY 024-910	<IOT Paper Size Mismatch> The paper size mismatch in Tray 1 is detected.	Flows 35 FIP-1. 35
Check Paper Size 024-911 ↓ Flip Load Tray 2 XX ↓ Flip Load Tray 2 YY XX: Paper Size YY: Paper Type	Actual paper size in tray and specified paper size are different. Load the specified paper in Tray 2. Paper Size: XX Paper Type: YY 024-911	<IOT Paper Size Mismatch> The paper size mismatch in Tray 2 is detected.	Flows 36 FIP-1. 36
Check Paper Size 024-914 ↓ Flip Load SSF XX ↓ Flip Load SSF YY XX; Paper Size YY: Paper Type	Actual paper size in tray and specified paper size are different. Load the specified paper in SSF. Paper Size: XX Paper Type: YY 024-914	<IOT Paper Size Mismatch> The paper size mismatch in SSF is detected.	Flows 37 FIP-1. 37
Load Tray 1 024-965 ↓ Flip Load Tray 1 XX ↓ Flip Load Tray 1 YY XX: Paper Size YY: Paper Type	No paper detected. Load the specified paper in Tray 1. Paper Size: XX Paper Type: YY 024-965	<No suitable paper> The paper empty is detected.	Flows 38 FIP-1. 38
Load Tray 2 024-966 ↓ Flip Load Tray 2 XX ↓ Flip Load Tray 2 YY XX: Paper Size YY: Paper Type	No paper detected. Load the specified paper in Tray 2. Paper Size: XX Paper Type: YY 024-966	<No suitable paper> The paper empty is detected.	Flows 39 FIP-1. 39

Error Message		Error Contents	FIP to be referred
Panel Message	Status Window		
Load SSF 024-969 ↓ Flip Load SSF XX ↓ Flip Load SSF YY XX: Paper Size YY: Paper Type	No paper detected. Load the specified paper in SSF. Paper Size: XX Paper Type: YY 024-969	<No suitable paper> The paper empty is detected.	Flows 40 FIP-1. 40
Pause Feed SSF 024-985 ↓ Flip Press Set to Feed	No Message.	<No suitable paper> The paper empty is detected.	Flows 40 FIP-1. 40
Over Heat 042-700 ↓ Flip Cooling down Please Wait	An internal temperature of the printer became a high temperature. Please wait for a while until falling in temperature. 042-700	<IOT Over Heat Stop> The temp. sensor sensed high temperature. The error displayed only at the time of Duplexer connection.	Flows 41 FIP-1. 41
Paper Jam 071-100 ↓ Flip Open Tray1 Remove Paper ↓ Flip Open & Close Front Cover	Paper Jam has occurred at the Tray 1. Remove the Tray 1 and remove the jammed paper. Open and close the Front Cover. Please click the Show Me How Button for details. 071-100	<IOT Tray1 Misfeed JAM> Regi Sensor is not turned ON within the specified time after feeding a paper from Tray 1.	Flows 42 FIP-1. 42
Paper Jam 072-100 ↓ Flip Open Tray2 Remove Paper ↓ Flip Open & Close Front Cover	Paper Jam has occurred at the Tray 2. Remove the Tray 2 and remove the jammed paper. Open and close the Front Cover. Please click the Show Me How Button for details. 072-100	<IOT Tray2 Misfeed JAM> Regi Sensor is not turned ON within the specified time after feeding a paper from Tray 2.	Flows 43 FIP-1. 43
Paper Jam 072-101 ↓ Flip Open Tray1 or 2 Remove Paper ↓ Flip Open & Close Front Cover	Paper Jam has occurred at the Tray 1 or 2. Remove the Tray 1 or 2, and remove the jammed paper. Open and close the Front Cover. Please click the Show Me How Button for details. 072-101	<IOT Feeder2 JAM> The paper remains at the Regi Sensor.	Flows 44 FIP-1. 44

Error Message		Error Contents	FIP to be referred
Panel Message	Status Window		
Paper Jam 072-908 ⇕ Flip Open Tray1 or 2 Remove Paper ⇕ Flip Open & Close Front Cover	Paper Jam has occurred at the Tray 1 or 2. Remove the Tray 1 or 2, and remove the jammed paper. Open and close the Front Cover. Please click the Show Me How Button for details. 072-908	<IOT Remain Option Feeder JAM> The paper remains at the Regi Sensor.	Flows 43 FIP-1. 43
Paper Jam 075-101 ⇕ Flip Open Front Cover Remove Paper	Paper Jam has occurred at the SSF. Open the Front Cover and remove the jammed paper. Open and close the Front Cover. Please click the Show Me How Button for details. 075-101	<IOT SSF Insert JAM> SSF No Paper Sensor detect when a paper is inserted from SSF.	Flows 45 FIP-1. 45
Paper Jam 075-102 ⇕ Flip Open Front Cover Remove Paper	Paper Jam has occurred at the SSF. Pull the jammed paper out of the SSF. Open and close the Front Cover. Please click the Show Me How Button for details. 075-102	<IOT SSF Paper Pullout JAM> Though it tried to feed a paper from SSF, the paper was not loaded or it was pulled out forcibly from SSF.	Flows 46 FIP-1. 46
Check SSF 075-922 ⇕ Flip Remove Paper SSF	No Message.	<IOT SSF Paper Staying> Feeding from Tray fails due to a sheet remaining in the SSF.	Flows 47 FIP-1. 47
Check SSF 075-923 ⇕ Flip Reseat Paper SSF	The SSF is not holding the paper correctly. Pull the paper out of the SSF. Reload the paper of the SSF. 075-923	<IOT SSF No Paper> Waiting for reseal paper of SSF.	Flows 40 FIP-1. 40
Paper Jam 077-100 ⇕ Flip Open Front Cover Remove Paper	No Message.	<IOT Regi On early JAM> The arrival time of the regi sensor is early than the specified time.	Flows 48 FIP-1. 48
Paper Jam 077-101 ⇕ Flip Open Front Cover Remove Paper	No Message.	<IOT Regi OFF Jam> The paper does not pass through the Regi Sensor within the specified time.	Flows 48 FIP-1. 48

Error Message		Error Contents	FIP to be referred
Panel Message	Status Window		
Paper Jam 077-102 ↕ Flip Open Front Cover Remove Paper	No Message.	<IOT Exit On JAM> The paper does not reach the Exit Sensor within the specified time.	Flows 49 FIP-1. 49
Paper Jam 077-103 ↕ Flip Open Front Cover Remove Paper	No Message.	<IOT Exit On early JAM> The paper reached Exit Sensor earlier than the specified time.	Flows 50 FIP-1. 50
Paper Jam 077-104 ↕ Flip Open Front Cover Remove Paper	No Message.	<IOT Exit Off JAM> The paper does not pass through the Exit Sensor within the specified time.	Flows 50 FIP-1. 50
Paper Jam 077-105 ↕ Flip Open Front Cover Remove Paper	No Message.	<IOT Exit Off early JAM> The paper passed through the Exit Sensor earlier than the specified time.	Flows 50 FIP-1. 50
Paper Jam 077-107 ↕ Flip Open Front Cover & Duplexer ↕ Flip Remove Paper	Paper Jam has occurred at the Duplexer. Push the Side Button to open the Front Cover and the Duplexer. Then remove the jammed paper. Close the Front Cover. Please click the Show Me How Button for details. 077-107	<IOT Duplex Misfeed JAM> The Regi sensor is not turned on within the specified time.	Flows 51 FIP-1. 51
Paper Jam 077-108 ↕ Flip Open Front Cover & Duplexer ↕ Flip Remove Paper	Paper Jam has occurred at the Duplexer. Push the Side Button to open the Front Cover and the Duplexer. Then remove the jammed paper. Close the Front Cover. Please click the Show Me How Button for details. 077-108	<IOT Duplex JAM> The paper reached Duplex earlier than the specified time.	Flows 52 FIP-1. 52
Close FrontCover 077-300 ↕ Flip Front Cover Is Open	The Front Cover is open. Close the Front Cover. 077-300	<IOT Cover Front Open> Front cover is open.	Flows 53 FIP-1. 53
Close Side Cover 077-301 ↕ Flip Side Cover Is Open	The Side Cover is open. Close the Side Cover. 077-301	<IOT Side Cover Open> Side cover is open.	Flows 54 FIP-1. 54

Error Message		Error Contents	FIP to be referred
Panel Message	Status Window		
Paper Jam 077-900 ⇕ Flip Open Front Cover Remove Paper	Paper Jam has occurred at the Output Tray. CAUTION: The Fuser is hot. Push the Side Button to open the Front Cover and remove the jammed paper. If the jammed paper is in the Fuser, lift the levers at both ends of the Fuser and remove the jammed paper. Please click the Show Me How Button for details. 077-900	<IOT Exit JAM> The paper remains at Exit Sensor.	Flows 55 FIP-1. 55
Paper Jam 077-901 ⇕ Flip Open Front Cover Remove Paper	Paper Jam has occurred at the Belt Unit. Push the Side Button to open the Front Cover and remove the jammed paper. Close the Front Cover. If the jammed paper is not easily removed, work after pulling out the tray. Please click the Show Me How Button for details. 077-901	<IOT Remain Registration JAM> The paper remains at the Regi Sensor.	Flows 56 FIP-1. 56
Paper Jam 077-907 ⇕ Flip Open Front Cover & Duplexer ⇕ Flip Remove Paper	Paper Jam has occurred at the Duplexer. Push the Side Button to open the Front Cover and the Duplexer. Then remove the jammed paper. Close the Front Cover. Please click the Show Me How Button for details. 077-907	<IOT Remain Duplex JAM> The paper remains at the Duplex.	Flows 57 FIP-1. 57
Ready to Print 091-402 ⇕ Flip Replace PHD Now ⇕ Flip Contact Support	Replace PHD unit Now. Contact customer support. Please click the Show Me How Button for details. 091-402	<IOT PHD Life Pre Warning> The PHD Unit is going to reach the replacement time.	Flows 58 FIP-1. 58
PHD 091-912 ⇕ Flip Reseat PHD	Printer error. Remove the ribbons from the PHD unit. Contact customer support if this failure is repeated. 091-912	<PHD Tape Staying> Detect the tape staying on the PHD Unit. (Toner patch error occurred at new PHD Unit installing.)	Flows 59 FIP-1. 59

Error Message		Error Contents	FIP to be referred
Panel Message	Status Window		
Replace PHD 091-935 ↓ Flip Replace PHD Now ↓ Flip Contact Support	Replace PHD unit Now. Contact customer support. Please click the Show Me How Button for details. 091-935	<IOT PHD Life Over> PHD Unit has reached the replacement time.	Flows 58 FIP-1. 58
Insert PHD 091-972 ↓ Flip Insert PHD	The PHD unit is either missing or not fully inserted into the printer. Open the Front Cover and make sure that the PHD unit have been fully installed. Please click the Show Me How Button for details. 091-972	<IOT PHD Detached> PHD Unit detached is detected.	Flows 60 FIP-1. 60
CTD Sensor Dirty 092-310 ↓ Flip Clean CTD Sensor	Printer error. Clean the CTD sensor. 092-310	<IOT CTD Sensor Contamination> Contamination of the CTD (ADC) Sensor is detected.	Flows 61 FIP-1. 61
Ready to Print 092-410 ↓ Flip Clean CTD Sensor	Clean the CTD sensor. 092-410	<CTD Sensor Contamination Pre Warning> Contamination of the CTD (ADC) Sensor is detected.	Flows 61 FIP-1. 61
Ready to Print 093-423 ↓ Flip Yellow Cartridge Is close to life	The Yellow Cartridge needs to be replaced soon. 093-423	<IOT Y CRU Near Life> Yellow Cartridge is going replacement time.	Flows 62 FIP-1. 62
Ready to Print 093-424 ↓ Flip MagentaCartridge Is close to life	The Magenta Cartridge needs to be replaced soon. 093-424	<IOT M CRU Near Life> Magenta Cartridge is going replacement time.	Flows 63 FIP-1. 63
Ready to Print 093-425 ↓ Flip Cyan Cartridge Is close to life	The Cyan Cartridge needs to be replaced soon. 093-425	<IOT C CRU Near Life> Cyan Cartridge is going replacement time.	Flows 64 FIP-1. 64
Ready to Print 093-426 ↓ Flip Black Cartridge Is close to life	The Black Cartridge needs to be replaced soon. 093-426	<IOT K CRU Near Life> Black Cartridge is going replacement time.	Flows 65 FIP-1. 65

Error Message		Error Contents	FIP to be referred
Panel Message	Status Window		
Shake Cartridge 093-919 ↕ Flip Remove and Shake Yellow Cartridge	The sealing tape is still on the Yellow Cartridge. Open the Side Cover. Pull the toner seal straight up to remove it. 093-919	<IOT Y Toner Low Density> Detects low density of yellow.	Flows 66 FIP-1. 66
Shake Cartridge 093-920 ↕ Flip Remove and Shake Magenta Cartridge	The sealing tape is still on the Magenta Cartridge. Open the Side Cover. Pull the toner seal straight up to remove it. 093-920	<IOT M Toner Low Density> Detects low density of magenta.	Flows 67 FIP-1. 67
Shake Cartridge 093-921 ↕ Flip Remove and Shake Cyan Cartridge	The sealing tape is still on the Cyan Cartridge. Open the Side Cover. Pull the toner seal straight up to remove it. 093-921	<IOT C Toner Low Density> Detects low density of cyan.	Flows 68 FIP-1. 68
Shake Cartridge 093-922 ↕ Flip Remove and Shake Black Cartridge	The sealing tape is still on the Black Cartridge. Open the Side Cover. Pull the toner seal straight up to remove it. 093-922	<IOT K Toner Low Density> Detects low density of black.	Flows 69 FIP-1. 69
Replace Cart. 093-930 ↕ Flip Replace Yellow Cartridge	The Yellow Cartridge need to be replaced now. Open the Side Cover. Then remove the used Yellow Cartridge and install a new one. Please click the Show Me How Button for details. 093-930	<IOT Y CRU Life Over> Yellow Cartridge has reached the replacement time.	Flows 62 FIP-1. 62
Replace Cart. 093-931 ↕ Flip Replace MagentaCartridge	The Magenta Cartridge need to be replaced now. Open the Side Cover. Then remove the used Magenta Cartridge and install a new one. Please click the Show Me How Button for details. 093-931	<IOT M CRU Life Over> Magenta Cartridge has reached the replacement time.	Flows 63 FIP-1. 63

Error Message		Error Contents	FIP to be referred
Panel Message	Status Window		
Replace Cart. 093-932 ⇕ Flip Replace Cyan Cartridge	The Cyan Cartridge need to be replaced now. Open the Side Cover. Then remove the used Cyan Cartridge and install a new one. Please click the Show Me How Button for details. 093-932	<IOT C CRU Life Over> Cyan Cartridge has reached the replacement time.	Flows 64 FIP-1. 64
Replace Cart. 093-933 ⇕ Flip Replace Black Cartridge	The Black Cartridge need to be replaced now. Open the Side Cover. Then remove the used Black Cartridge and install a new one. Please click the Show Me How Button for details. 093-933	<IOT K CRU Life Over> Black Cartridge has reached the replacement time.	Flows 65 FIP-1. 65
Replace Cart. 093-934 ⇕ Flip Replace Cyan Cartridge	The Cyan Cartridge need to be replaced now. Open the Side Cover. Then remove the used Cyan Cartridge and install a new one. Please click the Show Me How Button for details. 093-934	<IOT C CRU Waste Full> Waste Toner Counter value has reached replacement time.	Flows 70 FIP-1. 70
Replace Cart. 093-935 ⇕ Flip Replace MagentaCartridge	The Magenta Cartridge need to be replaced now. Open the Side Cover. Then remove the used Magenta Cartridge and install a new one. Please click the Show Me How Button for details. 093-935	<IOT M CRU Waste Full> Waste Toner Counter value has reached replacement time.	Flows 71 FIP-1. 71
Replace Cart. 093-936 ⇕ Flip Replace Yellow Cartridge	The Yellow Cartridge need to be replaced now. Open the Side Cover. Then remove the used Yellow Cartridge and install a new one. Please click the Show Me How Button for details. 093-936	<IOT Y CRU Waste Full> Waste Toner Counter value has reached replacement time.	Flows 72 FIP-1. 72

Error Message		Error Contents	FIP to be referred
Panel Message	Status Window		
Replace Cart. 093-937 ⇕ Flip Replace Black Cartridge	The Black Cartridge need to be replaced now. Open the Side Cover. Then remove the used Black Cartridge and install a new one. Please click the Show Me How Button for details. 093-937	<IOT K CRU Waste Full> Waste Toner Counter value has reached replacement time.	Flows 73 FIP-1. 73
CRUM ID 093-960 ⇕ Flip Reseat Yellow Cartridge	An unsupported Yellow Cartridge is installed. Open the Side Cover. Remove the unsupported Yellow Cartridge and install a supported one. Please click the Show Me How Button for details. 093-960	<IOT CRUM ID Error> CRUM ID error of Yellow Cartridge is detected.	Flows 74 FIP-1. 74
CRUM ID 093-961 ⇕ Flip Reseat MagentaCartridge	An unsupported Magenta Cartridge is installed. Open the Side Cover. Remove the unsupported Magenta Cartridge and install a supported one. Please click the Show Me How Button for details. 093-961	<IOT CRUM ID Error> CRUM ID error of Magenta Cartridge is detected.	Flows 75 FIP-1. 75
CRUM ID 093-962 ⇕ Flip Reseat Cyan Cartridge	An unsupported Cyan Cartridge is installed. Open the Side Cover. Remove the unsupported Cyan Cartridge and install a supported one. Please click the Show Me How Button for details. 093-962	<IOT CRUM ID Error> CRUM ID error of Cyan Cartridge is detected.	Flows 76 FIP-1. 76
CRUM ID 093-963 ⇕ Flip Reseat Black Cartridge	An unsupported Black Cartridge is installed. Open the Side Cover. Remove the unsupported Black Cartridge and install a supported one. Please click the Show Me How Button for details. 093-963	<IOT CRUM ID Error> CRUM ID error of Black Cartridge is detected.	Flows 77 FIP-1. 77

Error Message		Error Contents	FIP to be referred
Panel Message	Status Window		
CRUM ID 093-965 ⇕ Flip Reseat PHD	An unsupported PHD unit is installed. Open the Front Cover. Remove the unsupported PHD unit and install a supported one. Please click the Show Me How Button for details. 093-965	<IOT CRUM ID Error> CRUM ID error of PHD Unit is detected.	Flows 78 FIP-1. 78
Insert PrintCart 093-970 ⇕ Flip Insert Yellow Cartridge	The Yellow Cartridge is either missing or not fully inserted into the printer. Open the Side Cover and make sure that the Yellow Cartridge have been fully installed. Please click the Show Me How Button for details. 093-970	<IOT Y CRU Detached> Yellow Cartridge detached is detected.	Flows 79 FIP-1. 79
Insert PrintCart 093-971 ⇕ Flip Insert MagentaCartridge	The Magenta Cartridge is either missing or not fully inserted into the printer. Open the Side Cover and make sure that the Magenta Cartridge have been fully installed. Please click the Show Me How Button for details. 093-971	<IOT MCRU Detached> Magenta Cartridge detached is detected.	Flows 80 FIP-1. 80
Insert PrintCart 093-972 ⇕ Flip Insert Cyan Cartridge	The Cyan Cartridge is either missing or not fully inserted into the printer. Open the Side Cover and make sure that the Cyan Cartridge have been fully installed. Please click the Show Me How Button for details. 093-972	<IOT C CRU Detached> Cyan Cartridge detached is detected.	Flows 81 FIP-1. 81

Error Message		Error Contents	FIP to be referred
Panel Message	Status Window		
Insert PrintCart 093-973 ⇕ Flip Insert Black Cartridge	The Black Cartridge is either missing or not fully inserted into the printer. Open the Side Cover and make sure that the Black Cartridge have been fully installed. Please click the Show Me How Button for details. 093-973	<IOT K CRU Detached> Black Cartridge detached is detected.	Flows 82 FIP-1. 82
Ready to Print 094-422 ⇕ Flip Contact Support IfMessageReturns	Printer error. Contact customer support if this failure is repeated. 094-422	<IOT Transfer Belt Life Pre Warning> The Transfer Assy is going to reach the replacement time.	Flows 83 FIP-1. 83
094-911 Contact Support ⇕ Flip 094-911 IfMessageReturns	Printer error. Contact customer support if this failure is repeated. 094-911	<IOT Transfer Belt Life Over> Transfer Assy has reached the replacement time.	Flows 83 FIP-1. 83
Ready to Print 193-700 ⇕ Flip Non-Dell Toner Installed	No Message.	<Custom Toner Mode> Printer is in the Customer Toner Mode.	Flows 84 FIP-1. 84

3. ERROR CODE FIP

3.1 Troubleshooting for the call center

Flows 1 001-360 Restart Printer

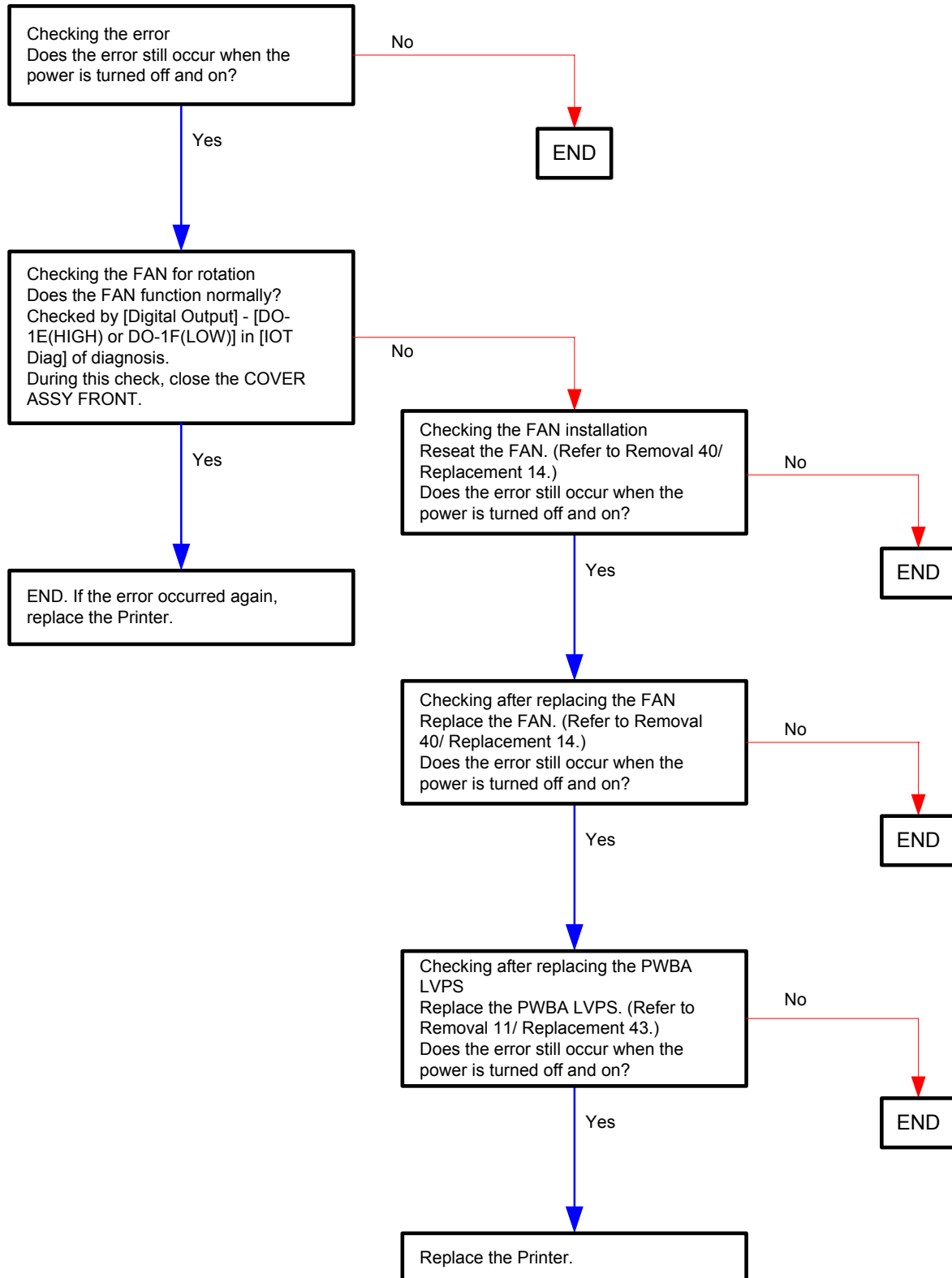

Flows 2 003-340 Restart Printer

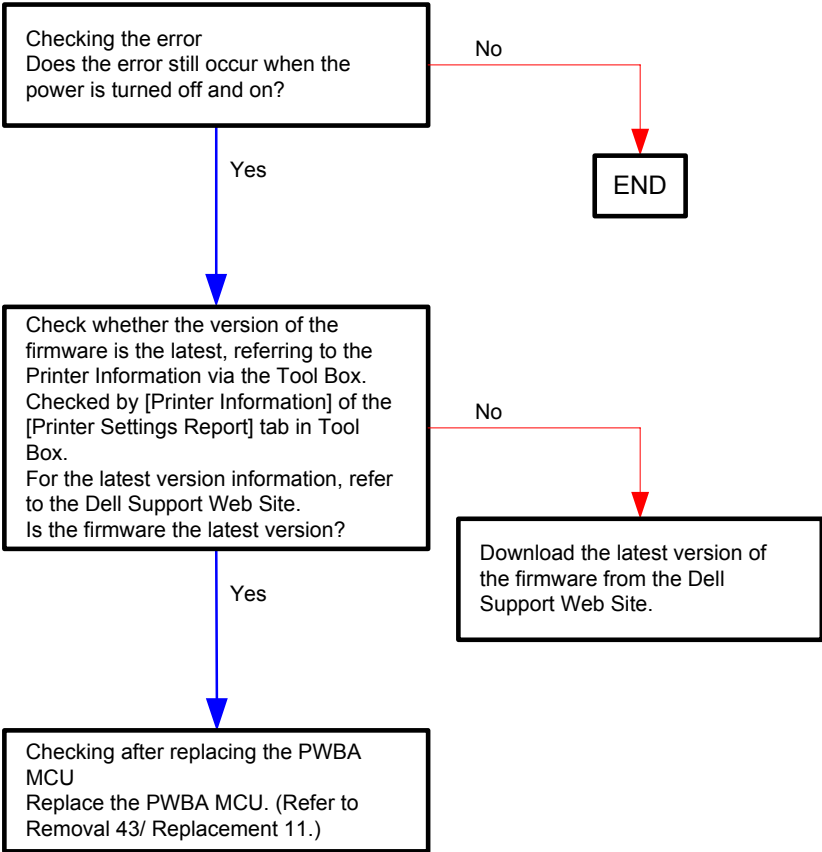

Flows 3 003-356 Restart Printer

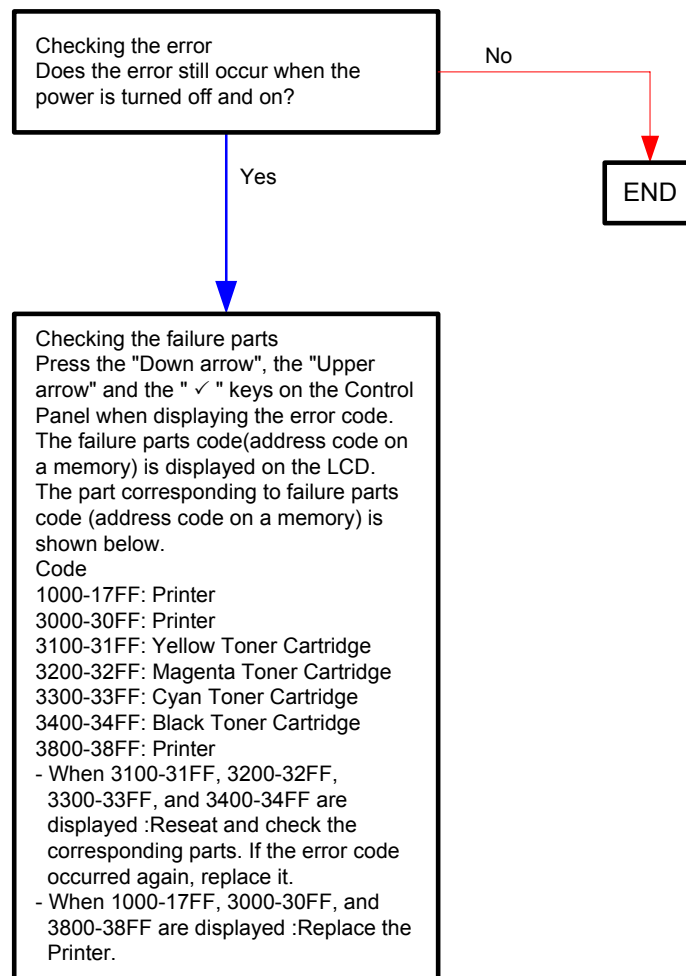

Flows 4 004-310 Restart Printer

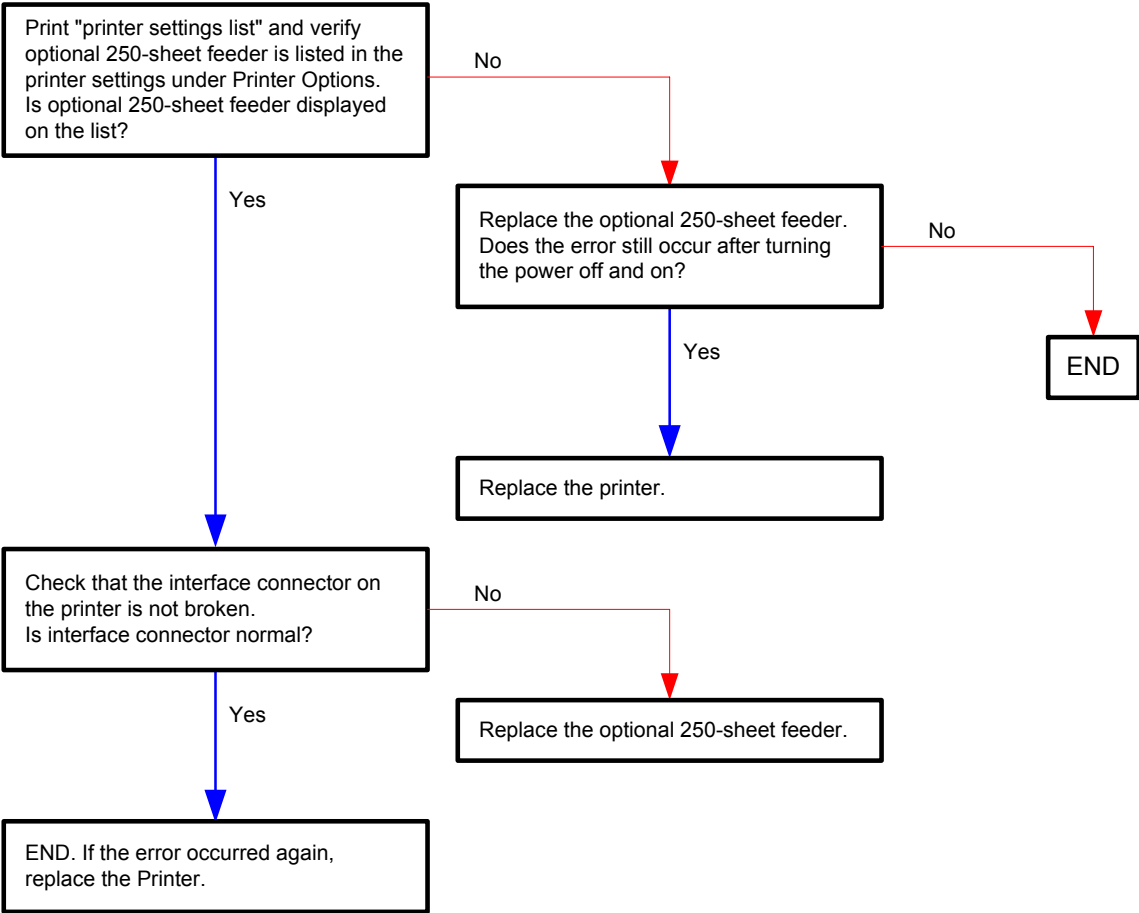

Flows 5 004-311 Restart Printer

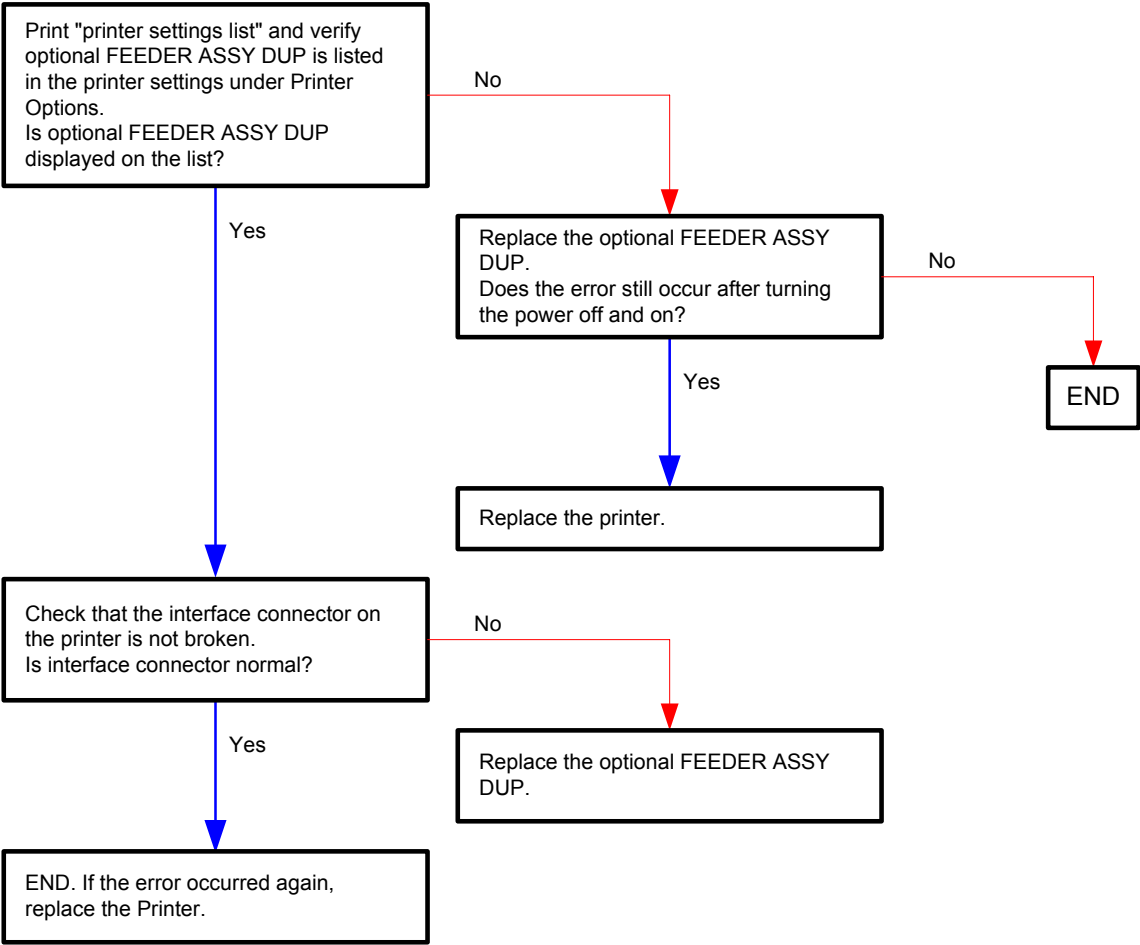

Flows 6 006-370 Restart Printer

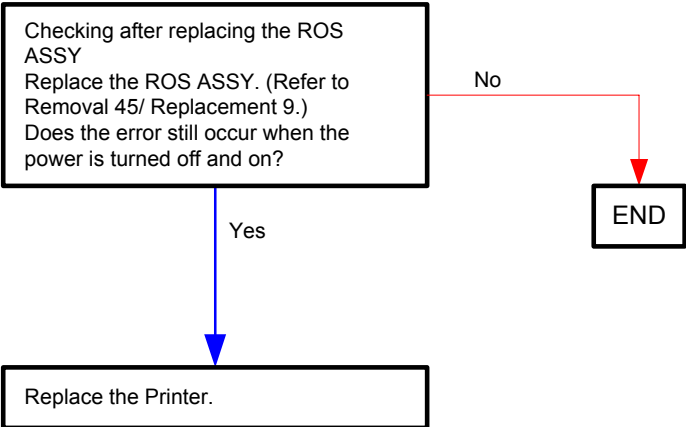

Flows 7 007-340 Restart Printer

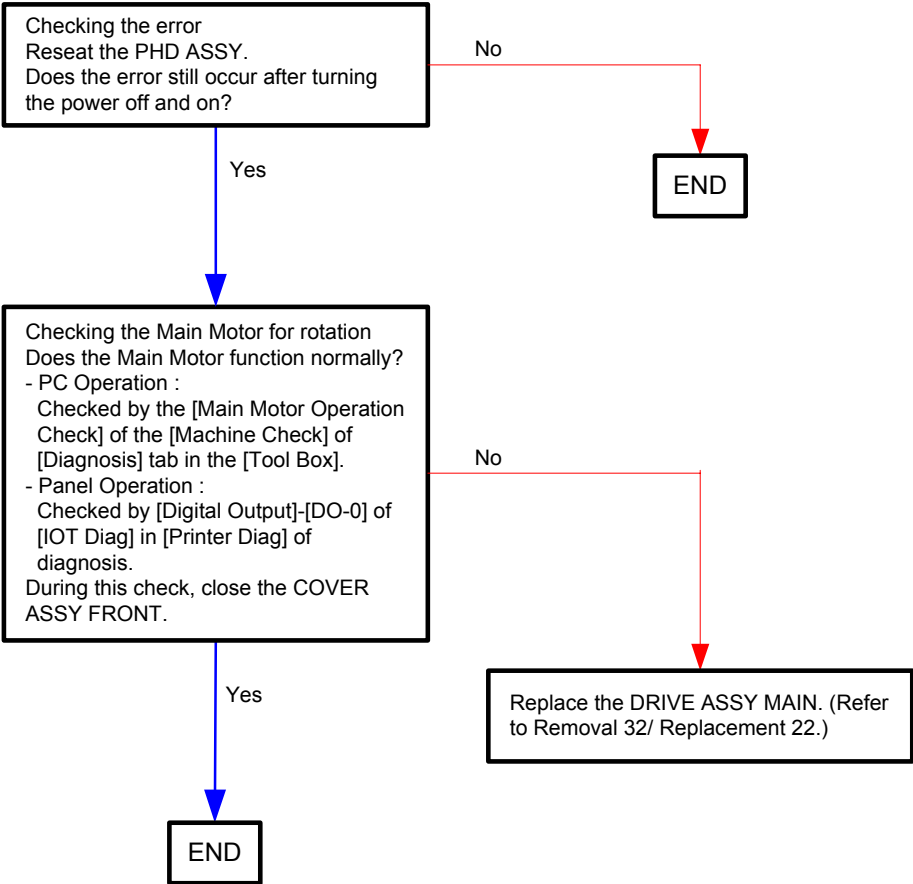

Flows 8 007-341 Restart Printer

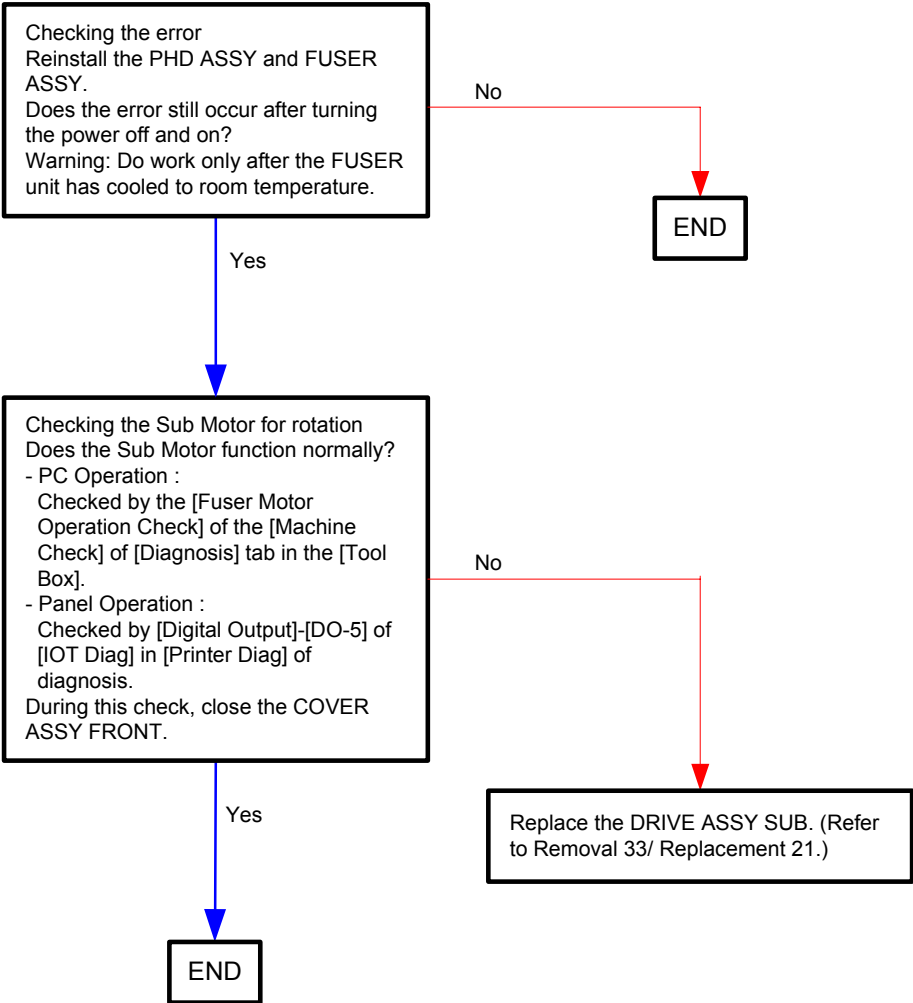

Flows 9 007-371/007-372 Restart Printer

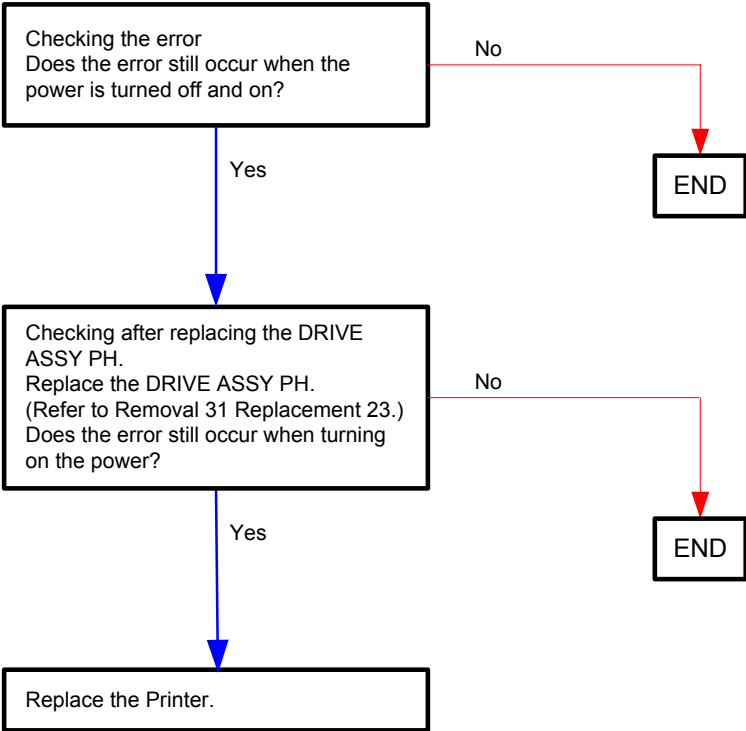

Flows 10 009-340 Restart Printer (Yellow Toner)



Work before troubleshooting.
Check the protection sheet on the PHD ASSY.
if there is the protection sheet, remove it.

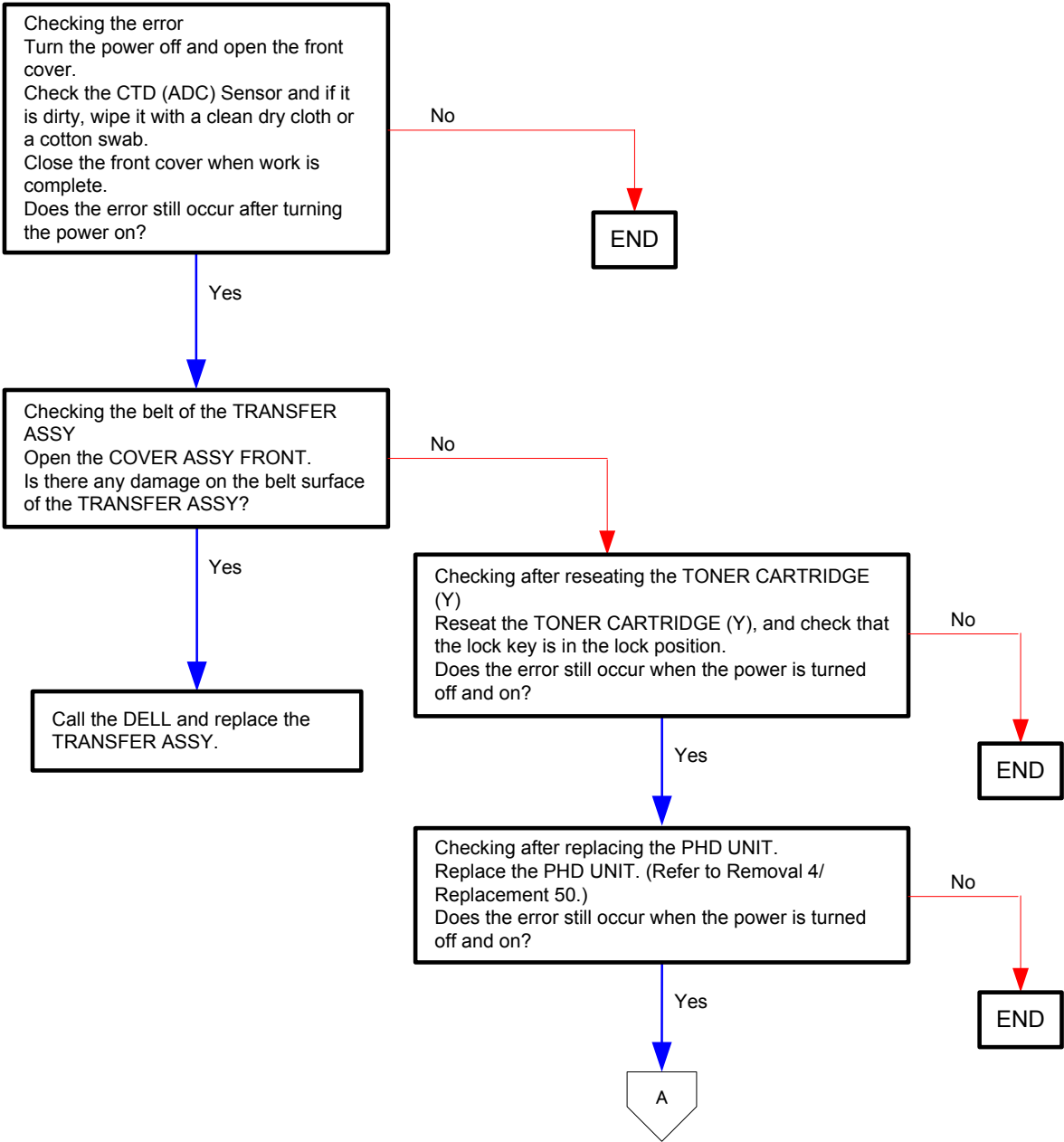

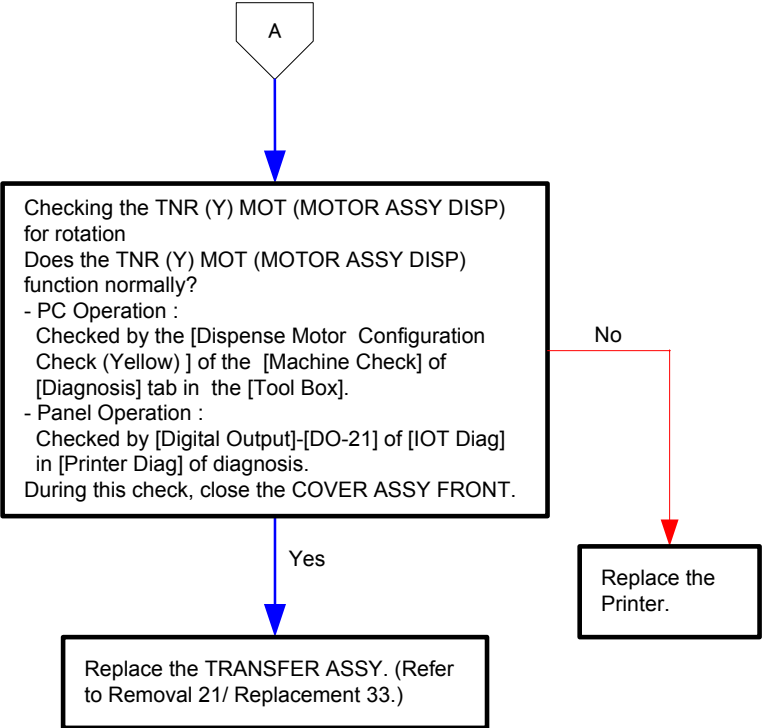

Flows 11 009-340 Restart Printer (Magenta Toner)



Work before troubleshooting.
Check the protection sheet on the PHD ASSY.
if there is the protection sheet, remove it.

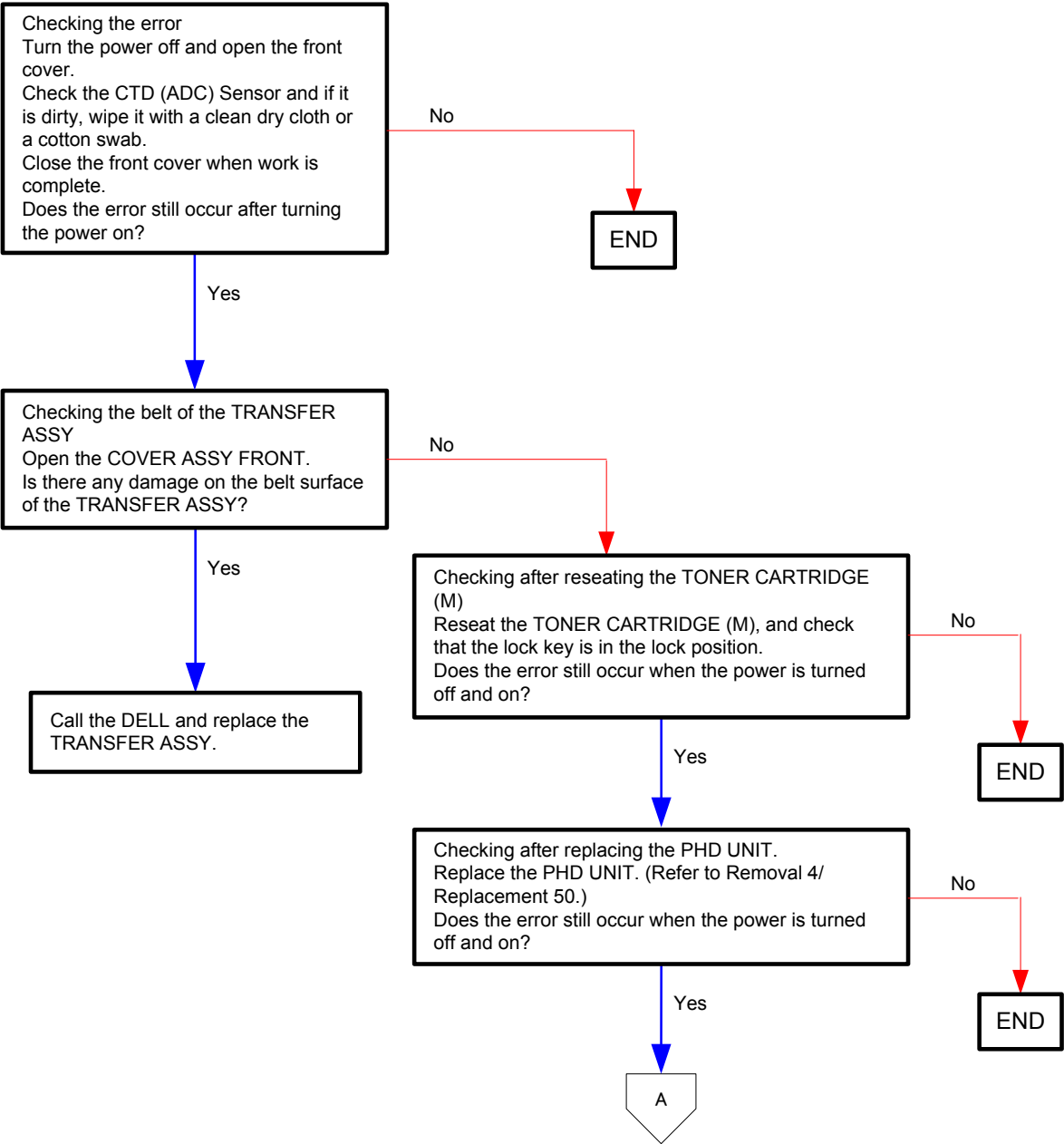

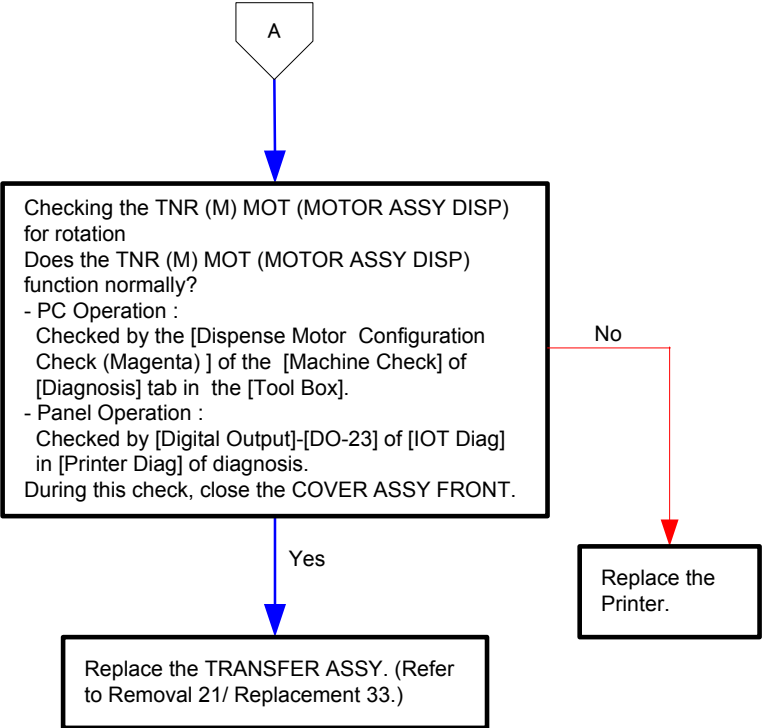

Flows 12 009-340 Restart Printer (Cyan Toner)



Work before troubleshooting.
Check the protection sheet on the PHD ASSY.
if there is the protection sheet, remove it.

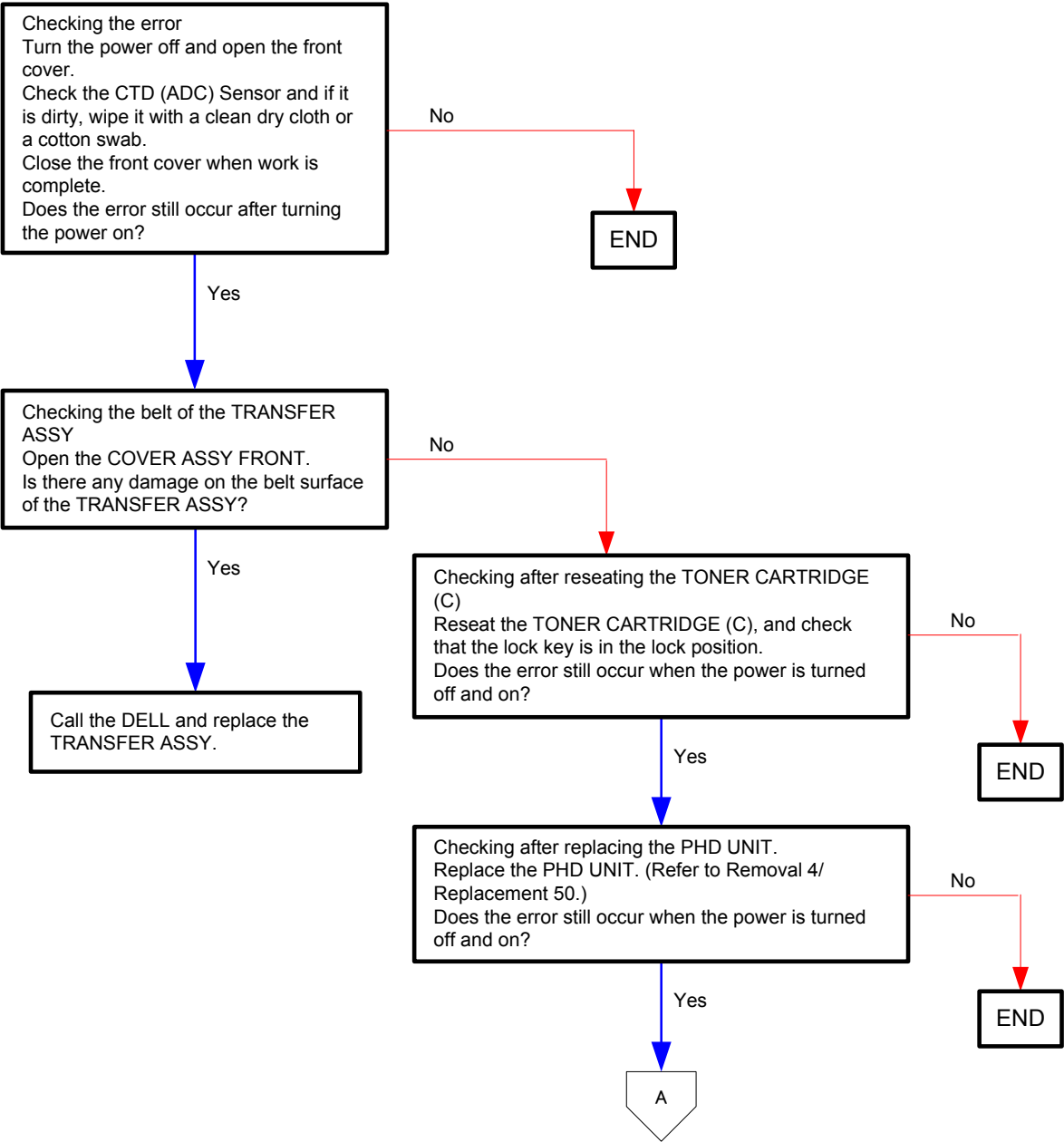

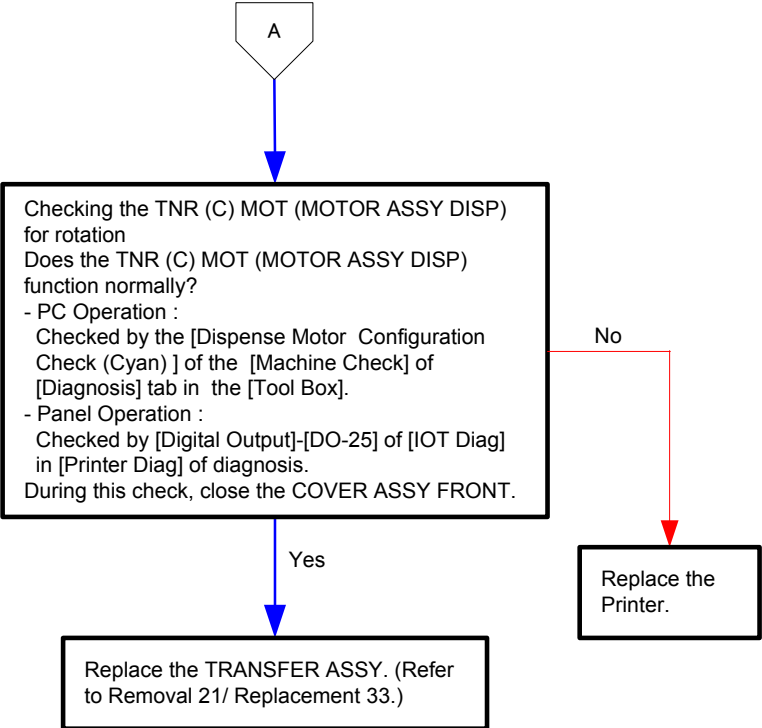

Flows 13 009-340 Restart Printer (Black Toner)



Work before troubleshooting.
Check the protection sheet on the PHD ASSY.
if there is the protection sheet, remove it.

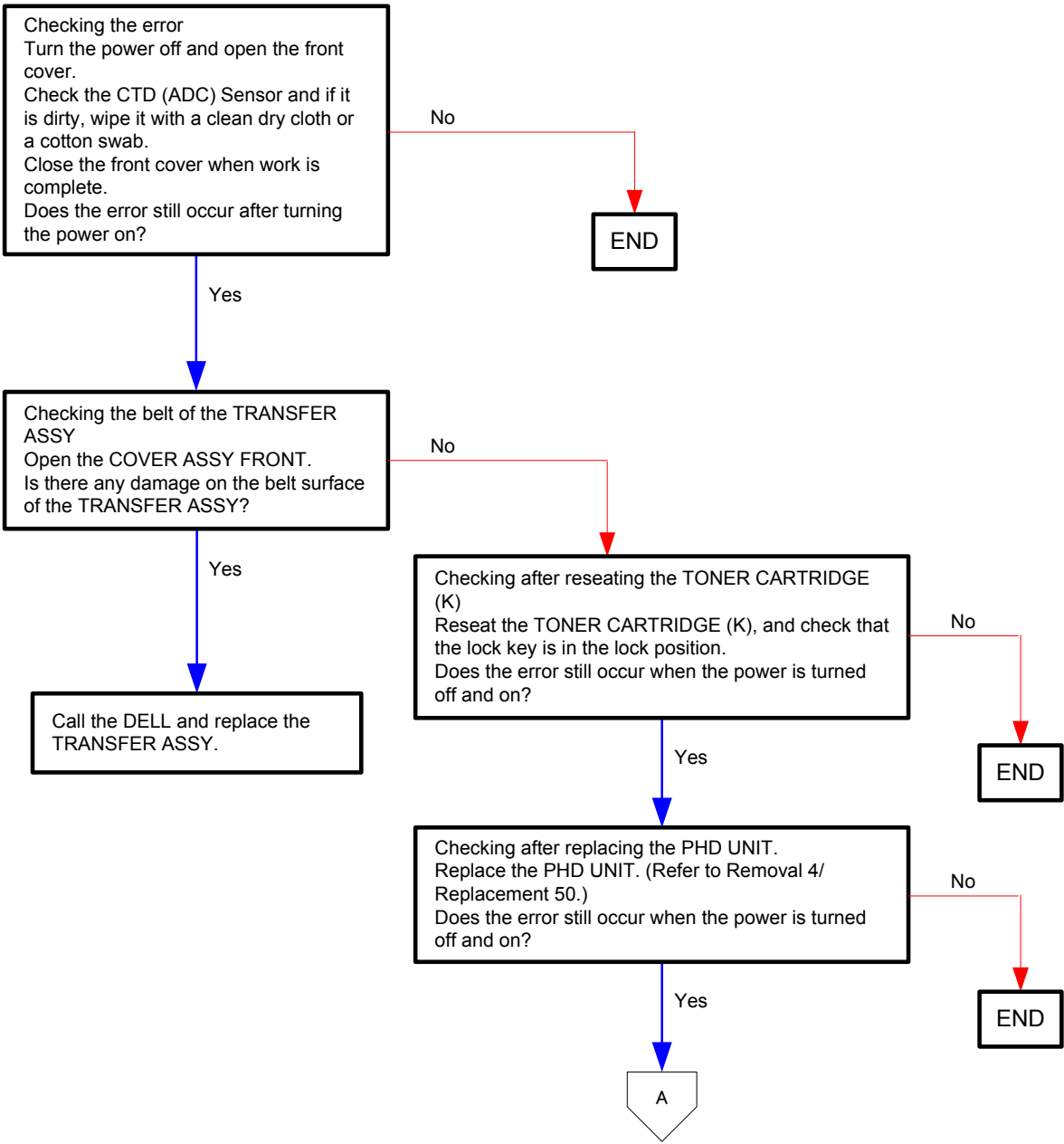

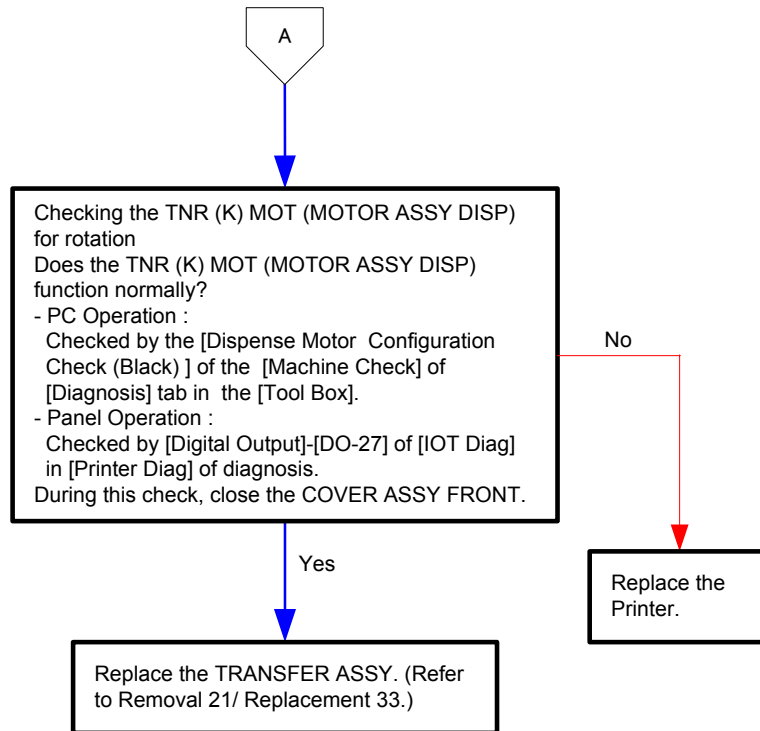

Flows 14 010-317 Restart Printer

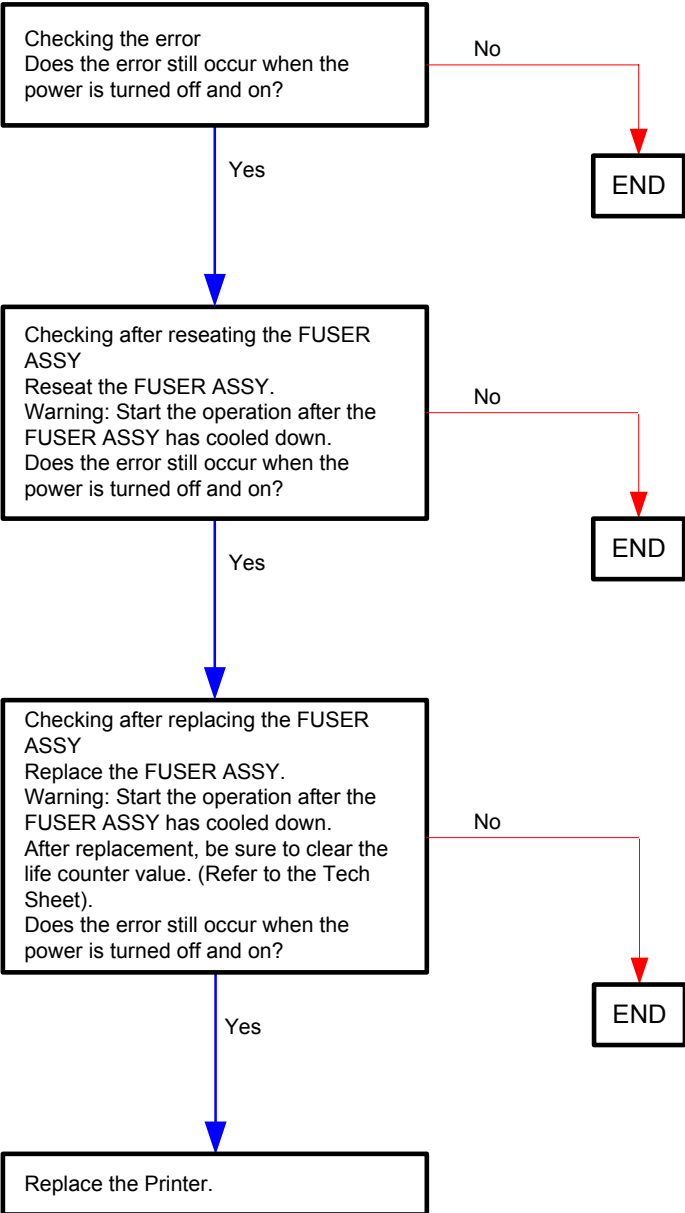

Flows 15 010-351 Restart Printer

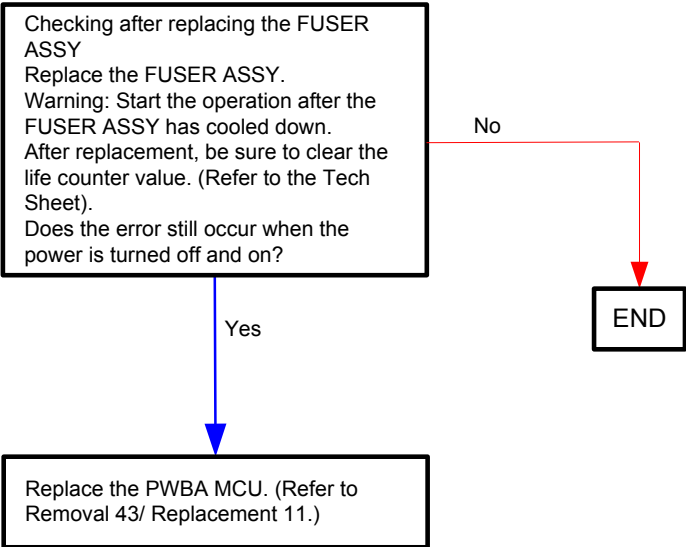

Flows 16 010-354 Restart Printer

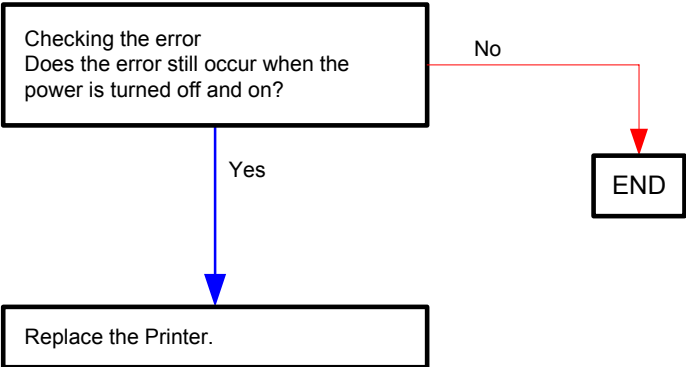

Flows 17 010-377 Restart Printer

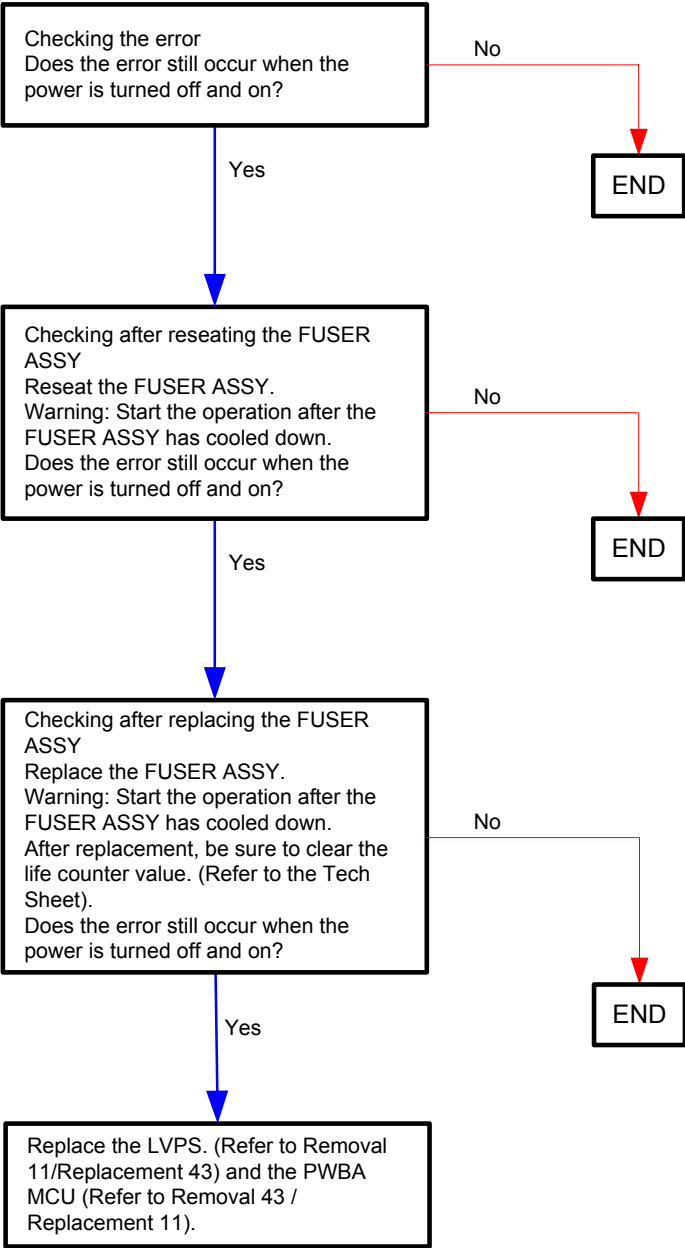

Flows 18 Ready to Print 010-421

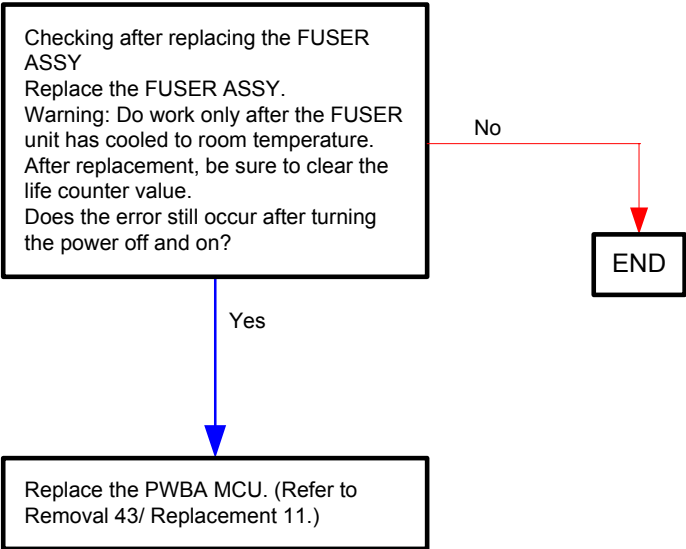

Flows 19 016-300/016-301/016-302/016-313/016-315/016-317/016-323/016-327/
016-344/016-345/016-346/016-347 Restart Printer

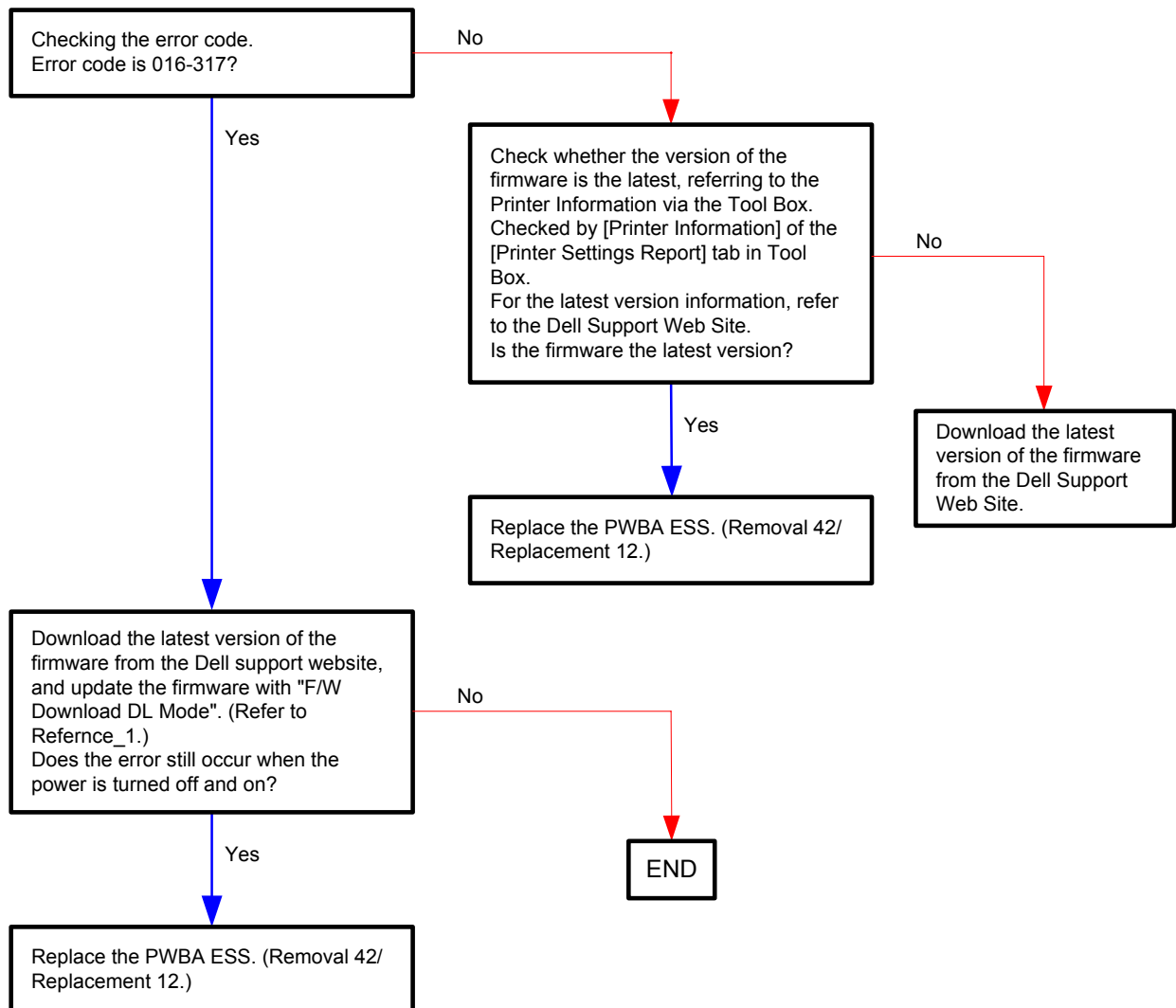

Reference_1:

1. Make sure that the printer is connected to the computer via USB port (remove the network cable). Then, try downloading as follows:
 - 1) Power on the printer while pressing the <X Cancel> and <✓> buttons.
 - 2) The printer goes into the Download Mode with a message "Download Mode Ready". Then, activate firmware update tool and follow the instruction displayed.

NOTE

While the firmware download is being executed, the printer displays a message "Writing...USB F/W" and the computer displays a progress bar and may be restarted during the downloading process. Never power off the printer or the computer until the downloading process completes, and never interrupt the downloading process.

Flows 19-1 016-340 Restart Printer

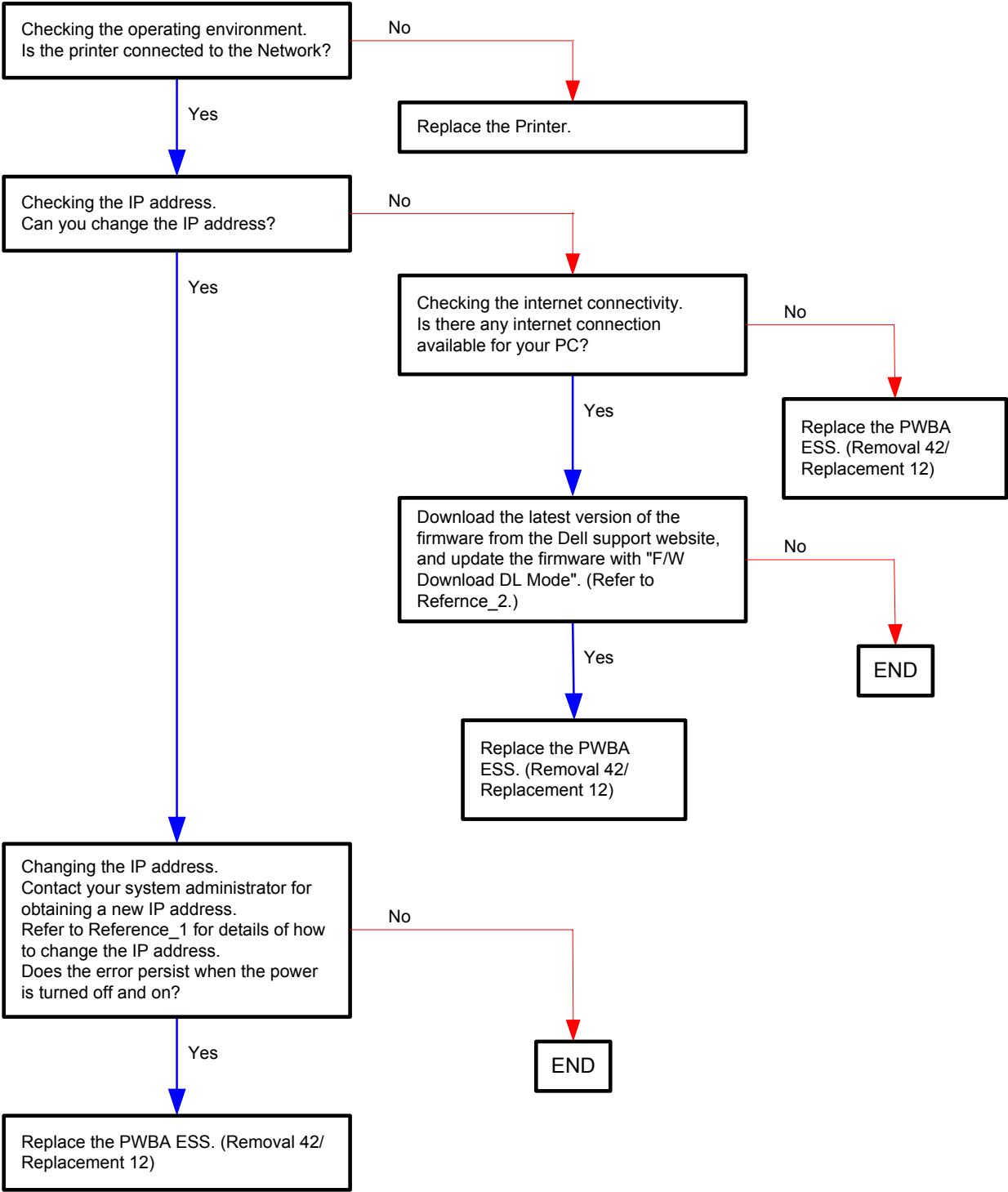

Reference_1: Changing the IP address

- 1) Remove the network cable, and power off the printer and then on
- 2) Change the IP address on the Control Panel.
- 3) Plug the network cable back into the printer, and then turn the power on.
- 4) On the Control Panel, open [Admin] > [Network] > [TCP/IP], and confirm that the IP address has been changed.

Reference_2:

1. Make sure that the printer is connected to the computer via USB port (remove the network cable). Then, try downloading as follows:
 - 1) Power on the printer while pressing the <X Cancel> and <✓> buttons.
 - 2) The printer goes into the Download Mode with a message "Download Mode Ready". Then, activate firmware update tool and follow the instruction displayed.

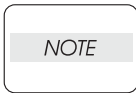

While the firmware download is being executed, the printer displays a message "Writing...USB F/W" and the computer displays a progress bar and may be restarted during the downloading process. Never power off the printer or the computer until the downloading process completes, and never interrupt the downloading process.

Flows 20 016-316/016-318 Restart Printer

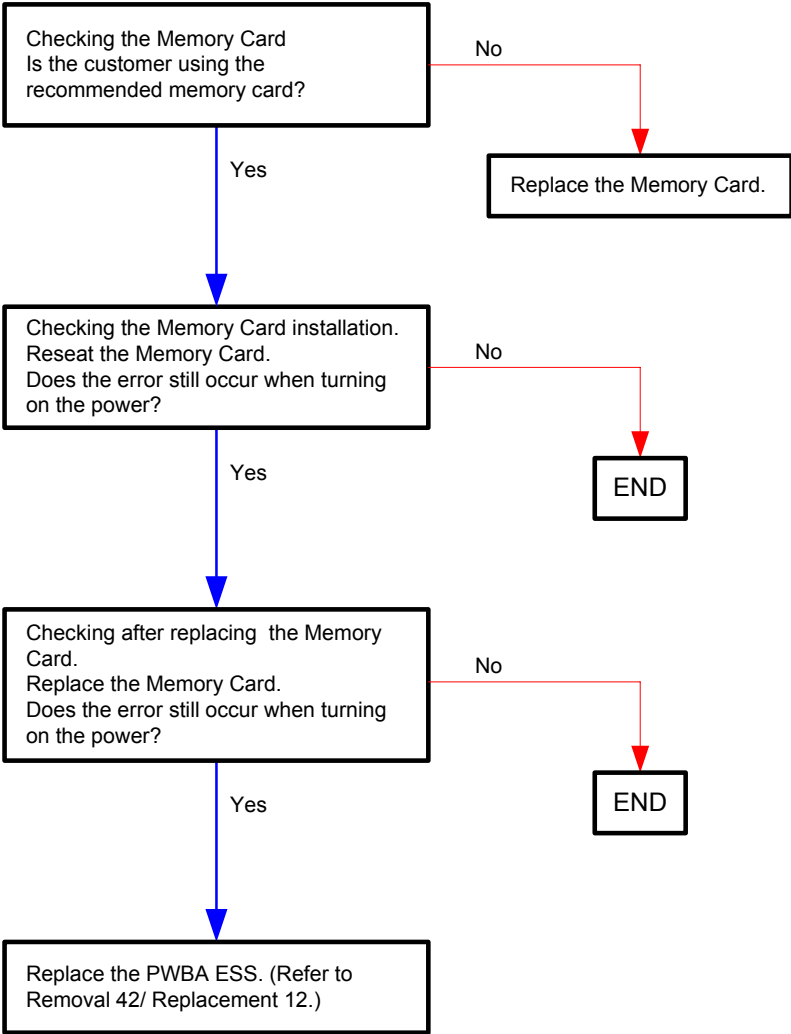

Flows 21 016-338 Restart Printer

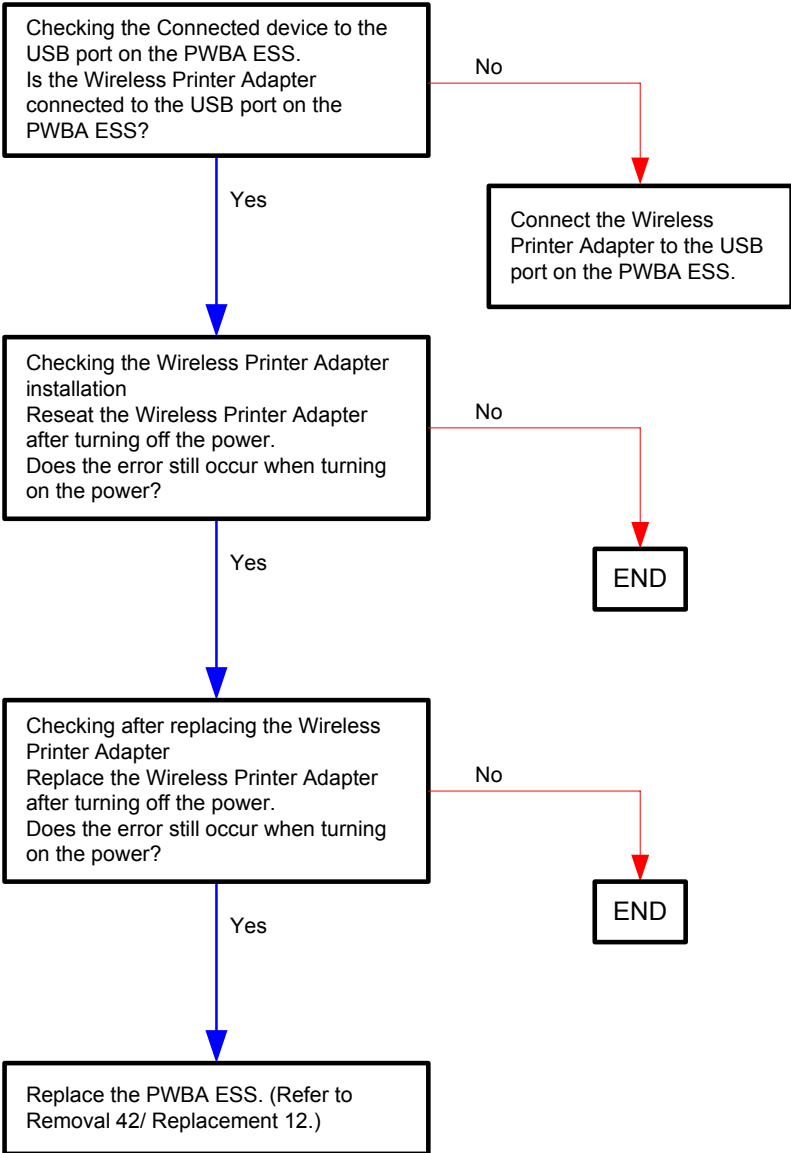

Flows 22 016-365 Restart Printer

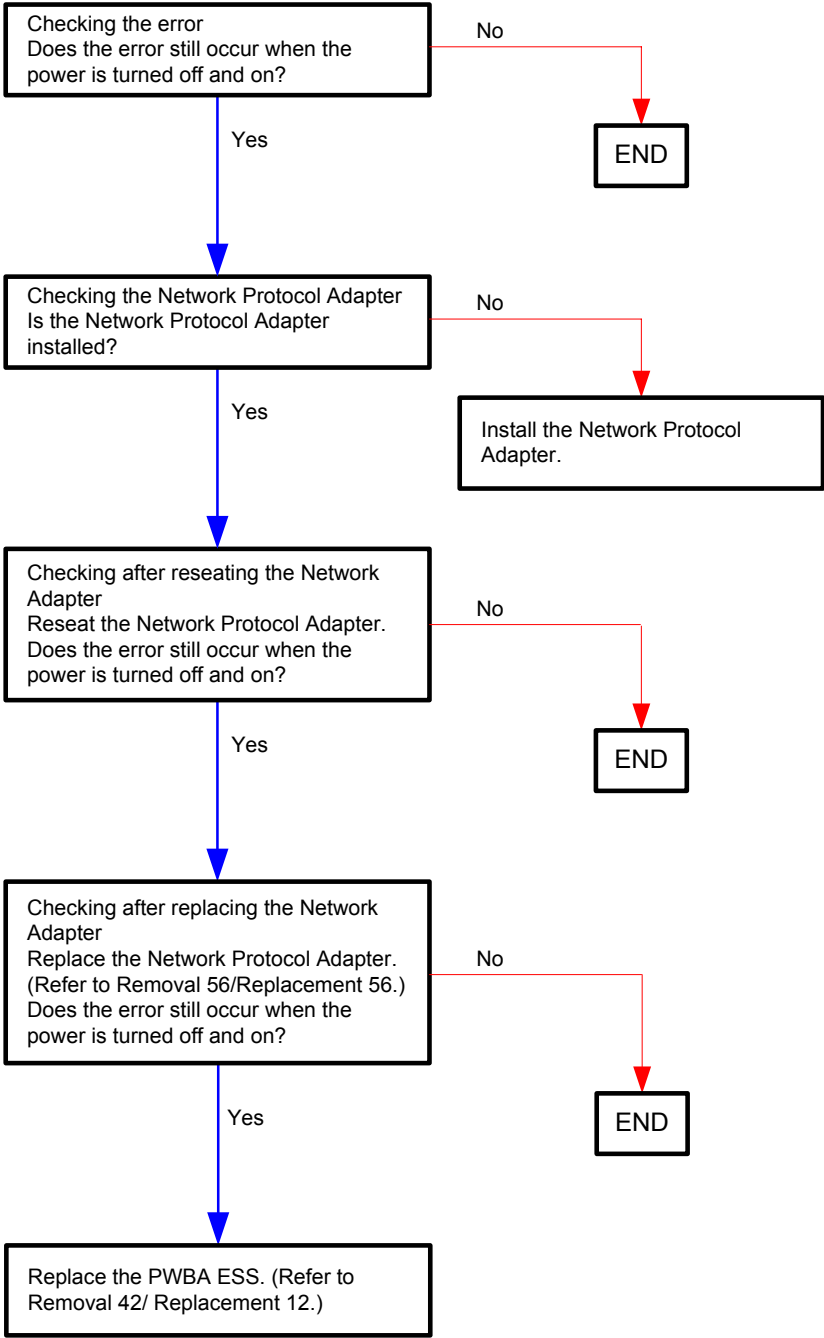

NOTE

- This error is displayed when the Network Protocol Adapter is installed on the printer and then removed, or when a contact failure has occurred at the Network Protocol Adapter.

Reinstalling the Network Protocol Adapter allows you to use the printer as it was before the error occurred.

- To return the printer to the state it was in before the Network Protocol Adapter was installed, reset the printer using the following procedure.

<Reset Procedure>

1. Power OFF the printer.
2. Power ON the printer while pressing the [MENU] button and [✓ (SET)] button at the same time.

Keep the buttons pressed until the message "Reset Security Init Network" is displayed.

3. Press the [✓ (SET)] button.
4. Press the [✓ (SET)] button when the message "Init Network Are you sure?"
5. Power OFF the printer and then ON when the message "Reset Security Init Network" is displayed.

- In the event of loss of the Network Protocol Adapter, the following network protocols will be unavailable. To use these protocols, purchase and install a new Network Protocol Adapter.

802.1x (Wired), NetWare (IP), SNMPv3, HTTPS or WSD (Print)

To use the printer without using the functions of the Network Protocol Adapter while waiting for a new Network Protocol Adapter to be delivered, reset the printer.

Flows 23 016-370 Restart Printer

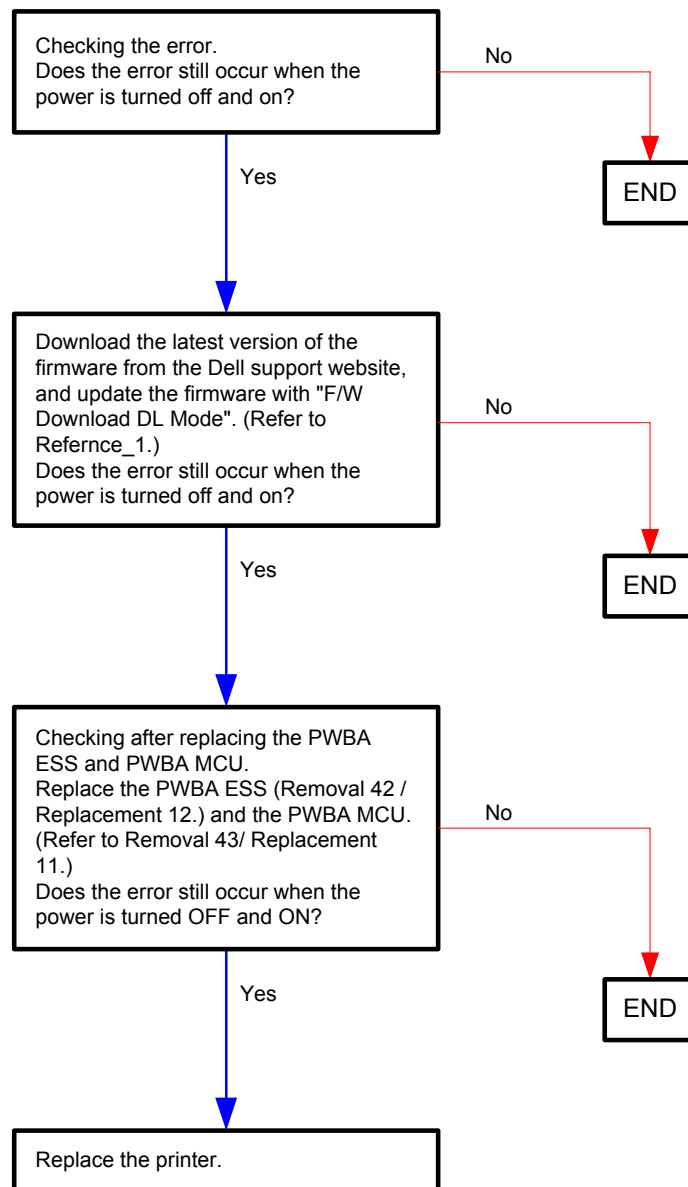

Reference_1:

1. Make sure that the printer is connected to the computer via USB port (remove the network cable). Then, try downloading as follows:
 - 1) Power on the printer while pressing the <X Cancel> and <✓> buttons.
 - 2) The printer goes into the Download Mode with a message "Download Mode Ready". Then, activate firmware update tool and follow the instruction displayed.

NOTE

While the firmware download is being executed, the printer displays a message "Writing...USB F/W" and the computer displays a progress bar and may be restarted during the downloading process. Never power off the printer or the computer until the downloading process completes, and never interrupt the downloading process.

Flows 24 Invalid ID 016-383 / Range Chk Error 016-384 / Header Error 016-385 / Check Sum Error 016-386 / Protection Error 016-391 / Erase Flash Err. 016-392 / Write Flash Err. 016-393 / Verify Error 016-394

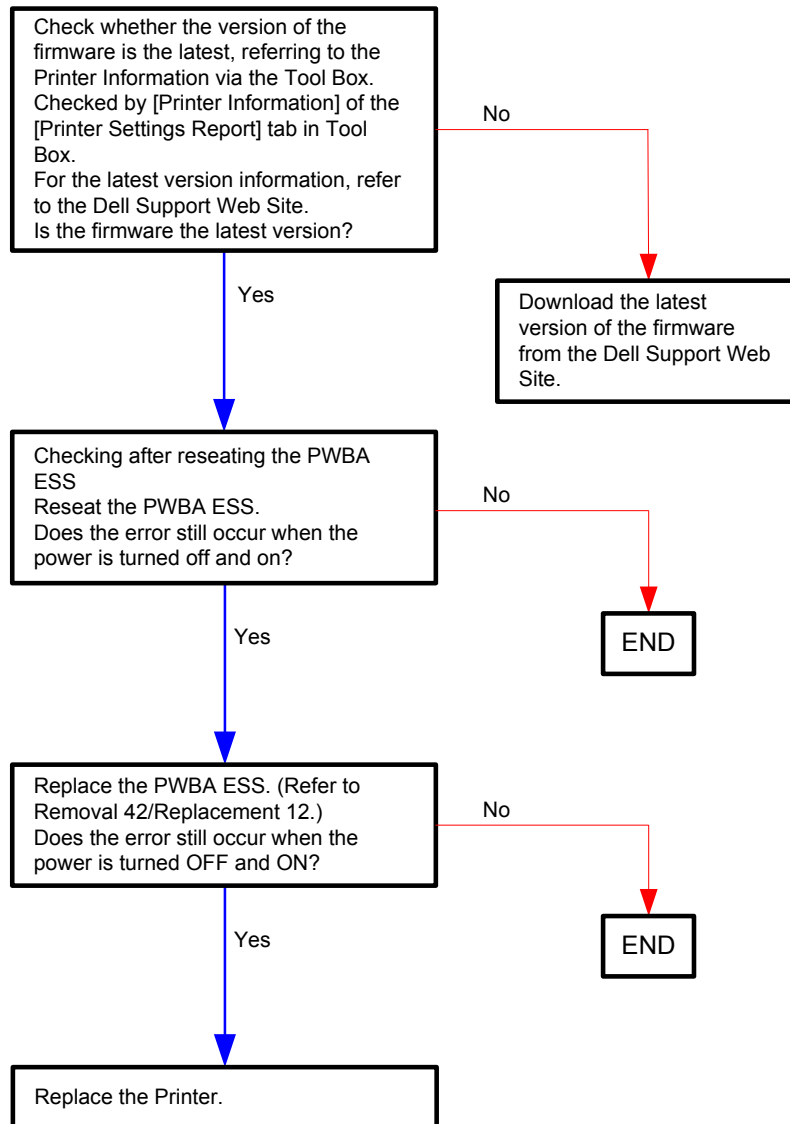

Flows 25 Out of Memory 016-700

NOTE

- Errors may be avoided by the following measures:
- When the RAM disk is set to "Available", cancel it or reduce the disk capacity.
 - Add the optional memory.

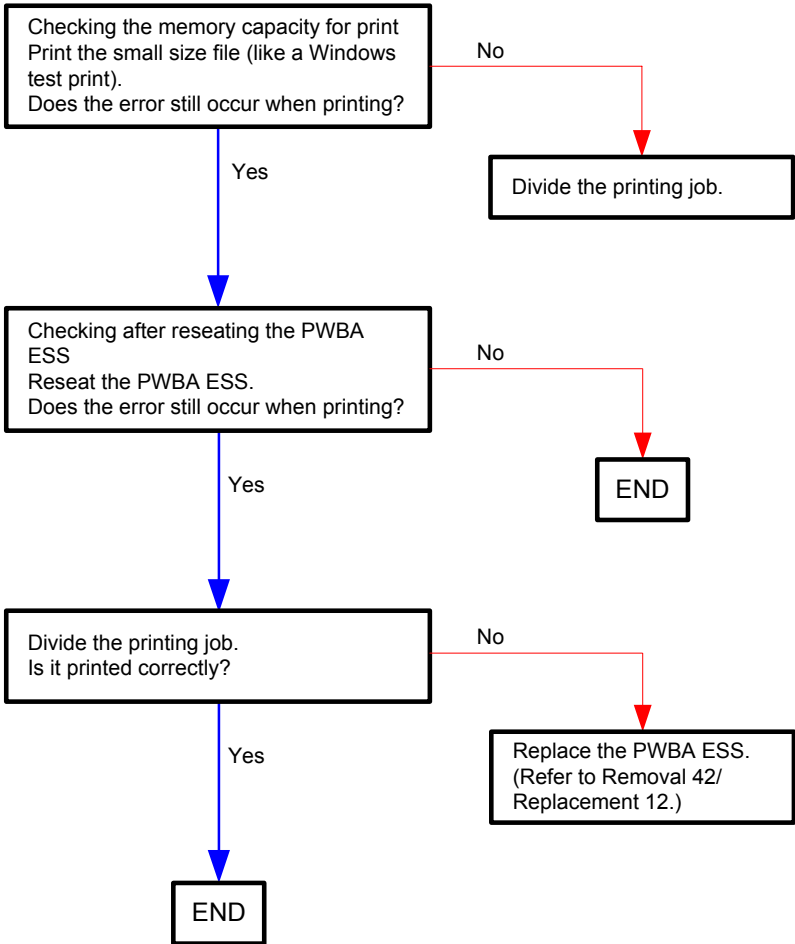

Flows 26 PDL Request 016-720

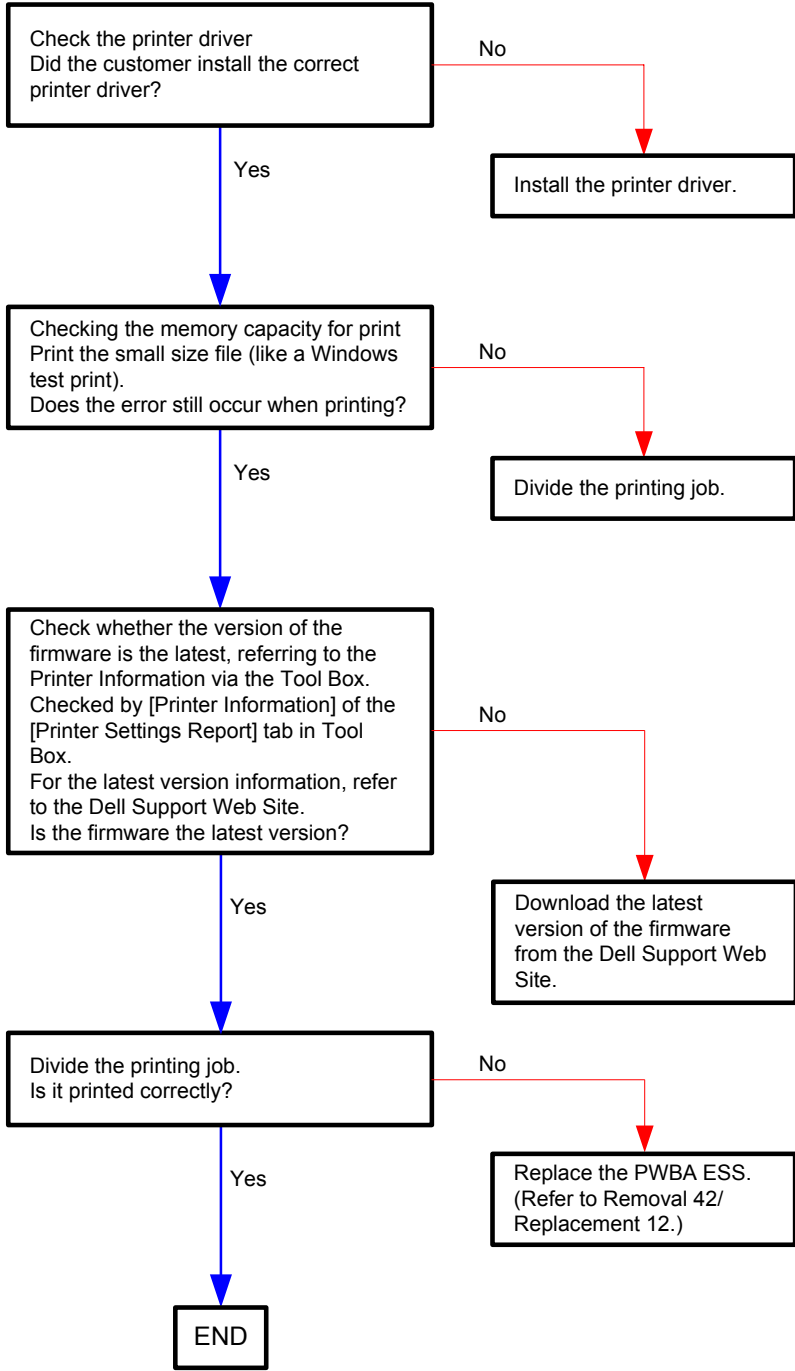

Flows 27 Invalid User 016-757

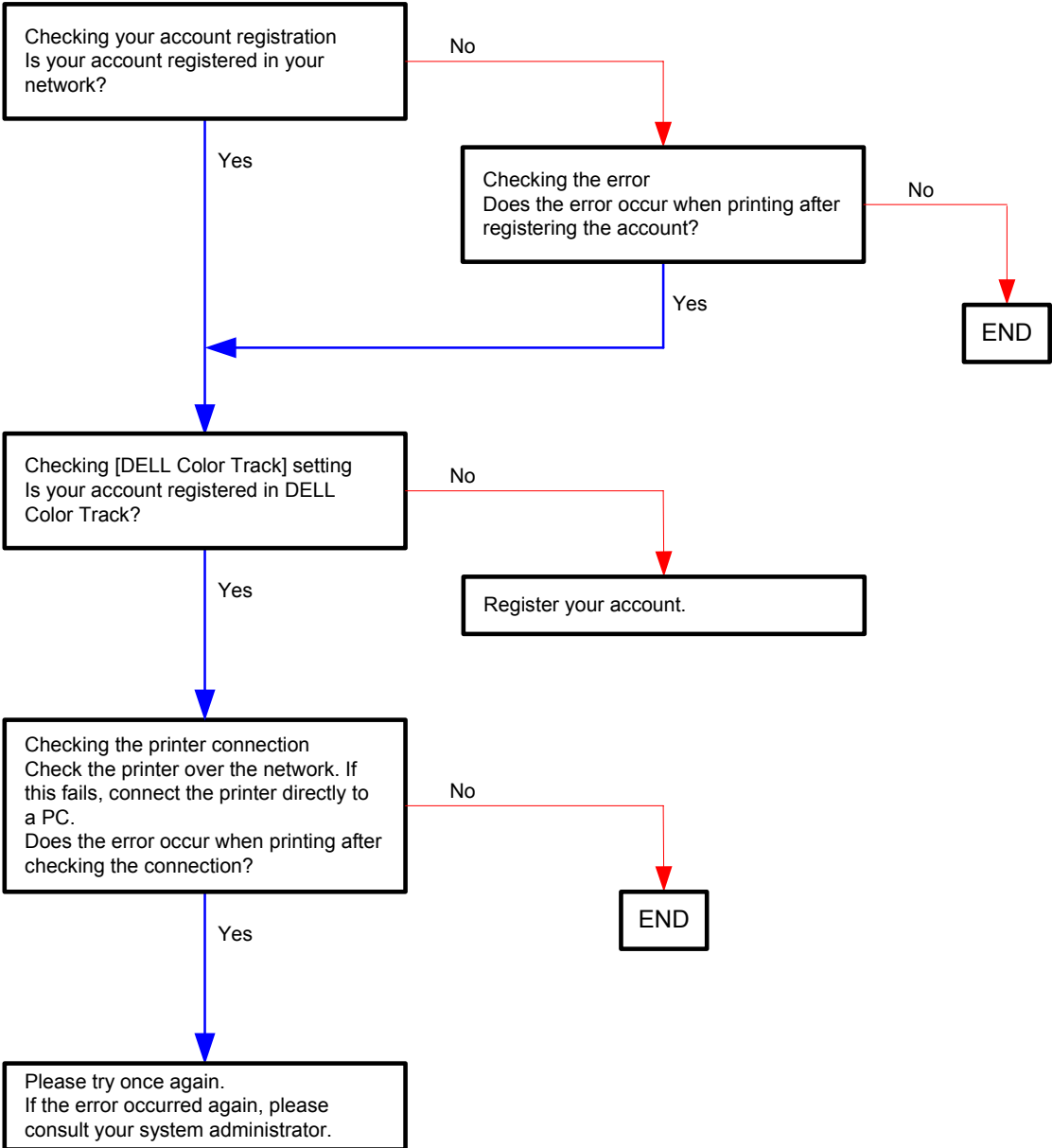

Flows 28 Disabled Func 016-758

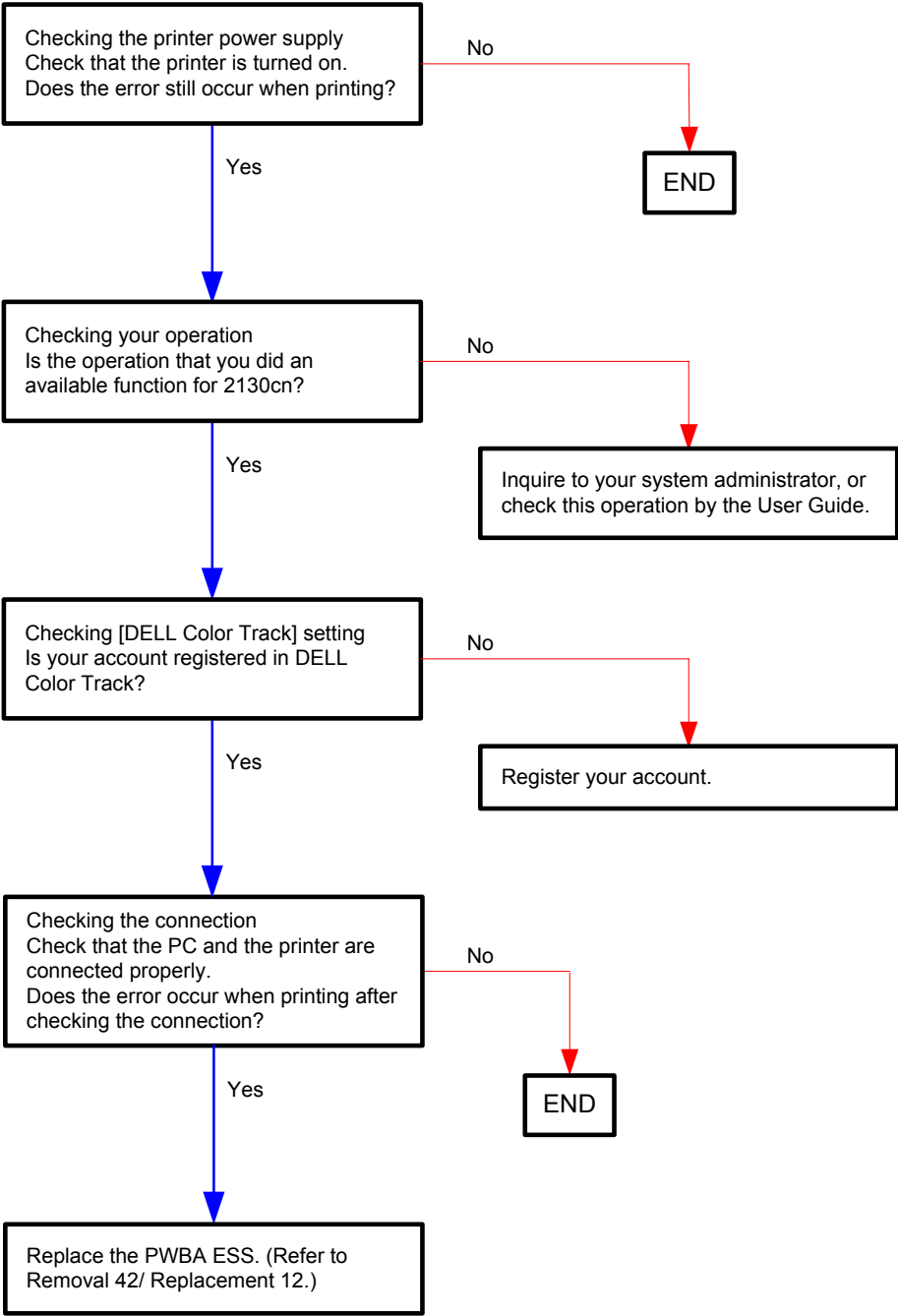

Flows 29 Reached Limit 016-759

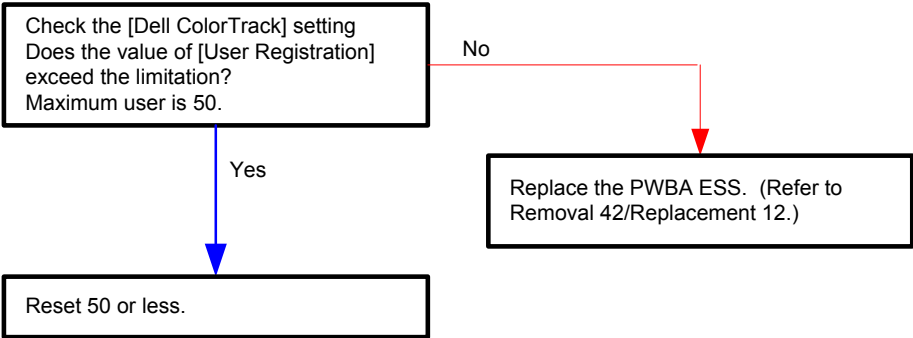

Flows 30 Invalid Job 016-799

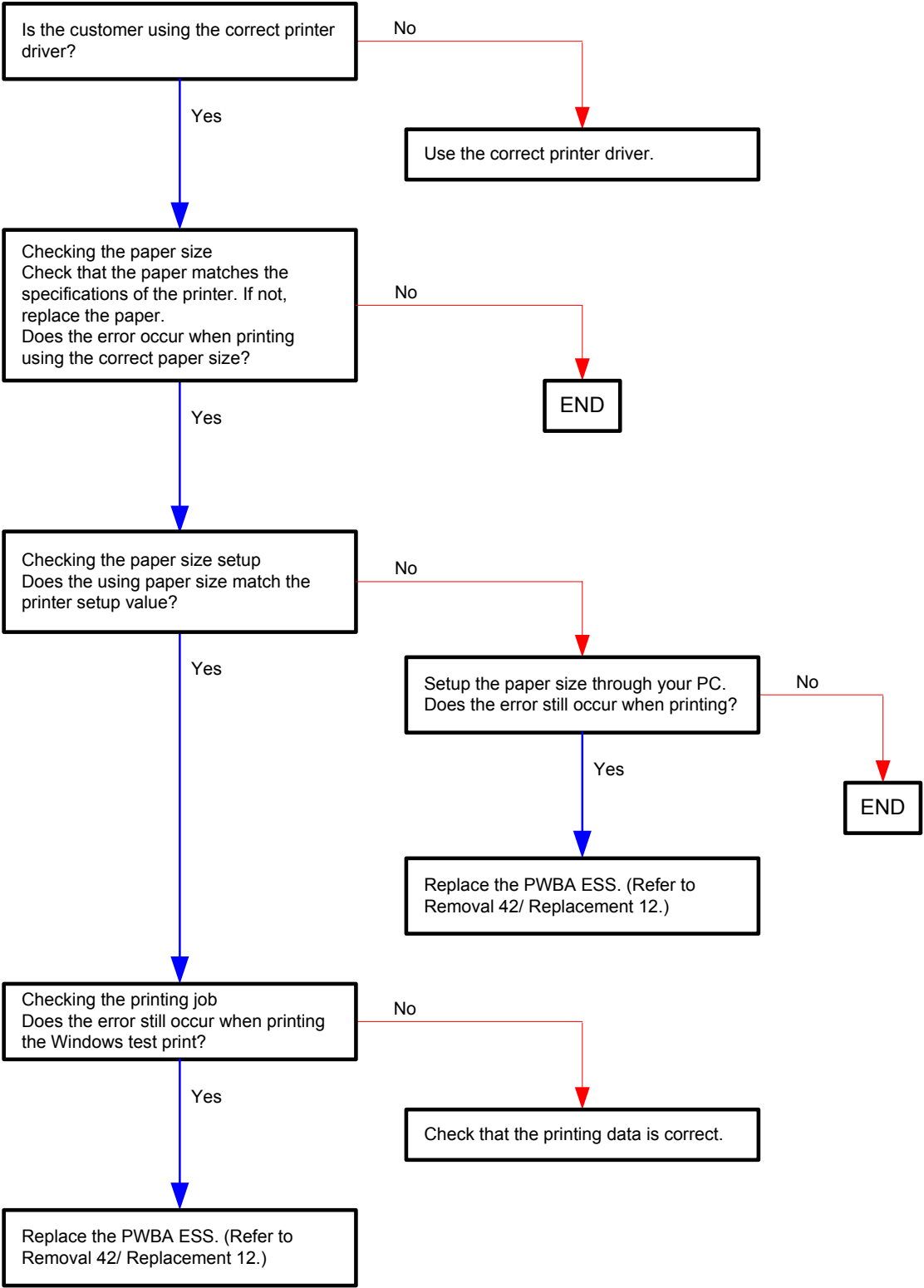

Flows 31 Disk Full 016-980

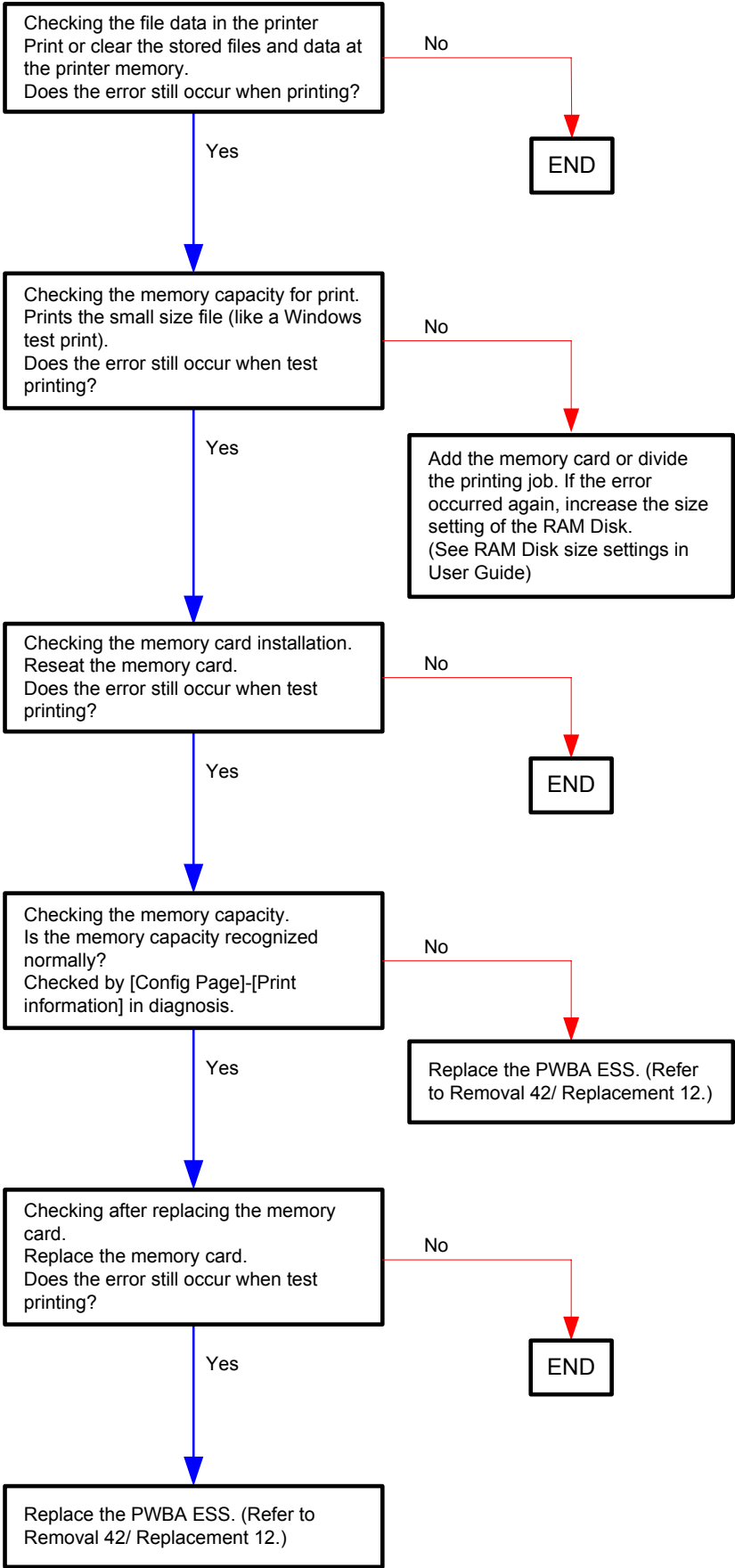

Flows 32 Collate Full 016-981

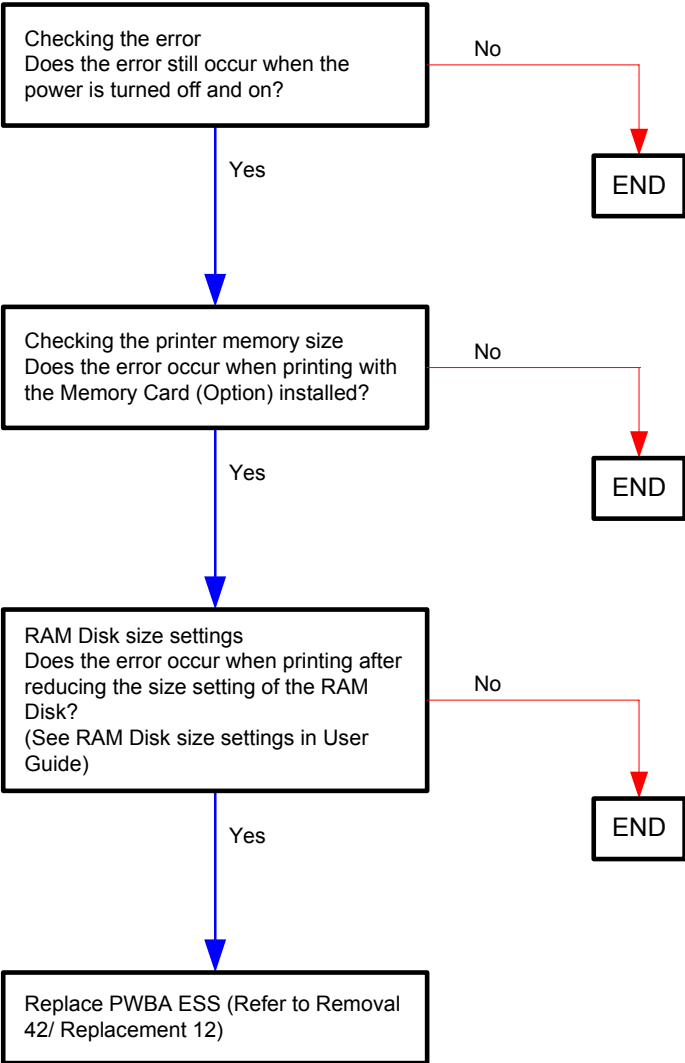

Flows 33 MCU Flash Error 024-360

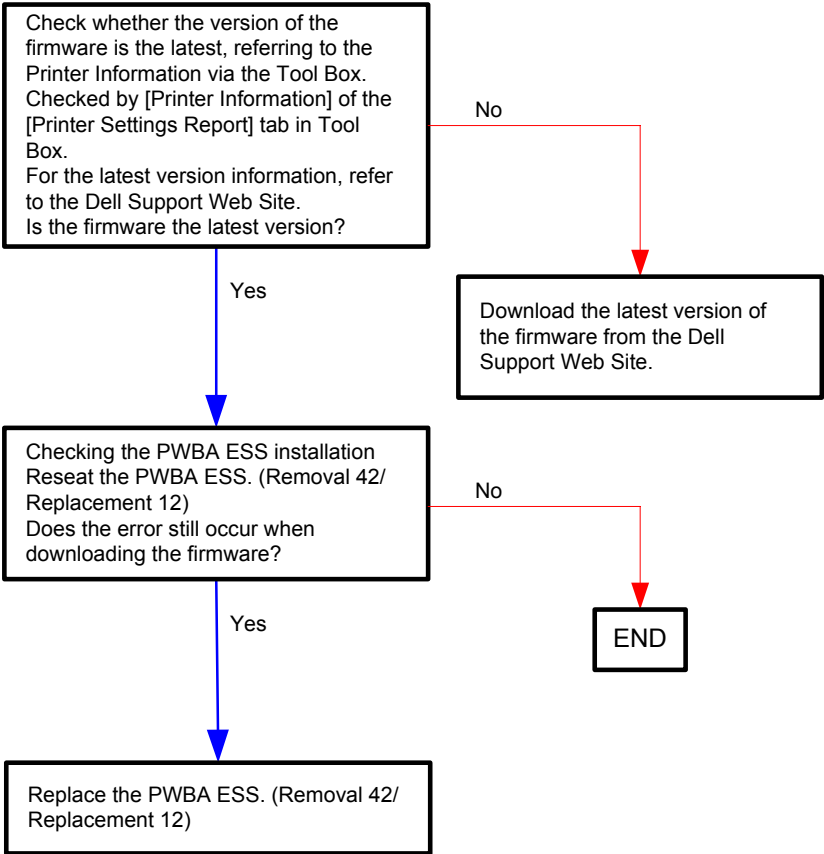

Flows 34 024-362 Restart Printer

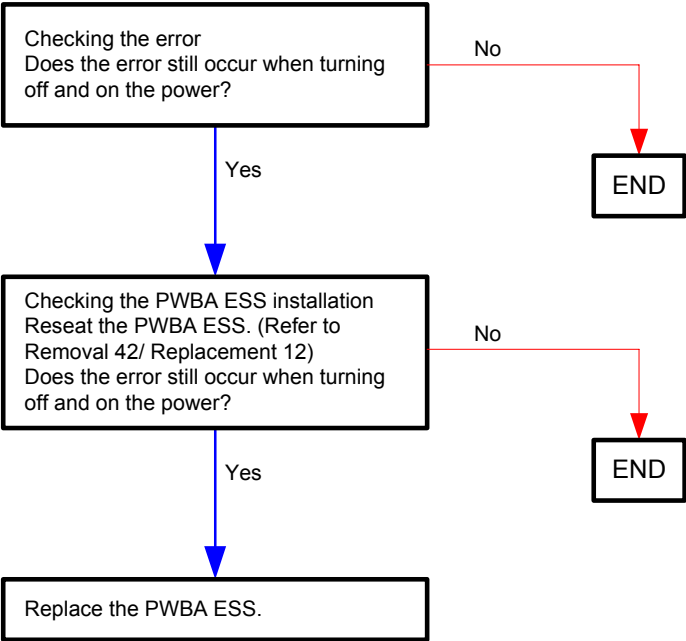

Flows 35 Check Paper Size 024-910

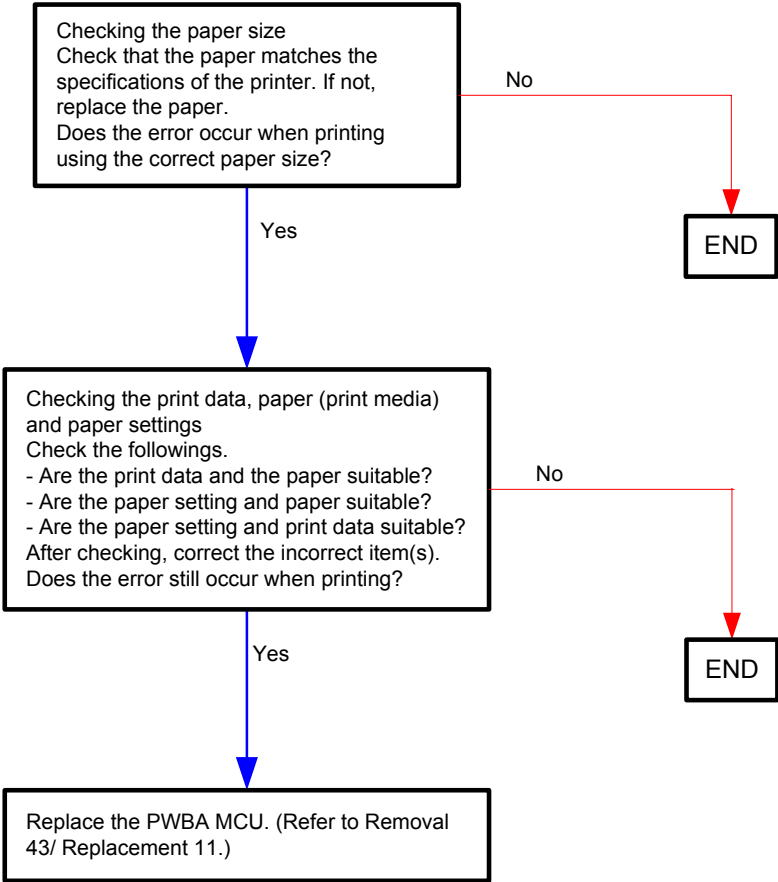

Flows 36 Check Paper Size 024-911

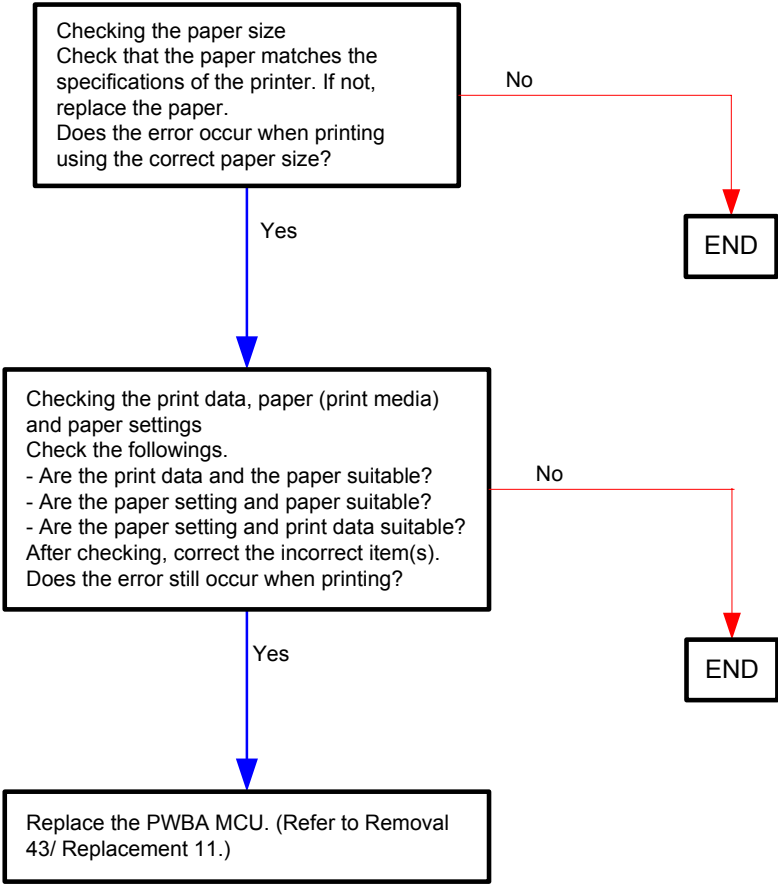

Flows 37 Check Paper Size 024-914

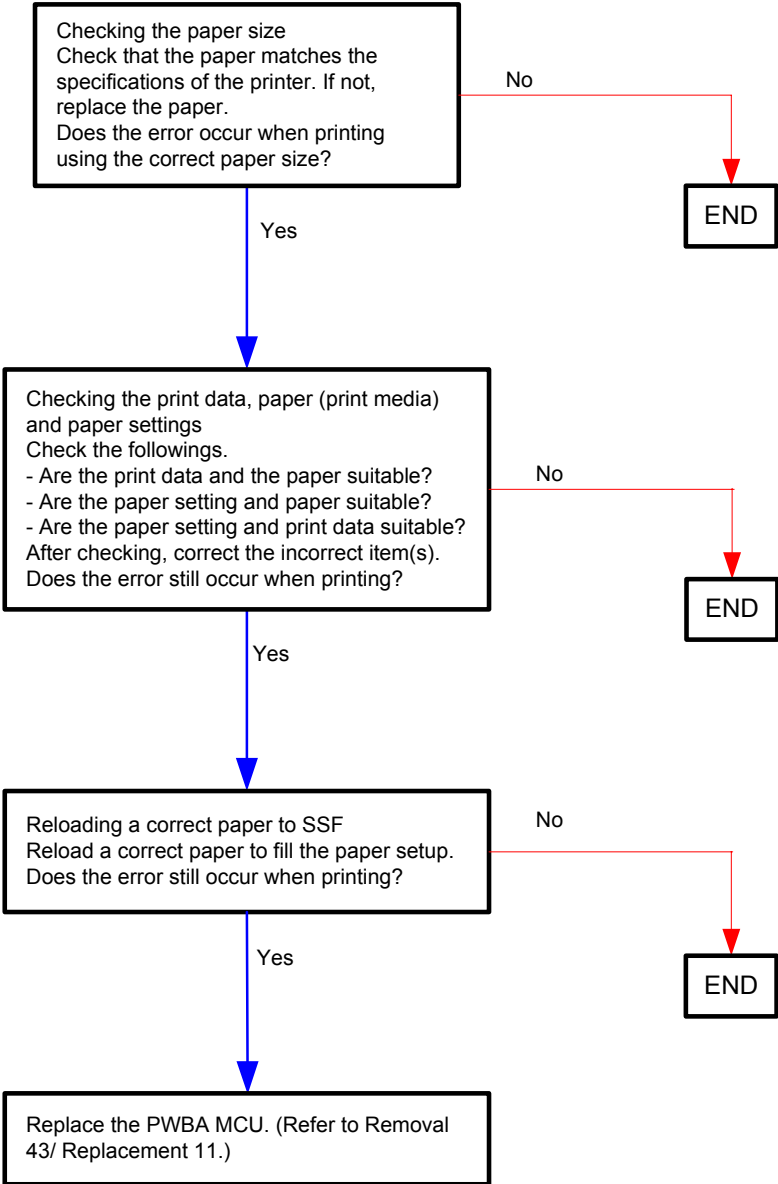

Flows 38 Load Tray 1 024-965

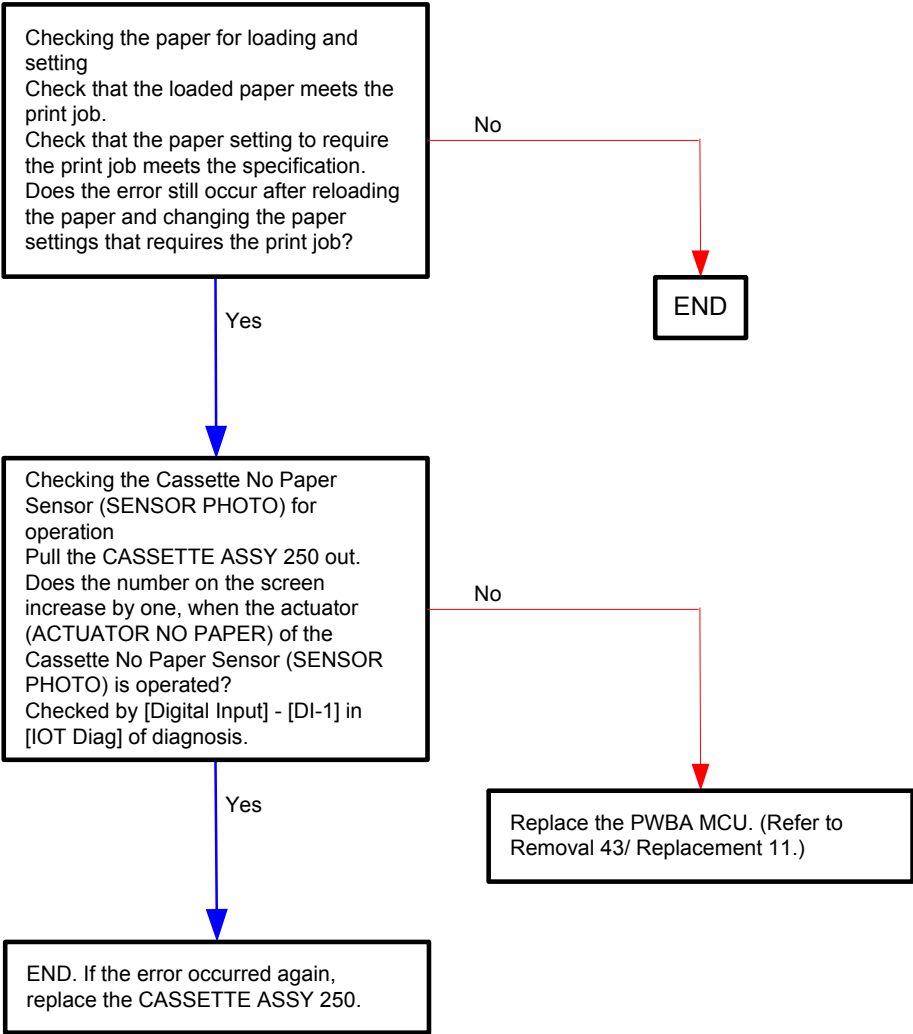

Flows 39 Load Tray 2 024-966

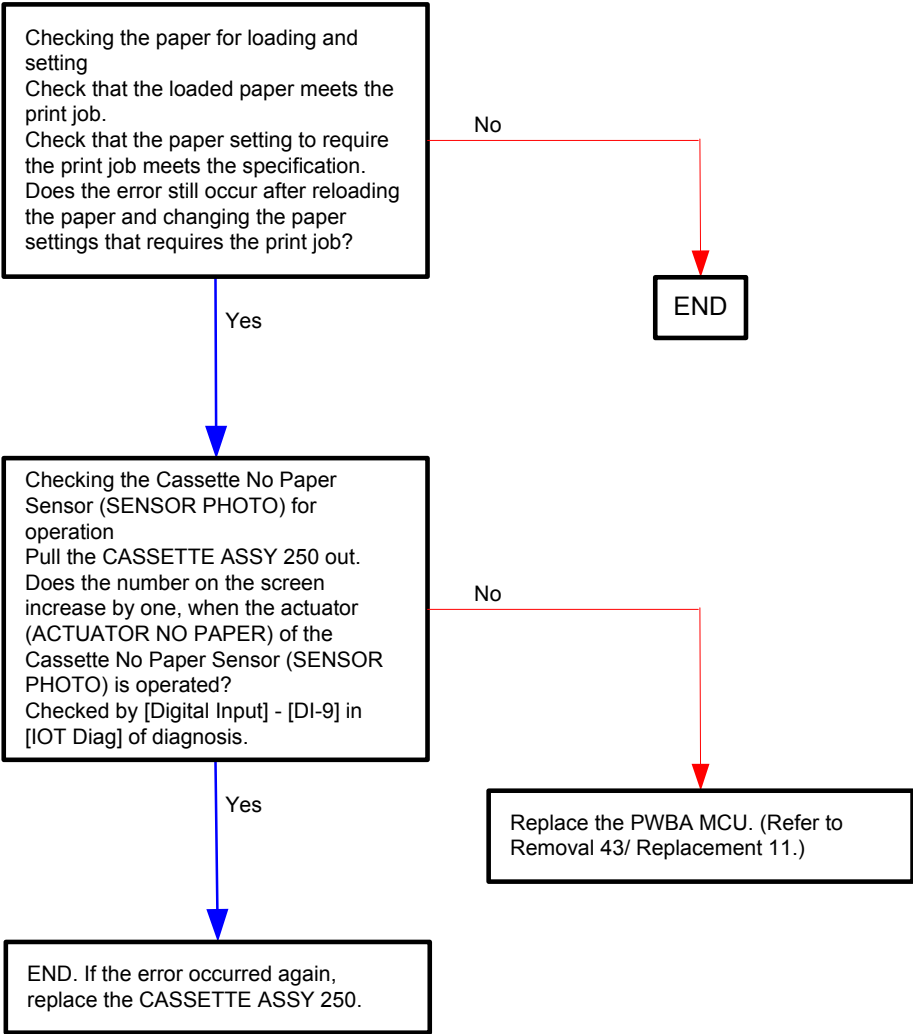

Flows 40 Load SSF 024-969 / Pause Feed SSF 024-985 / Check SSF 075-923

NOTE

When loading a sheet to the SSF, ensure that the lead edge of the sheet touches the back of the SSF (as far as 8 to 10cm from the lead edge). Otherwise, this error may occur.

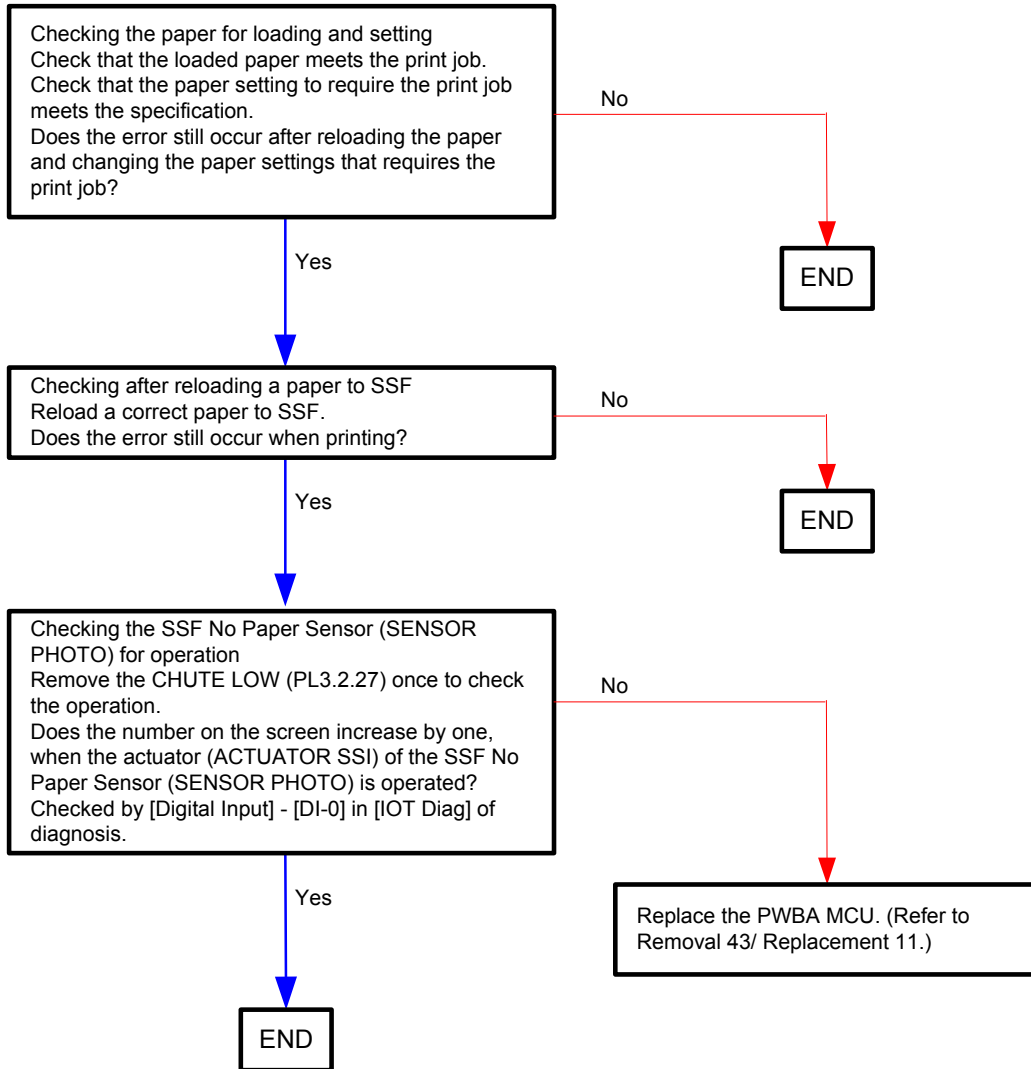

Flows 41 Over Heat 042-700

NOTE

This error occurs when the internal temperature of the printer rises to somewhere near the predetermined value during a high volume 2-sided print. Although this error is automatically recovered when the printer's internal temperature falls to a certain level, it takes a long time before the recovery.

When performing a high volume 2-sided print, divide the job in blocks and allow as long an interval as possible between them.

If this error code is displayed although you have not performed any large volume 2-sided printing, follow the following flow.

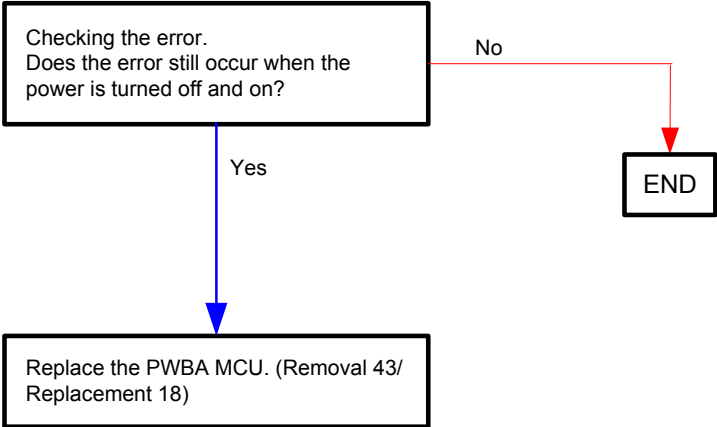

Flows 42 Paper Jam 071-100

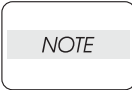

Do not load a sheet to the SSF while printing with the Paper Cassette as the media source. Otherwise, a Jam error occurs.

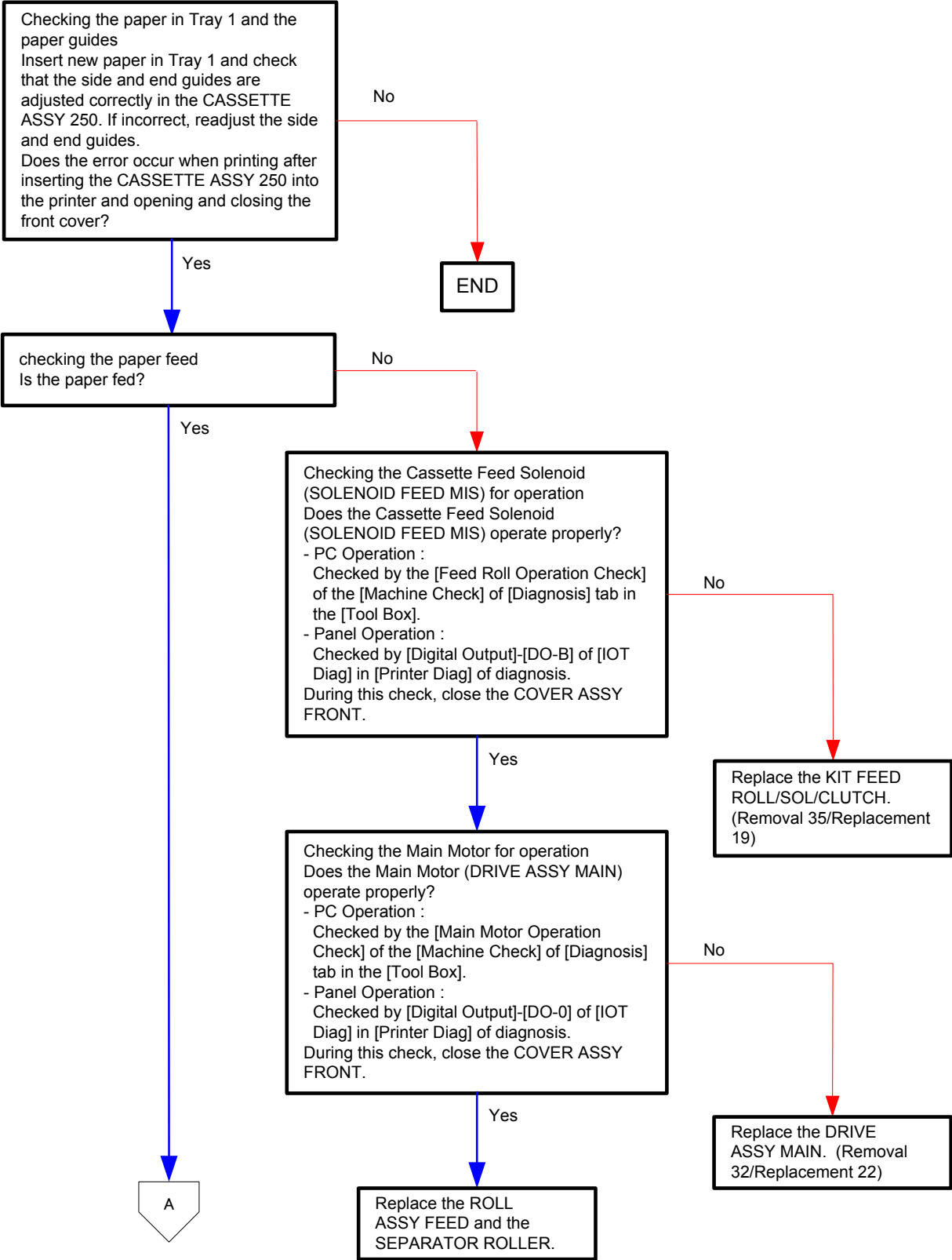

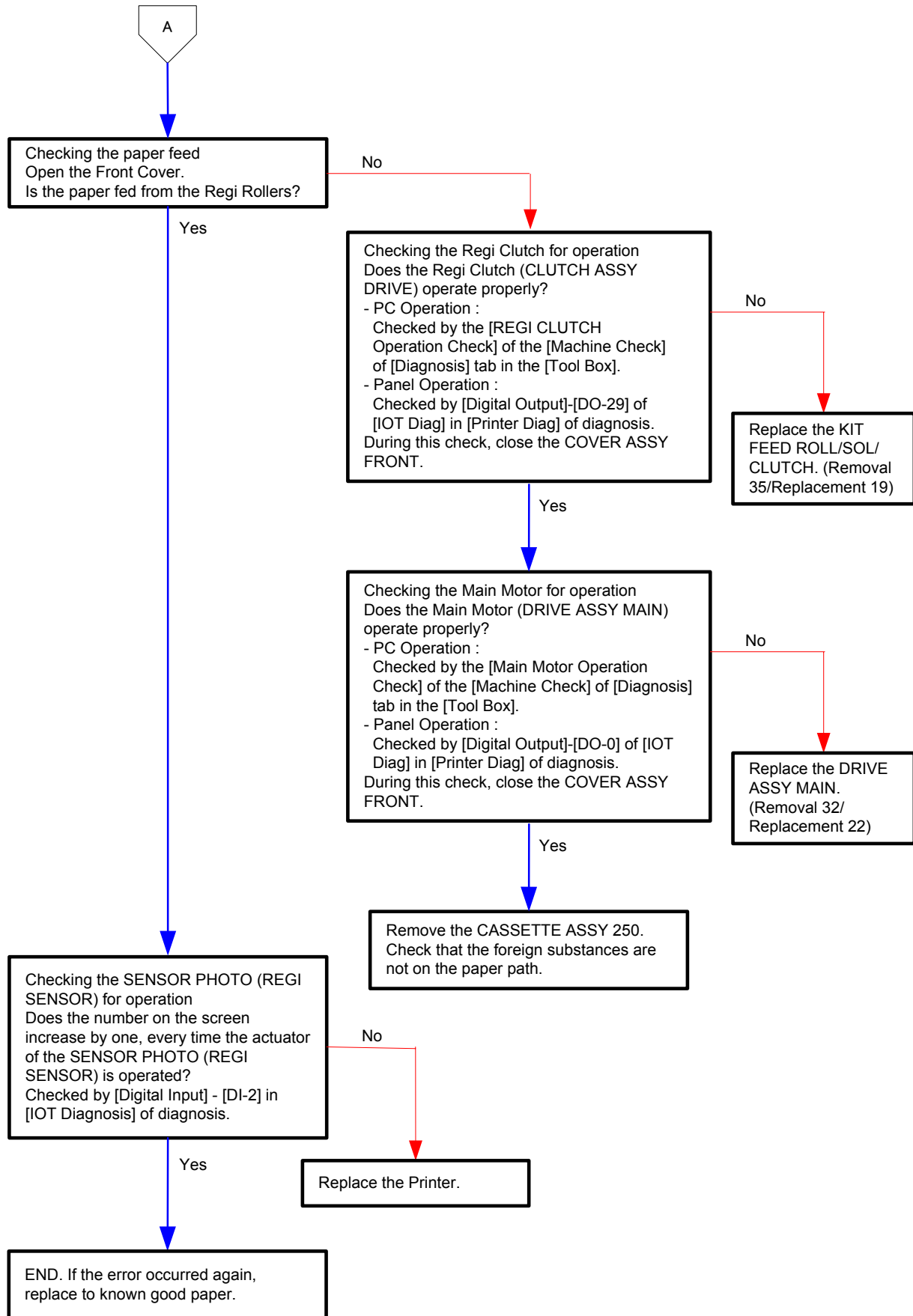

Flows 43 Paper Jam 072-100 / Paper Jam 072-908

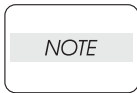

Do not load a sheet to the SSF while printing with the Paper Cassette as the media source. Otherwise, a Jam error occurs.

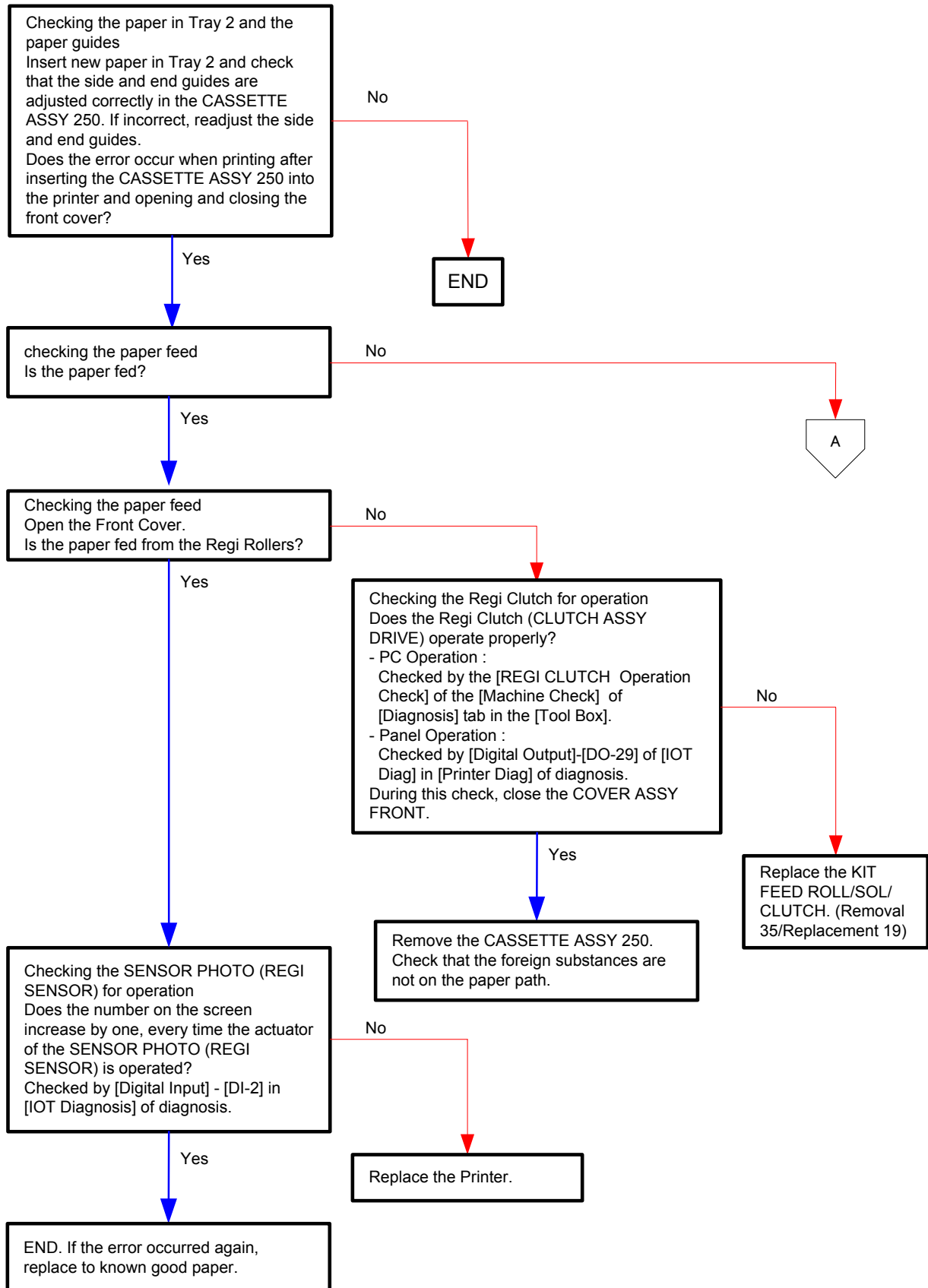

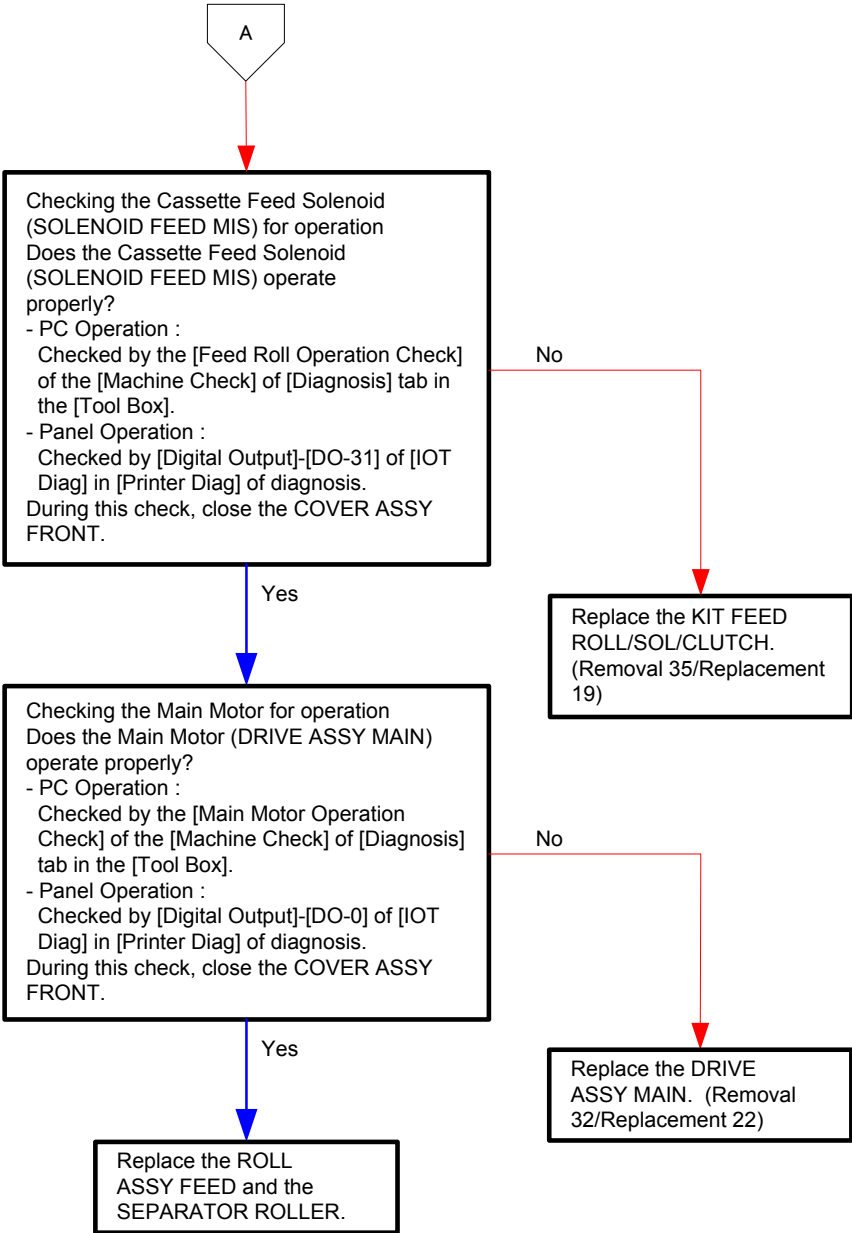

Flows 44 Paper Jam 072-101

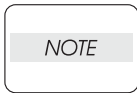

Do not load a sheet to the SSF while printing with the Paper Cassette as the media source. Otherwise, a Jam error occurs.

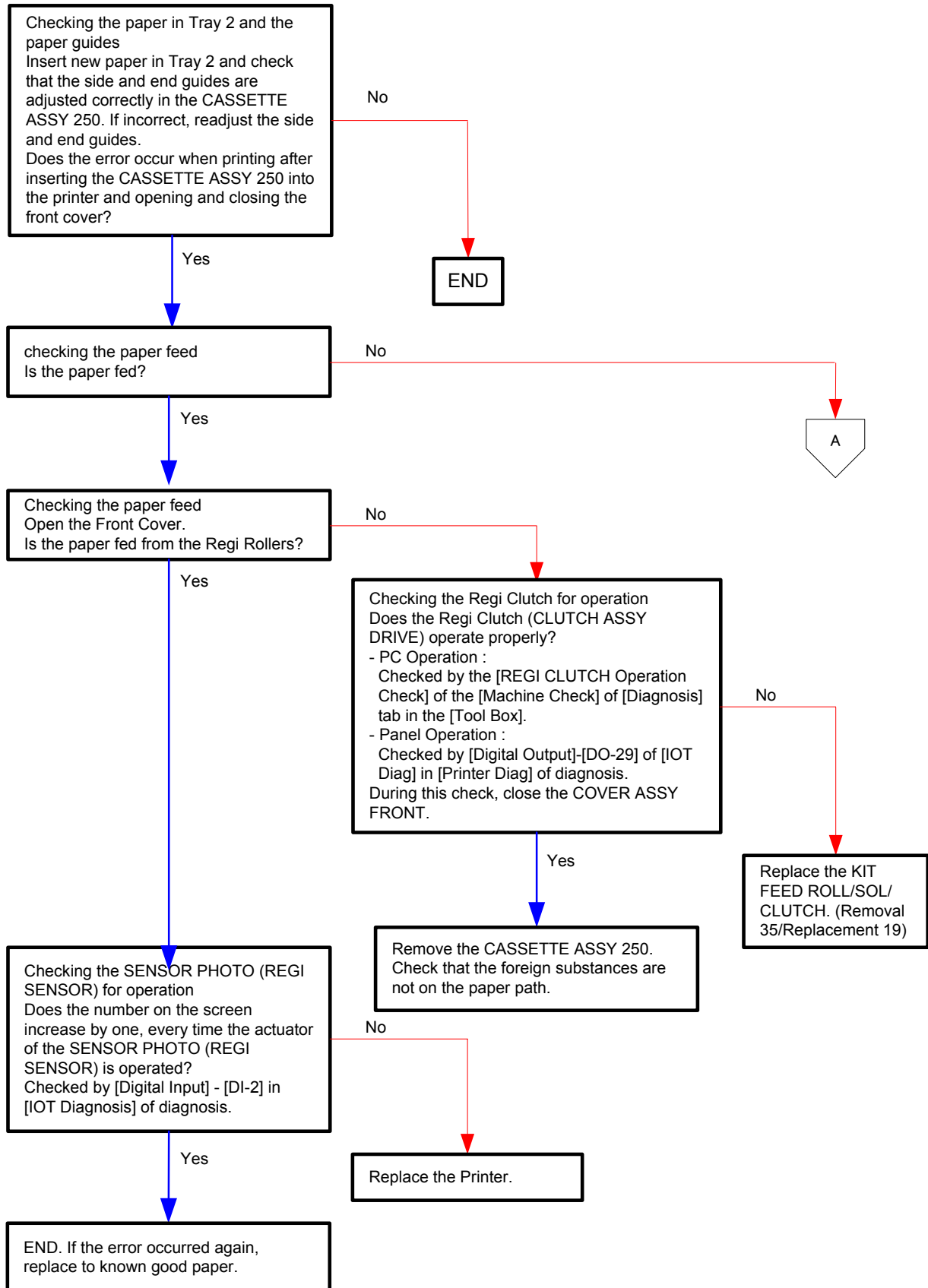

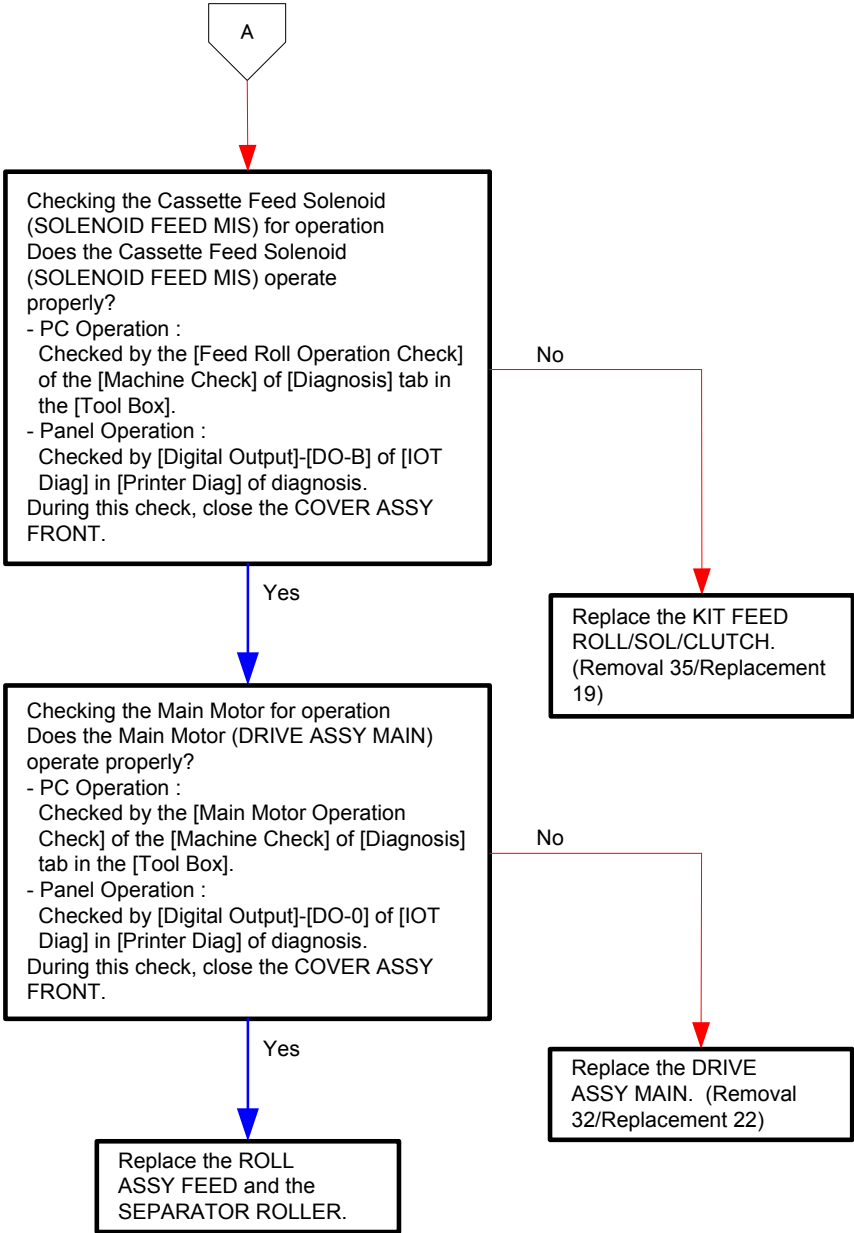

Flows 45 Paper Jam 075-101

NOTE

Do not load a sheet to the SSF while printing with the Paper Cassette as the media source. Otherwise, this error occurs. To restart printing, open the front cover and remove the document.

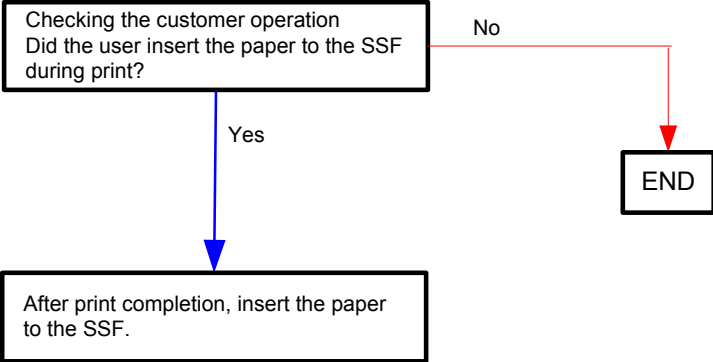

Flows 46 Paper Jam 075-102

NOTE

When starting SSF printing, an error will occur by pulling out a document on the SSF by force.

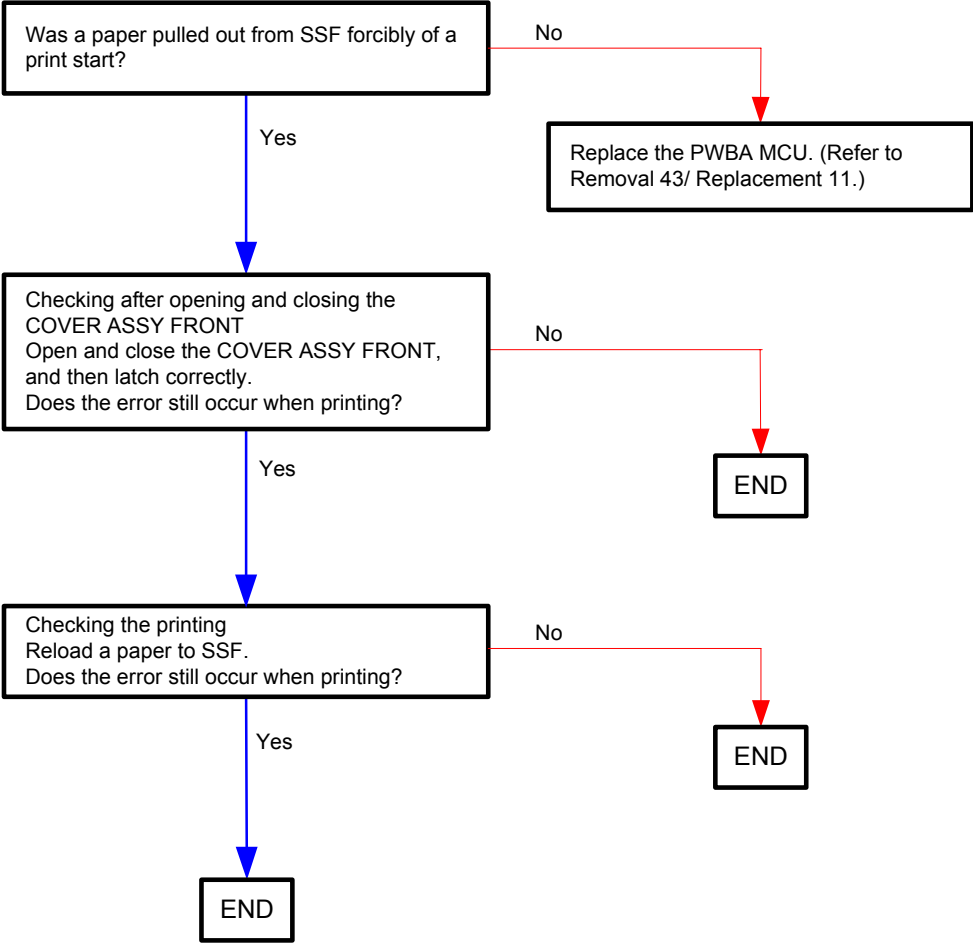

Flows 47 Check SSF 075-922

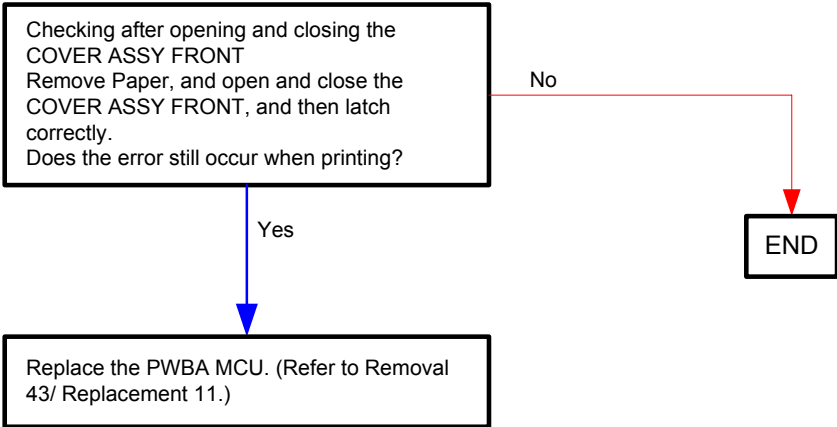

Flows 48 Paper Jam 077-100/077-101

NOTE

Do not load a sheet to the SSF while printing with the Paper Cassette as the media source. Otherwise, a Jam error occurs.

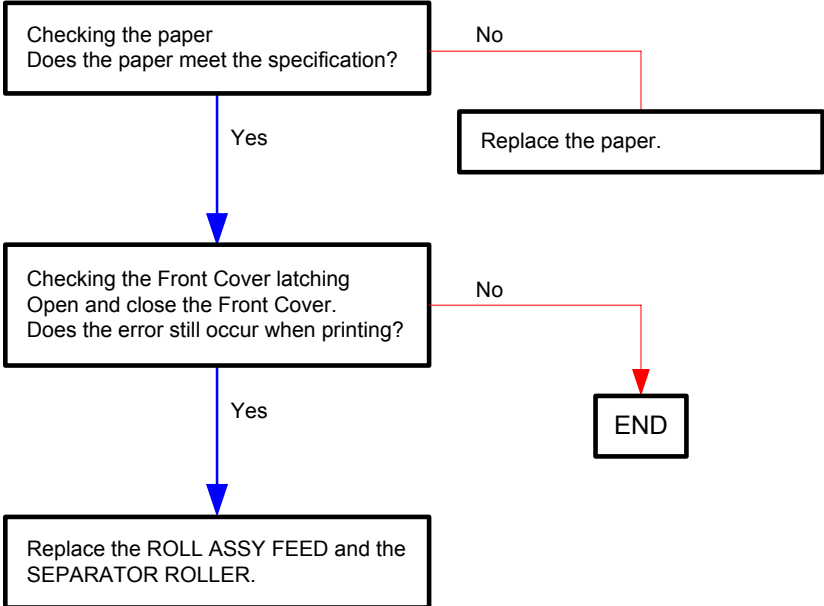

Flows 49 Paper Jam 077-102

NOTE

Do not load a sheet to the SSF while printing with the Paper Cassette as the media source. Otherwise, a Jam error occurs.

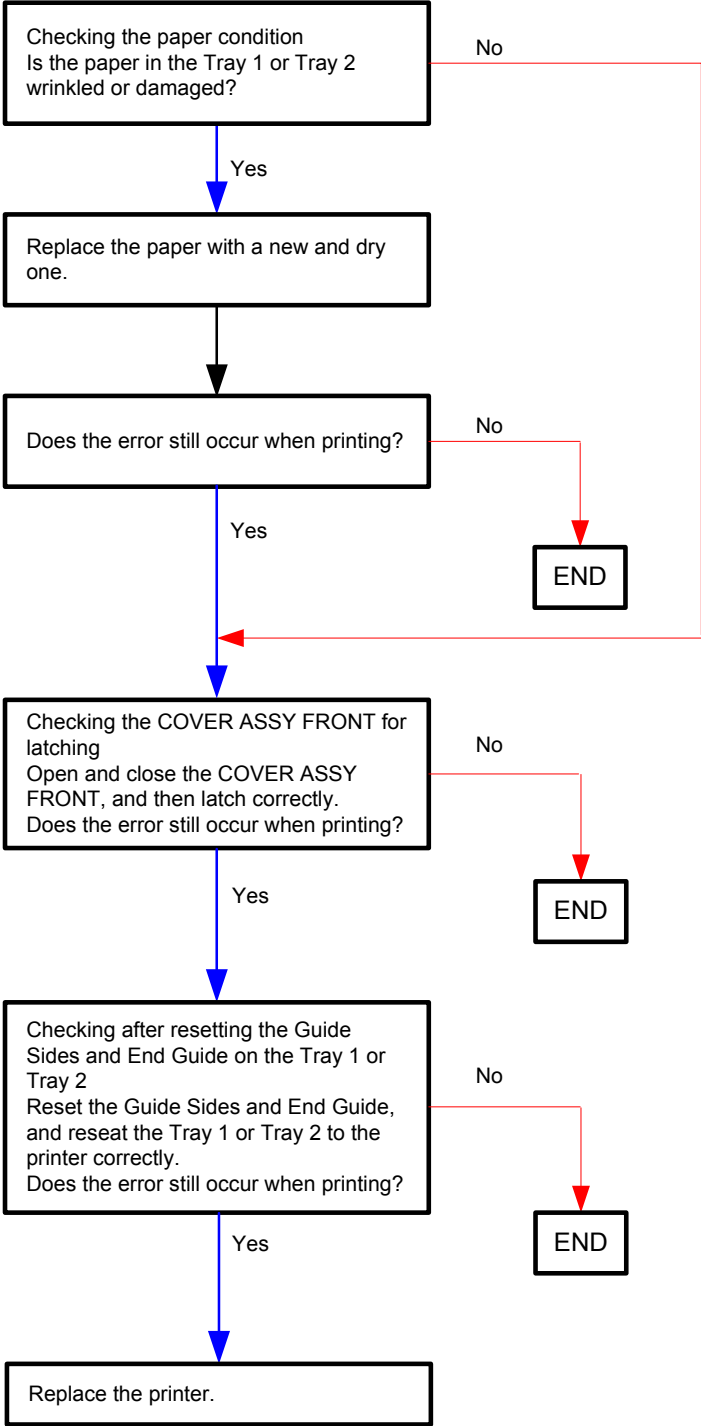

Flows 50 Paper Jam 077-103/077-104/077-105

NOTE

When starting SSF printing, an error will occur by pulling out a document on the SSF by force.

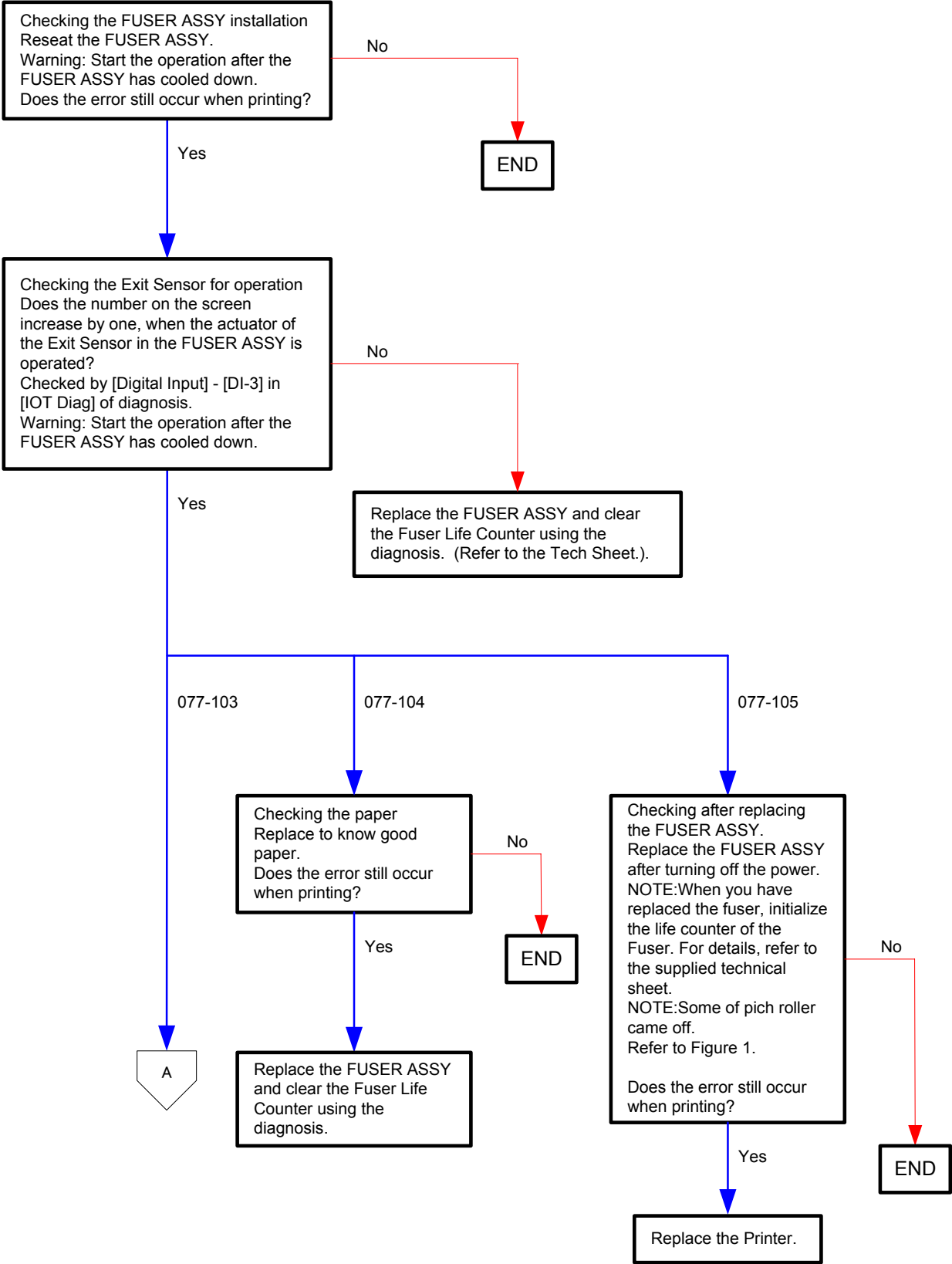

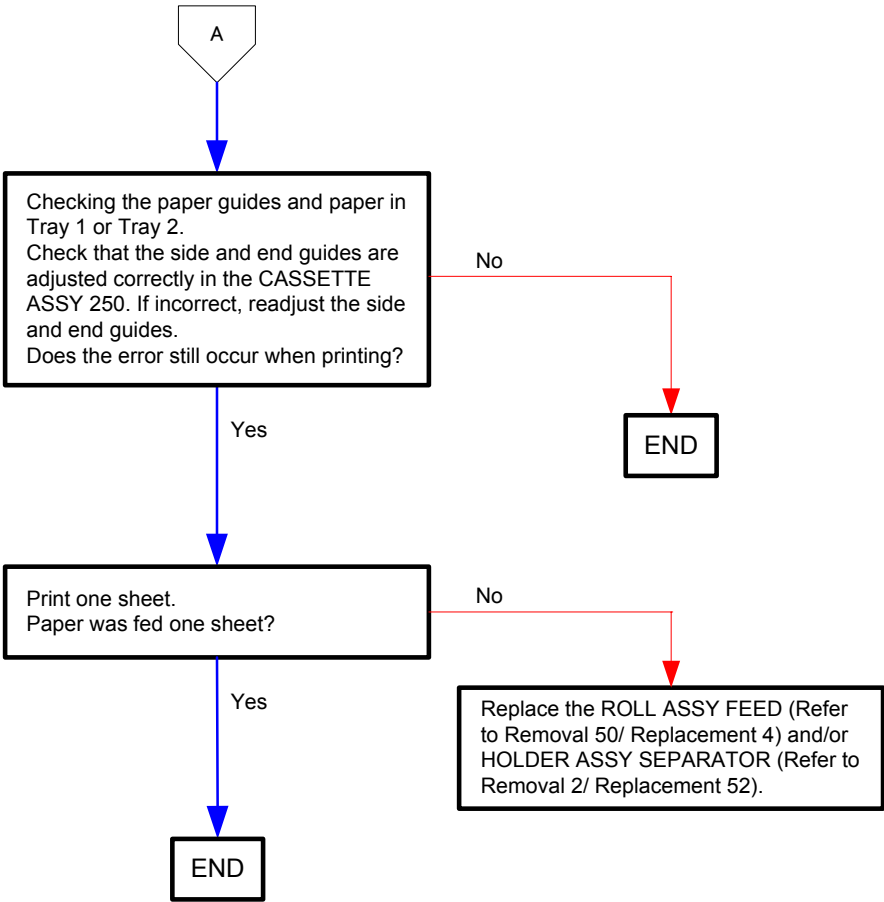
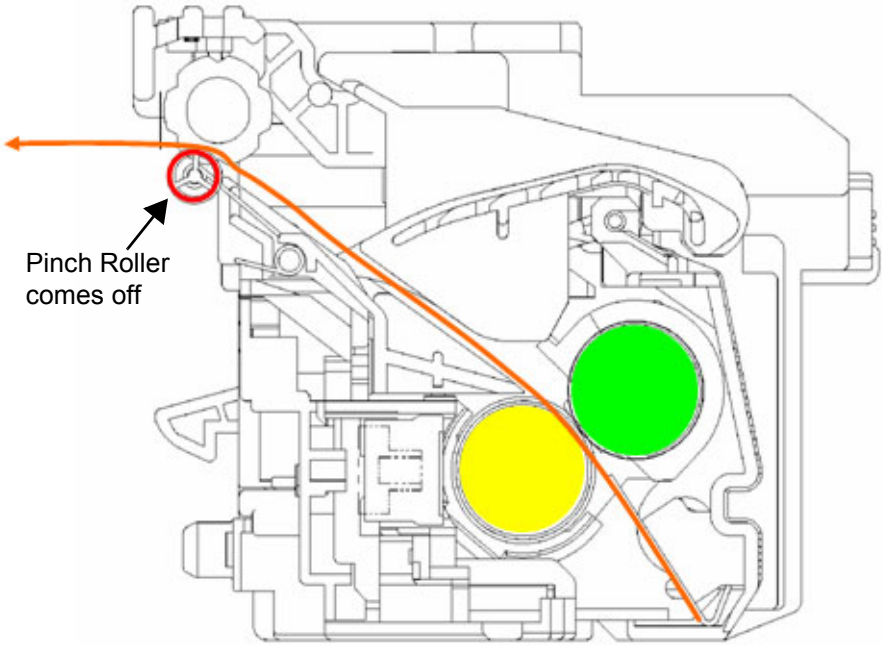

Figure 1:



Flows 51 Paper Jam 077-107

NOTE

Do not load a sheet to the SSF while printing with the Paper Cassette as the media source. Otherwise, a Jam error occurs.

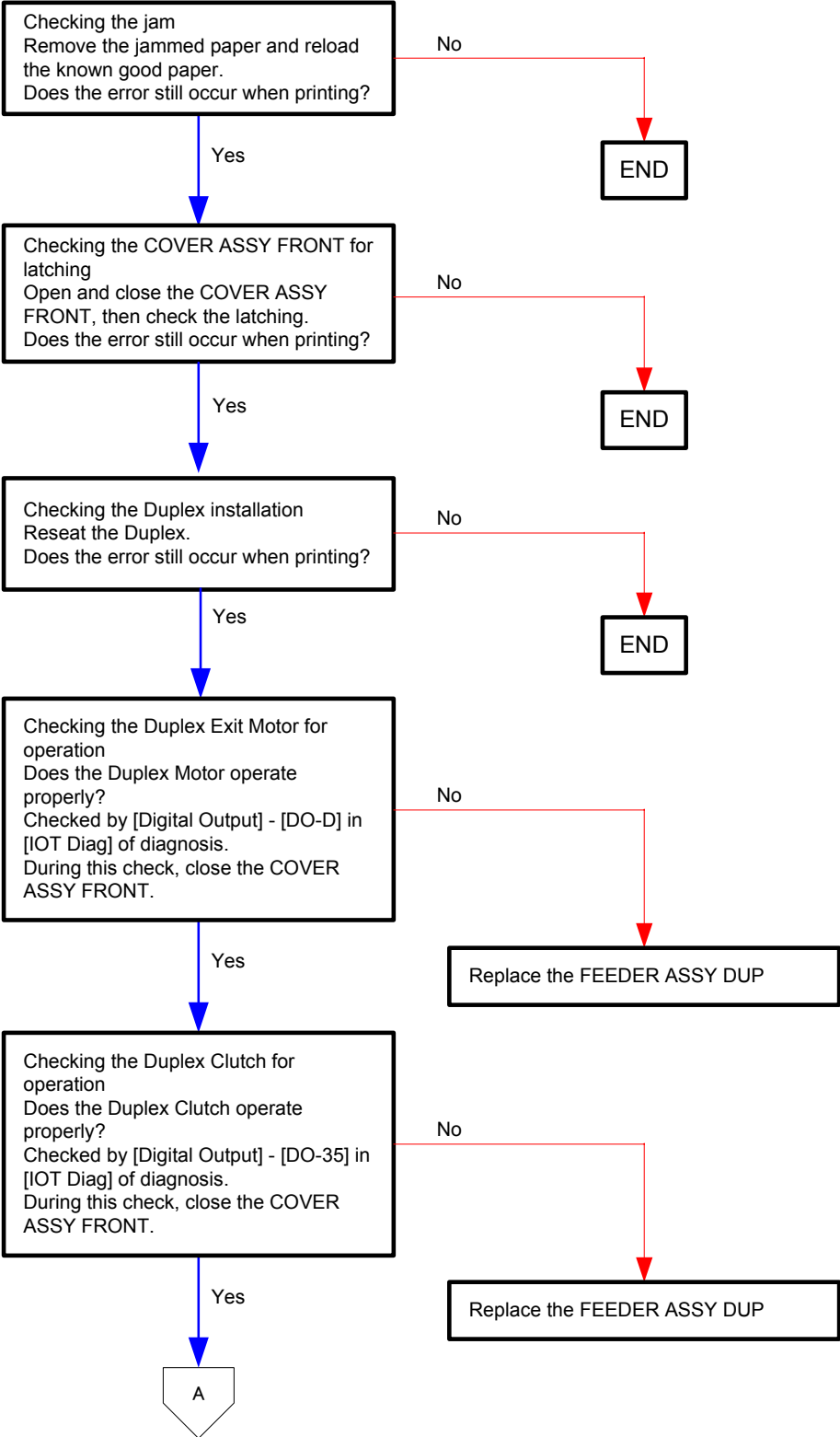

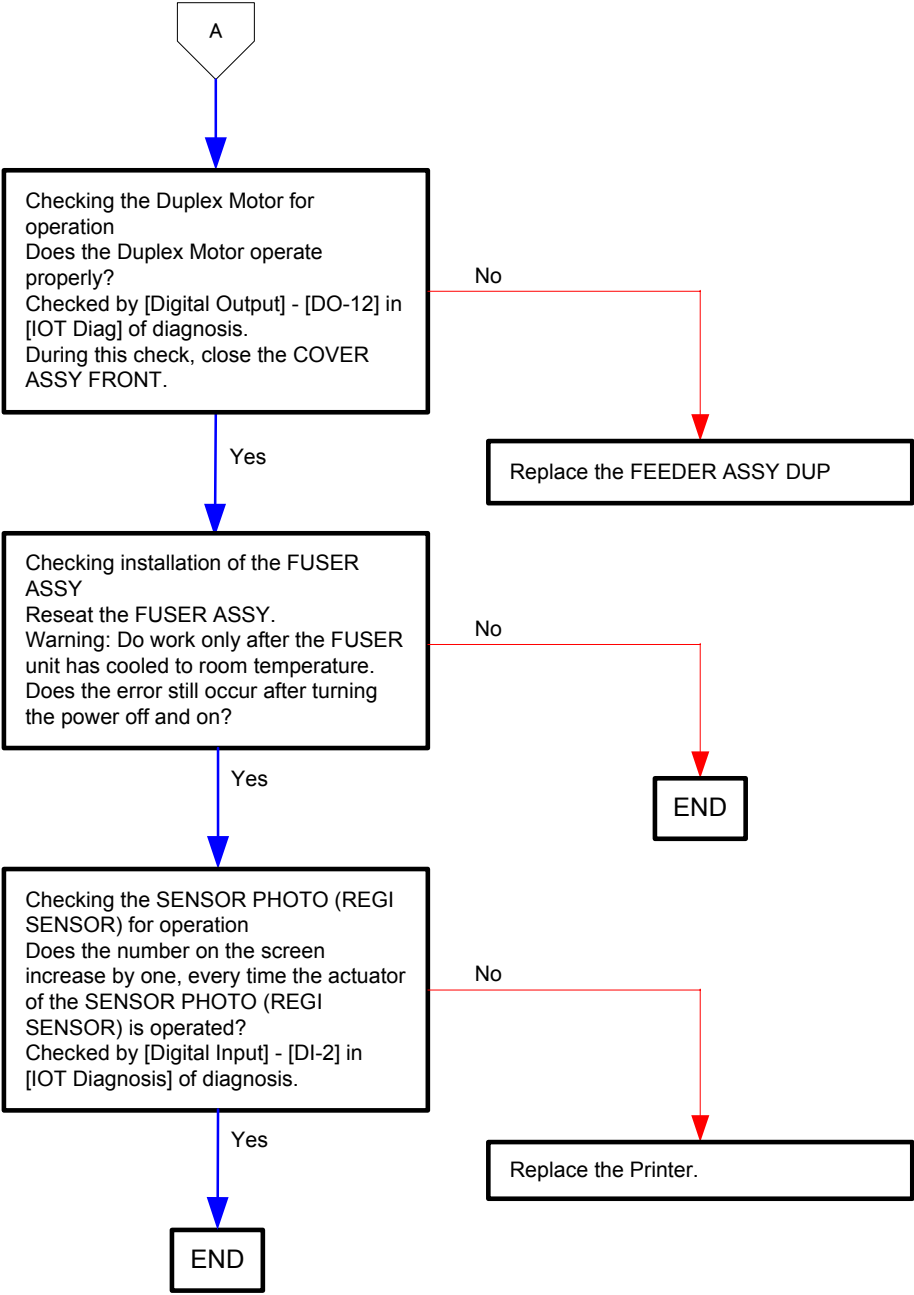

Flows 52 Paper Jam 077-108

NOTE

Do not load a sheet to the SSF while printing with the Paper Cassette as the media source. Otherwise, a Jam error occurs.

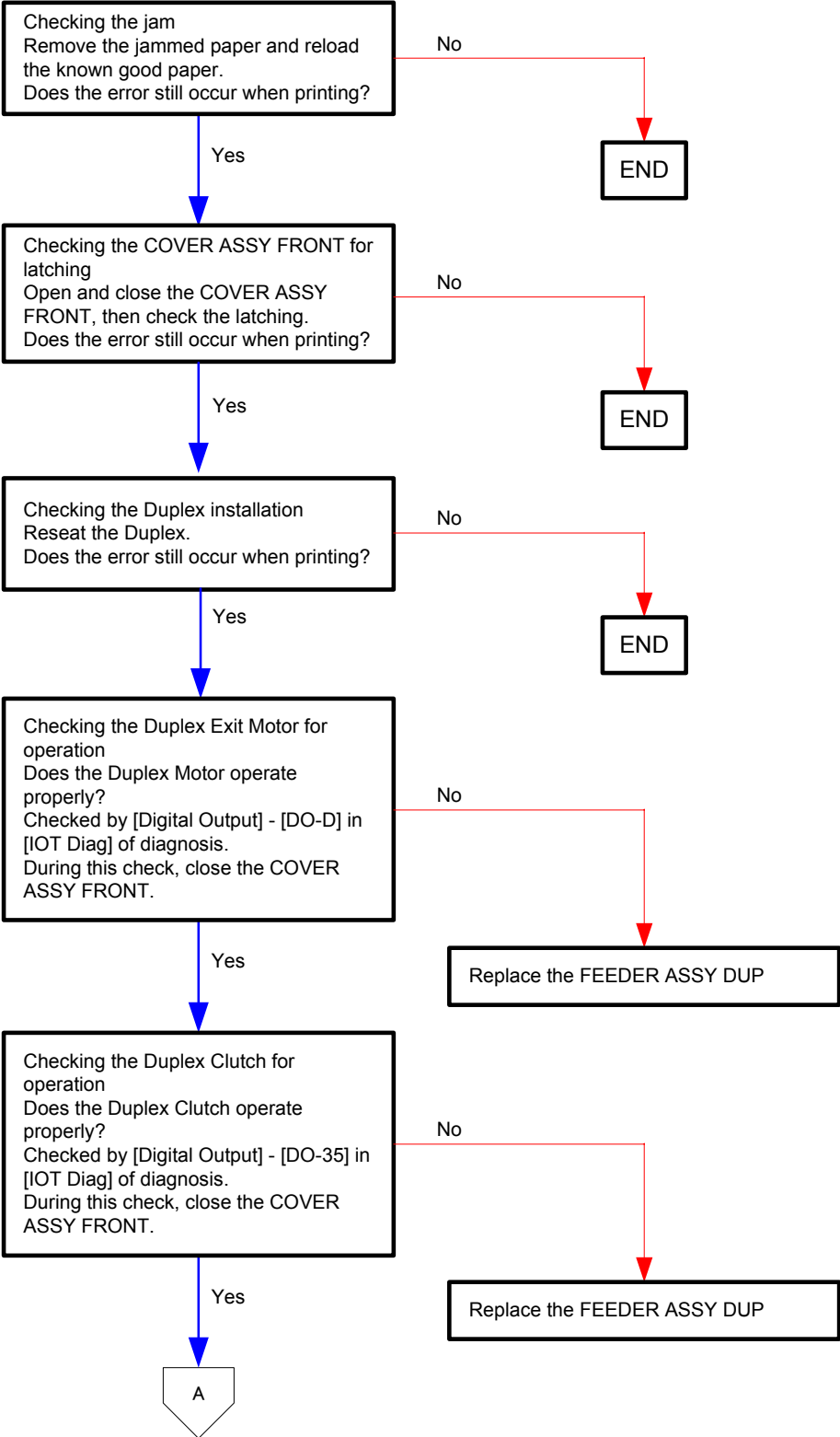

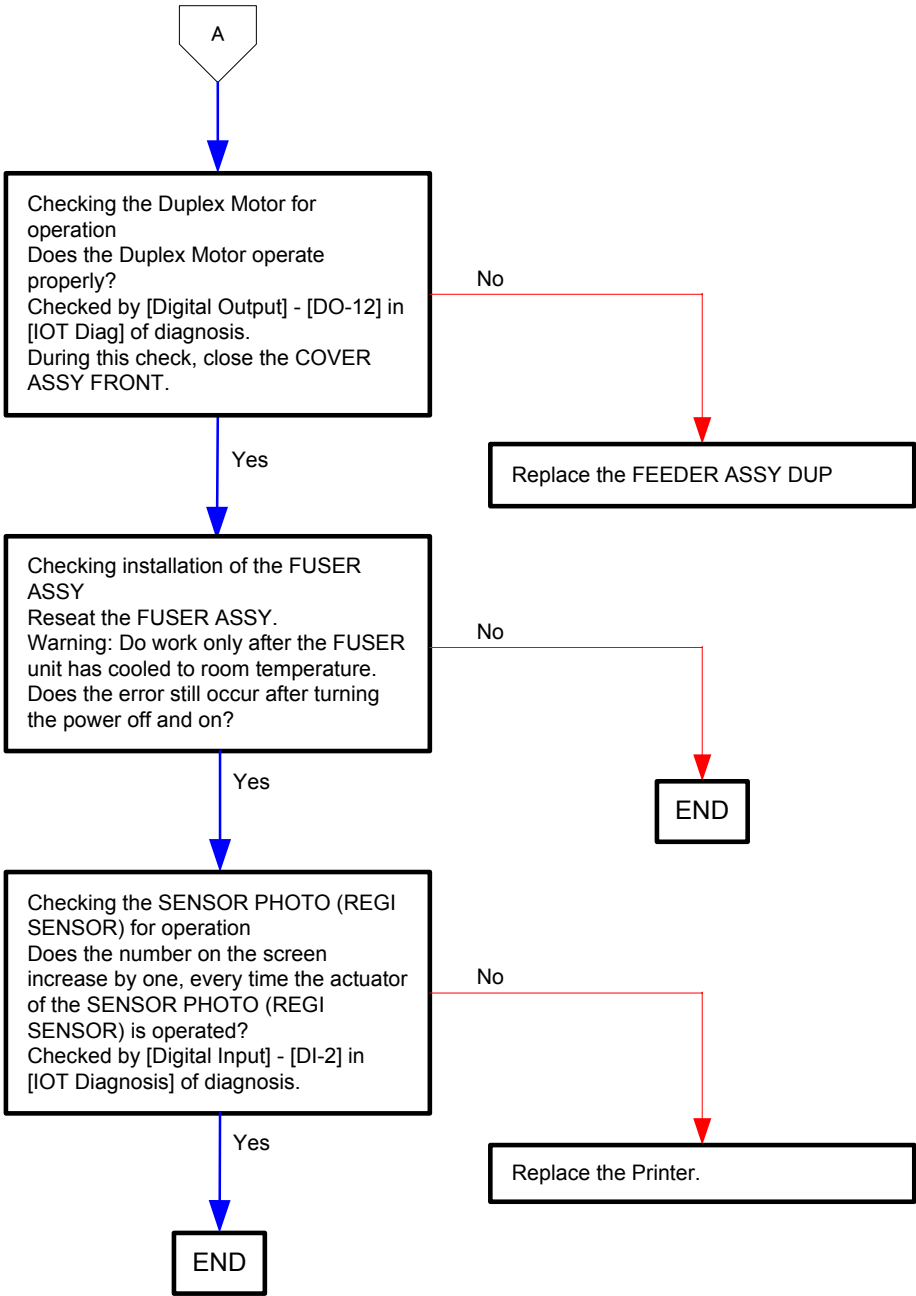

Flows 53 Close FrontCover 077-300

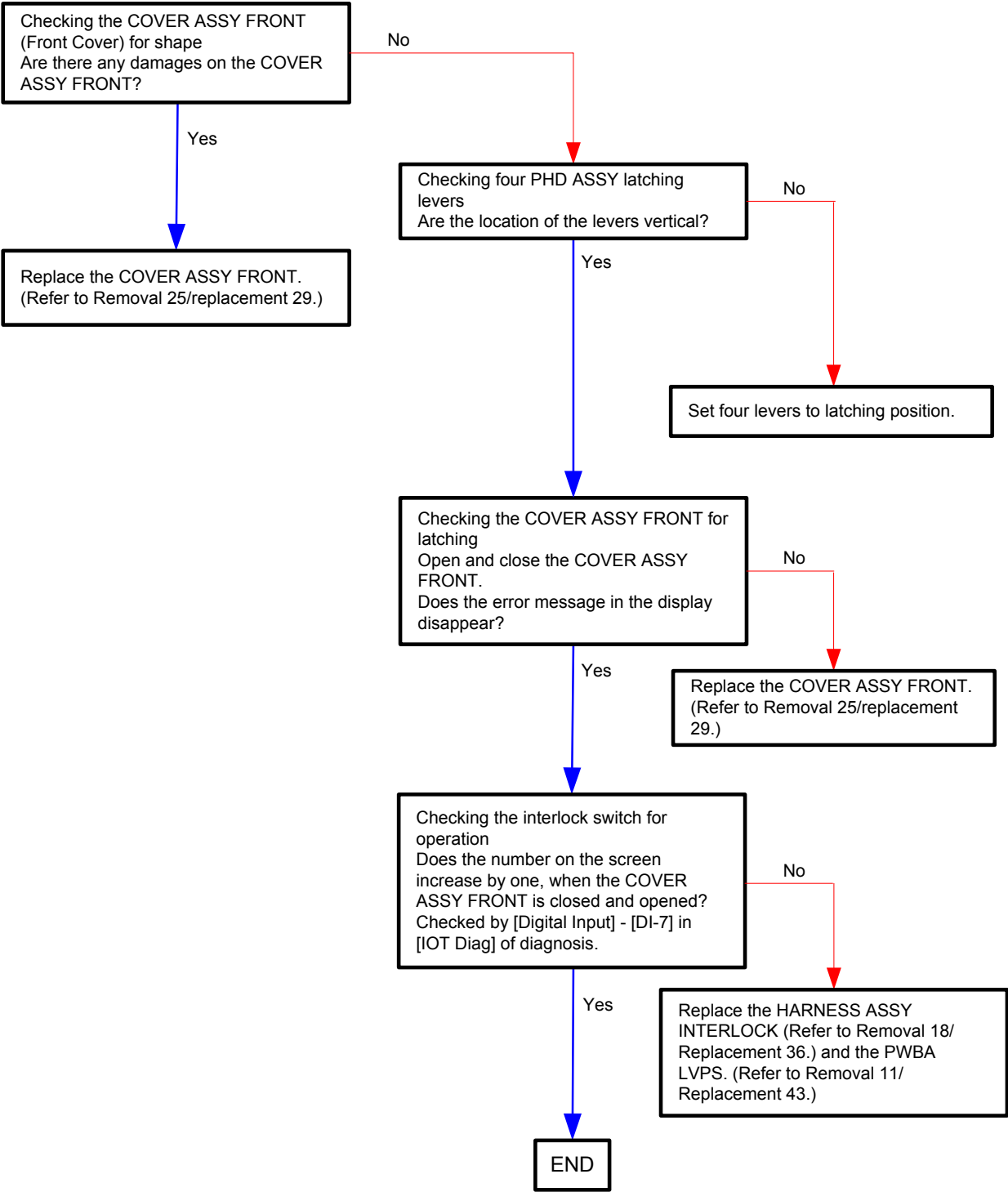

Flows 54 Close Side Cover 077-301

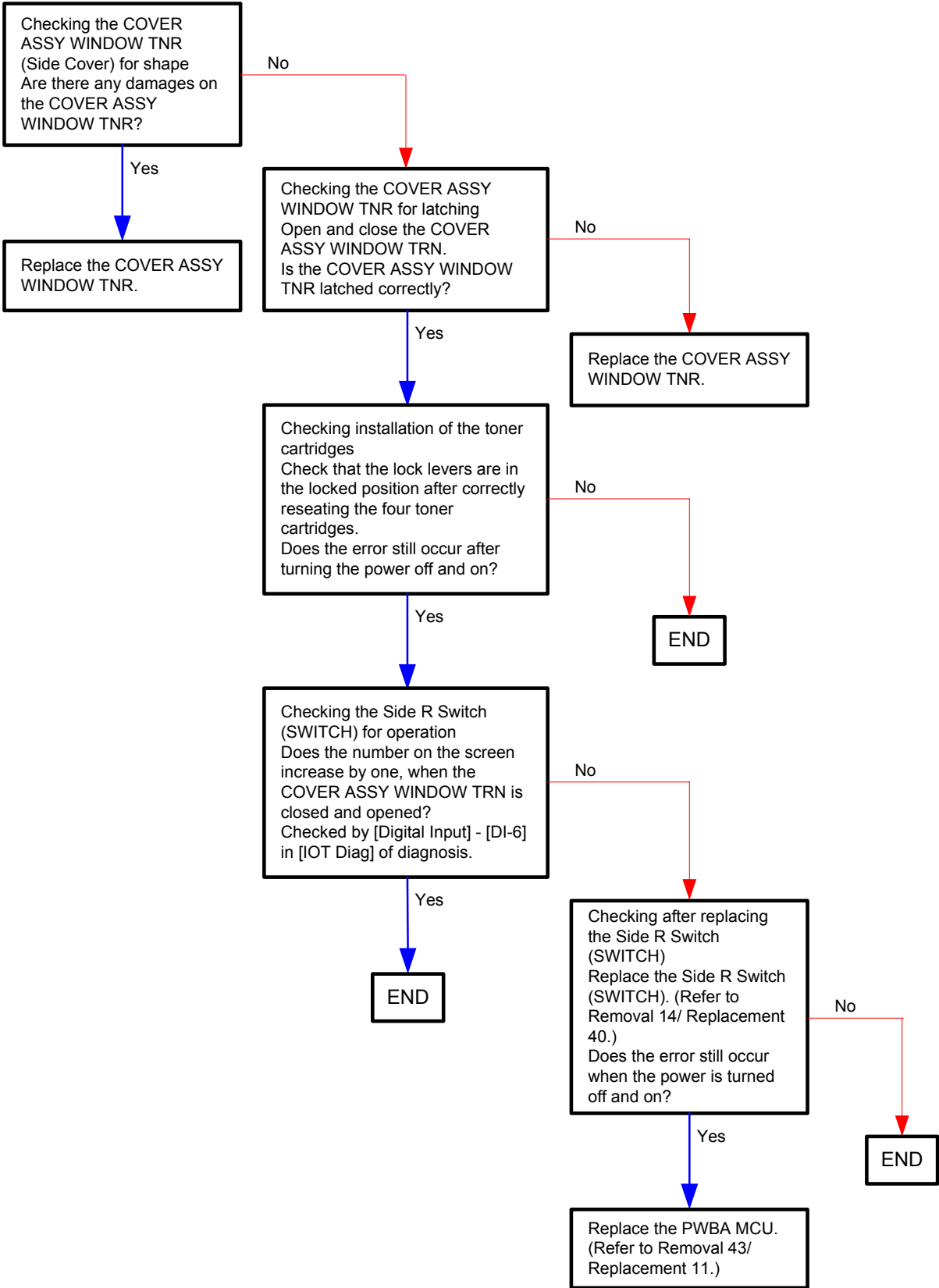

Flows 55 Paper Jam 077-900

NOTE

Do not load a sheet to the SSF while printing with the Paper Cassette as the media source. Otherwise, a Jam error occurs.

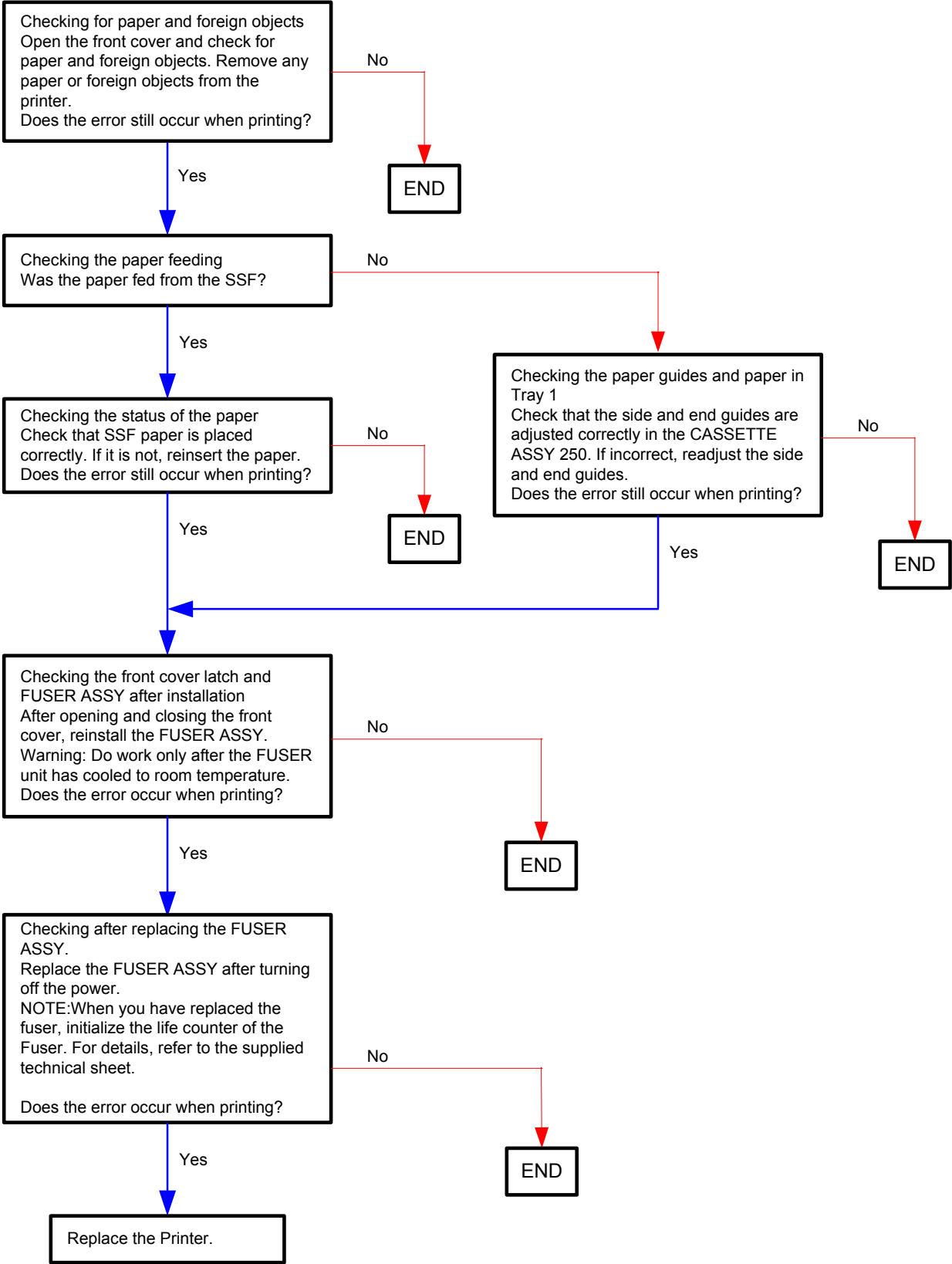

Flows 56 Paper Jam 077-901

NOTE

Do not load a sheet to the SSF while printing with the Paper Cassette as the media source. Otherwise, a Jam error occurs.

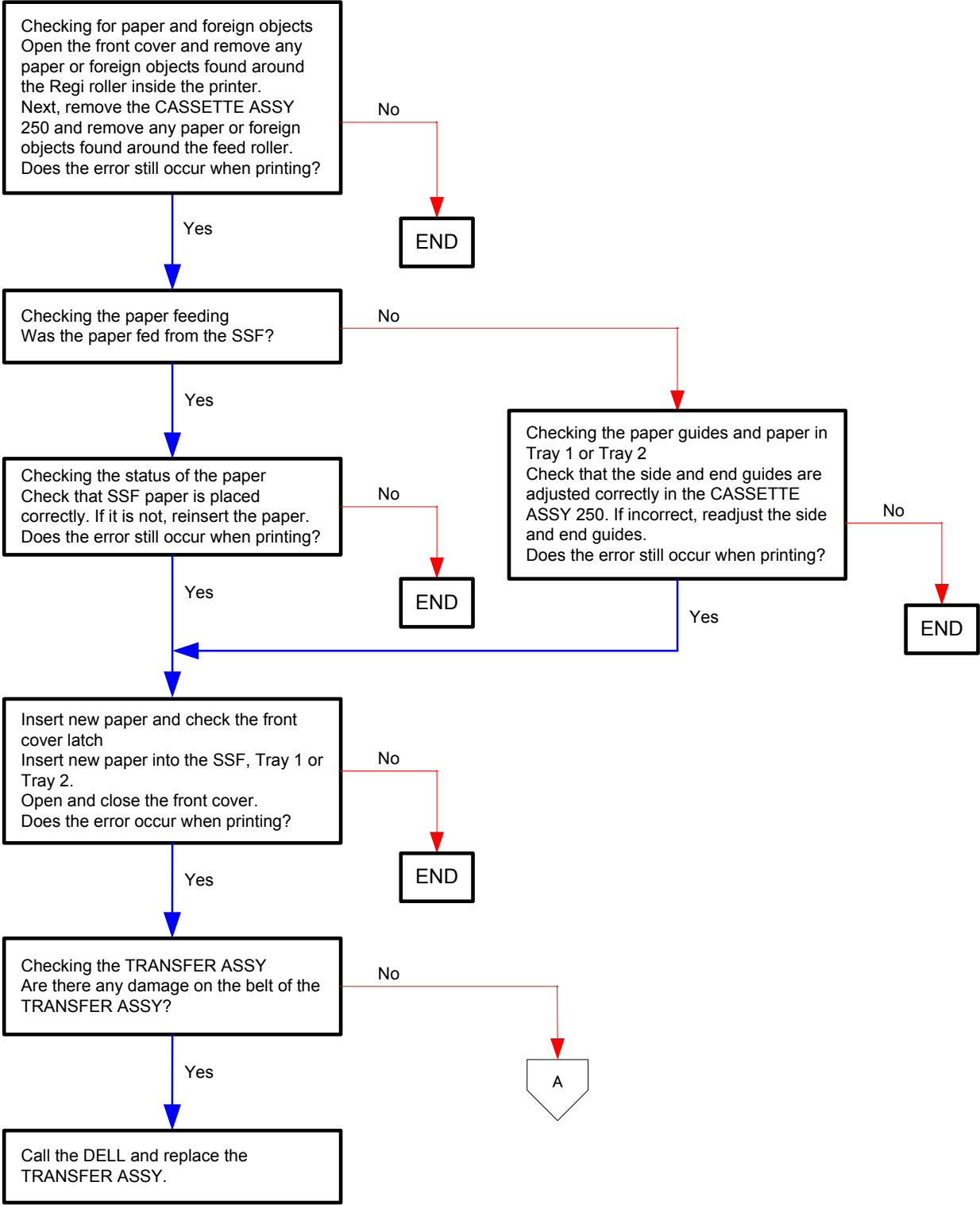

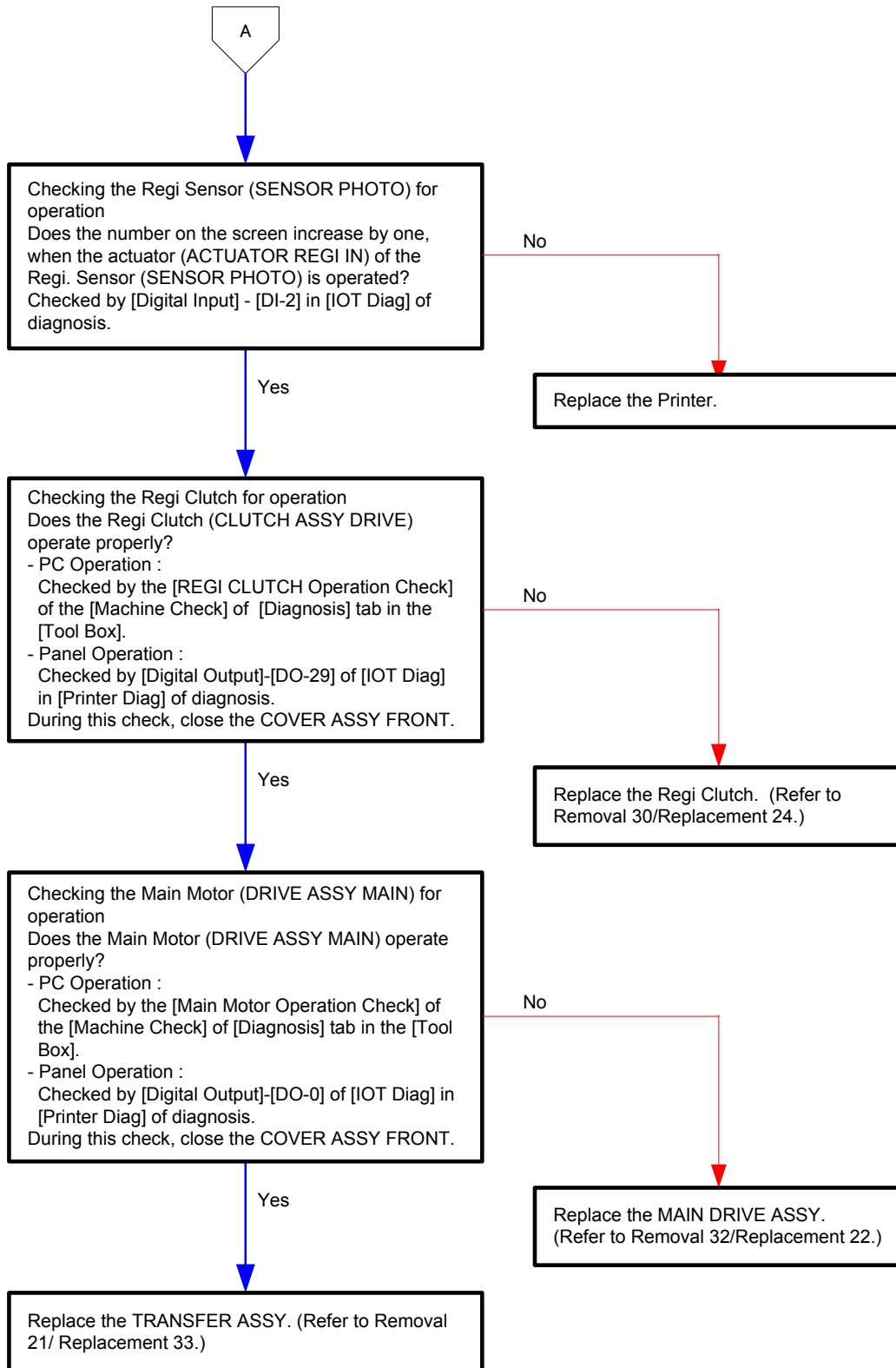

Flows 57 Paper Jam 077-907

NOTE

Do not load a sheet to the SSF while printing with the Paper Cassette as the media source. Otherwise, a Jam error occurs.

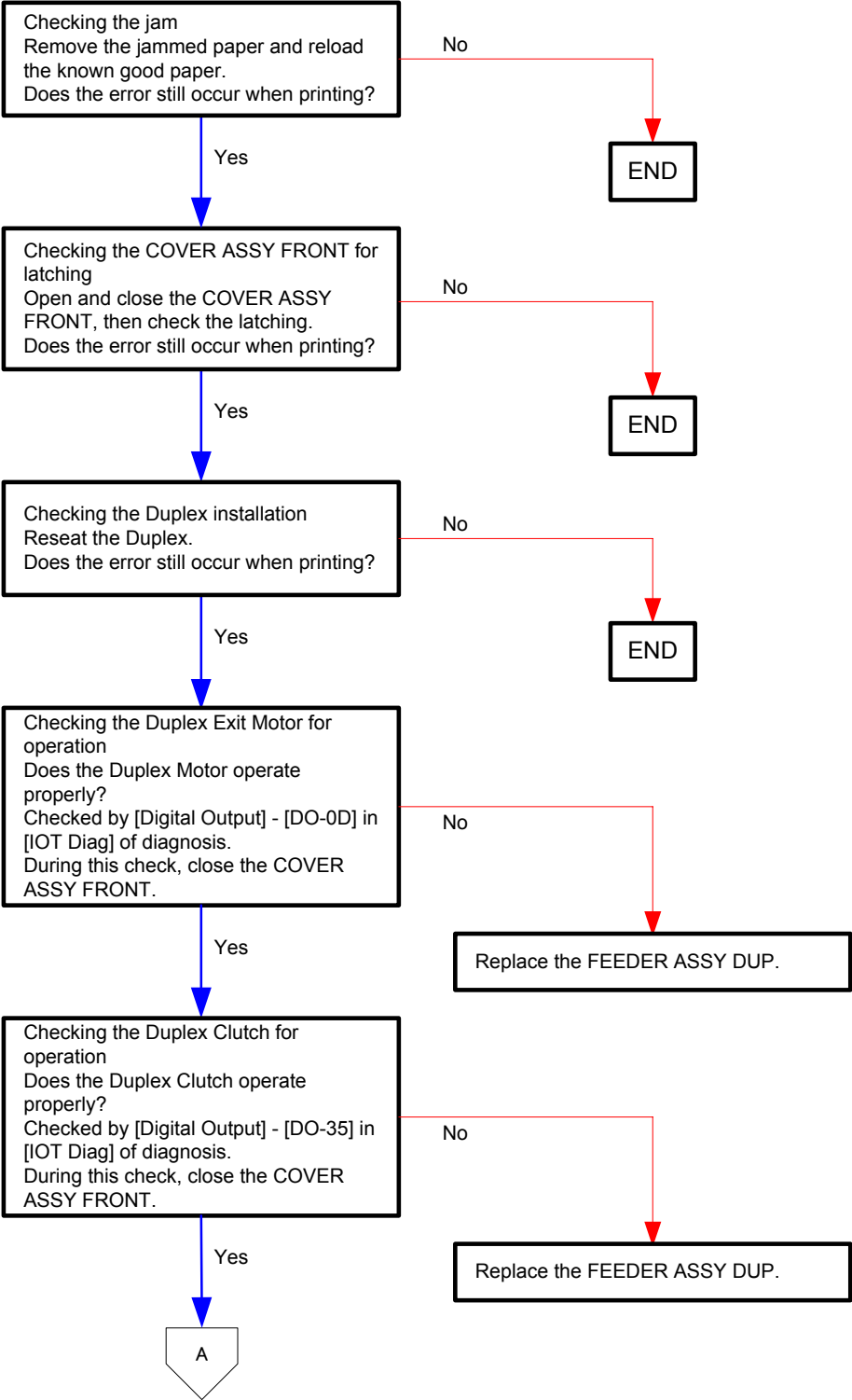

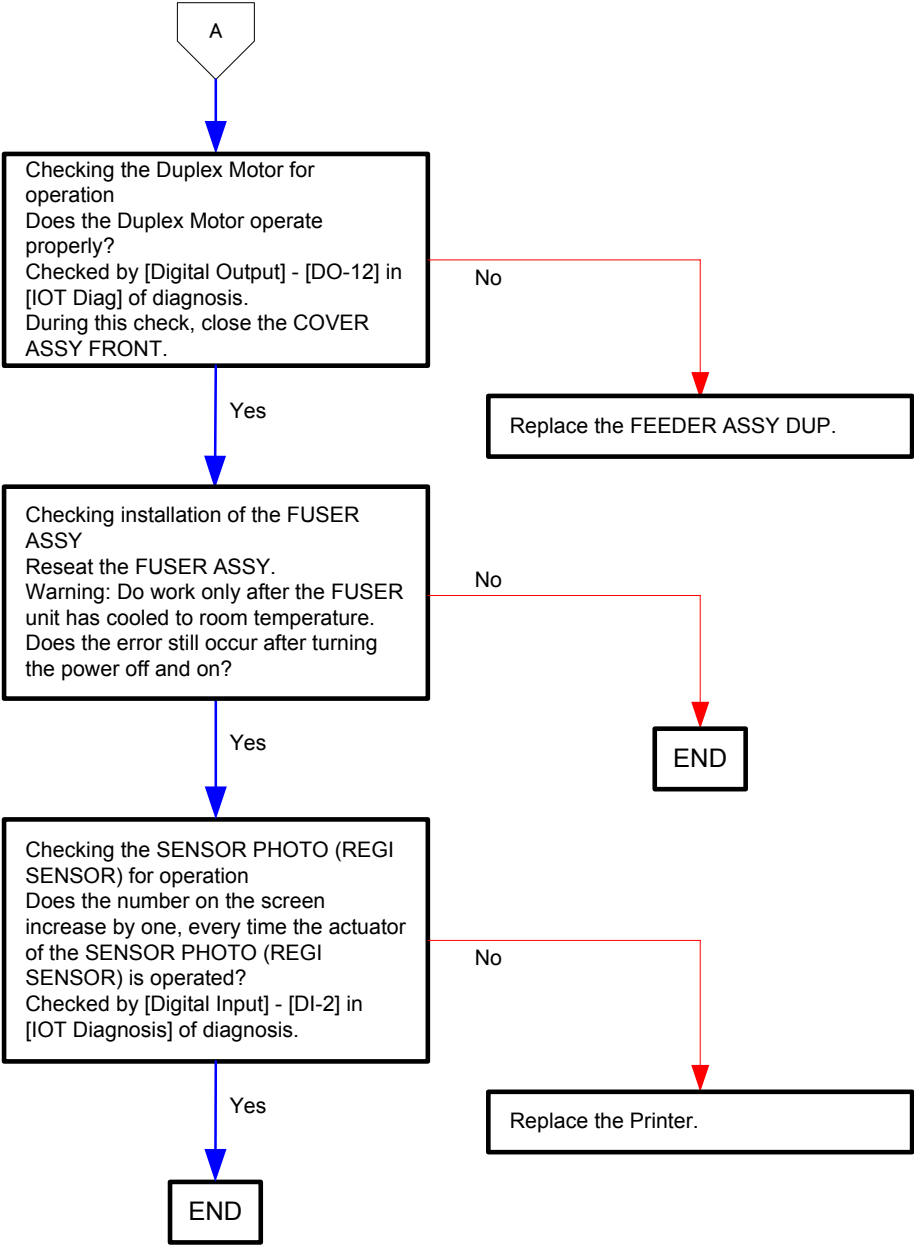

Flows 58 Ready to Print 091-402 / Replace PHD 091-935

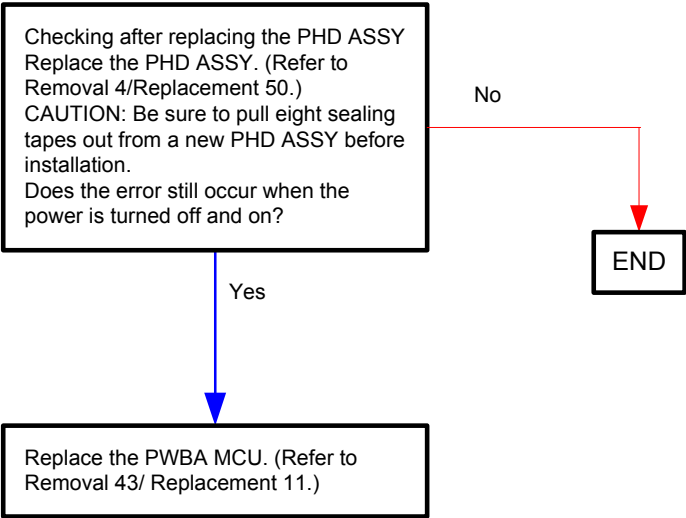

Flows 59 PHD 091-912

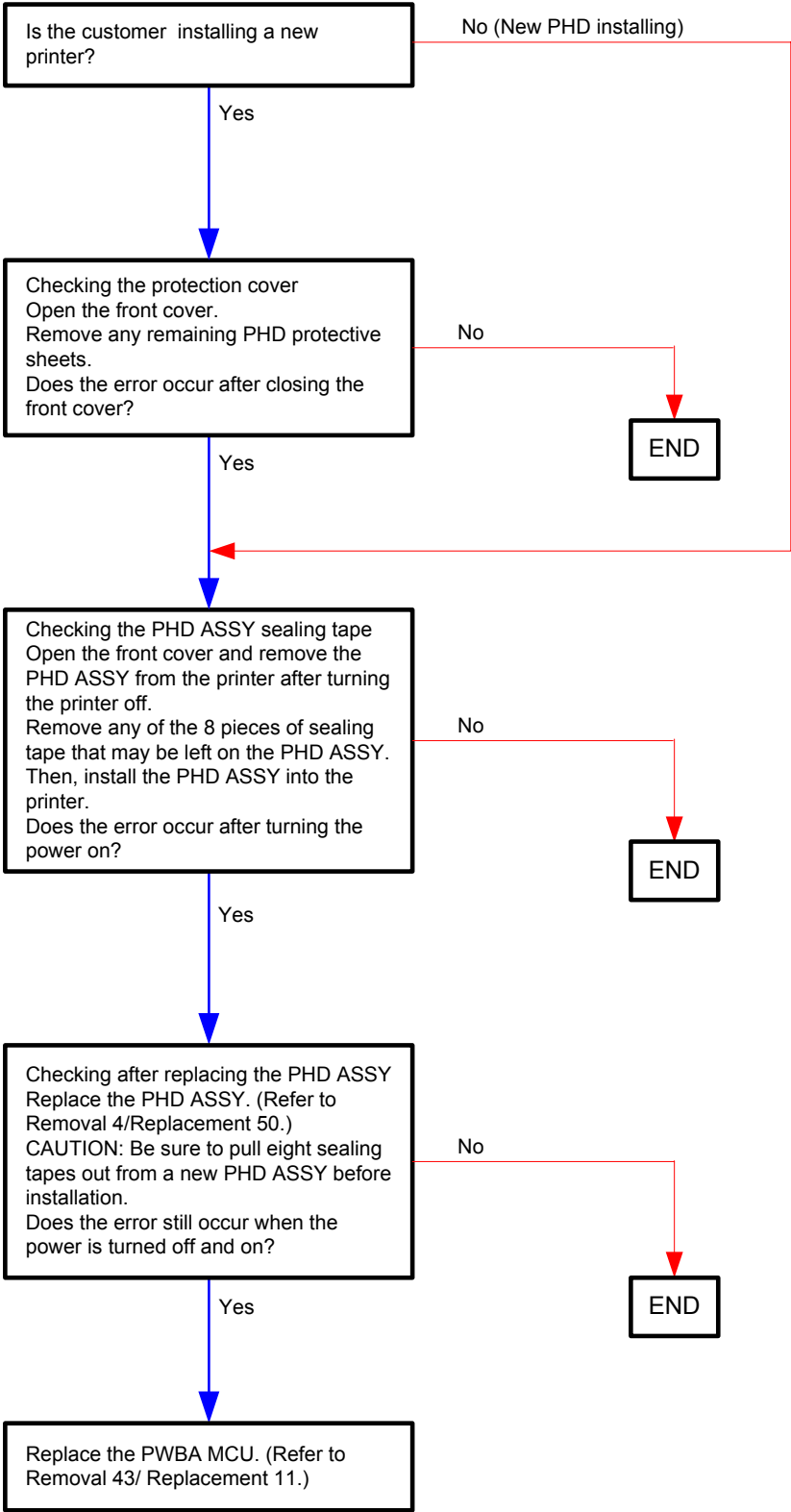

Flows 60 Insert PHD 091-972

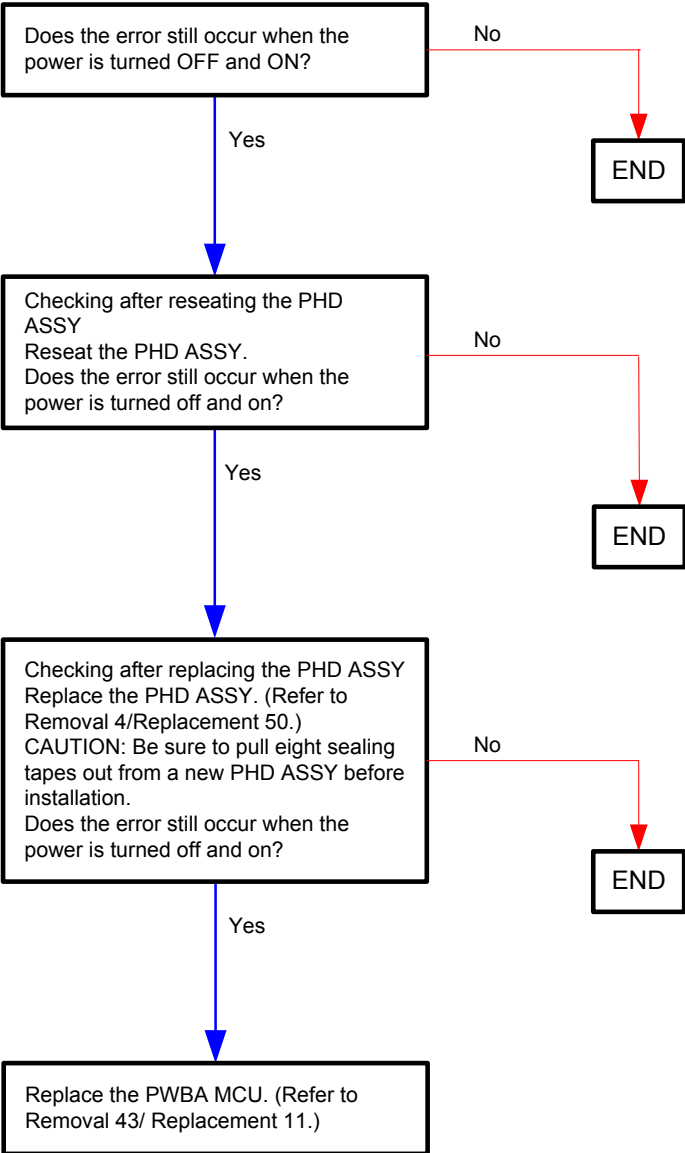

Flows 61 CTD Sensor Dirty 092-310 / Ready to Print 092-410

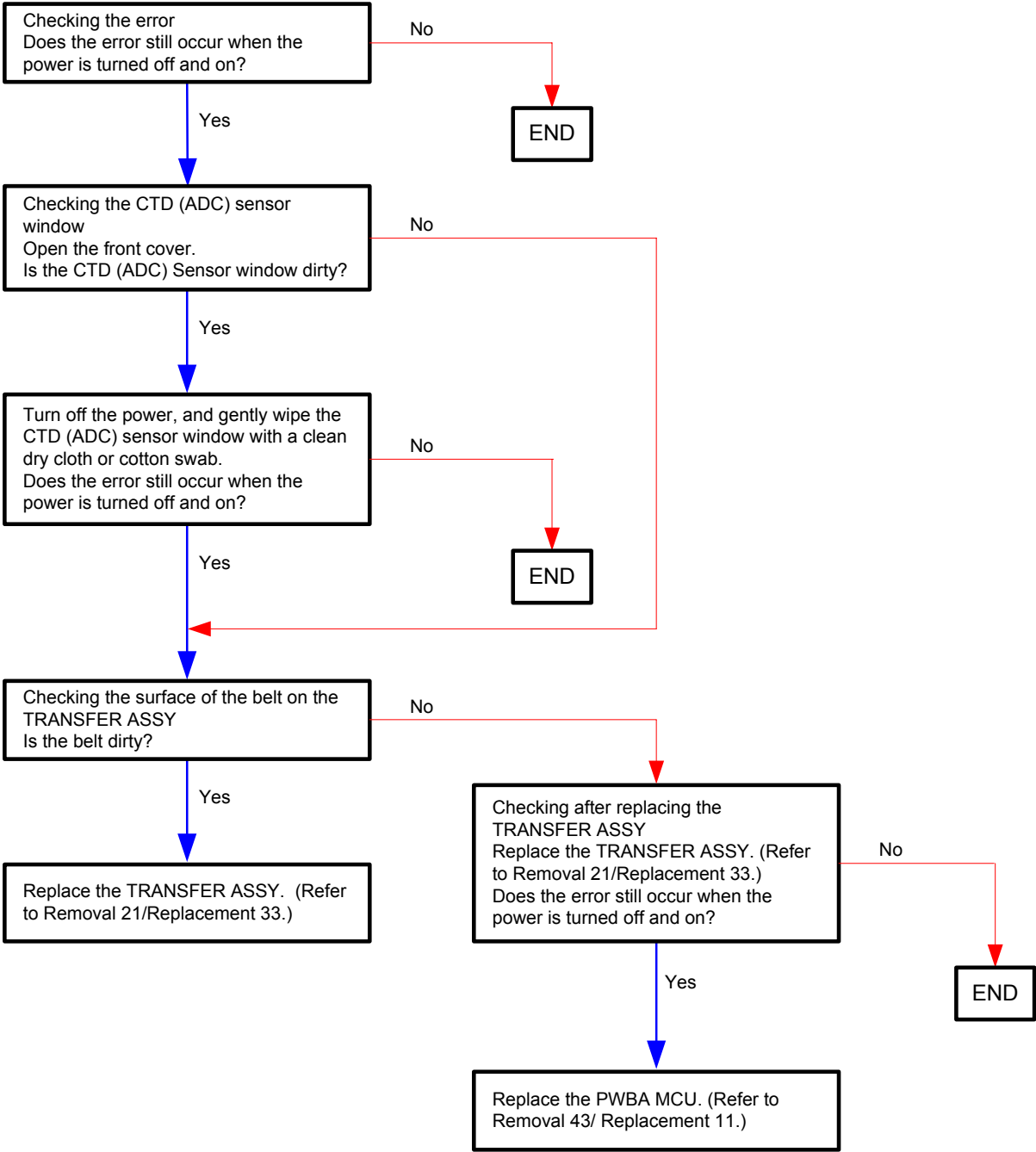

Flows 62 Ready to Print 093-423 / Replace Cart. 093-930

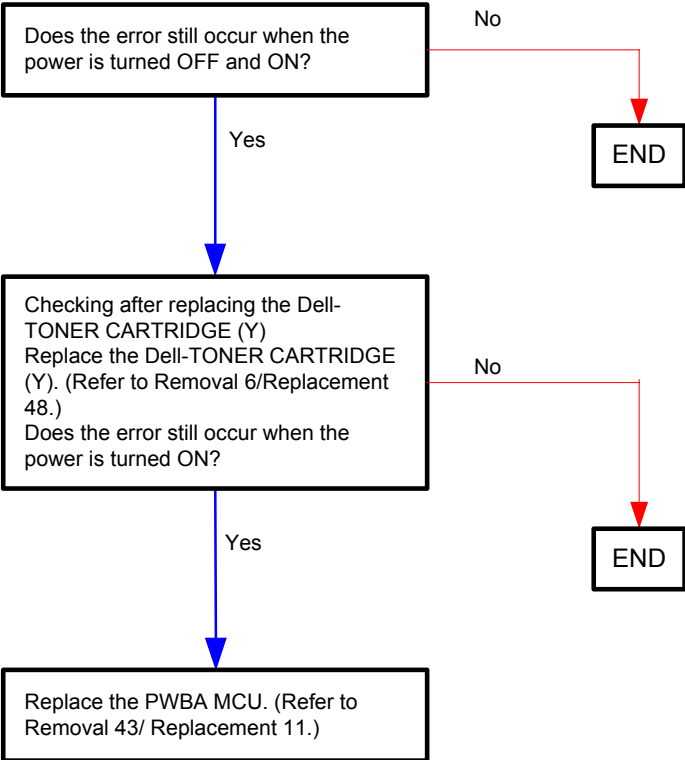

Flows 63 Ready to Print 093-424 / Replace Cart. 093-931

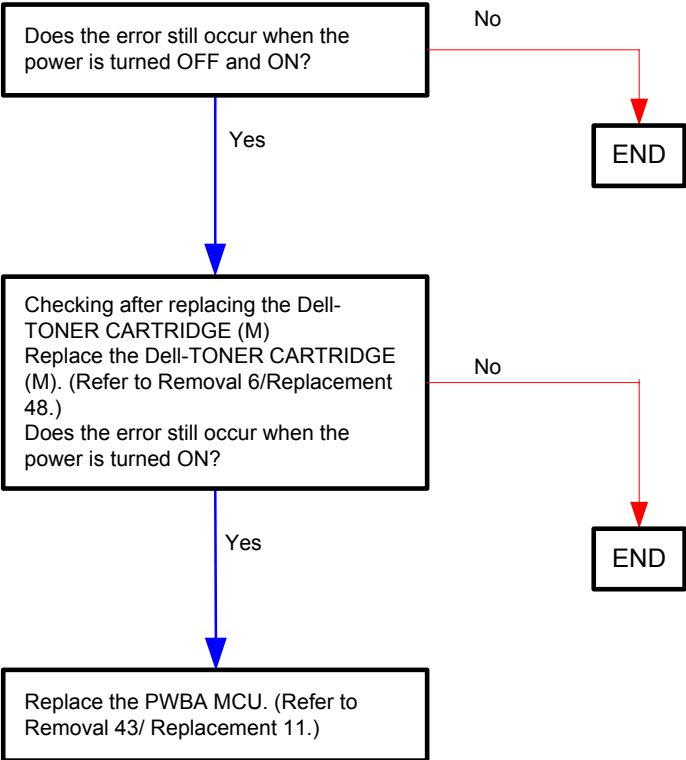

Flows 64 Ready to Print 093-425 / Replace Cart. 093-932

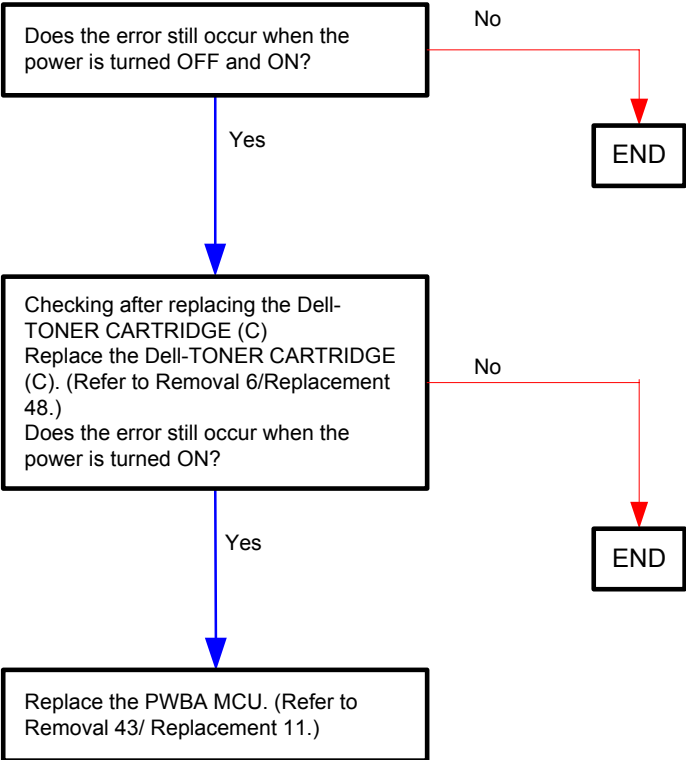

Flows 65 Ready to Print 093-426 / Replace Cart. 093-933

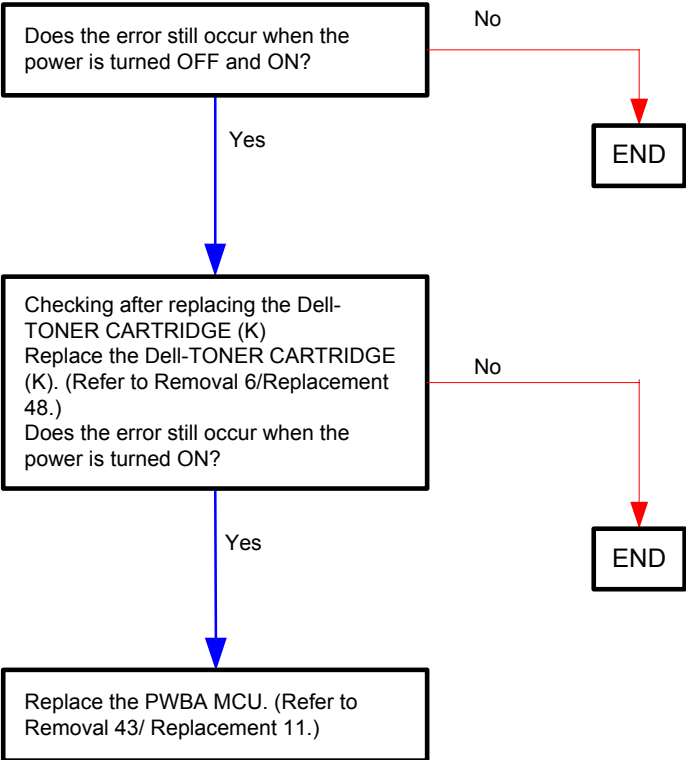

Flows 66 Shake Cartridge 093-919

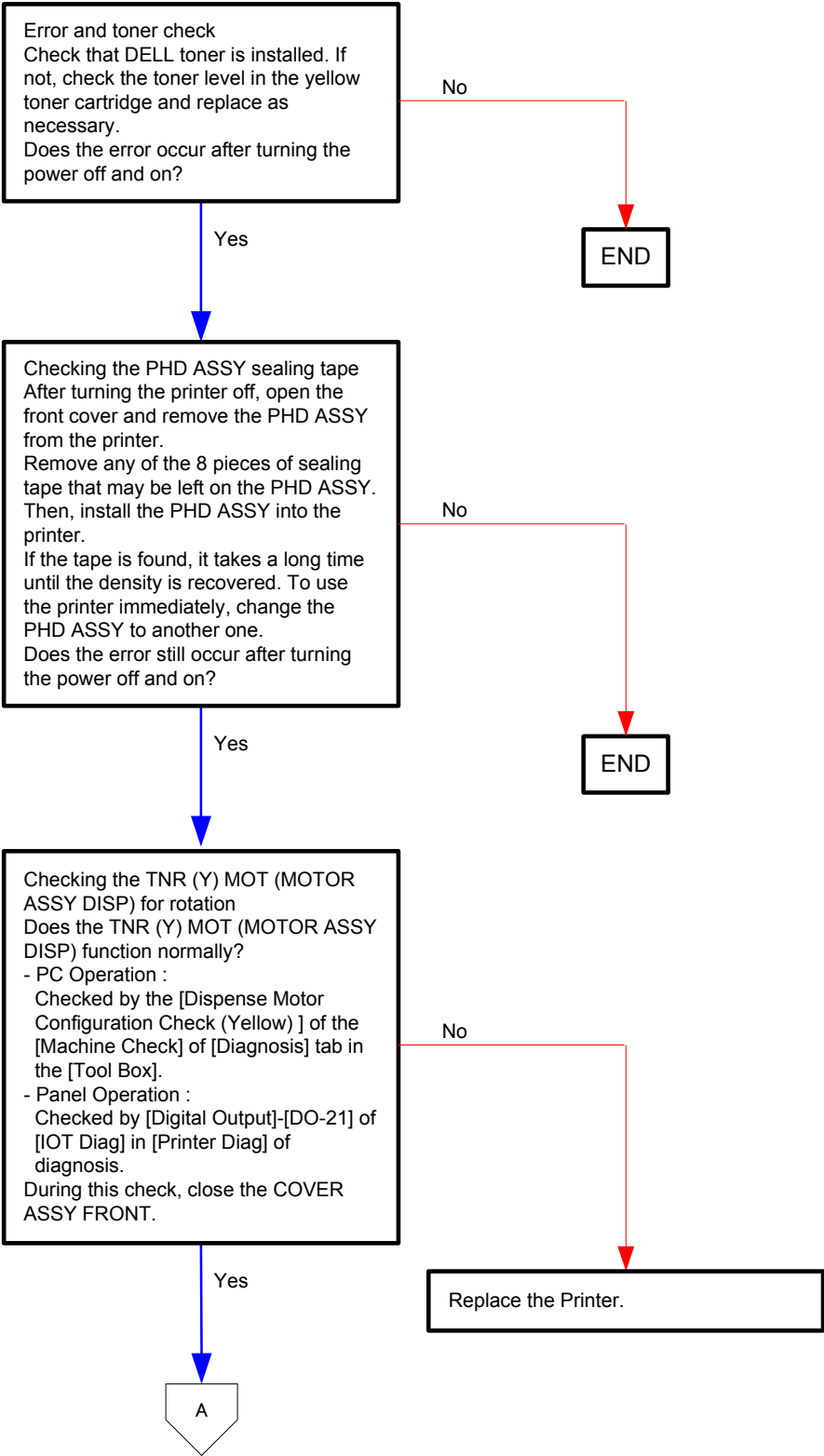

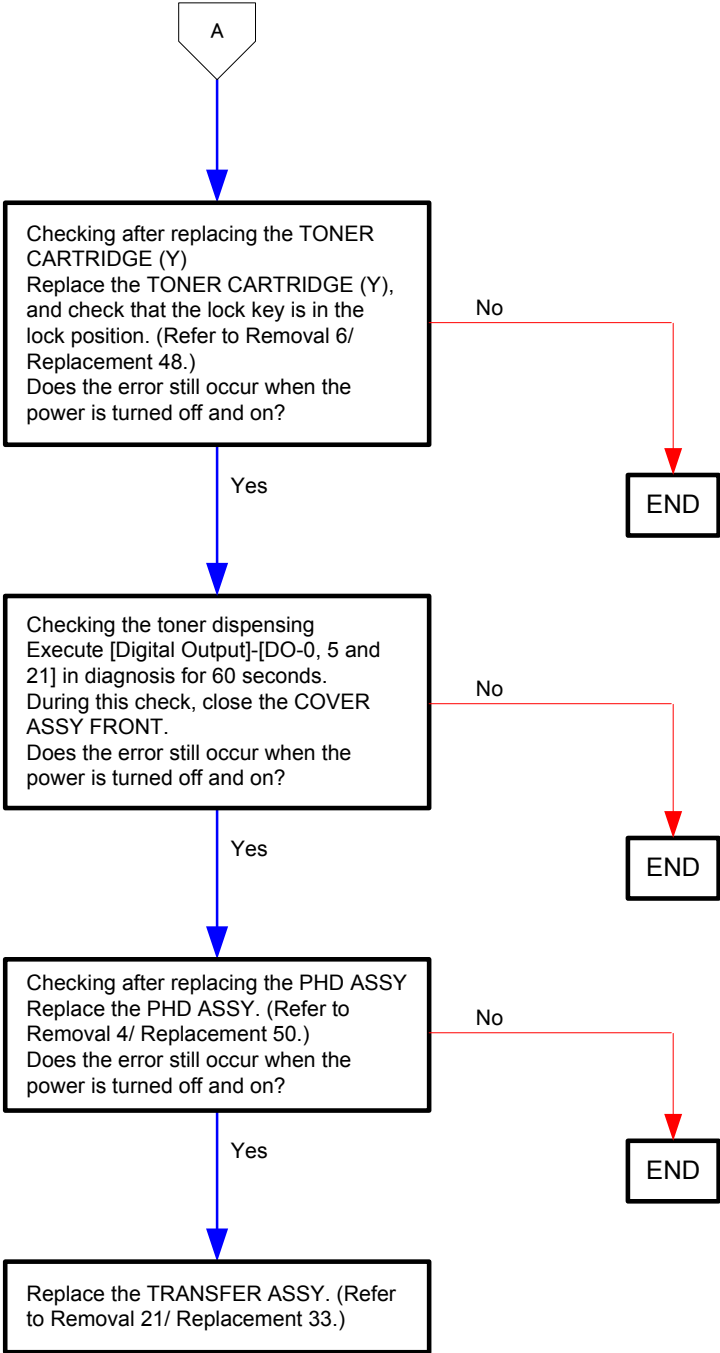

Flows 67 Shake Cartridge 093-920

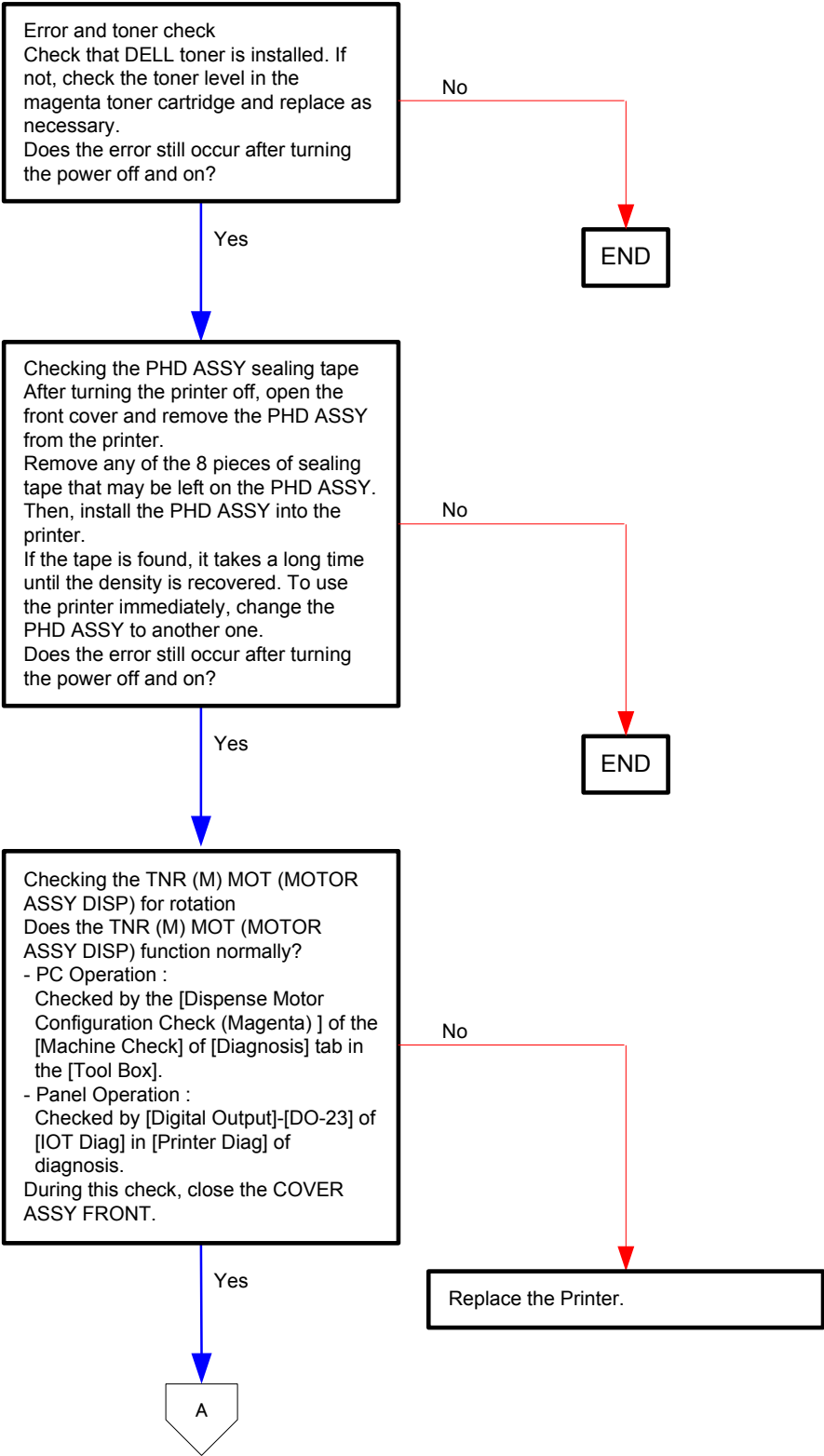

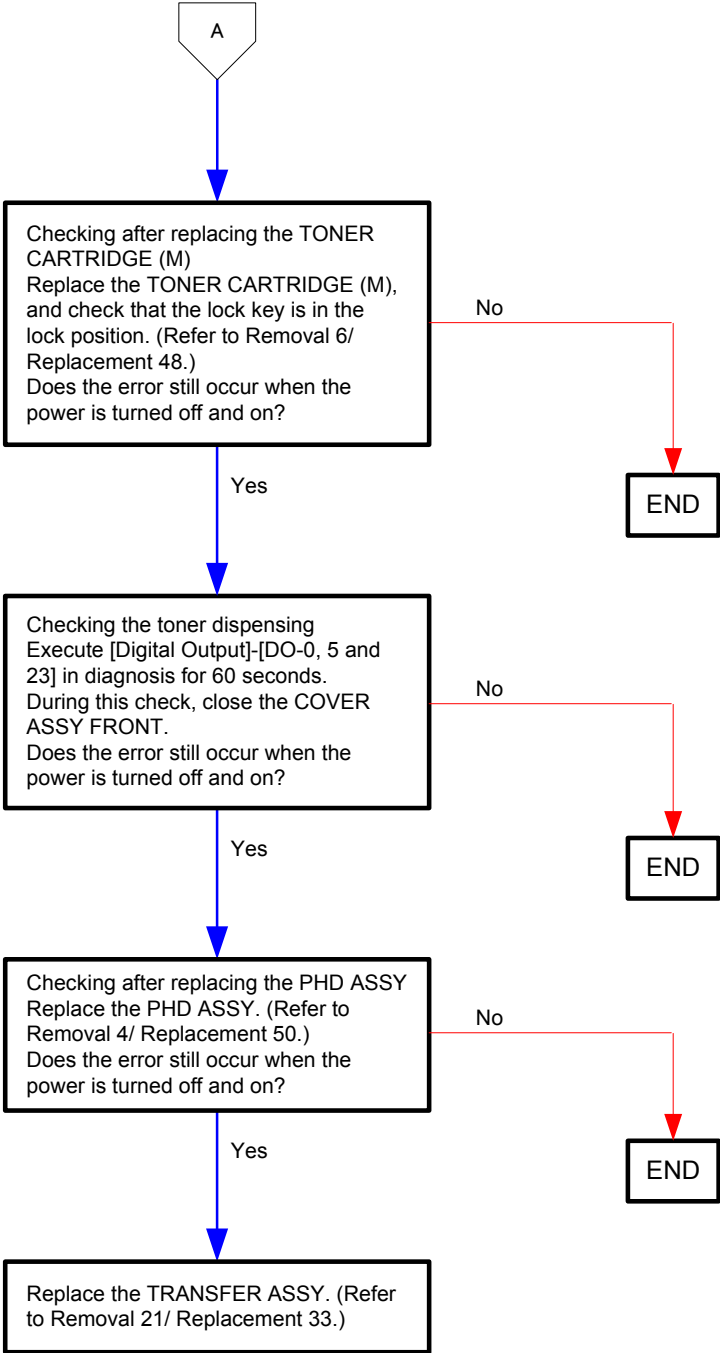

Flows 68 Shake Cartridge 093-921

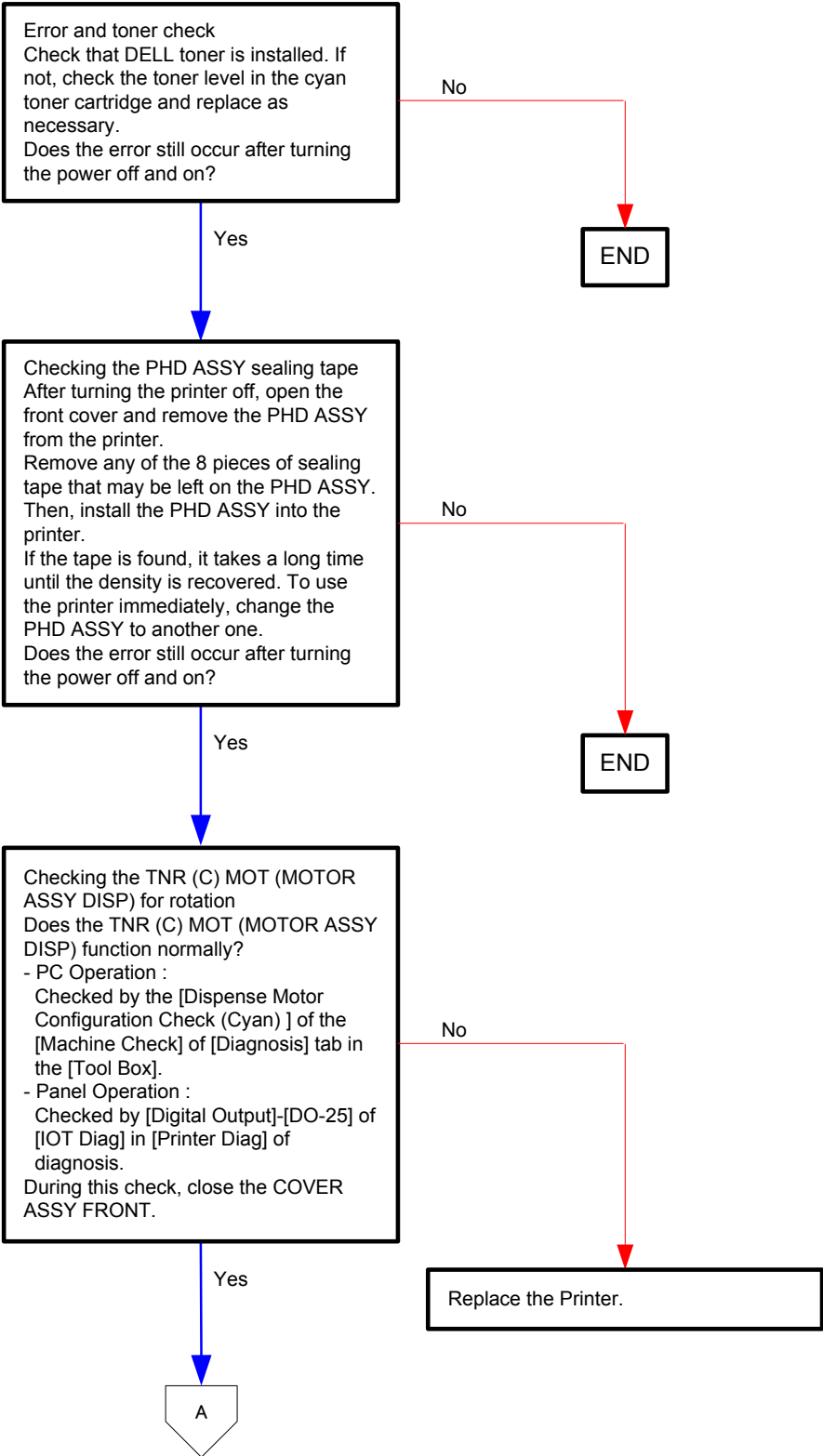

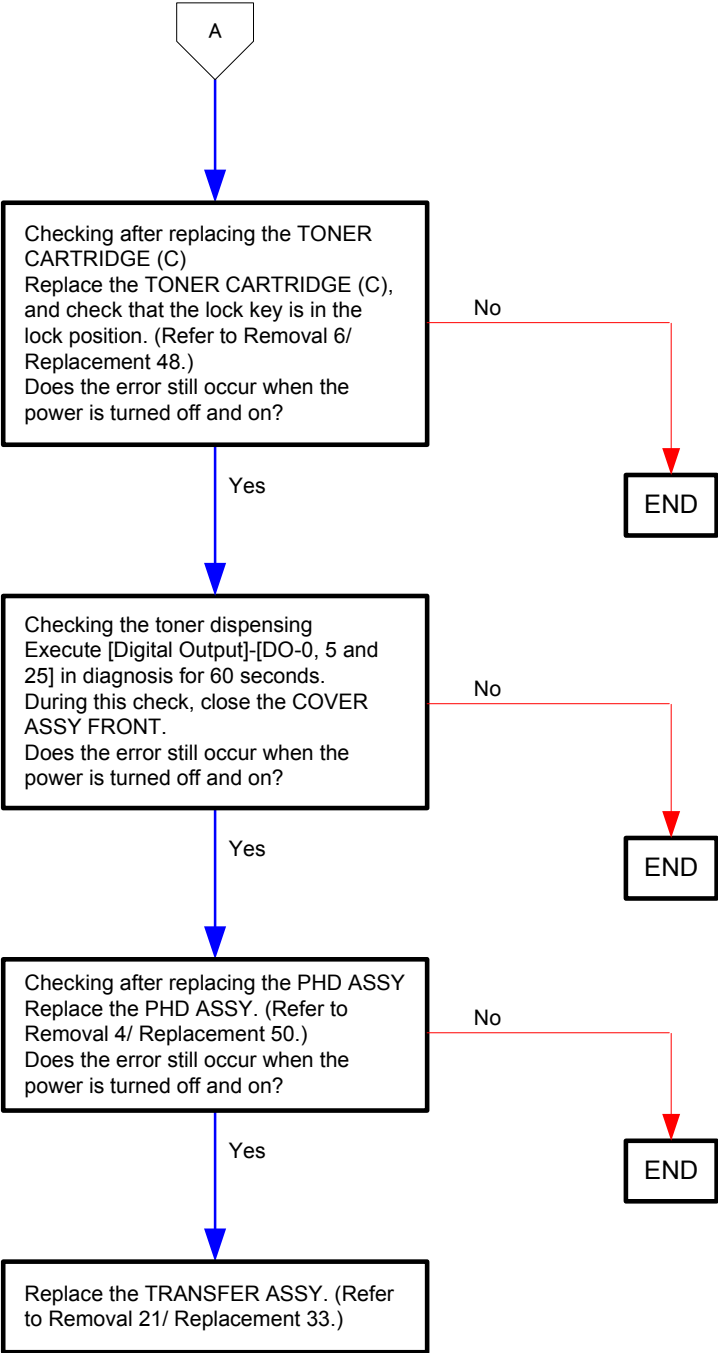

Flows 69 Shake Cartridge 093-922

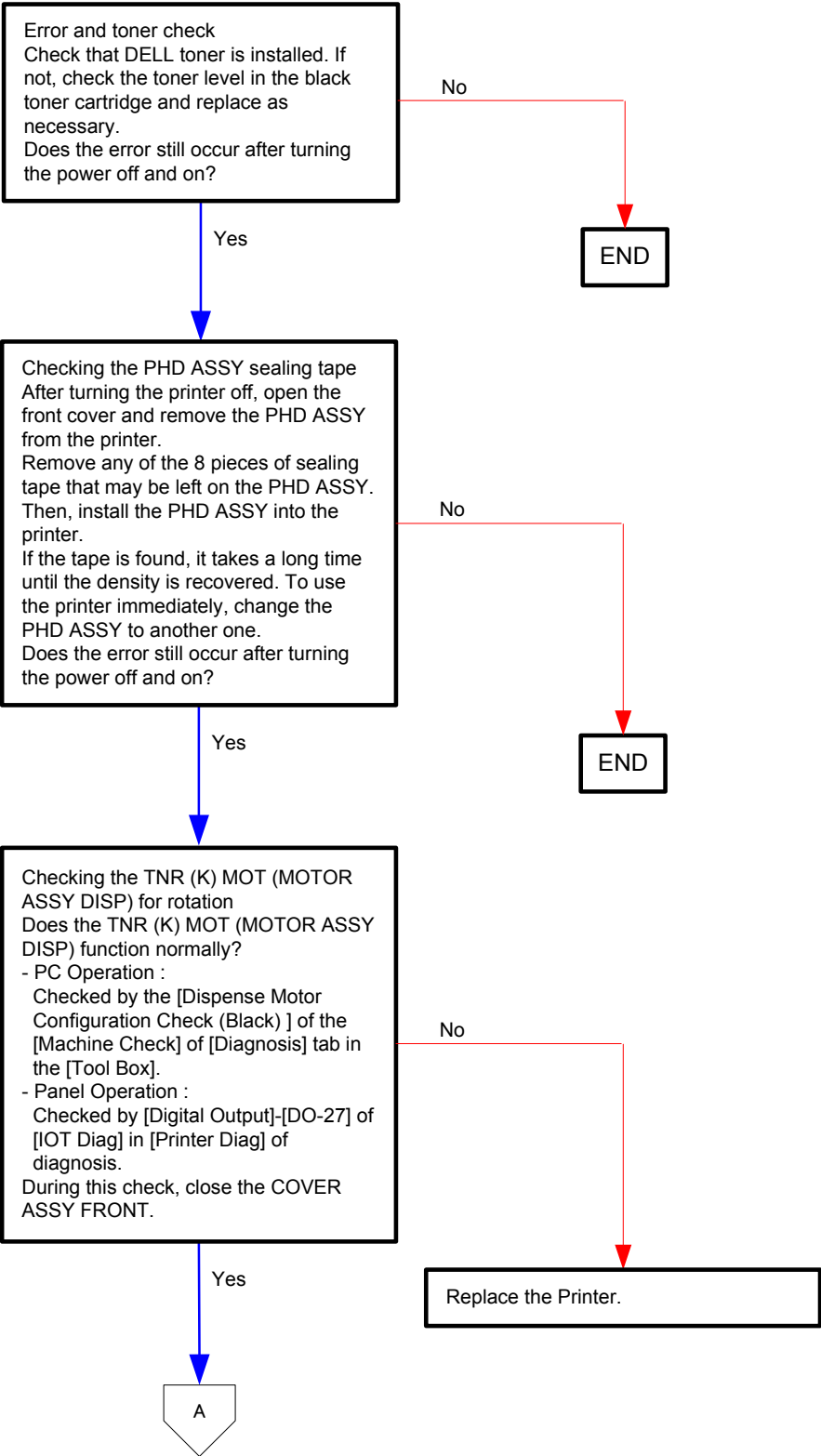

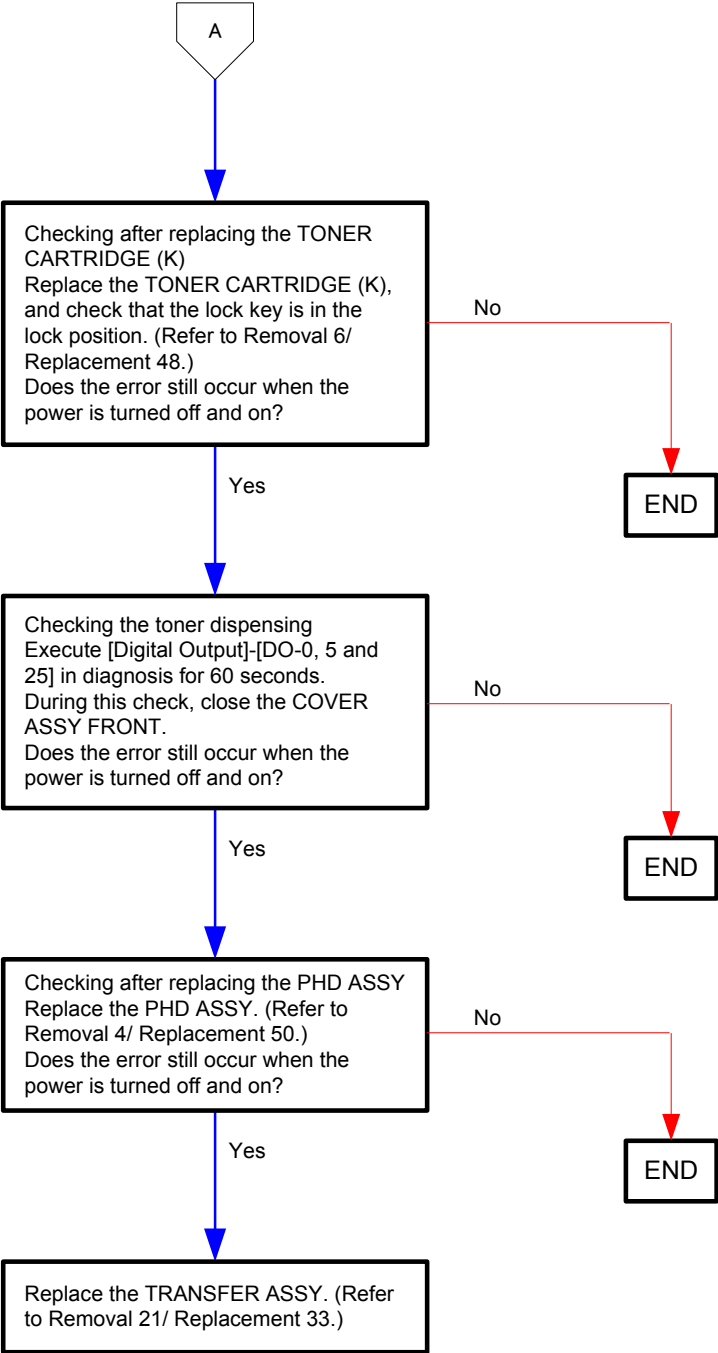

Flows 70 Replace Cart. 093-934

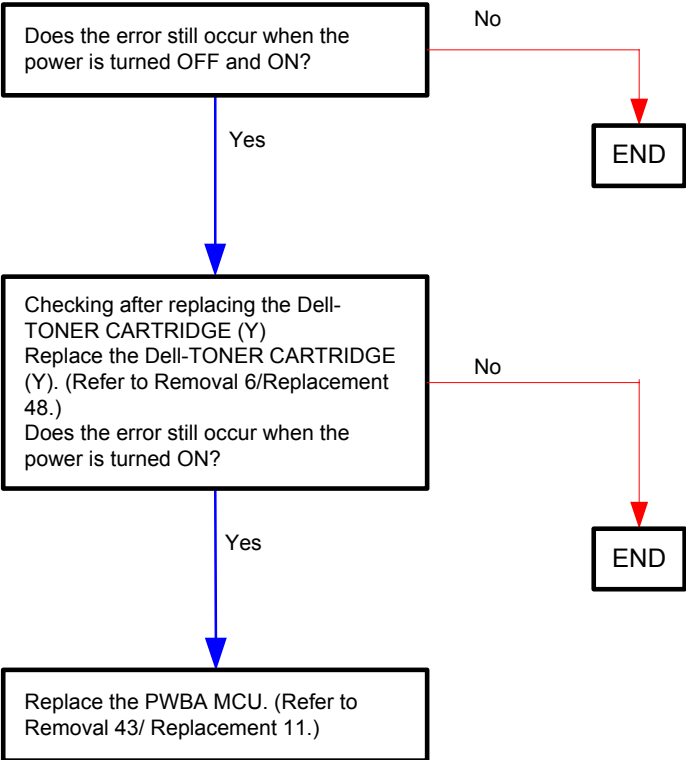

Flows 71 Replace Cart. 093-935

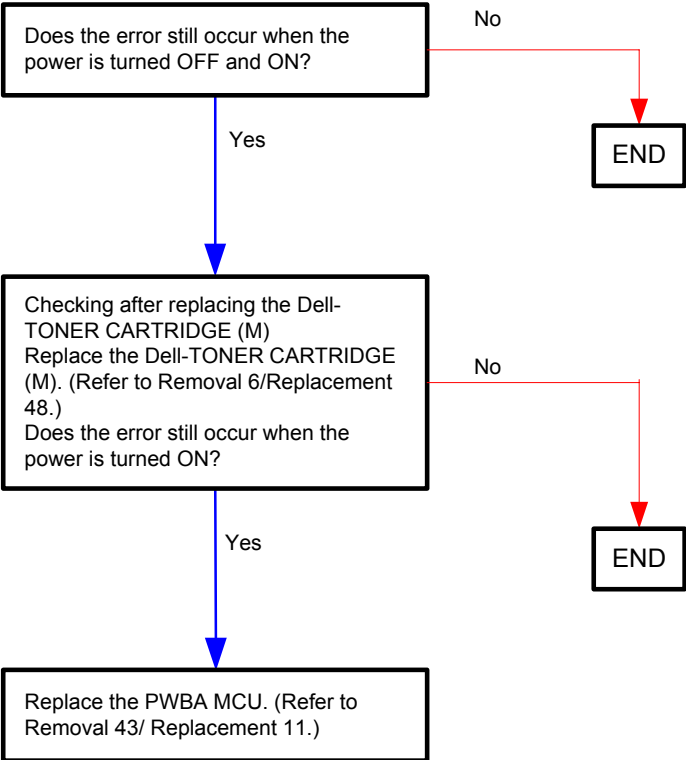

Flows 72 Replace Cart. 093-936

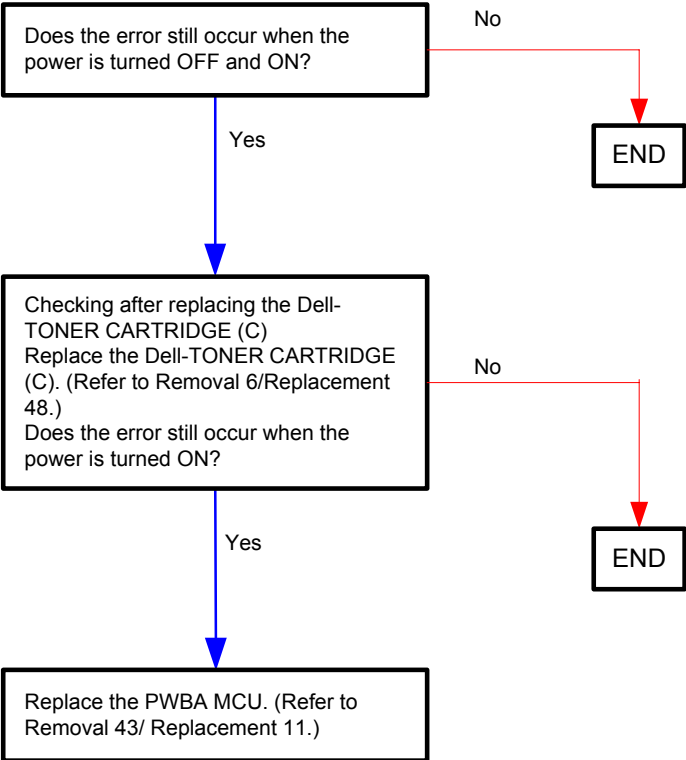

Flows 73 Replace Cart. 093-937

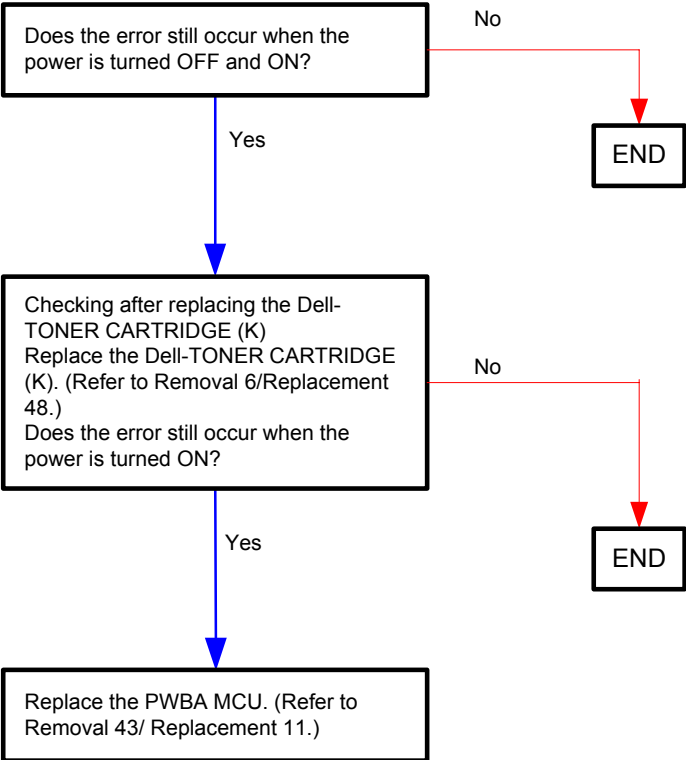

Flows 74 CRUM ID 093-960

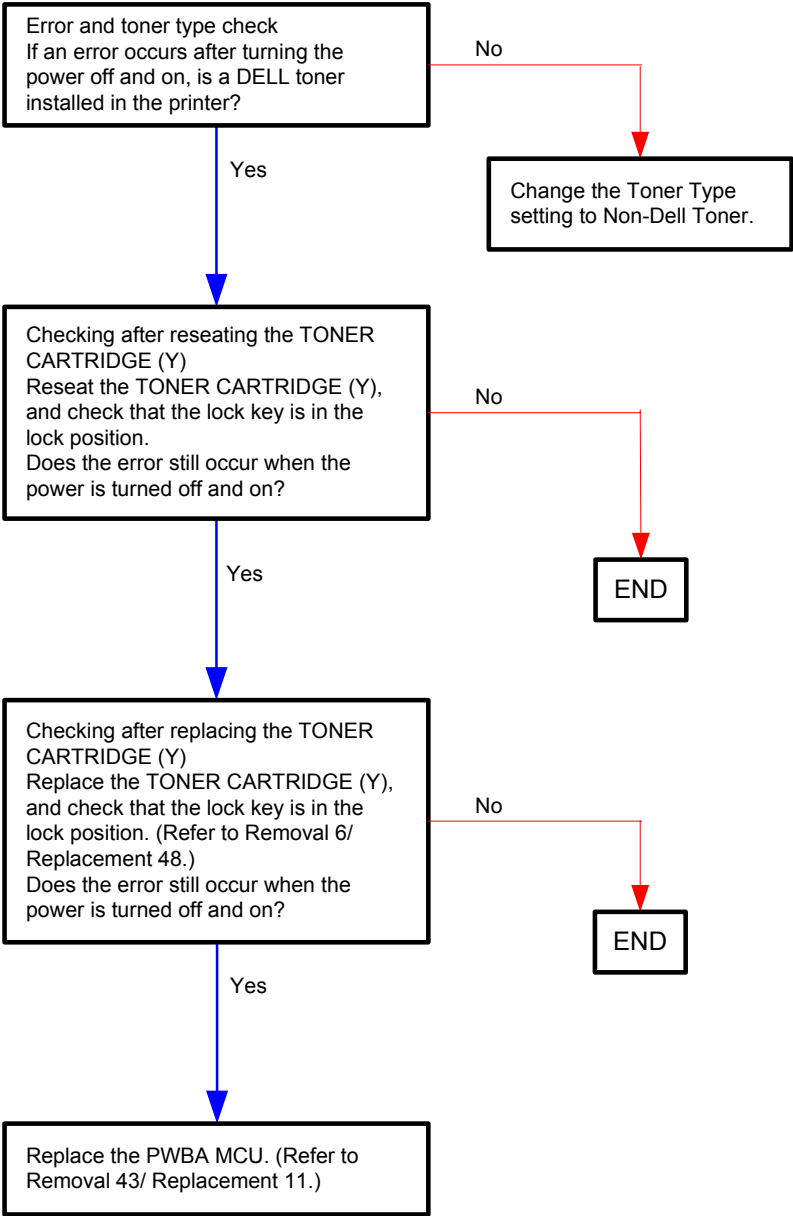

Flows 75 CRUM ID 093-961

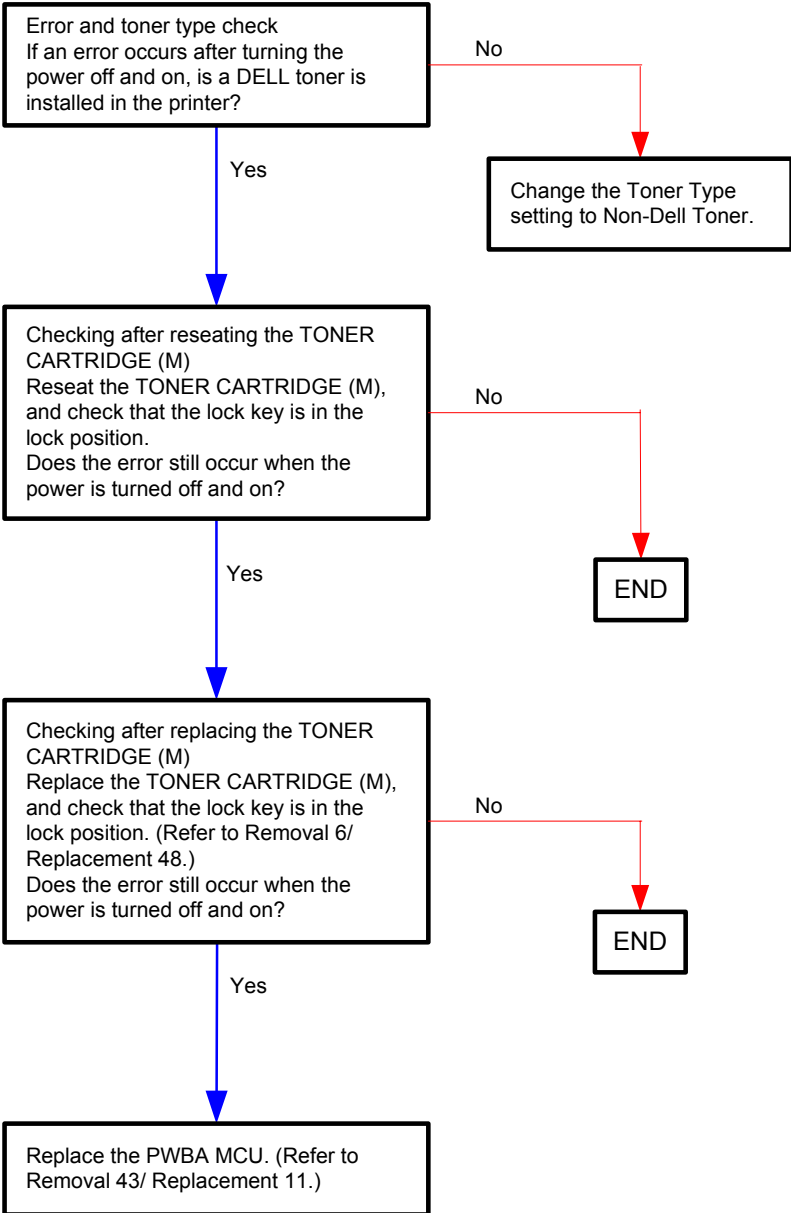

Flows 76 CRUM ID 093-962

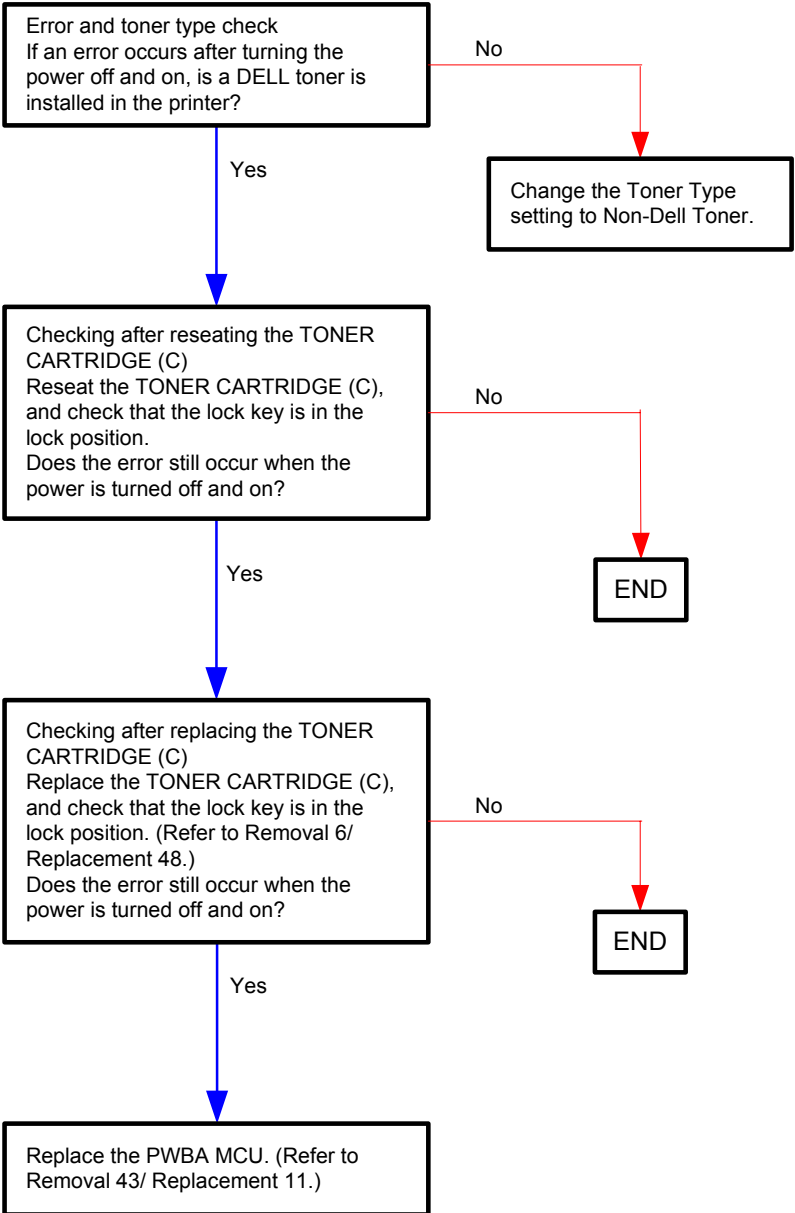

Flows 77 CRUM ID 093-963

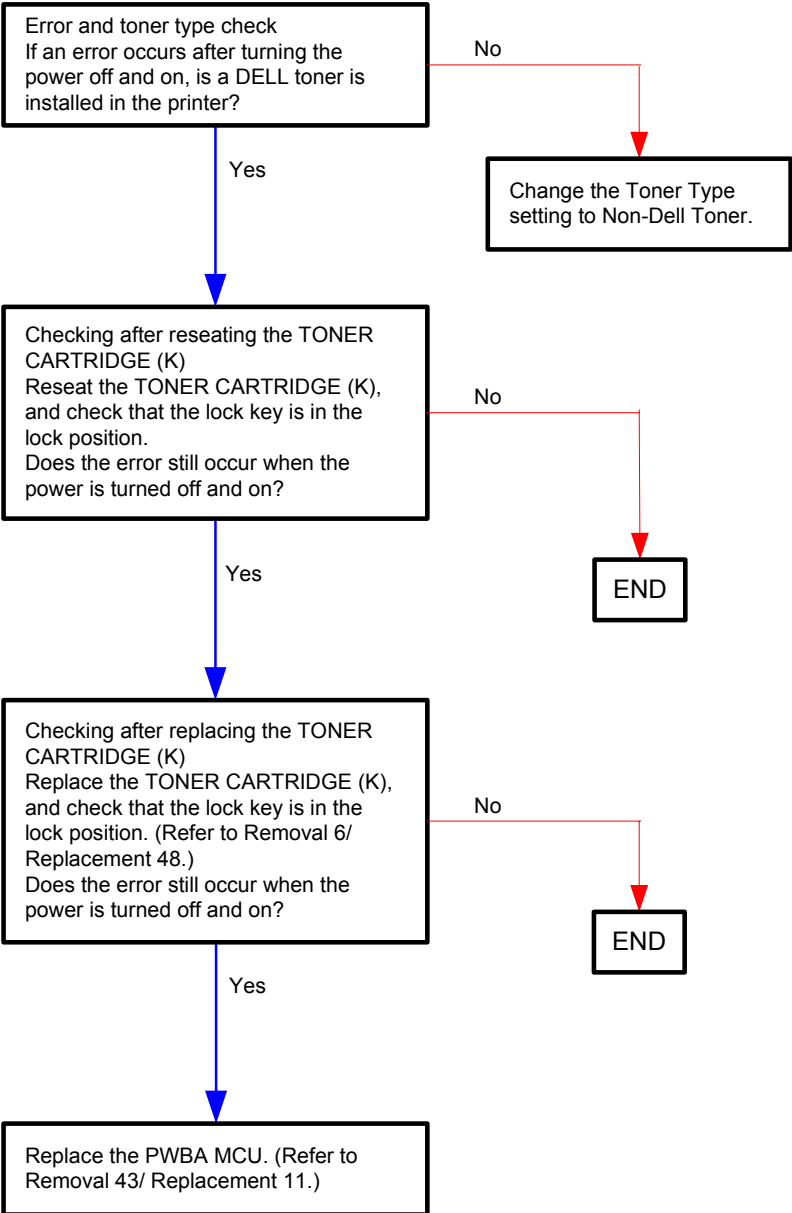

Flows 78 CRUM ID 093-965

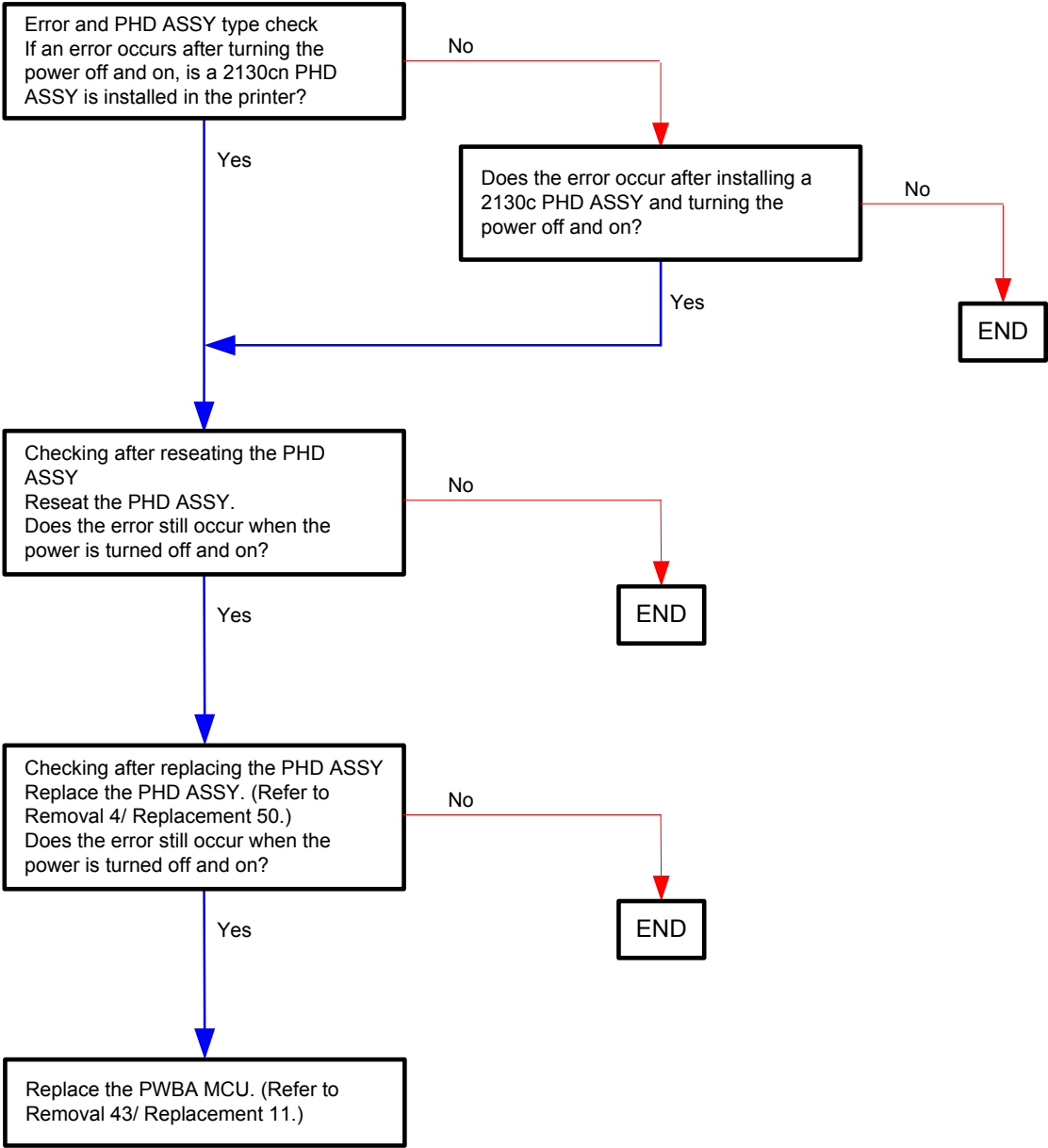

Flows 79 Insert PrintCart 093-970

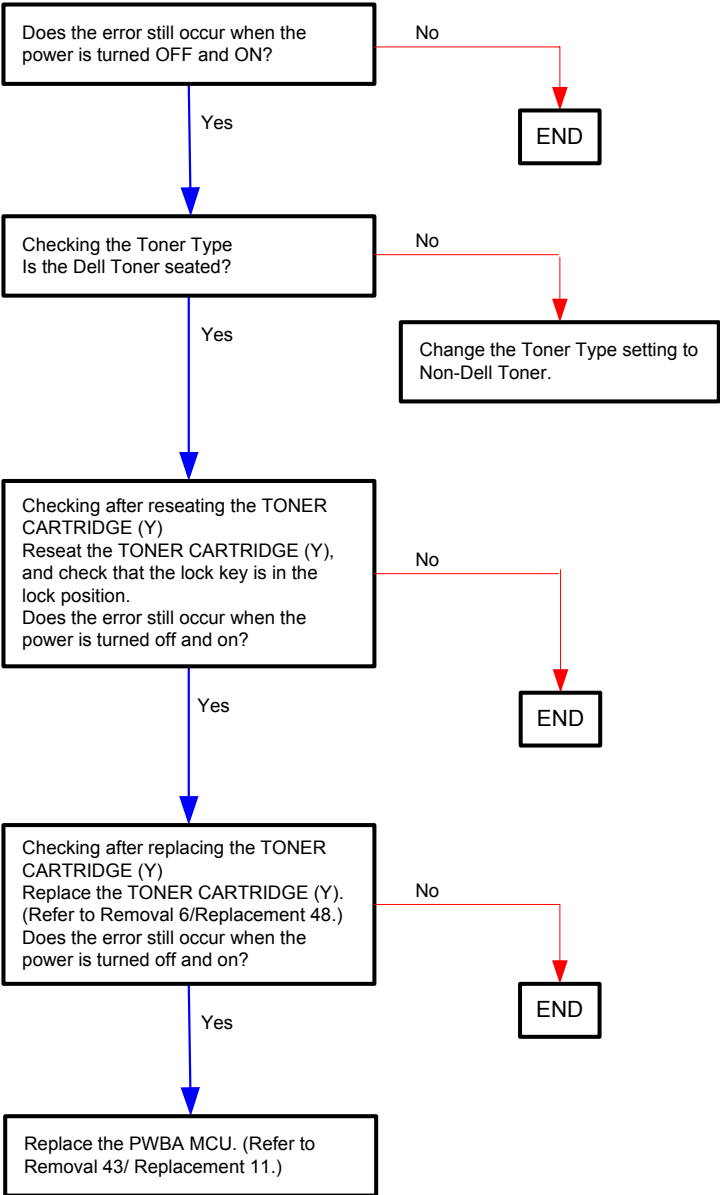

Flows 80 Insert PrintCart 093-971

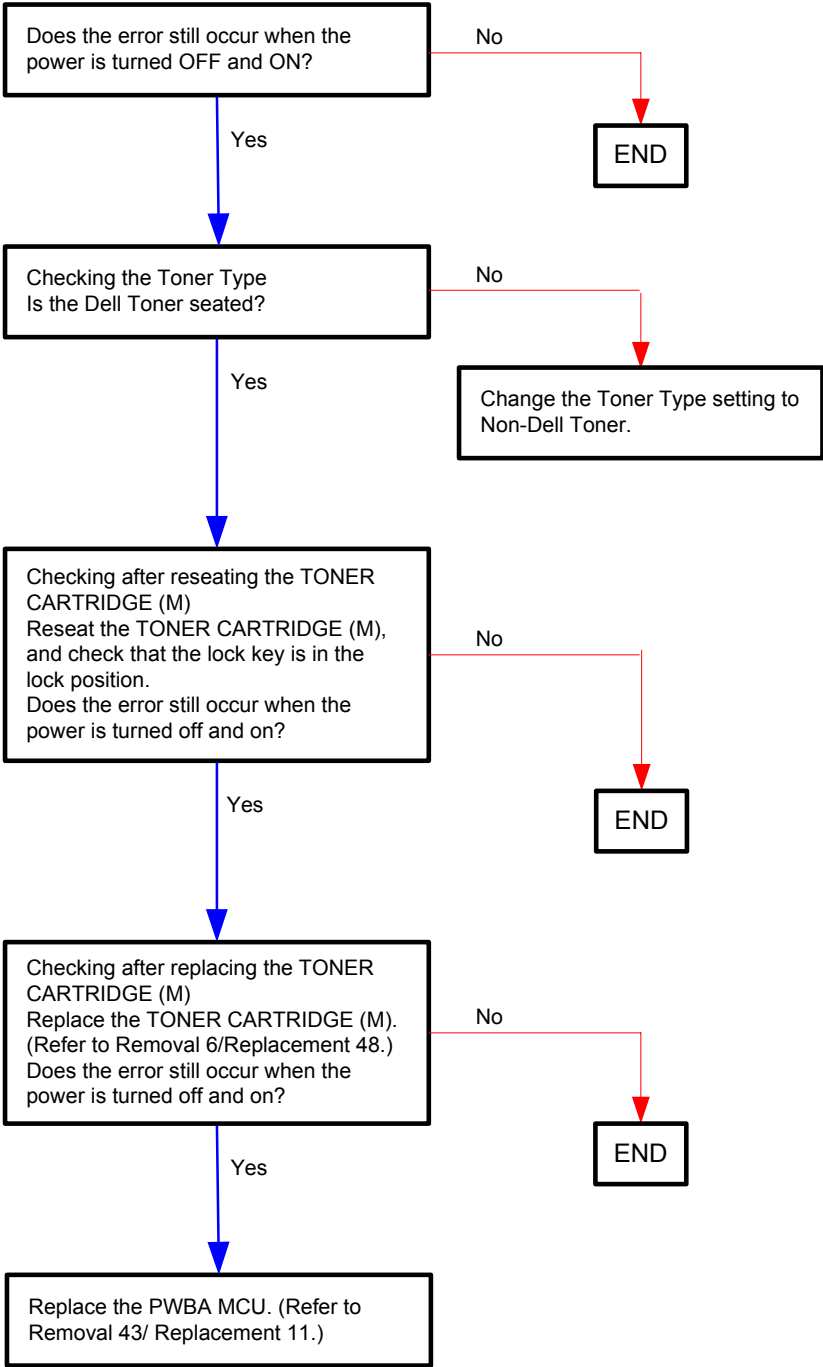

Flows 81 Insert PrintCart 093-972

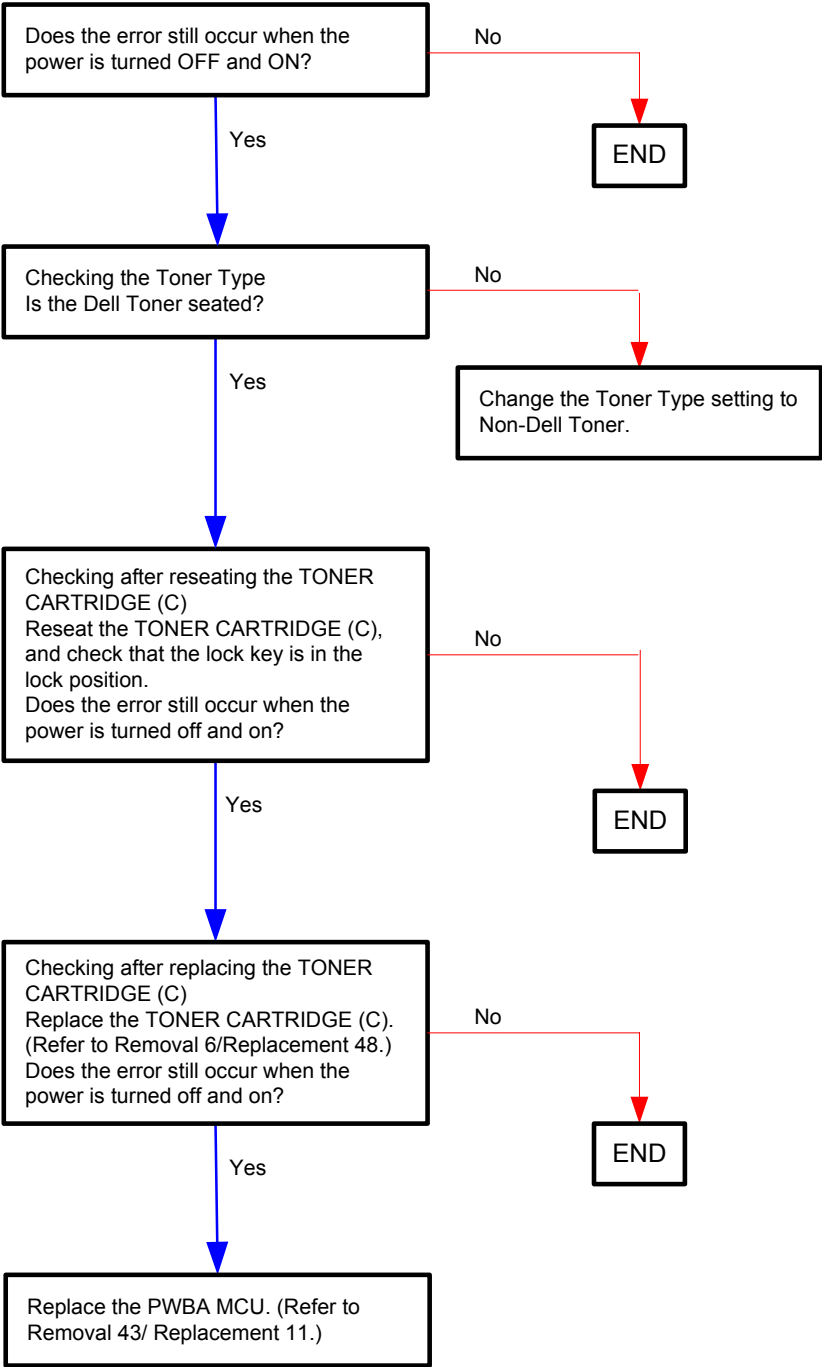

Flows 82 Insert PrintCart 093-973

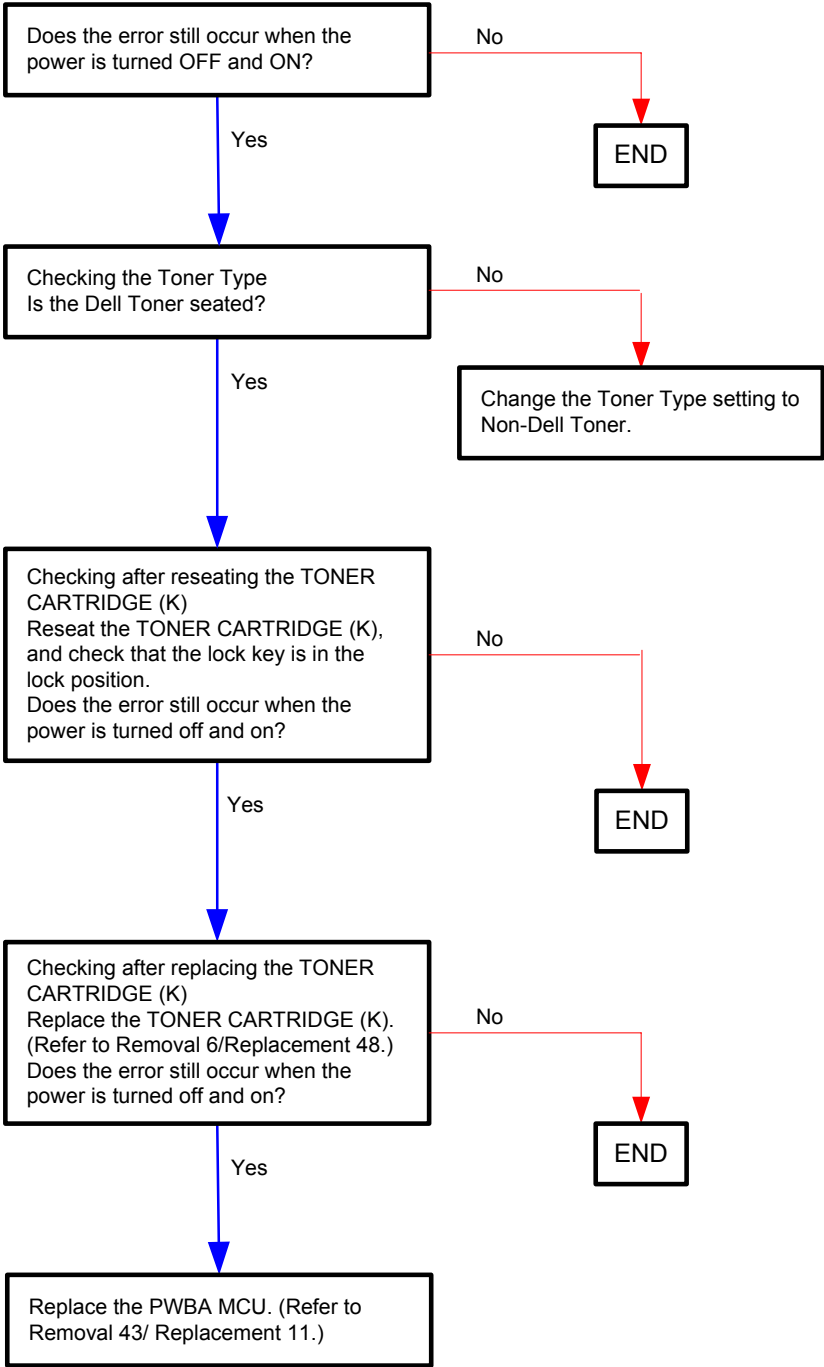

Flows 83 Ready to Print 094-422 / 094-911 Contact Support

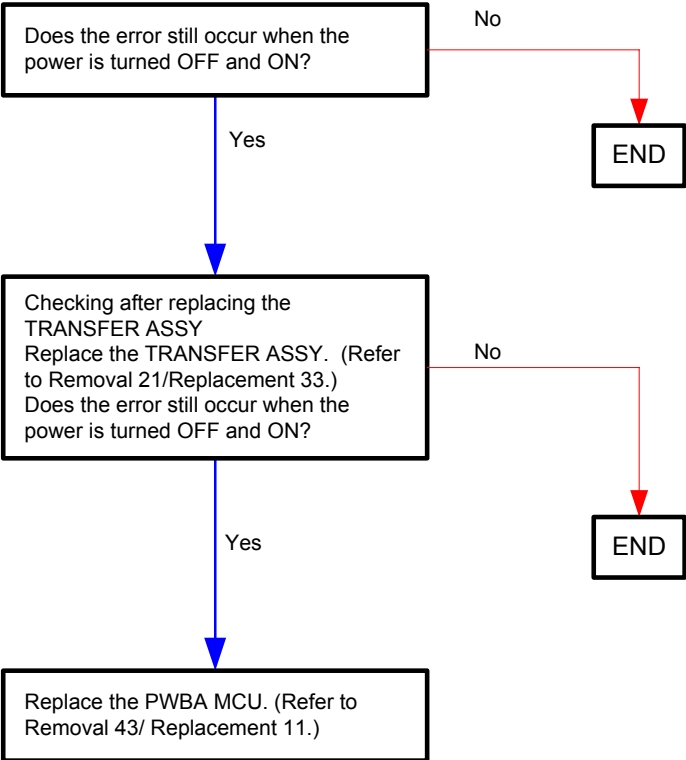

Flows 84 Ready to Print 193-700

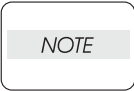

This message appears when [Non-Dell Toner] setting of [Maintenance] on [Admin Menu] is turned to [ON] for using non-Dell toner cartridge. Printing is available while this message is displayed.

When you use Dell toner cartridge, you can turn off the message by turning the [Non-DELL Toner] setting to [OFF].

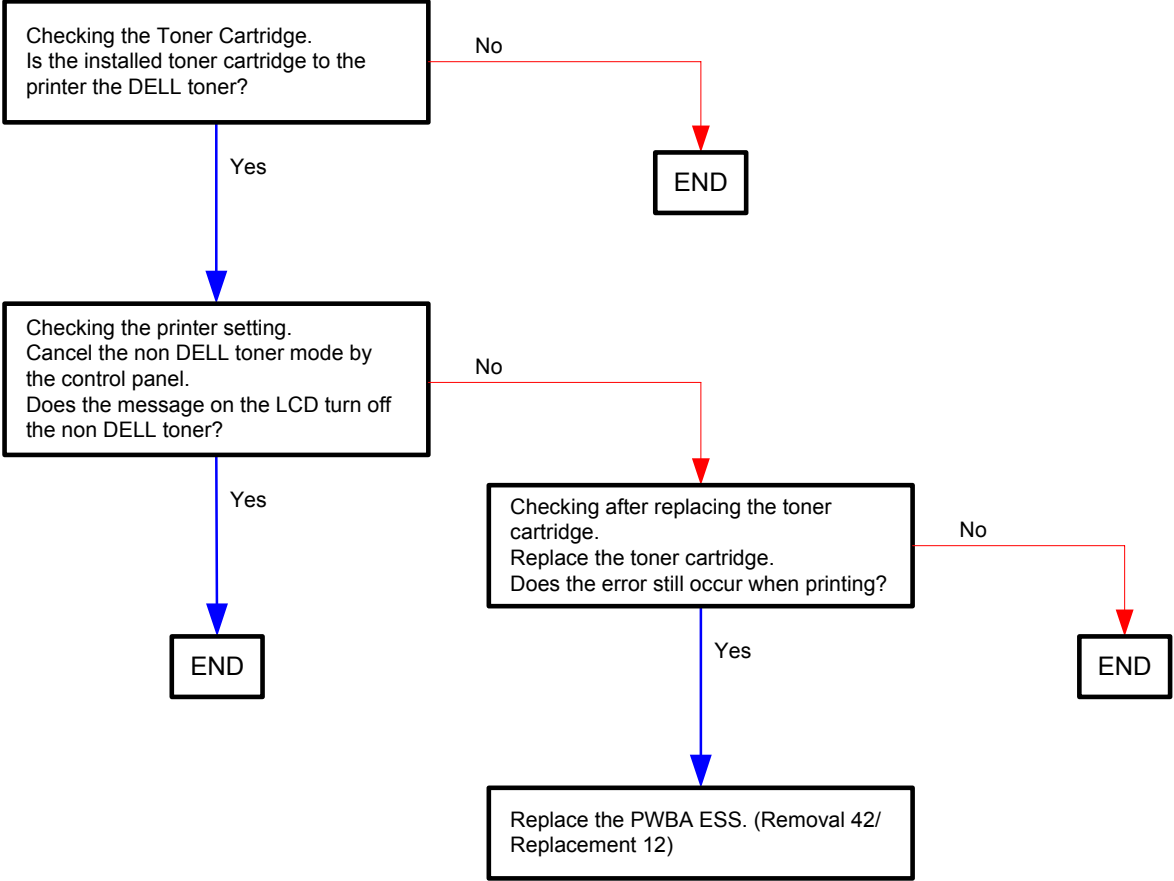

Flows 85 Faint print (Low contrast)

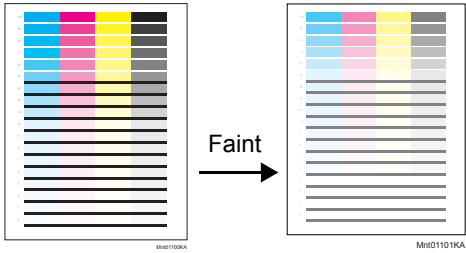

NOTE

If the copy finish is too light, restoring the default [Color balance Y, M, C and K] of [Copy Defaults] in [Copy] of [Default Settings] settings may solve it.

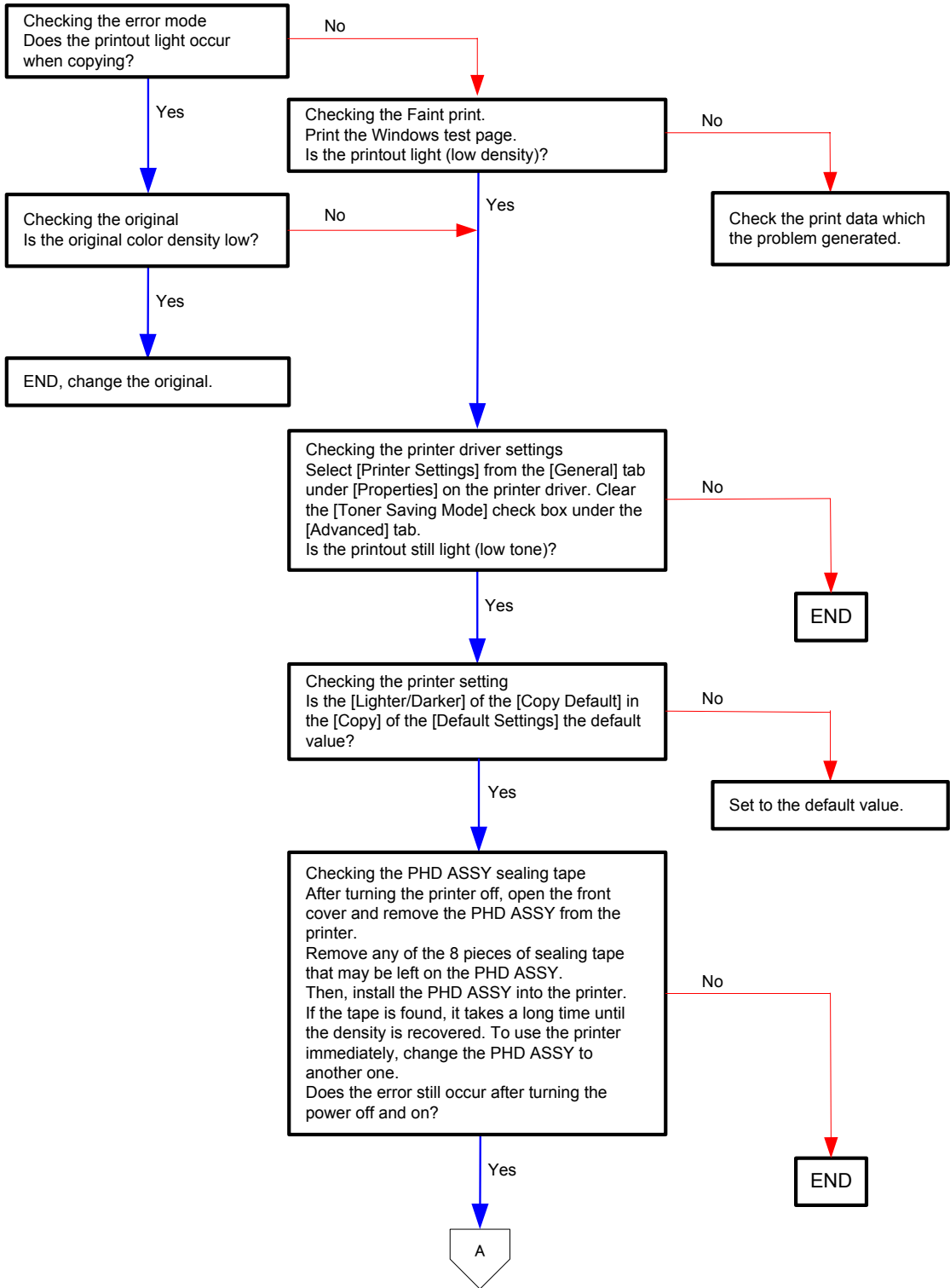

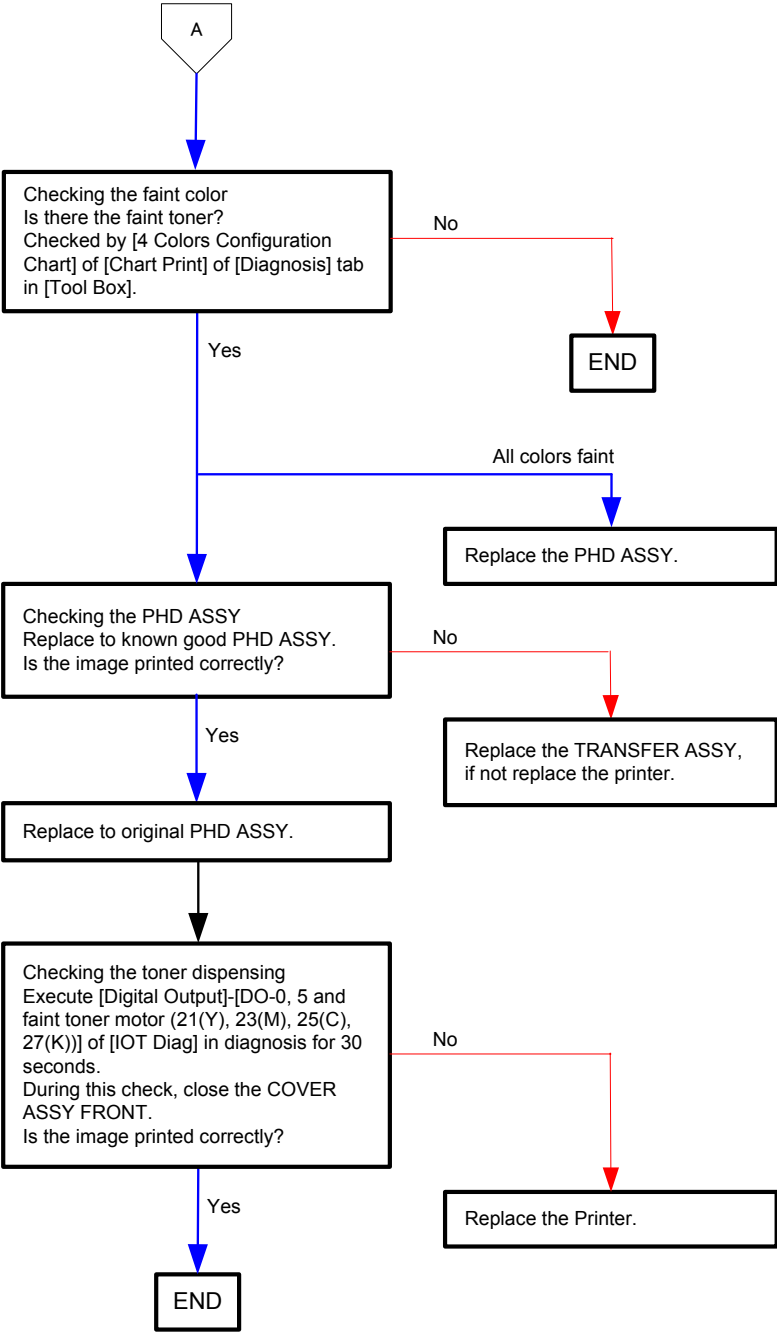

Flows 86 Blank print (No print)

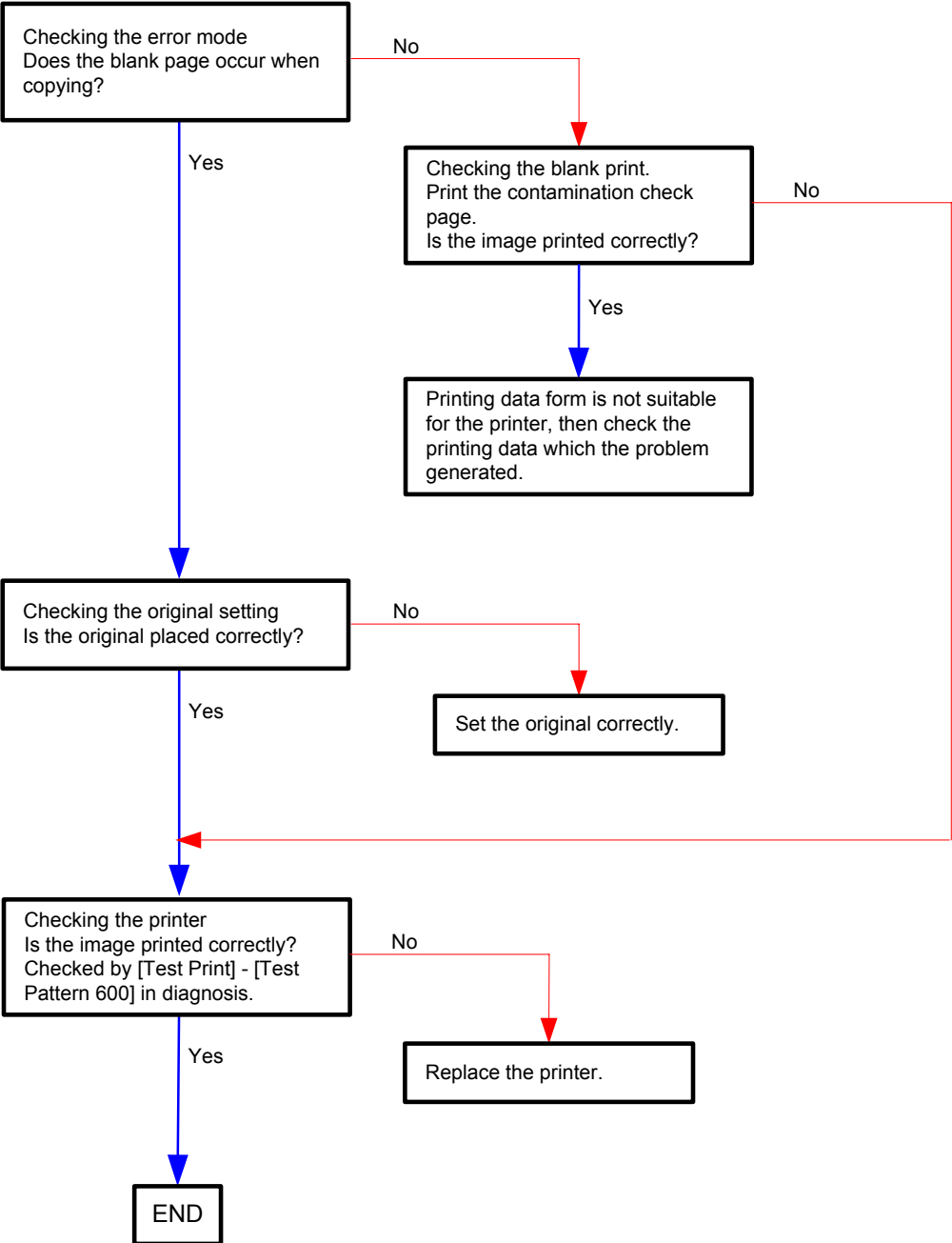
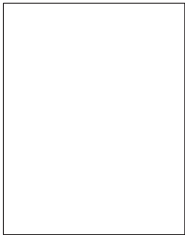

Flows 87 Solid black

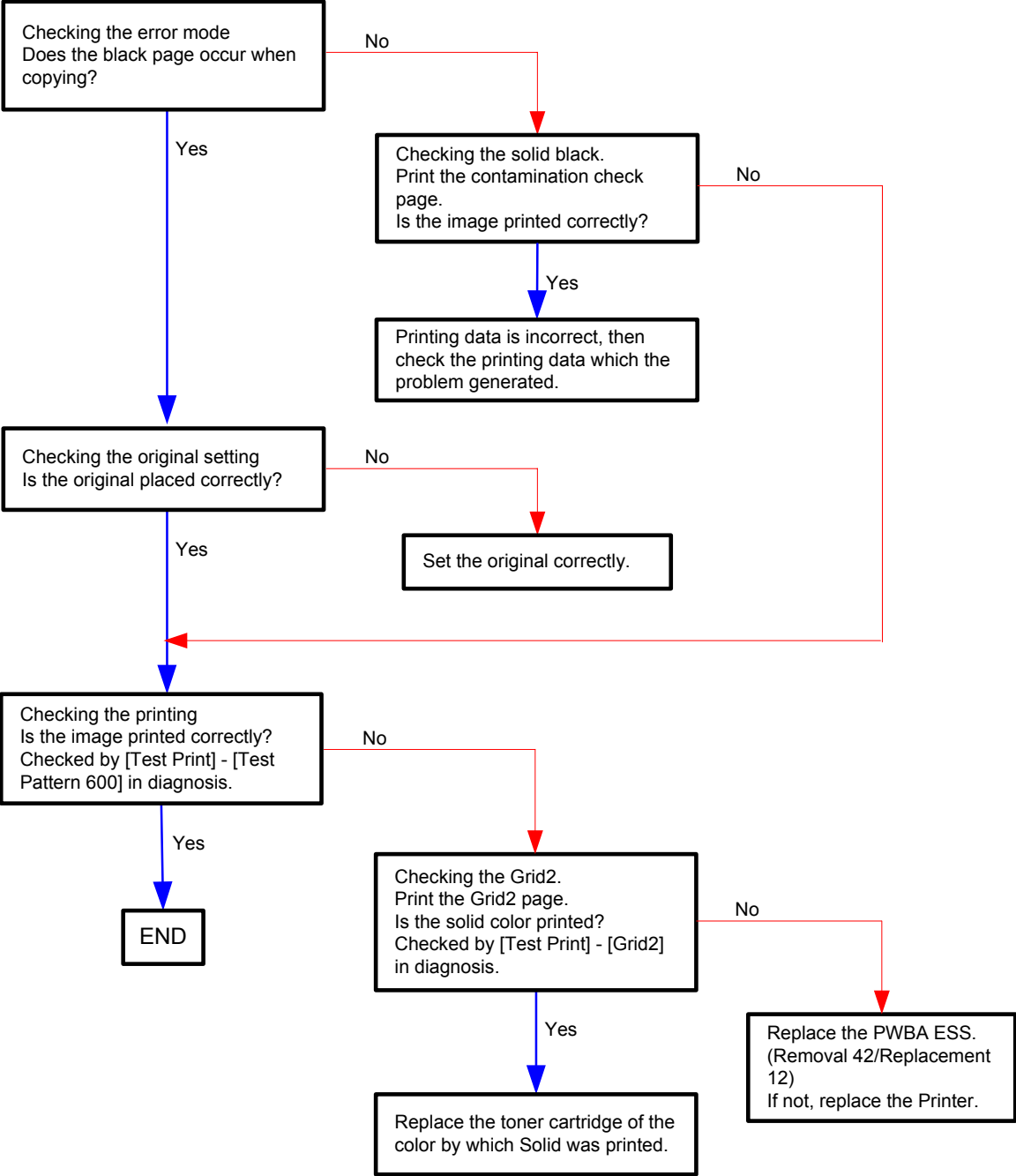

Flows 88 Vertical blank line (White stripes in paper transport direction)

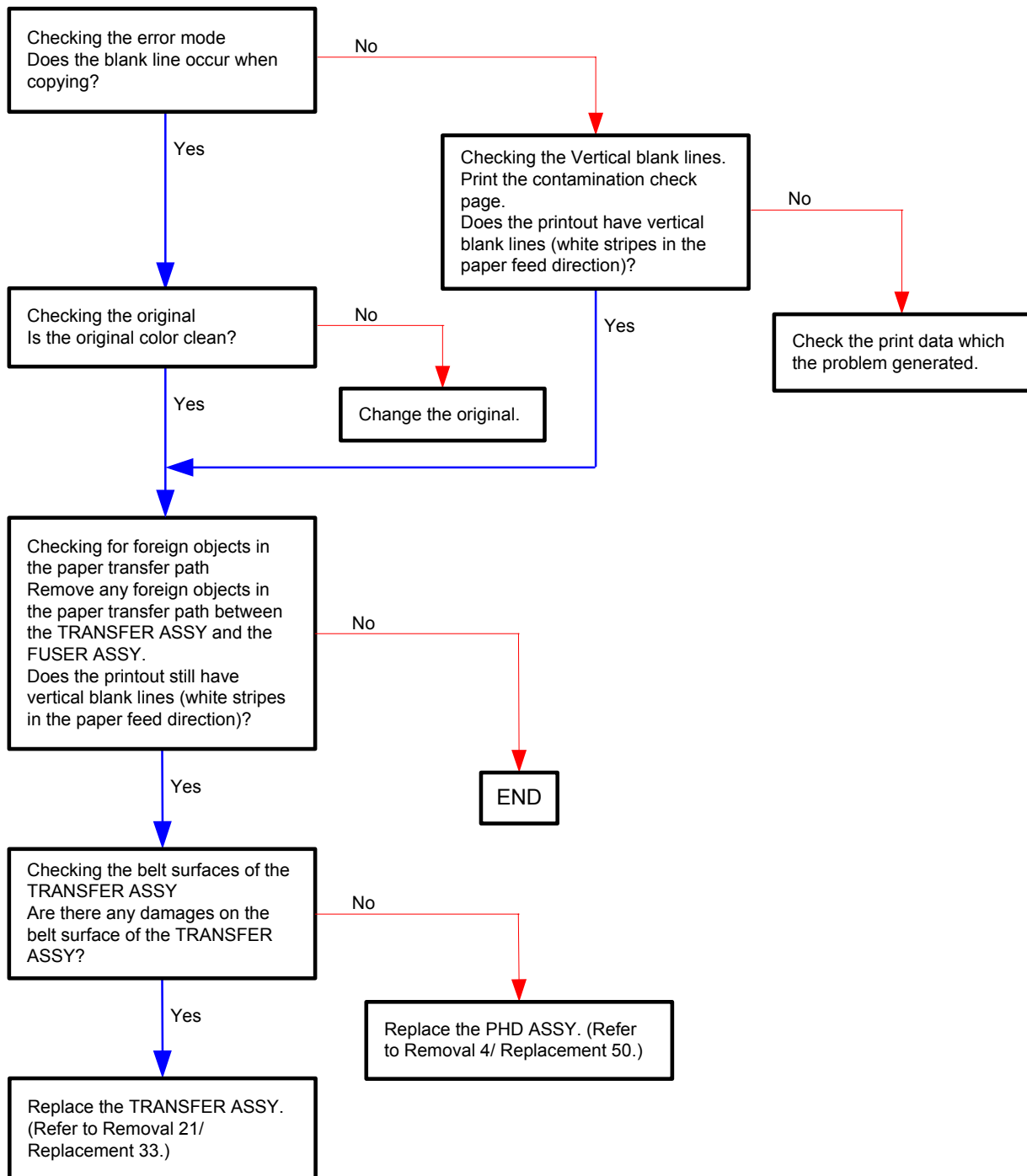
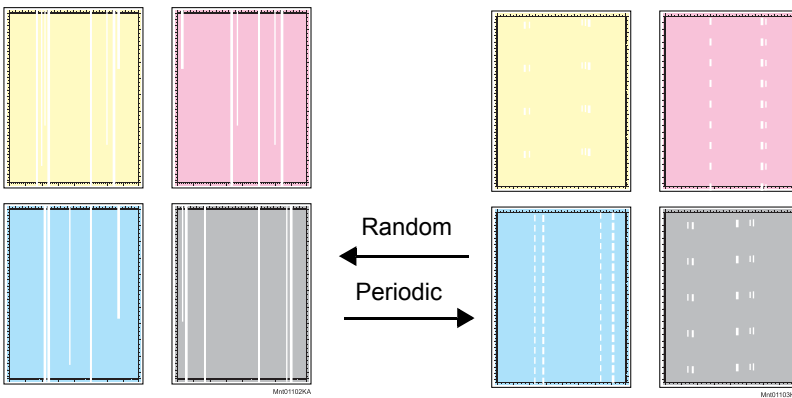

Flows 89 Horizontal band cross out (White stripe in horizontal direction)

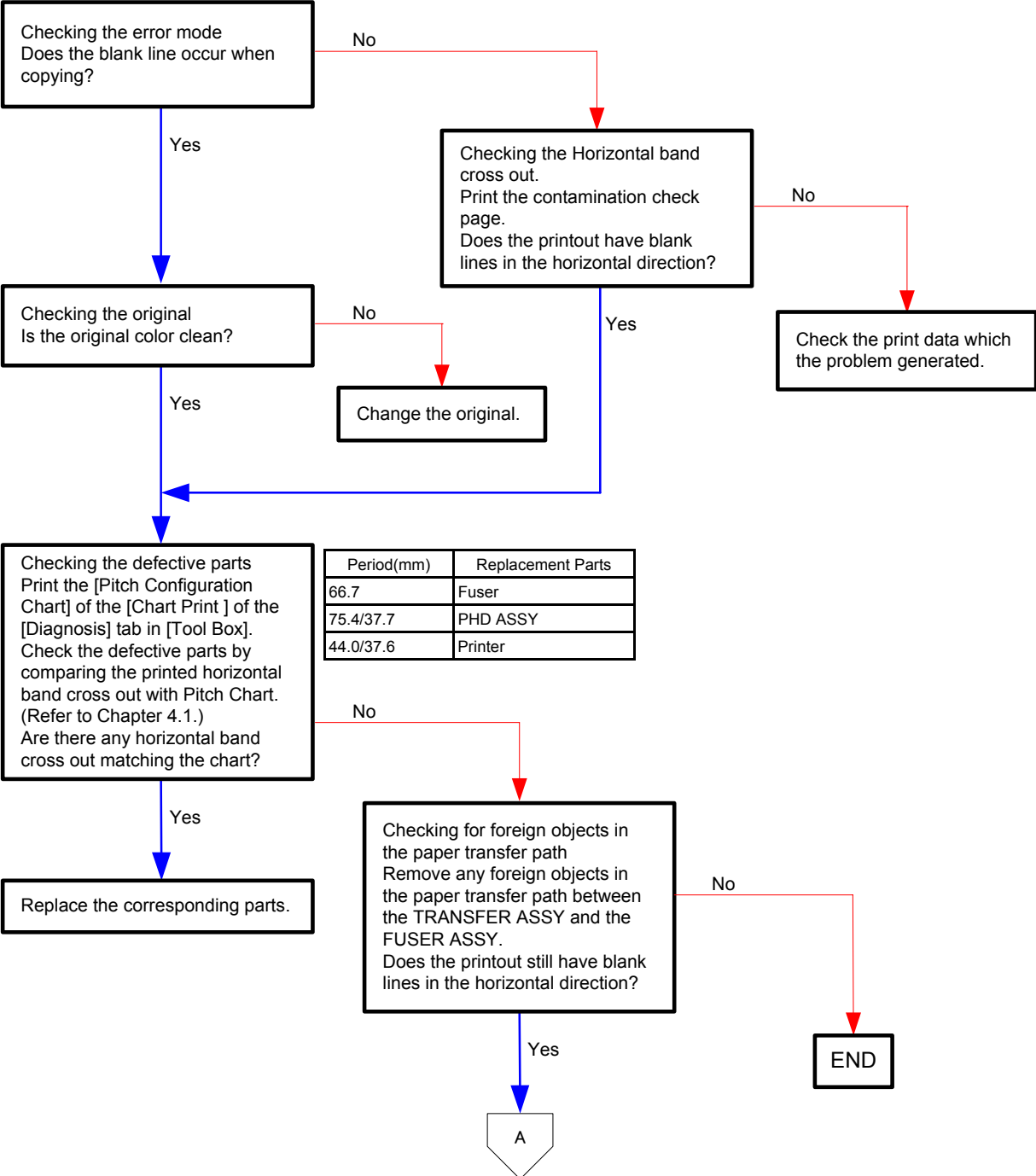
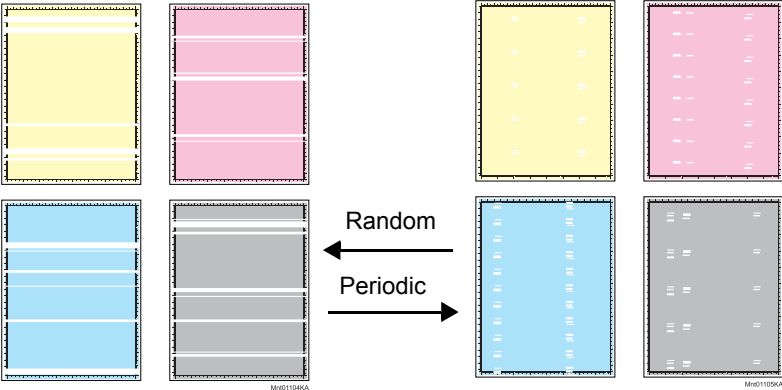

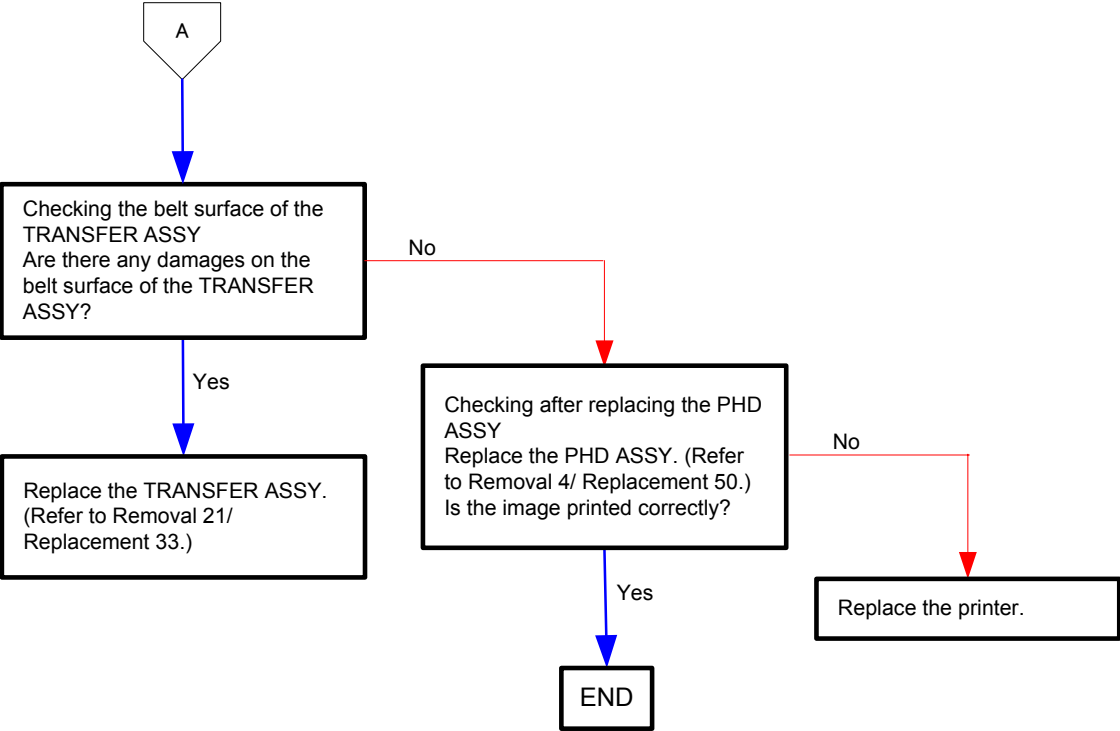

Flows 90 Vertical stripes

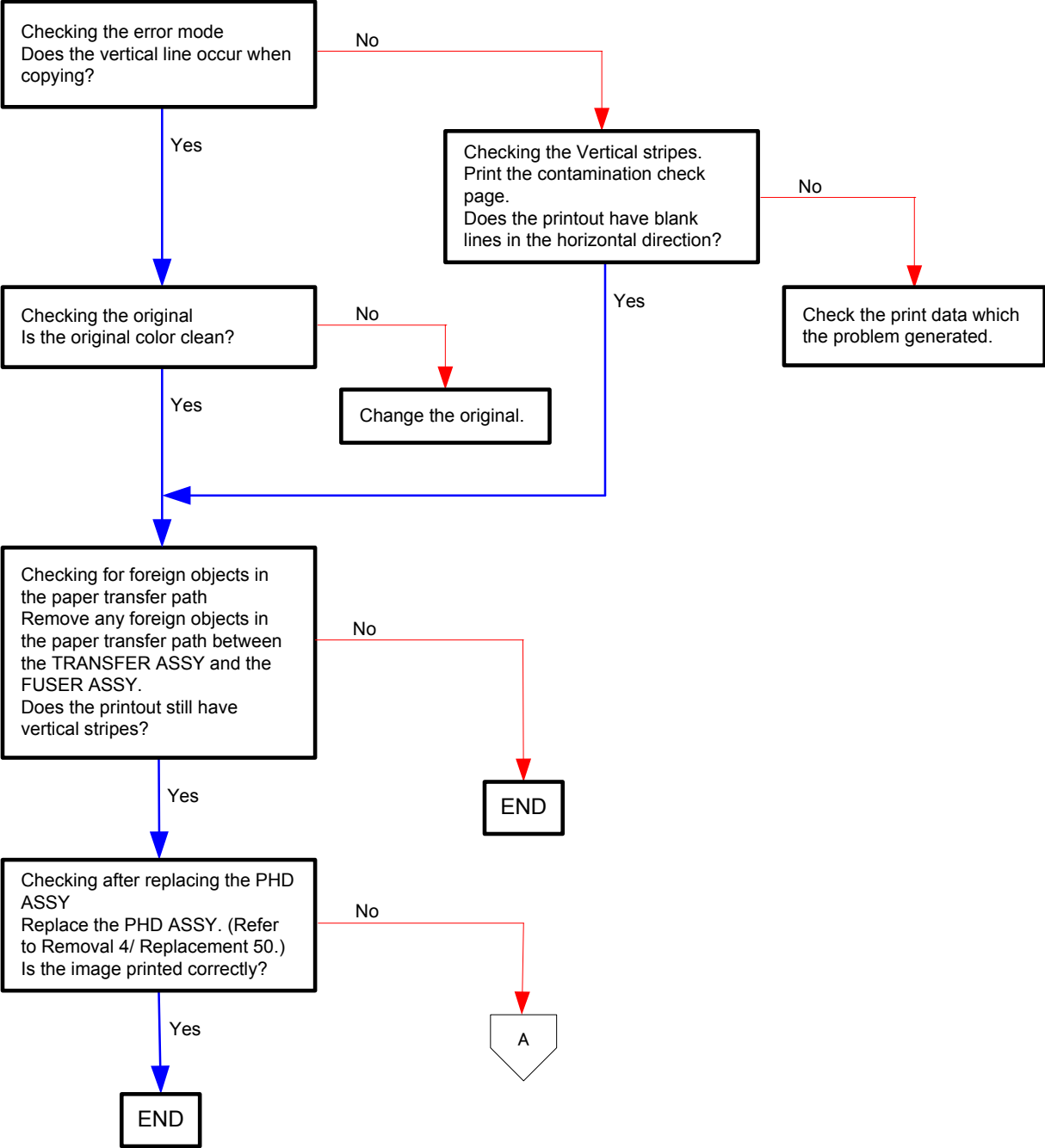
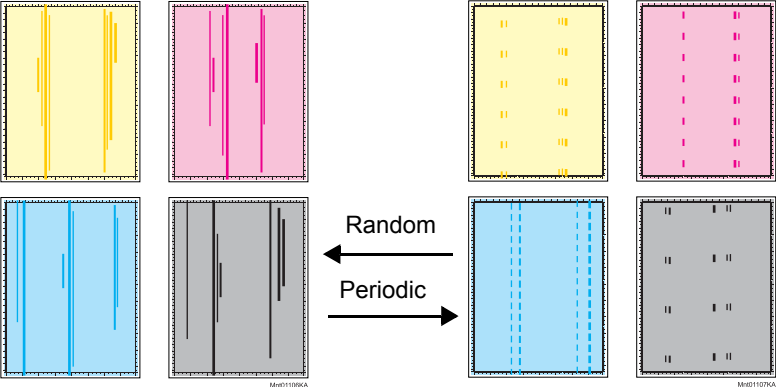

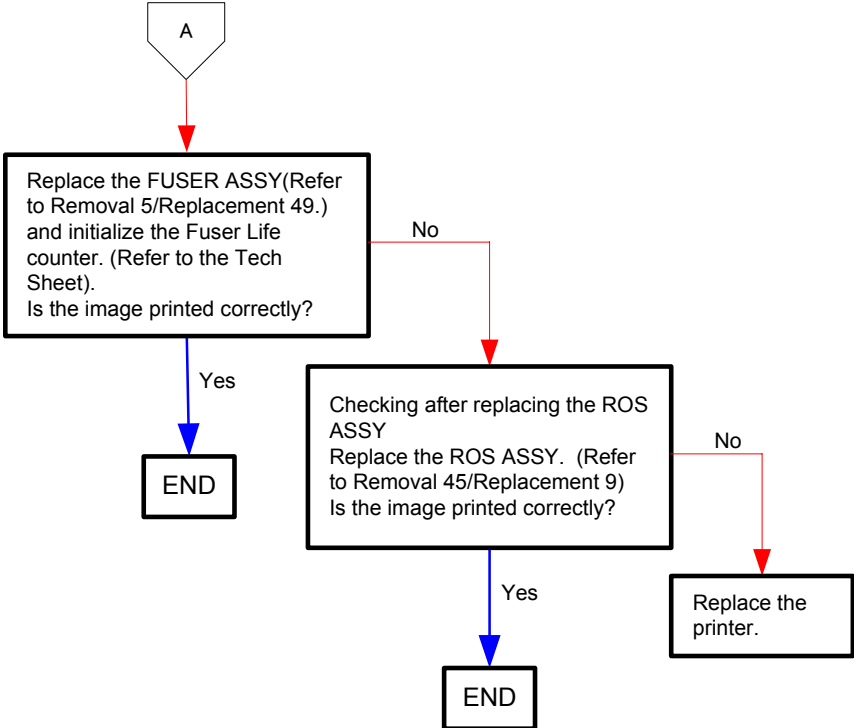

Flows 91 Horizontal stripes

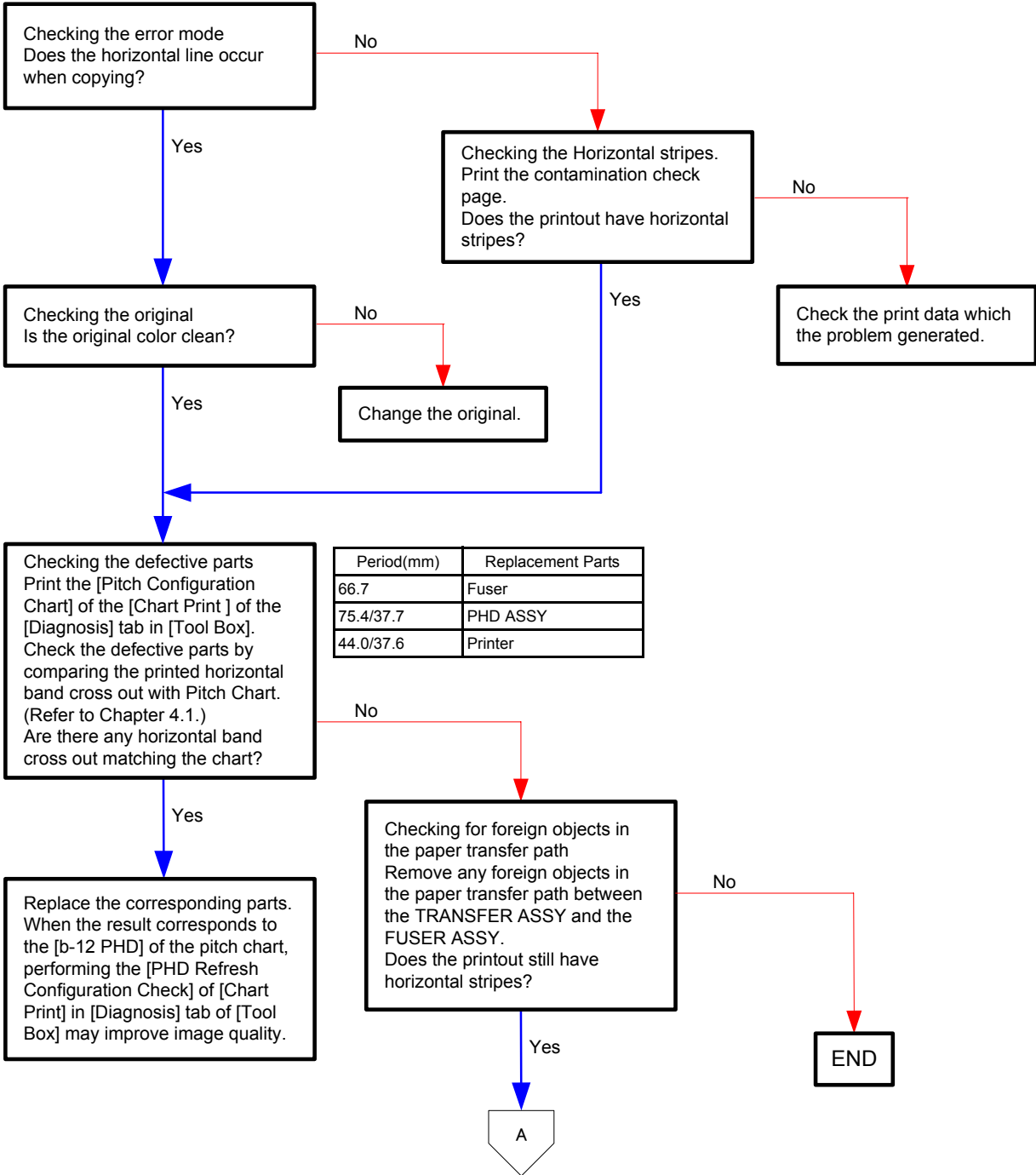
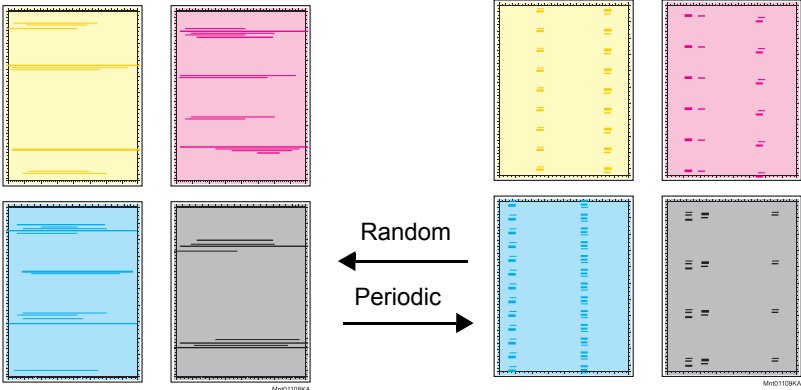

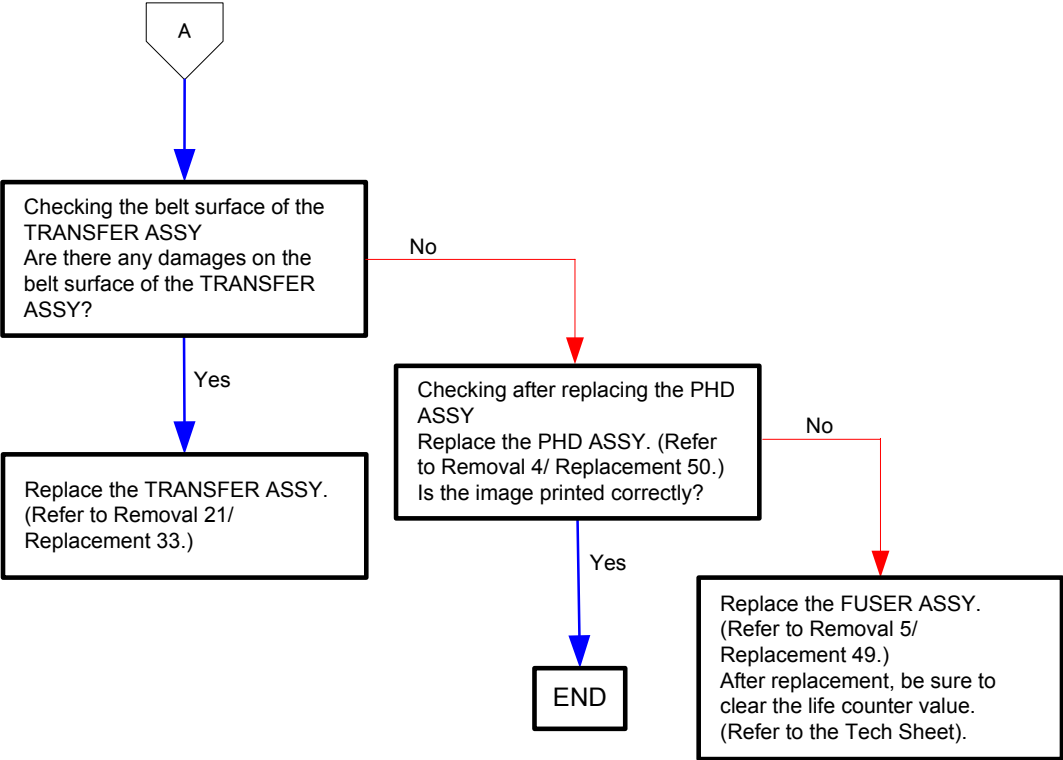

Flows 92 Partial Deletion

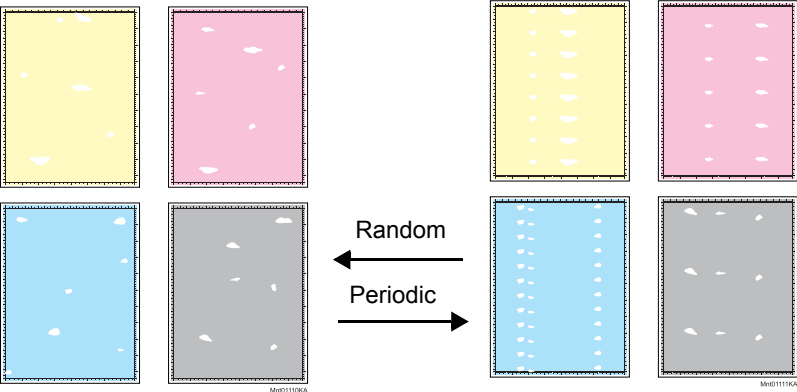

Checking the printer environment
Check that the printer is in a room where air conditioner is operating. If the air conditioner is not operating, turn it on or move the printer to a room with an air conditioner.

Checking the error mode
Does the partial lack occur when copying?

No

Checking the Partial Deletion.
Print the contamination check page.
Are parts of images still missing during printing?

No

Printing data is incorrect, then check the printing data which the problem generated.

Checking the original
Is the original color clean?

No
Change the original.

Yes

Checking the defective parts
Print the [Pitch Configuration Chart] of the [Chart Print] of the [Diagnosis] tab in [Tool Box].
Check the defective parts by comparing the printed horizontal band cross out with Pitch Chart. (Refer to Chapter 4.1.)
Are there any horizontal band cross out matching the chart?

Period(mm)	Replacement Parts
66.7	Fuser
75.4/37.7	PHD ASSY
44.0/37.6	Printer

No

A

Yes
Replace the corresponding parts

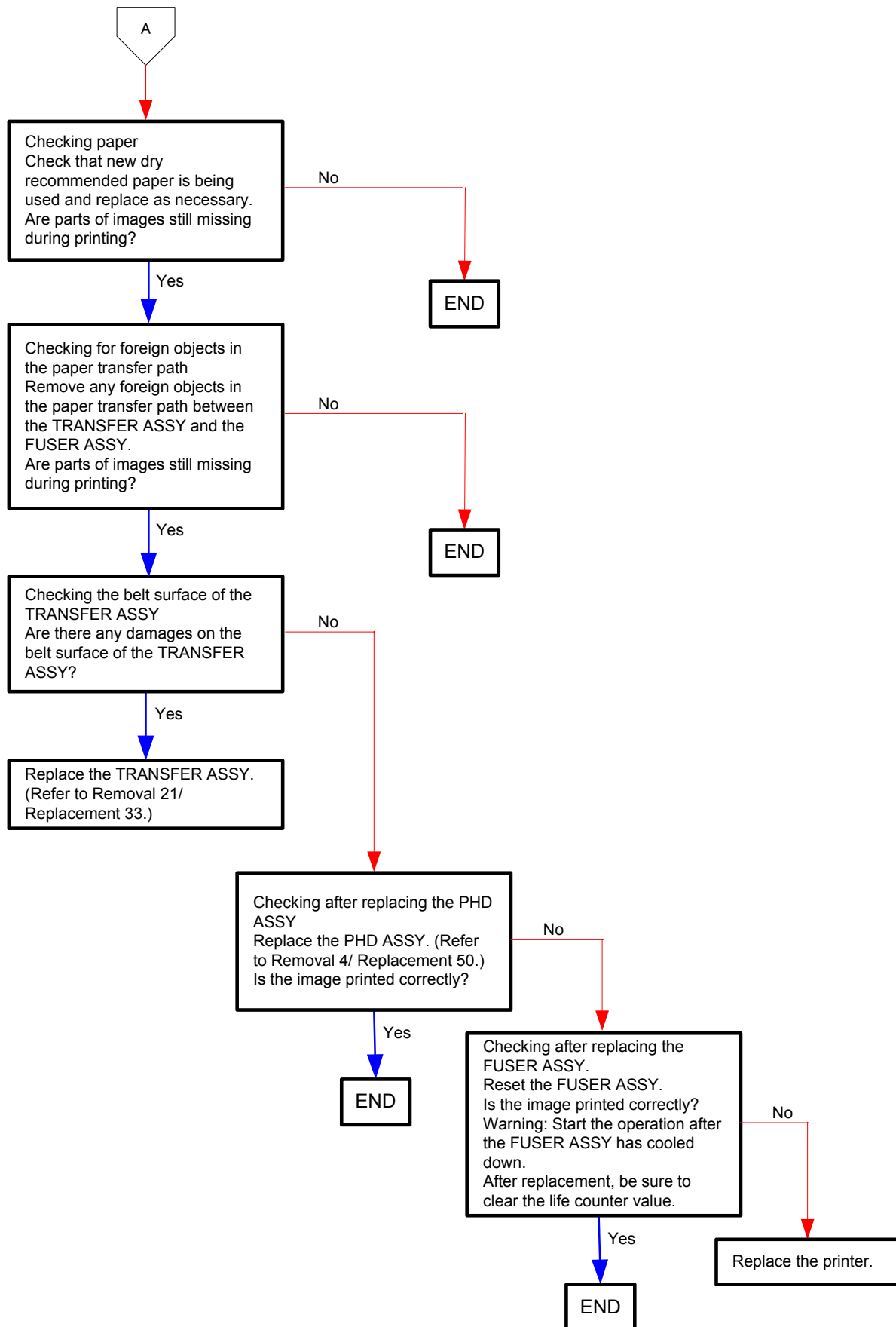

Flows 93 Spots

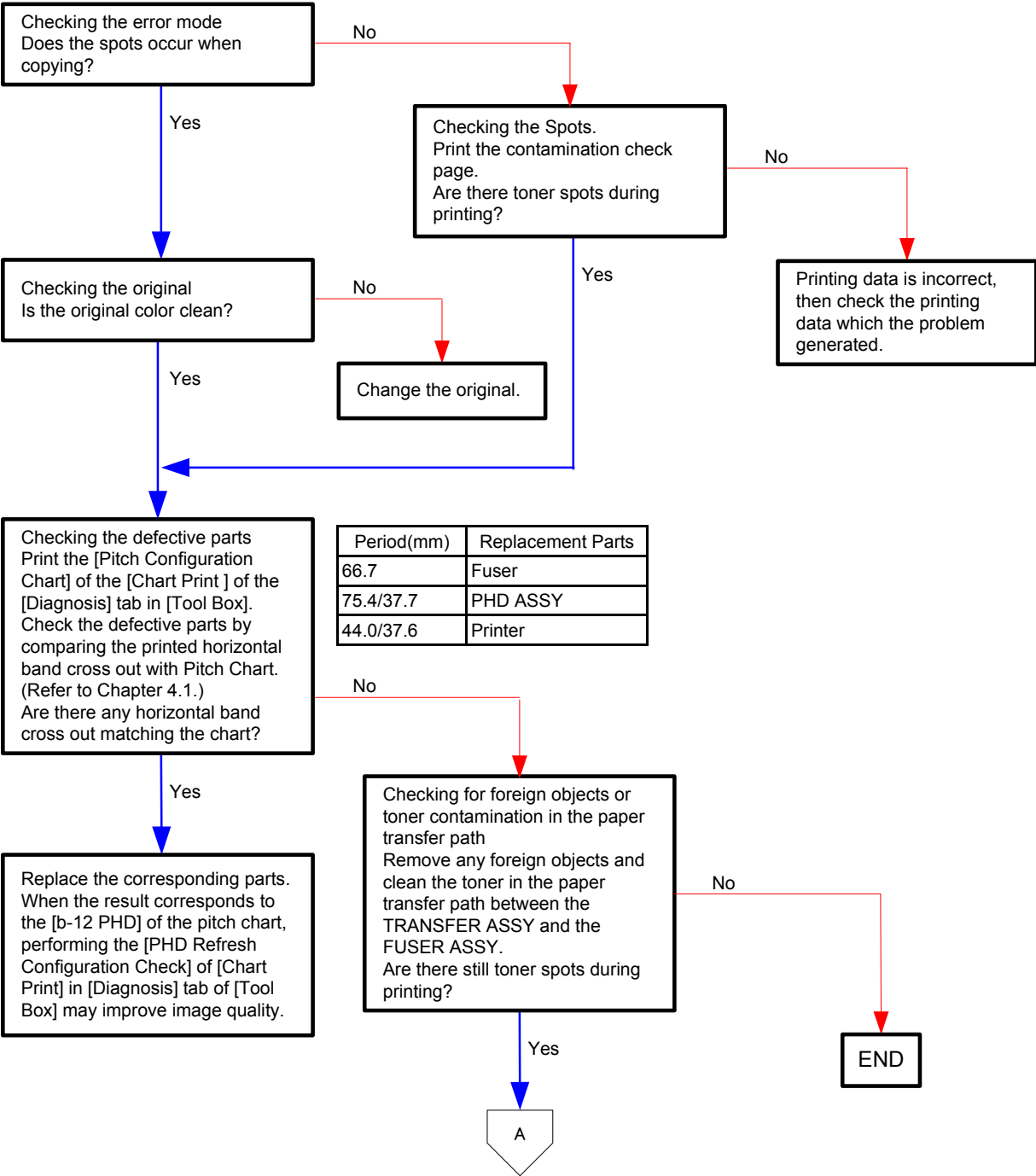
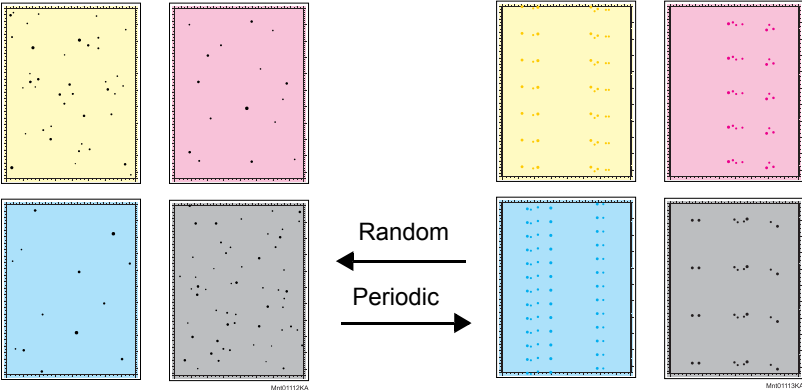

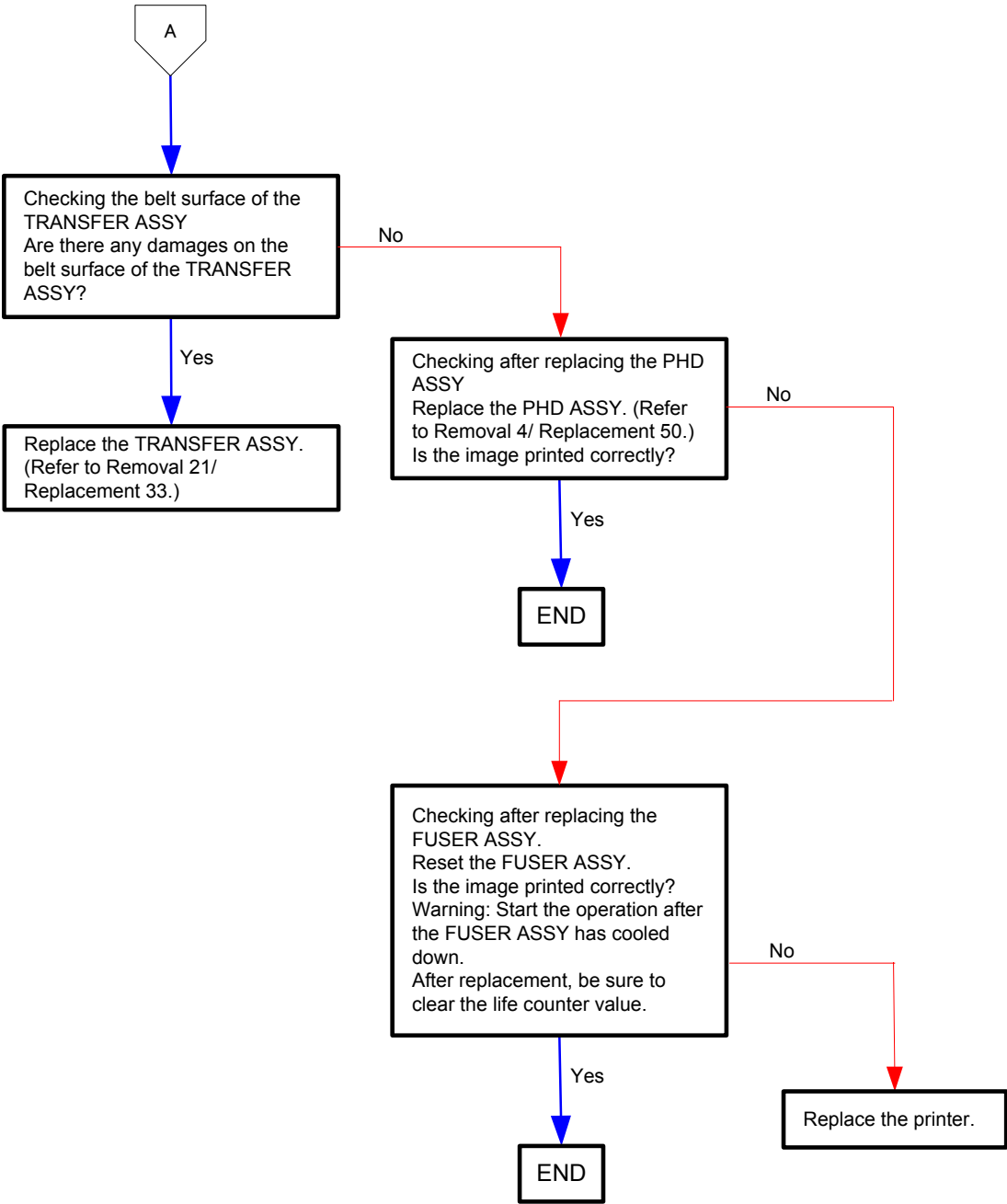

Flows 94 Afterimage (Ghost)

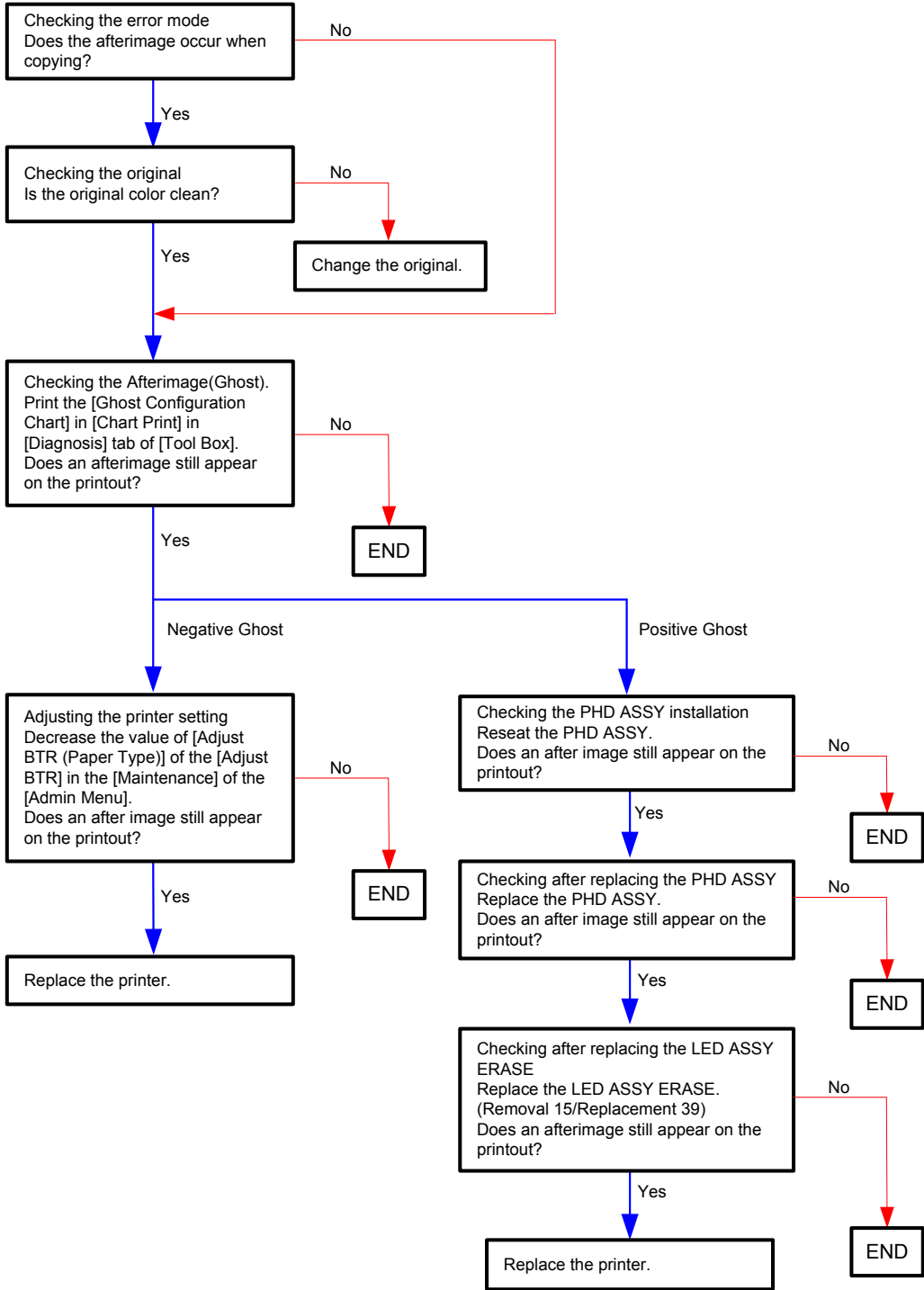
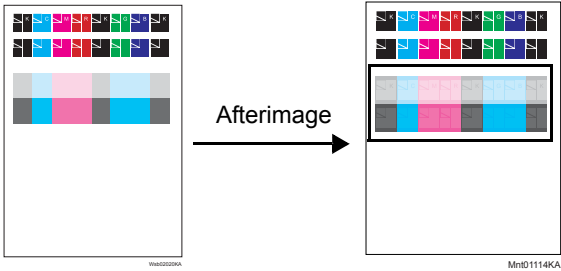

Flows 95 Grey Background

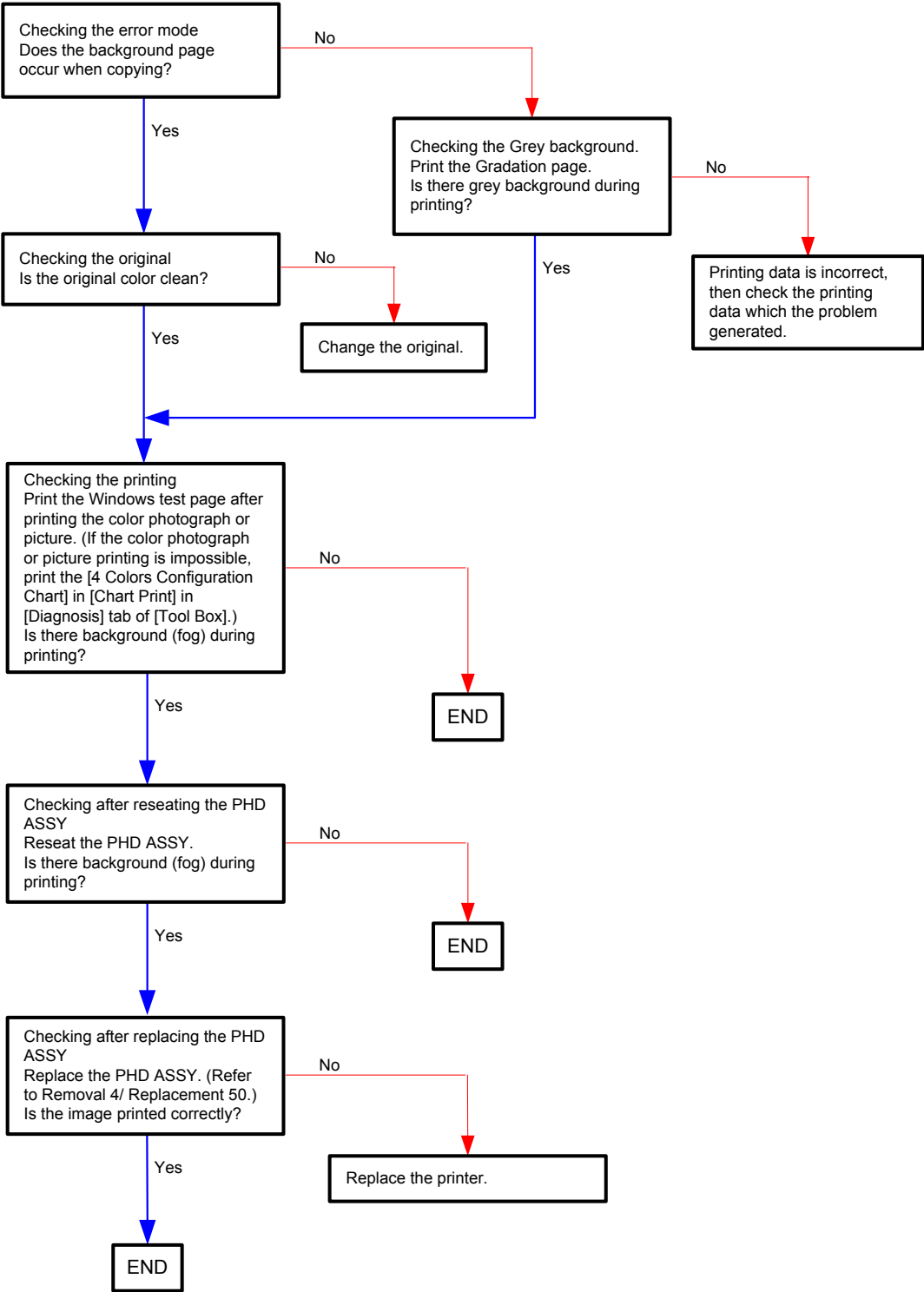
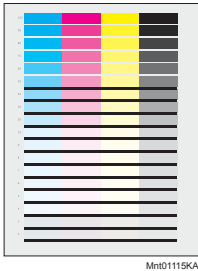

Flows 96 Skew

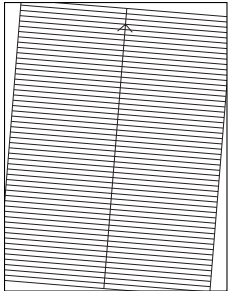

Mni01116KA

NOTE

Tray is recommended for paper feeding because sheets fed via SSF is prone to skew depending on how the sheet is placed of SSF.

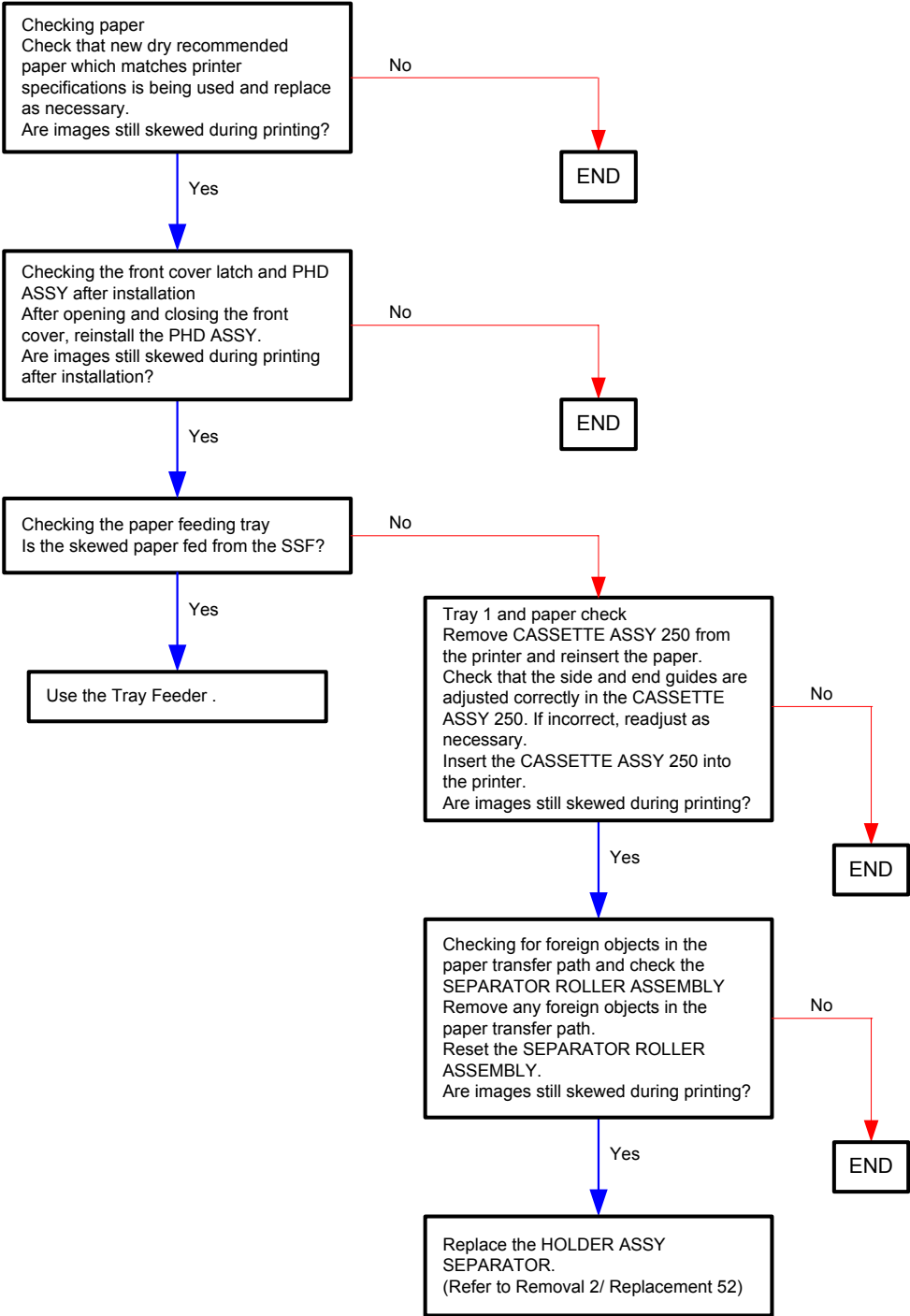

Flows 97 Paper damage

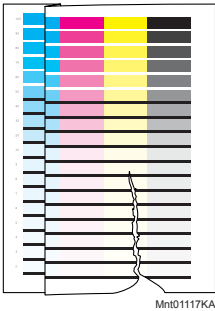

NOTE

Tray is recommended for paper feeding because sheets fed via SSF is prone to skew depending on how the sheet is placed on SSF.

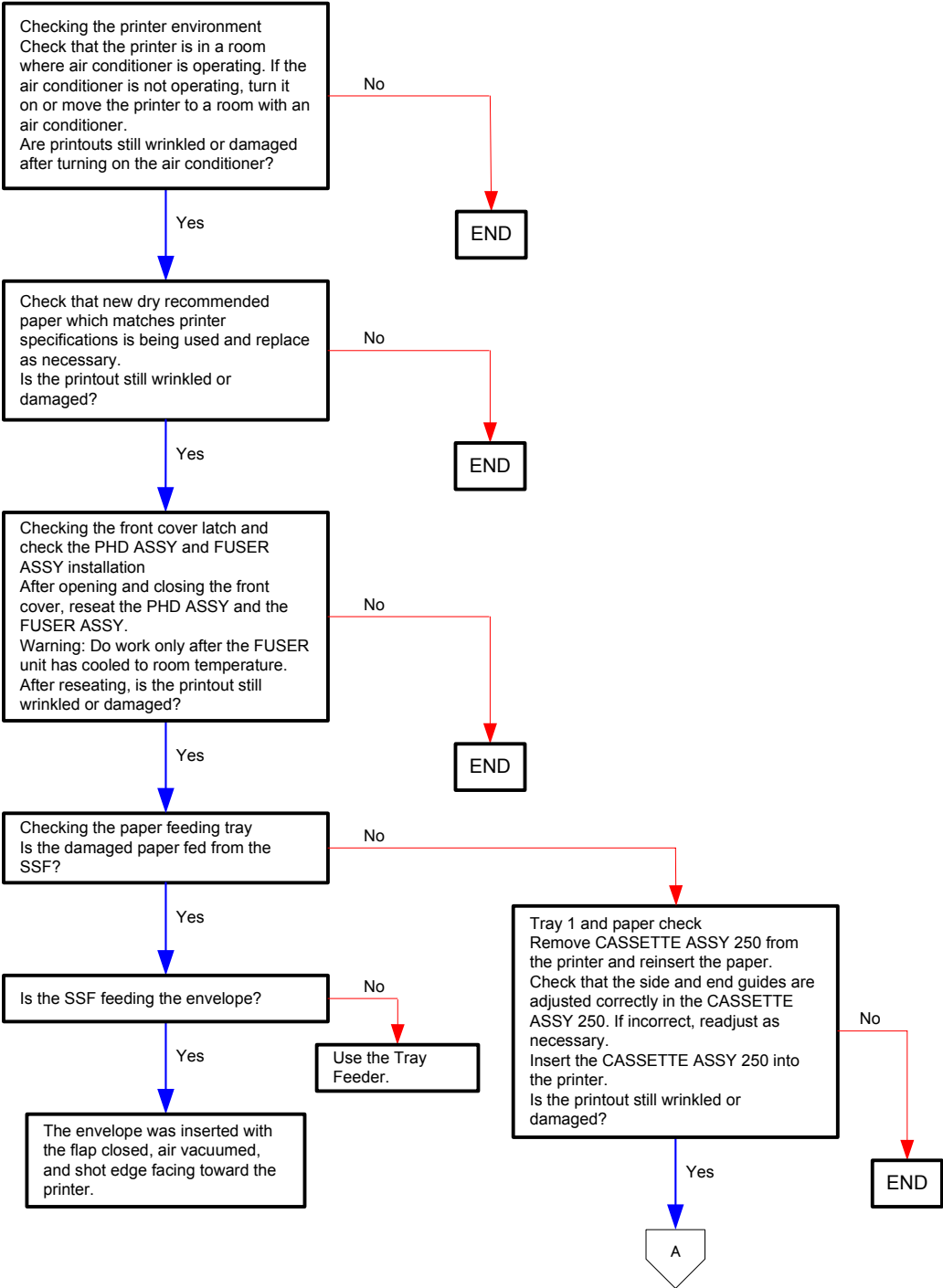

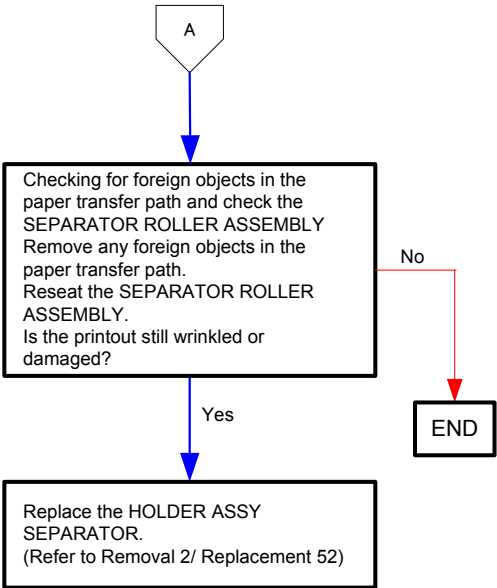

Flows 98 Unfusing

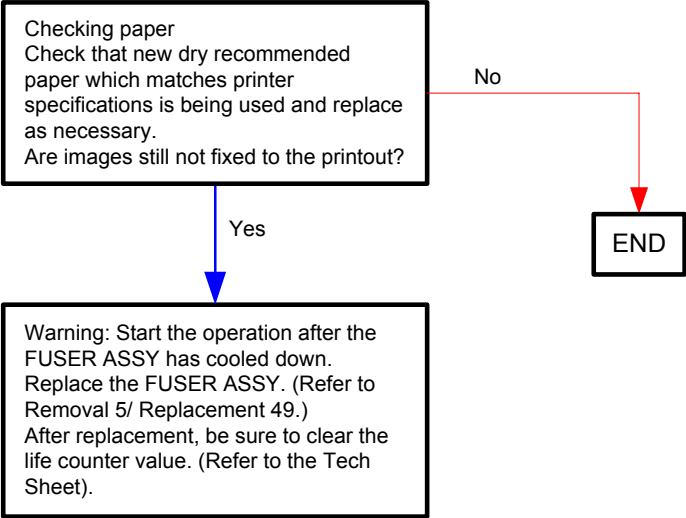
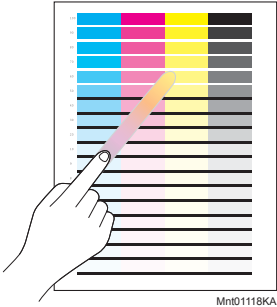

Flows 99 Color registration (Color shift) - Troubleshooting of a control system

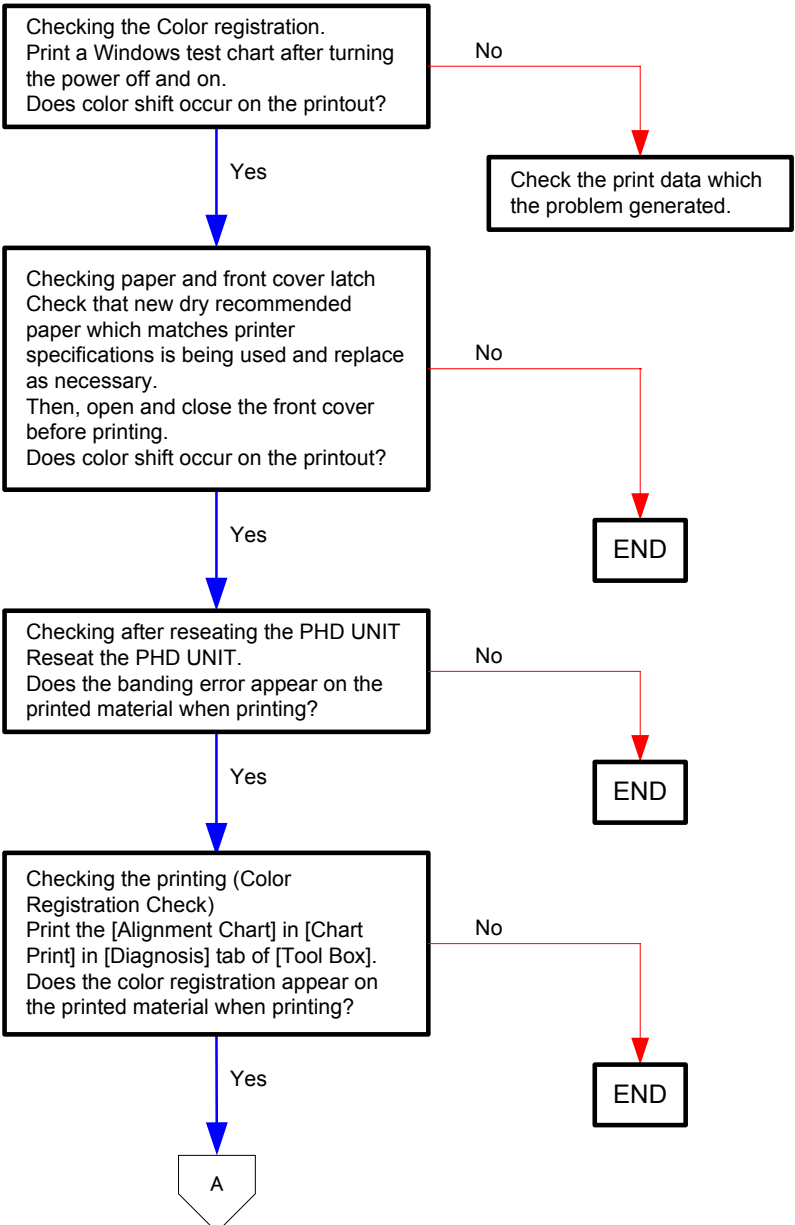

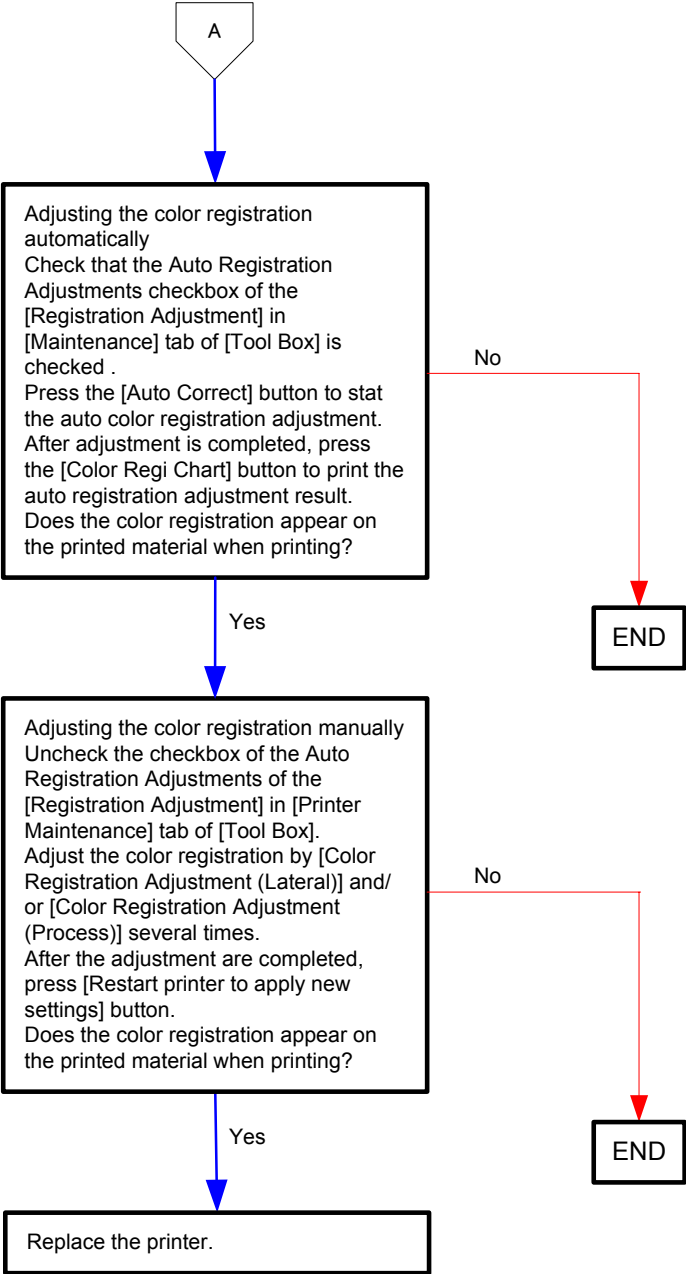

- Troubleshooting of a paper feeding system

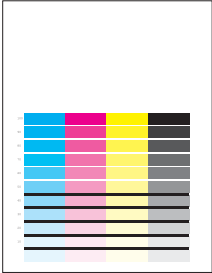

paper feeding is late.

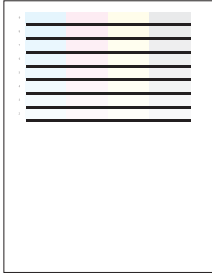

paper feeding is early.

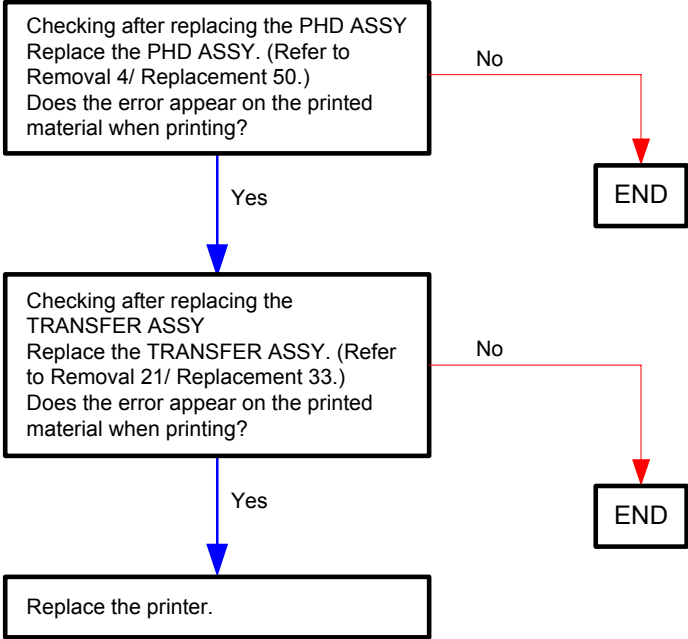

Flows 100 Noise :When power is turned on.

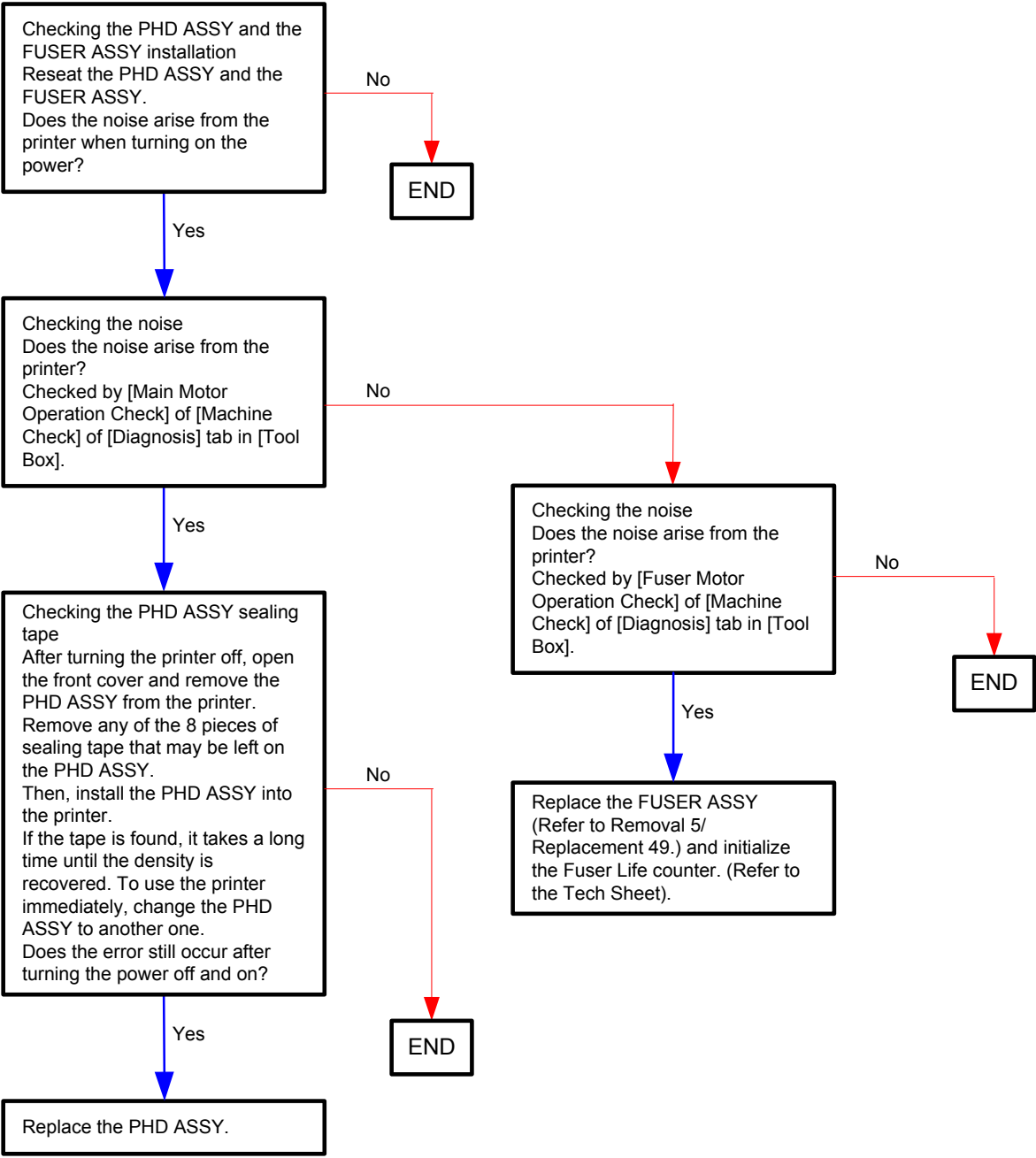

Flows 101 Noise During standby

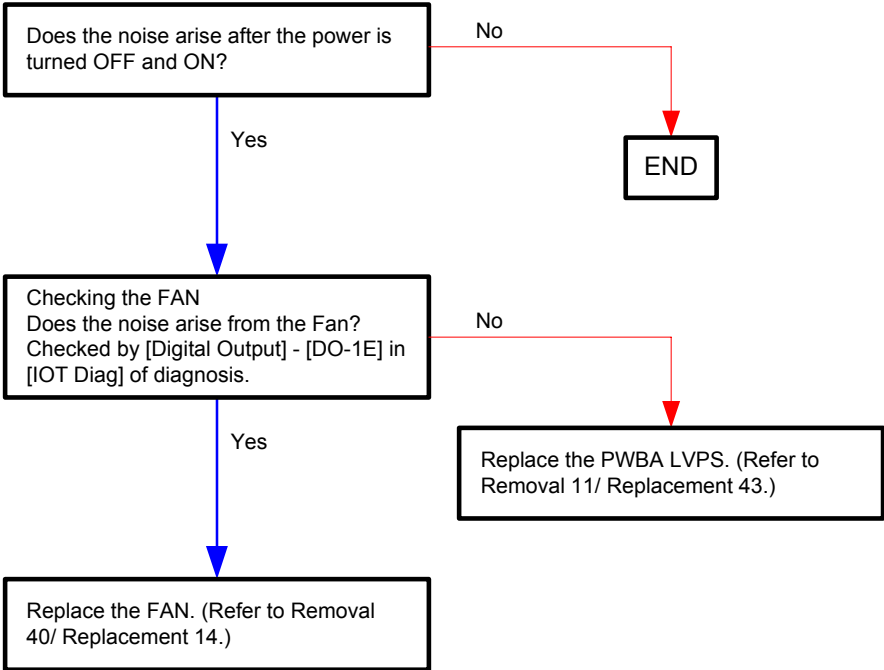

Flows 102 Noise During printing

NOTE

Work before troubleshooting.
Check the sealing tape on the PHD ASSY. if there is the sealing tape, remove it.

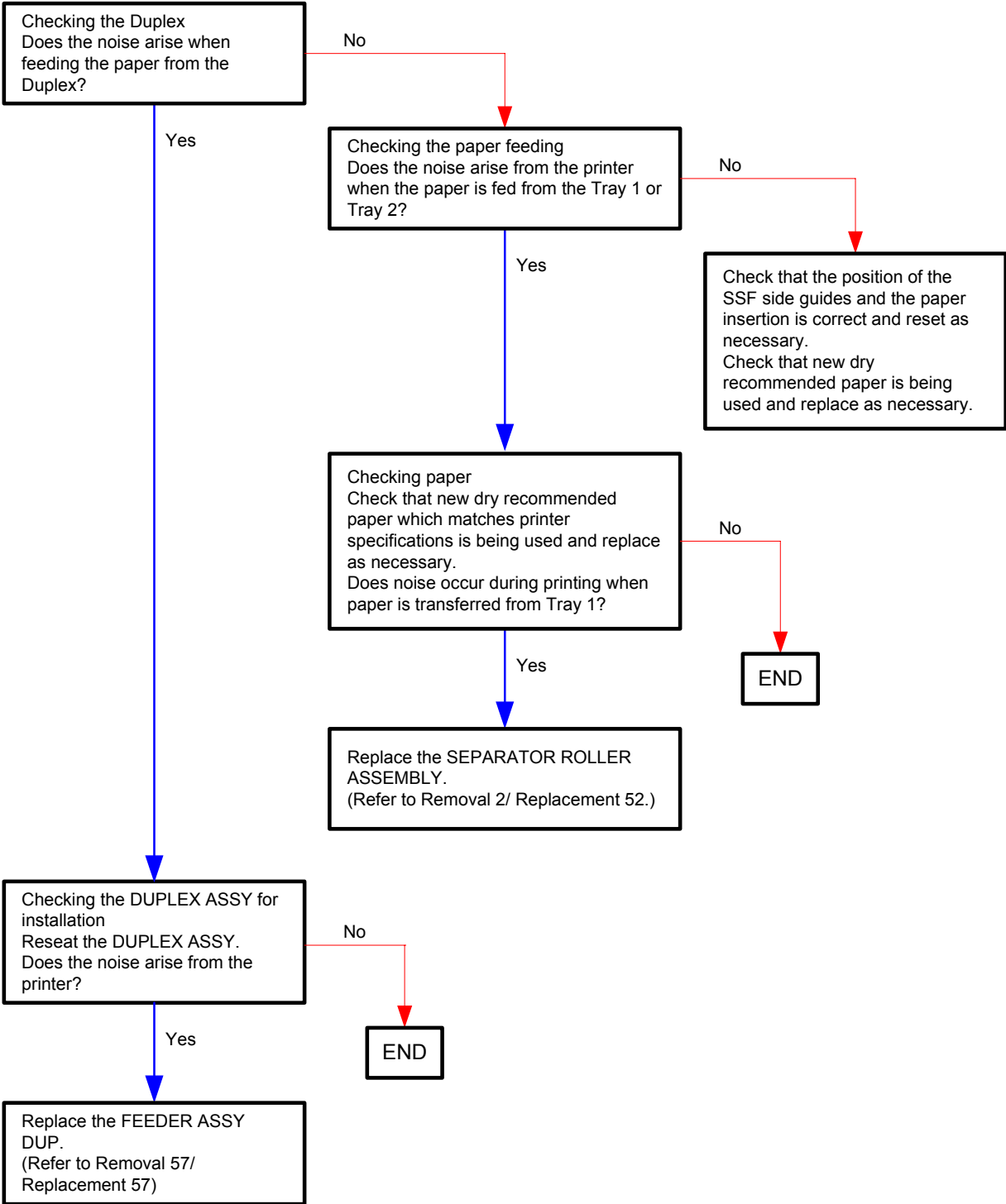

Flows 103 Electrical Noise

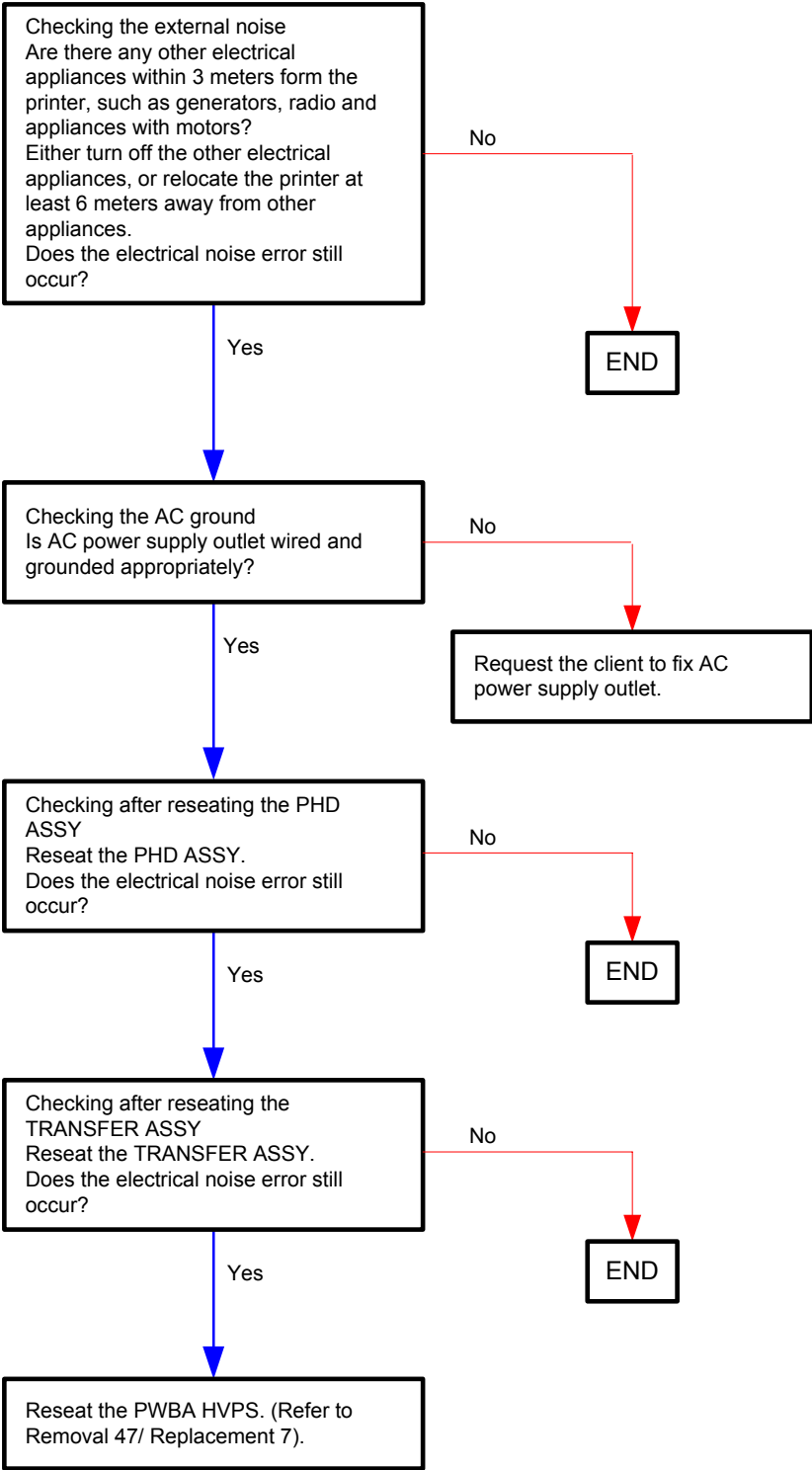

Flows 104 AC

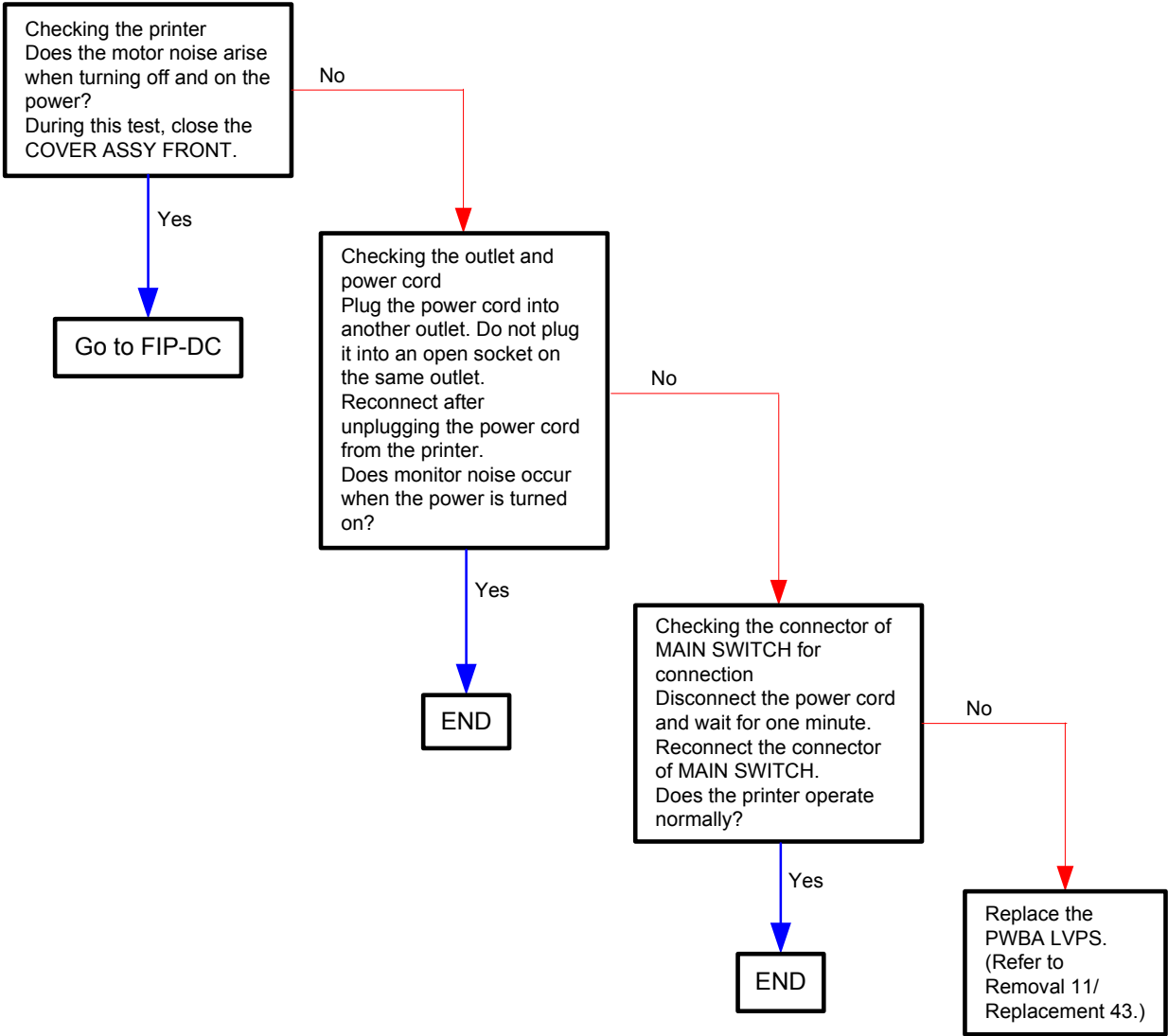

Flows 105 DC

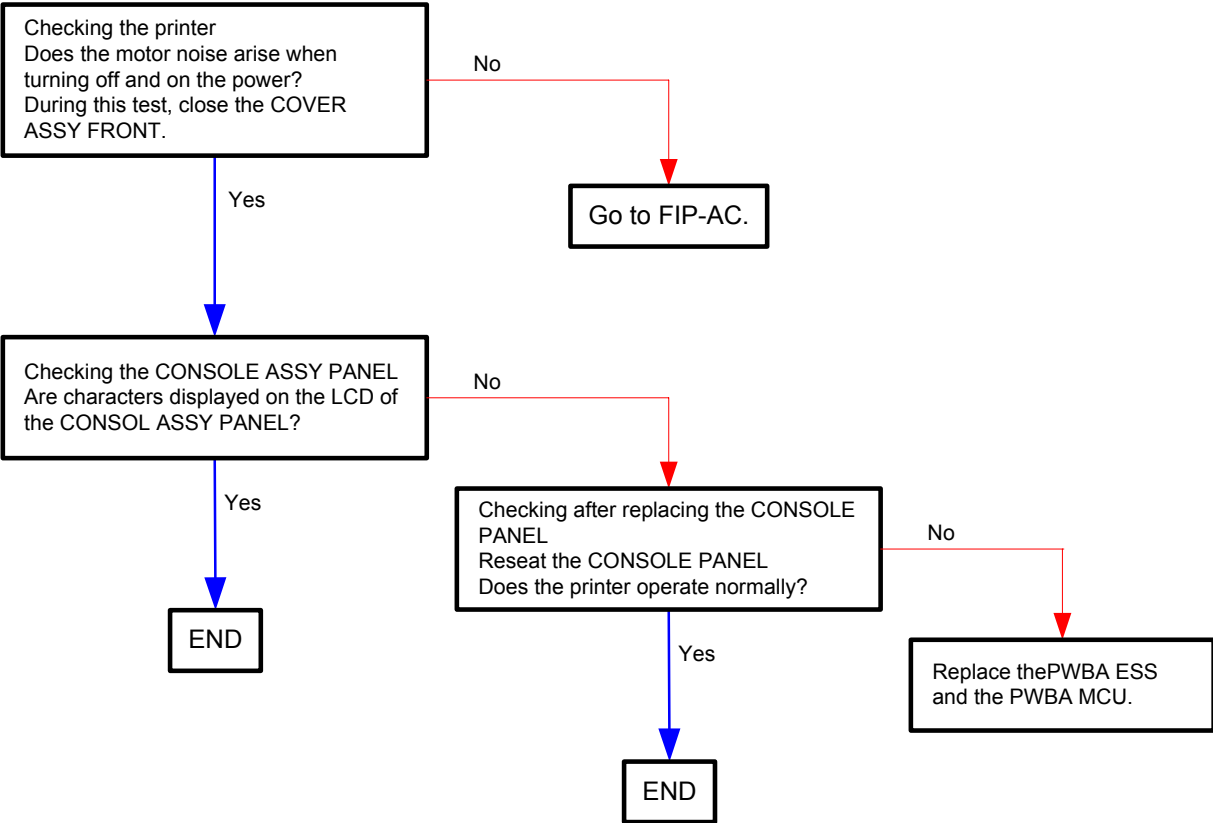

Flows 106 Multiple Feed

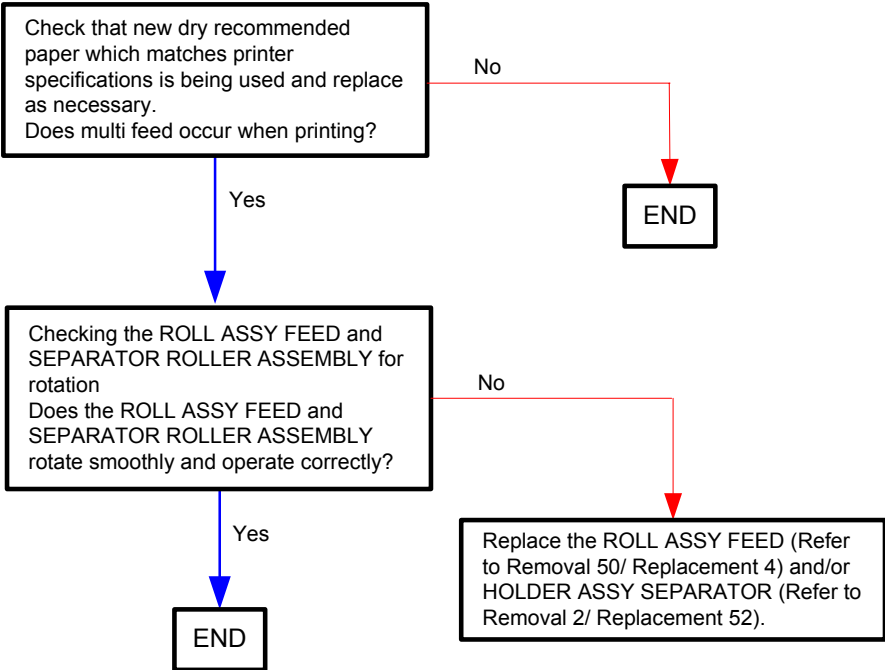

Flows 107 Control Panel Freezes

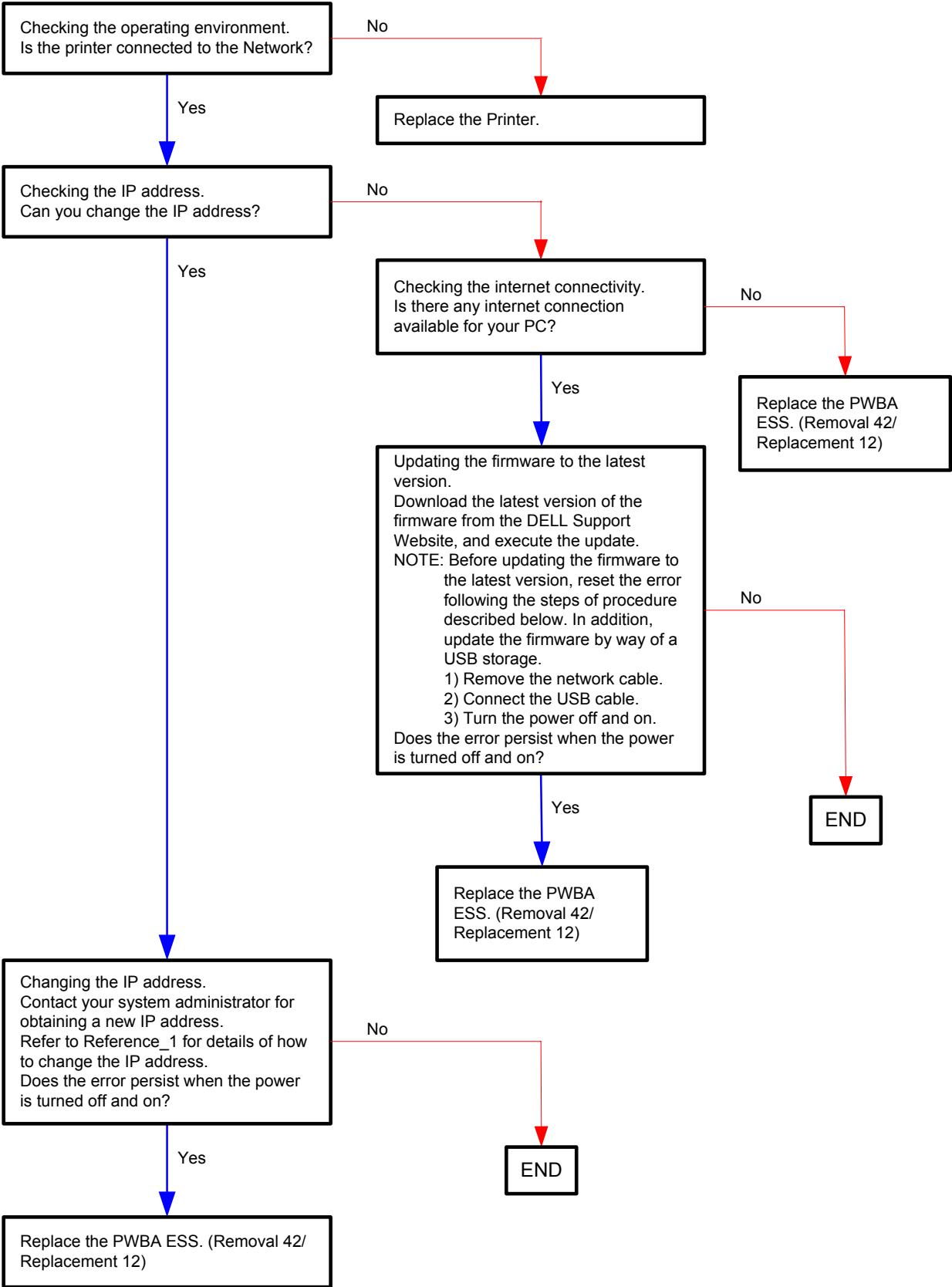

Reference_1: Changing the IP address

- 1) Remove the network cable, and power off the printer and then on
- 2) Change the IP address on the Control Panel.
- 3) Plug the network cable back into the printer, and then turn the power on.
- 4) On the Control Panel, open [Admin] > [Network] > [TCP/IP], and confirm that the IP address has been changed.

3.2 Troubleshooting for the repair center

FIP-1. 1 001-360 Restart Printer

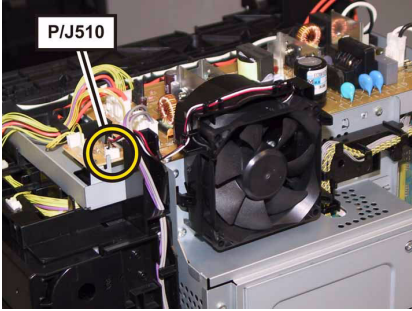
Step	Check	Remedy	
		Yes	No
	Possible causative parts: FAN (PL8.1.1) PWBA LVPS (PL8.2.1) PWBA MCU (PL8.2.13) PWBA FAN (PL8.2.20) HARN ASSY LVPS2 (PL9.1.3) HARN ASSY MCU HAN (PL9.1.13)		
1	Does the error still occur when the power is turned OFF and ON?	Go to step 2.	End of work.
2	Checking the FAN for rotation Does the FAN function normally? Checked by [Digital Output] - [DO-1E or DO-1F] in [IOT Diag] of diagnosis. During this check, close the COVER ASSY FRONT.	Replace the PWBA MCU. (Refer to Removal 43 / Replacement 11.)	Go to step 3.
3	Check the connection between the FAN and PWBA . Is P/J510 on PWBA FAN connected correctly? 	Go to step 5.	Reconnect the connector P/J510 correctly, then go to step 4.
4	Does the error still occur when the power is turned OFF and ON?	Go to step 5.	End of work.
5	Check the connection between the PWBA FAN and the PWBA LVPS Is P/J 520 on the PWBA FAN and P/J503 on the PWBA LVPS connected correctly?	Go to step 7.	Reconnect the connector P/J 520 and P/J 503 correctly, then go to step 6.
6	Does the error still occur when the power is turned OFF and ON?	Go to step 7.	End of work.
7	Check the connection between the PWBA FAN and the PWBA MCU Is P/J 530 on the PWBA FAN and P/J30 on the PWBA MCU connected correctly?	Go to step 9.	Reconnect the connector P/J 530 and P/J 30 correctly, then go to step 8.
8	Does the error still occur when the power is turned OFF and ON?	Go to step 9.	End of work.

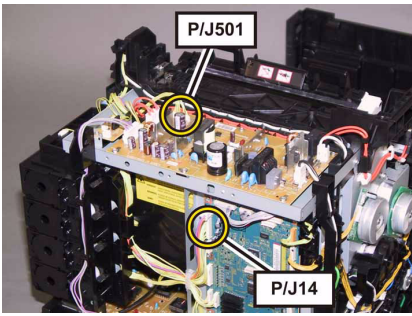
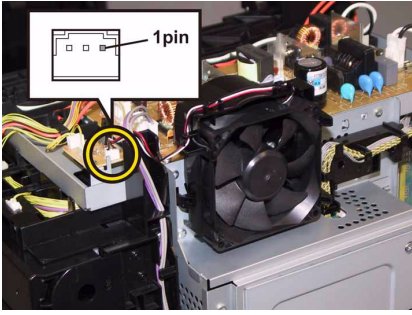
Step	Check	Remedy	
		Yes	No
9	<p>Check the connections between the PWBA LVPS and PWBA MCU. Are P/J501 and P/J14 connected correctly?</p> 	Go to step 11.	Reconnect the connector(s) P/J501 and P/J14 correctly, then go to step 10.
10	Does the error still occur when the power is turned OFF and ON?	Go to step 11.	End of work.
11	<p>Checking the HARN ASSY LVPS2 for continuity Disconnect J501 from the PWBA LVPS. Disconnect J14 from the PWBA MCU. Is each cable of J501 <=> J14 continuous?</p>	Go to step 12.	Replace the HARN ASSY LVPS2.
12	<p>Checking the HARN ASSY MCU HAN for continuity Disconnect the P/J 530 from the PWBA FAN. Disconnect the P/J 30 from the PWBA MCU. Is each cable of P/J 530 <=> P/J 30 continuous?</p>	Go to step 13.	Replace the HARN ASSY MCU HAR.
13	<p>Checking the power to the FAN Disconnect J503 from the PWBA LVPS. Is the voltage across P503-1pin <=> ground on the PWBA LVPS, about +24 VDC when the interlock switch (HARN ASSY INTERLOCK) is pushed?</p> 	Replace the FAN. (Refer to Removal 40/ Replacement 14.)	Go to step 14.
14	<p>Checking after replacing the PWBA FAN Replace the PWBA FAN. (Refer to Removal 12/ Replacement 42.) Does the error still occur when the power is turned OFF and ON?</p>	Go to step 15.	End of work.
15	<p>Checking after replacing the PWBA LVPS Replace the PWBA LVPS. (Refer to Removal 11/ Replacement 43.) Does the error still occur when the power is turned OFF and ON?</p>	Replace the PWBA MCU. (Refer to Removal 43/ Replacement 11.)	End of work.

FIP-1. 2 003-340 Restart Printer

Step	Check	Remedy	
		Yes	No
	Possible causative parts: PWBA MCU (PL8.2.13)		
1	Does the error still occur after several ON/OFF procedures of the power?	Go to step 2.	End of work. *1
2	Checking the firmware version Is the firmware the latest version?	Go to step 3.	Upgrade the firmware, then go to step 3.
3	Checking after reseating the PWBA MCU Reseat the PWBA MCU. Does the error still occur when the power is turned OFF and ON?	Go to step 4.	End of work. *1
4	Checking after replacing the PWBA MCU Replace the PWBA MCU. (Refer to Removal 43/ Replacement 11.) Does the error still occur when the power is turned OFF and ON?	Go to Electrical Noise.	End of work.

*1: Though some kind of foreign noise would be possible cause, go to FIP Electrical Noise in Other FIP and check, to make sure.

FIP-1.3 003-356 Restart Printer

NOTE

If the error occurred after replacing the PWBA MCU, transfer the internal data of the old PWBA MCU to a new one.

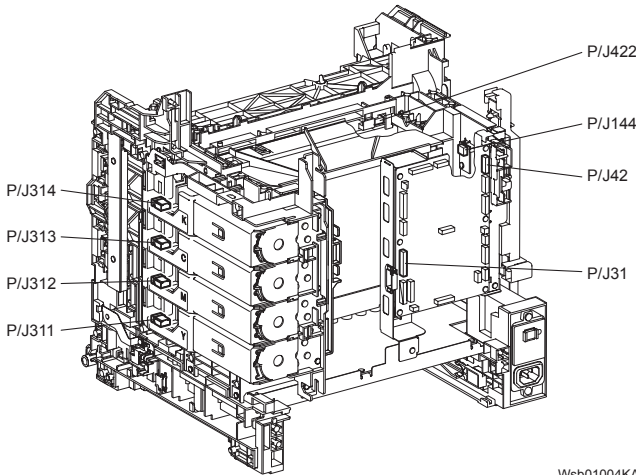
Step	Check	Remedy	
		Yes	No
	Possible causative parts: PHD ASSY (PL4.1.21) TONER CARTRIDGE (K) (PL5.1.21) TONER CARTRIDGE (C) (PL5.1.22) TONER CARTRIDGE (M) (PL5.1.23) TONER CARTRIDGE (Y) (PL5.1.24) HARN ASSY TONER CRUM (PL5.1.26) PWBA MCU (PL8.2.13) PWBA EEPROM (XPRO) (PL8.2.16) HARN ASSY PHD XPRO (PL9.1.11)		
1	Does the error still occur after several ON/OFF procedures of the power?	Go to step 2.	End of work. *1
2	Checking after reseating the PHD ASSY and TONER CARTRIDGES Reseat the PHD ASSY and four TONER CARTRIDGES. Does the error still occur when the power is turned OFF and ON?	Go to step 3.	End of work. *1
3	Checking after reseating the PWBA MCU Reseat the PWBA MCU. Does the error still occur when the power is turned OFF and ON?	Go to step 4.	End of work. *1
4	Checking the connectors for connection Are the following connectors connected correctly? - P/J311 on the Toner CRUM (Y) - P/J312 on the Toner CRUM (M) - P/J313 on the Toner CRUM (C) - P/J314 on the Toner CRUM (K) - P/J31 on the PWBA MCU - P/J42 on the PWBA MCU - P/J144 on the PWBA EEPROM (XPRO) - P/J422 on the PHD ASSY	Go to step 6.	Reconnect the connector(s) P/J311 to P/J314, P/J31, P/J42, P/J144 and/or P/J422 correctly, then go to step 5.
	 <p style="text-align: right; font-size: small;">Wsb01004KA</p>		
5	Does the error still occur when the power is turned OFF and ON?	Go to step 6.	End of work.

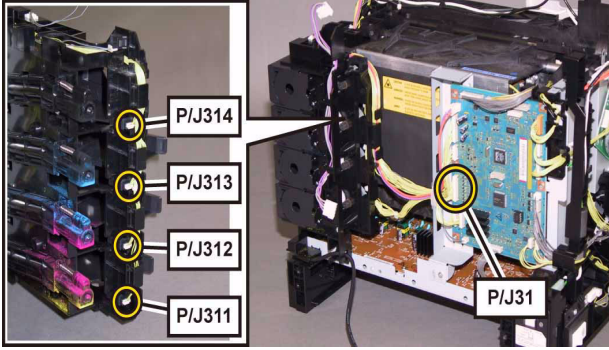
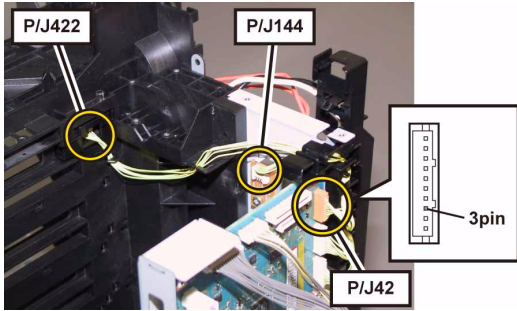
Step	Check	Remedy	
		Yes	No
6	<p>Checking the HARN ASSY TONER CRUM for continuity Disconnect J311 from the Toner CRUM (Y). Disconnect J312 from the Toner CRUM (M). Disconnect J313 from the Toner CRUM (C). Disconnect J314 from the Toner CRUM (K). Disconnect J31 from the PWBA MCU. Is each cable of J311 to J314 \Leftrightarrow J31 continuous?</p> 	Go to step 7.	Replace the HARN ASSY TONER CRUM.
7	<p>Checking the HARN ASSY PHD XPRO for continuity Disconnect J42 from the PWBA MCU. Disconnect J144 from the PWBA EEPROM (XPRO). Disconnect P422 from the PHD ASSY. Is each cable of J42 \Leftrightarrow J144 and P422 continuous?</p> 	Go to step 8.	Replace the HARN ASSY PHD XPRO.
8	<p>Checking the power to the PWBA EEPROM (XPRO) Disconnect J42 from the PWBA MCU. Is the voltage across P42-3pin \Leftrightarrow ground on the PWBA MCU, about +3.3 VDC?</p>	Replace the PWBA EEPROM (XPRO).	Go to step 9.
9	<p>Checking after replacing the PWBA MCU Replace the PWBA MCU. (Refer to Removal 43/ Replacement 11.) Does the error still occur when the power is turned OFF and ON?</p>	Go to Electrical Noise.	End of work.

*1: Though some kind of foreign noise would be possible cause, go to FIP Electrical Noise in Other FIP and check, to make sure.

FIP-1. 4 004-310 Restart Printer

Step	Check	Remedy	
		Yes	No
	Possible causative parts: HARN ASSY OPTION (PL3.1.20) PWBA MCU (PL8.2.13) 250 OPTION FEEDER (PL12.1.1) PWBA FEED H (PL12.2.1) HARN ASSY TRAY (PL12.3.23)		
1	Checking the Optional Feeder for installation Is the Optional Feeder installed correctly?	Go to step 3.	Reseat the Optional Feeder, then go to step 2.
2	Does the error still occur when the power is turned ON?	Go to step 3.	End of work.
3	Checking the connectors for connection Check the connections between the PWBA FEED H and PWBA MCU. Are P/J27, P/J273, and P/J419 connected surely?	Go to step 5.	Reconnect the connector(s) P/J27, P/J273 and/or P/J419 surely, then go to step 4.
4	Does the error still occur when the power is turned ON?	Go to step 5.	End of work.
5	Checking the HARN ASSY TRAY for continuity Disconnect P/J419 from the PWBA FEED H. Disconnect P/J273 from the HARN ASSY OPTION. Is each cable of P/J419 <=> P/J273 continuous?	Go to step 6.	Replace the HARN ASSY TRAY.
6	Checking the HARN ASSY OPTION for continuity Disconnect P/J27 from the PWBA MCU. Disconnect P/J273 from the HARN ASSY TRAY. Is each cable of P/J27 <=> P/J273 continuous?	Go to step 7.	Replace the HARN ASSY OPTION.
7	Checking after replacing the PWBA FEED H Replace the PWBA FEED H. (Refer to Removal 43/ Replacement 11.) Does the error still occur when the power is turned ON?	Go to step 8.	End of work.
8	Checking after replacing the 250 OPTION FEEDER Replace the 250 OPTION FEEDER. (Refer to Removal 58/ Replacement 58.) Does the error still occur when the power is turned ON?	Replace the PWBA MCU. (Refer to Removal 43/ Replacement 11.)	End of work.

FIP-1.5 004-311 Restart Printer

Step	Check	Remedy	
		Yes	No
	Possible causative parts: HARN ASSY DUP RELAY (PL1.2.13) HARN ASSY OPTION (PL3.2.20) PWBA MCU (PL8.2.13) HARN ASSY DUP (PL11.1.14) PWBA DUP (PL11.1.16)		
1	Checking the Option Duplex for installation Is the Option Duplex installed correctly?	Go to step 3.	Reseat the Option Duplex, then go to step 2.
2	Does the error still occur when the power is turned ON?	Go to step 3.	End of work.
3	Checking the connectors for connection Check the connections between the PWBA DUP and PWBA MCU. Are P/J27, P/J271, P/J272 and P/J 601 connected surely?	Go to step 5.	Reconnect the connector(s) P/J27, P/J271, P/J272 and/or P/J 601 surely, then go to step 4.
4	Does the error still occur when the power is turned ON?	Go to step 5.	End of work
5	Checking the HARNESS ASSY DUP for continuity Disconnect P/J601 from the PWBA DUP. Disconnect P/J272 from the HARNESS ASSY DUP RELAY. Is each cable of P/J601 <=> P/J272 continuous?	Go to step 6.	Replace the HARNESS ASSY DUP.
6	Checking the HARNESS ASSY DUP RELAY for continuity Disconnect P/J271 from the HARN ASSY OPTION. Disconnect P/J 272 from the HARNESS ASSY DUP. Is each cable of P/J271 <=> P/J272 continuous?	Go to step 7.	Replace the HARNESS ASSY FRONT COVER.
7	Checking the HARN ASSY R SIDE AIO for continuity Disconnect P/J272 from the HARNESS ASSY FRONT COVER. Disconnect P/J27 from the PWBA MCU. Is each cable of P/J272 <=> P/J27 continuous?	Go to step 8.	Replace the HARN ASSY OPTION.
8	Checking after replacing the PWBA DUP Replace the PWBA DUP. Does the error still occur when the power is turned ON?	Replace the PWBA MCU. (Refer to Removal 43/ Replacement 11.)	End of work.

FIP-1. 6 006-370 Restart Printer

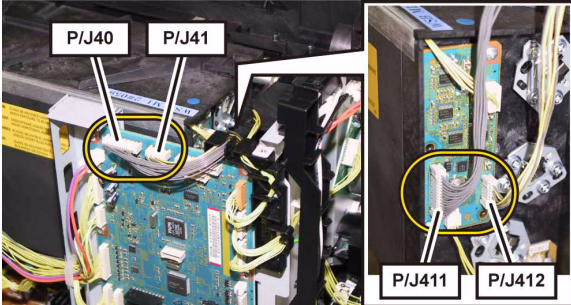
Step	Check	Remedy	
		Yes	No
	Possible causative parts: ROS ASSY (PL4.1.1) HARN ASSY ROS RE (PL4.1.22) HARN ASSY ROS VIDEO (PL4.1.23) PWBA MCU (PL8.2.13)		
1	Does the error still occur when the power is turned OFF and ON?	Go to step 2.	End of work.
2	Checking after reseating the PWBA MCU Reseat the PWBA MCU. Does the error still occur when the power is turned OFF and ON?	Go to step 3.	End of work.
3	Checking after reseating the ROS ASSY Reseat the ROS ASSY. Does the error still occur when the power is turned OFF and ON?	Go to step 4.	End of work.
4	Check the connections between the ROS ASSY and PWBA MCU. Are P/J40, P/J41, P/J411 and P/J412 connected correctly? 	Go to step 6.	Reconnect the connector(s) P/J40, P/J41, P/J411 and/or P/J412 correctly, then go to step 5.
5	Does the error still occur when the power is turned OFF and ON?	Go to step 6.	End of work.
6	Checking the HARN ASSY ROS RE for continuity Disconnect P/J40 from the PWBA MCU. Disconnect P/J411 from the ROS ASSY. Is each cable of J40 <=> J411 continuous?	Go to step 7.	Replace the HARN ASSY ROS RE.
7	Checking the HARN ASSY ROS VIDEO for continuity Disconnect J41 from the PWBA MCU. Disconnect J412 from the ROS ASSY. Is each cable of J41 <=> J412 continuous?	Go to step 8.	Replace the HARN ASSY ROS VIDEO.
8	Checking after replacing the ROS ASSY Replace the ROS ASSY. (Refer to Removal 45/ Replacement 9.) Does the error still occur when the power is turned OFF and ON?	Replace the PWBA MCU. (Refer to Removal 43/ Replacement 11.)	End of work.

FIP-1.7 007-340 Restart Printer

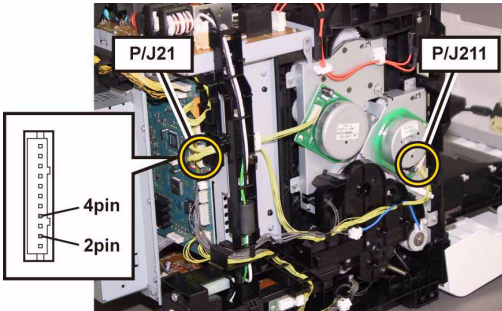
Step	Check	Remedy	
		Yes	No
	Possible causative parts: DRIVE ASSY MAIN (PL7.1.2) PWBA MCU (PL8.2.13) HARN ASSY MAIN MOT (PL9.1.7)		
1	Does the error occur when the power is turned OFF and ON?	Go to step 2.	End of work.
2	Checking after reseating the PHD ASSY Reseat the PHD ASSY. Does the error still occur when the power is turned OFF and ON?	Go to step 3.	End of work.
3	Checking the Main Motor for rotation Does the Main Motor function normally? Checked by the [Main Motor Operation Check] of the [Machine Check] of [Diagnosis] tab in the [Tool Box]. During this check, close the COVER ASSY FRONT.	Replace the PWBA MCU. (Refer to Removal 43/ Replacement 11.)	Go to step 4.
4	Checking the connectors of the MAIN MOTOR for connection Check the connections between the PWBA MCU and DRIVE ASSY MAIN. Are P/J21 and P/J211 connected correctly? 	Go to step 6.	Reconnect the connector(s) P/J21 and/or P/J211 correctly, then go to step 5.
5	Does the error still occur when the power is turned OFF and ON?	Go to step 6.	End of work.
6	Checking the HARN ASSY MAIN MOT for continuity Disconnect J21 from the PWBA MCU. Disconnect J211 from the DRIVE ASSY MAIN. Is each cable of J21 <=> J211 continuous?	Go to step 7.	Replace the HARN ASSY MAIN MOT.
7	Checking after reseating the DRIVE ASSY MAIN Reseat the DRIVE ASSY MAIN. Does the error still occur when the power is turned OFF and ON?	Go to step 8.	End of work.
8	Checking the power to the DRIVE ASSY MAIN Disconnect J21 from the PWBA MCU. Are the voltages across J21-2pin/J21-4pin <=> ground on the PWBA MCU, about +24 VDC when the interlock switch (HARN ASSY INTERLOCK) is pushed?	Replace the DRIVE ASSY MAIN. (Refer to Removal 32/ Replacement 22.)	Replace the PWBA MCU. (Refer to Removal 43/ Replacement 11.)

FIP-1. 8 007-341 Restart Printer

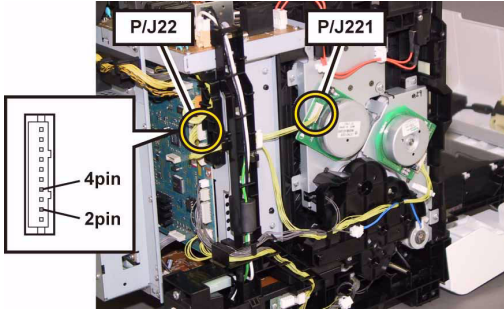
Step	Check	Remedy	
		Yes	No
	Possible causative parts: DRIVE ASSY SUB (PL7.1.1) PWBA MCU (PL8.2.13) HARN ASSY SUB MOT (PL9.1.8)		
1	Does the error still occur when the power is turned OFF and ON?	Go to step 2.	End of work.
2	Checking after reseating the FUSER ASSY and PHD ASSY Reseat the FUSER ASSY and PHD ASSY. Warning: Start the operation after the FUSER ASSY has cooled down. Does the error still occur when the power is turned OFF and ON?	Go to step 3.	End of work.
3	Checking the Sub Motor for rotation Does the Sub Motor function normally? Checked by the [Fuser Motor Operation Check] of the [Machine Check] of [Diagnosis] tab in the [Tool Box]. During this check, close the COVER ASSY FRONT.	Replace the PWBA MCU. (Refer to Removal 43/ Replacement 11.)	Go to step 4.
4	Checking the connectors of the SUB MOTOR for connection Check the connections between the PWBA MCU and DRIVE ASSY SUB. Are P/J22 and P/J221 connected correctly? 	Go to step 6.	Reconnect the connector(s) P/J22 and/or P/J221 correctly, then go to step 5.
5	Does the error still occur when the power is turned OFF and ON?	Go to step 6.	End of work.
6	Checking the HARN ASSY SUB MOT for continuity Disconnect J22 from the PWBA MCU. Disconnect J221 from the DRIVE ASSY SUB. Is each cable of J22 <=> J221 continuous?	Go to step 7.	Replace the HARN ASSY SUB MOT.
7	Checking after reseating the DRIVE ASSY SUB Reseat the DRIVE ASSY SUB. Does the error still occur when the power is turned OFF and ON?	Go to step 8.	End of work.
8	Checking the power to the DRIVE ASSY SUB Disconnect J22 from the PWBA MCU. Are the voltages across J22-2pin/J22-4pin <=> ground on the PWBA MCU, about +24 VDC when the interlock switch (HARN ASSY INTERLOCK) is pushed?	Replace the DRIVE ASSY SUB. (Refer to Removal 33/ Replacement 21.)	Replace the PWBA MCU. (Refer to Removal 43/ Replacement 11.)

FIP-1. 9 007-371/007-372 Restart Printer

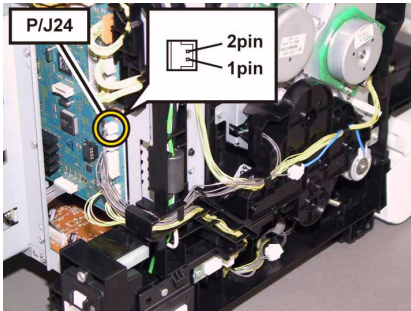
Step	Check	Remedy	
		Yes	No
	Possible causative parts: DRIVE ASSY PH (PL7.1.4) PWBA MCU (PL8.2.13) HARN ASSY KSNR REGCL (PL9.1.9)		
1	Does the error still occur when the power is turned OFF and ON?	Go to step 2.	End of work.
2	Checking the K Mode Solenoid (Color Mode Switching Solenoid) for operation Does the K Mode Solenoid function normally? Checked by [Digital Output] - [DO-13] in [IOT Diag] of diagnosis. During this check, close the COVER ASSY FRONT. Does the K Mode Solenoid click sound arise from the DRIVE ASSY PH, when the K Mode Solenoid check is performed?	Go to step 3.	Go to step 4.
3	Checking after reseating the DRIVE ASSY PH Reseat the DRIVE ASSY PH. Does the error still occur when the power is turned OFF and ON?	Go to step 8.	End of work.
4	Checking the connector of the K Mode Solenoid in the DRIVE ASSY PH for connection Check the connection between the PWBA MCU and K Mode Solenoid. Is P/J24 connected correctly? 	Go to step 6.	Reconnect the connector P/J24 correctly, then go to step 5.
5	Does the error still occur when the power is turned OFF and ON?	Go to step 6.	End of work.
6	Checking the power to the K Mode Solenoid Disconnect J24 from the PWBA MCU. Is the voltage across P24-1pin \leftrightarrow ground on the PWBA MCU, about +24 VDC when the Interlock Switch (HARN ASSY INTERLOCK) is pushed?	Go to step 7.	Replace the PWBA MCU. (Refer to Removal 43/ Replacement 11.)
7	Checking the K Mode Solenoid for resistance Disconnect P/J24 from the PWBA MCU. Is the resistance across J24-1 and J24-2 about 80 to 110-ohm?	Replace the PWBA MCU. (Refer to Removal 43/ Replacement 11.)	Replace the DRIVE ASSY PH. (Refer to Removal 31/ Replacement 23.)

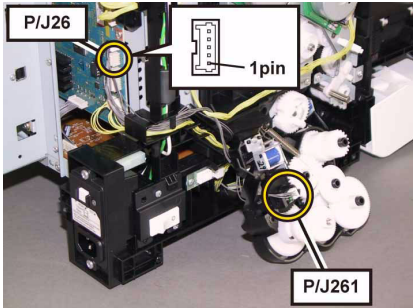
Step	Check	Remedy	
		Yes	No
8	<p>Checking the connectors of the K Mode Sensor in the DRIVE ASSY PH for connection Check the connections between the PWBA MCU and K Mode Sensor. Are P/J26 and P/J261 connected correctly?</p> 	Go to step 10.	Reconnect the connector(s) P/J26 and/or P/J261 correctly, then go to step 9.
9	Does the error still occur when the power is turned OFF and ON?	Go to step 10.	End of work.
10	<p>Checking the HARN ASSY KSNR REGCL for continuity Disconnect J26 from the PWBA MCU. Disconnect J261 from the K Mode Sensor. Is each cable of J26 <=> J261 continuous?</p>	Go to step 11.	Replace the HARN ASSY KSNR REGCL.
11	<p>Checking the power to the K Mode Sensor Disconnect J26 from the PWBA MCU. Is the voltage across P26-1pin <=> ground on the PWBA MCU, about +3.3 VDC?</p>	Go to step 12.	Replace the PWBA MCU. (Refer to Removal 43/ Replacement 11.)
12	<p>Checking the K Mode Sensor for operation Remove the DRIVE ASSY PH from the printer once, but P/J261 and P/J24 should be connected. Enter the [Digital Input] - [K Mode SNR] in [CE Diag] tab of [CE Diag]. During this check, close the COVER ASSY FRONT. Does the voltage change, when a piece of paper is inserted into the gap of the K Mode Sensor?</p>	Replace the PWBA MCU. (Refer to Removal 43/ Replacement 11.)	Replace the DRIVE ASSY PH. (Refer to Removal 31/ Replacement 23.)

FIP-1. 10 009-340 Restart Printer (Yellow Toner)

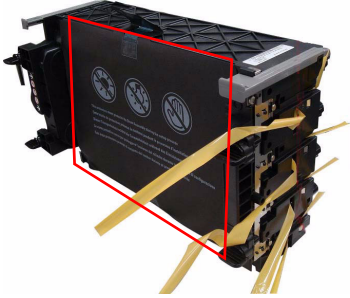
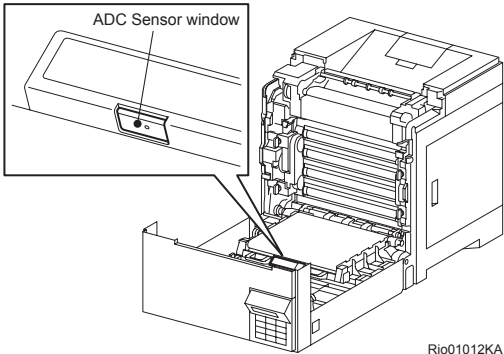
Step	Check	Remedy	
		Yes	No
	Possible causative parts: PHD ASSY (PL4.1.21) DISPENSER ASSY (PL5.1.1) FRAME ASSY MOT (PL5.1.2) MOTOR ASSY DISP (PL5.1.3) TONER CARTRIDGE (Y) (PL5.1.24) HARN ASSY TNR MOT (PL5.1.25) TRANSFER ASSY (PL6.1.7) PWBA MCU (PL8.2.13)		
1	Checking the protection sheet staying Is there the protection sheet on the PHD ASSY? 	Remove the protection sheet.	Go to step 2.
2	Checking the CTD (ADC) Sensor Window Open the COVER ASSY FRONT. Is the CTD (ADC) Sensor window dirty?  Rio01012KA	Go to step 3.	Go to step 4.
3	Turn off the power, and gently wipe the CTD (ADC) Sensor window with a clean dry cloth or cotton swab. After wiping the window, close the COVER ASSY FRONT. Does the error still occur when the power is turned OFF and ON?	Go to step 4.	End of work.
4	Checking after reseating the TONER CARTRIDGE (Y) Reseat the TONER CARTRIDGE (Y), and check that the lock key is in the lock position. Does the error still occur when the power is turned OFF and ON?	Go to step 5.	End of work.

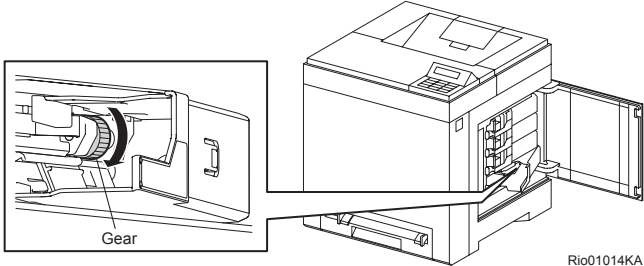
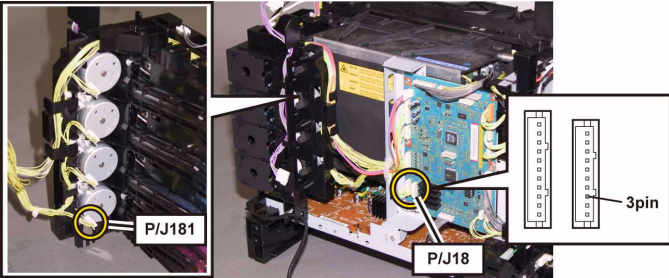
Step	Check	Remedy	
		Yes	No
5	<p>Checking the TNR (Y) MOT (MOTOR ASSY DISP) for rotation Does the TNR (Y) MOT (MOTOR ASSY DISP) function normally? Checked by [Digital Output] - [DO-1F] in [IOT Diag] of diagnosis. During this check, cheat the interlock switch (HARN ASSY INTERLOCK).</p>	Go to step 6.	Go to step 7.
6	<p>Checking the gears of the DISPENSER ASSY for shape and operation Are the shape and operation of the gears of the DISPENSER ASSY normal?</p> 	Go to step 11.	Replace the defective gear(s) or DISPENSER ASSY. (Refer to Removal 44/ Replacement 10.)
7	<p>Checking the connector for connection Check the connectors between the PWBA MCU and TNR (Y) MOT (MOTOR ASSY DISP). Are P/J18 and P/J181 connected correctly?</p> 	Go to step 9.	Reconnect the connector(s) P/J18 and/or P/J181 surly, then go to step 8.
8	Does the error still occur when the power is turned OFF and ON?	Go to step 9.	End of work.
9	<p>Checking the HARN ASSY TNR MOT for continuity Disconnect J18 from the PWBA MCU. Disconnect J181 from the TNR (Y) MOT. Is each cable of J18 <=> J181 continuous?</p>	Go to step 10.	Replace the HARN ASSY TNR MOT.
10	<p>Checking the power to TNR (Y) MOT (MOTOR ASSY DISP) Disconnect J18 from the PWBA MCU. Is the voltage across P18-3pin <=> ground on PWBA MCU, about +24 VDC when the interlock switch (HARN ASSY INTERLOCK) is pushed.</p>	Replace the MOTOR ASSY DISP or FRAME ASSY MOT. (Refer to Removal 44/ Replacement 10.)	Replace the PWBA MCU. (Refer to Removal 43/ Replacement 11.)
11	<p>Checking after reseating the PHD ASSY Reseat the PHD ASSY. Does the error still occur when the power is turned OFF and ON?</p>	Go to step 12.	End of work.

Step	Check	Remedy	
		Yes	No
12	Checking after replacing the TONER CARTRIDGE (Y) Replace the TONER CARTRIDGE (Y), and check that the lock key is in the lock position. (Refer to Removal 6/Replacement 48.) Does the error still occur when the power is turned OFF and ON?	Go to step 13.	End of work.
13	Checking after replacing the PHD ASSY Replace the PHD ASSY. (Refer to Removal 4/Replacement 50.) Does the error still occur when the power is turned OFF and ON?	Go to step 14.	End of work.
14	Checking after reseating the TRANSFER ASSY Reseat the TRANSFER ASSY. Does the error still occur when the power is turned OFF and ON?	Replace the CTD (ADC) Sensor or TRANSFER ASSY. (Refer to Removal 21/Replacement 33.)	End of work.

FIP-1. 11 009-340 Restart Printer (Magenta Toner)

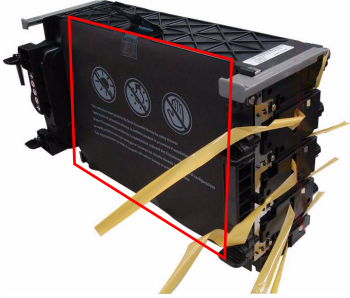
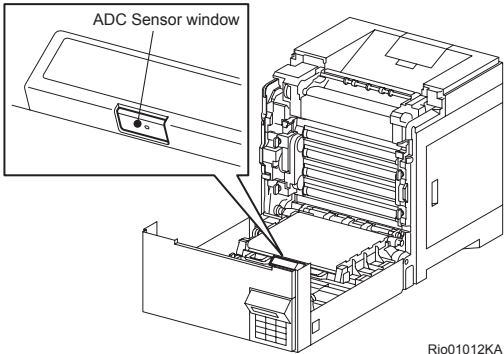
Step	Check	Remedy	
		Yes	No
	Possible causative parts: PHD ASSY (PL4.1.21) DISPENSER ASSY (PL5.1.1) FRAME ASSY MOT (PL5.1.2) MOTOR ASSY DISP (PL5.1.3) TONER CARTRIDGE (M) (PL5.1.23) HARN ASSY TNR MOT (PL5.1.25) TRANSFER ASSY (PL6.1.7) PWBA MCU (PL8.2.13)		
1	Checking the protection sheet staying Is there the protection sheet on the PHD UNIT? 	Remove the protection sheet.	Go to step 2.
2	Checking the CTD (ADC) Sensor Window Open the COVER ASSY FRONT. Is the CTD (ADC) Sensor window dirty? 	Go to step 3.	Go to step 4.
3	Turn off the power, and gently wipe the CTD (ADC) Sensor window with a clean dry cloth or cotton swab. After wiping the window, close the COVER ASSY FRONT. Does the error still occur when the power is turned OFF and ON?	Go to step 4.	End of work.
4	Checking after reseating the TONER CARTRIDGE (M) Reseat the TONER CARTRIDGE (M), and check that the lock key is in the lock position. Does the error still occur when the power is turned OFF and ON?	Go to step 5.	End of work.

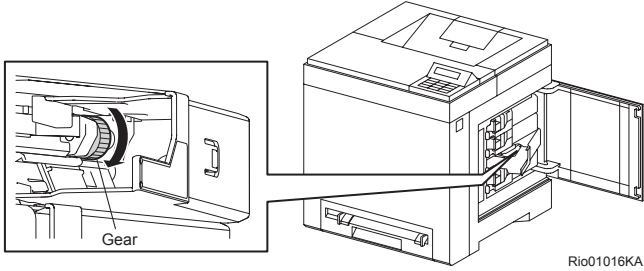
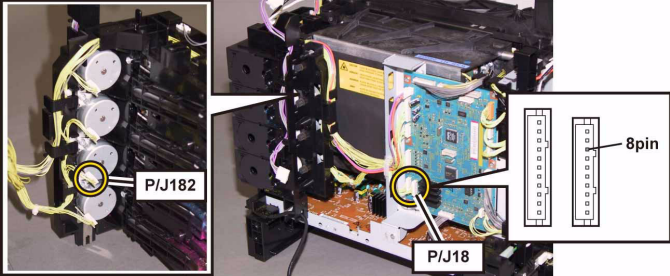
Step	Check	Remedy	
		Yes	No
5	<p>Checking the TNR (M) MOT (MOTOR ASSY DISP) for rotation Does the TNR (M) MOT (MOTOR ASSY DISP) function normally? Checked by [Digital Output] - [DO-21] in [IOT Diag] of diagnosis. During this check, cheat the interlock switch (HARN ASSY INTERLOCK).</p>	Go to step 6.	Go to step 7.
6	<p>Checking the gears of the DISPENSER ASSY for shape and operation Are the shape and operation of the gears of the DISPENSER ASSY normal?</p> 	Go to step 11.	Replace the defective gear(s) or DISPENSER ASSY. (Refer to Removal 44/ Replacement 10.)
7	<p>Checking the connector for connection Check the connectors between the PWBA MCU and TNR (M) MOT (MOTOR ASSY DISP). Are P/J18 and P/J182 connected correctly?</p> 	Go to step 9.	Reconnect the connector(s) P/ J18 and/or P/J182 surly, then go to step 8.
8	Does the error still occur when the power is turned OFF and ON?	Go to step 9.	End of work.
9	<p>Checking the HARN ASSY TNR MOT for continuity Disconnect J18 from the PWBA MCU. Disconnect J182 from the TNR (M) MOT. Is each cable of J18 <=> J182 continuous?</p>	Go to step 10.	Replace the HARN ASSY TNR MOT.
10	<p>Checking the power to TNR (M) MOT (MOTOR ASSY DISP) Disconnect J18 from the PWBA MCU. Is the voltage across P18-8pin <=> ground on PWBA MCU, about +24 VDC when the interlock switch (HARN ASSY INTERLOCK) is pushed.</p>	Replace the MOTOR ASSY DISP or FRAME ASSY MOT. (Refer to Removal 44/ Replacement 10.)	Replace the PWBA MCU. (Refer to Removal 43/ Replacement 11.)
11	<p>Checking after reseating the PHD ASSY Reseat the PHD ASSY. Does the error still occur when the power is turned OFF and ON?</p>	Go to step 12.	End of work.

Step	Check	Remedy	
		Yes	No
12	Checking after replacing the TONER CARTRIDGE (M) Replace the TONER CARTRIDGE (M), and check that the lock key is in the lock position. (Refer to Removal 6/ Replacement 48.) Does the error still occur when the power is turned OFF and ON?	Go to step 13.	End of work.
13	Checking after replacing the PHD ASSY Replace the PHD ASSY. (Refer to Removal 4/Replacement 50.) Does the error still occur when the power is turned OFF and ON?	Go to step 14.	End of work.
14	Checking after reseating the TRANSFER ASSY Reseat the TRANSFER ASSY. Does the error still occur when the power is turned OFF and ON?	Replace the CTD (ADC) Sensor or TRANSFER ASSY. (Refer to Removal 21/ Replacement 33.)	End of work.

FIP-1. 12 009-340 Restart Printer (Cyan Toner)

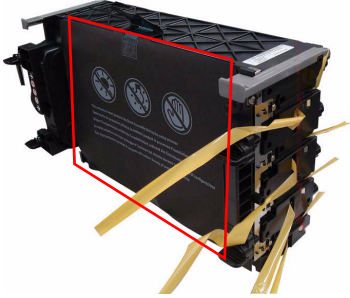
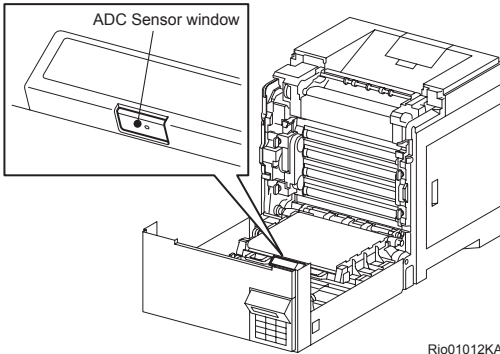
Step	Check	Remedy	
		Yes	No
	Possible causative parts: PHD ASSY (PL4.1.21) DISPENSER ASSY (PL5.1.1) FRAME ASSY MOT (PL5.1.2) MOTOR ASSY DISP (PL5.1.3) TONER CARTRIDGE (C) (PL5.1.22) HARN ASSY TNR MOT (PL5.1.25) TRANSFER ASSY (PL6.1.7) PWBA MCU (PL8.2.13)		
1	Checking the protection sheet staying Is there the protection sheet on the PHD UNIT? 	Remove the protection sheet.	Go to step 2.
2	Checking the CTD (ADC) Sensor Window Open the COVER ASSY FRONT. Is the CTD (ADC) Sensor window dirty? 	Go to step 3.	Go to step 4.
3	Turn off the power, and gently wipe the CTD (ADC) Sensor window with a clean dry cloth or cotton swab. After wiping the window, close the COVER ASSY FRONT. Does the error still occur when the power is turned OFF and ON?	Go to step 4.	End of work.
4	Checking after reseating the TONER CARTRIDGE (C) Reseat the TONER CARTRIDGE (C), and check that the lock key is in the lock position. Does the error still occur when the power is turned OFF and ON?	Go to step 5.	End of work.

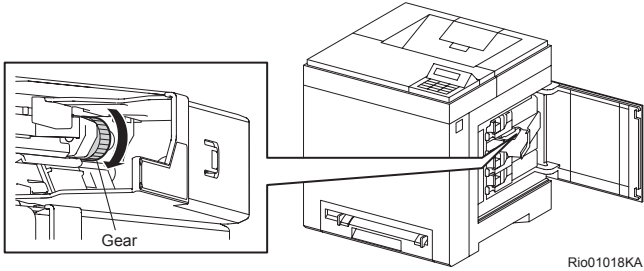
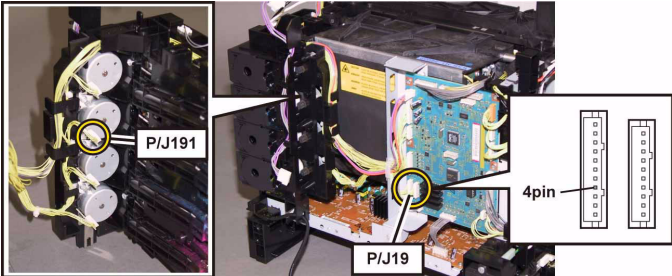
Step	Check	Remedy	
		Yes	No
5	<p>Checking the TNR (C) MOT (MOTOR ASSY DISP) for rotation Does the TNR (C) MOT (MOTOR ASSY DISP) function normally? Checked by [Digital Output] - [DO-23] in [IOT Diag] of diagnosis. During this check, cheat the interlock switch (HARN ASSY INTERLOCK).</p>	Go to step 6.	Go to step 7.
6	<p>Checking the gears of the DISPENSER ASSY for shape and operation Are the shape and operation of the gears of the DISPENSER ASSY normal?</p> 	Go to step 11.	Replace the defective gear(s) or DISPENSER ASSY. (Refer to Removal 44/ Replacement 10.)
7	<p>Checking the connector for connection Check the connectors between the PWBA MCU and TNR (C) MOT (MOTOR ASSY DISP). Are P/J19 and P/J191 connected correctly?</p> 	Go to step 9.	Reconnect the connector(s) P/J19 and/or P/J191 surly, then go to step 8.
8	Does the error still occur when the power is turned OFF and ON?	Go to step 9.	End of work.
9	<p>Checking the HARN ASSY TNR MOT for continuity Disconnect J19 from the PWBA MCU. Disconnect J191 from the TNR (C) MOT. Is each cable of J19 <=> J191 continuous?</p>	Go to step 10.	Replace the HARN ASSY TNR MOT.
10	<p>Checking the power to TNR (C) MOT (MOTOR ASSY DISP) Disconnect J19 from the PWBA MCU. Is the voltage across P19-4pin <=> ground on PWBA MCU, about +24 VDC when the interlock switch (HARN ASSY INTERLOCK) is pushed.</p>	Replace the MOTOR ASSY DISP or FRAME ASSY MOT. (Refer to Removal 44/ Replacement 10.)	Replace the PWBA MCU. (Refer to Removal 43/ Replacement 11.)
11	<p>Checking after reseating the PHD ASSY Reseat the PHD ASSY. Does the error still occur when the power is turned OFF and ON?</p>	Go to step 12.	End of work.

Step	Check	Remedy	
		Yes	No
12	Checking after replacing the TONER CARTRIDGE (C) Replace the TONER CARTRIDGE (C), and check that the lock key is in the lock position. (Refer to Removal 6/Replacement 48.) Does the error still occur when the power is turned OFF and ON?	Go to step 13.	End of work.
13	Checking after replacing the PHD ASSY Replace the PHD ASSY. (Refer to Removal 4/Replacement 50.) Does the error still occur when the power is turned OFF and ON?	Go to step 14.	End of work.
14	Checking after reseating the TRANSFER ASSY Reseat the TRANSFER ASSY. Does the error still occur when the power is turned OFF and ON?	Replace the CTD (ADC) Sensor or TRANSFER ASSY. (Refer to Removal 21/Replacement 33.)	End of work.

FIP-1. 13 009-340 Restart Printer (Black Toner)

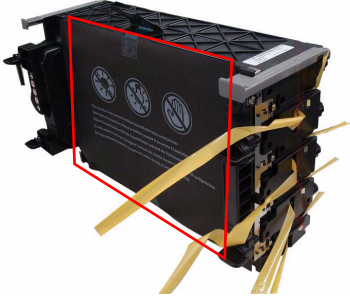
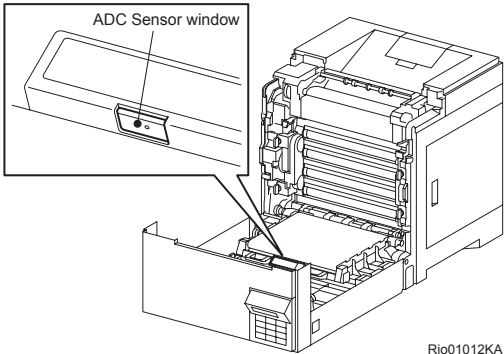
Step	Check	Remedy	
		Yes	No
	Possible causative parts: PHD ASSY (PL4.1.21) DISPENSER ASSY (PL5.1.1) FRAME ASSY MOT (PL5.1.2) MOTOR ASSY DISP (PL5.1.3) TONER CARTRIDGE (K) (PL5.1.21) HARN ASSY TNR MOT (PL5.1.25) TRANSFER ASSY (PL6.1.7) PWBA MCU (PL8.2.13)		
1	Checking the protection sheet staying Is there the protection sheet on the PHD UNIT? 	Remove the protection sheet.	Go to step 2.
2	Checking the CTD (ADC) Sensor Window Open the COVER ASSY FRONT. Is the CTD (ADC) Sensor window dirty?  Rio01012KA	Go to step 3.	Go to step 4.
3	Turn off the power, and gently wipe the CTD (ADC) Sensor window with a clean dry cloth or cotton swab. After wiping the window, close the COVER ASSY FRONT. Does the error still occur when the power is turned OFF and ON?	Go to step 4.	End of work.
4	Checking after reseating the TONER CARTRIDGE (K) Reseat the TONER CARTRIDGE (K), and check that the lock key is in the lock position. Does the error still occur when the power is turned OFF and ON?	Go to step 5.	End of work.

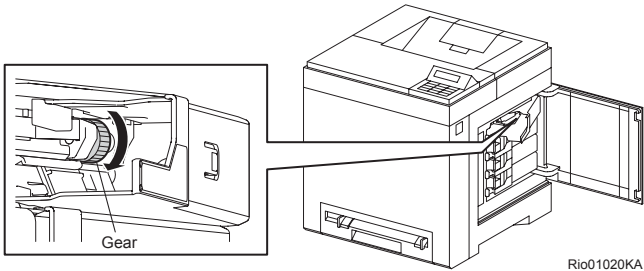
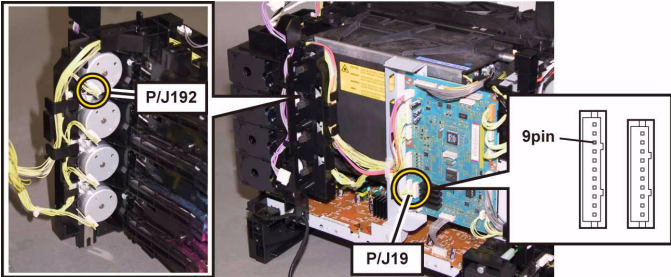
Step	Check	Remedy	
		Yes	No
5	<p>Checking the TNR (K) MOT (MOTOR ASSY DISP) for rotation Does the TNR (K) MOT (MOTOR ASSY DISP) function normally? Checked by [Digital Output] - [DO-25] in [IOT Diag] of diagnosis. During this check, cheat the interlock switch (HARN ASSY INTERLOCK).</p>	Go to step 6.	Go to step 7.
6	<p>Checking the gears of the DISPENSER ASSY for shape and operation Are the shape and operation of the gears of the DISPENSER ASSY normal?</p> 	Go to step 11.	Replace the defective gear(s) or DISPENSER ASSY. (Refer to Removal 44/ Replacement 10.)
7	<p>Checking the connector for connection Check the connectors between the PWBA MCU and TNR (K) MOT (MOTOR ASSY DISP). Are P/J19 and P/J192 connected correctly?</p> 	Go to step 9.	Reconnect the connector(s) P/J19 and/or P/J192 surly, then go to step 8.
8	Does the error still occur when the power is turned OFF and ON?	Go to step 9.	End of work.
9	<p>Checking the HARN ASSY TNR MOT for continuity Disconnect J19 from the PWBA MCU. Disconnect J192 from the TNR (K) MOT. Is each cable of J19 <=> J192 continuous?</p>	Go to step 10.	Replace the HARN ASSY TNR MOT.
10	<p>Checking the power to TNR (K) MOT (MOTOR ASSY DISP) Disconnect J19 from the PWBA MCU. Is the voltage across P19-9pin <=> ground on PWBA MCU, about +24 VDC when the interlock switch (HARN ASSY INTERLOCK) is pushed.</p>	Replace the MOTOR ASSY DISP or FRAME ASSY MOT. (Refer to Removal 44/ Replacement 10.)	Replace the PWBA MCU. (Refer to Removal 43/ Replacement 11.)
11	<p>Checking after reseating the PHD UNIT Reseat the PHD UNIT. Does the error still occur when the power is turned OFF and ON?</p>	Go to step 12.	End of work.

Step	Check	Remedy	
		Yes	No
12	Checking after replacing the TONER CARTRIDGE (K) Replace the TONER CARTRIDGE (K), and check that the lock key is in the lock position. (Refer to Removal 6/Replacement 48.) Does the error still occur when the power is turned OFF and ON?	Go to step 13.	End of work.
13	Checking after replacing the PHD ASSY Replace the PHD ASSY. (Refer to Removal 4/Replacement 50.) Does the error still occur when the power is turned OFF and ON?	Go to step 14.	End of work.
14	Checking after reseating the TRANSFER ASSY Reseat the TRANSFER ASSY. Does the error still occur when the power is turned OFF and ON?	Replace the CTD (ADC) Sensor or TRANSFER ASSY. (Refer to Removal 21/Replacement 33.)	End of work.

FIP-1. 14 010-317 Restart Printer

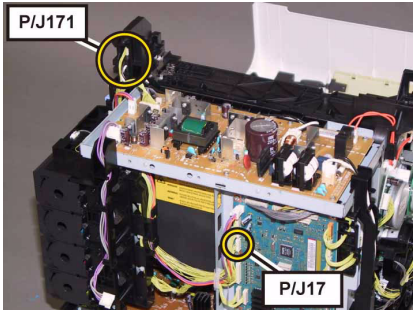
Step	Check	Remedy	
		Yes	No
	Possible causative parts: FUSER ASSY (PL6.1.1) HARN ASSY FUSER2 (PL6.1.2) PWBA MCU (PL8.2.13)		
1	Checking after reseating the FUSER ASSY Reseat the FUSER ASSY. Warning: Start the operation after the FUSER ASSY has cooled down. Does the error still occur when the power is turned OFF and ON?	Go to step 2.	End of work.
2	Checking the connectors for connection Remove the FUSER ASSY. Warning: Start the operation after the FUSER ASSY has cooled down. Check the connections between the PWBA MCU and FUSER ASSY. Are P/J17 and P/J171 connected correctly? 	Go to step 4.	Reconnect the connector(s) P/J17 and/or P/J171 correctly, then go to step 3.
3	Does the error still occur when the power is turned OFF and ON?	Go to step 4.	End of work.
4	Checking the HARN ASSY FUSER2 for continuity Remove the FUSER ASSY. Warning: Start the operation after the FUSER ASSY has cooled down. Disconnect J17 from the PWBA MCU. Is each cable of J17 <=> P171 continuous? NOTE: P171 is attached to the frame.	Go to step 5.	Replace the HARN ASSY FUSER2.

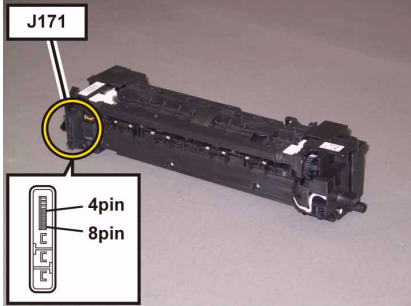
Step	Check	Remedy	
		Yes	No
5	<p>Checking the resistances of Temp. Sensor in the FUSER ASSY Remove the FUSER ASSY. Warning: Start the operation after the FUSER ASSY has cooled down. Check the resistances across the following pins of the removed FUSER ASSY. J171-5pin <=> J171-4pin J171-6pin <=> J171-8pin J171-6pin <=> J171-7pin Can the resistances be measured? (The resistances are 7 k-ohm at 180 degrees C).</p> 	<p>Replace the PWBA MCU. (Refer to Removal 43/ Replacement 11.)</p>	<p>Replace the FUSER ASSY. (Refer to Removal 5/ Replacement 49.) After replacement, be sure to clear the life counter value.</p>

FIP-1. 15 010-351 Restart Printer

Step	Check	Remedy	
		Yes	No
	Possible causative parts: FUSER ASSY (PL6.1.1) PWBA MCU (PL8.2.13)		
1	Checking the life counter value of the FUSER ASSY Does the life counter value show the near of the end?	Replace the FUSER ASSY. (Refer to Removal 5/ Replacement 49.) After replacement , be sure to clear the life counter value.	Go to step 2.
2	Checking after reseating the FUSER ASSY Reseat the FUSER ASSY. Warning: Start the operation after the FUSER ASSY has cooled down. Does the error still occur when the power is turned OFF and ON?	Go to step 3.	End of work.
3	Checking after replacing the FUSER ASSY Replace the FUSER ASSY. (Refer to Removal 5/ Replacement 49.) Warning: Start the operation after the FUSER ASSY has cooled down. Does the error still occur when the power is turned OFF and ON? NOTE: After replacement, be sure to clear the life counter value.	Replace the PWBA MCU. (Refer to Removal 43/ Replacement 11.)	End of work.

FIP-1. 16 010-354 Restart Printer

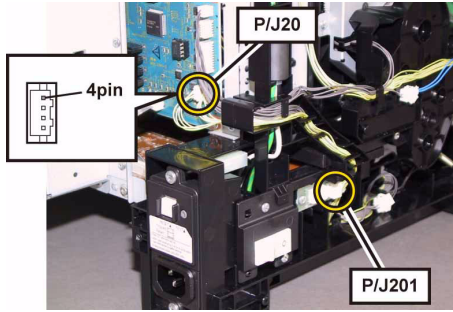
Step	Check	Remedy	
		Yes	No
	Possible causative parts: SENSOR HUM (PL8.2.7) PWBA MCU (PL8.2.13) HARN ASSY HUM (PL9.1.6)		
1	Does the error still occur when the power is turned OFF and ON?	Go to step 2.	End of work.
2	Checking after reseating the SENSOR HUM Reseat the SENSOR HUM. Does the error still occur when the power is turned OFF and ON?	Go to step 3.	End of work.
3	Checking the HARN ASSY HUM for continuity Disconnect J20 from the PWBA MCU. Disconnect J201 from the SENSOR HUM. Is each cable of J20 <=> J201 continuous? 	Go to step 4.	Replace the HARN ASSY HUM.
4	Checking the power to SENSOR HUM Disconnect the connector of J20 from the PWBA MCU. Is the voltage across P20-4pin <=> ground on the PWBA MCU, about +5 VDC?	Replace the SENSOR HUM. (Refer to Removal 19/ Replacement 35.)	Replace the PWBA MCU. (Refer to Removal 43/ Replacement 11.)

FIP-1. 17 010-377 Restart Printer

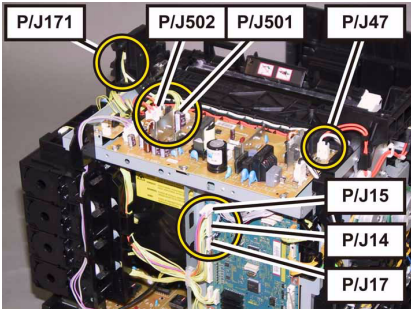
Step	Check	Remedy	
		Yes	No
	Possible causative parts: FUSER ASSY (PL6.1.1) HARN ASSY FUSER2 (PL6.1.2) PWBA LVPS (PL8.2.1) PWBA MCU (PL8.2.13) HARN ASSY LVPS2 (PL9.1.3)		
1	Does the error still occur when the power is turned OFF and ON?	Go to step 2.	End of work.
2	Checking after reseating the FUSER ASSY Reseat the FUSER ASSY. Warning: Start the operation after the FUSER ASSY has cooled down. Does the error still occur when the power is turned OFF and ON?	Go to step 3.	End of work.
3	Checking the connectors for connection Remove the FUSER ASSY. Warning: Start the operation after the FUSER ASSY has cooled down. Check the connections between the PWBA MCU (P/J17) and FUSER ASSY (P/J171). Check the connections between the FUSER ASSY (P/J171) and PWBA LVPS (P/J47). Check the connections between the PWBA LVPS (P/J501 and P/J502) and PWBA MCU (P/J14 and P/J15). Are these connectors connected correctly? 	Go to step 5.	"Reconnect the connector(s) P/J17, P/J47, P/J171, P/J501, P/J502, P/J14 and/or P/J15 correctly, then go to step 4."
4	Does the error still occur when the power is turned OFF and ON?	Go to step 5.	End of work.
5	Checking the HARN ASSY FUSER2 for continuity Disconnect J17 from the PWBA MCU. Disconnect J47 from the PWBA LVPS. Is each cable of J17 and J47 \Leftrightarrow P171 continuous? NOTE: P171 is attached to the frame.	Go to step 6.	Replace the HARN ASSY FUSER2.
6	Checking the HARN ASSY LVPS2 for continuity Disconnect J14 from the PWBA MCU. Disconnect J501 from the PWBA LVPS. Is each cable of J14 \Leftrightarrow J501 continuous?	Go to step 7.	Replace the HARN ASSY LVPS2.

Step	Check	Remedy	
		Yes	No
7	Checking after replacing the FUSER ASSY Replace the FUSER ASSY. (Refer to Removal 5/ Replacement 49.) Warning: Start the operation after the FUSER ASSY has cooled down. Does the error still occur when the power is turned OFF and ON? NOTE: After replacement, be sure to clear the life counter value.	Replace the PWBA MCU (Refer to Removal 43/ Replacement 11.)	End of work.

FIP-1. 18 Ready to Print 010-421

Step	Check	Remedy	
		Yes	No
	Possible causative parts: FUSER ASSY (PL6.1.1) PWBA MCU (PL8.2.13)		
1	Checking the FUSER ASSY for installation Is the FUSER ASSY installed correctly? Warning: Start the operation after the FUSER ASSY has cooled down.	Go to step 3.	Reseat the FUSER ASSY, then go step 2.
2	Does the error still occur when the power is turned ON?	Go to step 3.	End of work.
3	Checking after replacing the FUSER ASSY Replace the FUSER ASSY. (Refer to Removal 5/ Replacement 49.) Warning: Start the operation after the FUSER ASSY has cooled down. Does the error still occur when the power is turned ON? NOTE: After replacement, be sure to clear the life counter value.	Replace the PWBA MCU. (Refer to Removal 43/ Replacement 11.)	End of work

FIP-1. 19 016-300/016-301/016-302/016-313/016-315/016-317/016-323/016-327/016-340/
016-344/016-345/016-346/016-347 Restart Printer

Step	Check	Remedy	
		Yes	No
	Possible causative parts: PWBA ESS (PL8.1.7)		
1	Checking the error code. Error code is 016-317 or 016-340?	Go to step 2.	Go to step 3.
2	Download the latest version of the firmware from the Dell support website, and update the firmware with "F/W Download DL Mode" .(Refer to Reference_1.) Does the error still occur when the power is turned off and on?	Replace the PWBA ESS. (Refer to Removal 42/ Replacement 12.)	End of work.
3	Check whether the version of the firmware is the latest, referring to the Printer Information via the Tool Box. Checked by [Printer Information] of the [Printer Settings Report] tab in Tool Box. For the latest version information, refer to the Dell Support Web Site. Is the firmware the latest version?	Replace the PWBA ESS. (Refer to Removal 42/ Replacement 12.)	Download the latest version of the firmware from the Dell Support Web Site.

Reference_1:

1. Make sure that the printer is connected to the computer via USB port (remove the network cable). Then, try downloading as follows:
 - 1) Power on the printer while pressing the <X Cancel> and <✓> buttons.
 - 2) The printer goes into the Download Mode with a message "Download Mode Ready". Then, activate firmware update tool and follow the instruction displayed.

NOTE

While the firmware download is being executed, the printer displays a message "Writing...USB F/W" and the computer displays a progress bar and may be restarted during the downloading process. Never power off the printer or the computer until the downloading process completes, and never interrupt the downloading process.

FIP-1. 20 016-316/016-318 Restart Printer

Step	Check	Remedy	
		Yes	No
	Possible causative parts: PWBA ESS (PL8.1.7) Memory Card (Option)		
1	Is the customer using the recommended memory card?	Go to step 2.	Replace to the recommended memory card.
2	Checking the Memory Card installation. Reseat the Memory Card. Does the error still occur when turning on the power?	Go to step 3.	End of work.
3	Checking after reseating the Memory Card. Replace the Memory Card. Does the error still occur when turning on the power?	Replace the PWBA ESS. (Refer to Removal 42/ Replacement 12.)	End of work.

FIP-1. 21 016-338 Restart Printer

Step	Check	Remedy	
		Yes	No
	Possible causative parts: PWBA ESS (PL8.1.7) WIRELESS PRINTER ADAPTER (PL8.1.16)		
1	Does the error still occur when the power is turned OFF and ON?	Go to step 2.	End of work.
2	Checking the WIRELESS PRINTER ADAPTER installation Reseat the WIRELESS PRINTER ADAPTER. Does the error still occur when the power is turned OFF and ON?	Go to step 3.	End of work.
3	Checking after replacing the WIRELESS PRINTER ADAPTER Replace the WIRELESS PRINTER ADAPTER. Does the error still occur when the power is turned OFF and ON?	Go to step 4.	End of work.
4	Checking after reseating the PWBA ESS Reseat the PWBA ESS. Does the error still occur when the power is turned OFF and ON?	Replace the PWBA ESS. (Refer to Removal 42/ Replacement 12.)	End of work.

FIP-1. 22 016-365 Restart Printer

Step	Check	Remedy	
		Yes	No
	Possible causative parts: PWBA ESS (PL8.1.7) NETWORK PROTOCOL ADAPTER (PL8.1.18)		
1	Does the error still occur when the power is turned OFF and ON?	Go to step 2.	End of work.
2	Checking the Network Protocol Adapter Is the Network Protocol Adapter installed?	Go to step 3.	Install the Network Protocol Adapter.
3	Checking after reseating the Network Protocol Adapter Reseat the Network Protocol Adapter. Does the error still occur when the power is turned off and on?	Go to step 4.	End of work.
4	Checking after replacing the Network Protocol Adapter Replace the Network Protocol Adapter. (Refer to Removal 56/Replacement 56.) Does the error still occur when the power is turned off and on?	Replace the PWBA ESS. (Refer to Removal 42/ Replacement 12.)	End of work.

FIP-1. 23 016-370 Restart Printer

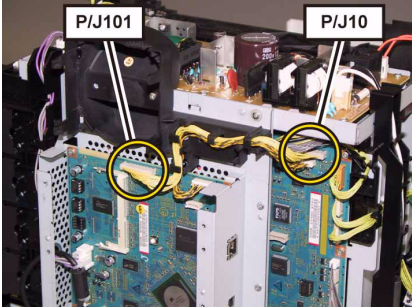
Step	Check	Remedy	
		Yes	No
	Possible causative parts: PWBA ESS (PL8.1.7) PWBA MCU (PL8.2.13) HARN ASSY ESS (PL9.1.1)		
1	Checking the error. Does the error still occur when the power is turned off and on?	Go to step 2.	End of work.
2	Download the latest version of the firmware from the Dell support website, and update the firmware with "F/W Download DL Mode". (Refer to Reference_1.) Does the error still occur when the power is turned off and on?	Go to step 3.	End of work.
3	Checking after reseating the PWBA ESS and PWBA MCU Reseat the PWBA ESS and PWBA MCU. Does the error still occur when the power is turned OFF and ON?	Go to step 4.	End of work.
4	Checking the connectors for connection Check the connections between the PWBA MCU and PWBA ESS. Are P/J10 and P/J101 connected correctly? 	Go to step 6.	Reconnect the connector(s) P/J10 and/or P/J101 correctly, then go to step 5.
5	Does the error still occur when the power is turned OFF and ON?	Go to step 6.	End of work.
6	Checking the HARN ASSY ESS for continuity Disconnect J10 from the PWBA MCU. Disconnect J101 from the PWBA ESS. Is each cable of J10 <=> J101 continuous?	Go to step 7.	Replace the HARN ASSY ESS.
7	Checking after replacing the PWBA MCU Replace the PWBA MCU. (Refer to Removal 43/ Replacement 11.) Does the error still occur when the power is turned OFF and ON?	Replace the PWBA ESS. (Refer to Removal 42/ Replacement 12.)	End of work.

Reference_1:

1. Make sure that the printer is connected to the computer via USB port (remove the network cable).
Then, try downloading as follows:

- 1) Power on the printer while pressing the <X Cancel> and <✓> buttons.

- 2) The printer goes into the Download Mode with a message "Download Mode Ready". Then, activate firmware update tool and follow the instruction displayed.

NOTE

While the firmware download is being executed, the printer displays a message "Writing...USB F/W" and the computer displays a progress bar and may be restarted during the downloading process. Never power off the printer or the computer until the downloading process completes, and never interrupt the downloading process.

FIP-1. 24 Invalid ID 016-383 / Range Chk Error 016-384 / Header Error 016-385 / Check Sum Error 016-386 / Protection Error 016-391 / Erase Flash Err. 016-392 / Write Flash Err. 016-393 / Verify Error 016-394

Step	Check	Remedy	
		Yes	No
	Possible causative parts: PWBA ESS (PL8.1.7)		
1	Checking the download file Was the file for 2130cn downloaded?	Go to step 2.	Re-download the correct file.
2	Checking the connection between PC and printer Are your PC and the printer correctly connected by USB or LAN? Disconnect and reconnect the USB or network cable. Does the error still occur when the power is turned OFF and ON?	Go to step 3.	End of work.
3	Checking after reseating the PWBA ESS Reseat the PWBA ESS. Does the error still occur when the power is turned OFF and ON?	Go to step 4.	End of work.
4	Checking re-downloading the correct file for 2130cn Re-download the correct file from Dell web site. Does the error still occur when the power is turned OFF and ON?	Replace the PWBA ESS. (Refer to Removal 42/ Replacement 12.)	End of work.

FIP-1. 25 Out of Memory 016-700

Step	Check	Remedy	
		Yes	No
	Possible causative parts: PWBA ESS (PL8.1.7)		
1	Checking the memory capacity for print Print the small size file (like a Windows test print). Does the error still occur when printing?	Go to step 2.	Divide the printing job.
2	Checking after reseating the PWBA ESS Reseat the PWBA ESS. Does the error still occur when printing?	Replace the PWBA ESS. (Refer to Removal 42/ Replacement 12.)	End of work.

FIP-1. 26 PDL Request 016-720

Step	Check	Remedy	
		Yes	No
	Possible causative parts: PWBA ESS (PL8.1.7)		
1	Checking the printing job Print the small size file (like a Windows test print). Does the error still occur when printing?	Go to step 2.	End of work.
2	Checking after reseating the PWBA ESS Reseat the PWBA ESS. Does the error still occur when printing?	Replace the PWBA ESS. (Refer to Removal 42/ Replacement 12.)	End of work.

FIP-1. 27 Invalid User 016-757

Step	Check	Remedy	
		Yes	No
	Possible causative parts:		
1	Checking your account registration Is your account registered in your network?	Go to step 3.	Request the registration to your system administrator, then go to step 2.
2	Does the error still occur when printing?	Go to step 3.	End of work.
3	Checking connection Is your PC surely connected with the printer via network?	Consult your system administrator.	Connect your PC with printer surely, then go to step 4.
4	Does the error still occur when printing?	Consult your system administrator.	End of work.

FIP-1. 28 Disabled Func 016-758

Step	Check	Remedy	
		Yes	No
	Possible causative parts: PWBA ESS (PL8.1.7)		
1	Checking the power of the printer Is the power of the printer turned ON?	Go to step 3.	Turn ON the power of the printer, and go to step 2.
2	Does the error still occur when printing?	Go to step 3.	End of work.
3	Checking your operation Is the operation that you did an available function for 2130cn?	Go to step 4.	Inquire to your system administrator, or check this operation by the User Guide.
4	Checking connection Is your PC surely connected with the printer?	Go to step 6.	Connect your PC with printer surely, then go to step 5.
5	Does the error still occur when printing?	Go to step 6.	End of work.
6	Checking after reseating the PWBA ESS Reseat the PWBA ESS. Does the error still occur when printing?	Replace the PWBA ESS. (Refer to Removal 42/ Replacement 12.)	End of work.

FIP-1. 29 Reached Limit 016-759

Step	Check	Remedy	
		Yes	No
	Possible causative parts: PWBA ESS (PL8.1.7)		
1	Check the [Dell ColorTrack] setting Does the value of [User Registration] exceed the limitation? Maximum user is 50.	Reset to 50 or less and go to step 2.	Go to step 3.
2	Does the error still occur when printing?	Go to step 3.	End of work.
3	Checking the PWBA ESS installation Reseat the PWBA ESS. (Refer to Removal 42/ Replacement 12) Does the error still occur when printing?	Replace the PWBA ESS.	End of work.

FIP-1. 30 Invalid Job 016-799

Step	Check	Remedy	
		Yes	No
	Possible causative parts: PWBA ESS (PL8.1.7)		
1	Checking the paper size Does the paper size in use meet the specifications?	Go to step 3.	Use the paper that meets the specifications, then go to step 2.
2	Does the error still occur when printing?	Go to step 3.	End of work.
3	Checking the paper size setup Does the using paper size match the printer setup value?	Go to step 5.	Go to step 4.
4	Setup the paper size through your PC. Does the error still occur when printing?	Replace the PWBA ESS. (Refer to Removal 42/ Replacement 12.)	End of work.
5	Checking the printing job Does the error still occur when printing the Windows test print?	Replace the PWBA ESS. (Refer to Removal 42/ Replacement 12.)	Check that the printing data is correct.

FIP-1. 31 Disk Full 016-980

Step	Check	Remedy	
		Yes	No
	Possible causative parts: PWBA CONT AIO (PL10.6.6)		
1	Checking the file data in the printer Print or clear the stored files and data at the printer memory. Does the error still occur when printing?	Go to step 2.	End of work.
2	Checking the memory capacity for print Print the small size file (like a Windows test page). Does the error still occur when printing?	Go to step 3.	Add the MEMORY CARD or divide the printing job.
3	Checking after reseating the MEMORY CARD Reseat the MEMORY CARD. Does the error still occur when printing?	Go to step 4.	End of work.
4	Checking the memory capacity. Is the memory capacity recognized normally? Checked by [Config Page] of [Print information] in diagnosis.	Go to step 5.	Replace the PWBA ESS. (Refer to Removal 42/ Replacement 12.)
5	Checking after replacing the MEMORY CARD Replace the MEMORY CARD. Does the error still occur when printing?	Replace the PWBA ESS. (Refer to Removal 42/ Replacement 12.)	End of work.

FIP-1. 32 Collate Full 016-981

Step	Check	Remedy	
		Yes	No
	Possible causative parts: PWBA ESS (PL8.1.7)		
1	Checking the error Does the error still occur when the power is turned off and on?	Go to step 2.	End of work.
2	Checking the printer memory size Does the error occur when printing with the Memory Card (Option) installed?	Go to step 3.	End of work.
3	RAM Disk size settings Does the error occur when printing after reducing the size setting of the RAM Disk? (See RAM Disk size settings in chapter 2)	Replace the PWBA ESS. (Refer to Removal 42/ Replacement 12.)	End of work.

FIP-1. 33 MCU Flash Error 024-360

Step	Check	Remedy	
		Yes	No
	Possible causative parts: PWBA ESS (PL8.1.7) PWBA MCU (PL8.2.13)		
1	Checking the error Does the error still occur when turning off the power?	Go to step 2.	End of work.
2	Checking the MCU firmware Is the download firmware the 2130cn?	Go to step 3.	Re-download the correct firmware.
3	Checking after replacing the PWBA MCU Replace the PWBA MCU. (Refer to Removal 43/ Replacement 11) Does the error still occur?	Replace the PWBA ESS. (Refer to Removal 42/ Replacement 12)	End of work.

FIP-1. 34 024-362 Restart Printer

Step	Check	Remedy	
		Yes	No
	Possible causative parts: PWBA ESS (PL8.1.7)		
1	Checking the error Does the error still occur when turning off and on the power?	Go to step 2.	End of work., if the error occurs again, go to step 2.
2	Checking the PWBA ESS installation Reseat the PWBA ESS. (Refer to Removal 42/ Replacement 12) Does the error still occur when turning off and on the power?	Replace the PWBA ESS.	End of work.

FIP-1. 35 Check Paper Size 024-910

Step	Check	Remedy	
		Yes	No
	Possible causative parts: PWBA ESS (PL8.1.7) PWBA MCU (PL8.2.13)		
1	Checking the paper size Does the using paper size meet the specification?	Go to step 3.	Use the paper that meets the specifications, then go to step 2.
2	Does the error still occur when printing?	Go to step 3.	End of work.
3	Checking the print data, paper (print media) and paper settings Check the followings. - Are the print data and the paper suitable? - Are the paper setting and paper suitable? - Are the paper setting and print data suitable? After checking, correct the incorrect item(s). Does the error still occur when printing?	Go to step 4.	End of work.
4	Checking after reloading a paper and the CASSETTE ASSY 250 Reload a correct paper into the CASSETTE ASSY 250. Reseat the CASSETTE ASSY 250 correctly. Does the error still occur when printing?	Go to step 5.	End of work.
5	Checking after replacing the PWBA MCU Replace the PWBA MCU. (Refer to Removal 43/ Replacement 11.) Does the error still occur when printing?	Replace the PWBA ESS. (Refer to Removal 42/ Replacement 12.)	End of work.

FIP-1. 36 Check Paper Size 024-911

Step	Check	Remedy	
		Yes	No
	Possible causative parts: PWBA ESS (PL8.1.7) PWBA MCU (PL8.2.13)		
1	Checking the paper size Does the using paper size meet the specification?	Go to step 3.	Use the paper that meets the specifications, then go to step 2.
2	Does the error still occur when printing?	Go to step 3.	End of work.
3	Checking the print data, paper (print media) and paper settings Check the followings. - Are the print data and the paper suitable? - Are the paper setting and paper suitable? - Are the paper setting and print data suitable? After checking, correct the incorrect item(s). Does the error still occur when printing?	Go to step 4.	End of work.
4	Checking after reloading a paper and the CASSETTE ASSY 250 (Option) Reload a correct paper into the CASSETTE ASSY 250 (Option). Reseat the CASSETTE ASSY 250 (Option) correctly. Does the error still occur when printing?	Go to step 5.	End of work.
5	Checking after replacing the PWBA MCU Replace the PWBA MCU. (Refer to Removal 43/ Replacement 11.) Does the error still occur when printing?	Replace the PWBA ESS. (Refer to Removal 42/ Replacement 12.)	End of work.

FIP-1. 37 Check Paper Size 024-914

Step	Check	Remedy	
		Yes	No
	Possible causative parts: PWBA ESS (PL8.1.7) PWBA MCU (PL8.2.13)		
1	Checking the paper size Does the using paper size meet the specification?	Go to step 3.	Use the paper that meets the specifications, then go to step 2.
2	Does the error still occur when printing?	Go to step 3.	End of work.
3	Checking the print data, paper (print media) and paper settings Check the followings. - Are the print data and the paper suitable? - Are the paper setting and paper suitable? - Are the paper setting and print data suitable? After checking, correct the incorrect item(s). Does the error still occur when printing?	Go to step 4.	End of work.
4	Reloading a correct paper to SSF Reload a correct paper to fill the paper setup. Does the error still occur when printing?	Replace the PWBA MCU (refer to Removal 43/ Replacement 11), if not, replace the PWBA ESS (refer to Removal 42/ Replacement 12).	End of work.

FIP-1. 38 Load Tray 1 024-965

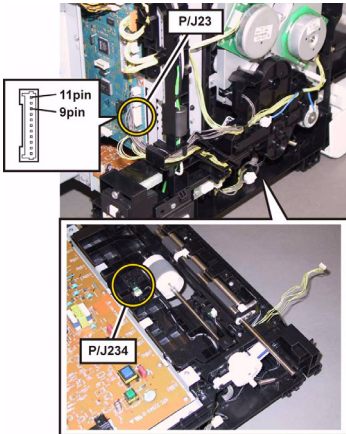
Step	Check	Remedy	
		Yes	No
	Possible causative parts: HARN ASSY L SIDE (PL3.1.18) SENSOR PHOTO (PL3.2.13) ACTUATOR NO PAPER (PL3.2.19) PWBA MCU (PL8.2.13)		
1	Checking the paper for loading and setting Check that the loaded paper meets the print job. Check that the paper setting to require the print job meets the specification. Does the error still occur after reloading the paper and changing the paper settings that requires the print job?	Go to step 2.	End of work.
2	Checking the ACTUATOR NO PAPER for shape and operation Pull the CASSETTE ASSY 250 out. Are the shape and operation of the ACTUATOR NO PAPER normal?	Go to step 3.	Reseat the ACTUATOR NO PAPER. If broken or deformed, replace the ACTUATOR NO PAPER.
3	Checking the Cassette No Paper Sensor (SENSOR PHOTO) for operation Pull the CASSETTE ASSY 250 out. Does the number on the screen increase by one, when the actuator (ACTUATOR NO PAPER) of the Cassette No Paper Sensor (SENSOR PHOTO) is operated? Checked by [Digital Input] - [DI-1] in [IOT Diag] of diagnosis.	Replace the PWBA MCU. (Refer to Removal 43/ Replacement 11.)	Go to step 4.
4	Checking the connectors of the SENSOR PHOTO (Cassette No Paper Sensor) for connection Check the connections between the PWBA MCU and SENSOR PHOTO. Are P/J23 and P/J234 connected correctly? 	Go to step 5.	Reconnect the connector(s) P/J23 and/or P/J234 correctly.
5	Checking the HARN ASSY L SIDE for continuity Disconnect J23 from the PWBA MCU. Disconnect J234 from the SENSOR PHOTO. Is each cable of J23 <=> J234 continuous?	Go to step 6.	Replace the HARN ASSY L SIDE.
6	Checking the power to the SENSOR PHOTO Disconnect J23 from the PWBA MCU. Is the voltage across P23-9pin <=> ground on the PWBA MCU, about +3.3 VDC?	Go to step 7.	Replace the PWBA MCU. (Refer to Removal 43/ Replacement 11.)

Step	Check	Remedy	
		Yes	No
7	Checking the SENSOR PHOTO for operation Check the voltage across J23-11pin <=> ground on the PWBA MCU. Does the voltage change, when the ACTUATOR NO PAPER is operated?	Replace the PWBA MCU. (Refer to Removal 43/ Replacement 11.)	Replace the SENSOR PHOTO.

FIP-1. 39 Load Tray 2 024-966

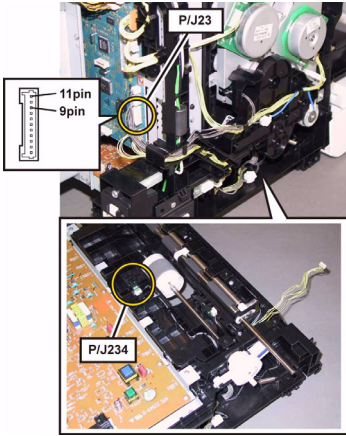
Step	Check	Remedy	
		Yes	No
	Possible causative parts: HARN ASSY OPTION (PL3.1.20) PWBA FEED H (PL12.1.1) HARN ASSY TRAY COMP (PL12.2.20) SENSOR PHOTO (PL12.4.13) ACTUATOR NO PAPER (PL12.4.19)		
1	Checking the paper for loading and setting Check that the loaded paper meets the print job. Check that the paper setting to require the print job meets the specification. Does the error still occur after reloading the paper and changing the paper settings that requires the print job?	Go to step 2.	End of work.
2	Checking the ACTUATOR NO PAPER for shape and operation Pull the CASSETTE ASSY 250 (Option) out. Are the shape and operation of the ACTUATOR NO PAPER normal?	Go to step 3.	Reseat the ACTUATOR NO PAPER. If broken or deformed, replace the ACTUATOR NO PAPER.
3	Checking the Cassette No Paper Sensor (SENSOR PHOTO) for operation Pull the CASSETTE ASSY 250 (Option) out. Does the number on the screen increase by one, when the actuator (ACTUATOR NO PAPER) of the Cassette No Paper Sensor (SENSOR PHOTO) is operated? Checked by [Digital Input] - [DI-9] in [IOT Diag] of diagnosis.	Replace the PWBA MCU. (Refer to Removal 43/ Replacement 11.)	Go to step 4.
4	Checking the connectors of the SENSOR PHOTO (Cassette No Paper Sensor) for connection Check the connections between the PWBA FEED H and SENSOR PHOTO. Are P/J421 and P/J4212 connected correctly? 	Go to step 5.	Reconnect the connector(s) P/J421 and/or P/J4212 correctly.
5	Checking the HARN ASSY TRAY COMP for continuity Disconnect J23 from the PWBA MCU. Disconnect J234 from the SENSOR PHOTO. Is each cable of J421 <=> J4212 continuous?	Go to step 6.	Replace the HARN ASSY TRAY COMP.

Step	Check	Remedy	
		Yes	No
6	Checking the power to the SENSOR PHOTO Disconnect J421 from the PWBA FEED H. Is the voltage across P421-9pin \leftrightarrow ground on the PWBA MCU, about +3.3 VDC?	Go to step 7.	Replace the PWBA FEED H. (Refer to Removal 43/ Replacement 11.)
7	Checking the SENSOR PHOTO for operation Check the voltage across J421-5pin \leftrightarrow ground on the PWBA MCU. Does the voltage change, when the ACTUATOR NO PAPER is operated?	Replace the PWBA FEED H. (Refer to Removal 43/ Replacement 11.)	Replace the SENSOR PHOTO.

FIP-1. 40 Load SSF 024-969 / Pause Feed SSF 024-985 / Check SSF 075-923

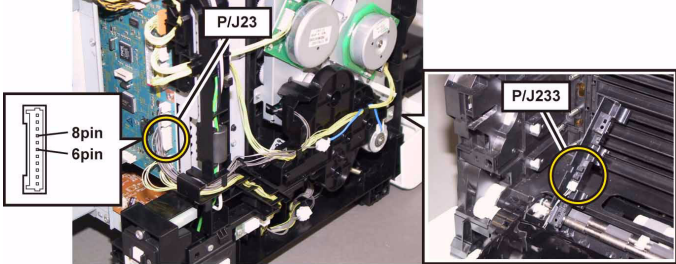
Step	Check	Remedy	
		Yes	No
	Possible causative parts: HARN ASSY L SIDE (PL3.1.18) SENSOR PHOTO (PL3.2.13) ACTUATOR SSI (PL3.2.14) PWBA MCU (PL8.2.13)		
1	Checking the paper for loading and setting Check that the loaded paper meets the print job. Check that the paper setting to require the print job meets the specification. Does the error still occur after reloading the paper and changing the paper settings that requires the print job?	Go to step 2.	End of work.
2	Checking after setting the guide sides of the SSF Reset the guide sides. Does the error still occur when printing?	Go to step 3.	End of work.
3	Checking after reloading a paper to SSF Reload a correct paper to fill the paper setup. Does the error still occur when printing?	Go to step 4.	End of work.
4	Checking the ACTUATOR SSI for shape and operation Remove the CHUTE LOW (PL3.2.27) once to check the shape and operation. Are the shape and operation of the ACTUATOR SSI normal?	Go to step 5.	Reseat the ACTUATOR SSI. If broken or deformed, replace the ACTUATOR SSI.
5	Checking the SSF No Paper Sensor (SENSOR PHOTO) for operation Remove the CHUTE LOW (PL3.2.27) once to check the operation. Does the number on the screen increase by one, when the actuator (ACTUATOR SSI) of the SSF No Paper Sensor (SENSOR PHOTO) is operated? Checked by [Digital Input] - [DI-0] in [IOT Diag] of diagnosis.	Replace the PWBA MCU. (Refer to Removal 43/ Replacement 11.)	Go to step 6.
6	Checking the connectors of the SENSOR PHOTO (SSF No Paper Sensor) for connection Check the connections between the PWBA MCU and SENSOR PHOTO. Are P/J23 and P/J233 connected correctly? 	Go to step 8.	Reconnect the connector(s) P/J23 and/or P/J233 correctly, then go to step 7.
7	Does the error still occur when printing?	Go to step 8.	End of work.
8	Checking the HARN ASSY L SIDE for continuity Disconnect J23 from the PWBA MCU. Disconnect J233 from the SENSOR PHOTO. Is each cable of J23 <=> J233 continuous?	Go to step 9.	Replace the HARN ASSY L SIDE.

Step	Check	Remedy	
		Yes	No
9	<p>Checking the power to the SENSOR PHOTO Disconnect J23 from the PWBA MCU. Is the voltage across P23-6pin \leftrightarrow ground on the PWBA MCU, about +3.3 VDC?</p>	Go to step 10.	Replace the PWBA MCU. (Refer to Removal 43/ Replacement 11.)
10	<p>Checking the SENSOR PHOTO for operation Check the voltage across J23-8pin \leftrightarrow ground on the PWBA MCU. Remove the CHUTE LOW (PL3.2.27) once to check the operation. Does the voltage change, when the ACTUATOR SSI is operated?</p>	Replace the PWBA MCU. (Refer to Removal 43/ Replacement 11.)	Replace the SENSOR PHOTO.

FIP-1. 41 Over Heat 042-700

Step	Check	Remedy	
		Yes	No
	Possible causative parts: PWBA MCU (PL8.2.13)		
1	Checking the printer after cool down Does the error occur when printing after the printer has cooled down for five minutes?	Go to step 2.	End of work.
2	Checking the PWBA MCU for installation Reseat the PWBA MCU. Does the error still occur when printing?	Replace the PWBA MCU. (Refer to Removal 43/ Replacement 11.)	End of work.

FIP-1. 42 Paper Jam 071-100

Step	Check	Remedy	
		Yes	No
	Possible causative parts: CASSETTE ASSY 250 (PL2.1.1) HOLDER ASSY SEPARATOR (PL2.1.5) CLUTCH ASSY DRV (PL3.1.1) SOLENOID FEED MSI (PL3.1.11) HARN ASSY L SIDE (PL3.1.18) ROLL ASSY FEED (PL3.2.4) ACTUATOR REGI ROLL (PL3.2.8) ACTUATOR REGI IN (PL3.2.11) SENSOR PHOTO (PL3.2.13) DRIVE ASSY MAIN (PL7.1.2) DRIVE ASSY PH (PL7.1.4) PWBA MCU (PL8.2.13) HARN ASSY MAIN MOT (PL9.1.7) HARN ASSY KSNR REGCL (PL9.1.9)		
1	Checking the paper condition Is the paper in the Tray 1 wrinkled or damaged?	Replace the paper with a new and dry one, then go to step 2.	Go to step 3.
2	Does the error still occur when printing?	Go to step 3.	End of work.
3	Checking after reloading a new paper Reload a new paper in the Tray 1. Does the error still occur when printing?	Go to step 4.	End of work.
4	Checking the COVER ASSY FRONT for latching Open and close the COVER ASSY FRONT, and then latch correctly. Does the error still occur when printing?	Go to step 5.	End of work.
5	Checking the Main Motor (DRIVE ASSY MAIN) for operation Does the Main Motor (DRIVE ASSY MAIN) operate properly? Checked by [Digital Output] - [DO-16] in [IOT Diag] of diagnosis. During this check, close the COVER ASSY FRONT.	Go to step 6.	Go to step 19.
6	Checking the DRIVE ASSY PH for operation Does the ROLL ASSY FEED, ROLL ASSY REGI and ROLL REGI METAL rotate properly? Checke by [Digital Output] - [DO-16] in [IOT Diag] of diagnosis. During this check, cheat the interlock switch (HARN ASSY INTERLOCK).	Go to step 7.	Reseat or replace the DRIVE ASSY PH. (Refer to Removal 31/ Replacement 23.)
7	Checking the paper feeding position Is the paper not fed from the Tray 1?	Go to step 8.	Go to step 12.
8	Checking after resetting the Guide Sides and End Guide on the Tray 1 Reset the Guide Sides and End Guide, and reseal the Tray 1 to the printer correctly. Does the error still occur when printing?	Go to step 9.	End of work.

Step	Check	Remedy	
		Yes	No
9	Checking the HOLDER ASSY SEPARATOR on the Tray 1 for shape and rotation Pull the Tray 1 out from the printer. Is the SEPARATOR ROLLER ASSEMBLY not contaminated and/or damaged, and rotated smoothly?	Go to step 10.	Replace the HOLDER ASSY SEPARATOR. (Refer to Removal 2/ Replacement 52.)
10	Checking the ROLL ASSY FEED for shape and rotation Pull the Tray 1 out from the printer. Is the ROLL ASSY FEED not contaminated and/or damaged, and rotated smoothly?	Go to step 11.	Replace the ROLL ASSY FEED. (Refer to Removal 9/ Replacement 45.)
11	Checking the Cassette Feed Solenoid (SOLENOID FEED MSI) for operation Does the Cassette Feed Solenoid (SOLENOID FEED MSI) operate properly? Check by [Digital Output] - [DO-13] in [CE Diag] tab of [CE Diag]. During this check, cheat the interlock switch (HARN ASSY INTERLOCK).	Replace the CASSETTE ASSY 250. (Refer to Removal 58/ Replacement 58.)	Go to step 22.
12	Checking the paper lead edge staying position Does the paper lead edge stay before the ROLL ASSY REGI and ROLL REGI METAL?	Go to step 13.	The paper lead edge stay after the ROLL ASSY REGI and ROLL REGI METAL, then go to step 16.
13	Checking the paper transfer path between the ROLL ASSY FEED and ROLL ASSY REGI. Are there any obstacles on the paper transfer path?	Remove the obstacles or stains from the paper transfer path.	Go to step 14.
14	Checking the ACTUATOR REGI IN for shape and operation Remove the CHUTE LOW (PL3.2.27) once to check the shape and operation. Are the shape and operation of the ACTUATOR REGI IN normal?	Go to step 15.	Reseat the ACTUATOR REGI IN. If broken or deformed, replace it.
15	Checking the Regi. Sensor (SENSOR PHOTO) for operation Does the number on the screen increase by one, when the actuator (ACTUATOR REGI IN) is operated? Remove the CHUTE LOW (PL3.2.27) once to check the operation. Checked by [Digital Input] - [DO-16] in [IOT Diag] of diagnosis.	Go to step 16.	Go to step 26.
16	Checking the Regi. Clutch (CLUTCH ASSY DRV) for operation, and ROLL ASSY REGI and ROLL REGI METAL for rotation Enter the [Digital Output] - [DO-0] in [CE Diag] tab, and then enter the [Digital Output] - [DO-27] in [CE Diag] tab of [CE Diag]. Does the Regi. Clutch (CLUTCH ASSY DRV) operate properly, and the ROLL ASSY REGI and ROLL REGI METAL rotate? During this check, cheat the interlock switch (HARN ASSY INTERLOCK).	Go to step 17.	Go to step 30.

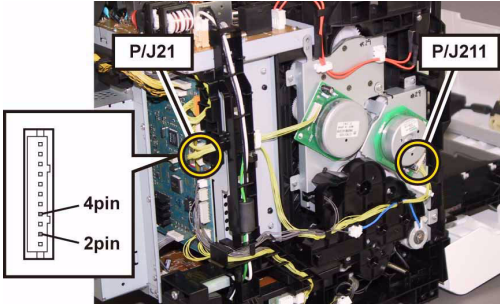
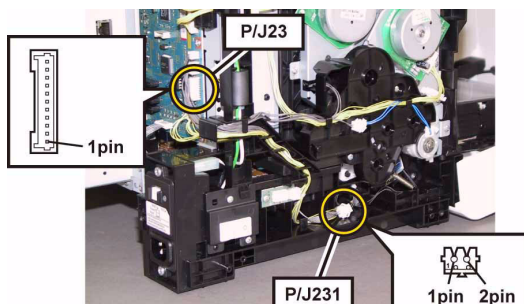
Step	Check	Remedy	
		Yes	No
17	<p>Checking the ACTUATOR REGI ROLL for shape and operation Remove the CHUTE LOW (PL3.2.27) once to check the shape and operation. Are the shape and operation of the ACTUATOR REGI ROLL normal?</p>	Go to step 18.	Reseat the ACTUATOR REGI ROLL. If broken or deformed, replace it with a new one.
18	<p>Checking the Regi. Sensor (SENSOR PHOTO) for operation Does the number on the screen increase by one, when the actuator (ACTUATOR REGI IN) is operated? Remove the CHUTE LOW (PL3.2.27) once to check the operation. Checked by [Digital Input] - [DO-16] in [IOT Diag] of diagnosis.</p>	Replace the PWBA MCU. (Refer to Removal 43/ Replacement 11.)	Go to step 26.
19	<p>Checking the connectors for connection Check the connections between the PWBA MCU and DRIVE ASSY MAIN (Main Motor). Are P/J21 and P/J211 connected correctly?</p> 	Go to step 20.	Reconnect the connector(s) P/J21 and/or P/J211 correctly.
20	<p>Checking the HARN ASSY MAIN MOT for continuity Disconnect J21 from the PWBA MCU. Disconnect J211 from the DRIVE ASSY MAIN. Is each cable of J21 <=> J211 continuous?</p>	Go to step 21.	Replace the HARN ASSY MAIN MOT.
21	<p>Checking the power to the DRIVE ASSY MAIN Disconnect J21 from the PWBA MCU. Are the voltages across J21-2pin/J21-4pin <=> ground on the PWBA MCU, about +24 VDC when the interlock switch (HARN ASSY INTERLOCK) is pushed?</p>	Replace the DRIVE ASSY MAIN. (Refer to Removal 32/ Replacement 22.)	Replace the PWBA MCU. (Refer to Removal 43/ Replacement 11.)
22	<p>Checking the connectors of the SOLENOID FEED MSI (Cassette Feed Solenoid) for connection Check the connections between the PWBA MCU and SOLENOID FEED MSI. Are P/J23 and P/J231 connected correctly?</p> 	Go to step 23.	Reconnect the connector(s) P/J23 and/or P/J231 correctly.

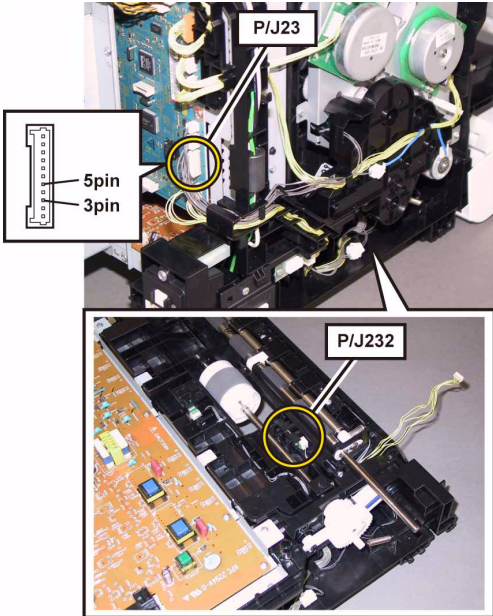
Step	Check	Remedy	
		Yes	No
23	Checking the HARN ASSY L SIDE for continuity Disconnect J23 from the PWBA MCU. Disconnect P231 from the SOLENOID FEED MSI. Is each cable of J23 <=> P231 continuous?	Go to step 24.	Replace the HARN ASSY L SIDE.
24	Checking the power to the SOLENOID FEED MSI Disconnect J23 from the PWBA MCU. Is the voltage across P23-1pin <=> ground on the PWBA MCU, about +24 VDC when the Interlock Switch (HARN ASSY INTERLOCK) is pushed?	Go to step 25.	Replace the PWBA MCU. (Refer to Removal 43/ Replacement 11.)
25	Checking the SOLENOID FEED MSI for resistance Disconnect P/J231 of the SOLENOID FEED MSI. Is the resistance across J231-1 and J231-2 about 96 ohm?	Replace the PWBA MCU. (Refer to Removal 43/ Replacement 11.)	Replace the SOLENOID FEED MSI. (Refer to Removal 35/ Replacement 19.)
26	Checking the connectors of the SENSOR PHOTO (Regi Sensor) for connection Check the connections between the PWBA MCU and SENSOR PHOTO. Are P/J23 and P/J232 connected correctly? 	Go to step 27.	Reconnect the connector(s) P/J23 and/or P/J232 correctly.
27	Checking the HARN ASSY L SIDE for continuity Disconnect J23 from the PWBA MCU. Disconnect J232 from the SENSOR PHOTO. Is each cable of J23 <=> J232 continuous?	Go to step 28.	Replace the HARN ASSY L SIDE.
28	Checking the power to the SENSOR PHOTO Disconnect J23 from the PWBA MCU. Is the voltage across P23-3pin <=> ground on the PWBA MCU, about +3.3 VDC?	Go to step 29.	Replace the PWBA MCU. (Refer to Removal 43/ Replacement 11.)
29	Checking the SENSOR PHOTO for operation Check the voltage across J23-5pin <=> ground on the PWBA MCU. Remove the CHUTE LOW (PL3.2.27) once to check the operation. Does the voltage change, when the actuator (ACTUATOR REGI IN) is operated?	Replace the PWBA MCU. (Refer to Removal 43/ Replacement 11.)	Replace the SENSOR PHOTO.

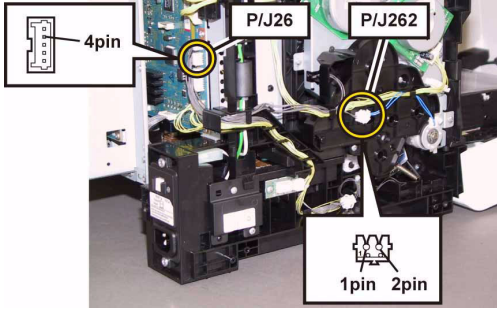
Step	Check	Remedy	
		Yes	No
30	<p>Checking the connectors of the CLUTCH ASSY DRV (Regi Clutch) for connection Check the connections between the PWBA MCU and CLUTCH ASSY DRV. Are P/J26 and P/J262 connected correctly?</p> 	Go to step 31.	Reconnect the connector(s) P/J26 and/or P/J262 correctly.
31	<p>Checking the HARN ASSY KSNR REGCL for continuity Disconnect J26 from the PWBA MCU. Disconnect P262 from the CLUTCH ASSY DRV. Is each cable of J26 <=> P262 continuous?</p>	Go to step 32.	Replace the HARN ASSY KSNR REGCL.
32	<p>Checking the power to the CLUTCH ASSY DRV Disconnect J26 from the PWBA MCU. Is the voltage across P26-4pin <=> ground on the PWBA MCU, about +24 VDC when the Interlock Switch (HARN ASSY INTERLOCK) is pushed?</p>	Go to step 33.	Replace the PWBA MCU. (Refer to Removal 43/ Replacement 11.)
33	<p>Checking the CLUTCH ASSY DRV for resistance Disconnect P/J262 of the CLUTCH ASSY DRV. Is the resistance across J262-1 and J262-2 approximately 280-ohm?</p>	Replace the PWBA MCU. (Refer to Removal 43/ Replacement 11.)	Replace the CLUTCH ASSY DRV. (Refer to Removal 30/ Replacement 24.)

FIP-1. 43 Paper Jam 072-100 / Paper Jam 072-908

Step	Check	Remedy	
		Yes	No
	Possible causative parts: PWBA MCU (PL8.2.13) HARN ASSY TEAY MOT (PL12.2.2) CLUTCH ASSY DRV (PL12.2.6) MOTOR ASSY SUB (PL12.2.16) ROLL ASSY FFED (PL12.4.4) SENSOR PHOTO (12.4.13) CASSETTE ASSY 250 OPT (PL12.5.1) HOLDER ASSY SEPARATOR (12.5.5)		
1	Checking the paper condition Is the paper in the Tray 2 wrinkled or damaged?	Replace the paper with a new and dry one, then go to step 2.	Go to step 3.
2	Does the error still occur when printing?	Go to step 3.	End of work.
3	Checking after reloading a new paper Reload a new paper in the Tray 2. Does the error still occur when printing?	Go to step 4.	End of work.
4	Checking the COVER ASSY FRONT for latching Open and close the COVER ASSY FRONT, and then latch correctly. Does the error still occur when printing?	Go to step 5.	End of work.
5	Checking the Paper Path Sensor (SENSOR PHOTO) for operation Does the number on the screen increase by one, when the actuator (ACTUATOR REGI IN) is operated? Checked by [Digital Input] - [DI-A] in [IOT Diag] of diagnosis.	Go to step 6.	Go to step 15.
6	Checking the MOTOR ASSY SUB for operation Does the MOTOR ASSY SUB operate properly? Checked by [Digital Output]-[DO-17] on [IOT Diag] of diagnosis. During this check, cheat the interlock switch (HARN ASSY INTERLOCK).	Go to step 7.	Go to step 19.
7	Checking the paper feeding Is the paper fed from the Tray 2?	Go to step 12.	Go to step 8.
8	Checking after resetting the Guide Sides and End Guide on the Tray 2 Reset the Guide Sides and End Guide, and reseal the Tray2 to the printer correctly. Does the error still occur when printing?	Go to step 9.	End of work.
9	Checking the HOLDER ASSY SEPARATOR on the Tray 2 for shape and rotation Pull the Tray 1 out from the printer. Is the HOLDER ASSY SEPARATOR not contaminated and/or damaged, and rotated smoothly?	Go to step 10.	Replace the HOLDER ASSY SEPARATOR. (Refer to Removal 39/ Replacement 15.)
10	Checking the ROLL ASSY FEED for shape and rotation Pull the Tray 1 out from the printer. Is the ROLL ASSY FEED not contaminated and/or damaged, and rotated smoothly?	Go to step 11.	Replace the ROLL ASSY FEED. (Refer to Removal 9/ Replacement 45.)

Step	Check	Remedy	
		Yes	No
11	Checking the Cassette Feed Solenoid (SOLENOID FEED) for operation Does the Cassette Feed Solenoid (SOLENOID FEED) operate properly? Checked by [Digital Output] - [DO-31] in [IOT Diag] of diagnosis. During this check, cheat the interlock switch (HARN ASSY INTERLOCK).	Replace the CASSETTE ASSY 250 OPT.	Go to step 22.
12	Checking the Feed Clutch (CLUTCH ASSY DRV) for operation Does the Cassette Feed Clutch (CLUTCH ASSY DRV) operate properly? Checked by [Digital Output] - [DO-33] in [IOT Diag] of diagnosis. During this check, cheat the interlock switch (HARN ASSY INTERLOCK).	Go to step 13.	Go to step 26.
13	Checking the paper lead edge staying position Does the paper lead edge stay before the ROLL ASSY REGI and ROLL REGI METAL?	Go to step 14.	Replace the FEEDER ASSY OPT.
14	Checking the paper path Remove the Tray 1 and Tray 2 paper cassettes. Are there any obstacles on the paper transfer path between the Tray 2 and the Regi Assy?	Remove the obstacles or stains from the paper transfer path.	Replace the FEEDER ASSY OPT.
15	Checking the connectors of the SENSOR PHOTO (Paper Path Sensor) for connection Check the connections between the PWBA FFE D and SENSOR PHOTO. Are P/J420 and P/J4200 connected correctly?	Go to step 16.	Reconnect the connector(s) P/J420 and/or P/J4200 correctly.
16	Checking the HARN ASSY TRAY COMP for continuity Disconnect J420 from the PWBA FEED H. Disconnect J4200 from the SENSOR PHOTO. Is each cable of J420 <=> J4200 continuous?	Go to step 17.	Replace the HARN ASSY TRAY COMP
17	Checking the power to the SENSOR PHOTO Disconnect J420 from the PWBA FEED H. Is the voltage across P420-6pin <=> ground on the PWBA FEED H, about +3.3 VDC?	Go to step 18.	Replace the PWBA FEED H.
18	Checking the SENSOR PHOTO for operation Check the voltage across J420-5pin <=> ground on the PWBA FEED H. Does the voltage change, when the actuator (ACTUATOR REGI IN) is operated?	Replace the PWBA FEED H.	Replace the SENSOR PHOTO (Paper Path Sensor).
19	Checking the connectors for connection Check the connections between the PWBA FEED H and MOTOR ASSY SUB. Are P/J422 and P/J211 connected correctly?	Go to step 20.	Reconnect the connector(s) P/J422 and/or P/J211 correctly.
20	Checking the HARN ASSY TEAY MOT for continuity Disconnect J422 from the PWBA FEED H. Disconnect J211 from the MOTOR ASSY SUB. Is each cable of J422 <=> J211 continuous?	Go to step 21.	Replace the HARN ASSY TRAY MOT.
21	Checking the power to the MOTOR Disconnect J422 from the PWBA FEED H. Are the voltages across J422-6pin <=> ground on the PWBA FEED H, about +24 VDC when the interlock switch (HARN ASSY INTERLOCK) is pushed?	Replace the MOTOR ASSY SUB.	Replace the PWBA FEED H.

Step	Check	Remedy	
		Yes	No
22	Checking the connectors of the SOLENOID FEED for connection Check the connections between the PWBA FEED H and SOLENOID FEED. Are P/J421 and P/J4231 connected correctly?	Go to step 23.	Reconnect the connector(s) P/J421 and/or P/J4213 correctly.
23	Checking the HARN TRAY COMP for continuity Disconnect J421 from the PWBA FEED H. Disconnect P4213 from the SOLENOID FEED. Is each cable of J421 <=> P4213 continuous?	Go to step 24.	Replace the HARN ASSY TRAY COMP.
24	Checking the power to the SOLENOID FEED Disconnect J421 from the PWBA FEED H. Is the voltage across P421-1pin <=> ground on the PWBA FEED H, about +24 VDC when the Interlock Switch (HARN ASSY INTERLOCK) is pushed?	Go to step 25.	Replace the PWBA FEED H.
25	Checking the SOLENOID FEED for resistance Disconnect P/J4213 of the SOLENOID FEED. Is the resistance across J4213-1 and J4213-2 approximately 96 ohm?	Replace the PWBA FEED H.	Replace the SOLENOID FEED. (Refer to Removal 35/ Replacement 19.)
26	Checking the connectors of the Feed Clutch (CLUTCH ASSY DRV) for connection Check the connections between the PWBA FEED H and Feed Clutch. Are P/J420 and P/J4201 connected correctly?	Go to step 27.	Reconnect the connector(s) P/J420 and/or P/J4201 correctly.
27	Checking the HARN TRAY COMP for continuity Disconnect J420 from the PWBA FEED H. Disconnect P4201 from the Feed Clutch. Is each cable of J420 <=> P4201 continuous?	Go to step 28.	Replace the HARN ASSY TRAY COMP.
28	Checking the power to the Feed Clutch Disconnect J420 from the PWBA FEED H. Is the voltage across P420-1pin <=> ground on the PWBA FEED H, about +24 VDC when the Interlock Switch (HARN ASSY INTERLOCK) is pushed?	Go to step 29.	Replace the PWBA FEED H.
29	Checking the Feed Clutch for resistance Disconnect P/J4201 of the Feed Clutch. Is the resistance across J4201-1 and J4201-2 approximately 280-ohm?	Replace the PWBA FEED H.	Replace the Feed Clutch (CLUTCH ASSY DRV). (Refer to Removal 30/ Replacement 24.)

FIP-1. 44 Paper Jam 072-101

Step	Check	Remedy	
		Yes	No
	Possible causative parts: CASSETTE ASSY 250 (PL2.1.1) HOLDER ASSY SEPARATOR (PL2.1.5) CLUTCH ASSY DRV (PL3.1.1) SOLENOID FEED MSI (PL3.1.11) HARN ASSY L SIDE (PL3.1.18) ROLL ASSY FEED (PL3.2.4) ACTUATOR REGI ROLL (PL3.2.8) ACTUATOR REGI IN (PL3.2.11) SENSOR PHOTO (PL3.2.13) DRIVE ASSY MAIN (PL7.1.2) DRIVE ASSY PH (PL7.1.4) PWBA MCU (PL8.2.13) HARN ASSY MAIN MOT (PL9.1.7) HARN ASSY KSNR REGCL (PL9.1.9)		
1	Checking the paper condition Is the paper in the Tray 1 or Tray 2 wrinkled or damaged?	Replace the paper with a new and dry one, then go to step 2.	Go to step 3.
2	Does the error still occur when printing?	Go to step 3.	End of work.
3	Checking after reloading a new paper Reload a new paper in the Tray 1 or Tray 2. Does the error still occur when printing?	Go to step 4.	End of work.
4	Checking the COVER ASSY FRONT for latching Open and close the COVER ASSY FRONT, and then latch correctly. Does the error still occur when printing?	Go to step 5.	End of work.
5	Checking the Main Motor (DRIVE ASSY MAIN) for operation Does the Main Motor (DRIVE ASSY MAIN) operate properly? Checked by [Digital Output] - [MAIN MOTOR ON] in [CE Diag] tab of [CE Diag]. During this check, cheat the interlock switch (HARN ASSY INTERLOCK).	Go to step 6.	Go to step 19.
6	Checking the DRIVE ASSY PH for operation Does the ROLL ASSY FEED, ROLL ASSY REGI and ROLL REGI METAL rotate properly? Checke by [Digital Output] - [CASSETTE1 FEED SOLENOID ON(Half Rotation)] in [CE Diag] tab of [CE Diag]. During this check, cheat the interlock switch (HARN ASSY INTERLOCK).	Go to step 7.	Reseat or replace the DRIVE ASSY PH. (Refer to Removal 31/ Replacement 23.)
7	Checking the paper feeding position Is the paper not fed from the Tray 1 or Tray 2?	Go to step 8.	Go to step 12.
8	Checking after resetting the Guide Sides and End Guide on the Tray 1 or Tray 2. Reset the Guide Sides and End Guide, and reseal the Tray 1 or Tray 2 to the printer correctly. Does the error still occur when printing?	Go to step 9.	End of work.

Step	Check	Remedy	
		Yes	No
9	Checking the HOLDER ASSY SEPARATOR on the Tray 1 or Tray 2 for shape and rotation Pull the Tray 1 or Tray 2 out from the printer. Is the SEPARATOR ROLLER ASSEMBLY not contaminated and/or damaged, and rotated smoothly?	Go to step 10.	Replace the HOLDER ASSY SEPARATOR. (Refer to Removal 2/ Replacement 52.)
10	Checking the ROLL ASSY FEED for shape and rotation Pull the Tray 1 or Tray 2 out from the printer. Is the ROLL ASSY FEED not contaminated and/or damaged, and rotated smoothly?	Go to step 11.	Replace the ROLL ASSY FEED. (Refer to Removal 9/ Replacement 45.)
11	Checking the Cassette Feed Solenoid (SOLENOID FEED MSI) for operation Does the Cassette Feed Solenoid (SOLENOID FEED MSI) operate properly? Check by [Digital Output] - [CASSETTE1 FEED SOLENOID ON(Auto OFF)] in [CE Diag] tab of [CE Diag]. During this check, cheat the interlock switch (HARN ASSY INTERLOCK).	Replace the CASSETTE ASSY 250. (Refer to Removal 58/ Replacement 58.)	Go to step 22.
12	Checking the paper lead edge staying position Does the paper lead edge stay before the ROLL ASSY REGI and ROLL REGI METAL?	Go to step 13.	The paper lead edge stay after the ROLL ASSY REGI and ROLL REGI METAL, then go to step 16.
13	Checking the paper transfer path between the ROLL ASSY FEED and ROLL ASSY REGI. Are there any obstacles on the paper transfer path?	Remove the obstacles or stains from the paper transfer path.	Go to step 14.
14	Checking the ACTUATOR REGI IN for shape and operation Remove the CHUTE LOW (PL3.2.27) once to check the shape and operation. Are the shape and operation of the ACTUATOR REGI IN normal?	Go to step 15.	Reseat the ACTUATOR REGI IN. If broken or deformed, replace it.
15	Checking the Regi. Sensor (SENSOR PHOTO) for operation Does the number on the screen increase by one, when the actuator (ACTUATOR REGI IN) is operated? Remove the CHUTE LOW (PL3.2.27) once to check the operation. Checked by [Digital Input] - [REG SNR] in [CE Diag] tab of [CE Diag].	Go to step 16.	Go to step 26.
16	Checking the Regi. Clutch (CLUTCH ASSY DRV) for operation, and ROLL ASSY REGI and ROLL REGI METAL for rotation Enter the [Digital Output] - [MAIN MOTOR ON] in [CE Diag] tab, and then enter the [Digital Output] - [REGI CLUTCH ON] in [CE Diag] tab of [CE Diag]. Does the Regi. Clutch (CLUTCH ASSY DRV) operate properly, and the ROLL ASSY REGI and ROLL REGI METAL rotate? During this check, cheat the interlock switch (HARN ASSY INTERLOCK).	Go to step 17.	Go to step 30.

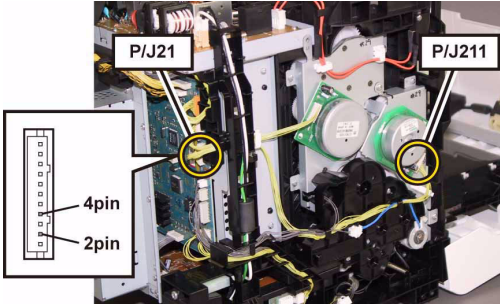
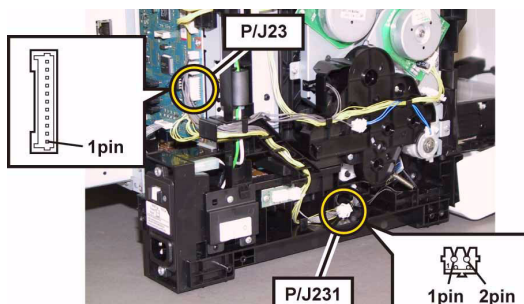
Step	Check	Remedy	
		Yes	No
17	<p>Checking the ACTUATOR REGI ROLL for shape and operation Remove the CHUTE LOW (PL3.2.27) once to check the shape and operation. Are the shape and operation of the ACTUATOR REGI ROLL normal?</p>	Go to step 18.	Reseat the ACTUATOR REGI ROLL. If broken or deformed, replace it with a new one.
18	<p>Checking the Regi. Sensor (SENSOR PHOTO) for operation Does the number on the screen increase by one, when the actuator (ACTUATOR REGI IN) is operated? Remove the CHUTE LOW (PL3.2.27) once to check the operation. Checked by [Digital Input] - [REG SNR] in [CE Diag] tab of [CE Diag].</p>	Replace the PWBA MCU. (Refer to Removal 43/ Replacement 11.)	Go to step 26.
19	<p>Checking the connectors for connection Check the connections between the PWBA MCU and DRIVE ASSY MAIN (Main Motor). Are P/J21 and P/J211 connected correctly?</p> 	Go to step 20.	Reconnect the connector(s) P/J21 and/or P/J211 correctly.
20	<p>Checking the HARN ASSY MAIN MOT for continuity Disconnect J21 from the PWBA MCU. Disconnect J211 from the DRIVE ASSY MAIN. Is each cable of J21 <=> J211 continuous?</p>	Go to step 21.	Replace the HARN ASSY MAIN MOT.
21	<p>Checking the power to the DRIVE ASSY MAIN Disconnect J21 from the PWBA MCU. Are the voltages across J21-2pin/J21-4pin <=> ground on the PWBA MCU, about +24 VDC when the interlock switch (HARN ASSY INTERLOCK) is pushed?</p>	Replace the DRIVE ASSY MAIN. (Refer to Removal 32/ Replacement 22.)	Replace the PWBA MCU. (Refer to Removal 43/ Replacement 11.)
22	<p>Checking the connectors of the SOLENOID FEED MSI (Cassette Feed Solenoid) for connection Check the connections between the PWBA MCU and SOLENOID FEED MSI. Are P/J23 and P/J231 connected correctly?</p> 	Go to step 23.	Reconnect the connector(s) P/J23 and/or P/J231 correctly.

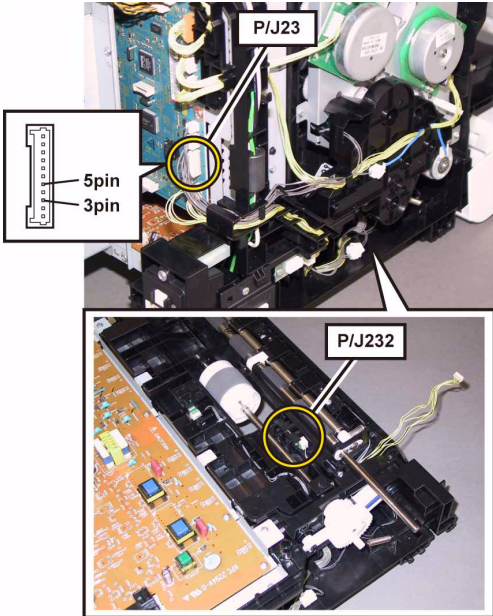
Step	Check	Remedy	
		Yes	No
23	Checking the HARN ASSY L SIDE for continuity Disconnect J23 from the PWBA MCU. Disconnect P231 from the SOLENOID FEED MSI. Is each cable of J23 <=> P231 continuous?	Go to step 24.	Replace the HARN ASSY L SIDE.
24	Checking the power to the SOLENOID FEED MSI Disconnect J23 from the PWBA MCU. Is the voltage across P23-1pin <=> ground on the PWBA MCU, about +24 VDC when the Interlock Switch (HARN ASSY INTERLOCK) is pushed?	Go to step 25.	Replace the PWBA MCU. (Refer to Removal 43/ Replacement 11.)
25	Checking the SOLENOID FEED MSI for resistance Disconnect P/J231 of the SOLENOID FEED MSI. Is the resistance across J231-1 and J231-2 about 96 ohm?	Replace the PWBA MCU. (Refer to Removal 43/ Replacement 11.)	Replace the SOLENOID FEED MSI. (Refer to Removal 35/ Replacement 19.)
26	Checking the connectors of the SENSOR PHOTO (Regi Sensor) for connection Check the connections between the PWBA MCU and SENSOR PHOTO. Are P/J23 and P/J232 connected correctly? 	Go to step 27.	Reconnect the connector(s) P/J23 and/or P/J232 correctly.
27	Checking the HARN ASSY L SIDE for continuity Disconnect J23 from the PWBA MCU. Disconnect J232 from the SENSOR PHOTO. Is each cable of J23 <=> J232 continuous?	Go to step 28.	Replace the HARN ASSY L SIDE.
28	Checking the power to the SENSOR PHOTO Disconnect J23 from the PWBA MCU. Is the voltage across P23-3pin <=> ground on the PWBA MCU, about +3.3 VDC?	Go to step 29.	Replace the PWBA MCU. (Refer to Removal 43/ Replacement 11.)
29	Checking the SENSOR PHOTO for operation Check the voltage across J23-5pin <=> ground on the PWBA MCU. Remove the CHUTE LOW (PL3.2.27) once to check the operation. Does the voltage change, when the actuator (ACTUATOR REGI IN) is operated?	Replace the PWBA MCU. (Refer to Removal 43/ Replacement 11.)	Replace the SENSOR PHOTO.

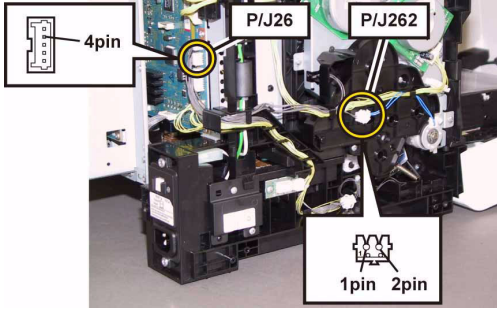
Step	Check	Remedy	
		Yes	No
30	<p>Checking the connectors of the CLUTCH ASSY DRV (Regi Clutch) for connection Check the connections between the PWBA MCU and CLUTCH ASSY DRV. Are P/J26 and P/J262 connected correctly?</p> 	Go to step 31.	Reconnect the connector(s) P/J26 and/or P/J262 correctly.
31	<p>Checking the HARN ASSY KSNR REGCL for continuity Disconnect J26 from the PWBA MCU. Disconnect P262 from the CLUTCH ASSY DRV. Is each cable of J26 <=> P262 continuous?</p>	Go to step 32.	Replace the HARN ASSY KSNR REGCL.
32	<p>Checking the power to the CLUTCH ASSY DRV Disconnect J26 from the PWBA MCU. Is the voltage across P26-4pin <=> ground on the PWBA MCU, about +24 VDC when the Interlock Switch (HARN ASSY INTERLOCK) is pushed?</p>	Go to step 33.	Replace the PWBA MCU. (Refer to Removal 43/ Replacement 11.)
33	<p>Checking the CLUTCH ASSY DRV for resistance Disconnect P/J262 of the CLUTCH ASSY DRV. Is the resistance across J262-1 and J262-2 approximately 280-ohm?</p>	Replace the PWBA MCU. (Refer to Removal 43/ Replacement 11.)	Replace the CLUTCH ASSY DRV. (Refer to Removal 30/ Replacement 24.)

FIP-1. 45 Paper Jam 075-101

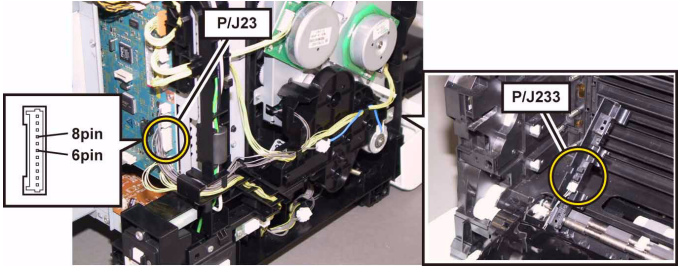
Step	Check	Remedy	
		Yes	No
	Possible causative parts: HARNASS ASSY L SIDE (PL3.1.18) SENSOR PHOTO (PL3.2.13) PWBA MCU (PL8.2.13)		
1	Checking the customer operation Did the customer insert the paper to the SSF during print?	After print completion, insert the paper to the SSF.	Go to step 2.
2	Checking the SSF No Paper Sensor for operation Does the number on the screen increase by one, when the actuator (ACTUATOR SSI) is operated by paper. Checked by [Digital Input] - [DO-0] in [IOT Diag] of diagnosis.	Go to step 3.	Go to step 4.
3	Checking the error Does the error still occur when printing?	Replace the PWBA MCU. (Refer to Removal 43/Replacement 11)	End of work.
4	Checking the connectors of the SENSOR PHOTO Paper Sensor) for connection Check the connections between the PWBA MCU and SENSOR PHOTO. Are P/J23 and P/J233 connected correctly? 	Go to step 6.	Reconnect the connector(s) P/J23 and/or P/J233 correctly, then go to step 5.
5	Does the error still occur when printing?	Go to step 6.	End of work.
6	Checking the HARN ASSY L SIDE for continuity Disconnect J23 from the PWBA MCU. Disconnect J23 from the SENSOR PHOTO. Is each cable of J23 <=> J233 continuous?	Go to step 7.	Replace the HARN ASSY L SIDE.
7	Checking the power to the SENSOR PHOTO Disconnect J23 from the PWBA MCU. Is the voltage across P23-6pin <=> ground on the PWBA MCU, about +3.3 VDC?	Go to step 8.	Replace the PWBA MCU. (Refer to Removal 43/Replacement 11)
8	Checking the SENSOR PHOTO for operation Check the voltage across J23-8pin <=> ground on the PWBA MCU. Remove the CHUTE LOW (PL3.2.27) once to check the operation. Does the voltage change, when the ACTUATOR SSI is operated?	Replace the PWBA MCU. (Refer to Removal 43/ Replacement 11.)	Replace the SENSOR PHOTO.

FIP-1. 46 Paper Jam 075-102

Step	Check	Remedy	
		Yes	No
	Possible causative parts: HARN ASSY L SIDE (PL3.1.18) ROLL ASSY REGI (PL3.2.9) ROLL REGI METAL (PL3.2.10) SENSOR PHOTO (PL3.2.13) ACTUATOR SSI (PL3.2.14) SPRING REGI R M (PL3.2.24) SPRING REGI L M (PL3.2.29) PWBA MCU (PL8.2.13)		
1	Was a paper pulled out from SSF forcibly of a print start?	Go to step 2.	Go to step 3.
2	Checking the printing Reload a paper to SSF. Does the error still occur when printing?	Go to step 3.	End of work.
3	Checking after opening and closing the COVER ASSY FRONT Open and close the COVER ASSY FRONT, and then latch correctly. Does the error still occur when the power is turned OFF and ON?	Go to step 4.	End of work.
4	Checking the ROLL ASSY REGI and ROLL REGI METAL for shape and operation Remove the PHD ASSY once to check the followings. Are ROLL ASSY REGI and ROLL REGI METAL seated correctly? Are they not contaminated and/or damaged, and rotated smoothly? Check these items by turning with your finger.	Go to step 5.	Clean or replace the defective ROLL(s).
5	Checking the ROLL ASSY REGI and ROLL REGI METAL for contacting Is the ROLL REGI METAL surely contacted with the ROLL ASSY REGI by the spring force on both sides of the ROLL REGI METAL? Check this item with your finger.	Go to step 6.	Replace the SPRING REGI R M and/or SPRING REGI L M.
6	Checking the ACTUATOR SSI for shape and operation Remove the CHUTE LOW (PL3.2.27) once to check the operation. Are the shape and operation of the ACTUATOR SSI normal?	Go to step 7.	Reseat the ACTUATOR SSI. If broken or damaged, replace the ACTUATOR SSI.
7	Checking the SSF No Paper Sensor (SENSOR PHOTO) for operation Remove the CHUTE LOW (PL3.2.27) once to check the operation. Does the number on the screen increase by one, when the actuator (ACTUATOR SSI) of the SSF No Paper Sensor (SENSOR PHOTO) is operated? Checked by [Digital Input] - [DO-0] in [IOT Diag] of diagnosis.	Replace the PWBA MCU. (Refer to Removal 43/ Replacement 11.)	Go to step 8.

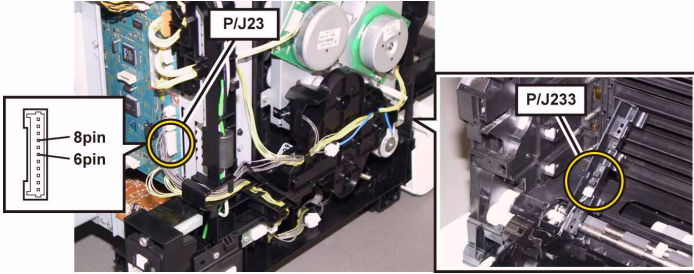
Step	Check	Remedy	
		Yes	No
8	<p>Checking the connectors of the SENSOR PHOTO (SSF No Paper Sensor) for connection Check the connections between the PWBA MCU and SENSOR PHOTO. Are P/J23 and P/J233 connected correctly?</p> 	Go to step 10.	Reconnect the connector(s) P/J23 and/or P/J233 correctly, then go to step 9.
9	Does the error still occur when printing?	Go to step 10.	End of work.
10	<p>Checking the HARN ASSY L SIDE for continuity Disconnect J23 from the PWBA MCU. Disconnect J233 from the SENSOR PHOTO. Is each cable of J23 <=> J233 continuous?</p>	Go to step 11.	Replace the HARN ASSY L SIDE.
11	<p>Checking the power to the SENSOR PHOTO Disconnect J23 from the PWBA MCU. Is the voltage across P23-6pin <=> ground on the PWBA MCU, about +3.3 VDC?</p>	Go to step 12.	Replace the PWBA MCU. (Refer to Removal 43/ Replacement 11.)
12	<p>Checking the SENSOR PHOTO for operation Check the voltage across J23-8pin <=> ground on the PWBA MCU. Remove the CHUTE LOW (PL3.2.27) once to check the operation. Does the voltage change, when the actuator of the SENSOR PHOTO is operated?</p>	Replace the PWBA MCU. (Refer to Removal 43/ Replacement 11.)	Replace the SENSOR PHOTO.

FIP-1. 47 Check SSF 075-922

Step	Check	Remedy	
		Yes	No
	Possible causative parts: CLUTCH ASSY DRV (PL3.1.1) HARN ASSY L SIDE (PL3.1.18) ACTUATOR REGI ROLL (PL3.2.8) SENSOR PHOTO (PL3.2.13) ACTUATOR SSI (PL3.2.14) DRIVE ASSY MAIN (PL7.1.2) DRIVE ASSY PH (PL7.1.4) PWBA MCU (PL8.2.13) HARN ASSY MAIN MOT (PL9.1.7) HARN ASSY KSNR REGCL (PL9.1.9)		
1	Checking the paper size Does the using paper size meet the specification?	Go to step 3.	Use the paper that meets the specifications, then go to step 2.
2	Does the error still occur when printing?	Go to step 3.	End of work.
3	Checking the paper condition Is the paper in the SSF wrinkled or damaged?	Replace the paper with a new and dry one, then go to step 4.	Go to step 5.
4	Does the error still occur when printing?	Go to step 6.	End of work.
5	Checking after reloading a new paper Reload a new paper in the SSF. Does the error still occur when printing?	Go to step 6.	End of work.
6	Checking the COVER ASSY FRONT for latching Open and close the COVER ASSY FRONT, and then latch correctly. Does the error still occur when printing?	Go to step 7.	End of work.
7	Checking the DRIVE ASSY PH for operation Does the ROLL ASSY REGI and ROLL REGI METAL rotate properly? Check by [Digital Output] - [DO-27] in [IOT Diag] of diagnosis. During this check, cheat the interlock switch (HARN ASSY INTERLOCK).	Go to step 8.	Reseat or replace the DRIVE ASSY PH. (Refer to Removal 31/ Replacement 23.)
8	Checking the paper lead edge staying position Does the paper lead edge stay before the ROLL ASSY REGI and ROLL REGI METAL?	Go to step 9.	The paper lead edge stay after the ROLL ASSY REGI and ROLL REGI METAL, then go to step 14.
9	Checking after resetting the guide sides of the SSF Reset the side guides. Does the error still occur when printing?	Go to step 10.	End of work.
10	Checking the paper transfer path between the SSF paper loading window and Regi.Sensor Are there any obstacles on the paper transfer path?	Remove the obstacles or stain from the paper transfer path, then go to step 11.	Go to step 12.
11	Does the error still occur when printing?	Go to step 12.	End of work.

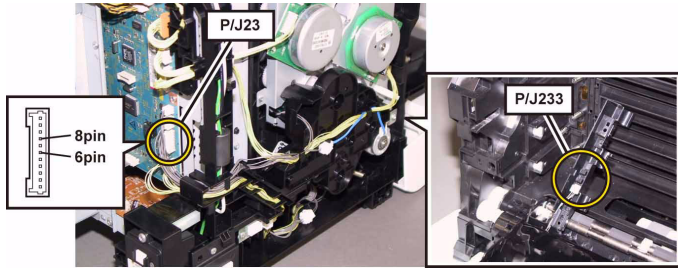
Step	Check	Remedy	
		Yes	No
12	<p>Checking the ACTUATOR SSI for shape and operation Remove the CHUTE LOW (PL3.2.27) once to check the operation. Are the shape and operation of the ACTUATOR SSI normal?</p>	Go to step 13.	Reseat the ACTUATOR SSI. If broken or damaged, replace the ACTUATOR SSI.
13	<p>Checking the SSF No Paper Sensor (SENSOR PHOTO) for operation Remove the CHUTE LOW (PL3.2.27) once to check the operation. Does the number on the screen increase by one, when the actuator (ACTUATOR SSI) of the SSF No Paper Sensor (SENSOR PHOTO) is operated? Checked by [Digital Input] - [SSI SNR] in [CE Diag] tab of [CE Diag].</p>	Go to step 14.	Go to step 17.
14	<p>Checking the Regi. Clutch (CLUTCH ASSY DRV) for operation, and ROLL ASSY REGI and ROLL REGI METAL for rotation Enter the [Digital Output] - [DO-0] in [IOT Diag], and then enter the [Digital Output] - [DO-27] in [IOT Diag] of diagnosis. Does the Regi. Clutch (CLUTCH ASSY DRV) operate properly, and the ROLL ASSY REGI and ROLL REGI METAL rotate? During this check, cheat the interlock switch (HARN ASSY INTERLOCK).</p>	Go to step 15.	Go to step 26.
15	<p>Checking the ACTUATOR REGI ROLL for shape and operation Remove the CHUTE LOW (PL3.2.27) once to check the shape and operation. Are the shape and operation of the ACTUATOR REGI ROLL normal?</p>	Go to step 16.	Reseat the ACTUATOR REGI ROLL. If broken or deformed, replace it with a new one.
16	<p>Checking the Regi. Sensor (SENSOR PHOTO) for operation Does the number on the screen increase by one, when the ACTUATOR REGI ROLL is operated? Remove the CHUTE LOW (PL3.2.27) once to check the operation. Checked by [Digital Input] - [REG SNR] in [CE Diag] tab of [CE Diag].</p>	Replace the PWBA MCU. (Refer to Removal 43/ Replacement 11.)	Go to step 22.
17	<p>Checking the connectors of the SENSOR PHOTO (SSF No Paper Sensor) for connection Check the connections between the PWBA MCU and SENSOR PHOTO (SSF No Paper Sensor). Are P/J23 and P/J233 connected correctly?</p> 	Go to step 19.	Reconnect the connector(s) P/J23 and/or P/J233 correctly, then go to step 18.
18	Does the error still occur when printing?	Go to step 19.	End of work.

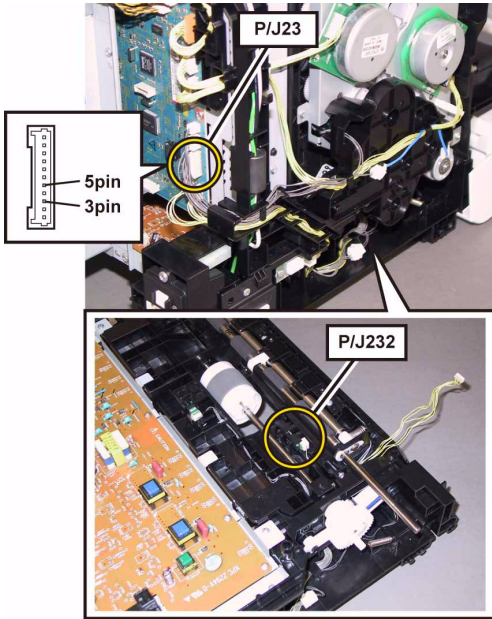
Step	Check	Remedy	
		Yes	No
19	Checking the HARN ASSY L SIDE for continuity Disconnect J23 from the PWBA MCU. Disconnect J233 from the SENSOR PHOTO. Is each cable of J23 <=> J233 continuous?	Go to step 20.	Replace the HARN ASSY L SIDE.
20	Checking the power to the SENSOR PHOTO Disconnect J23 from the PWBA MCU. Is the voltage across P23-6pin <=> ground on the PWBA MCU, about +3.3 VDC?	Go to step 21.	Replace the PWBA MCU. (Refer to Removal 43/ Replacement 11.)
21	Checking the SENSOR PHOTO for operation Check the voltage across J23-8pin <=> ground on the PWBA MCU. Remove the CHUTE LOW (PL3.2.27) once to check the operation. Does the voltage change, when the ACTUATOR SSI is operated?	Replace the PWBA MCU. (Refer to Removal 43/ Replacement 11.)	Replace the SENSOR PHOTO.
22	Checking the connectors of the SENSOR PHOTO (Regi Sensor) for connection Check the connections between the PWBA MCU and SENSOR PHOTO. Are P/J23 and P/J232 connected correctly? 	Go to step 23.	Reconnect the connector(s) P/ J23 and/or P/J232 correctly.
23	Checking the HARN ASSY L SIDE for continuity Disconnect J23 from the PWBA MCU. Disconnect J232 from the SENSOR PHOTO. Is each cable of J23 <=> J232 continuous?	Go to step 24.	Replace the HARN ASSY L SIDE.
24	Checking the power to the SENSOR PHOTO Disconnect J23 from the PWBA MCU. Is the voltage across P23-3pin <=> ground on the PWBA MCU, about +3.3 VDC?	Go to step 25.	Replace the PWBA MCU. (Refer to Removal 43/ Replacement 11.)

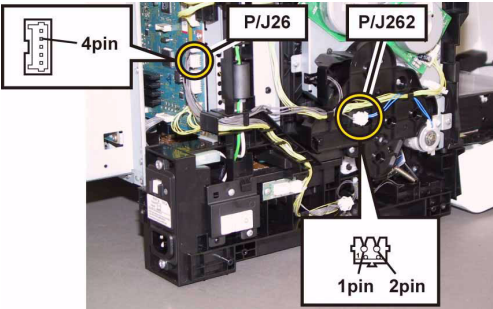
Step	Check	Remedy	
		Yes	No
25	<p>Checking the SENSOR PHOTO for operation Check the voltage across J23-5pin <=> ground on the PWBA MCU. Remove the CHUTE LOW (PL3.2.27) once to check the operation. Does the voltage change, when the ACTUATOR REGI ROLL is operated?</p>	Replace the PWBA MCU. (Refer to Removal 43/ Replacement 11.)	Replace the SENSOR PHOTO.
26	<p>Checking the connectors of the CLUTCH ASSY DRV (Regi Clutch) for connection Check the connections between the PWBA MCU and CLUTCH ASSY DRV. Are P/J26 and P/J262 connected correctly?</p> 	Go to step 27.	Reconnect the connector(s) P/J26 and/or P/J262 correctly.
27	<p>Checking the HARN ASSY KSNR REGCL for continuity Disconnect J26 from the PWBA MCU. Disconnect P262 from the CLUTCH ASSY DRV. Is each cable of J26 <=> P262 continuous?</p>	Go to step 28.	Replace the HARN ASSY KSNR REGCL.
28	<p>Checking the power to the CLUTCH ASSY DRV Disconnect J26 from the PWBA MCU. Is the voltage across P26-4pin <=> ground on the PWBA MCU, about +24 VDC when the Interlock Switch (HARN ASSY INTERLOCK) is pushed?</p>	Go to step 29.	Replace the PWBA MCU. (Refer to Removal 43/ Replacement 11.)
29	<p>Checking the CLUTCH ASSY DRV for resistance Disconnect P/J262 of the CLUTCH ASSY DRV. Is the resistance across J262-1 and J262-2 approximately 280-ohm?</p>	Replace the PWBA MCU. (Refer to Removal 43/ Replacement 11.)	Replace the CLUTCH ASSY DRV. (Refer to Removal 30/ Replacement 24.)

FIP-1. 48 Paper Jam 077-100/077-101

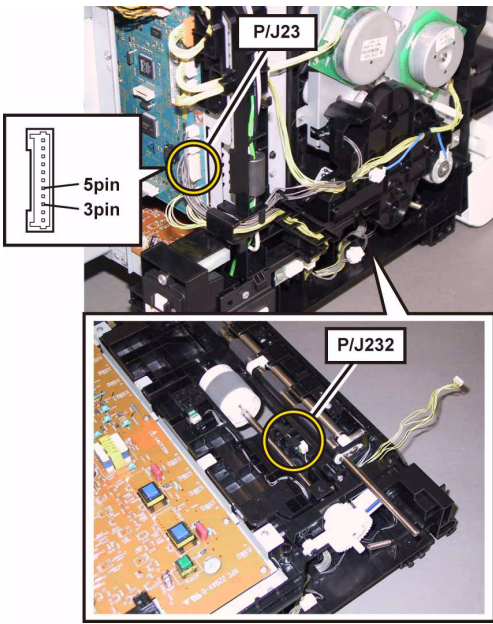
Step	Check	Remedy	
		Yes	No
	Possible causative parts: HARN ASSY L SIDE (PL3.1.18) ACTUATOR REGI IN (PL3.2.11) SENSOR PHOTO (PL3.2.13) PWBA MCU(PL8.2.13)		
1	Checking the error Replace to known good paper. Does the error still occur when printing?	Go to step 2.	End of work.
2	Checking the Regi Rolls installation Open the Front Cover and check the Regi Rolls installation. Is the ROLL REGI METAL pressed against the ROLL ASSY REGI by the spring pressure?	Go to step 3.	Replace the printer.
3	Checking the Regi Clutch Does the clutch noise occur? Checked by [Digital Output]-[DO-27] in [IOT Diag] of diagnosis.	Go to step 4.	Replace the printer.
4	Checking the Regi Sensor for operation Does the number on the screen increase by one, when the actuator (ACTUATOR REGI IN) is operated? Checked by [Digital Input]-[DI-2] on [IOT Diag] of diagnosis.	Replace the PWBA MCU. (Refer to Removal 43/ Replacement 11.)	Go to step 5.
5	Checking the ACTUATOR REGI IN for shape and operation Remove the CHUTE LOW (PL3.2.35) once to check the shape and operation. Are the shape and operation of the ACTUATOR REGI IN normal?	Go to step 6.	Reseat the ACTUATOR REGI IN. If broken or deformed, replace it.
6	Checking the connectors of the SENSOR PHOTO (Regi Sensor) for connection Check the connections between the PWBA MCU and SENSOR PHOTO. Are P/J23 and P/J232 connected correctly? 	Go to step 7.	Reconnect the connector(s) P/J23 and/or P/J232 correctly.

Step	Check	Remedy	
		Yes	No
7	Checking the HARN ASSY L SIDE for continuity Disconnect J23 from the PWBA MCU. Disconnect J232 from the SENSOR PHOTO. Is each cable of J23 <=> J232 continuous?	Go to step 8.	Replace the HARN ASSY L SIDE.
8	Checking the power to the SENSOR PHOTO Disconnect J23 from the PWBA MCU. Is the voltage across P23-3pin <=> ground on the PWBA MCU, about +3.3 VDC?	Go to step 9.	Replace the PWBA MCU. (Refer to Removal 43/ Replacement 11.)
9	Checking the SENSOR PHOTO for operation Check the voltage across J23-5pin <=> ground on the PWBA MCU. Remove the CHUTE LOW (PL3.2.35) once to check the operation. Does the voltage change, when the actuator (ACTUATOR REGI IN) is operated?	Replace the PWBA MCU. (Refer to Removal 43/ Replacement 11.)	Replace the SENSOR PHOTO.

FIP-1. 49 Paper Jam 077-102

Step	Check	Remedy	
		Yes	No
	Possible causative parts: CASSETTE ASSY 250 (PL2.1.1) SEPARATOR ROLLER ASSEMBLY (PL2.1.5) CLUTCH ASSY DRV (PL3.1.1) SOLENOID FEED (PL3.1.11) HARN ASSY L SIDE (PL3.1.18) ROLL ASSY FEED (PL3.2.4) ACTUATOR REGI ROLL (PL3.2.8) ACTUATOR REGI IN (PL3.2.11) SENSOR PHOTO (PL3.2.13) DRIVE ASSY MAIN (PL7.1.2) DRIVE ASSY PH (PL7.1.4) PWBA MCU (PL8.2.13) HARN ASSY MAIN MOT (PL9.1.7) HARN ASSY KSNR REGCL (PL9.1.9)		
1	Checking the paper condition Is the paper in the Tray 1 wrinkled or damaged?	Replace the paper with a new and dry one, then go to step 2.	Go to step 3.
2	Does the error still occur when printing?	Go to step 3.	End of work.
3	Checking after reloading a new paper Reload a new paper in the Tray 1. Does the error still occur when printing?	Go to step 4.	End of work.
4	Checking the COVER ASSY FRONT for latching Open and close the COVER ASSY FRONT, and then latch correctly. Does the error still occur when printing?	Go to step 5.	End of work.
5	Checking the Main Motor (DRIVE ASSY MAIN) for operation Does the Main Motor (DRIVE ASSY MAIN) operate properly? Checked by [Digital Output]-[DO-0] on [IOT Diag] of diagnosis. During this check, cheat the interlock switch (HARN ASSY INTERLOCK).	Go to step 6.	Go to step 18.
6	Checking the DRIVE ASSY PH for operation Does the ROLL ASSY FEED, ROLL ASSY REGI and ROLL REGI METAL rotate properly? Checked by [Digital Output]-[DO-B] on [IOT Diag] of diagnosis. During this check, cheat the interlock switch (HARN ASSY INTERLOCK).	Go to step 7.	Reseat or replace the DRIVE ASSY PH. (Refer to Removal 31/ Replacement 23.)
7	Checking the paper feeding position Is the paper not fed from the Tray 1?	Go to step 8.	Go to step 12.
8	Checking after resetting the Guide Sides and End Guide on the Tray 1 Reset the Guide Sides and End Guide, and reseat the Tray 1 to the printer correctly. Does the error still occur when printing?	Go to step 9.	End of work.

Step	Check	Remedy	
		Yes	No
9	Checking the SEPARATOR ROLLER ASSEMBLY on the Tray 1 for shape and rotation Pull the Tray 1 out from the printer. Is the SEPARATOR ROLLER ASSEMBLY not contaminated and/or damaged, and rotated smoothly?	Go to step 10.	Replace the SEPARATOR ROLLER ASSEMBLY. (Refer to Removal 2/ Replacement 52.)
10	Checking the ROLL ASSY FEED for shape and rotation Pull the Tray 1 out from the printer. Is the ROLL ASSY FEED not contaminated and/or damaged, and rotated smoothly?	Go to step 11.	Replace the ROLL ASSY FEED. (Refer to Removal 9/ Replacement 45.)
11	Checking the Cassette Feed Solenoid (SOLENOID FEED) for operation Does the Cassette Feed Solenoid (SOLENOID FEED) operate properly? Checked by [Digital Output]-[DO-29] on [IOT Diag] of diagnosis. During this check, cheat the interlock switch (HARN ASSY INTERLOCK).	Replace the CASSETTE ASSY 250. (Refer to Removal 58/ Replacement 58.)	Go to step 21.
12	Checking the paper lead edge staying position Does the paper lead edge stay before the ROLL ASSY REGI and ROLL REGI METAL?	Go to step 13.	The paper lead edge stay after the ROLL ASSY REGI and ROLL REGI METAL, then go to step 16.
13	Checking the paper transfer path between the ROLL ASSY FEED and ROLL ASSY REGI. Are there any obstacles on the paper transfer path?	Remove the obstacles or stains from the paper transfer path.	Go to step 14.
14	Checking the ACTUATOR REGI IN for shape and operation Remove the CHUTE LOW (PL3.2.27) once to check the shape and operation. Are the shape and operation of the ACTUATOR REGI IN normal?	Go to step 15.	Reseat the ACTUATOR REGI IN. If broken or deformed, replace it.
15	Checking the Regi. Sensor (SENSOR PHOTO) for operation Does the number on the screen increase by one, when the actuator (ACTUATOR REGI IN) is operated? Remove the CHUTE LOW (PL3.2.27) once to check the operation. Checked by [Digital Input]-[DI-2] on [IOT Diag] of diagnosis.	Go to step 16.	Go to step 25.
16	Checking the Regi. Clutch (CLUTCH ASSY DRV) for operation, and ROLL ASSY REGI and ROLL REGI METAL for rotation Checked by [Digital Output]-[DO-0 and 29] on [IOT Diag] of diagnosis. Does the Regi. Clutch (CLUTCH ASSY DRV) operate properly, and the ROLL ASSY REGI and ROLL REGI METAL rotate? During this check, cheat the interlock switch (HARN ASSY INTERLOCK).	Go to step 17.	Go to step 29.

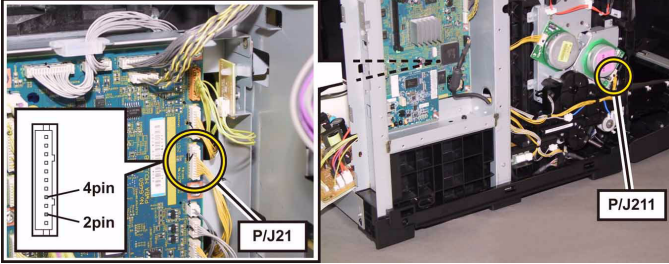
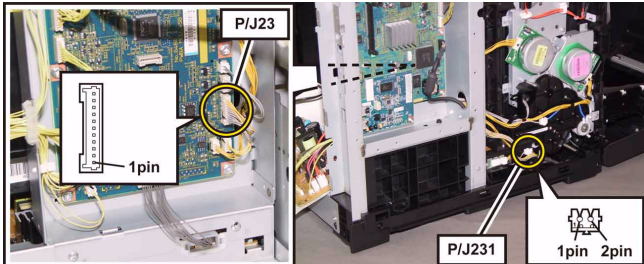
Step	Check	Remedy	
		Yes	No
17	<p>Checking the ACTUATOR REGI ROLL for shape and operation</p> <p>Remove the CHUTE LOW (PL3.2.27) once to check the shape and operation.</p> <p>Are the shape and operation of the ACTUATOR REGI ROLL normal?</p>	Replace the PWBA MCU. (Refer to Removal 43/ Replacement 11.)	Reseat the ACTUATOR REGI ROLL. If broken or deformed, replace it with a new one.
18	<p>Checking the connectors for connection</p> <p>Check the connections between the PWBA MCU and DRIVE ASSY MAIN (Main Motor).</p> <p>Are P/J21 and P/J211 connected correctly?</p> 	Go to step 19.	Reconnect the connector(s) P/J21 and/or P/J211 correctly.
19	<p>Checking the HARN ASSY MAIN MOT for continuity</p> <p>Disconnect J21 from the PWBA MCU.</p> <p>Disconnect J211 from the DRIVE ASSY MAIN.</p> <p>Is each cable of J21 <=> J211 continuous?</p>	Go to step 20.	Replace the HARN ASSY MAIN MOT.
20	<p>Checking the power to the DRIVE ASSY MAIN</p> <p>Disconnect J21 from the PWBA MCU.</p> <p>Are the voltages across J21-2pin/J21-4pin <=> ground on the PWBA MCU, about +24 VDC when the interlock switch (HARN ASSY INTERLOCK) is pushed?</p>	Replace the DRIVE ASSY MAIN. (Refer to Removal 32/ Replacement 22.)	Replace the PWBA MCU. (Refer to Removal 43/ Replacement 11.)
21	<p>Checking the connectors of the SOLENOID FEED (Cassette Feed Solenoid) for connection</p> <p>Check the connections between the PWBA MCU and SOLENOID FEED.</p> <p>Are P/J23 and P/J231 connected correctly?</p> 	Go to step 22.	Reconnect the connector(s) P/J23 and/or P/J231 correctly.
22	<p>Checking the HARN ASSY L SIDE for continuity</p> <p>Disconnect J23 from the PWBA MCU.</p> <p>Disconnect P231 from the SOLENOID FEED.</p> <p>Is each cable of J23 <=> P231 continuous?</p>	Go to step 23.	Replace the HARN ASSY L SIDE.
23	<p>Checking the power to the SOLENOID FEED</p> <p>Disconnect J23 from the PWBA MCU.</p> <p>Is the voltage across P23-1pin <=> ground on the PWBA MCU, about +24 VDC when the Interlock Switch (HARN ASSY INTERLOCK) is pushed?</p>	Go to step 24.	Replace the PWBA MCU. (Refer to Removal 43/ Replacement 11.)

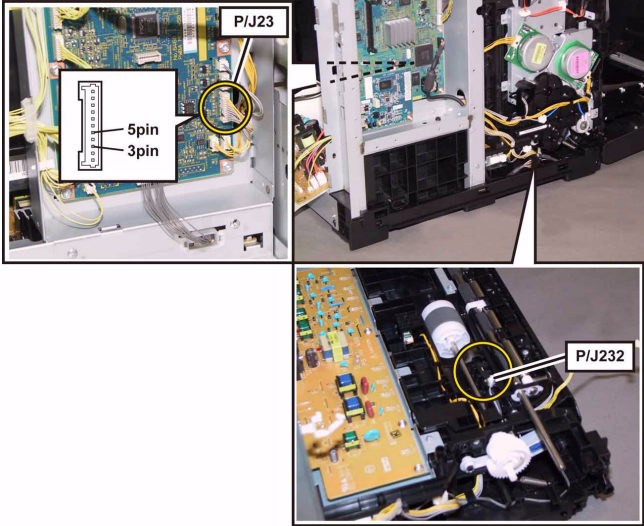
Step	Check	Remedy	
		Yes	No
24	<p>Checking the SOLENOID FEED for resistance Disconnect P/J231 of the SOLENOID FEED. Is the resistance across J231-1 and J231-2 about 96 ohm?</p>	Replace the PWBA MCU. (Refer to Removal 43/ Replacement 11.)	Replace the SOLENOID FEED. (Refer to Removal 35/ Replacement 19.)
25	<p>Checking the connectors of the SENSOR PHOTO (Regi Sensor) for connection Check the connections between the PWBA MCU and SENSOR PHOTO. Are P/J23 and P/J232 connected correctly?</p> 	Go to step 26.	Reconnect the connector(s) P/J23 and/or P/J232 correctly.
26	<p>Checking the HARN ASSY L SIDE for continuity Disconnect J23 from the PWBA MCU. Disconnect J232 from the SENSOR PHOTO. Is each cable of J23 <=> J232 continuous?</p>	Go to step 27.	Replace the HARN ASSY L SIDE.
27	<p>Checking the power to the SENSOR PHOTO Disconnect J23 from the PWBA MCU. Is the voltage across P23-3pin <=> ground on the PWBA MCU, about +3.3 VDC?</p>	Go to step 28.	Replace the PWBA MCU. (Refer to Removal 43/ Replacement 11.)
28	<p>Checking the SENSOR PHOTO for operation Check the voltage across J23-5pin <=> ground on the PWBA MCU. Remove the CHUTE LOW (PL3.2.27) once to check the operation. Does the voltage change, when the actuator (ACTUATOR REGI IN) is operated?</p>	Replace the PWBA MCU. (Refer to Removal 43/ Replacement 11.)	Replace the SENSOR PHOTO.

FIP-1. 50 Paper Jam 077-103/077-104/077-105

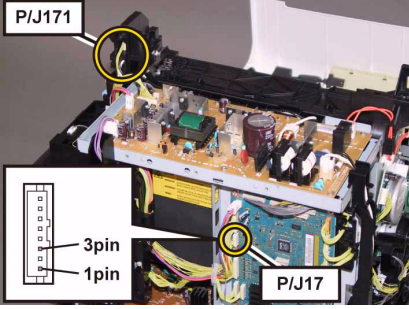
Step	Check	Remedy	
		Yes	No
	Possible causative parts: FUSER ASSY (PL6.1.1) PWBA MCU (PL8.2.13) HARN ASSY FUSER2 (PL6.1.2)		
1	Checking the error Replace to known good paper. Does the error still occur when printing?	Go to step 2.	End of work.
2	Checking the Exit Sensor for operation Does the number on the screen increase by one, when the actuator of the Exit Sensor in the FUSER ASSY is operated? Checked by [Digital Input]-[DI-3] on [IOT Diag] of diagnosis. Warning: Start the operation after the FUSER ASSY has cooled down.	Go to step 7.	Go to step 3.
3	Checking the connectors of the Exit Sensor in the FUSER ASSY for connection Check the connections between the PWBA MCU and FUSER ASSY. Are P/J17 and P/J171 connected correctly? 	Go to step 4.	Reconnect the connector(s) P/J17 and/or P/J171 correctly.
4	Checking the HARN ASSY FUSER2 for continuity Remove the FUSER ASSY. Disconnect J17 from the PWBA MCU. Is each cable of J17 \Leftrightarrow P171 continuous? NOTE: P171 is attached to the frame.	Go to step 5.	Replace the HARN ASSY FUSER2.
5	Checking the power to the Exit Sensor in the FUSER ASSY Disconnect the connector of J17 on the PWBA MCU. Is the voltage across J17-1pin \Leftrightarrow ground on the PWBA MCU, about +3.3 VDC?	Go to step 6.	Replace the PWBA MCU. (Refer to Removal 43/ Replacement 11.)
6	Checking the Exit Sensor for operation Check the voltage across J17-3pin \Leftrightarrow ground on the PWBA MCU. Does the voltage change, when the actuator of the Exit Sensor is operated?	Replace the PWBA MCU. (Refer to Removal 43/ Replacement 11.)	Replace the FUSER ASSY.
7	Checking the Regi Rolls installation Open the Front Cover and check the Regi Rolls installation. Is the ROLL REGI METAL pressed against the ROLL ASSY REGI by the spring pressure?	Go to step 8.	Replace the printer.
8	Checking the Regi Clutch Does the clutch noise occur? Checked by [REGI CLUTCH Operation Check] of the [Diagnosis] tab in the [Tool Box].	Replace the printer.	Replace the PWBA MCU. (Refer to Removal 43/ Replacement 11.)

FIP-1. 51 Paper Jam 077-107

Step	Check	Remedy	
		Yes	No
	Possible causative parts: HARN ASSY DUP RELAY (PL1.2.13) HARN ASSY L SIDE (PL3.1.18) HARN ASSY OPTION (PL3.1.20) ROLL ASSY REGI (PL3.2.9) ROLLREGI METAL (PL3.2.10/Regi Sensor (PL3.2.13) FUSER ASSY (PL6.1.1) PWBA MCU (PL8.2.13) FEEDER ASSY DUP (PL11.1.1)		
1	Checking the COVER ASSY FRONT for latching Open and close the COVER ASSY FRONT, then check the latching. Does the error still occur when printing?	Go to step 2.	End of work.
2	Checking after reseating the FUSER ASSY Reseat the FUSER ASSY. Warning: Start the operation after the FUSER ASSY has cooled down. Does the error still occur when printing?	Go to step 3.	End of work.
3	Checking after reseating the Duplex Reseat the Duplex. Does the error still occur when printing?	Go to step 4.	End of work.
4	Checking the DRIVE ASSY EXIT for operation Does the DRIVE ASSY EXIT operate properly? Checked by [Digital Output]-[DO-D] on [IOT Diag] of diagnosis. During this check, cheat the interlock switch (HARN ASSY INTERLOCK).	Go to step 5.	Replace FEEDER ASSY DUP.
5	Checking the DRIVE ASSY DUP for operation Does the DRIVE ASSY DUP operate properly? Checked by [Digital Output]-[DO-12] on [IOT Diag] of diagnosis. During this check, cheat the interlock switch (HARN ASSY INTERLOCK).	Go to step 6.	Replace FEEDER ASSY DUP.
6	Checking the Duplex Clutch for operation Does the Duplex Clutch operate properly? Checked by [Digital Output]-[DO-35] on [IOT Diag] of diagnosis. During this check, cheat the interlock switch (HARN ASSY INTERLOCK).	Go to step 7.	Replace FEEDER ASSY DUP.
7	Checking the SENSOR PHOTO (REGI SENSOR) for operation Does the number on the screen increase by one, every time the actuator of the SENSOR PHOTO (REGI SENSOR) is operated? Checked by [Digital Input]-[DI-2] in [IOT Diagnosis] of diagnosis.	Go to step 8.	Go to step 11.

Step	Check	Remedy	
		Yes	No
8	Checking the ROLL ASSY REGI and ROLL REGI METAL for shape and operation Remove the PHD UNIT once to check the followings. Are ROLL ASSY REGI and ROLL REGI METAL seated correctly? Also, are they not contaminated and/or damaged, and rotated smoothly? Check these items by turning with your finger.	Go to step 9.	Clean or replace the defective ROLL(s).
9	Checking the HARN ASSY OPTION for continuity Disconnect J127 from PWBA MCU. Disconnect P271 from HARN ASSY DUP RELAY. Is each cable of J127 <=> P271 continuous?	Go to step 10.	Replace HARN ASSY OPTION.
10	Checking the HARN ASSY DUP RELAY for continuity Remove Duplex. Disconnect J271 from HARN ASSY OPTION. Is each cable of J127 <=> P272 continuous?	Go to step 16.	Replace HARN ASSY DUP RELAY.
11	Checking the connectors of the SENSOR PHOTO (Regi Sensor) for connection Check the connections between the PWBA MCU and SENSOR PHOTO. Are P/J23 and P/J232 connected correctly?	Go to step 12.	Reconnect the connector(s) P/J23 and/or P/J232 correctly.
12	Checking the connectors of the SENSOR PHOTO (Regi Sensor) for connection Check the connections between the PWBA MCU and SENSOR PHOTO. Are P/J23 and P/J232 connected correctly?	Go to step 13.	Reconnect the connector(s) P/J23 and/or P/J232 correctly.
13	Checking the HARN ASSY L SIDE for continuity Disconnect J23 from the PWBA MCU. Disconnect J232 from the SENSOR PHOTO. Is each cable of J23 <=> J232 continuous?	Go to step 14.	Replace the HARN ASSY L SIDE.
14	Checking the power to the SENSOR PHOTO Disconnect J23 from the PWBA MCU. Is the voltage across P23-3pin <=> ground on the PWBA MCU, about +3.3 VDC?	Go to step 15.	Replace the PWBA MCU. (Refer to Removal 43/ Replacement 11.)
15	Checking the SENSOR PHOTO for operation Check the voltage across 23-5pin <=> ground on the PWBA MCU. Remove the CHUTE LOW (PL3.2.27) once to check the operation. Does the voltage change, when the actuator of the SENSOR PHOTO is operated?	Replace the PWBA MCU. (Refer to Removal 43/ Replacement 11.)	Replace the Regi Sensor.
16	Checking after replacing FEEDER ASSY DUP Replace FEEDER ASSY DUP. Does the error still occur when printing?	Go to step 17.	End of work.
17	Checking after replacing FUSER ASSY Replace FUSER ASSY. Warning: Start the operation after the FUSER ASSY has cooled down. Does the error still occur when printing? NOTE: After replacement, be sure to clear life counter value.	Replace the PWBA MCU. (Refer to Removal 43/ Replacement 11.)	End of work.

FIP-1. 52 Paper Jam 077-108

Step	Check	Remedy	
		Yes	No
	Possible causative parts: HARN ASSY DUP RELAY (PL1.2.13) HARN ASSY L SIDE (PL3.1.18) HARN ASSY OPTION (PL3.1.20) ROLL ASSY REGI (PL3.2.9) ROLLREGI METAL (PL3.2.10/Regi Sensor (PL3.2.13) FUSER ASSY (PL6.1.1) PWBA MCU (PL8.2.13) FEEDER ASSY DUP (PL11.1.1)		
1	Checking the COVER ASSY FRONT for latching Open and close the COVER ASSY FRONT, then check the latching. Does the error still occur when printing?	Go to step 2.	End of work.
2	Checking after reseating the FUSER ASSY Reseat the FUSER ASSY. Warning: Start the operation after the FUSER ASSY has cooled down. Does the error still occur when printing?	Go to step 3.	End of work.
3	Checking after reseating the Duplex Reseat the Duplex. Does the error still occur when printing?	Go to step 4.	End of work.
4	Checking the DRIVE ASSY EXIT for operation Does the DRIVE ASSY EXIT operate properly? Checked by [Digital Output]-[DO-D] on [IOT Diag] of diagnosis. During this check, cheat the interlock switch (HARN ASSY INTERLOCK).	Go to step 5.	Replace FEEDER ASSY DUP.
5	Checking the DRIVE ASSY DUP for operation Does the DRIVE ASSY DUP operate properly? Checked by [Digital Output]-[DO-12] on [IOT Diag] of diagnosis. During this check, cheat the interlock switch (HARN ASSY INTERLOCK).	Go to step 6.	Replace FEEDER ASSY DUP.
6	Checking the Duplex Clutch for operation Does the Duplex Clutch operate properly? Checked by [Digital Output]-[DO-35] on [IOT Diag] of diagnosis. During this check, cheat the interlock switch (HARN ASSY INTERLOCK).	Go to step 7.	Replace FEEDER ASSY DUP.
7	Checking the SENSOR PHOTO (REGI SENSOR) for operation Does the number on the screen increase by one, every time the actuator of the SENSOR PHOTO (REGI SENSOR) is operated? Checked by [Digital Input]-[DI-2] in [IOT Diagnosis] of diagnosis.	Go to step 8.	Go to step 11.

Step	Check	Remedy	
		Yes	No
8	Checking the ROLL ASSY REGI and ROLL REGI METAL for shape and operation Remove the PHD UNIT once to check the followings. Are ROLL ASSY REGI and ROLL REGI METAL seated correctly? Also, are they not contaminated and/or damaged, and rotated smoothly? Check these items by turning with your finger.	Go to step 9.	Clean or replace the defective ROLL(s).
9	Checking the HARN ASSY OPTION for continuity Disconnect J127 from PWBA MCU. Disconnect P271 from HARN ASSY DUP RELAY. Is each cable of J127 <=> P271 continuous?	Go to step 10.	Replace HARN ASSY OPTION.
10	Checking the HARN ASSY DUP RELAY for continuity Remove Duplex. Disconnect J271 from HARN ASSY OPTION. Is each cable of J127 <=> P272 continuous?	Go to step 16.	Replace HARN ASSY DUP RELAY.
11	Checking the connectors of the SENSOR PHOTO (Regi Sensor) for connection Check the connections between the PWBA MCU and SENSOR PHOTO. Are P/J23 and P/J232 connected correctly?	Go to step 12.	Reconnect the connector(s) P/J23 and/or P/J232 correctly.
12	Checking the connectors of the SENSOR PHOTO (Regi Sensor) for connection Check the connections between the PWBA MCU and SENSOR PHOTO. Are P/J23 and P/J232 connected correctly?	Go to step 13.	Reconnect the connector(s) P/J23 and/or P/J232 correctly.
13	Checking the HARN ASSY L SIDE for continuity Disconnect J23 from the PWBA MCU. Disconnect J232 from the SENSOR PHOTO. Is each cable of J23 <=> J232 continuous?	Go to step 14.	Replace the HARN ASSY L SIDE.
14	Checking the power to the SENSOR PHOTO Disconnect J23 from the PWBA MCU. Is the voltage across P23-3pin <=> ground on the PWBA MCU, about +3.3 VDC?	Go to step 15.	Replace the PWBA MCU. (Refer to Removal 43/ Replacement 11.)
15	Checking the SENSOR PHOTO for operation Check the voltage across 23-5pin <=> ground on the PWBA MCU. Remove the CHUTE LOW (PL3.2.27) once to check the operation. Does the voltage change, when the actuator of the SENSOR PHOTO is operated?	Replace the PWBA MCU. (Refer to Removal 43/ Replacement 11.)	Replace the Regi Sensor.
16	Checking after replacing FEEDER ASSY DUP Replace FEEDER ASSY DUP. Does the error still occur when printing?	Go to step 17.	End of work.
17	Checking after replacing FUSER ASSY Replace FUSER ASSY. Warning: Start the operation after the FUSER ASSY has cooled down. Does the error still occur when printing? NOTE: After replacement, be sure to clear life counter value.	Replace the PWBA MCU. (Refer to Removal 43/ Replacement 11.)	End of work.

FIP-1. 53 Close FrontCover 077-300

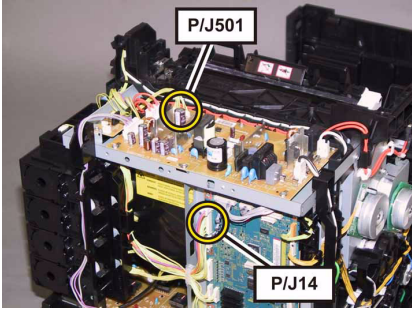
Step	Check	Remedy	
		Yes	No
	Possible causative parts: COVER ASSY FRONT (PL1.2.1) PWBA LVPS (PL8.2.1) HARN ASSY INTERLOCK (PL8.2.5) PWBA MCU (PL8.2.13) HARN ASSY LVPS2 (PL9.1.3)		
1	Checking the COVER ASSY FRONT (Front Cover) for shape Are there any damages on the COVER ASSY FRONT?	Replace the COVER ASSY FRONT. (Refer to Removal 25/ Replacement 29.)	Go to step 2.
2	Checking the COVER ASSY FRONT for latching Open and close the COVER ASSY FRONT. Is the COVER ASSY FRONT latched correctly?	Go to step 3.	Reseat or replace the COVER ASSY FRONT. (Refer to Removal 25/ Replacement 29.)
3	Checking the interlock switch for operation Does the number on the screen increase by one, when the COVER ASSY FRONT is closed and opened? Checked by [Digital Input] - [DI-7] in [IOT Diag] of diagnosis.	Replace the PWBA MCU. (Refer to Removal 43/ Replacement 11.)	Go to step 4.
4	Checking the connectors for connection Check the connections between PWBA MCU and PWBA LVPS. Are P/J14 and P/J501 connected correctly? 	Go to step 6.	Reconnect the connector(s) P/J14 and/or P/J501 correctly, then go to step 5.
5	Does the error still occur when the power is turned OFF and ON?	Go to step 6.	End of work.
6	Checking the HARN ASSY LVPS2 for continuity Disconnect J14 from the PWBA MCU. Disconnect J501 from the PWBA LVPS. Is each cable of J14 <=> J501 continuous?	Go to step 7.	Replace the HARN ASSY LVPS2.

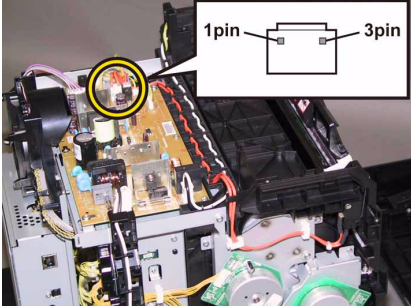
Step	Check	Remedy	
		Yes	No
7	<p>Checking the power to the Interlock Switch Disconnect the connector of J44 on the PWBA LVPS. Is the voltage across P44-1 \leftrightarrow ground on the PWBA LVPS, about +24 VDC?</p> 	Go to step 8.	Replace the PWBA LVPS. (Refer to Removal 11/ Replacement 43.)
8	<p>Checking the Interlock Switch for operation Check the voltage across P44-3pin \leftrightarrow ground on the PWBA LVPS. Does the voltage change, when the Interlock Switch is turned ON/OFF?</p>	Replace the PWBA LVPS. (Refer to Removal 11/ Replacement 43.)	Replace the HARN ASSY INTERLOCK. (Refer to Removal 18/ Replacement 36.)

FIP-1. 54 Close Side Cover 077-301

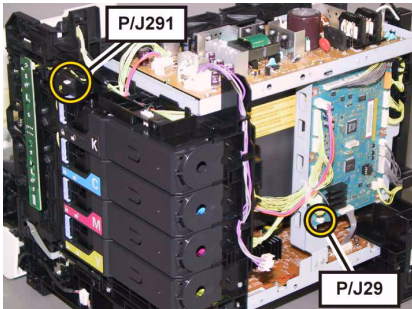
Step	Check	Remedy	
		Yes	No
	Possible causative parts: COVER ASSY WINDOW TNR (PL1.1.7) SWITCH (PL5.1.9) HARN ASSY SIDE SW (PL5.1.27) PWBA MCU (PL8.2.13)		
1	Checking the COVER ASSY WINDOW TNR (Side Cover) for shape Are there any damages on the COVER ASSY WINDOW TNR?	Replace the COVER ASSY WINDOW TNR. (Refer to Removal 8/ Replacement 46.)	Go to step 2.
2	Checking the COVER ASSY WINDOW TNR for latching Open and close the COVER ASSY WINDOW TRN. Is the COVER ASSY WINDOW TNR latched correctly?	Go to step 3.	Reseat or replace the COVER ASSY WINDOW TNR. (Refer to Removal 8/ Replacement 46.)
3	Checking the Side R Switch (SWITCH) for operation Does the number on the screen increase by one, when the COVER ASSY WINDOW TRN is closed and opened? Checked by [Digital Input] - [DI-6] in [IOT Diag] of diagnosis.	Replace the PWBA MCU. (Refer to Removal 43/ Replacement 11.)	Go to step 4.
4	Checking the HARN ASSY SIDE SW for continuity Disconnect J29 from the PWBA MCU. Disconnect J291 from the SIDE R SWITCH. Is each cable of J29 <=> J291 continuous? 	Go to step 5.	Replace the HARN ASSY SIDE SW.
5	Checking after replacing the Side R Switch (SWITCH) Replace the Side R Switch (SWITCH). (Refer to Removal 14/ Replacement 40.) Does the error still occur when the power is turned OFF and ON?	Replace the PWBA MCU. (Refer to Removal 43/ Replacement 11.)	End of work.

FIP-1. 55 Paper Jam 077-900

Step	Check	Remedy	
		Yes	No
	Possible causative parts: FUSER ASSY (PL6.1.1) HARN ASSY FUSER2 (PL6.1.2) PWBA MCU (PL8.2.13)		
1	Checking the paper feeding Was a paper fed from SSF?	Go to step 2.	Go to step 4.
2	Checking the paper setting Was the paper correctly set to SSF without slant?	Go to step 4.	Set the paper to SSF correctly, and go to step 3.
3	Does the error still occur when printing?	Go to step 4.	End of work.
4	Checking the paper condition Is the paper wrinkled or damaged?	Replace the paper with a new and dry one, then go to step 5.	Go to step 6.
5	Does the error still occur when printing?	Go to step 7.	End of work.
6	Checking after reloading a new paper Reload a new paper. Does the error still occur when printing?	Go to step 7.	End of work.
7	Checking the COVER ASSY FRONT for latching Open and close the COVER ASSY FRONT, and then latch correctly. Does the error still occur when printing?	Go to step 8.	End of work.
8	Checking the FUSER ASSY Are there any remaining paper and/or foreign substance in the FUSER ASSY? Warning: Start the operation after the FUSER ASSY has cooled down.	Remove the paper and/or substance, then go to step 9.	Go to step 9.
9	Checking after reseating the FUSER ASSY Reseat the FUSER ASSY. Warning: Start the operation after the FUSER ASSY has cooled down. Does the error still occur when printing?	Go to step 10.	End of work.
10	Checking the Exit Sensor for operation Does the number on the screen increase by one, when the actuator of the Exit Sensor in the FUSER ASSY is operated? Checked by [Digital Input] - [DI-3] in [IOT Diag] of diagnosis. Warning: Start the operation after the FUSER ASSY has cooled down.	Replace the PWBA MCU. (Refer to Removal 43/ Replacement 11.)	Go to step 11.

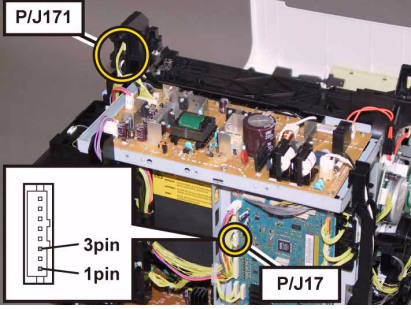
Step	Check	Remedy	
		Yes	No
11	<p>Checking the connectors of the Exit Sensor in the FUSER ASSY for connection Check the connections between the PWBA MCU and FUSER ASSY. Are P/J17 and P/J171 connected correctly?</p> 	Go to step 12.	Reconnect the connector(s) P/J17 and/or P/J171 correctly.
12	<p>Checking the HARN ASSY FUSER2 for continuity Remove the FUSER ASSY. Disconnect J17 from the PWBA MCU. Is each cable of J17 <=> P171 continuous? NOTE: P171 is attached to the frame.</p>	Go to step 13.	Replace the HARN ASSY FUSER2.
13	<p>Checking the power to the Exit Sensor in the FUSER ASSY Disconnect the connector of J17 on the PWBA MCU. Is the voltage across J17-1pin <=> ground on the PWBA MCU, about +3.3 VDC?</p>	Go to step 14.	Replace the PWBA MCU. (Refer to Removal 43/ Replacement 11.)
14	<p>Checking the Exit Sensor for operation Check the voltage across J17-3pin <=> ground on the PWBA MCU. Does the voltage change, when the actuator of the Exit Sensor is operated?</p>	Replace the PWBA MCU. (Refer to Removal 43/ Replacement 11.)	Replace the FUSER ASSY. (Refer to Removal 5/ Replacement 49.)

FIP-1. 56 Paper Jam 077-901

Step	Check	Remedy	
		Yes	No
	Possible causative parts: CLUTCH ASSY DRV (PL3.1.1) HARN ASSY L SIDE (PL3.1.18) ACTUATOR REGI ROLL (PL3.2.8) ROLL ASSY REGI (PL3.2.9) ROLL REGI METAL (PL3.2.10) ACTUATOR REGI IN (PL3.2.11) SENSOR PHOTO (PL3.2.13) TRANSFER ASSY (PL6.1.7) DRIVE ASSY MAIN (PL7.1.2) PWBA MCU (PL8.2.13) HARN ASSY MAIN MOT (PL9.1.7) HARN ASSY KSNR REGCL (PL9.1.9)		
1	Checking the paper size Does the using paper size meet the specification?	Go to step 3.	Use the paper that meets the specifications, then go to step 2.
2	Does the error still occur when printing?	Go to step 3.	End of work.
3	Checking the paper condition Is the paper wrinkled or damaged?	Replace the paper with a new and dry one, then go to step 4.	Go to step 5.
4	Does the error still occur when printing?	Go to step 6.	End of work.
5	Checking after reloading a new paper Reload a new paper. Does the error still occur when printing?	Go to step 6.	End of work.
6	Checking the COVER ASSY FRONT for latching Open and close the COVER ASSY FRONT, and then latch correctly. Does the error still occur when printing?	Go to step 7.	End of work.
7	Checking around the Regi Sensor Are there any remaining paper and/or foreign substance around the Regi Sensor?	Remove the paper and/or substance, then go to step 8.	Go to step 9.
8	Does the error still occur when printing?	Go to step 9.	End of work.
9	Checking the TRANSFER ASSY Are there any remaining paper and/or damage on the belt of the TRANSFER ASSY?	Remove the remaining paper. If the belt is damaged, replace the TRANSFER ASSY. (Refer to Removal 21/ Replacement 33.)	Go to step 10.
10	Checking the ROLL ASSY REGI and ROLL REGI METAL for shape and operation Remove the PHD ASSY once to check the followings. Are ROLL ASSY REGI and ROLL REGI METAL seated correctly? Also, are they not contaminated and/or damaged, and rotated smoothly? Check these items by turning with your finger.	Go to step 11.	Clean or replace the defective ROLL(s).

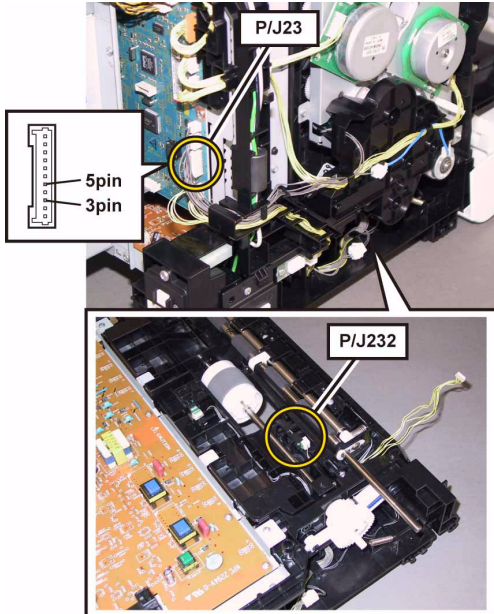
Step	Check	Remedy	
		Yes	No
11	<p>Checking the ACTUATOR REGI IN and ACTUATOR REGI ROLL for shape and operation Remove the CHUTE LOW (PL3.2.27) once to check the following. Are the shape and operation of the ACTUATOR REGI IN and ACTUATOR REGI ROLL normal?</p>	Go to step 12.	Reseat the ACTUATOR REGI IN and/or ACTUATOR REGI ROLL. If broken or deformed, replace it or they.
12	<p>Checking the Regi. Sensor (SENSOR PHOTO) for operation Does the number on the screen increase by one, when the actuator (ACTUATOR REGI IN) of the Regi. Sensor (SENSOR PHOTO) is operated? Remove the CHUTE LOW (PL3.2.27) once to check the operation. Checked by [Digital Input] - [D-2] in [IOT Diag] of diagnosis.</p>	Go to step 13.	Go to step 16.
13	<p>Checking the Regi. Clutch (CLUTCH ASSY DRV) for operation, and ROLL ASSY REGI and ROLL REGI METAL for rotation Checked by [Digital Output] - [DO-0] and [DO-27] on [IOT Diag] of diagnosis. Does the Regi. Clutch (CLUTCH ASSY DRV) operate properly, and the ROLL ASSY REGI and ROLL REGI METAL rotate? During this check, cheat the interlock switch (HARN ASSY INTERLOCK).</p>	Go to step 14.	Go to step 20.
14	<p>Checking the Main Motor (DRIVE ASSY MAIN) for operation Does the Main Motor (DRIVE ASSY MAIN) operate properly? Checked by [Digital Output] - [DO-0] in [IOT Diag] of diagnosis. During this check, cheat the interlock switch (HARN ASSY INTERLOCK).</p>	Go to step 15.	Go to step 24.
15	<p>Checking after reseating the TRANSFER ASSY Reseat the TRANSFER ASSY. Does the error still occur when printing?</p> 	Replace the TRANSFER ASSY. (Refer to Removal 21/ Replacement 33.)	End of work.

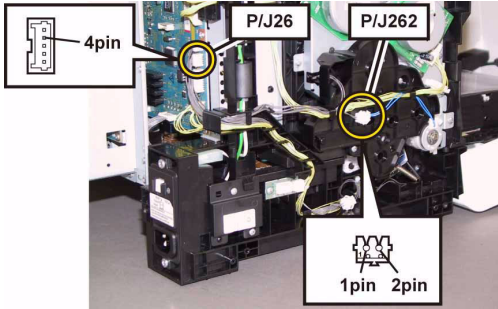
Step	Check	Remedy	
		Yes	No
16	Checking the connectors of the SENSOR PHOTO (Regi Sensor) for connection Check the connections between the PWBA MCU and SENSOR PHOTO. Are P/J23 and P/J232 connected correctly?	Go to step 17.	Reconnect the connector(s) P/J23 and/or P/J232 correctly.
17	Checking the HARN ASSY L SIDE for continuity Disconnect J23 from the PWBA MCU. Disconnect J232 from the SENSOR PHOTO. Is each cable of J23 <=> J232 continuous?	Go to step 18.	Replace the HARN ASSY L SIDE.
18	Checking the power to the SENSOR PHOTO Disconnect J23 from the PWBA MCU. Is the voltage across P23-3pin <=> ground on the PWBA MCU, about +3.3 VDC?	Go to step 19.	Replace the PWBA MCU. (Refer to Removal 43/ Replacement 11.)
19	Checking the SENSOR PHOTO for operation Check the voltage across 23-5pin <=> ground on the PWBA MCU. Remove the CHUTE LOW (PL3.2.27) once to check the operation. Does the voltage change, when the actuator of the SENSOR PHOTO is operated?	Replace the PWBA MCU. (Refer to Removal 43/ Replacement 11.)	Replace the SENSOR PHOTO.
20	Checking the connectors of the CLUTCH ASSY DRV (Regi Clutch) for connection Check the connections between the PWBA MCU and CLUTCH ASSY DRV (Regi Clutch). Are P/J26 and P/J262 connected correctly? 	Go to step 21.	Reconnect the connector(s) P/J26 and/or P/J262 correctly.
21	Checking the HARN ASSY KSNR REGCL for continuity Disconnect J26 from the PWBA MCU. Disconnect P262 from the CLUTCH ASSY DRV. Is each cable of J26 <=> P262 continuous?	Go to step 22.	Replace the HARN ASSY KSNR REGCL.
22	Checking the power to the CLUTCH ASSY DRV Disconnect J26 from the PWBA MCU. Is the voltage across P26-4pin <=> ground on the PWBA MCU, about +24 VDC when the Interlock Switch (HARN ASSY INTERLOCK) is pushed?	Go to step 23.	Replace the PWBA MCU. (Refer to Removal 43/ Replacement 11.)
23	Checking the CLUTCH ASSY DRV for resistance Disconnect P/J262 of the CLUTCH ASSY DRV. Is the resistance across J262-1 and J262-2 approximately 280-ohm?	Replace the PWBA MCU. (Refer to Removal 43/ Replacement 11.)	Replace the CLUTCH ASSY DRV. (Refer to Removal 30/ Replacement 24.)

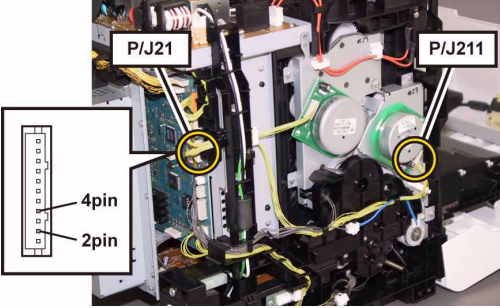
Step	Check	Remedy	
		Yes	No
24	<p>Checking the connectors for connection Check the connections between the PWBA MCU and DRIVE ASSY MAIN (Main Motor). Are P/J21 and P/J211 connected correctly?</p> 	Go to step 25.	Reconnect the connector(s) P/J21 and/or P/J211 correctly.
25	<p>Checking the HARN ASSY MAIN MOT for continuity Disconnect J21 from the PWBA MCU. Disconnect J211 from the DRIVE ASSY MAIN. Is each cable of J21 <=> J211 continuous?</p>	Go to step 26.	Replace the HARN ASSY MAIN MOT.
26	<p>Checking the power to the DRIVE ASSY MAIN Disconnect J21 from the PWBA MCU. Are the voltages across J21-2pin/J21-4pin <=> ground on the PWBA MCU, about +24 VDC when the interlock switch (HARN ASSY INTERLOCK) is pushed?</p>	Replace the DRIVE ASSY MAIN. (Refer to Removal 32/ Replacement 22.)	Replace the PWBA MCU. (Refer to Removal 43/ Replacement 11.)

FIP-1. 57 Paper Jam 077-907

Step	Check	Remedy	
		Yes	No
	Possible causative parts: HARN ASSY DUP RELAY (PL1.2.13) HARN ASSY L SIDE (PL3.1.18) HARN ASSY OPTION (PL3.1.20) ROLL ASSY REGI (PL3.2.9) ROLLREGI METAL (PL3.2.10/Regi Sensor (PL3.2.13) FUSER ASSY (PL6.1.1) PWBA MCU (PL8.2.13) FEEDER ASSY DUP (PL11.1.1)		
1	Checking the COVER ASSY FRONT for latching Open and close the COVER ASSY FRONT, then check the latching. Does the error still occur when printing?	Go to step 2.	End of work.
2	Checking after reseating the FUSER ASSY Reseat the FUSER ASSY. Warning: Start the operation after the FUSER ASSY has cooled down. Does the error still occur when printing?	Go to step 3.	End of work.
3	Checking after reseating the Duplex Reseat the Duplex. Does the error still occur when printing?	Go to step 4.	End of work.
4	Checking the DRIVE ASSY EXIT for operation Does the DRIVE ASSY EXIT operate properly? Checked by [Digital Output]-[DO-D] on [IOT Diag] of diagnosis. During this check, cheat the interlock switch (HARN ASSY INTERLOCK).	Go to step 5.	Replace FEEDER ASSY DUP.
5	Checking the DRIVE ASSY DUP for operation Does the DRIVE ASSY DUP operate properly? Checked by [Digital Output]-[DO-12] on [IOT Diag] of diagnosis. During this check, cheat the interlock switch (HARN ASSY INTERLOCK).	Go to step 6.	Replace FEEDER ASSY DUP.
6	Checking the Duplex Clutch for operation Does the Duplex Clutch operate properly? Checked by [Digital Output]-[DO-35] on [IOT Diag] of diagnosis. During this check, cheat the interlock switch (HARN ASSY INTERLOCK).	Go to step 7.	Replace FEEDER ASSY DUP.
7	Checking the SENSOR PHOTO (REGI SENSOR) for operation Does the number on the screen increase by one, every time the actuator of the SENSOR PHOTO (REGI SENSOR) is operated? Checked by [Digital Input]-[DI-2] in [IOT Diagnosis] of diagnosis.	Go to step 8.	Go to step 11.

Step	Check	Remedy	
		Yes	No
8	Checking the ROLL ASSY REGI and ROLL REGI METAL for shape and operation Remove the PHD UNIT once to check the followings. Are ROLL ASSY REGI and ROLL REGI METAL seated correctly? Also, are they not contaminated and/or damaged, and rotated smoothly? Check these items by turning with your finger.	Go to step 9.	Clean or replace the defective ROLL(s).
9	Checking the HARN ASSY OPTION for continuity Disconnect J127 from PWBA MCU. Disconnect P271 from HARN ASSY DUP RELAY. Is each cable of J127 <=> P271 continuous?	Go to step 10.	Replace HARN ASSY OPTION.
10	Checking the HARN ASSY DUP RELAY for continuity Remove Duplex. Disconnect J271 from HARN ASSY OPTION. Is each cable of J127 <=> P272 continuous?	Go to step 16.	Replace HARN ASSY DUP RELAY.
11	Checking the connectors of the SENSOR PHOTO (Regi Sensor) for connection Check the connections between the PWBA MCU and SENSOR PHOTO. Are P/J23 and P/J232 connected correctly?	Go to step 12.	Reconnect the connector(s) P/J23 and/or P/J232 correctly.
12	Checking the connectors of the SENSOR PHOTO (Regi Sensor) for connection Check the connections between the PWBA MCU and SENSOR PHOTO. Are P/J23 and P/J232 connected correctly?	Go to step 13.	Reconnect the connector(s) P/J23 and/or P/J232 correctly.
13	Checking the HARN ASSY L SIDE for continuity Disconnect J23 from the PWBA MCU. Disconnect J232 from the SENSOR PHOTO. Is each cable of J23 <=> J232 continuous?	Go to step 14.	Replace the HARN ASSY L SIDE.
14	Checking the power to the SENSOR PHOTO Disconnect J23 from the PWBA MCU. Is the voltage across P23-3pin <=> ground on the PWBA MCU, about +3.3 VDC?	Go to step 15.	Replace the PWBA MCU. (Refer to Removal 43/ Replacement 11.)
15	Checking the SENSOR PHOTO for operation Check the voltage across 23-5pin <=> ground on the PWBA MCU. Remove the CHUTE LOW (PL3.2.27) once to check the operation. Does the voltage change, when the actuator of the SENSOR PHOTO is operated?	Replace the PWBA MCU. (Refer to Removal 43/ Replacement 11.)	Replace the Regi Sensor.
16	Checking after replacing FEEDER ASSY DUP Replace FEEDER ASSY DUP. Does the error still occur when printing?	Go to step 17.	End of work.
17	Checking after replacing FUSER ASSY Replace FUSER ASSY. Warning: Start the operation after the FUSER ASSY has cooled down. Does the error still occur when printing? NOTE: After replacement, be sure to clear life counter value.	Replace the PWBA MCU. (Refer to Removal 43/ Replacement 11.)	End of work.

FIP-1. 58 Ready to Print 091-402 / Replace PHD 091-935

Step	Check	Remedy	
		Yes	No
	Possible causative parts: PHD ASSY (PL4.1.21) PWBA MCU (PL8.2.13)		
1	Checking the life counter value of the PHD ASSY Does the life count value show the near of the end?	Replace the PHD ASSY. (Refer to Removal 4/ Replacement 50.)	Go to step 2.
2	Checking after reseating the PHD ASSY Reseat the PHD ASSY. Does the error still occur when the power is turned OFF and ON?	Go to step 3.	End of work.
3	Checking after replacing the PHD ASSY Replace the PHD ASSY. (Refer to Removal 4/Replacement 50.) CAUTION: Be sure to pull eight sealing tapes out from a new PHD ASSY before installation. Does the error still occur when the power is turned OFF and ON?	Replace the PWBA MCU. (Refer to Removal 43/ Replacement 11.)	End of work.



FIP-1.59 PHD 091-912

Step	Check	Remedy	
		Yes	No
	Possible causative parts: PHD ASSY (PL4.1.21) PWBA MCU (PL8.2.13)		
1	Checking the sealing tapes of the PHD ASSY staying Turn off the power, and open the COVER ASSY FRONT. Remove the PHD ASSY. Has the sealing tapes (total eight sealing tapes) been pulled out? After checking, reseal the PHD ASSY correctly.	Go to step 3.	Pull the sealing tapes out, then go to step 2.
2	Does the error still occur when the power is turned OFF and ON?	Go to step 3.	End of work.
3	Checking after replacing the PHD ASSY Replace the PHD ASSY. (Refer to Removal 4/Replacement 50.) CAUTION: Be sure to pull eight sealing tapes out from a new PHD ASSY before installation. Does the error still occur when the power is turned OFF and ON?	Replace the PWBA MCU. (Refer to Removal 43/ Replacement 11.)	End of work.

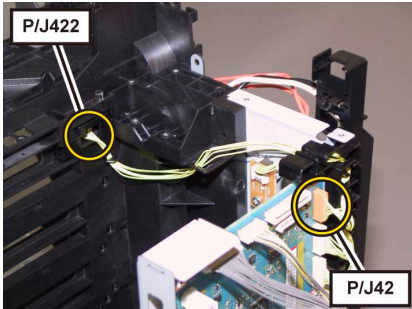
FIP-1. 60 Insert PHD 091-972

Step	Check	Remedy	
		Yes	No
	Possible causative parts: PHD ASSY (PL4.1.21) PWBA MCU (PL8.2.13) HARN ASSY PHD XPRO (PL9.1.11)		
1	Checking after reseating the PHD ASSY Reseat the PHD ASSY. Does the error still occur when the power is turned OFF and ON?	Go to step 2.	End of work.
2	Checking the connectors for connection Check the connectors between the PWBA MCU and PHD ASSY. Are P/J42 and P/J422 connected correctly? 	Go to step 4.	Reconnect the connector(s) P/J42 and/or P/J422 surly, then go to step 3.
3	Does the error still occur when the power is turned OFF and ON?	Go to step 4.	End of work.
4	Checking the HARN ASSY PHD XPRO for continuity Disconnect P422 from the PHD ASSY. Disconnect J42 from the PWBA MCU. Is each cable of P422 <=> J42 continuous?	Go to step 5.	Replace the HARN ASSY PHD XPRO.
5	Checking after replacing the PHD ASSY Replace the PHD ASSY. (Refer to Removal 4/Replacement 50.) CAUTION: Be sure to pull eight sealing tapes out from a new PHD ASSY before installation. Does the error still occur when the power is turned OFF and ON?	Replace the PWBA MCU. (Refer to Removal 43/ Replacement 11.)	End of work.

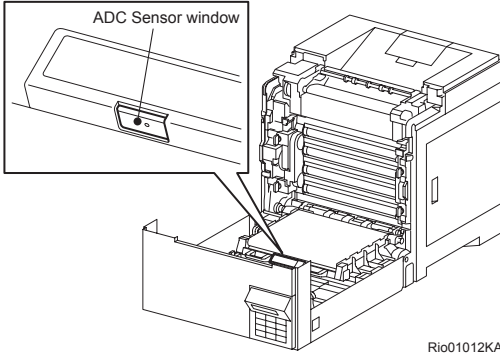
FIP-1. 61 CTD Sensor Dirty 092-310 / Ready to Print 092-410

Step	Check	Remedy	
		Yes	No
	Possible causative parts: HARN ASSY L SIDE (PL3.1.18) TRANSFER ASSY (PL6.1.7) PWBA MCU (PL8.2.13)		
1	Turn OFF the power, and gently wipe the CTD (ADC) Sensor window with a clean dry cloth or cotton swab. After wiping the window, close the COVER ASSY FRONT. Does the error still occur when the power is turned OFF and ON?  Rio01012KA	Go to step 2.	End of work.
2	Checking the connectors for connection Check the connectors between the PWBA MCU and CTD (ADC) Sensor. Are P/J28 and P/J281 connected correctly? 	Go to step 4.	Reconnect the connector(s) P/J28 and/or P/J281 correctly, then go to step 3.
3	Does the error still occur when the power is turned OFF and ON?	Go to step 4.	End of work.
4	Checking the HARN ASSY L SIDE for continuity Disconnect J28 from the PWBA MCU. Disconnect J281 from the TRANSFER ASSY. Is each cable of J28 <=> J281 continuous?	Go to step 5.	Replace the HARN ASSY L SIDE.
5	Checking the surface of the belt on the TRANSFER ASSY Is the belt dirty?	Clean the belt with a clean dry cloth, then go to step 6.	Go to step 7.
6	Does the error still occur when the power is turned OFF and ON?	Go to step 7.	End of work.
7	Checking after replacing the TRANSFER ASSY Replace the TRANSFER ASSY or CTD (ADC) Sensor. (Refer to Removal 21/Replacement 33.) Does the error still occur when the power is turned OFF and ON?	Replace the PWBA MCU. (Refer to Removal 43/ Replacement 11.)	End of work.

FIP-1. 62 Ready to Print 093-423 / Replace Cart. 093-930

Step	Check	Remedy	
		Yes	No
	Possible causative parts: TONER CARTRIDGE (Y) (PL5.1.24) PWBA MCU (PL8.2.13)		
1	Checking after replacing the Dell-TONER CARTRIDGE (Y) Replace the Dell-TONER CARTRIDGE (Y). (Refer to Removal 6/Replacement 48.) Does the error still occur when the power is turned OFF and ON?	Replace the PWBA MCU. (Refer to Removal 43/ Replacement 11.)	End of work.

FIP-1. 63 Ready to Print 093-424 / Replace Cart. 093-931

Step	Check	Remedy	
		Yes	No
	Possible causative parts: TONER CARTRIDGE (M) (PL5.1.23) PWBA MCU (PL8.2.13)		
1	Checking after replacing the Dell-TONER CARTRIDGE (M) Replace the Dell-TONER CARTRIDGE (M). (Refer to Removal 6/Replacement 48.) Does the error still occur when the power is turned OFF and ON?	Replace the PWBA MCU. (Refer to Removal 43/ Replacement 11.)	End of work.

FIP-1. 64 Ready to Print 093-425 / Replace Cart. 093-932

Step	Check	Remedy	
		Yes	No
	Possible causative parts: TONER CARTRIDGE (C) (PL5.1.22) PWBA MCU (PL8.2.13)		
1	Checking after replacing the Dell-TONER CARTRIDGE (C) Replace the Dell-TONER CARTRIDGE (C). (Refer to Removal 6/Replacement 48.) Does the error still occur when the power is turned OFF and ON?	Replace the PWBA MCU. (Refer to Removal 43/ Replacement 11.)	End of work.

FIP-1. 65 Ready to Print 093-426 / Replace Cart. 093-933

Step	Check	Remedy	
		Yes	No
	Possible causative parts: TONER CARTRIDGE (K) (PL5.1.21) PWBA MCU (PL8.2.13)		
1	Checking after replacing the Dell-TONER CARTRIDGE (K) Replace the Dell-TONER CARTRIDGE (K). (Refer to Removal 6/Replacement 48.) Does the error still occur when the power is turned OFF and ON?	Replace the PWBA MCU. (Refer to Removal 43/ Replacement 11.)	End of work.

FIP-1. 66 Shake Cartridge 093-919

Step	Check	Remedy	
		Yes	No
	Possible causative parts: PHD ASSY (PL4.1.21) DISPENSER ASSY (PL5.1.1) FRAME ASSY MOT (PL5.1.2) MOTOR ASSY DISP (PL5.1.3) GEAR IDLER (PL5.1.6) GEAR IDLER AUG (PL5.1.7) GEAR IDLER AGI (PL5.1.8) TONER CARTRIDGE (Y) (PL5.1.24) HARN ASSY TNR MOT (PL5.1.25) TRANSFER ASSY (PL6.1.7) PWBA MCU (PL8.2.13)		
1	Checking the Toner Type Is the Dell Toner seated?	Go to step 2.	Go to step 5.
2	Checking the sealing tapes on the PHD UNIT staying Are there sealing tapes on the PHD UNIT? 	Pull the tape out.	Go to step 3.
3	Checking the life count value of the TONER CARTRIDGE (Y) Check the life count value of the TONER CARTRIDGE (Y) in [Parameters] on the [CE Diag] tab of [CE Diag]. Does the remainder value shows the near of the end? (Refer to Chapter 2 for details of the life counter value.)	Replace the TONER CARTRIDGE (Y), then go to step 4. (Refer to Removal 6/ Replacement 48.)	Go to step 7.
4	Does the error still occur when the power is turned OFF and ON?	Go to step 7.	End of work.
5	Checking the toner remainder in the Non-Dell Toner Cartridge (Y) Is the toner that remains in the Non-Dell Toner Cartridge (Y) a little?	Replace the Non-Dell Toner Cartridge (Y), then go to step 6.	Go to step 7.
6	Does the error still occur when the power is turned OFF and ON?	Go to step 7.	End of work.
7	Checking the sealing tapes for yellow toner of the PHD ASSY staying Turn off the power, and open the COVER ASSY FRONT. Remove the PHD ASSY. Has the sealing tapes for yellow toner been pulled out? After checking, reseal the PHD ASSY.	Go to step 9.	Pull the sealing tapes out, then go to step 8.
8	Does the error still occur when the power is turned OFF and ON?	Go to step 9.	End of work.

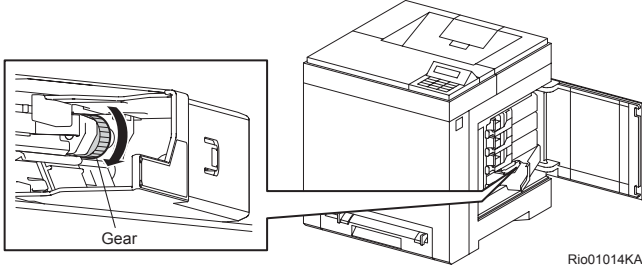
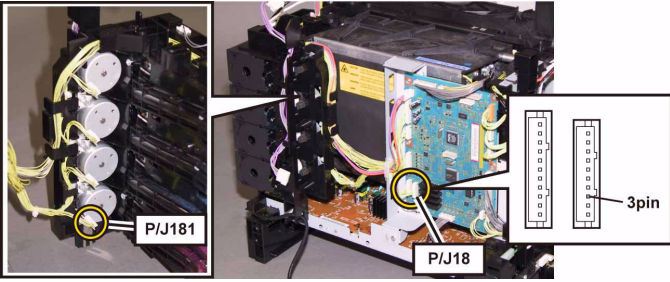
Step	Check	Remedy	
		Yes	No
9	<p>Checking after reseating the TONER CARTRIDGE (Y) Remove the TONER CARTRIDGE (Y), and shake it from side to side. Reseat the TONER CARTRIDGE (Y), and check that the lock key is in the lock position. Does the error still occur when the power is turned OFF and ON?</p>	Go to step 10.	End of work.
10	<p>Checking the TNR (Y) MOT (MOTOR ASSY DISP) for rotation Does the TNR (Y) MOT (MOTOR ASSY DISP) function normally? Checked by [Digital Output] - [DO-1F] in [IOT Diag] of diagnosis. During this check, cheat the interlock switch (HARN ASSY INTERLOCK).</p>	Go to step 11.	Go to step 12.
11	<p>Checking the gears of the DISPENSER ASSY for shape and operation Are the shape and operation of the gears of the DISPENSER ASSY normal?</p> 	Go to step 16.	Replace the defective gear(s) or DISPENSER ASSY. (Refer to Removal 44/ Replacement 10.)
12	<p>Checking the connector for connection Check the connectors between the PWBA MCU and TNR (Y) MOT (MOTOR ASSY DISP). Are P/J18 and P/J181 connected correctly?</p> 	Go to step 14.	Reconnect the connector(s) P/J18 and/or P/J181 surly, then go to step 13.
13	Does the error still occur when the power is turned OFF and ON?	Go to step 14.	End of work.
14	<p>Checking the HARN ASSY TNR MOT for continuity Disconnect J18 from the PWBA MCU. Disconnect J181 from the TNR (Y) MOT. Is each cable of J18 <=> J181 continuous?</p>	Go to step 15.	Replace the HARN ASSY TNR MOT.
15	<p>Checking the power to TNR (Y) MOT (MOTOR ASSY DISP) Disconnect J18 from the PWBA MCU. Is the voltage across P18-3pin <=> ground on PWBA MCU, about +24 VDC when the interlock switch (HARN ASSY INTERLOCK) is pushed.</p>	Replace the MOTOR ASSY DISP or FRAME ASSY MOT. (Refer to Removal 44/ Replacement 10.)	Replace the PWBA MCU. (Refer to Removal 43/ Replacement 11.)

Step	Check	Remedy	
		Yes	No
16	Checking after replacing the TONER CARTRIDGE (Y) Replace the TONER CARTRIDGE (Y), and check that the lock key is in the lock position. (Refer to Removal 6/Replacement 48.) Does the error still occur when the power is turned OFF and ON?	Go to step 17.	End of work.
17	Checking after replacing the PHD ASSY Replace the PHD ASSY. (Refer to Removal 4/Replacement 50.) Does the error still occur when the power is turned OFF and ON?	Go to step 18.	End of work.
18	Checking after reseating the TRANSFER ASSY Reseat the TRANSFER ASSY. Does the error still occur when the power is turned OFF and ON?	Replace the TRANSFER ASSY. (Refer to Removal 21/Replacement 33.)	End of work.

FIP-1. 67 Shake Cartridge 093-920

Step	Check	Remedy	
		Yes	No
	Possible causative parts: PHD ASSY (PL4.1.21) DISPENSER ASSY (PL5.1.1) FRAME ASSY MOT (PL5.1.2) MOTOR ASSY DISP (PL5.1.3) GEAR IDLER (PL5.1.6) GEAR IDLER AUG (PL5.1.7) GEAR IDLER AGI (PL5.1.8) TONER CARTRIDGE (M) (PL5.1.23) HARN ASSY TNR MOT (PL5.1.25) TRANSFER ASSY (PL6.1.7) PWBA MCU (PL8.2.13)		
1	Checking the Toner Type Is the Dell Toner seated?	Go to step 2.	Go to step 5.
2	Checking the sealing tapes on the PHD UNIT staying Are there sealing tapes on the PHD UNIT? 	Pull the tape out.	Go to step 3.
3	Checking the life count value of the TONER CARTRIDGE (M) Check the life count value of the TONER CARTRIDGE (M) in [Parameters] on the [CE Diag] tab of [CE Diag]. Does the remainder value shows the near of the end? (Refer to Chapter 2 for details of the life counter value.)	Replace the TONER CARTRIDGE (M), then go to step 4. (Refer to Removal 6/ Replacement 48.)	Go to step 7.
4	Does the error still occur when the power is turned OFF and ON?	Go to step 7.	End of work.
5	Checking the toner remainder in the Non-Dell Toner Cartridge (M) Is the toner that remains in the Non-Dell Toner Cartridge (M) a little?	Replace the Non-Dell Toner Cartridge (M), then go to step 6.	Go to step 7.
6	Does the error still occur when the power is turned OFF and ON?	Go to step 7.	End of work.
7	Checking the sealing tapes for magenta toner of the PHD ASSY staying Turn off the power, and open the COVER ASSY FRONT. Remove the PHD ASSY. Has the sealing tapes for magenta toner been pulled out? After checking, reseal the PHD ASSY.	Go to step 9.	Pull the sealing tapes out, then go to step 8.
8	Does the error still occur when the power is turned OFF and ON?	Go to step 9.	End of work.

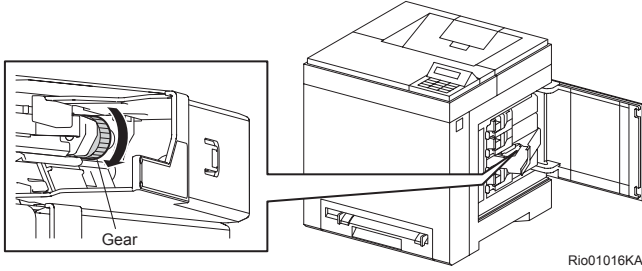
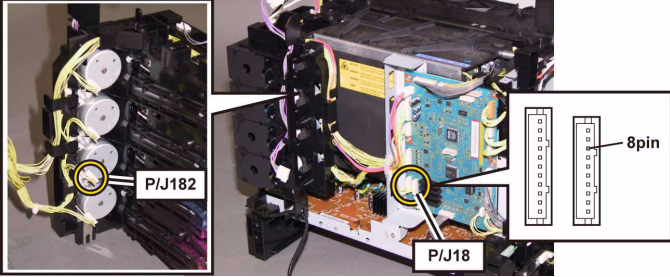
Step	Check	Remedy	
		Yes	No
9	<p>Checking after reseating the TONER CARTRIDGE (M) Remove the TONER CARTRIDGE (M), and shake it from side to side. Reseat the TONER CARTRIDGE (M), and check that the lock key is in the lock position. Does the error still occur when the power is turned OFF and ON?</p>	Go to step 10.	End of work.
10	<p>Checking the TNR (M) MOT (MOTOR ASSY DISP) for rotation Does the TNR (M) MOT (MOTOR ASSY DISP) function normally? Checked by [Digital Output] - [DO-21] in [IOT Diag] of diagnosis. During this check, cheat the interlock switch (HARN ASSY INTERLOCK).</p>	Go to step 11.	Go to step 12.
11	<p>Checking the gears of the DISPENSER ASSY for shape and operation Are the shape and operation of the gears of the DISPENSER ASSY normal?</p> 	Go to step 16.	Replace the defective gear(s) or DISPENSER ASSY. (Refer to Removal 44/ Replacement 10.)
12	<p>Checking the connector for connection Check the connectors between the PWBA MCU and TNR (M) MOT (MOTOR ASSY DISP). Are P/J18 and P/J182 connected correctly?</p> 	Go to step 14.	Reconnect the connector(s) P/J18 and/or P/J182 surly, then go to step 13.
13	<p>Does the error still occur when the power is turned OFF and ON?</p>	Go to step 14.	End of work.
14	<p>Checking the HARN ASSY TNR MOT for continuity Disconnect J18 from the PWBA MCU. Disconnect J182 from the TNR (M) MOT. Is each cable of J18 <=> J182 continuous?</p>	Go to step 15.	Replace the HARN ASSY TNR MOT.
15	<p>Checking the power to TNR (M) MOT (MOTOR ASSY DISP) Disconnect J18 from the PWBA MCU. Is the voltage across P18-8pin <=> ground on PWBA MCU, about +24 VDC when the interlock switch (HARN ASSY INTERLOCK) is pushed.</p>	Replace the MOTOR ASSY DISP or FRAME ASSY MOT. (Refer to Removal 44/ Replacement 10.)	Replace the PWBA MCU. (Refer to Removal 43/ Replacement 11.)

Step	Check	Remedy	
		Yes	No
16	Checking after replacing the TONER CARTRIDGE (M) Replace the TONER CARTRIDGE (M), and check that the lock key is in the lock position. (Refer to Removal 6/Replacement 48.) Does the error still occur when the power is turned OFF and ON?	Go to step 17.	End of work.
17	Checking after replacing the PHD ASSY Replace the PHD ASSY. (Refer to Removal 4/Replacement 50.) Does the error still occur when the power is turned OFF and ON?	Go to step 18.	End of work.
18	Checking after reseating the TRANSFER ASSY Reseat the TRANSFER ASSY. Does the error still occur when the power is turned OFF and ON?	Replace the TRANSFER ASSY. (Refer to Removal 21/Replacement 33.)	End of work.

FIP-1. 68 Shake Cartridge 093-921

Step	Check	Remedy	
		Yes	No
	Possible causative parts: PHD ASSY (PL4.1.21) DISPENSER ASSY (PL5.1.1) FRAME ASSY MOT (PL5.1.2) MOTOR ASSY DISP (PL5.1.3) GEAR IDLER (PL5.1.6) GEAR IDLER AUG (PL5.1.7) GEAR IDLER AGI (PL5.1.8) TONER CARTRIDGE (C) (PL5.1.22) HARN ASSY TNR MOT (PL5.1.25) TRANSFER ASSY (PL6.1.7) PWBA MCU (PL8.2.13)		
1	Checking the Toner Type Is the Dell Toner seated?	Go to step 2.	Go to step 5.
2	Checking the sealing tapes on the PHD UNIT staying Are there sealing tapes on the PHD UNIT? 	Pull the tape out.	Go to step 3.
3	Checking the life count value of the TONER CARTRIDGE (C) Check the life count value of the TONER CARTRIDGE (C) in [Parameters] on the [CE Diag] tab of [CE Diag]. Does the remainder value shows the near of the end? (Refer to Chapter 2 for details of the life counter value.)	Replace the TONER CARTRIDGE (C), then go to step 4. (Refer to Removal 6/ Replacement 48.)	Go to step 7.
4	Does the error still occur when the power is turned OFF and ON?	Go to step 7.	End of work.
5	Checking the toner remainder in the Non-Dell Toner Cartridge (C) Is the toner that remains in the Non-Dell Toner Cartridge (C) a little?	Replace the Non-Dell Toner Cartridge (C), then go to step 6.	Go to step 7.
6	Does the error still occur when the power is turned OFF and ON?	Go to step 7.	End of work.
7	Checking the sealing tapes for cyan toner of the PHD ASSY staying Turn off the power, and open the COVER ASSY FRONT. Remove the PHD ASSY. Has the sealing tapes for cyan toner been pulled out? After checking, reseal the PHD ASSY.	Go to step 9.	Pull the sealing tapes out, then go to step 8.
8	Does the error still occur when the power is turned OFF and ON?	Go to step 9.	End of work.

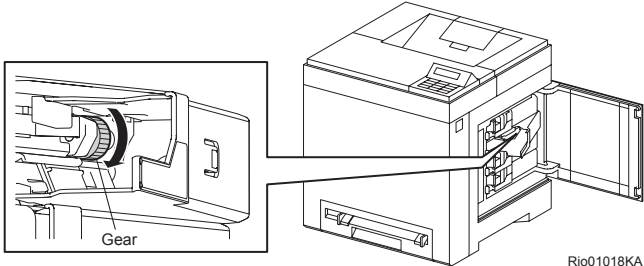
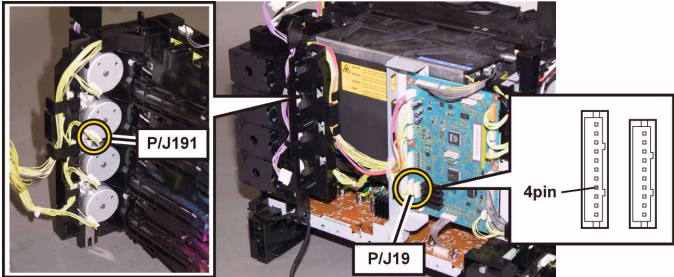
Step	Check	Remedy	
		Yes	No
9	<p>Checking after reseating the TONER CARTRIDGE (C) Remove the TONER CARTRIDGE (C), and shake it from side to side. Reseat the TONER CARTRIDGE (C), and check that the lock key is in the lock position. Does the error still occur when the power is turned OFF and ON?</p>	Go to step 10.	End of work.
10	<p>Checking the TNR (C) MOT (MOTOR ASSY DISP) for rotation Does the TNR (C) MOT (MOTOR ASSY DISP) function normally? Checked by [Digital Output] - [DO-23] in [IOT Diag] of diagnosis. During this check, cheat the interlock switch (HARN ASSY INTERLOCK).</p>	Go to step 11.	Go to step 12.
11	<p>Checking the gears of the DISPENSER ASSY for shape and operation Are the shape and operation of the gears of the DISPENSER ASSY normal?</p>  <p style="text-align: right; font-size: small;">Rio01018KA</p>	Go to step 16.	Replace the defective gear(s) or DISPENSER ASSY. (Refer to Removal 44/ Replacement 10.)
12	<p>Checking the connector for connection Check the connectors between the PWBA MCU and TNR (C) MOT (MOTOR ASSY DISP). Are P/J19 and P/J191 connected correctly?</p> 	Go to step 14.	Reconnect the connector(s) P/J19 and/or P/J191 surly, then go to step 13.
13	Does the error still occur when the power is turned OFF and ON?	Go to step 14.	End of work.
14	<p>Checking the HARN ASSY TNR MOT for continuity Disconnect J19 from the PWBA MCU. Disconnect J191 from the TNR (C) MOT. Is each cable of J19 <=> J191 continuous?</p>	Go to step 15.	Replace the HARN ASSY TNR MOT.
15	<p>Checking the power to TNR (C) MOT (MOTOR ASSY DISP) Disconnect J19 from the PWBA MCU. Is the voltage across P19-4pin <=> ground on PWBA MCU, about +24 VDC when the interlock switch (HARN ASSY INTERLOCK) is pushed.</p>	Replace the MOTOR ASSY DISP or FRAME ASSY MOT. (Refer to Removal 44/ Replacement 10.)	Replace the PWBA MCU. (Refer to Removal 43/ Replacement 11.)

Step	Check	Remedy	
		Yes	No
16	Checking after replacing the TONER CARTRIDGE (C) Replace the TONER CARTRIDGE (C), and check that the lock key is in the lock position. (Refer to Removal 6/Replacement 48.) Does the error still occur when the power is turned OFF and ON?	Go to step 17.	End of work.
17	Checking after replacing the PHD ASSY Replace the PHD ASSY. (Refer to Removal 4/Replacement 50.) Does the error still occur when the power is turned OFF and ON?	Go to step 18.	End of work.
18	Checking after reseating the TRANSFER ASSY Reseat the TRANSFER ASSY. Does the error still occur when the power is turned OFF and ON?	Replace the TRANSFER ASSY. (Refer to Removal 21/Replacement 33.)	End of work.

FIP-1. 69 Shake Cartridge 093-922

Step	Check	Remedy	
		Yes	No
	Possible causative parts: PHD ASSY (PL4.1.21) DISPENSER ASSY (PL5.1.1) FRAME ASSY MOT (PL5.1.2) MOTOR ASSY DISP (PL5.1.3) GEAR IDLER (PL5.1.6) GEAR IDLER AUG (PL5.1.7) GEAR IDLER AGI (PL5.1.8) TONER CARTRIDGE (K) (PL5.1.21) HARN ASSY TNR MOT (PL5.1.25) TRANSFER ASSY (PL6.1.7) PWBA MCU (PL8.2.13)		
1	Checking the Toner Type Is the Dell Toner seated?	Go to step 2.	Go to step 5.
2	Checking the sealing tapes on the PHD UNIT staying Are there sealing tapes on the PHD UNIT? 	Pull the tape out.	Go to step 3.
3	Checking the life count value of the TONER CARTRIDGE (K) Check the life count value of the TONER CARTRIDGE (K) in [Parameters] on the [CE Diag] tab of [CE Diag]. Does the remainder value shows the near of the end? (Refer to Chapter 2 for details of the life counter value.)	Replace the TONER CARTRIDGE (K), then go to step 4. (Refer to Removal 6/ Replacement 48.)	Go to step 7.
4	Does the error still occur when the power is turned OFF and ON?	Go to step 7.	End of work.
5	Checking the toner remainder in the Non-Dell Toner Cartridge (K) Is the toner that remains in the Non-Dell Toner Cartridge (K) a little?	Replace the Non-Dell Toner Cartridge (K), then go to step 6.	Go to step 7.
6	Does the error still occur when the power is turned OFF and ON?	Go to step 7.	End of work.
7	Checking the sealing tapes for black toner of the PHD ASSY staying Turn off the power, and open the COVER ASSY FRONT. Remove the PHD ASSY. Has the sealing tapes for black toner been pulled out? After checking, reseal the PHD ASSY.	Go to step 9.	Pull the sealing tapes out, then go to step 8.
8	Does the error still occur when the power is turned OFF and ON?	Go to step 9.	End of work.

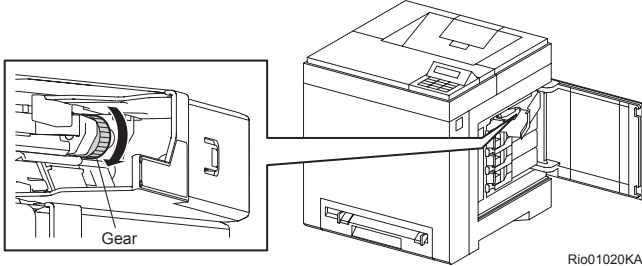
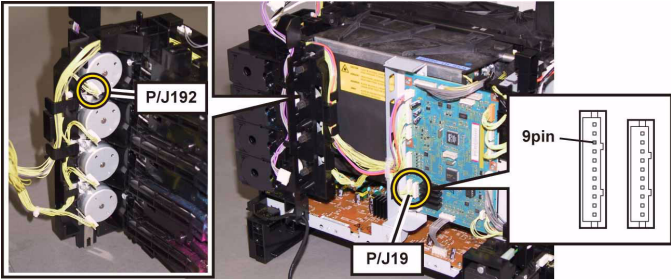
Step	Check	Remedy	
		Yes	No
9	<p>Checking after reseating the TONER CARTRIDGE (K) Remove the TONER CARTRIDGE (K), and shake it from side to side. Reseat the TONER CARTRIDGE (K), and check that the lock key is in the lock position. Does the error still occur when the power is turned OFF and ON?</p>	Go to step 10.	End of work.
10	<p>Checking the TNR (K) MOT (MOTOR ASSY DISP) for rotation Does the TNR (K) MOT (MOTOR ASSY DISP) function normally? Checked by [Digital Output] - [DO-25] in [IOT Diag] of diagnosis. During this check, cheat the interlock switch (HARN ASSY INTERLOCK).</p>	Go to step 11.	Go to step 12.
11	<p>Checking the gears of the DISPENSER ASSY for shape and operation Are the shape and operation of the gears of the DISPENSER ASSY normal?</p>  <p style="text-align: right; font-size: small;">Rio01020KA</p>	Go to step 16.	Replace the defective gear(s) or DISPENSER ASSY. (Refer to Removal 44/ Replacement 10.)
12	<p>Checking the connector for connection Check the connectors between the PWBA MCU and TNR (K) MOT (MOTOR ASSY DISP). Are P/J19 and P/J192 connected correctly?</p> 	Go to step 14.	Reconnect the connector(s) P/J19 and/or P/J192 surly, then go to step 13.
13	Does the error still occur when the power is turned OFF and ON?	Go to step 14.	End of work.
14	<p>Checking the HARN ASSY TNR MOT for continuity Disconnect J19 from the PWBA MCU. Disconnect J192 from the TNR (K) MOT. Is each cable of J19 <=> J192 continuous?</p>	Go to step 15.	Replace the HARN ASSY TNR MOT.
15	<p>Checking the power to TNR (K) MOT (MOTOR ASSY DISP) Disconnect J19 from the PWBA MCU. Is the voltage across P19-9pin <=> ground on PWBA MCU, about +24 VDC when the interlock switch (HARN ASSY INTERLOCK) is pushed.</p>	Replace the MOTOR ASSY DISP or FRAME ASSY MOT. (Refer to Removal 44/ Replacement 10.)	Replace the PWBA MCU. (Refer to Removal 43/ Replacement 11.)

Step	Check	Remedy	
		Yes	No
16	Checking after replacing the TONER CARTRIDGE (K) Replace the TONER CARTRIDGE (K), and check that the lock key is in the lock position. (Refer to Removal 6/Replacement 48.) Does the error still occur when the power is turned OFF and ON?	Go to step 17.	End of work.
17	Checking after replacing the PHD ASSY Replace the PHD ASSY. (Refer to Removal 4/Replacement 50.) Does the error still occur when the power is turned OFF and ON?	Go to step 18.	End of work.
18	Checking after reseating the TRANSFER ASSY Reseat the TRANSFER ASSY. Does the error still occur when the power is turned OFF and ON?	Replace the TRANSFER ASSY. (Refer to Removal 21/Replacement 33.)	End of work.

FIP-1. 70 Replace Cart. 093-934

Step	Check	Remedy	
		Yes	No
	Possible causative parts: TONER CARTRIDGE (Y) (PL5.1.24) PWBA MCU (PL8.2.13)		
1	Checking after replacing the Dell-TONER CARTRIDGE (Y) Replace the Dell-TONER CARTRIDGE (Y). (Refer to Removal 6/Replacement 48.) Does the error still occur when the power is turned OFF and ON?	Replace the PWBA MCU. (Refer to Removal 43/ Replacement 11.)	End of work.

FIP-1. 71 Replace Cart. 093-935

Step	Check	Remedy	
		Yes	No
	Possible causative parts: TONER CARTRIDGE (M) (PL5.1.23) PWBA MCU (PL8.2.13)		
1	Checking after replacing the Dell-TONER CARTRIDGE (M) Replace the Dell-TONER CARTRIDGE (M). (Refer to Removal 6/Replacement 48.) Does the error still occur when the power is turned OFF and ON?	Replace the PWBA MCU. (Refer to Removal 43/ Replacement 11.)	End of work.

FIP-1. 72 Replace Cart. 093-936

Step	Check	Remedy	
		Yes	No
	Possible causative parts: TONER CARTRIDGE (C) (PL5.1.22) PWBA MCU (PL8.2.13)		
1	Checking after replacing the Dell-TONER CARTRIDGE (C) Replace the Dell-TONER CARTRIDGE (C). (Refer to Removal 6/Replacement 48.) Does the error still occur when the power is turned OFF and ON?	Replace the PWBA MCU. (Refer to Removal 43/ Replacement 11.)	End of work.

FIP-1. 73 Replace Cart. 093-937

Step	Check	Remedy	
		Yes	No
	Possible causative parts: TONER CARTRIDGE (K) (PL5.1.21) PWBA MCU (PL8.2.13)		
1	Checking after replacing the Dell-TONER CARTRIDGE (K) Replace the Dell-TONER CARTRIDGE (K). (Refer to Removal 6/Replacement 48.) Does the error still occur when the power is turned OFF and ON?	Replace the PWBA MCU. (Refer to Removal 43/ Replacement 11.)	End of work.

FIP-1.74 CRUM ID 093-960

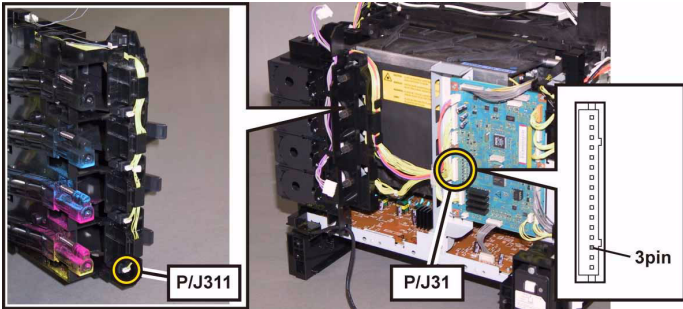
Step	Check	Remedy	
		Yes	No
	Possible causative parts: CONNECTOR CRUM (PL5.1.14) TONER CARTRIDGE (Y) (PL5.1.24) HARN ASSY TONER CRUM (PL5.1.26) PWBA MCU (PL8.2.13)		
1	Close the COVER ASSY WINDOW TNR correctly. Does the error still occur when the power is turned OFF and ON?	Go to step 2.	End of work.
2	Checking the Toner Type Is the Dell Toner seated?	Go to step 3.	Change the Toner Type setting to Non-Dell Toner.
3	Checking after reseating the TONER CARTRIDGE (Y) Reseat the TONER CARTRIDGE (Y), and check that the lock key is in the lock position. Does the error still occur when the power is turned OFF and ON?	Go to step 4.	End of work.
4	Checking after replacing the TONER CARTRIDGE (Y) Replace the TONER CARTRIDGE (Y), and check that the lock key is in the lock position. (Refer to Removal 6/ Replacement 48.) Does the error still occur when the power is turned OFF and ON?	Go to step 5.	End of work.
5	Checking the connector for connection Check the connectors between the PWBA MCU and CONNECTOR CRUM. Are P/J31 and P/J311 connected correctly? 	Go to step 7.	Reconnect the connector(s) P/J31 and/or P/J311 surly, then go to step 6.
6	Does the error still occur when the power is turned OFF and ON?	Go to step 7.	End of work.
7	Checking the HARN ASSY TONER CRUM for continuity Disconnect J31 from the PWBA MCU. Disconnect J311 from the CONNECTOR CRUM. Is each cable of J31 <=> J311 continuous?	Go to step 8.	Replace the HARN ASSY TONER CRUM.
8	Checking the power to CONNECTOR CRUM Disconnect J31 from the PWBA MCU. Is the voltage across P31-3pin <=> ground on the PWBA MCU, about +3.3 VDC?	Replace the CONNECTOR CRUM. (Refer to Removal 44/ Replacement 10.)	Replace the PWBA MCU. (Refer to Removal 43/ Replacement 11.)

FIP-1.75 CRUM ID 093-961

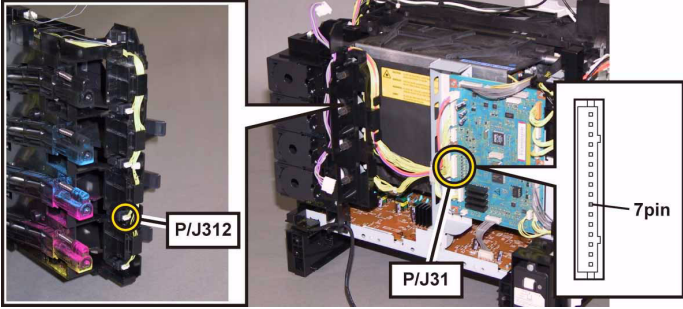
Step	Check	Remedy	
		Yes	No
	Possible causative parts: CONNECTOR CRUM (PL5.1.14) TONER CARTRIDGE (M) (PL5.1.23) HARN ASSY TONER CRUM (PL5.1.26) PWBA MCU (PL8.2.13)		
1	Close the COVER ASSY WINDOW TNR correctly. Does the error still occur when the power is turned OFF and ON?	Go to step 2.	End of work.
2	Checking the Toner Type Is the Dell Toner seated?	Go to step 3.	Change the Toner Type setting to Non-Dell Toner.
3	Checking after reseating the TONER CARTRIDGE (M) Reseat the TONER CARTRIDGE (M), and check that the lock key is in the lock position. Does the error still occur when the power is turned OFF and ON?	Go to step 4.	End of work.
4	Checking after replacing the TONER CARTRIDGE (M) Replace the TONER CARTRIDGE (M), and check that the lock key is in the lock position. (Refer to Removal 6/ Replacement 48.) Does the error still occur when the power is turned OFF and ON?	Go to step 5.	End of work.
5	Checking the connector for connection Check the connectors between the PWBA MCU and CONNECTOR CRUM. Are P/J31 and P/J312 connected correctly? 	Go to step 7.	Reconnect the connector(s) P/J31 and/or P/J312 surly, then go to step 6.
6	Does the error still occur when the power is turned OFF and ON?	Go to step 7.	End of work.
7	Checking the HARN ASSY TONER CRUM for continuity Disconnect J31 from the PWBA MCU. Disconnect J312 from the CONNECTOR CRUM. Is each cable of J31 <=> J312 continuous?	Go to step 8.	Replace the HARN ASSY TONER CRUM.
8	Checking the power to CONNECTOR CRUM Disconnect J31 from the PWBA MCU. Is the voltage across P31-7pin <=> ground on the PWBA MCU, about +3.3 VDC?	Replace the CONNECTOR CRUM. (Refer to Removal 44/ Replacement 10.)	Replace the PWBA MCU. (Refer to Removal 43/ Replacement 11.)

FIP-1.76 CRUM ID 093-962

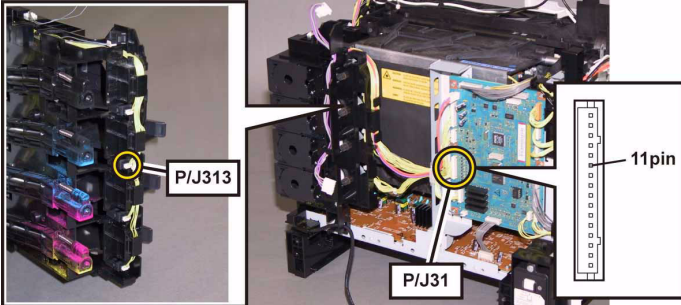
Step	Check	Remedy	
		Yes	No
	Possible causative parts: CONNECTOR CRUM (PL5.1.14) TONER CARTRIDGE (C) (PL5.1.22) HARN ASSY TONER CRUM (PL5.1.26) PWBA MCU (PL8.2.13)		
1	Close the COVER ASSY WINDOW TNR correctly. Does the error still occur when the power is turned OFF and ON?	Go to step 2.	End of work.
2	Checking the Toner Type Is the Dell Toner seated?	Go to step 3.	Change the Toner Type setting to Non-Dell Toner.
3	Checking after reseating the TONER CARTRIDGE (C) Reseat the TONER CARTRIDGE (C), and check that the lock key is in the lock position. Does the error still occur when the power is turned OFF and ON?	Go to step 4.	End of work.
4	Checking after replacing the TONER CARTRIDGE (C) Replace the TONER CARTRIDGE (C), and check that the lock key is in the lock position. (Refer to Removal 6/ Replacement 48.) Does the error still occur when the power is turned OFF and ON?	Go to step 5.	End of work.
5	Checking the connector for connection Check the connectors between the PWBA MCU and CONNECTOR CRUM. Are P/J31 and P/J313 connected correctly? 	Go to step 7.	Reconnect the connector(s) P/J31 and/or P/J313 surly, then go to step 6.
6	Does the error still occur when the power is turned OFF and ON?	Go to step 7.	End of work.
7	Checking the HARN ASSY TONER CRUM for continuity Disconnect J31 from the PWBA MCU. Disconnect J313 from the CONNECTOR CRUM. Is each cable of J31 <=> J313 continuous?	Go to step 8.	Replace the HARN ASSY TONER CRUM.
8	Checking the power to CONNECTOR CRUM Disconnect J31 from the PWBA MCU. Is the voltage across P31-11pin <=> ground on the PWBA MCU, about +3.3 VDC?	Replace the CONNECTOR CRUM. (Refer to Removal 44/ Replacement 10.)	Replace the PWBA MCU. (Refer to Removal 43/ Replacement 11.)

FIP-1.77 CRUM ID 093-963

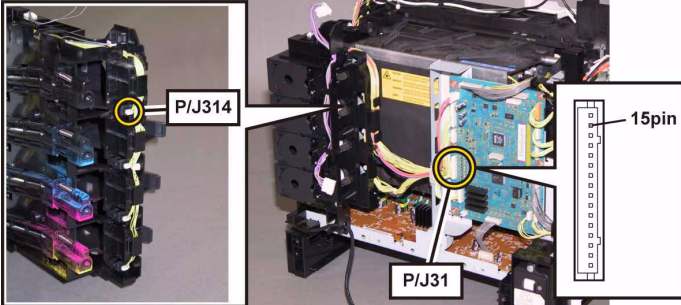
Step	Check	Remedy	
		Yes	No
	Possible causative parts: CONNECTOR CRUM (PL5.1.14) TONER CARTRIDGE (K) (PL5.1.21) HARN ASSY TONER CRUM (PL5.1.26) PWBA MCU (PL8.2.13)		
1	Close the COVER ASSY WINDOW TNR correctly. Does the error still occur when the power is turned OFF and ON?	Go to step 2.	End of work.
2	Checking the Toner Type Is the Dell Toner seated?	Go to step 3.	Change the Toner Type setting to Non-Dell Toner.
3	Checking after reseating the TONER CARTRIDGE (K) Reseat the TONER CARTRIDGE (K), and check that the lock key is in the lock position. Does the error still occur when the power is turned OFF and ON?	Go to step 4.	End of work.
4	Checking after replacing the TONER CARTRIDGE (K) Replace the TONER CARTRIDGE (K), and check that the lock key is in the lock position. (Refer to Removal 6/ Replacement 48.) Does the error still occur when the power is turned OFF and ON?	Go to step 5.	End of work.
5	Checking the connector for connection Check the connectors between the PWBA MCU and CONNECTOR CRUM. Are P/J31 and P/J314 connected correctly? 	Go to step 7.	Reconnect the connector(s) P/J31 and/or P/J314 surly, then go to step 6.
6	Does the error still occur when the power is turned OFF and ON?	Go to step 7.	End of work.
7	Checking the HARN ASSY TONER CRUM for continuity Disconnect J31 from the PWBA MCU. Disconnect J314 from the CONNECTOR CRUM. Is each cable of J31 <=> J314 continuous?	Go to step 8.	Replace the HARN ASSY TONER CRUM.
8	Checking the power to CONNECTOR CRUM Disconnect J31 from the PWBA MCU. Is the voltage across P31-15pin <=> ground on the PWBA MCU, about +3.3 VDC?	Replace the CONNECTOR CRUM. (Refer to Removal 44/ Replacement 10.)	Replace the PWBA MCU. (Refer to Removal 43/ Replacement 11.)

FIP-1.78 CRUM ID 093-965

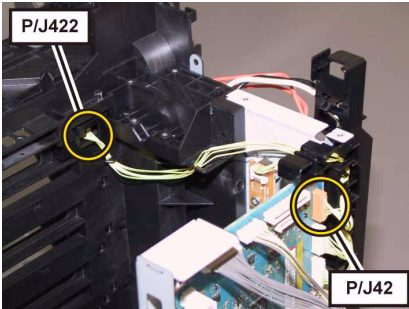
Step	Check	Remedy	
		Yes	No
	Possible causative parts: PHD ASSY (PL4.1.21) PWBA MCU (PL8.2.13) HARN ASSY PHD XPRO (PL9.1.11)		
1	Does the error still occur when the power is turned OFF and ON?	Go to step 2.	End of work.
2	Checking the PHD ASSY type Is the seated PHD ASSY for 1320c?	Go to step 4.	Replace the PHD ASSY for 1320c, then go to step 3.
3	Does the error still occur when the power is turned OFF and ON?	Go to step 4.	End of work.
4	Checking after reseating the PHD ASSY Reseat the PHD ASSY. Does the error still occur when the power is turned OFF and ON?	Go to step 5.	End of work.
5	Checking the connectors for connection Check the connectors between the PWBA MCU and PHD ASSY. Are P/J42 and P/J422 connected correctly?	Go to step 7.	Reconnect the connector(s) P/J42 and/or P/J422 surly, then go to step 6.
6	Does the error still occur when the power is turned OFF and ON?	Go to step 7.	End of work.
7	Checking the HARN ASSY PHD XPRO for continuity Disconnect P422 from the PHD ASSY. Disconnect J42 from the PWBA MCU. Is each cable of P422 <=> J42 continuous? 	Go to step 8.	Replace the HARN ASSY PHD XPRO.
8	Checking after replacing the PHD ASSY Replace the PHD ASSY. (Refer to Removal 4/Replacement 50.) Does the error still occur when the power is turned OFF and ON?	Replace the PWBA MCU. (Refer to Removal 43/ Replacement 11.)	End of work.

FIP-1. 79 Insert PrintCart 093-970

Step	Check	Remedy	
		Yes	No
	Possible causative parts: TONER CARTRIDGE (Y) (PL5.1.24) PWBA MCU (PL8.2.13)		
1	Does the error still occur when the power is turned OFF and ON?	Go to step 2.	End of work.
2	Checking the Toner Type Is the Dell Toner seated?	Go to step 3.	Change the Toner Type setting to Non-Dell Toner.
3	Checking after reseating the TONER CARTRIDGE (Y) Reseat the TONER CARTRIDGE (Y), and check that the lock key is in the lock position. Does the error still occur when the power is turned OFF and ON?	Go to step 4.	End of work.
4	Checking after replacing the TONER CARTRIDGE (Y) Replace the TONER CARTRIDGE (Y). (Refer to Removal 6/Replacement 48.) Does the error still occur when the power is turned OFF and ON?	Go to step 5.	End of work.
5	Checking the HARN ASSY TONER CRUM for continuity Disconnect J31 from the PWBA MCU. Disconnect J311 (Y) from the connector CRUM. Is each cable of J31 <=> J311 continuous?	Go to step 6.	Replace the HARN ASSY TONER CRUM
6	Checking after reseating the PWBA MCU Reseat the PWBA MCU. (Refer to Removal 43/Replacement 11.) Does the error still occur when the power is turned OFF and ON?	Replace the PWBA MCU. (Refer to Removal 43/Replacement 11.)	End of work.

FIP-1. 80 Insert PrintCart 093-971

Step	Check	Remedy	
		Yes	No
	Possible causative parts: TONER CARTRIDGE (M) (PL5.1.23) PWBA MCU (PL8.2.13)		
1	Does the error still occur when the power is turned OFF and ON?	Go to step 2.	End of work.
2	Checking the Toner Type Is the Dell Toner seated?	Go to step 3.	Change the Toner Type setting to Non-Dell Toner.
3	Checking after reseating the TONER CARTRIDGE (M) Reseat the TONER CARTRIDGE (M), and check that the lock key is in the lock position. Does the error still occur when the power is turned OFF and ON?	Go to step 4.	End of work.
4	Checking after replacing the TONER CARTRIDGE (M) Replace the TONER CARTRIDGE (M). (Refer to Removal 6/Replacement 48.) Does the error still occur when the power is turned OFF and ON?	Go to step 5.	End of work.
5	Checking the HARN ASSY TONER CRUM for continuity Disconnect J31 from the PWBA MCU. Disconnect J312 (M) from the connector CRUM. Is each cable of J31 <=> J312 continuous?	Go to step 6.	Replace the HARN ASSY TONER CRUM
6	Checking after reseating the PWBA MCU Reseat the PWBA MCU. (Refer to Removal 43/Replacement 11.) Does the error still occur when the power is turned OFF and ON?	Replace the PWBA MCU. (Refer to Removal 43/Replacement 11.)	End of work.

FIP-1. 81 Insert PrintCart 093-972

Step	Check	Remedy	
		Yes	No
	Possible causative parts: TONER CARTRIDGE (C) (PL5.1.22) PWBA MCU (PL8.2.13)		
1	Does the error still occur when the power is turned OFF and ON?	Go to step 2.	End of work.
2	Checking the Toner Type Is the Dell Toner seated?	Go to step 3.	Change the Toner Type setting to Non-Dell Toner.
3	Checking after reseating the TONER CARTRIDGE (C) Reseat the TONER CARTRIDGE (C), and check that the lock key is in the lock position. Does the error still occur when the power is turned OFF and ON?	Go to step 4.	End of work.
4	Checking after replacing the TONER CARTRIDGE (C) Replace the TONER CARTRIDGE (C). (Refer to Removal 6/Replacement 48.) Does the error still occur when the power is turned OFF and ON?	Go to step 5.	End of work.
5	Checking the HARN ASSY TONER CRUM for continuity Disconnect J31 from the PWBA MCU. Disconnect J313 (C) from the connector CRUM. Is each cable of J31 <=> J313 continuous?	Go to step 6.	Replace the HARN ASSY TONER CRUM
6	Checking after reseating the PWBA MCU Reseat the PWBA MCU. (Refer to Removal 43/Replacement 11.) Does the error still occur when the power is turned OFF and ON?	Replace the PWBA MCU. (Refer to Removal 43/Replacement 11.)	End of work.

FIP-1. 82 Insert PrintCart 093-973

Step	Check	Remedy	
		Yes	No
	Possible causative parts: TONER CARTRIDGE (K) (PL5.1.21) PWBA MCU (PL8.2.13)		
1	Does the error still occur when the power is turned OFF and ON?	Go to step 2.	End of work.
2	Checking the Toner Type Is the Dell Toner seated?	Go to step 3.	Change the Toner Type setting to Non-Dell Toner.
3	Checking after reseating the TONER CARTRIDGE (K) Reseat the TONER CARTRIDGE (K), and check that the lock key is in the lock position. Does the error still occur when the power is turned OFF and ON?	Go to step 4.	End of work.
4	Checking after replacing the TONER CARTRIDGE (K) Replace the TONER CARTRIDGE (K). (Refer to Removal 6/Replacement 48.) Does the error still occur when the power is turned OFF and ON?	Go to step 5.	End of work.
5	Checking the HARN ASSY TONER CRUM for continuity Disconnect J31 from the PWBA MCU. Disconnect J324 (K) from the connector CRUM. Is each cable of J31 <=> J324 continuous?	Go to step 6.	Replace the HARN ASSY TONER CRUM
6	Checking after reseating the PWBA MCU Reseat the PWBA MCU. (Refer to Removal 43/Replacement 11.) Does the error still occur when the power is turned OFF and ON?	Replace the PWBA MCU. (Refer to Removal 43/Replacement 11.)	End of work.

FIP-1. 83 Ready to Print 094-422 / 094-911 Contact Support

Step	Check	Remedy	
		Yes	No
	Possible causative parts: HARN ASSY L SIDE (PL3.1.18) TRANSFER ASSY (PL6.1.7) PWBA MCU (PL8.2.13)		
1	Does the error still occur when the power is turned OFF and ON?	Go to step 2.	End of work.
2	Checking the life counter value of the TRANSFER ASSY Does the life counter value show the near of the end? (Refer to Chapter 2 for details of the life counter value.)	Initialize the life counter value at the CE Diag., after replacing the TRANSFER ASSY. (Refer to Removal 21/ replacement 33.)	Replace the PWBA MCU. (Refer to Removal 43/ Replacement 11.)

FIP-1. 84 Ready to Print 193-700

Step	Check	Remedy	
		Yes	No
	Possible causative parts: PWBA ESS (PL8.1.7)		
1	Checking the Toner Cartridge. Is the installed toner cartridge to the printer the DELL toner?	Go to step 2.	End of work.
2	Checking the printer setting Is the [Non-Dell Toner] of the [Maintenance] on the [Admin Menu] of the [SET UP] the [On]?	Set to the [Off].	Go to step 3.
3	Checking the Toner Cartridge Replace to the known good toner cartridges. Does the error still occur when turning on the power?	Replace the PWBA ESS. (Removal 34/ Replacement 17)	End of work.

4. Image Quality Trouble

4.1 Entry Chart for Image Quality Troubleshooting

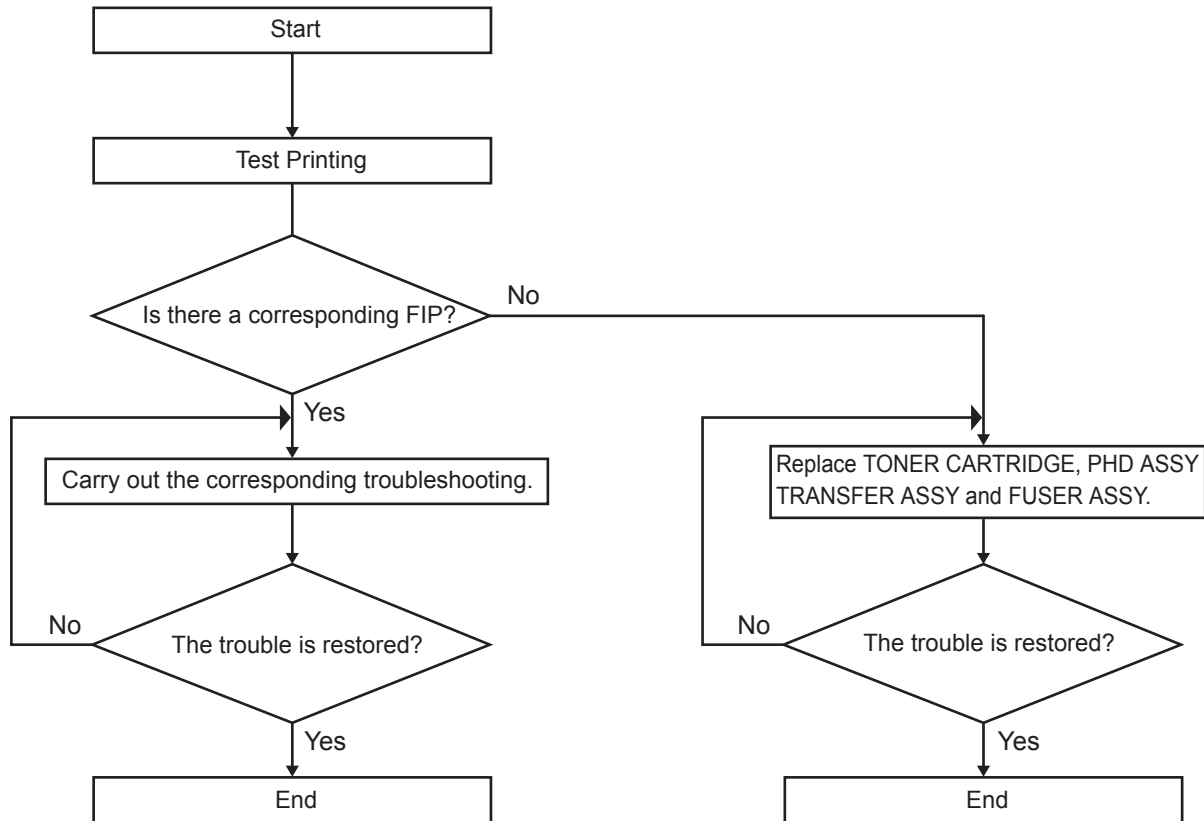

Leg_Sec001_001FA

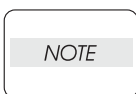

. It is stated as the ESS is normal. By operating test print with the Printer Engine only, if the trouble is on ESS side or the Printer Engine side can simply be diagnosed, except those phenomena that are not able to be diagnosed by test print.

- Test print result with the Printer Engine only is normal. --- >Malfunction on ESS side

- Test print result with the Printer Engine only is also abnormal. ---> Malfunction on the Printer Engine side

When it is the case of [Malfunction on ESS side], replace with normal ESS and normal Interface Cable, and check.

When the trouble still occurs after replacement, check the host side, and operate Troubleshooting efficiently, using the following image quality FIP according to each phenomenon.

When the image quality trouble of print occurs, get a print to judge, understand and treat the trouble substance precisely and appropriately, and then troubleshoot efficiently, using the image quality FIP table according to each phenomenon.

When trouble restorations with image quality FIP is not possible, check again with the image quality FIP, and then replace [Possible causative parts] in order and check, and operate Troubleshooting, using [Chapter 2 Diagnostic].

Image quality FIP states regarding the typical image quality trouble, as follows.

- FIP-1.P1 Faint print (Low contrast)
- FIP-1.P2 Blank print (No print)
- FIP-1.P3 Solid black
- FIP-1.P4 Vertical blank lines (White stripes in paper transport direction)
- FIP-1.P5 Horizontal band cross out (White stripes in the horizontal direction)
- FIP-1.P6 Vertical stripes
- FIP-1.P7 Horizontal stripes
- FIP-1.P8 Partial lack
- FIP-1.P9 Spots
- FIP-1.P10 Afterimage
- FIP-1.P11 Background (Fog)
- FIP-1.P12 Skew
- FIP-1.P13 Paper damage
- FIP-1.P14 No fix
- FIP-1.P15 Color registration (Color Shift)

NOTE

When horizontal lines and/or spot occur periodically, it is possibly caused by the trouble of a particular roll. In this case, compare the trouble intervals on the test print with the Pitch Chart. The interval does not necessarily match circumference of the roll. The trouble may be solved easily by the check.

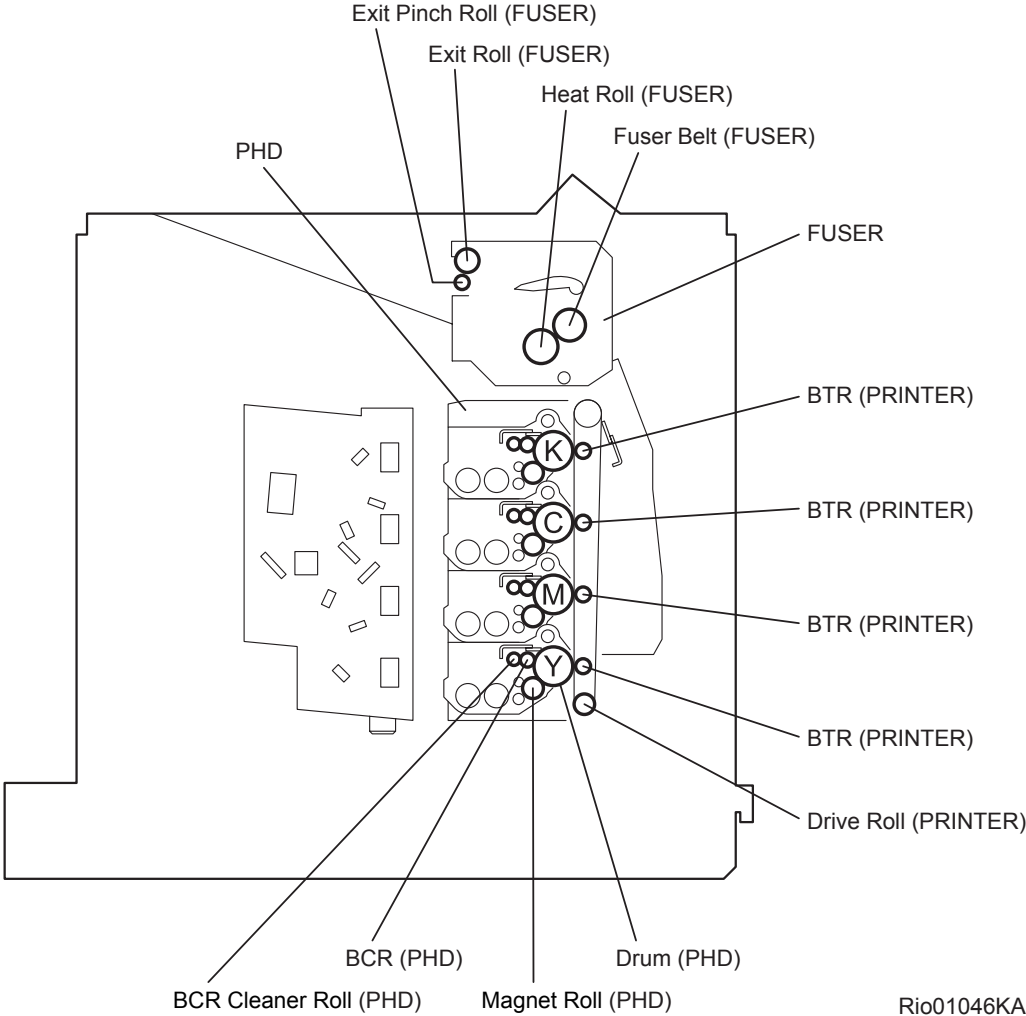

Rio01046KA

-Pitch Chart

The chart is printed [Contamination Check] in the [Diagnosis] tab of the [Tool Box].

Page 1

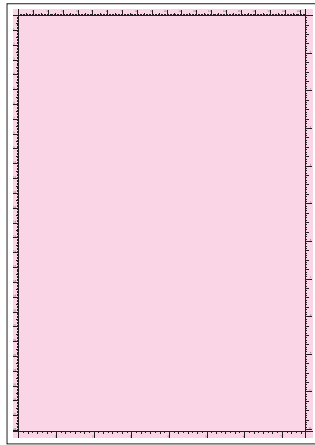

Wsb02028KA

Page 2

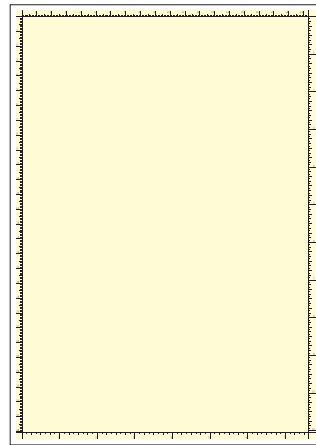

Wsb02027KA

Page 3

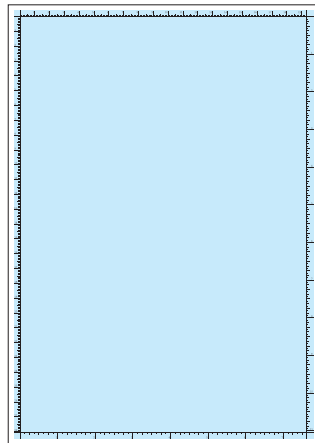

Wsb02029KA

Page 4



Wsb02030KA

Page 5

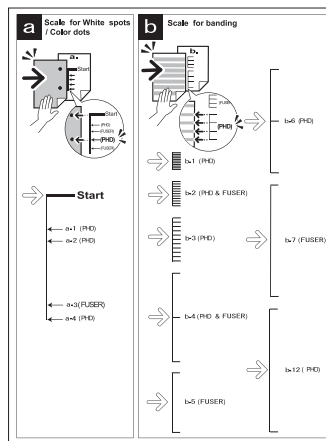

Wsb02025KA

4.2 Diagnosis Test Chart

The test charts to improve a defective image quality or to specify the cause of generation when a defective image was generated are in [Diagnosis] tab in [Tool Box].

Use the following test charts properly by the state of a defective image quality.

-PHD Refresh

When the result of [Contamination Check] corresponds to b-12 (PHD) of the pitch chart, performing this test print may improve image quality.

This chart is printed the [PHD Refresh Configuration Chart] of the [Diagnosis] tab in [Tool Box].

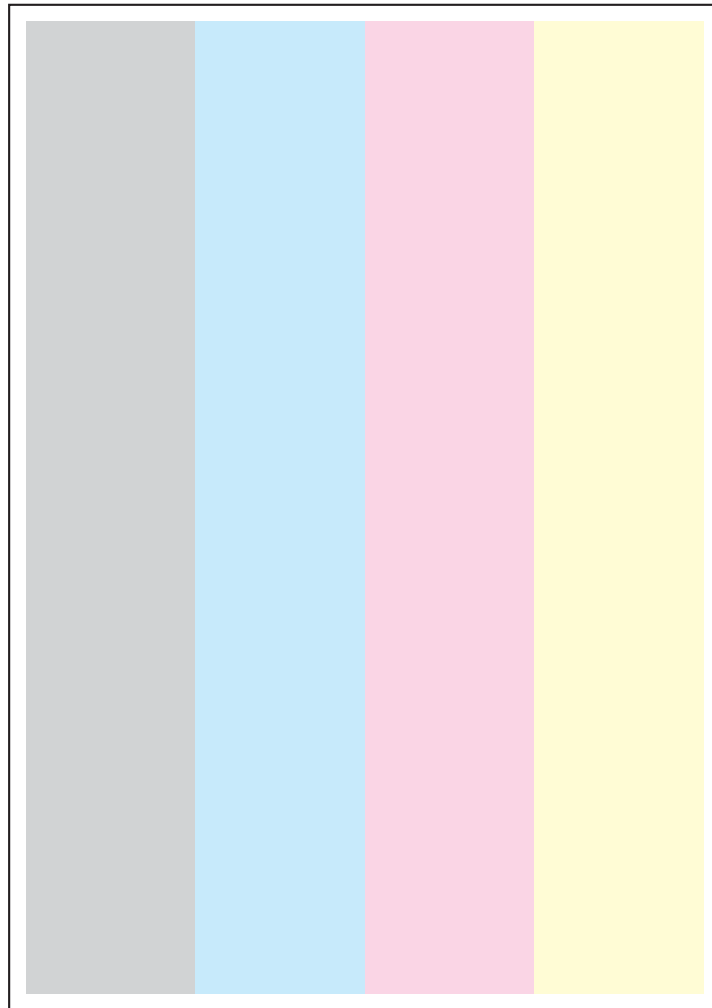

Wsb02021KA

-MQ Chart

This chart allows you to check for a banding if any occurs.

This chart is printed the [MQ Chart] of the [Diagnosis] tab in [Tool Box].

When the image quality is normal, the waves of Y, M, and C are confined within the frame. When the image quality is abnormal, the wave runs out the frame. Compare the pitch of the wave with the pitch chart of second page.

No	Roll Parts	Period (mm)	Replaceable parts
1	Heat Roll	66.7	Fuser
2	Drum	75.4	PHD ASSY
3	Mag Roll	37.7	PHD ASSY
4	Drive Roll	44.0	Printer
5	Regi Roll	37.6	Printer

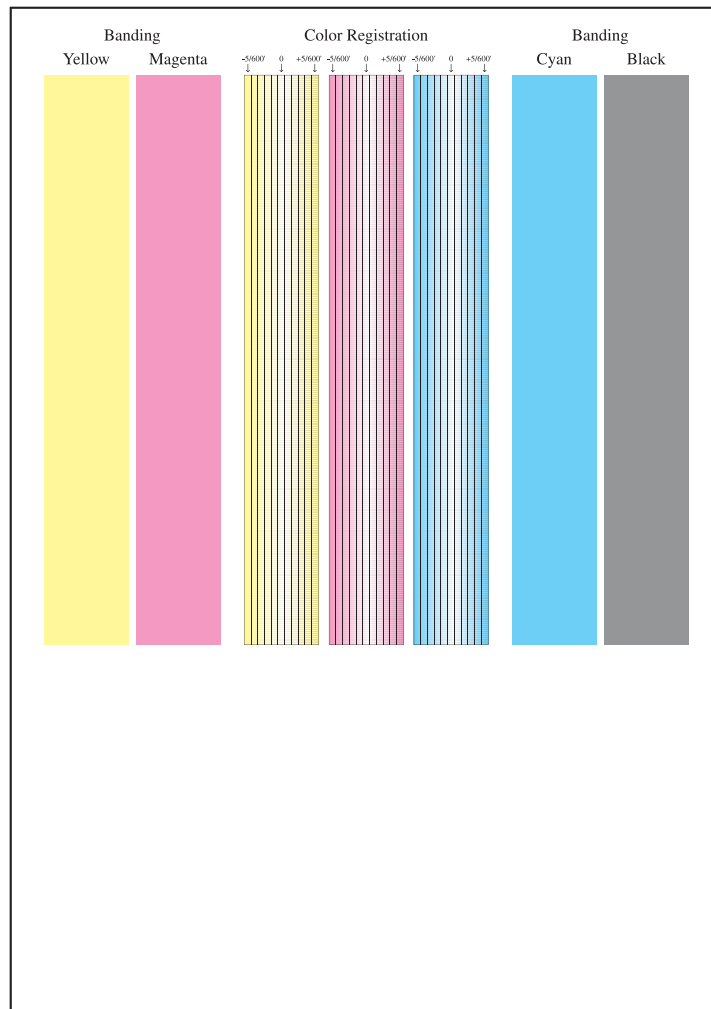

Wsb02024KA

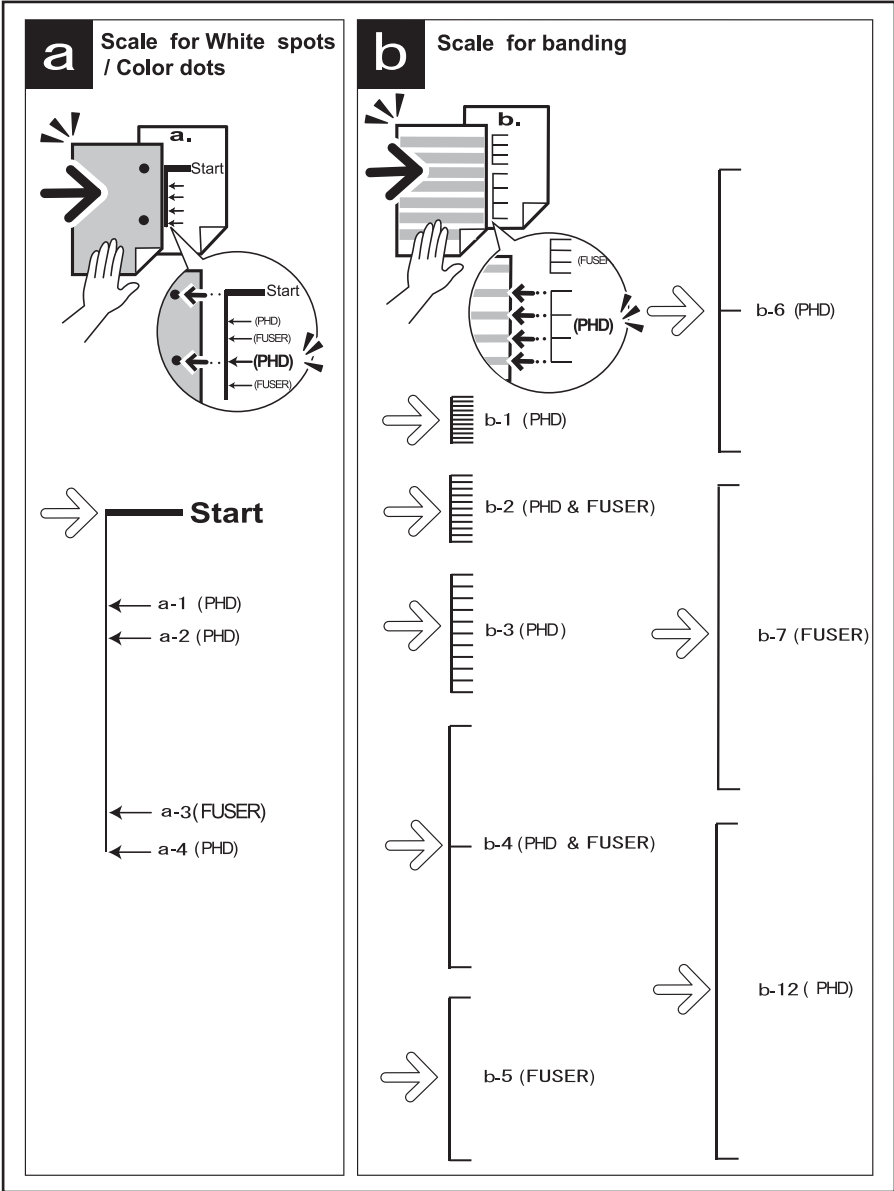

Wsb02025KA

-Alignment Chart

This chart allows you to check for the skewed paper if any occurs.
This chart is printed the [Alignment Chart] of the [Diagnosis] tab in [Tool Box].

When the sheet is fed normally, the vertical and horizontal lines are aligned parallel to the edges of the sheet. When there is a problem, this alignment is skewed.

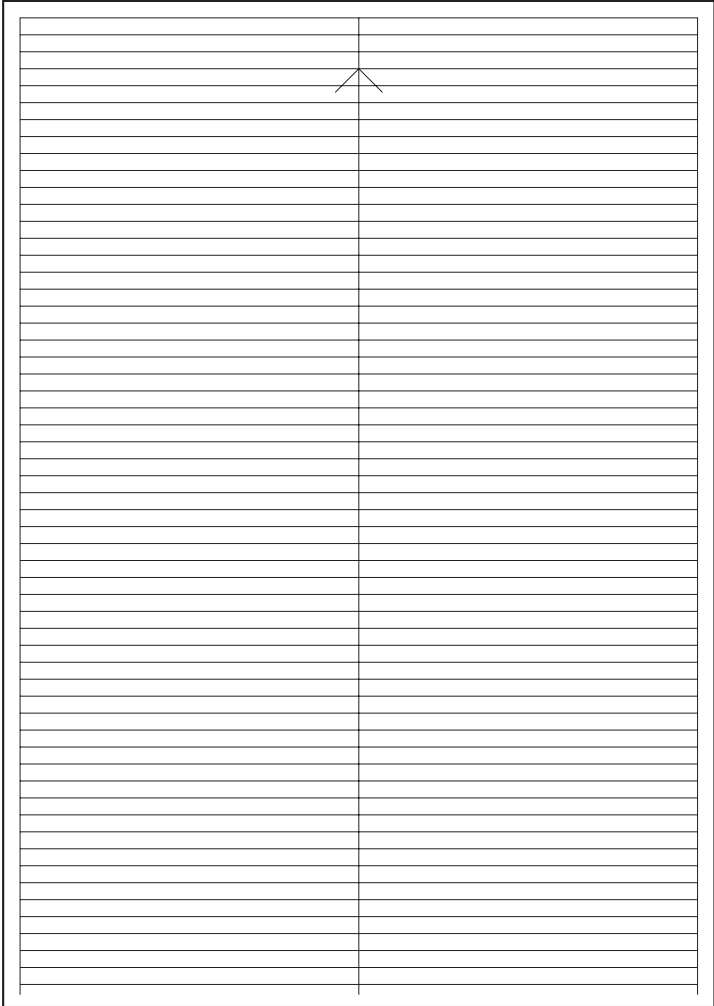

Wsb02022KA

-Ghost Chart

This chart allows you to check for a ghost if any occurs.

This chart is printed the [Ghost Configuratio Chart] of the [Diagnosis] tab in [Tool Box].

When a ghost occurs, the patches with open cross and character K/B/G/R/M/C appear on the light-colored patches K/C/M in the lower half of the chart, and the patches with open cross only appears on the dark-colored patches K/C/M below the light-colored patches.

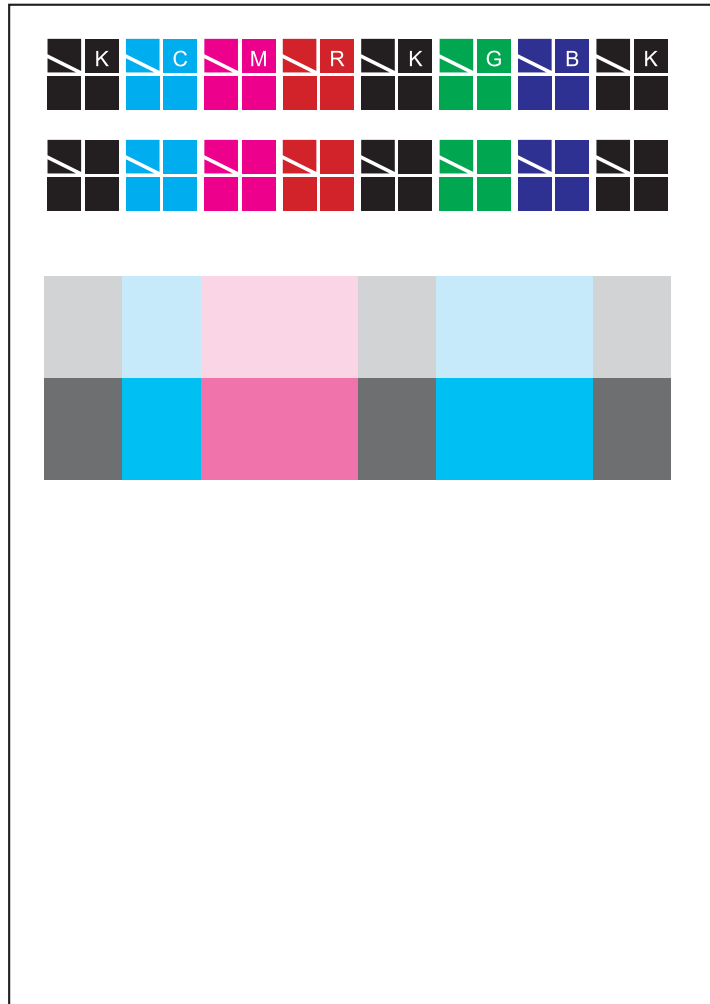

Wsb02020KA

4.3 Items to Be Confirmed Before Image Quality Troubleshooting

Print Quality Problems

Customers may need your help determining the cause of print quality issues such as streaking, fading, or dropouts. Here are some questions that may help you determine why your customer's printer is not printing optionally. First, confirm the following items to understand customer's operating condition.

- 1) Does your customer's print media fall within the Printer Media Guidelines? (Refer to "Printer Media Guidelines").
- 2) Is there enough toner?
- 3) Has the printer been cleaned recently?

Checking printer condition

Toner

Low toner can cause print quality problems such as fading, streaking, white lines, or dropouts. Have your customer print a small document from a different application to replicate the problem and verify the amount of toner available for printing. When your customers print a document, the Laser Printer Status Monitor should display a dialog box that estimates the amount of toner left in the cartridge.

If the toner is low, your customers can sometimes extend the cartridge life by removing the cartridge from the printer, gently shaking it from side-to-side, and replacing it (Rocking the toner cartridge from side-to-side loosens toner that may get stuck).

Cleaning

Paper, toner, and dust particles can accumulate inside the printer and cause print quality problems, such as smearing or toner specks. Clean inside the printer to prevent these problems.

Prior checks before troubleshooting

Check the following items if any print quality problems occur before going to each troubleshooting. Those actions may solve problems easily and simply.

If the any problems below have occurred, check and take actions described in each item.

- 1) Color is out of alignment:
 - a) Clean inside of the printer.
 - b) If you install a new black cartridge and a PHD ASSY cleaning has not been done, this problem will happen. Clean inside of the printer.
- 2) Print is too light
 - a) The toner may be low. Confirm the amount of the toner and change the toner cartridges if necessary.
 - b) Set the Toner Saving Mode check box to off in the [Advanced] tab on the printer driver.
 - c) If you are printing on an uneven print surface, change the Paper Type settings in the Tray Settings menu.
 - d) Verify that the correct print media is being used.
 - e) The PHD ASSY needs to be replaced. Change the PHD ASSY.
- 3) Toner smears or print comes off page:
 - a) If you are printing on an uneven print surface, change the Paper Type settings in the Tray Settings menu.
 - b) Verify that the print media is within the printer specifications. (Refer to "Printer Media Guidelines").

- 4) Toner spots appear on the page/printing is blurred:
 - a) Check the toner cartridge to make sure it is installed correctly.
 - b) Change the toner cartridge.
- 5) Entire page is white:
 - a) Make sure the packaging material is removed from the toner cartridge.
 - b) Check the toner cartridge to make sure it is installed correctly.
 - c) The toner may be low. Change the toner cartridge.
- 6) Streaks appear on the page:
 - a) The toner may be low. Change the toner cartridge.
 - b) If you are using preprinted forms, make sure the toner can withstand temperatures of 0°C to 35°C.
- 7) Characters have jagged or uneven edges:
 - a) If you are using downloaded fonts, verify that the fonts are supported by the printer, the host computer, and the software program.
- 8) Part or all of the page prints in black:
 - a) Check the toner cartridge to make sure it is installed correctly.
- 9) The job prints, but the top and side margins are incorrect:
 - a) Make sure the Paper Size setting in the Tray Settings is correct.
 - b) Make sure the margins are set correctly in your software program.

4.4 Print Image Quality Specifications

Image Quality Guarantee Conditions

The image quality is specified and guaranteed under the following conditions.

1) Environmental Condition

Temperature: 5°C - 32°C

Humidity: 15% RH - 85% RH (85% RH at 28°C)

Note that defect may occur due to condensation after around 30 minutes if the printer is turned on in a critical environment.

2) Guaranteed Paper

The print image quality specified in this chapter should be guaranteed when the standard paper is fed from the cassette tray. The print image quality is evaluated on the maximum size of each standard paper.

Color print quality: X-Pression 24 lb paper

Black and White quality: 4200 paper

3) Paper condition

The paper used is flesh paper immediately after unpacked, which has been left in the operating environment for 12 hours before unpacking.

4) Printer condition

The print image quality specified in this chapter is guaranteed with the printer in normal condition.

5) Criterion for judgment

The print image quality is guaranteed with Spec. In rate = 90% ($\lambda = 90\%$).

6) For Color chart, Parallelism, Perpendicularity, Skew, Linearity, Magnification Error, Registration and Printed Guaranteed Area, refer to each chart below.

Chart

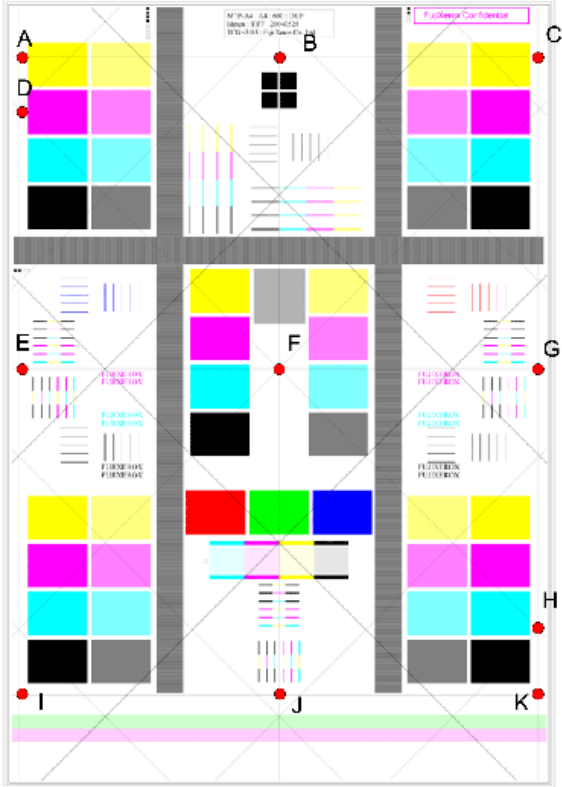

Parallelism

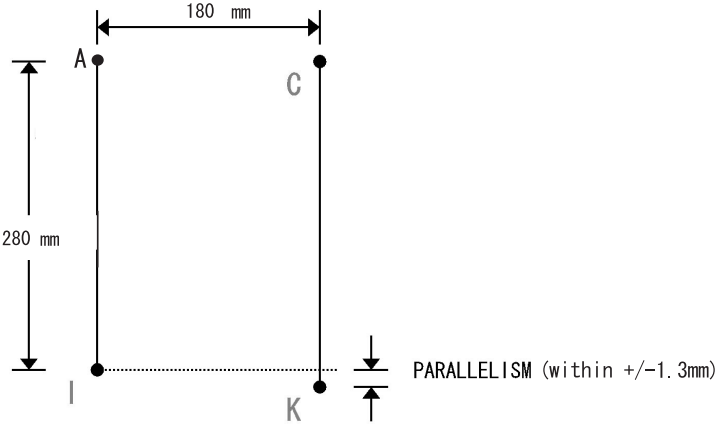

Perpendicularity

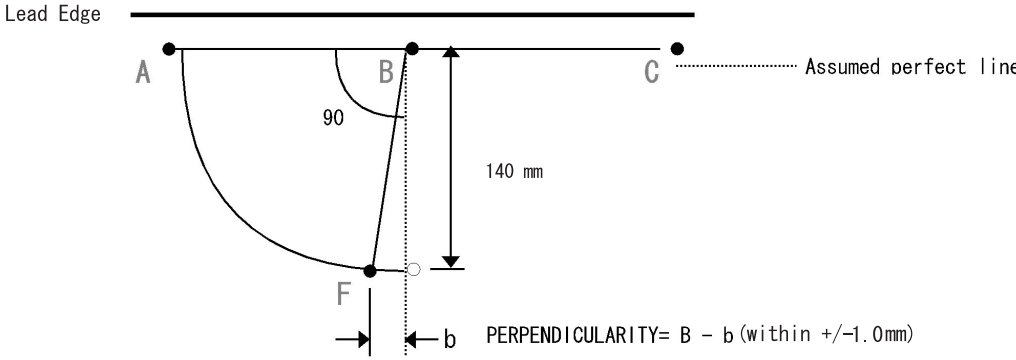

Skew

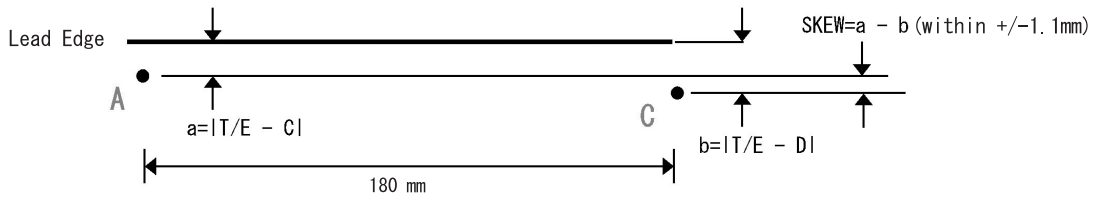

Linearity

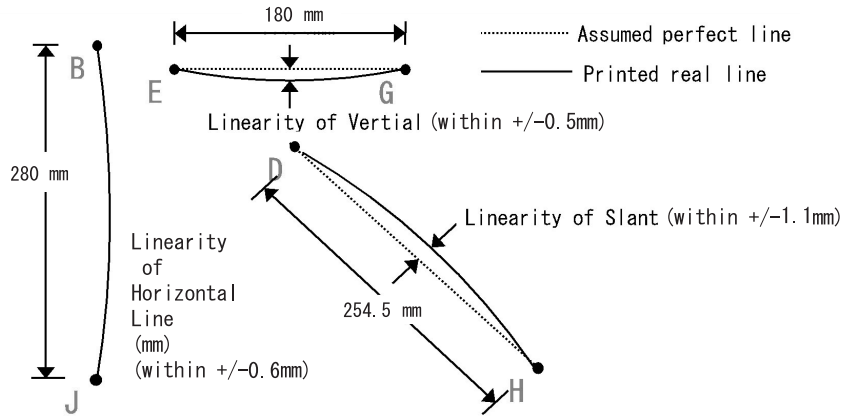

Magnification Error

Magnification = measured length ÷ Nominal
(within +/- 0.5%)

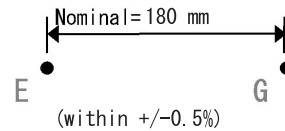
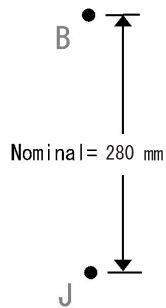

Registration

Registration = measured length - Nominal

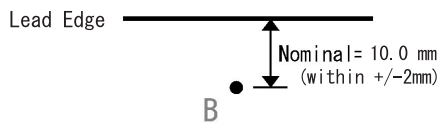

Side Edge (Left)

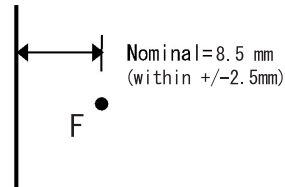

Guaranteed Printing Area

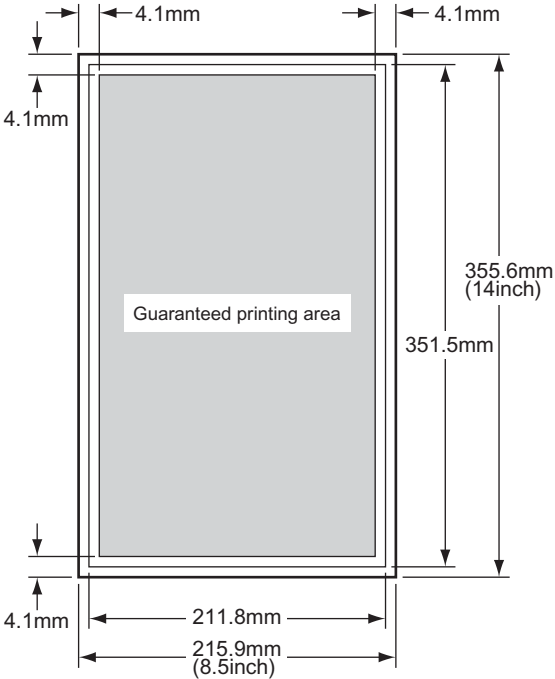

Rio01001KA

4.5 Image Quality FIP

FIP-1.P1 Faint print (Low contrast)

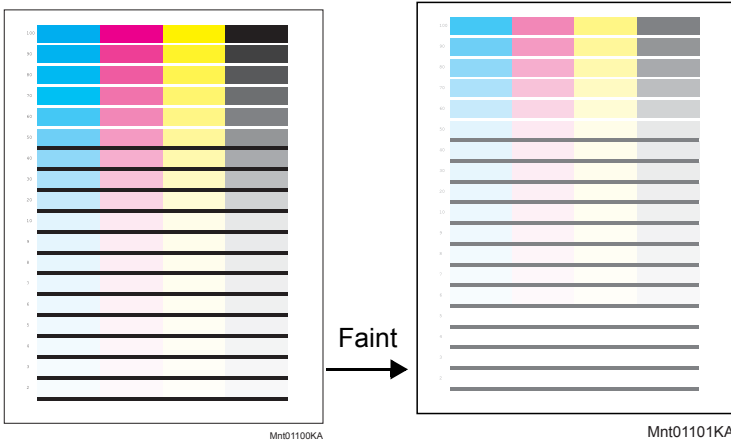

Trouble substance

The density of the image is entirely too faint.

ESS and possible causative parts

- ROS ASSY (PL4.1.1)
- PHD ASSY (PL4.1.21)
- FRAME ASSY MOT (PL5.1.2)
- MOTOR ASSY DISP (Y/M/C/K) (PL5.1.3)
- TONER CARTRIDGE K (PL5.1.21)
- TONER CARTRIDGE C (PL5.1.22)
- TONER CARTRIDGE M (PL5.1.23)
- TONER CARTRIDGE Y (PL5.1.24)
- TRANSFER ASSY (PL6.1.7)
- PWBA ESS (PL8.1.7)
- PWBA MCU (PL8.2.13)

Before commencing troubleshooting, check the paper transfer path. Make sure there is no foreign materials on the transfer path, such as staples, paper clips, scraps of paper and so on.

Step	Check	Remedy	
		Yes	No
1	Checking the Faint print. Print the Windows test page. Is the image printed correctly?	Check the printing data which the problem generated.	Go to step 2.
2	Checking the Toner Type Is the Dell Toner seated?	Go to step 3.	Replace the toner with the Dell toner.
3	Checking the sealing tapes on the PHD UNIT staying Turn off the power, and open the COVER ASSY FRONT. Remove the PHD UNIT. Are there sealing tapes on the PHD UNIT? 	Pull the sealing tapes out.	Go to step 4.

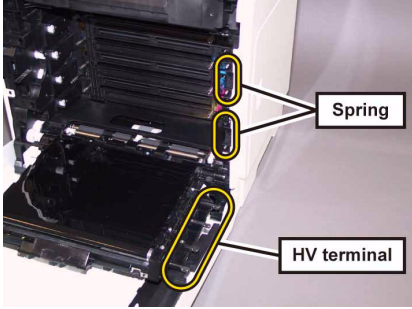
Step	Check	Remedy	
		Yes	No
4	Checking the paper condition Is the paper dry and recommended paper?	Go to step 6.	Replace the paper with a new dry and recommended one, then go to step 5.
5	Is the image printed correctly?	End of work.	Go to step 6.
6	Checking the menu settings Check the [Advanced] tab of the [Printing Preferences] on the [Properties] of the Printer Driver. Is the [Toner Saving Mode] selected?	Cancel the [Toner Saving Mode], then go to step 7.	Go to step 8.
7	Is the image printed correctly?	End of work.	Go to step 8.
8	Checking the faint color Is there the faint toner? Checked by [4 Colors Configuration Chart] of [Chart Print] in [Diagnosis] tab of [Tool Box].	Go to step 9.	Check the original printing data.
9	Checking after reseating the TONER CARTRIDGES Reseat the TONER CARTRIDGES, and check that their lock keys are in the lock positions. Is the image printed correctly?	End of work.	Go to step 10.
10	Checking the TRANSFER ASSY for connection Open the COVER ASSY FRONT. Are four HV terminals on the right side of the TRANSFER ASSY, and four springs on the frame (PL4.1.11, 12, 13 and 14) dirty and/or deformed? 	Clean or replace the TRANSFER ASSY or SPRING(s), then go to step 11.	Go to step 11.

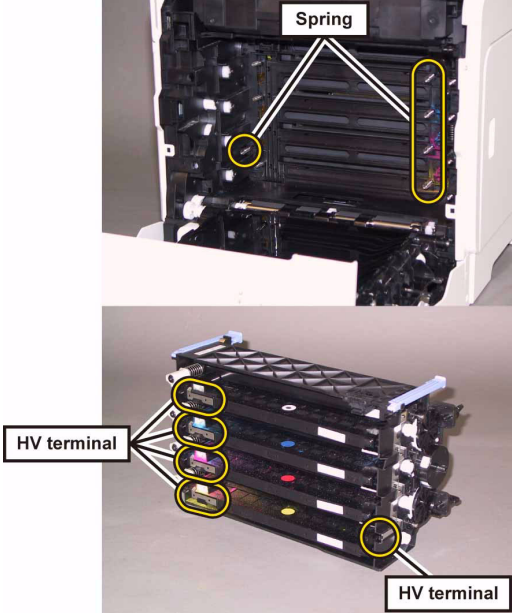
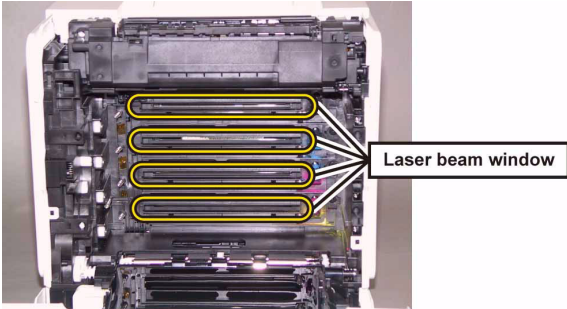
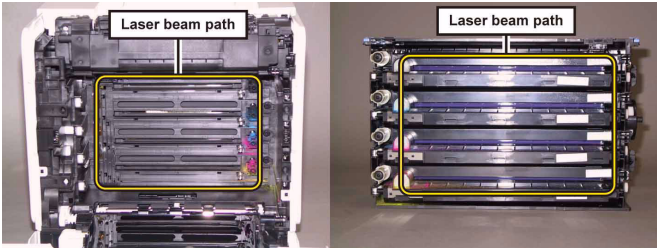
Step	Check	Remedy	
		Yes	No
11	<p>Checking the PHD ASSY for connection Remove the PHD ASSY. Are five HV terminals on the PHD ASSY, and five springs on the frame (PL4.1.10 and PL4.1.15 to 18) dirty and/or deformed?</p> 	Clean and/or replace the PHD ASSY or SPRING(s), then go to step 12.	Go to step 12.
12	<p>Checking after reseating the PHD ASSY Reseat the PHD ASSY. Is the image printed correctly?</p>	End of work.	Go to step 13.
13	<p>Checking the laser beam windows of the ROS ASSY Are the laser beam windows on the ROS ASSY clean?</p> 	Go to step 14.	Clean the window(s) with soft cloth or cotton swab gently.
14	<p>Checking the laser beam path Are there any foreign substances between the ROS ASSY and PHD ASSY?</p> 	Remove the foreign substances.	Go to step 15.

Step	Check	Remedy	
		Yes	No
15	Does the Toner Dispenser Motor function normally? Checked by [Digital Output] - [DO-1F(Y), DO-21(M), DO-23(C), DO-25(K)] in [IOT Diag] of diagnosis.	Go to step 17.	Replace the MOTOR ASSY DISP (Y, M, C or K) (refer to Removal 44/ Replacement 10), then go to step 16.
16	Is the image printed correctly?	End of work.	Replace the PWBA MCU. (Refer to Removal 43/ Replacement 11.)
17	Checking after reseating the PWBA MCU Reseat the PWBA MCU. Is the image printed correctly?	End of work.	Go to step 18.
18	Checking after reseating the PWBA ESS Reseat the PWBA ESS. Is the image printed correctly?	End of work.	Go to step 19.
19	Checking after reseating the TRANSFER ASSY Reseat the TRANSFER ASSY. Is the image printed correctly?	End of work.	Go to step 20.
20	Checking after replacing the TRANSFER ASSY Replace the TRANSFER ASSY. (Refer to Removal 21/ Replacement 33.) Is the image printed correctly?	End of work.	Go to step 21.
21	Checking after replacing the PHD ASSY Replace the PHD ASSY. (Refer to Removal 4/Replacement 50.) Is the image printed correctly?	End of work.	Go to step 22.
22	Checking after reseating the PWBA HVPS Reseat the PWBA HVPS. Is the image printed correctly?	End of work.	Go to step 23.
23	Checking after replacing the FRAME ASSY MOT Replace the FRAME ASSY MOT. (Refer to Removal 44/ Replacement 10.) Is the image printed correctly?	End of work.	Go to step 24.
24	Checking after replacing the ROS ASSY Replace the ROS ASSY. (Refer to Removal 45/ Replacement 9.) Is the image printed correctly?	End of work.	Replace the PWBA ESS. (Refer to Removal 42/ Replacement 12.)

FIP-1.P2 Blank print (No print)

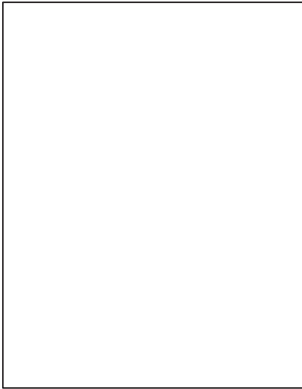
**Trouble substance**

The entire paper is printed pure white.

ESS and possible causative parts

- ROS ASSY (PL4.1.1)
- PHD ASSY (PL4.1.21)
- MOTOR ASSY DISP (Y/M/C/K) (PL5.1.3)
or FRAME ASSY MOT (PL5.1.2)
- TONER CARTRIDGE K (PL5.1.21)
- TONER CARTRIDGE C (PL5.1.22)
- TONER CARTRIDGE M (PL5.1.23)
- TONER CARTRIDGE Y (PL5.1.24)
- TRANSFER ASSY (PL6.1.7)
- DRIVE ASSY SUB (PL7.1.1)
- DRIVE ASSY MAIN (PL7.1.2)
- DRIVE ASSY PH (PL7.1.4)
- PWBA ESS (PL8.1.7)
- PWBA MCU (PL8.2.13)
- PWBA HYUI (PL13.4.1)

Before commencing troubleshooting, check the paper transfer path. Make sure there is no foreign materials on the transfer path, such as staples, paper clips, scraps of paper and so on.

Step	Check	Remedy	
		Yes	No
1	Checking the blank print. Print the contamination check page. Is the image printed correctly?	Printing data form is not suitable for the printer, then check the printing data which the problem generated.	Go to step 2.
2	Checking the Toner Type Is the Non-Dell Toner seated?	Replace the toner with the Dell toner, then go to step 3.	Go to step 4.
3	Is the image printed correctly?	End of work.	Replace the PWBA ESS. (Refer to Removal 42/ Replacement 12.)
4	Checking after reseating all TONER CARTRIDGES (Y/M/C/K) Reseat the TONER CARTRIDGES, and check that their lock keys are in the lock positions. Is the image printed correctly?	End of work.	Go to step 5.

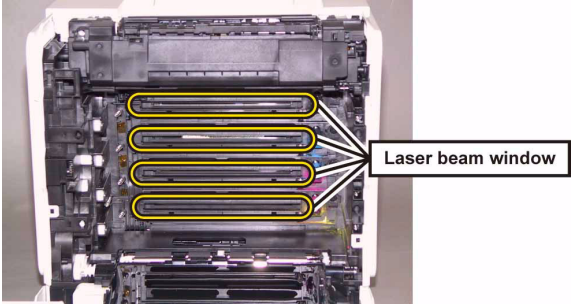
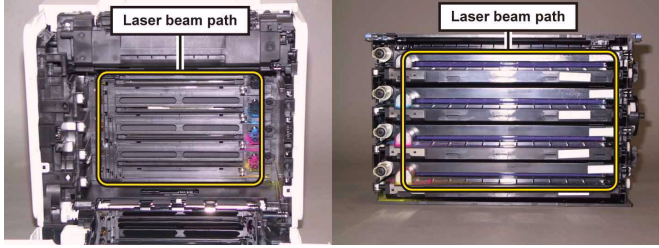
Step	Check	Remedy	
		Yes	No
5	Checking the TRANSFER ASSY for connection Open the COVER ASSY FRONT. Are four HV terminals on the TRANSFER ASSY, and four springs on the frame (PL4.1.11, 12, 13 and 14) dirty and/or deformed?	Clean or replace the TRANSFER ASSY or SPRING(s), then go to step 6.	Go to step 7.
6	Is the image printed correctly?	End of work.	Go to step 7.
7	Checking the paper condition Is the paper dry and recommended paper?	Go to step 9.	Replace the paper with a new dry and recommended one, then go to step 8.
8	Is the image printed correctly?	End of work.	Go to step 9.
9	Checking the life counter value of the TONER CARTRIDGES Check the life counter value of the TONER CARTRIDGES in [Parameters] on the [IOT Diag] of diagnosis. Does the remainder value show the near of the end? (Refer to Chapter 2 for details of the life counter value.)	Replace the TONER CARTRIDGE(s). (Refer to Removal 6/ Replacement 48.)	Go to step 10.
10	Checking the laser beam windows of the ROS ASSY Are the laser beam windows on the ROS ASSY clean? 	Go to step 11.	Clean the window(s) with soft cloth or cotton swab gently.
11	Checking the laser beam path Are there any foreign substances between the ROS ASSY and PHD ASSY? 	Remove the foreign substances.	Go to step 12.
12	Checking after reseating the PHD ASSY Reseat the PHD ASSY. Is the image printed correctly?	End of work.	Go to step 13.
13	Checking the Toner Dispenser Motors for function Does the Toner Dispenser Motors function normally? Checked by [Digital Output] - [DO-1F(Y), DO-21(M), DO-23(C), DO-25(K)] in [IOT Diag] of diagnosis.	Go to step 18.	Go to step 14.

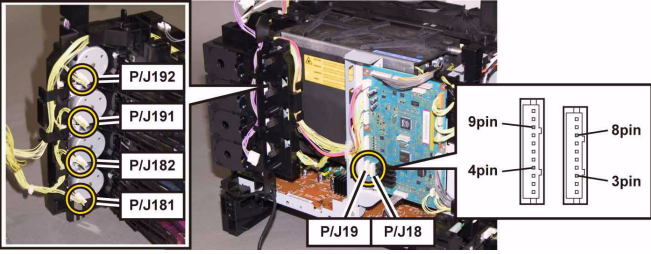
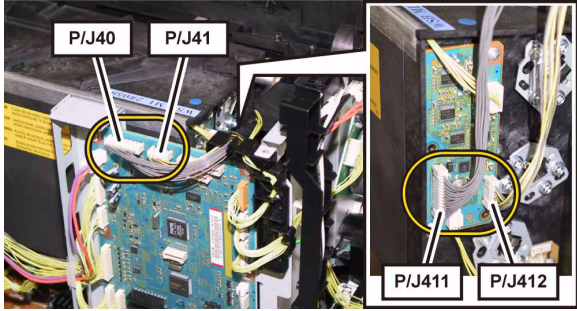
Step	Check	Remedy	
		Yes	No
14	<p>Checking the connector for connection Check the connectors between the PWBA MCU and TNR (Y/M/C/K) MOT (MOTOR ASSY DISP). Are P/J18, P/J19, P/J181, P/J182, P/J191 and P/J192 connected correctly?</p> 	Go to step 16.	Reconnect the connector(s) P/J18, P/J19, P/J181, P/J182, P/J191 and/or P/J192 surely, then go to step 15.
15	Is the image printed correctly?	End of work.	Go to step 16.
16	<p>Checking the HARN ASSY TNR MOT for continuity Disconnect J18 and J19 from the PWBA MCU. Disconnect J181, J182, J191 and J192 from the TNR (Y/M/C/K) MOT. Is each cable of J18 <=> J181 and J182 continuous? Is each cable of J19 <=> J191 and J192 continuous?</p>	Go to step 17.	Replace the HARN ASSY TNR MOT.
17	<p>Checking the power to TNR (Y/M/C/K) MOT (MOTOR ASSY DISP) Disconnect J18 and J19 from the PWBA MCU. Is the voltage across P18-3pin, P18-8pin, P19-4pin and P19-9pin <=> ground on PWBA MCU, about +24 VDC when the interlock switch (HARN ASSY INTERLOCK) is pushed.</p>	Replace the MOTOR ASSY DISP or FRAME ASSY MOT. (Refer to Removal 44/ Replacement 10.)	Replace the PWBA MCU. (Refer to Removal 43/ Replacement 11.)
18	<p>Checking the ROS ASSY for connection Check the connections between the ROS ASSY and PWBA MCU. Are P/J40, P/J41, P/J411 and P/J412 connected correctly?</p> 	Go to step 20.	Reconnect the connector(s) P/J40, P/J41, P/J411 and/or P/J412 surely, then go to step 19.
19	Is the image printed correctly?	End of work.	Go to step 20.
20	<p>Checking after reseating the PWBA MCU Reseat the PWBA MCU. Is the image printed correctly?</p>	End of work.	Go to step 21.
21	<p>Checking after reseating the PWBA ESS Reseat the PWBA ESS. Is the image printed correctly?</p>	End of work.	Go to step 22.
22	<p>Checking after reseating the TRANSFER ASSY Reseat the TRANSFER ASSY. Is the image printed correctly?</p>	End of work.	Go to step 23.

Step	Check	Remedy	
		Yes	No
23	Checking after replacing the PHD ASSY Replace the PHD ASSY. (Refer to Removal 4/Replacement 50.) Is the image printed correctly?	End of work.	Go to step 24.
24	Checking after replacing the TRANSFER ASSY Replace the TRANSFER ASSY. (Refer to Removal 21/ Replacement 33.) Is the image printed correctly?	End of work.	Go to step 25.
25	Checking after reseating the PWBA HVPS Reseat the PWBA HVPS. Is the image printed correctly?	End of work.	Go to step 26.
26	Checking after replacing the ROS ASSY Replace the ROS ASSY. (Refer to Removal 45/ Replacement 9.) Is the image printed correctly?	End of work.	Replace the PWBA ESS. (Refer to Removal 42/ Replacement 12.)

FIP-1.P3 Solid black

**Trouble substance**

The entire paper is printed jet-black.

ESS and possible causative parts

- ROS ASSY (PL4.1.1)
- PWBA HVPS (PL4.1.19)
- PHD ASSY (PL4.1.21)
- PWBA ESS (PL8.1.7)
- PWBA MCU (PL8.2.13)

Before commencing troubleshooting, check the paper transfer path. Make sure there is no foreign materials on the transfer path, such as staples, paper clips, scraps of paper and so on.

Step	Check	Remedy	
		Yes	No
1	Checking the solid black. Print the contamination check page. Is the image printed correctly?	Printing data is incorrect, then check the printing data which the problem generated.	Go to step 2.
2	Checking the Toner Type Is the Dell Toner seated?	Go to step 3.	Change the Toner Type setting to Non-Dell Toner.
3	Checking the printing Is the image printed correctly? Checked by [Test Print] - [Test Pattern 600] in diagnosis.	Go to step 4.	Go to step 5.
4	Checking the test printing Is the image printed correctly? Checked by printing the [TestPat (IOT)] in [Test Print] in [IOT Diag] of diagnosis.	Replace the PWBA ESS. (Refer to Removal 42/ Replacement 12.)	Go to step 5.
5	Checking the Grid2. Print the Grid2 page. Is the solid color printed? Checked by [Test Print] - [Grid2] in diagnosis.	Replace the toner cartridge of the color by which Solid was printed.	Go to step 6.
6	Checking after reseating the PWBA MCU Reseat the PWBA MCU. Is the image printed correctly?	End of work.	Go to step 7.
7	Checking after reseating the PWBA ESS Reseat the PWBA ESS. Is the image printed correctly?	End of work.	Go to step 8.
8	Checking after reseating the PWBA HVPS Reseat the PWBA HVPS. Is the image printed correctly?	End of work.	Go to step 9.
9	Is the image printed correctly?	End of work.	Go to step 10.

Step	Check	Remedy	
		Yes	No
10	Checking after replacing the PHD ASSY Replace the PHD ASSY. (Refer to Removal 4/Replacement 50.) Is the image printed correctly?	End of work.	Go to step 11.
11	Checking after replacing the PWBA ESS Replace the PWBA ESS. (Refer to Removal 42/ Replacement 12.) Is the image printed correctly?	End of work.	Go to step 12.
12	Checking after replacing the PWBA HVPS Replace the PWBA HVPS. (Refer to Removal 47/ Replacement 7.) Is the image printed correctly?	End of work.	Replace the PWBA MCU. (Refer to Removal 43/ Replacement 11.)

FIP-1.P4 Vertical blank lines (White stripes in paper transport direction)

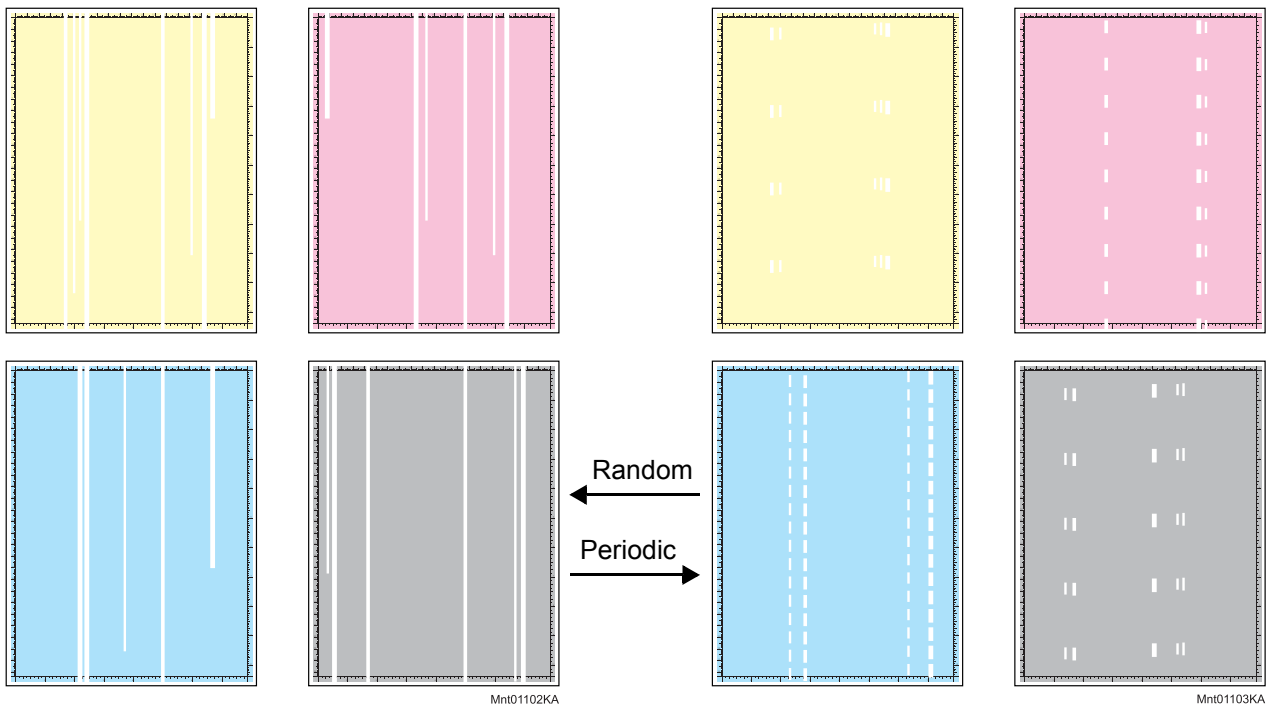

Trouble substance

There are some extremely faint or completely non-printed parts. Those nonprinted parts cover a wide area vertically, along the paper feeding direction.

ESS and possible causative parts

- ROS ASSY (PL4.1.1)
- PHD ASSY (PL4.1.21)
- TRANSFER ASSY (PL6.1.7)
- PWBA ESS (PL8.1.7)
- PWBA MCU (PL8.2.13)

Before commencing troubleshooting, check the paper transfer path. Make sure there is no foreign materials on the transfer path, such as staples, paper clips, scraps of paper and so on.

Step	Check	Remedy	
		Yes	No
1	Checking the Vertical blank lines. Print the contamination check page. Is the image printed correctly?	Printing data is incorrect, then check the printing data which the problem generated.	Go to step 2.

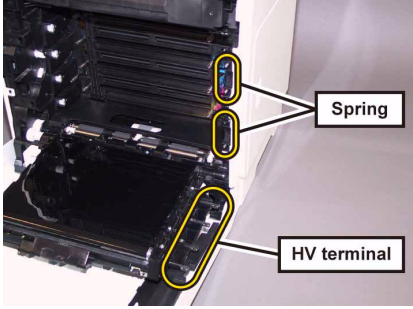
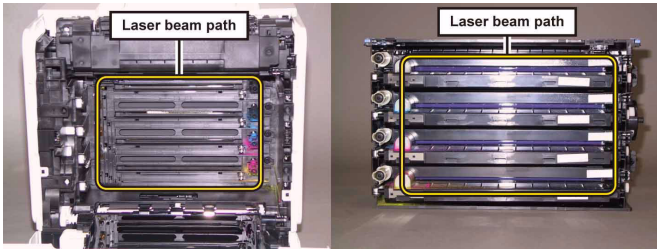
Step	Check	Remedy	
		Yes	No
2	<p>Checking the defective parts Print the [Pitch Configuration Chart] in [Chart Print] in [Diagnosis] tab of [Tool Box]. When the vertical blank lines of periodicity are observed, check the defective parts by comparing the printed vertical blank lines with the Pitch Chart. (Refer to Chapter 4.1.) Are there any vertical blank lines matching the chart?</p>	Replace the corresponding parts.	Go to step 3.
3	<p>Checking the paper condition Is the paper dry and recommended paper?</p>	Go to step 5.	Replace the paper with a new dry and recommended one, then go to step 4.
4	Is the image printed correctly?	End of work.	Go to step 5.
5	<p>Checking the foreign substances on the paper transfer path Are there any foreign substances on the paper transfer path between the TRANSFER ASSY and FUSER ASSY?</p>	Remove the foreign substances, then go to step 6.	Go to step 7.
6	Is the image printed correctly?	End of work.	Go to step 7.
7	<p>Checking the belt surfaces of the TRANSFER ASSY Are there any damages on the belt surface of the TRANSFER ASSY?</p>	Replace the TRANSFER ASSY. (Refer to Removal 21/ Replacement 33.)	Go to step 8.
8	<p>Checking the TRANSFER ASSY for connection Open the COVER ASSY FRONT. Are four HV terminals on the TRANSFER ASSY, and four springs on the frame (PL4.1.11, 12, 13 and 14) dirty and/or deformed?</p> 	Clean or replace the TRANSFER ASSY or SPRING(s).	Go to step 9.
9	<p>Checking the laser beam path Are there any foreign substances between the ROS ASSY and PHD ASSY?</p> 	Remove the foreign substances.	Go to step 10.

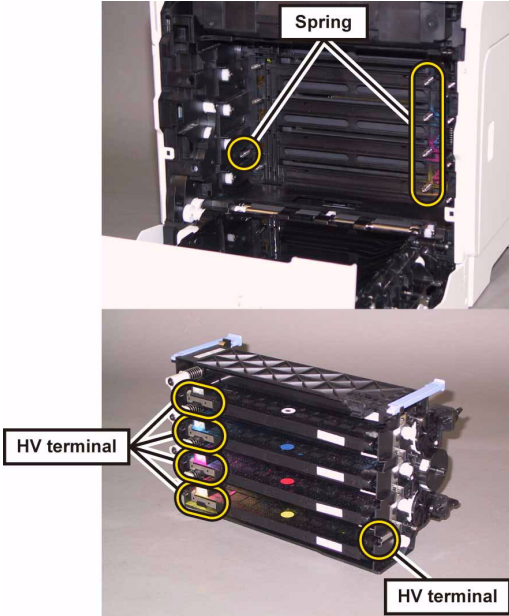
Step	Check	Remedy	
		Yes	No
10	<p>Checking the PHD ASSY for connection Remove the PHD ASSY. Are five HV terminals on the PHD ASSY, and five springs on the frame (PL4.1.10 and PL4.1.15 to 18) dirty and/or deformed?</p> 	Clean and/or replace the PHD ASSY or SPRING(s).	Go to step 11.
11	<p>Checking after reseating the PHD ASSY Reseat the PHD ASSY. Is the image printed correctly?</p>	End of work.	Go to step 12.
12	<p>Checking after reseating the FUSER ASSY Reseat the FUSER ASSY. Warning: Start the operation after the FUSER ASSY has cooled down. Is the image printed correctly?</p>	End of work.	Go to step 13.
13	<p>Checking after reseating the PWBA MCU Reseat the PWBA MCU. Is the image printed correctly?</p>	End of work.	Go to step 14.
14	<p>Checking after reseating the PWBA ESS Reseat the PWBA ESS. Is the image printed correctly?</p>	End of work.	Go to step 15.
15	<p>Checking after reseating the TRANSFER ASSY Reseat the TRANSFER ASSY. Is the image printed correctly?</p>	End of work.	Go to step 16.
16	<p>Checking after reseating the PWBA HVPS Reseat the PWBA HVPS. Is the image printed correctly?</p>	End of work.	Go to step 17.
17	<p>Checking after replacing the PHD ASSY Replace the PHD ASSY. (Refer to Removal 4/Replacement 50.) Is the image printed correctly?</p>	End of work.	Go to step 18.
18	<p>Checking after replacing the PWBA ESS Replace the PWBA ESS. (Refer to Removal 42/Replacement 12.) Is the image printed correctly?</p>	End of work.	Go to step 19.

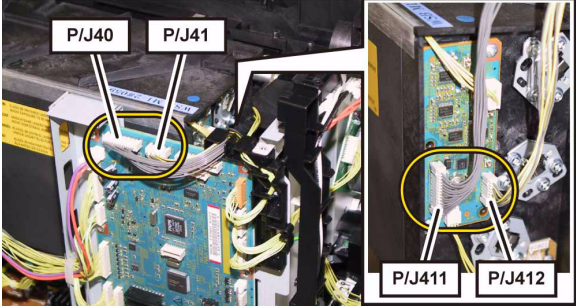
Step	Check	Remedy	
		Yes	No
19	<p>Checking the ROS ASSY for connection Check the connections between the ROS ASSY and PWBA MCU. Are P/J40, P/J 41, P/J411 and P/J 412 connected correctly?</p> 	Go to step 21.	Reconnect the connector(s) P/J40, P/J41, P/J411 and/or P/J412 surely, then go to step 20.
20	Is the image printed correctly?	End of work.	Go to step 21.
21	<p>Checking after replacing the ROS ASSY Replace the ROS ASSY. (Refer to Removal 45/ Replacement 9.) Is the image printed correctly?</p>	End of work.	Replace the PWBA MCU. (Refer to Removal 43/ Replacement 11.)

FIP-1.P5 Horizontal band cross out (White stripes in horizontal direction)

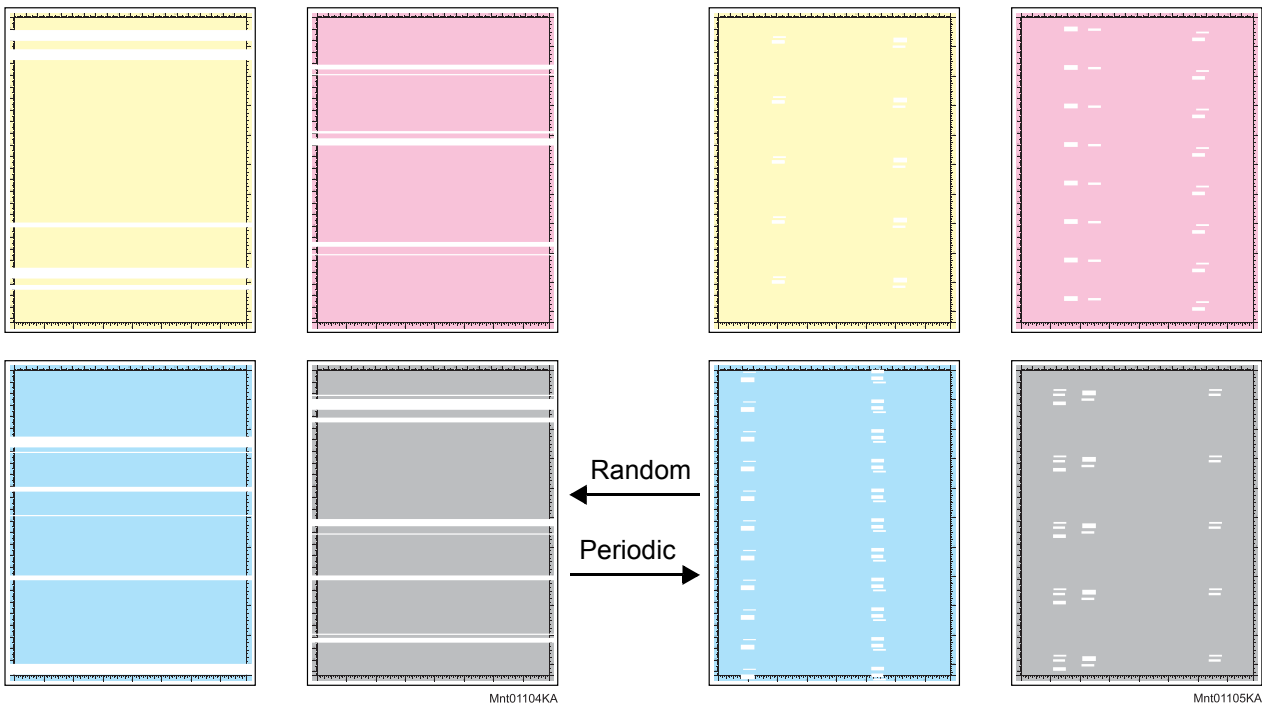
**Trouble substance**

There are some extremely faint or completely non-printed parts. Those nonprinted parts cover a wide area horizontally, perpendicular to the paper feeding direction.

ESS and possible causative parts

- ROS ASSY (PL4.1.1)
- PWBA HVPS (PL4.1.19)
- PHD ASSY (PL4.1.21)
- TONER CARTRIDGE K (PL5.1.21)
- TONER CARTRIDGE C (PL5.1.22)
- TONER CARTRIDGE M (PL5.1.23)
- TONER CARTRIDGE Y (PL5.1.24)
- TRANSFER ASSY (PL6.1.7)
- PWBA ESS (PL8.1.7)
- PWBA MCU (PL8.2.13)

Before commencing troubleshooting, check the paper transfer path. Make sure there is no foreign materials on the transfer path, such as staples, paper clips, scraps of paper and so on.

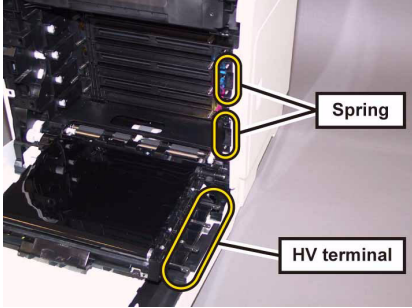
Step	Check	Remedy	
		Yes	No
1	Checking the Horizontal band cross out. Print the contamination check page. Is the image printed correctly?	Printing data is incorrect, then check the printing data which the problem generated.	Go to step 2.
2	Checking the defective parts Print the [Pitch Configuration Chart] in [Chart Print] in [Diagnosis] tab of [Tool Box]. Check the defective parts by comparing the printed horizontal band cross out with Pitch Chart. (Refer to Chapter 4.1.) Are there any horizontal band cross out matching the chart?	Replace the corresponding parts	Go to step 3.
3	Checking the paper condition Is the paper dry and recommended paper?	Go to step 5.	Replace the paper with a new dry and recommended one, then go to step 4.
4	Is the image printed correctly?	End of work.	Go to step 5.
5	Checking the belt surface of the TRANSFER ASSY Are there any damages on the belt surface of the TRANSFER ASSY?	Replace the TRANSFER ASSY. (Refer to Removal 21/ Replacement 33.)	Go to step 6.
6	Checking the TRANSFER ASSY for connection Open the COVER ASSY FRONT. Are four HV terminals on the TRANSFER ASSY, and four springs on the frame (PL4.1.11, 12, 13 and 14) dirty and/or deformed? 	Clean or replace the TRANSFER ASSY or SPRING(s).	Go to step 7.
7	Checking the laser beam path Are there any foreign substances between the ROS ASSY and PHD ASSY?	Remove the foreign substances.	Go to step 8.

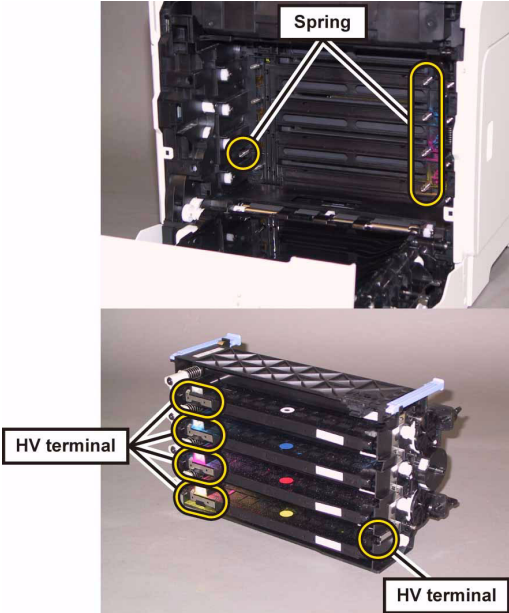
Step	Check	Remedy	
		Yes	No
8	<p>Checking the PHD ASSY for connection Remove the PHD ASSY. Are five HV terminals on the PHD ASSY, and five springs on the frame (PL4.1.10 and PL4.1.15 to 18) dirty and/or deformed?</p> 	Clean and/or replace the PHD ASSY or SPRING(s).	Go to step 9.
9	<p>Checking after reseating the PHD ASSY Reseat the PHD ASSY. Is the image printed correctly?</p>	End of work.	Go to step 10.
10	<p>Checking after reseating the FUSER ASSY Reseat the FUSER ASSY. Warning: Start the operation after the FUSER ASSY has cooled down. Is the image printed correctly?</p>	End of work.	Go to step 11.
11	<p>Checking after reseating the PWBA MCU Reseat the PWBA MCU. Is the image printed correctly?</p>	End of work.	Go to step 12.
12	<p>Checking after reseating the PWBA ESS Reseat the PWBA ESS. Is the image printed correctly?</p>	End of work.	Go to step 13.
13	<p>Checking after reseating the TRANSFER ASSY Reseat the TRANSFER ASSY. Is the image printed correctly?</p>	End of work.	Go to step 14.
14	<p>Checking after reseating the PWBA HVPS Reseat the PWBA HVPS. Is the image printed correctly?</p>	End of work.	Go to step 15.
15	<p>Checking after replacing the TONER CARTRIDGES Replace the TONER CARTRIDGE(s). (Refer to Removal 6/Replacement 48.) Is the image printed correctly?</p>	End of work.	Go to step 16.
16	<p>Checking after replacing the PHD ASSY Replace the PHD ASSY. (Refer to Removal 4/Replacement 50.) Is the image printed correctly?</p>	End of work.	Go to step 17.

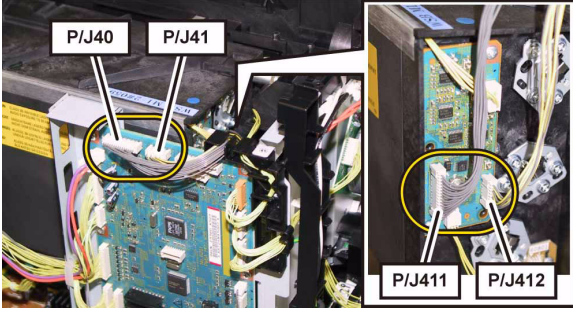
Step	Check	Remedy	
		Yes	No
17	Checking after replacing the PWBA ESS Replace the PWBA ESS. (Refer to Removal 42/ Replacement 12.) Is the image printed correctly?	End of work.	Go to step 18.
18	Checking the ROS ASSY for connection Check the connections between the ROS ASSY and PWBA MCU. Are P/J40, P/J 41, P/J411 and P/J 412 connected correctly? 	Go to step 20.	Reconnect the connector(s) P/J40, P/J41, P/J411 and/or P/J412 surely, then go to step 19.
19	Is the image printed correctly?	End of work.	Go to step 20.
20	Checking after replacing the PWBA HVPS Replace the PWBA HVPS. (Refer to Removal 47/ Replacement 7.) Is the image printed correctly?	End of work.	Go to step 21.
21	Checking after replacing the ROS ASSY Replace the ROS ASSY. (Refer to Removal 45/ Replacement 9.) Is the image printed correctly?	End of work.	Replace the PWBA MCU. (Refer to Removal 43/ Replacement 11.)

FIP-1.P6 Vertical stripes

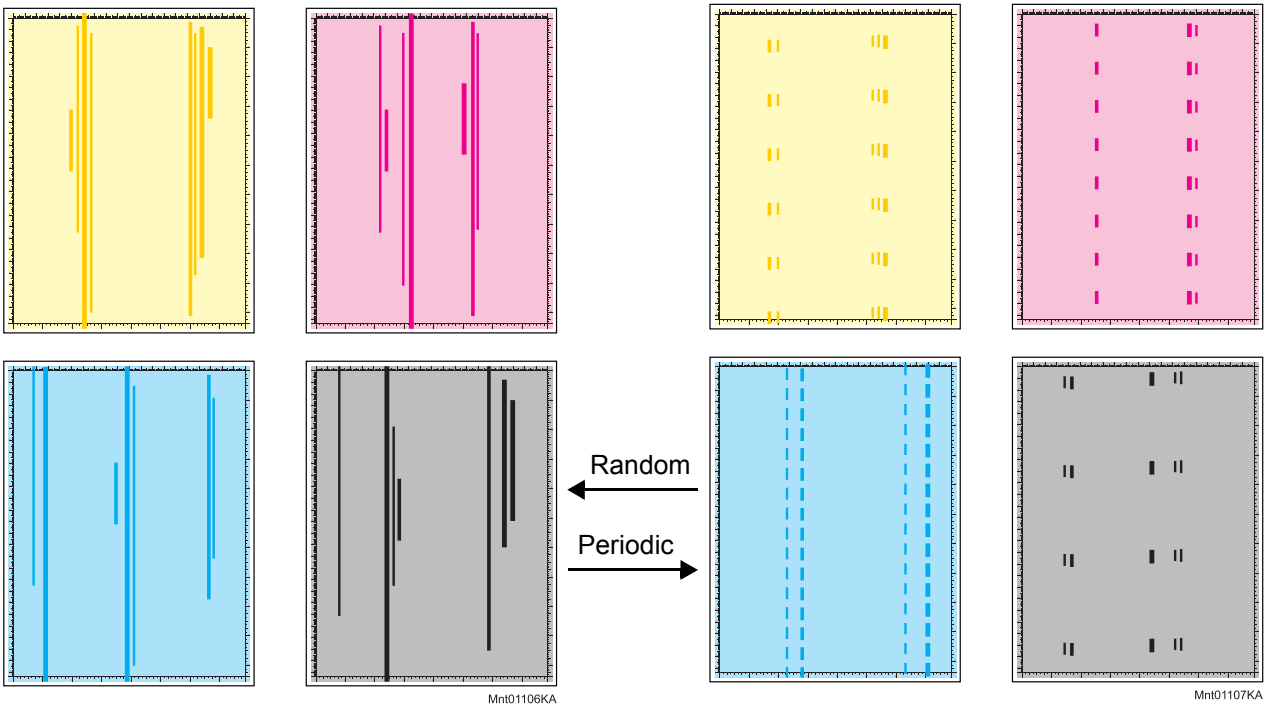

Trouble substance

There are vertical black stripes along the paper.

ESS and possible causative parts

- ROS ASSY (PL4.1.1)
- PHD ASSY (PL4.1.21)
- FUSER ASSY (PL6.1.1)
- TRANSFER ASSY (PL6.1.7)
- PWBA ESS (PL8.1.7)
- PWBA MCU (PL8.2.13)

Before commencing troubleshooting, check the paper transfer path. Make sure there is no foreign materials on the transfer path, such as staples, paper clips, scraps of paper and so on.

Step	Check	Remedy	
		Yes	No
1	Checking the Vertical stripes. Print the contamination check page. Is the image printed correctly?	Printing data is incorrect, then check the printing data which the problem generated.	Go to step 2.

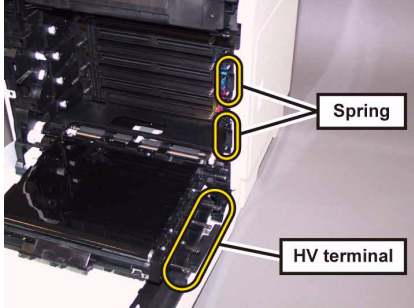
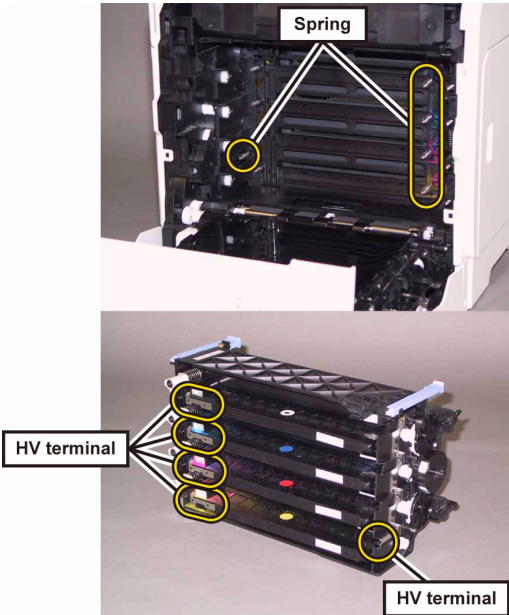
Step	Check	Remedy	
		Yes	No
2	<p>Checking the defective parts Print the [Pitch Configuration Chart] in [Chart Print] in [Diagnosis] tab of [Tool Box]. When the vertical stripes of periodicity are observed, check the defective parts by comparing the printed vertical stripes with the Pitch Chart. (Refer to Chapter 4.1.) Are there any vertical stripes matching the chart?</p>	<p>Replace the corresponding parts. When the result corresponds to the [b-12 PHD] of the pitch chart, performing the [PHD Refresh Configuration Check] of [Chart Print] in [Diagnosis] tab of [Tool Box] may improve image quality.</p>	Go to step 3.
3	<p>Checking the TRANSFER ASSY for connection Open the COVER ASSY FRONT. Are four HV terminals on the TRANSFER ASSY, and four springs on the frame (PL4.1.11, 12, 13 and 14) dirty and/or deformed?</p> 	<p>Clean or replace the TRANSFER ASSY or SPRING(s).</p>	Go to step 4.
4	<p>Checking the PHD ASSY for connection Remove the PHD ASSY. Are five HV terminals on the PHD ASSY, and five springs on the frame (PL4.1.10 and PL4.1.15 to 18) dirty and/or deformed?</p> 	<p>Clean and/or replace the PHD ASSY or SPRING(s).</p>	Go to step 5.

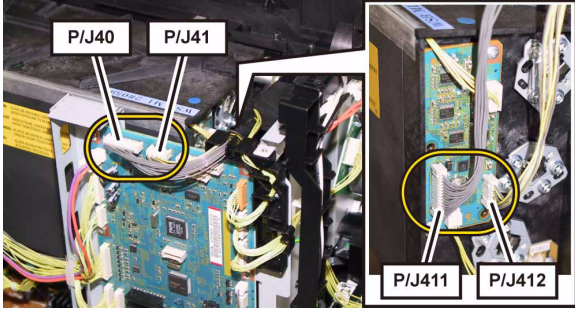
Step	Check	Remedy	
		Yes	No
5	Checking after reseating the PHD ASSY Reseat the PHD ASSY. Is the image printed correctly?	End of work.	Go to step 6.
6	Checking after reseating the FUSER ASSY Warning: Start the operation after the FUSER ASSY has cooled down. Reseat the FUSER ASSY. Is the image printed correctly?	End of work.	Go to step 7.
7	Checking after reseating the PWBA MCU Reseat the PWBA MCU. Is the image printed correctly?	End of work.	Go to step 8.
8	Checking after reseating the PWBA ESS Reseat the PWBA ESS. Is the image printed correctly?	End of work.	Go to step 9.
9	Checking after reseating the TRANSFER ASSY Reseat the TRANSFER ASSY. Is the image printed correctly?	End of work.	Go to step 10.
10	Checking after reseating the PWBA HVPS Reseat the PWBA HVPS. Is the image printed correctly?	End of work.	Go to step 11.
11	Checking the ROS ASSY for connection Check the connections between the ROS ASSY and PWBA MCU. Are P/J40, P/J 41, P/J411 and P/J 412 connected correctly? 	Go to step 13.	Reconnect the connector(s) P/J40, P/J41, P/J411 and/or P/J412 surely, then go to step 12.
12	Is the image printed correctly?	End of work.	Go to step 13.
13	Checking after replacing the PHD ASSY Replace the PHD ASSY. (Refer to Removal 4/Replacement 50.) Is the image printed correctly?	End of work.	Go to step 14.
14	Checking after replacing the FUSER ASSY Replace the FUSER ASSY. (Refer to Removal 5/Replacement 49.) Is the image printed correctly?	End of work.	Go to step 15.
15	Checking after replacing the PWBA ESS Replace the PWBA ESS. (Refer to Removal 42/Replacement 12.) Is the image printed correctly?	End of work.	Go to step 16.
16	Checking after replacing the ROS ASSY Replace the ROS ASSY. (Refer to Removal 45/Replacement 9.) Is the image printed correctly?	End of work.	Replace the PWBA MCU. (Refer to Removal 43/Replacement 11.)

FIP-1.P7 Horizontal stripes

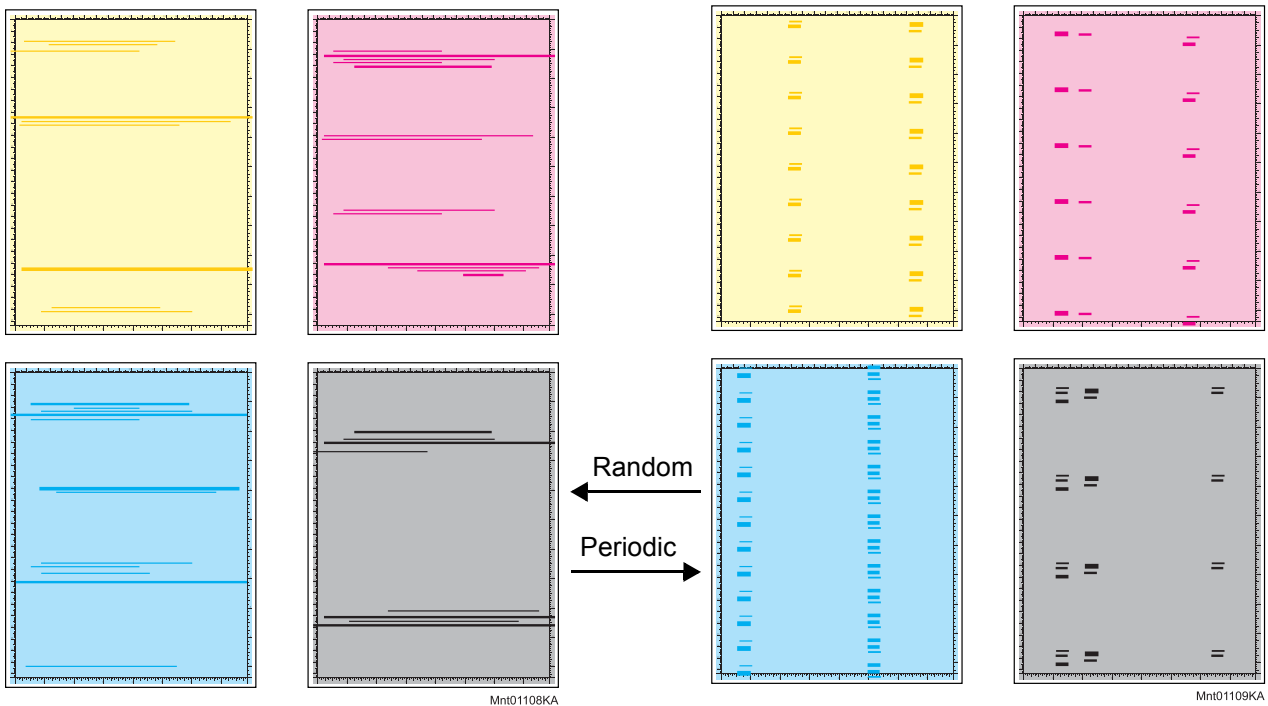
**Trouble substance**

There are horizontal black stripes (perpendicular to the paper path direction) along the paper.

ESS and possible causative parts

- ROS ASSY (PL4.1.1)
- PHD ASSY (PL4.1.21)
- TONER CARTRIDGE K (PL5.1.21)
- TONER CARTRIDGE C (PL5.1.22)
- TONER CARTRIDGE M (PL5.1.23)
- TONER CARTRIDGE Y (PL5.1.24)
- FUSER ASSY (PL6.1.1)
- TRANSFER ASSY (PL6.1.7)
- PWBA ESS (PL8.1.7)
- PWBA MCU (PL8.2.13)

Before commencing troubleshooting, check the paper transfer path. Make sure there is no foreign materials on the transfer path, such as staples, paper clips, scraps of paper and so on.

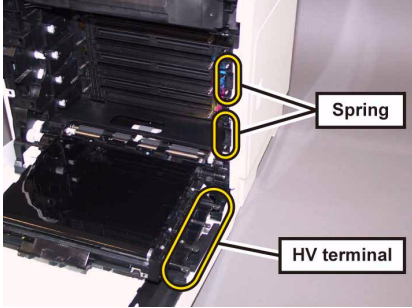
Step	Check	Remedy	
		Yes	No
1	<p>Checking the Horizontal stripes. Print the contamination check page. Is the image printed correctly?</p>	Printing data is incorrect, then check the printing check the printing data which the problem generated.	Go to step 2.
2	<p>Checking the defective parts Print the [Pitch Configuration Chart] in [Chart Print] in [Diagnosis] tab of [Tool Box]. Check the defective parts by comparing the printed horizontal stripes with Pitch Chart. (Refer to Chapter 4.1.) Are there any horizontal stripes matching the chart?</p>	<p>Replace the corresponding parts When the result corresponds to the [b-12 PHD] of the pitch chart, performing the [PHD Refresh Configuration Check] of [Chart Print] in [Diagnosis] tab of [Tool Box] may improve image quality.</p>	Go to step 3.
3	<p>Checking the TRANSFER ASSY for connection Open the COVER ASSY FRONT. Are four HV terminals on the TRANSFER ASSY, and four springs on the frame (PL4.1.11, 12, 13 and 14) dirty and/or deformed?</p> 	Clean or replace the TRANSFER ASSY or SPRING(s).	Go to step 4.
4	<p>Checking the paper path Are there any contaminations of the toner on the paper path?</p>	Clean the paper path.	Go to step 5.

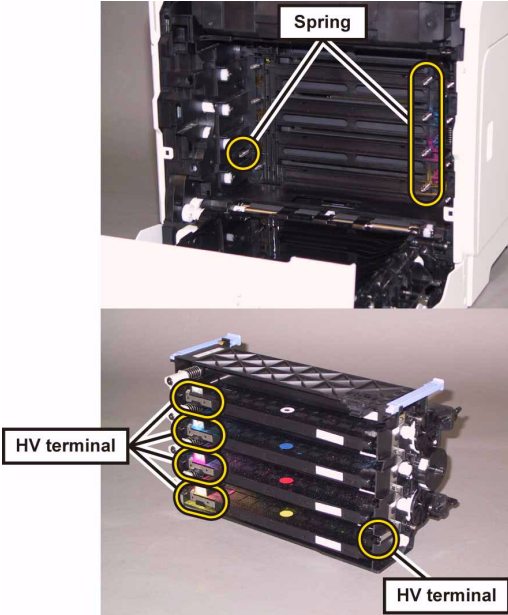
Step	Check	Remedy	
		Yes	No
5	<p>Checking the PHD ASSY for connection Remove the PHD ASSY. Are five HV terminals on the PHD ASSY, and five springs on the frame (PL4.1.10 and PL4.1.15 to 18) dirty and/or deformed?</p> 	Clean and/or replace the PHD ASSY or SPRING(s).	Go to step 6.
6	<p>Checking after reseating the PHD ASSY Reseat the PHD ASSY. Is the image printed correctly?</p>	End of work.	Go to step 7.
7	<p>Checking after reseating the FUSER ASSY Warning: Start the operation after the FUSER ASSY has cooled down. Reseat the FUSER ASSY. Is the image printed correctly?</p>	End of work.	Go to step 8.
8	<p>Checking the TONER CARTRIDGE (Y/M/C/K) Are the TONER CARTRIDGES that meet the specification installed to the correct position?</p>	Go to step 9.	Replace a new TONER CARTRIDGE (Y/M/C/K) meets the specification. (Refer to Removal 6/ Replacement 48.)
9	<p>Checking after reseating the PWBA MCU Reseat the PWBA MCU. Is the image printed correctly?</p>	End of work.	Go to step 10.
10	<p>Checking after reseating the PWBA ESS Reseat the PWBA ESS. Is the image printed correctly?</p>	End of work.	Go to step 11.
11	<p>Checking after reseating the TRANSFER ASSY Reseat the TRANSFER ASSY. Is the image printed correctly?</p>	End of work.	Go to step 12.
12	<p>Checking after reseating the PWBA HVPS Reseat the PWBA HVPS. Is the image printed correctly?</p>	End of work.	Go to step 13.

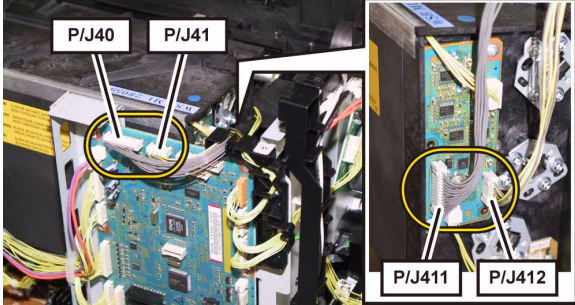
Step	Check	Remedy	
		Yes	No
13	<p>Checking the ROS ASSY for connection Check the connections between the ROS ASSY and PWBA MCU. Are P/J40, P/J 41, P/J411 and P/J 412 connected correctly?</p> 	Go to step 15.	Reconnect the connector(s) P/J40, P/J41, P/J411 and/or P/J412 surely, then go to step 14.
14	Is the image printed correctly?	End of work.	Go to step 15.
15	<p>Checking after replacing the PHD ASSY Replace the PHD ASSY. (Refer to Removal 4/Replacement 50.) Is the image printed correctly?</p>	End of work.	Go to step 16.
16	<p>Checking after replacing the FUSER ASSY Replace the FUSER ASSY. (Refer to Removal 5/Replacement 49.) Is the image printed correctly?</p>	End of work.	Go to step 17.
17	<p>Checking after replacing the PWBA ESS Replace the PWBA ESS. (Refer to Removal 42/Replacement 12.) Is the image printed correctly?</p>	End of work.	Go to step 18.
18	<p>Checking after replacing the ROS ASSY Replace the ROS ASSY. (Refer to Removal 45/Replacement 9.) Is the image printed correctly?</p>	End of work.	Replace the PWBA MCU. (Refer to Removal 43/ Replacement 11.)

FIP-1.P8 Partial Deletion

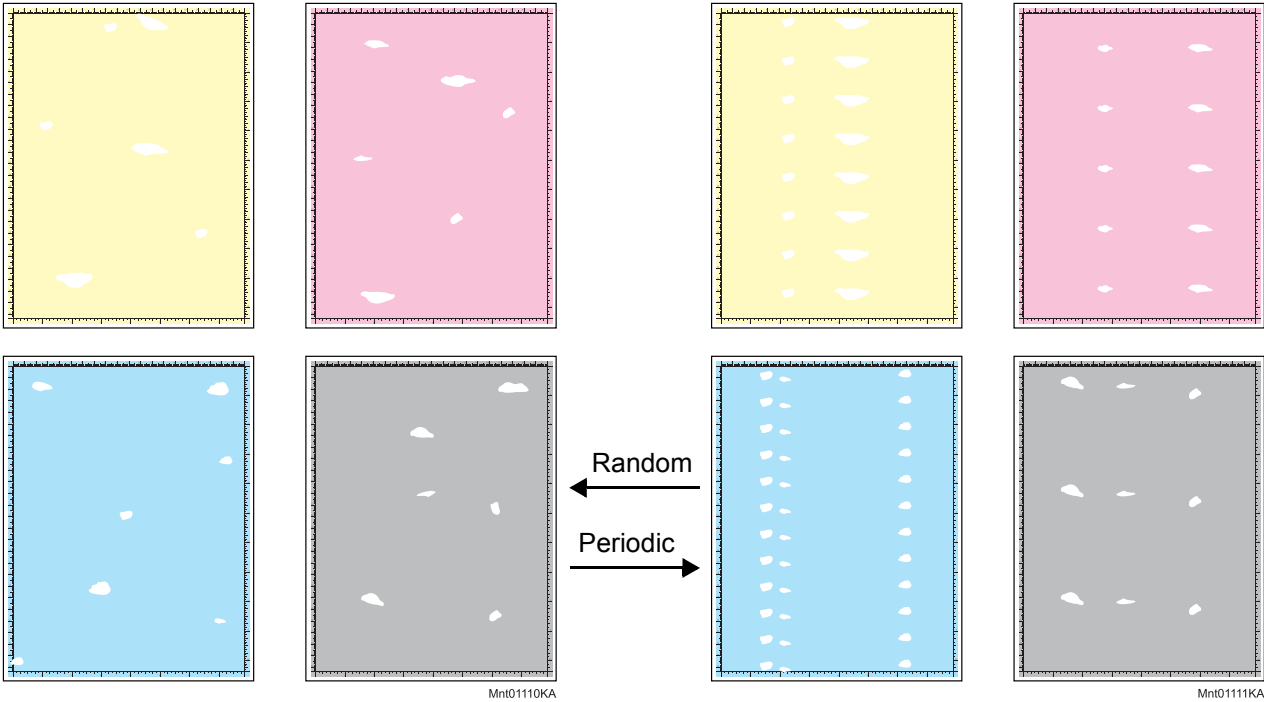

Trouble substance

There are some extremely faint or completely missing parts in a limited area on the paper.

ESS and possible causative parts

- ROS ASSY (PL4.1.1)
- PHD ASSY (PL4.1.21)
- TRANSFER ASSY (PL6.1.7)
- PWBA ESS (PL8.1.7)
- PWBA MCU (PL8.2.13)

Before commencing troubleshooting, check the paper transfer path. Make sure there is no foreign materials on the transfer path, such as staples, paper clips, scraps of paper and so on.

Step	Check	Remedy	
		Yes	No
1	Checking dew condensation Was the printer installed in the room where the air conditioner well works?	Go to step 3.	Turn on the power of the air conditioner and replace a new dray and recommended paper, then go to step 2.
2	Is the image printed correctly?	End of work.	Go to step 3.
3	Checking the Partial Deletion. Print the contamination check page. Is the image printed correctly?	Check the printing data which the problem generated.	Go to step 4.

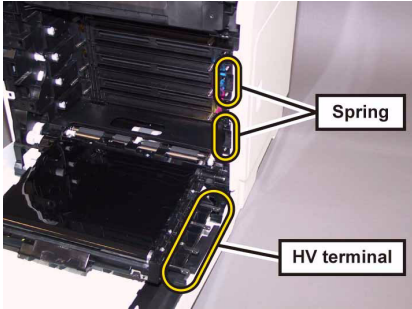
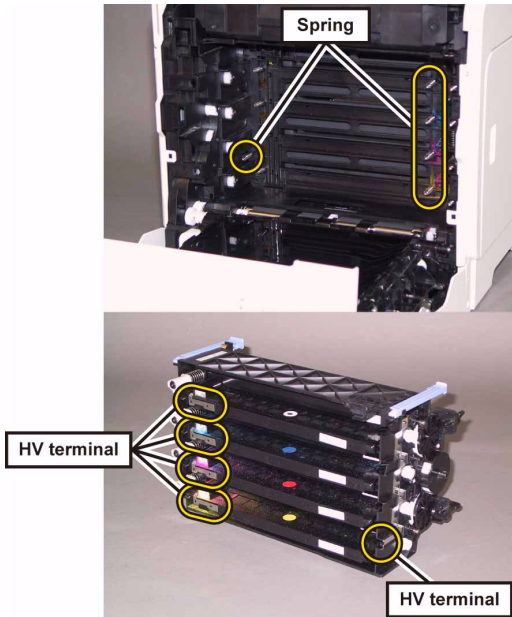
Step	Check	Remedy	
		Yes	No
4	<p>Checking the defective parts Print the [Pitch Configuration Chart] in [Chart Print] in [Diagnosis] tab of [Tool Box]. When the partial lacks of periodicity are observed, check the defective parts by comparing the printed partial lacks with the Pitch Chart. (Refer to Chapter 4.1.) Are there any partial lacks matching the chart?</p>	Replace the corresponding parts.	Go to step 5.
5	<p>Checking after replacing a new paper Replace the paper with a new dry and recommended one. Is the image printed correctly?</p>	End of work.	Go to step 6.
6	<p>Checking the belt surface of the TRANSFER ASSY Are there any damages on the belt surface of the TRANSFER ASSY?</p>	Replace the TRANSFER ASSY. (Refer to Removal 21/ Replacement 33.)	Go to step 7.
7	<p>Checking the TRANSFER ASSY for connection Open the COVER ASSY FRONT. Are four HV terminals on the TRANSFER ASSY, and four springs on the frame (PL4.1.11, 12, 13 and 14) dirty and/or deformed?</p> 	Clean or replace the TRANSFER ASSY or SPRING(s).	Go to step 8.
8	<p>Checking the PHD ASSY for connection Remove the PHD ASSY. Are five HV terminals on the PHD ASSY, and five springs on the frame (PL4.1.10 and PL4.1.15 to 18) dirty and/or deformed?</p> 	Clean and/or replace the PHD ASSY or SPRING(s).	Go to step 9.

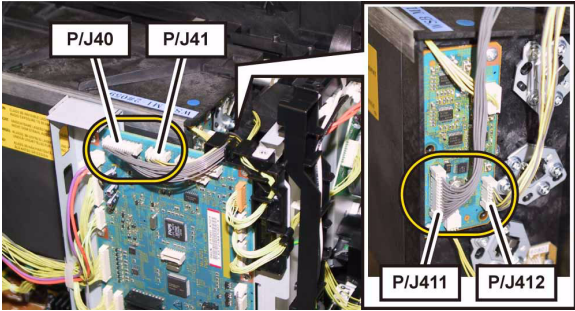
Step	Check	Remedy	
		Yes	No
9	Checking after reseating the PHD ASSY Reseat the PHD ASSY. Is the image printed correctly?	End of work.	Go to step 10.
10	Checking after reseating TONER CARTRIDGES (Y/M/C/K) Reseat the TONER CARTRIDGES (Y/M/C/K), and check that their lock keys are in the lock positions. Is the image printed correctly?	End of work.	Go to step 11.
11	Checking after reseating the PWBA MCU Reseat the PWBA MCU. Is the image printed correctly?	End of work.	Go to step 12.
12	Checking after reseating the PWBA ESS Reseat the PWBA ESS. Is the image printed correctly?	End of work.	Go to step 13.
13	Checking after reseating the TRANSFER ASSY Reseat the TRANSFER ASSY. Is the image printed correctly?	End of work.	Go to step 14.
14	Checking after reseating the PWBA HVPS Reseat the PWBA HVPS. Is the image printed correctly?	End of work.	Go to step 15.
15	Checking the ROS ASSY for connection Check the connections between the ROS ASSY and PWBA MCU. Are P/J40, P/J 41, P/J411 and P/J 412 connected correctly? 	Go to step 17.	Reconnect the connector(s) P/J40, P/J41, P/J411 and/or P/J412 surely, then go to step 16.
16	Is the image printed correctly?	End of work.	Go to step 17.
17	Checking after replacing the PHD ASSY Replace the PHD ASSY. (Refer to Removal 4/Replacement 50.) Is the image printed correctly?	End of work.	Go to step 18.
18	Checking after replacing the PWBA ESS Replace the PWBA ESS. (Refer to Removal 42/Replacement 12.) Is the image printed correctly?	End of work.	Go to step 19.
19	Checking after replacing the ROS ASSY Replace the ROS ASSY. (Refer to Removal 45/Replacement 9.) Is the image printed correctly?	End of work.	Replace the PWBA MCU. (Refer to Removal 43/Replacement 11.)

FIP-1.P9 Spots

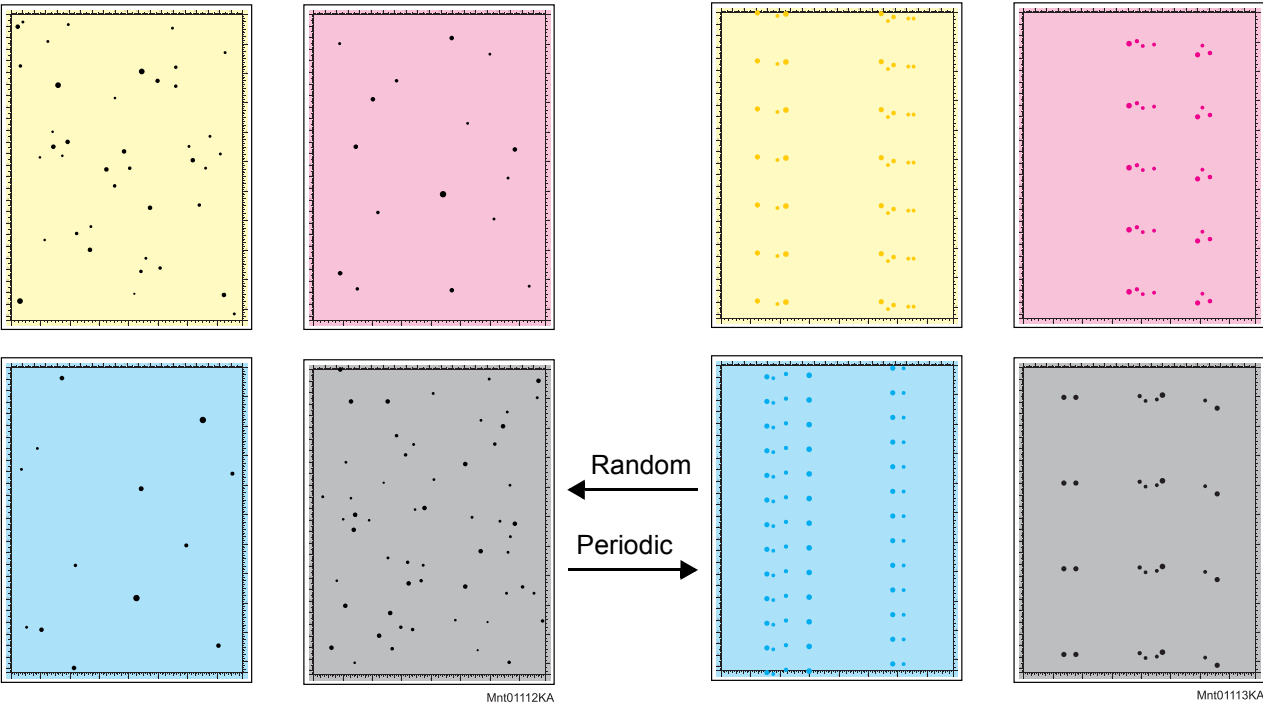

Trouble substance

There are toner spots all over the paper disorderedly.

ESS and possible causative parts

- ROS ASSY (PL4.1.1)
- PHD ASSY (PL4.1.21)
- TRANSFER ASSY (PL6.1.7)
- PWBA ESS (PL8.1.7)
- PWBA MCU (PL8.2.13)

Before commencing troubleshooting, check the paper transfer path. Make sure there is no foreign materials on the transfer path, such as staples, paper clips, scraps of paper and so on.

Step	Check	Remedy	
		Yes	No
1	Checking the contaminations on the paper transfer path Are there any contaminations on the paper transfer path?	Clean the contaminations with soft cloth or cotton swab, then go to step 2.	Go to step 3.
2	Is the image printed correctly?	End of work.	Go to step 3.

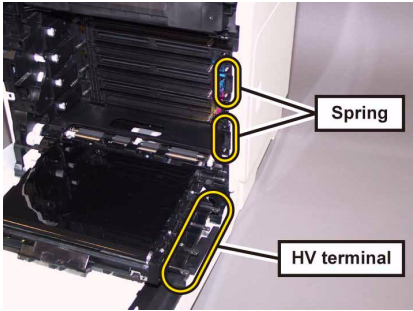
Step	Check	Remedy	
		Yes	No
3	<p>Checking the defective parts Print the [Pitch Configuration Chart] in [Chart Print] in [Diagnosis] tab of [Tool Box]. Check the defective parts by comparing the printed spots with Pitch Chart. (Refer to Chapter 4.1.) Are there any spots matching the chart?</p>	<p>Replace the corresponding parts When the result corresponds to the [b-12 PHD] of the pitch chart, performing the [PHD Refresh Configuration Check] of [Chart Print] in [Diagnosis] tab of [Tool Box] may improve image quality.</p>	Go to step 4.
4	<p>Checking the using paper Does the using paper meet the specifications?</p>	Go to step 6.	Use the paper that meets the specifications, then go to step 5.
5	Is the image printed correctly?	End of work.	Go to step 6.
6	<p>Checking the belt surface of the TRANSFER ASSY Are there any damages on the belt surface of the TRANSFER ASSY?</p>	Replace the TRANSFER ASSY. (Refer to Removal 21/ Replacement 33.)	Go to step 7.
7	<p>Checking the TRANSFER ASSY for connection Open the COVER ASSY FRONT. Are four HV terminals on the TRANSFER ASSY, and four springs on the frame (PL4.1.11, 12, 13 and 14) dirty and/or deformed?</p> 	Clean or replace the TRANSFER ASSY or SPRING(s).	Go to step 8.

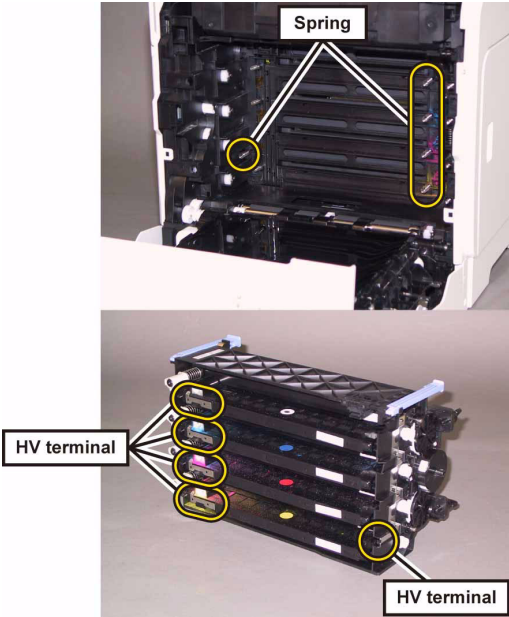
Step	Check	Remedy	
		Yes	No
8	<p>Checking the PHD ASSY for connection Remove the PHD ASSY. Are five HV terminals on the PHD ASSY, and five springs on the frame (PL4.1.10 and PL4.1.15 to 18) dirty and/or deformed?</p> 	Clean and/or replace the PHD ASSY or SPRING(s).	Go to step 9.
9	<p>Checking after reseating the PHD ASSY Reseat the PHD ASSY. Is the image printed correctly?</p>	End of work.	Go to step 10.
10	<p>Checking after reseating TONER CARTRIDGES (Y/M/C/K) Reseat the TONER CARTRIDGES (Y/M/C/K), and check that their lock keys are in the lock positions. Is the image printed correctly?</p>	End of work.	Go to step 11.
11	<p>Checking after reseating the FUSER ASSY Warning: Start the operation after the FUSER ASSY has cooled down. Reseat the FUSER ASSY. Is the image printed correctly?</p>	End of work.	Go to step 12.
12	<p>Checking after reseating the PWBA MCU Reseat the PWBA MCU. Is the image printed correctly?</p>	End of work.	Go to step 13.
13	<p>Checking after reseating the PWBA ESS Reseat the PWBA ESS. Is the image printed correctly?</p>	End of work.	Go to step 14.
14	<p>Checking after reseating the TRANSFER ASSY Reseat the TRANSFER ASSY. Is the image printed correctly?</p>	End of work.	Go to step 15.
15	<p>Checking after reseating the PWBA HVPS Reseat the PWBA HVPS. Is the image printed correctly?</p>	End of work.	Go to step 16.

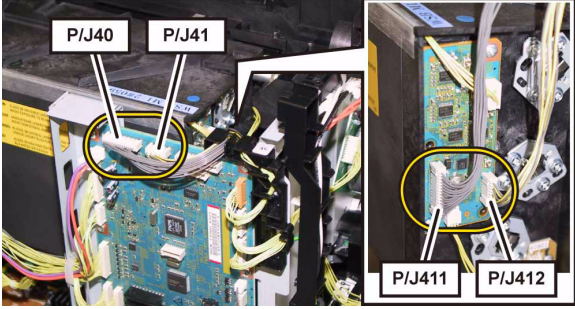
Step	Check	Remedy	
		Yes	No
16	<p>Checking the ROS ASSY for connection Check the connections between the ROS ASSY and PWBA MCU. Are P/J40, P/J 41, P/J411 and P/J 412 connected correctly?</p> 	Go to step 18.	Reconnect the connector(s) P/J40, P/J41, P/J411 and/or P/J412 surely, then go to step 17.
17	Is the image printed correctly?	End of work.	Go to step 18.
18	<p>Checking after replacing the PHD ASSY Replace the PHD ASSY. (Refer to Removal 4/Replacement 50.) Is the image printed correctly?</p>	End of work.	Go to step 19.
19	<p>Checking after replacing the PWBA ESS Replace the PWBA ESS. (Refer to Removal 42/Replacement 12.) Is the image printed correctly?</p>	End of work.	Go to step 20.
20	<p>Checking after replacing the ROS ASSY Replace the ROS ASSY. (Refer to Removal 45/Replacement 9.) Is the image printed correctly?</p>	End of work.	Replace the PWBA MCU. (Refer to Removal 43/ Replacement 11.)

FIP-1.P10 Afterimage (Ghost)

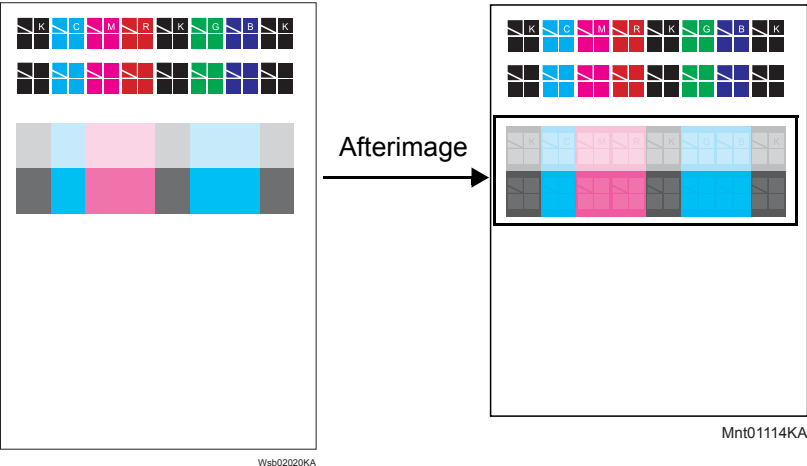

Trouble substance
 The ghost appears on the paper. The ghost may be the image of the previous page, or a part of the page currently printing.

- ESS and possible causative parts**
- LED ASSY ERASE (PL4.1.8)
 - PHD ASSY (PL4.1.21)
 - FUSER ASSY (PL6.1.1)
 - TRANSFER ASSY (PL6.1.7)
 - PWBA ESS (PL8.1.7)
 - PWBA MCU (PL8.2.13)
 - HARN ASSY LVPS (PL9.1.3)

Before commencing troubleshooting, check the paper transfer path. Make sure there is no foreign materials on the transfer path, such as staples, paper clips, scraps of paper and so on.

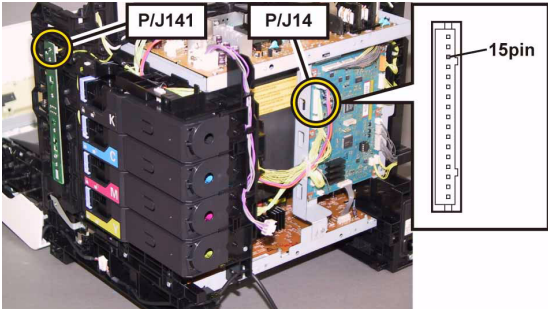
Step	Check	Remedy	
		Yes	No
1	Checking the printing Did the client print the same image of large volume?	Go to step 2.	Go to step 3.
2	Checking the Afterimage(Ghost). Print the Windows test page. Is the image printed correctly?	Check the printing data which the problem generated.	Go to step 3.
3	Checking the Afterimage(Ghost). Print the [Ghost Configuration Chart] in [Chart Print] in [Diagnosis] tab of [CE Diag]. Is the image printed correctly?	End of work.	Go to step 4.
4	Checking the erase lamps Open the COVER ASSY FRONT, and remove the PHD ASSY. Cheat the safty interlock switch. Does the four erase LEDs light correctly?	Go to step 8.	Go to step 5.
5	Checking the connectors for connection Check the connections between the PWBA MCU and LED ASSY ERASE. Are P/J141 and P/J14 connected correctly? 	Go to step 6.	Reconnect the connector(s) P/ J141 and/or P/J14 surely, then go to step 6.

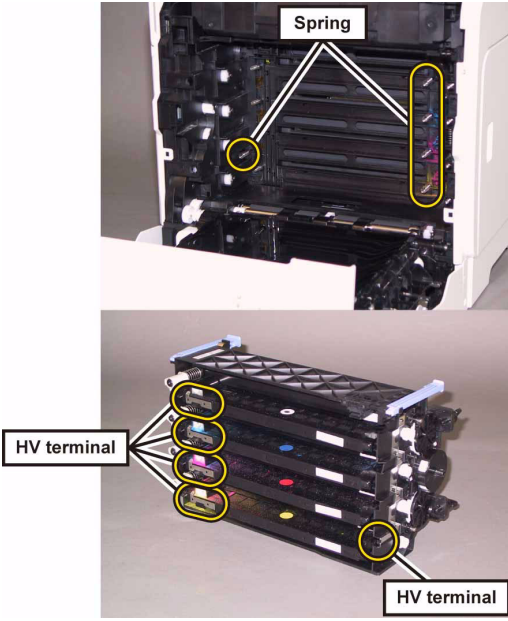
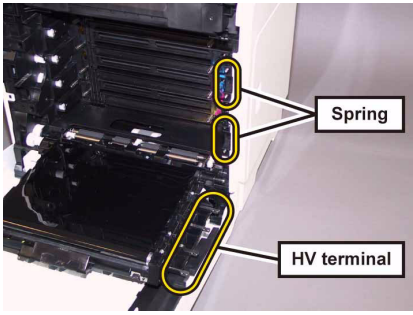
Step	Check	Remedy	
		Yes	No
6	Checking the HARN ASSY LVPS for continuity Disconnect J14 from the PWBA MCU. Disconnect J141 from the LED ASSY ERASE. Is each cable of J14 <=> J141 continuous?	Go to step 7.	Replace the HARN ASSY LVPS.
7	Checking the power to LED ASSY ERASE Disconnect the connector of J14 from the LED ASSY ERASE. Is the voltage across P14-15pin <=> ground on the PWBA MCU, about +3.3 VDC?	Replace the LED ASSY ERASE. (Refer to Removal 15/ Replacement 39.)	Replace the PWBA MCU. (Refer to Removal 43/ Replacement 11.)
8	Checking the PHD ASSY for connection Remove the PHD ASSY. Are five HV terminals on the PHD ASSY, and five springs on the frame (PL4.1.10 and PL4.1.15 to 18) dirty and/or deformed? 	Clean and/or replace the PHD ASSY or SPRING(s).	Go to step 9.
9	Checking after reseating the PHD ASSY Reseat the PHD ASSY. Is the image printed correctly?	End of work.	Go to step 10.
10	Checking the TRANSFER ASSY for connection Open the COVER ASSY FRONT. Are four HV terminals on the TRANSFER ASSY, and four springs on the frame (PL4.1.11, 12, 13 and 14) dirty and/or deformed? 	Clean or replace the TRANSFER ASSY or SPRING(s).	Go to step 11.
11	Checking after reseating the PWBA MCU Reseat the PWBA MCU. Is the image printed correctly?	End of work.	Go to step 12.

Step	Check	Remedy	
		Yes	No
12	Checking after reseating the PWBA ESS Reseat the PWBA ESS. Is the image printed correctly?	End of work.	Go to step 13.
13	Checking after reseating the TRANSFER ASSY Reseat the TRANSFER ASSY. Is the image printed correctly?	End of work.	Go to step 14.
14	Checking after reseating the PWBA HVPS Reseat the PWBA HVPS. Is the image printed correctly?	End of work.	Go to step 15.
15	Checking after replacing the PHD ASSY Replace the PHD ASSY. (Refer to Removal 4/Replacement 50.) Is the image printed correctly?	End of work.	Go to step 16.
16	Checking after replacing the FUSER ASSY Warning: Start the operation after the FUSER ASSY has cooled down. Replace the FUSER ASSY. (Refer to Removal 5/ Replacement 49.) Is the image printed correctly?	End of work.	Go to step 17.
17	Checking after replacing the PWBA MCU Replace the PWBA MCU. (Refer to Removal 43/ Replacement 11.) Is the image printed correctly?	End of work.	Replace the PWBA ESS. (Refer to Removal 42/ Replacement 12.)

FIP-1.P11 Grey Background

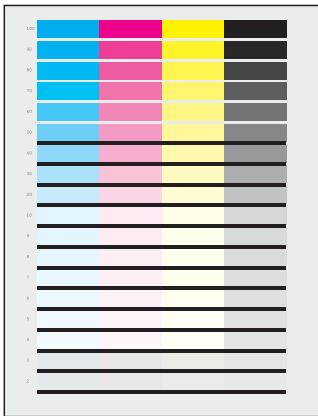
**Trouble substance**

There is toner stain all over or a part of the page. The stain appears as very bright gray stain.

ESS and possible causative parts

- LED ASSY ERASE (PL4.1.8)
- PHD ASSY (PL4.1.21)
- TRANSFER ASSY (PL6.1.7)
- PWBA ESS (PL8.1.7)
- PWBA MCU (PL8.2.13)
- HARN ASSY LVPS2 (PL9.1.3)

Before commencing troubleshooting, check the paper transfer path. Make sure there is no foreign materials on the transfer path, such as staples, paper clips, scraps of paper and so on.

Step	Check	Remedy	
		Yes	No
1	Checking the Grey background. Print the Gradation page. Is the image printed correctly?	Printing data is incorrect, then check the printing data which the problem generated.	Go to step 2.
2	Checking the contaminations on the paper transfer path Are there any contaminations on the paper transfer path?	Clean the contaminations with soft cloth or cotton swab, then go to step 3.	Go to step 4.
3	Is the image printed correctly?	End of work.	Go to step 4.
4	Checking the printing Print the Windows test page after printing the color photograph or picture. (If the color photograph or picture printing is impossible, print the [4 Colors Configuration Chart] in [Chart Print] in [Diagnosis] tab of [Tool Box].) Is the image printed correctly?	End of work.	Go to step 5.
5	Checking the erase lamps Open the COVER ASSY FRONT, and remove the PHD ASSY. Check the safety interlock switch. Does the four erase LEDs light correctly?	Go to step 9.	Go to step 6.

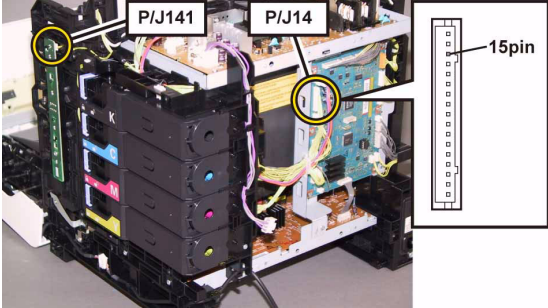
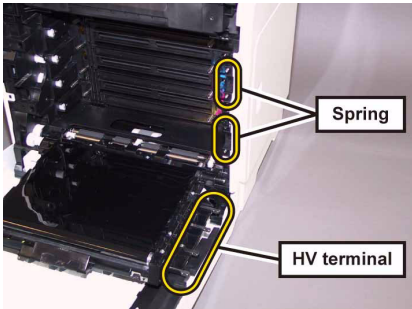
Step	Check	Remedy	
		Yes	No
6	<p>Checking the connectors for connection Check the connections between the PWBA MCU and LED ASSY ERASE. Are P/J141 and P/J14 connected correctly?</p> 	Go to step 7.	Reconnect the connector(s) P/J141 and/or P/J14 surely, then go to step 7.
7	<p>Checking the HARN ASSY LVPS2 for continuity Disconnect J14 from the PWBA MCU. Disconnect J141 from the LED ASSY ERASE. Is each cable of J14 <=> J141 continuous?</p>	Go to step 8.	Replace the HARN ASSY LVPS2.
8	<p>Checking the power to LED ASSY ERASE Disconnect the connector of J14 from the LED ASSY ERASE. Is the voltage across P14-15pin <=> ground on the PWBA MCU, about +3.3 VDC?</p>	Replace the LED ASSY ERASE. (Refer to Removal 15/ Replacement 39.)	Replace the PWBA MCU. (Refer to Removal 43/ Replacement 11.)
9	<p>Checking the TRANSFER ASSY for connection Open the COVER ASSY FRONT. Are four HV terminals on the TRANSFER ASSY, and four springs on the frame (PL4.1.11, 12, 13 and 14) dirty and/or deformed?</p> 	Clean or replace the TRANSFER ASSY or SPRING(s).	Go to step 10.

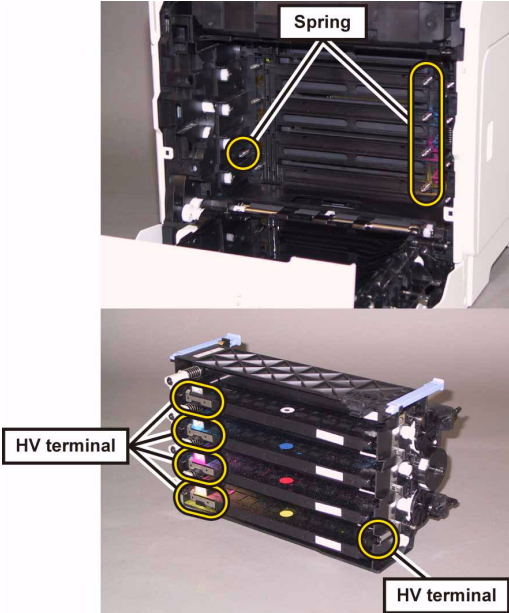
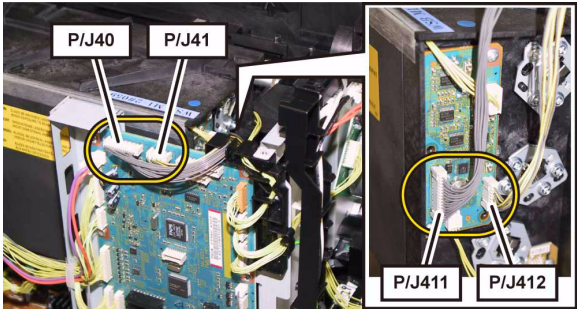
Step	Check	Remedy	
		Yes	No
10	<p>Checking the PHD ASSY for connection Remove the PHD ASSY. Are five HV terminals on the PHD ASSY, and five springs on the frame (PL4.1.10 and PL4.1.15 to 18) dirty and/or deformed?</p> 	Clean and/or replace the PHD ASSY or SPRING(s).	Go to step 11.
11	<p>Checking after reseating the PHD ASSY Reseat the PHD ASSY. Is the image printed correctly?</p>	End of work.	Go to step 12.
12	<p>Checking after reseating TONER CARTRIDGES (Y/M/C/K) Reseat the TONER CARTRIDGES (Y/M/C/K), and check that their lock keys are in the lock positions. Is the image printed correctly?</p>	End of work.	Go to step 13.
13	<p>Checking the ROS ASSY for connection Check the connections between the ROS ASSY and PWBA MCU. Are P/J40, P/J 41, P/J411 and P/J 412 connected correctly?</p> 	Go to step 15.	Reconnect the connector(s) P/J40, P/J41, P/J411 and/or P/J412 surely, then go to step 14.
14	<p>Is the image printed correctly?</p>	End of work.	Go to step 15.
15	<p>Checking after reseating the PWBA MCU Reseat the PWBA MCU. Is the image printed correctly?</p>	End of work.	Go to step 16.
16	<p>Checking after reseating the PWBA ESS Reseat the PWBA ESS. Is the image printed correctly?</p>	End of work.	Go to step 17.

Step	Check	Remedy	
		Yes	No
17	Checking after reseating the TRANSFER ASSY Reseat the TRANSFER ASSY. Is the image printed correctly?	End of work.	Go to step 18.
18	Checking after reseating the PWBA HVPS Reseat the PWBA HVPS. Is the image printed correctly?	End of work.	Go to step 19.
19	Checking after replacing the PHD ASSY Replace the PHD ASSY. (Refer to Removal 4/Replacement 50.) Is the image printed correctly?	End of work.	Go to step 20.
20	Checking after replacing the PWBA ESS Replace the PWBA ESS. (Refer to Removal 42/ Replacement 12.) Is the image printed correctly?	End of work.	Replace the PWBA MCU. (Refer to Removal 43/ Replacement 11.)

FIP-1.P12 Skew

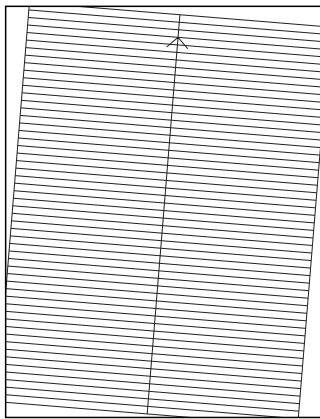

Mnt01116KA

Trouble substance

The printed image is not paralleled with both sides of the paper.

ESS and possible causative parts

- HOLDER ASSY SEPARATOR (PL2.1.5)
- ROLL ASSY FEED (PL3.2.4)
- ROLL ASSY REGI (PL3.2.9)
- ROLL REGI METAL (PL3.2.10)
- FEEDER ASSY DUP (PL11.1.1)

NOTE

. Tray is recommended for paper feeding because sheets fed via SSF is prone to skew depending on how the sheet is placed on SSF.

Before commencing troubleshooting, check the paper transfer path. Make sure there is no foreign materials on the transfer path, such as staples, paper clips, scraps of paper and so on.

Step	Check	Remedy	
		Yes	No
1	Checking the using paper Does the using paper meet the specifications?	Go to step 3.	Use the paper that meets the specifications, then go to step 2.
2	Is the image printed correctly?	End of work.	Go to step 3.
3	Checking the paper condition Is the paper dry and recommended paper?	Go to step 5.	Replace the paper with a new dry and recommended one, then go to step 4.
4	Is the image printed correctly?	End of work.	Go to step 5.
5	Checking the COVER ASSY FRONT for latching Open and close the COVER ASSY FRONT. Is the image printed correctly?	End of work.	Replace the defective parts, then go to step 6.
6	Is the image printed correctly?	End of work.	Go to step 7.
7	Checking after reseating the PHD ASSY Reseat the PHD ASSY. Is the image printed correctly?	End of work.	Go to step 8.
8	Checking after reseating the TRANSFER ASSY Reseat the TRANSFER ASSY. Is the image printed correctly?	End of work.	Go to step 9.
9	Checking the paper feeding tray Is the skewed paper fed from the SSF?	Go to step 10.	Go to step 17.
10	Checking the side guides setting of SSF Reset the side guides. Is the image printed correctly?	End of work.	Go to step 11.

Step	Check	Remedy	
		Yes	No
11	Checking the paper path Are there any foreign substances on the paper path?	Remove the foreign substances, then go to step 12.	Go to step 13.
12	Is the image printed correctly?	End of work.	Go to step 13.
13	Checking the ROLL ASSY REGI and ROLL ASSY METAL for rotation Enter the [Digital Output] - [DO-0] in [CE Diag] tab, and then enter the [Digital Output] - [DO-27] in [CE Diag] tab of [CE Diag]. Does the Roll Assy Regi and Roll Regi Metal rotate? During this check, cheat the interlock switch (HARN ASSY INTERLOCK).	End of work.	Replace the ROLL ASSY REGI and/or ROLL REGI METAL.
14	Checking the skewed mode Is the skewed paper fed from the Duplex?	Go to step 15.	Go to step 17.
15	Checking the FEEDER ASSY DUP for installation Reseat the FEEDER ASSY DUP. Does the error still occur when printing?	Go to step 16.	End of work
16	Checking the paper path Are there any foreign substances on the paper path?	Remove the foreign substances.	Replace the FEEDER ASSY DUP. (Refer to Removal 57/ Replacement 57.)
17	Checking after reseating the Paper Cassette Reseat the Paper Cassette. Is the image printed correctly?	End of work.	Go to step 18.
18	Checking after reseating the paper Reseat the paper in the Paper Cassette. Is the image printed correctly?	End of work.	Go to step 19.
19	Checking the side guides of the Paper Cassette Reset the side guides. Is the image printed correctly?	End of work.	Go to step 20.
20	Checking the paper path Are there any foreign substances on the paper path?	Remove the foreign substances, then go to step 21.	Go to step 22.
21	Is the image printed correctly?	End of work.	Go to step 22.
22	Checking after reseating the HOLDER ASSY SEPARATOR Reseat the HOLDER ASSY SEPARATOR. Is the image printed correctly?	End of work.	Go to step 23.
23	Checking after replacing the HOLDER ASSY SEPARATOR Replace the HOLDER ASSY SEPARATOR. (Refer to Removal 2/Replacement 52.) Is the image printed correctly?	End of work.	Go to step 24.
24	Checking after replacing the ROLL ASSY FEED Replace the ROLLER ASSY FEED. (Refer to Removal 9/ Replacement 45.) Is the image printed correctly?	End of work.	Go to step 25.

Step	Check	Remedy	
		Yes	No
25	<p>Checking the ROLL ASSY REGI and ROLL REGI METAL for rotation</p> <p>Enter the [Digital Output] - [DO-0] in [CE Diag] tab, and then enter the [Digital Output] - [DO-27] in [CE Diag] tab of [CE Diag].</p> <p>Does the ROLL ASSY REGI and ROLL REGI METAL rotate?</p> <p>During this check, cheat the interlock switch (HARN ASSY INTERLOCK).</p>	End of work.	Replace the ROLL ASSY REGI and/or ROLL REGI METAL.

FIP-1.P13 Paper damage

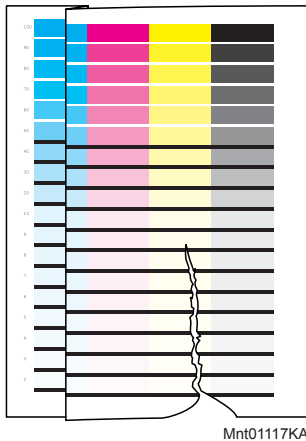
**Trouble substance**

The paper comes out from the printer wrinkled, folded or worn-out.

ESS and possible causative parts

- HOLDER ASSY SEPARATOR (PL2.1.5)
- ROLL ASSY FEED (PL3.2.4)
- ROLL ASSY REGI (PL3.2.9)
- ROLL REGI METAL (PL3.2.10)
- FEEDER ASSY DUP (PL11.1.1)

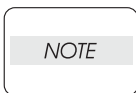

.Tray is recommended for paper feeding because sheets fed via SSF is prone to skew depending on how the sheet is placed on SSF.

Before commencing troubleshooting, check the paper transfer path. Make sure there is no foreign materials on the transfer path, such as staples, paper clips, scraps of paper and so on.

Step	Check	Remedy	
		Yes	No
1	Checking dew condensation Was the printer installed in the room where the air conditioner well works?	Go to step 3.	Turn on the power of the air conditioner, and replace a new dry and recommended paper, then go to step 2.
2	Is the image printed correctly?	End of work.	Go to step 3.
3	Checking the using paper Does the using paper meet the specifications?	Go to step 5.	Use the paper that meets the specifications, then go to step 4.
4	Is the image printed correctly?	End of work.	Go to step 5.
5	Checking the paper condition Is the paper dry and recommended paper?	Go to step 7.	Replace the paper with a new dry and recommended one, then go to step 6.
6	Is the image printed correctly?	End of work.	Go to step 7.
7	Checking the COVER ASSY FRONT for latching Open and close the COVER ASSY FRONT. Is the image printed correctly?	End of work.	Replace the defective parts, then go to step 8.
8	Is the image printed correctly?	End of work.	Go to step 9.
9	Checking after reseating the PHD ASSY Reseat the PHD ASSY. Is the image printed correctly?	End of work.	Go to step 10.

Step	Check	Remedy	
		Yes	No
10	Checking after reseating the FUSER ASSY Warning: Start the operation after the FUSER ASSY has cooled down. Reseat the FUSER ASSY. Is the image printed correctly?	End of work.	Go to step 11.
11	Checking after reseating the TRANSFER ASSY Reseat the TRANSFER ASSY. Is the image printed correctly?	End of work.	Go to step 12.
12	Checking the paper feeding tray Is the damaged paper fed from the SSF?	Go to step 13.	Go to step 20.
13	Checking the side guides setting of SSF Reset the side guides. Is the image printed correctly?	End of work.	Go to step 14.
14	Checking the paper path Are there any foreign substances on the paper path?	Remove the foreign substances, then go to step 15.	Go to step 16.
15	Is the image printed correctly?	End of work.	Go to step 16.
16	Checking the ROLL ASSY REGI and ROLL REGI METAL for rotation Enter the [Digital Output] - [DO-0] in [CE Diag] tab, and then enter the [Digital Output] - [DO-27] in [CE Diag] tab of [CE Diag]. Does the ROLL ASSY REGI and ROLL REGI METAL rotate? During this check, cheat the interlock switch (HARN ASSY INTERLOCK).	End of work.	Replace the ROLL ASSY REGI and/or ROLL REGI METAL.
17	Checking the damaged mode Is the damaged paper fed from the Duplex?	Go to step 18.	Go to step 20.
18	Checking the FEEDER ASSY DUP installtion Reseat the FEEDER ASSY DUP. Does the error still occur when printing?	Go to step 19.	End of work.
19	Checking the paper path Are there any foreign substances on the paper path?	Remove the foreign substances.	Replace the FEEDER ASSY DUP. (Refer to Removal 57/ Replacement 57.)
20	Checking after reseating the Paper Cassette Reseat the Paper Cassette. Is the image printed correctly?	End of work.	Go to step 21.
21	Checking the side guides of the Paper Cassette Reset the side guides. Is the image printed correctly?	End of work.	Go to step 22.
22	Checking after reseating a new paper Reseat a new paper in the Paper Cassette. Is the image printed correctly?	End of work.	Go to step 23.
23	Checking the paper path Are there any foreign substances on the paper path?	Remove the foreign substances, then go to step 24.	Go to step 25.
24	Is the image printed correctly?	End of work.	Go to step 25.

Step	Check	Remedy	
		Yes	No
25	Checking after reseating the HOLDER ASSY SEPARATOR Reseat the HOLDER ASSY SEPARATOR. Is the image printed correctly?	End of work.	Go to step 26.
26	Checking after replacing the HOLDER ASSY SEPARATOR Replace the HOLDER ASSY SEPARATOR. (Refer to Removal 2/Replacement 52.) Is the image printed correctly?	End of work.	Go to step 27.
27	Checking after replacing the ROLL ASSY FEED Replace the ROLL ASSY FEED. (Refer to Removal 9/Replacement 45.) Is the image printed correctly?	End of work.	Go to step 28.
28	Checking the ROLL ASSY REGI and ROLL REGI METAL for rotation Enter the [Digital Output] - [DO-0] in [CE Diag] tab, and then enter the [Digital Output] - [DO-27] in [CE Diag] tab of [CE Diag]. Does the ROLL ASSY REGI and ROLL REGI METAL rotate? During this check, cheat the interlock switch (HARN ASSY INTERLOCK).	End of work.	Replace the ROLL ASSY REGI and/or ROLL REGI METAL.

FIP-1.P14 Unfusing

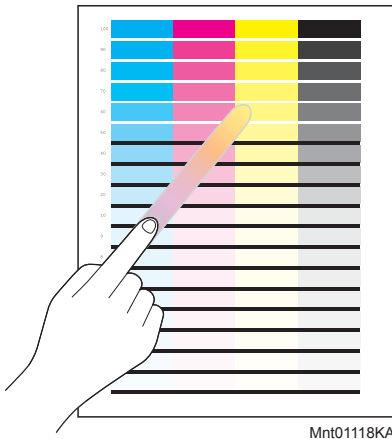
**Trouble substance**

The printed image is not fixed on the paper properly. The image easily comes off when rubbed.

ESS and possible causative parts

- FUSER ASSY (PL6.1.1)
- PWBA MCU (PL8.2.13)

Before commencing troubleshooting, check the paper transfer path. Make sure there is no foreign materials on the transfer path, such as staples, paper clips, scraps of paper and so on.

Step	Check	Remedy	
		Yes	No
1	Checking the using paper Does the using paper meet the specifications?	Go to step 3.	Use the paper that meets the specifications, then go to step 2.
2	Is the image printed correctly?	End of work.	Go to step 3.
3	Checking the paper condition Is the paper dry and recommended paper?	Go to step 5.	Replace the paper with a new dry and recommended one, then go to step 4.
4	Is the image printed correctly?	End of work.	Go to step 5.
5	Checking the Toner Type Is the Dell Toner seated?	Go to step 7.	Replace the toner with Dell Toner, then go to step 6.
6	Is the image printed correctly?	End of work.	Go to step 7.
7	Checking the power cord for connection Connect the power cord with other wall outlet. (Never connect the power cord into other connector of the same wall outlet.) Is the image printed correctly?	End of work.	Go to step 8.
8	Checking after reseating the FUSER ASSY Warning: Start the operation after the FUSER ASSY has cooled down. Reseat the FUSER ASSY. Is the image printed correctly?	End of work.	Go to step 9.
9	Checking after replacing the FUSER ASSY Warning: Start the operation after the FUSER ASSY has cooled down. Replace the FUSER ASSY and initialize the Fuser Life Counter. (Refer to Removal 5/ Replacement 49.) Does the error still occur when printing?	Replace the PWBA MCU. (Refer to Removal 43/ Replacement 11.)	End of work.

FIP-1.P15 Color registration (Color shift)

- Troubleshooting of a control system

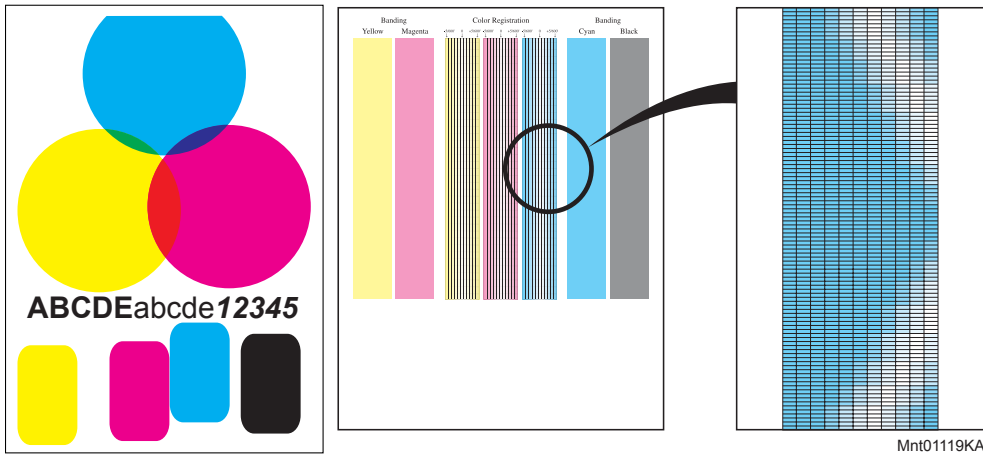

Trouble substance

A yellow or black image printed is not overlapped on a cyan or magenta image correctly.

ESS and possible causative parts

- PWBA MCU (PL8.2.13)

Before commencing troubleshooting, check the paper transfer path. Make sure there is no foreign materials on the transfer path, such as staples, paper clips, scraps of paper and so on.

Step	Check	Remedy	
		Yes	No
1	Turn OFF/ON the power. Does the color registration (color shift) appear on the printed material when printing?	Go to step 2.	End of work.
2	Checking the Color registration. Print the Windows test page. Is the image printed correctly?	Printing data is incorrect, then check the printing data which the problem generated.	Go to step 3.
3	Checking the paper condition Is the paper dry and recommended paper?	Go to step 5.	Replace the paper with a new dry and recommended one, then go to step 4.
4	Does the color registration appear on the printed material when printing?	Go to step 5.	End of work.
5	Checking the COVER ASSY FRONT for latching Open and close the COVER ASSY FRONT. Does the color registration appear on the printed material when printing?	Go to step 6.	End of work.
6	Checking the printing (Banding Error Check) Print the [MQ Chart] in [Chart Print] in [Diagnosis] tab of [CE Diag]. Does the banding error appear on the printed material?	Go to step 7.	Go to step 9.

Step	Check	Remedy	
		Yes	No
7	<p>Checking after reseating the PHD ASSY Reseat the PHD ASSY. Does the banding error appear on the printed material when printing?</p>	Go to step 8.	Go to step 9.
8	<p>Checking after reseating the TRANSFER ASSY Reseat the TRANSFER ASSY. Does the banding error appear on the printed material when printing?</p>	Go to step 9.	Go to step 9.
9	<p>Checking the printing (Color Registration Check) Print the [Alignment Chart] in [Chart Print] in [Diagnosis] tab of [Tool Box]. Does the color registration appear on the printed material when printing?</p>	Go to step 10.	End of work.
10	<p>Adjusting the color registration automatically Check that the Auto Registration Adjustments checkbox of the [Registration Adjustment] in [Printer Maintenance] tab of [Tool Box] is checked . Press the [Auto Correct] button to start the auto color registration adjustment. After adjustment is completed, press the [Color Regi Chart] Does the color registration appear on the printed material when printing?</p>	Go to step 11.	End of work.
11	<p>Adjusting the color registration manually Uncheck the checkbox of the Auto Registration Adjustments of the [Registration Adjustment] in [Printer Maintenance] tab of [Tool Box]. Adjust the color registration by [Color Registration Adjustment (Lateral)] and/or [Color Registration Adjustment (Process)] several times. After the adjustments are completed, press [Restart printer to apply new settings] button. Does the color registration appear on the printed material when printing?</p>	Replace the printer.	End of work.

- Troubleshooting of a paper feeding system

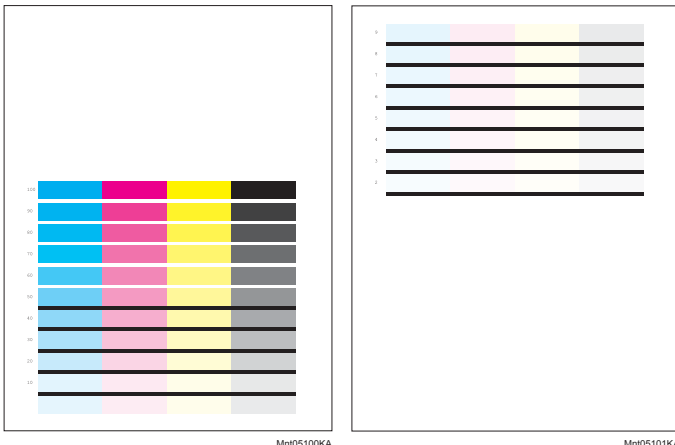

paper feeding is late.

paper feeding is early.

Trouble substance

A yellow or black image printed is not overlapped on a cyan or magenta image correctly.

ESS and possible causative parts

- PHD UNIT (PL4.1.21)
- FUSER ASSY (PL6.1.1)
- TRANSFER ASSY (PL6.1.7)
- PWBA MCU (PL10.7.7)

Before commencing troubleshooting, check the paper transfer path. Make sure there is no foreign materials on the transfer path, such as staples, paper clips, scraps of paper and so on.

Step	Check	Remedy	
		Yes	No
1	Checking after replacing the PHD ASSY Replace the PHD ASSY. (Refer to Removal 4/Replacement 50.) Does the error appear on the printed material when printing?	Go to step 2.	End of work.
2	Checking after replacing the TRANSFER ASSY Replace the TRANSFER ASSY. (Refer to Removal 21/Replacement 33.) Does the error appear on the printed material when printing?	Go to step 3.	End of work.
3	Checking after replacing the PWBA MCU Replace the PWBA MCU. (Refer to Removal 43/Replacement 11.) Does the error appear on the printed material when printing?	Replace the printer.	End of work.

5. Abnormal Noise Trouble

5.1 Entry Chart for Abnormal Noise Troubleshooting

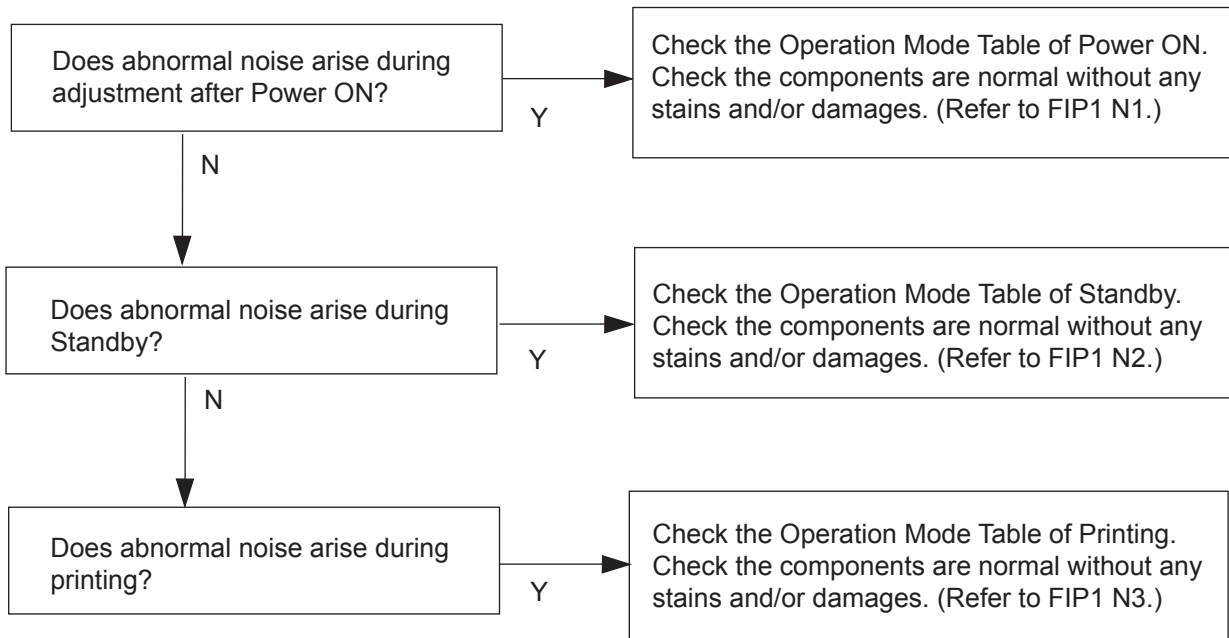

5.2 Operation Mode Table

FIP-1.N1 When Power is Turned On

Step	Check	Remedy	
		Yes	No
	Possible causative parts: PHD ASSY (PL4.1.21) FUSER ASSY (PL6.1.1) TRANSFER ASSY (PL6.1.7) DRIVE ASSY SUB (PL7.1.1) DRIVE ASSY MAIN (PL7.1.2)		
1	Checking the Main Motor Does the noise arise from the printer? Checked by [Digital Output] - [DO-0] in [CE Diag] tab of [CE Diag].	Go to step 2.	Go to step 5.
2	Checking after reseating the PHD ASSY Reseat the PHD ASSY. Does the noise arise from the printer? Checked by [Digital Output] - [DO-0] in [CE Diag] tab of [CE Diag].	Go to step 3.	End of work.
3	Checking after reseating the TRANSFER ASSY Reseat the TRANSFER ASSY. Does the noise arise from the printer? Checked by [Digital Output] - [DO-0] in [CE Diag] tab of [CE Diag].	Go to step 4.	End of work.
4	Checking after reseating the DRIVE ASSY MAIN Reseat the DRIVE ASSY MAIN. Does the noise arise from the printer? Checked by [Digital Output] - [DO-0] in [CE Diag] tab of [CE Diag].	Try replacing the PHD ASSY (refer to Removal 4/ Replacement 50), TRANSFER ASSY (refer to Removal 21/ Replacement 33) and DRIVE ASSY MAIN (refer to Removal 32/ Replacement 22) one after another.	End of work.
5	Checking the Sub Motor Does the noise arise from the printer? Checked by [Digital Output] - [DO-7] in [CE Diag] tab of [CE Diag].	Go to step 6.	Check the installation situation of printer.
6	Checking after reseating the PHD ASSY Reseat the PHD ASSY. Does the noise arise from the printer? Checked by [Digital Output] - [DO-7] in [CE Diag] tab of [CE Diag].	Go to step 7.	End of work.
7	Checking after reseating the FUSER ASSY Reseat the FUSER ASSY. Warning: Start the operation after the FUSER ASSY has cooled down. Does the noise arise from the printer? Checked by [Digital Output] - [DO-7] in [CE Diag] tab of [CE Diag].	Go to step 8.	End of work.

Step	Check	Remedy	
		Yes	No
8	Checking after reseating the DRIVE ASSY SUB Reseat the DRIVE ASSY SUB. Does the noise arise from the printer? Checked by [Digital Output] - [DO-7] in [CE Diag] tab of [CE Diag].	Try replacing the PHD UNIT (refer to Removal 4/ Replacement 50), FUSER ASSY (refer to Removal 5/ Replacement 49) and DRIVE ASSY SUB (refer to Removal 33/ Replacement 21) one after another.	End of work.

FIP-1.N2 During Standby

Step	Check	Remedy	
		Yes	No
	Possible causative parts: FAN (PL8.1.1) PWBA LVPS (PL8.2.1)		
1	Checking the FAN Does the noise arise from the Fan? Checked by [Digital Output] - [DO-1E] in [IOT Diag] of diagnosis.	Replace the FAN. (Refer to Removal 40/ Replacement 14.)	Replace the PWBA LVPS. (Refer to Removal 11/ Replacement 43.)

FIP-1.N3 During Printing

Step	Check	Remedy	
		Yes	No
	Possible causative parts: HOLDER ASSY SEPARATOR (PL2.1.5) ROLL ASSY FEED (PL3.2.4) ROLL ASSY REGI (PL3.2.9) ROLL REGI METAL (PL3.2.10) PHD ASSY (PL4.1.21) FUSER ASSY (PL6.1.1) TRANSFER ASSY (PL6.1.7) DRIVE ASSY SUB (PL7.1.1) DRIVE ASSY MAIN (PL7.1.2) FAN (PL8.1.1) FEEDER ASSY DUP (PL11.1.1)		
1	Checking the paper feeding Does the noise arise from the printer when the paper is fed from the Tray 1?	Go to step 2.	Go to step 6.
2	Checking the paper condition in the Paper Cassette Is the paper dry and recommended paper?	Go to step 4.	Replace the paper with a new dry and recommended one, then go to step 3.
3	Checking noise when the paper is fed from the Tray 1 Does the noise arise from the printer?	Go to step 4.	End of work.
4	Checking the HOLDER ASSY SEPARATOR in the Paper Cassette for rotation Remove the Paper Cassette from the printer. Does the SEPARATOR ROLLER rotate smoothly? Turning it with your finger.	Go to step 5.	Replace the HOLDER ASSY SEPARATOR. (Refer to Removal 2/ Replacement 52.)
5	Checking the ROLL ASSY FEED for rotation Remove the Paper Cassette from the printer. Enter the [Digital Output] - [DO-0] in [CE Diag] tab of [CE Diag], and then enter the [Digital Output] - [CASSETTE1 FEED SOLENOID ON(Auto OFF)] in [CE Diag] tab of [CE Diag]. Does the noise arise from this Roller? NOTE: After checking is completed, turn off [CASSETTE1 FEED SOLENOID ON(Auto OFF)] check first, and then turn off [MAIN MOTOR ON] check.	Replace the ROLL ASSY FEED. (Refer to Removal 9/ Replacement 45.)	Go to step 12.
6	Checking the paper guide sides setting and paper setting of SSF Were the paper guide sides of SSF correctly set, and was the paper correctly inserted into SSF?	Go to step 7.	Reset the paper guide sides, and correctly insert the paper to SSF, then go to step 7.
7	Checking the paper condition Is the paper dry and recommended paper?	Go to step 12.	Replace the paper with a new dry and recommended one, then go to step 8.
8	Checking noise when the paper is fed from the SSF Does the noise arise from the printer?	Go to step 12.	Go to step 9.

Step	Check	Remedy	
		Yes	No
9	Checking the Duplex Does the noise arise when feeding the paper from the Duplex?	Go to step 10.	Go to step 12.
10	Checking the DUPLEX ASSY for installation Reseat the DUPLEX ASSY. Does the noise arise from the printer?	Try replacing the FEEDER ASSY DUP.	Go to step 11.
11	Checking the Duplex Motor (MOTOR ASSY DUP) Does the noise arise from the printer? Checked by [Digital Output] - [DO-0] and [DO-12] in [IOT Diagnosis].	Try replacing the FEEDER ASSY DUP.	End of work.
12	Checking the Main Motor Does the noise arise from the printer? Checked by [Digital Output] - [DO-0] in [CE Diag] tab of [CE Diag].	Go to step 13.	Go to step 19.
13	Checking after reseating the PHD UNIT Reseat the PHD UNIT. Does the noise arise from the printer? Checked by [Digital Output] - [DO-0] in [CE Diag] tab of [CE Diag].	Go to step 14.	End of work.
14	Checking after reseating the TRANSFER ASSY Reseat the TRANSFER ASSY. Does the noise arise from the printer? Checked by [Digital Output] - [MAIN MOTOR ON] in [CE Diag] tab of [CE Diag].	Go to step 15.	End of work.
15	Checking the foreign substances on the surfaces of the ROLL ASSY REGI and ROLL REGI METAL Are there any foreign substances on the surfaces of these parts?	Remove the foreign substances, then go to step 16.	Go to step 17.
16	Checking noise when printing Does the noise arise from the printer?	Go to step 17.	End of work.
17	Checking the ROLL ASSY REGI and ROLL REGI METAL for rotation Enter the [Digital Output] - [DO-0] in [CE Diag] tab of [CE Diag], and then enter the [Digital Output] - [DO-27] in [CE Diag] tab of [CE Diag]. Does the noise arise from the Roller(s)?	Replace the ROLL ASSY REGI and/or ROLL REGI METAL.	Go to step 18.
18	Checking the DRIVE ASSY MAIN for installation Reseat the DRIVE ASSY MAIN. Does the noise arise from the printer? Checked by [Digital Output] - [DO-0] in [CE Diag] tab of [CE Diag].	Try replacing the PHD UNIT (refer to Removal 4/ Replacement 50), TRANSFER ASSY (refer to Removal 21/ Replacement 33) and DRIVE ASSY MAIN (refer to Removal 32/ Replacement 22) one after another.	End of work.
19	Checking the Sub Motor Does the noise arise from the printer? Checked by [Digital Output] - [DO-7] in [CE Diag] tab of [CE Diag].	Go to step 20.	Check the installation situation of the printer.

Step	Check	Remedy	
		Yes	No
20	Checking the PHD ASSY for installation Reseat the PHD ASSY. Does the noise arise from the printer? Checked by [Digital Output] - [DO-7] in [CE Diag] tab of [CE Diag].	Go to step 21.	End of work.
21	Checking the FUSER ASSY for installation Reseat the FUSER ASSY. Does the noise arise from the printer? Checked by [Digital Output] - [DO-7] in [CE Diag] tab of [CE Diag].	Go to step 22.	End of work.
22	Checking the DRIVE ASSY SUB for installation Reseat the DRIVE ASSY SUB. Does the noise arise from the printer? Checked by [Digital Output] - [DO-7] in [CE Diag] tab of [CE Diag].	Try replacing the PHD UNIT (refer to Removal 4/ Replacement 50), FUSER ASSY (refer to Removal 5/ Replacement 49) and DRIVE ASSY SUB (refer to Removal 33/ Replacement 21) one after another.	End of work.

6. Other FIP

Other FIP covers the Electrical Noise FIP, Power Supply FIP and Multiple Feed FIP, except Error Code FIP, Abnormal Noise FIP and Image Quality FIP.

FIP-Electrical Noise

Step	Check	Remedy	
		Yes	No
1	Checking the external noise Are there any other electrical appliances within 3 meters from the printer, such as generators, radio and appliances with motors? Either turn off the other electrical appliances, or relocate the printer at least 6 meters away from other appliances. Does the electrical noise error still occur?	Go to step 2.	End of work.
2	Checking the AC ground Is AC power supply outlet wired and grounded appropriately?	Go to step 3.	Request the client to fix AC power supply outlet.
3	Checking the TRANSFER ASSY for connection Open the COVER ASSY FRONT. Are four HV terminals on the TRANSFER ASSY, and four springs on the frame (PL4.1.11, 12, 13 and 14) dirty and/or deformed?	Clean or replace the TRANSFER ASSY or SPRING(s).	Go to step 4.
4	Checking the PHD ASSY for connection Remove the PHD ASSY. Are five HV terminals on the PHD ASSY, and five springs on the frame (PL4.1.10 and PL4.1.15 to 18) dirty and/or deformed?	Clean and/or replace the PHD ASSY or SPRING(s).	Go to step 5.
5	Checking after reseating the PHD ASSY Reseat the PHD ASSY. Does the electrical noise error still occur?	Go to step 6.	End of work.
6	Checking after reseating the TRANSFER ASSY Reseat the TRANSFER ASSY. Does the electrical noise error still occur?	Reseat the PWBA HVPS.	End of work.

FIP-AC

Step	Check	Remedy	
		Yes	No
1	Checking the printer Does the motor noise arise when turning on the power? During this test, close the COVER ASSY FRONT.	Go to FIP-DC.	Go to step 2.
2	Checking the power supply on wall outlet Connect the power cord with other wall outlet. Does the printer operate normally?	End of work.	Go to step 3.
3	Checking the power code for connection Reconnect the power cord. Does the printer operate normally?	End of work.	Go to step 4.
4	Checking the BREAKER GFI for operation Does the BREAKER GFI operate normally?	End of work.	Go to step 5.
5	Checking the connector of PWBA LVPS for connection Disconnect the power cord and wait for one minute. Reconnect the all connectors of PWBA LVPS. Does the printer operate normally?	End of work.	Go to step 6.
6	Checking the connector of MAIN SWITCH for connection Disconnect the power cord and wait for one minute. Reconnect the connector of MAIN SWITCH. Does the printer operate normally?	End of work.	Replace the PWBA LVPS. (Refer to Removal 11/ Replacement 43.)

FIP-DC

Step	Check	Remedy	
		Yes	No
1	Checking the connector of the PWBA LVPS for connection Disconnect the power cord and wait for one minute. Reconnect the all connectors of the PWBA LVPS. Does the printer operate normally?	End of work.	Go to step 2.
2	Checking the connector of the CONSOLE ASSY PANEL for connection Reconnect the connector (P/J220) of the CONSOLE ASSY PANEL. Does the CONSOLE ASSY PANEL operate normally?	End of work.	Go to step 3.
3	Checking after reseating the PWBA MCU Reseat the PWBA MCU. Does the printer operate normally?	End of work.	Replace the PWBA LVPS. (Refer to Removal 11/ Replacement 43.)

FIP-Multiple Feed

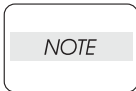

.This multiple feed trouble occurs only when the paper is fed from the Paper Cassette.

Step	Check	Remedy	
		Yes	No
	Possible causative parts HOLDER ASSY SEPARATOR (PL2.1.5) ROLL ASSY FEED (PL3.2.4) ROLL ASSY REGI (PL3.2.9) ROLL REGI METAL (PL3.2.10)		
1	Checking the using paper Does the using paper meet the specifications?	Go to step 3.	Use the paper that meets the specifications, then go to step 2.
2	Does the multi feed still occur when printing?	Go to step 3.	End of work.
3	Checking paper condition Is the paper dry and recommended paper?	Go to step 5.	Replace the paper with a new dry and recommended one, then go to step 4.
4	Does the multi feed still occur when printing?	Go to step 5.	End of work.
5	Checking the ROLL ASSY FEED and HOLDER ASSY SEPARATOR for rotation Does the ROLL ASSY FEED and HOLDER ASSY SEPARATOR rotate smoothly and operate correctly?	End of work.	Replace the ROLL ASSY FEED (refer to Removal 9/ Replacement 45) and/or SEPARATOR ROLLER ASSEMBLY (refer to Removal 2/ Replacement 52).

FIP-Control Panel Freezes

Step	Check	Remedy	
		Yes	No
	Possible causative parts PWBA ESS (PL8.1.7)		
1	Checking the operating environment. Is the printer connected to the Network?	Go to step 2.	Replace the Printer.
2	Checking the IP address. Can you change the IP address?	Go to step 5.	Go to step 3.
3	Checking the internet connectivity. Is there any internet connection available for your PC?	Go to step 4.	Replace the PWBA ESS. (Removal 42/ Replacement 12)
4	Updating the firmware to the latest version. Download the latest version of the firmware from the DELL Support Website, and execute the update. NOTE: Before updating the firmware to the latest version, reset the error following the steps of procedure described below. In addition, update the firmware by way of a USB storage. 1) Remove the network cable. 2) Connect the USB cable. 3) Turn the power off and on. Does the error persist when the power is turned off and on?	Replace the PWBA ESS. (Removal 42/ Replacement 12)	End of work.
5	Changing the IP address. Contact your system administrator for obtaining a new IP address. Refer to Reference_1 for details of how to change the IP address. Does the error persist when the power is turned off and on?	Replace the PWBA ESS. (Removal 42/ Replacement 12)	End of work.

Reference_1: Changing the IP address

- 1) Remove the network cable, and power off the printer and then on
- 2) Change the IP address on the Control Panel.
- 3) Plug the network cable back into the printer, and then turn the power on.
- 4) On the Control Panel, open [Admin] > [Network] > [TCP/IP], and confirm that the IP address has been changed.