

# **SERVICE** *Manual*

## Dell™ Laser MFP



## CONTENTS

1. Precautions
2. Reference Information
3. Specifications
4. Summary of product
5. Disassembly and Reassembly
6. Alignment and Adjustments
7. Troubleshooting
8. Exploded Views and Parts List
9. Block Diagram
10. Connection Diagram
11. Circuit Description
12. Schematic Diagram

Easy as **DELL**<sup>TM</sup>

# 1. Precautions

In order to prevent accidents and to prevent damage to the equipment please read the precautions listed below carefully before servicing the printer and follow them closely.

## 1.1 Safety Warning

- (1) Only to be serviced by appropriately qualified service engineers.

High voltages and lasers inside this product are dangerous. This printer should only be serviced by a suitably trained and qualified service engineer.

- (2) Use only Samsung replacement parts

There are no user serviceable parts inside the printer. Do not make any unauthorized changes or additions to the printer, these could cause the printer to malfunction and create electric shock or fire hazards.

- (3) Laser Safety Statement

The Printer is certified in the U.S. to conform to the requirements of DHHS 21 CFR, chapter 1 Subchapter J for Class 1(1) laser products, and elsewhere, it is certified as a Class I laser product conforming to the requirements of IEC 825. Class I laser products are not considered to be hazardous. The laser system and printer are designed so there is never any human access to laser radiation above a Class I level during normal operation, user maintenance, or prescribed service condition.

*Warning >> Never operate or service the printer with the protective cover removed from Laser/Scanner assembly. The reflected beam, although invisible, can damage your eyes. When using this product, these basic safety pre-cautions should always be followed to reduce risk of fire, electric shock, and injury to persons.*



CAUTION - INVISIBLE LASER RADIATION  
WHEN THIS COVER OPEN.  
DO NOT OPEN THIS COVER.

VORSICHT - UNSICHTBARE LASERSTRAHLUNG,  
WENN ABDECKUNG GEFFNET.  
NICHT DEM STRAHL AUSSETZEN.

ATTENTION - RAYONNEMENT LASER INVISIBLE EN CAS  
D'OUVERTURE. EXPOSITION DANGEREUSE  
AU FAISCEAU.

ATTENZIONE - RADIAZIONE LASER INVISIBILE IN CASO DI  
APERTURA. EVITARE L'ESPOSIZIONE AL  
FASCIO.

PRECAUCION - RADIACION LASER INVISIBLE CUANDO SE ABRE.  
EVITAR EXPONERSE AL RAYO.

ADVARSEL - USYNLIG LASERSTRÅLNING VED ÅBNING, N R  
SIKKERHEDSBRYDERE ER UDE AF FUNKTION.  
UNDG UDSÆTTELSE FOR STRÅLNING.

ADVARSEL - USYNLIG LASERSTRÅLNING N R DEKSEL  
PÅNES. STIRR IKKE INN I STRÅLEN.  
UNNG EKSPONERING FOR STRÅLEN.

VARNING - OSYNLIG LASERSTRÅLNING N R DENNA DEL  
R PÅNAD OCH SPÄRREN R URKOPPLAD.  
BETRAKTA EJ STRÅLEN. STRÅLEN R FARLIG.

VARO! - AVATTAESSA JA SUOJALUKITUS OHITETTAESSA  
OLET ALTTIINA N KYM TT M LLE LASER-  
S TEILYLLE L KATSO S TEESEEN.

注 意 - 严禁揭开此盖, 以免激光泄露灼伤

주 의 - 이 덮개를 열면 레이저광에 노출될 수 있으므로  
주의하십시오.

## 1.2 Caution for safety

---

### 1.2.1 Toxic material

---

This product contains toxic materials that could cause illness if ingested.

- (1) If the LCD control panel is damaged it is possible for the liquid inside to leak. This liquid is toxic. Contact with the skin should be avoided, wash any splashes from eyes or skin immediately and contact your doctor. If the liquid gets into the mouth or is swallowed see a doctor immediately.
- (2) Please keep toner cartridges away from children. The toner powder contained in the toner cartridge may be harmful and if swallowed you should contact a doctor.

### 1.2.2 Electric Shock and Fire Safety Precautions

---

Failure to follow the following instructions could cause electric shock or potentially cause a fire.

- (1) Use only the correct voltage, failure to do so could damage the printer and potentially cause a fire or electric shock.
- (2) Use only the power cable supplied with the printer. Use of an incorrectly specified cable could cause the cable to overheat and potentially cause a fire.
- (3) Do not overload the power socket, this could lead to overheating of the cables inside the wall and could lead to a fire.
- (4) Do not allow water or other liquids to spill into the printer, this can cause electric shock. Do not allow paper clips, pins or other foreign objects to fall into the printer these could cause a short circuit leading to an electric shock or fire hazard..
- (5) Never touch the plugs on either end of the power cable with wet hands, this can cause electric shock. When servicing the printer remove the power plug from the wall socket.
- (6) Use caution when inserting or removing the power connector. The power connector must be inserted completely otherwise a poor contact could cause overheating possibly leading to a fire. When removing the power connector grip it firmly and pull.
- (7) Take care of the power cable. Do not allow it to become twisted, bent sharply round corners or other wise damaged. Do not place objects on top of the power cable. If the power cable is damaged it could overheat and cause a fire or exposed cables could cause an electric shock. Replace a damaged power cable immediately, do not reuse or repair the damaged cable. Some chemicals can attack the coating on the power cable, weakening the cover or exposing cables causing fire and shock risks.
- (8) Ensure that the power sockets and plugs are not cracked or broken in any way. Any such defects should be repaired immediately. Take care not to cut or damage the power cable or plugs when moving the machine.
- (9) Use caution during thunder or lightening storms. Samsung recommend that this machine be disconnected from the power source when such weather conditions are expected. Do not touch the machine or the power cord if it is still connected to the wall socket in these weather conditions.
- (10) Avoid damp or dusty areas, install the printer in a clean well ventilated location. Do not position the machine near a humidifier. Damp and dust build up inside the machine can lead to overheating and cause a fire.
- (11) Do not position the printer in direct sunlight. This will cause the temperature inside the printer to rise possibly leading to the printer failing to work properly and in extreme conditions could lead to a fire.
- (12) Do not insert any metal objects into the machine through the ventilator fan or other part of the casing, it could make contact with a high voltage conductor inside the machine and cause an electric shock.

## 1.2.3 Handling Precautions

---

The following instructions are for your own personal safety, to avoid injury and so as not to damage the printer

- (1) Ensure the printer is installed on a level surface, capable of supporting its weight. Failure to do so could cause the printer to tip or fall.
- (2) The printer contains many rollers, gears and fans. Take great care to ensure that you do not catch your fingers, hair or clothing in any of these rotating devices.
- (3) Do not place any small metal objects, containers of water, chemicals or other liquids close to the printer which if spilled could get into the machine and cause damage or a shock or fire hazard.
- (4) Do not install the machine in areas with high dust or moisture levels, beside an open window or close to a humidifier or heater. Damage could be caused to the printer in such areas.
- (5) Do not place candles, burning cigarettes, etc on the printer, These could cause a fire.

## 1.2.4 Assembly / Disassembly Precautions

---

Replace parts carefully, always use Samsung parts. Take care to note the exact location of parts and also cable routing before dismantling any part of the machine. Ensure all parts and cables are replaced correctly. Please carry out the following procedures before dismantling the printer or replacing any parts.

- (1) Check the contents of the machine memory and make a note of any user settings. These will be erased if the mainboard or network card is replaced.
- (2) Ensure that power is disconnected before servicing or replacing any electrical parts.
- (3) Disconnect printer interface cables and power cables.
- (4) Only use approved spare parts. Ensure that part number, product name, any voltage, current or temperature rating are correct.
- (5) When removing or re-fitting any parts do not use excessive force, especially when fitting screws into plastic.
- (6) Take care not to drop any small parts into the machine.
- (7) Handling of the OPC Drum
  - The OPC Drum can be irreparably damaged if it is exposed to light. Take care not to expose the OPC Drum either to direct sunlight or to fluorescent or incandescent room lighting. Exposure for as little as 5 mins can damage the surface's photoconductive properties and will result in print quality degradation. Take extra care when servicing the printer. Remove the OPC Drum and store it in a black bag or other lightproof container. Take care when working with the covers (especially the top cover) open as light is admitted to the OPC area and can damage the OPC Drum.
  - Take care not to scratch the green surface of the OPC Drum Unit. If the green surface of the Drum Cartridge is scratched or touched the print quality will be compromised.

## 1.2.5 Disregarding this warning may cause bodily injury

**(1) Be careful with the high temperature part.**

The fuser unit works at a high temperature. Use caution when working on the printer. Wait for the fuser to cool down before disassembly.

**(2) Do not put finger or hair into the rotating parts.**

When operating a printer, do not put hand or hair into the rotating parts (Paper feeding entrance, motor, fan, etc.). If do, you can get harm.

**(3) When you move the printer.**

This printer weighs 15.6kg including toner cartridge and cassette. Use safe lifting and handling techniques. Use the lifting handles located on each side of the machine. Back injury could be caused if you do not lift carefully.

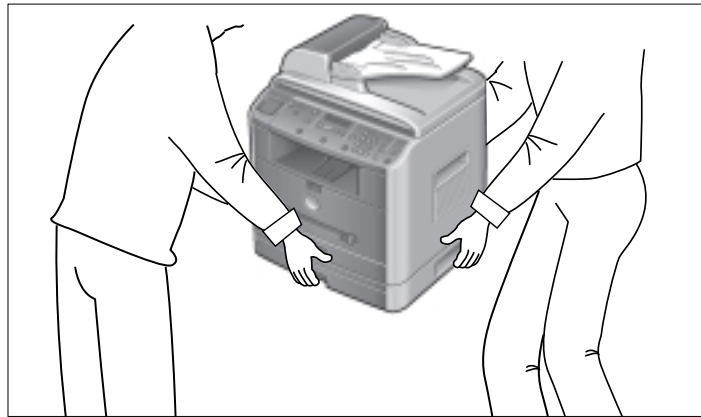

**(4) Ensure the printer is installed safely.**

The printer weighs 15.6Kg, ensure the printer is installed on a level surface, capable of supporting its weight. Failure to do so could cause the printer to tip or fall possibly causing personal injury or damaging the printer.

**(5) Do not install the printer on a sloping or unstable surface. After installation, double check that the printer is stable.**

## 1.3 ESD Precautions

---

Certain semiconductor devices can be easily damaged by static electricity. Such components are commonly called “Electrostatically Sensitive (ES) Devices”, or ESDs. Examples of typical ESDs are: integrated circuits, some field effect transistors, and semiconductor “chip” components.

The techniques outlined below should be followed to help reduce the incidence of component damage caused by static electricity.

*Caution >>Be sure no power is applied to the chassis or circuit, and observe all other safety precautions.*

1. Immediately before handling a semiconductor component or semiconductor-equipped assembly, drain off any electrostatic charge on your body by touching a known earth ground. Alternatively, employ a commercially available wrist strap device, which should be removed for your personal safety reasons prior to applying power to the unit under test.
2. After removing an electrical assembly equipped with ESDs, place the assembly on a conductive surface, such as aluminum or copper foil, or conductive foam, to prevent electrostatic charge buildup in the vicinity of the assembly.
3. Use only a grounded tip soldering iron to solder or desolder ESDs.
4. Use only an “anti-static” solder removal device. Some solder removal devices not classified as “anti-static” can generate electrical charges sufficient to damage ESDs.
5. Do not use Freon-propelled chemicals. When sprayed, these can generate electrical charges sufficient to damage ESDs.
6. Do not remove a replacement ESD from its protective packaging until immediately before installing it. Most replacement ESDs are packaged with all leads shorted together by conductive foam, aluminum foil, or a comparable conductive material.
7. Immediately before removing the protective shorting material from the leads of a replacement ESD, touch the protective material to the chassis or circuit assembly into which the device will be installed.
8. Maintain continuous electrical contact between the ESD and the assembly into which it will be installed, until completely plugged or soldered into the circuit.
9. Minimize bodily motions when handling unpackaged replacement ESDs. Normal motions, such as the brushing together of clothing fabric and lifting one’s foot from a carpeted floor, can generate static electricity sufficient to damage an ESD.

## 2. Reference Information

This chapter contains the tools list, list of abbreviations used in this manual, and a guide to the location space required when installing the printer. A definition of tests pages and Wireless Network information definition is also included.

### 2.1 Tool for Troubleshooting

The following tools are recommended safe and easy troubleshooting as described in this service manual.

- **DVM(Digital Volt Meter)**

Standard : Indicates more than 3 digits.

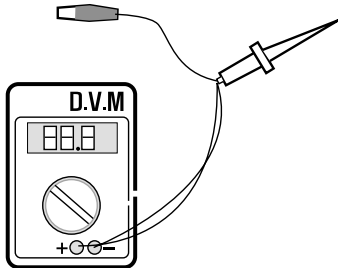

- **Driver**

Standard : "-" type, "+" type (M3 long, M3 short, M2 long, M2 short).

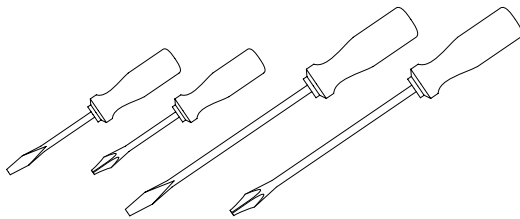

- **Tweezers**

Standard : For general home use, small type.



- **Cotton Swab**

Standard : For general home use, for medical service.



- **Cleaning Equipments**

Standard : An IPA(Isopropyl Alcohol)dry wipe tissue or a gentle neutral detergent and lint-free cloth.

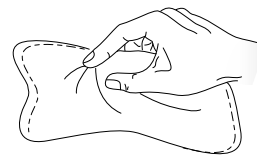

- **Vacuum Cleaner**

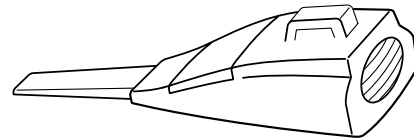

- **Spring Hook**

Standard : For general use



- **Software (Driver) installation CD ROM**

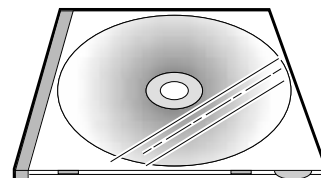



## 2.2 Acronyms and Abbreviations

The table in the below explains abbreviations used in this service manual.

The contents of this service manual are declared with abbreviations in many parts. Please refer to the table.

AC	Alternating Current	IDE	Intelligent Drive electronics or Imbedded Drive Electronics
ADF	Automatic Document Feeder	IEEE	Institute of Electrical and Electronics Engineers. Inc
ASIC	Application Specific Integrated Circuit	IPA	Isopropy Alcohol
ASSY	assembly	IPM	Images Per Minute
BIOS	Basic Input Output System	LAN	local area network
CCD	Charge Coupled Device	lb	pound(s)
CMOS	Complementary Metal Oxide Semiconductor	LBP	Laser Beam Printer
CN	connector	LCD	Liquid Crystal Display
CON	connector	LED	Light Emitting Diode
CPU	Central Processing Unit	LSU	Laser Scanning Unit
dB	decibel	MB	Megabyte
dbA	decibelampere	MHz	Megahertz
dBm	decibel milliwatt	NVRAM	Nonvolatile random access memory
DC	direct current	OPC	Organic Photo Conductor
DCU	Diagnostic Control Unit	PBA	Printed Board Assembly
DPI	Dot Per Inch	PCL	Printer Command Language , Printer Control Language
DRAM	Dynamic Random Access Memory	PDL	Page Discription Language
DVM	Digital Voltmeter	PPM	Page Per Minute
ECP	Enhanced Capability Port	PTL	Pre-Transfer Lamp
EEPROM	Electronically Erasable Programmable Read Only Memory	Q'ty	Quantity
EMI	Electro Magnetic Interference	RAM	Random Access Memory
EP	electrophotographic	ROM	Read Only Memory
EPP	Enhanced Parallel Port	SCF	Second Cassette Feeder
F/W	firmware	SMPS	Switching Mode Power Supply
GDI	graphics device interface	SPGP	Samsung Printer Graphic Processor
GND	ground	SPL	Samsung Printer Language
HBP	Host Based Printing	Spool	Simultaneous Peripheral Operation Online
HDD	Hard Disk Drive	SW	Switch
HV	high voltage	Sync	Synchronous or synchronization
HVPS	High Voltage Power Supply	USB	Universal Serial Bus
I/F	interface		
I/O	Input and Output		
IC	integrated circuit		

## 2.3 The Sample Pattern for the Test

The sample pattern shown in below is the standard pattern used in a factory.

The contents of the life span and the printing speed are measured with the pattern shown in below.

(The picture in the manual is 70% size of the actual A4 size.)

### 2.3.1 A4 5% Pattern

```

i o o e / A K 06 cs hh r m E ei *0 Y s r a i
r a) ( Y b S lM* s g .3 A A4 r n
t Leyi RS . s d u xo o lg P t f l
N l 0t f ' t psF ott O 2 ux-s o i t Anvp N 0 tQ
tl ti uso w'i ag' l u p O . n X0t li at
L ey oH m m n N: lc T c hrry x i t
ia* X 0 t' utst- N*Qir ep n b pepa We t
eo t s IT' i 'e dn o S b* te * G * srx is n
. auo s t s e l A cko o 9 0 gs
ne 3 o n l* r a/n i op r r i * ee
s O aeocs p * * Ke'0 sn*s z eo cr o - 0 ma go
FpT sonm da t s l xopr a r p . o ' - u
ac-n * / Sac Y t e (ty* mlaI p b t2 (l
i edu ar -0 l DPR e Dse ag c e sa6g p p'
*/mnoov p se* W a 0 r * gm 0 p p r P00
n t*n su n h*xv ri tp' o rg co ine s v0 -0 l T
y 01 m ' (lo M ' u/ r ne v0 o pe
0b o d t nu e n e lA apr0 iotre
s o e d o u' I si ESC o i X'ee
pe e t i md OPC e Letyo aoi t nn l tm e B
x i Xlo ) c aicn fern i)x i p n* n oi e u in D W
X Y X r eo 00l dE bs PB teo * Ro H g u*K
d s Fxr rCF a bh s p g s le r roJ n e pp
a p tr ps(s oadrr la s p z uis n oa
.m d t E *F i* opn E h i rudcr s 0
a petya b d e v" d t'e.p) . ro .h n s t
n p t e v t ho *f0x*a 0 ic 0 em i a c4 FA0
i2q n/ s8' i ) BZ P cd~ pso o 30a Or y*h
dr -e tu9 t F iet3 rhp * e mo dt x De
WTPP xix n m( wd lAacc a -0 z)l i i n e
5 e * sn o Pd .Xl o ic sa y X pk
i- p00 p h yb olo) C e ( w sco"o o ynn !Xnj
i va3 AC H a C Xt0rp ow ( ersico s lo a
Plplae a tid ep/tF t )s pn F 't g(ed e
so ss w l0h yxt OS p) Dno- o r
*dynM 0 u i i TP nly ne' l c X s(seo 0'c
i 08 BW ouch ue k EX t2' i Sonn * op
i sl n g ir r Q o X gr ny* tu 0 mxsar uj*
a 0/* p 8 ur f o t a ip p no e
es pn .i* i .t) .t W 5A * iyn t I O stn rtx
Ui c i7 e )SPX m uros3*is s .n n M o l L-g
at *sUr n2 7e u l X o o tH-res c p eo W
5* oe o( Q F0p nN * em'r*ud e t MM c iox5
iog s- a (os on d b so'6p s 6At eo . n s
Hist 0 J t R 6 ei T rJ iil ' i 0 ank'
p r e r0 F Bui op mm e0M 0 00 1Ee u e B u
q t i o XB iO *hn t r i a ses " t X t t s n
m) g p d G F I soy Ors fE*0 o Ie hd e n
p t E oo gnO' t H r s nZE e iea p * t - p/4e l
d X er s t o t idt *o s 0' p e t ll/R e
XX i g i e fg s p C . m x h te C g os ta e
Pa(00 n/t00'ozdI dno x .p O W ae or R t icF
(l xa B co o s )r s 8Y*x toe' ie t o ah
r B o rlr d t .l Ei etODa h n s7
c - s oolo t ga /r FM *d i*s 0 x o pe *

```

current printing page is : 1 of 1

## 2.3.2 A4 2% Pattern

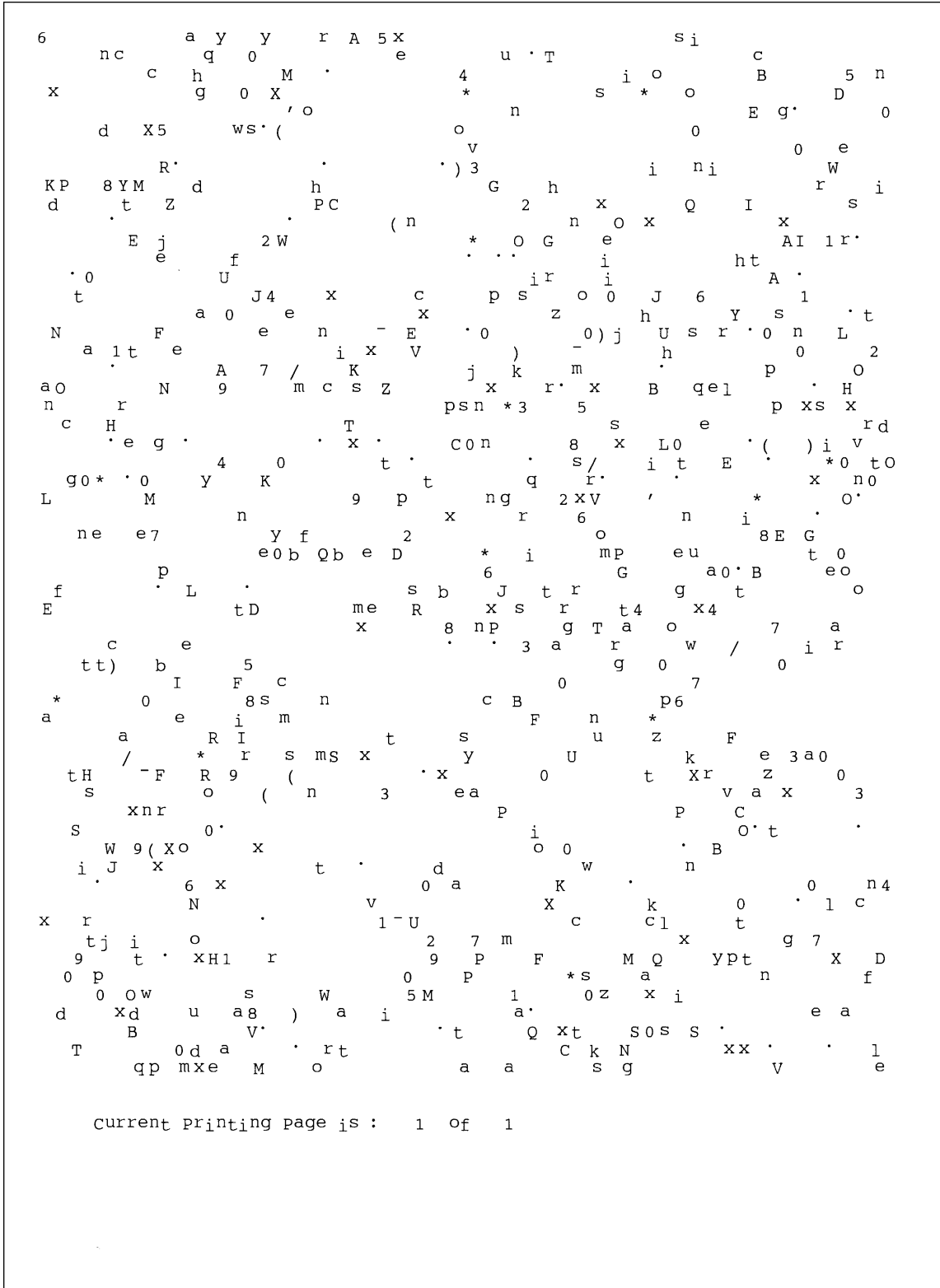

## 2.3.3 A4 IDC 5% Patten

### INTEROFFICE MEMORANDUM

**TO:** Cathy Scott  
**FROM:** Lane Wolters  
**SUBJECT:** The Typical Printed Page  
**DATE:** 07/14/09

What does the typical laser printer document look like? Well, across the diverse business community it would be impossible to capture all aspects of printing style within a single page document. However, if attention is focused on the majority of printing volume, text and simple business graphics would stand out as the most prevalent output from laser printers. This

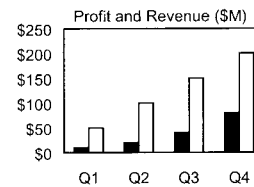

sample memo represents a reasonable example of the typical business document. This memo covers approximately 5% of a letter or A4-sized piece of paper. This number (5%) has historically been called the "average" page coverage by laser printer manufacturers. It may seem to the naked eye that there is much more than 5%, but in fact, alphanumeric characters rely on a large portion of white space for their composition.

Mileage Chart

City	London	Los Angeles	New York	Tokyo
London	--	5456	3453	5975
Los Angeles	5456	--	2468	5451
New York	3453	2468	--	6736
Tokyo	5975	5451	6736	--

There are many factors that can influence the actual page coverage of a document as well as the page-yield of a toner cartridge. Testing parameters such as font size and style, internal printer settings, print environment, paper stock, sample size, job length and criteria for determining "end of life", can all influence how long a toner cartridge will last. The best competitive analysis of printer page yield should occur under similar conditions using industry standards for the variables listed above.

## 2.3.4 A4 ISO 19752 Standard Pattern

This test page is reproduced at 70% of the normal A4 size

ABCDEFGHIJKLMN OPQRSTUVWXYZ1234567890ABCDEFGHIJKLMN OPQRSTUVWXYZ1234567890ABCDEFGHIJKLMN OPQRSTUVWXYZ1234567890ABCDEFGHIJKLMN OPQRSTUVWXYZ1234567890

---

Stephen J. Singel  
 Labanda Sinpat Abarress  
 Tendar, BSF  
 URANGLE

27 March 2003

Jonathan Q. Maderia

Inpert Mampem Abaress  
 2343 Stantin Dawer Lank  
 Benhibe, SDF

Mr. Maderia:

Nam liber tempor cum soluta nobis eleifend option cogue nihil consequat, velillum. Dolore eu zril feugiat nulla facilisis at vero eros accumsan et iust— odio dignissim qui blandit praesent lutatum ril lobortis nisl ut aliquip ex ea commodo consequat. Duis autem vel eum iriure dolor in hendreritin vulputate velit esse molestie tincidunt ut laoreet dolore magna aliquam erat volutpat. Ut wisi enim ad minim veniam, quis nostrud exerci tation ullamcorper suscipit lotis nisl ut aliquip ex ea commodo con-sequat. Lorem ipsum dolor sit.

Amet, consectetur adipiscing elit, s’ d diam nonummy nibh veniam, recneps adipiscing elit, sed diam nonummy nibtil laoreet dolore magna aliam erat volutpat. Ut wisi enim minim veniam, quisient nostrud. Soluta nobis eleifend optn cogue nihil imerdiet domg id quod mzim plerat facer posim aum. Lorem ipsum dolor sit amet, consectetur. Duis autem vel eum iriure dolor in hendreritin vulputate velit esse ea commodo molestie.

Nam liber tempor cum soluta nobis eleifend option cogue nihil consequat, velillum. Dolore eu zril feugiat nulla facilisis at vero eros accumsan et iust— odio dignissim qui blandit praesent lutatum ril lobortis nisl ut enod.

Singabet,

Stephen J. Singel  
 Demperta Aminerimum  
 Labanda Sinpat Abarress

SJS: dwg

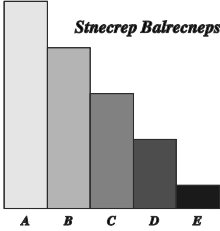
ABCDEFGHIJKLMN OPQRSTUVWXYZ1234567890ABCDEFGHIJKLMN OPQRSTUVWXYZ1234567890ABCDEFGHIJKLMN OPQRSTUVWXYZ1234567890ABCDEFGHIJKLMN OPQRSTUVWXYZ1234567890

## 3. Specifications

Specifications are correct at the time of printing. Product specifications are subject to change without notice. See below for product specifications.

### 3.1 General Specifications

Items		Tag Heuer	Remarks
		SCX-4920N/DELL	
Major Features		Fax, Copier, Print, Scan, ADF, N/W Print, Scan-to-Email	
Size (W*D*H) w/o Hand Set		450mmx423mmx456mm) (17.7x16.7x18")	
Net Weight(Inc. Toner Cartridge)		15.6kg	
Net Weight(exc. Toner Cartridge)		14.8kg	
Gross Weight(with package)		20.4kg	
LCD		16*2 Char	
I/O Interface		USB2.0 (High Speed)	
MPU		SPGPm / 166MHz	
Power Consumption	Printing Operation	400W	
	Sleep Mode	30 W Energy Star Compliant	
	Power Switch	Yes	
Power Supply	Input Voltage	Low Voltage : 110 ~ 127VAC (90~135VAC)	
		High Voltage : 220 ~ 240VAC (180~264VAC)	
	Input Frequency	50 / 60Hz(+/- 3Hz)	
Noise	Printing	54dBA	
	Copy	55dBA	
	Standby	33dBA	
Warm Up Time	from Cold Status	Less than 42 seconds	
Machine Life	Max. Monthly	Print	15,000pages
	Volume	Scan	1,000pages
	(Duty Cycle)	ADF	1,000pages
	Average Monthly Print Volume		1,500pages
	Machine Life	150000pages	

Items		Tag Heuer	Remarks
		SCX-4920N/DELL	
Periodic Replacing Parts	Pickup Roller	150,000 Pages	Investigating new material to prolong life of pickup roller Samsung confirm 150,000 Pages reliability.
	Pad Unit(Tray)	150,000 Pages	Samsung confirm 150,000 Pages reliability.
	Pad Unit (ADF)	20,000 Pages	
	Transfer Roller	60,000 Pages	
	Fuser Unit	80,000 Pages	
Environmental	Temperature	Operating	10~32 °C
		Non Operating	-20~40°...
	Humidity	Operating	20~80%
		Non Operating	10~90%
	Altitude		Max 8,200ft
EMI Approval		Class B	
Device Memory	Standard / Max.	32MB/160MB(Std./Max) 12MB(PS) + 4MB(FAX) + 2MB (System) + 2MB(Scan) = 20MB	
	Type	SDRAM	
	Expand Memory Slot , Type	SDRAM DIMM	Expand Memory specification would be defined separate note, 128MB Micron Memory will work only in GEU Burst mode off.
	Compression Technology	YES	

## 3.2 Print Specification

Items		Tag Heuer SCX-4920N/DELL	Remarks	
PRINT	Print Speed	22ppm/Ltr, 20ppm/A4 (600 dpi)		
	Print Emulation	GDI, PCL6, PCL5e PostScript Level3(Clone)		
	Auto Emulation Sensing	YES		
	Font	Type	45 Scalable, 1 Bitmap	
		Number	N/A	
	Power Save	Yes(5/10/15/30/45min.)		
	Resolution	Normal	600x600dpi (1200x1200,)	
		RET	Yes	
	Toner Save	Yes (No dedicated button on CP)		
	Memory	16MB		
	FPOT	From Stand by	Approx. 10 seconds (From LSU 'ON', A4)	
		From Cold Status	Less than 50 seconds	
	Duplex Print	N.A		
	Printable Area	208 x 273 mm (Letter)		
Halftone(Gray Scale)	128levels			



### 3.3 Scan Specification

Items		Tag Heuer		Remarks	
		SCX-4920N/DELL			
SCAN	Scan Method		Color CCD	USB 1.1, 300dpi, Letter Size, Pentium 4 1.xGHz, 128MB RAM	
	Scan Speed through ADF	Linearity	Approx. 75sec (USB 1.1)		
		Gray	Approx. 75sec (USB 1.1)		
		Color	Approx. 150sec (USB 1.1)		
	Scan Speed through Platen	Linearity	Approx. 75sec (USB 1.1)		
		Gray	Approx. 75sec (USB 1.1)		
		Color 75dpi/300dpi	Approx. 150sec (USB 1.1)		
	Resolution	Optical	600*1200dpi		
		Enhanced	4800dpi*4800dpi		
	Halftone		256level		for only optical resolution
	Scan Size	Max. Document Width	Max.216mm(8.5")		
		Effective Scan Width	Max 208mm(8.2inch)		
Scan-to		Scan-to-Application			
Scan Depth	Color	24 bit			
	Mono	1bit for Lineart, 8 Bit for Gray scale			

### 3.4 Copy Specification

Items		Tag Heuer		Remarks	
		SCX-4920N/DELL			
COPY	Copy Quality Selection or Original Image type selection Mode	Text	600x300dpi		
		Text/Photo	600x300dpi		
		Photo	600x600dpi for Platen		
		Other	N/A		
	FCOT	Stand by	Approx. 10 seconds:Platen Approx. 15 seconds:ADF		
		From Cold Status	50 seconds		
	Copy Speed / Letter	SDMC at all mode	22cpm/Ltr, 20cpm/A4	SDMC: Single Document Multiple Mixed Copy  MDMC: Multi-document Multiple Copy	
		MDMC at Text, (600x300dpi)	14cpm		
		MDMC at Photo Mode (600x600dpi)	8cpm		
	Origin Alignment	Platen	REAR LEFT		
		ADF	Center		
	Resolution		Scan:600x300dpi, 600*600dpi Print:600*600dpi		
	Zoom Range		25% to 400% for Platen 25% to 100% for ADF		
	Multi Copy		1~99		
	Preset		Yes		
	Darkness Control		3 level(by LED)		
	Copy Mode(=Quality)		Text, Mixed, Photo		
	Collation Copy		600x300dpi : Yes		
	Auto return to default mode		Yes		Time can be changeable 15,30,60,180sec, Off
	Changeable Default mode		Contrast, Image, Reduce/Enlarge, No. of Copies		
Special Copy	N-up copy	2-up, 4-up		* Copy 2-side printed original document into one page(ex. ID Card Copy)	
	Collation Copy	Yes(ADF only)			
	AutoFit Copy	Yes(Platen only)			
	2-side Copy	Yes(Platen only)			
	Clone	Yes(Platen only)			
	Poster	Yes(Platen only)			

Items		Tag Heuer	Remarks	
		SCX-4920N/DELL		
TELEPHONE	Handset	No		
	On hook Dial	Yes		
	Search	Yes(Phone Book)	by using Phone Book Button(Same as Rocky)	
	1-Touch Dial	10 Numeric Key pad (No dedicated keys)		
	Speed Dial	200 locations(00~199) include 1-touch dials	Total locations can be stored	
	TAD I/F	Yes		
	Tone/Pulse	Selectable in Technical Mode		
	Pause	Yes		
	Auto Redial	Yes		
	Last Number Redial	Yes		
	Distinctive Ring	Yes		
	Caller ID	No		
	External Phone Interface	Yes		
	Report & List Print out	Tx/Rx Journal	Yes	
		Confirmation	Yes	
		Help List	No	
		Auto Dial List	Yes	
		System Data List	List all user setting	
	Sound Control	Ring Volume	Yes(Off,Low,MED,HIGH)	
		Key Volume	Yes(On,Off)	
Alarm Volume		Yes(On,Off)		
Speaker		Yes(On,Off, Comm)		

### 3.5 Fax Specification

Items		Tag Heuer	Remarks	
		SCX-4920N/DELL		
Fax	Compatibility		ITU-T G3	
	Communication System			PSTN/PABX
	Modem Speed		33.6Kbps	
	TX Speed		3sec	LTRr/MMR
	Compression		MH/MR/MMR/JPEG	
	Color Fax		Yes(Send Only)	
	ECM		Yes	
	Resolution	Std	203*98dpi	
		Fine	203*196dpi	
		S.Fine	300*300dpi	
	Scan Speed	Std	2.5 sec/ LTR	1,200 PPS
	(ADF)	Fine/S.Fine	5 sec/ LTR	665 PPS
	Rx fax duplex print out		No	
	Multiple page scan speed		14 ppm/LTR, Std mode	203*98dpi, ITU-T #1
	Receive Mode		Fax, TEL, Ans/Fax, DRPD	
	Memory	Capacity	4MB	
		Optional Memory	No	
		Max locations to store to 1 Group Dial	199 locations	
		Fax Forward	Yes(On/Off)	
		Broadcasting	up to 209 locations	
		Cover page	Yes	
		Delayed fax	Yes	
		Memory RX	Yes	
	Functions	Voice Request	No	
		TTI	Yes	
		RTI	Yes	
Polling		No		
Earth/Recall		No		
Auto Reduction		Yes		
F/W Remote upgrade		Yes		
Junk Fax barrier		Yes		
Secure Receive		Yes		
Memory Back-up		Yes, Max. 43hours		

### 3.6 Other Specification

Items		Tag Heuer		Remarks
		SCX-4920N/DELL		
Network	Option		Yes (Standard)	
	Protocol		SPX/IPX, TCP/IP, Ethertalk, SNMP, HTTP 1.1, DLC/LLC	
	Operating System		MS Windows 98/2000/XP/NT/Me, MAC (English only, no status monitor, web download only)	
Paper Handling	Capacity( 20lbs)	Main Tray	250sheets	
		Bypass	Single Sheet	
	Optional Cassette		250sheets	
	Output Capacity		Face Down: 150Sheets/20lb Face Up: 1Sheet	
Paper Handling (Continued)	Output Control		Face down/Face up	
	Paper Size	Main Tray	A4,Letter,Legal ,Folio, Executive, B5	
		Bypass	Bypass:Envelope6 3/4, 7 3/4,#9, #10,DL,C5,B5	
	Paper Weight	Main Tray	16~24 lb.	
		Bypass	16~43 lb.	
	Paper Path	Standard output	Bottom to Middle Front (FIFO)	
		Straight Through	Face up, Single Sheet	
	Paper Size	Max	216 x 356mm(8.5"x14")	
		Min	76 x 127mm(3"x5")	
	ADF	Paper Weight	12.5~28lb	
		Capacity	50 sheets	
		Document Size Width	142mm - 216mm(5.6" - 8.5")	
		Document Size Length	148 mm - 356mm(5.8" - 14.0")	
	Jam Rate	Cassette, 2nd Feeder	1/2000	*In H/H and L/L condition, the spec. of JAM rate and Mis-pickup rate Double Feed is doubled.
		ADF	1/1000	
Multi_Feeding Rate	Cassette, 2nd Feeder	1/1000	Cassette : Jam:1/1000, Double Feed:1/500	
	ADF	1/500		
Printing Skew	Top	1.5/177.8mm (1st Tray) 2.0/177.8 (2nd Tray)		
	Side	2/243.5mm (1st Tray) 2.5/243.5mm (2nd Tray)		
Copy Skew	Top	2.5/190mm (1st Tray) 3.0/190mm (2nd Tray)		

Items		Tag Heuer		Remarks	
		SCX-4920N/DELL			
Software		Side	3.5/277mm (1st Tray) 4.0/277mm (2nd Tray)		
	Compatibility		DOS	No	
			Win 3.x	No	
			Win 95	No	
			Win 98	Yes	
			Win ME	Yes	
			Win NT 4.0	Yes	
			Win 2000	Yes	
			Win XP	Yes	
			Mac	English only web version	
			Linux	No	
	WHQL	MFP	Yes for 2000 & XP		
	Driver		Printer	GDI, PCL6, PCL5e(Std.) PostScript Level3(Std.)	
			TWAIN	Yes	
			WIA	Yes	
RCP			Yes		
PC-FAX			Yes (through PC modem and Fax S/W)		
Accessory	Quick setup guide		Yes		
	Owner's manual		Yes		
	S/W CD ROM		TBD CDs for Print Driver, Scan Driver, RCP		
	S/W	OCR	PaperPort		
		FAX	MS Fax		
		SCAN S/W	PaperPort		
	Toner Cartridge		1 EA (3K yield ISO 5% Coverage)		
	Power Cable		1 EA		
	Telephone Jack		1 EA		
Printer Cable		No			
Consumables	Type		One Piece Type		
	How to install		Front door open and front loading		
	Toner	Life	Initial 3Kpages (5% ISO Test Pattern) running Standard 3Kpages High yield : 5K pages		
		Level Sensor	No		
	Toner Count		Yes (Dot Counter)		

# MEMO



## 4. Summary of Product

This chapter describes the functions and operating principal of the main component.

### 4.1 Printer Components

#### 4.1.1 Front View

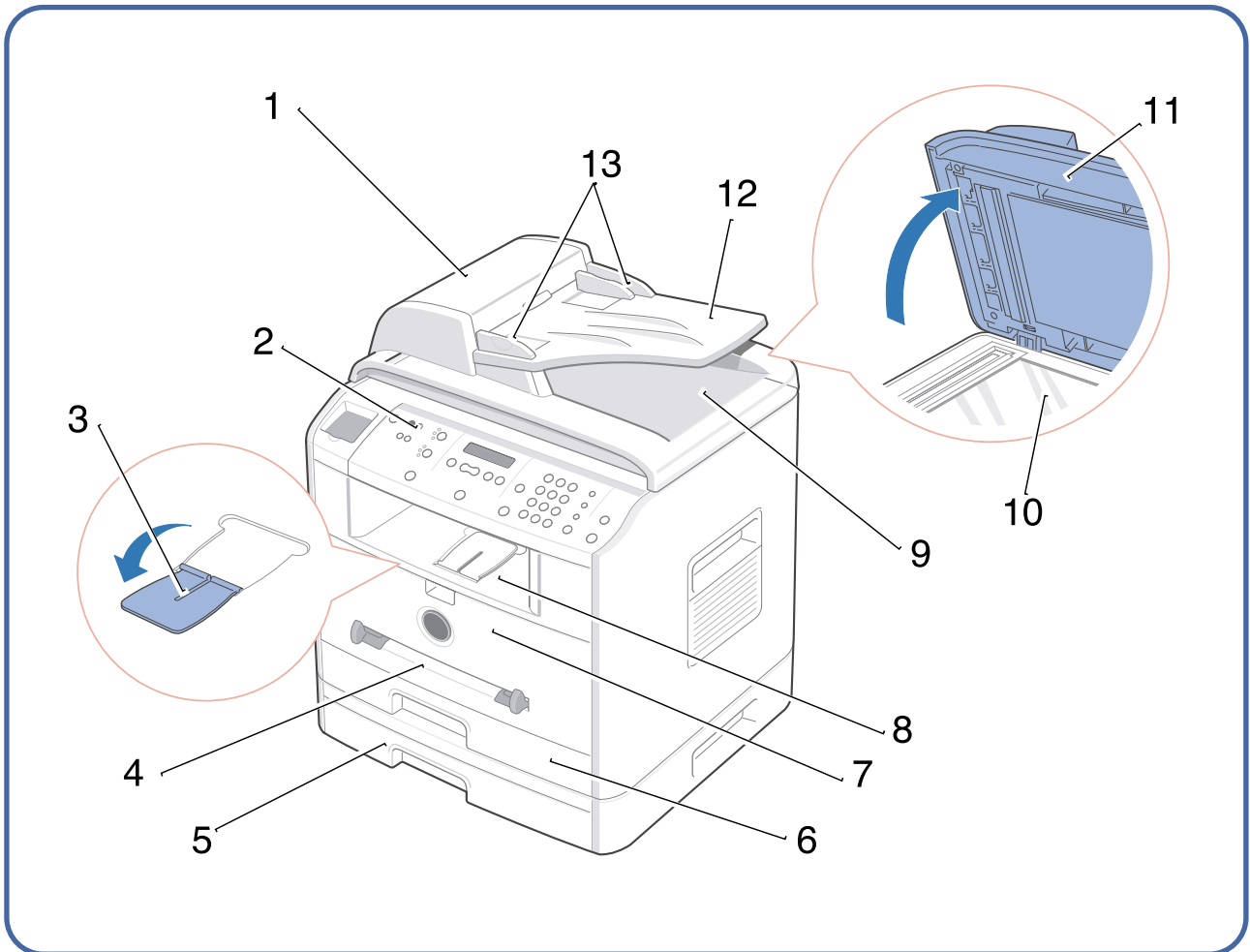



## 4.1.2 Rear View

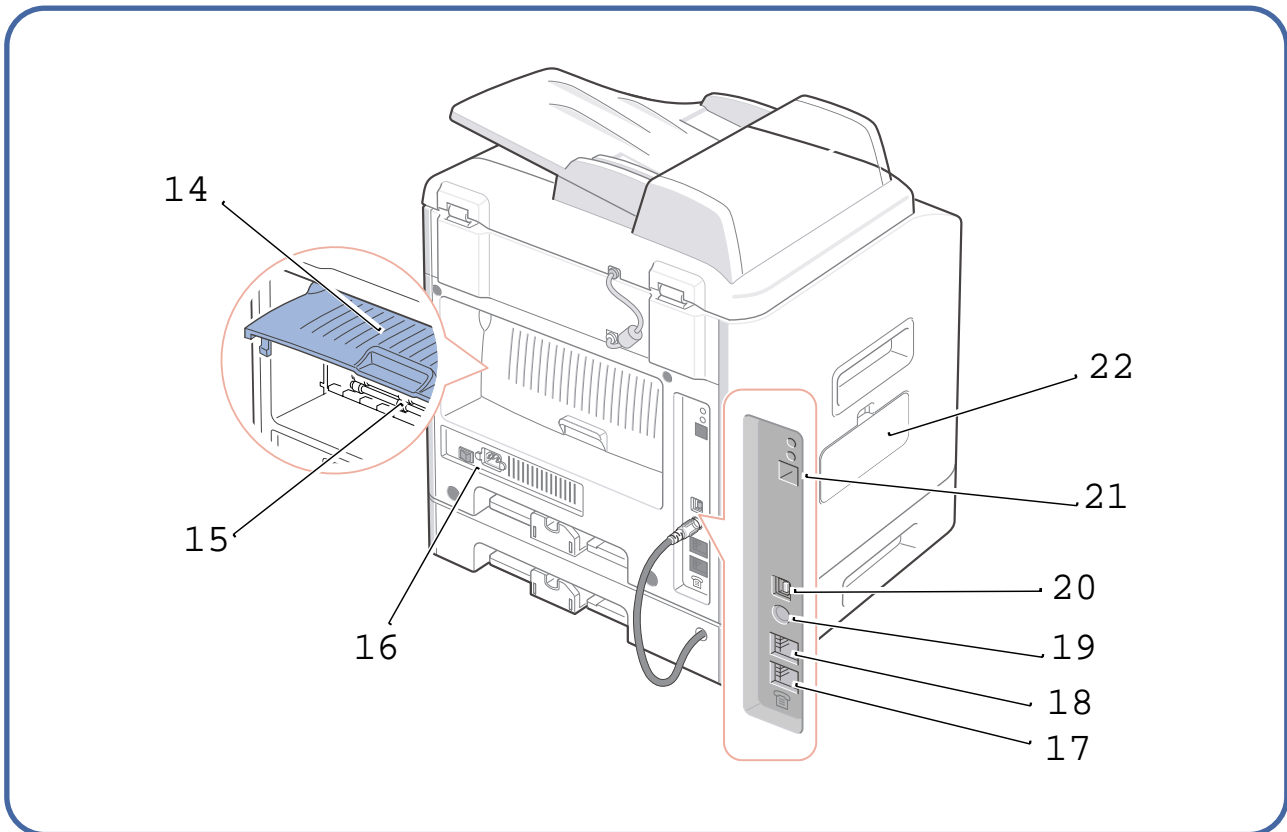







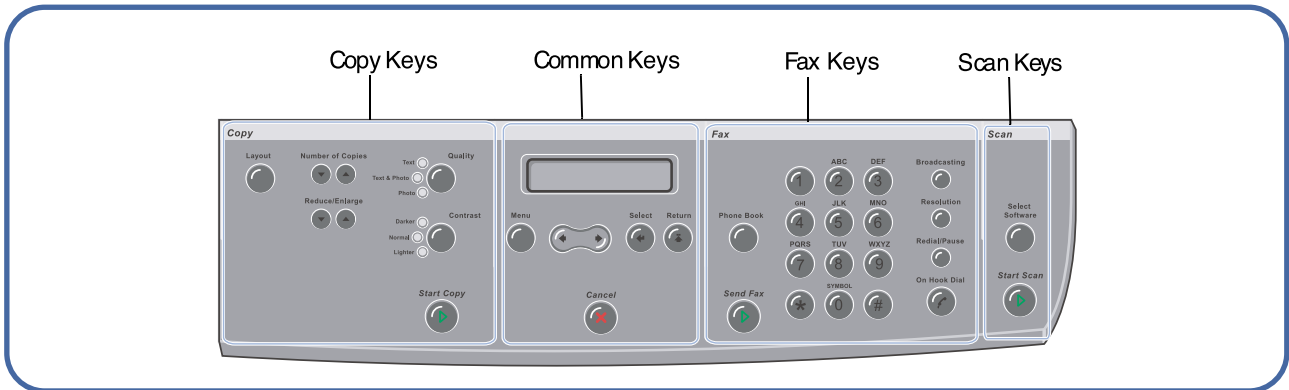













#	Use the:	When you want to:
1	Automatic Document Feeder	Load the document for copying, scanning, or sending faxes.
2	Operator Panel	Operate the machine.
3	Paper Output Extension	Keep print media from falling off the front output tray.
4	Bypass Tray	Load print media one sheet at a time.
5	Optional Tray2	Load paper into the optional Tray2.
6	Tray1	Load paper into the standard Tray1.
7	Front Cover	Access the toner cartridge.
8	Front Output Tray	Hold paper as it exits from the front of the machine.
9	ADF Output Tray	Hold the document as it exits the ADF.
10	Scanner Glass	Place a document on the scanner glass for copying, scanning and sending faxes.

#	Use the:	When you want to:
11	Document Cover	Open to place a document on the scanner glass.
12	Document Input Tray	Load the document for copying, scanning and sending faxes.
13	Document Guides	Ensure proper document feeding.
14	Rear Cover	Open to remove the paper jams and use the rear output slot when you print the documents from the Bypass tray.
15	Rear Output Slot	Hold paper as it exits at the rear of the machine.
16	Power Switch and AC Power Cord Connector	Supply power to the machine.
17	FAX Jack	Connect the telephone line to your machine. If you use this machine in the serial countries, such as Germany and Sweden, this socket may be blocked.
18	Phone Jack	Connect the telephone or answering machine to your machine.
19	Optional Tray2 Cable Connector	Connect the optional Tray2 to your machine.
20	USB Cable Connector	Insert the USB cable.
21	Network Port	Connect the printer to the network port.
22	Control Board Cover	Install the optional memory card.

### 4.1.3 Control Panel



#	Press:	To:
1		Allow you to use copy layout features, such as Auto Fit, Clone, Collation, 2-sided, 2/4 Up (multiple pages on a sheet), and Poster copying.
		Select the number of copies.
		Make a copy smaller or larger than the original document.
		Adjust the copy quality.
		Adjust the brightness of the documents for the current copy job.
		Start a copy.
2		Display the current status and prompt during an operation.
		Scroll through the options available for the selected menu item.
		Enter Menu mode and scroll through the menus available.

#	Press:	To:
2	Select 	Confirm the selection on the display.
	Return 	Exit the menu and return to Standby mode.
	Cancel 	Stop an operation at any time. In Standby mode, clear/cancel the copy options, such as the contrast, the image quality, the copy size, and the number of copies.
3	On Hook Dial 	Allow you to store frequently-dialed fax numbers using a one, two or three-digit speed dial or group number for automatic dialing and edit the stored numbers. It also allows you to print a Phonebook list.
	Send Fax 	Send a fax.
		Dial a number or enter alphanumeric characters.
	Broadcasting 	Allow you to send a fax to multiple destinations.
	Resolution 	Adjust the resolution of the documents for the current fax job.
	Redial/Pause 	Redial the last number in Standby mode or insert a pause into a fax number in edit mode.
4	On Hook Dial 	Engage the telephone line.
	Select Software 	Access a list of software programs that an image can be scanned to. You must configure the scan list using the software prior to this feature.
	Start Scan 	Start a scan.

## 4.2 System Layout

---

### 4.2.1 Feeding section

---

There is a universal cassette, which supplies paper to the machine, and the manual feeder, which supplies paper one by one. The cassette has the friction pad, which separates paper one by one and prevent multi-sheet feeding. There is a sensor to detect the existence of paper in the cassette.

- Feeding Method: Universal Cassette Type
- Feeding Standard: Center Loading
- Feeding Capacity: Cassette-250 sheets (80g/m<sup>2</sup>, 20lb paper standard)  
Manual 1 sheet (Paper, OHP, Envelope, etc.)
- Paper detecting sensor: Photo sensor
- Paper size sensor: None

### 4.2.2 Transfer Ass'y

---

It consists of the PTL (pre-transfer lamp) and the Transfer Roller. The PTL sends a light to the OPC drum, making the current on the drum surface to low and improves the transfer efficiency. The transfer roller transfers toner from the OPC drum surface to the paper.

- Life span: 60,000 sheets (in 15~30°C)

### 4.2.3 Drive Ass'y

---

- It is motor driven gear unit, which drives the feeding unit, the fusing unit, and the distributing unit

### 4.2.4 Fuser

---

- The fuser consists of the Heat Lamp, Heat Roller, Pressure Roller, Thermistor, and Thermostat. It melts the toner to the paper with pressure and a heat to complete the printing job.

#### 4.2.4.1 Thermostat

The thermostat is a temperature-sensing device, which cuts off the power to prevent overheating or a fire when the heat lamp or the heat coil of the heat roller becomes too hot.

#### 4.2.4.2 Thermistor

The Thermistor detects the surface temperature of the heat roller and it maintains the regular temperature of the heat roller by responding to the information of the heat roller's temperature.

#### 4.2.4.3 Heat Roller

The heat roller transfers the heat from the heat lamp coil to the surface of the paper. The melted toner cannot stick to the Teflon coated heat roller.

#### 4.2.4.4 Pressure roller

The pressure roller mounted right under the heat roller is made of the silicon resin. The toner fuses onto the paper when it passes between the heat roller and the pressure roller.

#### 4.2.4.5 Safety Relevant Facts

- Protecting device when overheating
  - 1st protecting device: H/W cuts off when detecting an overheating
  - 2nd protecting device: S/W cuts off when detecting an overheating
  - 3rd protecting device: Thermostat cuts off the power
- Safety device
  - The power to the fuser is cut off when the front cover is open.
  - The overheating safety device for the customer safety.
  - Maintains the surface temperature of the Fuser Cover below 80°C. A customer caution label is attached on the inside of the rear cover.

### 4.2.5 Scanner

---

It reads an image with a photosensitive sensor. It consists of a CCD module, Connection board, ADF board, AFE (Analog Front End), and Image Processor (Located in CPU), platen glass and ADF.

#### • CCD Module Specification

- 1.Resolution: 600dpi/A4
- 2.Maximum scan wide: 8.5"
- 3.Color filter: Red, Green, Blue
- 4.Output channel: 3 channels (R, G, B)
- 5.Effective pixel: 5,400 pixel \*3
- 6.Voltage: 24V & 5V
- 7.Pre-heating time: Maximum 30 seconds (70% of light reach to it)
- 8.The life span of a lamp: 30,000 hours (25°C)

#### • Image Processor Specification

- 1.Operating frequency: 66MHz
- 2.Image sensor interface: 200/300/600 dpi CIS or CCD
- 3.Line time: Copy, FAX, Binary (Lineart, Halftone) PC Scan: 1.5ms/Line Color PC Scan (Grey, 256 Color, True Color): 4.5ms/Line
- 4.A/D conversion: 10bit conversion

## 4.2.6 LSU (Laser Scanner Unit)

The LSU unit is controlled by the video controller. It scans the video data received from video controller with laser beam by using a rotating polygon mirror to create the latent image on the OPC drum. The OPC drum rotates at the same speed as the paper feeding speed. When it hits the corner of the polygon mirror, it generates the /HSYNC signal. The CPU forms the left margin of the image using this signal. After detecting the /HSYNC signal, the image data is sent to the LSU to arrange the its left margin on the paper.  
Each surface of the polygon mirror provides one line for scanning.

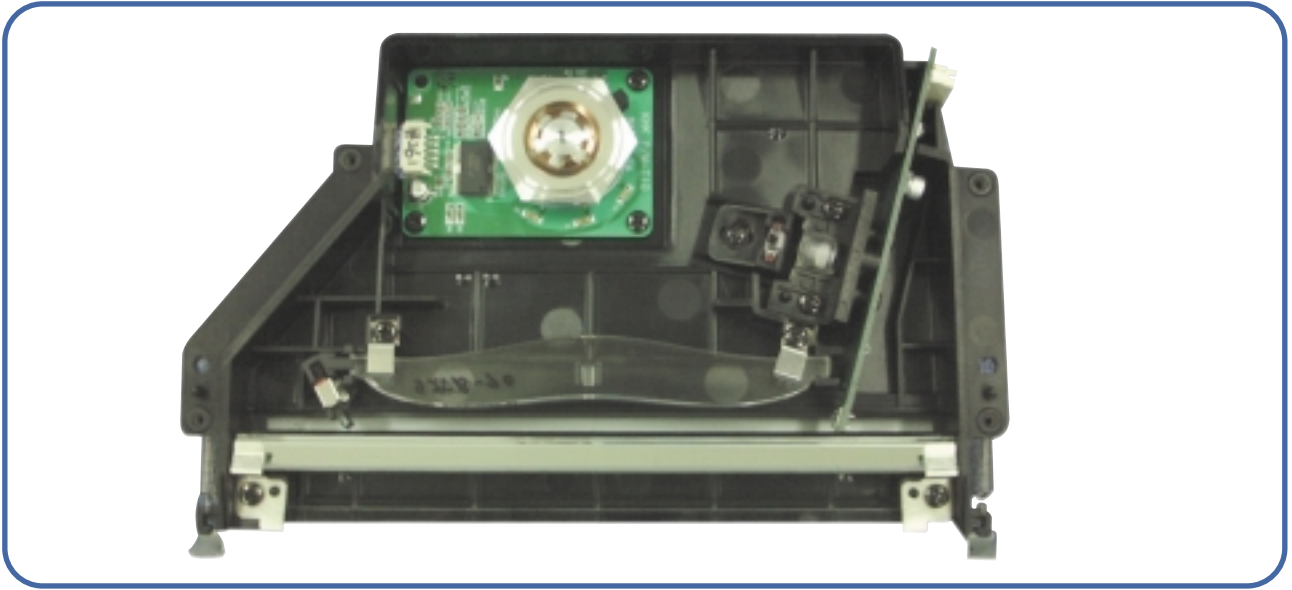

## 4.2.7 Toner Cartridge

By using the xerographic process, it creates a visual image. The Toner Cartridge contains the OPC Drum, developer and toner components in one unit. The OPC unit contains the OPC drum and charging roller. The developer unit contains toner, toner cartridge, supply roller, developing roller, and blade (Doctor blade)

- Developing Method: Non magnetic 1 element contacting method
- Toner: Non magnetic 1 element shatter type toner
- The life span of toner: 3,000 sheets (ISO Pattern)
- Toner remaining amount detecting sensor: None
- OPC Cleaning: Collect the toner by using electric static + FILM OPC
- Management of disusable toner: Collect the toner by using electric static (Clenerless Type- No disusable toner)
- OPC Drum protecting Shutter: None
- Classifying device for toner cartridge: ID is classified by interruption of the frame channel.

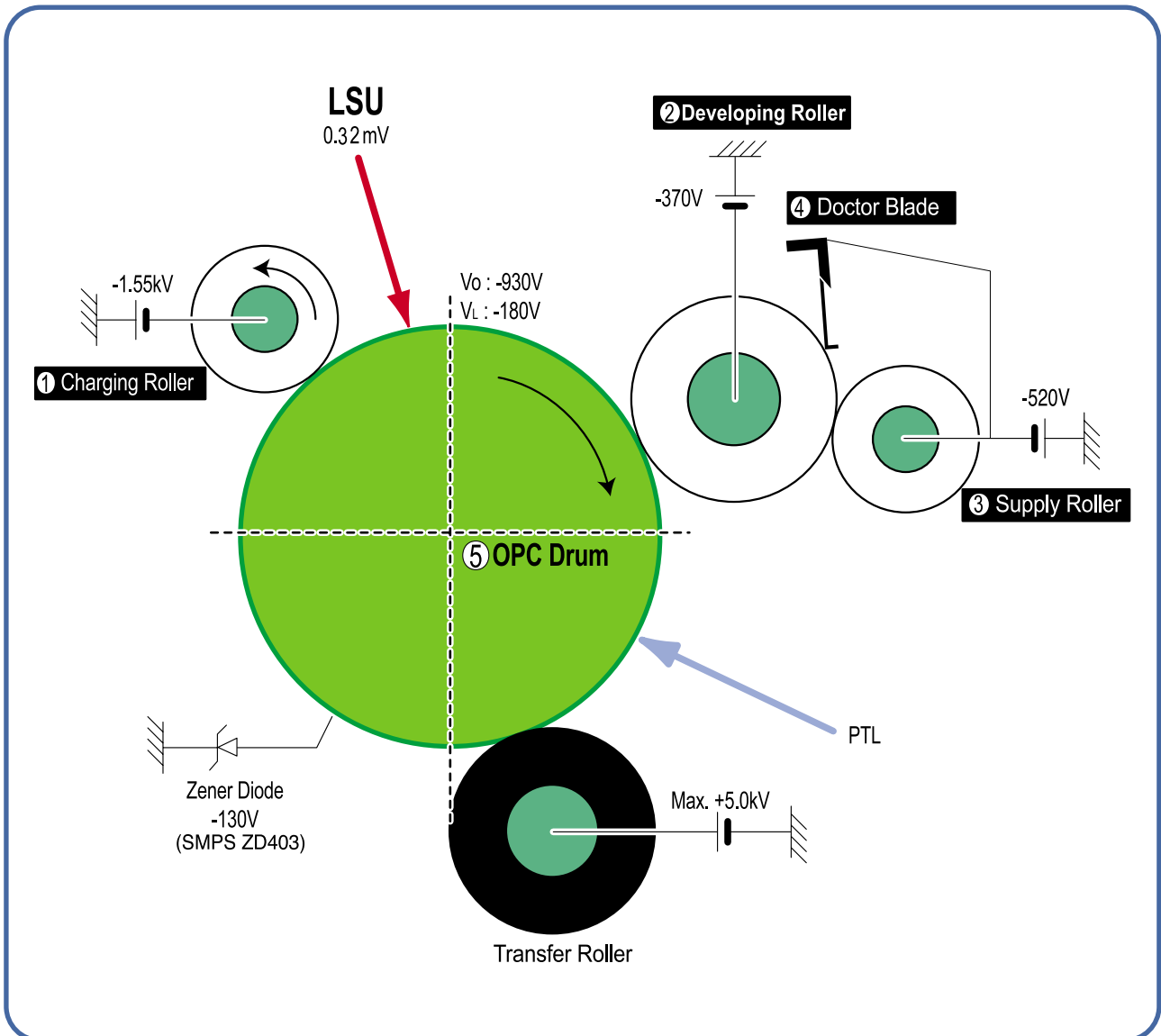



### 4.3 Main PBA

It is the functional center of the product. It controls the basic machine operations including the fax, scan, printer operations, sensor detection and power levels.

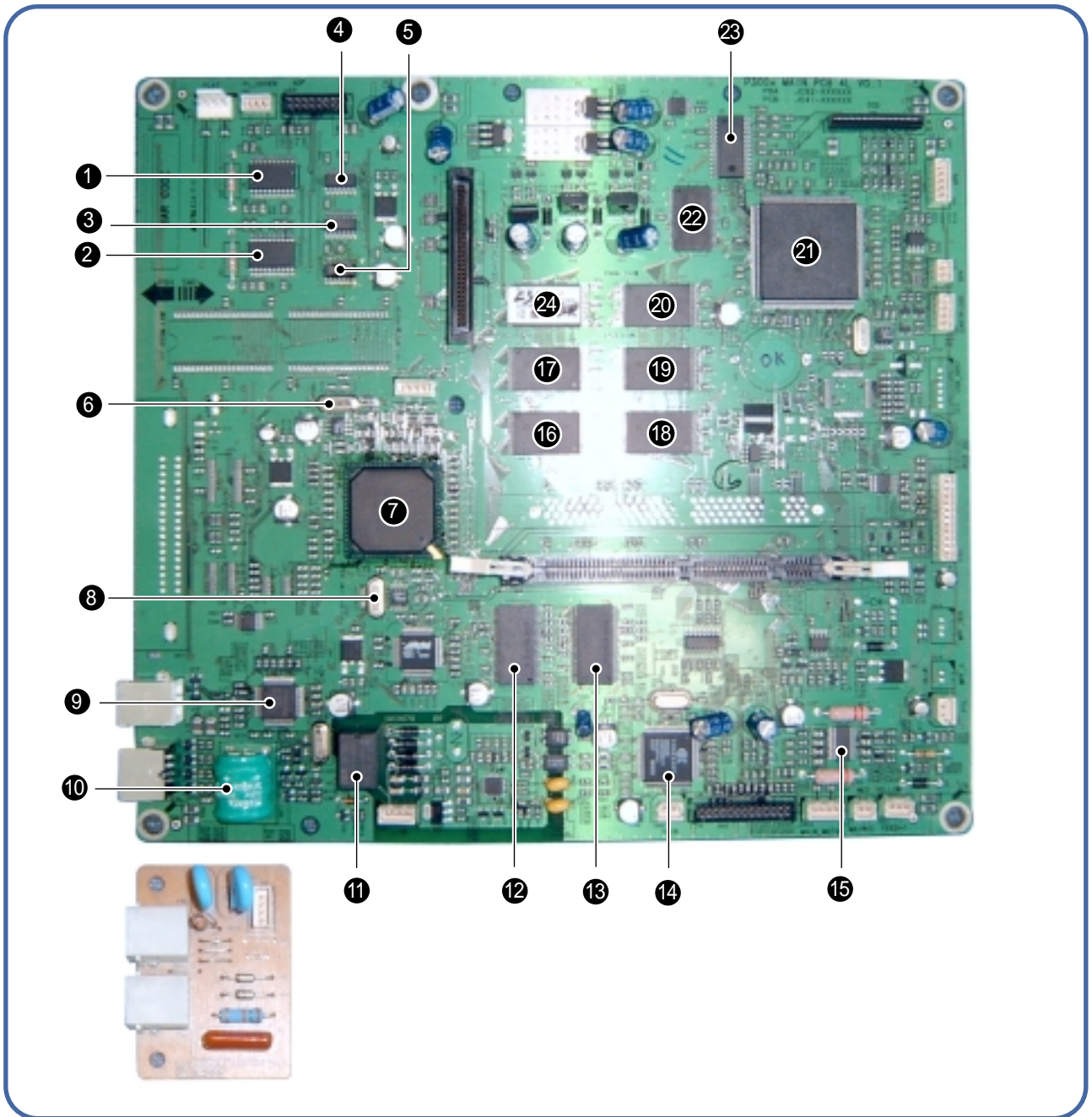

①	MOTOR DRIVER(TEA3718SFP) U6
②	MOTOR DRIVER(TEA3718SFP) U12
③	QUAD 2-INPUT OR GATE(74VHX32) U10
④	QUAD 2-INPUT OR GATE(74VHX32) U7
⑤	QUAD 2-INPUT OR GATE(74VHX32) U70
⑥	VEDIC X-TAL(19.6MHz) OSC2
⑦	PROCESSOR ASIC(SPGPM) U33
⑧	CPU X-TAL(12MHz) OSC10
⑨	USB 2.0(NET2272) U48
⑩	VARTA(3.6V BATT)
⑪	RELAY(HRSIKH) RE1
⑫	SDRAM(K4S281632E) U43
⑬	SDRAM(K4S281632E) U44
⑭	MODEM(CXB2500-11) U52
⑮	MOTOR DRIVER(A3977SLP) U50
⑯	FLASH MEMORY PCL-HIGH(29LV160DB) U27
⑰	FLASH MEMORY PS3-HIGH(29LV160DB) U19
⑱	FLASH MEMORY PCL6-LOW(29LV160DB) U28
⑲	FLASH MEMORY PS3-LOW(29LV160DB) U20
⑳	FLASH MEMORY COED-LOW(29LV160DB) U15
㉑	IMAGE PROCESSOR(CIP4E) U11
㉒	SRAM(K6R1016VID) U9
㉓	A/D CONVERTER(AFE-CIP4) U5
㉔	FLASH MEMORY CODE-HIGH(29LV160DB) U14

### 4.3.1 ASIC

---

Samsung's S3C46Q0X 16/32-bit RISC micro controller is designed to provide a cost-effective, low power, small die size and high performance micro-controller solution for MFP.

The S3C46Q0X is developed using ARM7TDMI core, 0.18(m CMOS standard cell, and memory cell.

#### • Main function block

- 1.8V internal, 3.3V external (I/O boundary) microprocessor with 4KByte Cache
- Image Processor
- On-chip clock generator with PLL
- Memory & External Bank Control
- DMA Control (5-channel)
- Interrupt Control
- 2-port USB Host /1- port USB Device (ver 1.1) Interface Control
- Parallel Port Interface Control
- UART (2 Channel)
- Synchronous Serial Interface Control
- Timer (4 Channel)
- Watch Dog Timer
- Power control: Normal, Slow, Idle, Stop and SL\_IDLE mode
- A/D Converter (10-bit, 2 Channel)
- General I/O Port Control
- Print Head Control
- Carrier Motor Control
- Paper Motor Control
- Tone Generator
- RTC with calendar function
- S/W Assistant function( Rotator )

### 4.3.2 Flash Memory

---

It stores the system program and downloads the system program through the PC interface.

- Capacity : 0.5 M Byte
- Access Time : 70 nsec

### 4.3.3 SDRAM

---

It is used as a buffer, system working memory area, etc. while printing.

- Access Time : 60 nsec

## 4.3.4 Sensor input circuit

### 1) Paper Empty Sensor

The Paper empty sensor (Photo Interrupter) on the engine board informs the CPU as to whether the cassette is empty or not with operation of the actuator.

When the cassette is empty, it detects the fact by reading the D0 Bit of CPU. It highlights this by selecting the second LED(yellow) among the panel LEDs.

### 2) MP Sensing

The MP Sensor (Photo Interrupter) on the engine board informs the CPU as to whether the MP is empty or not. It reads the D0 Bit of CPU to recognize paper in MP, and the paper is fed from MP if present.

### 3) Paper Feeding

When paper passes the actuator (feed sensor part), it detects the signal of Photo interrupter, informs the paper feeding state to the CPU, and then sends the image data after a certain time. If it doesn't detect the feed sensor within 1 sec. after paper is fed, paper Jam0 occurs (Red and Yellow will be turned on among the OP panel LEDs), and whether the developer is inserted or not is detected with the same principle. After the developer is mounted, the actuator is operated. The signal from the photo interrupter is detected when it is passing the actuator of the sensor part. That process is called developer ID sensing.

### 4) Paper Exit Sensing

The system detects the paper going out of the set with the exit sensor assembled to the actuator attached to the frame. Paper detects the on/off time of exit sensor, and the normal operation or jam information is passed to the CPU.

The paper JAM2 is informed.

### 5) Cover Open Sensing

The Cover open sensor is located on the front cover. After the front cover is opened, +24V (DC fan, solenoid, main motor, polygon motor part of LSU, HVPS), which is supplied to the each unit, is cut off.

The cover-open sensing is operated by the D0 bit of CPU, and the developer ID sensing is operated.

### 6) DC FAN / SOLENOID Driving

It is driven by transistor and controlled by D6 bit of CPU.

When it is high, the fan is driven by turning on the TR, and it is off when the sleep mode is selected. There are two solenoids, and they are driven by the paper pick-up and MP signal. Its drive time is 300ms. The diode protects the driving TR from the noise pulse, which is emitted when the solenoid is de-energizing.

### 7) Motor Driving

The motor driving circuit is formed when the Driver IC is selected. The A3977 (Motor driver IC) is used in this case. The resistance Rs value of sensing and the voltage value of the V reference can be changed by the motor driving voltage value.

## 4.4 SMPS & HVPS

The SMPS supplies the DC power to the system.

It takes 110V/220V and outputs the 5V, 12V and 24V to supply the power to the main board and ADF board.

The HVPS part creates the high voltage of THV/MHV/Supply/Dev and supplies it to the developer part for making the best condition to display the image. The HVPS part takes the 24V and outputs the high voltage for THV/MHV/BIAS, and the outputted high voltage is supplied to the toner, OPC cartridge, and transfer roller.

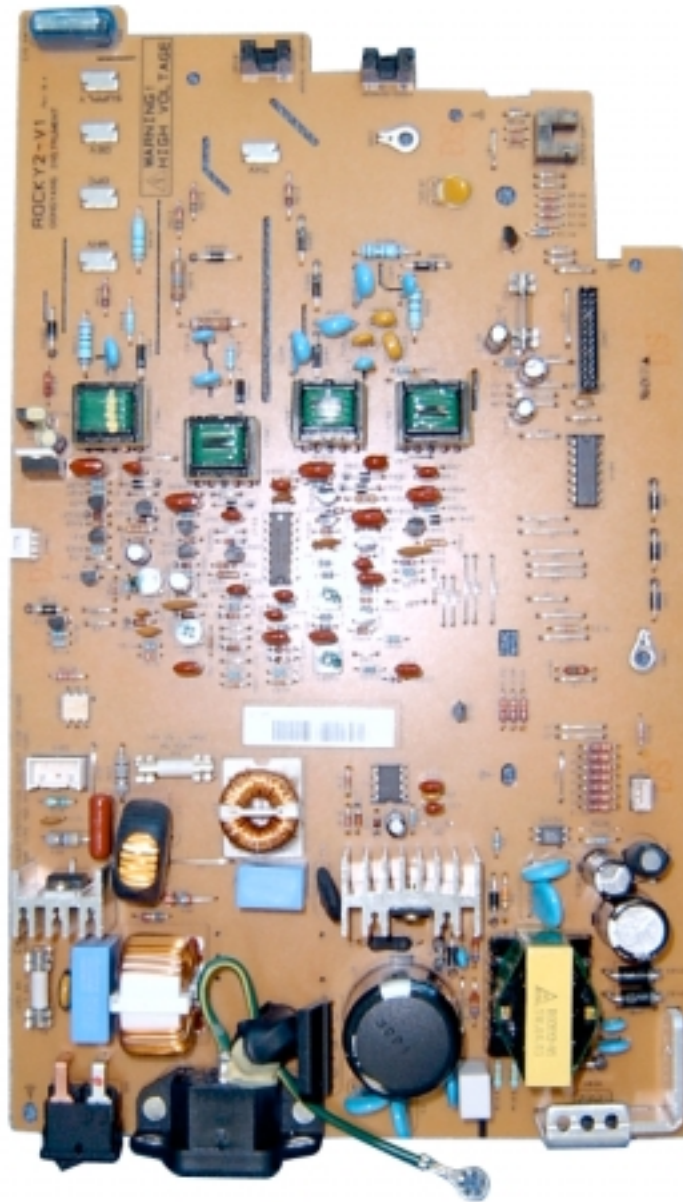

## 4.4.1 HVPS(High Voltage Power Supply)

---

### 1) Transfer High Voltage (THV+)

- Function : Voltage to transfer developed toner on OPC drum to a paper.
- Output voltage : +1300V DC $\pm$ 20V
- Error : If THV (+) doesn't output, a ghost status (same character is printed after one cycle (76mm) of OPC) with a low density occurs due to a toner on OPC drum cannot normally transfer to a paper.

### 2) Charge Voltage (MHV)

- Function : It is a voltage to charge entire surface of OPC with -900V ~ -1000V.
- Output voltage : -1550V DC  $\pm$  50V
- Error : If MHV doesn't output, a black paper is printed out because toner on developing roller moves to OPC drum due to the surface of OPC not being charged.

### 3)Cleaning Voltage (THV-)

- Function : It removes a dirty on a surface by sending a minus toner in a transfer roller to an OPC drum to recover toners.
- Output Voltage : +1000V/-1200V
- Error : Toner contamination occurs at the backside of a printed-paper.

### 4) Developing Voltage (DEV)

- Function: It is a voltage to develop a toner with using a difference of electronic potential on an exposed part by LSU (Laser Scanning Unit).
- \* Generally, the electronic potential of exposed OPC is -180V and exposed developer is -350V when printing, so toner with minus (-) is developed on an exposed part.
- Output voltage: -430V DC  $\pm$  20V
- Error: 1. If DEV is GND, a density is going significantly down.  
2. If DEV is floating due to instable contacting point of terminal, and etc., a density is significantly going up.

### 5) Supply Voltage (SUP)

- Function: It is a voltage to supply toner to a developing roller.
- Output voltage: : -580V DC  $\pm$  50V (Use ZENER, DEV Gear)
- Error: 1. If SUP is GND, a density is dramatically going down.  
2. If SUP is floating due to instable contacting point of terminal, and etc., a density is significantly going down as much as it cannot be recognized with eyes.

## 4.4.2 SMPS(Switching Mode Power Supply)

It is the power source of entire system. It is assembled by an independent module, so it is possible to use for common use. It is mounted at the bottom of the set.

It is consisted of the SMPS part, which supplies the DC power for driving the system, and the AC heater control part, which supplies the power to fuser. SMPS has two output channels. Which are +5V and +24V.

### 1) AC Input

- > Input Rated Voltage : AC 220V ~ 240V AC 120V / AC 220V(EXP version)
- > Input Voltage fluctuating range : AC 198V ~ 264V AC 90V ~ 135V / AC 198V ~ 264V
- > Rated Frequency : 50/60 Hz
- > Frequency Fluctuating range : 47 ~ 63 Hz
- > Input Current : Under 5.0Arms / 2.5Arms (But, the status when lamp is off or rated voltage is inputted/outputted )

### 2) Rated Output Power

NO	ITEM	CH2	CH3	Remark
1	CHANNEL NAME	+5V	+24.0V	
2	CONNECTOR PIN	CON 3 5V PIN: 8 GND PIN: 7	CON 3 24V PIN:11,12,13 GND PIN:9,10	
3	Rated Output	+5V & 5% (4.75 % 5.25V)	+24V & 10% (21.6 % 26.4V)	
4	Max. Output voltage	0.14 A	2.0 A	
5	Peak Loading voltage	0.14 A	2.5 A	1ms
6	RIPPLE NOISE Voltage	100mVp-p	Under 500mVp-p	
7	Maximum output	0.35W	48W	
8	Peak output	0.7W	60W	1ms
9	Protection for loading shortage and overflowing current		-	

### 3) Consumption Power

NO	ITEM	CH2 (+5V)	CH3 (+24V)	Remark
1	Stand-By	0.07A	0.4 A	AVG:55 Wh
2	PRINTING	0.14A	2.0 A	AVG 350 Wh
3	Sleep-Mode	0.01A	0.4A	AVG : 20 Wh

4) Length of Power Cord : 1830 ± 50mm

5) Power Switch : Use

## 6) Feature

- Insulating resistance : over 50M $\Omega$  (at DC500V)
- Insulating revisiting pressure : Must be no problem within 1min. (at 1500Vzc, 10mA)
- Leaking voltage : under 3.5mA
- Running voltage : under 40A peak (at 25 $^{\circ}$ c, Cold start) Under 60A peak (in other conditions)
- Rising Time : Within 2Sec
- Falling Time : Over 20ms
- Surge : Ring Wave 6KV-500A (Normal, Common)

## 7) Environment Condition

- Operating temperature range : 0 $^{\circ}$ c ~ 40 $^{\circ}$ c
- Maintaining temperature range : -25 $^{\circ}$ c ~ 85 $^{\circ}$ c
- Maintaining humid range : 30% ~ 90% RH
- Operating atmospheric pressure range : 1

## 8) EMI Requirement : CISPR ,FCC, CE, MIC, C-Tick,

## 9) Safety Requirement

- IEC950, C-UL, TUV,Semko,iK,CB, CCC, EPA,

## 4.4.3 Fuser AC Power Control

Fuser (HEAT LAMP) gets heat from AC power. The AC power controls the switch with the Triac, a semiconductor switch. The 'On/Off control' is operated when the gate of the Triac is turned on/off by Photo triac (insulating part).

In the other words, the AC control part is passive circuit, so it turns the heater on/off with taking signal from engine control part.

When the 'HEATER ON' signal is turned on at engine, the LED of PC1 (Photo Triac) takes the voltage and flashes. From the blinking light, the Triac part (light receiving part) takes the voltage, and the voltage is supplied to the gate of Triac and flows into the Triac. As a result, the AC current flows in the heat lamp, and heat is occurred.

On the other hand, when the signal is off, the PC1 is off, the voltage is cut off at the gate of Triac, the Triac becomes off, and then the heat lamp is turned off.

### 1) Triac (THY1) feature

- 12A,600V SWITCHING

### 2) Phototriac Coupler (PC3)

- Turn On If Current : 15mA ~ 50mA(Design: 16mA)
- High Repetive Peak Off State Voltage : Min 600V



## 4.5 Engine F/W

---

### 4.5.1 Feeding

---

If feeding from a cassette, the drive of the pickup roller is controlled by controlling the solenoid. The on/off of the solenoid is controlled by controlling the general output port or the external output port. If feeding from a manual feeder, insert the paper according to the operation of the manual sensor, and by driving the main motor, insert the paper in front of the feed sensor. While paper moves, occurrence of jam is judged as below. (Refer to the [6.2 Paper Transfer rout])

#### 4.5.1.1 Jam 0

- After picking up, paper cannot entered due to paper didn't feed.
- After picking up, paper entered but it cannot reach to the feed sensor in certain time due to slip, etc.
- After picking up, if the feed sensor is not on, repack up. After repacking up, if the feed sensor is not on after certain time, it is Jam 0.
  - It is a status that the leading edge of the paper doesn't pass the feed sensor.
- Even though the paper reaches the feed sensor, the feed sensor doesn't turn on.
  - It is a status that the leading edge of the paper already passes the feed sensor.

#### 4.5.1.2 Jam 1

- After the leading edge of the paper passes the feed sensor, the trailing edge of the paper cannot pass the feed sensor after certain time. (The feed sensor cannot be Off)
- After the leading edge of the paper passes the feed sensor, the paper cannot pass the exit sensor after certain time. (The exit sensor cannot be On)
  - The paper exists between the feed sensor and the exit sensor.

#### 4.5.1.3 Jam 2

- After the trailing edge of the paper passes the feed sensor, the paper cannot pass the exit sensor after certain time.

### 4.5.2 Drive

---

By gearing, the main motor drives the rollers such as feeding roller, developing roller, fuser roller, and distributing roller. The step motor is controlled for the sections, acceleration section and fixed speed section. In the initial stage of the motor run, appoint the acceleration section to prevent the isolation of the motor. It is controlled by the A3977 motor driver IC. The step signal and the enable signal are sent to make the phase for driving the motor in CPU.

### 4.5.3 Transfer

---

The charging voltage, developing voltage and the transfer voltage are controller by PWM (Pulse Width Modulation). The each output voltage is changeable due to the PWM duty. The transfer voltage admitted when the paper passes the transfer roller is decided by environment recognition. The resistance value of the transfer roller is changed due to the surrounding environment or the environment of the set, and the voltage value, which changes due to the environments, is changed through AD converter. The voltage value for impressing to the transfer roller is decided by the changed value.

## 4.5.4 Fusing

The temperature change of the heat roller's surface is changed to the resistance value through the thermistor. By converting the voltage value to a digital value, through the AD converter, the temperature is decided. The AC power is controlled by comparing the target temperature to the value from the thermistor. If the value from the thermistor is out of the controlling range while controlling the fusing, the error stated in the table occurs.

### 4.5.4.1 Error Type

Error	Description
Open heat error	When warming up, it has been lower than 68 °C over 25 sec
Lower heat error	<ul style="list-style-type: none"> <li>• Standby: It has been lower than 100°C over 25 sec</li> <li>• Printing:               <ul style="list-style-type: none"> <li>- 2 consecutive pages: it has been lower than 145°C over 5 sec</li> <li>- 3 consecutive page; it has been 40°C lower than the fixed fusing temperature over 4 seconds.</li> </ul> </li> </ul>
Over heat error	It have been higher than 220°C over 3 seconds

## 4.5.5 LSU

The LSU is consists of the LD (Laser Diode) and the polygon motor control. When the printing signal occurs, it turns the LD and drives the polygon motor. When the receiving light part detects the beam, Hsync occurs. When the polygon motor speed becomes normal, LReady occurs. If the two conditions are satisfied, the status bit of the LSU controller register becomes 1, the LSU is ready. If the two conditions are not satisfied, the error shown in below occurs.

Error	Description
Polygon motor error	When the polygon motor's speed doesn't become normal
Hsync error	The polygon motor's speed is normal, but the Hsync signal is not created.

## 4.6 LIU PBA

LIU board is a Line interface unit, and it is a circuit for interfacing a telephone line with a modem. The circuit is consisted of matching transfer to conform to impedance of a receiving telephone line and a circuit to conform to impedance of a modem.

Also, there is a ring detect circuit to detect a ring signal from a switchboard and a surge absorber to protect it from an external high voltage supply applied to a line input unit.



## 4.7 OPE PBA

OPE board is consists of various function keys and LCD to display an operation of key. MICOM creates a circuit with using HT48R50 MICOM of HOLTEC CO. and applies LED and LCD. A communication method with a CPU of a main board is UART, and related signals are /Reset, TXD, and RXD.

## 5. Disassembly and Reassembly

### 5.1 General Precautions on Disassembly

When you disassemble and reassemble components, you must use extreme caution. The close proximity of cables to moving parts makes proper routing a must.

If components are removed, any cables disturbed by the procedure must be restored as close as possible to their original positions. Before removing any component from the machine, note the cable routing that will be affected.

#### Whenever servicing the machine, you must perform as follows:

1. Check to verify that documents are not stored in memory.
2. Be sure to remove the toner cartridge before you disassemble parts.
3. Unplug the power cord.
4. Use a flat and clean surface.
5. Replace only with authorized components.
6. Do not force plastic-material components.
7. Make sure all components are in their proper position.

#### Releasing Plastic Latches

Many of the parts are held in place with plastic latches. The latches break easily; release them carefully.

To remove such parts, press the hook end of the latch away from the part to which it is latched.

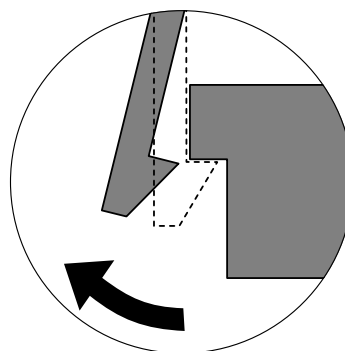

## 5.2 Rear Cover

1. Remove the four screws securing the Rear Cover.

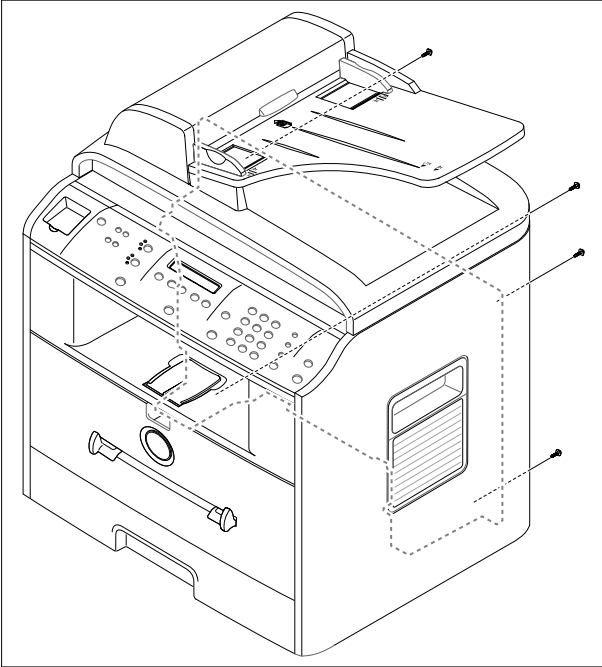

3. Unlatch the (Cover Face Up) securing the Rear cover, as shown below. Then lift the (Cover Face Up) out.

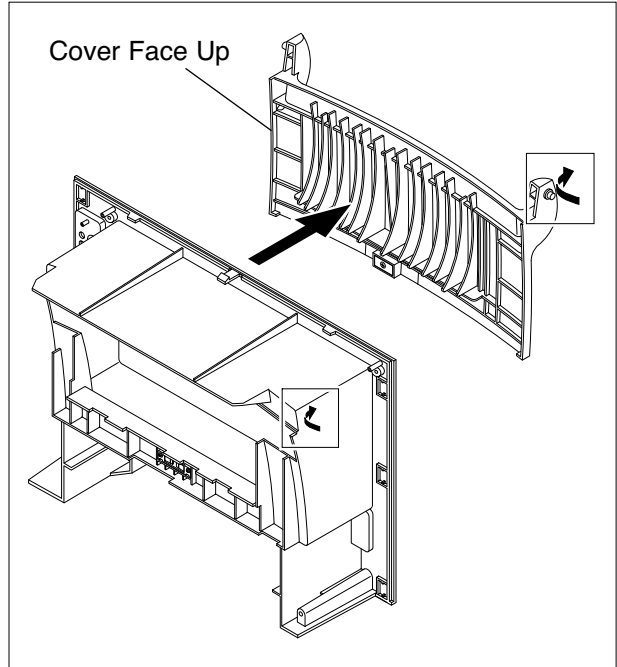

2. Remove the Rear Cover from the Frame Ass'y and Scanner Ass'y.

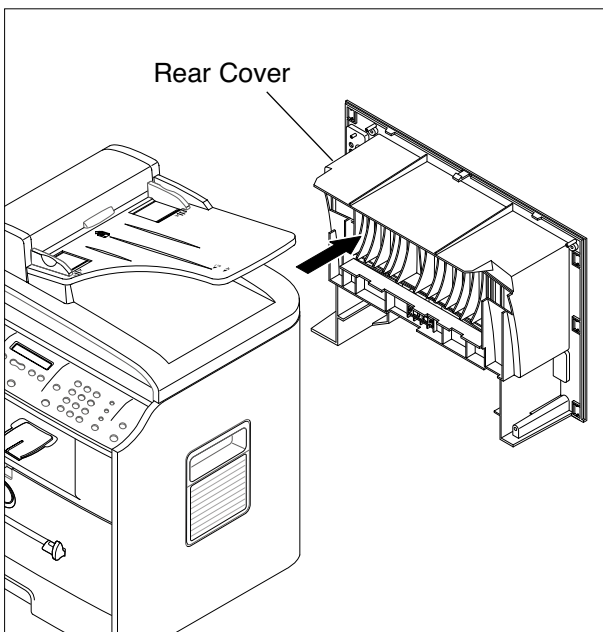

## 5.3 Side Cover (LH, RH)

1. Before you remove the Side Cover (LH, RH), you should remove:
  - Rear Cover (see page 5-2)

2. Take out the Cassette.

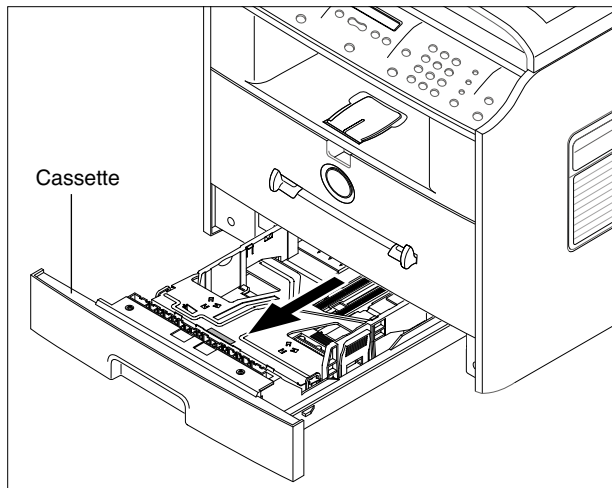

4. Open the front cover and remove the 2 screws on the front side. Push the side cover(LH) to the left and remove it from the Frame Assembly.

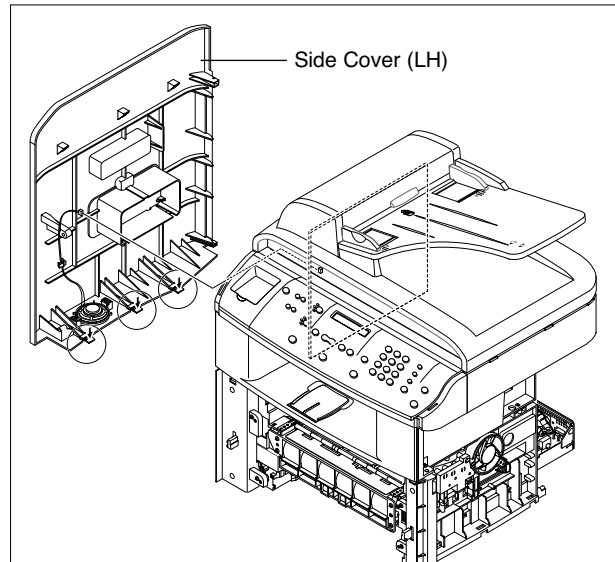

3. Open the front cover and remove the 2 screws on the front side and 1 screw on the back side. Push the side cover(RH) to the right and remove it from the Frame Assembly.

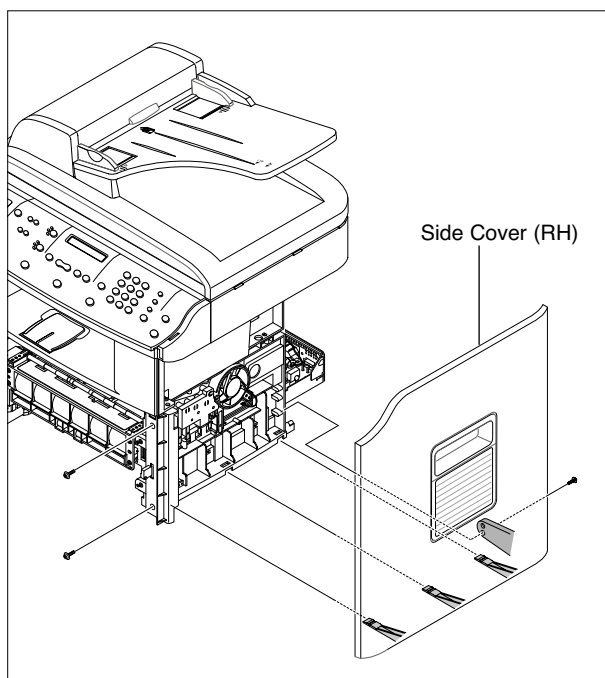

## 5.4 Front Cover

1. Open the Front Cover.

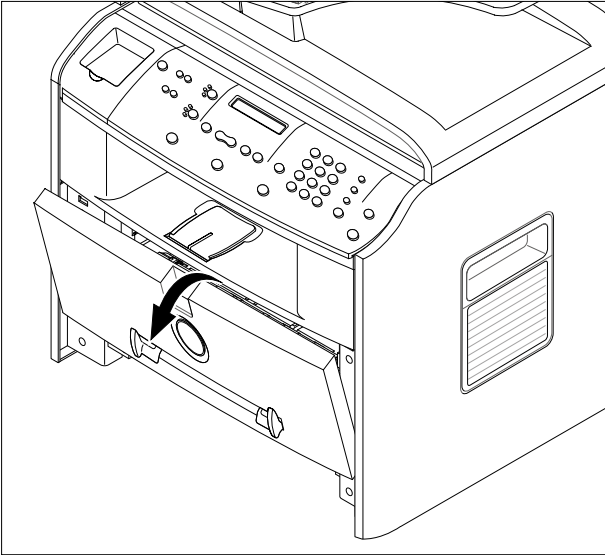

2. Unlatch the Front Cover securing the Frame Ass'y. Then remove the Front Cover, as shown below.

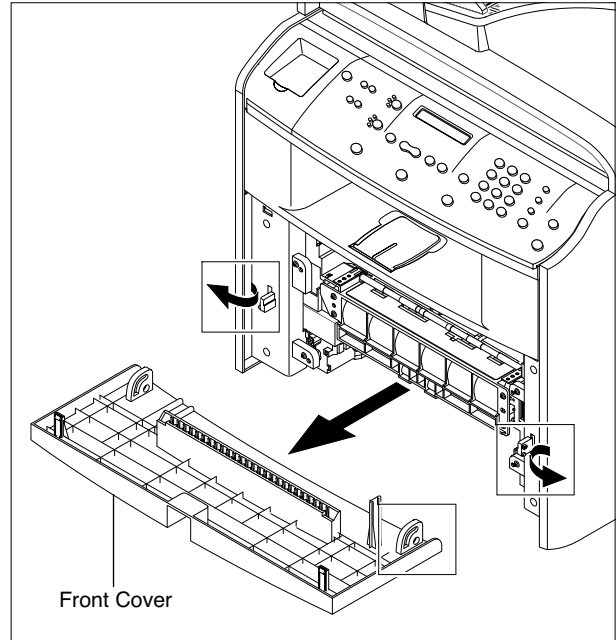

## 5.5 Scanner Ass'y

1. Before you remove the Scanner Ass'y, you should remove:

- Rear Cover (see page 5-2)
- Side Cover (LH, RH) (see page 5-3)

2. Remove the 2 screws securing the Scanner Ass'y, as shown below.

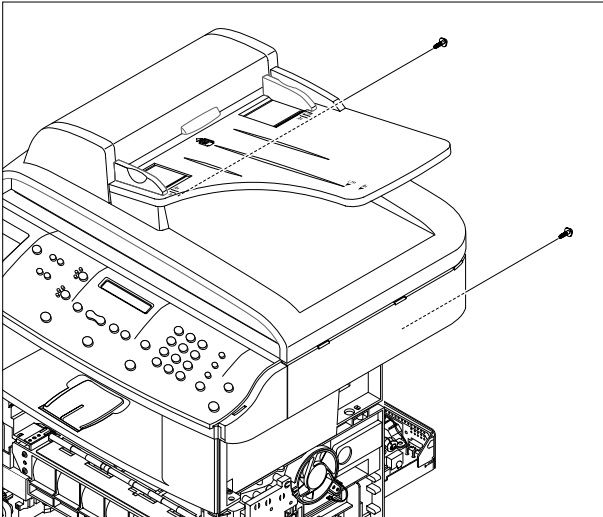

4. Pull up the Scanner Ass'y, as shown below.

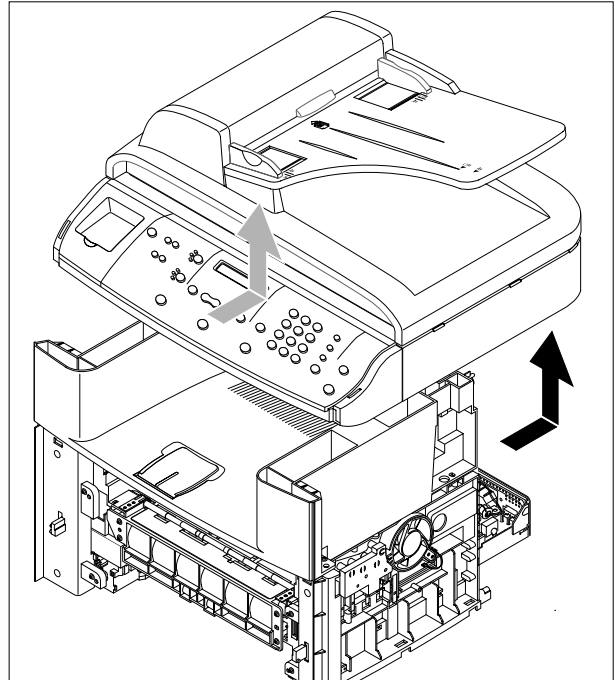

3. Remove the 5 connectors and the ground wire screw from the main PBA as shown below.

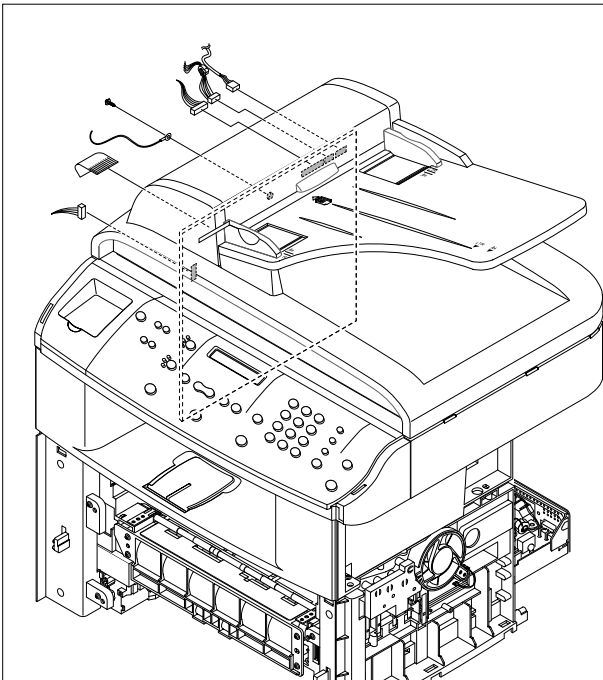

5. Pull the Platen Cover upward and remove it.

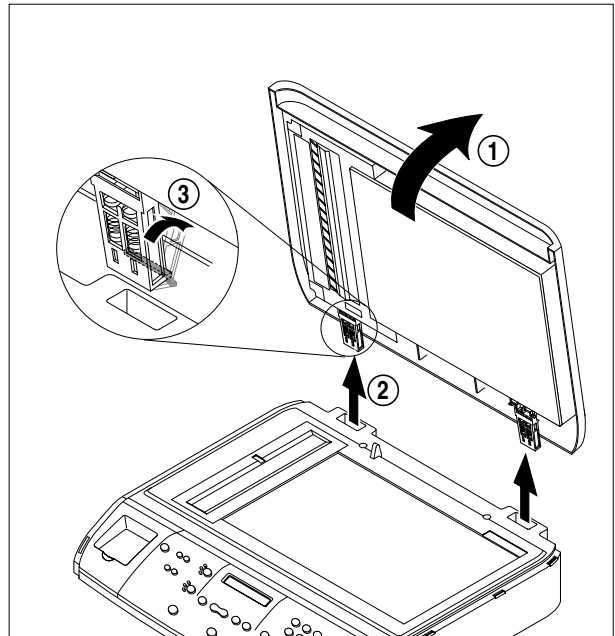



6. Remove the Scanner Harness Cable.

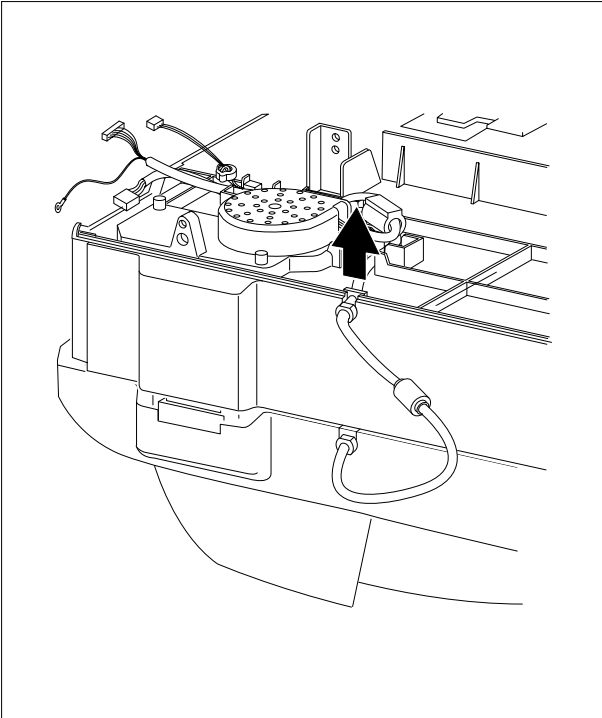

7. Lift the front part of the cover OPE dummy to release the hook connecting the cover with the scan assembly.

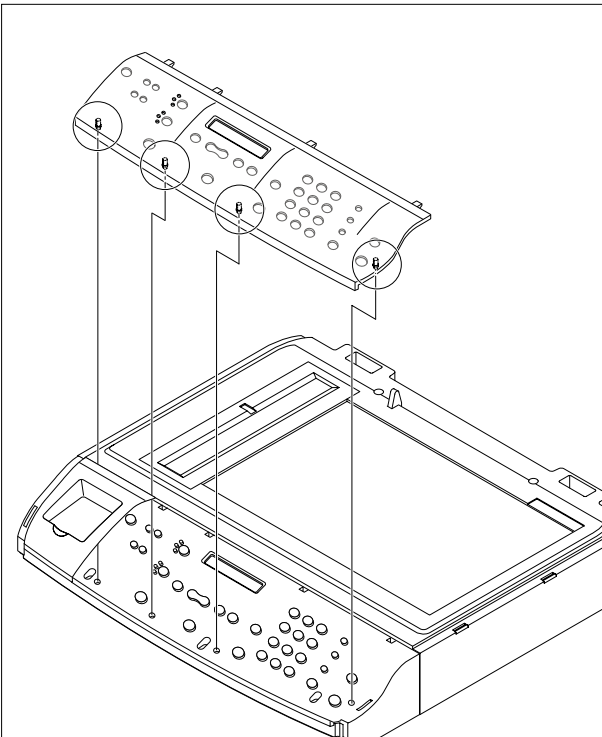

8. Remove the 3 screws and the connector and remove the OPE unit as shown below.

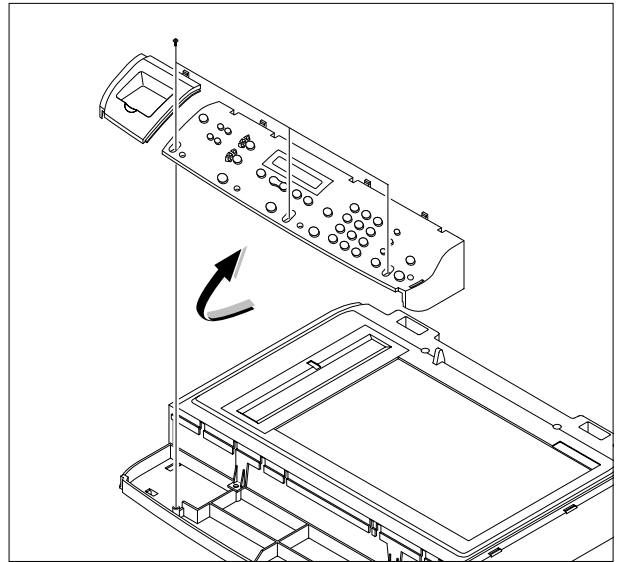

9. Remove the 4 screws securing the Scan Upper.

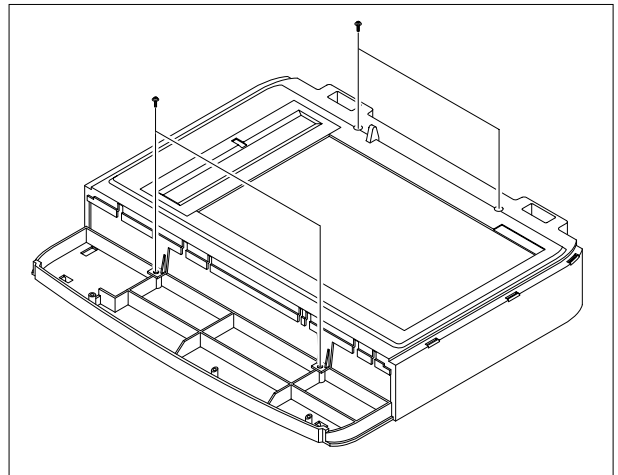

10. Unlatch the Scan Upper securing the Scan Ass'y. Then pull the Scan Upper upward and remove it.

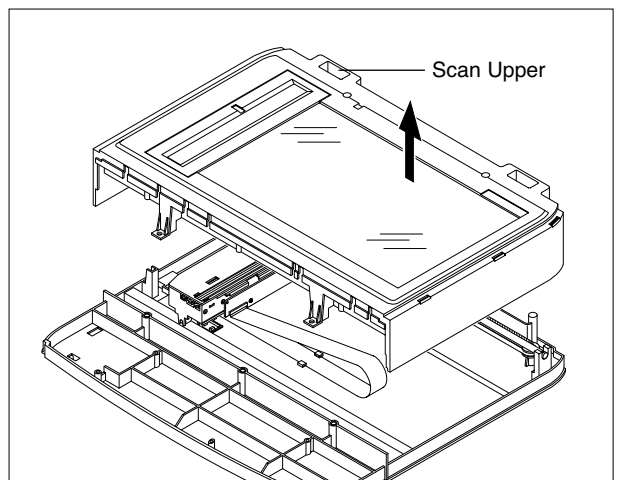

11. Remove the CCD Cable, as shown below.

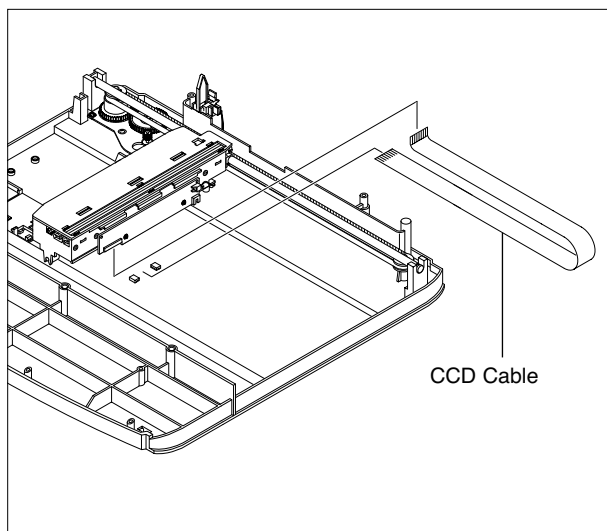

13. Push the Belt Holder and take out the Belt, as shown below.

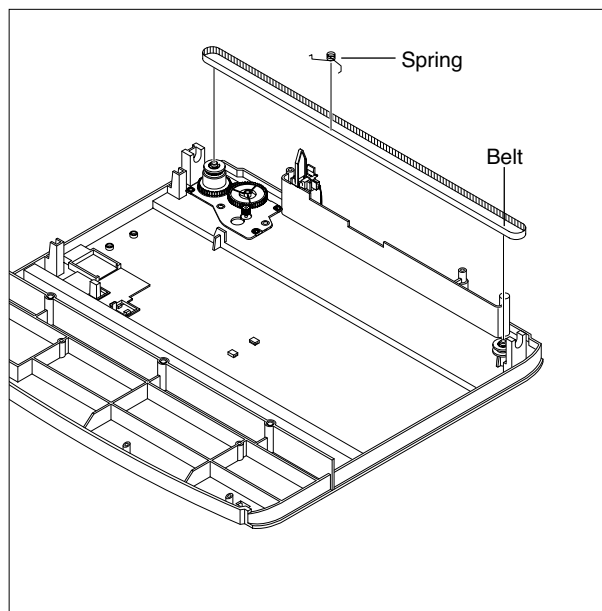

12. Pull up the CCD Shaft and take out the Scanner Module.

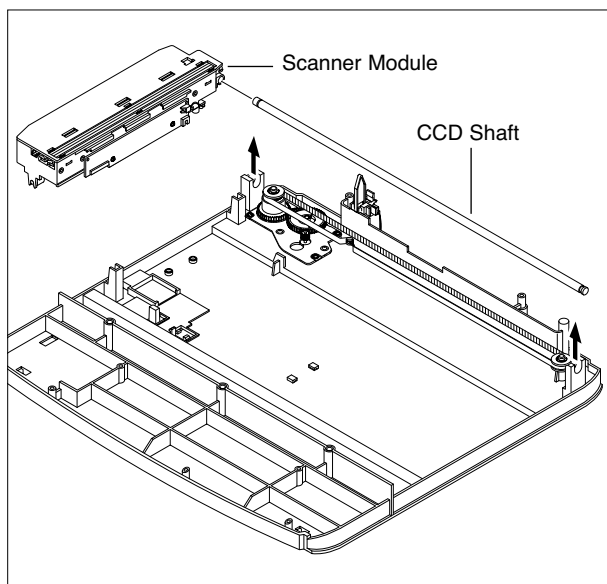

14. Remove the Reduction Gear and Idle Gear, as shown below.

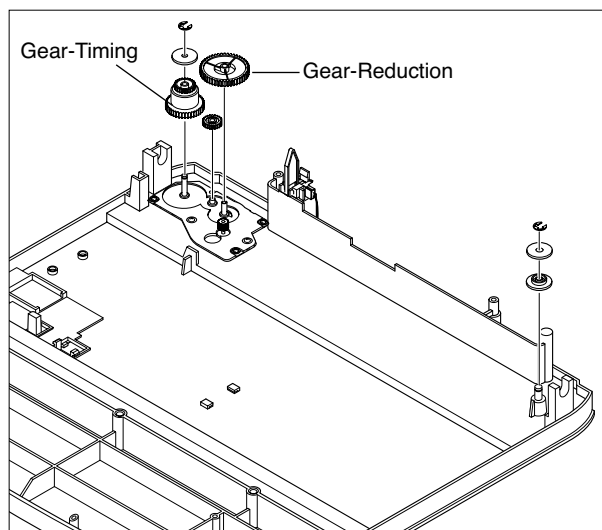

### Caution:

#### Assembling Scanner Module

When assembling the scanner module, the belt and the belt Spring, the belt spring must be located on the right side of the scanner module and the parts should be put as close to each other as possible as shown below.

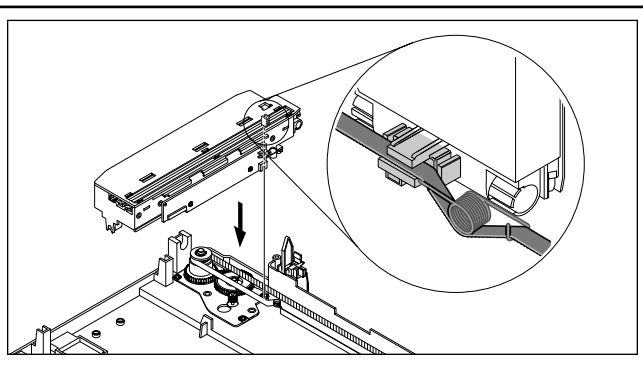

15. Remove the 3 screws and take out the Motor Bracket.

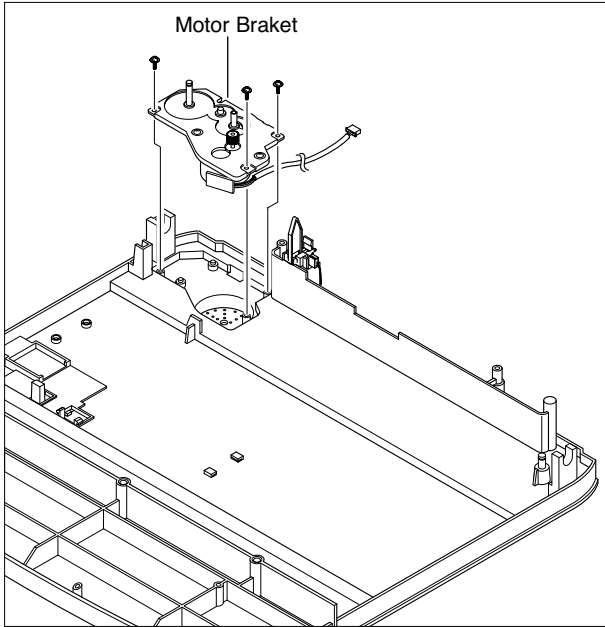

17. Unlatch the Open Sensor and remove it, as shown below.

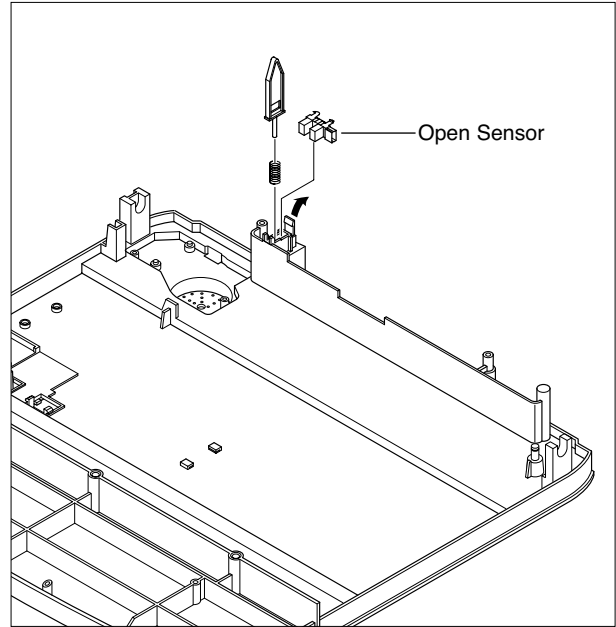

16. Unplug the one connector from the Open Sensor Ass'y.

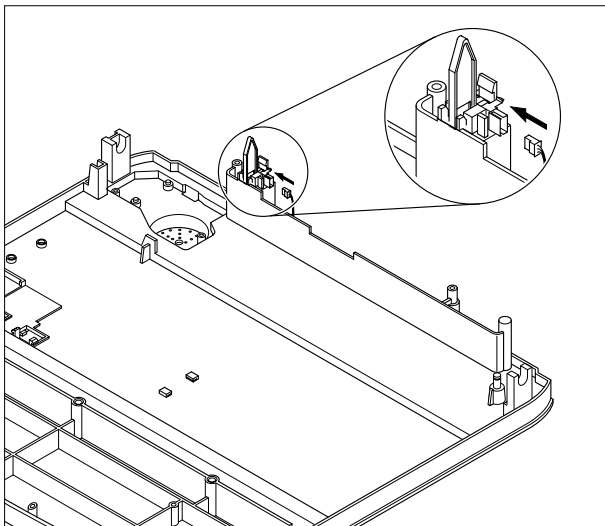

18. Remove the Holder CCD

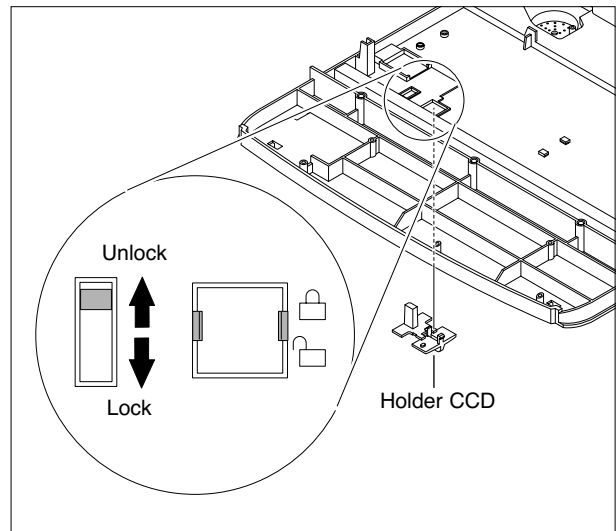

## 5.6 ADF Motor Ass'y

- Before you remove the ADF Motor Ass'y, you should remove:
  - Rear Cover (see page 5-2)
  - Side Cover (LH, RH) (see page 5-3)
  - Scanner Ass'y (see page 5-5)

- Remove the 2 screws securing the ADF Ass'y and remove it.

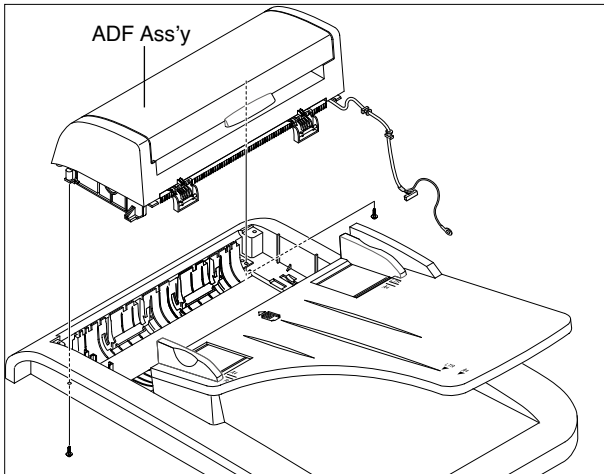

- Remove the Open Cover, as shown below.

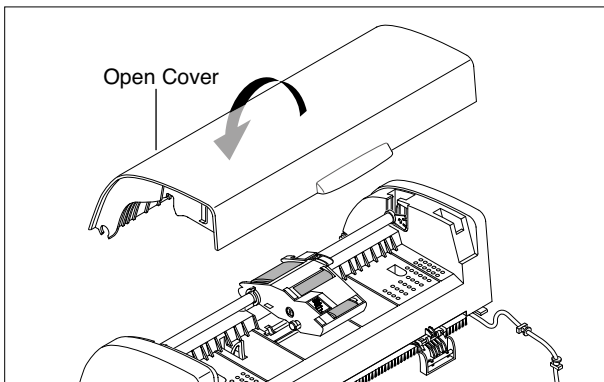

- Pull the White Bush, then rotate it until it reaches the slot, as shown below. Then lift the Pick-Up Ass'y out.

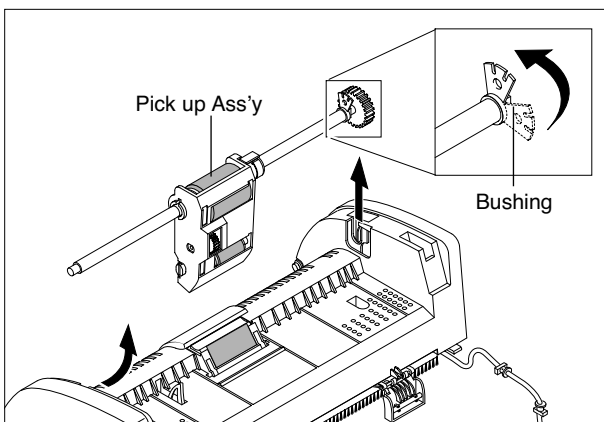

- Remove the 2 screws securing the Upper Cover and remove it, as shown below.

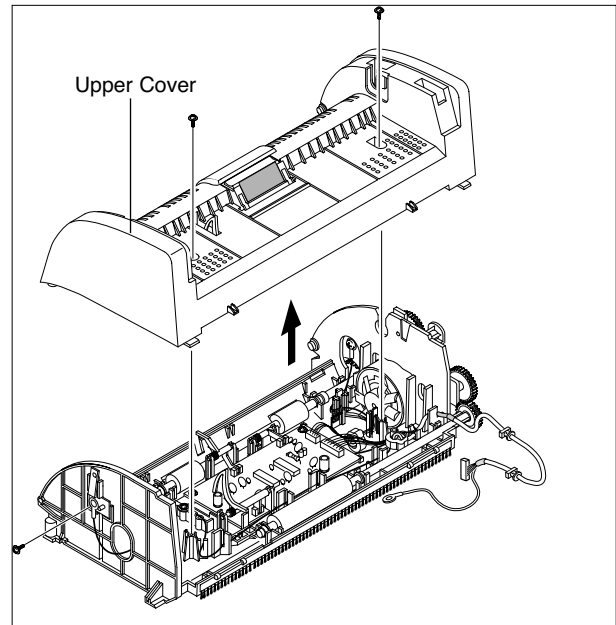

- Unplug the one connector and remove 5 screws securing the ADF Motor Ass'y. Then take out the ADF Motor Ass'y.

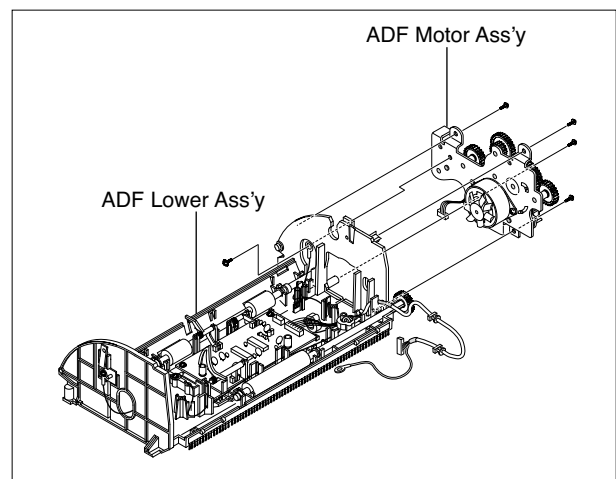

## 5.7 OPE Unit

1. Before you remove the OPE Unit, you should remove:
  - Rear Cover (see page 5-2)
  - Side Cover (LH, RH) (see page 5-3)
  - Scanner Ass'y (see page 5-5)

2. Remove the 5 screws securing the OPE PBA from the OPE Cover.

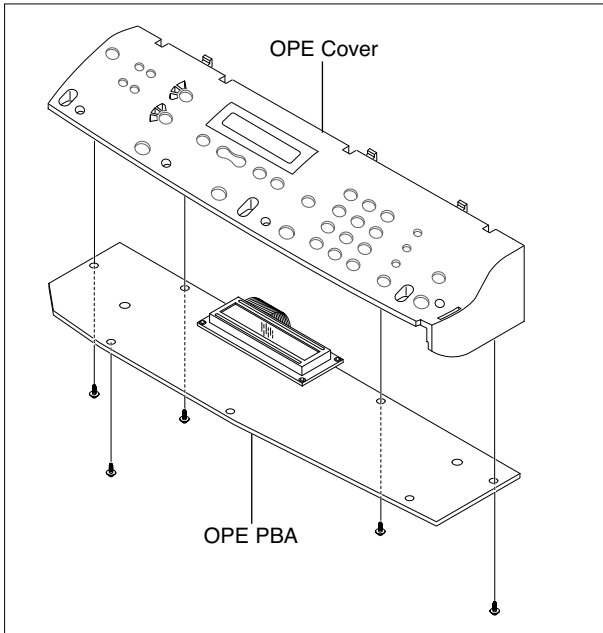

4. Remove the Key Pad from the OPE Cover.

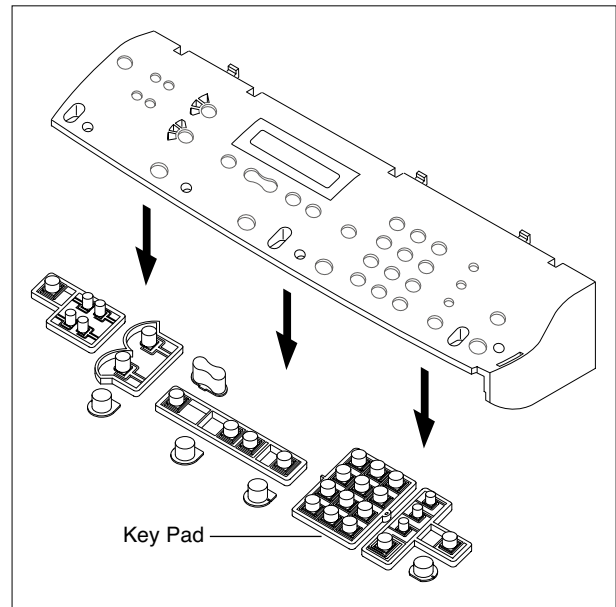

3. Remove the Contact Rubber from the OPE Cover.

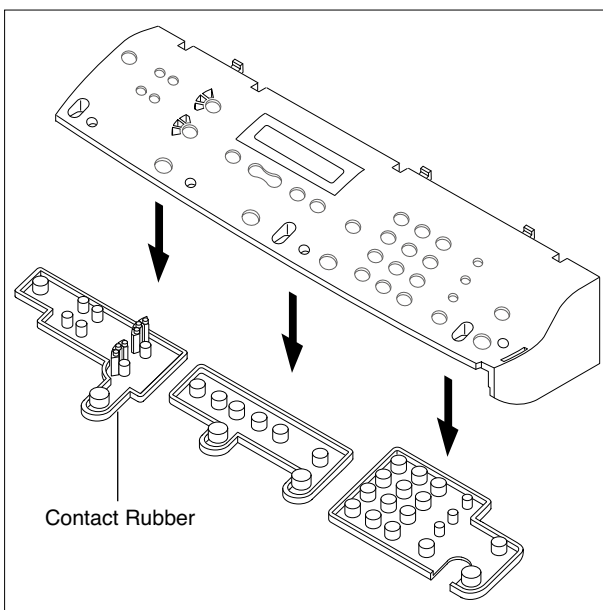

## 5.8 Middle Cover & Exit Roller

1. Before you remove the Exit Roller, you should remove:

- Rear Cover (see page 5-2)
- Side Cover (LH, RH) (see page 5-3)
- Scanner Ass'y (see page 5-5)
- Controller Shield Ass'y (see page 5-12)

2. Remove the 6 screws securing the Middle Cover and remove it.

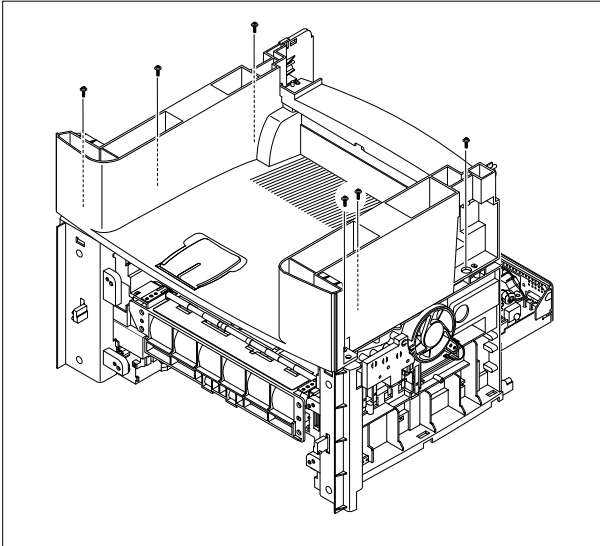

3. Unlatch the Middle Cover Securing the Frame Ass'y, using a proper tool as shown below. Then up ward the Top Cover out.

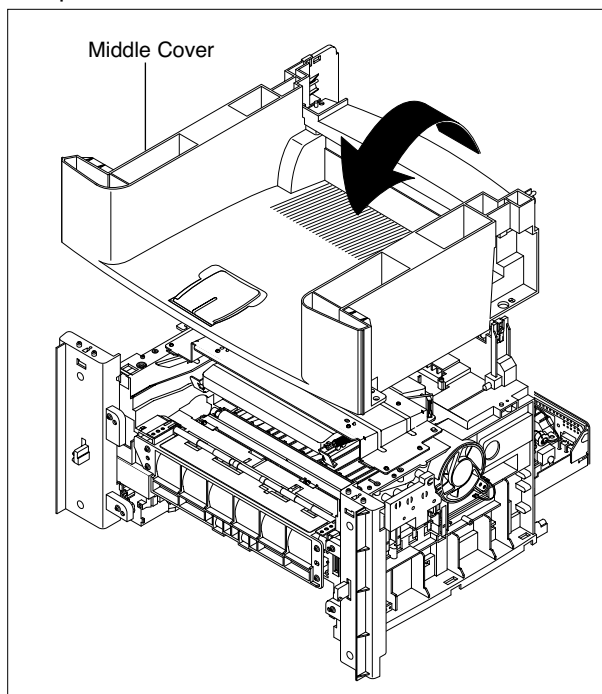

4. Remove the Exit Gear and Bearing, as shown below.

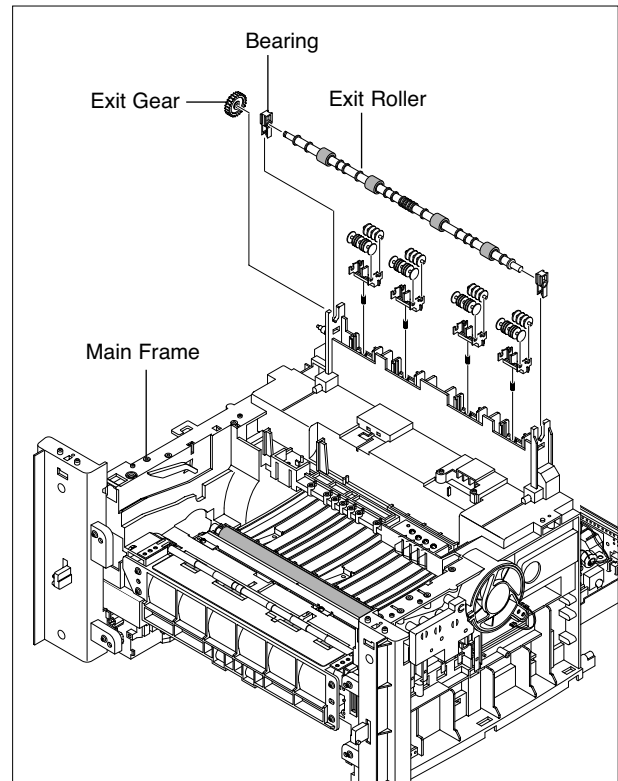

## 5.9 Controller Shield Ass'y

1. Before you remove the Main PBA, you should remove:

- Rear Cover (see page 5-2)
- Side Cover(LH, RH) (see page 5-3)

2. Remove the 8 connectors and the 5 screws connecting the Controller Shield Assembly to Middle Cover the frame and remove the assembly.

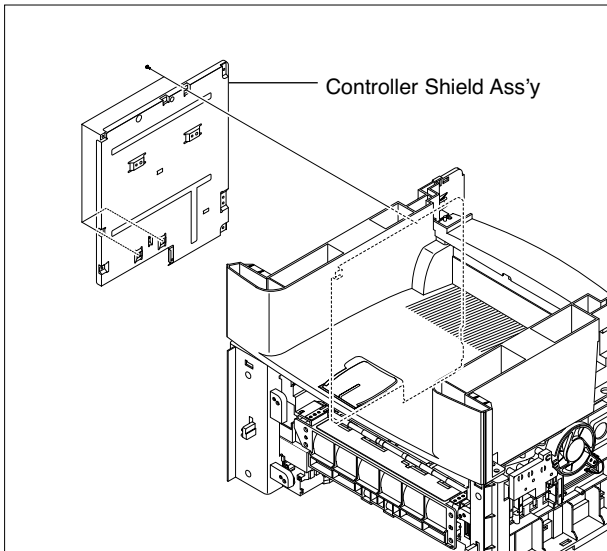

3. Remove the 2 screws connecting the NIC card to the Controller Shield Assembly and remove the card.

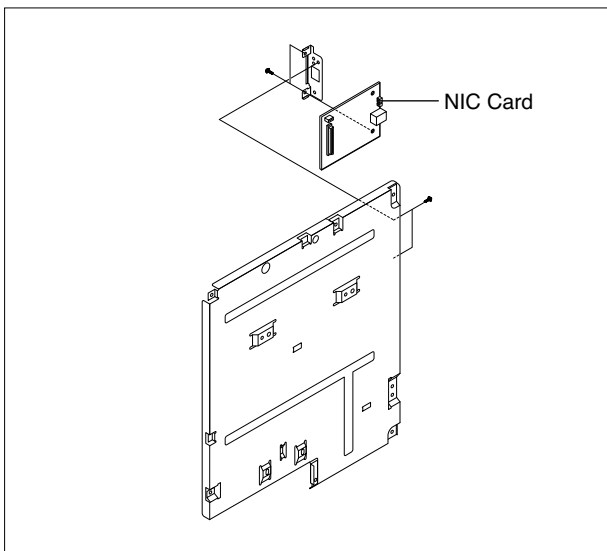

4. Remove the 2 screws connecting the LIU to the Controller Shield Ass'y and remove the LIU.

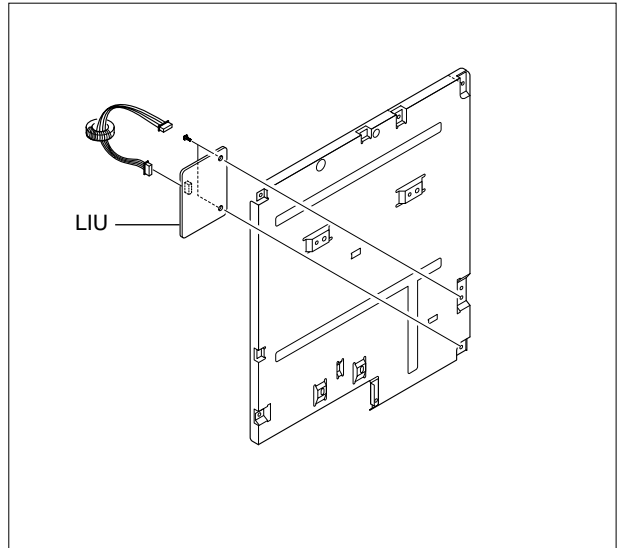

5. Remove the 3 screws to remove the bracket from the main board.

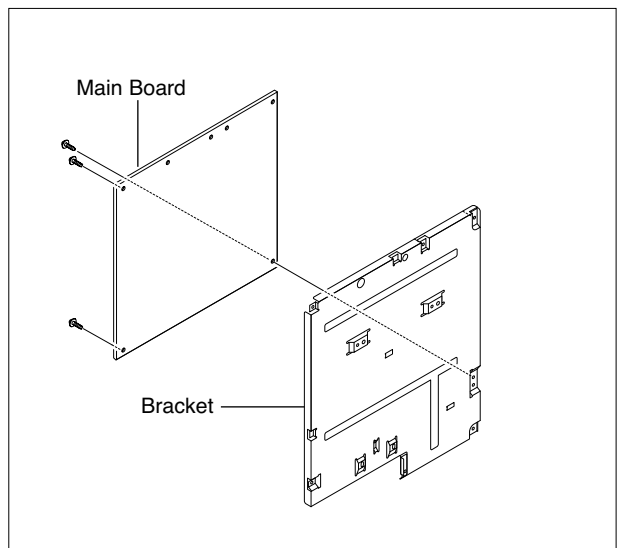

## 5.10 Engine Shield Ass'y & Exit Board

1. Before you remove the Engine Shield Ass'y, you should remove:

- Rear Cover (see page 5-2)
- Side Cover(LH, RH) (see page 5-3)
- Scanner (see page 5-5)

2. Unplug 4 connector.

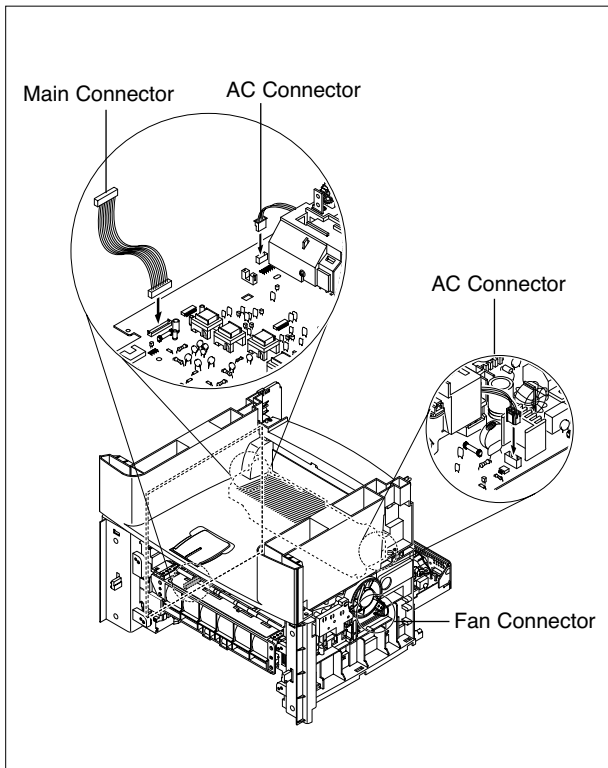

3. Remove the 12 screws securing the Engine Shield Ass'y and remove it. Then unplug all the connectors from the Main PBA and SMPS.

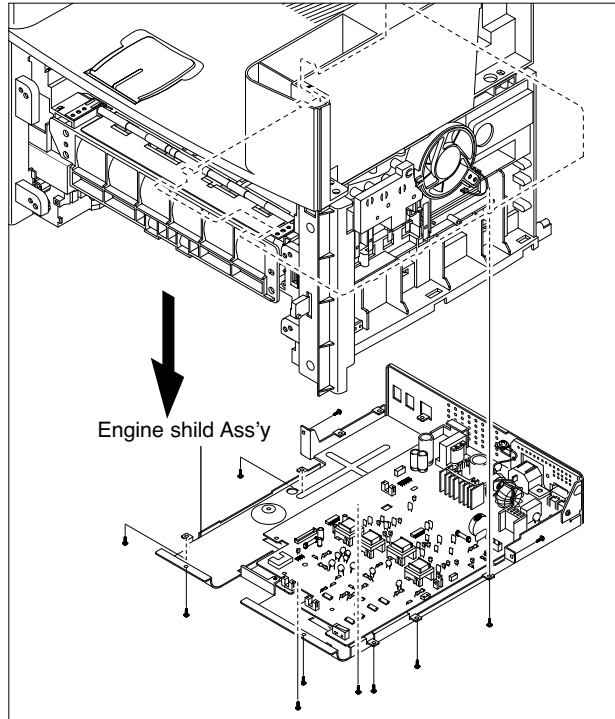

4. Remove the 2 screws to remove the exit board.

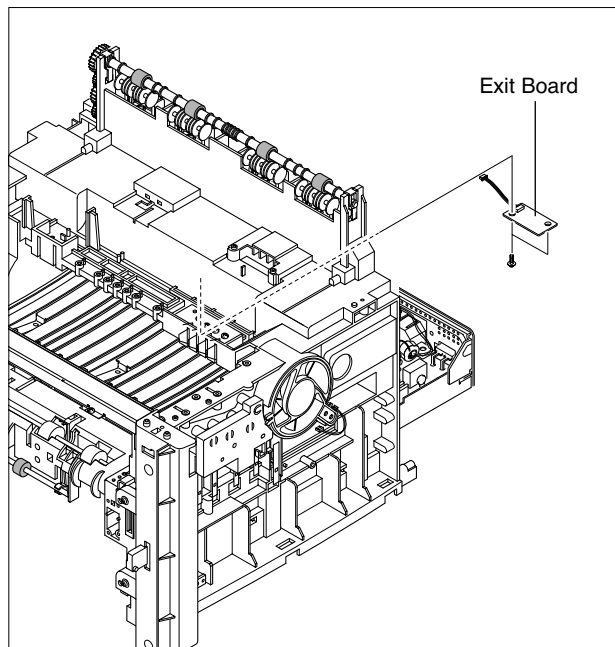



## 5.11 SMPS

1. Before you remove the SMPS, you should remove:

- Rear Cover (see page 5-2)
- Side Cover(LH, RH) (see page 5-3)
- Scanner Ass'y (see page 5-5)
- Engine Shield Ass'y(see page 5-12)

2. Remove the 3 screws securing the Inlet Bracket and remove it

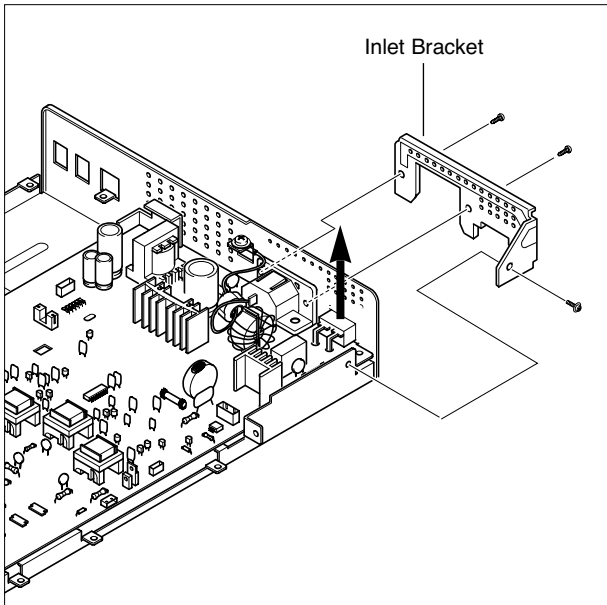

3. Remove the one screw securing the Engine Shield.

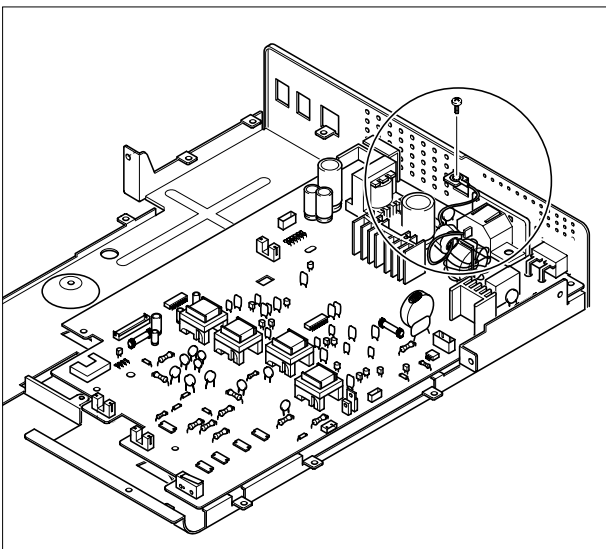

4. Remove the 4 screws securing the SMPS. Then lift the SMPS out, as shown below.

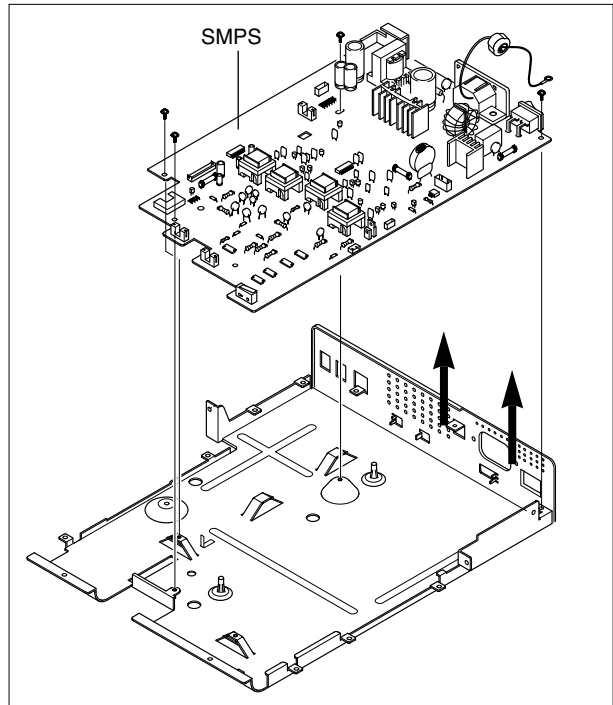

## 5.12 Fuser Ass'y

1. Before you remove the Fuser Ass'y, you should remove:
  - Rear Cover (see page 5-2)

2. Unplug the two connectors from the Main PBA and SMPS, as shown below. Then remove the 4 screws securing the Fuser Ass'y and remove it.

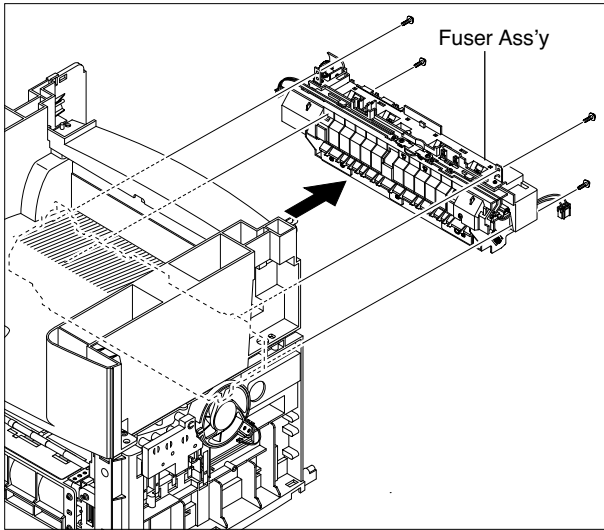

3. Remove the 2 screws securing the Thermostat. Then lift the Thermostat out

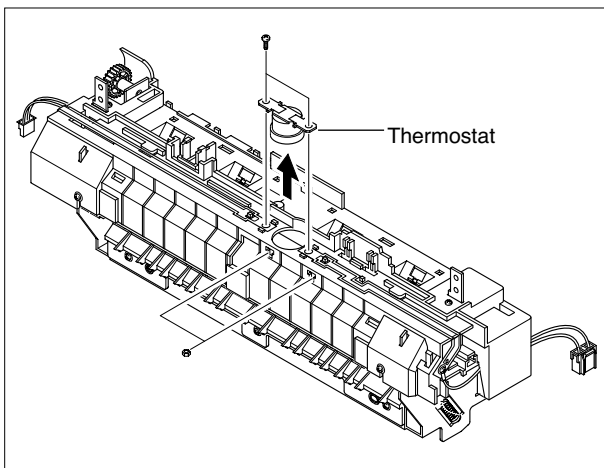

4. Remove the 2 screws securing the Halogen Lamp. Then take out the Halogen Lamp from the Heat Roller

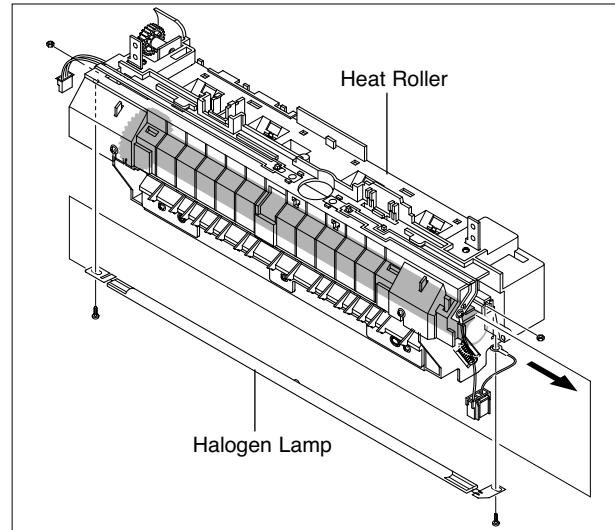

5. Remove the 4 screws to remove the fuser cover as below. Remove the 2 screws to remove the guide input..

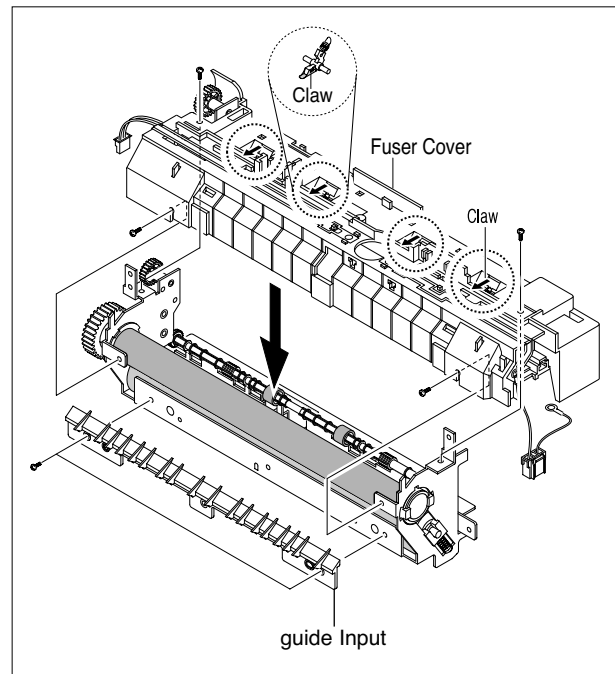

6. Unwrap the Thermistor Harness, as shown below.

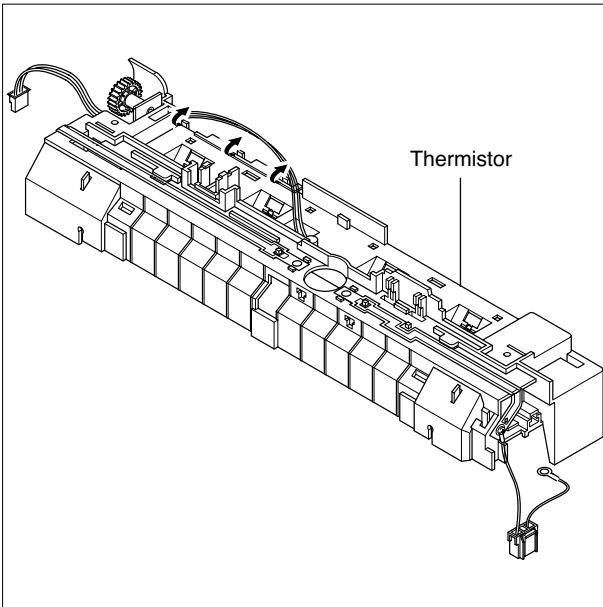

7. Remove the one screw securing the Thermistor and remove it, as shown below.

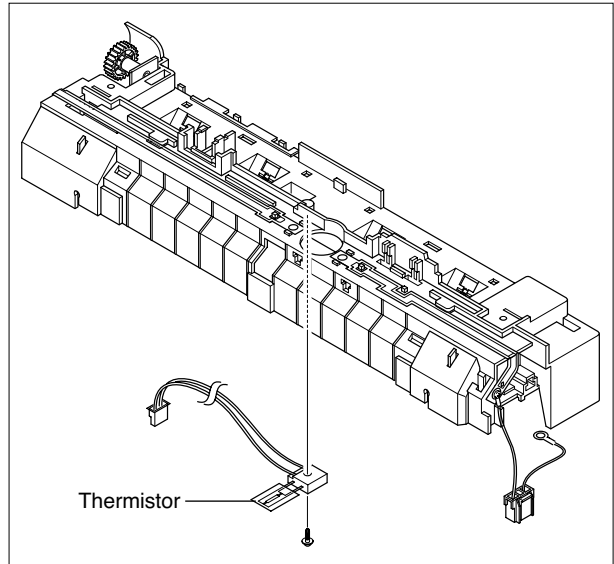

## 5.13 Fan

1. Before you remove the Fan, you should remove:
  - Rear Cover (see page 5-2)
  - Side Cover (RH) (see page 5-3)

2. Unplug the connector from the SMPS and remove the one screw. Then take out the Fan.

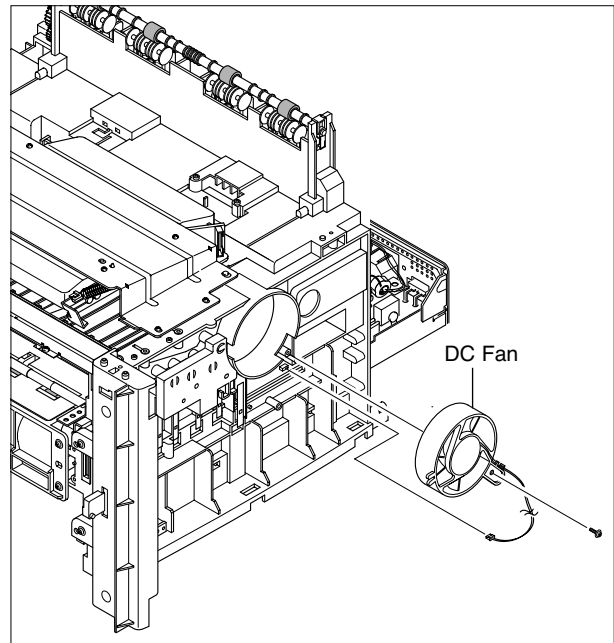

## 5.14 LSU

1. Before you remove the LSU, you should remove:

- Rear Cover (see page 5-2)
- Side Cover (LH, RH) (see page 5-3)
- Scanner Ass'y (see page 5-5)
- Front Cover (see page 5-4)
- Middle Cover (see page 5-11)

2. Remove the 4 screws securing the LSU and remove it.

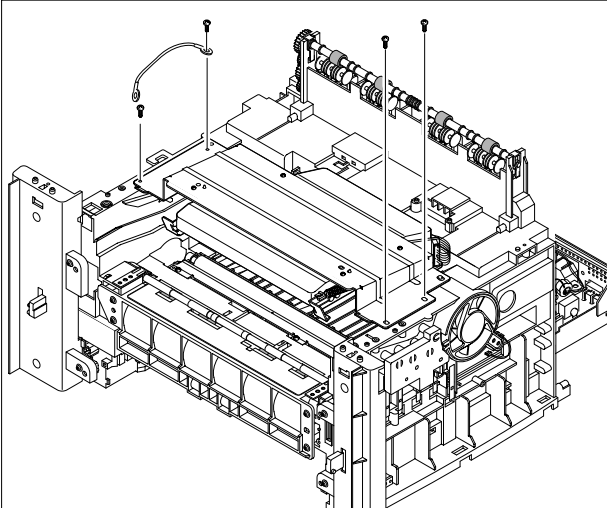

3. Unplug the two connectors.

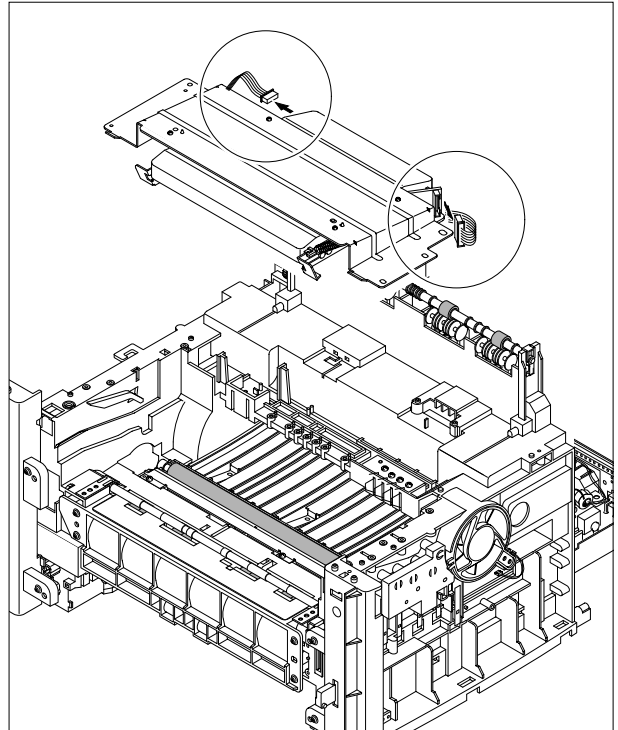

## 5.15 CRUM Board

1. Before you remove the CRUM Board, you should remove:

- Rear Cover (see page 5-2)
- Side Cover (LH, RH) (see page 5-3)
- Scanner Ass'y (see page 5-5)
- Front Cover (see page 5-4)
- Middle Cover (see page 5-11)
- LSU (see page 5-18)

2. Remove the 4 screws to separate the CRUM board from the main frame as below.

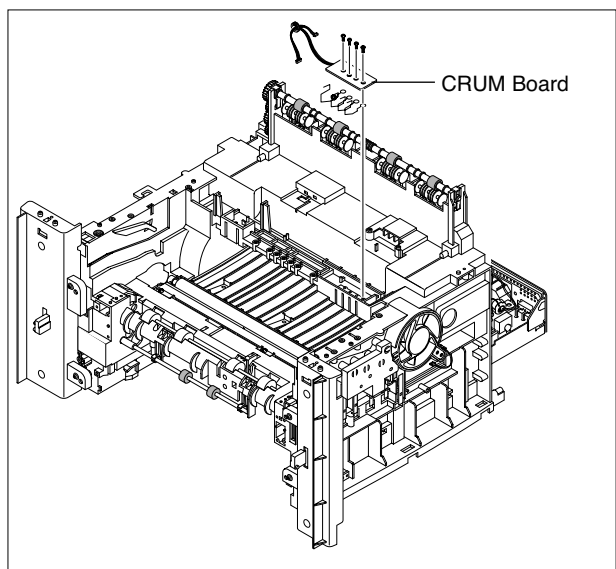

## 5.16 Drive Ass'y

1. Before you remove the Drive Ass'y, you should remove:
  - Rear Cover (see page 5-2)
  - Side Cover (LH) (see page 5-3)
  - Shield Controller Ass'y (see page 5-9)
2. Remove the 5 screws securing the Drive Ass'y.

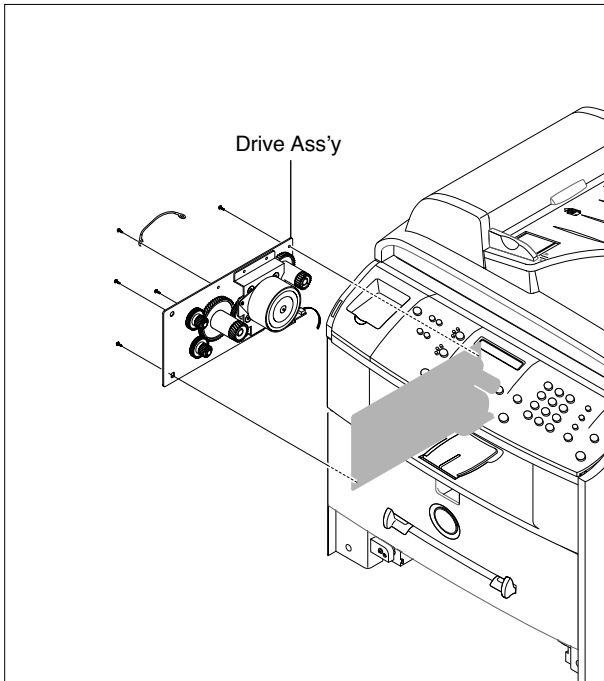

3. Take out the Drive Ass'y, then unplug the connector from the Motor PBA, as shown below.

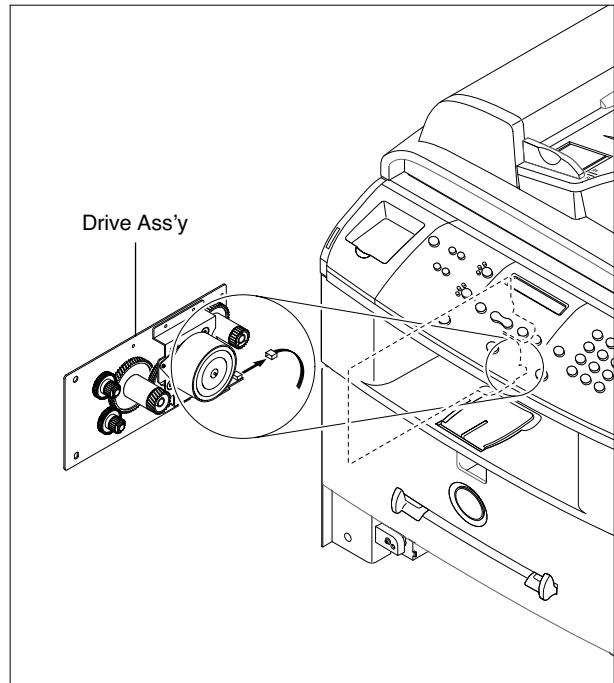

## 5.17 Transfer Ass'y

1. Before you remove the Transfer Ass'y, you should remove:

- Rear Cover (see page 5-2)
- Side Cover (LH, RH) (see page 5-3)
- Scanner Ass'y (see page 5-5)
- Front Cover (see page 5-4)
- Middle Cover (see page 5-11)
- LSU (see page 5-18)

2. Remove the 3 screws securing the Transfer Earth and remove it.

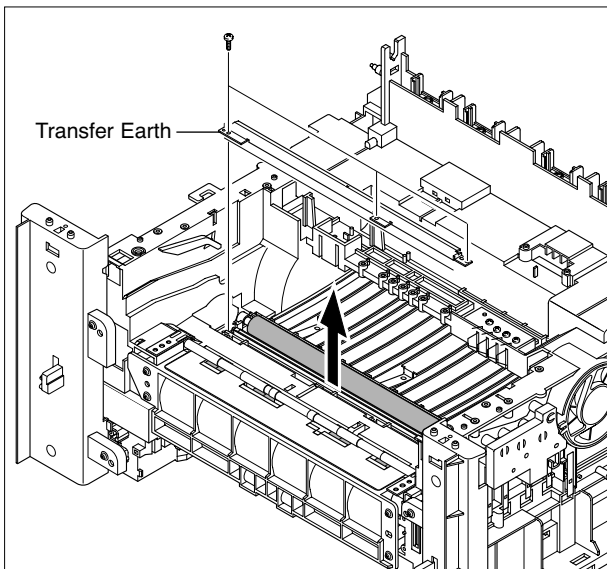

3. Unplug the PTL Holder connector, then remove the PTL Holder and PTL Lens, as shown below.

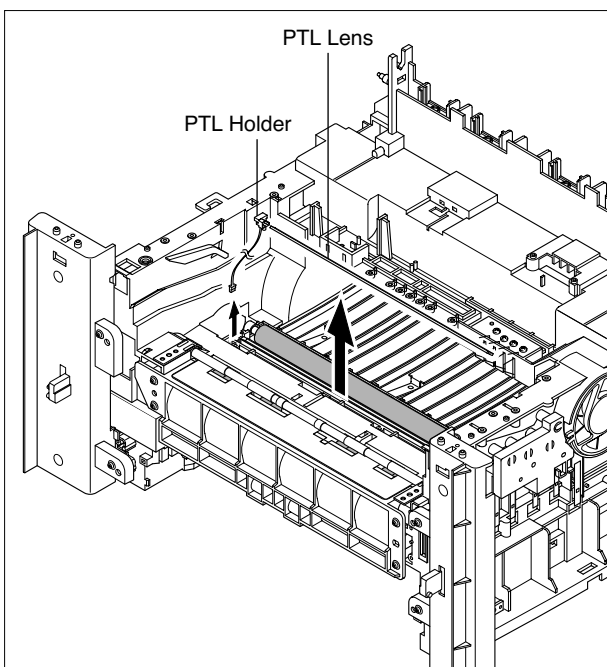

4. Remove the transfer roller by pressing the hook securing the roller to the right using a tool.

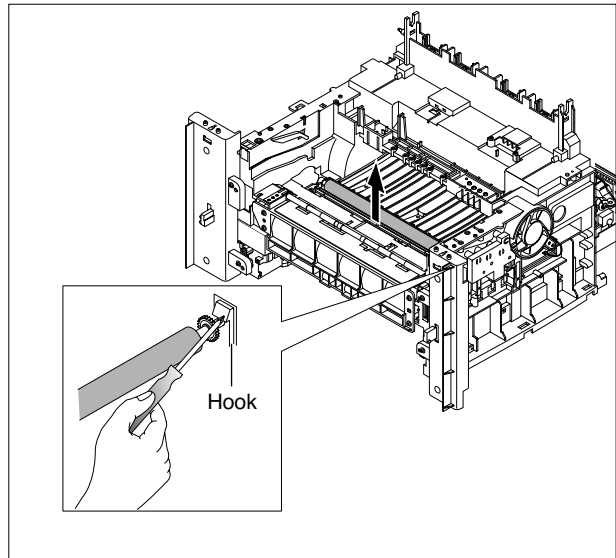

5. Unlatch the Bushing and remove it. Then lift the Transfer Roller out, as shown below.

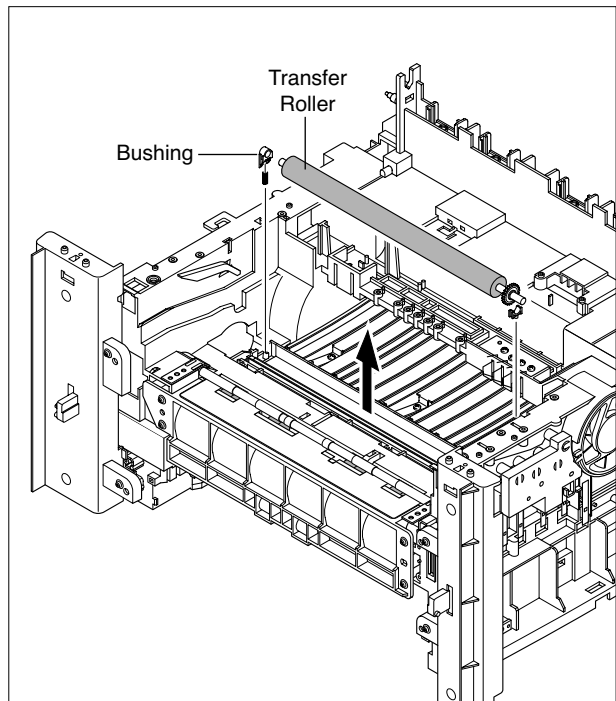

## 5.18 Feed Ass'y

1. Before you remove the Feed Ass'y, you should remove:

- Rear Cover (see page 5-2)
- Side Cover (LH, RH) (see page 5-3)
- Scanner Ass'y (see page 5-5)
- Front Cover (see page 5-4)
- Middle Cover (see page 5-11)
- Drive Ass'y (see page 5-18)
- Controller Shield Ass'y (see page 5-12)

2. Remove the 4 screws securing the Guide Paper Front and remove it.

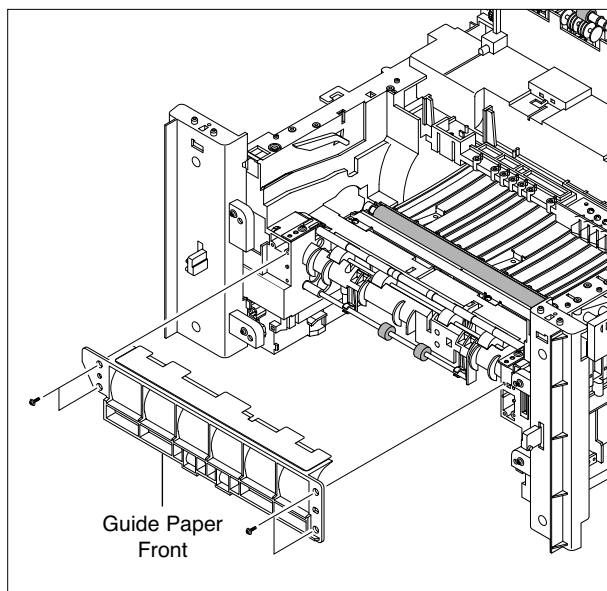

3. Remove the screws on the right and left sides of the guide paper to remove it as well as the spring as below.

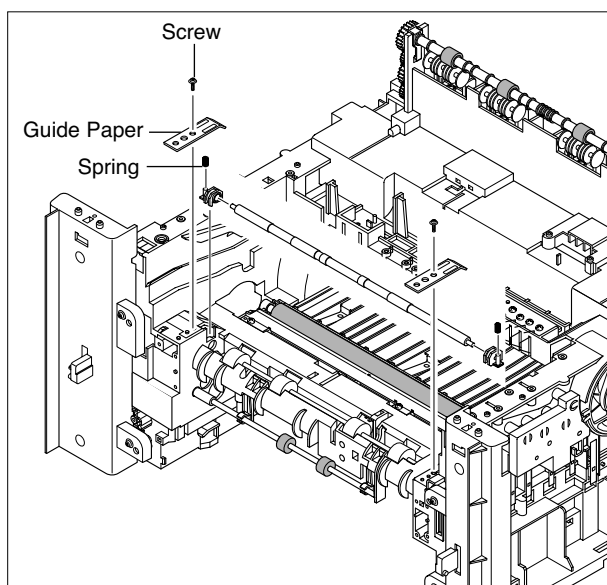

4. Remove the 3 screws securing the Feed Bracket and remove it.

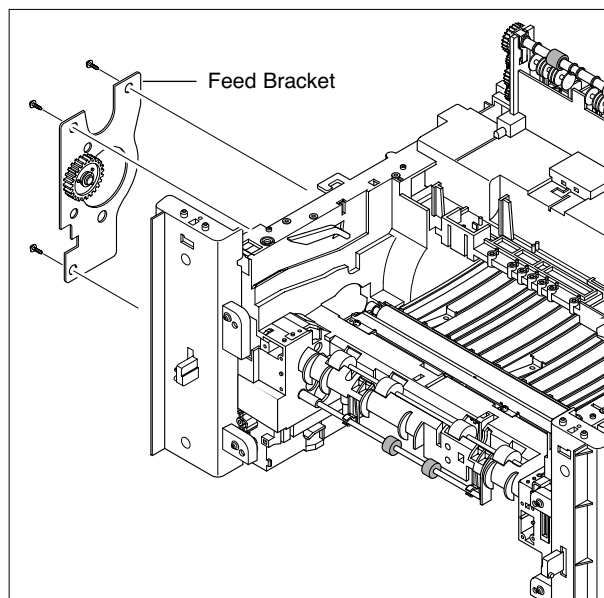

5. Remove the Feed Gear2.

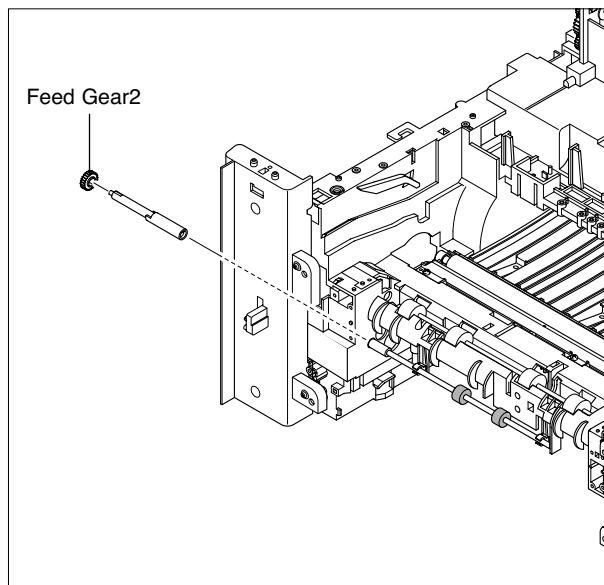



6. Remove the Feed Gear1 Ass'y.

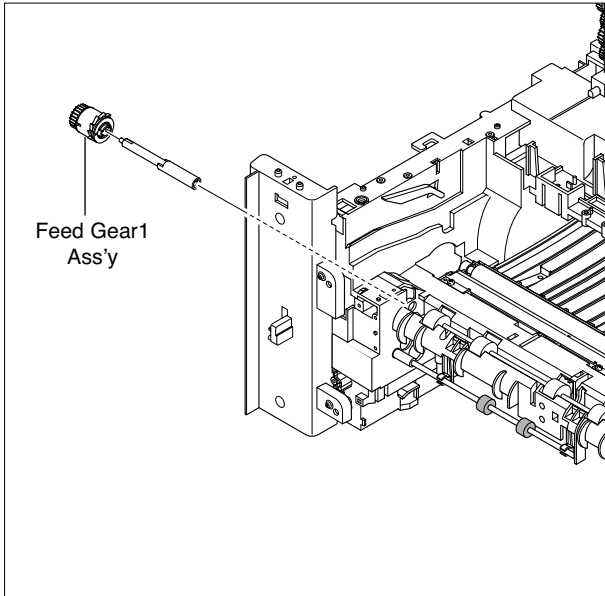

7. Pull up the Feed Roller and Feed Roller1.

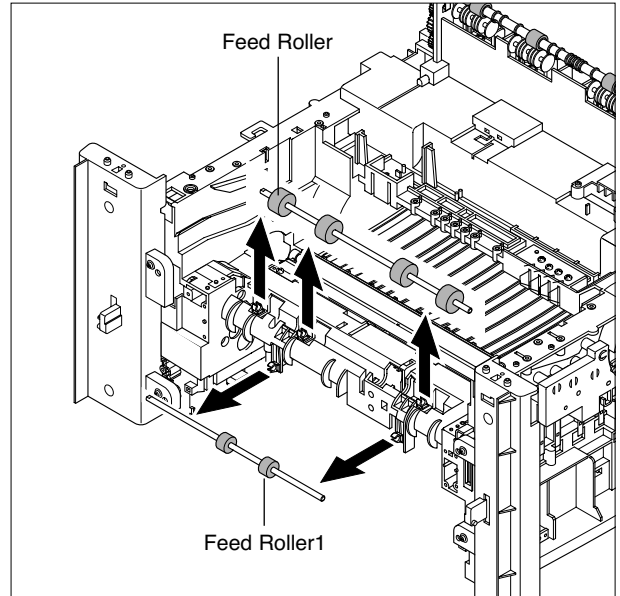

## 5.19 Pick-Up Ass'y & Solenoid

1. Before you remove the Pick-Up Ass'y, you should remove:

- Rear Cover (see page 5-2)
- Side Cover (LH, RH) (see page 5-3)
- Front Cover (see page 5-4)
- Scanner Ass'y (see page 5-5)
- Middle Cover (see page 5-11)
- Engine Shield Ass'y (see page 5-13)
- Drive Ass'y (see page 5-18)
- Controller Shield Ass'y (see page 5-12)
- Feed Bracket (see page 5-21)

2. Remove the Pick-Up Gear Ass'y.

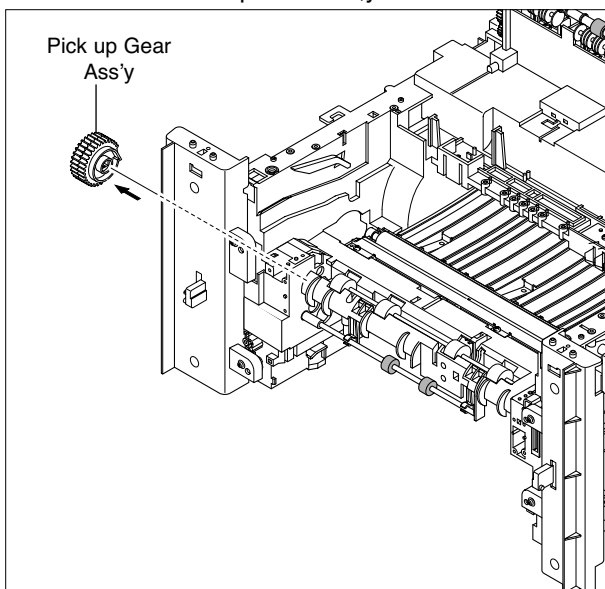

3. Take out the Pick-Up Ass'y, as shown below.

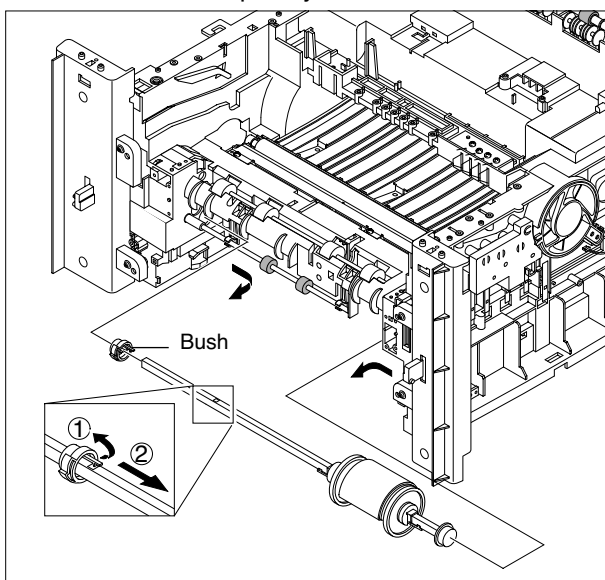

4. Remove the 2 screws securing the Manual Solenoid and Pick-Up Solenoid. Then remove Manual Solenoid and Pick-Up Solenoid.

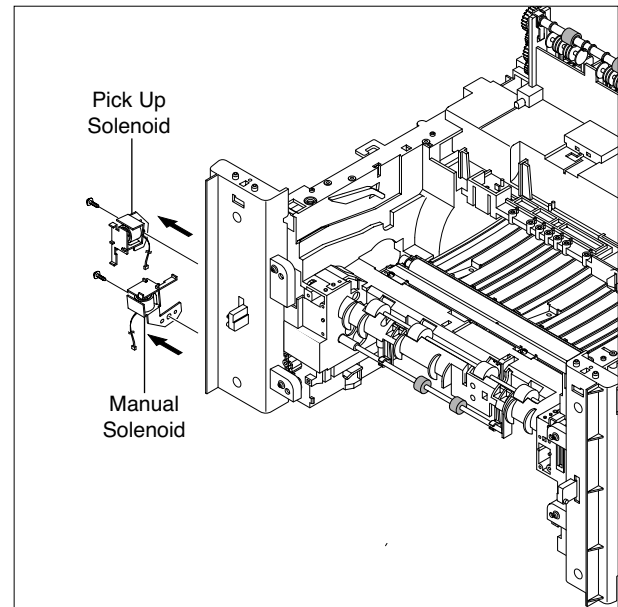

5. To replace the pick up roller, move the stopper securing the sponge-roller to the right and then turn the sponge-roller to remove it from the shaft.

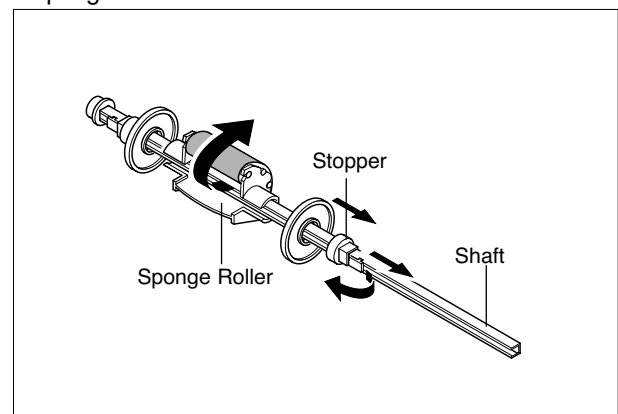

When replacing the pick up roller only, it is possible to remove it by turning over the set after removing the cassette and the processor.

## 6. Alignment and Adjustments

This chapter describes the main functions for service, such as the product maintenance method, the test output related to maintenance and repair, DCU using method, Jam removing method, and so on. It includes the contents of manual.

### 6.1 Paper path

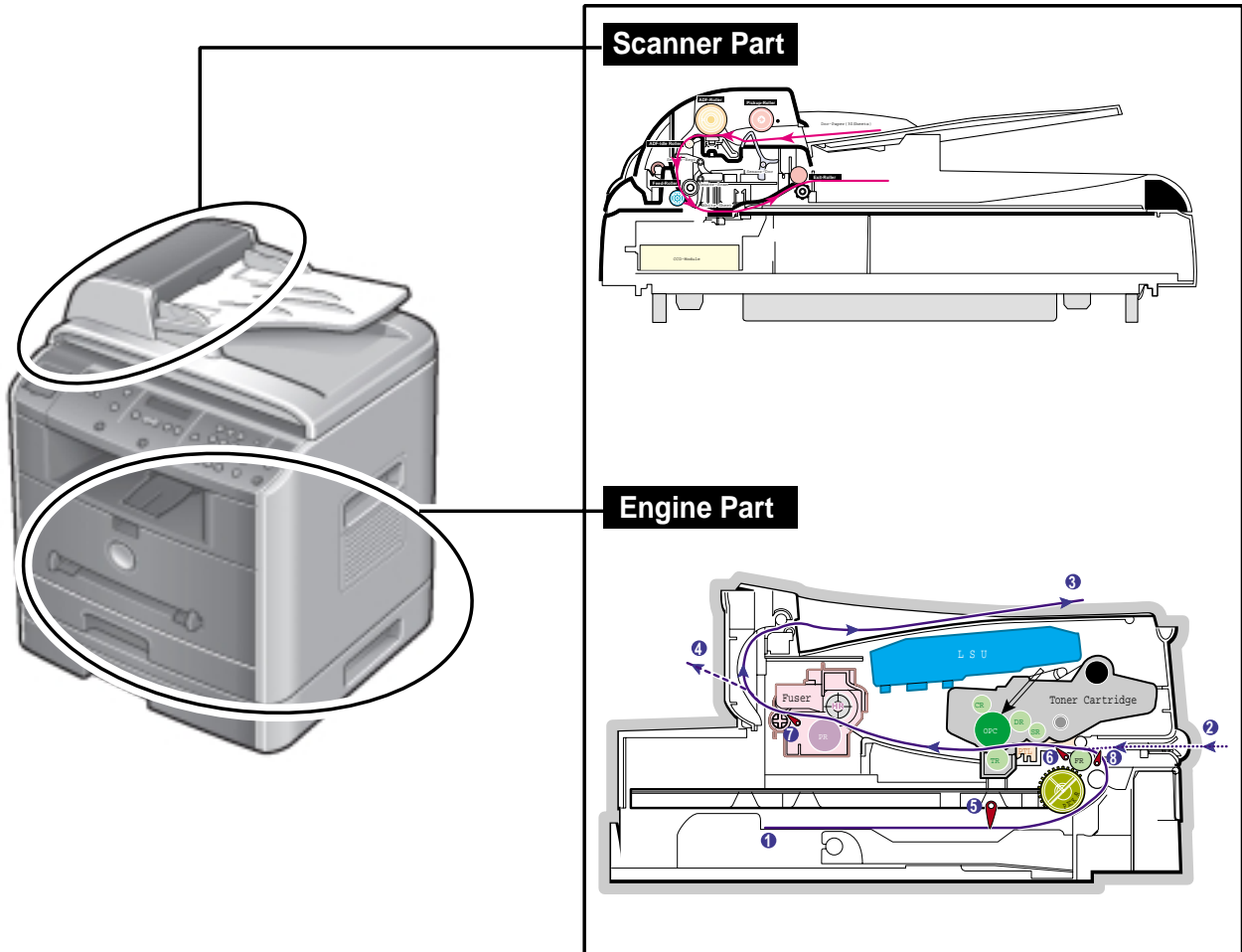

### 6.1.1 Copy & Scan Document Path

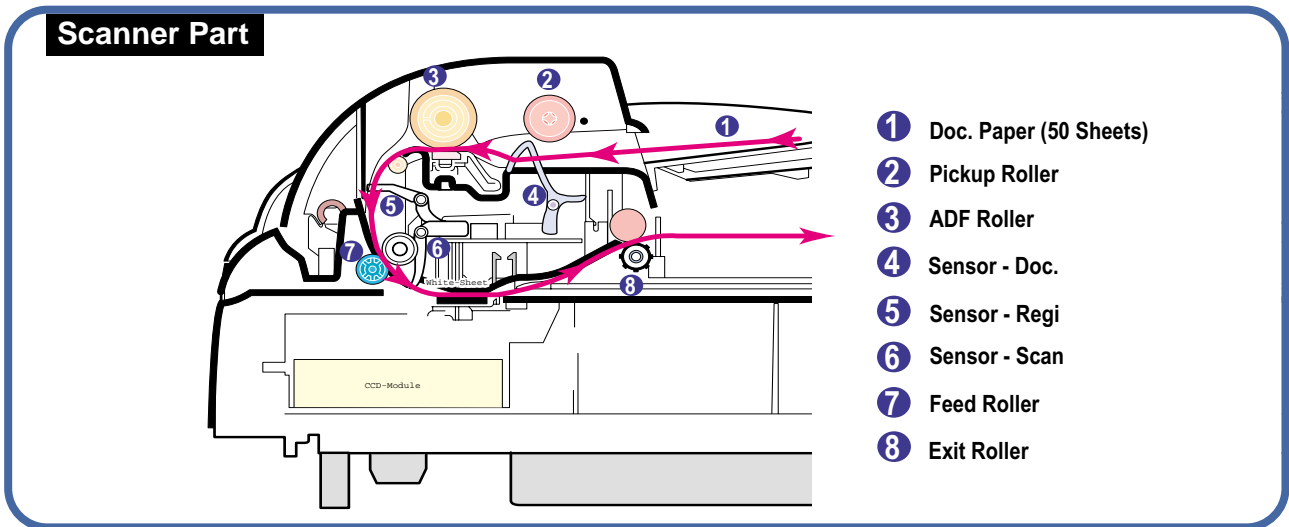

### 6.1.2 Printer Paper Path

- 1) After receiving print job, the printer feeds the printing paper from the cassette or manual feeder.
- 2) The fed paper passes the paper feeding sensor. (Jam 0 occurs if the sensor is not operated after certain time passes)
- 3) The paper passed the paper feeding sensor moves to the paper exit sensor via printing process. (Jam 1 occurs if the sensor is not operated after certain time passes)
- 4) The paper passed the paper exit sensor moves out from the set. (Jam 2 occurs sometime after if the tailing edge of the paper has not exited out from the set after the leading edge of paper passes the paper exit sensor.)

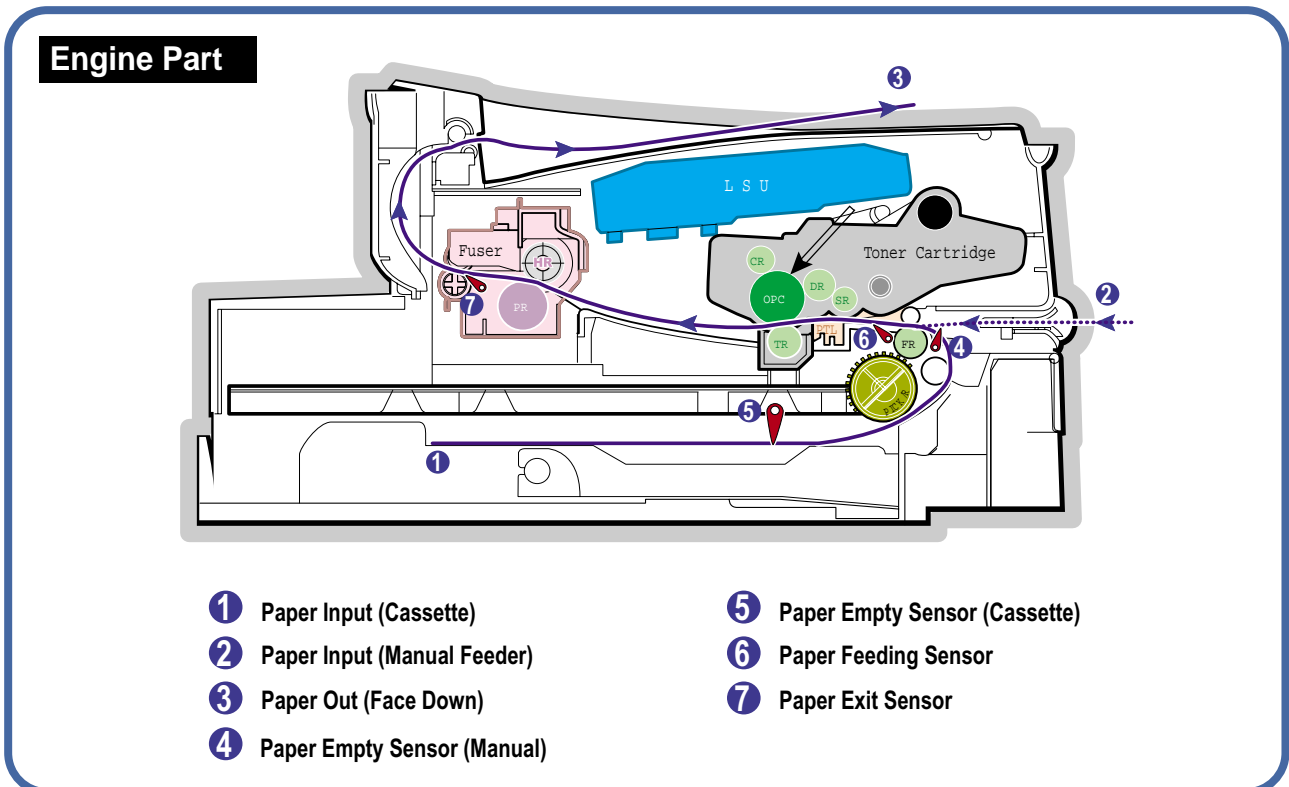

## 6.2 Clearing Paper Jams

Occasionally, paper can be jammed during a print job. Some of the causes include:

- The tray is loaded improperly or overfilled.
- The tray has been pulled out during a print job.
- The front cover has been opened during a print job.
- Paper was used that does not meet paper specifications.
- Paper that is outside of the supported size range was used.

If a paper jam occurs, the On Line/Error LED on the control panel lights red. Find and remove the jammed paper. If you don't see the paper, open the covers.

Do not use a pinset or a sharp metal tool when removing a jam.

The covering of a metal part can be removed which can cause an electric leakage.

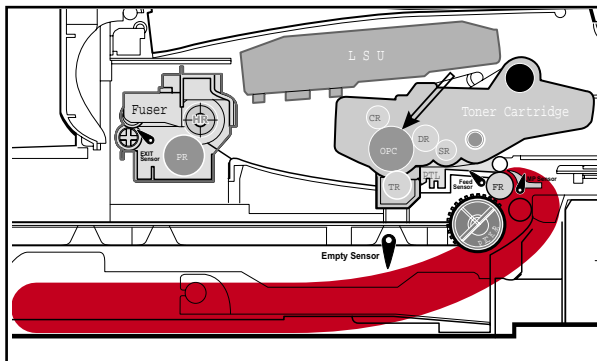

**Paper Jam0**

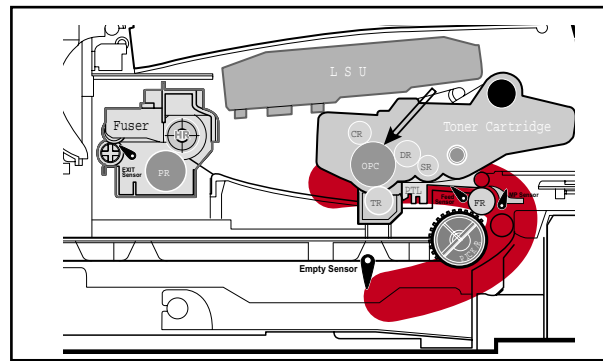

**Paper Jam1**

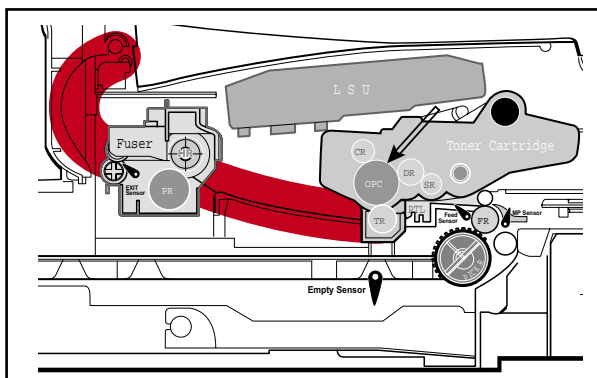

**Paper Jam2**

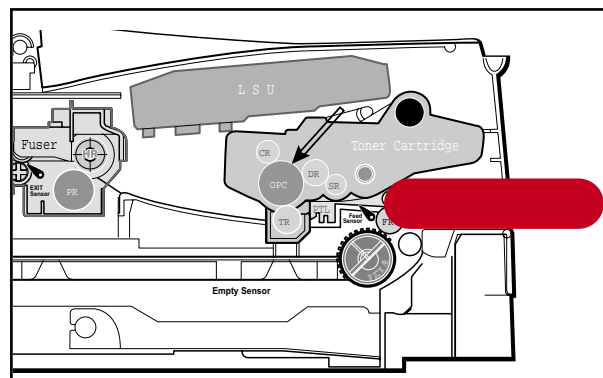

**Bypass Jam**

## 6.2.1 Clearing Document Jams

If a document jams while it is feeding through the ADF (Automatic Document Feeder), "DOCUMENT JAM" appears on the display.

### 6.2.1.1 Input Misfeed

- 1) Open the ADF top cover.

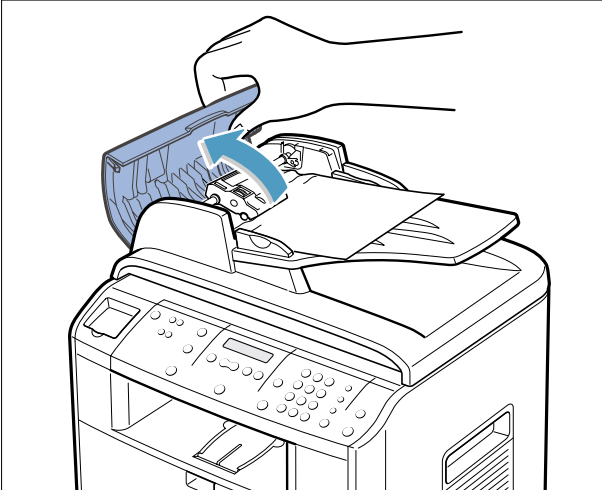

- ADF.
- 3) Close the ADF top cover. Then load the documents back into the ADF.

**NOTE:** To prevent document jams, use the document glass for the thick, thin or mixed documents.

- 2) Pull the document gently to the right and out of the

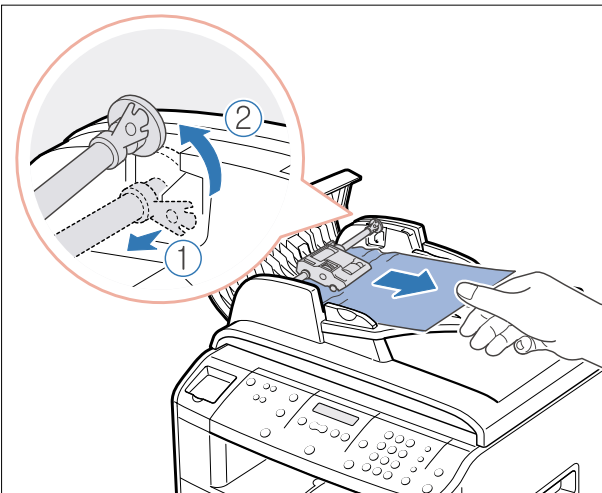

### 6.2.1.2 Exit Misfeed

- 1) Open the document cover and turn the release knob to remove the misfed documents from the exit area.
- 2) Close the document cover. Then load the documents back into the ADF.

### 6.2.1.3 Roller Misfeed

- 1) Open the document cover.

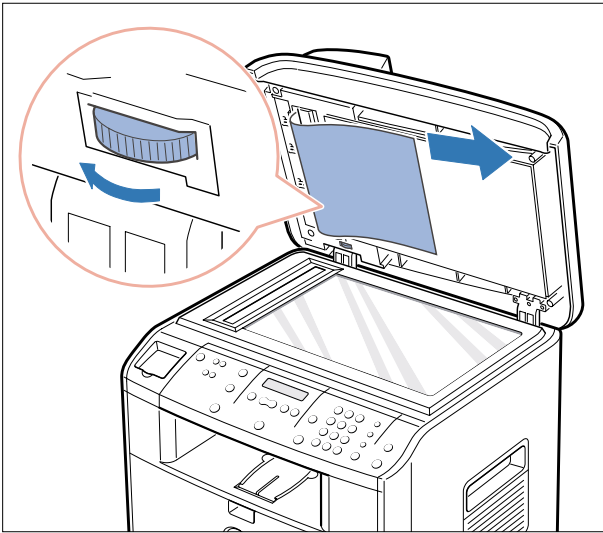

- 2) Turn the release knob so that you can easily remove the misfed document, and remove the document from the ADF or the feed area by carefully pulling it towards the right by using both hands.

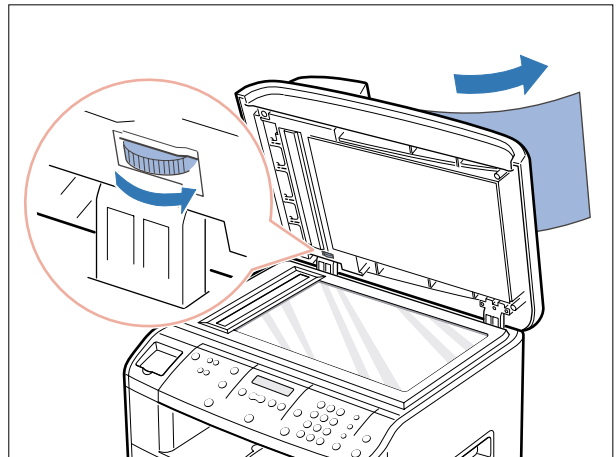

- 3) Close the document cover. Then load the documents back into the ADF.

## 6.2.2 Clearing Paper Jams

If paper jams occur, "PAPER JAM" appears on the display. Refer to the table below to locate and clear the paper jam.

PAPER JAM 0	: In the paper feed area
PAPER JAM 2	: In the paper exit area
PAPER JAM 1	: In the fuser area or around the toner cartridge
BYPASS JAM	: In the Bypass tray

Follow the steps below to clear a jam. To avoid tearing the paper, pull the jammed paper out gently and slowly.

### 6.2.2.1 JAM0 (In the Paper Feed Area)

- 1) Open and close the front cover. The jammed paper automatically exits the machine.  
If the paper does not exit, continue to Step 2.

- 2 Pull the paper tray open.

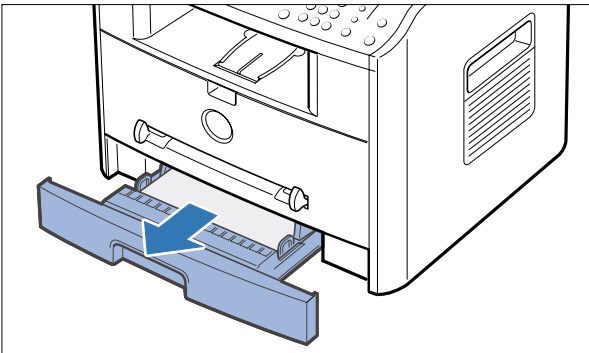

- 3) Remove the jammed paper by gently pulling it straight out.

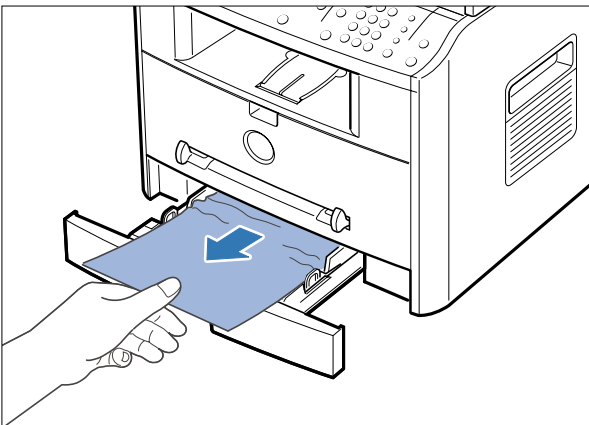

If there is any resistance when you pull the paper or the paper is not seen in this area, skip to the fuser area around the toner cartridge

- 4) Insert the paper tray into the machine until it snaps into place.

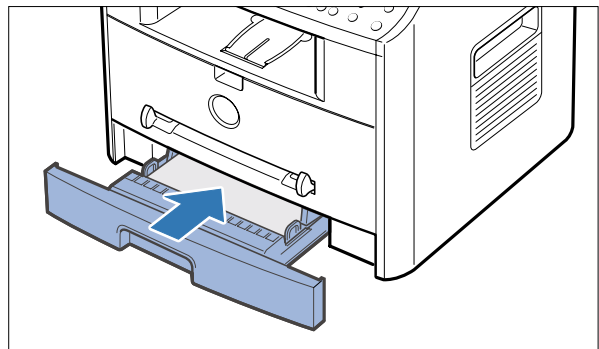

- 5) Open and close the front cover to resume printing.



### 6.2.2.2 JAM 2 (In the Paper Exit Area)

- 1) Open and close the front cover. The jammed paper automatically exits the machine. If the paper does not exit, continue to Step 2.
- 2) Gently pull the paper out of the front output tray.

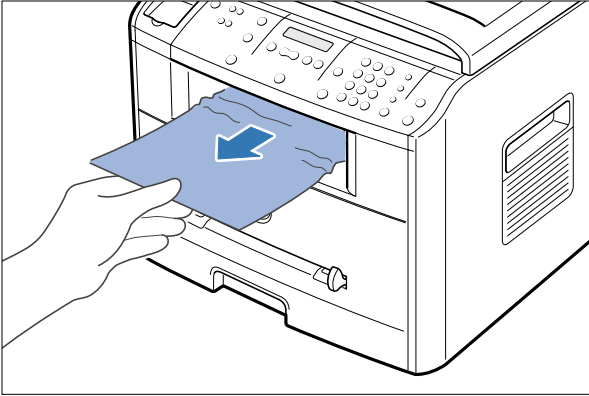

- 3) If there is any resistance when you pull the paper or the paper is not seen in the front output tray, open the rear cover.

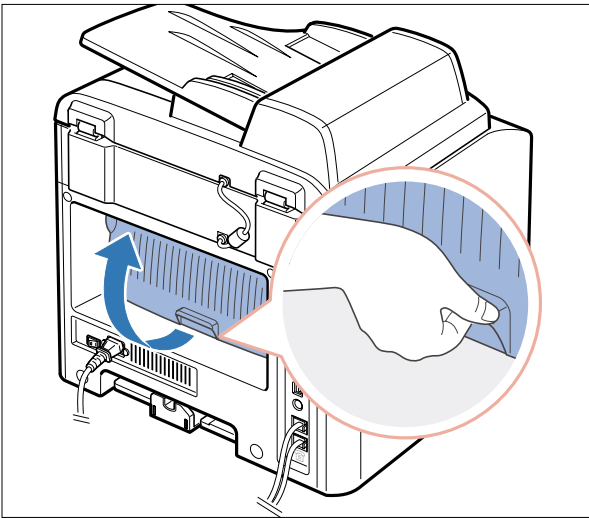

- 4) Remove the jammed paper by gently pulling it straight out..

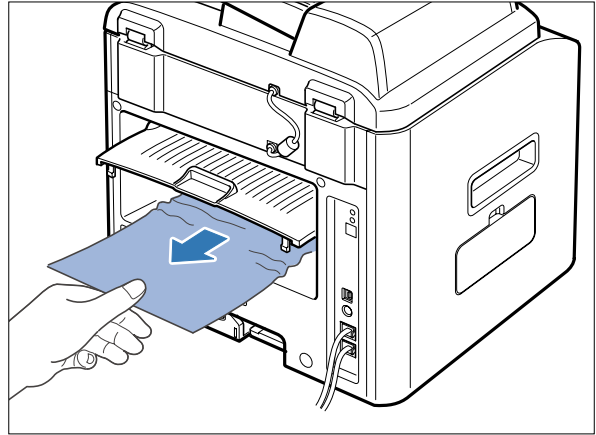

- 5) Close the rear cover.
- 6) Open and close the front cover to resume printing.

### 6.2.2.3 JAM1 (In the Fuser Area of Around the Toner Cartridge Area)

NOTE : The fuser area is hot. Be careful when removing paper from the machine.

1) Open the front cover and remove the toner cartridge.

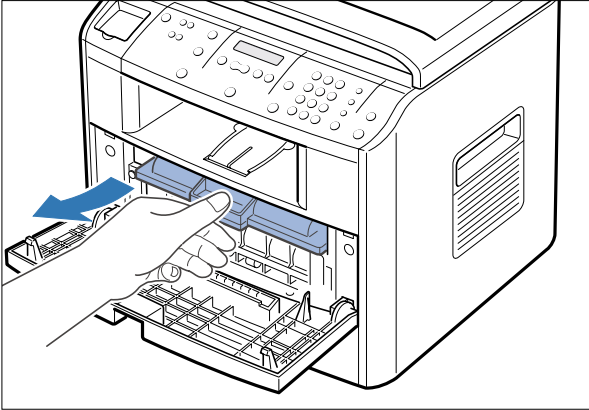

3) Replace the toner cartridge and close the front cover. Printing automatically resumes.

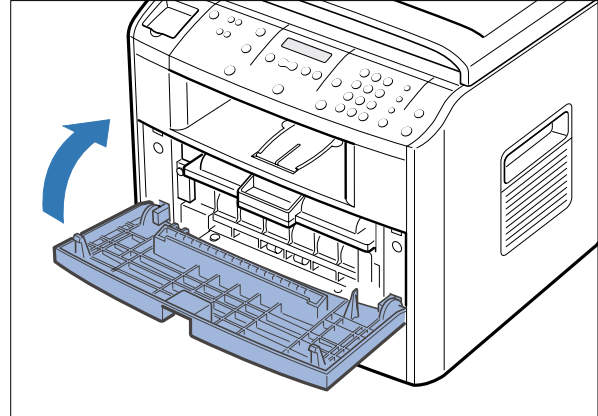

2) Remove the jammed paper by gently pulling it straight out.

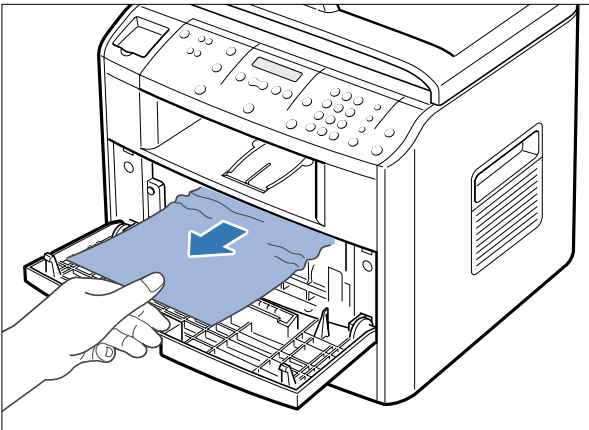

### 6.2.2.4 BYPASS JAM (In the Bypass Tray)

“BYPASS JAM ” appears on the display when the machine does not detect paper in the Bypass tray due to no paper or improper paper loading when you try to print using the Bypass tray.

“BYPASS JAM ” also may occur when the paper is not properly fed into the machine through the Bypass tray. In that case, pull the paper out of the machine.

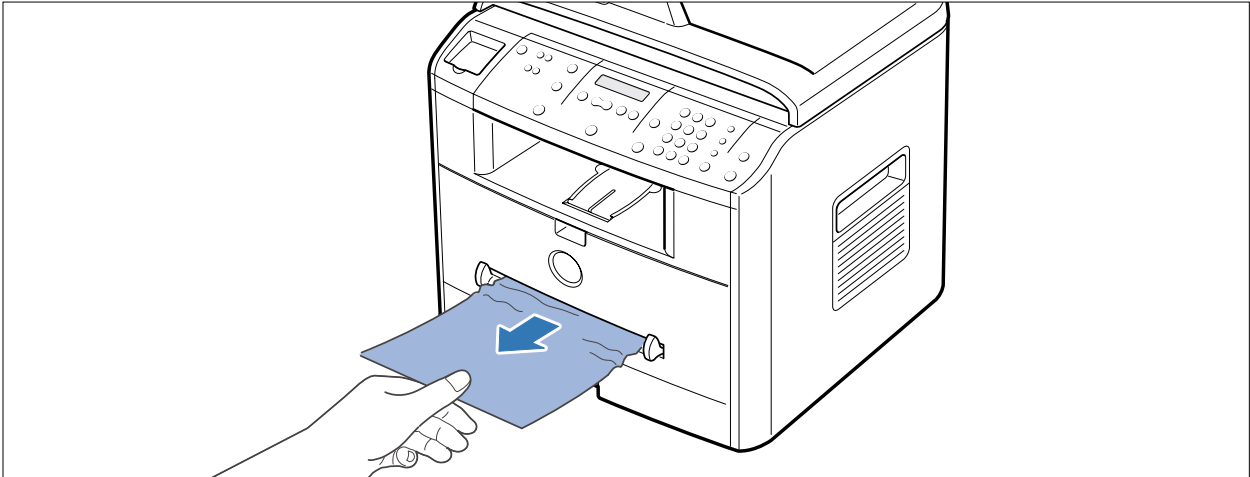

### 6.2.2.5 Tips for Avoiding Paper Jams

By selecting the correct paper types, most paper jams can be avoided. If a paper jam occurs, follow the steps outlined in “Clearing Paper Jams ”

- Follow the procedures in “Loading Paper ” .Ensure that the adjustable guides are positioned correctly.
- Do not overload the paper tray..Ensure that the paper is below the paper capacity mark on the inside wall of the paper tray.
- Do not remove the paper from the tray while printing..
- Flex,,fan and straighten the paper before loading.
- Do not use creased,,damp or highly curled paper.
- Do not mix paper types in the paper tray..
- Use only recommended print materials..See “Paper Specifications ”
- Ensure that the recommended print side is facing down when loading paper in the paper tray and facing up in the Bypass tray.

### 6.3 User Mode(SCX-4920N)

The table in the bellow explains the possible setting functions by user. The details about the ways to use are explained in the user manual.

In the service manual, the items are about the possible set-up by user.

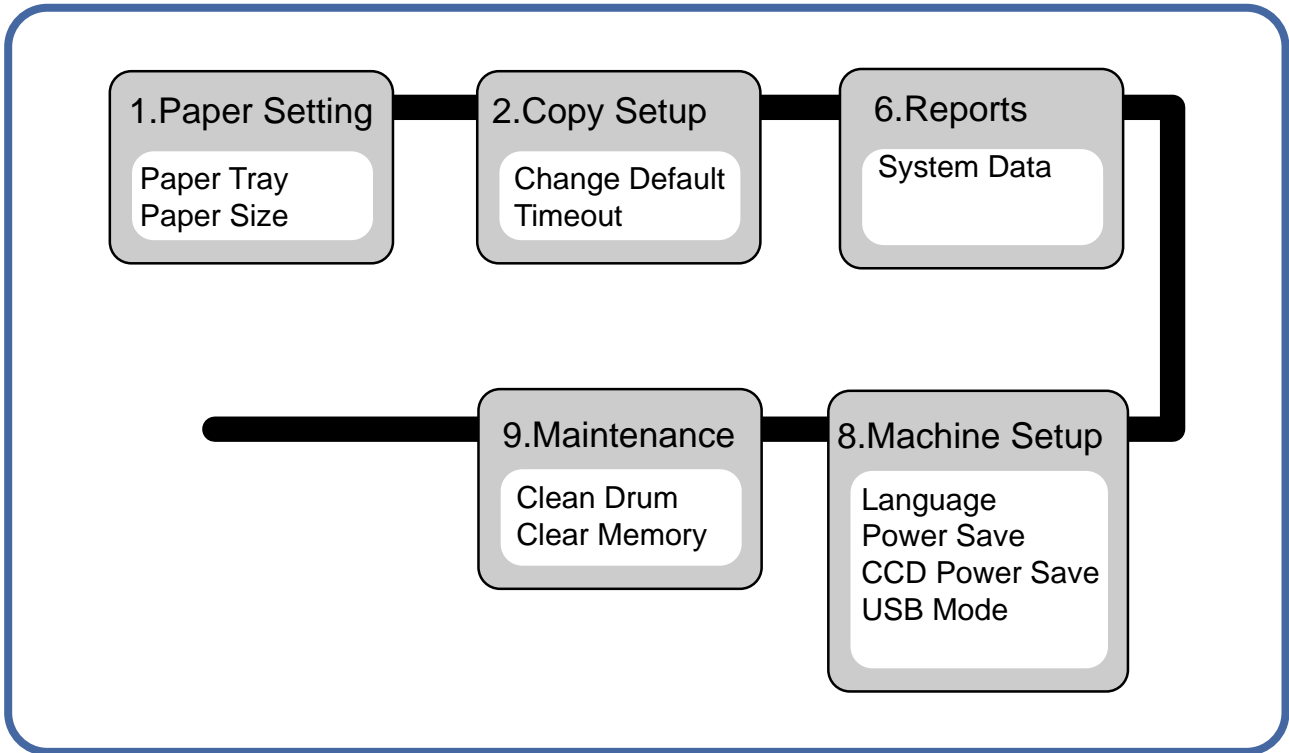

## 6.3 User Mode(SCX-4920N)

The table in the bellow explains the possible setting functions by user. The details about the ways to use are explained in the user manual.

In the service manual, the items are about the possible set-up by user.

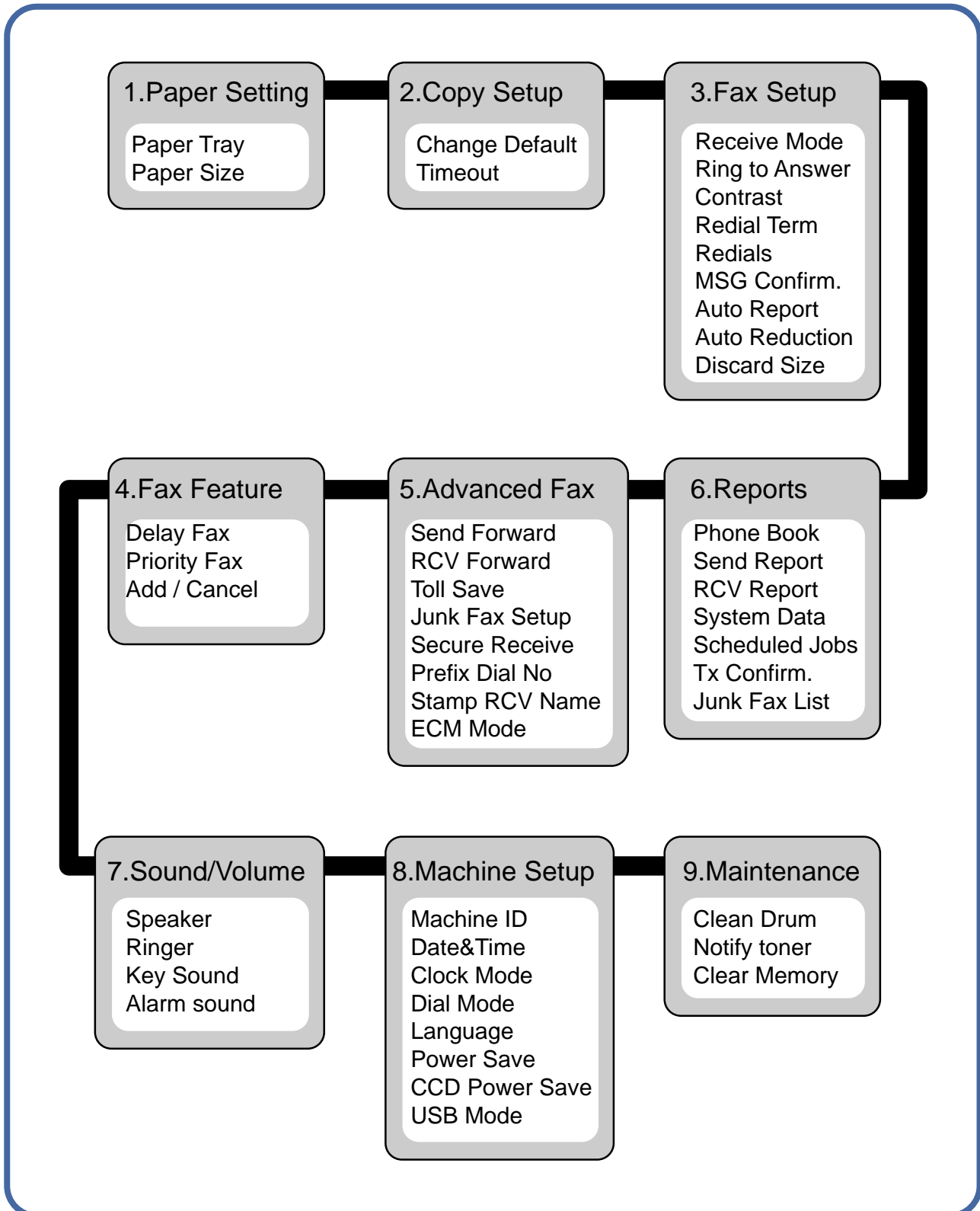







## 6.4 Tech Mode

### 6.4.1 How to Enter Tech Mode

In service (tech) mode, the technician can check the machine and perform various test to isolate the cause of a malfunction.

While in Tech mode, the machine still performs all normal operations.

#### To enter the Tech mode

To enter the Tech mode, press  →  →  →  →  →  in sequence, and the LCD briefly displays 'TECH', the machine has entered service (tech) mode.

### 6.4.2 Setting-up System in Tech Mode

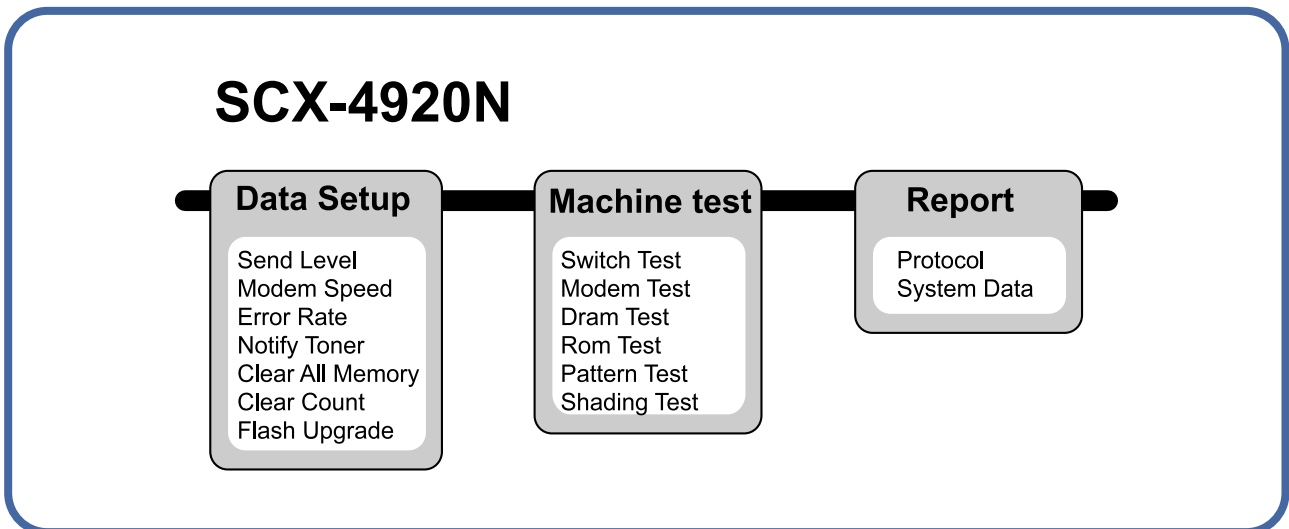

## 6.4.3 Data Setup

### SEND LEVEL

You can set the level of the transmission signal. Typically, the Tx level should be under -12 dBm.

**Caution :** *The Send Fax Level is set at the best condition in the shipment from factory. Never change settings arbitrarily.*

### DIAL MODE

This function can choose dial method.

\*Default : Dial(Dial/Pulse)

### MODEM SPEED

You can set the maximum modem speed.

Communication is done with modem speed automatically set at lower speed when communicating with a slower speed modem since communication is done on the standard of the side where modem speed is low for transmission/reception. It is best set 33.6Kbps as default setting.

### ERROR RATE

When the error rate is about exceed the set value, the Baud rate automatically adjusts to 2400 bps.

This ensures that the error rate remains below the set value.

You can select the rate between 5% and 10%.

### CLEAR ALL MEMORY

The function resets the system to factory default settings.

This function is used to reset the system to the initial value when the product is functioning abnormally. All the values are returned to the default values, and all the information, which was set by the user, will be erased.

#### < Method >

1. Select the [MEMORY CLEAR] at the TECH MODE.
2. Push the ENTER button.
3. Select you country. (There are four country groups. Refer to the table below.)
4. Push the ENTER button then it will clear all memory.

**NOTICE :** *Always perform a memory clear after replacing the main board. Otherwise, the system may not operate properly.*

Country Group	USA/Canada	UK	Russia	Southafrica
Country	USA/Canada Mexico Brazil	UK Germany France Italy Spain Austria Netherlands Belgium Portugal Sweden Norway Denmark Finland Switzerland Greece Ireland Turkey	Russia India Oman Poland Bangladesh Kuwait Moroco Algeria Pakistan UAE Bahrain Srilanka Saudi Arabia Chile Peru Argentina Hungary Romania Bulgaria Czech	South Africa

## FLASH UPGRADE

The Firmware Upgrade function has two methods, Local and Remote.

### (1) Local Machine

#### • RCP(Remote Control Panel) mode

This method is for Parallel Port or USB Port. Connect to PC and activate RCP(Remote Control Panel) to upgrade the Firmware.

< Method >

How to Update Firmware using RCP

1. Connect PC and Printer with Parallel Cable or USB Cable.
2. Execute RCP and select Firmware Update.
3. Search Firmware file to update with Browse Icon.
4. Click Update icon, firmware file is transmitted to Printer automatically and printer is initialized when it finished.
5. Click Refresh icon and check what is updated.

#### • DOS Command mode

This method is just for Parallel Port. Connect to PC with Parallel cable and enter DOS Command to upgrade the Firmware.

< Method >

1. The first of all, need the files : down.bat, down\_com.bin, fprt.exe, and Rom File: file name for upgrade. Save the files in the same folder.
2. In the DOS, input as below and push the enter key. Then, it will be automatically upgraded.
3. There are two commands for the conditions of product.
  - \* When the product is in idle condition **down "rom file"**
  - \* When the product is in Ready condition (TECH MODE → DATA SETUP → FLASH UPGRADE → LOCAL) **fprt "rom file"**
4. Do not turn off the power while upgrading process.

### (2) Remote FAX

This is a function that a fax with the latest firmware sends files to a fax in long distance through telephone line.

< Method >

1. Operate a fax with the latest firmware to prepare it being upgrade.  
(TECH MODE → DATA SETUP → FLASH UPGRADE → REMOTE)
2. Input the fax number, which needs to be upgraded.  
(Several faxes can be upgraded at the same time. In this case, enter the each fax number.)
3. After push the enter button, send the firmware file by calling to the appointed number.  
(Around 10~15 minutes needs to send the file.)

< Caution >

1. sending and receiving fax must be the same model.
2. A sending fax must be set up as ECM mode, and a receiving memory must be set up as 100%.  
If not, the function operates abnormally.



## 6.4.4 Machine Test

### SWITCH TEST

Use this feature to test all keys on the operation control panel. The result is displayed on the LCD window each time you press a key.

### MODEM TEST

Use this feature to hear various transmission signals to the telephone line from the modem and to check the modem. If no transmission signal sound is heard, it means the modem part of the main board malfunctioned.

### DRAM TEST

Use this feature to test the machine's DRAM. The result appears in the LCD display.

If all memory is working normally, the LCD shows << O K >>

### ROM TEST

Use this feature to test the machine'S ROM. The result and the software version appear in the LCD display.

- FLASH VER : 1.00 V
- ENGINE VER :1.00V

### PATTERN TEST

Using this pattern printout, you can check if the printer mechanism is functioning properly. It is needed in the production progress. Service person doesn't need to use it.

### SHADING TEST

The function is to get the optimum scan quality by the specific character of the CCD(Charge Coupled Device). If the copy image quality is poor, perform this function to check the condition CCD unit.

#### < Method >

1. Select the [ADJUST SHADING] at the TECH MODE.
2. Push the SET UP button then an image will be scanned.
3. After the scan, CCD SHADING PROFILE will be print out.
4. If the printed image is different to the image, the CCD is defect.

**NOTICE :** When you test CCD, make sure that the cover is closed.

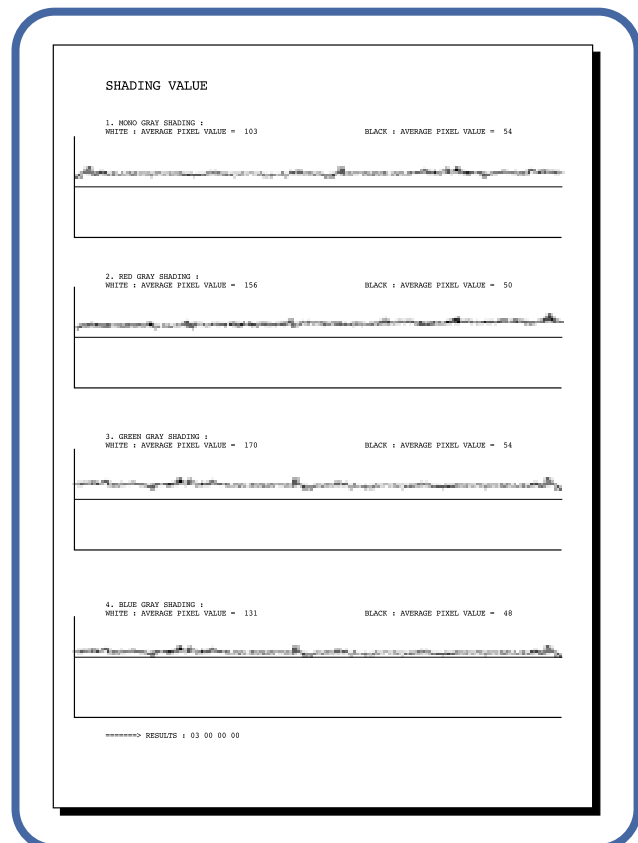

## 6.4.5 Report

---

### **PROTOCOL LIST**

This list shows the sequence of the CCITT group 3 T.30 protocol during the most recent sending or receiving operation. Use this list to check for send and receive errors. If a communication error occurs while the machine is in TECH mode, the protocol list will print automatically.

### **SYSTEM DATA**

This list provides a list of the user system data settings and tech mode settings.

## 6.5 Engine Test Mode







The Engine Tests Mode supplies useful functions to check the condition of the engine. It tests the condition of each device and displays the result of the test on the LCD. It is classified into 5 functions (0~4), and are shown below.

### Outline

- In order to enter "Engine Test" mode, the method should be especial because this mode is developed for related engineers, not for users
- After Entering the mode, the message, "Engine Test Mode" is displayed..
- On the mode, an engineer should press the "Menu Key=>#=>1=>9=>3=>1" to search each function he would like to test..
- Turn the power off, after the test is entirely end.

### 6.5.1 To enter the Engine Test Mode

#### To enter the Engine Test mode

Press  →  →  →  →  →  in sequence, and the LCD briefly displays 'Engine Test', the machine has entered Engine Test Mode.

### 6.5.2 Diagnostic

NO.	Sub No.	Engine test	Remark
0	1	Motor Test	1 : On, 2 : Off
	2	PickUp Test	1 : On, 2 : Off
	3	Fan Test	1 : On, 2 : Off
	4	Manual Clt Test	1 : On, 2 : Off
	5	PTL Test	1 : On, 2 : Off
1	1	LSU Motor Test	1 : On, 2 : Off
	2	LSU Hsync Test	1 : On, 2 : Off
	3	LD Test	1 : On, 2 : Off
2	1	Feed Sen Test	Check : Check Start
			Next : Next Sensor Check
	2	Exit Sen Test	Check : Check Start
			Next : Next Sensor Check
	3	Cover Sen Test	Check : Check Start
			Next : Next Sensor Check
4	Empty Sen Test	Check : Check Start	
		Next : Next Sensor Check	
5	Manual Sen Text	Check : Check Start	
		Next : Next Sensor Check	
3	1	Therm ADC 180	1 : On, 2 : Off (maintain the fusing temp. 80C)
	2	Therm ADC 140	1 : On, 2 : Off (maintain the fusing temp. 135C)
	3	Therm ADC 120	1 : On, 2 : Off (maintain the fusing temp. 160C)
	4	Therm ADC 100	1 : On, 2 : Off (maintain the fusing temp. 191C)
4	1	MHV Test	1 : On, 2 : Off (-1550V ± 50V)
	2	Dev Bias Test	1 : On, 2 : Off (-430V ± 20V)
	3	THV EN/NEG Test	1 : On, 2 : Off (-1000V +300V/-150V)
	4	THV ON (1300V)	1 : On, 2 : Off (+1300V ± 20V)
	5	THV ADC 1300V	1 : On, 2 : Off (ADC Value : 101 ± 5)
	6	THV ADC 600V~3500V	1 : On, 2 : Off (Compare each ADC Value)

### 6.5.3 Detail Description(Engine Test Mode)

Function Name	Description	Display
01.Motor Test	The main motor keeps running after the execution key is chosen and stops when the stop key is chosen.	Main Motor On(Off)
02.Pick Up Test	automatically stops, when the execution is chosen.	Tray 1,2 Solenoid On/Off
03.Fan Test	The fan keeps running after the execution key is chosen and stops when the stop key is chosen.	Fan On(Off)
04.Manual Clutch Test	The tray2,3 clutch is on for 1sec and then it automatically stops, when the execution is chosen.On this function, the main motor runs before 2sec from the point of the clutch on in order to check the clutch state.	Tray 2,3 Clutch On/Off
05.PTL Test	PTL(Pre-Transfer Lamp) is on after the execution key is chosen and it stops when the stop key is chosen.	PTL On(Off)
11.LSU Motor	Test The laser motor keeps running after the execution key is chosen and stops when the stop key is chosen.	Laser Motor On(Off)
12.LSU Hsync Test	"Laser Leady" is displayed, When the Laser Scanning Unit is ready to print. On the other case "Laser Error"	Laser Leady On(Off)
13.LD Test	"Diode On" is displayed, when the laser diode is on. On the other case "Diode Off" is displayed.	Diode On(Off)
21.Feed Sen Test	These Functions are considered to check the present state (normal or not)of the Sensors.	"Sensor Off"to " Sensor On "
22.Exit Sen Test		
23.Cover Sen Test		"Cover Open" to "Cover Close"
24.Empty Sen Test	These Functions are considered to check the present state (normal or not)of the Sensors.	"Sensor Off"to " Sensor On "
25.Manual Sen Test		
31.Them ADC 180	"current value"is displayed on the upper line of the panel, and "target value"on the bottom line. Target value is limited from "191°C" to "80°C"	Input and output value are ADC value.(refer to the ADC table)
32.Them ADC 140		
33.Them ADC 120		
34.Them ADC 100		
41.MHV Test	These Functions are considered to check whether the control for HVPS is normal or not.	MHV On(Off)
42.Dev Bias Test		Dev Bias On(Off)
43.THV EN/NEG Test		THV EN/NEG On(Off)
44.THV ON(1300V)		THV On(Off)
45.THV ADC 1300V		ADC value displayed.
46.THV ADC 600V~3500		ADC value displayed.

## 6.6 Identify Sale Date

---

This function confirms the date that consumer bought product and used the product for the first time. When the consumer first operate the machine, it will start a scan and page count. The time the machine was first used is remembered.

These settings are are remembered after memory delete (Clear All Memory).

### < Method >

Press MENU, #, 1, 9, 3, # in sequence. Firmware version is displayed on LCD.

Press 1( in the number keypad) : The LCD display shows "Updated date"

Press 2( in the number keypad) : The LCD display shows "Product first use date"

## 6.7 Consumables and Replacement Parts

---

The cycle period outlined below is a general guideline for maintenance.  
The example list is for an average usage of 50 transmitted and received documents per day.  
Environmental conditions and actual use will may vary.  
The cycle period given below is for reference only.

COMPONENT	REPLACEMENT CYCLE
ADF Rubber	20,000 Pages
ADF Roller	60,000 Pages
Pick-up Roller	60,000 Pages
Friction Pad	60,000 Pages
Transfer Roller	60,000 Pages
Fuser	80,000 Pages
Toner Cartridge	3,000 Pages (A4 ISO 5% Pattern)

## 6.8 Abnormal Image Printing and Defective Roller

If abnormal image prints periodically, check the parts shown below.

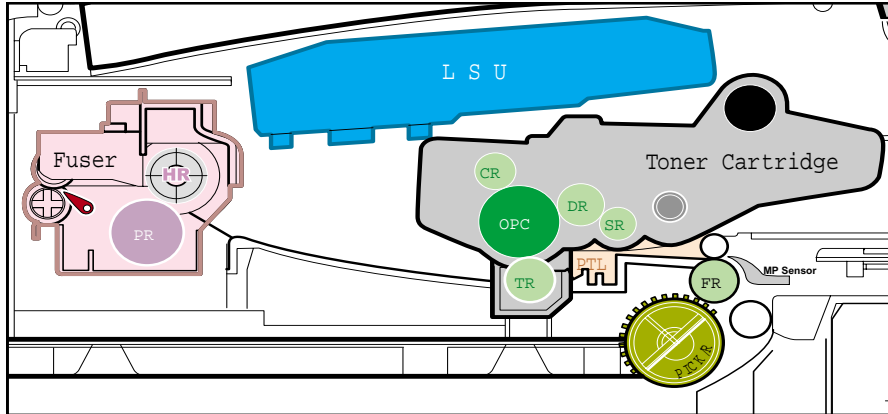

- ① OPC Drum
  - ② Charge Roller
  - ③ Supply Roller
  - ④ Developing Roller
- ⑤ Transfer Roller
  - ⑥ Heat Roller
  - ⑦ Pressure Roller

No	Roller	Abnormal image period	Kind of abnormal image
1	OPC Drum	75.5mm	White spot, Block spot
2	Charge Roller	37.7mm	Black spot
3	Supply Roller	37.0mm	Horizontal density band
4	Develop Roller	35.2mm	Horizontal density band
5	Transfer Roller	45.3mm	Black side contamination/transfer fault
6	Heat Roller	77.8mm	Black spot and fuser ghost
7	Pressure Roller	75.4mm	Black side contamination

## 6.9 Error Messages

---

The display on the front panel shows the messages to indicate the printer's status or errors. Refer to the tables below to understand the message's meaning and clear the problem if necessary. The messages and their meanings are listed in alphabetical order, with numbered messages following.

### **[Manual F. Jam]**

Meaning: A paper jam has occurred in the manual feeder or the multi-function printer detects improper feeding from the manual feeder.

Solution: Clear the paper jam. Load paper in the manual feeder correctly.

### **Cancel ? 1. Yes 2. No**

Meaning: Your printer's memory is full and cannot store the document to send a fax into its memory.

Solution: To cancel the fax job, press the 1 button to accept "Yes."

If you want to send the pages that were stored, press the 2 button to accept "No." You should send the remaining pages later when memory is available.

### **[COMM. Error]**

Meaning: The multi-function printer has a communication problem.

Solution: Ask the sender to try again.

### **CRU Fuse Error [Low Heat Error]**

Meaning: There is a problem in the fuser unit.

Solution: Check thermostat, thermister contact point & Heating Lamp.

### **CRU Fuse Error [Over Heat]**

Meaning: The printer has overheated.

Solution: Your unit will automatically return to the standby mode when it cools down to normal operating temperature.

If failure persists, check the ELA HOU-FUSER.

### **Delayed Function**

Meaning: The delayed fax jobs are full.

Solution: Cancel the unnecessary delayed fax job.

### **Document Jam**

Meaning: The loaded document has jammed in the Automatic Document Feeder (ADF).

Solution: Clear the document jam.

### **[Door Open]**

Meaning: The front or rear cover is not securely latched.

Solution: Close the cover until it locks into place.

### **Enter Again**

Meaning: You entered an unavailable item.

Solution: Enter the correct item again.

### **Function Not Available**

Meaning: You have tried to use a combination of printer functions that can not be used at the same time.

Solution: Reduce the number of selected functions or use only one function at a time.

### **Group No. is assigned**

Meaning: The group dial location you tried to select has speed dial numbers assigned to it.

Solution: Press <Return> to start over with another group dial location.



**Group Not Available**

Meaning: You have tried to select a group location number where only a single location number can be used, such as when adding locations for a broadcasting operation.

Solution: Use a speed dial number or dial the number manually using the number keypad.

**[Hsync Error] [LSU Error]**

Meaning: A problem has occurred in the Laser Scanning Unit (LSU).

Solution: Use TECH mode to test LSU. Replace the LSU

**[No Cartridge]**

Meaning: The toner cartridge is not installed.

Solution: Install the toner cartridge.

**[Line Error]**

Meaning: Your machine cannot connect with the remote machine or has lost contact because of a problem with the phone line.

Solution: Try again. If the problem persists, wait an hour or so for the line to clear and try again. Or, turn the ECM on.

**Memory Full**

Meaning: The memory is full.

Solution: Delete unnecessary documents, retransmit after more memory becomes available or split the transmission into more than one operation.

**[No Answer]**

Meaning: The remote fax machine has not answered after several redial attempts.

Solution: Try again. Verify the number to make sure a fax can be received.

**No. Not Assigned**

Meaning: The speed dial location you tried to use has no number assigned to it.

Solution: Dial the number manually using the number keypad or assign the number.

**No. Not Available**

Meaning: You have tried to delete the number for the delayed fax job.

Solution: Verify the number to be deleted and try again.  
Or Delete the number after the delayed fax job is

**[No Paper] Add Paper**

Meaning: The paper in the paper tray has run out.

Solution: Load paper in the paper tray.

**No Job Found**

Meaning: You are performing an Add / Cancel operation, but there are no jobs waiting.

Solution: Check the display to see if there are any scheduled jobs. The display should indicate if any scheduled jobs are in Standby mode, for example, Delay Fax.

**[Paper Jam 0] Open/Close Door**

Meaning: Paper has jammed in the feeding area of the paper tray.

Solution: Clear the jam.

**[Paper Jam 1] Check Inside**

Meaning: Paper has jammed in the paper exit area.

Solution: Clear the jam.

**[Paper Jam 2] Check Outside**

Meaning: Paper has jammed in the fuser area.

Solution: Clear the jam.

**Power Failure**

Meaning: The power has been turned off and then on and the printer's memory has not been saved.

Solution: The printer's memory was not saved due to a power failure. The job will need to be started over.

**Registered**

Meaning: The group dial location is already registered with another speed dial number.

Solution: Select another group dial location.

**Retry Redial?**

Meaning: The multi-function printer is waiting for a specified time interval to redial a previously busy station.

Solution: You can press <Select>to immediately redial, or <Cancel>to cancel the redial operation.

**[Toner Low]**

Meaning: The toner is almost empty.

Solution: Take out the toner cartridge and gently shake it. By doing this, you can temporarily reestablish printing operations.

Or Replace the toner cartridge with a new one for the best print quality.

# 7. Troubleshooting

## 7.1 Paper Feeding Problems

### 7.1.1 Wrong Print Position

- **Description** Printing begins when the paper is in the wrong position.

Check and Cause	Solution
A defective feed sensor actuator can cause incorrect timing.	Replace the defective actuator

### 7.1.2 JAM 0

- **Description**
  1. Paper has not exited from the cassette.
  2. Jam-0 occurs if the paper feeds into the printer.

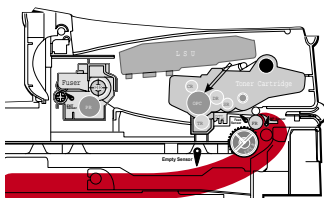

Check and Cause	Solution
1. Check the Solenoid by using Engine Test Mode : Diagnostic Mode code 0	1. Replace the solenoid.
2. Check if the pad is loose due to bad sealing of the side-pad.	2. Replace the side-pad Assembly L or R, if necessary.
3. Check the surface of the roller-pick-up for foreign matter.	3. Clean with soft cloth dampened with IPA(Isopropyl Alcohol) or water.
4. If continuous clusters occur, check whether the assembly slot between shaft-pickup and housing-pickup become open or is broken away.	4. Replace the Housing-Pickup and/or Shaft-Pickup.
5. If the paper feeds into the printer and Jam 0 occurs, perform DCU to check feed-sensor of the engine board.	

### 7.1.3 JAM 1

- **Description**
1. Recording paper is jammed in front of or inside the fuser.
  2. Recording paper is stuck in the discharge roller and in the fuser just after passing through the Actuator-Feed.

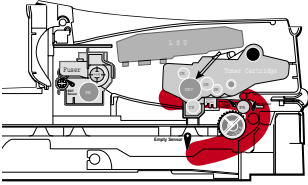

Check and Cause	Solution
<ol style="list-style-type: none"> <li>1. If the recording paper is jammed in front of or inside the fuser.</li> <li>2. If the recording paper is stuck in the discharge roller and the fuser just after passing through the Actuator-Feed, Feed Actuator may be defective.</li> </ol>	<ol style="list-style-type: none"> <li>1. Replace the SMPS.</li> <li>2. Reassemble the Actuator-Feed and Spring-Actuator if the return is bad.</li> </ol>

### 7.1.4 JAM 2

- **Description**
1. Recording paper is jammed in front of or inside the fuser.
  2. Recording paper is stuck in the discharge roller and in the fuser just after passing through the Actuator-Feed.

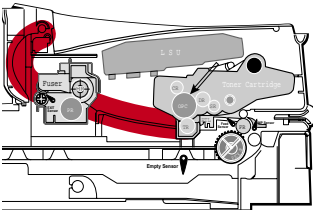

Check and Cause	Solution
<ol style="list-style-type: none"> <li>1. If the paper is completely fed out of the printer, but Jam 2 occurs : Exit sensor is defective.                             <ul style="list-style-type: none"> <li>• After the paper is completely discharged, actuator Exit should return to the original position to shut off the photo-sensor. Sometimes it takes longer than it should and does not return.</li> </ul> </li> <li>2. If the paper is rolled in the Fuser Roller:                             <ul style="list-style-type: none"> <li>• This occurs when a Guide claw is broken away or transformed.</li> <li>• It occurs when the Guide slaw spring is broken away or transformed.</li> <li>• It occurs when the Heat-Roller or Pressure-Roller is seriously contaminated with toner powder.</li> </ul> </li> <li>3. Paper is accordion jammed in fuser.</li> </ol>	<ol style="list-style-type: none"> <li>1. Check if the exit sensor actuator is defective.                             <ul style="list-style-type: none"> <li>• Check if the actuator exit is deformed (Check if the lever part is deformed in shape).</li> <li>• Check whether burrs occur in the assembly part of the actuator exit or not and if the actuator is smoothly operated.</li> <li>• Check if foreign matters and wire get caught in the actuator exit's operation.</li> </ul> </li> <li>2. If the paper is stuck in the fuser : disassemble the fuser and remove the jammed paper, and clean the surface of the pressure roller with dry gauze.</li> <li>3. Remove the jammed paper after disassembling the fuser : Clean the surface of the pressure roller with dry gauze.                             <ul style="list-style-type: none"> <li>• Remove the toner particles stained on the rib.</li> <li>• Check the assemblage and performance of the exit.</li> </ul> </li> </ol>

### 7.1.5 Multi-Feeding

• **Description** Multiple sheets of paper are fed at once.

Check and Cause	Solution
<ol style="list-style-type: none"> <li>1. Solenoid malfunction(the solenoid does not work properly): Perform Engine Test Mode : Diagnostic Mode code 0.</li> <li>2. Friction-Pad is contaminated with foreign matter.(oil..)</li> <li>3. The face of paper is blended.</li> </ol>	<ol style="list-style-type: none"> <li>1. Replace the solenoid if necessary.</li> <li>2. Clean the friction-pad with soft cloth dampened with IPA(Isopropyl Alcohol).</li> <li>3. Use the smooth paper.</li> </ol>

### 7.1.6 Paper rolled in the fuser

• **Description** If contaminated at intervals of 57mm on the back of a paper.

Check and Cause	Solution
<ol style="list-style-type: none"> <li>1. Contamination of the pressure roller. (Background, Hot off set)</li> </ol>	<ol style="list-style-type: none"> <li>1. Disassemble the fuser, clean the area between the Heat-roller and Thermistor and remove the foreign matter off of the pressure roller.</li> <li>2. If background appears badly in the printing, fix it by referring to the solutions for background. (See 4.5.8 Background)</li> </ol>

### 7.1.7 Paper rolled in the OPC

• **Description** Paper is rolled up in the OPC.

Check and Cause	Solution
<ol style="list-style-type: none"> <li>1. Paper is too thin.</li> <li>2. The face of paper is curled.</li> </ol>	<ol style="list-style-type: none"> <li>1. Recommend to use normal paper thickness.</li> <li>2. How to remove the rolled paper in the OPC.                             <ul style="list-style-type: none"> <li>• Remove the paper while turning the OPC against the ongoing direction.</li> <li>• Clean fingerprints on the OPC softly with soft cloth dampened with IPA(Isopropyl Alcohol) or tissue.</li> </ul> </li> </ol>

### 7.1.8 Defective ADF

• **Description** ADF (Automatic document Feeder) is not properly operated.

Check and Cause	Solution
<ol style="list-style-type: none"> <li>1. Check if ADF rubber and HOLDER rubber are damaged.</li> <li>2. Check if the document sensors of ADF Ass'y (3 paper sensors) are normal.</li> </ol>	<ol style="list-style-type: none"> <li>1. Replace the contaminated or damaged part.</li> <li>2. If you cannot confirm the damaged part with the naked eye, try to replace the ADF Ass'y.</li> </ol>

## 7.2. Printing Problems (malfunction)

### 7.2.1 Defective Operation (LCD WINDOW ■■■ ) Display

- **Description** Strange characters are displayed on the OPE Panel and buttons are not operated.

Check and Cause	Solution
<ol style="list-style-type: none"> <li>1. Clear the memory.(see page 6.5.3)</li> <li>2. Check if OPE HARNESS is connected to the Connection B'd correctly.</li> </ol>	<ol style="list-style-type: none"> <li>1. Try again after clearing the memory.</li> <li>2. After confirming that OPE HARNESS is connected to the Connection B'd correctly, if it is so, then replace the OPE Ass'y and Main Board in sequence.</li> </ol>

### 7.2.2 Defective LCD Operation

- **Description** Defective LCD Operation

Check and Cause	Solution
<ol style="list-style-type: none"> <li>1. Clear the memory. (See page 6.5.3).</li> <li>2. Confirm to catch a click sound, while a key on the OPE panel is pressed on.</li> </ol>	<ol style="list-style-type: none"> <li>1. The key is wrong itself or wrongly assembled.</li> <li>2. Even after the key has been replaced, it is still wrong, try to replace the OPE Ass'y and the Main B'd in sequence.</li> </ol>

### 7.2.3 Not functioning of the fuser gear due to melting away

- **Description** The Motor breaks away from its place due to gear melting away.

Check and Cause	Solution
1. Check the Heat Lamp.	1. Replace the Fuser.  2. Replace the Main PBA.  3. Replace the SMPS.

### 7.2.4 Paper Empty

- **Description** The paper lamp on the operator panel is on even when paper is loaded in the cassette.

Check and Cause	Solution
1. Bending or deformation of the actuator of the paper sensor.  2. The function of the Main PBA is defective Perform Engine Test Mode : Perform Engine Test Mode diagnostic code 2.	1. Replace the defective actuator.  2. Replace the Main PBA.

### 7.2.5 Paper Empty without indication

- **Description** The paper lamp on the operator panel does not come on when the paper cassette is empty.

Check and Cause	Solution
1. Bending or deformation of the actuator of the paper sensor.  2. The function of the Main PBA is defective Perform.	1. Replace the defective actuator.  2. Replace the Main PBA.



## 7.2.6 Door Open

- **Description** The ERROR lamp is on even when the print Door is closed.

Check and Cause	Solution
<ol style="list-style-type: none"> <li>1. The hook lever in the Front Cover may be defective.</li> <li>2. Check the Connector(CN1) and Circuit of the Cover Switch department in the Main PBA.</li> </ol>	<ol style="list-style-type: none"> <li>1. Replace the hook lever, if defective.</li> <li>2. Check the insertion of the Door Open S/W Connect.</li> <li>3. Replace the Main PBA or Door Open S/W.</li> </ol>

## 7.2.7 No Beep on when the Door is open

- **Description** The ERROR lamp does not come on even when the printer Door is open.

Check and Cause	Solution
<p>Check the Connector(CN1) and Circuit of the Cover Switch department in the Main PBA.</p>	<ol style="list-style-type: none"> <li>1. Check the insertion of the Door S/W Connect.</li> <li>2. Replace the Main PBA or Door Open S/W.</li> </ol>

### 7.2.8 Defective Motor operation

• **Description** Main Motor is not driving when printing, and paper does not feed into the printer, resulting 'Jam 0'.

Check and Cause	Solution
<ol style="list-style-type: none"> <li>1. Motor harness or sub PCB may be defective.</li> <li>2. Perform Engine Test Mode diagnostic code 0 and Check the Motor operation.</li> </ol>	<ol style="list-style-type: none"> <li>1. Check the Motor harness, replace it, if defective.</li> <li>2. Replace the SMPS, if necessary.</li> </ol>

### 7.2.9 No Power

• **Description** When system power is turned on, all lamps on the operator panel do not come on.

Check and Cause	Solution
<ol style="list-style-type: none"> <li>1. Check if the power input and SMPS output are normal.</li> <li>2. Check for defective of LCD-Panel on the front-cover if the LCD of Panel does not appear after normal warming-up.</li> </ol>	<ol style="list-style-type: none"> <li>1. Replace the power supply cord or SMPS.</li> <li>2. Replace the control board.</li> <li>3. Replace the LCD-panel.</li> </ol>

### 7.2.10 Vertical Line Getting Curved

- **Description** When printing, vertical line gets curved.

Check and Cause	Solution
1. If the supply of +24v is unstable in the Main Control board linking with LSU, check drive by Engine Test Mode : Diagnostic Code 1 LSU Motor on.	1. Replace LSU.  2. Replace the Main Control board.

## 7.3 Printing Quality Problems

### 7.3.1 Vertical Black Line and Band

- **Description** 1. Straight thin black vertical line occurs in the printing.  
2. Dark black vertical band occur in the printing.

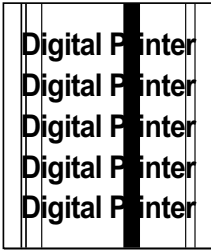

Check and Cause	Solution
<ol style="list-style-type: none"> <li>1. Damaged develop roller in the Developer. Deformed Doctor-blade.</li> <li>2. Scratched surface of the charge roller in the developer.</li> <li>3. Partial depression or deformation on the surface of the transfer roller.</li> </ol>	<ol style="list-style-type: none"> <li>1. If causes 1 and 2 occur in the developer cartridge, replace the developer and try to print out.</li> <li>2. Replace the transfer roller if occurred as No. 3.</li> </ol>

### 7.3.2 Vertical White Line

- **Description** White vertical voids in the image.

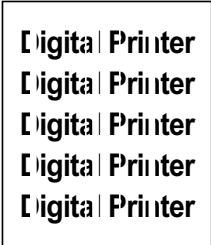

Check and Cause	Solution
<ol style="list-style-type: none"> <li>1. Foreign matter stuck onto the window of internal lenses of LSU mirror.</li> <li>2. Foreign matter or toner particles between the developer roller and blade. (In case the life of the developer has been expired, white lines or light image occur in front of the image.)</li> <li>3. It may occur when a Burr and foreign substances are on the window of the developer frame.</li> <li>4. If the fuser is defective, voids occur periodically at the top of a black image.</li> </ol>	<ol style="list-style-type: none"> <li>1. Foreign matter stuck onto the window : Clean the LSU window with recommended cleaner(IPA) Clean the window with a clean cotton swab.</li> <li>2. Foreign matter in the LSU : Open the cover of LSU and clean with a cotton swab on the surface of the reflex mirror.</li> <li>3. No 3. : Remove the foreign matter and burr of the exposure window. (Developer cartridge)</li> <li>4. No. 4. : Open the front cover and check ribs that corresponds to the position of the voids. Remove if found.</li> <li>5. If the problems are not solved, replace the developer cartridge.</li> </ol>

### 7.3.3 Horizontal Black Band

- **Description** 1. Dark or blurry horizontal stripes occur in the printing periodically.  
(They may not occur periodically.)

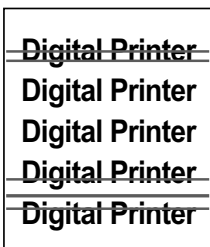

Check and Cause	Solution
1. Bad contacts of the voltage terminals to developer.  2. The rollers of developer may be stained. Charge roller = 37.7 mm Supply roller = 37 mm Develop roller = 35.3 mm Transfer roller = 45.3 mm	1. Clean each voltage terminal of the Charge, Supply, Develop and Transfer roller. (remove the toner particles and paper particles)  2. Clean the right Gear that has a relatively small gap of the teeth in the OPC.  3. If the malfunction persists, replace the developer.

### 7.3.4 Black/White Spot

- **Description** 1. Dark or blurry black spots occur periodically in the printing.  
2. White spots occur periodically in the printing.



Check and Cause	Solution
1. If dark or blurry black spots occur periodically, the rollers in the Developer may be contaminated with foreign matter or paper particles. ( Charge roller : 37.7 mm interval OPC drum : 75.5 mm interval)  2. If faded areas or voids occur in a black image at intervals of 75.5 mm, or black spots occur elsewhere, the OPC drum surface is damaged.  3. If a black image is partially broken, the transfer voltage is abnormal or the transfer roller's life has expired.	1. Run OPC cleaning Mode Print and run the Self-test 2 or 3 times.  2. In case of 75.5 mm interval unremovable in 1, cleanly remove foreign substances stuck on the OPC location equivalent to black spots and white spots with a dry duster.  3. The transfer roller guarantees 60,000 sheets printing. If the roller's life is expired, replace it.  4. In case of 37.7 mm interval unremovable in 1, take measures as to replace the developer cartridge and try to print out.  5. Clean the inside of the set against the paper particles and foreign matter in order not to cause the trouble.

### 7.3.5 Light Image

- **Description** The printed image is light, with no ghost.

Digital Printer  
 Digital Printer  
 Digital Printer  
 Digital Printer  
 Digital Printer

Check and Cause	Solution
1. Develop roller is stained when the toner of developer cartridge is almost consumed.	1. Check if the Toner Save Mode is off.
2. Ambient temperature is below than 10°C.	2. No 1 : Replace the developer cartridge and try to print out.
3. Bad contact caused by the toner stains between the high voltage terminal in the HVPS and the one in the set.	3. No 2 : Wait 30 minutes after printer is powered on before you start printing.
4. Abnormal output from the HVPS. (Run self-test and check 1~4)	4. No3 : Clean up the contaminated area by the toner.
	5. Replace the HVPS if the problems are not solved by the above four directions.

### 7.3.6 Dark Image or a Black

- **Description** The printed image is dark.

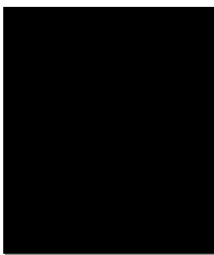

Check and Cause	Solution
1. No charge voltage in the Main PBA. ( Perform Engine Test Mode : Diagnostic code 4 HVPS check.)	1. Clean the high voltage charge terminal.
2. Charge voltage is not turned on due to the bad contacts between power supply in the side of the Developer and charge terminal of HVPS.	2. Check the state of the connector which connects the engine board and HVPS.
	3. If steps 1 and 2 above did not correct the problem, replace the HVPS .

### 7.3.7 Uneven Density

• **Description** Print density is uneven between left and right.

Digital Printer  
 Digital Printer  
 Digital Printer  
 Digital Printer  
 Digital Printer

Check and Cause	Solution
1. The pressure force on the left and right springs of the transfer roller is not even, the springs are damaged, the transfer roller is improperly installed, or the transfer roller bushing or holder is damaged.	1. Replace both the left and right Spring Holder.
2. The life of the Developer has expired.	2. Problem with the toner cartridge, replace the toner cartridge and try to print out.
3. The toner level is not even on the developer roller due to the bad blade.	

### 7.3.8 Background

• **Description** Light dark background appears in whole area of the printing.

Digital Printer  
 Digital Printer  
 Digital Printer  
 Digital Printer  
 Digital Printer

Check and Cause	Solution
1. Recycled recording paper has been used.	1. Quality is not guaranteed when using recycled paper.
2. The life of the Developer has expired.	2. Replace the toner cartridge.
3. The up-to-down movement of the transfer roller is swift?	3. Clean the busing on the transfer roller.
4. The HVPS is normal? (Perform Engine Test Mode diagnostic code 4)	4. Replace the HVPS.

### 7.3.9 Ghost (1)

- **Description** Ghost occurs at 75.5 mm intervals of the OPC drum in the whole printing.

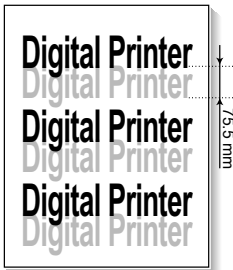

Check and Cause	Solution
1. Bad contacts caused by contamination from toner particles between high voltage terminal in the main body and the electrode of the Developer.	1. Clean the contaminated terminals.
2. Bad contacts caused by contamination from toner particles between high voltage terminal in the main body and the one in the HVPS board.	2. Problem in the toner cartridge, replace the toner cartridge and try to print out.
3. The life of developer is expired.	3. Replace the engine board if not solved by the above directions 1-2.
4. Transfer roller lifetime(60,000 sheets) has expired.	4. If not solved by the direction 3, check the transfer roller lifetime and replace it.
5. Abnormal low temperature(below 10°C).	5. Wait about 1 hour after power on before using printer.
6. Damaged cleaning blade in the developer.	6. Problem in the toner cartridge, replace the toner cartridge and try to print out.

### 7.3.10 Ghost (2)

- **Description** Ghost occurs at 75 mm intervals of the OPC drum in the whole printing. (When printing on card stock or transparencies using manual feeder)



Check and Cause	Solution
When printing on card stock thicker than normal paper or transparencies such as OHP, higher transfer voltage is required.	Select 'Thick Mode' on paper type menu from the software application and after use, we recommend returning to the original Mode.



### 7.3.11 Ghost (3)

• **Description** White ghost occurs in the black image printing at 35 mm intervals.



Check and Cause	Solution
<ol style="list-style-type: none"> <li>1. The life of the developer may be expired.</li> <li>2. The abnormal voltage and bad contact of the terminal of the supply roller</li> </ol>	<ol style="list-style-type: none"> <li>1. Problem in the toner cartridge, replace the toner cartridge and try to print out.</li> <li>2. Check the approved voltage of the supply roller and contact of the terminal and adjust if necessary.</li> </ol>

### 7.3.12 Ghost (4)

• **Description** Ghost occurs at 78 mm intervals.



Check and Cause	Solution
<p>The temperature of the fuser is maintained high.</p>	<ol style="list-style-type: none"> <li>1. Disassemble the fuser and remove the contaminated toner particles on the roller and clean the foreign matter between Thermistor and Heat roller. ( ▲ Caution: can be deformed)</li> </ol>

### 7.3.13 Stains on the front of the page

• **Description** The background on the face of the printed page is stained.



Check and Cause	Solution
<ol style="list-style-type: none"> <li>1. Toner leakage due to improperly sealed developer.</li> <li>2. If the transfer roller is contaminated, stains on the face of page will occur.</li> </ol>	<ol style="list-style-type: none"> <li>1. Replace the toner cartridge.</li> <li>2. If the transfer roller is contaminated, run PC Cleaning Mode Print 2 or 3 times. And perform Self-Test 2 or 3 times to remove contamination.</li> </ol>

### 7.3.14 Stains on back of the page

- **Description** The back of the page is stained at 56.1 mm intervals.

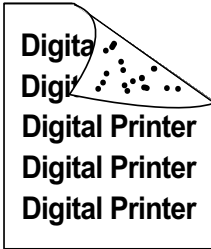

Check and Cause	Solution
1. Transfer roller is contaminated.	1. Perform the OPC Cleaning Mode Print 2 or 3 times. Run Self-Test to remove the contamination of the transfer roller.
2. Pressure roller is contaminated.	2. Replace the transfer roller if contaminated severely.
	3. Disassemble the fuser and clean the H/R(Heat Roller) and P/R(Pressure roller). And check the area between H/R and Thermistor. If contaminated, clean the area is should not be deformed.

### 7.3.15 Blank Page Print out (1)

- **Description** Blank page is printed.

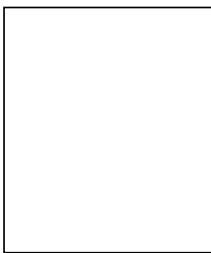

Check and Cause	Solution
Bad ground contacts in OPC and/or developer.	Remove contamination of the terminals of the toner cartridge and the printer.

### 7.3.16 Blank Page Print out (2)

- **Description**
  1. Blank page is printed.
  2. One or several blank pages are printed.
  3. When the printer turns on, several blank pages print.

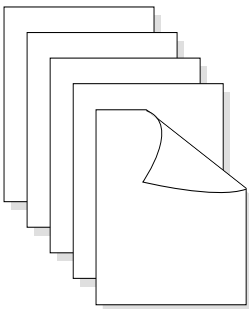

Check and Cause	Solution
1. Bad ground contacts in OPC and/or developer.	1. Remove contamination of the terminals of the toner cartridge.
2. Abnormal solenoid.	2. Perform the engine self test using Engine Test Mode diagnostic Mode code 0 if the Solenoid is normal.
	3. If not solved by the above directions 1-2, Replace the engine board.
	4. Turn the power off, clear the print job on the computer, and try printing again.

## 7.4 Fax & Phone Problems

### 7.4.1 No Dial Tone

- **Description** While on-hook button is pressed, there is no dial tone.

Check and Cause	Solution
<ol style="list-style-type: none"> <li>1. Check if the telephone line cord is connected to TEL LINE correctly.</li> <li>2. Check if it makes CLICK sound while OHD key is pressed.</li> <li>3. Check the connection of HARNESS between the LIU and the Main B'd.</li> <li>4. Check if the SPEAKER is connected correctly.</li> </ol>	<ol style="list-style-type: none"> <li>1. If the telephone cord is normal but there is no dial tone, then try to replace the LIU B'd.</li> <li>2. If you cannot hear the OHD CLICK sound, the OPE Ass'y may be defective. Try to replace the OPE Ass'y.</li> <li>3. Check the Speaker connection, and try to replace it.</li> <li>4. Lastly, try to replace the Main B'd.</li> </ol>

### 7.4.2 Defective MF DIAL

- **Description** The MF DIAL is not functioning.

Check and Cause	Solution
<ol style="list-style-type: none"> <li>1. Check if the telephone line is connected correctly.</li> <li>2. While the BUTTON KEY is pressed, check to catch a CLICK sound.</li> <li>3. Check the connection of HARNESS between the LIU and the Main PBA.</li> </ol>	<ol style="list-style-type: none"> <li>1. If you cannot catch the OHD CLICK sound, the OPE Ass'y may be defective. Try to replace the OPE Ass'y.</li> <li>2. If you can catch a CLICK sound, after checking the connection of HARNESS between the LIU and the Main PBA, try to replace the HARNESS.</li> <li>3. The problem still persists, then replace the LIU and the main B'd in sequence.</li> </ol> <p><b>Notes:</b> Product supports the MF DIAL type only.</p>

### 7.4.3 Defective FAX FORWARD/RECEIVE

- **Description** The FAX FORWARD/RECEIVE is not functioning.

Check and Cause	Solution
<ol style="list-style-type: none"> <li>1. Check if you can catch a dial tone by pressing OHD.</li> <li>2. Check if you can catch a RECEIVE tone while MODEM testing in the TECH Mode.</li> </ol>	<ol style="list-style-type: none"> <li>1. If the MODEM testing is normal and there is no dial tone, then try to replace the LIU B'd.</li> <li>2. If the MODEM testing is abnormal, try to replace the Main B'd.</li> </ol>

### 7.4.4 Defective FAX FORWARD

- **Description** RECEIVE is functioning, but FORWARD is not functioning or the received data are broken.

Check and Cause	Solution
<ol style="list-style-type: none"> <li>1. Check if there is NOISE when pressing on-hook dial.</li> <li>2. Check the RECEIVE condition by trying to forward a FAX to another fax machine from the forwarding side FAX.</li> <li>3. Check if the telephone line connected to the Product is contaminated or gets stripped off or down.</li> </ol>	<ol style="list-style-type: none"> <li>1. If it makes NOISE while using on-hook dial, replace or repair the telephone line.</li> </ol>

### 7.4.5 Defective FAX RECEIVE (1)

- **Description** FORWARD is functioning, but RECEIVE is not functioning or the received data are broken.

Check and Cause	Solution
<ol style="list-style-type: none"> <li>1. Check if there is NOISE when pressing on-hook dial.</li> <li>2. Check the RECEIVE condition by trying to receive a FAX at another fax machine.</li> </ol>	<ol style="list-style-type: none"> <li>1. If it makes NOISE while on-hooking, replace or repair the telephone line.</li> </ol>

### 7.4.6 Defective FAX RECEIVE (2)

- **Description** The received data are lengthened or cut in the printing.

Check and Cause	Solution
<ol style="list-style-type: none"> <li>1. Check if there is NOISE when pressing on-hook dial.</li> <li>2. Ask to the forwarding side, check the image quality of another machine receiving a FAX additionally sent to.</li> </ol>	<ol style="list-style-type: none"> <li>1. If it makes NOISE, rearrange the telephone line. (Refer to 'Defective FAX RECEIVE'.)</li> <li>2. Check if the FAX status of the forwarding side is also normal.</li> </ol>

### 7.4.7 Defective FAX RECEIVE (3)

- **Description** The phone is ringing continuously, but it cannot receive.

Check and Cause	Solution
<p>Check if the RECEIVE Mode is TEL MODE or FAX MODE.</p>	<p>Even when the RECEIVE Mode is changed to FAX MODE, it cannot receive, then replace the LIU and the Main B'd in sequence.</p>

### 7.4.8 Defective FAX RECEIVE (4)

- **Description** The received data is reduced by more than 50% in the printing.

Check and Cause	Solution
Check the FAX status of the forwarding side.	After checking the data of the forwarding side, correct the FAX of the forwarding side.

### 7.4.9 Defective Automatic Receiving

- **Description** The automatic receiving function is not working.

Check and Cause	Solution
1. Check if the RECEIVE Mode is TEL MODE or FAX MODE.	1. If the RECEIVE Mode is set to the TEL MODE, reset it to the FAX MODE.  2. Even after the RECEIVE Mode is changed to the FAX Mode, it cannot receive, then try to replace the LIU and the Main B'd in sequence.

## 7.5 Copy Problems

### 7.5.1 White Copy

- **Description** Blank page is printed out when copy.

Check and Cause	Solution
<ol style="list-style-type: none"> <li>1. Check the Scan-Cover open.</li> <li>2. Check shading profile.</li> <li>3. Check white/black reference voltage in Main PBA.</li> </ol>	<ol style="list-style-type: none"> <li>1. Room light ca transit a thin original.</li> <li>2. Remake shading profile in the tech mode.</li> <li>3. Replace U60 if it is defective.                             <ul style="list-style-type: none"> <li>• U60-154 = 0.5V</li> <li>• U60-155 = 3.3V</li> </ul> </li> </ol>

### 7.5.2 Black Copy

- **Description** Black page is printed out when Copy.

Check and Cause	Solution
<ol style="list-style-type: none"> <li>1. Check the CCD problem in Main PBA.</li> <li>2. Check shading profile.</li> </ol>	<ol style="list-style-type: none"> <li>1. Check the CCD harness contact.</li> <li>2. Remake shading profile in the tech mode.</li> </ol>

### 7.5.3 Abnormal noise

- **Description** There is noise when copy.

Check and Cause	Solution
<ol style="list-style-type: none"> <li>1. Check the Scanner Motor and any mechanical disturbance.</li> <li>2. Check the Motor Driver in Driver PBA.</li> </ol>	<ol style="list-style-type: none"> <li>1. Check the right position of the Scanner Motor, and check the any mechanical disturbance in the CCD carriage part.</li> <li>2. If any driver is defective, replace it.                             <ul style="list-style-type: none"> <li>• Connection PBA U4-1, 19 or U5-1, 19=0V to 24V swing signal when operating.</li> </ul> </li> </ol>

### 7.5.4 Defective Image Quality

- **Description** The copied image is light or bad.

Check and Cause	Solution
<ol style="list-style-type: none"> <li>1. Check shading profile.</li> <li>2. Check the gap between original and scanner glass.</li> <li>3. Check printing quality.</li> </ol>	<ol style="list-style-type: none"> <li>1. Remake shading profile in the tech mode.</li> <li>2. The gap above 0.5 mm can cause a blurred image.</li> <li>3. See "Print" troubleshooting.</li> </ol>



## 7.6 Scanning Problems

### 7.6.1 Defective PC Scan

- **Description** The PC Scan is not functioning at all.

Check and Cause	Solution
<ol style="list-style-type: none"> <li>1. Check the Cable (USB or Parallel)</li> <li>2. Check if the driver is installed properly.</li> <li>3. Check if copy function operates normally.</li> </ol>	<ol style="list-style-type: none"> <li>1. If the PC and the cable are not connected properly, reconnect it.</li> <li>2. After confirming that it is proper by performing a PC printing test related to driver setup, if it is not so, reinstall it. (Refer to User's Manual.)</li> <li>3. If copy function works, replace the Main PBA. If copy function doesn't work, replace the CCD Ass'y and try again.</li> </ol>

### 7.6.2 Defective Image Quality of PC Scan

- **Description** The image PC scanned is not clear or bad.

Check and Cause	Solution
<ol style="list-style-type: none"> <li>1. Check the waveform form by performing a CCD test in TECH Mode.</li> <li>2. Check if the resolution is set too low in PC Scan options. (Refer to User's Manual.)</li> </ol>	<ol style="list-style-type: none"> <li>1. If the CCD waveform form is abnormal, try to replace the CCD Ass'y.</li> <li>2. If the resolution is set to low, let the user be acquainted with the using method well.</li> </ol>

## 7.7 Toner Cartridge Service

It is not guaranteed for the default caused by using other toner cartridge other than the cartridge supplied by the Samsung Electronic or caused by non-licensed refill production.

### 7.7.1 Precautions on Safe-keeping of Toner Cartridge

Excessive exposure to direct light more than a few minutes may cause damage to the cartridge.

### 7.7.2 Service for the Life of Toner Cartridge

If the printed image is light due to the life of the toner, you can temporarily improve the print quality by redistributing the toner (Shake the toner cartridge), however, you should replace the toner cartridge to solve the problem thoroughly.

#### 7.7.2. 1 Redistributing Toner

When the toner cartridge is near the end of its life, white streaks or light print occurs. The LCD displays the warning message, "Toner Low." You can temporarily reestablish the print quality by redistributing the remaining toner in the cartridge.

1. Open the Front Cover.

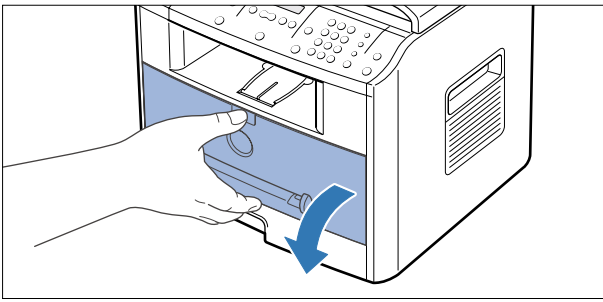

2. Lightly pushing the used cartridge down, pull it out.

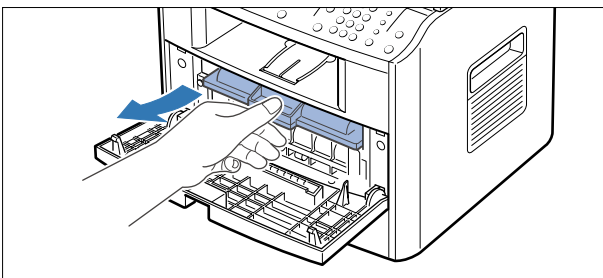

*Note : Help the environment by recycling your used toner cartridge. Refer to the recycling brochure packed with the toner cartridge for details.*

3. Unpack the new toner cartridge and gently shake it horizontally four or five times to distribute the toner evenly inside the cartridge.

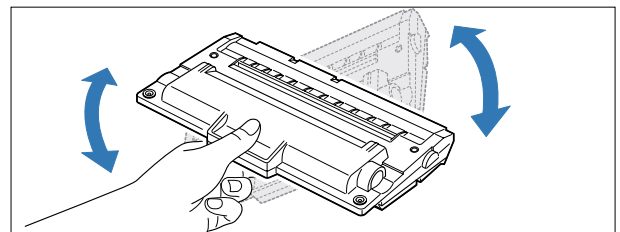

4. Save the box and the cover for shipping. Slide the new toner cartridge in until it locks into place.

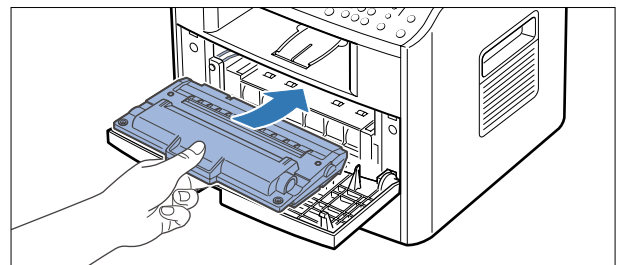

5. Close the front cover.

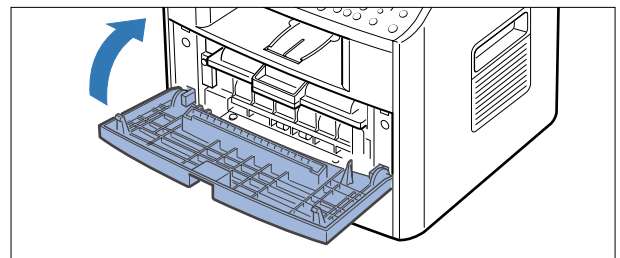

### 7.7.3 Service for Judgement of Inferior Expendables and the Standard of Guarantee

Please refer to User's Manual or Instructions on Fax/Printer Expendables SVC for the judgement of inferior expendables and the standard of guarantee besides this service manual.

### 7.7.4 Signs and Measures at Poor toner cartridge

Fault	Signs	Cause & Check	Solution
<p><b>Light image and partially blank image (The life is ended.)</b></p>	<ul style="list-style-type: none"> <li>• The printed image is light or unclean and untidy.</li> <li>• Some part of the image is not printed.</li> <li>• Periodically a noise as "tick tick" occurs.</li> </ul>	<ol style="list-style-type: none"> <li>1. If the image is light or unclean and untidy printed image - Shake the developer and then recheck.                             <ul style="list-style-type: none"> <li>(1)NG: Check the weight of the developer</li> <li>(2)OK: Lack of toner, so the life is nearly closed.</li> </ul> </li> <li>2. Some part of image is not printed - Shake the developer and then recheck.                             <ul style="list-style-type: none"> <li>(1)NG: Check the weight of the developer and clean the LSU window with a cotton swab, then recheck.</li> <li>(2)OK: Lack of toner, so the life is nearly closed.</li> </ul> </li> <li>3. Periodically a noise as "tick tick" occurs - Measure the cycle and the weight of the developer.</li> <li>4. White vertical stripes on the whole screen or partly : Check the weight of the developer.</li> </ol>	<ol style="list-style-type: none"> <li>1. All of 1, 2, 3 above-                             <ul style="list-style-type: none"> <li>(1)The weight of the developer ended: 800g ± 20g</li> <li>(2)If it become better by shaking, replace with a new developer after 50-100 sheets in the closing state of the life span.</li> </ul> </li> <li>2. In case of 2- If it becomes better after cleaning the LSU window, then the developer is normal. (Because of foreign substance on the LSU window, the image has not been printed partly.)</li> <li>3. In case of 3- If the cycle of noise is about 2 seconds, the toner inside the developer has been nearly exhausted.( Purchase and replace with a new developer after using about 200 sheets at the point of occurrence)</li> <li>4. In case of 3- This is a phenomenon caused by lack of toner, so replace with a new developer.</li> </ol>
<p><b>Toner Contamination</b></p>	<ul style="list-style-type: none"> <li>• Toner is fallen on the papers periodically.</li> <li>• Contaminated with toner on prints partly or over the whole surface.</li> </ul>	<ol style="list-style-type: none"> <li>1. Toner is fallen on the paper periodically.                             <ul style="list-style-type: none"> <li>(1)Check the cycle of the falling of the toner.</li> <li>(2)Check the appearance of both ends of the developer OPC drum.</li> </ul> </li> <li>2.The center of the printed matter is contaminated with toner.                             <ul style="list-style-type: none"> <li>(1)Check whether foreign substances or toner are stuck to the terminal (contact point) of the developer.</li> <li>(2)Check whether the state of the terminal assembly is normal.</li> </ul> </li> </ol>	<ol style="list-style-type: none"> <li>1. If both ends of the OPC drum are contaminated with toner: Check the life of the developer. (In case of less than 820g, the life may be expired.)</li> <li>2. Check whether it could be recycled.</li> <li>3. If it cannot be recycled: Replace the developer.</li> </ol>

Fault	Signs	Cause & Check	Solution
<p><b>White Black spot</b></p>	<ul style="list-style-type: none"> <li>• Light or dark black dots on the image occur periodically.</li> <li>• White spots occur in the image periodically.</li> </ul>	<ol style="list-style-type: none"> <li>1. If light or dark periodical black dots occur, this is because the developer rollers are contaminated with foreign substance or paper particles.                             <ol style="list-style-type: none"> <li>(1) 37.7 mm interval : Charged roller</li> <li>(2) 75.5 mm interval : OPC cycle</li> </ol> </li> <li>2. If white spots occur in a black image at intervals of 75mm, or black spots occur elsewhere, the OPC drum is damaged or foreign substance is stuck to the surface.</li> <li>3. If a black and white or graphic image is partially broken at irregular intervals, the transfer roller's life has been expired or the transfer voltage is abnormal.</li> </ol>	<ol style="list-style-type: none"> <li>1. In case of 1 above - Run OPC Cleaning Mode Print 4-5 times repeatedly to remove. Especially check foreign substance on the OPC surface, then remove them with a clean gauze moistened with IPA(Isopropyl Alcohol) not to damage OPC if necessary. <b>Never use usual alcohol.</b></li> <li>2. In case of 2 If they are not disappeared by running OPC Cleaning Mode Print 4-5 times. : at intervals of 37.7 mm - Replace the developer. : at intervals of 75.5 mm - Remove foreign substance. : Broken image - Replace the developer according to carelessness.</li> <li>3. In case of 3 - Exchange the transfer roller because the life of the transfer roller in use has been expired. (Check the transfer voltage and readjust if different.)</li> </ol>
<p><b>Recycled product</b></p>	<ul style="list-style-type: none"> <li>• Poor appearance of the developer.</li> <li>• Unclean and rough printouts.</li> <li>• Bad background in the image.</li> </ul>	<ol style="list-style-type: none"> <li>1. Poor appearance of the developer.                             <ol style="list-style-type: none"> <li>(1) Check the damage to label and whether different materials are used.</li> <li>(2) Check the appearance of parts of the developer, such as frame, hopper.</li> </ol> </li> <li>2. Unclean and rough printouts.                             <ol style="list-style-type: none"> <li>(1) Check whether foreign substance or toner are stuck to the terminal (contact point) of the developer.</li> <li>(2) Check whether the state of the terminal assembly is normal.</li> </ol> </li> </ol>	<ol style="list-style-type: none"> <li>1. In case of 1 -                             <ol style="list-style-type: none"> <li>(1) If there is an evidence of disassembling the developer.</li> <li>(2) If materials other than normal parts of the developer are added or substituted.</li> </ol> </li> <li>2. In case of 2 - If there are any abnormal in connection with the situation of 1.                             <ol style="list-style-type: none"> <li>(1) It occurs when the developer is recycled over 2 times.</li> <li>(2) If toner nearly being expired are collected to use, it is judged as the recycled developer.</li> </ol> </li> </ol>

Fault	Signs	Cause & Check	Solution
<p><b>Ghost &amp; Image Contamination</b></p>	<ul style="list-style-type: none"> <li>• The printed image is too light or dark, or partially contaminated black.</li> <li>• Totally contaminated black. (Black image printed out)</li> <li>• The density of print-outs is too dark and ghost occurs.</li> </ul>	<ol style="list-style-type: none"> <li>1. The printed image is too light or dark, or partially contaminated black.               <ol style="list-style-type: none"> <li>(1) Check whether foreign substance or toner are stuck to the terminal (point of contact) of the developer.</li> <li>(2) Check whether the terminal assembly is normal.</li> </ol> </li> <li>2. Totally contaminated black. (Black image printed out)               <ol style="list-style-type: none"> <li>(1) Check whether foreign substances are stuck to the terminal (point of contact) of the developer and the state of assembly. (Especially check the charged roller terminal.)</li> </ol> </li> <li>3. The printed image is dark and ghost occurs.               <ol style="list-style-type: none"> <li>(1) Check foreign substance attached to the terminal (point of contact) of the developer and the state of assembly. (Especially check the developing roller terminal.)</li> </ol> </li> </ol>	<ol style="list-style-type: none"> <li>1. All of 1, 2, 3 above               <ol style="list-style-type: none"> <li>(1) Remove toner and foreign substances adhered to the contact point of the developer.</li> <li>(2) The contact point of the unit facing that of the developer also must be cleaned.</li> <li>(3) If the terminal assembly is unsafe:                   <ul style="list-style-type: none"> <li>• Fully stick the terminal to or reassemble it after disassembling.</li> <li>• Disassemble the side plate and push the terminal to be stuck, then reassemble it.</li> </ul> </li> </ol> </li> <li>2. In case of 2 It is a phenomenon when the OPC drum of the developer is not electrically charged. Clean the terminals of the charged roller, then recheck it.</li> <li>3. In case of 3 It is a phenomenon as the developing bias voltage of the developer. Clean the terminals of the developing roller, then recheck it.</li> </ol>

## 7.8 Network Problems Troubleshooting

### 7.8.1 General Problems

Problem	Solution
System does not function with some wrong values entered by mistake while configuring.	Possibly the parameters in PortThru are corrupted. Restart the system and set to factory defaults on the printer front panel or on your computer using SyncThru.
Not able to access from SNMP Manager. SyncThru is unable to automatically detect print servers.	Try pinging from the same system on which SNMP manager is running. If it does not succeed, there must be a problem with network connectivity between the manager and PortThru. If ping succeeds, verify that community names with sufficient permissions have been used.
SyncThru is unable to automatically detect print servers.	Check the environment as described in Auto Detection of Print Server. Check NetWare file server consoles for error messages regarding nodes with conflicting network numbers.
You cannot see any of DHCP server, BOOTP server or RARP server, when you want to set IP address to print server.	On Network Interface in SyncThru, you should set "Static" to "IP Address Assignment Method" in TCP/IP tab. You should set IP address, Subnet Mask and Default Gateway to print server.
Print server does not print using TCP/IP protocol.	1. Check whether TCP/IP protocol is installed in your PC. 2. Check whether your PC is on the same network with print server.
Unable to print in NetWare environment.	Use SyncThru to see if PortThru indicates that queue is serviceable. If not, the login permissions may have changed or the configuration information for queues, printers and print servers may have been changed. Verify using PCONSOLE and NWADMIN that the configuration is correct and check the job queue to see if the print job exists. Check that NetWare is enabled on PortThru. Check that the Check Job every is configured on PortThru.
The status of printer is displayed 'unknown' in SyncThru.	1. Check the protocol of your PC and install DLC/LLC or IPX/SPX protocol. 2. Assign IP Address to PortThru using the front panel.
The name of printer is displayed empty while adding a port and the printer doesn't function.	1. Check the protocol of your PC and install DLC/LLC or IPX/SPX protocol. 2. Assign IP Address to PortThru using the front panel.

### 7.8.2 Macintosh Problems

Problem	Solution
The printer name is not displayed in the Chooser.	<ol style="list-style-type: none"> <li>1. Make sure the printer is connected to network correctly.</li> <li>2. Make sure the printer is configured in SyncThru using the new name.</li> <li>3. After turning on the printer, wait 3 minutes, then check it again.</li> <li>4. Make sure that your Macintosh is connected to the network through Ethernet.</li> <li>5. When the Macintosh and network printer are in the same network, check above items again. Otherwise check whether the router can support AppleTalk protocol. If the router can not support the AppleTalk protocol, then ask the network manager to solve this problem.</li> </ol>
The printer drops letters.	<ol style="list-style-type: none"> <li>1. Make sure the PS option is installed in your printer correctly.</li> <li>2. Make sure the SIMM provided with PS option is installed correctly. Check that the total memory is 12MB by printing a self-test page.</li> </ol>

### 7.8.3 Windows Problems

Problem	Solution
After installing PortThru, the print server name is not displayed under New Print Server in SyncThru.	<ol style="list-style-type: none"> <li>1. Verify that the printer power switch is turned on and the 'READY' message is displayed on the printer front panel.</li> <li>2. Verify that the LAN cable is plugged into the PortThru card.</li> <li>3. Verify that the second LED on the PortThru card blinks. <ul style="list-style-type: none"> <li>• If the second LED blinks regularly, turn off the printer, then turn it back on. If the problem continues, contact your local dealer.</li> <li>• If the first LED on the PortThru card does not blink, check that the card is installed snugly. If the problem continues, contact your local dealer.</li> </ul> </li> <li>4. Confirm whether the print server and the PC which searches for the New Print Server is on the same LAN. If you want to search for a New Print Server, your PC and the print server should be on the same LAN.</li> </ol>
The print server name is displayed, but the test page is not printed.	Select the Network menu from the front panel menus. Check that the test page is printed. If the Network menu is not displayed, or the test page is not printed, turn off the printer, then turn it back on.
Firmware upgrade process is completed. But upgrading is not executed.	<p>An IP address should be assigned to upgrade the Firmware.</p> <p>Make sure that IP address is entered in Print Server.</p> <p>If an IP address is not entered, reassign it and try again.</p>

Problem	Solution
SyncThru is unable to automatically detect printers.	<ol style="list-style-type: none"> <li>1. Check LAN cable is connected to the printers.                             <ul style="list-style-type: none"> <li>• Check LAN cable is connected to the printers yourself.</li> <li>• Make sure that there are the connected printers shown in network neighborhood. If not, check the communication status of the printers.</li> <li>• If IP address is assigned to the computers, try ping command.</li> </ul> </li> <li>2. If the protocols of NPC are disabled, DLC/LLC should be installed in the computers.                             <ul style="list-style-type: none"> <li>• If SyncThru is unable to detect printers with DLC/LLC installed in the computers, check whether NPC and PC are on the same LAN.</li> <li>• If LAN is connected by routers, SyncThru is unable to detect the printers.</li> </ul> </li> <li>3. If more than one of the protocols of NPC are enabled and DLC/LLC is installed in the computers, check NPC and PC are on the same LAN.                             <ul style="list-style-type: none"> <li>• If LAN is connected by routers, SyncThru is unable to detect the printers. In this case, one of protocols which are enabled in NPC should be installed in the computers.</li> </ul> </li> <li>4. In case that the protocol which is enabled in NPC is installed in the computers:                             <ul style="list-style-type: none"> <li>• If TCP/IP installed, check entry values of IP address, subnet mask and default gateway.</li> </ul> </li> </ol>
The printer does not print.	Try Add a Port.

### 7.8.4 SyncThru Installation Problems

Problem	Solution
"File Transfer Error" message appears when you execute Installation.	<ol style="list-style-type: none"> <li>1. Make sure the previously installed SyncThru is uninstalled.</li> <li>2. If the SyncThru is uninstalled, restart your PC.</li> <li>3. If the problem continues, In Windows 95/98, delete the "sammon.dll" file in the system directory of Windows in MS-DOS mode, restart Windows and reinstall it. In Windows NT, stop the spooler service with 'Services' in Control Panel, delete the "sammon.dll" file in the system32 directory of Windows NT, start spooler service and reinstall it.</li> </ol>
'Unable to add the Port list of Samsung ports' message appears, when you add a port.	Verify that your PC restarts after installing SyncThru.



# 8. Exploded Views and Parts List

- 8.1 Main Assembly Exploded view ..... page(8-2)
- 8.2 Rx Drive Ass'y Exploded view ..... page(8-5)
- 8.3 ADF Assembly Exploded view ..... page(8-6)
- 8.4 OPE Assembly Exploded view ..... page(8-10)
- 8.5 Scanner Assembly Exploded view ..... page(8-12)
- 8.6 Middle Cover Assembly Exploded view ..... page(8-14)
- 8.7 Frame Ass'y Exploded view ..... page(8-15)
- 8.8 Fuser Ass'y Exploded view ..... page(8-18)
- 8.9 Cassette Ass'y Exploded view ..... page(8-21)
- 8.10 SCF(Option Cassette Frame) Exploded view ..... page(8-23)

- Deal drawings and service parts are declared for the items with higher rate of inferiority and replaceable in the level of service description only.
- If inferiority occurs, you can replace the parts by the unit declared in deal drawings and service items.

### Way to observe Part Code & Description

Part code and Description is quoted and controlled by determined standard. Refer to this determined standard, it will help with ordering Part.

- There are two kinds of Part code inscription type.

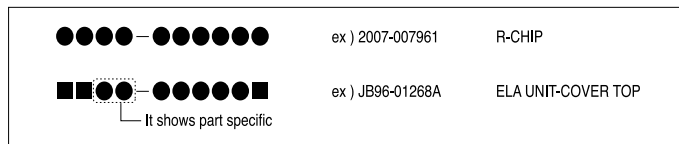

( ● : figure, ■ : character (alphabet) )

**Type 1** : Controlled by Company : It can be commonly used for all kinds of product SEC produce. Mostly, electronics Parts.

**Type 2** : Controlled by Division : It is used or one produce. Mostly, Mostly, mechanical Parts.

- **A/S privately used part** : It is only used for A/S .
- **Ass'y part** : Assembled by more than 2 Parts. If necessary part is not A/S Part, Ass'y part including necessary par can be used. It is shown in the diagram and drawing of SVC manual.
- Ass'y part and A/S privately used Part is distinguished by part Code and Description. The are inscription type 2. It is recognized by Part character and front side of description.

DIVISION	PART CODE	DESCRIPTION
A/S Private	**81-***** (JB81-00039A)	AS-***** (AS-USE)
ASS'Y Part	**75-***** (JB75-00068A)	MEC-***** (MEC-CHUTE)
ASS'Y Part	**92-***** (JB92-01131A)	PBA ***** (PBA MAIN-CONTROLLER)
ASS'Y Part	**97-***** (JB97-01089A)	MEA ***** (MEA UNIT-PULLEY IDLE)

# 8.1 Main Assembly

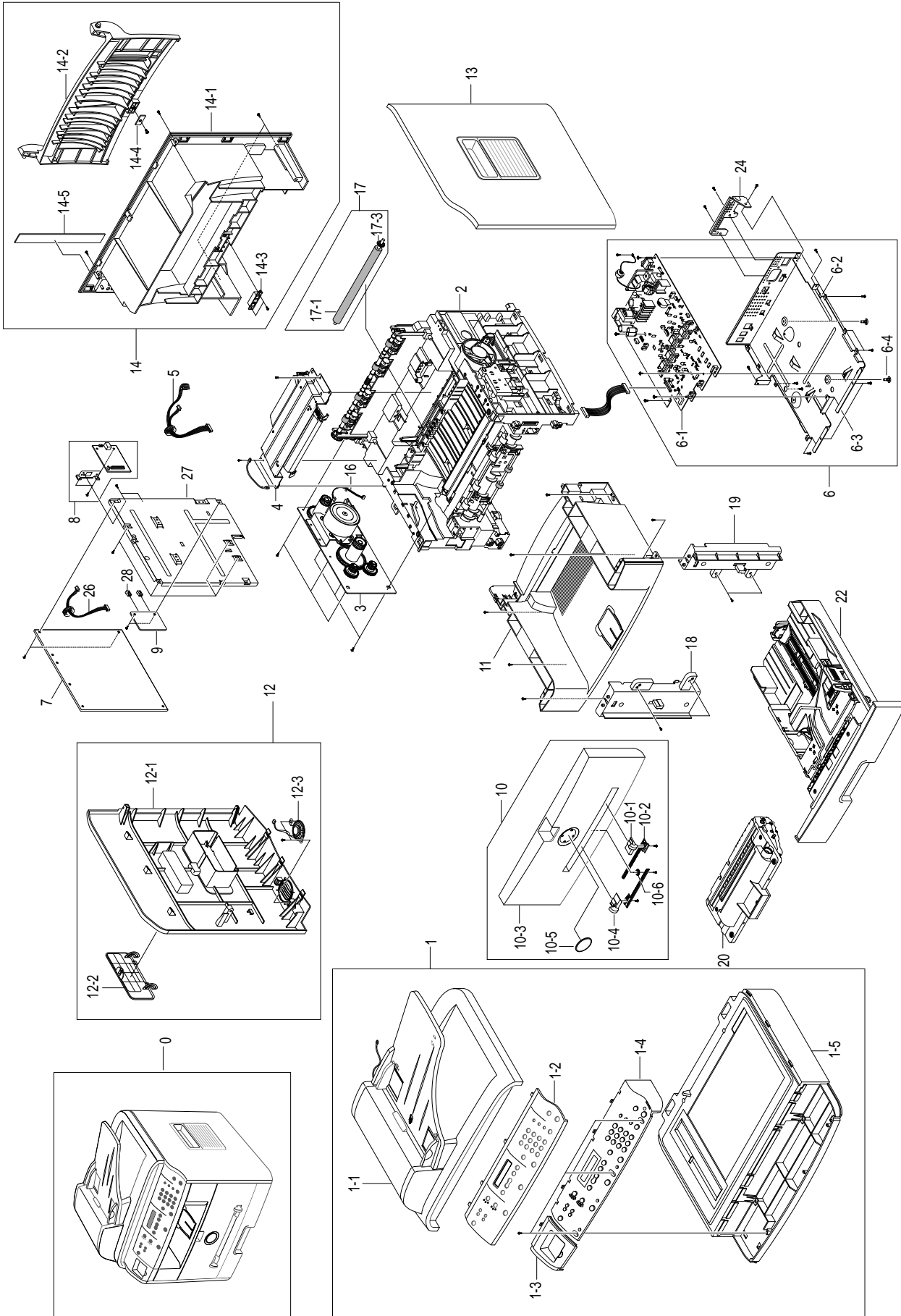

## Main Assembly Parts List

SA : Service Available

O : Service available X : Service not available

No.	Description	SEC.Code	Q'ty	SA	Remark
0	MFP 1600n	SCX-4920N/DEH			
	MFP 1600n	SCX-4920N/DEL			
	MFP 1600n	SCX-4920N/DLH			
	MFP 1600n	SCX-4920N/DLL			
	MFP 1600n	SCX-4920N/DTH			
	MFP 1600n	SCX-4920N/DTL			
1	ELA HOU-UNIT SCAN	JC96-03080A	1	X	
1-1	ELA HOU-ADF	JC96-03604A	1	O	
1-2	COVER-OPE DUMMY R2	JC63-00377A	1	O	
1-3	COVER-OPE POCKET	JC63-00378A	1	O	
1-4	ELA HOU-OPE	JC96-03070A	1	O	
1-5	ELA HOU-PLATEN	JC96-03067A	1	O	
2	ELA UNIT-FRAME DELL	JC96-03098A	1	O	
3	ELA UNIT-RX DRIVE	JC96-03078A	1	O	
4	UNIT-HUMMINGBIRD LSU	JC59-00018B	1	O	
5	CBF HARNESS-LSU	JC39-00321A	1	O	
6	ELA HOU-SHIELD ASS'Y LV, 110V	JC96-03107A	1	O	⚠ 110V
6-1	ELA HOU-SHIELD ASS'Y HV, 220V	JC96-03108A	1	O	⚠ 220V
	SMPS-SMPS(V1)+HVPS, 110V	JC44-00070A	1	O	⚠ 110V
	SMPS-SMPS(V2)+HVPS, 220V	JC44-00071A	1	O	⚠ 220V
6-2	MEA UNIT-SHIELD ENGINE	JC97-01794A	1	O	
6-3	SHIELD-ENGINE R2	JC63-00399A	1	X	
6-4	SUPPORTER	6103-001056	2	X	
7	PBA MAIN-MAIN CONTROLLER	JC92-01601A	1	O	
8	ELA HOU-NPC3_PRT	JC96-02906A	1	O	
8-1	PBA SUB-NPC3_PRT	JC92-01466A	1	X	
8-2	BRA CKET-NPC	JC61-00809A	1	X	
9	MODULAR JACK ASSY	JC92-01607A	1	O	
10	MEA UNIT-COVER FRONT	JC97-01933A	1	O	
10-1	ADJUST-MANUAL R_R2	JC70-00475A	1	X	
10-2	ADJUST RACK-M-MANUAL	JC70-00304A	2	X	
10-3	COVER-FRONT R2	JC63-00389A	1	X	
10-4	ADJUST-MANUAL L_R2	JC70-00474A	1	X	
10-5	GEAR-RACK_PINION	JC66-00387A	1	X	
11	MEA UNIT-COVER MIDDLE	JC97-01932A	1	O	
12	ELA HOU-COVER SIDE L	JC96-09079A	1	O	
12-1	COVER-SIDE L_R2	JC96-03079A	1	X	
12-2	COVER-DIMM R2	JC63-00390A	1	X	
12-3	SPEAKER	3001-001293	1	X	

## Main Assembly Parts List

SA : Service Available

O : Service available X : Service not available

No.	Description	SEC.Code	Q'ty	SA	Remark
13	COVER-SIDE R_R2	JC63-00384A	1	O	
14	MEA UNIT-COVER REAR	JC97-01934A	1	O	
14-1	COVER-REAR R2	JC63-00392A	1	X	
14-2	COVER-FACE UP R2	JC63-00393A	1	O	
14-3	MAGNETIC CATCH	JC61-00961A	1	X	
14-4	COUNTER PART	JC61-00962A	1	X	
14-5	LABEL-PORT(REAR-COVER)/330	JC68-01345A	1	X	
15	BADGE-DELL	JC64-00131A	1	O	
16	CBF HARNESS-MOTOR	JC39-00241A	1	O	
17	MEA ETC TR	JC97-01917A	1	O	
17-1	ROLLER-TRANSFER R2	JC66-00703A	1	X	
17-2	GEAR-TRANSFER	JC66-00395A	1	X	
18	COVER-MIDDLE FRONT L	JC63-00386A	1	O	
19	COVER-MIDDLE FRONT R	JC63-00387A	1	O	
20	PBA SUB-LIU	JC96-01607A	1	O	
22	MEA UNIT-CASSETTE, USA	JC97-01919A	1	O	
23	CBF HARNESS-ENGINE	JC39-00240C	1	O	
24	BRACKET-P-INLET, ROCKY	JC61-00693A	1	O	
26	CBF HARNESS MODULA JACK	JC39-00144A	1	O	
27	SHIELD-CONTROLLER R2	JC63-00400A	1	O	
28	COVER-DUMMY JACK	JC63-00509A	1	O	

## 8.2 RX Drive Assembly

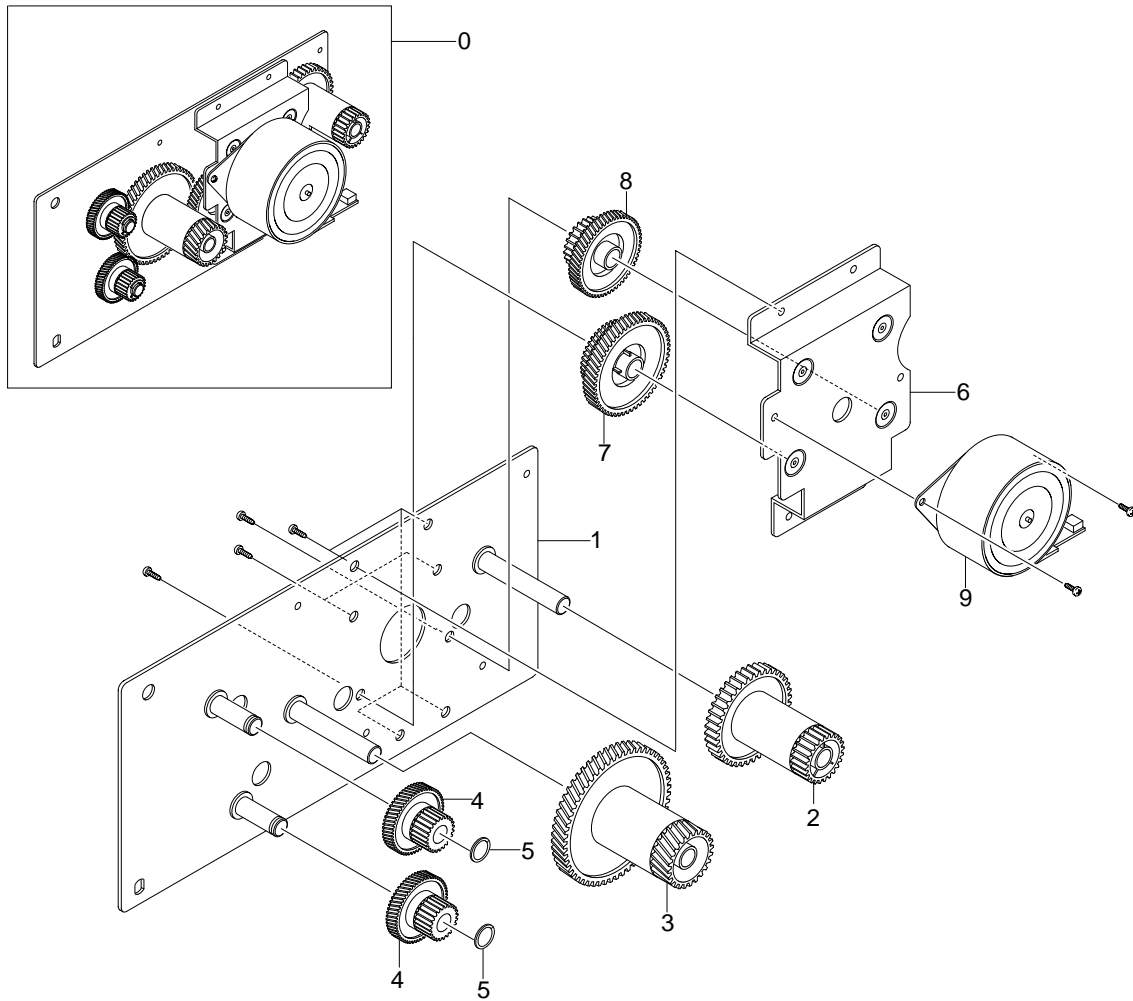

### RX Drive Assembly Parts List

**SA : Service Available**  
 O : Service available X : Service not available

No.	Description	SEC.Code	Q'ty	SA	Remark
0	ELA UNIT-RX DRIVE	JC96-03078A	1	O	
1	BRACKET-GEAR MAIN	JC61-00891A	1	X	
2	GEAR-RDCN 53/26	JC66-00388A	1	X	
3	GEAR-RDCN 113/33	JC66-00706A	1	X	
4	GEAR-RDCN 57/18	JC66-00389A	2	X	
5	WASHER-PLAIN	6031-000023	2	X	
6	BRACKET-MOTOR MAIN R2	JC61-00916A	1	X	
7	GEAR-RDCN 103/41	JC66-00390A	1	X	
8	GEAR-RDCN 90/31	JC66-00392A	1	X	
9	MOTOR STEP-MAIN	JC31-00037A	1	O	

# 8.3 ADF Assembly

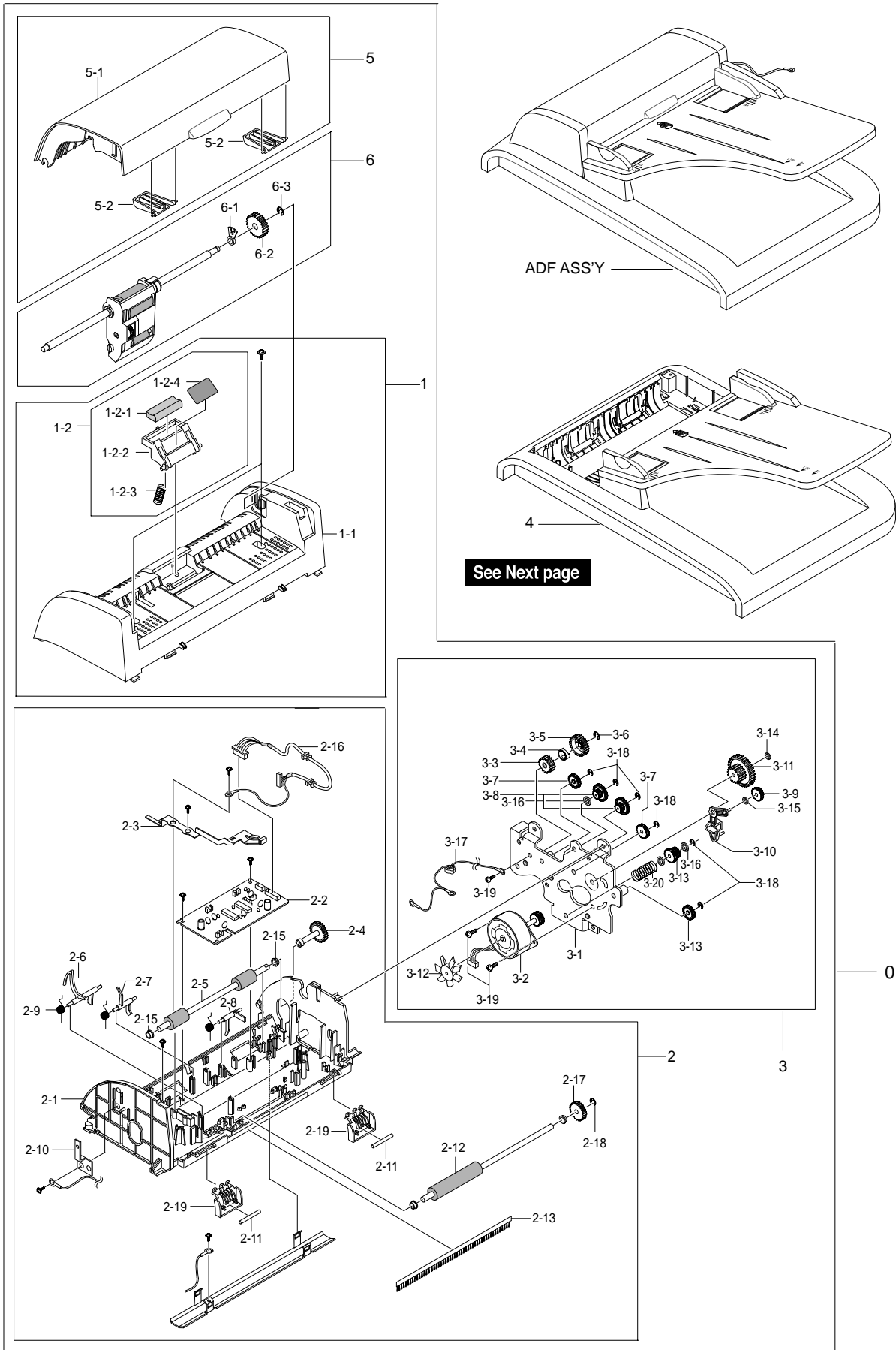

# ADF Assembly Continued.

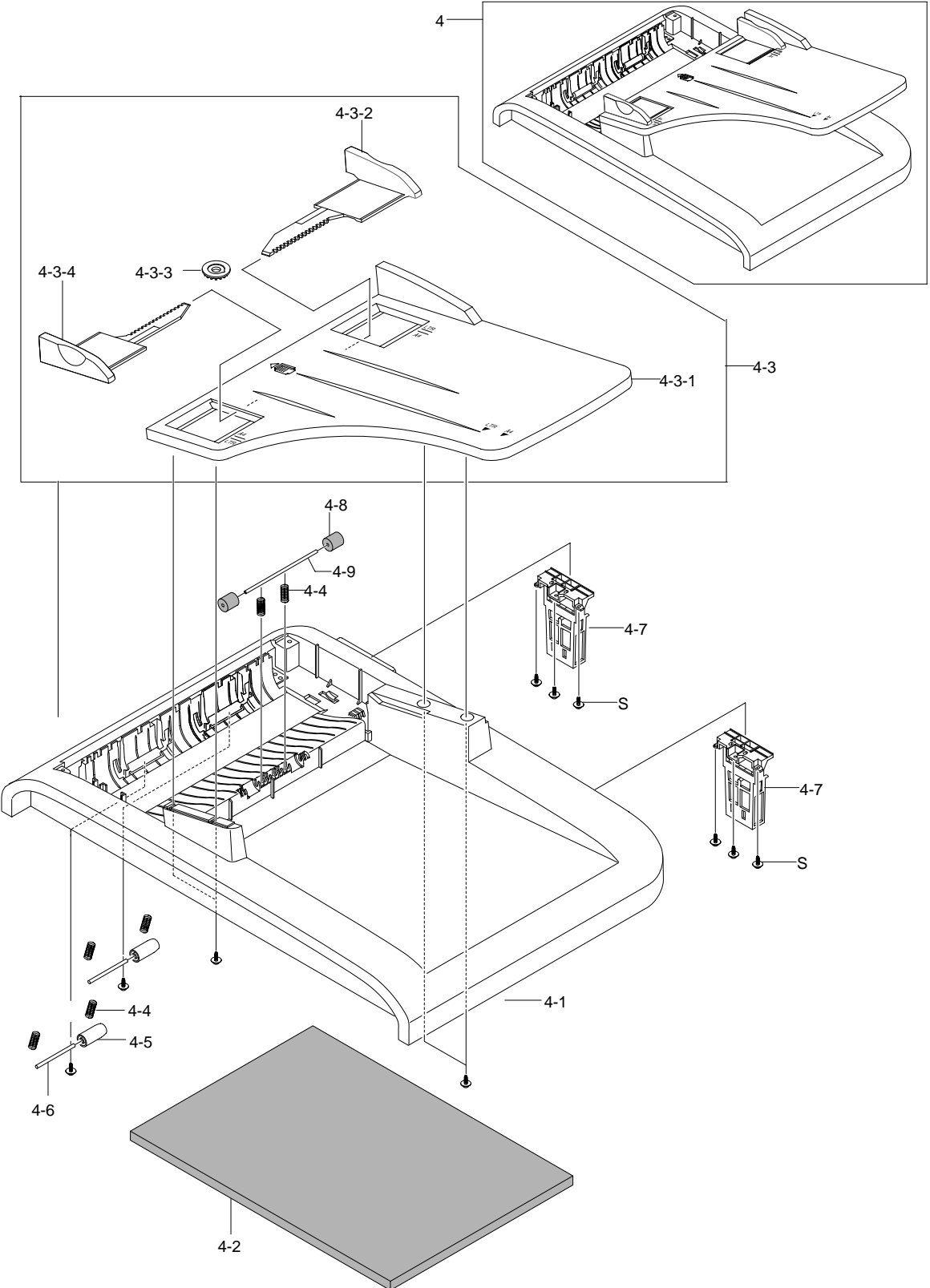

## ADF Assembly Parts List

SA : Service Available  
 O : Service available X : Service not available

No.	Description	SEC.Code	Q'ty	SA	Remark
0	ELA HOU-ADF-ENGINE	JC96-03133A	1	O	
1	MEA UNIT-ADF UPPER	JC97-01939A	1	O	
1-1	COVER-ADF UPPER R2	JC63-00450A	1	X	
1-2	MEA UNIT-HOLDER ADF	JC97-01940A	1	O	
1-2-1	RMO-ADF RUBBER	JB73-00052A	1	X	
1-2-2	HOLDER-PAD ADF	JC61-00893A	1	X	
1-2-3	SPRING ETC-PAD	JC61-00387A	1	X	
1-2-4	SHEET-ADF HOLDER	JC63-00373A	1	X	
2	ELA HOU-ADF LOWER	JC96-03066A	1	X	
2-1	COVER-ADF LOWER R2	JC63-00370A	1	X	
2-2	PBA SUB-ADF	JC92-01618A	1	O	
2-3	GROUND-ADF R2	JC63-00372A	1	X	
2-4	SHAFT-M-FEED GEAR 38	JC66-00460A	1	X	
2-5	ROLLER-DRIVE	JC66-00560A	1	X	
2-6	PMO-ACT EMPTY ADF	JC72-01320A	1	O	
2-7	PMO-ACTUATOR REGI SENSOR	JC72-01010A	1	O	
2-8	PMO-ACTUATOR SCAN SENSOR	JC72-01011A	1	O	
2-9	SPRING ETC-TORSION DOC (CC2-F)	JB61-00076A	3	X	
2-10	IPR-GROUND_ROLLER	JC70-10467A	1	X	
2-12	ROLLER-EXIT	JC66-00559A	1	X	
2-13	MEC-BRUSH ANTISTATIC	JC75-00095A	1	X	
2-14	PPR-WHITE BAR SHEET	JC72-00752A	1	X	
2-15	PMO-BUSH	JB72-00819A	4	X	
2-16	CBF HARNESS-ADF	JC39-00278A	1	X	
2-17	GEAR-AGITATOR-2	JC66-00310A	1	X	
2-18	RING-C	6044-000159	1	X	
2-19	GUIDE-STACKER SUB	JC61-00712A	2	X	
2-20	CBF HARNESS ADF ROLLER GND	JC39-00187A	1	X	
2-21	IPR-BRKT WHITE BAR	JC70-00225A	1	X	
2-22	SPRING ETC WHITE BAR	JC61-00548A	2	X	
3	ELA HOU-ADF MOTOR	JC96-03065A	1	O	
3-1	BRACKET-GEAR ADF	JC61-00892A	1	X	
3-2	MOTOR BLOWER-ADF	JC31-00023A	1	X	
3-3	GEAR-CLUTCH 29	JB66-00101A	1	O	
3-4	PMO-WHITE CLUTCH SUB 29	JB72-00844A	1	X	
3-5	GEAR-CLUTCH 39	JC66-00322A	1	X	
3-6	RING-C	6044-000159	1	X	
3-7	GEAR-IDLE 35 ADF	JC66-00458A	2	X	
3-8	GEAR-40/21 ADF	JC66-00456A	1	X	



## ADF Assembly Parts List(cont.)

SA : Service Available

O : Service available X : Service not available

No.	Description	SEC.Code	Q'ty	SA	Remark
3-9	GEAR-SWING 31/20 ADF	JC66-00457A	1	X	
3-10	LINK-M-SWING ADF	JC66-00454A	1	X	
3-11	GEAR-58/25 ADF	JC66-00455A	1	X	
3-12	IMPELLER-ADF	JC66-00556A	1	X	
3-13	GEAR-REMOVE ADF	JC66-00557A	1	X	
3-15	IPR-WASHER WAVE	JB70-00070A	1	X	
3-16	WASHER-PLAIN	6031-000019	3	X	
3-17	CBF HARNESS-MOTOR GROUND	JC39-00355A	1	X	
3-18	RING-E	6044-000125	6	X	
3-19	SCREW-TAPTITE	6003-000269	3	X	
4	MEA UNIT-COVER PLATEN	JC97-01937A	1	O	
4-1	COVER-PLATEN R2	JC63-00374A	1	O	
4-2	SHEET-WHITE SPONGE	JC63-00209A	1	O	
4-3	MEA-TX STACKER	JC97-01938A	1	O	
4-3-1	COVER-STACKER TX	JC63-00457A	1	X	
4-3-2	GUIDE-DOC L	JC61-00958A	1	X	
4-3-3	GEAR-PINION	JG66-40003A	1	X	
4-3-4	GUIDE-DOC R	JC61-00959A	1	X	
4-4	SPRING ETC-FEED	JC61-00011A	6	O	
4-5	PMO-ROLL PINCH	JG72-40663A	2	O	
4-6	ICT-SHAFT PINCH	JF70-40521B	1	O	
4-7	MEA UNIT-HINGE	JC97-01707A	2	O	
4-8	RPR-ROLLER EXIT IDLE	JC66-00728A	2	O	
4-9	SHAFT-IDLE FEED	JC66-00558A	2	O	
5	MEA UNIT-COVER OPEN	JC97-01936A	1	O	
5-1	COVER-ADF OPEN R2	JC63-00498A	1	X	
5-2	PMO-GUIDE PAPER	JB72-00843A	2	X	
5-3	DAMPER-PICKUP ADF	JC66-00726A	1	X	
6	MEA UNIT-PICKUP	JC97-01962A	1	O	
6-1	PMO-BUSHING WHITE	JF72-41306A	1	X	
6-2	GEAR-ADF 38	JB66-00103A	1	X	
6-3	RING-C	6044-000159	1	X	

## 8.4 OPE Unit Assembly

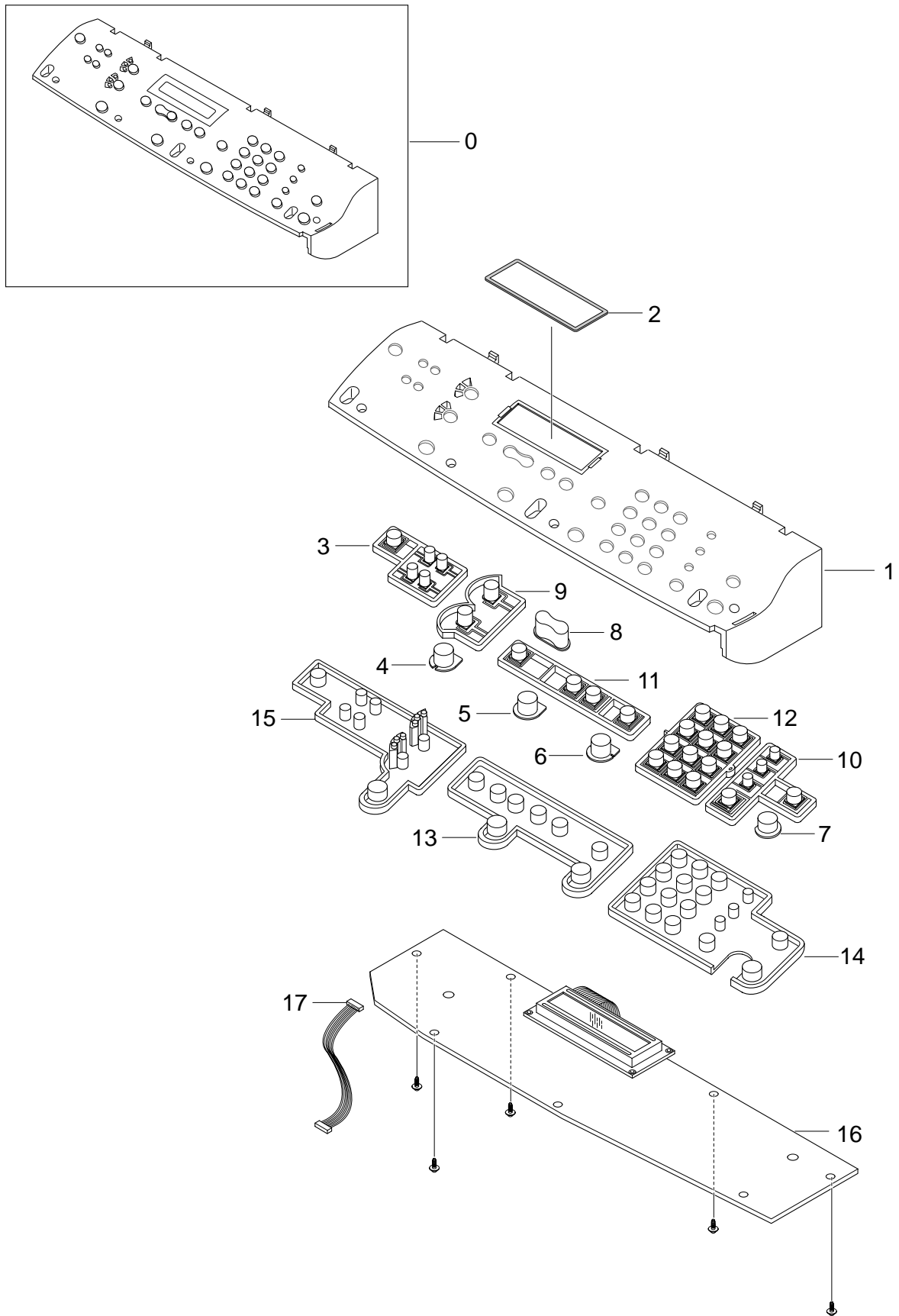

## OPE Unit Assembly Parts List

SA : Service Available

O : Service available X : Service not available

No.	Description	SEC.Code	Q'ty	SA	Remark
0	ELA HOU-OPE	JC96-03070A	1	O	
1	COVER-OPE R2_DELL	JC63-00376A	1	O	
2	WINDOW-LCD	JC64-00130A	1	O	
3	KEY-COPY_DELL	JC64-00120A	1	O	
4	KEY-START COPY	JC64-00126A	1	O	
5	KEY-CANCEL	JC64-00127A	1	O	
6	KEY-SEND FAX	JC64-00128A	1	O	
7	KEY-START SCAN	JC64-00129A	1	O	
8	KEY-SCROLL_DELL	JC64-00123A	1	O	
9	KEY-QUALTY	JC64-00121A	1	O	
10	KEY-FAX_DELL	JC64-00125A	1	O	
11	KEY-MENU	JC64-00122A	1	O	
12	KEY-TEL_DELL	JC64-00124A	1	O	
13	RUBBER-SCROLL_DELL	JC73-00176A	1	O	
14	RUBBER-TEL/FAX_DELL	JC73-00177A	1	O	
15	RUBBER-COPY_DELL	JC73-00178A	1	O	
16	PBA SUB-OPE	JC92-01503A	1	O	
S	SCREW-TAPTITE	6003-000196	7	X	

## 8.5 Scanner Assembly

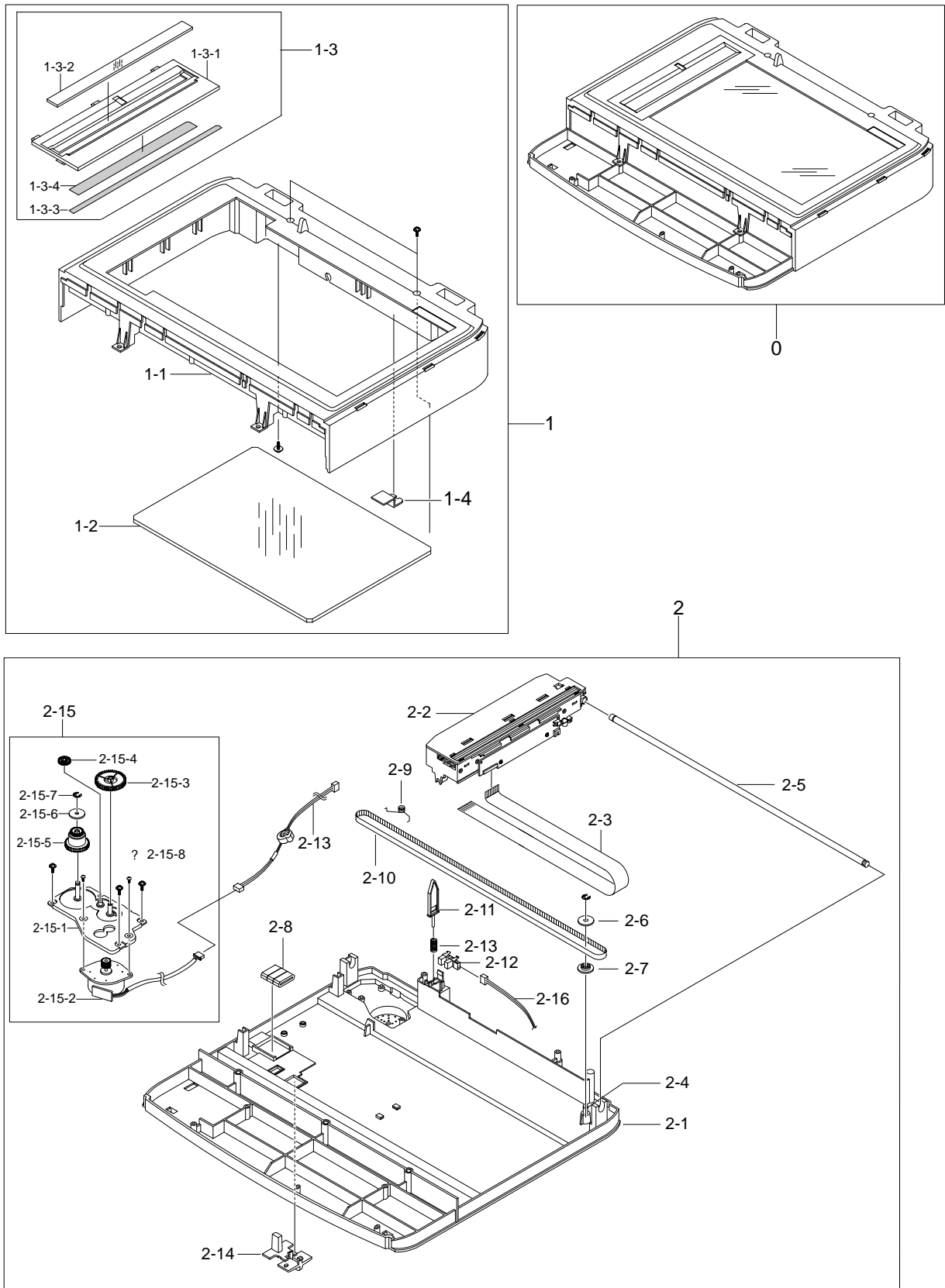

## Scanner Assembly Parts List

SA : Service Available

O : Service available X : Service not available

No.	Description	SEC.Code	Q'ty	SA	Remark
0	ELA HOU-PLATEN	JC96-03067A	1	O	
1	MEA UNIT-SCAN UPPER	JC97-01942A	1	O	
1-1	COVER-SCAN UPPER DELL	JC63-00380A	1	O	
1-2	GLASS-SCAN	JC01-00001A	1	O	
1-3	MEA UNIT-SCAN DUMMY	JC97-01941A	1	O	
1-3-1	COVER-SCAN DUMMY R2	JC63-00456A	1	O	
	COVER-SCAN DUMMY R2	JC63-00377B	1	O	French
	COVER-SCAN DUMMY R2	JC63-00377C	1	O	Spanish
	COVER-SCAN DUMMY R2	JC63-00377D	1	O	German
	COVER-SCAN DUMMY R2	JC63-00377F	1	O	Italian
1-3-2	MCT-GLASS ADF	JC74-00021A	1	X	
1-3-3	TAPE-DOUBLE FACE	0203-001266	1	X	
1-3-4	LABEL(P)-SHADING	JB68-00644A	1	X	
1-4	IPR-HOLDER GLASS	JB70-00148A	2	O	
2	ELA HOU-SCAN LOWER	JC96-03068A	1	O	
2-1	COVER-SCAN LOWER DELL	JC63-00379A	1	X	
2-2	ELA HOU-CCD MODULE	JC96-02759A	1	O	
2-3	CBF SIGNAL-CCD FFC	JC39-00269A	1	O	
2-4	ICT-INSERT SHAFT	JB70-00154A	1	X	
2-5	ICT-SHAFT CCD	JB70-00145A	1	X	
2-6	PMO-HOLDER BELT	JB72-00764A	1	X	
2-7	PMO-PULLEY	JB72-00763A	1	X	
2-8	ELA UNIT-CORE	JB96-01381A	3	X	
2-9	SPRING ETC-BELT	JB61-00059A	1	X	
2-10	BELT-TIMING GEAR	6602-001067	1	O	
2-11	PMO-LEVER SENSOR	JC72-00755A	1	X	
2-12	PHOTO-INTERRUPTER	0604-001095	1	X	
2-13	SPRING-CS	6107-001135	1	X	
2-14	HOLDER-CCD	JC61-00894A	1	X	
2-15	ELA HOU-SCAN MOTOR	JC96-03069A	1	O	
2-15-1	BRACKET-SCAN MOTOR R2	JC61-00895A	1	X	
2-15-2	MOTOR STEP-SCAN	JB31-00011A	1	X	
2-15-3	GEAR-REDUCTION	JC66-00530A	1	X	
2-15-4	GEAR-IDLE	JB66-00083A	1	X	
2-15-5	GEAR-TIMING	JC66-00531A	1	X	
2-15-6	PMO-HOLDER BELT	JB72-00764A	1	X	
2-15-7	RING-E	6044-000125	1	X	
2-16	CBF-HARNES-OP	JC39-00348A	1	X	

## 8.6 Middle Cover Assembly

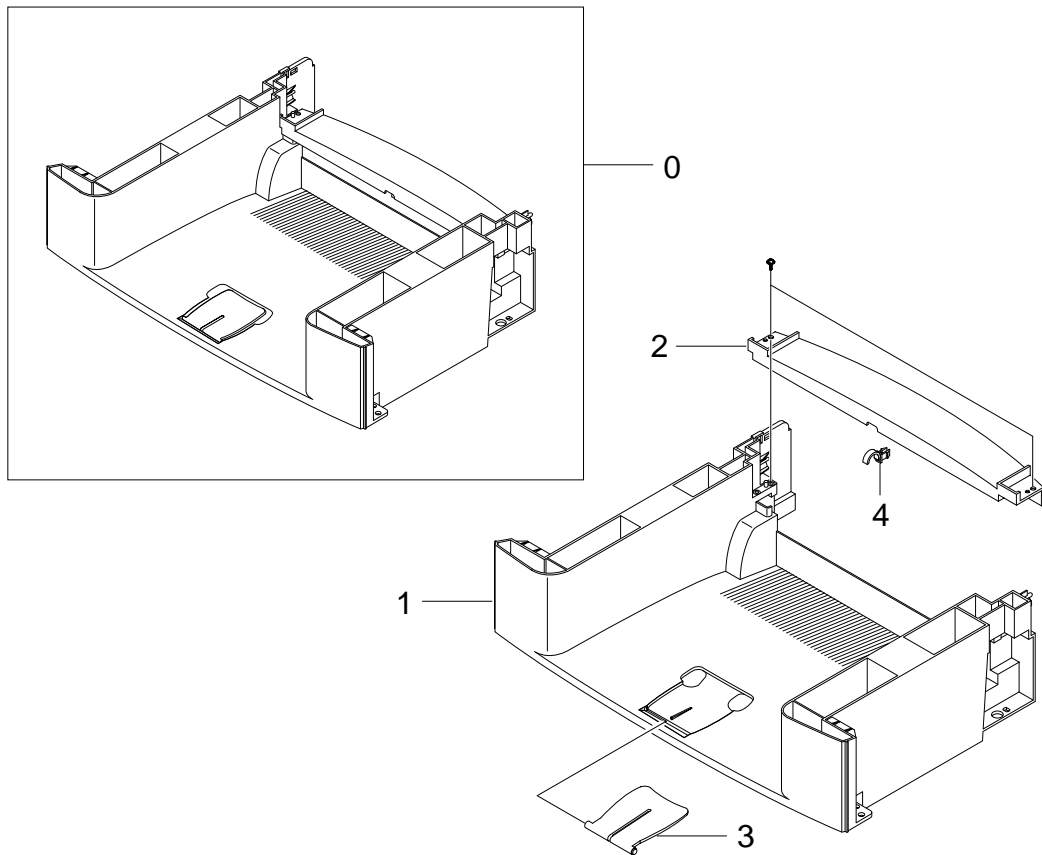

### Middle Cover Assembly Parts List

SA : Service Available

O : Service available X : Service not available

No.	Description	SEC.Code	Q'ty	SA	Remark
0	MEA UNIT-COVER MIDDLE	JC97-01932A	1	O	
1	COVER-MIDDLE R2	JC63-00385A	1	X	
2	COVER-REAR UPPER	JC63-00388A	1	X	
3	COVER-STAKEP RX	JC63-00513A	1	X	
4	BUSH-F/DOWN R2	JC61-00902A	1	X	

# 8.7 Frame Assembly

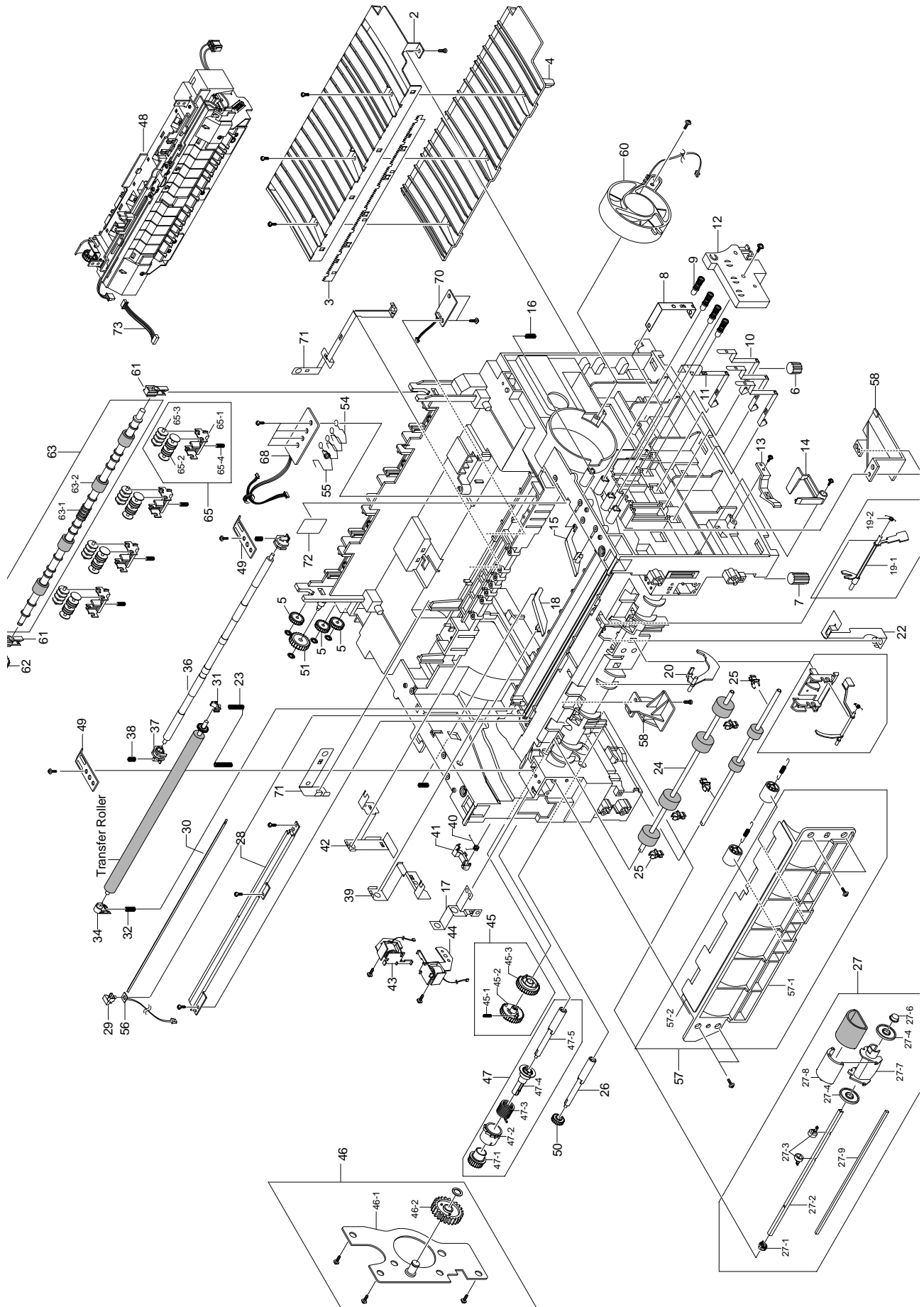

## Frame Assembly Parts List

SA : Service Available

O : Service available X : Service not available

No.	Description	SEC.Code	Q'ty	SA	Remark
0	ELA UNIT-FRAME DELL	JC96-03098A	1	O	
1	FRAME-BASE R2	JC61-00906A	1	X	
2	GUIDE-P-TR	JC61-00607A	1	X	
3	PLATE-P-SAW	JC61-00604A	1	X	
4	GUIDE-M-TR RIB	JC61-00594A	1	X	
5	PMO-GEAR_EXIT_DRV16	JC72-00143A	3	X	
6	FOOT-BACK	JC61-00835A	2	X	
7	FOOT-FRONT	JC61-00836A	2	O	
8	GROUND-GUDIE TR R2	JC63-00397A	1	X	
9	MEC-TERMINAL	JC75-00049A	4	O	
10	PLATE-TERMINAL CON R2	JC61-00903A	3	X	
11	PLATE-TERMINAL CR R2	JC61-00904A	1	X	
12	HOUSING-TERMINAL R2	JC61-00911A	1	X	
13	PMO-LOCKER CST	JC72-00983A	2	X	
14	PMO-ACTUATOR CVR OPEN	JC72-00974A	1	X	
15	PMO-PLATE GUIDE DEVE_R	JC72-00985A	1	X	
16	SPRING ETC-GUIDE DEVE	JC61-70932A	2	X	
17	GROUND-PUSH BUSHING	JC63-00401A	1	X	
18	PMO-PLATE GUIDE DEVE_L	JC72-00984A	1	X	
19	PMO-ACT FEED R2	JC72-01323A	1	X	
20	PMO-ACTUATOR EMPTY	JC72-00975A	1	O	
21	PMO-ACT MANUAL R2	JC72-01324A	1	O	
22	GROUND-EARTH TR R2	JC63-00395A	1	X	
23	GROUND-TERMINAL TR	JC63-00403A	1	X	
24	ROLLER-FEED ROLLER 1	JC66-00526A	1	O	
25	PMO-BUSHING FEED	JC72-00382B	5	O	
26	SHAFT-FEED	JC66-00398A	1	O	
27	MEA UNIT-PICKUP	JC97-01926A	1	O	
27-1	BUSH-M-PICK_UP L	JC61-00586A	1	X	
27-2	SHAFT-P-PICK_UP	JC66-00399A	1	X	
27-3	STOPPER-PICK UP_R2	JC61-00915A	2	X	
27-4	PMO-IDLE PICK_UP	JC72-00982A	2	X	
27-5	SPONGE-ROLLER PICK_UP	JC72-01231A	1	X	
27-6	BUSH-M-PICK_UP R	JC61-00587A	1	X	
27-7	HOUSING-PICK UP_R2	JC61-00909A	1	X	
27-8	HOUSING-PICK UP2_R2	JC61-00910A	1	X	
27-9	SHAFT-CORE	JC65-00720A	2	X	



## Frame Assembly Parts List(Cont.)

SA : Service Available

O : Service available X : Service not available

No.	Description	SEC.Code	Q'ty	SA	Remark
28	IPR-P-EARTH TRANSFER	JC70-00307A	1	O	
29	HOLDER-PTL R2	JC61-00907A	1	O	
30	LENS-PTL	JC67-00027A	1	O	
31	PMO-BUSHING_TR(L)	JC72-00102A	1	X	
32	SPRING ETC-TR L HAWK	JC61-00047A	1	X	
33	ROLLER-FEED	JC66-00598A	1	X	
34	BUSH-M-TR L	JC61-00588A	1	X	
35	GROUND-FUSER R2	JC63-00396A	1	X	
36	SHAFT-FEED IDLE	JC66-00527A	1	X	
37	BUSH-M-FEED IDLE	JC61-00585A	2	X	
38	SPRING ETC-TR	JC61-70958A	2	X	
39	GROUND-DRIVE2 R2	JC63-00398A	1	X	
40	SPRING-TS	6107-001170	1	X	
41	CAM-M-PICK_UP	JC66-00377A	1	X	
42	GROUND-DRIVE R2	JC63-00394A	1	X	
43	SOLENOID-FEED ROCKY2	JC33-00014A	1	O	
44	SOLENOID-HB (MANUAL)	JC33-00010A	1	O	
45	MEA UNIT-GEAR PICKUP	JC97-01929A	1	O	
45-1	GEAR-PICK UP B_R2	JC66-00705A	1	X	
45-2	GEAR-PICK UP A_R2	JC66-00704A	1	X	
45-3	SPRING-CS	6107-001167	1	X	
46	MEA UNIT-BRACKET FEED	JC97-01925A	1	O	
46-1	BRACKET-FEED R2	JC61-00913A	1	O	
46-2	GEAR-Z35 IDLE	JC66-00690A	1	X	
47	MEA UNIT-CLUTCH	JC97-01788A	1	O	
47-1	GEAR-FEED 1	JC66-00393A	1	X	
47-2	PMO-COLLAR_SPRING	JC72-00978A	1	X	
47-3	SPRING-TS	6107-001171	1	X	
47-4	PMO-HUB CLUTCH	JC72-00981A	1	X	
47-5	SHAFT-FEED	JC66-00398A	1	X	
48	ELA HOU-FUSER 110V	JC96-03061A	1	O	⚠ 110V
	ELA HOU-FUSER 220V	JC96-03062A	1	O	⚠ 220V
49	PLATE-PUSH BUSHING	JC61-00914A	2	X	
50	GEAR-FEED 2	JC66-00394A	1	X	
51	GEAR-IDLE 23	JC66-00396A	1	X	
52	SPRING-TS	6107-001164	1	X	
53	SPRING-TS	6107-001165	1	X	
54	IPR-P-TERMINAL DEVE KEY	JC70-00340A	3	X	

## Frame Assembly Parts List(Cont.)

SA : Service Available

O : Service available X : Service not available

No.	Description	SEC.Code	Q'ty	SA	Remark
55	GROUND-TERMINAL DEVE	JC63-00458A	1	X	
56	PBA SUB-PTL	JC92-01620A	1	O	
57	MEA UNIT-GUIDE PAPER	JC97-01924A	1	O	
57-1	GUIDE-PAPER FRONT	JC61-00905A	1	X	
57-2	SHEET-GUIDE PAPER	JC63-00470A	1	X	
57-3	ROLLER-M-IDLE FEED	JC66-00529A	2	X	
57-4	SPRING-ES	6107-001047	2	X	
58	HOLDER-TERMINAL R2	JC61-00908A	1	X	
59	HOLDER-ACT MANUAL R2	JC61-00912A	1	X	
61	MEC-BEARING,EXIT	JC75-10529A	2	X	
62	GEAR-EXIT F/DOWN	JC66-00038A	1	X	
63	ROLLER-EXIT F/DOWN	JC66-00378A	1	X	
64	RMO-RUBBER EXIT	JC73-40915A	4	X	
65	MEA RACK-EXIT ROLLER	JC97-01034A	4	O	
65-1	PMO-HOLDER EXIT ROLL	JC72-41006A	1	X	
65-2	PMO-ROLLER FD F	JC72-41007A	1	X	
65-3	PMO-ROLLER FD R	JC72-41008A	1	X	
65-4	SPRING ETC-EXIT ROLL FD	JC61-70911A	1	X	
66	GUIDE-SUB FRONT	JC61-00917A	1	X	
68	PBA-SUB-CRUM	JC92-01605A	1	O	
69	CBF HARNESS CRUM2	JC39-00356A	1	O	
70	PBA SUB-EXIT SENSOR	JC92-01604A	1	O	
71	GROUND-SHIELD R2	JC63-00402A	1	X	
72	LABEL(R)-HOT CAUTION,KME	JC68-00317A	1	X	
73	FAN-DC	JC31-00025A	1	O	

# 8.8 Fuser Assembly

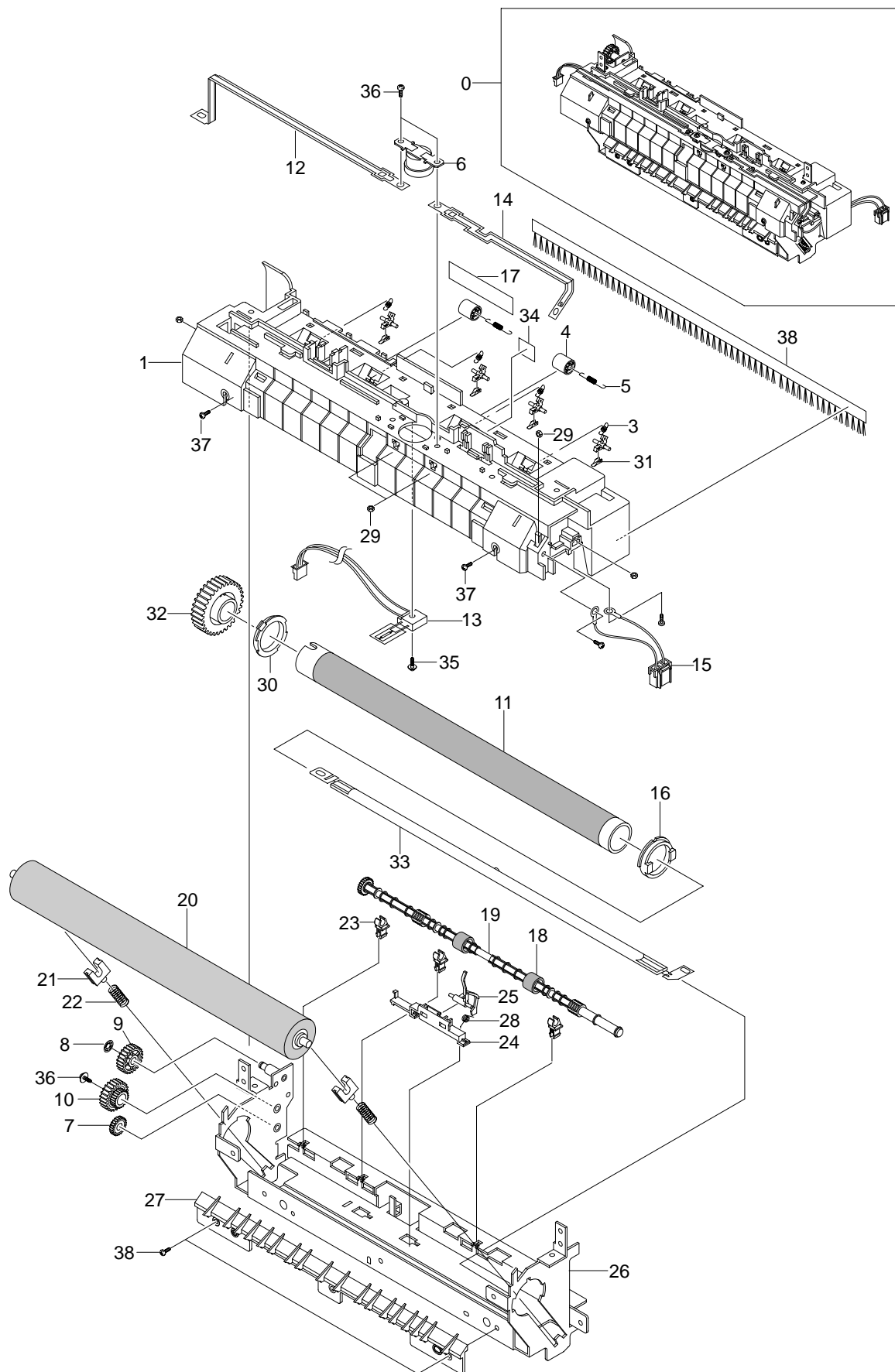

## Fuser Assembly Parts List

SA : Service Available

O : Service available X : Service not available

No.	Description	SEC.Code	Q'ty	SA	Remark
0	ELA HOU-FUSER 110V	JC96-03061A	1	O	⚠ 110V
	ELA HOU-FUSER 220V	JC96-03062A	1	O	⚠ 220V
1	COVER-FUSER R2	JC63-00363A	1	X	
2	HOLDER-PLATE CLAW R2	JC61-00886A	4	X	
3	SPRING ETC-CLAW	JC61-00064A	4	X	
4	PMO-ROLLER_EXIT	JC72-40361A	2	X	
5	SPRING ETC-FUSER EXIT	JC61-70976A	2	X	
6	THERMOSTAT-150	JC47-00005A	1	O	
7	PMO-GEAR_EXIT_DRV16	JC72-00143A	1	X	
8	GEAR-IDLE 23	JC66-00396A	1	X	
9	RING-E	6044-000125	1	X	
10	GEAR-RDCN 25/15	JC66-00397A	1	X	
11	ROLLER-HEATER	JC66-00729A	1	O	
12	ELECTRODE-LFET R2	JC70-00473A	1	X	
13	THERMISTOR-NTC	1404-001337	1	O	
14	ELECTRODE-RIGHT R2	JC70-00472A	1	X	
15	CBF HARNESS-FUSER 110V	JC39-00353A	1	X	WHITE
	CBF HARNESS-FUSER 220V	JC39-00354A	1	X	BLACK
16	BUSH-HR R_R2	JC61-00887A	1	X	
17	LABEL(P)-CAUTION, HOT_FUSER	JC68-30928D	1	X	
18	RMO-RUBBER_EXIT	JC73-00017A	2	X	
19	ROLLER-M-EXIT F/UP	JC66-00380A	1	X	
20	ROLLER-PRESSURE	JC66-00600B	1	O	
21	BEARING-PRESSURE/R	JC66-10901A	2	X	
22	SPRING-CS	6107-001168	2	X	
23	PMO-BUSHING TX	JC72-00382A	3	X	
24	HOLDER-ACTUATOR	JC61-00581A	1	X	
25	PMO-ACTUATOR EXIT R2	JC72-01319A	1	X	
26	FRAME-FUSER R2	JC61-00890A	1	X	
27	GUIDE-INPUT R2	JC61-00889A	1	X	
28	SPRING-TS	6107-001165	1	X	
29	NUT-HEXAGON	6021-000222	5	X	
30	BUSH-HR L_R2	JC61-00888A	1	X	
31	PLATE-P-CLAW	JC61-00605A	4	X	
32	GEAR-FUSER R2	JC66-00695A	1	X	
33	LAMP-HALOGEN 110V	4713-001182	1	O	⚠ 110V
	LAMP-HALOGEN 220V	4713-001183	1	O	⚠ 220V
34	LABEL(R)-LV FUSER	JC68-00408A	1	X	
35	SCREW-TAPTIEE	6003-000196	1	X	
36	SCREW-ASS'Y MACH	6006-001193	6	X	
37	SCREW-TAPTIEE	6003-000269	6	X	
38	BRUSH-ANTISTAIC	JC75-00095A	1	X	

# 8.9 Cassette Assembly

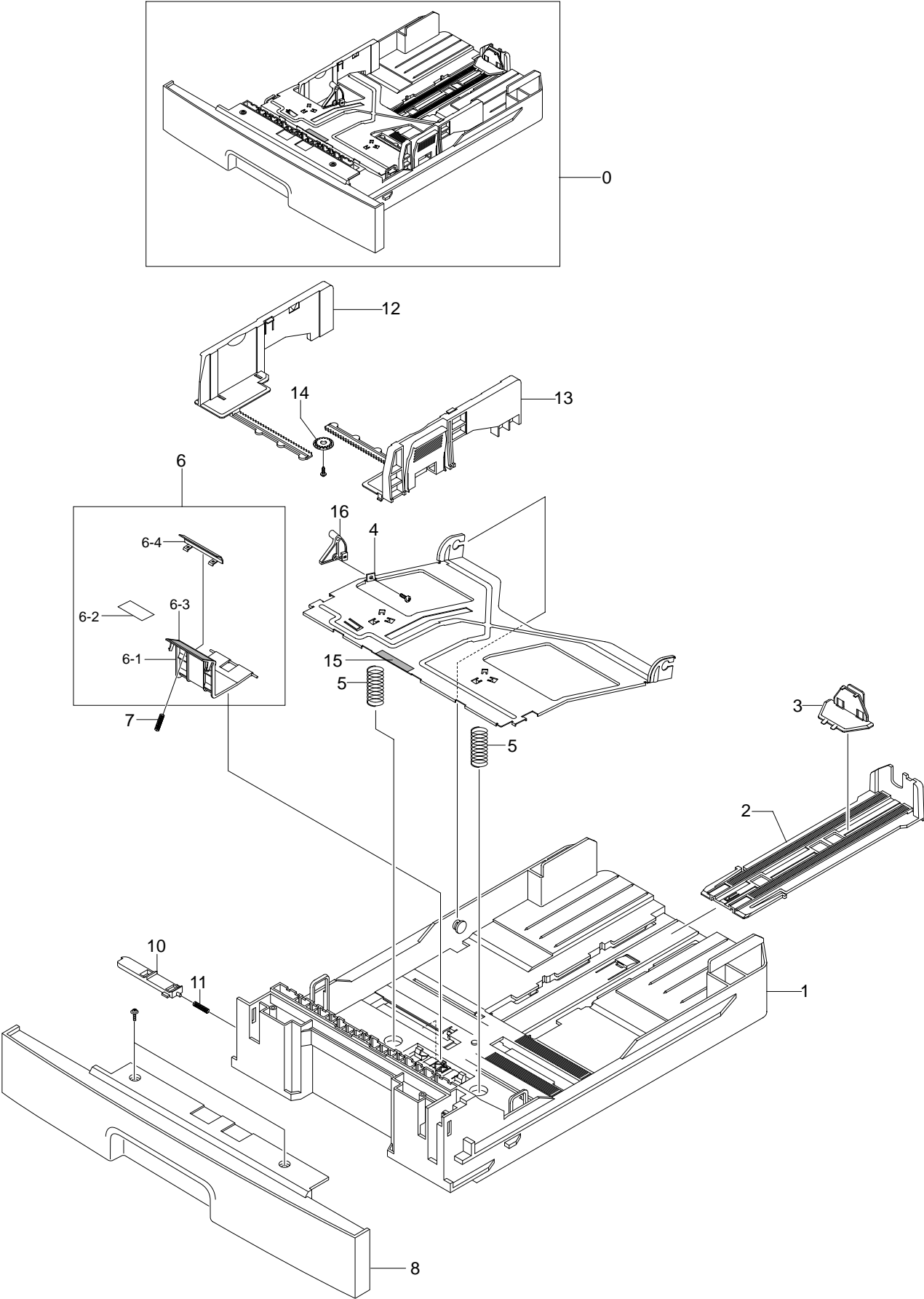

## Cassette Assembly Parts List

SA : Service Available

O : Service available X : Service not available

No.	Description	SEC.Code	Q'ty	SA	Remark
0	MEA UNIT-CASSETTE, USA	JC97-01919A	1	O	
1	FRAME-M-CASSETTE	JC61-00876A	1	X	
2	GUIDE-M-EXTENSION LARGE	JC61-00918A	1	X	
3	GUIDE-EXTENSION SMALL	JC61-00960A	1	X	
4	PLATE-P-KNOCK_UP	JC61-00603A	1	X	
5	SPRING-CS	6107-001166	2	X	
6	MEA UNIT-HOLDER PAD	JC97-01931A	1	O	
6-1	HOLDER-M-PAD	JC61-00580A	1	X	
6-2	SHEET-HOLDER PAD R2	JC63-00407A	1	X	
6-3	RPR-FRICTION PAD	JC73-00140A	1	X	
6-4	IPR-PLATE PAD	JC70-00314A	1	X	
7	SPRING ETC-EXIT ROLL FD	JC61-70911A	1	X	
8	COVER-SUB CASSETTE R2	JC63-00368A	1	X	
10	PMO-PLATE_LOCKER	JC72-00972A	1	X	
11	SPRING ETC-LOCKER,PLATE	JG61-70531A	1	X	
12	ADJUST-M-CASSETTE_L	JC70-00300G	1	X	
13	ADJUST-M-CASSETTE_R	JC70-00301G	1	X	
14	GEAR-PINION	JG66-40003A	1	X	
15	RPR-PAD CASSETTE	JC73-00141A	1	X	
16	CAM-KNOCK UP	JC66-00719A	1	X	

# 8.10 SCF(Option Cassette Frame) Exploded view

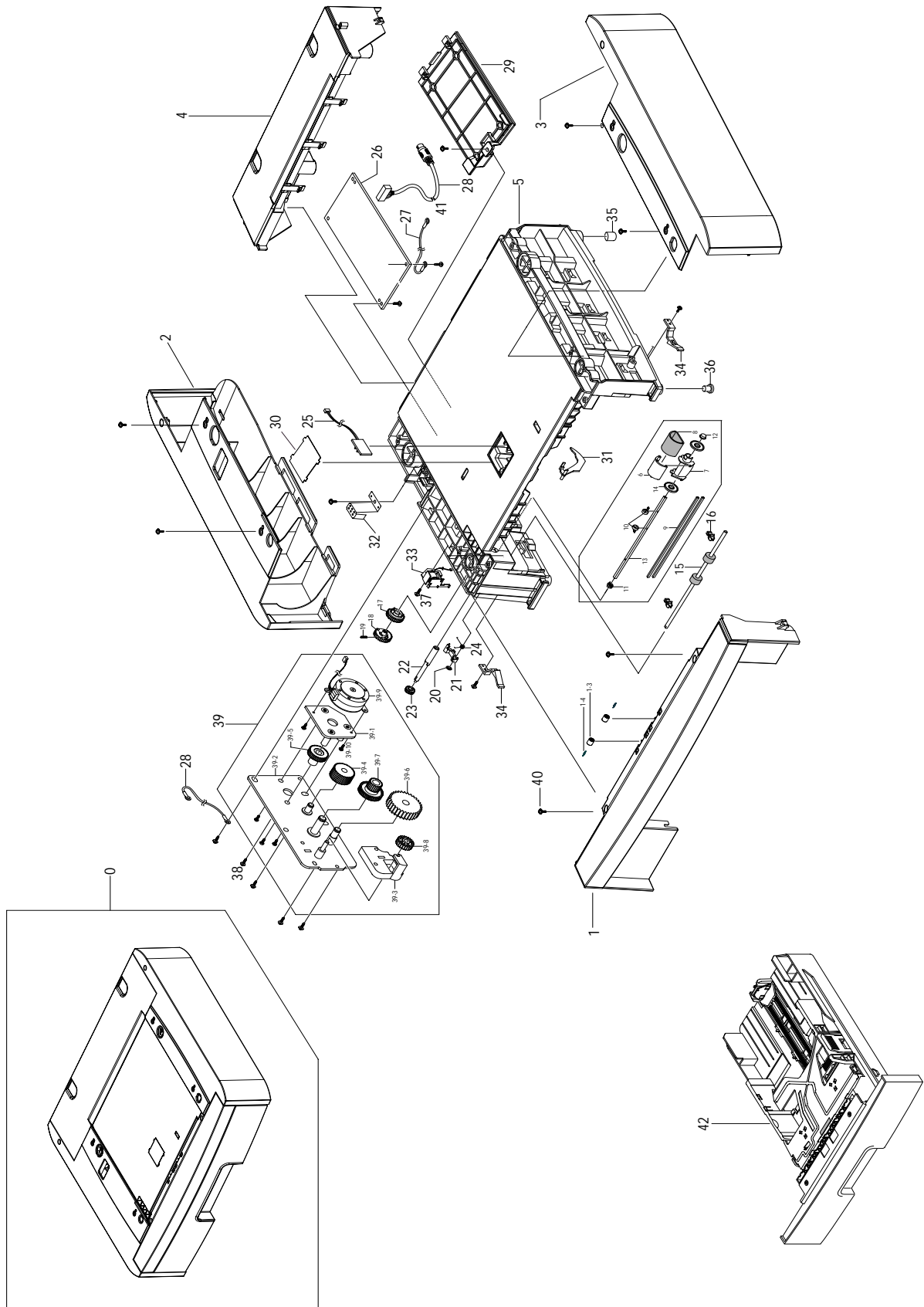

## SCF(Optional Cassette Frame) Assembly Parts List

SA : Service Available

O : Service available X : Service not available

No.	Description	SEC.Code	Q'ty	SA	Remark
0	ELAHOU-SCF R2	JC96-03096A	1	X	
1	COVER-M-FRONT SCF R2	JC63-00364A	1	X	
2	COVER-M-LEFT SCF R2	JC63-00365A	1	O	
3	COVER-M-RIGHT SCF R2	JC63-00366A	1	O	
4	COVER-M-REAR SCF R2	JC63-00367A	1	O	
5	FRAME	JC61-00877C	1	X	
6	HOUSING-M-PICKUP_R2	JC61-00909A	1	O	
7	HOUSING-M-PICKUP2_R2	JC61-00910A	1	O	
8	SPONGE -ROLLER PICK_UP	JC72-01231A	1	O	
9	SHAFT-P-CORE	JC66-00720A	2	X	
10	BUSHING-PICK_UP	JC61-00593A	2	X	
11	BUSH-M-PICK_UP L	JC61-00586A	1	X	
12	BUSH-M-PICK_UP R	JC61-00587A	1	X	
13	SHAFT-P-PICK_UP	JC66-00399A	1	X	
14	PMO-IDLE PICK_UP	JC72-00982A	2	X	
15	ROLLER -FEED	JC66-00598A	1	X	
16	PMO-BUSHING TX	JC72-00382A	2	X	
17	PMO-GEAR PICK_UP A	JC72-00979A	1	X	
18	PMO-GEAR PICK_UP B	JC72-00980A	1	X	
19	SPRING-CS	6107-001167	1	X	
20	RING-CS	6044-000001	1	X	
21	CAM-M-PICK_UP	JC66-00377A	1	X	
22	SHAFT-FEED	JC66-00527A	1	X	
23	GEAR -FEED 2	JC66-00394A	1	X	
24	SPRING-TS	6107-001170	1	X	
25	PCB-SENSOR	JC92-01364B	1	X	
26	PBASUB-SCF	JC92-01614A	1	O	
27	CBF HARNESS -SCF GND	JC39-00366A	1	X	
28	CBF HARNESS -SCF	JC39-00357A	1	O	
29	COVER-M-SIMM R2	JC63-00492A	1	X	
30	SHEET-COVER SENSOR	JC63-00369A	1	X	
31	PMO-ACTUATOR EMPTY	JC72-00975A	1	X	
32	IPR-GND TOP	JC70-11028A	1	X	
33	SOLENOID-HB(MANUAL)	JC33-00010A	1	X	
34	PMO-LOCKER CST	JC72-00983A	1	X	
35	FOOT-BACK	JC61-00835A	1	X	
36	FOOT-FRONT	JC61-00836A	2	X	
37	SCREW-ASS'Y TAPT	6006-001078	1	X	



## SCF(Optional Cassette Frame) Assembly Parts List

SA : Service Available

O : Service available X : Service not available

No.	Description	SEC.Code	Q'ty	SA	Remark
38	SCREW-TAPTITE	6003-000196	10	X	
39	ELA HOU-MOTOR SCF	JC96-03003A	1	O	
39-1	BRKT-P-MOTOR SCF	JC61-00879A	1	X	
39-2	BRKT-P-GEAR SCF	JC61-00881A	1	X	
39-3	BRKT-M-FEED SCF	JC61-00878A	1	X	
39-4	GEAR 61/47 IDLE	JC66-00688A	1	X	
39-5	GEAR 59 IDLE	JC66-00689A	1	X	
39-6	GEAR 35 IDLE	JC66-00690A	1	X	
39-7	GEAR-RDCN 57/18	JC66-00389A	1	X	
39-8	GEAR-IDLE 23	JC66-00396A	1	X	
39-9	MOTOR STEP(SCF)	JC31-00009A	1	O	
39-10	SCREW-MACHINE	6001-000131	5	X	
39-11	CORE-FERRITE	3301-001635	1	X	
39-12	CABLE TIE	6501-000004	1	x	
40	BUSH CABLE	JC61-00804A	1	X	
41	SCREW-TAPTITE	6003-000196	1	X	
42	MEA UNIT-CASSETTE	JC97-01919A	1	X	

*MEMO*



# 9. Block Diagram

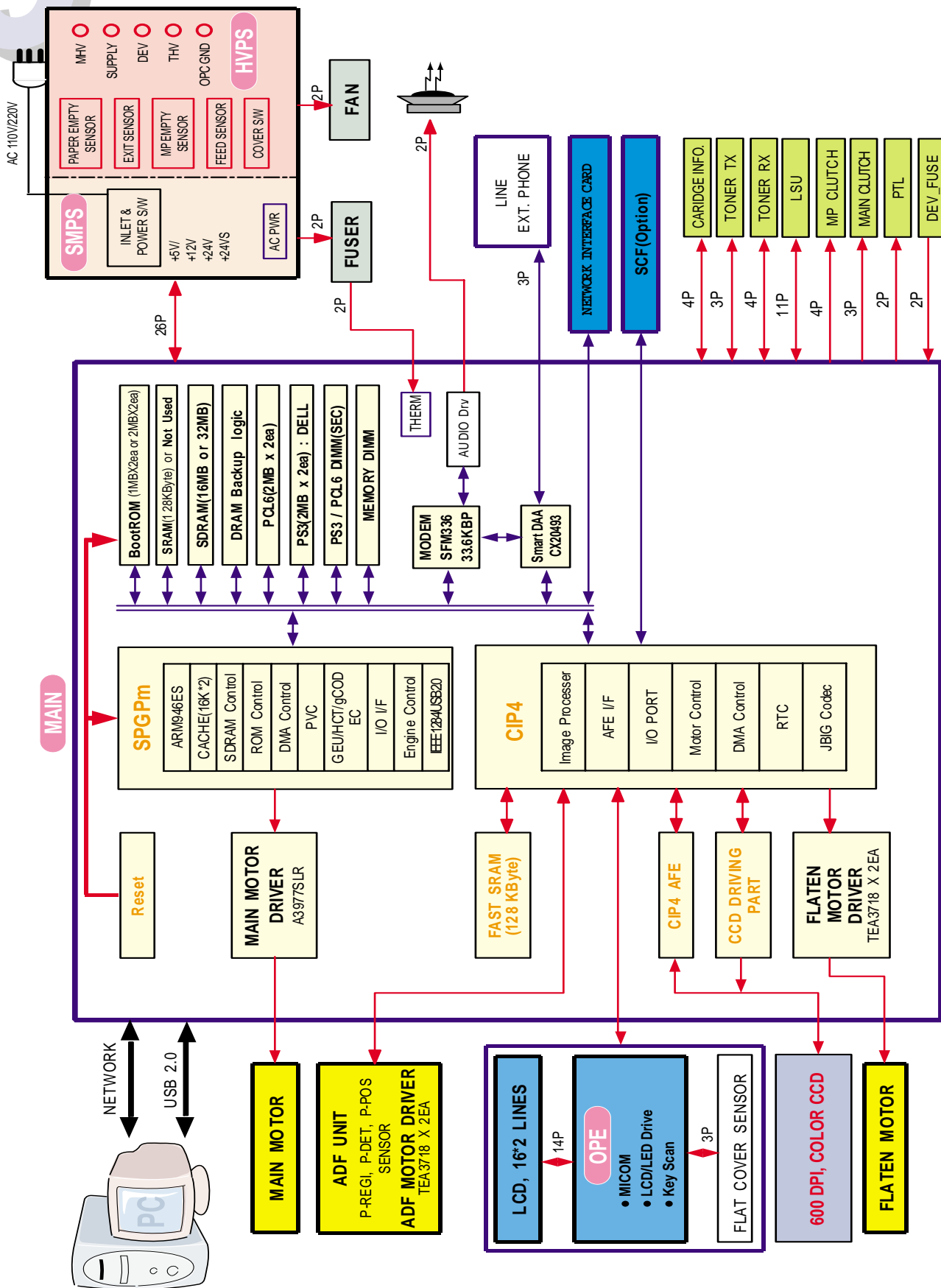

# 10. Connection Diagram

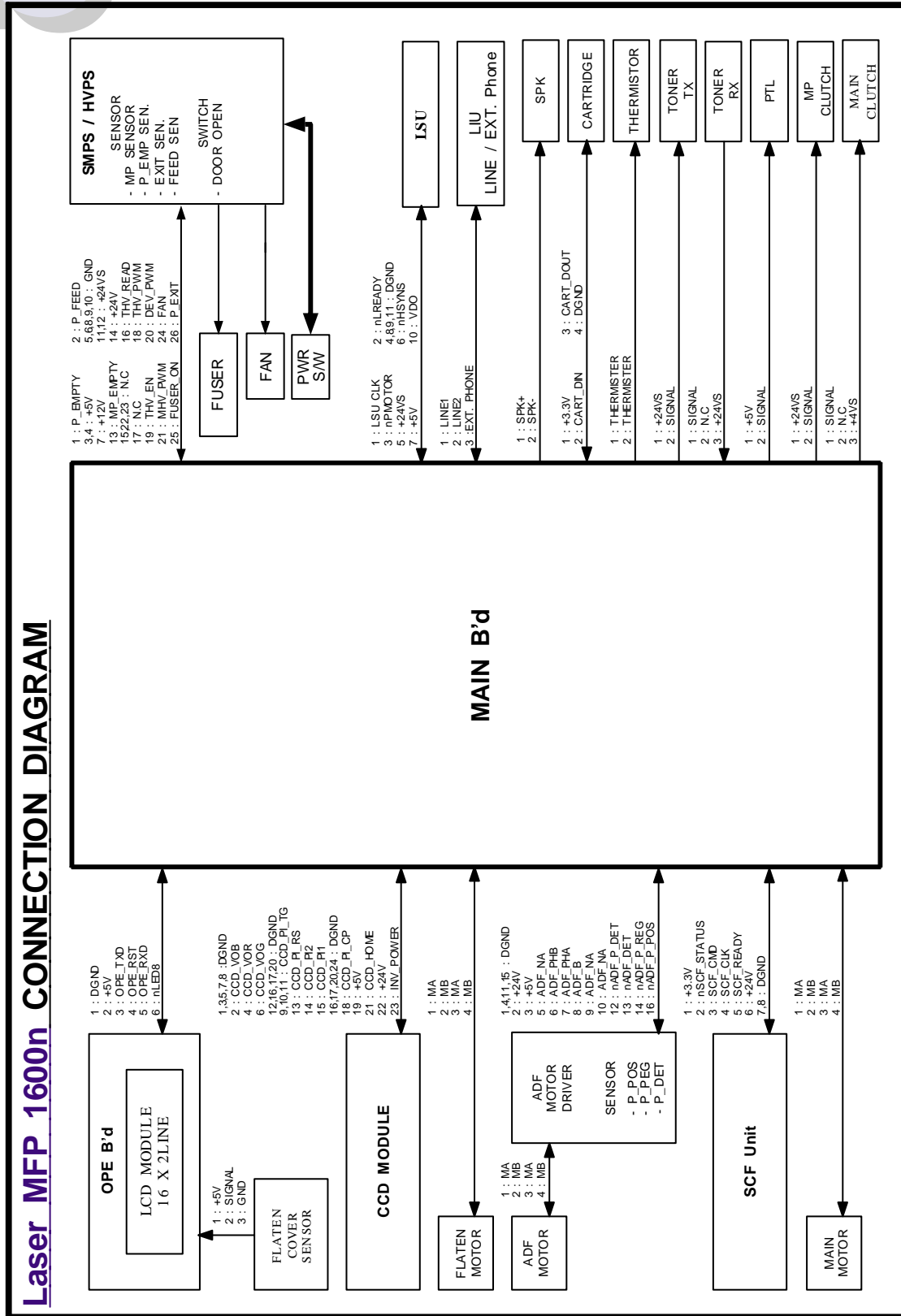

# 11. Circuit Description

## 11.1 System Configurations

**SCX-4920N** is roughly made up Main Control part, Operation Panel part, Scanner part, Line Interface part and Power part. Each Part is separated Module which focus on common and standard design of different kind products. main control part adopting Fax & LBP Printer exclusive Controller is composed of 2 CPU and 1 Board. Scanner part is composed of ADF and Platen and is connected with Main by Harness . Line Interface part is designed to apply TBR21 standard(Domestic, Europe,etc..)

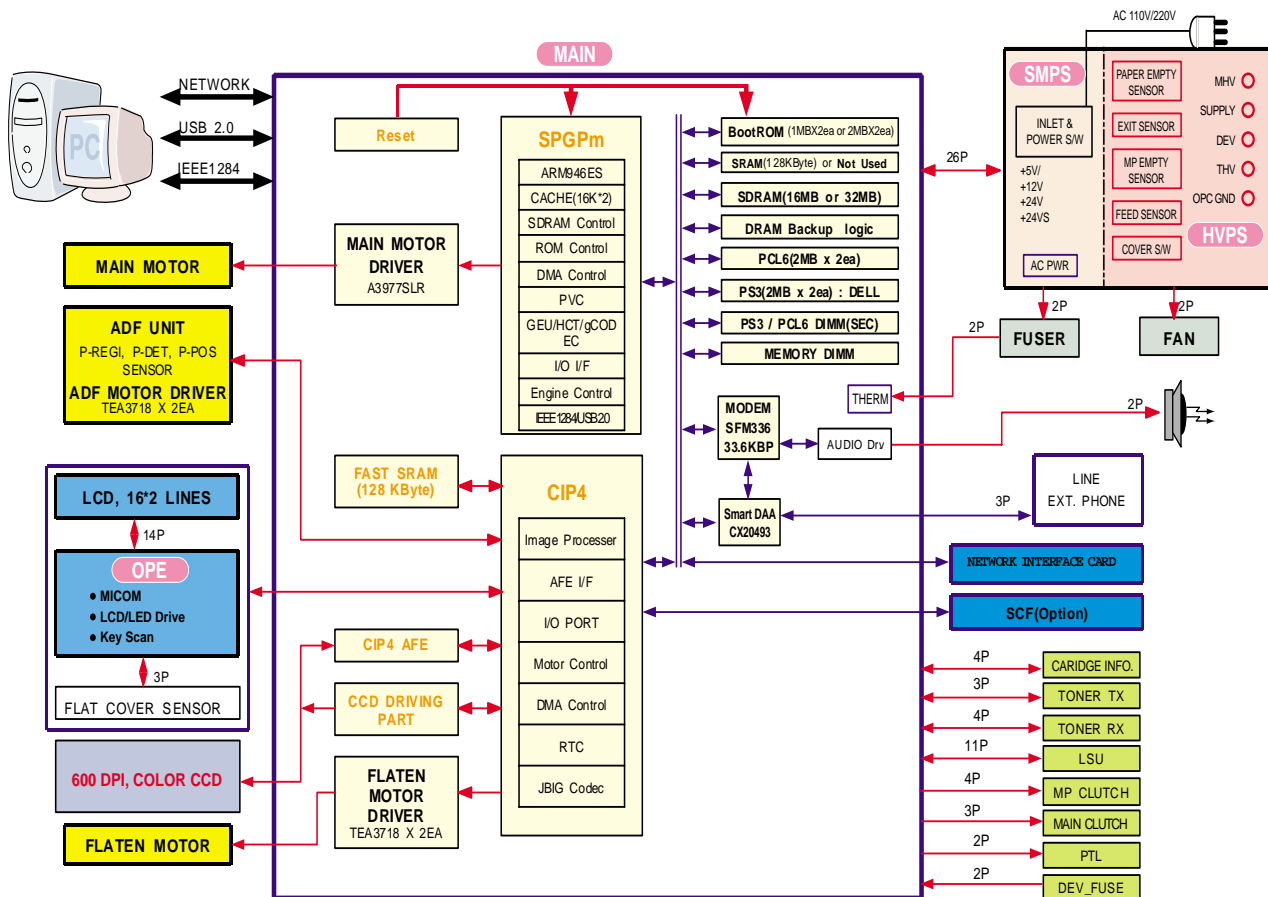

### Laser MFP 1600n CONNECTION DIAGRAM

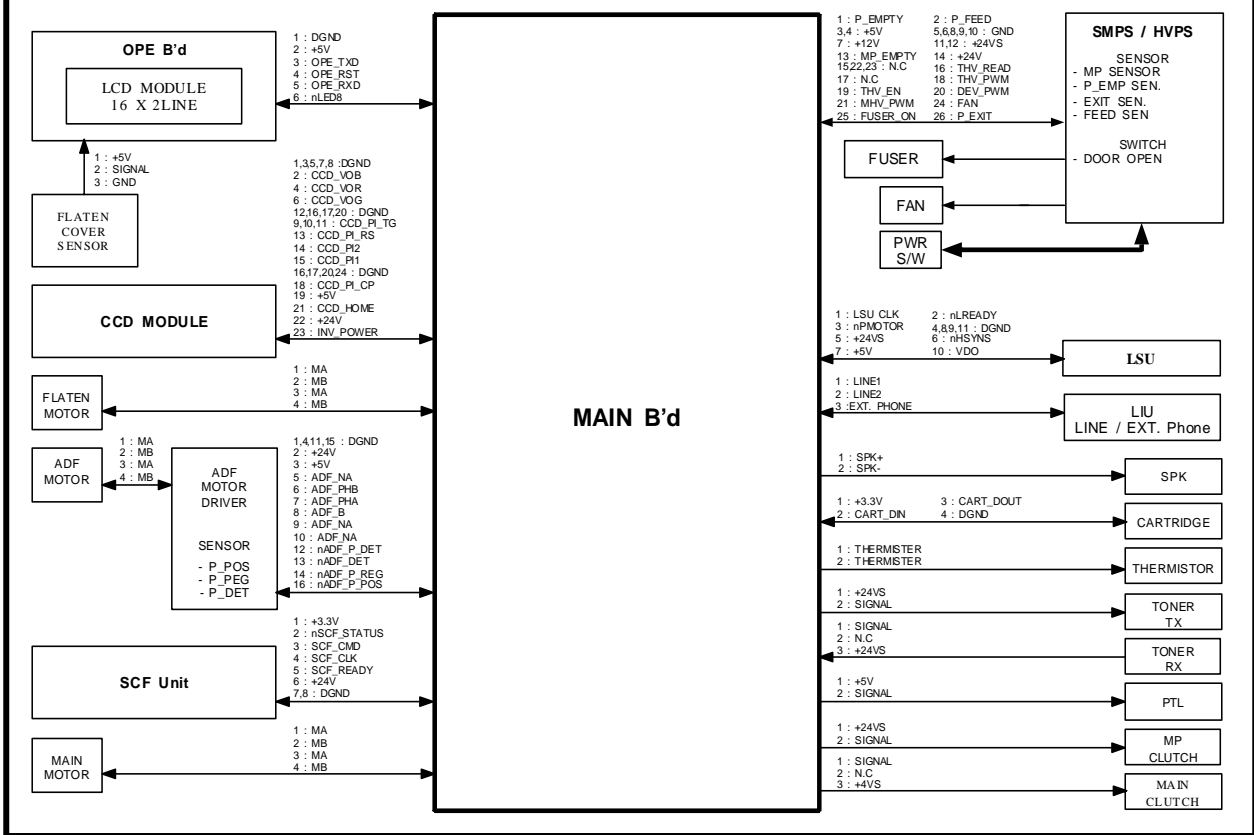

### CPU Part

- 1) CPU : Use 32Bit RISC Processor, ARM946ES, which is exclusive controller to execute Printer & FAX Function and to execute operation block by flash memory within system program, and to control whole system.
  - Main function block
  - Completely Integrated System for Embedded Applications,
  - 32 Bit Risc Architecture, Efficient and Powerful ARM9 Core.
  - LSU Interface Module for Interfacing PVC or HPVC with LSU
  - 2 Channel General Purpose DMA Controller for High Speed I/O
  - Dual Memory Bus Architecture
  - Operation Frequency : AHB Bus: 60MHz, Internal System Bus: 120MHz
  - Operation Voltage : 3.3V
  - POWER ON RESET TIME :

2) Flash Memory : Record System Program, and download System Program by PC INTERFACE.  
FAX for Journal List, and Memory for One Touch Dial, Speed Dial List.

- Size : 4M Byte
- Access Time : 70 nsec

3) SDRAM : is used as Swath Buffer in Printing, Scan Buffer in Scanning, ECM Buffer in FAX receiving, and System Working Memory Area

- size 32MB : 32Mbyte(Basic).
- TBD MB :System Working Memory Area and Scan Buffer
- TBD MB :FAX Memory Receive Area
- TBD MB :Printing System Working Memory Area
- Max Frequency : 133MHz
- store Fax Receive Memory Data by using Battery

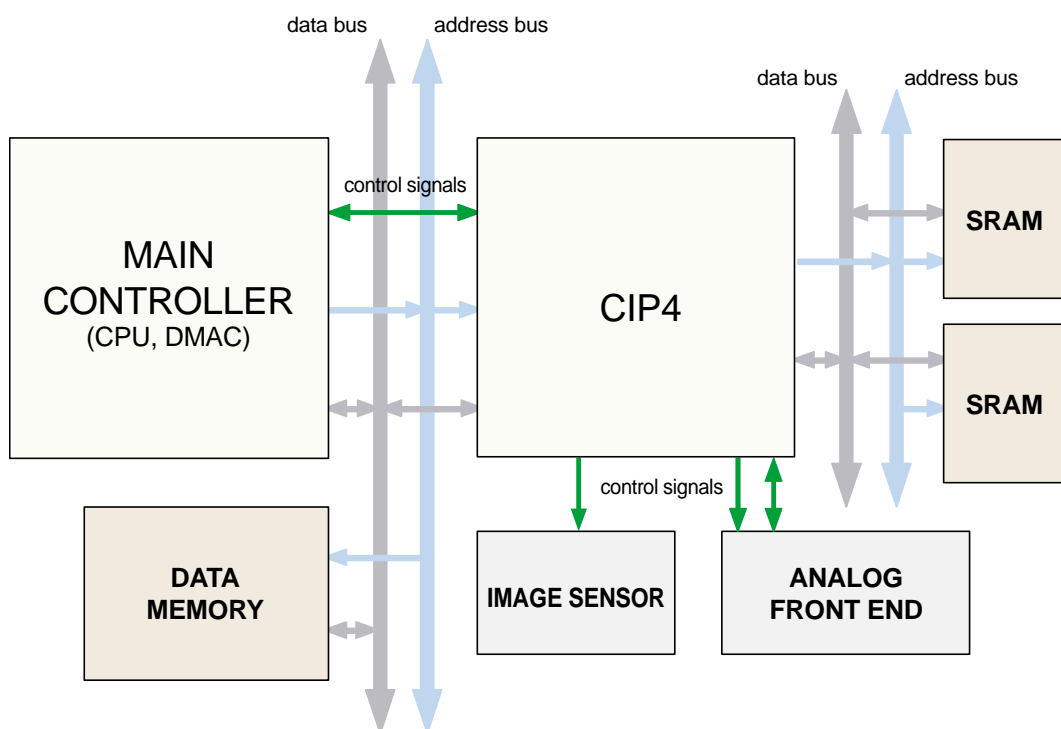

## 11.2 FAX Section

### 11.2.1 Modem Part

#### 11.2.1.1 BLOCK DIAGRAM

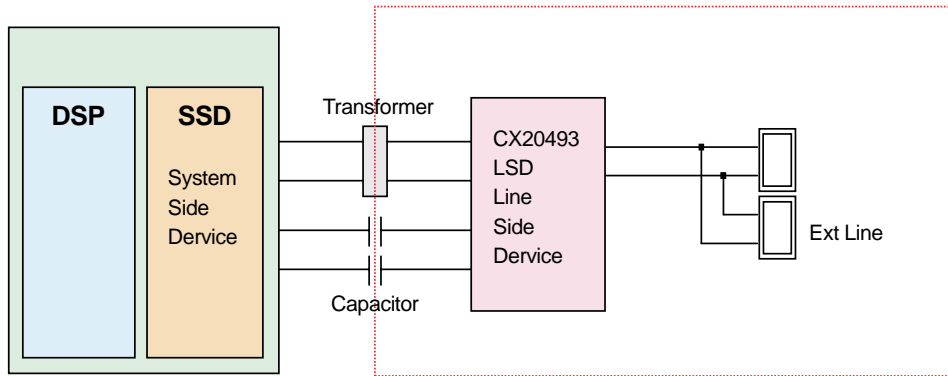

Implemented by based on Conexant DAA (Data Access Arrangement) Solution , and is roughly composed of two kinds Chip Solution

- CX82500(SFM336) : Existing Modem Chip which adds SSD (System Side Device) for interfacing between -
- LSD and DIB of FM336Plus Core
- CX20493(LSD) : LIU (Line Interface Unit) Chip which is controlled by SSD and satisfies each PSTN requirements by modulating internal Configuration with connecting Tel Line.



### 11.2.1.2 Modem(SFM336) specification

- 2-wire half-duplex fax modem modes with send and receive data rates up to 14,400 bps V.17, V.33, V.29, V.27 ter, and V.21 Channel 2
  - Short train option in V.17 and V.27 ter
- PSTN session starting
  - V.8 and V.8bis signaling
- HDLC support at all speeds
  - Flag generation, 0-bit stuffing, ITU CRC-16 or CRC-32 calculation and generation
  - Flag detection, 0-bit deletion, ITU CRC-16 or CRC-32 check sum error detection
  - FSK flag pattern detection during high-speed receiving
- Tone modes and features
  - Programmable single or dual tone generation
  - DTMF receiver
  - Tone detection with three programmable tone detectors
- Receive dynamic range:
  - 0 dBm to -43 dBm for V.17, V.33, V.29, V.27 ter and V.21 Channel 2
- Programmable transmit level: -9 to -15 dBm
- Serial synchronous data
- Parallel synchronous data
- TTL and CMOS compatible DTE interface
  - ITU-T V.24 (EIA/TIA-232-E) (data/control)
  - Microprocessor bus (data/configuration/control)

- 1) Line Interface Signal of Tel Line and LSD is Analog Signal.
- 2) there is A/D, D/A Converter in LSD, so Analog Signal from Tel Line is transited in Digital through A/D Converter in DAA and transfer to SSD by DIB Capacitor Digital Signal from SSD is converted to Analog by D/A Converter in DAA and transfer to Tel Line

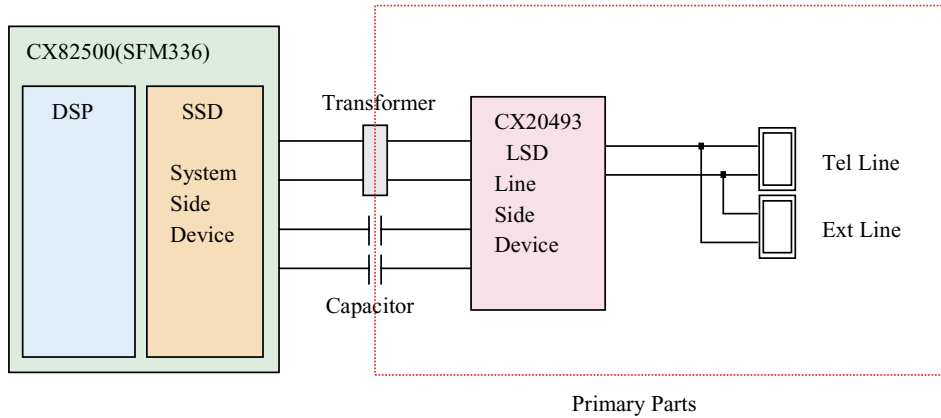

- 3) Transformer transfer Clock from SSD to LSD and Clock Frequency is 4.032MHz. LSD fullwave rectifies Clock to use as inner Power supply and also use as Main Clock for DIB Protocol Syncn between LSD and SSD. Transformer transfer Clock by separatin Primary and Secondary, and amplifies Clock Level to LSD by Coil Turns Ratio 1:1.16.

### 11.2.1.3 Clock

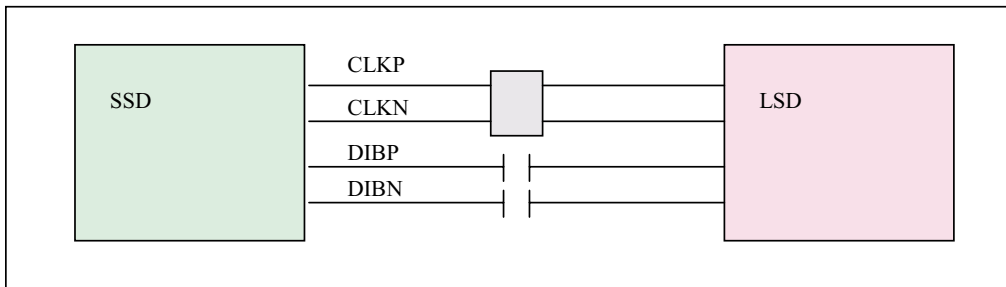

- Clock is supplied by transformer from SSD to LSD, and There is PWROUT to adjust output impedance of Clock Out Driver is inside SSD and CLKSHIGH Register to adjust duty of HLPWR Register and Clcok. Clock from SSD to LSD has Differential structure of 180 phase difference for Noise Robustness DIB Data transfer Data From SSD to LSD By Capacitor, and also transfer specific data from LSD to SSD. after transferring data to SSD, RSP is transfered and LSD recognize RSP and change LSD to output Driver transfer Data to SSD. DIB Data form SSD to LSD by Capacitor has Differential structure of 180 phase difference between DIBP and DIBN for Noise Robustness

- 1) Application Network: 3 PSTN (RJ-11)
- 2) Communication Mode: Half-Duplex, ITU V.8, V.34, V.17, V.29, V.21, ECM  
> Modem will auto train down only.  
> .
- 3) Communication Standard: ITU-T Group 3
- 4) Max. Modem Speed: 33.6 Kbps
- 5) Encoding: MH, MR, MMR, JPEG
- 6) Transfer Rate: 3 seconds (standard resolution, MMR, 33.6kbps)  
> Phase "C" by ITU-T No.1 Chart/Memory Transmission/ECM
- 7) Fax Modes: Standard (203 x 98 dpi)  
> Fine (203 x 196 dpi)  
> Super Fine (300 x 300 dpi)
- 8) Fax Contrast: Adjustable 3 levels (Light/Normal/Dark)
- 9) Fax Memory: 4MB (About 300 Sheets of CCITT No.1 Chart at standard resolution).  
User selectable parameters will be stored in NVRAM.
- 10) TX/RX Journal : Available.
- 11) Tel/ID List: Available.
- 12) Confirmation Reports for Send: Upon successful transmission  
> Upon failure  
> Reduced image of first page (except OHD, and partial page for complexity of the images)  
> Customer On/Off selectable
- 13) Management Reports:  
> System Data List  
> Image TCR for Memory TX
- 14) TTI/RTI: TTI (Transmit Terminal Identification) printed at top of Fax Image.  
> RTI(Receiver Terminal Identification) printed at bottom of Fax Image the Transmitting devices fax number is substituted for receiving devices fax number is this footer..
- 15) Line Control Unit (LIU):  
> Input Sensitivity: Not programmable  
> Output Level: 9 to 15 db (programmable)  
> Cable Equalization: Not programmable  
> Input/Output Impedance: per PTT requirements (programmable)  
> DC Resistance: per PTT requirements (programmable)  
> Insulation Resistance: Minimum 5M ohm
- 16) Header Transmission (Always On): Local Machine date and time  
> Local Machine ID  
> Local Machine Name  
> Transmit page count (3 digits)

This is Connection Part between system and PSTN(Public Switched Telephone Network), and 1 st side circuit is usually located. Main functions are Line Interface, Telephone Connection and Line Condition Monitoring.

### 1. Telephone Line Connection

- Modular Plug : RJ-11C
- LIU PBA Modular Type : 623 PCB4-4
- Line Code Length : 2m
- Line Code Color : Ivory

#### 11.2.1.4 ON HOOK state Characteristic

##### 1) DC Resistance

- DP Dial Mode (Direct Current 30mA) : 50 ~ 300ohm
- DTMF Dial Mode (Direct Current 20mA) : 50 ~ 540ohm

##### 2) Ring Sensitivity

- Ring detection Voltage : 40Vrms % 150Vrms (condition : Current=25mA, Frequency=15Hz)  
product Margin : 30Vrms % 150Vrms
- Ring detection Frequency : 15.3Hz % 68Hz (condition : Voltage=45Vrms, Current=25mA )  
product Margin : 15Hz % 70Hz
- Ring detection Current : 20mA % 100mA (condition : Voltage=40Vrms, Frequency=20Hz)  
product Margin : over 15mA

##### 3) False Ring Sound

- Ring Frequency : 750Hz + 1020Hz
- Ring interrupt Cycle : On/Off depending on input Ring Signal Cycle.

## 11.3 Scanner Section

### 11.3.1 Scan Part

Pictorial signal input part : output signal of CCD passes through Bypass\_Cap change to ADC at AFE\_CIP4 , and defined signal between AFE\_CIP4 and CIP4 processes the Image signal. When AFE accept each pixel, CDS(Correlated Double Sampling ) technique which samples arm-level twice is used on each pixel by using CIP4 signal.

1) Pictorial image processing part : read CCD Pixel data in terms of 600dpi Line and process LAT algorithm on Text mode, Error Diffusion Algorithm on Mixed mode, and store Data at Scan Buffer on PC Scan mode without algorithm. on every mode Shading Correction and Gamma Correction are executed ahead, then processing is executed later

#### \* Scan Image Control Specification

- Minimum Scan Line Time : 0.72ms
- Scan Resolution : Max. 600DPI
- Scan Width : 216mm
- main function
  - Internal 12bit ADC
  - White Shading Correction
  - Gamma Correction
  - CCD Interface
  - 256 Gray Scale

2) CCD Operating Part : CCD Image sensor use +5V and Inverter uses +24V

- CCD Maximum Operating Frequency : 10MHz
- CCD Line time : 0.72ms
- White Data output Voltage : 0.7V & 0.5V (Mono Copy, 0.72ms/line)
- Maximum Inverter Current : 600 mA Max.( +24V)

### 11.3.2 IP Block Diagram

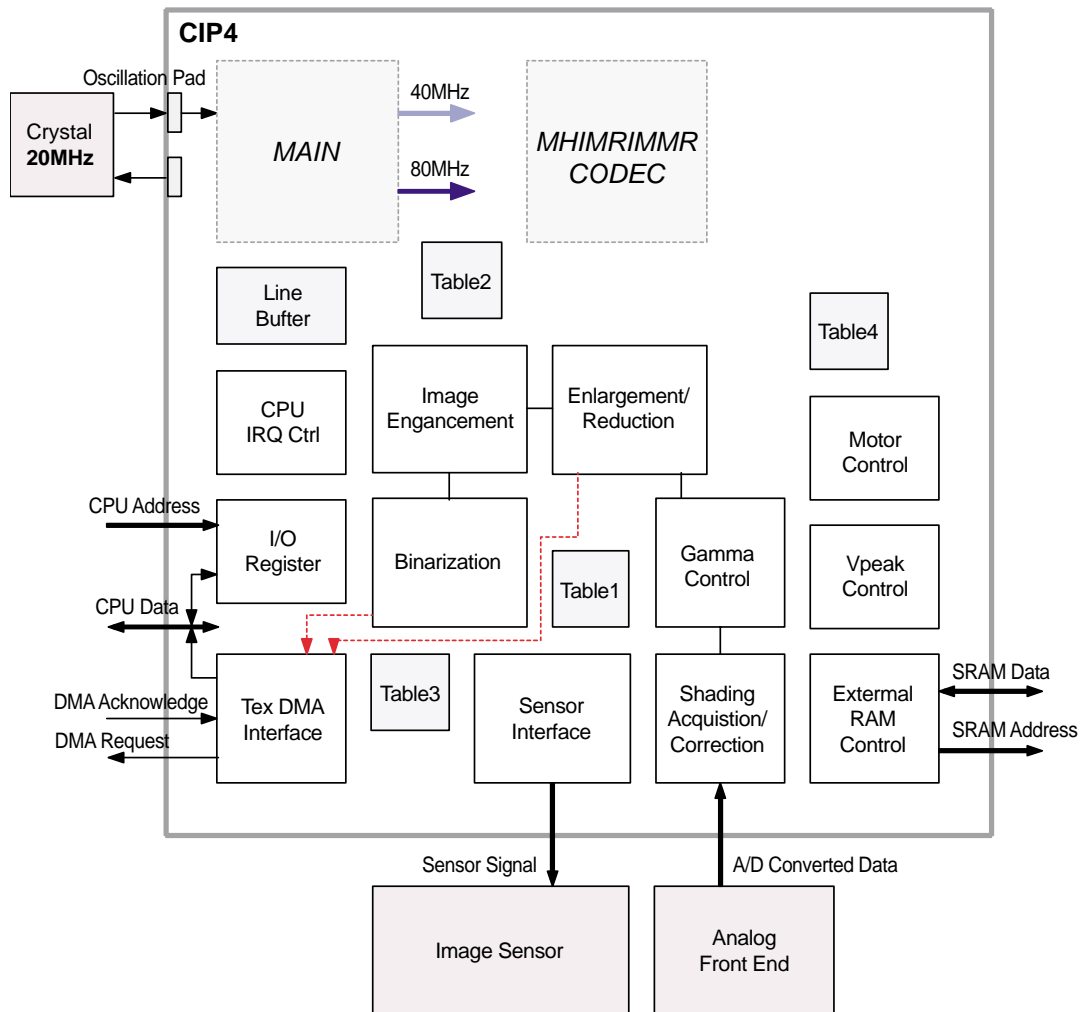

- Internal Core
- Internal SRAM
- External Circuit

- Table1: Gamma Table
- Table2: IEM Table
- Table3: Binary Table
- Table4: Motor Table

- 1) Scanning Device: Color CCD (Charge Coupled Device) Module
- 2) Supported Operating Systems: Windows 98/2000/NT4.0/ME/XP, MAC (English only, no status monitor, web download only)
- 3) Compatibility: TWAIN Standard
- 4) Maximum Scan Width: 216mm (8.5 inches)
- 5) Effective Scan Width: 208mm (8.2 inches)
- 6) Optical Resolution: 600x1200 dpi
- 7) Interpolated Resolution: Maximum 4800 dpi
- 8) Preview Scan: 75 dpi
- ADF Linearity : 20 sec. (Letter, 300dpi, USB)
- Gray Scale : 64 sec. (Letter, 300dpi, USB)
- Color : 64 sec. (Letter, 300dpi, USB)

(USB 1.1, 300dpi, Letter Size, Pentium 4 1.xGHz, 128MB RAM)	ADF	Linearity :	20sec.(Letter, 300dpi, USB)
		Gray Scale :	64 sec. (Letter, 300dpi, USB)
		Color :	64 sec. (Letter, 300dpi, USB)
	Platen	Linearity :	18 sec. (Letter, 300dpi, USB)
		Gray Scale :	62 sec. (Letter, 300dpi, USB)
		Color :	62 sec. (Letter, 300dpi, USB)

- 9) Scan Modes/Speeds:
- 10) ADF Capacity: 50 sheets (20 lb)
- 11) Image Compression: None
- 12) PC Interface: > USB (without HUB mode)  
Requires 6 ft. USB Cable (not supplied by SEC)
- (USB & Parallel are not simultaneously supported)
- >
- 13) Minimum PC Specification: Pentium-II 233MHz, 64MB RAM, 120MB free disk space
- 14) Registration Position for Original: > Platen: Rear-Left Corner(when facing front/operator panel).  
> ADF: Center
- 15) Number of Copes: 2 digits (99 maximum for LCD display and reports)

### 11.3.3 Ope Pannel Section

#### (1)Configuration

operation Panel uses Main Control and separated Ope Chip Micom and work as inner program, systemic operation is serial system which exchange Date with SIO Port of Main Control. Ope Panel is approximately composed of Micom part, Matrix part and LCD.

#### (2) Micom controller

Micom has ROM, RAM, I/O Port built-in and displays and lights LCD by CPU command of Main Control Part and report Key recognition Data to Main Control Board.

## 11.4 Printer Section

Printer is consisted of the Engine parts and F/W, and said engine parts is consisted of the mechanical parts comprising Frame, Feeding, Developing, Driving, Transferring, Fusing, Cabinet and H/W comprising the main control board, power board, operation panel, PC Interface.

The main controller is consisted of Asic(SPGPm) parts, Memory parts, Engine interface parts and it functions as Bus Control, I/O Handling, drivers & PC Interface by CPU.

Memory Access supports 16bit Operation, and Program Memory 2MB and Working Memory as well.

The Engine Board and the Controller Board are in one united board, and it is consisted of CPU part and print part in functional aspect. The CPU is functioned as the bus control, I/O handling, drivers, and PC interface. The main board sends the Current Image, Video data to the LSU and manages the conduct of Electrophotography for printing. It is consisted of the circuits of the motor (paper feed, pass) driving, clutch driving, pre-transfer lamp driving, current driving, and fan driving. The signals from the paper feed jam sensor and paper empty sensor are directly inputted to the main board.

- 1) Printing Method: Laser-based Electrophotography
- 2) Supported Operating Systems: Windows 98/2000/NT4.0/ME/XP/ MAC (English only, no status monitor, web download only)
- 3) Emulation: SPL(GDI) , PCL6, PS3,PCL5e
- 4) Maximum Paper Size: Legal
- 5) Effective Printing Width:
  - > Letter/Legal: 208mm
  - > A4: 202mm
- 6) Resolution:
  - > Addressable 1200 x1200 dpi
  - (selectable from Print Driver) > 600x600 dpi (True; no RET)
- 7) Speed: 22ppm (Letter)
- 8) Input Paper Capacity:
  - > Tray: 250 sheets (20 lb)
  - > Bypass: Single sheet
- 9) Output Paper Capacity: 150 sheets (20 lb; sequenced 1 to N, face down)
- 10) Feed Direction: Front In, Front Out (FIFO)
- 11) PC Interface:
  - > USB 2.0(without HUB mode)
  - Requires 6 ft. USB Cable (not supplied by SEC)
- 12) Toner Cartridge:
  - > Toner Low Sensor: None
  - > Toner Low Indicator: Message displayed on LCD
  - > Cartridge Missing Indicator: Message displayed on LCD
- 13) Paper Sensing:
  - > Tray: "Add Paper" message displayed on LCD
  - > Bypass: "Add Paper" message displayed on LCD



## 11.4.1 ASIC

- ARM946ES
  - 32-bit RISC embedded processor core
  - 16KB instruction cache and 16KB data cache
  - No Tightly Coupled Memory
  - Memory Protection Unit & CP15 control program
- Dual bus architecture for bus traffic distribution
  - AMBA High performance Bus (AHB)
  - System Bus with SDRAM
- Printer Video Controller for LBP engines
- Graphic Execution Unit for banding support of Printer Languages
- Printer Video Controller for LBP engines
  - PVC : Printer Video Controller without RET Algorithm
  - HPVC : Printer Video Controller with RET algorithm  
(Line Memory & Lookup Table Memory : 512 x 8 , 4096 x 16)
- Engine Controller
  - Motor Control Unit
  - Motor Speed Lookup Table Memory (128 x 16 x 2)
  - Pulse Width Modulation Unit
  - 4 Channels are supported
  - ADC Interface Unit
  - 3 ADC Channels are available
  - ADC Core (ADC8MUX8) maximum clock frequency : 3 MHz
- USB 2.0 Interface
- Package : 272 pins PBGA
- Power : 1.8V(Core), 3.3V(IO) power operation

### 11.4.2 Speed : 166MHz core(ARM946ES) operation, 60MHz bus operation

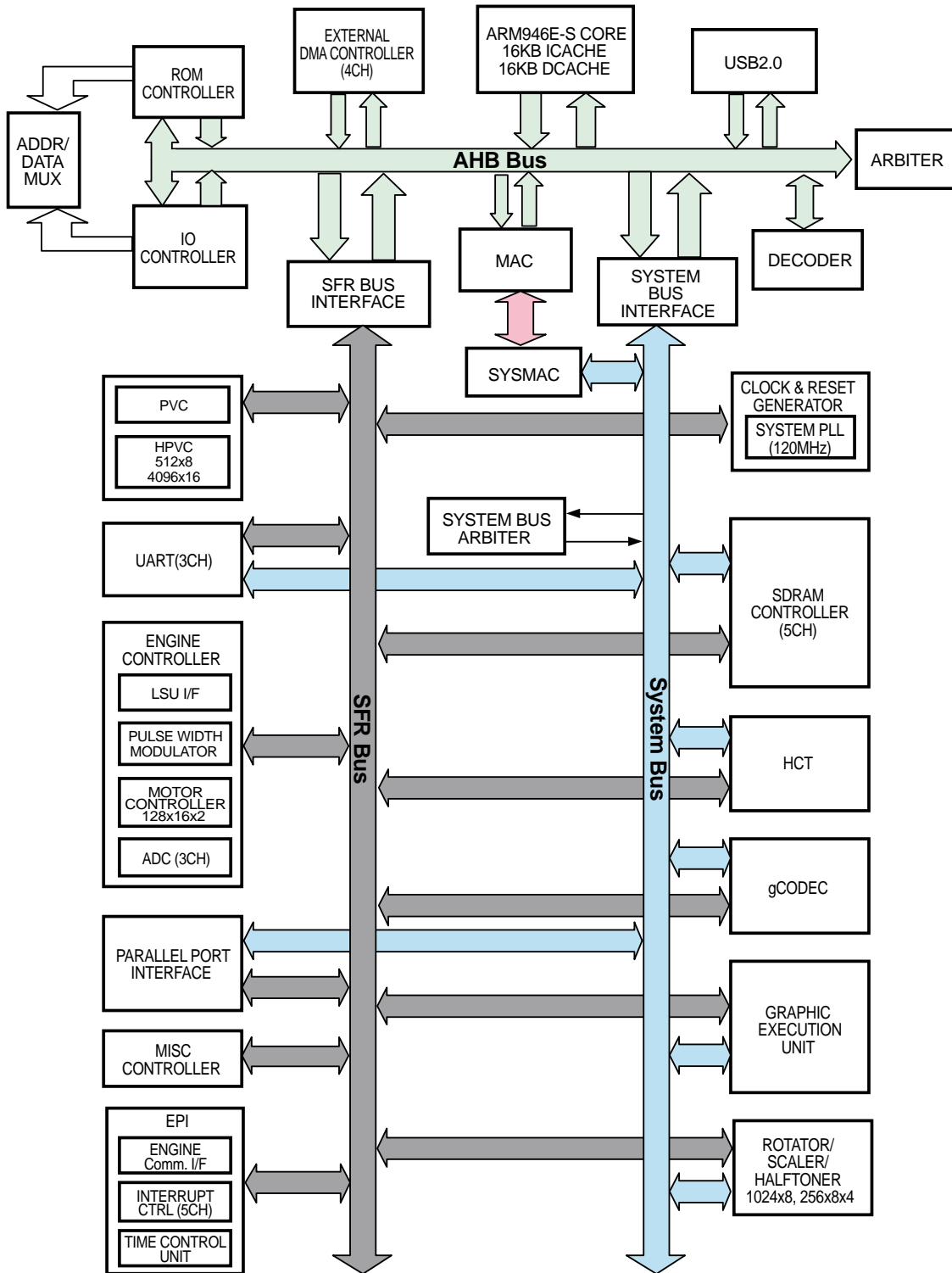

## 11.5 Copier Section

- |  |   |
|--|---|
| 1) Copy Mode:  | Black and White   |
| 2) Scanner Type:                                       | CCD with Flatbed/Platen and ADF   |
| 3) Maximum Size of Original:                           | > Platen: 216 x 297 mm<br>> ADF: Legal (216 x 356 mm)                   |
| (max. width = 218 mm,<br>max length = 400 mm)          |   |
| 4) Optical Resolution:                                 | 600 x 600 dpi   |
| 5) Copy Quality - H x V:                               | > Text : 600 x 300 dpi (default)  |
| (User selectable via Content button)                   | > Mixed : 600 x 300 dpi<br>> Photo : 600 x 600 dpi                      |
| 6) Supported Media Types:                              | Plain, Label, Cardstock, Transparency                                   |
| 7) Copy Speed:   | > Platen, SDMP: 22cpm (Letter)  |
| (SDMP = Single Document,<br>Multiple Printout,         | > ADF, SDMP: 22cpm (Letter)   |
| MDSP = Multiple Document,<br>Single Printout)          | > ADF, MDSP: 7cpm (Letter, Text or Mixed)<br>4cpm (Letter, Photo)       |
| 8) Reduce/Enlarge:                                     | Platen: 25% - 400% (1% increments)<br>> ADF: 25% - 100% (1% increments) |
| 9) Non-printable Area:                                 | 4 mm (Top, Bottom, and each Side)                                       |
| 10) Copy Count:  | 1 to 99   |
| (Page count displayed on LCD<br>during copy operation) |   |
| 11) Copy Modes:  | Text, Mixed, Photo  |
| 12) Fixed R/E Setting: 1                               | 00%, Auto-fit, 2(4)-Up  |
| 13) Darkness Control:                                  | 3 levels  |
| 14) First Copy Output Time (FCOT):                     | > Platen: 10 sec. (600 x 300 dpi)<br>> ADF: 15 sec. (600 x 300 dpi)     |
| 15) Duplex Copy  | > TBD   |

## 11.6 Telephone Section

---

1) Speed Dial:	200 Locations (46 digits maximum per location)
2) On-hook Dial (manual fax):	Yes
3) Last Number Redial:	Yes
4) Automatic Redial:	Yes
5) Pause:	Yes (using Redial key)
6) Ringer Volume:	Off, Low, Medium, High
7) Tone/Pulse:	Selectable (Tech Mode Only no Telecom certification for Pulse mode)

## 11.7 SMPS & HVPS Section

---

The SMPS supplies DC Power to the System.

It takes 110V/220V and outputs the +5V, +24V to supply the power to the main board and ADF board. The HVPS board creates the high voltage of THV/MHV/Supply/Dev and supplies it to the developer part for making best condition to display the image. The HVPS part takes the 24V and outputs the high voltage for THV/MHV/BIAS, and the outputted high voltage is supplied to the toner, OPC cartridge, and transfer roller.

### 11.7.1 HVPS (High Voltage Power Supply)

- **Transfer High Voltage (THV+)**

- > Input Voltage : 24 V DC & 15%
- > Output Voltage : MAX +5.0KV & 5 %,(Duty Variable, no loading )
  - 1.2KV & 15% (when cleaning,200 ( )
- > Output Voltage Trigger : 6.5 )
- > Input contrast of the Voltage stability degree :under & 5 % (fluctuating input 21.6V % 26.4V)  
Loading contrast : & 5 % or less
- > Output Voltage Rising Time : 100 ms Max
- > Output Voltage Falling Time : 100 ms Max
- > Fluctuating transfer voltage with environmental various : +650 V(Duty 10%) ~ 5 KV (Duty 90%)
- > Environment Recognition Control Method : The THV-PWM ACTIVE is transfer active signal. It detects the resistance by recognizing the voltage value, F/B, while permits the environmental recognition voltage.
- > Output Voltage Control Method : Transfer Output Voltage is outputted and controlled by changing Duty of THVPWM Signal. 10% Duty : +650V, 90% Duty : +5KV & 5%

**• Charge Voltage (MHV)**

- > Input Voltage : 24 V DC & 15%
- > Output Voltage : -1.3KV ~ -1.8KV DC +/- 50V
- > Output Voltage Rising Time : 50 ms Max
- > Output Voltage Falling Time : 50 ms Max
- > Output Loading range : 30 M \* ~ 1000 M \*
- > Output Control Signal(MHV-PWM) : CPU is HV output when PWM is Low

**• Cleaning Voltage (THV-)**

- > The (+) Transfer Voltage is not outputted because the THV PWM is controlled with high.
- > The (-) Transfer Voltage is outputted because the THV-Enable Signal is controlled with low
- > The output fluctuation range is big because there is no Feedback control.

**• Developing Voltage (DEV)**

- > Input Voltage : 24 V DC & 15%
- > Output Voltage: -200V ~ -600V DC & 20 V
- > Output Voltage Fluctuation range: PWM Control
- > Input contrast of the output stability degree : & 5 % or less  
Loading contrast : & 5 % or less
- > Output Voltage Rising Time : 50 ms Max
- > Output Voltage Falling Time : 50 ms Max
- > Output Loading range : 10M \* ~ 1000 M \*
- > Output Control Signal (BIAS-PWM) : the CPU output is HV output when PWM is low.

**•S upply**

- > Output Voltage : -400 V ~ -800V DC & 50 V(ZENER using, DEV )
- > Input contrast of the output stability degree : under & 5 %  
Loading contrast : & 5 % or less
- > Output Voltage Rising Time : 50 ms Max
- > Output Voltage Falling Time : 50 ms Max
- > Output Loading range : 10 M \* ~ 1000 M \*
- > Output Control Signal (BIAS-PWM) : the CPU is HV output when PWM is low.

## 11.7.2 SMPS (Switching Mode Power Supply)

It is the power source of entire system. It is assembled by an independent module, so it is possible to use for common use. It is mounted at the bottom of the set.

It is consisted of the SMPS part, which supplies the DC power for driving the system, and the AC heater control part, which supplies the power to fuser. SMPS has two output channels. Which are +5V and +24V.

### • AC Input

- > Input Rated Voltage : AC 220V ~ 240V AC 120V / AC 220V(EXP version)
- > Input Voltage fluctuating range : AC 198V ~ 264V AC 90V ~ 135V / AC 198V ~ 264V
- > Rated Frequency : 50/60 Hz
- > Frequency Fluctuating range : 47 ~ 63 Hz
- > Input Current : Under 5.0Arms / 2.5Arms (But, the status when lamp is off or rated voltage is inputted/outputted )

### • Rated Output Power

NO	ITEM	CH2	CH3	Remark
1	CHANNEL NAME	+5V	+24.0V	
2	CONNECTOR PIN	CON 3 5V PIN: 8 GND PIN: 7	CON 3 24V PIN:11,12,13 GND PIN:9,10	
3	Rated Output	+5V & 5% (4.75 % 5.25V)	+24V & 10% (21.6 % 26.4V)	
4	Max. Output voltage	0.14 A	2.0 A	
5	Peak Loading voltage	0.14 A	2.5 A	1ms
6	RIPPLE NOISE Voltage	100mVp-p	Under 500mVp-p	
7	Maximum output	0.35W	48W	
8	Peak output	0.7W	60W	1ms
9	Protection for loading shortage and overflowing current		-	

- **Consumption Power**

NO	ITEM	CH2 (+5V)	CH3 (+24V)	Remark
1	Stand-By	0.07A	0.4 A	AVG:55 Wh
2	PRINTING	0.14A	2.0 A	AVG 350 Wh
3	Sleep-Mode	0.01A	0.4A	AVG : 20 Wh

- **Length of Power Cord : 1830 & 50mm**

- **Power Switch : Use**

- **Feature**

- > Insulating Resistance : 50 ( or more (at DC 500V)
- > Insulating revisiting pressure : Must be no problem within 1 min. (at 1500Vac,10mA)
- > Leaking Current : under 3.5mA
- > Running Current : under 40A PEAK (AT 25 + , COLD START)  
under 60A PEAK (In other conditions)
- > Rising Time : within 2Sec
- > Falling Time : over 20ms
- > Surge : Ring Wave 6KV-500A (Normal, Common)

- **Environment Condition**

- > Operating temperature range : 0 +% 40 +
- > Maintaining temperature range : -25 +% 85 +
- > Preserving Humidity Condition : 30% % 90% RH
- > Operating atmospheric pressure range : 1atm

- **EMI Requirement : CISPR ,FCC, CE, MIC, C-Tick.**

- **Safety Requirement :IEC950 UL1950, CSA950, C-UL,NOM,TUV,Semko,Nemko,iK,CB, CCC(CCIB),GOST, EPA, Power Save**

### 11.7.3 Fuser Ac Power Control

Fuser(HEAT LAMP) gets heat from AC power. The AV power controls the switch with the Triac, a semiconductor switch. The 'ON/OFF control' is operated when the gate of the Triac is turned on/off by Phototriac (insulating part). In other words, the AC control part is passive circuit, so it turns the heater on/off with taking signal from engine control part.

When the 'HEATER ON' signal is turned on at engine, the LED of PC1 (Photo Triac) takes the voltage and flashes. From the flashing light, the Triac part (light receiving part) takes the voltage, and the voltage is supplied to the gate of Triac and flows into the Triac. As a result, the AC current flows in the heat lamp, and heat is occurred. On the other hand, when the signal is off, the PC1 is off, the voltage is cut off at the gate of Triac, the Triac becomes off, and then the heat lamp is turned off.

- **Triac (THY1) feature :12A, 600V SWITCHING**
- **Phototriac Coupler (PC3)**
  - > Turn On If Current : 15mA % 50mA(Design: 16mA)
  - > High Repetive Peak Off State Voltage : Min 600V



# 12. Schematic Diagrams

## 12.1 Dell Schematic Main(1/17)

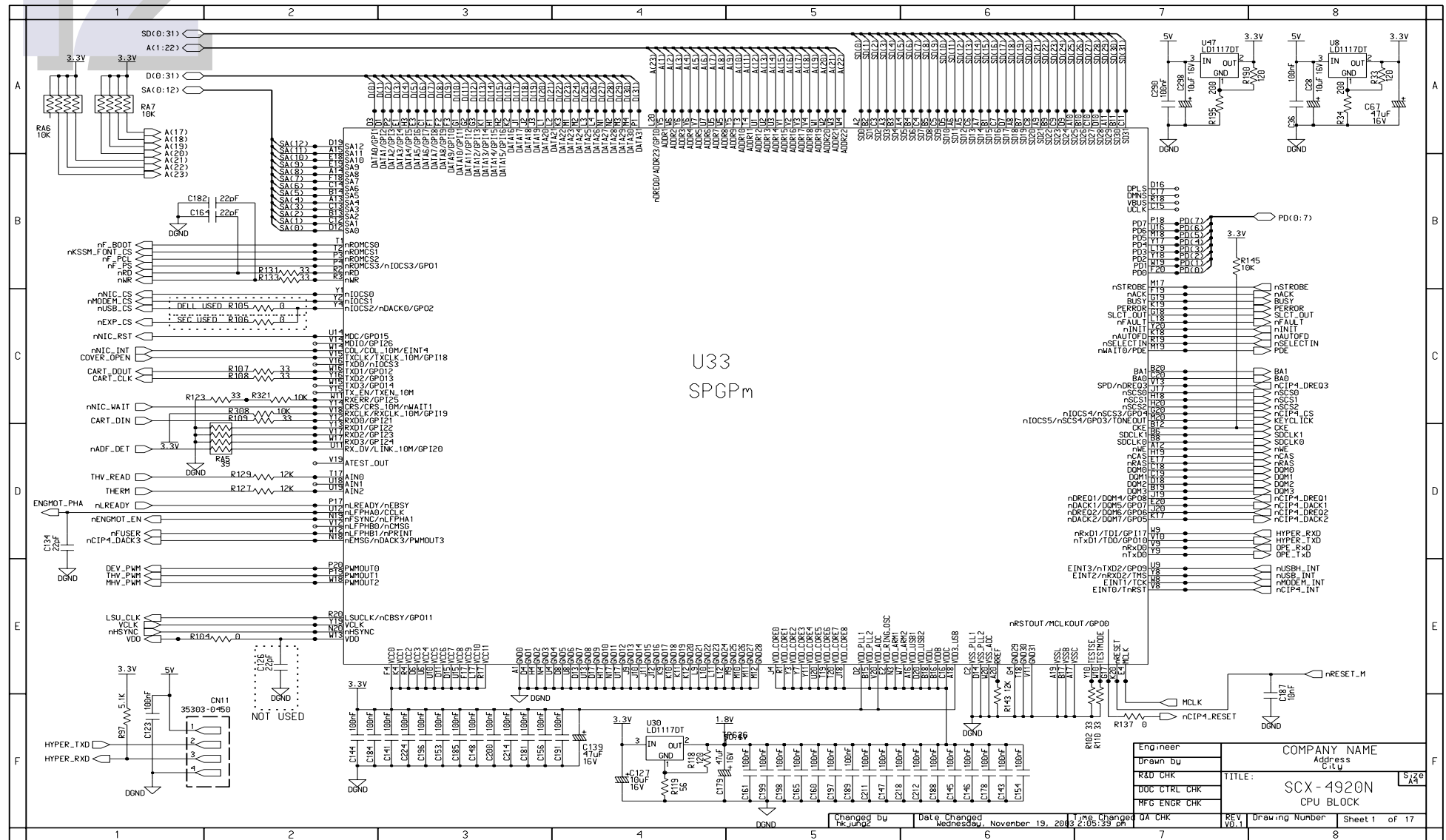

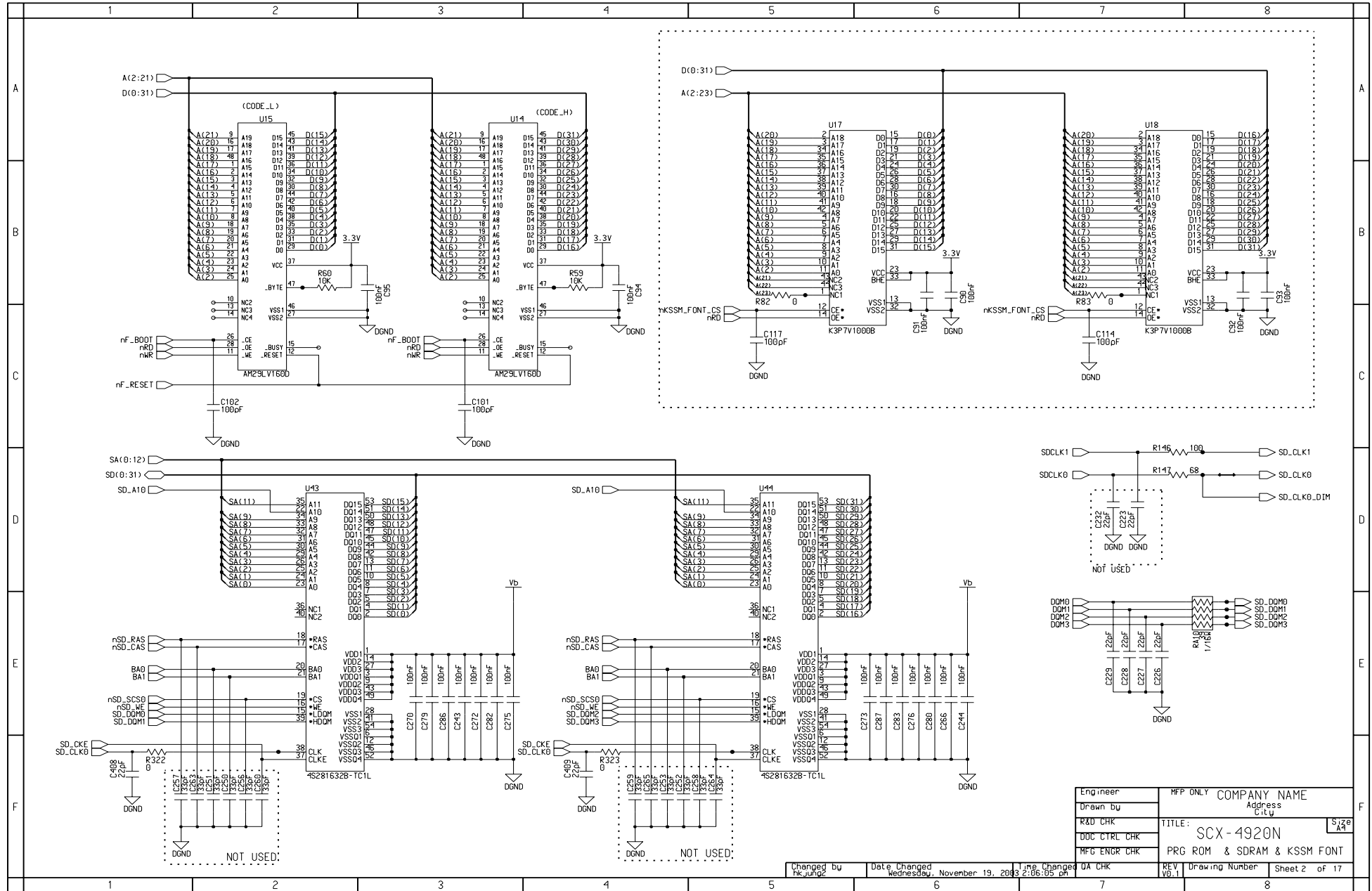

Engineer	HFP ONLY COMPANY NAME
Drawn by	Address
R&D CHK	City
DOC CTRL CHK	TITLE: SCX - 4920N
MFG ENGR CHK	PRG ROM & SDRAM & KSSM FONT

Changed by	Date Changed	Time Changed	UA CHK	REV	Drawing Number	Sheet 2 of 17
16_04_02	Wednesday, November 19, 2003 2:06:03 PM			01		

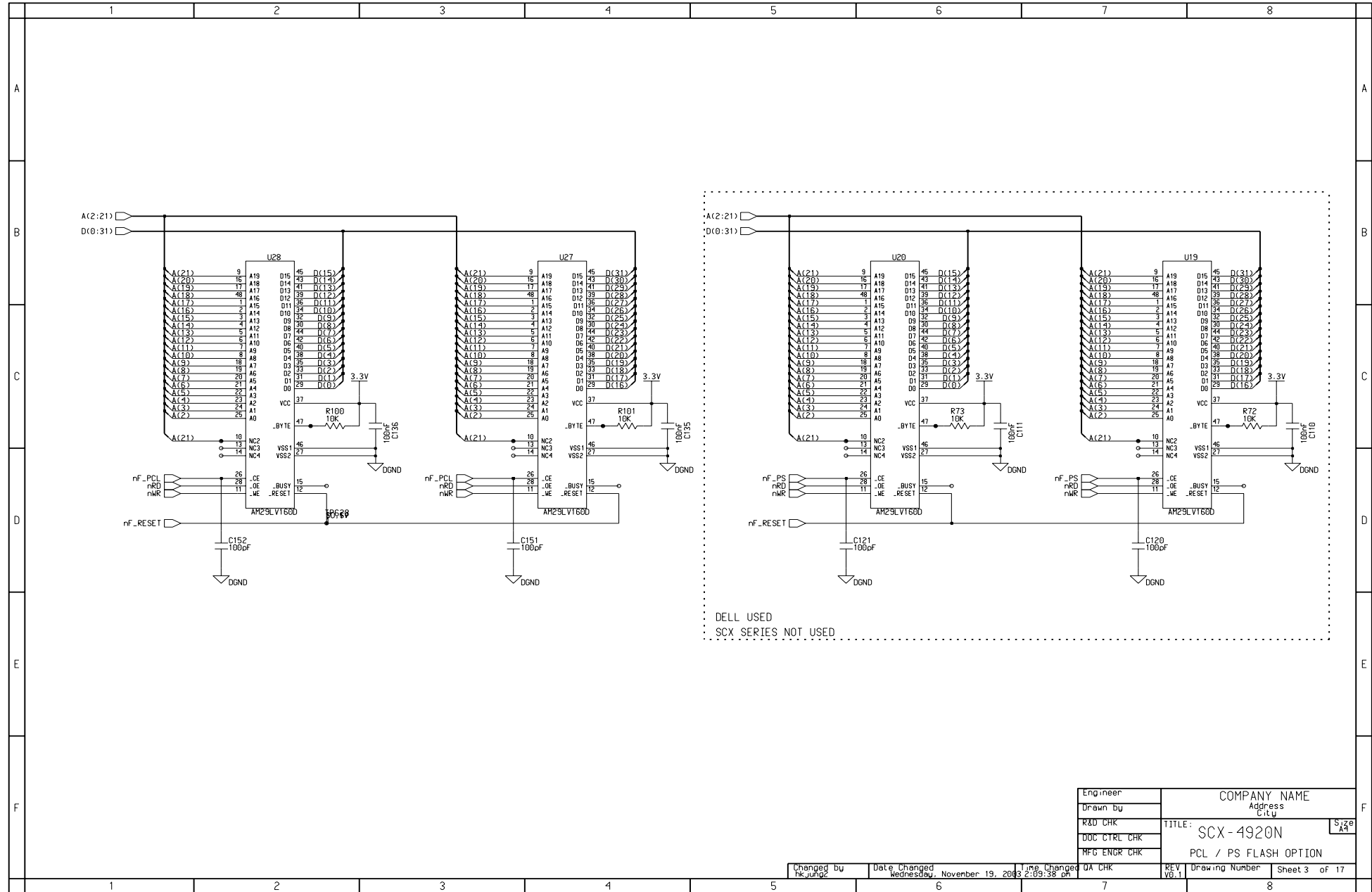

Engineer	10	COMPANY NAME
Drawn by	13	Address
R&D CHK	14	City
DOC CTRL CHK		TITLE: SCX - 4920N
MFG ENGR CHK		PCL / PS FLASH OPTION
QA CHK		REV 06.1

Changed by	Date Changed	Time Changed	QA CHK	REV	Drawing Number	Sheet 3 of 17
hk_pjg	November 19, 2003	2:09:38 pm		06.1		

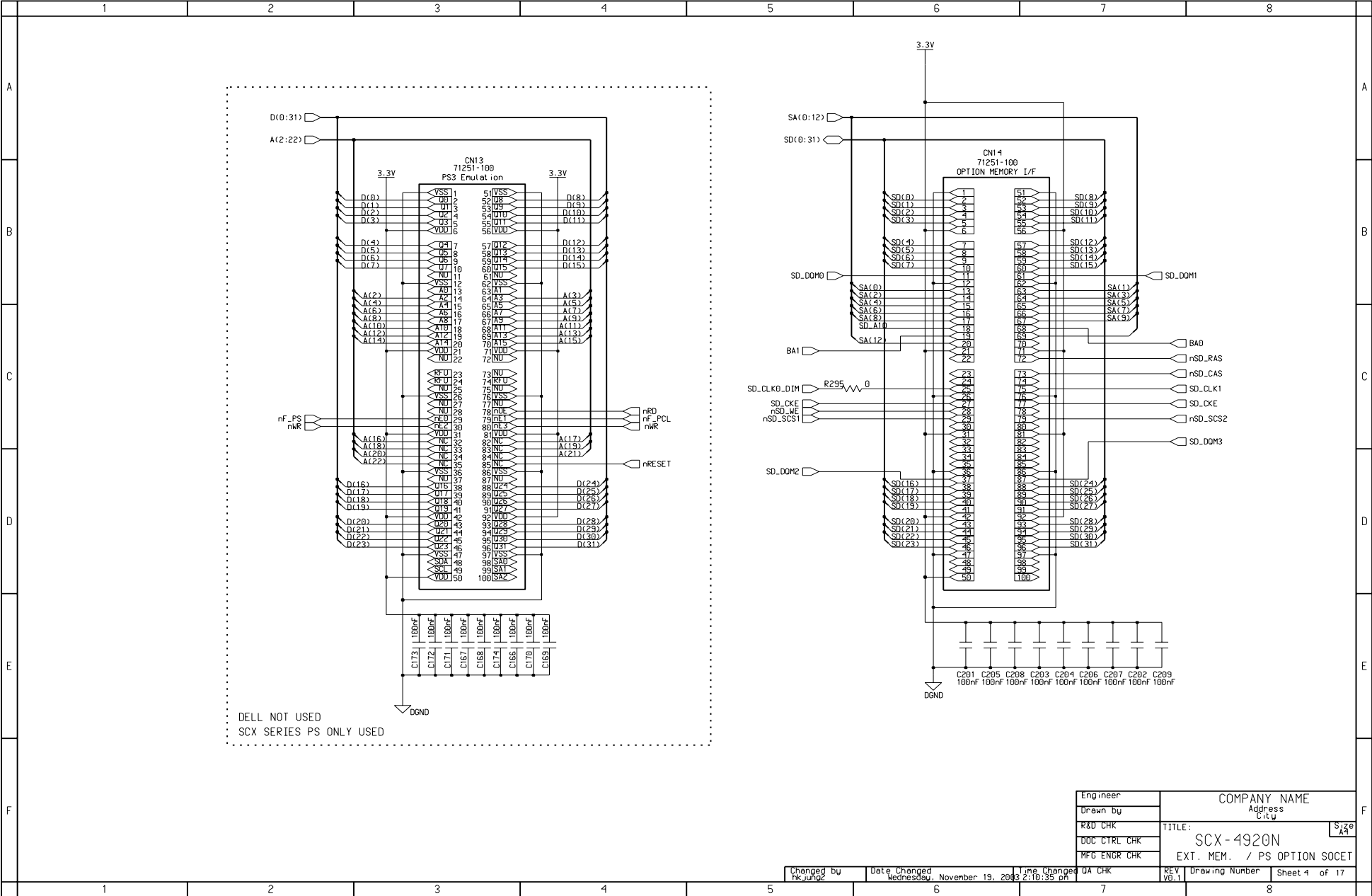

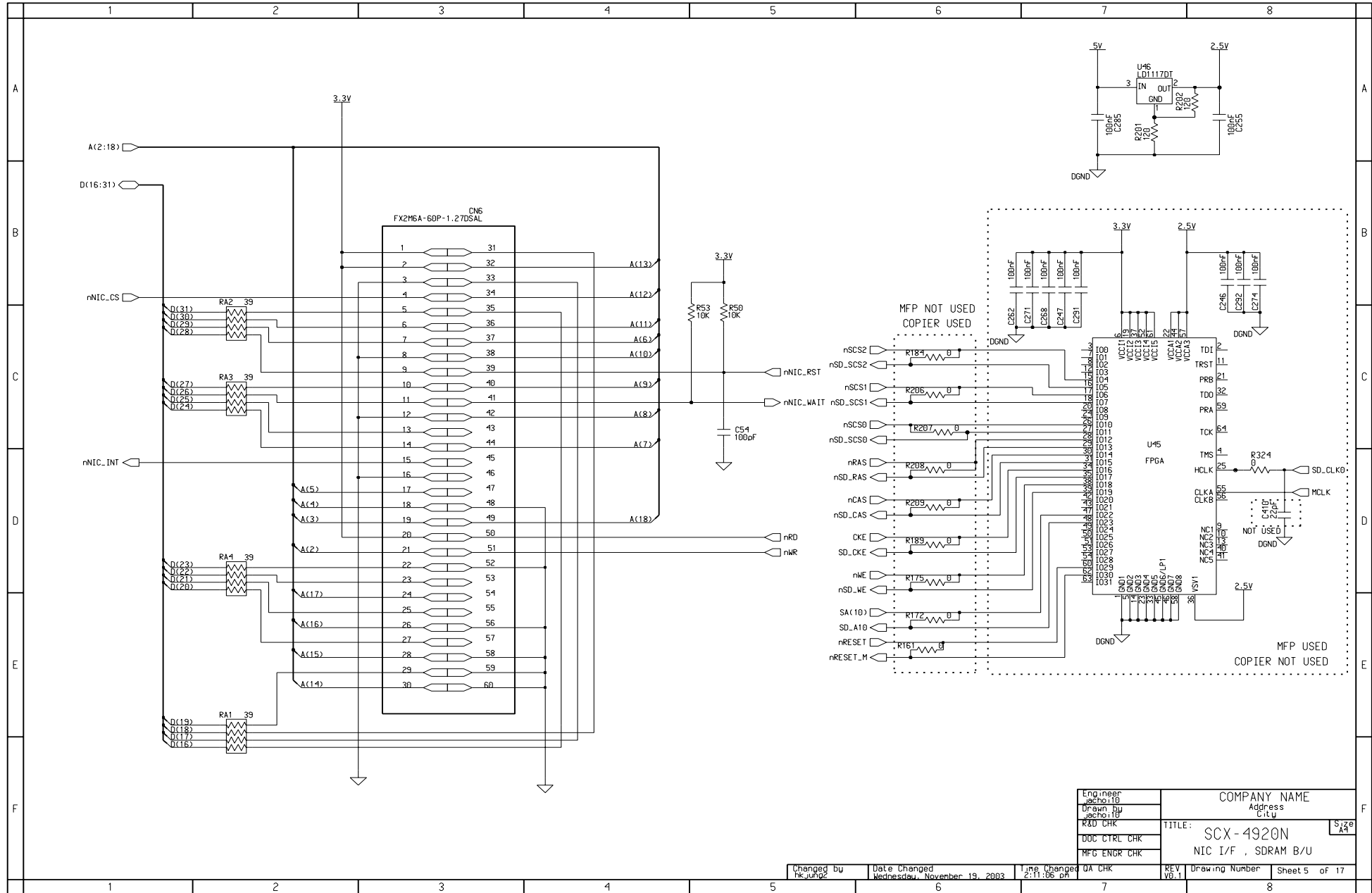

Engineer jecho10	COMPANY NAME
Drawn by jecho10	Address
R3D CHK	City
DOC CTRL CHK	TITLE: SCX-4920N
MFG ENGR CHK	NIC I/F , SDRAM B/U

Changed by hk_jcho	Date Changed Wednesday, November 19, 2003	Time Changed 2:11:06 pm	QA CHK	REV 1	Drawing Number	Sheet 5 of 17
-----------------------	--	----------------------------	--------	-------	----------------	---------------

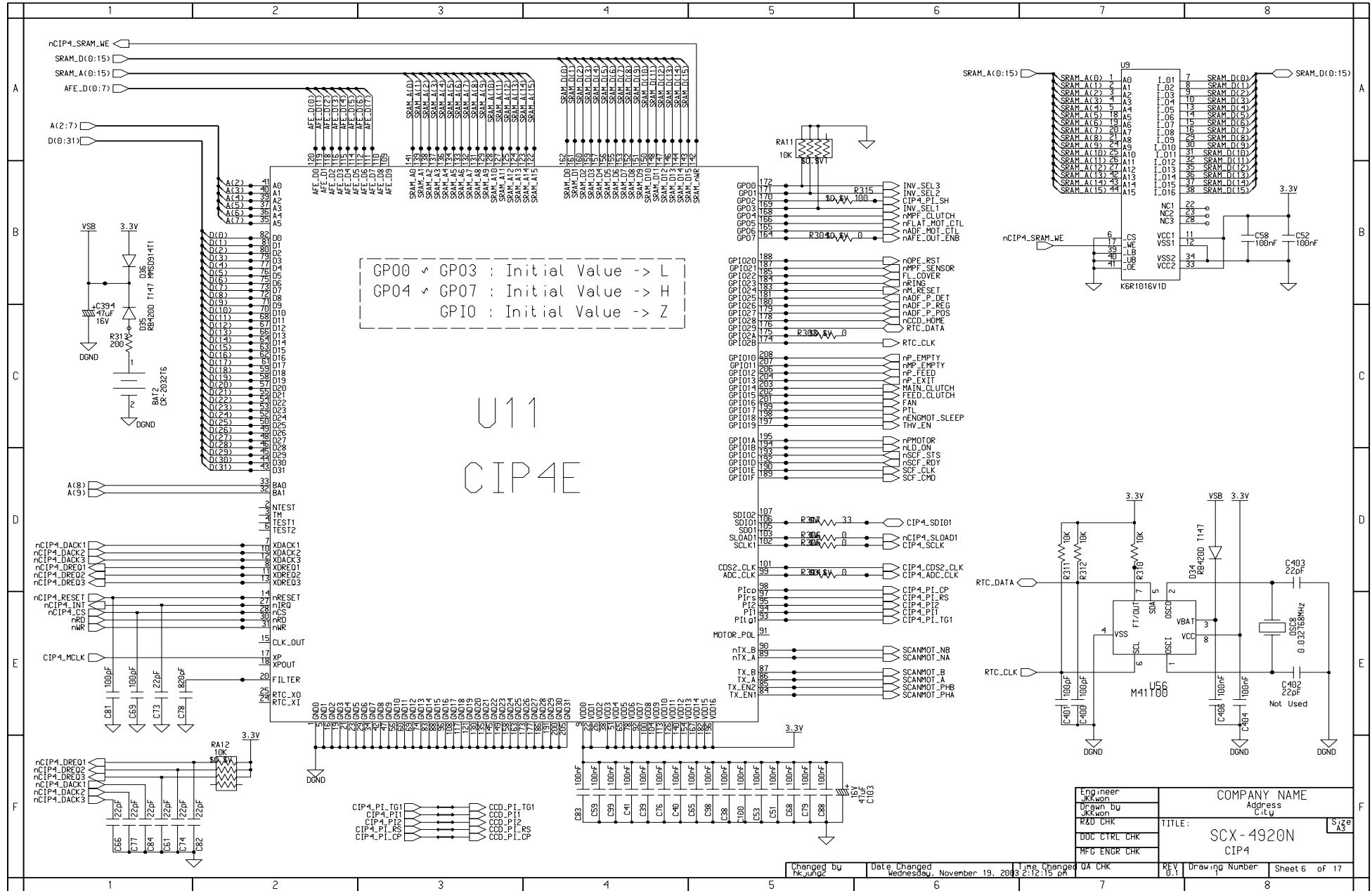

Engineer J.Kwon	COMPANY NAME
Drawn by J.Kwon	Address
DOC CTRL CHK	CITY
MFG ENGR CHK	TITLE:
	SCX-4920N
	CIP4

Changed by hs.jung	Date Changed Wednesday, November 19, 2003 2:12:19 pm	Time Changed 0A:CHK	REV 0.1	Drawing Number 1	Sheet 6 of 17
-----------------------	---	------------------------	------------	---------------------	---------------

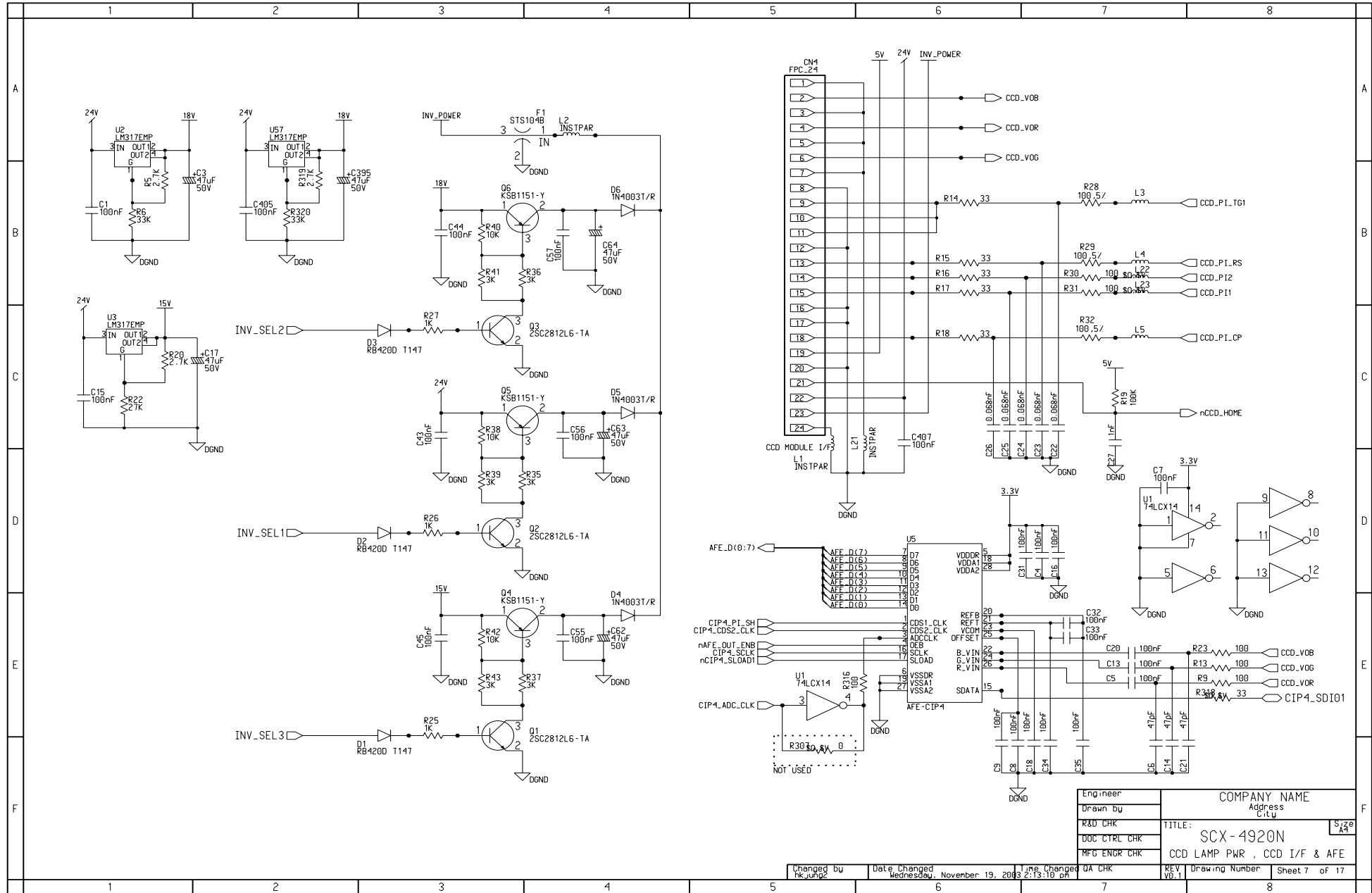

Engineer	COMPANY NAME
Drawn by	Address
R&D CHK	City
DOC CTRL CHK	TITLE: SCX-4920N
MFG ENGR CHK	CCD LAMP PWR , CCD I/F & AFE
QA CHK	REV 1
Changed by	Drawing Number
Date Changed	Sheet 7 of 17

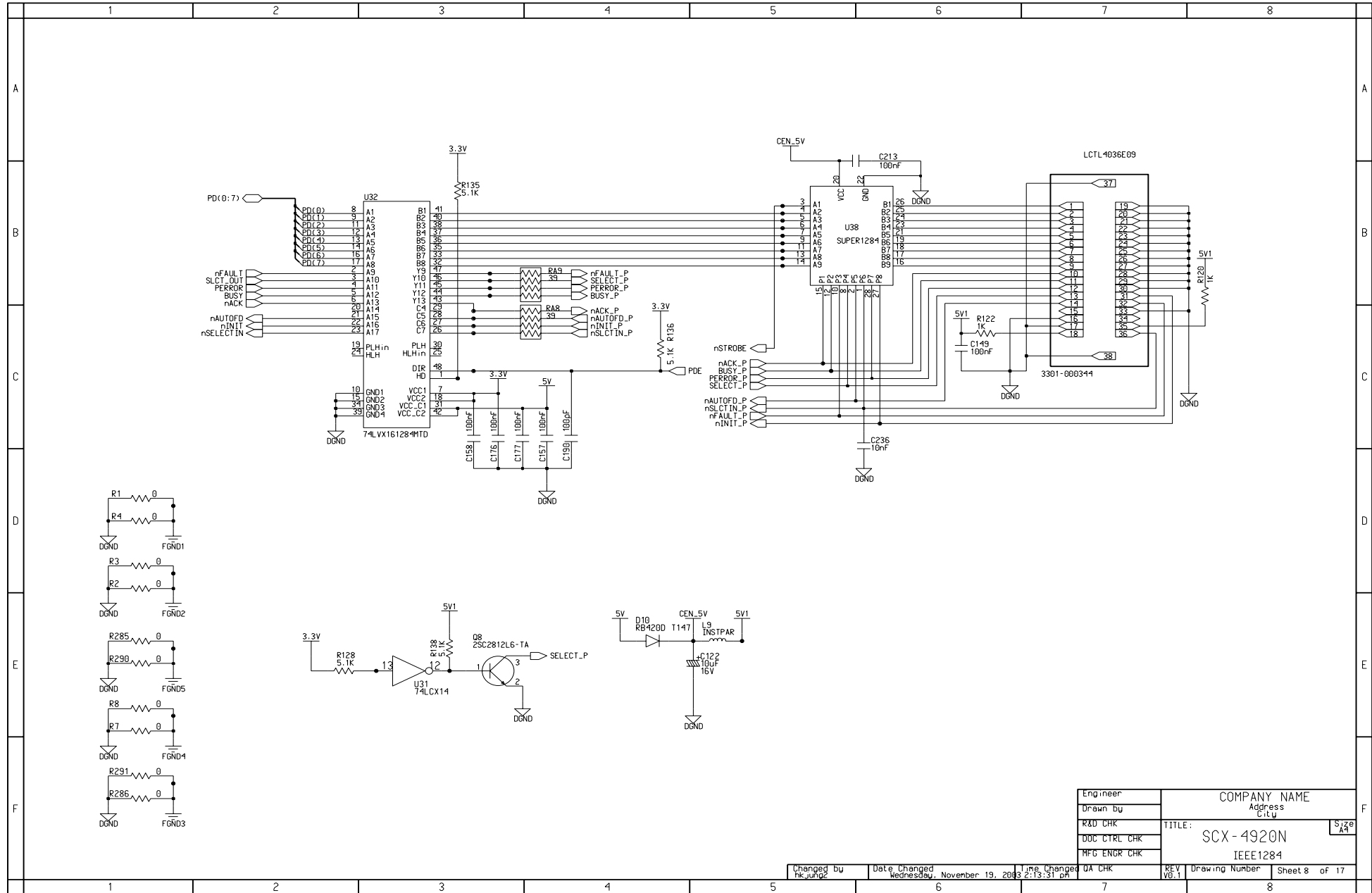

Engineer	COMPANY NAME
Drawn by	Address
R&D CHK	CITY
DOC CTRL CHK	TITLE: SCX - 4920N
MFG ENGR CHK	IEEE1284
UA CHK	REV

Changed by	Date Changed	Time Changed	Drawing Number	Sheet 8 of 17
rk_jay2	Wednesday, November 19, 2003 2:13:31 pm			



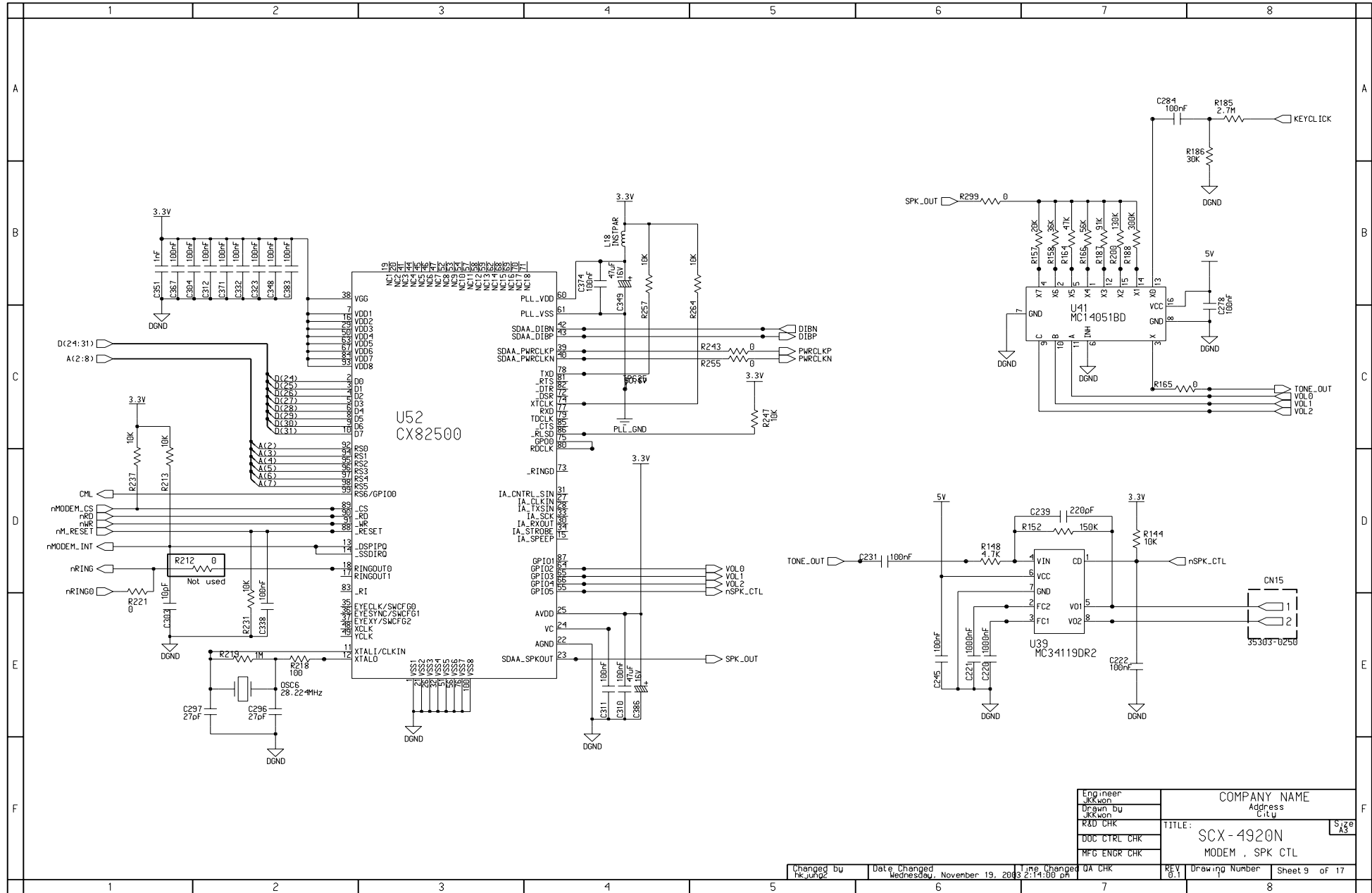

Engineer JKKwon	COMPANY NAME
Drawn by JKKwon	Address
R3D CHK	City
DOC CTRL CHK	TITLE: SCX - 4920N
MFG ENGR CHK	MODEM , SPK CTL

Changed by hk_jk@dc	Date Changed Wednesday, November 19, 2003 2:14:00 pm	Time Changed 04:00	QA CHK	REV 0	Drawing Number	Sheet 9 of 17
------------------------	---	-----------------------	--------	----------	----------------	---------------

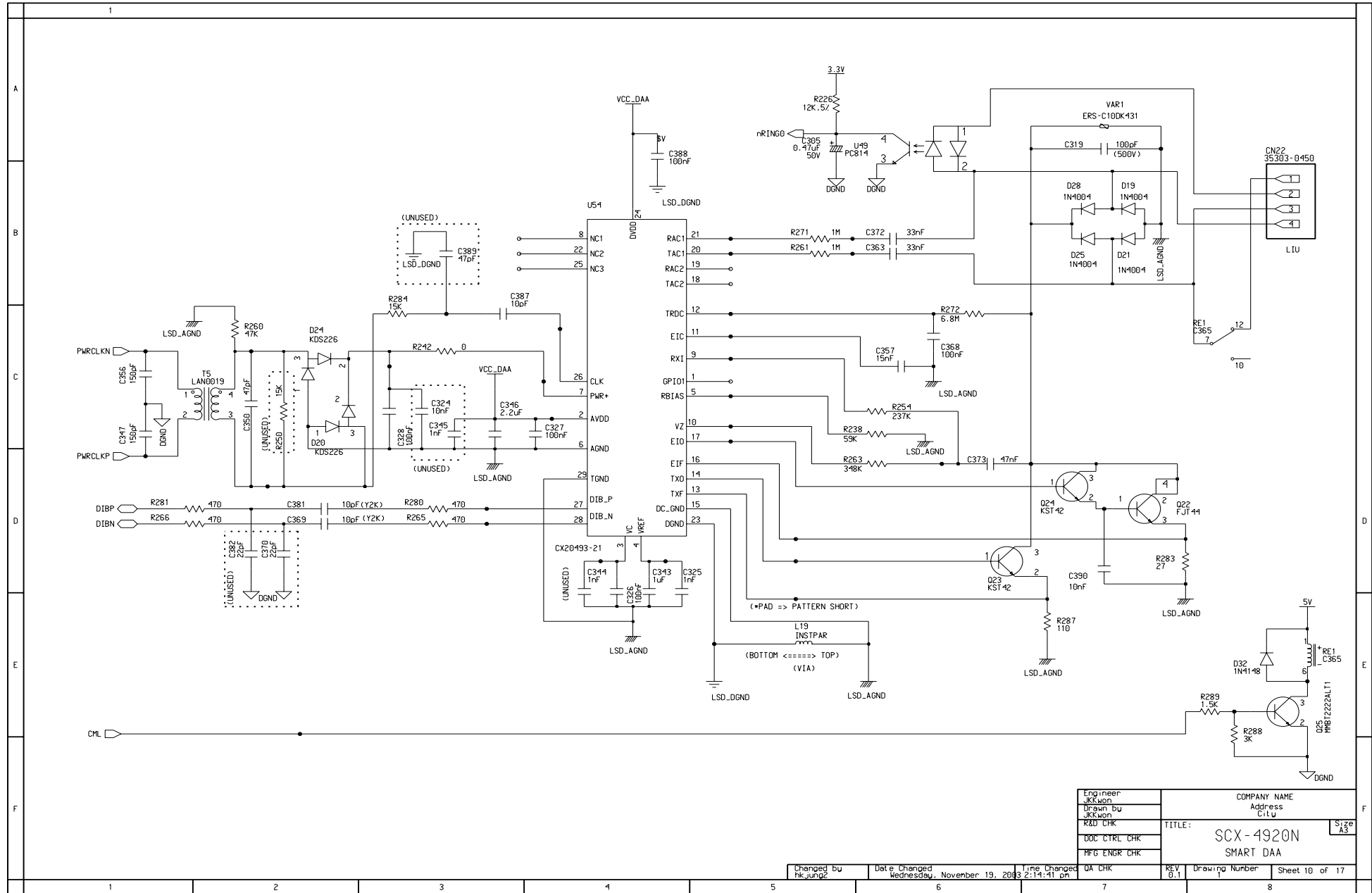

Engineer JKKwon	COMPANY NAME Address City
Drawn by JKKwon	TITLE: SCX-4920N SMART DAA
R&D CHK	
DOC CTRL CHK	
PRG ENGR CHK	

Changed by hk_jung	Date Changed Wednesday, November 19, 2003 2:14:41 pm	Time Changed 0A:CHK	REV 0.1	Drawing Number 1	Sheet 10 of 17
-----------------------	---	------------------------	------------	---------------------	----------------

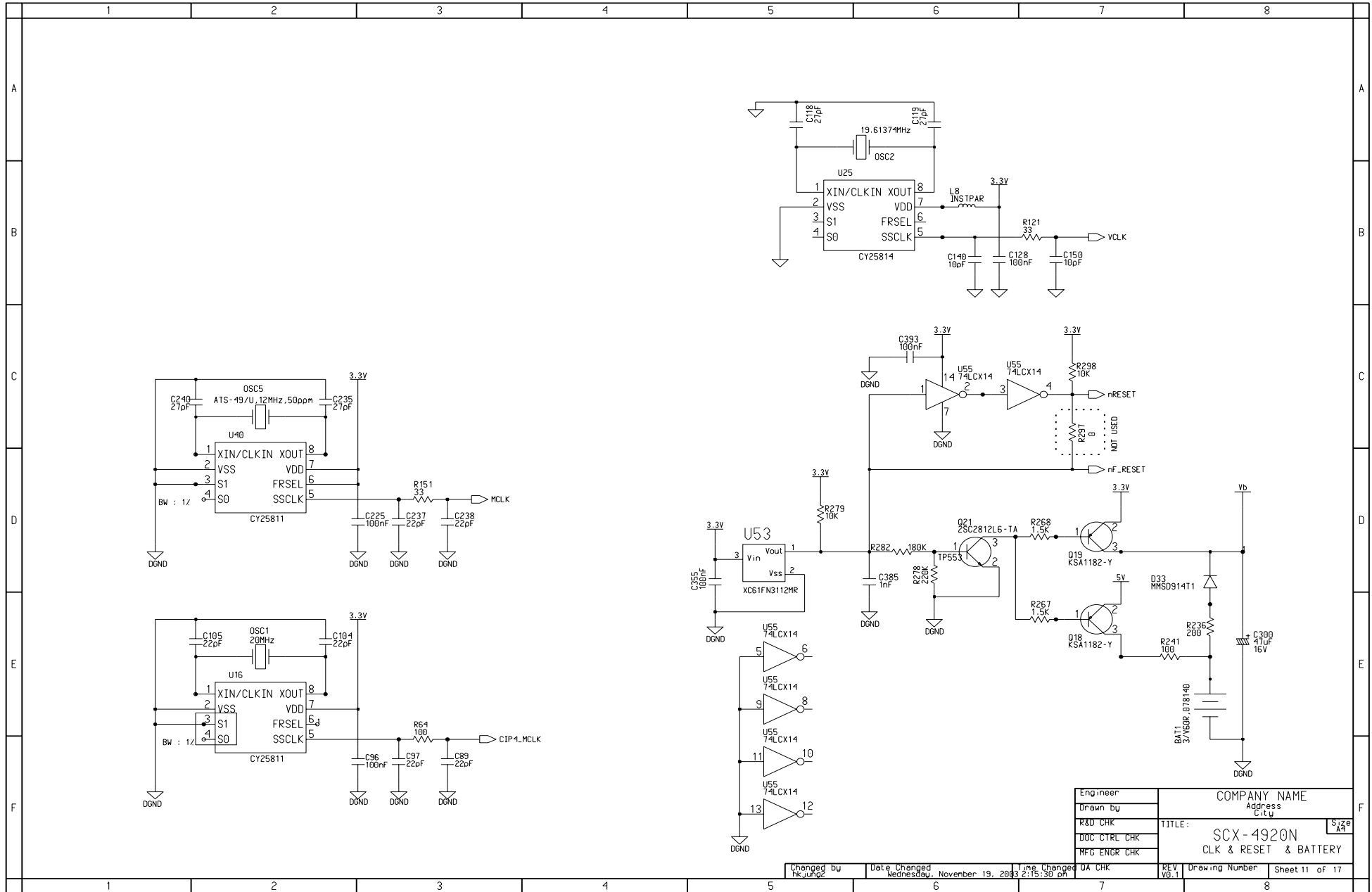

Engineer	COMPANY NAME
Drawn by	Address
R&D CHK	CITY
DOC CTRL CHK	TITLE: SCX-4920N
MFG ENGR CHK	CLK & RESET & BATTERY

Changed by hk_dhpc	Date Changed Wednesday, November 19, 2003 2:15:30 pm	Time Changed 04:15:30 pm	QA CHK	REV V0.1	Drawing Number	Sheet 11 of 17
-----------------------	---	-----------------------------	--------	-------------	----------------	----------------

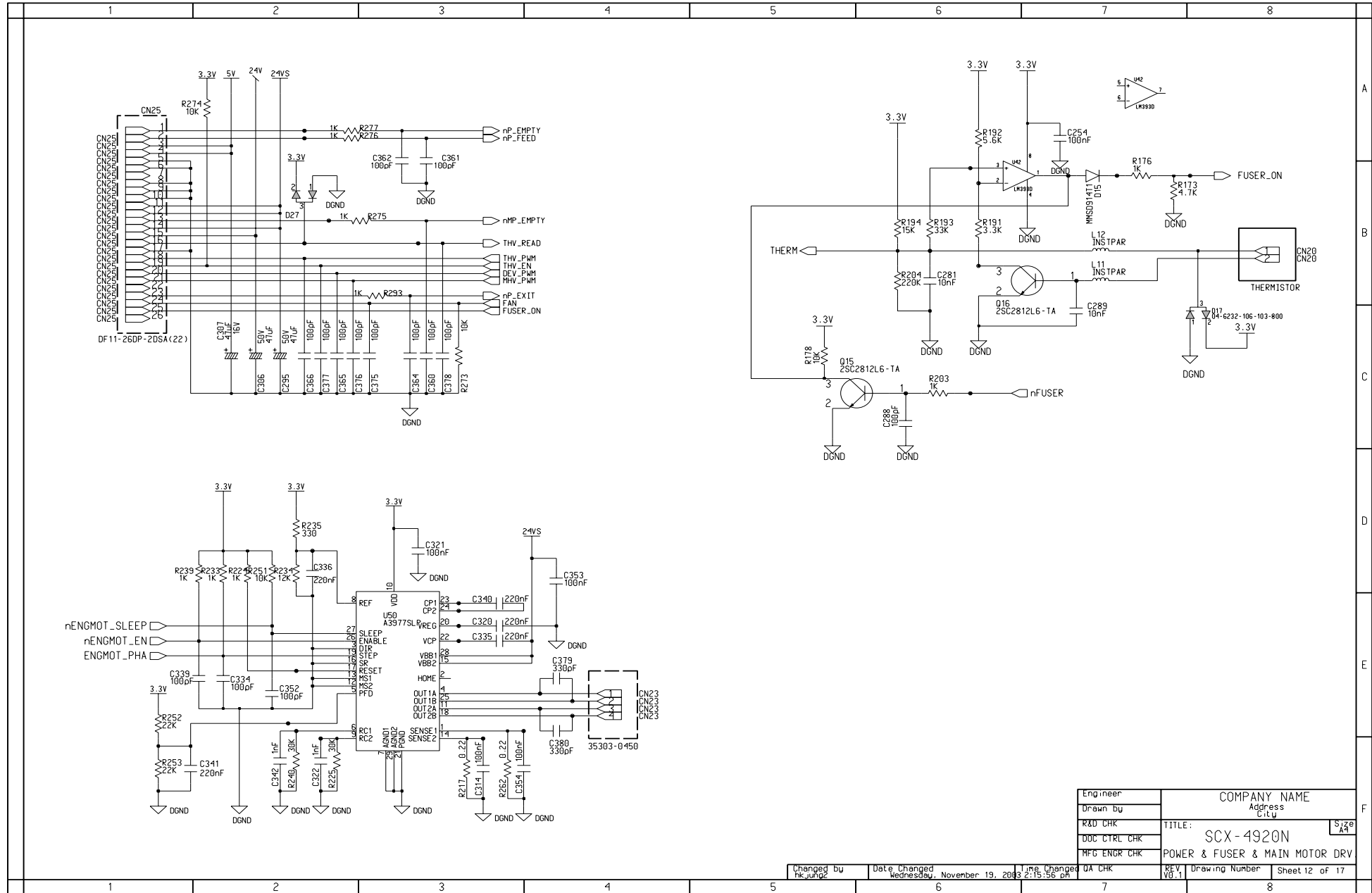

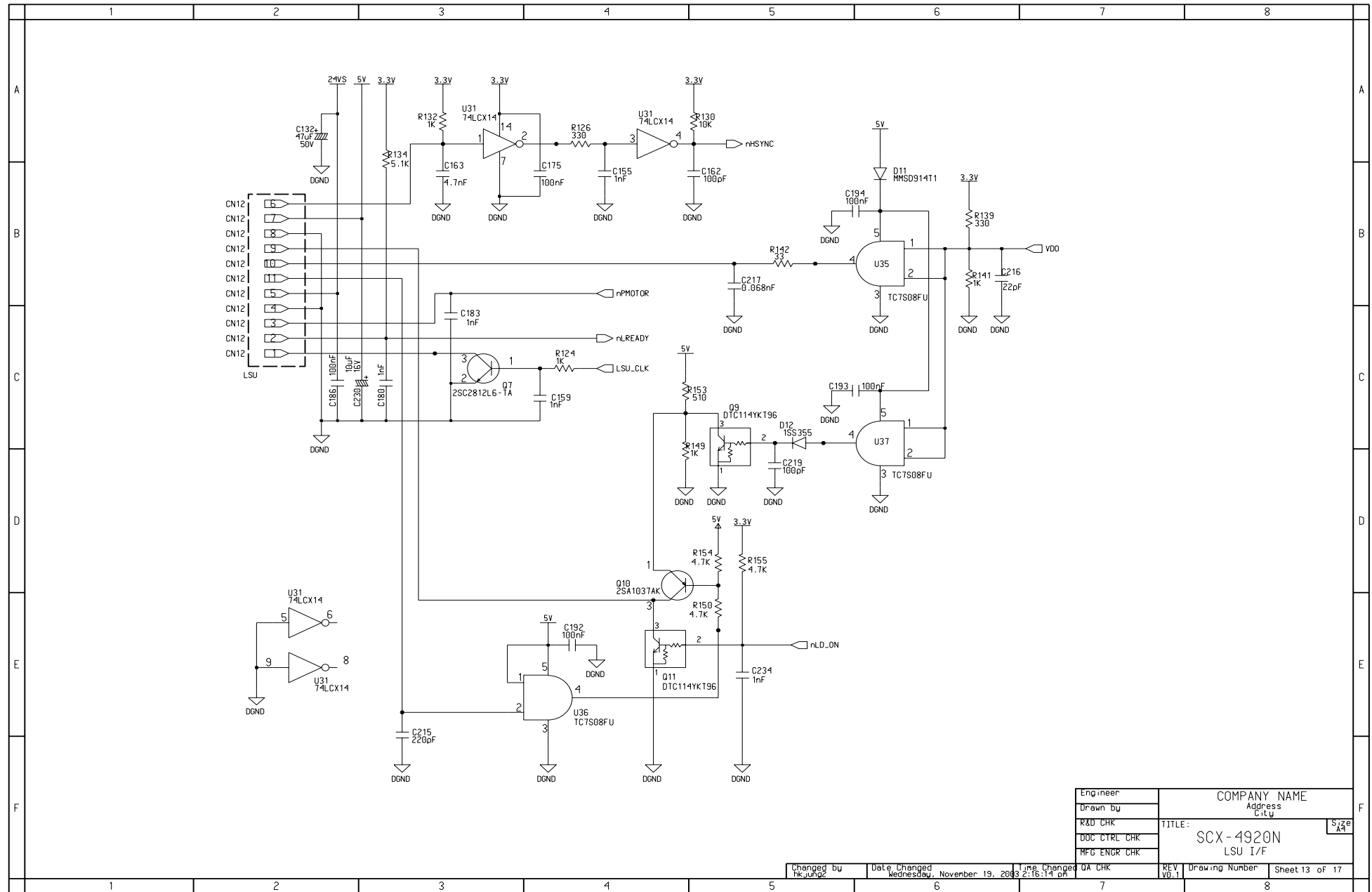

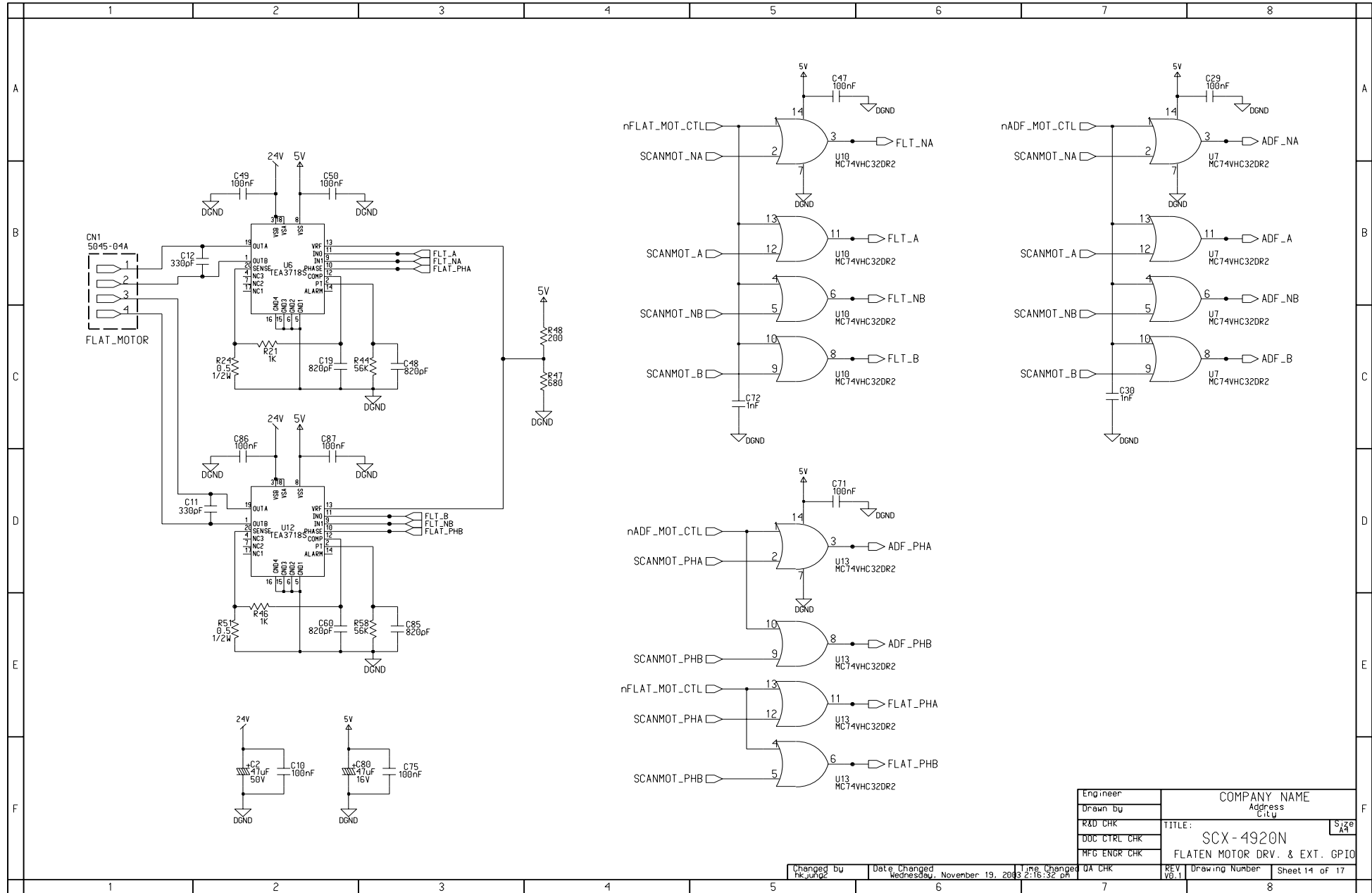

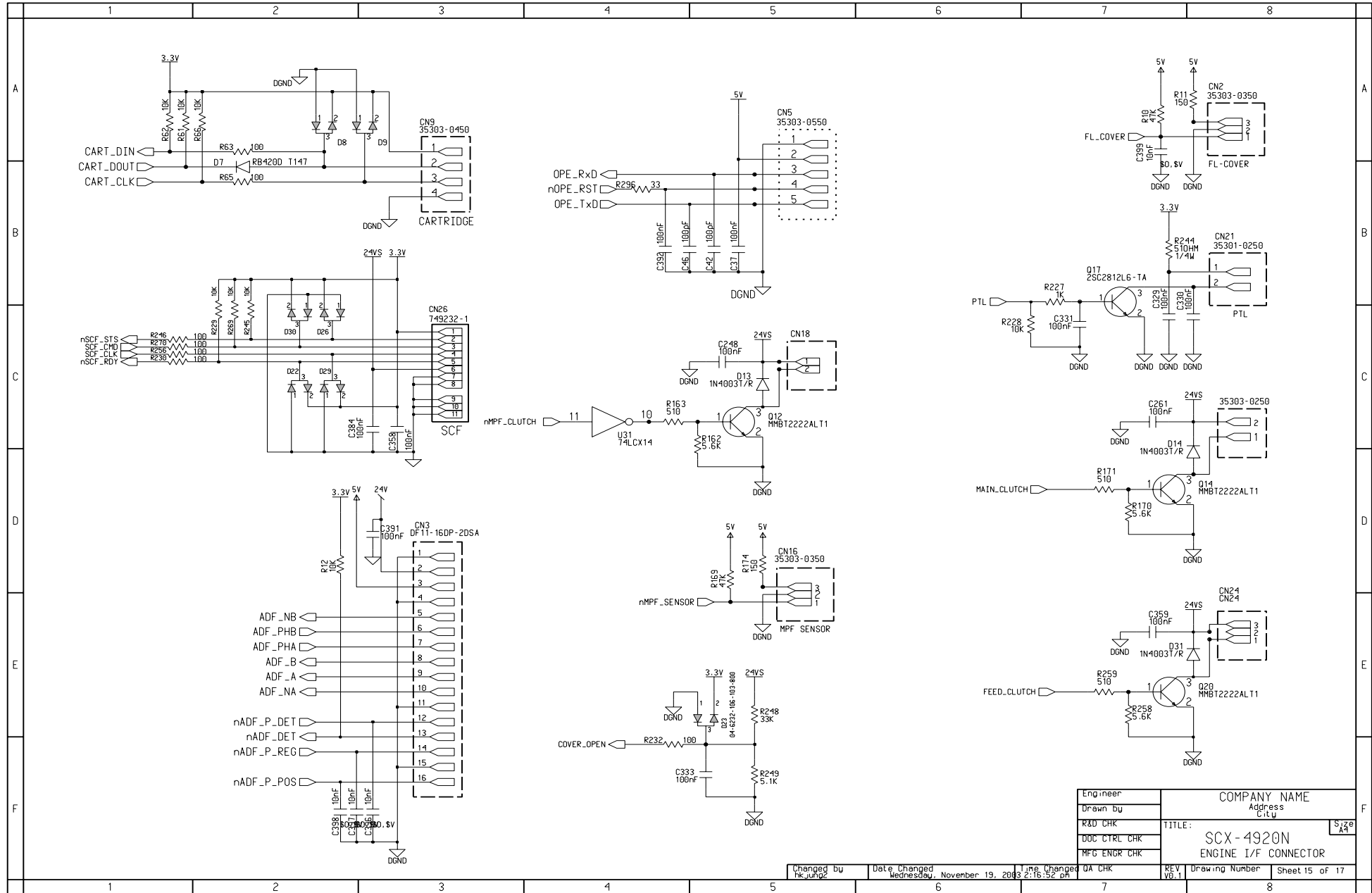

Engineer	COMPANY NAME
Drawn by	Address
R&D CHK	City
DOC CTRL CHK	TITLE:
MFG ENGR CHK	SCX-4920N
	ENGINE I/F CONNECTOR

Changed by	Date Changed	Time Changed	QA CHK	REV	Drawing Number	Sheet 15 of 17
hk_jah	Wednesday, November 19, 2003 2:16:52 pm			V0.1		

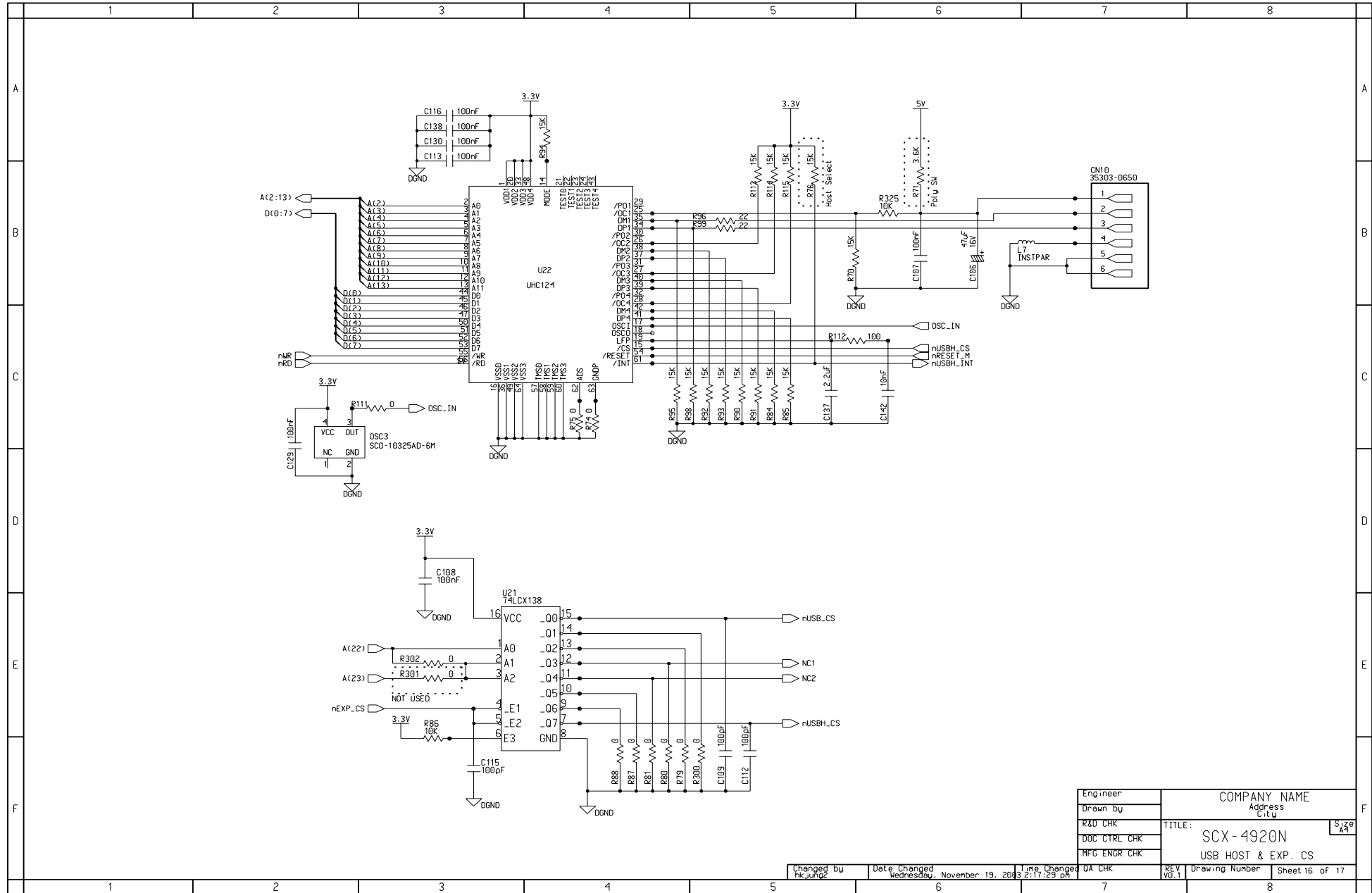

Engineer	COMPANY NAME
Drawn by	Address
R&D CHK	City
DOC CTRL CHK	TITLE: SCX - 4920N
MFG ENGR CHK	USB HOST & EXP. CS
UA CHK	REV 06.1

Changed by	Date Changed	Time Changed	Drawing Number	Sheet 16 of 17
16.04.02	Wednesday, November 19, 2003 2:17:23 pm			





# 12.2 SMPS Circuit Diagram(1/3)

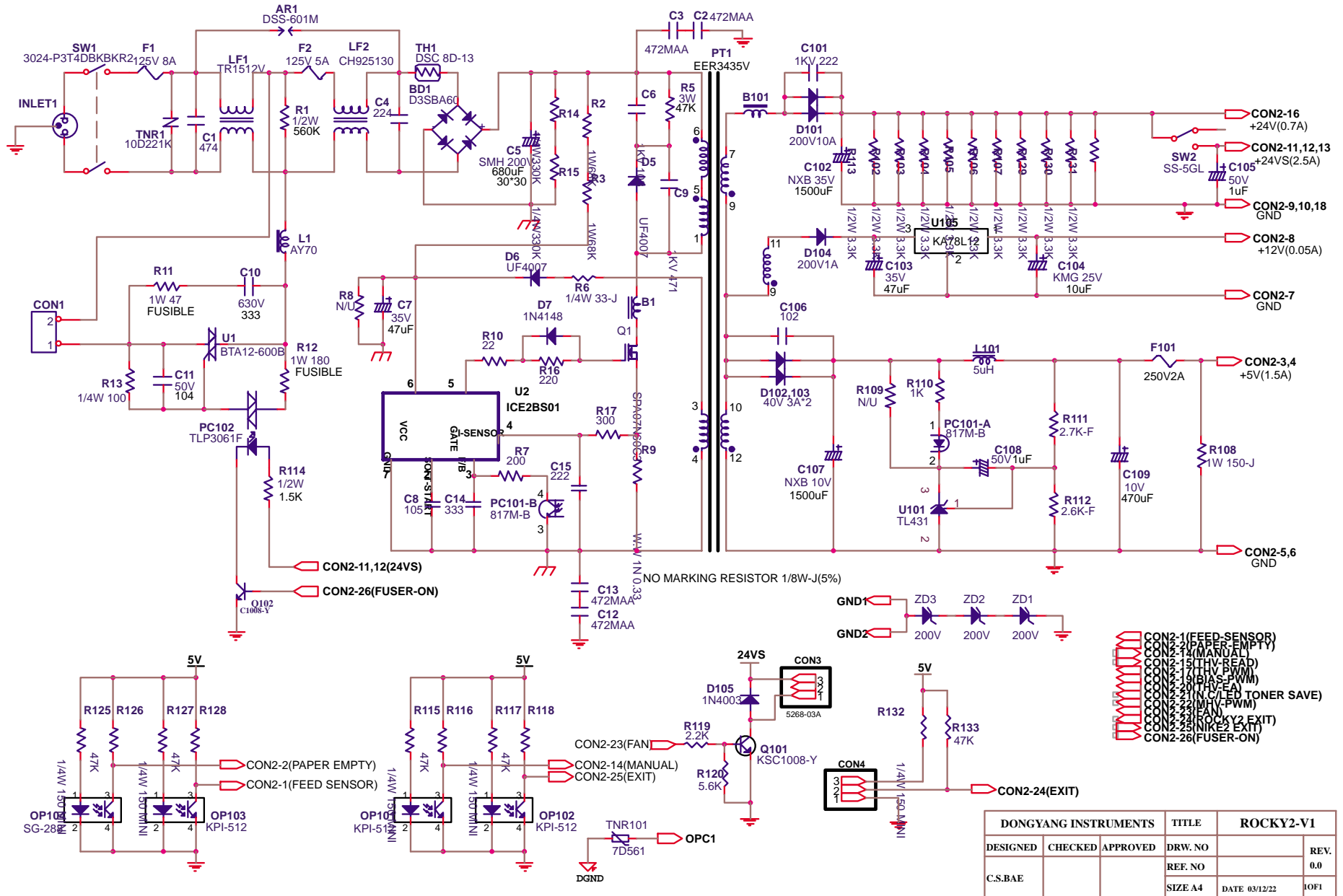

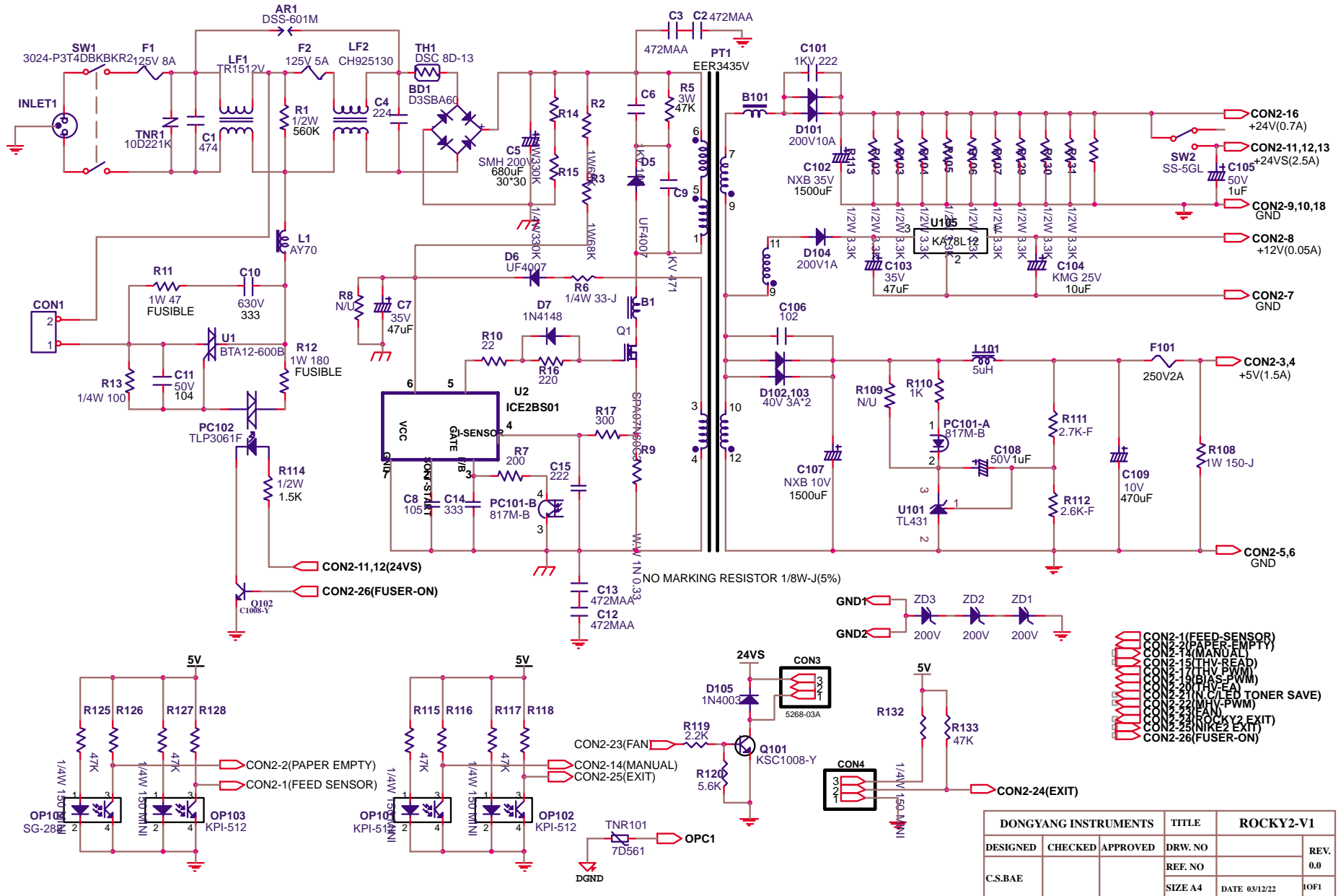

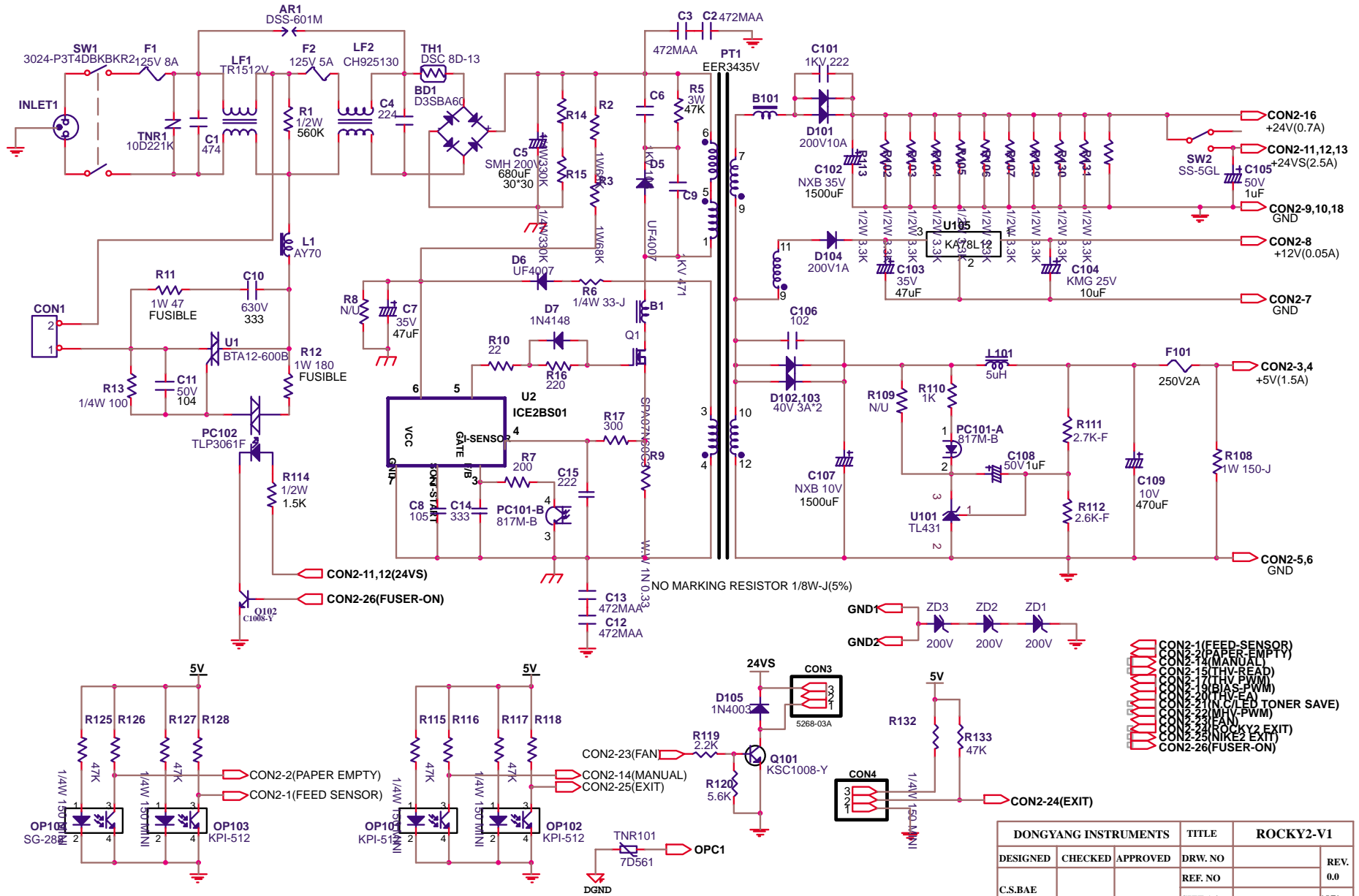

DONGYANG INSTRUMENTS			TITLE		ROCKY2-V1	
DESIGNED	CHECKED	APPROVED	DRW. NO		REV.	
C.S.BAE			REF. NO		0.0	
			SIZE A4	DATE 03/12/22	IOF1	

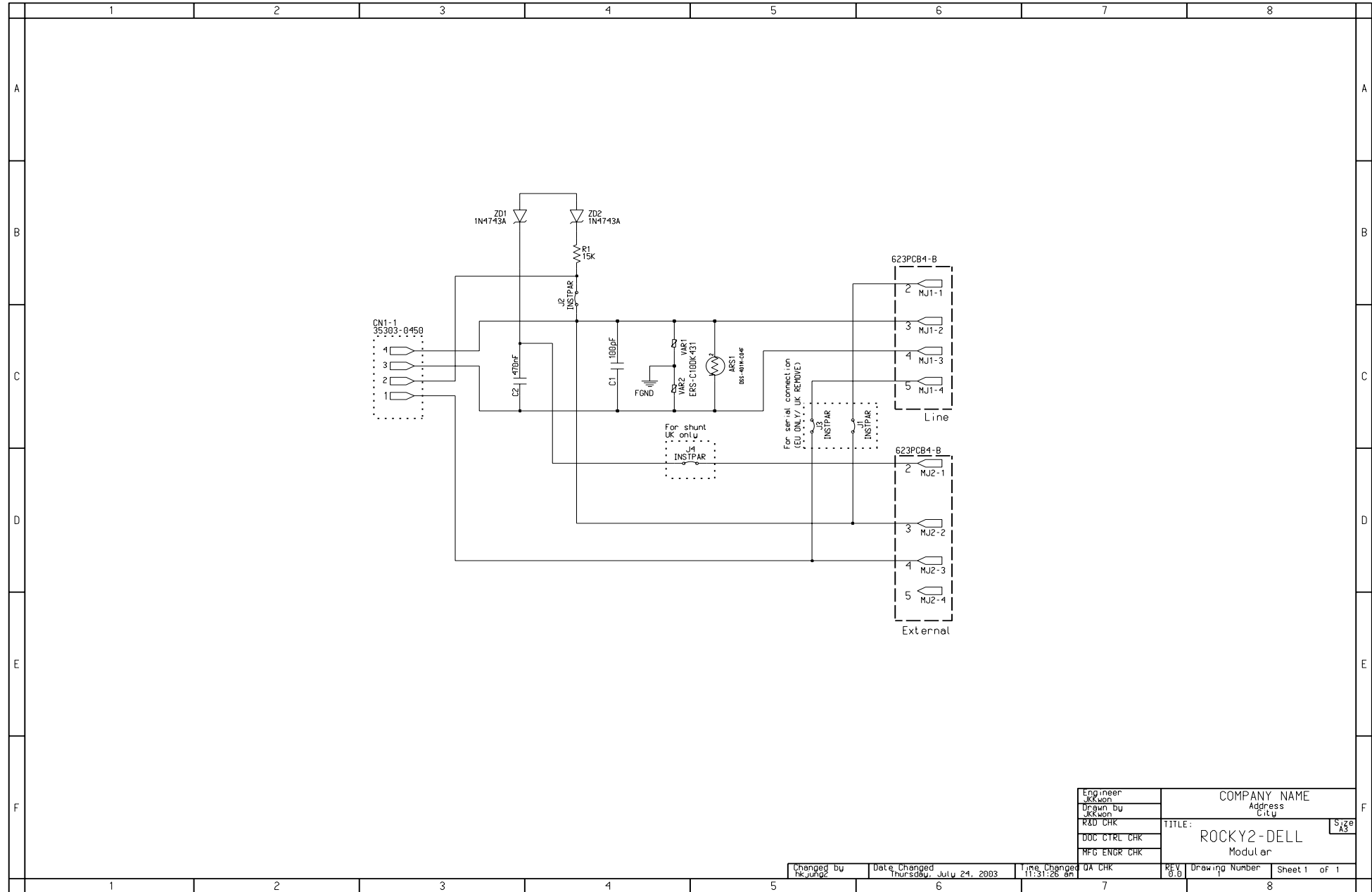

Engineer JKwon	COMPANY NAME
Drawn by JKwon	Address
R3D CHK	City
DOC CTRL CHK	TITLE: ROCKY2-DELL
MFG ENGR CHK	Modular
QA CHK	REV 0.0
Changd by hk.jung	Date Changd Thursday, July 24, 2003
Time Changd 11:31:26 am	Drawing Number
	Sheet 1 of 1