

Service Manual

iR4570/3570, 2870/2270 Series
iR3035

Canon

Application

This manual has been issued by Canon Inc. for qualified persons to learn technical theory, installation, maintenance, and repair of products. This manual covers all localities where the products are sold. For this reason, there may be information in this manual that does not apply to your locality.

Corrections

This manual may contain technical inaccuracies or typographical errors due to improvements or changes in products. When changes occur in applicable products or in the contents of this manual, Canon will release technical information as the need arises. In the event of major changes in the contents of this manual over a long or short period, Canon will issue a new edition of this manual.

The following paragraph does not apply to any countries where such provisions are inconsistent with local law.

Trademarks

The product names and company names used in this manual are the registered trademarks of the individual companies.

Copyright

This manual is copyrighted with all rights reserved. Under the copyright laws, this manual may not be copied, reproduced or translated into another language, in whole or in part, without the written consent of Canon Inc.

COPYRIGHT © 2001 CANON INC.









Printed in Japan

Caution

Use of this manual should be strictly supervised to avoid disclosure of confidential information.



Symbols Used

This documentation uses the following symbols to indicate special information:

Symbol	Description
	Indicates an item of a non-specific nature, possibly classified as Note, Caution, or Warning.
	Indicates an item requiring care to avoid electric shocks.
	Indicates an item requiring care to avoid combustion (fire).
	Indicates an item prohibiting disassembly to avoid electric shocks or problems.
	Indicates an item requiring disconnection of the power plug from the electric outlet.
 Memo	Indicates an item intended to provide notes assisting the understanding of the topic in question.
 REF.	Indicates an item of reference assisting the understanding of the topic in question.
	Provides a description of a service mode.
	Provides a description of the nature of an error indication.

The following rules apply throughout this Service Manual:

1. Each chapter contains sections explaining the purpose of specific functions and the relationship between electrical and mechanical systems with reference to the timing of operation.

In the diagrams,  represents the path of mechanical drive; where a signal name accompanies the symbol, the arrow  indicates the direction of the electric signal.

The expression "turn on the power" means flipping on the power switch, closing the front door, and closing the delivery unit door, which results in supplying the machine with power.

2. In the digital circuits, '1' is used to indicate that the voltage level of a given signal is "High", while '0' is used to indicate "Low". (The voltage value, however, differs from circuit to circuit.) In addition, the asterisk (*) as in "DRMD*" indicates that the DRMD signal goes on when '0'.

In practically all cases, the internal mechanisms of a microprocessor cannot be checked in the field. Therefore, the operations of the microprocessors used in the machines are not discussed: they are explained in terms of from sensors to the input of the DC controller PCB and from the output of the DC controller PCB to the loads.

The descriptions in this Service Manual are subject to change without notice for product improvement or other purposes, and major changes will be communicated in the form of Service Information bulletins.

All service persons are expected to have a good understanding of the contents of this Service Manual and all relevant Service Information bulletins and be able to identify and isolate faults in the machine."

Contents

Chapter 1 Introduction

1.1 Product Specifications	1- 1
1.1.1 Safety	1- 1
1.1.1.1 Safety of the Laser Light	1- 1
1.1.1.2 CDRH Regulations.....	1- 1
1.1.1.3 Handling the Laser Unit	1- 1
1.1.1.4 Safety of Toner	1- 1

Chapter 2 Installation

2.1 Unpacking and Installation	2- 1
2.1.1 Connecting the Cable	2- 1
2.2 Installing the Reader Heater	2- 1
2.2.1 Checking the Parts	2- 1
2.2.2 Turning Off the Host Machine.....	2- 1
2.2.3 Installation Procedure	2- 1
2.3 Installing the Cassette Heater for the Cassette Pedestal	2- 2
2.3.1 Checking the Contents	2- 2
2.3.2 Checking the Contents	2- 2
2.3.3 Checking the Contents	2- 3
2.3.4 Turning Off the Host Machine.....	2- 3
2.3.5 Installation Procedure (Cassette Heater Unit 29)	2- 3
2.3.6 Installation Procedure (Cassette Heater AttachmentD2).....	2- 4
2.3.7 Installation Procedure (Cassette Heater Unit36)	2- 5
2.4 Installing the Deck Heater	2- 6
2.4.1 Checking the Parts to Install.....	2- 6
2.4.2 Turning Off the Host Machine.....	2- 7
2.4.3 Installation Procedure.....	2- 7
2.5 Installing the Voice Guidance Kit.....	2- 10
2.5.1 A point to keep in mind at installation	2- 10
2.5.2 Checking the Contents	2- 10
2.5.3 Turning Off the Host Machine.....	2- 11
2.5.4 Installation Procedure	2- 12
2.6 Installing the Voice Operation Kit	2- 18
2.6.1 A point to keep in mind at installation	2- 18
2.6.2 Checking the Contents	2- 18
2.6.3 Turning Off the Host Machine.....	2- 19
2.6.4 Installation Procedure.....	2- 20

Chapter 3 Main Controller

3.1 Construction	3- 1
3.1.1 Construction and Mechanisms	3- 1
3.2 Construction of the Electrical Circuitry.....	3- 1
3.2.1 Main Controller PCB.....	3- 1
3.2.2 HDD.....	3- 2
3.3 Start-Up Sequence	3- 4
3.3.1 Overview.....	3- 4
3.3.2 Start-Up Sequence	3- 4
3.4 Shut-Down Sequence.....	3- 6

3.4.1 Overview	3- 6
3.4.2 Flow of Operation.....	3- 6
3.5 Image Processing.....	3- 6
3.5.1 Overview of the Image Flow	3- 6
3.5.2 Construction of the Image Processing Module	3- 7
3.5.3 Reader Unit Input Image Processing	3- 7
3.5.4 Compressio/ Extesion/ Editing Block	3- 8
3.5.5 Printer unit Output Image Processing	3- 8
3.6 Flow of Image Data	3- 9
3.6.1 Flow of Image Data According to Copy Functions.....	3- 9
3.6.2 Flow of Image Data for the Box Function.....	3- 9
3.6.3 Flow of Image Data for the SEND Function.....	3- 10
3.6.4 Flow of Image Data for the Fax Transmission	3- 10
3.6.5 Flow of Image Data for the Fax Reception Function.....	3- 11
3.6.6 Flow of Image Data for the PDL Function.....	3- 11
3.7 Parts Replacement Procedure	3- 12
3.7.1 Main Controller PCB	3- 12
3.7.1.1 Removing the Rear Cover	3- 12
3.7.1.2 Removing the Main Controller PCB	3- 12
3.7.2 SDRAM.....	3- 13
3.7.2.1 Removing the Face Cover	3- 13
3.7.2.2 Removing the SDRAM.....	3- 13
3.7.3 Boot ROM	3- 13
3.7.3.1 Removing the Face Cover	3- 13
3.7.3.2 Removing the Boot ROM.....	3- 13
3.7.4 HDD	3- 14
3.7.4.1 Removing the Face Cover	3- 14
3.7.4.2 Removing the Counter PCB.....	3- 14
3.7.4.3 Removing the HDD	3- 14

Chapter 4 Laser Exposure

4.1 Construction	4- 1
4.1.1 Specifications, Control Mechanism, and Functions	4- 1
4.1.2 Major Components.....	4- 1
4.1.3 Construction of the Control System	4- 2
4.2 Basic Sequence	4- 3
4.2.1 Basic Sequence	4- 3
4.3 Various Controls.....	4- 4
4.3.1 Controlling the Laser Activation Timing	4- 4
4.3.1.1 Turning On and off the Laser Light	4- 4
4.3.1.2 Main Scanning Synchronous Control.....	4- 5
4.3.2 Controlling the Intensity of Laser Light.....	4- 6
4.3.2.1 APC Control	4- 6
4.3.3 Controlling the Laser Scanner Motor	4- 6
4.3.3.1 Controlling the Laser Scanner Motor	4- 6
4.3.4 Controlling the Laser Shutter	4- 6
4.3.4.1 Controlling the Laser Shutter	4- 6
4.4 Parts Replacement Procedure	4- 7
4.4.1 Laser Scanner Unit.....	4- 7
4.4.1.1 Removing the Front Cover Unit	4- 7
4.4.1.2 Removing the Left Cover	4- 7
4.4.1.3 Removing the Laser Unit	4- 7

Chapter 5 Image Formation

5.1 Construction	5- 1
------------------------	------

5.1.1 Specifications of the Image Formation System	5- 1
5.1.2 Major Components of the Image Formation System	5- 2
5.2 Image Formation Process	5- 2
5.2.1 Image Formation Process (outline)	5- 2
5.2.2 Image Formation Process (image formation)	5- 3
5.3 Basic Sequence	5- 3
5.3.1 Sequence of Operation (initial rotation)	5- 3
5.3.2 Sequence of Operation (copying)	5- 4
5.3.3 Sequence of Operation (last rotation)	5- 4
5.4 Image Stabilization Control	5- 4
5.4.1 Overview	5- 4
5.4.2 APVC Control	5- 5
5.4.3 ATVC Control	5- 5
5.5 Drum Unit	5- 5
5.5.1 Charging Mechanism	5- 5
5.5.1.1 Controlling the Primary Charging Bias	5- 5
5.5.1.2 Primary Charging Roller Cleaning Mechanism	5- 5
5.6 Drum Cleaner Unit	5- 6
5.6.1 Photosensitive Drum Cleaning	5- 6
5.7 Developing Unit	5- 6
5.7.1 Controlling the Developing Bias	5- 6
5.8 Toner Container	5- 6
5.8.1 Overview	5- 6
5.8.2 Route of Toner Supply	5- 7
5.8.3 Controlling the Drive of the Toner Cartridge	5- 8
5.8.4 Toner Supply Control	5- 8
5.8.5 Recovery Sequence	5- 9
5.8.6 Toner Level Detection	5- 9
5.9 Transfer Unit	5- 9
5.9.1 Outline of the Transfer Unit	5- 9
5.9.1.1 Outline	5- 9
5.9.2 Controlling the Transfer Bias	5- 9
5.9.2.1 Transfer Roller Bias Control	5- 9
5.9.3 Cleaning	5- 9
5.9.3.1 Transfer Roller Cleaning Mechanism	5- 9
5.9.4 Separation Mechanism	5- 10
5.9.4.1 Controlling the Static Eliminator Bias	5- 10
5.10 Transfer Mechanism	5- 10
5.10.1 Transfer Guide Bias	5- 10
5.10.1.1 Transfer Guide Bias Control	5- 10
5.11 Photosensitive Drum Cleaning	5- 10
5.11.1 Outline	5- 10
5.11.2 Collection of Waste Toner	5- 10
5.11.3 Checking the Waste Toner Box	5- 10
5.12 Parts Replacement Procedure	5- 11
5.12.1 Pre-Exposure Lamp	5- 11
5.12.1.1 Removing the Front Cover Unit	5- 11
5.12.1.2 Removing the Waste Toner Case	5- 11
5.12.1.3 Removing the Toner Cartridge	5- 11
5.12.1.4 Removing the Drum Unit	5- 11
5.12.1.5 Removing the Developing Assembly	5- 12
5.12.1.6 Removing the Upper Tray	5- 13
5.12.1.7 Removing the Toner Cartridge Cover	5- 13
5.12.1.8 Removing the Pre-Exposure Lamp	5- 14
5.12.2 Drum Unit	5- 14
5.12.2.1 Removing the Front Cover Unit	5- 14

5.12.2.2 Removing the Waste Toner Case	5- 14
5.12.2.3 Removing the Drum Unit.....	5- 14
5.12.3 Hopper Assembly.....	5- 15
5.12.3.1 Removing the Front Cover Unit.....	5- 15
5.12.3.2 Removing the Waste Toner Case	5- 15
5.12.3.3 Removing the Toner Cartridge.....	5- 16
5.12.3.4 Removing the Drum Unit.....	5- 16
5.12.3.5 Removing the Developing Assembly	5- 17
5.12.3.6 Removing the Upper Tray	5- 18
5.12.3.7 Removing the Toner Cartridge Cover	5- 18
5.12.3.8 Removing the Pre-Exposure Lamp	5- 18
5.12.3.9 Removing the Left Cover	5- 18
5.12.3.10 Removing the Laser Unit.....	5- 18
5.12.3.11 Removing the Hopper Assembly.....	5- 19
5.12.4 Sub Hopper	5- 20
5.12.4.1 Removing the Front Cover Unit.....	5- 20
5.12.4.2 Removing the Waste Toner Case	5- 20
5.12.4.3 Removing the Toner Cartridge.....	5- 20
5.12.4.4 Removing the Drum Unit.....	5- 21
5.12.4.5 Removing the Developing Assembly	5- 21
5.12.4.6 Removing the Upper Tray	5- 22
5.12.4.7 Removing the Toner Cartridge Cover	5- 22
5.12.4.8 Removing the Pre-Exposure Lamp	5- 23
5.12.4.9 Removing the Left Cover	5- 23
5.12.4.10 Removing the Laser Unit.....	5- 23
5.12.4.11 Removing the Hopper Assembly.....	5- 24
5.12.4.12 Removing the Toner Feedscrew Motor.....	5- 24
5.12.4.13 Removing the Sub Hopper.....	5- 24
5.12.5 Developing Assembly.....	5- 26
5.12.5.1 Removing the Front Cover Unit.....	5- 26
5.12.5.2 Removing the Waste Toner Case	5- 26
5.12.5.3 Removing the Developing Assembly	5- 26
5.12.6 Developing Cylinder	5- 27
5.12.6.1 Detaching the Developing Cylinder.....	5- 27
5.12.7 Transfer Charging Roller.....	5- 28
5.12.7.1 Removing the Transfer Roller	5- 28
5.12.8 Waste Toner Box	5- 29
5.12.8.1 Removing the Front Cover Unit.....	5- 29
5.12.8.2 Removing the Waste Toner Case	5- 29
5.12.9 Toner Level Sensor.....	5- 29
5.12.9.1 Removing the Front Cover Unit.....	5- 29
5.12.9.2 Removing the Waste Toner Case	5- 30
5.12.9.3 Removing the Toner Cartridge.....	5- 30
5.12.9.4 Removing the Drum Unit.....	5- 30
5.12.9.5 Removing the Developing Assembly	5- 31
5.12.9.6 Removing the Upper Tray	5- 32
5.12.9.7 Removing the Toner Cartridge Cover	5- 32
5.12.9.8 Removing the Pre-Exposure Lamp	5- 32
5.12.9.9 Removing the Left Cover	5- 33
5.12.9.10 Removing the Laser Unit.....	5- 33
5.12.9.11 Removing the Hopper Assembly.....	5- 33
5.12.9.12 Removing the Toner Level Sensor.....	5- 34
5.12.10 Toner Feedscrew Motor	5- 34
5.12.10.1 Removing the Front Cover Unit.....	5- 34
5.12.10.2 Removing the Waste Toner Case	5- 34
5.12.10.3 Removing the Toner Cartridge.....	5- 35
5.12.10.4 Removing the Drum Unit.....	5- 35
5.12.10.5 Removing the Developing Assembly.....	5- 36
5.12.10.6 Removing the Upper Tray	5- 37
5.12.10.7 Removing the Toner Cartridge Cover	5- 37
5.12.10.8 Removing the Pre-Exposure Lamp	5- 37

5.12.10.9 Removing the Left Cover.....	5- 37
5.12.10.10 Removing the Laser Unit.....	5- 37
5.12.10.11 Removing the Hopper Assembly.....	5- 38
5.12.10.12 Removing the Toner Feedscrew Motor.....	5- 39
5.12.11 Static Charge Eliminator.....	5- 39
5.12.11.1 Removing the Static Eliminator.....	5- 39
Chapter 6 Pickup/Feeding System	
6.1 Construction.....	6- 1
6.1.1 Specifications, Controls, and Functions.....	6- 1
6.1.2 Division into Blocks.....	6- 2
6.1.3 Arrangement of Rollers.....	6- 3
6.1.4 Diagram of Paper Paths (printer on its own).....	6- 4
6.1.5 Diagram of Paper Paths (w/ 3 Way Unit-A1 /copy tray).....	6- 4
6.1.6 Diagram of Paper Paths (w/ Finisher-S1/copy tray).....	6- 5
6.1.7 Diagram of Paper Paths (w/ Finisher-Q3/Saddle Finisher-Q4).....	6- 6
6.1.8 Arrangement of Sensors.....	6- 6
6.1.9 Route of Drive.....	6- 7
6.2 Basic Sequence.....	6- 7
6.2.1 Basic Sequence.....	6- 7
6.2.2 Increase in Speed.....	6- 8
6.3 Detecting Jams.....	6- 10
6.3.1 Delay Jams.....	6- 10
6.3.1.1 Delay Jam Outside the Cassette Pickup Assembly.....	6- 10
6.3.1.2 Delay Jam in the Cassette Pickup Assembly.....	6- 10
6.3.2 Stationary Jams.....	6- 11
6.3.2.1 Common Stationary Jam.....	6- 11
6.3.2.2 Stationary Jam at Power-On.....	6- 11
6.3.3 Other Jams.....	6- 11
6.3.3.1 Door Open Jam.....	6- 11
6.4 Cassette Pick-Up Unit.....	6- 11
6.4.1 Overview.....	6- 11
6.4.2 Basic Sequence.....	6- 12
6.4.3 Identifying the Paper Size.....	6- 12
6.4.4 Setting Up the Universal Cassette.....	6- 14
6.4.5 Paper Level Sensor.....	6- 14
6.5 Manual Feed Pickup Unit.....	6- 16
6.5.1 Overview.....	6- 16
6.5.2 Basic Sequence of Operation.....	6- 17
6.5.3 Identifying the Paper Size.....	6- 17
6.5.4 Paper Retaining Mechanism.....	6- 18
6.6 Registration Unit.....	6- 19
6.6.1 Overview.....	6- 19
6.6.2 Checking Horizontal Registration.....	6- 20
6.7 Duplex Feeding Unit.....	6- 20
6.7.1 Overview.....	6- 20
6.7.2 Sequence of Image Formation.....	6- 22
6.7.3 Flow of Paper (w/o/ delivery option).....	6- 22
6.7.4 Flow of Paper (w/ delivery option).....	6- 27
6.8 Parts Replacement Procedure.....	6- 32
6.8.1 Pick-up Unit 1.....	6- 32
6.8.1.1 Removing the Right Cover (rear).....	6- 32
6.8.1.2 Removing the Right Door.....	6- 32
6.8.1.3 Removing the Right Cover (lower front).....	6- 33
6.8.2 Pick-up Unit 2.....	6- 33
6.8.2.1 Removing the Right Cover (rear).....	6- 33

6.8.2.2 Removing the Right Cover (lower front).....	6- 33
6.8.3 Pickup Roller.....	6- 33
6.8.3.1 Removing the Pickup Roller/Feed Roller/Separation Roller.....	6- 33
6.8.4 Sensor Mount.....	6- 34
6.8.4.1 Removing the Right Cover (rear).....	6- 34
6.8.4.2 Removing the Right Door.....	6- 34
6.8.4.3 Removing the Right Cover (lower front).....	6- 35
6.8.4.4 Removing the Sensor Mounting Plate.....	6- 35
6.8.4.5 Mounting the Sensor Mounting Plate.....	6- 35
6.8.5 Cassette Pick-up Motor 1.....	6- 36
6.8.5.1 Removing the Rear Cover.....	6- 36
6.8.5.2 Removing the Right Cover (rear).....	6- 36
6.8.5.3 Removing the Pickup Motor Base.....	6- 36
6.8.5.4 Removing the Cassette Pickup Motor 1.....	6- 36
6.8.6 Cassette Pick-up Motor 2.....	6- 37
6.8.6.1 Removing the Rear Cover.....	6- 37
6.8.6.2 Removing the Right Cover (rear).....	6- 37
6.8.6.3 Removing the Pickup Motor Base.....	6- 37
6.8.6.4 Removing the Cassette Pickup Motor 2.....	6- 38
6.8.7 Cassette Size Sensor.....	6- 38
6.8.7.1 Removing the Right Cover (rear).....	6- 38
6.8.7.2 Removing the Right Door.....	6- 38
6.8.7.3 Removing the Right Cover (lower front).....	6- 39
6.8.7.4 Removing the Cassette Size Sensor.....	6- 39
6.8.8 Cassette Retry Paper Sensor.....	6- 40
6.8.8.1 Removing the Right Cover (rear).....	6- 40
6.8.8.2 Removing the Right Door.....	6- 40
6.8.8.3 Removing the Right Cover (lower front).....	6- 41
6.8.8.4 Removing the Sensor Mounting Plate.....	6- 41
6.8.8.5 Removing the Cassette Retry Paper Sensor.....	6- 41
6.8.9 Cassette Paper Sensor.....	6- 42
6.8.9.1 Removing the Right Cover (rear).....	6- 42
6.8.9.2 Removing the Right Door.....	6- 42
6.8.9.3 Removing the Right Cover (lower front).....	6- 43
6.8.9.4 Removing the Sensor Mounting Plate.....	6- 43
6.8.9.5 Removing the Cassette Paper Sensor.....	6- 43
6.8.10 Cassette Paper Level Sensor (A/B).....	6- 43
6.8.10.1 Removing the Right Cover (rear).....	6- 43
6.8.10.2 Removing the Right Door.....	6- 43
6.8.10.3 Removing the Right Cover (lower front).....	6- 44
6.8.10.4 Removing the Sensor Mounting Plate.....	6- 44
6.8.10.5 Removing the Cassette Paper Level Sensor (A/B).....	6- 45
6.8.11 Slide Resistor.....	6- 45
6.8.11.1 Removing the Right Cover (rear).....	6- 45
6.8.11.2 Removing the Right Door.....	6- 45
6.8.11.3 Removing the Manual Feed Unit.....	6- 46
6.8.11.4 Removing the Manual Tray Unit.....	6- 47
6.8.11.5 Removing the Slide Resistor.....	6- 47
6.8.12 Cassette Pickup Solenoid.....	6- 47
6.8.12.1 Removing the Right Cover (rear).....	6- 47
6.8.12.2 Removing the Right Door.....	6- 48
6.8.12.3 Removing the Right Cover (lower front).....	6- 48
6.8.12.4 Removing the Cassette Pickup Solenoid.....	6- 49
6.8.13 Cassette Size Sensor Relay PCB.....	6- 49
6.8.13.1 Removing the Right Cover (rear).....	6- 49
6.8.13.2 Removing the Right Door.....	6- 49
6.8.13.3 Removing the Right Cover (lower front).....	6- 50
6.8.13.4 Removing the Cassette Size Sensor Relay PCB.....	6- 50
6.8.14 Manual Tray Assembly.....	6- 50
6.8.14.1 Removing the Right Cover (rear).....	6- 50

6.8.14.2 Removing the Right Door.....	6- 50
6.8.14.3 Removing the Manual Feed Unit.....	6- 51
6.8.14.4 Removing the Manual Feed Tray Assembly.....	6- 52
6.8.15 Manual Feed Unit.....	6- 52
6.8.15.1 Removing the Right Cover (rear).....	6- 52
6.8.15.2 Removing the Right Door.....	6- 52
6.8.15.3 Removing the Manual Feed Unit.....	6- 53
6.8.16 Manual Pickup Roller.....	6- 54
6.8.16.1 Removing the Right Cover (rear).....	6- 54
6.8.16.2 Removing the Right Door.....	6- 54
6.8.16.3 Removing the Manual Feed Unit.....	6- 55
6.8.16.4 Removing the Manual Feed Pickup Roller.....	6- 55
6.8.17 Manual Pick-up Clutch.....	6- 56
6.8.17.1 Removing the Right Cover (rear).....	6- 56
6.8.17.2 Removing the Right Door.....	6- 56
6.8.17.3 Removing the Rear Cover.....	6- 57
6.8.17.4 Removing the Main Power Switch.....	6- 57
6.8.17.5 Removing the Manual Feed Pickup Clutch.....	6- 57
6.8.18 Manual Separation Pad.....	6- 58
6.8.18.1 Removing the Right Cover (rear).....	6- 58
6.8.18.2 Removing the Right Door.....	6- 58
6.8.18.3 Removing the Manual Feed Unit.....	6- 58
6.8.18.4 Removing the Manual Feed Pickup Roller.....	6- 59
6.8.18.5 Removing the Manual Feed Separation pad.....	6- 59
6.8.19 Registration Clutch.....	6- 60
6.8.19.1 Removing the Rear Cover.....	6- 60
6.8.19.2 Removing the Main Drive Assembly.....	6- 60
6.8.19.3 Removing the Registration Clutch.....	6- 60
6.8.20 Feeding Roller.....	6- 60
6.8.20.1 Removing the Pickup Roller/Feed Roller/Separation Roller.....	6- 60
6.8.21 Vertical Path Roller.....	6- 61
6.8.21.1 Removing the Right Cover (rear).....	6- 61
6.8.21.2 Removing the Right Door.....	6- 61
6.8.21.3 Removing the Right Cover (lower front).....	6- 62
6.8.21.4 Removing the Sensor Mounting Plate.....	6- 62
6.8.21.5 Removing the Vertical Path Roller.....	6- 62
6.8.22 Duplex Feed Roller 2.....	6- 63
6.8.22.1 Removing the Right Cover (rear).....	6- 63
6.8.22.2 Removing the Right Door.....	6- 63
6.8.22.3 Removing the Duplex Feed Roller 2.....	6- 64
6.8.23 Duplex Feed Sensor.....	6- 64
6.8.23.1 Removing the Right Cover (rear).....	6- 64
6.8.23.2 Removing the Right Door.....	6- 64
6.8.24 Delivery Assembly 1.....	6- 65
6.8.24.1 Removing the Right Cover (rear).....	6- 65
6.8.24.2 Removing the Front Cover Unit.....	6- 65
6.8.24.3 Removing the Delivery Tray.....	6- 66
6.8.24.4 Removing the Right Door.....	6- 66
6.8.24.5 Removing the Extension Delivery Kit.....	6- 67
6.8.24.6 Removing the Delivery Assembly 1.....	6- 67
6.8.25 Fixing/ Delivery Drive Assembly.....	6- 67
6.8.25.1 Removing the Right Cover (rear).....	6- 67
6.8.25.2 Removing the Front Cover Unit.....	6- 68
6.8.25.3 Removing the Delivery Tray.....	6- 68
6.8.25.4 Removing the Right Door.....	6- 68
6.8.25.5 Removing the Delivery Assembly 1.....	6- 69
6.8.25.6 Removing the Fixing Unit.....	6- 69
6.8.25.7 Removing the Fixing/Delivery Drive Assembly.....	6- 70
6.8.26 Separation Roller.....	6- 70
6.8.26.1 Removing the Pickup Roller/Feed Roller/Separation Roller.....	6- 70

Chapter 7 Fixing System

7.1 Construction	7- 1
7.1.1 Specifications, Control Mechanisms, and Functions	7- 1
7.1.2 Major Components.....	7- 1
7.2 Basic Sequence	7- 1
7.2.1 Power-On Sequence.....	7- 1
7.2.2 Down Sequence.....	7- 2
7.3 Various Control Mechanisms	7- 2
7.3.1 Controlling the Speed of the Fixing Film	7- 2
7.3.1.1 Controlling the Fixing Film Speed in Response to Low Temperature	7- 2
7.3.1.2 Controlling the Fixing Film Speed	7- 2
7.3.2 Controlling the Fixing Film Temperature.....	7- 2
7.3.2.1 Controlling the Power Supply in Response to Low Temperature	7- 2
7.3.2.2 Controlling the Feeding in Response to Low Temperature.....	7- 2
7.3.2.3 Controlling the Power Supply at Start-Up	7- 2
7.3.2.4 Copying Temperature Control.....	7- 3
7.3.2.5 Changing the Fixing Film Control Temperature	7- 3
7.3.2.6 Temperature Control in Response to Automatic Double-Sided Copy.....	7- 3
7.3.2.7 Temperature Control in Response to Change of Paper Size.....	7- 3
7.3.3 Cleaning.....	7- 3
7.3.3.1 Fixing Film Cleaning	7- 3
7.3.4 Detecting the Passage of Paper	7- 3
7.3.4.1 Detecting the Passage of Paper	7- 3
7.4 Protective Functions	7- 4
7.4.1 Protective Functions	7- 4
7.4.2 Detecting an Error.....	7- 4
7.5 Parts Replacement Procedure	7- 5
7.5.1 Fixing Unit.....	7- 5
7.5.1.1 Removing the Right Cover (rear)	7- 5
7.5.1.2 Removing the Right Door.....	7- 5
7.5.1.3 Removing the Fixing Unit.....	7- 6
7.5.2 Pressure Roller	7- 7
7.5.2.1 Removing the inside delivery cover unit (old)	7- 7
7.5.2.2 Removing the inside delivery cover unit (new)	7- 8
7.5.2.3 Removing the Grounding Plate.....	7- 9
7.5.2.4 Removing the Fixing Film Cover.....	7- 9
7.5.2.5 Removing the Left Side Plate	7- 9
7.5.2.6 Releasing the Locking Plate	7- 10
7.5.2.7 Removing the Fixing Film Unit.....	7- 10
7.5.2.8 Removing the Inlet Guide	7- 11
7.5.2.9 Removing the Pressure Roller	7- 11
7.5.3 Cleaning Roller	7- 12
7.5.3.1 Removing the inside delivery cover unit (old)	7- 12
7.5.3.2 Removing the inside delivery cover unit (new)	7- 14
7.5.3.3 Removing the Cleaning Roller	7- 14
7.5.4 Fixing Film.....	7- 14
7.5.4.1 Removing the inside delivery cover unit (old)	7- 14
7.5.4.2 Removing the inside delivery cover unit (new)	7- 16
7.5.4.3 Removing the Grounding Plate.....	7- 16
7.5.4.4 Removing the Fixing Film Cover.....	7- 16
7.5.4.5 Removing the Left Side Plate	7- 16
7.5.4.6 Releasing the Locking Plate	7- 17
7.5.4.7 Removing the Fixing Film Unit.....	7- 17
7.5.5 Internal Delivery Sensor.....	7- 18
7.5.5.1 Removing the inside delivery cover unit (old)	7- 18
7.5.5.2 Removing the inside delivery cover unit (new)	7- 20
7.5.5.3 Removing the Grounding Plate.....	7- 20
7.5.5.4 Removing the Fixing Film Cover.....	7- 20
7.5.5.5 Removing the Left Side Plate	7- 21

7.5.5.6 Releasing the Locking Plate	7- 21
7.5.5.7 Removing the Fixing Film Unit	7- 22
7.5.5.8 Removing the Inside Delivery Sensor	7- 23
7.5.6 Fixing Film Sensor	7- 23
7.5.6.1 Removing the inside delivery cover unit (old)	7- 23
7.5.6.2 Removing the inside delivery cover unit (new)	7- 24
7.5.6.3 Removing the Grounding Plate	7- 25
7.5.6.4 Removing the Fixing Film Sensor	7- 25

Chapter 8 External and Controls

8.1 Parts Replacement Procedure	8- 1
8.1.1 Main Drive Assembly	8- 1
8.1.1.1 Removing the Rear Cover	8- 1
8.1.1.2 Removing the Main Drive Assembly	8- 1
8.1.2 Power Supply Unit	8- 1
8.1.2.1 Removing the Rear Cover	8- 1
8.1.2.2 Removing the Left Cover (lower)	8- 2
8.1.2.3 Removing the Accessories Power Supply PCB	8- 2
8.1.2.4 Removing the Main Power Supply	8- 2
8.1.3 Control Panel	8- 3
8.1.3.1 Removing the Control Panel	8- 3
8.1.4 Control Panel LCD Unit	8- 4
8.1.4.1 Removing the Control Panel	8- 4
8.1.4.2 Removing the Control Panel Base Cover	8- 4
8.1.4.3 Removing the Control Panel Inside Frame	8- 5
8.1.4.4 Removing the Control Panel LCD	8- 5
8.1.5 DC Controller PCB	8- 5
8.1.5.1 Removing the Rear Cover	8- 5
8.1.5.2 Removing the DC Controller PCB	8- 5
8.1.6 Control Panel Inverter PCB	8- 6
8.1.6.1 Removing the Control Panel	8- 6
8.1.6.2 Removing the Control Panel Base Cover	8- 6
8.1.6.3 Removing the Control Panel Inverter PCB	8- 7
8.1.7 Control Panel Key Switch PCB	8- 7
8.1.7.1 Removing the Control Panel	8- 7
8.1.7.2 Removing the Control Panel Base Cover	8- 7
8.1.7.3 Removing the Control Panel Frame	8- 8
8.1.7.4 Removing the Control Panel Key Switch PCB	8- 8
8.1.8 Control Panel CPU PCB	8- 8
8.1.8.1 Removing the Control Panel	8- 8
8.1.8.2 Removing the Control Panel Base Cover	8- 9
8.1.8.3 Removing the Controller Panel CPU PCB	8- 9
8.1.9 All Night Power Supply PCB	8- 9
8.1.9.1 Removing the Rear Cover	8- 9
8.1.9.2 Removing the All-Night Power Supply PCB	8- 9
8.1.10 Controller Power Supply PCB	8- 10
8.1.10.1 Removing the Rear Cover	8- 10
8.1.10.2 Removing the Left Cover (lower)	8- 10
8.1.10.3 Removing the Left Cover (Rear)	8- 10
8.1.10.4 Removing the Accessories Power Supply PCB	8- 10
8.1.10.5 Removing the Controller Power Supply PCB	8- 10
8.1.11 Option Power Supply PCB	8- 11
8.1.11.1 Removing the Rear Cover	8- 11
8.1.11.2 Removing the Left Cover (lower)	8- 11
8.1.11.3 Removing the Left Cover (Rear)	8- 11
8.1.11.4 Removing the Accessories Power Supply PCB	8- 11
8.1.12 High-Voltage PCB	8- 12
8.1.12.1 Removing the Front Cover Unit	8- 12
8.1.12.2 Removing the Waste Toner Case	8- 12

8.1.12.3 Removing the Toner Cartridge	8- 12
8.1.12.4 Removing the Drum Unit	8- 13
8.1.12.5 Removing the Developing Assembly	8- 13
8.1.12.6 Removing the Upper Tray	8- 14
8.1.12.7 Removing the Toner Cartridge Cover	8- 14
8.1.12.8 Removing the Pre-Exposure Lamp	8- 15
8.1.12.9 Removing the Left Cover	8- 15
8.1.12.10 Removing the Laser Unit	8- 15
8.1.12.11 Removing the Hopper Assembly	8- 16
8.1.12.12 Removing the Right Cover (rear)	8- 16
8.1.12.13 Removing the Right Door	8- 16
8.1.12.14 Removing the Right Door	8- 17
8.1.12.15 Removing the Fixing Unit	8- 18
8.1.12.16 Removing the Gear	8- 19
8.1.12.17 Removing the High-Voltage PCB	8- 19
8.1.13 Exhaust Fan	8- 20
8.1.13.1 Removing the Heat Discharge Fan	8- 20
8.1.14 Motor of Main Drive Assembly	8- 20
8.1.14.1 Removing the Rear Cover	8- 20
8.1.14.2 Removing the Main Drive Assembly	8- 20
8.1.14.3 Removing the Main Drive Motor	8- 21
8.1.15 Fixing Driver Motor	8- 21
8.1.15.1 Removing the Rear Cover	8- 21
8.1.15.2 Removing the DC Controller PCB	8- 22
8.1.15.3 Removing the Fixing Drive Motor	8- 22
8.1.16 Right Door	8- 22
8.1.16.1 Removing the Right Cover (rear)	8- 22
8.1.16.2 Removing the Right Door	8- 23
8.1.17 Circuit Braker	8- 23
8.1.17.1 Removing the Rear Cover	8- 23
8.1.17.2 Removing the Circuit Breaker	8- 24

Chapter 9 Correcting Faulty Images

9.1 Troubleshooting	9- 1
9.1.1 Image Faults	9- 1
9.1.1.1 Light Image/Weak Density	9- 1
9.1.2 Faulty Feeding	9- 1
9.1.2.1 Skew Feed	9- 1
9.1.3 Malfunction	9- 1
9.1.3.1 Malfunction/Faulty Detection	9- 1
9.1.3.2 Noise	9- 1
9.1.3.3 User Warning Message	9- 3
9.1.3.4 Other Defect	9- 3
9.1.4 Network	9- 3
9.1.4.1 Connection Problem	9- 3
9.1.5 Transmission/fax-related	9- 3
9.1.5.1 Reception Problem	9- 3
9.1.6 Jam (Main Unit)	9- 3
9.1.6.1 0105/0101/0102/0103/0201/0202/0203/0204 Jam Code: Paper lint adheres to surface of vertical path roller	9- 3
9.1.6.2 0107 Jam Code: Machine with cassette heater causes separation failure jam at duplex transfer assembly due to moistened paper/2nd page crashes into cleaner, causing jam	9- 4
9.1.6.3 0109 Jam Code is indicated because DC Controller PCB on Machine has poor contact: Inner 2-way Tray-D1	9- 4
9.1.6.4 0208/0A08 Jam Code: No.1 delivery sensor (PS14) is faulty	9- 4
9.1.7 Error Code	9- 5
9.1.7.1 Description on measure for E064-0001	9- 5
9.1.8 FAX ## Code	9- 5
9.1.8.1 ##1017 FAX Error Code occurs when FAX message from G4 FAX to G3 FAX	9- 5
9.1.9 Specifications-related FAQ	9- 5
9.1.9.1 FAQ on Main Unit Specifications	9- 5

9.1.9.2 FAQ on G3FAX Specifications..... 9- 7

Chapter 1 Introduction

Contents

1.1 Product Specifications.....	1-1
1.1.1 Safety	1-1
1.1.1.1 Safety of the Laser Light.....	1-1
1.1.1.2 CDRH Regulations.....	1-1
1.1.1.3 Handling the Laser Unit.....	1-1
1.1.1.4 Safety of Toner.....	1-1

1.1 Product Specifications

1.1.1 Safety

1.1.1.1 Safety of the Laser Light

Laser light can prove to be hazardous to the human body. The machine's laser unit is fully enclosed in a protective housing and external covers so that its light will not escape outside as long as the machine is used normally.

1.1.1.2 CDRH Regulations

The Center for Devices and Radiological Health of the US Food and Drug Administration put into force regulations concerning laser products on August 2, 1976. These regulations apply to laser products manufactured on and after August 1, 1976, and the sale of laser products not certified under the regulations is banned within the United States. The label shown here indicates compliance with the CDRH regulations, and its attachment is required on all laser products that are sold in the United States.



F-1-1



A different description may be used for a different product.

1.1.1.3 Handling the Laser Unit

If you must service the area around the machine's laser unit, be sure to take full care to avoid exposure to laser light: do not insert a tool (e.g., screwdriver or those with a high reflectance) into the laser path; also, remove watches, rings, and the like before starting the work, as they reflect laser light. The machine's laser light is red in color, and an appropriate label ([1], [2]) is attached to all covers that can reflect laser light. Keep also in mind that the machine's laser unit cannot be adjusted in the field.

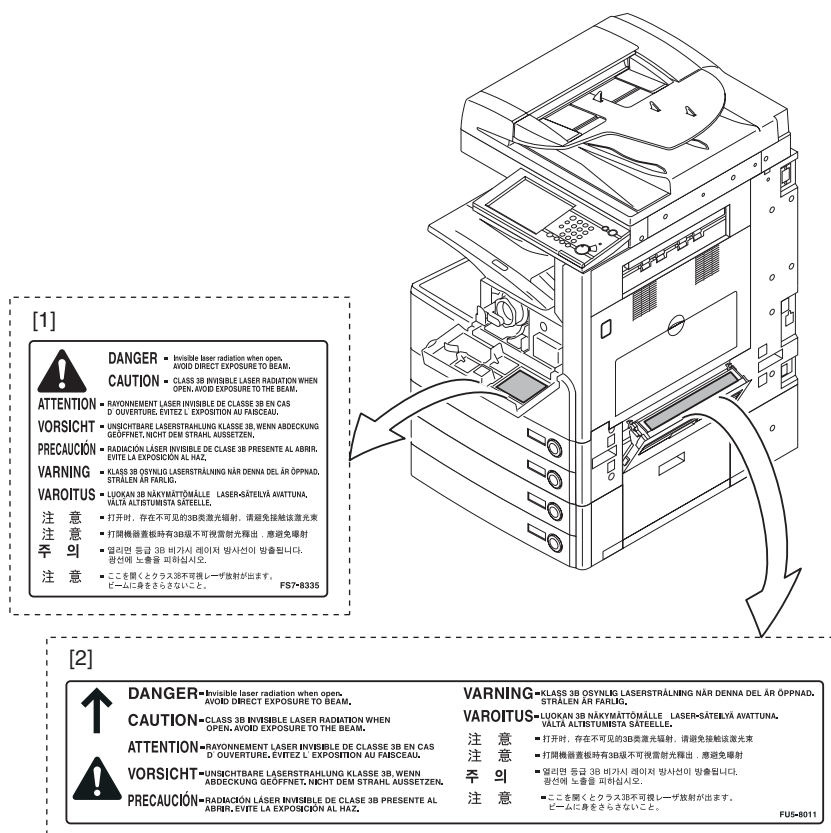

F-1-2

1.1.1.4 Safety of Toner

The machine's toner is a non-toxic material made of plastic, iron, and small amounts of dye.



Do not throw toner into fire. It may cause explosion.

Toner on Clothing or Skin

1. If your clothing or skin has come into contact with toner, wipe it off with tissue; then, wash it off with water.
2. Do not use warm water, which will cause the toner to jell and fuse permanently with the fibers of the cloth.
3. Do not bring toner into contact with plastic material. It tends to react easily.

Chapter 2 Installation

Contents

2.1 Unpacking and Installation	2-1
2.1.1 Connecting the Cable	2-1
2.2 Installing the Reader Heater.....	2-1
2.2.1 Checking the Parts	2-1
2.2.2 Turning Off the Host Machine.....	2-1
2.2.3 Installation Procedure	2-1
2.3 Installing the Cassette Heater for the Cassette Pedestal	2-2
2.3.1 Checking the Contents	2-2
2.3.2 Checking the Contents	2-2
2.3.3 Checking the Contents	2-3
2.3.4 Turning Off the Host Machine.....	2-3
2.3.5 Installation Procedure (Cassette Heater Unit 29).....	2-3
2.3.6 Installation Procedure (Cassette Heater AttachmentD2)	2-4
2.3.7 Installation Procedure (Cassette Heater Unit36).....	2-5
2.4 Installing the Deck Heater.....	2-6
2.4.1 Checking the Parts to Install	2-6
2.4.2 Turning Off the Host Machine.....	2-7
2.4.3 Installation Procedure	2-7
2.5 Installing the Voice Guidance Kit.....	2-10
2.5.1 A point to keep in mind at installation	2-10
2.5.2 Checking the Contents	2-10
2.5.3 Turning Off the Host Machine.....	2-11
2.5.4 Installation Procedure	2-12
2.6 Installing the Voice Operation Kit.....	2-18
2.6.1 A point to keep in mind at installation.....	2-18
2.6.2 Checking the Contents	2-18
2.6.3 Turning Off the Host Machine.....	2-19
2.6.4 Installation Procedure	2-20

2.1 Unpacking and Installation

2.1.1 Connecting the Cable

- 1) If you are installing a cassette pedestal, remove the lattice connector cover, and fit the lattice connector [1] of the cassette pedestal to the machine.

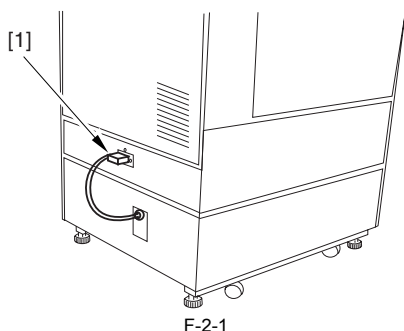

- 2) Connect the power plug to the power outlet.



Use the correct power code to match the location/area of installation. Make sure not to leave unused power code at the site.



1. Power supply voltage shall be +/-10% of the rating.
2. The amperage of the power supply must be as rated.
3. Before connecting the power plug, check to be sure that the main power switch is off.

- 3) Turn on the main power switch.

- The machine issues a message to indicate that it is loading programs.
- The machine issues a message to indicate that its printer is getting ready for a job.



Turning Off the Main Power

Whenever you have to turn off the main power, be sure to go through the following to avoid damage to the hard disk:

1. Hold down the control panel power switch for 3 sec or more.
2. Go through the instructions for the shut-down sequence shown on the display so that the main power switch may be turned off.
3. Turn off the main power switch.

2.2 Installing the Reader Heater

2.2.1 Checking the Parts

Prepare the following parts because each part of the reader heater is assigned as service part.

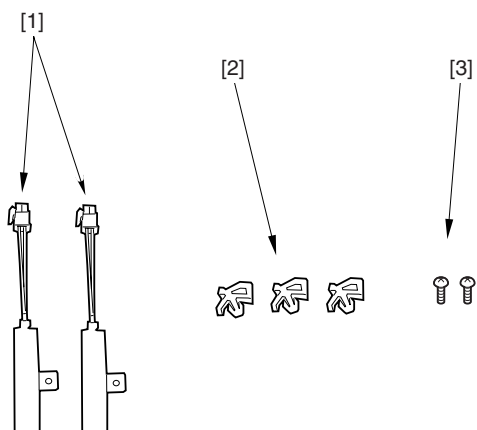

No.	Name	Part No.	Qty.
[1]	Reader Heater	FK2-0228-000	2 pc.
[2]	Clamp	WT2-0507-000	3 pc.
[3]	Screw (Binding M4X6)	XB3-6400-805	2 pc.

2.2.2 Turning Off the Host Machine



How to Turn Off the Main Power

When turning off the main power, be sure to go through the following steps to protect the hard disk:

- 1) Hold down the control panel power switch for 3 sec or more.
- 2) Follow the instructions on the shutdown sequence screen to let the main power switch be ready to turn off.
- 3) Turn off the power switch.
- 4) Disconnect the power cables (for the power outlet).

2.2.3 Installation Procedure

- 1) Open the copyboard cover/DADF.
- 2) Remove the 2 screws [1], and detach the glass retainer (right) [2].
- 3) Remove the copyboard glass (for copyboard cover) [3].
- 4) Remove the 2 screws [4], and detach the glass retainer (left) [5].
- 5) Remove the copyboard glass (for DADF) [6].

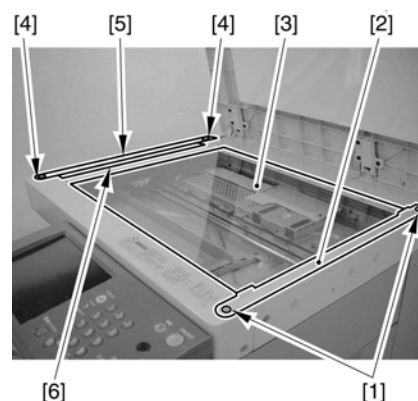

When removing the copyboard glass, take care not to touch the glass surface and the white plate on its back. (The presence of dirt will cause a black line in the images.)

- 6) Mount the clamp [1].
- 7) Fix the heater [3] in place using a screw [2].
- 8) Fit the connector [4] of the heater, and fix the harness of the heater in place using the clamp [1].

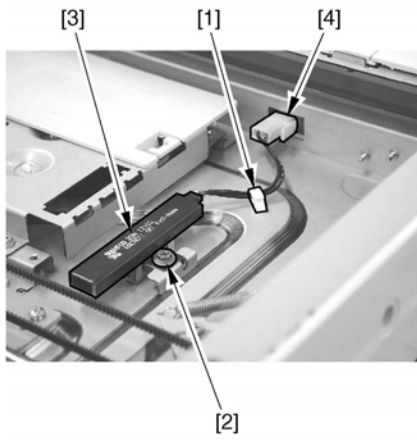

F-2-4

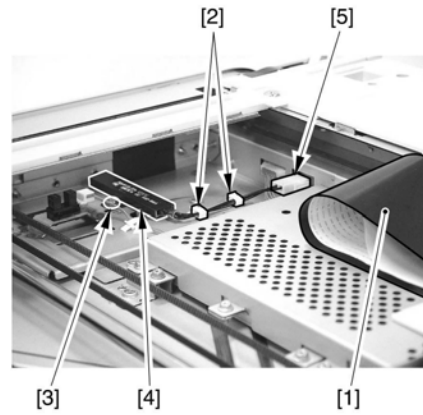

F-2-6

⚠ Points to Note When Routing the Harness
 Check to see that the harness [1] is in contact with the reader base plate.
 If not, hold the harness [1] down with your hand to keep it in contact with the reader base plate.

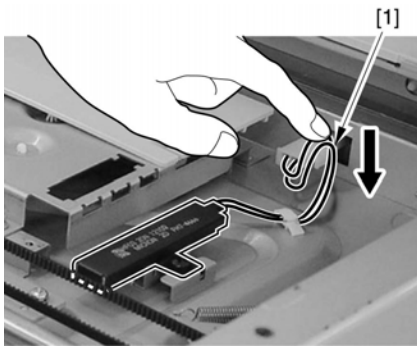

9) Pull the drive belt (front side) [1] to the right to move the contact sensor unit [2] to the center.

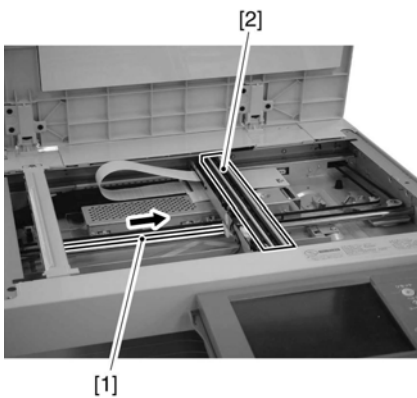

F-2-5

10) Peel off the protective sheet [1], and fit the 2 clamps [2].
 (Keep the protective sheet peeled until step 12.)
 11) Fix the heater [4] in place using a screw (Binding; M4X6)[[3].
 12) Fit the connector [5] of the heater in place, and fit the harness of the heater to the clamp [2].

13) Put back the protective sheet.
 14) Mount the copyboard glass (for DADF) and the copyboard glass (for copyboard cover).
 15) Mount the glass retainer (let, right) using 2 screws each.
 16) Connect the power cable.

2.3 Installing the Cassette Heater for the Cassette Pedestal

2.3.1 Checking the Contents

<Cassette Heater Unit 29>

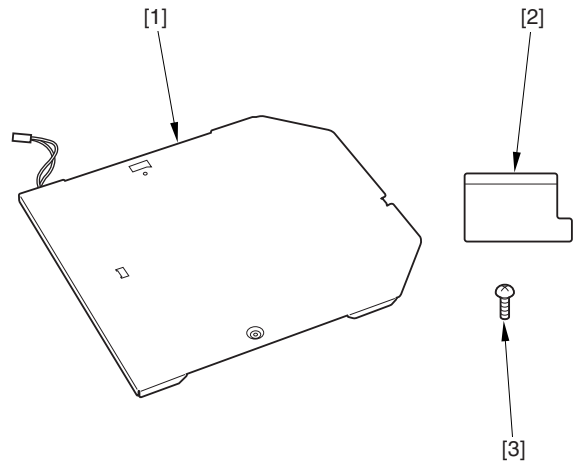

F-2-7

[1]	Heater unit	1pc
[2]	Plastic film	1pc
[3]	Screw (binding; M4X6)	1pc

2.3.2 Checking the Contents

<Cassette Heater AttachmentD2>

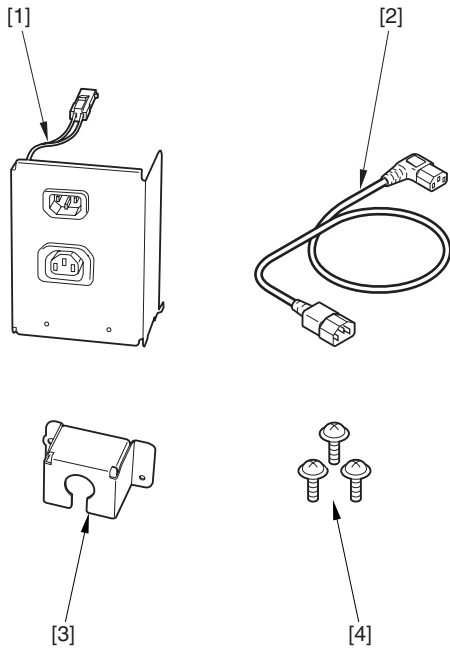

F-2-8

[1]	Power Code Unit	1pc
[2]	Power Code	1pc
[3]	Plug Cover	1pc
[4]	Screw (TP; M3X6)	3pc

2.3.3 Checking the Contents

<Cassette Heater Unit36>

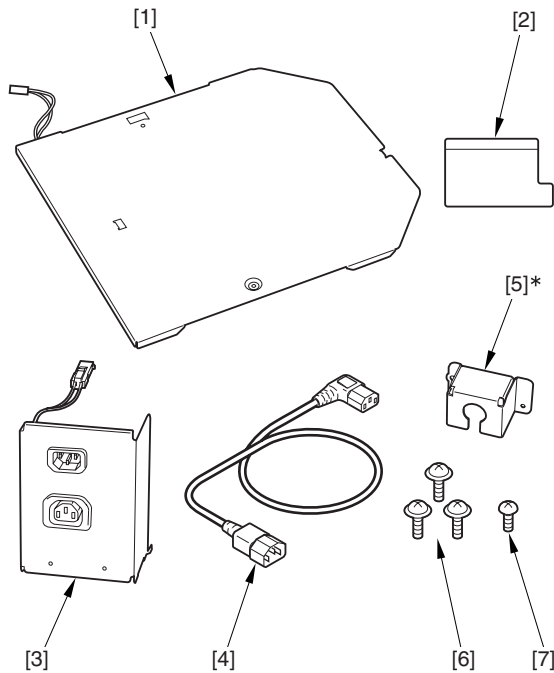

F-2-9

[1]	Heater unit	1pc
[2]	Plastic film	1pc
[3]	Power Code Unit	1pc
[4]	Power Code	1pc
[5]	Plug Cover	1pc
[6]	Screw (TP; M3X6)	3pc
[7]	Screw (binding; M4X4)	1pc

[7] Screw (binding; M4X4) 1pc
 * not used in this machine

2.3.4 Turning Off the Host Machine

⚠ How to Turn Off the Main Power
 When turning off the main power, be sure to go through the following steps to protect the hard disk:

- 1) Hold down the control panel power switch for 3 sec or more.
- 2) Follow the instructions on the shutdown sequence screen to let the main power switch be ready to turn off.
- 3) Turn off the power switch.
- 4) Disconnect the power cables (for the power outlet).

2.3.5 Installation Procedure (Cassette Heater Unit 29)

⚠
 To operate the Cassette Heater Unit 29, the Cassette Heater AttachmentD2 needs to be mounted.

- 1) Pull out the cassette 3 and 4.
- 2) While removing the hook by inserting the part indicated as [1] from the front side of the host machine with a flat blade screwdriver, detach the connector cover [2].

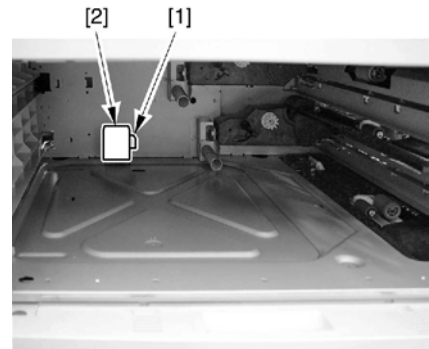

F-2-10

- 3) Fit the 3 hooks [2] of the heater unit [1] to the slit of the base plate to match the hole positions.

⚠
 In the case of mounting the heater unit, make sure to check that the 3 hooks [2] are tightly fitted and there is no jiggle.

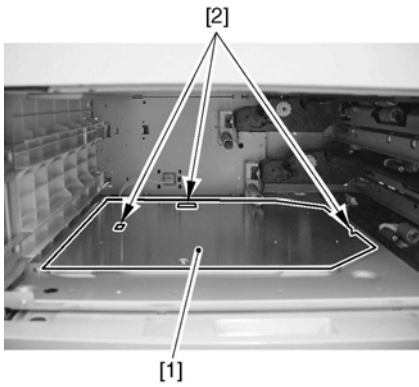

F-2-11

4) Mount the heater unit [1] with the screw (binding: M4X6) [2], and connect the connector [3].

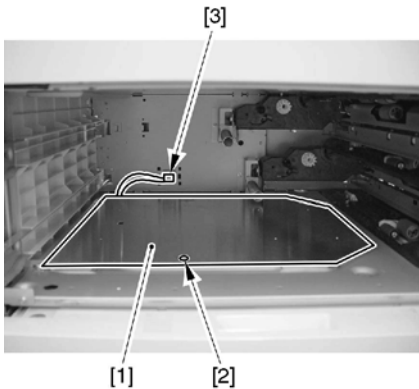

F-2-12

5) Attach the connector cover [1].
 6) Attach the plastic film [2] (for protecting the AC cable) over the cable [3] to fit the end of the connector cover [A] and the end of the rear side of the host machine [B].

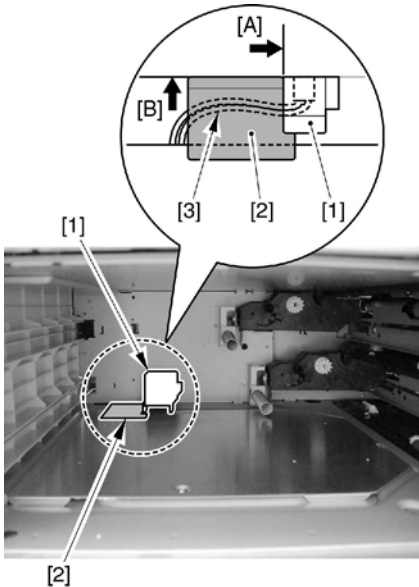

F-2-13

7) Put back the cassette 3 and 4.

2.3.6 Installation Procedure (Cassette Heater AttachmentD2)

1) Disconnect the lattice connector [1] of the cassette pedestal.

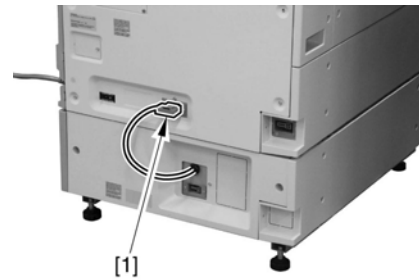

F-2-14

2) Detach the rear cover [1] of the cassette pedestal.
 - 4 screws [2]

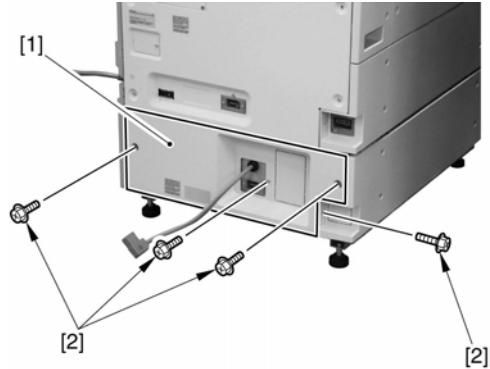

F-2-15

3) Using nippers, cut off the face plate [2] of the rear cover [1] of the cassette pedestal.

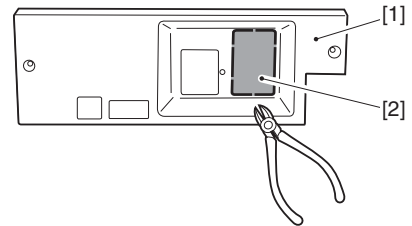

F-2-16

4) Connect the connector [1] of the power code unit, and while fitting the hooks [2] to the holes [3] found at the bottom of the cassette pedestal, attach it with 2 screws (TP; M3X6) [4].

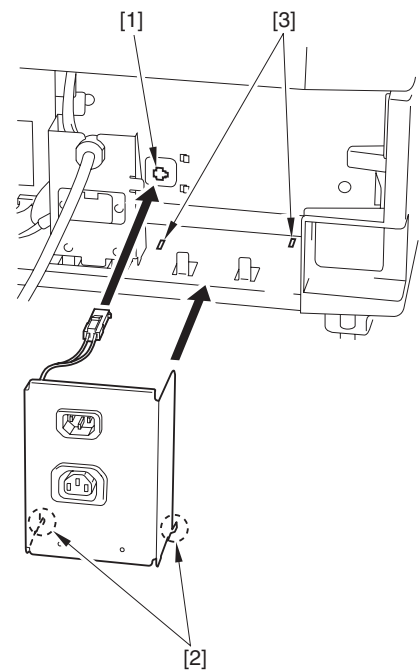

F-2-17

2.3.7 Installation Procedure (Cassette Heater Unit36)

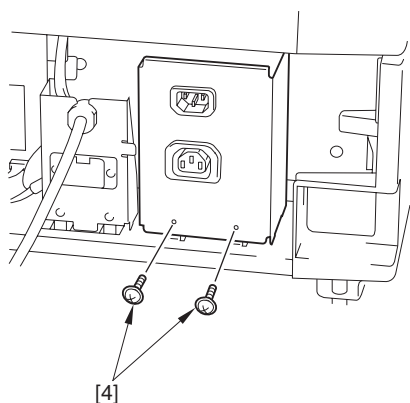

F-2-18

- 5) Attach the rear cover of the cassette pedestal.
- 6) Connect the lattice connector to the host machine.
- 7) Connect the power code [1] to the power code unit [2] and the environment heater outlet [3] of the host machine.

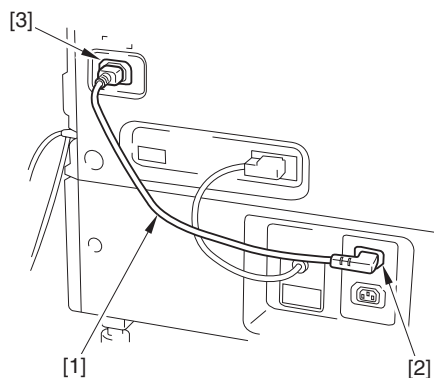

F-2-19

- 8) Remove the screw [1] of the environment heater outlet.

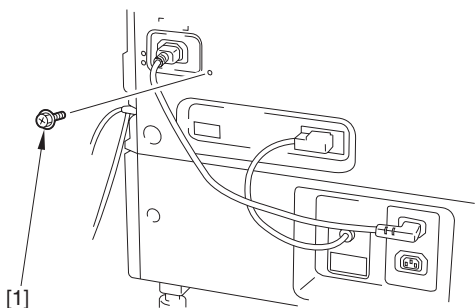

F-2-20

- 9) Attach the plug cover [1] on the power code [2].
 - 1 screw [3] (use the screw that was removed in the step 8)
 - 1 screw (TP; M3X6) [4]

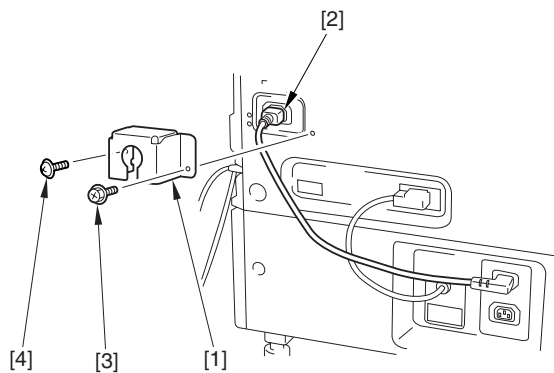

F-2-21

⚠ (Excluding iR 3045/3035/3030/3025)
It is necessary to install the heater PCB and the environment heater outlet in the machine to activate the Cassette Heater Unit 36.

- 1) Pull out the cassette 3 and 4.
- 2) While removing the hook by inserting the part indicated as [1] from the front side of the host machine with a flat blade screwdriver, detach the connector cover [2].

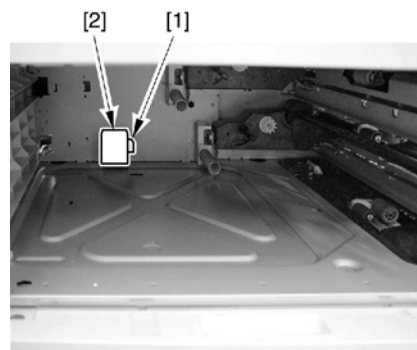

F-2-22

- 3) Fit the 3 hooks [2] of the heater unit [1] to the slit of the base plate to match the hole positions.

⚠
In the case of mounting the heater unit, make sure to check that the 3 hooks [2] are tightly fitted and there is no jiggle.

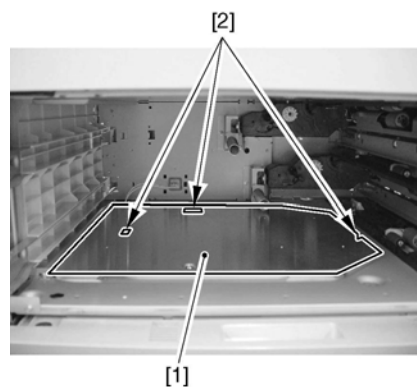

F-2-23

- 4) Mount the heater unit [1] with the screw (binding; M4X6) [2], and connect the connector [3].

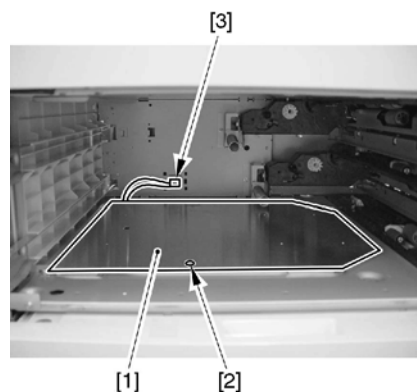

F-2-24

- 5) Attach the connector cover [1].
- 6) Attach the plastic film [2] (for protecting the AC cable) over the cable [3] to fit the end of the connector cover [A] and the end of the rear side of the host machine [B].

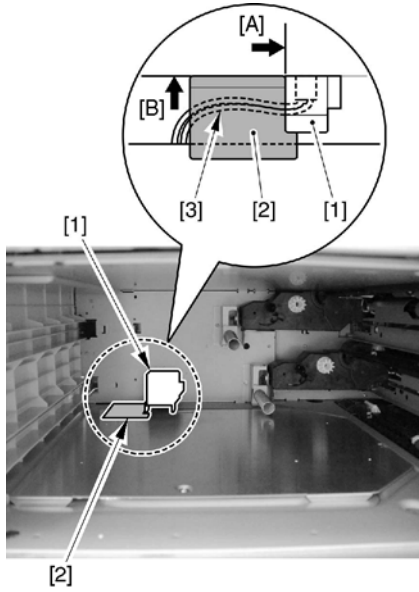

F-2-25

- 7) Put back the cassette 3 and 4.
- 8) Disconnect the lattice connector [1] of the cassette pedestal.

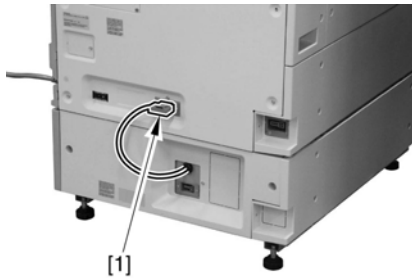

F-2-26

- 9) Detach the rear cover [1] of the cassette pedestal.
- 4 screws [2]

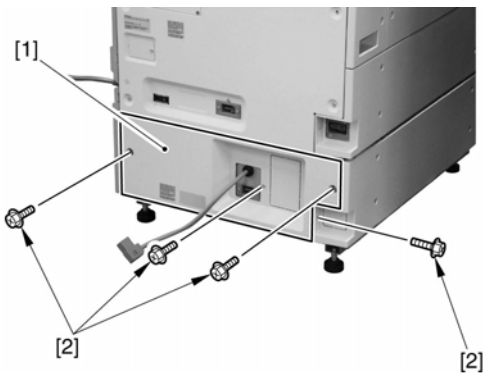

F-2-27

- 10) Using nippers, cut off the face plate [2] of the rear cover [1] of the cassette pedestal.

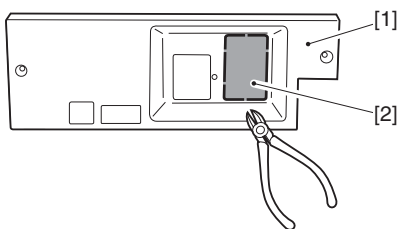

F-2-28

- 11) Connect the connector [1] of the power code unit, and while fitting the hooks [2] to the holes [3] found at the bottom of the cassette pedestal, at-

tach it with 2 screws (TP; M3X6) [4].

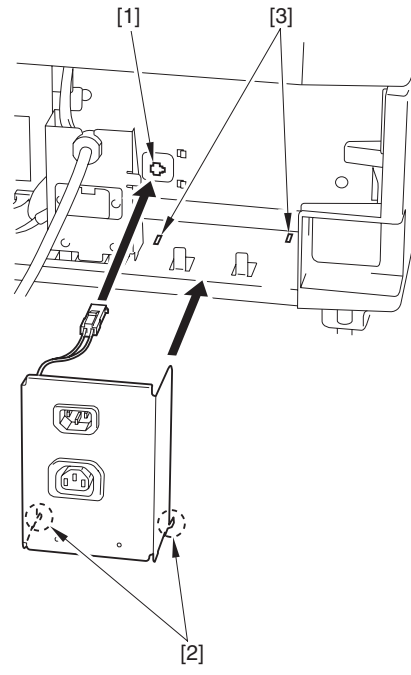

F-2-29

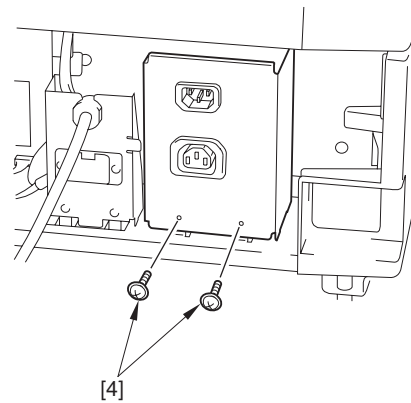

F-2-30

- 12) Attach the rear cover of the cassette pedestal.
- 13) Connect the lattice connector to the host machine.
- 14) Connect the power code [1] to the power code unit [2] and the environment heater outlet [3] of the host machine.

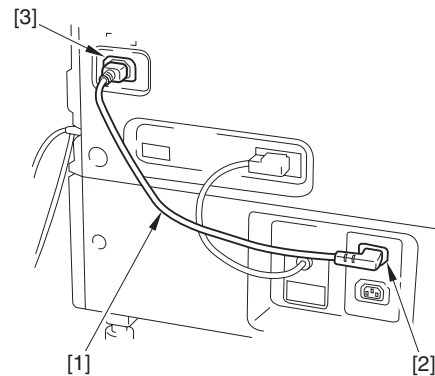

F-2-31

- 15) Turn ON the heater switch.

2.4 Installing the Deck Heater

2.4.1 Checking the Parts to Install

Every components of the cassette heater unit are supplied as service parts, so have the following parts on hand.

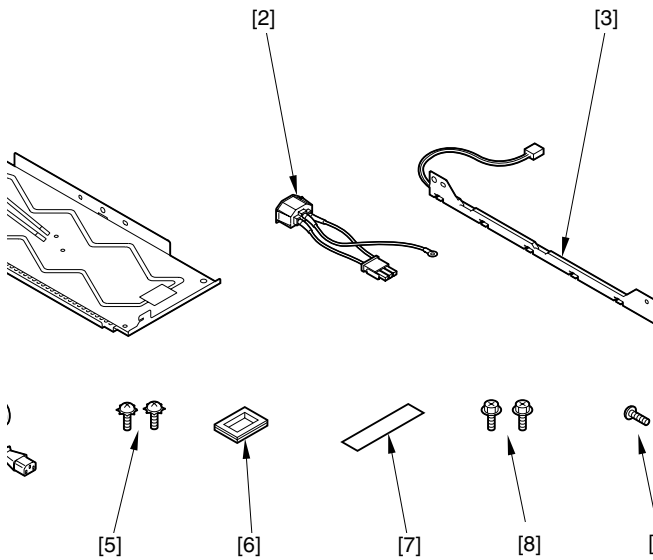

F-2-32

No.	Part name	Part number	QTY	No.	Part name	Part number	QTY
[1]	Heater unit	FG6-9651-000	1pc.	[6]	Cable protection bush	WT2-5098-000	1pc.
[2]	Power supply code base	FG6-1117-000	1pc.	[7]	Power supply label	FS6-8725-000	1pc.
[3]	Relay harness unit	FG6-2957-000	1pc.	[8]	Screw (RS tight; M4X8)	XA9-0628-000	2pcs.
[4]	AC cable	FK2-1777-000	1pc.	[9]	Screw (Binding; M4X4)	XB1-2400-409	1pc.
[5]	Screw (w/ washer)	XA9-0266-000	2pcs.	[10]	Plug cover	FC6-5776-000	1pc.

2.4.2 Turning Off the Host Machine



How to Turn Off the Main Power

When turning off the main power, be sure to go through the following steps to protect the hard disk:

- 1) Hold down the control panel power switch for 3 sec or more.
- 2) Follow the instructions on the shutdown sequence screen to let the main power switch be ready to turn off.
- 3) Turn off the power switch.
- 4) Disconnect the power cables (for the power outlet).



Be sure to attach after installation of the host machine and the paper deck.

- 1) Disconnect the cable [1] of the paper deck from the host machine.

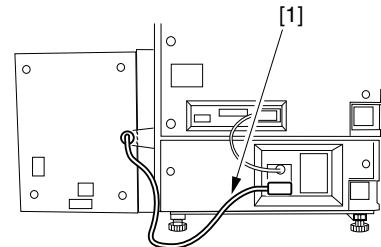

F-2-33

- 2) Hold down the paper deck release grip [1] to release the paper deck from the host machine. Hold down the latch plate [2] with a finger to open the compartment.

2.4.3 Installation Procedure



In order to operate the cassette heater unit, it is required to install the cassette pedestal heater kit/heater PCB. Refer to the corresponding page for its installation procedure.

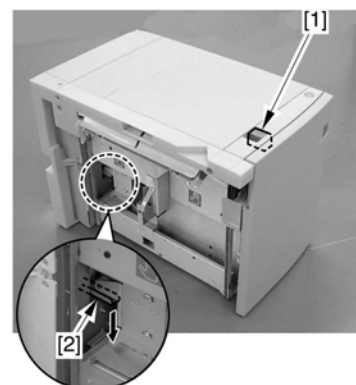

F-2-34

- Remove the 3 screws [1], and then detach the right cover [2] of the paper deck.

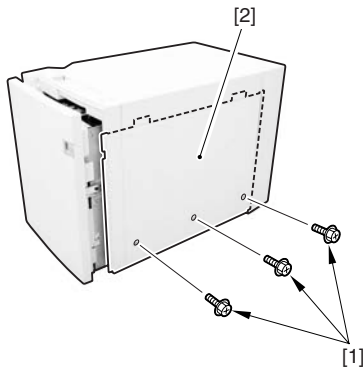

F-2-35

- Remove the 6 screws [1], and then detach the rear cover [2] of the paper deck.

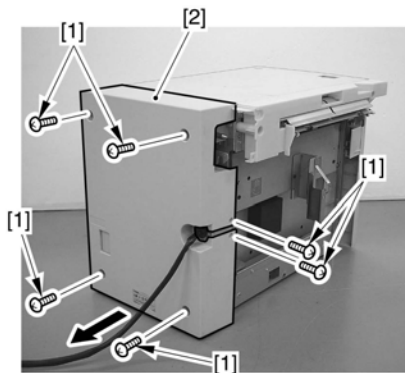

F-2-36

- Remove the 3 screws [1], disconnect the 1 connector [2], and then detach the front cover (upper) [3].

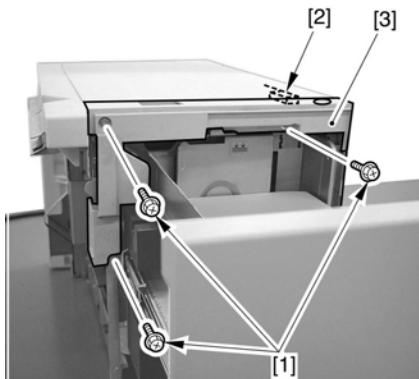

F-2-37

- Remove the 2 screws [1], and then detach the upper cover [2].

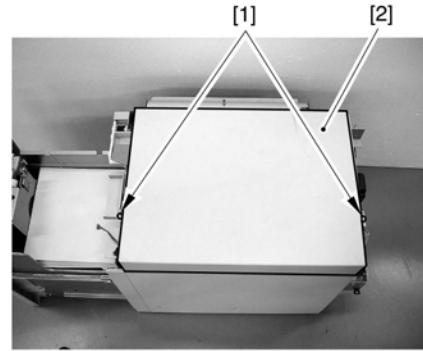

F-2-38

- Attach the cable protective bush [1] included with the package to the hole [2] on the top board of the paper deck.

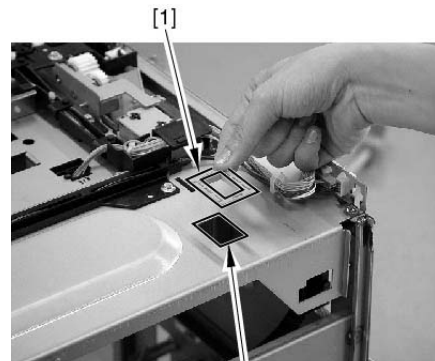

F-2-39

- Place the heater unit [1] under the top board of the paper deck, and pull out the connector [2] from the hole [3] on the top board.
- Hook the 2 hooks on the heater unit to the slit [4] on the top board of the paper deck, and fix it on the paper deck with the screw with washer [5].

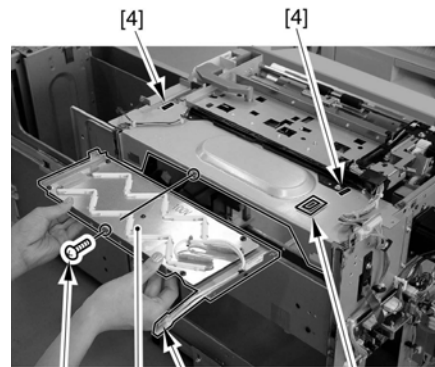

F-2-40

- Set the connector [2] of the heater to the panel mount [1].

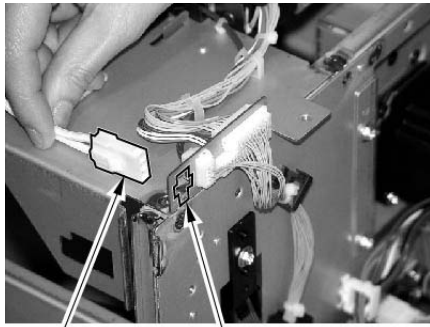

[2] [1]
F-2-41

- 11) Remove the screw [2] to remove the blanking plate [1] attached on the power cord mount of the paper deck.

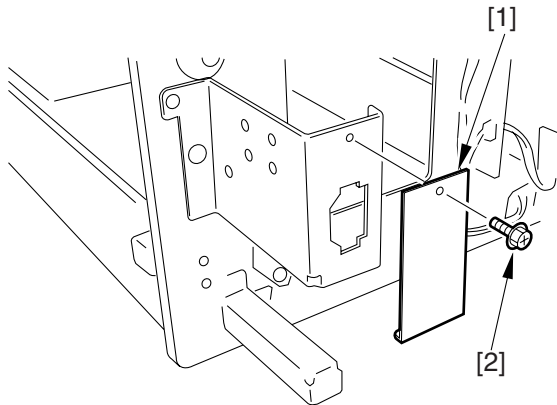

F-2-42

- 12) Connect the AC inlet connector [1] included with the package.
13) Attach the grounding wire [2] with the screw [3] with washer.

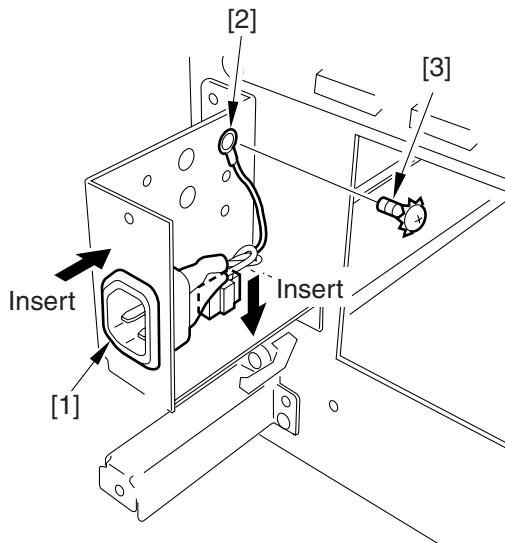

F-2-43

- 14) Attach the harness [1] to the rear end plate of the paper deck with the 2 screws [2] (M4X8).

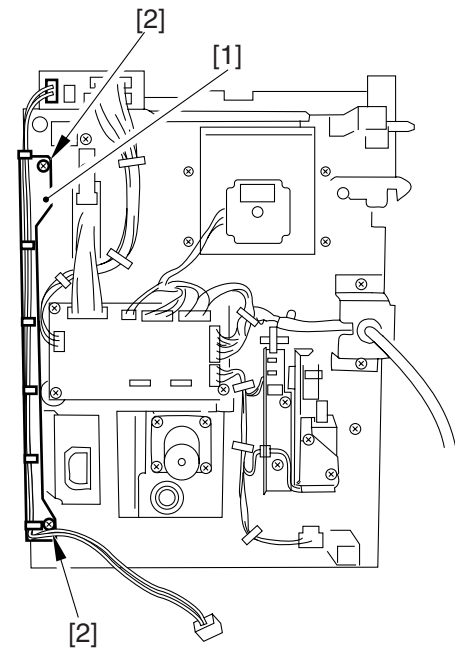

F-2-44

- 15) Wrap the harness [1] around the cable guide [2] on the power cord mount. (One and a half turn)

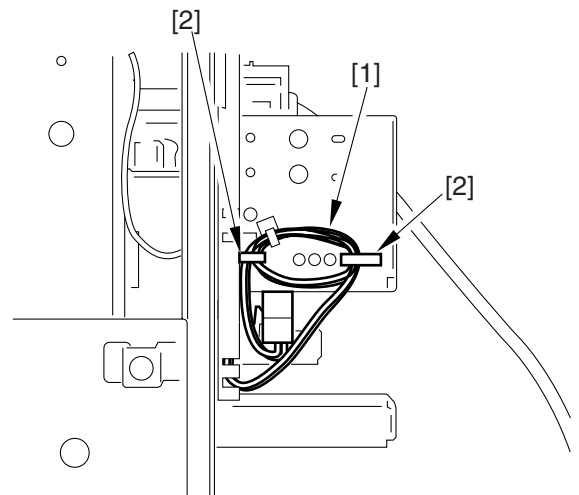

F-2-45

- 16) Connect each of the connectors at both ends of the harness unit to the heater connector and the AC power supply connector respectively.
17) Attach the external cover of the paper deck in the following orders.
[1] Upper cover (Make sure that the cable is not stuck in) (M4X8: 2 screws)
[2] Upper front cover (Connect the connector) (M4X8: 3 screws)
[3] Rear cover (M3X8: 2 screws, M4X8: 4 screws)
[4] Right cover (M4X8: 3 screws)
18) Slide the paper deck in the left direction and set it to the host machine.
19) Connect the paper deck connector [1] to the rear surface of the host machine.

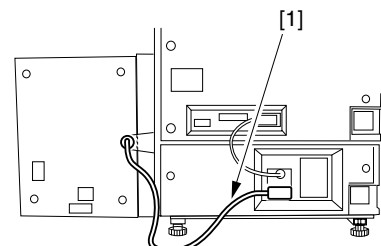

F-2-46

- 20) Connect one of the AC cable [1] (for the host machine outlet) to the power cord mount [2] of the heater, and the other to the cassette pedestal of the host machine.
21) Put the plug cover [3] to the AC cable connector, and fix it with the screw [4].
22) Affix the power label [5] to the rear cover of the paper deck as shown in

the figure below.

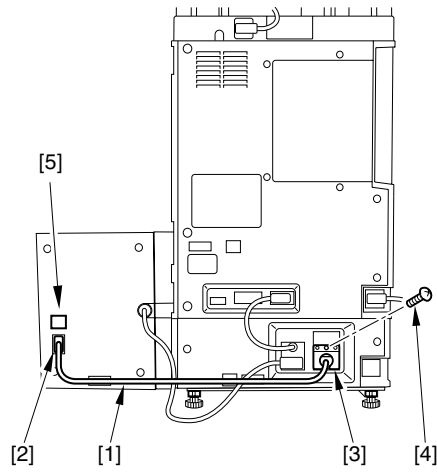

F-2-47

⚠
Be sure to tell the users not to place any things within the shaded area for not disturbing opening/closing the paper deck when connecting the power plug of the heater.

[1] Host machine
[2] Front side
[3] Paper deck

2.5 Installing the Voice Guidance Kit

2.5.1 A point to keep in mind at installation



- In order to install this equipment, "Expansion Bus-B1" is required.
- In case of installing this equipment, "Voice Operation Kit-A1" cannot be installed.

2.5.2 Checking the Contents

<Voice Guidance Kit-B1>

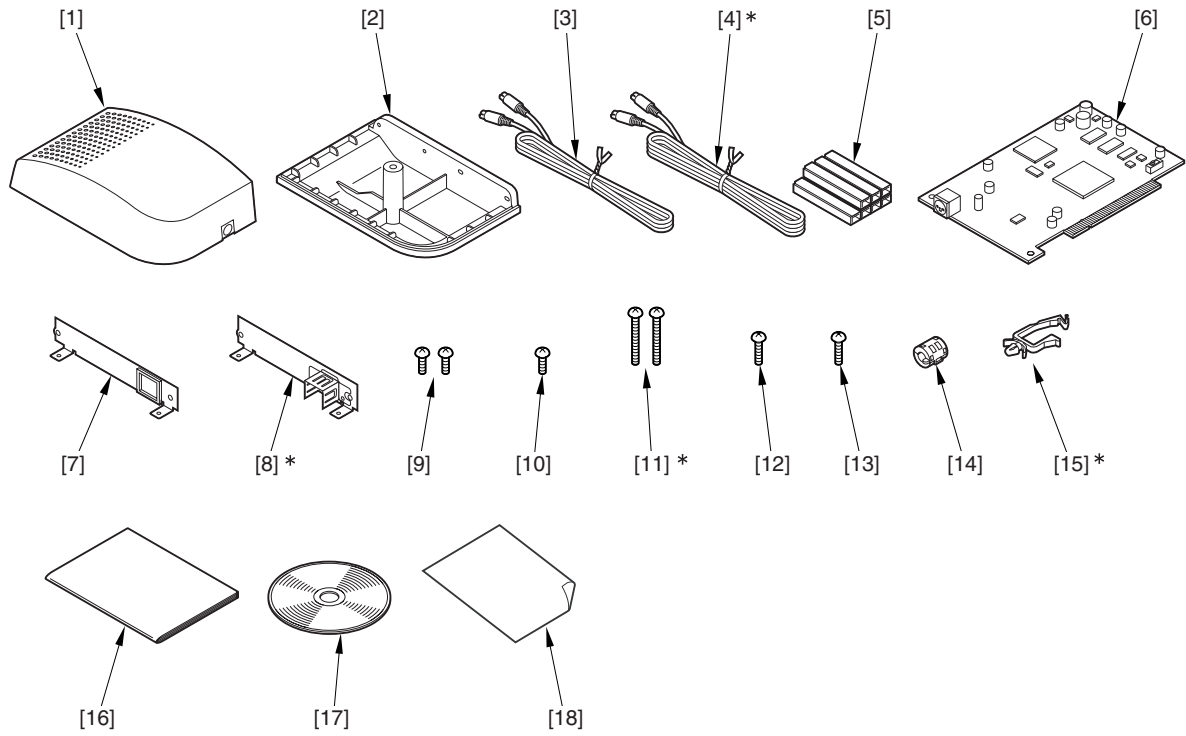

F-2-48

[1]	Speaker Unit (Upper)	1pc.	[2]	Speaker Unit (Lower)	1pc.
[3]	Cable (1300 mm)	1pc.	[4]*	Cable (1850 mm)	1pc.
[5]	Cable Guide	7pc.	[6]	Voice Board	1pc.
	(Use either 4 or 5 cable guide(S))				
[7]	Voice Board instruction plate	1pc.	[8]*	Voice Board instruction plate	1pc.
[9]	Screw (binding; M3X6)	2pc.	[10]	Screw (binding; M4X6)	1pc.
[11]*	Screw (binding; M4X40)	2pc.	[12]	Screw (binding; M3X16)	1pc.
[13]	Screw (binding; M4X16)	1pc.	[14]	Ferrite Core	1pc.
[15]*	Wire Saddle	1pc.	[16]	Voice Guidance Kit Users Guide	1pc.
[17]	Voice Guidance Kit Users Guide CD	1pc.	[18]	FCC/IC Sheet	1pc.

* Do not use for this machine.

2.5.3 Turning Off the Host Machine

How to Turn Off the Main Power

When turning off the main power, be sure to go through the following steps to protect the hard disk:

- 1) Hold down the control panel power switch for 3 sec or more.
- 2) Follow the instructions on the shutdown sequence screen to let the main power switch be ready to turn off.
- 3) Turn off the power switch.
- 4) Disconnect the power cables (for the power outlet).

2.5.4 Installation Procedure

1. Installation Procedure

- 1) Detach the face cover [1] in the direction shown by the arrow.
 - 4 screws [2] (to remove)
 - 2 screws [3] (to loosen)

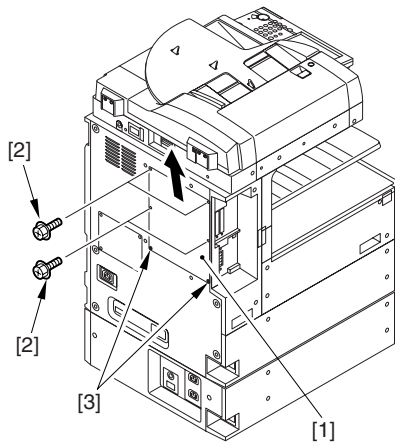

F-2-49

- 2) Detach the blanking plate [1] (Do not use the detached blanking plate).
 - 2 screws [2]

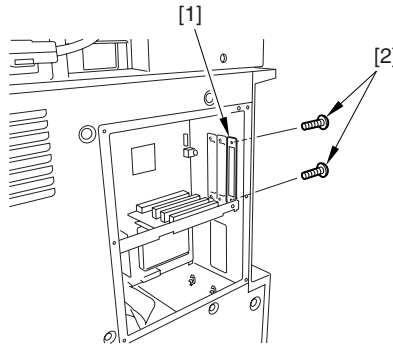

F-2-50

- 3) Attach the voice board instruction plate [2] to the voice board [1].
 - 2 screws (binding; M3X6) [3]

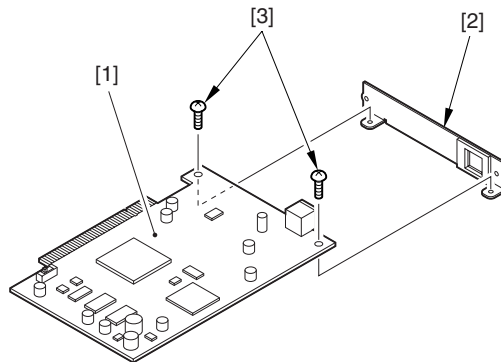

F-2-51



Checking the Position of the Slide Switch (SW1) on the Voice Guidance Board

The slide switch (SW1) on the Voice Guidance Board is provided as a means of switching frequencies (33 MHz/66 MHz) to suit the transfer speed of the PCI bus. It is important for the switch setting to suit the transfer speed so that the voice will be free of interruption. If you inadvertently moved the slide, be sure to put it back to its correct position. For the Board, the frequency must be set to 33 MHz.

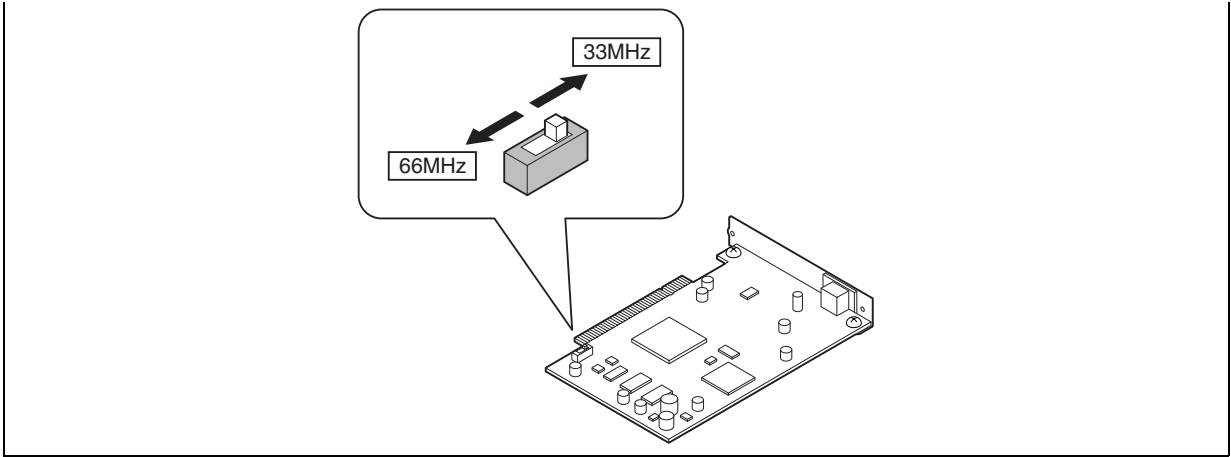

4) Fit the voice board [1] to the PCI Bus Expansion Kit-B1 [A], and fix it in place using the 2 screws [2] removed in step 2).

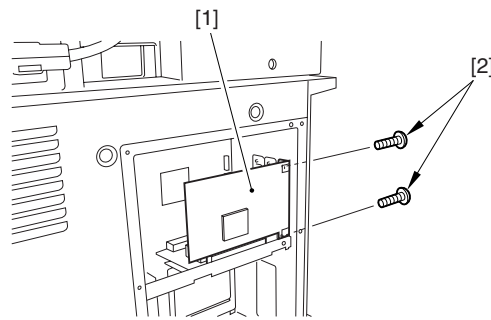
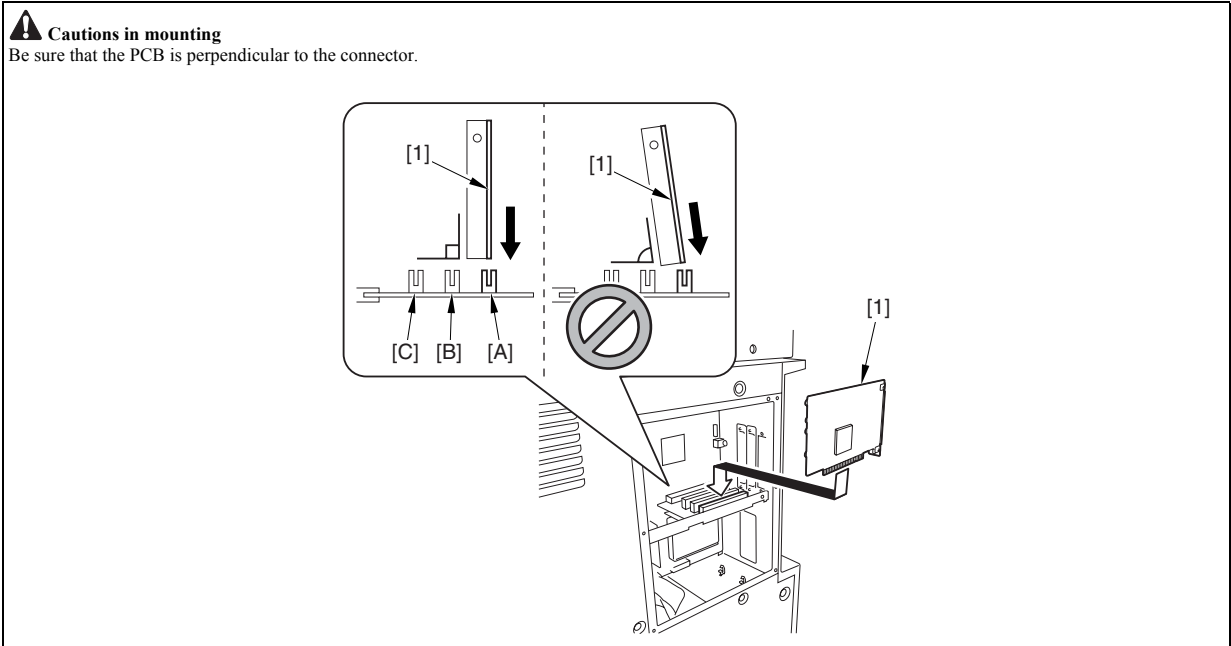

F-2-52

5) Detach the face cover.

6) Remove the screw [1] and the blanking seal [2] fixed to the right upper cover (Do not use the removed screw and blanking seal).

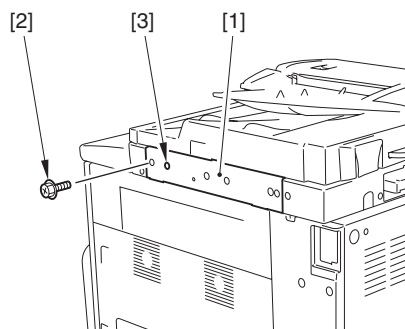

F-2-53

- 7) Mount the speaker unit (lower) [1].
- 1 screw (binding; M3X16) [2]
- 1 screw (binding; M4X16) [3]

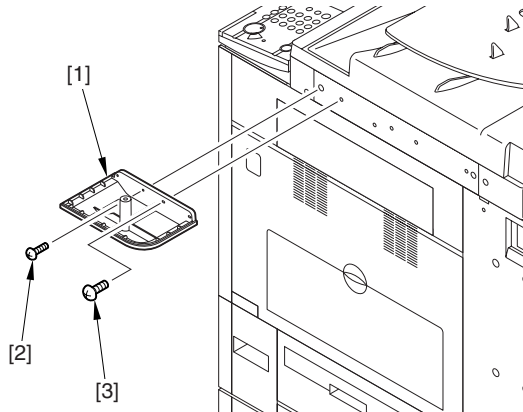

F-2-54

- 8) Mount the speaker unit (upper) [1] on the speaker unit (lower), fix them with a screw (binding; M4X6) [2] from beneath.

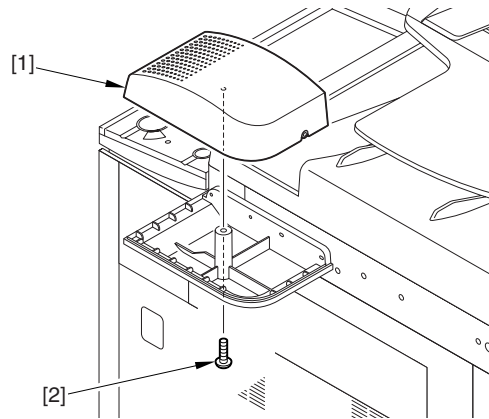

F-2-55

- 9) Detach the cover [1] on the cable guide.

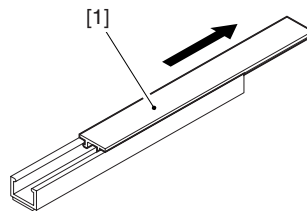

F-2-56

- 10) Peel off the released paper of the cable guide [1] and affix it to the host machine as shown in the figure.
A: When a card reader is not mounted on the host machine
The right side --- 2 places

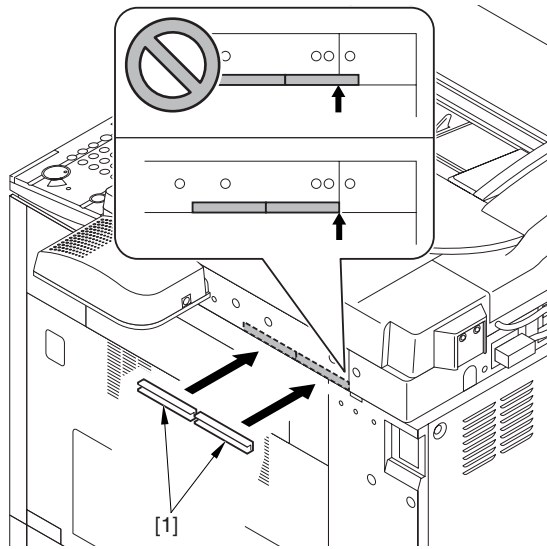

F-2-57

B: When a card reader is mounted on the host machine
The right side --- 1 place

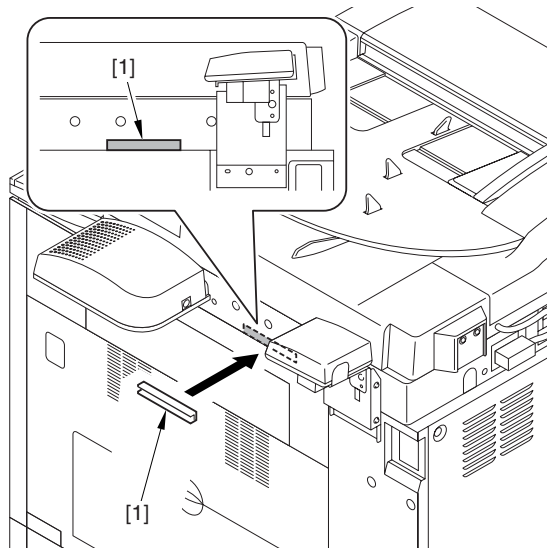

F-2-58

11) Connect the cable [2] into the speaker unit [1].

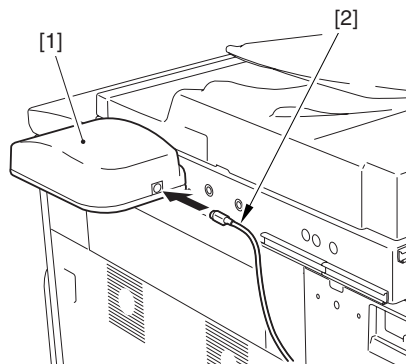

F-2-59

12) Run the cable [1] through the cable guide [2] and mount the cable guide cover [3].



There should no excessive bending of the cable.

A: When a card reader is not mounted on the host machine
The right side

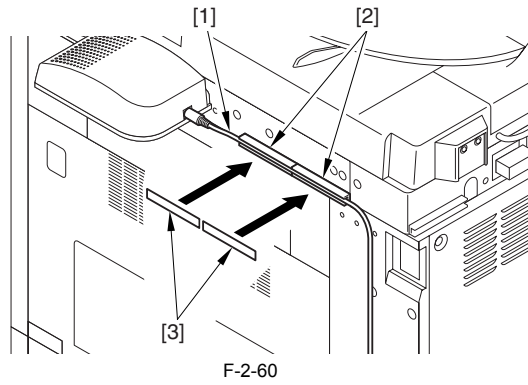

F-2-60

B: When a card reader is mounted on the host machine
The right side

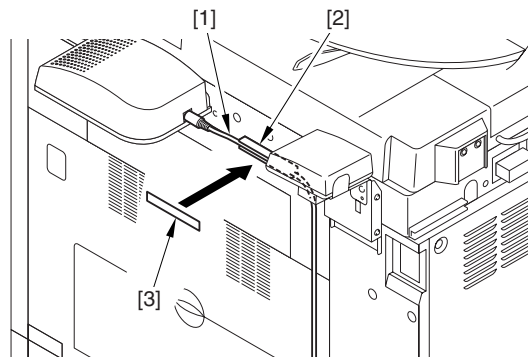

F-2-61

13) Attach the ferrite core [1] to the cable. Be sure that the length [2] is 50 mm or shorter.

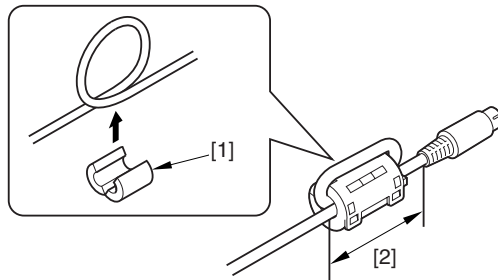

F-2-62

14) Connect the cable [1] to the terminal [2] of the voice board.

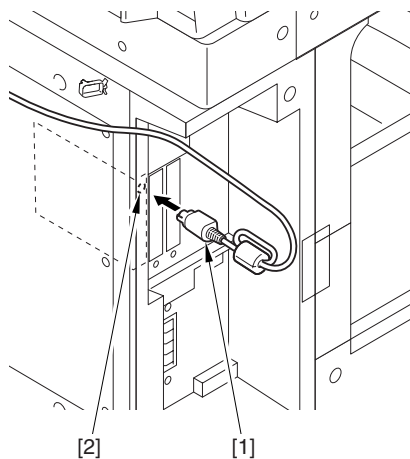

F-2-63

15) Run the cable [1] through the code guide [2] and mount the code guide cover [3].



There should no excessive bending of the cable.

A: When a card reader is not mounted on the host machine
The rear

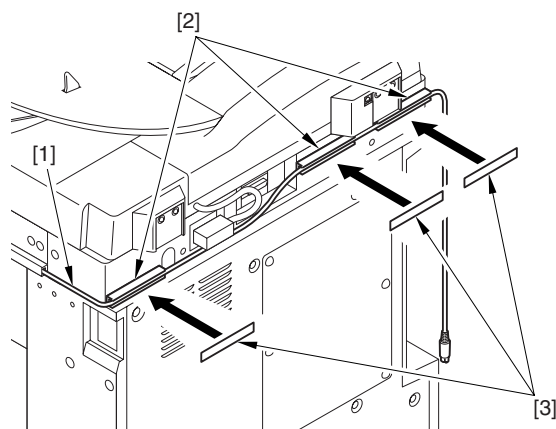

F-2-64

B: When a card reader is mounted on the host machine

The rear

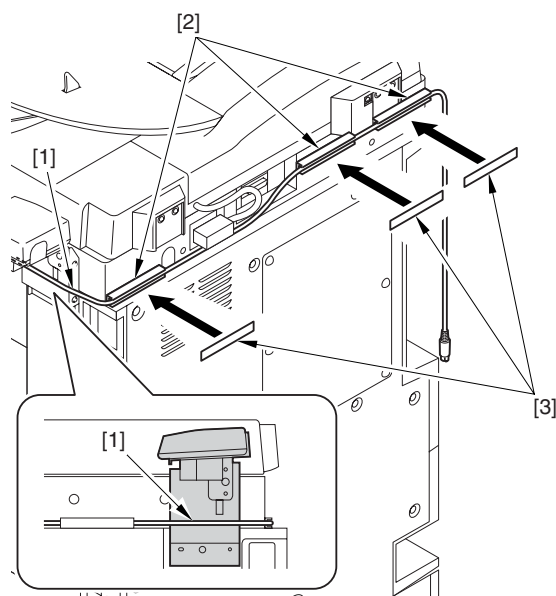

F-2-65

- 16) Connect the power cable to the outlet.
- 17) Turn ON the main power switch.
- 18) Check if the voice board is recognized.
 - Service mode
 - Select COPIER > DISPLAY > ACC-STS > PCI.
 - If "Voice Board" is displayed, that means that the voice board is correctly recognized.

2. Checking Settings

After the power on of the machine, check the following settings to use the voice guidance kit.

- 1) Select [Additional Function] > [System Settings] > [Voice Navigation Guide] > [Use Voice Navigation].
- 2) Check that the setting is ON.

3. Operation Check

<When Using the Voice Guidance>

- 1) Press the reset key for 3 sec or longer.
- 2) When the display of the number of copy is enclosed with red lines on the screen, voice guidance kit becomes enabled.

<When Stopping the Usage>

- 1) Press the reset key for 3 sec or longer.

2.6 Installing the Voice Operation Kit

2.6.1 A point to keep in mind at installation



- In order to install this equipment, "Expansion Bus-B1" is required.
- In case of installing this equipment, "Voice Guidance Kit-B1" cannot be installed.

2.6.2 Checking the Contents

<Voice Operation Kit-A1>

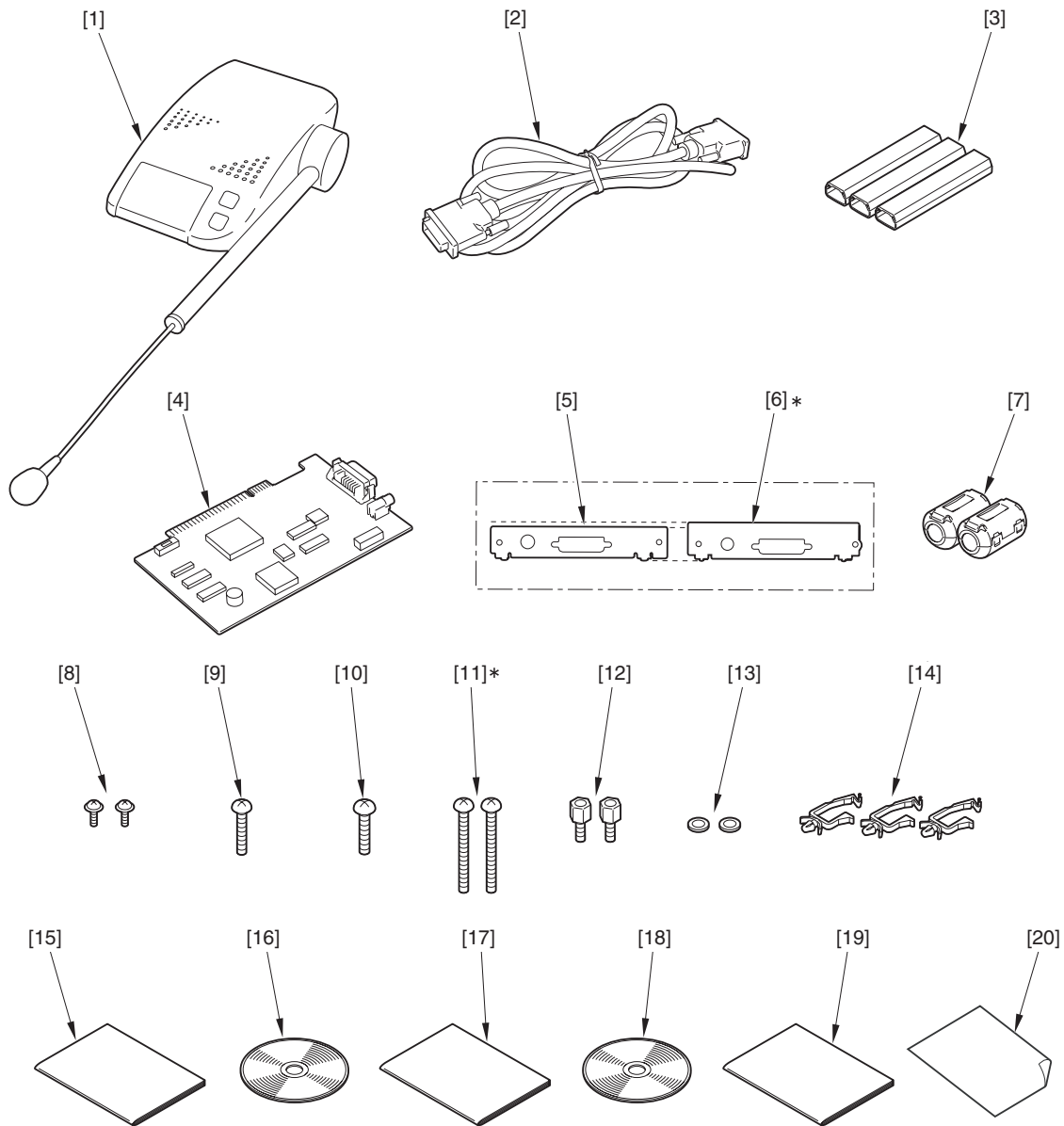

F-2-66

[1]	Speaker Unit	1pc.	[2]	Cable	1pc.
[3]	Cable Guide	3pc.	[4]	Voice Operation Board	1pc.
	(Use 1pc in this machine)				
[5]	Board Support Plate	1pc.	[6]*	Board Support Plate	1pc.
[7]	Ferrite Core	2pc.	[8]	Screw (TP; M3X6)	2pc.
[9]	Screw (binding; M3X20)	1pc.	[10]	Screw (binding; M4X20)	1pc.

[11]*	Screw (binding; M4X40)	1pc.	[12]	Hex Screw	2pc.
[13]	Washer	2pc.	[14]	Wire Saddle	3pc.
[15]	Voice Guidance Kit Users Guide	1pc.	[16]	Voice Guidance Kit Users Guide CD	1pc.
[17]	Voice Operation Kit Users Guide	1pc.	[18]	Voice Operation Kit Users Guide CD	1pc.
[19]	Voice Operation Quick Guide	1pc.	[20]	FCC/IC Sheet	1pc.

* Do not use for this machine.

2.6.3 Turning Off the Host Machine



How to Turn Off the Main Power

When turning off the main power, be sure to go through the following steps to protect the hard disk:

- 1) Hold down the control panel power switch for 3 sec or more.
- 2) Follow the instructions on the shutdown sequence screen to let the main power switch be ready to turn off.
- 3) Turn off the power switch.
- 4) Disconnect the power cables (for the power outlet).

2.6.4 Installation Procedure

1. Installation Procedure

- 1) Detach the face cover [1] in the direction shown by the arrow.
 - 4 screws [2] (to remove)
 - 2 screws [3] (to loosen)

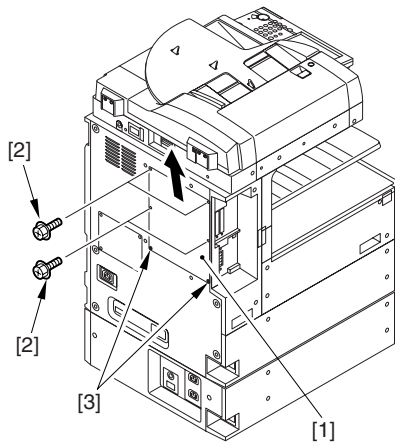

F-2-67

- 2) Detach the blanking plate [1] (Do not use the detached blanking plate).
 - 2 screws [2]

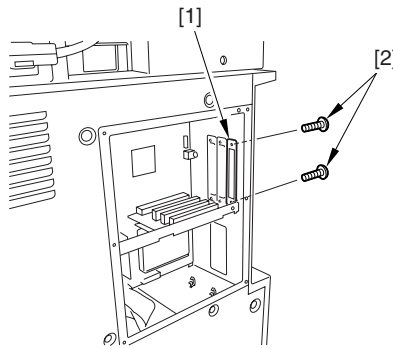

F-2-68

- 3) Attach the board support plate [2] to the voice operation board [1].
 - 2 screws (TP: M3X6) [3]
 - 2 washers [4]
 - 2 hex screws [5]

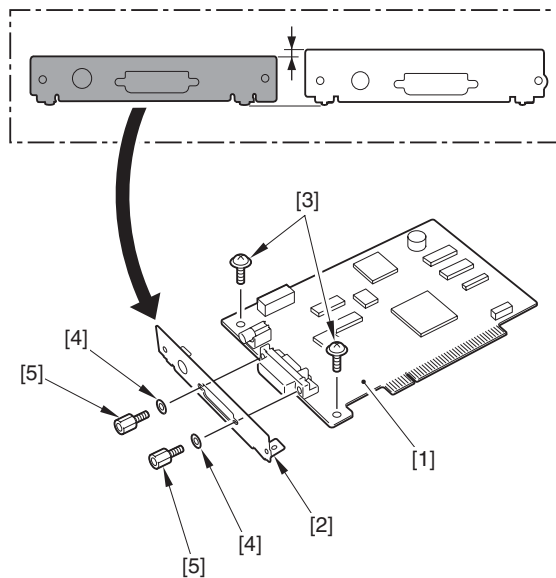

F-2-69

⚠ Checking the Position of the Slide Switch (SW1) on the Voice Guidance Board

The slide switch (SW1) on the Voice Guidance Board is provided as a means of switching frequencies (33 MHz/66 MHz) to suit the transfer speed of the PCI bus. It is important for the switch setting to suit the transfer speed so that the voice will be free of interruption. If you inadvertently moved the slide, be sure to put it back to its correct position. For the Board, the frequency must be set to 33 MHz.

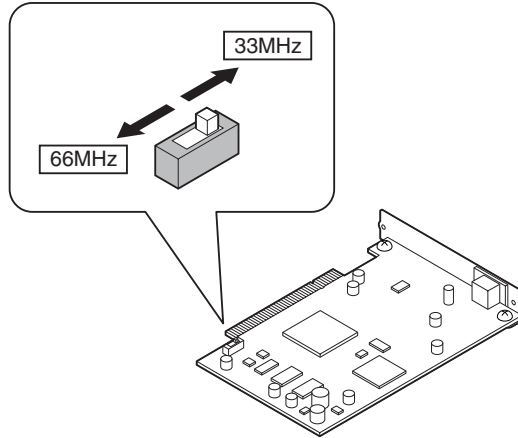

4) Fit the voice board [1] to the PCI Bus Expansion Kit-B1 [A], and fix it in place using the 2 screws [2] removed in step 2).

⚠ Cautions in mounting

Be sure that the PCB is perpendicular to the connector.

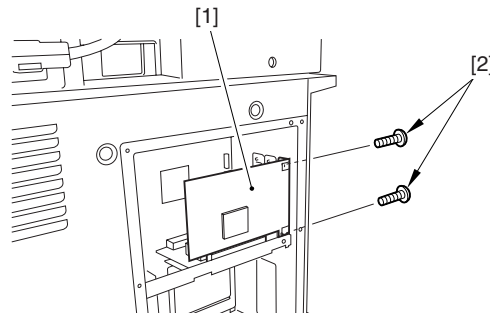
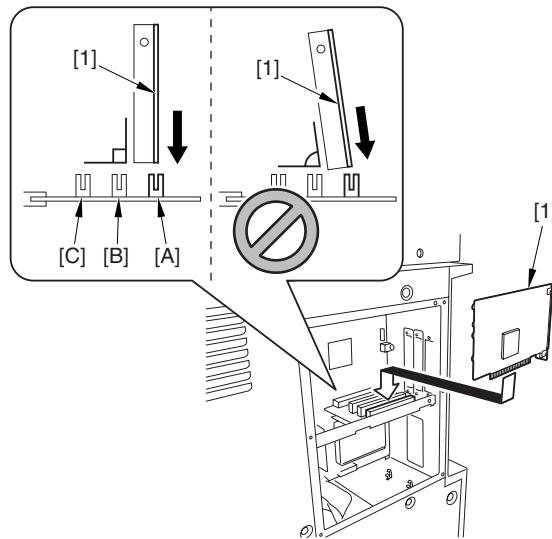

F-2-70

5) Attach the face cover.

6) Remove the screw [1] and the blanking seal [2] fixed to the right upper cover (Do not use the removed screw and blanking seal).

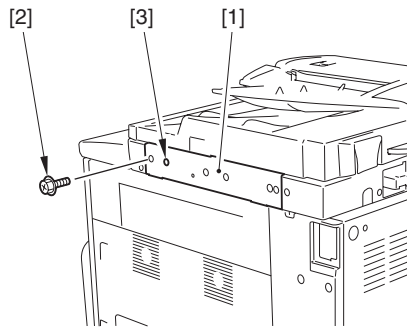

F-2-71

7) Remove the two screws [1] from the speaker unit and then remove the speaker unit (lower) [2].

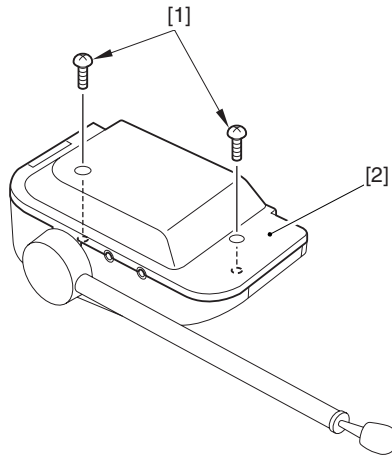

F-2-72

8) Mount the speaker unit (lower) [1].
- 1 screw (binding; M3X20) [2]
- 1 screw (binding; M4X20) [3]

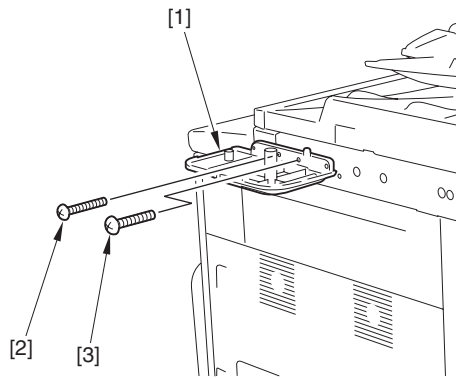

F-2-73

9) Mount the speaker unit (upper) [1] to the speaker unit (lower) using the two screws [2] that have been removed in step 7) from underneath.

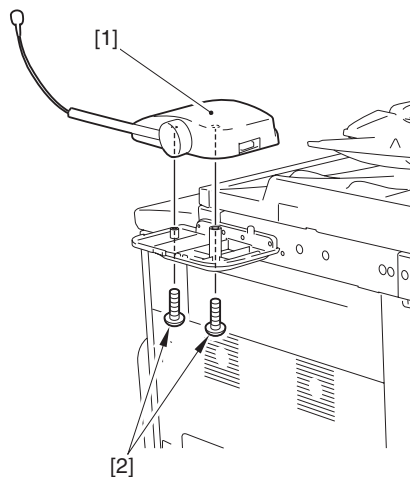

F-2-74

10) Detach the cover [1] of the cable guide.

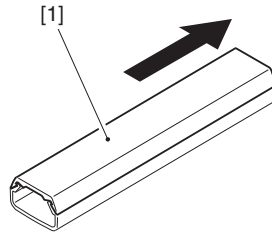

F-2-75

11) Peel off the released paper of the code guide [1] and affix it to the host machine as shown in the figure.

A: When a card reader is not mounted on the host machine

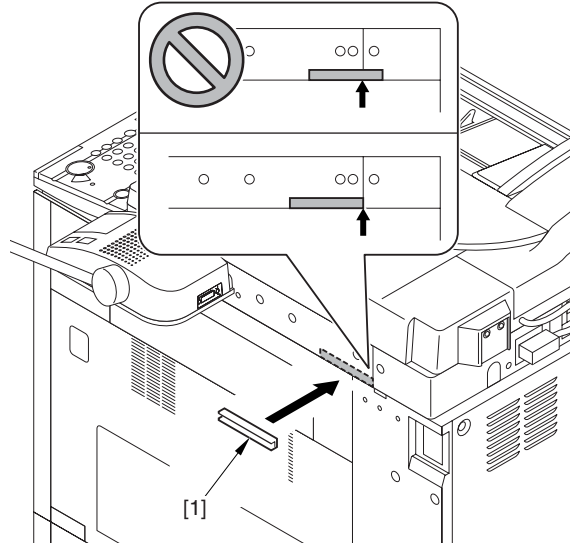

F-2-76

B: When a card reader is mounted on the host machine

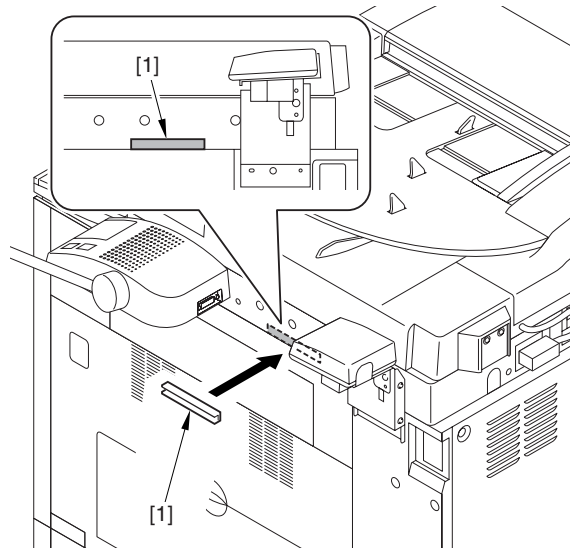

F-2-77

12) Attach the ferrite core [1] to the cable. Be sure that the length [2] is 50 mm. Fix it on the opposite side in the same procedure.

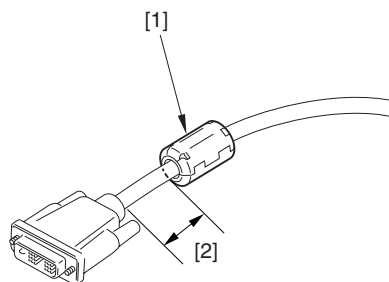

F-2-78

13) Connect the cable [2] to the speaker unit [1].

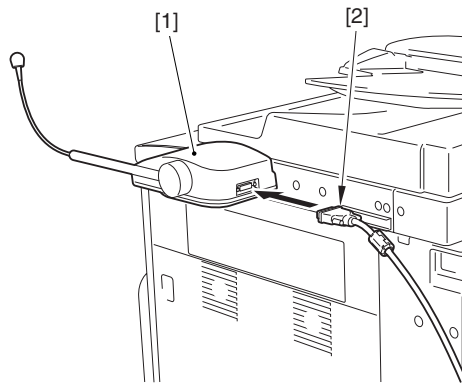

F-2-79

14) Run the cable [1] through the code guide [2] and mount the code guide cover [3].



There should no excessive bending of the cable.

A: When a card reader is not mounted on the host machine

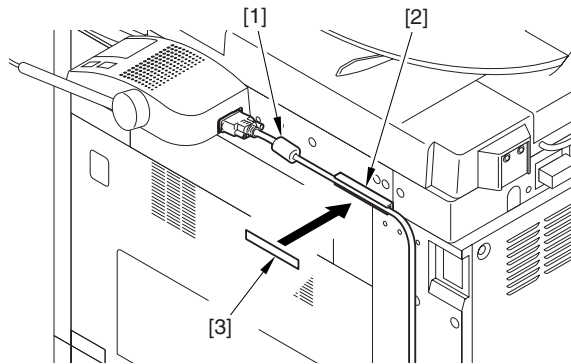

F-2-80

B: When a card reader is mounted on the host machine

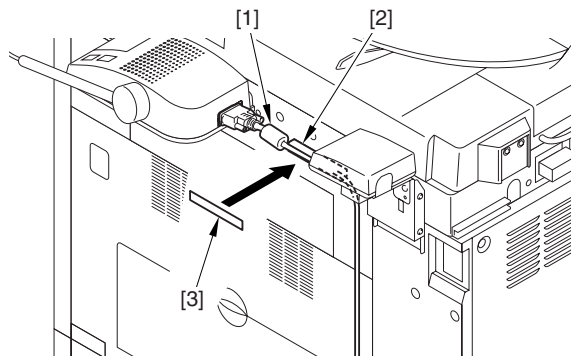

F-2-81

15) Connect another cable [1] to the terminal [2] of the voice operation board.

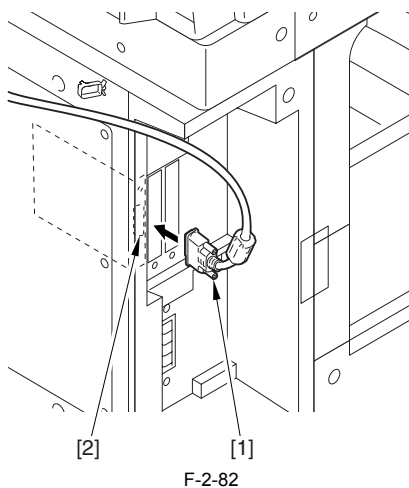

F-2-82

16) Fix the 3 wire saddles [2] with the rear cover [1].

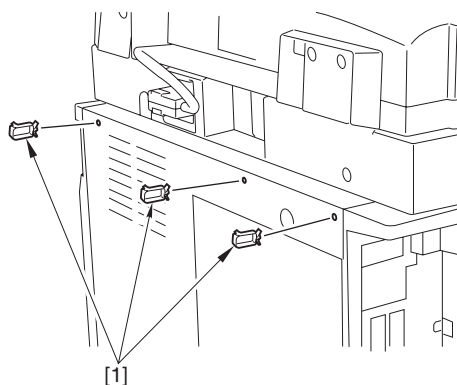

F-2-83

17) Fix it with 3 wire saddles [2] so that there is no bending of the cable [1].

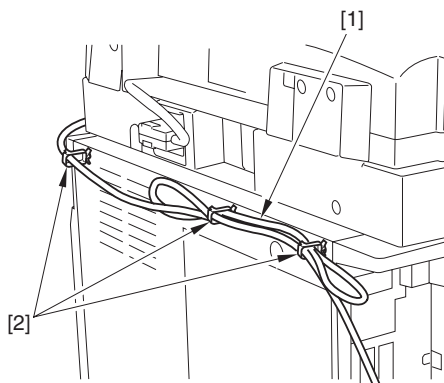

F-2-84

18) Connect the power cable to the power plug.

19) Turn ON the main power switch.

20) Check if the voice operation board is recognized.

Service mode.

Select COPIER > DISPLAY > ACC-STS > PCI 1.

If "Voice Operation" is displayed, that means that the voice operation board is correctly recognized.

2. Checking Settings

After the power on of the machine, check the following settings to use the voice operation kit.

1) Select [Additional Function] > [System Settings] > [Voice Navigation Management Settings] > [Use Voice Navigation].

2) Check that the setting is ON.

3. Operation Check

<When Using the Voice Operation Kit>

1) Press the reset key or the voice recognition button [1] three seconds or longer.

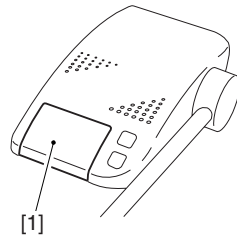

F-2-85

2) Select the voice mode type (Voice Guide + Recognition/Voice Guide/Voice Recognition) on the control panel, and press [OK].

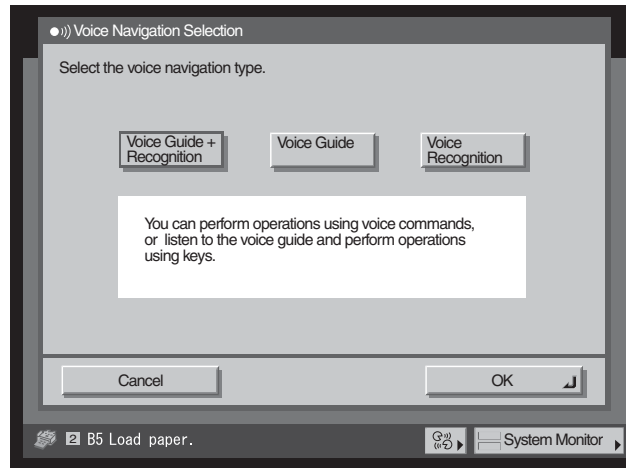

F-2-86

3) When the display of the number of copy is enclosed with red lines on the screen, "Voice Operation Kit" becomes enabled.



If 'Voice Operation Kit' does not work, check the following points.

- Is the slide switch on the voice operation board switched to 66MHz?
- TTS-JA/TTS-EN and ASR-JA/ASR-EN should be installed properly in the Service mode: COPIER > Display > VERSION.

<When Stopping the Usage>

1) Press the reset key or the voice recognition button three seconds or longer.

Chapter 3 Main Controller

Contents

3.1 Construction	3-1
3.1.1 Construction and Mechanisms	3-1
3.2 Construction of the Electrical Circuitry	3-1
3.2.1 Main Controller PCB	3-1
3.2.2 HDD	3-2
3.3 Start-Up Sequence	3-4
3.3.1 Overview	3-4
3.3.2 Start-Up Sequence	3-4
3.4 Shut-Down Sequence	3-6
3.4.1 Overview	3-6
3.4.2 Flow of Operation	3-6
3.5 Image Processing	3-6
3.5.1 Overview of the Image Flow	3-6
3.5.2 Construction of the Image Processing Module	3-7
3.5.3 Reader Unit Input Image Processing	3-7
3.5.4 Compressio/ Extesion/ Editing Block	3-8
3.5.5 Printer unit Output Image Processing	3-8
3.6 Flow of Image Data	3-9
3.6.1 Flow of Image Data According to Copy Functions	3-9
3.6.2 Flow of Image Data for the Box Function	3-9
3.6.3 Flow of Image Data for the SEND Function	3-10
3.6.4 Flow of Image Data for the Fax Transmission	3-10
3.6.5 Flow of Image Data for the Fax Reception Function	3-11
3.6.6 Flow of Image Data for the PDL Function	3-11
3.7 Parts Replacement Procedure	3-12
3.7.1 Main Controller PCB	3-12
3.7.1.1 Removing the Rear Cover	3-12
3.7.1.2 Removing the Main Controller PCB	3-12
3.7.2 SDRAM	3-13
3.7.2.1 Removing the Face Cover	3-13
3.7.2.2 Removing the SDRAM	3-13
3.7.3 Boot ROM	3-13
3.7.3.1 Removing the Face Cover	3-13
3.7.3.2 Removing the Boot ROM	3-13
3.7.4 HDD	3-14
3.7.4.1 Removing the Face Cover	3-14
3.7.4.2 Removing the Counter PCB	3-14
3.7.4.3 Removing the HDD	3-14

3.1 Construction

3.1.1 Construction and Mechanisms

The machine's main controller block consists of the following and has the following functions:

Item	Description
Main controller PCB	Controls system operation, memory, printer unit output, image processing, printer unit image input processing, rendering, color LCD controller, card printer unit interface, fax image processing, etc.
SRAM	Retains service mode settings (by SRAM), HDD management information
Image memory (SDRAM)	Temporarily retains image data (256 MB; 512 MB max.)
BOOTROM	Stores boot program
HDD	Stores system software, retains image data for Box/Fax function (20 GB)
USB port	USB2.0 interface
Ethernet port (10/100Base-T)	Ethernet interface

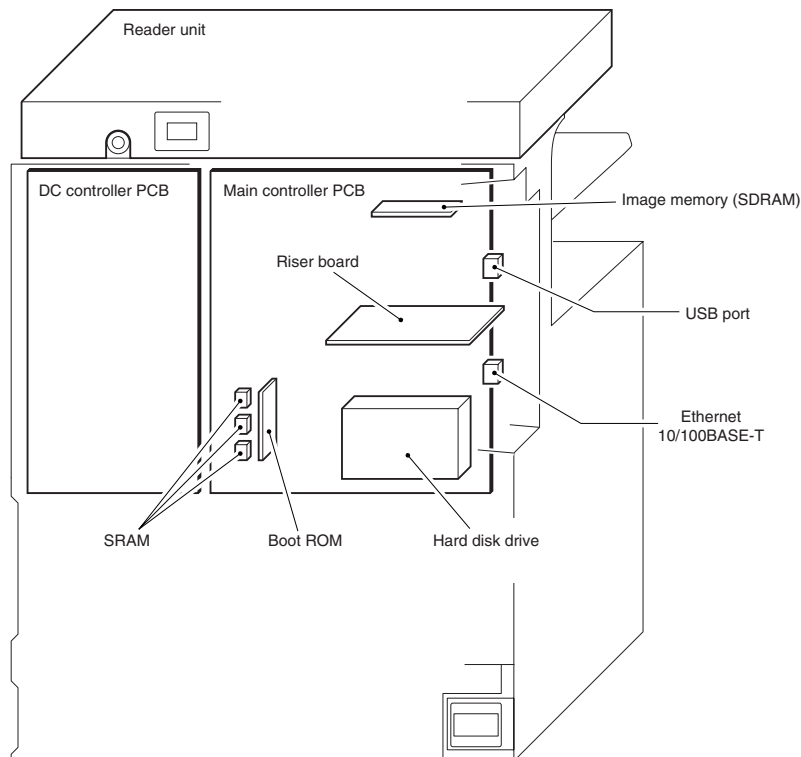

F-3-1

3.2 Construction of the Electrical Circuitry

3.2.1 Main Controller PCB

The following is a diagram showing the major control mechanisms of the main controller according to connectors:

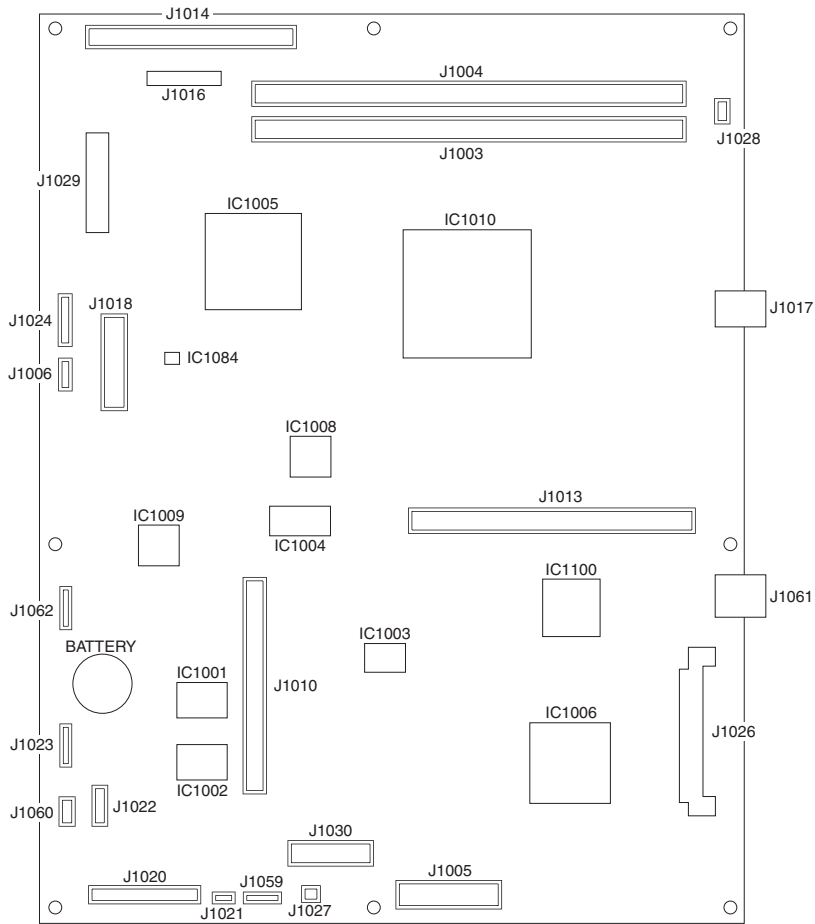

F-3-2
T-3-2

Connector	Description
J1003	SDRAM connection slot
J1004	SDRAM connection slot
J1005	Fax connector (2-port)
J1010	Boot ROM connector slot
J1013	Riser board connection slot
J1014	Scanner DDI
J1017	USB port
J1018	Control panel connector
J1020	Power supply connector
J1026	Hard disk connector
J1029	Printer DDI
J1030	Fax connector (1-port)
J1061	Ethernet port (10/100BaseT)

3.2.2 HDD

The HDD is divided into 11 partitions (blocks), each assigned with specific functions.

T-3-3

Partition	Description
FSTDEV	Collects compressed image data.
TMP_GEN	Stores temporary files, log data.
TMP_PSS	PDL spool
TMP_FAX	Ensures fax reception.
APL_SEND	Stores user data (address book, transfer settings).

Partition	Description
APL_MEAP	Stores MEAP applications.
APL_GEN	Mode memory data, standard mode data History (e.g., print job history) iFax image data Fax image data Other
IMG_MNG	Stores file management table, profile.
PDL_DEV	Stores PDL font, etc.
BOOTDEV	Stores execution module, message data file, RUI content, etc.
FSTCDEV	Chasing (not used)

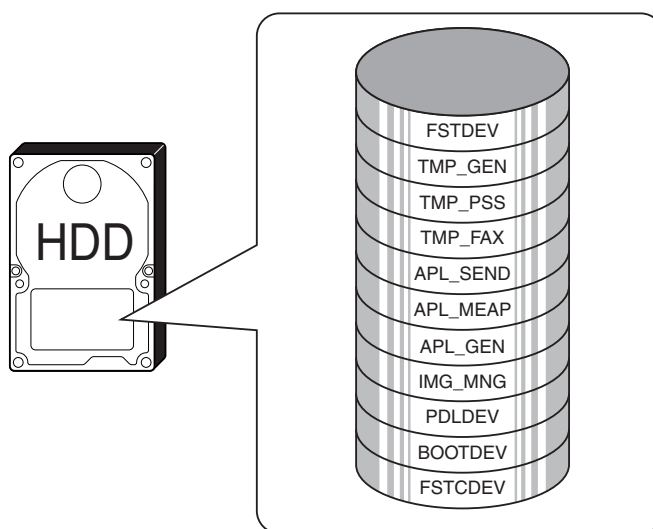

F-3-3

The following shows the construction of the machine's system software:

T-3-4

System software	Description	Location	Remarks
System	System module (controls mechanism as a whole)	HDD (BOOTDEV)	
Language	Language module (controls LCD indications)	HDD (BOOTDEV)	
RUI	Remote user interface module	HDD (BOOTDEV)	
Boot	Starts up the machine	BootROM	DIMM (FAX board)
G3FAX	Controls G3 Fax	HDD (BOOTDEV)	1-line
Deon	Controls the DC controller	DC controller PCB	Mask ROM (soldered)
Rcon	Controls the printer unit controller	Printer unit controller PCB	Flash ROM (soldered)
Meapcont	Controls MEAP applications	HDD (BOOTDEV)	

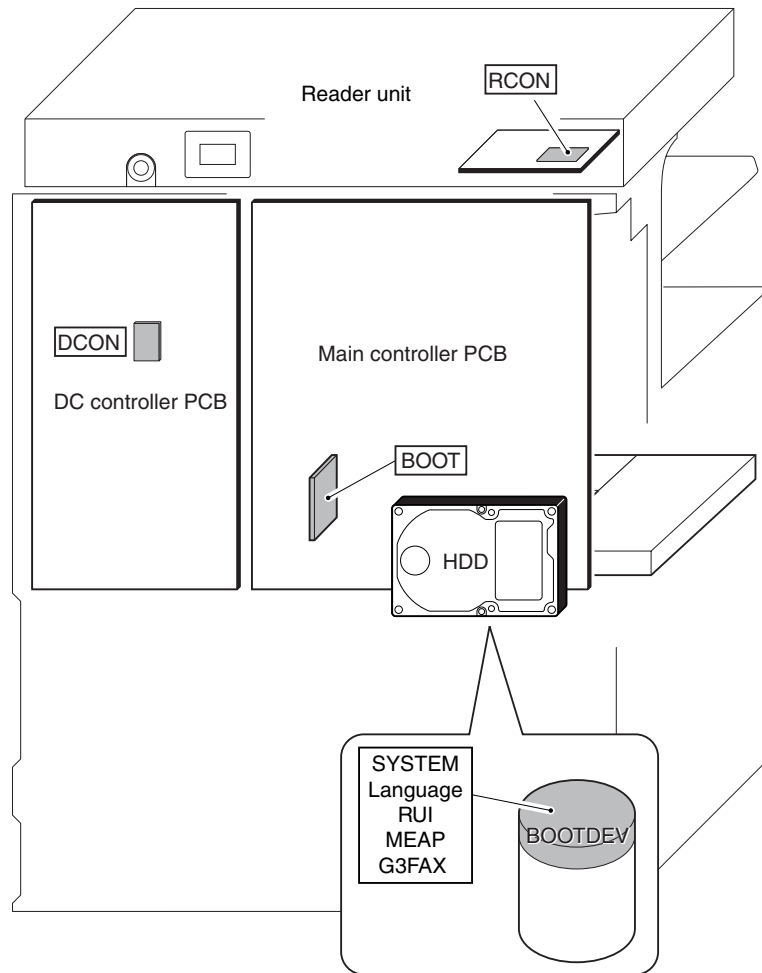

F-3-4

3.3 Start-Up Sequence

3.3.1 Overview

The system software used to control the machine is stored on the HDD. When the machine is started, the CPU on the main controller PCB reads the system software from the HDD according to the instructions of the boot ROM boot program, and writes it to the image memory (SDRAM) of the controller PCB. While the CPU reads the system software from the HDD to the image memory (DRAM), the control panel shows the following screen, using a progress bar to indicate the progress of the start-up sequence.

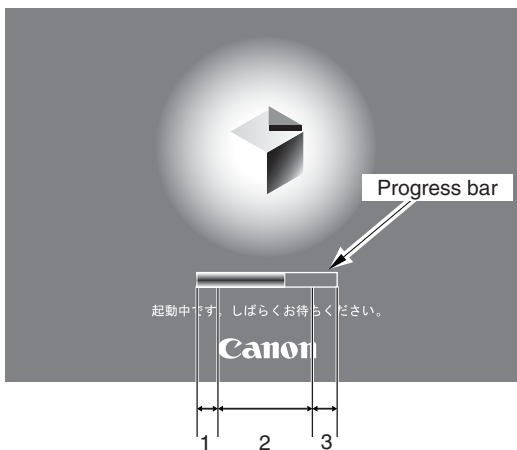

F-3-5

⚠ Do not turn off the main power while the progress bar is indicated, as access is being made to the HDD. Turning off the power can cause a fault on the HDD (identified by E602).

3.3.2 Start-Up Sequence

<Boot ROM Area>

-Self Diagnosis Program (interval 1)

The self-diagnosis program is run by the CPU on the main controller PCB when the main power switch is turned on. The program is used to check the condition of the image memory (SDRAM) and the HDD. The machine will indicate an error code if it finds a fault while running the program.

-Boot Program (interval 2)

When the self-diagnosis program ends normally, the CPU on the main controller PCB executes the boot program. The program is used to read the system software from the HDD to write it into the image memory (SDRAM).

<Image Memory (SDRAM) Area> (interval 3)

The system software written by the boot program initializes the various functional blocks (e.g., I/F settings of the main controller).

When all the foregoing ends normally, the machine becomes ready to accept a job (i.e., the control panel shows the Operation screen, and the LED on the Start key changes from red to green).

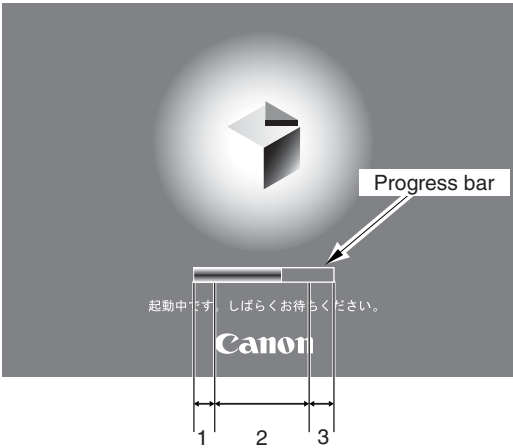

F-3-6

- While the Self-Diagnosis Program Is Being Executed

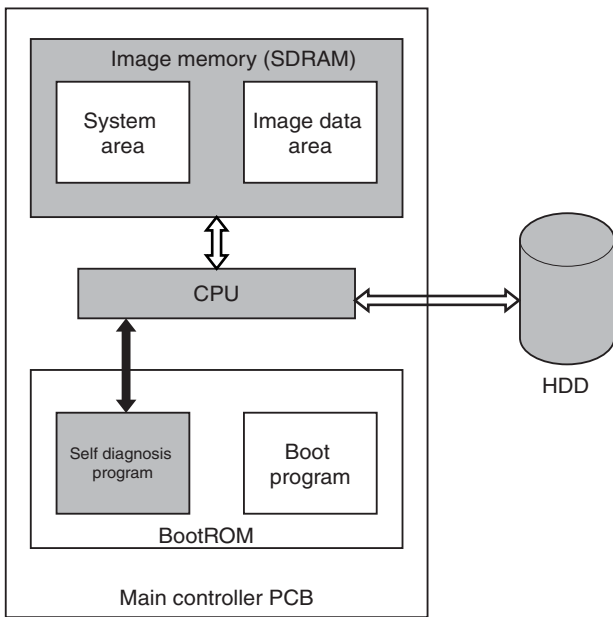

↔ : access to the program during execution
 ⇔ : access for checking

F-3-7

- While the Boot Program Is Being Run

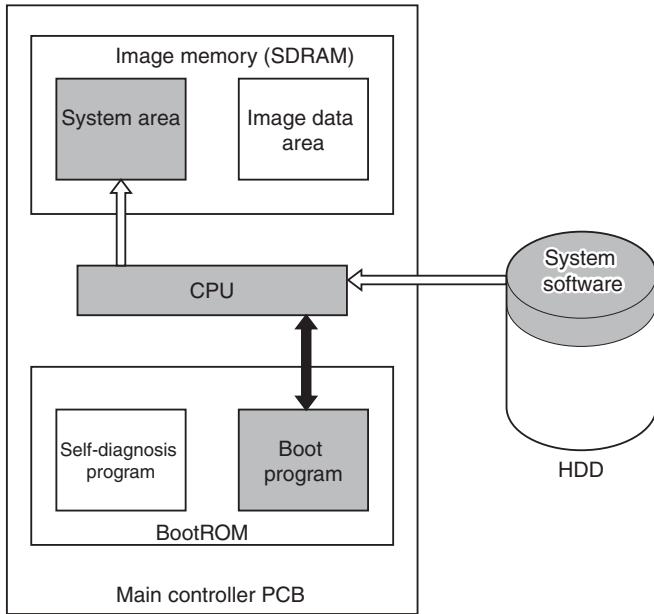

↔ : access to the program during execution.

← : flow of the system program.

F-3-8

3.4 Shut-Down Sequence

3.4.1 Overview

If the main power switch is turned off while the machine is accessing its HDD, damage can well occur on the HDD. To avoid such damage, the machine is provided with a shut-down sequence.

3.4.2 Flow of Operation

The following diagram shows the flow of shut-down operation:

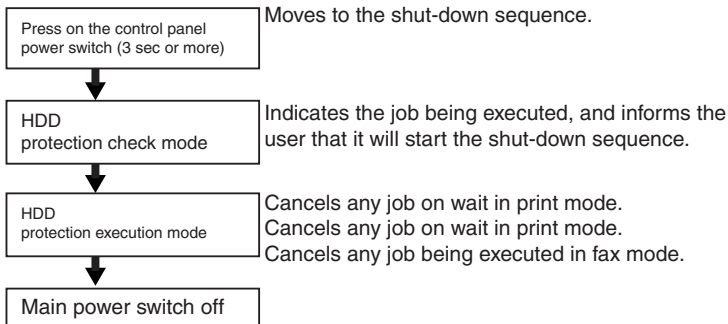

F-3-9

3.5 Image Processing

3.5.1 Overview of the Image Flow

The following shows the flow of images in relation to the machine's functions:

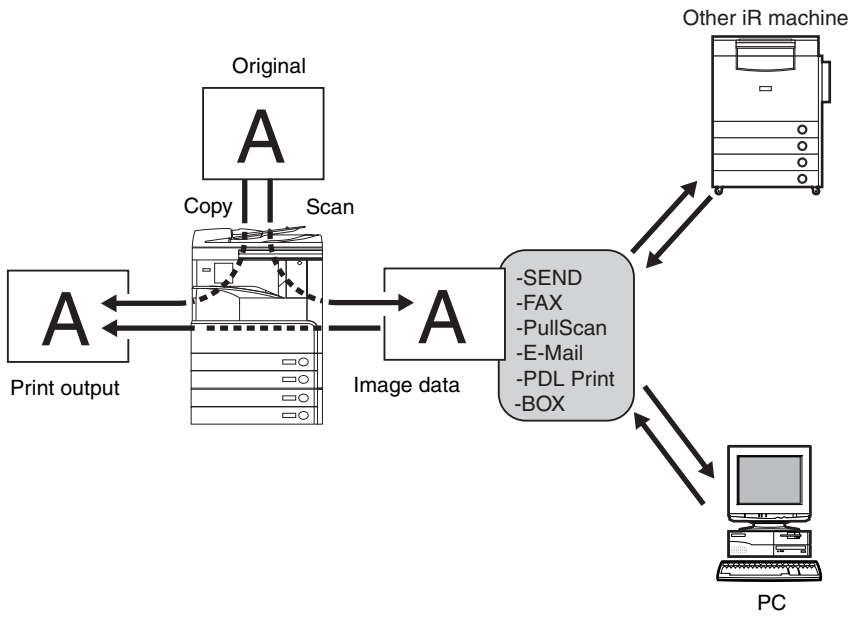

F-3-10

3.5.2 Construction of the Image Processing Module

The machine's major image processing is executed by the main controller PCB. The following shows the construction of the modules associated with image processing:

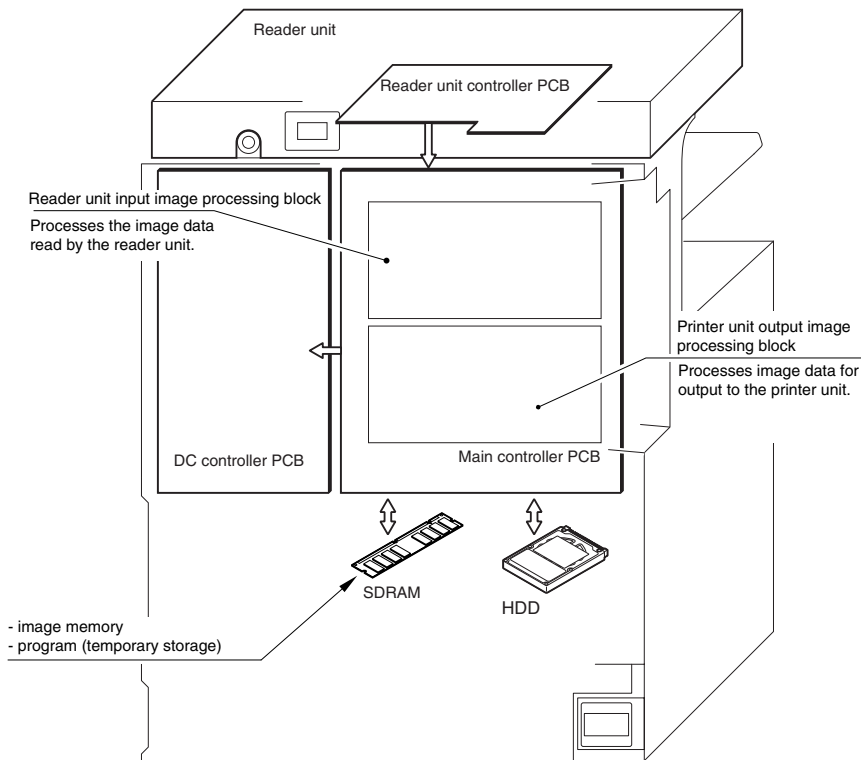

F-3-11

3.5.3 Reader Unit Input Image Processing

The image data collected by the contact image sensor is processed by the main controller PCB.

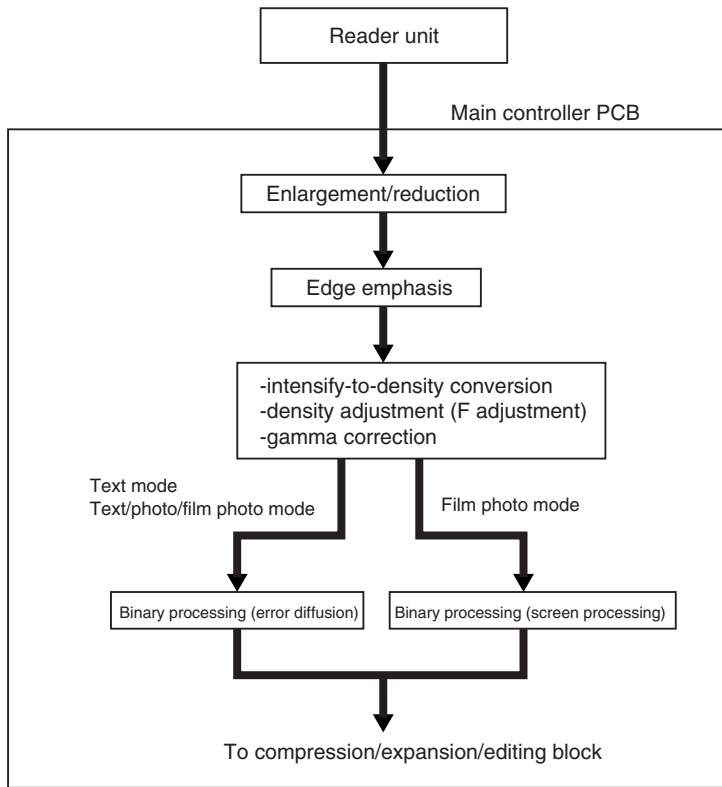

F-3-12

3.5.4 Compressio/ Extesion/ Editing Block

Here, image data is processed for compression, extension, and editing.

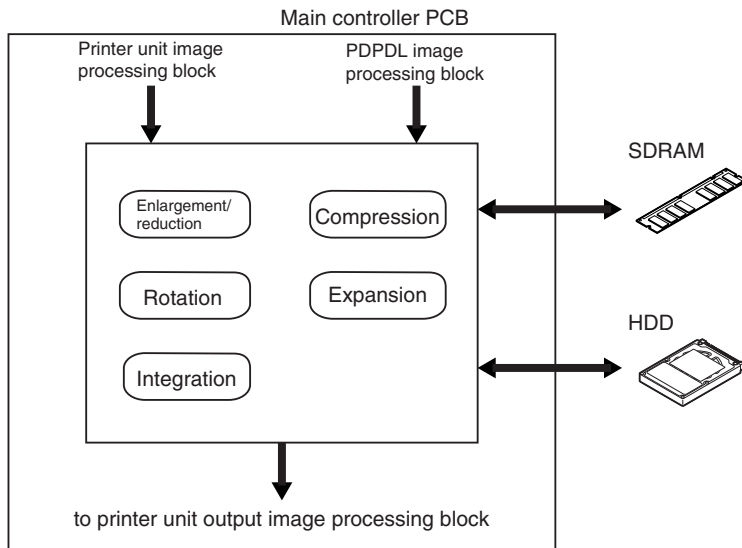

F-3-13

3.5.5 Printer unit Output Image Processing

The main controller processes the image data coming from the printer unit for output to the printer unit.

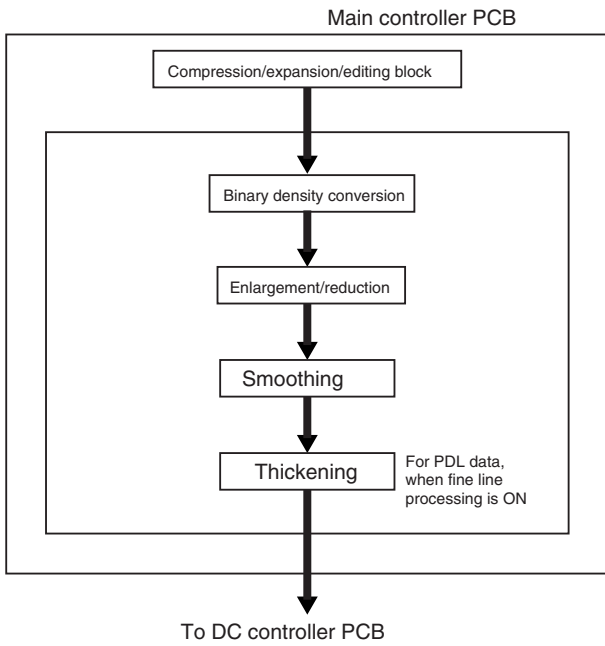

F-3-14

3.6 Flow of Image Data

3.6.1 Flow of Image Data According to Copy Functions

The following is the flow of image data when the Copy Function is in use:

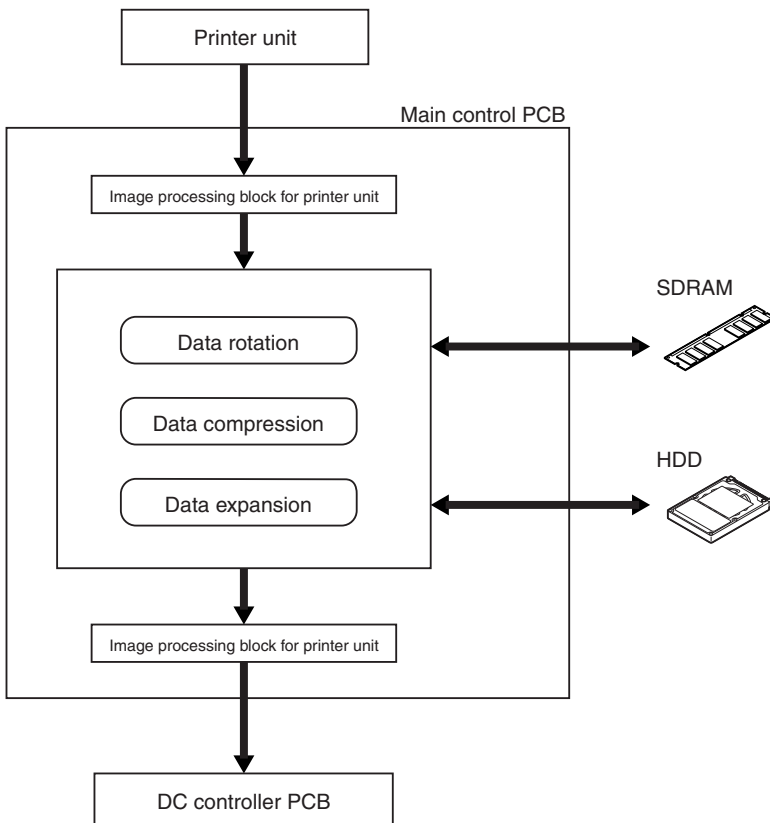

F-3-15

3.6.2 Flow of Image Data for the Box Function

The following is the flow of image data when the Box function is in use:

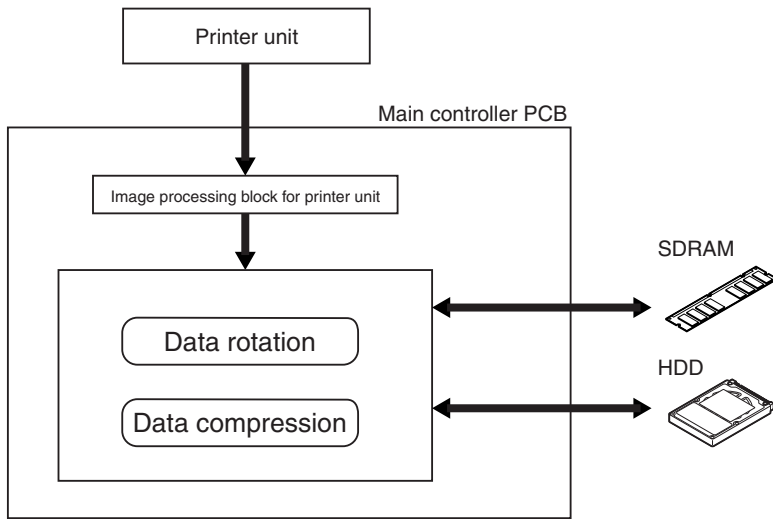

F-3-16

3.6.3 Flow of Image Data for the SEND Function

The following is the flow of image data when the SEND function is in use.

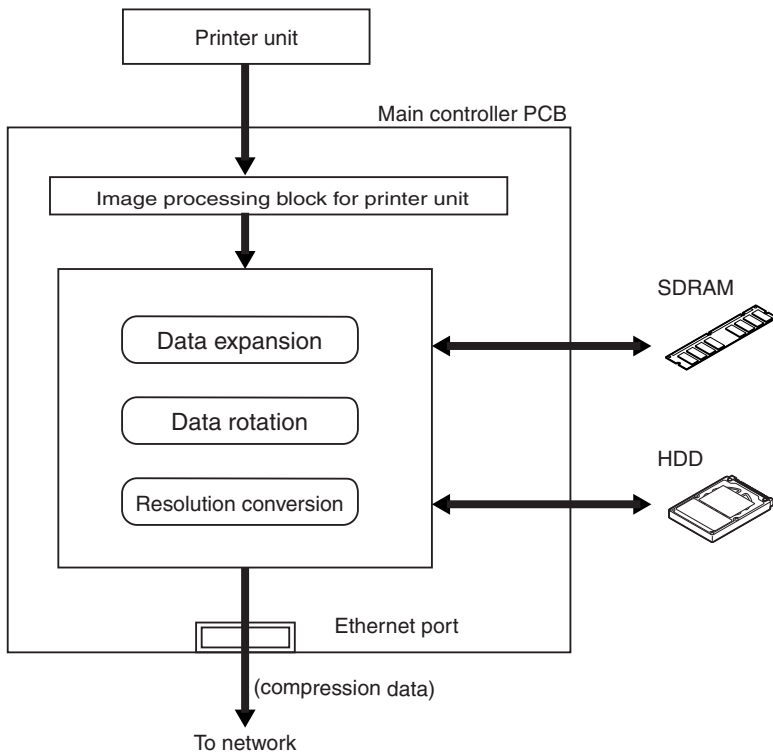

F-3-17

3.6.4 Flow of Image Data for the Fax Transmission

The following is the flow of image data when the fax transmission function is in use:

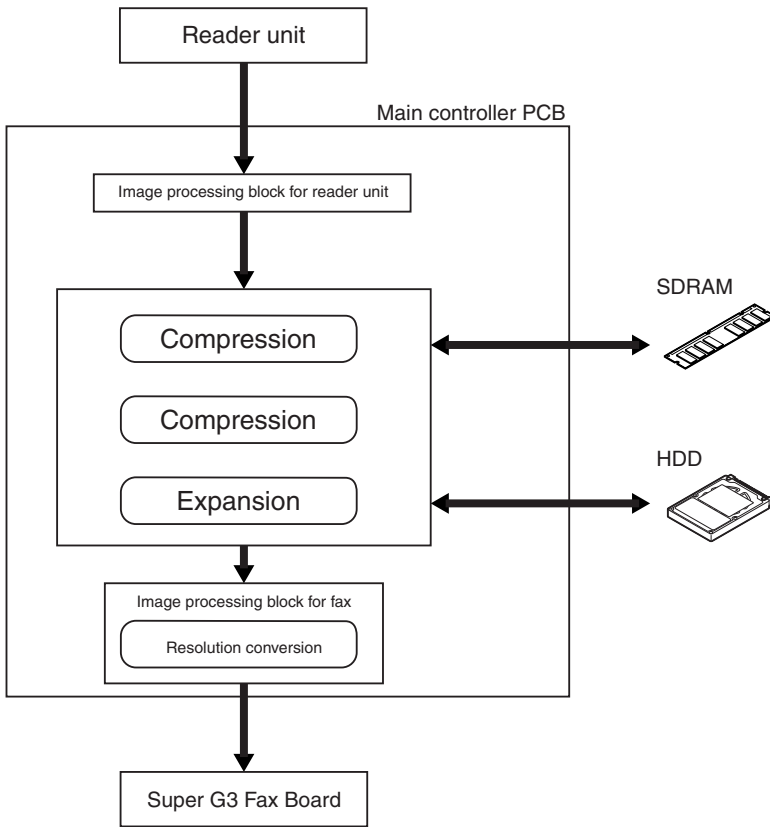

F-3-18

3.6.5 Flow of Image Data for the Fax Reception Function

The following is the flow of image data when the fax reception function is in use:

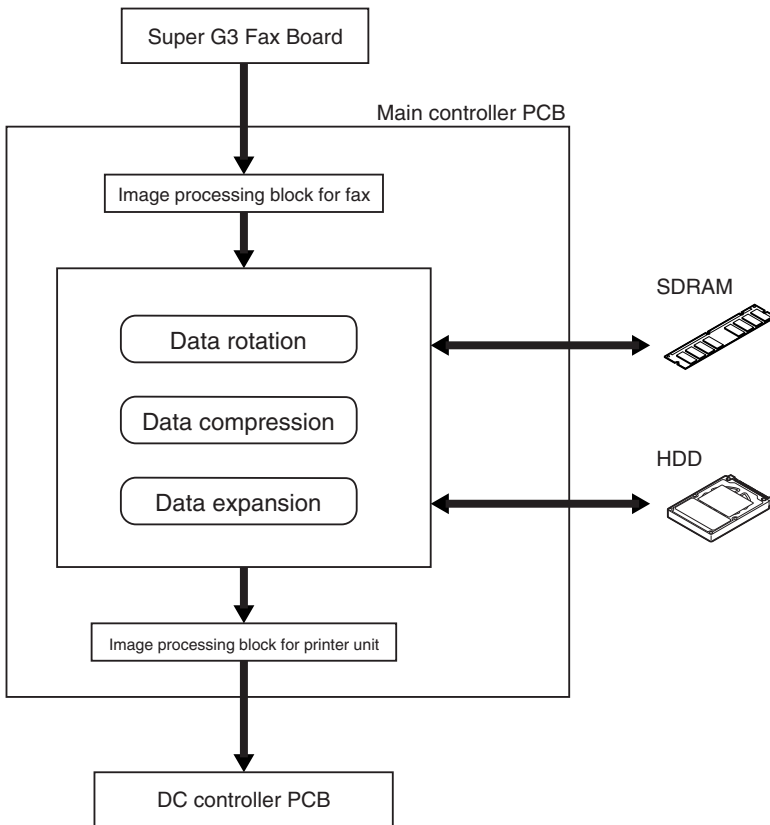

F-3-19

3.6.6 Flow of Image Data for the PDL Function

The following is the flow of image data when the PDL function is in use:

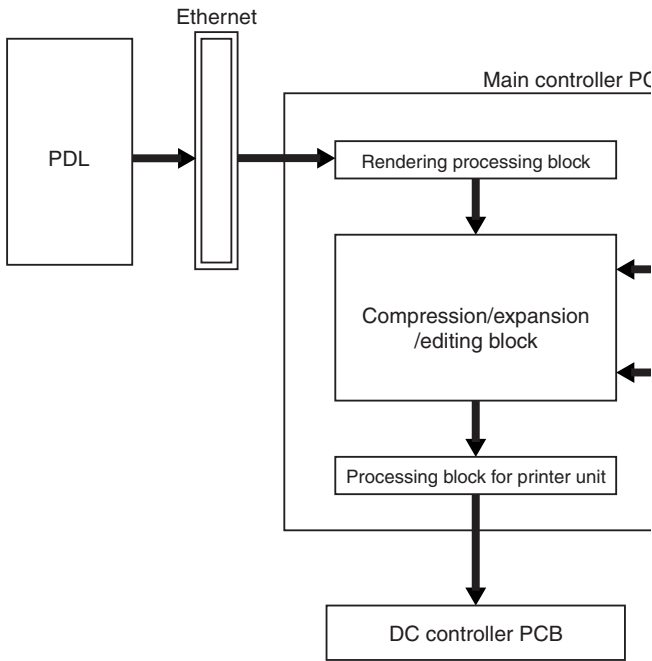

F-3-20

3.7 Parts Replacement Procedure

3.7.1 Main Controller PCB

3.7.1.1 Removing the Rear Cover

1) Remove the 13 screws [1] and then the other screw [2]; then, detach the rear cover [3].



If the left cover (lower) has already been detached, the screw [3] should also have been removed.

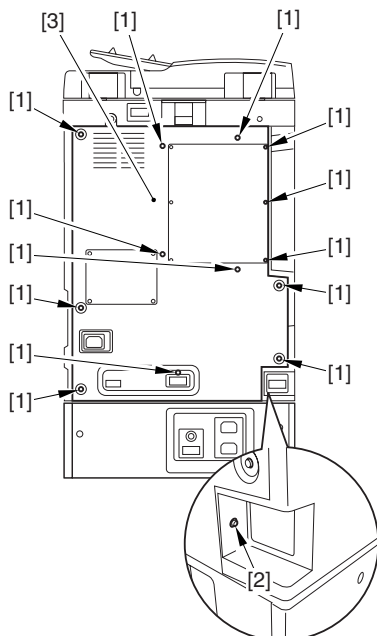

F-3-21

3.7.1.2 Removing the Main Controller PCB

1) Disconnect the connector [1].

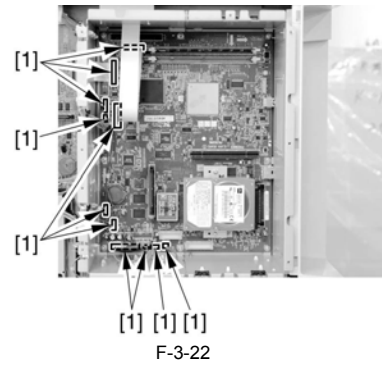

F-3-22

Freeing the Flexible Cable

To free the flexible cable [1], shift up the lock first as shown.

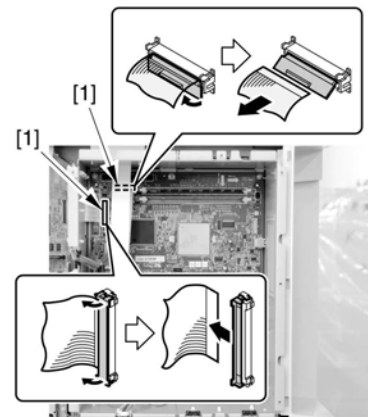

F-3-23

2) Remove the 9 screws [1], and detach the main controller PCB [2].

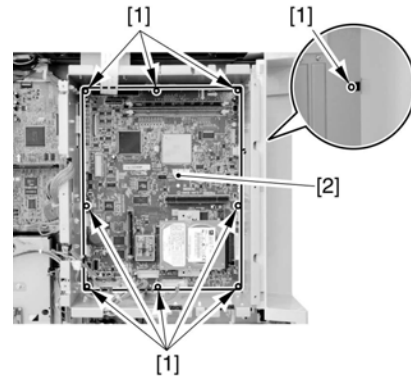

F-3-24



Points to Note When Replacing the Main Controller PCB
Remove the following components of the detached main controller PCB. Thereafter, be sure to mount them to the new main controller PCB.

- [1] Boot ROM
- [2] Hard disk
- [3] SDRAM
- [4] FRAM

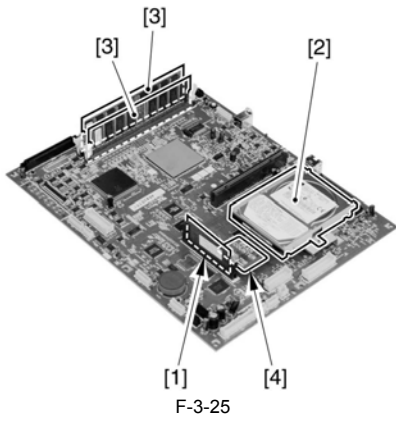

3.7.2 SDRAM

3.7.2.1 Removing the Face Cover

- 1) Remove the 4 screws [1].
- 2) Loosen the 2 screws [2].

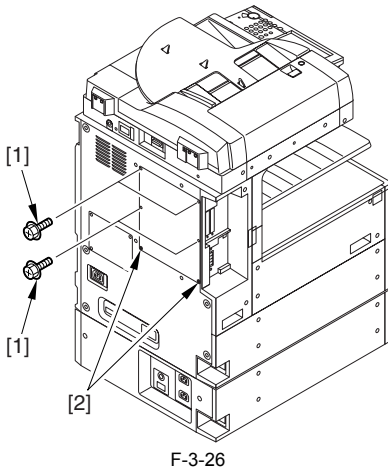

- 3) Pull off the face cover [1] in upward direction.

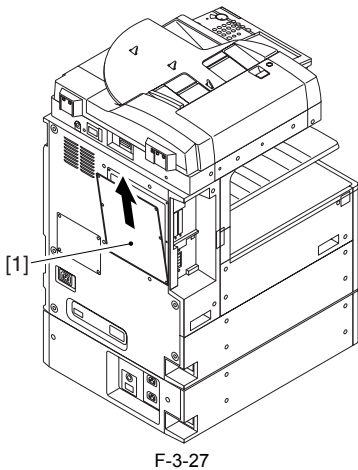

3.7.2.2 Removing the SDRAM

- 1) Release the 2 locking levers [1], and detach the SDRAM [2].

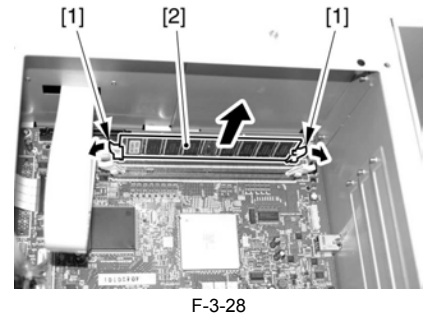

3.7.3 Boot ROM

3.7.3.1 Removing the Face Cover

- 1) Remove the 4 screws [1].
- 2) Loosen the 2 screws [2].

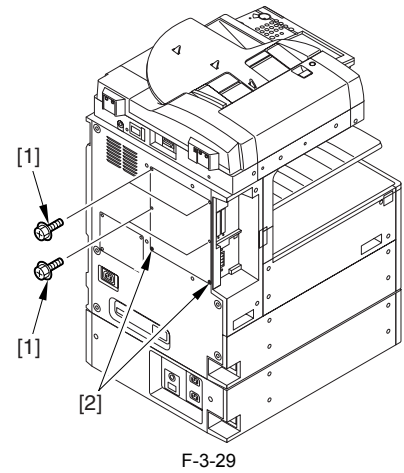

- 3) Pull off the face cover [1] in upward direction.

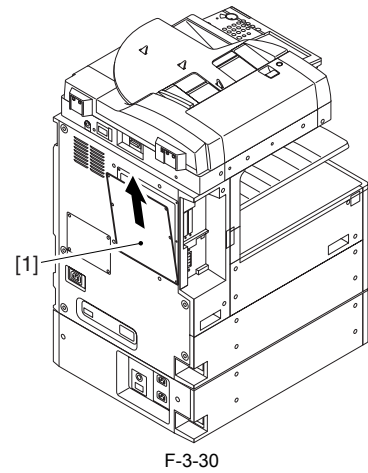

3.7.3.2 Removing the Boot ROM

- 1) Push the locking lever [1], and detach the boot ROM [2].

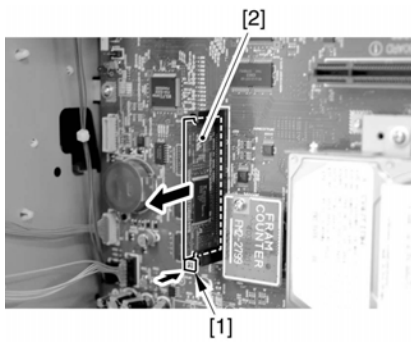

F-3-31

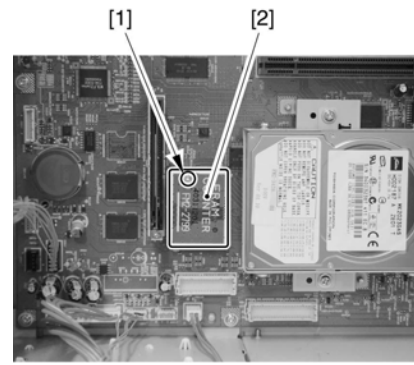

F-3-34

3.7.4 HDD

3.7.4.1 Removing the Face Cover

- 1) Remove the 4 screws [1].
- 2) Loosen the 2 screws [2].

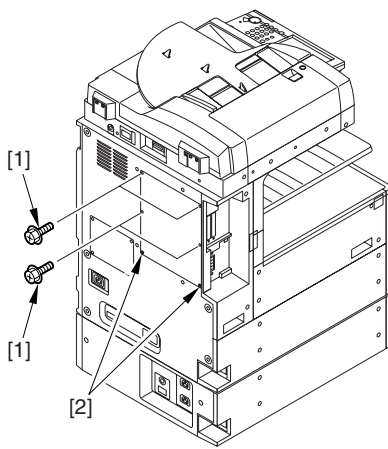

F-3-32

- 3) Pull off the face cover [1] in upward direction.

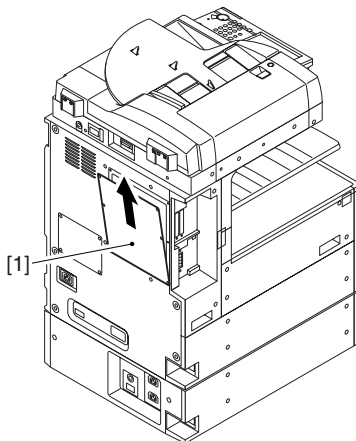

F-3-33

3.7.4.2 Removing the Counter PCB

- 1) Remove the screw [1], and detach the counter PCB [2].

3.7.4.3 Removing the HDD

- 1) Remove the 2 screws [1], and detach the HDD [2] in the direction of the arrow.

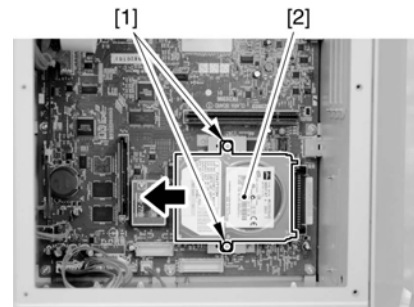

F-3-35

Chapter 4 Laser Exposure

Contents

4.1 Construction	4-1
4.1.1 Specifications, Control Mechanism, and Functions	4-1
4.1.2 Major Components.....	4-1
4.1.3 Construction of the Control System.....	4-2
4.2 Basic Sequence	4-3
4.2.1 Basic Sequence	4-3
4.3 Various Controls	4-4
4.3.1 Controlling the Laser Activation Timing.....	4-4
4.3.1.1 Turning On and off the Laser Light.....	4-4
4.3.1.2 Main Scanning Synchronous Control	4-5
4.3.2 Controlling the Intensity of Laser Light	4-6
4.3.2.1 APC Control.....	4-6
4.3.3 Controlling the Laser Scanner Motor	4-6
4.3.3.1 Controlling the Laser Scanner Motor.....	4-6
4.3.4 Controlling the Laser Shutter.....	4-6
4.3.4.1 Controlling the Laser Shutter	4-6
4.4 Parts Replacement Procedure.....	4-7
4.4.1 Laser Scanner Unit.....	4-7
4.4.1.1 Removing the Front Cover Unit.....	4-7
4.4.1.2 Removing the Left Cover.....	4-7
4.4.1.3 Removing the Laser Unit	4-7

4.1 Construction

4.1.1 Specifications, Control Mechanism, and Functions

Laser Light

	T-4-1
Number of laser beams	2
Output	5mW (iR2270/2870/2230/2830) 10mW (iR3570/4570/3530)
Wave length	785 nm - 800 nm (infrared light)

Scanner Motor

	T-4-2
Type of motor	DC brushless motor
Number of revolutions	16000 rpm (approx.; single control) (iR2270/2870/2230/2830) 27000 rpm/16000 rpm (approx.; double control) (iR3570/4570/3530)
Type of bearing	Oil

Polygon Mirror

	T-4-3
Number of facets	6 (40-mm dia.)

Control Mechanism

	T-4-4
Synchronous control	Main scanning direction
Light intensity control	APC
Others	Laser activation/deactivation Laser scanner motor control Laser shutter control

4.1.2 Major Components

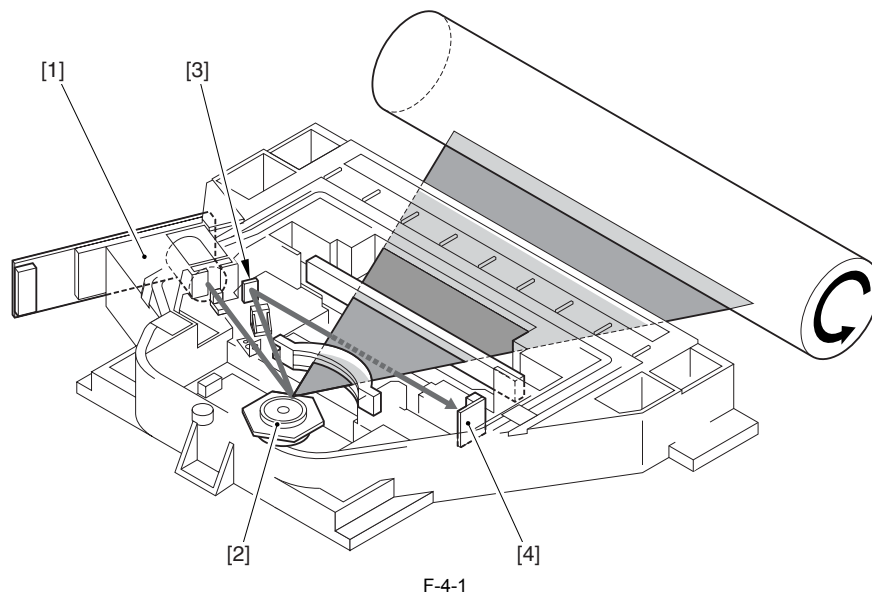

Name	Description
[1] Laser unit	Generates laser light
[2] Polygon mirror	Scans laser light in main scanning direction.
[3] BD mirror	Reflects laser light in the direction of the BD PCB.
[4] BD PCB	Generates the BD signal.

4.1.3 Construction of the Control System

The laser exposure system is primarily controlled by the DC controller PCB.
 iR2270/2270F/2870/2870F/2230/2230F/2830
 iR2270/iR2270F/iR2870/iR2870F

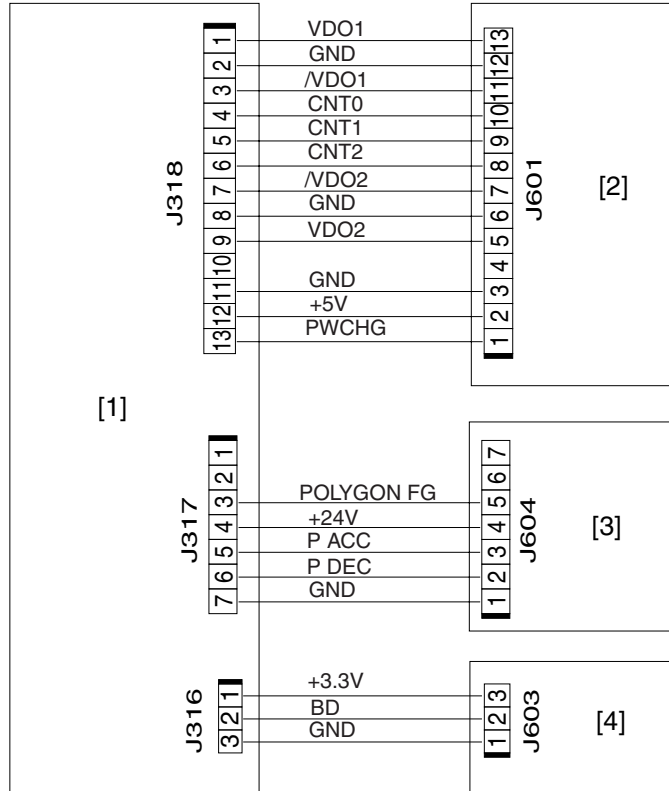

F-4-2

iR3570/3570F/4570/4570F/3530

iR3570/iR3570F/iR4570/iR4570F

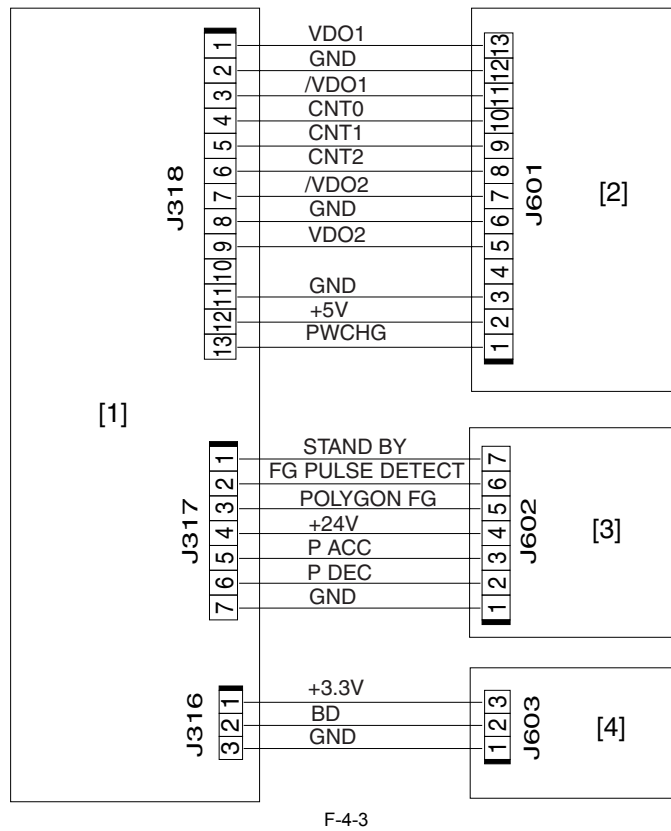

- [1]DC controller PCB
- [2]Laser driver PCB
- [3]Scanner motor PCB
- [4]BD PCB

Single	Description
VDO1	Image data single input
CNT0	Laser driver control signal
CNT1	Laser driver control signal
CNT2	Laser driver control signal
VDO2	Image data signal input
PWCHG	Light intensify switchover signal
FG PULSE DETECT	FG PULSE detecting signal
POLYGON FG	FG output signal
P ACC	Motor acceleration signal
P DEC	Motor deceleration signal
BD	BD output level single

4.2 Basic Sequence

4.2.1 Basic Sequence

When the control panel power switch is turned on, the laser scanner starts to rotate; when the motor rotation reaches its target revolution, the machine turns on the laser unit. Thereafter, when the Start key is turned on, the machine generates the image request signal (PVREQ) on the printer side, and turns on the laser beam with reference to the generated signal.

A4, 1 Copy

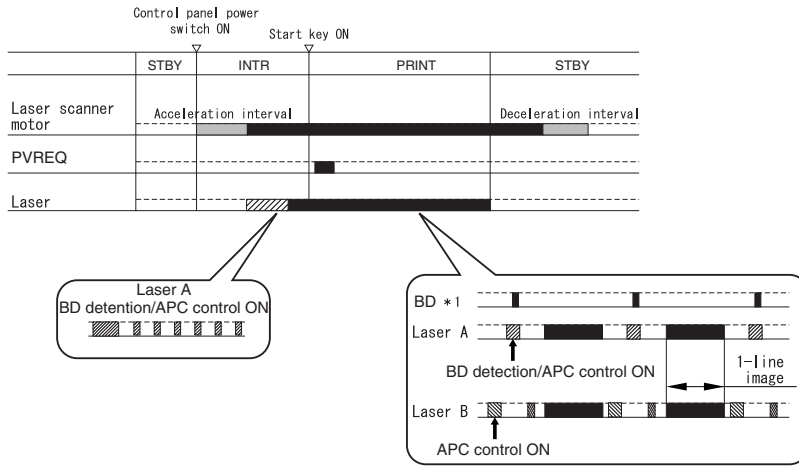

*1: The BD signal is generated in reference to the light from laser A. The BD sensor of the BD PCB receives light from laser A but not light from laser B.

F-4-4

4.3 Various Controls

4.3.1 Controlling the Laser Activation Timing

4.3.1.1 Turning On and off the Laser Light

The laser light is turned on and off according to the combination of laser control signals (CNT0/1/2) from the DC controller PCB.

T-4-7

Laser control signal			Laser status	
CNT2	CNT1	CNT0	Laser A	Laser B
0	1	0	ON (for APC control)	OFF
0	1	1	OFF	OFF
0	0	1	OFF	ON (for APC control)
0	1	1	OFF	OFF
1	1	1	Video signal input enabled	Video signal input enabled
0	1	1	OFF	OFF
0	0	1	OFF	ON (for APC control)
0	1	1	OFF	OFF

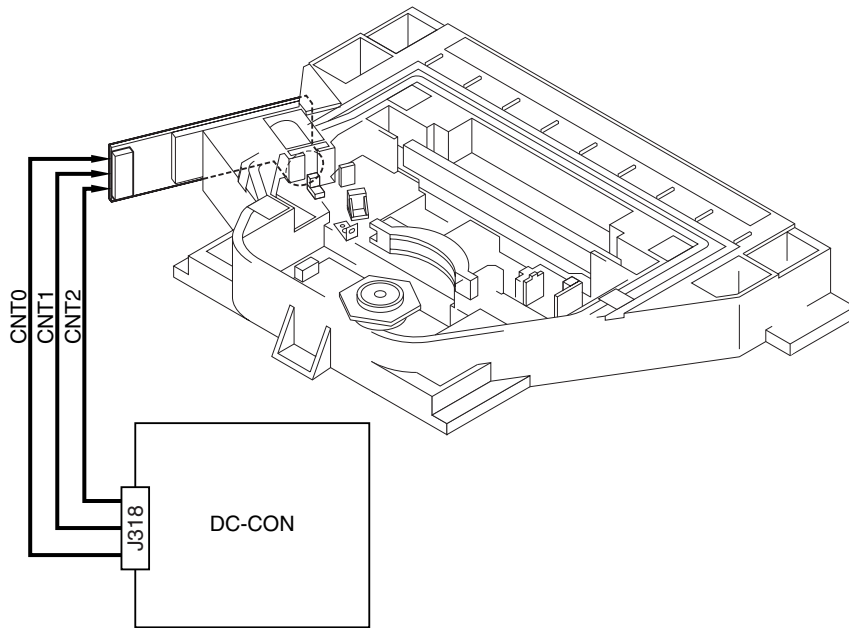

F-4-5

4.3.1.2 Main Scanning Synchronous Control

The synchronous control in the main scanning direction is performed in the synch circuit based on the BD synch signal. Using the BD signal generated based on the light from laser A, the DC controller PCB generates the BD synch signal for laser A and the BD synch signal for laser B. The image data written to line memory is read out by the readout enable signal (RE_A, RE_B) generated based on the BD synch signal (BD_A, BD_B) for output to the laser driver PCB.

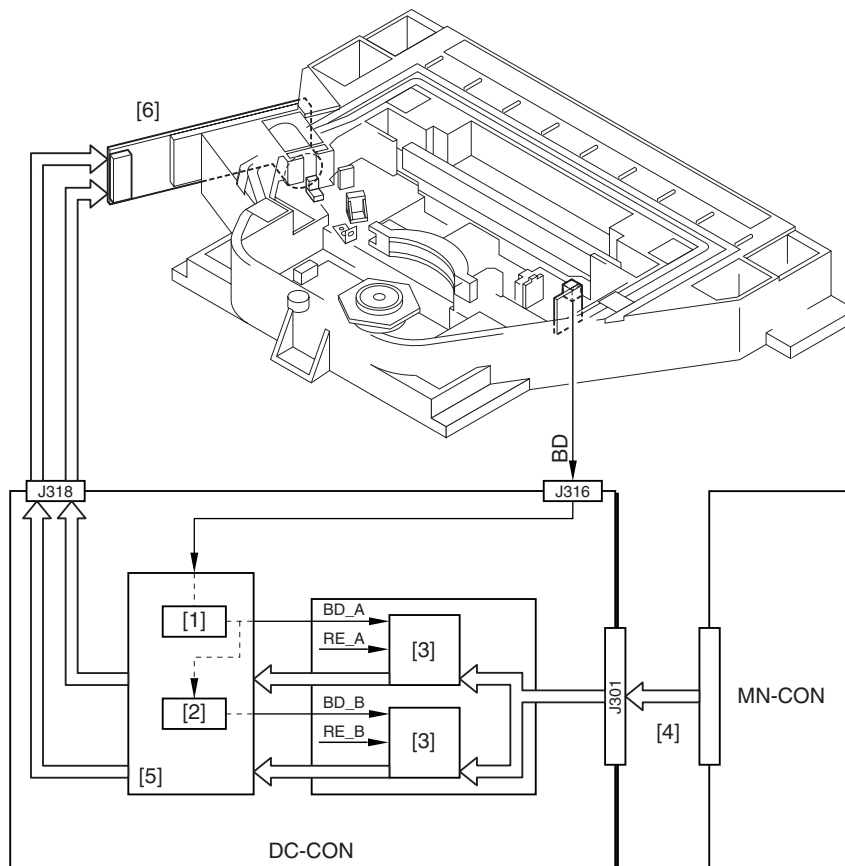

F-4-6

- [1] Sync circuit
- [2] Delay circuit
- [3] Line memory
- [4] VDO
- [5] VDO signal processing block
- [6] Laser driver PCB
- BD_A/B : BD synch signal
- RE_A/B : readout enable signal

Memo:

The BD sensor of the BD PCB receives light from laser A only, and is free of light from laser B, i.e., the BD signal is generated based on the light from laser A.

4.3.2 Controlling the Intensity of Laser Light

4.3.2.1 APC Control

The laser light hitting the photodiode included in the laserdiode is monitored and is controlled so that it remains a specific level at all times.

4.3.3 Controlling the Laser Scanner Motor

4.3.3.1 Controlling the Laser Scanner Motor

The laser scanner motor is controlled with reference to the laser scanner motor revolution signal (FG signal).

The revolution of the laser scanner motor is controlled by means of the acceleration signal (ACC signal) and the deceleration signal (DEC signal).

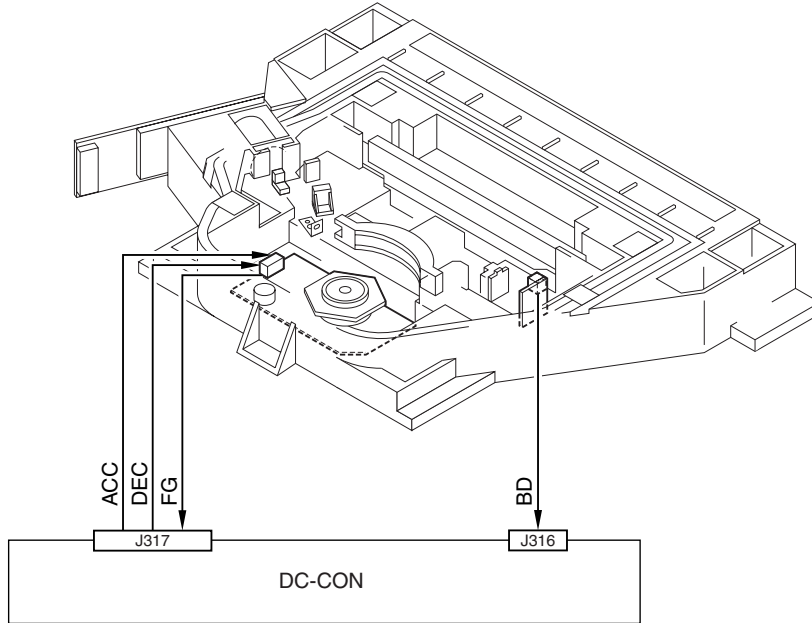

F-4-7

4.3.4 Controlling the Laser Shutter

4.3.4.1 Controlling the Laser Shutter

When the right door is opened, the laser shutter link operating in conjunction with the cover causes the laser shutter to move down, thus blocking the path of the laser light. If the machine identifies the front cover or the right door as having been opened, it will turn off the laser scanner motor and the laser output.

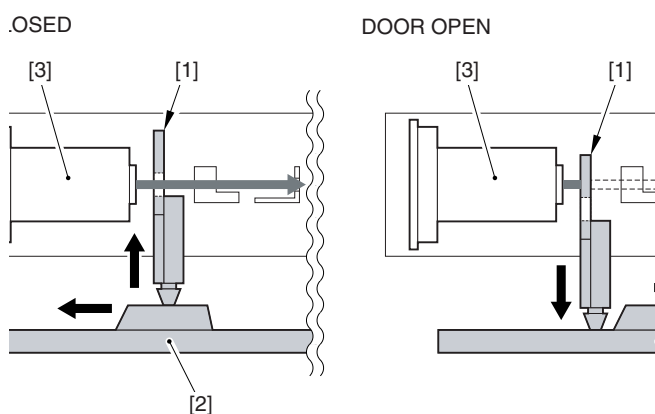
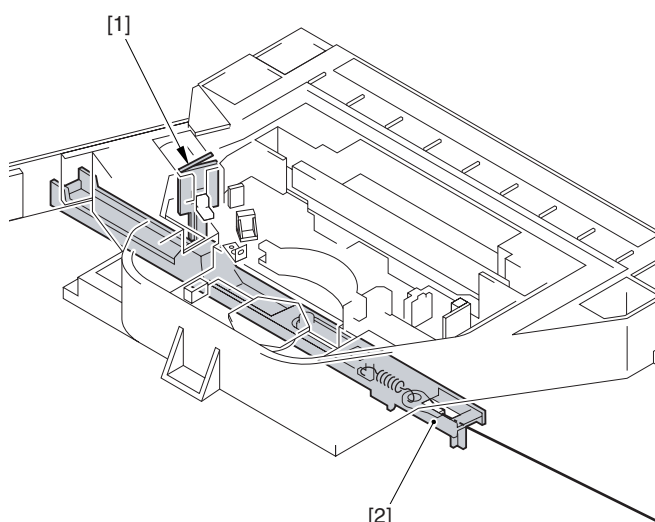

F-4-8

- [1] Laser shutter
- [2] Laser shutter link (operates in conjunction with front cover)
- [3] Laser unit

4.4 Parts Replacement Procedure

4.4.1 Laser Scanner Unit

4.4.1.1 Removing the Front Cover Unit

- 1) Open the front cover [1].

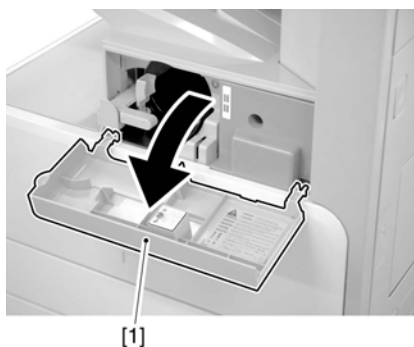

F-4-9

- 2) Remove the face cover rubber [1].
- 3) Remove the binding screw [2].
- 4) Remove the RS tightening screw [3].
- 5) Detach the front cover unit [4] by moving it in the direction of the arrow.

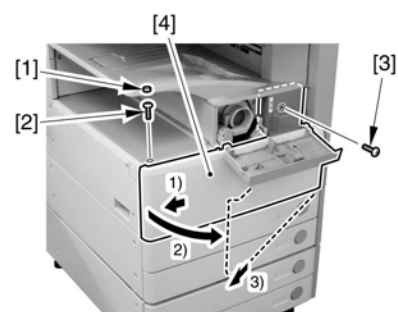

F-4-10

4.4.1.2 Removing the Left Cover

- 1) Remove the 4 screws [1], and detach the left cover [2].

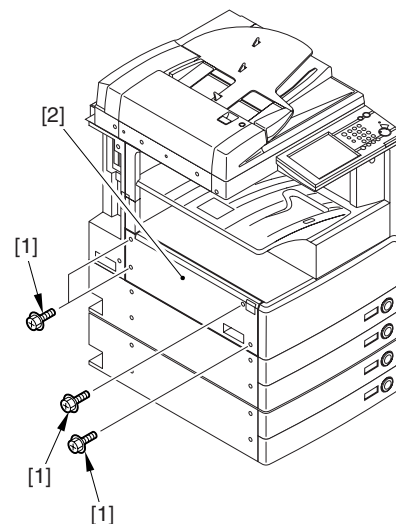

F-4-11

4.4.1.3 Removing the Laser Unit

- 1) Open the 2 wire saddles [1], and disconnect the 2 connectors [2].

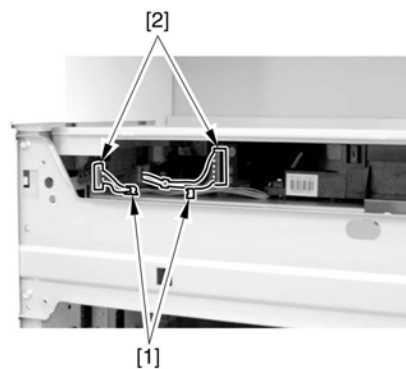

F-4-12



When you have disconnected the connector [1], be sure to take care so that it will not come into contact with the PCB that is mounted to the laser scanner unit. (The PCB is equipped with a laser intensity adjustment variable resistor. Contact with the PCB can change the adjustment setting.)

- 2) Open the wire saddle [1], and disconnect the connector [2].

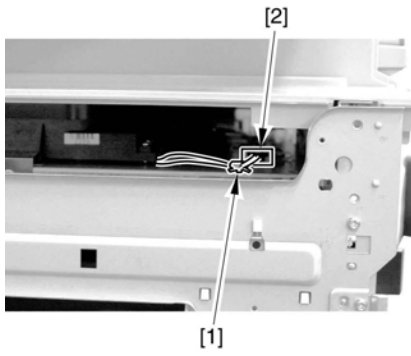

F-4-13

3) Remove the screw [1], and detach the fixing [2].

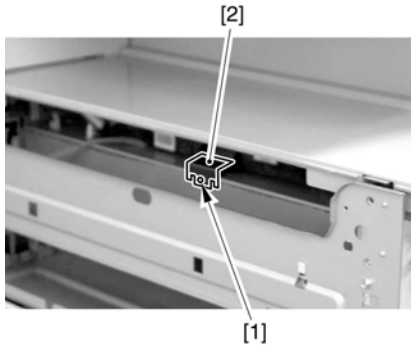

F-4-14

4) Lift the front of the laser unit [1], and slide it to the front.

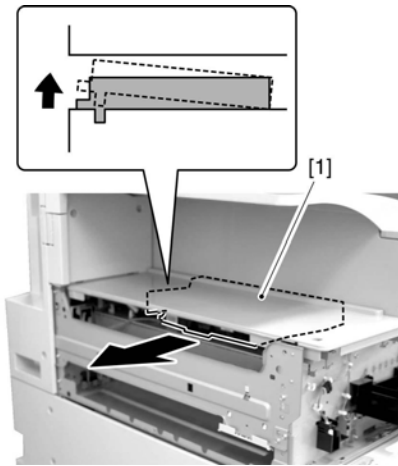

F-4-15



When sliding out the laser scanner unit, be sure to take care not to touch the PCB mounted to the laser scanner unit. (The PCB is equipped with a laser scanner intensity adjustment variable resistor, and contact with the PCB can change the adjustment setting.)

Chapter 5 Image Formation

Contents

5.1 Construction	5-1
5.1.1 Specifications of the Image Formation System	5-1
5.1.2 Major Components of the Image Formation System	5-2
5.2 Image Formation Process	5-2
5.2.1 Image Formation Process (outline)	5-2
5.2.2 Image Formation Process (image formation)	5-3
5.3 Basic Sequence	5-3
5.3.1 Sequence of Operation (initial rotation)	5-3
5.3.2 Sequence of Operation (copying)	5-4
5.3.3 Sequence of Operation (last rotation)	5-4
5.4 Image Stabilization Control	5-4
5.4.1 Overview	5-4
5.4.2 APVC Control	5-5
5.4.3 ATVC Control	5-5
5.5 Drum Unit	5-5
5.5.1 Charging Mechanism	5-5
5.5.1.1 Controlling the Primary Charging Bias	5-5
5.5.1.2 Primary Charging Roller Cleaning Mechanism	5-5
5.6 Drum Cleaner Unit	5-6
5.6.1 Photosensitive Drum Cleaning	5-6
5.7 Developing Unit	5-6
5.7.1 Controlling the Developing Bias	5-6
5.8 Toner Container	5-6
5.8.1 Overview	5-6
5.8.2 Route of Toner Supply	5-7
5.8.3 Controlling the Drive of the Toner Cartridge	5-8
5.8.4 Toner Supply Control	5-8
5.8.5 Recovery Sequence	5-9
5.8.6 Toner Level Detection	5-9
5.9 Transfer Unit	5-9
5.9.1 Outline of the Transfer Unit	5-9
5.9.1.1 Outline	5-9
5.9.2 Controlling the Transfer Bias	5-9
5.9.2.1 Transfer Roller Bias Control	5-9
5.9.3 Cleaning	5-9
5.9.3.1 Transfer Roller Cleaning Mechanism	5-9
5.9.4 Separation Mechanism	5-10
5.9.4.1 Controlling the Static Eliminator Bias	5-10
5.10 Transfer Mechanism	5-10
5.10.1 Transfer Guide Bias	5-10
5.10.1.1 Transfer Guide Bias Control	5-10
5.11 Photosensitive Drum Cleaning	5-10
5.11.1 Outline	5-10
5.11.2 Collection of Waste Toner	5-10
5.11.3 Checking the Waste Toner Box	5-10
5.12 Parts Replacement Procedure	5-11
5.12.1 Pre-Exposure Lamp	5-11
5.12.1.1 Removing the Front Cover Unit	5-11
5.12.1.2 Removing the Waste Toner Case	5-11
5.12.1.3 Removing the Toner Cartridge	5-11

5.12.1.4 Removing the Drum Unit	5-11
5.12.1.5 Removing the Developing Assembly	5-12
5.12.1.6 Removing the Upper Tray	5-13
5.12.1.7 Removing the Toner Cartridge Cover	5-13
5.12.1.8 Removing the Pre-Exposure Lamp.....	5-14
5.12.2 Drum Unit	5-14
5.12.2.1 Removing the Front Cover Unit	5-14
5.12.2.2 Removing the Waste Toner Case.....	5-14
5.12.2.3 Removing the Drum Unit	5-14
5.12.3 Hopper Assembly.....	5-15
5.12.3.1 Removing the Front Cover Unit	5-15
5.12.3.2 Removing the Waste Toner Case.....	5-15
5.12.3.3 Removing the Toner Cartridge	5-16
5.12.3.4 Removing the Drum Unit	5-16
5.12.3.5 Removing the Developing Assembly	5-17
5.12.3.6 Removing the Upper Tray	5-18
5.12.3.7 Removing the Toner Cartridge Cover	5-18
5.12.3.8 Removing the Pre-Exposure Lamp.....	5-18
5.12.3.9 Removing the Left Cover	5-18
5.12.3.10 Removing the Laser Unit.....	5-18
5.12.3.11 Removing the Hopper Assembly.....	5-19
5.12.4 Sub Hopper	5-20
5.12.4.1 Removing the Front Cover Unit	5-20
5.12.4.2 Removing the Waste Toner Case.....	5-20
5.12.4.3 Removing the Toner Cartridge	5-20
5.12.4.4 Removing the Drum Unit	5-21
5.12.4.5 Removing the Developing Assembly	5-21
5.12.4.6 Removing the Upper Tray	5-22
5.12.4.7 Removing the Toner Cartridge Cover	5-22
5.12.4.8 Removing the Pre-Exposure Lamp.....	5-23
5.12.4.9 Removing the Left Cover	5-23
5.12.4.10 Removing the Laser Unit.....	5-23
5.12.4.11 Removing the Hopper Assembly.....	5-24
5.12.4.12 Removing the Toner Feedscrew Motor	5-24
5.12.4.13 Removing the Sub Hopper.....	5-24
5.12.5 Developing Assembly.....	5-26
5.12.5.1 Removing the Front Cover Unit	5-26
5.12.5.2 Removing the Waste Toner Case.....	5-26
5.12.5.3 Removing the Developing Assembly	5-26
5.12.6 Developing Cylinder.....	5-27
5.12.6.1 Detaching the Developing Cylinder	5-27
5.12.7 Transfer Charging Roller	5-28
5.12.7.1 Removing the Transfer Roller	5-28
5.12.8 Waste Toner Box	5-29
5.12.8.1 Removing the Front Cover Unit	5-29
5.12.8.2 Removing the Waste Toner Case.....	5-29
5.12.9 Toner Level Sensor.....	5-29
5.12.9.1 Removing the Front Cover Unit	5-29
5.12.9.2 Removing the Waste Toner Case.....	5-30
5.12.9.3 Removing the Toner Cartridge	5-30
5.12.9.4 Removing the Drum Unit	5-30
5.12.9.5 Removing the Developing Assembly	5-31
5.12.9.6 Removing the Upper Tray	5-32
5.12.9.7 Removing the Toner Cartridge Cover	5-32
5.12.9.8 Removing the Pre-Exposure Lamp.....	5-32
5.12.9.9 Removing the Left Cover	5-33
5.12.9.10 Removing the Laser Unit.....	5-33
5.12.9.11 Removing the Hopper Assembly.....	5-33
5.12.9.12 Removing the Toner Level Sensor	5-34
5.12.10 Toner Feedscrew Motor.....	5-34
5.12.10.1 Removing the Front Cover Unit	5-34

5.12.10.2 Removing the Waste Toner Case	5-34
5.12.10.3 Removing the Toner Cartridge.....	5-35
5.12.10.4 Removing the Drum Unit.....	5-35
5.12.10.5 Removing the Developing Assembly.....	5-36
5.12.10.6 Removing the Upper Tray.....	5-37
5.12.10.7 Removing the Toner Cartridge Cover.....	5-37
5.12.10.8 Removing the Pre-Exposure Lamp.....	5-37
5.12.10.9 Removing the Left Cover.....	5-37
5.12.10.10 Removing the Laser Unit.....	5-37
5.12.10.11 Removing the Hopper Assembly.....	5-38
5.12.10.12 Removing the Toner Feedscrew Motor.....	5-39
5.12.11 Static Charge Eliminator.....	5-39
5.12.11.1 Removing the Static Eliminator.....	5-39

5.1 Construction

5.1.1 Specifications of the Image Formation System

T-5-1

Drum Unit Specifications

Photosensitive drum	
Drum type	OPC
Drum diameter	30 mm
Cleaning mechanism	by cleaning blade
Process speed	230 mm/sec (iR3570/4570/3530) 137 mm/sec (iR2270/2870/2230/2830)
Primary charging	
Charging method	by roller (AC + DC)
Charging roller diameter	16 mm
Cleaning mechanism	by brush roller (reciprocating mechanism)
Transfer charging	
Charging method	by roller (DC)
Charging roller diameter	16 mm

T-5-2

Pre-Exposure Unit Specifications

LED	12 pc.
Timing of light emission	in response to drum rotation

T-5-3

Developing Unit Specifications

Developing cylinder diameter	20 mm
Development method	by dry, single-component toner projection method (application of AC + DC)
Toner	single-component insulating magnetic toner
Toner level detection	by toner level sensor (inside sub hopper and developing assembly)

T-5-4

Toner Cartridge Specifications

Toner level detection	none
Toner variable resistor	1220 g (iR3570/4570/3530) 1060 g (iR2270/2870/2230/2830)

T-5-5

Others

separation method	by static eliminator + curvature
Waste toner	collection to waste toner case

5.1.2 Major Components of the Image Formation System

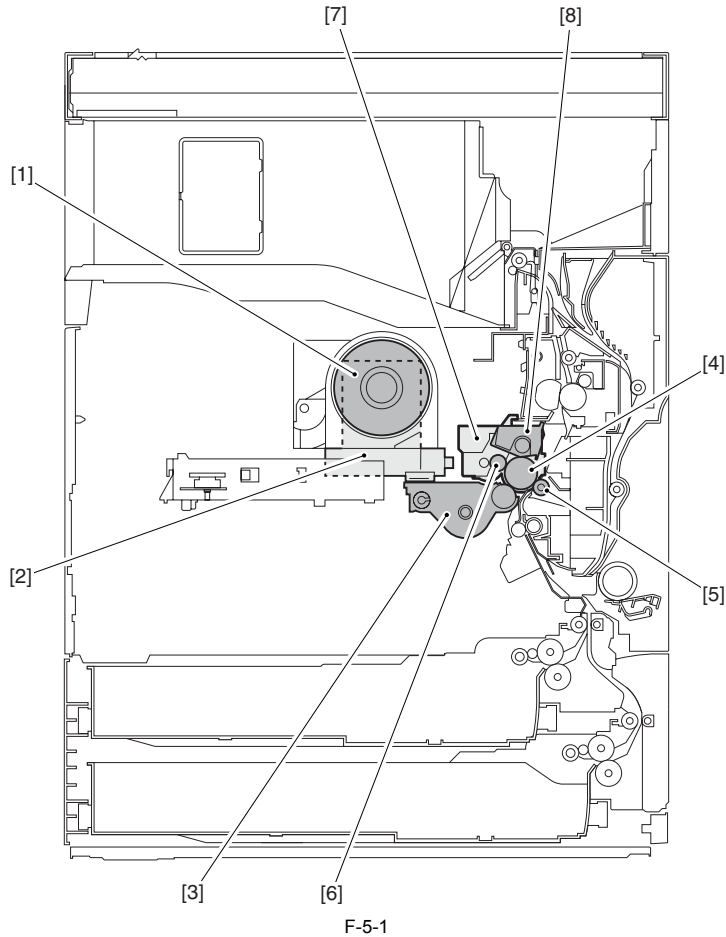

- [1] Toner cartridge
- [2] Sub hopper
- [3] Developing unit
- [4] Photosensitive drum
- [5] Transfer roller
- [6] Primary charging roller
- [7] Drum unit
- [8] Drum cleaning unit

5.2 Image Formation Process

5.2.1 Image Formation Process (outline)

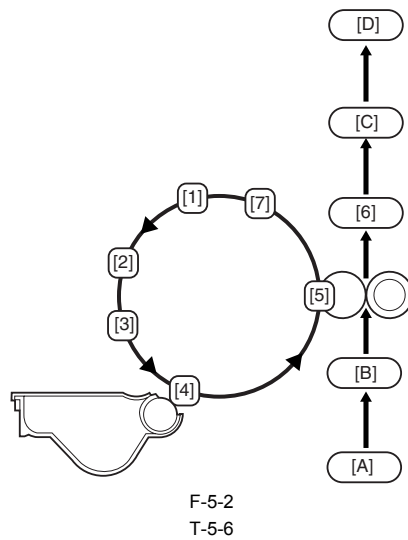

Item	Description
[1] Pre-exposure	removes residual charges from the drum.

Item	Description
[2]Primary charging	charges the surface of the photosensitive drum to a uniform negative potential.
[3]Laser exposure	forms a latent static image on the drum.
[4]Development	forms a visible image on the drum.
[5]Transfer	transfers images from the drum to paper.
[6]Separation	separates paper from the drum.
[7]Drum cleaning	removes toner from the drum.

- [A]Pickup
- [B]Registration
- [C]Fixing
- [D]Delivery

5.2.2 Image Formation Process (image formation)

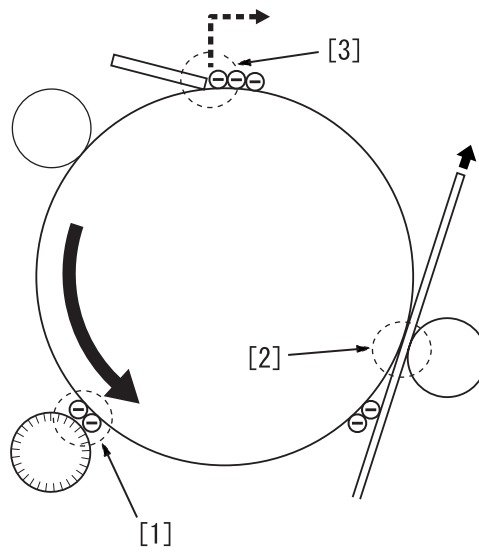

F-5-3

- [1] The difference in potential between the drum surface and the developing sleeve causes toner to adhere to the latent static image on the drum, turning the image into a visible image.
- [2] The bias voltage applied to the transfer roller causes the toner to move from the drum to paper.
- [3] The cleaning blade in contact with the drum scrapes off the residual toner from the drum.

5.3 Basic Sequence

5.3.1 Sequence of Operation (initial rotation)

The sequence of operation of initial rotation is as follows:
Pickup from the Cassette

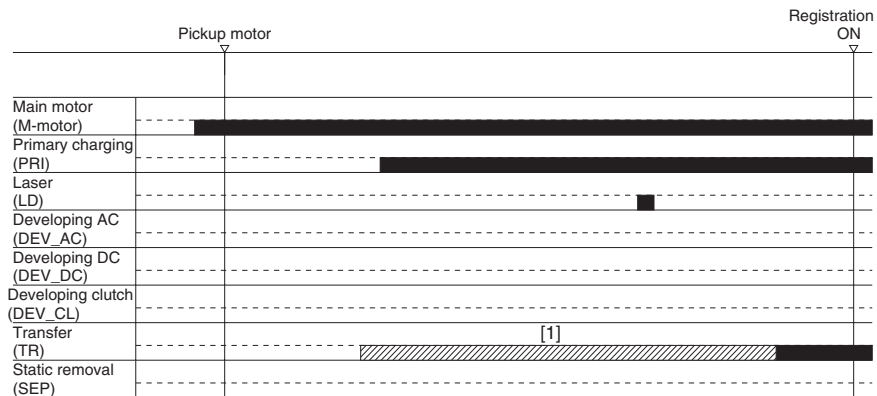

F-5-4

Pickup from the Manual Feeder

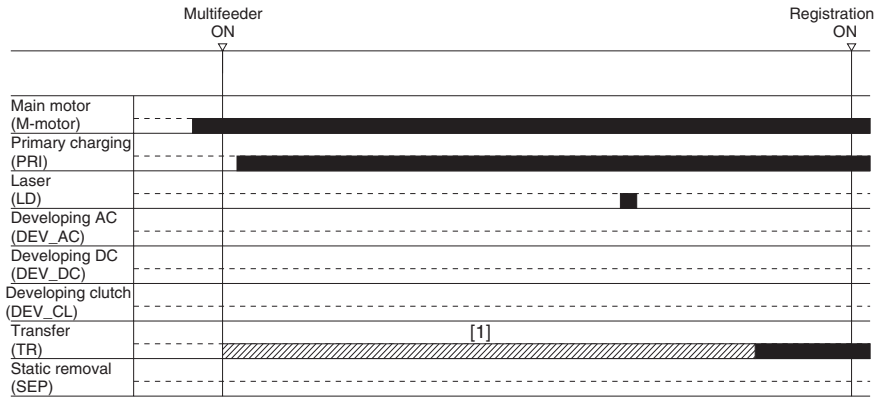

F-5-5



In [1] above, a cleaning bias (-2600 V) is applied.

5.3.2 Sequence of Operation (copying)

The sequence of operation during copying is as follows:

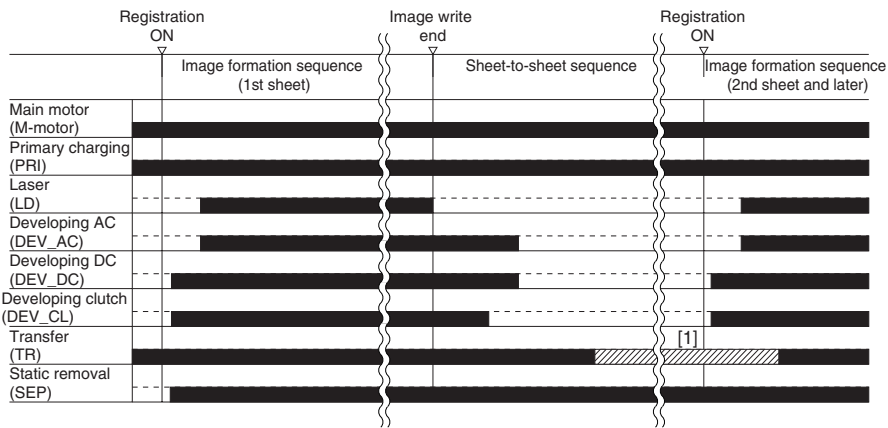

F-5-6



In [1] above, a cleaning bias (-2600 V) is applied.

5.3.3 Sequence of Operation (last rotation)

The sequence of operation of last rotation is as follows:

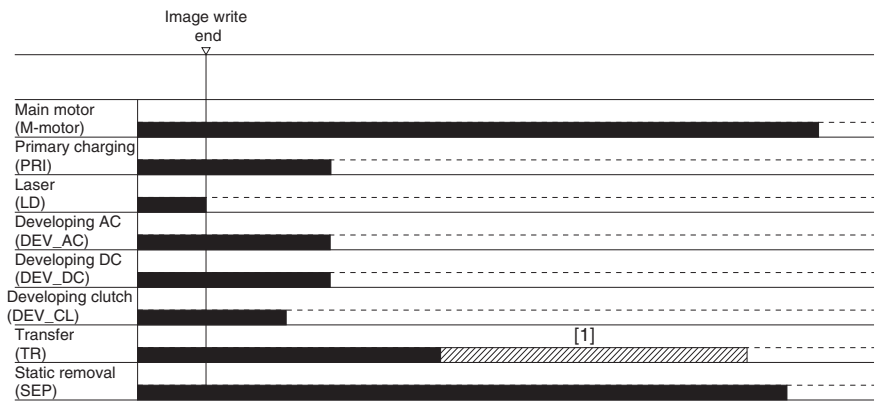

F-5-7



In [1] above, a cleaning bias (-2600 V) is applied.

5.4 Image Stabilization Control

5.4.1 Overview

At times, changes in the environment or wear on the machine can cause its image output to become unstable. To make sure that its output will remain stable at all times, the machine uses the following control mechanisms:

T-5-7

[1] Drum film thickness detection control	corrects the development contrast.
[2] Developing contrast control	determines the appropriate primary charging DC bias and developing DC bias.
[3] ATVC control	corrects the transfer bias.

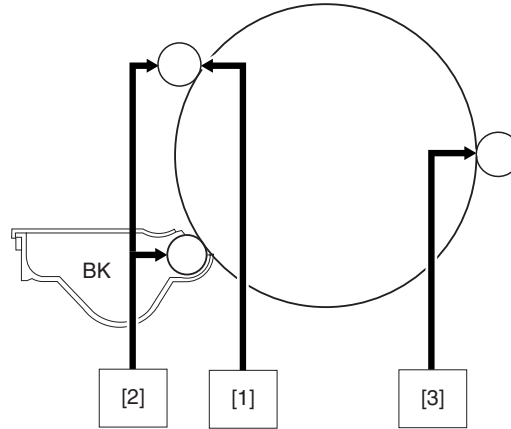

F-5-8

5.4.2 APVC Control

The term APVC stands for "auto primary voltage control," and it is a mechanism used to control the primary charging application voltage (DC component) to suit the film thickness of the machine's photosensitive drum. APVC is performed every 500 sheets while the machine is in operation. It is forcibly performed when the drum unit is replaced.

5.4.3 ATVC Control

The machine is provided with a constant current control mechanism that can be enabled or disabled in service mode: COPIER>OPTION>BODY>TRANS-SW.

5.5 Drum Unit

5.5.1 Charging Mechanism

5.5.1.1 Controlling the Primary Charging Bias

T-5-8

Primary Charging Bias

AC bias	2700 Vp-p (max.)
DC bias	-450 V to -850 V



These AC and DC biases are applied between sheets while an image is being formed (until the end of the ongoing job).

5.5.1.2 Primary Charging Roller Cleaning Mechanism

The machine uses a brush [3] to clean the primary charging roller [2], which remains in contact with the photosensitive drum [1]. The brush has a reciprocating mechanism and is driven by a cam [4], operating while the photosensitive drum is being driven.

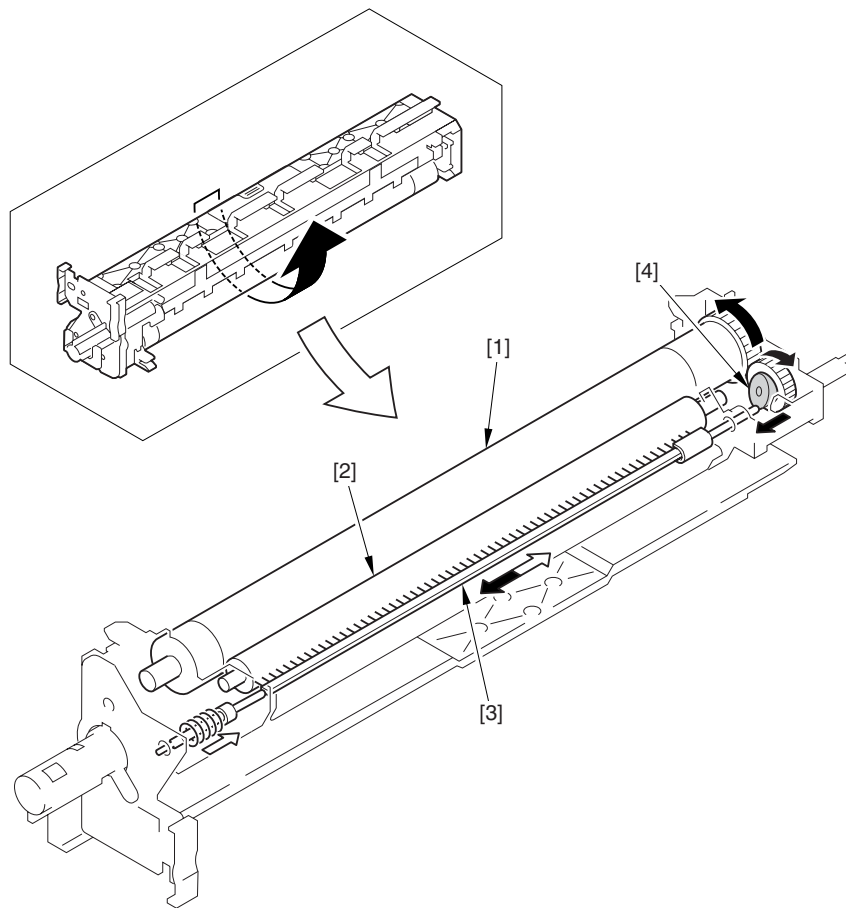

F-5-9

5.6 Drum Cleaner Unit

5.6.1 Photosensitive Drum Cleaning

The cleaning blade is kept in contact with the surface of the photosensitive drum. It serves to scrape off the residual toner left behind from transfer to paper for collection in the waste toner box.

5.7 Developing Unit

5.7.1 Controlling the Developing Bias

T-5-9

Developing Bias

AC bias	800 Vp-p
DC bias	-450 V to -650 V



Both these AC and DC biases are applied while an image is being formed, but are not applied between sheets.

5.8 Toner Container

5.8.1 Overview

The toner cartridge is constructed as shown in the following figure. The cartridge is filled with 1-component insulating magnetic toner (if iR3570/4570, 1220 g; if iR2270/2870, 1060 g). When the sub hopper requests a supply of toner, the cartridge itself rotates to feed toner. The machine's toner cartridge serves as a hopper (as it is found in past models).

iR3570 / iR4570

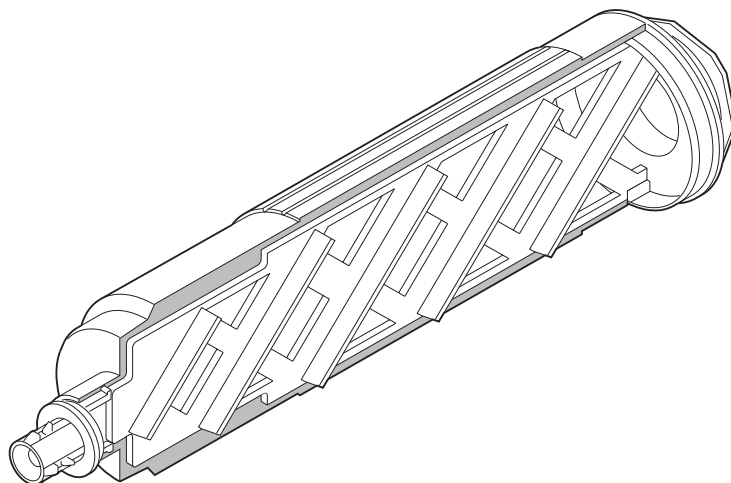

F-5-10

iR2270 / iR2870

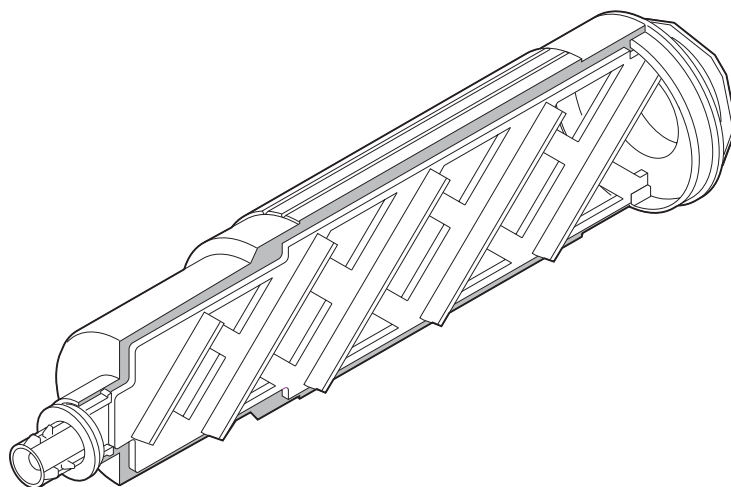

F-5-11

▲ Points to Note on Handling the Toner Cartridge

1. Care should be taken not to bump the toner stop [1] against the covers or the like when and after removing the toner cartridge. Since the toner stop comes off easily, toner scattering may be resulted if it comes off by accident.
2. Keep the toner cartridge horizontal after removing. Since the toner stop [1] comes off easily as mentioned above, toner scattering may be resulted if the toner cartridge is placed with the toner stop side down.

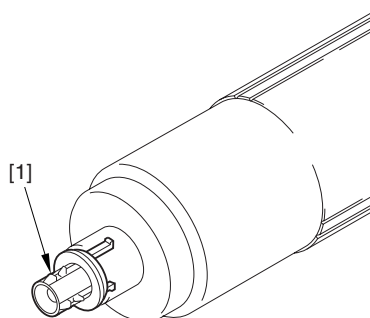

F-5-12

5.8.2 Route of Toner Supply

When the user fits the toner cartridge [1] in place, toner is temporarily stored in the sub hopper [2], inside which is a sensor that makes sure that the amount of toner remains at a specific level at all times. When the developing assembly [4] requests a supply of toner, the machine rotates the feedscrew [3] to move toner from the sub hopper to the developing assembly.
The machine's toner cartridge serves as a hopper (as found in past models).

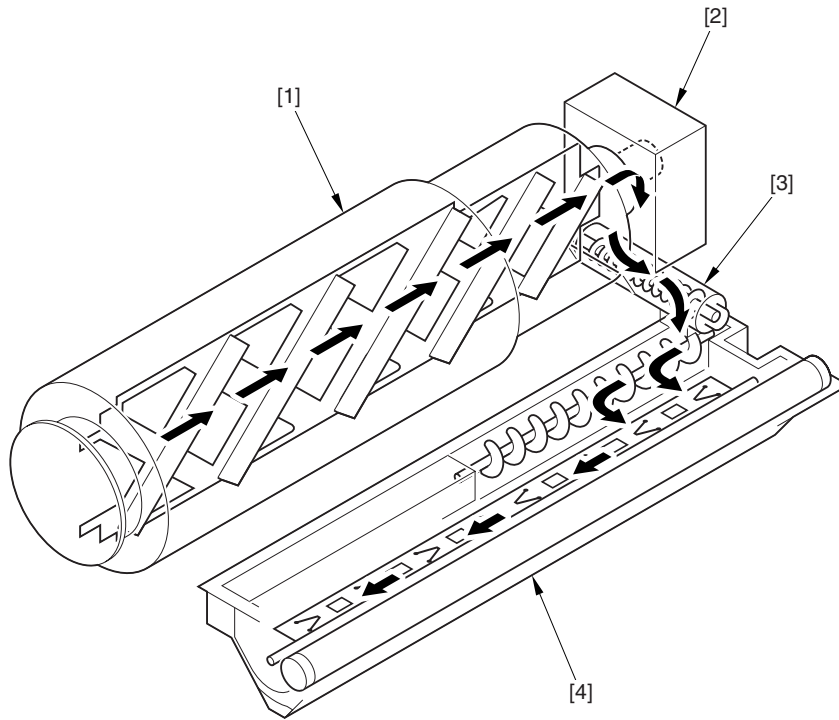

F-5-13

5.8.3 Controlling the Drive of the Toner Cartridge

When a request is made for a supply of toner, the toner cartridge drive motor rotates in the direction shown in the following figure; its drive is transmitted from the drive motor to the toner cartridge, thus rotating the toner cartridge.

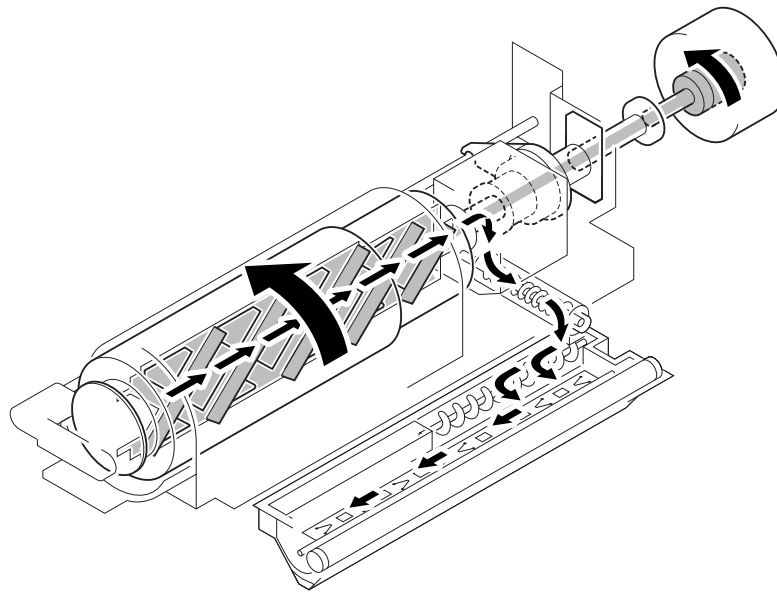

F-5-14

5.8.4 Toner Supply Control

Supply of Toner from the Toner Bottle to the Sub Hopper

If the "absence of toner inside the sub hopper" is detected while the main motor is rotating, the bottle motor is rotated intermittently (on for 3 sec, off for 2 sec), and the length of time during which the absence is detected is checked using a counter that increases its count for each on-off cycle. When the count reaches 20 (about 100 sec), the machine will assume that the sub hopper has become empty, and will indicate the Add Toner message on its control panel. The counter is reset when the presence of toner inside the sub hopper is detected during any on-off cycle.

If the "absence of toner inside the developing assembly" is detected while the main motor is rotating and the developing clutch is on, the machine rotates the sub hopper feedscrew motor intermittently (on for 1 sec, off for 1 sec). The rotation is monitored by a counter that increases its count when the developing sensor state is off during a single on-off cycle; when its reading reaches 20 (about 40 sec), the machine will assume that its developing assembly is more or less empty (i.e., there is a possibility of the ongoing generating black prints if printing continues), and will issue a No Toner error, suspending image formation operation. The counter is reset when the presence of toner is detected inside the developing assembly.



E020-0000

If the absence of toner is detected by the developing assembly toner level sensor and the presence of toner is detected by the hopper toner level sensor, the route of supply from the sub hopper to the developing assembly may be clogged or the output of these toner sensors may be faulty.

This error code will be indicated when the soft counter reaches 194 (about 388 sec). The counter is designed to increase its count when the hopper sensor level is on during a single on-off cycle while toner is being supplied from the sub hopper to the developing assembly.

5.8.5 Recovery Sequence

The machine is not equipped with a mechanism to detect the replacement of its toner cartridge, but is designed to execute toner recovery sequence in response to the following, assuming that the cartridge has been replaced:

1. the front cover has been opened and closed after the machine has detected the absence of toner inside the toner cartridge and the developing assembly.
2. the machine has been turned off and then on after it has detected the absence of toner inside the toner cartridge and the developing assembly.

The machine's recovery sequence is as follows:

1. the machine rotates the toner cartridge motor. (intermittently by rotating it for 3 sec and stopping it for 2 sec)
2. if the toner level sensor inside the sub hopper detects the "presence of toner," the machine stops the recovery sequence.
3. after repeating the foregoing intermittent operation 20 times and if the toner level sensor inside the sub hopper still does not detect the "presence of toner," the machine will assume that the toner cartridge has not been replaced and cause the toner cartridge motor to stop.

5.8.6 Toner Level Detection

Detecting the Level of Toner Inside the Sub Hopper

The machine checks the level of the toner sensor located inside the sub hopper every 100 msec, and will assume the presence of toner inside the sub hopper if the sensor goes on twice or more continuously (200 msec or more).

If the machine detects the absence of toner 100 times or more (10 sec or more) as the result of its check on the sensor level made every 100 msec, the machine will assume that there is no toner inside the sub hopper.

The machine executes the foregoing detection at all times regardless of the state (on or off) of the main motor and the developing clutch.

Detecting the Level of Toner Inside the Developing Assembly

1. The machine samples the output of the toner level sensor located inside the developing assembly every 100 msec (only if the developing clutch is on).

2. The machine uses a period of 1.5 sec (15 times; cumulative sampling of periods when the clutch is on) as the unit of measurement: if the presence of toner is detected 3 times or more, it will assume that there is toner inside the developing assembly; if the presence of toner is detected less than 3 times, on the other hand, it will assume that there is no toner inside the developing assembly.

However, in the case of the iR3570/iR4570 Series machines, the drive of the main motor is controlled to 2 different speeds, and the toner inside the developing assembly is driven by the main motor (using a clutch), requiring a switchover of methods of detection as follows:

Normal Speed Mode

The machine uses a period of 1.5 sec (25 times; cumulative sampling of periods when the clutch is on) as the unit of measurement: if the presence of toner is detected 3 times or more, it will assume that there is toner inside the developing assembly.

Low-Speed Mode

The machine uses a period of 2.5 sec (42 times; cumulative sampling of periods when the clutch is on) as the unit of measurement: if it detects the presence of toner 5 times or more, it will assume that there is toner inside the developing assembly.

The machine converts the number of samplings and the number of times toner detection has been executed when switching over methods of detection. (The conversion is based on the speed-to-amount relationship.)

5.9 Transfer Unit

5.9.1 Outline of the Transfer Unit

5.9.1.1 Outline

The transfer unit [1] consists of the transfer roller and the static eliminator.

The transfer roller rotates in connection with the photosensitive drum.

Bias is applied to the static eliminator so that sheets can be separated from the drum.

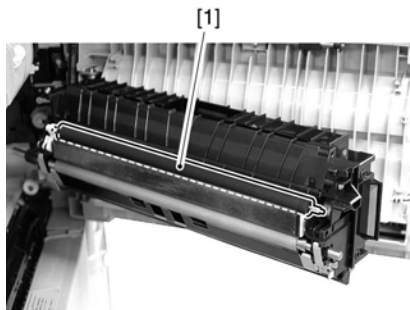

F-5-15

5.9.2 Controlling the Transfer Bias

5.9.2.1 Transfer Roller Bias Control

The machine changes the output depending on the site environment (absolute moisture content), paper type, paper width, and source of paper.

Environment: 5 settings according to absolute moisture content

Paper type: plain paper, envelope, heavy paper, tracing paper, transparency, bond paper, label sheet

Paper width: size boundaries as defined by 2 points

Source of paper: if from cassette (including pedestal); if from multi-feeder, i.e., 1st side (half-speed), 2nd side (half-speed)

Transfer bias

Transfer bias: 1000 to 6000 V

Transfer bias for cleaning: -2600 V



The transfer bias is used at time of image formation, while a voltage of a specific level is applied between sheets for cleaning of the transfer roller.

5.9.3 Cleaning

5.9.3.1 Transfer Roller Cleaning Mechanism

The machine uses the transfer roller cleaning mechanism to return the toner sticking to the transfer roller back to the photosensitive drum by applying a cleaning bias to the roller.

Once the toner reaches the drum, it is scraped by the photosensitive drum cleaning blade for collection in the waste toner box.

5.9.4 Separation Mechanism

5.9.4.1 Controlling the Static Eliminator Bias

Static Eliminator Bias

1st side: -2300 V
2nd side: -3000 V



A DC bias is applied between sheets while an image is being formed. (It is applied until the ongoing job is over.)

5.10 Transfer Mechanism

5.10.1 Transfer Guide Bias

5.10.1.1 Transfer Guide Bias Control

To prevent soiling of the transfer guide with toner or the photosensitive drum with toner images, the following transfer guide bias is applied to the transfer guide. The surface of the transfer guide is covered with an insulating sheet.

Transfer guide bias

1st side: -570 V
2nd side: -740 V

5.11 Photosensitive Drum Cleaning

5.11.1 Outline

The photosensitive drum cleaning mechanism uses the photosensitive drum cleaning blade to scrape off the residual toner left behind from transfer; the toner thus collected is moved to the waste toner box.

5.11.2 Collection of Waste Toner

The waste toner scraped off by the cleaning blade is moved by the waste toner feedscrew to the waste toner box found at the front of the machine. The waste toner feedscrew is operated by the drive from the drum flange.

5.11.3 Checking the Waste Toner Box

To prevent leakage of waste toner from the waste toner box or to prevent overloading the waste toner feedscrew, the machine is equipped with a waste toner detection mechanism. The waste toner box can hold about 2043 cc of toner, and the machine identifies the waste toner box as being full when there is about 1766 cc of toner or when the toner comes to weigh about 1050 g.

When the weight of waste toner increases, the waste toner case itself lowers on its own, thus causing the machine to assume that the case has become full.

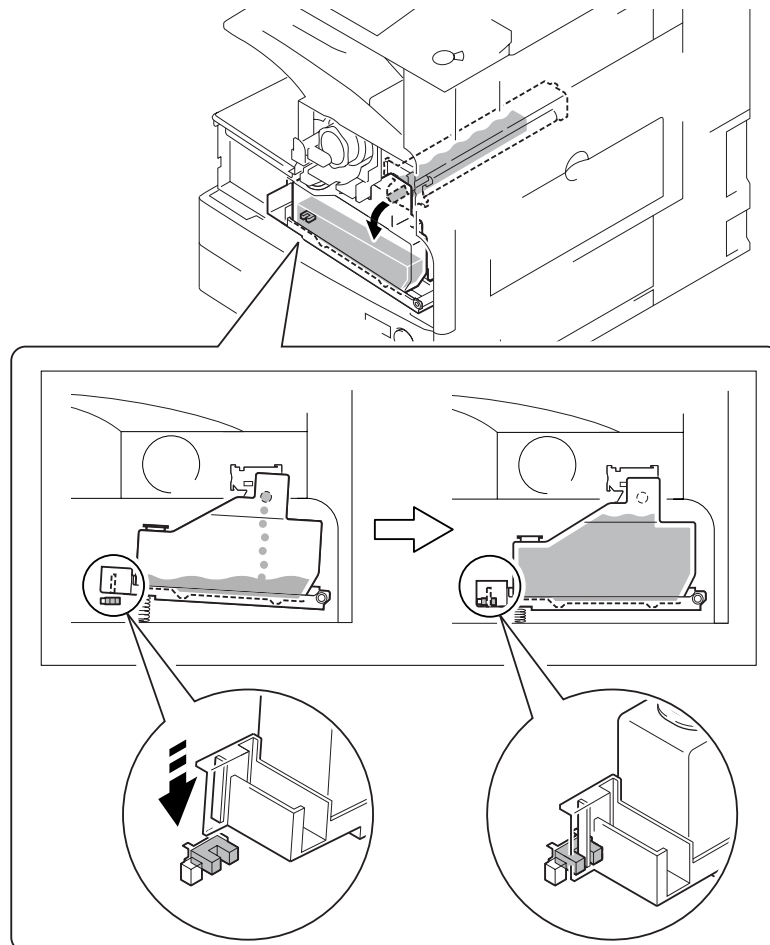

F-5-16



E190-0000

When the machine identifies the waste toner full sensor as being continuously on for 2000 sheets, it will indicate a warning; if it then detects the activation of the sensor for 100 sheets continuously, it will indicate 'E190-000'. (The count is increased coinciding with delivery.)

5.12 Parts Replacement Procedure

5.12.1 Pre-Exposure Lamp

5.12.1.1 Removing the Front Cover Unit

- 1) Open the front cover [1].

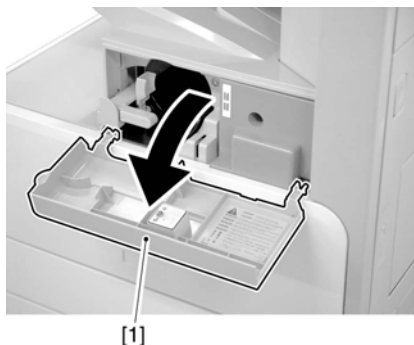

F-5-17

- 2) Remove the face cover rubber [1].
- 3) Remove the binding screw [2].
- 4) Remove the RS tightening screw [3].
- 5) Detach the front cover unit [4] by moving it in the direction of the arrow.

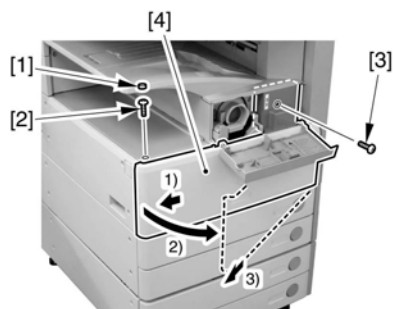

F-5-18

5.12.1.2 Removing the Waste Toner Case

- 1) Remove the waste toner case [1].

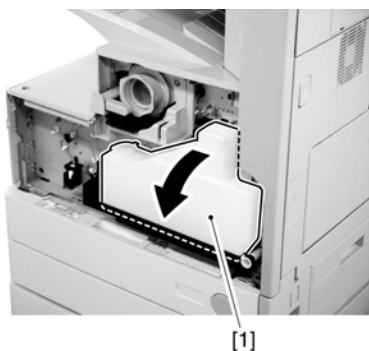

F-5-19

⚠ Point to note after attaching the waste toner receptacle
After attaching the waste toner receptacle, move the waste toner full detection lever [1] up and down to make sure that the lever is moved smoothly. Faulty detection may be resulted if the lever is caught in something and is not moved smoothly.

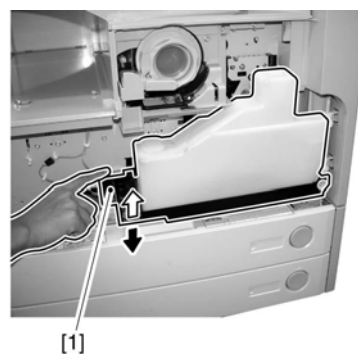

F-5-20

5.12.1.3 Removing the Toner Cartridge

- 1) Shift up the lever [1].

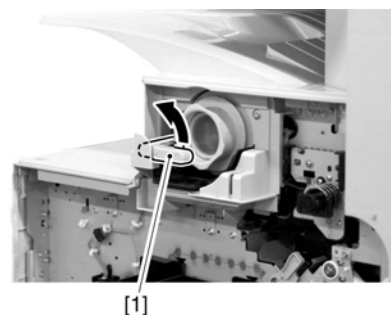

F-5-21

- 2) Remove the toner cartridge [1].

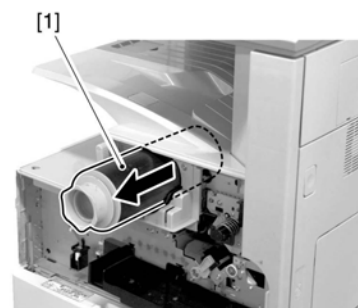

F-5-22

⚠ Points to Note on Handling the Toner Cartridge

1. Care should be taken not to bump the toner stop [1] against the covers or the like when and after removing the toner cartridge. Since the toner stop comes off easily, toner scattering may be resulted if it comes off by accident.
2. Keep the toner cartridge horizontal after removing. Since the toner stop [1] comes off easily as mentioned above, toner scattering may be resulted if the toner cartridge is placed with the toner stop side down.

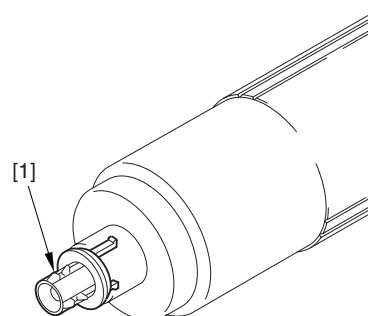

F-5-23

5.12.1.4 Removing the Drum Unit

- 1) Open the right door [1].



F-5-24

2) Remove the screw [1].

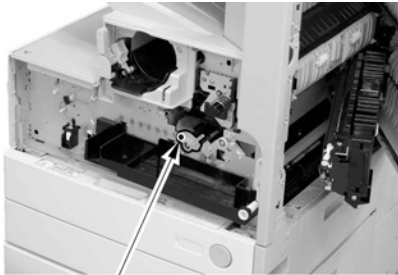

[1]

F-5-25

3) Shift the locking lever [1] to the left to release the developing assembly.



[1]

F-5-26

4) Remove the screw [1].

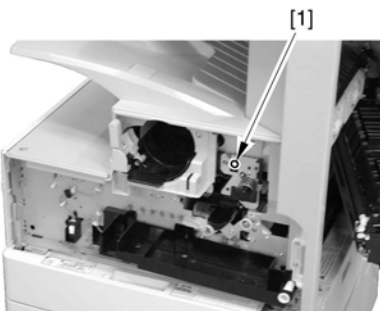

F-5-27

5) Remove the drum unit [1].



[1]

F-5-28

 Be sure to hold the drum unit as shown.

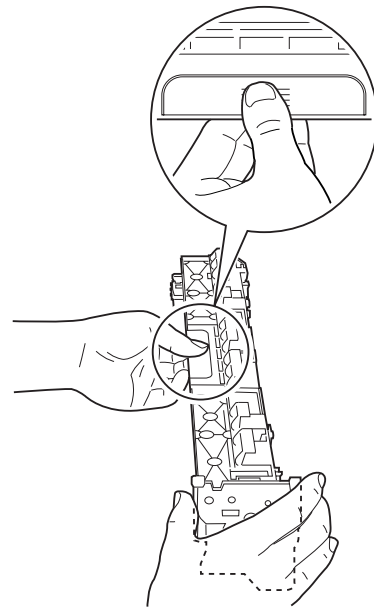

F-5-29

5.12.1.5 Removing the Developing Assembly

1) Remove the screw [1].

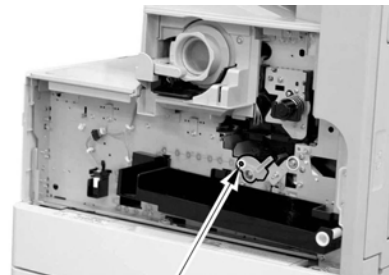

[1]

F-5-30

2) Shift the locking lever [1] to the left to release the developing assembly.

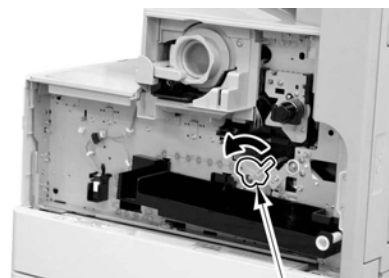

[1]

F-5-31

3) Slide the developing assembly [1] slightly to the front; then, disconnect the connector [2].

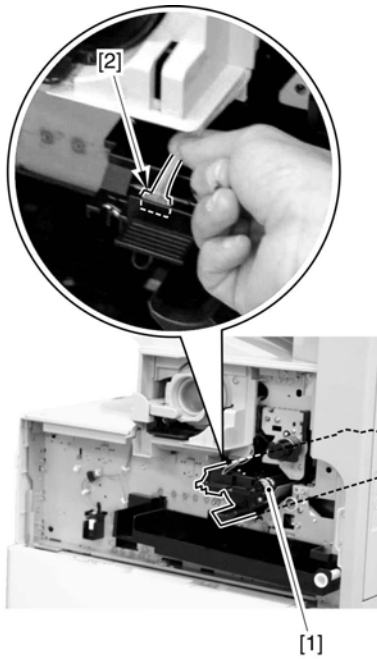

F-5-32

4) Remove the developing assembly [1].

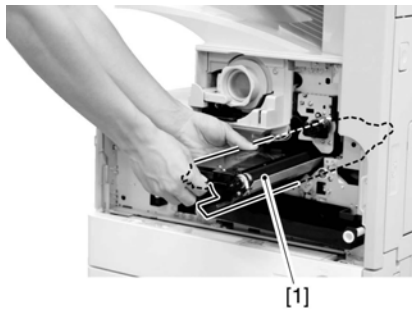

F-5-33



Be sure to hold the developing assembly as shown.

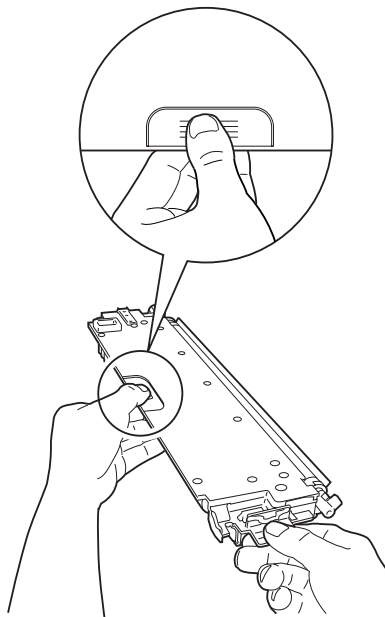

F-5-34



When fitting the developing assembly, be sure to fit the lower right segment [2] of the developing assembly [1] in the rail [3] of the machine. Thereafter, slide the developing assembly so that [A] of the developing assembly matches [B] of the rail.

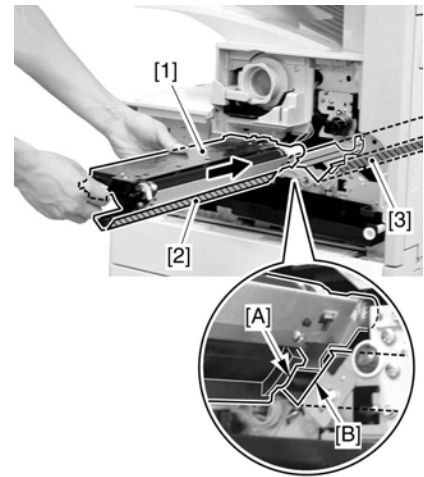

F-5-35

5.12.1.6 Removing the Upper Tray

1) Remove the 2 screws [1], and detach the upper tray [2].

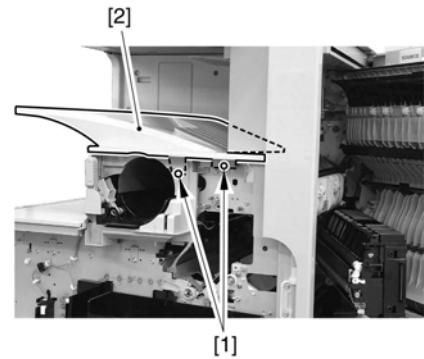

F-5-36

Reference:

Lift the front of the upper tray [1], and detach it as if to slide it toward the front.

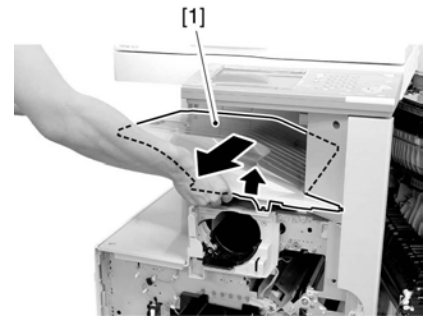

F-5-37

5.12.1.7 Removing the Toner Cartridge Cover

1) Remove the 2 screws [1]; then, detach the toner bottle cover [2].

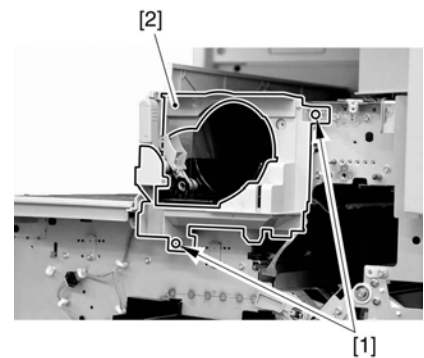

F-5-38

5.12.1.8 Removing the Pre-Exposure Lamp

1) Open the 2 wire saddles [1], and disconnect the 2 relay connectors [2].

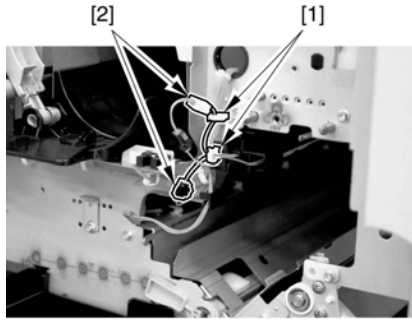

F-5-39

2) While freeing the lock [1] toward the right, detach the pre-exposure lamp [2].

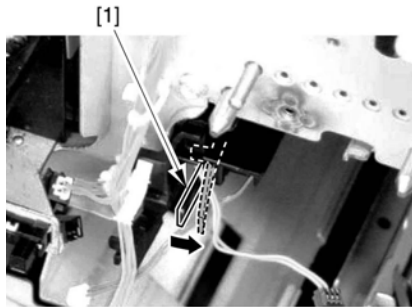

F-5-40

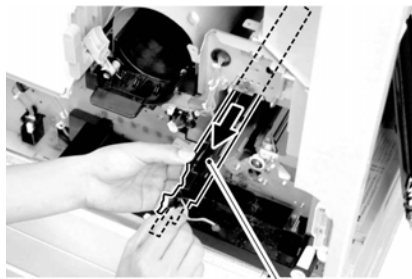

F-5-41

5.12.2 Drum Unit

5.12.2.1 Removing the Front Cover Unit

1) Open the front cover [1].

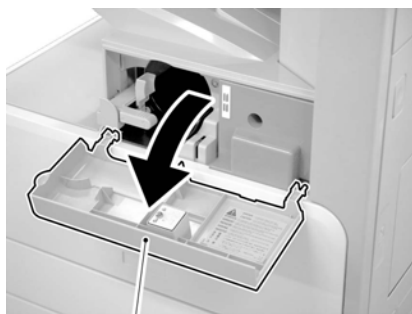

F-5-42

- 2) Remove the face cover rubber [1].
- 3) Remove the binding screw [2].
- 4) Remove the RS tightening screw [3].
- 5) Detach the front cover unit [4] by moving it in the direction of the arrow.

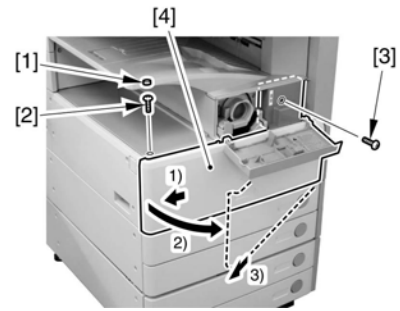

F-5-43

5.12.2.2 Removing the Waste Toner Case

1) Remove the waste toner case [1].

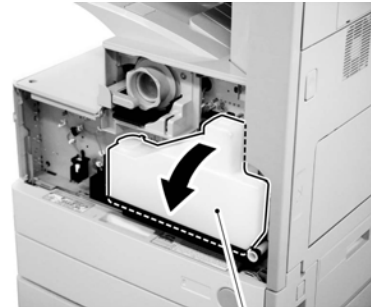

F-5-44

⚠ Point to note after attaching the waste toner receptacle
After attaching the waste toner receptacle, move the waste toner full detection lever [1] up and down to make sure that the lever is moved smoothly. Faulty detection may be resulted if the lever is caught in something and is not moved smoothly.

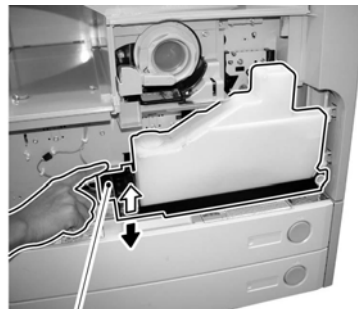

F-5-45

5.12.2.3 Removing the Drum Unit

1) Open the right door [1].



F-5-46

2) Remove the screw [1].

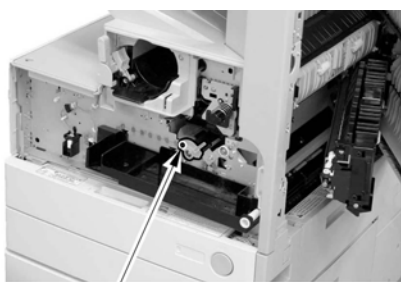

[1]

F-5-47

3) Shift the locking lever [1] to the left to release the developing assembly.



[1]

F-5-48

4) Remove the screw [1].

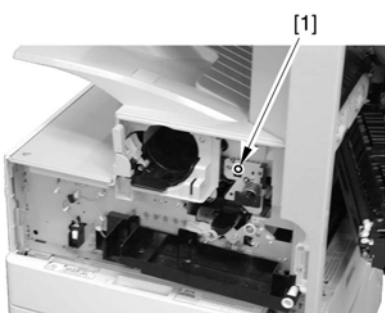

[1]

F-5-49

5) Remove the drum unit [1].



[1]

F-5-50



Be sure to hold the drum unit as shown.

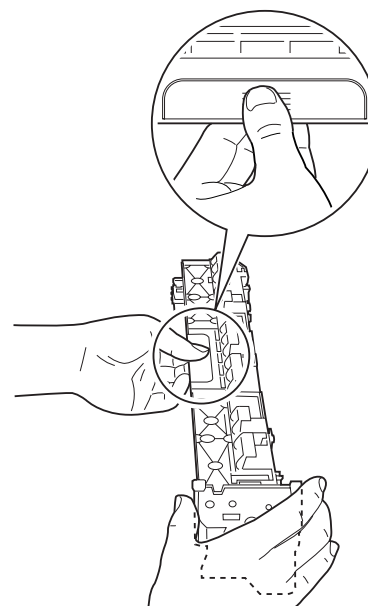

F-5-51

5.12.3 Hopper Assembly

5.12.3.1 Removing the Front Cover Unit

1) Open the front cover [1].

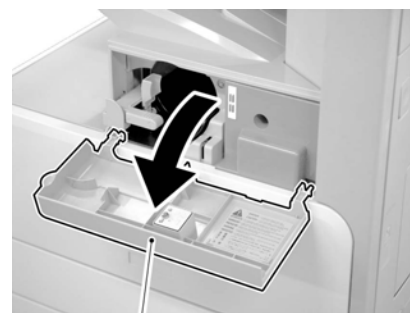

[1]

F-5-52

- 2) Remove the face cover rubber [1].
- 3) Remove the binding screw [2].
- 4) Remove the RS tightening screw [3].
- 5) Detach the front cover unit [4] by moving it in the direction of the arrow.

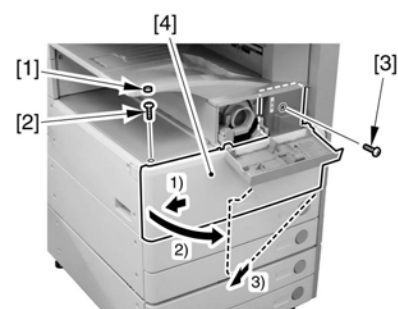

F-5-53

5.12.3.2 Removing the Waste Toner Case

1) Remove the waste toner case [1].

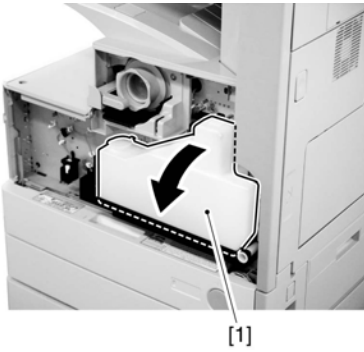

F-5-54

⚠ Point to note after attaching the waste toner receptacle
 After attaching the waste toner receptacle, move the waste toner full detection lever [1] up and down to make sure that the lever is moved smoothly. Faulty detection may be resulted if the lever is caught in something and is not moved smoothly.

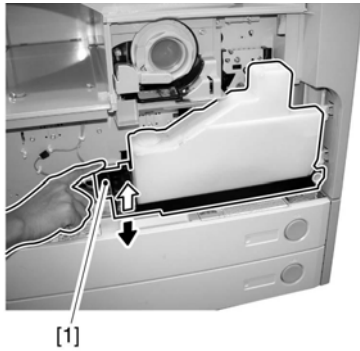

F-5-55

5.12.3.3 Removing the Toner Cartridge

1) Shift up the lever [1].

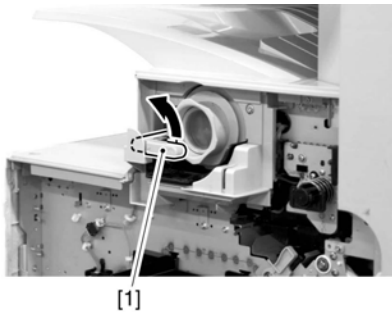

F-5-56

2) Remove the toner cartridge [1].

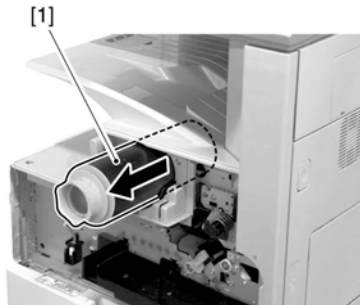

F-5-57

⚠ Points to Note on Handling the Toner Cartridge
 1. Care should be taken not to bump the toner stop [1] against the covers or the like when and after removing the toner cartridge. Since the toner stop comes off easily, toner scattering may be resulted if it comes off by accident.
 2. Keep the toner cartridge horizontal after removing. Since the toner stop [1] comes off easily as mentioned above, toner scattering may be resulted if the toner cartridge is placed with the toner stop side down.

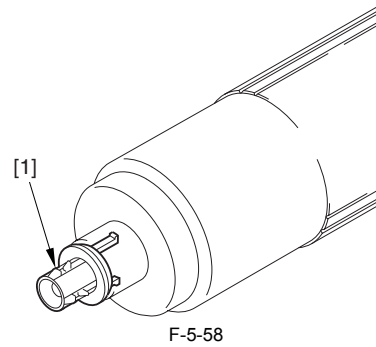

F-5-58

5.12.3.4 Removing the Drum Unit

1) Open the right door [1].



F-5-59

2) Remove the screw [1].

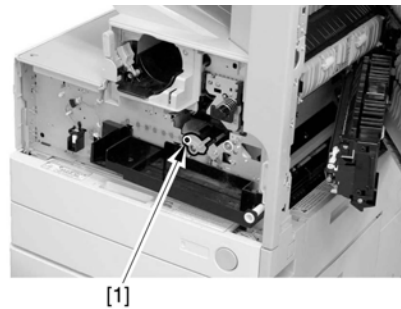

F-5-60

3) Shift the locking lever [1] to the left to release the developing assembly.

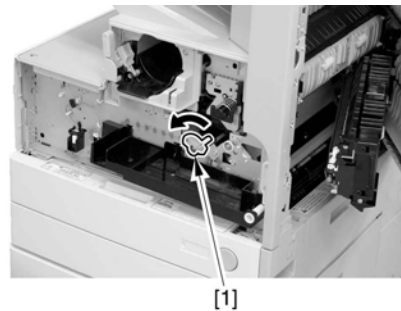

F-5-61

4) Remove the screw [1].

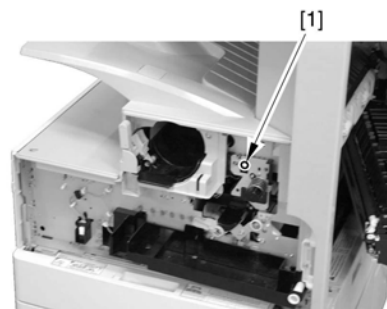

F-5-62

5) Remove the drum unit [1].



F-5-63



Be sure to hold the drum unit as shown.

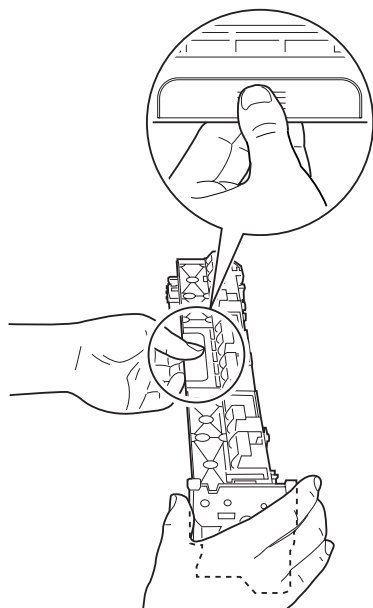

F-5-64

5.12.3.5 Removing the Developing Assembly

1) Remove the screw [1].

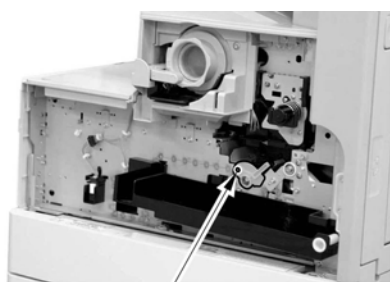

[1]

F-5-65

2) Shift the locking lever [1] to the left to release the developing assembly.

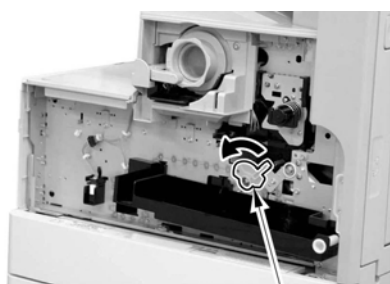

[1]

F-5-66

3) Slide the developing assembly [1] slightly to the front; then, disconnect the connector [2].

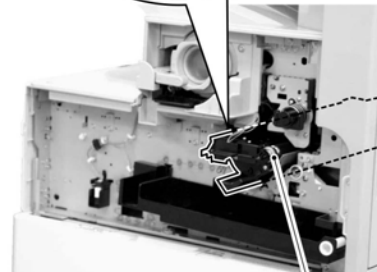
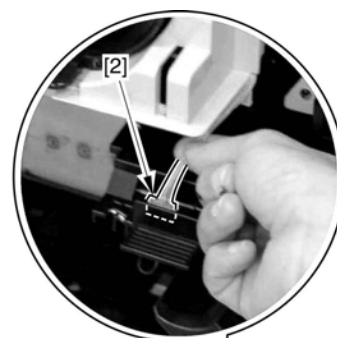

[1]

F-5-67

4) Remove the developing assembly [1].



[1]

F-5-68



Be sure to hold the developing assembly as shown.

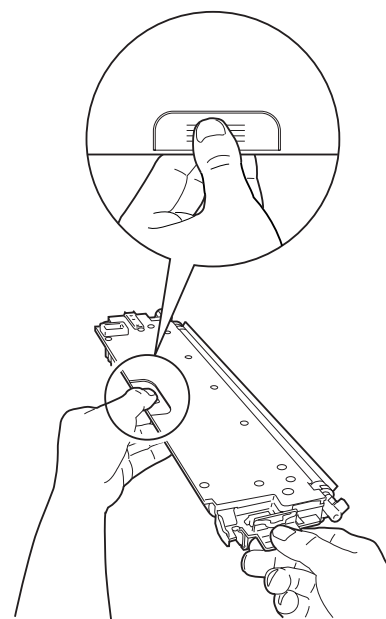

F-5-69



When fitting the developing assembly, be sure to fit the lower right segment [2] of the developing assembly [1] in the rail [3] of the machine. Thereafter, slide the developing assembly so that [A] of the developing assembly matches [B] of the rail.

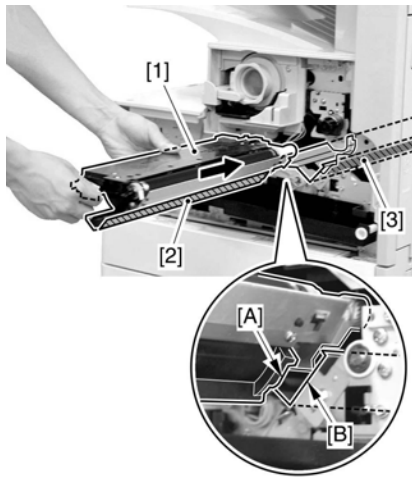

F-5-70

5.12.3.6 Removing the Upper Tray

1) Remove the 2 screws [1], and detach the upper tray [2].

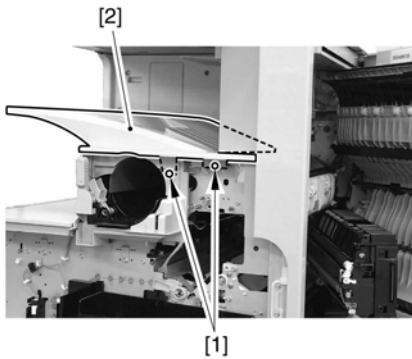

F-5-71

Reference:
Lift the front of the upper tray [1], and detach it as if to slide it toward the front.

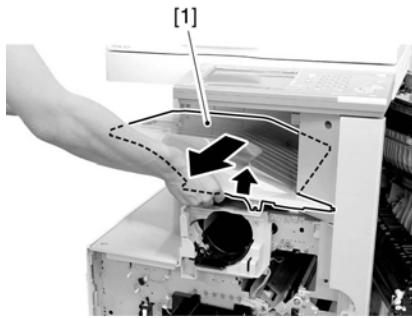

F-5-72

5.12.3.7 Removing the Toner Cartridge Cover

1) Remove the 2 screws [1]; then, detach the toner bottle cover [2].

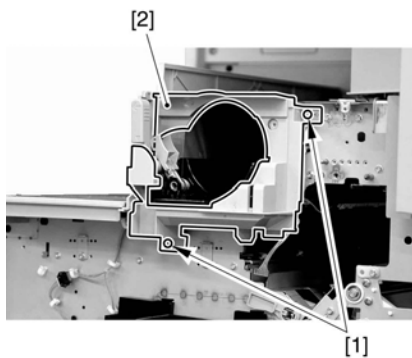

F-5-73

5.12.3.8 Removing the Pre-Exposure Lamp

1) Open the 2 wire saddles [1], and disconnect the 2 relay connectors [2].

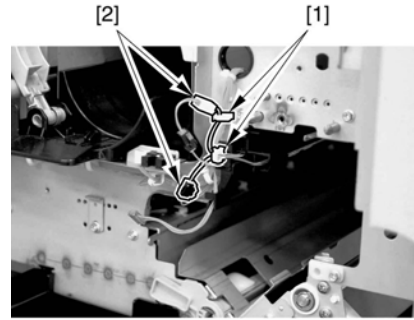

F-5-74

2) While freeing the lock [1] toward the right, detach the pre-exposure lamp [2].

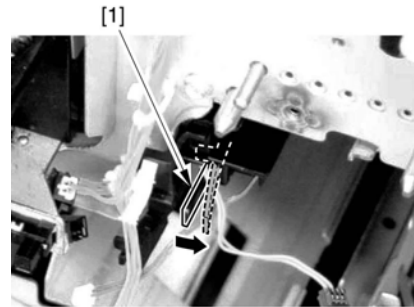

F-5-75

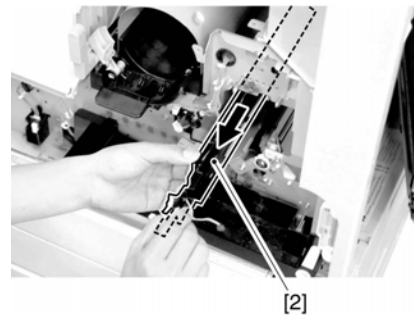

F-5-76

5.12.3.9 Removing the Left Cover

1) Remove the 4 screws [1], and detach the left cover [2].

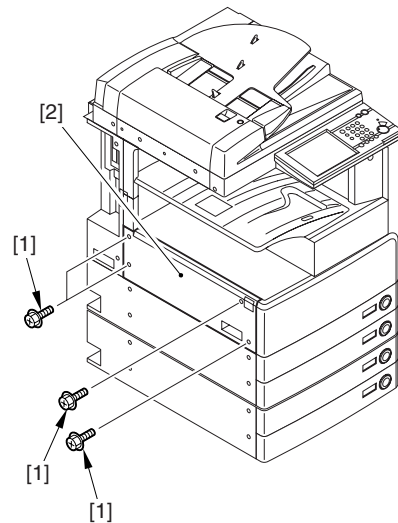

F-5-77

5.12.3.10 Removing the Laser Unit

1) Open the 2 wire saddles [1], and disconnect the 2 connectors [2].

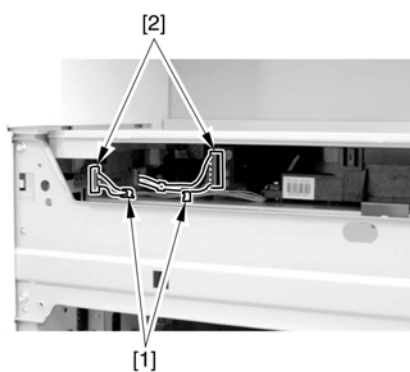

F-5-78



When you have disconnected the connector [1], be sure to take care so that it will not come into contact with the PCB that is mounted to the laser scanner unit. (The PCB is equipped with a laser intensity adjustment variable resistor. Contact with the PCB can change the adjustment setting.)

2) Open the wire saddle [1], and disconnect the connector [2].

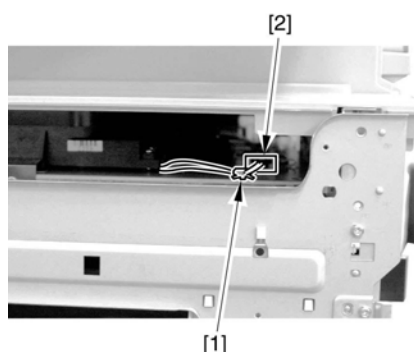

F-5-79

3) Remove the screw [1], and detach the fixing [2].

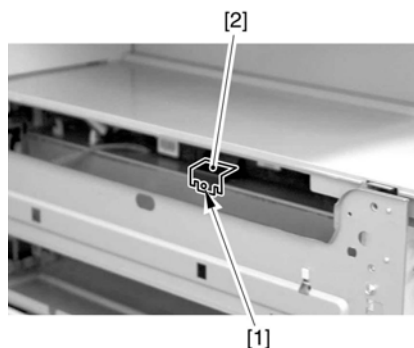

F-5-80

4) Lift the front of the laser unit [1], and slide it to the front.

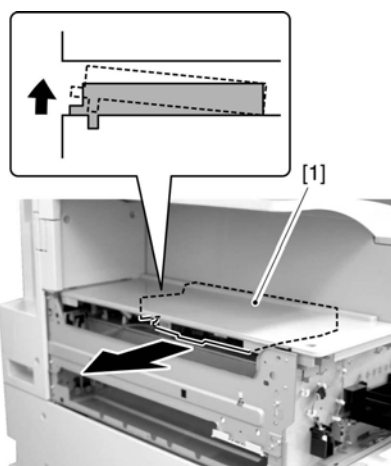

F-5-81



When sliding out the laser scanner unit, be sure to take care not to touch the PCB mounted to the laser scanner unit. (The PCB is equipped with a laser scanner intensity adjustment variable resistor, and contact with the PCB can change the adjustment setting.)

5.12.3.11 Removing the Hopper Assembly

1) Remove the inside base cover [1] and the inside right color [2].

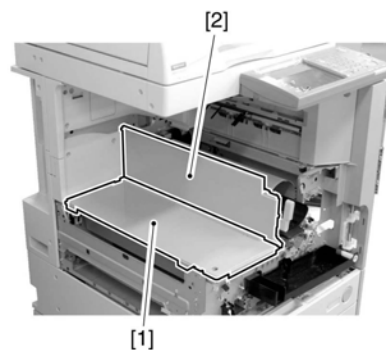

F-5-82

2) Disconnect the 3 connectors [1] found at the front and the connector [2] found at the rear.

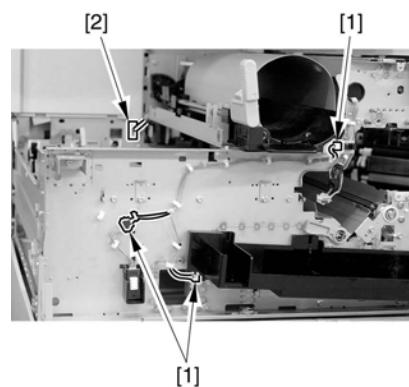

F-5-83

3) Open the 11 wire saddles [1], and pull out the harness [3] through the hole [2] in the plate.

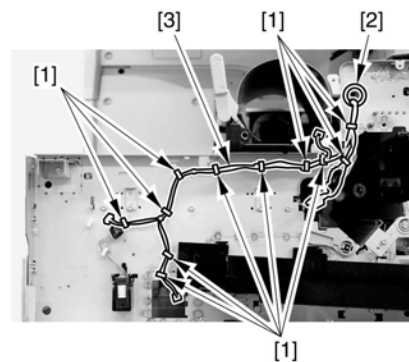

F-5-84

4) Remove the 3 screws [1], and detach the hopper assembly [2].

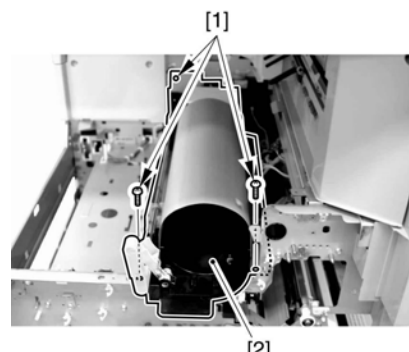

F-5-85



When fitting the hopper assembly to the machine, be sure that the connectors [1] are securely connected. If the connectors [1] are not connected, the environment heater will not be supplied with power, leading to image faults.

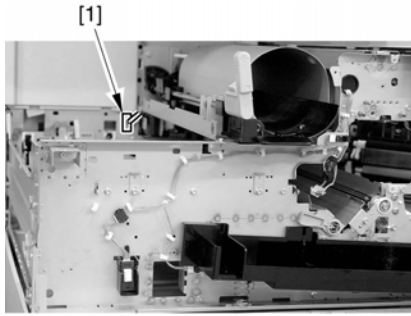

F-5-86

5.12.4 Sub Hopper

5.12.4.1 Removing the Front Cover Unit

1) Open the front cover [1].

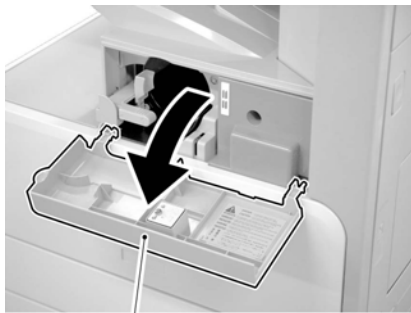

[1]
F-5-87

- 2) Remove the face cover rubber [1].
- 3) Remove the binding screw [2].
- 4) Remove the RS tightening screw [3].
- 5) Detach the front cover unit [4] by moving it in the direction of the arrow.

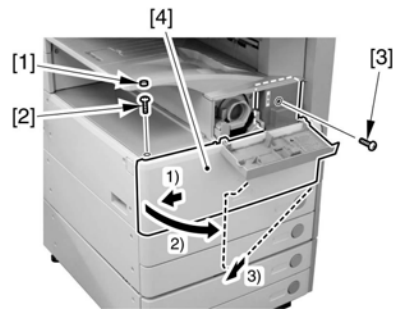

F-5-88

5.12.4.2 Removing the Waste Toner Case

1) Remove the waste toner case [1].

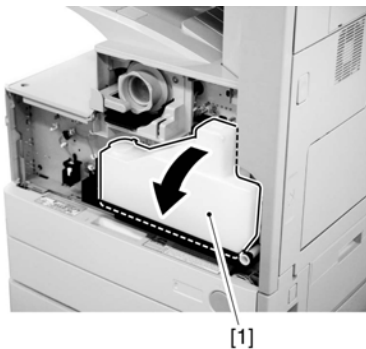

F-5-89



Point to note after attaching the waste toner receptacle
After attaching the waste toner receptacle, move the waste toner full detection lever [1] up and down to make sure that the lever is moved smoothly. Faulty detection may be resulted if the lever is caught in something and is not moved smoothly.

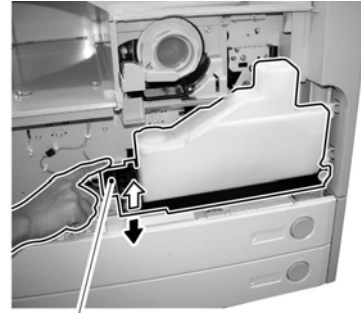

[1]
F-5-90

5.12.4.3 Removing the Toner Cartridge

1) Shift up the lever [1].

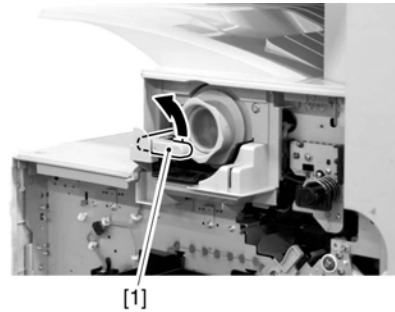

[1]
F-5-91

2) Remove the toner cartridge [1].

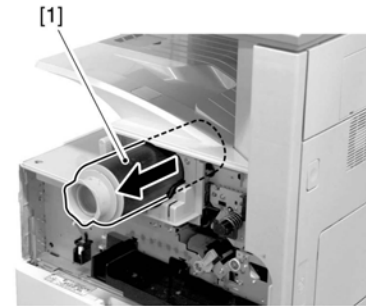

[1]
F-5-92



Points to Note on Handling the Toner Cartridge

1. Care should be taken not to bump the toner stop [1] against the covers or the like when and after removing the toner cartridge. Since the toner stop comes off easily, toner scattering may be resulted if it comes off by accident.
2. Keep the toner cartridge horizontal after removing. Since the toner stop [1] comes off easily as mentioned above, toner scattering may be resulted if the toner cartridge is placed with the toner stop side down.

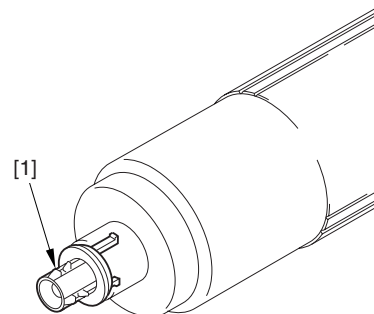

[1]
F-5-93

5.12.4.4 Removing the Drum Unit

1) Open the right door [1].



F-5-94

2) Remove the screw [1].

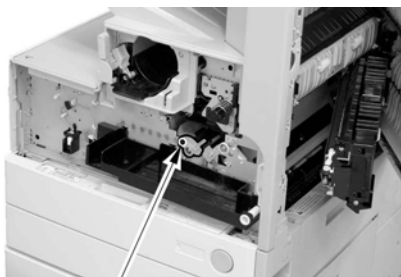

[1]

F-5-95

3) Shift the locking lever [1] to the left to release the developing assembly.



[1]

F-5-96

4) Remove the screw [1].

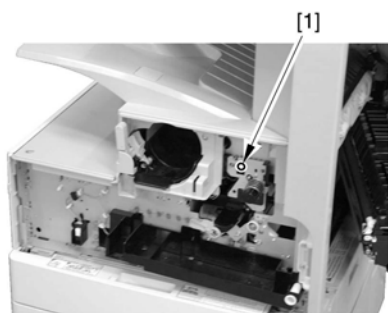

F-5-97

5) Remove the drum unit [1].



F-5-98

Be sure to hold the drum unit as shown.

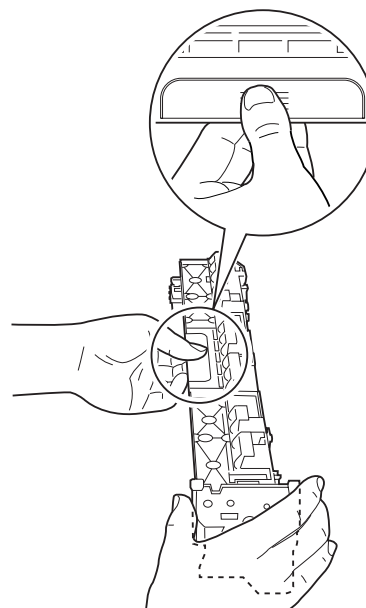

F-5-99

5.12.4.5 Removing the Developing Assembly

1) Remove the screw [1].

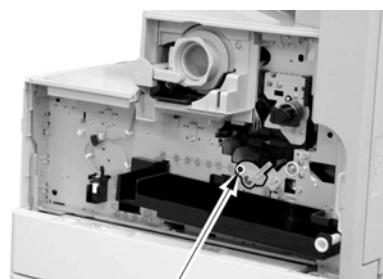

[1]

F-5-100

2) Shift the locking lever [1] to the left to release the developing assembly.

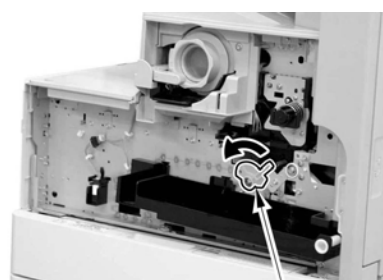

[1]

F-5-101

3) Slide the developing assembly [1] slightly to the front; then, disconnect the connector [2].



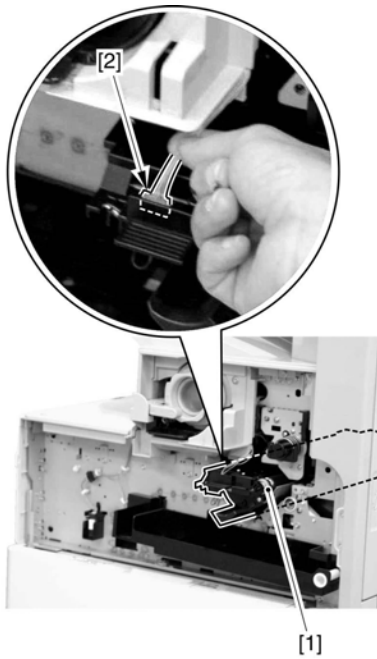

F-5-102

4) Remove the developing assembly [1].

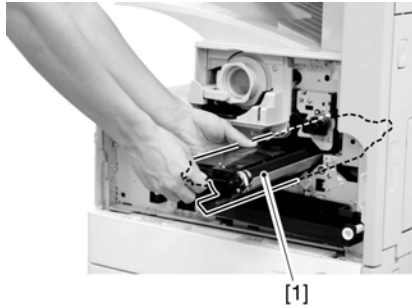

F-5-103



Be sure to hold the developing assembly as shown.

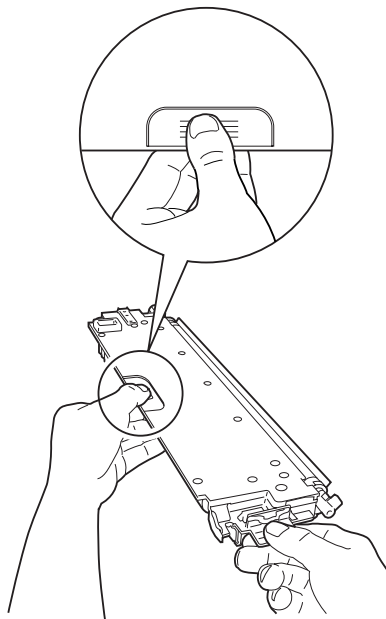

F-5-104



When fitting the developing assembly, be sure to fit the lower right segment [2] of the developing assembly [1] in the rail [3] of the machine. Thereafter, slide the developing assembly so that [A] of the developing assembly matches [B] of the rail.

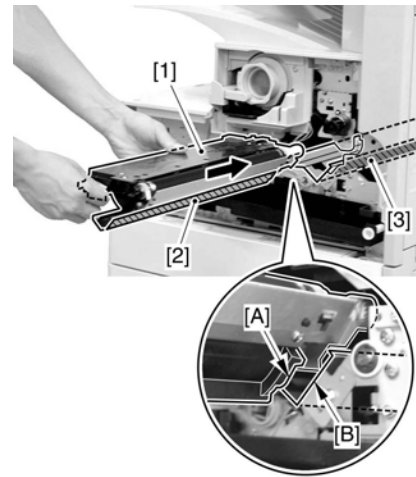

F-5-105

5.12.4.6 Removing the Upper Tray

1) Remove the 2 screws [1], and detach the upper tray [2].

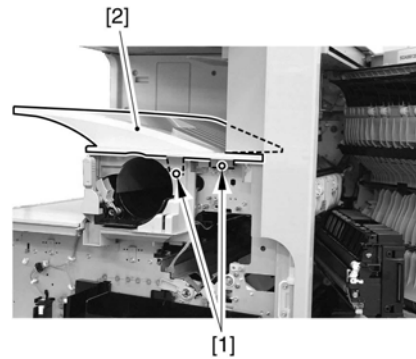

F-5-106

Reference:

Lift the front of the upper tray [1], and detach it as if to slide it toward the front.

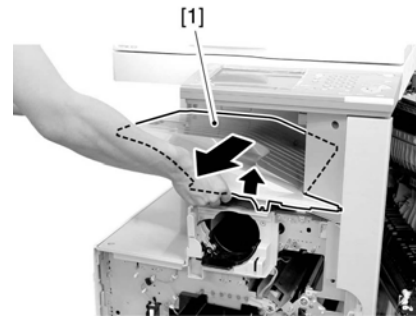

F-5-107

5.12.4.7 Removing the Toner Cartridge Cover

1) Remove the 2 screws [1]; then, detach the toner bottle cover [2].

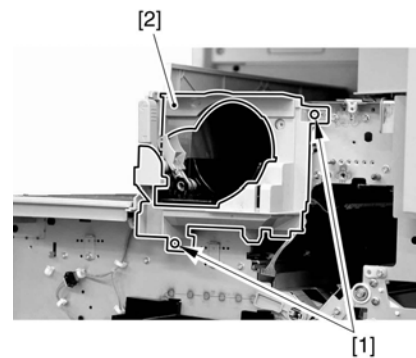

F-5-108

5.12.4.8 Removing the Pre-Exposure Lamp

1) Open the 2 wire saddles [1], and disconnect the 2 relay connectors [2].

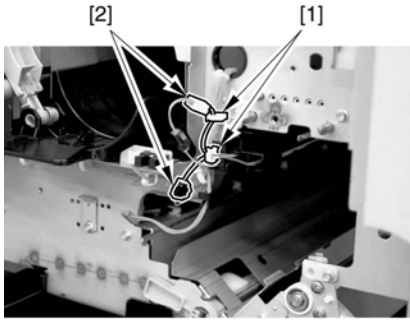

F-5-109

2) While freeing the lock [1] toward the right, detach the pre-exposure lamp [2].

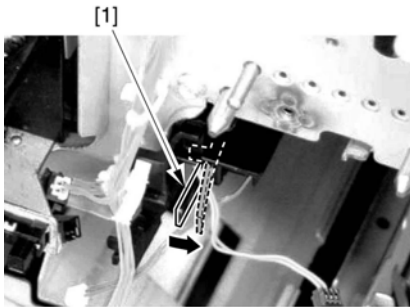

F-5-110

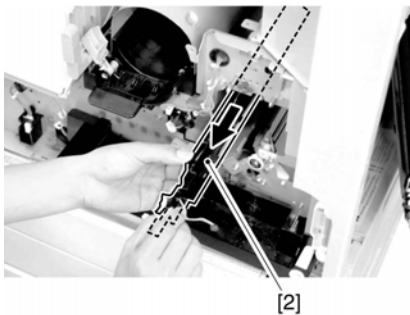

F-5-111

5.12.4.9 Removing the Left Cover

1) Remove the 4 screws [1], and detach the left cover [2].

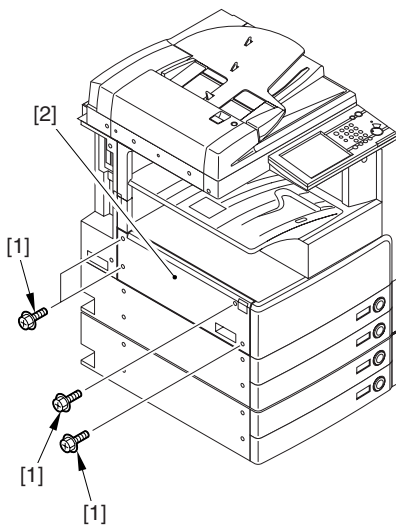

F-5-112

5.12.4.10 Removing the Laser Unit

1) Open the 2 wire saddles [1], and disconnect the 2 connectors [2].

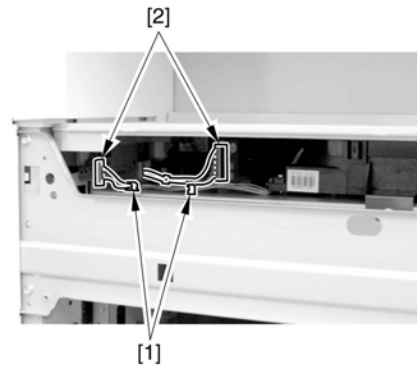

F-5-113



When you have disconnected the connector [1], be sure to take care so that it will not come into contact with the PCB that is mounted to the laser scanner unit. (The PCB is equipped with a laser intensity adjustment variable resistor. Contact with the PCB can change the adjustment setting.)

2) Open the wire saddle [1], and disconnect the connector [2].

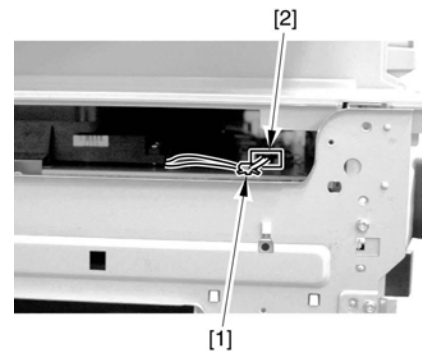

F-5-114

3) Remove the screw [1], and detach the fixing [2].

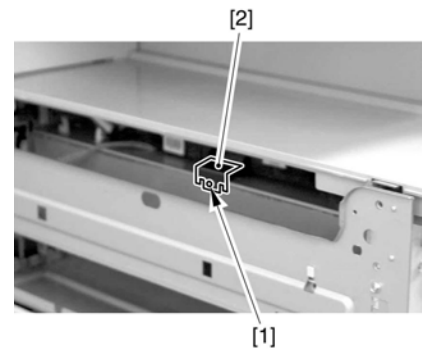

F-5-115

4) Lift the front of the laser unit [1], and slide it to the front.

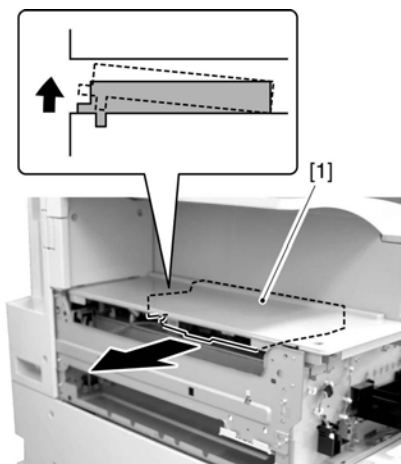

F-5-116



When sliding out the laser scanner unit, be sure to take care not to touch the PCB mounted to the laser scanner unit. (The PCB is equipped with a laser scanner intensity adjustment variable resistor, and contact with the PCB can change the adjustment setting.)

5.12.4.11 Removing the Hopper Assembly

- 1) Remove the inside base cover [1] and the inside right color [2].

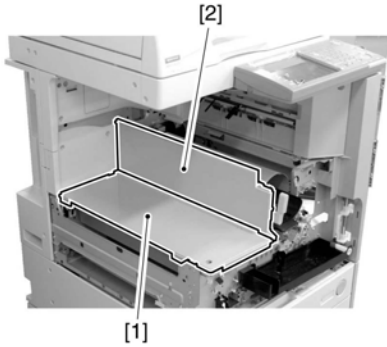

F-5-117

- 2) Disconnect the 3 connectors [1] found at the front and the connector [2] found at the rear.

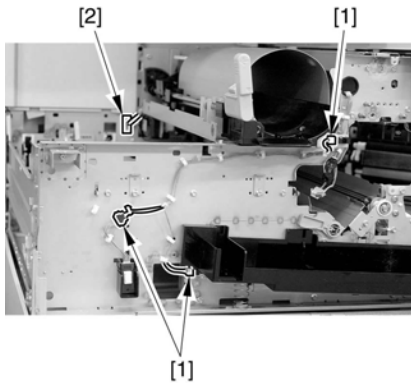

F-5-118

- 3) Open the 11 wire saddles [1], and pull out the harness [3] through the hole [2] in the plate.

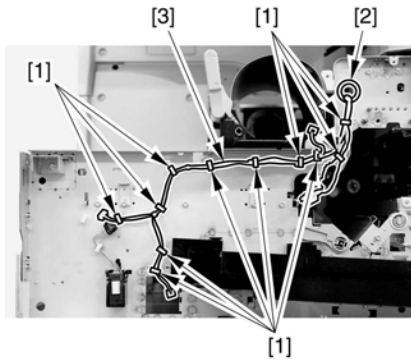

F-5-119

- 4) Remove the 3 screws [1], and detach the hopper assembly [2].

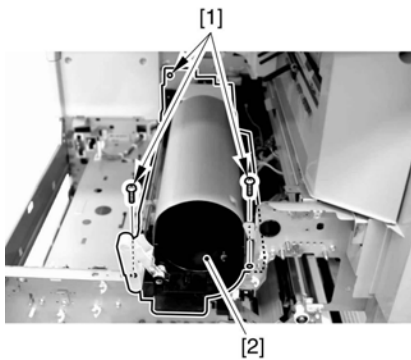

F-5-120



When fitting the hopper assembly to the machine, be sure that the connectors [1] are securely connected. If the connectors [1] are not connected, the environment heater will not be supplied with power, leading to image faults.

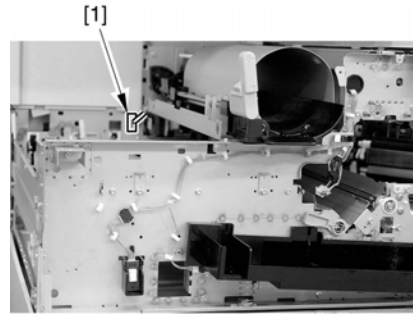

F-5-121

5.12.4.12 Removing the Toner Feedscrew Motor

- 1) Disconnect the connector [1].

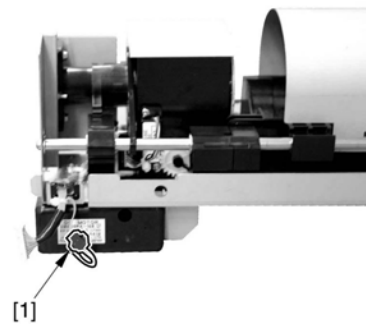

F-5-122

- 2) Remove the screw [1], and detach the toner feedscrew motor assembly [2].

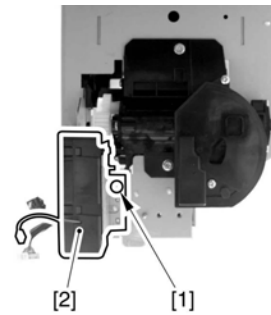

F-5-123

- 3) Remove the screw [1], and detach the toner feedscrew motor [3] from the base.

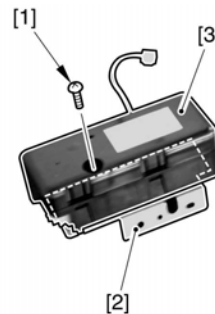

F-5-124

5.12.4.13 Removing the Sub Hopper

- 1) Remove the 2 screws [2] from the back of the sub hopper [1].



F-5-125

2) Check the phase of the gear [1] shown in the figure.

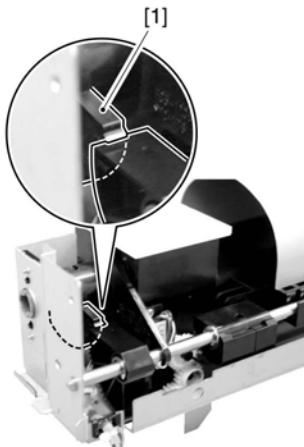

F-5-126

3) Remove the 3 screws [1].

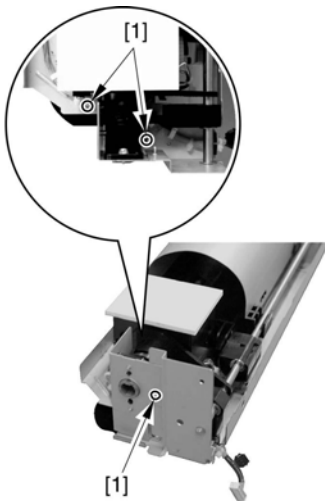

F-5-127

4) Free the cable from the edge saddle [1].

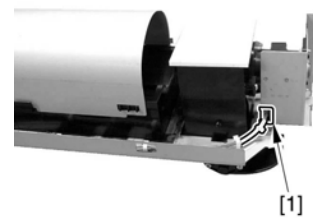

F-5-128

5) Remove the screw [1], and release the arm [2].

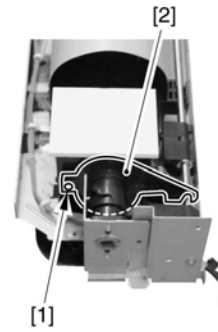

F-5-129

6) Remove the bushing unit [2] from the sub hopper [1].

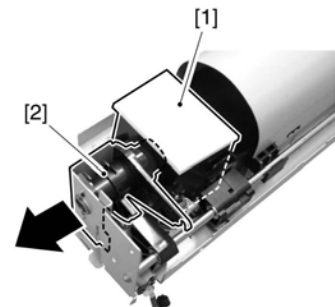

F-5-130

7) Disconnect the connector [1].

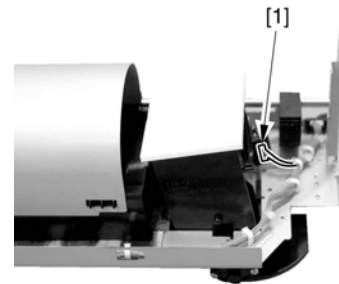

F-5-131

8) Detach the sub hopper [1] from the bottom.

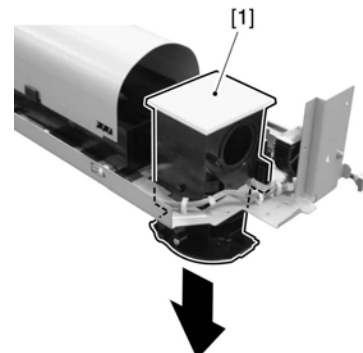

F-5-132

5.12.5 Developing Assembly

5.12.5.1 Removing the Front Cover Unit

1) Open the front cover [1].

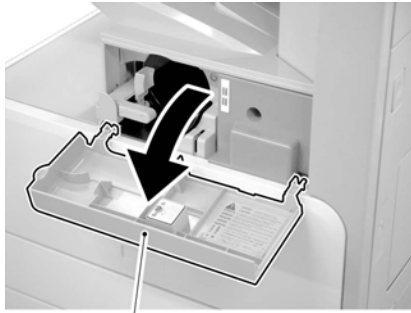

[1]

F-5-133

- 2) Remove the face cover rubber [1].
- 3) Remove the binding screw [2].
- 4) Remove the RS tightening screw [3].
- 5) Detach the front cover unit [4] by moving it in the direction of the arrow.

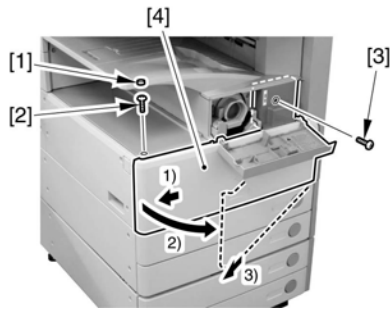

F-5-134

5.12.5.2 Removing the Waste Toner Case

1) Remove the waste toner case [1].

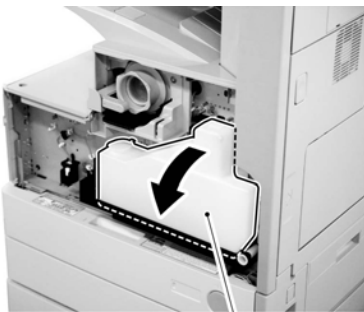

[1]

F-5-135

⚠ Point to note after attaching the waste toner receptacle
 After attaching the waste toner receptacle, move the waste toner full detection lever [1] up and down to make sure that the lever is moved smoothly. Faulty detection may be resulted if the lever is caught in something and is not moved smoothly.



[1]

F-5-136

5.12.5.3 Removing the Developing Assembly

1) Remove the screw [1].

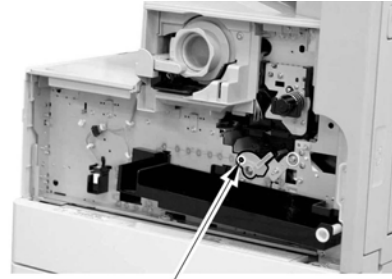

[1]

F-5-137

2) Shift the locking lever [1] to the left to release the developing assembly.

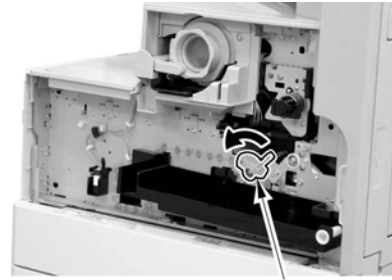

[1]

F-5-138

3) Slide the developing assembly [1] slightly to the front; then, disconnect the connector [2].

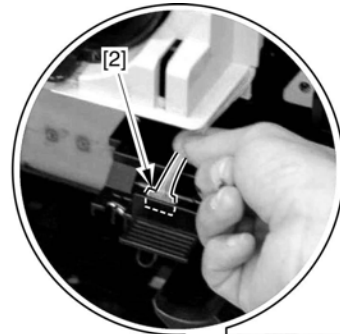

[2]

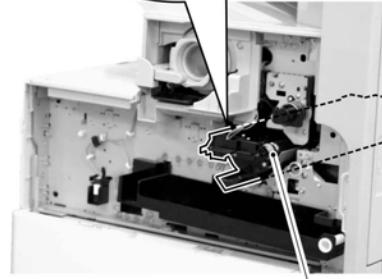

[1]

F-5-139

4) Remove the developing assembly [1].



[1]

F-5-140



Be sure to hold the developing assembly as shown.

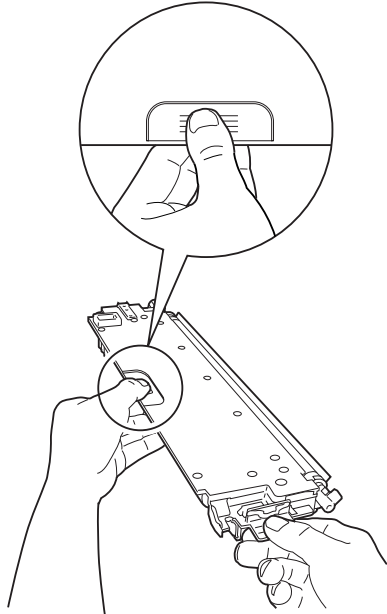

F-5-141



When fitting the developing assembly, be sure to fit the lower right segment [2] of the developing assembly [1] in the rail [3] of the machine. Thereafter, slide the developing assembly so that [A] of the developing assembly matches [B] of the rail.

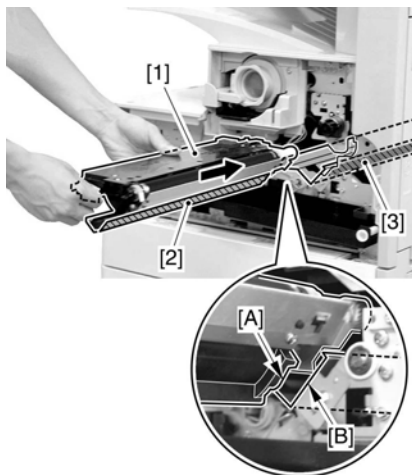

F-5-142

5.12.6 Developing Cylinder

5.12.6.1 Detaching the Developing Cylinder



When you remove a developing cylinder from the developing assembly housing, be careful with the following points.

1. Lots of self-tapping screws are used in the developing unit. Be careful not to damage tapped holes by tightening self-tapping screws.
 2. Remove the developing cylinder after detaching the blade unit with the developing blade.
 3. Mount the developing cylinder on the developing assembly housing before attaching the blade unit.
 4. Do not touch nor give a shock to the developing cylinder.
- 1) Unscrew 5 self-tapping screws [1] and a washer screw [2], and detach the top cover [3].

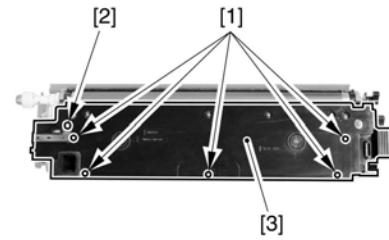

F-5-143

- 2) Slide out the sleeve front guide [2] in the direction of the arrow while releasing the claw [1].

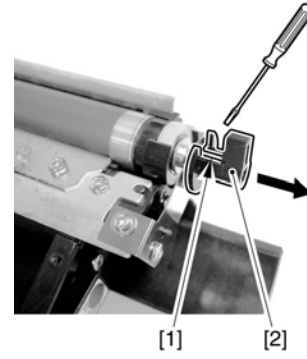

F-5-144

- 3) Unscrew a self-tapping screw [1] and a washer screw [2], and remove the angle adjustment plate [3].

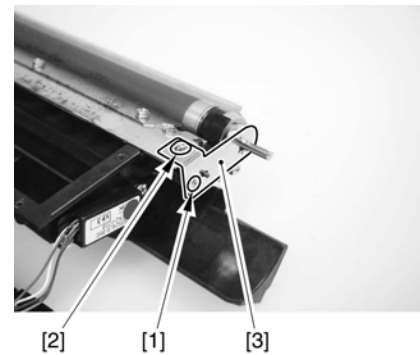

F-5-145

- 4) Remove the E-ring [1], a washer [2], a bearing [3], a gear [4], and a dowel pin [5].

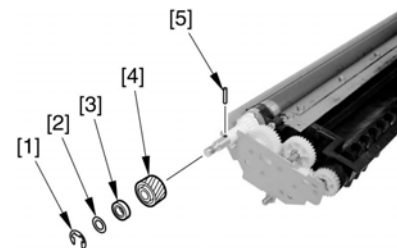

F-5-146

- 5) Unscrew a screw [1] and remove the gear unit [2].

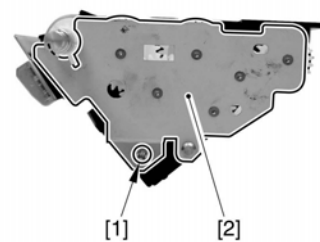

F-5-147

- 6) Remove a sleeve bushing [1], a gear [2], and a dowel pin [3].

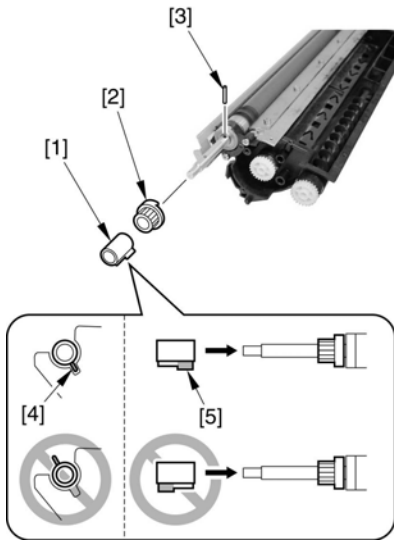

F-5-148

⚠ When mounting the sleeve bushing, be careful with the following points. Match the projection [4] of the sleeve bushing to the depression of the gear unit side plate to mount. (If mounting in the wrong direction, the projection of the sleeve bushing might come into contact with the surface of the photo-sensitive drum.)

Pay attention to the mounting direction of the sleeve bushing. (Mount the sleeve bushing with longer projection on the developing cylinder. If the mounting direction is wrong, the gear unit cannot be attached.)

7) Unscrew 2 screws [1], and detach the blade unit [2].

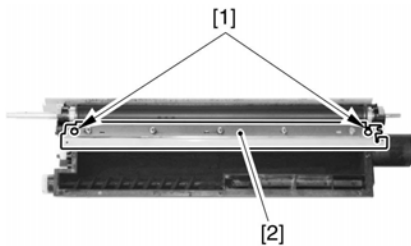

F-5-149

8) Unscrew 4 screws [1] which fix the sleeve holders (front/rear).
9) Push up the developing cylinder [2] and remove it along with a roller or others.

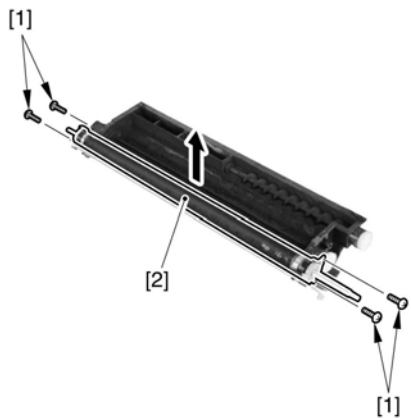

F-5-150

10) Remove a push-on roller [1], a sleeve holder [2], a bearing [3], and a sleeve holder (rear) [3] from the developing cylinder.

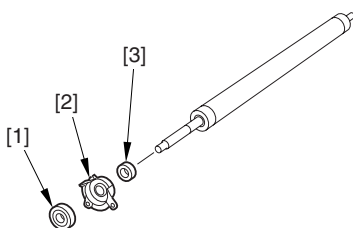

F-5-151

11) Remove a grip ring [1], a washer [2], a push-on roller [3], a sleeve holder (front) [4] and a bearing [5] from the developing cylinder.

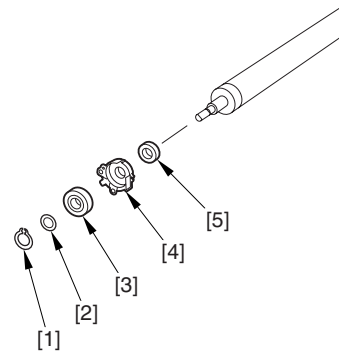

F-5-152

5.12.7 Transfer Charging Roller

5.12.7.1 Removing the Transfer Roller

1) Open the right door [1].



F-5-153

2) Pull off the pin [1] toward the front.

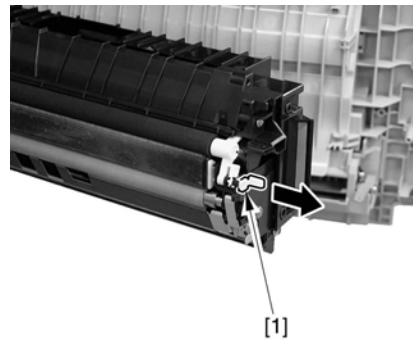

F-5-154

3) Remove the holder [1] from the front of the transfer roller.

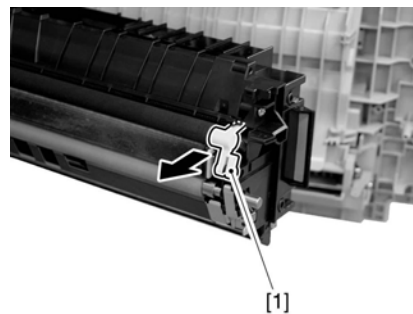

F-5-155

4) Remove the transfer roller [1] toward the front.

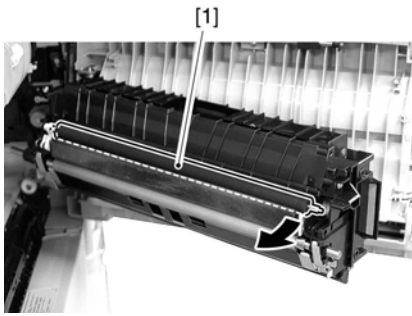

F-5-156



Points to Note When Attaching the Transfer Roller
Be sure that the top of the holder [1] is on the inside of the static eliminator [2].

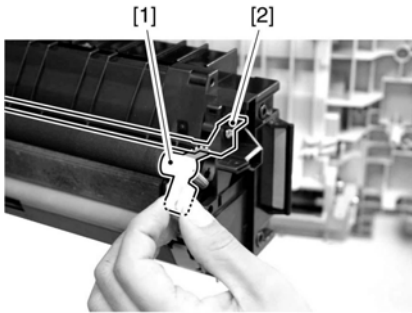

F-5-157

Be sure that the spring [1] of the holder is against the butting point [2].

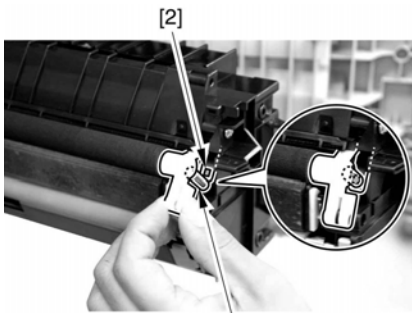

F-5-158

5.12.8 Waste Toner Box

5.12.8.1 Removing the Front Cover Unit

- 1) Open the front cover [1].

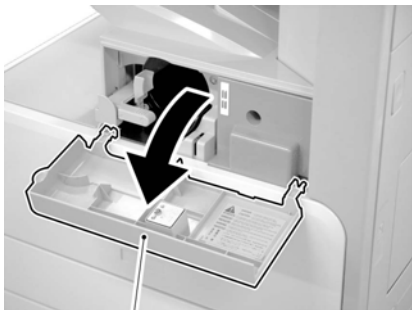

F-5-159

- 2) Remove the face cover rubber [1].
- 3) Remove the binding screw [2].
- 4) Remove the RS tightening screw [3].
- 5) Detach the front cover unit [4] by moving it in the direction of the arrow.

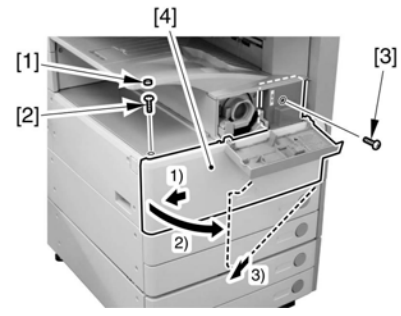

F-5-160

5.12.8.2 Removing the Waste Toner Case

- 1) Remove the waste toner case [1].

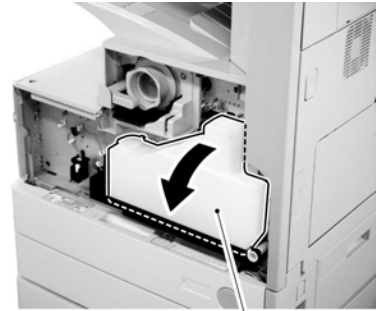

F-5-161



Point to note after attaching the waste toner receptacle
After attaching the waste toner receptacle, move the waste toner full detection lever [1] up and down to make sure that the lever is moved smoothly. Faulty detection may be resulted if the lever is caught in something and is not moved smoothly.

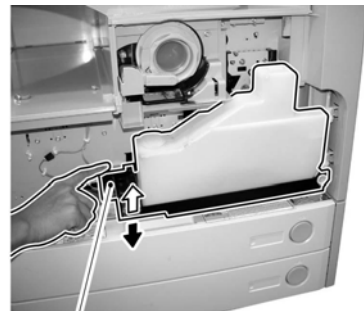

F-5-162

5.12.9 Toner Level Sensor

5.12.9.1 Removing the Front Cover Unit

- 1) Open the front cover [1].

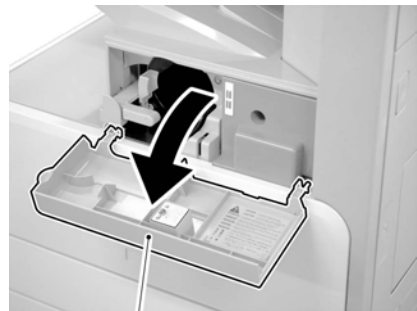

F-5-163

- 2) Remove the face cover rubber [1].
- 3) Remove the binding screw [2].
- 4) Remove the RS tightening screw [3].

5) Detach the front cover unit [4] by moving it in the direction of the arrow.

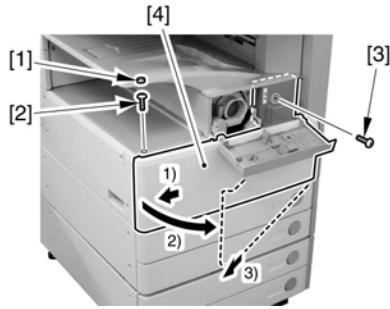

F-5-164

5.12.9.2 Removing the Waste Toner Case

1) Remove the waste toner case [1].

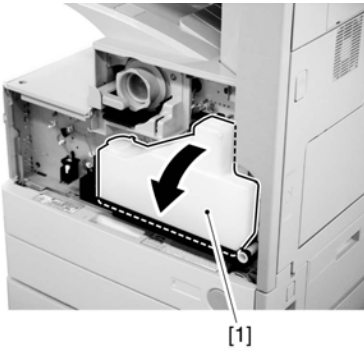

F-5-165

! Point to note after attaching the waste toner receptacle
After attaching the waste toner receptacle, move the waste toner full detection lever [1] up and down to make sure that the lever is moved smoothly. Faulty detection may be resulted if the lever is caught in something and is not moved smoothly.

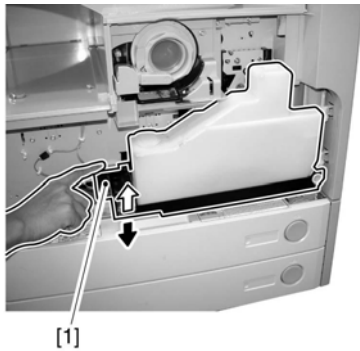

F-5-166

5.12.9.3 Removing the Toner Cartridge

1) Shift up the lever [1].

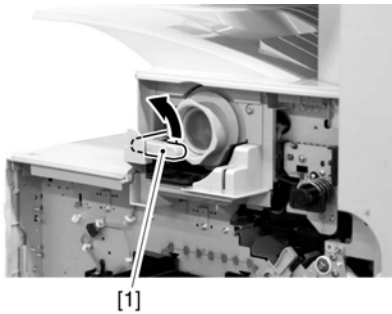

F-5-167

2) Remove the toner cartridge [1].

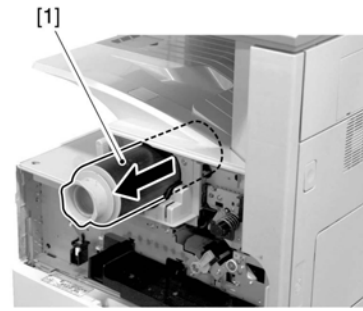

F-5-168

! Points to Note on Handling the Toner Cartridge

1. Care should be taken not to bump the toner stop [1] against the covers or the like when and after removing the toner cartridge. Since the toner stop comes off easily, toner scattering may be resulted if it comes off by accident.
2. Keep the toner cartridge horizontal after removing. Since the toner stop [1] comes off easily as mentioned above, toner scattering may be resulted if the toner cartridge is placed with the toner stop side down.

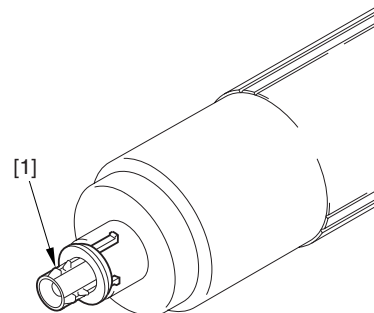

F-5-169

5.12.9.4 Removing the Drum Unit

1) Open the right door [1].



F-5-170

2) Remove the screw [1].

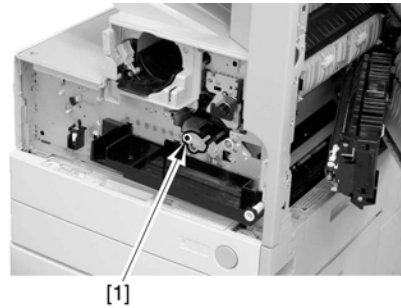

F-5-171

3) Shift the locking lever [1] to the left to release the developing assembly.



[1]
F-5-172

4) Remove the screw [1].

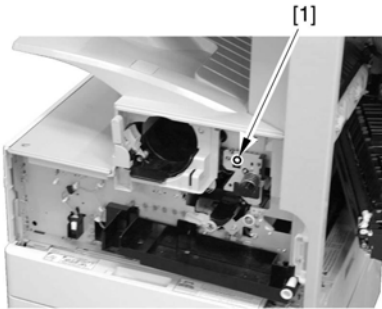

F-5-173

5) Remove the drum unit [1].



F-5-174

! Be sure to hold the drum unit as shown.

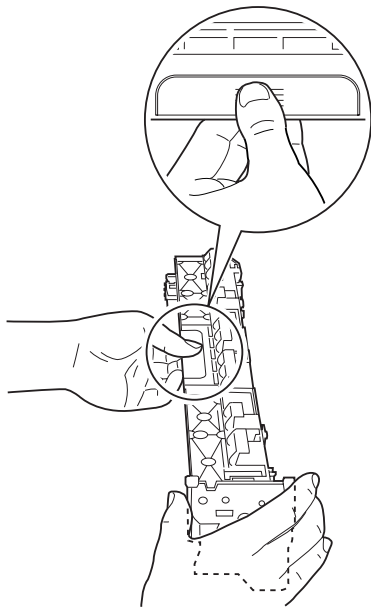

F-5-175

5.12.9.5 Removing the Developing Assembly

1) Remove the screw [1].

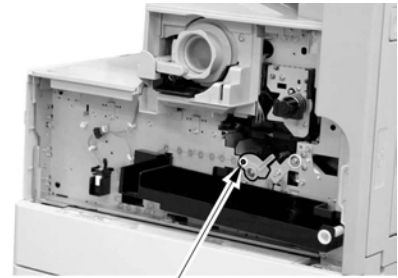

[1]
F-5-176

2) Shift the locking lever [1] to the left to release the developing assembly.

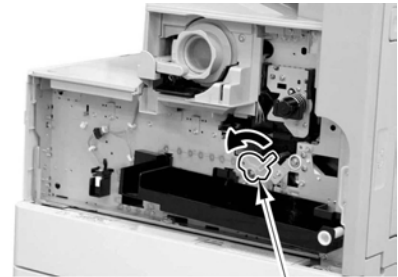

F-5-177

3) Slide the developing assembly [1] slightly to the front; then, disconnect the connector [2].

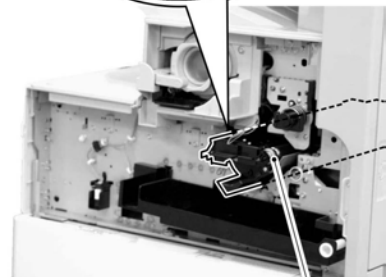
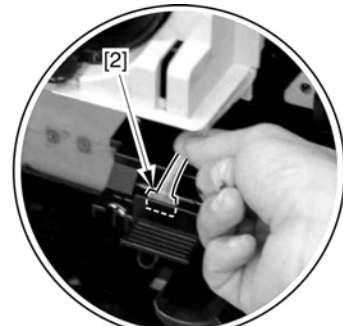

F-5-178

4) Remove the developing assembly [1].



F-5-179

! Be sure to hold the developing assembly as shown.

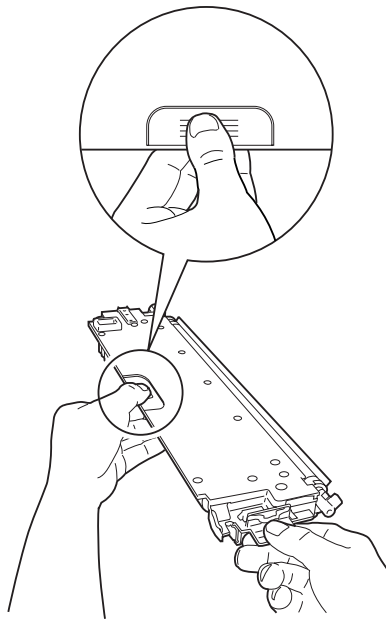

F-5-180



When fitting the developing assembly, be sure to fit the lower right segment [2] of the developing assembly [1] in the rail [3] of the machine. Thereafter, slide the developing assembly so that [A] of the developing assembly matches [B] of the rail.

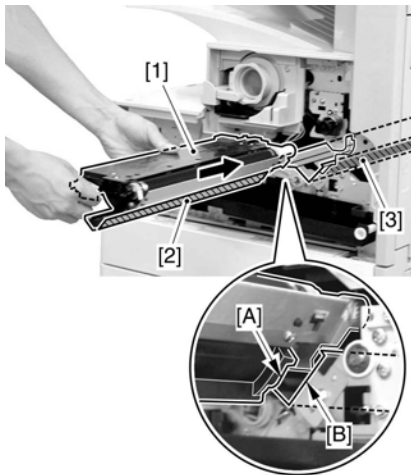

F-5-181

5.12.9.6 Removing the Upper Tray

1) Remove the 2 screws [1], and detach the upper tray [2].

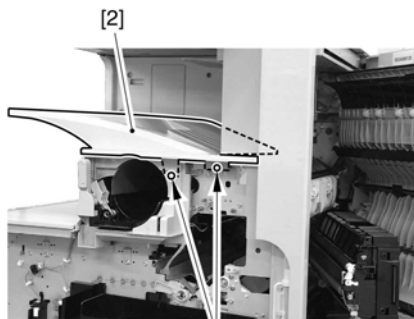

F-5-182

Reference:
Lift the front of the upper tray [1], and detach it as if to slide it toward the front.

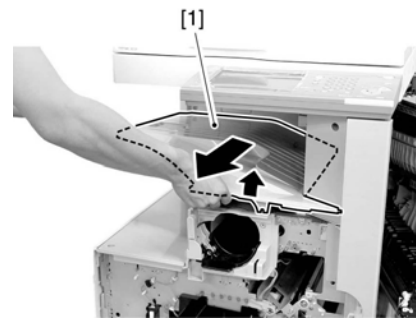

F-5-183

5.12.9.7 Removing the Toner Cartridge Cover

1) Remove the 2 screws [1]; then, detach the toner bottle cover [2].

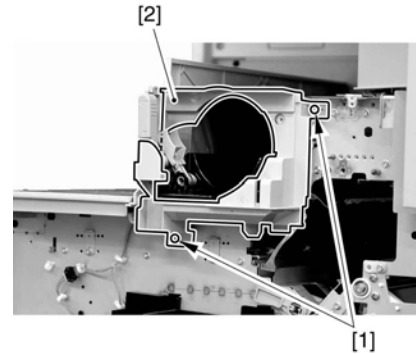

F-5-184

5.12.9.8 Removing the Pre-Exposure Lamp

1) Open the 2 wire saddles [1], and disconnect the 2 relay connectors [2].

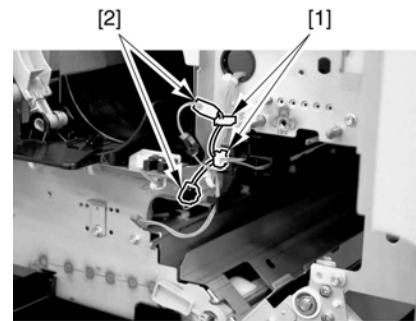

F-5-185

2) While freeing the lock [1] toward the right, detach the pre-exposure lamp [2].

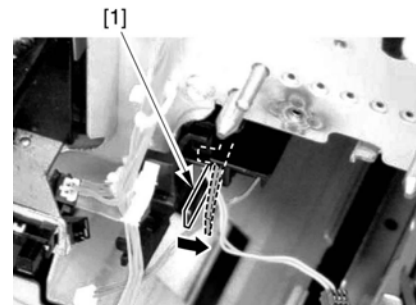

F-5-186

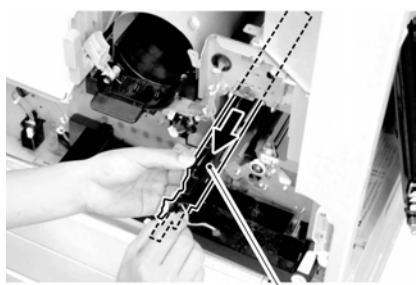

F-5-187

5.12.9.9 Removing the Left Cover

1) Remove the 4 screws [1], and detach the left cover [2].

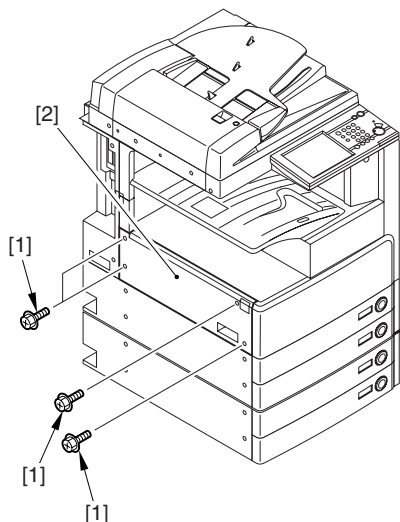

F-5-188

5.12.9.10 Removing the Laser Unit

1) Open the 2 wire saddles [1], and disconnect the 2 connectors [2].

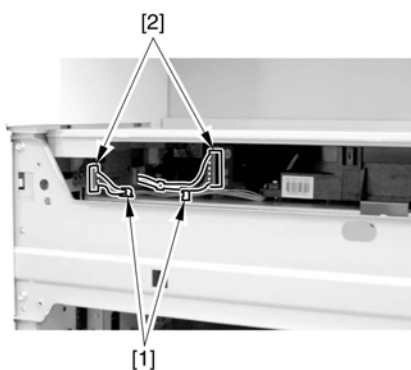

F-5-189



When you have disconnected the connector [1], be sure to take care so that it will not come into contact with the PCB that is mounted to the laser scanner unit. (The PCB is equipped with a laser intensity adjustment variable resistor. Contact with the PCB can change the adjustment setting.)

2) Open the wire saddle [1], and disconnect the connector [2].

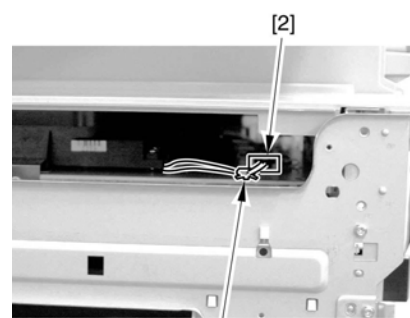

F-5-190

3) Remove the screw [1], and detach the fixing [2].

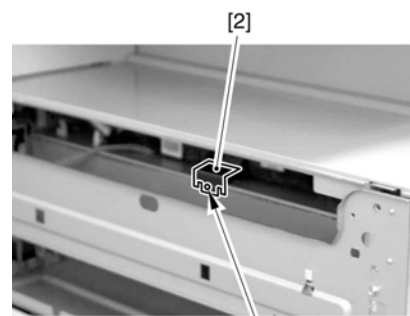

F-5-191

4) Lift the front of the laser unit [1], and slide it to the front.

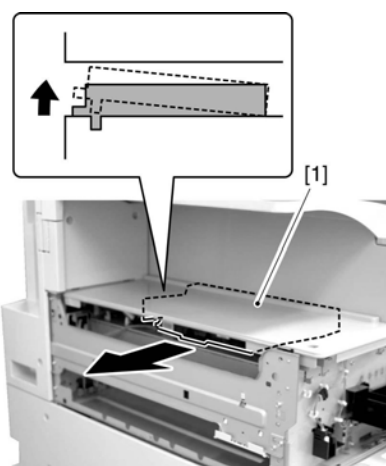

F-5-192



When sliding out the laser scanner unit, be sure to take care not to touch the PCB mounted to the laser scanner unit. (The PCB is equipped with a laser scanner intensity adjustment variable resistor, and contact with the PCB can change the adjustment setting.)

5.12.9.11 Removing the Hopper Assembly

1) Remove the inside base cover [1] and the inside right color [2].

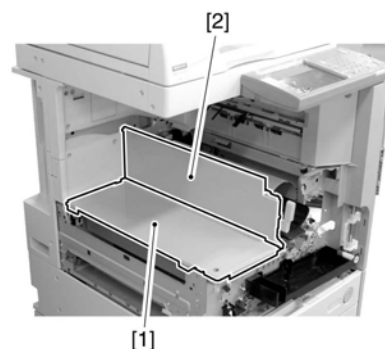

F-5-193

- 2) Disconnect the 3 connectors [1] found at the front and the connector [2] found at the rear.

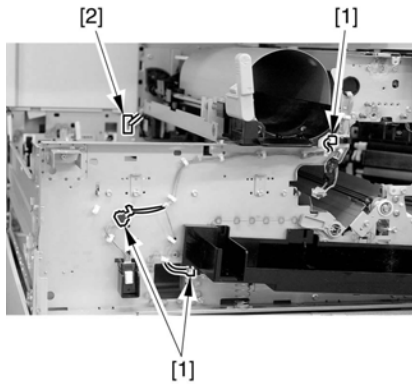

F-5-194

- 3) Open the 11 wire saddles [1], and pull out the harness [3] through the hole [2] in the plate.

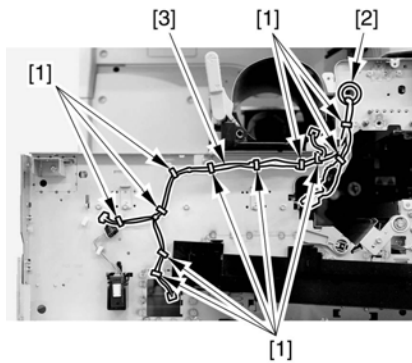

F-5-195

- 4) Remove the 3 screws [1], and detach the hopper assembly [2].

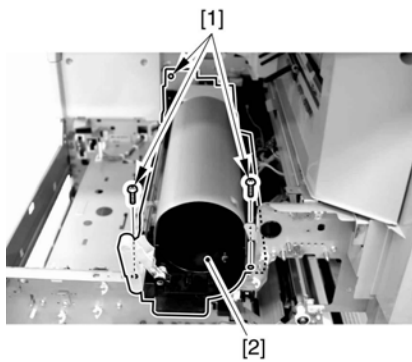

F-5-196



When fitting the hopper assembly to the machine, be sure that the connectors [1] are securely connected. If the connectors [1] are not connected, the environment heater will not be supplied with power, leading to image faults.

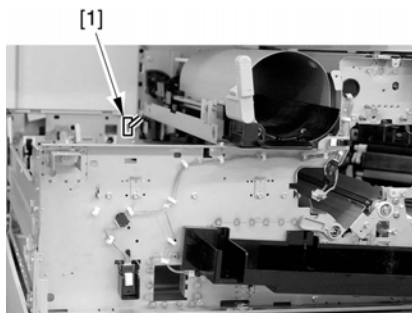

F-5-197

5.12.9.12 Removing the Toner Level Sensor

- 1) Remove the 2 screws [1], and disconnect the connector [2]; then, detach the toner sensor [3].

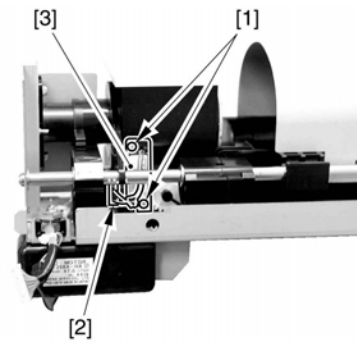

F-5-198

5.12.10 Toner Feedscrew Motor

5.12.10.1 Removing the Front Cover Unit

- 1) Open the front cover [1].

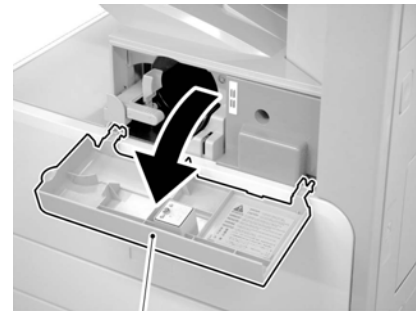

F-5-199

- 2) Remove the face cover rubber [1].
 3) Remove the binding screw [2].
 4) Remove the RS tightening screw [3].
 5) Detach the front cover unit [4] by moving it in the direction of the arrow.

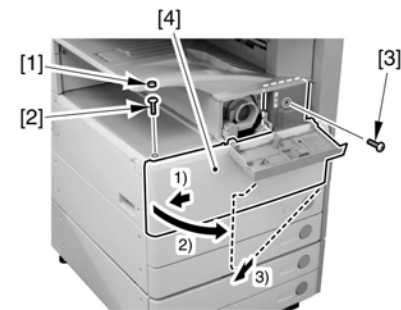

F-5-200

5.12.10.2 Removing the Waste Toner Case

- 1) Remove the waste toner case [1].

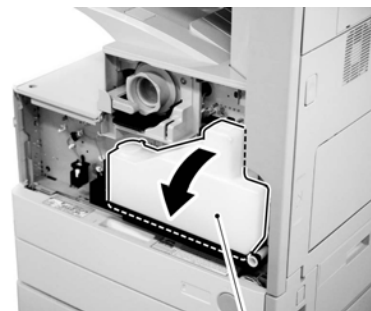

F-5-201



Point to note after attaching the waste toner receptacle
 After attaching the waste toner receptacle, move the waste toner full detection lever [1] up and down to make sure that the lever is moved smoothly. Faulty detection may be resulted if the lever is caught in something and is not

moved smoothly.

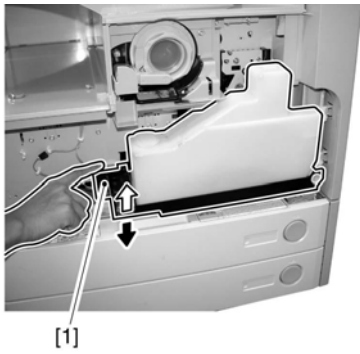

F-5-202

5.12.10.3 Removing the Toner Cartridge

1) Shift up the lever [1].

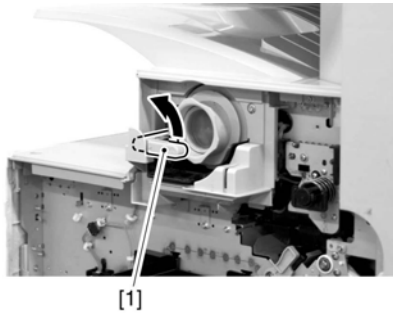

F-5-203

2) Remove the toner cartridge [1].

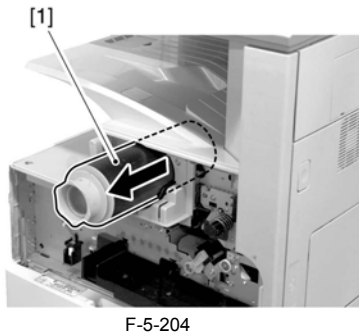

F-5-204

⚠ Points to Note on Handling the Toner Cartridge

1. Care should be taken not to bump the toner stop [1] against the covers or the like when and after removing the toner cartridge. Since the toner stop comes off easily, toner scattering may be resulted if it comes off by accident.
2. Keep the toner cartridge horizontal after removing. Since the toner stop [1] comes off easily as mentioned above, toner scattering may be resulted if the toner cartridge is placed with the toner stop side down.

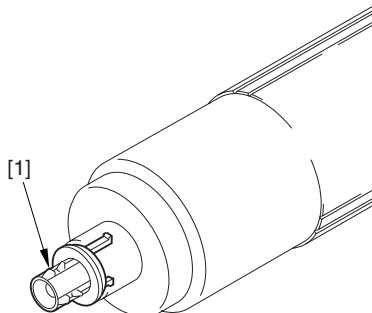

F-5-205

5.12.10.4 Removing the Drum Unit

1) Open the right door [1].



F-5-206

2) Remove the screw [1].

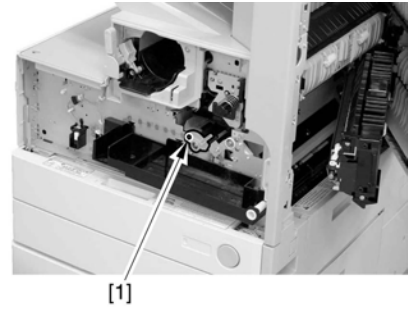

F-5-207

3) Shift the locking lever [1] to the left to release the developing assembly.

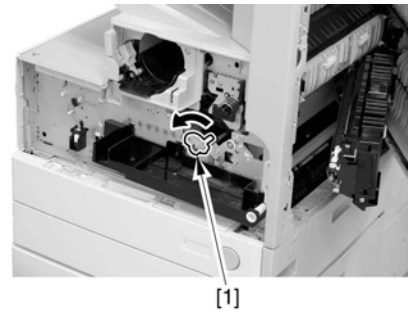

F-5-208

4) Remove the screw [1].

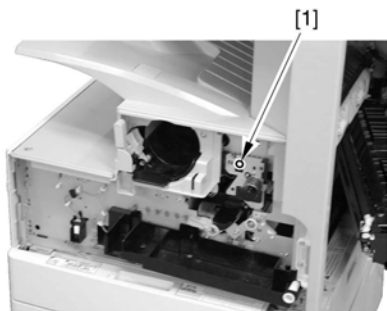

F-5-209

5) Remove the drum unit [1].



F-5-210

⚠ Be sure to hold the drum unit as shown.

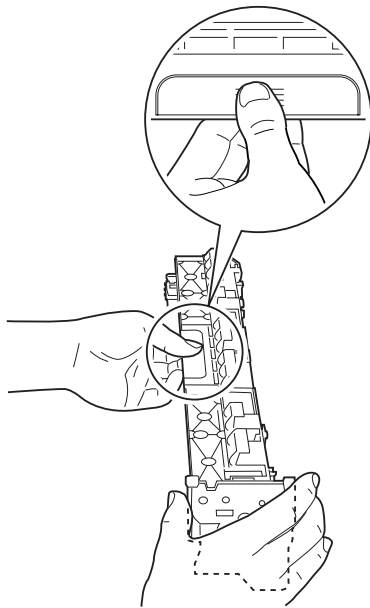

F-5-211

5.12.10.5 Removing the Developing Assembly

1) Remove the screw [1].

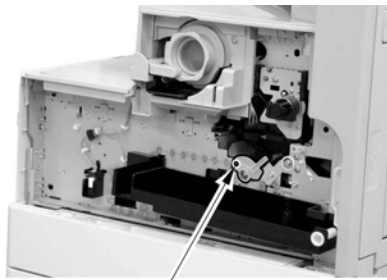

[1]

F-5-212

2) Shift the locking lever [1] to the left to release the developing assembly.

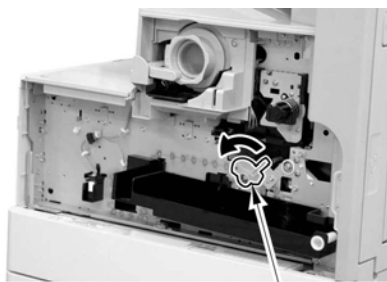

[1]

F-5-213

3) Slide the developing assembly [1] slightly to the front; then, disconnect the connector [2].

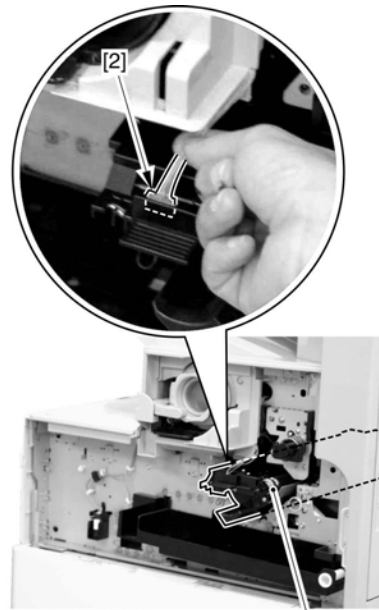

[1]

F-5-214

4) Remove the developing assembly [1].



[1]

F-5-215



Be sure to hold the developing assembly as shown.

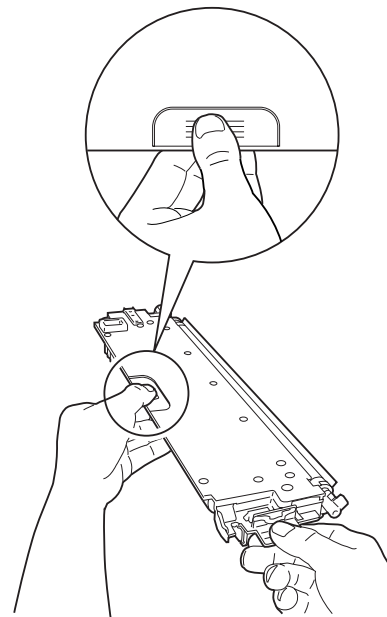

F-5-216



When fitting the developing assembly, be sure to fit the lower right segment [2] of the developing assembly [1] in the rail [3] of the machine. Thereafter, slide the developing assembly so that [A] of the developing assembly matches [B] of the rail.

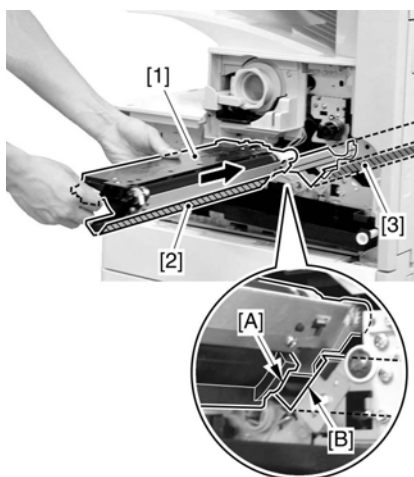

F-5-217

5.12.10.6 Removing the Upper Tray

1) Remove the 2 screws [1], and detach the upper tray [2].

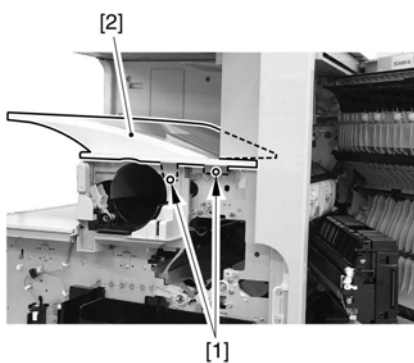

F-5-218

Reference:

Lift the front of the upper tray [1], and detach it as if to slide it toward the front.

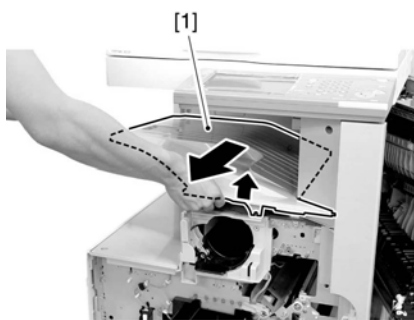

F-5-219

5.12.10.7 Removing the Toner Cartridge Cover

1) Remove the 2 screws [1]; then, detach the toner bottle cover [2].

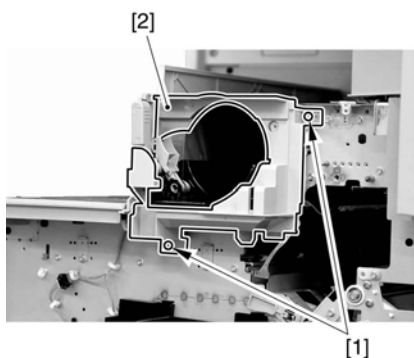

F-5-220

5.12.10.8 Removing the Pre-Exposure Lamp

1) Open the 2 wire saddles [1], and disconnect the 2 relay connectors [2].

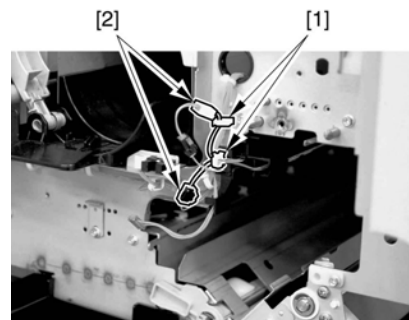

F-5-221

2) While freeing the lock [1] toward the right, detach the pre-exposure lamp [2].

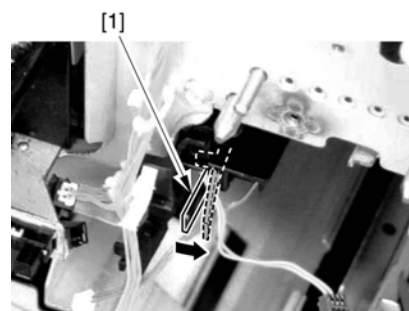

F-5-222

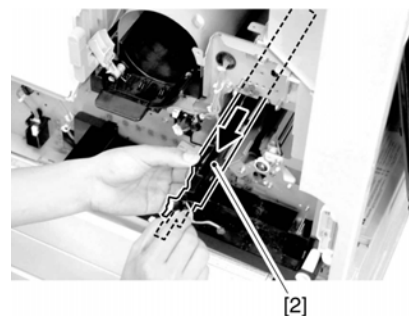

F-5-223

5.12.10.9 Removing the Left Cover

1) Remove the 4 screws [1], and detach the left cover [2].

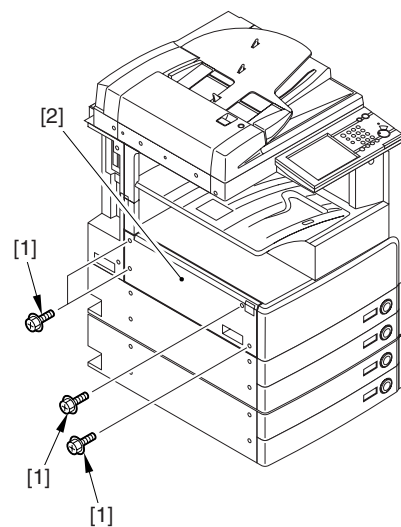

F-5-224

5.12.10.10 Removing the Laser Unit

1) Open the 2 wire saddles [1], and disconnect the 2 connectors [2].

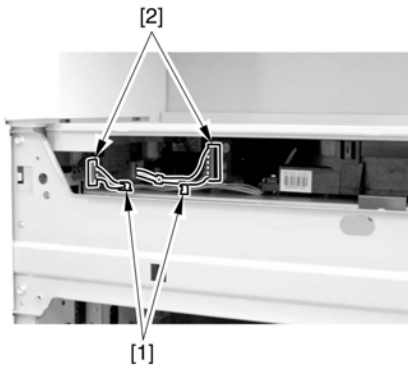

F-5-225



When you have disconnected the connector [1], be sure to take care so that it will not come into contact with the PCB that is mounted to the laser scanner unit. (The PCB is equipped with a laser intensity adjustment variable resistor. Contact with the PCB can change the adjustment setting.)

2) Open the wire saddle [1], and disconnect the connector [2].

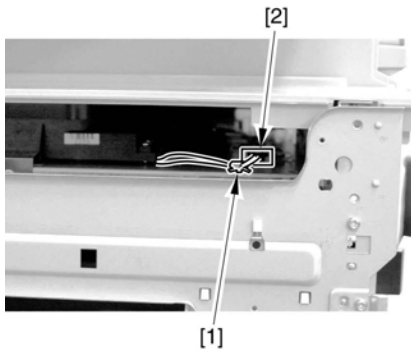

F-5-226

3) Remove the screw [1], and detach the fixing [2].

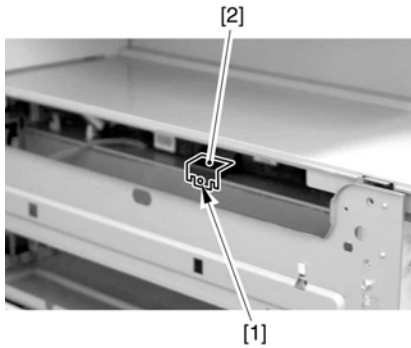

F-5-227

4) Lift the front of the laser unit [1], and slide it to the front.

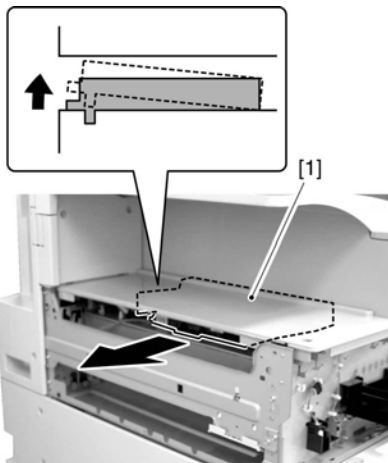

F-5-228



When sliding out the laser scanner unit, be sure to take care not to touch the PCB mounted to the laser scanner unit. (The PCB is equipped with a laser scanner intensity adjustment variable resistor, and contact with the PCB can change the adjustment setting.)

5.12.10.11 Removing the Hopper Assembly

1) Remove the inside base cover [1] and the inside right color [2].

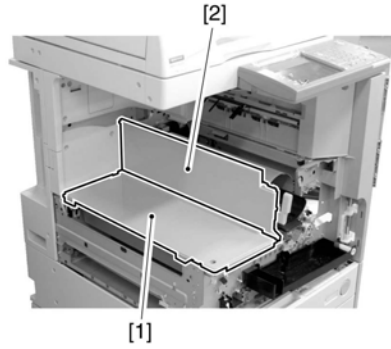

F-5-229

2) Disconnect the 3 connectors [1] found at the front and the connector [2] found at the rear.

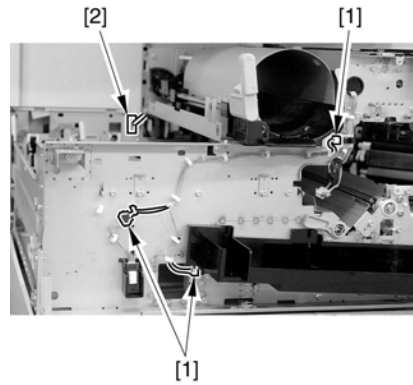

F-5-230

3) Open the 11 wire saddles [1], and pull out the harness [3] through the hole [2] in the plate.

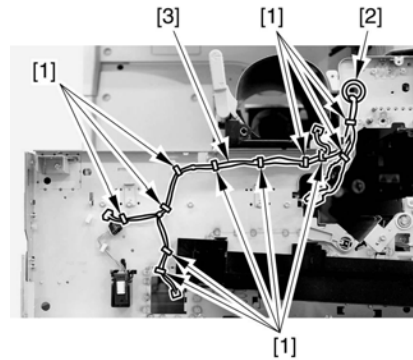

F-5-231

4) Remove the 3 screws [1], and detach the hopper assembly [2].

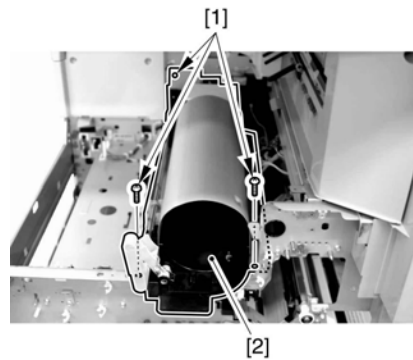

F-5-232



When fitting the hopper assembly to the machine, be sure that the connectors [1] are securely connected. If the connectors [1] are not connected, the environment heater will not be supplied with power, leading to image faults.

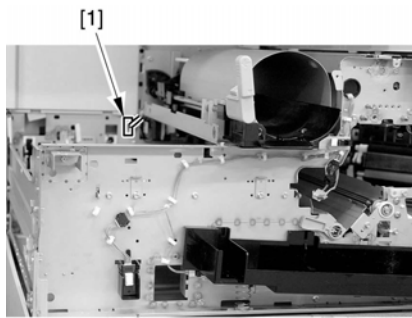

F-5-233

5.12.10.12 Removing the Toner Feedscrew Motor

1) Disconnect the connector [1].

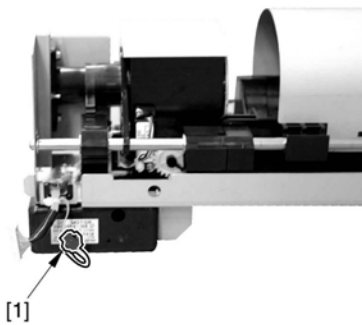

F-5-234

2) Remove the screw [1], and detach the toner feedscrew motor assembly [2].

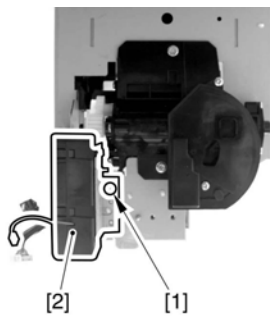

F-5-235

3) Remove the screw [1], and detach the toner feedscrew motor [3] from the base.

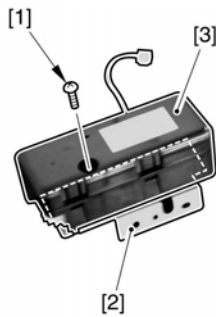

F-5-236

5.12.11 Static Charge Eliminator

5.12.11.1 Removing the Static Eliminator

1) Open the right door [1].



F-5-237

2) Remove the screw [1].

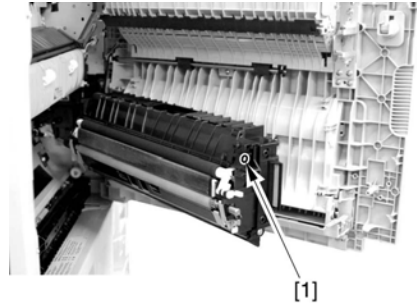

F-5-238

3) Detach the static eliminator [1] to the front.

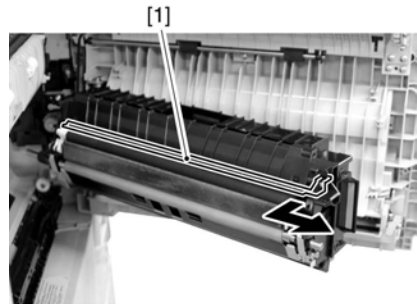

F-5-239

Chapter 6 Pickup/Feeding System

Contents

6.1 Construction	6-1
6.1.1 Specifications, Controls, and Functions	6-1
6.1.2 Division into Blocks	6-2
6.1.3 Arrangement of Rollers	6-3
6.1.4 Diagram of Paper Paths (printer on its own)	6-4
6.1.5 Diagram of Paper Paths (w/ 3 Way Unit-A1 /copy tray)	6-4
6.1.6 Diagram of Paper Paths (w/ Finisher-S1/copy tray)	6-5
6.1.7 Diagram of Paper Paths (w/ Finisher-Q3/Saddle Finisher-Q4)	6-6
6.1.8 Arrangement of Sensors	6-6
6.1.9 Route of Drive	6-7
6.2 Basic Sequence	6-7
6.2.1 Basic Sequence	6-7
6.2.2 Increase in Speed	6-8
6.3 Detecting Jams	6-10
6.3.1 Delay Jams	6-10
6.3.1.1 Delay Jam Outside the Cassette Pickup Assembly	6-10
6.3.1.2 Delay Jam in the Cassette Pickup Assembly	6-10
6.3.2 Stationary Jams	6-11
6.3.2.1 Common Stationary Jam	6-11
6.3.2.2 Stationary Jam at Power-On	6-11
6.3.3 Other Jams	6-11
6.3.3.1 Door Open Jam	6-11
6.4 Cassette Pick-Up Unit	6-11
6.4.1 Overview	6-11
6.4.2 Basic Sequence	6-12
6.4.3 Identifying the Paper Size	6-12
6.4.4 Setting Up the Universal Cassette	6-14
6.4.5 Paper Level Sensor	6-14
6.5 Manual Feed Pickup Unit	6-16
6.5.1 Overview	6-16
6.5.2 Basic Sequence of Operation	6-17
6.5.3 Identifying the Paper Size	6-17
6.5.4 Paper Retaining Mechanism	6-18
6.6 Registration Unit	6-19
6.6.1 Overview	6-19
6.6.2 Checking Horizontal Registration	6-20
6.7 Duplex Feeding Unit	6-20
6.7.1 Overview	6-20
6.7.2 Sequence of Image Formation	6-22
6.7.3 Flow of Paper (w/o/ delivery option)	6-22
6.7.4 Flow of Paper (w/ delivery option)	6-27
6.8 Parts Replacement Procedure	6-32
6.8.1 Pick-up Unit 1	6-32
6.8.1.1 Removing the Right Cover (rear)	6-32
6.8.1.2 Removing the Right Door	6-32
6.8.1.3 Removing the Right Cover (lower front)	6-33
6.8.2 Pick-up Unit 2	6-33
6.8.2.1 Removing the Right Cover (rear)	6-33
6.8.2.2 Removing the Right Cover (lower front)	6-33
6.8.3 Pickup Roller	6-33
6.8.3.1 Removing the Pickup Roller/Feed Roller/Separation Roller	6-33

6.8.4 Sensor Mount	6-34
6.8.4.1 Removing the Right Cover (rear)	6-34
6.8.4.2 Removing the Right Door	6-34
6.8.4.3 Removing the Right Cover (lower front)	6-35
6.8.4.4 Removing the Sensor Mounting Plate	6-35
6.8.4.5 Mounting the Sensor Mounting Plate	6-35
6.8.5 Cassette Pick-up Motor 1	6-36
6.8.5.1 Removing the Rear Cover	6-36
6.8.5.2 Removing the Right Cover (rear)	6-36
6.8.5.3 Removing the Pickup Motor Base	6-36
6.8.5.4 Removing the Cassette Pickup Motor 1	6-36
6.8.6 Cassette Pick-up Motor 2	6-37
6.8.6.1 Removing the Rear Cover	6-37
6.8.6.2 Removing the Right Cover (rear)	6-37
6.8.6.3 Removing the Pickup Motor Base	6-37
6.8.6.4 Removing the Cassette Pickup Motor 2	6-38
6.8.7 Cassette Size Sensor	6-38
6.8.7.1 Removing the Right Cover (rear)	6-38
6.8.7.2 Removing the Right Door	6-38
6.8.7.3 Removing the Right Cover (lower front)	6-39
6.8.7.4 Removing the Cassette Size Sensor	6-39
6.8.8 Cassette Retry Paper Sensor	6-40
6.8.8.1 Removing the Right Cover (rear)	6-40
6.8.8.2 Removing the Right Door	6-40
6.8.8.3 Removing the Right Cover (lower front)	6-41
6.8.8.4 Removing the Sensor Mounting Plate	6-41
6.8.8.5 Removing the Cassette Retry Paper Sensor	6-41
6.8.9 Cassette Paper Sensor	6-42
6.8.9.1 Removing the Right Cover (rear)	6-42
6.8.9.2 Removing the Right Door	6-42
6.8.9.3 Removing the Right Cover (lower front)	6-43
6.8.9.4 Removing the Sensor Mounting Plate	6-43
6.8.9.5 Removing the Cassette Paper Sensor	6-43
6.8.10 Cassette Paper Level Sensor (A/B)	6-43
6.8.10.1 Removing the Right Cover (rear)	6-43
6.8.10.2 Removing the Right Door	6-43
6.8.10.3 Removing the Right Cover (lower front)	6-44
6.8.10.4 Removing the Sensor Mounting Plate	6-44
6.8.10.5 Removing the Cassette Paper Level Sensor (A/B)	6-45
6.8.11 Slide Resistor	6-45
6.8.11.1 Removing the Right Cover (rear)	6-45
6.8.11.2 Removing the Right Door	6-45
6.8.11.3 Removing the Manual Feed Unit	6-46
6.8.11.4 Removing the Manual Tray Unit	6-47
6.8.11.5 Removing the Slide Resistor	6-47
6.8.12 Cassette Pickup Solenoid	6-47
6.8.12.1 Removing the Right Cover (rear)	6-47
6.8.12.2 Removing the Right Door	6-48
6.8.12.3 Removing the Right Cover (lower front)	6-48
6.8.12.4 Removing the Cassette Pickup Solenoid	6-49
6.8.13 Cassette Size Sensor Relay PCB	6-49
6.8.13.1 Removing the Right Cover (rear)	6-49
6.8.13.2 Removing the Right Door	6-49
6.8.13.3 Removing the Right Cover (lower front)	6-50
6.8.13.4 Removing the Cassette Size Sensor Relay PCB	6-50
6.8.14 Manual Tray Assembly	6-50
6.8.14.1 Removing the Right Cover (rear)	6-50
6.8.14.2 Removing the Right Door	6-50
6.8.14.3 Removing the Manual Feed Unit	6-51
6.8.14.4 Removing the Manual Feed Tray Assembly	6-52

6.8.15 Manual Feed Unit	6-52
6.8.15.1 Removing the Right Cover (rear).....	6-52
6.8.15.2 Removing the Right Door	6-52
6.8.15.3 Removing the Manual Feed Unit	6-53
6.8.16 Manual Pickup Roller	6-54
6.8.16.1 Removing the Right Cover (rear).....	6-54
6.8.16.2 Removing the Right Door	6-54
6.8.16.3 Removing the Manual Feed Unit	6-55
6.8.16.4 Removing the Manual Feed Pickup Roller	6-55
6.8.17 Manual Pick-up Clutch	6-56
6.8.17.1 Removing the Right Cover (rear).....	6-56
6.8.17.2 Removing the Right Door	6-56
6.8.17.3 Removing the Rear Cover	6-57
6.8.17.4 Removing the Main Power Switch	6-57
6.8.17.5 Removing the Manual Feed Pickup Clutch	6-57
6.8.18 Manual Separation Pad	6-58
6.8.18.1 Removing the Right Cover (rear).....	6-58
6.8.18.2 Removing the Right Door	6-58
6.8.18.3 Removing the Manual Feed Unit	6-58
6.8.18.4 Removing the Manual Feed Pickup Roller	6-59
6.8.18.5 Removing the Manual Feed Separation pad	6-59
6.8.19 Registration Clutch	6-60
6.8.19.1 Removing the Rear Cover	6-60
6.8.19.2 Removing the Main Drive Assembly	6-60
6.8.19.3 Removing the Registration Clutch	6-60
6.8.20 Feeding Roller	6-60
6.8.20.1 Removing the Pickup Roller/Feed Roller/Separation Roller	6-60
6.8.21 Vertical Path Roller	6-61
6.8.21.1 Removing the Right Cover (rear).....	6-61
6.8.21.2 Removing the Right Door	6-61
6.8.21.3 Removing the Right Cover (lower front).....	6-62
6.8.21.4 Removing the Sensor Mounting Plate	6-62
6.8.21.5 Removing the Vertical Path Roller	6-62
6.8.22 Duplex Feed Roller 2	6-63
6.8.22.1 Removing the Right Cover (rear).....	6-63
6.8.22.2 Removing the Right Door	6-63
6.8.22.3 Removing the Duplex Feed Roller 2	6-64
6.8.23 Duplex Feed Sensor	6-64
6.8.23.1 Removing the Right Cover (rear).....	6-64
6.8.23.2 Removing the Right Door	6-64
6.8.24 Delivery Assembly 1	6-65
6.8.24.1 Removing the Right Cover (rear).....	6-65
6.8.24.2 Removing the Front Cover Unit	6-65
6.8.24.3 Removing the Delivery Tray	6-66
6.8.24.4 Removing the Right Door	6-66
6.8.24.5 Removing the Extension Delivery Kit	6-67
6.8.24.6 Removing the Delivery Assembly 1	6-67
6.8.25 Fixing/ Delivery Drive Assembly	6-67
6.8.25.1 Removing the Right Cover (rear).....	6-67
6.8.25.2 Removing the Front Cover Unit	6-68
6.8.25.3 Removing the Delivery Tray	6-68
6.8.25.4 Removing the Right Door	6-68
6.8.25.5 Removing the Delivery Assembly 1	6-69
6.8.25.6 Removing the Fixing Unit	6-69
6.8.25.7 Removing the Fixing/Delivery Drive Assembly	6-70
6.8.26 Separation Roller	6-70
6.8.26.1 Removing the Pickup Roller/Feed Roller/Separation Roller	6-70

6.1 Construction

6.1.1 Specifications, Controls, and Functions

The major specifications, controls, and functions of the pickup/feeding system are as follows:

T-6-1

Item	Description	-
Paper compartment	front loading	
Pickup method	cassette	separation retard
	manual feeder	separation pad
Paper reference	center	
Paper volume	cassette 1/2	550 sheets (80 g/m ²)
	manual feed tray	50 sheets (80 g/m ²)
Paper size	cassette 1	B4, A4, B5, LGL, LTR, EXE, A4R, B5R, LTRR, A5R, STMTR,
	cassette 2	A3, B4, A4, B5, LGL, LTR, EXE, LDR, A4R, B5R, LTRR, A5R, STMTR
	manual feed tray	A3, B4, A4, B5, LDR, LGL, LTR, A4R, B5R, LTRR, A5R, STMTR, EXE, postcard, envelope, free size
Paper weight	cassette 1/2	64 to 80 g/m ² (single-sided)
		64 to 80 g/m ² (auto double-sided)
	manual feed tray	64 to 128 g/m ² (if double-sided, manual feeding only; no auto duplexing)
Paper size switch-over	cassette 1/2	by the user
	manual feed tray	by the user
Duplexing method	through path	
	envelopes: Com10, Monarch, DL, ISO-C5, ISO-B5	
	postcard: A6R non-default, A5R non-default, A4 non-default	
Speed of process	iR2270/2870	137 mm/sec
	iR3570/4570	230mm /sec (nomal mode) 137mm /sec (low speed mode: manual feeding)

Item	Description	-
Delivery accessory	3 Way Unit-A1 (standard with iR4570/3570 model) Inner 2-Way Tray-D1 Copy Tray-J1 Finisher-S1 Buffer Path Unit-E1 Finisher-Q3 Saddle Finisher-Q4 Inner Puncher Kit-Q1/R1/S1/T1 Punch Unit-L1/M1/N1/P1	
Pickup accessory	Cassette Feeding Unit-Y2 Side Paper Deck-Q1 Envelope Cassette Attachment-C1	

6.1.2 Division into Blocks

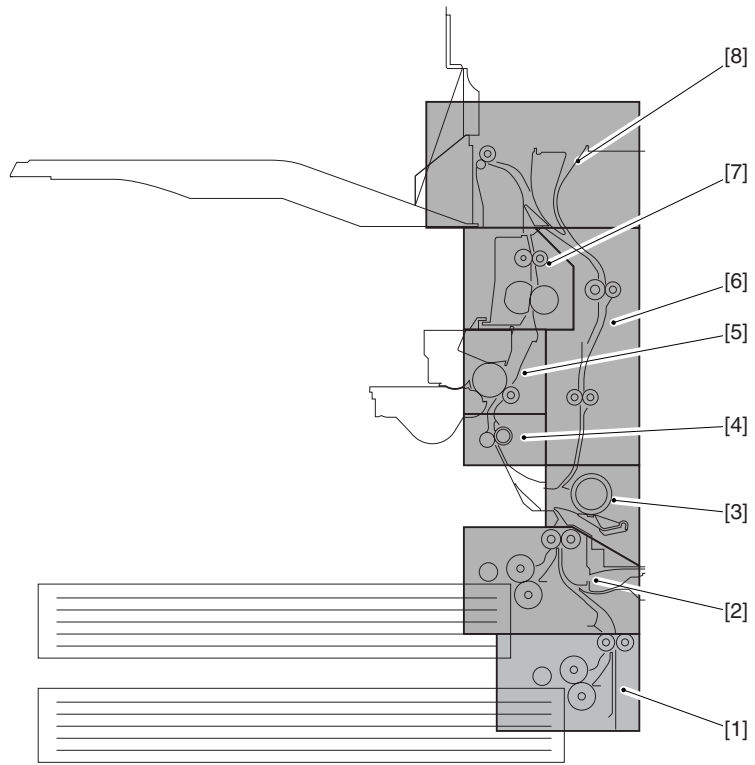

F-6-1

- [1] Pickup assembly (cassette 2)
- [2] Pickup assembly (cassette 1)
- [3] Manual feed pickup assembly
- [4] Registration roller assembly
- [5] Transfer assembly
- [6] Duplexing/feeding assembly
- [7] Fixing assembly
- [8] No.1 delivery assembly

6.1.3 Arrangement of Rollers

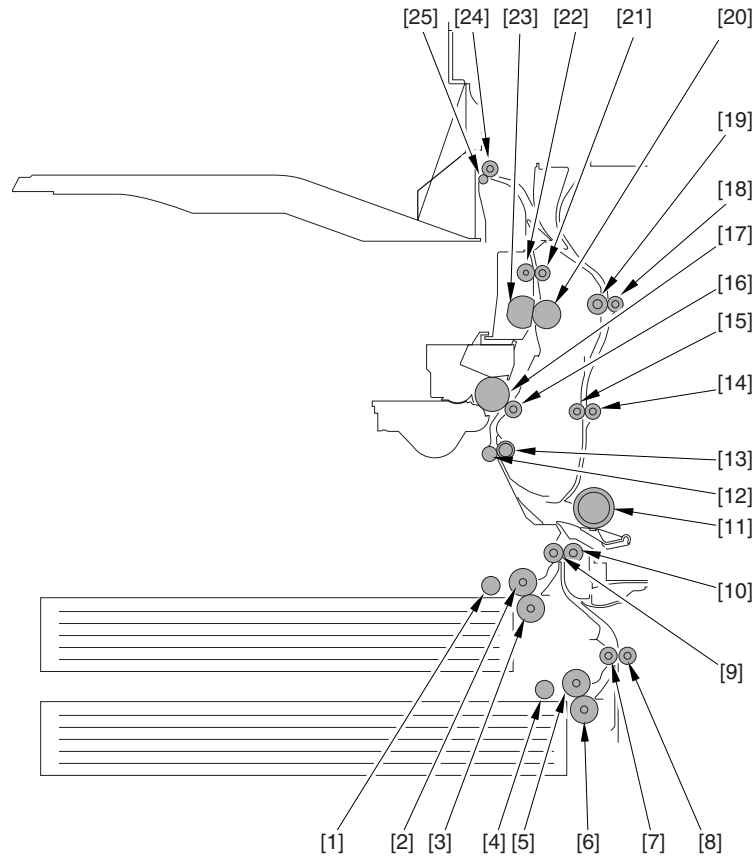

F-6-2

- [1] Pickup roller (cassette 1)
- [2] Feeding roller (cassette 1)
- [3] Separation roller (cassette 1)
- [4] Pickup roller (cassette 2)
- [5] Feeding roller (cassette 2)
- [6] Separation roller (cassette 2)
- [7] Vertical path roller 2
- [8] Vertical path slave roller 2
- [9] Vertical path roller 1
- [10] Vertical path slave roller 1
- [11] Manual feed pickup roller
- [12] Registration roller (inside)
- [13] Registration roller (outside)
- [14] Duplexing/feed roller 2
- [15] Duplexing/feeding member 2
- [16] Transfer roller
- [17] Drum
- [18] Duplexing/feed roller 1
- [19] Duplexing/feeding member 1
- [20] Pressure roller
- [21] Fixing outlet roller
- [22] Fixing outlet member
- [23] Fixing film
- [24] Delivery roller
- [25] Delivery member

6.1.4 Diagram of Paper Paths (printer on its own)

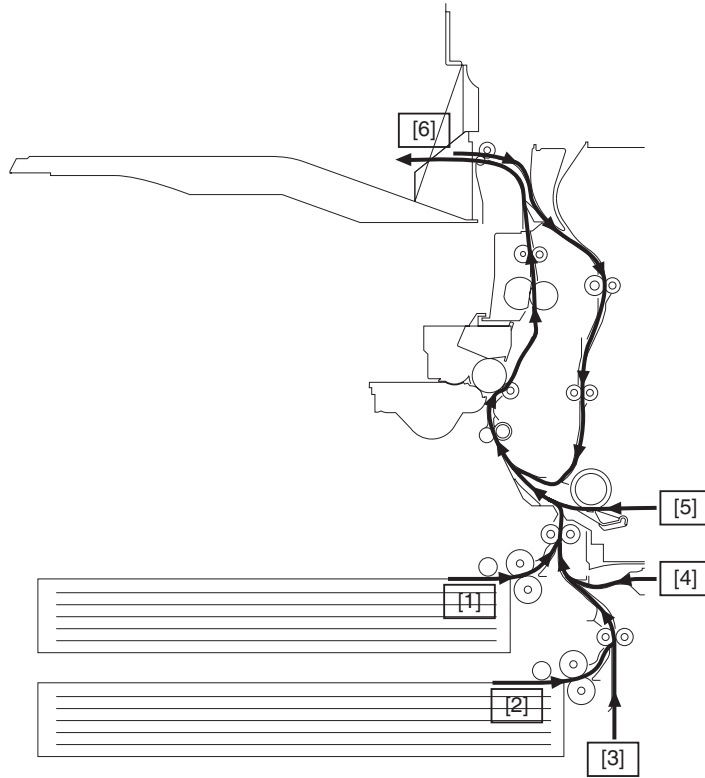

F-6-3

- [1] Pickup from cassette 1
- [2] Pickup from cassette 2
- [3] Pickup from cassette pedestal
- [4] Pickup from side paper deck
- [5] Pickup from manual feeder
- [6] Delivery from copy tray 1

6.1.5 Diagram of Paper Paths (w/ 3 Way Unit-A1 /copy tray)

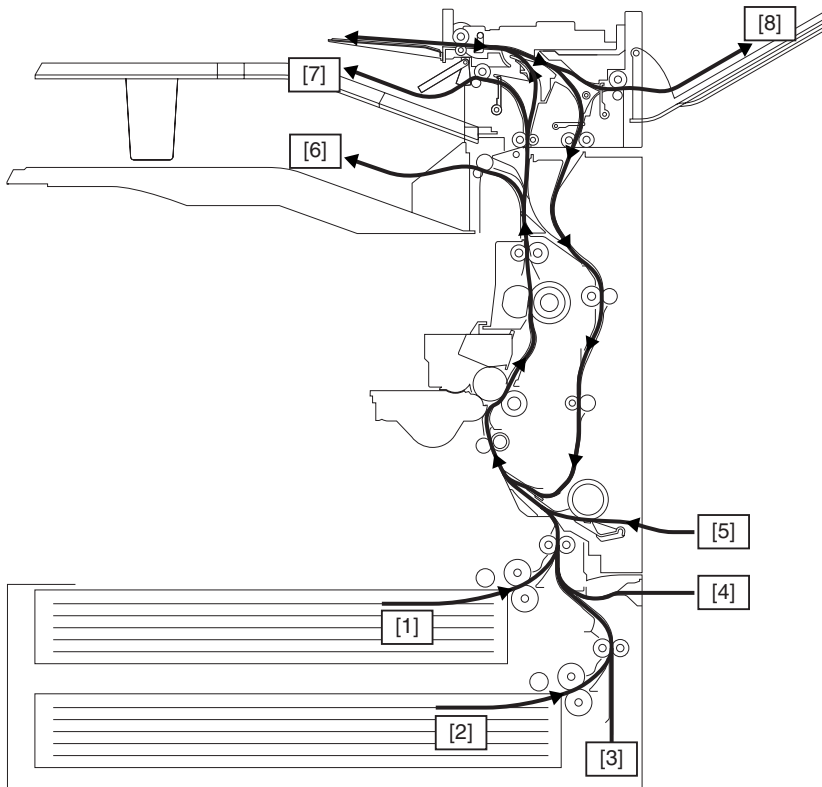

F-6-4

- [1] Pickup from cassette 1

- [2] Pickup from cassette 2
- [3] Pickup from cassette pedestal (option)
- [4] Pickup from side paper deck (option)
- [5] Pickup from manual feeder
- [6] Delivery to copy tray 1
- [7] Delivery to copy tray 2 (option)
- [8] Delivery to copy tray 3 (option)

6.1.6 Diagram of Paper Paths (w/ Finisher-S1/copy tray)

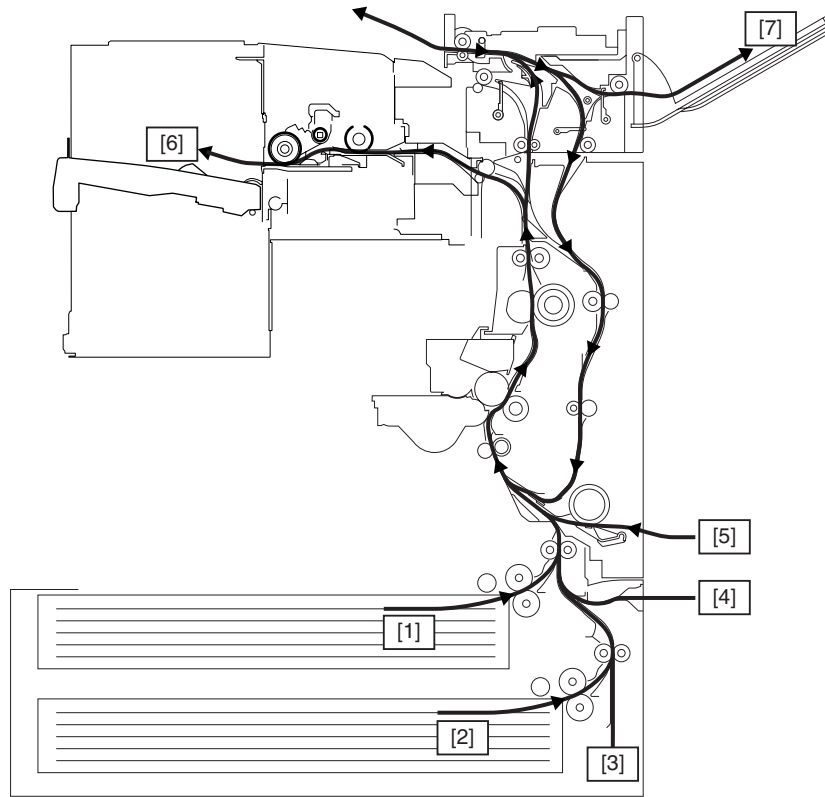

F-6-5

- [1] Pickup from cassette 1
- [2] Pickup from cassette 2
- [3] Pickup from cassette pedestal (option)
- [4] Pickup from paper deck (option)
- [5] Pickup from manual feeder
- [6] Delivery to Finisher-S1 (option)
- [7] Delivery to copy tray 3 (option)

6.1.7 Diagram of Paper Paths (w/ Finisher-Q3/Saddle Finisher-Q4)

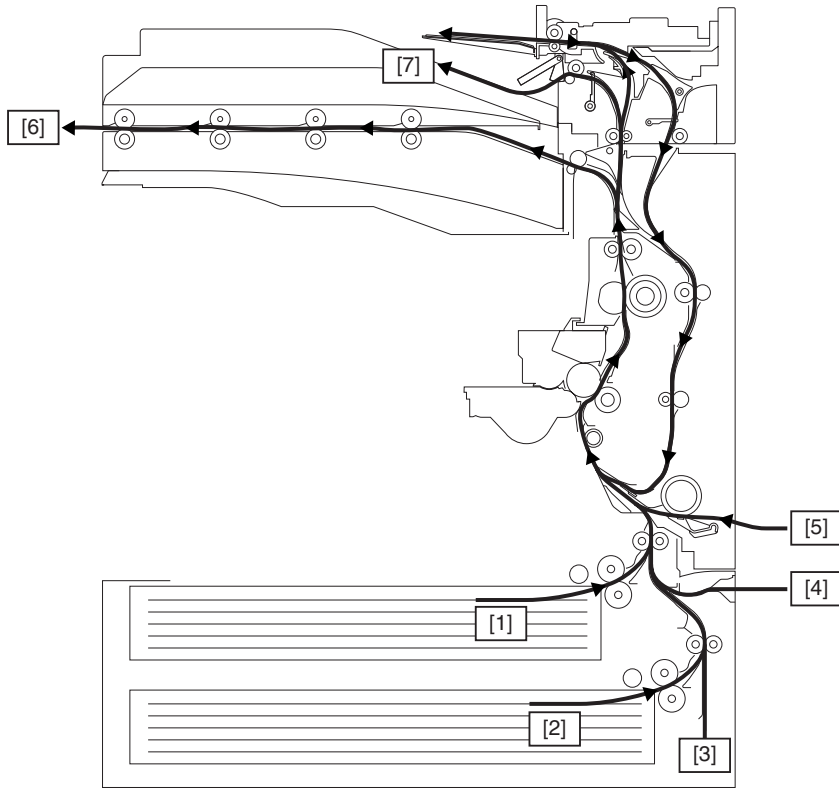

F-6-6

- [1] Pickup from cassette 1
- [2] Pickup from cassette 2
- [3] Pickup from cassette pedestal (option)
- [4] Pickup from paper deck (option)
- [5] Pickup from manual feeder
- [6] Delivery to Finisher-Q3/Saddle Finisher-Q4 (option)
- [7] No.2 delivery assembly (option)

6.1.8 Arrangement of Sensors

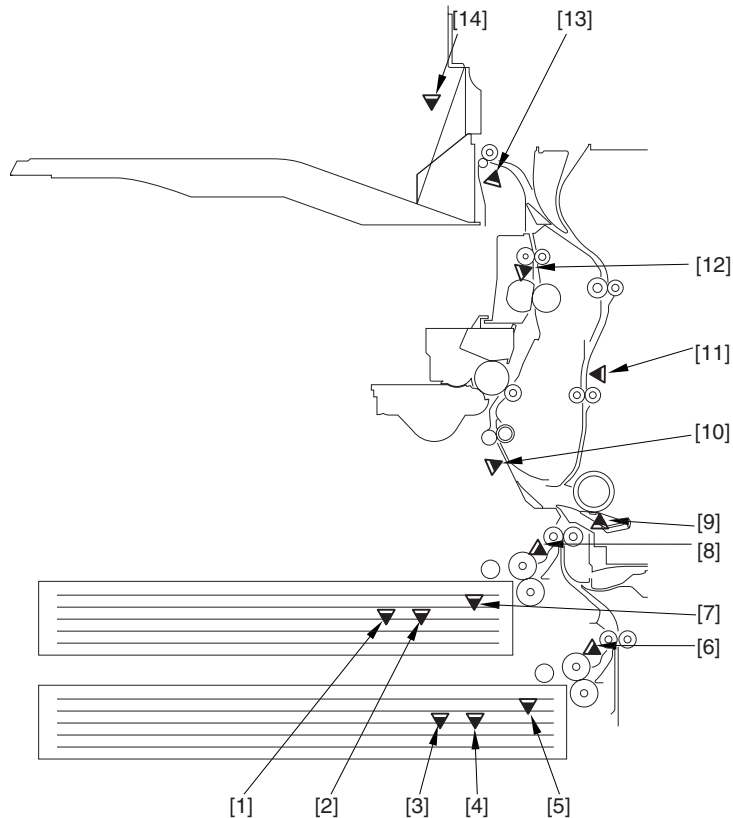

F-6-7

- [1] Cassette 1 paper level sensor B (PS4)
- [2] Cassette 1 paper level sensor A (PS3)
- [3] Cassette 2 paper level sensor B (PS6)
- [4] Cassette 2 paper level sensor A (PS5)
- [5] Cassette 2 paper sensor (PS2)
- [6] Cassette 2 retry sensor (PS11)
- [7] Cassette 1 paper sensor (PS1)
- [8] Cassette 1 retry sensor (PS10)
- [9] Manual feeder paper sensor (PS7)
- [10] Registration sensor (PS9)
- [11] Duplexing/feed sensor (PS17)
- [12] Fixing/delivery paper sensor (PS13)
- [14] Delivery sensor 1 (PS14)
- [15] Delivery paper full sensor 1 (PS15)

6.1.9 Route of Drive

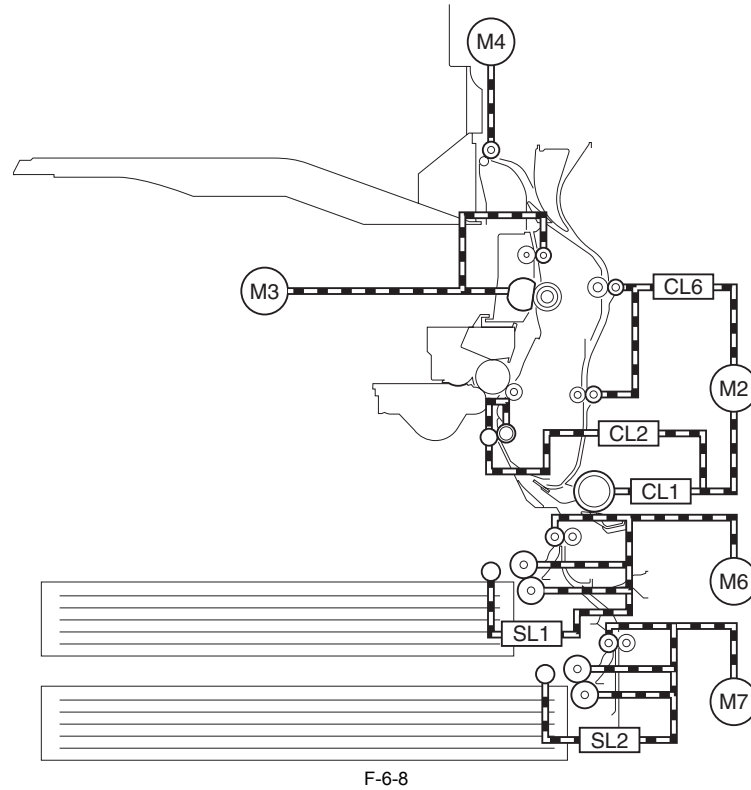

- M2 Main motor
- M3 Fixing motor
- M4 No.1 delivery motor
- M6 Cassette 1 pickup motor
- M7 Cassette 2 pickup motor
- SL1 Cassette 1 pickup solenoid
- SL2 Cassette 2 pickup solenoid
- CL1 Manual pickup clutch
- CL2 Registration clutch
- CL6 Duplexing clutch

6.2 Basic Sequence

6.2.1 Basic Sequence

- Basic Sequence of Operation for Making 3 Prints

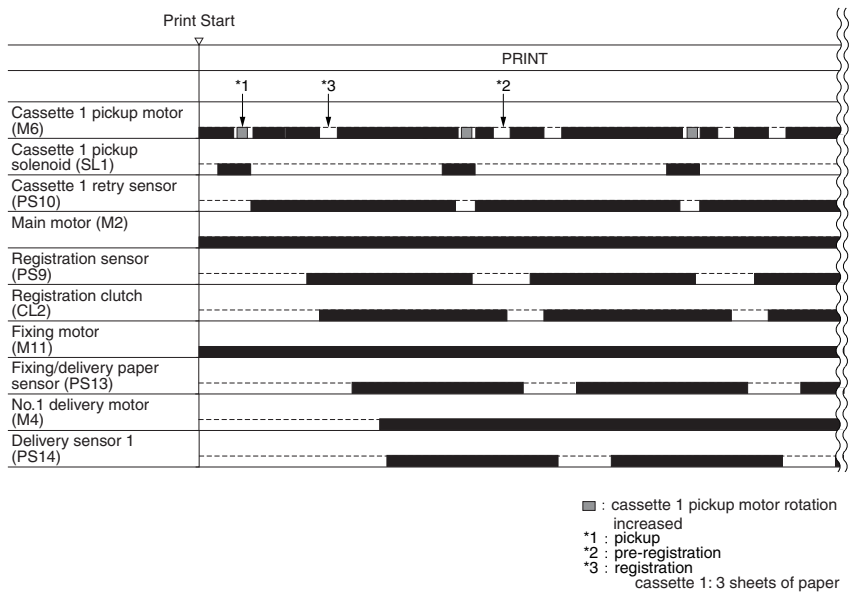

F-6-9

6.2.2 Increase in Speed

The machine increases the speed of moving paper over specific intervals. An overview and the associated accessories for the increase in speed are as follows:

- No Delivery Accessory

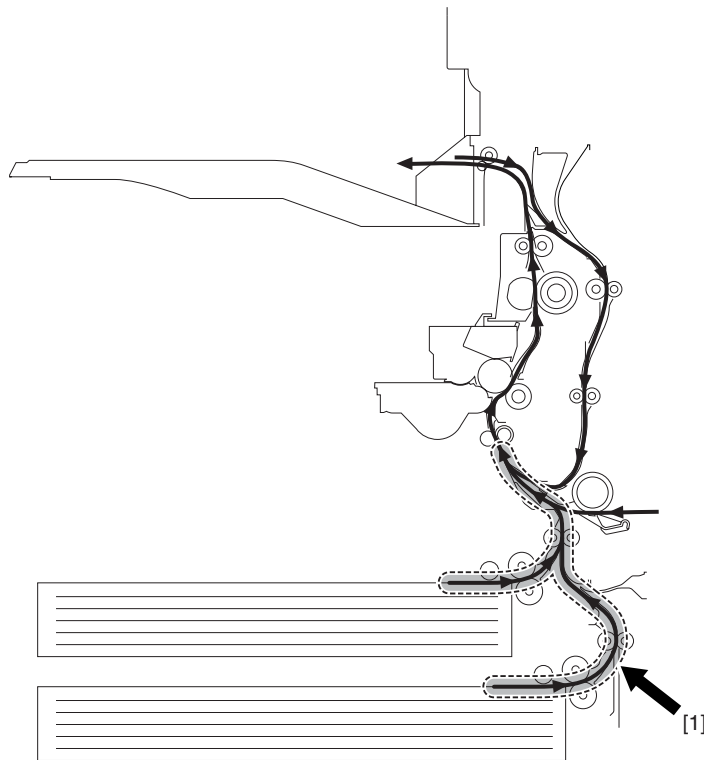

F-6-10

1. Increase in Speed for Pickup Operation

The speed is 1.5 times as high as the process speed (no increase if for manual feed pickup/in the case of the 1st sheet from cassette 1, accelerates to about twice as fast).

- Finisher-S1 in Use

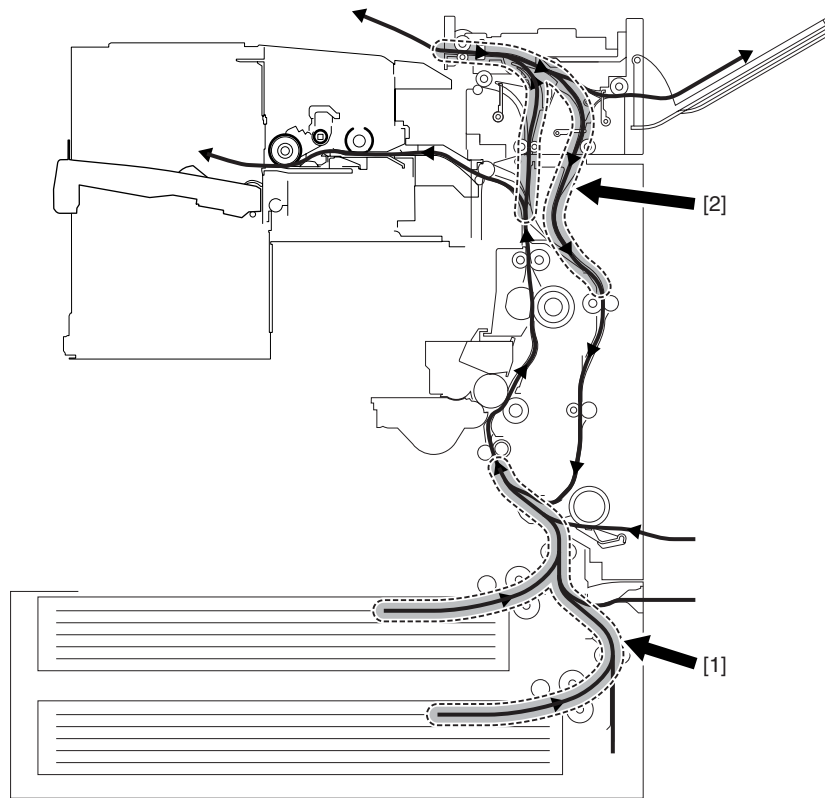

F-6-11

1. Increase in Speed for Pickup Operation

The speed is 1.5 times as high as the process speed (no increase if for manual feed pickup/in the case of the 1st sheet from cassette 1, accelerates to about twice as fast).

2. Increase in Speed for Reversal

The speed is 3.4 times as high as the process speed (no increase if for delivery to tray 3).

- Finisher-Q3/Q4 in Use

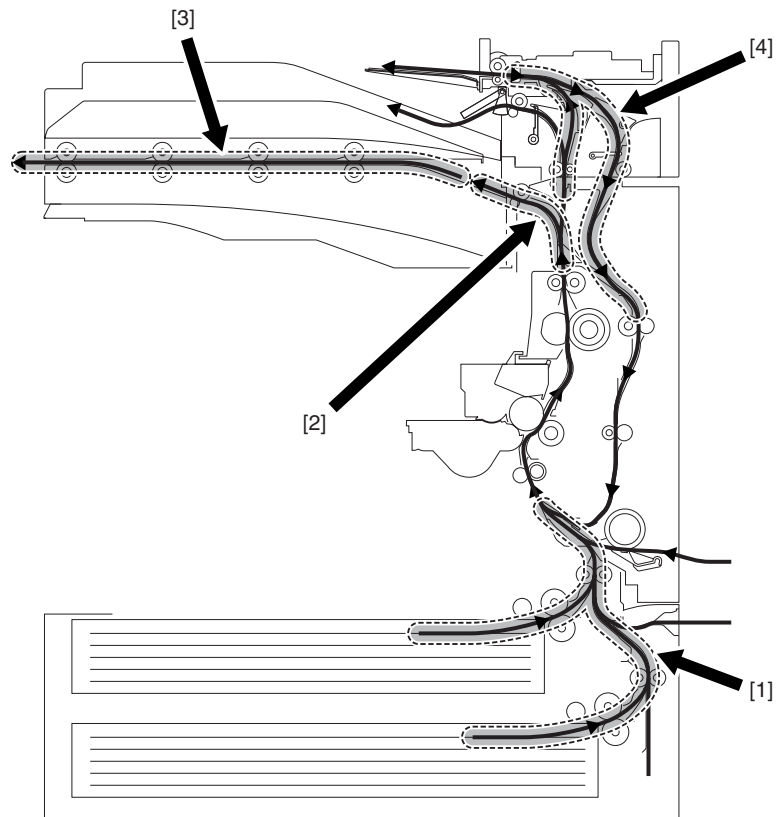

F-6-12

1. Increase in Speed for Pickup Operation

The speed is 1.5 times as high as the process speed (no increase if for manual feed pickup/in the case of the 1st sheet from cassette 1, accelerates to about twice as fast).

2. Increase in Speed After Fixing

The speed is 2.5 times as high as the process speed.

3. Increase in Speed for the Buffer Path

The speed is 2.5 times as high as the process speed (no increase if for delivery to saddle).

4. Increase in Speed for Reversal

The speed is 3.4 times as high as the process speed.

6.3 Detecting Jams

6.3.1 Delay Jams

6.3.1.1 Delay Jam Outside the Cassette Pickup Assembly

A delay jam outside the cassette pickup assembly is identified as follows:

The length of time it takes for paper to move from the sensor N-1 to the delay jam sensor N is kept under control; a delay jam is identified if the delay jam sensor does not go on within a specific length of time after the sensor N has gone on.

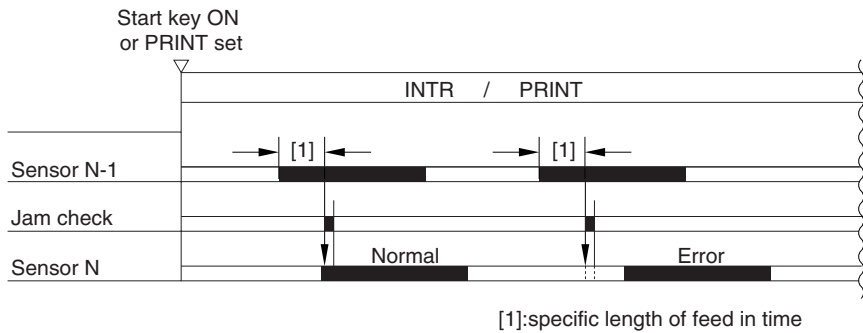

F-6-13
T-6-2

Sensor

- Registration sensor (PS9)
- Fixing delivery sensor (PS13)
- No. 1 delivery sensor (PS14)
- Duplex feed sensor (PS17)

6.3.1.2 Delay Jam in the Cassette Pickup Assembly

The leading edge of paper does not reach the sensor after the cassette 1/2 pickup motor has started to rotate.

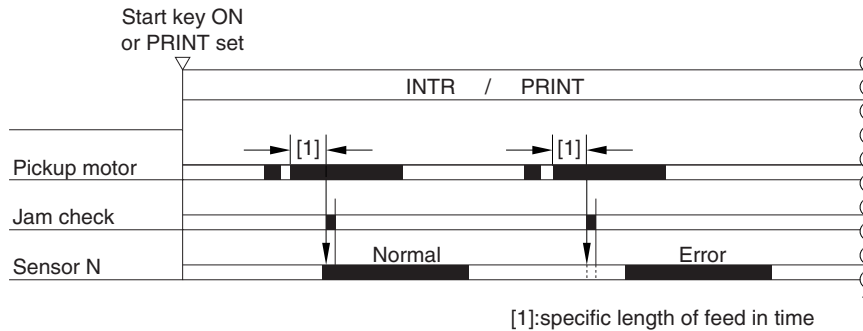

F-6-14
T-6-3

Source of paper	Motor	Sensor
Cassette 1	cassette 1 pickup motor	cassette 1 retry sensor (PS10)
Cassette 2	cassette 2 pickup motor	cassette 2 retry sensor (PS11)

6.3.2 Stationary Jams

6.3.2.1 Common Stationary Jam

The sensor N does not go off within a specific length of time after the sensor has gone on.

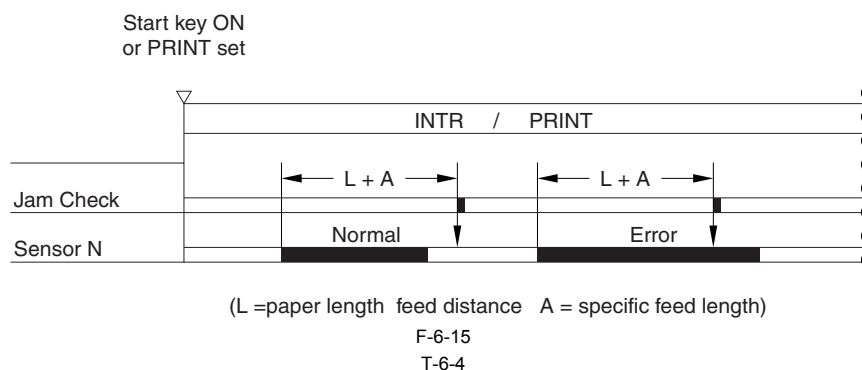

Sensor

Cassette 1 retry sensor (PS10)
Cassette 2 retry sensor (PS11)
Registration sensor (PS9)
Fixing outlet sensor (PS13)
No. 1 delivery sensor (PS14)
Duplex feed sensor (PS17)

6.3.2.2 Stationary Jam at Power-On

The machine makes a check to see that there is no paper over the following sensors before it starts initial multiple rotation at power-on:

T-6-5

Sensor

Cassette 1 retry sensor (PS10)
Cassette 2 retry sensor (PS11)
Registration sensor (PS9)
Fixing outlet sensor (PS13)
No. 1 delivery sensor (PS14)
Duplex feed sensor (PS17)

6.3.3 Other Jams

6.3.3.1 Door Open Jam

A door open jam is identified when the machine detects the opening of the door while it is making copies/prints.

T-6-6

Sensor

Front cover open sensor (PS22)
Right cover open sensor (PS18)

6.4 Cassette Pick-Up Unit

6.4.1 Overview

The paper inside the cassette is held up by the lifter plate. When pickup takes place, the pickup roller moves down to come into contact with the surface of paper. The pickup roller is moved down when the pickup solenoid goes on.

The feed roller and the separation roller serve to make sure that a single sheet of paper is moved to the feed path, and the paper is moved as far as the registration roller by the work of the vertical path roller.

The pickup vertical path roller, pickup roller, feed roller, and separation roller are driven by the cassette pickup motor.

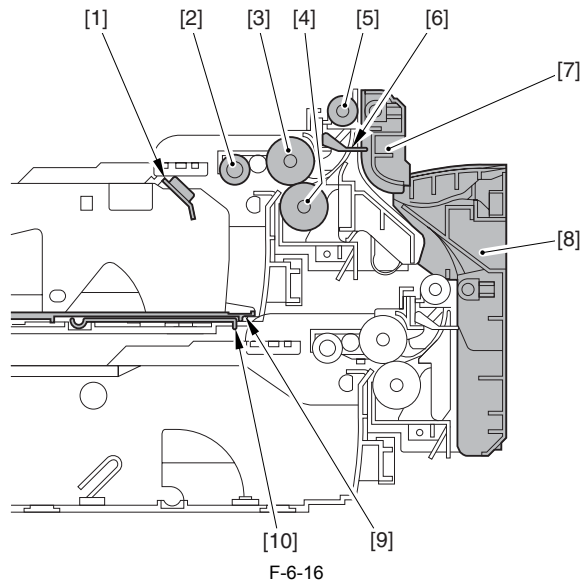

- [1] Cassette paper sensor
- [2] Pickup roller (roller A)
- [3] Feed roller (roller B)
- [4] Separation roller (roller C)
- [5] Pickup vertical path roller
- [6] Cassette retry paper sensor
- [7] Vertical path guide
- [8] Lower right cover
- [9] Holding plate
- [10] Lifter plate

6.4.2 Basic Sequence

- Basic Sequence of Operation for Making 3 Prints

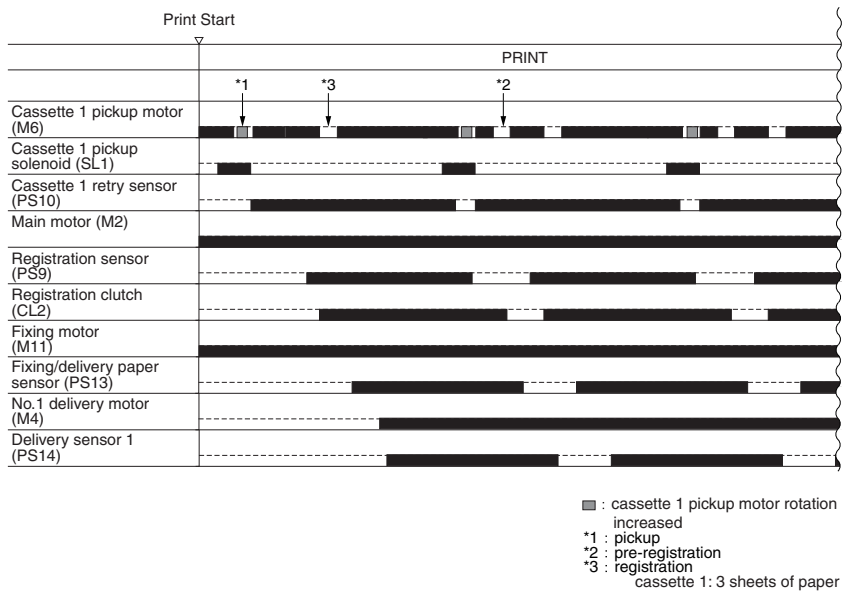

F-6-17

6.4.3 Identifying the Paper Size

The size of paper inside the cassette is detected by the cassette size dial, and is communicated to the cassette size detection PCB. As many as 15 positions may be detected with reference to the combinations of on and off states of the array of 4 actuators mounted to the cassette size detection PCB on the printer side and operating in conjunction with the cassette size dial. In the absence of a cassette, all 4 actuators are off, causing the machine to assume there is no cassette.

AB/Inch Switch

The cassette size dial is equipped with a switch operated to change between AB and Inch configurations; the cassette size detecting switch will detect the configuration as soon as a cassette is fitted in the machine.

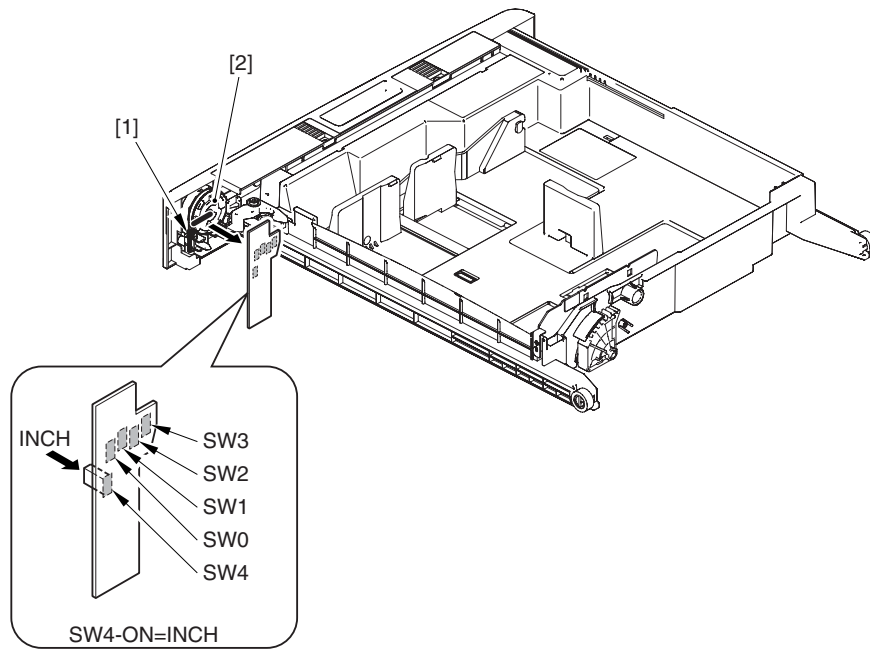

F-6-18

- [1] AB/Inch switch
- [2] Cassette size dial
- [3] Cassette size detection PCB

T-6-7

AB-configuration

Size	SW0	SW1	SW2	SW3	SW4
(no cassette)	OFF	OFF	OFF	OFF	OFF
A5R	ON	OFF	ON	ON	OFF
A4	ON	ON	ON	ON	OFF
A4R	OFF	ON	ON	ON	OFF
A3	OFF	ON	OFF	ON	OFF
B5	ON	ON	OFF	ON	OFF
B5R	OFF	OFF	OFF	ON	OFF
B4	ON	OFF	OFF	ON	OFF
U1	OFF	ON	OFF	OFF	OFF
U2	OFF	ON	ON	OFF	OFF
Envelope	ON	OFF	ON	OFF	ON/OFF

SW4 is used to detect the state of the AB/Inch-configuration switch. The machine will assume the absence of a cassette if it detects a combination not found in the table. At this time, it does not move up the cassette lifter. Since the paper size is not identified, there will be no indication of a paper size on the control panel; when the cassette in question is selected, the machine will indicate a message prompting the supply of paper. If an envelope size is detected, an envelope cassette must be fitted.

T-6-8

Inch-configuration

Size	SW0	SW1	SW2	SW3	SW4
(no cassette)	OFF	OFF	OFF	OFF	OFF
STMTR	ON	OFF	ON	ON	ON

Inch-configuration					
LTR	ON	ON	ON	ON	ON
LTRR	OFF	ON	ON	ON	ON
LGL	OFF	ON	OFF	ON	ON
11X17	ON	ON	OFF	ON	ON
EXEC	OFF	OFF	OFF	ON	ON
U3	OFF	ON	OFF	OFF	ON
U4	OFF	ON	ON	OFF	ON
Envelope	ON	OFF	ON	OFF	ON/OFF

SW4 is used to detect the state of the AB/Inch-configuration switch.

The machine will assume the absence of a cassette if it detects a combination not found in the table. At this time, it does not move up the cassette lifter.

Since the paper size is not identified, there will be no indication of a paper size on the control panel; when the cassette in question is selected, the machine will indicate a message prompting the supply of paper.

If an envelope size is detected, an envelope cassette must be fitted.

6.4.4 Setting Up the Universal Cassette

The following are default sizes the machine will assume when U1 through U4 are detected:

T-6-9

U1	G-LTR
U2	FLSC
U3	G-LGL
U4	A-LTR

The following is a list of sizes that may be assigned in addition to default sizes in service mode:

T-6-10

Universal U1 Through U4

Size
FLSC
OFI
E-OFI
B-OFI
A-OFI
M-OFI
FOLI
A-FLS
G-LTR
G-LGL
A-LTR (LTR)
A-LTRR (LTRR)

6.4.5 Paper Level Sensor

The level of paper inside the cassette is checked using the following sensors:

T-6-11

	Cassette 1	Cassette 2
Paper level sensor A	PS3	PS5
Paper level sensor B	PS4	PS6
Paper sensor	PS1	PS2

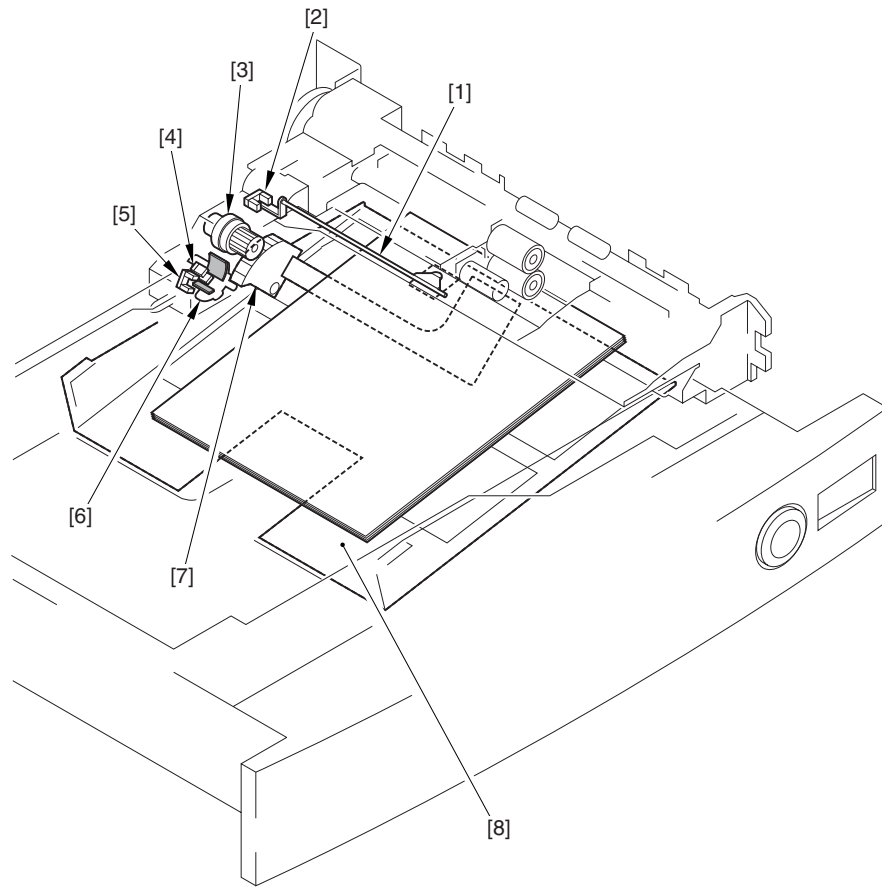

F-6-19

- [1] Flag
- [2] Cassette paper sensor
- [3] Lifter clutch
- [4] Cassette paper level sensor A
- [5] Cassette paper level sensor B
- [6] Paper level sensor flag
- [7] Lifter gear
- [8] Tray

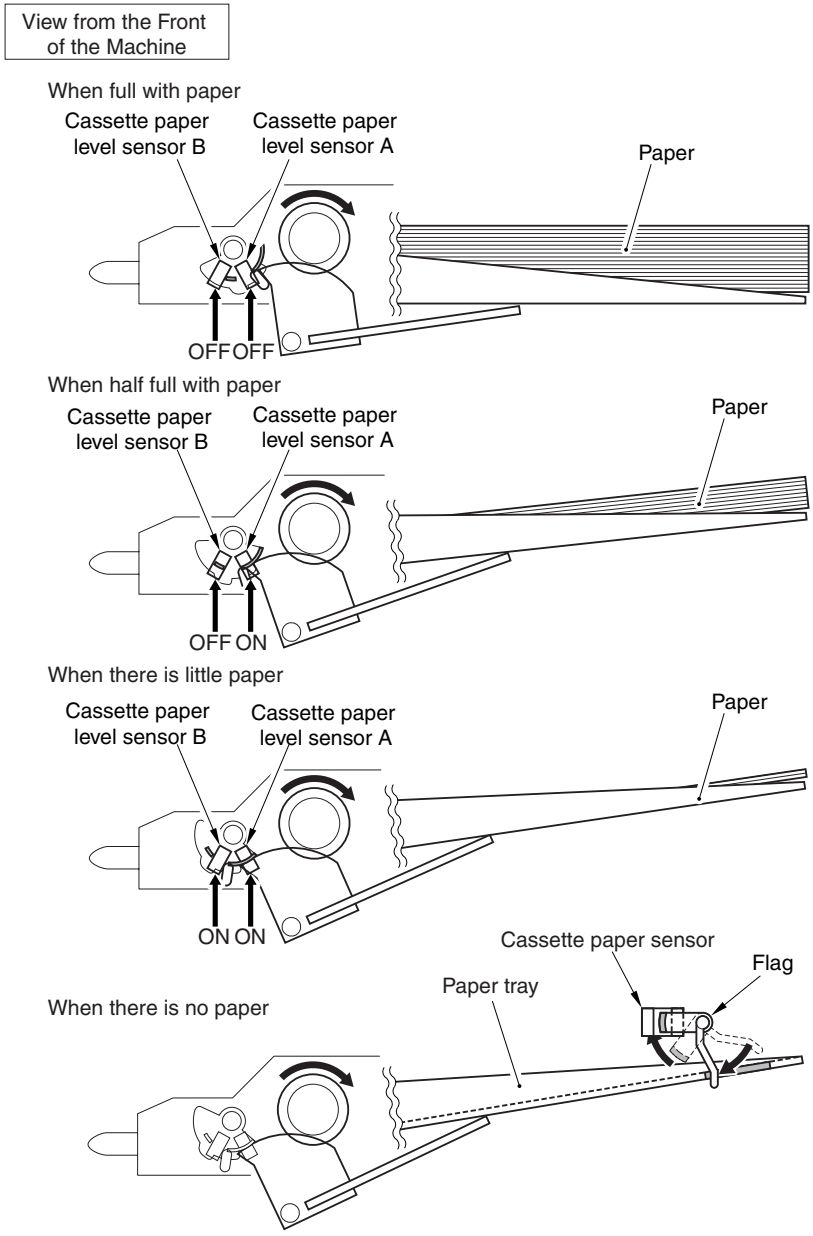

F-6-20

T-6-12

Paper level sensor A	Paper level sensor B	Paper sensor	Paper level	Control panel indication
OFF	OFF	OFF	100% to 50% of capacity	
ON	OFF	OFF	50% to 50 sheets (approx.)	
ON	ON	OFF	50 sheets or less (approx.)	
---	---	ON	No paper	

6.5 Manual Feed Pickup Unit

6.5.1 Overview

The paper in the tray of the manual feed pickup unit is forced against the manual feed pickup roller by the work of the pickup guide plate; the manual feed pickup roller and the separation pad serve to make sure that only a single sheet of paper is separated and moved into the machine:

- (1) the pickup guide plate is locked in place at all times, and does not require drive for pickup operation.
 (2) multi-pickup roller is driven by the main motor (M2) through the manual feed pickup clutch (CL1).

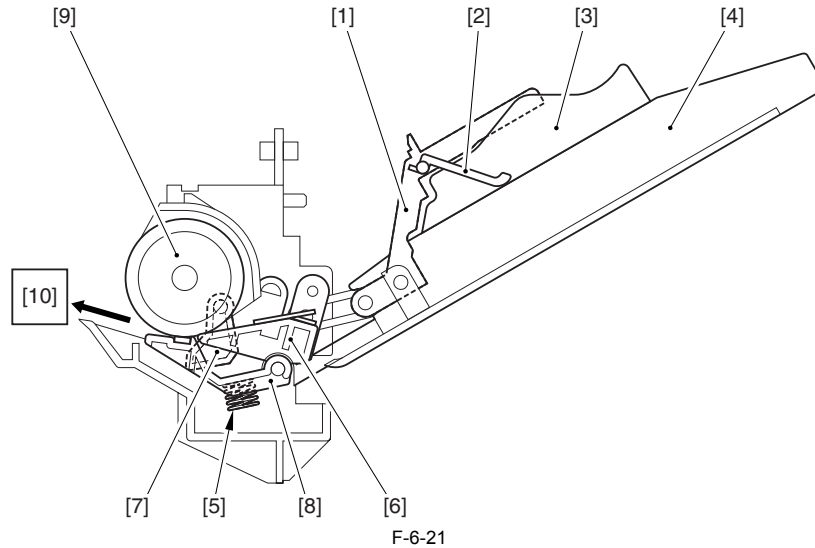

- [1] Upper guide
 [2] Stopper plate
 [3] Side guide
 [4] Manual feed pickup tray
 [5] Pressure spring
 [6] Holding plate
 [7] Manual feed paper sensor flag
 [8] Separation pad
 [9] Manual feed pickup roller
 [10] (to registration roller assembly)

REF

The machine's manual feed pickup unit is not equipped with a sensor that may detect the last sheet of paper.

6.5.2 Basic Sequence of Operation

The multi-pickup roller starts to rotate when the manual pickup clutch (CL1) goes on to start upper separation to pick up a single sheet of paper. When the leading edge of the sheet reaches the registration sensor (PS26) and is moved a specific distance, the manual pickup clutch goes off, causing the sheet to arch in the registration roller area.

When the registration clutch (CL2) goes on, the manual feed pickup clutch (CL1) once again goes on to pick up paper. The manual feed pickup clutch (CL1) goes off immediately before the trailing edge of paper moves past the manual feed pickup roller; thereafter, the registration roller serves to pull off the paper.

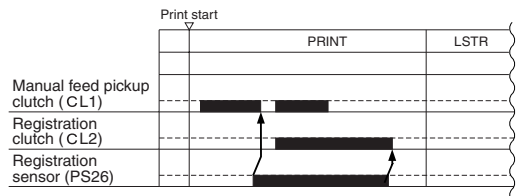

F-6-22

6.5.3 Identifying the Paper Size

The width of paper is detected with reference to the output of the variable resistor (SVR1), which operates in conjunction with the movement of the side guide. The side guide in the manual feed tray is set when the user moves it to place paper in the cassette.

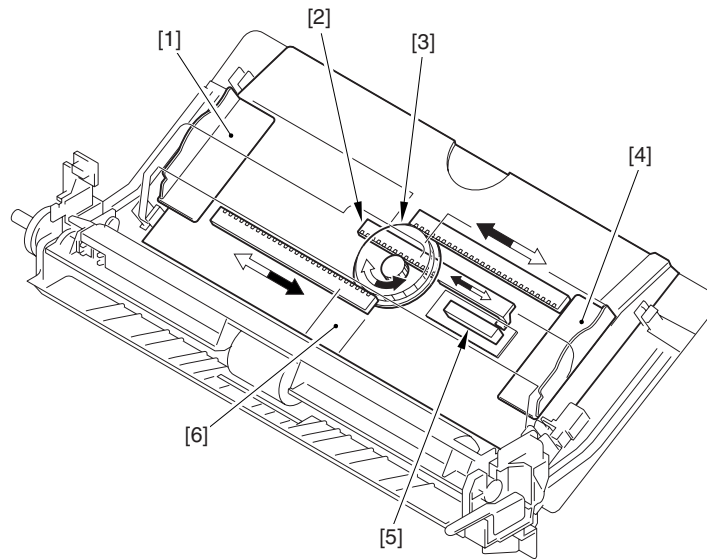

F-6-23

- [1] Side guide (rear)
- [2] Stop arm
- [3] Center gear
- [4] Side guide (front)
- [5] Variable resistor (SVR1)
- [6] Manual feed tray

6.5.4 Paper Retaining Mechanism

The holding plate of the machine's cassette is fixed in position at all times, and does not move up/down at time of pickup, and must temporarily be released when paper is set between it and the manual feed pickup roller. It is linked to the upper guide so that it opens when the user opens the guide; to prevent the user from placing paper without opening the upper guide, the guide is equipped with a stopper plate.

1. When the upper guide is closed, the holding plate is locked in place, and the stopper plate prevents the user from placing paper.

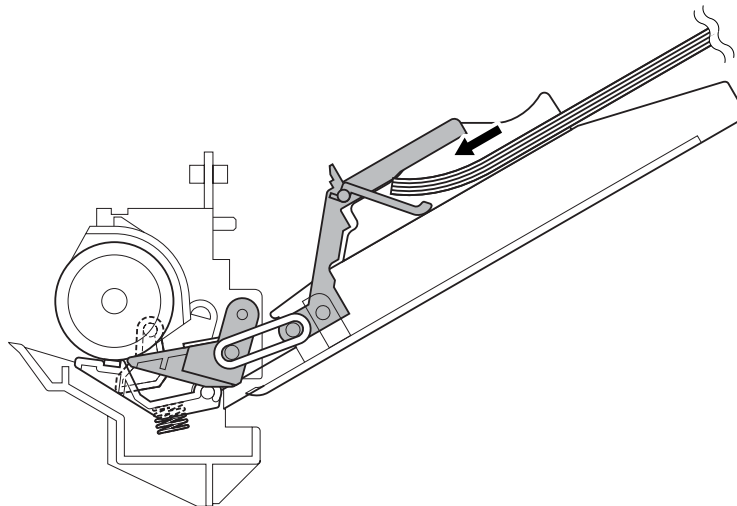

F-6-24

2. When the upper guide is open, the holding plate is freed, and the stopper plate opens, permitting the user to place paper.

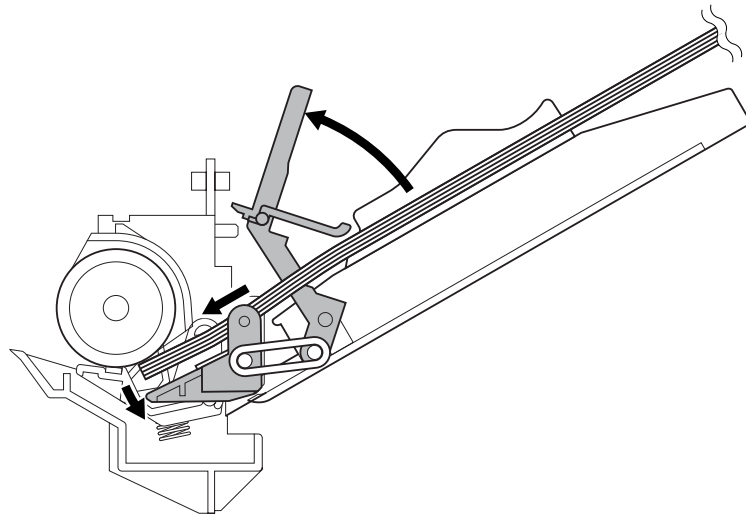

F-6-25

3. When the upper guide is closed once again, the holding plate becomes locked in position once again.

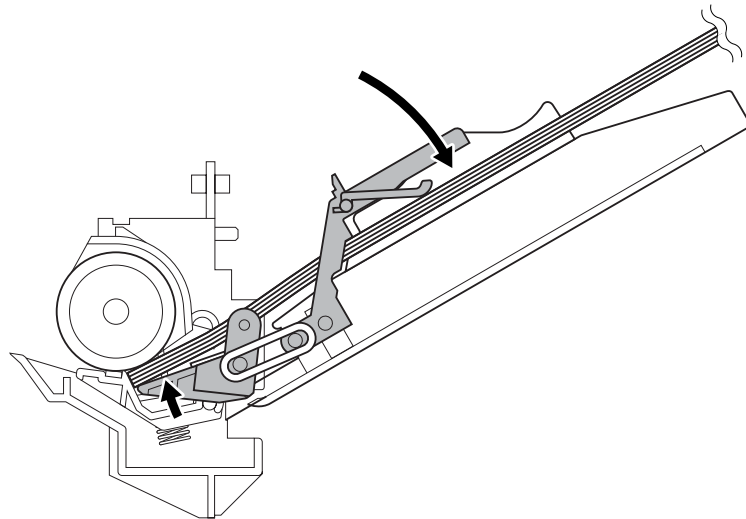

F-6-26

6.6 Registration Unit

6.6.1 Overview

The registration roller is driven by the main motor (M2). In between the registration roller and the main motor is the registration clutch (SL2), servicing to turn on and off the registration roller so that the paper will be matched in relation to the image on the drum at correct registration.

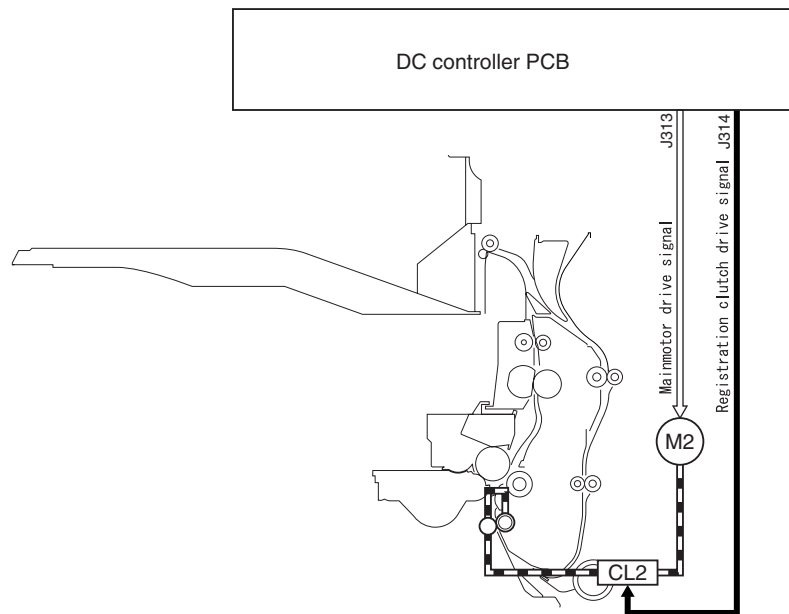

F-6-27

6.6.2 Checking Horizontal Registration

The machine does not have a mechanism to check horizontal registration for both 1st and 2nd sides of a print. The point of horizontal registration for the 2nd side may be adjusted in service mode (i.e., the image write start position).

The degree of arching for registration on the 2nd side of a double-sided print must be adjusted separately from the adjustment for the 1st side to accommodate the fact that different feed paths are used up to the registration roller for 1st and 2nd sides.

Service Mode:

COPIER>ADJUST>FEED-ADJ>ADJ-REFE

Use it to adjust the horizontal registration for the 2nd side of small-size double-sided prints.

COPIER>ADJUST>FEED-ADJ>ADJ-RE-L

Use it to adjust the horizontal registration for the 2nd side of large-size double-sided prints.

COPIER>ADJUST>FEED-ADJ>LOOPREFE

Use it to adjust the degree of arching for the 2nd side of double-sided prints.

Reference:

small-size: A4, B5, and the like, whose side in paper feed direction is shorter than that of LTR.
Large-size: A3, A4R, B5R, and the like, whose side in feed direction is longer than that of LTR.

The term "2nd side of a double-sided print" as used in relation to the machine's service mode refers to the side that receives an image second in order; in other words, it corresponds to the 1st side of the original.

6.7 Duplex Feeding Unit

6.7.1 Overview

Inside the duplexing assembly are found two sets of rollers that are driven by the main motor (M2) and the duplexing clutch (CL6).

Different sets of rollers are used to turn over the sheet for duplexing depending on whether or not the machine is equipped with a delivery accessory*:

If a delivery accessory is present, the reversing rollers are used to turn over the sheet.
If no delivery accessory is present, the delivery rollers are used to turn over the sheet.

*3 Way Unit-A1

Configuration of Components If Without a Delivery Accessory

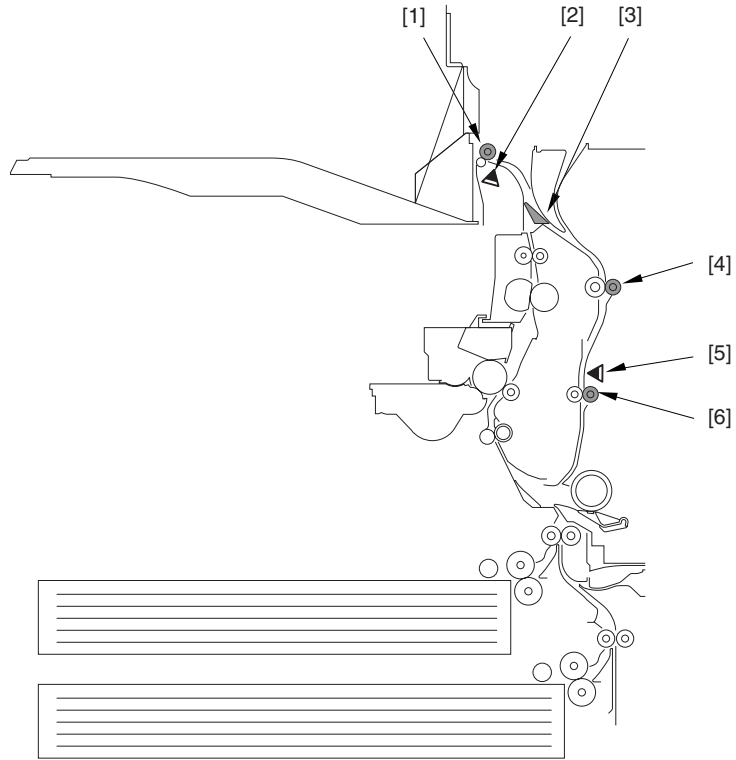

F-6-28

- [1] Delivery roller
- [2] Delivery sensor 1 (PS14)
- [3] Reversing flapper
- [4] Duplexing feeding roller 1
- [5] Duplexing feed sensor (PS17)
- [6] Duplexing feeding roller 1

Configuration of the Components If With a Delivery Accessory

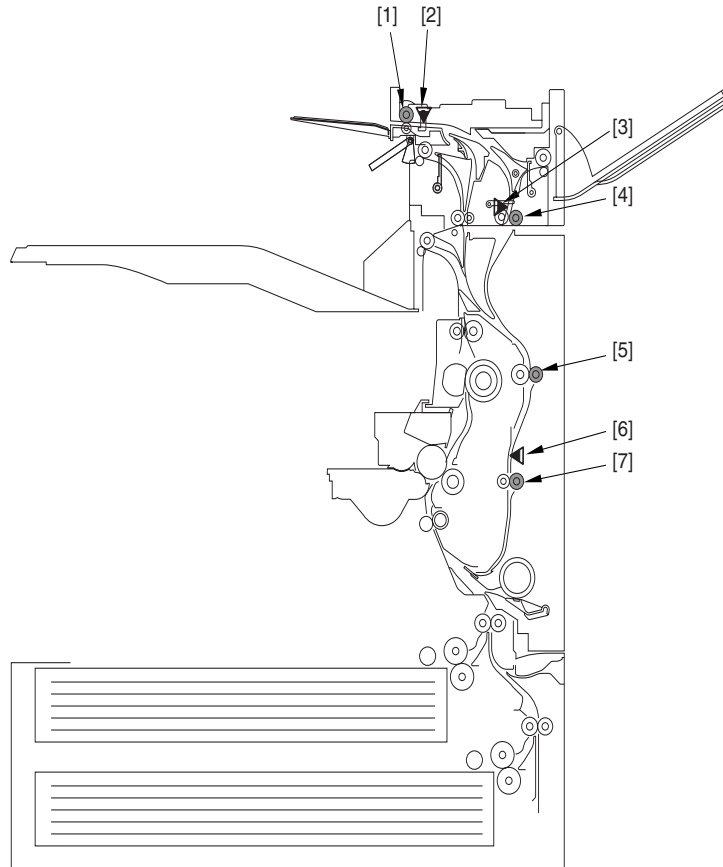

F-6-29

- [1] Reversing roller
- [2] Reversal sensor (PS4A)

- [3] Duplexing inlet sensor (PS3A)
- [4] Duplexing inlet roller
- [5] Duplexing feeding roller 1
- [6] Duplexing feed sensor (PS17)
- [7] Duplexing feeding roller 2

6.7.2 Sequence of Image Formation

The machine goes through the following sequence to form images when making double-sided copies/prints:

- Configuration Without an Accessory Installed

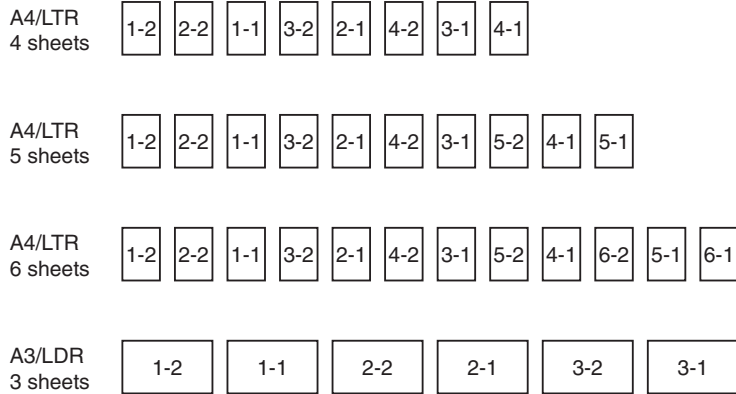

EX: 1-1 : indicates the 1st side of the 1st sheet

1-2 : indicates the 2nd side of the 1st sheet

F-6-30

- Configuration with an Accessory Installed

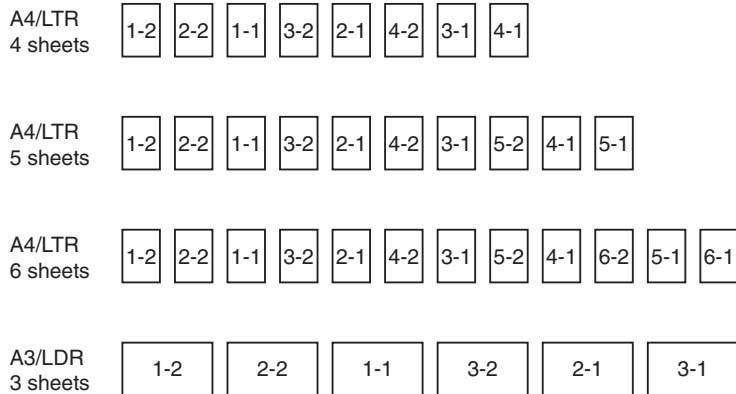

EX: 1-1 : indicates the 1st side of the 1st sheet

1-2 : indicates the 2nd side of the 1st sheet

F-6-31



However, in the case of delivery to tray 3 (outside), the machine uses single-sheet circulation.

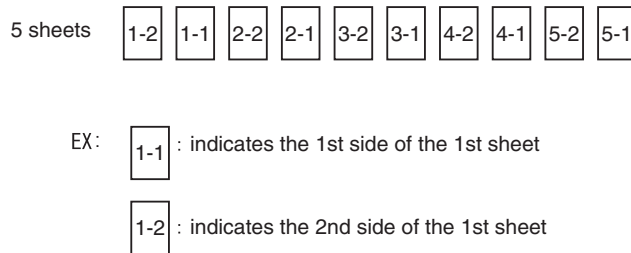

F-6-32

6.7.3 Flow of Paper (w/o delivery option)

A4/LTR, 5 Sheets

A number in a circle indicates the 1st side, while a number in a square indicates the 2nd side.

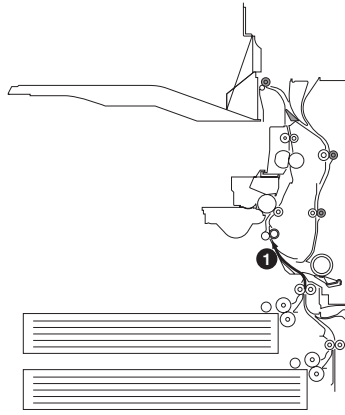

F-6-33

The 1st sheet is picked up.

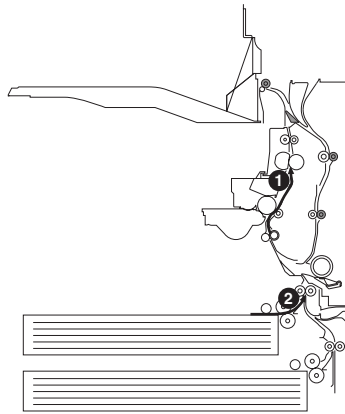

F-6-34

An image is formed for the 2nd side of the 1st sheet. The 2nd sheet is picked up.

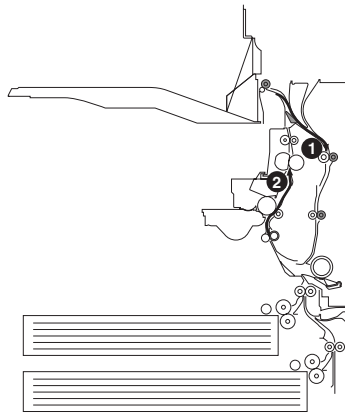

F-6-35

The 1st sheet is turned over and moved to duplexing registration. An image is formed for the 2nd side of the 2nd sheet.

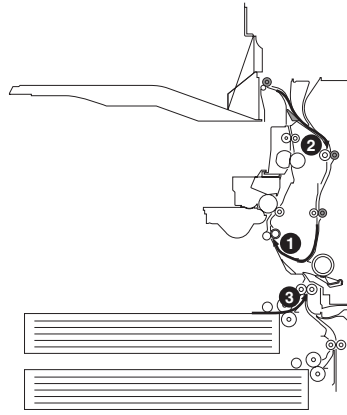

F-6-36

The 1st sheet is moved for registration once again. The 2nd sheet is turned over and moved for duplexing registration. The 3rd sheet is picked up.

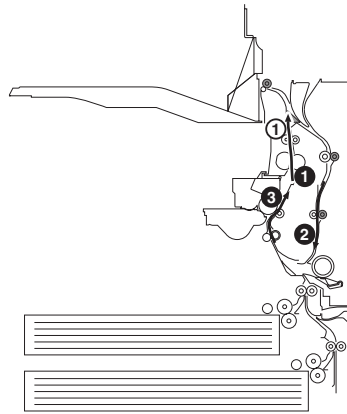

F-6-37

An image is formed for the 1st side of the 1st sheet and for the 2nd side of the 3rd sheet. The 2nd sheet is moved for duplexing.

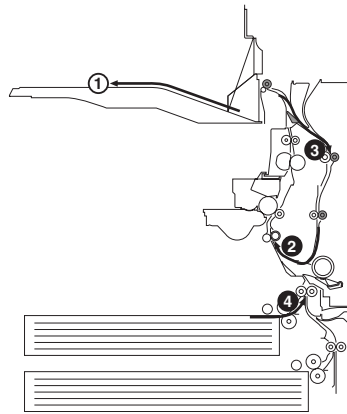

F-6-38

The 1st sheet is delivered. The 3rd sheet is turned over and moved for duplexing registration. The 2nd sheet is moved for registration once again. The 4th sheet is picked up.

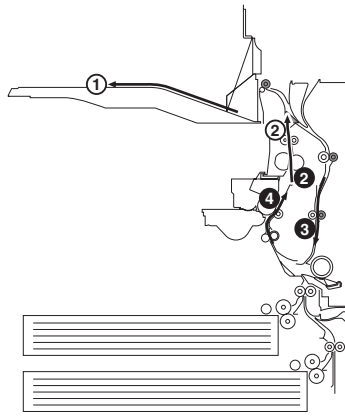

F-6-39

An image is formed for the 1st side of the 2nd sheet and for the 2nd side of the 4th sheet. The 3rd sheet is moved for duplexing.

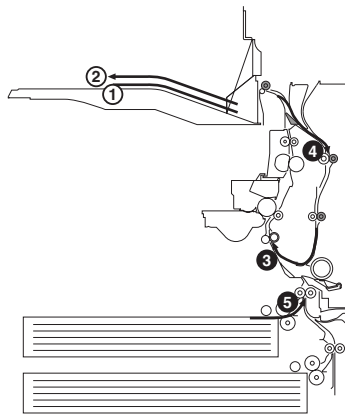

F-6-40

The 2nd sheet is delivered. The 4th sheet is reversed and is moved for duplexing registration. The 3rd sheet is picked for registration once again. The 5th sheet is picked up.

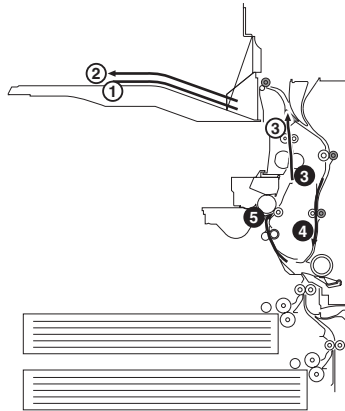

F-6-41

An image is formed for the 1st side of the 3rd sheet and for the 2nd side of the 5th sheet. The 4th sheet is moved for duplexing.

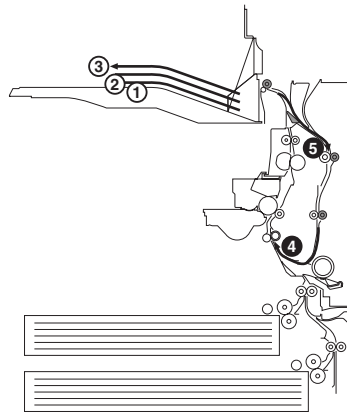

F-6-42

The 3rd sheet is delivered. The 5th sheet is turned over and moved for registration. The 4th sheet is moved for registration once again.

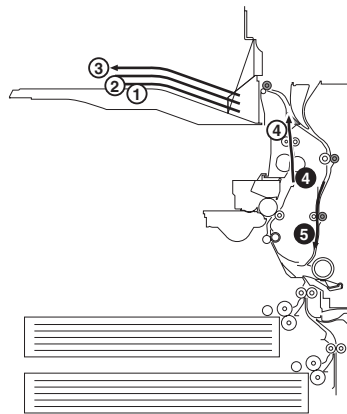

F-6-43

An image is formed for the 1st side of the 4th sheet. The 5th sheet is moved for duplexing.

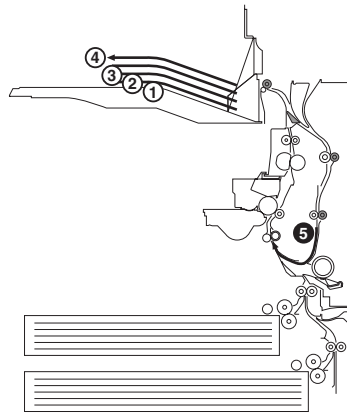

F-6-44

The 4th sheet is delivered. The 5th sheet is moved for registration once again.

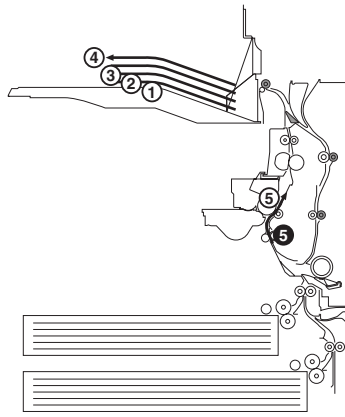

F-6-45

An image is formed for the 1st side of the 5th sheet.

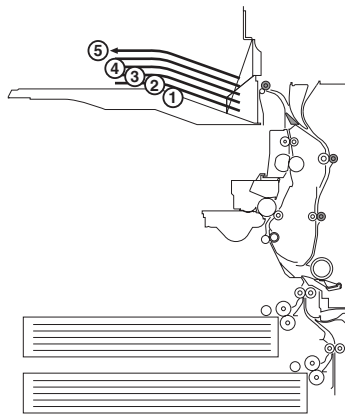

F-6-46

The 5th sheet is delivered.

6.7.4 Flow of Paper (w/ delivery option)

A4/LTR, 5 Sheets, Delivery to Tray 1/2

A number in a circle indicates the 1st side, while a number in a square indicates the 2nd side.

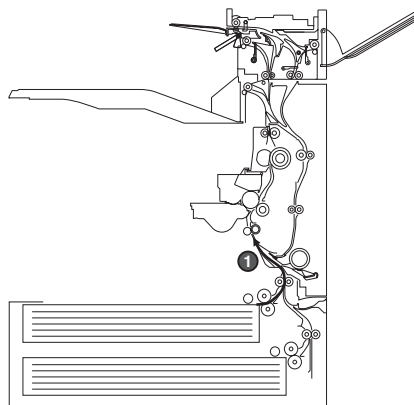

F-6-47

The 1st sheet is picked up.

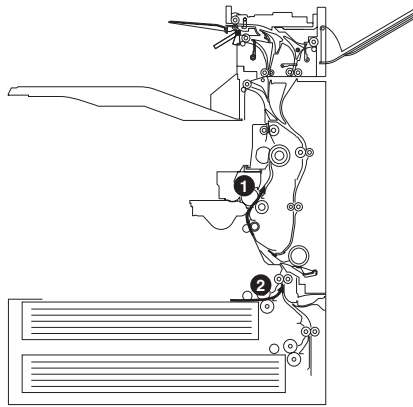

F-6-48

An image is formed for the 2nd side of the 1st sheet. The 2nd sheet is picked up.

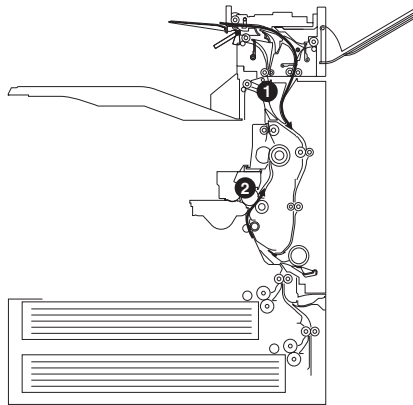

F-6-49

The 1st sheet is turned over, and is moved for duplexing registration. An image is formed for the 2nd side of the 2nd sheet.

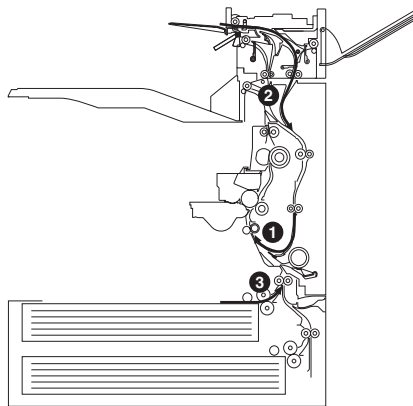

F-6-50

The 1st sheet is moved for registration once again. The 2nd sheet is turned over and moved for duplexing registration. The 3rd sheet is picked up.

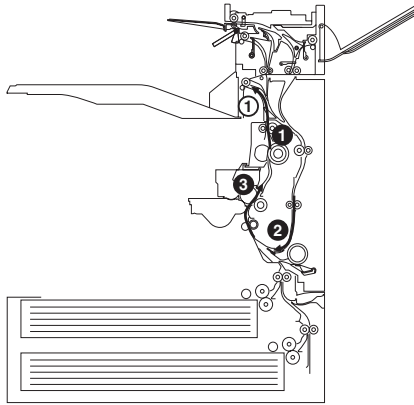

F-6-51

An image is formed for the 1st side of the 1st sheet and the 2nd side of the 3rd sheet. The 2nd sheet is moved for duplexing.

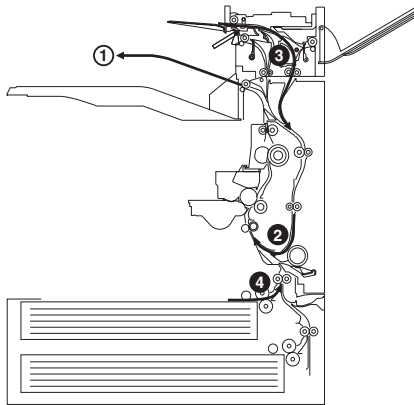

F-6-52

The 1st sheet is delivered. The 3rd sheet is turned over and is moved for duplexing registration. The 2nd sheet is moved for registration once again. The 4th sheet is picked up.

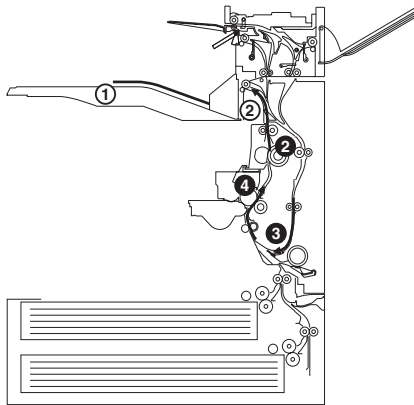

F-6-53

An image is formed for the 1st side of the 2nd sheet and for the 2nd side of the 4th sheet. The 3rd sheet is moved for duplexing.

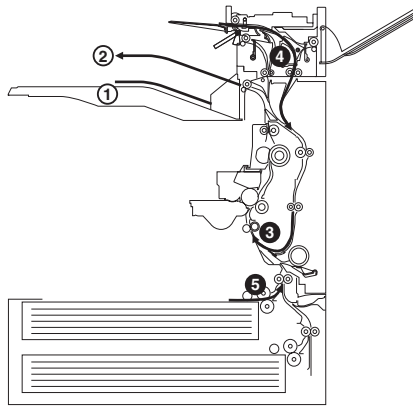

F-6-54

The 2nd sheet is delivered. The 4th sheet is turned over, and is moved for duplexing registration. The 3rd sheet is moved for registration once again. The 5th sheet is picked up.

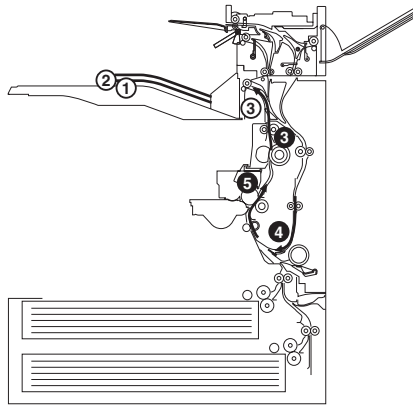

F-6-55

An image is formed for the 1st side of the 3rd sheet and for the 2nd side of the 5th sheet. The 5th sheet is moved for duplexing.

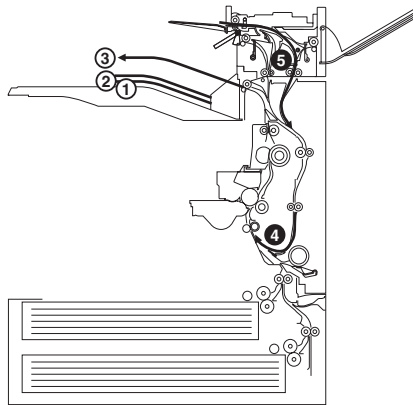

F-6-56

The 3rd sheet is delivered. The 5th sheet is turned over, and is moved for duplexing registration. The 4th sheet is moved for registration once again.

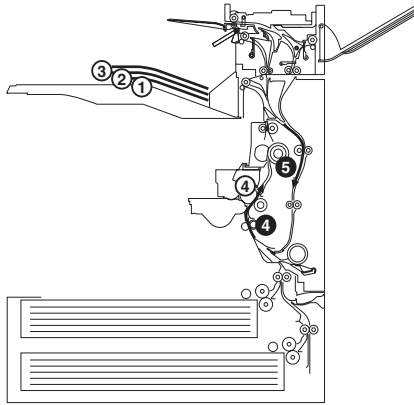

F-6-57

An image is formed for the 1st side of the 4th sheet. The 5th sheet is moved for duplexing.

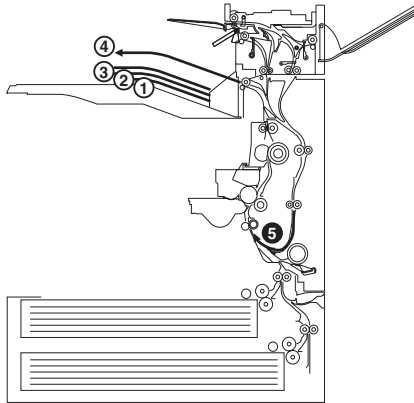

F-6-58

The 4th sheet is delivered. The 5th sheet is moved for registration once again.

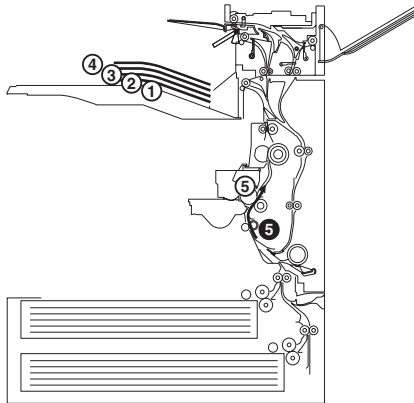

F-6-59

An image is formed for the 1st side of the 5th sheet.

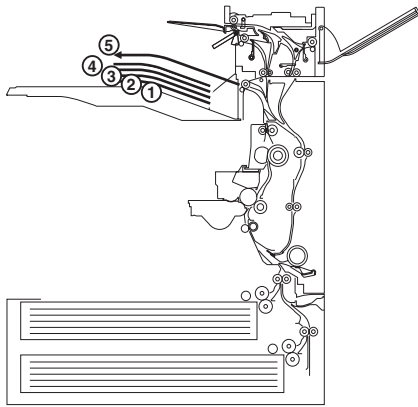

F-6-60

The 5th sheet is delivered.

6.8 Parts Replacement Procedure

6.8.1 Pick-up Unit 1

6.8.1.1 Removing the Right Cover (rear)

- 1) Open the pedestal right door [1]. (if equipped with a 2-Cassette Pedestal-Y2)
- 2) Open the right lower door [2].
- 3) Remove the 5 screws [3], and detach the right cover (rear) [4].

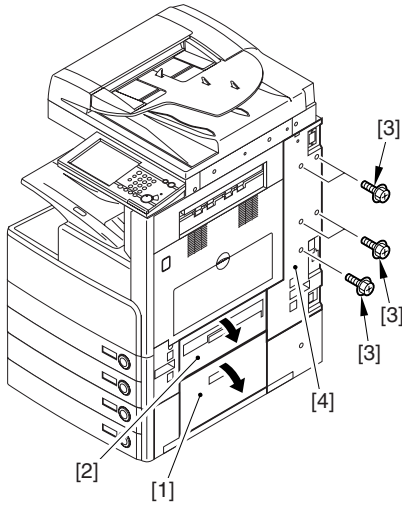

F-6-61

6.8.1.2 Removing the Right Door

- 1) Open the right door.



F-6-62

- 2) Remove the screw [1], and detach the fixing plate [2].

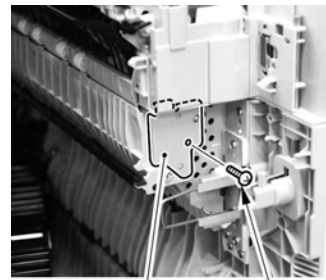

F-6-63

- 3) Remove the joint shaft [1], and free the extension delivery unit [2] from the right door.

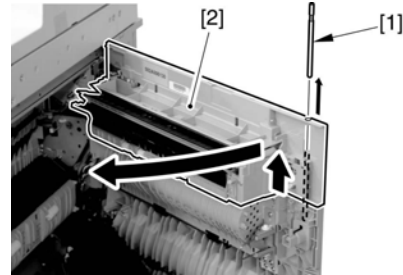

F-6-64

- 4) Disconnect the connector [1], and remove the reuse band [2]; then, remove the 2 screws (M4x8; RS tightening).

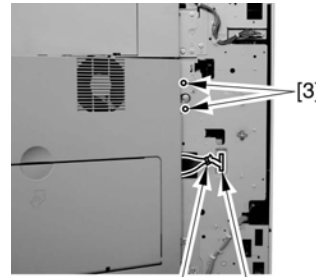

F-6-65

- 5) While freeing the hinge assembly [2], detach the right door.

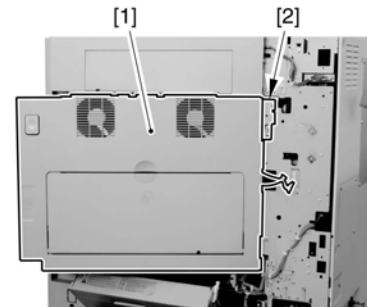

F-6-66

Attaching the Right Door

- 1) Match the hinge [1] found at the bottom of the right door against the lug.
- 2) Engage the hinge [2] found on the top of the right door with the hook found on the side plate.

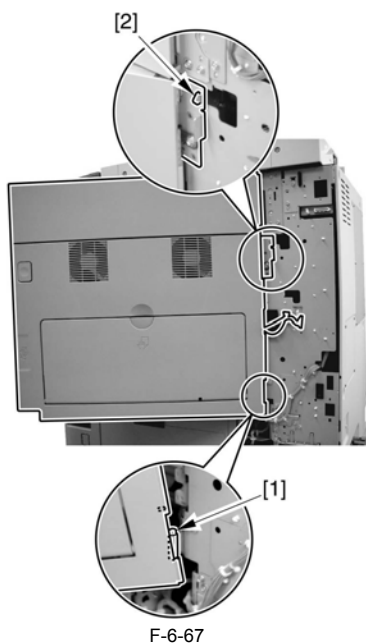

F-6-67



When tightening the 2 screws used to fix the hinge in place, be sure to close the right door first.

6.8.1.3 Removing the Right Cover (lower front)

- 1) Open the pedestal right door [1]. (if equipped with a Cassette Feeding Unit-Y2)
- 2) Open the lower right door [2].
- 3) Remove the 2 screws [3], and detach the right cover (lower front) [4].

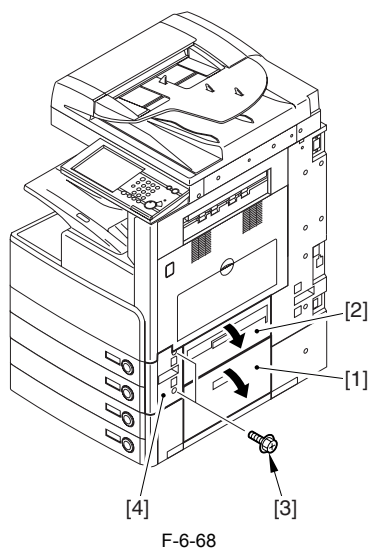

F-6-68

6.8.2 Pick-up Unit 2

6.8.2.1 Removing the Right Cover (rear)

- 1) Open the pedestal right door [1]. (if equipped with a 2-Cassette Pedestal-Y2)
- 2) Open the right lower door [2].
- 3) Remove the 5 screws [3], and detach the right cover (rear) [4].

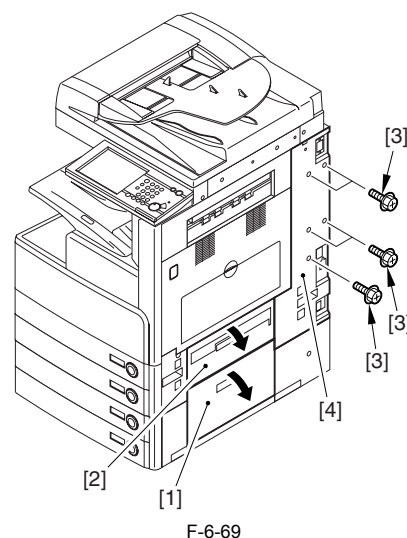

F-6-69

6.8.2.2 Removing the Right Cover (lower front)

- 1) Open the pedestal right door [1]. (if equipped with a Cassette Feeding Unit-Y2)
- 2) Open the lower right door [2].
- 3) Remove the 2 screws [3], and detach the right cover (lower front) [4].

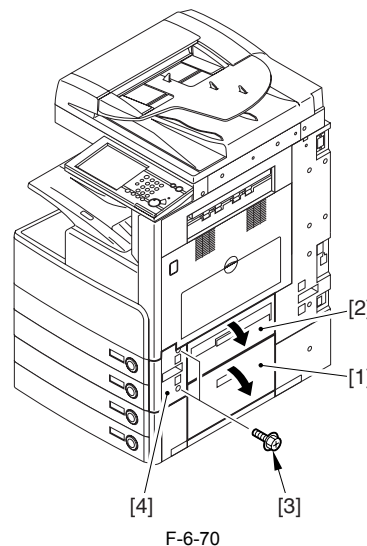

F-6-70

6.8.3 Pickup Roller

6.8.3.1 Removing the Pickup Roller/Feed Roller/ Separation Roller

- 1) Slide out the cassette.
- 2) Open the right door (in the case of the separation roller).
- 3) Pick the tabs of the individual rollers, and detach the pickup roller [1], feed roller [2], and separation roller [3].

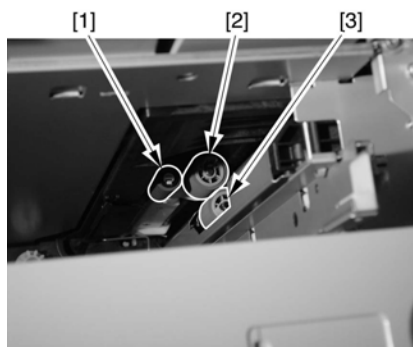

F-6-71



Point to Note When Replacing the Feed/Separation Roller 1

The collar (roller core) of the machine's feed/separation roller is black.

6.8.4 Sensor Mount

6.8.4.1 Removing the Right Cover (rear)

- 1) Open the pedestal right door [1]. (if equipped with a 2-Cassette Pedestal-Y2)
- 2) Open the right lower door [2].
- 3) Remove the 5 screws [3], and detach the right cover (rear) [4].

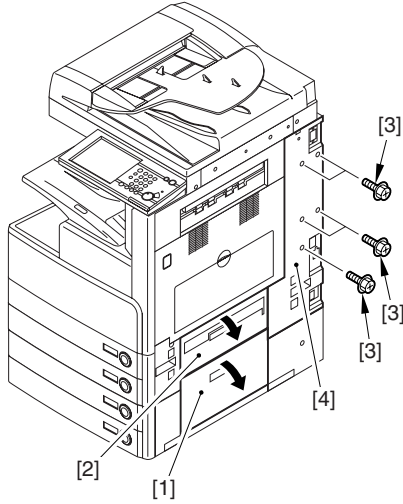

F-6-72

6.8.4.2 Removing the Right Door

- 1) Open the right door.



F-6-73

- 2) Remove the screw [1], and detach the fixing plate [2].

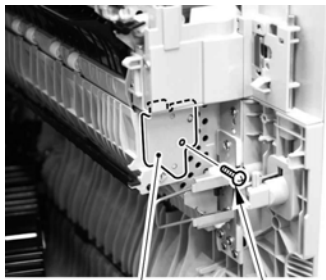

F-6-74

- 3) Remove the joint shaft [1], and free the extension delivery unit [2] from the right door.

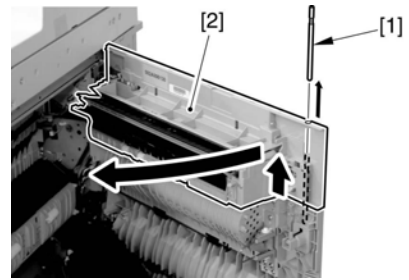

F-6-75

- 4) Disconnect the connector [1], and remove the reuse band [2]; then, remove the 2 screws (M4x8; RS tightening).

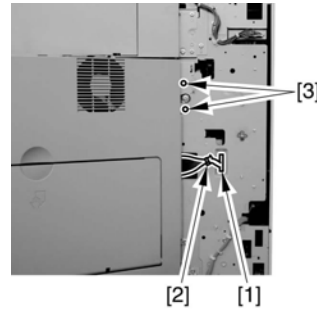

F-6-76

- 5) While freeing the hinge assembly [2], detach the right door.

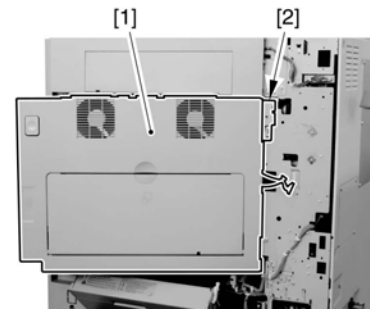

F-6-77

Attaching the Right Door

- 1) Match the hinge [1] found at the bottom of the right door against the lug.
- 2) Engage the hinge [2] found on the top of the right door with the hook found on the side plate.

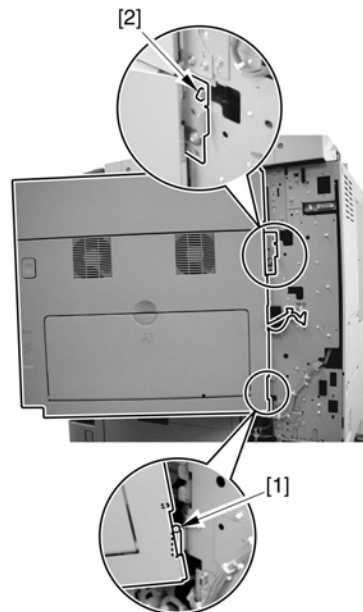

F-6-78



When tightening the 2 screws used to fix the hinge in place, be sure to close the right door first.

6.8.4.3 Removing the Right Cover (lower front)

- 1) Open the right door [1] of the pedestal (if a 2-Cassette Pedestal-Y1 is installed).
- 2) Open the lower right cover [2].
- 3) Remove the 2 screws, and detach the right cover (lower front) [3].

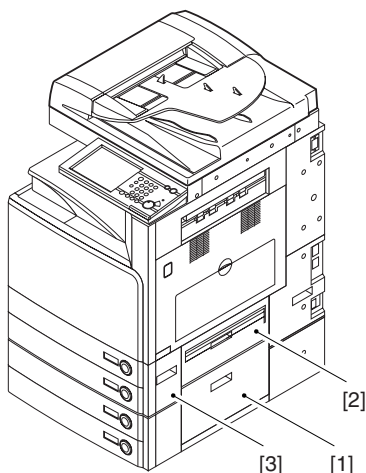

F-6-79

6.8.4.4 Removing the Sensor Mounting Plate

- 1) Remove the 2 TP screws [1] and the binding screw [2] from the rear of the pickup assembly, and detach the bracket [3].

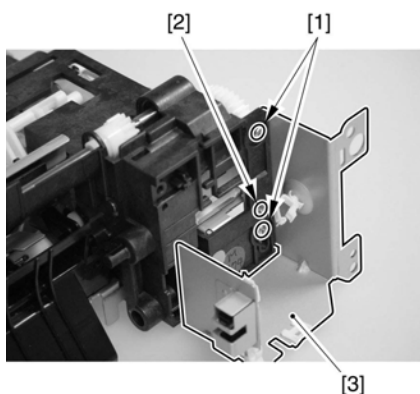

F-6-80

Pickup Unit 1

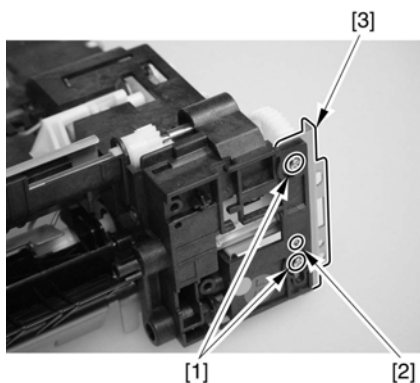

F-6-81

Pickup Unit 2

- 2) Disconnect the connector [1], and remove the screw; then, detach the cassette pickup solenoid [3].
- 3) Remove the bushing [4] and the 5 screws [5]; then, detach the sensor base [6].

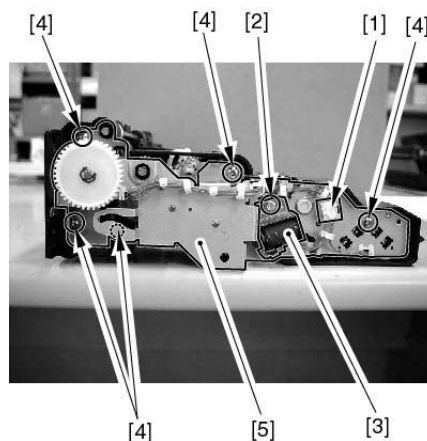

F-6-82

6.8.4.5 Mounting the Sensor Mounting Plate



Be sure not to make the pickup unit facing down when attaching the sensor base, otherwise, the gears will fall out.

- 1) Fit the 6 points [A] indicated in the figure into the holes of the sensor base securely, and then attach the sensor base [2] with the 5 screws [1].

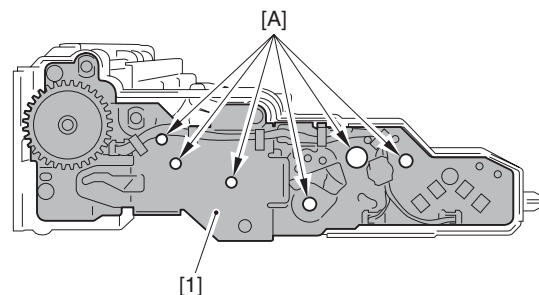

F-6-83

- 2) Attach the cassette pickup solenoid [1].



Be sure that the stop plate [2] is fully engaged with the cam gear [3].

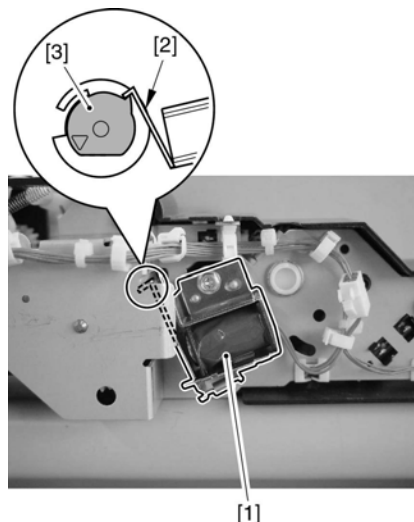

F-6-84



Try turning the gears to be sure that they turn properly.

6.8.5 Cassette Pick-up Motor 1

6.8.5.1 Removing the Rear Cover

1) Remove the 13 screws [1] and then the other screw [2]; then, detach the rear cover [3].



If the left cover (lower) has already been detached, the screw [3] should also have been removed.

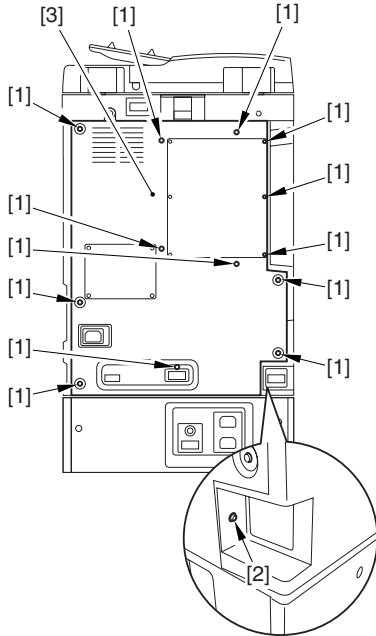

F-6-85

6.8.5.2 Removing the Right Cover (rear)

1) Open the pedestal right door [1]. (if equipped with a 2-Cassette Pedestal-Y2)
 2) Open the right lower door [2].
 3) Remove the 5 screws [3], and detach the right cover (rear) [4].

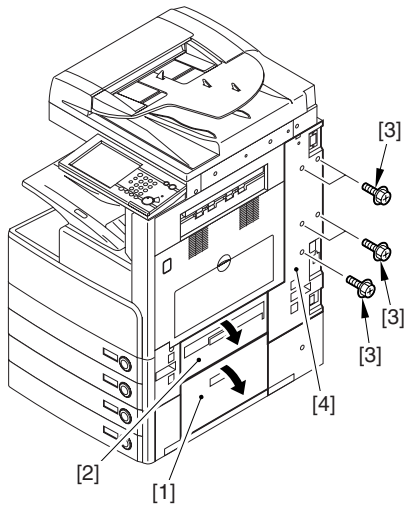

F-6-86

6.8.5.3 Removing the Pickup Motor Base

1) Free the harness [1] from the 2 wire saddles [2].

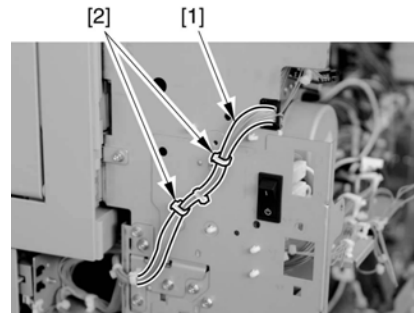

F-6-87

2) Remove the 5 screws [1]. Remove the power cord base [2].

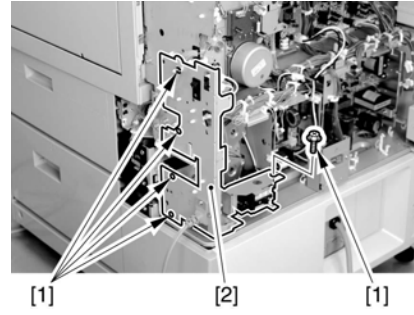

F-6-88

3) Disconnect the 2 connectors [1].

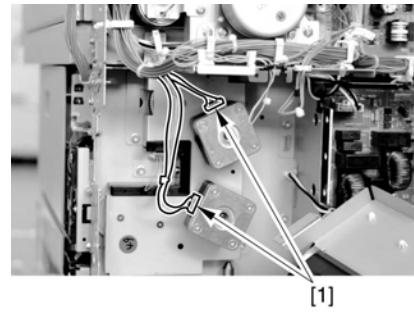

F-6-89

4) Remove the 5 screws [1], and detach the pickup motor base [2].

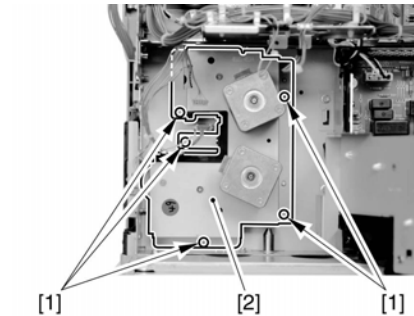

F-6-90

6.8.5.4 Removing the Cassette Pickup Motor 1

1) Remove the 2 screws, and detach the cassette pickup motor 1 [2].

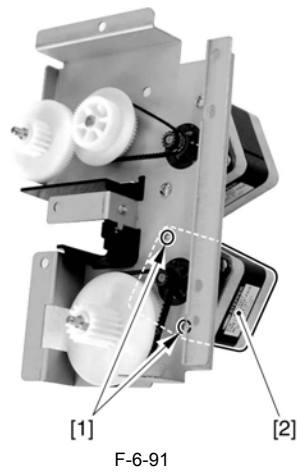

6.8.6 Cassette Pick-up Motor 2

6.8.6.1 Removing the Rear Cover

1) Remove the 13 screws [1] and then the other screw [2]; then, detach the rear cover [3].



If the left cover (lower) has already been detached, the screw [3] should also have been removed.

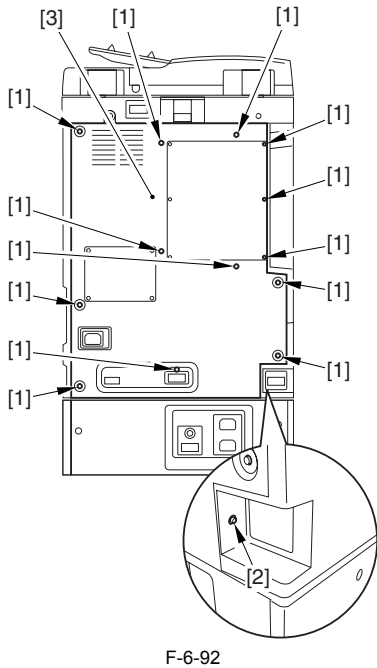

6.8.6.2 Removing the Right Cover (rear)

- 1) Open the pedestal right door [1]. (if equipped with a 2-Cassette Pedestal-Y2)
- 2) Open the right lower door [2].
- 3) Remove the 5 screws [3], and detach the right cover (rear) [4].

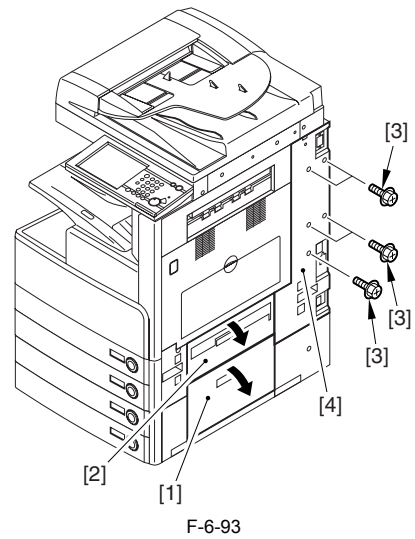

6.8.6.3 Removing the Pickup Motor Base

1) Free the harness [1] from the 2 wire saddles [2].

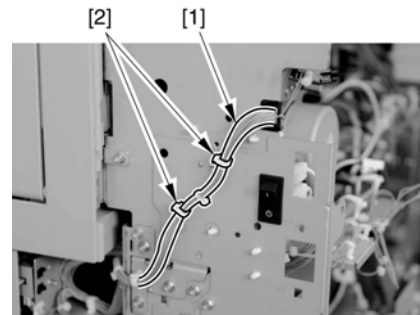

2) Remove the 5 screws [1]. Remove the power cord base [2].

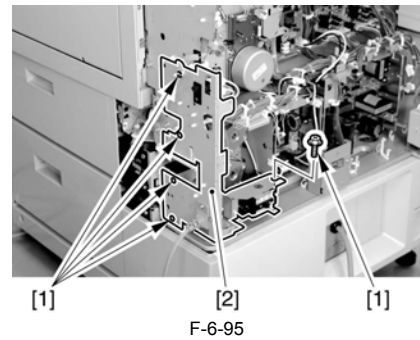

3) Disconnect the 2 connectors [1].

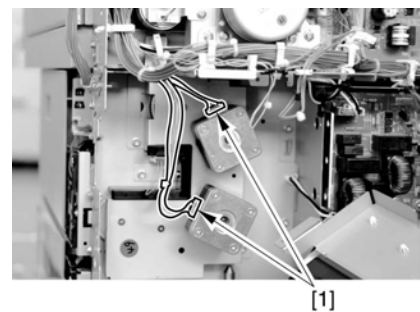

4) Remove the 5 screws [1], and detach the pickup motor base [2].

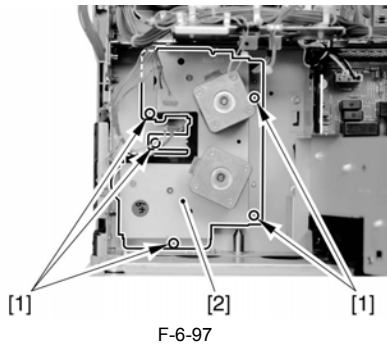

F-6-97

6.8.6.4 Removing the Cassette Pickup Motor 2

- 1) Remove the 2 screws [1], and detach the cassette pickup motor 2 [2].

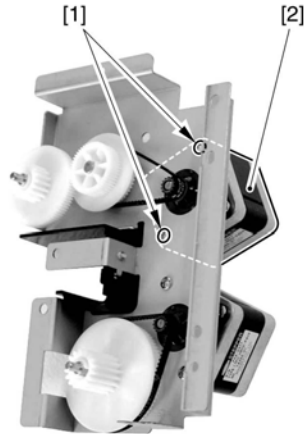

F-6-98

6.8.7 Cassette Size Sensor

6.8.7.1 Removing the Right Cover (rear)

- 1) Open the pedestal right door [1]. (if equipped with a 2-Cassette Pedestal-Y2)
- 2) Open the right lower door [2].
- 3) Remove the 5 screws [3], and detach the right cover (rear) [4].

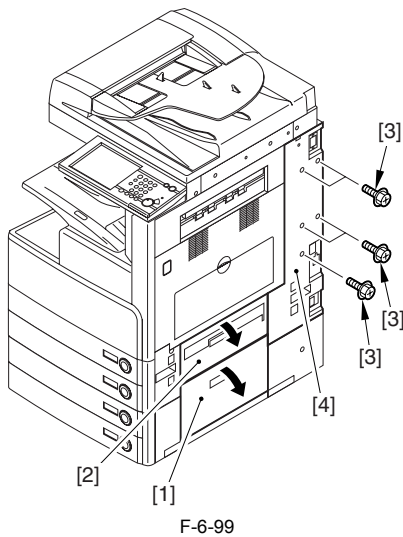

F-6-99

6.8.7.2 Removing the Right Door

- 1) Open the right door.



F-6-100

- 2) Remove the screw [1], and detach the fixing plate [2].

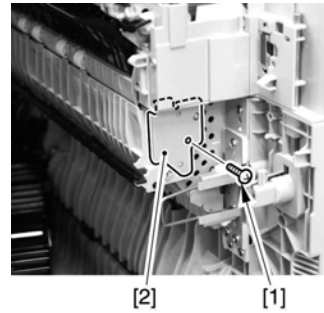

F-6-101

- 3) Remove the joint shaft [1], and free the extension delivery unit [2] from the right door.

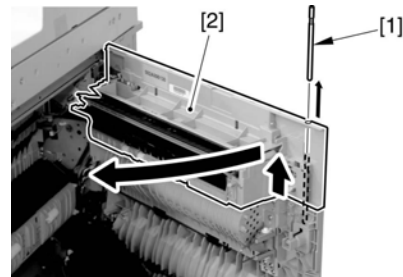

F-6-102

- 4) Disconnect the connector [1], and remove the reuse band [2]; then, remove the 2 screws (M4x8; RS tightening).

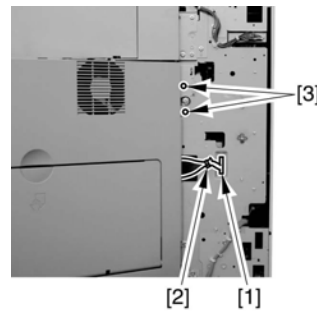

F-6-103

- 5) While freeing the hinge assembly [2], detach the right door.

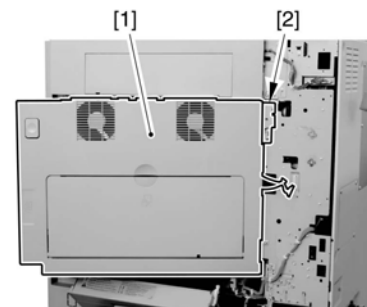

F-6-104

Attaching the Right Door

- 1) Match the hinge [1] found at the bottom of the right door against the lug.
- 2) Engage the hinge [2] found on the top of the right door with the hook found on the side plate.

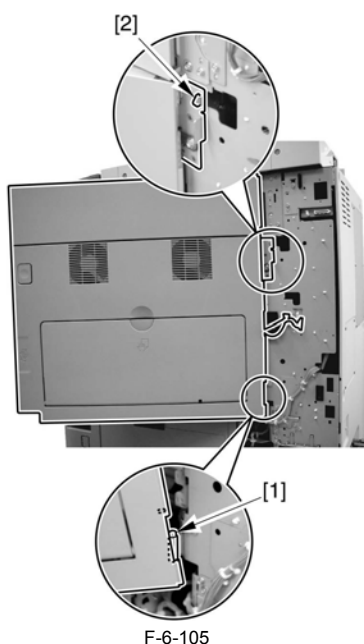

F-6-105



When tightening the 2 screws used to fix the hinge in place, be sure to close the right door first.

6.8.7.3 Removing the Right Cover (lower front)

- 1) Open the pedestal right door [1]. (if equipped with a Cassette Feeding Unit-Y2)
- 2) Open the lower right door [2].
- 3) Remove the 2 screws [3], and detach the right cover (lower front) [4].

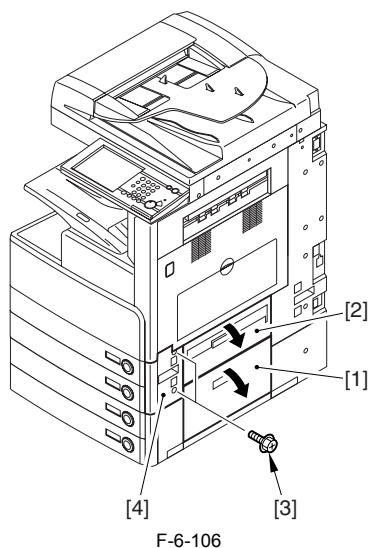

F-6-106

6.8.7.4 Removing the Cassette Size Sensor

- 1) Detach the PCB cover [1] (snap stopper).

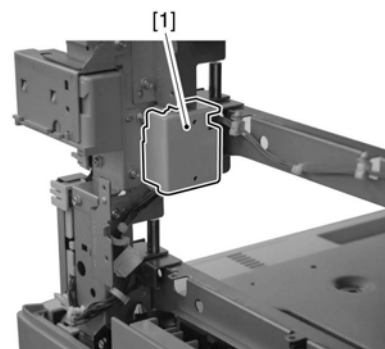

F-6-107

- 2) Disconnect the connector from the cassette size sensor relay PCB.
 - In case of cassette size sensor 1: connector [1]
 - In case of cassette size sensor 2: connector [2]
- 3) Free the cable from the wire saddle.
 - In case of cassette size sensor 1: 2 wire saddles [3]
 - In case of cassette size sensor 2: 2 wire saddles each [3] [4]

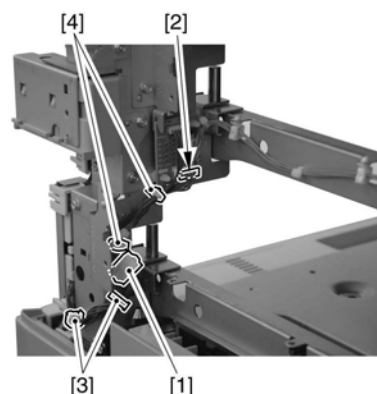

F-6-108

- 4) Remove the cassette size sensor base [2].
 - 1 screw each [1]
 Although the base of cassette size sensor 2 can be removed by itself, the base of the cassette size sensor 1 has to be removed together with the base of the cassette size sensor 2.

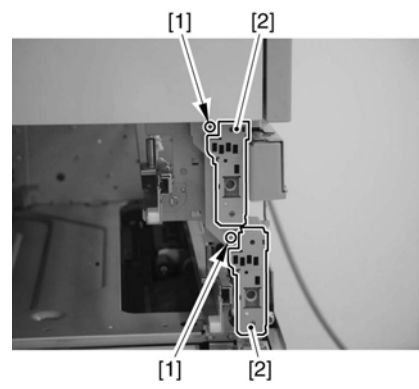

F-6-109

- 5) Detach the cover [1] from the base.

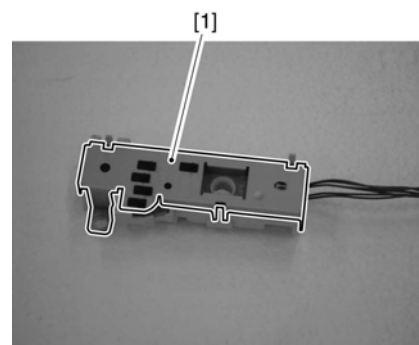

F-6-110

- 6) Detach the cassette size sensor [1] from the base.

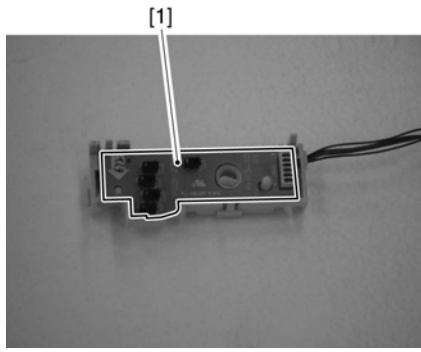

F-6-111

6.8.8 Cassette Retry Paper Sensor

6.8.8.1 Removing the Right Cover (rear)

- 1) Open the pedestal right door [1]. (if equipped with a 2-Cassette Pedestal-Y2)
- 2) Open the right lower door [2].
- 3) Remove the 5 screws [3], and detach the right cover (rear) [4].

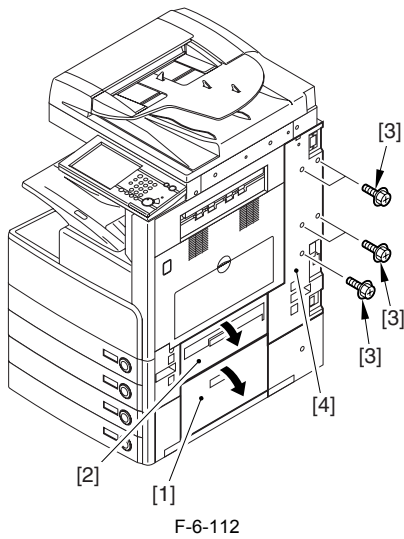

F-6-112

6.8.8.2 Removing the Right Door

- 1) Open the right door.

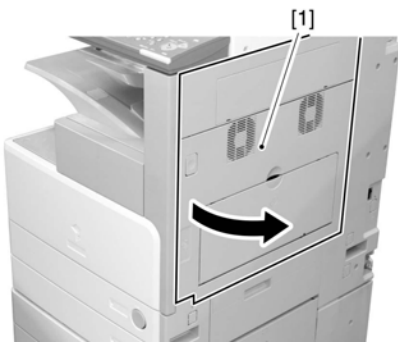

F-6-113

- 2) Remove the screw [1], and detach the fixing plate [2].

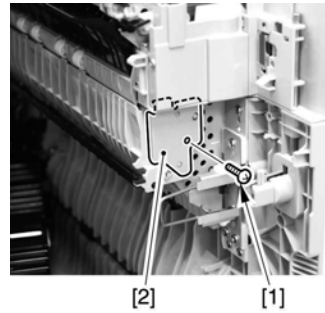

F-6-114

- 3) Remove the joint shaft [1], and free the extension delivery unit [2] from the right door.

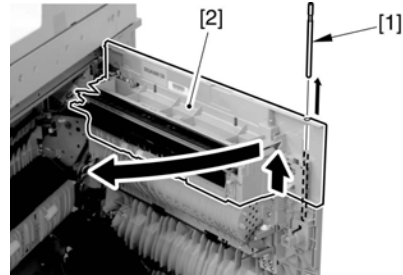

F-6-115

- 4) Disconnect the connector [1], and remove the reuse band [2]; then, remove the 2 screws (M4x8; RS tightening).

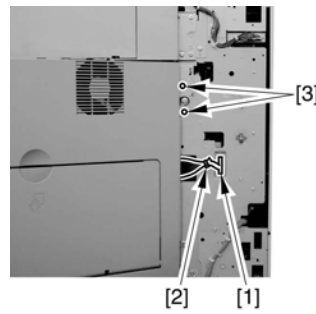

F-6-116

- 5) While freeing the hinge assembly [2], detach the right door.

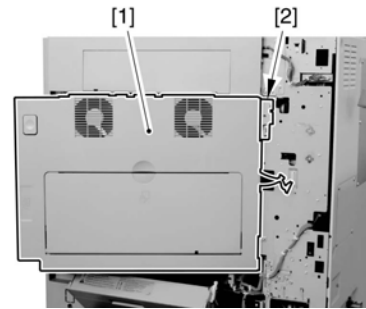

F-6-117

Attaching the Right Door

- 1) Match the hinge [1] found at the bottom of the right door against the lug.
- 2) Engage the hinge [2] found on the top of the right door with the hook found on the side plate.

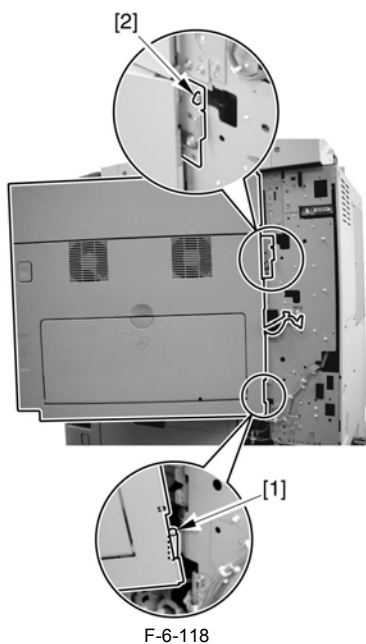

F-6-118



When tightening the 2 screws used to fix the hinge in place, be sure to close the right door first.

6.8.8.3 Removing the Right Cover (lower front)

- 1) Open the pedestal right door [1]. (if equipped with a Cassette Feeding Unit-Y2)
- 2) Open the lower right door [2].
- 3) Remove the 2 screws [3], and detach the right cover (lower front) [4].

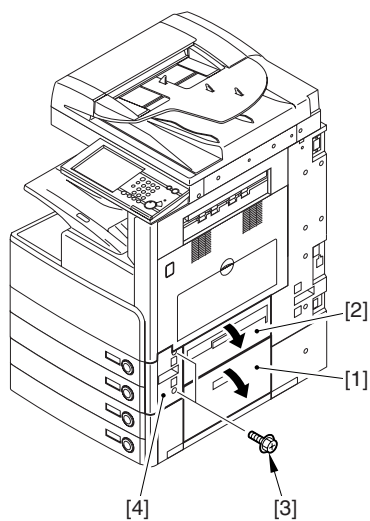

F-6-119

6.8.8.4 Removing the Sensor Mounting Plate

- 1) Remove the 2 TP screws [1] and the binding screw [2] from the rear of the pickup assembly, and detach the bracket [3].

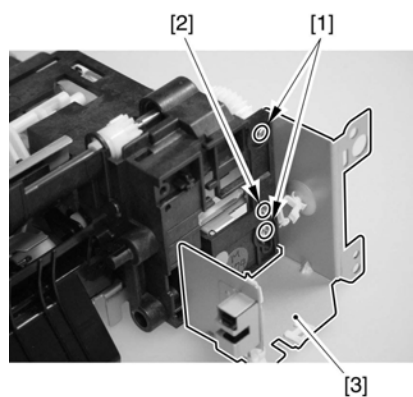
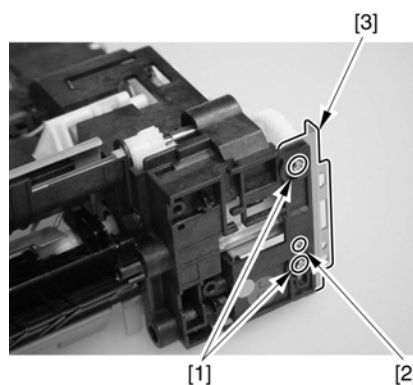
F-6-120
Pickup Unit 1F-6-121
Pickup Unit 2

- 2) Disconnect the connector [1], and remove the screw; then, detach the cassette pickup solenoid [3].
- 3) Remove the bushing [4] and the 5 screws [5]; then, detach the sensor base [6].

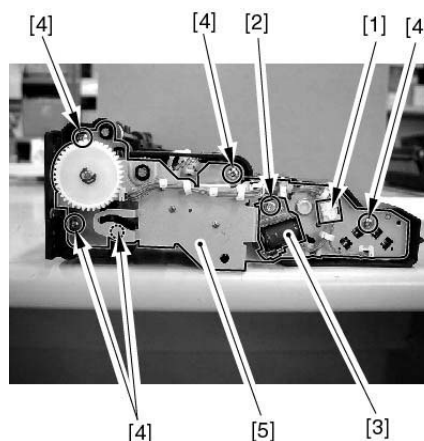

F-6-122

6.8.8.5 Removing the Cassette Retry Paper Sensor

- 1) Remove the cassette retry paper sensor [2].
- 1 connector [1]

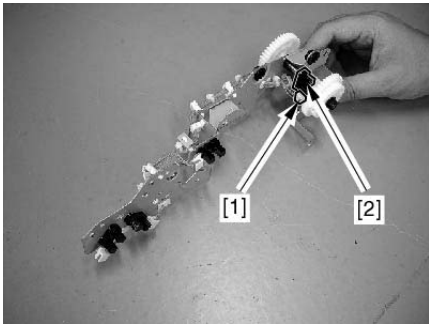

F-6-123

6.8.9 Cassette Paper Sensor

6.8.9.1 Removing the Right Cover (rear)

- 1) Open the pedestal right door [1]. (if equipped with a 2-Cassette Pedestal-Y2)
- 2) Open the right lower door [2].
- 3) Remove the 5 screws [3], and detach the right cover (rear) [4].

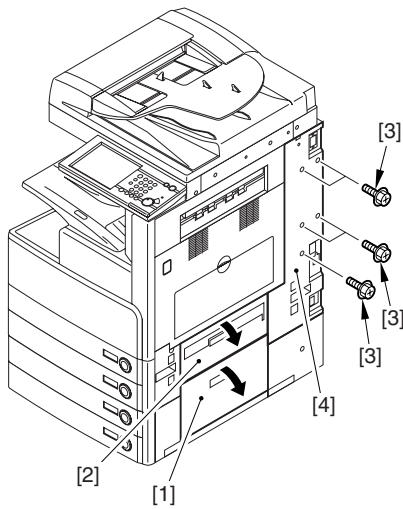

F-6-124

6.8.9.2 Removing the Right Door

- 1) Open the right door.



F-6-125

- 2) Remove the screw [1], and detach the fixing plate [2].

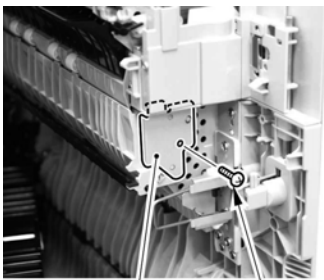

F-6-126

- 3) Remove the joint shaft [1], and free the extension delivery unit [2] from the right door.

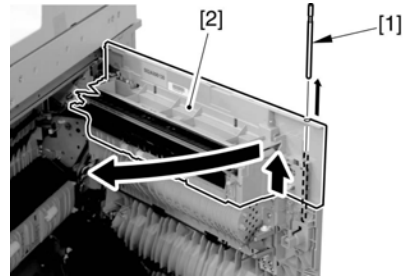

F-6-127

- 4) Disconnect the connector [1], and remove the reuse band [2]; then, remove the 2 screws (M4x8; RS tightening).

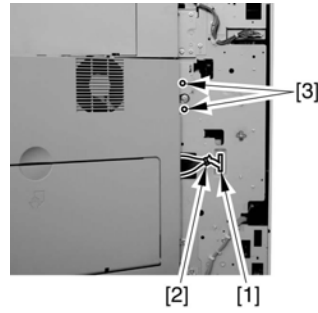

F-6-128

- 5) While freeing the hinge assembly [2], detach the right door.

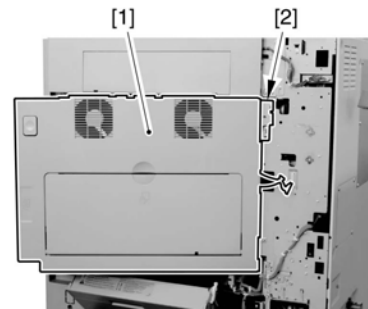

F-6-129

Attaching the Right Door

- 1) Match the hinge [1] found at the bottom of the right door against the lug.
- 2) Engage the hinge [2] found on the top of the right door with the hook found on the side plate.

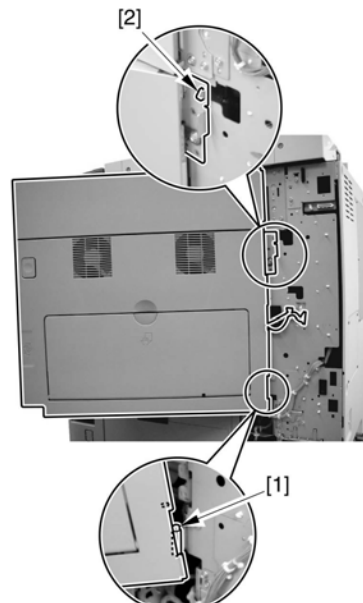

F-6-130



When tightening the 2 screws used to fix the hinge in place, be sure to close the right door first.

6.8.9.3 Removing the Right Cover (lower front)

- 1) Open the pedestal right door [1]. (if equipped with a Cassette Feeding Unit-Y2)
- 2) Open the lower right door [2].
- 3) Remove the 2 screws [3], and detach the right cover (lower front) [4].

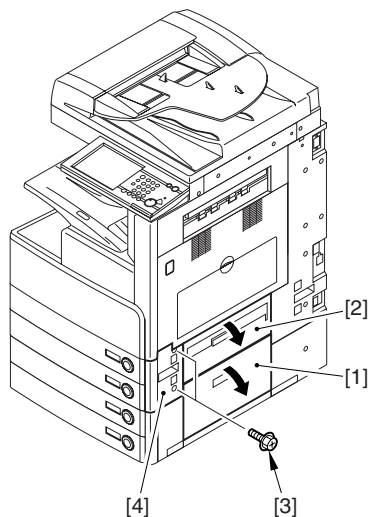

F-6-131

6.8.9.4 Removing the Sensor Mounting Plate

- 1) Remove the 2 TP screws [1] and the binding screw [2] from the rear of the pickup assembly, and detach the bracket [3].

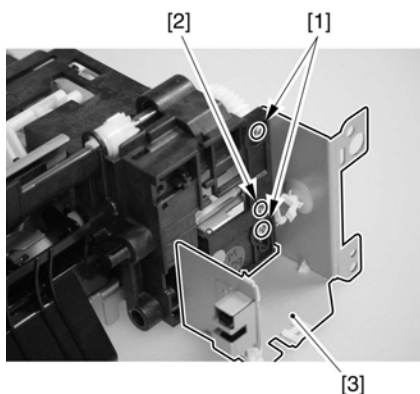

F-6-132

Pickup Unit 1

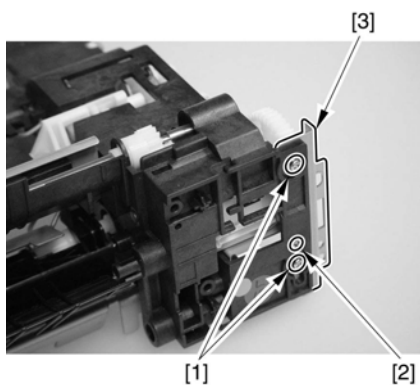

F-6-133

Pickup Unit 2

- 2) Disconnect the connector [1], and remove the screw; then, detach the cassette pickup solenoid [3].

- 3) Remove the bushing [4] and the 5 screws [5]; then, detach the sensor base [6].

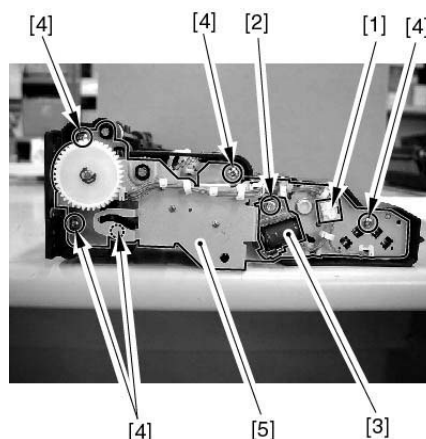

F-6-134

6.8.9.5 Removing the Cassette Paper Sensor

- 1) Remove the cassette paper sensor [2].
- 1 connector [1]

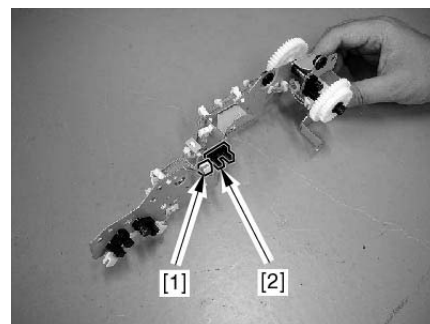

F-6-135

6.8.10 Cassette Paper Level Sensor (A/B)

6.8.10.1 Removing the Right Cover (rear)

- 1) Open the pedestal right door [1]. (if equipped with a 2-Cassette Pedestal-Y2)
- 2) Open the right lower door [2].
- 3) Remove the 5 screws [3], and detach the right cover (rear) [4].

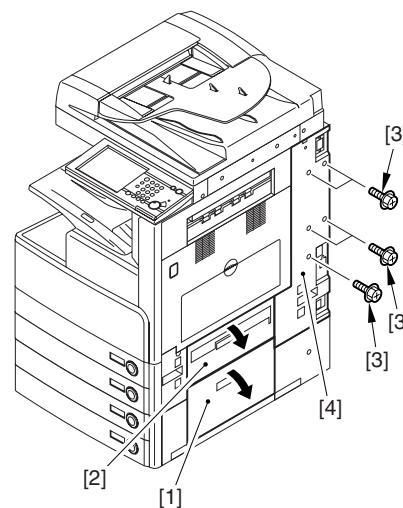

F-6-136

6.8.10.2 Removing the Right Door

- 1) Open the right door.

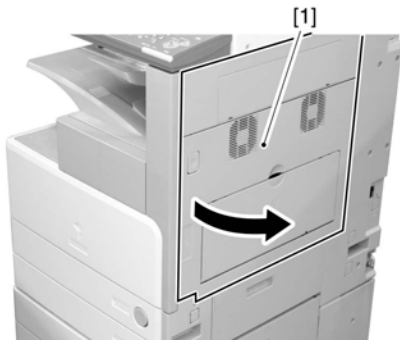

F-6-137

2) Remove the screw [1], and detach the fixing plate [2].

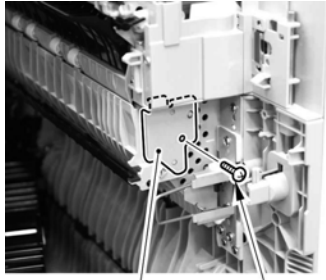

F-6-138

3) Remove the joint shaft [1], and free the extension delivery unit [2] from the right door.

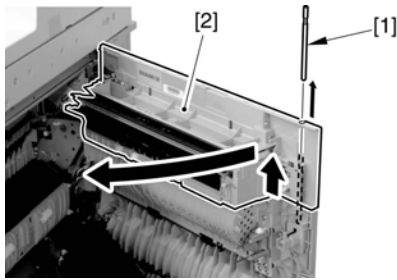

F-6-139

4) Disconnect the connector [1], and remove the reuse band [2]; then, remove the 2 screws (M4x8; RS tightening).

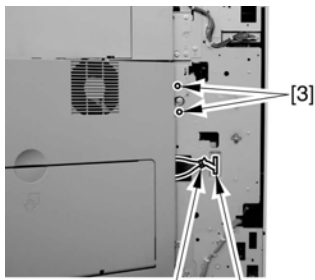

F-6-140

5) While freeing the hinge assembly [2], detach the right door.

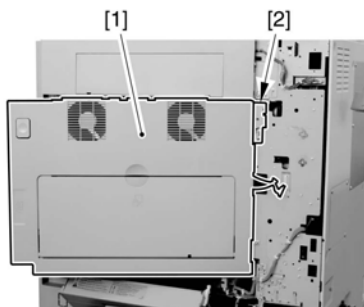

F-6-141

Attaching the Right Door

- 1) Match the hinge [1] found at the bottom of the right door against the lug.
- 2) Engage the hinge [2] found on the top of the right door with the hook found on the side plate.

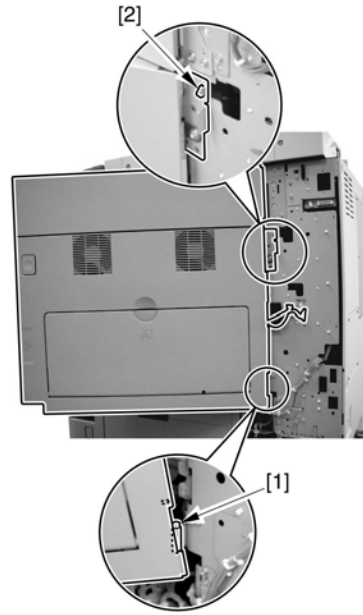

F-6-142



When tightening the 2 screws used to fix the hinge in place, be sure to close the right door first.

6.8.10.3 Removing the Right Cover (lower front)

- 1) Open the pedestal right door [1]. (if equipped with a Cassette Feeding Unit-Y2)
- 2) Open the lower right door [2].
- 3) Remove the 2 screws [3], and detach the right cover (lower front) [4].

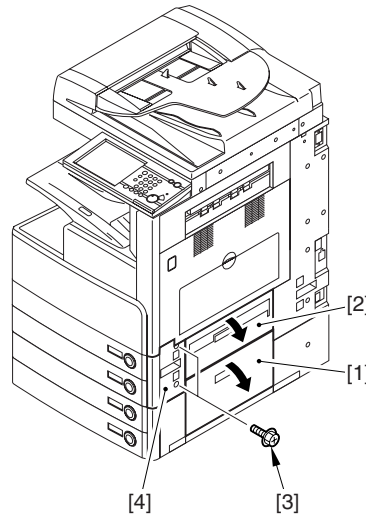

F-6-143

6.8.10.4 Removing the Sensor Mounting Plate

- 1) Remove the 2 TP screws [1] and the binding screw [2] from the rear of the pickup assembly, and detach the bracket [3].

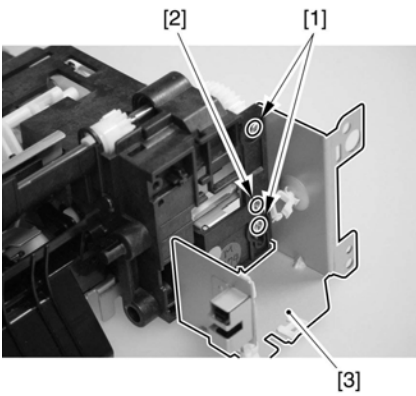

F-6-144
Pickup Unit 1

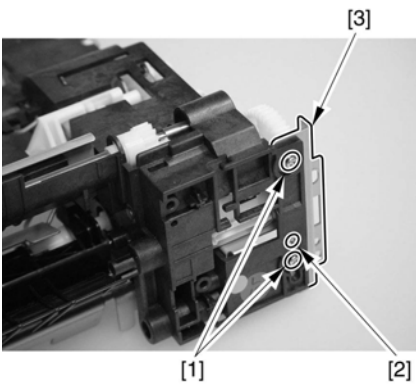

F-6-145
Pickup Unit 2

- 2) Disconnect the connector [1], and remove the screw; then, detach the cassette pickup solenoid [3].
- 3) Remove the bushing [4] and the 5 screws [5]; then, detach the sensor base [6].

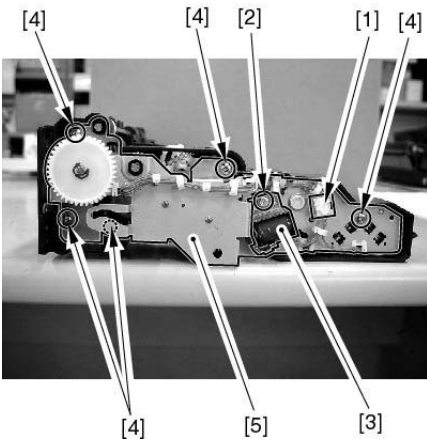

F-6-146

6.8.10.5 Removing the Cassette Paper Level Sensor (A/B)

- 1) Remove the cassette paper level sensor (A/B) [2].
- 1 connector each [1]

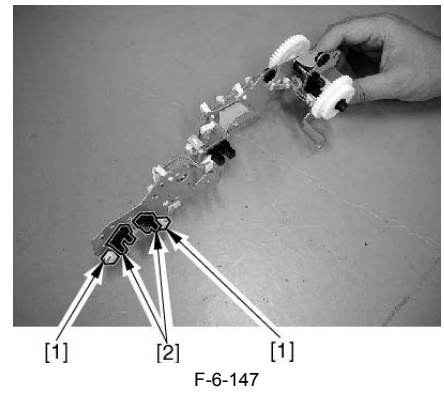

F-6-147

6.8.11 Slide Resistor

6.8.11.1 Removing the Right Cover (rear)

- 1) Open the pedestal right door [1]. (if equipped with a 2-Cassette Pedestal-Y2)
- 2) Open the right lower door [2].
- 3) Remove the 5 screws [3], and detach the right cover (rear) [4].

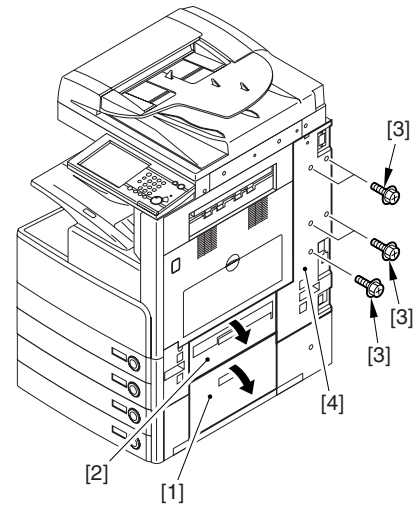

F-6-148

6.8.11.2 Removing the Right Door

- 1) Open the right door.



F-6-149

- 2) Remove the screw [1], and detach the fixing plate [2].

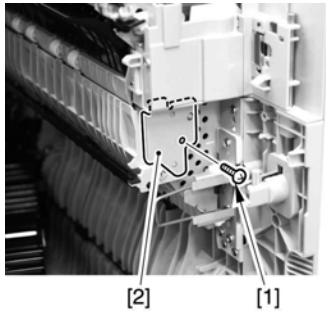

F-6-150

- 3) Remove the joint shaft [1], and free the extension delivery unit [2] from the right door.

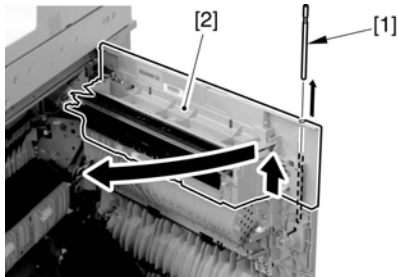

F-6-151

- 4) Disconnect the connector [1], and remove the reuse band [2]; then, remove the 2 screws (M4x8; RS tightening).

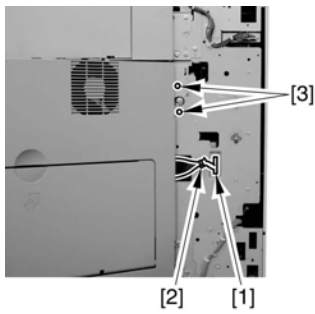

F-6-152

- 5) While freeing the hinge assembly [2], detach the right door.

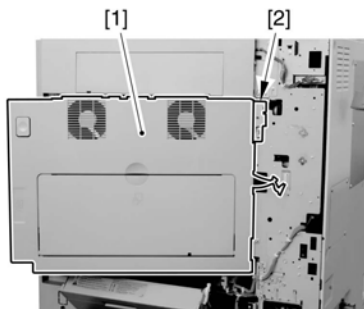

F-6-153

Attaching the Right Door

- 1) Match the hinge [1] found at the bottom of the right door against the lug.
- 2) Engage the hinge [2] found on the top of the right door with the hook found on the side plate.

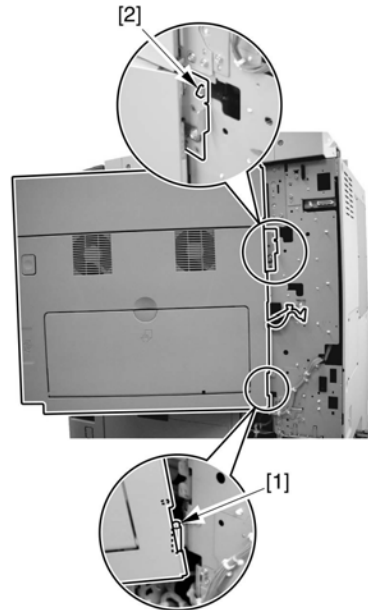

F-6-154



When tightening the 2 screws used to fix the hinge in place, be sure to close the right door first.

6.8.11.3 Removing the Manual Feed Unit

- 1) Remove the manual feed guide link [1].
 - 1 plastic E-ring [2]
 - 1 boss [3]

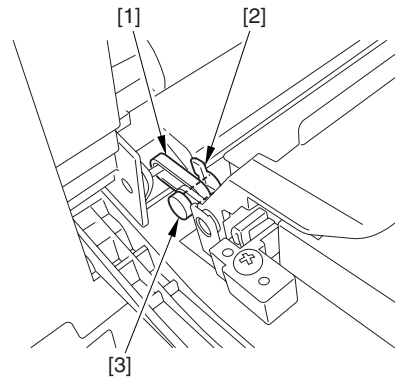

F-6-155

- 2) Remove the manual feed pickup guide [1].
 - 1 screw [2]

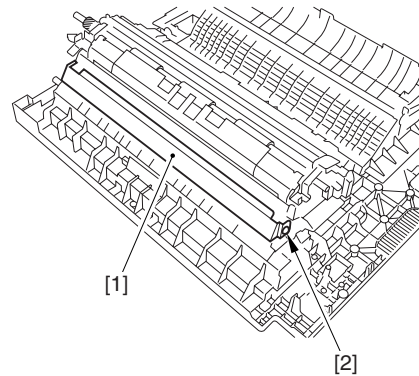

F-6-156

- 3) Detach the connector cover [1] (snap stopper).

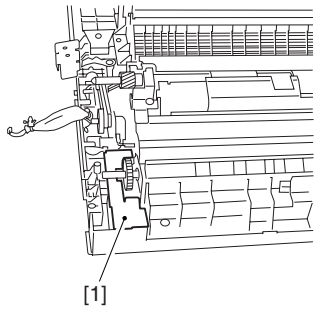

F-6-157

- 4) Disconnect the connector [1].
- 5) Remove the manual feed unit [3].
- 4 screws [2]

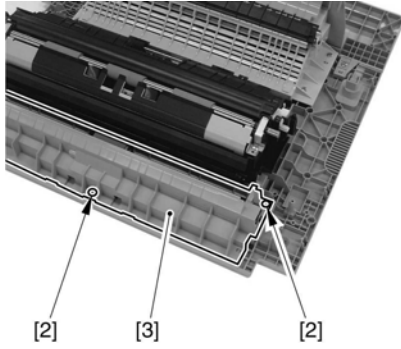

F-6-158

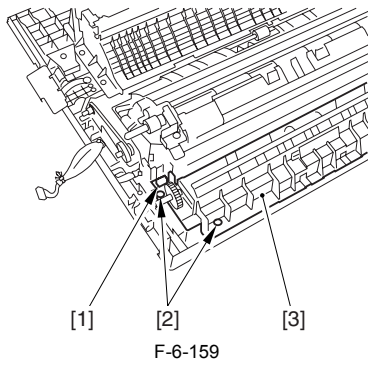

F-6-159

6.8.11.4 Removing the Manual Tray Unit

- 1) Disconnect the connector [1] and remove the tie-wrap [2].

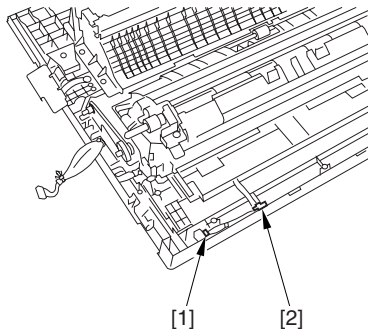

F-6-160

- 2) Remove the manual feed tray unit [3].

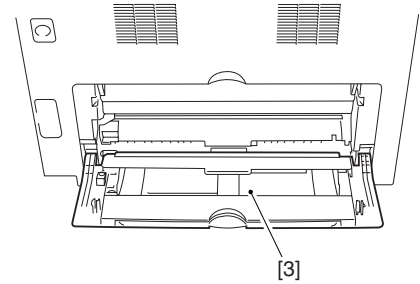

F-6-161

6.8.11.5 Removing the Slide Resistor

- 1) Detach the manual feed tray upper cover [2].
- 2 screws [1]

! Be sure to mark the horizontal registration position before detaching the manual feed tray upper cover.

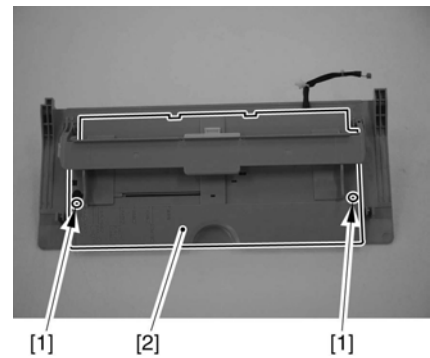

F-6-162

- 2) Remove the slide resistor [1].
- 1 connector [2]

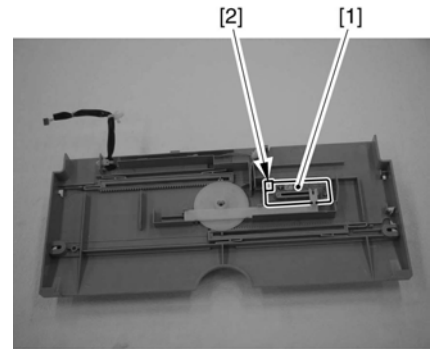

F-6-163

6.8.12 Cassette Pickup Solenoid

6.8.12.1 Removing the Right Cover (rear)

- 1) Open the pedestal right door [1]. (if equipped with a 2-Cassette Pedestal-Y2)
- 2) Open the right lower door [2].
- 3) Remove the 5 screws [3], and detach the right cover (rear) [4].

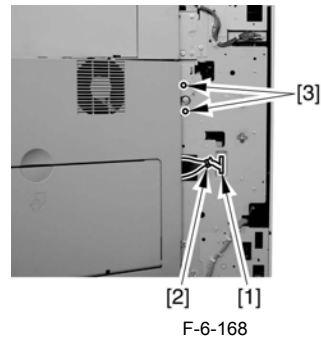
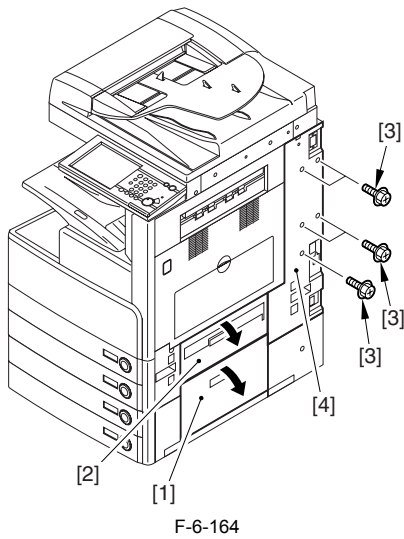

5) While freeing the hinge assembly [2], detach the right door.

6.8.12.2 Removing the Right Door

1) Open the right door.

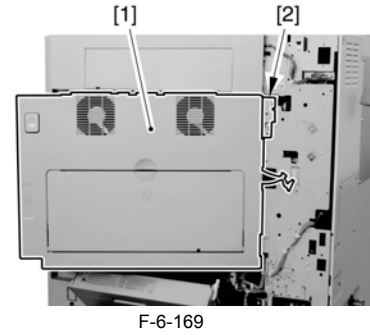

Attaching the Right Door

- 1) Match the hinge [1] found at the bottom of the right door against the lug.
- 2) Engage the hinge [2] found on the top of the right door with the hook found on the side plate.

2) Remove the screw [1], and detach the fixing plate [2].

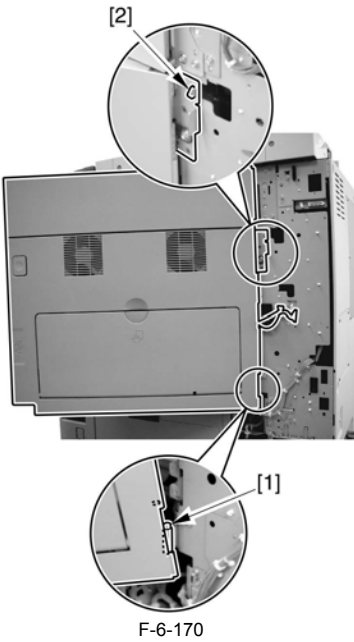
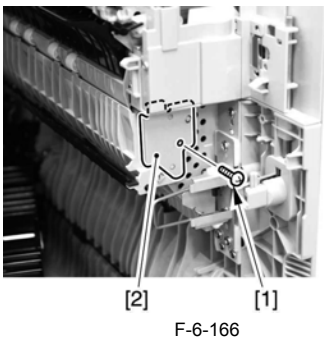

3) Remove the joint shaft [1], and free the extension delivery unit [2] from the right door.

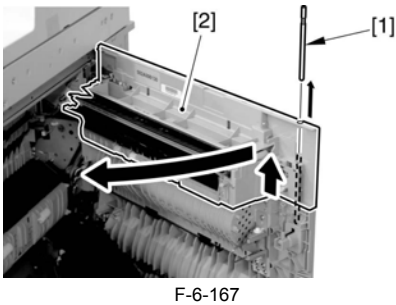

4) Disconnect the connector [1], and remove the reuse band [2]; then, remove the 2 screws (M4x8; RS tightening).



When tightening the 2 screws used to fix the hinge in place, be sure to close the right door first.

6.8.12.3 Removing the Right Cover (lower front)

- 1) Open the pedestal right door [1]. (if equipped with a Cassette Feeding Unit-Y2)
- 2) Open the lower right door [2].
- 3) Remove the 2 screws [3], and detach the right cover (lower front) [4].

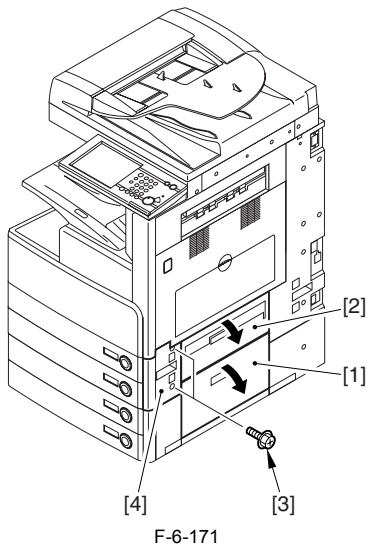

6.8.12.4 Removing the Cassette Pickup Solenoid

- 1) Remove the cassette pickup solenoid [3].
 - 1 connector [1]
 - 1 screw [2]

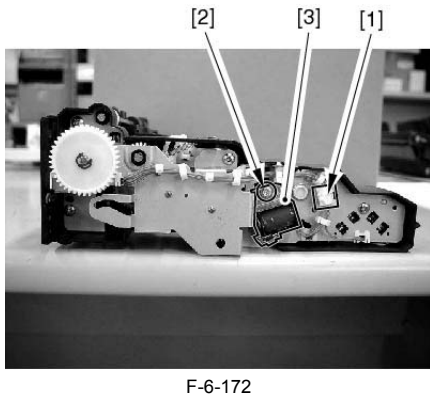

6.8.13 Cassette Size Sensor Relay PCB

6.8.13.1 Removing the Right Cover (rear)

- 1) Open the pedestal right door [1]. (if equipped with a 2-Cassette Pedestal-Y2)
- 2) Open the right lower door [2].
- 3) Remove the 5 screws [3], and detach the right cover (rear) [4].

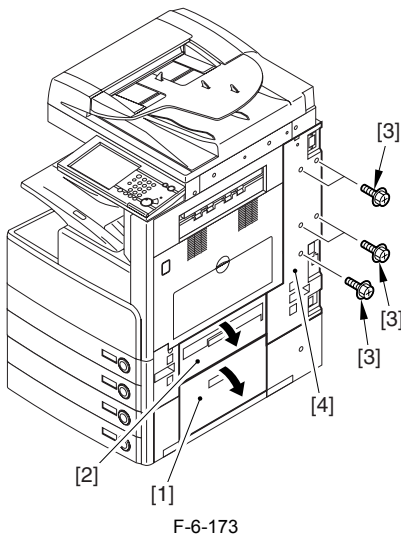

6.8.13.2 Removing the Right Door

- 1) Open the right door.



- 2) Remove the screw [1], and detach the fixing plate [2].

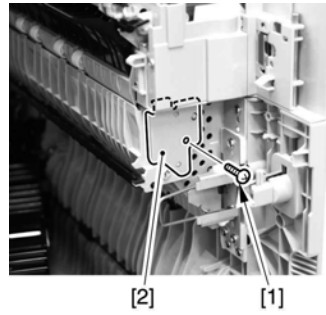

- 3) Remove the joint shaft [1], and free the extension delivery unit [2] from the right door.

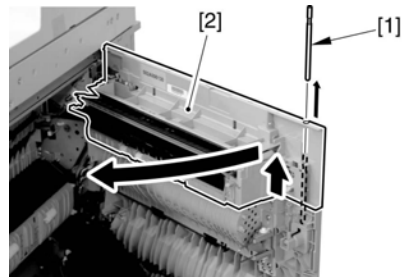

- 4) Disconnect the connector [1], and remove the reuse band [2]; then, remove the 2 screws (M4x8; RS tightening).

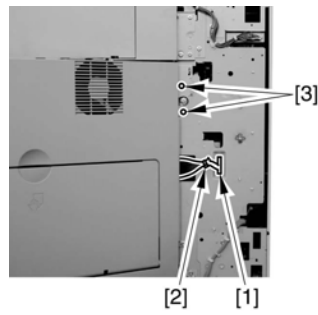

- 5) While freeing the hinge assembly [2], detach the right door.

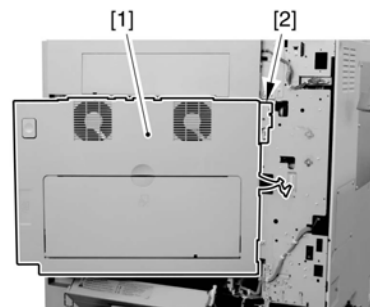

Attaching the Right Door

- 1) Match the hinge [1] found at the bottom of the right door against the lug.
- 2) Engage the hinge [2] found on the top of the right door with the hook found on the side plate.

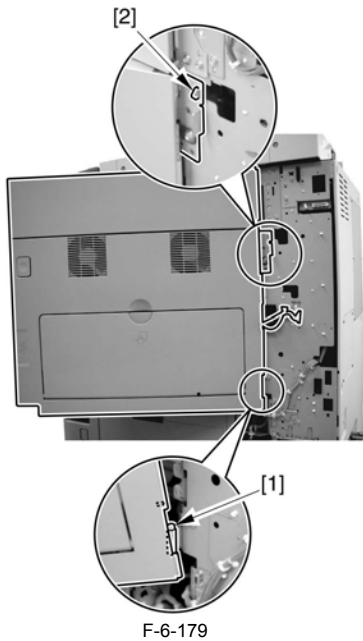

F-6-179



When tightening the 2 screws used to fix the hinge in place, be sure to close the right door first.

6.8.13.3 Removing the Right Cover (lower front)

- 1) Open the pedestal right door [1]. (if equipped with a Cassette Feeding Unit-Y2)
- 2) Open the lower right door [2].
- 3) Remove the 2 screws [3], and detach the right cover (lower front) [4].

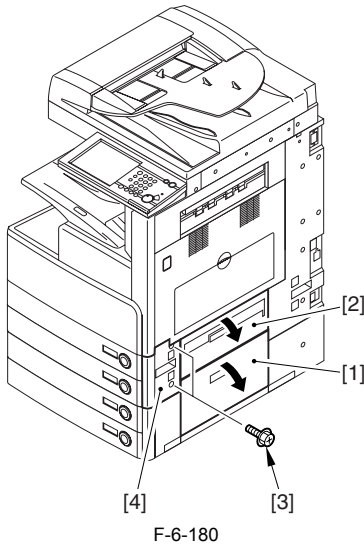

F-6-180

6.8.13.4 Removing the Cassette Size Sensor Relay PCB

- 1) Detach the PCB cover [1] (snap stopper).

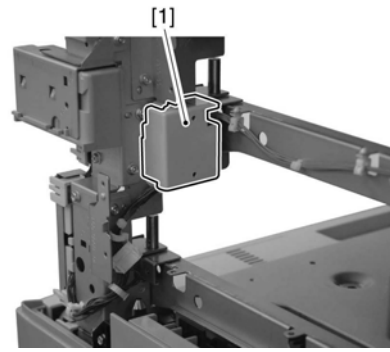

F-6-181

- 2) Remove the cassette size sensor relay PCB [1].
 - 3 connectors [2]
 - 2 wire saddles [3]

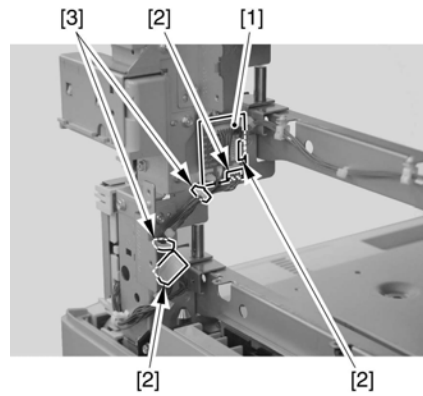

F-6-182

6.8.14 Manual Tray Assembly

6.8.14.1 Removing the Right Cover (rear)

- 1) Open the pedestal right door [1]. (if equipped with a 2-Cassette Pedestal-Y2)
- 2) Open the right lower door [2].
- 3) Remove the 5 screws [3], and detach the right cover (rear) [4].

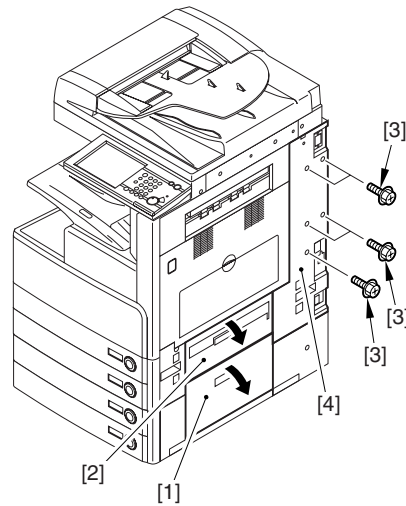

F-6-183

6.8.14.2 Removing the Right Door

- 1) Open the right door.



F-6-184

- 2) Remove the screw [1], and detach the fixing plate [2].

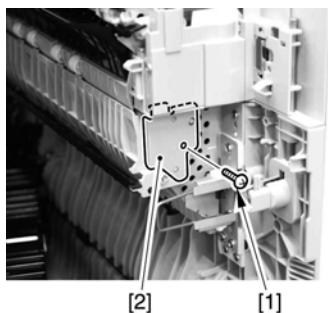

F-6-185

- 3) Remove the joint shaft [1], and free the extension delivery unit [2] from the right door.

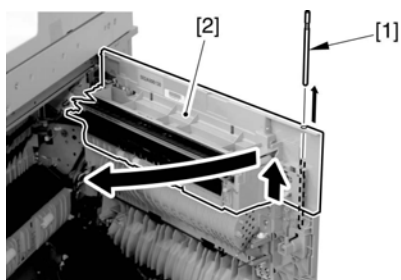

F-6-186

- 4) Disconnect the connector [1], and remove the reuse band [2]; then, remove the 2 screws (M4x8; RS tightening).

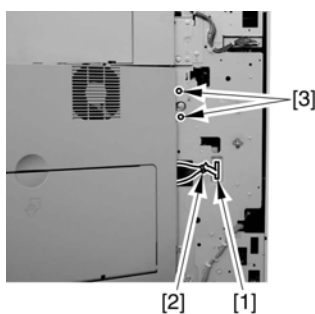

F-6-187

- 5) While freeing the hinge assembly [2], detach the right door.

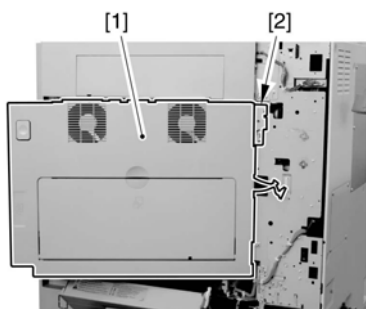

F-6-188

Attaching the Right Door

- 1) Match the hinge [1] found at the bottom of the right door against the lug.
- 2) Engage the hinge [2] found on the top of the right door with the hook found on the side plate.

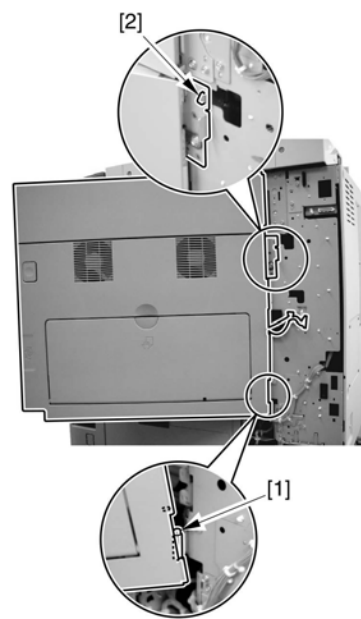

F-6-189



When tightening the 2 screws used to fix the hinge in place, be sure to close the right door first.

6.8.14.3 Removing the Manual Feed Unit

- 1) Remove the manual feed guide link [1].
 - 1 plastic E-ring [2]
 - 1 boss [3]

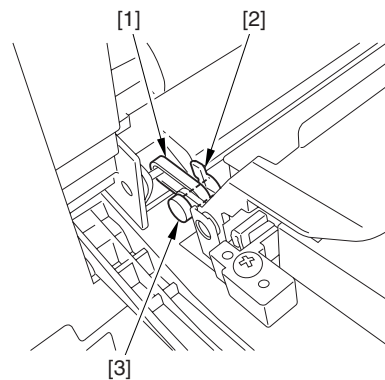

F-6-190

- 2) Remove the manual feed pickup guide [1].
 - 1 screw [2]

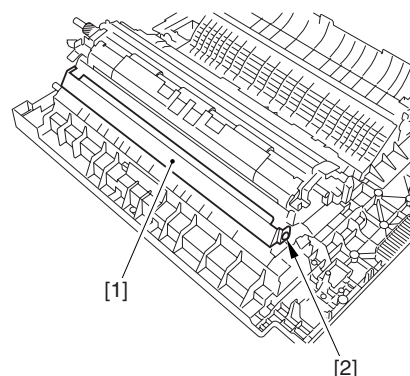

F-6-191

- 3) Detach the connector cover [1] (snap stopper).

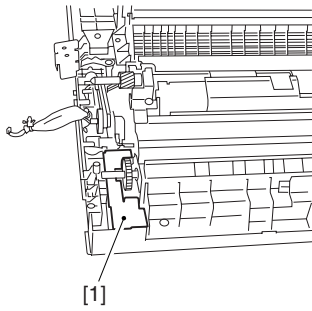

F-6-192

- 4) Disconnect the connector [1].
- 5) Remove the manual feed unit [3].
- 4 screws [2]

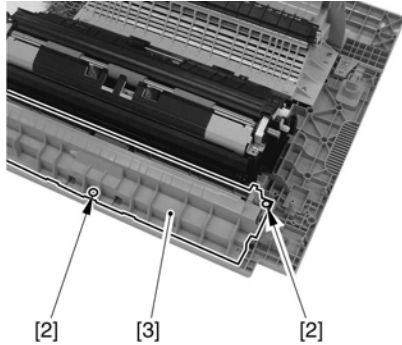

F-6-193

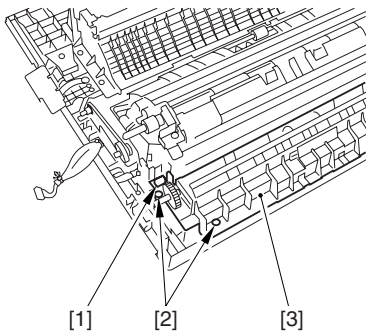

F-6-194

6.8.14.4 Removing the Manual Feed Tray Assembly

- 1) Disconnect the connector [1].
- 2) Remove the tie-wrap [2].

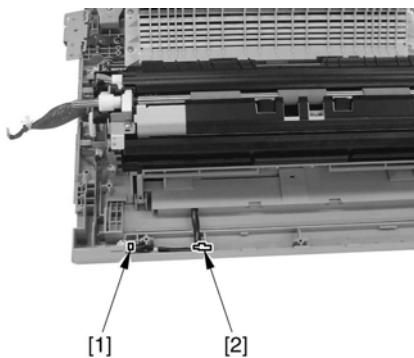

F-6-195

- 3) Remove the manual feed tray unit [3].

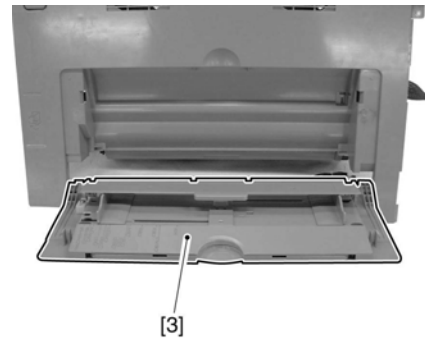

F-6-196

6.8.15 Manual Feed Unit

6.8.15.1 Removing the Right Cover (rear)

- 1) Open the pedestal right door [1]. (if equipped with a 2-Cassette Pedestal-Y2)
- 2) Open the right lower door [2].
- 3) Remove the 5 screws [3], and detach the right cover (rear) [4].

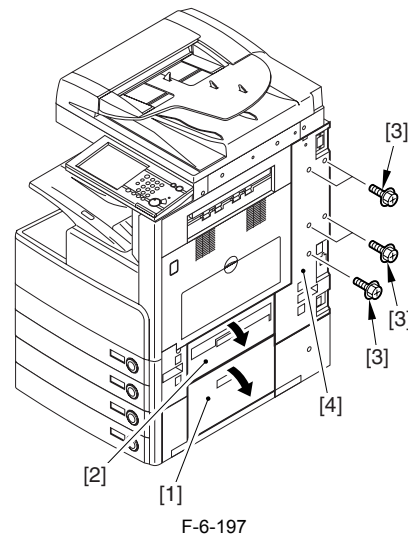

F-6-197

6.8.15.2 Removing the Right Door

- 1) Open the right door.



F-6-198

- 2) Remove the screw [1], and detach the fixing plate [2].

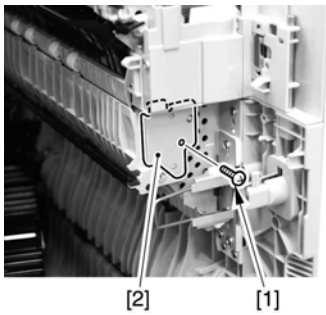

F-6-199

3) Remove the joint shaft [1], and free the extension delivery unit [2] from the right door.

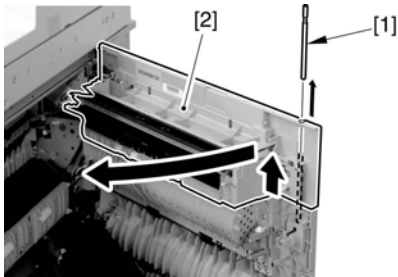

F-6-200

4) Disconnect the connector [1], and remove the reuse band [2]; then, remove the 2 screws (M4x8; RS tightening).

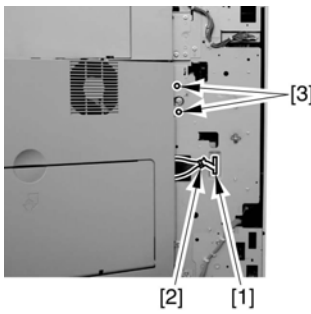

F-6-201

5) While freeing the hinge assembly [2], detach the right door.

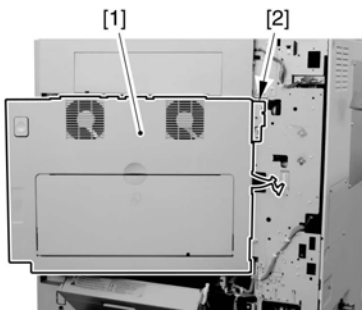

F-6-202

Attaching the Right Door

- 1) Match the hinge [1] found at the bottom of the right door against the lug.
- 2) Engage the hinge [2] found on the top of the right door with the hook found on the side plate.

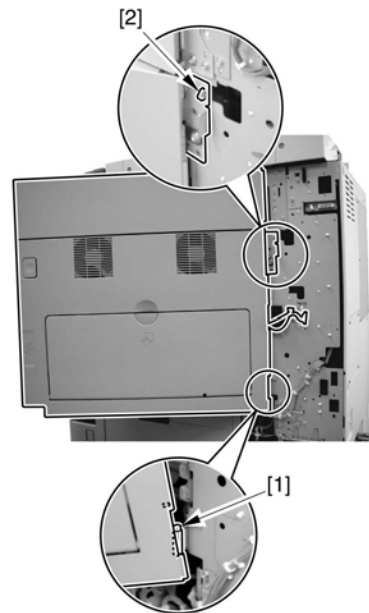

F-6-203



When tightening the 2 screws used to fix the hinge in place, be sure to close the right door first.

6.8.15.3 Removing the Manual Feed Unit

- 1) Remove the manual feed guide link [1].
 - 1 plastic E-ring [2]
 - 1 boss [3]

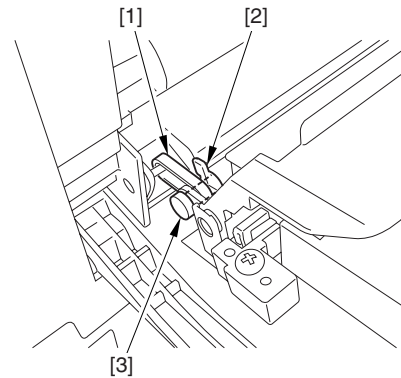

F-6-204

- 2) Remove the manual feed pickup guide [1].
 - 1 screw [2]

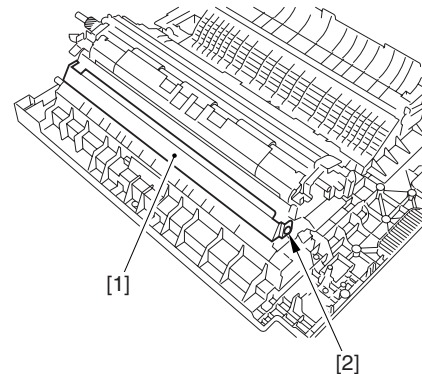

F-6-205

- 3) Detach the connector cover [1] (snap stopper).

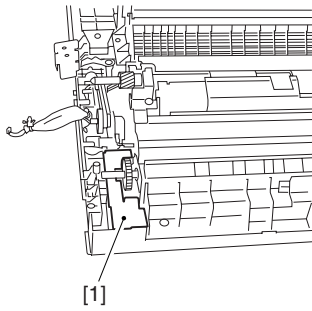

F-6-206

- 4) Disconnect the connector [1].
- 5) Remove the manual feed unit [3].
- 4 screws [2]

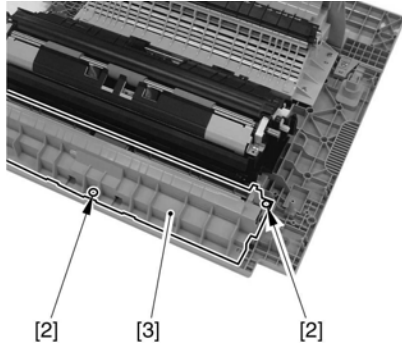

F-6-207

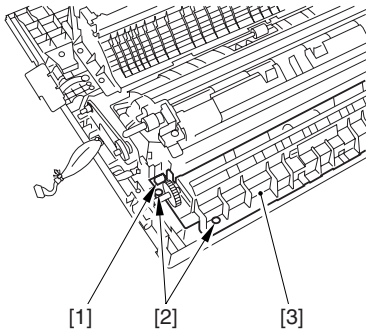

F-6-208

6.8.16 Manual Pickup Roller

6.8.16.1 Removing the Right Cover (rear)

- 1) Open the pedestal right door [1]. (if equipped with a 2-Cassette Pedestal-Y2)
- 2) Open the right lower door [2].
- 3) Remove the 5 screws [3], and detach the right cover (rear) [4].

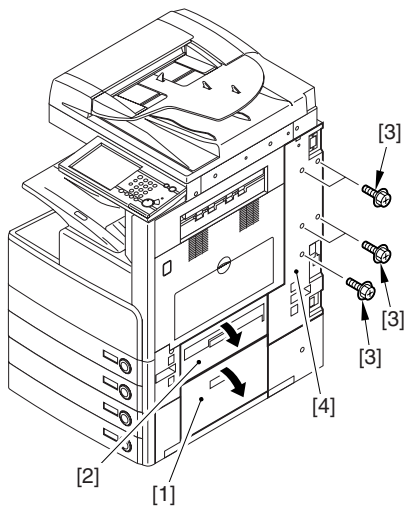

F-6-209

6.8.16.2 Removing the Right Door

- 1) Open the right door.

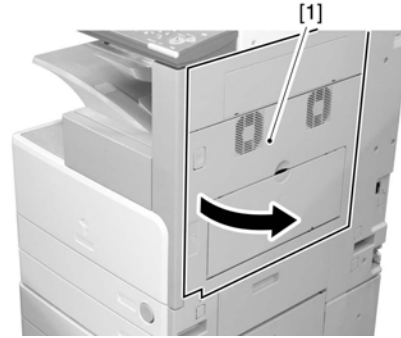

F-6-210

- 2) Remove the screw [1], and detach the fixing plate [2].

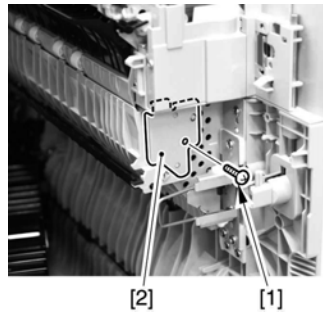

F-6-211

- 3) Remove the joint shaft [1], and free the extension delivery unit [2] from the right door.

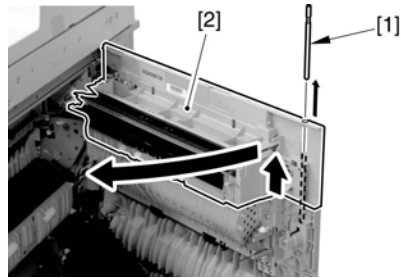

F-6-212

- 4) Disconnect the connector [1], and remove the reuse band [2]; then, remove the 2 screws (M4x8; RS tightening).

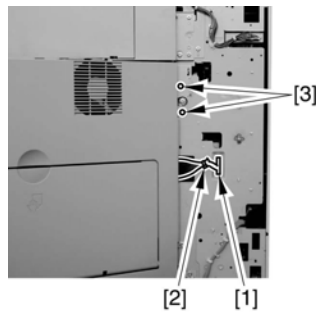

F-6-213

- 5) While freeing the hinge assembly [2], detach the right door.

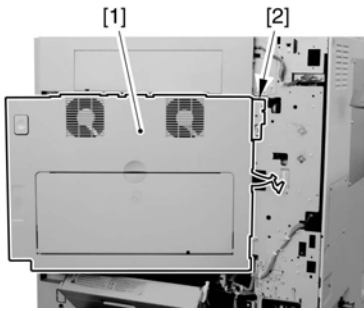

F-6-214

Attaching the Right Door

- 1) Match the hinge [1] found at the bottom of the right door against the lug.
- 2) Engage the hinge [2] found on the top of the right door with the hook found on the side plate.

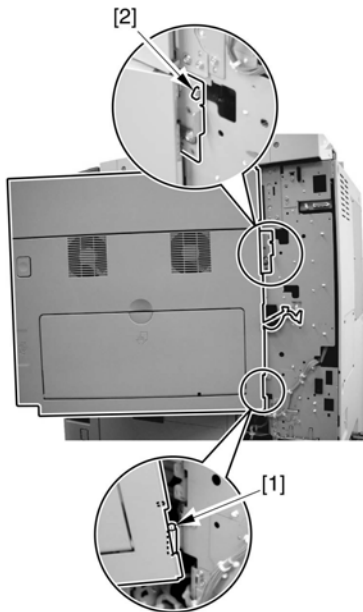

F-6-215



When tightening the 2 screws used to fix the hinge in place, be sure to close the right door first.

6.8.16.3 Removing the Manual Feed Unit

- 1) Remove the manual feed guide link [1].
 - 1 plastic E-ring [2]
 - 1 boss [3]

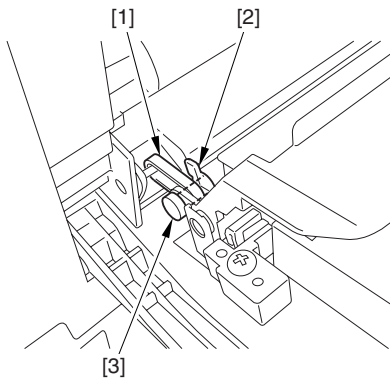

F-6-216

- 2) Remove the manual feed pickup guide [1].
 - 1 screw [2]

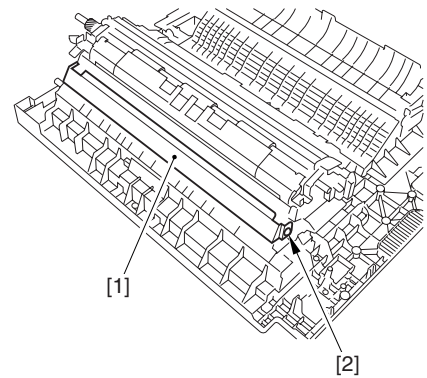

F-6-217

- 3) Detach the connector cover [1] (snap stopper).

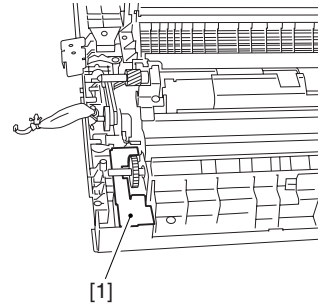

F-6-218

- 4) Disconnect the connector [1].
- 5) Remove the manual feed unit [3].
 - 4 screws [2]

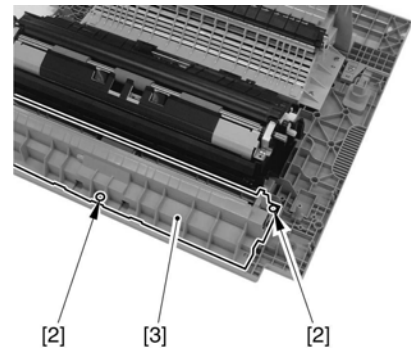

F-6-219

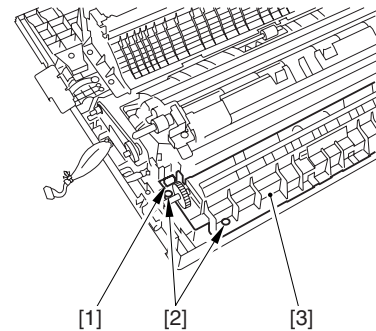

F-6-220

6.8.16.4 Removing the Manual Feed Pickup Roller

- 1) Detach the manual feed pickup upper cover [1] (snap stopper).

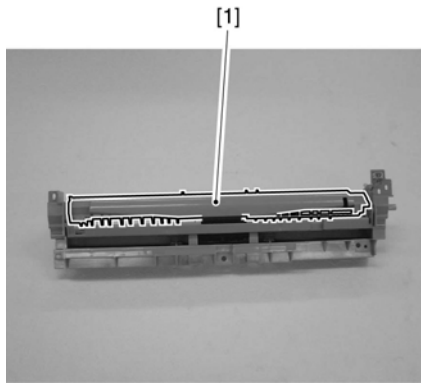

F-6-221

- 2) Remove the manual feed pickup roller [3] together with the shaft.
 - 1 bushing [2]
- 3) Remove the manual feed pickup roller [3] from the shaft.
 - 1 plastic E-ring [4]

! Do not drop the parallel pin when removing the manual feed pickup roller.

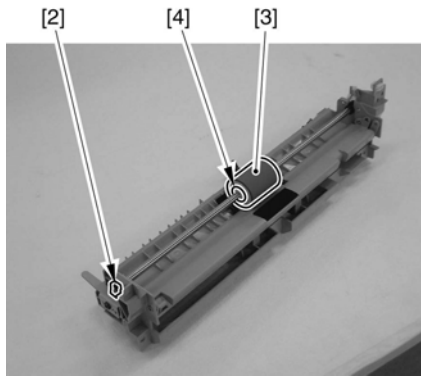

F-6-222

6.8.17 Manual Pick-up Clutch

6.8.17.1 Removing the Right Cover (rear)

- 1) Open the pedestal right door [1]. (if equipped with a 2-Cassette Pedestal-Y2)
- 2) Open the right lower door [2].
- 3) Remove the 5 screws [3], and detach the right cover (rear) [4].

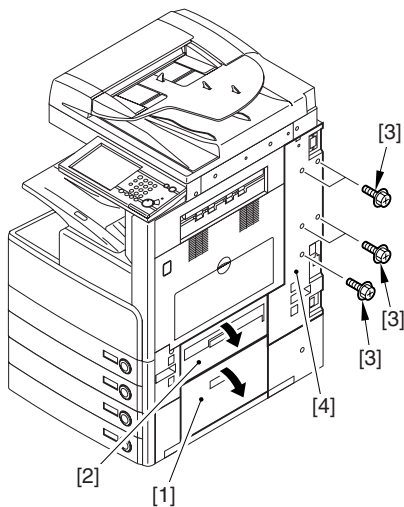

F-6-223

6.8.17.2 Removing the Right Door

- 1) Open the right door.

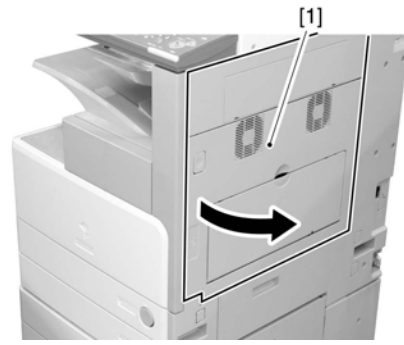

F-6-224

- 2) Remove the screw [1], and detach the fixing plate [2].

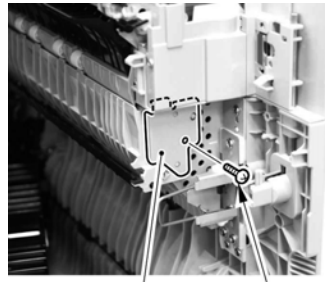

F-6-225

- 3) Remove the joint shaft [1], and free the extension delivery unit [2] from the right door.

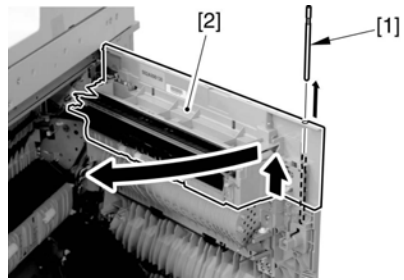

F-6-226

- 4) Disconnect the connector [1], and remove the reuse band [2]; then, remove the 2 screws (M4x8; RS tightening).

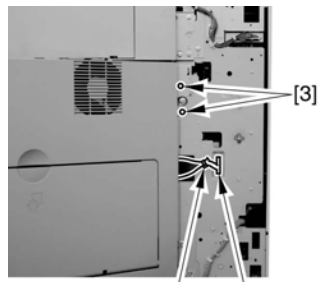

F-6-227

- 5) While freeing the hinge assembly [2], detach the right door.

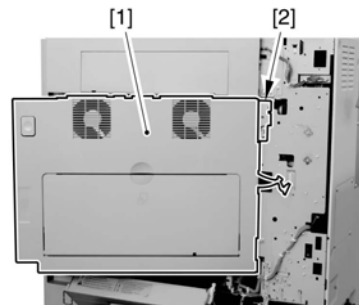

F-6-228

Attaching the Right Door

- 1) Match the hinge [1] found at the bottom of the right door against the lug.
- 2) Engage the hinge [2] found on the top of the right door with the hook found on the side plate.

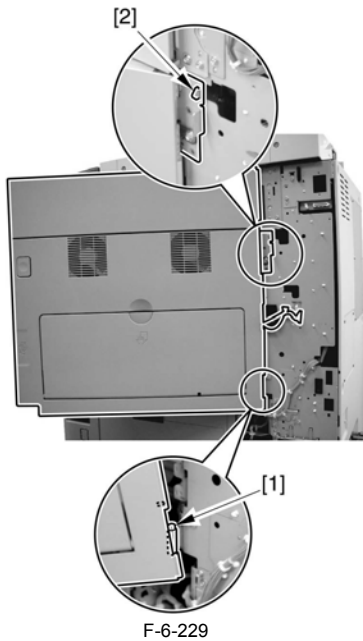

F-6-229

! When tightening the 2 screws used to fix the hinge in place, be sure to close the right door first.

6.8.17.3 Removing the Rear Cover

- 1) Remove the 13 screws [1] and then the other screw [2]; then, detach the rear cover [3].

! If the left cover (lower) has already been detached, the screw [3] should also have been removed.

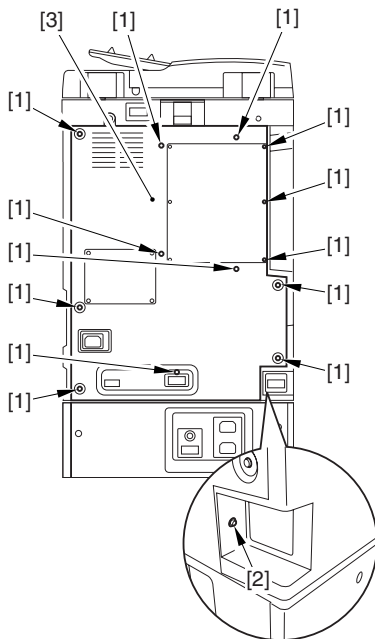

F-6-230

6.8.17.4 Removing the Main Power Switch

- 1) Remove the 4 fastens [1], and detach the main power switch [2]. (snap-on type)

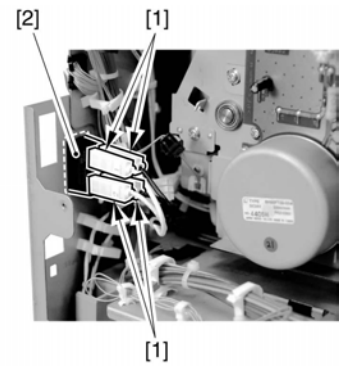

F-6-231

! When connecting the 4 fastens, be sure that they are located as indicated by their specific location numbers.

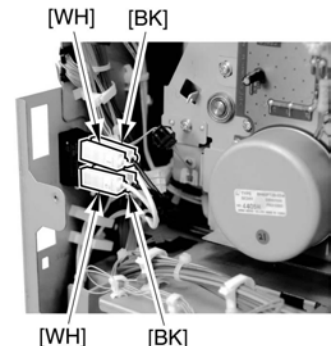

F-6-232

6.8.17.5 Removing the Manual Feed Pickup Clutch

- 1) Disconnect the connector (2P) [1].
- 2) Free the clutch cable [2] from the wire saddle [3].
- 3) Remove the fixing plate [4]. (2 screws [5])

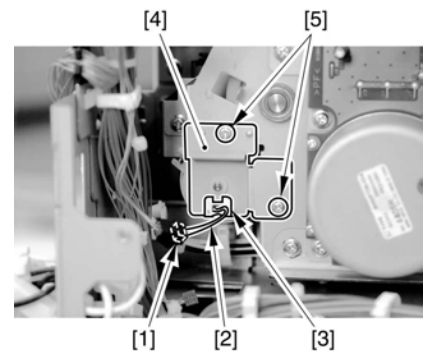

F-6-233

- 4) Pull out the manual feed pickup clutch [1].

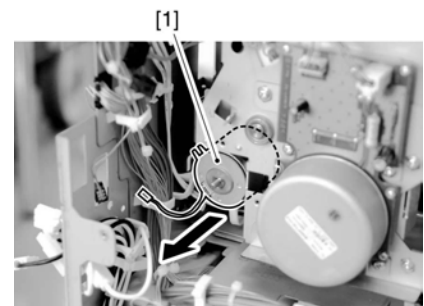

F-6-234

6.8.18 Manual Separation Pad

6.8.18.1 Removing the Right Cover (rear)

- 1) Open the pedestal right door [1]. (if equipped with a 2-Cassette Pedestal-Y2)
- 2) Open the right lower door [2].
- 3) Remove the 5 screws [3], and detach the right cover (rear) [4].

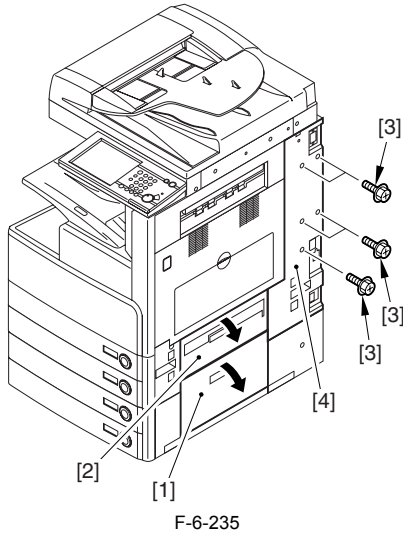

6.8.18.2 Removing the Right Door

- 1) Open the right door.



- 2) Remove the screw [1], and detach the fixing plate [2].

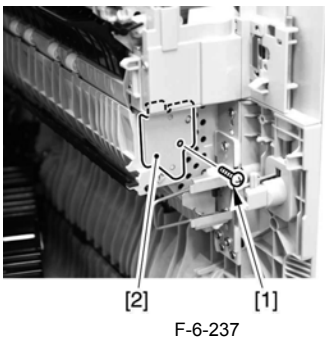

- 3) Remove the joint shaft [1], and free the extension delivery unit [2] from the right door.

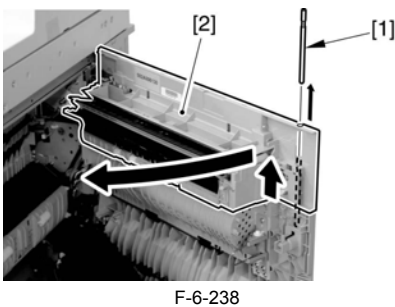

- 4) Disconnect the connector [1], and remove the reuse band [2]; then, remove the 2 screws (M4x8; RS tightening).

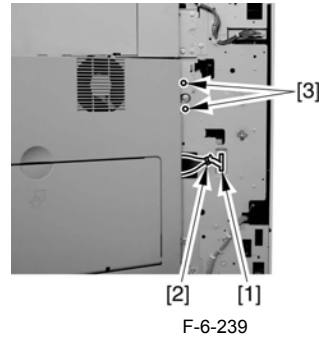

- 5) While freeing the hinge assembly [2], detach the right door.

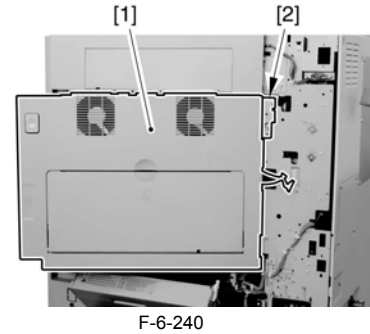

Attaching the Right Door

- 1) Match the hinge [1] found at the bottom of the right door against the lug.
- 2) Engage the hinge [2] found on the top of the right door with the hook found on the side plate.

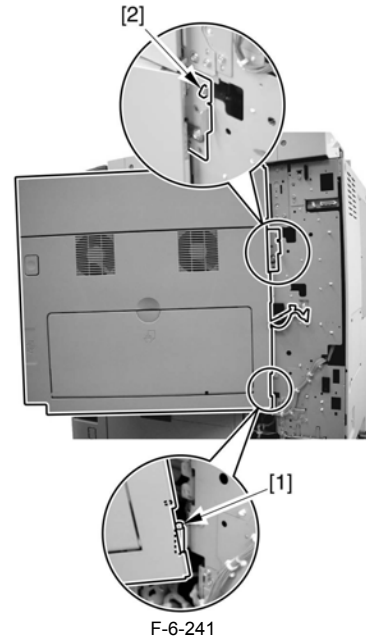

! When tightening the 2 screws used to fix the hinge in place, be sure to close the right door first.

6.8.18.3 Removing the Manual Feed Unit

- 1) Remove the manual feed guide link [1].
 - 1 plastic E-ring [2]
 - 1 boss [3]

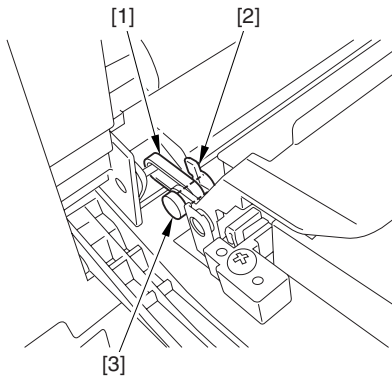

F-6-242

- 2) Remove the manual feed pickup guide [1].
- 1 screw [2]

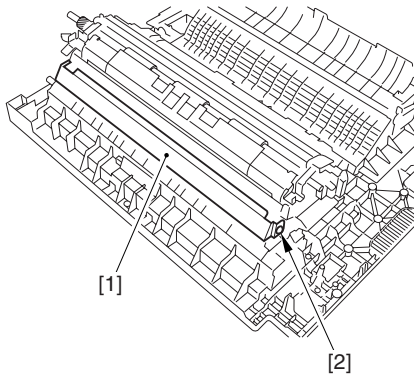

F-6-243

- 3) Detach the connector cover [1] (snap stopper).

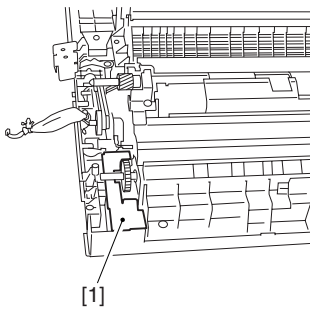

F-6-244

- 4) Disconnect the connector [1].
- 5) Remove the manual feed unit [3].
- 4 screws [2]

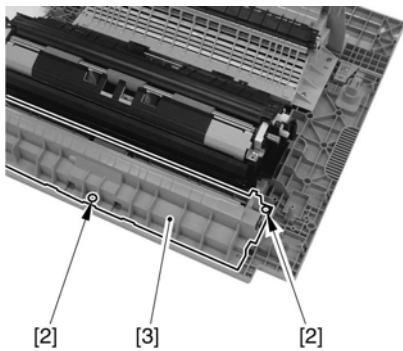

F-6-245

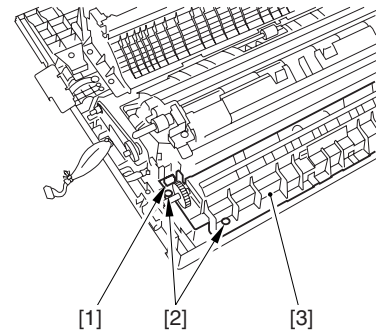

F-6-246

6.8.18.4 Removing the Manual Feed Pickup Roller

- 1) Detach the manual feed pickup upper cover [1] (snap stopper).

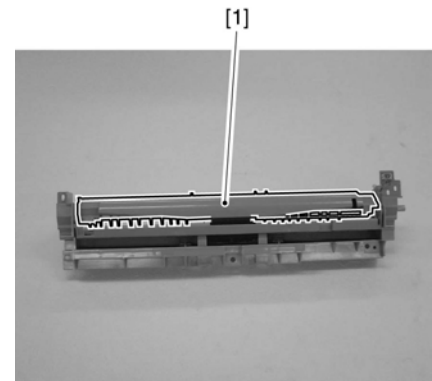

F-6-247

- 2) Remove the manual feed pickup roller [3] together with the shaft.
- 1 bushing [2]
- 3) Remove the manual feed pickup roller [3] from the shaft.
- 1 plastic E-ring [4]

⚠ Do not drop the parallel pin when removing the manual feed pickup roller.

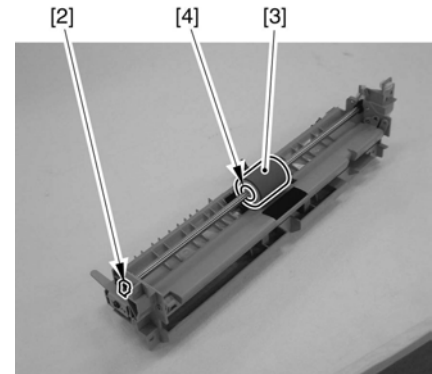

F-6-248

6.8.18.5 Removing the Manual Feed Separation pad

- 1) Detach the holding plate [5].
- 2) Remove the manual feed separation pad [6].

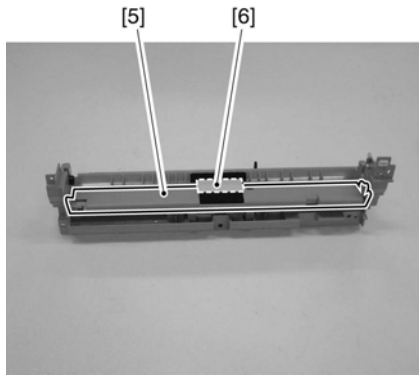

F-6-249

6.8.19 Registration Clutch

6.8.19.1 Removing the Rear Cover

1) Remove the 13 screws [1] and then the other screw [2]; then, detach the rear cover [3].



If the left cover (lower) has already been detached, the screw [3] should also have been removed.

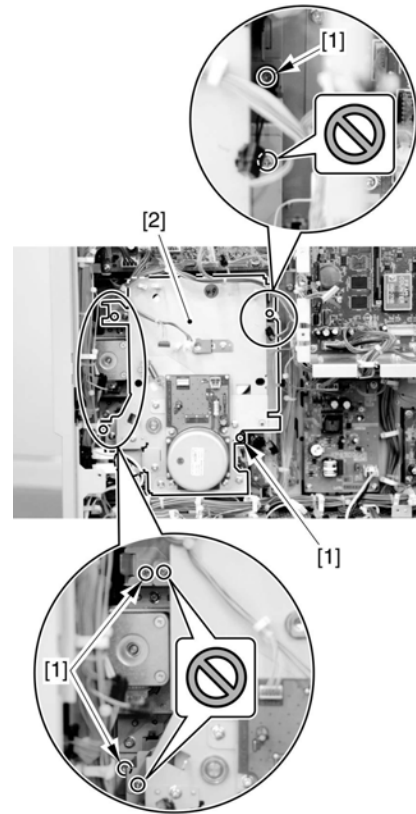

F-6-252

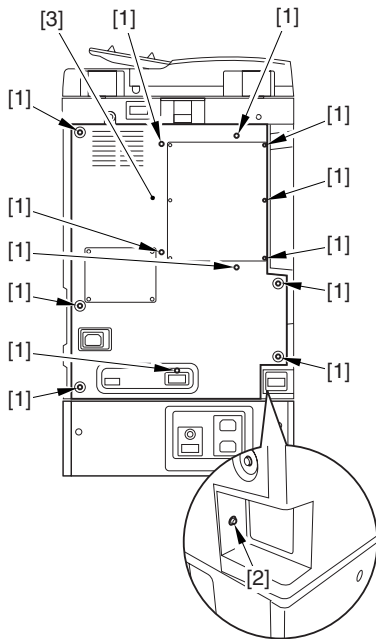

F-6-250



Do not touch the screws that are glued in place.

6.8.19.3 Removing the Registration Clutch

1) Disconnect the connector (2P) [1], and free the cable from the edge saddle [2] and the 3 wire saddles [3].
2) Remove the E-ring [4], and detach the registration clutch [5].

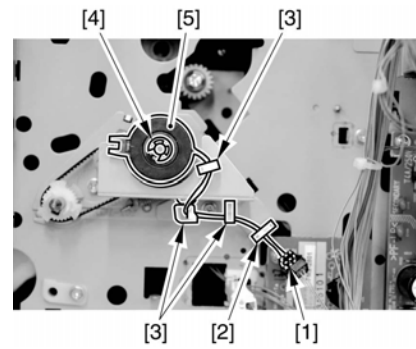

F-6-253

6.8.19.2 Removing the Main Drive Assembly

1) Disconnect the connector [1], and free the harness [2] from the wire saddle.

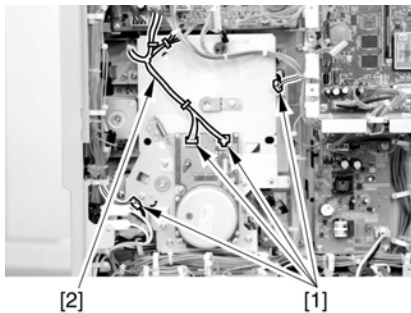

F-6-251

2) Remove the 4 screws [1], and detach the main drive assembly [2].

6.8.20 Feeding Roller

6.8.20.1 Removing the Pickup Roller/Feed Roller/ Separation Roller

1) Slide out the cassette.
2) Open the right door (in the case of the separation roller).
3) Pick the tabs of the individual rollers, and detach the pickup roller [1], feed roller [2], and separation roller [3].

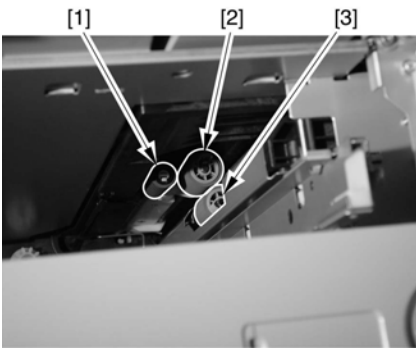

F-6-254

⚠ Point to Note When Replacing the Feed/Separation Roller 1
The collar (roller core) of the machine's feed/separation roller is black.

6.8.21 Vertical Path Roller

6.8.21.1 Removing the Right Cover (rear)

- 1) Open the pedestal right door [1]. (if equipped with a 2-Cassette Pedestal-Y2)
- 2) Open the right lower door [2].
- 3) Remove the 5 screws [3], and detach the right cover (rear) [4].

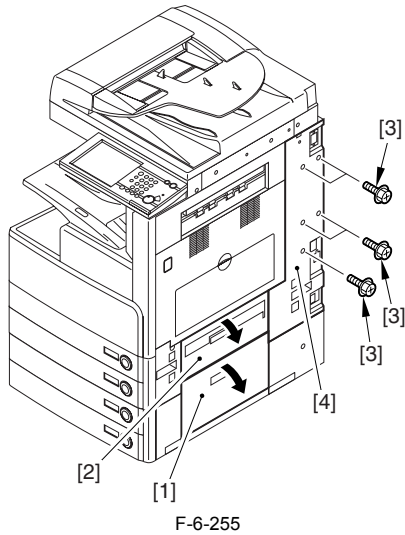

F-6-255

6.8.21.2 Removing the Right Door

- 1) Open the right door.



F-6-256

- 2) Remove the screw [1], and detach the fixing plate [2].

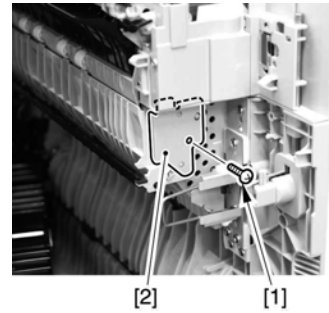

F-6-257

- 3) Remove the joint shaft [1], and free the extension delivery unit [2] from the right door.

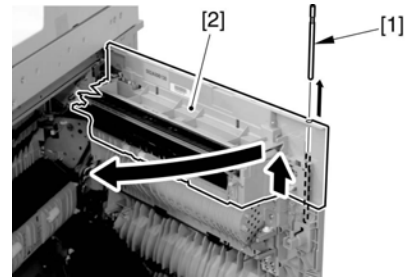

F-6-258

- 4) Disconnect the connector [1], and remove the reuse band [2]; then, remove the 2 screws (M4x8; RS tightening).

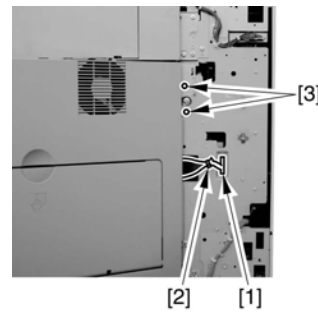

F-6-259

- 5) While freeing the hinge assembly [2], detach the right door.

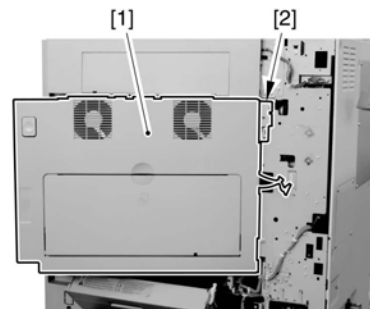

F-6-260

Attaching the Right Door

- 1) Match the hinge [1] found at the bottom of the right door against the lug.
- 2) Engage the hinge [2] found on the top of the right door with the hook found on the side plate.

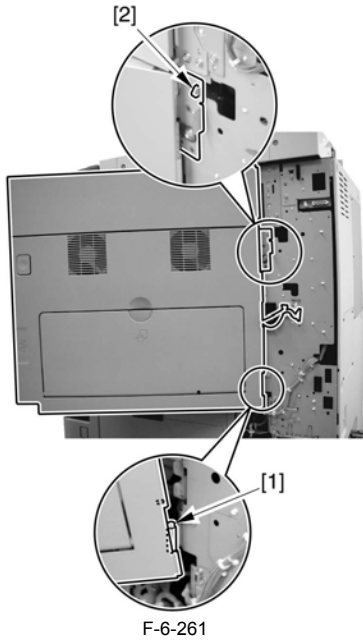

F-6-261



When tightening the 2 screws used to fix the hinge in place, be sure to close the right door first.

6.8.21.3 Removing the Right Cover (lower front)

- 1) Open the pedestal right door [1]. (if equipped with a Cassette Feeding Unit-Y2)
- 2) Open the lower right door [2].
- 3) Remove the 2 screws [3], and detach the right cover (lower front) [4].

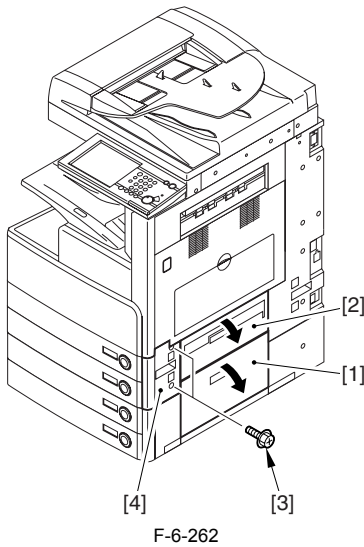

F-6-262

6.8.21.4 Removing the Sensor Mounting Plate

- 1) Remove the 2 TP screws [1] and the binding screw [2] from the rear of the pickup assembly, and detach the bracket [3].

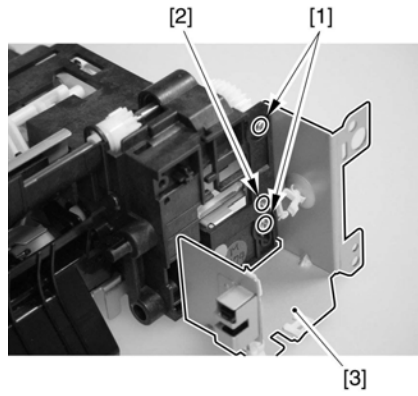

F-6-263
Pickup Unit 1

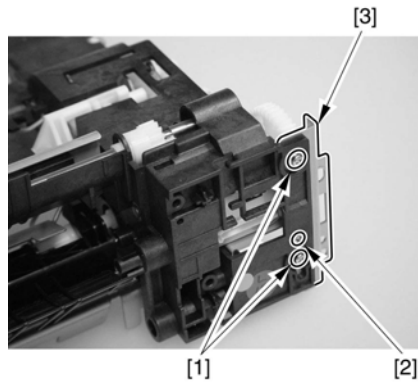

F-6-264
Pickup Unit 2

- 2) Disconnect the connector [1], and remove the screw; then, detach the cassette pickup solenoid [3].
- 3) Remove the bushing [4] and the 5 screws [5]; then, detach the sensor base [6].

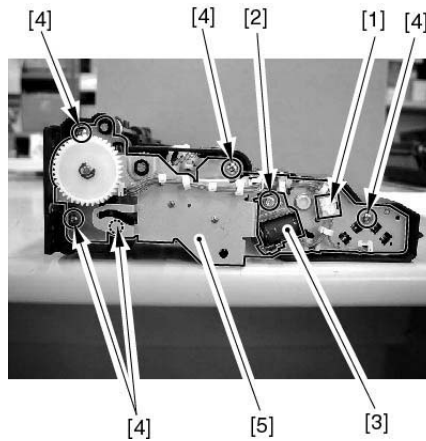

F-6-265

6.8.21.5 Removing the Vertical Path Roller

- 1) Release the claw [A] of the gear [1] at the rear, and remove the gear [1] and the bushing [2].

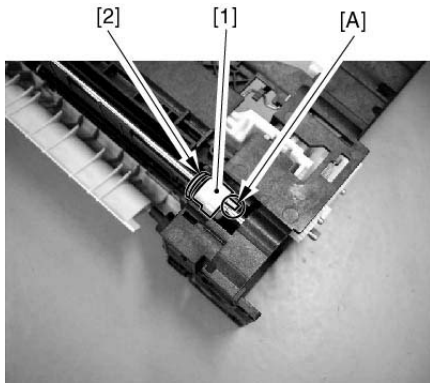

F-6-266

- 2) Release the claw [A] of the bushing [1] at the front to move it toward the rear, and then remove the vertical path roller [2] upward.

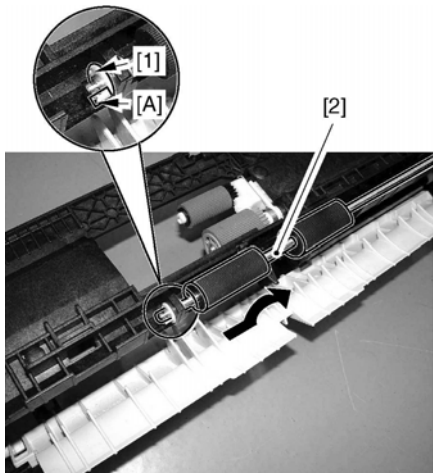

F-6-267

6.8.22 Duplex Feed Roller 2

6.8.22.1 Removing the Right Cover (rear)

- 1) Open the pedestal right door [1]. (if equipped with a 2-Cassette Pedestal-Y2)
- 2) Open the right lower door [2].
- 3) Remove the 5 screws [3], and detach the right cover (rear) [4].

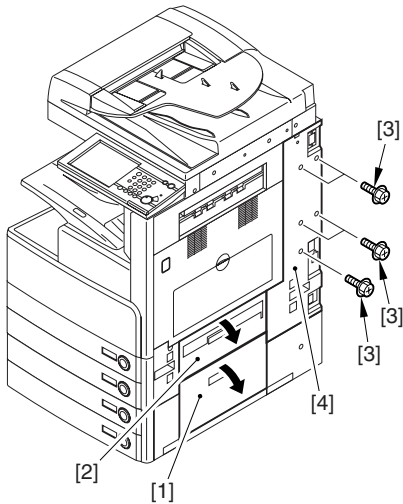

F-6-268

6.8.22.2 Removing the Right Door

- 1) Open the right door.

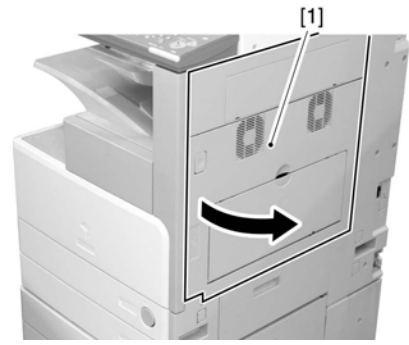

F-6-269

- 2) Remove the screw [1], and detach the fixing plate [2].

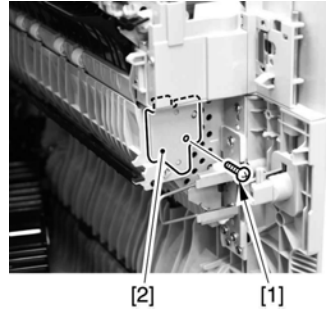

F-6-270

- 3) Remove the joint shaft [1], and free the extension delivery unit [2] from the right door.

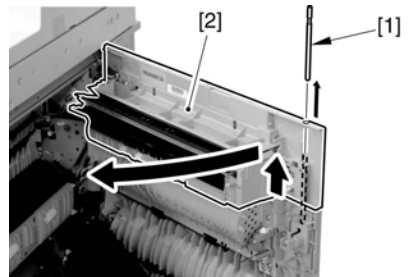

F-6-271

- 4) Disconnect the connector [1], and remove the reuse band [2]; then, remove the 2 screws (M4x8; RS tightening).

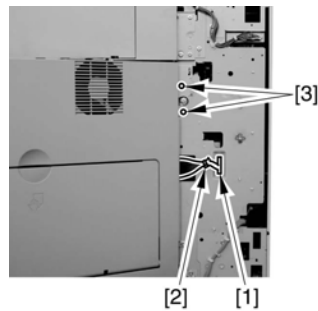

F-6-272

- 5) While freeing the hinge assembly [2], detach the right door.

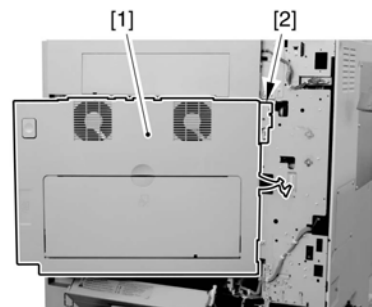

F-6-273

Attaching the Right Door

- 1) Match the hinge [1] found at the bottom of the right door against the lug.
- 2) Engage the hinge [2] found on the top of the right door with the hook found on the side plate.

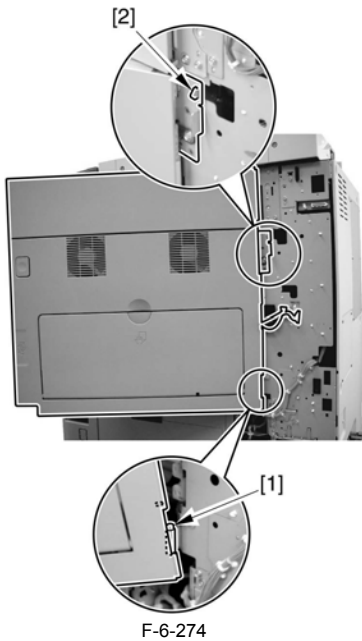

F-6-274



When tightening the 2 screws used to fix the hinge in place, be sure to close the right door first.

6.8.22.3 Removing the Duplex Feed Roller 2

- 1) Release the coil spring [1].
- 2) Remove the E-ring [2] to remove the shaft [3], and detach the duplex feed frame [4].

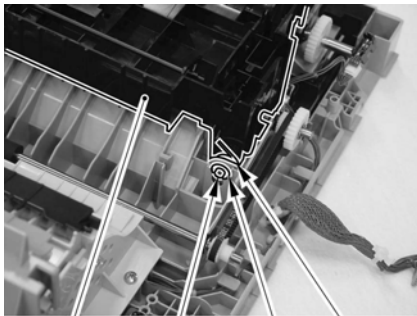

F-6-275

- 3) Remove the one-way gear [2].
- 1 E-ring [1]

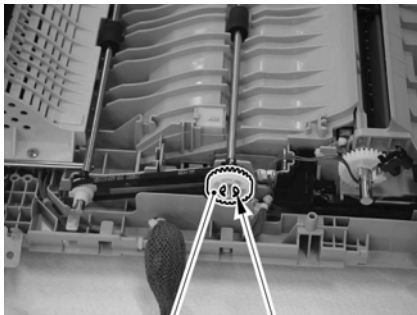

F-6-276

- 4) Remove the duplex feed roller 2 [2].
- 1 E-ring [1]

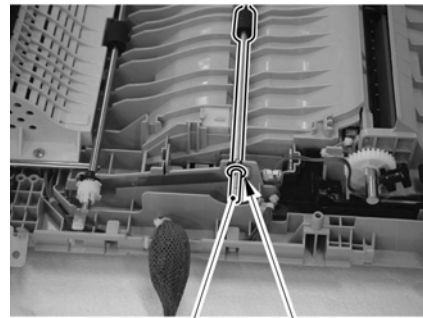

F-6-277

6.8.23 Duplex Feed Sensor

6.8.23.1 Removing the Right Cover (rear)

- 1) Open the pedestal right door [1]. (if equipped with a 2-Cassette Pedestal-Y2)
- 2) Open the right lower door [2].
- 3) Remove the 5 screws [3], and detach the right cover (rear) [4].

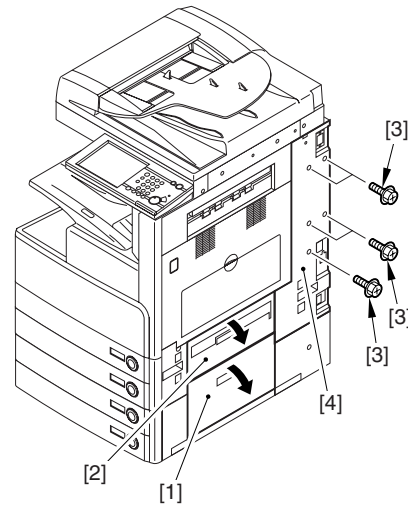

F-6-278

6.8.23.2 Removing the Right Door

- 1) Open the right door.



F-6-279

- 2) Remove the screw [1], and detach the fixing plate [2].

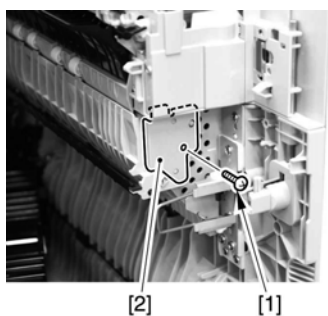

F-6-280

- 3) Remove the joint shaft [1], and free the extension delivery unit [2] from the right door.

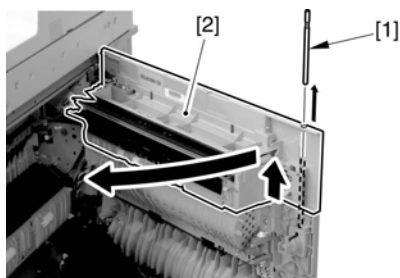

F-6-281

- 4) Disconnect the connector [1], and remove the reuse band [2]; then, remove the 2 screws (M4x8; RS tightening).

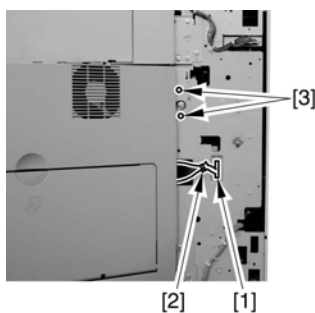

F-6-282

- 5) While freeing the hinge assembly [2], detach the right door.

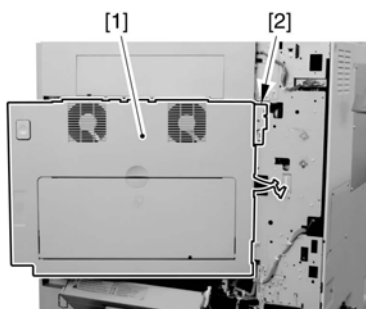

F-6-283

Attaching the Right Door

- 1) Match the hinge [1] found at the bottom of the right door against the lug.
- 2) Engage the hinge [2] found on the top of the right door with the hook found on the side plate.

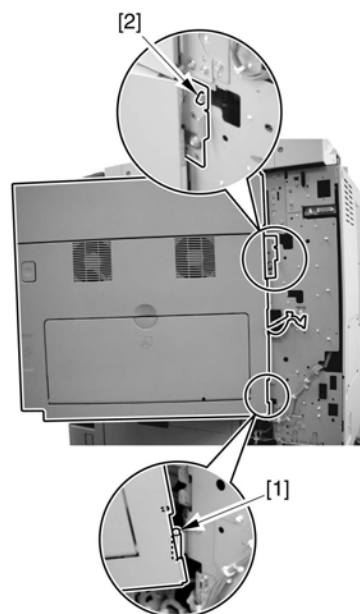

F-6-284



When tightening the 2 screws used to fix the hinge in place, be sure to close the right door first.

6.8.24 Delivery Assembly 1

6.8.24.1 Removing the Right Cover (rear)

- 1) Open the pedestal right door [1]. (if equipped with a 2-Cassette Pedestal-Y2)
- 2) Open the right lower door [2].
- 3) Remove the 5 screws [3], and detach the right cover (rear) [4].

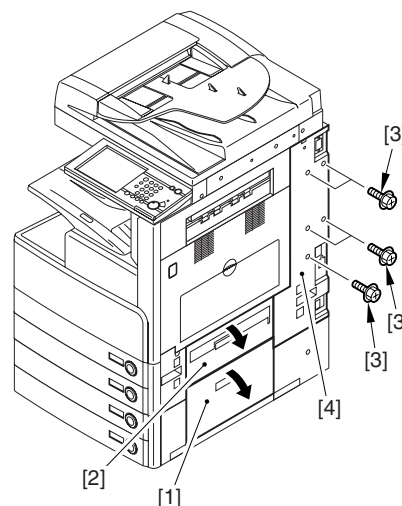

F-6-285

6.8.24.2 Removing the Front Cover Unit

- 1) Open the front cover [1].

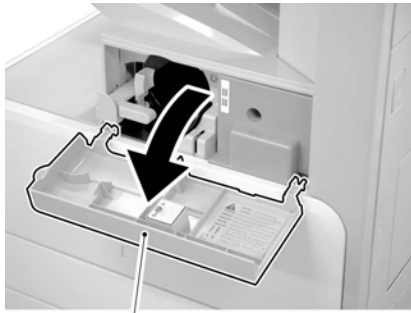

F-6-286

- 2) Remove the face cover rubber [1].
- 3) Remove the binding screw [2].
- 4) Remove the RS tightening screw [3].
- 5) Detach the front cover unit [4] by moving it in the direction of the arrow.

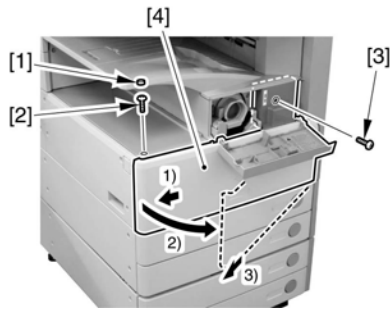

F-6-287

6.8.24.3 Removing the Delivery Tray

- 1) Loosen the screw [1].
- 2) Remove the screw [2].
- 3) Detach the delivery tray [3].

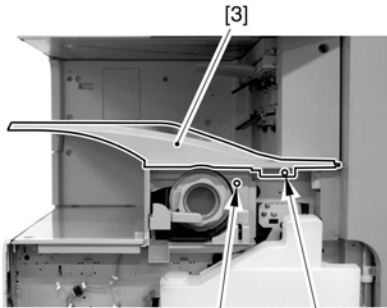

F-6-288

6.8.24.4 Removing the Right Door

- 1) Open the right door.

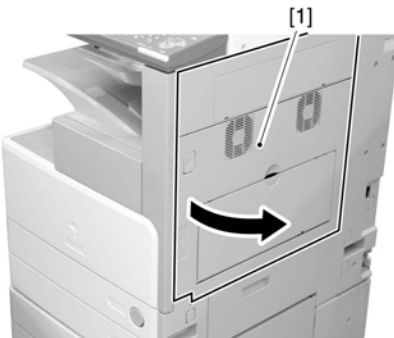

F-6-289

- 2) Remove the screw [1], and detach the fixing plate [2].

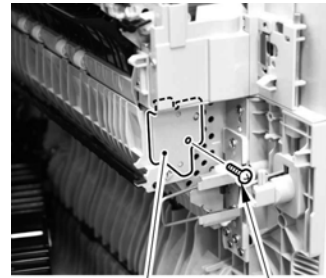

F-6-290

- 3) Remove the joint shaft [1], and free the extension delivery unit [2] from the right door.

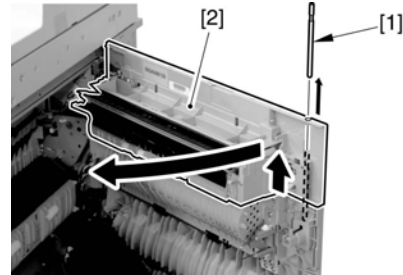

F-6-291

- 4) Disconnect the connector [1], and remove the reuse band [2]; then, remove the 2 screws (M4x8; RS tightening).

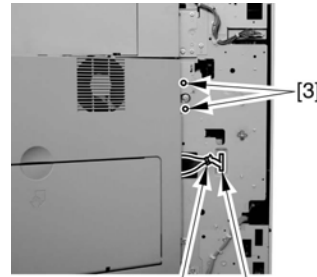

F-6-292

- 5) While freeing the hinge assembly [2], detach the right door.

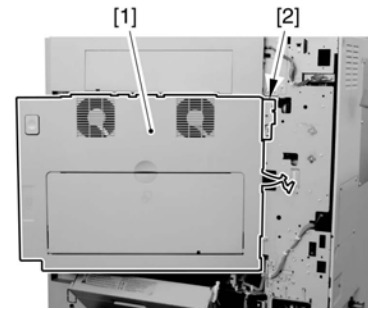

F-6-293

Attaching the Right Door

- 1) Match the hinge [1] found at the bottom of the right door against the lug.
- 2) Engage the hinge [2] found on the top of the right door with the hook found on the side plate.

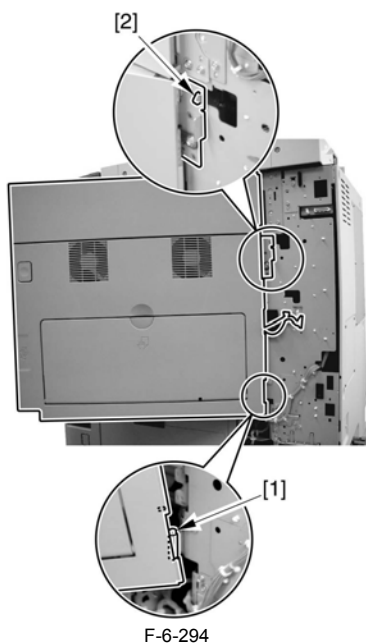

F-6-294



When tightening the 2 screws used to fix the hinge in place, be sure to close the right door first.

6.8.24.5 Removing the Extension Delivery Kit

- 1) Remove the self-tapping screw [1], and detach the upper inside cover [2].

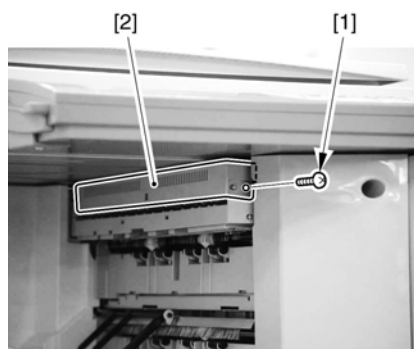

F-6-295

- 2) Free the harness [2] from the cable clamp [3], and detach the 2 re-use bands.
- 3) Disconnect the connector [1] from the machine terminal.

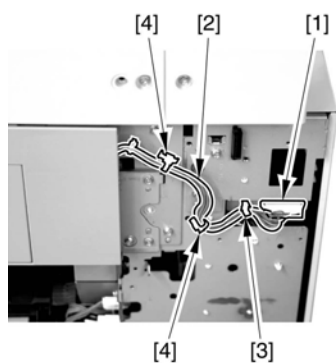

F-6-296

- 4) Open the Extension Delivery Kit [1].
- 5) Remove the 2 screws [3].
- 6) Remove the 2 screws [2], and close the Extension Delivery Kit.

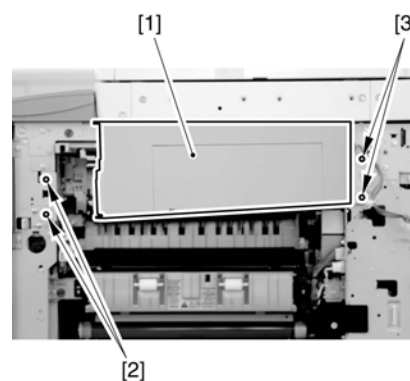

F-6-297

- 7) Pull out the Extension Delivery Kit [1] from the machine.

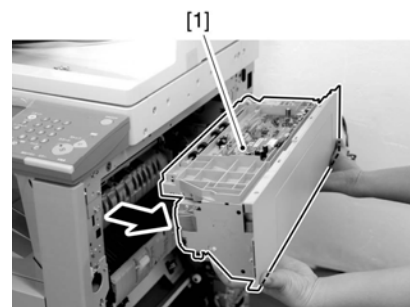

F-6-298

6.8.24.6 Removing the Delivery Assembly 1

- 1) Remove the delivery assembly 1 [1]. (3 screws [2]; 2 stepped screws on the left)

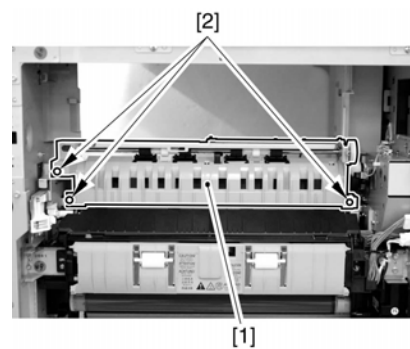

F-6-299

6.8.25 Fixing/ Delivery Drive Assembly

6.8.25.1 Removing the Right Cover (rear)

- 1) Open the pedestal right door [1]. (if equipped with a 2-Cassette Pedestal-Y2)
- 2) Open the right lower door [2].
- 3) Remove the 5 screws [3], and detach the right cover (rear) [4].

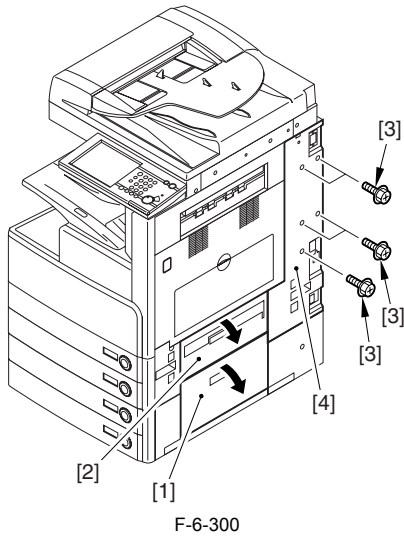

6.8.25.2 Removing the Front Cover Unit

- 1) Open the front cover [1].

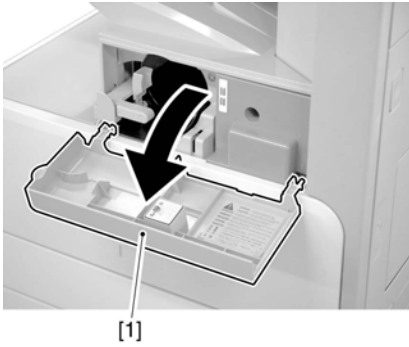

F-6-301

- 2) Remove the face cover rubber [1].
- 3) Remove the binding screw [2].
- 4) Remove the RS tightening screw [3].
- 5) Detach the front cover unit [4] by moving it in the direction of the arrow.

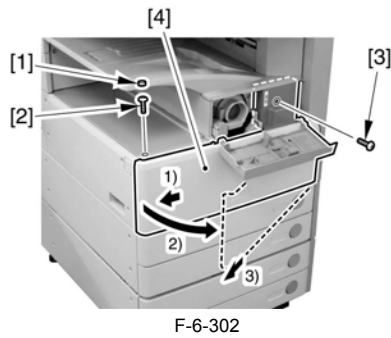

F-6-302

6.8.25.3 Removing the Delivery Tray

- 1) Loosen the screw [1].
- 2) Remove the screw [2].
- 3) Detach the delivery tray [3].

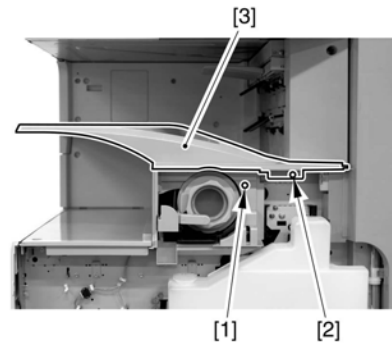

F-6-303

6.8.25.4 Removing the Right Door

- 1) Open the right door.



F-6-304

- 2) Remove the screw [1], and detach the fixing plate [2].

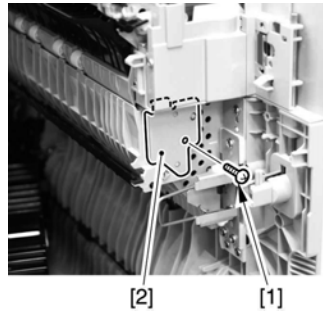

F-6-305

- 3) Remove the joint shaft [1], and free the extension delivery unit [2] from the right door.

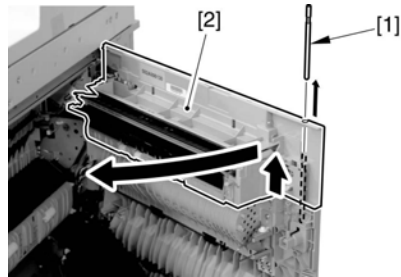

F-6-306

- 4) Disconnect the connector [1], and remove the reuse band [2]; then, remove the 2 screws (M4x8; RS tightening).

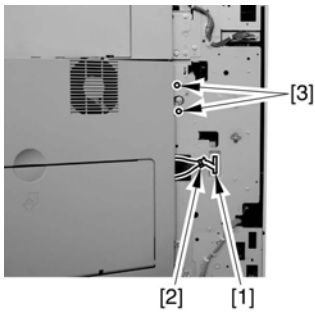

F-6-307

5) While freeing the hinge assembly [2], detach the right door.

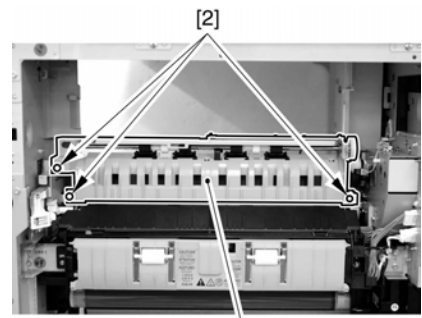

F-6-310

6.8.25.6 Removing the Fixing Unit

1) Remove the screw [1], and detach the harness cover [2].

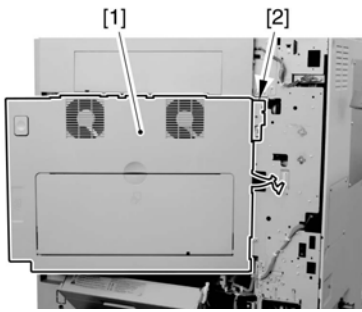

F-6-308

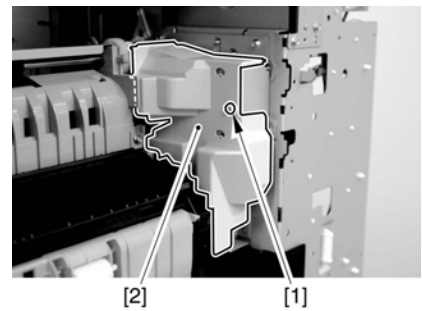

F-6-311

Attaching the Right Door

- 1) Match the hinge [1] found at the bottom of the right door against the lug.
- 2) Engage the hinge [2] found on the top of the right door with the hook found on the side plate.

2) Disconnect the 3 connectors [1].

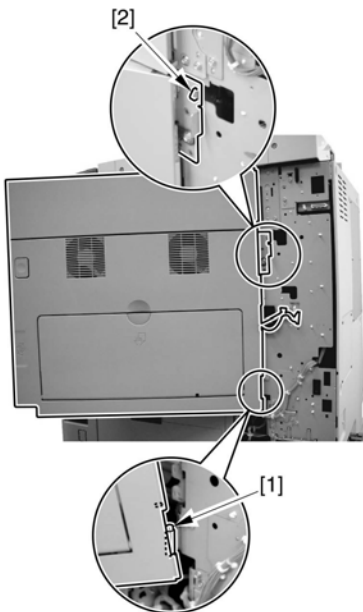

F-6-309

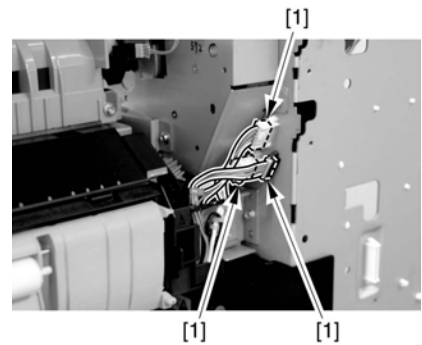

F-6-312

3) Remove the 4 screws [1].

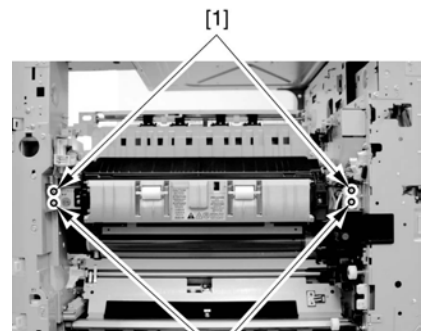

F-6-313

4) Detach the fixing unit [1] toward the front.



When tightening the 2 screws used to fix the hinge in place, be sure to close the right door first.

6.8.25.5 Removing the Delivery Assembly 1

1) Remove the delivery assembly 1 [1]. (3 screws [2]; 2 stepped screws on the left)

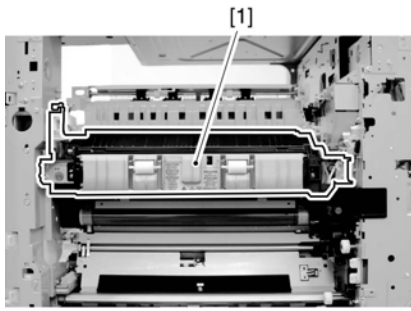

F-6-314



When mounting the harness cover [1], be sure to keep the harness [2] within the space [3] indicated in the figure so that the harness [2] will not come into contact with the gear [4].

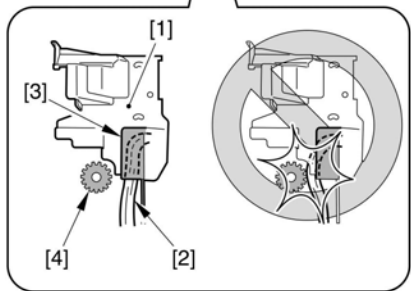
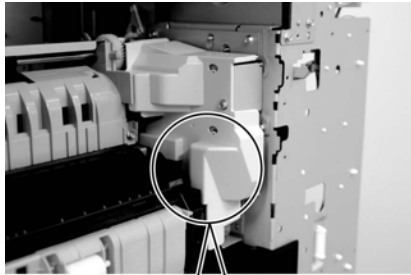

F-6-315



Do not touch the screw [1]. Turning it will change the pressure of the fixing assembly, which cannot be adjusted in the field, necessitating the replacement of the fixing assembly.

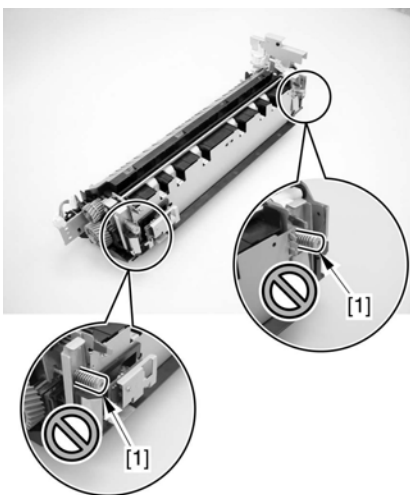

F-6-316

6.8.25.7 Removing the Fixing/Delivery Drive Assembly

- 1) Remove the screw [1], and detach the harness cover [2].

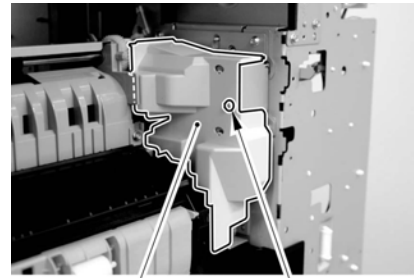

F-6-317

- 2) Disconnect the connector [1] of the harness, and free the harness from the cable clamp [2].

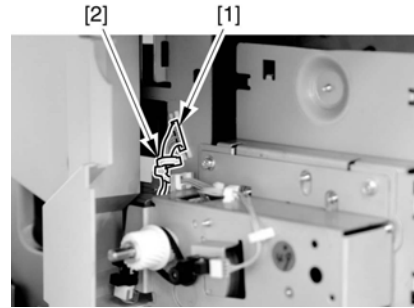

F-6-318

- 3) Remove the 4 screws [1], and detach the fixing/delivery drive assembly 1 [2].

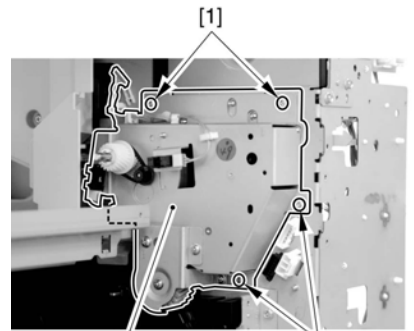

F-6-319

6.8.26 Separation Roller

6.8.26.1 Removing the Pickup Roller/Feed Roller/ Separation Roller

- 1) Slide out the cassette.
- 2) Open the right door (in the case of the separation roller).
- 3) Pick the tabs of the individual rollers, and detach the pickup roller [1], feed roller [2], and separation roller [3].

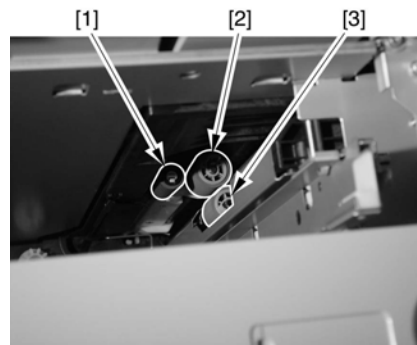

F-6-320



Point to Note When Replacing the Feed/Separation Roller 1
The collar (roller core) of the machine's feed/separation roller is black.

Chapter 7 Fixing System

Contents

7.1 Construction	7-1
7.1.1 Specifications, Control Mechanisms, and Functions	7-1
7.1.2 Major Components	7-1
7.2 Basic Sequence	7-1
7.2.1 Power-On Sequence	7-1
7.2.2 Down Sequence	7-2
7.3 Various Control Mechanisms	7-2
7.3.1 Controlling the Speed of the Fixing Film	7-2
7.3.1.1 Controlling the Fixing Film Speed in Response to Low Temperature	7-2
7.3.1.2 Controlling the Fixing Film Speed	7-2
7.3.2 Controlling the Fixing Film Temperature	7-2
7.3.2.1 Controlling the Power Supply in Response to Low Temperature	7-2
7.3.2.2 Controlling the Feeding in Response to Low Temperature	7-2
7.3.2.3 Controlling the Power Supply at Start-Up	7-2
7.3.2.4 Copying Temperature Control	7-3
7.3.2.5 Changing the Fixing Film Control Temperature	7-3
7.3.2.6 Temperature Control in Response to Automatic Double-Sided Copy	7-3
7.3.2.7 Temperature Control in Response to Change of Paper Size	7-3
7.3.3 Cleaning	7-3
7.3.3.1 Fixing Film Cleaning	7-3
7.3.4 Detecting the Passage of Paper	7-3
7.3.4.1 Detecting the Passage of Paper	7-3
7.4 Protective Functions	7-4
7.4.1 Protective Functions	7-4
7.4.2 Detecting an Error	7-4
7.5 Parts Replacement Procedure	7-5
7.5.1 Fixing Unit	7-5
7.5.1.1 Removing the Right Cover (rear)	7-5
7.5.1.2 Removing the Right Door	7-5
7.5.1.3 Removing the Fixing Unit	7-6
7.5.2 Pressure Roller	7-7
7.5.2.1 Removing the inside delivery cover unit (old)	7-7
7.5.2.2 Removing the inside delivery cover unit (new)	7-8
7.5.2.3 Removing the Grounding Plate	7-9
7.5.2.4 Removing the Fixing Film Cover	7-9
7.5.2.5 Removing the Left Side Plate	7-9
7.5.2.6 Releasing the Locking Plate	7-10
7.5.2.7 Removing the Fixing Film Unit	7-10
7.5.2.8 Removing the Inlet Guide	7-11
7.5.2.9 Removing the Pressure Roller	7-11
7.5.3 Cleaning Roller	7-12
7.5.3.1 Removing the inside delivery cover unit (old)	7-12
7.5.3.2 Removing the inside delivery cover unit (new)	7-14
7.5.3.3 Removing the Cleaning Roller	7-14
7.5.4 Fixing Film	7-14
7.5.4.1 Removing the inside delivery cover unit (old)	7-14
7.5.4.2 Removing the inside delivery cover unit (new)	7-16
7.5.4.3 Removing the Grounding Plate	7-16
7.5.4.4 Removing the Fixing Film Cover	7-16
7.5.4.5 Removing the Left Side Plate	7-16
7.5.4.6 Releasing the Locking Plate	7-17
7.5.4.7 Removing the Fixing Film Unit	7-17
7.5.5 Internal Delivery Sensor	7-18

7.5.5.1 Removing the inside delivery cover unit (old)	7-18
7.5.5.2 Removing the inside delivery cover unit (new)	7-20
7.5.5.3 Removing the Grounding Plate	7-20
7.5.5.4 Removing the Fixing Film Cover	7-20
7.5.5.5 Removing the Left Side Plate	7-21
7.5.5.6 Releasing the Locking Plate	7-21
7.5.5.7 Removing the Fixing Film Unit	7-22
7.5.5.8 Removing the Inside Delivery Sensor	7-23
7.5.6 Fixing Film Sensor	7-23
7.5.6.1 Removing the inside delivery cover unit (old)	7-23
7.5.6.2 Removing the inside delivery cover unit (new)	7-24
7.5.6.3 Removing the Grounding Plate	7-25
7.5.6.4 Removing the Fixing Film Sensor	7-25

7.1 Construction

7.1.1 Specifications, Control Mechanisms, and Functions

The machine's fixing system has the following major functions:

T-7-1

Item	Description
Fixing method	by fixing film + pressure roller
Fixing heater	plate-type heater
Control temperature	180 deg C (at PSTBY)
Fixing drive control	by control of fixing film speed
Fixing temperature detection	by main thermistor
Protective mechanism	by sub thermistor
Cleaning method	by cleaning roller

7.1.2 Major Components

The machine's fixing system has the following major components:

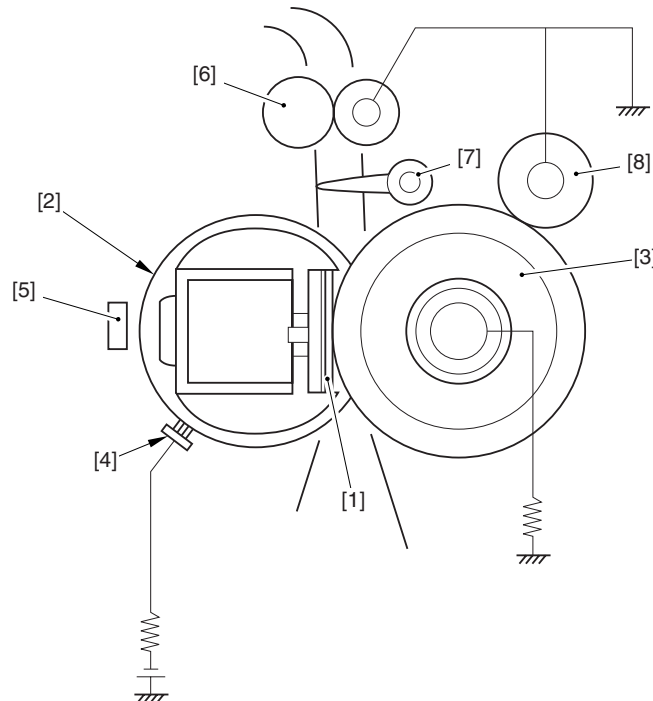

F-7-1

- [1] Fixing heater
- [2] Fixing film unit
- [3] Pressure roller
- [4] Power supply brush
- [5] Film sensor
- [6] Delivery roller
- [7] Fixing inside delivery sensor flag
- [8] Cleaning roller

7.2 Basic Sequence

7.2.1 Power-On Sequence

If the thermistor detection temperature is less than 100 deg C when the power is turned on or the sleep mode is released, the control described below is performed.

1. Increases the speed of the fixing motor in phases (1/4 speed to 1/2 speed and then to normal speed).
 2. Performs the start-up current control.
 3. Performs the temperature control at 200 deg C for 10 sec.
 4. Stops the fixing motor. When the fixing motor is stopped, the fixing temperature control is also stopped, and the machine enters the stand-by mode.



When the print preparation request is received during wait time, the control described below is performed.

1. Increases the speed of the fixing motor in phases (1/4 speed to 1/2 speed and then to normal speed).
 2. Performs the start-up current control.

3. Starts measuring the time passed after the machine reaches the target temperature T deg C.
Target temperature T deg C = 200 deg C (iR3570/iR4570); 190 deg C (iR2270/iR2870)
4. Starts feeding in the case of printing in plain paper mode.
5. Starts feeding when 5 sec have passed after the machine reached the target temperature in the case of printing in special paper mode.

7.2.2 Down Sequence

Down sequence is to prevent the machine from operating when the temperature of the end portion of the fixing film exceeds a specific temperature as when using small-size paper continuously. The details of the control are described below:

1. The sub thermistor detection temperature is 275 deg C or more.
2. Reduces the number of sheets passed by increasing the paper interval.
3. Returns the number of sheets to the normal when the sub thermistor detection temperature is 265 deg C or less.

7.3 Various Control Mechanisms

7.3.1 Controlling the Speed of the Fixing Film

7.3.1.1 Controlling the Fixing Film Speed in Response to Low Temperature

As in the morning, driving the fixing film in a low-temperature environment without warm-up could cause the film to become displaced. In consideration of this fact, the fixing motor is started up in phases (1/4 speed to 1/2 speed and then to normal speed).

7.3.1.2 Controlling the Fixing Film Speed

The rotation cycle of the fixing film is monitored to control the fixing motor to a specific speed.

When the fixing film rotates and, as a result, the reflecting member positioned in the loop of the film approaches the speed sensor, the machine detects the rotation of the fixing film.

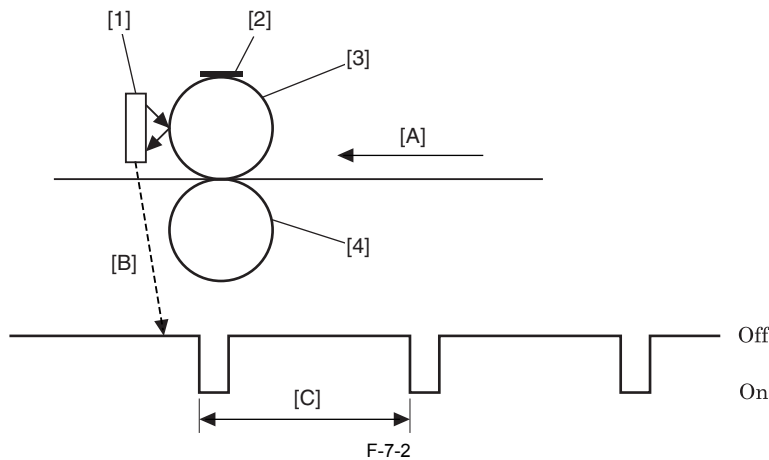

- [1]Speed sensor
- [2]Reflecting member
- [3]Fixing film (driven by fixing motor)
- [4]Pressure roller
- [A]Paper feed direction
- [B]Speed sensor output
- [C]1 rotation of fixing film

Timing of Control
The speed of fixing film rotation is monitored at all times after the fixing motor goes on and its speed reaches a specific value. The speed of the fixing motor is then controlled so that it remains at a specific level at all times.

7.3.2 Controlling the Fixing Film Temperature

7.3.2.1 Controlling the Power Supply in Response to Low Temperature

In a low temperature environment, the heater is supplied with power before the fixing film is driven so as to soften the grease applied to the fixing film. The mechanism of control is as follows:

If the temperature of the fixing film detected by the thermistor is lower than a specific level, the heater is supplied with power for a specific period of time before a normal start-up mechanism is initiated.

If the temperature of the fixing film detected by the thermistor is higher than a specific level, the normal start-up mechanism is initiated.

7.3.2.2 Controlling the Feeding in Response to Low Temperature

In a low temperature environment, the feeding timing is changed according to the temperature detected by the environment sensor so as to enhance the fixing capability. The details are described below.

When the environment sensor detection temperature is 13 deg C or less, the feeding timing is delayed by 5000 msec.



In thick paper mode, the feeding timing is not changed even if the environment sensor detection temperature is 13 deg C or less.

7.3.2.3 Controlling the Power Supply at Start-Up

When the thermistor detection temperature is 180 deg C or less, the power control to compensate for the heater, (varying according to input voltage and a heater resistor value) is performed so as to raise the temperature of the fixing unit to the required temperature for fixing in a short time.

1. starts 65% power supply.
2. uses thermistor reading = T1 (deg C) occurring 400 msec after the start of 65% power supply.
- 3)uses thermistor reading = T2 (deg C) occurring 500 msec after the start of 65% power supply.
4. computes the difference between T2 and T1, refers to a power supply ratio table to compute a power supply ratio X (%), and uses the result.
5. uses the thermistor reading = T3 (deg C) occurring 200 msec after the start of X (%) power supply.
6. uses the thermistor reading = T4 (deg C) occurring 300 msec after the start of the X (%) power supply.
7. computes the difference between T4 and T2, refers to a power supply ratio table, computes a power supply ratio Y (%), and uses the result.
8. repeats step 5 through 7 until the start-up control target temperature is reached.

9. when the start-up control temperature is reached, shifts to copying temperature control.

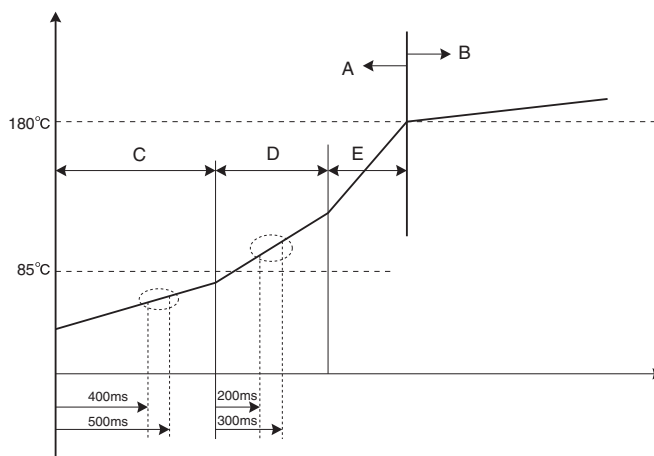

F-7-3

A: start-up control
 B: copying temperature control
 C: 65 (%) power supply
 D: X (%) power supply
 E: Y (%) power supply

7.3.2.4 Copying Temperature Control

The machine uses this mechanism to control the temperature of the fixing heater to an optimum level while a recording medium is passing through the fixing film assembly; specifically,

- the machine varies the power ratio in relation to the difference between the temperature detected by the thermistor and the target control temperature.
- if the temperature detected by the thermistor is higher than the target control temperature for a specific period of time (0.6 sec), the machine will decrease the power ratio; if lower, it will increase the power rate.

7.3.2.5 Changing the Fixing Film Control Temperature

When a fixing failure occurs or ceases appear, the fixing film control temperature can be changed in the service mode as shown below.

COPIER> OPTION> BODY> TEMP-CON (to switch the fixing temperature mode for heavy paper)
 COPIER> OPTION> BODY> TEMPCON2 (to switch the fixing temperature mode)
 0: OFF (default), 1: -10 deg C, 2: -6 deg C, 3: -3 deg C, 4: +3 deg C, 5: +6 deg C, 6: +10 deg C, 7: 15 deg C

7.3.2.6 Temperature Control in Response to Automatic Double-Sided Copy

The second side of an automatic double-sided copy requires lower control temperature in comparison with the first side. For this reason, the control temperature is lowered for the second side of an automatic double-sided copy so as to prevent adverse effects such as rises in temperature.

7.3.2.7 Temperature Control in Response to Change of Paper Size

The machine has a function to switch the paper size during continuous mode such as in rotation sort. When small-size paper is generated continuously, the temperature of the end portion of the fixing film rises. Immediately thereafter, if large-size paper is passed, high-temperature offset might occur at the end portion where the temperature is likely to have risen. To prevent high-temperature offset, the control temperature is changed when the paper size changes.

7.3.3 Cleaning

7.3.3.1 Fixing Film Cleaning

Purpose

In the event of a jam or when wear on the fixing film advances, the fixing film is rotated idly for collection of toner from both the film and the pressure roller to the cleaning roller.

The timing of control is as follows:

- If the reading of the cleaning counter has exceeded the interval (expressed in terms of the number of sheets), the machine starts cleaning with the fixing motor rotating at 1/4 speed. The length, timing, and intervals of cleaning may be set in service mode: COPIER>OPTION>BODY>FIX-CLN. Further, the cleaning counter reading is reset at the end of cleaning.

T-7-2

COPIER > OPTION > BODY > FIX-CLN

	0 (default)	1	2	3
Cleaning control temperature	0	225	225	225
Cleaning control time	0	60	60	60
Cleaning intervals	0	500	200	100

If a copy or print job arrives while cleaning is under way, the machine will not pick up paper until the ongoing cleaning ends.

If last rotation is under way in response to a rise in temperature at the film edge, the machine will hold cleaning until the end of the ongoing last rotation.

- If a jam has been removed, the machine starts cleaning at time of recovery, at 220 deg C and for 10 sec.

7.3.4 Detecting the Passage of Paper

7.3.4.1 Detecting the Passage of Paper

The paper passage detection configuration in the fixing unit is shown below.

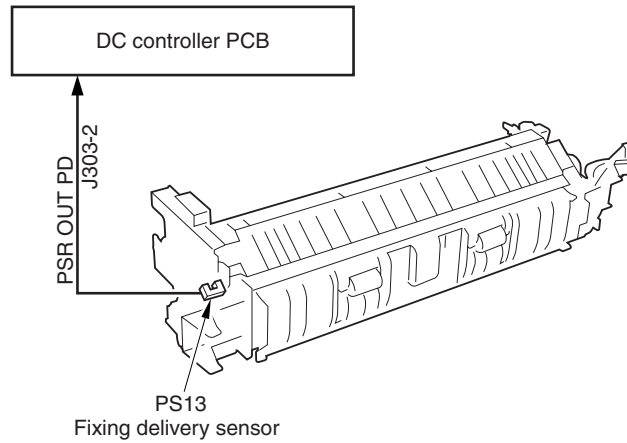

F-7-4

When a delay jam of the fixing delivery sensor (PS13) occurs, the fixing motor is stopped immediately so as to prevent paper from wrapping around the fixing roller. The pressure of the fixing film and the pressure roller is released when a jam occurs so that jammed paper can be taken out easily.

7.4 Protective Functions

7.4.1 Protective Functions

As part of its protective mechanism, the machine has a thermo switch, triacs, and a relay. Protective measures according to location are described below:

1. When the thermistor is out of order
Software detects a failure, and the triac and the relay are turned off.
The thermo switch is turned off.
2. When the CPU goes out of control
The latch circuit detects the excessive temperature rise, and the relay is turned off.
The thermo switch is turned off.
3. When the triac short-circuits
Software detects failure, and the relay is turned off.
The latch circuit detects the excessive temperature rise, and the relay is turned off.
The thermo switch is turned off.

Protective Circuit Block Configuration Diagram

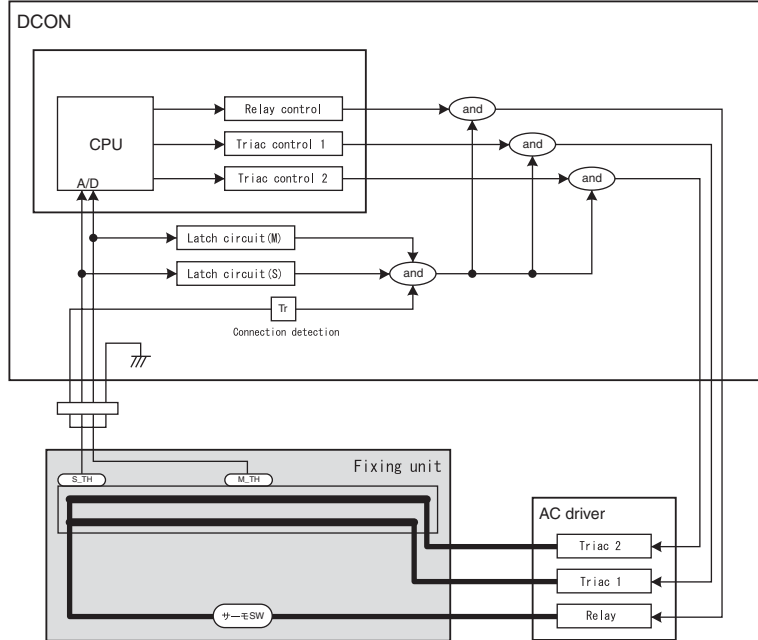

F-7-5

7.4.2 Detecting an Error

As part of its protective mechanism, the machine checks for the following error conditions:

T-7-3

Error code	Detail code	Symptom	Description
E000	0000	The fixing temperature fails to increase.	In the course of start-up control, the thermistor reading is less than 30 deg C 1 sec after the start of power supply or is less than 70 deg C 2 sec after the start of power supply; the machine will identify an error condition if any of the foregoing continues for 200 msec or more.

Error code	Detail code	Symptom	Description
E001	0000	The thermistor detects overheating.	The thermistor detects 235 deg C for 200 msec or more continuously.
	0001	A hardware circuit detects overheating.	A hardware circuit detects overheating in relation to the thermistor (main or sub).
	0002	The sub thermistor detects overheating.	The thermistor detects 295 deg C or more for 200 msec or more continuously.
E002	0000	The fixing temperature fails to reach a specific level.	In the course of start-up control, the thermistor detects a temperature lower than 115 deg C for 200 msec continuously after it has detected 100 deg C; the thermistor detects a temperature less than 150 deg C for 200 msec or more continuously after it has detected 140 deg C; or, the thermistor detects a temperature lower than 165 deg C for 20 msec or more continuously 1 sec after it has detected 160 deg C.
E003	0000	The fixing temperature has dropped to an abnormally low level.	In the course of normal temperature control, the thermistor detects a temperature lower than 140 deg C for 20 msec or more continuously.
E007	0000	The fixing film rotates in an abnormal way.	The reading of the main thermistor is in excess of 100 deg C with the fixing motor in a locked state and, in addition, the machine fails to detect the marker signal for 6 sec.
E014	0000	The machine detects a fixing motor error.	During operation, the machine detects an overload condition continuously for 3 sec or more.

7.5 Parts Replacement Procedure

7.5.1 Fixing Unit

7.5.1.1 Removing the Right Cover (rear)

- 1) Open the pedestal right door [1]. (if equipped with a 2-Cassette Pedestal-Y2)
- 2) Open the right lower door [2].
- 3) Remove the 5 screws [3], and detach the right cover (rear) [4].

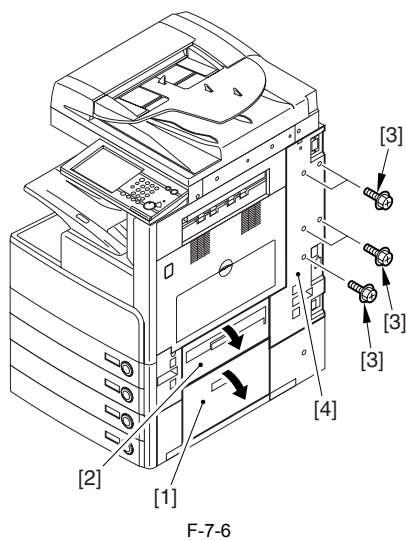

7.5.1.2 Removing the Right Door

- 1) Open the right door.



- 2) Remove the screw [1], and detach the fixing plate [2].

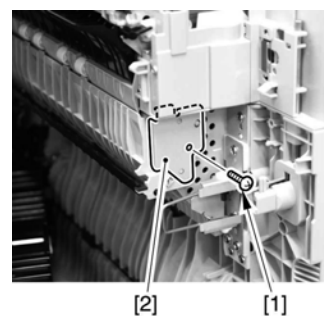

- 3) Remove the joint shaft [1], and free the extension delivery unit [2] from the right door.

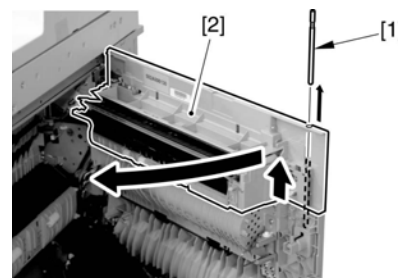

- 4) Disconnect the connector [1], and remove the reuse band [2]; then, remove the 2 screws (M4x8; RS tightening).

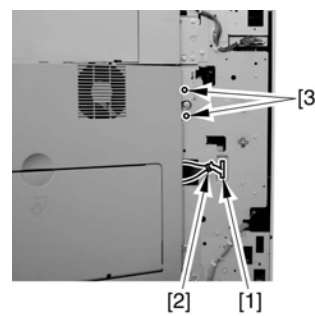

- 5) While freeing the hinge assembly [2], detach the right door.

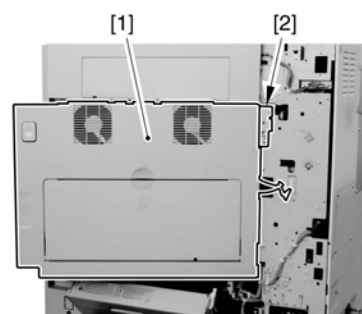

Attaching the Right Door

- 1) Match the hinge [1] found at the bottom of the right door against the lug.
- 2) Engage the hinge [2] found on the top of the right door with the hook found on the side plate.

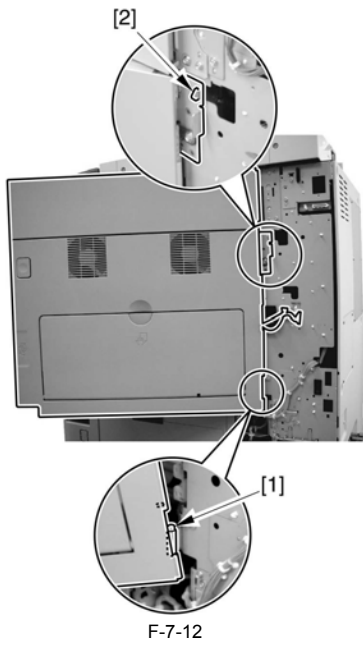

⚠ When tightening the 2 screws used to fix the hinge in place, be sure to close the right door first.

7.5.1.3 Removing the Fixing Unit

1) Remove the screw [1], and detach the harness cover [2].

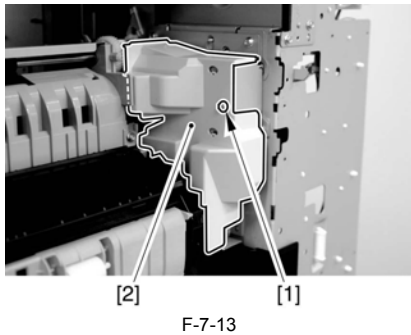

2) Disconcert the 3 connectors [1].

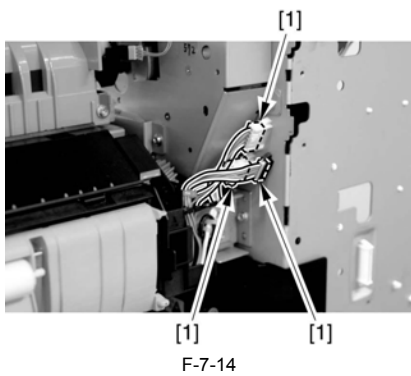

3) Remove the 4 screws [1].

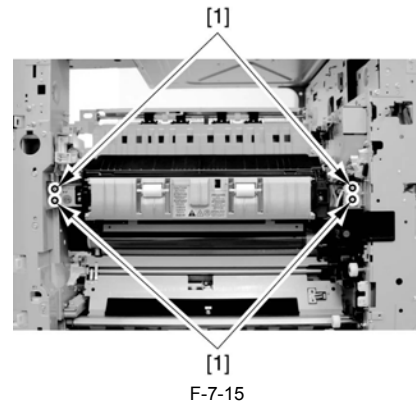

4) Detach the fixing unit [1] toward the front.

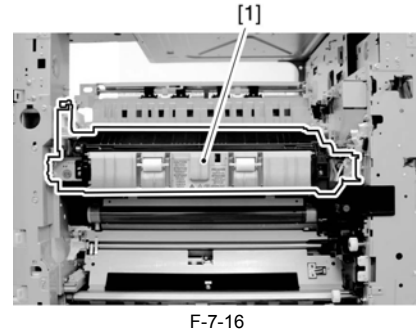

⚠ When mounting the harness cover [1], be sure to keep the harness [2] within the space [3] indicated in the figure so that the harness [2] will not come into contact with the gear [4].

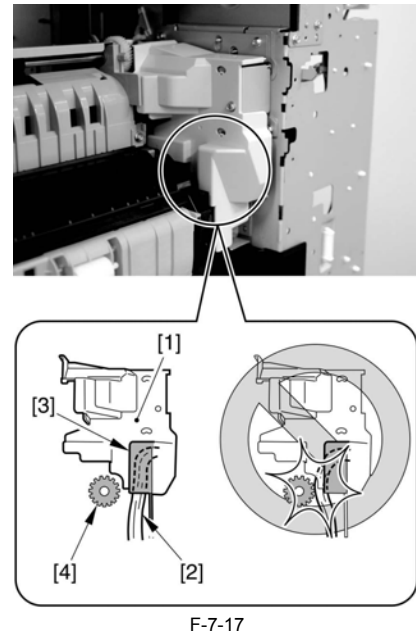

⚠ Do not touch the screw [1]. Turning it will change the pressure of the fixing assembly, which cannot be adjusted in the field, necessitating the replacement of the fixing assembly.

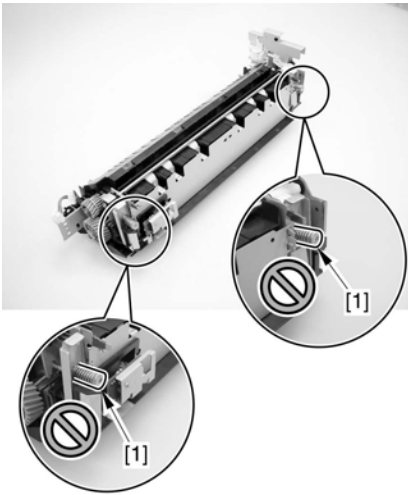

F-7-18

7.5.2 Pressure Roller

7.5.2.1 Removing the inside delivery cover unit (old)

The difference between new and old inside delivery cover unit:
Old inside delivery cover unit does not have a grip ring [1] at hinge. In this case, detach the cover following the procedure below.

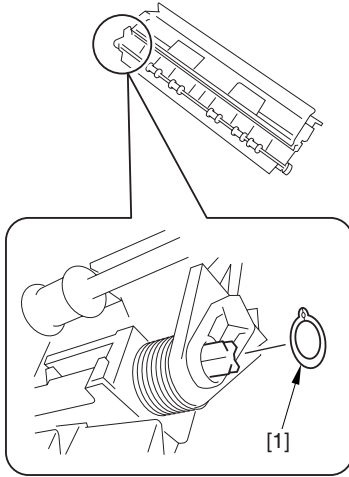

F-7-19

- 1) Remove the screw [1] and the stepped screw [2], and detach the inside delivery cover unit [3].

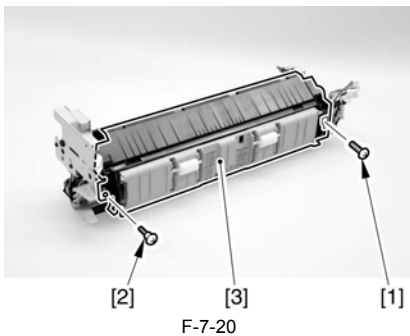

F-7-20

Note 1

Point to note when removing the inside delivery cover unit
Remove the inside delivery cover unit while supporting the guide [1] in the arrow direction A and opening it in the arrow direction B in the figure. Otherwise, the guide may come off the inside delivery cover unit.

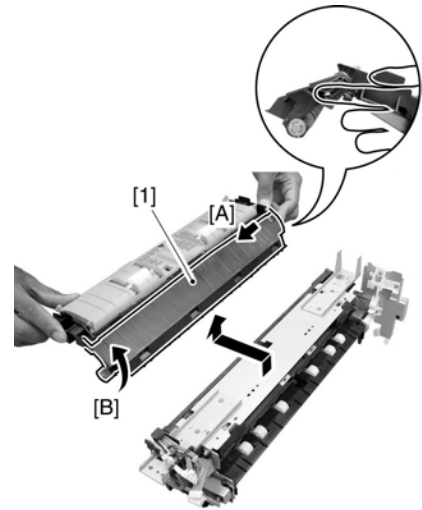

F-7-21

Note 2

Procedure for attaching the guide

Perform the following steps if the guide has come off the inside delivery cover unit.

- 1) Attach the torsion spring [2] to the duplexing support feeder mount [1]. At this time, hook the edge of the torsion spring on the area A of the duplexing support feeder mount.

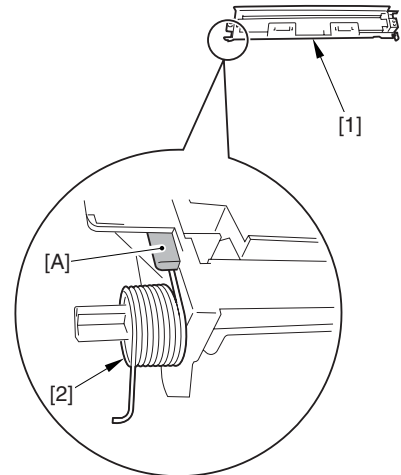

F-7-22

- 2) Attach the guide [1] to the duplexing support feeder mount [2]. At this time, fit [b] into [a] and [d] into [c]. Make sure that the edge [e] of the torsion spring is outside the guide.

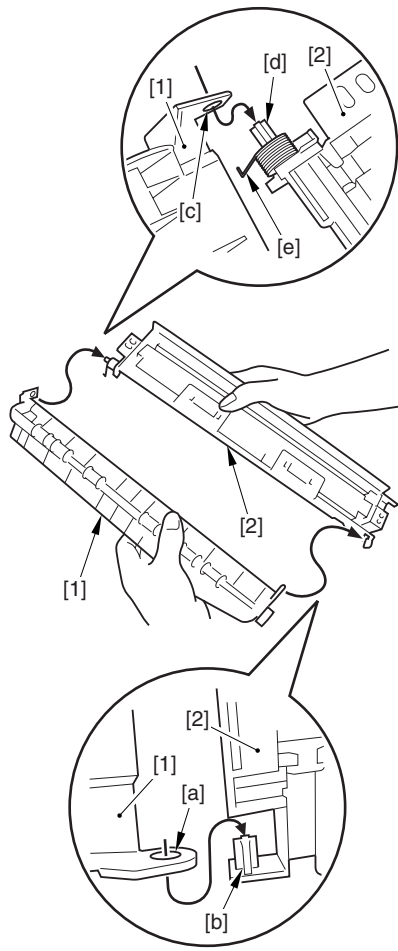

F-7-23

3) Hook the edge [1] of the torsion spring on the spring-hook area [2] of the inside delivery cover.

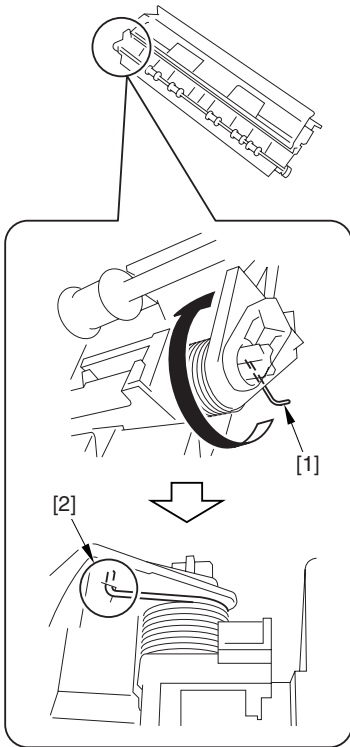

F-7-24

Note 3
Attaching the inside delivery cover unit

1) Attach the inside delivery cover unit while supporting the guide [1] in the arrow direction A and opening it in the arrow direction B. Opening the guide can prevent it from coming off the inside delivery cover unit. After attaching, make sure that the guide [1] rotates smoothly.

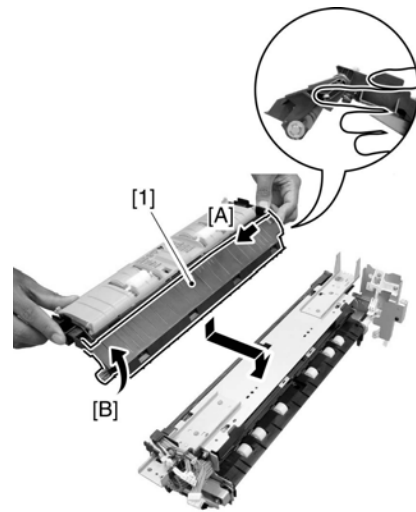

F-7-25

2) Attach the screw [1] and the stepped screw [2], and fix the inside delivery cover unit [3].

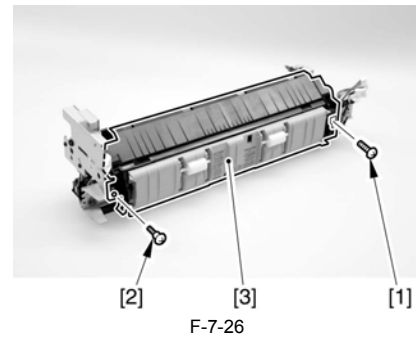

F-7-26

7.5.2.2 Removing the inside delivery cover unit (new)

The difference between new and old inside delivery cover unit:

New inside delivery cover unit has a grip ring [1] at hinge. In this case, detach the cover following the procedure below.

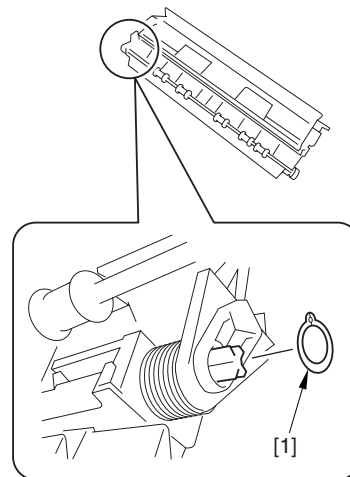

F-7-27

1) Remove the screw [1] and the stepped screw [2], and detach the inside delivery cover unit [3].

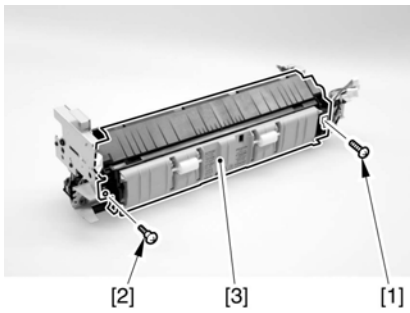

F-7-28

7.5.2.3 Removing the Grounding Plate

1) Remove the 2 screws [1], and detach the grounding plate [2].

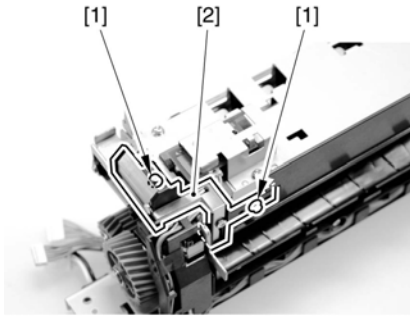

F-7-29

7.5.2.4 Removing the Fixing Film Cover

1) Remove the 3 screws [1], and remove the self-tapping screw [2]; then, detach the fixing film cover [3].

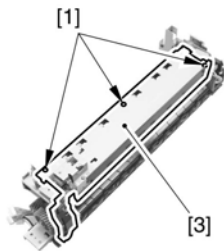

F-7-30

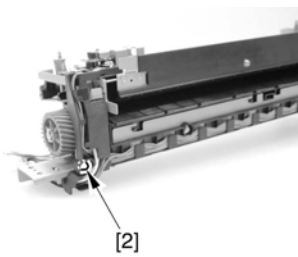

F-7-31

⚠ When mounting the fixing film cover unit, be sure to check that it has not ridden over the emboss [1] indicated by the arrow in the figure before tightening the screw.

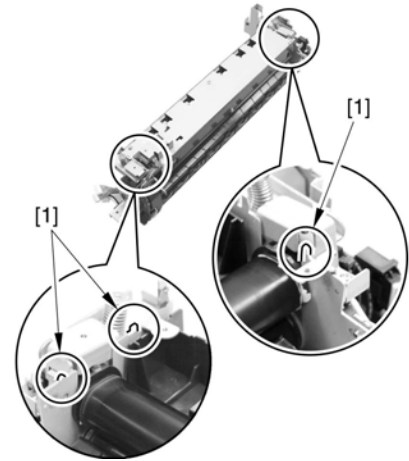

F-7-32

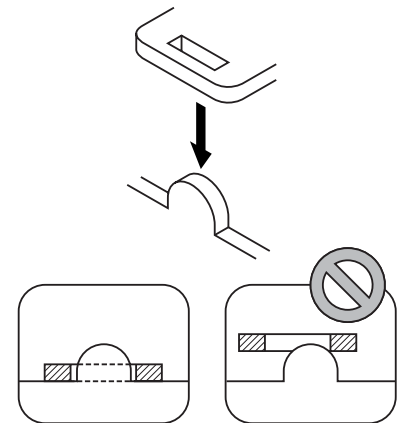

F-7-33

7.5.2.5 Removing the Left Side Plate

1) Remove the screw [1], and detach the left side plate cover [2].

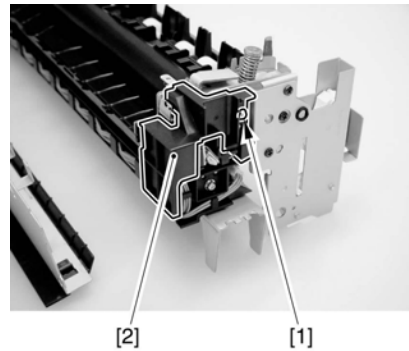

F-7-34

2) Remove the 2 screws [1].

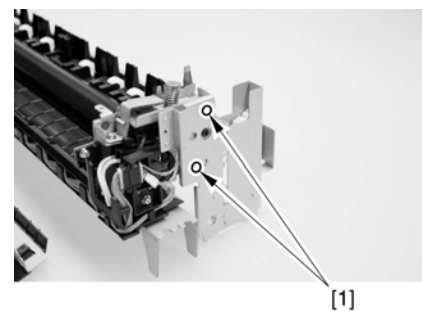

F-7-35

3) Slide the left side plate [1] in the direction of the arrow to detach.

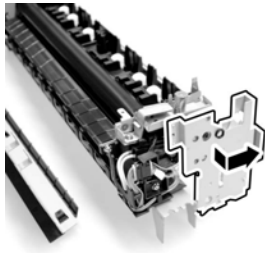

F-7-36

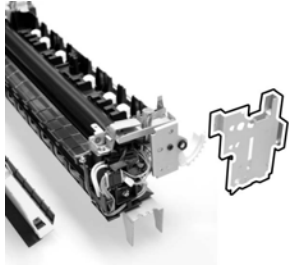

F-7-37



When mounting the left side plate, be sure that it is correctly positioned so that the locking lever and the teeth are correctly engaged. (See the figure.)

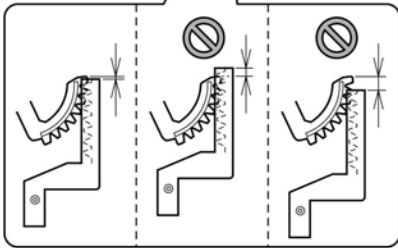
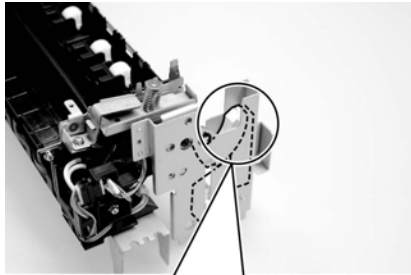

F-7-38

7.5.2.6 Releasing the Locking Plate

1) Turn the locking gear [1] in the direction of the arrow to release the locking roller.

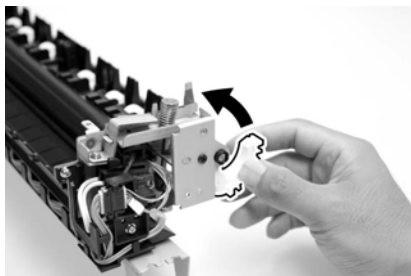

F-7-39

2) Remove the 2 screws [1].

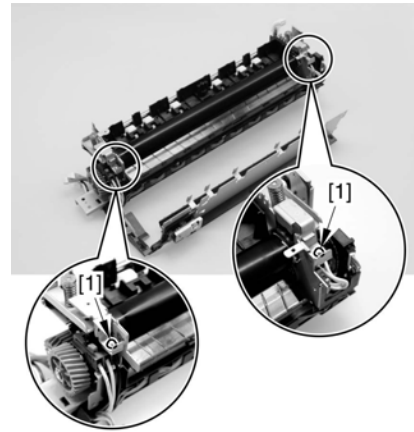

F-7-40



Do not touch the screw [1] used to keep the fixing assembly in place. Turning the screw will change the pressure of the fixing assembly, which cannot be adjusted in the field, necessitating the replacement of the fixing assembly.



F-7-41

3) Turn the locking plate [1] in the direction of the arrow to release it.

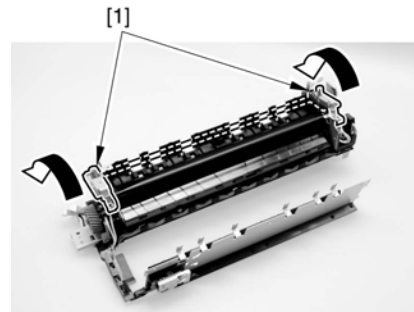

F-7-42

7.5.2.7 Removing the Fixing Film Unit

1) While pushing down the release lever (front) [1], pull out the heater contact [2].

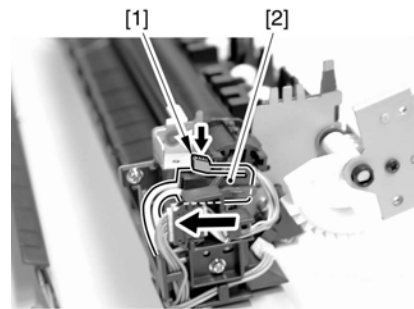

F-7-43

2) While pushing down the release lever (rear) [1], pull out the heater contact [2].

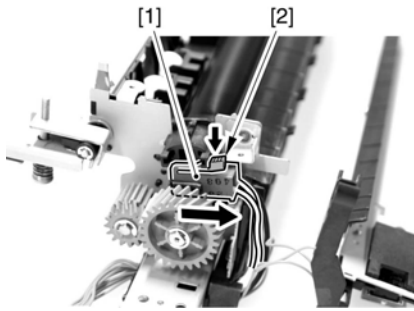

F-7-44

3) Remove the screw [1], and free the AC harness [2].

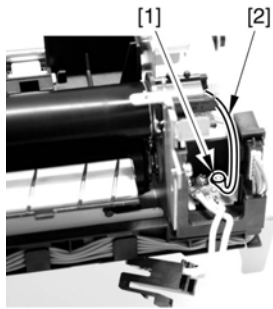

F-7-45

4) Free the AC harness [1] from the edge saddle [2].

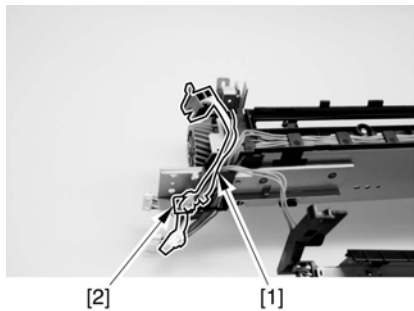

F-7-46

5) Free the relay connector [1] of the signal cable from the connector holder [2].

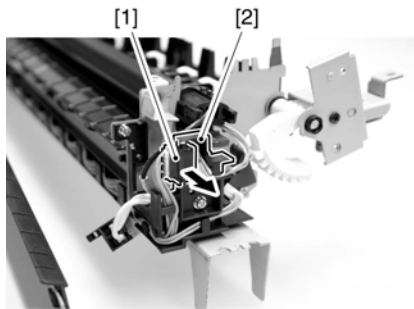

F-7-47

6) Disconnect the connector [2] from the relay connector [1].

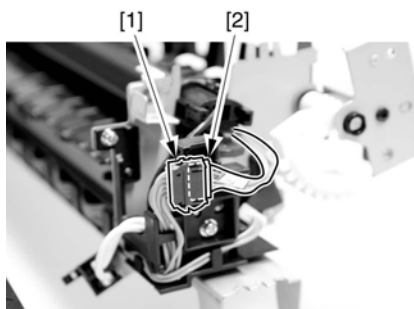

F-7-48

7) Remove the fixing film unit [1].

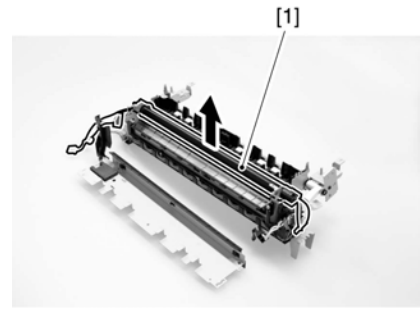

F-7-49

7.5.2.8 Removing the Inlet Guide

1) Slide the inlet guide [1] in the direction of the arrow to detach.

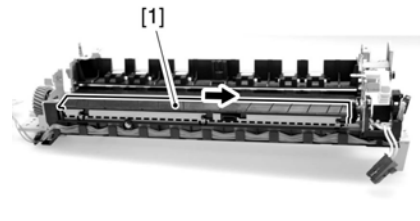

F-7-50

7.5.2.9 Removing the Pressure Roller

1) Remove the E-ring [1], and detach the drive gear [2].

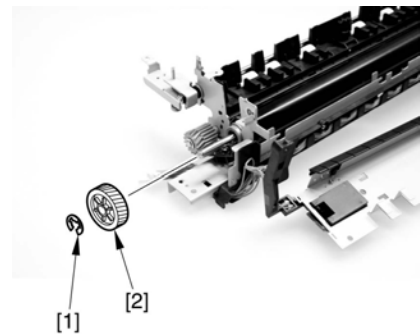

F-7-51

2) Lift the front of the pressure roller [1].

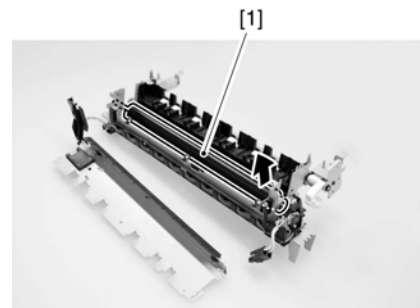

F-7-52

3) Push in the bush [1] found at the rear in the direction of the arrow to free it; then, detach the pressure roller.

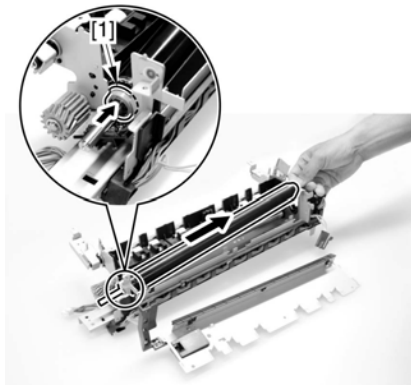

F-7-53



Be sure to pay attention to the position and the orientation of the insulating bush.

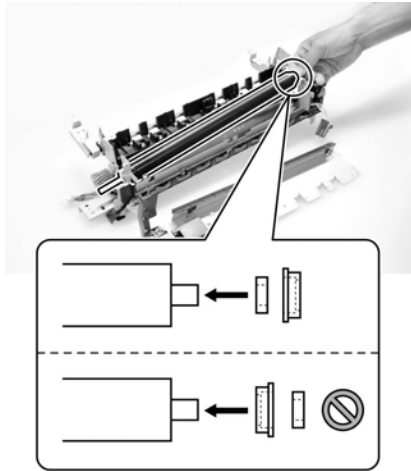

F-7-54



The insulating bush may be of 2 different shapes: one for the iR3570/4570 and the other for the iR2270/2870. If the machine is an iR2270/2870, be sure to pay attention to the direction of the protrusion of the insulating bush.

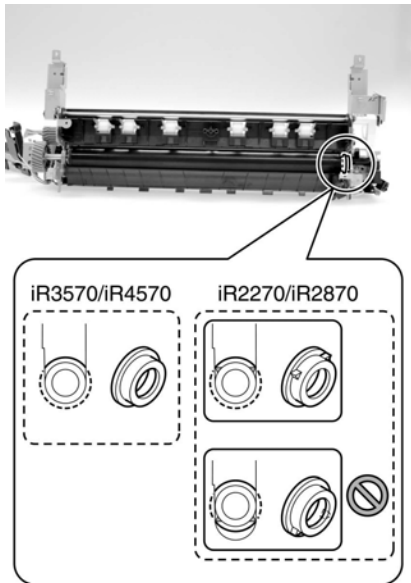

F-7-55

7.5.3 Cleaning Roller

7.5.3.1 Removing the inside delivery cover unit (old)

The difference between new and old inside delivery cover unit:
Old inside delivery cover unit does not have a grip ring [1] at hinge. In this case, detach the cover following the procedure below.

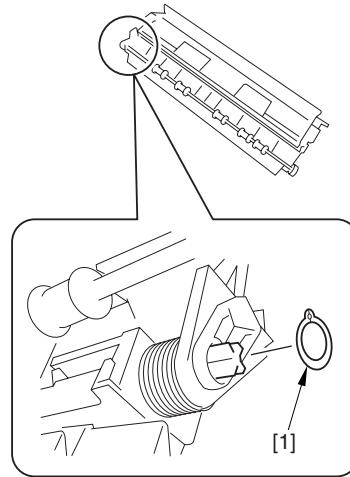

F-7-56

- 1) Remove the screw [1] and the stepped screw [2], and detach the inside delivery cover unit [3].

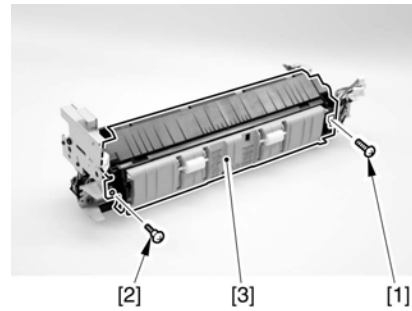

F-7-57

Note 1

Point to note when removing the inside delivery cover unit

Remove the inside delivery cover unit while supporting the guide [1] in the arrow direction A and opening it in the arrow direction B in the figure. Otherwise, the guide may come off the inside delivery cover unit.

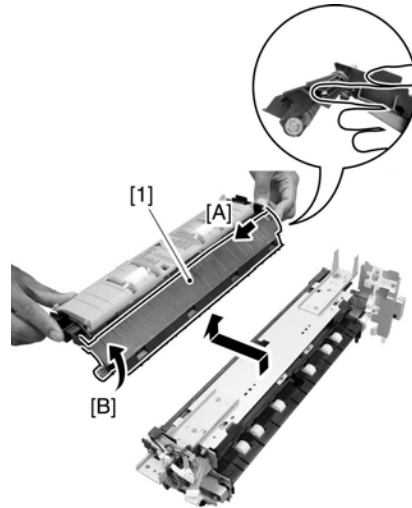

F-7-58

Note 2

Procedure for attaching the guide

Perform the following steps if the guide has come off the inside delivery cover unit.

- 1) Attach the torsion spring [2] to the duplexing support feeder mount [1]. At this time, hook the edge of the torsion spring on the area A of the duplexing support feeder mount.

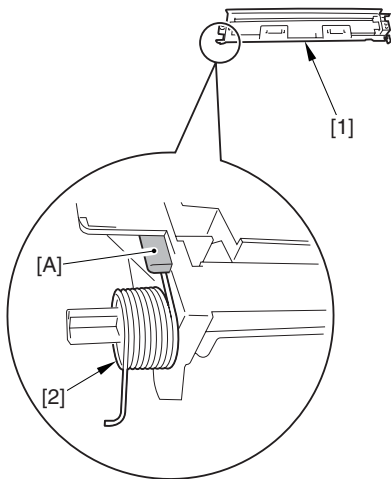

F-7-59

2) Attach the guide [1] to the duplexing support feeder mount [2]. At this time, fit [b] into [a] and [d] into [c]. Make sure that the edge [e] of the torsion spring is outside the guide.

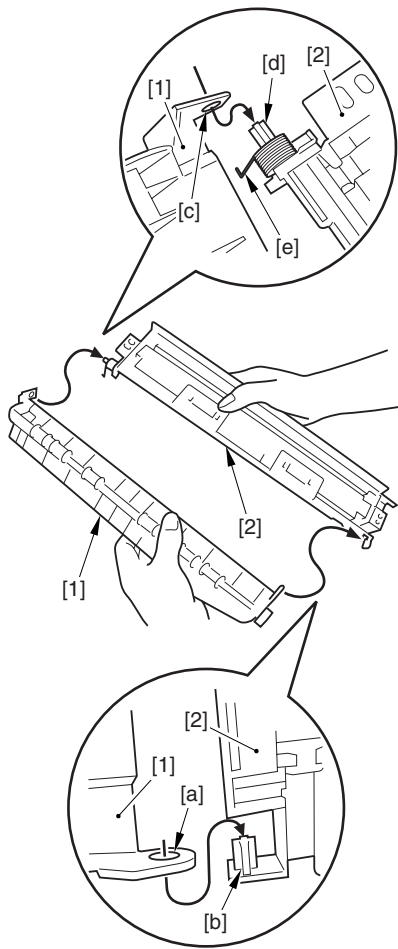

F-7-60

3) Hook the edge [1] of the torsion spring on the spring-hook area [2] of the inside delivery cover.

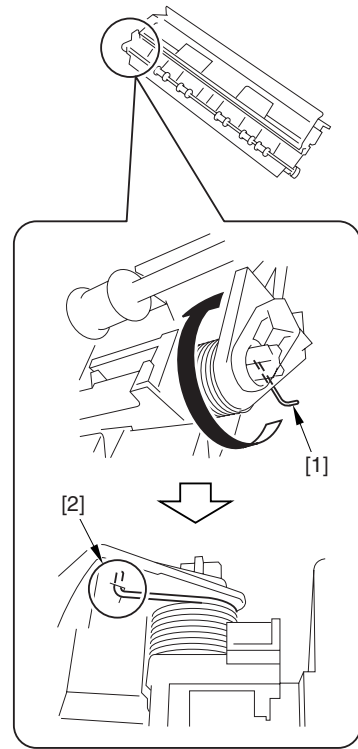

F-7-61

Note 3

Attaching the inside delivery cover unit

1) Attach the inside delivery cover unit while supporting the guide [1] in the arrow direction A and opening it in the arrow direction B. Opening the guide can prevent it from coming off the inside delivery cover unit. After attaching, make sure that the guide [1] rotates smoothly.

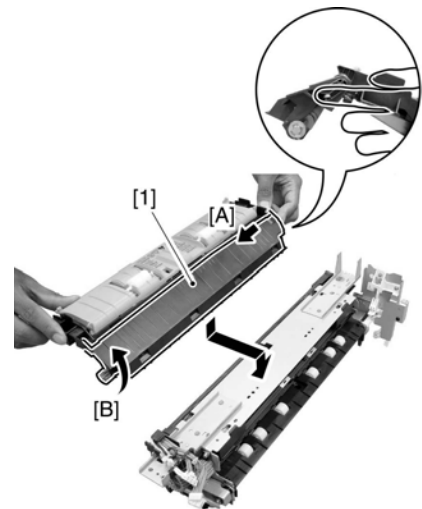

F-7-62

2) Attach the screw [1] and the stepped screw [2], and fix the inside delivery cover unit [3].

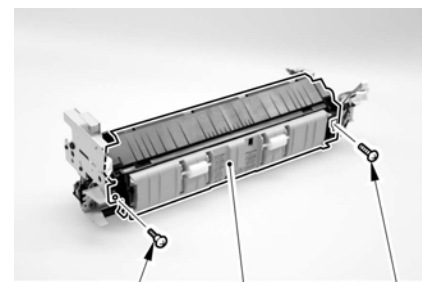

F-7-63

7.5.3.2 Removing the inside delivery cover unit (new)

The difference between new and old inside delivery cover unit:
New inside delivery cover unit has a grip ring [1] at hinge. In this case, detach the cover following the procedure below.

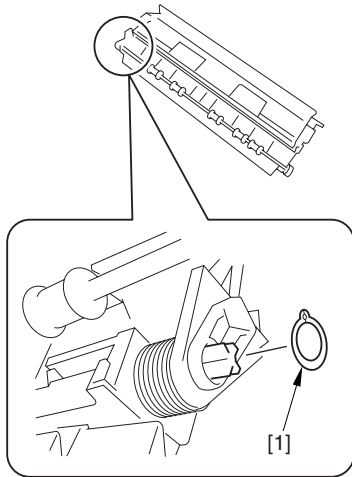

F-7-64

1) Remove the screw [1] and the stepped screw [2], and detach the inside delivery cover unit [3].

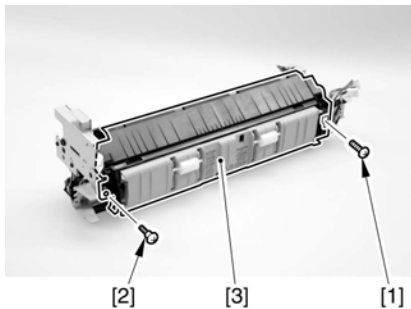

F-7-65

7.5.3.3 Removing the Cleaning Roller

1) Remove the 2 self-tapping screws [1], and detach the cleaning roller together with the cleaning roller holder [2].

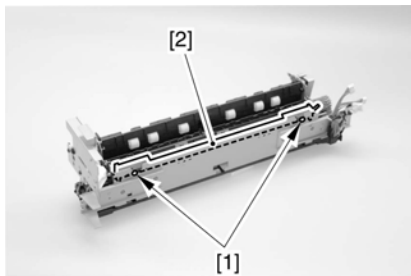

F-7-66

2) Remove the cleaning roller holder [1].

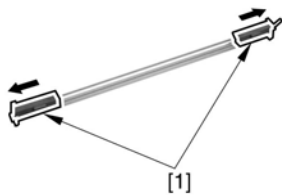

F-7-67



The foregoing steps assume that the fixing unit has already been removed from the machine. The cleaning roller may also be removed without first removing the fixing unit from the machine in the same way.

7.5.4 Fixing Film

7.5.4.1 Removing the inside delivery cover unit (old)

The difference between new and old inside delivery cover unit:
Old inside delivery cover unit does not have a grip ring [1] at hinge. In this case, detach the cover following the procedure below.

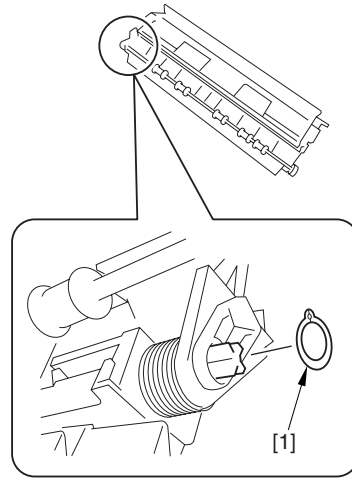

F-7-68

1) Remove the screw [1] and the stepped screw [2], and detach the inside delivery cover unit [3].

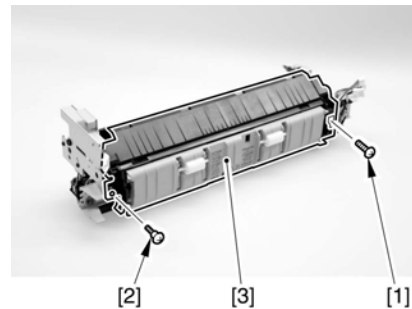

F-7-69

Note 1

Point to note when removing the inside delivery cover unit
Remove the inside delivery cover unit while supporting the guide [1] in the arrow direction A and opening it in the arrow direction B in the figure. Otherwise, the guide may come off the inside delivery cover unit.

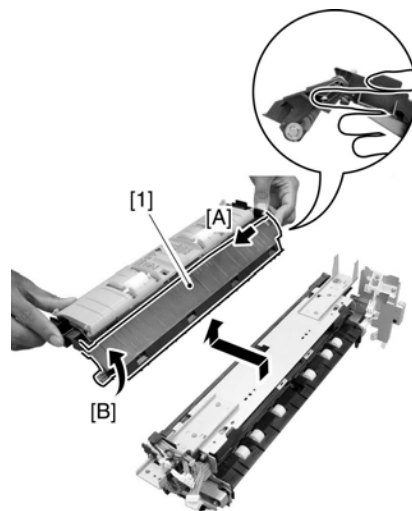

F-7-70

Note 2

Procedure for attaching the guide
Perform the following steps if the guide has come off the inside delivery cover unit.

1) Attach the torsion spring [2] to the duplexing support feeder mount [1]. At this time, hook the edge of the torsion spring on the area A of the duplexing support feeder mount.

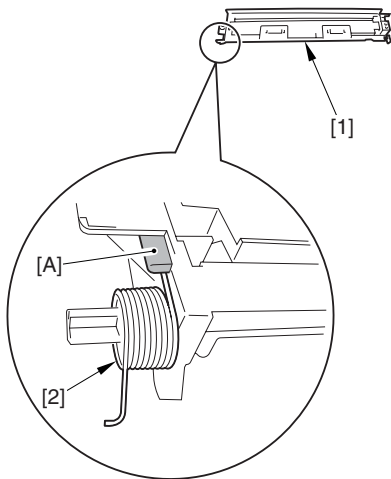

F-7-71

2) Attach the guide [1] to the duplexing support feeder mount [2]. At this time, fit [b] into [a] and [d] into [c]. Make sure that the edge [e] of the torsion spring is outside the guide.

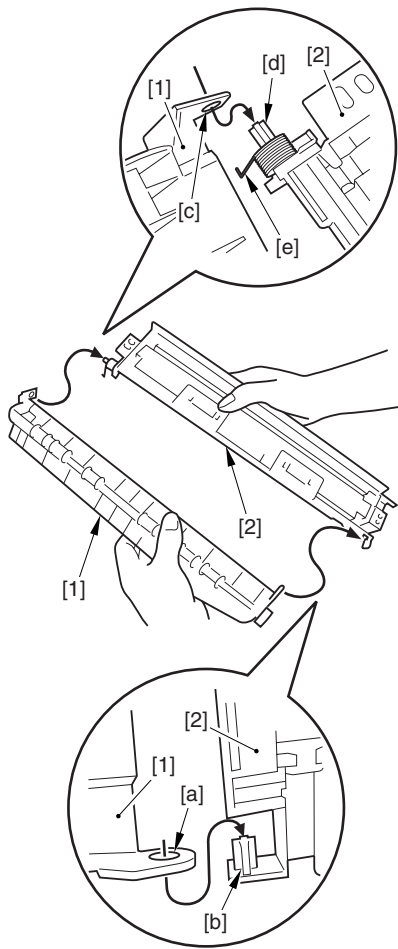

F-7-72

3) Hook the edge [1] of the torsion spring on the spring-hook area [2] of the inside delivery cover.

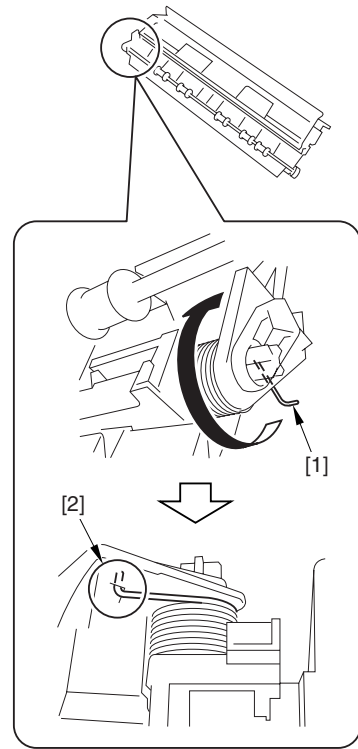

F-7-73

Note 3

Attaching the inside delivery cover unit

1) Attach the inside delivery cover unit while supporting the guide [1] in the arrow direction A and opening it in the arrow direction B. Opening the guide can prevent it from coming off the inside delivery cover unit. After attaching, make sure that the guide [1] rotates smoothly.

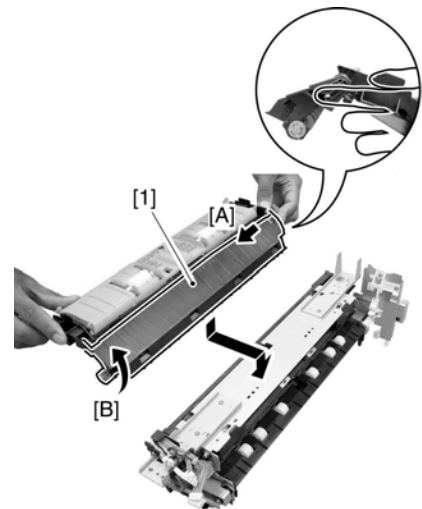

F-7-74

2) Attach the screw [1] and the stepped screw [2], and fix the inside delivery cover unit [3].

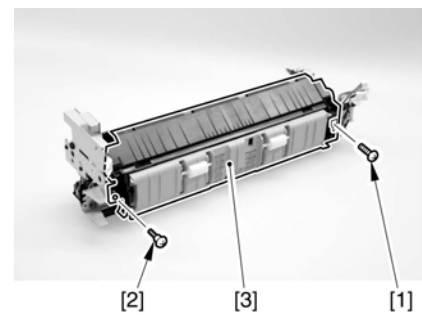

F-7-75

7.5.4.2 Removing the inside delivery cover unit (new)

The difference between new and old inside delivery cover unit:
 New inside delivery cover unit has a grip ring [1] at hinge. In this case, detach the cover following the procedure below.

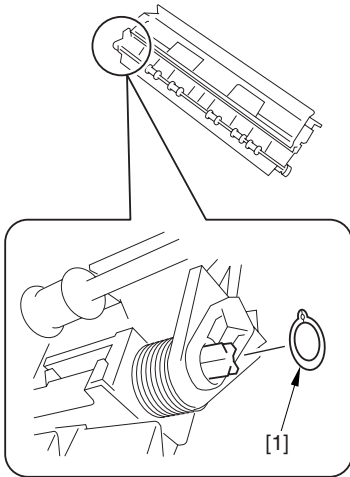

F-7-76

1) Remove the screw [1] and the stepped screw [2], and detach the inside delivery cover unit [3].

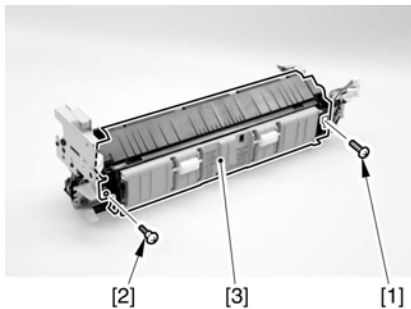

F-7-77

7.5.4.3 Removing the Grounding Plate

1) Remove the 2 screws [1], and detach the grounding plate [2].

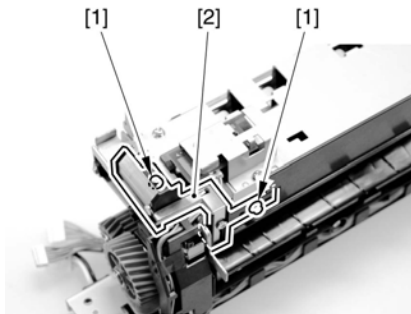

F-7-78

7.5.4.4 Removing the Fixing Film Cover

1) Remove the 3 screws [1], and remove the self-tapping screw [2]; then, detach the fixing film cover [3].

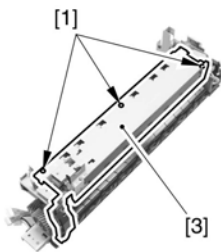

F-7-79

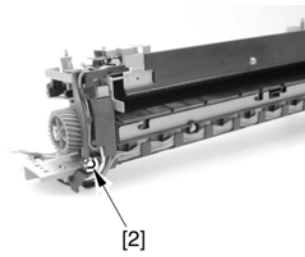

F-7-80



When mounting the fixing film cover unit, be sure to check that it has not ridden over the emboss [1] indicated by the arrow in the figure before tightening the screw.

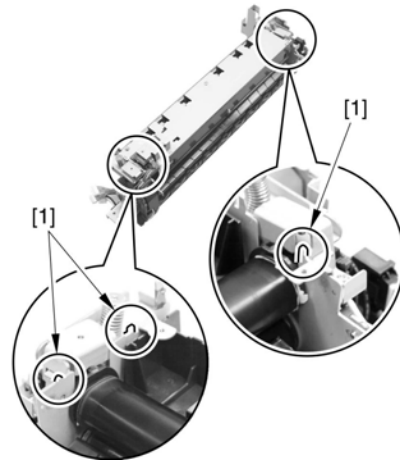

F-7-81

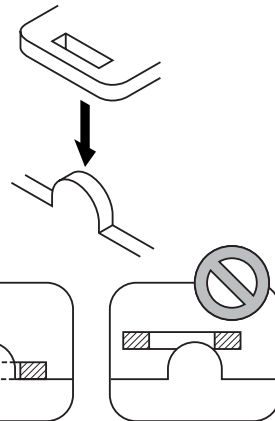

F-7-82

7.5.4.5 Removing the Left Side Plate

1) Remove the screw [1], and detach the left side plate cover [2].

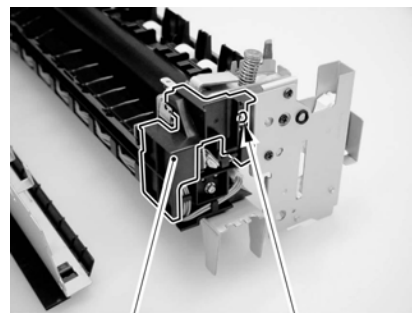

F-7-83

2) Remove the 2 screws [1].

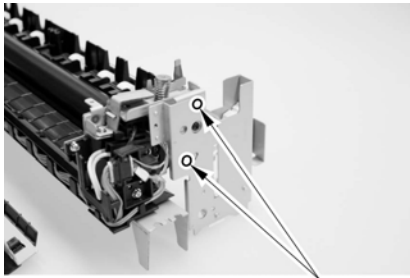

[1]

F-7-84

3) Slide the left side plate [1] in the direction of the arrow to detach.

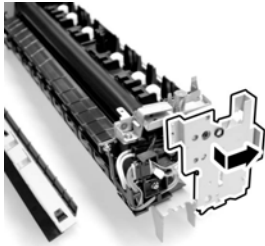

F-7-85

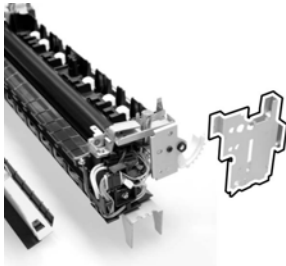

F-7-86

! When mounting the left side plate, be sure that it is correctly positioned so that the locking lever and the teeth are correctly engaged. (See the figure.)

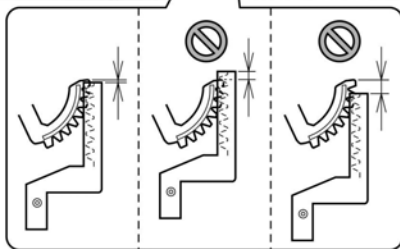
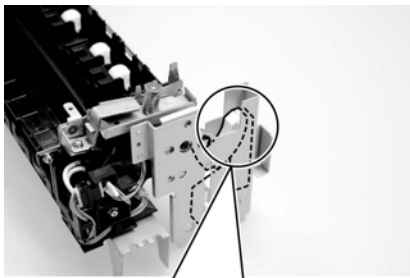

F-7-87

7.5.4.6 Releasing the Locking Plate

1) Turn the locking gear [1] in the direction of the arrow to release the locking roller.

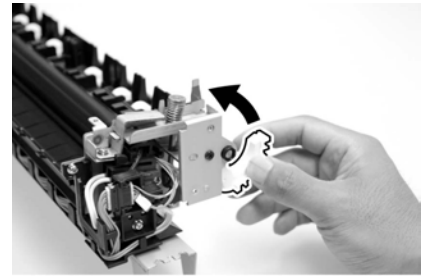

F-7-88

2) Remove the 2 screws [1].

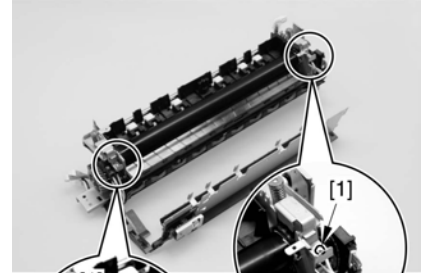

F-7-89

! Do not touch the screw [1] used to keep the fixing assembly in place. Turning the screw will change the pressure of the fixing assembly, which cannot be adjusted in the field, necessitating the replacement of the fixing assembly.



F-7-90

3) Turn the locking plate [1] in the direction of the arrow to release it.

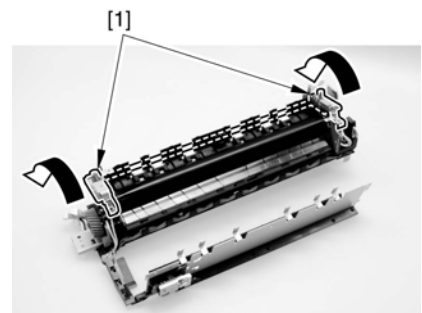

F-7-91

7.5.4.7 Removing the Fixing Film Unit

1) While pushing down the release lever (front) [1], pull out the heater contact [2].

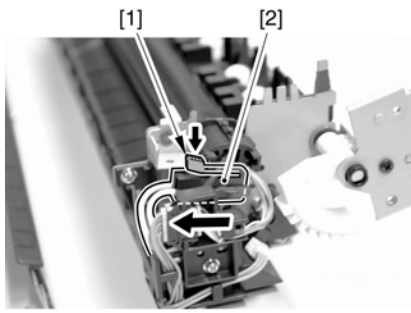

F-7-92

2) While pushing down the release lever (rear) [1], pull out the heater contact [2].

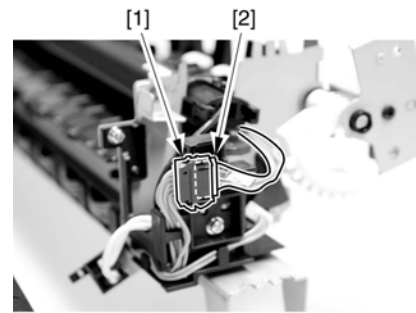

F-7-97

7) Remove the fixing film unit [1].

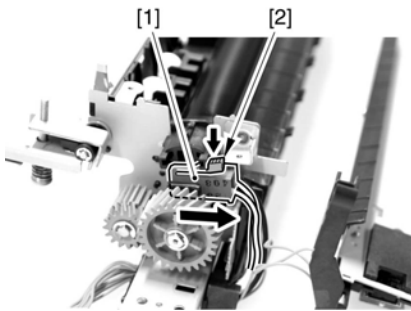

F-7-93

3) Remove the screw [1], and free the AC harness [2].

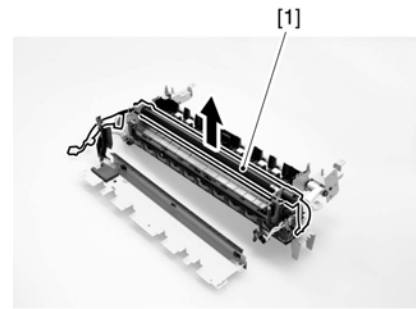

F-7-98

7.5.5 Internal Delivery Sensor

7.5.5.1 Removing the inside delivery cover unit (old)

The difference between new and old inside delivery cover unit:
Old inside delivery cover unit does not have a grip ring [1] at hinge. In this case, detach the cover following the procedure below.

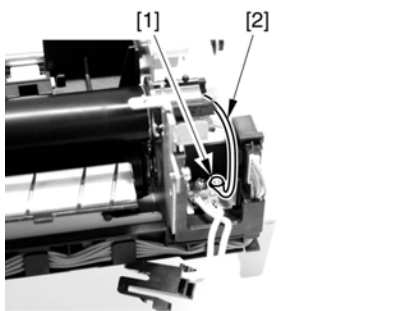

F-7-94

4) Free the AC harness [1] from the edge saddle [2].

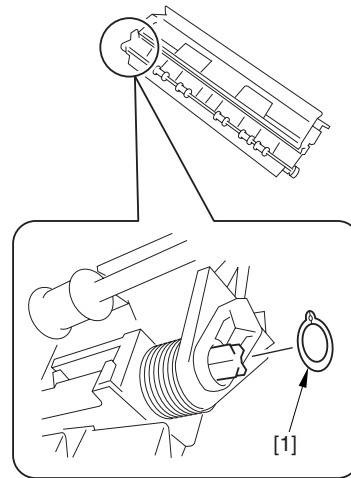

F-7-99

1) Remove the screw [1] and the stepped screw [2], and detach the inside delivery cover unit [3].

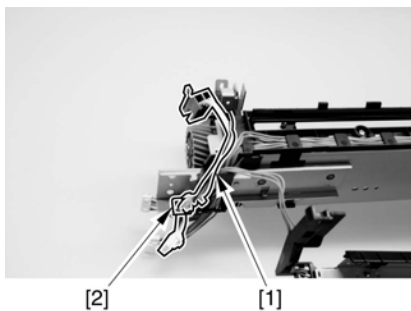

F-7-95

5) Free the relay connector [1] of the signal cable from the connector holder [2].

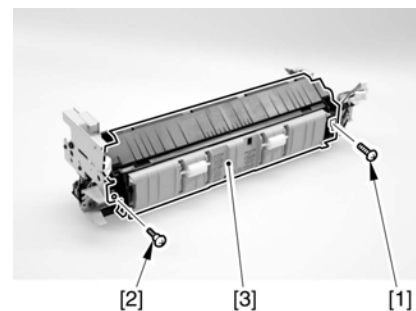

F-7-100

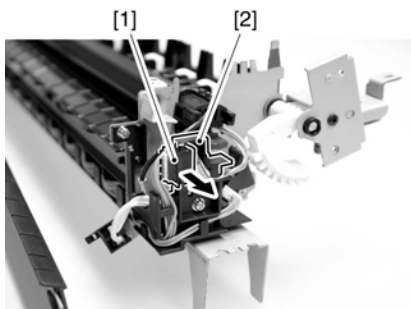

F-7-96

6) Disconnect the connector [2] from the relay connector [1].

Note 1

Point to note when removing the inside delivery cover unit
Remove the inside delivery cover unit while supporting the guide [1] in the arrow direction A and opening it in the arrow direction B in the figure. Oth-

erwise, the guide may come off the inside delivery cover unit.

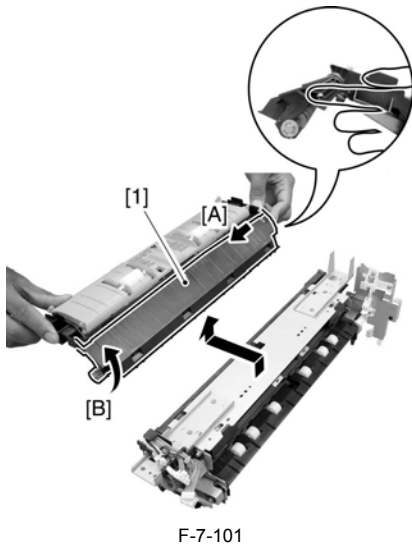

F-7-101

Note 2

Procedure for attaching the guide

Perform the following steps if the guide has come off the inside delivery cover unit.

- 1) Attach the torsion spring [2] to the duplexing support feeder mount [1]. At this time, hook the edge of the torsion spring on the area A of the duplexing support feeder mount.

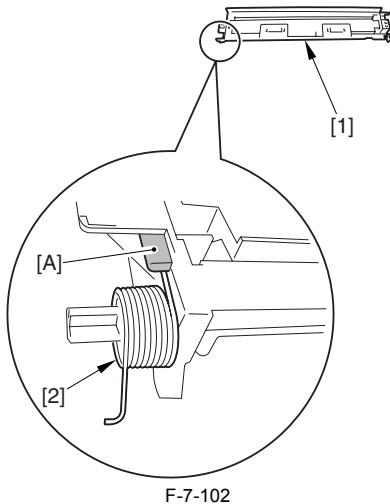

F-7-102

- 2) Attach the guide [1] to the duplexing support feeder mount [2]. At this time, fit [b] into [a] and [d] into [c]. Make sure that the edge [e] of the torsion spring is outside the guide.

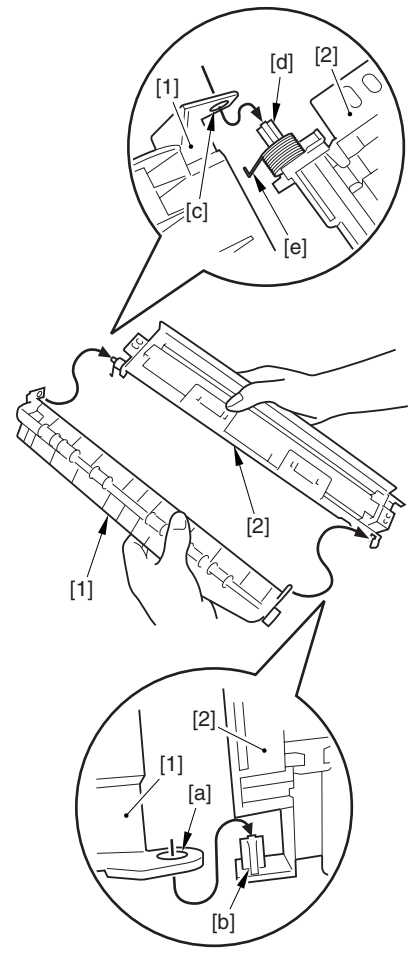

F-7-103

- 3) Hook the edge [1] of the torsion spring on the spring-hook area [2] of the inside delivery cover.

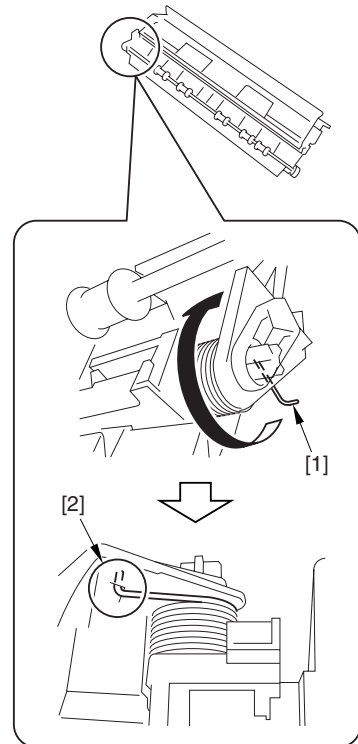

F-7-104

Note 3

Attaching the inside delivery cover unit

- 1) Attach the inside delivery cover unit while supporting the guide [1] in the arrow direction A and opening it in the arrow direction B. Opening the guide can prevent it from coming off the inside delivery cover unit. After attaching, make sure that the guide [1] rotates smoothly.

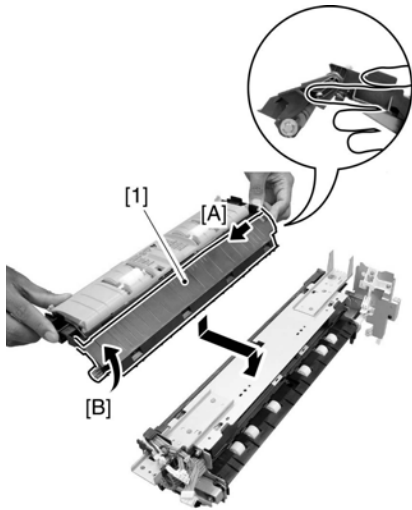

F-7-105

2) Attach the screw [1] and the stepped screw [2], and fix the inside delivery cover unit [3].

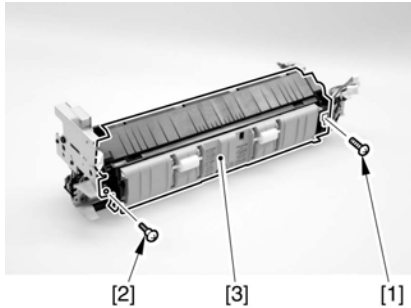

F-7-106

7.5.5.2 Removing the inside delivery cover unit (new)

The difference between new and old inside delivery cover unit:
New inside delivery cover unit has a grip ring [1] at hinge. In this case, detach the cover following the procedure below.

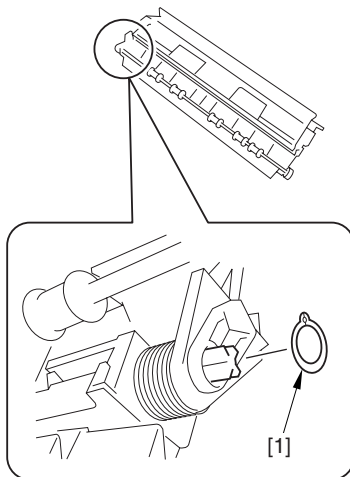

F-7-107

1) Remove the screw [1] and the stepped screw [2], and detach the inside delivery cover unit [3].

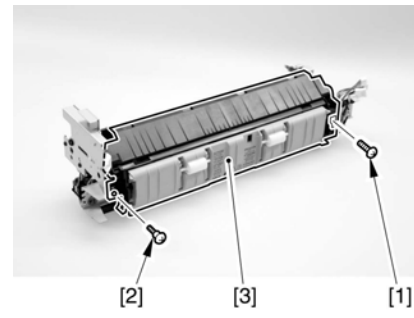

F-7-108

7.5.5.3 Removing the Grounding Plate

1) Remove the 2 screws [1], and detach the grounding plate [2].

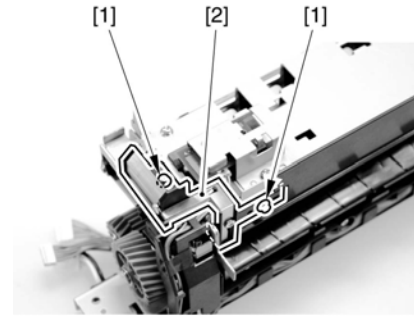

F-7-109

7.5.5.4 Removing the Fixing Film Cover

1) Remove the 3 screws [1], and remove the self-tapping screw [2]; then, detach the fixing film cover [3].

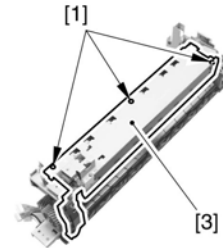

F-7-110

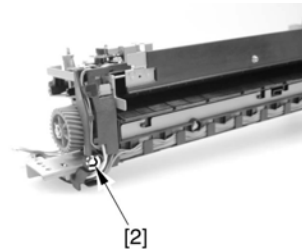

F-7-111



When mounting the fixing film cover unit, be sure to check that it has not ridden over the emboss [1] indicated by the arrow in the figure before tightening the screw.

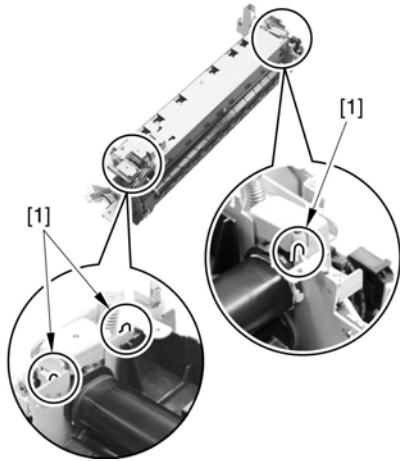

F-7-112

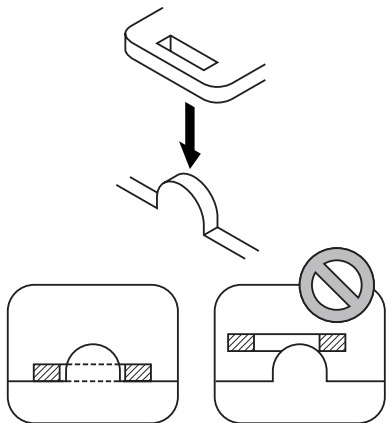

F-7-113

7.5.5.5 Removing the Left Side Plate

1) Remove the screw [1], and detach the left side plate cover [2].

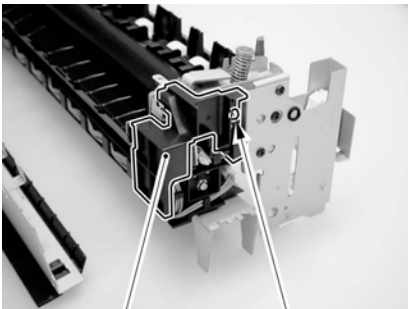

F-7-114

2) Remove the 2 screws [1].

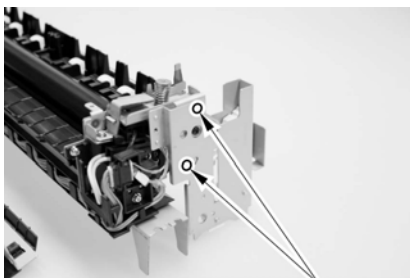

F-7-115

3) Slide the left side plate [1] in the direction of the arrow to detach.

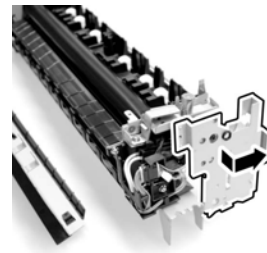

F-7-116

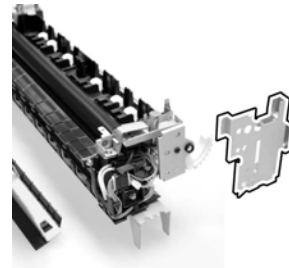

F-7-117



When mounting the left side plate, be sure that it is correctly positioned so that the locking lever and the teeth are correctly engaged. (See the figure.)

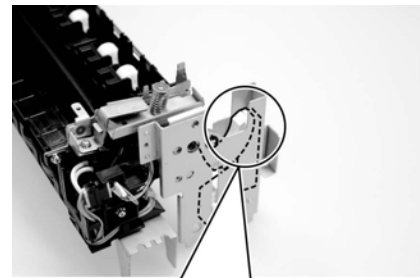

F-7-118

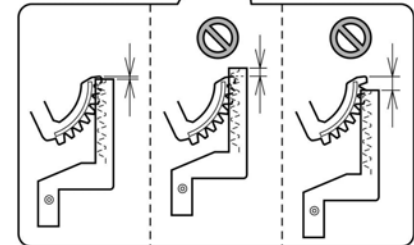

7.5.5.6 Releasing the Locking Plate

1) Turn the locking gear [1] in the direction of the arrow to release the locking roller.

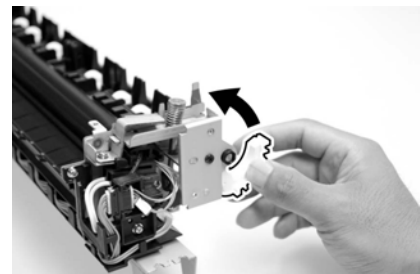

F-7-119

2) Remove the 2 screws [1].

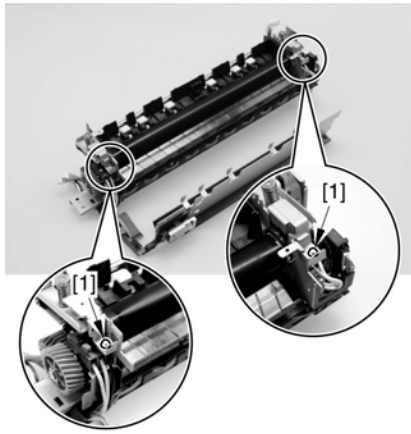

F-7-120



Do not touch the screw [1] used to keep the fixing assembly in place. Turning the screw will change the pressure of the fixing assembly, which cannot be adjusted in the field, necessitating the replacement of the fixing assembly.



F-7-121

3) Turn the locking plate [1] in the direction of the arrow to release it.

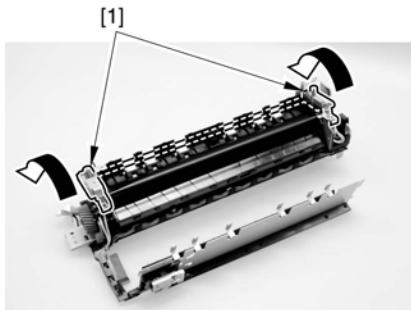

F-7-122

7.5.5.7 Removing the Fixing Film Unit

1) While pushing down the release lever (front) [1], pull out the heater contact [2].

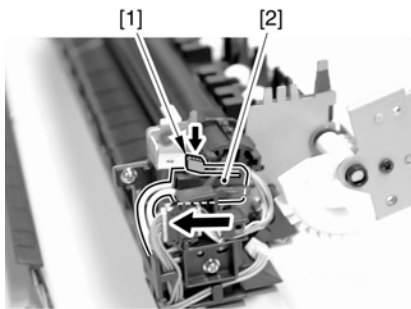

F-7-123

2) While pushing down the release lever (rear) [1], pull out the heater contact [2].

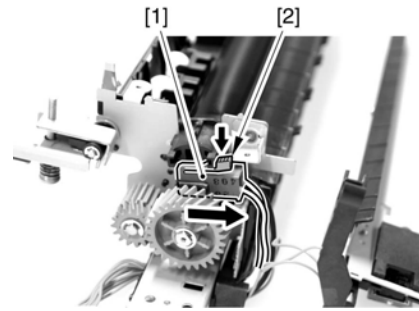

F-7-124

3) Remove the screw [1], and free the AC harness [2].

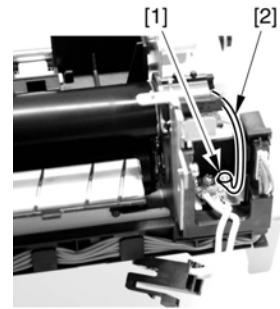

F-7-125

4) Free the AC harness [1] from the edge saddle [2].

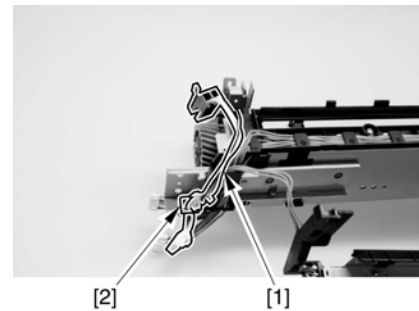

F-7-126

5) Free the relay connector [1] of the signal cable from the connector holder [2].

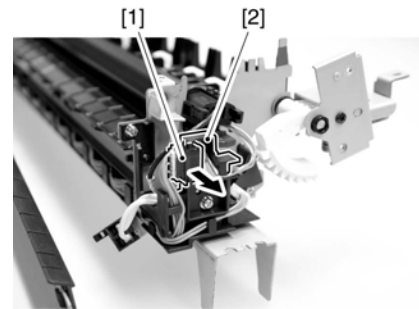

F-7-127

6) Disconnect the connector [2] from the relay connector [1].

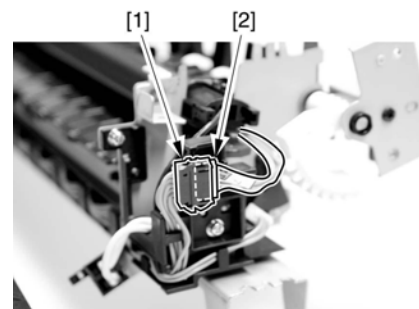

F-7-128

7) Remove the fixing film unit [1].

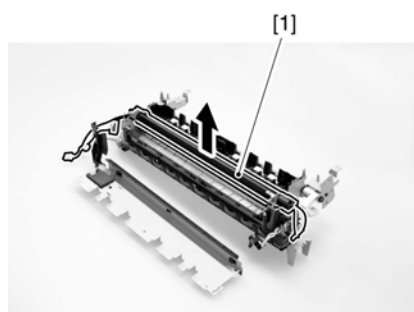

F-7-129

7.5.5.8 Removing the Inside Delivery Sensor

- 1) Disconnect the connector [2] of the harness [1].

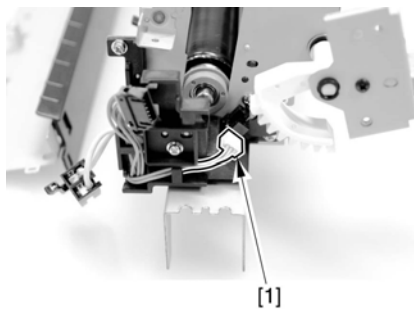

F-7-130

- 2) Remove the front latch [2] of the inside delivery sensor [1]; then, detach the inside delivery sensor.

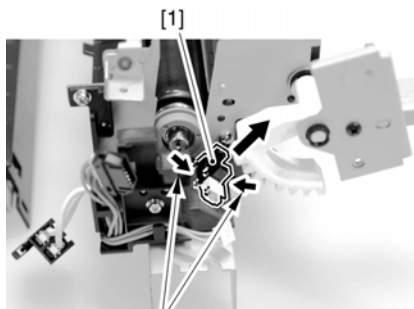

F-7-131

7.5.6 Fixing Film Sensor

7.5.6.1 Removing the inside delivery cover unit (old)

The difference between new and old inside delivery cover unit:
Old inside delivery cover unit does not have a grip ring [1] at hinge. In this case, detach the cover following the procedure below.

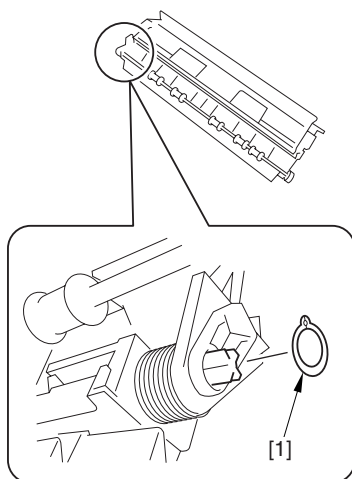

F-7-132

- 1) Remove the screw [1] and the stepped screw [2], and detach the inside de-

livery cover unit [3].

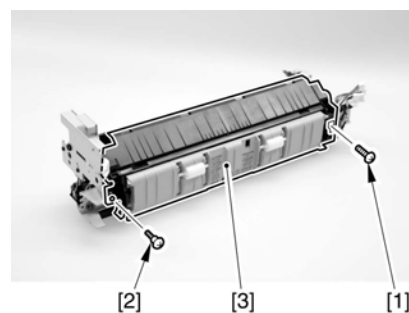

F-7-133

Note 1

Point to note when removing the inside delivery cover unit

Remove the inside delivery cover unit while supporting the guide [1] in the arrow direction A and opening it in the arrow direction B in the figure. Otherwise, the guide may come off the inside delivery cover unit.

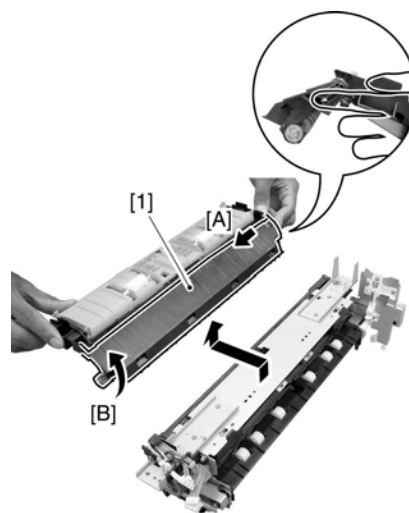

F-7-134

Note 2

Procedure for attaching the guide

Perform the following steps if the guide has come off the inside delivery cover unit.

- 1) Attach the torsion spring [2] to the duplexing support feeder mount [1]. At this time, hook the edge of the torsion spring on the area A of the duplexing support feeder mount.

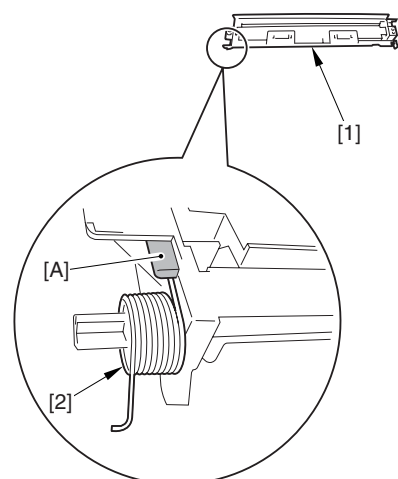

F-7-135

- 2) Attach the guide [1] to the duplexing support feeder mount [2]. At this time, fit [b] into [a] and [d] into [c]. Make sure that the edge [e] of the torsion spring is outside the guide.

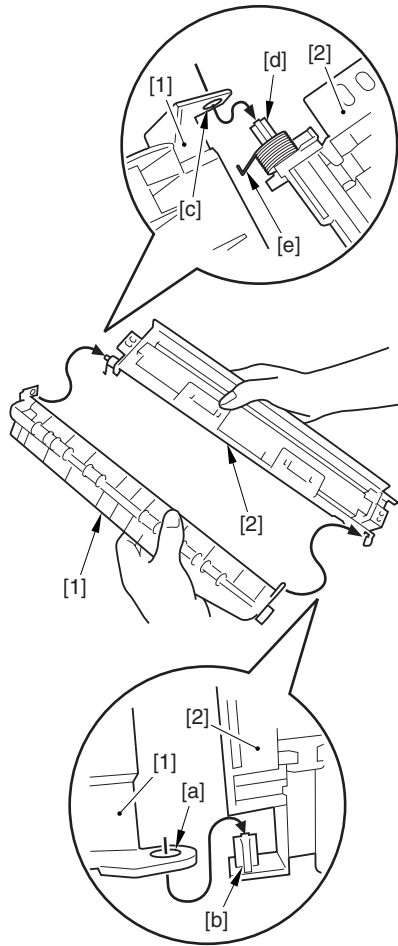

F-7-136

3) Hook the edge [1] of the torsion spring on the spring-hook area [2] of the inside delivery cover.

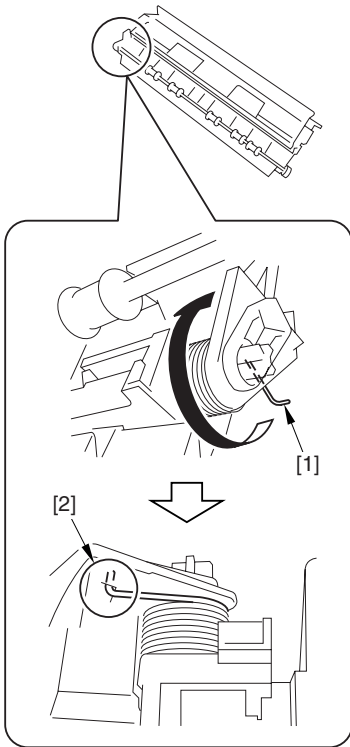

F-7-137

Note 3
Attaching the inside delivery cover unit

1) Attach the inside delivery cover unit while supporting the guide [1] in the arrow direction A and opening it in the arrow direction B. Opening the guide can prevent it from coming off the inside delivery cover unit. After attaching, make sure that the guide [1] rotates smoothly.

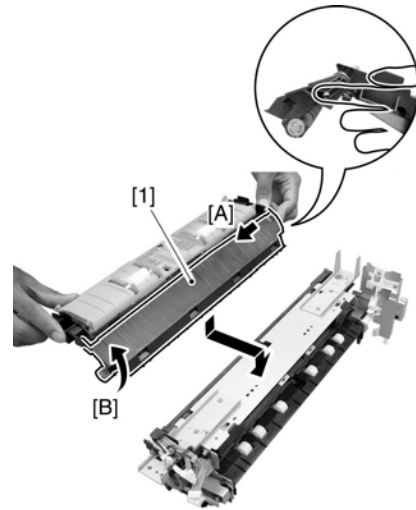

F-7-138

2) Attach the screw [1] and the stepped screw [2], and fix the inside delivery cover unit [3].

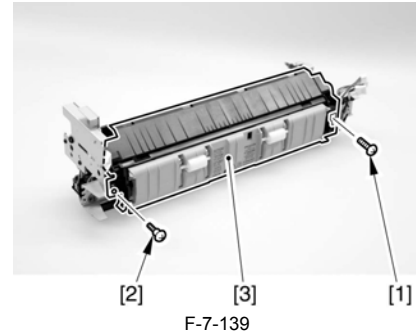

F-7-139

7.5.6.2 Removing the inside delivery cover unit (new)

The difference between new and old inside delivery cover unit:

New inside delivery cover unit has a grip ring [1] at hinge. In this case, detach the cover following the procedure below.

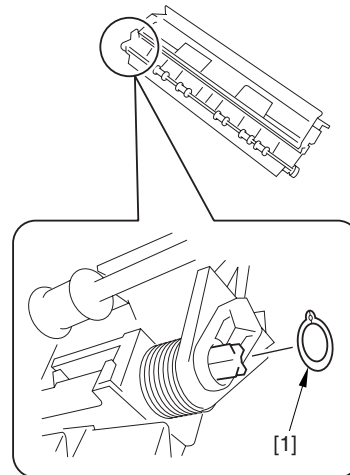

F-7-140

1) Remove the screw [1] and the stepped screw [2], and detach the inside delivery cover unit [3].

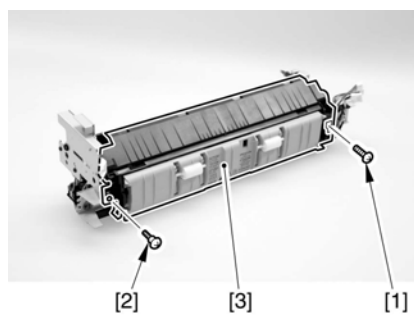

F-7-141

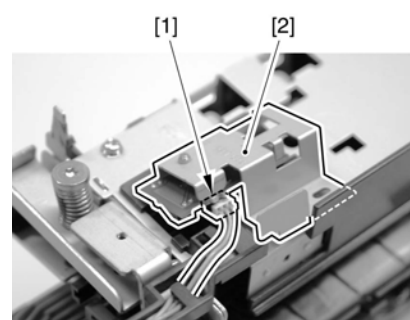

F-7-145

7.5.6.3 Removing the Grounding Plate

1) Remove the 2 screws [1], and detach the grounding plate [2].

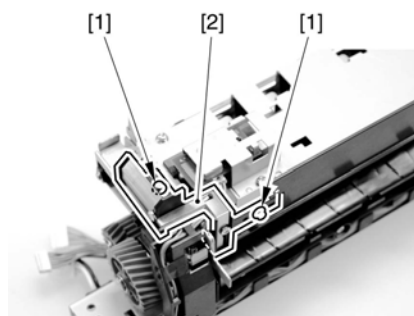

F-7-142

7.5.6.4 Removing the Fixing Film Sensor

1) Remove the screw [1].

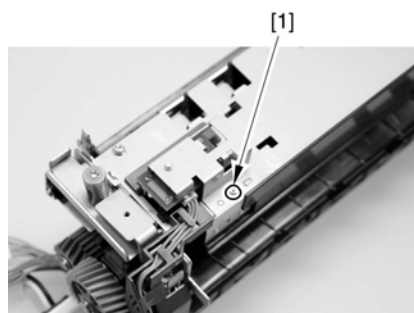

F-7-143

2) Detach the harness [1] from the guide [2].

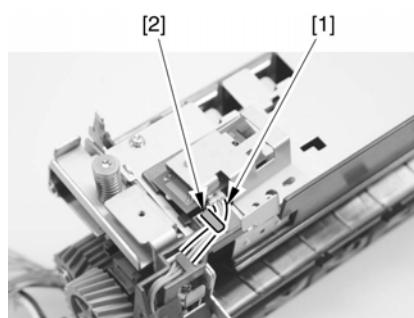

F-7-144

3) Disconnect the connector [1], and detach the fixing film sensor [2].

Chapter 8 External and Controls

Contents

8.1 Parts Replacement Procedure.....	8-1
8.1.1 Main Drive Assembly.....	8-1
8.1.1.1 Removing the Rear Cover.....	8-1
8.1.1.2 Removing the Main Drive Assembly.....	8-1
8.1.2 Power Supply Unit.....	8-1
8.1.2.1 Removing the Rear Cover.....	8-1
8.1.2.2 Removing the Left Cover (lower).....	8-2
8.1.2.3 Removing the Accessories Power Supply PCB.....	8-2
8.1.2.4 Removing the Main Power Supply.....	8-2
8.1.3 Control Panel.....	8-3
8.1.3.1 Removing the Control Panel.....	8-3
8.1.4 Control Panel LCD Unit.....	8-4
8.1.4.1 Removing the Control Panel.....	8-4
8.1.4.2 Removing the Control Panel Base Cover.....	8-4
8.1.4.3 Removing the Control Panel Inside Frame.....	8-5
8.1.4.4 Removing the Control Panel LCD.....	8-5
8.1.5 DC Controller PCB.....	8-5
8.1.5.1 Removing the Rear Cover.....	8-5
8.1.5.2 Removing the DC Controller PCB.....	8-5
8.1.6 Control Panel Inverter PCB.....	8-6
8.1.6.1 Removing the Control Panel.....	8-6
8.1.6.2 Removing the Control Panel Base Cover.....	8-6
8.1.6.3 Removing the Control Panel Inverter PCB.....	8-7
8.1.7 Control Panel Key Switch PCB.....	8-7
8.1.7.1 Removing the Control Panel.....	8-7
8.1.7.2 Removing the Control Panel Base Cover.....	8-7
8.1.7.3 Removing the Control Panel Frame.....	8-8
8.1.7.4 Removing the Control Panel Key Switch PCB.....	8-8
8.1.8 Control Panel CPU PCB.....	8-8
8.1.8.1 Removing the Control Panel.....	8-8
8.1.8.2 Removing the Control Panel Base Cover.....	8-9
8.1.8.3 Removing the Controller Panel CPU PCB.....	8-9
8.1.9 All Night Power Supply PCB.....	8-9
8.1.9.1 Removing the Rear Cover.....	8-9
8.1.9.2 Removing the All-Night Power Supply PCB.....	8-9
8.1.10 Controller Power Supply PCB.....	8-10
8.1.10.1 Removing the Rear Cover.....	8-10
8.1.10.2 Removing the Left Cover (lower).....	8-10
8.1.10.3 Removing the Left Cover (Rear).....	8-10
8.1.10.4 Removing the Accessories Power Supply PCB.....	8-10
8.1.10.5 Removing the Controller Power Supply PCB.....	8-10
8.1.11 Option Power Supply PCB.....	8-11
8.1.11.1 Removing the Rear Cover.....	8-11
8.1.11.2 Removing the Left Cover (lower).....	8-11
8.1.11.3 Removing the Left Cover (Rear).....	8-11
8.1.11.4 Removing the Accessories Power Supply PCB.....	8-11
8.1.12 High-Voltage PCB.....	8-12
8.1.12.1 Removing the Front Cover Unit.....	8-12
8.1.12.2 Removing the Waste Toner Case.....	8-12
8.1.12.3 Removing the Toner Cartridge.....	8-12
8.1.12.4 Removing the Drum Unit.....	8-13
8.1.12.5 Removing the Developing Assembly.....	8-13
8.1.12.6 Removing the Upper Tray.....	8-14
8.1.12.7 Removing the Toner Cartridge Cover.....	8-14

8.1.12.8 Removing the Pre-Exposure Lamp.....	8-15
8.1.12.9 Removing the Left Cover	8-15
8.1.12.10 Removing the Laser Unit.....	8-15
8.1.12.11 Removing the Hopper Assembly.....	8-16
8.1.12.12 Removing the Right Cover (rear)	8-16
8.1.12.13 Removing the Right Door.....	8-16
8.1.12.14 Removing the Right Door.....	8-17
8.1.12.15 Removing the Fixing Unit	8-18
8.1.12.16 Removing the Gear	8-19
8.1.12.17 Removing the High-Voltage PCB	8-19
8.1.13 Exhaust Fan.....	8-20
8.1.13.1 Removing the Heat Discharge Fan	8-20
8.1.14 Motor of Main Drive Assembly.....	8-20
8.1.14.1 Removing the Rear Cover.....	8-20
8.1.14.2 Removing the Main Drive Assembly	8-20
8.1.14.3 Removing the Main Drive Motor	8-21
8.1.15 Fixing Driver Motor.....	8-21
8.1.15.1 Removing the Rear Cover.....	8-21
8.1.15.2 Removing the DC Controller PCB	8-22
8.1.15.3 Removing the Fixing Drive Motor	8-22
8.1.16 Right Door	8-22
8.1.16.1 Removing the Right Cover (rear)	8-22
8.1.16.2 Removing the Right Door.....	8-23
8.1.17 Circuit Braker.....	8-23
8.1.17.1 Removing the Rear Cover.....	8-23
8.1.17.2 Removing the Circuit Breaker	8-24

8.1 Parts Replacement Procedure

8.1.1 Main Drive Assembly

8.1.1.1 Removing the Rear Cover

1) Remove the 13 screws [1] and then the other screw [2]; then, detach the rear cover [3].

⚠ If the left cover (lower) has already been detached, the screw [3] should also have been removed.

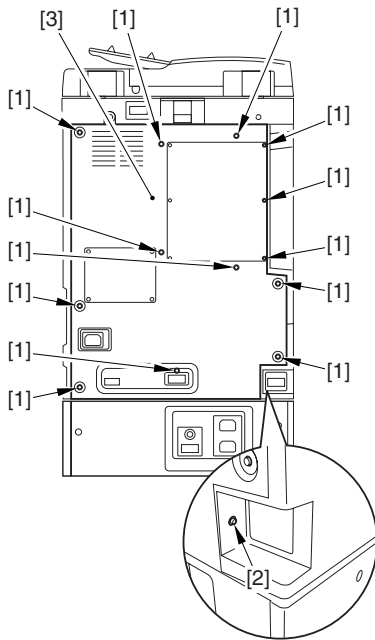

F-8-1

8.1.1.2 Removing the Main Drive Assembly

1) Disconnect the connector [1], and free the harness [2] from the wire saddle.

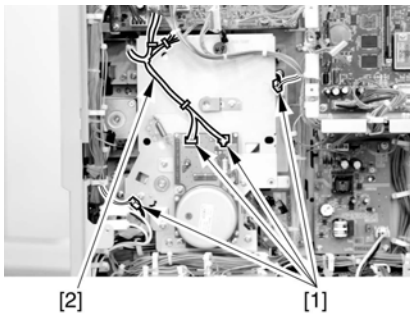

F-8-2

2) Remove the 4 screws [1], and detach the main drive assembly [2].

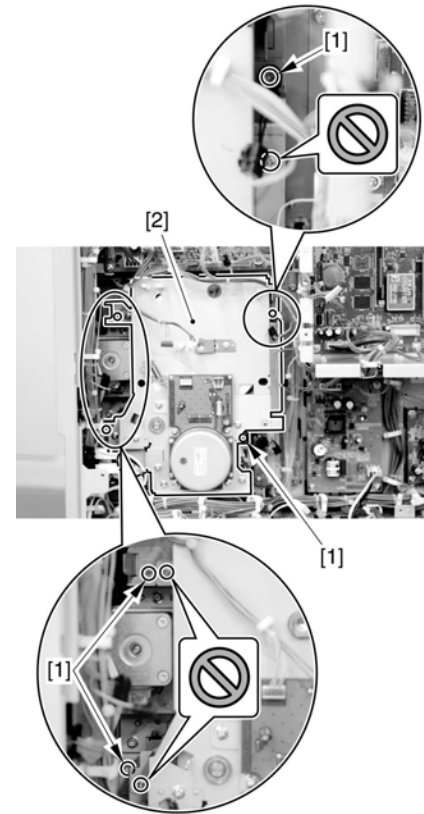

F-8-3

⚠ Do not touch the screws that are glued in place.

8.1.2 Power Supply Unit

8.1.2.1 Removing the Rear Cover

1) Remove the 13 screws [1] and then the other screw [2]; then, detach the rear cover [3].

⚠ If the left cover (lower) has already been detached, the screw [3] should also have been removed.

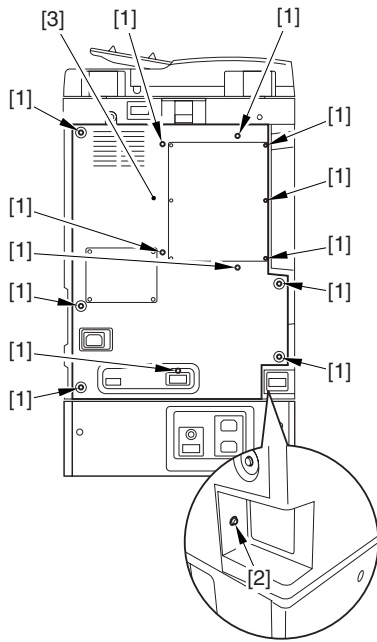

F-8-4

8.1.2.2 Removing the Left Cover (lower)

- 1) Take out the cassettes 1 and 2 [1].
- 2) Remove the 4 screws [2] and the other screw [3]; then, detach the left cover (lower) [4].



If the rear cover has already been detached, the screw [3] should also have been removed.

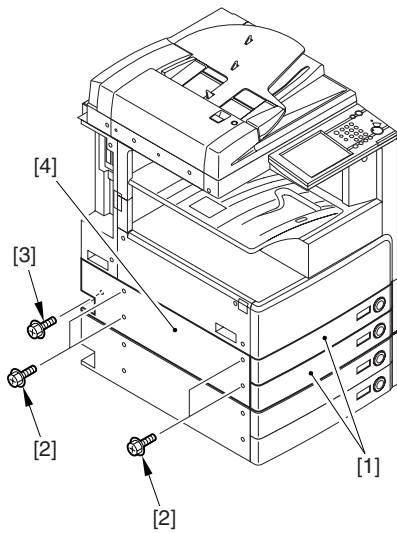

F-8-5

8.1.2.3 Removing the Accessories Power Supply PCB

- 1) Disconnect the connector J640 [1].

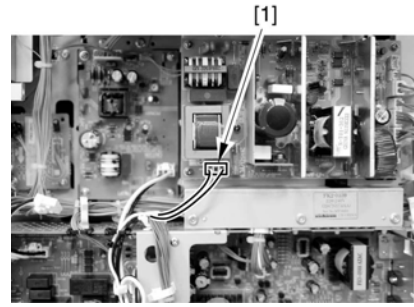

F-8-6

- 2) Remove the 6 connectors [1], and free the harness from the cable clamp [2].

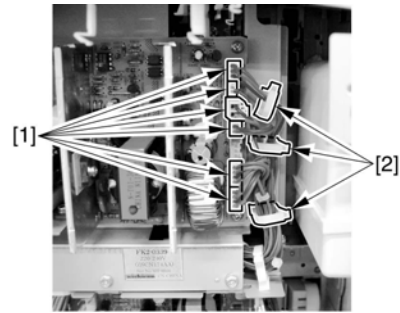

F-8-7

- 3) Remove the 5 binding screws [1], and detach the accessories power supply PCB [2].

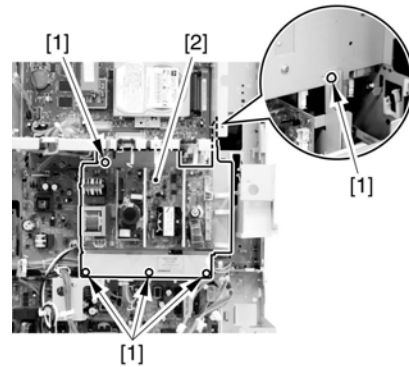

F-8-8

8.1.2.4 Removing the Main Power Supply

- 1) Remove the screw [1], and disconnect the finisher connector [2].

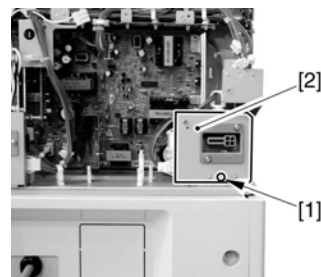

F-8-9

- 2) Remove the screw [1], and disconnect the pedestal connector [2].

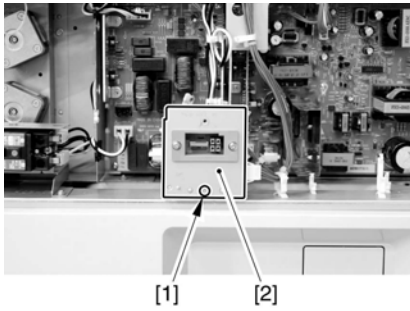

F-8-10

3) Free the harness [1] of the pedestal connector from the lamp [2].

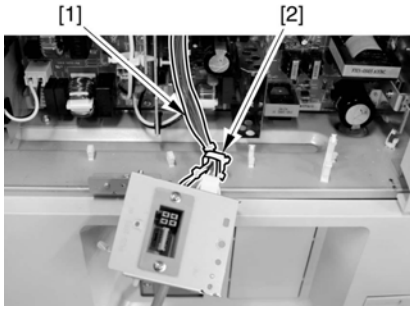

F-8-11

4) Disconnect the 7 connectors [1], and free the harness from the 4 clamps [2].

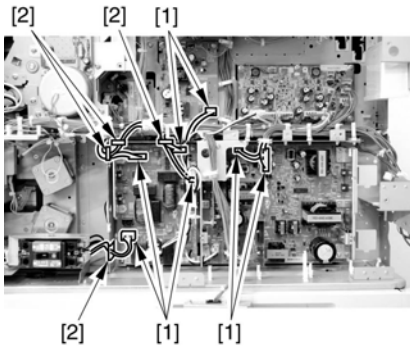

F-8-12

5) Free the harness [1] from the clamp [2].

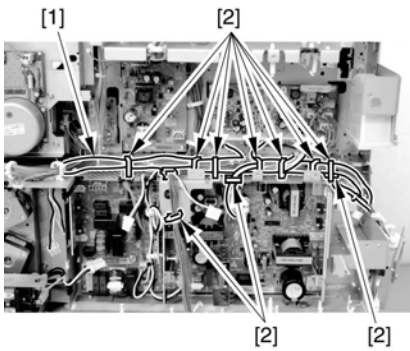

F-8-13

6) Remove the 4 screws [1], and detach the main power supply [2].

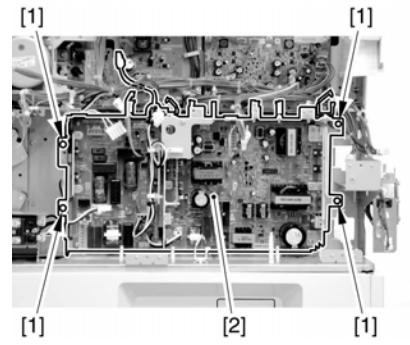

F-8-14

8.1.3 Control Panel

8.1.3.1 Removing the Control Panel

1) Remove the rubber cap [1], and remove the screw [2].

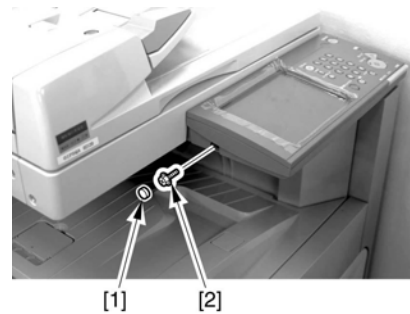

F-8-15

2) Open the right door [1].



F-8-16

3) Remove the 2 screws [1].

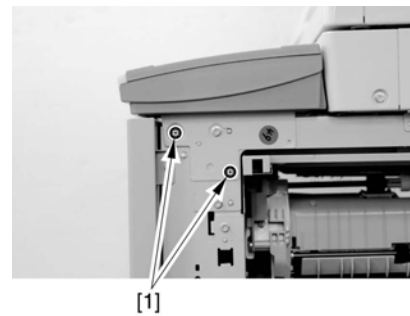

F-8-17

4) Slide the control panel [1] in the direction of the arrow.

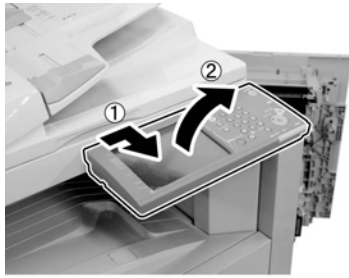

F-8-18

5) Free the harness [2] from the clamp [1].

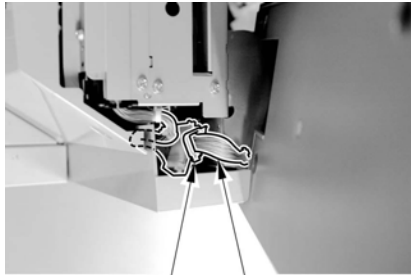

F-8-19

6) Disconnect the connector [1], and detach the control panel.

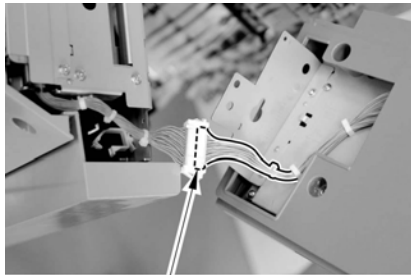

F-8-20

8.1.4 Control Panel LCD Unit

8.1.4.1 Removing the Control Panel

1) Remove the rubber cap [1], and remove the screw [2].



F-8-21

2) Open the right door [1].

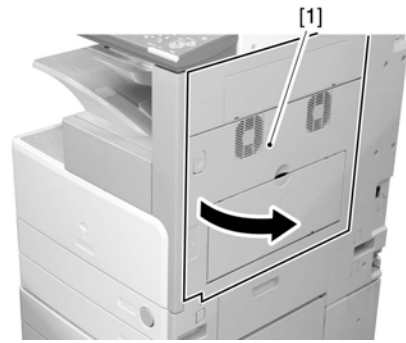

F-8-22

3) Remove the 2 screws [1].

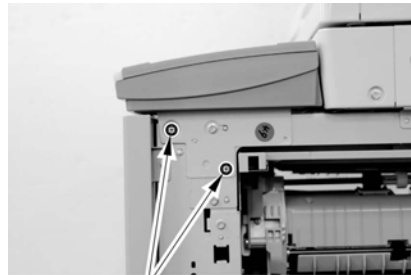

F-8-23

4) Slide the control panel [1] in the direction of the arrow.



F-8-24

5) Free the harness [2] from the clamp [1].



F-8-25

6) Disconnect the connector [1], and detach the control panel.

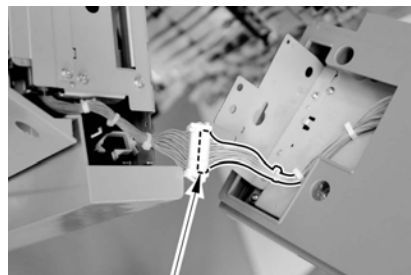

F-8-26

8.1.4.2 Removing the Control Panel Base Cover

1) Remove the 4 screws [1], and detach the control panel base cover [2].

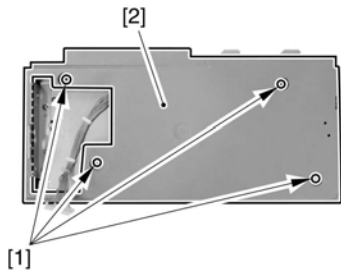

F-8-27

8.1.4.3 Removing the Control Panel Inside Frame

- 1) Disconnect the 2 connectors between the control panel PCB and the control panel key switch PCB; then, free the harness from the 2 clamps [2].
- 2) Disconnect the 2 connectors [3] between the control panel PCB and the control panel LCD.

⚠ Be sure to move the stopper in the direction of the arrow to detach. These 2 stoppers are moved in different directions.

- 3) Disconnect the 2 connectors [3] between the control panel inverter PCB.

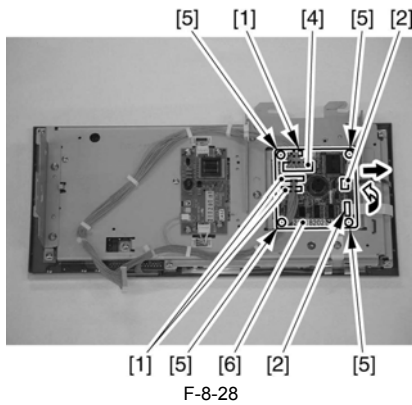

F-8-28

- 4) Remove the control panel inside frame [1]. (2 TP screws [2], and 11 self-tapping screws [3])

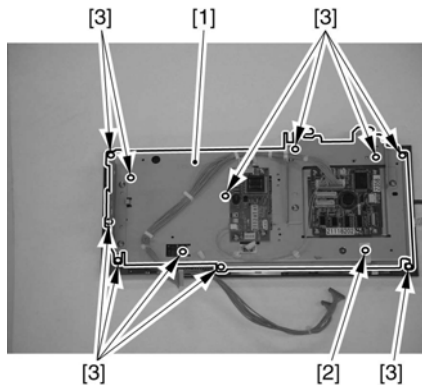

F-8-29

8.1.4.4 Removing the Control Panel LCD

- 1) Remove the screw [1], and detach the control panel LCD [2].

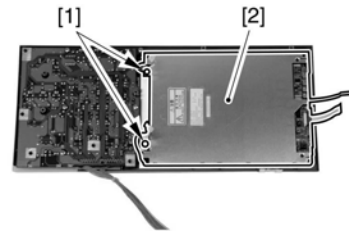

F-8-30

8.1.5 DC Controller PCB

8.1.5.1 Removing the Rear Cover

- 1) Remove the 13 screws [1] and then the other screw [2]; then, detach the rear cover [3].

⚠ If the left cover (lower) has already been detached, the screw [3] should also have been removed.

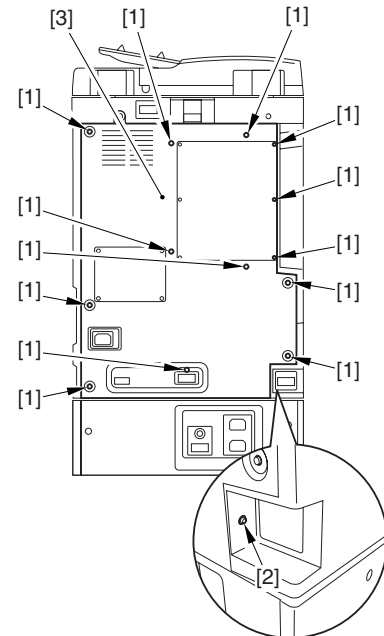

F-8-31

8.1.5.2 Removing the DC Controller PCB

- 1) Disconnect the connector [1].

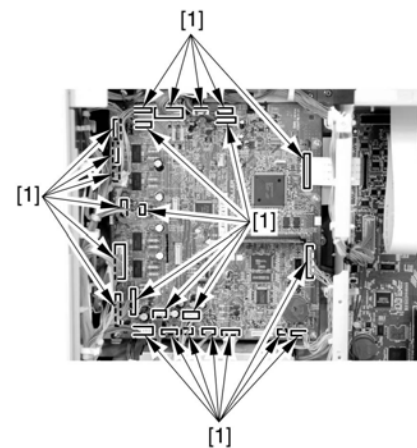

F-8-32



How to Remove the Flexible Cable [1]

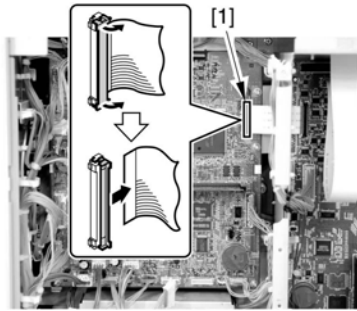

F-8-33

2) Remove the screw [1], and detach the DC controller PCB.

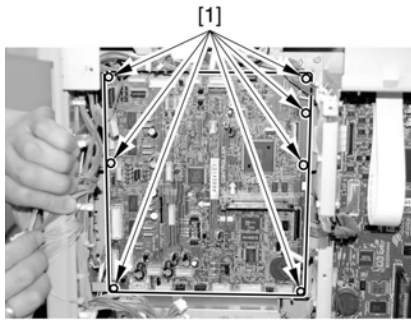

F-8-34



Points to Note When Replacing the DC Controller PCB
Be sure to remove the boot ROM [1] from the exiting DC controller PCB, and mount it to the new DC controller PCB.

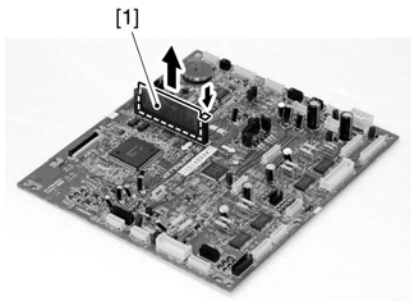

F-8-35

8.1.6 Control Panel Inverter PCB

8.1.6.1 Removing the Control Panel

1) Remove the rubber cap [1], and remove the screw [2].



F-8-36

2) Open the right door [1].

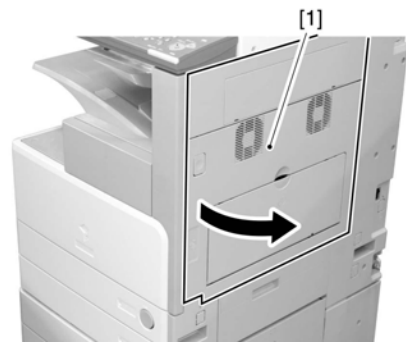

F-8-37

3) Remove the 2 screws [1].

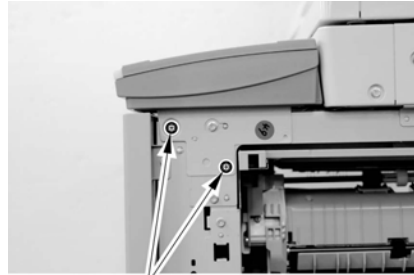

F-8-38

4) Slide the control panel [1] in the direction of the arrow.



F-8-39

5) Free the harness [2] from the clamp [1].



F-8-40

6) Disconnect the connector [1], and detach the control panel.

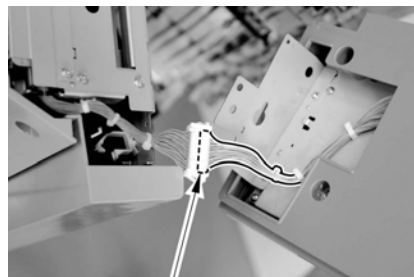

F-8-41

8.1.6.2 Removing the Control Panel Base Cover

1) Remove the 4 screws [1], and detach the control panel base cover [2].

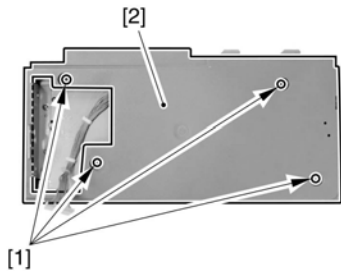

F-8-42

8.1.6.3 Removing the Control Panel Inverter PCB

- 1) Remove the control panel inverter PCB [1].
 - 3 connectors [2]
 - 4 screws [3]

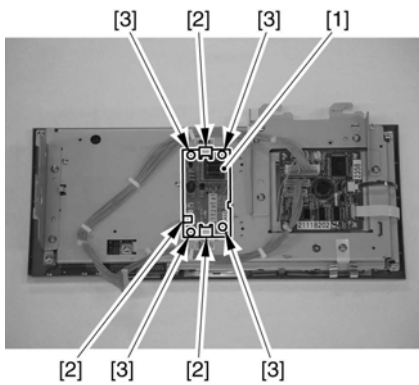

F-8-43

8.1.7 Control Panel Key Switch PCB

8.1.7.1 Removing the Control Panel

- 1) Remove the rubber cap [1], and remove the screw [2].

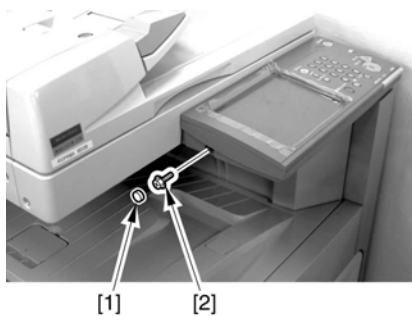

F-8-44

- 2) Open the right door [1].



F-8-45

- 3) Remove the 2 screws [1].

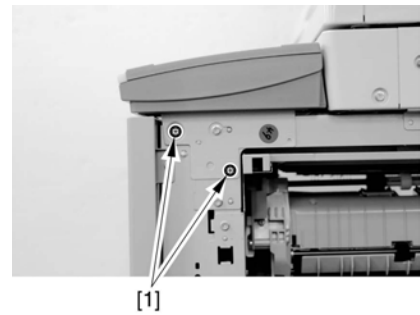

F-8-46

- 4) Slide the control panel [1] in the direction of the arrow.

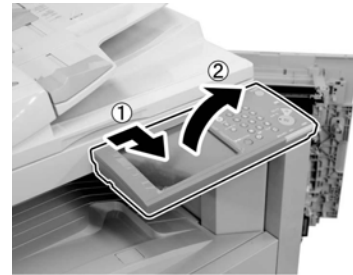

F-8-47

- 5) Free the harness [2] from the clamp [1].

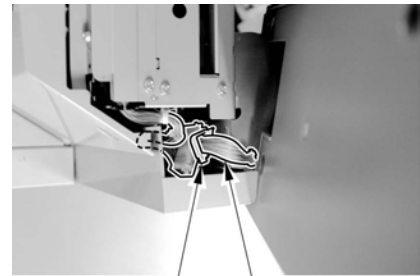

F-8-48

- 6) Disconnect the connector [1], and detach the control panel.

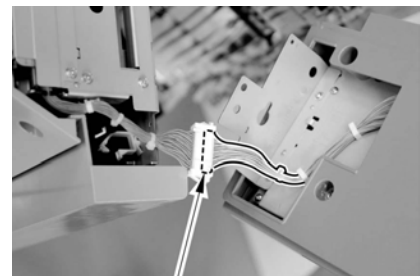

F-8-49

8.1.7.2 Removing the Control Panel Base Cover

- 1) Remove the 4 screws [1], and detach the control panel base cover [2].

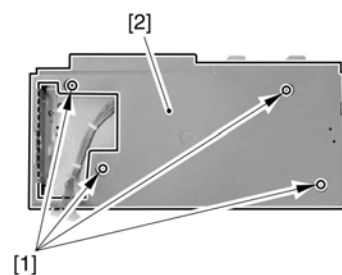

F-8-50

8.1.7.3 Removing the Control Panel Frame

- 1) Disconnect the 2 connectors [1] between the control panel PCB and the control panel key switch PCB; then, free the harness front the 3 clamps [2].
- 2) Disconnect the 2 connectors [3] between the control panel PCB and the control panel LCD.

⚠ Be sure to move the stopper in the direction of the arrow. These 2 stoppers are moved in different directions.

- 3) Disconnect the 2 connectors [4] of the control panel inverter PCB.
- 4) Remove the control panel inside frame [1]. (1 TP screw [2]; 11 self-tapping screws [3])

8.1.7.4 Removing the Control Panel Key Switch PCB

- 1) Disconnect the 2 connectors [3] between the control panel PCB and the control panel LCD.

⚠ Be sure to move the stopper in the direction of the arrow. These 2 stoppers must be moved in different directions.

- 2) Disconnect the 2 connectors [4] between the control panel inverter PCB.

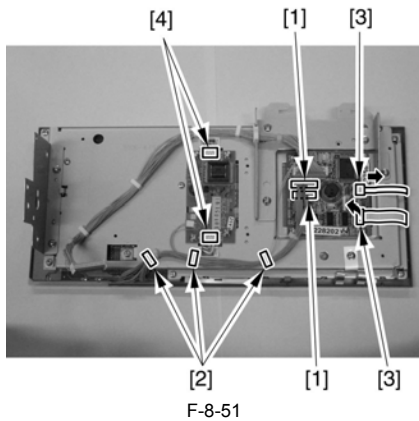

- 3) Remove the control panel inside frame [1]. (1 TP screw [2]; 11 self-tapping screws [3])

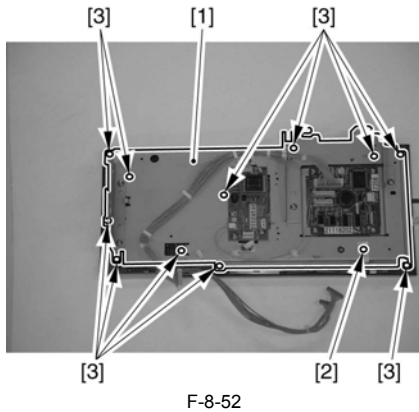

- 4) Remove the control panel key switch PCB [1]. (5 self-tapping screws [2])

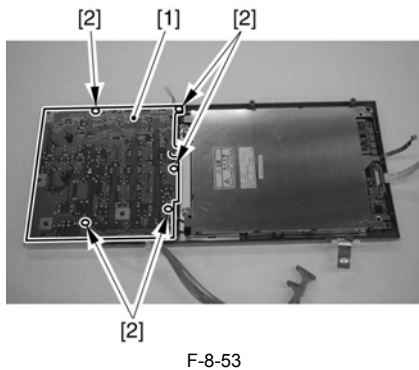

8.1.8 Control Panel CPU PCB

8.1.8.1 Removing the Control Panel

- 1) Remove the rubber cap [1], and remove the screw [2].

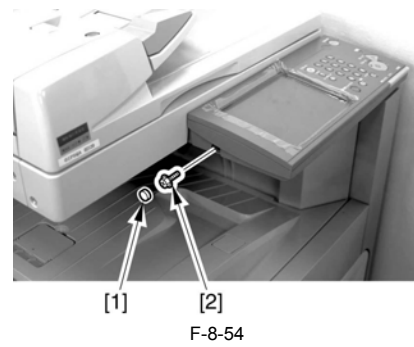

- 2) Open the right door [1].



- 3) Remove the 2 screws [1].

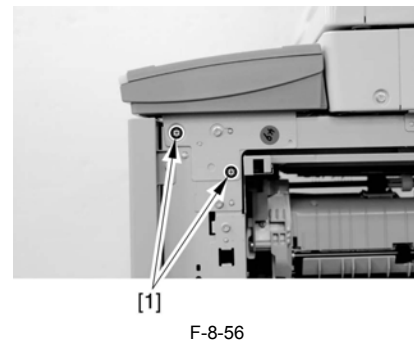

- 4) Slide the control panel [1] in the direction of the arrow.

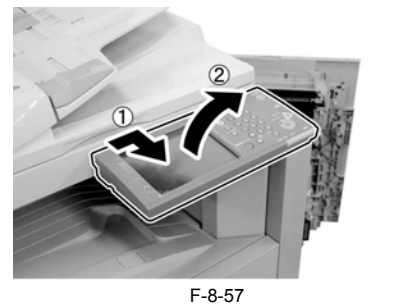

- 5) Free the harness [2] from the clamp [1].

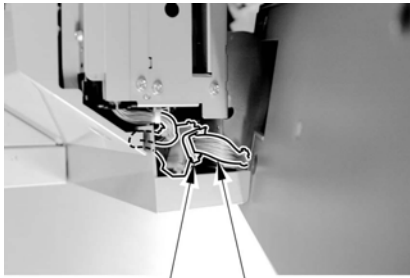

F-8-58

6) Disconnect the connector [1], and detach the control panel.

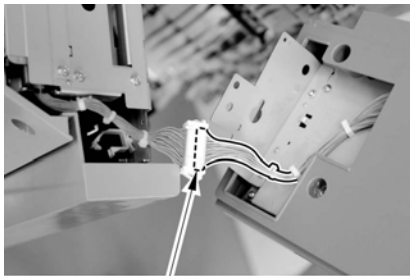

F-8-59

8.1.8.2 Removing the Control Panel Base Cover

1) Remove the 4 screws [1], and detach the control panel base cover [2].

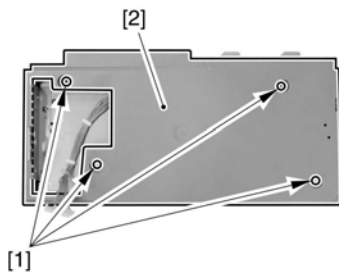

F-8-60

8.1.8.3 Removing the Controller Panel CPU PCB

- 1) Disconnect the 3 connectors [1] of the cable used between the control panel PCB and the control panel KEY PCB.
- 2) Disconnect the 2 connectors [2] used between the control panel PCB and the control panel LCD.



Be sure to remove the stoppers to the direction of the arrow. The 2 stoppers are moved to the different directions, respectively.

- 3) Disconnect the control panel cable [4].
- 4) Remove the control panel CPU PCB [6].
- 4 TP screws [5]

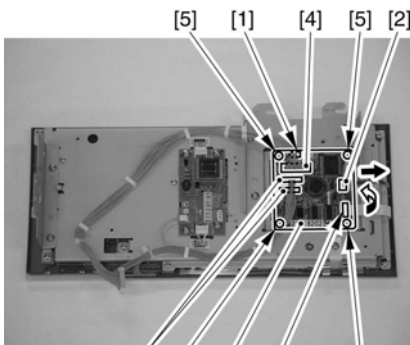

F-8-61

8.1.9 All Night Power Supply PCB

8.1.9.1 Removing the Rear Cover

1) Remove the 13 screws [1] and then the other screw [2]; then, detach the rear cover [3].



If the left cover (lower) has already been detached, the screw [3] should also have been removed.

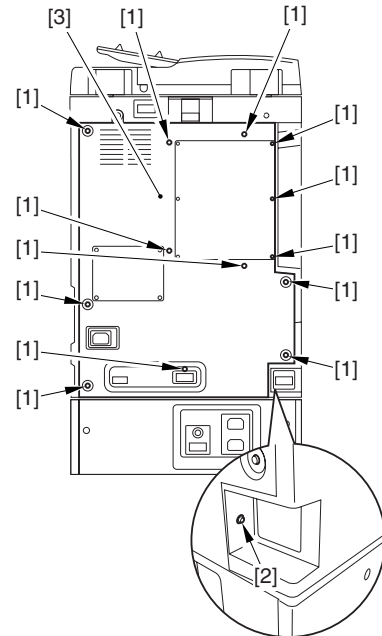

F-8-62

8.1.9.2 Removing the All-Night Power Supply PCB

1) Disconnect the 4 connectors [1].

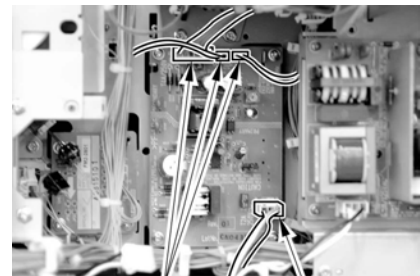

F-8-63

2) Remove the 4 screws [1], and detach the all-night power supply PCB [2].

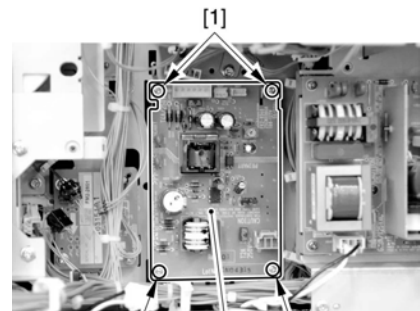

F-8-64

8.1.10 Controller Power Supply PCB

8.1.10.1 Removing the Rear Cover

1) Remove the 13 screws [1] and then the other screw [2]; then, detach the rear cover [3].



If the left cover (lower) has already been detached, the screw [3] should also have been removed.

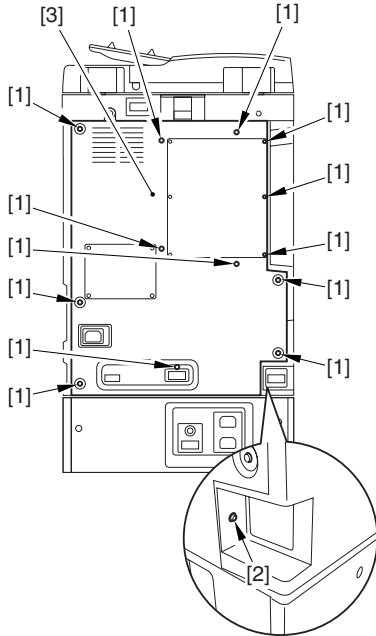

F-8-65

8.1.10.2 Removing the Left Cover (lower)

1) Take out the cassettes 1 and 2 [1].
2) Remove the 4 screws [2] and the other screw [3]; then, detach the left cover (lower) [4].



If the rear cover has already been detached, the screw [3] should also have been removed.

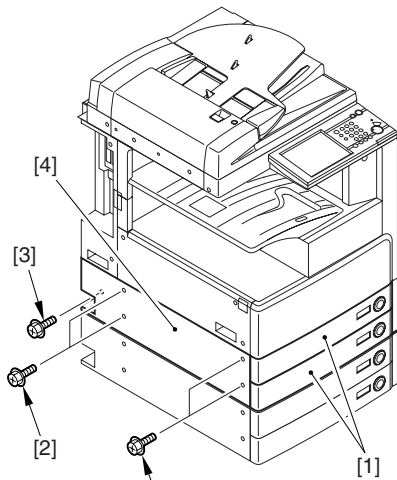

F-8-66

8.1.10.3 Removing the Left Cover (Rear)

1) Remove the 2 screws [1]; then, detach the left cover (rear) [2].

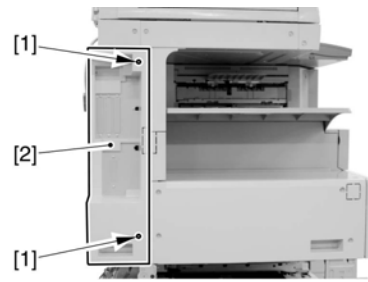

F-8-67

8.1.10.4 Removing the Accessories Power Supply PCB

1) Disconnect the connector J640 [1].

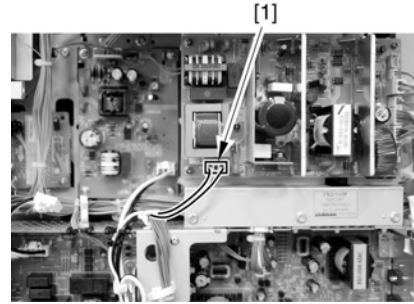

F-8-68

2) Remove the 6 connectors [1], and free the harness from the cable clamp [2].



F-8-69

3) Remove the 5 binding screws [1], and detach the accessories power supply PCB [2].

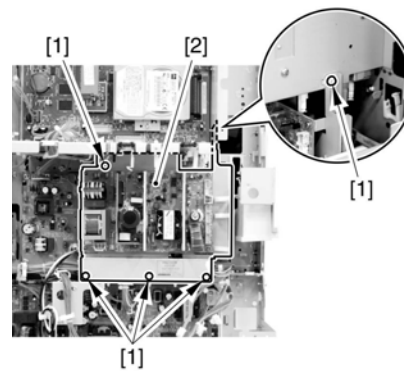

F-8-70

8.1.10.5 Removing the Controller Power Supply PCB

1) Disconnect the connector [1].

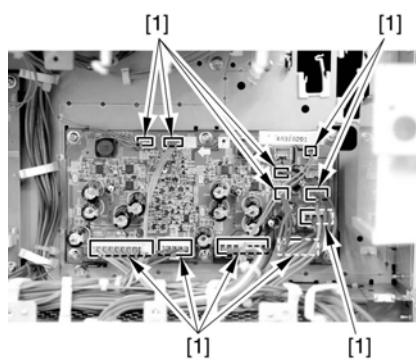

F-8-71

- 2) Remove the 6 screws [1], and detach the controller power supply PCB [2].

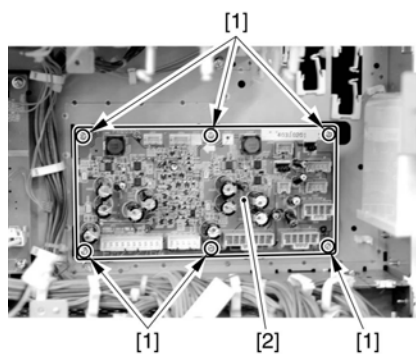

F-8-72

8.1.11 Option Power Supply PCB

8.1.11.1 Removing the Rear Cover

- 1) Remove the 13 screws [1] and then the other screw [2]; then, detach the rear cover [3].



If the left cover (lower) has already been detached, the screw [3] should also have been removed.

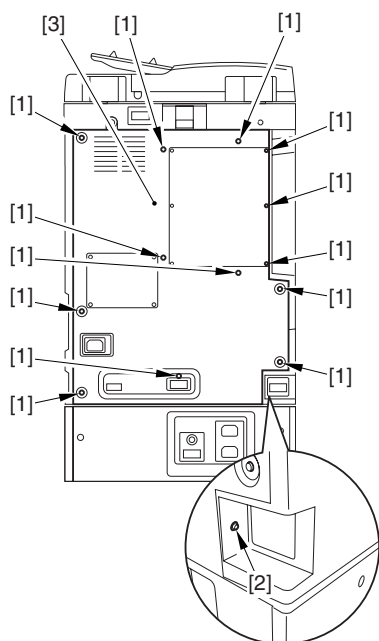

F-8-73

8.1.11.2 Removing the Left Cover (lower)

- 1) Take out the cassettes 1 and 2 [1].
2) Remove the 4 screws [2] and the other screw [3]; then, detach the left cover (lower) [4].



If the rear cover has already been detached, the screw [3] should also have been removed.

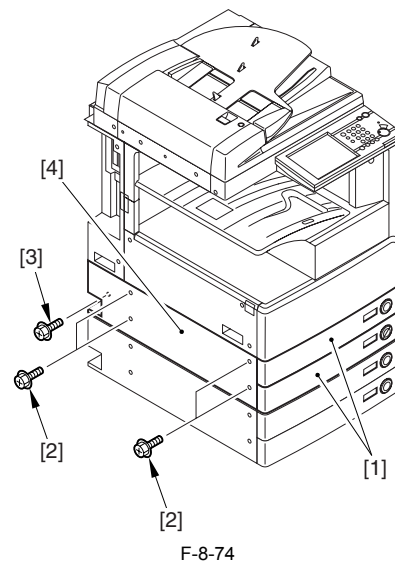

F-8-74

8.1.11.3 Removing the Left Cover (Rear)

- 1) Remove the 2 screws [1]; then, detach the left cover (rear) [2].

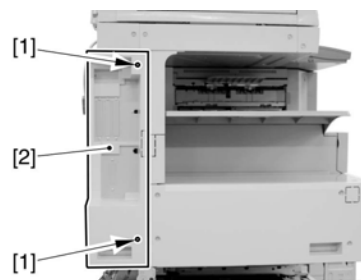

F-8-75

8.1.11.4 Removing the Accessories Power Supply PCB

- 1) Disconnect the connector J640 [1].

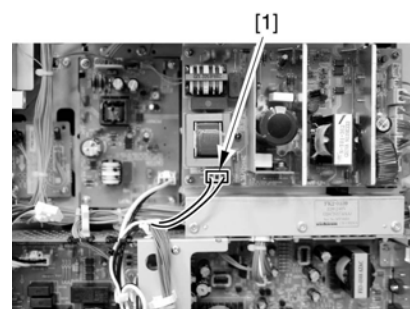

F-8-76

- 2) Remove the 6 connectors [1], and free the harness from the cable clamp [2].

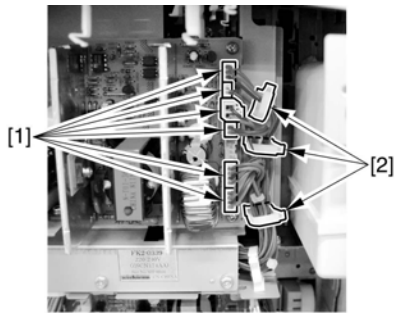

F-8-77

3) Remove the 5 binding screws [1], and detach the accessories power supply PCB [2].

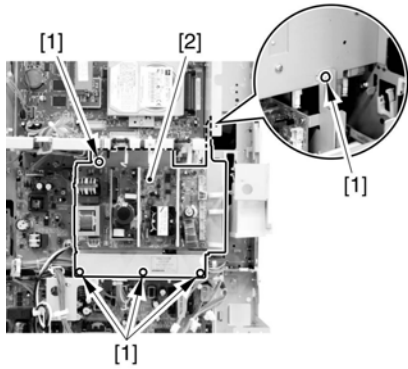

F-8-78

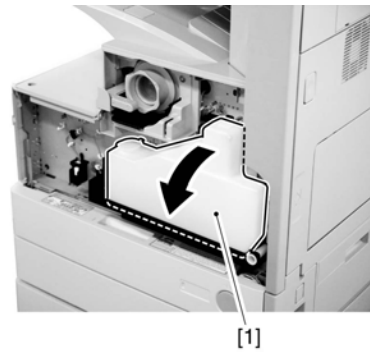

F-8-81

⚠ Point to note after attaching the waste toner receptacle
After attaching the waste toner receptacle, move the waste toner full detection lever [1] up and down to make sure that the lever is moved smoothly. Faulty detection may be resulted if the lever is caught in something and is not moved smoothly.

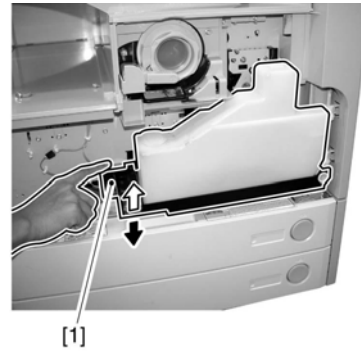

F-8-82

8.1.12 High-Voltage PCB

8.1.12.1 Removing the Front Cover Unit

1) Open the front cover [1].

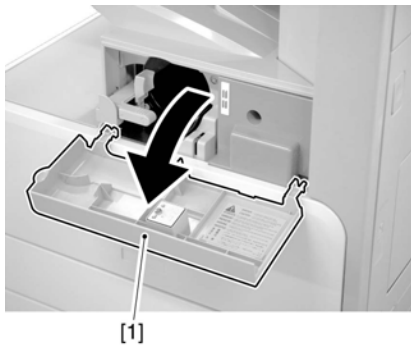

F-8-79

2) Remove the face cover rubber [1].
3) Remove the binding screw [2].
4) Remove the RS tightening screw [3].
5) Detach the front cover unit [4] by moving it in the direction of the arrow.

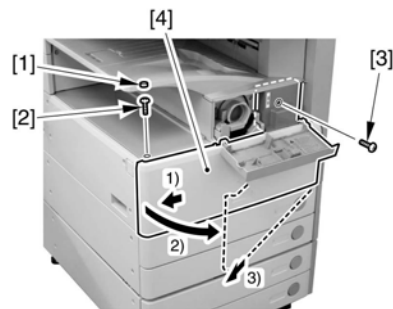

F-8-80

8.1.12.2 Removing the Waste Toner Case

1) Remove the waste toner case [1].

8.1.12.3 Removing the Toner Cartridge

1) Shift up the lever [1].

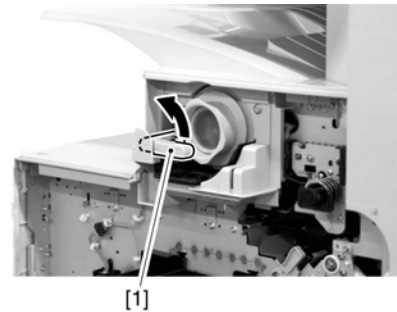

F-8-83

2) Remove the toner cartridge [1].

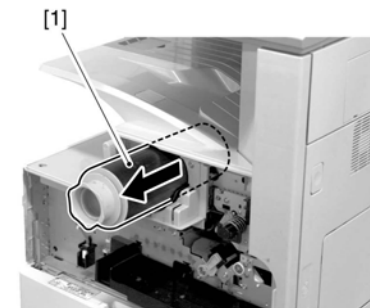

F-8-84

⚠ Points to Note on Handling the Toner Cartridge

1. Care should be taken not to bump the toner stop [1] against the covers or the like when and after removing the toner cartridge. Since the toner stop comes off easily, toner scattering may be resulted if it comes off by accident.
2. Keep the toner cartridge horizontal after removing. Since the toner stop [1] comes off easily as mentioned above, toner scattering may be resulted if the toner cartridge is placed with the toner stop side down.

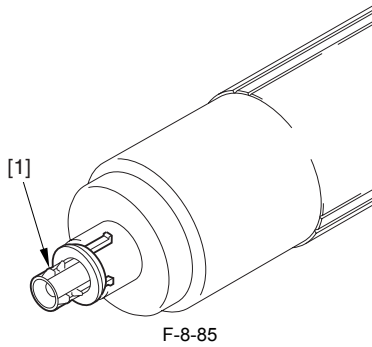

5) Remove the drum unit [1].

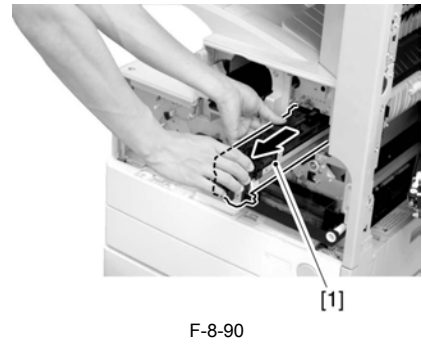

8.1.12.4 Removing the Drum Unit

1) Open the right door [1].

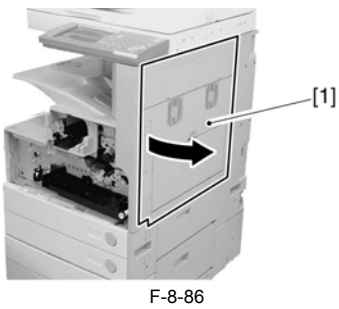

2) Remove the screw [1].

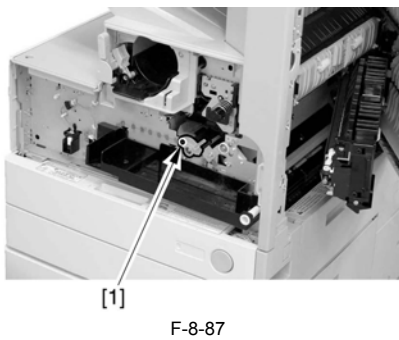

3) Shift the locking lever [1] to the left to release the developing assembly.

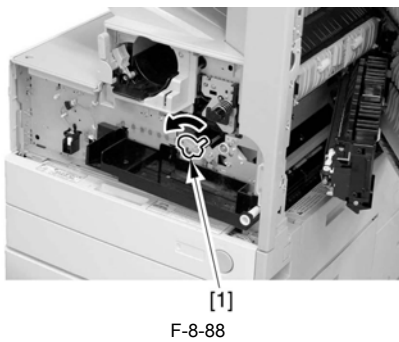

4) Remove the screw [1].

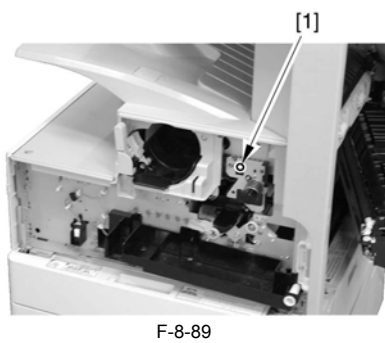

Be sure to hold the drum unit as shown.

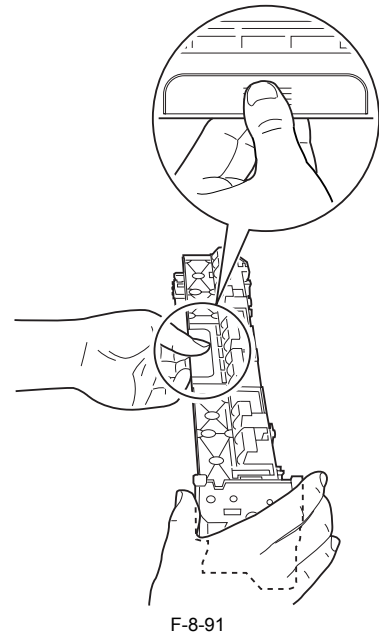

8.1.12.5 Removing the Developing Assembly

1) Remove the screw [1].

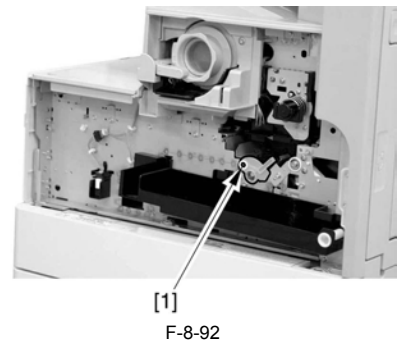

2) Shift the locking lever [1] to the left to release the developing assembly.

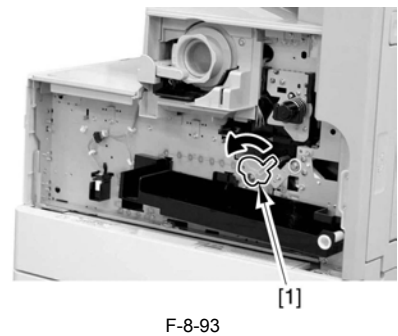

3) Slide the developing assembly [1] slightly to the front; then, disconnect the connector [2].

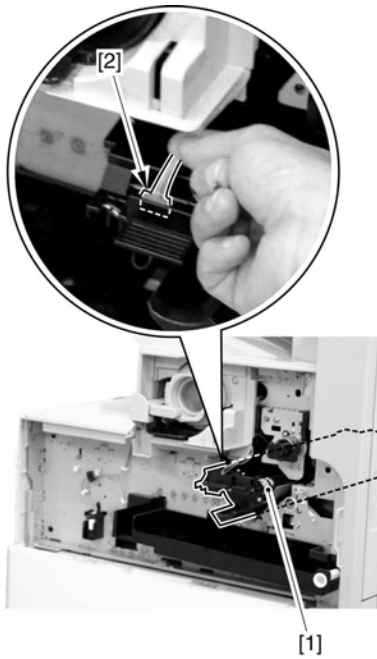

F-8-94

4) Remove the developing assembly [1].

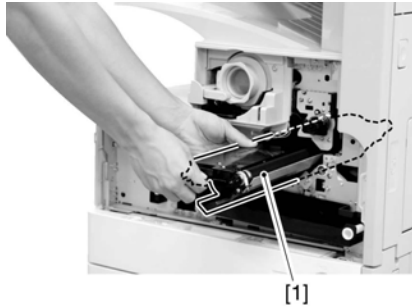

F-8-95



Be sure to hold the developing assembly as shown.

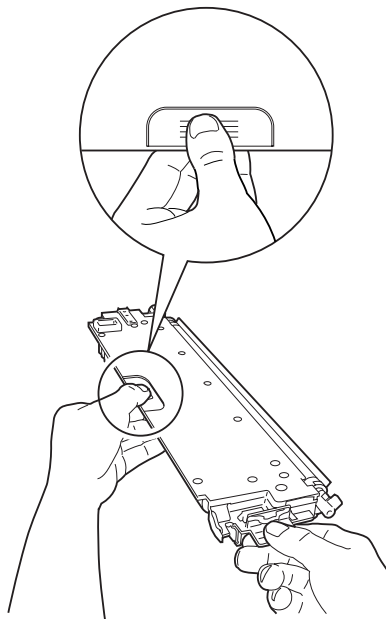

F-8-96



When fitting the developing assembly, be sure to fit the lower right segment [2] of the developing assembly [1] in the rail [3] of the machine. Thereafter, slide the developing assembly so that [A] of the developing assembly matches [B] of the rail.

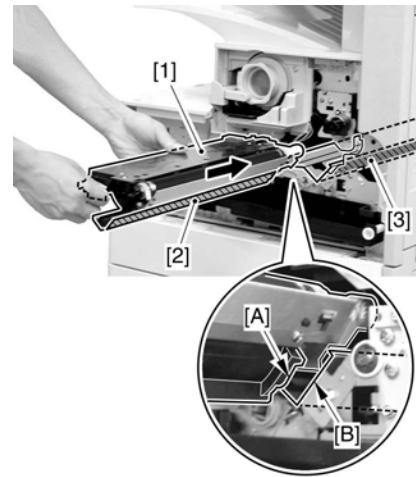

F-8-97

8.1.12.6 Removing the Upper Tray

1) Remove the 2 screws [1], and detach the upper tray [2].

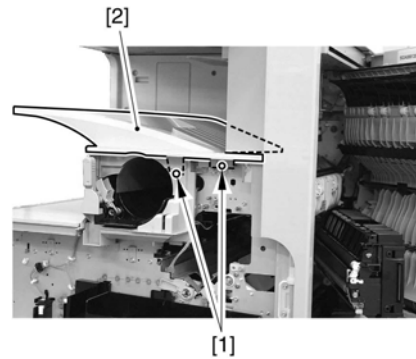

F-8-98

Reference:

Lift the front of the upper tray [1], and detach it as if to slide it toward the front.

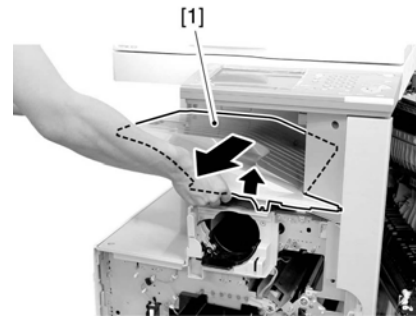

F-8-99

8.1.12.7 Removing the Toner Cartridge Cover

1) Remove the 2 screws [1]; then, detach the toner bottle cover [2].

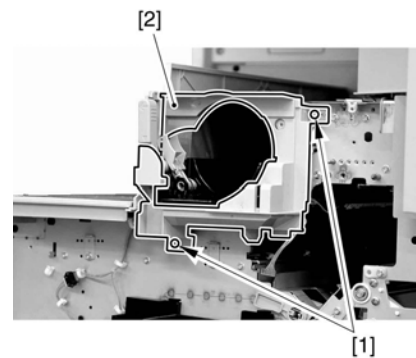

F-8-100

8.1.12.8 Removing the Pre-Exposure Lamp

1) Open the 2 wire saddles [1], and disconnect the 2 relay connectors [2].

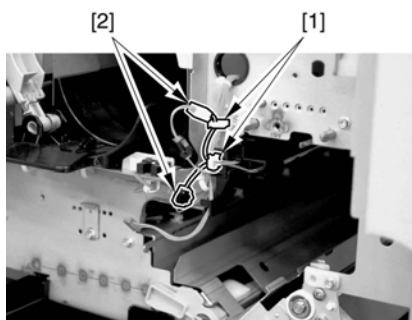

F-8-101

2) While freeing the lock [1] toward the right, detach the pre-exposure lamp [2].

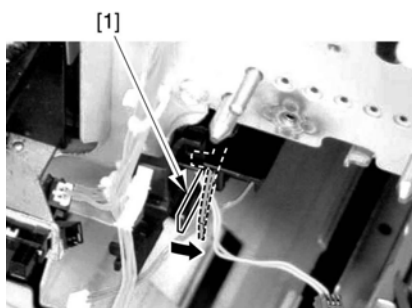

F-8-102

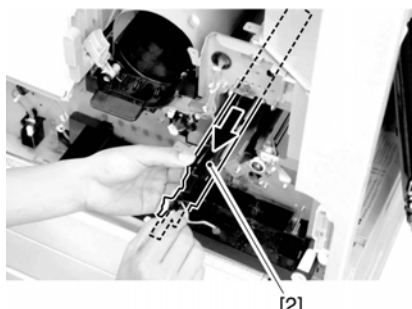

F-8-103

8.1.12.9 Removing the Left Cover

1) Remove the 4 screws [1], and detach the left cover [2].

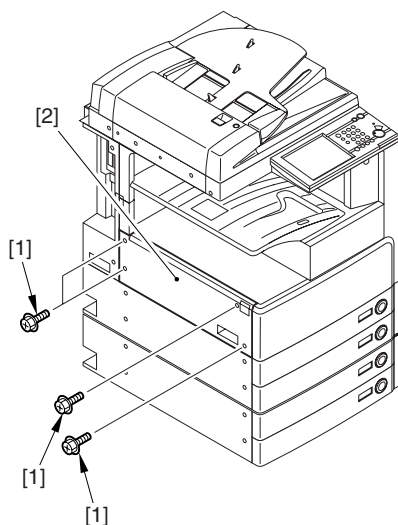

F-8-104

8.1.12.10 Removing the Laser Unit

1) Open the 2 wire saddles [1], and disconnect the 2 connectors [2].

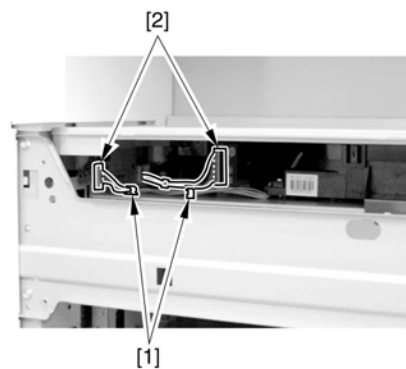

F-8-105



When you have disconnected the connector [1], be sure to take care so that it will not come into contact with the PCB that is mounted to the laser scanner unit. (The PCB is equipped with a laser intensity adjustment variable resistor. Contact with the PCB can change the adjustment setting.)

2) Open the wire saddle [1], and disconnect the connector [2].

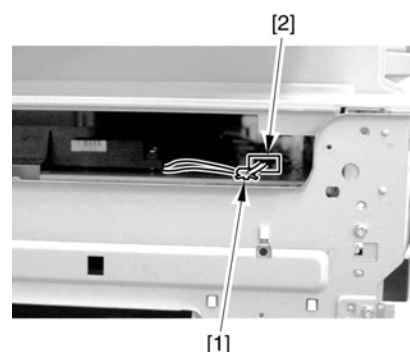

F-8-106

3) Remove the screw [1], and detach the fixing [2].

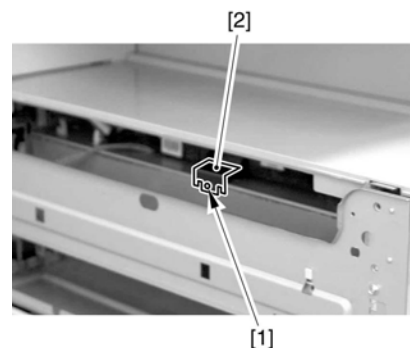

F-8-107

4) Lift the front of the laser unit [1], and slide it to the front.

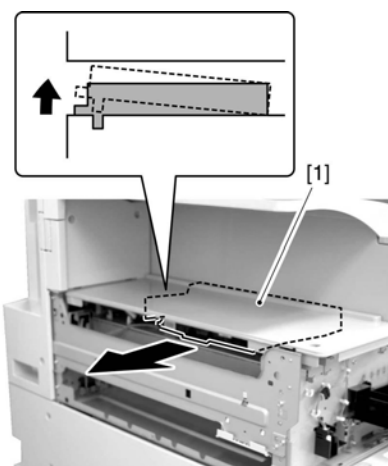

F-8-108



When sliding out the laser scanner unit, be sure to take care not to touch the PCB mounted to the laser scanner unit. (The PCB is equipped with a laser scanner intensity adjustment variable resistor, and contact with the PCB can change the adjustment setting.)

8.1.12.11 Removing the Hopper Assembly

- 1) Remove the inside base cover [1] and the inside right color [2].

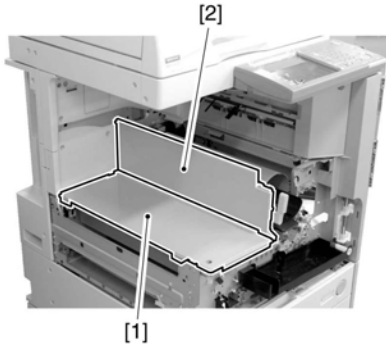

F-8-109

- 2) Disconnect the 3 connectors [1] found at the front and the connector [2] found at the rear.

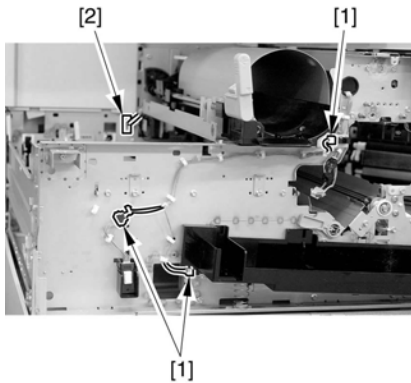

F-8-110

- 3) Open the 11 wire saddles [1], and pull out the harness [3] through the hole [2] in the plate.

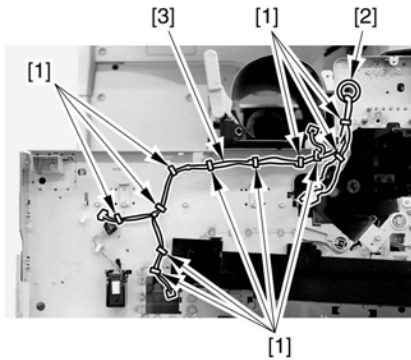

F-8-111

- 4) Remove the 3 screws [1], and detach the hopper assembly [2].

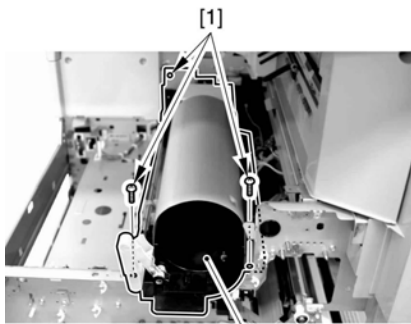

F-8-112



When fitting the hopper assembly to the machine, be sure that the connectors [1] are securely connected. If the connectors [1] are not connected, the environment heater will not be supplied with power, leading to image faults.

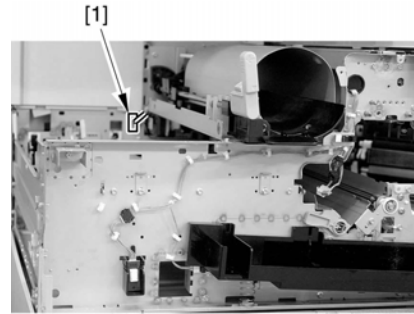

F-8-113

8.1.12.12 Removing the Right Cover (rear)

- 1) Open the pedestal right door [1]. (if equipped with a 2-Cassette Pedestal Y2)
- 2) Open the right lower door [2].
- 3) Remove the 5 screws [3], and detach the right cover (rear) [4].

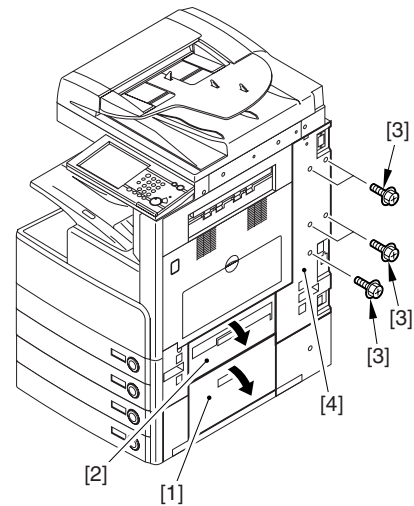

F-8-114

8.1.12.13 Removing the Right Door

- 1) Open the right door.



F-8-115

- 2) Remove the screw [1], and detach the fixing plate [2].

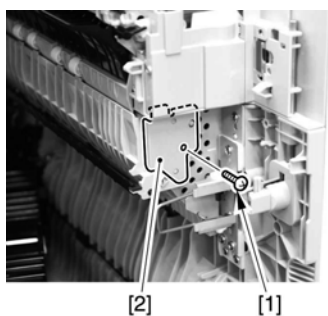

F-8-116

- 3) Remove the joint shaft [1], and free the extension delivery unit [2] from the right door.

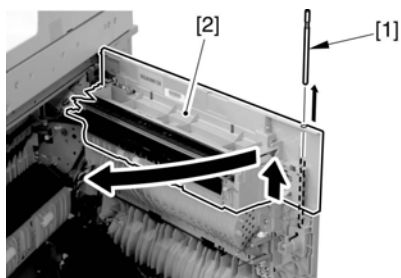

F-8-117

- 4) Disconnect the connector [1], and remove the reuse band [2]; then, remove the 2 screws (M4x8; RS tightening).

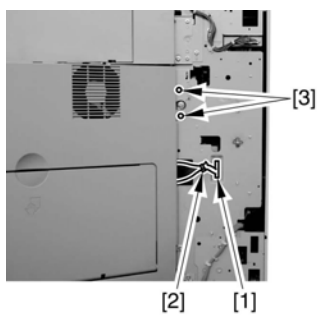

F-8-118

- 5) While freeing the hinge assembly [2], detach the right door.

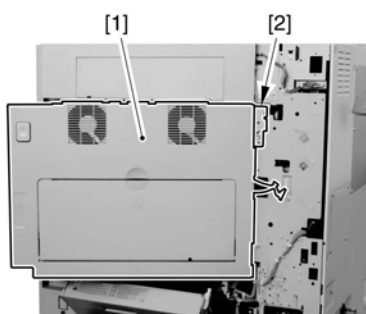

F-8-119

Attaching the Right Door

- 1) Match the hinge [1] found at the bottom of the right door against the lug.
- 2) Engage the hinge [2] found on the top of the right door with the hook found on the side plate.

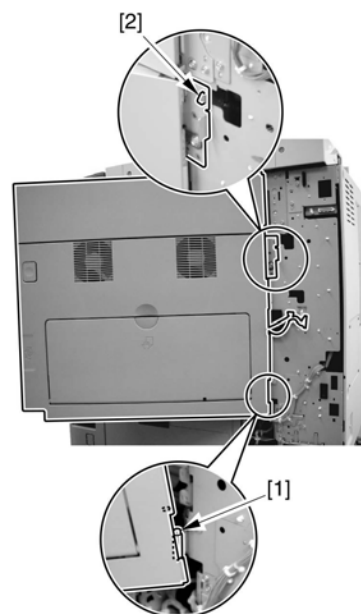

F-8-120



When tightening the 2 screws used to fix the hinge in place, be sure to close the right door first.

8.1.12.14 Removing the Right Door

- 1) Open the right door.



F-8-121

- 2) Remove the screw [1], and detach the fixing plate [2].



F-8-122

- 3) Remove the joint shaft [1], and free the extension delivery unit [2] from the right door.

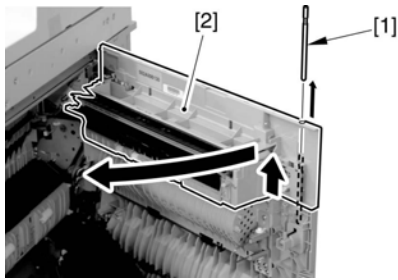

F-8-123

4) Disconnect the connector [1], and remove the reuse band [2]; then, remove the 2 screws (M4x8; RS tightening).

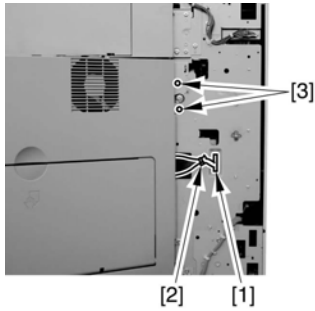

F-8-124

5) While freeing the hinge assembly [2], detach the right door.

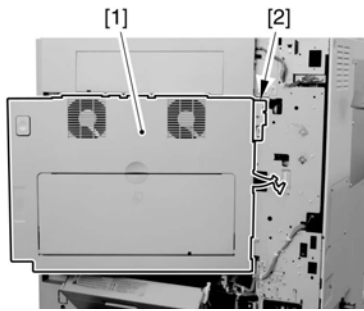

F-8-125

Attaching the Right Door

1) Match the hinge [1] found at the bottom of the right door against the lug.
 2) Engage the hinge [2] found on the top of the right door with the hook found on the side plate.

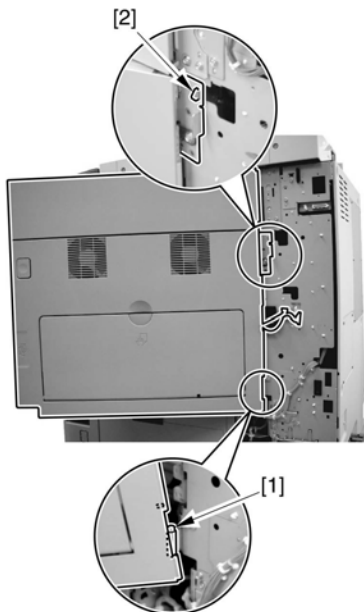

F-8-126



When tightening the 2 screws used to fix the hinge in place, be sure to close the right door first.

8.1.12.15 Removing the Fixing Unit

1) Remove the screw [1], and detach the harness cover [2].

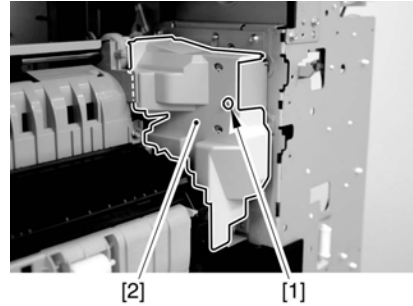

F-8-127

2) Disconnect the 3 connectors [1].

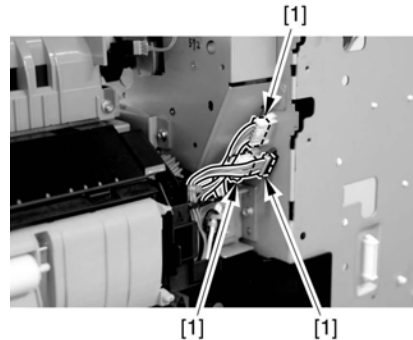

F-8-128

3) Remove the 4 screws [1].

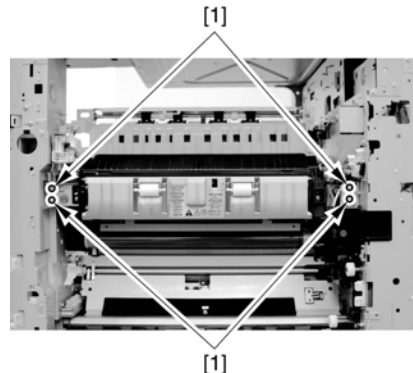

F-8-129

4) Detach the fixing unit [1] toward the front.

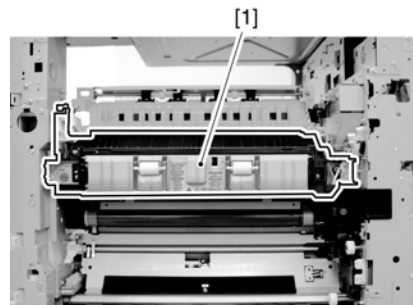

F-8-130



When mounting the harness cover [1], be sure to keep the harness [2] within the space [3] indicated in the figure so that the harness [2] will not come into contact with the gear [4].

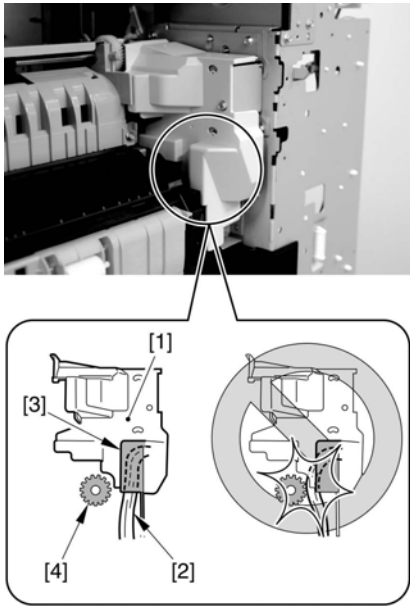

F-8-131



Do not touch the screw [1]. Turning it will change the pressure of the fixing assembly, which cannot be adjusted in the field, necessitating the replacement of the fixing assembly.

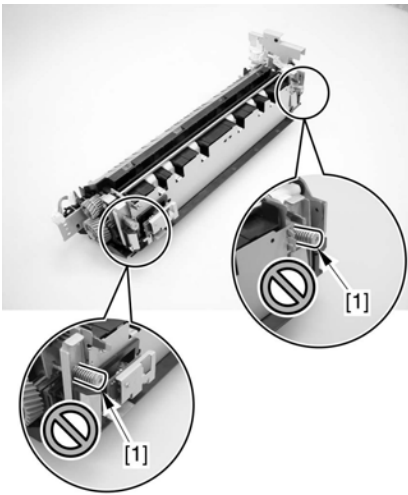

F-8-132

8.1.12.16 Removing the Gear

1) Remove the 4 screws [1], and detach the gear cover [2].

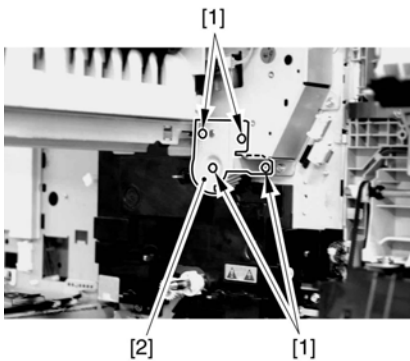

F-8-133

2) Remove the gear [1].

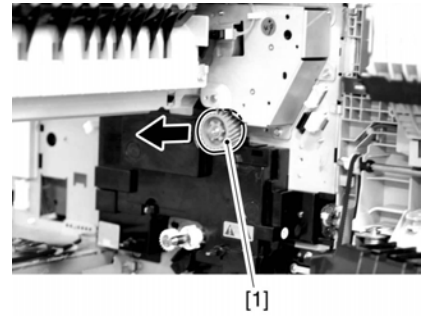

F-8-134

8.1.12.17 Removing the High-Voltage PCB

1) Remove the screw [1], and detach the fixing member [2].

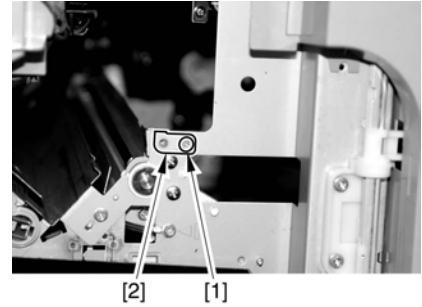

F-8-135

2) Slide the guide [1] as shown to detach.

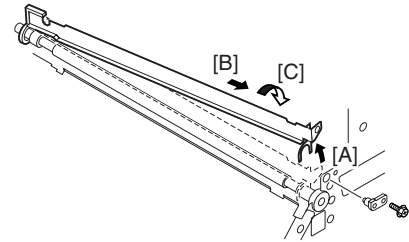

F-8-136

3) Disconnect the connector [1], and remove the latch [2] and 3 screws [3]; then, detach the high-voltage PCB [4].

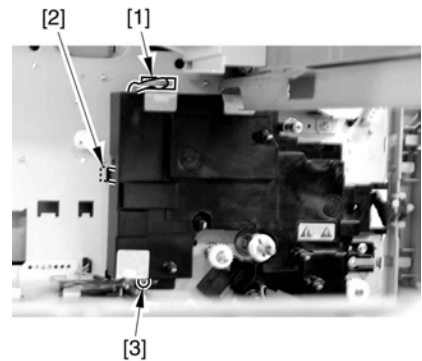

F-8-137

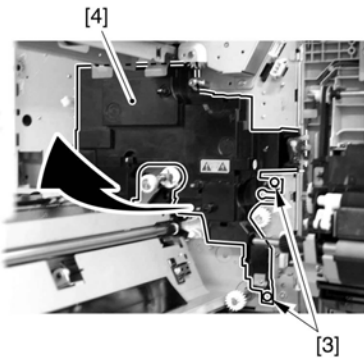

F-8-138

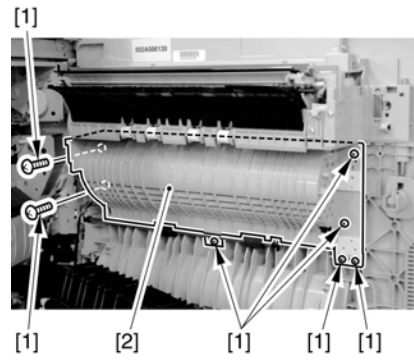

F-8-142

5) Disconnect the connector [1], and detach the heat discharge fan [2].

8.1.13 Exhaust Fan

8.1.13.1 Removing the Heat Discharge Fan

1) Open the right door.



F-8-139

2) Remove the screw [1], and detach the fixing plate [2].

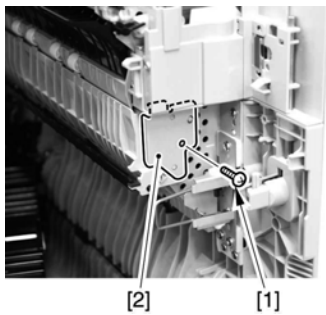

F-8-140

3) Remove the feed guide [1].

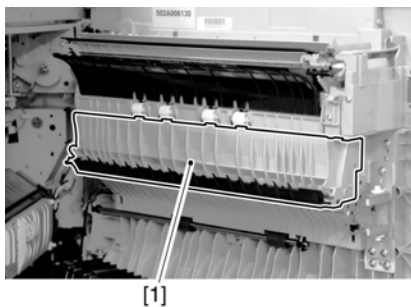

F-8-141

4) Remove the 7 screws [1], and detach the feed guide (lower) [2].

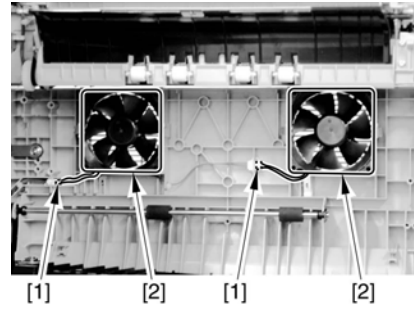

F-8-143

8.1.14 Motor of Main Drive Assembly

8.1.14.1 Removing the Rear Cover

1) Remove the 13 screws [1] and then the other screw [2]; then, detach the rear cover [3].



If the left cover (lower) has already been detached, the screw [3] should also have been removed.

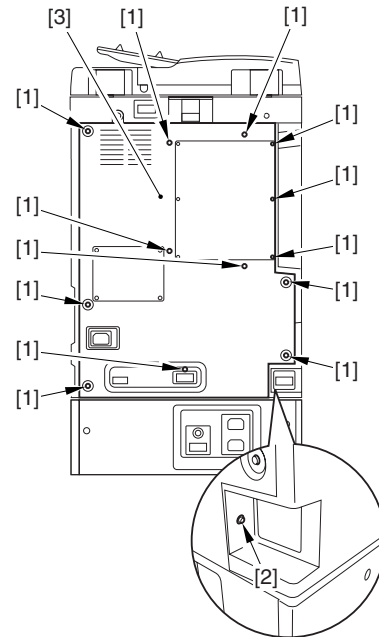

F-8-144

8.1.14.2 Removing the Main Drive Assembly

1) Disconnect the connector [1], and free the harness [2] from the wire saddle.

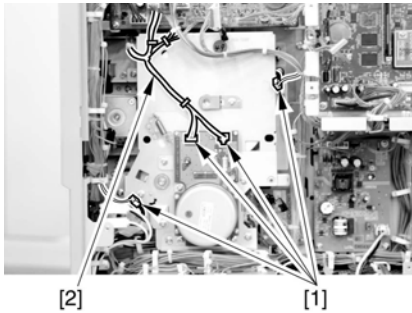

F-8-145

2) Remove the 4 screws [1], and detach the main drive assembly [2].

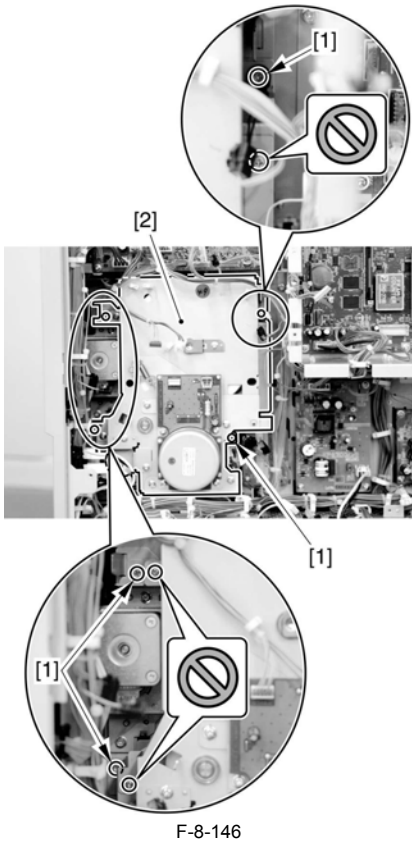

F-8-146



Do not touch the screws that are glued in place.

8.1.14.3 Removing the Main Drive Motor

1) Remove the 4 screws [1], and detach the main drive motor [2].

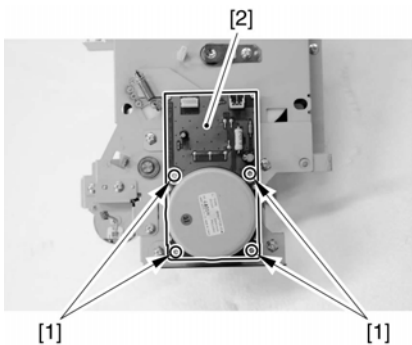

F-8-147



Points to Note During the Work

Be sure that the 2 timing belts [2] are fitted to the shaft [1] of the main drive motor as shown.

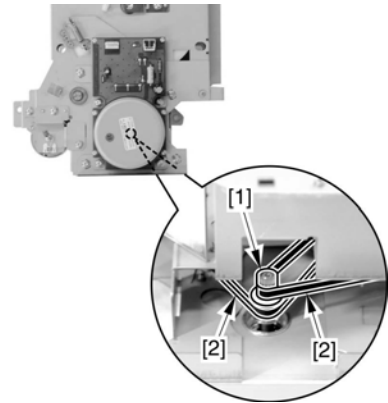

F-8-148



Adjusting the Tension of the Main Drive Motor

- 1) Temporarily fix the main drive motor in place to the main motor base.
- 2) So that the motor gear [1] and the teeth [2] of the pulley mesh correctly, move the motor in the direction of the arrow.

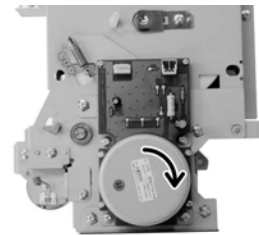

F-8-149

3) Tighten the screws [1] of the main drive motor in the order indicated.

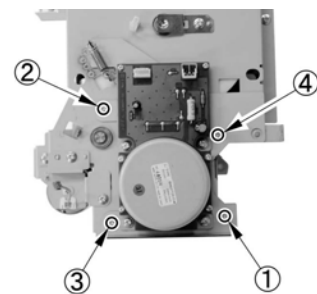

F-8-150

8.1.15 Fixing Driver Motor

8.1.15.1 Removing the Rear Cover

1) Remove the 13 screws [1] and then the other screw [2]; then, detach the rear cover [3].



If the left cover (lower) has already been detached, the screw [3] should also have been removed.

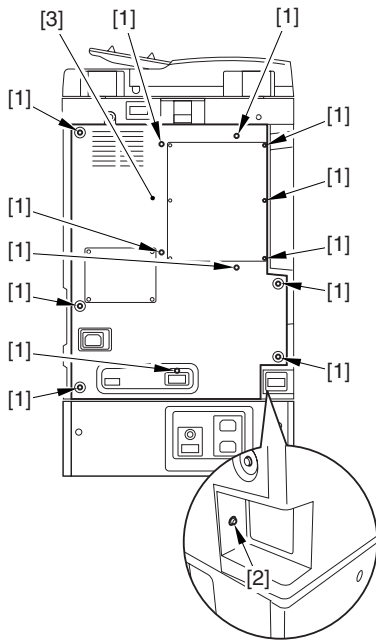

F-8-151

8.1.15.2 Removing the DC Controller PCB

1) Disconnect the connector [1].

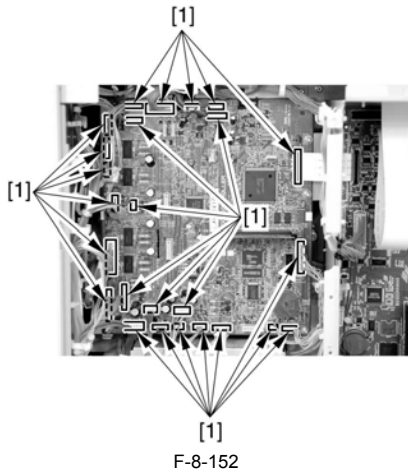

F-8-152

⚠ How to Remove the Flexible Cable [1]

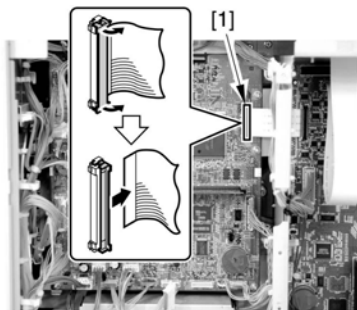

F-8-153

2) Remove the screw [1], and detach the DC controller PCB.

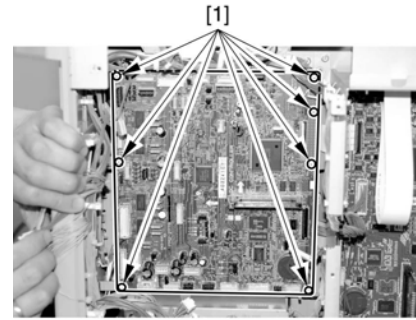

F-8-154

⚠ Points to Note When Replacing the DC Controller PCB
Be sure to remove the boot ROM [1] from the exiting DC controller PCB, and mount it to the new DC controller PCB.

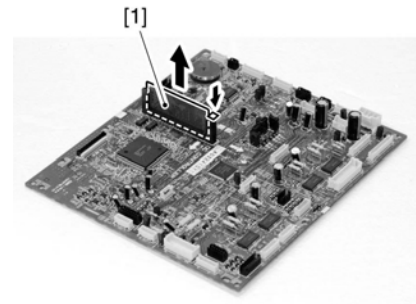

F-8-155

8.1.15.3 Removing the Fixing Drive Motor

1) Disconnect the 2 connectors [1].

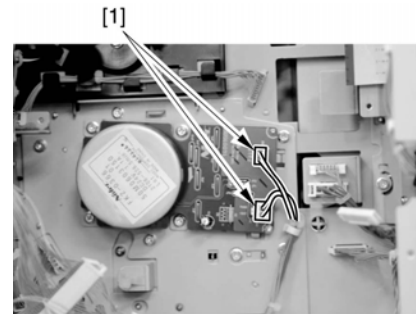

F-8-156

2) Remove the 4 screws [1], and detach the fixing drive motor [2].

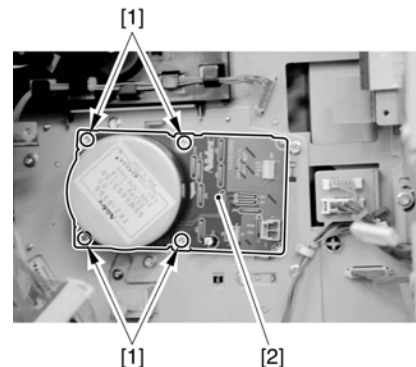

F-8-157

8.1.16 Right Door

8.1.16.1 Removing the Right Cover (rear)

- 1) Open the pedestal right door [1]. (if equipped with a 2-Cassette Pedestal-Y2)
- 2) Open the right lower door [2].
- 3) Remove the 5 screws [3], and detach the right cover (rear) [4].

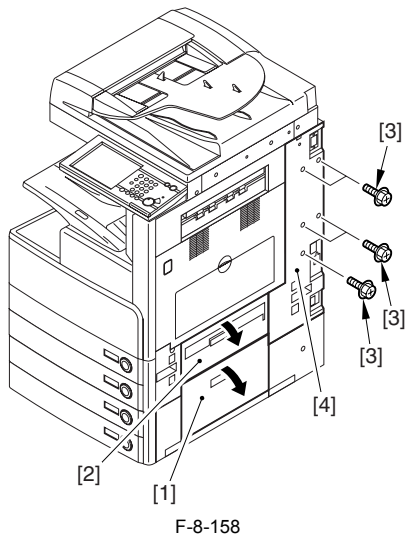

8.1.16.2 Removing the Right Door

1) Open the right door.



2) Remove the screw [1], and detach the fixing plate [2].

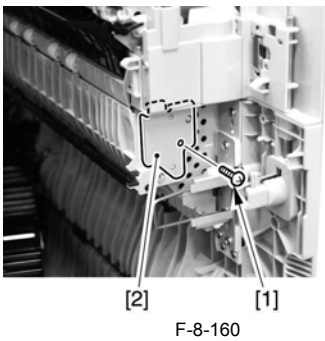

3) Remove the joint shaft [1], and free the extension delivery unit [2] from the right door.

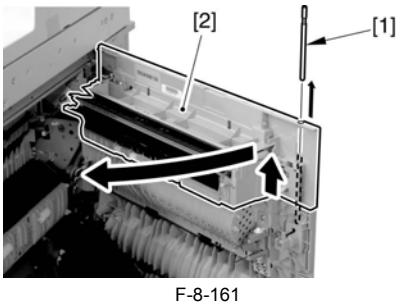

4) Disconnect the connector [1], and remove the reuse band [2]; then, remove the 2 screws (M4x8; RS tightening).

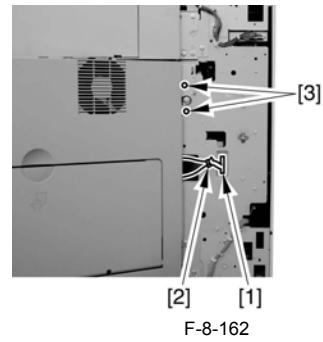

5) While freeing the hinge assembly [2], detach the right door.

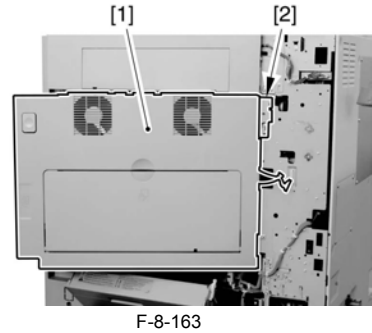

Attaching the Right Door

1) Match the hinge [1] found at the bottom of the right door against the lug.
 2) Engage the hinge [2] found on the top of the right door with the hook found on the side plate.

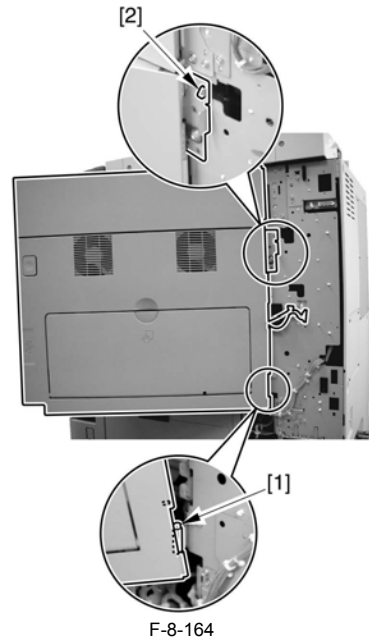

! When tightening the 2 screws used to fix the hinge in place, be sure to close the right door first.

8.1.17 Circuit Braker

8.1.17.1 Removing the Rear Cover

1) Remove the 13 screws [1] and then the other screw [2]; then, detach the rear cover [3].

! If the left cover (lower) has already been detached, the screw [3] should also have been removed.

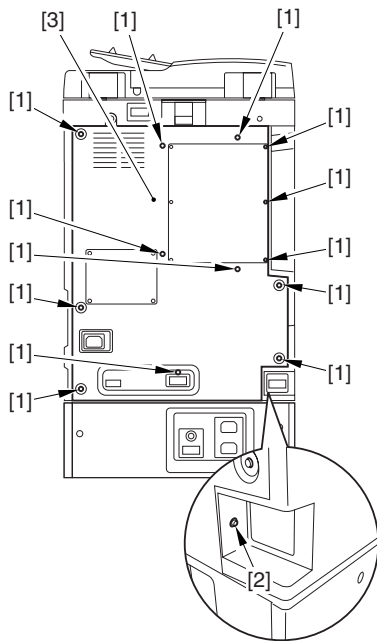

F-8-165

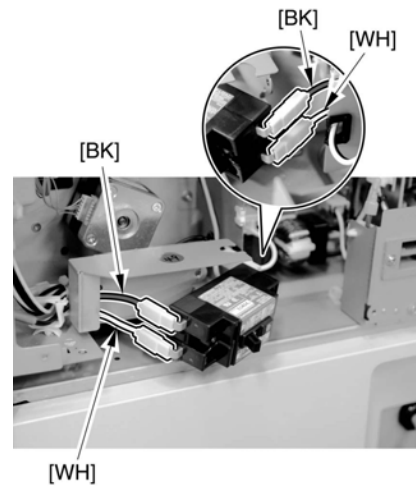

F-8-168

8.1.17.2 Removing the Circuit Breaker

1) Remove the 2 screws [1].

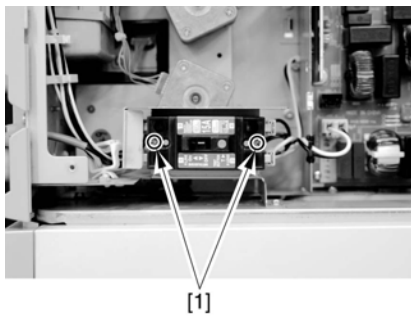

F-8-166

2) Remove the 4 fastons [1], and detach the circuit breaker [2].

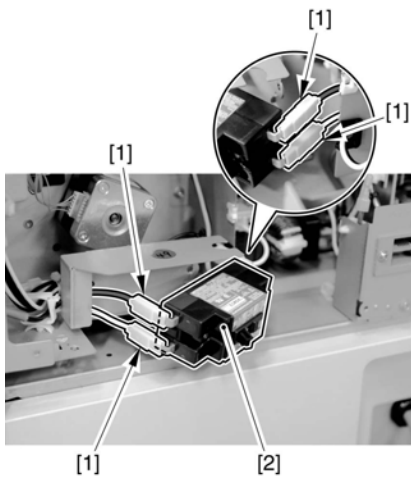

F-8-167



Points to Note When Mounting
When mounting the circuit breaker, be sure that the AC harness is identified correctly by color as shown.

Chapter 9 Correcting Faulty Images

Contents

9.1 Troubleshooting	9-1
9.1.1 Image Faults	9-1
9.1.1.1 Light Image/Weak Density	9-1
9.1.1.1.1 Light image occurs when copying blue original (iR3025/3030/3035/3045)	9-1
9.1.2 Faulty Feeding	9-1
9.1.2.1 Skew Feed	9-1
9.1.2.1.1 Paper skewing/jam: Tab in rear side of vertical path guide is broken	9-1
9.1.3 Malfunction	9-1
9.1.3.1 Malfunction/Faulty Detection	9-1
9.1.3.1.1 Super G3 Fax Board-Q1 is not recognized: Connector of Super G3 Fax Board has poor contact	9-1
9.1.3.2 Noise	9-1
9.1.3.2.1 When machine recovers from sleep mode and displays message "Black toner is low. Replacement not yet needed" or "No Toner.", abnormal noise occurs from Toner Supply Motor (M5)	9-1
9.1.3.2.2 Abnormal sound: At pickup, gear of DADF-N1 causes meshing failure	9-2
9.1.3.2.3 Abnormal noise intermittently occurs when paper is passing fixing assembly: Duplex feed clutch (CL6) in rear side of Main Drive Assembly is faulty (iR2270/iR2870/iR2270F/iR2270N/iR2870F/iR2870N/iR2230/iR2230F)	9-2
9.1.3.3 User Warning Message	9-3
9.1.3.3.1 When connecting RUI (using same PC and IP address) upon replacement of machine, message "(!) A error has occurred" is displayed in IE browser	9-3
9.1.3.4 Other Defect	9-3
9.1.3.4.1 Card Reader-C1 cannot recognize magnetic card although optical card can be recognized	9-3
9.1.4 Network	9-3
9.1.4.1 Connection Problem	9-3
9.1.4.1.1 Message "Check the network connection." is displayed: Main Controller PCB is faulty	9-3
9.1.5 Transmission/fax-related	9-3
9.1.5.1 Reception Problem	9-3
9.1.5.1.1 Machine cannot receive FAX message: "Power Consumption at Sleep" is set to "High"	9-3
9.1.6 Jam (Main Unit)	9-3
9.1.6.1 0105/0101/0102/0103/0201/0202/0203/0204 Jam Code: Paper lint adheres to surface of vertical path roller	9-3
9.1.6.2 0107 Jam Code: Machine with cassette heater causes separation failure jam at duplex transfer assembly due to moistened paper/2nd page crashes into cleaner, causing jam	9-4
9.1.6.3 0109 Jam Code is indicated because DC Controller PCB on Machine has poor contact: Inner 2-way Tray-D1	9-4
9.1.6.4 0208/0A08 Jam Code: No.1 delivery sensor (PS14) is faulty	9-4
9.1.7 Error Code	9-5
9.1.7.1 Description on measure for E064-0001	9-5
9.1.8 FAX ## Code	9-5
9.1.8.1 ##1017 FAX Error Code occurs when FAX message from G4 FAX to G3 FAX	9-5
9.1.9 Specifications-related FAQ	9-5
9.1.9.1 FAQ on Main Unit Specifications	9-5
9.1.9.1.1 How to display only Copy tab on LCD (How to hide FAX/SEND tab)	9-5
9.1.9.1.2 Instead of Copy tab, black bar appears on LCD: Main power switch is not turned OFF/ON after changing service mode setting	9-6
9.1.9.1.3 Jam is not detected when feeding paper whose size is different from cassette paper setting	9-6
9.1.9.1.4 Description on document image front position adjustment for DADF-N1	9-6
9.1.9.1.5 Description on printable number of copies per NGP-26 toner bottle	9-6
9.1.9.1.6 Description on service mode used to deactivate sleep function	9-7
9.1.9.2 FAQ on G3FAX Specifications	9-7
9.1.9.2.1 Cordless handset does not ring after switching FAX reception mode to F/T mode	9-7

9.1 Troubleshooting

9.1.1 Image Faults

9.1.1.1 Light Image/Weak Density

9.1.1.1.1 Light image occurs when copying blue original (iR3025/3030/3035/3045)

0016-4309

[Verified by Canon Inc.]

Description

Since characters and lines were copied pale in color when copying an original including blue characters such as pressure-sensitive paper and transmittal form, sharpness was adjusted for solution.

Note: As this symptom was related to original scanning of this machine, the same symptom occurred in FAX transmission.

Field Remedy

When the foregoing symptom occurs, perform the following procedure a. or b.

a. Adjustment by means of user mode

In Special Features > Sharpness, adjust the level of sharpness in the direction of "High", and then press OK.

b. Adjustment by means of service mode

In Service Mode > COPIER > Option > BODY > SHARP, set the setting value to '4'. (Default setting: 3)

9.1.2 Faulty Feeding

9.1.2.1 Skew Feed

9.1.2.1.1 Paper skewing/jam: Tab in rear side of vertical path guide is broken

0016-4091

[Inspected by Canon Inc.]

Description

Since the tab [A] in the rear side of the vertical path guide [1] was broken when opening/closing the right lower door, the guide came from the paper pick-up assembly, causing paper to skew or get stuck on the vertical path when feeding.

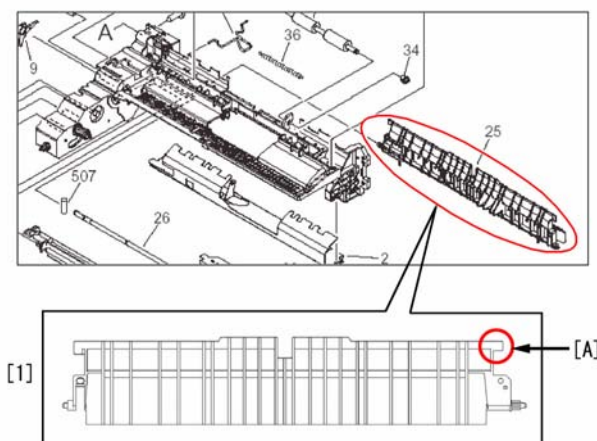

F-9-1

Field Remedy

When the symptom occurs, check the tab of the vertical path guide; if it has been broken, replace the vertical path guide with a new one.

9.1.3 Malfunction

9.1.3.1 Malfunction/Faulty Detection

9.1.3.1.1 Super G3 Fax Board-Q1 is not recognized: Connector of Super G3 Fax Board has poor contact

0015-1350

[Case in the field]

Description

This machine failed to recognize the Super G3 Fax Board because the connector of this optional equipment had poor contact at mounting.

Field Remedy

1. Re-fit the connector of the fax cable that comes with the Fax Board.
2. If the symptom still occurs, re-fit the connector of the Fax power cable that comes with the Fax Board.
3. If the symptom still occurs, re-fit the connector of the modular cable that comes with the Fax Board.

9.1.3.2 Noise

9.1.3.2.1 When machine recovers from sleep mode and displays message "Black toner is low. Replacement not yet needed" or "No Toner.", abnormal noise occurs from Toner Supply Motor (M5)

0015-1332

[Inspected by Canon Inc.]

Description

When the front cover is opened and closed without replacing the toner bottle after the message "Black toner is low. Replacement not yet needed" or "No Toner." is displayed, the toner supply motor intermittently rotates for about 100 sec. However, a user complained about this motor operating noise as an abnormal noise.

Cause

When the front door is opened and closed with a toner bottle being empty, or when this machine recovers from sleep mode (including power-on), the toner bottle motor rotates for about 100 sec. This is a normal operation of this machine, but the following 2 modifications were made in order to avoid users' complaint about this operating noise.

a. So that the machine can display the message "Checking toner" to inform users that the toner supply motor is rotating to supply toner, the DC Controller software was updated to Ver. 18.01.

b. So that the noise made when the toner bottle motor is rotating will be reduced, the drive motor was changed from the brush type to the brushless one.

Starting the following serial numbers, the factory is using the brushless type motor.

iR4570: TFJ00811 / iR4570F: TFT01332 / iR3570: TFG00936 / iR3570F: Å@TFS01887 / iR2870: TFF00654 / iR2870F: TFR01220 / iR2270: TFE01073 / iR2270F: TFQ03125 / iR2230F: TFK03078

Field Remedy

When the user complains about the motor operating noise, perform the following procedure.

1. As for machines with serial numbers earlier than the above, replace the toner bottle motor with the bluishless type.

2. If the version of the DC controller software is earlier than Ver. 18.01, upgrade the software to Ver. 18.01 or later.

Note: The DC controller software has to be used together with the main controller software of Ver. 33.05 or later.

FK2-0393 DC Motor

9.1.3.2.2 Abnormal sound: At pickup, gear of DADF-N1 causes meshing failure

0016-4196

[Case in the field]

Description

When picking up paper from the DADF-N1, a gear causes a meshing failure, consequently causing abnormal sound.

Field Remedy

1. Disassemble the one-way pulley (highlighted in red in the figure) found inside the paper feeder assembly, clean it with alcohol, apply lubricant (CK-0551), and then re-assemble it.

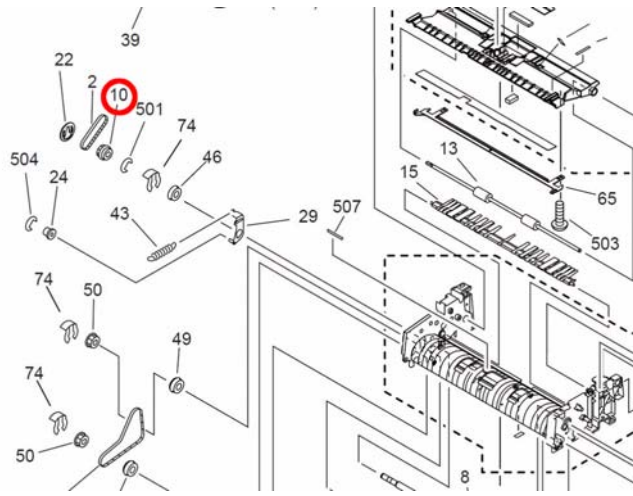

F-9-2

2. If Step 1 does not work on the symptom, replace the paper feeder assembly with a new one.

FM2-2959 Paper Feeder Assembly

9.1.3.2.3 Abnormal noise intermittently occurs when paper is passing fixing assembly: Duplex feed clutch (CL6) in rear side of Main Drive Assembly is faulty (iR2270/iR2870/iR2270F/iR2270N/iR2870F/iR2870N/iR2230/iR2230F)

0016-4198

[Case in the field]

Description

Since abnormal noise occurred intermittently when paper was passing the fixing assembly, the duplex feed clutch (CL6) in the rear side of the Main Driver Assembly was replaced with a new one.

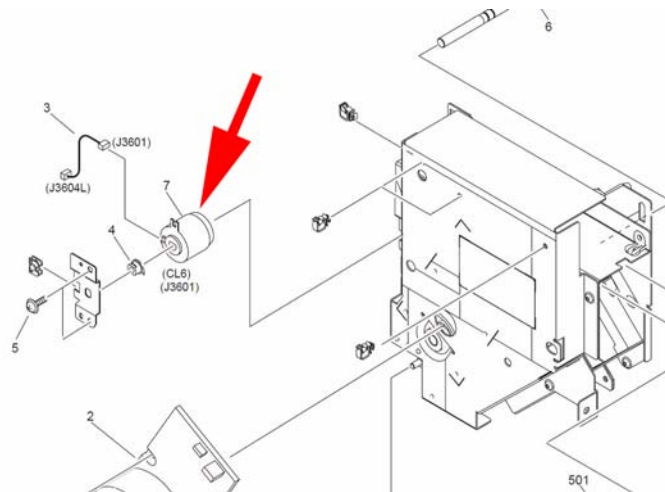

F-9-3

Field Remedy

1. Check if the abnormal noise occurs when paper is passing the fixing assembly.

2. If the noise occurs, re-fit the connector of CL6.
3. If Step 2 does not work on the symptom, replace CL6 with a new one.
FH6-5005 Electro Magnetic Clutch

9.1.3.3 User Warning Message

9.1.3.3.1 When connecting RUI (using same PC and IP address) upon replacement of machine, message "(!) A error has occurred" is displayed in IE browser

0015-7325

[Case in the field]

Description

When trying to connect the Remote UI with the same IP address in use after replacing this machine, the message "(!) A error has occurred" was displayed and the connection ended in failure.

Field Remedy

Perform the following procedure (cache clear) in the IE browser: [Tools > Internet Options > General > Temporary Internet Files > Delete files].

Cause

When a file is stored in cache, the browser uses the file for obtaining the connection instead of sending a request to this machine. In case of a model change, the content of the file may have been changed even though the name of the file is same as the one for the previous model. However, the machine neither notice this content change nor receive expected parameters, consequently causing the message.

9.1.3.4 Other Defect

9.1.3.4.1 Card Reader-C1 cannot recognize magnetic card although optical card can be recognized

0016-4197

[Case in the field]

Description

Since Card Reader-C1 could not recognize the magnetic card although it could do the optical card, the setting for the card was changed in service mode for solution.

Field Remedy

Change the setting from '0' to '1' in Service Mode > COPIER > Function > INSTALL > CARD; and then turn the main power switch OFF/ON.

9.1.4 Network

9.1.4.1 Connection Problem

9.1.4.1.1 Message "Check the network connection." is displayed: Main Controller PCB is faulty

0015-1351

[Case in the field]

Description

Since the Main Controller PCB was faulty, the message "Check the network connection." was displayed and access to this machine from a PC via a network was denied.

In this field case, the Ping command was executed normally, however, access from a tool PC connected with a cross cable was also denied. (Access by means of USB connection was accepted.)

Field Remedy

1. Check to see if the Ping command sent from the PC is executed normally; if it isn't, suspect a network failure.
2. If the Ping command is executed normally, re-fit the connector of the Main Controller PCB.
3. If the symptom still occurs, replace the Main Controller PCB by a new one.
FM2-4551 Main Controller PCB Assembly

9.1.5 Transmission/fax-related

9.1.5.1 Reception Problem

9.1.5.1.1 Machine cannot receive FAX message: "Power Consumption at Sleep" is set to "High"

0016-4202

[Case in the field]

Description

Since this machine failed to receive a FAX message in nighttime, the setting of power consumption at sleep was changed from "Low" to "High" for solution. In this field case, this machine could receive a FAX message in modes other than sleep mode.

Field Remedy

Change the setting for the power consumption at sleep from "Low" to "High" in User Mode > Common Settings > Power Consumption at Sleep.

9.1.6 Jam (Main Unit)

9.1.6.1 0105/0101/0102/0103/0201/0202/0203/0204 Jam Code: Paper lint adheres to surface of vertical path roller

[Inspected by Canon Inc.]

Description

Since a type of paper that can easily generate lint was used, the paper lint adhered to the surface of the vertical path roller and decreased the paper feed performance of the roller, causing the jam code "0105."

Depending on paper sources, the following jams occur.

- Cassette 1: 0105 (registration sensor PS9 delay)/0201(cassette1 retry sensor PS10 stationary)
- Cassette 2: 0101 (cassette 1 retry sensor PS10 delay)/0202(cassette 2 retry sensor PS11 (cassette pedestal) delay)
- Cassette 3: 0102 (cassette 2 retry sensor PS11 delay)/0203 (cassette 3 retry sensor PS1 (cassette pedestal) delay)
- Cassette 4: 0103 (cassette 3 retry sensor PS1 (cassette pedestal) delay)/0204 (cassette 4 retry sensor PS2 (cassette pedestal) delay jam)

To prevent this, a vertical path roller to which paper is hard to adhere was used for the following machines (the color of the roller was changed from black to gray).

- iR2230 120V THF03592 and later/120V TW SHD00033 and later /220V CN SHC01553 and later/230V EUR THG02606 and later /230V THH00339 and later
- iR2270 120V SLH28893 and later/120V TW KJN00097 and later/ 220V CN KJL00763 and later/230V EUR KGL54733 and later/230V KGM03613 and later/230V CA SLF02281 and later
- iR2830 120V THK01045 and later/220V CN SHE01035 and later
- iR2870 120V SLG13303 and later/120V TW KJR00054 and later/220V CN KJP00589 and later/230V EUR KGD13135 and later/230V KGE00333 and later

late/230V CA SLD00411 and later
 - iR3530 120V THL01319 and later/120V TW SHK00085 and later/220V CN SHH00829 and later/230V EUR THM01596 and later/230V THN00209 and later
 - iR3570 120V SKV61037 and later/120V TW KJU00760 and later/220V CN KJS00928 and later/230V EUR KFW21901 and later/230V KFX02555 and later/230V CA SKT01761 and later
 - iR4570 120V SKU23728 and later/120V TW KJX00122 and later/220V CN KJV00690 and later/230V EUR KFQ15439 and later/230V KFR02186 and later/230V CA SKQ01030 and later

Field Remedy

When the symptom occurs with the machine without the foregoing serial numbers, replace the vertical path roller.

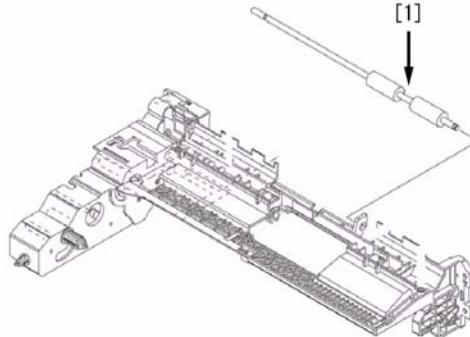

F-9-4

FB6-4852 Vertical Path Roller

9.1.6.2 0107 Jam Code: Machine with cassette heater causes separation failure jam at duplex transfer assembly due to moistened paper/2nd page crashes into cleaner, causing jam

[Inspected by Canon Inc.]

Description

Since paper loaded on a cassette was moistened, 2nd page failed to separate and crashed into the cleaner, causing the jam code "0107." As the remedy, a cassette heater was mounted. However, a paper jam occurred at rare occasions thereafter. Since the remedial cassette heater turns ON when the machine goes into sleep mode, it may not completely prevent paper from absorbing moisture in the extremely high temperature and humidity environment. To prevent this, the heater switch PCB was modified so that the cassette heater stays ON.

- 0107 Jam Code: Delay jam at the fixing delivery sensor (PS13).

Cause

Since paper was moistened considerably, it curled significantly in the side opposite to the printed image side at copying the 1st side, and matched with the curb of the drum at copying the 2nd side, consequently causing a failure in separating from the drum.

Field Remedy

If the machine has already had a cassette heater, replace the heater switch PCB [1] by a new one so that the heater will stay ON.

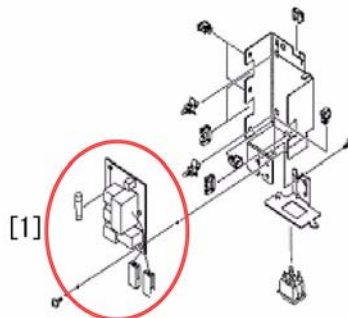

F-9-5

FM2-2787 Heater Switch PCB Assembly

9.1.6.3 0109 Jam Code is indicated because DC Controller PCB on Machine has poor contact: Inner 2-way Tray-D1

[Case in the field]

Description

Since the DC Controller PCB on the main body side had poor contact, the solenoid on the Inner 2-way Tray-D1 failed to work, causing the jam code "0109."
 - 0109 Jam Code: Delay jam at the No.2 delivery sensor

Field Remedy

1. Re-fit the connector that connects the 3-way Unit-A1 to the main body.
2. If the symptom still occurs, re-fit all the connectors of the DC Controller PCB on the main body side.

9.1.6.4 0208/0A08 Jam Code: No.1 delivery sensor (PS14) is faulty

[Case in the field]

Description

Since a jam code "0208" or "0A08" was displayed, the No.1 delivery sensor (PS14) was replaced with a new one for solution.
 - 0208: No.1 delivery sensor stationary jam

- 0A08: No.1 delivery full sensor residual jam

Field Remedy

1. When a jam code "0208" or "0A08" occurs, interchange the No.1 delivery sensor (PS14) with the No. 1 delivery full sensor (PS15).
2. After Step 1, if the other code than displayed before Step 1 appears, the No. 1 delivery sensor is faulty. Replace the sensor with a new one.

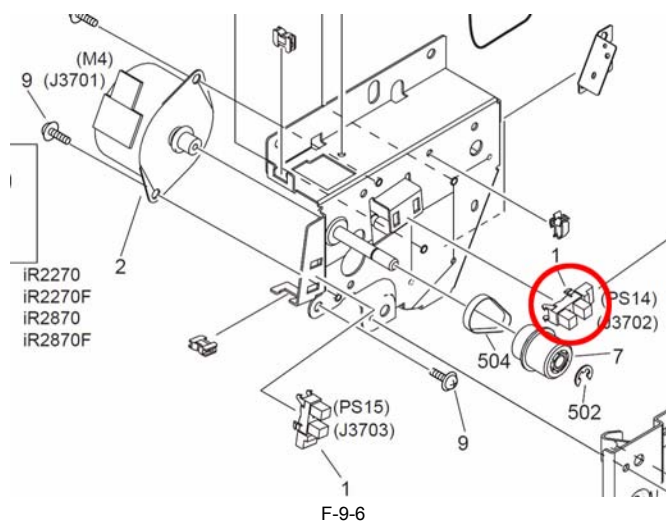

FK2-0149 Photointerrupter

9.1.7 Error Code

9.1.7.1 Description on measure for E064-0001

[Manual-related]

Description

E064-0001 can be displayed when the value read from EEPROM inside the H.V Transformer PCB exceeds the specified value. When this error is indicated, perform the following field remedy.

Note: The EEPROM can not be replaced independently. Therefore, please replace by H.V. Transformer PCB.

Field Remedy

1. Turn the main power switch OFF and then ON.
2. If the symptom still occurs, replace the H.V. Transformer PCB by a new one.

FM2-0261 H.V. Transformer PCB Assembly

9.1.8 FAX ## Code

9.1.8.1 ##1017 FAX Error Code occurs when FAX message from G4 FAX to G3 FAX

[Case in the field]

Description

When sending a FAX message from a G4 FAX machine (this machine) to a G3 FAX machine, the FAX error code "##1017" was indicated.
- ##1017 FAX error code can be displayed when a private branch exchange disconnects the connection on the D-channel (the user in the receiving side is busy.)

Field Remedy

1. Send the FAX message again after a while.
2. If the symptom still occurs, change the destination condition to "G3" in the Address Book (One-touch) setup page, and then send the message again.

9.1.9 Specifications-related FAQ

9.1.9.1 FAQ on Main Unit Specifications

9.1.9.1.1 How to display only Copy tab on LCD (How to hide FAX/SEND tab)

0015-0817

[Manual-related]

Description

Changing the UI settings by making the following selections in sequence will enable the LCD to hide all the tabs on it: [Service mode (Level2) > COPIER > Option> BODY].

- FAX: UI-FAX/SEND: UI-SEND/BOX: UI-BOX

Field Remedy

1. Service mode (Level 2) > COPIER > Option > BODY > select the mode for the tab you want to hide (here, [UI-FAX] is selected as an example) > change the setting from '1' to '0' > OK. As in the same manner, select the service mode of the tab that you want to hide, and change its setting.
2. Turn the control panel switch OFF > turn the main power switch OFF and then ON > check to make sure that the tab you changed its service mode setting goes away from the LCD.

Note: In a field case, the setting of [UI-COPY] alone was changed, but the main power switch was not turned OFF/ON. Therefore, a black bar was displayed instead of the Copy tab. When changing the service mode setting, be sure to refer to Step 3 and turn the main power switch OFF and then ON without fail.

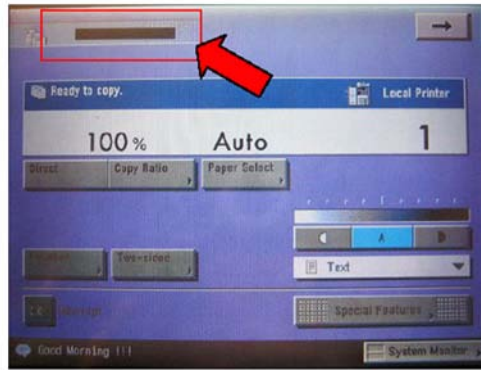

F-9-7

9.1.9.1.2 Instead of Copy tab, black bar appears on LCD: Main power switch is not turned OFF/ON after changing service mode setting

0015-0819

[Manual-related]

Description

Instead of the Copy tab, a black bar was displayed on the LCD. This was because the main power switch was not turned OFF and then ON after the service mode setting for the Copy tab was changed to hide the tab from the LCD.

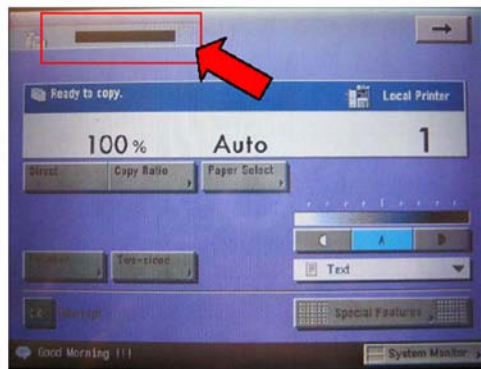

F-9-8

Field Remedy

After changing a service mode setting, be sure to turn the control panel switch OFF, and then turn the main power switch OFF/ON to activate the changed setting.

9.1.9.1.3 Jam is not detected when feeding paper whose size is different from cassette paper setting

0015-3887

[Manual-related]

Description

When making copies after loading A4-size papers on a cassette whose paper size was set to A4R, a jam was not detected and the papers were fed normally. (The original was placed with reference to the "A4R" notations.) This was because the black-and-white machine is so controlled that it will minimize the execution of jam detection as much as possible with regard to the sizes of papers that it can fed without troubles.

Nevertheless, it detects a jam when the length of used paper is longer than the paper size setting for the cassette. Additionally, if paper shorter than the cassette paper setting is used for the reverse delivery, its reverse position is changed, possibly causing a jam.

Reference: The color machine indicates a jam when a mismatch occurs between the actual paper and the cassette paper setting. This is because the machine may soil the parts and rollers around the process area or cause short life of parts when paper is fed without determining the cassette paper size.

9.1.9.1.4 Description on document image front position adjustment for DADF-N1

0016-4199

[Manual-related]

Description

When the document read position of the ADF is shifted, perform the following procedure.

Field Remedy

Adjust the setting value in Service mode > FEEDER > Adjust > DOCST.

Adjustable range is -50 to 50. (Default: 0)

- if the image is displayed to the lead edge: decrease the setting value.

- if the image is displayed to the trail edge: increase the setting value.

9.1.9.1.5 Description on printable number of copies per NGP-26 toner bottle

0016-4200

[Manual-related]

Description

In case A4-size standard original (image ratio: 5%) is used, the NGP-26 toner bottle can make approx. 24,000 copies.

This toner bottle includes 1,220g of toner.

Note: In case an original with image ratio of higher than 5% is used, the printable number will be less than 24,000 copies.

9.1.9.1.6 Description on service mode used to deactivate sleep function0016-4201**[Manual-related]****Description**

It is possible to activate/deactivate the sleep function in service mode. (Default: 1 the sleep function is activated.)

Field Remedy

To deactivate the sleep function, change the setting value to '0' in Service Mode > COPIER > Option > USER > SLEEP.

9.1.9.2 FAQ on G3FAX Specifications**9.1.9.2.1 Cordless handset does not ring after switching FAX reception mode to F/T mode**0016-4195**[Case in the field]****Description**

After switching FAX reception mode to F/T mode, a cordless handset stopped ringing even in case of an incoming call.

Cause

Once FAX reception mode is switched to F/T mode, this machine answers an incoming call without ring, and by means of a signal tone from the telephone line, it determines whether the call is FAX or TEL. In case that the call is FAX, it receives the FAX message. On the other hand, if the call is TEL, this machine makes its speaker sound; at that time, however, it does not make a cordless handset ring because a ring signal does not come from the line.

Field Remedy

To make a cordless handset ring, change FAX reception mode to auto reception mode.

Sep 4 2007

Canon