

imageRUNNER 7105/7095/7086

SERVICE MANUAL



Canon

DU7-1166-000

NOVEMBER 2005
REV. 0

Application

This manual has been issued by Canon Inc. for qualified persons to learn technical theory, installation, maintenance, and repair of products. This manual covers all localities where the products are sold. For this reason, there may be information in this manual that does not apply to your locality.

Corrections

This manual may contain technical inaccuracies or typographical errors due to improvements or changes in products. When changes occur in applicable products or in the contents of this manual, Canon will release technical information as the need arises. In the event of major changes in the contents of this manual over a long or short period, Canon will issue a new edition of this manual.

The following paragraph does not apply to any countries where such provisions are inconsistent with local law.

Trademarks

The product names and company names used in this manual are the registered trademarks of the individual companies.

Copyright

This manual is copyrighted with all rights reserved. Under the copyright laws, this manual may not be copied, reproduced or translated into another language, in whole or in part, without the written consent of Canon Inc.

COPYRIGHT © 2001 CANON INC.









Printed in Japan

Caution

Use of this manual should be strictly supervised to avoid disclosure of confidential information.



Symbols Used

This documentation uses the following symbols to indicate special information:

Symbol	Description
	Indicates an item of a non-specific nature, possibly classified as Note, Caution, or Warning.
	Indicates an item requiring care to avoid electric shocks.
	Indicates an item requiring care to avoid combustion (fire).
	Indicates an item prohibiting disassembly to avoid electric shocks or problems.
	Indicates an item requiring disconnection of the power plug from the electric outlet.
 Memo	Indicates an item intended to provide notes assisting the understanding of the topic in question.
 REF.	Indicates an item of reference assisting the understanding of the topic in question.
	Provides a description of a service mode.
	Provides a description of the nature of an error indication.

The following rules apply throughout this Service Manual:

1. Each chapter contains sections explaining the purpose of specific functions and the relationship between electrical and mechanical systems with reference to the timing of operation.

In the diagrams,  represents the path of mechanical drive; where a signal name accompanies the symbol, the arrow  indicates the direction of the electric signal.

The expression "turn on the power" means flipping on the power switch, closing the front door, and closing the delivery unit door, which results in supplying the machine with power.

2. In the digital circuits, '1' is used to indicate that the voltage level of a given signal is "High", while '0' is used to indicate "Low". (The voltage value, however, differs from circuit to circuit.) In addition, the asterisk (*) as in "DRMD*" indicates that the DRMD signal goes on when '0'.

In practically all cases, the internal mechanisms of a microprocessor cannot be checked in the field. Therefore, the operations of the microprocessors used in the machines are not discussed: they are explained in terms of from sensors to the input of the DC controller PCB and from the output of the DC controller PCB to the loads.

The descriptions in this Service Manual are subject to change without notice for product improvement or other purposes, and major changes will be communicated in the form of Service Information bulletins.

All service persons are expected to have a good understanding of the contents of this Service Manual and all relevant Service Information bulletins and be able to identify and isolate faults in the machine."

Contents

Chapter 1 Introduction

1.1 System Construction	1- 1
1.1.1 System Configuration with Input/Output Accessories.....	1- 1
1.1.2 Combination of Delivery Accessories	1- 2
1.1.3 System Configuration with Printing/Transmission Accessories	1- 4
1.1.4 Functions of Printing/Transmission Accessories	1- 4
1.2 Product Specifications	1- 5
1.2.1 Names of Parts	1- 5
1.2.1.1 External View.....	1- 5
1.2.1.2 Cross Section	1- 6
1.2.2 Using the Machine	1- 7
1.2.2.1 Power Switch.....	1- 7
1.2.2.2 Points to Note About Turning Off the Main Power Switch	1- 8
1.2.2.3 Control Panel.....	1- 9
1.2.3 User Mode Items	1- 9
1.2.3.1 Common Settings	1- 9
1.2.3.2 Timer Settings	1- 12
1.2.3.3 Adjustment/Cleaning	1- 13
1.2.3.4 Report Settings	1- 14
1.2.3.5 System Settings.....	1- 14
1.2.3.6 Copy Settings	1- 16
1.2.3.7 Communications Settings.....	1- 17
1.2.3.8 Mail Box Settings	1- 17
1.2.3.9 Address Book Settings.....	1- 18
1.2.3.10 Voice Guide Settings.....	1- 18
1.2.4 Safety	1- 18
1.2.4.1 Safety About Laser Light	1- 18
1.2.4.2 CDRH Regulations	1- 18
1.2.4.3 Handling of the Laser Assembly.....	1- 19
1.2.4.4 Safety of Toner.....	1- 19
1.2.5 Product Specifications	1- 20
1.2.5.1 Product Specifications	1- 20
1.2.6 Function List.....	1- 22
1.2.6.1 Print Speed	1- 22
1.2.6.2 Paper Type	1- 23
1.2.7 RDS Specification	1- 24
1.2.7.1 Embedded RDS (e-RDS)	1- 24

Chapter 2 Installation

2.1 Making Pre-Checks	2- 1
2.1.1 Points to Note Before Starting the Installation Work.....	2- 1
2.1.2 Selecting the Site of Installation	2- 1

2.1.3 Installation Space	2- 3
2.1.4 Checking the Contents	2- 4
2.1.5 Order of Installing Accessories	2- 6
2.2 Unpacking and Installation	2- 7
2.2.1 Points to Note When Turning On/Off the Main Power	2- 7
2.2.2 Unpacking	2- 7
2.2.3 Mounting the Scanner System	2- 9
2.2.4 Mounting the Fixing Assembly	2- 10
2.2.5 Mounting the Charging Assembly	2- 10
2.2.6 Mounting the Charging Assembly	2- 12
2.2.7 Mounting the Developing Assembly	2- 15
2.2.8 Mounting the Pickup Assembly	2- 17
2.2.9 Mounting the Control Panel	2- 17
2.2.10 Supplying Toner	2- 23
2.2.11 Turning On the Main Power	2- 23
2.2.12 Stirring the Toner	2- 23
2.2.13 Index Sheet Attachment	2- 24
2.2.14 Other attachment	2- 24
2.2.15 Others	2- 24
2.2.16 Attaching the Labels, Placing Paper, and Checking Images and Operation (user mode)	2- 25
2.2.17 Adjusting the Horizontal Registration	2- 27
2.2.18 Adjusting the Lead Edge Registration	2- 29
2.2.19 Setting the Cassette	2- 29
2.2.20 Correcting the Skew	2- 29
2.2.21 Switching Over the Paper Size for the Front Deck (right, left)	2- 30
2.2.22 Checking the Operation in a System Configuration	2- 30
2.3 Checking the Connection to the Network	2- 31
2.3.1 Checking the Network Connections	2- 31
2.3.2 Using the PING Command	2- 31
2.3.3 Making a Check Using a Remote Host Address	2- 31
2.4 Troubleshooting the Network	2- 32
2.4.1 Troubleshooting the Network	2- 32
2.4.2 Making a Check Using a Loop Back Address	2- 32
2.4.3 Making a Check Using a Local Host Address	2- 32
2.5 Installing the Card Reader	2- 32
2.5.1 Checking the Contents	2- 32
2.5.2 Installing the Card Reader-D1	2- 32
2.6 Installing the Voice Guidance Kit	2- 36
2.6.1 Checking Items in the Package	2- 36
2.6.2 Turning Off the Host Machine	2- 37
2.6.3 Installation Procedure	2- 37

Chapter 3 Basic Operation

3.1 Construction	3- 1
3.1.1 Functional Construction	3- 1
3.1.2 Wiring Diagram of the Major PCBs	3- 2
3.1.3 Controlling the Main Motor (M1)	3- 3
3.2 Basic Sequence	3- 4

3.2.1 Basic Sequence of Operations (power-on).....	3- 4
--	------

Chapter 4 Main Controller

4.1 Construction.....	4- 1
4.1.1 Construction/Functions	4- 1
4.2 Construction of the Electrical Circuitry	4- 2
4.2.1 Main Controller PCB.....	4- 2
4.3 Start-Up Sequence	4- 3
4.3.1 Overview	4- 3
4.3.2 Start-Up Sequence	4- 3
4.3.3 Action to Take in Response to E602	4- 6
4.4 Shut-Down Sequence	4- 9
4.4.1 Flow of Operation	4- 9
4.5 Image Processing.....	4- 9
4.5.1 Overview of the Image Flow	4- 9
4.5.2 Configuration of the Image Processing Modules.....	4- 10
4.5.3 Reader Input Image Processing.....	4- 10
4.5.4 Compression/Expansion/Editing Block	4- 11
4.5.5 Printer Output Image Processing.....	4- 11
4.6 Parts Replacement Procedure	4- 12
4.6.1 Main Controller Box	4- 12
4.6.2 Main Controller PCB	4- 13
4.6.3 SDRAM	4- 16
4.6.4 Boot ROM.....	4- 16
4.6.5 HDD	4- 17
4.6.6 Video PCB.....	4- 18
4.6.7 Reader I/F PCB	4- 19
4.6.8 Controller Fan	4- 20

Chapter 5 Original Exposure System

5.1 Construction.....	5- 1
5.1.1 Specifications, Controls, and Functions <iR7105/7095>	5- 1
5.1.2 Specifications, Controls, and Functions <iR7086>	5- 2
5.1.3 Major Components <iR7105/7095>.....	5- 2
5.1.4 Major Components <iR7086>.....	5- 4
5.1.5 Construction of the Control System <iR7105/7095>.....	5- 5
5.1.6 Construction of the Control System <iR7086>.....	5- 6
5.2 Basic Sequence	5- 6
5.2.1 Basic Sequence of Operations <iR7105/7095>.....	5- 6
5.2.2 Basic Sequence of Operations <iR7086>.....	5- 6
5.2.3 Basic Sequence of Operation in Response to a Press on the Start Key <iR7105/7095>	5- 7
5.2.4 Basic Sequence of Operation in Response to a Press on the Start Key <iR7086>	5- 7
5.3 Various Control	5- 8
5.3.1 Controlling the Scanner Drive System.....	5- 8
5.3.1.1 Overview	5- 8
5.3.1.2 Controlling the Scanner Motor <iR7105/7095>	5- 8
5.3.1.3 Controlling the Scanner Motor <iR7086>	5- 9

5.3.2	Enlargement/Reduction	5- 10
5.3.2.1	Changing the Reproduction Ratio in Main Scanning Direction.....	5- 10
5.3.2.2	Changing the Reproduction Ratio in Sub Scanning Direction <iR7105/7095>.....	5- 10
5.3.2.3	Changing the Reproduction Ratio in Sub Scanning Direction <iR7086>.....	5- 10
5.3.3	Controlling the Scanning Lamp	5- 11
5.3.3.1	Overview <iR7105/7095>	5- 11
5.3.3.2	Overview <iR7086>	5- 11
5.3.3.3	Scanning Lamp.....	5- 12
5.3.3.4	Controlling the Activation	5- 12
5.3.4	Detecting the Size of Originals	5- 12
5.3.4.1	Overview.....	5- 12
5.3.4.2	Points of Measurement Used for Original Size Identification.....	5- 12
5.3.4.3	Overview of Operation <iR7105/7095>	5- 14
5.3.4.4	Overview of Operation <iR7086>	5- 15
5.3.5	Dirt Sensor Control.....	5- 17
5.3.5.1	Dust Detection in Stream Reading Mode <iR7105/7095>	5- 17
5.3.5.2	Dust Detection in Stream Reading Mode <iR7086>	5- 18
5.3.5.3	White Plate Dust Detection Control.....	5- 19
5.3.6	Image Processing.....	5- 20
5.3.6.1	Overview <iR7105/7095>	5- 20
5.3.6.2	Overview <iR7086>	5- 21
5.3.6.3	CCD Drive <iR7105/7095>.....	5- 22
5.3.6.4	CCD Drive <iR7086>.....	5- 22
5.3.6.5	CCD Output Gain Correction, Offset Correction	5- 23
5.3.6.6	CCD Output A/D Conversion	5- 23
5.3.6.7	Outline of Shading Correction.....	5- 23
5.3.6.8	Shading Adjustment.....	5- 23
5.3.6.9	Shading Correction	5- 23
5.4	Parts Replacement Procedure.....	5- 24
5.4.1	CCD Unit.....	5- 24
5.4.2	Copyboard glass.....	5- 24
5.4.3	Standard White Plate	5- 26
5.4.4	Scanning Lamp	5- 26
5.4.5	Reader Controller PCB.....	5- 29
5.4.6	Interface PCB.....	5- 31
5.4.7	Inverter PCB.....	5- 33
5.4.8	Scanner Motor.....	5- 33
5.4.9	ADF Open/Close Sensor.....	5- 35
5.4.10	Original Size Sensor	5- 36
5.4.11	Scanner Home Position Sensor	5- 37
5.4.12	Cooling Fan	5- 39
5.4.13	Scanner Drive Cable.....	5- 40

Chapter 6 Laser Exposure

6.1	Construction.....	6- 1
6.1.1	Outline of the Laser Exposure System.....	6- 1
6.2	Basic Sequence	6- 3
6.2.1	Basic Sequence of Operations (laser exposure system).....	6- 3

6.3 Various Controls	6- 3
6.3.1 Controlling the Laser Activation Timing	6- 3
6.3.1.1 Turning On and Off the Laser Unit.....	6- 3
6.3.1.2 Flow of the BD Signal.....	6- 4
6.3.2 Controlling the Intensity of Laser Light	6- 5
6.3.2.1 APC Control.....	6- 5
6.3.3 Controlling the Laser Scanner Motor	6- 6
6.3.3.1 Outline	6- 6
6.3.4 Controlling the Laser Shutter.....	6- 7
6.3.4.1 Controlling the Laser Shutter	6- 7
6.4 Parts Replacement Procedure	6- 8
6.4.1 Laser Scanner Unit	6- 8

Chapter 7 Image Formation

7.1 Construction.....	7- 1
7.1.1 Outline	7- 1
7.1.2 Major Components	7- 1
7.1.3 Pre-Transfer Exposure LED.....	7- 2
7.2 Image Formation Process	7- 2
7.2.1 Overview	7- 2
7.3 Basic Sequence	7- 3
7.3.1 Basic Sequence	7- 3
7.4 Potential Control	7- 4
7.4.1 Outline	7- 4
7.4.2 Basics Sequence of Operations	7- 5
7.4.3 Determining the Optimum Grid Bias.....	7- 6
7.4.4 Grid Bias Corrective Control	7- 6
7.4.5 Determining the Optimum Laser Output	7- 7
7.4.6 Laser Output Corrective Control.....	7- 7
7.4.7 Determining the Optimum Developing Bias	7- 8
7.4.8 Potential Control for Transparency Mode	7- 9
7.4.9 Target Potential Correction in Each Mode.....	7- 10
7.5 Charging Mechanism	7- 12
7.5.1 Primary Charging Mechanism	7- 12
7.5.1.1 Outline	7- 12
7.5.1.2 Primary Charging Assembly Cleaning Mechanism	7- 13
7.5.1.3 Others	7- 13
7.5.2 Dust-Collecting Roller Bias	7- 14
7.5.2.1 Outline	7- 14
7.5.3 Pre-Transfer Charging Mechanism	7- 15
7.5.3.1 Outline	7- 15
7.5.3.2 Controlling the Output to Suit the Environment (fuzzy control)	7- 16
7.5.3.3 Pre-Transfer Charging Assembly Cleaning Mechanism	7- 16
7.5.3.4 Others	7- 17
7.6 Drum Cleaner Unit.....	7- 17
7.6.1 Outline	7- 17
7.6.2 Detecting the Waste Toner (case full condition).....	7- 18
7.7 Developing Assembly.....	7- 19

7.7.1 Outline.....	7- 19
7.7.2 Controlling the Developing Assembly	7- 20
7.7.3 Controlling the Toner Cartridge Drive Mechanism	7- 21
7.7.4 Controlling the Developing Bias.....	7- 22
7.7.5 Detecting the Toner Level and Controlling the Toner Supply Mechanism	7- 23
7.8 Transfer Mechanism.....	7- 27
7.8.1 Transfer Guide Bias	7- 27
7.8.1.1 Overview.....	7- 27
7.8.1.2 Controlling the Output to Suit the Environment.....	7- 28
7.8.2 Transfer Charging Mechanism	7- 29
7.8.2.1 Outline.....	7- 29
7.8.2.2 Controlling the Output to Suit the Environment (fuzzy control).....	7- 30
7.8.2.3 Correcting the Output at the Trailing Edge of Paper	7- 30
7.8.2.4 Transfer Charging Assembly Cleaning Mechanism	7- 31
7.8.2.5 Others	7- 32
7.9 Separation Mechanism	7- 33
7.9.1 Separation Charging Mechanism.....	7- 33
7.9.1.1 Outline.....	7- 33
7.9.1.2 Correcting the Output to Suit the Environment and the Toner Deposit.....	7- 34
7.9.1.3 Correcting the Output upon Detection of Leakage	7- 34
7.9.1.4 Others	7- 34
7.10 Parts Replacement Procedure.....	7- 35
7.10.1 Process Unit	7- 35
7.10.2 Pre-Exposure Lamp	7- 36
7.10.3 Primary Charging Assembly	7- 37
7.10.4 Pre-Transfer Charging Assembly.....	7- 37
7.10.5 Photosensitive Drum	7- 38
7.10.6 Drum Cleaner Unit.....	7- 39
7.10.7 Photosensitive Drum Heater	7- 40
7.10.8 Sub Hopper.....	7- 40
7.10.9 Developing Assembly	7- 42
7.10.10 Developing Cylinder	7- 43
7.10.11 Developing Blade.....	7- 44
7.10.12 Developing Cylinder Deceleration Clutch	7- 45
7.10.13 Developing Cylinder Clutch.....	7- 46
7.10.14 Transfer/Separation Charging Assembly.....	7- 46
7.10.15 Pre-Transfer Exposure LED.....	7- 47
7.10.16 Separation Claw/Separation Claw Drive Assembly	7- 47
7.10.17 Potential Sensor.....	7- 48
7.10.18 Dust-Collecting Roller	7- 50
7.10.19 Charging Wire	7- 50

Chapter 8 Pickup/Feeding System

8.1 Construction	8- 1
8.1.1 Specifications and Construction	8- 1
8.1.2 Arrangement of Rollers and Sensors.....	8- 1
8.1.3 Control System	8- 2
8.1.4 Controlling the Pickup Motor (M2).....	8- 3

8.1.5 Index Paper Attachment	8- 3
8.2 Basic Sequence	8- 4
8.2.1 Right Deck	8- 4
8.2.2 Pickup from the cassette 4	8- 4
8.3 Detecting Jams	8- 5
8.3.1 Jam Detection Outline	8- 5
8.3.1.1 Outline	8- 5
8.3.2 Delay Jams.....	8- 6
8.3.2.1 Cassette Pickup (Right deck, Left deck, cassette 3, 4)	8- 6
8.3.2.2 Other Delay Jams	8- 6
8.3.3 Stationary Jams	8- 7
8.3.3.1 Common Stationary Jams	8- 7
8.3.3.2 Stationary Jam at Power-On.....	8- 7
8.4 Cassette Pick-Up Unit.....	8- 8
8.4.1 Outline	8- 8
8.4.2 Detecting the Presence/Absence of Paper.....	8- 9
8.4.3 Detecting the Level of Paper.....	8- 10
8.4.4 Cassette 3/4.....	8- 11
8.4.5 Markings on the Width Guide Rail	8- 12
8.4.6 Paper Size	8- 12
8.5 Manual Feed Pickup Unit	8- 14
8.5.1 Pickup Operation	8- 14
8.5.2 Detecting the Paper Size.....	8- 15
8.6 Deck.....	8- 16
8.6.1 Outline	8- 16
8.6.2 Lifter Limiter (deck right/left)	8- 17
8.6.3 Detecting the Presence/Absence of Paper.....	8- 18
8.6.4 Detecting the Level of Paper.....	8- 18
8.6.5 Cassette Deck Right/Left.....	8- 19
8.7 Registration Unit	8- 20
8.7.1 Outline	8- 20
8.7.2 Sequence of Operations (registration brake)	8- 20
8.8 Duplex Feeding Unit.....	8- 21
8.8.1 Copying on the First Side	8- 21
8.8.2 Copying on the Second Side	8- 21
8.8.3 Sequence of Operations.....	8- 22
8.8.4 Controlling the reversal motor (M11)	8- 22
8.8.5 Controlling the duplexing feeder motor (M12).....	8- 23
8.8.6 No-Stacking Operation.....	8- 23
8.8.7 Detecting the Horizontal Registration Position.....	8- 29
8.8.8 Controlling the Horizontal Registration Motor (M15).....	8- 30
8.9 Delivery.....	8- 31
8.9.1 Reversal Delivery.....	8- 31
8.10 Detecting the Double-Feed	8- 32
8.10.1 Detecting Double Feeding.....	8- 32
8.11 Parts Replacement Procedure	8- 34
8.11.1 Cassette Pickup Assembly	8- 34
8.11.2 Cassette Lifter Motor	8- 34
8.11.3 Right Deck Pickup Assembly	8- 35

8.11.4 Left Deck Pickup Assembly	8- 35
8.11.5 Left Deck Pickup Sensor	8- 36
8.11.6 Right Deck Pickup Sensor	8- 36
8.11.7 Manual Tray Assembly	8- 36
8.11.8 Manual Feed Pull-Out Roller Unit	8- 37
8.11.9 Manual Pickup Roller	8- 38
8.11.10 Manual Feed Roller	8- 38
8.11.11 Manual Separation Roller	8- 40
8.11.12 Manual Feed Tray paper sensor	8- 40
8.11.13 Manual Feed Pickup Solenoid	8- 41
8.11.14 Registration Roller	8- 42
8.11.15 Registration Clutch	8- 42
8.11.16 Registration Brake Clutch	8- 43
8.11.17 Fixing/Feed Unit	8- 43
8.11.18 Feeding Roller	8- 44
8.11.19 Vertical Path Roller	8- 44
8.11.20 Fixing Feeding Unit Releasing Lever Sensor	8- 45
8.11.21 Feeding Belt	8- 45
8.11.22 Duplexing Unit	8- 46
8.11.23 Separation Roller	8- 50
8.11.24 Double Feeding Detection Sensor (Transmission)	8- 51
8.11.25 Double Feeding Detection Sensor (Reception)	8- 53

Chapter 9 Fixing System

9.1 Construction	9- 1
9.1.1 Outline	9- 1
9.1.2 Major Components	9- 1
9.1.3 Overview of the Fixing Drive System	9- 2
9.1.4 Controlling the Fixing Roller Drive	9- 3
9.1.5 Controlling the Cleaning Web Drive	9- 3
9.1.6 Controlling the Thermistor Reciprocating Mechanism	9- 4
9.1.7 Controlling the Upper Separation Claw Reciprocating Mechanism	9- 4
9.1.8 Controlling the Fixing Inlet Sensor Drive	9- 5
9.2 Basic Sequence	9- 6
9.2.1 Basic Sequence of Operations	9- 6
9.3 Various Control Mechanisms	9- 7
9.3.1 Controlling the Fixing Roller Temperature	9- 7
9.3.1.1 Controlling the Down Sequence	9- 7
9.3.1.2 Transparency Mode	9- 8
9.3.1.3 Heavy Paper Mode	9- 8
9.3.1.4 Power Save Mode	9- 9
9.4 Protective Functions	9- 10
9.4.1 Error Detection	9- 10
9.5 Parts Replacement Procedure	9- 12
9.5.1 Fixing Unit	9- 12
9.5.2 Upper Fixing Roller	9- 13
9.5.3 Lower Fixing Roller	9- 14
9.5.4 External Delivery Roller	9- 15

9.5.5 Internal Delivery Roller	9- 16
9.5.6 Main Thermistor	9- 16
9.5.7 Sub Thermistor	9- 17
9.5.8 Thermal Switch	9- 17
9.5.9 Fixing Heater	9- 18
9.5.10 Fixing Cleaning Belt	9- 19
9.5.11 Claw Jam Sensor	9- 20
9.5.12 External Delivery Sensor	9- 20
9.5.13 Internal Delivery Sensor	9- 21
9.5.14 Reversal Sensor	9- 21
9.5.15 Fixing Inlet Sensor	9- 21
9.5.16 Fixing/Feeding Outlet Sensor	9- 22
9.5.17 Delivery Speed Switch Clutch	9- 22
9.5.18 Upper Separation Claw	9- 23
9.5.19 Lower Separation Claw	9- 23

Chapter 10 External and Controls

10.1 Control Panel	10- 1
10.1.1 Overview	10- 1
10.2 Counters	10- 2
10.2.1 Soft Counter	10- 2
10.3 Fans	10- 3
10.3.1 Fans <iR7086>	10- 3
10.3.2 Fans <iR7105/7095>	10- 5
10.3.3 Sequence of Fan Operation	10- 6
10.4 Power Supply System	10- 7
10.4.1 Power Supply	10- 7
10.4.1.1 Overview of the Power Supply System	10- 7
10.4.2 Backup Battery	10- 7
10.4.2.1 Back-Up Battery	10- 7
10.4.3 Energy-Saving Function	10- 7
10.4.3.1 Overview	10- 7
10.5 Parts Replacement Procedure	10- 9
10.5.1 Left Pickup Drive Assembly	10- 9
10.5.2 Pickup Drive Assembly	10- 9
10.5.3 Developing Drive Assembly	10- 10
10.5.4 Vertical Path Drive Assembly	10- 10
10.5.5 Waste Toner Drive Assembly	10- 11
10.5.6 Multifeeder Pickup Drive Assembly	10- 11
10.5.7 Lifter Drive Assembly	10- 12
10.5.8 Main Drive Assembly	10- 12
10.5.9 Drum Drive Assembly	10- 13
10.5.10 Cassette Pickup Drive Assembly	10- 14
10.5.11 Power Supply Unit	10- 14
10.5.12 Control Panel	10- 15
10.5.13 Control Panel LCD Unit	10- 16
10.5.14 Cover Switch Assembly	10- 17
10.5.15 Manual Feed Tray Switch Assembly	10- 17

10.5.16 Drum Heater Switch Assembly.....	10- 18
10.5.17 DC Controller PCB	10- 18
10.5.18 Control Panel Inverter PCB.....	10- 19
10.5.19 Control Panel Key Switch PCB	10- 19
10.5.20 Control Panel Family PCB	10- 20
10.5.21 Control Panel CPU PCB.....	10- 20
10.5.22 AC Driver PCB	10- 21
10.5.23 All Night Power Supply PCB.....	10- 21
10.5.24 Relay PCB	10- 22
10.5.25 High-Voltage Transformer (AC).....	10- 22
10.5.26 HV-AC PCB	10- 22
10.5.27 HV-DC PCB.....	10- 23
10.5.28 High-Voltage PCB	10- 23
10.5.29 Motor Driver PCB.....	10- 24
10.5.30 Transceiver PCB.....	10- 24
10.5.31 Double Feeding Detection PCB (Transmission).....	10- 25
10.5.32 Double Feeding Detection PCB (Reception)	10- 26
10.5.33 Fixing Heat Discharge Fan.....	10- 26
10.5.34 Laser Cooling Fan	10- 27
10.5.35 De-Curling Fan.....	10- 27
10.5.36 Drum Fan	10- 28
10.5.37 Pre-Transfer Charging Assembly Fan.....	10- 28
10.5.38 Power Supply Cooling Fan 1	10- 28
10.5.39 Power Supply Cooling Fan 2	10- 29
10.5.40 Separation Fan.....	10- 29
10.5.41 Developing Fan	10- 29
10.5.42 Delivery Anti-Adhesion Fan	10- 30
10.5.43 Duplex Feed Fan	10- 30
10.5.44 Separation Heat Discharge Fan.....	10- 31
10.5.45 Reader Heat Discharge Fan 2.....	10- 31
10.5.46 Fixing Inlet Sensor Motor	10- 31

Chapter 11 MEAP

11.1 MEAP.....	11- 1
11.1.1 Overview.....	11- 1
11.1.2 MEAP Counter.....	11- 1
11.1.3 Construction of the MEAP Platform	11- 2

Chapter 12 RDS

12.1 RDS.....	12- 1
12.1.1 Application operation mode.....	12- 1
12.1.2 Service Center URL and Port Specification.....	12- 1
12.1.3 Communication test	12- 1
12.1.4 Communication log	12- 1
12.1.5 Detailed Communication log	12- 1
12.1.6 SOAP communication function	12- 1
12.1.7 Resend at SOAP transmission error.....	12- 2

12.1.8 e-RDS setting screen	12- 3
12.1.9 Sleep operation	12- 5
12.1.10 Network Setting (Maintenance)	12- 5
12.1.11 e-RDS Setting (Maintenance).....	12- 6
12.1.12 Trouble shoot.....	12- 6
12.1.13 Error message.....	12- 7

Chapter 13 Maintenance and Inspection

13.1 Periodically Replaced Parts	13- 1
13.1.1 Overview	13- 1
13.1.2 Machine Proper.....	13- 1
13.2 Durables and Consumables.....	13- 1
13.2.1 Overview	13- 1
13.2.2 Machine Proper.....	13- 2
13.3 Scheduled Servicing Basic Procedure	13- 4
13.3.1 Scheduled Servicing Basic Procedure	13- 4
13.3.2 Scheduled Servicing Chart.....	13- 6
13.3.3 Scheduled Maintenance Work Procedure	13- 8
13.3.4 Points to Note About Schedule Servicing	13- 12

Chapter 14 Standards and Adjustments

14.1 Image Adjustment Basic Procedure	14- 1
14.1.1 Making Pre-Checks	14- 1
14.1.2 Making Checks on the Printer Side (Checking the Images)	14- 1
14.1.3 Making Checks on the Printer Side (Checking the Density Slope).....	14- 2
14.1.4 Making Checks on the Printer Side (Checking the Solid Black Density)	14- 3
14.1.5 Making Checks on the Printer Side (Checking for fogging)	14- 4
14.1.6 Making Checks on the Printer Side (Checking Halftone Density).....	14- 4
14.1.7 Making Checks on the Reader Unit	14- 5
14.1.8 Potential Control System Conversion Table.....	14- 7
14.2 Image Adjustments.....	14- 11
14.2.1 Standards of Image Position.....	14- 11
14.2.2 Checking the Image Position	14- 11
14.2.3 Adjusting Side Registration	14- 11
14.2.4 Adjusting the Image Leading Edge Margin.....	14- 13
14.2.5 Adjusting the Left/Right Non-Image Width	14- 14
14.2.6 Adjusting the Leading Edge Non-Image Width	14- 14
14.3 Scanning System	14- 14
14.3.1 When Replacing Components of the Scanning System.....	14- 14
14.3.2 When Replacing Components of the Scanning System.....	14- 14
14.3.3 Adjusting the Position of the No. 1/No. 2 Mirror Base	14- 14
14.4 Laser Exposure System.....	14- 16
14.4.1 When Replacing the Laser Scanner Unit.....	14- 16
14.4.2 Checking the Laser Power	14- 16
14.5 Image Formation System	14- 17
14.5.1 Adjusting the Height of the Charging Wire	14- 17
14.6 Fixing System.....	14- 17

14.6.1 Adjusting the Lower Roller Pressure (nip)	14- 17
14.6.2 Points to Note When Mounting the Fixing Heater.....	14- 17
14.7 Electrical Components	14- 18
14.7.1 After Replacing the Hard Disk.....	14- 18
14.7.2 After Replacing the Main Controller	14- 18
14.7.3 After Replacing the DC Controller PCB.....	14- 20
14.7.4 After Replacing the Reader Controller PCB	14- 20
14.7.5 After Replacing the Reader Controller PCB	14- 20
14.7.6 After Replacing the HV-DC PCB	14- 21
14.7.7 When Replacing the Potential Sensor/Potential Control PCB.....	14- 21
14.7.8 Checking the Surface Potential Control System.....	14- 22
14.7.9 Checking the Environment Sensor.....	14- 24
14.8 Pickup/Feeding System	14- 25
14.8.1 Orientation of the Deck/Cassette Pickup Roller.....	14- 25
14.8.2 Orientation of the Deck/Cassette Separation Roller.....	14- 25
14.8.3 Orientation of the Feeding Roller of the Deck/Cassette Pickup Assembly.....	14- 25
14.8.4 Orientation of the Pickup Roller of the Manual Feed Tray/Side Paper	14- 25
14.8.5 Orientation of the Feeding Roller of the Manual Feed Tray.....	14- 26
14.8.6 Orientation of the Feeding Roller of the Side Paper Deck	14- 26
14.8.7 Adjusting the Pressure of the Deck/Cassette Separation Roller.....	14- 26
14.8.8 Adjusting the Pressure of the Pickup/Feeding Roller of the Manual	14- 26
14.8.9 Location of the solenoids	14- 27
14.8.10 Position of the Fixing Web Solenoid (SL2)	14- 27
14.8.11 Position of the Delivery Flapper Solenoid (SL3)	14- 27
14.8.12 Position the Fixing/Feeder Unit Locking Solenoid (SL4)	14- 27
14.8.13 Position of the Multifeeder Latch Solenoid (SL6).....	14- 28
14.8.14 Position of the Deck (right) Pickup Solenoid (SL7).....	14- 28
14.8.15 Position of the Deck (Left) Pickup Solenoid (SL8).....	14- 28
14.8.16 Position of the Cassette 3/4 Pickup Solenoid (SL9/10)	14- 28
14.8.17 Position of the Side Paper Deck Pickup Roller Releasing Solenoid.....	14- 29
14.8.18 Fitting the Side Guide Timing Belt of the Manual Feed Tray Assembly.....	14- 29
14.8.19 Fitting the Drive Belt	14- 29

Chapter 15 Correcting Faulty Images

15.1 Making Initial Checks.....	15- 1
15.1.1 Checking the Side of Installation	15- 1
15.1.2 Checking the Originals	15- 1
15.1.3 Checking the Copyboard Cover, Copyboard Glass, and Standard White Plate.....	15- 1
15.1.4 Checking the Charging Assemblies	15- 1
15.1.5 Cheiking the Develop Unit	15- 1
15.1.6 Checking the Paper	15- 1
15.1.7 Checking the Periodically Replaced Parts	15- 1
15.1.8 Others	15- 2
15.2 Outline of Electrical Components	15- 3
15.2.1 Clutch/Solenoid.....	15- 3
15.2.1.1 Clutches.....	15- 3
15.2.1.2 Solenoids.....	15- 4
15.2.2 Motor.....	15- 5

15.2.2.1 Motors	15- 5
15.2.3 Fan	15- 7
15.2.3.1 Fans	15- 7
15.2.3.2 Fans	15- 8
15.2.4 Sensor	15- 10
15.2.4.1 Sensor (reader) <iR7105/7095>.....	15- 10
15.2.4.2 Sensor (reader) <iR7086>.....	15- 11
15.2.4.3 Sensor 1	15- 12
15.2.4.4 Sensor 2	15- 17
15.2.5 Switch.....	15- 18
15.2.5.1 Switches	15- 18
15.2.6 Lamps, Heaters, and Others	15- 19
15.2.6.1 Heaters, Lamps, and Others.....	15- 19
15.2.7 PCBs	15- 21
15.2.7.1 PCBs.....	15- 21
15.2.8 Variable Resistors (VR), Light-Emitting Diodes (LED), and Check Pins by PCB	15- 23
15.2.8.1 Variable Resistors (VR), Light-Emitting Diodes (LED), and Check Pins by PCB.....	15- 23
15.2.8.2 Main controller PCB	15- 23
15.2.8.3 DC controller PCB	15- 24

Chapter 16 Self Diagnosis

16.1 Error Code Table	16- 1
16.1.1 Error Code Table	16- 1
16.2 Error Code Details	16- 3
16.2.1 Error Code Details	16- 3
16.2.2 Detail in E602	16- 15
16.3 Jam Code.....	16- 18
16.3.1 Jam Code (printer).....	16- 18
16.3.2 Jam Code (DADF-Q1) <iR7105/7095>	16- 18
16.3.3 Jam Code (DADF-M1) <iR7086>	16- 22
16.4 Alarm Code.....	16- 24
16.4.1 Alarm Code.....	16- 24

Chapter 17 Service Mode

17.1 Outline	17- 1
17.1.1 Service mode screen configuration	17- 1
17.1.2 Entering or selecting service modes.....	17- 2
17.1.3 Exiting service modes	17- 2
17.1.4 Backing Up Service Mode	17- 2
17.1.5 Initial screen.....	17- 3
17.1.6 Main/intermediate item screen	17- 3
17.1.7 Sub-item screen.....	17- 3
17.2 DISPLAY (Status Display Mode).....	17- 4
17.2.1 COPIER	17- 4
17.2.1.1 COPIER Items.....	17- 4
17.2.2 FEEDER	17- 13
17.2.2.1 FEEDER Items.....	17- 13

17.3 I/O (I/O Display Mode).....	17- 14
17.3.1 Overview.....	17- 14
17.3.2 <DC-CON>.....	17- 15
17.3.3 <R-CON>.....	17- 22
17.3.4 <R-CON>.....	17- 24
17.3.5 <FEEDER>	17- 25
17.3.6 <FEEDER>	17- 28
17.3.7 <SORTER>	17- 29
17.3.8 <MN-CONT>.....	17- 38
17.4 ADJUST (Adjustment Mode).....	17- 39
17.4.1 COPIER.....	17- 39
17.4.1.1 COPIER Items	17- 39
17.4.2 FEEDER.....	17- 46
17.4.2.1 FEEDER Items	17- 46
17.4.3 SORTER	17- 46
17.4.3.1 SORTER Items.....	17- 46
17.5 FUNCTION (Operation/Inspection Mode).....	17- 47
17.5.1 COPIER.....	17- 47
17.5.1.1 COPIER Items	17- 47
17.5.2 FEEDER.....	17- 57
17.5.2.1 FEEDER Items	17- 57
17.5.3 SORTER	17- 59
17.5.3.1 SORTER Items.....	17- 59
17.6 OPTION (Machine Settings Mode)	17- 60
17.6.1 COPIER.....	17- 60
17.6.1.1 COPIER Items	17- 60
17.6.1.2 Soft Counter Specifications	17- 77
17.6.2 FEEDER.....	17- 86
17.6.2.1 FEEDER Items	17- 86
17.6.3 SORTER	17- 86
17.6.3.1 SORTER Items.....	17- 86
17.6.4 BOARD.....	17- 87
17.6.4.1 BOARD Items	17- 87
17.7 TEST (Test Print Mode)	17- 88
17.7.1 COPIER.....	17- 88
17.7.1.1 COPIER Items	17- 88
17.8 COUNTER (Counter Mode)	17- 89
17.8.1 COPIER.....	17- 89
17.8.1.1 COPIER Items	17- 89

Chapter 18 Upgrading

18.1 Outline.....	18- 1
18.1.1 Overview of Upgrading Work	18- 1
18.1.2 Outline of the Functions and Operations.....	18- 2
18.1.3 Points to Note at Time of Downloading	18- 4
18.2 Making Preparations.....	18- 5
18.2.1 Installing the System Software (System CD -> SST).....	18- 5
18.2.2 Copying the System Software (SST -> USB).....	18- 5

18.2.3 Making Connections (SST in use)	18- 7
18.2.4 Making Connections (USB device in use)	18- 7
18.3 Formatting the HDD	18- 9
18.3.1 Formatting the HDD for All Partition	18- 9
18.3.2 Formatting the HDD for Selected Partitions	18- 10
18.3.3 Formatting the Partitions	18- 10
18.4 Downloading System Software.....	18- 12
18.4.1 Downloading the System Software (ALL).....	18- 12
18.4.1.1 Outline	18- 12
18.4.1.2 Downloading Procedure	18- 12
18.4.2 Downloading the System Software (Single).....	18- 13
18.4.2.1 Downloading Procedure	18- 13
18.4.3 Uploading and Downloading Backup Data.....	18- 15
18.4.3.1 Outline	18- 15
18.4.3.2 Uploading Procedure	18- 16
18.4.3.3 Downloading Procedure	18- 17
18.4.4 Version Upgrade using USB.....	18- 18
18.4.4.1 Overview of Menus and Functions.....	18- 18
18.4.4.2 Points to Note	18- 18
18.4.4.3 Downloading/Writing the System Software (auto).....	18- 19
18.4.4.4 Downloading the System Software (auto or selective)	18- 19
18.4.4.5 Downloading the System Software (overwriting).....	18- 20
18.4.4.6 Formatting the HDD	18- 21
18.4.4.7 Other Functions.....	18- 22

Chapter 19 Service Tools

19.1 Service Tools.....	19- 1
19.1.1 Special Tools Table	19- 1
19.1.2 Solvents/Oils.....	19- 2

Appendix

General Timing Chart.....	1- 2
Signal Names.....	5-6
General Circuit Diagrams.....	7-28

Chapter 1

Introduction

Contents

1.1 System Construction	1- 1
1.1.1 System Configuration with Input/Output Accessories.....	1- 1
1.1.2 Combination of Delivery Accessories.....	1- 2
1.1.3 System Configuration with Printing/Transmission Accessories	1- 4
1.1.4 Functions of Printing/Transmission Accessories	1- 4
1.2 Product Specifications	1- 5
1.2.1 Names of Parts	1- 5
1.2.1.1 External View.....	1- 5
1.2.1.2 Cross Section	1- 6
1.2.2 Using the Machine	1- 7
1.2.2.1 Power Switch.....	1- 7
1.2.2.2 Points to Note About Turning Off the Main Power Switch	1- 8
1.2.2.3 Control Panel.....	1- 9
1.2.3 User Mode Items	1- 9
1.2.3.1 Common Settings	1- 9
1.2.3.2 Timer Settings	1- 12
1.2.3.3 Adjustment/Cleaning	1- 13
1.2.3.4 Report Settings	1- 14
1.2.3.5 System Settings	1- 14
1.2.3.6 Copy Settings	1- 16
1.2.3.7 Communications Settings.....	1- 17
1.2.3.8 Mail Box Settings	1- 17
1.2.3.9 Address Book Settings.....	1- 18
1.2.3.10 Voice Guide Settings.....	1- 18
1.2.4 Safety	1- 18
1.2.4.1 Safety About Laser Light	1- 18
1.2.4.2 CDRH Regulations	1- 18
1.2.4.3 Handling of the Laser Assembly.....	1- 19
1.2.4.4 Safety of Toner.....	1- 19
1.2.5 Product Specifications	1- 20
1.2.5.1 Product Specifications	1- 20
1.2.6 Function List.....	1- 22
1.2.6.1 Print Speed	1- 22
1.2.6.2 Paper Type	1- 23
1.2.7 RDS Specification	1- 24
1.2.7.1 Embedded RDS (e-RDS)	1- 24

1.1 System Construction

1.1.1 System Configuration with Input/Output Accessories

The following shows a typical system configuration:

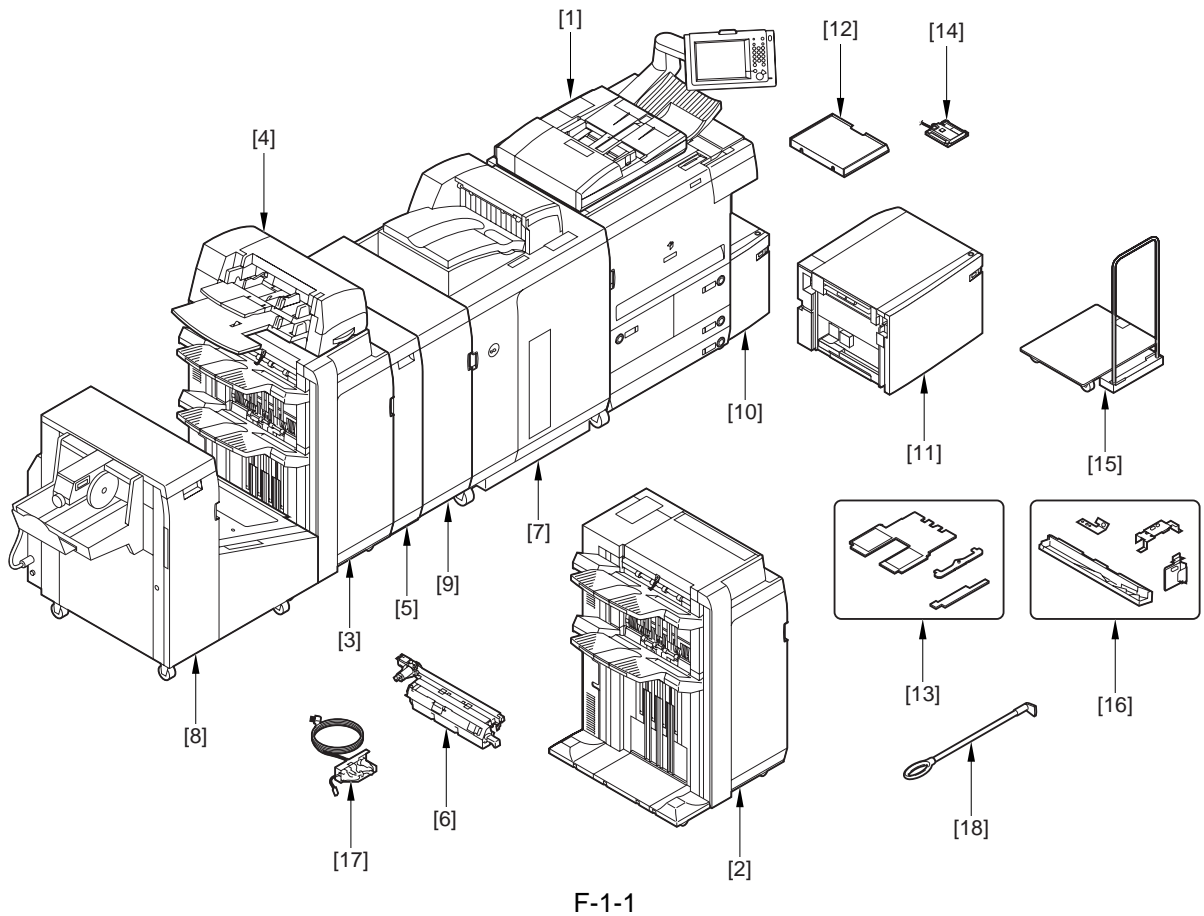

- [1] DADF-Q1/M1 (standard)
- [2] Finisher-V1
- [3] Saddle Finisher-V2
- [4] Document Insertion Unit-C1
- [5] Paper Folding Unit-D1
- [6] Punch Unit-U1/V1/W1/X1
- [7] High Capacity Stacker-A1
- [8] Booklet Trimmer-B1
- [9] Professional Puncher-A1
- [10] Paper Deck-W1
- [11] Paper Deck-X1
- [12] Document Tray-L1
- [13] Tab Feeding Attachment-A1 (standard)
- [14] Card Reader-D1
- [15] Stacker Dolly-A1
- [16] Double Feeding Detection Kit-A1
- [17] Finisher Option Power Supply Unit-R1
- [18] ADF Access Handle-A1

⚠ Not all products are necessarily available in all sales areas.

1.1.2 Combination of Delivery Accessories

3 Possible Combinations

1. Main Unit + Finisher

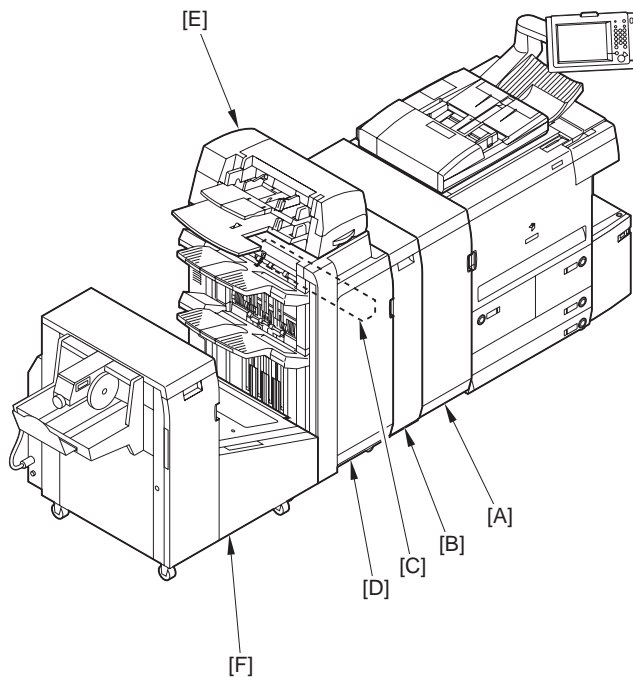

F-1-2

[A] Professional Puncher (outside Japan)

[B] Paper Folding Unit

[C] Punch Unit

[D] Finisher

[E] Insertion Unit

[F] Booklet Trimmer

* Either a professional puncher or a punch unit may be used.

* A trimmer must be used in combination with a saddle finisher.

2. Main Unit + High Capacity Stacker

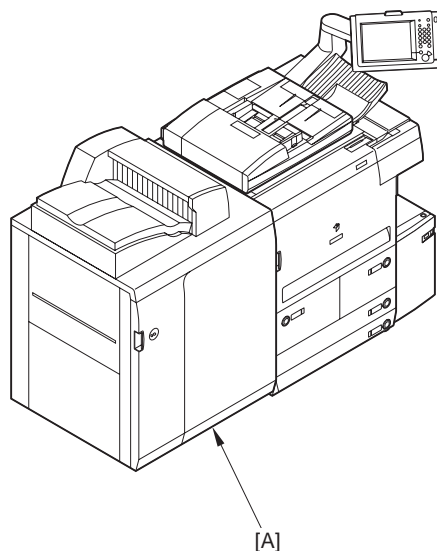

F-1-3

[A] High Capacity Stacker

3. Main Unit + High Capacity Stacker + Finisher

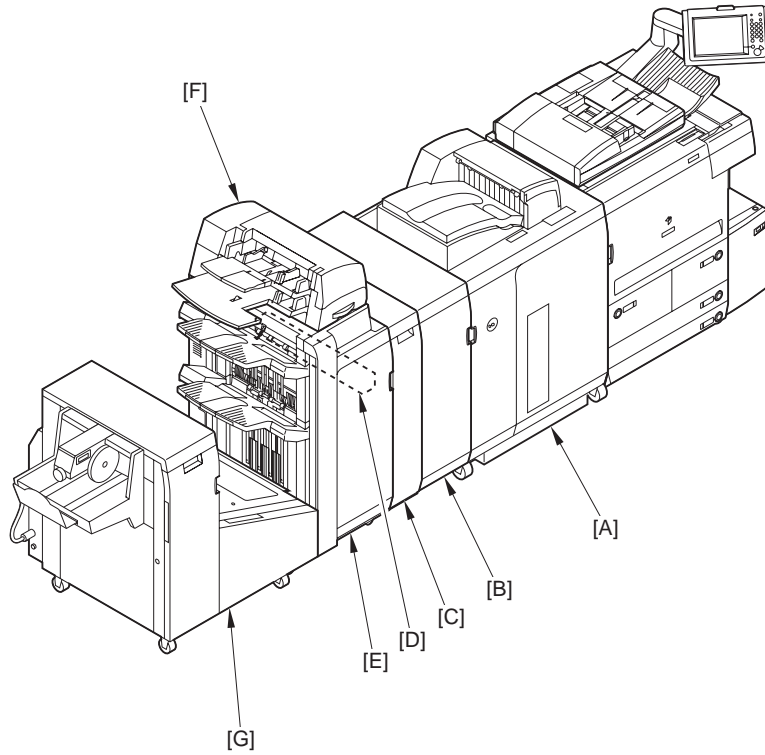

F-1-4

- | | |
|--|---------------------|
| [A] High Capacity Stacker | [E] Finisher |
| [B] Professional Puncher (outside Japan) | [F] Insertion Unit |
| [C] Paper Folding Unit | [G] Booklet Trimmer |
| [D] Punch Unit | |

- * Either a professional puncher or a punch unit may be used.
- * A trimmer must be used in combination with a saddle finisher.

1.1.3 System Configuration with Printing/Transmission Accessories

The following is a diagram of the system configuration:

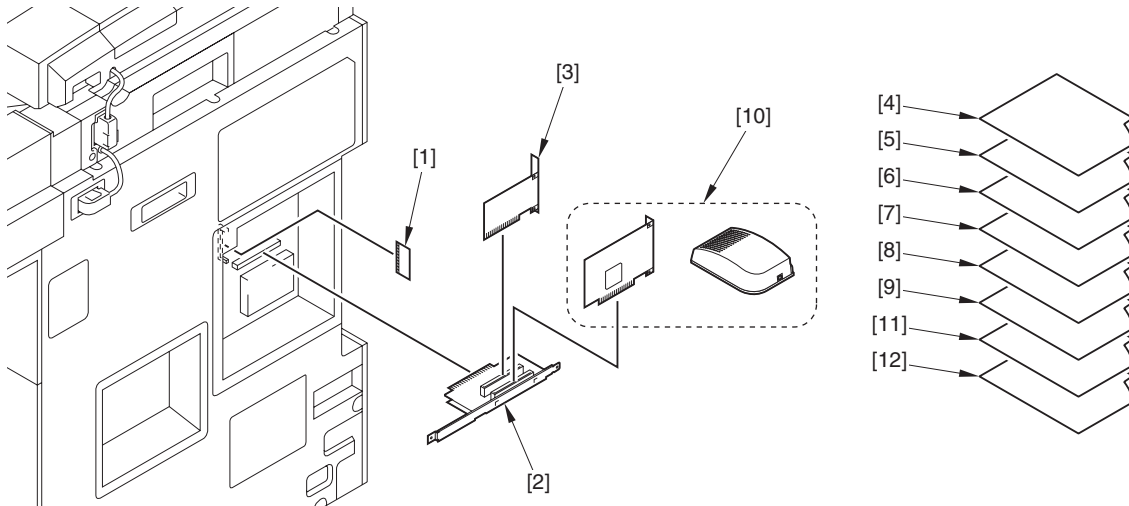

F-1-5

- [1] Multi-PDL Printer Kit-H1 (Boot)
- [2] Expansion Bus-D1
- [3] Security Expansion Board-F1
- [4] iR Security Kit-A2 (license certificate)
- [5] Univrsal Send Kit-E1 (license certificate)
- [6] Universal Send Enhancement Kit-C1 (license certificate)
- [7] Encrypted Printing Software-A3 (license certificate)
- [8] Web Access Software-C1 (license certificate)
- [9] Remote Operators Software Kit-A1 (license certificate)
- [10] Voice Guidance Kit-A2
- [11] Barcode Printing Kit-B1 (license certificate)
- [12] Security Mark-A1 (license certificate)

1.1.4 Functions of Printing/Transmission Accessories

The following shows the accessories needed for individual functions:

T-1-1

UFR II/PCL/PS printing + PDF/ Tiff direct printing	==>	Multi-PDL Printer Kit-H1
transmission	==>	Univrsal Send Kit-E1
security function (HDD formatting + encryption)	==>	Security Expansion Board-F1 Expansion Bus-D1 iR Security Kit-A2
encryption PDF function + searchable PDF function	==>	Univrsal Send Kit-E1 Universal Send Enhancement Kit-C1
voice guidance	==>	Voice Guidance Kit-A2 Expansion Bus-D1
remote operation	==>	Remote Operators Software Kit-A1
web browsing	==>	Web Access Software-C1
barcode printing	==>	Multi-PDL Printer Kit-H1 Barcode Printing Kit-B1
secure printing	==>	Encrypted Printing Software-A3
security mark printing	==>	Security Mark-A1

1.2 Product Specifications

1.2.1 Names of Parts

1.2.1.1 External View

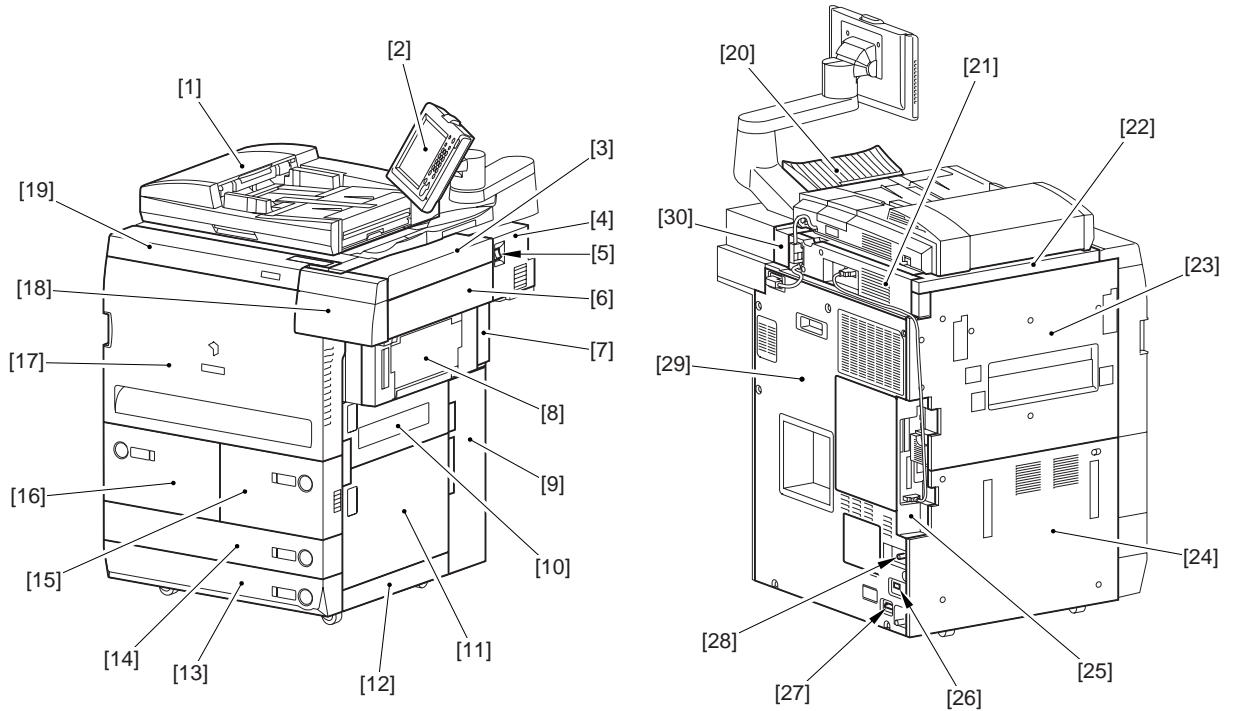

F-1-6

[1]	ADF	[16]	Left deck
[2]	Control panel	[17]	Front cover
[3]	Reader right cover	[18]	Toner supply cover
[4]	Main power supply cover	[19]	Upper front cover
[5]	Main power supply switch	[20]	Original delivery tray
[6]	Upper right cover	[21]	Reader rear cover
[7]	Rear right upper cover	[22]	Reader left cover
[8]	Manual feeder tray	[23]	Upper left cover
[9]	Rear right lower cover	[24]	Lower left cover
[10]	Upper right door	[25]	Rear left cover
[11]	Lower right door	[26]	Heater switch
[12]	Lower right cover	[27]	Leakage breaker
[13]	Cassette 4	[28]	ARCNET connector
[14]	Cassette 3	[29]	Rear cover
[15]	Right deck	[30]	Reader right rear cover

1.2.1.2 Cross Section

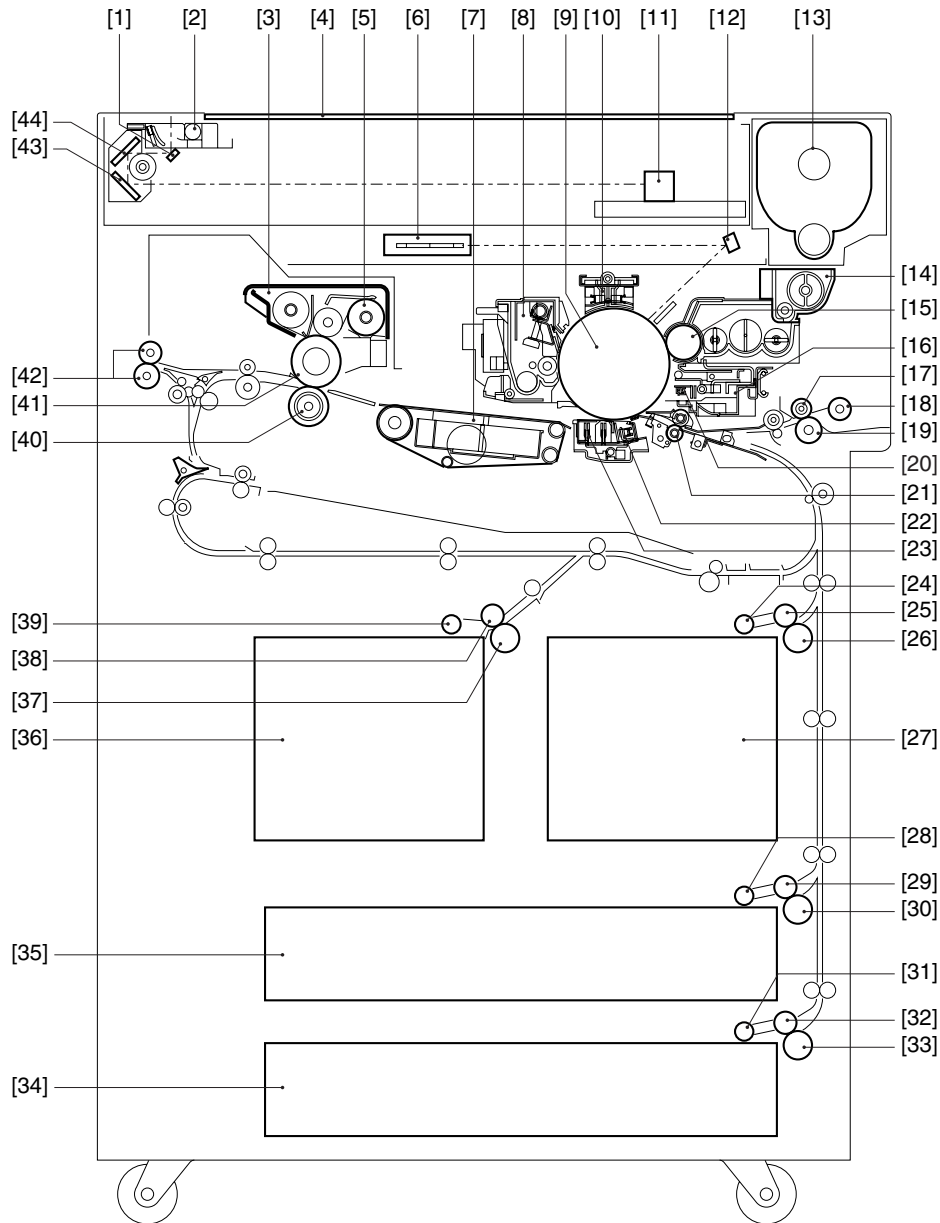
F-1-7
T-1-2

- | | | |
|-------------------------------------|------------------------------------|-----------------------------------|
| [1] No.1 mirror | [16] Manual feed feeding roller | [30] Cassette 4 pickup roller |
| [2] Scanning lamp | [17] Manual feed pick roller | [31] Cassette 4 feeding roller |
| [3] Fixing assembly | [18] Manual feed separation roller | [32] Cassette 4 separation roller |
| [4] Copyboard glass | [19] Pre-transfer exposure LED | [33] Cassette 4 |
| [5] Fixing web | [20] Registration roller | [34] Cassette 3 |
| [6] Feeding assembly | [21] Transfer charging assembly | [35] Left deck |
| [7] Drum cleaner assembly | [22] Separate charging assembly | [36] Left deck separation roller |
| [8] Photosensitive drum | [23] Right deck pickup roller | [37] Left deck feeding roller |
| [9] Primary charging assembly | [24] Right deck feeding roller | [38] Left deck pickup roller |
| [10] CCD unit | [25] Right deck separation roller | [39] Fixing lower roller |
| [11] Laser/scanner unit | [26] Right deck | [40] Fixing upper roller |
| [12] Toner bottle | [27] Cassette 3 pickup roller | [41] External delivery roller |
| [13] Buffer unit | [28] Cassette 3 feeding roller | [42] No.3 mirror |
| [14] Developing cylinder | [29] Cassette 3 separation roller | [43] No.2 mirror |
| [15] Pre-transfer charging assembly | | |

1.2.2 Using the Machine

1.2.2.1 Power Switch

The machine is equipped with 2 switches: main power switch and control panel power switch. The machine goes on when the main power switch is turned on. To end power save mode, low power mode, or sleep mode, turn on the control panel power switch.

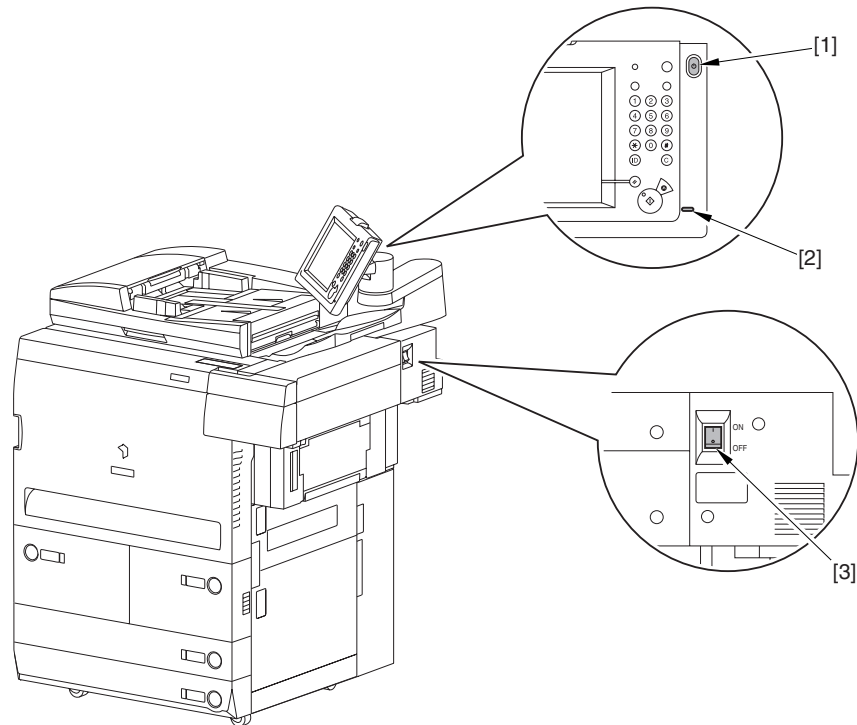

F-1-8

- [1] Control panel power switch
- [2] Main power lamp
- [3] Main power switch



Do not turn off the main power while the progress bar is indicated (access to the HDD under way). Otherwise, the HDD can suffer damage (E602).



F-1-9

1.2.2.2 Points to Note About Turning Off the Main Power Switch

⚠ Points to Note When Turning Off the Main Power Switch

Before turning off the main power switch, be sure to hold down the control panel power switch for 3 sec or more and go through the shut-down sequence while keeping the following in mind:

1. be sure that the Execute/Memory lamp on the control panel is off.
2. do not turn off the main power switch while downloading is under way. Otherwise, the machine may fail to operate.
3. If the heater switch is on, the cassette heater and the drum heater remain powered even after the main power switch has been turned off.

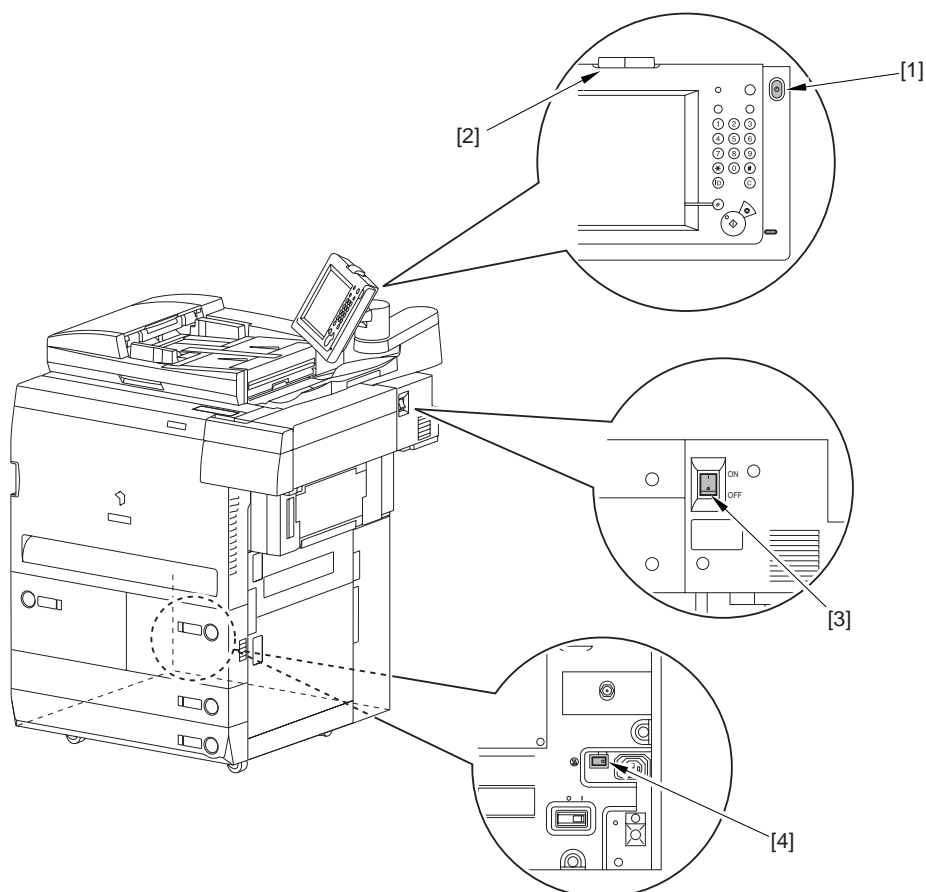

F-1-10

- [1] Control panel power switch
- [2] Processing/data indicator
- [3] Main power switch
- [4] Heater switch

1.2.2.3 Control Panel

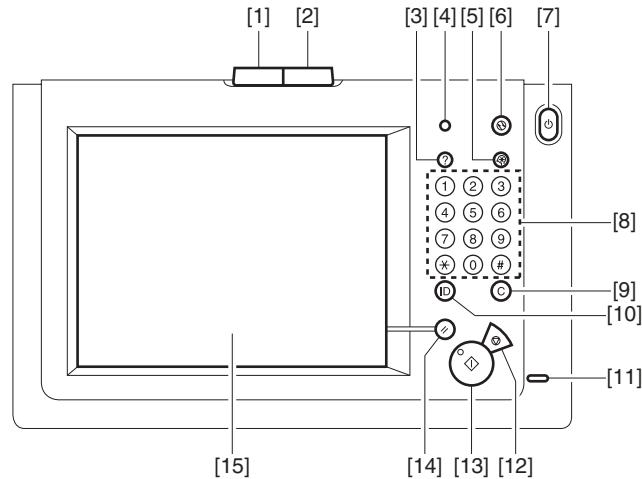

F-1-11

[1] Processing/data indicator	[9] Clear key
[2] Error indicator	[10] ID key
[3] Help key	[11] Main power indicator
[4] Counter Check key	[12] Stop key
[5] Additional functions key	[13] Start key
[6] Energy save key	[14] Reset key
[7] Control panel power switch	[15] Touch panel display
[8] Numeric keys	

1.2.3 User Mode Items

1.2.3.1 Common Settings

*1 Indicates the default setting.

*2 Indicates items that appear only when the appropriate optional equipment is attached.

*3 Indicates information that is delivered only if the number of output trays in the host machine and client machines is the same.

T-1-3

Item	Settings
Initial Function	Select Initial Function: Copy*1, Send, Mail Box, MEAP Set System Monitor as the Initial Function: On/Off*1 Set the default screen for System Monitor: Settings: Print Status*1, Consumables, Others (Copy*1, Send, Receive), Status*1, Log
Auto Clear Setting	Initial Function*1/Selected Function
Function Order Settings	Function Order Settings: Copy*1, Send*2, Mail Box, Scan, Printer*2
Audible Tones	Settings for Function Group Order: Group A, Group B, MEAP Entry Tone: On*1, Off Invalid Entry Tone: On, Off*1 Restock Supplies Tone: On, Off*1 Error Tone: On*1, Off Job Done Tone: On*1, Off Forgot Original Tone (for the imageRUNNER 7086): On, Off*1
Display Remaining Paper Message	ON*1/OFF

Item	Settings
Inch Entry	ON*1/OFF
Drawer Eligibility For APS/ADS	Copy, Printer, Mail Box, Receive, Other: (Stack Bypass: On/Off*1, All Other Paper Sources: On*1/Off)
Register Paper Type	Copy: Consider Paper Type: On/Off*1 Paper Drawers 1 and 2 and Paper Deck-W1 or Paper Deck-X1: Plain*1, Recycled, Color, Letterhead, Bond, 3-Hole Punch, Heavy Paper Drawers 3 and 4: Plain*1, Recycled, Color, Letterhead, Bond, 3-Hole Punch, Heavy, Tab Paper
Energy Saver Mode	-10%*1/-25%/-50%/None
Energy Consumption in Sleep Mode	Low*1/High
LTRR/STMT Original Selection	Distinguish Manually, Use LTRR Format*1, Use STMT Format
Tray Designation*2*3	If the Optionl Finisher-V1 or Saddle Finisher-V2 Is Attached: Tray A: Copy*1, Mail Box*1, Printer*1, Receive*1, Other*1 Tray B: Copy*1, Mail Box*1, Printer*1, Receive*1, Other*1 If the Optional Finisher-V1 or Saddle Finisher-V2, and High Capacity Stacker A1 Are Attached: Tray A: Copy*1, Mail Box*1, Printer*1, Receive, Other Tray B: Copy*1, Mail Box*1, Printer*1, Receive, Other Tray C: Receive*1, Other*1
High Volume Stack Mode*2	ON/OFF*1
Printing Priority	Copy: 1*1/2/3 Printer : 1/2*1/3 Mail Box, Receive, Other: 1/2/3*1
Register Form for Form Composition	Register (Entire Image Composition*1, Transparent Image), Erase, Check Print, Details
Register Characters for Page No./Watermark	Register, Edit, Erase
Stack Bypass Standard Settings	ON/OFF*1
Registering Irregular Size for Stack Bypass	Register/Edit, Erase, Register Name

Item	Settings
Standard Local Print Settings	<p>Paper Select: Auto*1, All Paper Sources</p> <p>Copies: 1*1 to 9,999 sets</p> <p>Finishing:</p> <p>If the Optional Finisher-V1 or Saddle Finisher-V2 Attached: Do Not Collate, Collate, Offset Collate*1, Group, Staple (Corner: Top Left, Bottom Left, Top Right, Bottom Right) (Double: Left, Right)</p> <p>If the Optional Punch Unit-V1 Is Attached to the Optional Finisher-V1 or Saddle Finisher-V2: Do Not Collate, Collate, Offset Collate*1, Group, Offset Group, Staple (Corner: Top Left, Bottom Left, Top Right, Bottom Right), (Double: Left, Right), Hole Punch</p> <p>If the Optional Paper Folding Unit-D1 Is Attached to the Optional Finisher-V1 or Saddle Finisher-V2: Do Not Collate, Collate, Offset Collate*1, Group, Offset Group, Staple (Corner: Top Left, Bottom Left, Top Right, Bottom Right), (Double: Left, Right), Z-Fold</p> <p>If the Optional Punch Unit-V1 and Paper Folding Unit-D1 Are Attached to the Optional Finisher-V1 or Saddle Finisher-V2: Do Not Collate, Collate, Offset Collate*1, Group, Offset Group, Staple (Corner: Top Left, Bottom Left, Top Right, Bottom Right), (Double: Left, Right), Hole Punch, Z-Fold</p> <p>If the Optional High Capacity Stacker-A1 Is Attached Do Not Collate, Collate, Offset Collate*1, Group, Offset Group</p> <p>If the Optional High Capacity Stacker-A1 and Finisher-V1 or Saddle Finisher-V2 Are Attached: Do Not Collate, Collate, Offset Collate*1, Group, Offset Group, Staple (Corner: Top Left, Bottom Left, Top Right, Bottom Right) (Double: Left, Right)</p> <p>If the Optional High Capacity Stacker-A1 and Punch Unit-V1 Are Attached to the Optional Finisher-V1 or Saddle Finisher-V2: Do Not Collate, Collate, Offset Collate*1, Group, Offset Group, Staple (Corner: Top Left, Bottom Left, Top Right, Bottom Right) (Double: Left, Right), Hole Punch</p> <p>If the Optional High Capacity Stacker-A1 and Paper Folding Unit-D1 Are Attached to the Optional Finisher-V1 or Saddle Finisher-V2: Do Not Collate, Collate, Offset Collate*1, Group, Offset Group, Staple (Corner: Top Left, Bottom Left, Top Right, Bottom Right) (Double: Left, Right), Z-Fold</p> <p>If the Optional High Capacity Stacker-A1, Punch Unit-V1 and Paper Folding Unit-D1 Are Attached to the Optional Finisher-V1 or Saddle Finisher-V2: Do Not Collate, Collate, Offset Collate*1, Group, Offset Group, Staple (Corner: Top Left, Bottom Left, Top Right, Bottom Right) (Double: Left, Right), Hole Punch, Z-Fold</p> <p>Offset: 1*1 to 9,999 sets</p> <p>Face Up/Face Down: Auto*1, Face Down (Normal), Face Up (Reverse)</p> <p>Stack. Destination*2 Stacker*1, Output Tray</p> <p>Two-sided Print: On (Book Type, Calendar Type), Off*1</p> <p>Merge Documents: On, Off*1</p> <p>Language Switch ON/OFF*1</p>

Item	Settings
Reversed Display (Color)	ON/OFF*1
Offset Jobs*2	ON*1/OFF
Job Separator between Jobs	ON/OFF*1
Job Separator between Copies	ON/OFF*1
Number of Copies/Wait Time Status Display	ON*1/OFF
Register Sizes for Side Paper Deck*2	A3/A4/A4R/B4/B5/11"X17"/LGL/LTR/LTRR
Different Paper Sizes for the Output Tray*2	ON*1/OFF
Cleaning Display for the Original Scanning Area	ON*1/OFF
Limited Functions Mode*2	Finisher Tray A/B: ON/OFF*1 Finisher Saddle Stitcher Unit: ON/OFF*1 Finisher Inserter: ON/OFF*1 Folding Unit: ON/OFF*1 Puncher Unit: ON/OFF*1 Stacker: ON/OFF*1
Shutdown Mode	Press [Start]
Initialize Common Settings	Initialize

1.2.3.2 Timer Settings

*1 Indicates the default setting.

T-1-4

Item	Setting
Time Fine Adjustment	00:00 to 23:59, in one minute increments
Auto Sleep Time	10, 15, 20, 30, 40, 50 min., 1 hour*1, 90 min., 2, 3, 4 hours
Auto Clear Time	0 (Off) to 9 minutes, in one minute increments; 2 min.*1
Time Until Unit Quiets Down	0 (Off) to 9 minutes, in one minute increments; 1 min.*1
Daily Timer Settings	Sunday to Saturday, 00:00 to 23:59, in one minute increments
Low-power Mode Time	10, 15*1, 20, 30, 40, 50 min., 1 hour, 90 min., 2, 3, 4 hours

1.2.3.3 Adjustment/Cleaning

*1 Indicates the default setting.

*2 Indicates items that appear only when the appropriate optional equipment is attached.

T-1-5

Item	Setting
Zoom Fine Adjustment	X/Y: -1.0% to +1.0% in 0.1% increments; 0.0%*1
Saddle Stitch Position Adjustment*2	All paper size: -2.0 mm to +2.0 mm, in 0.25 mm increments; 1.00 mm*1
Double Staple Space Adjustment	4 3/4" to 5 7/8" (120 mm to 150 mm), 4 3/4" (120 mm)*1
Trim Width Adjustment	0.08" to 0.78" (2.00 mm to 20.00 mm), in 0.01" (0.1 mm) increments; 0.08" (2.00 mm)*1
Adjust Creep (Displacement) Correction	Correction (for each paper type) 0.000" to 0.078" (0.00 mm to 2.00 mm), 0.002" (0.05 mm) increments; 0.010" (0.25 mm)*1
Exposure Recalibration	Copy/Inbox, Send: Light, Dark: 1 to 9 levels; 5*1
Character/Background Contrast Adjustment	Relative Contrast Value: -7 to +7; 0*1 Sample Print Sample Print Settings: Background Pattern: None*1, Arabesque, Fans, Polka Dots, Stars, Mesh, Clouds, Cherry Blossoms, Leaves Size: Small (36 pt.), Medium (54 pt.)*1, Large (72 pt.) White Letters on Colored Background: On, Off*1 Print Characters Vertically: On, Off*1 Standard Value Settings: 0 to 64; 20*1 Sample Print Print Settings: Sample Print Settings: Background Pattern: None*1, Arabesque, Fans, Polka Dots, Stars, Mesh, Clouds, Cherry Blossoms, Leaves Size: Small (36 pt.), Medium (54 pt.)*1, Large (72 pt.) White Letters on Colored Background: On, Off*1 Print Characters Vertically: On, Off*1 Latent String Density: 0 to 36; 8*1
Feeder Cleaning	Press [Start]
Wire Cleaning	Press [Start]

1.2.3.4 Report Settings

*1 Indicates the default setting.

*2 Indicates items that appear only when the appropriate optional equipment is attached.

*4 The Activity Report does not appear when the optional iR Security Kit is activated.

T-1-6

Item	Setting
Settings: Send*2	
TX Report	For Error Onry*1, On, Off Report With TX Image: On*1, Off
Activity Report*4	Aut Print: On*1, Off Daily Activity Report Time: On, Off*1 Timer Setting: 00:00 to 23:59 Send/Receive Separate: On, Off*1
Print List: Send*2	
Address Book List	Address Book 1 to 10; Address Book 1*1, One-touch Buttons, Print Lisst
User's Data List	Print List
Print List: Netwoak*2	
Print List: Printer*2	

1.2.3.5 System Settings

*1 Indicates the default setting.

*2 Indicates items that appear only when the appropriate optional equipment is attached.

*5 Indicates items that are not delivered as device information.

T-1-7

Item	Setting
System Manager Settings	System Manager ID: 7 digit number maximum System Password: 7 digit number maximum System Manager: 32 characters maximum E-mail Address: 64 characters maximum Contact Information: 32 characters maximum Comment: 32 characters maximum
Dept. ID Management	Dept. ID Management: On, Off*1 Register Dept. ID/Password: Register, Edit, Erase, Limit Functions Page Totals: Clear, Print List, Clear All Totals Allow Printer Jobs With Unknown IDs: On*1, Off Allow Remote Scan Jobs with Unknown IDs: On*1, Off
Communications Settings*2	E-mail/I-Fax Settings Maximum Data Size For Sending: 0 (OFF), 1 to 99 MB; 3 MB*1 Full Mode TX Timeout: 1 to 99 hours, 24 hours*1 Divided Data RX Timeout: 0 to 99 hours, 24 hours*1 Default Subject: 40 characters maximum; Attached*1 Print MDN/DSN on Receipt: On, Off*1 Always send notice for RX errors: On*1, Off Use Send Via Server: On, Off*1 Memory RX Inbox Settings Memory RX Inbox Password: 7 digit number Use I-Fax Memory Lock: On, Off*1 Memory Lock Start Time: Everyday, Select Days, Off*1 Memory Lock End Time: Everyday, Select Days, Off*1
Remote UI	On*1, Off Use SSL*5: On, Off*1
Restrict Access to Destinations*2	Address Book Password: 7 digit number Access Number Management: On, Off*1 Restrict New Addresses: On, Off*1 E-Mail/I-Fax Domain Sending Restriction: Restrict Sending to Domain: On (Register*5, Edit*5, Erase*5), Off*1

Item	Setting
Device Information Settings	Device Name: 32 maximum Location: 32 maximum
Network Settings*2	
Forwarding Settings*2	Validate/Invalidate, Register, Forward w/o Conditions E-mail Priority, Edit, Erase, Print List
Clear Message Board	Clear
Auto Online/Offline	Auto Online: On, Off*1 Auto Offline: On, Off*1
Date & Time Settings	Date and Time Setting (12 digit number) Time Zone: GMT -12:00 to GMT +12:00; GMT -05:00*1 Daylight Saving Time: On*1, Off
Register LDAP Server*2	Register, Edit, Erase, Print List
License Registration	24 characters maximum
Copy Set Numbering Option Settings	Copy Set Num. Op: On (Dept. ID: On, Off; Date: On, Off; Characters: On, Off), Off*1
MEAP Settings	Use HTTP: On*1, Off Use SSL*5: On, Off*1 Print System Information: Print
Device Information Delivery Settings	Transmitting Settings Register Destinations: Select All, Auto Search/Register, Register, Details, Erase, Print List Auto Delivery Settings: Everyday, Select Days, Off*1 Add. Functions Settings Value: On (Network Settings: Include, Exclude*1), Off*1 Dept. ID: On, Off*1 Address Book: On, Off*1 Select All, Details Manual Delivery Add. Functions Settings Value: On (Network Settings: Include, Exclude*1), Off*1 Dept. ID: On, Off*1 Address Book: On, Off*1 Select All, Details, Manual delivery Start Receiving Settings Restrictions for Receiving Device Info.: On, Off*1 Restore Data: Add. Functns Set. Value, Dept. ID, Address Book Press [Start]. Receive Restriction for Each Function: Add. Functions Settings Value: On*1, Off Dept. ID: On*1, Off Address Book: On*1, Off Communication Log: Details, Print List, Report Settings: Auto Print: On*1, Off Daily Activity Report Time: On*1, Off Separate Report Type: On, Off*1
Initialize All Data/Settings	Initialize
Display Dept.ID/User Name	On*1, Off
Use Asterisks to Enter Access No./Passwords	On*1, Off

Item	Setting
Forced Secure Watermark Mode*2	Copy: Do Not Set*1, Set Watermark: (COPY, INVALID, CONFIDENTIAL, FILE COPY, TOP SECRET, Create: Enter, Register) Date: Select the date format. Copy Set Numbering: 1 to 9,999; 1*1 Serial Number: Print Dept. ID: Print Mail Box: Do Not Set*1, Set Watermark: (COPY, INVALID, CONFIDENTIAL, FILE COPY, TOP SECRET, Create: Enter, Register) Date: Select the date format. Copy Set Numbering: 1 to 9,999; 1*1 Serial Number: Print Dept. ID: Prin Printer: Do Not Set*1, Set Watermark: (COPY, INVALID, CONFIDENTIAL, FILE COPY, TOP SECRET, Create: Enter, Register) Date: Select the date format. Copy Set Numbering: 1 to 9,999; 1*1 Serial Number: Print Dept. ID: Print

1.2.3.6 Copy Settings

*1 Indicates the default setting.

*2 Indicates items that appear only when the appropriate optional equipment is attached.

T-1-8

Item	Settings
Screen Display Setting	Regular Copy Only*1, Regular and Express Copy, Express Copy Only Regular Copy Screen Priority: On*1, Off
Paper Select Key Size for Express Copy Screen	Large*1: Four paper sources maximum (Stack Bypass, Stack Bypass Settings, Paper Drawer 1, Paper Drawer 2, Paper Drawer 3, Paper Drawer 4, or Paper Deck-W1/X1), Small
Standard Key 1, 2 Settings for Regular Screen	Various modes; No Settings*1
Standard Key Settings for Express Copy Screen	Displayed Standard Keys: Up to 5 Set Keys*1, Up to 10 Set Keys, Settings: Various modes; No Settings*1
Auto Collate*2	On*1, Off
Image Orientation Image Orientation	On, Off*1
Auto Orientation	On*1, Off
Photo Mode	On, Off*1
Standard Settings	Store, Initialize
Register Remote Device	Register (Seven devices maximum), Details, Erase, Move To Top
Remote Device Transmission Timeout	5 to 30 seconds; 30 seconds*1
Initialize Copy Settings	Initialize

1.2.3.7 Communications Settings

*1 Indicates the default setting.

*2 Indicates items that appear only when the appropriate optional equipment is attached.

T-1-9

Item	Settings
Common Settings: TX Settings	
Unit Name*2	24 characters maximum
Erased Failed TX*2	On*1, Off
Handle Documents with Forwarding Errors*2	Always Print, Store/Print, Off*1
Photo Mode*2	On, Off*1
Retry Times*2	0 to 5 times; 3 times*1
Edit Standard Send Settings*2	Scanning Mode, File Format, Divide into Pages, Stamp (for the imageRUNNER 7086 only)
Register Favorites Button*2	Register/Edit, Erase (M1 to M18)
PDF(OCR) Settings*2	Smart Scan: On*1, Off Num. of Char. for Doc. Name Setting: 1 to 24 characters; 10 characters*1
Default Screen for Send*2	Favorites Buttons, One-touch Buttons, New Address*1
TX Terminal ID*2	On*1 (Printing Position: Inside, Outside*1; Display Destination Name: On*1, Off), Off
Initialize TX Settings*2	Initialize
Common Settings: RX Settings	
Two-sided Print*2	On, Off*1
Select Cassette*2	Switch A: On*1, Off Switch B: On*1, Off Switch C: On*1, Off Switch D: On*1, Off
Receive Reduction*2	On*1: RX Reduction: Auto*1, Fixed Reduction, Reduce % Reduce Direction: Vertical & Horizontal, Vertical Only*1 Off
Received Page Footer*2	On, Off*1
2 On 1 Log*2	On, Off*1

1.2.3.8 Mail Box Settings

*1 Indicates the default setting.

*2 Indicates items that appear only when the appropriate optional equipment is attached.

*5 Indicates items that are not delivered as device information.

T-1-10

Item	Settings
User Inboxes Settings	Inbox No.: 00 to 99 Register Inbox Name: 24 characters maximum Password*5: Seven digits maximum Time until Doc. Auto Erase: 0 (Off), 1, 2, 3, 6, 12 hours, 1, 2, 3*1, 7, 30 days URL Send Settings Print upon storing from the printer driver: On, Off*1 Initialize*5
Photo Mode	On, Off*1
Standard Scan Settings	Store, Initialize
Confidential Fax Inboxes Settings*2	Inbox No.: 00 to 49 Register Inbox Name: 24 characters maximum Password*5: Seven digits maximum URL Send Settings Initialize*5

1.2.3.9 Address Book Settings

*1 Indicates the default setting.

*2 Indicates items that appear only when the appropriate optional equipment is attached.

T-1-11

Item	Settings
Register Address*2	Register New Address, Edit, Erase
Register Address Book Name*2	Address Book 1 to 10; Address Book 1*1, Register Name (16 characters maximum)
One-touch Buttons*2	Register/Edit (from 001 to 200), Erase

1.2.3.10 Voice Guide Settings

*1 Indicates the default setting.

*2 Indicates items that appear only when the appropriate optional equipment is attached.

T-1-12

Mode	Description
voice guide reading volume/ speed*2	volume: 1 to 5*1 to 9 speed: (slow) -5 to 0*1 to +5 (fast)
voice type*2	male/female*1
auto clear in voice guide*2	ON/OFF*1
initialize voice guide settings*2	Is it OK to initialize? yes/no
speaker/headphone switch*2	speaker*1/headphone

1.2.4 Safety

1.2.4.1 Safety About Laser Light

Laser light can be harmful to the human body. The machine's laser system is completely blocked by means of a protective housing and external covers, and its light will not escape outside the machine as long as it is used for its intended purposes.

1.2.4.2 CDRH Regulations

The Center for Devices and Radiological Health of the US Food and Drug Administration put into effect regulations to govern laser products on August 2, 1976. These regulations apply to laser products manufactured on and after August 1, 1976, and all laser products must be certified under the regulations for sale within the United States.

The following shows the label used to certify compliance with the CDRH regulations, and laser products intended for sale in the US are required to bear this label.

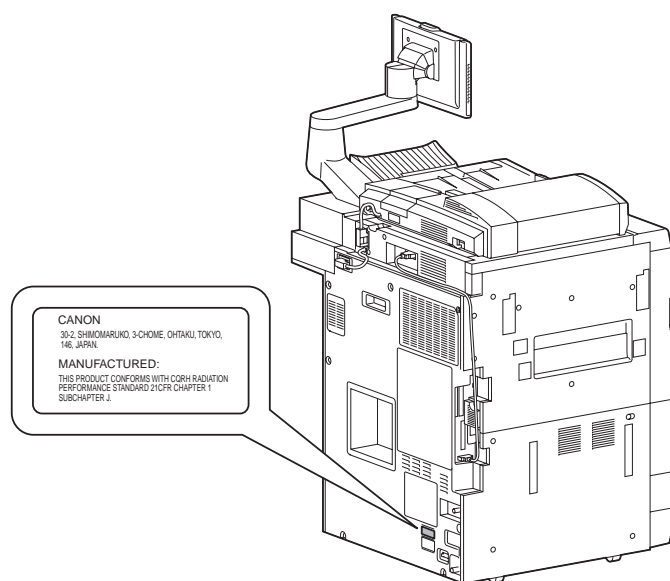

F-1-12



The text on the label may differ among product models.

1.2.5 Product Specifications

1.2.5.1 Product Specifications

Body	Console
Copyboard	Fixed
Light source type	Xenon lamp
Lens type	fixed array
Photosensitive medium	Amorphous silicon drum (108-mm dia.)
Reproduction method	indirect static charging
Charging method	by corona
Exposure method	by 4-beam laser
Copy density adjustment function	Auto or manual
Development method	dry, 1-component toner projection
Pickup method	- Paper deck (2 cassettes; right deck, left deck) - Cassette (2 cassettes; cassette 3, cassette 4) - Manual feed tray
Cassette pickup method	Separation retard
Paper deck pickup method	Separation retard
Multifeeder pickup method	Separation retard
Transfer method	corona transfer, post charging/exposure
Separation method	Electrostatic
Drum cleaning method	Blade + magnet roller
Fixing method	Heat roller
Counter	Soft counter
Toner type	Magnetic, positive toner
Toner supply type	Toner bottle
Original type	Sheet, book, 3-D object (2 kg max.)
Maximum original size	A3/279.4 x 431.8 mm (11 x 17)
Reproduction ratio	100% (1:1), reduce (1:0.250, 1:0.500, 1:0.611, 1:0.707, 1:0.816, 1:0.865), enlarge (1:1.154, 1:1.224, 1:1.414, 1:2.000, 1:4.000), zoom (1:0.250 to 4.000) (25% to 400%:in increments of 1%)
Fine adjustment of reproduction ratio	for 100%, in user mode
Warm-up time	6 min or less (20 deg C, rated input)
First print time	feeder: 4.1 sec (stream reading, right deck (manual), 1 original, 100%, A4/LTR, non-AE, straight delivery, lamp pre-heating included) copyboard: 2.8 sec (book mode, right deck, manual, 100%, A4/LTR, non-AE, straight delivery, lamp pre-heating not included)
Continuous reproduction	1 to 9999 prints
Reading speed	iR7105/7095 single-sided: 85 ipm double-sided: 40 ipm iR7086 single-sided: 68 ipm double-sided: 46 ipm
Printing speed	iR7105: 105 ppm iR7095: 95 ppm iR7086: 86 ppm
Reading resolution	600dpi X 600dpi
Writing resolution	1200 (equivalent) x 600 dpi
Gradation	256 gradations
Paper deck capacity	right/left: 1500 sheets (80 g/m2 paper)
Cassette capacity	cassette 3/4: 550 sheets (80 g/m2 paper)

Multifeeder tray capacity	manual feeder tray: 50 sheets (80 g/m ² paper)
Hard disk	40GB
Non-image width (leading edge)	Direct/R-E: 4.0 + 1.5/-1.0 mm (when an ADF is used: 4.0 -/+1.8 mm/-1.4 mm)
Non-image width (trailing edge)	Direct/R-E: 2.5 -/+1.5 mm (when an ADF is used: 2.5 -/+1.8mm)
Non-image width (left/right)	Direct/R-E: 2.5 -/+1.5 mm (when an ADF is used: 2.5 -/+1.8mm)
Image margin (leading edge)	Direct/R-E: 4.0 + 1.5/-1.0 mm (when an ADF is used: 4.0 -/+1.5/-1.0 mm)
Image margin (trailing edge)	Direct/R-E: (one-sided) 2.5 -/+1.5 mm (when an ADF is used: 2.5 -/+1.5 mm) Direct/R-E: (two-sided) 2.5 -/+2.0 mm (when an ADF is used: 2.5 -/+2.0 mm)
Image margin (left/right)	Direct/R-E: 2.5 + 1.5 mm (when an ADF is used: 2.5 -/+1.5mm) (on left, 0.5 mm or more)
Auto Clear	yes (2 min standard; may be varied between 0 and 9 min in 1-min increments)
Auto power off	No
Low-power mode	yes (15 min standard; may be varied for following in user mode: 10, 15, 20, 30, 40, 50, 60, 90 min; 2, 3, 4 hr)
Sleep mode	yes (60 min standard; may be varied for following in user mode: 10, 15, 20, 30, 40, 50, 60, 90 min; 2, 3, 4 hr)
Energy save mode	yes (-10% standard; may be varied for following in user mode: -10%, -25%, -50%; 0% if no return)
Option	See "System Configuration."
Operating environment (temperature range)	See Installation>Selecting the Site of Installation.
Operating environment (humidity range)	See Installation>Selecting the Site of Installation.
Operating environment (atmospheric pressure)	810.6 to 1013.3 hpa (0.8 to 1.0 atm)
Power supply rating	200 V/15 A (50/60 Hz) 208 V/12 A (60 Hz) 230 V/13 A (50 Hz)
Power consumption (maximum)	2.5 kw or less
Noise	during copying: 79 dB or less; during standby: 63 dB or less
Ozone	initially, 0.02 ppm or less avr and 63 dB or less during standby over time (after 250,000 prints), 0.05 ppm or less avr, 0.10 ppm or less max.
Dimensions	1163 mm (W) x 795 (D) x 1430 (H) mm approx.
Weight	280 kg (approx.; including ADF)
Environmental consideration	drum heater: standard for all models cassette heater (common for all): standard for 100/200V model; not offered for 208V model; offered as service part for 230V model reader heater (common for all): optional for 100/200V model; not offered for 208V model; offered as service part for 230V model deck heater (common for all): optional for 100/200V model; not offered for 208V model; offered as service part for 230V model

1.2.6 Function List

1.2.6.1 Print Speed

The value in brackets <> represents the iR7095.

The value in brackets [] represents the iR7086.

- AB

T-1-13

Enlargement/reduction	Size	Paper size	Copies/min (1-to-N)		
			cassette/deck	manual feeder	
Direct	A3 (297 x 420 mm)	A3	53 <50> [44]	50 <47> [44]	
	A4 (210 x 297 mm)	A4	105 <95> [86]	90 <90> [86]	
	B4 (257 x 364 mm)	B4	62 <59> [56]	57 <56> [55]	
	B5 (182 x 257 mm)	B5	105 <95> [86]	90 <90> [86]	
	A4R (297 x 210 mm)	A4R	72 <68> [63]	72 <68> [63]	
	B5R (257 x 182 mm)	B5R	84 <79> [73]	80 <78> [73]	
	A5R (210 x 148 mm)	A5R	100 <95> [86]	90 <90> [86]	
Reduce	II (50.0 %)	A3 -> A5R	A5R	100 <95> [86]	90 <90> [86]
	III (61.1 %)	A3 -> B5R	B5R	84 <79> [73]	80 <78> [73]
	IV (70.7 %)	B4 -> B5R	B5R	84 <79> [73]	80 <78> [73]
		A3 -> A4R	A4R	72 <68> [63]	72 <68> [63]
	V (81.6 %)	B4 -> A4R	A4R	72 <86> [63]	72 <68> [63]
		B5R -> A5R	A5R	100 <95> [86]	90 <90> [86]
	VI (86.5 %)	A4 -> B5	B5	105 <95> [86]	90 <90> [86]
A3 -> B4		B4	62 <59> [56]	57 <56> [55]	
Enlarge	IV (200.0 %)	A5R -> A3	A3	53 <50> [44]	50 <47> [44]
	III (141.4 %)	A4R -> A3	A3	53 <50> [44]	50 <47> [44]
		B5R -> B4	B4	62 <59> [56]	57 <56> [55]
	II (122.4 %)	A4R -> B4	B4	62 <59> [56]	57 <56> [55]
		A5 -> B5	B5	105 <95> [86]	90 <90> [86]
	I (115.4 %)	B4 -> A3	A3	53 <50> [44]	50 <47> [44]
B5 -> A4		A4	105 <95> [86]	90 <90> [86]	

Delivery from copier, auto paper select, density auto adjust, non-sort, deck/cassette

T-1-14

- Inch

Enlargement/reduction		Size	Paper size	size Copies/min (1-to-N)	
				cassette/deck	manual feeder
Direct		279.4 x 431.8 mm (11 x 17)	279.4 x 431.8 mm (11 x 17)	53 <49> [43]	49 <46> [43]
		LTR	LTR	105 <95> [86]	90 <90> [86]
		LTR (index sheet)	LTR (index sheet)	95 <87> [80]	79 <79> [79]
		LGL	LGL	63 <60> [57]	59 <56> [52]
		LTRR	LTRR	77 <72> [67]	75 <72> [67]
		STMTR	STMTR	100 <95> [86]	90 <90> [86]
Reduce	II (50.0 %)	279.4 x 431.8 mm (11 x 17) -> STMTR	STMTR	100 <95> [86]	90 <90> [86]
	III (64.7 %)	279.4 x 431.8 mm (11 x 17) -> LTRR	LTRR	77 <72> [67]	76 <72> [67]
	IV (73.3 %)	279.4 x 431.8 mm (11 x 17)->LGL	LGL	63 <60> [57]	59 <56> [52]
	V (78.6 %)	LGL -> LTRR	LTRR	77 <72> [67]	76 <72> [67]
Enlarge	III (200.0 %)	STMTR* -> 279.4 x 431.8 mm (11 x 17)	279.4 x 431.8 mm (11 x 17)	53 <49> [43]	49 <46> [43]
	II (129.4 %)	LTRR -> 279.4 x 431.8 mm (11 x 17)	279.4 x 431.8 mm (11 x 17)	53 <49> [43]	49 <46> [43]
	I (121.4 %)	LGL-> 279.4 x 431.8 mm (11 x 17)	279.4 x 431.8 mm (11 x 17)	53 <49> [43]	49 <46> [43]

Delivery from copier, auto paper select, density auto adjust, non-sort, deck/cassette

* The ADF does not accommodate STMTR originals.

The values in the foregoing tables are subject to change for product revisions.

1.2.6.2 Paper Type

T-1-15

Type		Size	Source		
			cassette	deck (left/ right)	manual feeder
Plain paper (64 to 90g/m2)		A3, B4, A4R, A5R, B5R, 11"x17", LGL, LTRR, STMTR, 8K, 16K	yes	no	yes
Recycled paper					
Colored paper					
Heavy paper (91 to 200g/m2)		A4, B5, LTR	yes	yes	yes
Bond paper		EXEACTIVE	no	no	yes
Letterhead					
Special paper	Transparency	A4, A4R, LTR, LTRR	no	no	yes
	Postcard	Postcard, Reply Postcard, 4 on 1 Pcard	no	no	yes
	label sheet	A4, A4R, B4, LTR, LTRR	no	no	yes
	index sheet	A4, LTR	yes	no	no
	Tracing paper	A3, B4, A4R, A4	no	no	yes
	3-hole paper	A4, LTR	yes	yes	yes
	Card Stock	4"x6", 5"x8"	no	no	yes

1.2.7 RDS Specification

1.2.7.1 Embedded RDS (e-RDS)

Product Overview

Embedded RDS (hereafter, e-RDS) is a front-end module of e-Maintenance system built into the network module of the device controller.

Product package composition/commodity composition

It is built in the network module of the device.

Feature

It is built into the network module of the device controller, and the front-end module of e-Maintenance system is achieved without needing hardware other than the device.

In a past e-Maintenance system, software for e-Maintenance was installed in special hardware such as a small box Linux computer or Windows PC in the front end. (RDS Agent or RDS server).

The e-Maintenance system can be introduced without putting a strain in the user by being built in the device controller.

Moreover, the serviceman's loads for the installation are greatly reduced.

e-RDS transmits device information on counter, trouble, and articles of consumption, etc. by using the SOAP protocol for the back end server of e-Maintenance system (hereafter, UGW).

List of Supported Devices

Model name	e-RDS Supported version		e-RDS Full supported version	
	Version number	Point of correction	Version number	Point of correction
iR2270, iR2870, iR3570, iR4570	v31.01	#1, #2	v32.02	#3
iR2230, iR2830, iR3530 (Make sure that the device can be connected on network)	v5.xx	#1, #2	v20.25	#3
iR5570, iR6570	v12.04	#1, #2	v20.65	#3
iR85+, iR8070, iR105, iR9070	v10.40	#1, #2	v11.05	#3
imageRunner C3170	v10.15	#2	v20.29	#3
imageRunner C6870 / C5870 iR7105/7095/7086	From the first mass production machine			
Title	Description			
#1 e-RDS Proxy server connection trouble	It cannot connect a proxy server via e-RDS			
#2 e-RDS freeze	At rare intervals, the e-RDS gets into the freezing, and does not send the billing counter data.			
#3 e-RDS Parts counter trouble	The e-RDS sends the wrong value of parts counter sometimes.			

Chapter 2

Installation

Contents

2.1 Making Pre-Checks	2- 1
2.1.1 Points to Note Before Starting the Installation Work.....	2- 1
2.1.2 Selecting the Site of Installation	2- 1
2.1.3 Installation Space	2- 3
2.1.4 Checking the Contents.....	2- 4
2.1.5 Order of Installing Accessories.....	2- 6
2.2 Unpacking and Installation	2- 7
2.2.1 Points to Note When Turning On/Off the Main Power	2- 7
2.2.2 Unpacking	2- 7
2.2.3 Mounting the Scanner System	2- 9
2.2.4 Mounting the Fixing Assembly.....	2- 10
2.2.5 Mounting the Charging Assembly	2- 10
2.2.6 Mounting the Charging Assembly	2- 12
2.2.7 Mounting the Developing Assembly	2- 15
2.2.8 Mounting the Pickup Assembly	2- 17
2.2.9 Mounting the Control Panel.....	2- 17
2.2.10 Supplying Toner	2- 23
2.2.11 Turning On the Main Power	2- 23
2.2.12 Stirring the Toner	2- 23
2.2.13 Index Sheet Attachment	2- 24
2.2.14 Other attachment	2- 24
2.2.15 Others	2- 24
2.2.16 Attaching the Labels, Placing Paper, and Checking Images and Operation (user mode).....	2- 25
2.2.17 Adjusting the Horizontal Registration	2- 27
2.2.18 Adjusting the Lead Edge Registration	2- 29
2.2.19 Setting the Cassette.....	2- 29
2.2.20 Correcting the Skew	2- 29
2.2.21 Switching Over the Paper Size for the Front Deck (right, left).....	2- 30
2.2.22 Checking the Operation in a System Configuration	2- 30
2.3 Checking the Connection to the Network	2- 31
2.3.1 Checking the Network Connections.....	2- 31
2.3.2 Using the PING Command.....	2- 31
2.3.3 Making a Check Using a Remote Host Address	2- 31
2.4 Troubleshooting the Network.....	2- 32
2.4.1 Troubleshooting the Network.....	2- 32
2.4.2 Making a Check Using a Loop Back Address.....	2- 32
2.4.3 Making a Check Using a Local Host Address.....	2- 32
2.5 Installing the Card Reader.....	2- 32
2.5.1 Checking the Contents.....	2- 32
2.5.2 Installing the Card Reader-D1	2- 32
2.6 Installing the Voice Guidance Kit	2- 36
2.6.1 Checking Items in the Package.....	2- 36
2.6.2 Turning Off the Host Machine.....	2- 37
2.6.3 Installation Procedure	2- 37

2.1 Making Pre-Checks

2.1.1 Points to Note Before Starting the Installation Work



- 1) Moving a machine from a cold to warm place can cause condensation, in which drops of water form on metal surfaces, leading to image faults if used as they are.
If the machine has just been brought from a cold place, leave it alone for 1 hr or more without unpacking so that it becomes used to the room temperature.
- 2) When moving the machine to/from the user's, be sure to take note of the following if the move involves the use of stairs:
 - a. before starting to move, remove the ADF assembly, fixing transport assembly, intermediate tray assembly, and copy paper; move them separately from the machine body.
 - b. when lifting the machine, do not use the grips found on the pickup and delivery assemblies; instead, support the machine at its 4 bottom corners.
- 3) Check to be sure that the 2 adjusters (front) found on the bottom of the machine are shifted up and are unlocked. Also, take care that the adjusters will not fall out during the move.
- 4) Be sure to work in a group of 4 when installing the machine. Particularly when removing the pad, have one person stand at the rear and another at the front holding one grip each and tilting the machine; another person then may remove the pad with the remaining person supporting the machine for safety.
- 5) All accessories (e.g., side paper deck, finisher, paper feeding unit) must be removed from the machine to prevent damage before moving the machine into or out of the user's.

2.1.2 Selecting the Site of Installation

The site of installation must meet the following requirements, and it is a good idea to visit the user's before delivery of the machine:

- 1) There must be a properly grounded source of power that may be used exclusively by the machine: for the 100V model, 90 to 110 V, 15 A or more; for the 200V model, 180 to 220 V, 15 A or more; for the 208V model, 188 to 228 V, 12 A or more; for the 230V model, 198 to 264 V, 13 A or more.
- 2) The temperature and the humidity of the site must be as follows, and the machine must not be installed near a water faucet, water boiler, humidifier, or refrigerator:

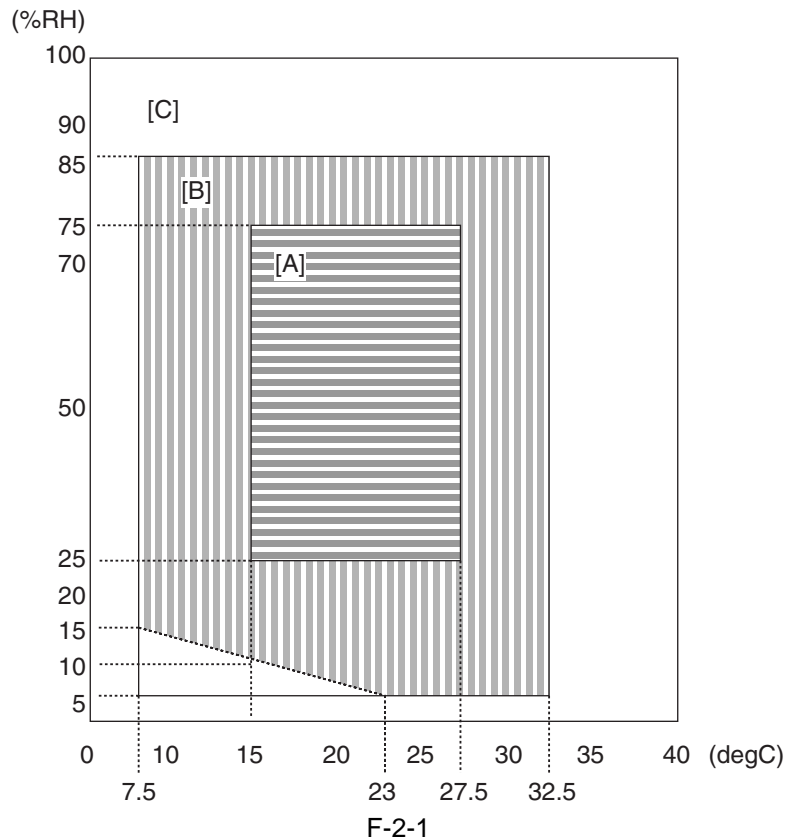

<Site Environment Classification>

[A]: zone A; a site that satisfies all requirements imposed by quality standards.

[B]: zone B; a site that may fail to satisfy some of the requirements imposed by quality standards as fully as a site in zone A. Some of the items may not be applicable to the site.

[C]: zone C: a site free from concerns, malfunctions, and wrong indications that can affect safety, permitting normal machine operation.

- 3) The machine must not be installed near a source of fire or in an area subject to dust or ammonium gas. If the area is subject to direct rays of the sun, there must be shades or curtains to block the rays.
- 4) The level of ozone generated by the machine is not likely to affect the health of the individuals around it. Some, nevertheless, may find the odor rather unpleasant, and it is important that the room be well ventilated.
- 5) The machine's feet must be in contact with the floor, and the machine must remain level.
- 6) There must be enough space around the machine for printing work. (See the outline of the installation space.)
- 7) Be sure the area is well ventilated.
If multiple machines exist, it is important to make sure that the exhaust from another machine will not be drawn into the machine. Also, the machine must not be installed near the air vent of the room.

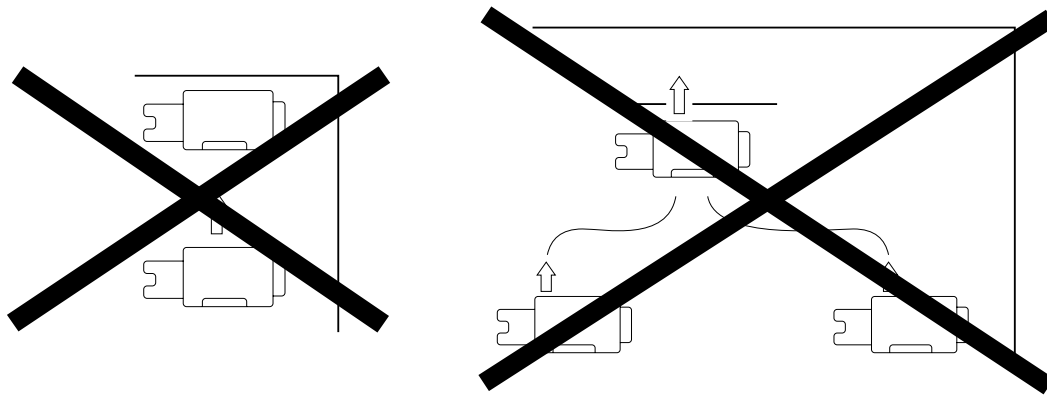

F-2-2

MEMO:

In general, the silicon gas (vapor of silicone oil from the fixing assembly) tends to soil the corona charging wire, reducing its life. This is particularly true of a low humidity environment.)

2.1.3 Installation Space

Diagram of the Work Space

There must be enough space around the machine. The following diagram shows the minimum dimensions; whenever possible, be sure there will be more space than indicated:

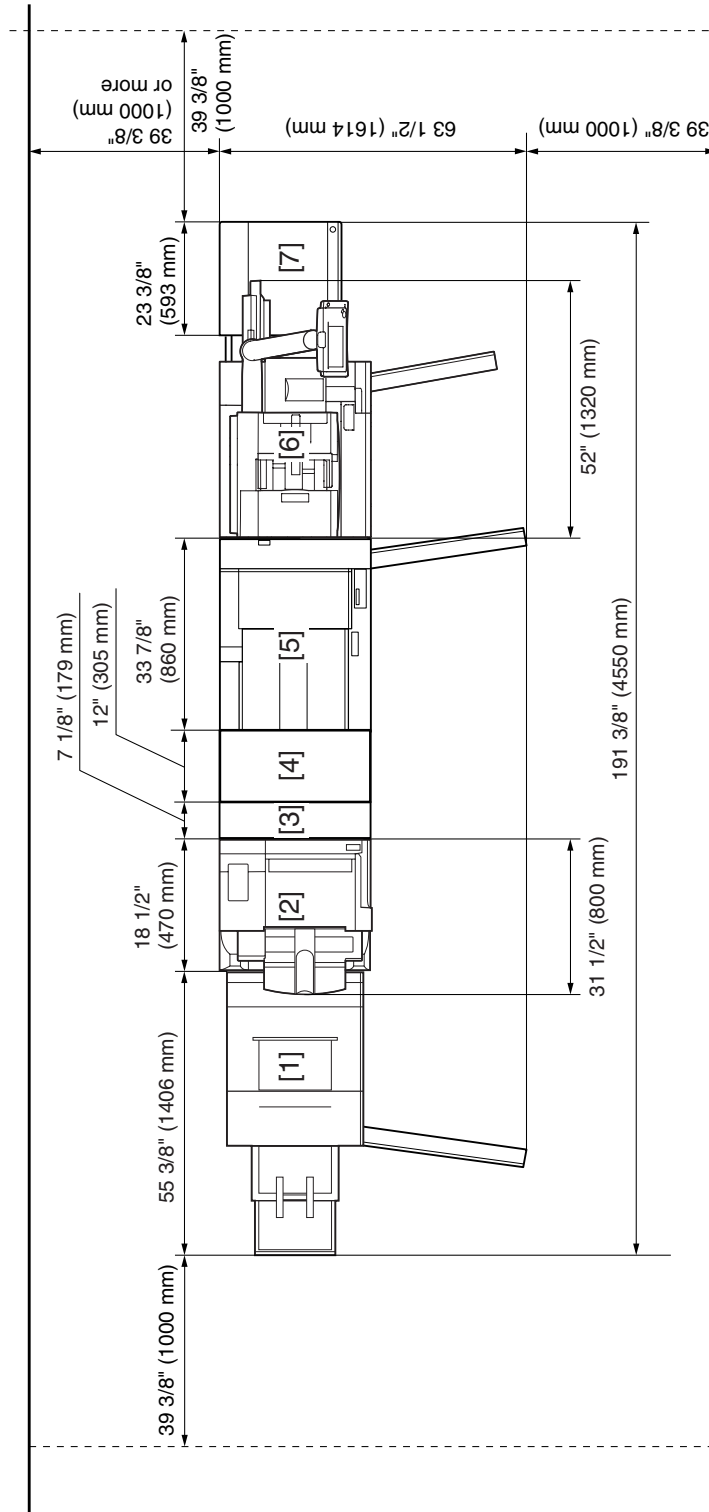

F-2-3

- | | |
|------------------------------|---------------------|
| [1] Trimmer | [5] PRO.Puncher |
| [2] Finisher/Saddle Finisher | [6] Host Machine |
| [3] Paper Folding Unit | [7] Side Paper Deck |
| [4] High Capacity Stacker | |

2.1.4 Checking the Contents

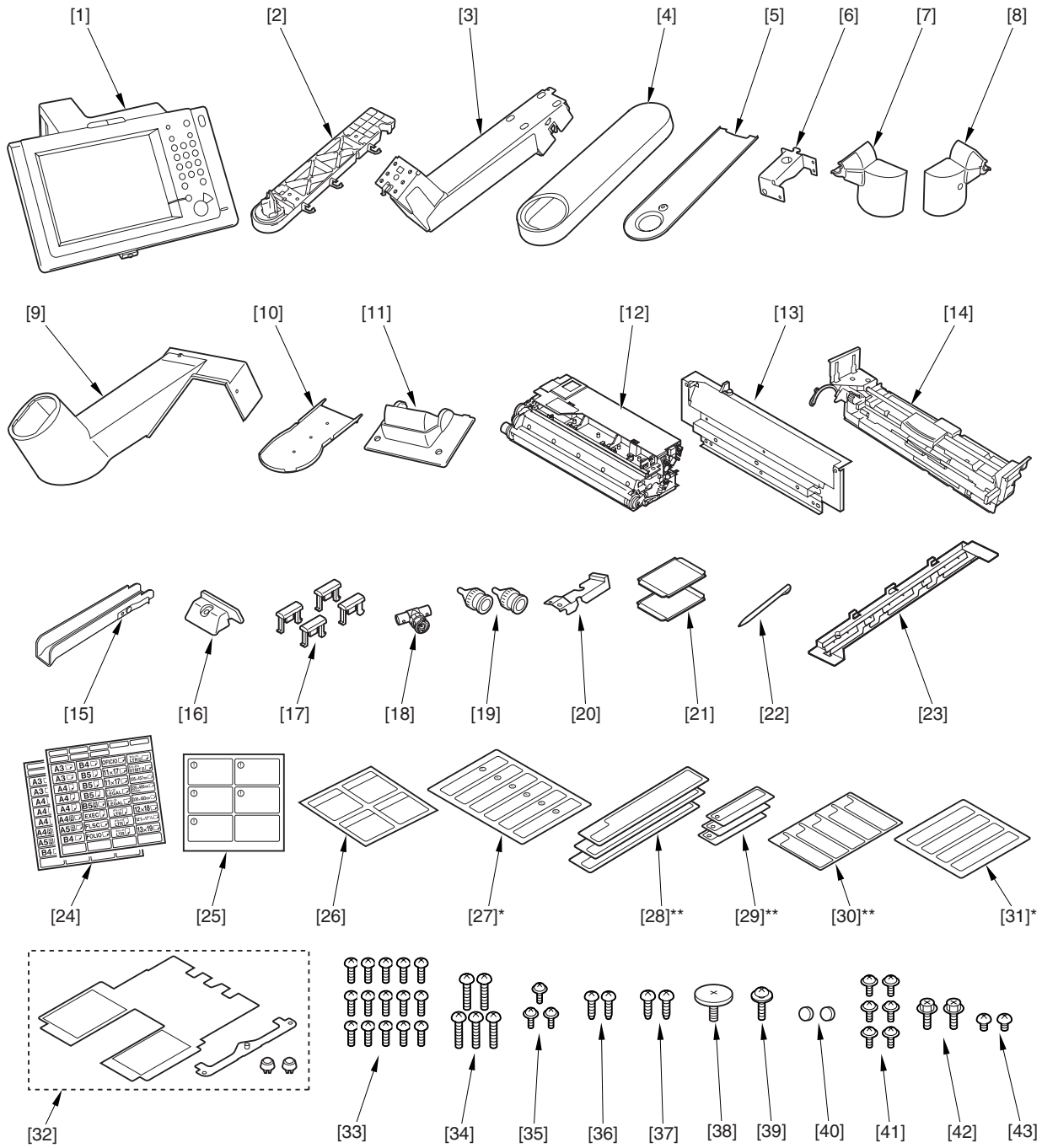

F-2-4

[1]	Control panel	1 pc.	[23]	Included Delivery Guide	1 pc.
[2]	Arm unit	1 pc.	[24]	Cassette size label	2 pc.
[3]	Control panel arm unit	1 pc.	[25]	Shut-down instructions label	1 pc.
[4]	Arm cover 1	1 pc.	[26]	3-hole paper placement label	1 pc.
[5]	Arm cover 4	1 pc.	[27]*	Cleaning Position label	1 pc.
[6]	Cover support plate	1 pc.	[28]**	Cleaning Instructions label	3 pc.
[7]	Lock hinge cover R	1 pc.	[29]**	Lamp Warning label	3 pc.
[8]	Lock hinge cover L	1 pc.	[30]**	Manual Feeder Set label	1 pc.
[9]	Arm cover 2	1 pc.	[31]*	Original Size label	1 pc.
[10]	Arm cover 3	1 pc.	[32]	Index paper attachment	1 pc.
[11]	Hinge slide cover	1 pc.	[33]	Screw (binding; M4X10)	15 pc.
[12]	Developing assembly	1 pc.	[34]	Screw (binding; M4X14)	5 pc.
[13]	Developing assembly locking unit	1 pc.	[35]	Screw (binding; M3X6; white)	3 pc.
[14]	Pull-off unit	1 pc.	[36]	Screw (P tightening; M3X10)	2 pc.
[15]	Grip	1 pc.	[37]	Screw (P tightening; M4X10)	2 pc.
[16]	Left deck locking plate	1 pc.	[38]	Flat-head screw (M4X10)	1 pc.
[17]	Inch-stop roll	4 pc.	[39]	Screw (W sems; M4X12)	1 pc.
[18]	T-shaped connector	1 pc.	[40]	Cover rubber (for M3)	2 pc.
[19]	Coaxial connector	2 pc.	[41]	Screw (TP; M4X6 black)	6 pc.
[20]	Connector cover	1 pc.	[42]	Screw (RS tightening; M4X10)	2 pc.
[21]	Size plate	2 pc.	[43]	Screw (binding; M3X4)	2 pc.
[22]	Touch pen	1 pc.			

* iR7086 onry

** iR7015/7095 onry

Check the contents (User's Manual, CD, and others) against the following tables:

Network ScanGear CD-ROM
Reference Guide
Copy Guide
Mail Box Guide
Copy Machine Warranty
Drum Unit Warranty
Registration Card
MEAP Administration CD-ROM
Installation Check List
Universal Send Trial Kit (envelope)

2.1.5 Order of Installing Accessories

If you are planning to install other accessories also, go through the following in the order indicated:

1. side paper deck [1] (See the Side Paper Deck Installation Procedure.)
2. high-capacity stacker [2] (See the high-Capacity Stacker Installation Procedure.)
3. finisher [3]/saddle finisher [4] (See the "Preparing the Finisher" in "Finisher/Saddle Finisher Installation Procedure".)
4. finisher accessories power supply unit [5] (See the Finisher Accessories Power Supply Unit Installation Procedure.)
5. inner puncher unit [6]* (See the Puncher Unit Installation Procedure.)
6. paper folding unit [7] (See the Paper Folding Unit Installation Procedure.)
7. professional puncher (non-Japanese model only) [8]* (See the Professional Puncher Installation Procedure.)
8. inserter [9] (See the Inserter Installation Procedure.)
9. trimmer [10] (See the Trimmer Installation Procedure.)

* The inner puncher unit [6] and the professional puncher unit (non-Japanese model only) [8] cannot be installed as part of the same system.

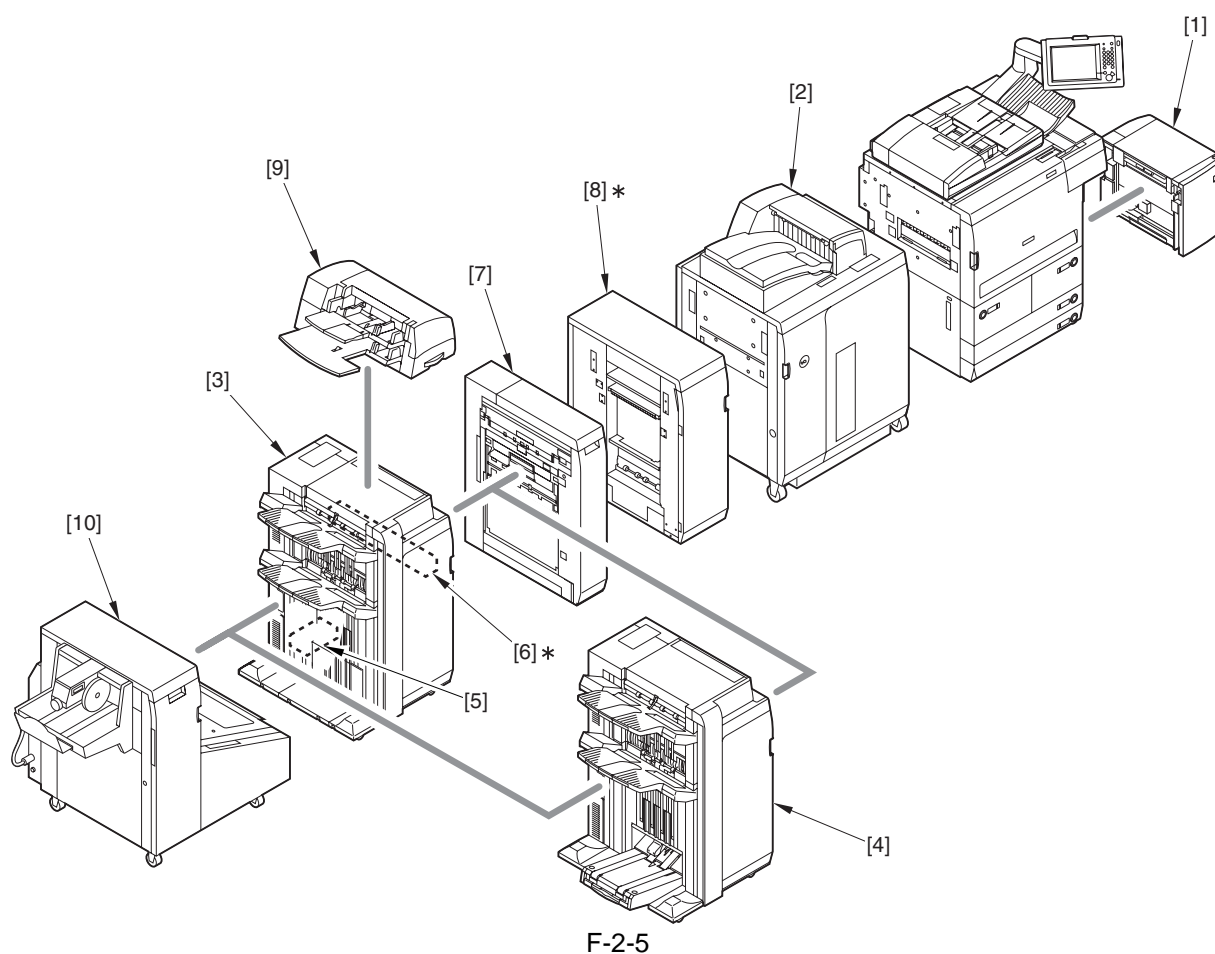

2.2 Unpacking and Installation

2.2.1 Points to Note When Turning On/Off the Main Power

▲ Turning Off the Main Power (host machine)

Be sure to go through the following when turning off the main power to protect the hard disk:

1. Hold down the control panel power switch for 3 sec or more.
2. Go through the instructions on the shut-down sequence screen so that the main switch may be turned off.
3. Turn off the main power switch.
4. Disconnect the power cable (for the power outlet).

▲ Order of Turning On/Off the Machines (host machine + accessories)

If a delivery accessory (e.g., finisher) is installed, be sure to respect the following order when turning them on/off:

<Turning On the Power>

1. high-capacity stacker, finisher (either)
2. professional puncher (non-Japanese model only)
3. host machine

<Turning Off the Power>

1. host machine
2. high-capacity stacker, finisher (either)
3. professional puncher (non-Japanese only)

- Failure to observe the order of turning on the machines prevents the host machine from recognizing the accessories.
- Failure to observe the order of turning off the machines will lead to an error ('E730' or 'E503').

2.2.2 Unpacking

- 1) Unpack the machine.
Open the plastic bag.
- 2) Remove the grip cover (rear) [1] found on the right side of the machine using a flat-blade screwdriver, and shift up the grip [2] found at the rear.

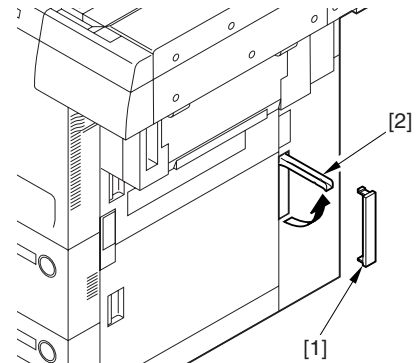

F-2-6

- 3) Take out the grip [1] from the contents box.

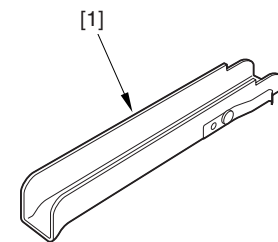

F-2-7

- 4) Open the upper right cover, and slide the face over (small) [1] toward the rear to detach; then, remove the other face cover (large) [2]. Fit the grip [3] removed in step 3) into the front of the machine.

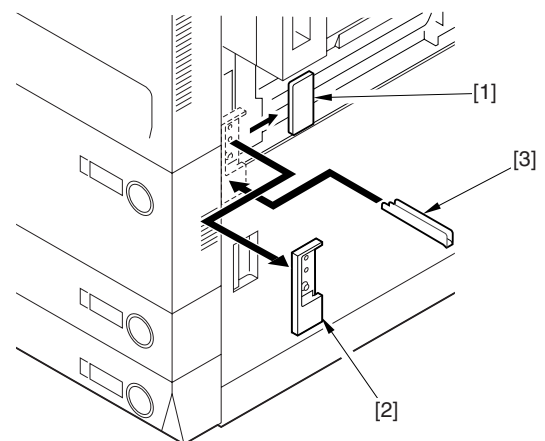

F-2-8

- 5) Close the upper right cover.
- 6) Shift up the grip (front, rear) [1] found on the left side of the machine.

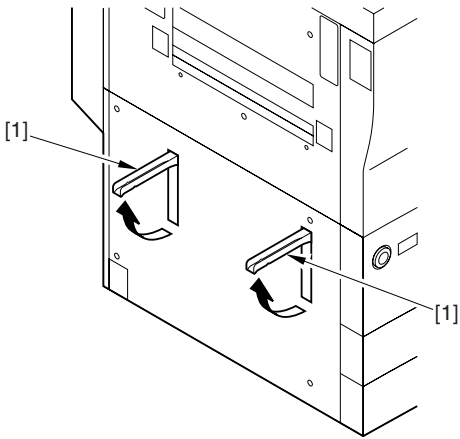

F-2-9

⚠ Be sure to go through steps 7) and 8) in correct sequence; otherwise, the machine can become displaced.

- 7) Holding the grips (front, rear) on the delivery side of the machine, lift the machine slightly to remove the pad. At this time, put away the plastic bag toward the pad.

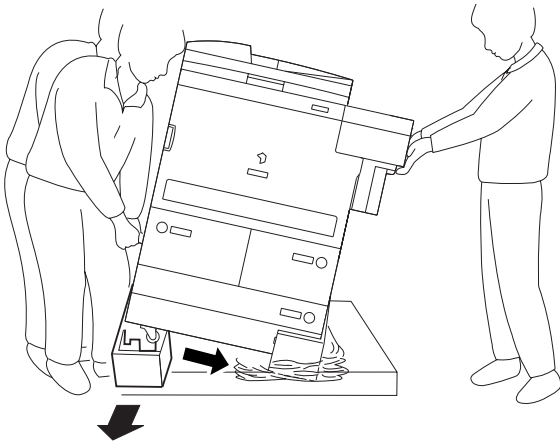

F-2-10

- 8) Holding the grips (front, rear) on the pickup side of the machine, lift the machine slightly, and remove the remaining pad and the plastic bag at the same time.

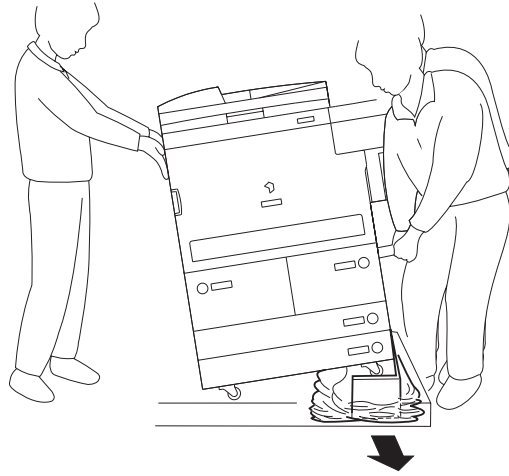

F-2-11

- 9) Shift the 2 adjusters (front) [1] found at the bottom of the machine so that they face upward, making sure that they are unlocked.

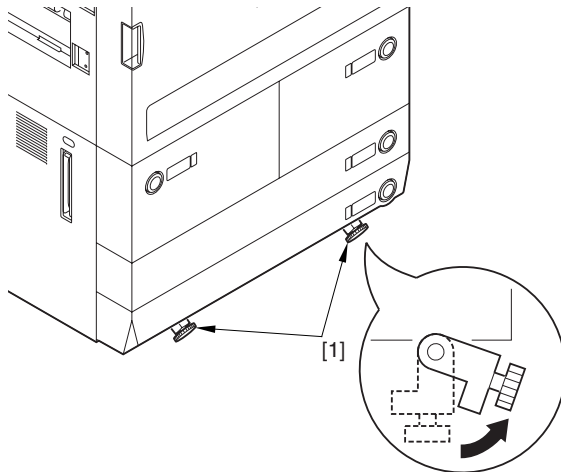

F-2-12

- 10) Take out the 2 slope plates [2] from the middle of the skid [1].

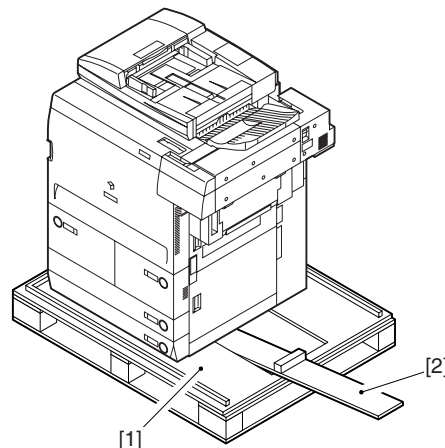

F-2-13

- 11) Remove the 2 pins [2] taped in place to the slope plate [1].

Turn over the slope plate [1], and match the pin hole of the skid and the pin hole of the slope plate; then, fit a pin [2] (1 pc. each) through the holes.

Holding the grips (front, rear) on the delivery side of the machine, move the machine off the skid by sliding it along the slope plates.

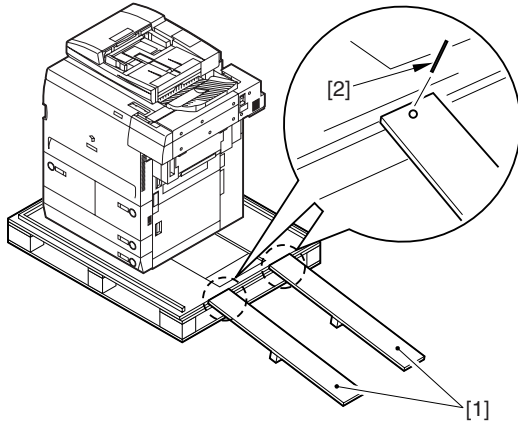

F-2-14

- 12) Remove the grip [1] fitted in step 4) while pushing the leaf spring with a flat-blade screwdriver.

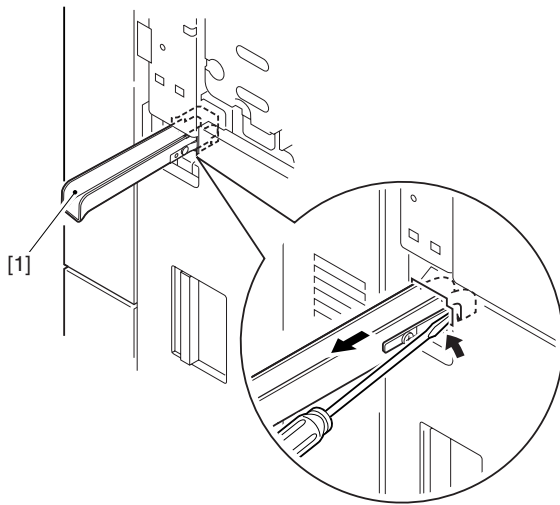

F-2-15

- 13) Remove the packing tape from the machine.
14) Open the front cover [1].

- 15) Open the compartment cover [2] found behind the front cover, and put in the grip [3] for storage.

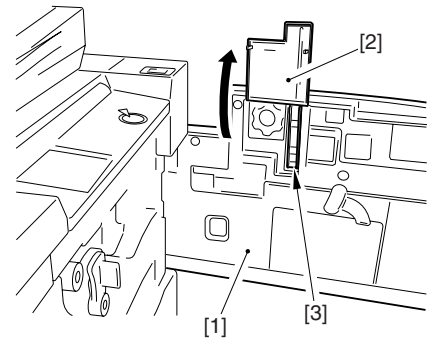

F-2-16

- 16) Open the upper right cover, and mount the face cover (small, large).
17) Close the upper right cover.



If condensation is found on the outside or inside of the machine at this point, stop the work and wait until the machine becomes fully used to the room temperature. Resume the work after making sure that the machine is free of condensation.

2.2.3 Mounting the Scanner System

- 1) Open the ADF.
Remove the copyboard glass protective pad and tape.
2) Remove the scanner system fixing screw [1].
(Store the screw away for possible relocation of the machine in the future.)

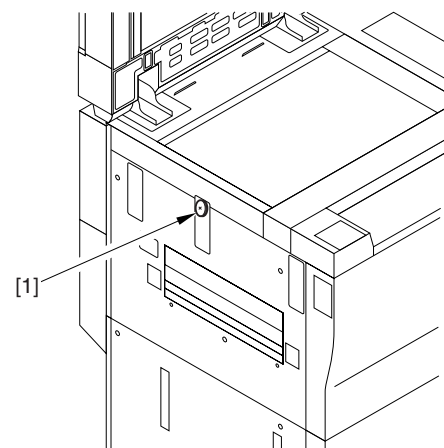

F-2-17

2.2.4 Mounting the Fixing Assembly

- 1) Open the front cover.
- 2) Shift the fixing transport assembly release lever [1] in the direction of the arrow (left side) to unlock the transfer/separation charging assembly.

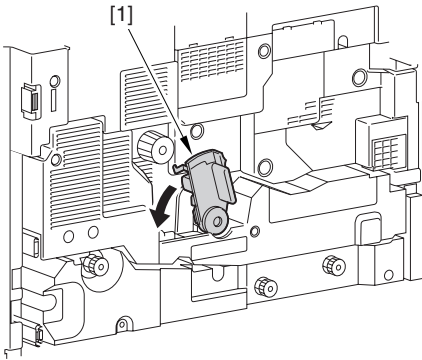

F-2-18

- 3) Slide out the fixing transport unit [1] to the front.

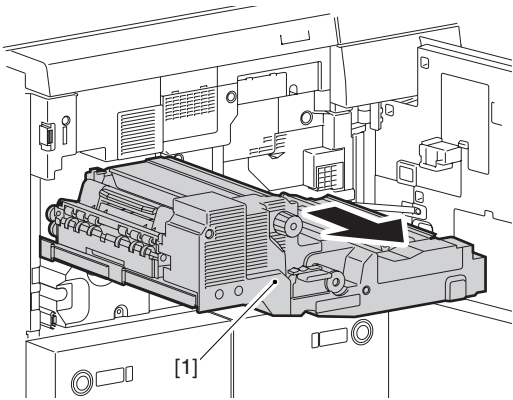

F-2-19

- 4) Remove the tape [1]; then, remove the tag [2] of the fixing transport assembly and the separation release member [3].

⚠ Remove all foreign matter (e.g., glue from tape) from the transport belt.

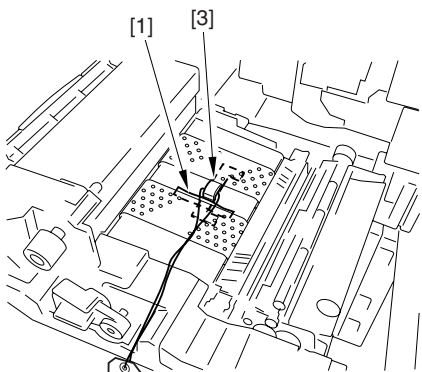

F-2-20

- 5) Remove the tape used to keep the tag in place, and open the delivery assembly [1]; then, remove the 2 fixing nip release screws [2] from the front and the rear.

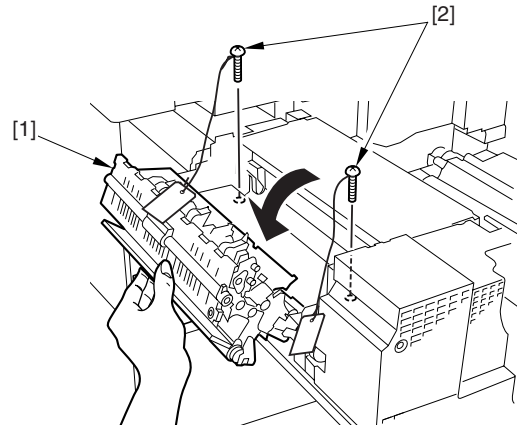

F-2-21

- 6) Close the delivery assembly.

2.2.5 Mounting the Charging Assembly

- 1) Remove the screw [2], and detach the transfer/separation assembly front cover [1].

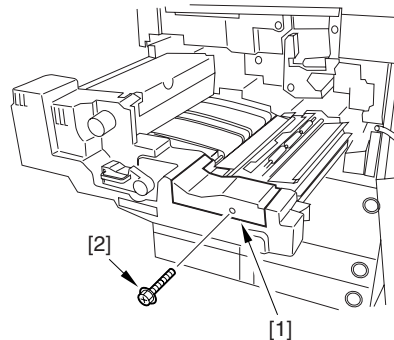

F-2-22

- 2) Remove the fixing [1] (1 screw [2]), and disconnect the connector [3].

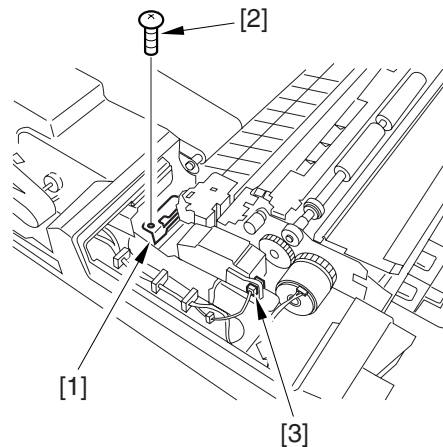

F-2-23

- 3) While holding down the front and rear of the transfer/separation charging assembly [1], pull it by 1 cm toward the front; then, detach it toward the upper left.
Using alcohol, clean the transfer/ separation charging wire.

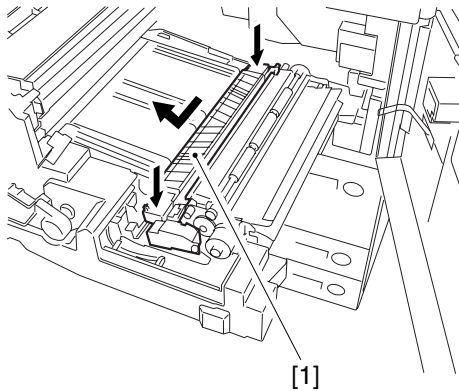

F-2-24

- 4) While keeping the following in mind, mount the transfer/separation charging assembly:
- The solvent must completely be dry.
 - The gut wire must not be brought into contact with the transfer guide [1] to avoid a cut.
 - The grounding plate [2] must be on the outside of the charging assembly frame [3] (See the figure).

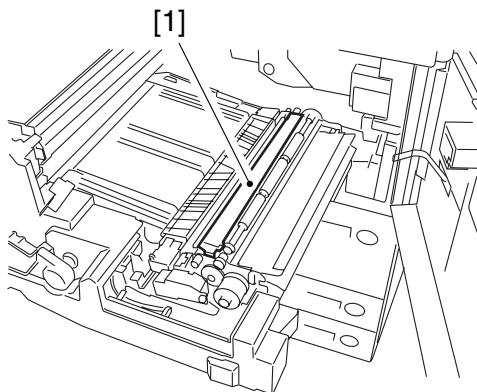

F-2-25

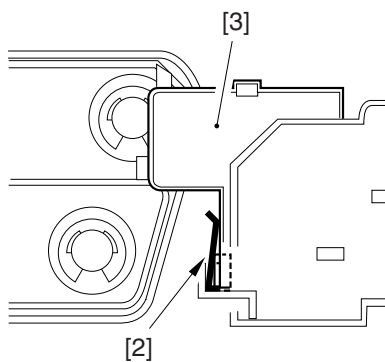

F-2-26

- 5) Connect the connector of the transfer/ separation charging assembly, and mount the fixing.
6) Using a screw, mount the toner/separation charging assembly front cover. Push in the fixing/feeding assembly inside the machine, and shift the fixing/feeding assembly releasing lever [1] back into position.

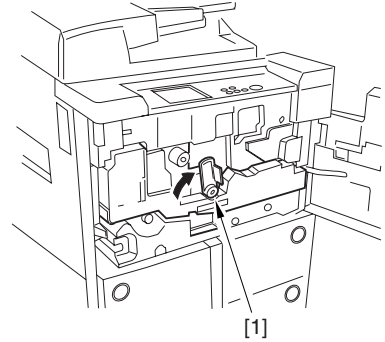

F-2-27

- 7) Remove the screw [1], and detach the primary charging assembly front cover [2].

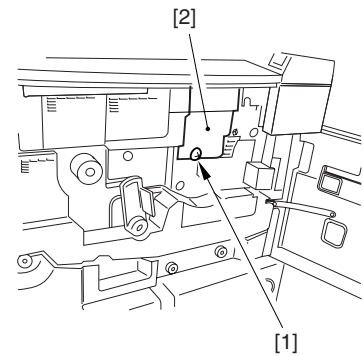

F-2-28

- 8) Disconnect the connector [1], and release the locking lever [3] of the primary charging assembly [2]; then, take out the primary charging assembly.
Using alcohol, clean the primary charging assembly and the grid wire.

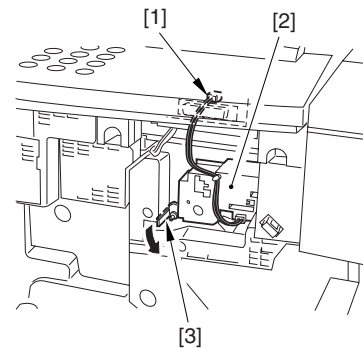

F-2-29



Do not start mounting work before the solvent has become completely dry.

9) Remove the screw [1], and detach the pretransfer charging assembly cover [2].

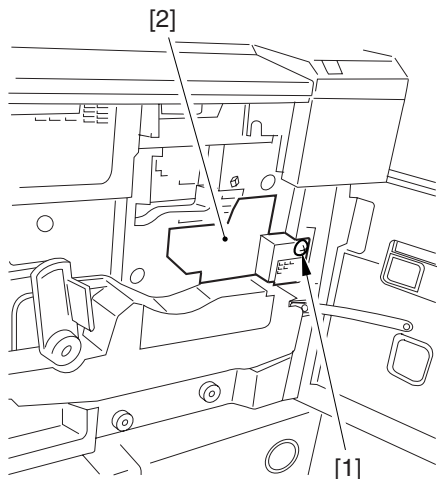

F-2-30

10) Disconnect the connector [1], and release the locking lever [3] of the pre-transfer charging assembly [2]; then, take out the pre-transfer charging assembly.

Using alcohol, clean the pre-transfer charging wire.

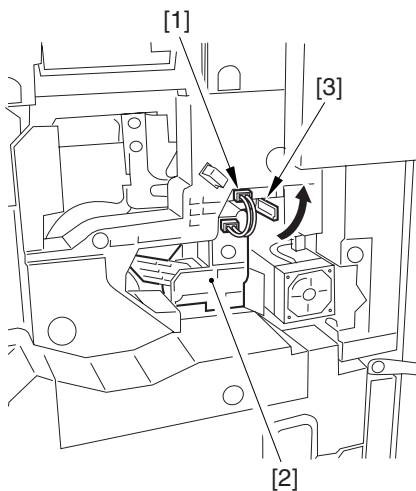

F-2-31

11) With the lock released, slide in the primary charging assembly, and connect the connector.

⚠ Check to make sure that the solvent is fully dry.

12) With the lock released, slide in the pretransfer charging assembly, and connect the connector.

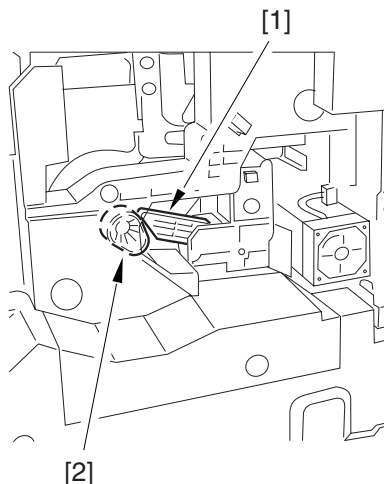

F-2-32



- Check to make sure that the solvent is fully dry.
- Check to make sure that the one-way arm [1] of the pretransfer charging assembly is on the eccentric cam [2].

13) Mount the primary charging assembly cover and the pre-transfer charging assembly cover with a screw (1 pc. each).

14) Close the front cover.

2.2.6 Mounting the Charging Assembly

1) Remove the transfer separation charging assembly front cover [1].

- screw [2]

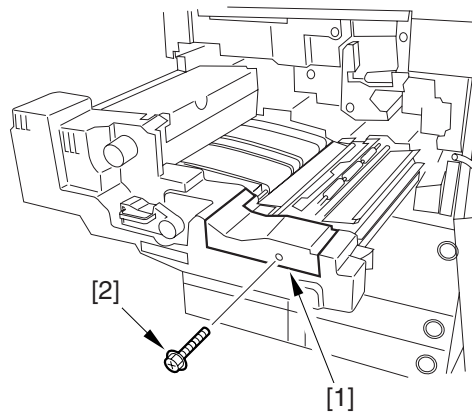

F-2-33

- 2) Remove the fixing [1] (1 screw [2]), and disconnect the connector [3].

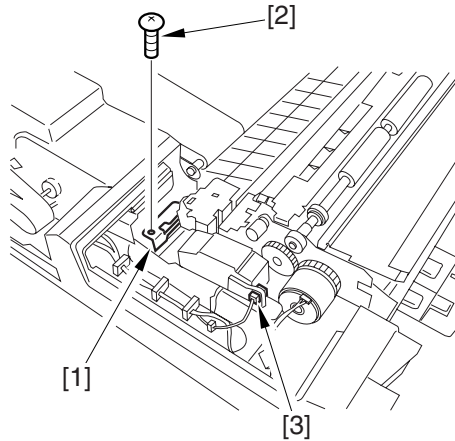

F-2-34

- 3) While holding down the front and rear of the transfer separation charging assembly [1], pull it toward the front about 1 cm, and then detach toward the rear left in upward direction. Clean the transfer separation charging wire using alcohol.

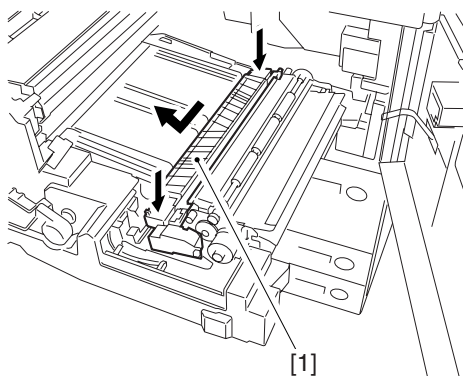

F-2-35

- 4) Mount the transfer separation charging assembly [1] while keeping the following in mind:
- all solvent must be fully dry.
 - the gut wire must not be in contact with the transfer guide [2] to avoid a cut.
 - the grounding plate [3] must be outside the charging assembly frame.

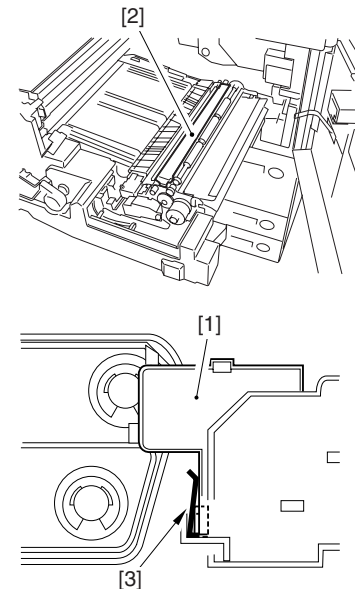

F-2-36

- 5) Connect the connector of the transfer separation charging assembly, and fit the fixing in place.
- 6) Attach the transfer separation charging assembly front cover.
- 7) Fit the fixing transport assembly in place inside the machine, and shift the fixing transport assembly lever [1] to lock the assembly in place.

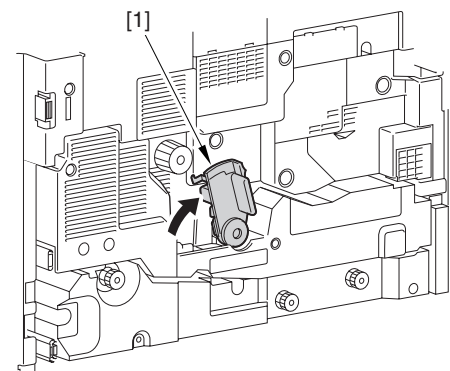

F-2-37

- 8) Remove the primary charging assembly front cover [1].
- screw [2]

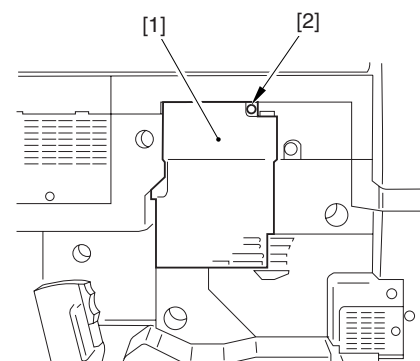

F-2-38

- 9) Disconnect the connector [1], and release the locking lever [2] of the primary charging assembly to remove the primary charging assembly [3].
Clean the primary charging wire and the grid wire using alcohol.

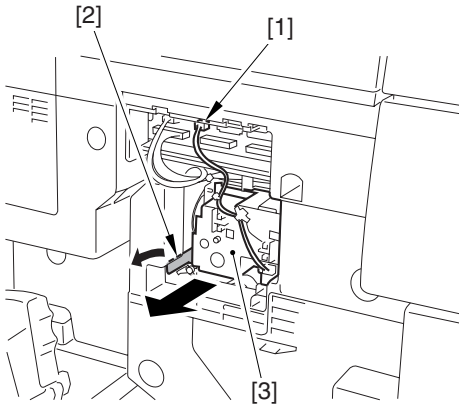

F-2-39



All solvent must be fully dry before fitting the parts back in place.

- 10) Remove the pre-transfer charging assembly front cover [1].
- screw [2]

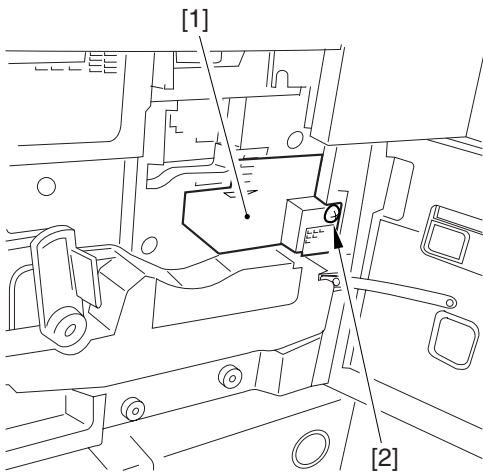

F-2-40

- 11) If a double-feeding detection PCB (transmitting) [3] is found, disconnect the 2 connectors [1] and remove the screw [2], and open the PCB in the direction of the arrow.

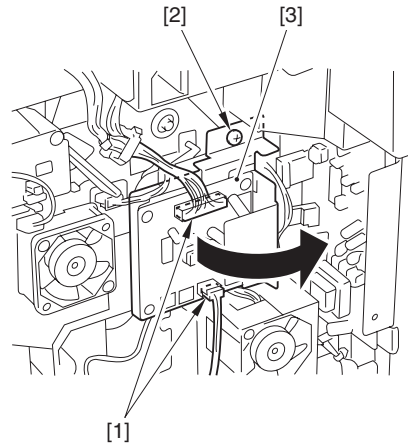

F-2-41

- 12) Disconnect the connector [1], and release the locking lever [2] of the pre-transfer charging assembly; then, remove the pre-transfer charging assembly [3].
Clean the pre-transfer charging assembly using alcohol.

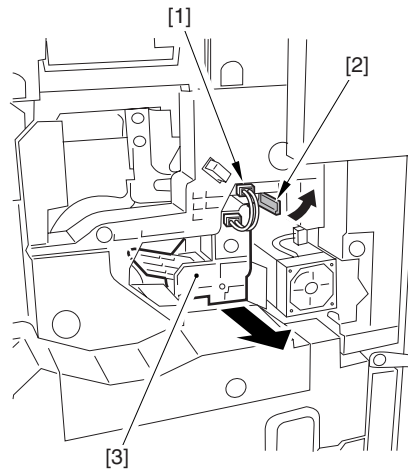

F-2-42

- 13) While keeping it unlocked, fit in the primary charging assembly, and connect the connector.



Check to make sure that the solvent is fully dry.

- 14) While keeping it unlocked, fit the pre-transfer charging assembly in place, and connect the connector.



- Check to be sure that the solvent is fully dry.
- Check to be sure that the one-way arm [1] of the pre-transfer charging assembly is on the eccentric cam [2].

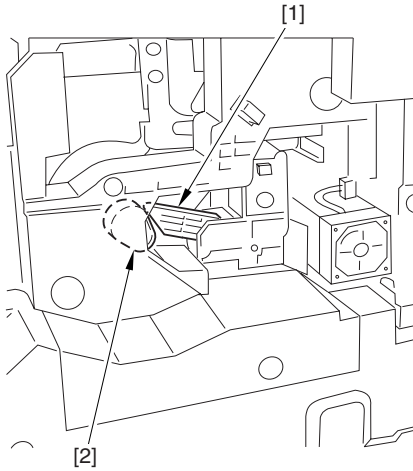

F-2-43

- 15) Mount the double-feeding detection PCB (transmitting).
- 16) Mount the primary charging assembly front cover and the pre-transfer charging assembly cover.
- 17) Close the front cover.

2.2.7 Mounting the Developing Assembly

- 1) Open the manual feeder tray cover.
- 2) Remove the tape [1]; then, remove the hopper supply mouth cover [2].

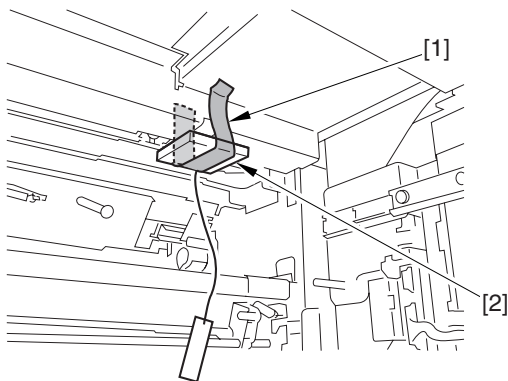

F-2-44

- 3) Holding the developing assembly [1] as shown, fit it in place in the machine.



When mounting the developing assembly, take care not to hit against the developing cylinder [2].

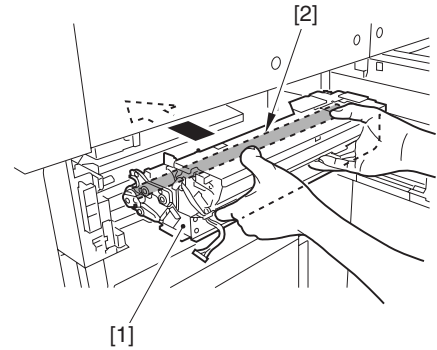

F-2-45

- 4) Connect the connectors [1], [2].



Check to be sure that the connector will not become disconnected. Poor contact will lead to blank prints.

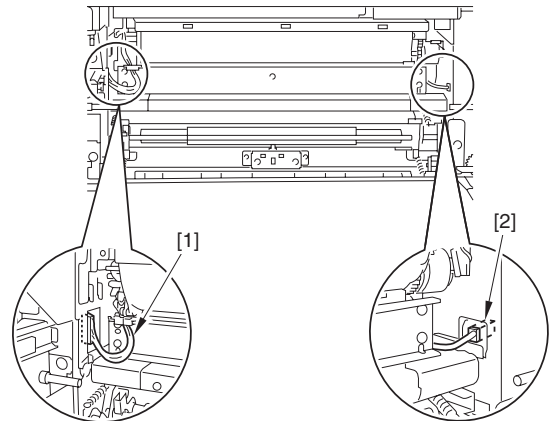

F-2-46

- 5) Mount the developing assembly locking plate [1].
 - 2 bosses [2]
 - 6 screws (TP; M4X6; black) [3]

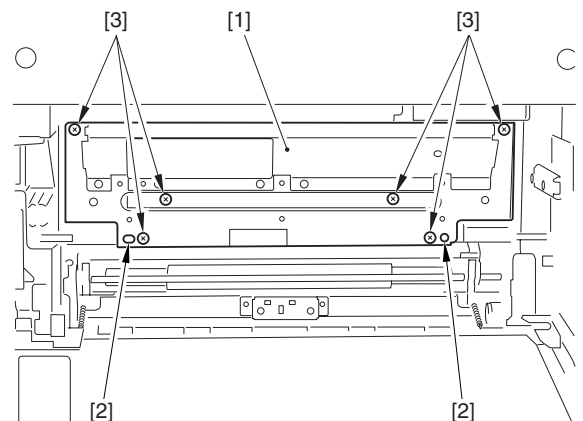

F-2-47



Check to be sure that the developing assembly locking plate is free of a gap and displacement, which are likely to cause image faults. (Especially, it must not be riding over the bosses found below.)

When mounting the developing assembly locking plate, take care not to trap the cable [1].

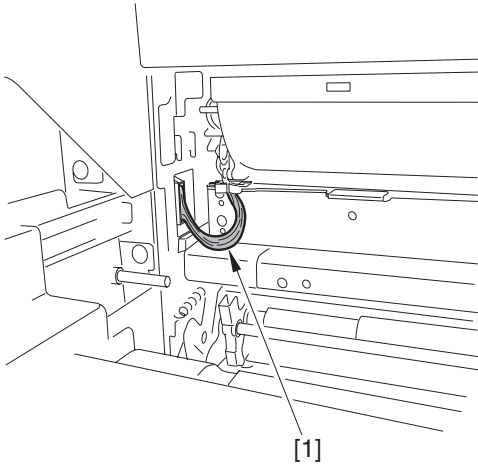

F-2-48

6) Slide out the 2 rails [1] of the pull-off unit.

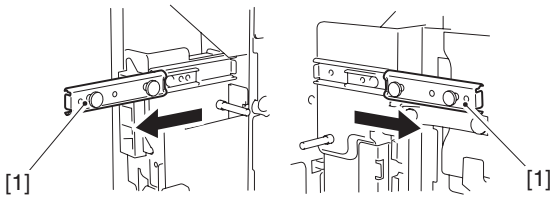

F-2-49

7) Remove the tape from the pull-off unit.

8) Hold the pull-off unit [1] as follows, and hook the 4 holes [3] of the pull-off unit on the 4 protrusions [2] of the rail.

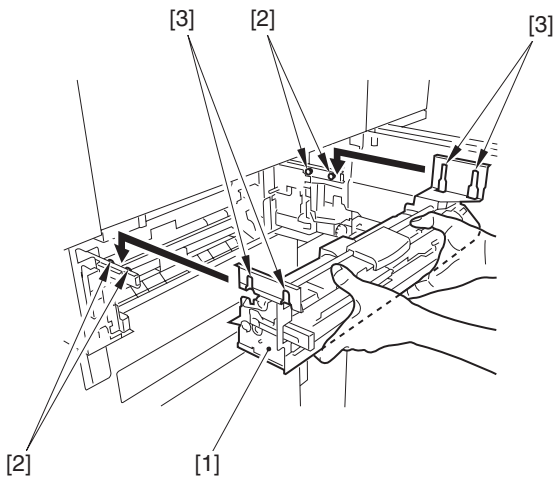

F-2-50

9) Secure the pull-off unit in place with 2 screws (binding; M3X4) [1] in place, and push in the pull-off unit until it is locked in place.

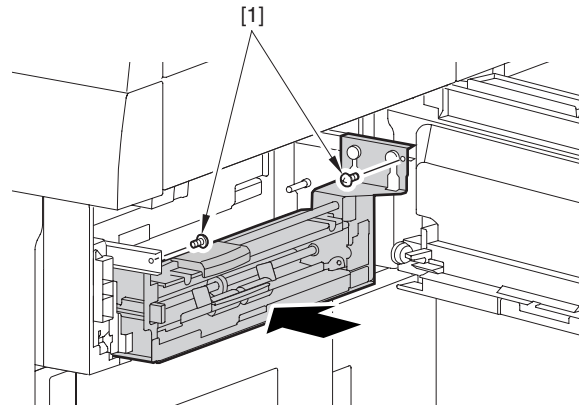

F-2-51

10) Fit the reuse band [1] in the hole [2] of the host machine.

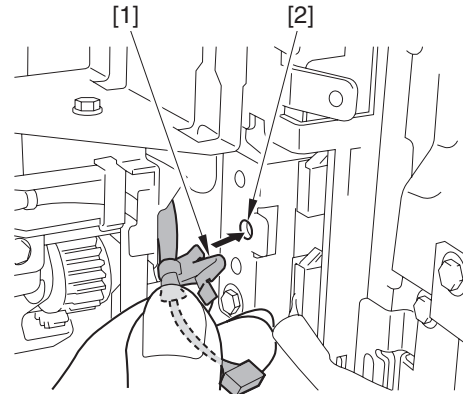

F-2-52

11) Connect the connector [1].

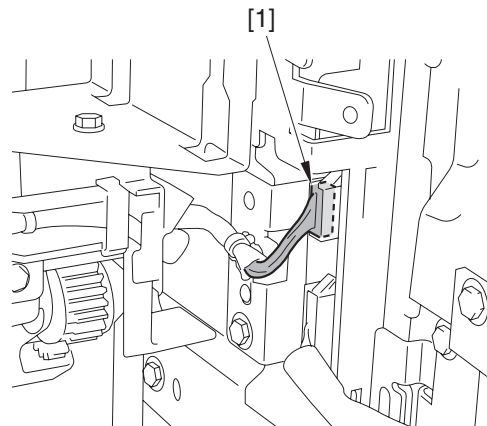

F-2-53

- 12) Attach the connector cover [1].
- screw (RS tightening; M4X10) [2]

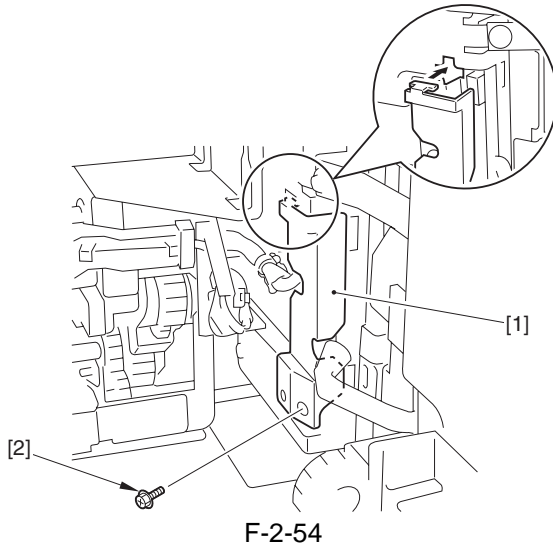

F-2-54

2.2.8 Mounting the Pickup Assembly

- 1) Shift the lever [1] in the direction of the arrow, and remove the pickup roller release spacer [2].

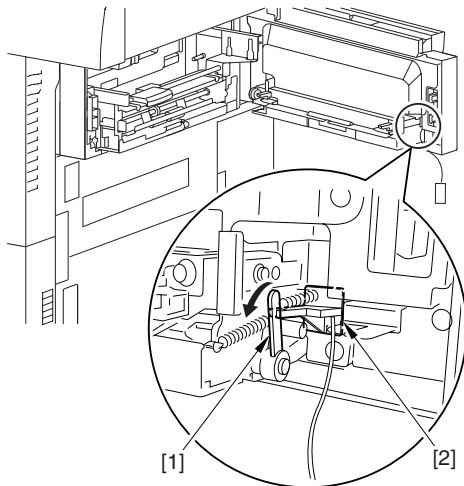

F-2-55

- 2) Close the manual feeder tray unit.
- 3) Push the release button of the front deck (right) and the cassette 3/4, and slide them out halfway.
- 4) Slide out the cassette 3/4, and remove the packing tape from where the host machine and the cassette come into contact (left side of the host machine and right side of cassette 4).
- 5) Open the upper right cover [1] and the lower right cover [2], and remove the 3 pickup roller release spacers [3].

MEMO:

If the deck/cassette is inside the machine, the spacer is locked in place and cannot be removed; be sure to slide the unit out halfway to unlock it.

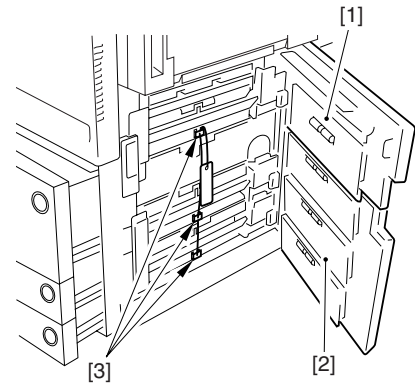

F-2-56

- 6) Close the upper right cover and the lower right cover.
- 7) Close the front deck (right) and the cassette 3/4.
- 8) Press the release button of the front deck (left), and slide out the deck.
- 9) Mount the included deck locking plate [1] to the front deck (left).
- screw (RS tightening; M4X10; white) [2]
Front Deck (left)

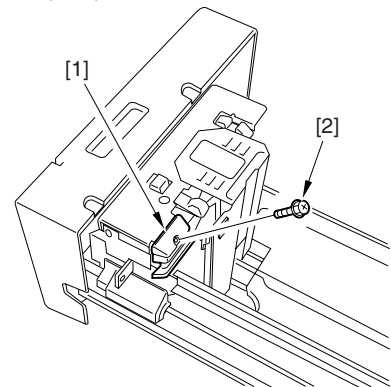

F-2-57

- 10) Close the front deck (left).

2.2.9 Mounting the Control Panel

- 1) Remove the upper rear right cover [1].
- 3 screws [2]

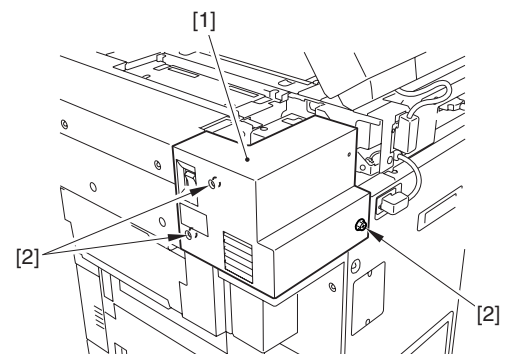

F-2-58

- 2) Match the 2 bosses [3] of the arm cover 3 [2] with the Control panel arm unit [1], and fix it in place with a screw (binding; M4X10) [4].

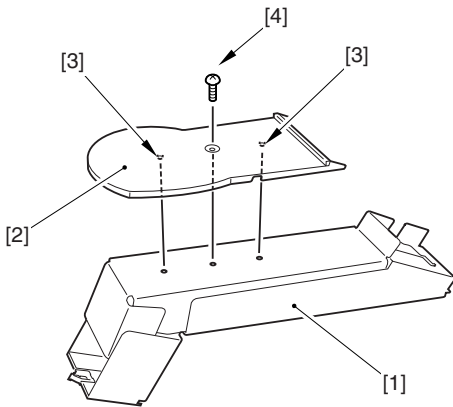

F-2-59

- 3) Route the control panel interface cable through the Control panel arm unit [1], and fix it in place with the edge saddle [3].

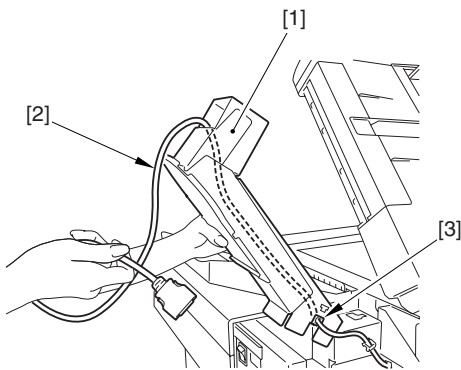

F-2-60

- 4) Hook the claw [2] of the Control panel arm unit [1], and tighten the 4 screws (binding; M4X10) [3] and 4 screws [4].

- !**
 - Be sure to tighten the screws in the correct order.
 - Do not drop the screws.

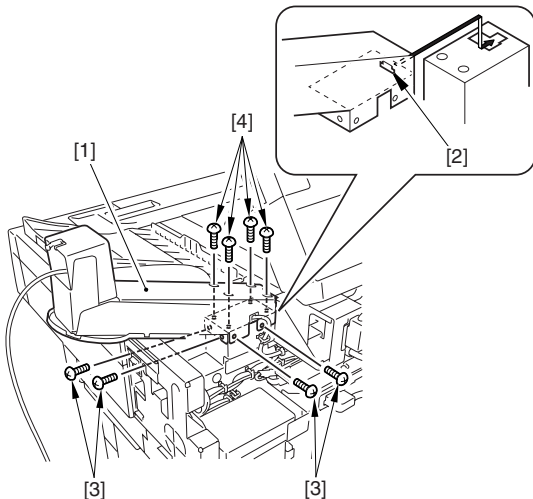

F-2-61

- 5) Adjust the control panel interface cable [1] so that the length [4] from the edge saddle [2] and the marking [3] is about 5 cm, and fix it in place using the edge saddle.

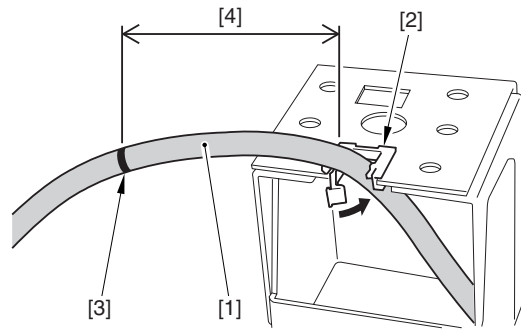

F-2-62

- 6) Hook the claw [2] of the cover support plate [1], and fix it in place using 2 screws (binding; M4X10) [3].

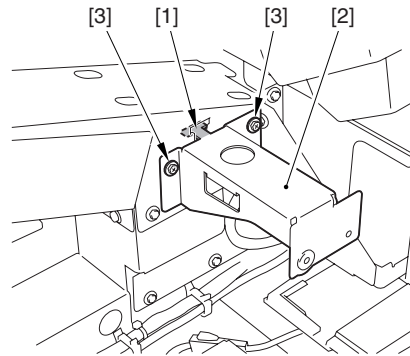

F-2-63

- 7) Open the DF, and lead the control panel interface cable [2] along the arm cover 2 [1]; then, put the cover over the control panel arm unit.

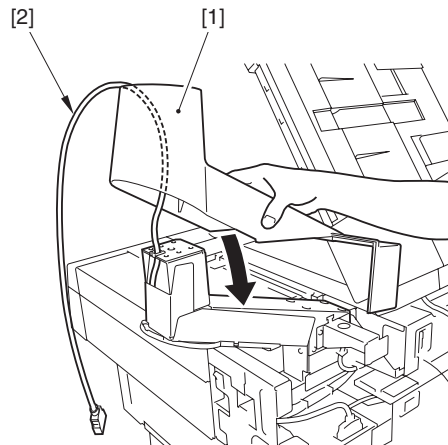

F-2-64



When putting the arm cover 2 in place, be sure it is correctly oriented in relation to the plate [1].

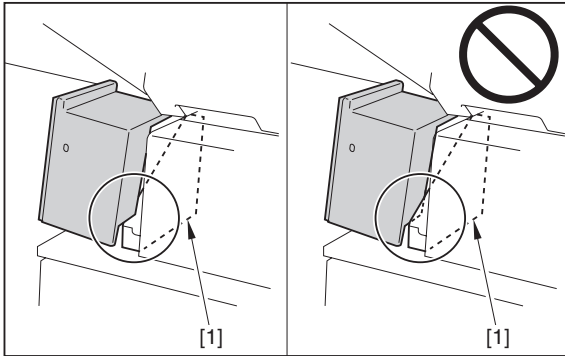

F-2-65

8) Tighten the screw (binding; M4X10) [1].



When tightening the screw [1], be sure to hold down the arm cover 2.

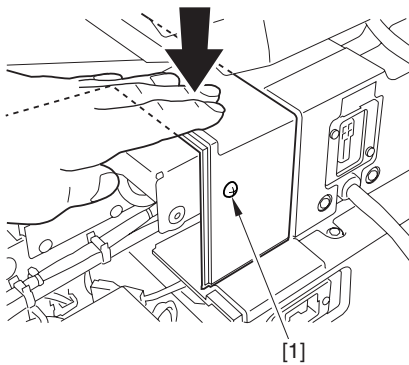

F-2-66

9) Tighten the screw (binding; M4X10) [1].



Be sure to tighten the screw at an angle.

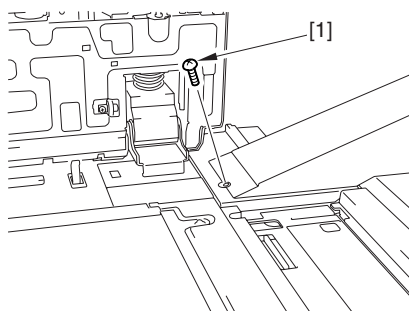

F-2-67

10) Hook the claw [1] of the arm unit on the hole [2] in the Control panel arm unit.

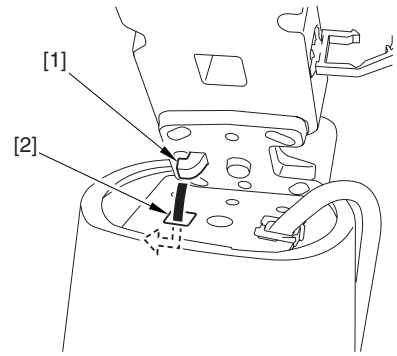

F-2-68

11) Turn it in the direction of the arrow until the screw hole [1] of the arm unit matches the hole in the Control panel arm unit.

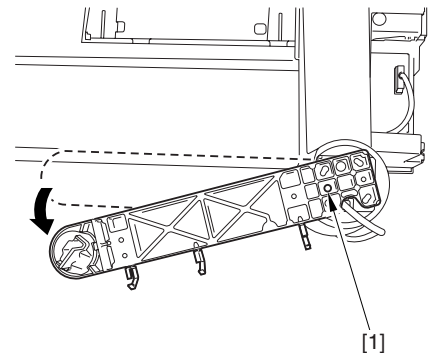

F-2-69

12) Tighten the screw (binding; M4X14) [2] and then the 4 screws [3] of the arm unit [1].



- Be sure to tighten the screws in the correct order.
- Be sure to tighten the screws while keeping the arm in the direction of the arrow to avoid contact with the extension tray.

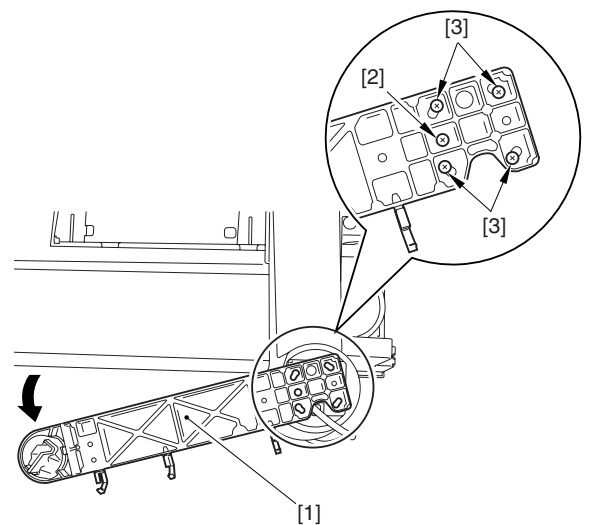

F-2-70

13) Fix the control panel interface cable [1] in place using the 3 wire saddles [2].

⚠
Match the wire saddle at the rear and the marking [3].

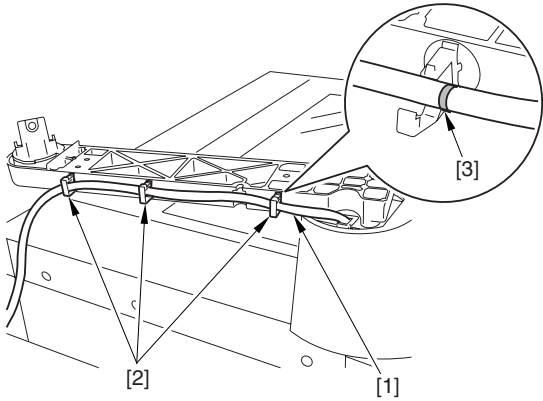

F-2-71

14) Route the control panel interface cable [1] through the arm cover 1 [2].

15) Hook the claw [3] on the cut-off [4] of the arm unit, and put the arm cover 1 [2] in place.

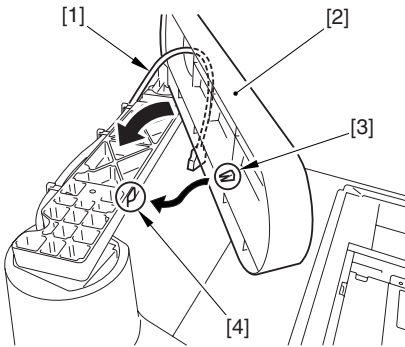

F-2-72

⚠
Take care not to trap the cable.

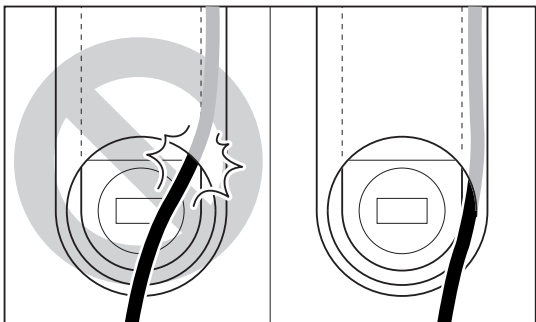

F-2-73

16) Fix the arm cover 1 in place from behind the arm unit.

- 2 screws (P tightening; M4x10) [1]

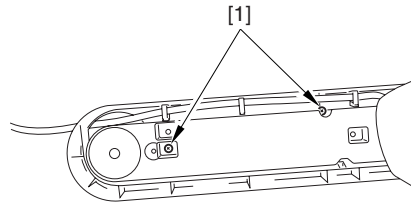

F-2-74

⚠
Make sure there is no discrepancy between the arm cover 1 and the arm cover 2.

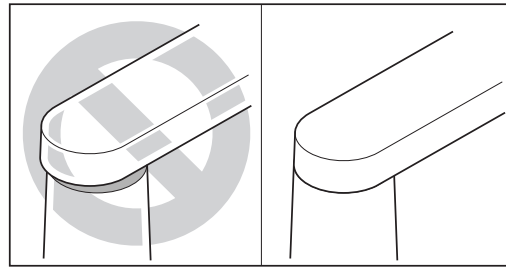

F-2-75

17) Fit the shaft [1] of the control panel in place on the arm unit [2].

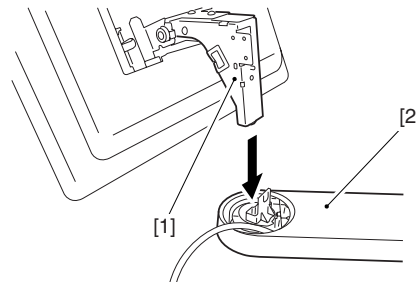

F-2-76

⚠
Fit the tip of the shaft [1] of the control panel in the round hole of the arm unit.

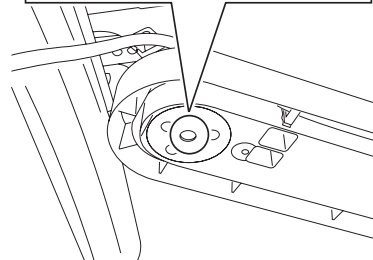
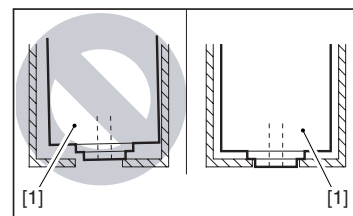

F-2-77

- 18) Tighten the screw (flat-head; M4X10) [1] from behind the arm unit.

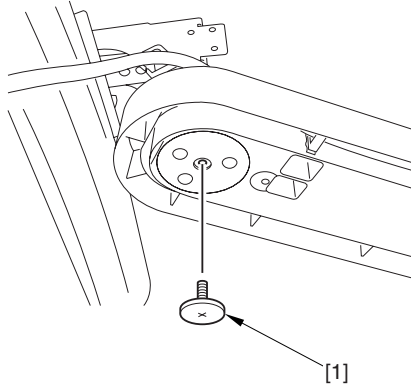

F-2-78

- 19) Tighten the screw (W sems; M4X10) [1] from behind the control panel.

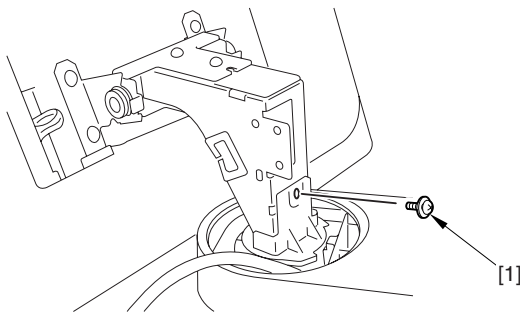

F-2-79

- 20) Fix the control panel interface cable [1] in place using the 2 edge saddles [2] and the wire saddle [3]; then, connect the connector [4] to the control panel.

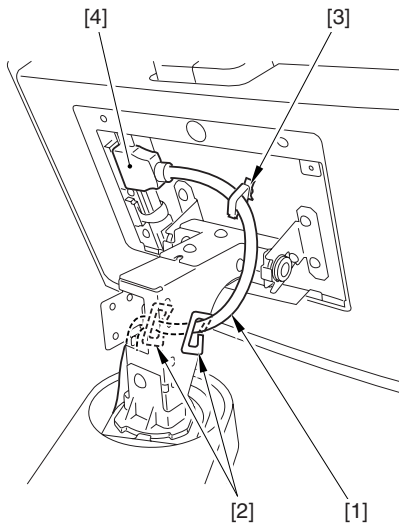

F-2-80



Be sure to adjust the length of the cable [1] so that it is inside the plate [2].

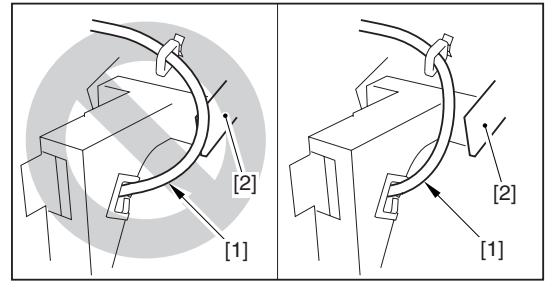

F-2-81

MEMO:

If the control panel is tilting, go through the following steps to correct:

- 1) Loosen the 4 screws [1] found on the back of the control panel.
- 2) Shift the control panel [2] to its correct orientation, and tighten the screws loosened previously.

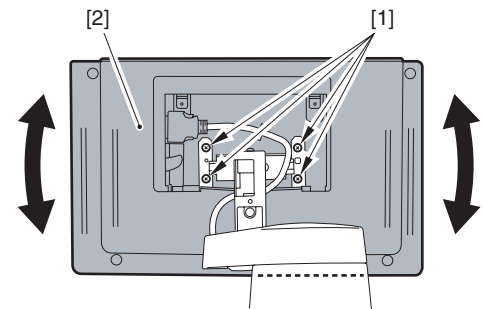

F-2-82

- 21) Peel off the protective sheet of the arm cover 4.
- 22) Mount the arm cover 4 [1] from behind the arm unit.
- screw (binding; M4X10) [2]

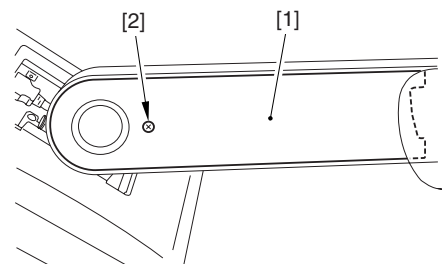

F-2-83

- 23) Mount the lock hinge cover R [1].
 - 2 bosses [2]
 - 2 screws (P tightening; M3X10) [3]

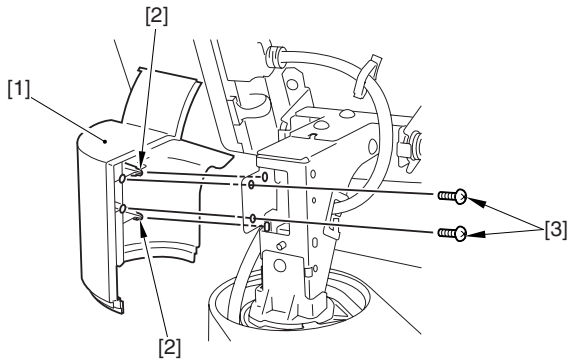

F-2-84

- 24) Mount the lock hinge cover L [1].
 - 2 bosses [2]
 - screw (TP; M3x6) [3]

MEMO:

Keep the arm and the control panel upright to facilitate mounting of the lock hinge cover R.

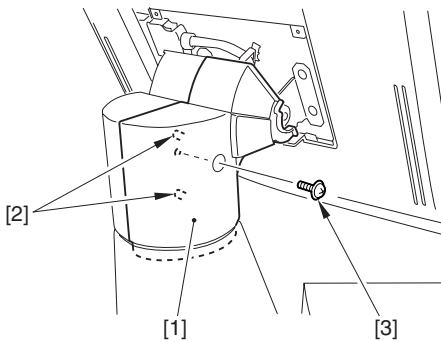

F-2-85

- 25) Tilt the control panel [1] in the direction of the arrow.

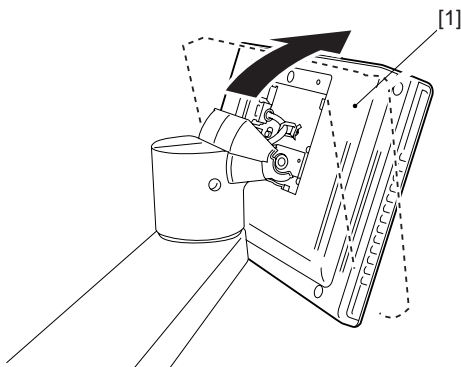

F-2-86

- 26) Fit the Hinge slide cover [1] in the direction of the arrow.

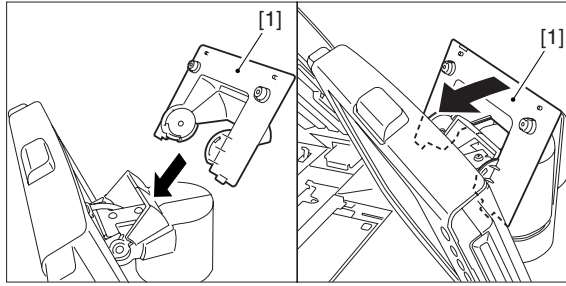

F-2-87

- 27) Fix the Hinge slide cover in place.
 - 2 screws (TP; M3X6) [1]
 - 2 Cover rubber (for M3)

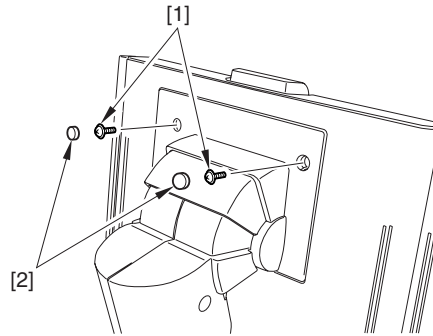

F-2-88

- 28) Hook the claw [1] of the rear upper right cover on the hole [2] of the cover support plate; then, fit the rear upper right cover [3] in place.
 - 3 screws [4] (removed in step 1)
 - screw (included; binding; M4X10) [5]

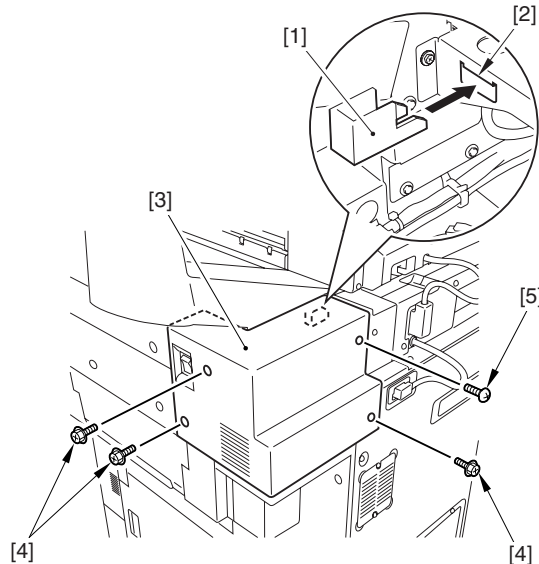

F-2-89

2.2.10 Supplying Toner

- 1) Open the hopper cover [1].

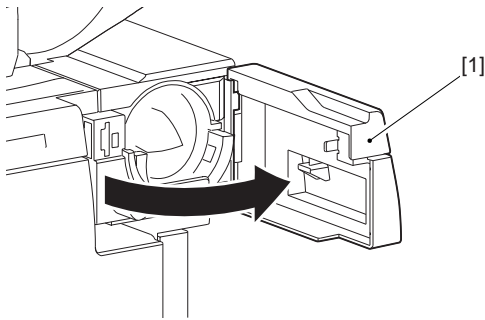

F-2-90

- 2) Peel off the packing tape from the machine.
3) Shift the toner cartridge locking lever [1] to the left to release.

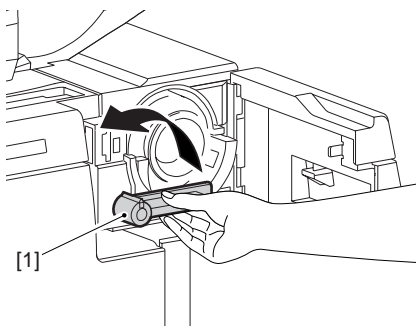

F-2-91

- 4) Hold the toner bottle [1] as shown, and turn the cap [2] in the direction of the arrow to detach the cap from the bottle.



Do not shake the toner bottle.

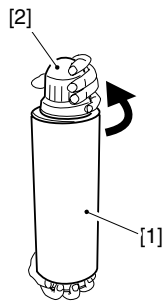

F-2-92

- 5) Fit the toner bottle [1] in place.



Be sure to push it until it stops.

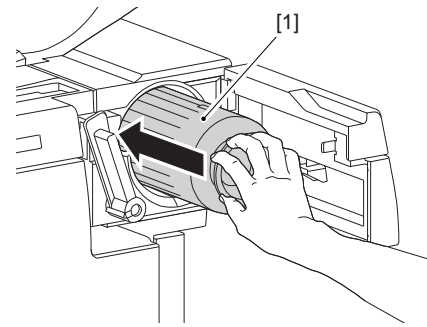

F-2-93

- 6) Shift the toner cartridge locking lever [1] to the right to lock it in place.

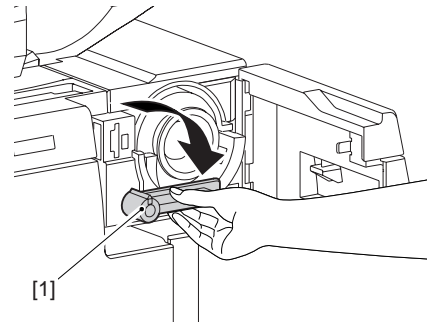

F-2-94

- 7) Close the hopper cover.

2.2.11 Turning On the Main Power



Be sure to remove all packing material from inside the cassette before turning on the main power.

- 1) Slide out the duplexing unit, and check to make sure there is no foreign matter and damage.
- 2) Check to make sure that the main power switch is at OFF; then, connect the machine's power plug to the power outlet.
- 3) Turn on the main power switch by shifting it to ON.
 - A screen appears indicating that programs are being loaded.
 - A message appears indicating that the machine is starting up.

2.2.12 Stirring the Toner

When the wait period is over, start service mode to supply toner to the developing unit.

- 1) Start service mode. (⊗) > '2' and '8' at the same time > (⊗)
- 2) Make the following selections: COPIER > FUNCTION > INSTALL > TONER-S.
- 3) See that the following message has appeared: "Check the Developer."
- 4) Check to see that the developing assembly is mounted properly; then, press the OK key.
 - The supply operation lasts about 8 to 10 min,

and stops automatically. (At the end of the operation, the message "STOP!" appears.)

- 5) End service mode.



Do not turn off the machine while the machine is in operation.

2.2.13 Index Sheet Attachment

- 1) Choose cassette 1 or 2 for use with index sheets.
Press the release button of the cassette you have chosen, and slide out the cassette.
Match the 2 one-touch supports [1] against the holes [2] of the cassette, and fit in the pins to attach.
- 2) Holding it so that the protrusion is at the top, match the hole in the index sheet attachment [3] against the one-touch support [1].
- 3) Place the base sheet [4] into the cassette, and put the cassette back into the machine.

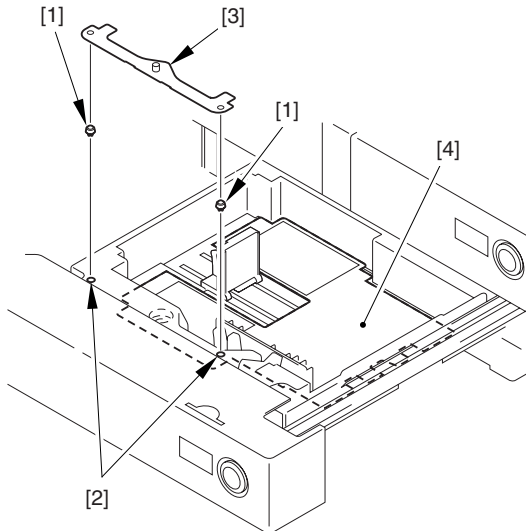

F-2-95

2.2.14 Other attachment

- Shut-Down Warning Label

- 1) Select the Shut-Down Warning label [1] of the appropriate language; then, attach it to the left of the main power switch of the machine's right cover (rear).

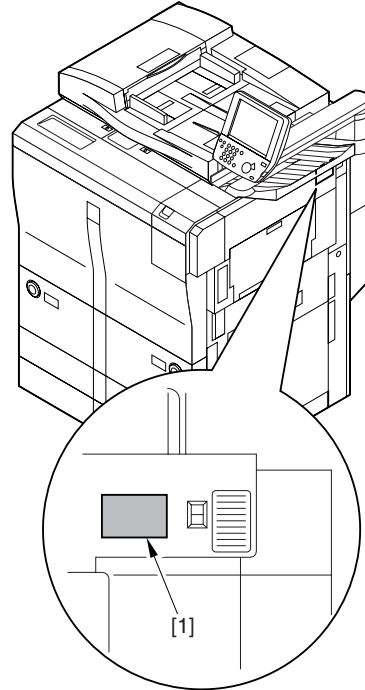

F-2-96

2.2.15 Others

- Shut-Down Caution Label

- 1) Choose the shut-down warning label [1] of the desired language, and attach it within the frame under the main power switch of the right cover (rear).

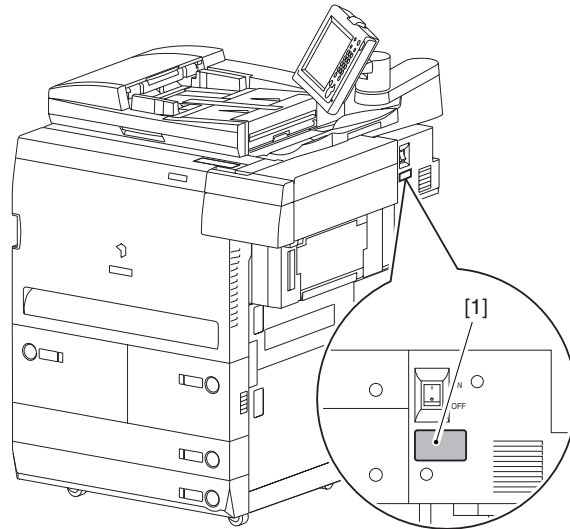

F-2-97

iR7086 Only

<Cleaning Position Label>

- 1) Fit the Cleaning Position label [1] as indicated on the front cover, and attach it in place.

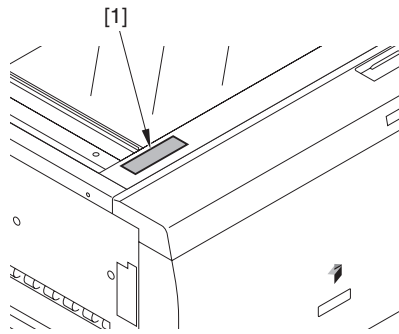

F-2-98

<Original Size Label>

- 1) Fit the Original Size label [1] as indicated on the ADF open/close cover, and attach it in place.

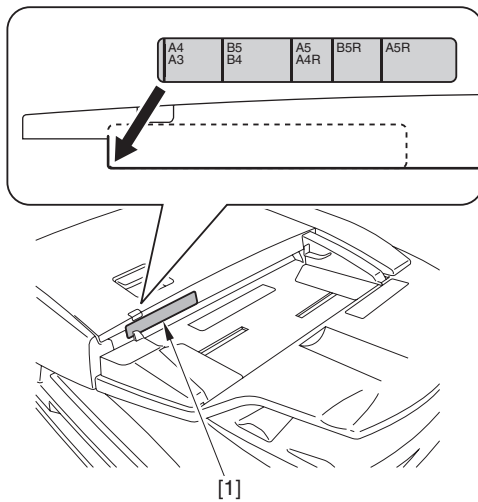

F-2-99

iR7105/7095 Only

<Cleaning Instructions Label>

- 1) Fit the cleaning instructions label [1] of the appropriate language on the upper rear cover as indicated, and attach it over the existing label. (The English label is attached at time of shipment.)

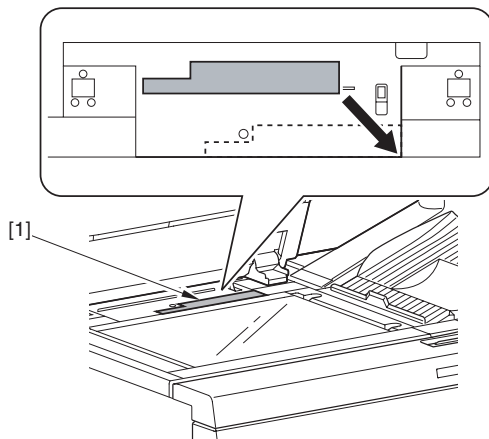

F-2-100

<Lamp Warning Label>

- 1) Fit the Lamp Warning Label [1] of the appropriate language on the upper rear cover as indicated, and attach it over the existing label. (The English label is attached at time of shipment.)

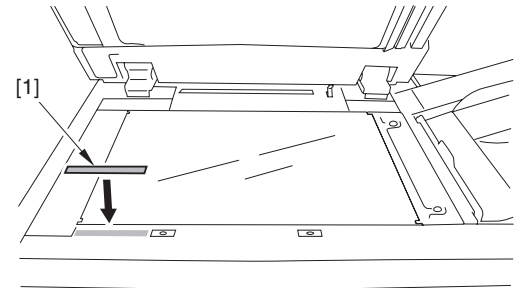

F-2-101

<Manual Feeder Set Label>

- 1) Open the manual feeder assembly [1] of the ADF; then, fit the Manual Feeder Set Label [2] as indicated, and attach it in place.

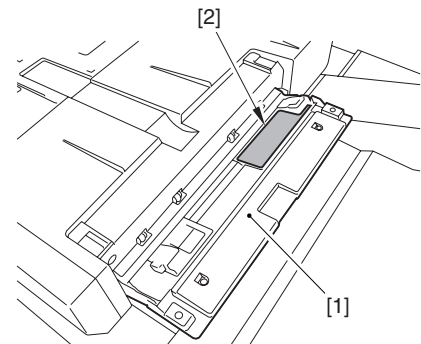

F-2-102

2.2.16 Attaching the Labels, Placing Paper, and Checking Images and Operation (user mode)

- 1) Check with the user to find out the size of paper that will be used.
- 2) Press the release button of the front deck (right, left), and slide out the deck.



If you are changing the size of the front deck (right, left), refer to the instructions under "Switching Over the Front Deck (right/left) Paper Size."

- 3) Attach the 3-hole paper placement label [1].

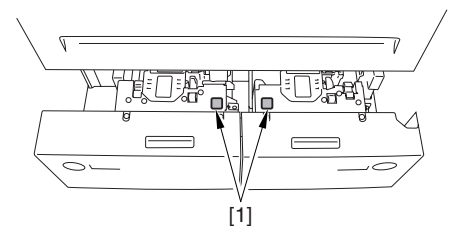

F-2-103

- 4) Put paper in the front deck (right/left).
- 5) Close the front deck (right/left). Remove the appropriate size label (cassette/deck) from the backing paper, and attach it to the paper size plate of the deck.

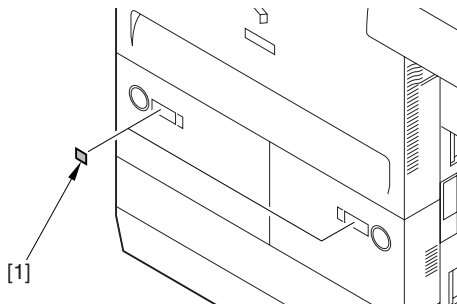

F-2-104

- 6) Press the release button of the cassette 3/4, and slide out the cassette.
- 7) Attach the 3-hole paper placement label [1].

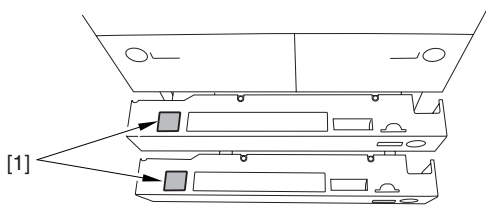

F-2-105

- 8) Remove the appropriate paper size label (cassette/deck) from the backing paper, and attach it to the paper size plate [2] of the cassette. Fit the paper size plate to the cassette cover.

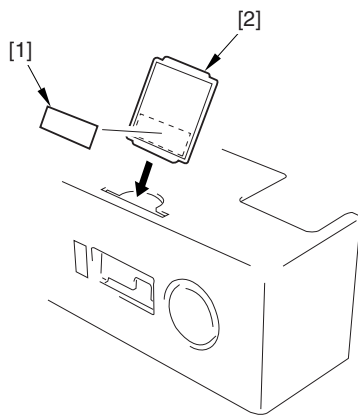

F-2-106

- 9) Close the deck/cassette.
- 10) To ensure stable reproduction of images, generate 2 solid black prints (A3) as follows:
- 11) Start service mode. (\odot) '2' and '8' at the same time > (\odot)
- 12) Make the following selections: COPIER > TEST > PG > PG-PICK.
- 13) Select the source of paper containing A3 paper, and press the OK key.
('3' for cassette 3; '4' for cassette 4)
- 14) Make the following selections: COPIER > TEST > PG > TYPE.
- 15) Type in '7', and press the OK key.

('7' for solid black; PG-TYPE7)

- 16) Press the Start key to generate a single solid black (A3) print. Check the output, and wait for about 5 sec. Then, press the Start key to generate another print.
- 17) When done, press the Reset key twice to end service mode.
- 18) Place the test sheet on the copyboard, and check the copy image.
Check to be sure that the pickup operation for all sources of paper is normal (by making 3 test copies each from decks and cassettes).
 - check to be sure that there is no abnormal noise.
 - check to see that images at all default magnifications are normal.
 - check to see that as many copies as specified are made normally.
 - if there is a difference in density between left and right, correct it by adjusting the height of the primary charging wire at the front or the rear.
 - Check to see that copying operation is normal.

horizontal registration standard (margin at image left): 2.5 +/-1.5 mm

lead edge registration standard (margin at image lead edge): 4.0 +1.5/-1.0 mm

If not as indicated, make adjustments by referring to the instructions under "Adjusting the Horizontal Registration" and "Adjusting the Lead Edge Registration."



At times, the first 10 copies or so may show soiled images because of toner dropping from the drum separation claw. The symptom should disappear as additional copies are made.

- 19) Make double-sided copies to check the machine operation.
- 20) Make standard settings in user mode and service mode to suit the needs of the user.
- 21) Press the Reset key twice to end service mode.
- 22) Clean up the area around the machine.
- 23) Move the machine to its final place, and fix it in place using the adjusters.
- 24) If you are installing accessories, do so according to their respective Installation Procedures.

MEMO:

For the Card Reader-D1, see "Card Reader-D1 Installation Procedure."

- 25) Fill out the service sheet.

2.2.17 Adjusting the Horizontal Registration

<Cassette 3/4>

- 1) Press the release button of cassette 3/4, and slide out the cassette.
- 2) Shift down the cassette front cover [1] in the direction of the arrow.
- 2 screws [2]

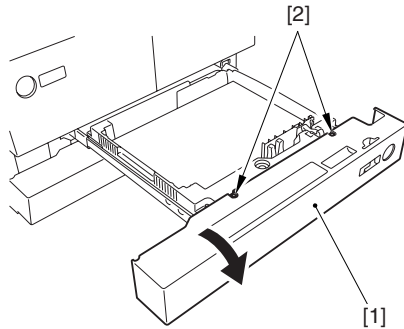

F-2-107

- 3) Loosen the 2 fixing screws [1] found on the right/left of the cassette.
- 4) Move the cassette case [2] to the front or the rear to make adjustments.
- move it to the rear to decrease the horizontal registration (left margin).
- move it to the front to increase the horizontal registration (left margin).

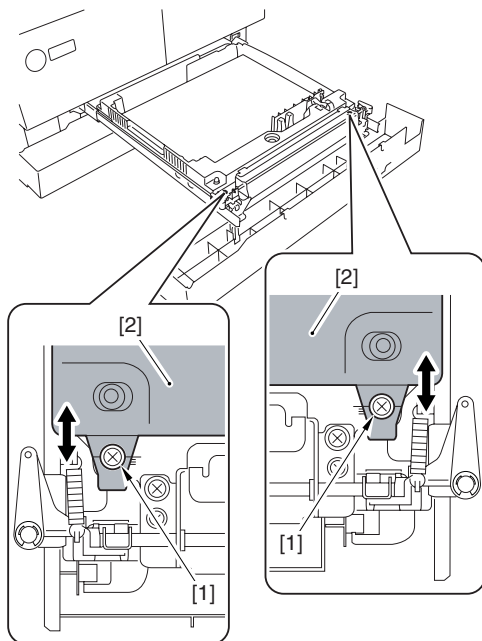

F-2-108

- 5) Check to make sure that the horizontal registration value (L; left margin) of the image made on paper from cassette 3/4 is 2.5 +/-1.5 mm.

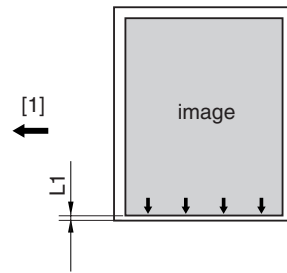

F-2-109

- [1] Paper movement

- 6) When done, tighten the 2 fixing screws loosened in step 3).
- 7) Shift up the cassette front cover [1] in the direction of the arrow, and secure it in place using 2 screws [2].

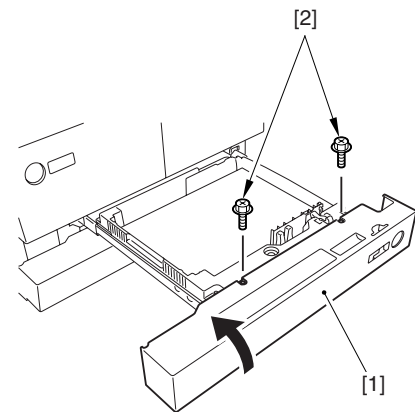

F-2-110

- 8) Put cassette 3/4 back inside the machine.
- 9) When done, execute the following service mode items:

Cassette 3

COPIER > FUNCTION > CST > C3-STMTR
COPIER > FUNCTION > CST > C3-A4R

Register the paper width basic value for cassette 3.

9-1) Place STMTR paper in the cassette 3, and move the side guide plate to suit the STMTR width.

9-2) Select C3-STMTR in service mode to highlight, and press the OK key so that adjustment will be executed and the value will be registered automatically.

9-3) Likewise, repeat steps 9.1) and 9.2) for A4R.

Cassette 4

COPIER > FUNCTION > CST > C4-STMTR
COPIER > FUNCTION > CST > C4-A4R

Perform the work you performed for cassette 3.

<Front Deck Left/Right>

- 1) Press the release button of the front deck (left/right), and slide out the deck.
- 2) Loosen the 4 screws [1].

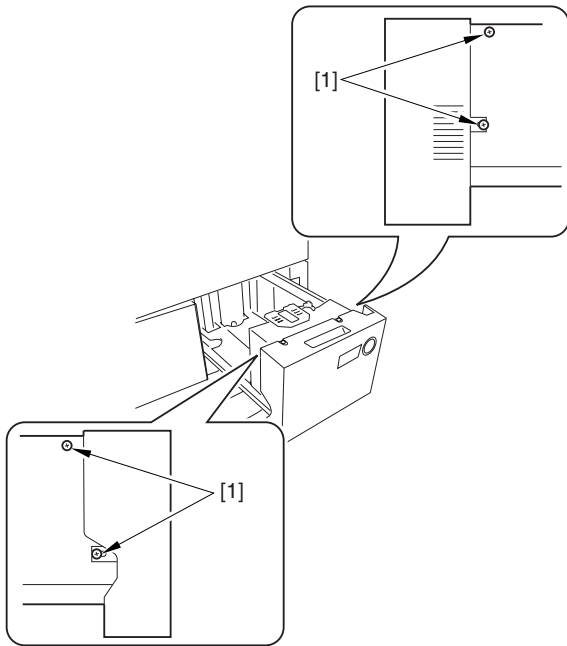

F-2-111

- 3) Move the cassette guide assembly (front) [1] to the front or the rear to make adjustments.
 - move the guide plate to the rear to decrease the horizontal registration (left margin).
 - move the guide plate to the front to increase the horizontal registration (left margin).

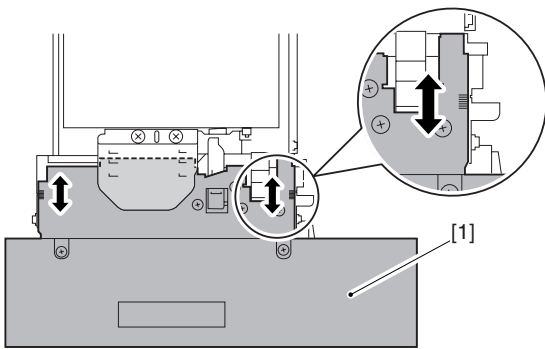

F-2-112

- 4) Check to see that the horizontal registration (L; left/right margin) of the images made on paper from the front deck (left/right) is 2.5 +/-1.5 mm.

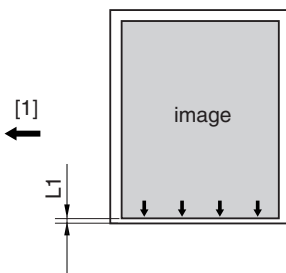

F-2-113

- 5) Tighten the 4 screws you loosened in step 2).
- 6) Put the front deck (left/right) back in place.

<Manual Feeder Tray>

- 1) Move the side guide plate [1] to the center, and loosen the 2 manual feeder tray mounting screws [2]; then, adjust the position of the manual feeder tray.

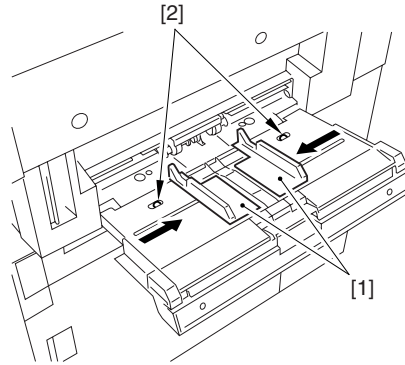

F-2-114

<Duplexing Transport Unit>

- 1) Make the following selections in service mode: COPIER > ADJUST > FEED-ADJ > ADJ-REFER so that the image margin on the 2nd side will be as indicated.
 - if the margin is too large, decrease the setting of ADJ-REFER (a change of 10 will decrease the margin by 1 mm).
 - if the margin is too small, increase the setting of DJ-REFER (a change of 10 will increase the margin by 1 mm).

W1=2.5 +/-2.0 mm

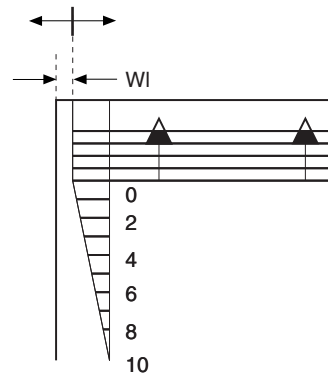

F-2-115

2.2.18 Adjusting the Lead Edge Registration

- 1) Make the following selections in service mode so that the image margin will be as indicated: COPIER > ADJUST > FEED-ADJ > REGIST.
 - if the margin is too large, increase the setting of REGIST (a change of 10 will decrease the margin by 1 mm).
 - if the margin is too small, decrease the setting of REGIST (a change of 10 will increase the margin by 1 mm).

$$L_f = 4.0 + 1.5 / -1.0$$

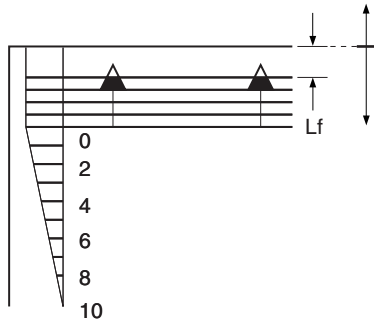

F-2-116

2.2.19 Setting the Cassette

- 1) Press the release button of cassette 3/4, and slide out the cassette.
- 2) Fit the side guide plate [1] in the hole (A4/A3) identified by the marking M [2].

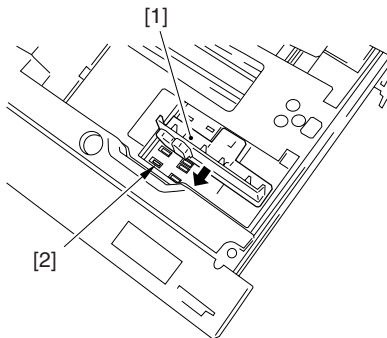

F-2-117

- 3) Fit the included inch block from inside the cassette so that the hole (STMT-R) of marking A [1] and the hole (LTR-R) of marking H [2] are covered.



- Be sure there is no gap.
- Perform the foregoing steps if the user is going to use AB series sheets only.

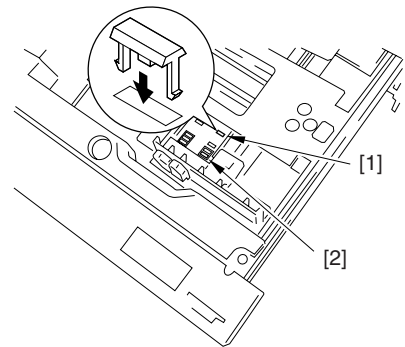

F-2-118

- 4) Put the cassettes back in the machine.

2.2.20 Correcting the Skew

If paper from the left/right deck moves askew, go through the following:

- 1) Loosen the 2 screws [1].
- 2) Push the side guide plate (front) [2] against the paper.

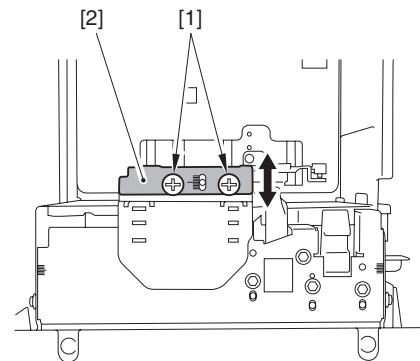

F-2-119

- 3) With the side guide plate (front) against the paper, tighten the screw.

2.2.21 Switching Over the Paper Size for the Front Deck (right, left)

- 1) Press the front deck release button, and slide out the deck.
- 2) Remove the screw [2] of the rear guide plate [1], and fix the guide plate in place to match the size specified by the user.

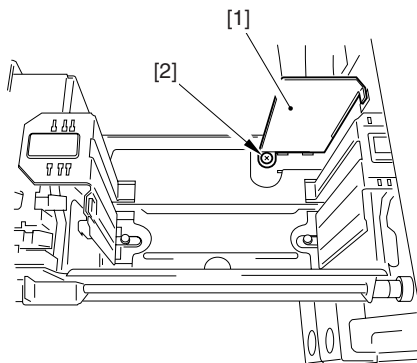

F-2-120

- 3) Remove the screw [2] from the left/right guide plate [1], and fix the guide plate in place to match the size specified by the user.

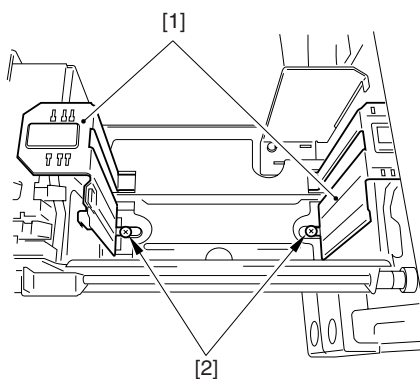

F-2-121

- 4) Put paper in the front deck.
- 5) Close the front deck.
- 6) Choose the appropriate deck size label [1] from the backing paper (cassette/deck), and attach it to the paper size plate of the deck.

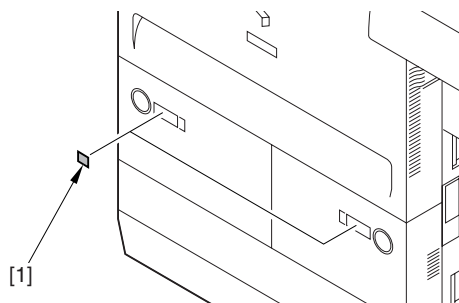

F-2-122

- 7) Start service mode, and register the front deck paper size.

MEMO:

right deck: COPIER > OPTION > CST > P-SZ-C1

left deck: COPIER > OPTION > CST > P-SZ-C2
A4=6, B5=15, LTR=18

- 8) When done, go through the shut-down sequence to turn off and then on the main power.

2.2.22 Checking the Operation in a System Configuration

- 1) Install the accessories according to their respective Installation Procedures.
- 2) Check to make sure that all accessories have been connected correctly.
 - Make a check in service mode:
 - Start service mode, and make the following selections: COPIER > OPTION > ACCPST-D > ACC1 through 8.
 - Check to see that the order and the model names are indicated correctly.
 - End service mode.
 - Click 'system status/stop' to check the device information.
 - Check to make sure that all connected accessories are indicated.
- 3) Check the operation using the accessories.
 - Make sure paper does not jam, move askew, or fail to deposit properly.

2.3 Checking the Connection to the Network

2.3.1 Checking the Network Connections



Perform the following work only if the machine is connected to a network.

- 1) Go through the shut-down sequence to turn off the main power.
- 2) Connect the network cable to the machine, and turn on the main power switch.
- 3) Tell the user's system administrator that the machine has been installed, and ask him/her to make the machine's network settings.



The following user mode items must be set to 'ON' when making network settings:

system administrator setup > network setup > change network settings/check connection.

- 4) When the network settings have been made, go through steps 1) thorough 3) to turn off and then on the main power so that the settings will become valid.

2.3.2 Using the PING Command



Perform the following work only if the machine is connected to a network:

If the user environment is TCP/IP, use the PING command to see if the main controller PCB has been correctly mounted and the network settings have been correctly made.

If the user environment is IPX/SPX or Apple-Talk, on the other hand, these checks are not necessary.

- 1) Make the following settings in service mode:
COPIER > TEXT > NETWORK > PING.
- 2) Type in the IP address using the control panel keypad, and press the OK key.
- 3) Press the OK key.
 - When the check with the PING command is successful, 'OK' will be indicated; otherwise, 'NG' will be indicated.

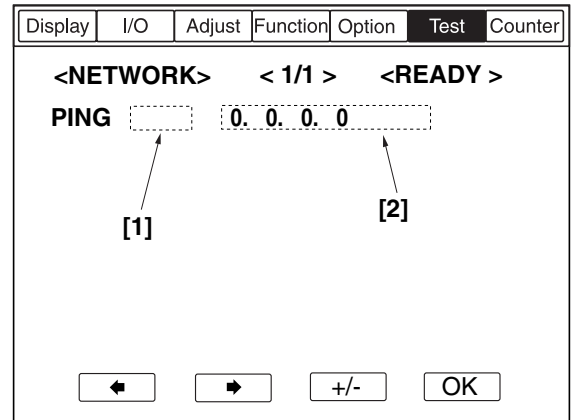

F-2-123

2.3.3 Making a Check Using a Remote Host Address

You can check to see if the connection to the network is correct by executing the PING command using a remote host address.

MEMO:

A remote host address refers to the IP address of a PC connected to the TCP/IP network to which the machine is also connected.

- 1) Tell the user's system administrator that you are going to check the connection to the network using the PING command.
- 2) Check with the system administrator to find out the remote host address.
- 3) Type in the remote host address for 'PING'.
- 4) If 'OK' is indicated, the connection to the network is correct.
- 5) If 'NG' is indicated, the connection to the network is not correct; go through the following steps:

2.4 Troubleshooting the Network

2.4.1 Troubleshooting the Network



Perform the following work only if the machine is connected to the network:

An attempt to connect to the network may fail because of the following:

- faulty connection between network and main controller PCB
- incorrect machine settings or TCP/IP settings
- faulty main controller PCB, faulty mounting of the PCB
- faulty user network

2.4.2 Making a Check Using a Loop Back Address

A loop back address comes back before reaching the main controller PCB. Executing the PING command using it will enable a check on the TCP/IP settings of the machine.

- Type in the loop back address (127.0.0.1) for 'PING'.

- if 'NG' is indicated, check the TCP/IP settings of the machine, and execute the PING command once again.

- if 'OK' is indicated, check the local host address.

2.4.3 Making a Check Using a Local Host Address

A local host address is the IP address of the machine, and it comes back after reaching the main controller PCB, thus enabling a check on the machine itself.

- Type in the IP address of the machine for 'PING'

- if 'NG' is indicated, make the following checks or take the following action, and execute the PING command once again:

- the IP address of the machine may be faulty. Check with the system administrator to see if the IP address settings of the machine are correct and the IP address assigned to the machine is correct.

- the main controller PCB may have poor connection. Check the connectors of the main controller PCB.

- the main controller PCB may be faulty. Replace the controller PCB.

- if 'OK' is indicated, suspect a fault in the user's network environment. Report to the system administrator for remedial action.

2.5 Installing the Card Reader

2.5.1 Checking the Contents

T-2-1

[1]	Card reader unit	1 pc.
[2]	Screw (binding; B tight; M3x10)	4 pc.*
[3]	Screw (flat-head; small; M4x6)	1 pc.*

*No use in the iR7105/7095/7086 Series.

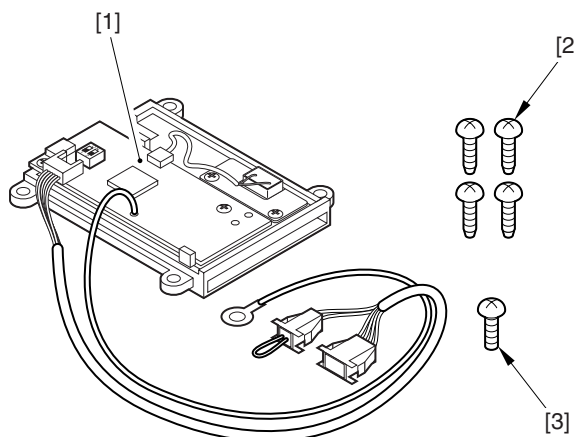

F-2-124

2.5.2 Installing the Card Reader-D1

- Start service mode, and make the following selections:

COPIER > FUNCTION > INSTALL > CARD;
then, type in the lowest of the card numbers to be used (1 through 2001). As many as 1000 cards starting with the number you have entered may be used.

- Go through the shut-down sequence to turn off the main power.
- Open the hopper cover [1].

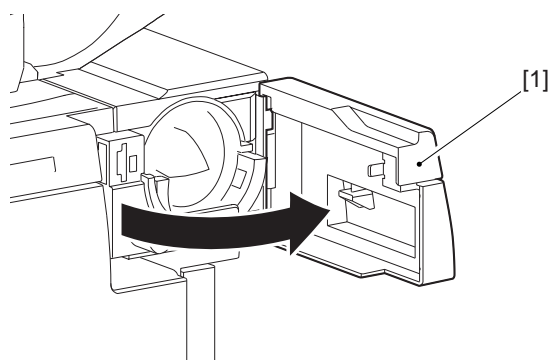

F-2-125

- 4) Open the front cover.
5) Slide out the fixing transport unit [1].

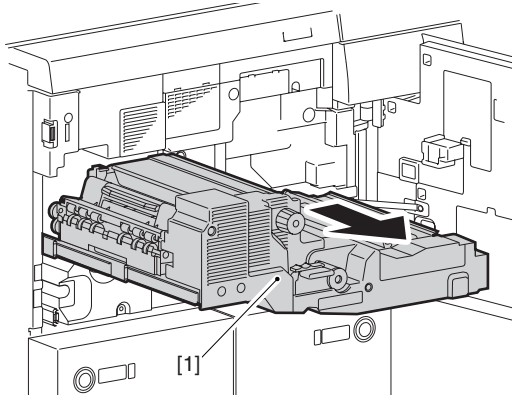

F-2-126

- 6) Remove the primary charging assembly front cover [1].
- screw [2]

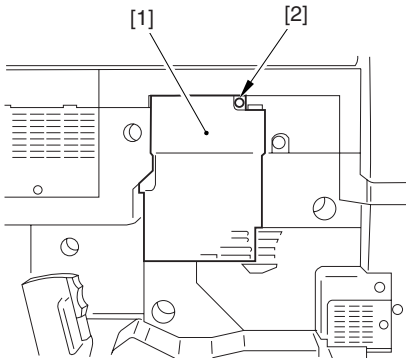

F-2-127

- 7) Remove the process unit cover [1].
- 4 screws [2]

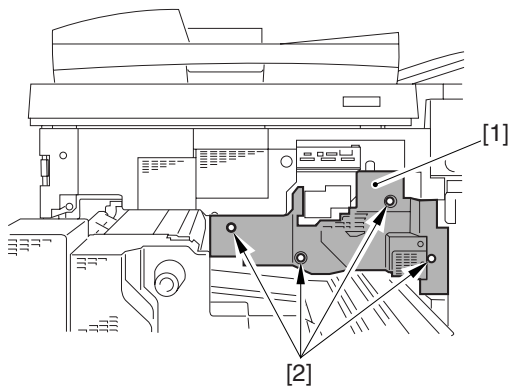

F-2-128

- 8) Disconnect the 3 connectors [1].

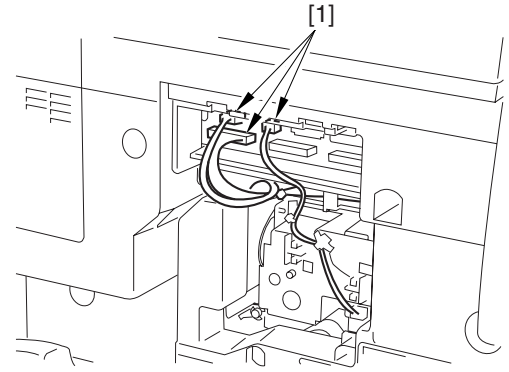

F-2-129

- 9) Remove the upper inside cover [1].
- 5 screws [2]

⚠
Do not drop the screws.

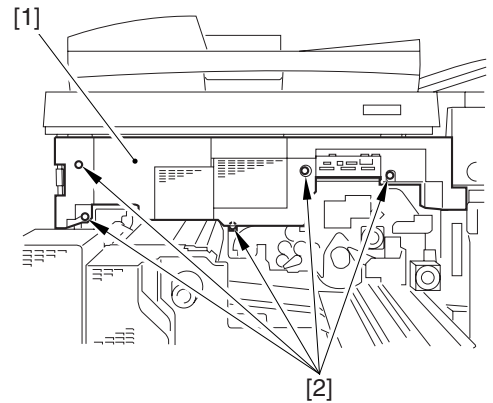

F-2-130

- 10) Remove the upper front cover unit [1].
- 3 screws [2]

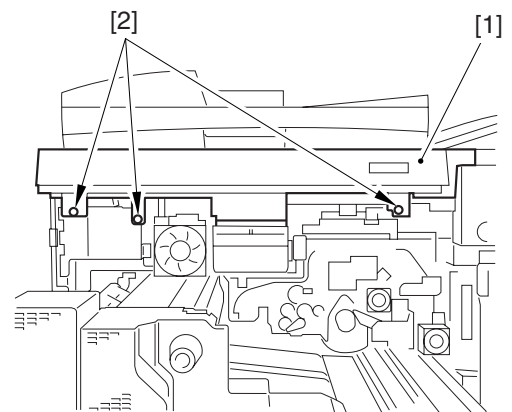

F-2-131

- 11) Remove the upper front cover unit lower cover [1].
- 8 screws [2]

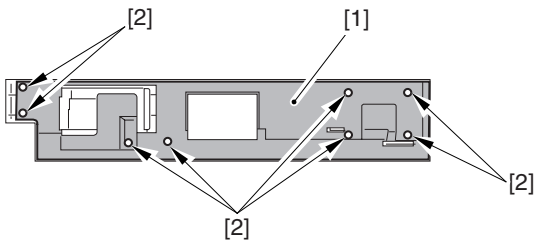

F-2-132

- 12) Remove the card reader base [1].
- screw [2]

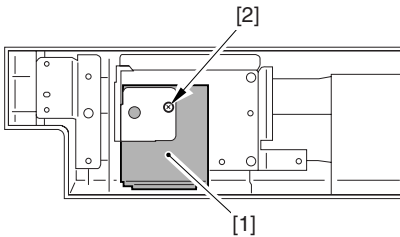

F-2-133

- 13) Remove the face plate [2] from the card reader base [1].
- 2 screws [3]
(The removed part will be used in step 18.)

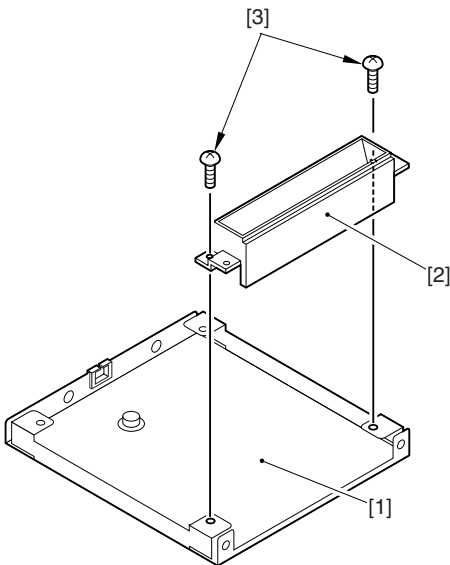

F-2-134

- 14) Remove the 2 screws [1] from the top of the card reader base.
15) Mount the card reader [3] using the 2 screws [2] used to hold the face plate in place and the 2 screws [1] you have removed previously.
16) Route the harness [4] and the grounding wire [5] under the card reader as shown and through the edge saddle [6].

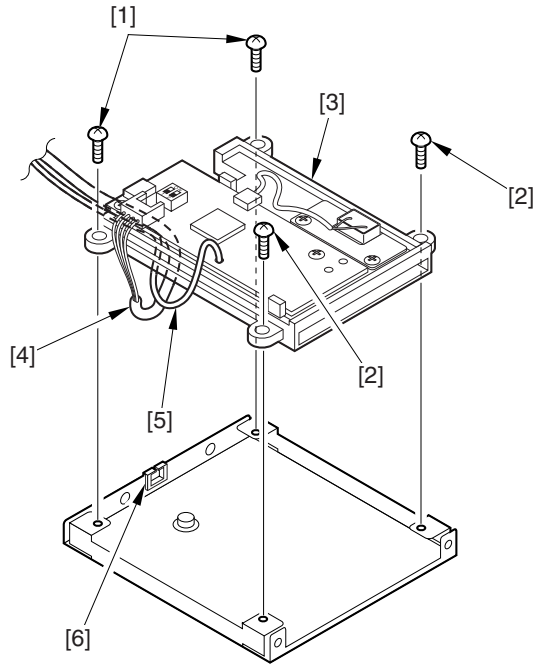

F-2-135

- 17) Remove the toothed screw [1] from the rear of the card reader base.
Fix the grounding wire [2] in place using the toothed screw [1] you have removed.

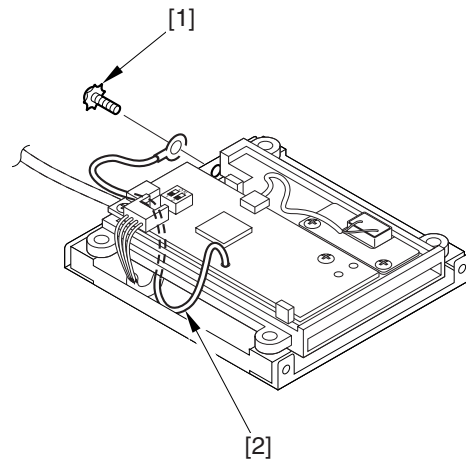

F-2-136

- 18) Remove the 2 screws [1] from the front of the card reader base.
Change the orientation of the face plate [2] you have removed in step 13), and fix it in place using 2 screws [1] you have removed previously.

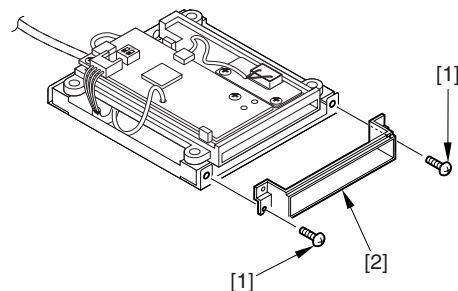

F-2-137

- 19) Mount the card reader base to the upper front cover unit.

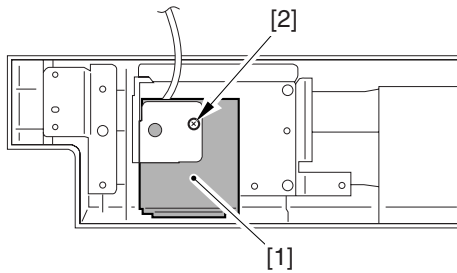

F-2-138

- 20) Mount the upper front cover unit lower cover to the upper front cover unit.



Take care not to trap the cable by the upper front cover unit and the upper front cover unit lower cover.

- 21) Lead the cable [1] of the card reader to the front of the upper front cover unit [2], and mount the upper front cover unit [2] to the machine.
- 3 screws [3]

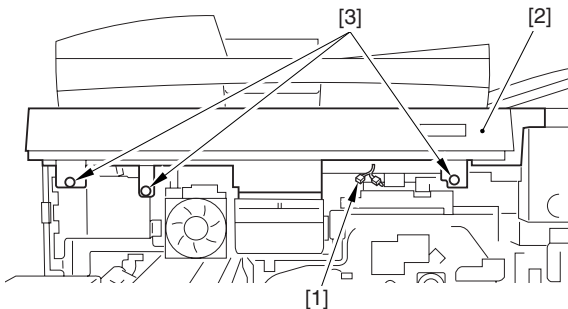

F-2-139

- 22) Connect the connector [1] of the machine and the relay connector [2] of the card reader.

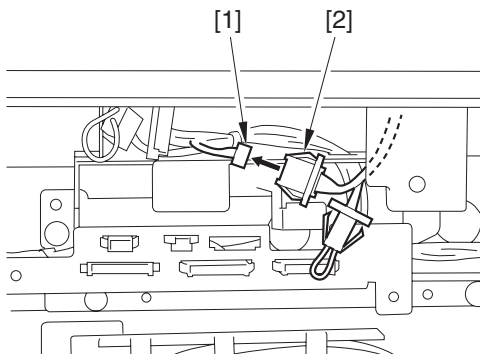

F-2-140

- 23) Mount the covers by going through the steps used to remove them but only in reverse:
- mount the upper inside cover.
- connect the connector.
- mount the process unit cover.
- mount the primary charging assembly front cover.
- push in the fixing transport unit.
- close the front cover and the hopper cover.
- 24) Connect the machine's power plug, and turn on the main power switch.

2.6 Installing the Voice Guidance Kit

2.6.1 Checking Items in the Package

Below are the items included in the Voice Guidance Kit package.

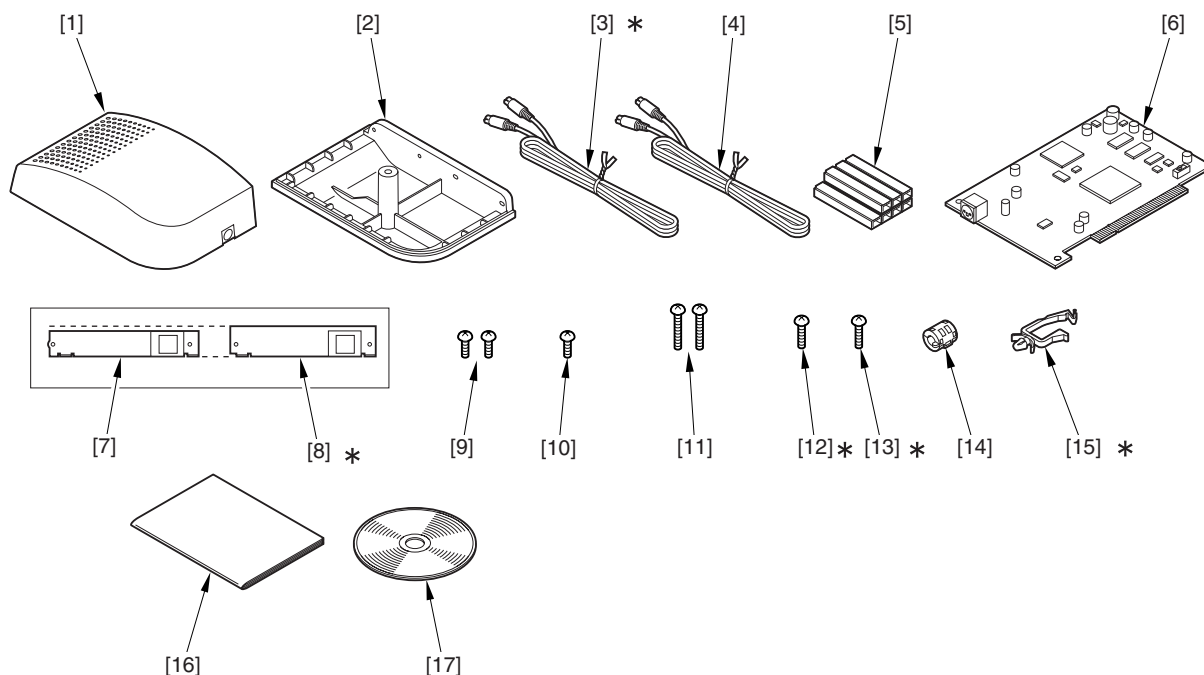

F-2-141

[1]	Speaker unit (upper)	1 pc.
[2]	Speaker unit (lower)	1 pc.
[3]*	Cable (1300mm)	1 pc.
[4]	Cable (1850mm)	1 pc.
[5]	Cord guide (4 cord guide to be used)	7 pc.
[6]	Voice Guidance Board	1 pc.
[7]	Voice Guidance Board Face Plate	1 pc.
[8]*	Voice Guidance Board Face Plate	1 pc.
[9]	Binding screw (M3X6)	2 pc.
[10]	Binding screw (M4X6)	1 pc.
[11]	Binding screw (M4X40)	2 pc.
[12]*	Binding screw (M3X16)	1 pc.
[13]*	Binding screw (M4X16)	1 pc.
[14]	Ferrite core	1 pc.
[15]*	Clamp	1 pc.
[16]	Users Guide	1 pc.
[17]	User Manual CD-ROM	1 pc.

*Not to be used for this machine

2.6.2 Turning Off the Host Machine

⚠ Turning Off the Main Power

When turning off the main power, be sure to go through the following in strict sequence to protect the machine's hard disk:

- [1] Hold down on the power switch on the control panel for 3 sec or more.
- [2] Operate on the touch panel according to the shut-down sequence indicated so that the main power switch may be turned off.
- [3] Turn off the main power switch.
- [4] Disconnect the power cable (for the power outlet).

2.6.3 Installation Procedure

1. Installation Procedure

⚠

Before starting to install the Voice Guidance Kit, check to be sure that the Expansion Bus-D1 has properly been installed.

2. Installation

- 1) Remove the main controller box cover [1].
- 10 screws [2]

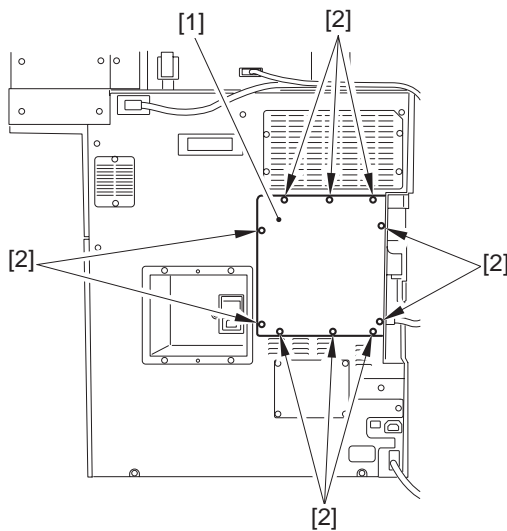

F-2-142

- 2) Mount the facing plate [2] to the voice board [1] by 2 binding screws (M3X6) [3].

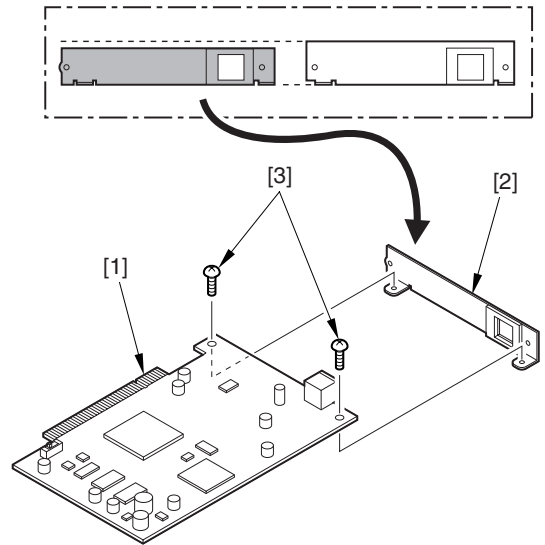

F-2-143

- 3) The slide switch SW1 found on the voice guidance board is set to 33 MHz at time of shipment; be sure to set it to 66 MHz for use on this machine.

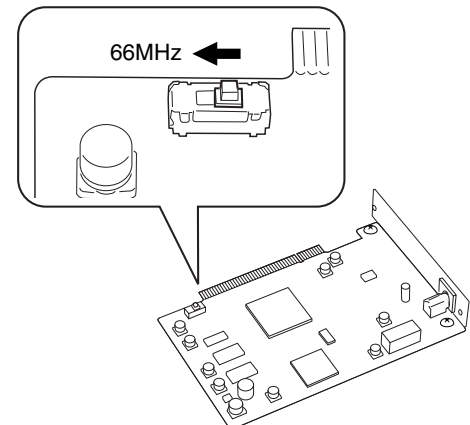

F-2-144

⚠ Checking the slide switch SW1 on the voice guidance board

The slide switch (SW1) on the Voice Guidance Board-A1 is provided as a means of switching frequencies (33 MHz/66 MHz) to suit the transfer speed of the PCI bus. It is important for the switch setting to suit the transfer speed so that the voice will be free of interruption. For the machine, 66MHz is the correct position of the switch.

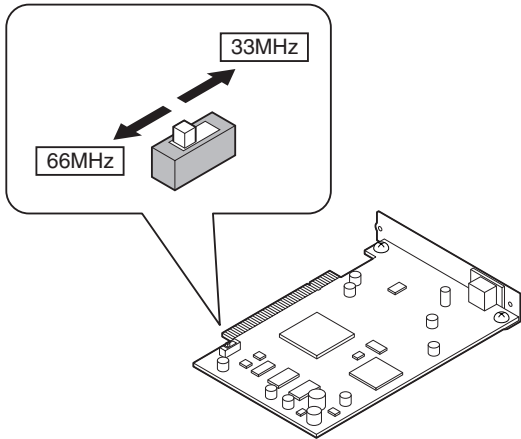

F-2-145

- 4) Remove the face plate [1].
- 2 screws [2]

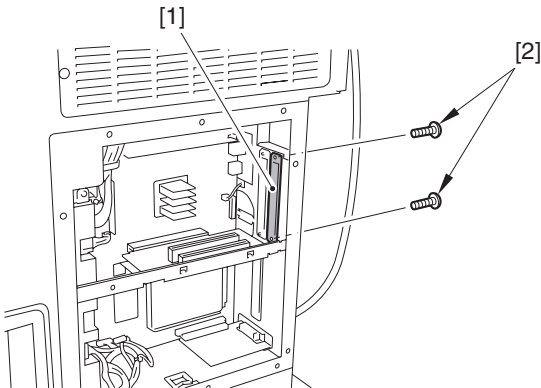

F-2-146

- 5) Fit the voice guidance board [1] into the slot found at the front of the Expansion Bus-D1; then, fix it in place using the 2 screws [2] removed in step 3).

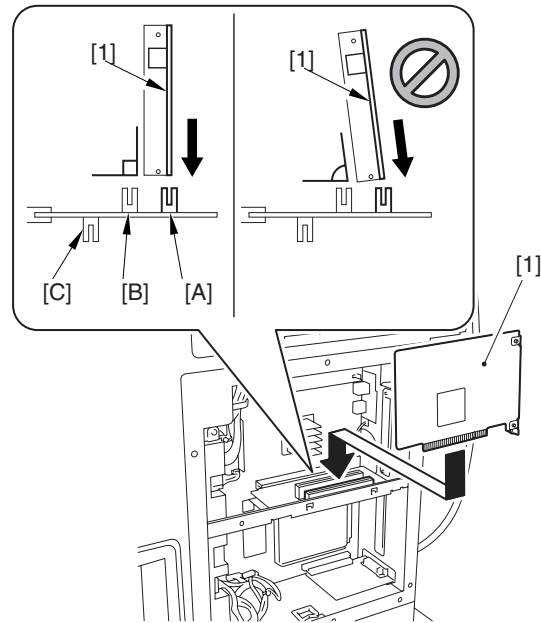

F-2-147

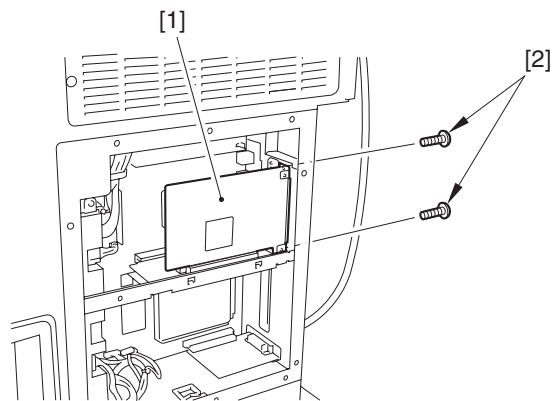

F-2-148

⚠ Points to Note

The Voice Guidance Kit [1] must be fitted in a specific slot. Be sure to use slot A of the Expansion Bus-D1, avoiding slots B and C.



If slot A has been taken, relocate the existing board, and use slot A for the Voice Guidance Board



Be sure to hold the PCB perpendicular in relation to the connector.

- 6) Attach the main controller box cover.

- 7) Remove the 2 rubber caps [1] and the 2 screws found on the upper right cover.

MEMO:

The removed rubber caps will no longer be used.

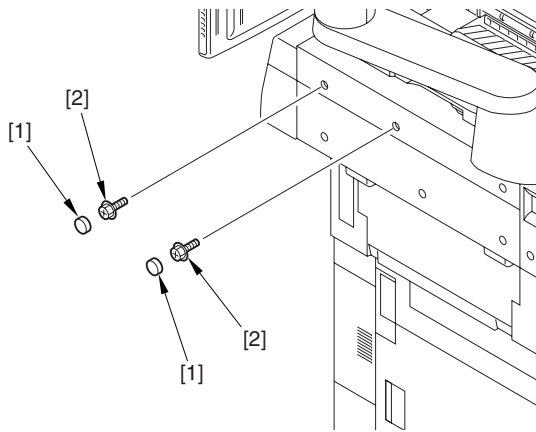

F-2-149

8) Attach the speaker unit (lower) [1] to the upper right cover of the machine using 2 screws (binding; M4x40) [2].

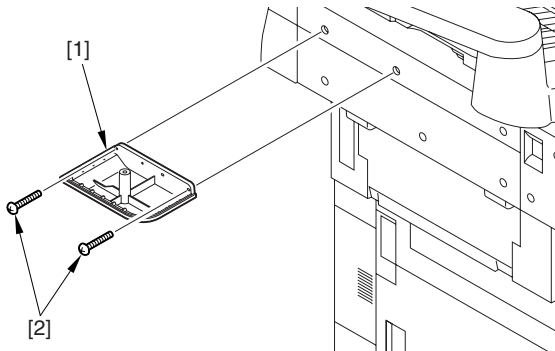

F-2-150

9) Mount the speaker unit (upper) [1] to the speaker unit (lower) you have mounted in step 8); then, secure it in place from below with a screw (binding; M4x6) [2].

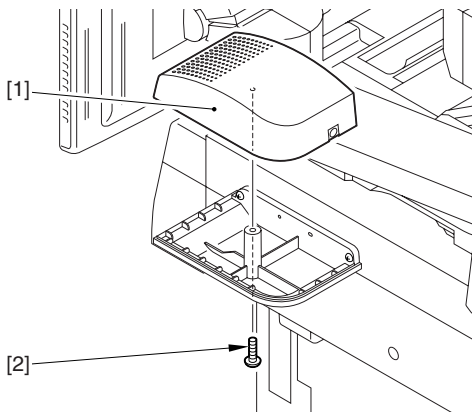

F-2-151

10) Remove a cord guide cover [1].

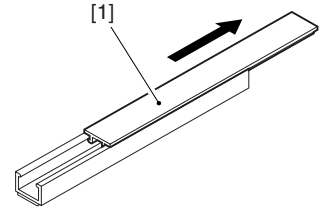

F-2-152

11) Peel off the release paper of cord guide [1] and affix them as shown in the figure.

right side: 2 locations

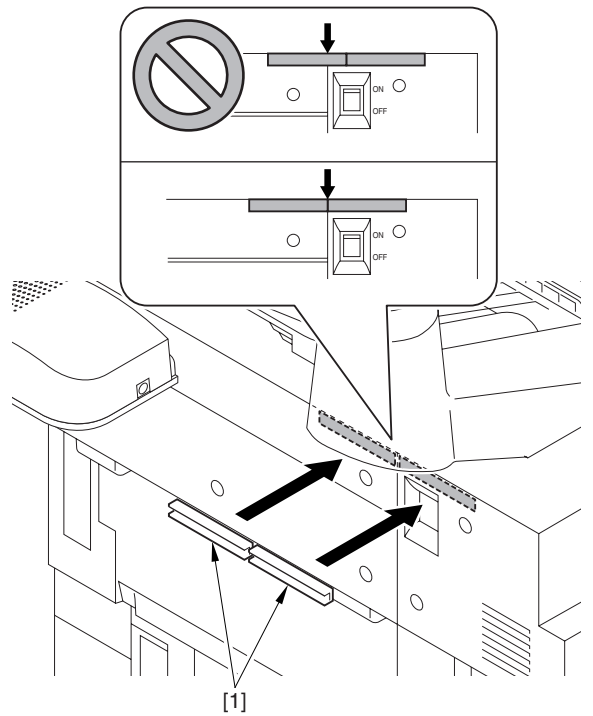

F-2-153

rear side: 4 locations

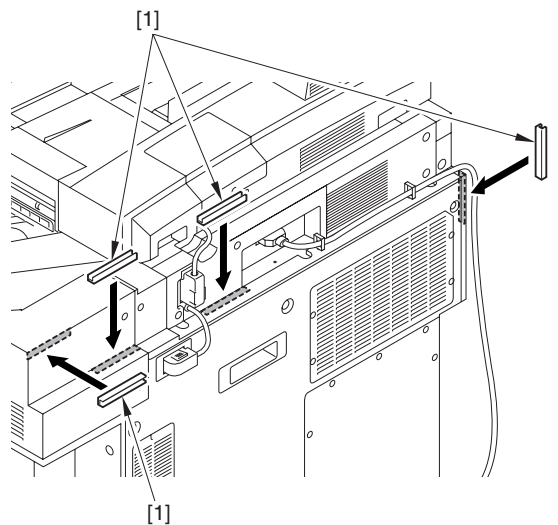

F-2-154

12) Plug the cable [2] into the speaker unit [1].

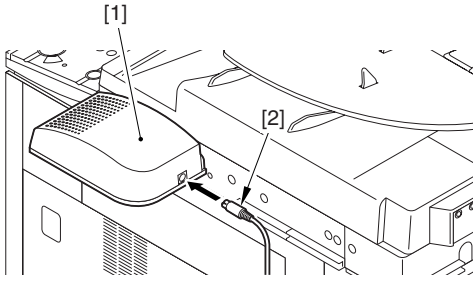

F-2-155

13) Run the cable [1] through the cord guide [2] and mount the cord guide cover [3].



Be sure that there is no slack of the cable.

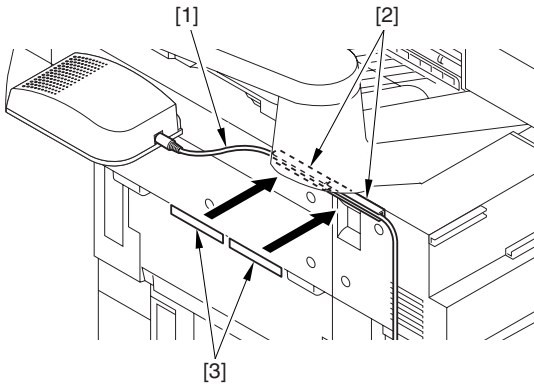

F-2-156

14) Route the cable [1] under the cable [2] and through the 4 cord guides [3]; then, fix it in place using the 2 clamps [4]. Attach the cord guide cover [5] (4 locations).



Be sure that there is no slack of the cable.

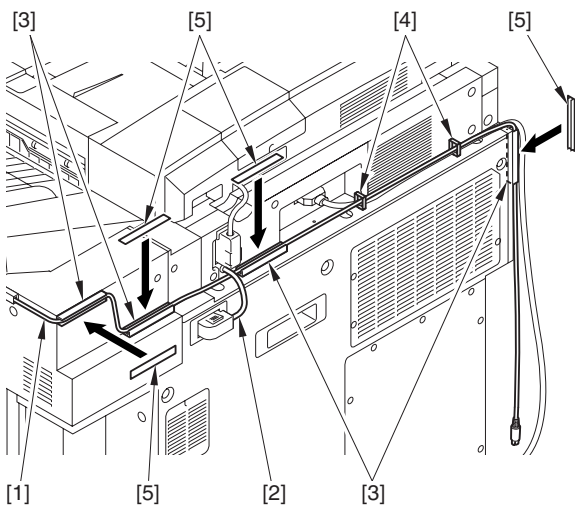

F-2-157

15) Mount the ferrite core [1] on the cable. The length [2] should be less than 50mm.

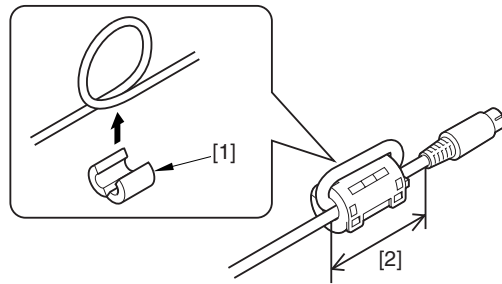

F-2-158

16) Plug the cable [1] into the terminal [2] of voice board.

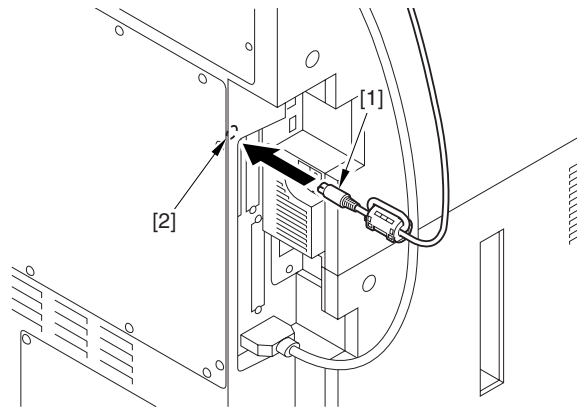

F-2-159

17) Plug the power cable of host machine into a wall outlet

18) Turn on the main power switch.

19) Check if the voice board is recognized.

Enter service mode ("⊗" -> "2" & "8" at the same time -> "⊗")

COPIER > DISPLAY > ACC-STS > PCI1

If 'voice board' is indicated for PCI1, the board is correctly recognized by the machine.

3. Making Settings After Installation

To make use of the Voice Guidance Kit-A2 after turning on the host machine, you need to make the following settings in Additional Function:

1) Additional Function > System Setting > Voice Guide Management Setting > Use Voice Guide.

2) Select [ON].

3) Press [OK].

default : OFF

4. Checking the Operation

- To Enable

1) Hold down the Reset key 3 sec or more.

2) See that the copy count on the screen is enclosed in red, indicating 'Voice Guidance' is ready for use.

- To Disable

1) Hold down the Reset key for 3 sec or more.

Chapter 3

Basic Operation

Contents

3.1 Construction.....	3- 1
3.1.1 Functional Construction	3- 1
3.1.2 Wiring Diagram of the Major PCBs.....	3- 2
3.1.3 Controlling the Main Motor (M1).....	3- 3
3.2 Basic Sequence	3- 4
3.2.1 Basic Sequence of Operations (power-on).....	3- 4

3.1 Construction

3.1.1 Functional Construction

The copier is divided into the following five functional blocks

- Original exposure system
- Laser exposure system
- Image formation system
- Pickup/feeding system
- Control system

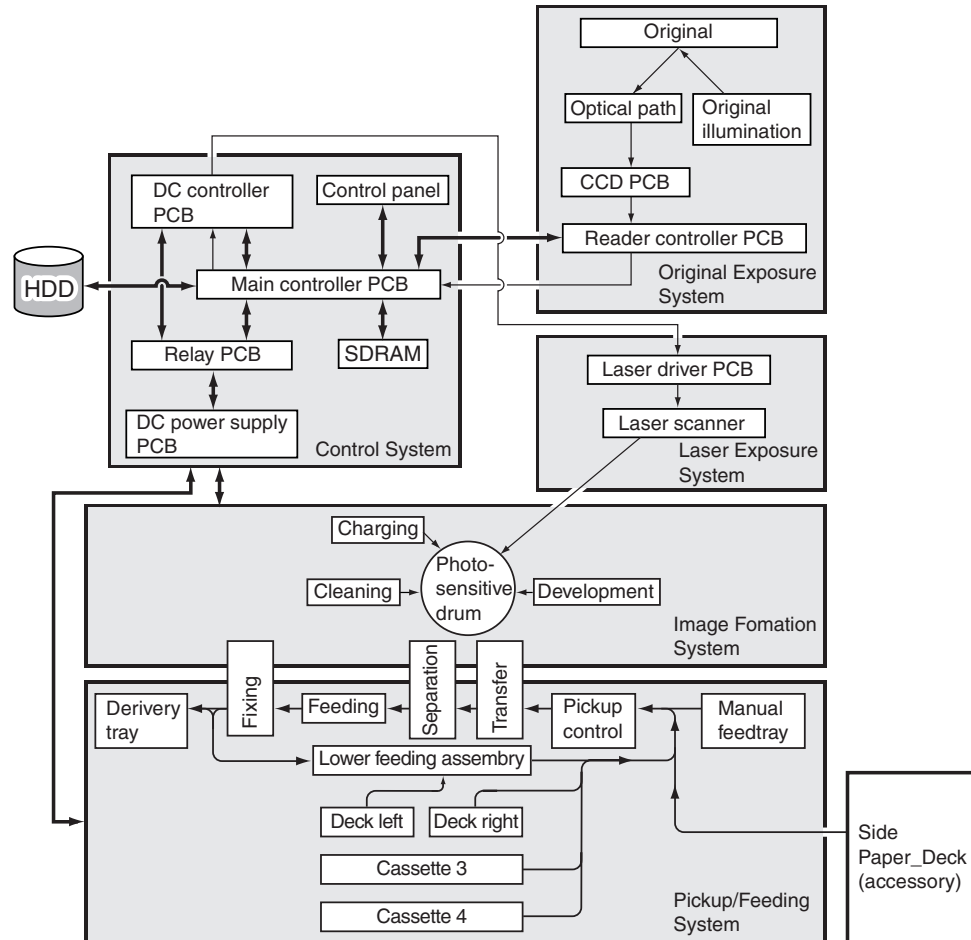

F-3-1

3.1.3 Controlling the Main Motor (M1)

Table shows the functions of the main motor control circuit, and Figure is a block diagram of the circuit.

T-3-1

Item	Description
Power supply	38 V from the relay PCB.
Drive signal	Signals (MAIN_MOTOR_ON) from the DC controller PCB.
Operating/drive assembly	Waste toner feeding screw Cleaner assembly Feeding belt Internal delivery roller External delivery roller Reversing roller Separation claw (reciprocating operation) Developing assembly unit (through CL10)
Control	ON/OFF control Constant speed control
Error detection	Error code E010

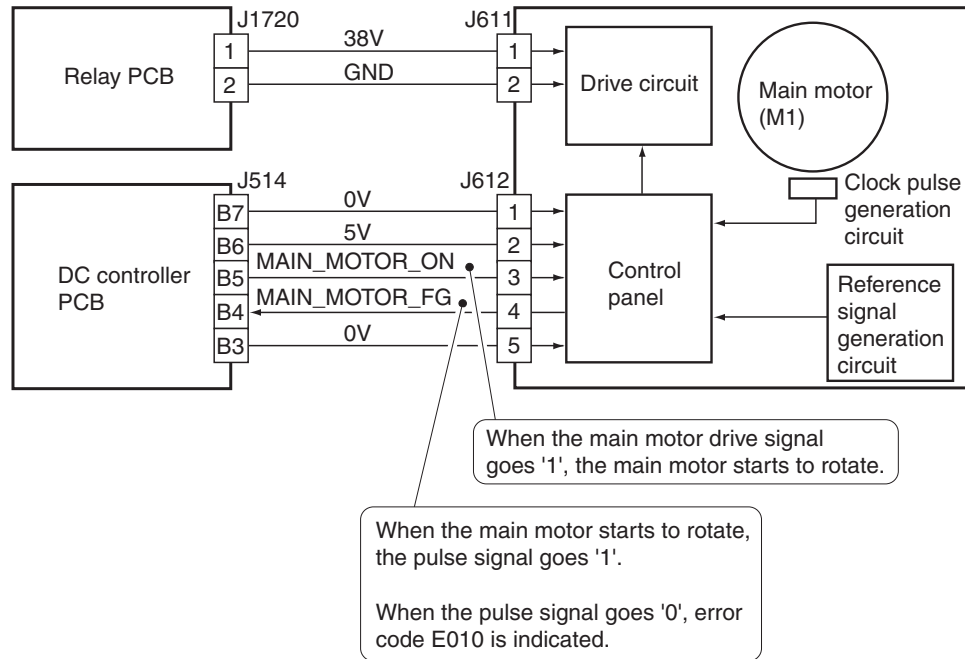

F-3-3

3.2 Basic Sequence

3.2.1 Basic Sequence of Operations (power-on)

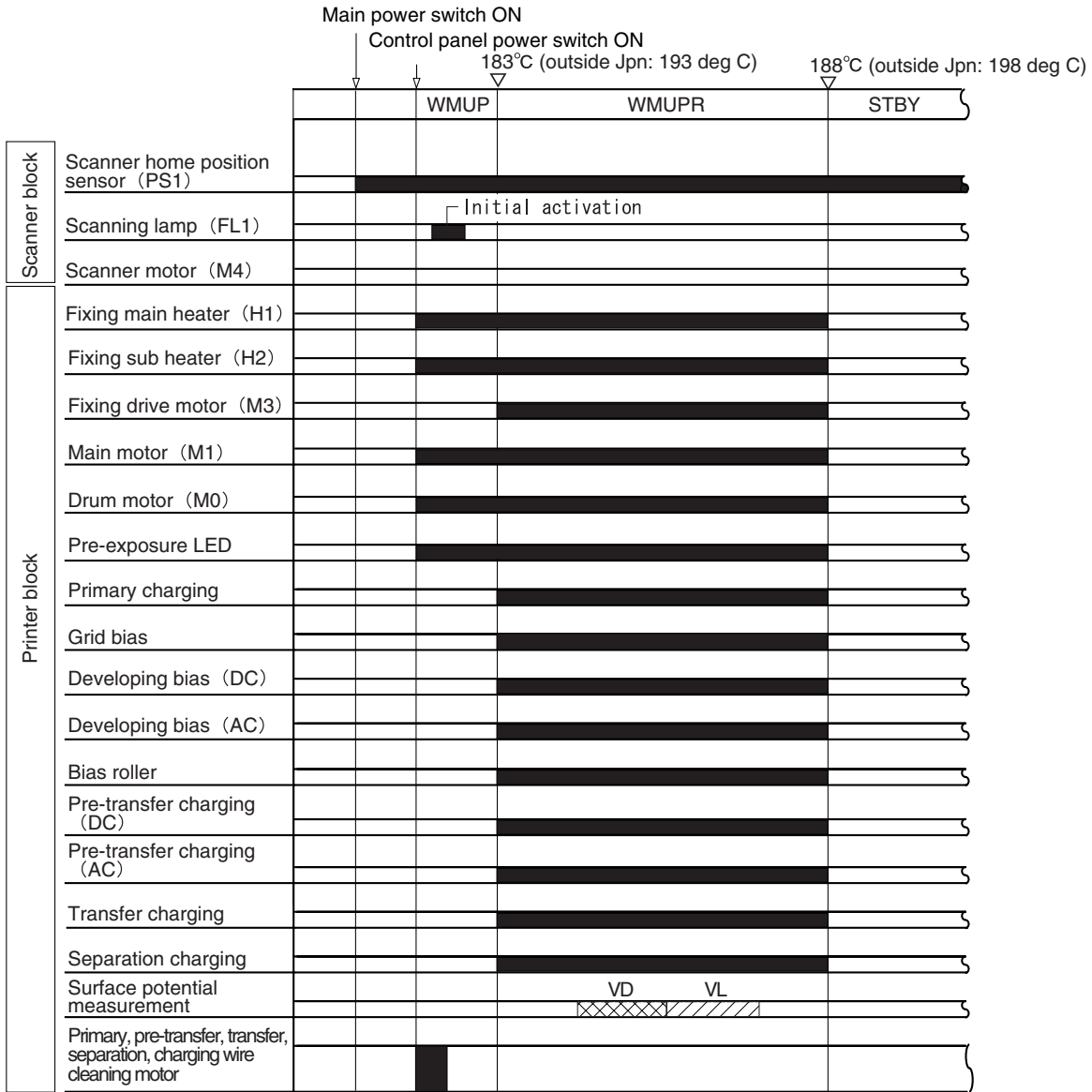

F-3-4
T-3-2

Period	Description
WMUP (warm-up)	From when the power switch is turned on to when the surface temperature of the fixing assembly reaches 193 degrees.
WMUPR (warm-up rotation)	To execute potential stabilization control and surface potential control.

Chapter 4

Main Controller

Contents

4.1 Construction.....	4- 1
4.1.1 Construction/Functions	4- 1
4.2 Construction of the Electrical Circuitry	4- 2
4.2.1 Main Controller PCB.....	4- 2
4.3 Start-Up Sequence	4- 3
4.3.1 Overview	4- 3
4.3.2 Start-Up Sequence	4- 3
4.3.3 Action to Take in Response to E602	4- 6
4.4 Shut-Down Sequence	4- 9
4.4.1 Flow of Operation	4- 9
4.5 Image Processing.....	4- 9
4.5.1 Overview of the Image Flow	4- 9
4.5.2 Configuration of the Image Processing Modules.....	4- 10
4.5.3 Reader Input Image Processing.....	4- 10
4.5.4 Compression/Expansion/Editing Block	4- 11
4.5.5 Printer Output Image Processing	4- 11
4.6 Parts Replacement Procedure	4- 12
4.6.1 Main Controller Box	4- 12
4.6.2 Main Controller PCB	4- 13
4.6.3 SDRAM	4- 16
4.6.4 Boot ROM.....	4- 16
4.6.5 HDD	4- 17
4.6.6 Video PCB	4- 18
4.6.7 Reader I/F PCB	4- 19
4.6.8 Controller Fan	4- 20

4.1 Construction

4.1.1 Construction/Functions

Component	Description
[1] Main controller PCB	controls the system; controls the memory; serves as an interface for printer/reader inputs/outputs; processes images; controls the control panel; controls the network communications
[2] SRAM	retains service mode settings and HDD management information (backed up by a lithium battery)
[3] DDR SDRAM (image memory)	temporarily stores image data; temporarily stores system software (capacity: 1 GB)
[4] Boot ROM	holds the start-up program
[5] Hard disk	retains image data; holds system software (40 GB)
[6] Lithium battery	backs up data in SRAM Life: about 10 years
[7] PCI slot (peripheral component interconnect)	connects the PCI expansion board (optional) using the functional expansion slot; the PCI expansion board accommodates an encryption board and a voice board (options)
[8] USB (H) port	USB 2.0 host I/F
[9] USB (D) port	USB2.0 device I/F
[10] Network port	Ethernet I/F
[11] Reader I/F PCB	Reader I/F
[12] Video PCB	executes pixel/line conversion; controls the laser scanner motor

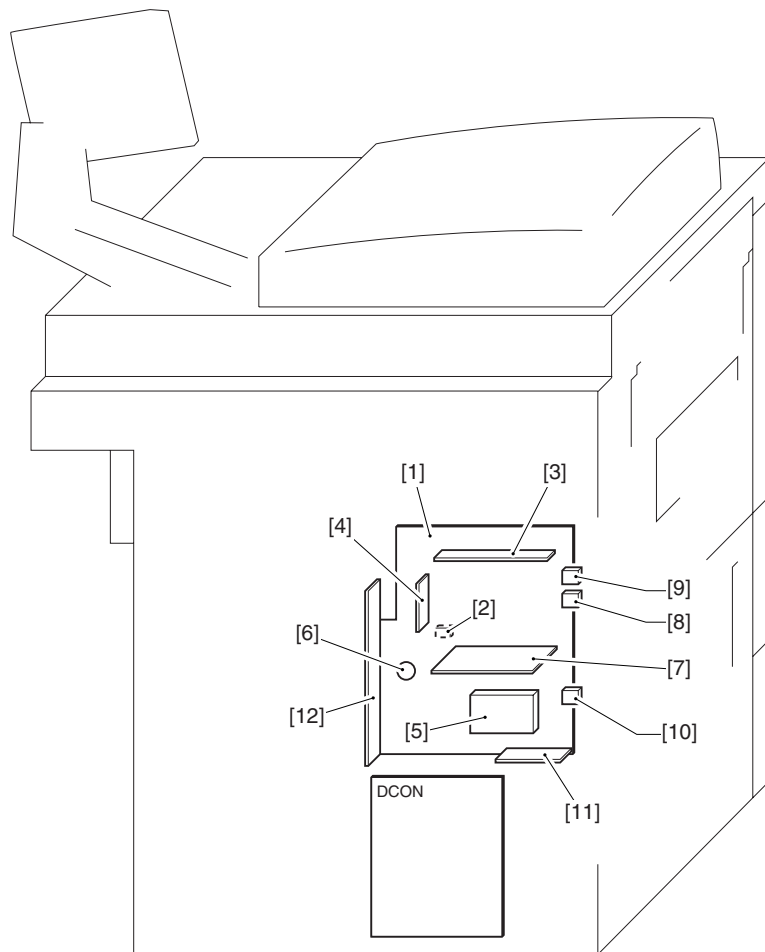

F-4-1

4.2 Construction of the Electrical Circuitry

4.2.1 Main Controller PCB

The following diagram shows the connectors found on the main controller PCB, each connector with its specific function described in the table that follows:

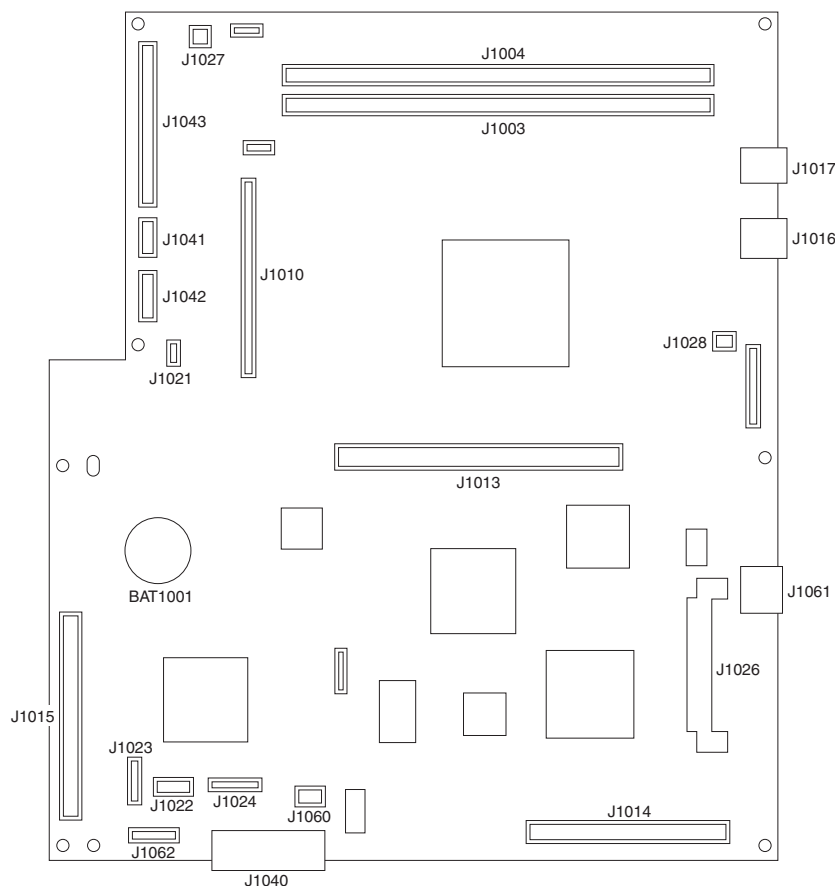

F-4-2

Notation	Name	Notation	Name
J1003	DDR SDRAM connection slot	J1026	Hard disk connector
J1004			
J1010	Boot ROM connection slot	J1027	Connector cooling fan/LCD power supply connector (12V)
J1013	PCI expansion board connection slot	J1028	Controller cooling fan power supply control connector
J1014	Reader I/F connector	J1040	Control panel connector (copier model only)
J1015	Printer I/F connector	J1041	Power supply connector (5V continuous)
J1016	USB host I/F connector	J1042	Power supply connector (3.3V continuous)
J1017	USB device I/F connector	J1043	Power supply connector (3.3V, continuous/non-continuous)
J1021	Power supply control connector	J1060	CC-V connector
J1022	NE controller connector	J1061	LAN connector
J1024	New card reader connector	J1062	New coin robot connector

4.3 Start-Up Sequence

4.3.1 Overview

The system software that controls the machine is stored on its HDD.

When the main power is turned on, the CPU on the main controller PCB loads the system software from the HDD to the work memory (DDR-SDRAM) of the main controller PCB according to the instructions of the boot program stored in the boot ROM.

While the CPU is initializing the memory or loading the system software, the following graphic will appear on the control panel screen, with a bar indicating the progress of processing under way:

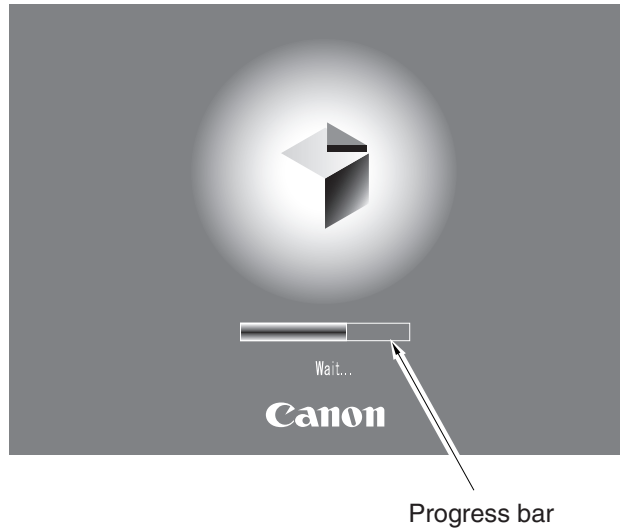

F-4-3



Do not turn off the main power while the progress bar is on the screen, indicating that the HDD is being accessed; otherwise, the HDD can suffer damage (E602).

4.3.2 Start-Up Sequence

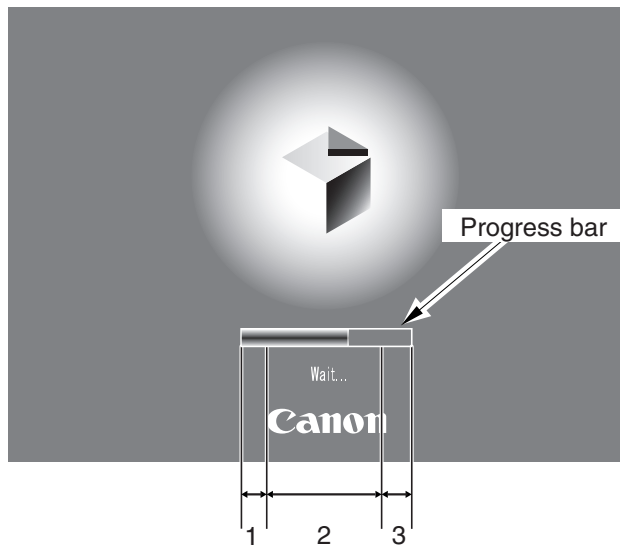

F-4-4

<Boot Program Area>**- Boot Program (interval 1)**

When the main power switch is turned on, the CPU on the main controller PCB runs a self-diagnostic program.

The machine checks the condition of the image memory (DDR-SDRAM) and the HDD, indicating an error code upon detection of a fault. If all is normal, the machine loads the control program from the HDD to the image memory.

- When Executing the Boot Program

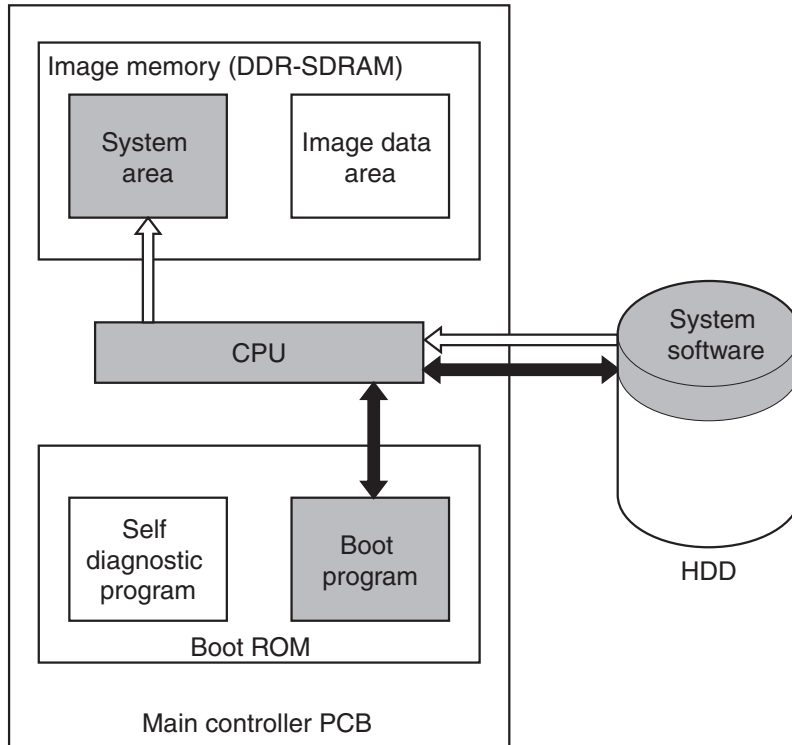

↔ : access to the program at time of execution.

⇔ : flow of system program operations.

F-4-5

<Control Program Area>**- Control Program 1 (interval 2)**

- 1) The machine checks and initializes the various hardware on the main controller PCB.
- 2) If the previous shut-down sequence was not performed normally, the machine recovers the system files as needed. (In this case, the start-up time tends to be longer than usual.)
- 3) The machine initializes the various program modules.

- Control Program 2 (interval 3)

- 1) The machine initializes the various software modules, and checks the configuration of the printer/reader.
- 2) If the printer/reader is found to be normal, the machine ends the start-up sequence; otherwise, it will indicate E732/E733.

- When Executing the Control Program

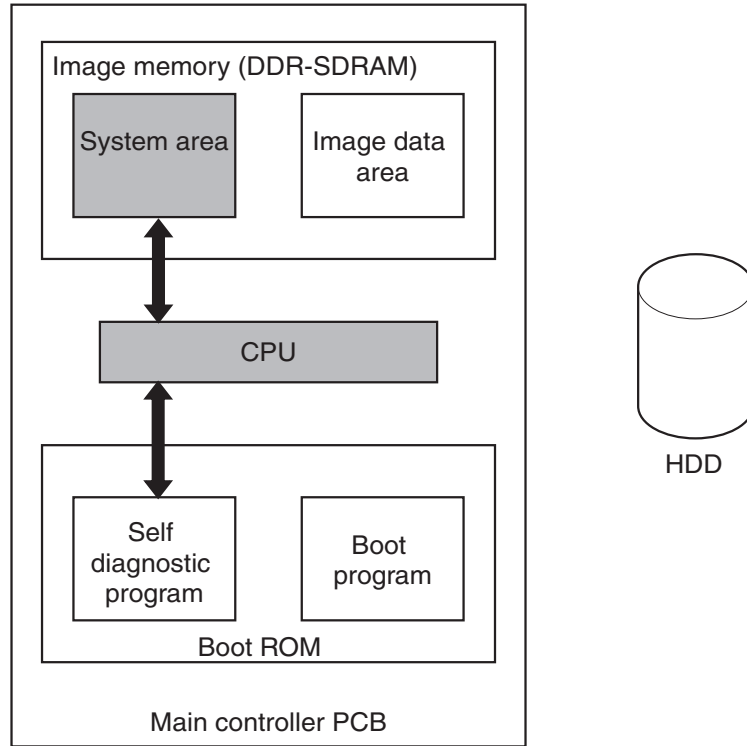

↔ : access to the program at time of execution.

F-4-6

When the start-up sequence ends normally, the machine becomes ready for a job.
(It shows a control screen in the control panel, and causes the Start Key LED to change from red to green.)

4.3.3 Action to Take in Response to E602

<E602-XXYY>

XX= "00"

T-4-1

XX	YY	Description	Action to take
00	01	The HDD cannot be recognized.	<ul style="list-style-type: none"> - Turn off the power, and check the HDD cable. Thereafter, turn off the power. - Turn on the power, and listen for a sound from the HDD or touch the HDD, to see if the HDD is rotating. - Replace the HDD, and reinstall the system software. - Replace the main controller PCB.
	02	There is no system software for the main CPU. At time of start-up, no start-up partition (BOOTDEV) is found.	<ul style="list-style-type: none"> - Start up in safe mode, and perform full formatting using the SST and reinstall the system software; then, turn off and then on the power. - Replace the HDD, and reinstall the system software.
	03	An interrupt has been detected while data is being written to the boot device.	<p>Take action according to the type of error code screen: <error code screen is black-and-white></p> <ul style="list-style-type: none"> - Turn off the power, and turn on the power while holding down the 1 and 9 keys. <p>In response, the machine will automatically start to repair the sector in which the write operation has been interrupted. (The screen changes to solid black.) While repairs are being made, the progress of processing will be indicated on the screen, turning white at its end. When done, turn off and then back on the power.</p> <ul style="list-style-type: none"> - Start up in safe mode, and perform full formatting using the SST and reinstall the system software; then, turn off and the back on the power. - Replace the HDD, and reinstall the system software. <p><error core screen is normal (spanner mark)></p> <ul style="list-style-type: none"> - Set CHK-TYPE=0, and execute HD-CHECK; then, turn off and then back on the power. - Start up in safe mode, and execute full formatting using the SST and reinstall the system software; then, turn off and back on the power. - Replace the HDD, and reinstall the system software.
	06	No system software is found for the sub CPU.	<ul style="list-style-type: none"> - Start up in safe mode, and perform full formatting using the SST and reinstall the system software; then, turn off and then back on the power. - Replace the HDD, and reinstall the system software.
	12	A file used by the Web browser to make references is damaged, or has been deleted.	<ul style="list-style-type: none"> - Reinstall the content of the Web browser. - Replace the HDD, and reinstall the system software.

XX= "01" to "FF"

T-4-2

XX				YY					
XX	CHK - TYP E	Partition	Description	Occurrence at time of start-up			Occurrence during normal execution		
				03	05	00,0 1,02, 04	11,2 1	13,2 5	10,12, 14,22, 23,24
				Action			Action		
01	1	FSTDEV	compressed image data (e.g., Box)						
02		IMG_MNG	file management table, profile						
03		FSTCDEV	job archiving (changing)						
04	2	APL_GEN	general-purpose data	*1	*5				
05		TMP_GEN	general-purpose data (temporary file)						
06		TMP_FAX	not used						
07		TMP_PSS	for PDL spool (temporary file)						
08	3	PDLDEV	PDL-related file						
09	4	BOOTDEV	firmware (system, MEAP, key, certificate, PDF dictionary, RUI, content, voice dictionary)	*3	*8	*9	*10	*11	*12
10	5	APL_MEA P	MEAP application	*1	*5				
11	6	APL_SEN D	address book, filter	*2	*6				
12	7	APL_KEEP	for non-initialization data storage	*3	*8				
13	8	APL_LOG	system log	*1	*5				
FF	0	not specified	check for and recovery of HDD full-fault sectors	*4	*7				

	YY	Description	Action
*1	03	The ongoing write operation is interrupted (at start-up).	- Set the partition number in question for CHK-TYPE, and execute HD-CLEAR; then, turn off and then back on the power. - Enter CHK-TYPE in question (for the partition), and execute HD-CLEAR; then, turn off and then back on the power.
*2			- Ask the user to download the address book data using a remote UI. - Set the partition number in question for CHK-TYPE, and execute HD-CLEAR; then, turn off and then back on the power. - Start download mode, and perform full formatting using the SST and reinstall the system software; then turn off and then back on the power.
*3			The recovery operation for the boot partition is not possible without the use of the SST in save mode. - Set CHK-TYPE=0, and execute HD-CHECK; then, turn off and then back on the power. - Start download mode, and perform full formatting using the SST and reinstall the system software; then, turn off and then back on the power.
*4			- Set CHK-TYPE=0, and execute HD-CHECK; then, turn off and then back on the power. - Set CHK-TYPE=1, 2, 3, 5, and execute HD-CLEAR; then, turn off and then back on the power.

	YY	Description	Action
*5			- Enter CHK-TYPE in question (for the partition), and execute HD-CLEAR; then, turn off and then back on the power. - Replace the HDD, and reinstall the system software.
*6	05	A file system error has occurred.	The machine is designed so that execution of HD-CLEAR is not possible in service mode (so as to prevent loss of information, e.g., address book, filter information). - Ask the user to download the address book data using a remote UI. - In service mode, start download mode, and execute full formatting using the SST and reinstall the system software; then, turn off and then back on the power.
*7			- Set CHK-TYPE=1, 2, 3, 5, and execute HD-CLEAR; then, turn off and then back on the power. - Replace the HDD, and reinstall the system software.
*8			The recovery operation for the boot partition is not possible without the use of the SST in save mode. - Start up in safe mode, and execute full formatting using the SST and reinstall the system software; then, turn off and back on the power. - Replace the HDD, and reinstall the system software.
*9	00 01 02 04	The HDD has poor contact, or a system error has occurred.	- Check the cable and the power cord. - Start up in safe mode, and execute full formatting using the SST and reinstall the system software; then, turn off and back on the power. - Replace the HDD, and reinstall the system software.
*10	11 21	The HDD has poor contact.	- Check the cable and the power cord. - Replace the HDD, and reinstall the system software.
*11	13 25	The ongoing write operation has been interrupted.	There is a strong possibility of damage in the file data (e.g., Box) stored on the HDD. - Set the partition number in question for CHK-TYPE, and execute HD-CHECK; then, turn off and back on the power. - Set the partition number in question for CHK-TYPE, and execute HD-CLEAR; then, turn off and back on the power. (In the case of BOOTDEV, BOOTDEV2 or APL_SEND, execute reformatting using the SST, and reinstall the system software.) - Replace the HDD, and reinstall the system software.
*12	10 12 14 22 23 24	A system error or a packet error has been detected.	- Start up in safe mode, and perform full formatting using the SST and reinstall the system software; then, turn off and back on the power. - Replace the HDD, and reinstall the system software.

4.4 Shut-Down Sequence

4.4.1 Flow of Operation

If the main power is turned off while the HDD is being accessed, the HDD can suffer damage. It is, therefore, important to perform the shut-down sequence (HDD protection mode), which will stop the ongoing access to the HDD and enable the machine to be turned off safely.

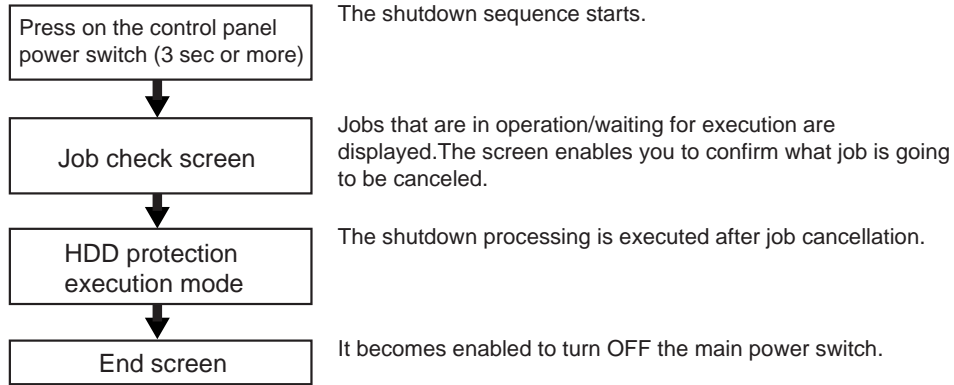

F-4-7

4.5 Image Processing

4.5.1 Overview of the Image Flow

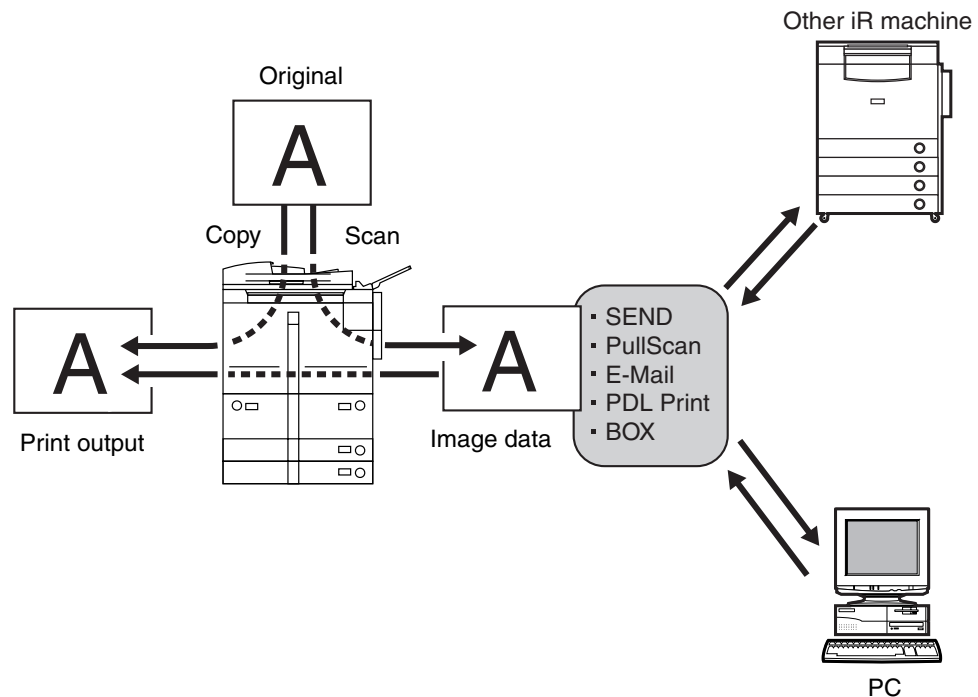

F-4-8

4.5.2 Configuration of the Image Processing Modules

The machine primarily uses the main controller PCB for image processing. The following shows the construction of the modules associated with image processing:

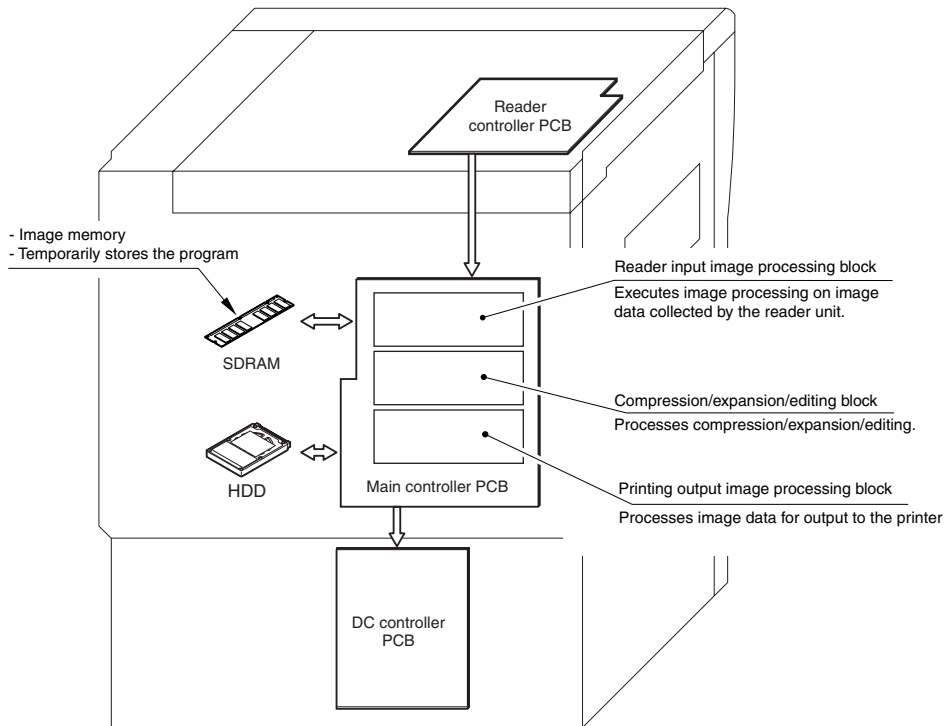

4.5.3 Reader Input Image Processing

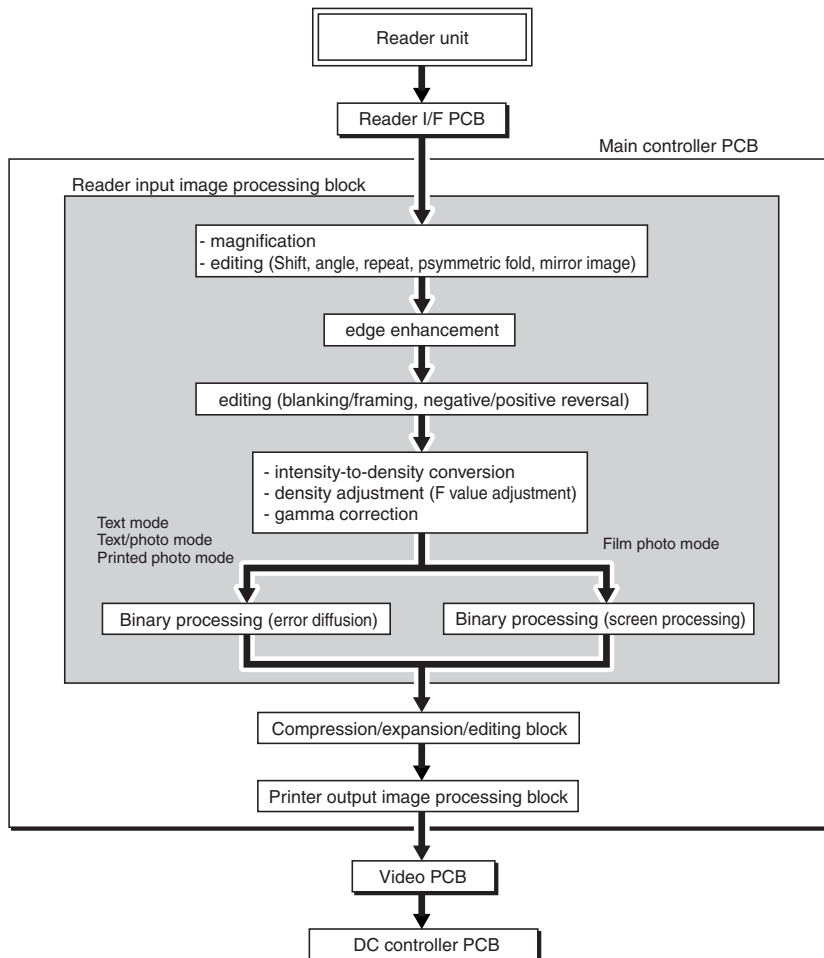

F-4-9

4.5.4 Compression/Expansion/Editing Block

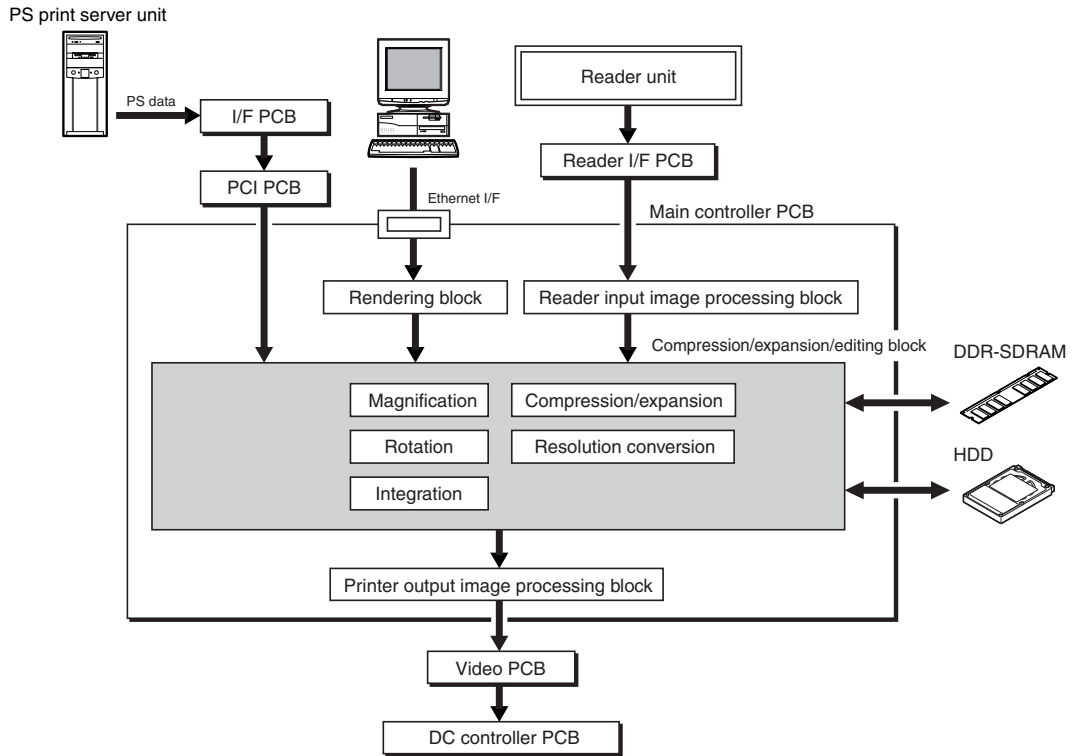

4.5.5 Printer Output Image Processing

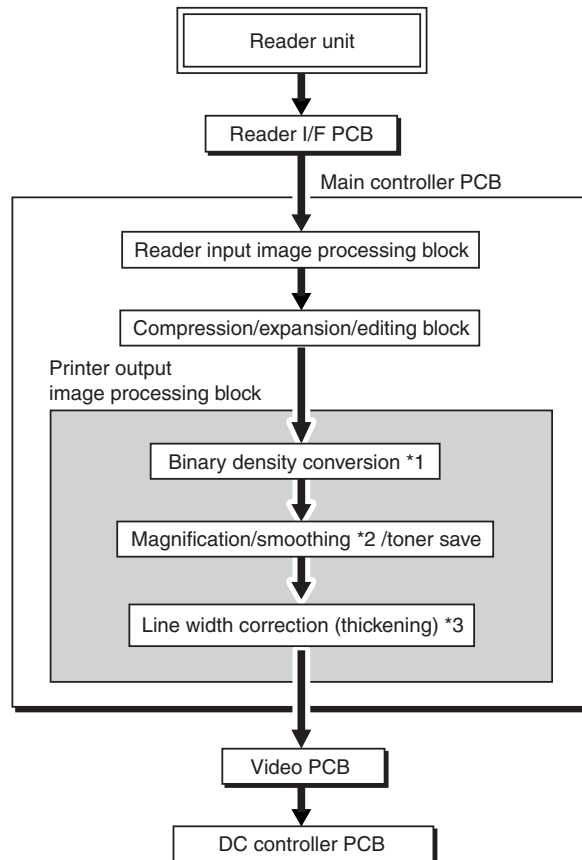

F-4-10

*1: only at time of copying.

*2: only in text mode and text/photo mode.

*3: may be set for print (user mode).

Printer Settings > Settings > Print Quality > Horizontal Line Refinement, Vertical Line Refinement

4.6 Parts Replacement Procedure

4.6.1 Main Controller Box

4.6.1.1 Making Preparations

- 1) Remove the main controller box cover [1].
- 10 screws [2]

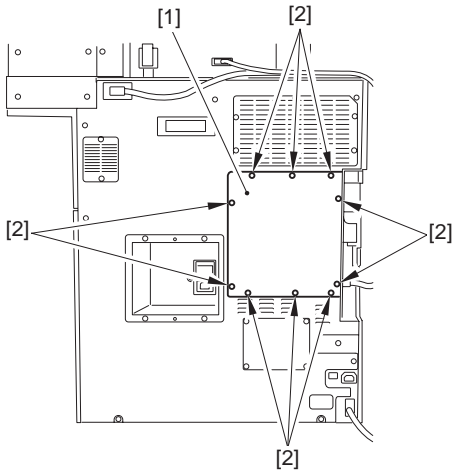

F-4-11

- 2) Remove the rear cover [1].
- reader power cable [2]
- 8 screws [3]

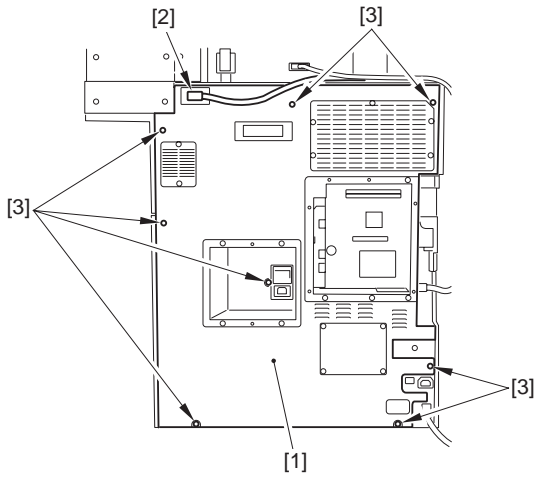

F-4-12

- 3) Disconnect the reader communications cable [1].

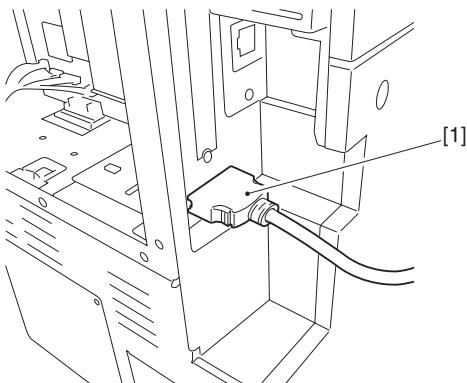

F-4-13

4.6.1.2 Removing the Main Controller Box

- 1) Disconnect the connector [1].

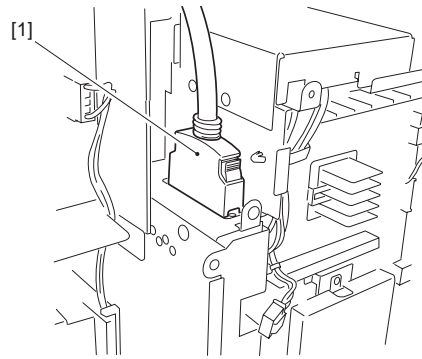

F-4-14

- 2) Disconnect the connector [1], and free the cable from the edge saddle [2].

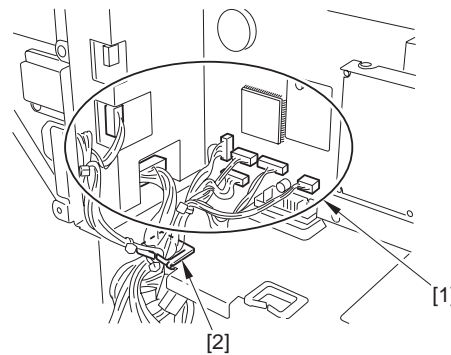

F-4-15

- 3) Free the cable [1] from the wire saddle [2].

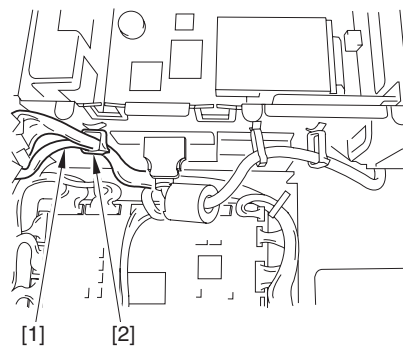

F-4-16

- 4) Disconnect the connector [1], and free the cable [2] from the 2 wire saddles [3].

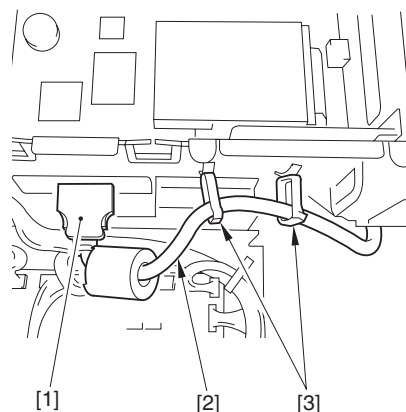

F-4-17

- 5) Open the main controller box [1].
- 4 screws [2]

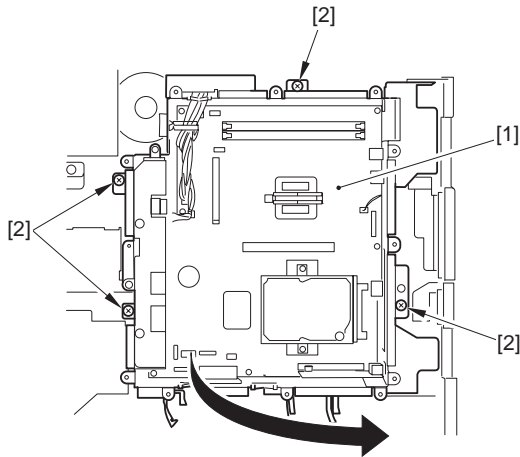

F-4-18

- 6) Remove the main controller box [1].
- connector [2]
- 2 hinges [3]

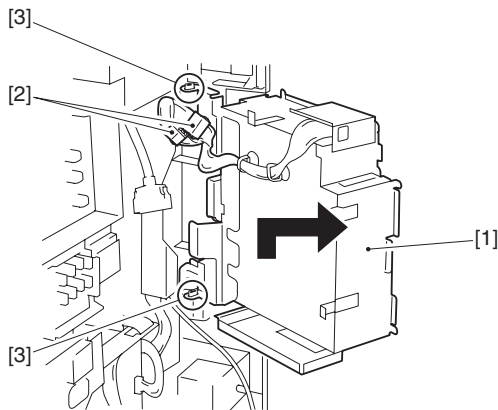

F-4-19

4.6.2 Main Controller PCB

4.6.2.1 Making Preparations

- 1) Remove the main controller box cover [1].
- 10 screws [2]

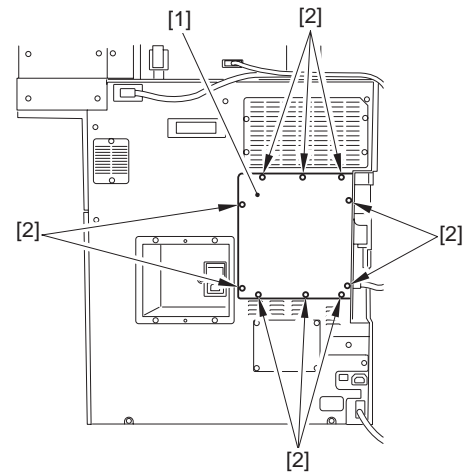

F-4-20

- 2) Remove the rear cover [1].
- reader power cable [2]
- 8 screws [3]

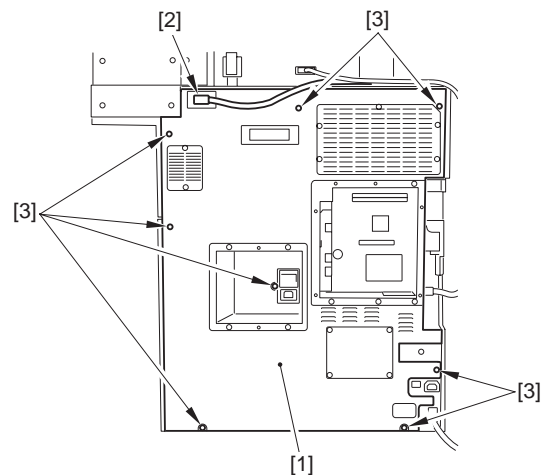

F-4-21

- 3) Disconnect the reader communications cable [1].

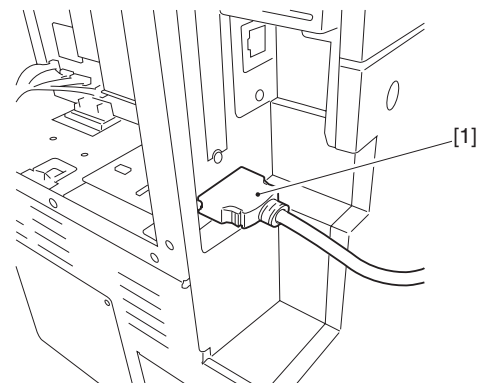

F-4-22

- 4) Remove the reader I/F PCB [1].
- 2 screws [2]

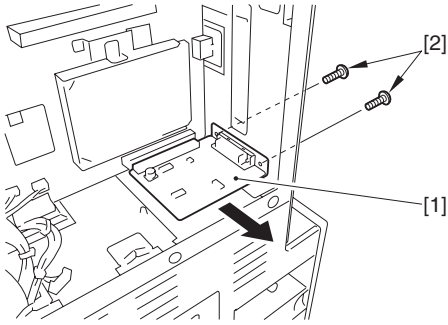

F-4-23

- 5) Disconnect the 4 connectors [1] of the video PCB.

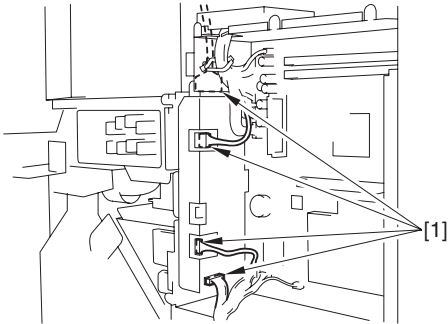

F-4-24

- 6) Remove the video PCB unit [1].
- 2 screws [2]

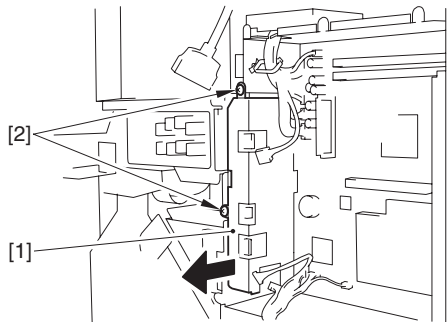

F-4-25

4.6.2.2 Removing the Main Controller PCB

- 1) Disconnect the 11 connectors [1].

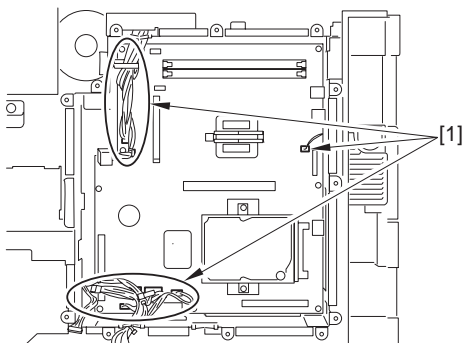

F-4-26

- 2) Remove the main controller PCB [1].
- 9 screws [2]
- 2 screws [3] (using a precision screwdriver)

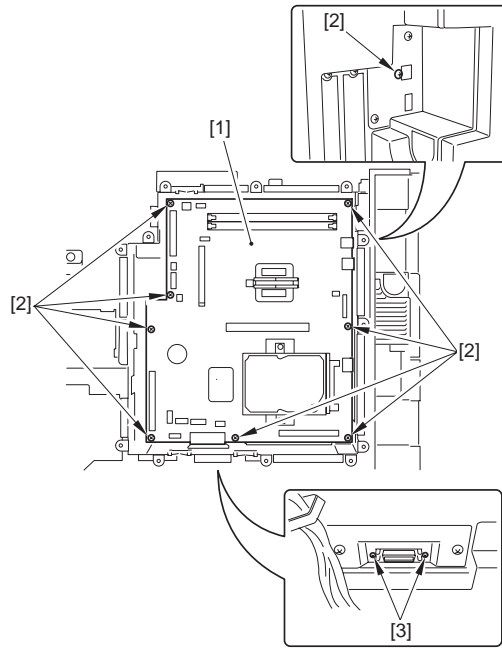

F-4-27

4.6.2.3 When Replacing the Main Controller PCB

⚠ Before Starting the Work (backing up the data)

If possible, perform the following:

- Using the SST, download the data stored in the RAM of the main controller.
- Print out the user mode/service mode data.

- If you are replacing the main controller PCB, be sure to physically transfer the following from the existing to the new PCB:

- [1] BootROM
- [2] HDD
- [3] image memory (DDR-SDRAM)
- [4] counter memory PCB

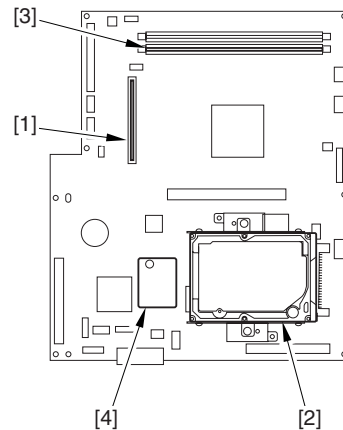

F-4-28

MEMO: Image memory (DDR-SDRAM)

The machine is equipped with the following image memory:

capacity: 1 GB

quantity: 1 pc.

Use one of the 2 slots. There is no optional memory for expansion.

- 1) Turn on the power. If there is a backup of the SRAM data (i.e., if downloaded using the SST), upload it.
- 2) Execute the following service mode item:
COPIER > FUNCTION > CLEAR > CA-KEY (Level 2)
- 3) Turn off and then on the power.

MEMO:

Execution of the following may delete the keys/certificates used for encrypted communications and the CA certificates used for authentication of external server certificates:

- replacement/formatting of the HDD
- replacement of the main controller PCB/initialization of the RAM

If a key/certificate for encrypted communications has been deleted, the control panel screen will indicate a message to the effect that the key has been corrupted; however, the key/certificate/CA certificate installed at time of shipment from the factory may be

brought back by executing the following: COPIER>FUNCTION>CLEAR>CA-KEY. If doing so has failed, use the SST to install the key/certificate/CA certificate, and execute CA-KEY once again.

▲ Points to Note When Executing Service Mode Item CA-KEY

If the user has generated/added a key/certificate/CA certificate on his/her own, executing CA-KEY will also delete these files. Inform the user of this, and ask him/her to re-install them as necessary after the execution of CA-KEY.

▲ Points to Note When Fitting the Security Expansion Board

Whenever possible, do not replace the main controller PCB as part of the troubleshooting work conducted in relation to the installation of the security expansion board (option).

The machine checks the compatibility between the HDD and the main controller PCB when a security expansion board is installed. Replacement with a new board will cause the formatting of the HDD to start automatically, thus deleting all user data.

Data item deleted	Backup possibility
address data registered in the address book	Yes
settings made in user mode	Yes *1
settings stored in memory	Yes
license file for MEAP application	Yes
user authentication information stored using SDL (simple device login)	Yes
data stored using MEAP application	Yes *2
mode memory stored using copy function or Box function	No
data in Box	Yes *3
read mode settings stored using transmission function	No
files yet to be read (those selected for timer transmission or reserved for transmission)	No
forms stored for image synthesis	No
MEAP application	No
password for MEAP SMS (service management services); returns to factory default	No
job history information	No
user authentication information stored in relation to SSO (local device authentication)	Yes
key pairs and server certificates stored in conjunction with system control settings	No

*1: limited to those settings that may be exported using a remote UI or transmitted as part of machine information.

*2: limited to when the MEAP application in question offers a backup function.

*3: limited to data within the User Box.

When Replacing the Main Controller PCB

- Explain to the user that all user data will be deleted.

- As necessary, ask the user to make a backup of those data items that permit making of a backup.

- Explain to the user that the following data items do not permit making of a backup, and require remedial action:

<Suggestions for Remedial Action>

- for mode settings stored using the copy/Box function, ask the user to newly enter the settings.

- for read mode settings stored using the transmission function, ask the user to newly enter the settings.

- for files that are yet to be transmitted (i.e., files for selected timer transmission or reserved for transmission), ask the user to newly transmit them.

- for registered forms used in image synthesis, ask the user to newly enter them.
- for MEAP applications, ask the user to newly install them.
- for MEAP SMS (service management services) passwords, access the following: <http://<iR IP address>:8000/SMS>. (Use the factory password "MeapSmsLogin" (case-sensitive) to log in and change the password.
- for job histories, if a record is needed, ask the user to store away the history using a remote UI. (However, there is no way of returning the history to the HDD.)
- for key pairs and server certificates, if the user has added any, ask for re-installation.

4.6.3 SDRAM

4.6.3.1 Making Preparations

- 1) Remove the main controller box cover [1].
- 10 screws [2]

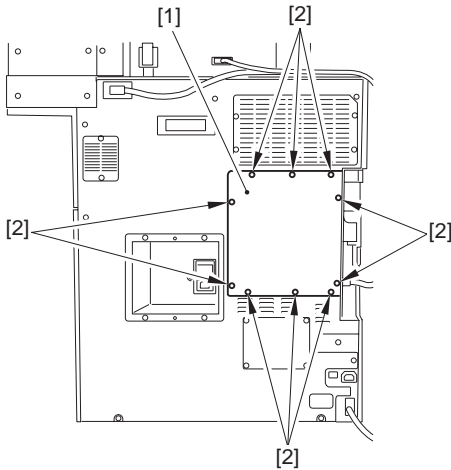

F-4-29

4.6.3.2 Removing the DDR-SDRAM

- 1) Free the 2 fixing levers [1] of the slot, and detach the DDR-SDRAM [2].

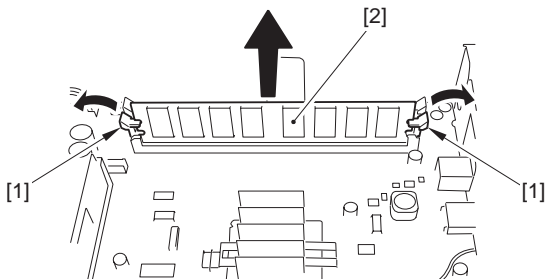

F-4-30

4.6.4 Boot ROM

4.6.4.1 Making Preparations

- 1) Remove the main controller box cover [1].
- 10 screws [2]

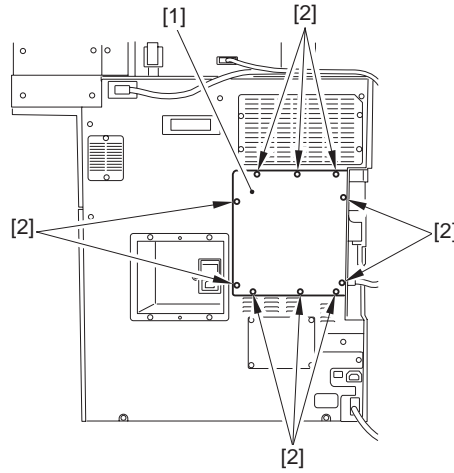

F-4-31

4.6.4.2 Removing the Boot ROM

- 1) Free the fixing lever [1], and detach the boot ROM [2].

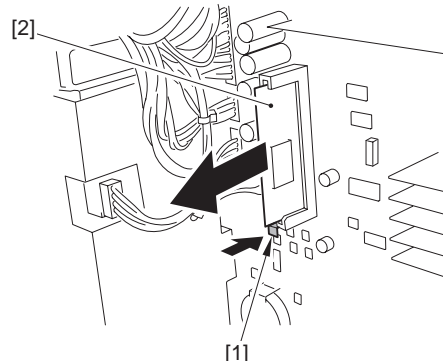

F-4-32

4.6.5 HDD

4.6.5.1 Points to Note on Handling the Hard Disk



Keep the following in mind when attaching/removing the hard disk.

1. Take countermeasures against electrostatic before work to prevent the hard disk from being damaged by electrostatic discharge.
2. Do not give a shock to the hard disk.

4.6.5.2 Making Preparations

- 1) Remove the main controller box cover [1].
- 10 screws [2]

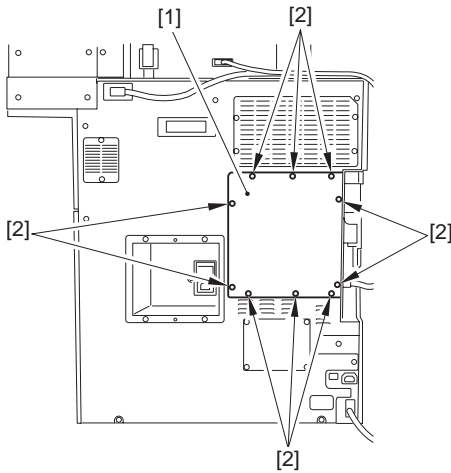

F-4-33

4.6.5.3 Removing the Hard Disk

- 1) Remove the counter PCB [1].
- screw [2]

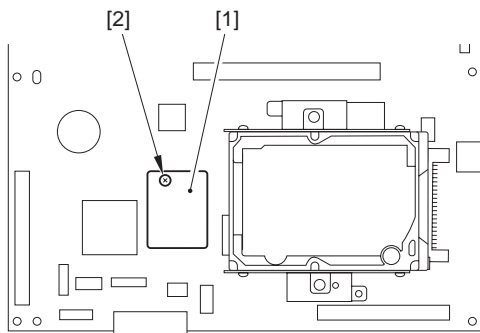

F-4-34



Be sure to remove the counter PCB before removing the hard disk, which otherwise could hit the PCB and suffer damage.

- 2) Remove the hard disk [1].
- 2 screws [2]

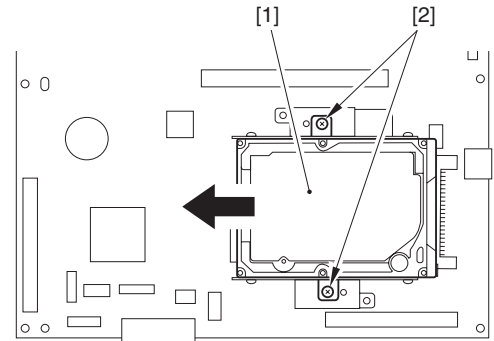

F-4-35

4.6.5.4 Points to Note When Mounting the Hard Disk

- When mounting the hard disk, fit the claw [1] found on the back of the hard disk into the opening [2] of the hard disk mounting plate; then, push it in horizontally. If the connector of the hard disk is at an angle in relation to the socket (on the main control PCB), forcing it in could well damage the connector.

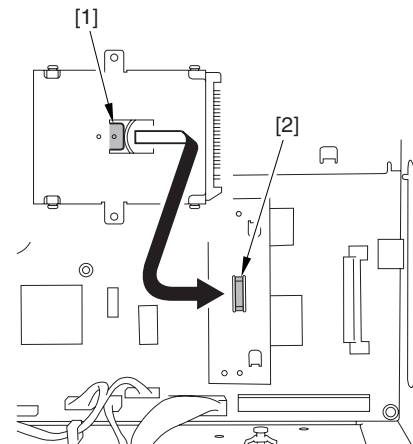

F-4-36

4.6.5.5 After Replacing the Hard Disk

1) Formatting the HDD

Start up the machine in safe mode (i.e., turn on the main power while holding down the 2 and 8 keys).

Using the HD formatting function of the SST, execute full partition formatting. (For details, see the chapter on upgrading.)

2) Downloading the System Software

Using the SST, download the following: System, LANG, RUI, PS-FONT, OCR dictionary, SSL encryption key, SSL CA certificate, MEAP content.

3) Execute the following service mode item:

COPIER > FUNCTION > CLEAR > CA-KEY (Level 2)

4) Turn off and then on the power.

MEMO:

Execution of the following may delete the keys/certificates used for encrypted communications and the CA certificates used for authentication of external server certificates:

- replacement/formatting of the HDD
- replacement of the main controller PCB/initialization of the RAM

If a key/certificate for encrypted communications has been deleted, the control panel screen will indicate a message to the effect that the key has been corrupted: however, the key/certificate/CA certificate installed at time of shipment from the factory may be

brought back by executing the following: COPIER>FUNCTION>CLEAR>CA-KEY. If doing so has failed, use the SST to install the key/certificate/CA certificate, and execute CA-KEY once again.

▲ Points to Note When Executing Service Mode Item CA-KEY

If the user has generated/added a key/certificate/CA certificate on his/her own, executing CA-KEY will also delete these files. Inform the user of this, and ask him/her to re-install them as necessary after the execution of CA-KEY.

4.6.6 Video PCB

4.6.6.1 Making Preparations

- 1) Remove the main controller box cover [1].
- 10 screws [2]

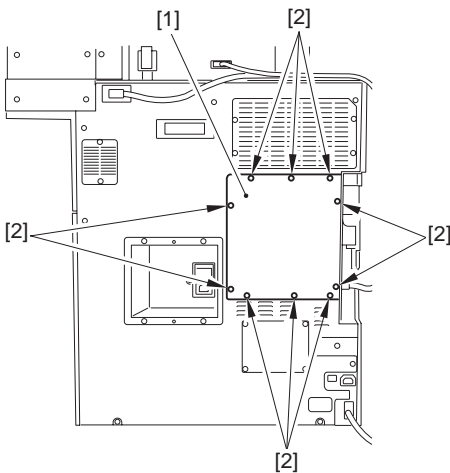

F-4-37

- 2) Remove the rear cover [1].
- reader power supply cable [2]
- 8 screws [3]

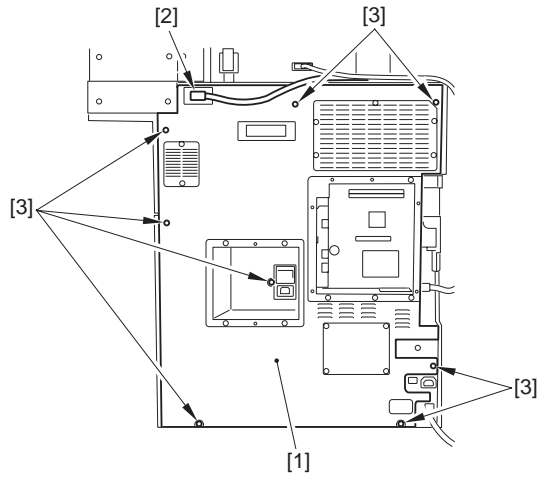

F-4-38

4.6.6.2 Removing the Video PCB

- 1) Disconnect the 4 connectors [1] of the video PCB.

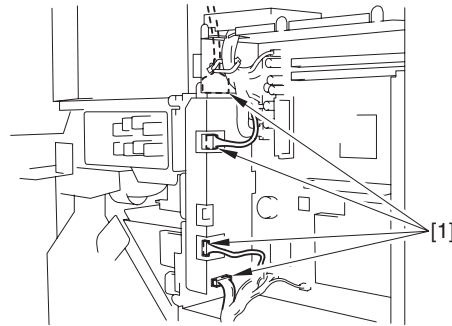

F-4-39

- 2) Remove the video PCB unit [1].
- 2 screws [2]

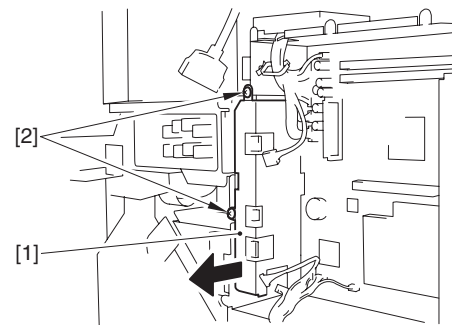

F-4-40

- 3) Remove the shielding plate [1].
- 4 screws [2]

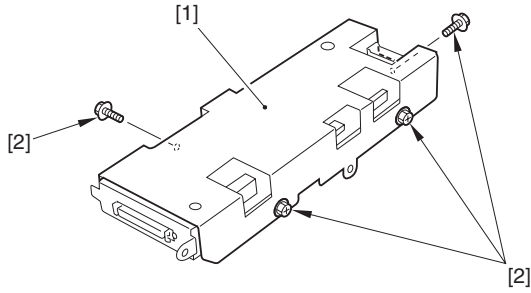

F-4-41

- 4) Remove the video PCB [1].
- 2 screws [2]
- 6 screws [3]

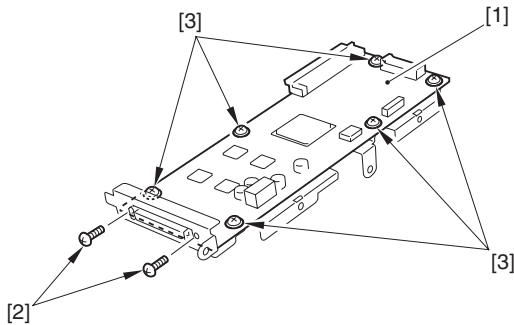

F-4-42

4.6.7 Reader I/F PCB

4.6.7.1 Making Preparations

- 1) Remove the main controller box cover [1].
- 10 screws [2]

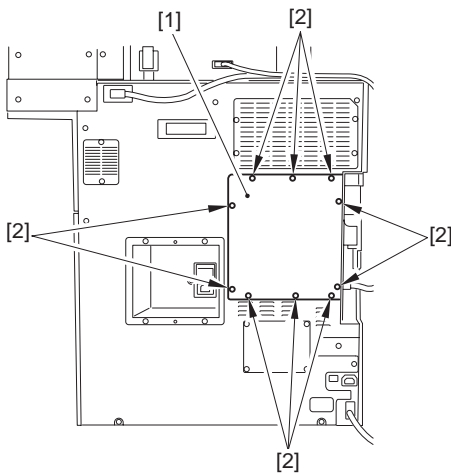

F-4-43

- 2) Remove the rear cover [1].
- reader power cable [2]
- 8 screws [3]

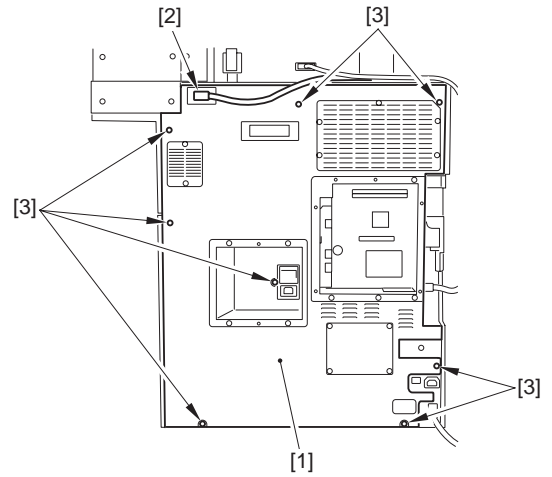

F-4-44

- 3) Disconnect the reader communications cable [1].

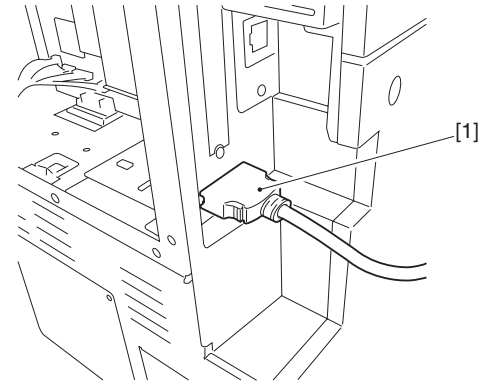

F-4-45

4.6.7.2 Removing the Reader I/F PCB

- 1) Remove the reader I/F PCB [1].
- 2 screws [2]

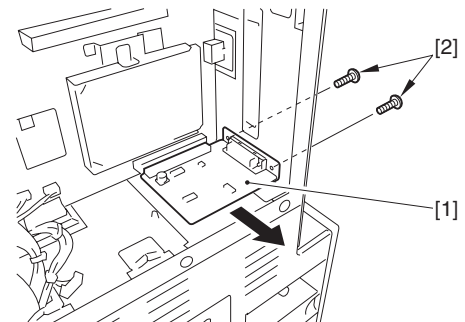

F-4-46

4.6.8 Controller Fan

4.6.8.1 Making Preparations

- 1) Remove the main control box cover [1].
- 10 screws [2]

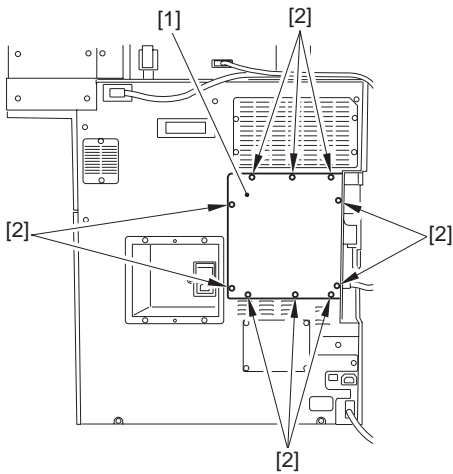

F-4-47

- 2) Remove the rear cover [1].
- reader power cable [2]
- 8 screws [3]

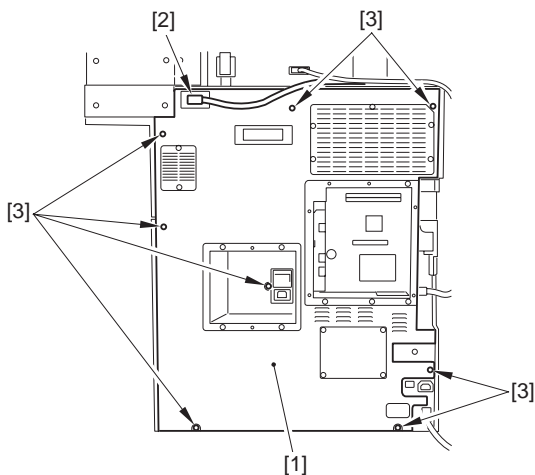

F-4-48

- 3) Disconnect the reader communications cable [1].

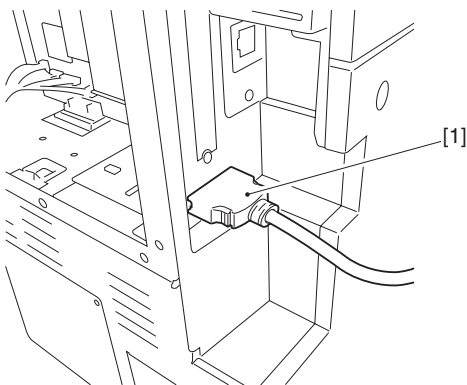

F-4-49

- 4) Remove the rear right cover [1].
- 2 screws [2]

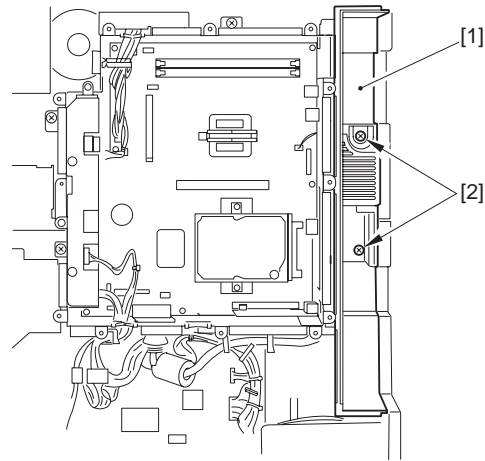

F-4-50

4.6.8.2 Removing the Controller Fan

- 1) Disconnect the connector [1], and free the cable out the edge saddle [2].

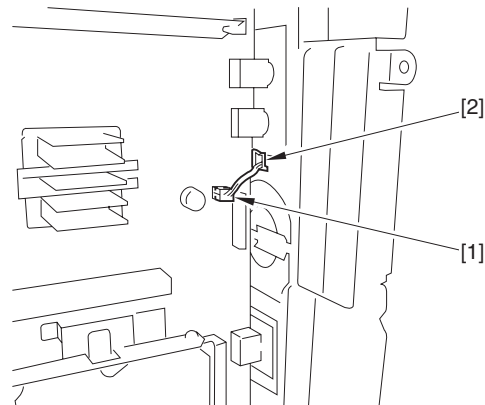

F-4-51

- 2) Remove the controller cooling fan [1].
- 2 screws [2]

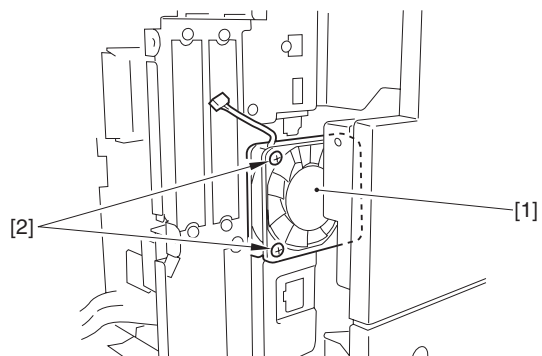

F-4-52

Chapter 5

Original Exposure System

Contents

5.1 Construction.....	5- 1
5.1.1 Specifications, Controls, and Functions <iR7105/7095>	5- 1
5.1.2 Specifications, Controls, and Functions <iR7086>	5- 2
5.1.3 Major Components <iR7105/7095>.....	5- 2
5.1.4 Major Components <iR7086>.....	5- 4
5.1.5 Construction of the Control System <iR7105/7095>.....	5- 5
5.1.6 Construction of the Control System <iR7086>.....	5- 6
5.2 Basic Sequence	5- 6
5.2.1 Basic Sequence of Operations <iR7105/7095>.....	5- 6
5.2.2 Basic Sequence of Operations <iR7086>.....	5- 6
5.2.3 Basic Sequence of Operation in Response to a Press on the Start Key <iR7105/7095>	5- 7
5.2.4 Basic Sequence of Operation in Response to a Press on the Start Key <iR7086>	5- 7
5.3 Various Control	5- 8
5.3.1 Controlling the Scanner Drive System.....	5- 8
5.3.1.1 Overview	5- 8
5.3.1.2 Controlling the Scanner Motor <iR7105/7095>	5- 8
5.3.1.3 Controlling the Scanner Motor <iR7086>	5- 9
5.3.2 Enlargement/Reduction.....	5- 10
5.3.2.1 Changing the Reproduction Ratio in Main Scanning Direction	5- 10
5.3.2.2 Changing the Reproduction Ratio in Sub Scanning Direction <iR7105/7095>	5- 10
5.3.2.3 Changing the Reproduction Ratio in Sub Scanning Direction <iR7086>	5- 10
5.3.3 Controlling the Scanning Lamp.....	5- 11
5.3.3.1 Overview <iR7105/7095>.....	5- 11
5.3.3.2 Overview <iR7086>.....	5- 11
5.3.3.3 Scanning Lamp	5- 12
5.3.3.4 Controlling the Activation.....	5- 12
5.3.4 Detecting the Size of Originals.....	5- 12
5.3.4.1 Overview	5- 12
5.3.4.2 Points of Measurement Used for Original Size Identification	5- 12
5.3.4.3 Overview of Operation <iR7105/7095>.....	5- 14
5.3.4.4 Overview of Operation <iR7086>	5- 15
5.3.5 Dirt Sensor Control.....	5- 17
5.3.5.1 Dust Detection in Stream Reading Mode <iR7105/7095>.....	5- 17
5.3.5.2 Dust Detection in Stream Reading Mode <iR7086>	5- 18
5.3.5.3 White Plate Dust Detection Control	5- 19
5.3.6 Image Processing.....	5- 20
5.3.6.1 Overview <iR7105/7095>.....	5- 20
5.3.6.2 Overview <iR7086>.....	5- 21
5.3.6.3 CCD Drive <iR7105/7095>	5- 22
5.3.6.4 CCD Drive <iR7086>	5- 22
5.3.6.5 CCD Output Gain Correction, Offset Correction.....	5- 23
5.3.6.6 CCD Output A/D Conversion	5- 23
5.3.6.7 Outline of Shading Correction.....	5- 23
5.3.6.8 Shading Adjustment	5- 23

5.3.6.9 Shading Correction	5- 23
5.4 Parts Replacement Procedure.....	5- 24
5.4.1 CCD Unit.....	5- 24
5.4.2 Copyboard glass.....	5- 24
5.4.3 Standard White Plate	5- 26
5.4.4 Scanning Lamp	5- 26
5.4.5 Reader Controller PCB.....	5- 29
5.4.6 Interface PCB.....	5- 31
5.4.7 Inverter PCB.....	5- 33
5.4.8 Scanner Motor.....	5- 33
5.4.9 ADF Open/Close Sensor.....	5- 35
5.4.10 Original Size Sensor	5- 36
5.4.11 Scanner Home Position Sensor	5- 37
5.4.12 Cooling Fan	5- 39
5.4.13 Scanner Drive Cable.....	5- 40

5.1 Construction

5.1.1 Specifications, Controls, and Functions <iR7105/7095>

The specifications, controls, and functions of the machine's original exposure system are as follows:

T-5-1

Item	Description
Scanning lamp	xenon lamp
Original scanning	book mode: by moving the scanner
	ADF mode (one-side reading): by stream reading (2 fixed points of small-size reading and large-size reading)
	ADF mode (double-sided reading): by moving the scanner (Fixed reading)
Original reading resolution	600 x 600 dpi (main scanning x sub scanning)
Halftone	256 gradations
Scanning position detection	by scanner HP sensor
lens	single-focal point, fixed type
Magnification	[1] in platen mode, Fixed reading: 25% to 400%
	main scanning direction: image processing by controller block
	sub scanning direction: scanning speed variation (No. 1 mirror base; 100% or higher)
	in combination with image processing by reader block (50% or higher and lower than 100%)
	in combination with image processing in reader block and controller block (lower than 50%)
	[2] ADF mode: 25% to 200%
	main scanning direction: image processing in controller block
	sub scanning direction: original movement speed variation (89% or higher) in combination with image processing by reader block (50% or higher and lower than 89%) in combination with image processing in reader block and controller block (lower than 50%)
Scanner drive control	No. 1/2 mirror base: control by pulse motor
Scanning lamp control	[1]activation control by pulse motor
	[2]error detection control
Original size detection	[1]book mode
	sub scanning direction: by reflection type sensor
	main scanning direction: by CCD
	[2] ADF mode
	main scanning direction: by slide guide in ADF sub scanning direction: by photosensor in ADF

5.1.2 Specifications, Controls, and Functions <iR7086>

The specifications, controls, and functions of the machine's original exposure system are as follows:

T-5-2

Item	Description
Scanning lamp	xenon lamp
Original scanning	book mode: by moving the scanner
	ADF mode: by moving original
Original reading resolution	600 x 600 dpi (main scanning x sub scanning)
Halftone	256 gradations
Scanning position detection	by scanner HP sensor
lens	single-focal point, fixed type
Magnification	[1] in platen mode: 25% to 400%
	main scanning direction: image processing by controller block
	sub scanning direction: scanning speed variation (No. 1 mirror base; 100% or higher)
	in combination with image processing by reader block (50% or higher and lower than 100%)
	in combination with image processing in reader block and controller block (lower than 50%)
	[2] ADF mode: 25% to 200%
	main scanning direction: image processing in controller block
	sub scanning direction: original movement speed variation (50% or higher); in combination with image processing in controller block (lower than 50%)
Scanner drive control	No. 1/2 mirror base: control by pulse motor
Scanning lamp control	[1]activation control by pulse motor
	[2]error detection control
Original size detection	[1]book mode
	sub scanning direction: by reflection type sensor
	main scanning direction: by CCD
	[2] ADF mode
	main scanning direction: by slide guide in ADF
sub scanning direction: by photosensor in ADF	

5.1.3 Major Components <iR7105/7095>

The major components of the original exposure system are as follows:

T-5-3

Item	Notation	Description
Scanning lamp	LA1	xenon lamp (120,000 lx)
Scanner motor	M501	2-phase pulse motor (pulse control)
Reader Cooling fan 1	FM501	cools the reader block
Reader Cooling fan 2	FM502	cools the reader block
ADF open/closed sensor	PS501	detects the state (open/closed) of the ADF; at 25 deg
Scanner HP sensor	PS502	detects scanner home position
Original size sensor (AB)	---	detects the size in sub scanning direction (AB-configuration)
Original size sensor (inch)	---	detects size in sub scanning direction (inch)
Mirror	---	No. 1, 2, 3 mirrors
Inverter PCB	---	drives the scanning lamp
CCD unit	---	collects image data, performs analog image processing
Reader controller PCB	---	controls the reader unit as a whole, performs digital image processing

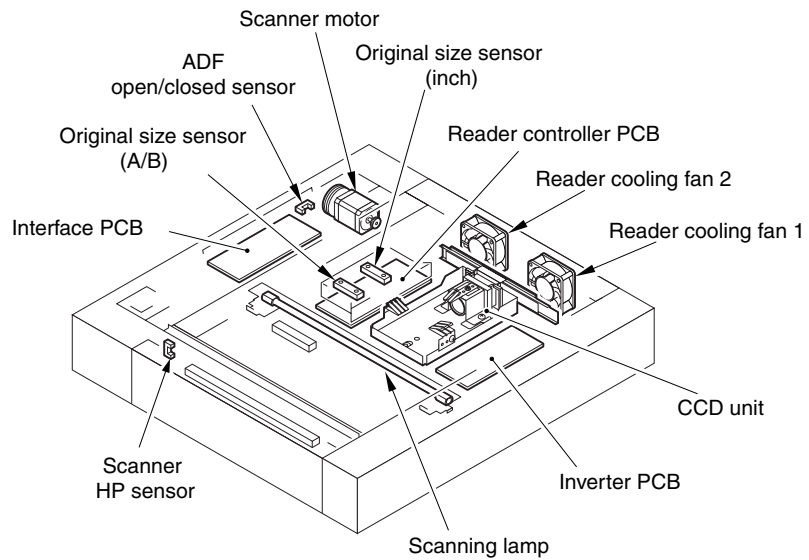

F-5-1

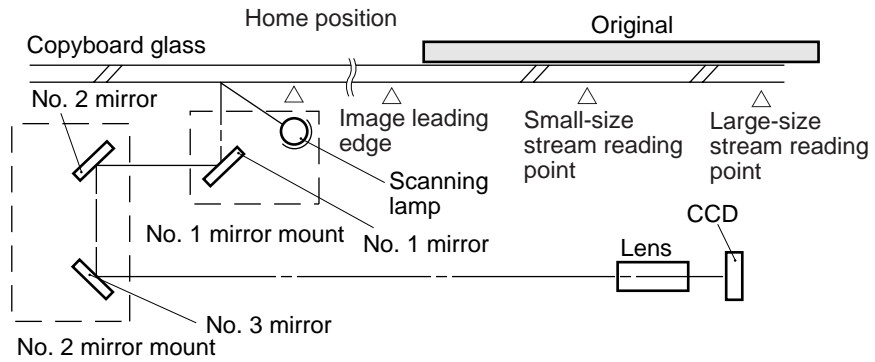

F-5-2

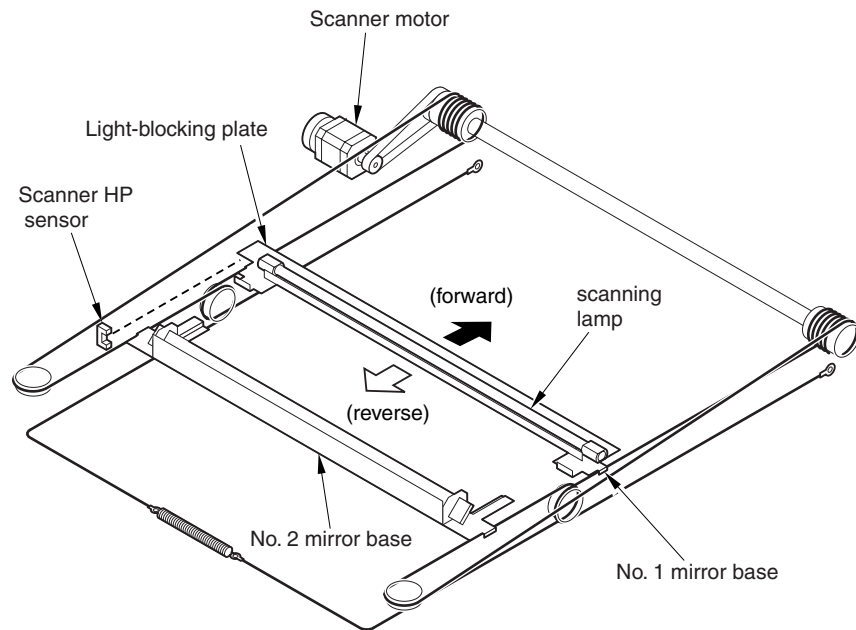

F-5-3

5.1.4 Major Components <iR7086>

The major components of the original exposure system are as follows:

T-5-4

Item	Notation	Description
Scanning lamp	LA1	xenon lamp (90,000 lx)
Scanner motor	M501	2-phase pulse motor (pulse control)
Reader Cooling fan	FM501	cools the reader block
ADF open/closed sensor 1	PS501	detects the state (open/closed) of the ADF; at 5 deg
Scanner HP sensor	PS502	detects scanner home position
ADF open/closed sensor 2	PS503	detects the state (open/closed) of the ADF (detects timing of size detection at 25 deg)
Original size sensor (AB)	---	detects the size in sub scanning direction (AB-configuration)
Original size sensor (inch)	---	detects size in sub scanning direction (inch)
Mirror	---	No. 1, 2, 3 mirrors
Inverter PCB	---	drives the scanning lamp
CCD unit	---	collects image data, performs analog image processing
Reader controller PCB	---	controls the reader unit as a whole, performs digital image processing

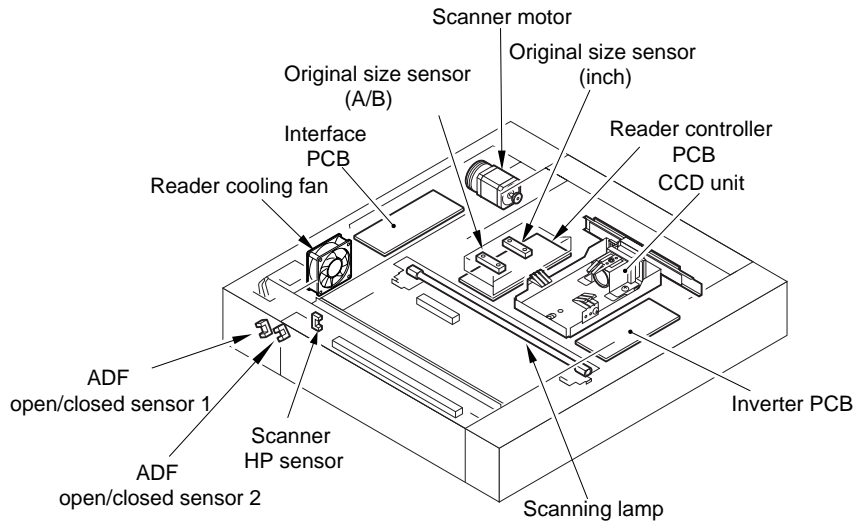

F-5-4

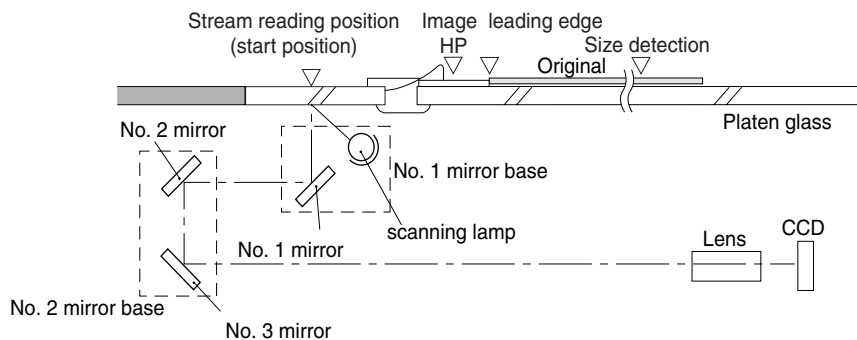

F-5-5

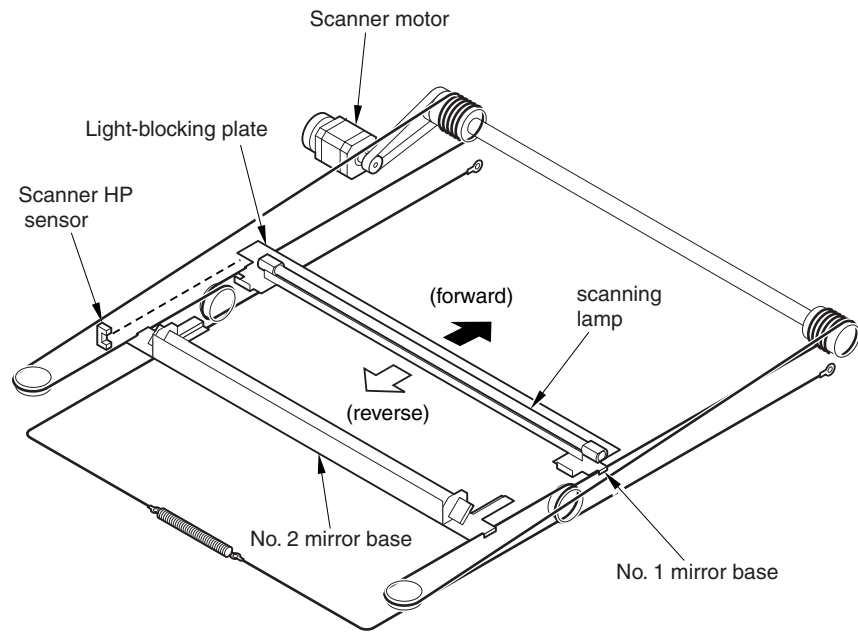

F-5-6

5.1.5 Construction of the Control System <iR7105/7095>

The construction of the control system of the machine's original exposure system is as follows:

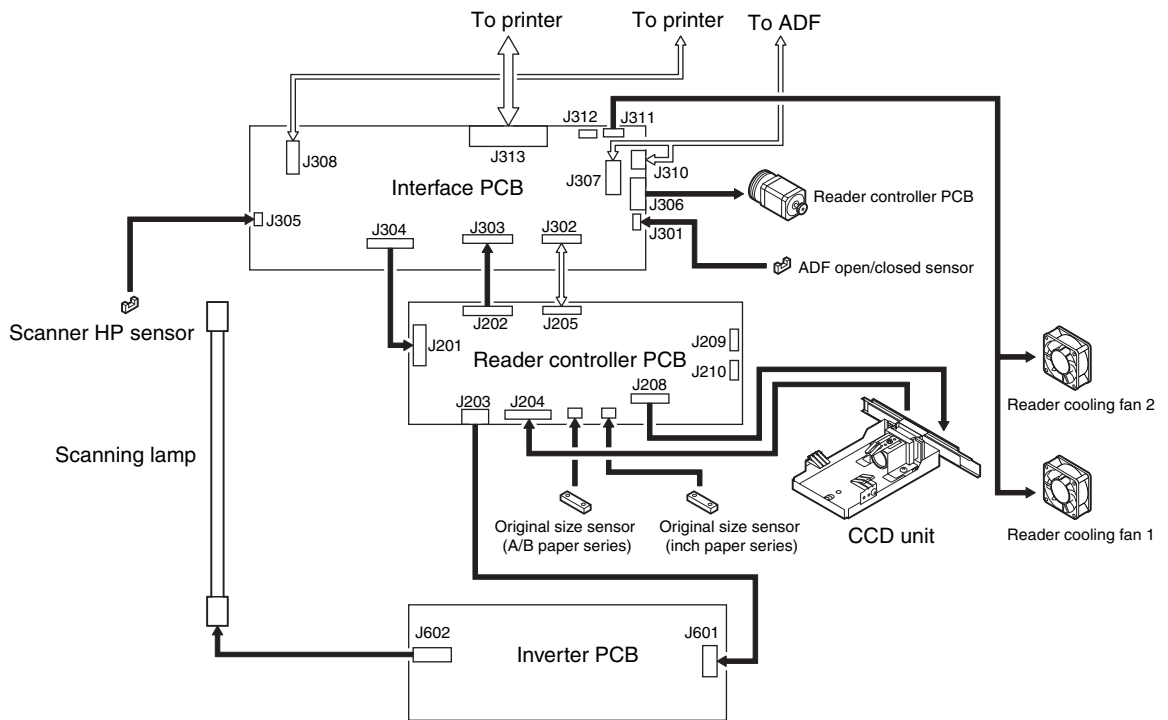

F-5-7

5.1.6 Construction of the Control System <iR7086>

The construction of the control system of the machine's original exposure system is as follows:

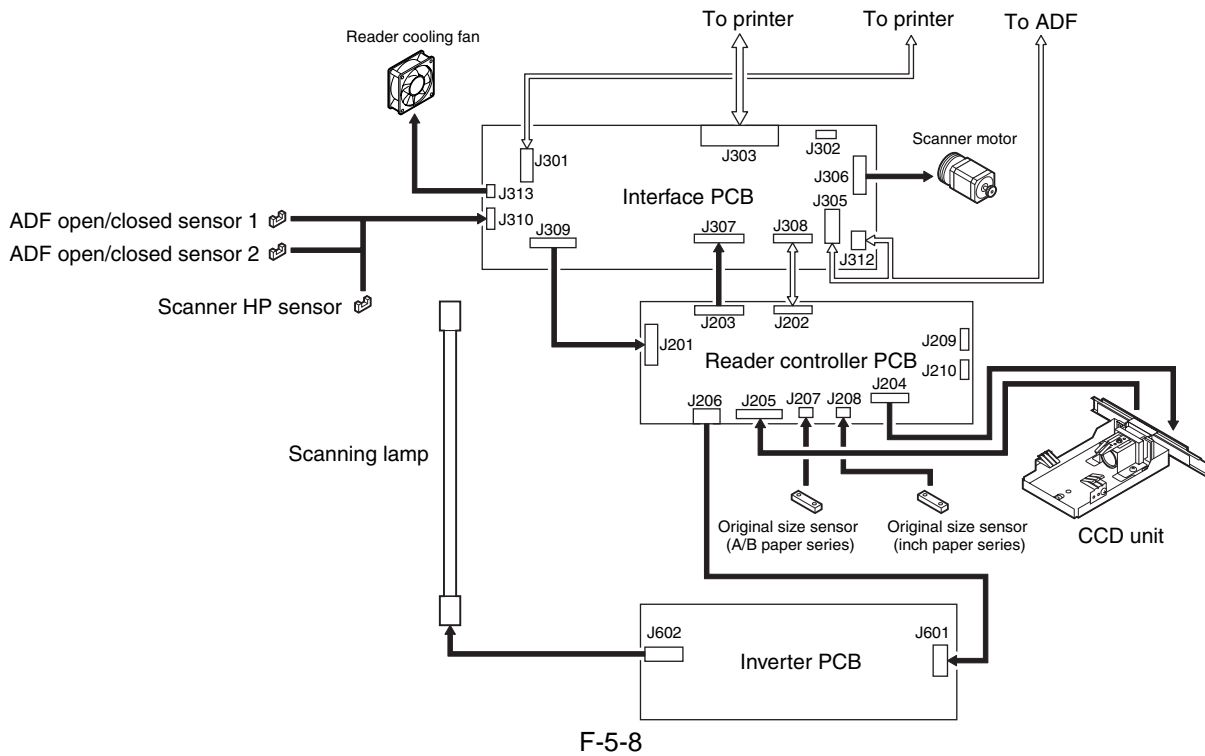

F-5-8

5.2 Basic Sequence

5.2.1 Basic Sequence of Operations <iR7105/7095>

Basic Sequence of Operation at Power-On

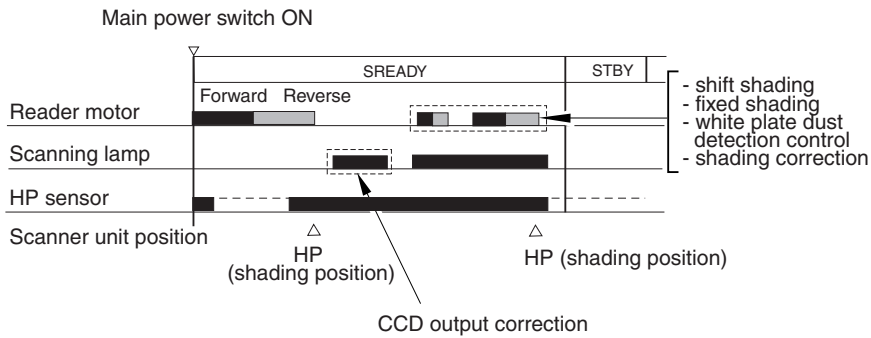

F-5-9

5.2.2 Basic Sequence of Operations <iR7086>

Basic Sequence of Operation at Power-On

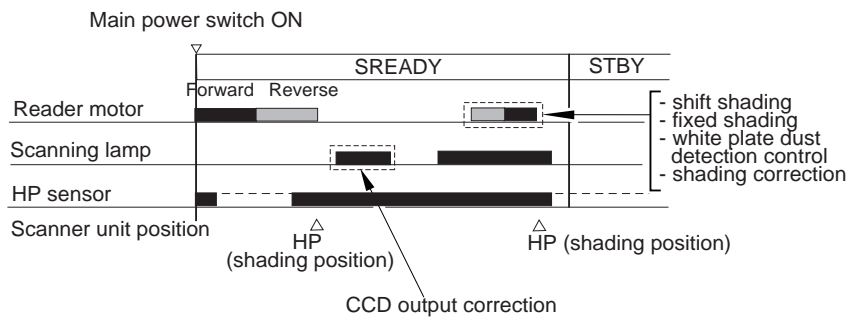

F-5-10

5.2.3 Basic Sequence of Operation in Response to a Press on the Start Key <iR7105/7095>

Basic Sequence of Operation in Response to a Press on the Start Key (book mode; 1 original)

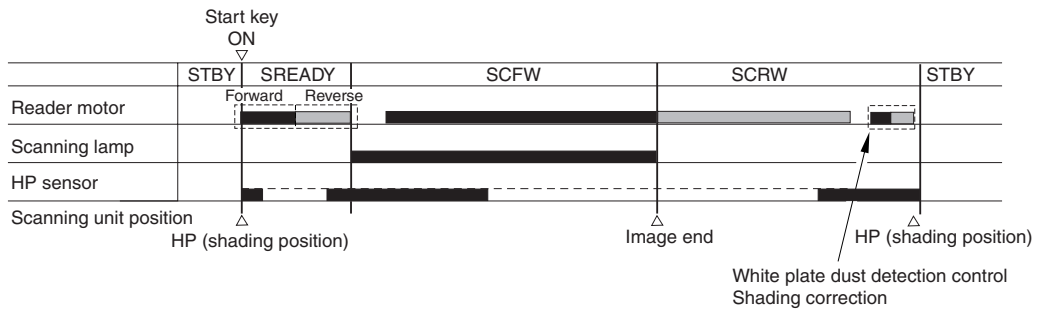

F-5-11

Basic Sequence of Operation in Response to a Press on the Start Key (ADF mode; 1 original)

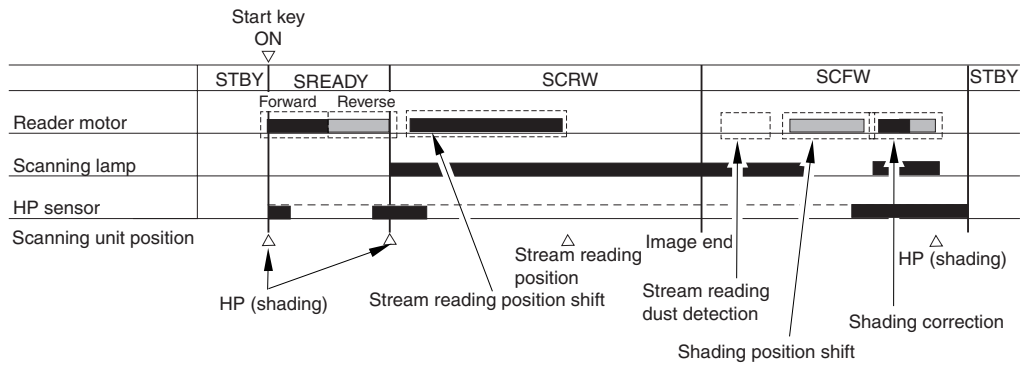

F-5-12

5.2.4 Basic Sequence of Operation in Response to a Press on the Start Key <iR7086>

Basic Sequence of Operation in Response to a Press on the Start Key (book mode; 1 original)

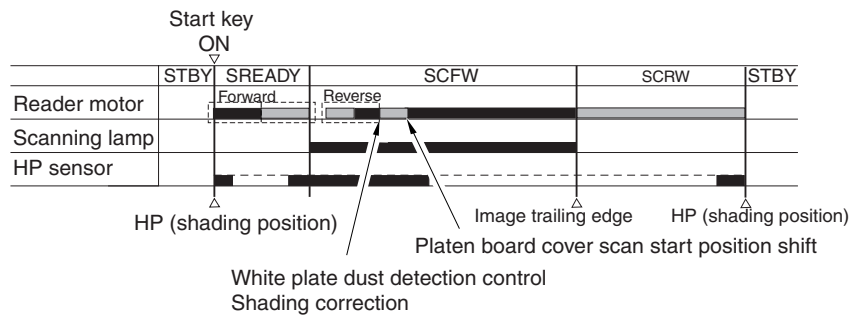

F-5-13

Basic Sequence of Operation in Response to a Press on the Start Key (ADF mode; 1 original)

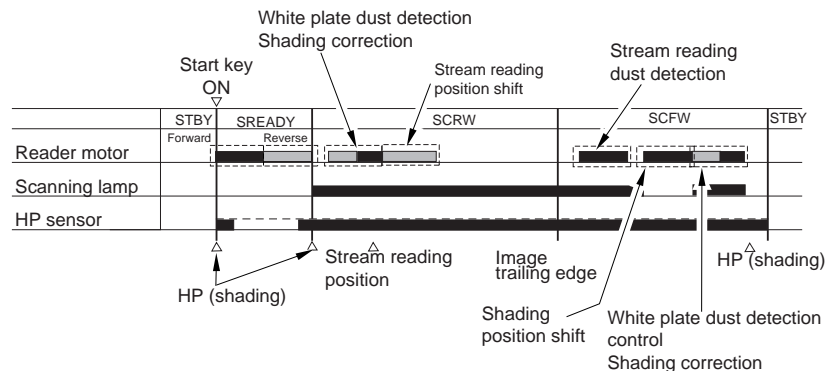

F-5-14

5.3 Various Control

5.3.1 Controlling the Scanner Drive System

5.3.1.1 Overview

The following shows the components associated with the scanner drive system:

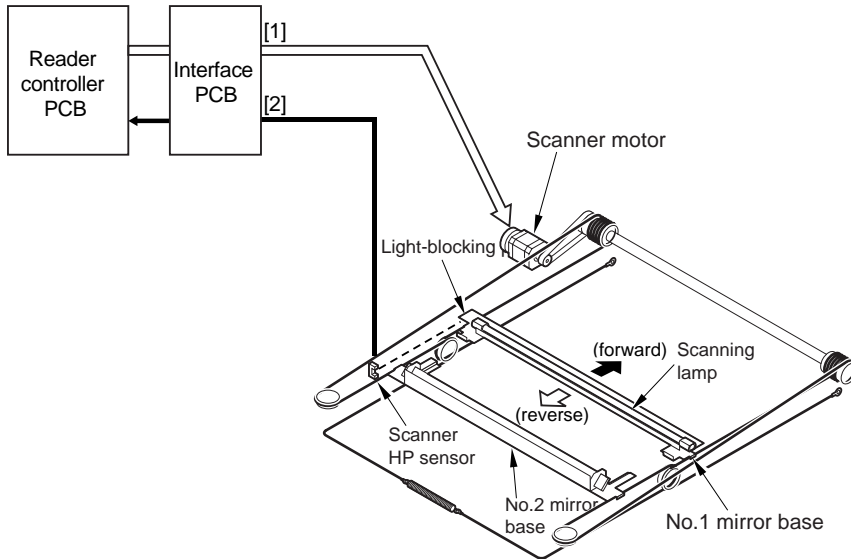

F-5-15

- [1] Scanner Motor M501 Drive Signal starts/stops the motor; controls the direction and speed of its rotation
- [2] Scanner HP Detection Signal detects the presence of the No. 1 mirror base at home position

5.3.1.2 Controlling the Scanner Motor <iR7105/7095>

The configuration of the system used to control the scanner motor is as follows; the motor driver on the interface PCB operates according to the signals from the CPU to start/stop the scanner motor and to control the direction and speed of its rotation

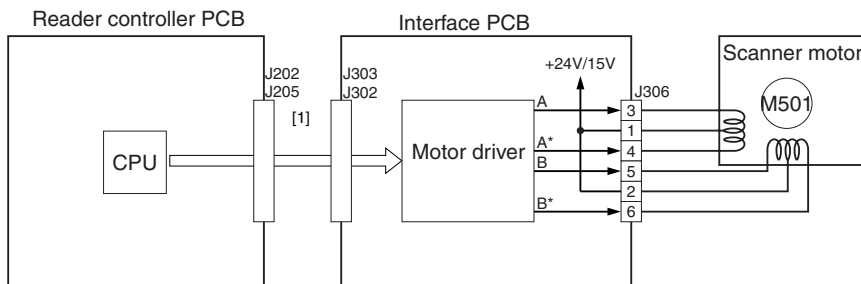

[1] Scanner motor control signal

F-5-16

a. Reverse Movement After a Scan

After an image scan, the No. 1 mirror base is moved in reverse as far as the shading position at 325 mm/sec regardless of the selected magnification.

b. Forward Movement During a Scan

During an image scan, the No. 1 mirror base is controlled at the speed indicated in the following figure; the No. 1 mirror base is moved forward at 325 mm/sec for 100% magnification.

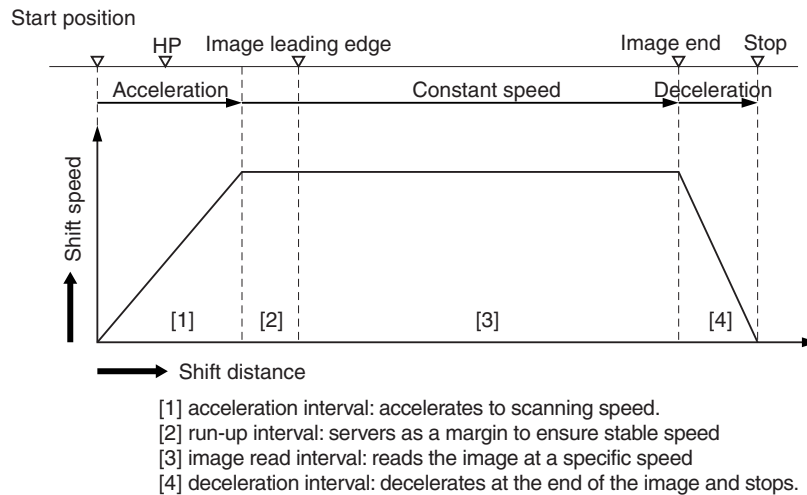

F-5-17

ERROR CODE:**E202 (HP detection error)**

-0001: when the No. 1 mirror base is moving forward, it fails to reach the HP sensor within a specific period of time

-0002: when the No. 1 mirror base is moving in reverse, it fails to reach the HP sensor within a specific period of time

SERVICE MODE:**COPIER>ADJUST>ADJ-XY>ADJ-X (scanner image leading edge position adjustment)**

Enter a value to adjust the image leading edge position.

settings range: 0 to 2970 (a change of '12' causes a shift of 1 mm)

COPIER>AJST>ADJ-XY>ADJ-S (scanner home position)

Do not change the setting.

5.3.1.3 Controlling the Scanner Motor <iR7086>

The configuration of the system used to control the scanner motor is as follows; the motor driver on the interface PCB operates according to the signals from the CPU to start/stop the scanner motor and to control the direction and speed of its rotation

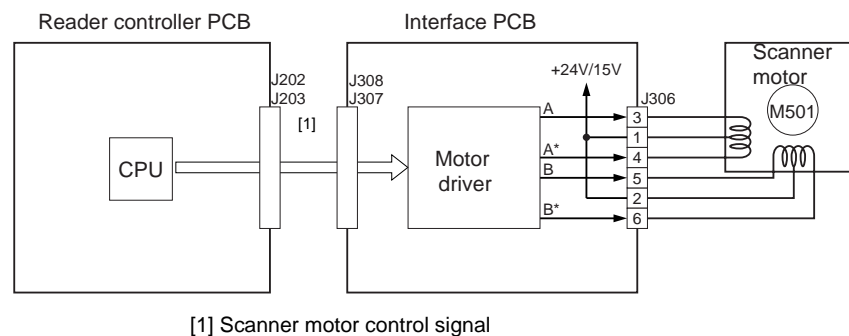

F-5-18

a. Reverse Movement After a Scan

After an image scan, the No. 1 mirror base is moved in reverse as far as the shading position at 325 mm/sec regardless of the selected magnification.

b. Forward Movement During a Scan

During an image scan, the No. 1 mirror base is controlled at the speed indicated in the following figure; the No. 1 mirror base is moved forward at 325 mm/sec for 100% magnification.

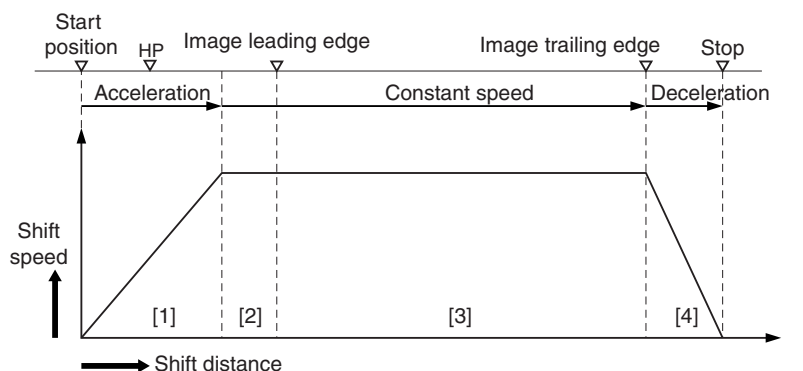

- [1] Acceleration interval: accelerates up to scan speed
 [2] Run-up interval: run-up margin used to ensure stable speed
 [3] Image read interval: segment over which images are read
 [4] Deceleration interval: at the image trailing edge, decelerates and stops as soon as possible

F-5-19

ERROR CODE:**E202 (HP detection error)**

-0001: when the No. 1 mirror base is moving forward, it fails to reach the HP sensor within a specific period of time

-0002: when the No. 1 mirror base is moving in reverse, it fails to reach the HP sensor within a specific period of time

SERVICE MODE:**COPIER>ADJUST>ADJ-XY>ADJ-X (scanner image leading edge position adjustment)**

Enter a value to adjust the image leading edge position.

settings range: 0 to 2970 (a change of '12' causes a shift of 1 mm)

COPIER>AJST>ADJ-XY>ADJ-S (scanner home position)

Do not change the setting.

5.3.2 Enlargement/Reduction**5.3.2.1 Changing the Reproduction Ratio in Main Scanning Direction**

To change the magnification in main scanning direction (for both platen and ADF modes), the machine reads the image at 100% and applies appropriate image processing in the main controller block.

5.3.2.2 Changing the Reproduction Ratio in Sub Scanning Direction <iR7105/7095>

To execute scaling, the moving speed of the mirror 1 mount is changed.

Also, digital scaling is concurrently used under the following conditions:

- Fixed reading: scaling is from 25 to 99.9%
- Stream reading: scaling is from 25 to 88.9%

MEMO:

Stream reading is basically executed when a copy is made with the ADF. However, fixed reading is executed instead if scaling is from 25 to 49.9% or a 2-sided copy is made at any scaling factor. Fixed reading is executed whenever a copy is made in book mode.

5.3.2.3 Changing the Reproduction Ratio in Sub Scanning Direction <iR7086>

To execute scaling, the moving speed of the mirror 1 mount is changed.

Also, digital scaling is concurrently used under the following conditions:

- Fixed reading: scaling is from 25 to 99.9%
- Stream reading: scaling is from 25 to 50%

5.3.3 Controlling the Scanning Lamp

5.3.3.1 Overview <iR7105/7095>

The following shows the items of control and the components of the control system associated with the activation of the scanning lamp:

1) Controlling the Activation

The machine turns on or off the scanning lamp using the drive signal (XE-ON) generated by the CPU on the reader controller PCB. In response to the signal, the inverter PCB generates high-frequency high voltage in the activation motor circuit using the drive voltage (+24 V) supplied by the reader controller PCB, thus turning on the scanning lamp.

2) Detecting an Error

The machine identifies an error in the intensity of light as an activation error occurring when the lamp is initially turned on (shading correction).

ERROR CODE:

E225

-0001: at time of shading, the detected intensity of light falls short of a specific level.

-0002: in ADF mode, the intensity of light between originals falls short of a specific level.

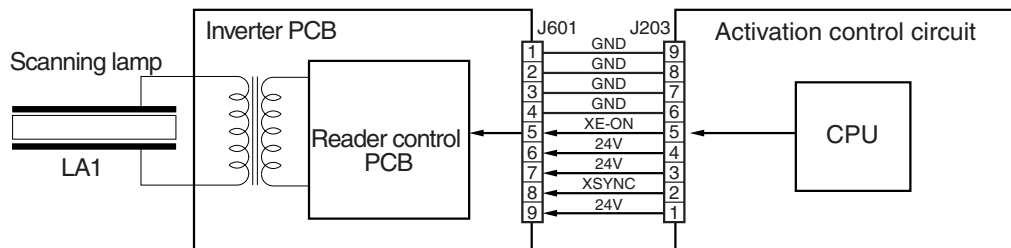

F-5-20

5.3.3.2 Overview <iR7086>

The following shows the items of control and the components of the control system associated with the activation of the scanning lamp:

1) Controlling the Activation

The machine turns on or off the scanning lamp using the drive signal (XE-ON) generated by the CPU on the reader controller PCB. In response to the signal, the inverter PCB generates high-frequency high voltage in the activation motor circuit using the drive voltage (+24 V) supplied by the reader controller PCB, thus turning on the scanning lamp.

2) Detecting an Error

The machine identifies an error in the intensity of light as an activation error occurring when the lamp is initially turned on (shading correction).

ERROR CODE:

E225

-0001: at time of shading, the detected intensity of light falls short of a specific level.

-0002: in ADF mode, the intensity of light between originals falls short of a specific level.

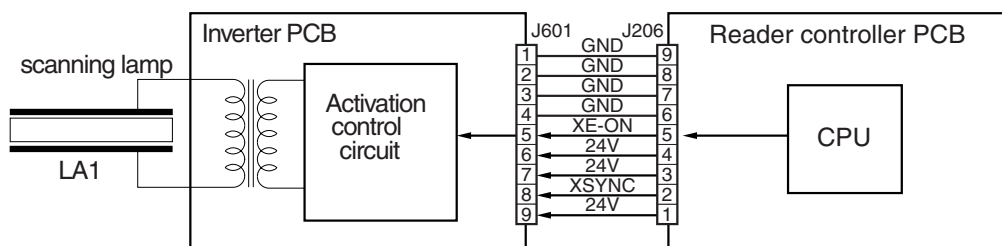

F-5-21

5.3.3.3 Scanning Lamp

The machine's scanning lamp is a xenon lamp consisting of a tube in which xenon gas is sealed. On the inner side of the glass tube are 2 electrodes running parallel to the tube axis, while the inner side is coated with fluorescent material. When high-frequency high voltage is applied to the electrodes, the gas inside the tube starts to discharge, thus illuminating the fluorescent material.

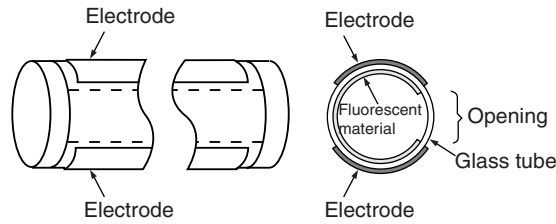

F-5-22

5.3.3.4 Controlling the Activation

The machine turns on or off the scanning lamp using the drive signal (XE_ON) from the CPU on the reader controller PCB. In response to the signal, the inverter PCB generates high-frequency high voltage in the activation control circuit using the drive voltage (+24 V) supplied by the reader controller PCB, thus turning on the xenon lamp.

5.3.4 Detecting the Size of Originals

5.3.4.1 Overview

The machine identifies the size of an original with reference to the combination of measurements taken of the light reflected at specific points of the CCD and the output of a reflection type sensor. It takes measurements at 2 points for individual sizes to ensure correct identification even in the event that the original is displaced while the ADF is being closed.

- for main scanning direction, by the CCD (for AB, 8 points; for inch-configuration, 6 points)
- for sub scanning direction, by a reflection type photosensor (for AB-configuration, 1 point; for inch-configuration, 1 point)

The machine identifies the size of an original as follows:

1) External Light (main scanning direction only)

While keeping the scanning lamp off, the machine measures the CCD level at individual points of measurement in main scanning direction.

2) Sensor Output Level

The machine turns on the scanning lamp, and measures the CCD level at individual points of measurement in main scanning direction. Also, the machine turns on the LED of the reflection type photosensor in sub scanning direction to measure the sensor output. It uses the combination of the measurement and the output to identify the size of the original in question.

5.3.4.2 Points of Measurement Used for Original Size Identification

For main scanning direction, the machine moves the No. 1 mirror base to the point of CCD original detection to measure the CCD level at individual points of measurement. For sub scanning direction, the machine uses the outputs of original sensors 1 and 3.

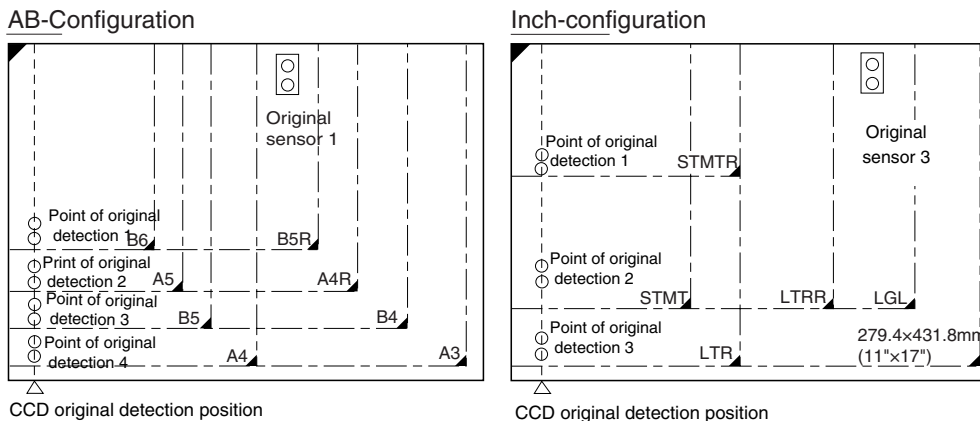

F-5-23

1. Checking the Presence/Absence of an Original at 2 Points (individual points of detection)

For main scanning direction, the machine identifies the presence/absence of an original with reference to the CCD output at 2 points (nearest).

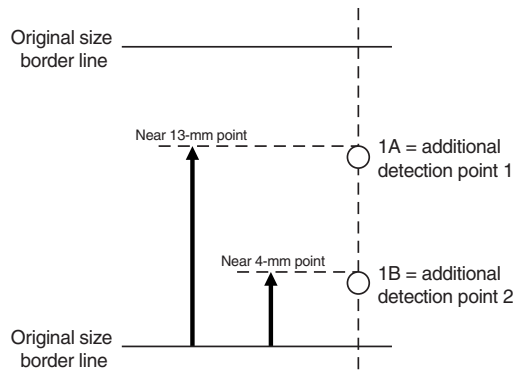

F-5-24
T-5-5

Result of movement		Result of identification
A	B	
no	no	original absent
yes	no	original present
no	yes	original present
yes	yes	original present

Note:

Change in the Signal in Response to ADF Open -> Closed

change present: no

other: yes

The OR argument is applied to the outputs at 2 points.

2. Priority on the Presence of an Original at the Front

If the machine detects the absence of an original at the rear in spite of detection of the presence at the front for main scanning direction, the machine will identify the size of the original upholding the result of detection at the front.

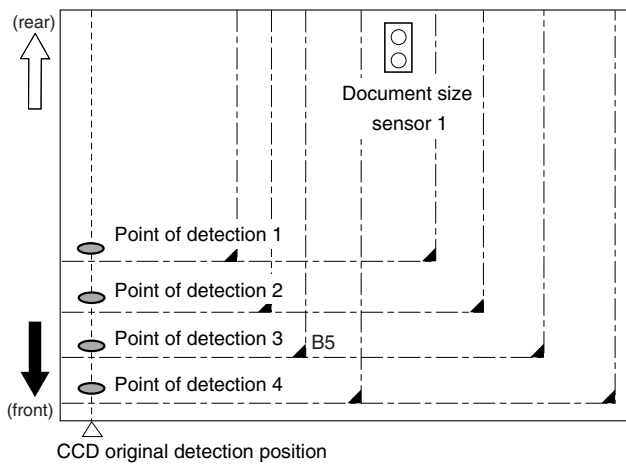

F-5-25

EX (B5 original)

T-5-6

Point of detection	Result of detection present/absent	Result of identification
1	present	present
2	absent	present
3	present	present
4	absent	absent
		B5

5.3.4.3 Overview of Operation <iR7105/7095>

1. In a Wait State

No. 1 mirror base: at shading position
 scanning lamp: off
 original sensor

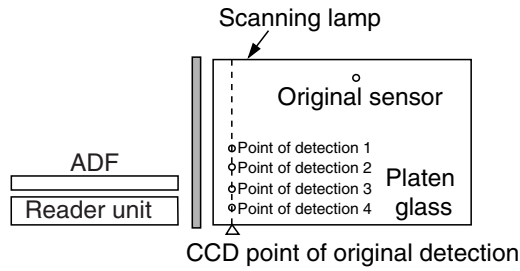

F-5-26

2. ADF Being Opened

No.1 mirror base: moves to a specific point of original detection
 scanning lamp: off
 original sensor: off

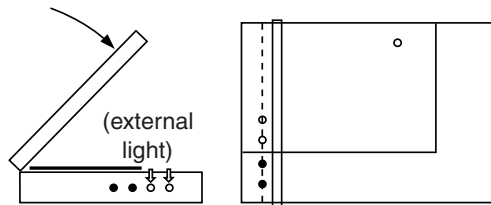

F-5-27

3. ADF Being Closed

No. 1 mirror base: at point of original detection
 scanning lamp: off -> on
 original sensor: original detection operation

- When the ADF is at 25 deg or lower, the external light within the width of any original is kept out of external light, thus causing the machine to assume the absence of an original at points of external light detection (external light search operation).

The ADF open/closed sensor (main body) identifies the state as being "closed," and the machine starts original size detection.

Here, B5, B4, A4, and A3 are eliminated from the list of possible sizes.

- When the external light search is over, the machine turns on the xenon lamp for the main scanning lamp, and checks the CCD (4 points) for external light. For sub scanning direction, the machine starts to operate the original sensor.

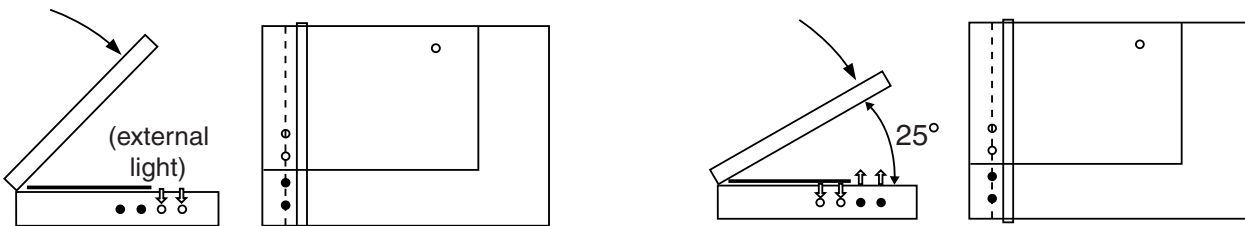

F-5-28

4. ADF Fully Closed (8 deg or less)

No. 1 mirror base: at point of original detection
 scanning lamp: on
 original sensor: original detection operation

The machine looks for a change in the output level of individual sensors for a period of 2 sec after the ADF open/closed sensor (ADF) has identified the current state as being "closed." The absence of a change in the level causes the machine to assume the presence of an original at the point in question. The machine uses the combination of changes in the levels of 5 points to identify the size of the original in question.

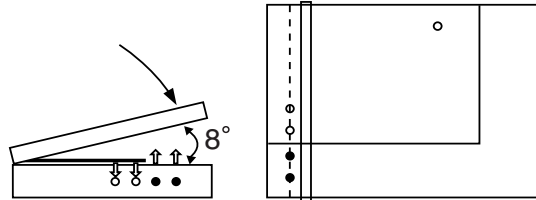

F-5-29

5. In a Wait State (for a press on the Start key)

No.1 mirror base: at point of original detection
 scanning lamp: off
 original sensor: off

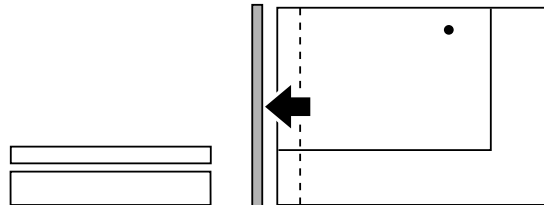

F-5-30

AB-Configuration							Inch-configuration						
Original size	Point of CCD detection						Original size	Point of CCD detection					
	A	B	A	B	A	B		A	B	A	B	sensor 3	
A3	○	○	○	○	○	○	11"x17"	○	○	○	○	○	○
B4	○	○	○	○	●	○	LGL	○	○	○	○	○	○
A4R	○	○	○	○	○	○	LTRR	○	○	○	○	○	○
A4	○	○	○	○	○	○	LTR	○	○	○	○	○	○
B5	○	○	○	○	○	○	STMTR	○	○	○	○	○	○
B5R	○	○	○	○	○	○	STMT	○	○	○	○	○	○
A5	○	○	○	○	○	○	absent	●	●	●	●	●	●
B6	○	○	○	○	○	○							
absent	○	○	○	○	○	○							

○:unchanged ●:changed

F-5-31

5.3.4.4 Overview of Operation <iR7086>

1. In a Wait State

No. 1 mirror base: at shading position
 scanning lamp: off
 original sensor

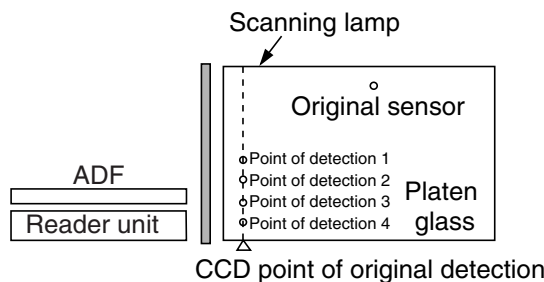

CCD point of original detection

F-5-32

2. ADF Being Opened

No.1 mirror base: moves to a specific point of original detection
 scanning lamp: off
 original sensor: off

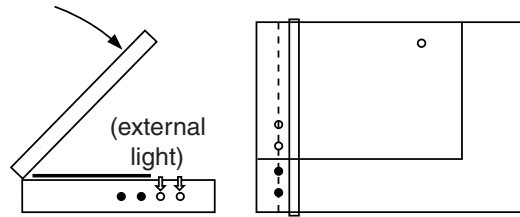

F-5-33

3. ADF Being Closed

No. 1 mirror base: at point of original detection
 scanning lamp: off -> on
 original sensor: original detection operation

- When the ADF is at 25 deg or lower, the external light within the width of any original is kept out of external light, thus causing the machine to assume the absence of an original at points of external light detection (external light search operation).

The ADF open/closed sensor 2 identifies the state as being "closed," and the machine starts original size detection.

Here, B5, B4, A4, and A3 are eliminated from the list of possible sizes.

- When the external light search is over, the machine turns on the xenon lamp for the main scanning lamp, and checks the CCD (4 points) for external light. For sub scanning direction, the machine starts to operate the original sensor.

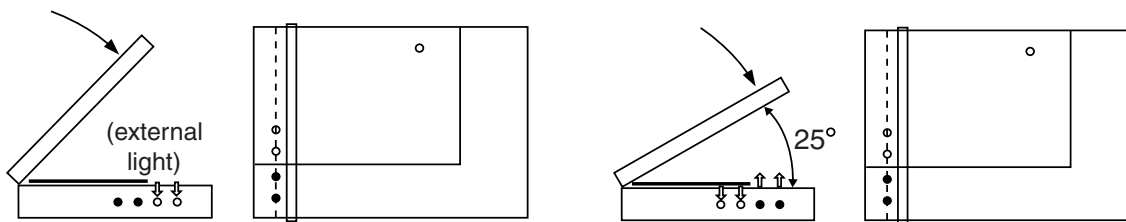

F-5-34

4. ADF Fully Closed (5 deg or less)

No. 1 mirror base: at point of original detection
 scanning lamp: on
 original sensor: original detection operation

The machine looks for a change in the output level of individual sensors for a period of 2 sec after the ADF open/closed sensor 1 has identified the current state as being "closed." The absence of a change in the level causes the machine to assume the presence of an original at the point in question.

The machine uses the combination of changes in the levels of 5 points to identify the size of the original in question.

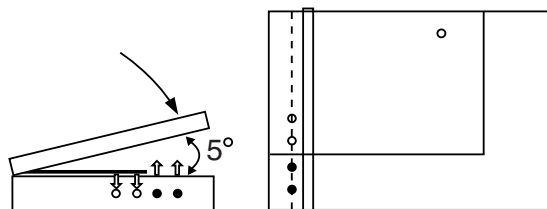

F-5-35

5. In a Wait State (for a press on the Start key)

No.1 mirror base: at point of original detection
 scanning lamp: off
 original sensor: off

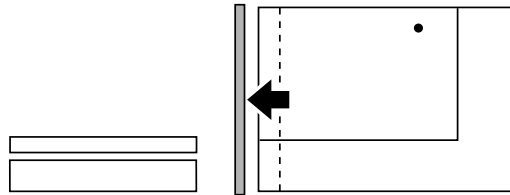

F-5-36

AB-Configuration						Inch-configuration						
Original size	CCD point of detection				Original sensor 1	Original size	CCD point of detection				Original sensor 3	
	1 A	1 B	2 A	2 B			3 A	3 B	4 A	4 B		
A3	○	○	○	○	○	○	○	○	○	○	○	○
B4	○	○	○	○	●	●	○	○	○	○	○	○
A4R	○	○	○	○	●	●	○	○	○	○	○	○
A4	○	○	○	○	○	○	○	○	○	○	●	●
B5	○	○	○	○	○	○	○	○	○	○	●	●
B5R	○	○	○	○	○	○	○	○	○	○	○	○
A5	○	○	○	○	○	○	○	○	○	○	○	○
B6	○	○	○	○	○	○	○	○	○	○	○	○
none	○	○	○	○	○	○	○	○	○	○	○	○

○:change absent ●:change present

F-5-37

5.3.5 Dirt Sensor Control

5.3.5.1 Dust Detection in Stream Reading Mode <iR7105/7095>

In addition to the common points for stream reading, the machine uses an additional 6 points each for small-size and large-size sheets at intervals of 0.5 mm to avoid areas of dust (in total, 7 points for small-size and 7 points for large-size).

If it detects dust, however, it changes the point of reading to prevent dust from appearing in images. The detection of dust is executed at the end of each single job that uses stream reading; the machine moves the ADF belt idly when stream reading is selected and identifies any black line as an area of dust.

When it detects dust, it resets the current point of stream reading, and uses the point of reference on the leftmost edge for dust detection; if dust is detected, it moves the point of stream reading to the right by 1 point (0.5 mm) for detection of dust for a second time. If dust is not detected, the machine uses that point as the point for stream reading. If dust is detected once again, it will use the next point. If dust is detected at all 7 points, the machine will indicate the message "Copyboard Glass Soiled," which will remain until the ADF is opened and the copyboard glass is cleaned. The machine will not use stream reading but use fixed reading as long as the message remains.

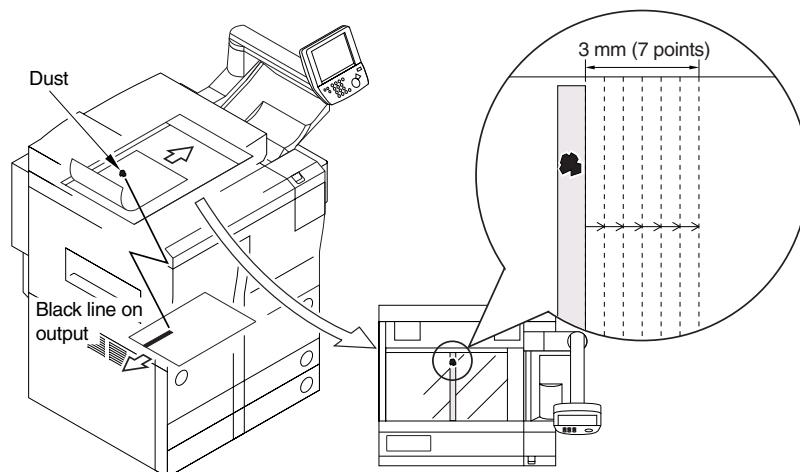

F-5-38

Advise the user to clean the area where the CCD stops in stream reading if the message has appeared. A label indicating the points for stream reading (for small-size and large-size) is attached to the rear of the copyboard glass.

If a jam has occurred, the machine will not execute dust detection at the end of a job. If the ongoing job is cancelled, it will execute dust detection at the end of operation.

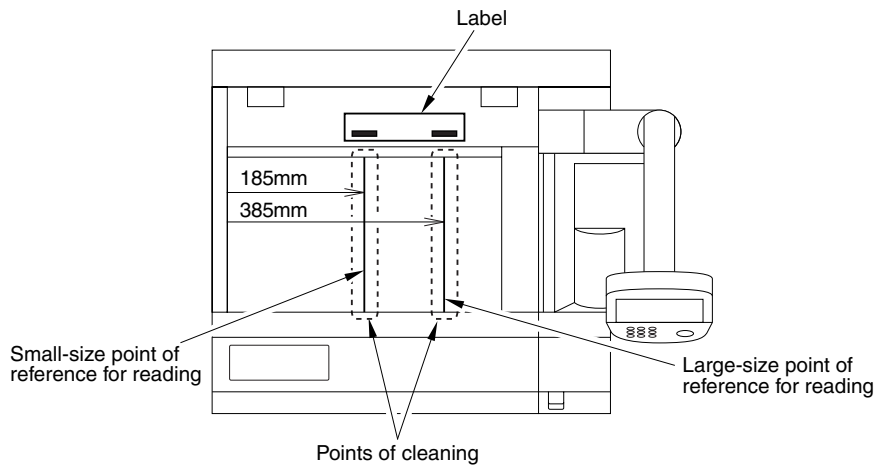

F-5-39

SERVICE MODE:

COPIER>OPTION>BODY>DFDST-L1 (level 2)

use it to adjust dust detection level between sheets (for small size paper)

COPIER>OPTION>BODY>DFDST-L2 (level 2)

use it to adjust dust detection level at the end of a job (for small size paper)

COPIER>OPTION>BODY>DFDST-L3 (level 2)

use it to adjust dust detection level between sheets (for large size paper)

COPIER>OPTION>BODY>DFDST-L4 (level 2)

use it to adjust dust detection level at the end of a job (for large size paper)

5.3.5.2 Dust Detection in Stream Reading Mode <iR7086>

In addition to the common points for stream reading, the machine uses an additional 4 points at intervals of 0.5 mm to avoid areas of dust (in total, 5 points).

If it detects dust, however, it changes the point of reading to prevent dust from appearing in images. The detection of dust is executed at the end of each single job that uses stream reading; the machine moves the ADF belt idly when stream reading is selected and identifies any black line as an area of dust.

When it detects dust, it resets the current point of stream reading, and uses the point of reference on the leftmost edge for dust detection; if dust is detected, it moves the point of stream reading to the right by 1 point (0.5 mm) for detection of dust for a second time. If dust is not detected, the machine uses that point as the point for stream reading. If dust is detected once again, it will use the next point. If dust is detected at all 5 points, the machine will indicate the message "Copyboard Glass Soiled," which will remain until the ADF is opened and the copyboard glass is cleaned.

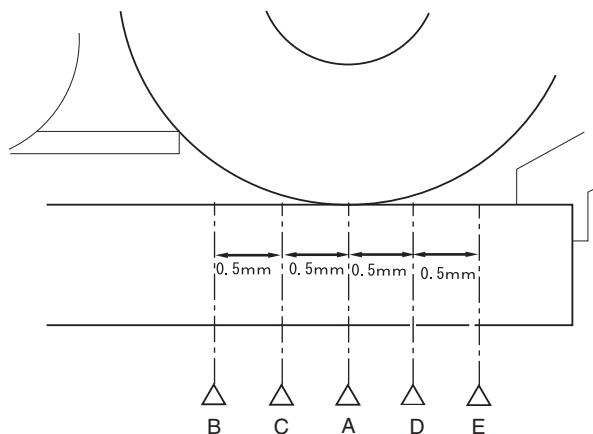

F-5-40

Advise the user to clean the area where the CCD stops in stream reading if the message has appeared.

SERVICE MODE:

COPIER>OPTION>BODY>DFDST-L1 (level 1)

use it to adjust dust detection level between sheets

COPIER>OPTION>BODY>DFDST-L2 (level 1)

use it to adjust dust detection level at the end of a job

5.3.5.3 White Plate Dust Detection Control

The white plate can collect stray dust inside the reader unit, causing lines in images, and the machine is equipped with a mechanism to check for dust on the plate and correct it to limit its effects on output images.

Timing of Control

1. Before a Job

- white plate dust detection
- white plate dust correction

2. After a Job

- white plate dust detection
- white plate dust correction

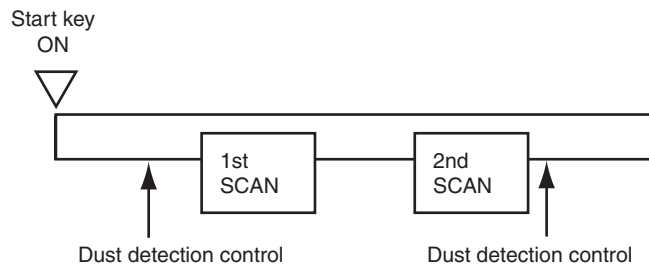

F-5-41

Particulars of Control

- White Plate Dust Detection

The machine compares the data on the light reflected by the white plate at time of fixed shading and shift shading to check for dust on the white plate while at the same time identifying the coordinates and width of the area of dust.

- White Plate Dust Correction

If the machine detects the presence of dust, it corrects the shading correction coefficient of the area of dust by means of a correction coefficient used for both sides of the area with dust, thus limiting the effects of the dust.

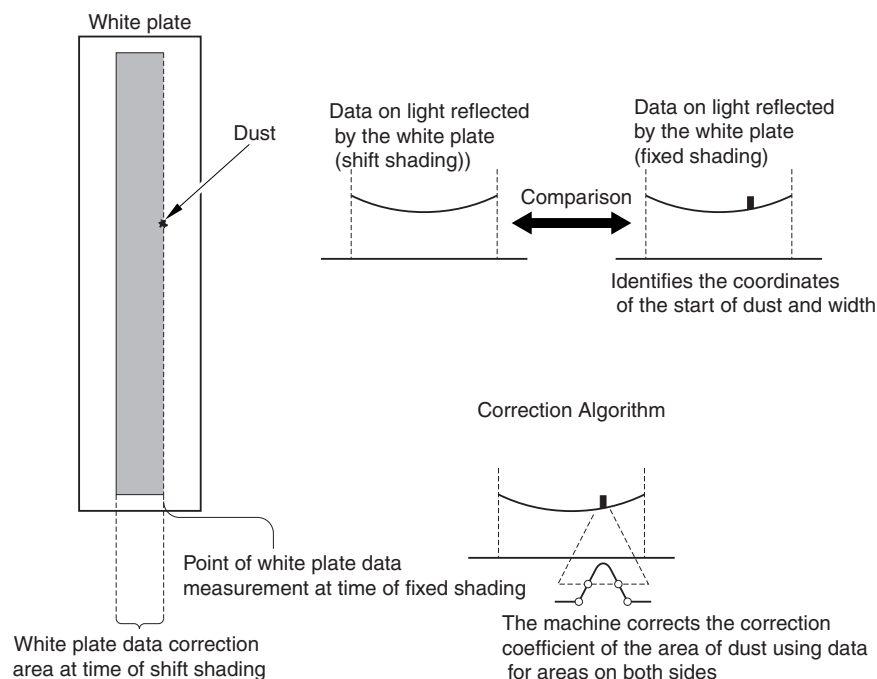

F-5-42

5.3.6 Image Processing

5.3.6.1 Overview <iR7105/7095>

The PCBs used in the image processing system have the following functions:

CDD/AP PCB: CCD drive, analog image processing, A/D conversion

Reader controller PCB: shading correction, image data conversion (4 channels -> 2 channels)

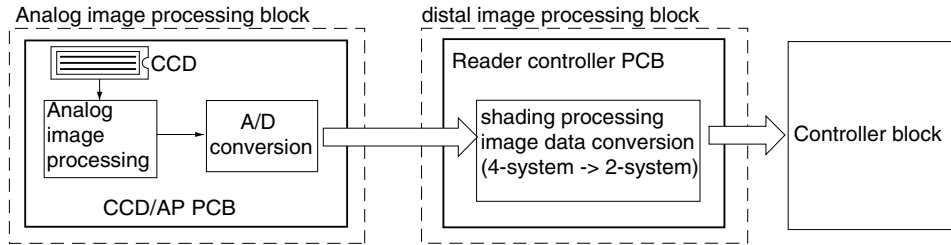

F-5-43

1. Analog Image processing

- CCD drive
- CCD output gain correction, offset correction
- CCD output A/D conversion

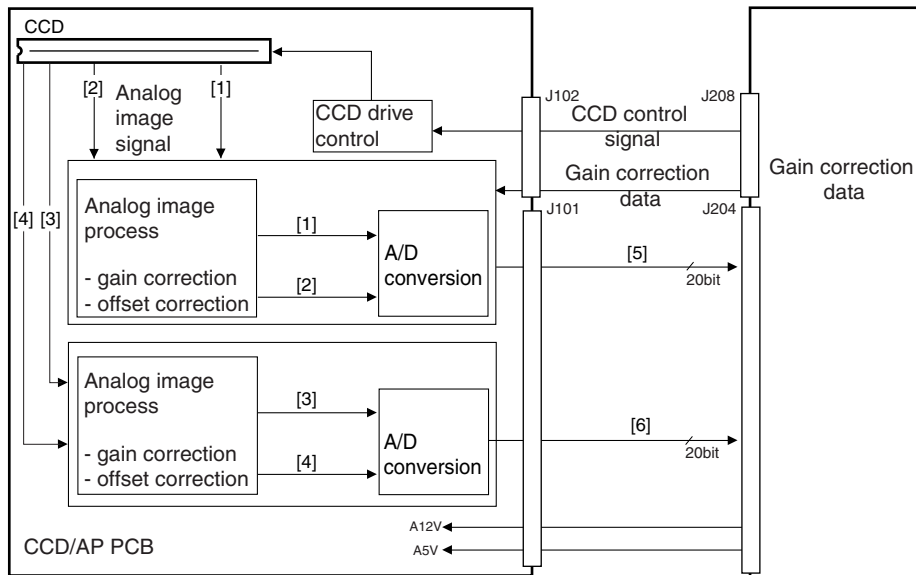

F-5-44

[1] 1st half even-numbered pixel analog image signal	[4] 2nd half odd-numbered pixel analog image signal
[2] 1st half odd-numbered pixel analog image signal	[5] 1st half digital image signal
[3] 2nd half even-numbered pixel analog image signal	[6] 2nd half digital image signal

2. Digital Image Processing
- shading correction

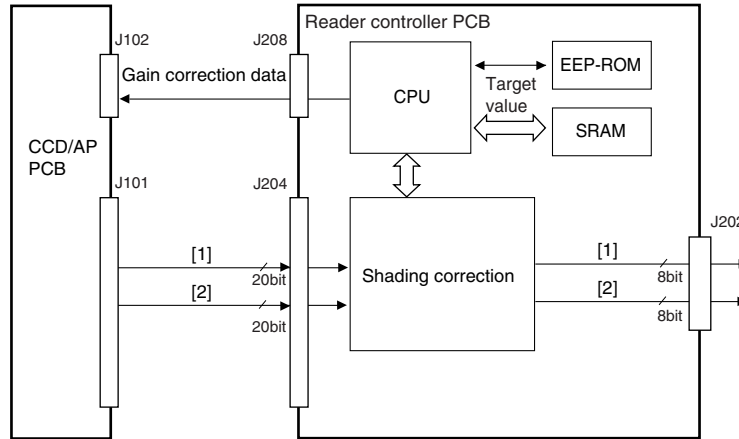

F-5-45

- [1] 1st-half digital image signal
- [2] 2nd-half digital image signal

5.3.6.2 Overview <iR7086>

The PCBs used in the image processing system have the following functions:

CCD/AP PCB: CCD drive, analog image processing, A/D conversion

Reader controller PCB: shading correction

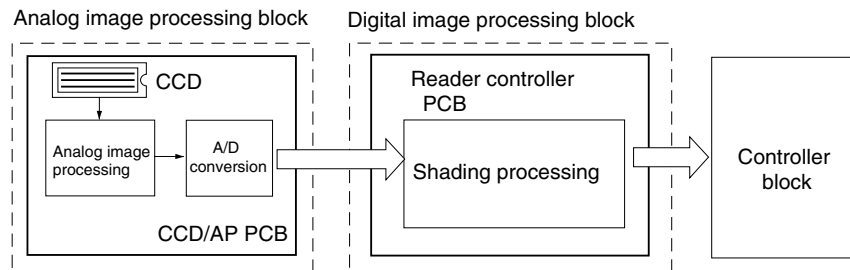

F-5-46

1. Analog Image processing

- CCD drive
- CCD output gain correction, offset correction
- CCD output A/D conversion

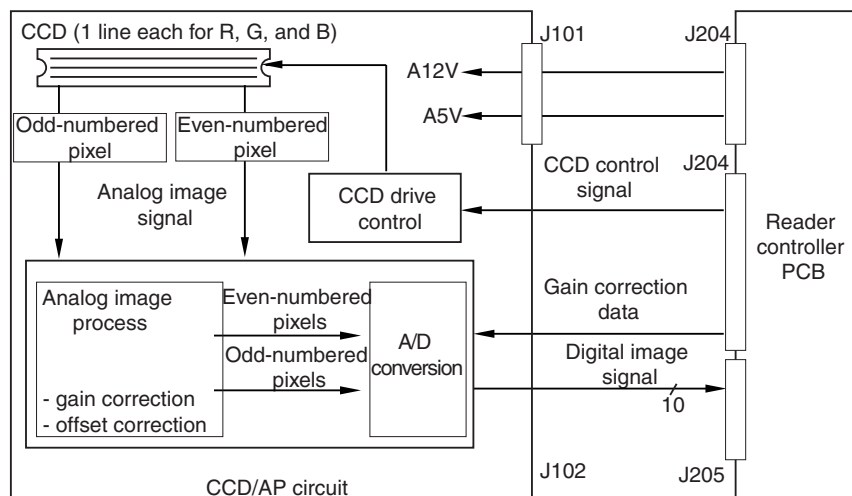

F-5-47

2. Digital Image Processing
- shading correction

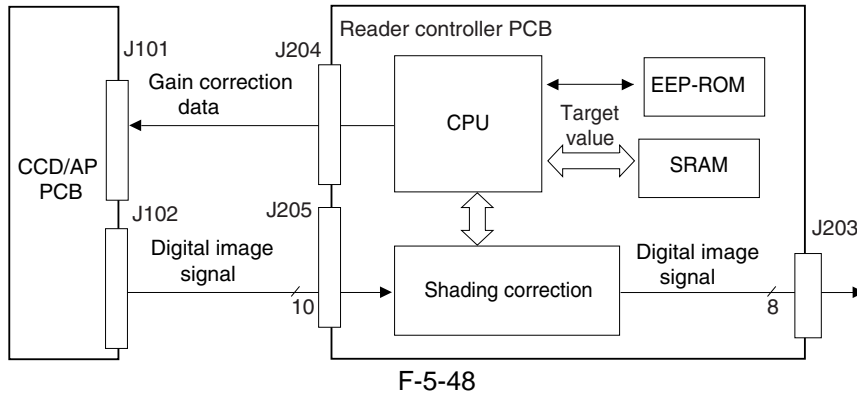

5.3.6.3 CCD Drive <iR7105/7095>

1. CCD

The CCD used in the machine is a 1-line linear image sensor.

- Number of pixels: 7400
- Size of a pixel: 4.7 x 4.7 μ m

2. CCD Drive

The signals converted by the light-receiving block are sent out in 2 analog video signal channels (even-numbered pixels, odd-numbered pixels).

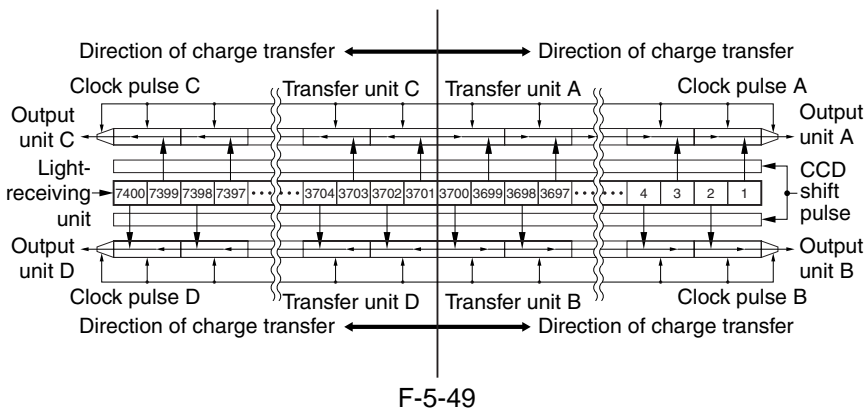

5.3.6.4 CCD Drive <iR7086>

1. CCD

The CCD used in the machine is a 1-line linear image sensor.

- Number of pixels: 7450
- Size of a pixel: 4.7 x 4.7 μ m

2. CCD Drive

The signals converted by the light-receiving block are sent out in 2 analog video signal channels (even-numbered pixels, odd-numbered pixels).

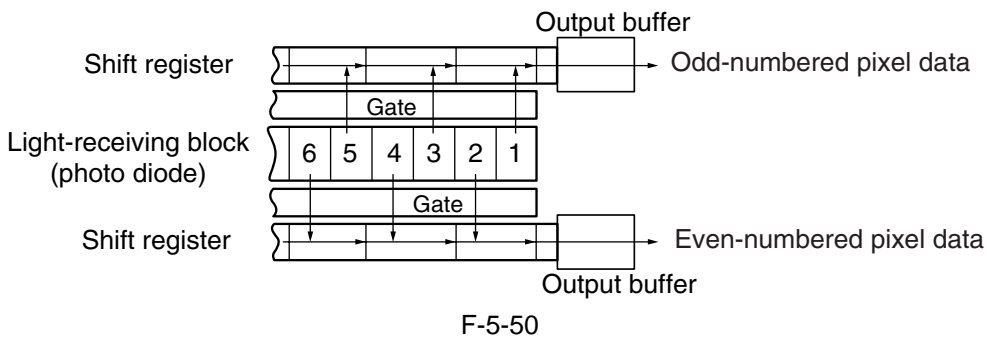

5.3.6.5 CCD Output Gain Correction, Offset Correction

The machine processes the analog video signals from the CCD so that the rate of their amplitude is a specific level. The machine also makes sure that the output voltage in the absence of incident light is of a specific level (offset correction).

5.3.6.6 CCD Output A/D Conversion

The odd-numbered and even-numbered pixel analog video signals after correction are further converted into 12-bit digital signals representing specific pixel voltage levels by the A/D converter.

5.3.6.7 Outline of Shading Correction

The machine executes shading correction so that the CCD output will be even when the density of the original is even.

The output of the CCD may not necessarily be even because of the following factors even if the density of the original is perfectly even:

1. variation in the sensitivity of the individual pixels of the CCD
2. difference in the degree of light passing through the center of the lens and through its edge
3. difference in the intensity of light between the center and ends of the scanning lamp
4. deterioration of the scanning lamp

The machine executes shading correction to make up for the variation in the output of the CCD.

Shading correction may be shading adjustment executed to determine a service mode target value or shading correction executed for every job.

5.3.6.8 Shading Adjustment

In shading adjustment, the machine measures the density of a white sheet of paper and the standard white plate, and stores the measurements in memory. The machine then computes these measurements for use as the target value for shading correction. Shading adjustment is executed at time of machine installation or scanning lamp replacement, or when a change has occurred in the intensity of light over time.

Service Mode:

COPIER>FUNCTION>CCD>CCD-ADJ

5.3.6.9 Shading Correction

The machine executes shading correction for every scan of an original.

The machine shines the light of the scanning lamp against the standard white plate, and measures the light reflected by the plate; it then uses the analog image processing block of the CCD/AP PCB to turn the measurements into digital data, which will be sent to the shading correction circuit of the reader controller PCB in the form of a shading coefficient.

In the shading correction circuit, the shading coefficient is compared against the target value stored in memory, and the machine uses the differences as the shading correction value.

The shading correction value is used to make up for the variation among individual pixels of the CCD occurring at each scan, thus evening out the image density level.

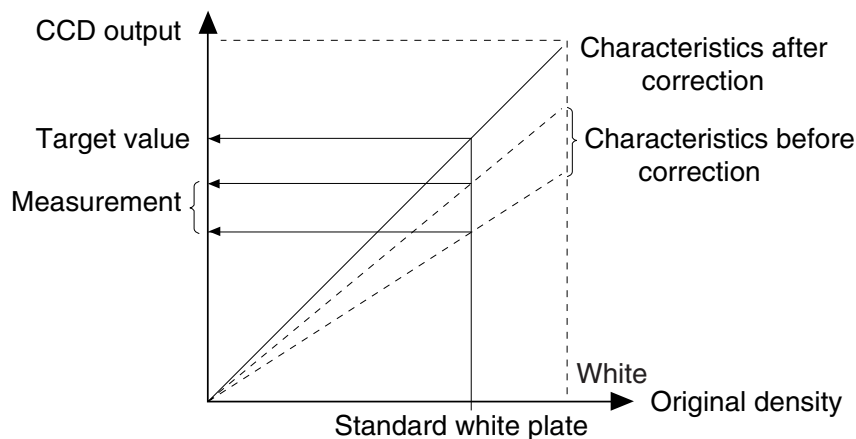

F-5-51

5.4 Parts Replacement Procedure

5.4.1 CCD Unit

5.4.1.1 Before Starting the Work

- 1) Remove the copyboard glass.
- 2) Remove the CCD unit cover [1].
- 9 screws [2]

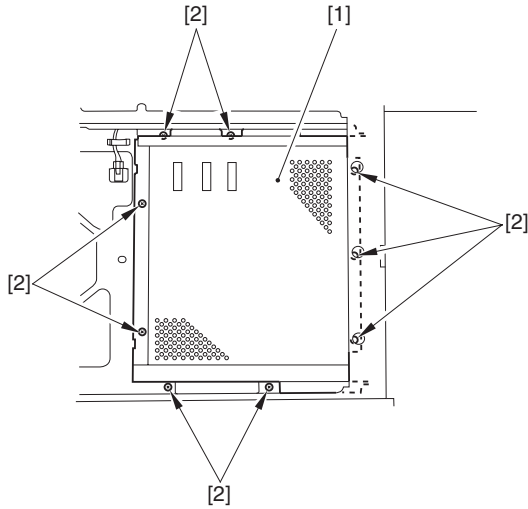

F-5-52

- 3) Remove the original size sensor unit.

5.4.1.2 Removing the CCD Unit

- 1) Disconnect the 2 flat cables [1] of the reader controller PCB; then, remove the 2 screw [2] and the 2 leaf springs [3]. Thereafter, detach the CCD unit [4].

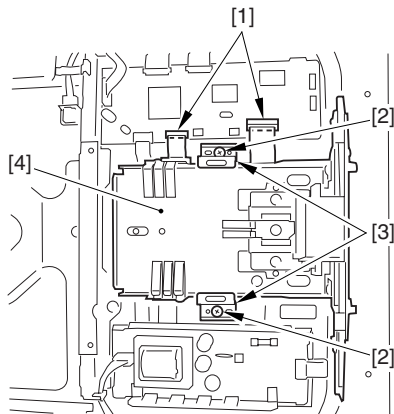

F-5-53

5.4.1.3 When Replacing Components of the Scanning System <iR7105/7095>

<Components>

CCD unit, copyboard glass, scanning lamp, standard white plate, inverter PCB

<Procedure>

Execute the following service mode item:

- 1) COPIER> FUNCTION> CCD> CCD-ADJ
(shading correction based on the standard white plate)

5.4.1.4 When Replacing Components of the Scanning System <iR7086>

<Components>

CCD unit, copyboard glass, stream reading glass, scanning lamp, inverter PCB

<Procedure>

Execute the following service mode items:

- 1) COPIER> FUNCTION> CCD> CCD-ADJ
(shading correction based on the standard white plate)
- 2) COPIER> FUNCTION> CCD> DF-WLVL1
(ADF white level; for copyboard mode)
- 3) COPIER> FUNCTION> CCD> DF-WLVL2
(ADF white level; for stream reading mode)

5.4.2 Copyboard glass

5.4.2.1 Removing the Copyboard Glass

- 1) Open the ADF.
- 2) Remove the copyboard glass [1].
- 2 screws [2]
- right glass retainer [3]

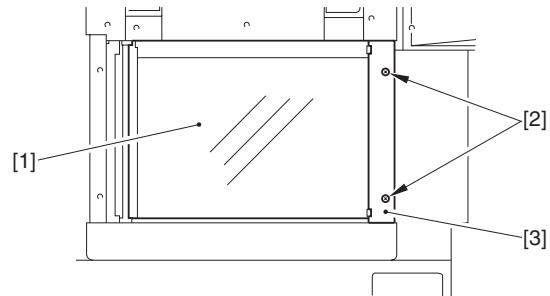

F-5-54



When removing the copyboard glass, take care not to touch the white plate found on its back. (Dirt will lead to lines in images.) Use lint-free paper moistened with alcohol to remove dirt.



Take care not to deform the sponge [2] attached to the right glass retainer [1].

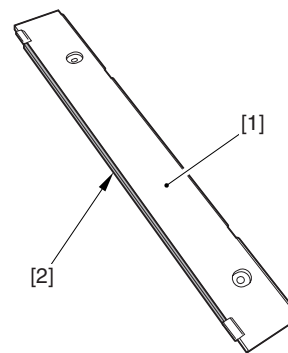

F-5-55

5.4.2.2 Removing the Stream Reading Glass <iR7086>

- 1) Open the ADF.

2) Remove the stream reading glass [1].

- 2 screws [2]

- stream reading glass retainer [3]

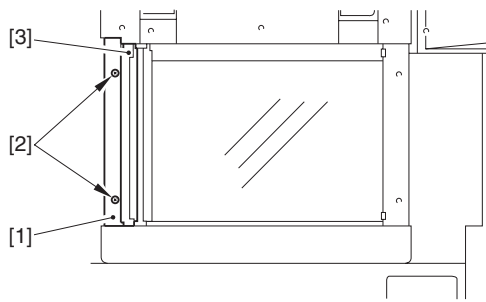

F-5-56



When removing the stream reading glass retainer, be sure to take care so that the leaf spring will not come off.



- When mounting the stream reading glass retainer, be sure to hold down both sides of the leaf spring [A] with your fingers. (Do not bend the leaf spring.)
- Be sure to mount the stream reading glass [C] while forcing the stream reading glass retainer [B] against the glass.
- Check to make sure that the side of the stream reading glass and the leaf spring [D] of the stream reading glass retainer are in contact. Otherwise, the possible collection of dust on the stream reading glass will lead to lines in images.

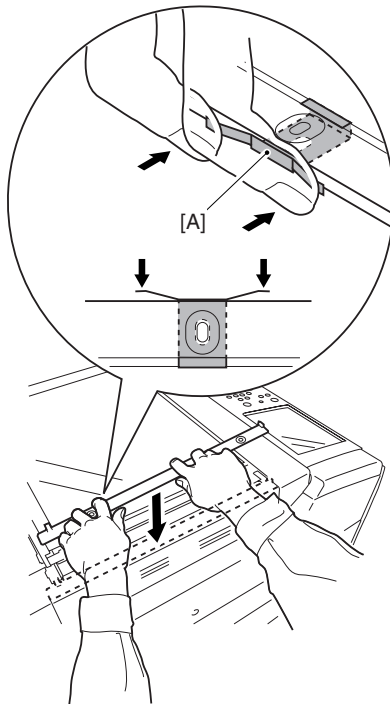

F-5-57

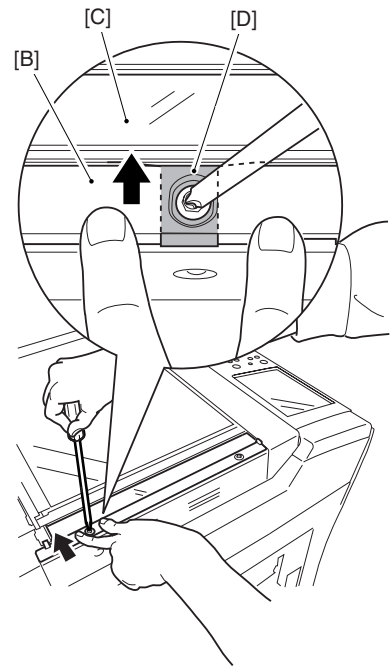

F-5-58

5.4.2.3 When Replacing Components of the Scanning System <iR7105/7095>

<Components>

CCD unit, copyboard glass, scanning lamp, standard white plate, inverter PCB

<Procedure>

Execute the following service mode item:

- 1) COPIER> FUNCTION> CCD> CCD-ADJ
(shading correction based on the standard white plate)

5.4.2.4 When Replacing Components of the Scanning System <iR7086>

<Components>

CCD unit, copyboard glass, stream reading glass, scanning lamp, inverter PCB

<Procedure>

Execute the following service mode items:

- 1) COPIER> FUNCTION> CCD> CCD-ADJ
(shading correction based on the standard white plate)
- 2) COPIER> FUNCTION> CCD> DF-WLVL1
(ADF white level; for copyboard mode)
- 3) COPIER> FUNCTION> CCD> DF-WLVL2
(ADF white level; for stream reading mode)

5.4.3 Standard White Plate

5.4.3.1 Removing the Standard White Plate <iR7105/7095>

- 1) Remove the 2 small covers [1]. (Use a precision screwdriver to release the claw.)

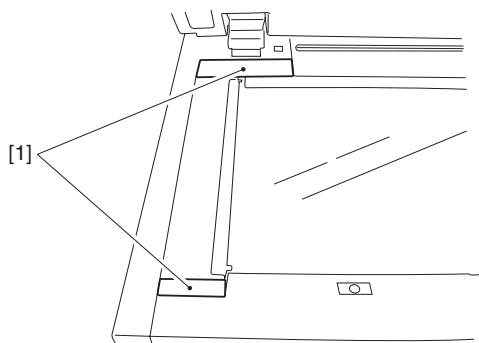

F-5-59

- 2) Remove the standard white plate [1].
- 4 screws [2]

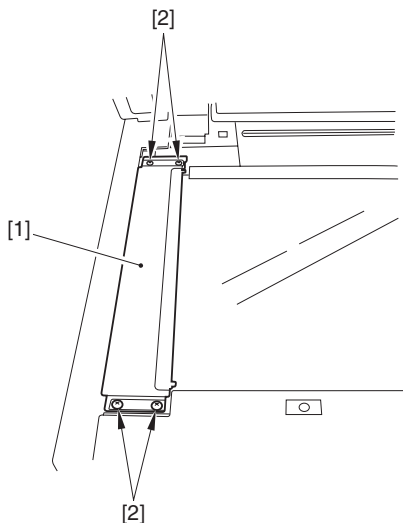

F-5-60

5.4.3.2 When Replacing Components of the Scanning System <iR7105/7095>

<Components>

CCD unit, copyboard glass, scanning lamp, standard white plate, inverter PCB

<Procedure>

Execute the following service mode item:

- 1) COPIER> FUNCTION> CCD> CCD-ADJ
(shading correction based on the standard white plate)

5.4.4 Scanning Lamp

5.4.4.1 Before Starting the Work <iR7105/7095>

- 1) Remove the copyboard glass.
- 2) Remove the hopper upper cover.
- 3) Remove the primary charging assembly cover.
- 4) Remove the process unit cover.
- 5) Remove the upper inside cover.
- 6) Remove the upper front cover unit [1].
- 3 screws [2]

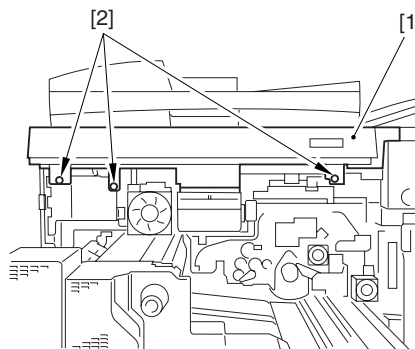

F-5-61

- 7) Remove the lower left cover.
- 8) Remove the upper left cover.
- 9) Remove the reader front cover [1].
- 2 screws [2]
- 2 magnets [3]

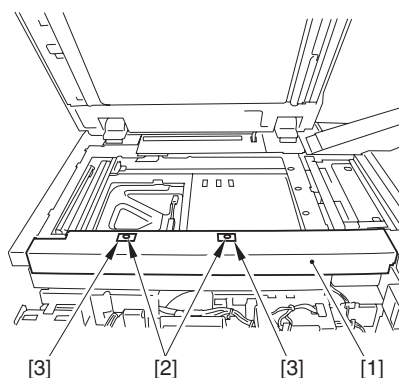

F-5-62

- 10) Remove the reader left cover [1].
- 4 screws [2]

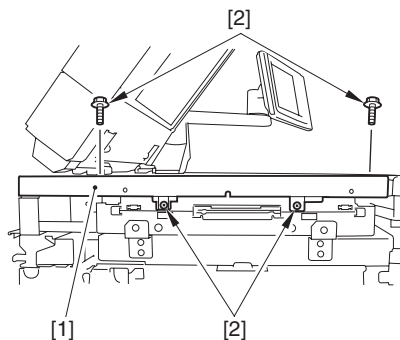

F-5-63

- 11) Remove the reader rear cover [1].
 - 2 connectors [2]
 - 5 screws [3]

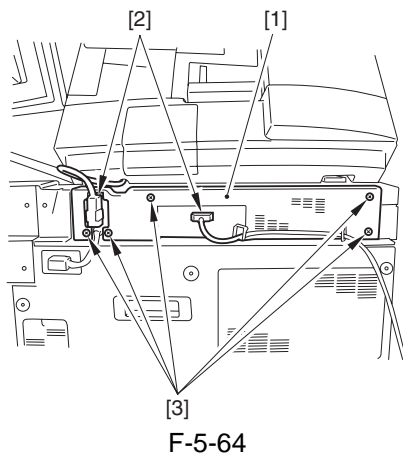

- 12) Remove the reader upper rear cover [1].
 - 1 screw [2]

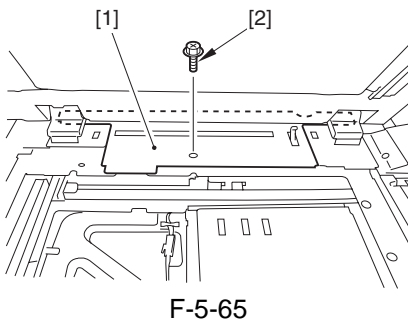

- 13) Remove the scanning lamp inside cover [1].
 - 2 screws [2]

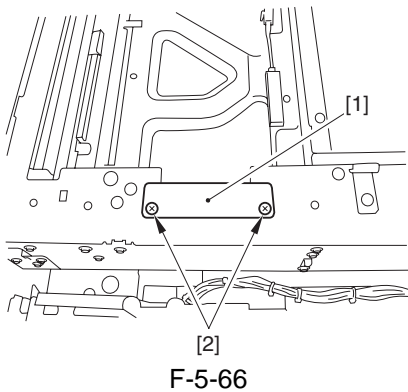

5.4.4.2 Before Starting the Work <iR7086>

- 1) Remove the copyboard glass.
 2) Remove the hopper upper cover.
 3) Remove the reader right cover [1].

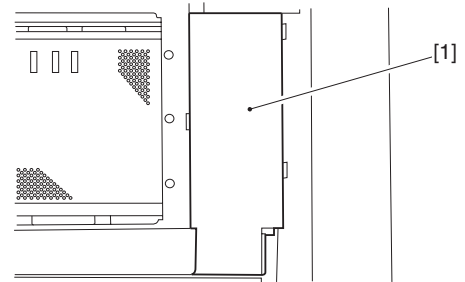

- 4) Remove the reader right plate [1].
 - 4 screws [2]

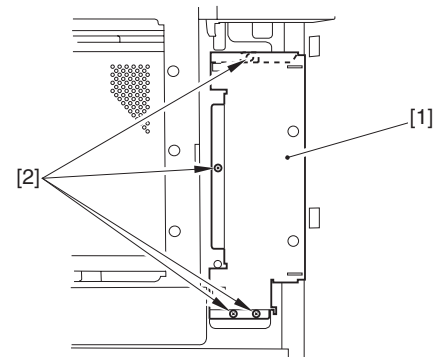

- 5) Remove the lower left cover.
 6) Remove the upper left cover.
 7) Remove the reader left cover [1].
 - 2 screws [2]

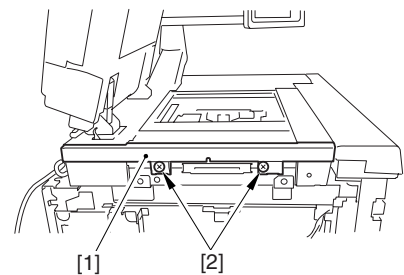

- 8) Remove the reader front cover [1].
 - 1 screw [2]

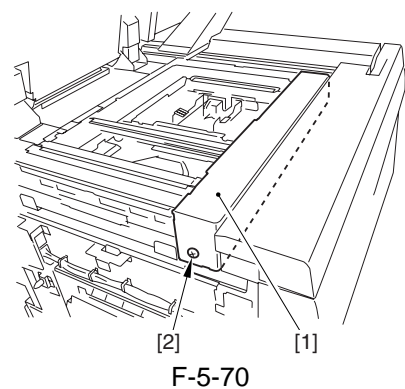

9) Disconnect the 3 connectors [1] at the rear.

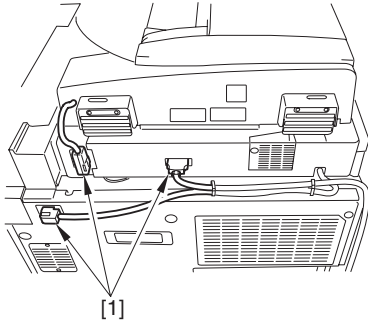

F-5-71

10) Remove the upper rear cover [1].
- 3 cables [2]
- 3 screws [3]

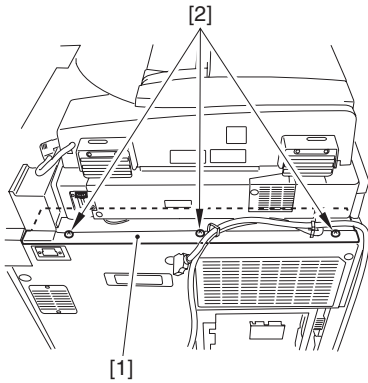

F-5-72

11) Remove the reader rear cover [1].
- 5 screws [2]

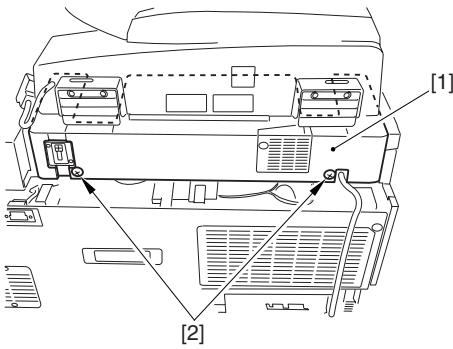

F-5-73

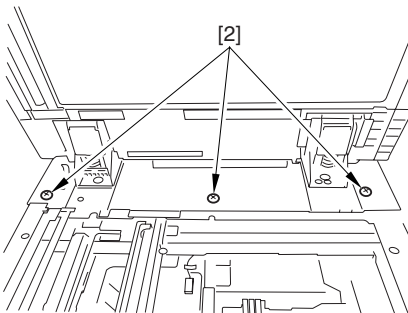

F-5-74

5.4.4.3 Removing the Scanning Lamp

- 1) Disconnect the connector [1], and free the cable [2] from the cable guide [3] and the snap band [4].
- 2) Open the ferrite core [5] to detach. (100/230V machine)

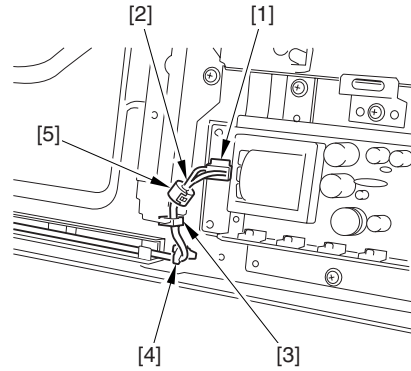

F-5-75



When replacing the scanning lamp, be sure to fit the removed ferrite core to the new lamp. (100/230V machine)

- 3) Slide the No. 1 mirror base [1] to the right so that it matches against the cut-off [2] of the frame.



When detaching the No. 1 mirror base, be sure to hold it by the bend [A] on the mirror stay.

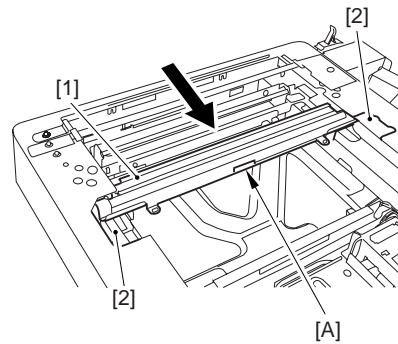

F-5-76

- 4) Remove the 2 screws [1], and detach the scanning lamp [2].

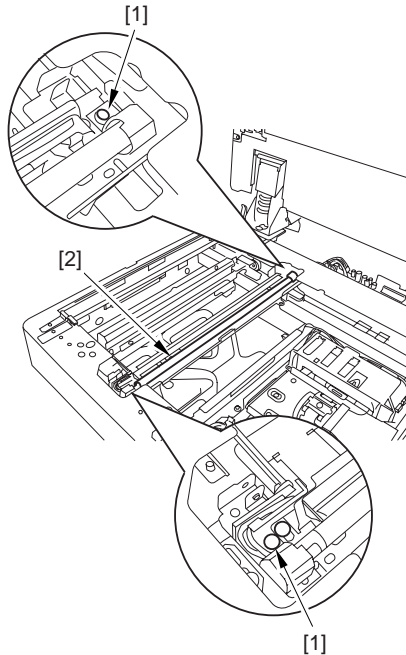

F-5-77

5.4.4.4 When Replacing Components of the Scanning System <iR7105/7095>

<Components>

CCD unit, copyboard glass, scanning lamp, standard white plate, inverter PCB

<Procedure>

Execute the following service mode item:

- 1) COPIER> FUNCTION> CCD> CCD-ADJ
(shading correction based on the standard white plate)

5.4.4.5 When Replacing Components of the Scanning System <iR7086>

<Components>

CCD unit, copyboard glass, stream reading glass, scanning lamp, inverter PCB

<Procedure>

Execute the following service mode items:

- 1) COPIER> FUNCTION> CCD> CCD-ADJ
(shading correction based on the standard white plate)
- 2) COPIER> FUNCTION> CCD> DF-WLVL1
(ADF white level; for copyboard mode)
- 3) COPIER> FUNCTION> CCD> DF-WLVL2
(ADF white level; for stream reading mode)

5.4.5 Reader Controller PCB

5.4.5.1 Before Starting the Work

- 1) Remove the copyboard glass.
- 2) Remove the CCD unit cover [1].
- 9 screws [2]

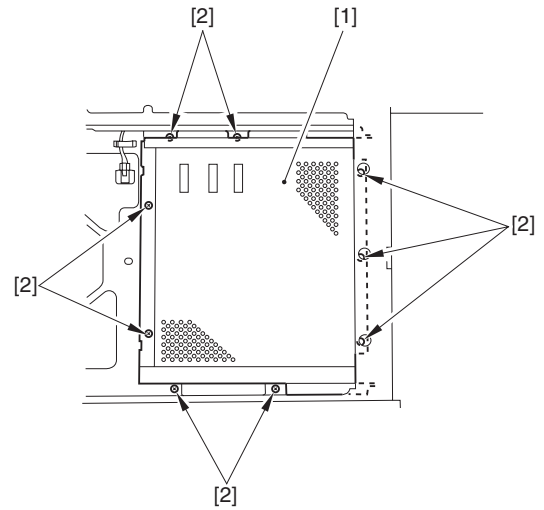

F-5-78

- 3) Remove the original size sensor unit.

5.4.5.2 Removing the Reader Controller PCB

- 1) Disconnect the 5 flat cables [1] and the connector [2], and remove the 4 screws [3]; then, detach the reader controller PCB [4].

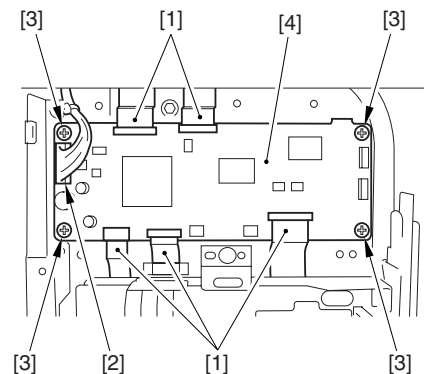

F-5-79

▲ How to Disconnect the Flat Cable
Slide the locking lever [1] in the direction of the arrow to release; then, detach the flat cable [2].

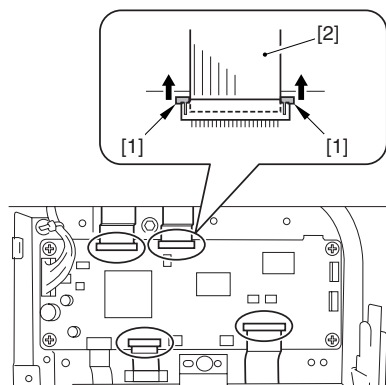

F-5-80

5.4.5.3 After Replacing the Reader Controller PCB <iR7105/7095>

▲ Before Starting the Work (backing up the data)

If possible, perform the following:

- Using the SST, download the data stored in the RAM of the reader controller PCB.
- Print out the user mode/service mode data.

1) Turn on the power, and execute the following service mode item:

COPIER > FUNCTION > CLEAR > R-CON

2) If the data has successfully been downloaded using the SST before the replacement, upload the data.

3) Set the values indicated on the service label for their respective service mode items.

COPIER > ADJUST > ADJ-XY > ADJ-X (adjustment of image read start position in sub scanning direction; image lead edge)

COPIER > ADJUST > ADJ-XY > ADJ-Y (adjustment of image read start position in main scanning direction; horizontal registration)

COPIER > ADJUST > ADJ-XY > ADJ-S (adjustment of shading correction data measurement position)

COPIER > ADJUST > ADJ-XY > ADJ-Y-DF (adjustment of main scanning position for ADF stream reading)

COPIER > ADJUST > ADJ-XY > ADJ-Y-FX (adjustment of main scanning position for ADF fixed reading)

COPIER > ADJUST > ADJ-XY > ADJ-X-MG (fine-adjustment of magnification in sub scanning direction for copyboard reading)

4) Execute the following service mode item:

COPIER > FUNCTION > CCD > CCD-ADJ (shading correction based on standard white plate)

5) Turn off and then on the power.

5.4.5.4 After Replacing the Reader Controller PCB <iR7086>

▲ Before Starting the Work (backing up the data)

If possible, perform the following:

- Using the SST, download the data stored in the RAM of the reader controller PCB.
- Print out the user mode/service mode data.

1) Turn on the power, and execute the following service mode item:

COPIER > FUNCTION > CLEAR > R-CON

2) If the data has successfully been downloaded using the SST before the replacement, upload the data.

3) Set the values indicated on the service label for their respective service mode items.

COPIER > ADJUST > ADJ-XY > ADJ-X (adjustment of image read start position in sub scanning direction; image lead edge)

COPIER > ADJUST > ADJ-XY > ADJ-Y (adjustment of image read start position in main scanning direction; horizontal registration)

COPIER > ADJUST > ADJ-XY > ADJ-S (adjustment of shading correction data measurement position)

COPIER > ADJUST > ADJ-XY > ADJ-Y-DF (adjustment of main scanning position for ADF stream reading)

COPIER > ADJUST > ADJ-XY > STRD-POS (adjustment of CCD read position for ADF stream reading)

COPIER > ADJUST > ADJ-XY > ADJ-X-MG (fine-adjustment of magnification in sub scanning direction for copyboard reading)

FEEDER > ADJUST > DOCST (adjustment of original stop position for ADF pickup)

FEEDER > ADJUST > LA-SPEED (adjustment of original transport speed for ADF stream reading)

4) Execute the following service mode items:

COPIER > FUNCTION > CCD > CCD-ADJ (shading correction based on standard white plate)

COPIER > FUNCTION > CCD > DF-WLVL1 (ADF white level adjustment; for copyboard reading)

COPIER > FUNCTION > CCD > DF-WLVL2 (ADF white level adjustment; for stream reading)

5) Turn off and then on the power.

MEMO:

In the case of the model with the DADF-M1 (outside Japan: iR7086), the ADF-related service mode data is stored in the RAM of the reader controller. As such, if you have initialized the RAM on the reader controller PCB or replaced the PCB, it is important that you newly enter service mode

settings and execute appropriate adjustment items.

5.4.6 Interface PCB

5.4.6.1 Before Starting the Work <iR7105/7095>

- 1) Remove the reader rear cover [1].
 - 2 connectors [2]
 - 5 screws [3]

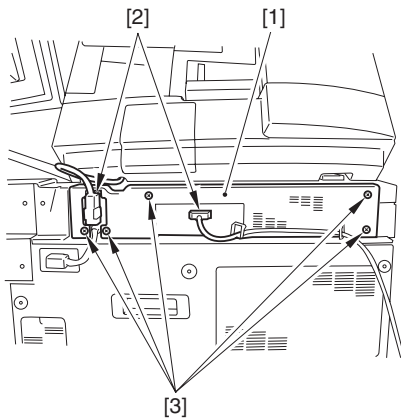

F-5-81

- 2) Remove the reader upper rear cover.

5.4.6.2 Removing the Interface PCB <iR7105/7095>

- 1) Remove the interface PCB cover [1].
 - 2 screws [2]
 - 8 screws [3]

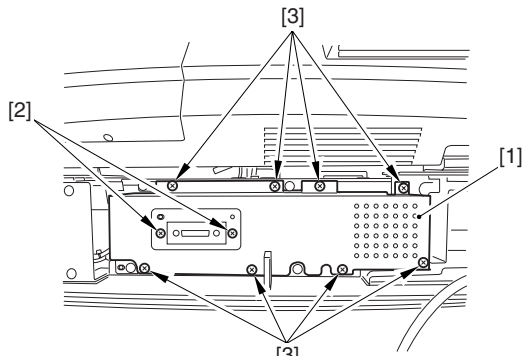

F-5-82

- 2) Remove the interface PCB [1].
 - connectors/flat cables on PCB
 - 7 screws [2]
 - 2 screws [3]

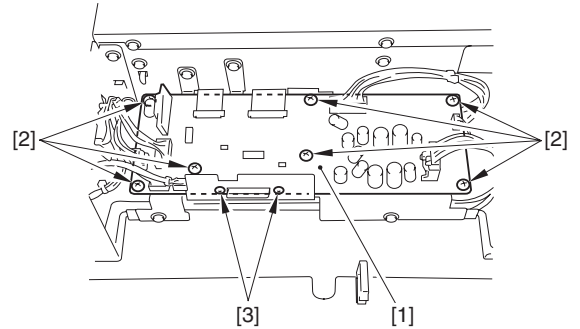

F-5-83

⚠ How to Disconnect the Flat Cable
Slide the locking lever [1] in the direction of the arrow, and detach the flat cable [2].

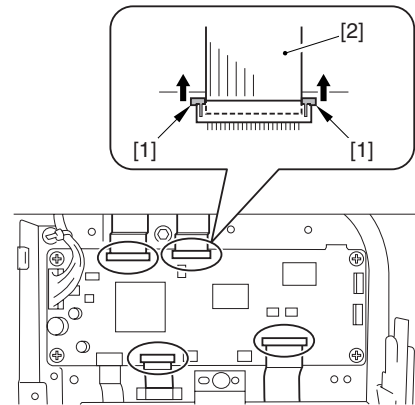

F-5-84

5.4.6.3 Before Starting the Work <iR7086>

- 1) Disconnect the 3 connectors [1].

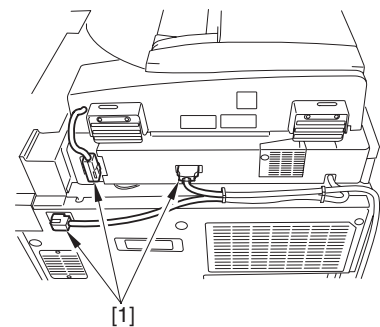

F-5-85

- 2) Remove the upper rear cover [1].
- 3 screws [2]

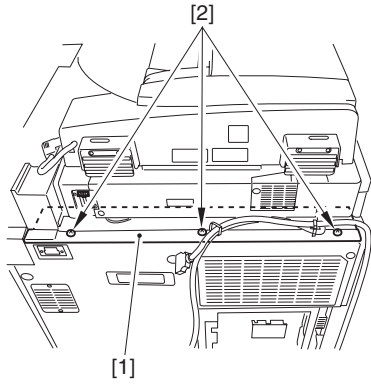

F-5-86

- 3) Remove the reader rear cover [1].
- 5 screws [2]

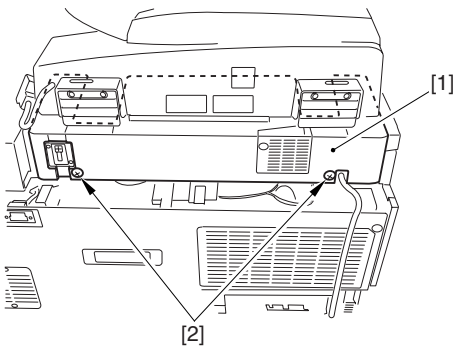

F-5-87

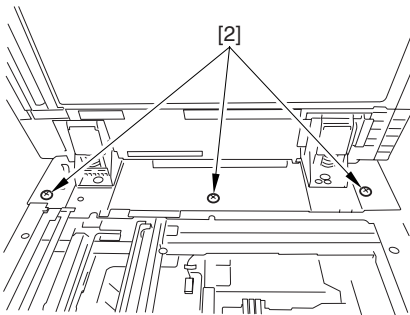

F-5-88

5.4.6.4 Removing the Interface PCB <iR7086>

- 1) Remove the 4 RS tightening screws [1] and the 2 binding screws [2]; then, detach the interface PCB cover [3].

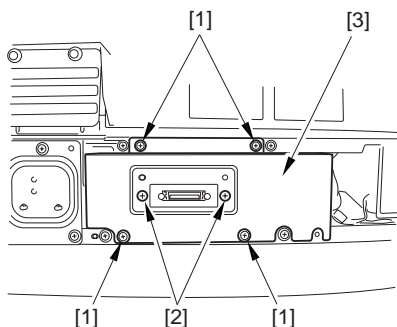

F-5-89

- 2) Disconnect the 7 connectors [1] and the 2 flat cables [2], and remove the 5 screws; then, detach the interface PCB unit [4].

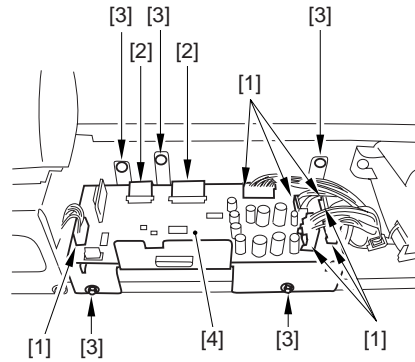

F-5-90

- ⚠ How to Disconnect the Flat Cable**
Slide the locking lever [1] in the direction of the arrow to release; then, detach the flat cable [2].

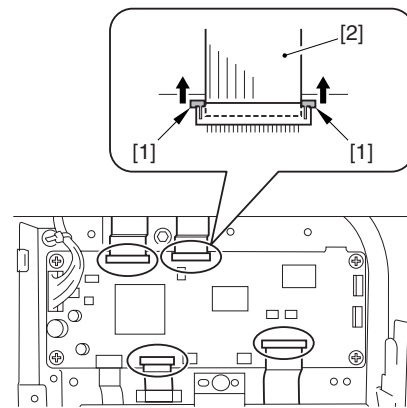

F-5-91

- 3) Remove the 9 screws [1], and detach the interface PCB [2].

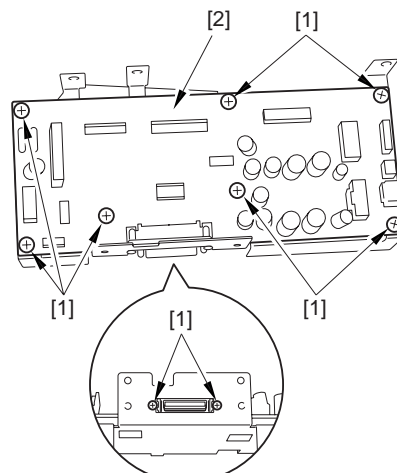

F-5-92

5.4.7 Inverter PCB

5.4.7.1 Before Starting the Work

- 1) Remove the copyboard glass.
- 2) Remove the CCD unit cover [1].
- 9 screws [2]

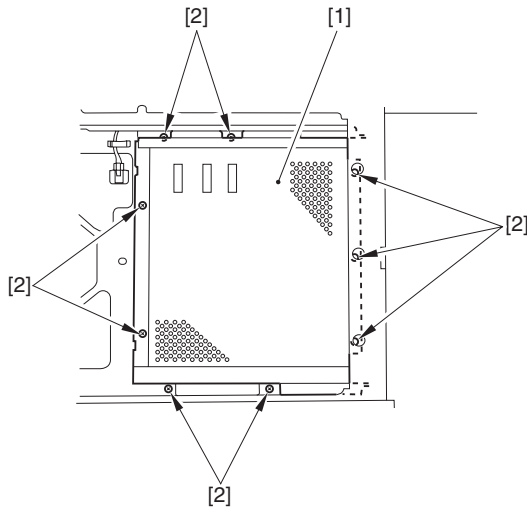

F-5-93

- 3) Remove the original size sensor unit.

5.4.7.2 Removing the Inverter PCB

- 1) Disconnect the connector [1] and the flat cable [2]; then, release the 2 PCB supports [4] to detach the inverter PCB [5].

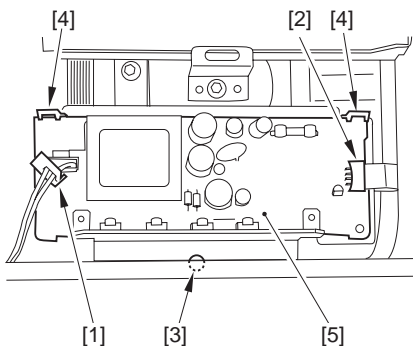

F-5-94

5.4.7.3 When Replacing Components of the Scanning System <iR7105/7095>

<Components>

CCD unit, copyboard glass, scanning lamp, standard white plate, inverter PCB

<Procedure>

Execute the following service mode item:

- 1) COPIER> FUNCTION> CCD> CCD-ADJ (shading correction based on the standard white plate)

5.4.7.4 When Replacing Components of the Scanning System <iR7086>

<Components>

CCD unit, copyboard glass, stream reading glass, scanning lamp, inverter PCB

<Procedure>

Execute the following service mode items:

- 1) COPIER> FUNCTION> CCD> CCD-ADJ (shading correction based on the standard white plate)
- 2) COPIER> FUNCTION> CCD> DF-WLVL1 (ADF white level; for copyboard mode)
- 3) COPIER> FUNCTION> CCD> DF-WLVL2 (ADF white level; for stream reading mode)

5.4.8 Scanner Motor

5.4.8.1 Before Starting the Work <iR7105/7095>

- 1) Remove the reader rear cover.
- 2) Remove the reader upper rear cover.
- 3) Remove the interface PCB cover.

5.4.8.2 Before Starting the Work <iR7086>

- 1) Disconnect the 3 connectors [1].

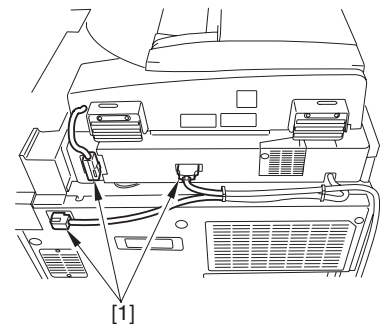

F-5-95

- 2) Remove the upper rear cover [1].
- 3 screws [2]

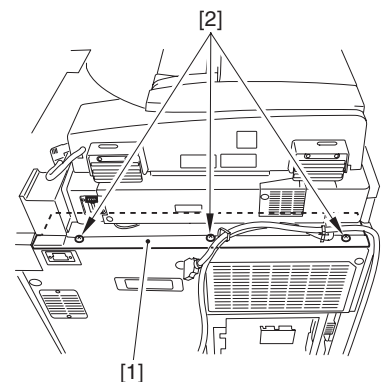

F-5-96

- 3) Remove the reader rear cover [1].
- 5 screws [2]

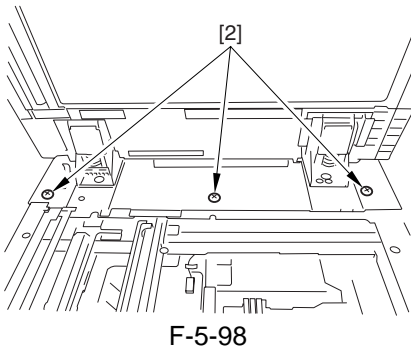
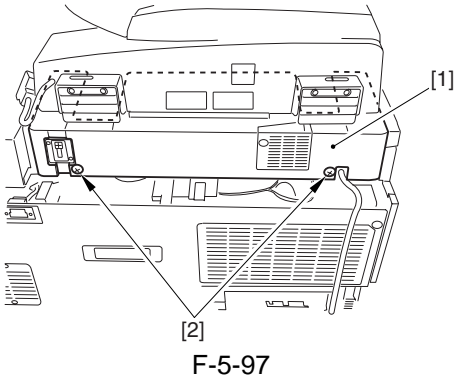

5.4.8.3 Removing the Scanner Motor

- 1) Slide out the reader power supply cover [1].
- 4 screws [2]
- Free the cable from the wire saddle found behind the cover.

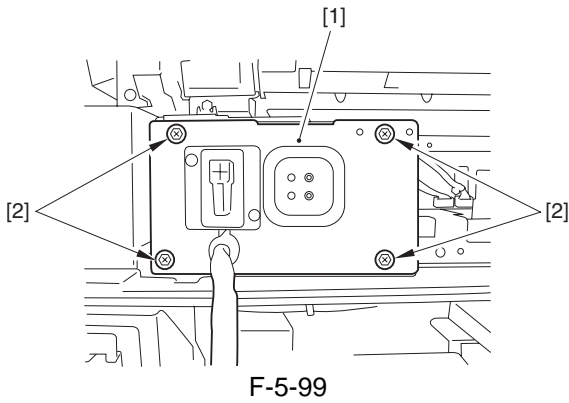

- 2) Disconnect the connector [1] of the interface PCB.

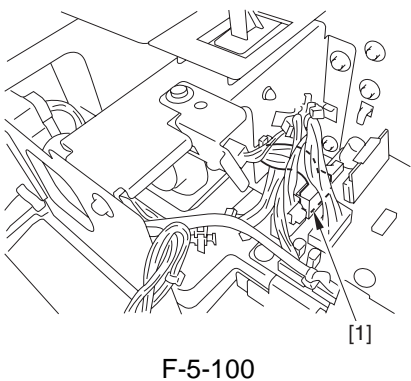

- 3) Shift the scanner motor [1] in the direction of the arrow to detach.
- 2 springs [2]
- 3 screws [3]

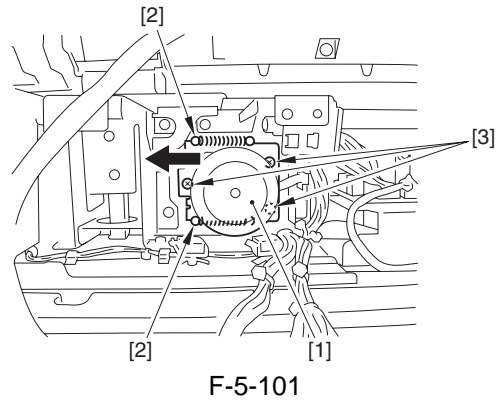

5.4.8.4 Mounting the Scanner Motor

When mounting the scanner motor, check to be sure that the timing belt [3] is properly fitted to the scanner pulley [1] and the motor shaft [2].

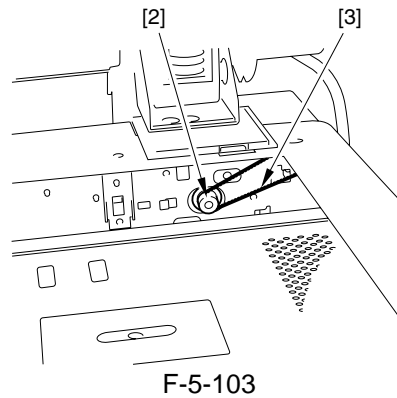
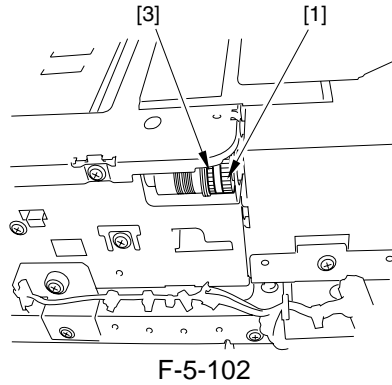

5.4.9 ADF Open/Close Sensor

5.4.9.1 Before Starting the Work <iR7105/7095>

- 1) Remove the reader rear cover.
- 2) Remove the reader upper rear cover.
- 3) Remove the interface PCB cover.

5.4.9.2 Removing the ADF Open/Closed Sensor <iR7105/7095>

- 1) Remove the sensor mounting plate [1].
 - 1 connector [2]
 - 1 screw [3]

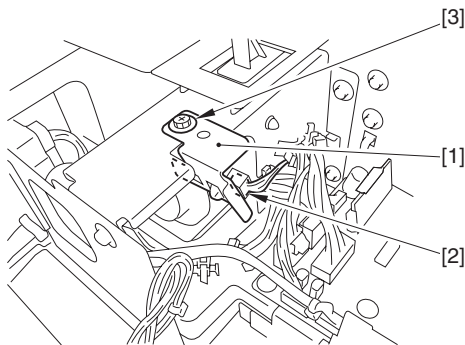

F-5-104

- 2) Remove the ADF Open/Closed Sensor.

5.4.9.3 Before Starting the Work <iR7086>

- 1) Disconnect the 3 connectors [1].

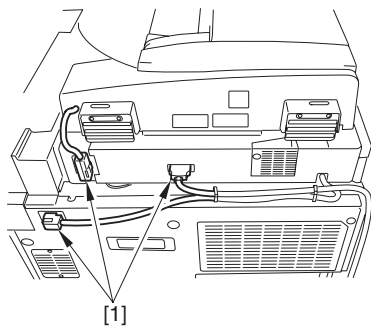

F-5-105

- 2) Remove the upper rear cover [1].
 - 3 screws [2]

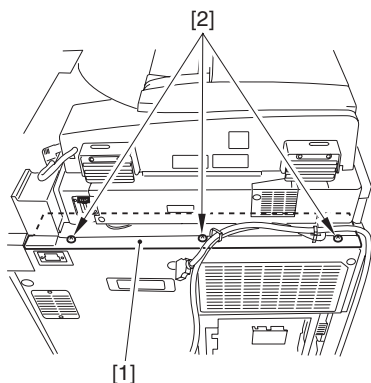

F-5-106

- 3) Remove the reader rear cover [1].
 - 5 screws [2]

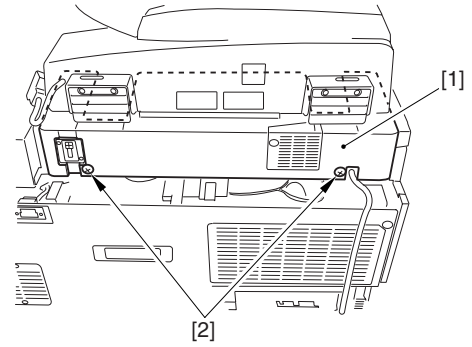

F-5-107

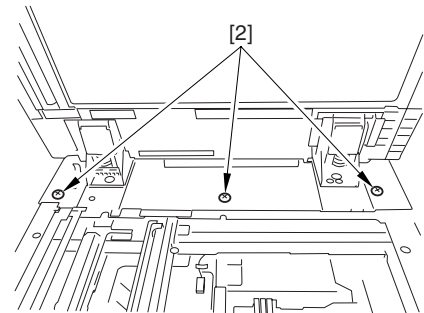

F-5-108

5.4.9.4 Removing the ADF Open/Closed Sensor 1, 2 <iR7086>

- 1) Disconnect the connector [1].

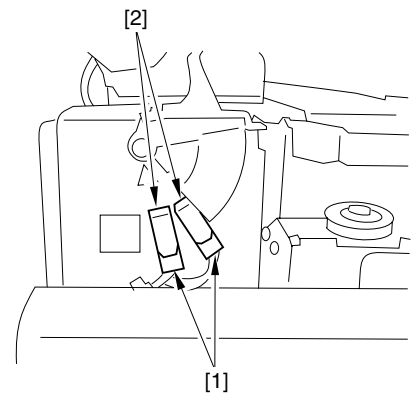

F-5-109

- 2) Remove the 4 screws [1], and detach the reinforcing plate [2].

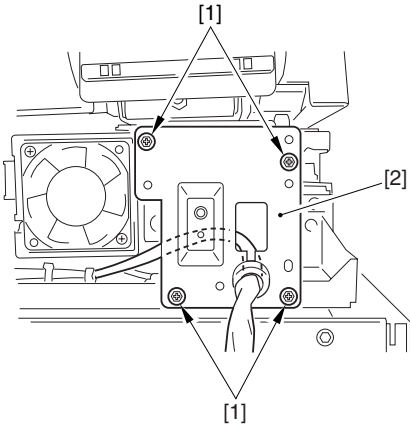

F-5-110

- 3) Remove the hook, and detach the ADF open/closed sensor (1, 2).

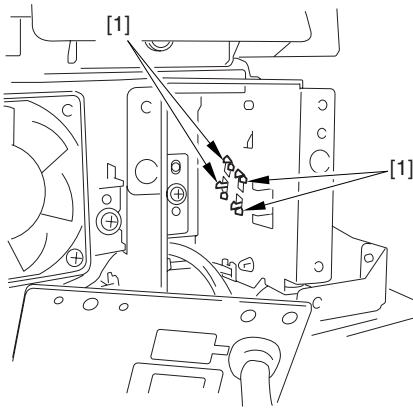

F-5-111

5.4.10 Original Size Sensor

5.4.10.1 Before Starting the Work

- 1) Remove the copyboard glass.
- 2) Remove the CCD unit cover [1].
- 9 screws [2]

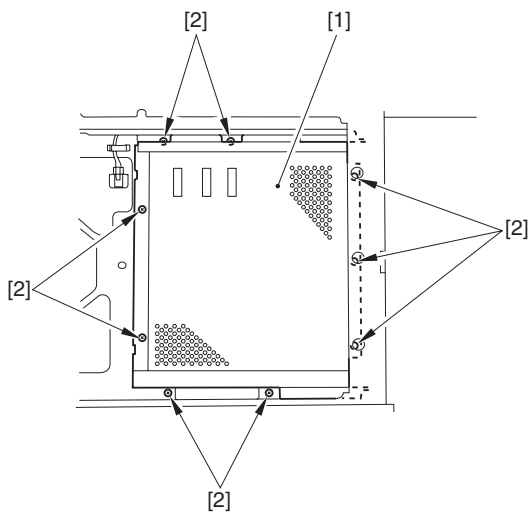

F-5-112

- 3) Remove the original size sensor unit.

5.4.10.2 Removing the Original Size Sensor Unit

- 1) Remove the 3 screws [1], and shift the original size detection unit [2].

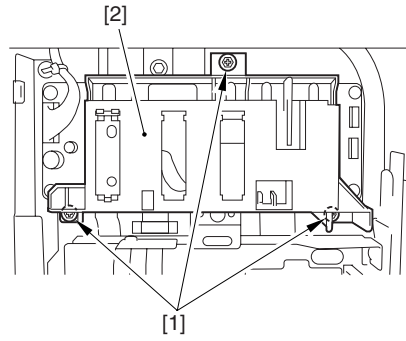

F-5-113

- 2) Disconnect the connector [1], and detach the original size sensor unit [2].

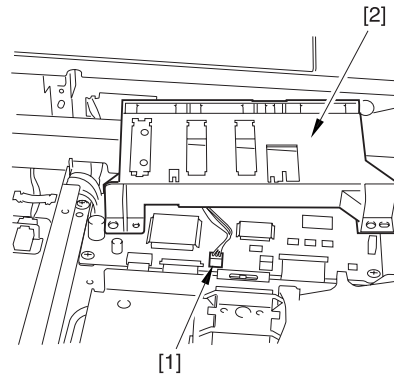

F-5-114

5.4.10.3 Removing the Original Size Sensor

- 1) While releasing the claw at the end, detach the original size sensor [1].

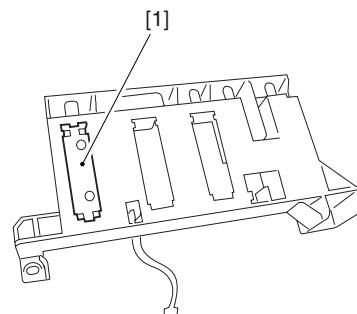

F-5-115

5.4.11 Scanner Home Position Sensor

5.4.11.1 Before Starting the Work <iR7105/7095>

- 1) Remove the reader rear cover [1].
- 2 connectors [2]
- 5 screws [3]

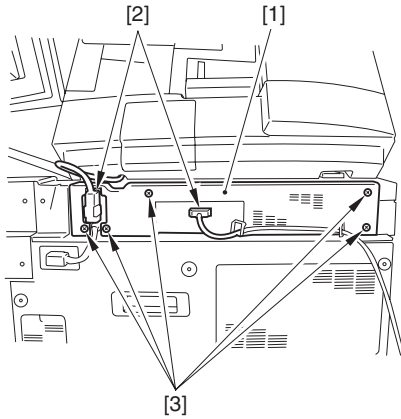

F-5-116

- 2) Remove the reader upper rear cover.
- 3) Remove the interface PCB cover [1].
- 2 screws [2]
- 8 screws [3]

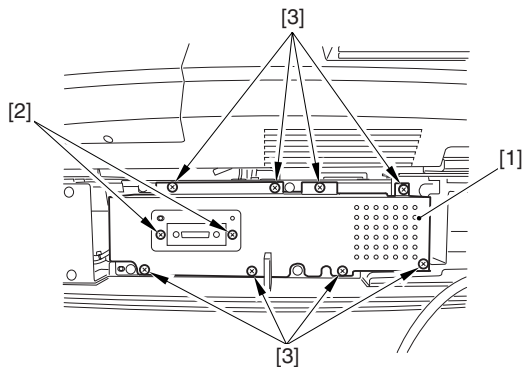

F-5-117

- 4) Slide out the rear upper cover [1] to the front.
- 3 screws [2]

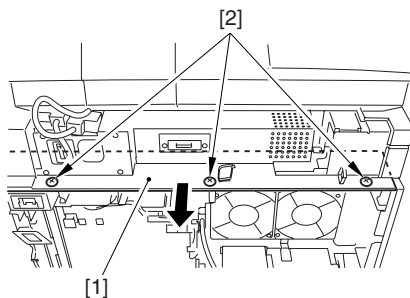

F-5-118

5.4.11.2 Removing the Scanner Home Position Sensor <iR7105/7095>

- 1) Remove the reader rear cover (small) [1].
- 1 screw [2]
- 2) Remove the plate [3].
- 3 screws [4]

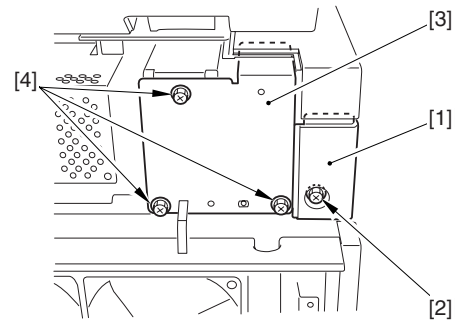

F-5-119

- 3) Remove the sensor mounting plate [1].
- 1 screw [2]

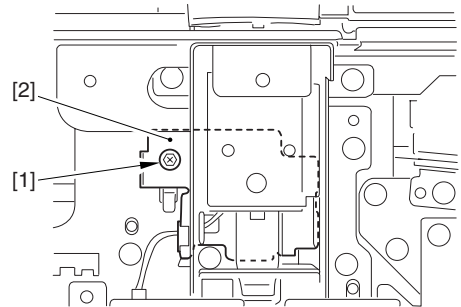

F-5-120

- 4) Remove the scanner home position sensor [1].
- 1 connector [2]

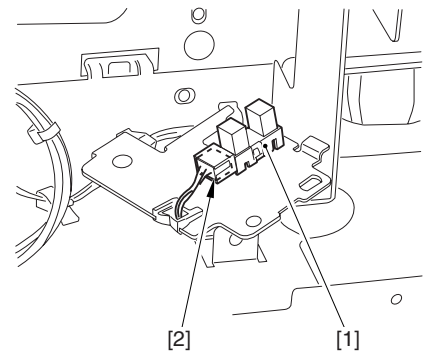

F-5-121

5.4.11.3 Before Starting the Work <iR7086>

1) Disconnect the 3 connectors [1].

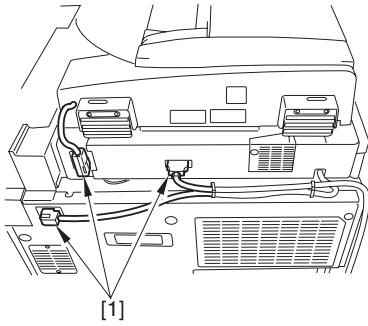

F-5-122

2) Remove the upper rear cover [1].
- 3 screws [2]

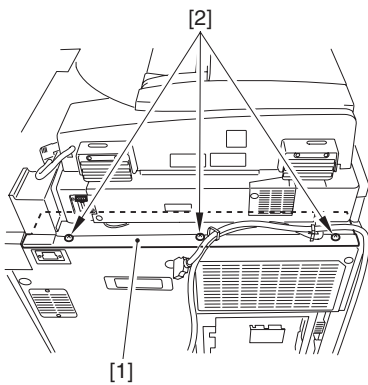

F-5-123

3) Remove the reader rear cover [1].
- 5 screws [2]

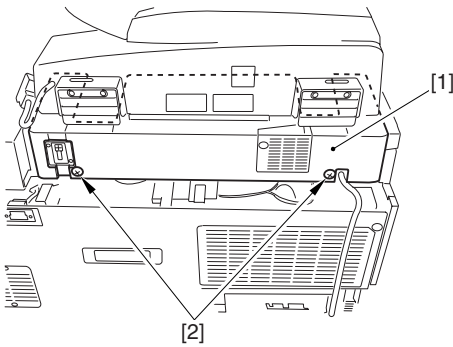

F-5-124

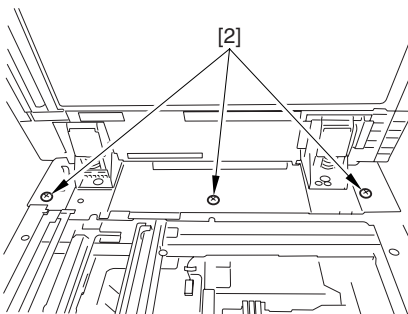

F-5-125

5.4.11.4 Removing the Scanner Home Position Sensor <iR7086>

1) Remove the 4 screws [1], and detach the plate [2].

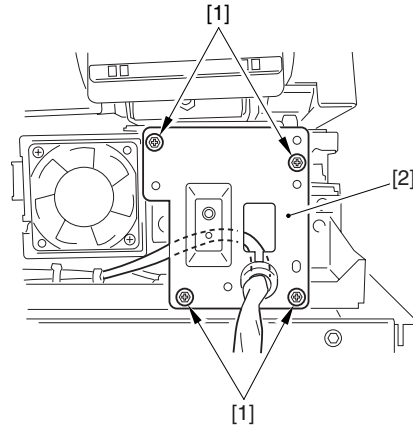

F-5-126

2) Remove the screw [1], and detach the sensor base [2].

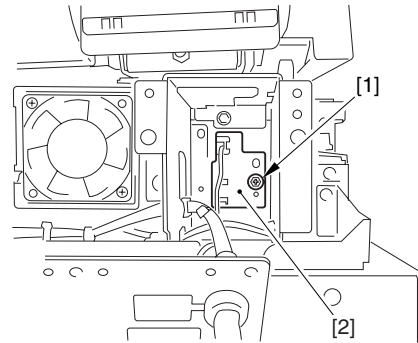

F-5-127

3) Disconnect the connector [1], and detach the home position sensor [1].

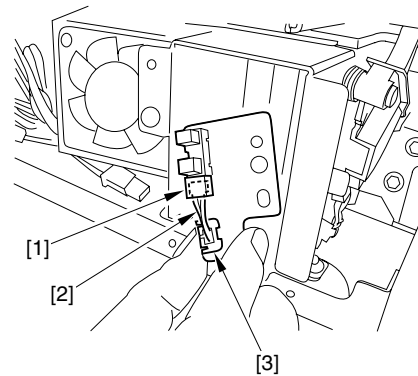

F-5-128

- 4) Remove the hook [1], and detach the home position sensor [2].

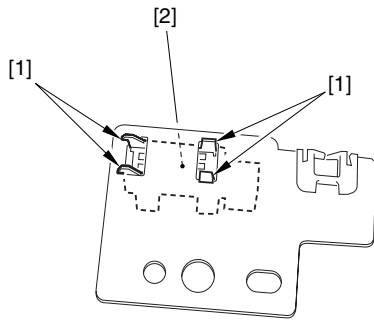

F-5-129

5.4.12 Cooling Fan

5.4.12.1 Before Starting the Work <iR7105/7095>

- 1) Remove the sub hopper unit.
2) Remove the upper right cover [1].
- 2 screws [2]

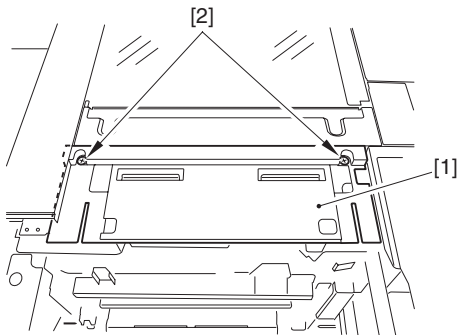

F-5-130

5.4.12.2 Removing the Reader Cooling Fan 1/2 <iR7105/7095>

- 1) Remove the fan cover [1] and the 2 air filters [2].
- 1 screw [3]

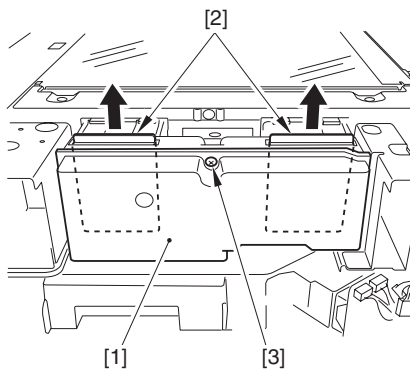

F-5-131

- 2) Remove the fan inside cover [1].
- 4 screws [2]

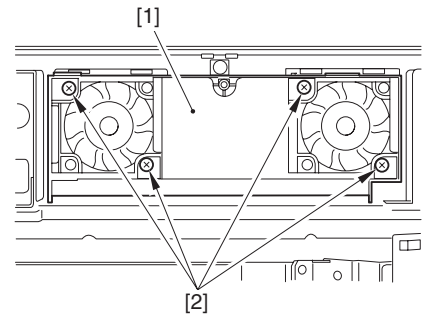

F-5-132

- 3) Remove the scanner motor cooling fan [1].
- 1 connector [2]
- 2 screws [3]

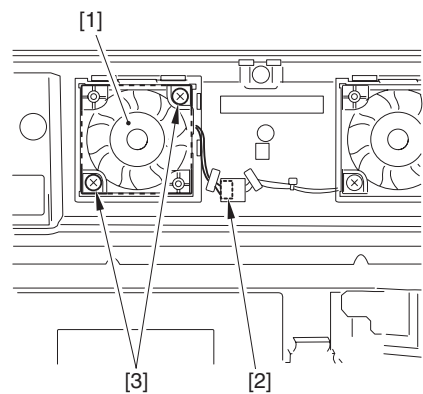

F-5-133

- 4) Remove the reinforcing plate [1].
- 3 screws [2]

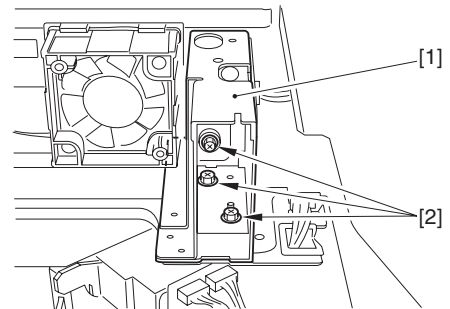

F-5-134

- 5) Remove the scanner motor cooling fan 2 [1].
- 1 connector [2]
- 2 screws [3]

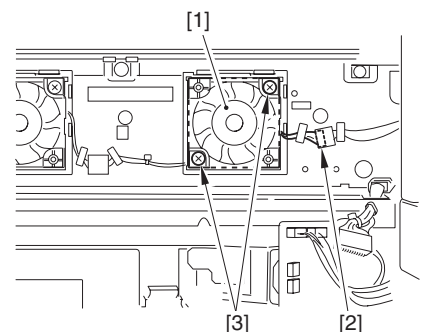

F-5-135

5.4.12.3 Before Starting the Work <iR7086>

- 1) Disconnect the 3 connectors [1].

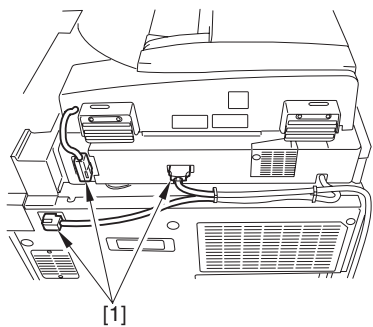

F-5-136

- 2) Remove the upper rear cover [1].
- 3 screws [2]

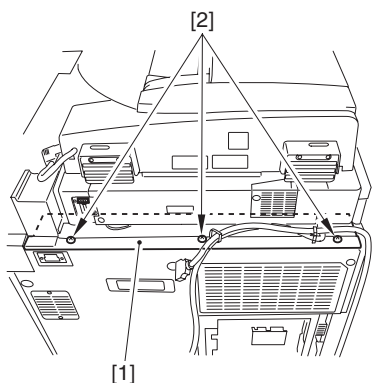

F-5-137

- 3) Remove the reader rear cover [1].
- 5 screws [2]

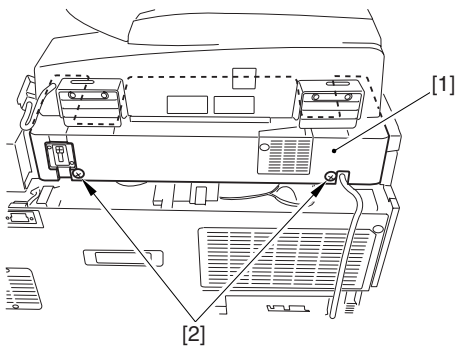

F-5-138

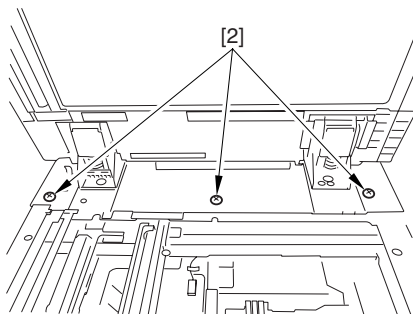

F-5-139

5.4.12.4 Removing the Reader Cooling Fan <iR7086>

- 1) Open the wire saddle [1], and disconnect the connector [2].
- 2) Remove the 2 screws [3], and detach the cooling fan [4].

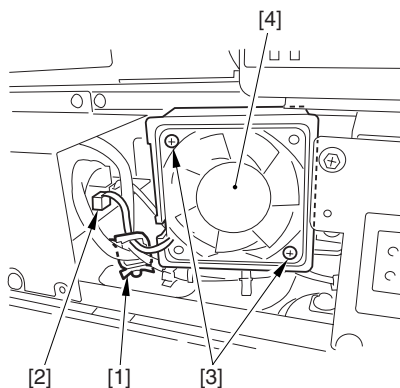

F-5-140

5.4.13 Scanner Drive Cable

5.4.13.1 Before Starting the Work <iR7105/7095>

- 1) Remove the ADF.
- 2) Remove the original delivery tray.
- 3) Remove the control panel support unit.
- 4) Remove the copyboard glass.
- 5) Remove the standard white plate.
- 6) Remove the upper front cover unit.
- 7) Remove the reader front cover.
- 8) Remove the reader left cover.
- 9) Remove the reader rear cover.
- 10) Remove the reader upper rear cover.
- 11) Remove the interface PCB cover.
- 12) Remove the ADF right hinge base cover [1] and the reader upper rear right cover [2].
- 4 screws [3]

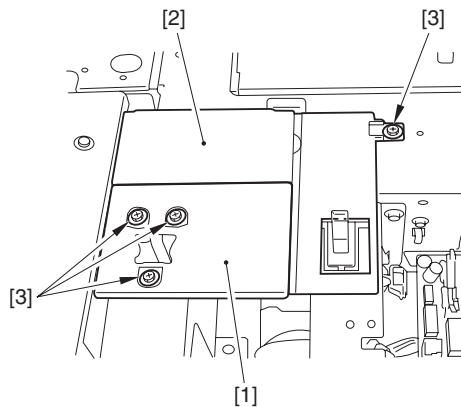

F-5-141

- 13) Shift the reader power supply cover to the front.
 14) Remove the ADF right hinge base [1].
 - 7 screws [2]

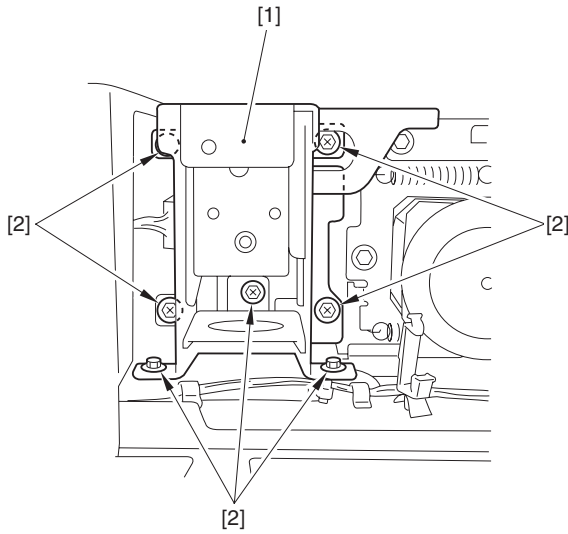

F-5-142

- 15) Remove the 4 screws [1], and shift the ADF open/closed sensor assembly [2] and the ADF open/closed sensor lever assembly [3] to the front.

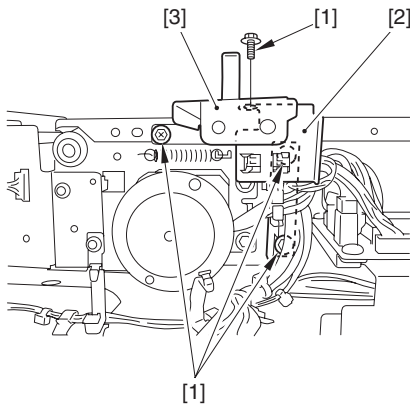

F-5-143

- 16) Remove the reader rear cover (small) [1].
 - 1 screw [2]
 17) Remove the plate [3].
 - 3 screws [4]

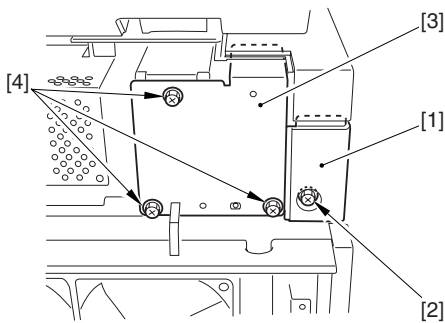

F-5-144

- 18) Remove the ADF left hinge base [1].
 - 7 screws [2]

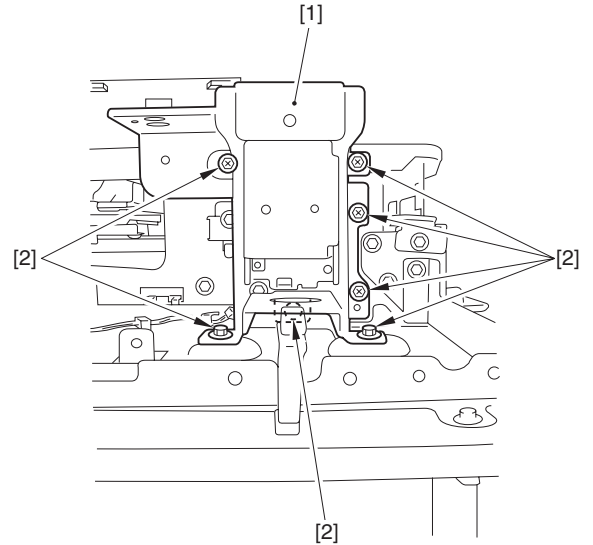

F-5-145

5.4.13.2 Before Starting the Work

<iR7086>

- 1) Remove the control panel support unit.
 2) Remove the control panel support unit base [1].
 - 5 screws [2]

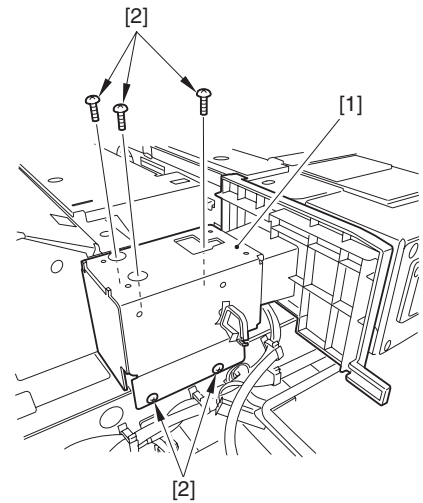

F-5-146

- 3) Remove the hopper upper cover.
 4) Remove the reader right cover [1].

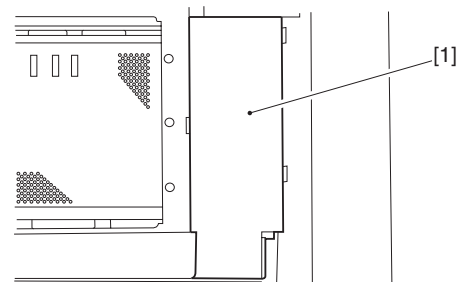

F-5-147

- 5) Remove the reader left cover [1].
- 2 screws [2]

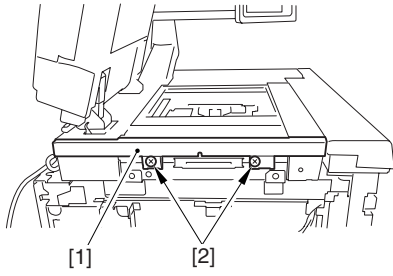

F-5-148

- 6) Remove the reader front cover [1].
- 1 screw [2]

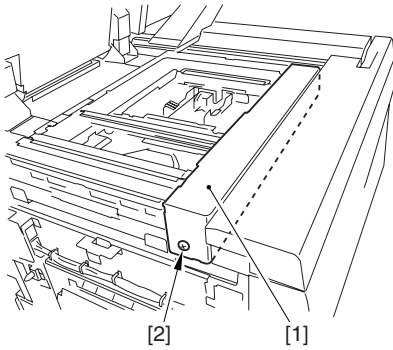

F-5-149

- 7) Disconnect the 3 connectors [1] at the rear.

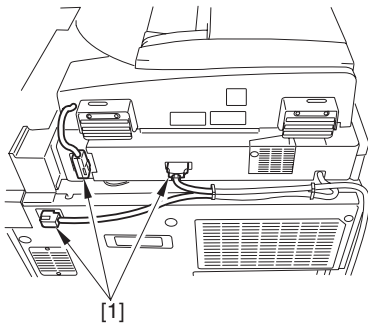

F-5-150

- 8) Remove the upper rear cover [1].
- 3 cables [2]
- 3 screws [3]

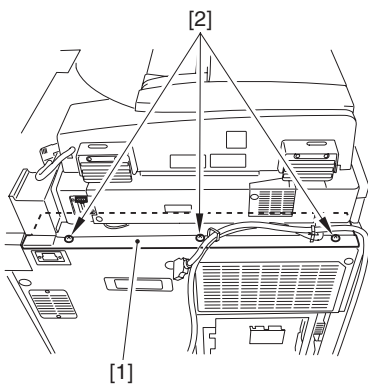

F-5-151

- 9) Remove the reader rear cover [1].
- 5 screws [2]

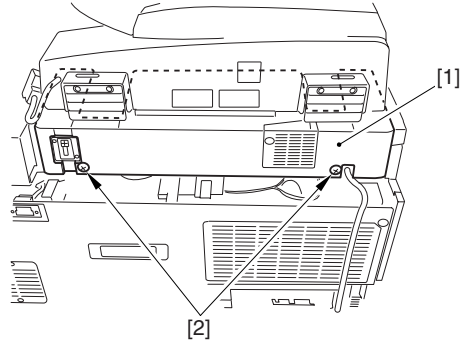

F-5-152

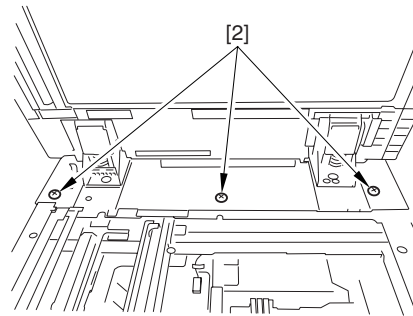

F-5-153

- 10) Remove the ADF.
- 3 screws [1]

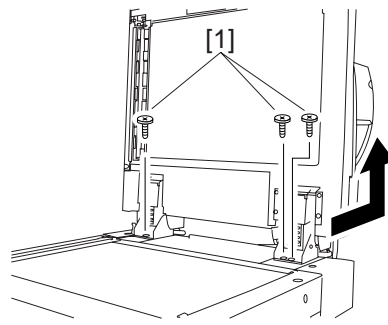

F-5-154

- 11) Remove the screw [1], and detach the ADF screw right cover [2].

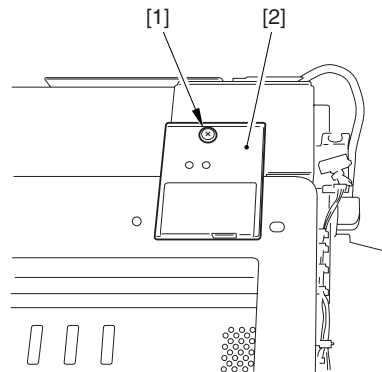

F-5-155

- 12) Remove the screw [1], and detach the ADF screw left cover [2].

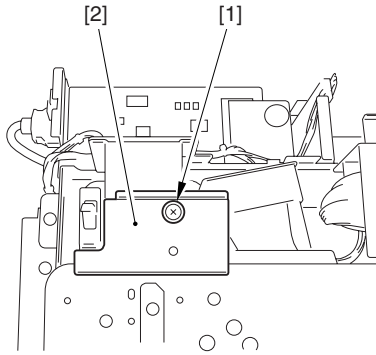

F-5-156

- 13) Remove the 2 screws [1], and detach the stream reading glass retainer [2].
 14) Remove the stream reading glass [3].
 15) Remove the 2 screws [4], and detach the glass left retainer [5].

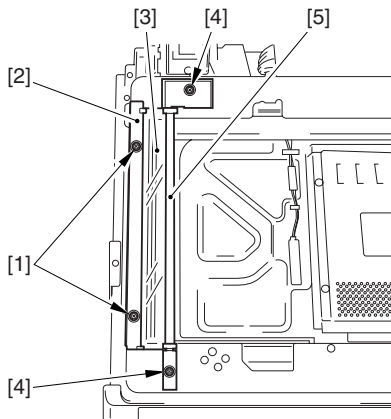

F-5-157

- 16) Remove the interface PCB cover.
 17) Open the 2 wire saddle [1].
 18) Remove the 4 screws [2], and detach the ADF power supply cover [3] together with the harness.

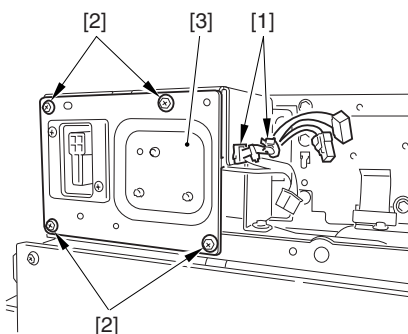

F-5-158

- 19) Free the harness from the wire saddle [1], and remove the 6 screws [2]; then, detach the motor support plate [3].

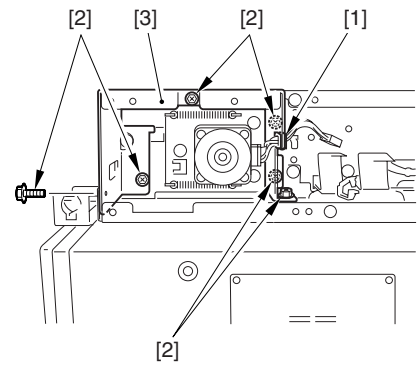

F-5-159

- 20) Remove the 4 screws [1], and slide out the ADF open/closed sensor cover [2] to the front.

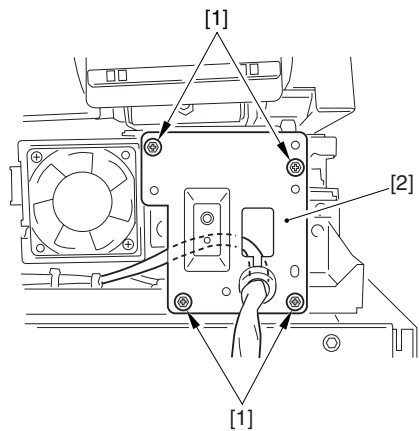

F-5-160

- 21) Remove the 2 screws [1], and shift the scanner motor cooling fan [2] to the side.

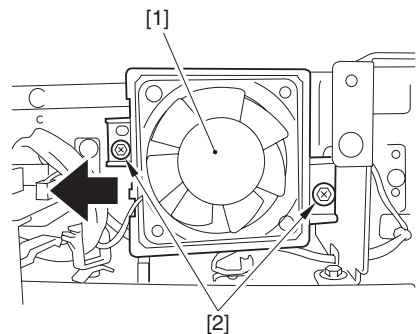

F-5-161

- 22) Remove the 5 screws [1], and slide out the ADF open/closed sensor base [2] to the front.

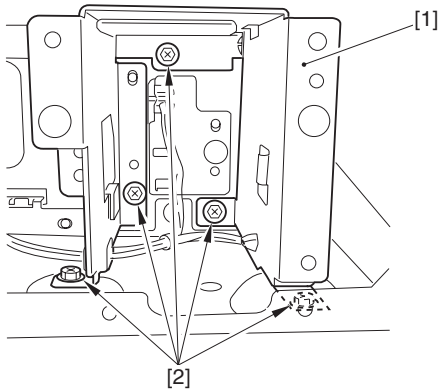

F-5-162

5.4.13.3 Removing the Scanner Drive Cable

- 1) Remove the 24 screws [1], and detach the reader upper frame [2].

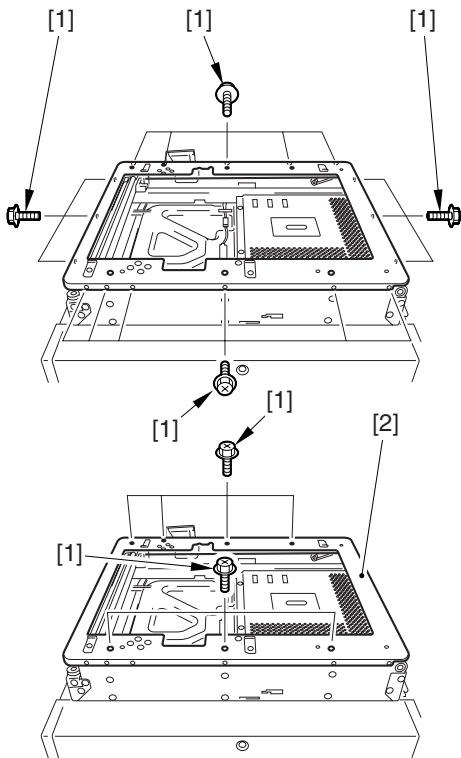

F-5-163

- 2) Remove the 2 cable fixing screws [2] of the No. 1 mirror base [1].
 3) Remove the cable fixing screws [3].
 4) Free the 2 hooks [4] of the cable from the right side of the reader unit frame.
 5) Detach the cable for the pulleys.

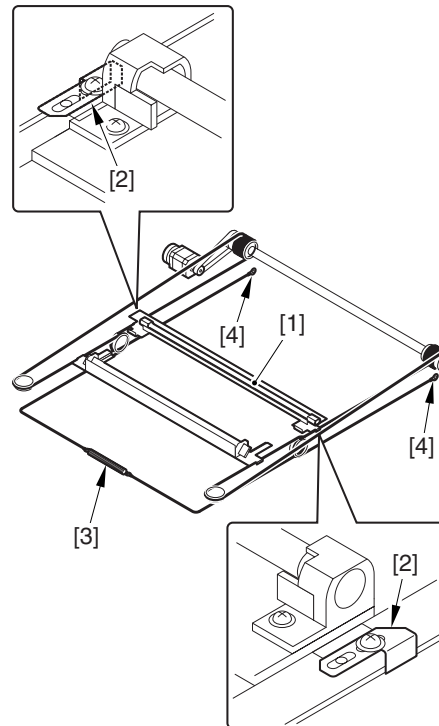

F-5-164

5.4.13.4 Fitting the Scanner Drive Cable

- 1) Put the ball of the cable into the hole of the drive pulley [1], and wind the cable (4 times inside; 5 times outside); then, tape it in place. At this time, make sure that the cable fixing [2] is on the inside.
- 2) Fit the cable on the pulleys; then, fit one end on the left side hook [3] and the other end on the right side hook [4].
- 3) Temporarily fix the cable fixing plate [2] in place on the No. 1 mirror base [5].
- 4) Mount the reader unit upper frame.

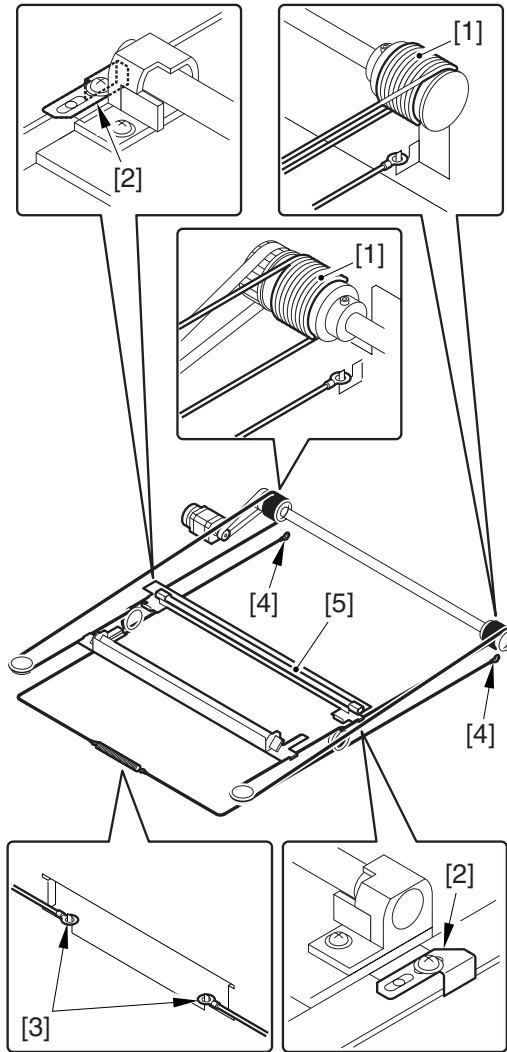

F-5-165

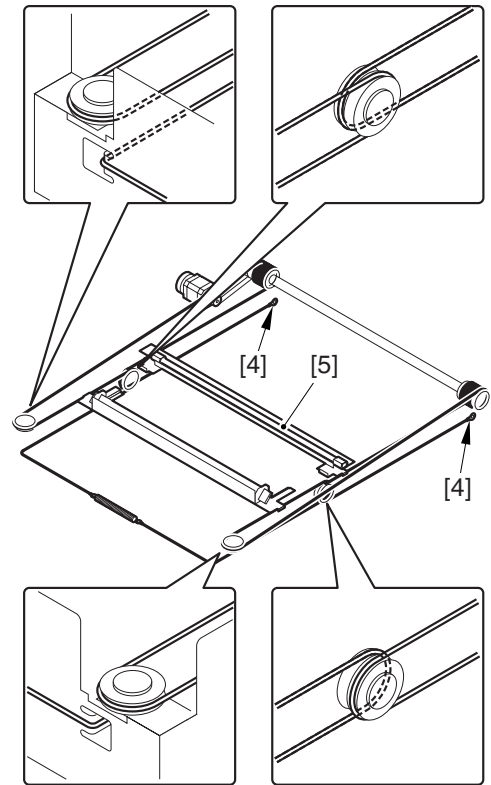

F-5-166

5.4.13.5 Adjusting the Position of the No. 1/No. 2 Mirror Base

- 1) Arrange the mirror positioning tool (FY9-3009-040) so that it is ready for use in the machine (by changing the pin position; REAR).

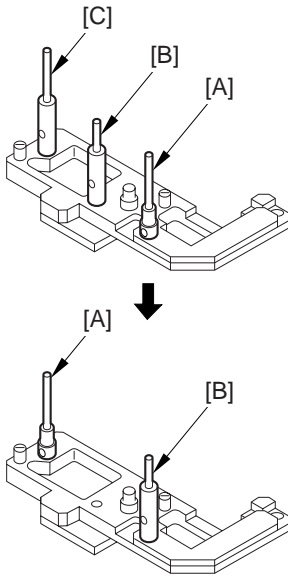

F-5-167

- 2) Arrange the mirror positioning tool so that it is ready for use in the machine (by changing the pin position; FRONT).

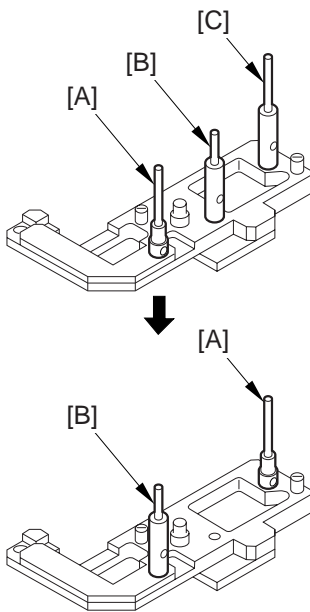

F-5-168

- 3) Fit the pins of the mirror positioning tool (front [2]; rear [3]) into the appropriate holes of the No. 1/No. 2 mirror base.

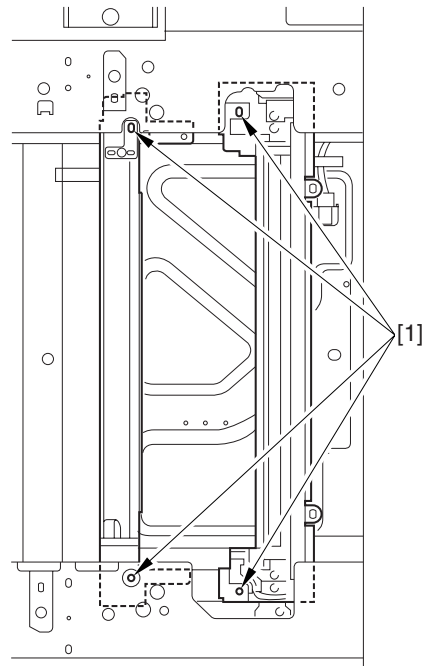

F-5-169

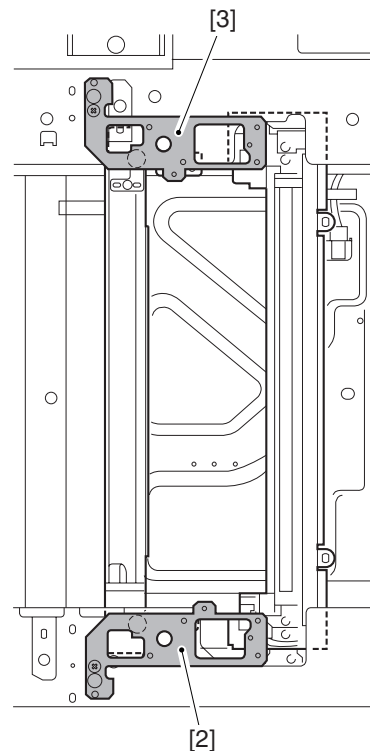

F-5-170

- 4) Secure the end of the cable that has temporarily been fixed in place on the hook of the reader unit frame.
- 5) Fully tighten the screws on the cable fixing plate both at the front and the rear.
- 6) Detach the mirror positioning tool (FRONT, REAR).
- 7) Put the detached parts back on by reversing the foregoing steps.

Chapter 6

Laser Exposure

Contents

6.1 Construction.....	6- 1
6.1.1 Outline of the Laser Exposure System.....	6- 1
6.2 Basic Sequence	6- 3
6.2.1 Basic Sequence of Operations (laser exposure system)	6- 3
6.3 Various Controls	6- 3
6.3.1 Controlling the Laser Activation Timing	6- 3
6.3.1.1 Turning On and Off the Laser Unit.....	6- 3
6.3.1.2 Flow of the BD Signal.....	6- 4
6.3.2 Controlling the Intensity of Laser Light	6- 5
6.3.2.1 APC Control.....	6- 5
6.3.3 Controlling the Laser Scanner Motor	6- 6
6.3.3.1 Outline	6- 6
6.3.4 Controlling the Laser Shutter.....	6- 7
6.3.4.1 Controlling the Laser Shutter	6- 7
6.4 Parts Replacement Procedure	6- 8
6.4.1 Laser Scanner Unit	6- 8

6.1 Construction

6.1.1 Outline of the Laser Exposure System

The laser exposure system consists of a laser unit (source of laser beams) and a polygon mirror. It scans the photosensitive drum (main scanning direction) to create a latent static image. It is a 4-laser mechanism (laser A, laser B, laserC, laserD).

T-6-1

Laser Light

Wave length	645 to 665 nm (visible light)
Output	20mW
Number of beams	4

T-6-2

Laser Scanner Motor

Type of motor	DC brushless
Revolution	29527 rpm (approx.)

T-6-3

Polygon Mirror

Number of facets	12 (35-mm dia.)
------------------	-----------------

T-6-4

Control Mechanism

Synchronization	main scanning direction
	sub scanning direction
Light intensity	APC
Others	laser activation/deactivation*1 (exposes "light" areas)
	laser scanner motor
	laser shutter

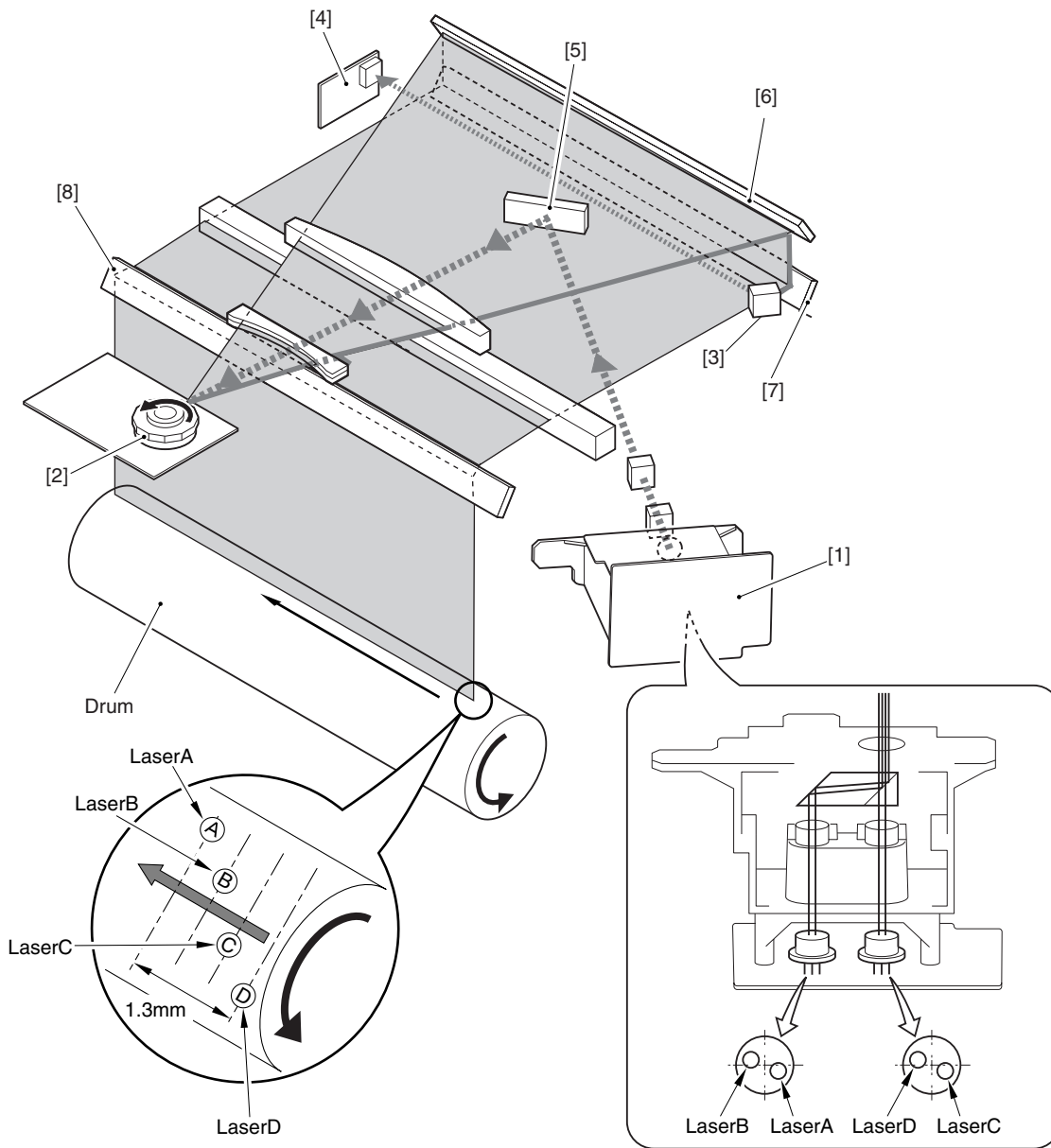

F-6-1
T-6-5

Item	Description
[1]	Laser unit emits laser light.
[2]	Polygon mirror scans laser light in main scanning direction.
[3]	BD mirror reflects laser light, directing it to the BD PCB.
[4]	BD PCB generates the BD signal.
[5]	Laser mirror 1 reflects laser light, directing it to the photosensitive drum.
[6]	Laser mirror 2 reflects laser light, directing it to the photosensitive drum.
[7]	Laser mirror 3 reflects laser light, directing it to the photosensitive drum.
[8]	Routing mirror reflects laser light, directing it to the photosensitive drum.

6.2 Basic Sequence

6.2.1 Basic Sequence of Operations (laser exposure system)

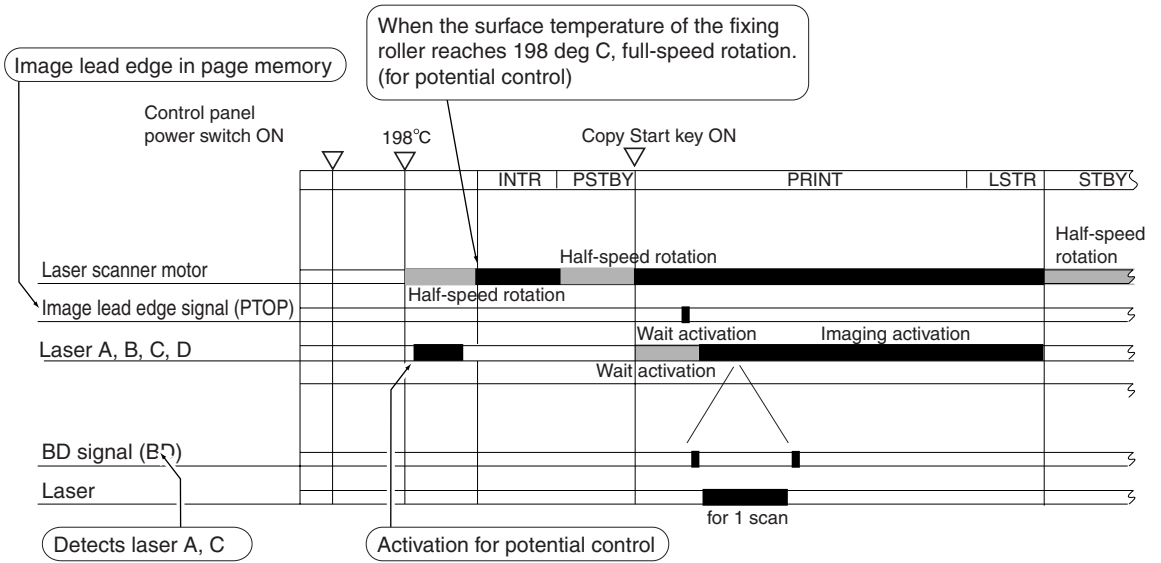

F-6-2

6.3 Various Controls

6.3.1 Controlling the Laser Activation Timing

6.3.1.1 Turning On and Off the Laser Unit

The laser unit is turned on or off by the laser driver PCB 1 in response to the laser control signal (CTL0a/CTL1a/CTL2a/CTL0b/CTL1b/CTL2b) coming from the DC controller PCB.

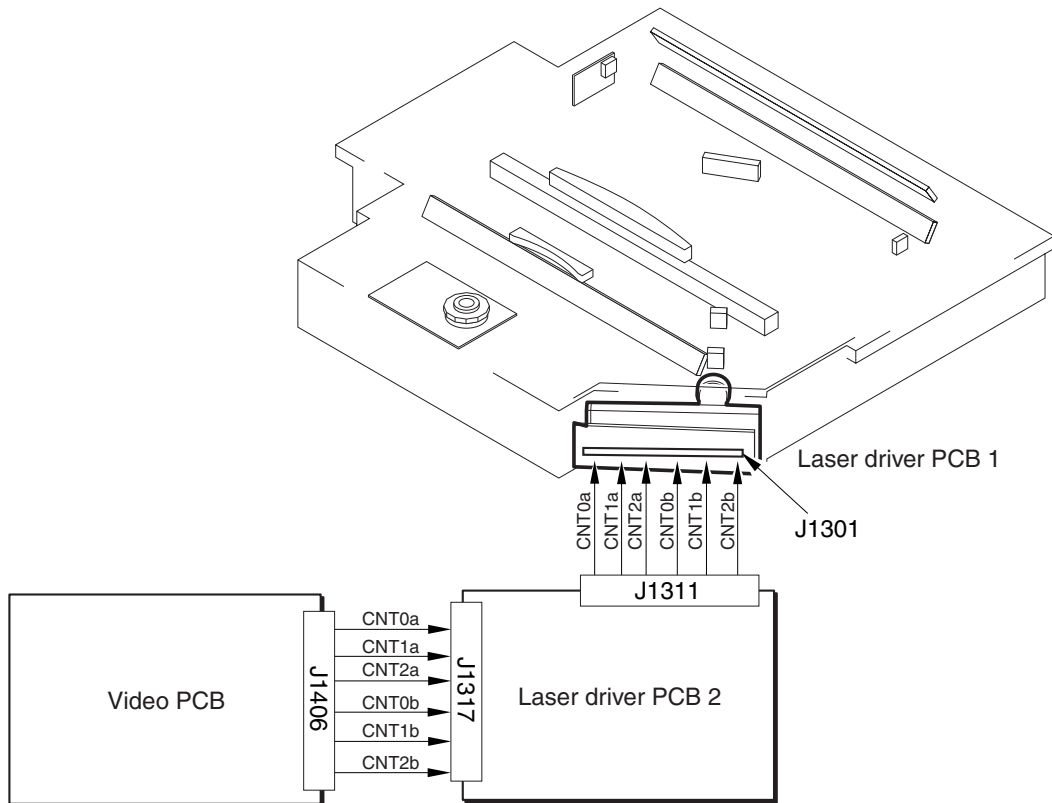

F-6-3

6.3.1.2 Flow of the BD Signal

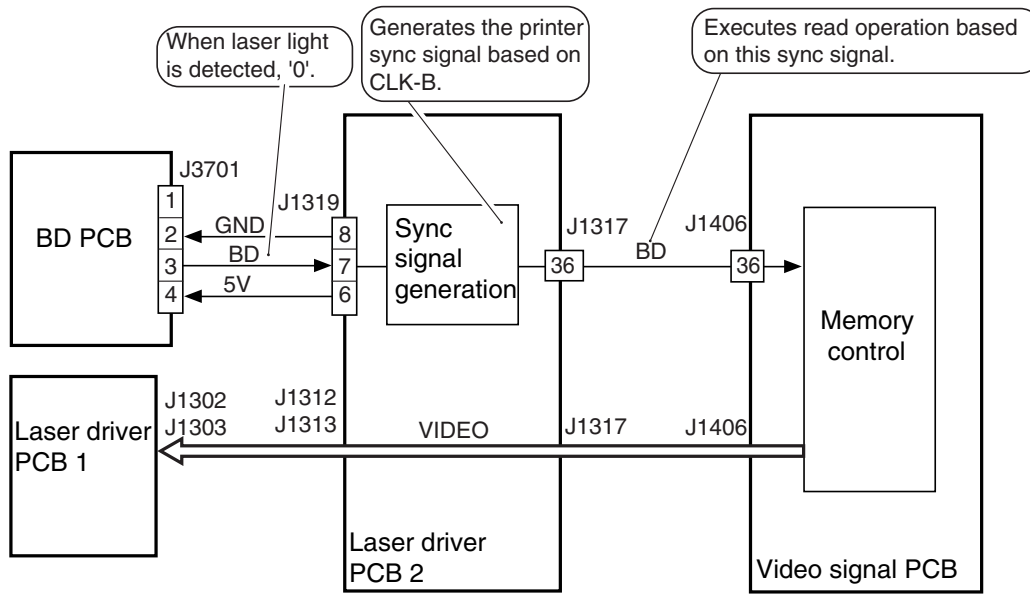

F-6-4

Related Service Mode:

- COPIER > ADJUST > LASER > PVE-OFST (laser projection position adjustment)

If you have replaced the image processor PCB or initialized the RAM on the image processor PCB, enter the adjustment value.

Setting range: -300 to 300

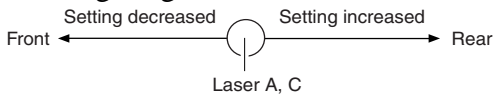

Note that the laser B move in sync with the laser A.

The laser D move in sync with the laser C.

6.3.2 Controlling the Intensity of Laser Light

6.3.2.1 APC Control

The machine uses APC control to make sure that the intensity of laser light remains at a specific level by controlling the output of the laser diode of the laser driver.

For the control, the machine causes the Video controller to send the laser control signal (CTL0a, CTL1a, CTL2a, CTL0b, CTL1b, CTL2b) to the laser drive IC on the laser driver PCB. As a result, the laser drive IC is set to APC mode, thus forcing the laser diode (LD) to emit light. While the control is under way, the laser driver IC uses the photo diode (PD) to monitor the laser diode (LD), adjusting the output of the laser diode until a specific level of intensity is reached.

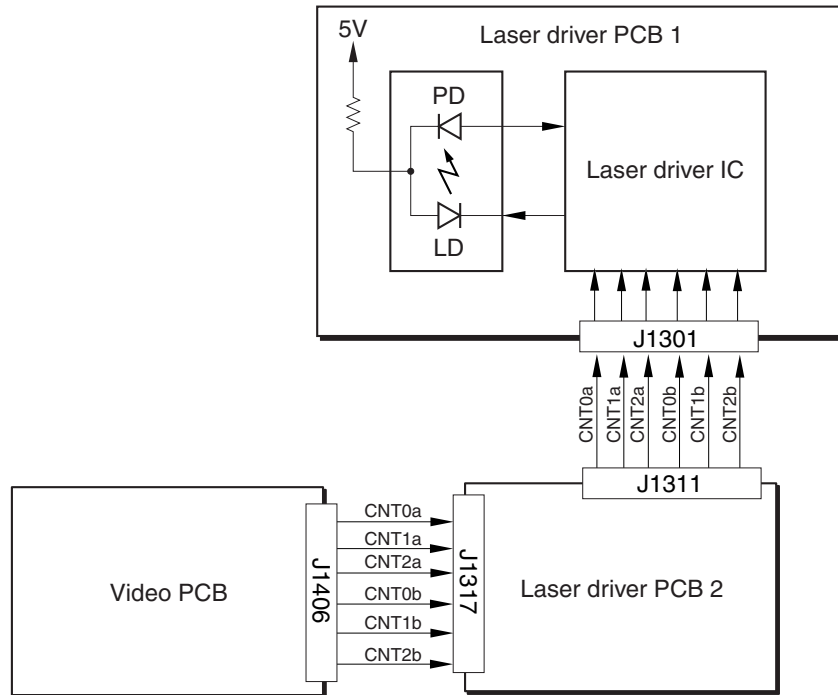

F-6-5

SERVICE MODE:

COPIER > FUNCTION > LASER > POWER-A, B, C, D (activation for laser power adjustment)

Use this mode to turn on the laser when checking laser activation.

6.3.3 Controlling the Laser Scanner Motor

6.3.3.1 Outline

The machine controls the laser scanner motor so that the motor rotates at a specific speed using its motor speed control mechanism and reference signal generation mechanism found inside the Video controller PCB.

The motor speed control mechanism detects the speed detection signal (FG, BD), and compares it against the reference signal generated by the reference signal generation mechanism, thereby controlling the acceleration signal (ACC) and the deceleration signal (DEC) to make sure that the motor rotates at a specific speed.

The machine checks different references for speed detection to suit the state of the printer unit, ultimately reducing the length of time used to control the scanner motor speed. The FG signal is a detection signal used to roughly adjust the scanner motor speed. The BD signal, on the other hand, is a detection signal used to finely adjust the motor speed.

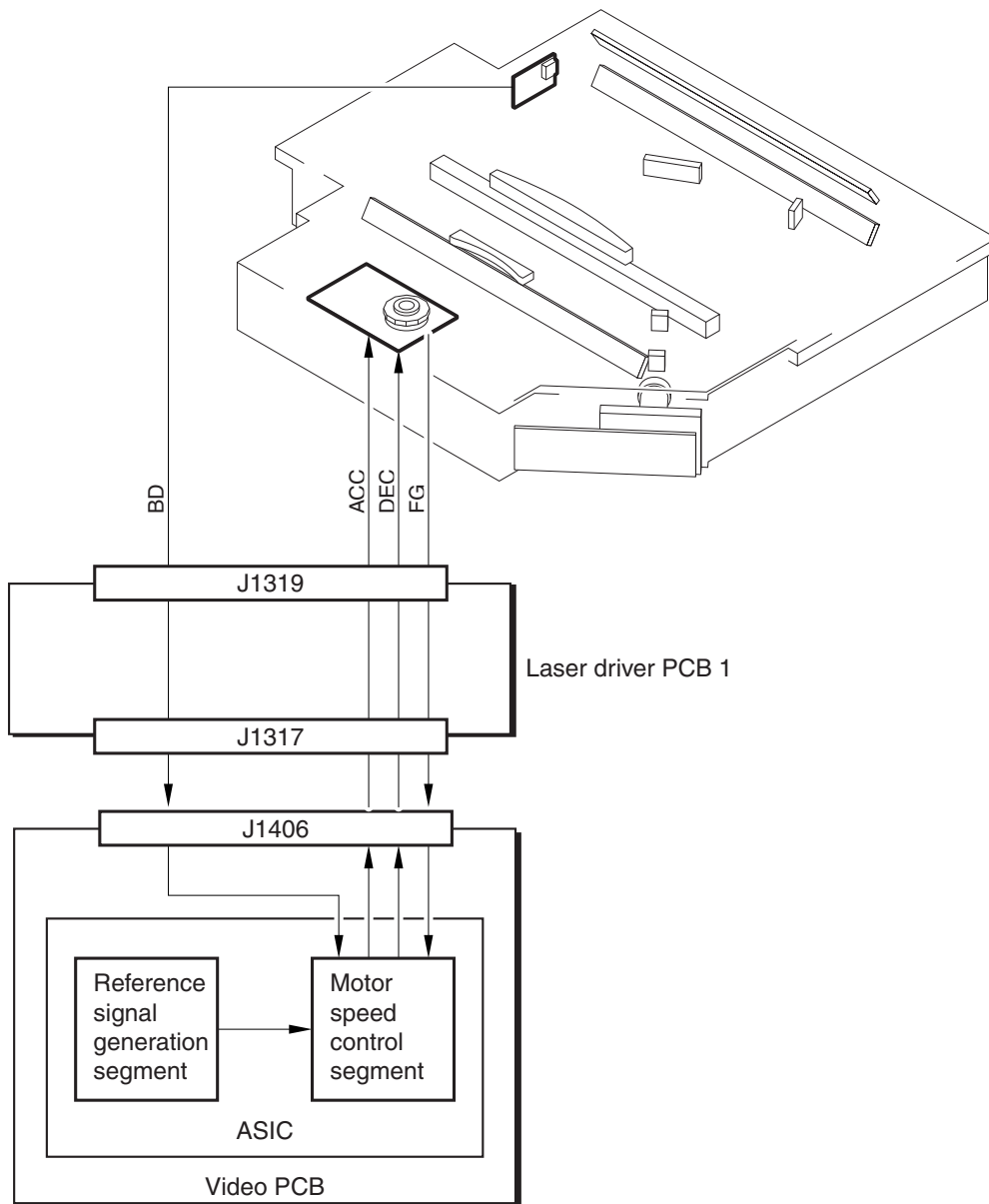

F-6-6

ERROR CODE:

E110 (scanner motor error)

The FG signal is not detected a specific period of time after the scanner motor starts up.
The FG signal is not detected while the scanner motor is rotating at a constant speed.

6.3.4 Controlling the Laser Shutter

6.3.4.1 Controlling the Laser Shutter

The machine is equipped with a mechanism to protect against exposure of its inside by laser light when the primary changing assembly front cover is opened. When the primary changing assembly front cover is opened, the protrusion attached to the cover releases the laser shutter, causing the laser shutter to close so that the laser path is closed.

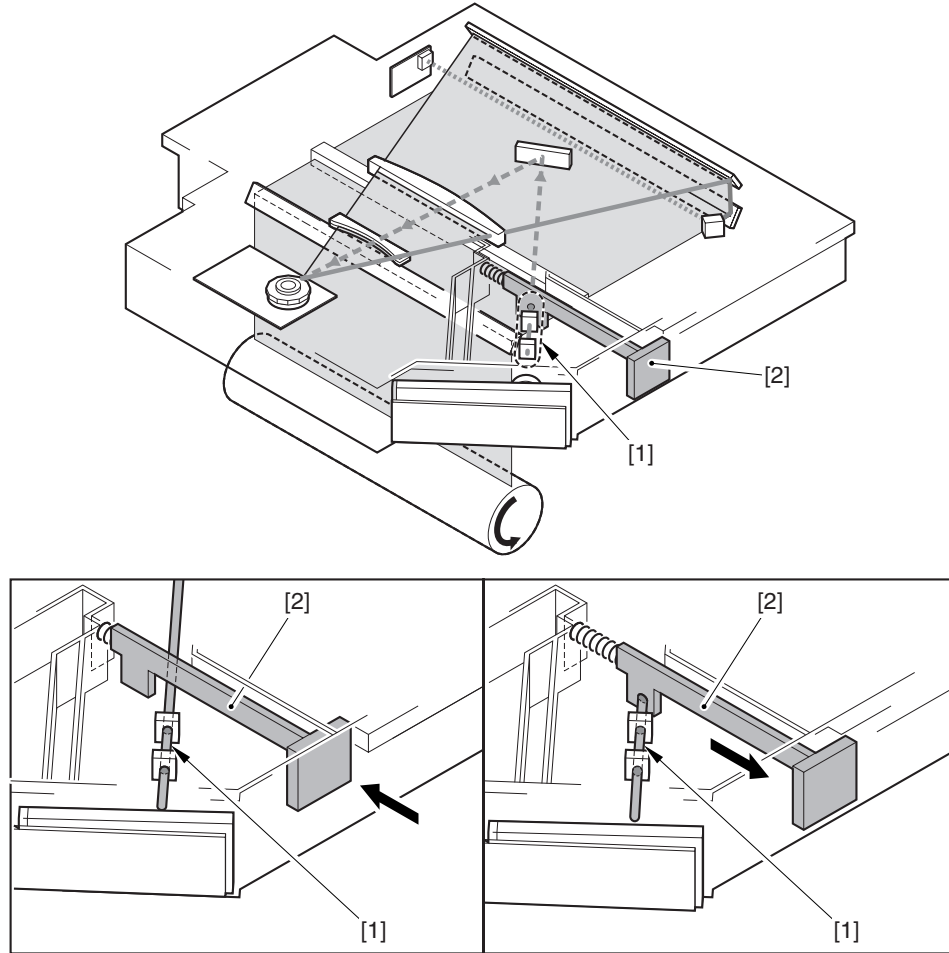

F-6-7

- [1] Laser light
- [2] Laser shutter

6.4 Parts Replacement Procedure

6.4.1 Laser Scanner Unit

6.4.1.1 Before Starting the Work

- 1) Remove the manual feed pull-off roller unit.
- 2) Remove the developing assembly locking plate.
- 3) Remove the developing assembly.
- 4) Remove the sub hopper unit.

6.4.1.2 Removing the Laser Scanner Unit

- 1) Disconnect all connectors [1], and detach the 2 anti-vibration plates [2].
- 2 screws [3]

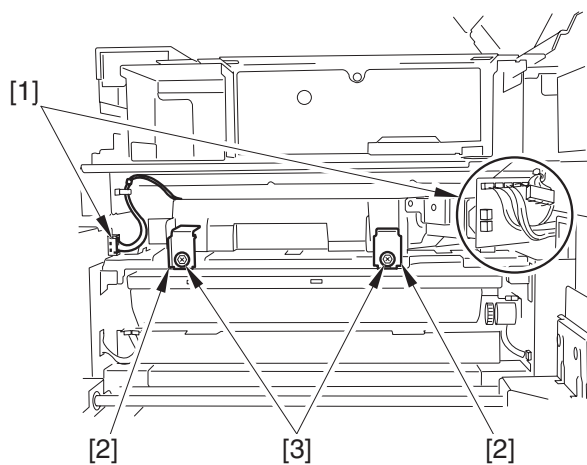

F-6-8

- 2) Remove the laser scanner unit [1].
- 2 bosses [2]

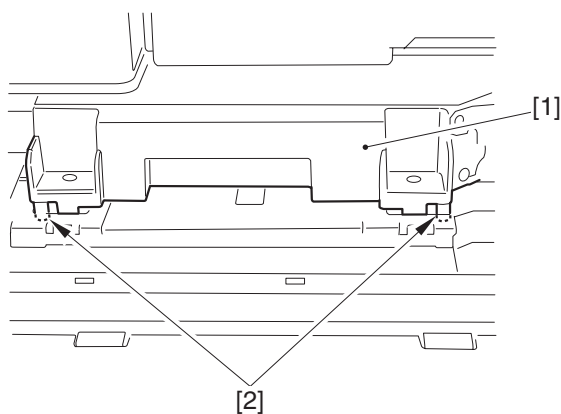

F-6-9

6.4.1.3 When Replacing the Laser Scanner Unit

There is no special work in conjunction with the replacement of the laser scanner unit.

Image Formation

Contents

7.1 Construction.....	7- 1
7.1.1 Outline	7- 1
7.1.2 Major Components	7- 1
7.1.3 Pre-Transfer Exposure LED.....	7- 2
7.2 Image Formation Process	7- 2
7.2.1 Overview	7- 2
7.3 Basic Sequence	7- 3
7.3.1 Basic Sequence	7- 3
7.4 Potential Control	7- 4
7.4.1 Outline	7- 4
7.4.2 Basics Sequence of Operations.....	7- 5
7.4.3 Determining the Optimum Grid Bias.....	7- 6
7.4.4 Grid Bias Corrective Control	7- 6
7.4.5 Determining the Optimum Laser Output	7- 7
7.4.6 Laser Output Corrective Control.....	7- 7
7.4.7 Determining the Optimum Developing Bias	7- 8
7.4.8 Potential Control for Transparency Mode	7- 9
7.4.9 Target Potential Correction in Each Mode.....	7- 10
7.5 Charging Mechanism	7- 12
7.5.1 Primary Charging Mechanism.....	7- 12
7.5.1.1 Outline	7- 12
7.5.1.2 Primary Charging Assembly Cleaning Mechanism	7- 13
7.5.1.3 Others	7- 13
7.5.2 Dust-Collecting Roller Bias	7- 14
7.5.2.1 Outline	7- 14
7.5.3 Pre-Transfer Charging Mechanism	7- 15
7.5.3.1 Outline	7- 15
7.5.3.2 Controlling the Output to Suit the Environment (fuzzy control)	7- 16
7.5.3.3 Pre-Transfer Charging Assembly Cleaning Mechanism	7- 16
7.5.3.4 Others	7- 17
7.6 Drum Cleaner Unit.....	7- 17
7.6.1 Outline	7- 17
7.6.2 Detecting the Waste Toner (case full condition).....	7- 18
7.7 Developing Assembly.....	7- 19
7.7.1 Outline	7- 19
7.7.2 Controlling the Developing Assembly.....	7- 20
7.7.3 Controlling the Toner Cartridge Drive Mechanism	7- 21
7.7.4 Controlling the Developing Bias	7- 22
7.7.5 Detecting the Toner Level and Controlling the Toner Supply Mechanism	7- 23
7.8 Transfer Mechanism.....	7- 27
7.8.1 Transfer Guide Bias	7- 27
7.8.1.1 Overview	7- 27
7.8.1.2 Controlling the Output to Suit the Environment	7- 28
7.8.2 Transfer Charging Mechanism.....	7- 29

7.8.2.1 Outline.....	7- 29
7.8.2.2 Controlling the Output to Suit the Environment (fuzzy control).....	7- 30
7.8.2.3 Correcting the Output at the Trailing Edge of Paper.....	7- 30
7.8.2.4 Transfer Charging Assembly Cleaning Mechanism.....	7- 31
7.8.2.5 Others.....	7- 32
7.9 Separation Mechanism.....	7- 33
7.9.1 Separation Charging Mechanism.....	7- 33
7.9.1.1 Outline.....	7- 33
7.9.1.2 Correcting the Output to Suit the Environment and the Toner Deposit.....	7- 34
7.9.1.3 Correcting the Output upon Detection of Leakage.....	7- 34
7.9.1.4 Others.....	7- 34
7.10 Parts Replacement Procedure.....	7- 35
7.10.1 Process Unit.....	7- 35
7.10.2 Pre-Exposure Lamp.....	7- 36
7.10.3 Primary Charging Assembly.....	7- 37
7.10.4 Pre-Transfer Charging Assembly.....	7- 37
7.10.5 Photosensitive Drum.....	7- 38
7.10.6 Drum Cleaner Unit.....	7- 39
7.10.7 Photosensitive Drum Heater.....	7- 40
7.10.8 Sub Hopper.....	7- 40
7.10.9 Developing Assembly.....	7- 42
7.10.10 Developing Cylinder.....	7- 43
7.10.11 Developing Blade.....	7- 44
7.10.12 Developing Cylinder Deceleration Clutch.....	7- 45
7.10.13 Developing Cylinder Clutch.....	7- 46
7.10.14 Transfer/Separation Charging Assembly.....	7- 46
7.10.15 Pre-Transfer Exposure LED.....	7- 47
7.10.16 Separation Claw/Separation Claw Drive Assembly.....	7- 47
7.10.17 Potential Sensor.....	7- 48
7.10.18 Dust-Collecting Roller.....	7- 50
7.10.19 Charging Wire.....	7- 50

7.1 Construction

7.1.1 Outline

The image formation system has the following principal functions:

T-7-1

Item	Description
Pre-exposure	LED array (64 LEDs) on/off control
Primary charging control	DC constant current control: switched over 3 settings in service mode
Grid bias control	DC constant voltage control: determined by potential control
Developing bias control	AC constant voltage control: switched over (frequencies) in service mode DC constant voltage control: determined by potential control
Dust-collecting roller bias control	DC constant voltage control: on/off control only (+1000 V)
Pre-transfer charging control	AC constant current control: fuzzy control by environment sensor DC constant voltage control: on/off control only
transfer guide bias control	DC constant voltage control: switched over according to temperature/humidity (high-humidity environment +200 V, low/normal environment +600 V)
Transfer charging control	DC constant current control: fuzzy control by environment sensor
Separation charging control	DC constant current control: fuzzy control by environment sensor and toner deposit AC constant voltage control
Potential control	[1] determines grid bias [2] sets optimum laser output [3] sets optimum developing bias (DC)
Wire auto cleaning	[1] primary charging wire [2] pre-transfer charging wire

7.1.2 Major Components

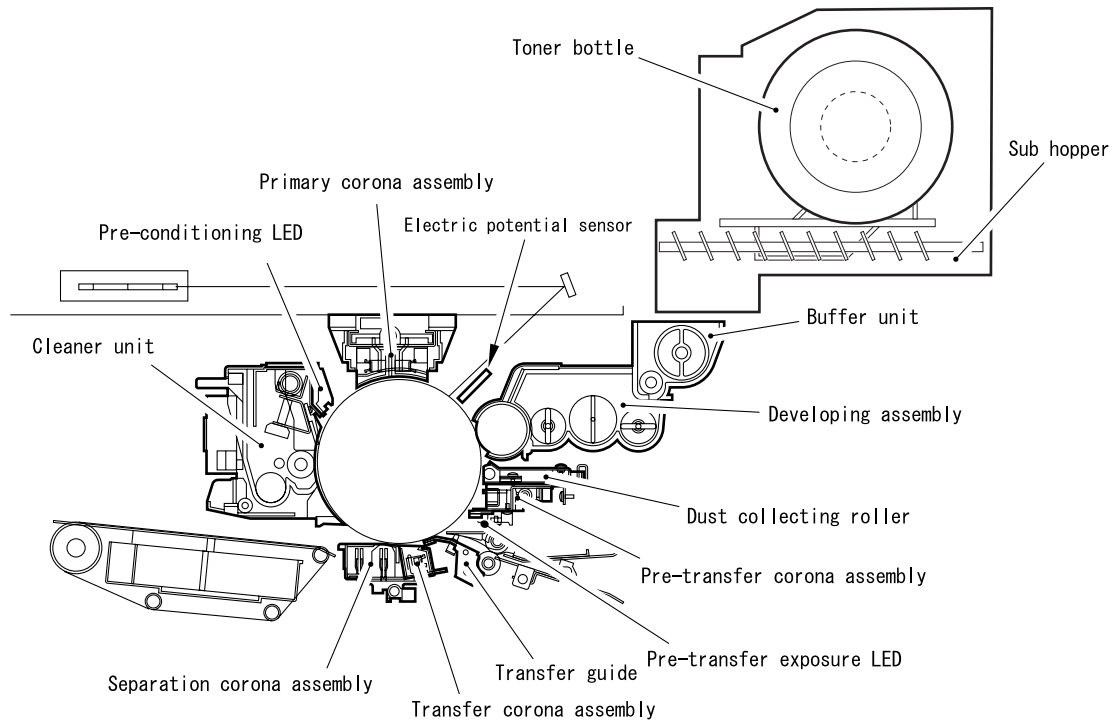

F-7-1

7.1.3 Pre-Transfer Exposure LED

The machine's processing speed is set to 500 mm/sec, thus enabling 105 prints/min (A4, 100%; iR7105). To make up for a drop in charging, the machine uses a photosensitive drum capable of a high charging efficiency and a pre-exposure lamp emitting light of a short wave length (660 nm). A high process speed can also adversely affect static separation, which would lead to poor separation if left alone, and pre-transfer exposure LED is used to ensure correct separation.

Reference:

Pre-Transfer Exposure

Function: In the initial state of the transfer process, the machine decreases the photosensitive drum potential (background potential) in advance so as to reduce the static bonding between the photosensitive drum and the transfer medium, thus facilitating separation.

Timing: 100 msec before the lead edge of the image reaches the point of activation of the pre-transfer exposure LED until the trail edge of the image moves past the point.

7.2 Image Formation Process

7.2.1 Overview

The machine's image formation process consists of the following 8 steps:

step 1	pre-exposure
step 2	primary charging (positive DC)
step 3	laser exposure
step 4	development (AC + positive DC)
step 5	transfer (negative DC)
step 6	separation (AC + positive DC)
step 7	fix
step 8	drum cleaning

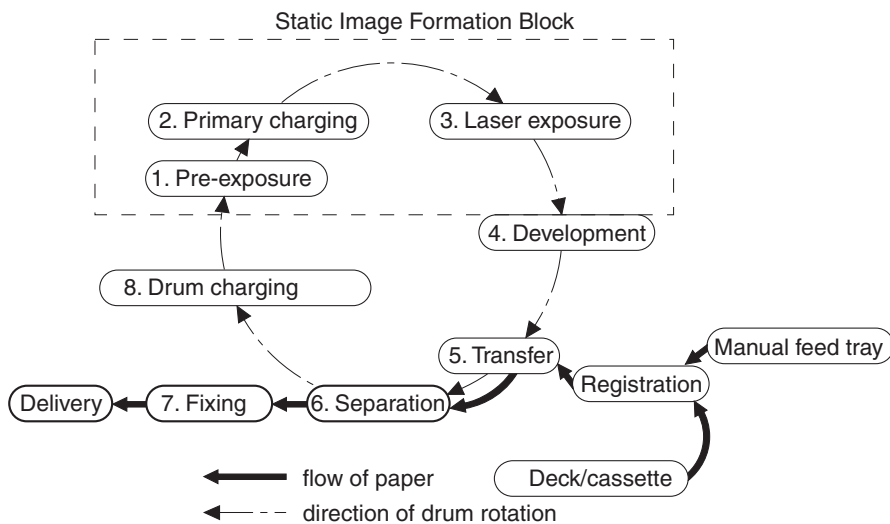

F-7-2

7.3 Basic Sequence

7.3.1 Basic Sequence

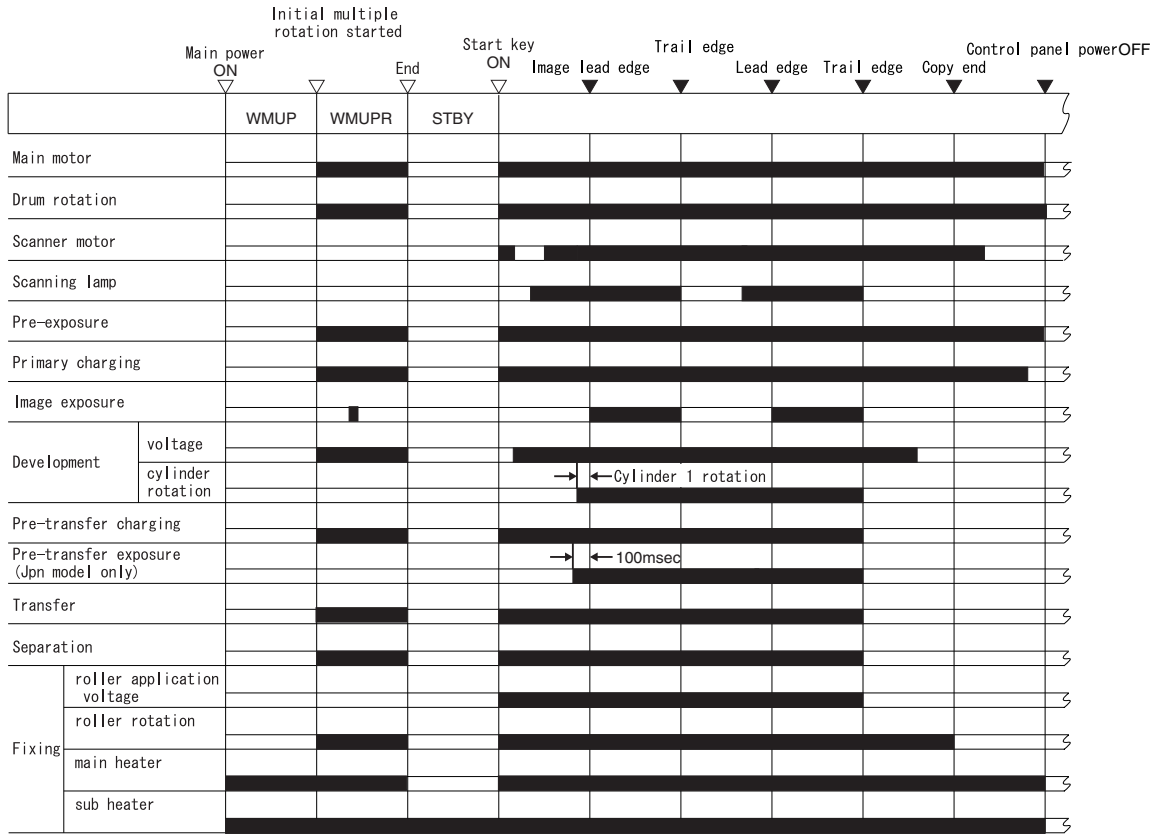

F-7-3

7.4 Potential Control

7.4.1 Outline

The potential control system is associated with the following control items:

- [1] Determination of optimum grid bias (VD control)
- [2] Determination of optimum laser output (VL control)
- [3] Determination of optimum developing bias (DC; Vdc control)

The following shows the construction of the control system associated with the machine's potential control:

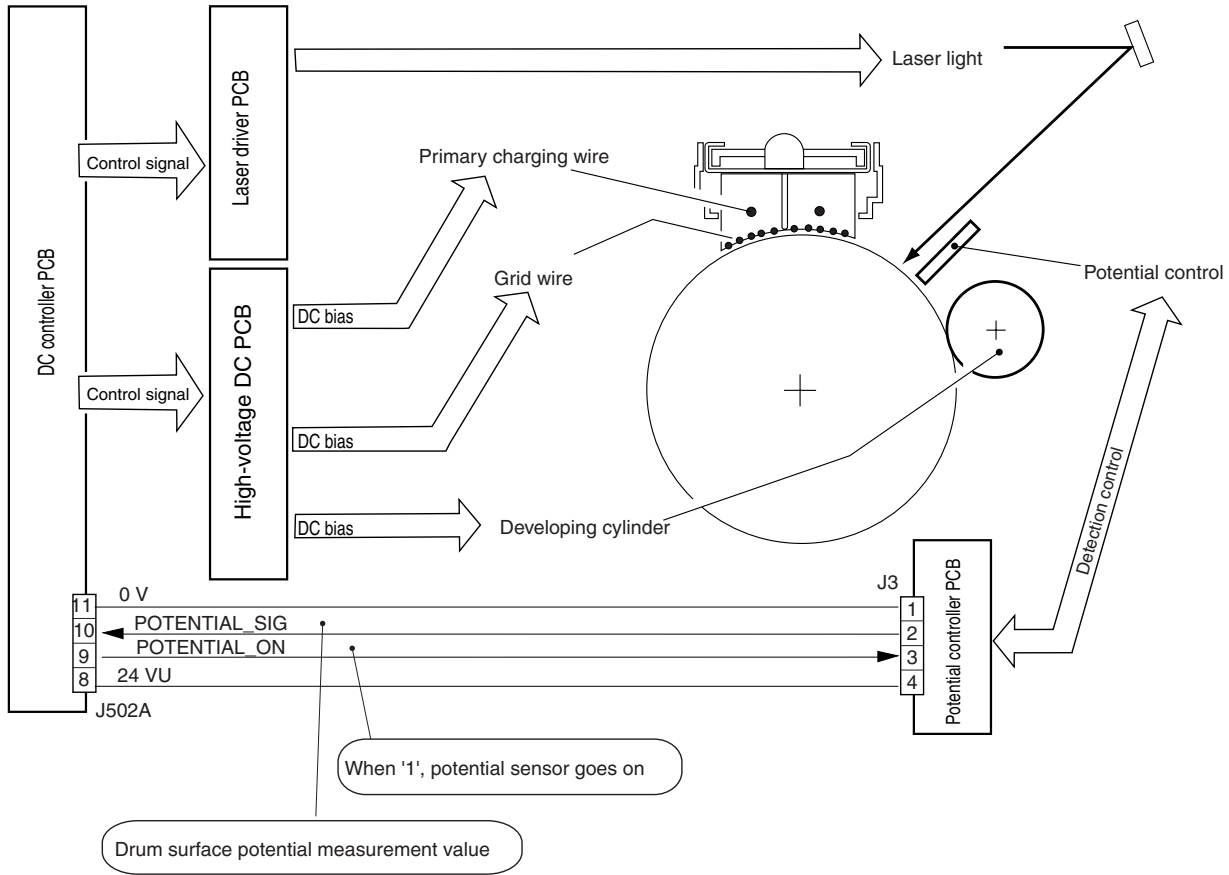

F-7-4

7.4.2 Basics Sequence of Operations

The following shows the basic sequence of operations and timing of operations associated with the machine's control system:

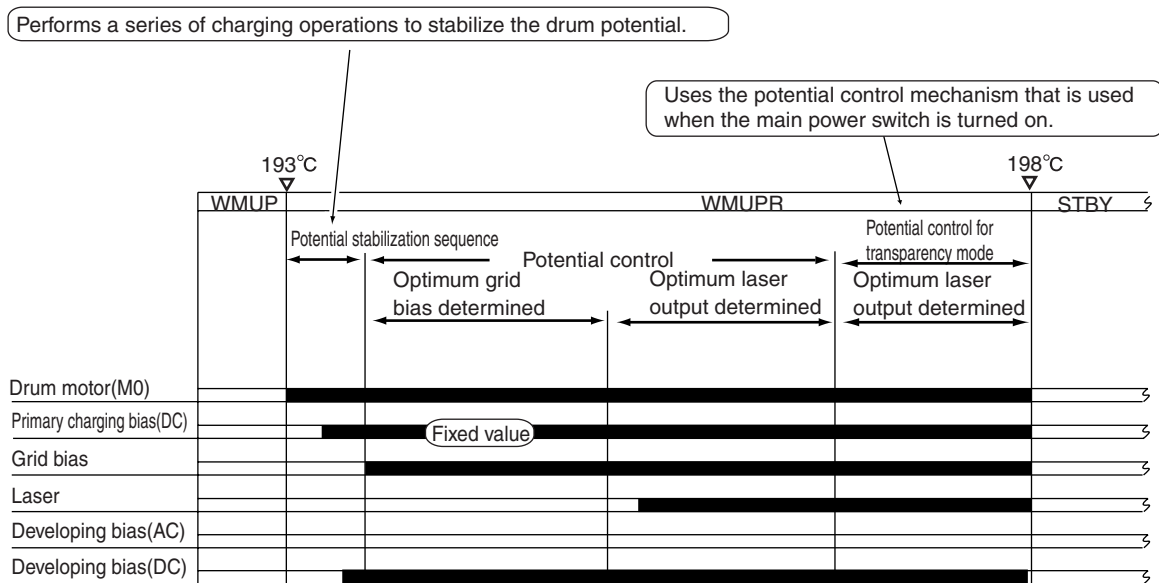

F-7-5

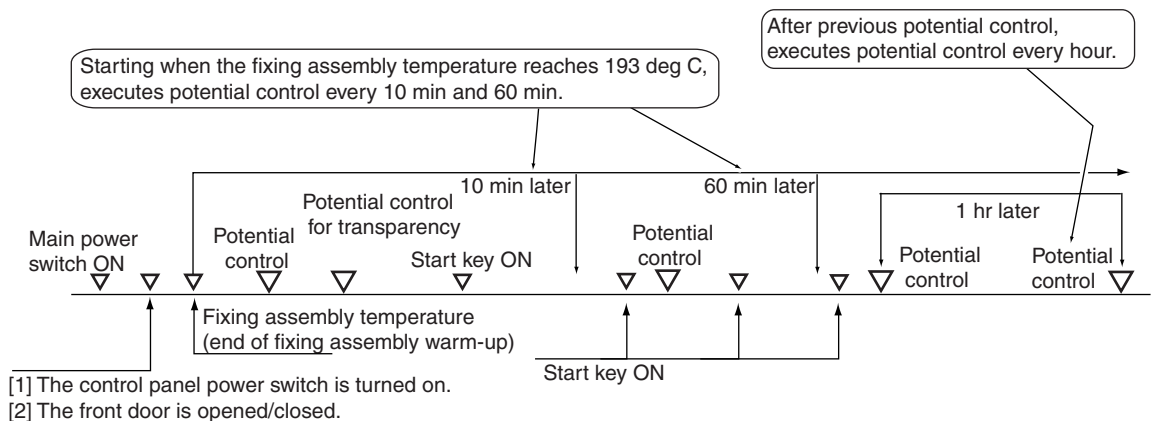

F-7-6

SERVICE MODE:

- **COPIER> OPTION> BODY> PO-CNT** (enabling/disabling potential control)

0: potential control OFF

1: potential control ON (default)

- **COPIER> ADJUST> V-CONT> EPOTOFS** (potential sensor offset value input)

If the DC controller PCB has been replaced or the RAM on the DC controller PCB has been initialized, enter the value indicated on the service label.

- **COPIER> ADJUST> V-CONT> VL-OFST** (VL target potential offset value input)

If the DC controller PCB has been replaced or the RAM on the DC controller PCB has been initialized, enter the value indicated on the service label.

- **COPIER> ADJUST> V-CONT> VD-OFST** (VD target potential offset value input)

If the DC controller PCB has been replaced or the RAM on the DC controller has been initialized, enter the value indicated on the service label.

- **COPIER> FUNCTION> DPC> OFST** (potential sensor offset adjustment)

This mode item is part of the series of procedures that must be performed when the potential sensor unit is replaced. It is not performed on its own.

7.4.3 Determining the Optimum Grid Bias

The grid bias is determined so that the drum surface potential will be identical to the target potential. (The primary charging bias is set to a fixed value.)

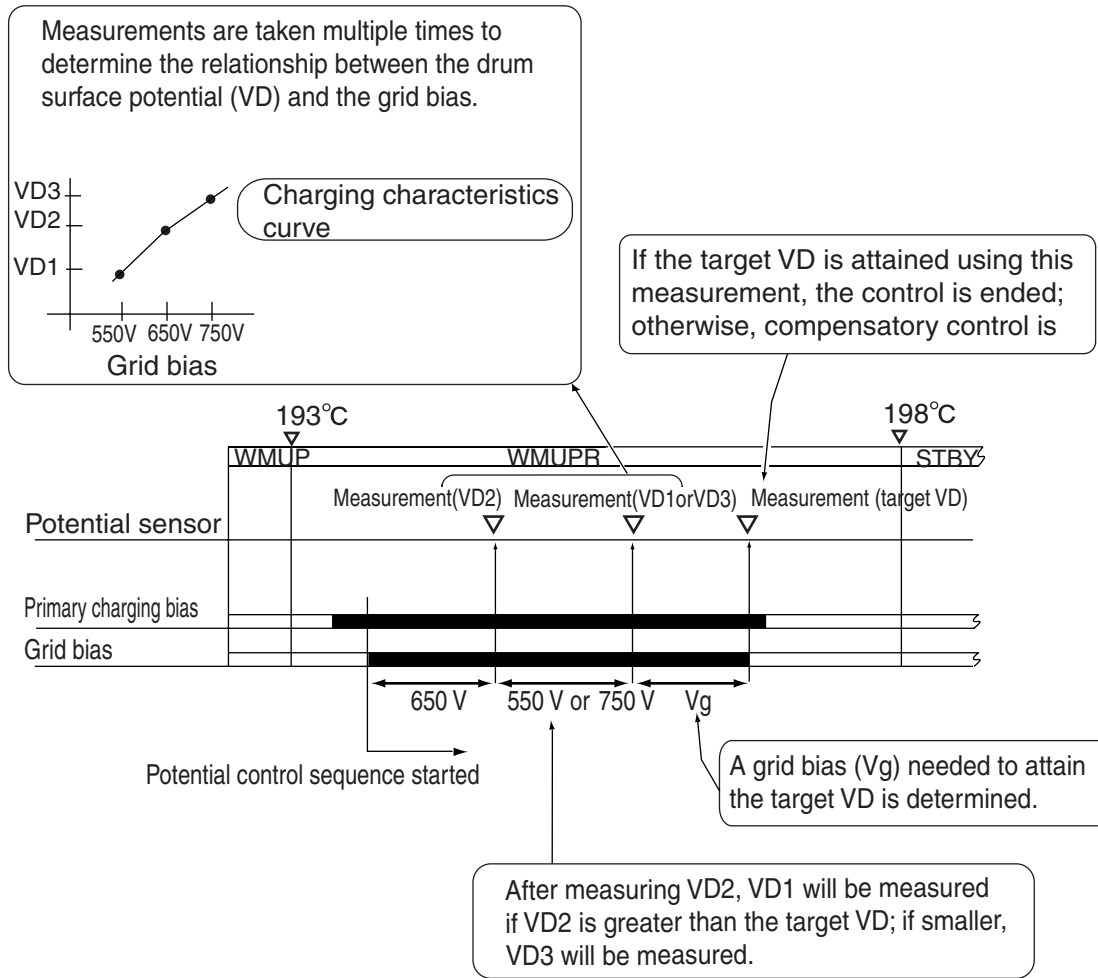

F-7-7

7.4.4 Grid Bias Corrective Control

If the optimum grid bias cannot be determined at the end of drum surface potential measurement, the machine starts its compensatory control sequence to determine the bias.

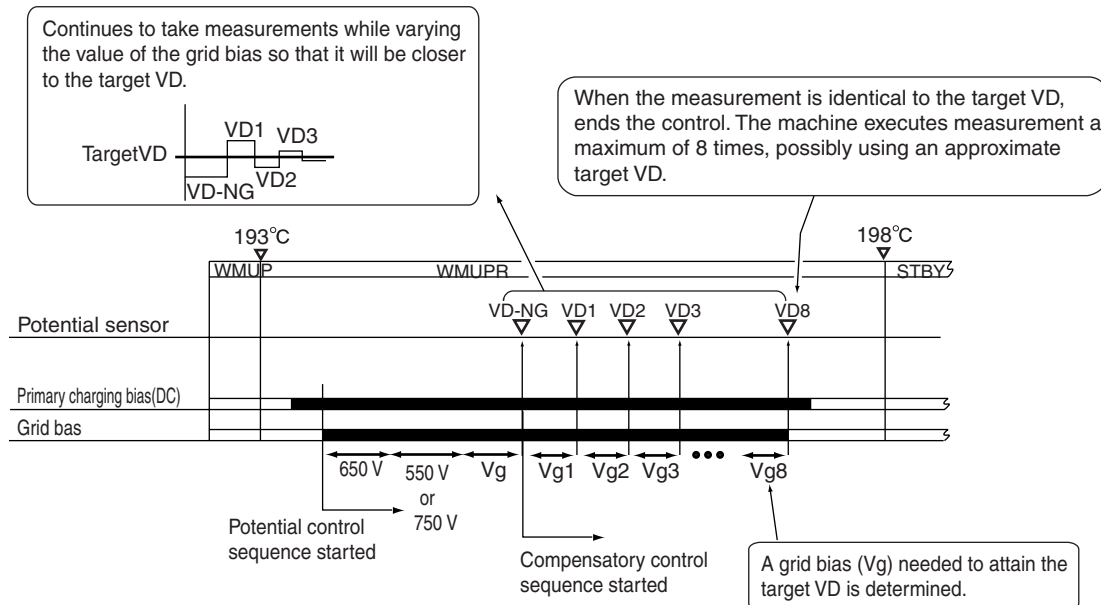

F-7-8

7.4.5 Determining the Optimum Laser Output

The machine determines the optimum laser output so that the drum surface potential (light area potential VL) is identical to the target potential.

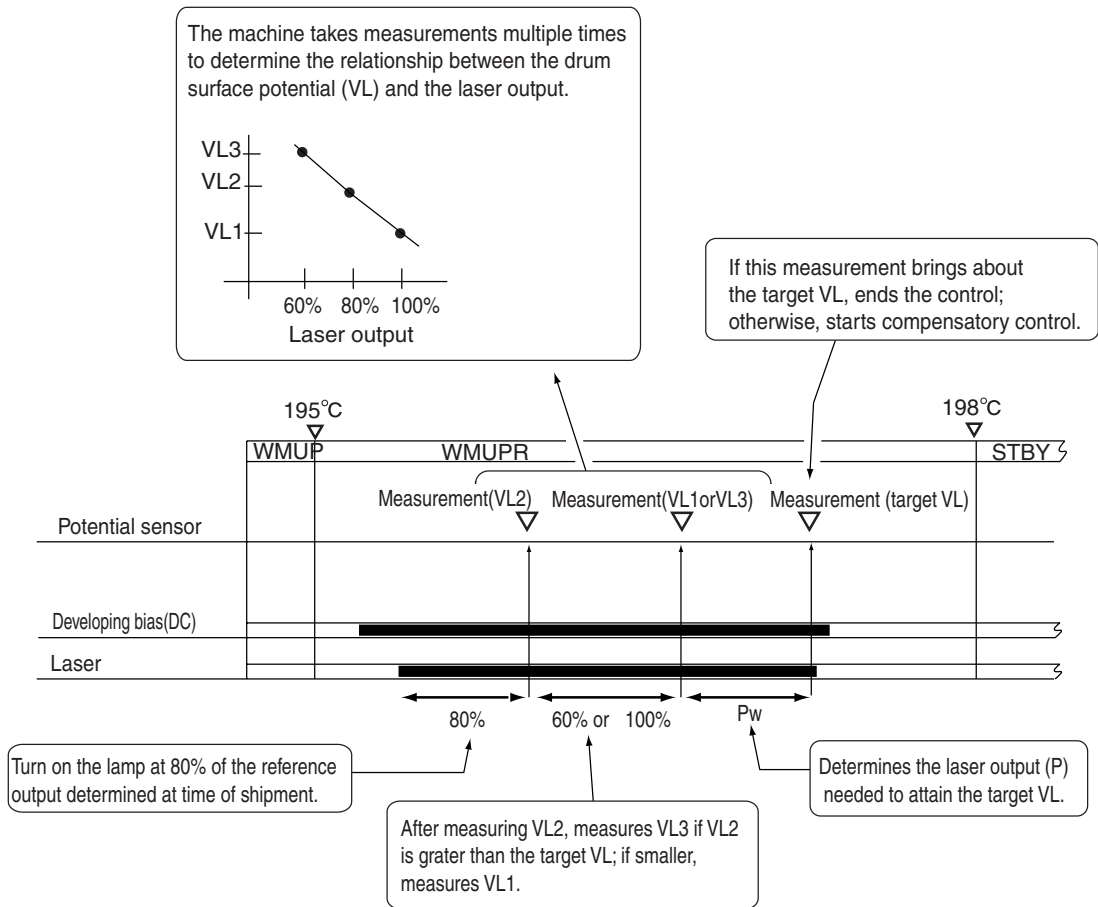

F-7-9

7.4.6 Laser Output Corrective Control

If the optimum laser output cannot be determined after measuring the drum surface potential, the machine starts its compensatory control sequence to determine the optimum laser output.

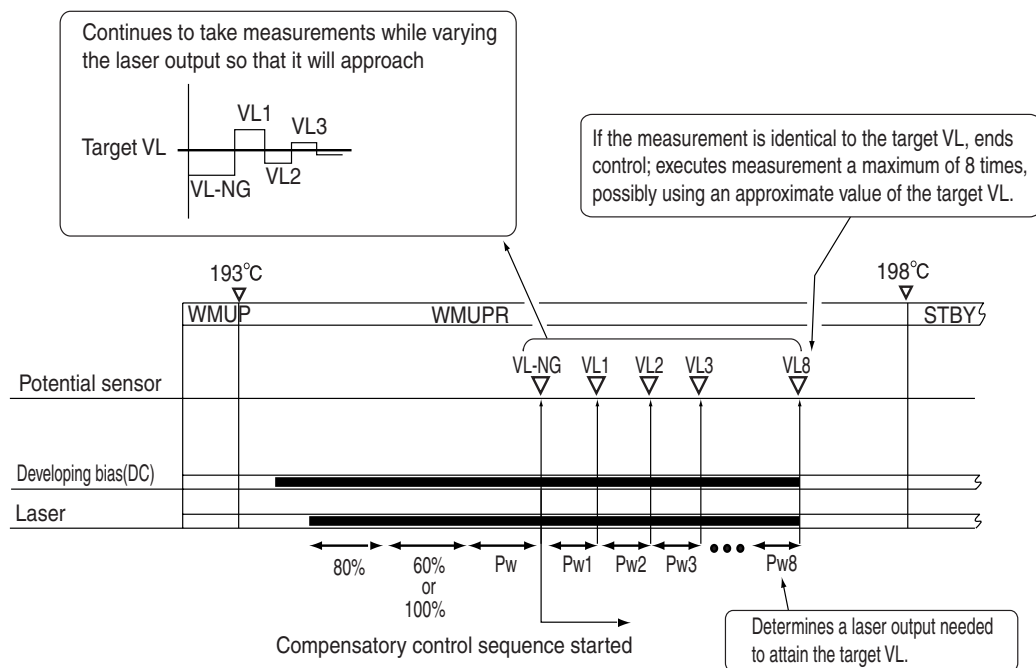

F-7-10

7.4.7 Determining the Optimum Developing Bias

The machine uses the optimum drum surface potential (VD) to compute the optimum developing bias (Vdc).

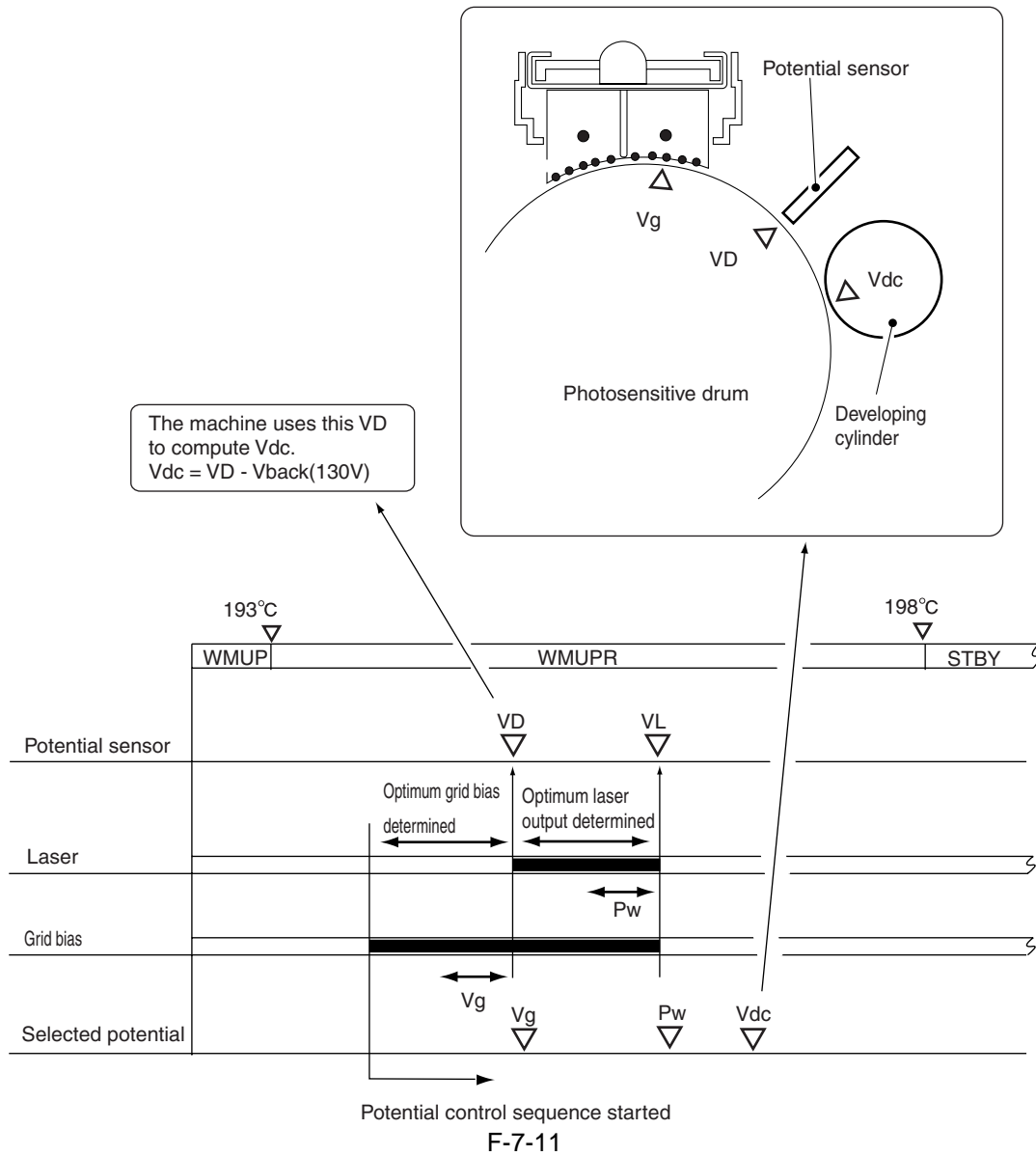

7.4.8 Potential Control for Transparency Mode

To prevent detachment of toner in high-density areas of a transparency print, the machine decreases the contrast to reduce the toner deposit. To that end, the machine executes potential control for transparency mode, thus determining the target value for transparency mode.

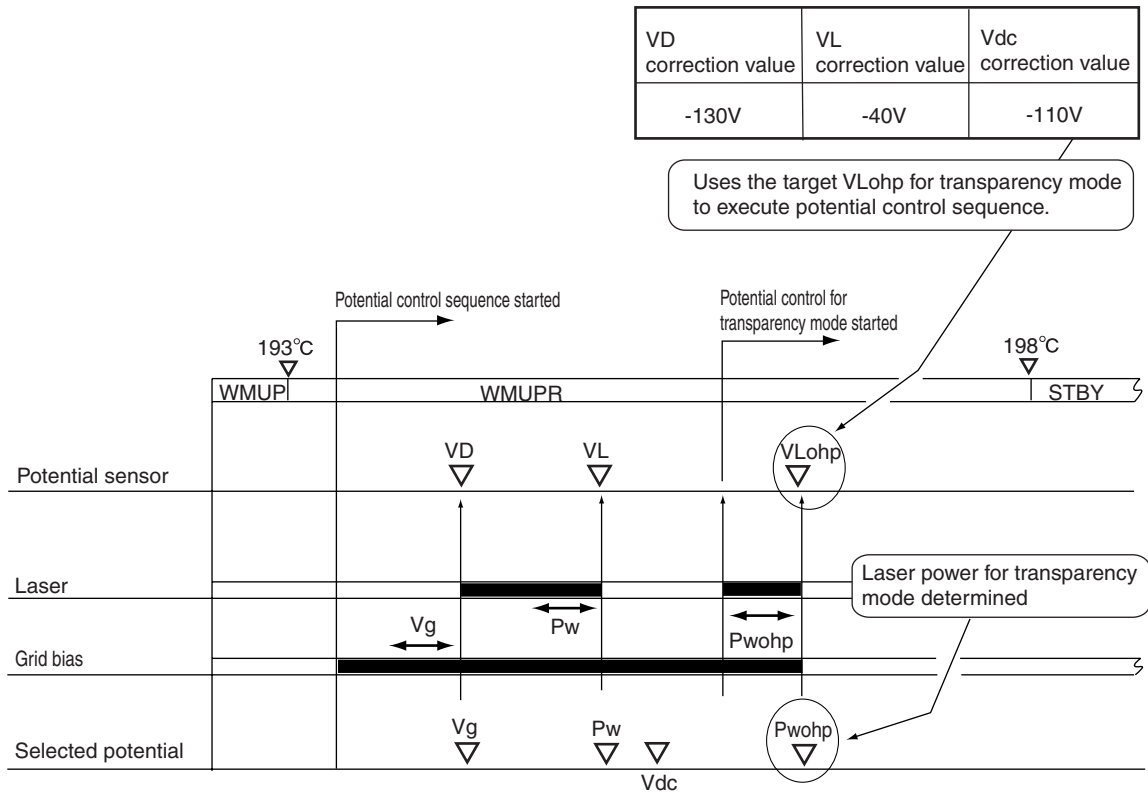

F-7-12

SERVICE MODE:

- **COPIER> OPTION> BODY> OHP-CNT** (enabling/disabling potential control for transparency mode)

1: uses the target value obtained as a result of potential control for transparency mode executed at time of transparency mode operation. (default)

0: does not execute potential control for transparency mode.

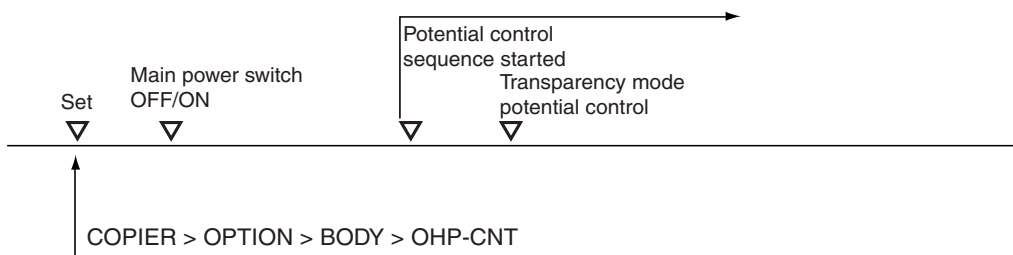

F-7-13

7.4.9 Target Potential Correction in Each Mode

For the following, the machine corrects the laser power/developing bias determined as part of potential control, using the result as the target value for the individual modes:

T-7-2

	Purpose	Correction
Density adjustment during printing (PDL input)	To enable reproduction of fine lines suited to the needs of the user (PDF data from a PC).	Corrects the laser power/developing bias to suit the F value setting.
Density adjustment during printing (scanner input)	To enable a specific level of density suited to the needs of the user.	Corrects the laser power/developing bias to suit the F value setting

1. Adjusting the Density during Printing (PDL input)

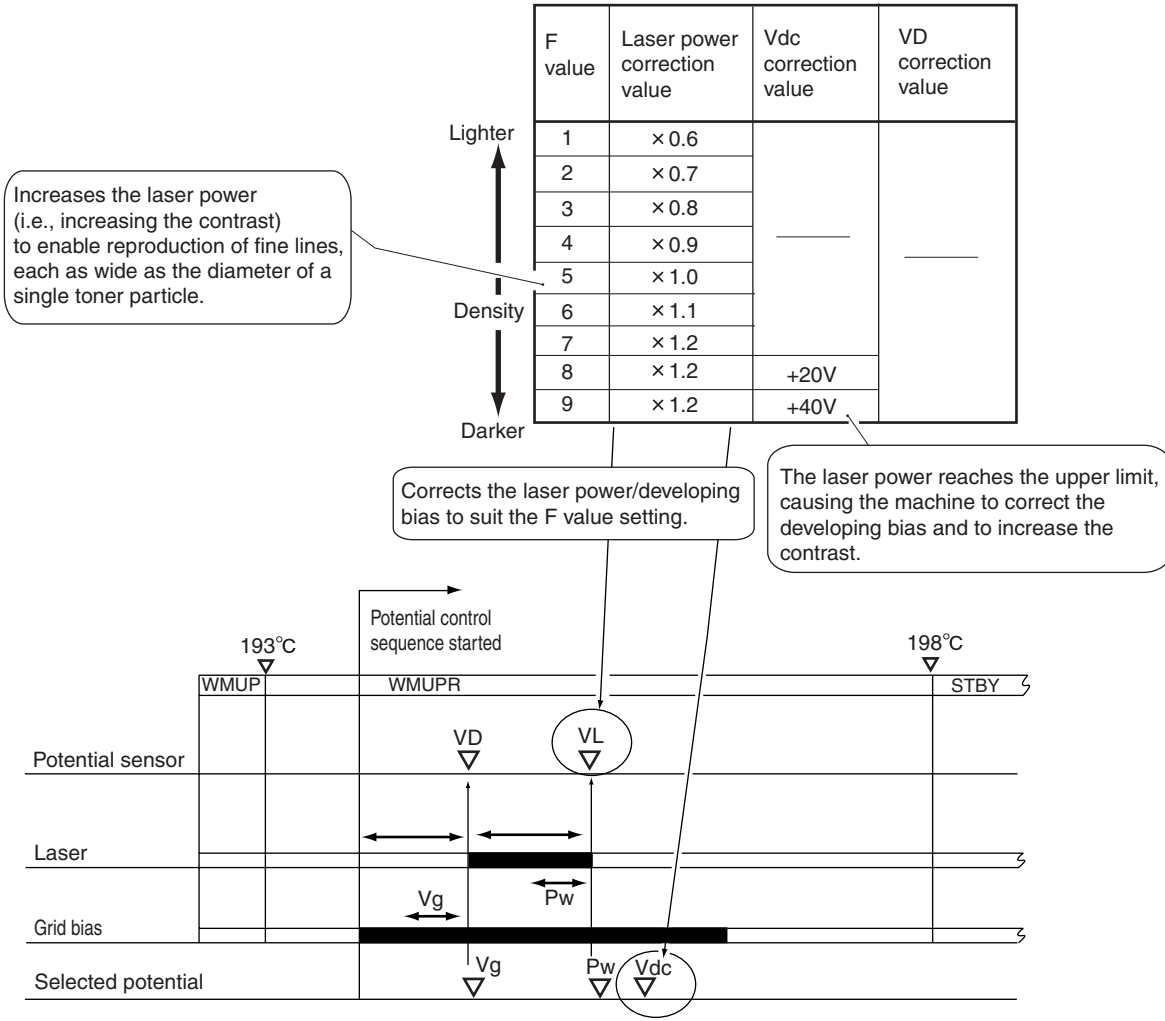

F-7-14

SERVICE MODE:

- **COPIER > OPTION > BODY > CNT-W/PR** (enabling/disabling density variable mode during printing)

0: corrects the target value to permit variation of density during printing. (default)

1: does not permit variation of density during printing.

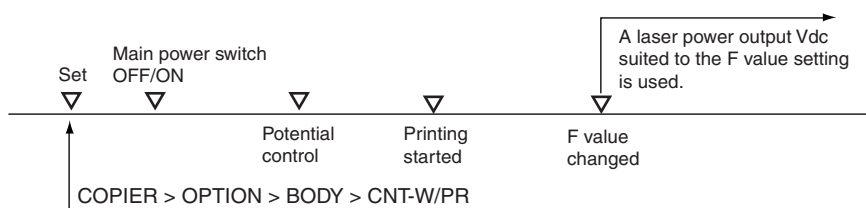

F-7-15

2. Adjustment of Density During Printing (scanner input)

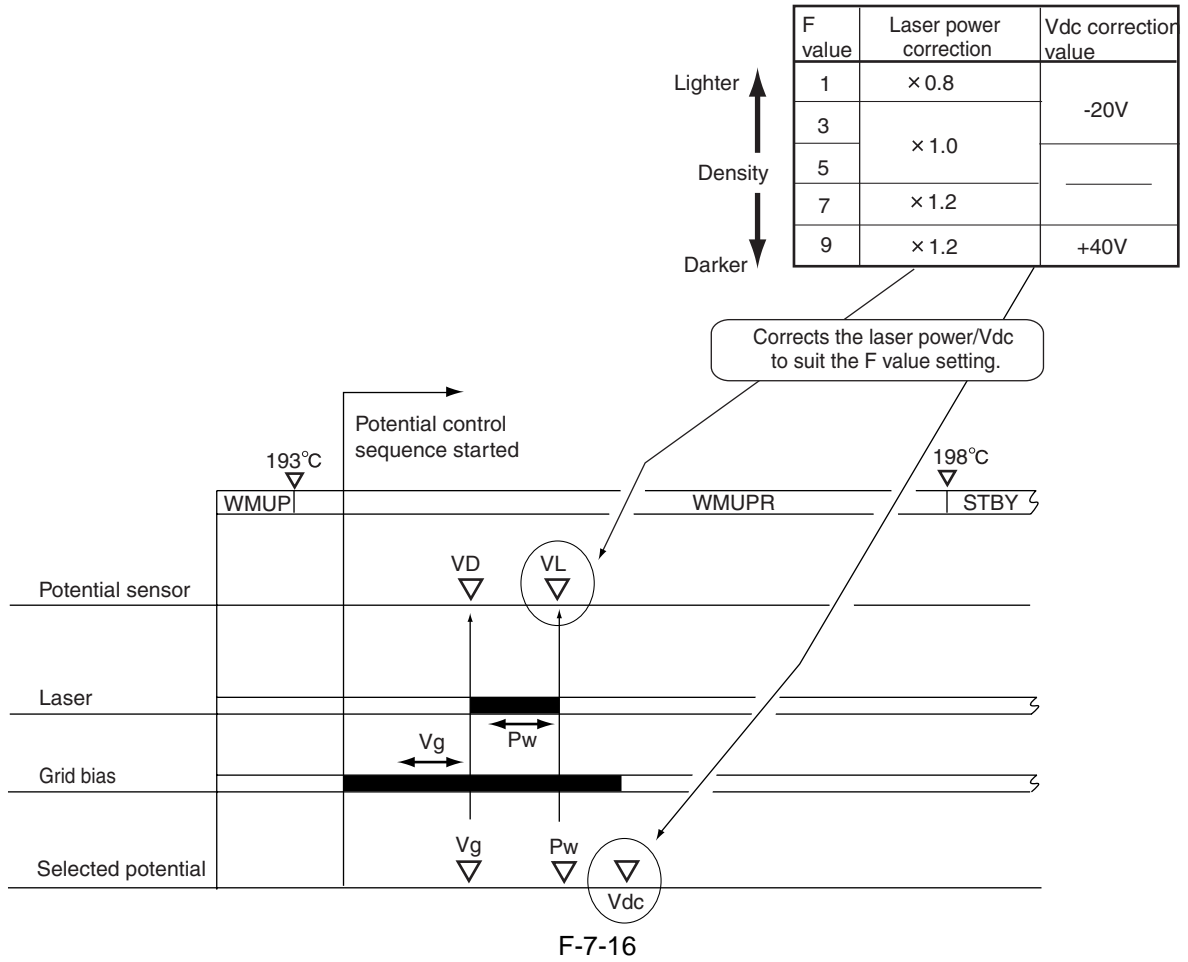

7.5 Charging Mechanism

7.5.1 Primary Charging Mechanism

7.5.1.1 Outline

The primary charging mechanism is controlled for the following:

- [1] primary charging bias constant current control
- [2] grid bias constant voltage control

The following shows the construction of the system that relates to primary charging control:

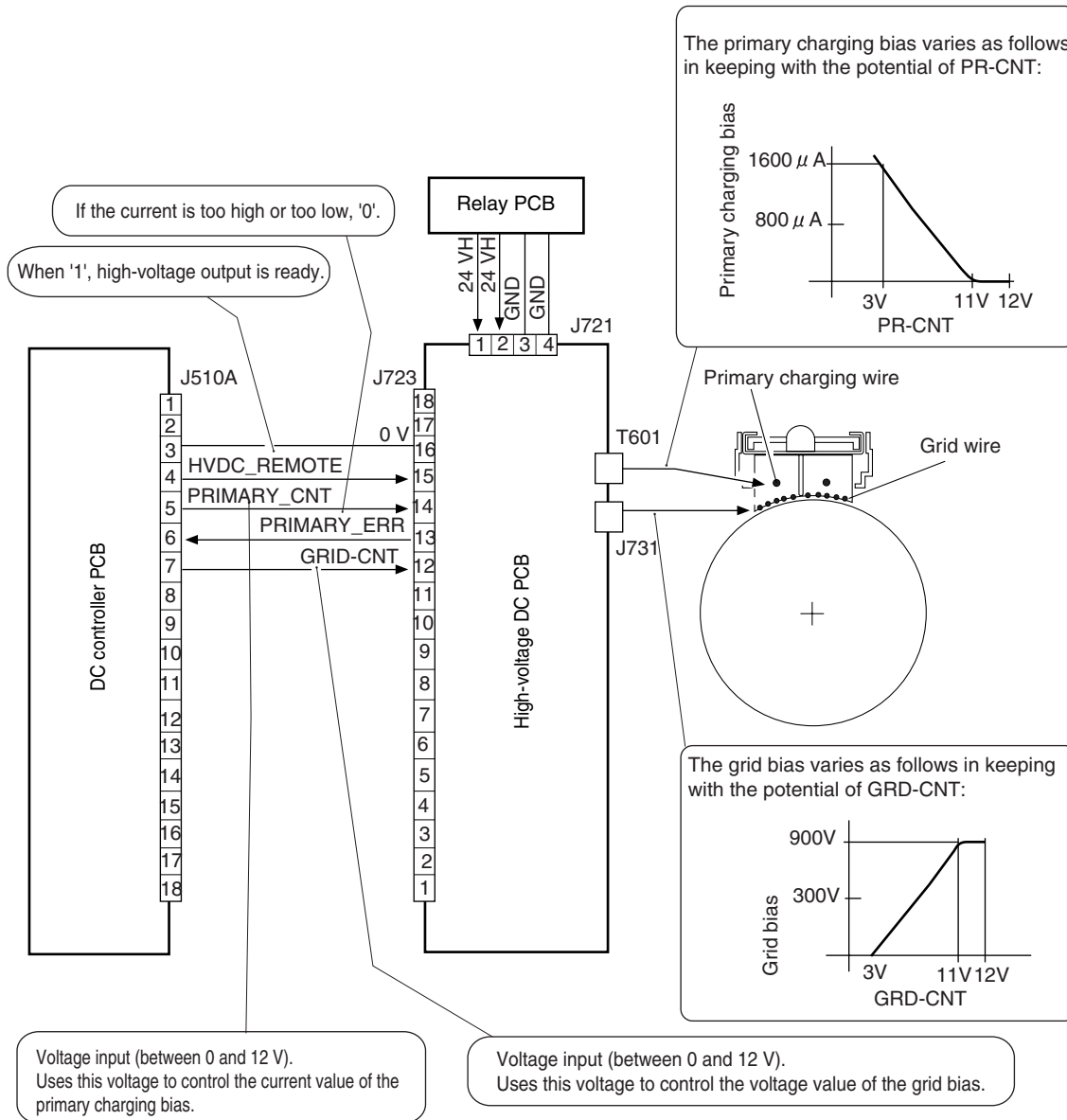

F-7-17

7.5.1.2 Primary Charging Assembly Cleaning Mechanism

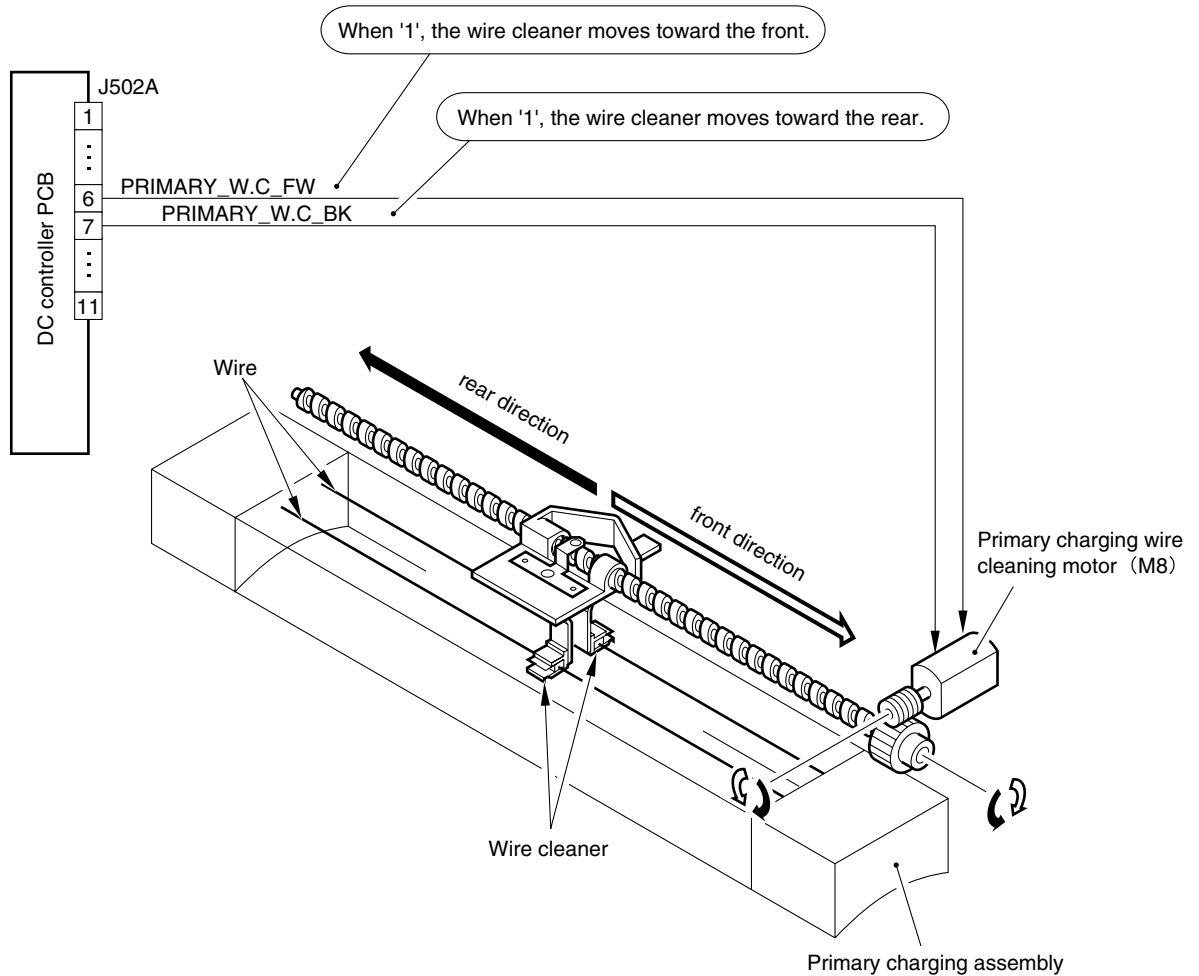

F-7-18

Reference:

Timing of Cleaning Operation

[1] when wire cleaning is executed in user mode.

[2] at the end of LSTR after making 6000 prints since previous wire cleaning.

7.5.1.3 Others

SERVICE MODE:

- **COPIER> ADJUST> HV-PRI> GRID** (grid bias output adjustment input)

If the DC controller PCB has been replaced or the RAM on the DC controller PCB has been initialized, enter the value indicated on the service label.

ERROR CODE:

- **E065** (primary charging output error)

Indicates that over-current has been detected (PRIMARY_ERR=1) because of leakage.

7.5.2 Dust-Collecting Roller Bias

7.5.2.1 Outline

The following is associated with the dust-collecting roller bias control system:
 [1] enabling/disabling the dust-collecting roller bias

The following shows the construction of the control system that relates to the dust-collecting roller bias:

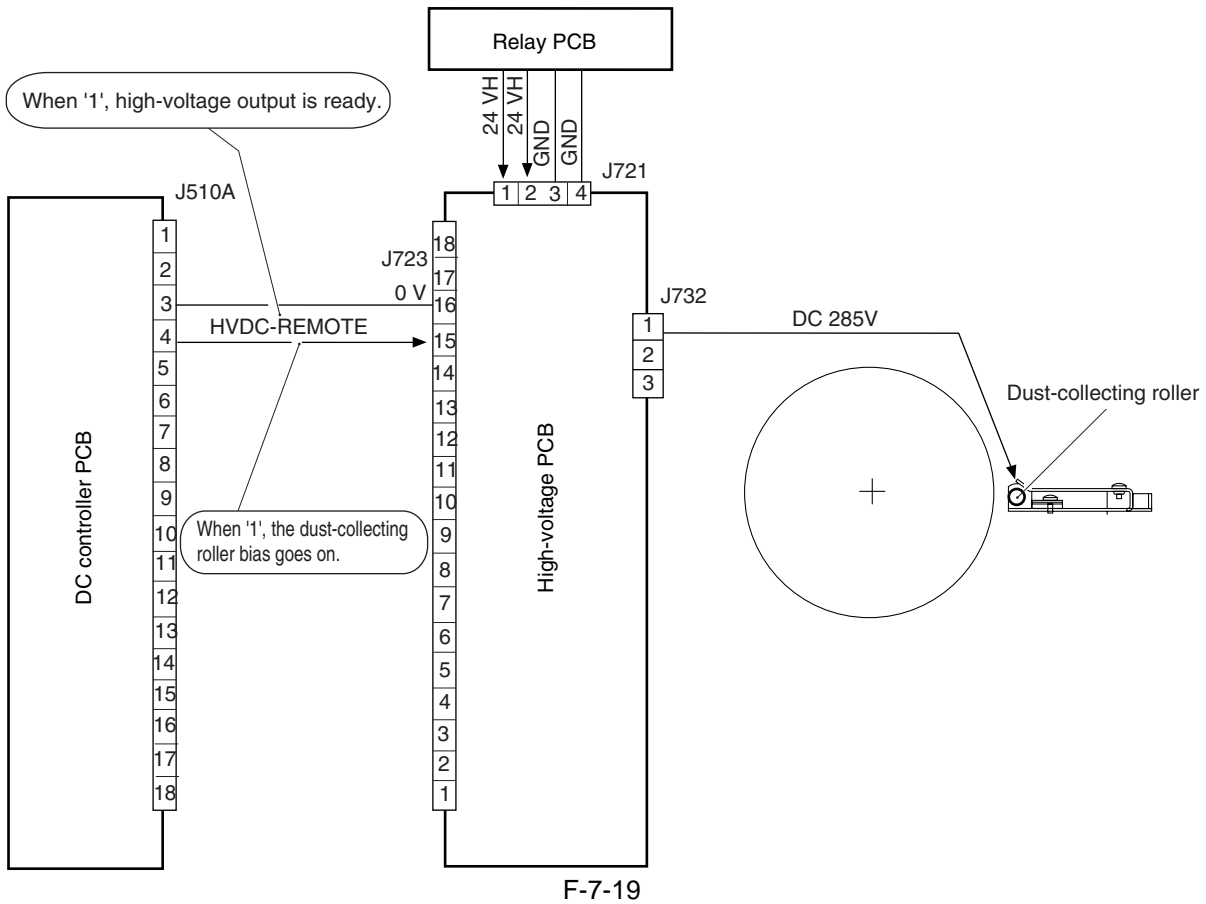

7.5.3 Pre-Transfer Charging Mechanism

7.5.3.1 Outline

The following items are associated with the pre-transfer charging control system:

- [1] DC bias constant current control
- [2] AC bias constant voltage control
- [3] output control suited to environment (fuzzy control)

The following shows the components related to the pre-transfer charging control system:

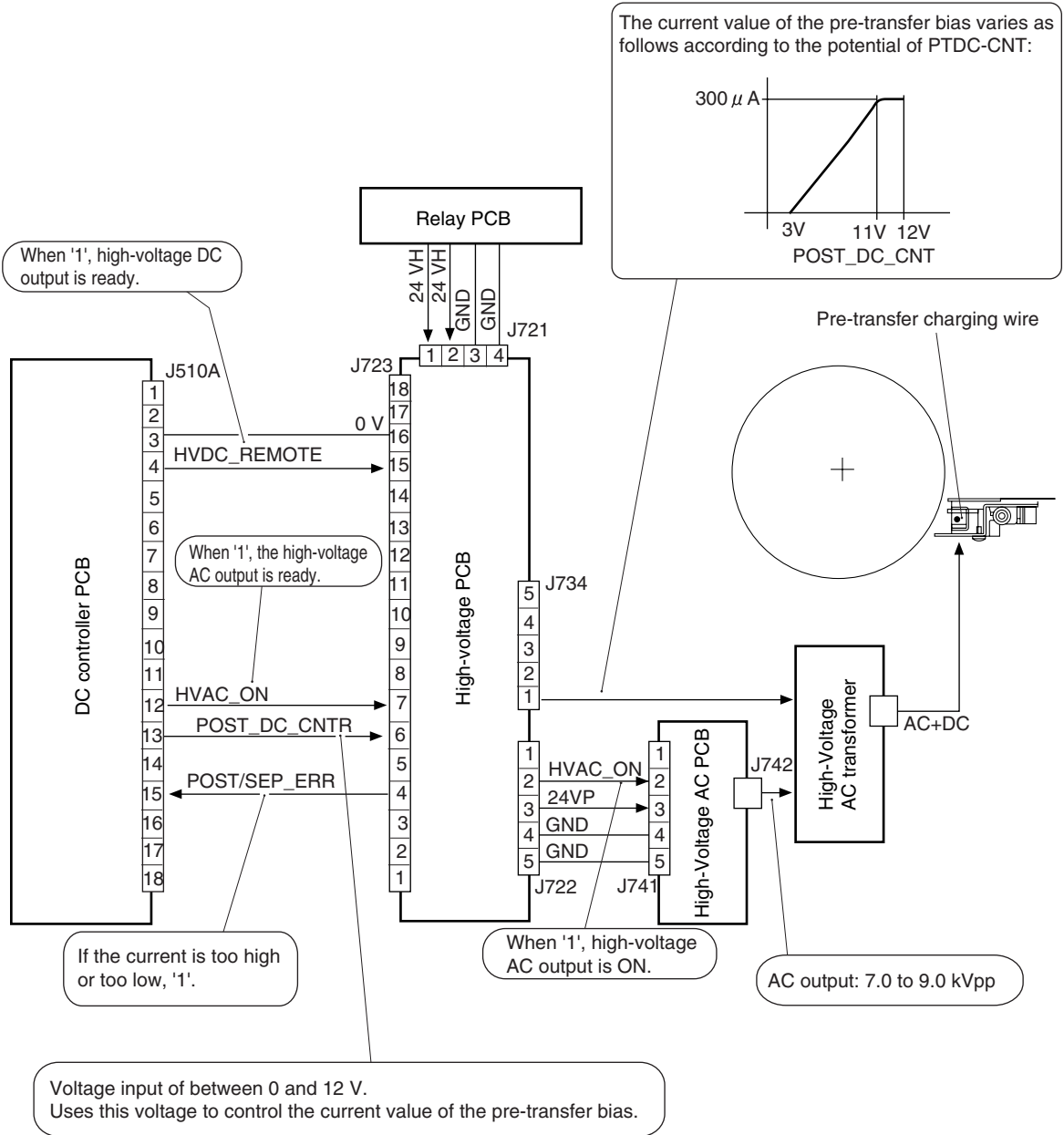

F-7-20

7.5.3.2 Controlling the Output to Suit the Environment (fuzzy control)

The pre-transfer charging current is optimized to suit the environment (as determined based on the readings of the environment sensor).

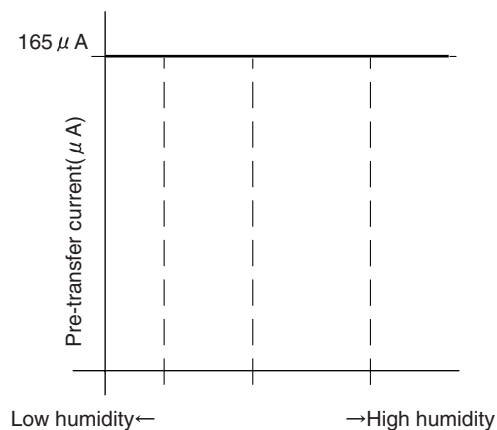

F-7-21

Related Service Mode Item:

- COPIER> OPTION> BODY> FUZZY (enabling/disabling fuzzy control)

0: enables fuzzy control (default)

1: low humidity environment mode (pre-transfer charging current is lower than standard)

2: normal humidity environment mode

3: high humidity environment mode (pre-transfer charging current is higher than standard)

If set to '1' through '3', the control will be free of the readings of the environment sensor.

7.5.3.3 Pre-Transfer Charging Assembly Cleaning Mechanism

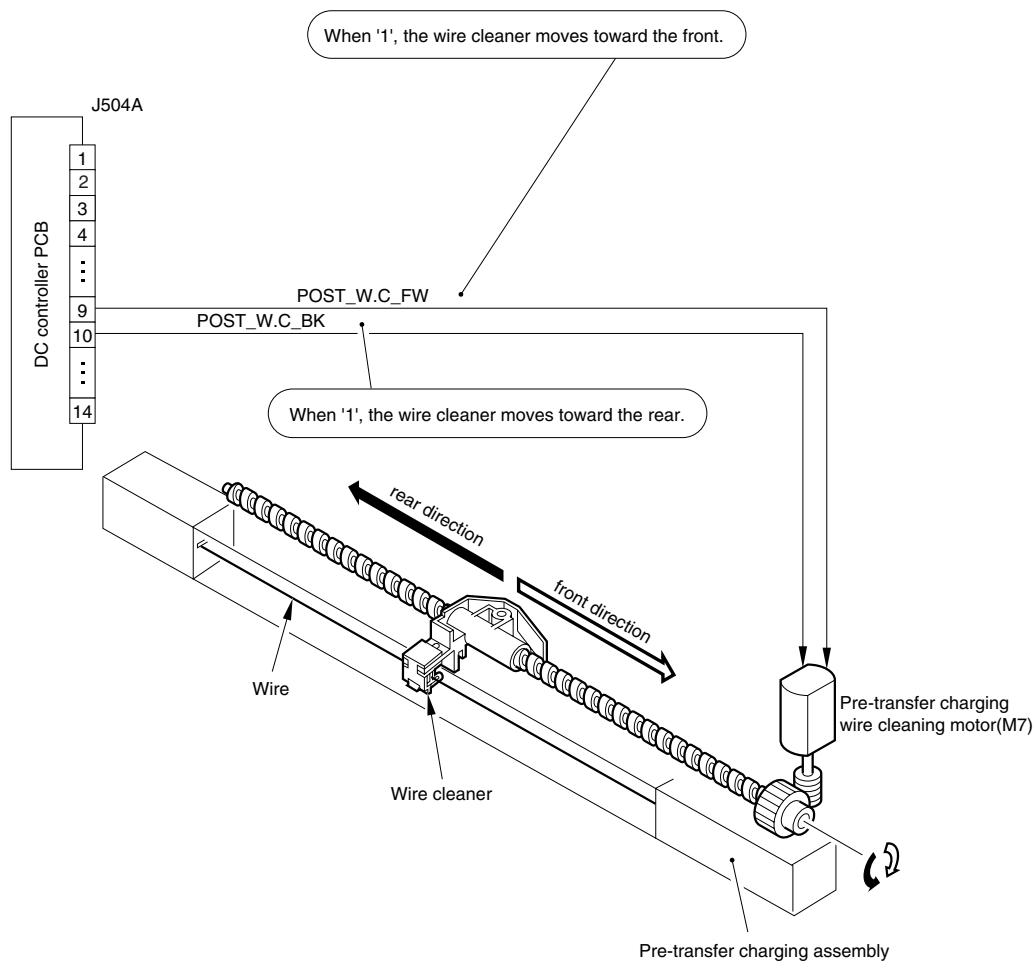

F-7-22

Reference:**Timing of Cleaning**

- [1] if the surface temperature of the fixing roller is 100 deg C or less when the control panel power switch is turned on.
- [2] when wire cleaning is executed in user mode.
- [3] at the end of LSTR after making 2000 prints since previous wire cleaning

7.5.3.4 Others**SERVICE MODE:**

- **COPIER> ADJUST> HV-TR> PRE-TR** (pre-transfer charging current output adjustment value input)
- If the DC controller PCB has been replaced or the RAM on the DC controller PCB has been initialized, enter the value indicated on the service label.

ERROR CODE:

- **E068** (pre-transfer charging output error)
- The presence of over-current has been detected (POST/SEP_ERR=1), possibly caused by leakage.

7.6 Drum Cleaner Unit**7.6.1 Outline**

The following shows the components of the machine's drum cleaner unit:

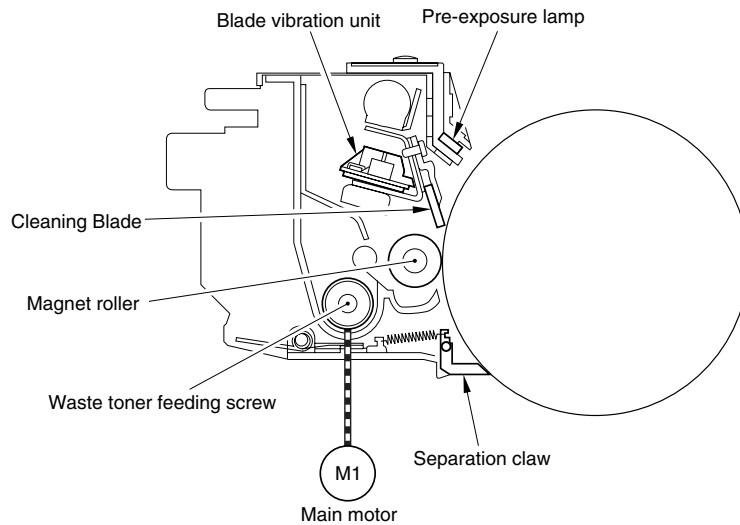

F-7-23

The presence of a cake of toner on the cleaning blade inside the cleaner unit is likely to prevent normal cleaning of the drum, and the machine uses 2 blade vibration units to prevent adhesion of toner. When these units vibrate, the entire blade will vibrate to shake off the toner, thereby eliminating cleaning faults otherwise caused by cakes of toner.

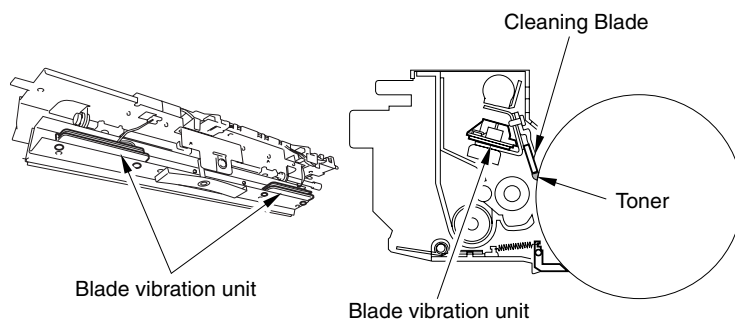

F-7-24

The blade vibration unit is driven for the following:

- after initial multiple rotation imitated by turning on the main power (5 or 1 vibration)
 - at time of STOP sequence (1 vibration)
 - during wire cleaning associated with pre-transfer, transfer, and separation (1 vibration)
- 1 vibration: ON for 0.6 sec
 5 vibrations: ON for 0.6 sec, OFF for 0.3 sec

SERVICE MODE:

You can check the activation of the blade vibration unit in service mode: COPIER>FUNCTION>PART-CHK>MTR.

7.6.2 Detecting the Waste Toner (case full condition)

The following shows the construction of the control system associated with the detection of the state of the waste toner bottle (full):

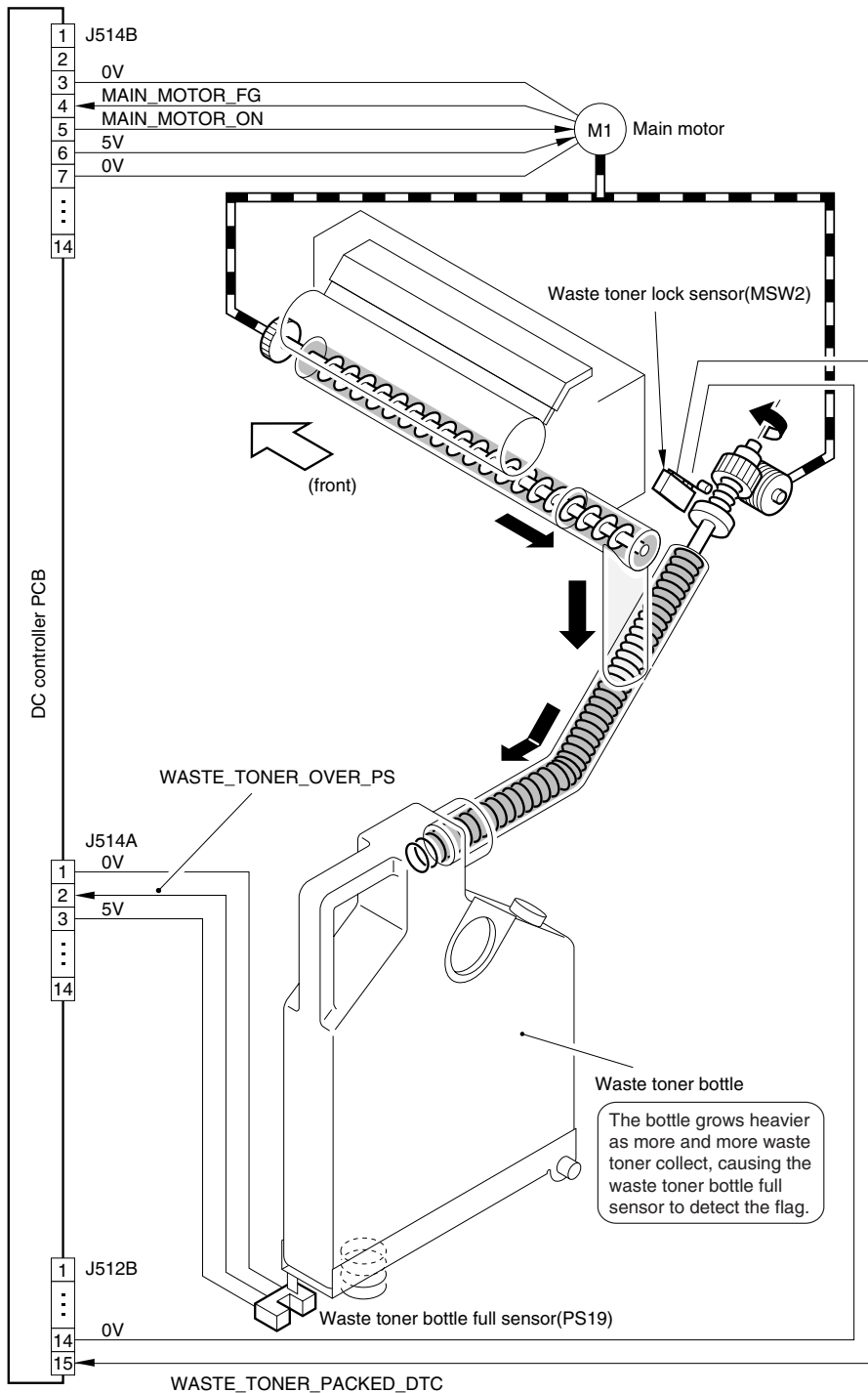

F-7-25

ERROR CODE:**- E013 (waste toner lock)**

The waste toner lock sensor (MSW2) remains ON for 4 sec or more.

- E019 (waste toner bottle full)

After the waste toner bottle has been identified as being full (by PS19), 50,000 prints or more have been made.

7.7 Developing Assembly

7.7.1 Outline

The following shows the components associated with the machine's developing assembly:

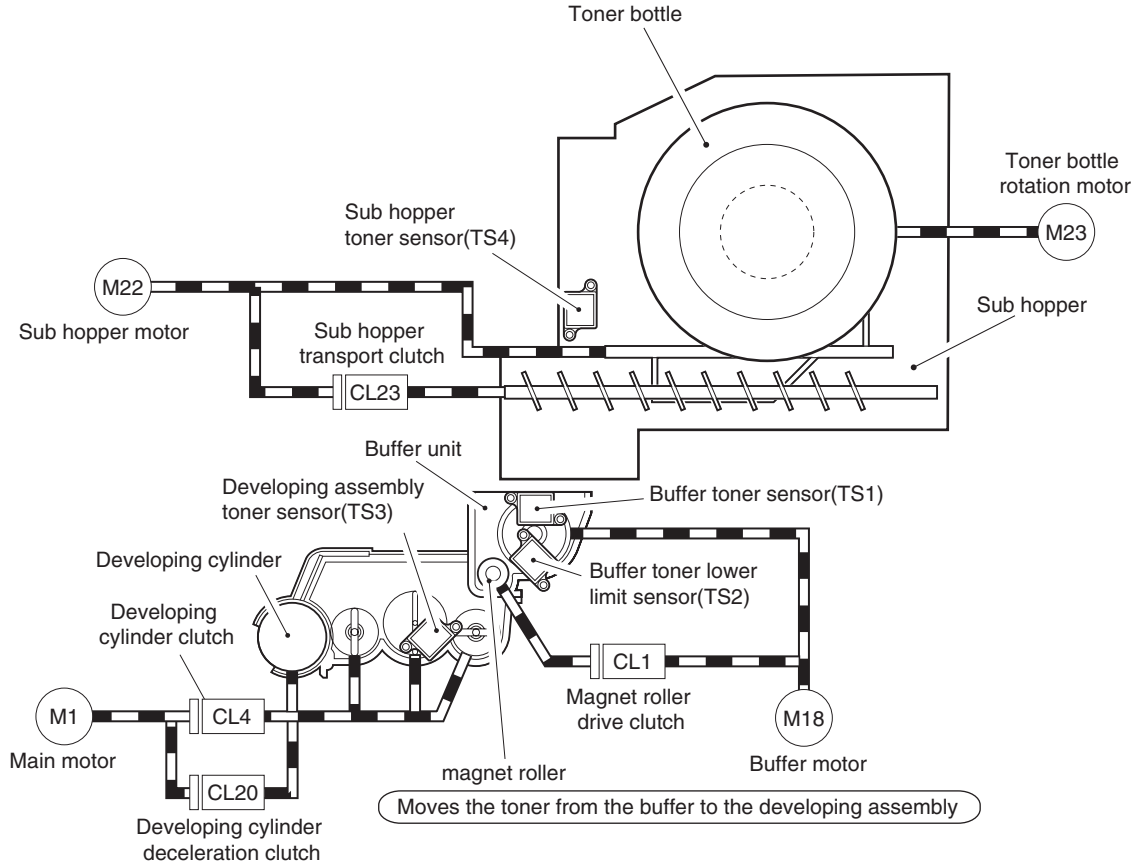

F-7-26

7.7.2 Controlling the Developing Assembly

The following shows the construction of the control system associated with the developing assembly drive mechanism:

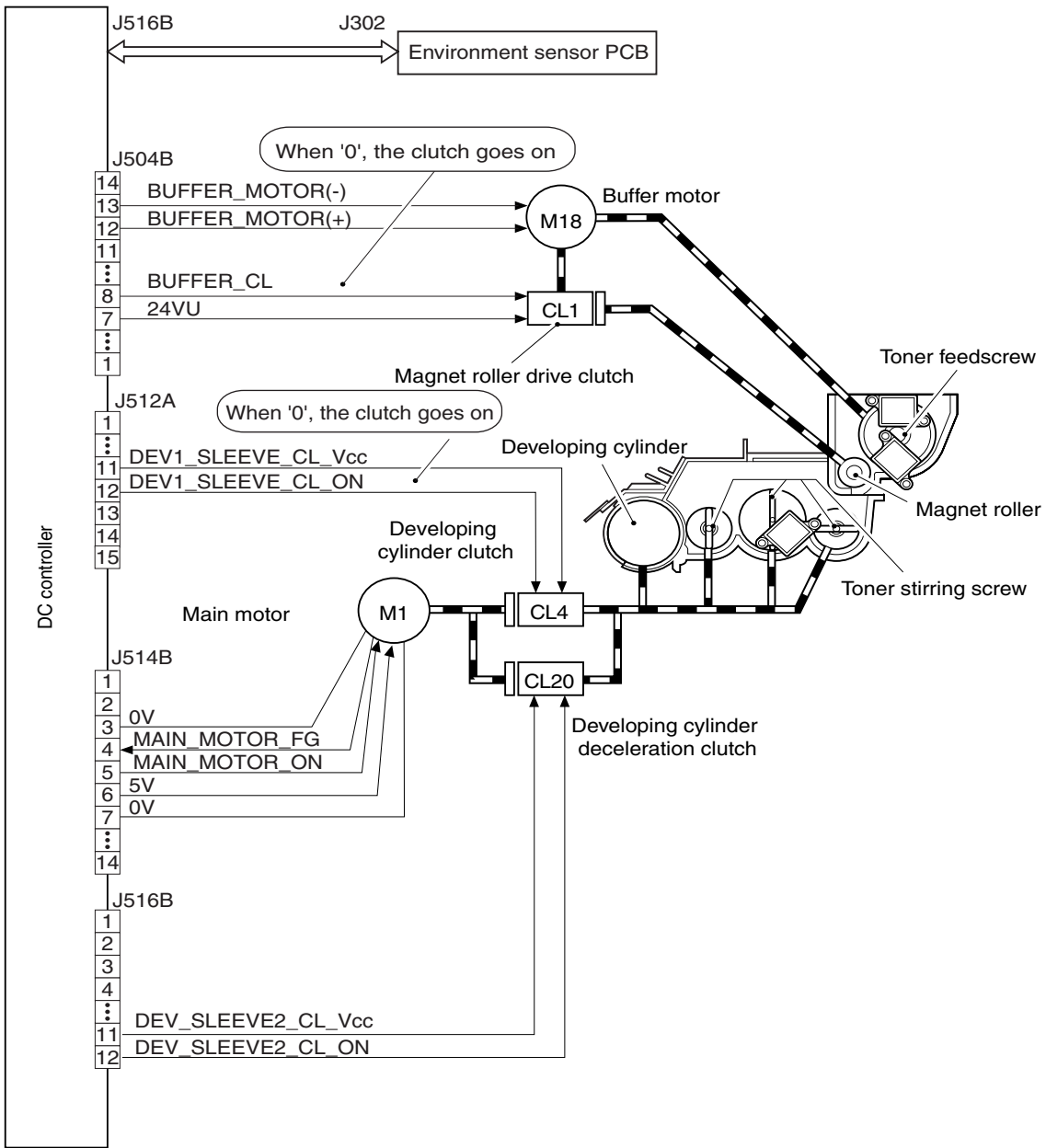

F-7-27

7.7.3 Controlling the Toner Cartridge Drive Mechanism

The following shows the construction of the control system associated with the toner cartridge drive mechanism:

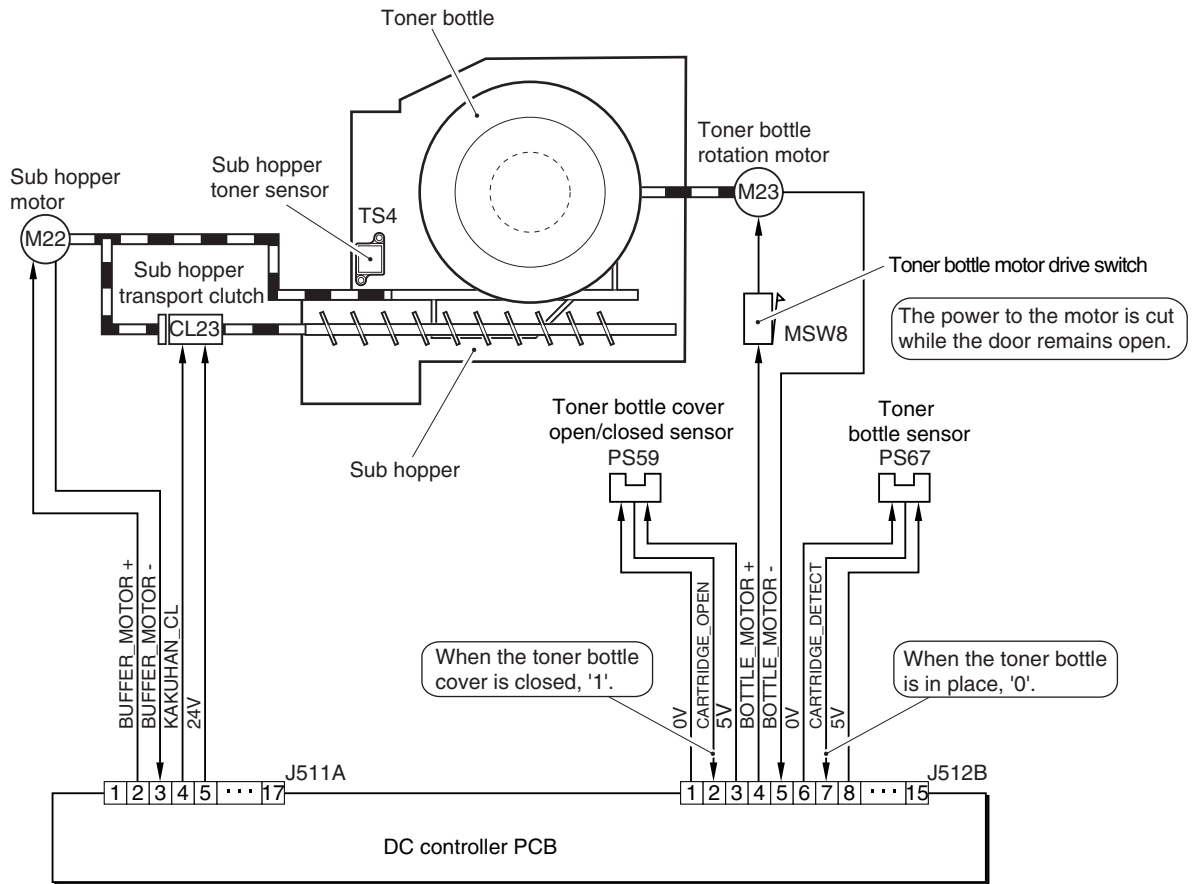

F-7-28

7.7.4 Controlling the Developing Bias

The following items are associated with the developing bias control system:

- [1] DC bias constant voltage control
- [2] AC bias constant voltage control

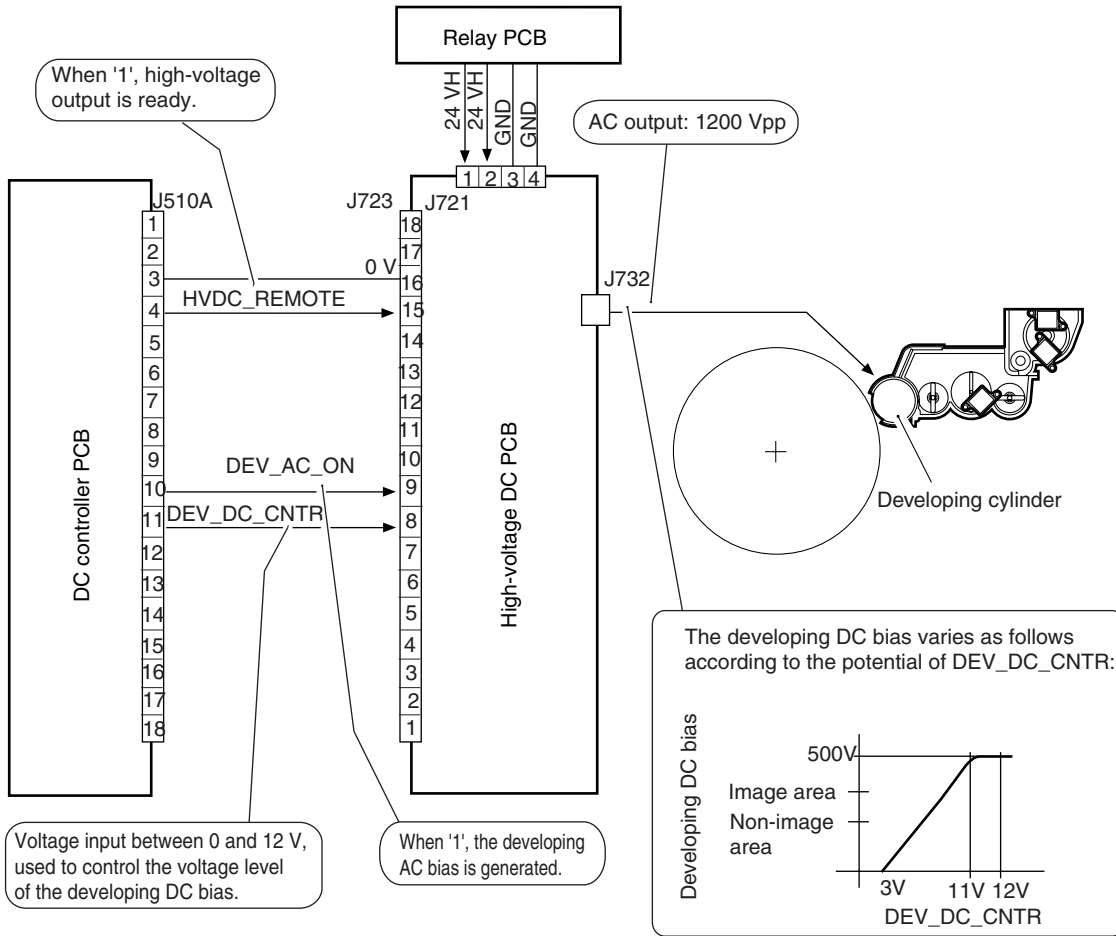

F-7-29

7.7.5 Detecting the Toner Level and Controlling the Toner Supply Mechanism

The following shows the components associated with the machine's toner supply control system:

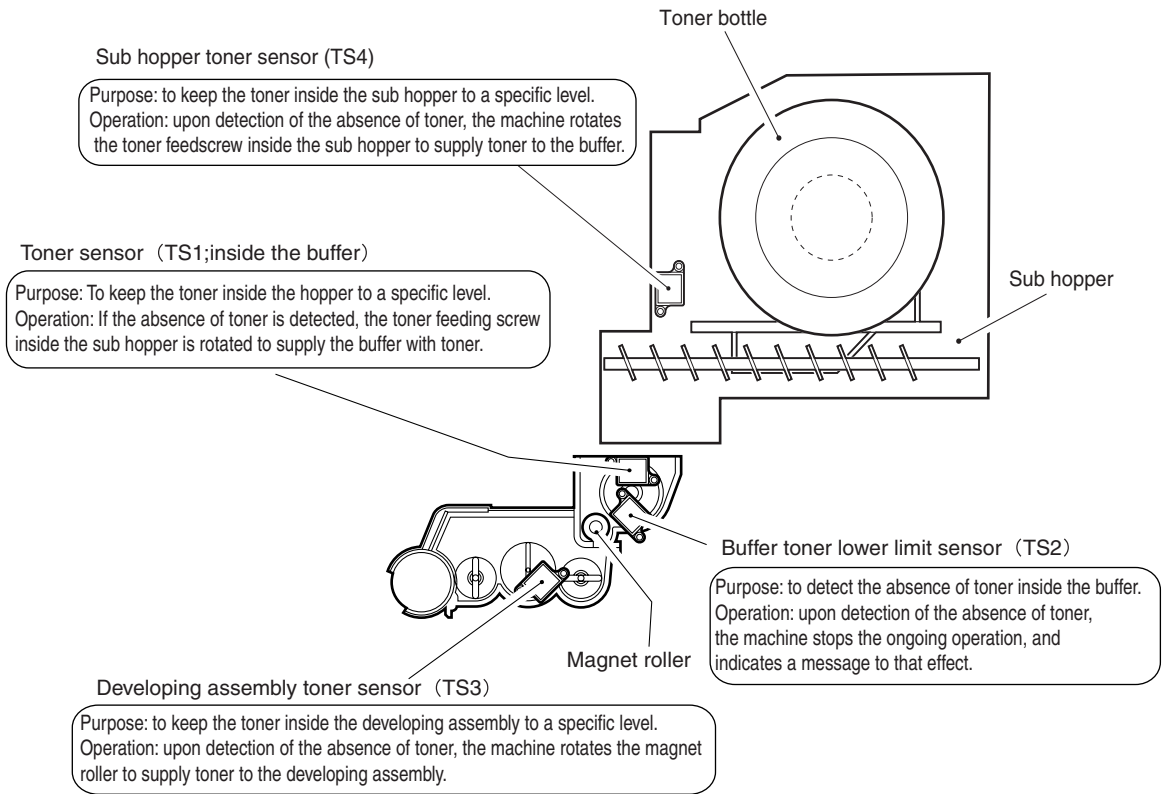

F-7-30

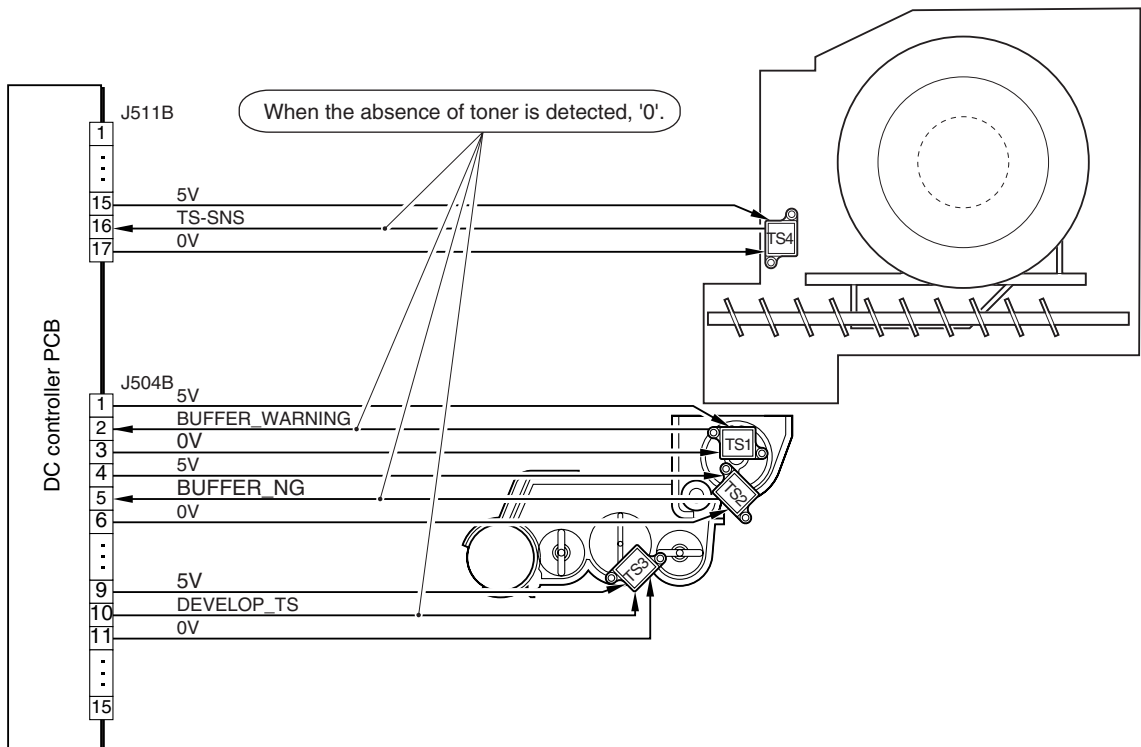

F-7-31

The following is an outline of the sequence of operations used by the machine to supply toner:

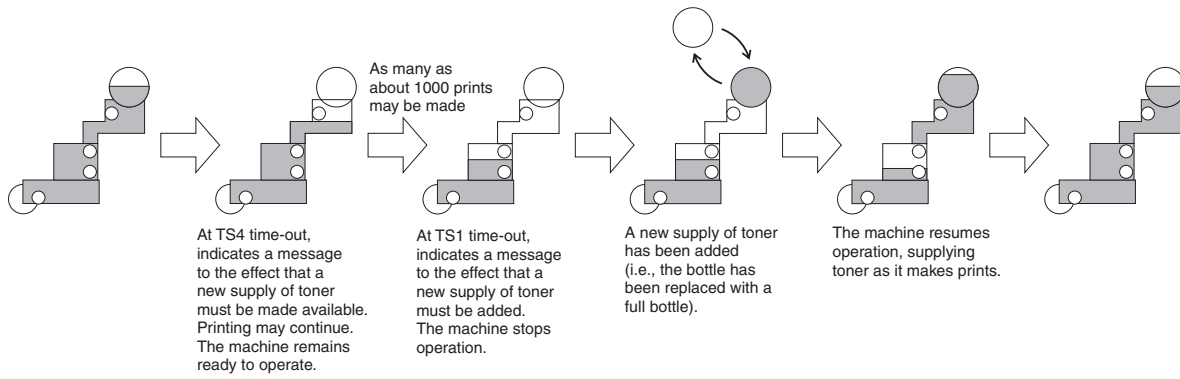

F-7-32

The following shows the sequence of operations used to supply toner from the buffer to the developing assembly:

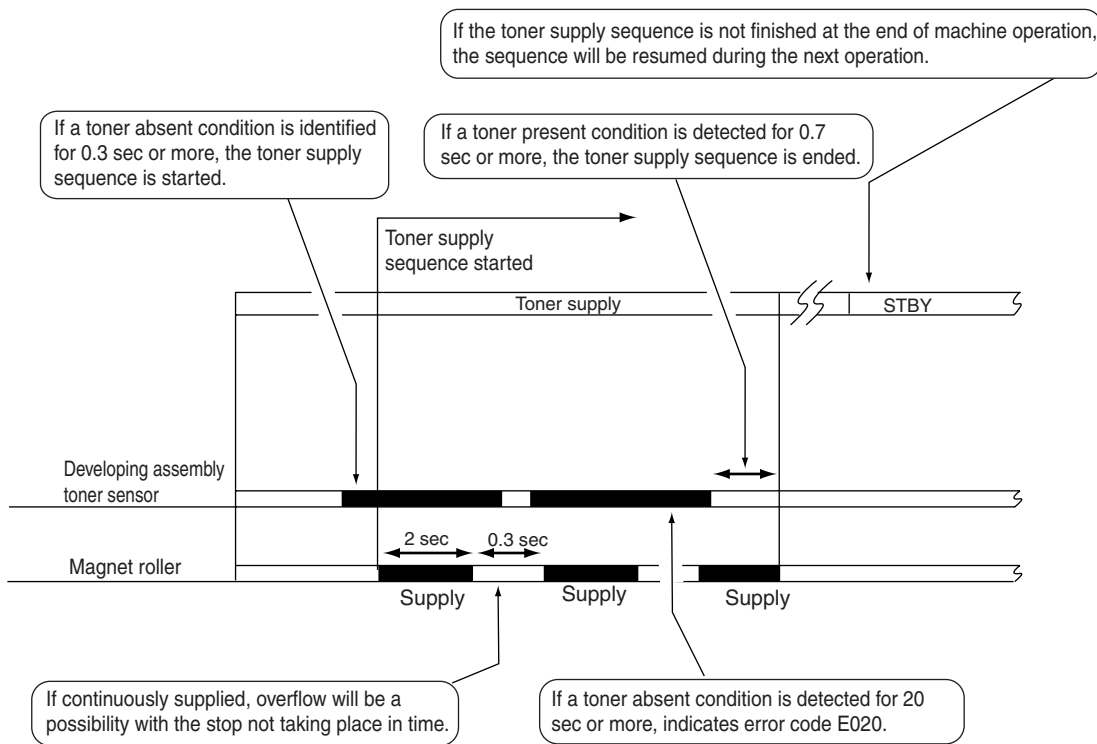

F-7-33

The following shows the sequence used to supply toner from the sub hopper to the buffer:

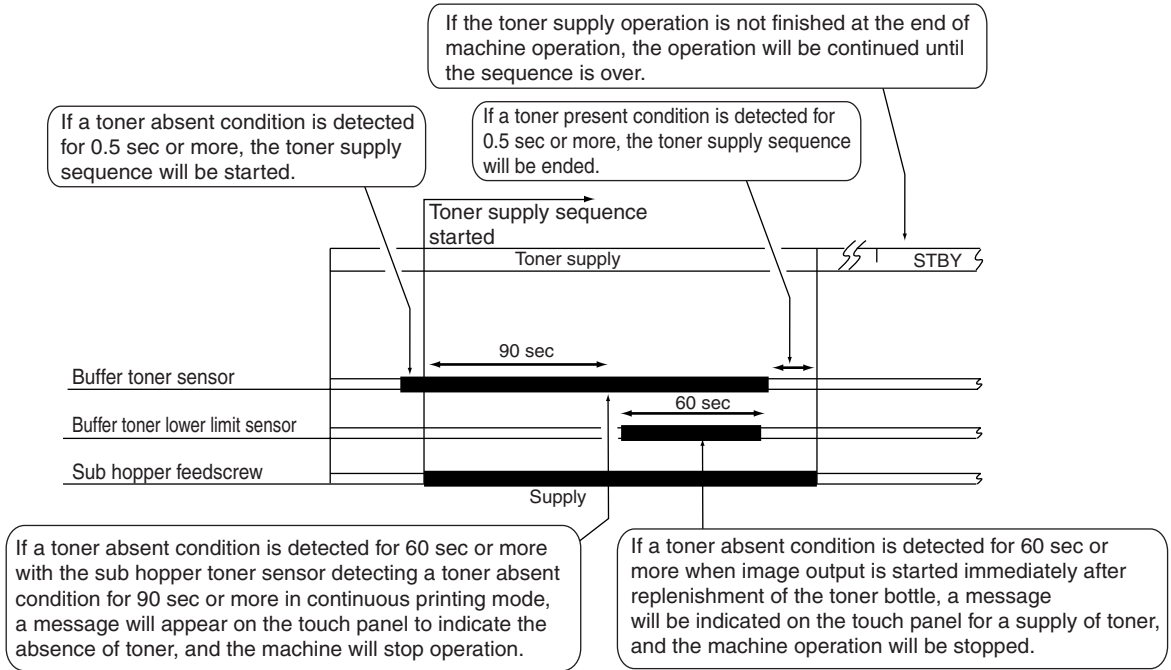

F-7-34

The machine uses the following sequence of operations to move toner from the toner bottle to the sub hopper:

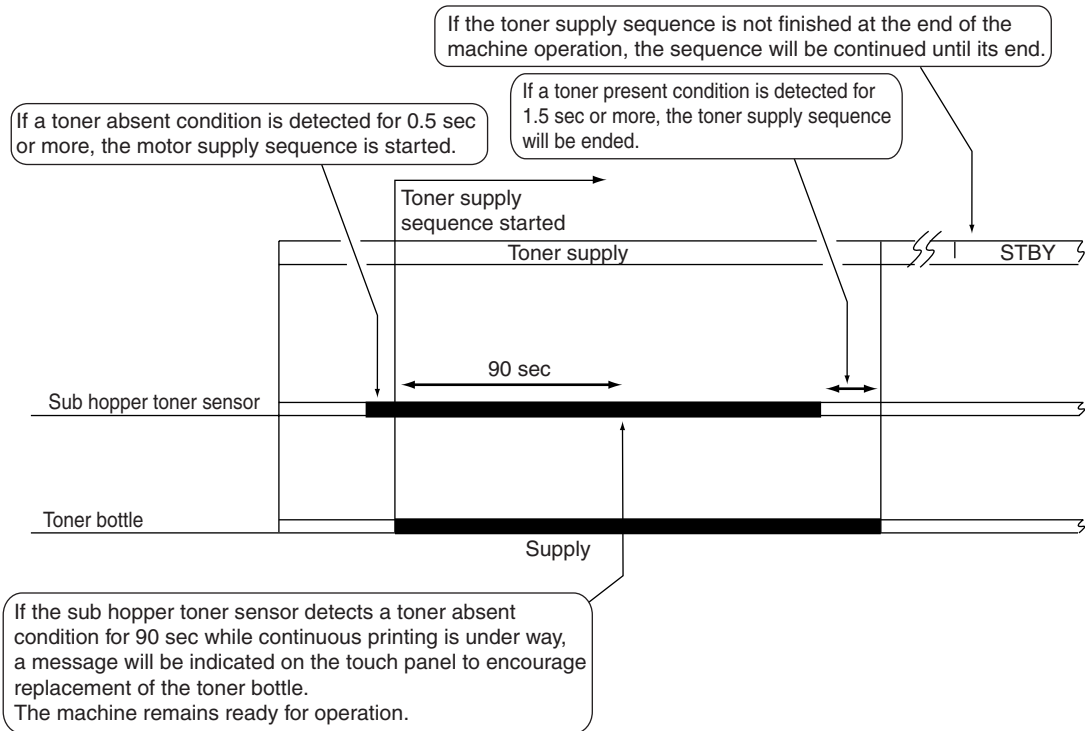

F-7-35

ERROR CODE:

- E020

0001 (Absence of toner in the developer)

The developer toner sensor (TS3) detects the absence of toner for more than 120 seconds although toner has been supplied to the developer.

0002 (Failure in feeding toner from the sub hopper to the buffer)

The buffer toner sensor (TS1) detects the absence of toner for more than 60 seconds and toner exists in the sub hopper although toner has been supplied to the buffer.

0003 (Failure in feeding toner from the sub hopper to the buffer)

The buffer toner sensor (TS1) detects the absence of toner for more than 210 seconds and toner exists in the sub hopper although toner has been supplied to the buffer after the toner bottle was replaced.

0004 (Failure in feeding toner from the sub hopper to the buffer)

The buffer toner sensor (TS2) detects the absence of toner for more than 150 seconds and toner exists in the sub hopper although toner has been supplied to the buffer after the toner bottle was replaced.

0005 (Absence of toner in the developer at installation)

The developer toner sensor (TS3) detects the absence of toner for more than 600 seconds at installation.

0006 (Absence of toner in the developer at installation)

The developer toner sensor (TS3) detects the absence of toner for more than 600 seconds after the sensor detected the presence of toner at installation.

0007 (Absence of toner in the buffer at installation)

The buffer toner sensor (TS1) detects the absence of toner for more than 60 seconds at installation.

0008 (Failure in the toner feeder motor)

When the toner feeder motor drives, a failure in the motor is detected for more than 3 seconds.

0009 (Failure in the buffer motor)

When the buffer motor drives, a failure in the motor is detected for more than 3 seconds.

0010 (Required to clear the E020 error)

The power was turned OFF/ON without the error being cleared.

7.8 Transfer Mechanism

7.8.1 Transfer Guide Bias

7.8.1.1 Overview

The machine applies a bias whose polarity is the same as that of the toner to the transfer guide to prevent soiling of the surface of the transfer guide with toner (if left alone, the toner will soil the back of paper). The following items are associated with the system used to control the charging of the transfer guide:

- [1] transfer guide bias constant voltage control
- [2] output control to suit the environment

The following shows the components associated with the machine's transfer guide charging control system:

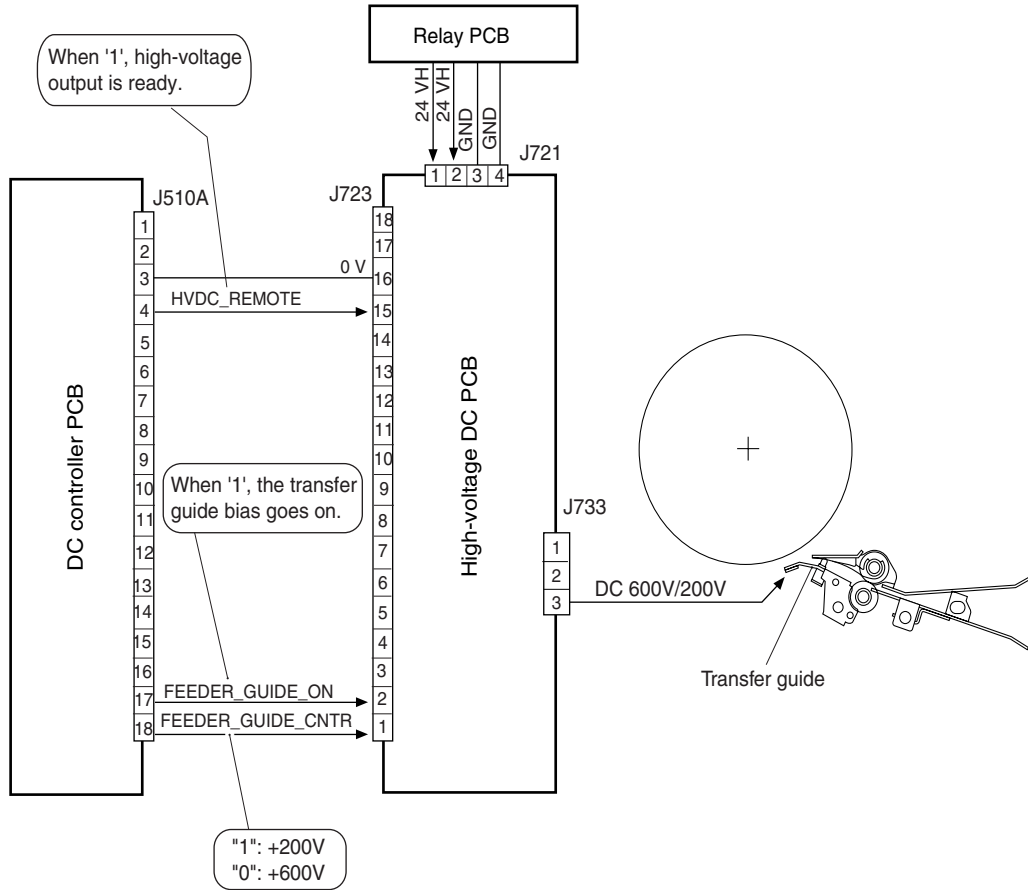

F-7-36

7.8.1.2 Controlling the Output to Suit the Environment

The transfer guide bias is optimized to suit the environment (identified with reference to the data from the environment sensor).

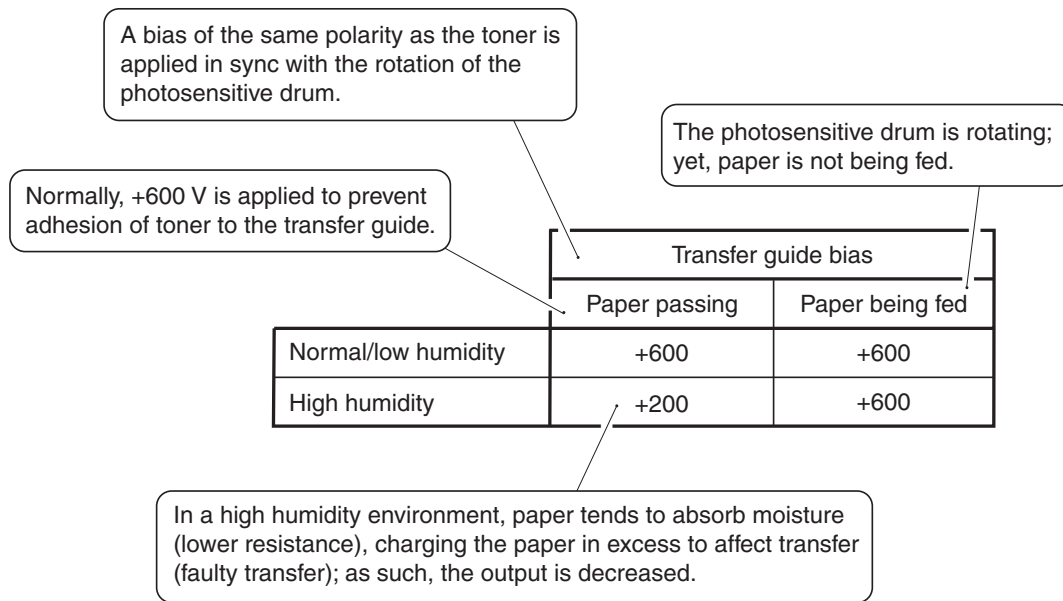

F-7-37

SERVICE MODE:

- **COPIER> OPTION> BODY> TRNSG-SW** (transfer guide bias control mode switchover)

0: switches to +200 V in a high-humidity environment (default)

1: fix the transfer guide bias to +600 V

2: fix the transfer guide bias to +200 V

3: switches to +200 V in a normal humidity condition

4: switches to +200 V in a low humidity condition

Set it to '2' through '4' if a transfer fault is noted.

7.8.2 Transfer Charging Mechanism

7.8.2.1 Outline

The following items are associated with the machine's transfer charging control system:

- [1] DC bias constant current control
- [2] output control to suit the environment (fuzzy control)
- [3] output control at the trail edge of paper

The following shows the components associated with the transfer charging control system:

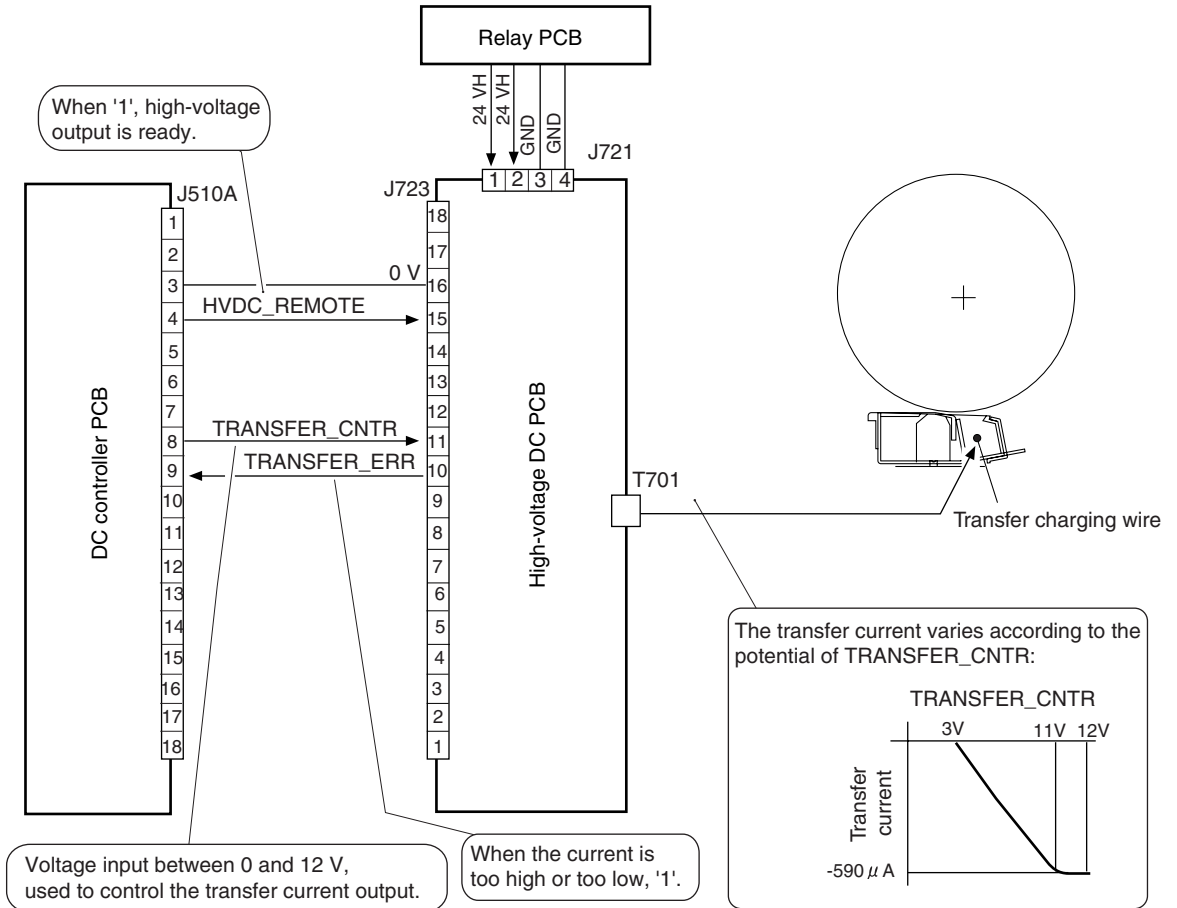

F-7-38

7.8.2.2 Controlling the Output to Suit the Environment (fuzzy control)

The transfer current output is optimized to suit the environment (data for the environment sensor).

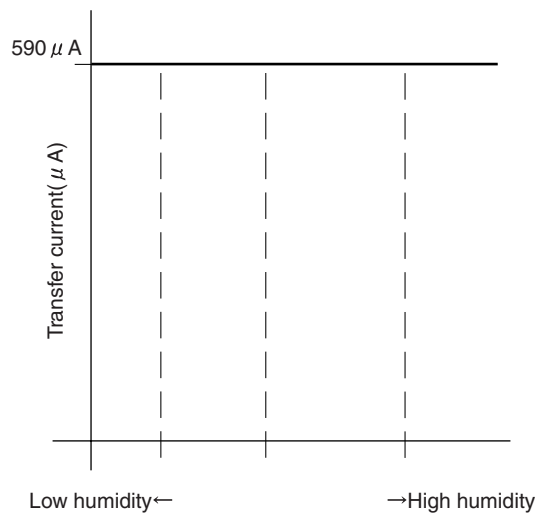

SERVICE MODE:

- **COPIER> OPTION> BODY> FUZZY** (enabling/disabling fuzzy control)

0: enables fuzzy control (default)

1: low humidity environment mode (the transfer current is lower than standard)

2: normal humidity environment mode

3: humidity environment mode (the transfer current is higher than standard)

If set to '1' through '3', the control will be independent of the environment sensor.

7.8.2.3 Correcting the Output at the Trailing Edge of Paper

When copy paper moves in contact with the transfer charging assembly, the resistance of the assembly drops abruptly as soon as the paper leaves, possibly permitting discharge current to flow momentarily, causing transfer faults or image smears along the trail edge of the image. The machine is designed to correct (decrease) the transfer current to prevent these faults.

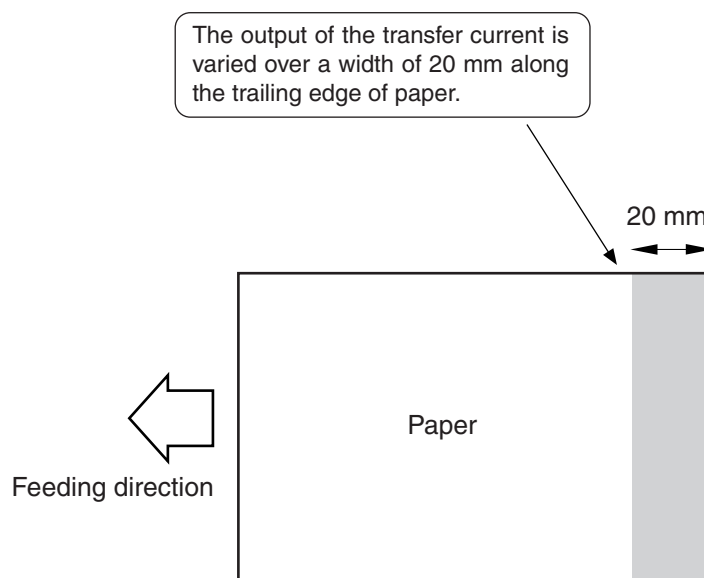

When making a double-sided print, paper will absorb fixing oil and tend to collect less charges (low resistance); since the discharge current along the trailing edge of paper will be low, the output is not varied.

In a low humidity environment, paper tends to dry up collecting excess charges (high resistance); to counter, the output is reduced.

	Transfer current correction (μA)	
	Single-sided printing	Double-sided printing
Low humidity	+220	—
Normal humidity	+150	—
High humidity	—	—

F-7-41

SERVICE MODE:

- **COPIER> OPTION> BODY> TRSW-P-B** (enabling/disabling transfer current output correction control)
- 1: does not vary the transfer current value (default)
(transfer faults occurring along the trail edge of paper)
- 0: corrects the transfer current value along the trail edge of paper

7.8.2.4 Transfer Charging Assembly Cleaning Mechanism

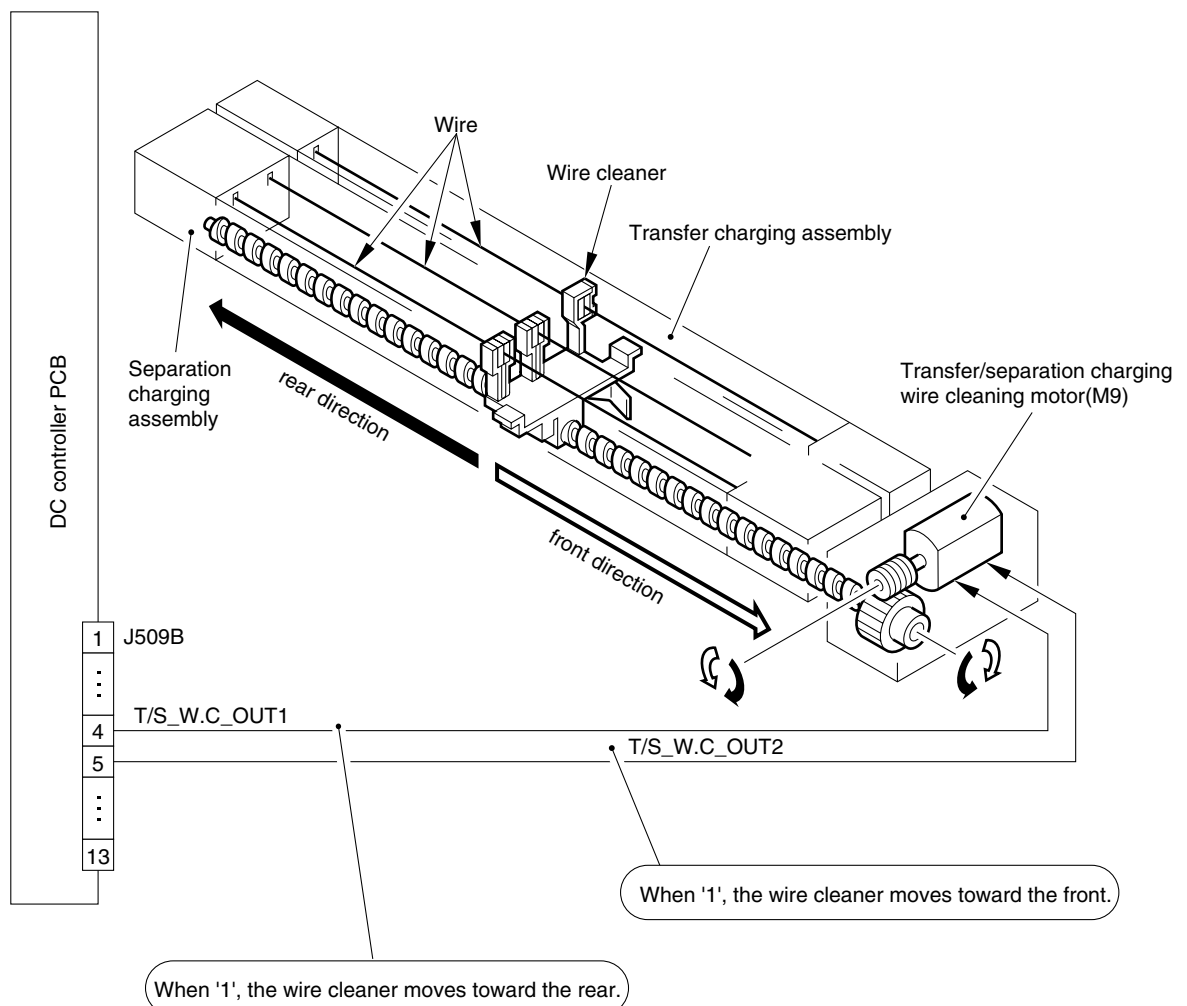

F-7-42

Reference:

Timing of Cleaning

[1] the surface temperature of the fixing roller is 100 deg C or lower when the control panel power switch

is turned on

[2] when wire cleaning is executed in user mode

[3] at the end of LSTR after making 2000 prints since previous wire cleaning

7.8.2.5 Others

SERVICE MODE:

- **COPIER> ADJUST> HV-TR> TR-N1** (output adjustment for plain paper simplexing or for 1st side of duplexing)

If the DC controller PCB has been replaced or the RAM on the DC controller PCB has been initialized, enter the value indicated on the service label.

- **COPIER> ADJUST> HV-TR> TR-N2** (output adjustment for 2nd side of plain paper duplexing)

If the DC controller PCB has been replaced or the RAM to the DC controller PCB has been initialized, enter the value indicated on the service label.

ERROR CODE:

- **E069** (transfer charging output error)

The presence of over-current (TRERR=1) is detected, as caused by leakage.

7.9 Separation Mechanism

7.9.1 Separation Charging Mechanism

7.9.1.1 Outline

The following items are associated with the machine's separation charging control system:

- [1] DC bias constant current control
- [2] AC bias constant voltage control
- [3] output correction to suit the environment and deposit of toner (fuzzy control)
- [4] output correction after detection of leakage

The following shows the components associated with the machine's separation charging control system:

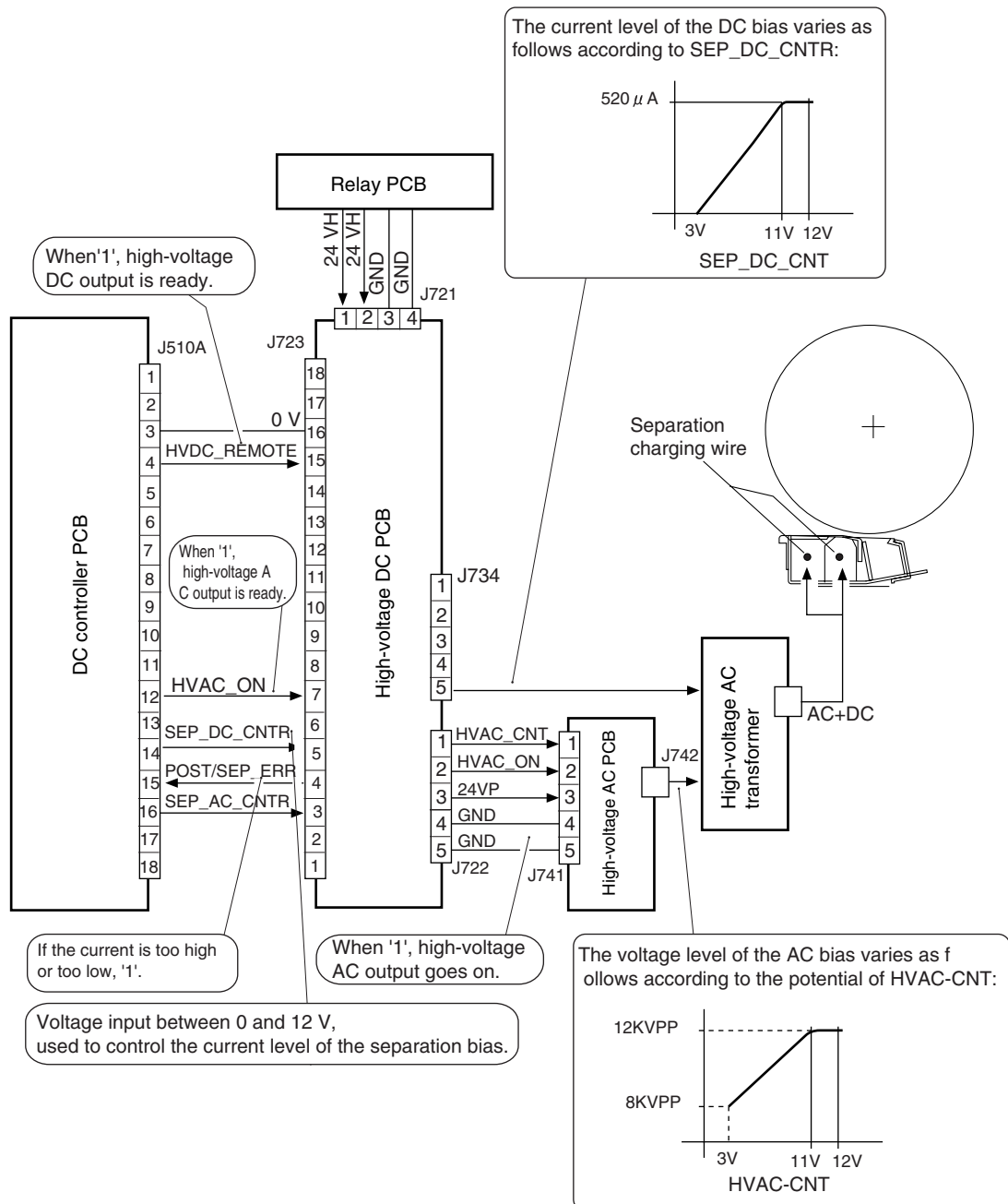

F-7-43

7.9.1.2 Correcting the Output to Suit the Environment and the Toner Deposit

The separation current output is optimized according to the environment (as identified based on the data from the environment sensor) and the deposit of toner (3 levels: low, standard, high).

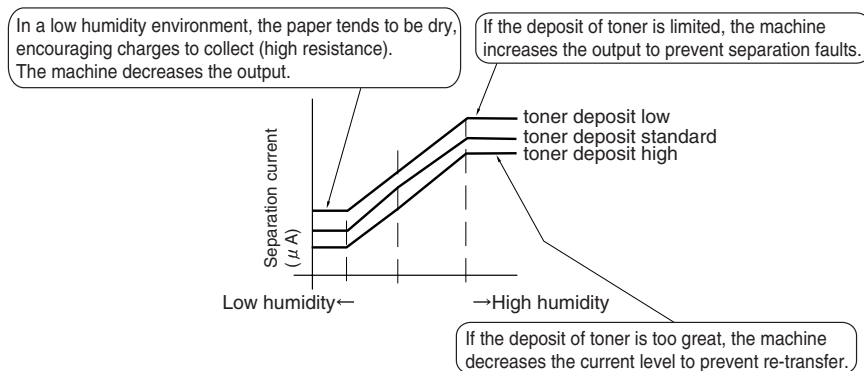

F-7-44

SERVICE MODE:

- **COPIER> OPTION> BODY> FUZZY** (enabling/disabling fuzzy control)

0: enables fuzzy control (default)

1: low humidity mode (the separation current is lower than standard)

2: normal humidity mode

3: high humidity environment mode (the separation current is higher than standard)

If set to '1' through '3', the control will be independent of the environment sensor.

7.9.1.3 Correcting the Output upon Detection of Leakage

If leakage is detected, the separation output will be supplied at a lowered output level.

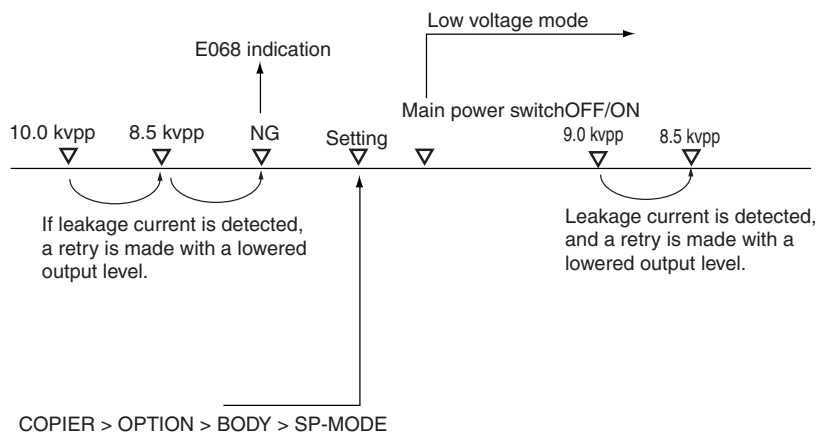

F-7-45

SERVICE MODE:

- **COPIER> OPTION> BODY> SP-MODE** (enabling/disabling separation current output correction control)

0: standard mode (AC output is 10.0 kVpp, default)

1: low voltage mode (AC output is 9.0 kVpp; if error is frequent because of leakage)

7.9.1.4 Others

SERVICE MODE:

- **CODIER> ADJUST> HV-SP> SP-N1** (output adjustment for plain paper simplex or 1st side of duplexing)

If the DC controller PCB has been replaced or the RAM on the DC controller has been initialized, enter the value indicated on the service label.

- **CODIER> ADJUST> HV-SP> SP-N2** (output adjustment for 2nd side of plain paper duplexing)

If the DC controller PCB has been replaced or the RAM on the DC controller has been initialized, enter the value indicated on the service label.

7.10 Parts Replacement Procedure

7.10.1 Process Unit

7.10.1.1 Before Starting the Work

- 1) Remove the manual feeder pull-off roller unit.
- 2) Remove the developing assembly.
- 3) Remove the primary charging assembly cover.
- 4) Remove the process unit cover.
- 5) Remove the upper inside cover.
- 6) Slide out the fixing/feeding unit.
- 7) Remove the waste toner cover (lower rear right); then, detach the drum protective sheet, and place it on the fixing/feeding unit.
- 8) If a double-feeding detection PCB (transmitting) [3] is found, disconnect the 2 connectors [1] and remove the screw [2], and open the PCB in the direction of the arrow.

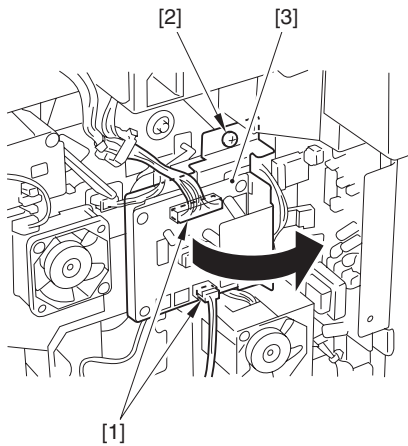

F-7-46

- 9) Disconnect the connector [1], and release the stop lever [2] to detach the primary charging assembly [3].
- 10) Disconnect the connector [4], and release the stopper lever [5] to detach the pre-transfer charging assembly [6].

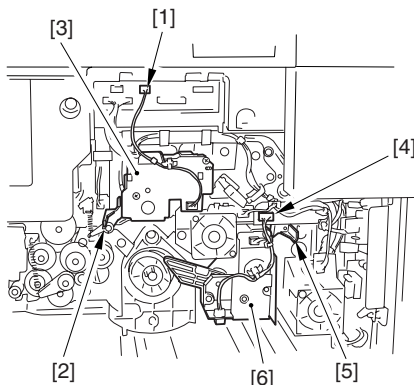

F-7-47

7.10.1.2 Removing the Process Unit

- 1) While keeping the drum in place using the drum stop tool [1] found behind the compartment cover (front cover), remove the drum fixing roll [3].

- 2) Remove the drum stop tool [1].
- 3) Remove the 3 screws [4], and disconnect the connector [5]; then, slide out the process unit [6].

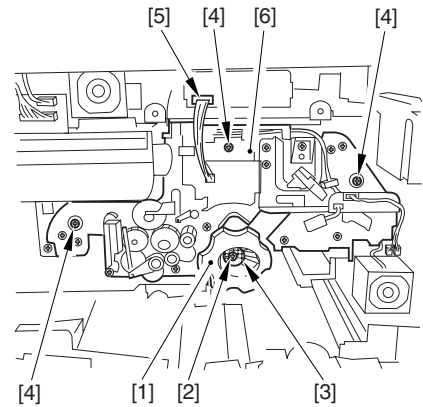

F-7-48

- 4) Slide out the process unit [1] fully; then, slide out the grip [2] on the right side.
- 5) Hold the grip [2] on the right and the grip [3] on the left, and detach the unit in upward direction.

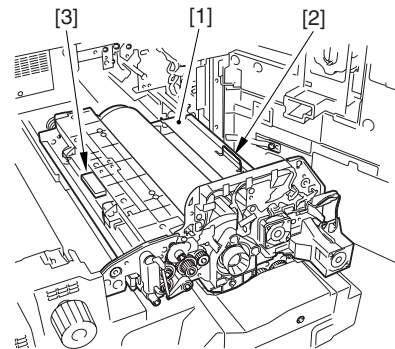

F-7-49



When placing the removed process unit, be sure to turn the kit support plate [1] in counterclockwise direction to create space between the drum surface and the floor.

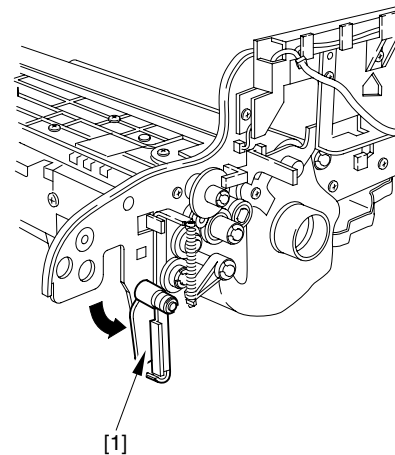

F-7-50

7.10.1.3 Mounting the Process Unit

Keep the following in mind when mounting the process unit [1] to the slide rail:

- 1) Be sure to match the notch [2] found at the tip of the left slide rail against the front plate [3] of the process unit.
- 2) Be sure to match the bend [4] at the front of the right slide rail against the front plate [3] of the process unit.

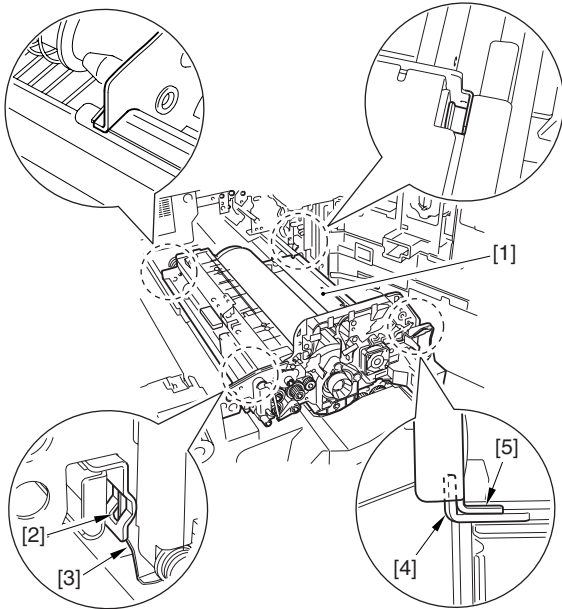

F-7-51



Waste toner can drop on the duplex unit when the process unit is removed. After mounting the process unit, be sure to slide out the duplex unit and remove the waste toner.

7.10.2 Pre-Exposure Lamp

7.10.2.1 Removing the Pre-Exposure Lamp Unit

- 1) Open the front cover.
- 2) Slide out the process unit.



Cover the drum with A3 paper or the like when you have slid out the process unit.

- 3) Disconnect the connector [1], and remove the two screws [2]; then, detach the preexposure unit [3].

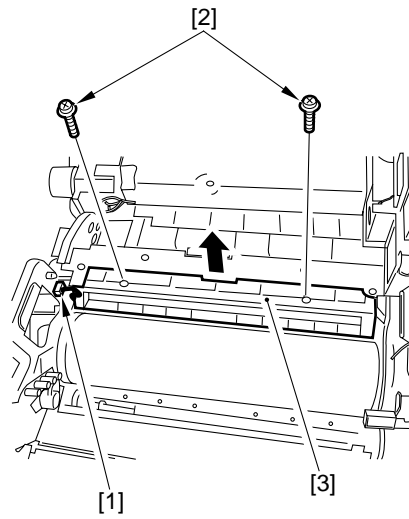

F-7-52

- 4) Remove the three screws [1], and detach the pre-exposure holder [2]; then, detach the pre-exposure lamp [3].

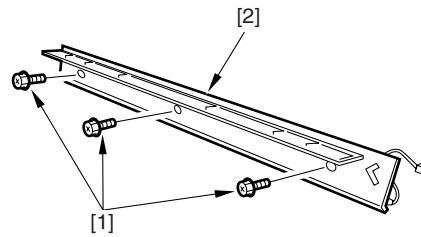

F-7-53

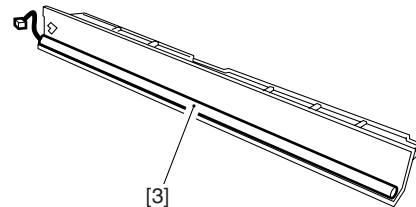

F-7-54

7.10.3 Primary Charging Assembly

7.10.3.1 Removing the Primary Charging Assembly

- 1) Open the front cover.
- 2) Remove the primary charging assembly cover [1].
- 1 screw [2]

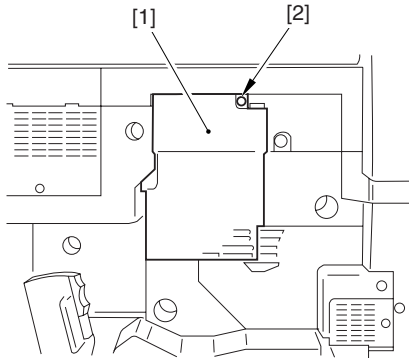

F-7-55

- 3) Disconnect the connector [1]; then, while turning the stop lever [2] in the direction of the arrow, slide out the primary charging assembly [3].

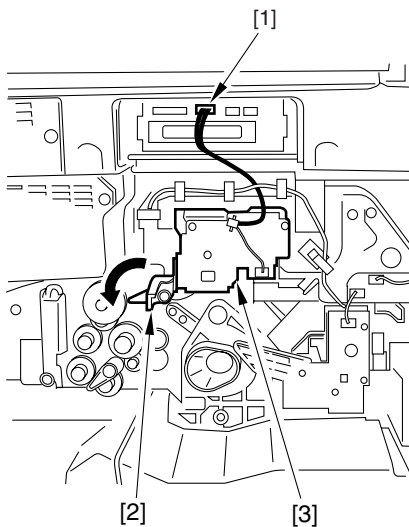

F-7-56

7.10.4 Pre-Transfer Charging Assembly

7.10.4.1 Removing the Pre-Transfer Charging Assembly

- 1) Open the front cover.
- 2) Remove the primary charging assembly cover [1].
- 1 screw [2]

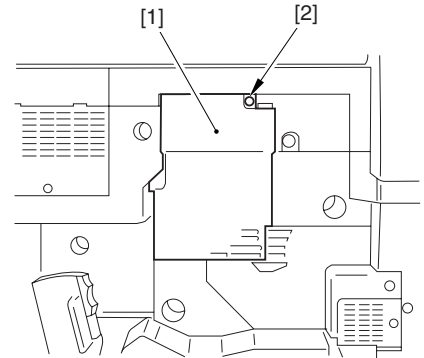

F-7-57

- 3) Remove the process unit cover.
- 4) If a double-feeding detection PCB (transmitting) [3] is found, disconnect the 2 connectors [1] and remove the screw [2]; then, open the PCB in the direction of the arrow.

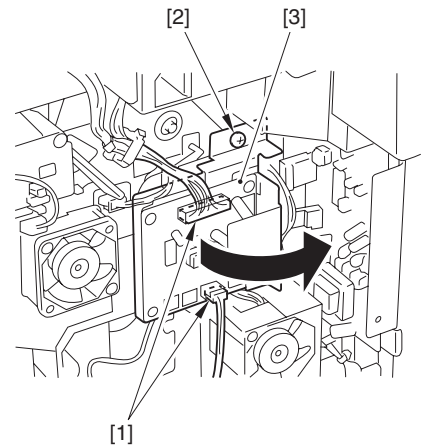

F-7-58

- 5) Disconnect the connector [1]; then, while turning the stop lever [2] in the direction of the arrow, slide out the pre-transfer charging assembly [3].

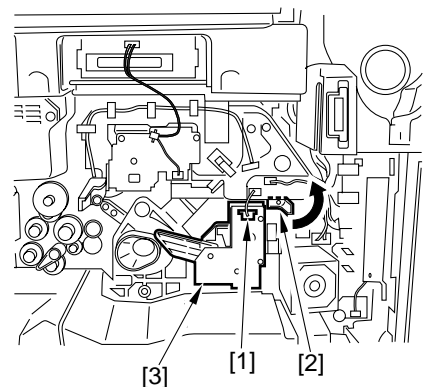

F-7-59

7.10.5 Photosensitive Drum

7.10.5.1 Points to Note About Handling the Photosensitive Drum

The machine's photosensitive drum is a high-sensitivity amorphous silicon drum, whose sensitivity tends to deteriorate if not handled properly. Be sure to observe the following whenever handling the process unit or the photosensitive drum:

1. If you have removed the process unit, be sure to protect the photosensitive drum against light by covering it with its protective sheet or wrapping it with 6 or more sheets of A3 paper.
2. Do not place the process unit or the photosensitive drum near a window or an area subject to direct rays of the sun.
3. Do not store the process unit or the photosensitive drum in a place subject to high/low temperature/humidity to a rapid change in these environmental conditions.
4. Do not store the process unit or the photosensitive drum in a place subject to dust, ammonium gas, or organic solvent gas.

The foregoing rules equally apply to all types of photosensitive drums.

7.10.5.2 Removing the Photosensitive Drum

- 1) Remove the developing fan.
- 2) Slide out the process unit.
- 3) Remove the 3 screws [1], and disconnect the 2 connectors [2]; then, detach the sub plate assembly [3].

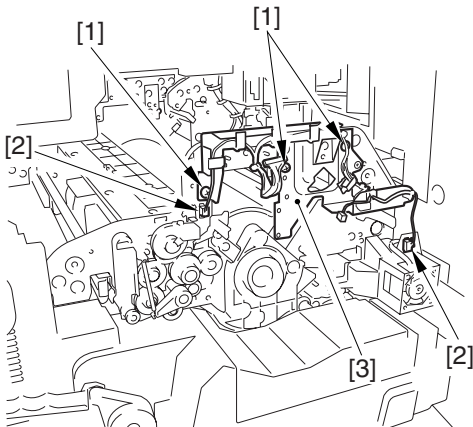

F-7-60

- 4) Remove the 2 screws [1], and detach the positioner holder [2].

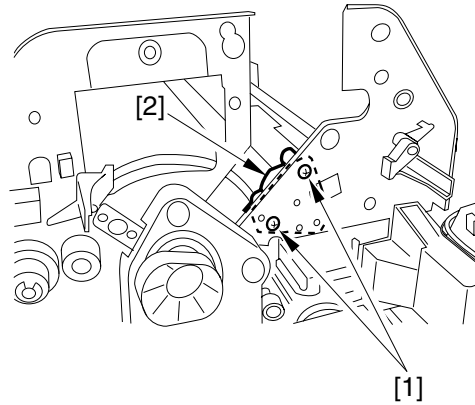

F-7-61

- 5) Remove the 3 screws [1], and detach the drum fixing plate [2].

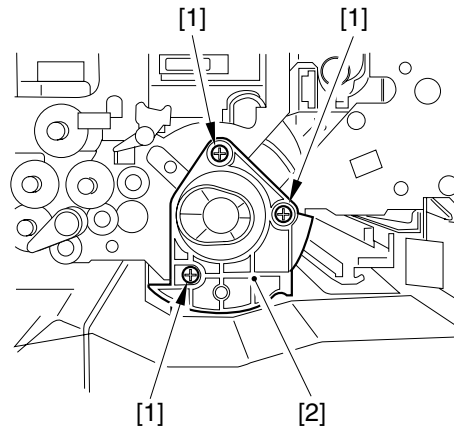

F-7-62

- 6) Remove the screw [1], and detach the bearing stopper [2]; then, shift the photosensitive drum [3] to the front (in the direction of the arrow) to lift.

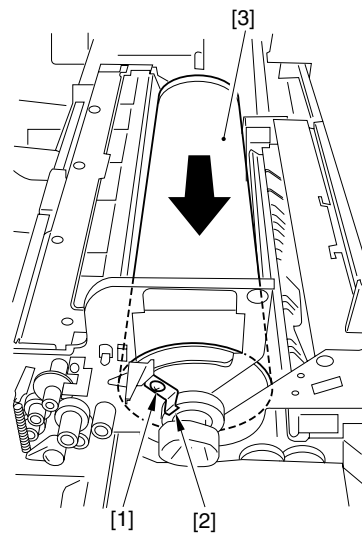

F-7-63

7.10.6 Drum Cleaner Unit

7.10.6.1 Construction

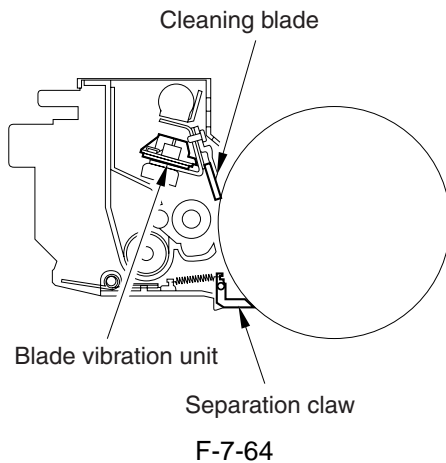

7.10.6.2 Removing the Cleaning Blade

- 1) Slide out the process unit.
- 2) Remove the screw [1], and detach the reciprocating arm [2].

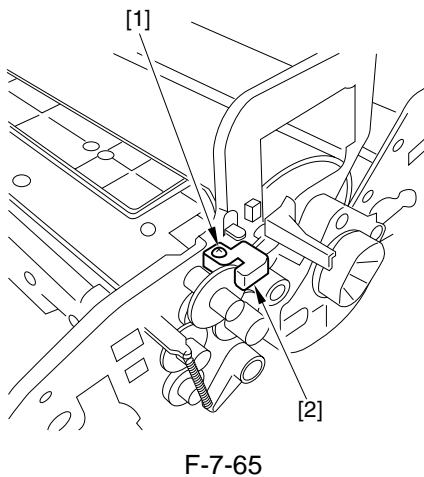

- 3) Disconnect the 2 connectors [1], and remove the 5 screws [2]; then, lift the rear and push it in to detach the cleaning blade together with the mounting plate [3].

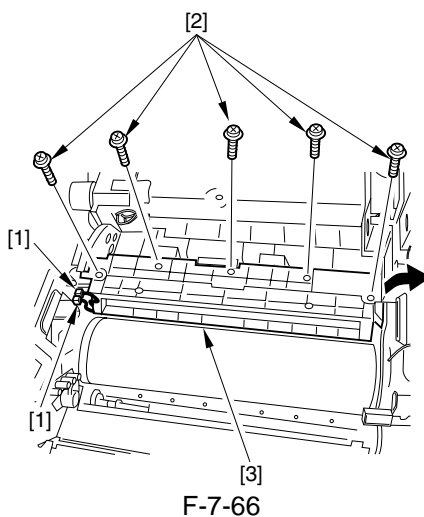

- 4) Remove the E-ring [1], and detach the pressure plate [2] to detach the cleaning blade assembly [3].

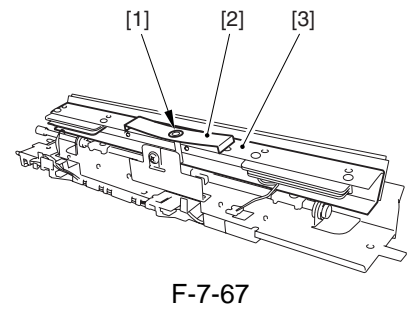

The pressure plate looks like the one used for the GP600 Sires or iR8500 Series machines; however, it is a different part with a different parts number. Do not use the wrong part.

- 5) Remove the blade vibration unit from the cleaner blade unit.
- 6) Remove the 5 screws [1], and detach the blade retaining plate [2] to detach the cleaning blade [3].

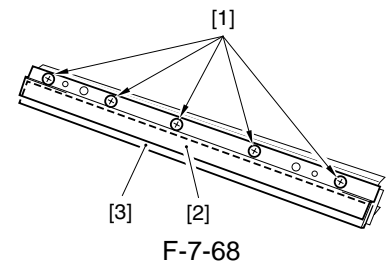

7.10.6.3 Mounting the Cleaning Blade

See "Maintenance and Inspection".

7.10.6.4 Removing the Blade Vibrating Unit

- 1) Remove the blade unit.
 - 2) Disconnect the connector [1], and remove the 2 screws [2]; then, detach the blade vibrating unit [3].
- (The rear and front blade vibrating units may be disassembled in the same way.)

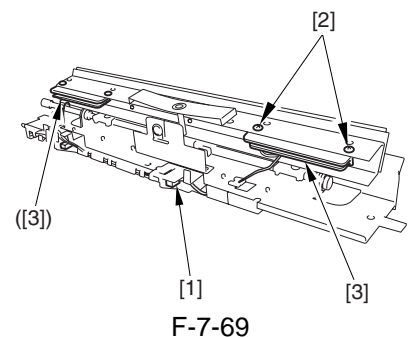

7.10.7 Photosensitive Drum Heater

7.10.7.1 Replacing the Photosensitive Drum Heater

- 1) Remove the photosensitive drum from the main body.
- 2) Remove the two mounting screws [1], and detach the flange [2] at the front; then, disconnect the connector [3].

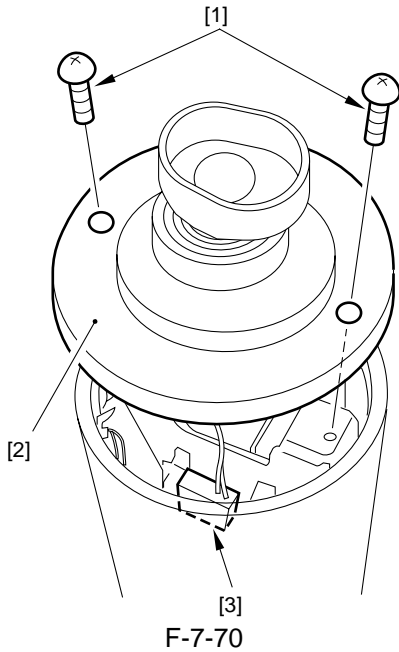

- 3) Pull out the flange at the rear [1], and detach the power supply unit [2] from the photosensitive drum.

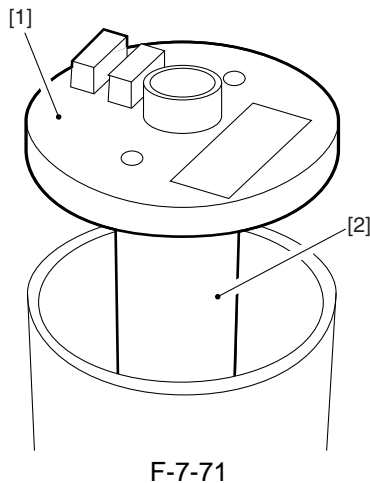

- 4) Pull out the flat heater (drum heater) [1] from inside the drum cylinder.

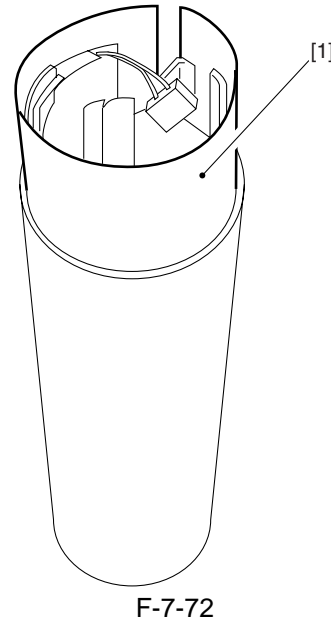

⚠ Points to Note When Mounting the Flange
 There is hardly a gap between the flange and the inner side of the drum, causing the flange to get stuck if pushed at an angle.
 When mounting the flange, push it in a parallel direction to the drum without applying excessive force.

7.10.8 Sub Hopper

7.10.8.1 Before Starting the Work

- 1) Open the manual feeder cover.
- 2) Remove the developing assembly locking plate.
- 3) Remove the original delivery tray [1]. (DADF-Q1 model only)
 - 2 screws [2]

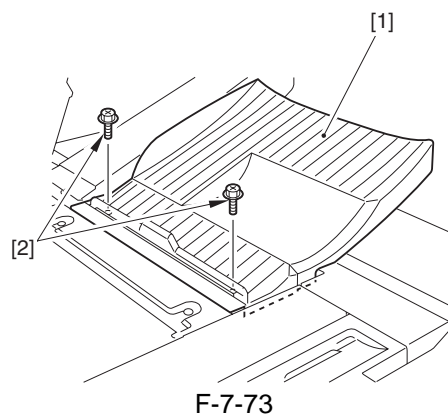

- 4) Remove the toner bottle.

7.10.8.2 Removing the Sub Hopper Unit

- 1) Remove the upper rear right cover [1].
- 3 screws [2]

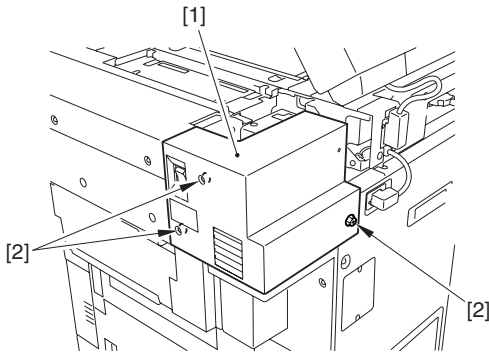

F-7-74

- 2) Remove the hopper upper cover [1].
- 3 blocking rubber pieces [2]
- 3 screws [3]
3) Remove the hopper right cover [4].
- 3 blocking rubber pieces [5]
- 3 screws [6]

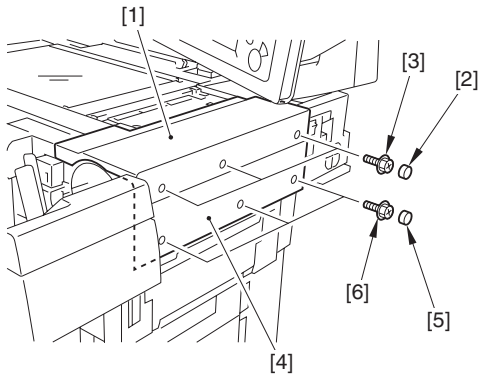

F-7-75

- 4) Remove the fixing plate [1].
- 3 screws [2]

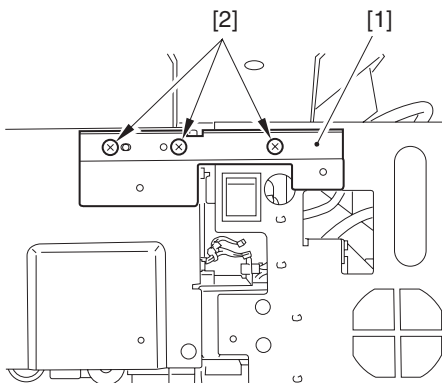

F-7-76

- 5) Remove the toner supply cover [1].
- 3 screws [2]

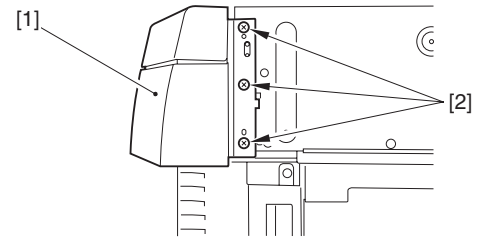

F-7-77

- 6) Remove the blocking cover [1].
- 1 screw [2]

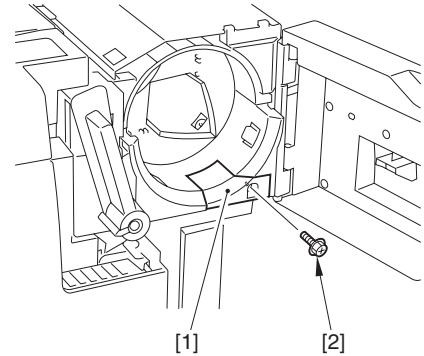

F-7-78

- 7) Remove the screw [1].

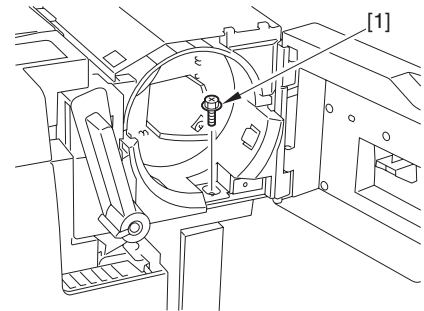

F-7-79

- 8) Disconnect the 3 connectors [1], and remove the 2 screws [2]. (found on the inner side of the main power switch)

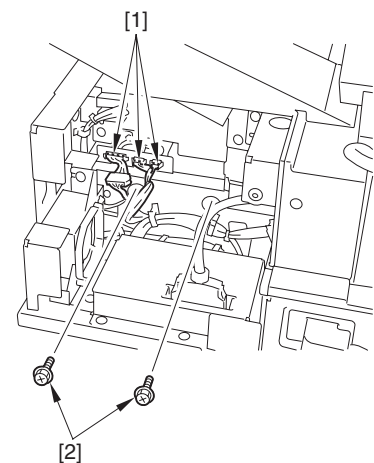

F-7-80

- 9) Slide the sub hopper unit [1] to the right to detach.

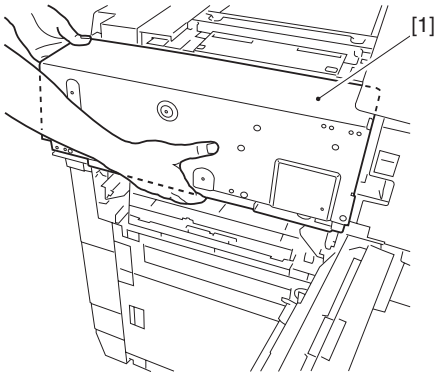

F-7-81

7.10.9 Developing Assembly

7.10.9.1 Before Starting the Work

- 1) Open the manual feeder tray cover.
- 2) Remove the pull-off roller unit.
- 3) Removing the developing assembly stay.

7.10.9.2 Removing the Developing Assembly

- 1) Disconnect the two connectors [1], and slide out the developing assembly [2] to the front.

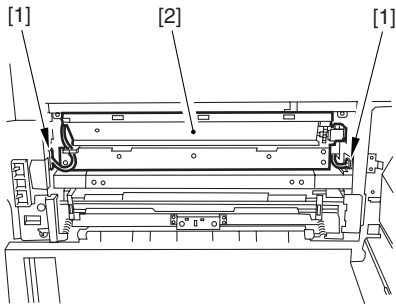

F-7-82

7.10.9.3 Points to Note When the Developing Assembly

- ⚠** When mounting the developing assembly, take care not to hit against the developing cylinder [2].

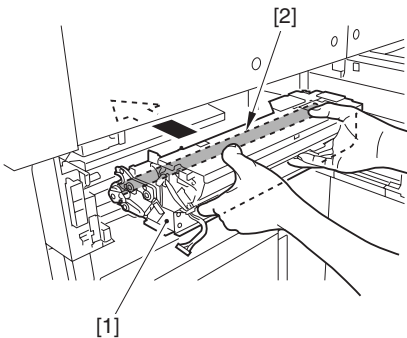

F-7-83

- ⚠** Check to be sure that the connector will not become disconnected. Poor contact will lead to blank prints.

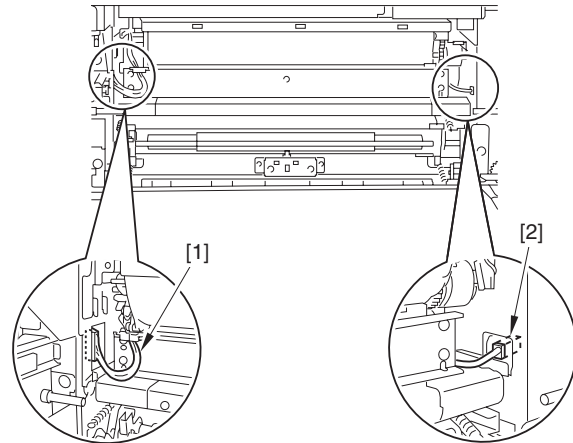

F-7-84

- ⚠** Check to be sure that the developing assembly locking plate is free of a gap and displacement, which are likely to cause image faults. (Especially, it must not be riding over the bosses found below.)
When mounting the developing assembly locking plate, take care not to trap the cable [1].

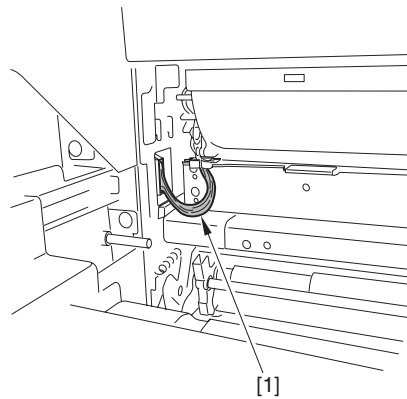

F-7-85

7.10.9.4 Removing the Hopper

- 1) Remove the developing assembly.
- 2) Remove the four mounting screws [1], and disconnect the connector [2]; then, detach the hopper [3].

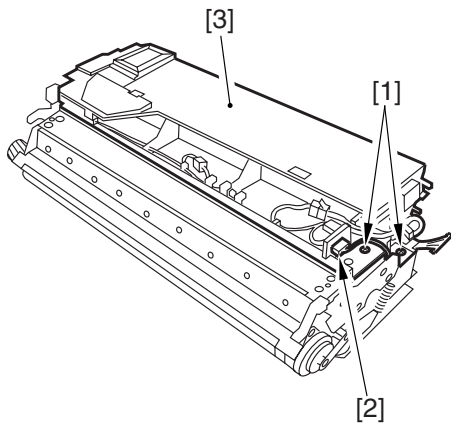

F-7-86

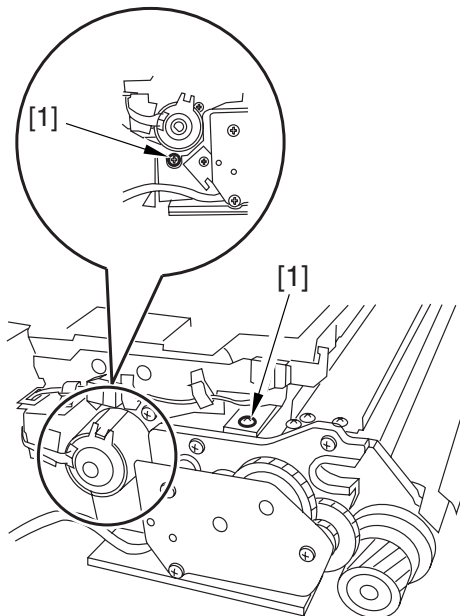

F-7-87

7.10.10 Developing Cylinder

7.10.10.1 Removing the Developing Cylinder

- 1) Remove the developing assembly.
- 2) Remove the hopper assembly.
- 3) Remove the blade unit.
- 4) Remove the three mounting screws [1] from the rear, and detach the deceleration gear retainer [2].

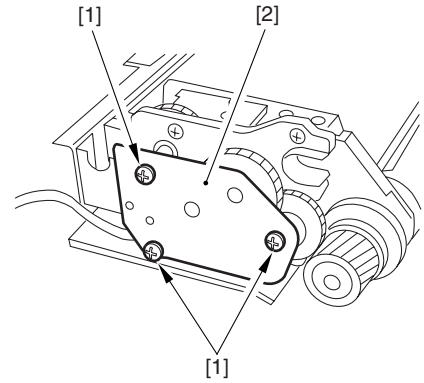

F-7-88

- 5) Remove the three gears [1].

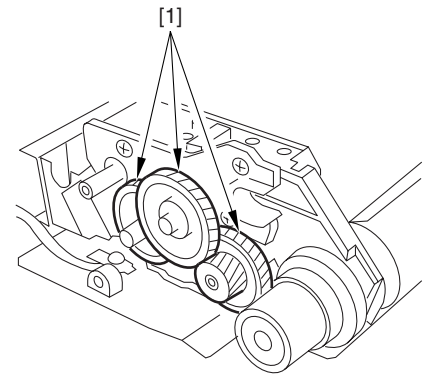

F-7-89

- 6) Remove the E-ring [1], and detach the pressure arm [2].

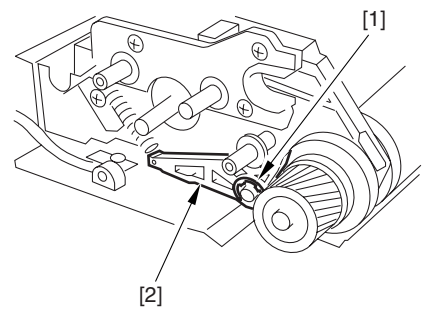

F-7-90

- 7) Remove the E-ring [1], gear [2], pressure roll [3], washer [4], grip ring [5], seal [6], butting roll [7], washer [4], and bearing [8] in the order indicated.

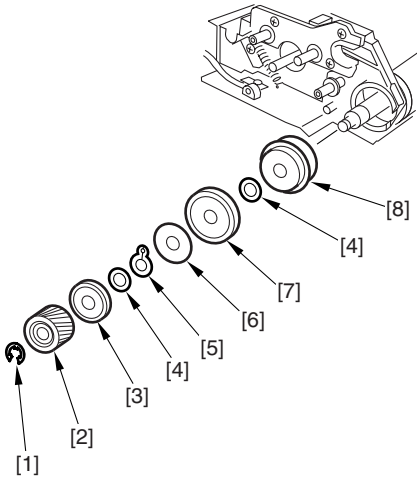

F-7-91

- 8) Remove the E-ring [1] and the pressure arm [2] at the front.

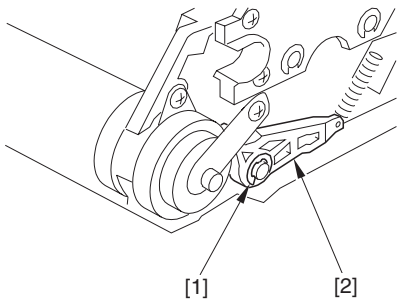

F-7-92

- 9) Remove the C-ring [1], washer [2], pressure roll [3], seal [4], washer [2], butting roll [5], C-ring [1], and bearing [6]; then, remove the two screws [7], and detach the bushing [8] and then the developing sleeve [9].

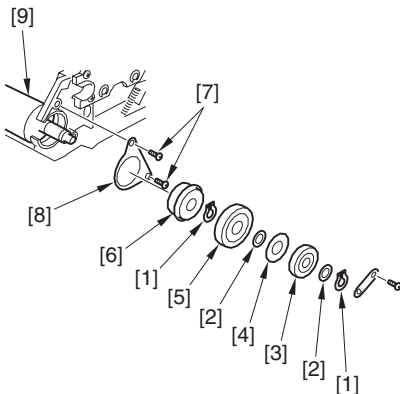

F-7-93

⚠ Do not leave fingerprints or oil on the surface of the developing cylinder. Wipe off any with lint-free paper. (Do not use solvent.)

⚠ Points to Note When Mounting the Developing Cylinder

Both front and rear sides of the developing assembly and the developing cylinder are equipped with a magnetic seal plate [1]. When mounting the developing cylinder, take care not to bring the magnetic seal plate into contact with the surface of the cylinder to avoid damage.

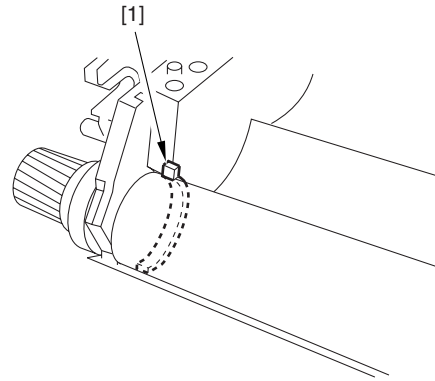

F-7-94

7.10.11 Developing Blade

7.10.11.1 Before Starting the Work

- 1) Open the manual feeder tray cover.
- 2) Remove the pull-off roller unit.
- 3) Remove the developing assembly stay.
- 4) Remove the developing assembly.
- 5) Remove the hopper.

7.10.11.2 Removing the Blade Unit

- 1) Remove the four mounting screws [1], and detach the sleeve cover [2].

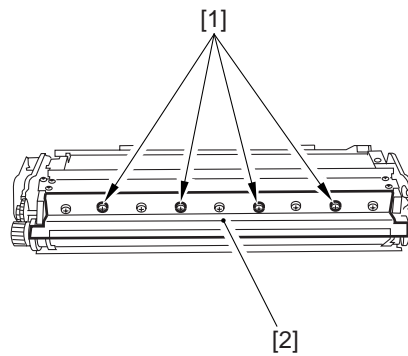

F-7-95

- Remove the screw [3], and detach the polarity plate [4]; then, remove the five screws [5], and detach the blade [6] together with the mounting plate [7].

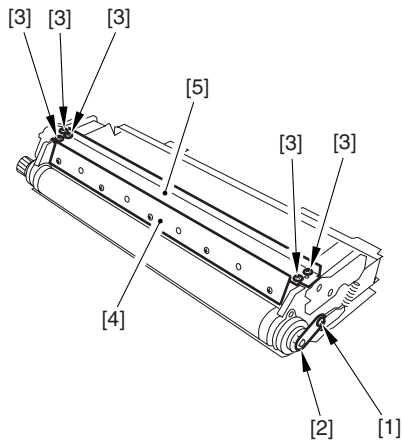

F-7-96



The blade must be adjusted to an extremely high accuracy. Do not remove it on its own in the field. (Detach it together with its mounting plate.)

7.10.11.3 Mounting the Blade

Mount the blade by reversing the steps used to remove it.

- Butt the blade mounting plate against the developing assembly, and secure it in place with five screws.

Be sure to put paper over the developing cylinder for protection before starting to mount the blade.

- Mount the polarity plate with a screw.

7.10.12 Developing Cylinder Deceleration Clutch

7.10.12.1 Before Starting the Work

- Remove the rear cover.
- Remove the high-voltage assembly.
- Remove the flywheel [1].
- 2 screws [2]

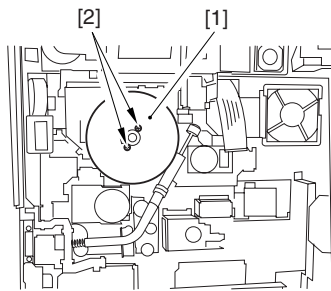

F-7-97

- Disconnect the 2 connectors [1], and remove the 5 screws [2]; then, detach the clutch mounting plate [3].

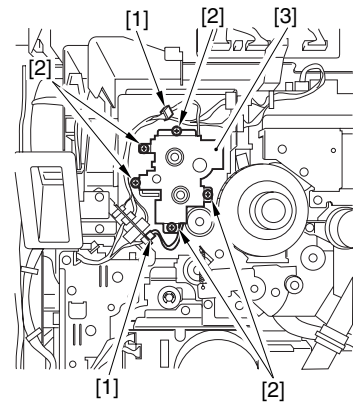

F-7-98

7.10.12.2 Removing the Developing Cylinder Decelerating Clutch

- Slide out the developing cylinder deceleration clutch [1].

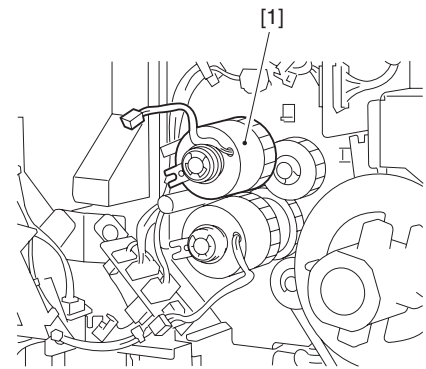

F-7-99

- Remove the 4 E-rings [1], 2 bearings [2], gear [3], and pin [4]; then, detach the clutch [5].

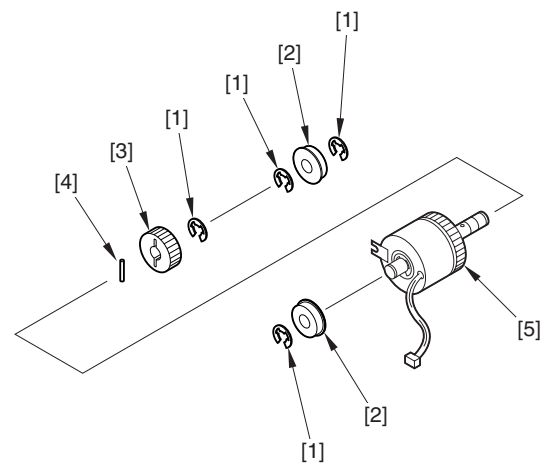

F-7-100

7.10.13 Developing Cylinder Clutch

7.10.13.1 Before Starting the Work

- 1) Remove the rear cover.
- 2) Remove the high-voltage assembly.
- 3) Remove the flywheel [1].
- 2 screws [2]

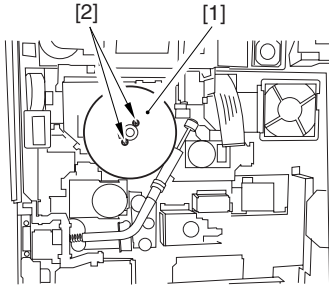

F-7-101

- 4) Disconnect the 2 connectors [1], and remove the 5 screws [2]; then, detach the clutch mounting plate [3].

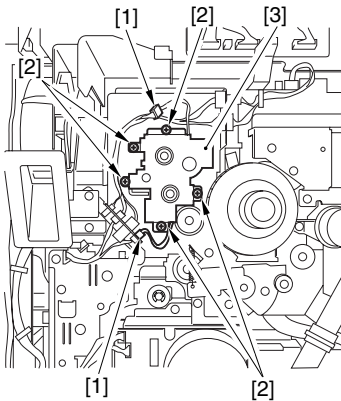

F-7-102

7.10.13.2 Removing the Developing Cylinder Clutch

- 1) Remove the developing cylinder clutch [1].

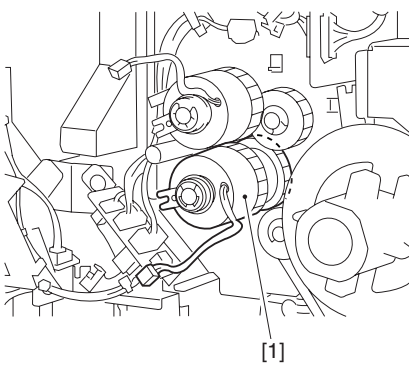

F-7-103

- 2) Remove the 6 E-rings [1], 2 bearings [2], 2 gears [3], and pin; then, detach the clutch [5].

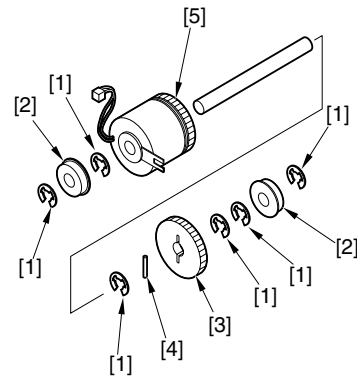

F-7-104

7.10.14 Transfer/Separation Charging Assembly

7.10.14.1 Removing the Transfer/Separation Charging Assembly

- 1) Open the front cover.
- 2) Slide out the fixing/feeding assembly.
- 3) Remove the screw [1], and detach the charging cover [2].

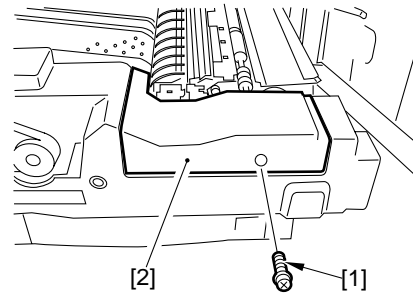

F-7-105

- 4) Remove the screw [1], and detach the fixing plate [2]; then, disconnect the connector [3], and detach the transfer/separation charging assembly [4].

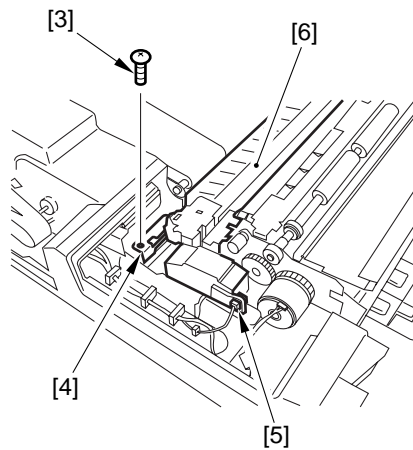

F-7-106

▲ Points to Note When Mounting

- The transfer/separation charging assembly is equipped with a positioning boss on its front and rear.

When mounting the assembly, be sure to hook the bosses on the cut-offs in the stay.

- If the charging assembly cleaner is on the front side, the home position detecting microswitch can become damaged; be sure to set the charging cleaner at the center.

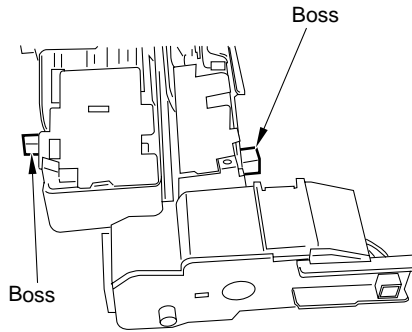

F-7-107

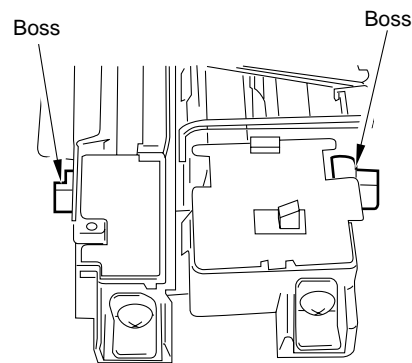

F-7-108

7.10.15 Pre-Transfer Exposure LED

7.10.15.1 Removing the Pre-Transfer Exposure LED

- 1) Slide out the pre-transfer charging assembly.



When placing the removed pretransfer charging assembly, be sure to take care not to subject the LED to impact.

- 2) Turn over the pre-transfer charging assembly, and remove the 3 screws [1] found on the bottom; then, detach the LED cover [2].

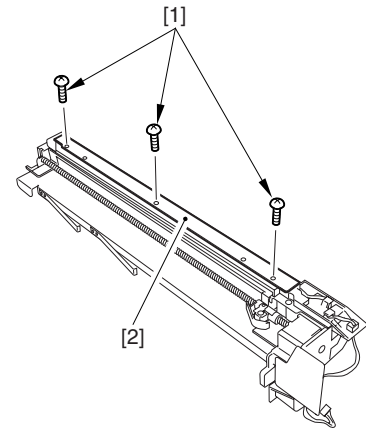

F-7-109

- 3) Disconnect the connector [1], and remove the pre-transfer exposure LED [2].

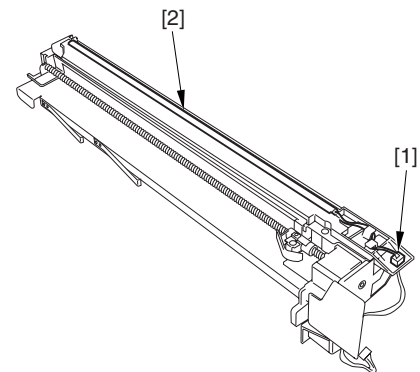

F-7-110

7.10.16 Separation Claw/Separation Claw Drive Assembly

7.10.16.1 Separation Claw/Separation Claw Drive Assembly

- 1) Open the front cover.
- 2) Take out the process unit.
- 3) Remove the E-ring [1], and slide out the separation claw holder shaft [2] to the front to detach the separation holder [3].

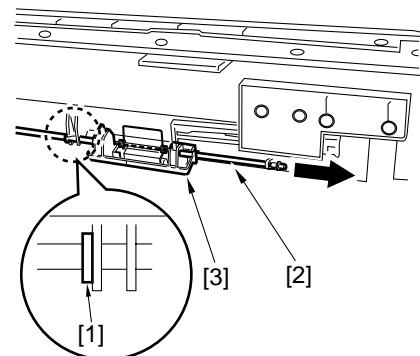

F-7-111

- 4) Remove the spring [1], and detach the separation claw [2].

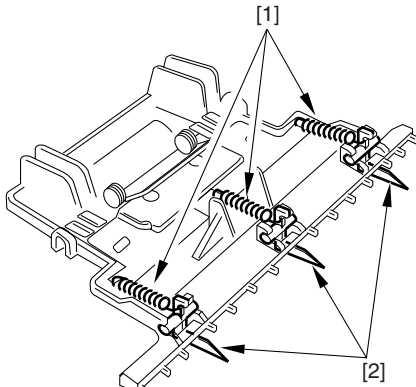

F-7-112

⚠ Points to Note When Mounting

When mounting the separation claw holder, be sure that the separation claw spring is butted against the drum cleaner case. Further, check to make sure that the rack of the separation claw 3 drive assembly is engaged with the groove in the separation claw holder.

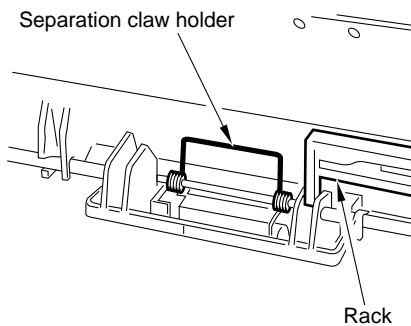

F-7-113

7.10.17 Potential Sensor

7.10.17.1 Removing the Potential Sensor Unit

- 1) Open the front cover.
- 2) Remove the process unit.
- 3) Push in the fixing/feeding assembly.
- 4) Remove the cable guide [1].
- 1 screw [2]
- 5) Slide out the dust-blocking glass [3] to detach.

- 6) Remove the potential sensor unit [4].
- 1 connector [5]
- 1 screw [6]

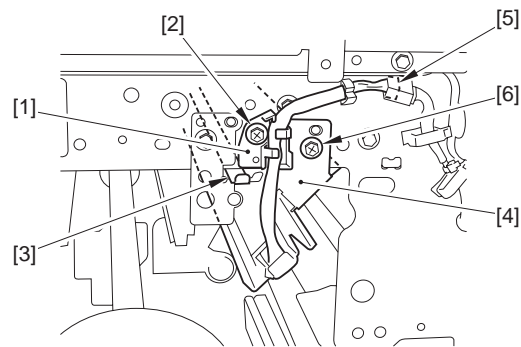

F-7-114



It is rather difficult to slide out the potential sensor unit in horizontal direction. As shown, push it down before sliding it out to facilitate the work.

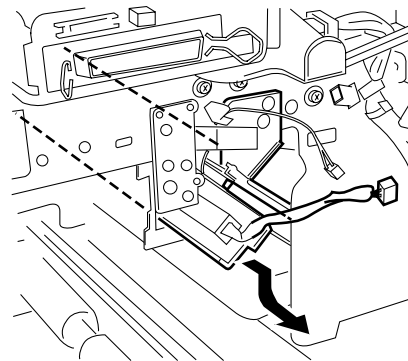

F-7-115

- 7) Remove the 2 screws [1], and detach the potential sensor cover [2]; then, detach the potential sensor [3].

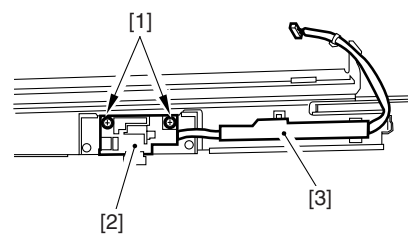

F-7-116



Be sure to replace the potential sensor at the same time as the potential controller PCB.



When mounting it, fit the protrusion on the rear of the potential sensor stay in the hole of the side plate found at the rear of the machine; then, match it on the side plate found at the front to screw it in place.

7.10.17.2 Removing the Potential Control PCB

- 1) Remove the primary charging assembly cover.
- 2) Remove the process unit cover.
- 3) Remove the double-feed detection PCB (receiving) if found.
- 4) Remove the 2 screws [1], and disconnect the 2 connectors [2]; then, detach the pre-transfer charging assembly fan [3].

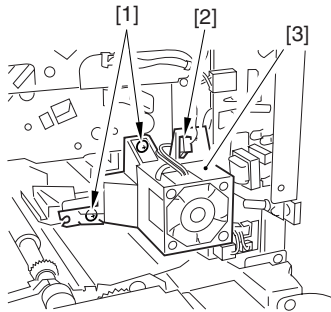

F-7-117

- 5) Disconnect the 3 connectors [1], and remove the screw [2]; then, detach the potential control PCB [3].

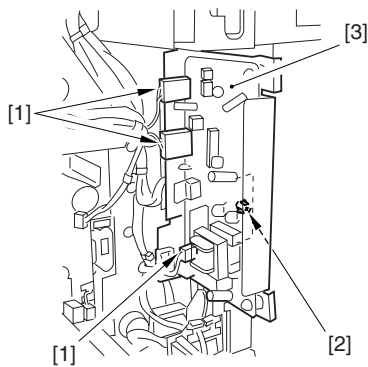

F-7-118

7.10.17.3 When Replacing the Potential Sensor/Potential Control PCB



The machine remains powered after the main power switch is turned off as long as the power plug is connected to the power outlet. Be sure to disconnect the power plug from the power outlet.

- 1) Turn off the power.
- 2) Remove the developing assembly, and slide out the process unit.

- 3) Disconnect the connector [1] of the potential sensor.

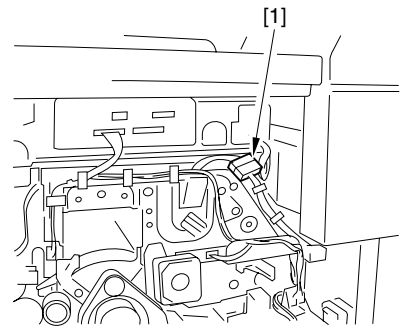

F-7-119

- 4) Remove the 2 screws [1], and detach the potential sensor support plate [2].

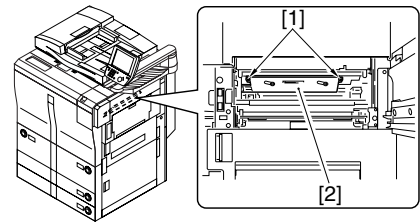

F-7-120

- 5) Put back the developing assembly and the process unit.
- 6) Connect the connector [1] of the potential sensor.

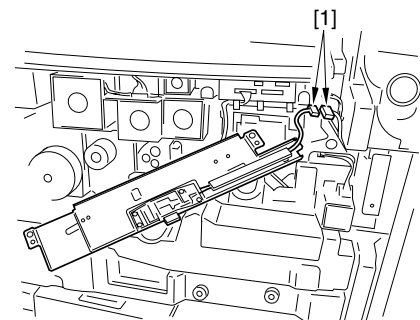

F-7-121

- 7) Fit the potential checker electrode (FY9-3041) [2] to the potential sensor [1].

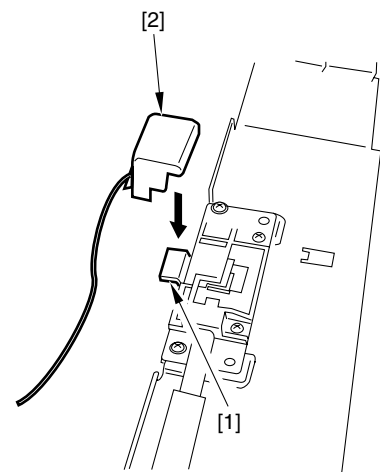

F-7-122



When fitting the checker electrode to the potential sensor, make sure that the magnet of the checker electrode will not come into contact with the potential sensor cover.

- 8) Connect the cable [1] of the potential sensor checker electrode to the frame assembly (GND) [2] of the machine.



Never bring the clip into contact with the sensor cover. Be sure to fit it fully away from the sensor window.

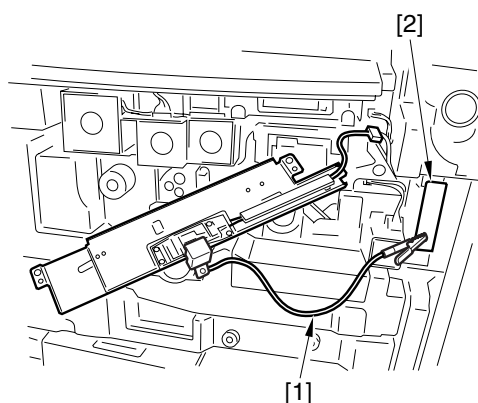

F-7-123

- 9) Fit the door switch actuator in the door switch assembly.
- 10) Turn on the power.
- 11) Execute the following service mode items:
COPIER > FUNCTION > DPC > OFST
- 12) Record the value of <OFST> on the service sheet.
- 13) Turn off the main power switch.
- 14) Detach the potential sensor checker electrode.
- 15) Put back the potential sensor support plate.
- 16) Turn on the power.

7.10.18 Dust-Collecting Roller

7.10.18.1 Removing the Dust-Collecting Roller

- 1) Remove the pre-transfer charging assembly.
- 2) Remove the two screws [1], and detach the motor cover [2].

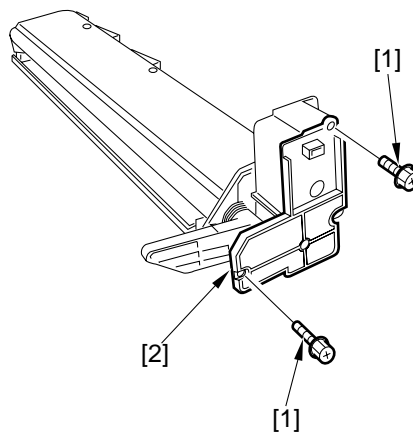

F-7-124

- 3) Remove the dust-collecting roller arm [1] and the twisted spring [2]; then, detach the dust-collecting roller [3].

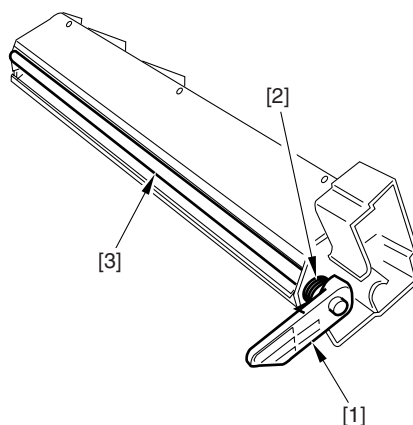

F-7-125

7.10.19 Charging Wire

7.10.19.1 Outline

As many as 3 charging wires are found around the photosensitive drum (primary, pre-transfer, transfer/separation); these wires are 0.06 mm in diameter.

7.10.19.2 Removing the Wire Cleaner for the Primary Charging Assembly

- 1) Remove the primary charging assembly.
- 2) Move the clip base [1] fully to the rear, and remove the screw [2]; then, remove the support plate [4] of the wire clean motor shaft [3], and detach the clip base [1] from the cut-off [6] of the shielding plate [5] together with the wire cleaner motor shaft [3].

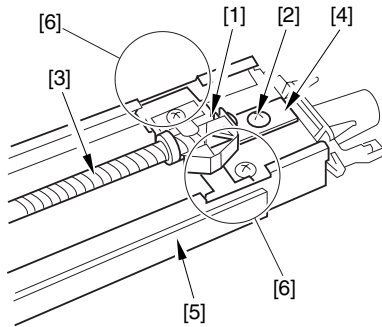

F-7-126

- 3) Pick the wire cleaner with small pliers, and free the hook with your fingers.

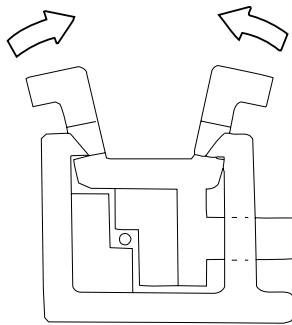

F-7-127

7.10.19.3 Removing the Wire Cleaner of the Transfer Separation Charging Assembly

- 1) Remove the transfer/separation charging assembly.
- 2) Move the felt holder [1] to the front as far as it moves.

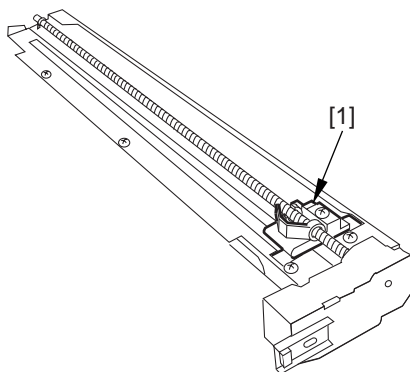

F-7-128

- 3) Remove the motor cover [1] together with the motor.

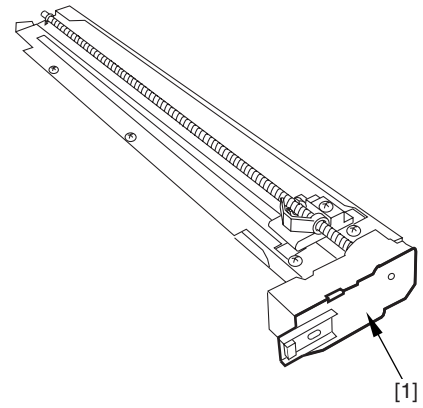

F-7-129

- 4) Remove the E-ring [1]; then, pull the screw [2] to the front, and remove it upward.

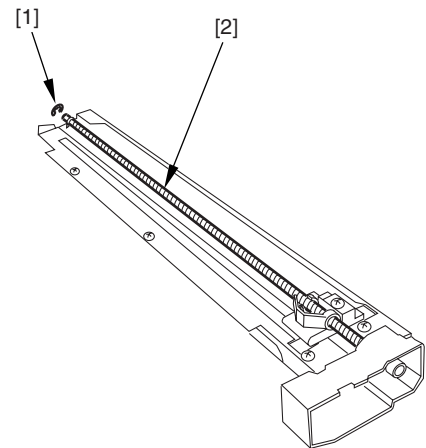

F-7-130

- 5) From the cut-off of the shielding plate [1], free the felt holder [2].
- 6) Pick the wire cleaner with a pair of fine-tipped pliers, and free the hook with your finger.

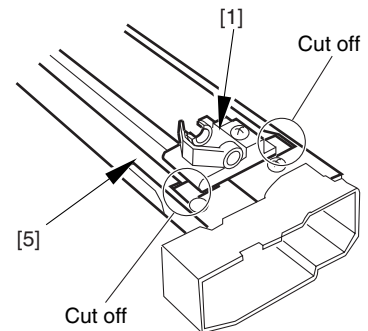

F-7-131

7.10.19.4 Stringing the Charging Wire

As a rule, the charging wire (except the grid wire) may be strung in the same way for all charging assemblies. The following uses the primary charging assembly as an example:

1) Remove the 2 screws [1], and detach the shielding plate (left, right) [2] of the charging assembly.

To prevent deformation (slack) of the primary charging assembly, be sure to work on the left and right shielding plates separately. (Do not loosen the screw for the left/right shielding plate.)

2) Remove the wire cleaner.

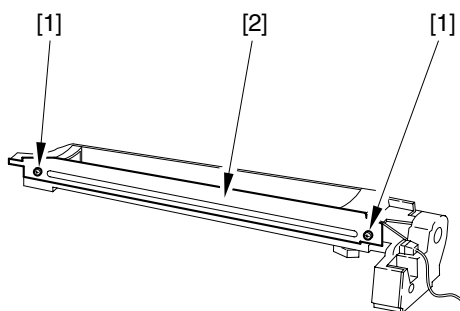

F-7-132

⚠ For other charging assemblies, remove the lid (2 pc.)

3) Free a length of about 5 cm from a charging wire reel (wire dia. of 0.06 mm), and form a loop at the end about 2 mm in diameter.

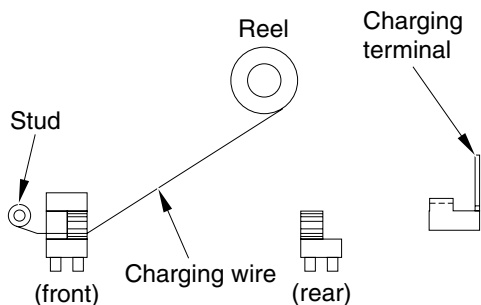

F-7-133

MEMO:

To form a loop, wind the charging wire once around a hex key, and twist the key 3 to 4 times.

4) Cut the end (excess) for the twisted charging wire.

5) Hook the loop on the stud.

6) Hook the charging wire on the charging wire positioner at the rear, and hook the charging wire tension spring on the charging wire, and twist it.

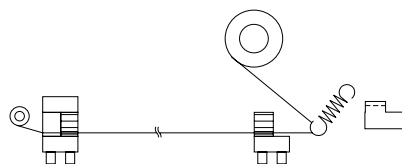

F-7-134

7) Cut the excess of the charging wire with a nipper.

8) Pick the end of the charging wire tension spring with tweezers, and hook it on the charging wire terminal. In the case of the pre-transfer charging assembly, hook the spring at the front.

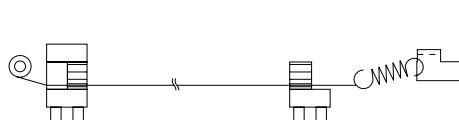

F-7-135

⚠ Be sure of the following:
 - The charging wire is free of bends and twists.
 - The charging wire is in the bottom of the V-groove of the charging wire positioner.

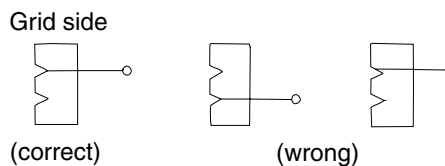

F-7-136

9) Fit the cushion to the front of the charging wire. (except for primary charging assembly)
 10) Mount the shielding plate (left, right).

⚠ For other charging assemblies, fit the lid (2 pc.).

⚠ After stringing the charging wire of each charging assembly, check to make sure that the length of the tension spring is as follows:

Primary charging assembly	A=12.0±1mm	
Pre-transfer charging assembly	A=12.0±1mm	
Transfer charging assembly	A=12.0±0.5mm	
Separation charging assembly	A=12.0±0.5mm	

F-7-137

- 11) Mount the wire cleaner. At this time, pay attention to the orientation of the wire cleaner.
- 12) Wipe the charging wire with lint-free paper moistened with alcohol.

7.10.19.5 Stringing the Grid of the Primary Charging Assembly

- 1) Check to make sure that the 4 screws used to keep the front/rear block and shielding plate are not loose.

Then, hook the end of the charging wire on stud A, and then route it for 41 runs; then, hook it on B, C, and D; thereafter, fit it between the double washers [1], give a 1/2 turn around the screw [2], and secure it in place.

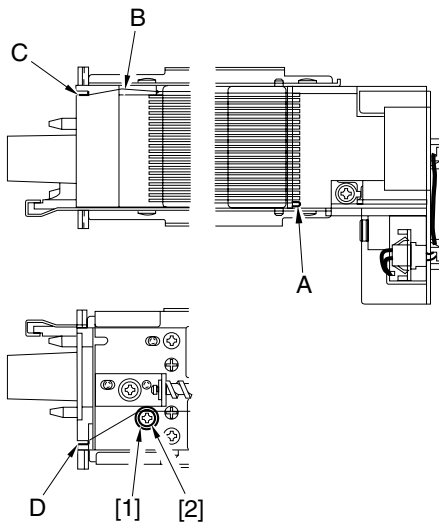

F-7-138

- 2) Loosen the screws [1], [2], [3], [4]; then, tighten the screw [5] to a torque of $1.5 \text{ } \pm 0.2 \text{ kg-cm}$. thereafter, tighten the screws [1], [2], [3], [4] to a torque of 8 kg-cm in the order indicated.

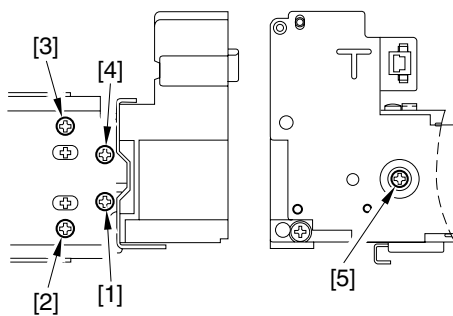

F-7-139

7.10.19.6 Adjusting the Height of the Charging Wire

T-7-3

Height of charging wire	
Primary	
Pre-transfer	
Separation	
Transfer	

MEMO:

The height (position) of the primary and transfer charging wires may be adjusted by turning the screw found at the rear of the charging assembly. A full turn of the screw changes the position of the charging wire by about 0.7 mm.

Pickup/Feeding System

Contents

8.1 Construction.....	8- 1
8.1.1 Specifications and Construction.....	8- 1
8.1.2 Arrangement of Rollers and Sensors	8- 1
8.1.3 Control System.....	8- 2
8.1.4 Controlling the Pickup Motor (M2)	8- 3
8.1.5 Index Paper Attachment.....	8- 3
8.2 Basic Sequence	8- 4
8.2.1 Right Deck	8- 4
8.2.2 Pickup from the cassette 4.....	8- 4
8.3 Detecting Jams	8- 5
8.3.1 Jam Detection Outline	8- 5
8.3.1.1 Outline	8- 5
8.3.2 Delay Jams.....	8- 6
8.3.2.1 Cassette Pickup (Right deck, Left deck, cassette 3, 4)	8- 6
8.3.2.2 Other Delay Jams	8- 6
8.3.3 Stationary Jams.....	8- 7
8.3.3.1 Common Stationary Jams	8- 7
8.3.3.2 Stationary Jam at Power-On.....	8- 7
8.4 Cassette Pick-Up Unit.....	8- 8
8.4.1 Outline	8- 8
8.4.2 Detecting the Presence/Absence of Paper.....	8- 9
8.4.3 Detecting the Level of Paper.....	8- 10
8.4.4 Cassette 3/4.....	8- 11
8.4.5 Markings on the Width Guide Rail	8- 12
8.4.6 Paper Size	8- 12
8.5 Manual Feed Pickup Unit	8- 14
8.5.1 Pickup Operation	8- 14
8.5.2 Detecting the Paper Size.....	8- 15
8.6 Deck.....	8- 16
8.6.1 Outline	8- 16
8.6.2 Lifter Limiter (deck right/left)	8- 17
8.6.3 Detecting the Presence/Absence of Paper.....	8- 18
8.6.4 Detecting the Level of Paper.....	8- 18
8.6.5 Cassette Deck Right/Left.....	8- 19
8.7 Registration Unit	8- 20
8.7.1 Outline	8- 20
8.7.2 Sequence of Operations (registration brake)	8- 20
8.8 Duplex Feeding Unit.....	8- 21
8.8.1 Copying on the First Side	8- 21
8.8.2 Copying on the Second Side	8- 21
8.8.3 Sequence of Operations.....	8- 22
8.8.4 Controlling the reversal motor (M11)	8- 22
8.8.5 Controlling the duplexing feeder motor (M12).....	8- 23
8.8.6 No-Stacking Operation.....	8- 23

8.8.7 Detecting the Horizontal Registration Position.....	8- 29
8.8.8 Controlling the Horizontal Registration Motor (M15).....	8- 30
8.9 Delivery.....	8- 31
8.9.1 Reversal Delivery.....	8- 31
8.10 Detecting the Double-Feed.....	8- 32
8.10.1 Detecting Double Feeding.....	8- 32
8.11 Parts Replacement Procedure.....	8- 34
8.11.1 Cassette Pickup Assembly.....	8- 34
8.11.2 Cassette Lifter Motor.....	8- 34
8.11.3 Right Deck Pickup Assembly.....	8- 35
8.11.4 Left Deck Pickup Assembly.....	8- 35
8.11.5 Left Deck Pickup Sensor.....	8- 36
8.11.6 Right Deck Pickup Sensor.....	8- 36
8.11.7 Manual Tray Assembly.....	8- 36
8.11.8 Manual Feed Pull-Out Roller Unit.....	8- 37
8.11.9 Manual Pickup Roller.....	8- 38
8.11.10 Manual Feed Roller.....	8- 38
8.11.11 Manual Separation Roller.....	8- 40
8.11.12 Manual Feed Tray paper sensor.....	8- 40
8.11.13 Manual Feed Pickup Solenoid.....	8- 41
8.11.14 Registration Roller.....	8- 42
8.11.15 Registration Clutch.....	8- 42
8.11.16 Registration Brake Clutch.....	8- 43
8.11.17 Fixing/Feed Unit.....	8- 43
8.11.18 Feeding Roller.....	8- 44
8.11.19 Vertical Path Roller.....	8- 44
8.11.20 Fixing Feeding Unit Releasing Lever Sensor.....	8- 45
8.11.21 Feeding Belt.....	8- 45
8.11.22 Duplexing Unit.....	8- 46
8.11.23 Separation Roller.....	8- 50
8.11.24 Double Feeding Detection Sensor (Transmission).....	8- 51
8.11.25 Double Feeding Detection Sensor (Reception).....	8- 53

8.1 Construction

8.1.1 Specifications and Construction

Table shows the major functions of the pickup/feeding system.

T-8-1

Item	Description	
Paper feeding reference	Center	
Paper stacking capacity	Paper deck (right, left): Cassette (3, 4): Multifeeder:	1,500 sheets (80 g/m ²) 550 sheets (80 g/m ²) 50 sheets (80 g/m ²)
Paper size switch	Paper deck (right, left): Cassette (3, 4): Multifeeder:	by the service person by the user by the user
Duplexing system	No-stacking	
Related user mode	Turning on and off the cassette selection mechanism, Selecting paper icons	
Related mechanical adjustment	Deck horizontal registration, Cassette horizontal registration Manual feed tray horizontal registration	

8.1.2 Arrangement of Rollers and Sensors

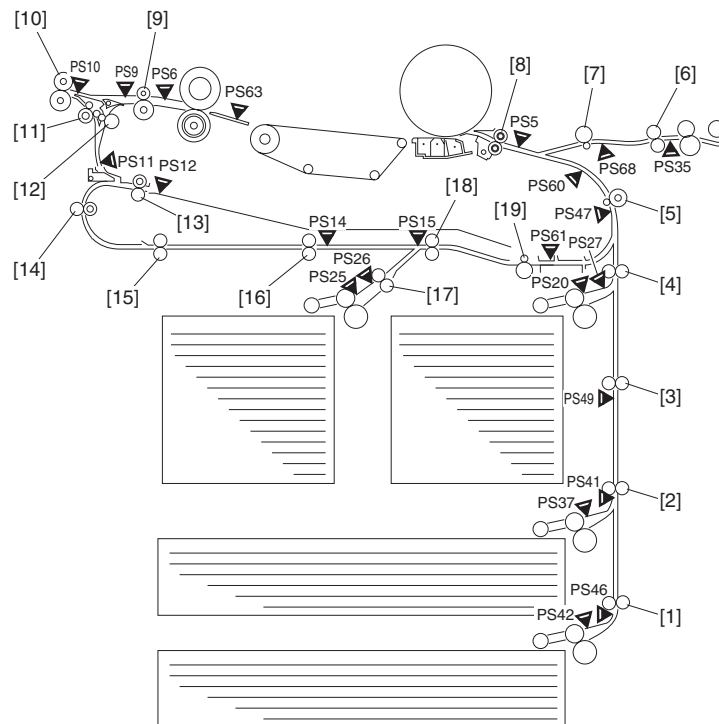
F-8-1
T-8-2

- sensor

PS5: registration sensor	PS35: multifeeder pickup sensor
PS6: claw jam sensor	PS37: cassette 3 pickup sensor*
PS9: internal delivery sensor	PS41: vertical path 3 sensor*
PS10: external delivery sensor	PS42: cassette 4 pickup sensor*
PS11: fixing/feeding outlet sensor	PS46: vertical path 4 sensor *
PS12: duplex reversal sensor	PS47: vertical path 1 sensor
PS14: pre-confluence reversal sensor	PS49: vertical path 2 sensor
PS15: post-confluence sensor	PS60: image write start sensor
PS20: right deck pickup sensor*	PS61: duplex outlet sensor
PS25: left deck pickup sensor*	PS63: fixing inlet sensor
PS26: left deck feed sensor*	PS68: multiple curling prevention sensor
PS27: right deck feed sensor*	* Optical sensor.

- roller

- | | |
|--|----------------------------------|
| [1] Vertical path 4 roller | [11] Delivery auxiliary roller |
| [2] Vertical path 3 roller | [12] Reversal auxiliary roller |
| [3] Vertical path 2 roller | [13] Reversing roller |
| [4] Vertical path 1 roller | [14] U-turn roller 1 |
| [5] Pre-registration roller | [15] U-turn roller 2 |
| [6] Multifeder feeding roller | [16] Pre-confluence roller |
| [7] multiple curling prevention roller | [17] Left deck feeding roller |
| [8] Registration roller | [18] Lower feeding middle roller |
| [9] Internal delivery roller | [19] Lower feeding right roller |
| [10] External delivery roller | |

8.1.3 Control System

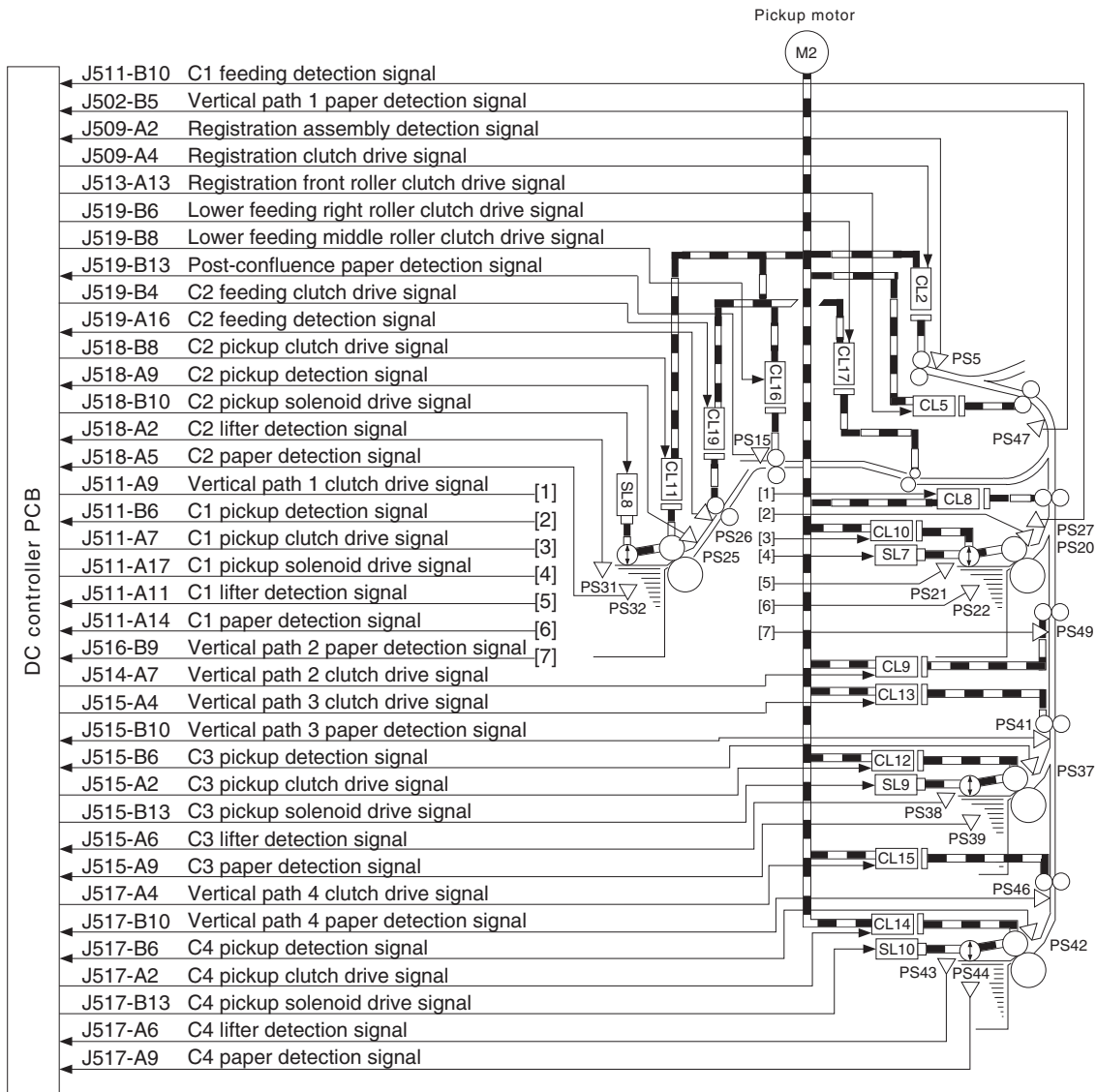

F-8-2

8.1.4 Controlling the Pickup Motor (M2)

Table shows the functions of the pickup motor control circuit, and Figure is a block diagram of the circuit.

T-8-3

Item	Description
Power supply	Supplies 38 V from the relay PCB.
Drive signal	Signal (M2-ON) from the DC controller PCB.
Operating/driving assembly	See Figure.
Control	On/off control Constant speed control
Error detection	Error code "E015"

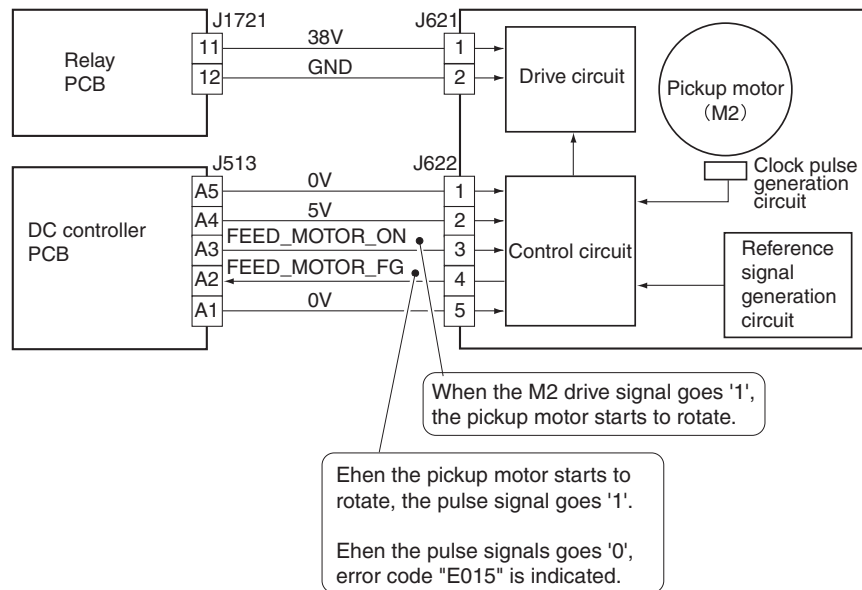

F-8-3

8.1.5 Index Paper Attachment

The machine allows the use of index paper as a transfer medium. Start user mode, and select index sheet mode and fit an Index Paper Attachment-A1 so that an index sheet may be inserted between sheets (index sheet insert mode) or print in the index area (index production mode).

Index sheets are fed from the source of index sheets (cassette 3/4) selected from the control panel. (For details, see the User Guide.)

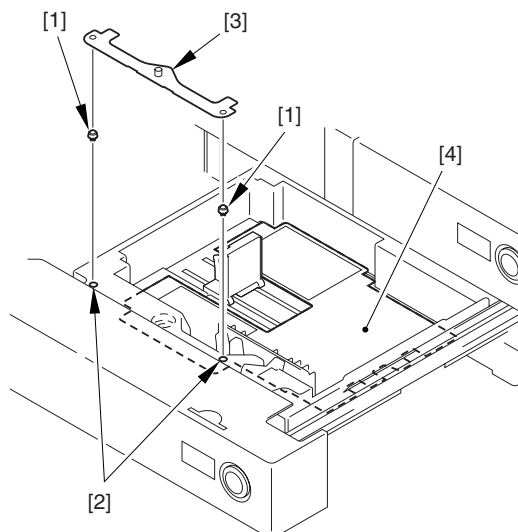

F-8-4

- | | |
|-----------------------|----------------------------|
| [1] One-touch support | [3] Index paper attachment |
| [2] Cassette holes | [4] Backing sheet |

8.2 Basic Sequence

8.2.1 Right Deck

- A4, 2 Sheets, Continuous

The copier's deck pickup assembly uses separation rollers to separate paper.

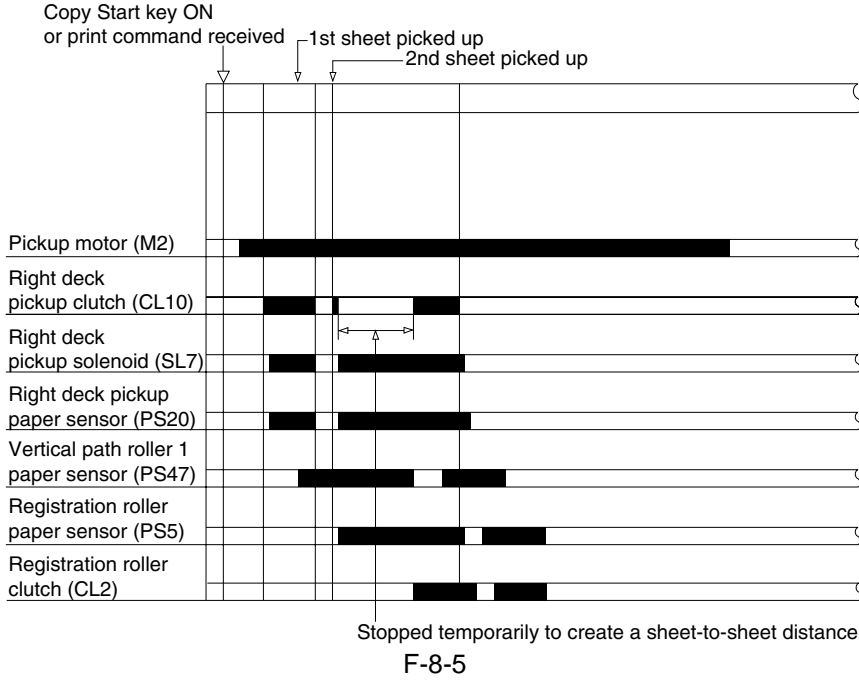

8.2.2 Pickup from the cassette 4

- A4, 2 Sheets, Continuous

The copier's cassette pickup assembly uses separation rollers.

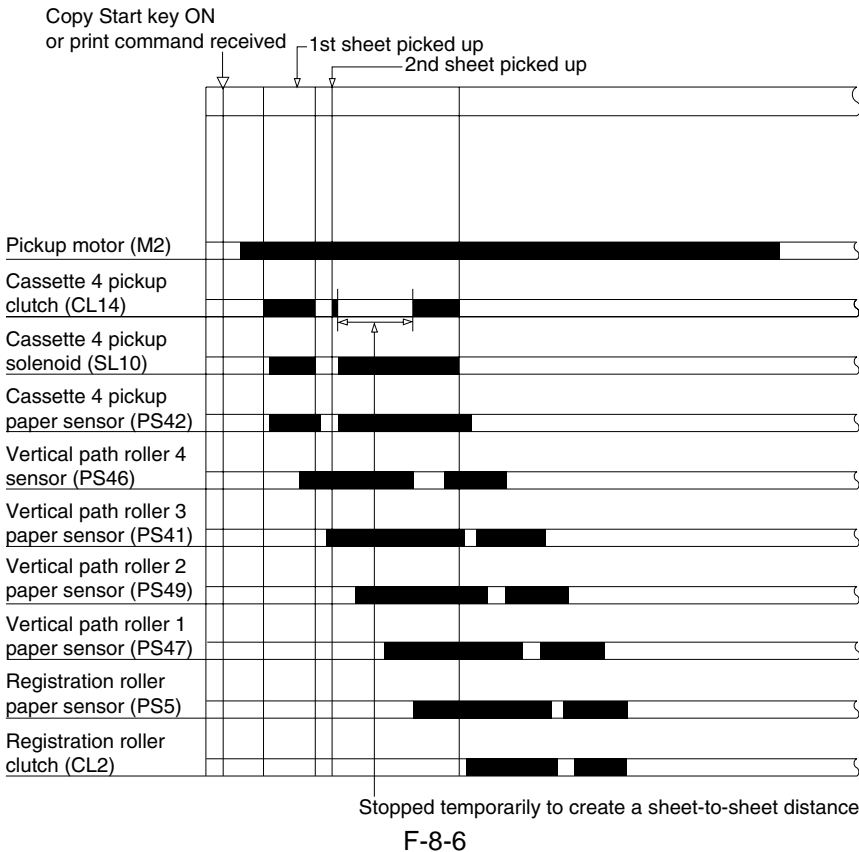

8.3 Detecting Jams

8.3.1 Jam Detection Outline

8.3.1.1 Outline

Arrangement of Jam Sensors

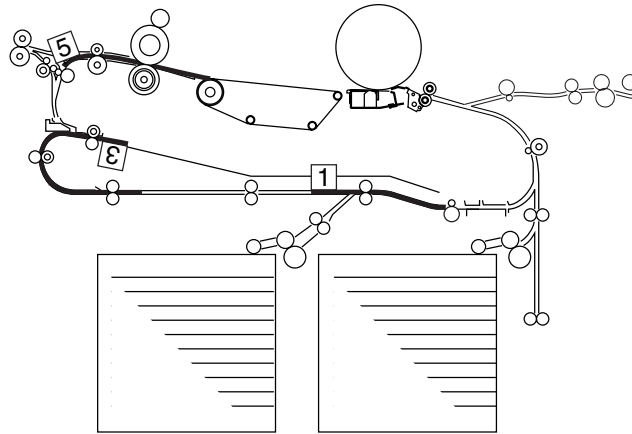

F-8-7

Type of Jams

T-8-4

Sensor		Delay jam	Stationary jam	Stationary jam from power-on
Right deck pickup sensor	PS20	Present	Absent	Absent
Left deck pickup sensor	PS25	Present	Absent	Absent
Cassette 3 pickup sensor	PS37	Present	Absent	Absent
Cassette 4 pickup sensor	PS42	Present	Absent	Absent
Right deck feed sensor	PS27	Present	Present	Present
Left deck feed sensor	PS26	Present	Present	Present
Manual feed sensor	PS35	Present	Absent	Present
Vertical path 1 sensor	PS47	Present	Present	Present
Vertical path 2 sensor	PS49	Present	Present	Present
Vertical path 3 sensor	PS41	Present	Absent	Present
Vertical path 4 sensor	PS46	Present	Absent	Present
Registration roll sensor	PS5	Present	Present	Present
Claw jam sensor	PS6	Absent	Present	Present
Internal delivery sensor	PS9	Present	Present	Present
External delivery sensor	PS10	Present	Present	Present
image write start sensor	PS60	Present	Present	Present
Fixing feeding outlet sensor	PS11	Absent	Absent	Present
Duplexing reversal sensor	PS12	Present	Present	Present
Duplex outlet sensor	PS61	Present	Present	Present
Pre-confluence sensor	PS14	Present	Present	Present
Post-confluence sensor	PS15	Present	Present	Present
multiple curling prevention sensor	PS68	Present	Present	Present
Fixing inlet sensor	PS63	Absent	Absent	Present

8.3.2 Delay Jams

8.3.2.1 Cassette Pickup (Right deck, Left deck, cassette 3, 4)

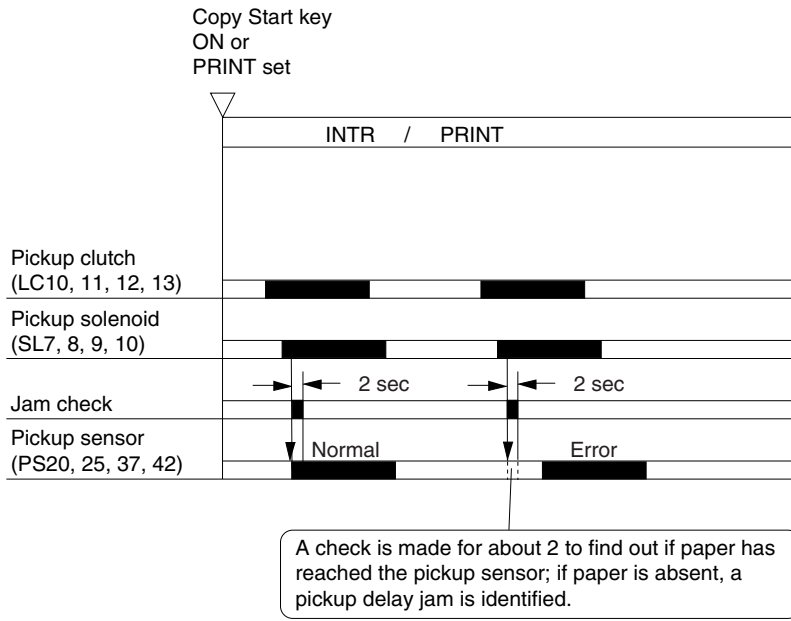

F-8-8

8.3.2.2 Other Delay Jams

Basically, the same principles are used to detect delay jams other than pickup sensor delay jams.

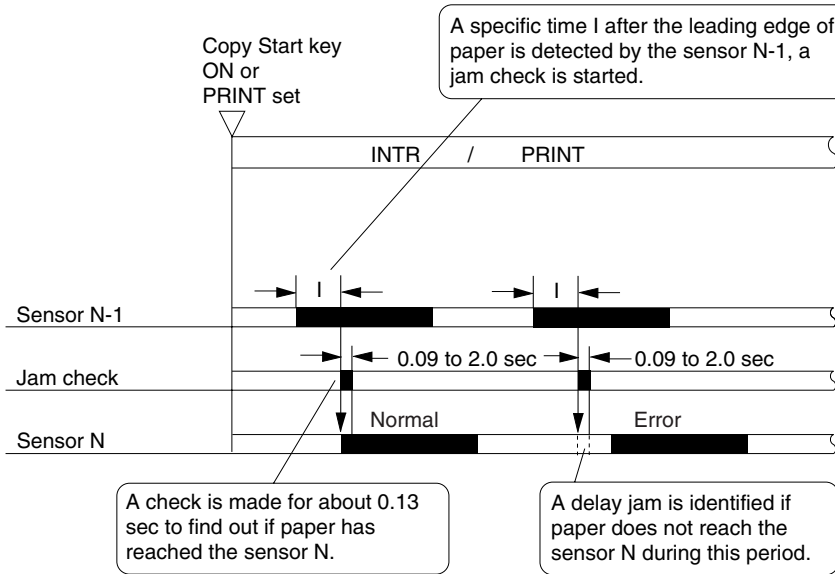

F-8-9
T-8-5

Delay jam sensor N	Sensor N-1
Right deck feed sensor (PS27)	Right deck pickup sensor (PS20)
Left deck feed sensor (PS26)	Left deck pickup sensor (PS25)
Vertical path 1 sensor (PS47)	Right deck feed sensor (PS27)
Vertical path 1 sensor (PS47)	duplex outlet sensor (PS61)
Vertical path 1 sensor (PS47)	option deck sensor (side paper deck)
Vertical path 2 sensor (PS49)	Vertical path 3 sensor (PS41)
Vertical path 3 sensor (PS41)	Vertical path 4 sensor (PS46)
Vertical path 3 sensor (PS41)	Cassette 3 pickups sensor (PS37)
Vertical path 4 sensor (PS46)	Cassette 4 pickups sensor (PS42)

Delay jam sensor N	Sensor N-1
multiple curling prevention sensor (PS68)	Manual feed sensor (PS35)
image write start sensor (PS60)	Vertical path 1 sensor (PS47)
Registration sensor (PS5)	image write start sensor (PS60)
Registration sensor (PS5)	multiple curling prevention sensor (PS68)
Internal delivery sensor (PS9)	Registration sensor (PS5)
External delivery sensor (PS10)	Internal delivery sensor (PS9)
Post-confluence sensor (PS15)	Pre-confluence sensor (PS14)
Post-confluence sensor (PS15)	Left deck feed sensor (PS26)

8.3.3 Stationary Jams

8.3.3.1 Common Stationary Jams

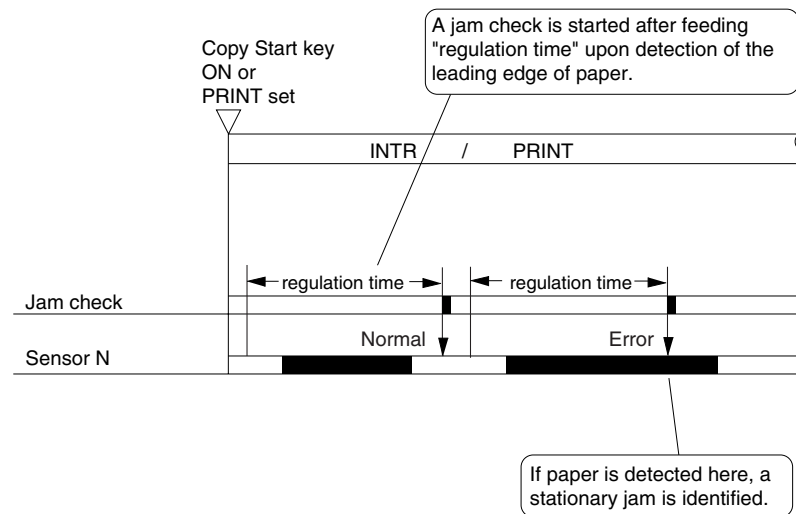

F-8-10

8.3.3.2 Stationary Jam at Power-On

A stationary jam at power-on is identified in relation to the presence/absence of paper over a specific sensor about 1 sec after the control panel power switch is turned on.

8.4 Cassette Pick-Up Unit

8.4.1 Outline

When the deck or the cassette is slid in, the cassette open/closed sensor turns on and, at the same time, the pickup roller starts to move down, causing the light-blocking plate to leave the lifter sensor, driving the cassette lifter motor and, ultimately, moving up the lifter.

The lifter keeps moving up until the lifter sensor detects the surface of paper. (In the case of the deck right/left, a limiter is mounted to stop the lifter if it fails to stop moving up.)

When the deck or cassette open button is pushed, the drive gear of the lifter becomes free to let the lifter move down on its own weight.

T-8-6

	Right deck	Left deck	Cassette 3	Cassette 4
Cassette open/closed detection	Deck right open/closed sensor (PS23)	Deck left open/closed sensor (PS33)	Cassette 3 open/closed sensor (PS40)	Cassette 4 open/closed sensor (PS45)
Lifter position detection	Lifter sensor (PS21)	Lifter sensor (PS31)	Lifter sensor (PS38)	Lifter sensor (PS43)
Paper presence/absence detection	Deck right paper sensor (PS22)	Deck left paper sensor (PS32)	Cassette 3 paper sensor (PS39)	Cassette 4 paper sensor (PS44)
Paper level detection	Deck right paper level middle sensor (PS51) Deck right paper level upper sensor (PS52)	Deck lifter paper level middle sensor (PS54) Cassette 2 paper level upper sensor (PS55)	Cassette 3 paper level detection PCB (variable resistor)	Cassette 4 paper level detection PCB (variable resistor)
Lifter upper limiter	Deck right limit sensor (PS24)	Deck left limit sensor (PS34)	---	---
Drive motor	Deck right lifter motor (M13)	Deck lifter motor (M14)	Cassette 3 lifter motor (M16)	Cassette 4 lifter motor (M17)

- deck

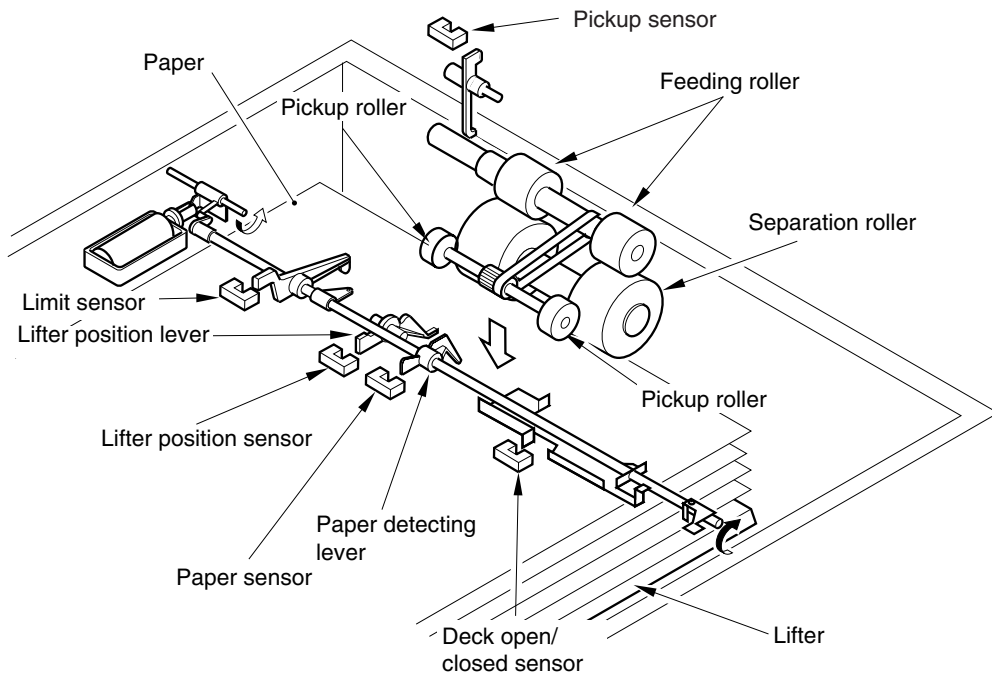

F-8-11

- cassette

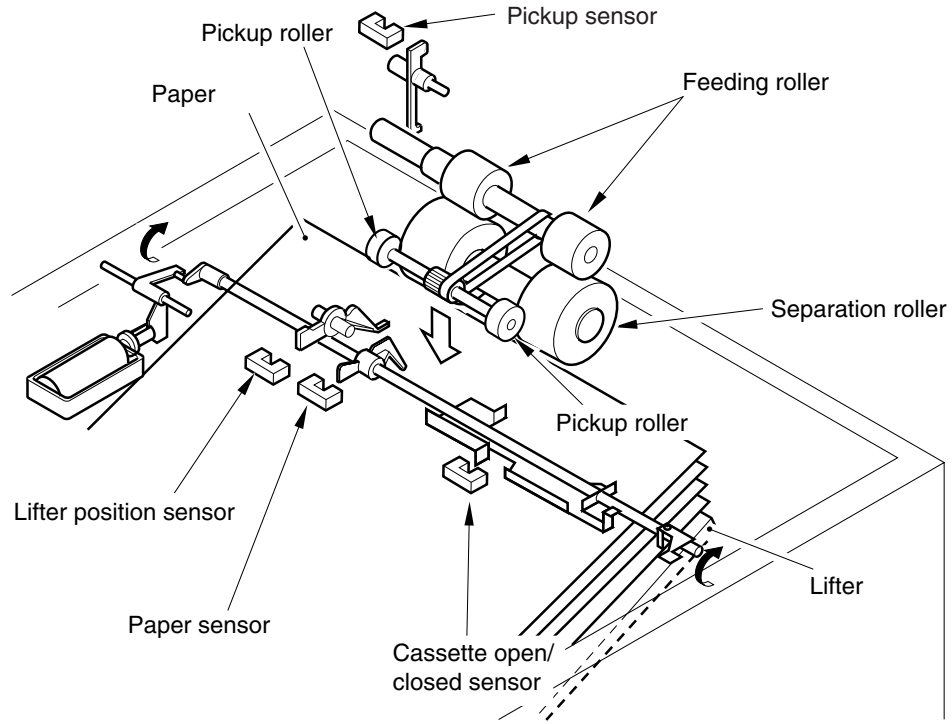

F-8-12

8.4.2 Detecting the Presence/Absence of Paper

The presence/absence of paper inside the deck and the cassette is detected by the cassette paper sensor.

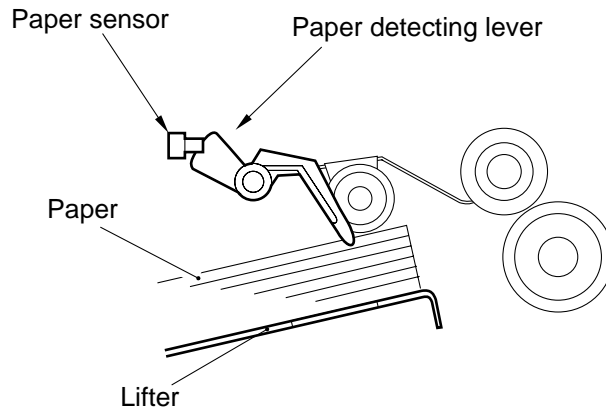

F-8-13

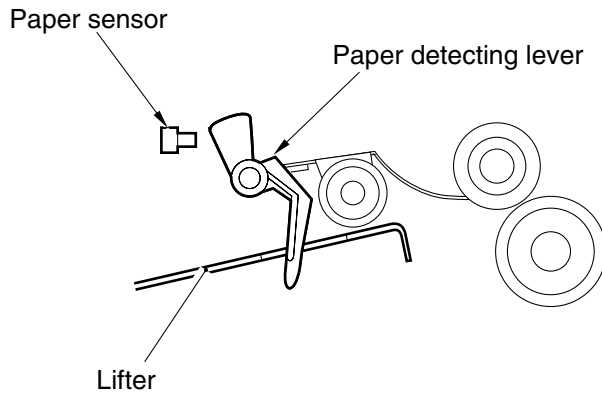

F-8-14

8.4.3 Detecting the Level of Paper

The machine indicates the level of paper inside the deck and the cassette in four readings (including No Paper) on the control panel.

T-8-7

Level of paper	Indication on control panel
100% to about 50% of capacity	
about 50% to about 10% of capacity	
about 10% of capacity or less	
No paper	

In the case of the deck right/left, two sensors are used to detect the position of the deck, and combinations of the states of the sensors (on/off) are used to find out the level of paper. For the absence of paper, an exclusive sensor is used.

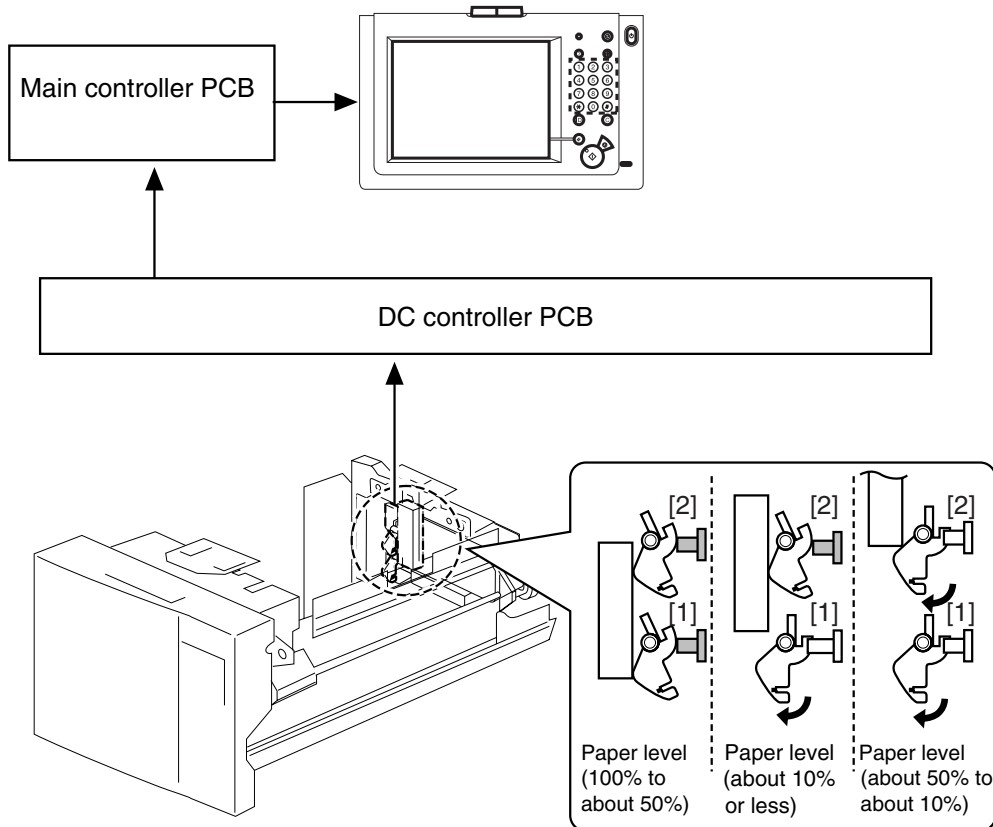

F-8-15
T-8-8

Paper level	Deck right			Deck left		
	[1] Sensor (PS51)	[2] Sensor (PS52)	Sensor (PS22)	[1] Sensor (PS54)	[2] Sensor (PS55)	Sensor (PS32)
100% to about 50%	ON	ON	OFF	ON	ON	OFF
About 50% to about 10	OFF	ON	OFF	OFF	ON	OFF
About 10% or less	OFF	OFF	OFF	OFF	OFF	OFF
None	OFF	OFF	ON	OFF	OFF	ON

In the case of cassette 3/4, the resistance of the variable resistor operating in conjunction with the movement of the lifter drive shaft is used to find out the level of paper.

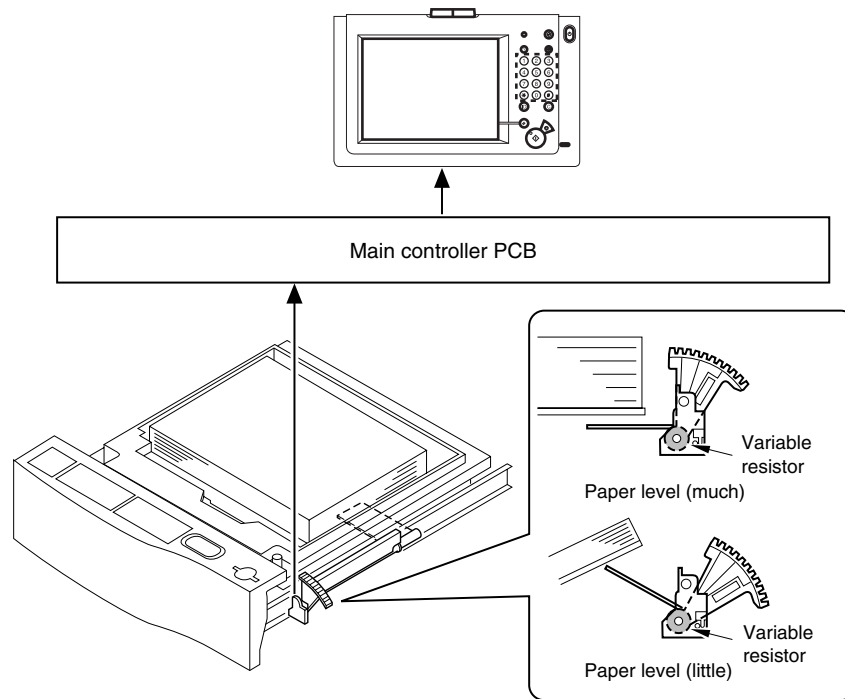

F-8-16

SERVICE MODE:**COPIER > ADJUST > CST-ADJ > C3-LVOL**

Use it to enter a stack height for the cassette 3. (50 sheets) Record the above readings on the service label.

COPIER > ADJUST > CST-ADJ > C3-HVOL

Use it to enter a stack height for the cassette 3. (275 sheets) Record the above readings on the service label.

COPIER > ADJUST > CST-ADJ > C4-LVOL

Use it to enter a stack height for the cassette 4. (50 sheets) Record the above readings on the service label.

COPIER > ADJUST > CST-ADJ > C4-HVOL

Use it to enter a stack height for the cassette 4. (275 sheets) Record the above readings on the service label.

8.4.4 Cassette 3/4

1. The length of paper is detected by two photointerrupters (each cassette).
2. The width of paper is detected by a slide volume.

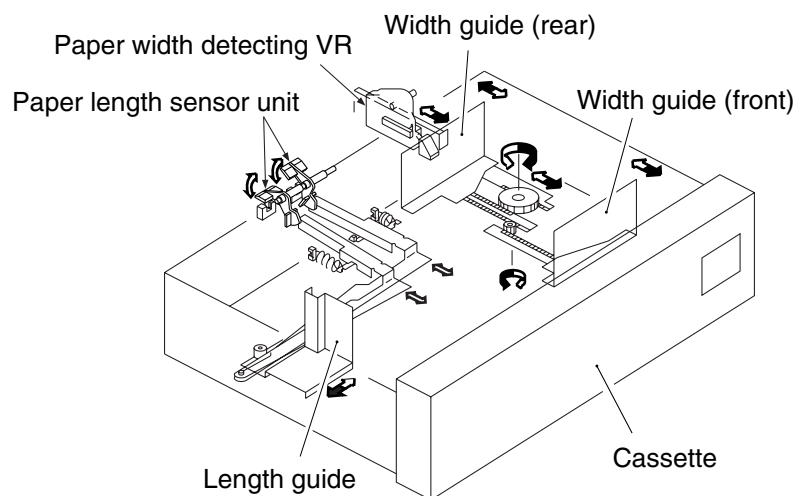
F-8-17
T-8-9

	Cassette 3	Cassette 4
Length detection	SV1 (2 photointerrupters)	SV2 (2 photointerrupters)
Width detection	SV2	SVR3

8.4.5 Markings on the Width Guide Rail

The width guide rail inside the cassette is equipped with paper size positioning holes, which are marked A through M as shown in Table.

Refer to these markings if the user reports skew movement of paper, thereby deciding whether the paper width is set correctly. (Note that this information is not disclosed to the user.)

T-8-10

Marking	Paper size	Remarks
A	STMT-R	
B	A5-R	
C	B5-R	
D	KLGL-R	
E	GLTR-R	
F	G-LGL	U3
G	A4-R	
H	LGL/LTR-R	
I	FLSC	U2
J	B4/B5	
K	G-LTR	U1
L	279.4X431.8mm (11"X17")/LTR	U4
M	A3/A4	

8.4.6 Paper Size

The microprocessor on the DC controller PCB determines the size of paper based on the inputs on paper width and paper length.

Table shows the paper size groupings selected in service mode.

*Paper size selected at time of shipment.

Length sensor	PS102/	PS101/	PS102/	PS101/	PS102/	PS101/	PS102/	PS101/	
	PS104	PS103	PS104	PS103	PS104	PS103	PS104	PS103	
Width sensor (slice level) Unit:mm	Signal	SZ 2	SZ 1	SZ 2	SZ 1	SZ 2	SZ 1	SZ 2	SZ 1
	ON/OFF	0	0	0	1	1	0	1	1
288.5		A4	—	—	A3	—	—	—	—
		(U4)	—	—	279.4 × 431.8mm (11" × 17")	—	—	—	—
273.7		(U1)	—	—	—	—	—	—	—
261.8		B5	—	—	B4	—	—	—	—
238.0		STMT	—	—	LGL	—	—	(U2)	—
212.9		A5	—	—	A4R	—	—	—	(U3)
206.6		G-LTRR	—	—	—	—	—	—	—
196.6		K-LGLR	—	—	—	—	—	—	—
186.0		B5R	—	—	—	—	—	—	—
165.2		A5R	—	—	—	—	—	—	—
144.1		STMTR	—	—	—	—	—	—	—

F-8-18
T-8-11

Group	Size	Group	Size
U1	* G-LTR	U3	* G-LGL
			FOLIO
U2	* FOOLSCAP		AUS-FLS
	OFFICIO	U4	* LTR
	E-OFFI		A-LTR
	A-OFFI		
	M-OFFI		

SERVICE MODE:**COPIER > OPTION > CST > CST-U1**

31: G-LTR *, 22: K LGL

COPIER > OPTION > CST > CST-U2

24: FLSC *, 26: OFI, 27: E-OFI, 36: A-OFI, 37: M-OFI

COPIER > OPTION > CST > CST-U3

34: G-LGL *, 35: FOLI, 25: A-FLS

COPIER > OPTION > CST > CST-U4

18: LTR *, 29: A-LTR

*: Factory setting.

COPIER > ADJUST > CST-ADJ > C3-STMTR

Use it to adjust the paper width basic value for STMTR in the cassette 3.

COPIER > ADJUST > CST-ADJ > C3-A4R

Use it to adjust the paper width basic value for A4R in the cassette 3.

COPIER > ADJUST > CST-ADJ > C4-STMTR

Use it to adjust the paper width basic value for STMTR in the cassette 4.

COPIER > ADJUST > CST-ADJ > C4-A4R

Use it to adjust the paper width basic value for A4R in the cassette 4.

- Papers Supported by the Machine

T-8-12

Paper	Notation	Size (verticalxhorizontal; mm)
A3	A3	(297 -/+1)X(420 -/+1)
A4R	A4R	(210 -/+1)X(297 -/+1)
A4	A4	(297 -/+1)X(210 -/+1)
A5	A5	(210 -/+1)X(148.5 -/+1)
A5R	A5R	(148.5 -/+1)X(210 -/+1)
B4	B4	(257 -/+1)X(364 -/+1)
B5R	B5R	(182 -/+1)X(257 -/+1)
B5	B5	(257 -/+1)X(182 -/+1)
11X17	11x17	(279 -/+1)X(432 -/+1)
LTRR	LTRR	(216 -/+1)X(279 -/+1)
LTR	LTR	(279 -/+1)X(216 -/+1)
STMT	STMT	(216 -/+1)X(139.5 -/+1)
STMTR	STMTR	(139.5 -/+1)X(216 -/+1)
LEGAL	LGL	(216 -/+1)X(356 -/+1)
Korean Government	K-LGL	(265 -/+1)X(190 -/+1)
Korean Government R	K-LGLR	(190 -/+1)X(265 -/+1)
FOOLSCAP	FLSC	(216 -/+1)X(330 -/+1)
Australian FOOLSCAP	A-FLS	(206 -/+1)X(337 -/+1)
OFICIO	OFI	(216 -/+1)X(317 -/+1)
Ecuadorian OFFICIO	E-OFI	(220 -/+1)X(320 -/+1)
Bolivian OFFICIO	B-OFI	(216 -/+1)X(355 -/+1)
Argentine LTR	A-LTR	(280 -/+1)X(220 -/+1)
Argentine LTRR	A-LTRR	(220 -/+1)X(280 -/+1)
Government LTR	G-LTR	(267 -/+1)X(203 -/+1)
Government LTRR	G-LTRR	(203 -/+1)X(267 -/+1)
Argentine LGL	A-LGL	(220 -/+1)X(340 -/+1)
Government LGL	G-LGL	(203 -/+1)X(330 -/+1)
FOLIO	FOLI	(210 -/+1)X(330 -/+1)
Argentine OFFICIO	A-OFI	(220 -/+1)X(340 -/+1)
Mexico OFFICIO	M-OFI	(216 -/+1)X(341 -/+1)

8.5 Manual Feed Pickup Unit

8.5.1 Pickup Operation

T-8-13

Pickup drive:	pickup motor (M2)
Pickup roller contro:	manual feed tray pickup clutch (CL7) manual feed tray pickup solenoid (SL6)
Paper feed detection:	manual feed sensor (PS35) multiple curling prevention sensor (PS68)

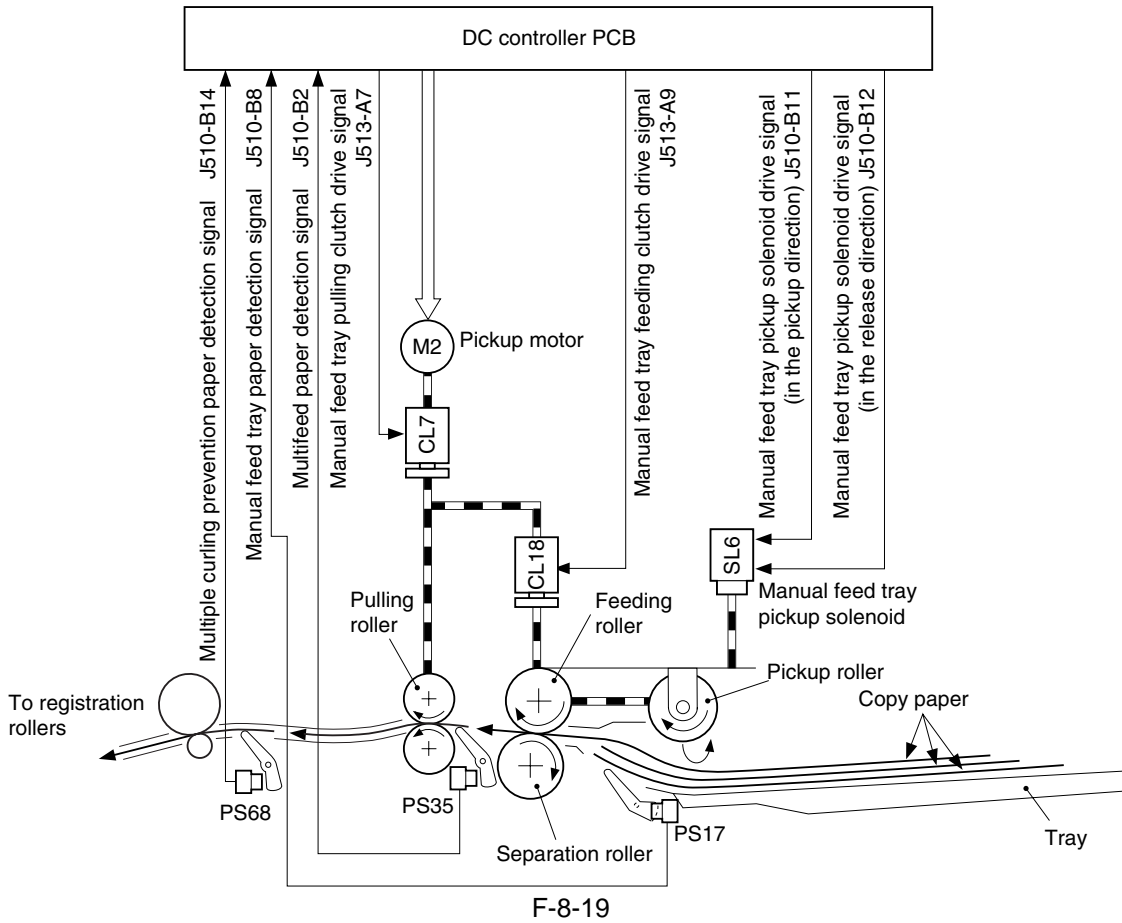

8.5.2 Detecting the Paper Size

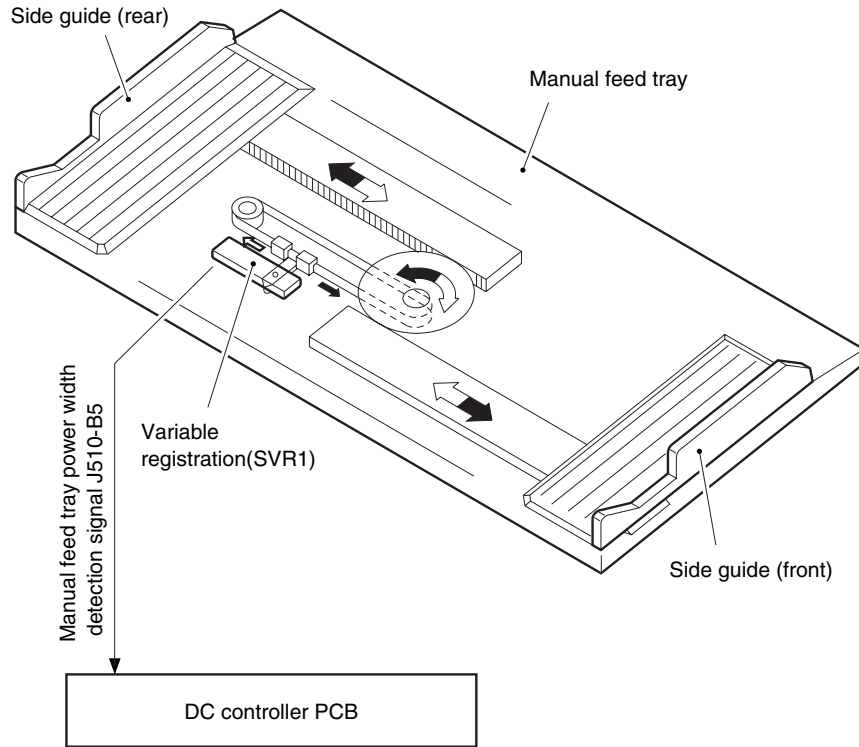

F-8-20

SERVICE MODE:

COPIER > ADJUST > CST-ADJ > MF-A4R

Use it to change the paper width basic value for A4R on the manual feed tray.

COPIER > ADJUST > CST-ADJ > MF-A6R

Use it to adjust the paper width basic value for A6R on the manual feed tray.

COPIER > ADJUST > CST-ADJ > MF-A4

Use it to adjust the paper width basic value for A4 on the manual feed tray.

8.6 Deck

8.6.1 Outline

When the deck or the cassette is slid in, the cassette open/closed sensor turns on and, at the same time, the pickup roller starts to move down, causing the light-blocking plate to leave the lifter sensor, driving the cassette lifter motor and, ultimately, moving up the lifter.

The lifter keeps moving up until the lifter sensor detects the surface of paper. (In the case of the deck right/left, a limiter is mounted to stop the lifter if it fails to stop moving up.)

When the deck or cassette open button is pushed, the drive gear of the lifter becomes free to let the lifter move down on its own weight.

T-8-14

	Right deck	Left deck	Cassette 3	Cassette 4
Cassette open/closed detection	Deck right open/closed sensor (PS23)	Deck left open/closed sensor (PS33)	Cassette 3 open/closed sensor (PS40)	Cassette 4 open/closed sensor (PS45)
Lifter position detection	Lifter sensor (PS21)	Lifter sensor (PS31)	Lifter sensor (PS38)	Lifter sensor (PS43)
Paper presence/absence detection	Deck right paper sensor (PS22)	Deck left paper sensor (PS32)	Cassette 3 paper sensor (PS39)	Cassette 4 paper sensor (PS44)
Paper level detection	Deck right paper level middle sensor (PS51) Deck right paper level upper sensor (PS52)	Deck lifter paper level middle sensor (PS54) Cassette 2 paper level upper sensor (PS55)	Cassette 3 paper level detection PCB (variable resistor)	Cassette 4 paper level detection PCB (variable resistor)
Lifter upper limiter	Deck right limit sensor (PS24)	Deck left limit sensor (PS34)	---	---
Drive motor	Deck right lifter motor (M13)	Deck lifter motor (M14)	Cassette 3 lifter motor (M16)	Cassette 4 lifter motor (M17)

- deck

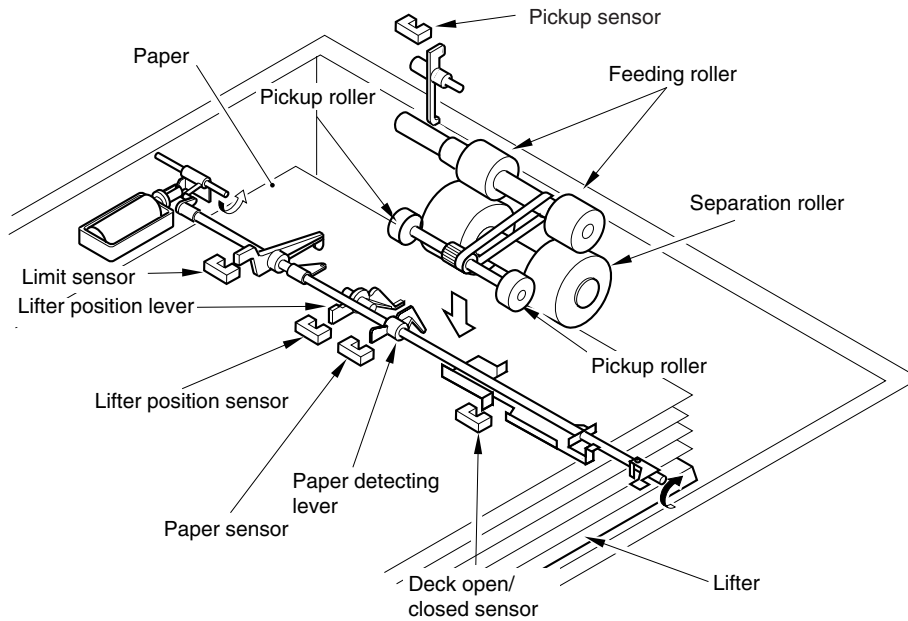

F-8-21

- cassette

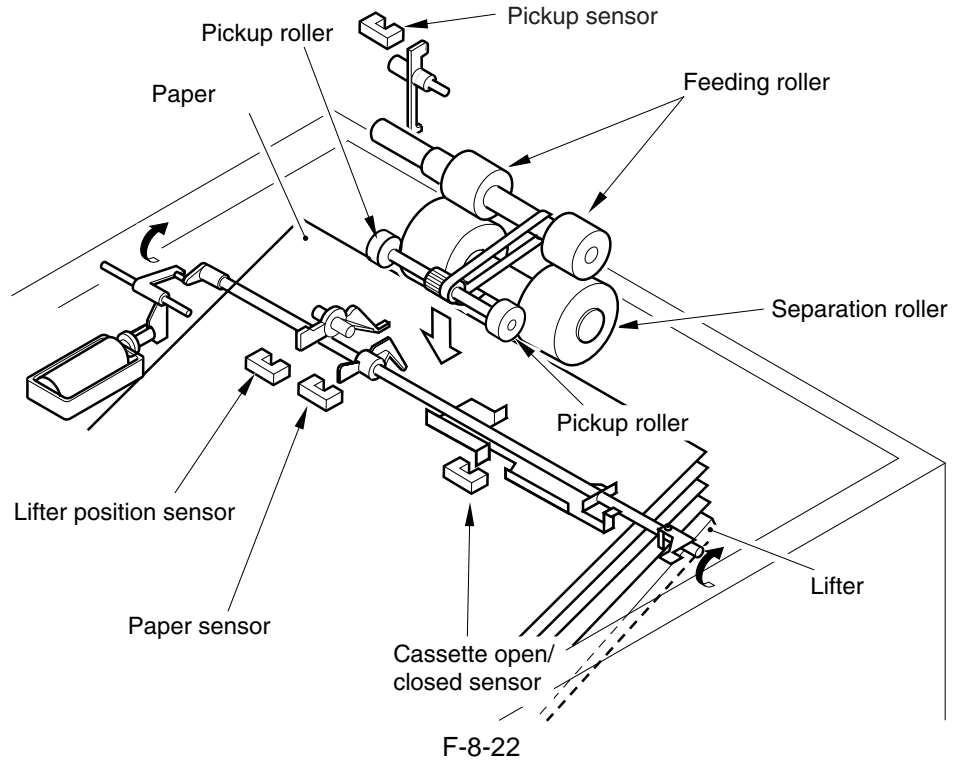

8.6.2 Lifter Limiter (deck right/left)

When the lifter moves up and the surface of paper reaches the cassette limit sensor, the drive to the lifter motor stops.

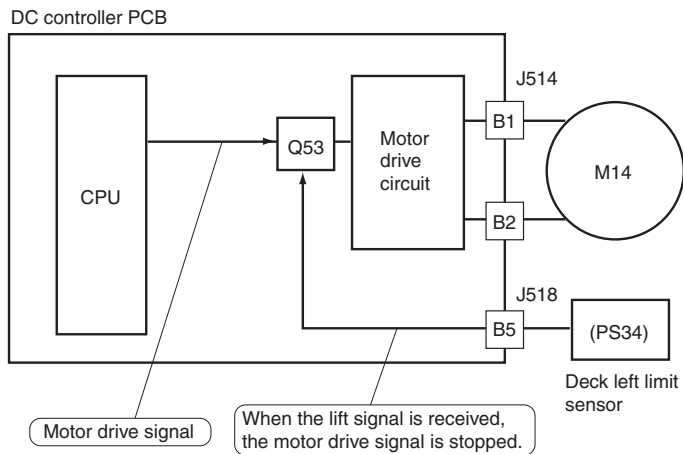
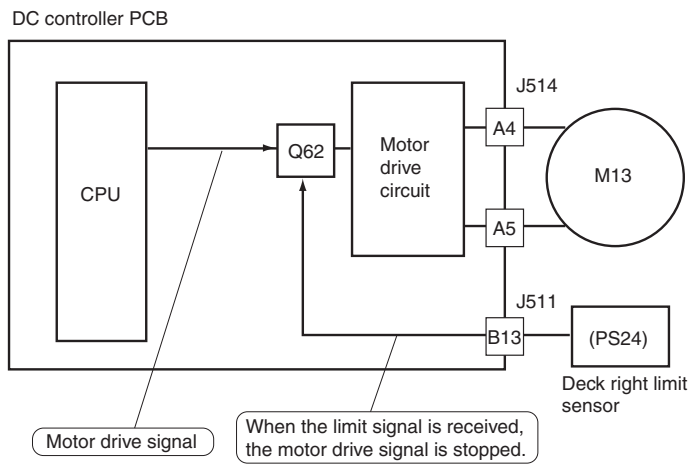

F-8-23

8.6.3 Detecting the Presence/Absence of Paper

The presence/absent of paper inside the deck and the cassette is detected by the cassette paper sensor.

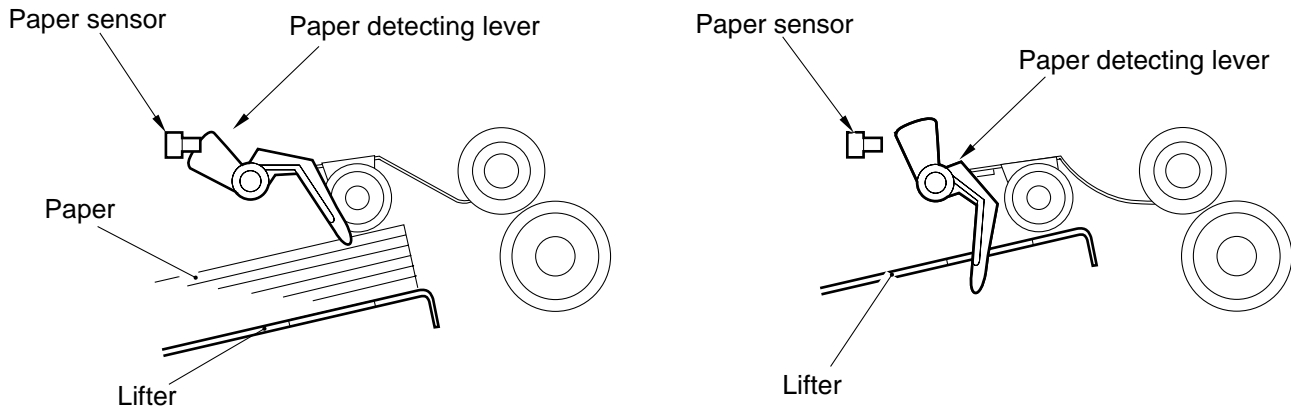

F-8-24

8.6.4 Detecting the Level of Paper

The machine indicates the level of paper inside the deck and the cassette in four readings (including No Paper) on the control panel.

T-8-15

Level of paper	Indication on control panel
100% to about 50% of capacity	
about 50% to about 10% of capacity	
about 10% of capacity or less	
No paper	

In the case of the deck right/left, two sensors are used to detect the position of the deck, and combinations of the states of the sensors (on/off) are used to find out the level of paper. For the absence of paper, an exclusive sensor is used.

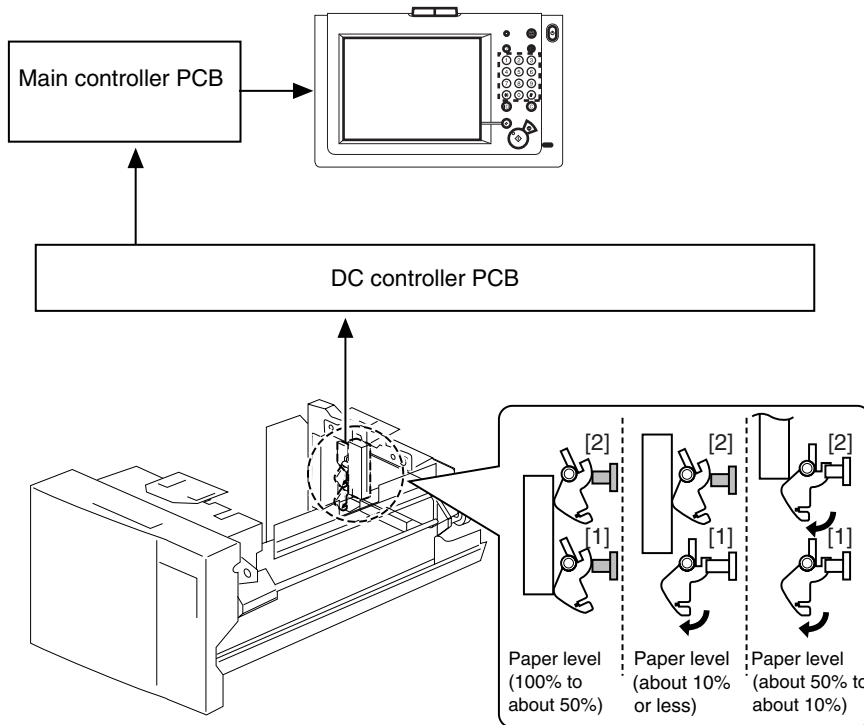

F-8-25

T-8-16

Paper level	Deck right			Deck left		
	[1] Sensor (PS51)	[2] Sensor (PS52)	Sensor (PS22)	[1] Sensor (PS54)	[2] Sensor (PS55)	Sensor (PS32)
100% to about 50%	ON	ON	OFF	ON	ON	OFF
About 50% to about 10	OFF	ON	OFF	OFF	ON	OFF
About 10% or less	OFF	OFF	OFF	OFF	OFF	OFF
None	OFF	OFF	ON	OFF	OFF	ON

In the case of cassette 3/4, the resistance of the variable resistor operating in conjunction with the movement of the lifter drive shaft is used to find out the level of paper.

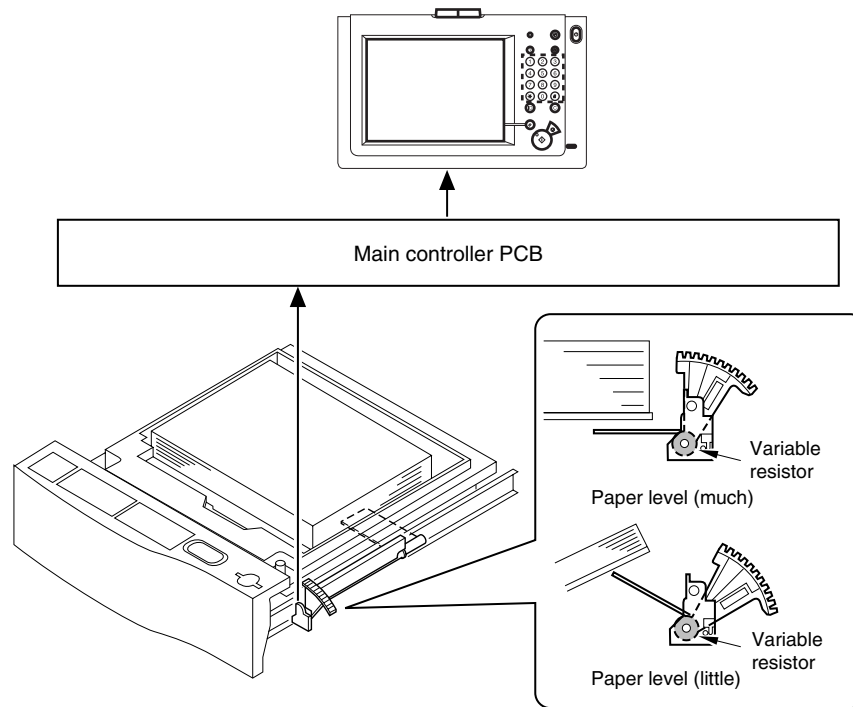

F-8-26

SERVICE MODE:**COPIER > ADJUST > CST-ADJ > C3-LVOL**

Use it to enter a stack height for the cassette 3. (50 sheets) Record the above readings on the service label.

COPIER > ADJUST > CST-ADJ > C3-HVOL

Use it to enter a stack height for the cassette 3. (275 sheets) Record the above readings on the service label.

COPIER > ADJUST > CST-ADJ > C4-LVOL

Use it to enter a stack height for the cassette 4. (50 sheets) Record the above readings on the service label.

COPIER > ADJUST > CST-ADJ > C4-HVOL

Use it to enter a stack height for the cassette 4. (275 sheets) Record the above readings on the service label.

8.6.5 Cassette Deck Right/Left

The cassette deck right/left is not equipped with a paper detecting mechanism, and the paper size is switched as follows (A4, B5, and LTR):

1. By changing the paper size plate of the cassette.
2. By registering the new paper size in service mode.

SERVICE MODE:

COPIER > OPTION > CST > P-SZ-C1 (Use it to specify paper size used in the right deck)

6: A4[default], 15: B5, 18: LTR

COPIER > OPTION > CST > P-SZ-C2 (Use it to specify paper size used in the left deck)

6: A4[default], 15: B5, 18: LTR

8.7 Registration Unit

8.7.1 Outline

T-8-17

Registration clutch	CL2
Registration brake clutch	CL3
Shift clutch activation timing	service mode COPIER > ADJUST > FEED-ADJ > REGIST (-100 to 100)

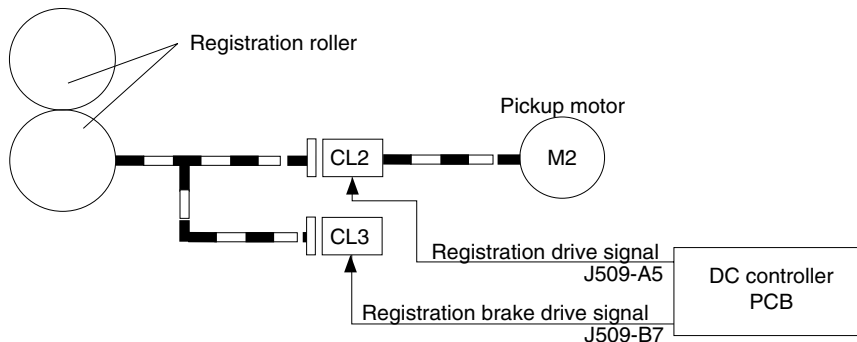

F-8-27

8.7.2 Sequence of Operations (registration brake)

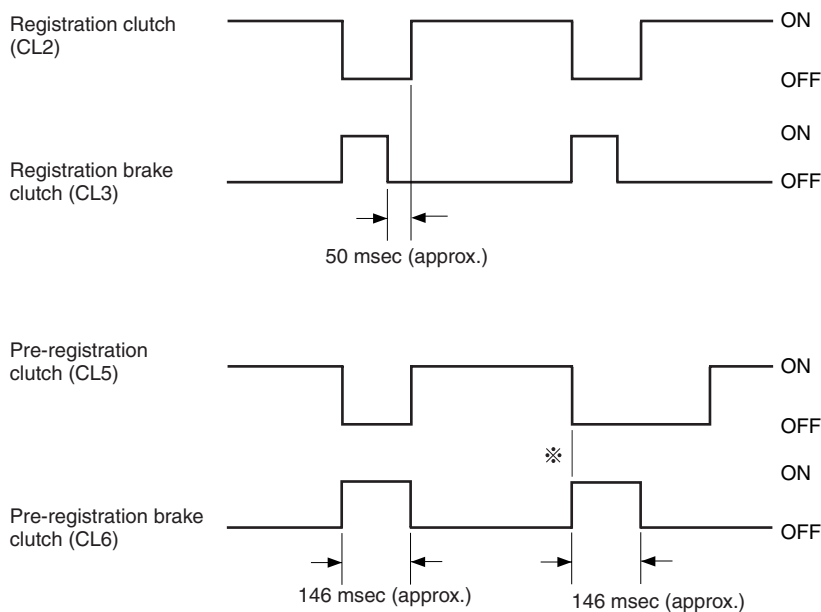

Note: If paper stops for a long time before the registration roller,
 • ADF original processing time
 • Finisher delivery processing time

F-8-28

As soon as the registration drive signal turns off, the registration brake clutch is kept on depending on the way paper is being fed for a specific period of time to prevent idle rotation otherwise caused by inertia.

SERVICE MODE:

COPIER > ADJUST > FEED-ADJ > REGIST (Adjustment of the timing the registration roller clutch is turned on.)

-100 to 100 (unit: 0.1 mm)

8.8 Duplex Feeding Unit

8.8.1 Copying on the First Side

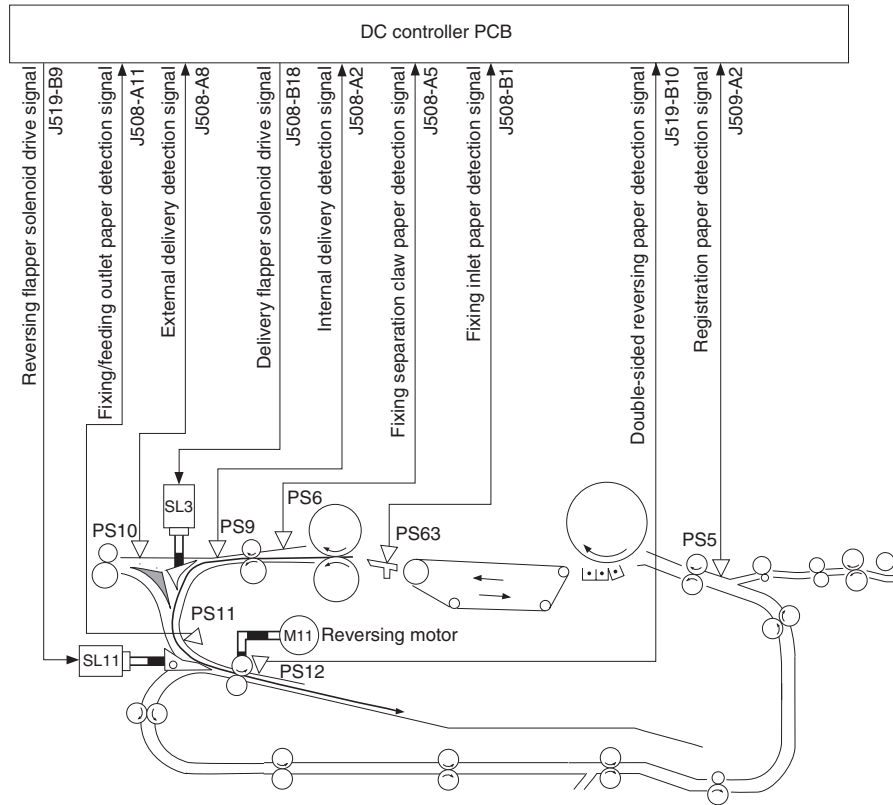

F-8-29

8.8.2 Copying on the Second Side

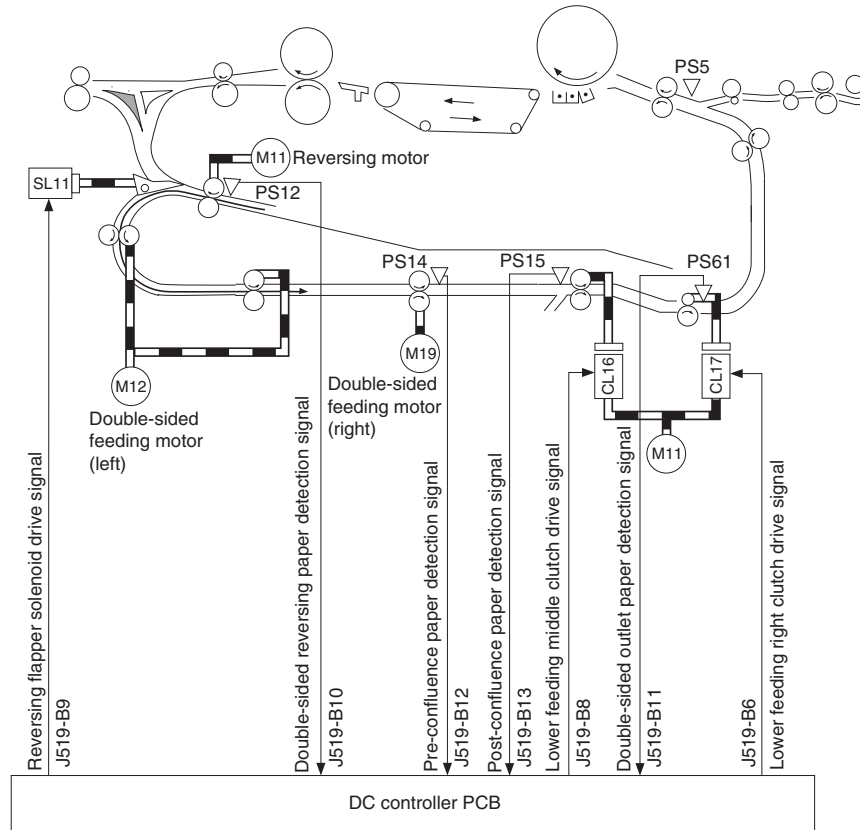

F-8-30

8.8.3 Sequence of Operations

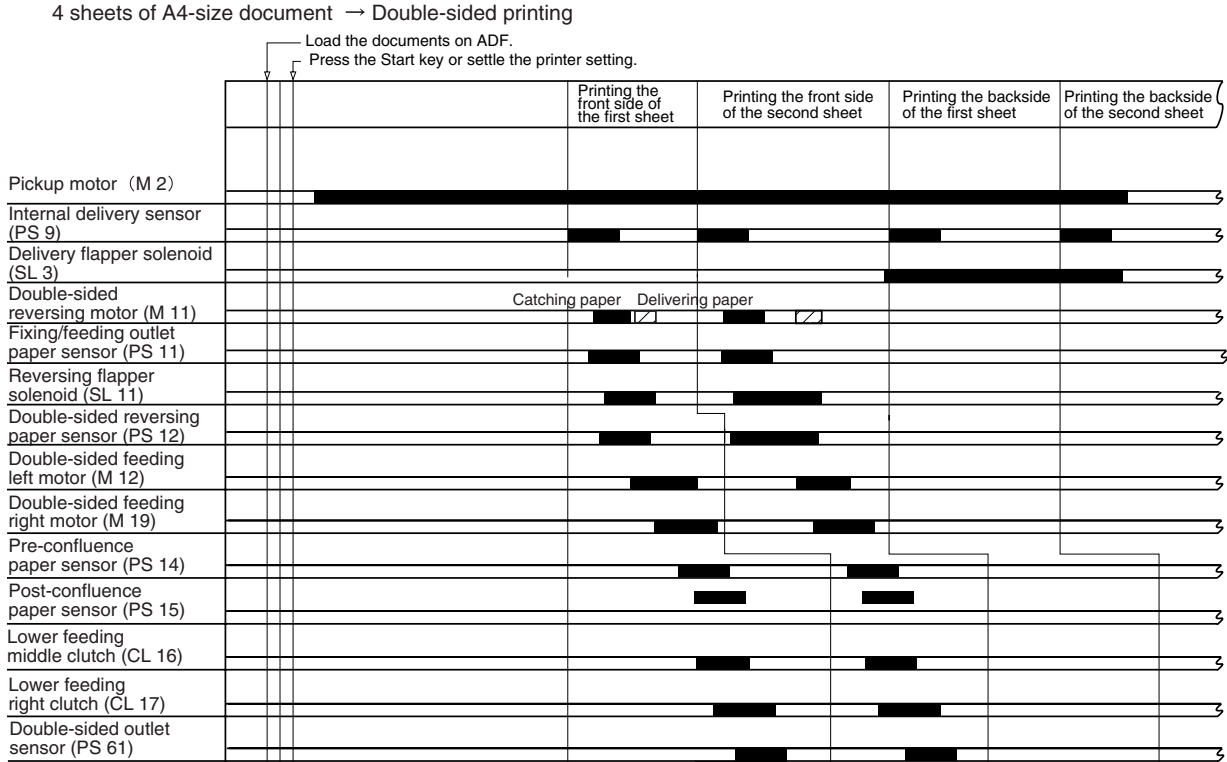

F-8-31

8.8.4 Controlling the reversal motor (M11)

Table shows the function of the reversal motor control circuit, and Figure is a block diagram of the circuit.

T-8-18

Item	Description
Power supply	Supplies 24 V from the no-stacking feeder driver PCB.
Drive signal	Signal (DUP_INV_ON) from the DC controller PCB.
Operating/drive assembly	See Figure.
Control	ON/OFF control Direction control
Error detection	No error code; however, if a fault in the drive of the motor, a jam will occur.

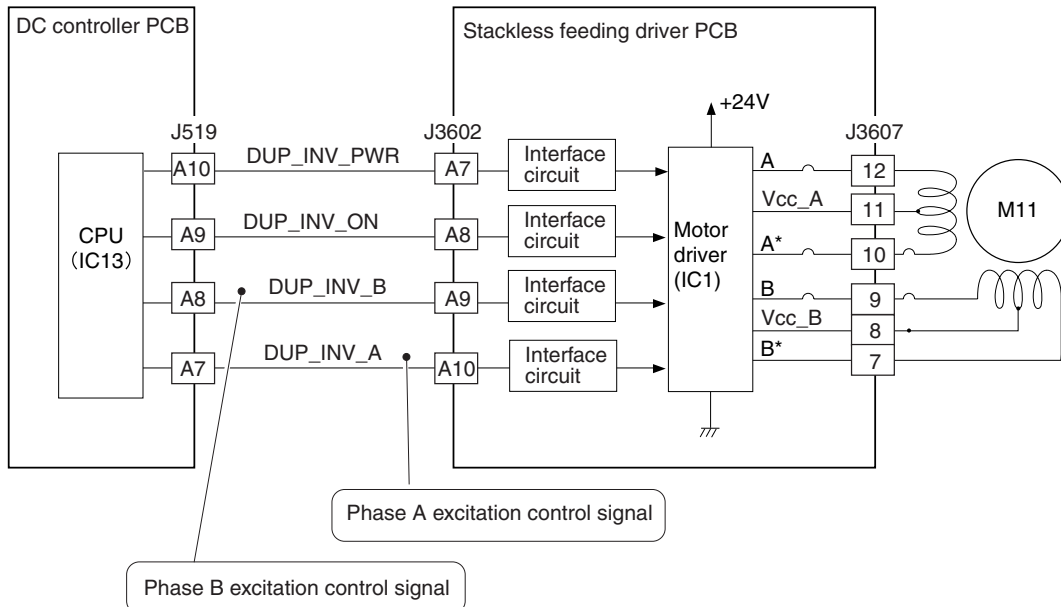

F-8-32

8.8.5 Controlling the duplexing feeder motor (M12)

Table shows the functions of the duplexing feeder motor control circuit, and Figure is a block diagram of the circuit.

T-8-19

Item	Description
Power supply	24 V is supplied by the no-stacking feeding driver PCB.
Drive signal	Signal (DUP_FEED_ON) from the DC controller PCB.
Operating/drive assembly	See Figure.
Control	ON/OFF control Rotation control
Error detection	No error code; however, a fault in the motor drive will cause a jam.

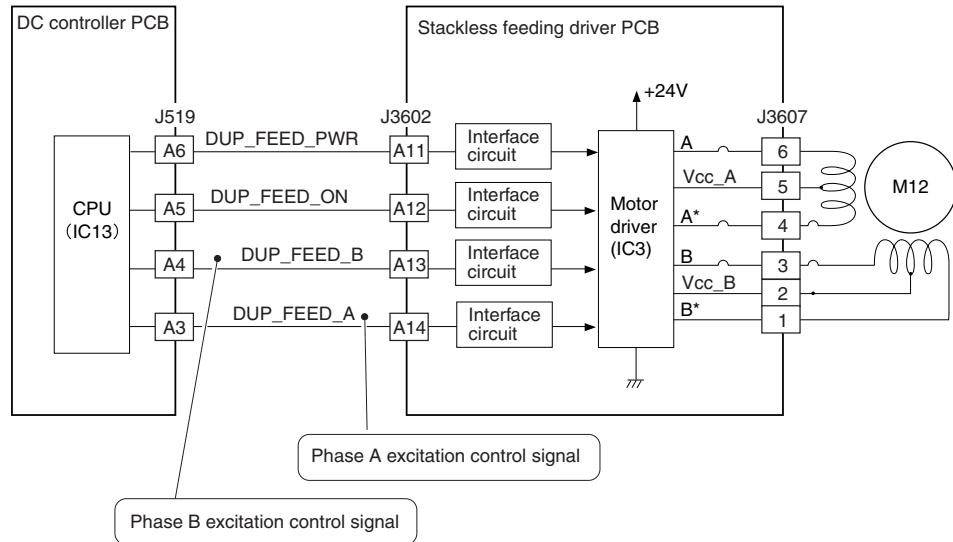

F-8-33

8.8.6 No-Stacking Operation

Outline of Operations

For instance, no-stacking operation takes place as follows when making one set of doublesided copies of 10 originals.

1. The 1st sheet is picked up from the deck right.

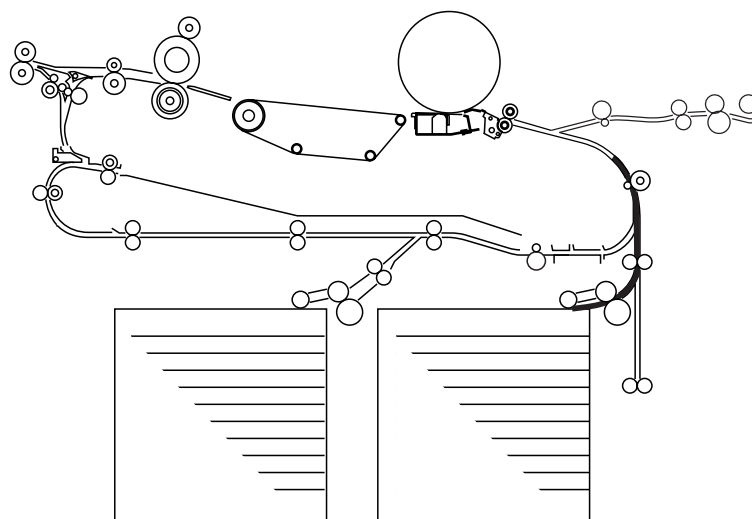

F-8-34

- The 1st side is printed on the 1st sheet.
The 2nd sheet is picked up.

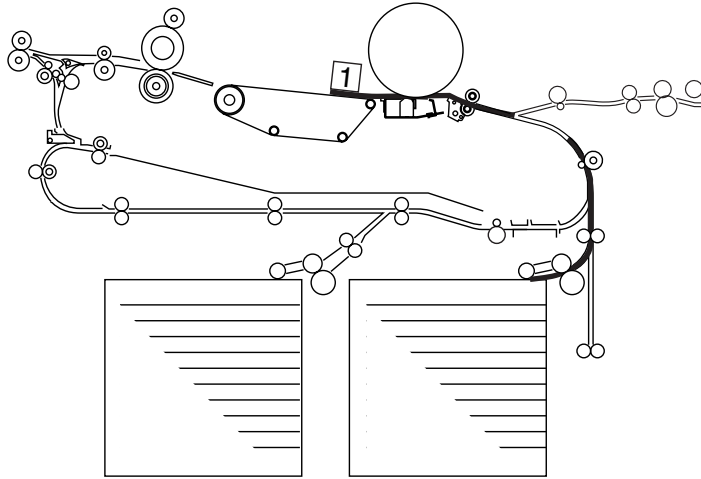

F-8-35

- The 3rd side is printed on the 2nd sheet.
The 1st sheet is moved to the holding tray assembly.
The 3rd sheet is picked up.

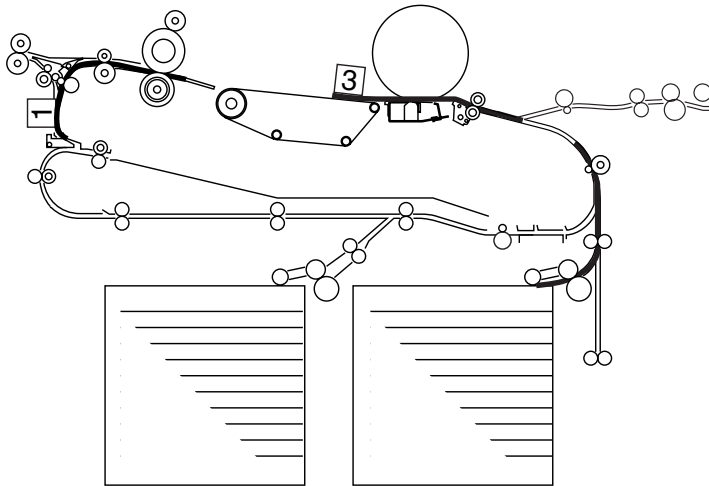

F-8-36

- The 1st sheet is moved to the reversing assembly.

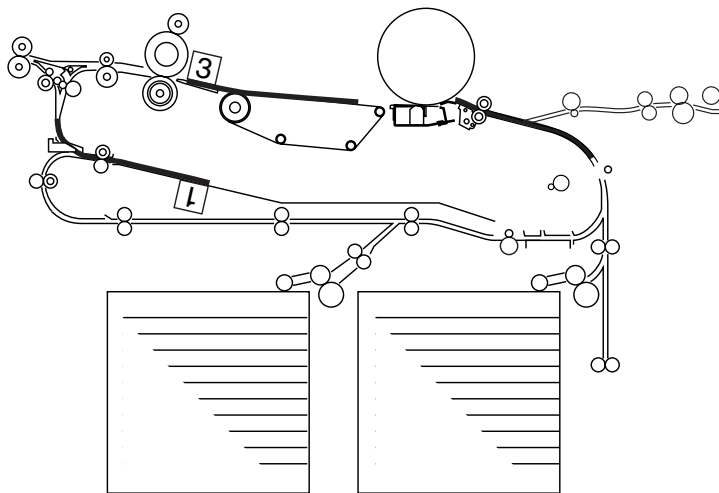

F-8-37

5. The 1st sheet is moved to the lower feeding assembly.
 The 5th side is printed on the 3rd sheet.

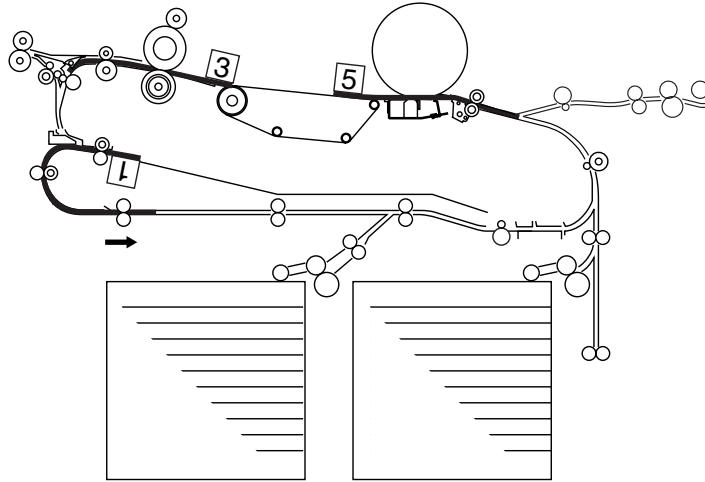

F-8-38

6. The 1st sheet is re-picked up from the lower feeding assembly.

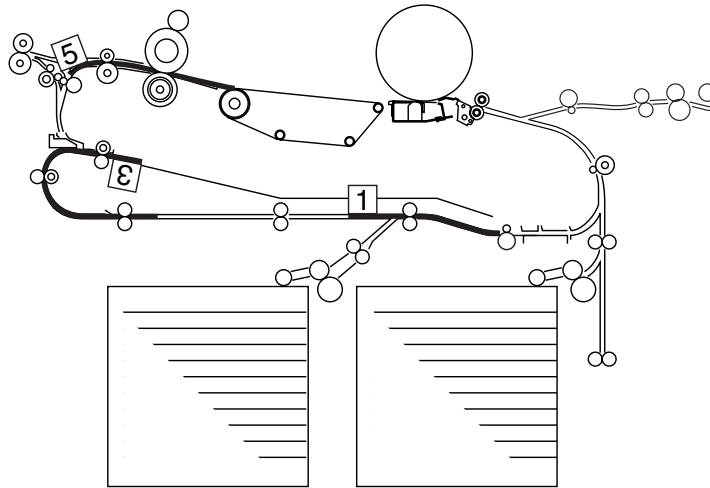

F-8-39

7. The 2nd side is printed on the 1st sheet.
 The 2nd sheet is kept in wait, and the 4th sheet is picked up.

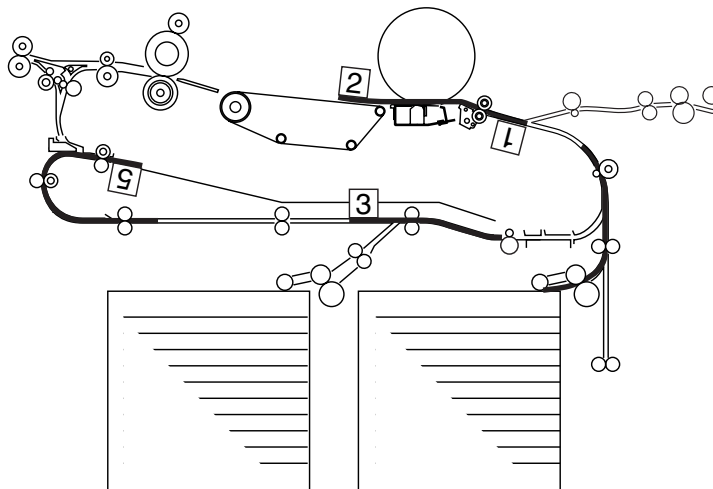

F-8-40

8. The 7th side is printed on the 4th sheet, and the 1st sheet is discharged.

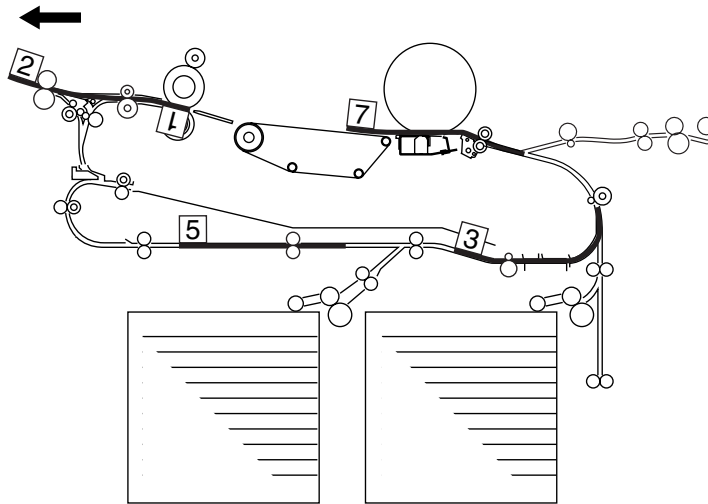

F-8-41

9. The 4th side is printed on the 2nd sheet, and the 3rd sheet is kept in wait in the lower feeding assembly. The 5th sheet is picked up.

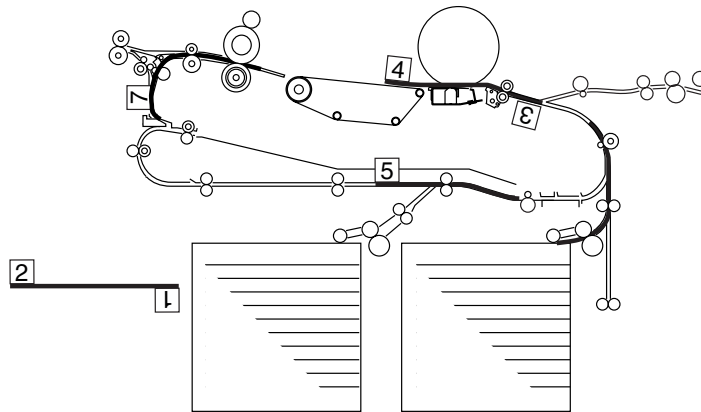

F-8-42

10. The 2nd sheet is discharged. The 9th side is printed on the 5th sheet.

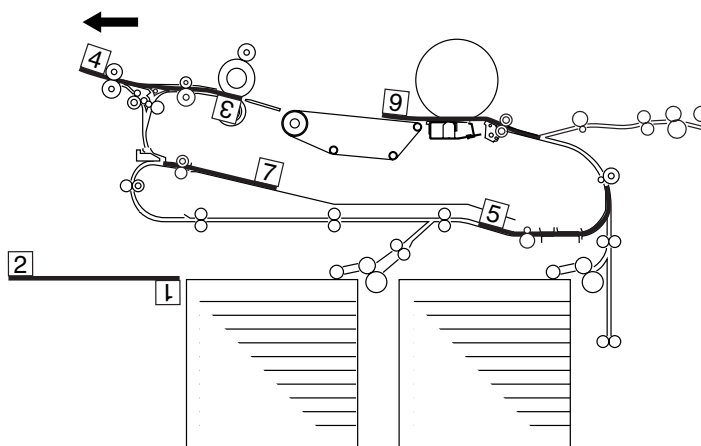

F-8-43

11. The 6th side is printed on the 3rd sheet.

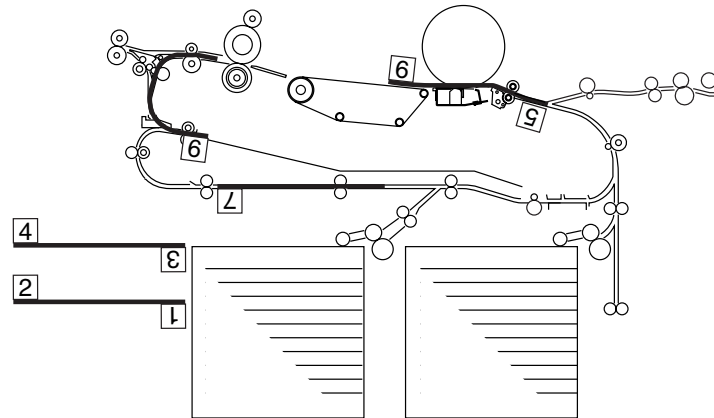

F-8-44

12. The 3rd sheet is discharged.

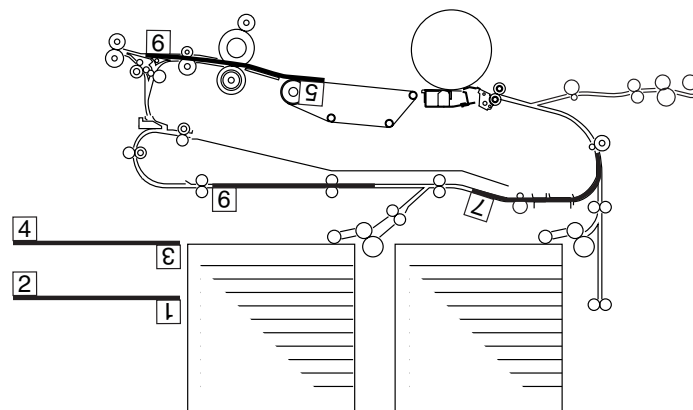

F-8-45

13. The 8th side is printed on the 4th sheet.

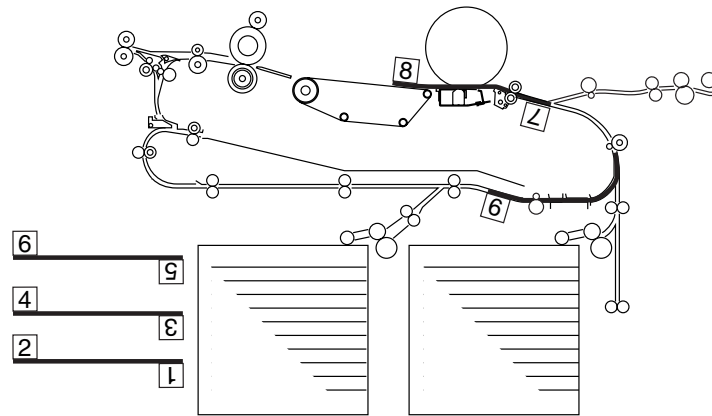

F-8-46

14. The 4th sheet is discharged, and the 10th side is printed on the 5th sheet.

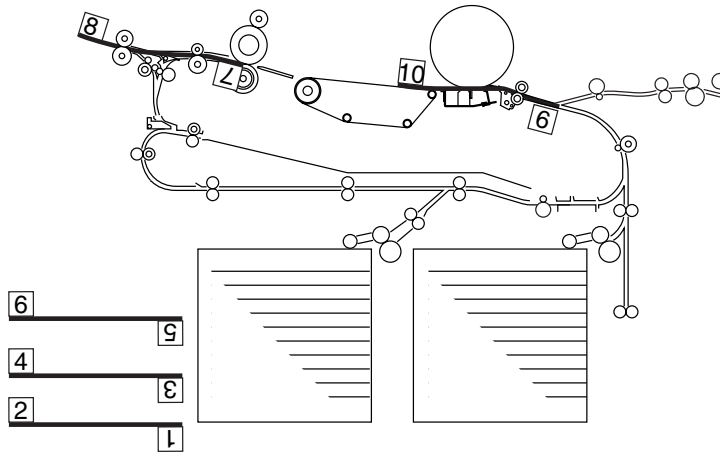

F-8-47

15. The 5th sheet is discharged.

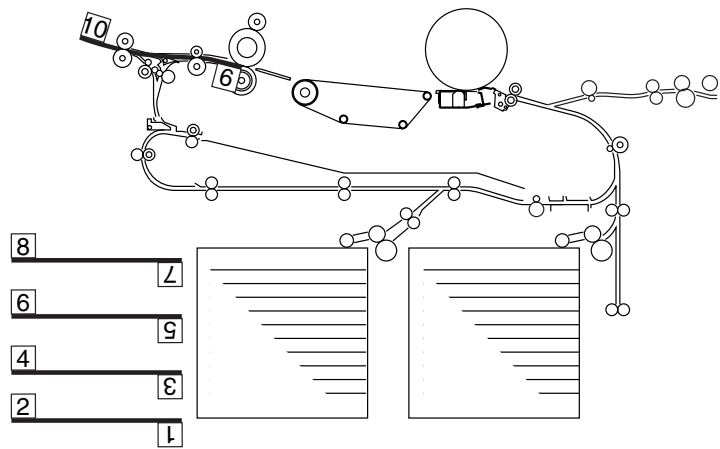

F-8-48
T-8-20

Related Service Mode

COPIER > ADJUST > FEED-ADJ > ADJ-REFE

Use it to adjust the image write start position in main scanning direction for re-pickup.
(-10 to 10 mm)

8.8.7 Detecting the Horizontal Registration Position

T-8-21

Paper position detection	By the horizontal registration sensor (PS18)
Detection start timing	By the post-confluence sensor (PS15)
Drive	By the horizontal registration motor (M15)
Position measurement	By controlling the horizontal registration motor pulses (1 pulse = about 0.16 mm)
Related service mode	COPIER > ADJUST > FEED-ADJ > ADJ-REFE
Related error code	E051: The home position cannot be detected within a specific period of time.

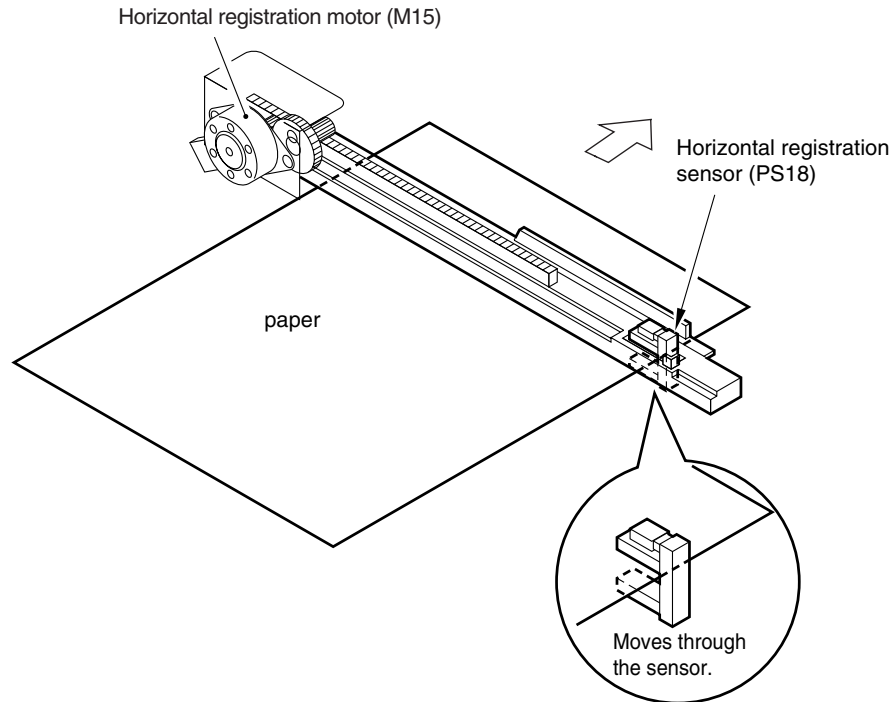

F-8-49

The horizontal registration sensor moves to the start position (A4 detection position) when the main power switch is turned on or the front cover is closed, and moves to a detection position to suit the size of paper expected in the lower feeding assembly. Its position of detection is "paper width +2 mm."

The paper detection mechanism starts when paper moved to the lower feeding assembly has moved past the confluence sensor (PI 15) and has been moved over a specific distance (about 10mm past the horizontal registration sensor).

The position of paper is detected with reference to the start position and by finding out the difference between the start position and the actual paper position from the number of drive pulses (1 pulse = about 0.16 mm) of the motor.

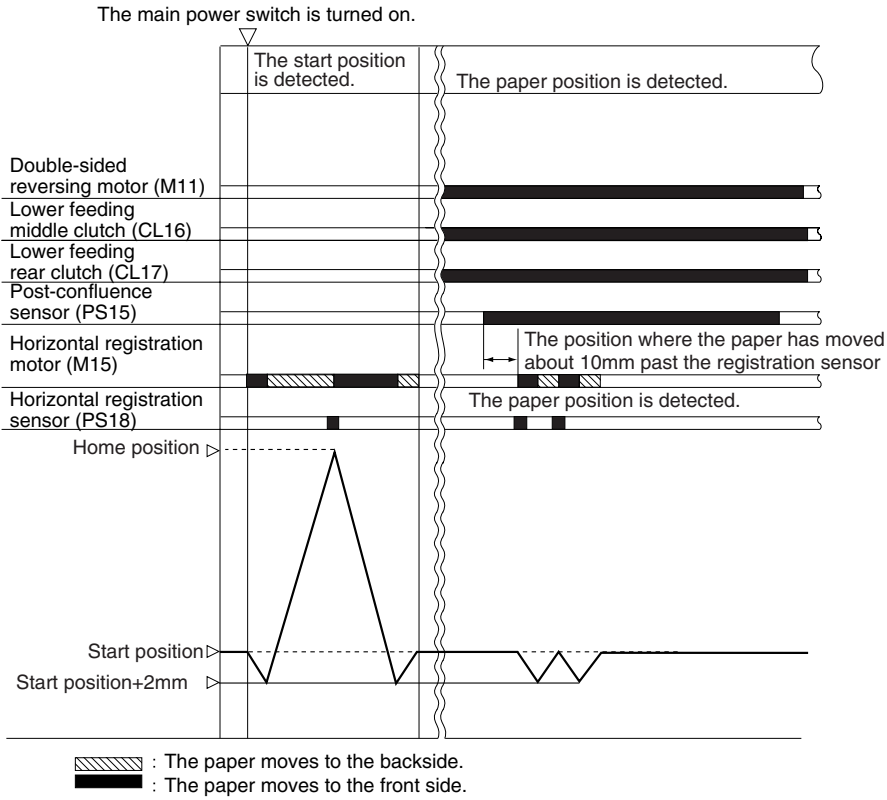

F-8-50

8.8.8 Controlling the Horizontal Registration Motor (M15)

Table shows the functions of the reversal motor control circuit, and the Figure is a block diagram of the circuit.

T-8-22

Item	Description
Power supply	24 V is supplied by the no-stacking feeding driver PCB.
Drive signal	Signal (SIDE_REGI_M_ON) from the DC controller PCB.
Operating/drive assembly	See Figure.
Control	ON/OFF control Rotation control Stop position retention
Error detection	Error code "E051"

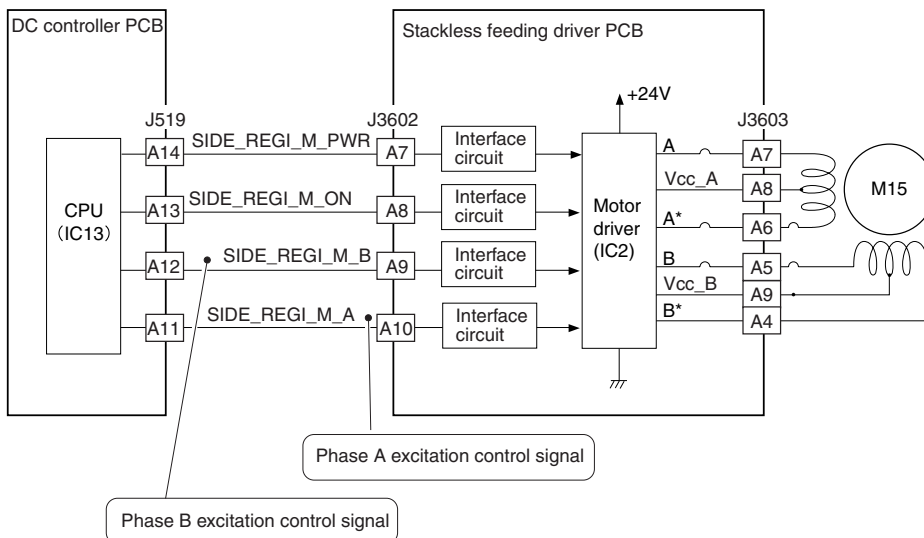

F-8-51

8.9 Delivery

8.9.1 Reversal Delivery

The copier discharges paper either in face-up delivery or in face-down delivery mode.

T-8-23

Delivery	Copying operation
Face-up	<ul style="list-style-type: none"> - Making copies on transparencies (However, the images will be mirror images.) - USER MODE Setting the face-up delivery mode by Printer Settings > Settings > Face Up/Down
Face-down	- Other than above

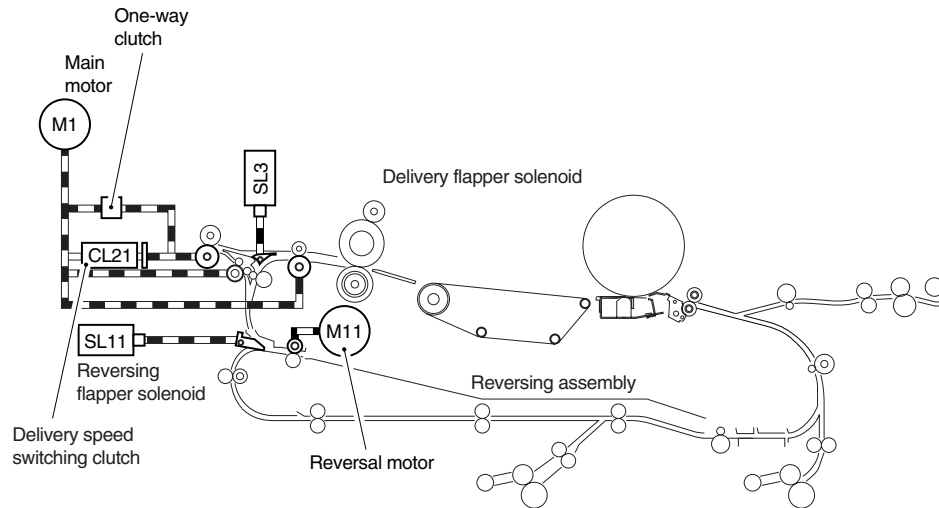

F-8-52
T-8-24

Parts (notation)	Description
Main motor (M1)	Drives the feeding roller.
Delivery flapper solenoid (SL3)	Turns on in face-up mode to lead paper to the delivery assembly.
Delivery speed switching clutch (CL21)	Turns on in reversal delivery mode to speed up the rotation of the external delivery roller.
Reversing flapper solenoid (SL11)	Turns off in reversal delivery mode to lead paper to the reversing assembly.
Reversal motor (M11)	Moves paper to the reversing assembly.

8.10 Detecting the Double-Feed

8.10.1 Detecting Double Feeding

The machine uses the ultra-sonic wave sensor (for transmission, reception) located downstream of the registration roller to check for double feeding, and stops the ongoing printing operation upon detection. Ultrasonic waves are often characterized as follows, and may be used for the detection of double feeding regardless of the type of medium used (plain paper, heavy paper, colored paper, transparency, etc.).

- propagation is subject to significant attenuation between different densities (e.g., air and paper).
- propagation is free of attenuation in regard to the color or thickness of the object being checked.

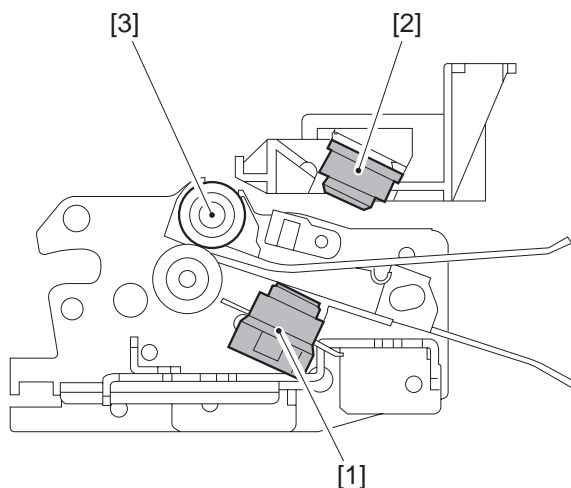

F-8-53

- [1] Double feeding sensor (transmission)
- [2] Double feeding sensor (reception)
- [3] Registration roller

MEMO:

Some models (for sale in specific countries) may not come standard with this detection mechanism. Its use requires a Double Feeding Detection Kit (optional).

<Timing of Detection>

- interval extending several 100s of msec after the registration roller clutch goes on

<Sequence of Operation>

- 1) The mechanism is started.
- 2) The machine identifies double feeding.
- 3) The machine turns off the fixing motor as soon as the paper reaches the fixing nip area.
 - The paper stops at the fixing nip area, with paper found downstream thereof discharged outside the machine.
 - The control panel screen indicates the presence of a jam (0C00).

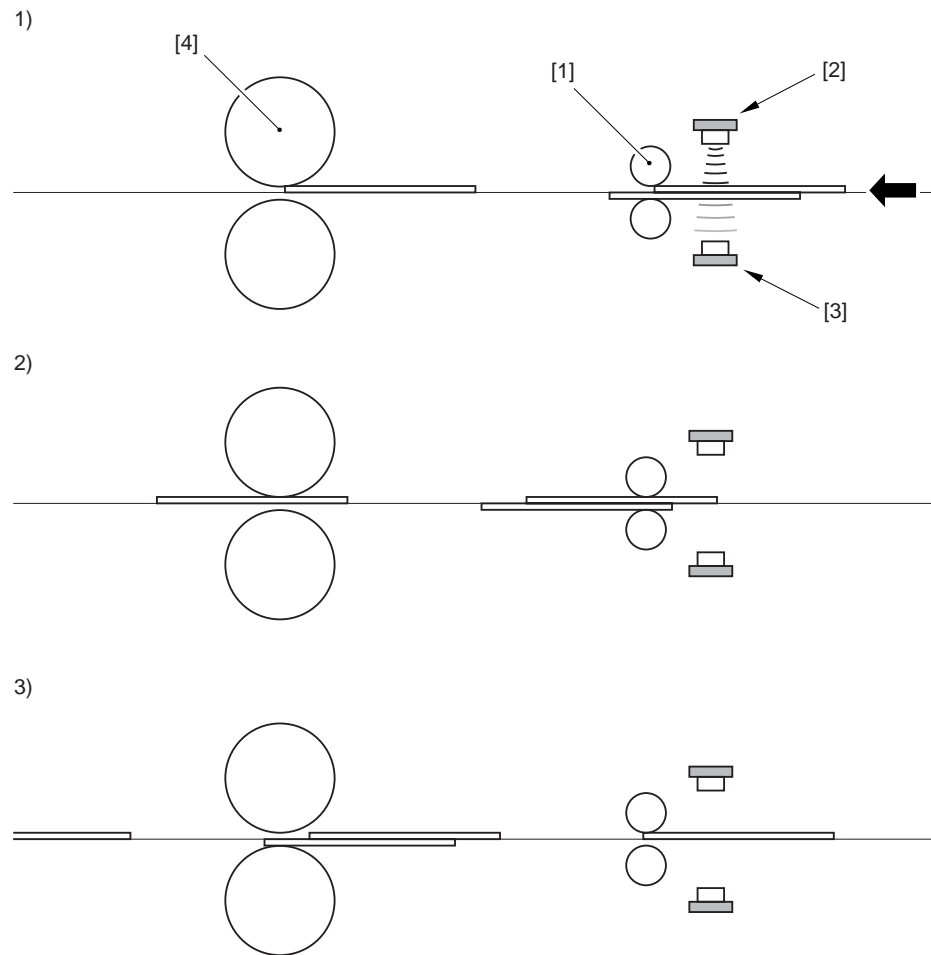

F-8-54

- [1] Registration roller
- [2] Double feeding sensor (transmission)
- [3] Double feeding sensor (reception)
- [4] Fixing roller

Error code:**E850-0000** (The double-feeding detection unit is faulty)

The double feeding sensor (reception) cannot attain a specific ultrasonic signal level.

Service Mode:**COPIER > OPTION > BODY > OVLP-MD** (Level 1)

Use it to enable/disable the double feeding detection mechanism.

0: enabled; 1: disabled

- If an accessory is installed, set it to '0'.

- To temporarily disable the mechanism (as for a fault or wrong detection), set it to '1'.

8.11 Parts Replacement Procedure

8.11.1 Cassette Pickup Assembly

8.11.1.1 Removing the Right Deck / Cassette Pickup Assembly

The removal procedure of a right door and a left door is the same. An illustration makes a right door an example and explains it.

- 1) Slide out the right deck / cassette 3 / cassette 4.
- 2) Open the right upper cover and the right lower cover.



An attempt to remove the pickup assembly without removing the deck will cause the lifter to get trapped, not holding the pickup assembly from sliding out.

- 3) Remove the mounting screw [1], and detach the connector cover [2]; then, disconnect the connector [3].
- 4) Remove the three mounting screws [4], and detach the pickup assembly [5].

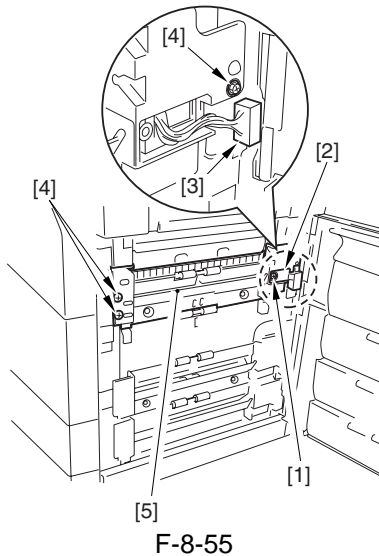

F-8-55

8.11.1.2 Removing the Vertical Path 3/4 Sensor and the Cassette 3/4 Pickup Sensor

- 1) Remove the cassette 3/4 pickup assembly.
- 2) Remove the screw, and detach the static eliminator [2].

- 3) Remove the screw [3], and detach the pickup assembly sensor base.

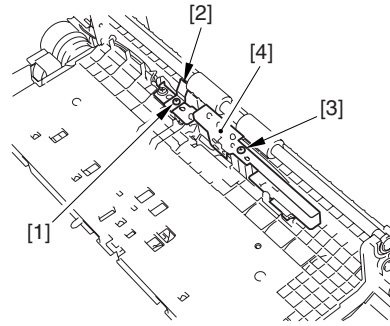

F-8-56

- 4) Disconnect the connector [1] (1 pc. each), and free the claw; then, detach the vertical path 3/4 sensor [2] and the cassette 3/4 pickup sensor [3].

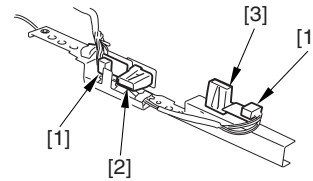

F-8-57

8.11.2 Cassette Lifter Motor

8.11.2.1 Removing the Lifter Motor (M16/M17) of the Cassette (3/4)

- 1) Slide out the front deck (right); then, slide out the cassette 3/4.
- 2) Remove the front lower right cover of the cassette assembly as instructed under "Removing the Vertical Path Roller 2."
- 3) Remove the two fixing screws [1] of the lifter motor (M16/M17), and disconnect the connector [2]; then, detach the lifter motor [3].

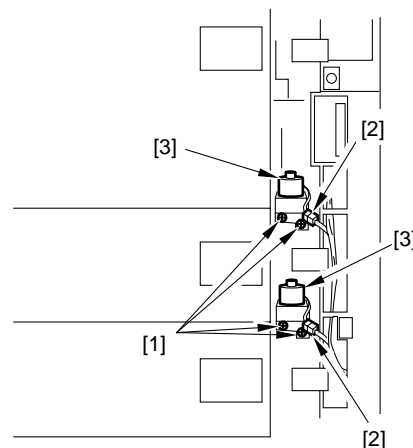

F-8-58

8.11.3 Right Deck Pickup Assembly

8.11.3.1 Removing the Right Deck / Cassette Pickup Assembly

The removal procedure of a right door and a left door is the same. An illustration makes a right door an example and explains it.

- 1) Slide out the right deck / cassette 3 / cassette 4.
- 2) Open the right upper cover and the right lower cover.



An attempt to remove the pickup assembly without removing the deck will cause the lifter to get trapped, not holding the pickup assembly from sliding out.

- 3) Remove the mounting screw [1], and detach the connector cover [2]; then, disconnect the connector [3].
- 4) Remove the three mounting screws [4], and detach the pickup assembly [5].

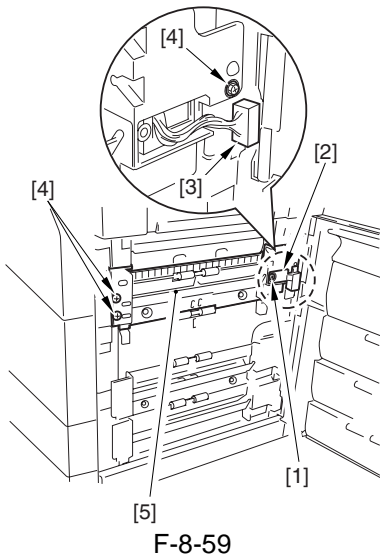

F-8-59

8.11.4 Left Deck Pickup Assembly

8.11.4.1 Removing the Left Deck Pickup Assembly

- 1) Slide out the left deck.
- 2) Remove the two screws [1] found on the left and right sides of the left deck [2]; then, detach the left deck [2].

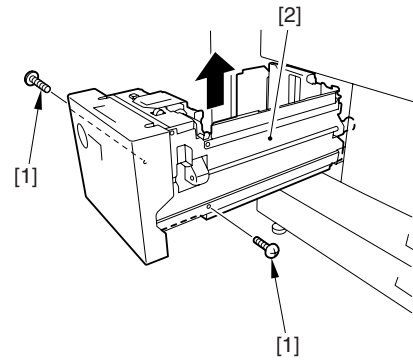

F-8-60

- 3) Open the front cover.
- 4) Disconnect the connector [1] from inside the machine, and remove the locking support [2].

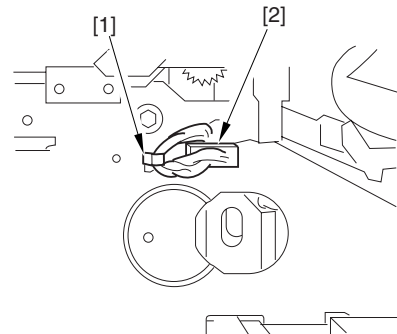

F-8-61

- 5) Remove the two screws [1], and detach the two pickup fixing plates [2]; then, detach the left deck pickup assembly [3].



Keep supporting the pickup assembly; otherwise, the pickup assembly could drop when the fixing plate is removed.

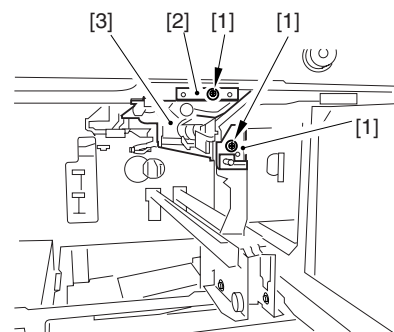

F-8-62

8.11.5 Left Deck Pickup Sensor

8.11.5.1 Removing the Left Deck Pickup Sensor

- 1) Remove the front deck (left) pickup assembly.
- 2) Remove the screw [1], and detach the pickup sensor unit [2].

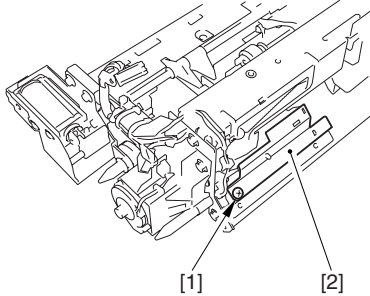

F-8-63

- 3) Disconnect the connector [1], and detach the left deck pickup sensor [2].

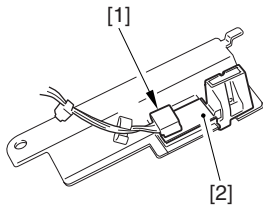

F-8-64



When removing the scanner sensor, be sure to remove the paint used to lock the claw in place in advance to prevent breaking the claw. When mounting it, be sure the claw is not displaced or the sensor is not disoriented.

8.11.6 Right Deck Pickup Sensor

8.11.6.1 Removing the Right Deck Feed Sensor/Right Deck Pickup Sensor

- 1) Remove the front deck (right) pickup assembly.
- 2) Remove the guide plate [1].

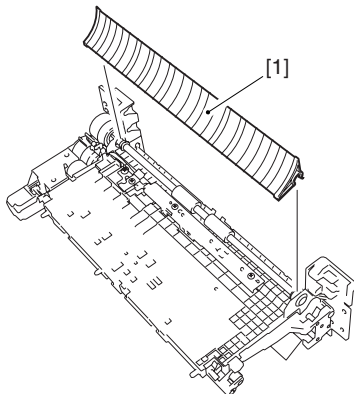

F-8-65

- 3) Remove the screw [1], and detach the stack eliminator [2].
- 4) Remove the 2 screws [3], and detach the pickup assembly sensor base [4].

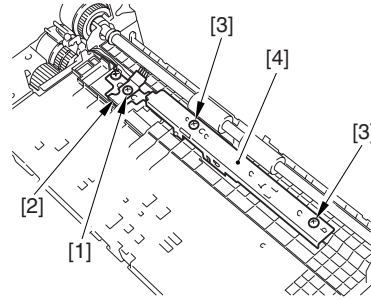

F-8-66

- 5) Disconnect the connector [1] (1 pc. each), and free the claw; then, detach the right deck feed sensor [2] and the right deck pickup sensor [3].

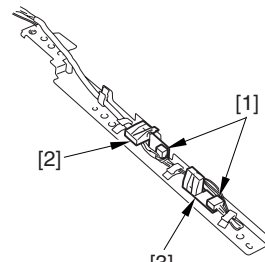

F-8-67



When removing the scanner sensor, be sure to remove the paint used to lock the claw in place in advance to prevent breaking the claw. When mounting it, be sure the claw is not displaced or the sensor is not disoriented.

8.11.7 Manual Tray Assembly

8.11.7.1 Removing the Manual Feeder Tray Unit

- 1) Open the manual feeder tray cover.
- 2) Remove the door tape [1].
 - 1 screw [2]
- 3) Remove the connector cover [3].
 - 1 screw [4]

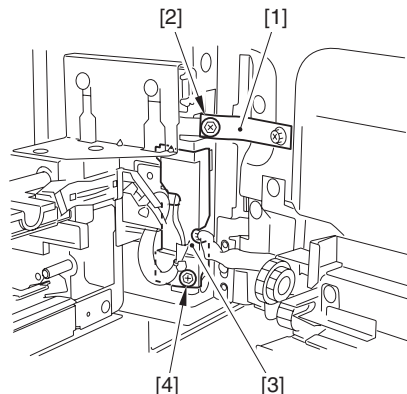

F-8-68

- 4) Disconnect the connector [1], and free the cable from the plate of the host machine (fixed in place using a cable clamp).

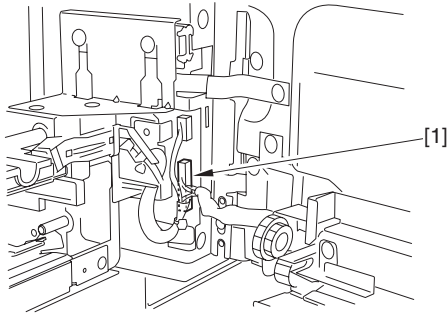

F-8-69

- 5) Remove the stopper plate [1].
- 1 screw [2]

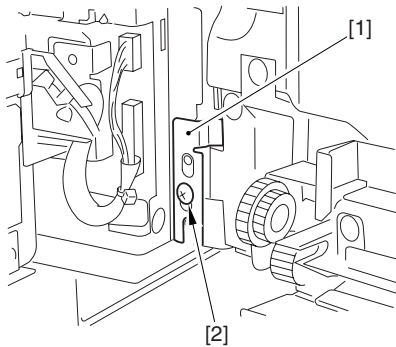

F-8-70

- 6) Remove the manual feeder tray unit [1] in the direction of the arrow.

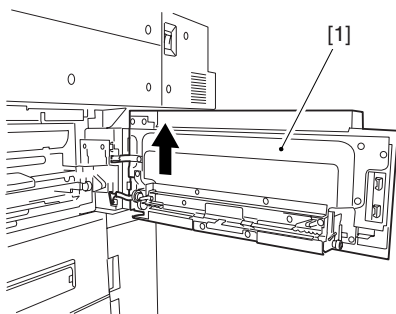

F-8-71

8.11.7.2 Fitting the Side Guide Timing Belt for the Manual Feed Tray Assembly

Butt the rack plate [1] of the manual feed tray against section A (open state). Move the slide volume [2] in the direction of B, and fit the timing belt [3] to the pulley [4].

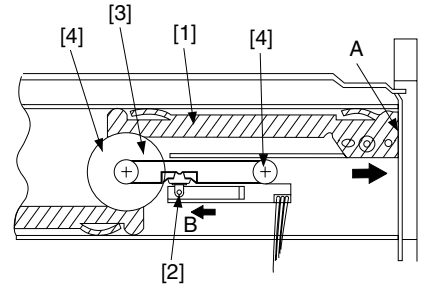

F-8-72

8.11.8 Manual Feed Pull-Out Roller Unit

8.11.8.1 Removing the Manual Feeder Pull-Off Roller Unit

- 1) Open the manual feeder tray cover.
- 2) Remove the connector cover [1].
- 1 screw [2]

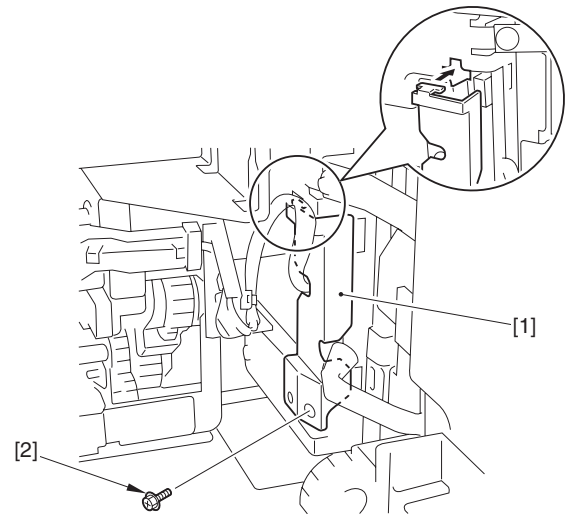

F-8-73

- 3) Disconnect the connector [1], and remove the cable clamp fixed to the plate.

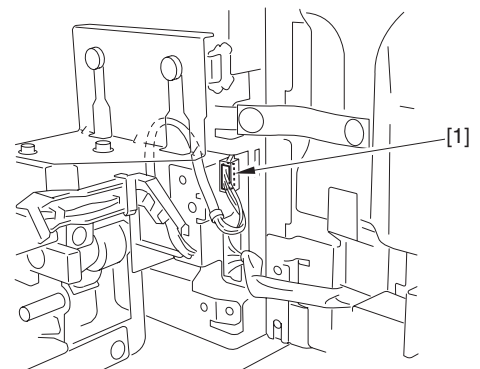

F-8-74

- 4) Release the lever [1] in upward direction; then, slide out the pull-off roller unit [2], and remove the 2 screws [3].

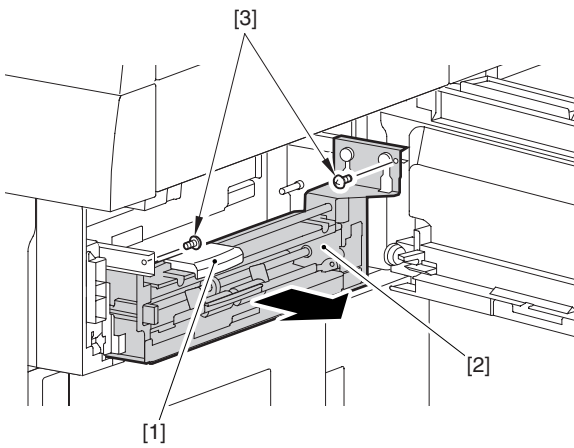

F-8-75

- 5) Remove the pull-off roller unit [1] in the direction of the arrow.

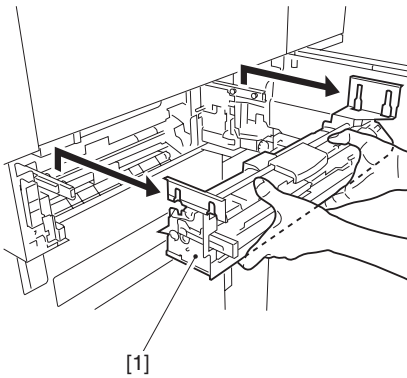

F-8-76

8.11.9 Manual Pickup Roller

8.11.9.1 Removing the Pickup Roller

- 1) Open the manual tray paper guide.
- 2) Remove the left/right stop rings [1] (two each), shutters [2] (two each), spacers [3] (two each), and rolls [4] (two each).

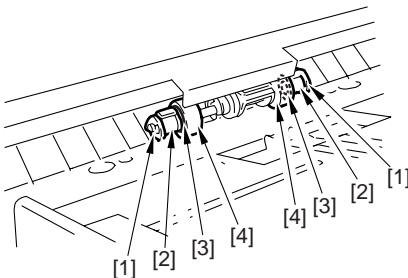

F-8-77



If the multifeder is used during installation or if the multifeder has not been used for a long time, pickup can fail. If such happens, detach the protective sheet from the sponge roller, and dry wipe the sponge roller.

8.11.9.2 Mounting the Pickup Roller

Mount the pickup roller by reversing the steps used to remove it with the following in mind:

- The front pickup roller and the rear pickup roller are not interchangeable.
- The front pickup roller is identified by its silver-colored collar.

When mounting the pickup roller [1] to the pickup assembly, be sure that the round marking [2] on the collar (silver) is toward the machine's front,

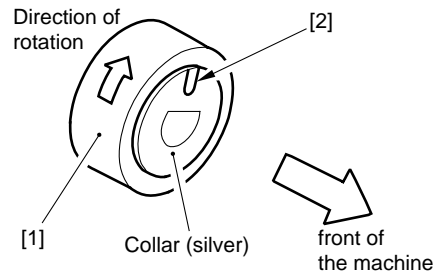

F-8-78

- The rear pickup roller is identified by its gold collar.

When mounting the pickup roller [3] to the pickup assembly, be sure that the round marking [4] on the side of the roller and the round marking [5] on its collar (gold) are toward the machine's rear.

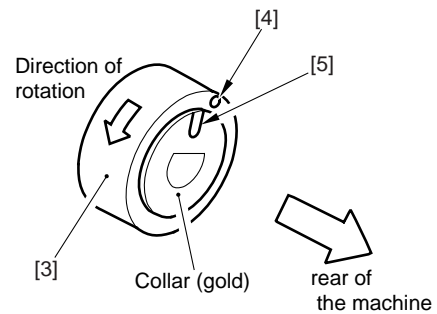

F-8-79

8.11.10 Manual Feed Roller

8.11.10.1 Removing the Feeding Roller

- 1) Remove the pickup roller, and remove the stop ring.
- 2) Remove the two screws [1], and detach the manual feed tray guide [2].

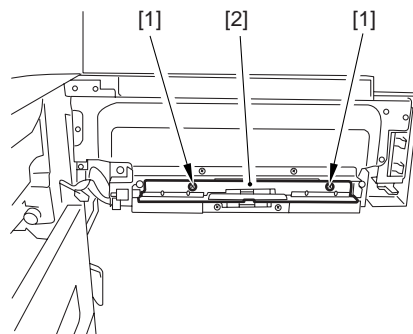

F-8-80

- 3) Remove the stop ring [3] from the front of the feeding roller assembly, and move the feeding roller assembly [5] together with the timing belt [4] to detach.

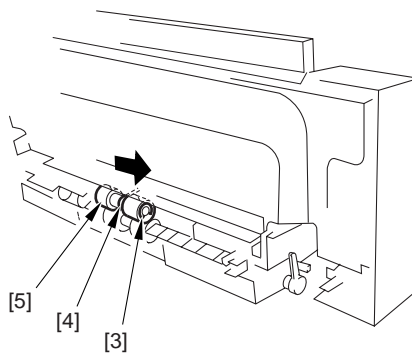

F-8-81

8.11.10.2 Orientation of the Feeding Roller

When mounting the feeding roller [6] to the manual feed tray pickup assembly, be sure that the belt pulley [7] and the round marking [8] are toward the machine's front.

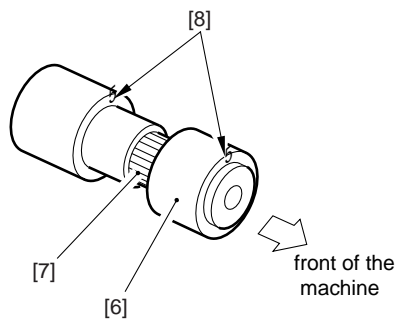

F-8-82

8.11.10.3 Removing the multiple curling prevention roller

- 1) Open the manual feeder tray cover and the upper right cover.
 - 2) Remove the manual feeder tray unit.
 - 3) Remove the manual feeder pull-off roller unit.
 - 4) Remove the rear upper right cover.
 - 5) Remove the hopper upper cover.
 - 6) Remove the hopper right cover.
 - 7) Remove the right inside front cover [1].
- 2 screws [2]

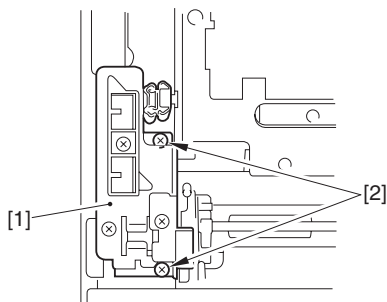

F-8-83

- 8) Remove the rail base (front) [1].
- 2 screws [2]

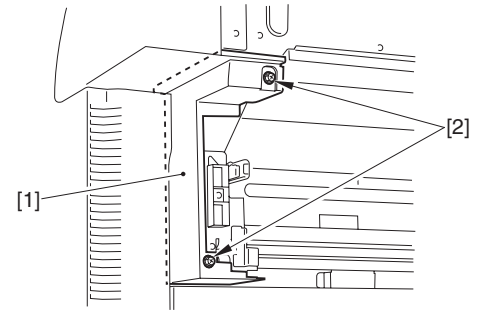

F-8-84

- 9) Remove the screw [2], and detach the rear fixing plate [1]; then, detach the rear fixing plate [3].

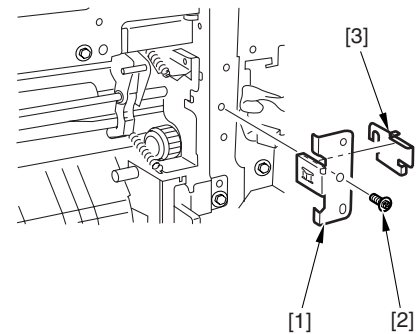

F-8-85

- 10) Remove the following at the front and the rear: E-ring [1], space [2], bearing [3]. Then, detach the multifeder curl-removing roller [4].

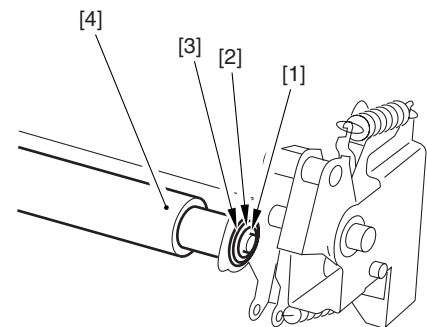

F-8-86

8.11.10.4 Mounting the multiple curling prevention roller

- 1) Set the multiple curling prevention roller assembly to the main body.
- 2) Mount the rear fixing plate 2 and the rear fixing plate 1 in the order indicated; then, secure them in place with the mounting screw [3].

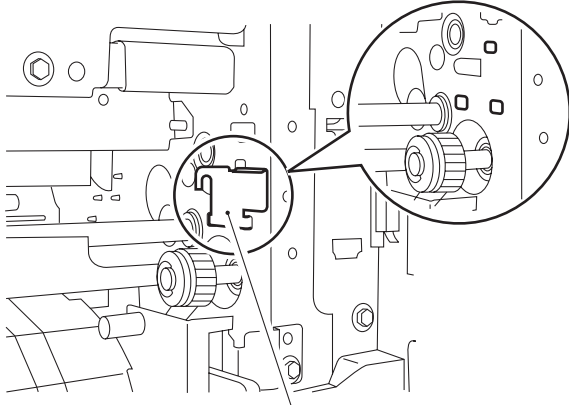

Rear fixing plate 2
F-8-87



When mounting the multiple curling prevention roller, hook the two claws of the rear fixing plate 2 on the three holes in the rear side plate; then, mount the rear fixing plate 1 to secure.

8.11.11 Manual Separation Roller

8.11.11.1 Removing the Separation Roller

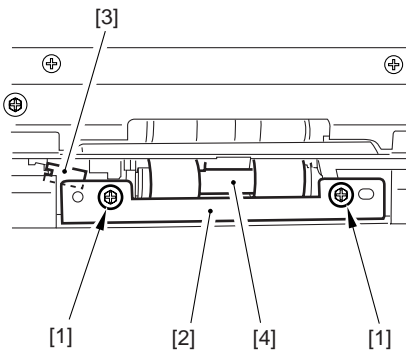

F-8-88



When removing the separation roller, pay attention to the bushing at the front. It will slip off.



Initially, the urethane sponge of the part is pink, and changes over time (accelerated if exposed to light). Its tone will change from pink to orange and to yellow; it is a general characteristic of urethane sponge, and no physical deterioration (in per-

formance) exists because of changes in color, and the part is not identified by color.

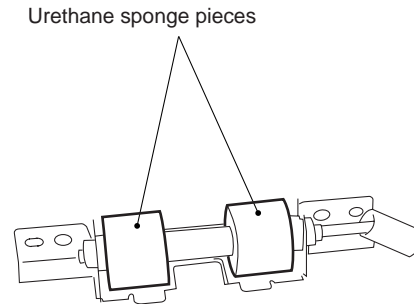

F-8-89

8.11.12 Manual Feed Tray paper sensor

8.11.12.1 Removing the Manual Feed Tray Paper Sensor

- 1) Open the manual feed tray unit, and remove the door tape from the machine side.
- 2) Remove the mounting screw [1], and detach the solenoid cover [3]. (A claw [2] is hooked on the L-shaped opening; pull it down lightly, and move it as if to open it.)

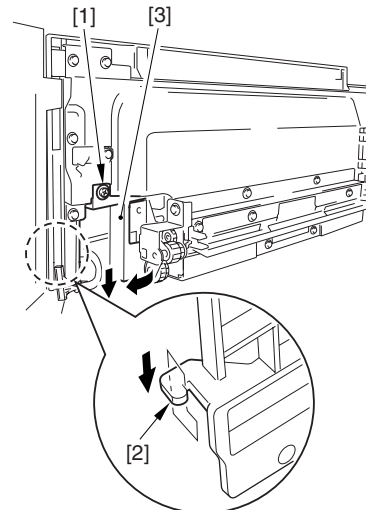

F-8-90

- 3) Disconnect the connector [1].
- 4) Remove heater mounting screw [2], and detach the pickup roller releasing solenoid [3] together with the support plate.

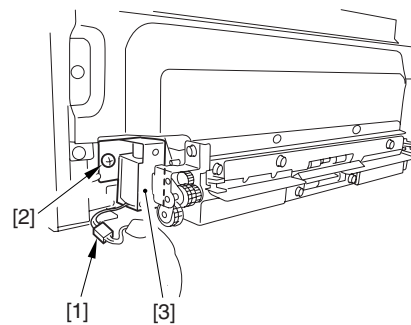

F-8-91

- 5) Remove the screw [1], and detach the connector cover [2]; then, disconnect the connector [3].

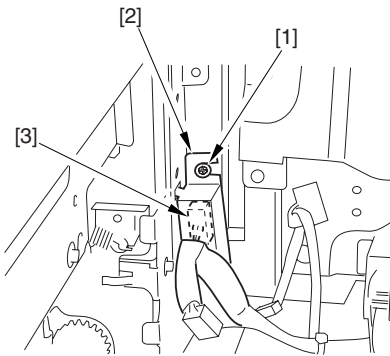

F-8-92

- 6) Open the manual feed tray.
7) Remove the 11 mounting screws [1], and detach the manual feed tray pickup assembly [2].

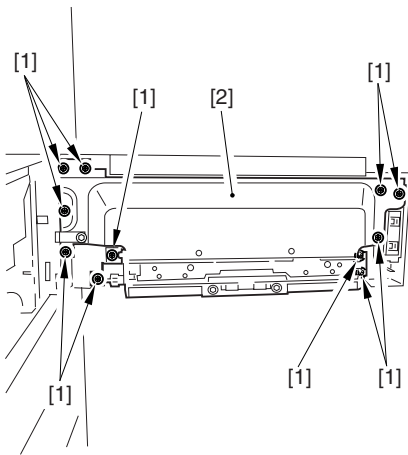

F-8-93

- 8) Remove the 2 mounting screws [1], and detach the upper guide plate [2].

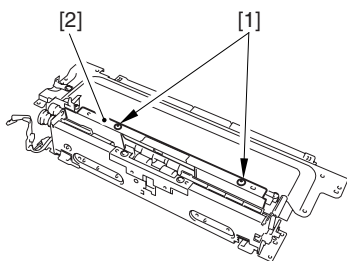

F-8-94

- 9) Remove the 2 mounting screws [1] found at the bottom, and detach the lower cover [2].

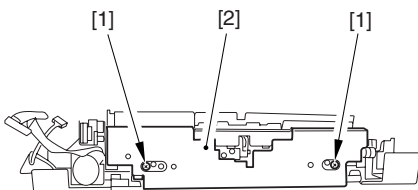

F-8-95

- 10) Remove the 2 mounting screws [1], and detach the middle guide plate [2].

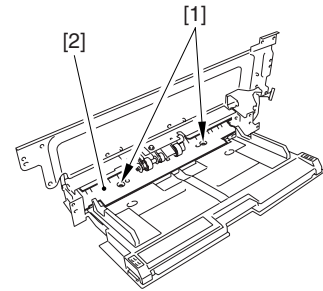

F-8-96

- 11) Remove the 2 mounting screws [2] of the sensor unit [1].

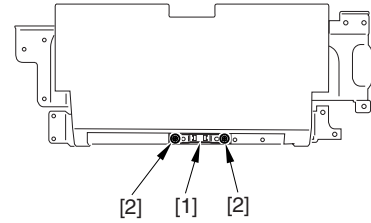

F-8-97

- 12) Disconnect the connector [1], and detach the sensor unit [2].
13) Remove the sensor [3] from the sensor unit [2].

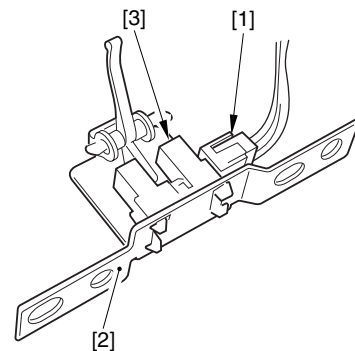

F-8-98

8.11.13 Manual Feed Pickup Solenoid

8.11.13.1 Position of the Pickup Roller Release Solenoid of the Manual Feed Tray

To make fine adjustments, slide the solenoid in the direction of A so that the gap between the shutter [1] and the shutter plate [2] is 0.4 +/-0.2 mm while the solenoid is being pulled.

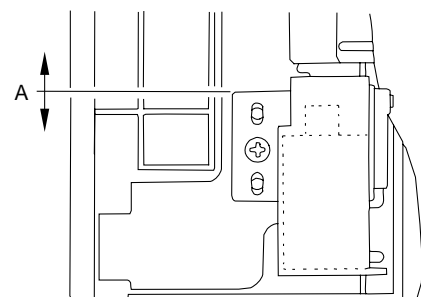

F-8-99

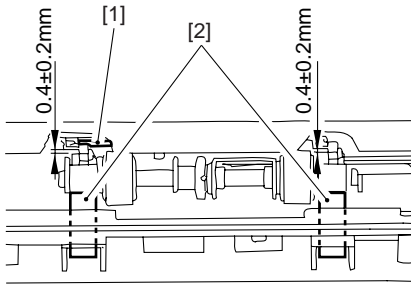

F-8-100

8.11.14 Registration Roller

8.11.14.1 Removing the Pre-Registration Roller

- 1) Open the middle right cover, and remove the screw [1]; detach the connector cover [2], and remove the two screws [3]; then, detach the rear fixing plate [4].

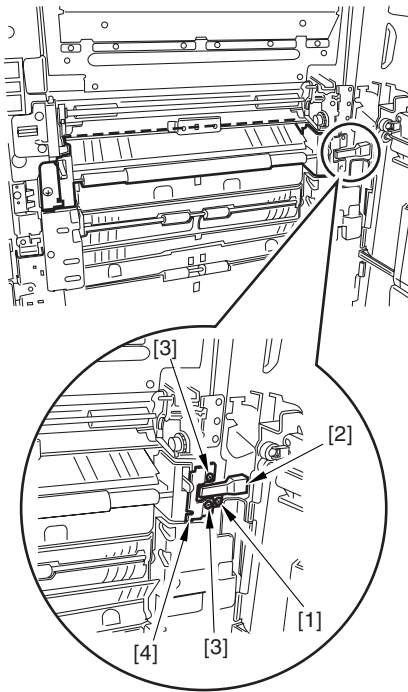

F-8-101

- 2) Remove the screw [5], and detach the front fixing plate [6]; then, detach the preregistration roller assembly [7].

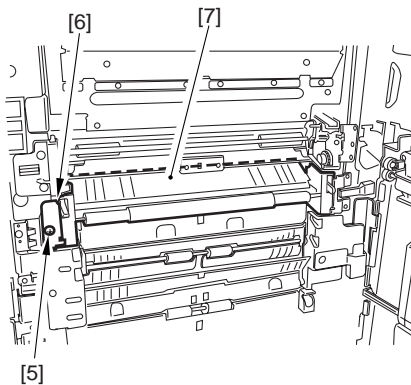

F-8-102

- 3) Remove the two springs [8], E-ring [9], and arm support shaft [10] at the front.
- 4) Remove the E-ring [11], spacer [12], and bearing [13].

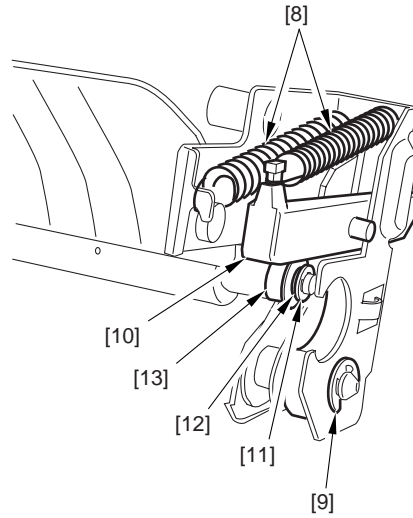

F-8-103

- 5) Perform steps 3) and 4) for the rear; then, detach the pre-registration roller assembly.

8.11.15 Registration Clutch

8.11.15.1 Removing the Registration Clutch

- 1) Remove the fixing/feed unit.
- 2) Shift up the releasing lever.
- 3) Disconnect the connector [1], and detach the harness of the clutch from the clutch cover [2].
- 4) Remove the screw [3], and detach the clutch cover [2] and the bearing [4].

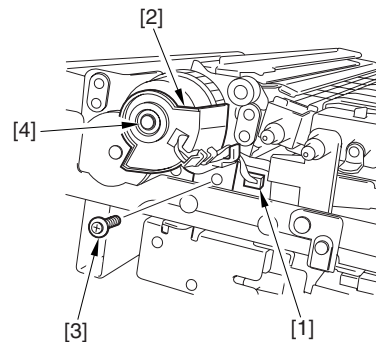

F-8-104

- 5) Loosen the 2 adjusting screws [1], and detach the registration clutch [2].

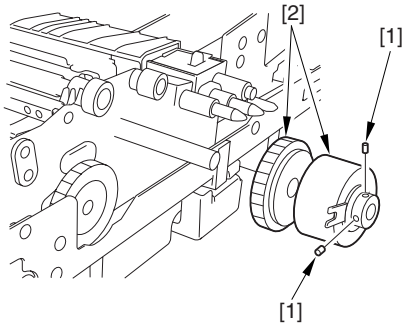

F-8-105

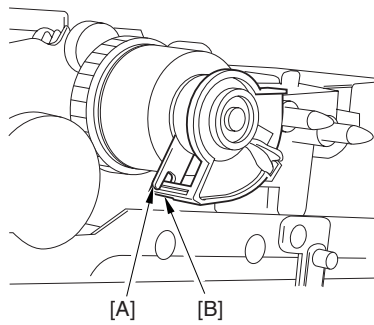

F-8-106



When mounting the registration clutch, be sure to hook the clutch stop [A] on the protrusion [B] of the clutch cover.

8.11.16 Registration Brake Clutch

8.11.16.1 Removing the Registration Brake Clutch

- 1) Remove the transfer separation charging assembly front cover. (1 screw)
- 2) Disconnect the connector [1], and loosen the 2 screws [2] (w/ hex hole); then, detach the registration brake clutch [3].

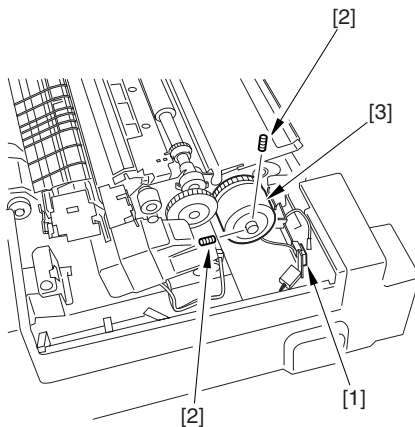

F-8-107

8.11.17 Fixing/Feed Unit

8.11.17.1 Removing the Fixing/Feed Unit

- 1) Slide out the fixing/feed unit.
- 2) Remove the 2 stepped screws [1].

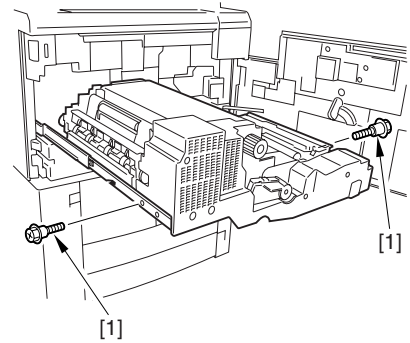

F-8-108

- 3) Remove the fixing/feed unit [1] from the slide rail [2].

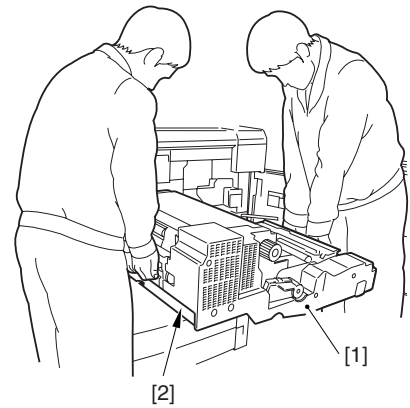

F-8-109



Be sure to work as a group of two.

8.11.18 Feeding Roller

8.11.18.1 Removing the Feeding Roller

- 1) Remove the pickup assembly from the main body.
- 2) Remove the screw [2], and detach the feeding roller cover [1].
- 3) Remove the stop ring [3] from the front of the fixing roller.
- 4) Remove the stop ring [4] and the pickup roller [5] at the front; then, detach the feeding roller [7] together with the timing belt [6].

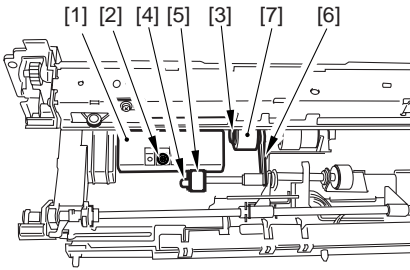

F-8-110

8.11.18.2 Orientation of the Feeding Roller of the Deck/Cassette Pickup Assembly

When mounting the feeding roller assembly to the deck/cassette pickup assembly, be sure that the belt pulley [2] is to the front of the machine. When mounting the feeding roller [3] to the feeding roller shaft [4], be sure that the round marking [5] is toward the front of the machine.

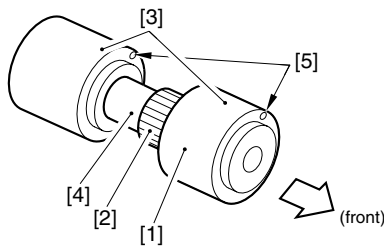

F-8-111

8.11.19 Vertical Path Roller

8.11.19.1 Removing the Vertical Path Roller 1/3/4

- 1) Remove the deck right/cassette pickup assembly.
- 2) Remove the E-ring [1] and the bearing [2] from the front, and remove the grip ring [3], clutch [4], and bearing [5] from the rear.

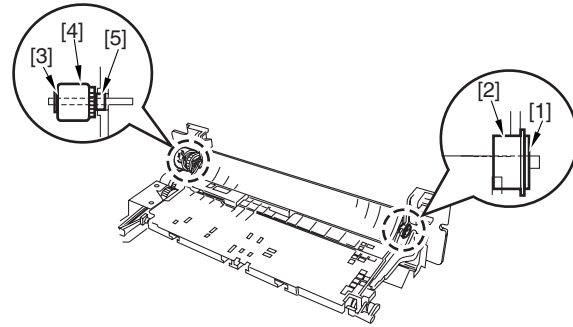

F-8-112

- 3) Remove the E-ring [1] of the front and the rear of the roller shaft, and move the bearings [2] toward the inside; then, detach the guide plate [3].

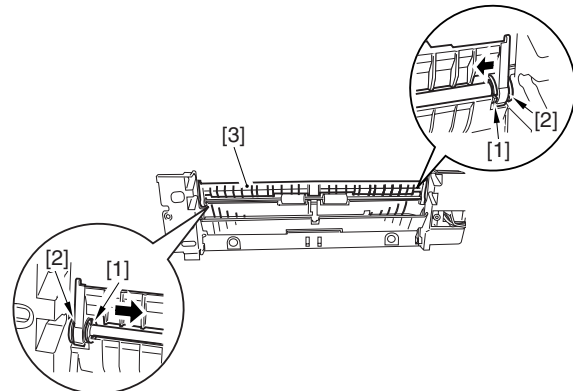

F-8-113

- 4) Remove the E-ring [1], and remove the bearing [2] to detach the vertical path roller [3].

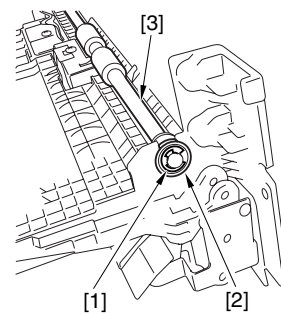

F-8-114

8.11.19.2 Removing the Vertical Path Roller 2

- 1) Slide out the deck (right) and the caste 3/4.
- 2) Remove the 3 screws [1], and detach the right lower front cover [2].

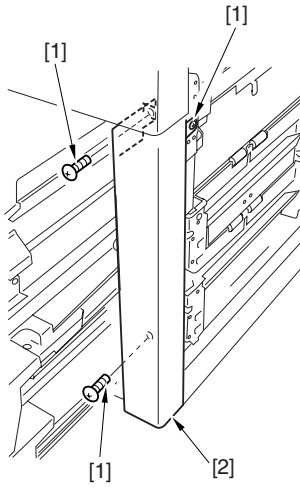

F-8-115

- 3) Disconnect the connector [1] and the screw [2]; then, detach the guide plate [3].

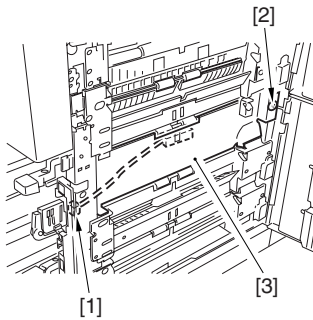

F-8-116

- 4) Remove the E-ring [1] at the front of the roller shaft, and move the bearing [2] toward the inside; then, detach the vertical path roller 2 [3].

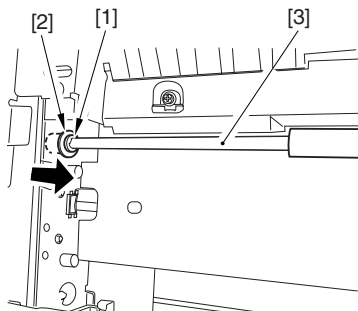

F-8-117

8.11.20 Fixing Feeding Unit Releasing Lever Sensor

8.11.20.1 Removing the Fixing Feeding Unit Releasing lever Sensor

- 1) Slide out the fixing feeding unit from the main body.

- 2) Detach the fixing feeding unit front cover.
- 3) Release the claw of the fixing feeding unit releasing lever sensor [1].

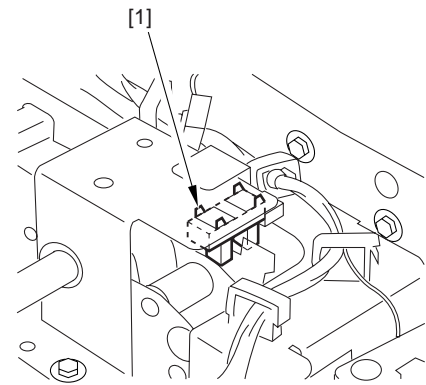

F-8-118

8.11.21 Feeding Belt

8.11.21.1 Removing the Feeding Belt

- 1) Slide out the fixing feeding unit from the main body.
- 2) Remove the fixing feeding unit front cover.
- 3) Disconnect the three connectors [1], and remove the screw [2]; then, detach the harness guide [3].

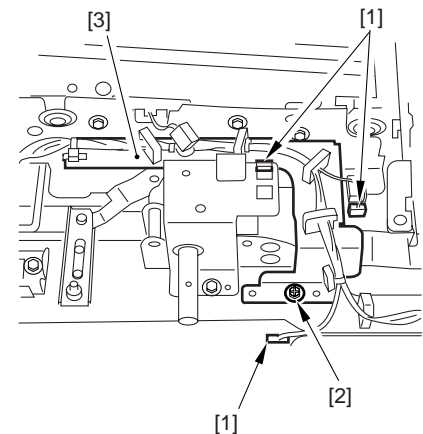

F-8-119

- 4) Remove the two screws [4], and detach the fixing feeding unit releasing lever support plate [5].

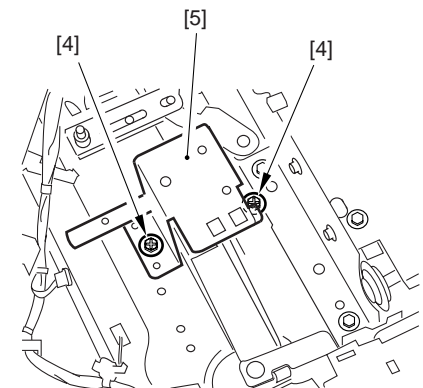

F-8-120

- Remove the E-ring [6], bearing [7], and three screws [8].

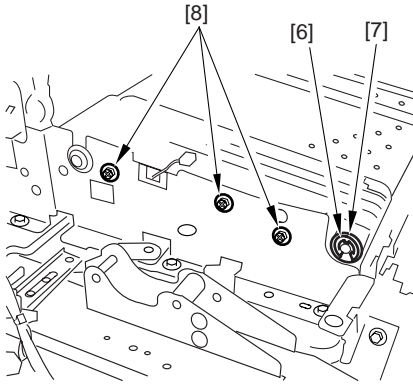

F-8-121

- Remove the E-ring [9], gear [10], pin [11], three screws [12], E-ring [13], and bearing [14].

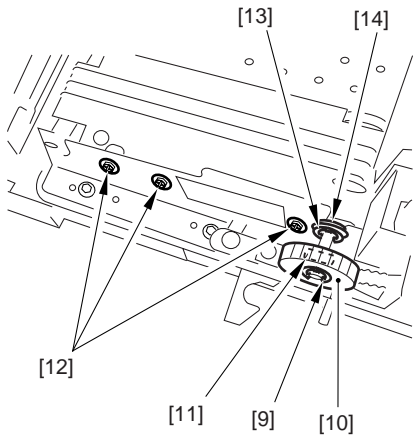

F-8-122

- Remove the feeding belt unit [15], and detach the feeding belt [16] and the postcard belt [17].

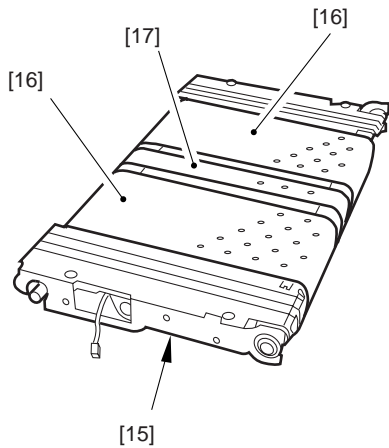

F-8-123

8.11.22 Duplexing Unit

8.11.22.1 Removing the Duplexing Unit

- Slide out the duplexing unit from the main body.

- Holding the left and right grips of the duplexing unit, detach it from the main body.

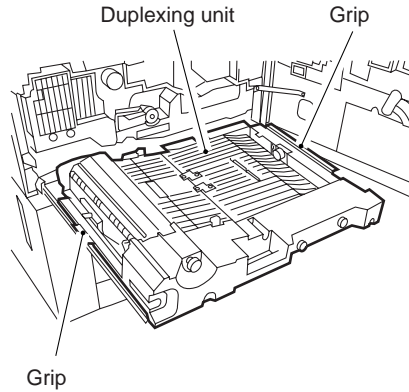

F-8-124



Take care not to trap your hand between the grip and the rail. Do not place the duplexing unit where it is subjected to damage.

8.11.22.2 Removing the Reversal Motor

- Remove the duplex feed fan unit.
- Loosen the screw [1]; then, while pulling the tension support plate [2] in the direction of the arrow, tighten the screw [1] (to loosen the tension of the belt [2]).
- Disconnect the connector [4], and remove the 2 screws [5]; then, detach the reversal motor [6].

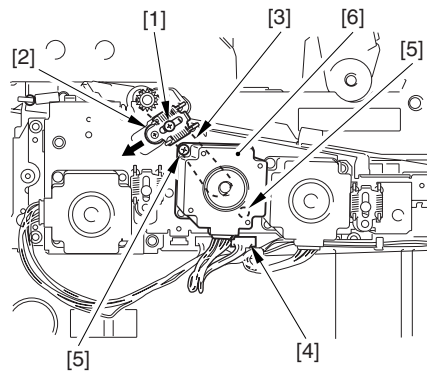

F-8-125

8.11.22.3 Removing the Front Cover of the Duplexing Unit

- 1) Remove the 4 screws [1] and the knob [2]; then, detach the front cover [3].

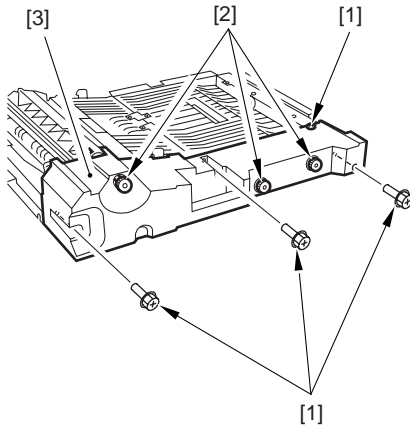

F-8-126

8.11.22.4 Removing the Duplex Left Feed Motor

- 1) Remove the duplex feed fan unit.
- 2) Loosen the screw [1]; then, while pulling the tension support plate [2] in the direction of the arrow, tighten the screw [1] (to loosen the tension of the belt [3]).
- 3) Disconnect the connector [4], and remove the 2 screws [5]; then, detach the duplex left feed motor [6].

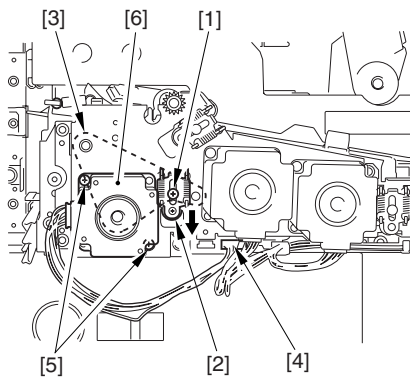

F-8-127

8.11.22.5 Removing the Duplex Right Feed Motor

- 1) Remove the front cover of the duplex unit. (4 screws, 3 knobs)
- 2) Loosen the screw [1]; then, while pulling the tension support plate [2] in the direction of the arrow, tighten the screw [1] (to loosen the tension of the belt [3]).

- 3) Disconnect the connector [4], and remove the 2 screws [5]; then, detach the duplex right feed motor [6].

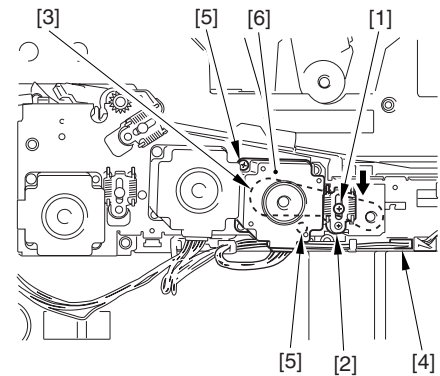

F-8-128

8.11.22.6 Removing the Reversing Flapper Solenoid

- 1) Remove the duplexing unit from the main body.
- 2) Remove the two screws [1], and disconnect the connector [2]; then, detach the reversing flapper solenoid [3].

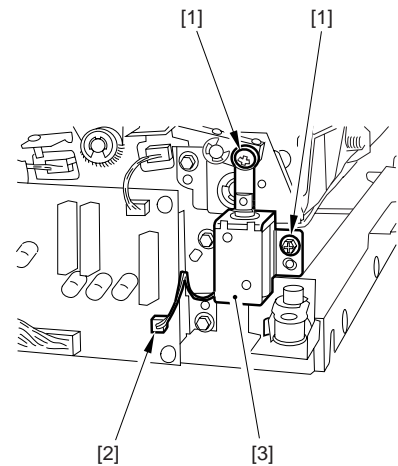

F-8-129

8.11.22.7 Removing the Left Deck Feed Sensor

- 1) Slide out the duplex unit assembly.
- 2) Remove the screw [1], and detach the sensor base [2].

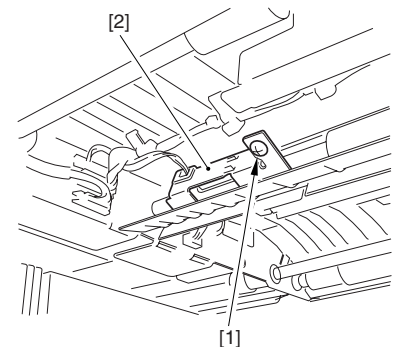

F-8-130

- 3) Disconnect the connector [1], and free the claw to detach the left deck feed sensor [2].

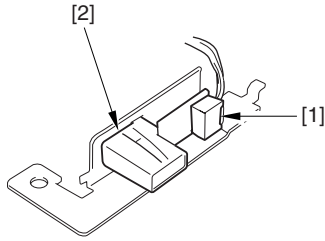

F-8-131



When removing the scanner sensor, be sure to remove the paint used to lock the claw in place in advance to prevent breaking the claw. When mounting it, be sure the claw is not displaced or the sensor is not disoriented.

8.11.22.8 Removing the Horizontal Registration Motor

- 1) Remove the duplexing unit from the main body.
- 2) Remove the two screws [1], and detach the upper cover [2].

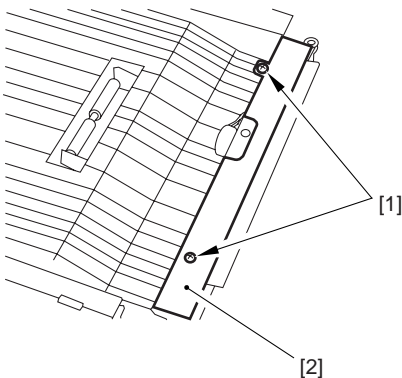

F-8-132

- 3) Disconnect the connector [3], and remove the screw [4]; then, detach the horizontal registration motor [5].

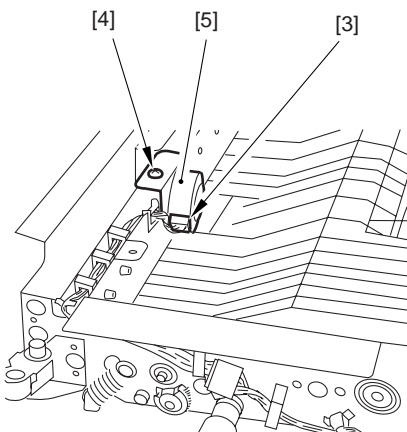

F-8-133

8.11.22.9 Removing the Deck (left) Draw-Out Clutch/Lower Feeder Middle Clutch

- 1) Remove the duplexing unit from the main body.
- 2) Remove the front cover.
- 3) Remove the two set screws [2] to detach the locking ring [1]; then, disconnect the connector [3], and detach the clutch [4]. (Be sure to perform this for each pair.)

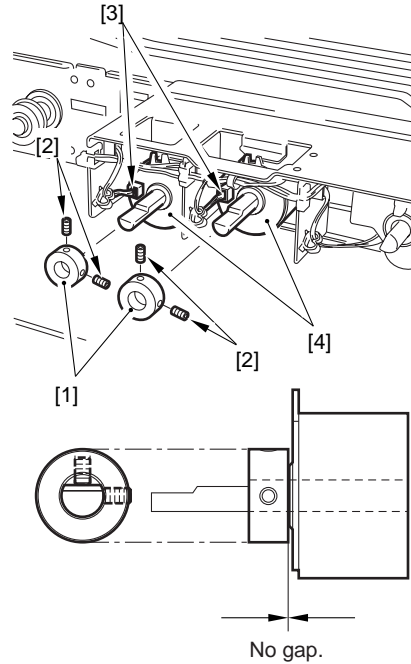

F-8-134



When fixing the lock ring in place, be sure that it is perpendicular in relation to the D-cut face and one of the 2 set screws.

8.11.22.10 Removing the Lower Feeding Right Clutch

- 1) Remove the duplexing unit from the main body.
- 2) Remove the front cover.
- 3) Disconnect the connector [1], and remove the two screws [2]; then, detach the latch plate [3].

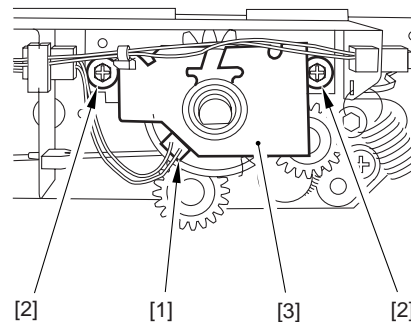

F-8-135

- 4) Remove the bearing [4] and spacer [5]; then, detach the lower feeding right clutch [6].

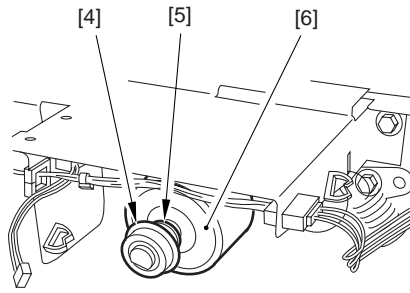

F-8-136

8.11.22.11 Removing the Pre-Confluence Sensor

- 1) Disconnect the connector [1] from the bottom of the duplexing unit; then, remove the screw [2], and detach the preconfluence sensor [3].

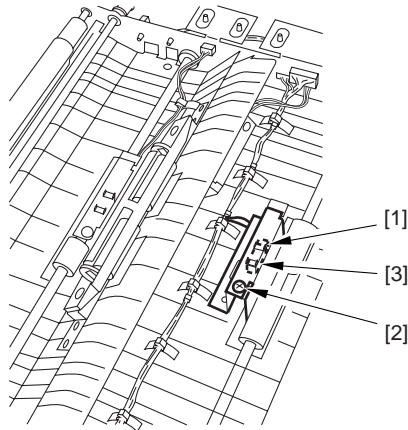

F-8-137

8.11.22.12 Removing the Post-Confluence Sensor

- 1) Remove the two screws [1] from the bottom of the duplexing unit; then, detach the left deck feeding roller assembly [2].

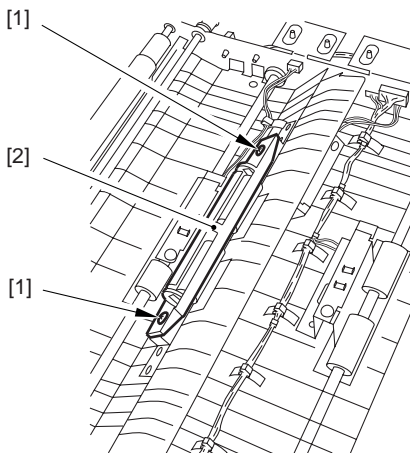

F-8-138

- 2) Disconnect the connector [3]; then, remove the screw [4], and detach the postconfluence sensor [5].

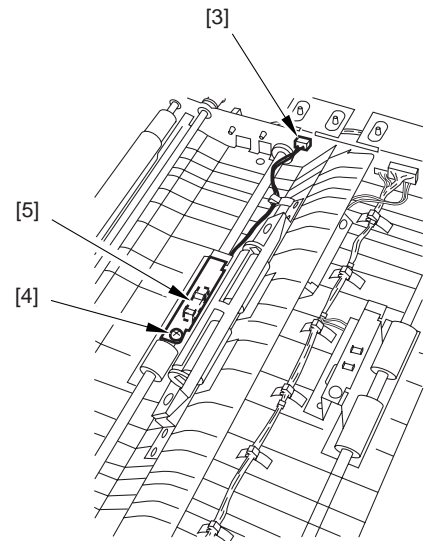

F-8-139

8.11.22.13 Removing the Front Deck (lifter) Draw-Out Sensor

- 1) Disconnect the connector [1] from the bottom of the duplexing unit; then, remove the screw [2], and detach the front deck (left) feed sensor [3].

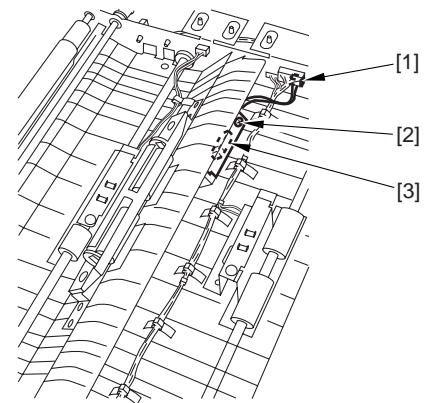

F-8-140

8.11.22.14 Removing the Horizontal Registration Sensor

- 1) Remove the duplexing unit from the main body.
- 2) Remove the front cover.
- 3) Disconnect the connector [1], and remove the three screws [2].

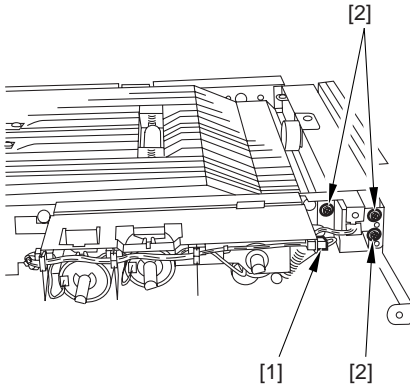

F-8-141

- 4) Remove the screw [3], and detach the duplexing unit right fixing assembly [4]; then, remove the two screws [5] at the rear, and detach the right grip plate [6].

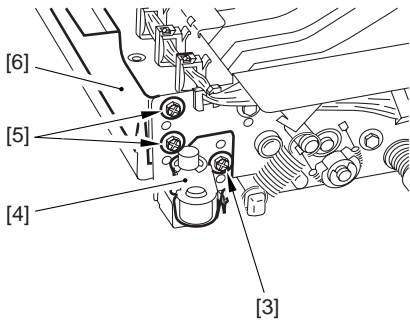

F-8-142

⚠ When mounting the right grip plate, be sure that the boss on the grip plate is in the hole of the side plate.

- 5) Remove the screw [7], and detach the horizontal registration sensor [8].

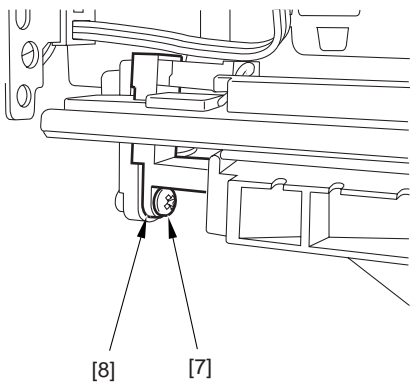

F-8-143

8.11.23 Separation Roller

8.11.23.1 Removing the Separation Roller

- 1) Remove the two mounting screws [1], and remove the feeding guide plate [2]; then, detach the open/close guide [3]. (Skip this step for the pickup assembly of the front deck left.)

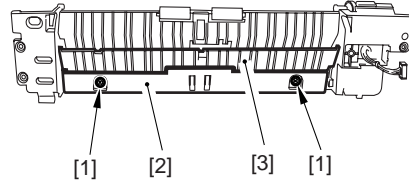

F-8-144

- 2) Remove the two mounting screws [4], and remove the separation roller assembly [5] from the joint. (If for the pickup assembly of the front deck left, remove one screw.)

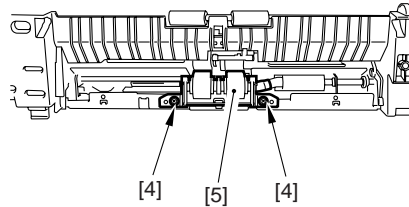

F-8-145

- 3) Detach the separation roller [6] from the separation roller shaft mount.

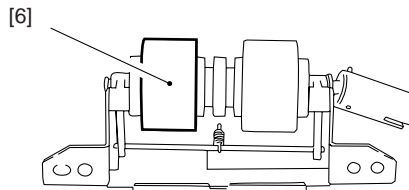

F-8-146

⚠ Initially, the urethane sponge of the part is pink, and changes over time (accelerated if exposed to light). Its tone will change from pink to orange and to yellow; it is a general characteristic of urethane sponge, and no physical deterioration (in performance) exists because of changes in color, and the part is not identified by color.

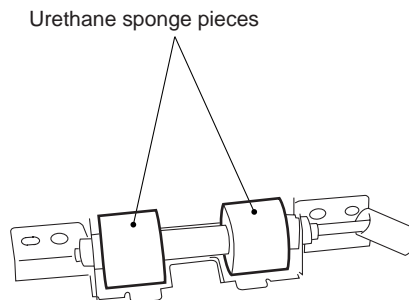

F-8-147

8.11.23.2 Orientation of the Separation Roller

Keep the following in mind when replacing the separation roller.

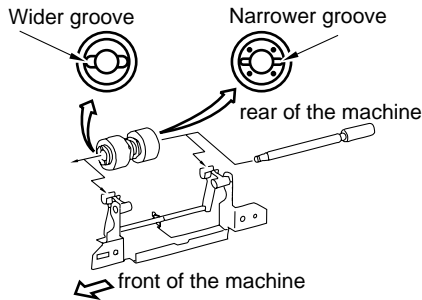

F-8-148



If mounted in the wrong orientation, interference with the clamp washer can lead to faults. Take care.

8.11.24 Double Feeding Detection Sensor (Transmission)

8.11.24.1 Before Starting the Work

- 1) Slide to the fixing/feeding unit.
- 2) Remove the transfer/separation charging assembly cover.
- 3) Remove the transfer/separation charging assembly.
- 4) Remove the 2 knobs [1].
- 2 screws [2]

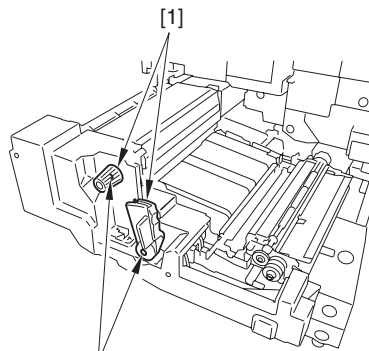

F-8-149

- 5) Remove the fixing/feeding unit cover [1].
- 2 screws [2]

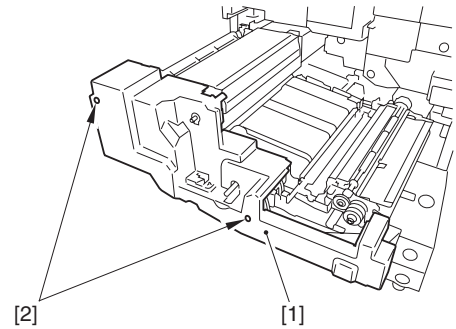

F-8-150

- 6) Free the 2 cables [1] from the edge saddle [1]; then, disconnect the 2 connectors [3].
- 7) Remove the registration roller [4].
- 2 screws [5] (using hex wrench)

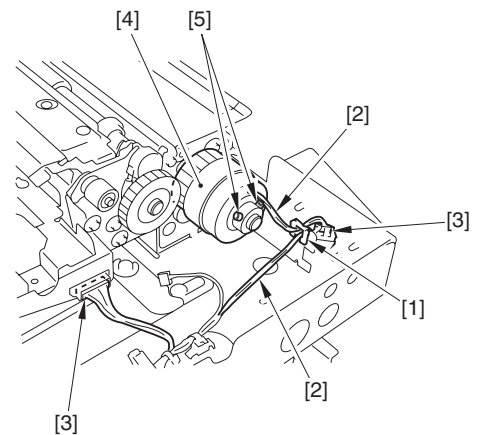

F-8-151

- 8) Remove the 3 screws [1].

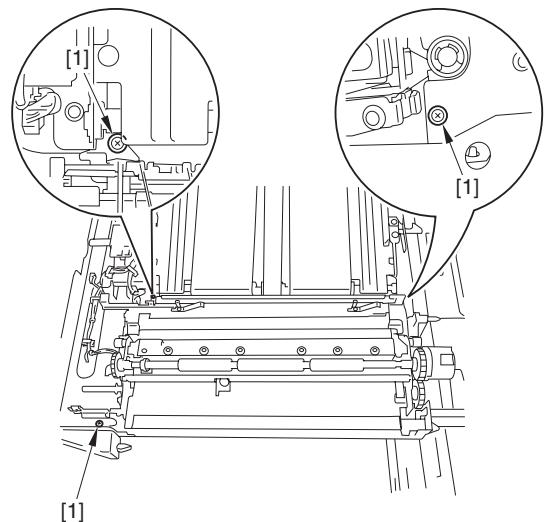

F-8-152

- 9) Remove the bushing [1] in the direction of the arrow, and remove the registration transfer unit [2].
- E-ring [3]
 - bushing [4]

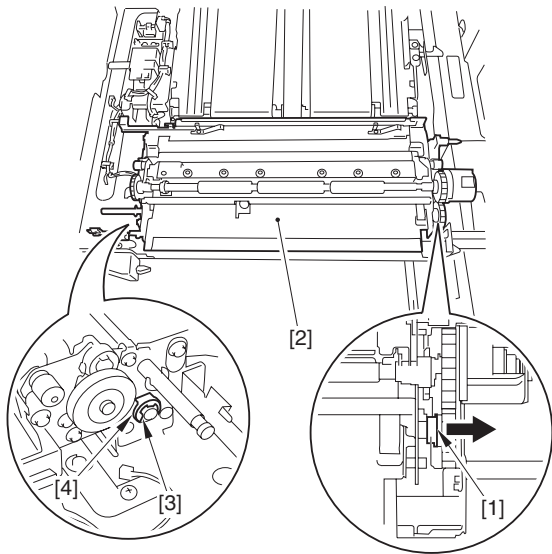

F-8-153

8.11.24.2 Removing the Double-Feed Sensor (transmitting)

- 1) Turn over the registration transfer unit, and detach the harness protective sheet [1].

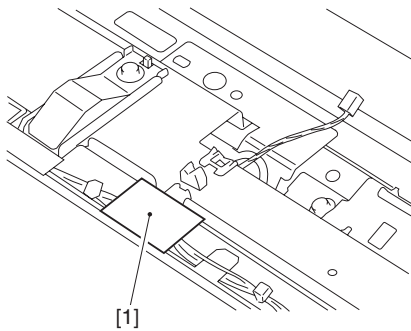

F-8-154

- 2) Disconnect the cable [1].
- 1 edge saddle [2]
 - 1 clamp [3]
 - 1 connector [4]

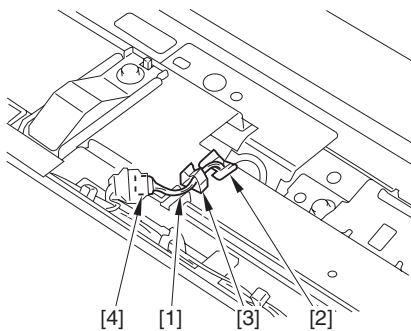

F-8-155

- 3) Remove the double-feed sensor assembly [1].
- 1 screws [2]

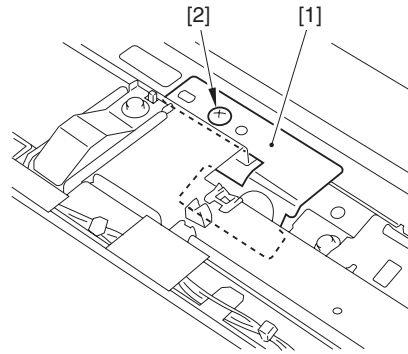

F-8-156

- 4) Remove the double-feed sensor (transmitting) [1].
- 1 screw [2]
 - 1 sensor holder [3]

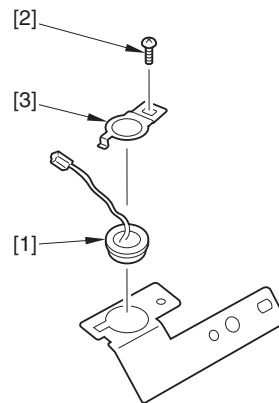

F-8-157

8.11.25 Double Feeding Detection Sensor (Reception)

8.11.25.1 Before Starting the Work

- 1) Remove the developing assembly.
- 2) Remove the primary charging assembly.
- 3) Remove the pre-transfer charging assembly.
- 4) Remove the process unit.

8.11.25.2 Removing the Double-Feed Sensor (receiving)

- 1) Remove the pre-transfer charging assembly fan duct assembly [1].
- 4 screws [2]

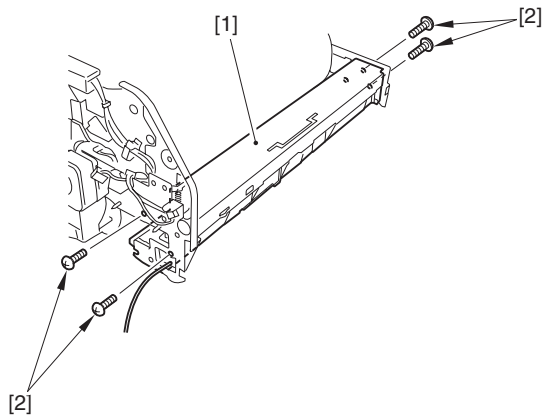

F-8-158

- 2) Remove the pre-transfer charging assembly fan duct [1].
- 3 screws [2]

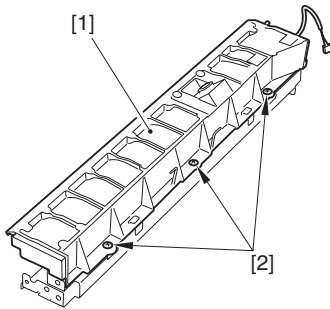

F-8-159

- 3) Remove the double-feed sensor (receiving) [1].
- 2 screws [2]
- 1 connector [3]

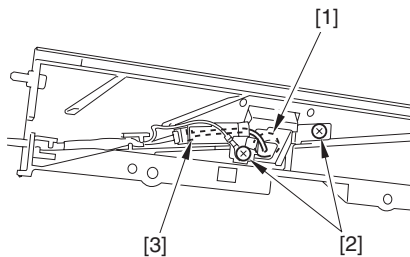

F-8-160

Fixing System

Contents

9.1 Construction.....	9- 1
9.1.1 Outline	9- 1
9.1.2 Major Components	9- 1
9.1.3 Overview of the Fixing Drive System.....	9- 2
9.1.4 Controlling the Fixing Roller Drive	9- 3
9.1.5 Controlling the Cleaning Web Drive.....	9- 3
9.1.6 Controlling the Thermistor Reciprocating Mechanism.....	9- 4
9.1.7 Controlling the Upper Separation Claw Reciprocating Mechanism.....	9- 4
9.1.8 Controlling the Fixing Inlet Sensor Drive.....	9- 5
9.2 Basic Sequence	9- 6
9.2.1 Basic Sequence of Operations	9- 6
9.3 Various Control Mechanisms	9- 7
9.3.1 Controlling the Fixing Roller Temperature	9- 7
9.3.1.1 Controlling the Down Sequence.....	9- 7
9.3.1.2 Transparency Mode	9- 8
9.3.1.3 Heavy Paper Mode.....	9- 8
9.3.1.4 Power Save Mode	9- 9
9.4 Protective Functions.....	9- 10
9.4.1 Error Detection	9- 10
9.5 Parts Replacement Procedure	9- 12
9.5.1 Fixing Unit.....	9- 12
9.5.2 Upper Fixing Roller	9- 13
9.5.3 Lower Fixing Roller	9- 14
9.5.4 External Delivery Roller.....	9- 15
9.5.5 Internal Delivery Roller	9- 16
9.5.6 Main Thermistor.....	9- 16
9.5.7 Sub Thermistor	9- 17
9.5.8 Thermal Switch	9- 17
9.5.9 Fixing Heater.....	9- 18
9.5.10 Fixing Cleaning Belt.....	9- 19
9.5.11 Claw Jam Sensor	9- 20
9.5.12 External Delivery Sensor.....	9- 20
9.5.13 Internal Delivery Sensor	9- 21
9.5.14 Reversal Sensor	9- 21
9.5.15 Fixing Inlet Sensor	9- 21
9.5.16 Fixing/Feeding Outlet Sensor.....	9- 22
9.5.17 Delivery Speed Switch Clutch	9- 22
9.5.18 Upper Separation Claw	9- 23
9.5.19 Lower Separation Claw	9- 23

9.1 Construction

9.1.1 Outline

The following shows the major functions of the machine's fixing system:

T-9-1

Component	Notation	Description
Fixing upper roller		heat roller, 60mm dia.
Fixing lower roller		Pressure roller, 50mm dia.
Fixing motor	M3	DC motor, 33 W
Fixing inlet sensor lifter motor	M21	TBD
main heater	H1	200V model: 1150 W (100V model: 1000 W) 208V model: 1120 W (208V model: 900 W) 230V model: 1185 W (230V model: 965 W)
Sub heater	H2	200V model: 565W (100V model: 400) 208V model: 600W (208V model: 600W) 230V model: 645W (230V model: 645W) The values in parentheses represent the iR7086.
Main thermistor	TH1	temperature control, error detection (contact)
Sub thermistor	TH2	temperature control (non-contact)
Thermal switch	TP1	operating temperature: 226 +/-5 deg C
Cleaning web		driven by the web drive solenoid (SL2) for large-size paper (B4 or larger), goes on twice for small-size paper (smaller than B4), goes on once fixed

Inlet guide

9.1.2 Major Components

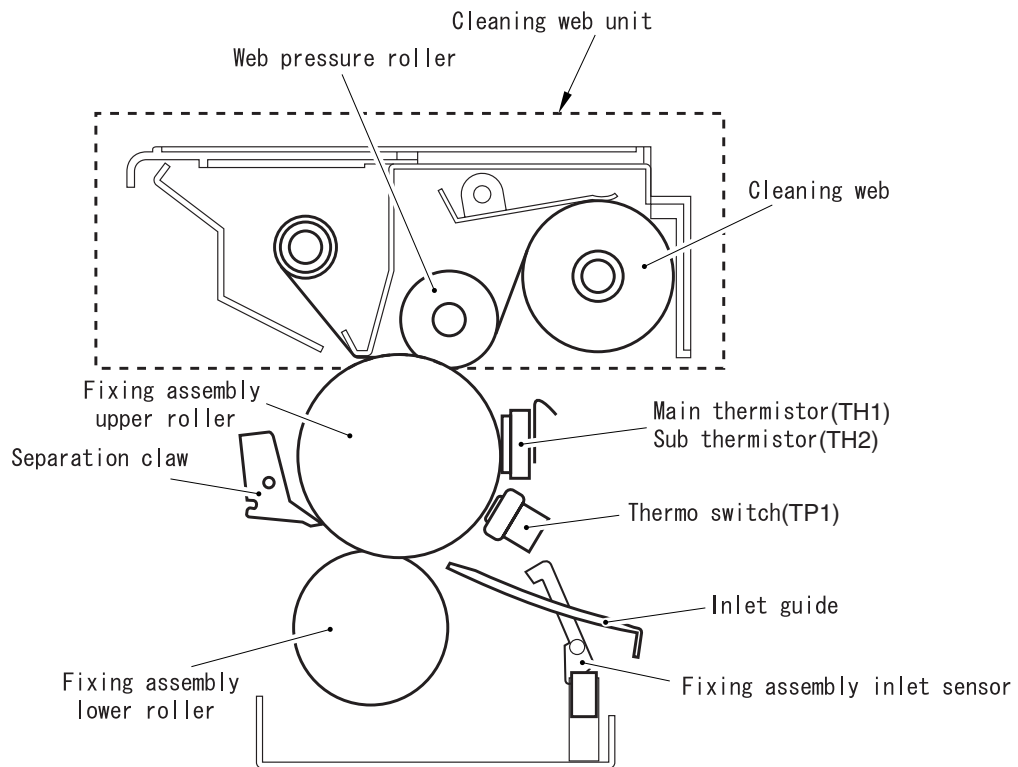

F-9-1

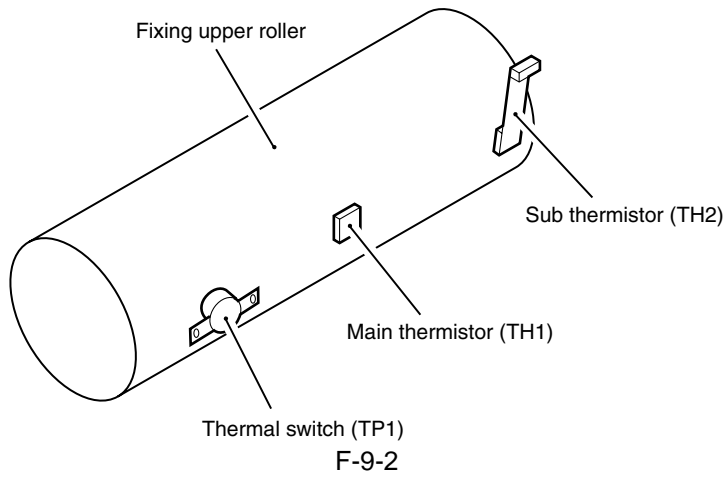

9.1.3 Overview of the Fixing Drive System

The following items are associated with the machine's fixing drive system:

- [1] fixing roller drive control
- [2] cleaning web drive control
- [3] thermistor reciprocating mechanism drive control
- [4] upper separation claw reciprocating drive mechanism
- [5] fixing inlet sensor drive control

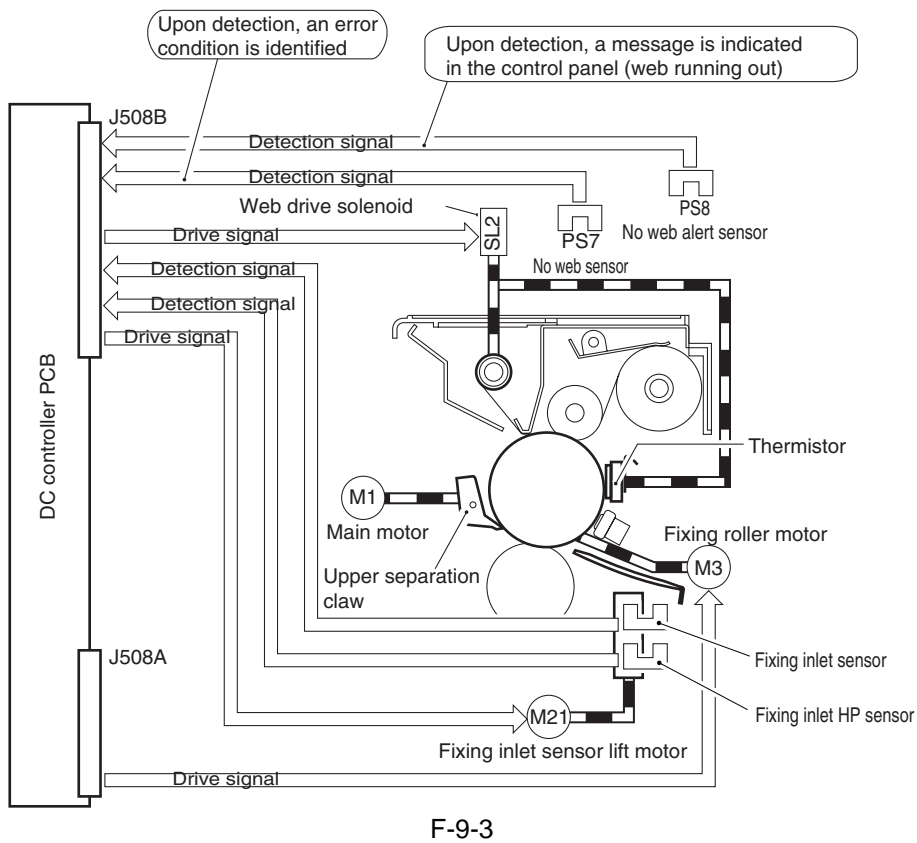

9.1.4 Controlling the Fixing Roller Drive

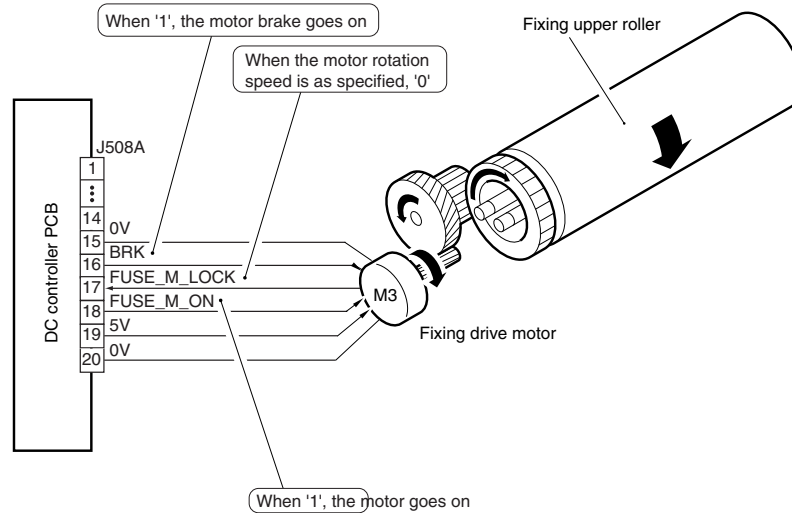

F-9-4

The machine controls the braking mechanism to prevent paper from fully wrapping around the fixing roller.

In response to detection of an inside delivery delay jam, the machine causes the motor brake to go on to stop the motor. This operation is executed exclusively in response to an inside delivery sensor delay jam.

ERROR CODE:

E014 (fixing motor speed error)

When the motor is rotating (i.e., FUSE_M_ON=1), FUSE_M_LOCK=1 is true for 2 sec or more.

9.1.5 Controlling the Cleaning Web Drive

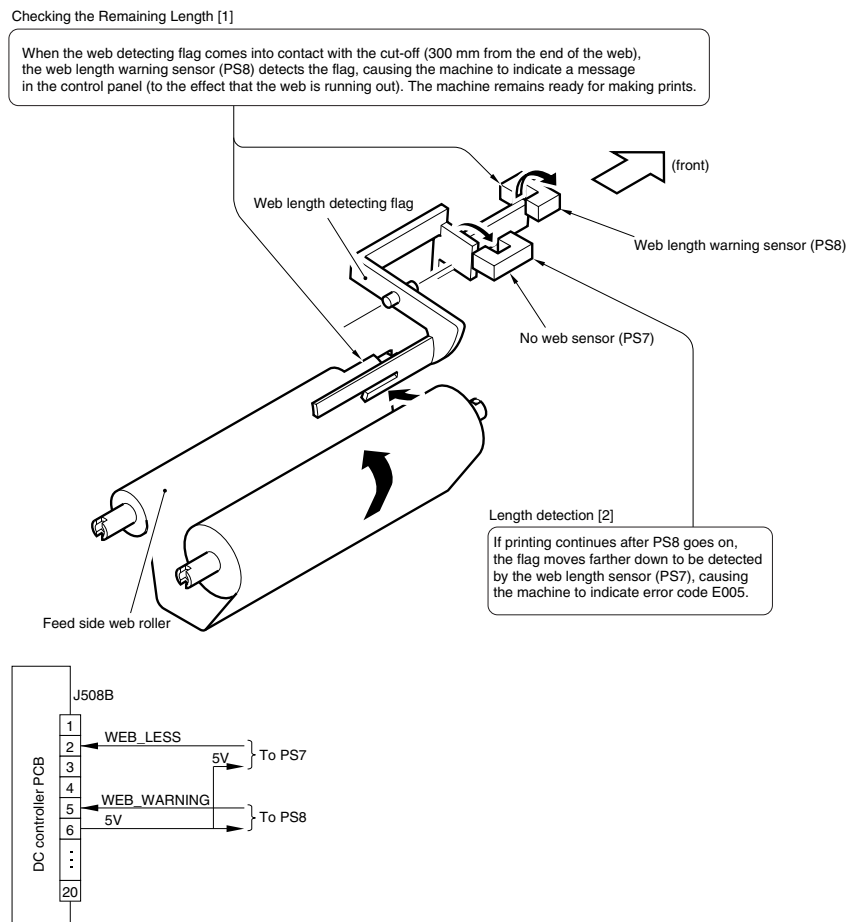

F-9-5

MEMO:

The machine can make about 100,000 prints (A4) after indicating the message (in the case of A3, 50,000 prints).

9.1.6 Controlling the Thermistor Reciprocating Mechanism

To prevent the thermistor (TH1) from scratching the fixing upper roller, the machine moves the thermistor back and forth 12 mm in the axial direction of the fixing upper roller.

The drive used to move the thermistor is obtained from the web drive solenoid (SL2) by way of a one-way arm (to reach the reciprocating cam).

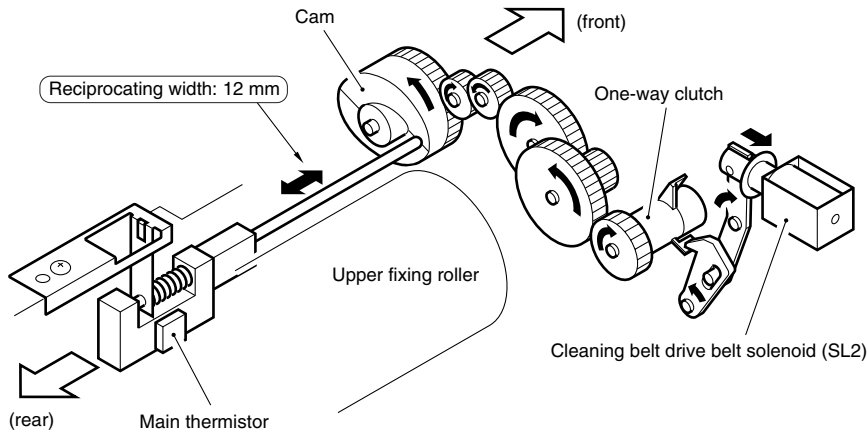

F-9-6

9.1.7 Controlling the Upper Separation Claw Reciprocating Mechanism

Figure shows the control system used to control the reciprocating mechanism of the upper separation claw.

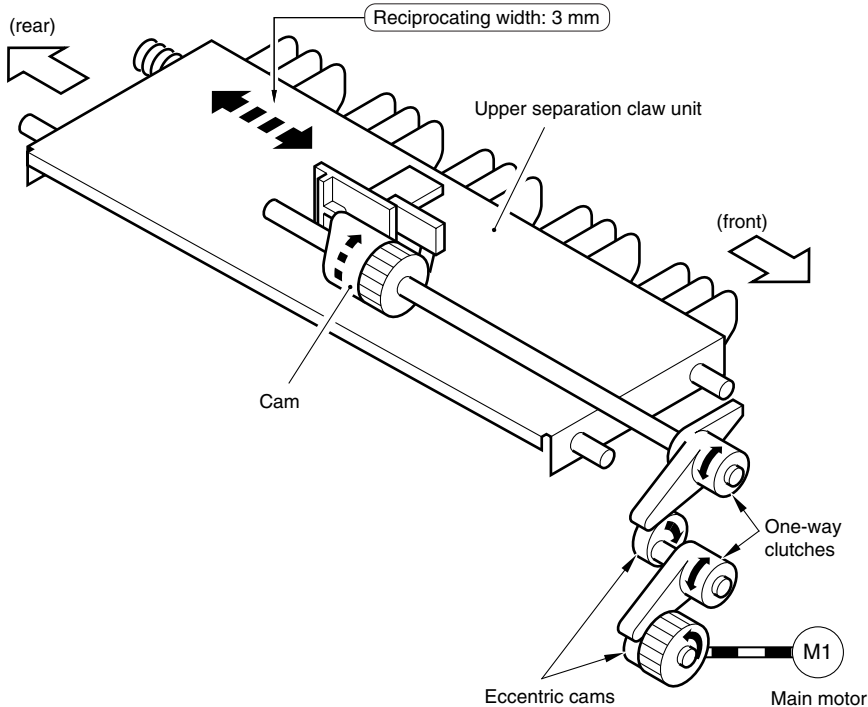

F-9-7

9.1.8 Controlling the Fixing Inlet Sensor Drive

The machine is equipped with a fixing inlet sensor to prevent paper from remaining inside the fixing assembly. The output of the sensor is used to move a lift mechanism, thereby making sure paper movement will not be disrupted.

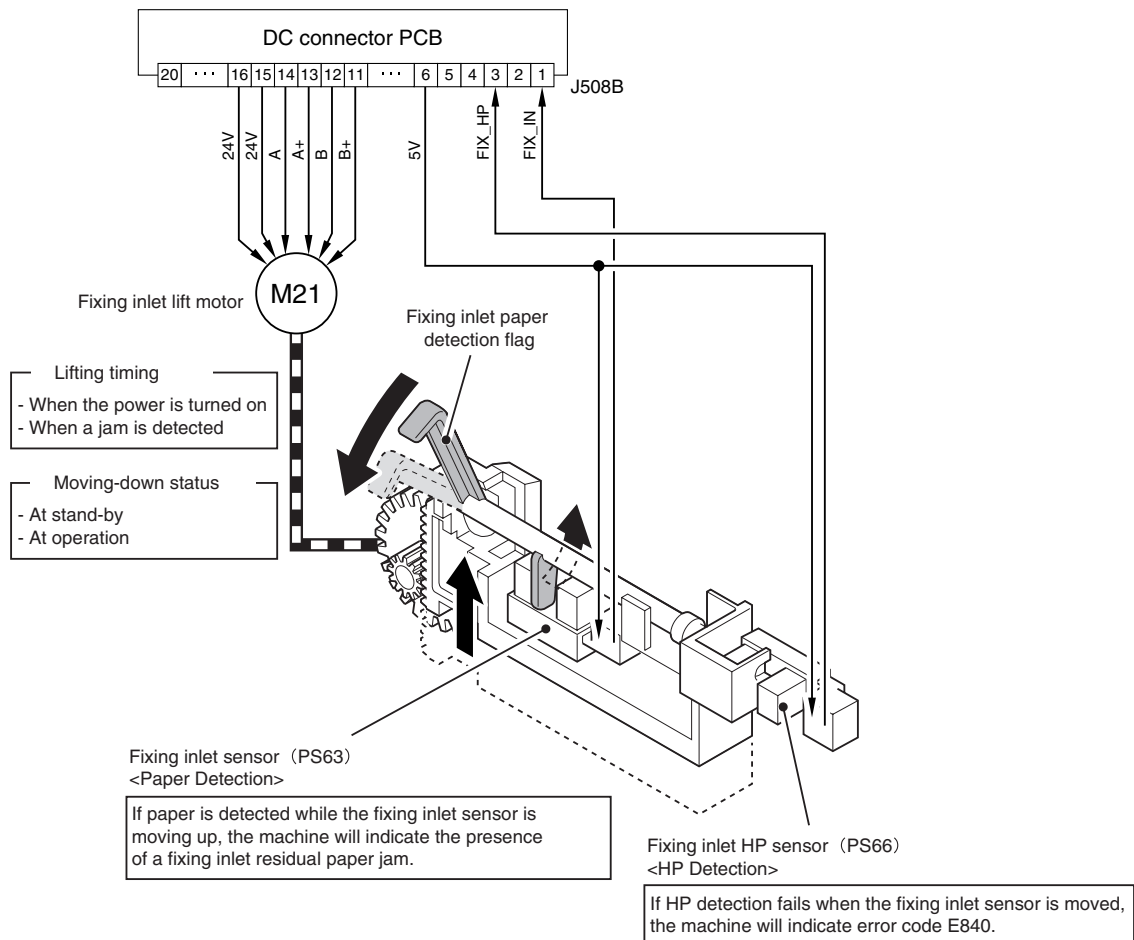

F-9-8

Reference:

Sheets of paper detected by the fixing inlet sensor must be B5 or larger.

ERROR CODE:

E840 (fixing inlet sensor movement error)

Indicates that a fault occurred while the wrap sensor is being moved up/down, thus causing HP detection to fail.

9.2 Basic Sequence

9.2.1 Basic Sequence of Operations

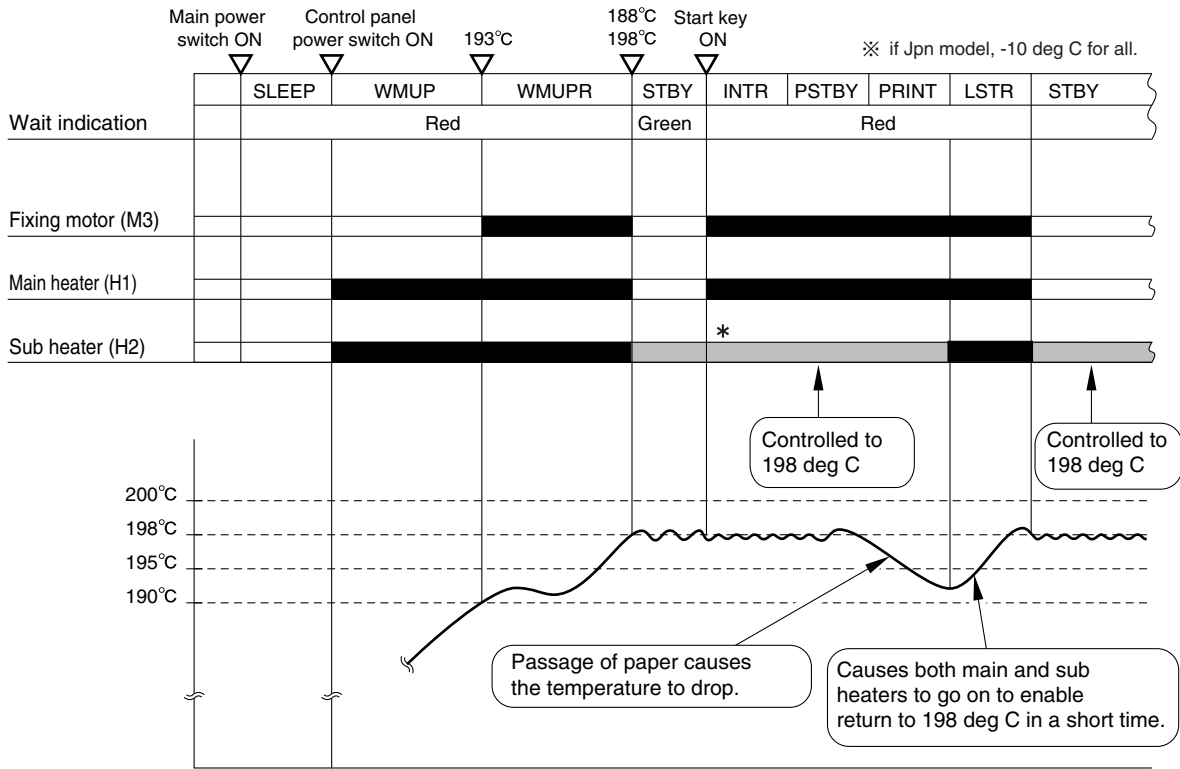

*iR7086 Jpn model (no temperature control is performed for the sub heater while paper is passing).

F-9-9

9.3 Various Control Mechanisms

9.3.1 Controlling the Fixing Roller Temperature

9.3.1.1 Controlling the Down Sequence

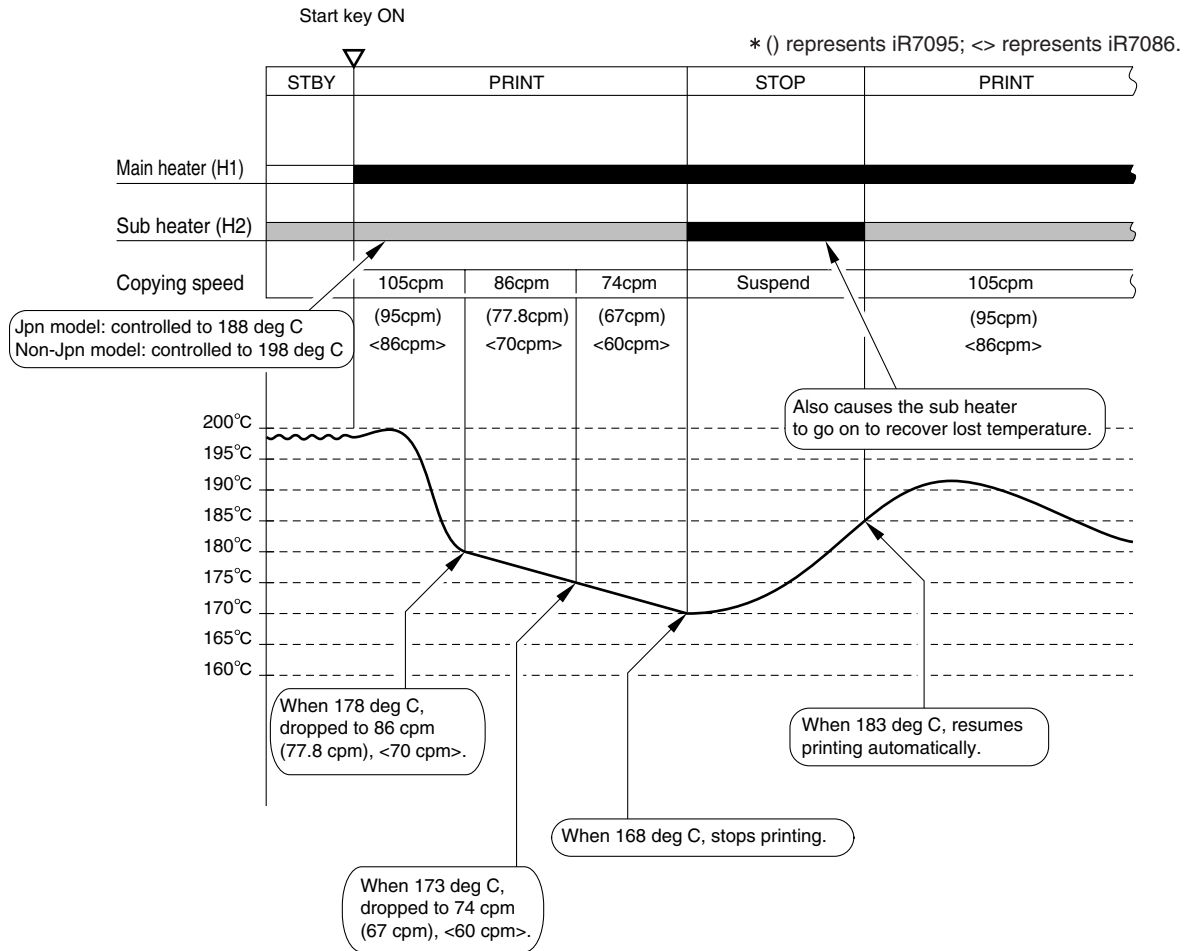

F-9-10

SERVICE MODE:

COPIER > OPTION > BODY > FIX-TMP (down sequence setting)

Setting	iR7105	86cpm	74cpm	Suspend	Resume
	iR7095	77.8cpm	67cpm	Suspend	Resume
	iR7086	70cpm	60cpm	Suspend	Resume
Setting 0		183 deg C	178 deg C	173 deg C	188 deg C
Setting 1 (default)		178 deg C	173 deg C	168 deg C	183 deg C
Setting 2		173 deg C	168 deg C	163 deg C	178 deg C

Set it to '0' to place priority on image quality; or, set it to '2' to place priority on speed.

9.3.1.2 Transparency Mode

In transparency mode, the machine decreases the fixing roller surface temperature to prevent wrapping of a transparency around the fixing roller (otherwise the heat of the roller could melt the film surface).

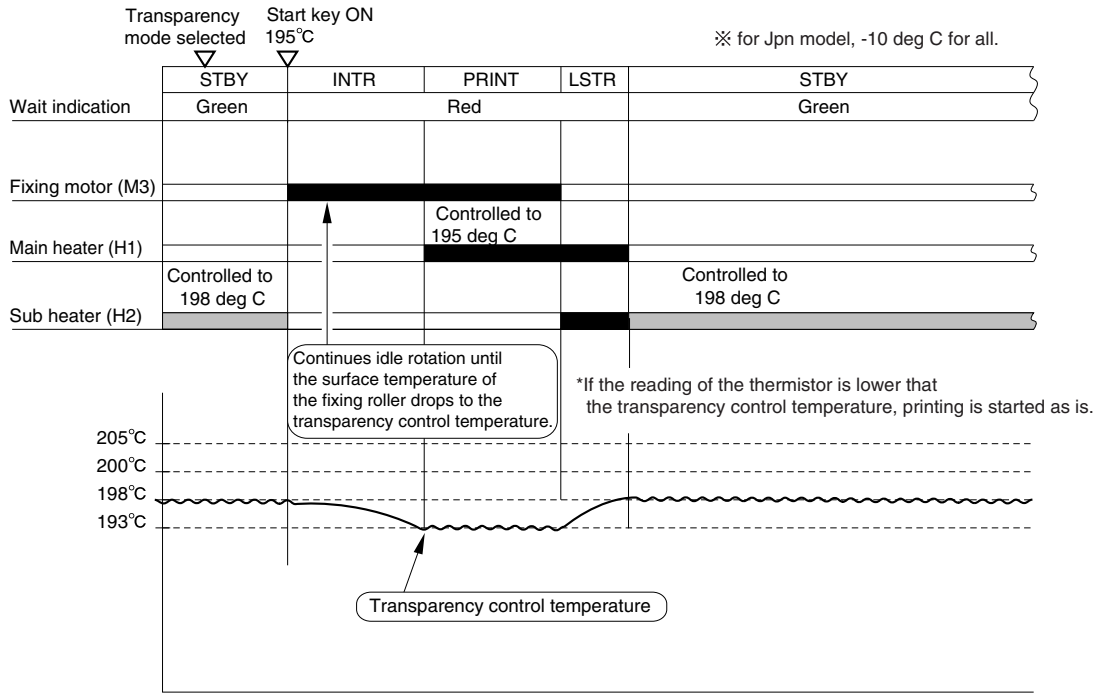

F-9-11

SERVICE MODE:

COPIER > OPTION > BODY > OHP-TEMP (transparency mode temperature setting switchover)

- 0: 198 dg C (default)
- 1: 193 dg C
- 2: 188 dg C
- 3: 183 dg C

9.3.1.3 Heavy Paper Mode

To prevent a drop in the surface temperature of the fixing roller in heavy paper mode, the machine uses a higher down sequence shift temperature.

The machine uses heavy paper down sequence mode when 'heavy paper' is selected for the following in user mode: common settings>paper type.

SERVICE MODE:

COPIER > OPTION > BODY > FIX-TEMP (heavy paper down sequence start temperature setting)

Setting	iR7105	86 cpm	74 cpm	Suspend	Resume
	iR7095	77.8 cpm	67 cpm	Suspend	Resume
	iR7086	70 cpm	60 cpm	Suspend	Resume
0 (default)		194 deg C	193 deg C	183 deg C	198 deg C
1		189 deg C	188 deg C	178 deg C	193 deg C
2		184 deg C	183 deg C	173 deg C	188 deg C

COPIER > OPTION > BODY > TEMP-TBL (heavy paper mode copy temperature setting; Jpn model only)

To prevent down sequence from starting with the 1st sheet in heavy paper mode, the machine uses heavy paper temperature control (in view of the fact that the Japanese model uses a control temperature of 188 deg C for printing).

Setting	Heavy paper copy temperature
0	+10 deg C
1 to 4	+0 deg C

9.3.1.4 Power Save Mode

A press on the Power Save key of the control panel causes the machine to decrease the STBY control temperature to reduce power consumption.

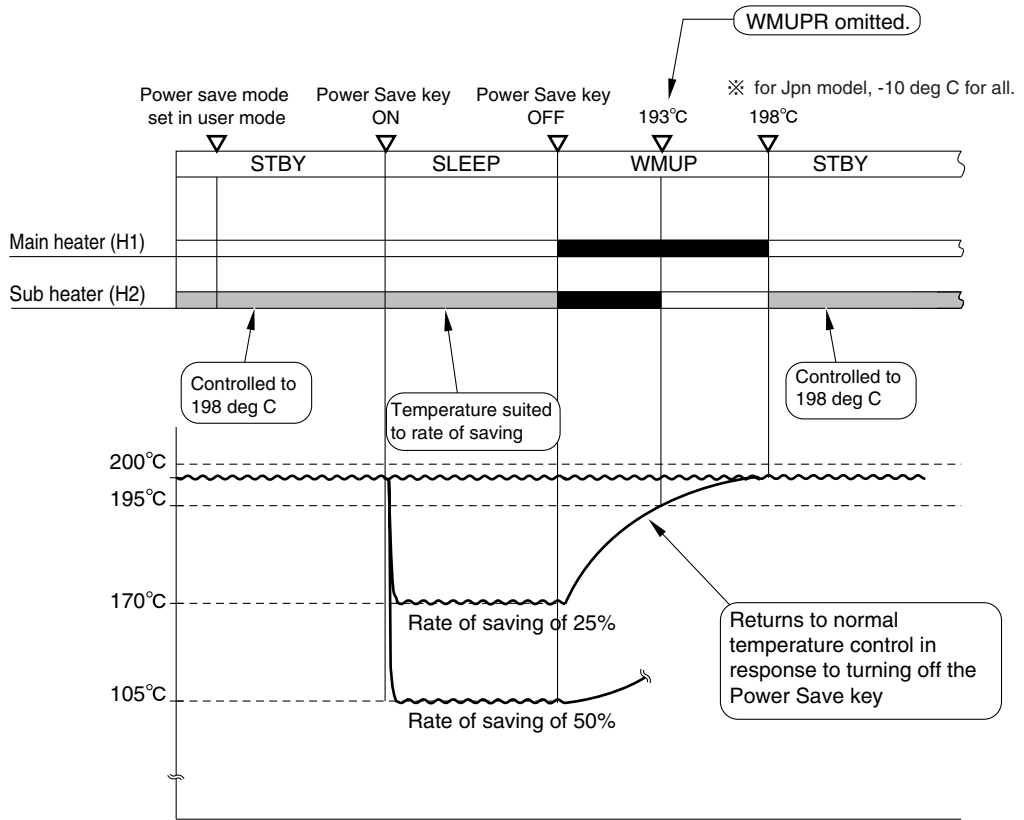

F-9-12

9.4 Protective Functions

9.4.1 Error Detection

The machine checks for the following types of errors in relation to its fixing temperature control mechanism:

- [1] temperature control error by main thermistor (tH1)
- [2] sensor error by sub thermistor (TH2)
- [3] current shut-down in response to overheating by thermal switch (TP1)

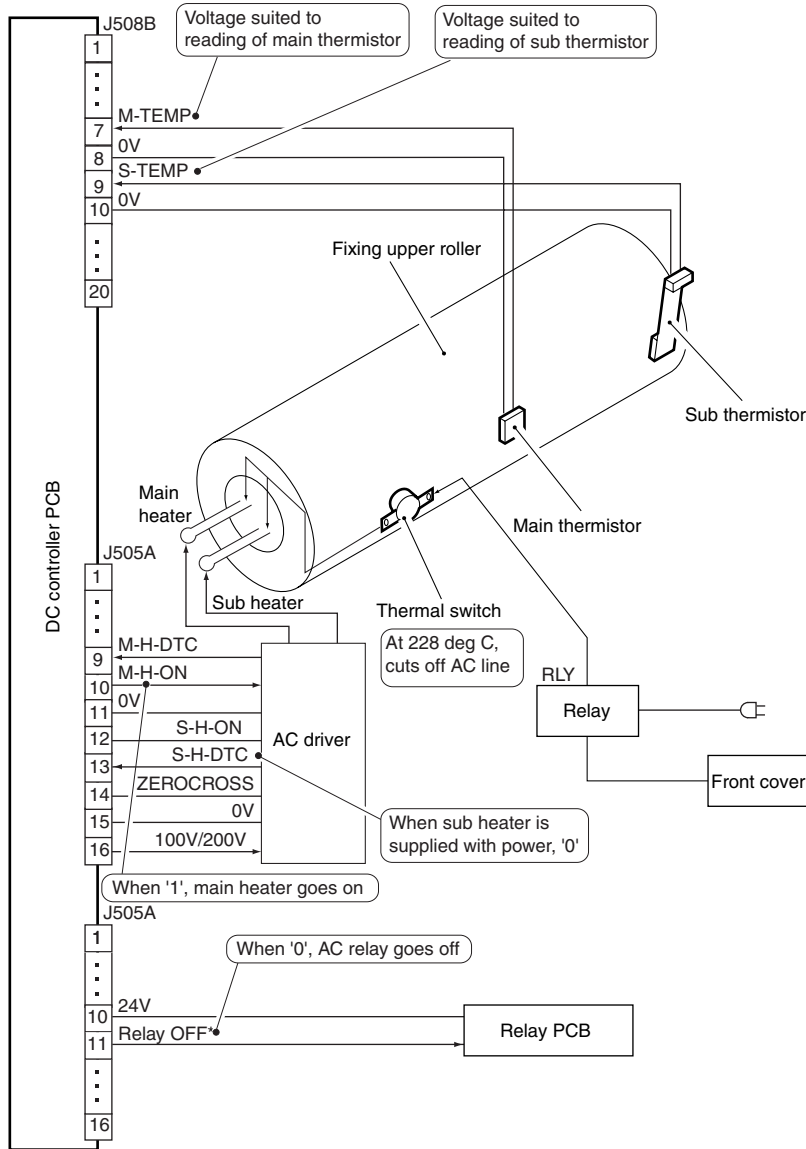

F-9-13

ERROR CODE:

E000 (heating failure)

0000 After the power is turned on, the reading of the main thermistor fails to reach 70 deg C or more within 3.5 min.

E001 (overheating)

0001 The reading of the main or sub thermistor is 230 deg C or more for 2 sec (detection by hardware).

0002 The reading of the main or sub thermistor is 230 deg C or more for 2 sec (detection by software).

0003 The difference between the readings of the main thermistor and the sub thermistor is 50 deg C for 1 sec or more (main > sub).

0004 The difference between the readings of the main and the sub thermistor is 50 deg C for 1 sec or more (main >= sub).

E002 (heating failure)

0001 The reading of the main thermistor is 70 deg C or more but does not reach 100 deg C within 2.5 min.

0002 The reading of the main thermistor exceeds 100 deg C but does not reach 150 deg C within 2.5 min thereafter.

E003 (low temperature)

0000 With the reading of the main thermistor in excess of 100 deg C, a temperature of 70 deg C or less is detected for 2 sec.

E004 (SSR short circuit)

0000 The SSR is identified as having a short circuit for 5 sec or more while the sub heater is on.

0001 The SSR is identified as having a short circuit for 5 sec while the main heater is on.

Reference:

If E000 through E004 is indicated, the code will not be reset even when the main power switch is turned off. To reset, use service mode (COPIER > FUNCTION > CLEAR > ERR).

9.5 Parts Replacement Procedure

9.5.1 Fixing Unit

9.5.1.1 Removing the Fixing Assembly

- 1) Slide the fixing/feeding unit halfway out the main body.
- 2) While pushing on the stopper [2] on both ends of the fixing/feeding unit rail [1], slide the fixing/feeding unit farther out.

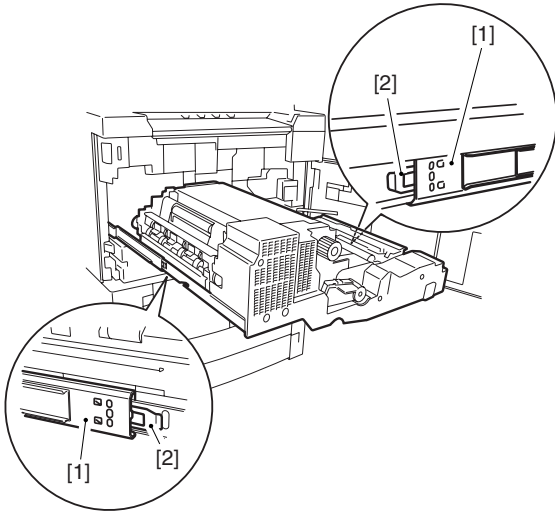

F-9-14

- 3) While pushing the releasing lever link [1] found at the rear of the fixing/feeding unit, shift up the fixing/feeding unit releasing lever [2], and remove the screw [3] to detach.

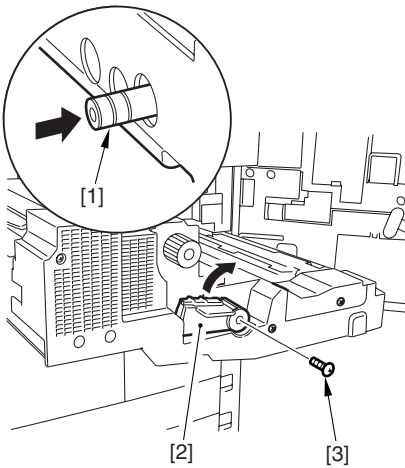

F-9-15



When setting the fixing/feeding unit in the main body, be sure to mount the releasing lever, and shift the lever while pressing the releasing lever link.

- 4) Remove the two screws [1], pre-transfer charging assembly cover [2], and fixing roller knob [3]; then, remove the two screws [4], and detach the fixing/feeding unit cover [5].

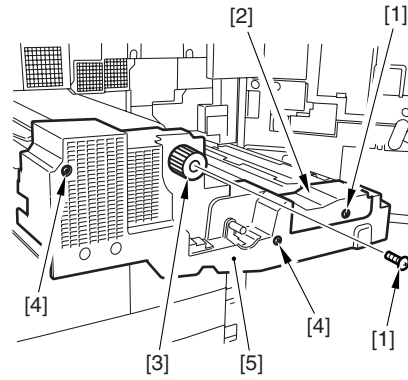

F-9-16

- 5) Remove the fixing motor [1].
 - 2 connectors [2]
 - Free the cable from the edge saddle [3]
 - 3 screws [4]
 - 5 connectors [5]

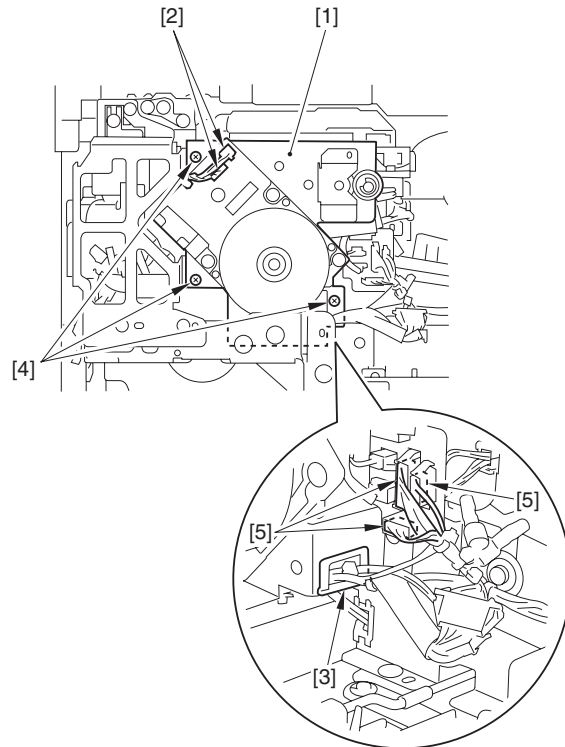

F-9-17

- 6) Open the fixing/delivery assembly, and remove the screw [1]; then, holding the front [3] and the rear [4] of the fixing assembly [2], detach the fixing assembly from the main body.

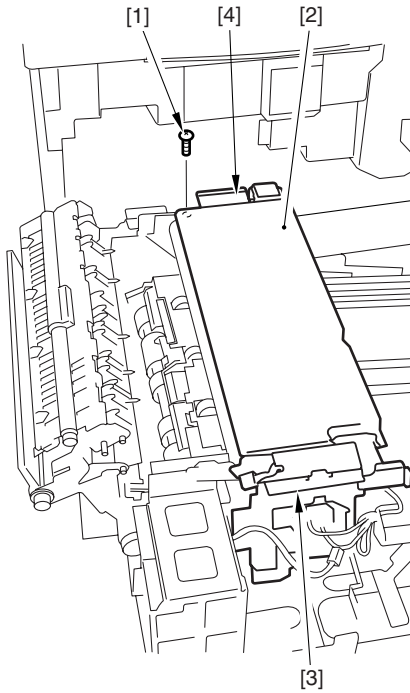

F-9-18

9.5.2 Upper Fixing Roller

9.5.2.1 Removing the Fixing Upper Roller

- 1) Remove the fixing assembly.
- 2) Remove the fixing web, and clean the oil pan.
- 3) Remove the 2 fixing heaters.
- 4) Remove the screw [1], and detach the pressure support plate [2] at the front.

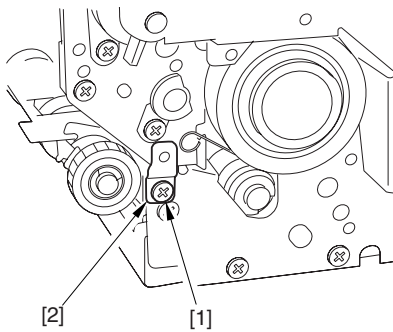

F-9-19

- 5) Remove the screw, and detach the pressure support plate [2] at the rear.

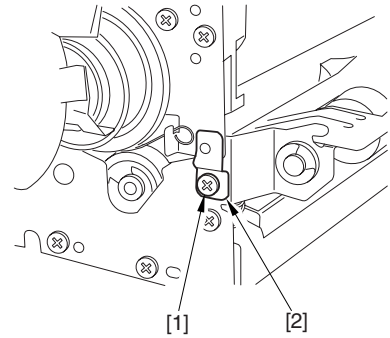

F-9-20

- 6) Open the fixing upper unit [1].

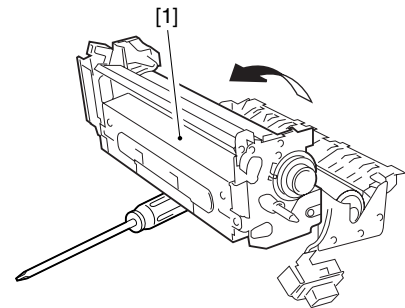

F-9-21



When opened, the fixing upper unit becomes unstable. Be sure to use a screwdriver as shown to support it.

- 7) Remove the stopper [1] from the front and the rear.

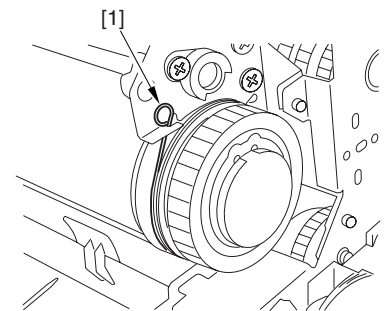

F-9-22

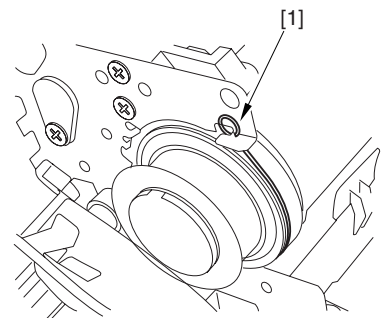

F-9-23

- 8) While paying attention to the thermal switch and the thermistor, remove the upper roller assembly.
- 9) Remove the C-ring [1] at the front, and remove the gear [2], bushing [3], and bearing [4].

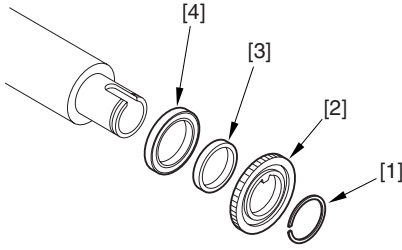

F-9-24

- 10) Remove the C-ring [1] at the rear, and remove the electrode plate [2], spacer [3], bearing [4], and bushing [5].

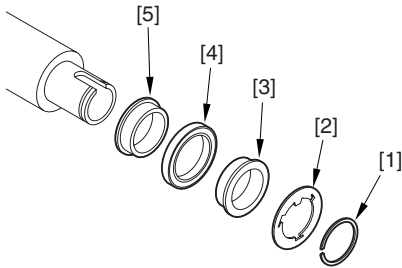

F-9-25

9.5.2.2 Mounting the Fixing Upper Roller

Mount the upper roller by reversing the steps used to remove it.



- a. To prevent the surface of the roller from dirt or damage, wrap paper after removing it.
- b. Be sure that the longer cutoff A shown in the figure is toward the rear.

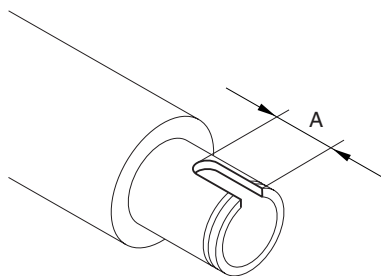

F-9-26

- c. When mounting, clean the electrode plate [1] and the electrode terminal [2].

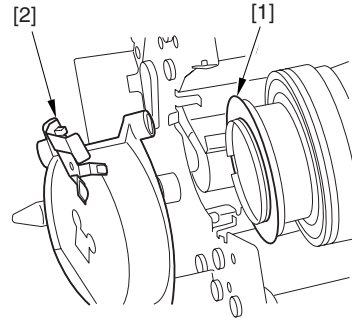

F-9-27

9.5.3 Lower Fixing Roller

9.5.3.1 Removing the Lower Fixing Roller

- 1) Remove the fixing assembly from the main body.
- 2) Remove the fixing cleaning belt; then, clean and detach the oil pan.
- 3) Open the upper fixing unit.
- 4) Remove the two screws [1], and detach the lower separation claw support plate [2].

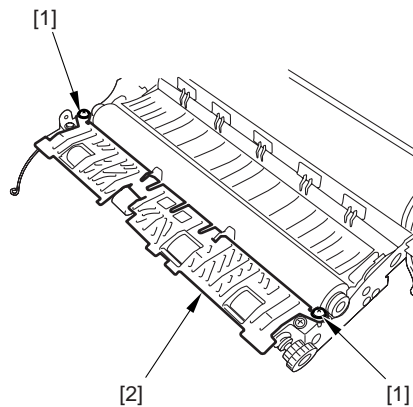

F-9-28

- 5) Remove the lower roller [3] from the fixing assembly, and remove the E-rings [4] and the bearings [5] from both front and rear.

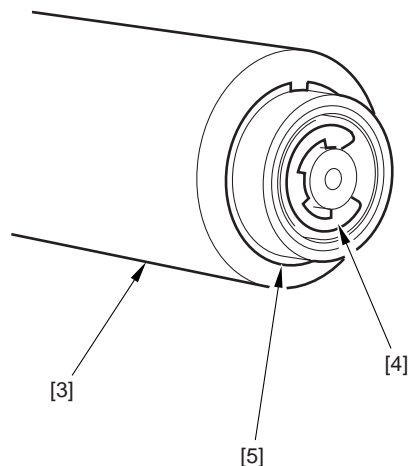

F-9-29

9.5.3.2 Adjusting the Lower Roller Pressure (nip)

The nip width must be as indicated in figure; if not, adjust it using the pressure adjusting nut.

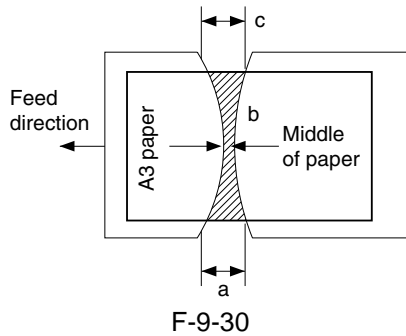

F-9-30



a and c are points 10 mm from both edges of paper.

T-9-2

Dimension	Measure with upper and lower rollers fully heated
b	200 V: 9.0 -/+ 0.5 mm, 208/230 V: 10.0 -/+ 0.5 mm
a-c	0.5 mm or less

a. Generating Output for Nip Width Measurement

Wait for 15 min after the copier ends its warm-up period; make 20 A4 copies, and measure the nip.

- 1) Place A3 copy paper in the manual feed tray.
- 2) Make the following selections in service mode to generate output:
COPIER > FUNCTION > FIXING > NIP-CHK.

The A3 paper will be picked up, and a copy like the one shown in figure will be delivered.

9.5.4 External Delivery Roller

9.5.4.1 Removing the External Delivery Roller

- 1) Remove the fixing assembly.
- 2) Remove the 3 screws [1]; then, while opening the upper delivery assembly [2], remove the delivery roller guide [3].

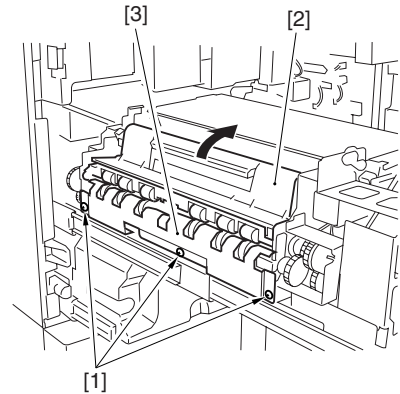

F-9-31

- 3) Remove the E-ring [1] at the front, slide the bearing [2] in the direction of the gear.

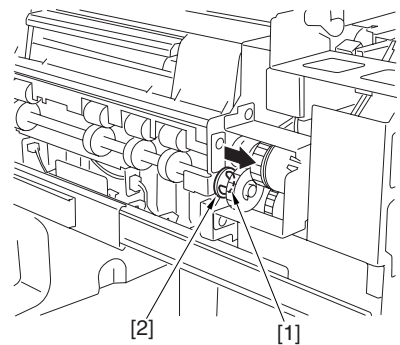

F-9-32

- 4) Remove the E-ring [1], and slide the bearing [2] toward the rear; then, detach the external delivery roller assembly [3].

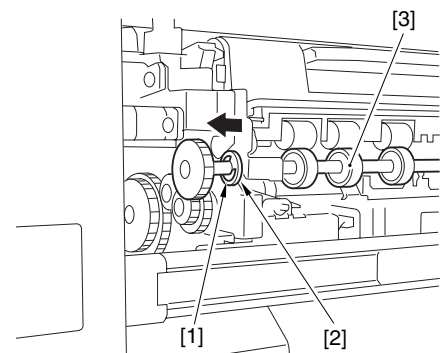

F-9-33

- 5) Remove the E-ring [1], one-way gear [2], and bearing [3] at the rear of the external roller shaft; then, remove the 2 Erings [4] and the 2 rollers [5] of each roller.

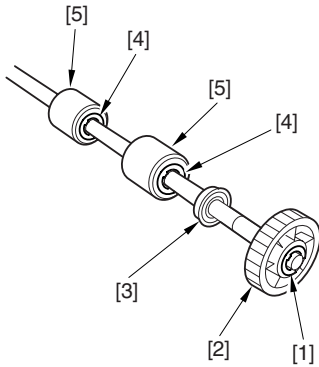

F-9-34



Take care not to lose the parallel pin used in each roller.

9.5.5 Internal Delivery Roller

9.5.5.1 Removing the Internal Delivery Roller

- 1) Remove the fixing assembly.
- 2) Remove the internal delivery roller [1], bearing [2], 3 E-rings [3], and bushing holder [4]; then, detach the drive gear [5].

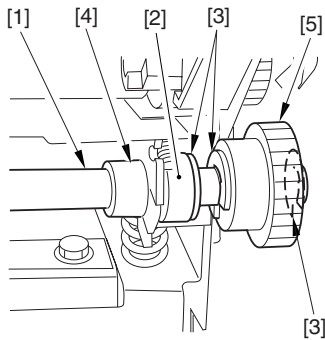

F-9-35

- 3) Remove the E-ring [1] and the bushing [2] at the rear of the shaft; then, detach the internal delivery roller [3].

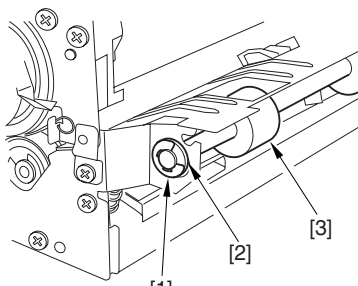

F-9-36

9.5.6 Main Thermistor

9.5.6.1 Removing the Main Thermistor

- 1) Remove the fixing assembly.
- 2) Remove the fixing web and the oil pan.
- 3) Remove the fixing harness cover.
- 4) Disconnect the connector [1] of the thermistor. Remove the screw [2], and shift the thermistor assembly [3] to the rear to detach.

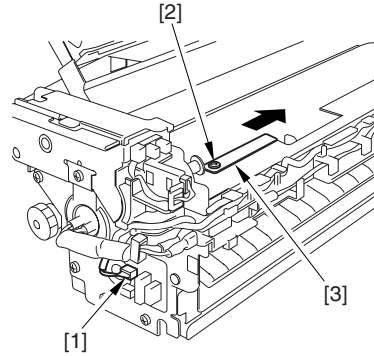

F-9-37



When shifting the thermistor assembly to the rear, take care not to damage the fixing roller with the thermistor.

- 5) Remove the 2 thermistor retaining springs [1], and detach the main thermistor [2].

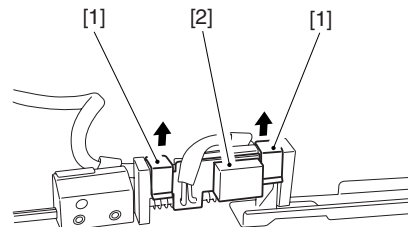

F-9-38

9.5.6.2 Mounting the Main Thermistor

When mounting the main thermistor to the fixing assembly, be sure that the tie-wrap [1] is as shown.

The tie-wrap serves as a stopper by butting against the claw [2].

Check also to be sure that the main thermistor and the fixing roller are not away from each other.

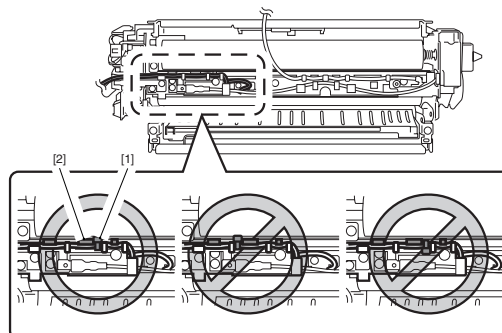

F-9-39

9.5.7 Sub Thermistor

9.5.7.1 Removing the Sub Thermistor

- 1) Slide out the fixing assembly.
- 2) Remove the fixing web and the oil pan.
- 3) Remove the fixing harness cover.
- 4) Disconnect the connector [1] and remove the screw [2]; then, detach the sub thermistor assembly [3].

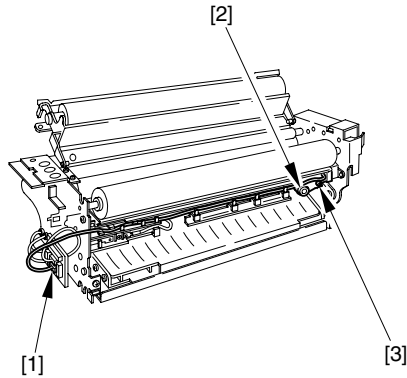

F-9-40

- 5) Remove the screw [1], and detach the sub thermistor [2].

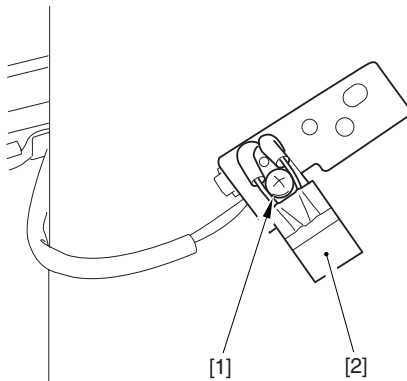

F-9-41

9.5.8 Thermal Switch

9.5.8.1 Removing the Thermal Switch Unit

- 1) Remove the fixing assembly.
- 2) Remove the fixing web; then, remove the 2 screws [1] and the oil pan [2], and detach the fixing harness cover [3].

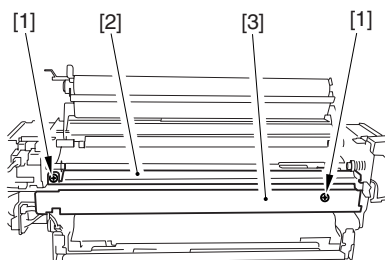

F-9-42

- 3) Remove the faston [1], and remove the 2 screws [2]; then, detach the electrode assembly [3] and the thermal switch holder [4].

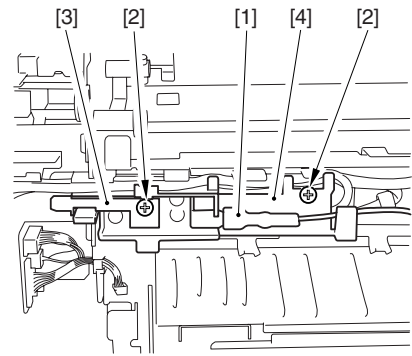

F-9-43

- 4) Remove the 4 screws [1], and detach the thermal switch unit [2].

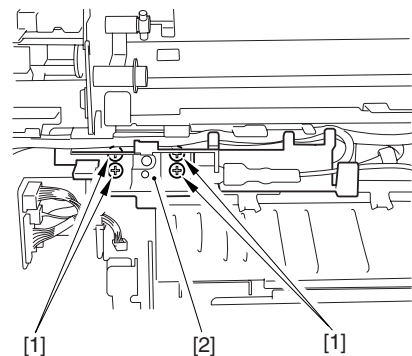

F-9-44

9.5.8.2 Mounting the Thermal Switch Unit

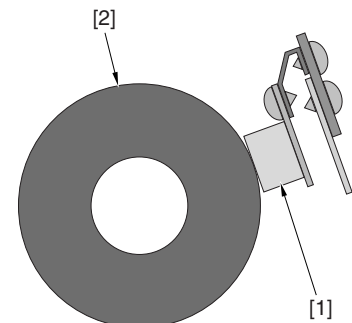

F-9-45



- When mounting the thermal switch [1], be sure that it is in contact with the fixing roller [2] as shown.
- The thermal switch must be replaced as the thermal switch unit.
- Do not use again the thermal switch whose contact point become open.

9.5.9 Fixing Heater

9.5.9.1 Removing the Main/Sub Heater

- 1) Remove the fixing assembly.
- 2) Remove the 2 screws [1], and detach the fixing connector unit [2]; then, remove the screw [3] and the terminal plate [4] at the rear to pull out the faston [5]. (2 locations)

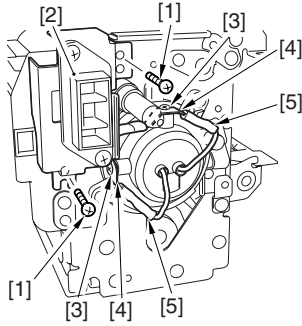

F-9-46

- 3) Remove the 2 screw [1], and detach the heater positioning plate (rear) [2].

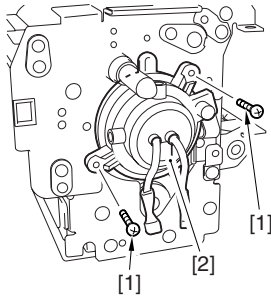

F-9-47

- 4) Remove the 2 fastons [1] at the front, and remove the screw [2] to detach the heater positioning plate (front) [3].

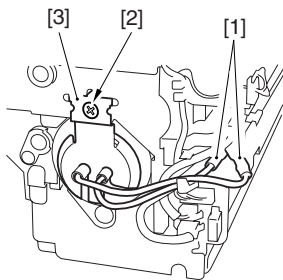

F-9-48

- 5) Remove the main/sub heater.

9.5.9.2 Mounting the Main/Sub Heater

To mount the fixing heater, reverse the steps used to remove it with the following in mind:

- a. Do not touch the surface of the heater.
- b. For both, mount the heater so that the side with the longer harness is to the front.
- c. Viewing from the front of the fixing assembly, mount the main heater [1] to the right and the sub heater [2] to the left.

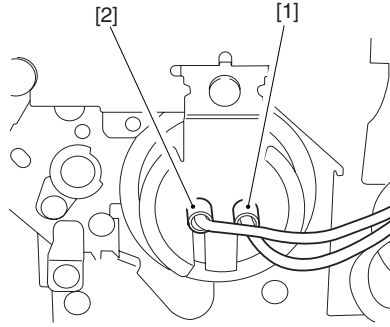

F-9-49

9.5.9.3 Points to Note When Mounting the Fixing Heater

1. Do not touch the heater surface.
2. For both heaters, mount so that the side with the longer heater harness is toward the front.
3. Viewing from the front of the fixing assembly, mount the main heater on the right (for 200V model, 1150 W; for 208V model, 1220 W; for 230V model, 1185 W) and the sub heater on the left (for 200V model, 565 W; for 208V model, 600 W; for 230V model, 645 W).
4. Viewing from the rear, connect the right side of the faston of the heater at the rear to the main heater, and connect the top side to the sub heater.

Height of the Fixing Inlet Guide

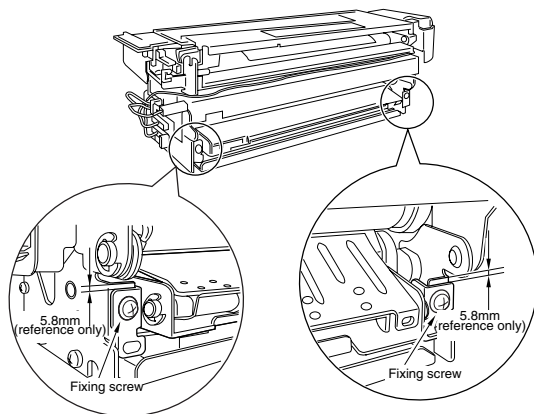

F-9-50



Do not loosen the fixing screw on the inlet guide, as you will have to adjust the position of the inlet guide if you remove the inlet guide base. If you must loosen it, be sure to adjust the position of the inlet guide afterward by referring to the index on the fixing assembly.

9.5.10 Fixing Cleaning Belt

9.5.10.1 Removing the Fixing Cleaning Belt

- 1) Slide the fixing/feeding unit halfway out; then, release the stoppers on both rails, and slide the unit farther out.
- 2) Remove the pre-transfer charging assembly cover, fixing feeding unit releasing lever, and fixing roller knob.
- 3) Remove the screw [1], and detach the fixing assembly upper cover [2].

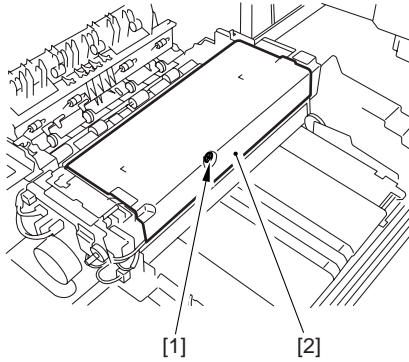

F-9-51

- 4) Remove the two screws [3] used to secure the fixing cleaning belt assembly, and open the top of the fixing cleaning belt assembly upward.

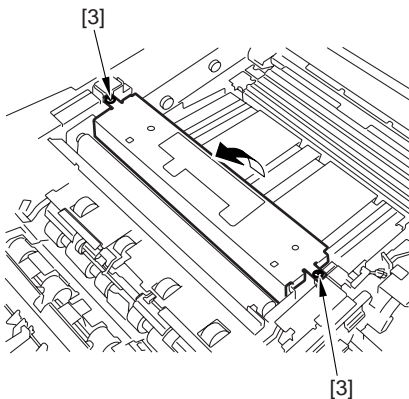

F-9-52

- 5) While pushing the cleaning belt feeding roller [4] and the take-up roller [5] toward the rear, detach the cleaning belt [6].

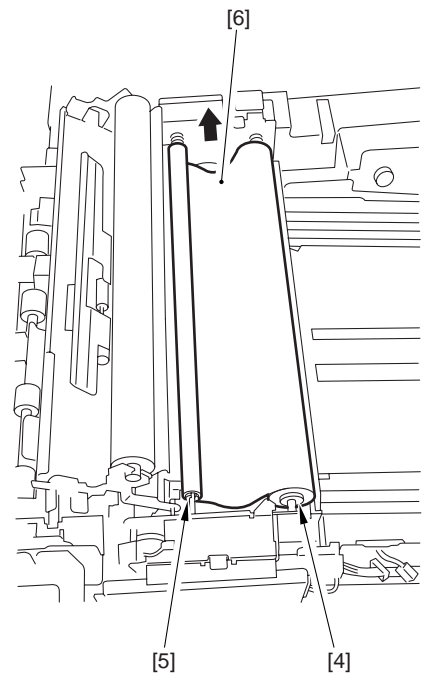

F-9-53



When cleaning the silicone oil pan, be sure to remove the silicone oil collecting in the oil pan [7] found under the cleaning belt feeding roller.

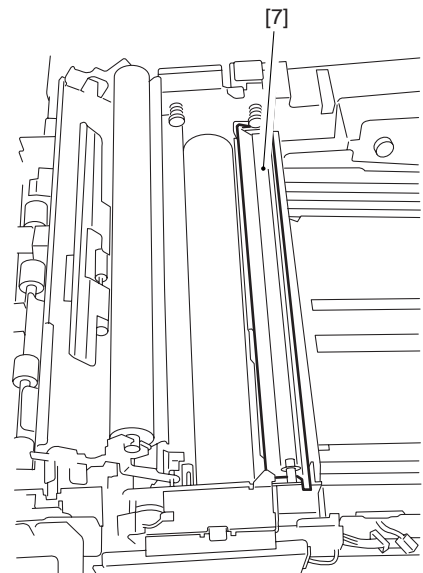

F-9-54

9.5.10.2 Mounting the Fixing Cleaning Belt

Mount the fixing cleaning belt by reversing the steps used to remove it.

- 1) Wind the cleaning belt [2] around the cleaning belt take-up roller [1] two to three times, and mount it so that the arm guide plate [3] at the front is on the outside of the take-up roller. At this time, check to make sure that the area of contact with the roller is impregnated with oil.

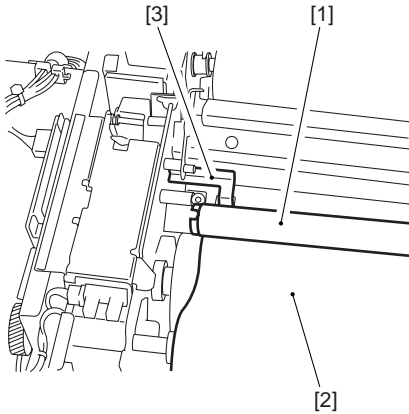

F-9-55



Check the fixing cleaning belt for skew, wrapping, and wrinkling. Further, be sure that the winding direction and the mounting orientation are as indicated.

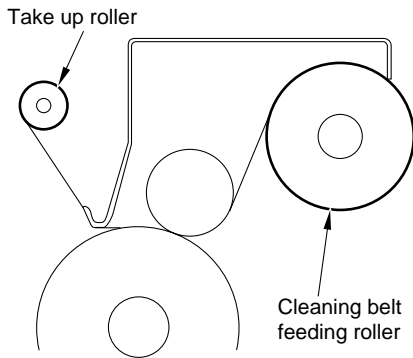

F-9-56

- 2) After mounting the fixing cleaning belt, move the plunger [4] of the cleaning belt feeding solenoid into the direction of the arrow.

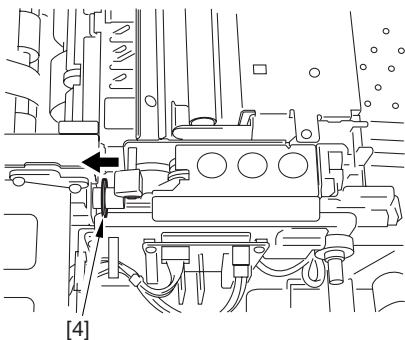

F-9-57



If you have replaced the cleaning belt, be sure to return the setting under COPIER > COUNTER > MISC > FIX-WEB to '0' in service mode.

9.5.11 Claw Jam Sensor

9.5.11.1 Removing the Claw Jam Sensor

- 1) Remove the fixing assembly.
- 2) Remove the 2 screws, and detach the lower separation claw assembly.
- 3) Detach the claw jam sensor [1] from the right side of the lower delivery assembly.

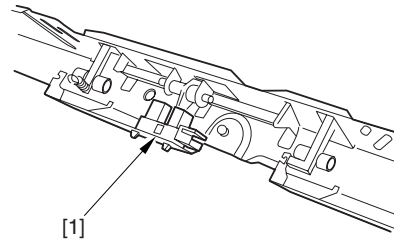

F-9-58

9.5.12 External Delivery Sensor

9.5.12.1 Remove the External Delivery Sensor

- 1) Remove the external delivery roller.
- 2) Remove the 2 screws [1], and disconnect the connector [2]; then, detach the external sensor assembly [3].

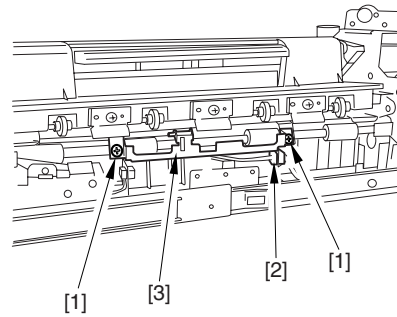

F-9-59

- 3) Disconnect the connector [1], and detach the external delivery sensor [2].

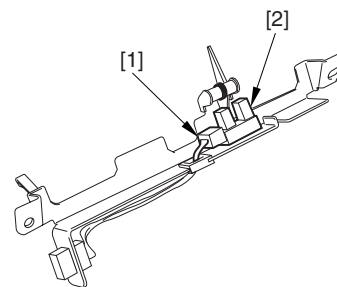

F-9-60

9.5.13 Internal Delivery Sensor

9.5.13.1 Removing the Internal Delivery Sensor

- 1) Remove the fixing assembly.
- 2) Open the upper delivery assembly, and remove the 2 screws [1]; then, detach the internal delivery sensor assembly [2].

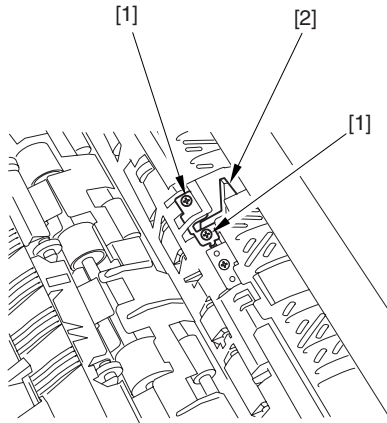

F-9-61

- 3) Disconnect the connector [1], and detach the internal delivery sensor [2].

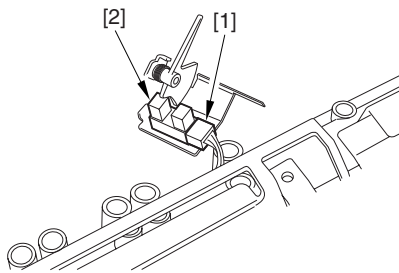

F-9-62

9.5.14 Reversal Sensor

9.5.14.1 Removing the Reversal Sensor

- 1) Remove the fixing assembly from the machine.
- 2) Open the upper delivery assembly; then, remove the screw [1], and detach the reversal sensor [2].

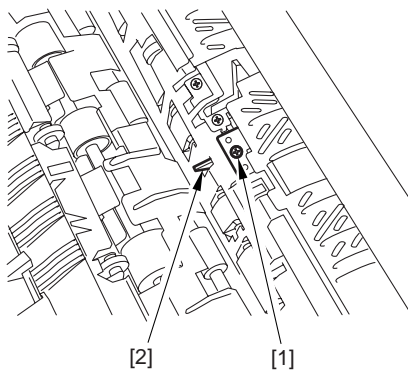

F-9-63

9.5.15 Fixing Inlet Sensor

9.5.15.1 Before Starting the Work

- 1) Remove the fixing assembly.
- 2) Remove the fixing web, and clean the oil pan.
- 3) Remove the 2 fixing heaters.
- 4) Remove the screw [1], and detach the locking support plate [2] found at the front.

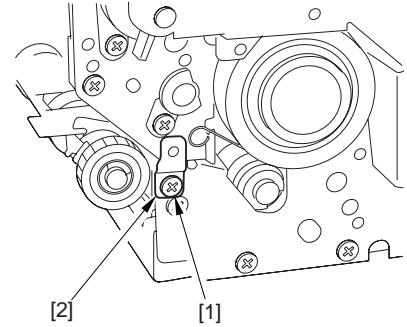

F-9-64

- 5) Remove the screw [1], and detach the locking support plate [2] found at the rear.

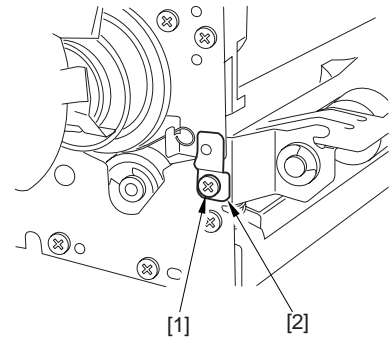

F-9-65

- 6) Open the fixing upper unit [1].

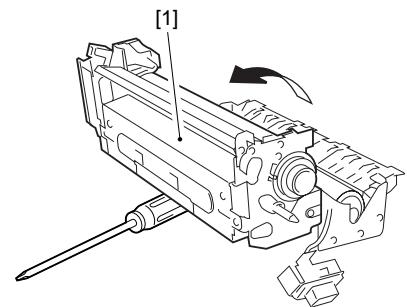

F-9-66



When opened, the fixing upper unit is in an unstable state. Use the shift of the screwdriver as a support as shown.

- 7) Remove the 2 screws [1], and detach the lower separation claw support plate [2].

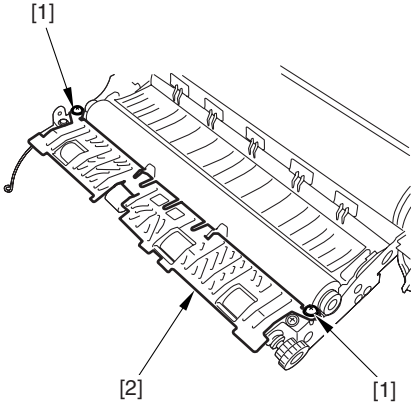

F-9-67

- 8) Remove the fixing lower roller.
 9) Remove the fixing inlet guide [1].
 - 2 screws [2]
 10) Remove the 2 screws [3].

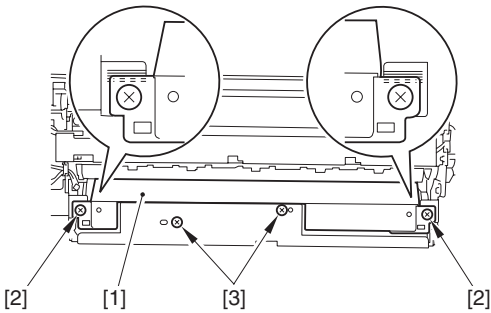

F-9-68

9.5.15.2 Removing the Fixing Inlet Sensor/Fixing Inlet HP Sensor

- 1) Remove the fixing inlet sensor [1] and the fixing inlet HP sensor [2].
 - 1 connector [3] (1 pc. each)

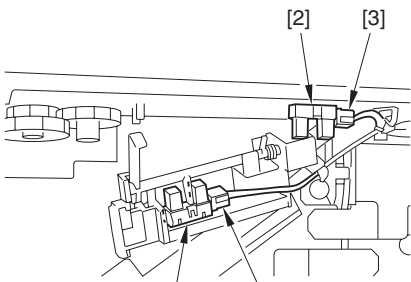

F-9-69

9.5.16 Fixing/Feeding Outlet Sensor

9.5.16.1 Remove the Fixing/Feeder Unit Outlet Sensor

- 1) Slide out the fixing/feed unit
 2) Remove the screw [1] from the bottom face of the fixing/feeder unit; then, detach the fixing/feed outlet sensor [2].

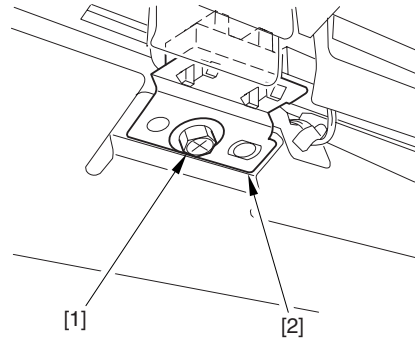

F-9-70

- 3) Disconnect the connector [1], and detach the fixing/feed outlet sensor [2].

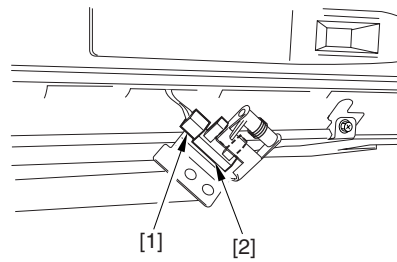

F-9-71

9.5.17 Delivery Speed Switch Clutch

9.5.17.1 Removing the Delivery Speed Switching Clutch

- 1) Slide out the fixing/feeder unit.
 2) Remove the fixing motor.
 3) Remove the 3 screws [1], and detach the fixing front support base [2].

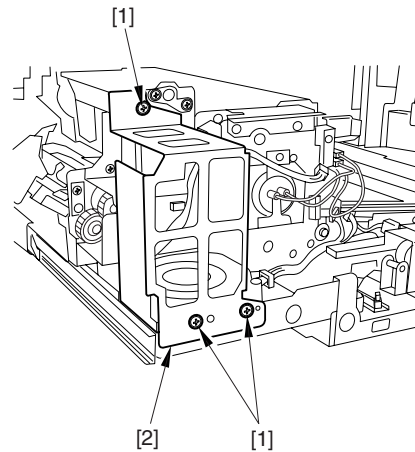

F-9-72

- 4) Disconnect the 2 connectors [1], and remove the 2 screws [2]; then, detach the delivery speed switching clutch [3].

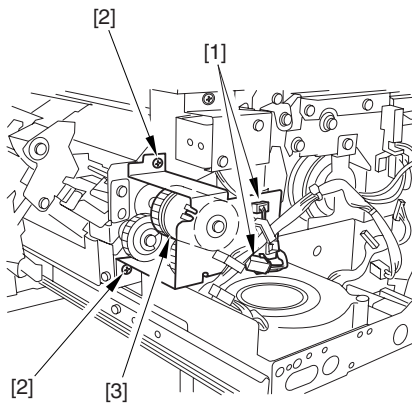

F-9-73



When detaching the delivery speed switching clutch, take care not to lose the bearings on both ends of the clutch shaft and the washer at the rear.

9.5.18 Upper Separation Claw

9.5.18.1 Removing the Upper Separation Claw

- 1) Slide out the fixing/feeding unit from the main body.
- 2) Release the spring [1] used to open the fixing/delivery assembly; then, detach the upper separation claw [2].

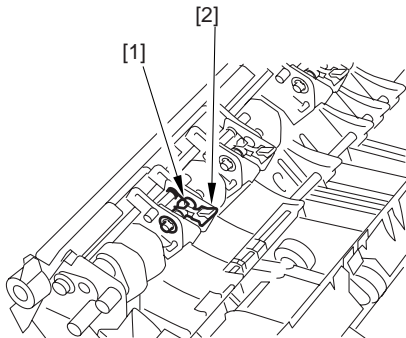

F-9-74

9.5.19 Lower Separation Claw

9.5.19.1 Removing the Lower Separation Claw

- 1) Remove the fixing assembly from the main body.
- 2) Remove the two screws, and detach the lower separation claw assembly together with the support plate.
- 3) Remove the spring [1] from the lower separation claw.

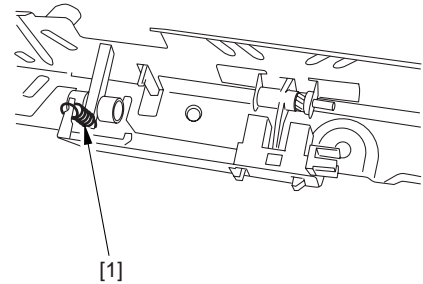

F-9-75

- 4) Remove the three screws [2], and detach the lower separation claw support plate [3]; then, detach the separation claw.

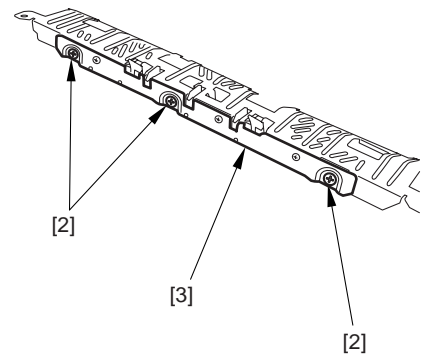

F-9-76

External and Controls

Contents

10.1 Control Panel.....	10- 1
10.1.1 Overview	10- 1
10.2 Counters.....	10- 2
10.2.1 Soft Counter.....	10- 2
10.3 Fans	10- 3
10.3.1 Fans <iR7086>.....	10- 3
10.3.2 Fans <iR7105/7095>.....	10- 5
10.3.3 Sequence of Fan Operation.....	10- 6
10.4 Power Supply System.....	10- 7
10.4.1 Power Supply	10- 7
10.4.1.1 Overview of the Power Supply System	10- 7
10.4.2 Backup Battery	10- 7
10.4.2.1 Back-Up Battery	10- 7
10.4.3 Energy-Saving Function.....	10- 7
10.4.3.1 Overview	10- 7
10.5 Parts Replacement Procedure	10- 9
10.5.1 Left Pickup Drive Assembly.....	10- 9
10.5.2 Pickup Drive Assembly.....	10- 9
10.5.3 Developing Drive Assembly.....	10- 10
10.5.4 Vertical Path Drive Assembly	10- 10
10.5.5 Waste Toner Drive Assembly.....	10- 11
10.5.6 Multifeeder Pickup Drive Assembly.....	10- 11
10.5.7 Lifter Drive Assembly	10- 12
10.5.8 Main Drive Assembly	10- 12
10.5.9 Drum Drive Assembly.....	10- 13
10.5.10 Cassette Pickup Drive Assembly.....	10- 14
10.5.11 Power Supply Unit.....	10- 14
10.5.12 Control Panel	10- 15
10.5.13 Control Panel LCD Unit.....	10- 16
10.5.14 Cover Switch Assembly.....	10- 17
10.5.15 Manual Feed Tray Switch Assembly.....	10- 17
10.5.16 Drum Heater Switch Assembly	10- 18
10.5.17 DC Controller PCB	10- 18
10.5.18 Control Panel Inverter PCB	10- 19
10.5.19 Control Panel Key Switch PCB	10- 19
10.5.20 Control Panel Family PCB.....	10- 20
10.5.21 Control Panel CPU PCB	10- 20
10.5.22 AC Driver PCB.....	10- 21
10.5.23 All Night Power Supply PCB.....	10- 21
10.5.24 Relay PCB	10- 22
10.5.25 High-Voltage Transformer (AC)	10- 22
10.5.26 HV-AC PCB.....	10- 22
10.5.27 HV-DC PCB.....	10- 23
10.5.28 High-Voltage PCB	10- 23

10.5.29 Motor Driver PCB.....	10- 24
10.5.30 Transceiver PCB.....	10- 24
10.5.31 Double Feeding Detection PCB (Transmission).....	10- 25
10.5.32 Double Feeding Detection PCB (Reception)	10- 26
10.5.33 Fixing Heat Discharge Fan.....	10- 26
10.5.34 Laser Cooling Fan	10- 27
10.5.35 De-Curling Fan.....	10- 27
10.5.36 Drum Fan	10- 28
10.5.37 Pre-Transfer Charging Assembly Fan.....	10- 28
10.5.38 Power Supply Cooling Fan 1	10- 28
10.5.39 Power Supply Cooling Fan 2	10- 29
10.5.40 Separation Fan.....	10- 29
10.5.41 Developing Fan.....	10- 29
10.5.42 Delivery Anti-Adhesion Fan	10- 30
10.5.43 Duplex Feed Fan	10- 30
10.5.44 Separation Heat Discharge Fan.....	10- 31
10.5.45 Reader Heat Discharge Fan 2.....	10- 31
10.5.46 Fixing Inlet Sensor Motor	10- 31

10.1 Control Panel

10.1.1 Overview

The machine's control panel consists of the following PCBs and a liquid crystal panel (LCD):

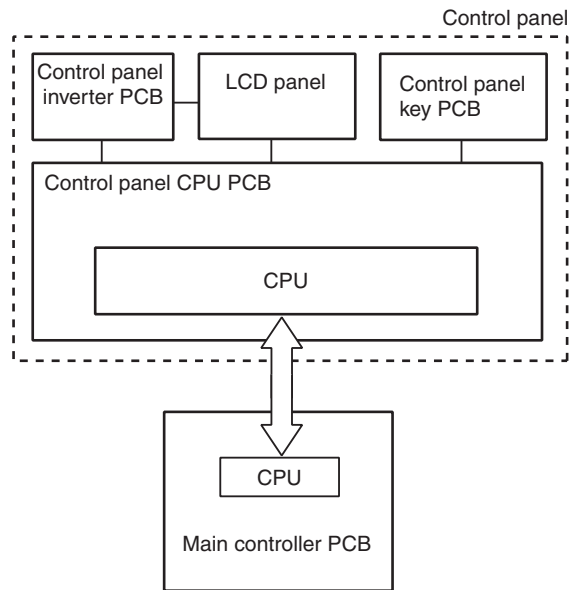

F-10-1

Related service mode:

COPIER > FUNCTION > PANEL > LCD-CHK	use it to check the LCD for missing dots
COPIER > FUNCTION > PANEL > LED-CHK	use it to check the activation of the LEDs on the control panel
COPIER > FUNCTION > PANEL > LED-OFF	use it to check the de-activation of the LEDs on the control panel
COPIER > FUNCTION > PANEL > KEY-CHK	use it to start a check on key inputs
COPIER > FUNCTION > PANEL > TOUCHCHK	use it to adjust coordinates of the touch panel

10.2 Counters

10.2.1 Soft Counter

The machine is equipped with soft counters to count the number of prints made, and the counter readings may be indicated by pressing the Check key on the control panel.

The counter is controlled by the main controller PCB, and increases the count each time a copy/print is made (as identified by the following sensors):

T-10-1

Copying/printing operation	Source of input
Simplexing	finisher delivery sensor
Duplexing	1st side PS14
	2nd side finisher delivery sensor

The machine's counting mechanism consists of 8 modes, 2 each according to paper size (small-size, large-size; a total of 16 modes):

T-10-2

Copying/printing operation	Large-size	Small-size*1
local copy	A	B
PDL print	C	D
Box print	E	F
remote copy print	G	H
fax reception print*2	I	J
report print	K	L
duplexing print	M	N
scan	O	P

*1: At time of shipment, B4 or smaller. To count B4 as a large-size sheet, use service mode.

*2: The machine does not have a fax function, and will not count fax reception prints.

The following table describes the counters according to model:

- 100V/200V

T-10-3

Counter	Type*1	Default	Default switchover*2
Counter 1	total (A through L)	ON	fixed
Counter 2	-	OFF	variable
Counter 3	-	OFF	variable
Counter 4	-	OFF	variable
Counter 5	-	OFF	variable
Counter 6	-	OFF	variable

- 208/230V Non-European Model

T-10-4

Counter	Type*1	Default indication	Default switchover*2
Counter 1	total (A through L)	ON	fixed
Counter 2	total large (ACEGIK)	ON	variable
Counter 3	copy 1 (ABGH)	ON	variable
Counter 4	copy 1 large (AG)	ON	variable
Counter 5	-	OFF	variable
Counter 6	-	OFF	variable

- 230V European Model

T-10-5

Counter	Type*1	Default indication	Default switchover*2
Counter 1	total (A through L)	ON	fixed
Counter 2	total large (ACEGIK)	ON	variable
Counter 3	total small (BDFHJ)	ON	variable
Counter 4	scan total (OP)	ON	variable
Counter 5	-	OFF	variable
Counter 6	-	OFF	variable

*1: The description in parentheses represents the basic counter mode.

*2: The counter indication may be enabled/disabled in service mode (except the counter 1 setting).

10.3 Fans

10.3.1 Fans <iR7086>

The following shows the arrangement of the fans and the direction of air, followed by their names and functions:

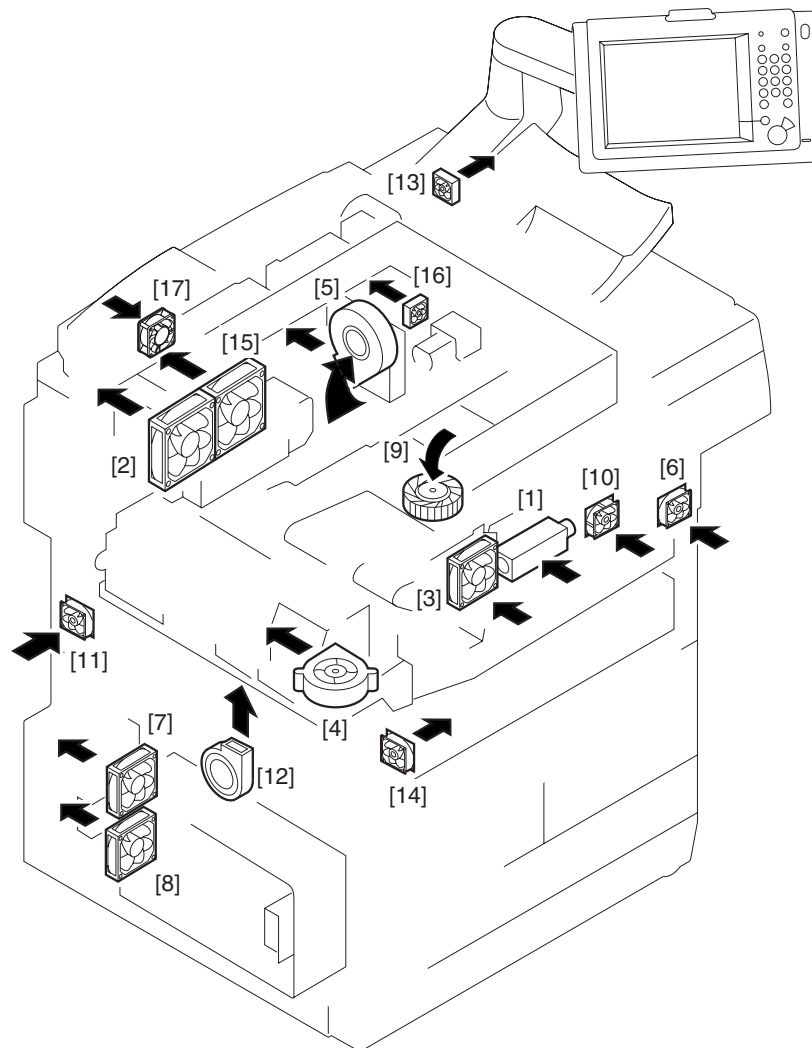

F-10-2

T-10-6

Ref.	Notation	Name	Discipline	Error code	Alarm code
[1]	FM1	polygon mirror cooling fan	cools the laser scanner motor; thermally insulates the unit from the fixing assembly; prevents soiling of the wire of the primary charging assembly	E111-1111	-
[2]	FM2	fixing heat discharge fan	discharges heat from around the fixing assembly	E805-0001	-
[3]	FM3	laser cooling fan	cools the laser scanner unit	E121-0001	-
[4]	FM6	de-curling fan	cools paper	-	33-0001
[5]	FM8	drum fan	draws out the ozone and stray toner from around the drum; cools the area	E820-0000	-
[6]	FM10	pre-transfer charging assembly fan	discharges the ozone from around the pre-transfer charging assembly	E823-0000	-
[7]	FM11	power supply cooling fan 1	cools the DC power supply PCB	E804-0000	-
[8]	FM12	power supply cooling fan 2	cools the DC power supply PCB	E804-0000	-
[9]	FM13	separation fan	helps separate paper from the drum	E830-0000	-
[10]	FM15	developing fan	cools the developing assembly	-	33-0006
[11]	FM16	system fan	cools the PCBs inside the system box	-	00-0804
[12]	FM17	delivery anti-adhesion fan	cools paper being delivered	-	33-0007
[13]	FM18	scanner heat discharge fan 2	discharges heat from around the laser scanner unit	E121-0003	-
[14]	FM19	duplexing transport fan	cools the duplexing transport motor	-	33-0009
[15]	FM20	separation heat discharge fan	discharges heat from around the separation assembly; improves separation	E805-0002	-
[16]	FM21	scanner heat discharge fan 1	discharges heat from around the laser scanner unit	E121-0001	-
[17]	FM501	reader cooling fan 1	cools the reader assembly	-	33-0003

10.3.2 Fans <iR7105/7095>

The following shows the arrangement of fans and the direction of air, followed by the names and functions of the parts:

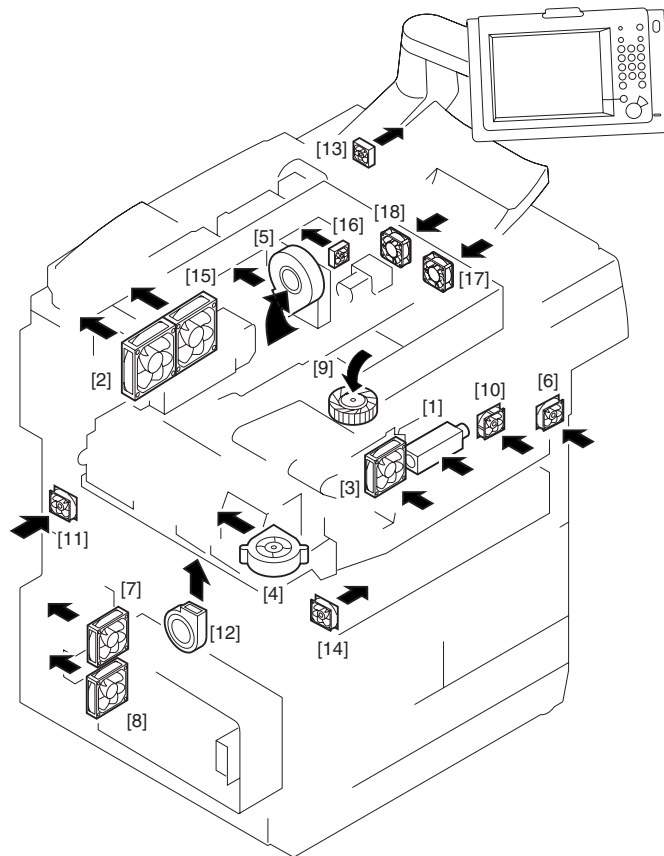

F-10-3
T-10-7

Ref.	Notation	Name	Description	Error code	Alarm code
[1]	FM1	polygon cooling fan	cools the laser scanner motor; thermally insulates the unit from the fixing assembly; prevents soiling of the wire of the primary charging assembly	E111-1111	-
[2]	FM2	fixing heat discharge fan	discharges heat from around the fixing assembly	E805-0001	-
[3]	FM3	laser cooling fan	cools the laser scanner unit	E121-0001	-
[4]	FM6	de-curling fan	cools paper	-	33-0001
[5]	FM8	drum fan	draws out ozone and stray toner from around the drum; cools the area	E820-0000	-
[6]	FM10	pre-transfer charging assembly fan	discharges ozone from around the pre-transfer charging assembly	E823-0000	-
[7]	FM11	power supply cooling fan 1	cools the DC power supply PCB	E804-0000	-
[8]	FM12	power supply cooling fan 2	cools the DC power supply PCB	E804-0000	-
[9]	FM13	separation fan	helps separation of paper from the drum	E830-0000	-
[10]	FM15	developing fan	cools the developing assembly	-	33-0006
[11]	FM16	system fan	cools the PCBs inside the system box	-	00-0804
[12]	FM17	delivery anti-adhesion fan	cools paper being delivered	-	33-0007
[13]	FM18	scanner heat discharge fan 2	discharges heat from around the laser scanner unit	E121-0003	-

Ref.	Notation	Name	Description	Error code	Alarm code
[14]	FM19	duplexing transport fan	cools the duplexing transport motor	-	33-0009
[15]	FM20	separation heat discharge fan	discharges heat from around the separation assembly; improves separation	E805-0002	-
[16]	FM21	scanner heat discharge fan 1	discharges heat from around the laser scanner unit	E121-0001	-
[17]	FM50	reader cooling fan 1	cools the reader assembly	-	33-0003
[18]	FM50	reader cooling fan 2	cools the reader assembly	-	33-0004

10.3.3 Sequence of Fan Operation

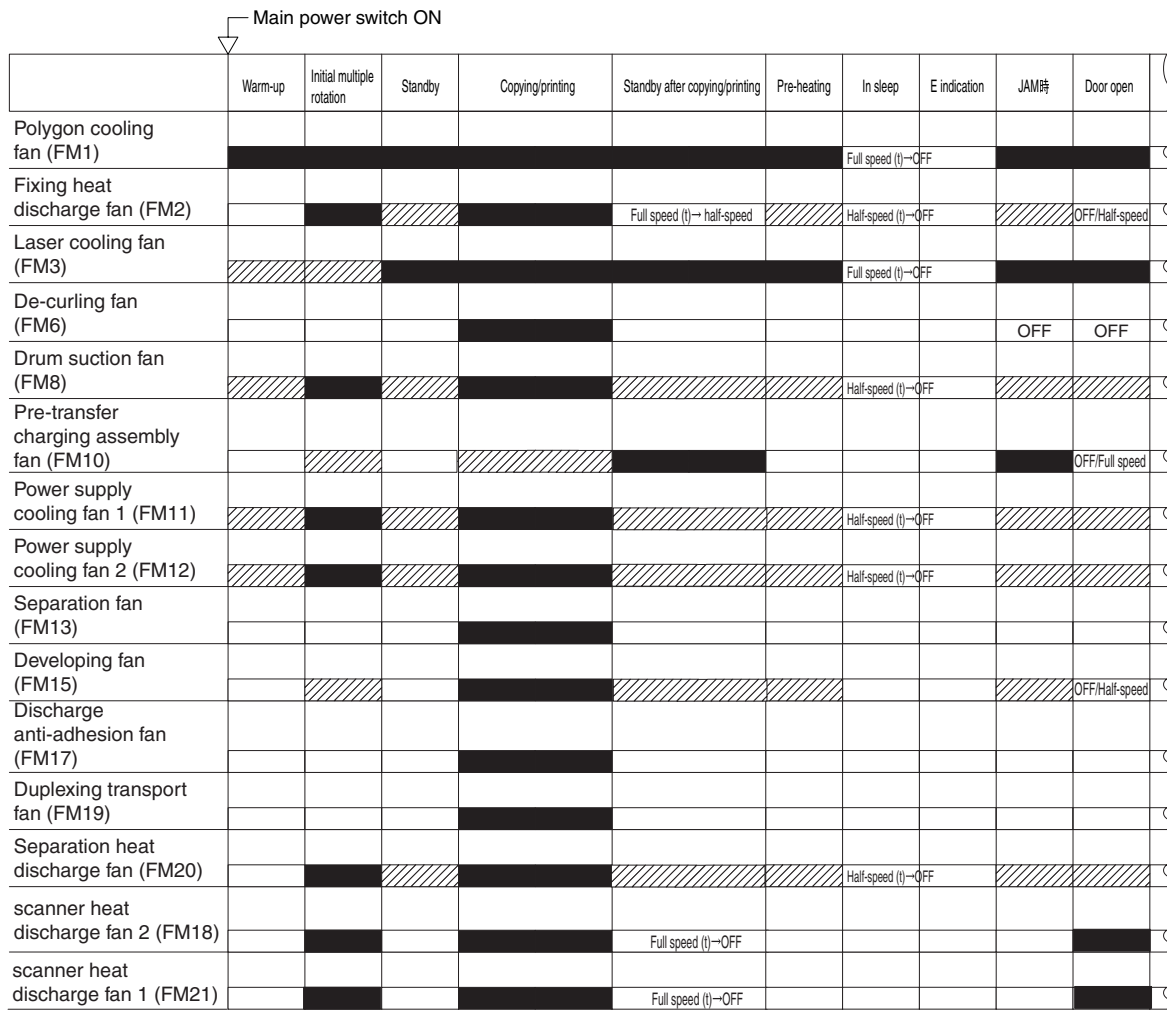

■ : Full speed ▨ : Half-speed

F-10-4

10.4 Power Supply System

10.4.1 Power Supply

10.4.1.1 Overview of the Power Supply System

The machine's DC power supply is controlled by the DC power supply PCB and the relay PCB:
T-10-8

PCB	Description
DC power supply PCB	- generates DC power from AC power - protects against over-current
Relay PCB	- generates DC power from DC power (24 V to 18 V) - supplies DC power to loads - protects individual loads against over-current

10.4.2 Backup Battery

10.4.2.1 Back-Up Battery

The machine's main controller PCB, DC controller PCB, and reader controller PCB are each equipped with a lithium battery for use in the event of power failure and power plug disconnection.

T-10-9

Main controller PCB	dioxide manganese lithium battery (3 V, 1000 mAh)
DC controller PCB	lithium battery (3 V, 600 mAh)
Life of battery	main controller PCB: about 10 yr DC controller PCB: about 10 yr
Replacement of battery	battery cannot be replaced on its own in the field



Risk of explosion if battery is replaced by an incorrect type.
Dispose of used batteries according to the instructions.

10.4.3 Energy-Saving Function

10.4.3.1 Overview

1. Standby Mode

The machine is in operation or is ready to start operation, with all its loads supplied with power.

2. Power Save Mode

The machine decreases the control temperature while the fixing assembly is in a standby state according to the selected power save rating (variable through 'change power save mode' in user mode; default: -10%), thus decreasing the power consumption.

Conditions Initiating a Shift from Standby Mode (standby -> power save)

- press on the Power Save key

Conditions Initiating a Shift Back to Standby Mode (power save -> standby)

- press on the Power Save key

- press on the control panel power switch

3. Low Power Mode

The machine keeps the temperature of the fixing assembly low (140 deg C), with the reader unit and the printer unit supplied with a reduced level of power.

Conditions Initiating a Shift from Standby/Power Save Mode (standby -> low power)

- after a specific period of time in standby/power save mode (variable through 'low power mode shift interval'; default: 15 min)

Conditions Initiating a Shift Back to Standby Mode (low power -> standby)

- press on Power Save key
 - press on control panel power switch
-

MEMO:

If the same setting is used for both 'low power mode shift interval' and 'auto sleep time', a shift is made to sleep mode if a specific period of time passes from a standby state (i.e., no shift takes place to low power mode).

4. Sleep Mode

The machine's sleep mode consists of 'sleep mode 1' (high rate of power saving in sleep) and 'sleep mode 3' (low rate of power saving in sleep), and the selection of one over the other depends on how the machine is set and the presence/absence of paper.

Conditions Initiating a Shift (standby/power save/low power -> sleep)

- The machine remains in a standby state for a specific period of time (variable through 'auto sleep time' in user mode; default: 60 min).
- The control panel power switch is turned off while the machine is in a standby state.

When a condition has occurred activating a shift to a sleep state, the machine drives the heat discharge fan for a specific period of time (6 min) to cool the inside of the machine and then enters sleep mode.

Conditions Initiating Standby Mode (sleep -> standby)

- press on the control panel power switch

5. Power-Off Mode

The machine enters and remains in power-off mode when its main power switch is turned off.

To return from power-off mode, the machine's main power switch must be turned on, in response to which it will automatically return to standby mode.

10.5 Parts Replacement Procedure

10.5.1 Left Pickup Drive Assembly

10.5.1.1 Removing the Left Pickup Drive Assembly

Construction

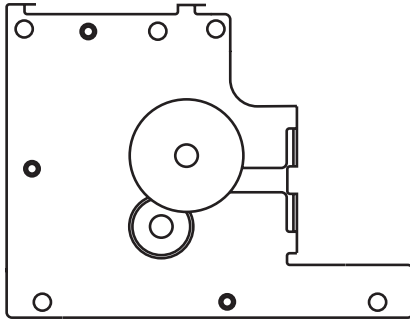

F-10-5

- 1) Remove the rear cover.
- 2) Open the main controller box assembly.
- 3) Remove the high-voltage PCB unit.
- 4) While detaching the belt [1], remove the three screws [2], and detach the left pickup drive assembly [3].

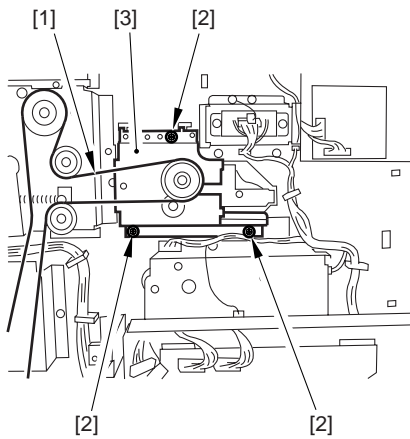

F-10-6

10.5.2 Pickup Drive Assembly

10.5.2.1 Removing the Pickup Drive Assembly

Construction

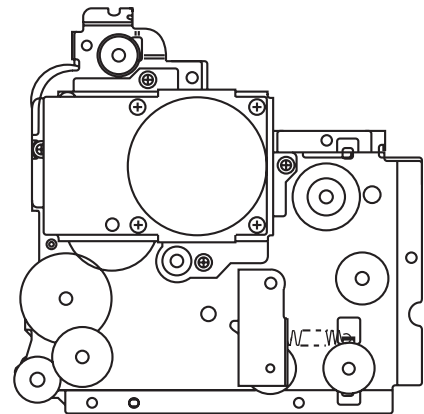

F-10-7

- 1) Remove the rear cover.
- 2) Remove the high-voltage PCB unit.
- 3) Remove the flywheel.
- 4) Remove the drum gear.
- 5) Remove the waste toner pipe.
- 6) Remove the two screws [1], and loosen the harness guide [2]; disconnect the two connectors [3], and remove the six screws [4]; then, detach the pickup drive assembly [5].

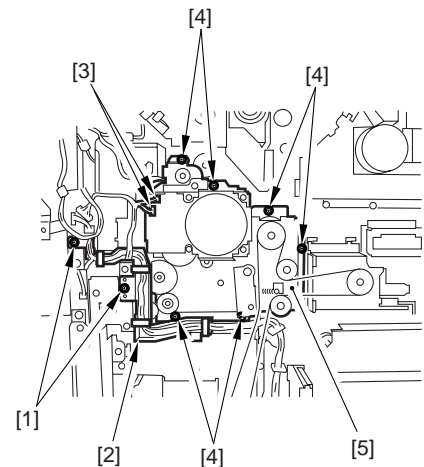

F-10-8

10.5.3 Developing Drive Assembly

10.5.3.1 Removing the Developing Drive Assembly

Construction

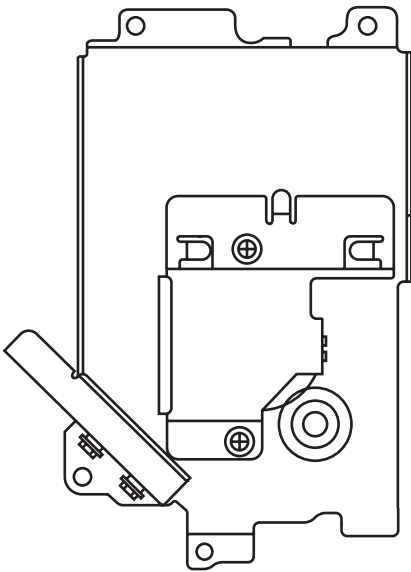

F-10-9

- 1) Remove the rear cover.
- 2) Remove the high-voltage PCB unit.
- 3) Remove the flywheel.
- 4) Remove the drum gear.
- 5) Remove the waste toner pipe.
- 6) Remove the drum drive assembly.
- 7) Remove the waste toner drive assembly.
- 8) Remove the two screws [1], and disconnect the connector [2]; then, detach the drum fan [3].

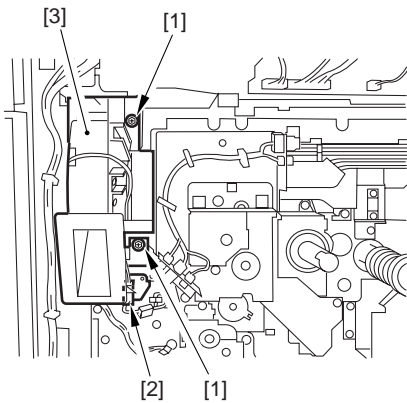

F-10-10

- 9) Disconnect the two connectors [4], and remove the four screws [5]; then, detach the developing drive assembly [6].

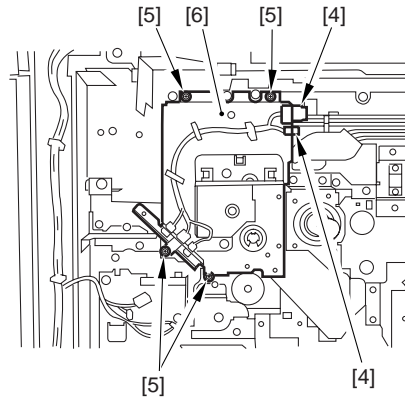

F-10-11

10.5.4 Vertical Path Drive Assembly

10.5.4.1 Removing the Vertical Path Drive Assembly

Construction

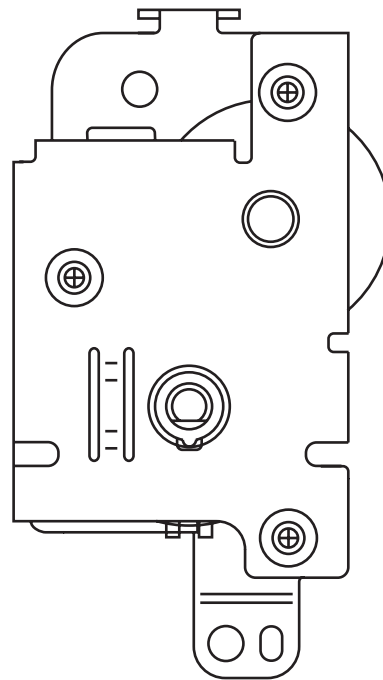

F-10-12

- 1) Remove the rear cover.
- 2) Remove the waste toner case.
- 3) Remove the two screws [1], and detach the harness guide [2].

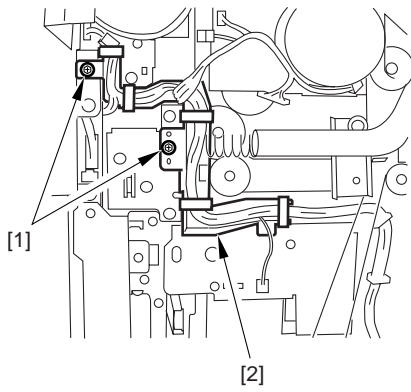

F-10-13

- 4) Disconnect the connector [3], and remove the two screws [4]; then, detach the vertical path drive assembly [5].

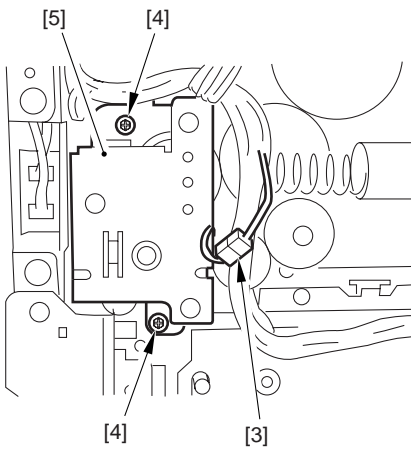

F-10-14

10.5.5 Waste Toner Drive Assembly

10.5.5.1 Removing the Waste Toner Drive Assembly

Construction

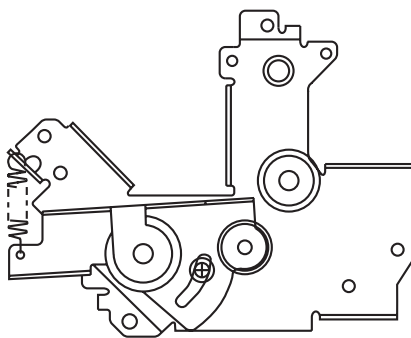

F-10-15

- 1) Remove the rear cover.
- 2) Remove the high-voltage PCB unit.
- 3) Remove the flywheel.
- 4) Remove the drum gear.
- 5) Remove the waste toner pipe.
- 6) Remove the drum drive assembly.

- 7) Remove the six screws [1], and detach the waste toner drive assembly [2].

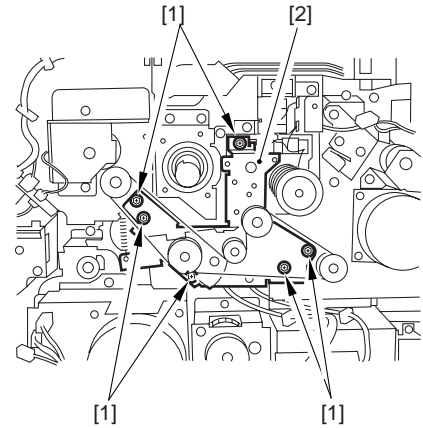

F-10-16

10.5.6 Multifeder Pickup Drive Assembly

10.5.6.1 Removing the Multifeder Pickup Drive Assembly

Construction

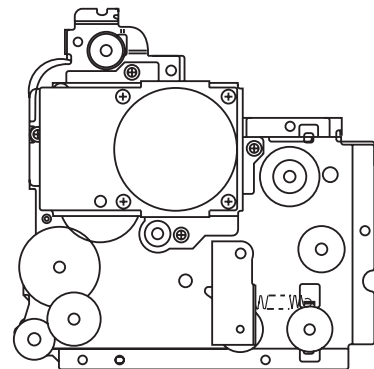

F-10-17

- 1) Remove the rear cover.
- 2) Remove the high-voltage PCB unit.
- 3) Loosen the mounting screw on the rear fixing plate of the registration roller assembly.
- 4) Remove the four screws [1], and disconnect the four connectors [2]; then, detach the multifeder pickup drive assembly [3].

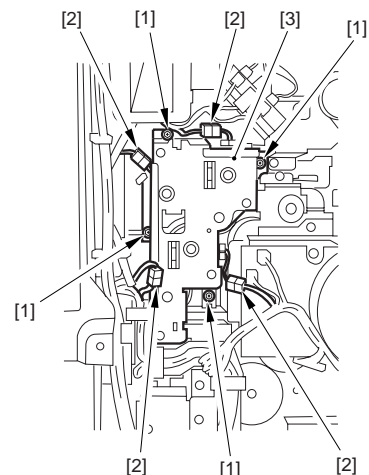

F-10-18

10.5.7 Lifter Drive Assembly

10.5.7.1 Removing the Lifter Drive Assembly (right deck)

Construction

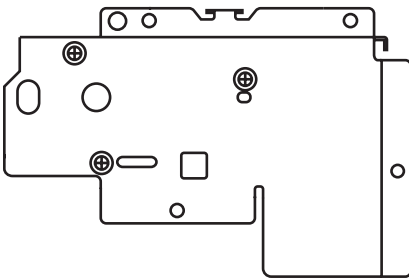

F-10-19

- 1) Remove the rear cover.
- 2) Remove the high-voltage PCB unit.
- 3) Remove the flywheel.
- 4) Remove the drum gear.
- 5) Remove the waste toner pipe.
- 6) Remove the screw, and loosen the harness guide [1]; disconnect the two connectors [2], and remove the four screws [3]; then, detach the lifter drive assembly (for the right deck) [4].

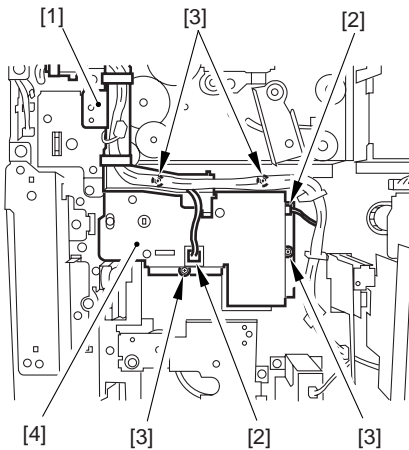

F-10-20

10.5.7.2 Removing the Lifter Drive Assembly (left deck)

Construction

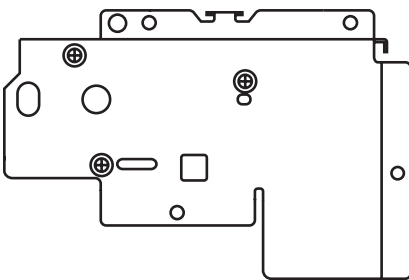

F-10-21

- 1) Remove the rear cover.
- 2) Open the main controller box assembly.
- 3) Remove the DC controller assembly.

- 4) Disconnect the three connectors [1], and remove the four screws [2]; then, detach the lifter drive assembly (for the left deck) [3].

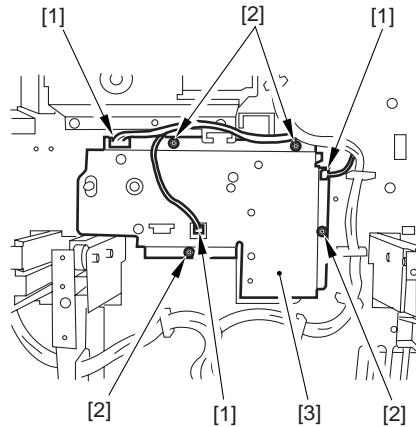

F-10-22

10.5.8 Main Drive Assembly

10.5.8.1 Removing the Main Drive Assembly

Construction

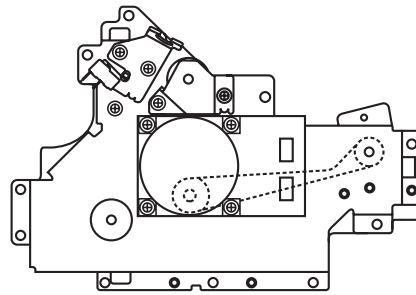

F-10-23

- 1) Remove the rear cover.
- 2) Remove the high-voltage PCB unit.
- 3) Remove the flywheel.
- 4) Remove the drum gear.
- 5) Remove the waste toner pipe.
- 6) Remove the drum drive assembly.
- 7) Remove the waste toner drive assembly.
- 8) Disconnect the two connectors [1], and remove the nine screws [2]; then, detach the main drive assembly [3].

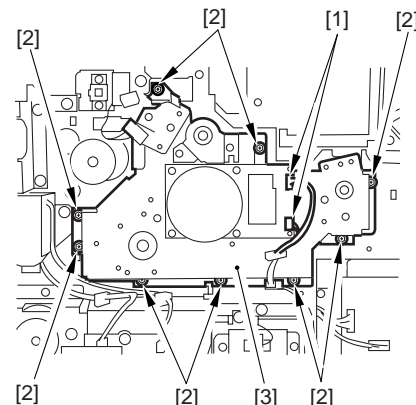

F-10-24



When mounting the main drive assembly, be sure to slide out the fixing/feeding assembly in advance. (A coupling and a spring are mounted to the back of the main drive assembly. If the fixing/feeding assembly is inside, the action of the spring will hinder mounting work.)

10.5.9 Drum Drive Assembly

10.5.9.1 Removing the Drum Drive Assembly

- 1) Remove the HV-DC PCB.
- 2) Remove the 2 screws [1], and detach the flywheel [2].

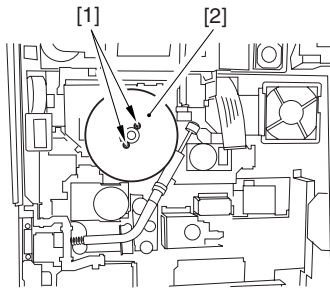

F-10-25

- 3) Loosen the 2 screws [1] (w/ hex hole), and remove the binding screw [2] (w/spring); then, detach the gear [3] of the drum shaft.

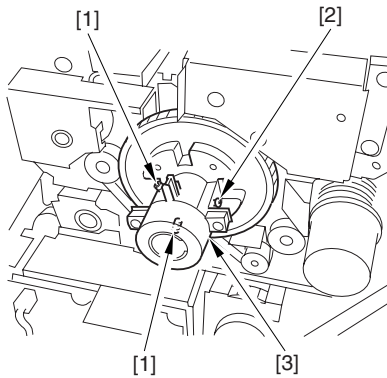

F-10-26



When removing the screw from the drum shaft gear, be sure to pay attention to the direction of gear rotation, i.e., turn it counterclockwise.

- 4) Remove the water toner case; then, remove the 5 screws [1], and disconnect the 4 connectors [2] to detach the waste toner case base [3].

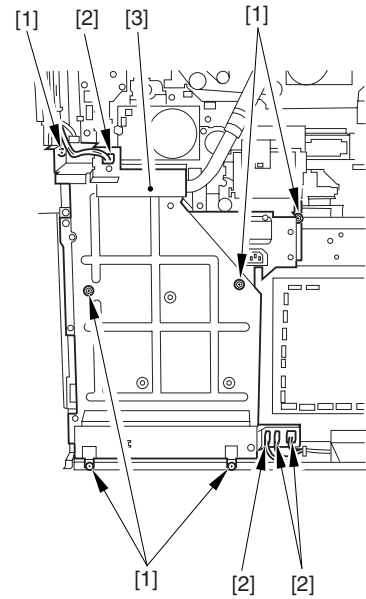

F-10-27

- 5) Remove the E-ring [2] at the tip of the waste toner pipe [1], and shift the bushing [3] up to remove the 2 screws [4]; then, detach the waste toner pipe [1].

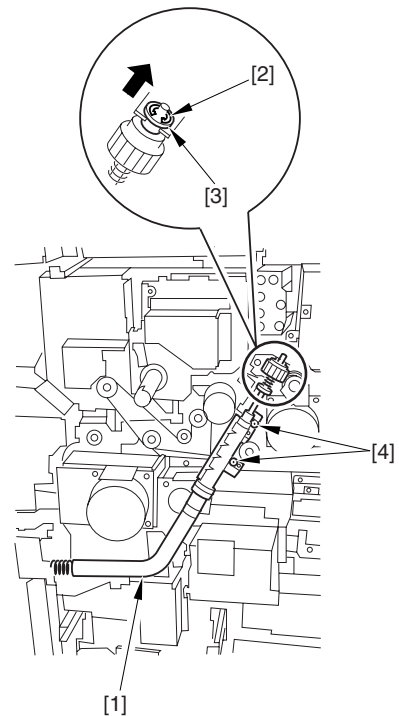

F-10-28

- 6) Remove the screw [1], and detach the drum cleaner pipe cover [2].

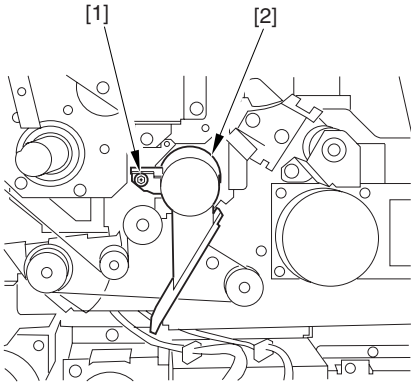

F-10-29

- 7) Disconnect the 4 connectors [1], and remove the 5 screws [2]; then, detach the drum drive assembly [3].

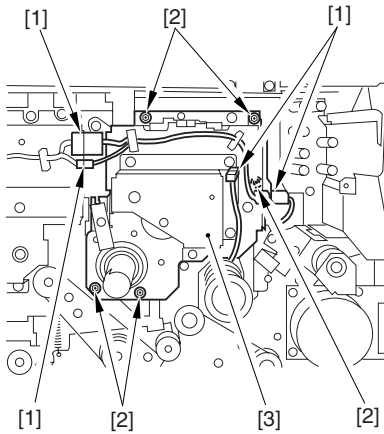

F-10-30

10.5.10 Cassette Pickup Drive Assembly

10.5.10.1 Removing the Cassette Pickup Drive Assembly

- 1) Remove the waste toner case base.
- 2) Remove the cassette pickup assembly (upper, lower).
- 3) Remove the 5 screws [1], and detach the cassette pickup drive assembly [2].

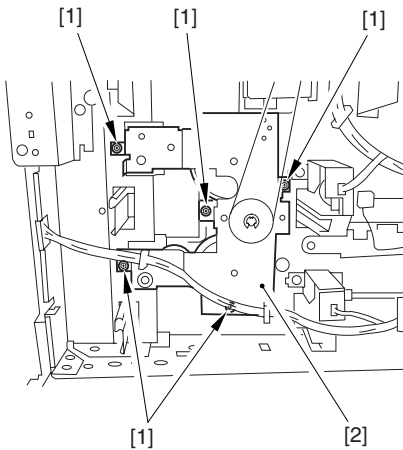

F-10-31

10.5.11 Power Supply Unit

10.5.11.1 Removing the Power Supply Unit

- 1) Remove the lower left cover [1].
 - Slide out the left deck/cassette 3/cassette 4 [2].
 - 4 screws [3]

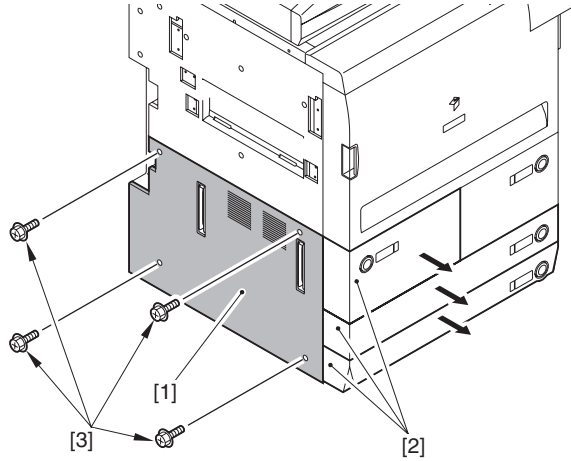

F-10-32

- 2) Remove the upper left cover [1].
 - Open the front cover [2].
 - 9 screws [2]

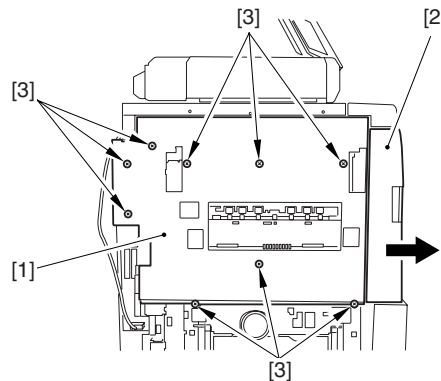

F-10-33

- 3) Remove the cover plate [1].
 - 5 screws [2]

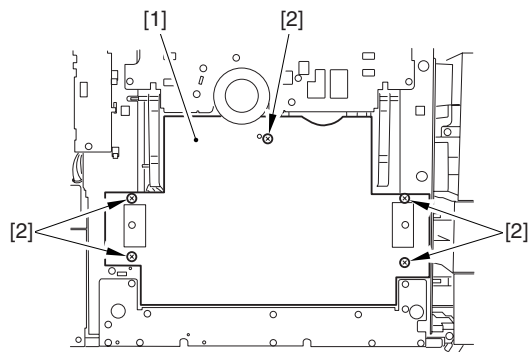

F-10-34

- 4) Remove the delivery anti-adhesion fan mounting plate [1].
 - 1 connector [2]
 - 6 screws [3]

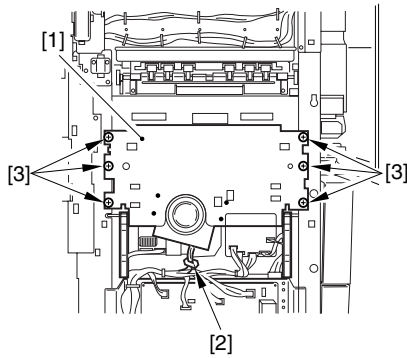

F-10-35

- 5) Remove the AC driver PCB.
 6) Remove the all-night power supply PCB.
 7) Remove cover plate [1].
 - 2 screws [2]

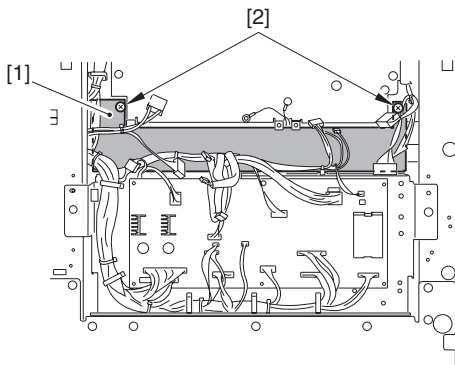

F-10-36

- 8) Remove the power supply unit [1].
 - 1 connector [2]
 - all connectors of the relay PCB
 - 2 screws [3]

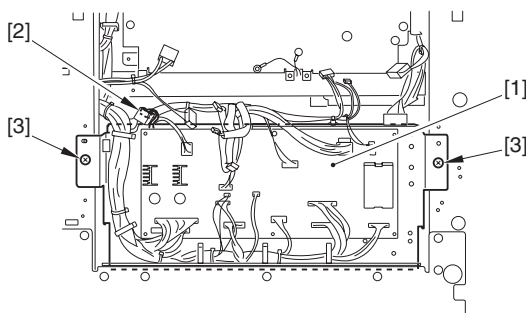

F-10-37

10.5.12 Control Panel

10.5.12.1 Removing the Control Panel

- 1) Remove the control panel rear cover [1].
 - 2 blocking rubber pieces [2]
 - 2 screws [3]

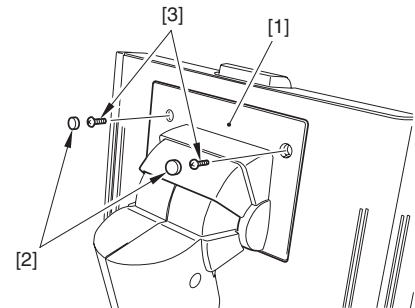

F-10-38

- 2) Remove the locking hinge left cover [1].
 - 1 screw [2]

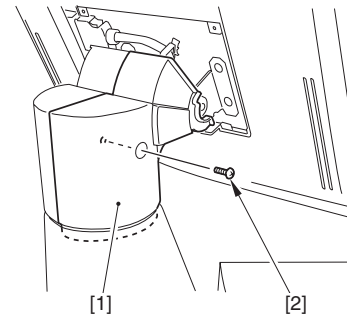

F-10-39

- 3) Remove the lock hinge right cover [1].
 - 2 screws [2]

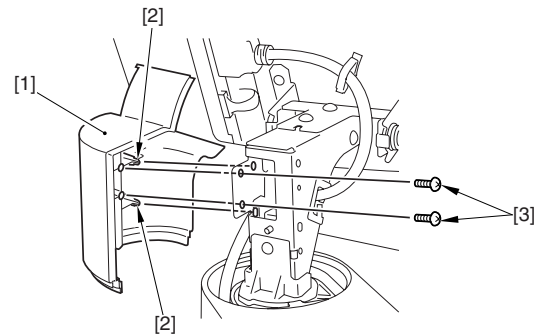

F-10-40

- 4) Remove the control panel [1].
 - 1 control panel cable [2]
 - 4 screws [3]

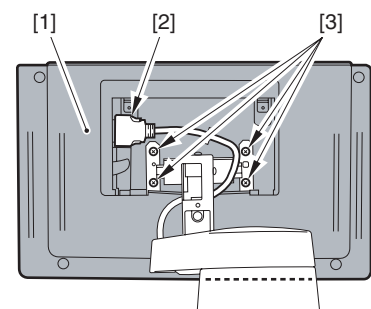

F-10-41

10.5.12.2 Removing the Control Panel Interface PCB

- 1) Remove the upper rear right cover.
- 2) Disconnect the 3 connectors [1], and free the cable from the edge saddle [2].

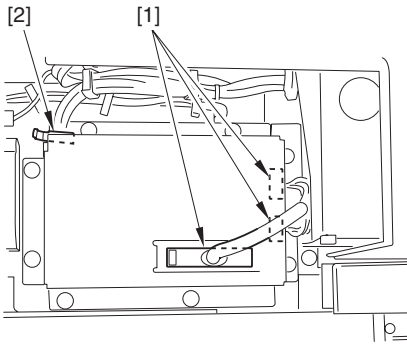

F-10-42

- 3) Remove the control panel interface cover [1].
- 2 screws [2]
- 8 screws [3]

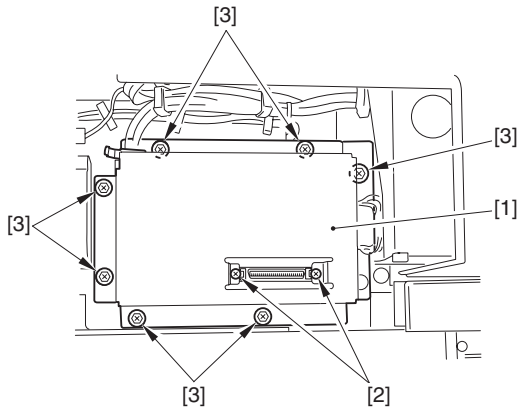

F-10-43

- 4) Remove the control panel interface PCB [1].
- 6 connectors [2]
- 4 screws [3]

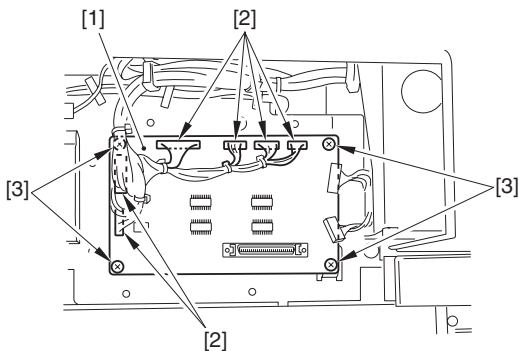

F-10-44

10.5.13 Control Panel LCD Unit

10.5.13.1 Before Starting the Work

- 1) Remove the control panel.
- 2) Remove the 5 rubber pieces [1] from the back of the control panel.

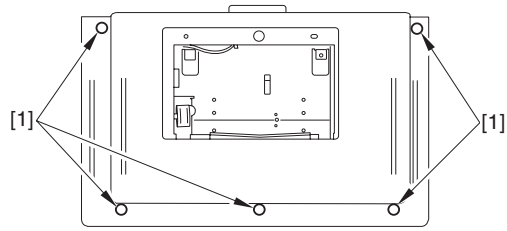

F-10-45

- 3) Remove the control panel rear cover [1].
- 6 screws [2]

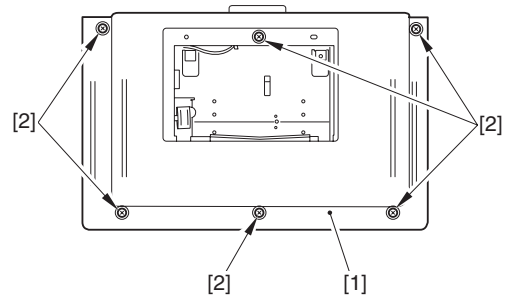

F-10-46

- 4) Remove the shielding plate assembly [1].
- 5 connectors [2]
- 2 screws [3]
- 8 screws [4]

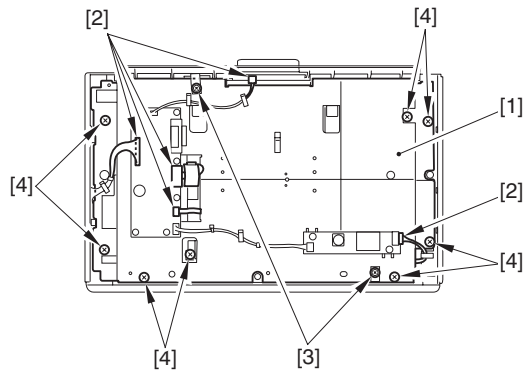

F-10-47

10.5.13.2 Removing the Control Panel LCD

- 1) Remove the control panel LCD [1].
- 2 screws [2]

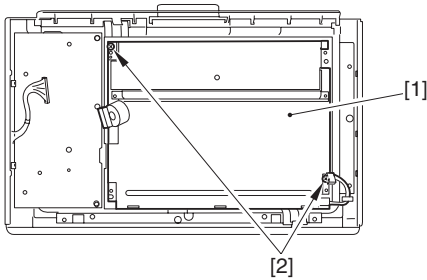

F-10-48

10.5.14 Cover Switch Assembly

10.5.14.1 Removing the Front Cover Switch Assembly

- 1) Remove the upper front cover unit.
- 2) Remove the 3 screws [1], and detach the cover switch assembly [2].

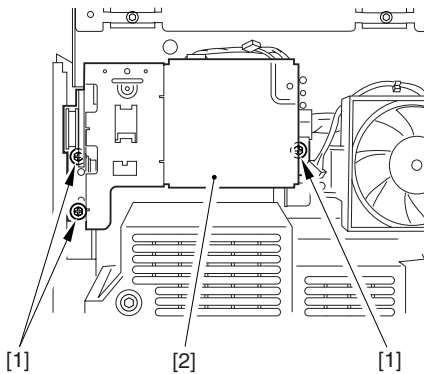

F-10-49

- 3) Disconnect the 3 connectors [1], and detach the cover switch assembly [2].

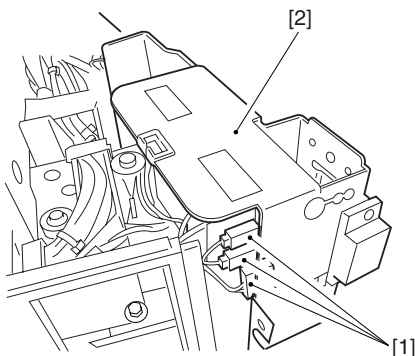

F-10-50

10.5.15 Manual Feed Tray Switch Assembly

10.5.15.1 Removing the Manual Feed Tray Switch Assembly

- 1) Remove the process unit cover. (4 screws)
- 2) Remove the 2 screws [1], and disconnect the 2 connectors [2]; then, detach the pre-transfer charging assembly fan [3].

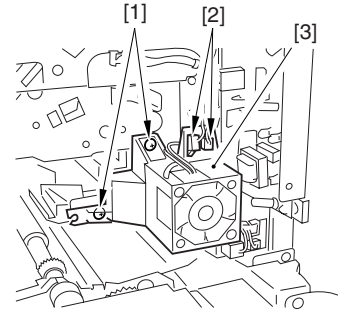

F-10-51

- 3) Disconnect the 3 connectors [1], and remove the screw [2]; then, detach the potential sensor PCB [3].

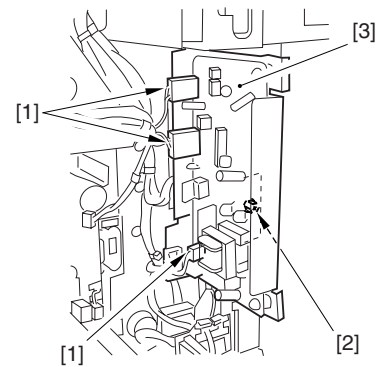

F-10-52

- 4) Remove the screw [1], and disconnect the 2 connectors [2]; then, detach the manual feed tray switch assembly [3].

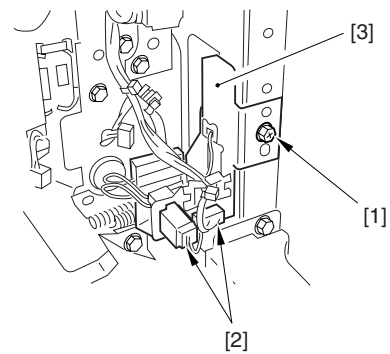

F-10-53

10.5.16 Drum Heater Switch Assembly

10.5.16.1 Removing the Drum Heater Switch Assembly

- 1) Remove the rear cover.
- 2) Remove the left lower cover. (4 screws)
- 3) Remove the 3 screws [1], and disconnect the 7 connectors [2]; then, detached power cord base [3]. thereafter, free the fixing claw to detach the drum heat switch [4].

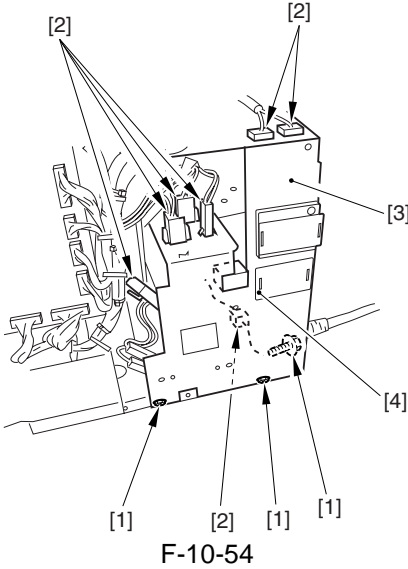

10.5.17 DC Controller PCB

10.5.17.1 Removing the DC Controller PCB

- 1) Remove the rear cover.
- 2) Disconnect all connectors of the PCB, and remove the 4 screws [1]; then, detach the DC controller PCB [2].

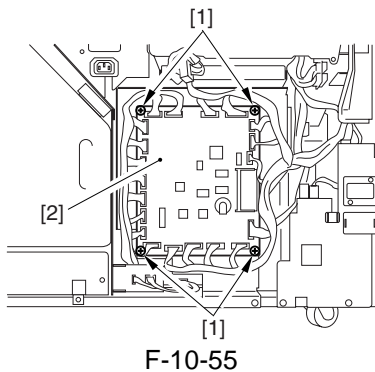

10.5.17.2 After Replacing the DC Controller PCB

⚠ Before Starting the Work (backing up the data)

If possible, perform the following:

- Using the SST, download the data stored in the RAM of the DC controller.
- Print out the user mode/service mode data.

- 1) Turn on the power, and execute the following service mode:

COPIER > FUNCTION > CLEAR > DC-CON

- 2) If the data has been successfully downloaded using the SST as instructed in step 1) above, upload it.

- 3) Using the following service mode item, specify the order of connecting delivery accessories:

COPIER > OPTION > ACCPSD-D > ACC1 to ACC8

- 4) Set the values indicated on the service mode for their respective service mode items.

- 5) Set '0' for the following service mode item:

COPIER > OPTION > BODY > FIX-EXP (fixing smear repression mode)

- 6) Execute the following service mode item:

COPIER > FUNCTION > MISC-P > CL-ADJ

COPIER > FUNCTION > SENS-ADJ > OP-SENS (Level 2)

- 7) Enter the values indicated on the label attached to the new DC controller PCB for their respective service mode items:

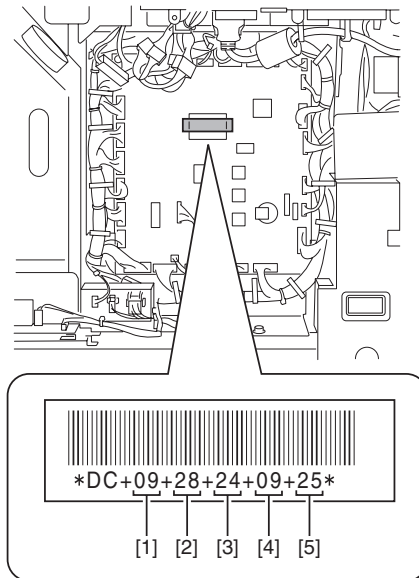

- [1] COPIER > ADJUST > DEVELOP > D-HV-DE

- [2] COPIER > ADJUST > HV-TR > D-HV-TR

- [3] COPIER > ADJUST > HV-TR > D-PRE-TR

- [4] COPIER > ADJUST > HV-SP > D-HV-SP

- [5] COPIER > ADJUST > DEVELOP > OFF-SETDA

- 8) Turn off and then on the power.

10.5.18 Control Panel Inverter PCB

10.5.18.1 Before Starting the Work

- 1) Remove the control panel.
- 2) Remove the 5 rubber pieces [1] from the back of the control panel.

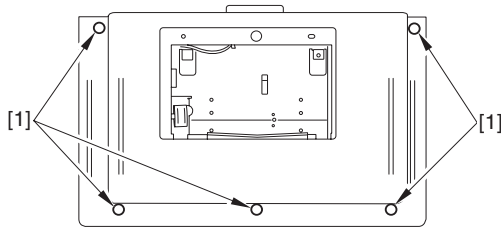

F-10-57

- 3) Remove the control panel rear cover [1].
- 6 screws [2]

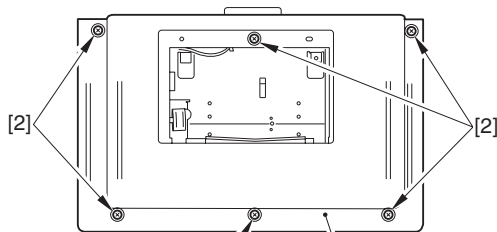

F-10-58

10.5.18.2 Removing the Control Panel Inverter PCB

- 1) Remove the control panel inverter PCB [1].
- 2 connectors [2]
- 2 screws [3]

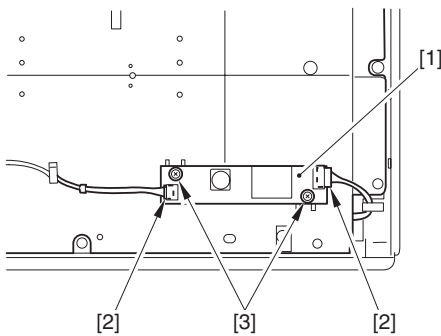

F-10-59

10.5.19 Control Panel Key Switch PCB

10.5.19.1 Before Starting the Work

- 1) Remove the control panel.
- 2) Remove the 5 rubber pieces [1] from the back of the control panel.

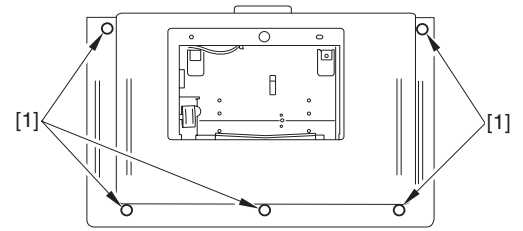

F-10-60

- 3) Remove the control panel rear cover [1].
- 6 screws [2]

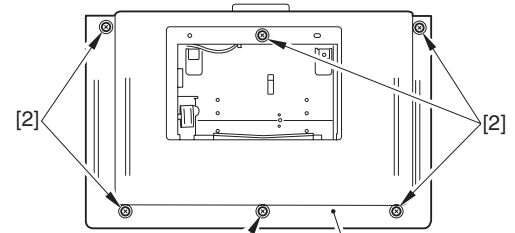

F-10-61

- 4) Remove the shielding plate assembly [1].
- 5 connectors [2]
- 2 screws [3]
- 8 screws [4]

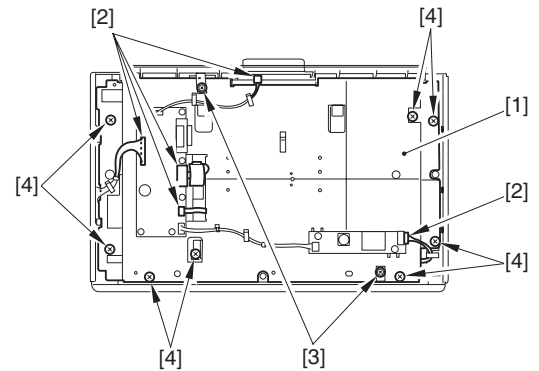

F-10-62

10.5.19.2 Removing the Control Panel KEY PCB

- 1) Remove the control panel KEY PCB [1].
- 4 screws [2]

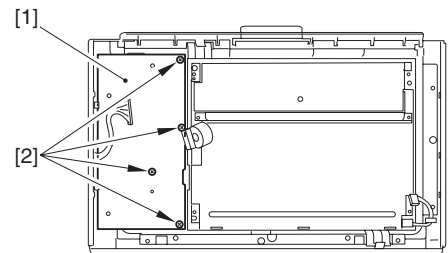

F-10-63

10.5.20 Control Panel Family PCB

10.5.20.1 Before Starting the Work

- 1) Remove the control panel.
- 2) Remove the 5 blocking rubber pieces [1] from the back of the control panel.

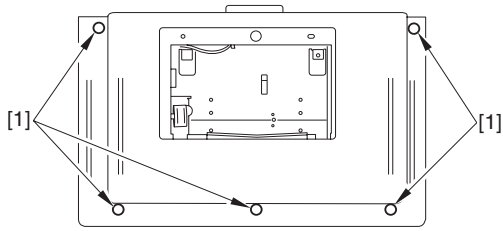

F-10-64

- 3) Remove the control panel rear cover [1].
- 6 screws [2]

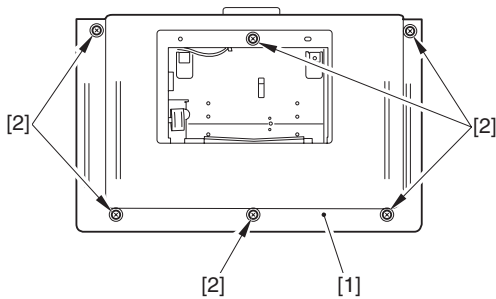

F-10-65

- 4) Remove the shielding plate assembly [1].
- 5 connectors [2]
- 2 screws [3]
- 8 screws [4]

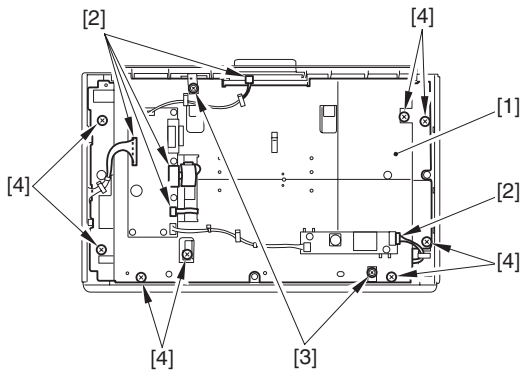

F-10-66

- 5) Remove the control panel KEY PCB.
- 6) Remove the control panel LCD.

10.5.20.2 Removing the Control Panel LED PCB

- 1) Remove the control panel LED PCB [1].
- 3 screws [2]

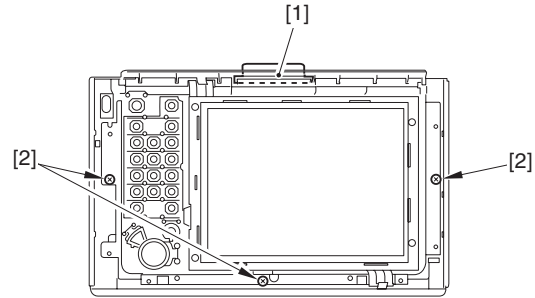

F-10-67

10.5.21 Control Panel CPU PCB

10.5.21.1 Before Starting the Work

- 1) Remove the control panel.
- 2) Remove the 5 rubber pieces [1] from the back of the control panel.

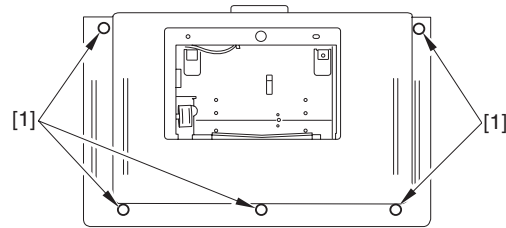

F-10-68

- 3) Remove the control panel rear cover [1].
- 6 screws [2]

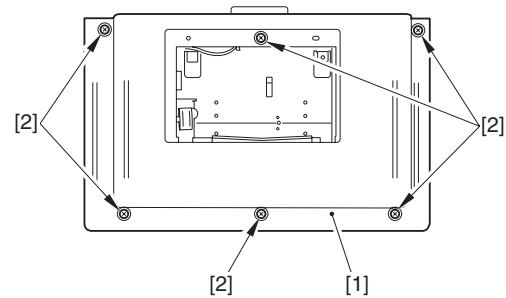

F-10-69

10.5.21.2 Removing the Control Panel CPU PCB

- 1) Remove the control panel CPU PCB [1].
- 5 connectors [2]
- 6 screws [3]

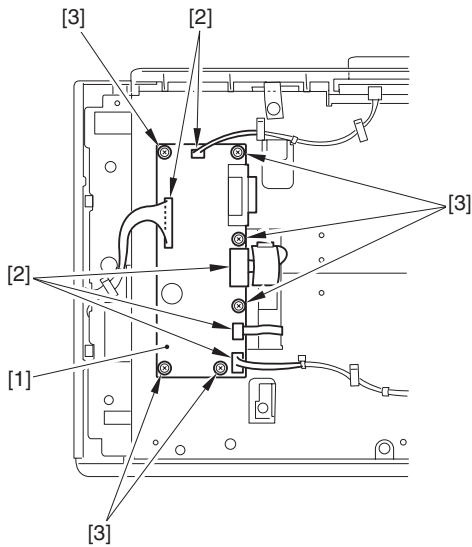

F-10-70

10.5.22 AC Driver PCB

10.5.22.1 Before Starting the Work

- 1) Remove the lower left cover.
 - 2) Remove the upper left cover.
 - 3) Remove the cover plate.
 - 4) Remove the delivery anti-adhesion fan mounting plate [1].
- 1 connector [2]
 - 6 screws [3]

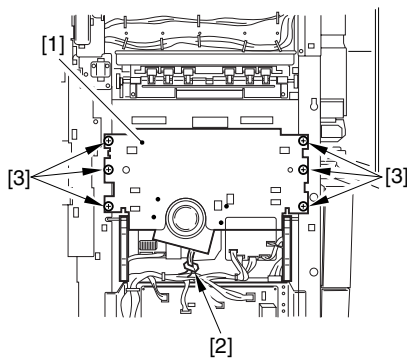

F-10-71

10.5.22.2 Removing the AC Driver PCB

- 1) Remove the AC driver PCB [1].
- all connectors of PCB
- 4 screws [2]
- 1 screw [3] (w/ washer)

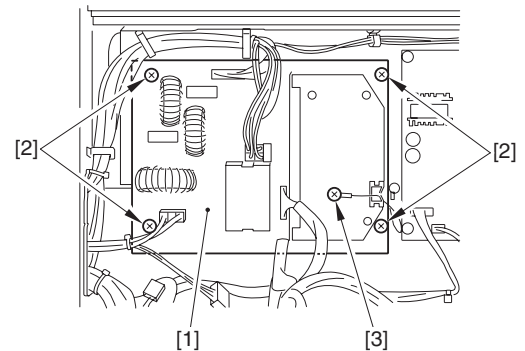

F-10-72

10.5.23 All Night Power Supply PCB

10.5.23.1 Before Starting the Work

- 1) Remove the lower left cover.
 - 2) Remove the upper left cover.
 - 3) Remove the cover plate.
 - 4) Remove the delivery anti-adhesion fan mounting plate [1].
- 1 connector [2]
 - 6 screws [3]

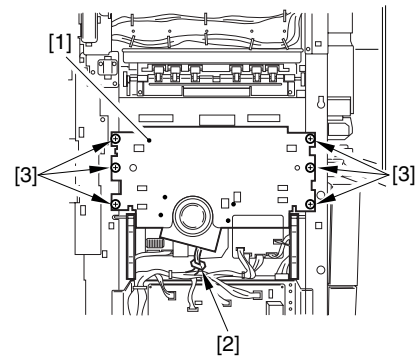

F-10-73

10.5.23.2 Removing the All Night Power Supply PCB

- 1) Remove the all night power supply PCB [1].
 - all connectors of PCB
 - 4 screws [2]

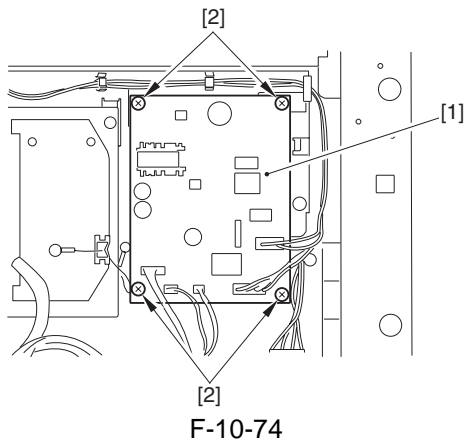

10.5.24 Relay PCB

10.5.24.1 Removing the Relay PCB

- 1) Remove the left lower cover. (4 screws)
- 2) Disconnect the connector from the PCB; then, remove the screw [1], and detach the relay PCB [1] from the four PCB holders [2].

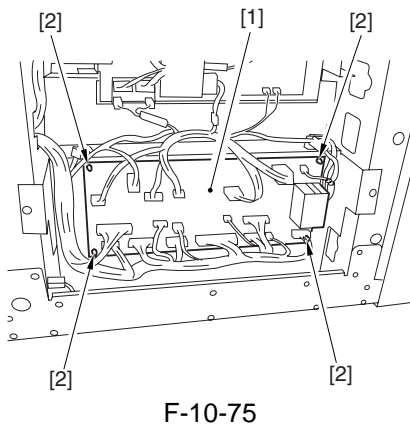

10.5.25 High-Voltage Transformer (AC)

10.5.25.1 Removing the High-Voltage Transformer Assembly (AC)

- 1) Remove the rear cover.
- 2) Remove the HV-AC PCB together with its mounting base.
 - 2 connectors [2]
 - 2 screws [3]

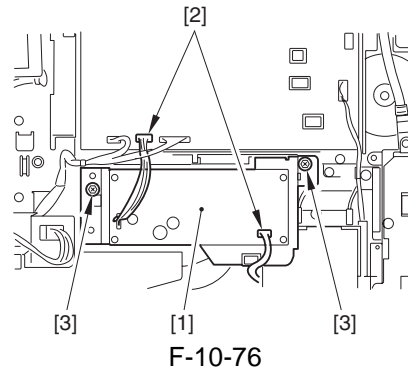

- 3) Disconnect the 3 connectors [1], and remove the screw [2]; then, detach the high-voltage transformer assembly (AC) [3].

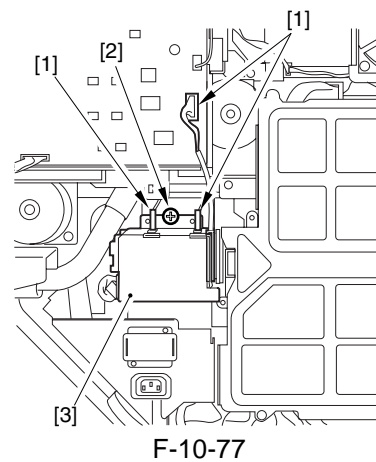

10.5.26 HV-AC PCB

10.5.26.1 Removing the HV-AC PCB

- 1) Remove the rear cover.
- 2) Remove the HV-AC PCB [1].
 - 2 connectors [2]
 - 4 screws [3]

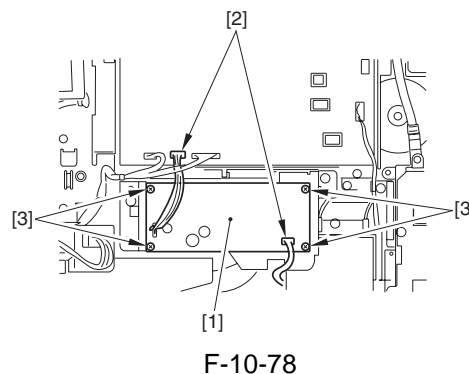

10.5.27 HV-DC PCB

10.5.27.1 Removing the HV-DC PCB

- 1) Remove the rear cover.
- 2) Remove the high-voltage contact [1].
 - 3 connectors [2]
 - 2 screws [3]

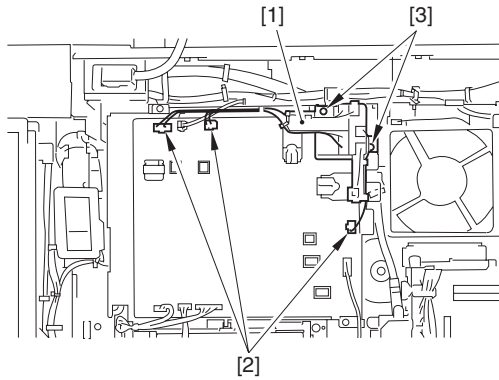

F-10-79

- 3) Remove the HV-DC PCB [1].
 - 5 connectors [2]
 - Free the cable from the wire saddle [3].
 - 2 screws [4]
 - 1 screw [5]

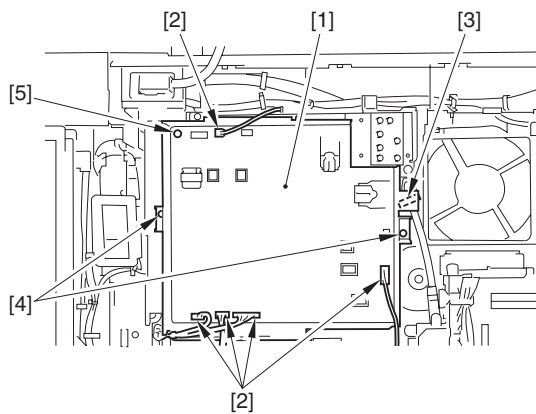

F-10-80

10.5.27.2 After Replacing the HV-DC PCB

- 1) Set the values (5 types) indicated on the label attached to the new HV-DC PCB for the respective service mode items:

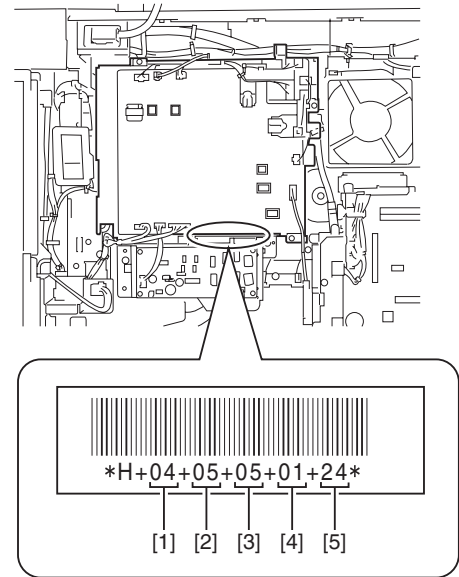

F-10-81

- [1] COPIER > ADJUST > HV-TR > H-PRE-TR
- [2] COPIER > ADJUST > HV-TR > HVT-TR
- [3] COPIER > ADJUST > HV-SP > HVT-SP
- [4] COPIER > ADJUST > DEVELOP > HVT-DE
- [5] COPIER > ADJUST > DEVELOP > OFF-SETAC

- 2) Turn off and then on the power.

10.5.28 High-Voltage PCB

10.5.28.1 Removing the High-Voltage Assembly

- 1) Remove the rear cover.
- 2) Disconnect the 4 connectors [1], and remove the 3 screws [2]; then, free the cable from the wire saddle [3].

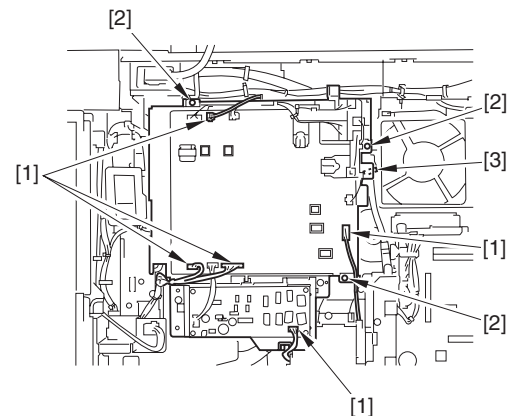

F-10-82

- 3) Slide out the high-voltage assembly [1] along the rails on both sides to detach.

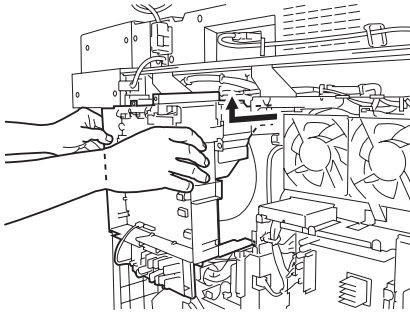

F-10-83

10.5.29 Motor Driver PCB

10.5.29.1 Before Starting the Work

- 1) Remove the main controller box cover [1].
- 10 screws [2]

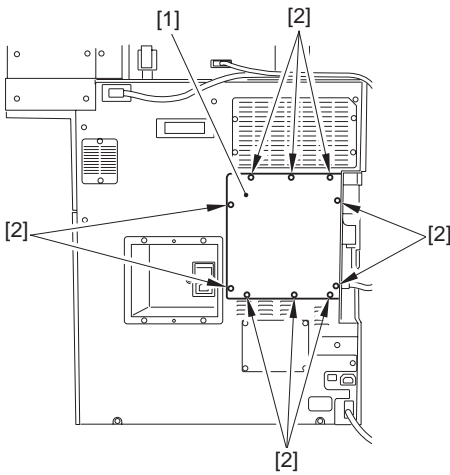

F-10-84

- 2) Remove the rear cover [1].
- 1 reader power supply cable [2]
- 8 screws [3]

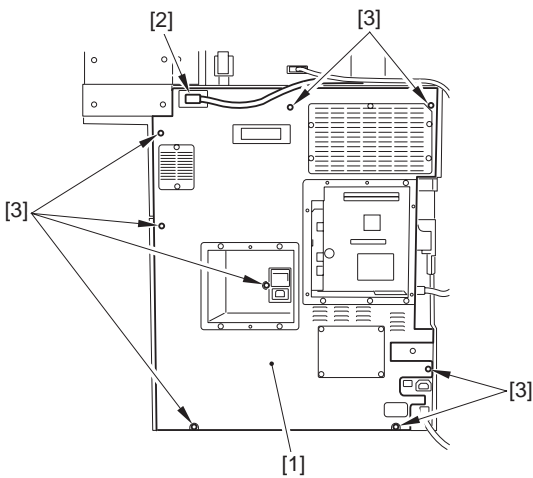

F-10-85

10.5.29.2 Removing the Fixing Inlet Sensor Lift Motor Driver PCB

- 1) Remove the fixing inlet sensor lift motor driver PCB [1].
- 2 connectors [2]
- 4 screws [3]

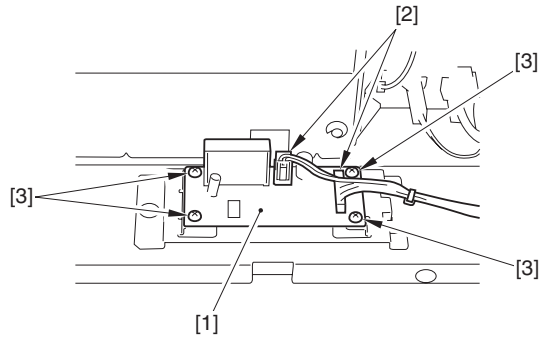

F-10-86

10.5.30 Transceiver PCB

10.5.30.1 Before Starting the Work

- 1) Remove the main controller box cover [1].
- 10 screws [2]

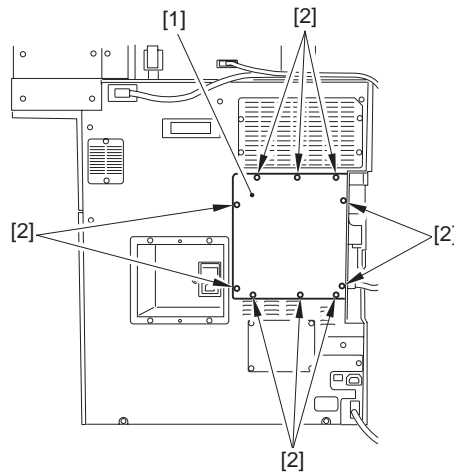

F-10-87

- 2) Remove the rear cover [1].
- 1 reader power supply cable [2]
- 8 screws [3]

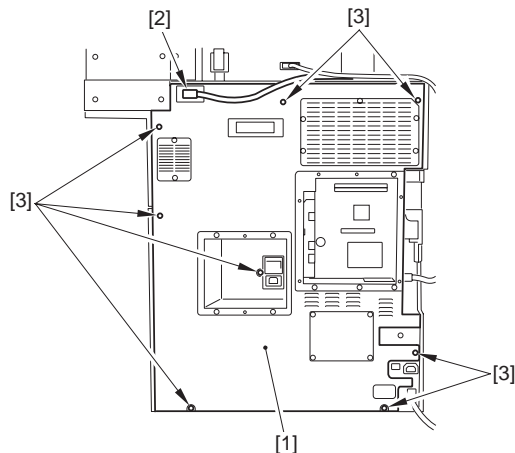

F-10-88

- 3) Remove the lower left cover [1].
- 4 screws [2]

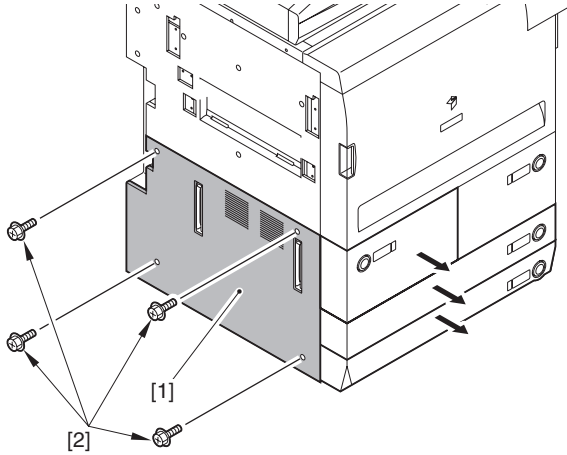

F-10-89

- 4) Remove the power code base [1].
- 4 screws [2]
- 4 connectors [3]

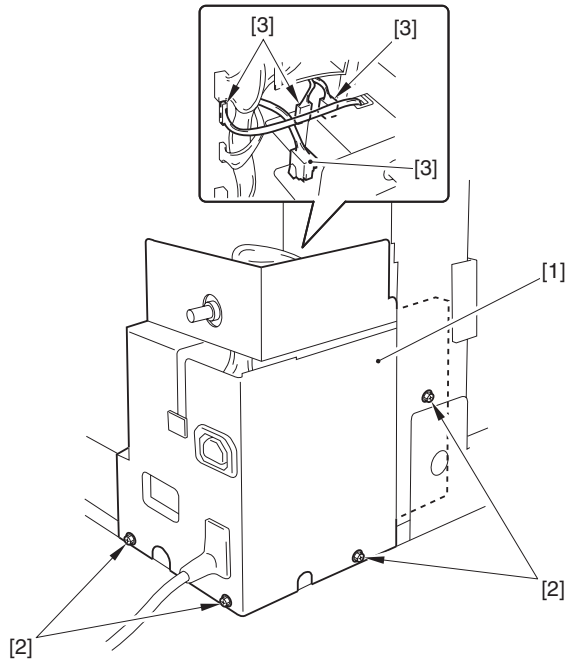

F-10-90

10.5.30.2 Removing the Transceiver PCB

- 1) Remove the transceiver unit [1].
- 2 screws [2]

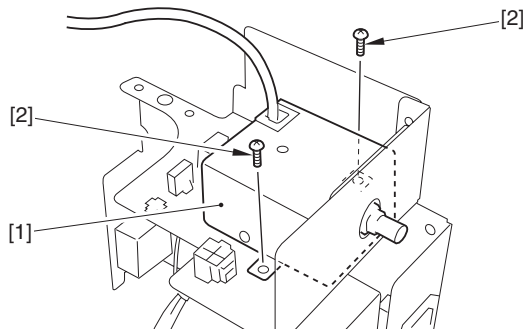

F-10-91

- 2) Free the cable from the edge saddle [1]; then, remove the 4 screws [2] to detach the transceiver unit cover [3].

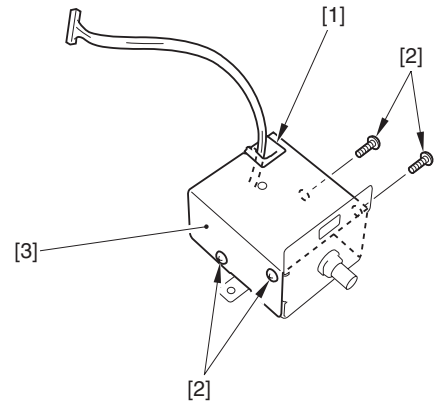

F-10-92

- 3) Remove the transceiver PCB [1].
- nut [2]
- washer [3]
- 2 screws [4]
- 2 locking supports [5]

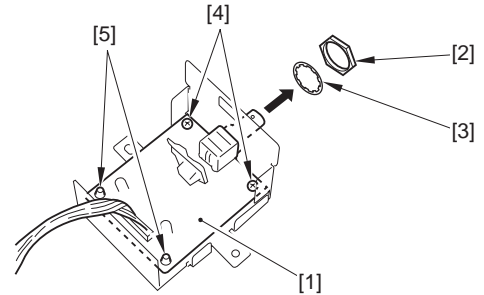

F-10-93

10.5.31 Double Feeding Detection PCB (Transmission)

10.5.31.1 Before Starting the Work

- 1) Slide out the fixing/feeding unit.
2) Remove the transfer/separation charging assembly cover.
3) Remove the 2 knobs [1].
- 2 screws [2]

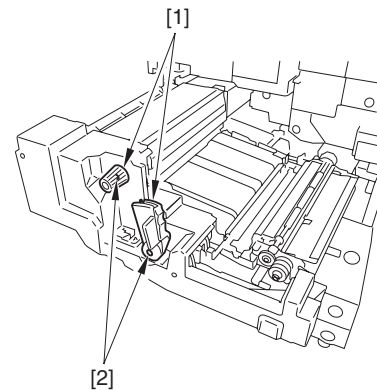

F-10-94

- 4) Remove the fixing/feeding unit cover [1].
- 2 screws [2]

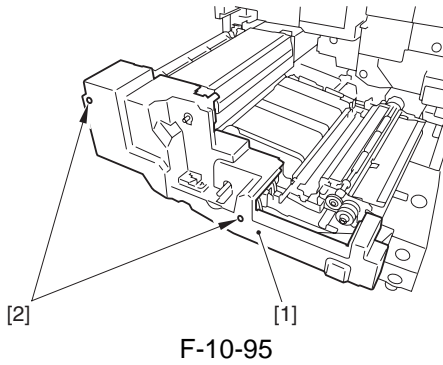

10.5.31.2 Removing the Double-Feed Detection Unit (transmitting)

- 1) Remove the double-feed Detection PCB (transmitting) [1].
- 2 connectors [2]
- 4 screws [3]

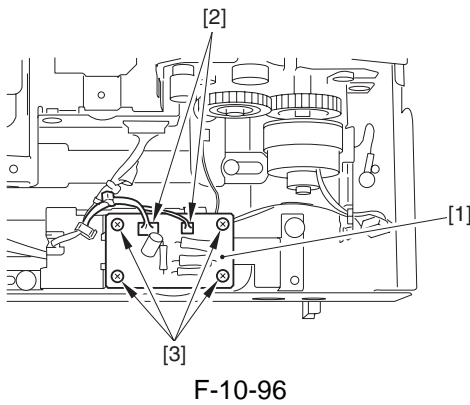

10.5.32 Double Feeding Detection PCB (Reception)

10.5.32.1 Before Starting the Work

- 1) Remove the primary charging assembly cover.
- 2) Remove the process unit cover.

10.5.32.2 Removing the Double-Feed Detection Unit (reception)

- 1) Remove the double-Feed Detection PCB (reception) [1].
- 2 connectors [2]
- 4 screws [3]

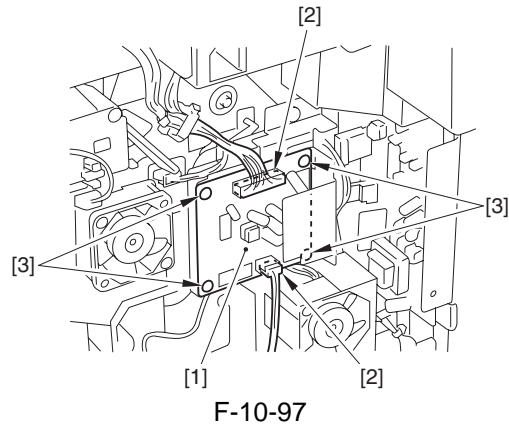

10.5.33 Fixing Heat Discharge Fan

10.5.33.1 Removing the Fixing Heat Discharge Fan (FM2)

- 1) Remove the rear cover.
- 2) Remove the 2 screws [1], and disconnect the connector [2]; then, detach the fixing heat discharge fan [3].

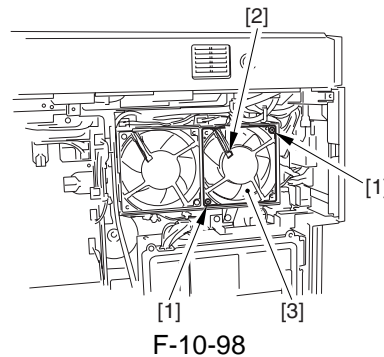

When mounting the fan, be sure that the direction of air current is as indicated by the arrow.

10.5.34 Laser Cooling Fan

10.5.34.1 Removing the Laser Motor Cooling Fan (FM1)

- 1) Remove the inside upper cover.
- 2) Disconnect the connector [1], and remove the harness lock [2] from the plate.
- 3) Remove the 4 screws [3], and detach the laser motor cooling fan [4].

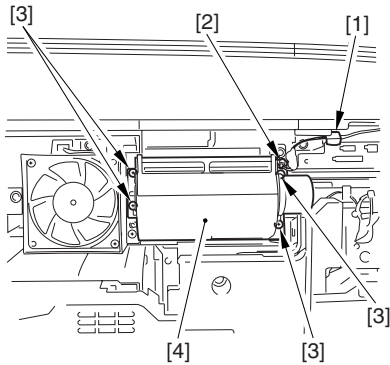

F-10-99

10.5.34.2 Removing the Laser Cooling Fan 1 (FM3)

- 1) Remove the inside upper cover.
- 2) Disconnect the connector, and remove the 2 screws [2]; then, detach the laser cooling fan 1 [3].

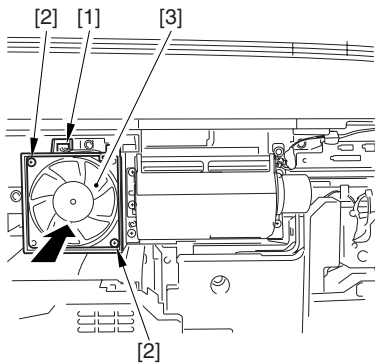

F-10-100



When mounting the fan, be sure that the direction of air current is as indicated by the arrow.

10.5.35 De-Curling Fan

10.5.35.1 Removing the Curl-Removing Fan

- 1) Remove the fixing/feeding unit cover.

- 2) Remove the fixing motor base [1].
Free the cable from the edge saddle [2].
- 3 screws [3]
- 1 screws [4]

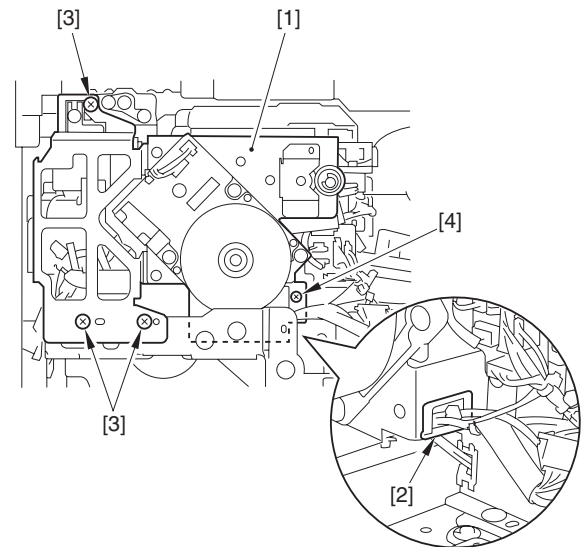

F-10-101

- 3) Remove the 2 screws [1], and disconnect the 2 connectors [2]; then, detach the delivery speed switchover clutch [3].

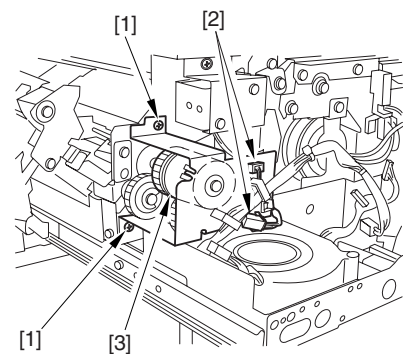

F-10-102



When detaching the delivery speed switching clutch, take care not to lose the bearing and washer (rear only) on both sides of the clutch shaft.

- 4) Disconnect the 2 connectors [1], and remove the 2 screws [2]; then, detach the curl-removing fan [3].

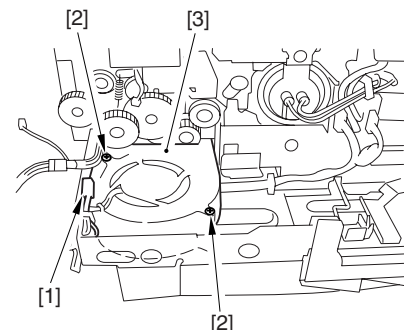

F-10-103

10.5.36 Drum Fan

10.5.36.1 Removing the Drum Fan (FM8)

- 1) Remove the HV-DC PCB.
- 2) Remove the 2 screws [1], and disconnect that connector [2]; then, detach the drum fan unit [3].

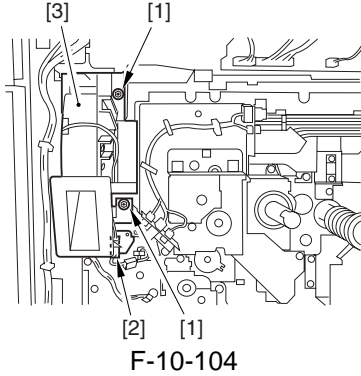

- 3) Disconnect the connector [1], and remove the 3 screws [2]; then, detach the drum fan [3].

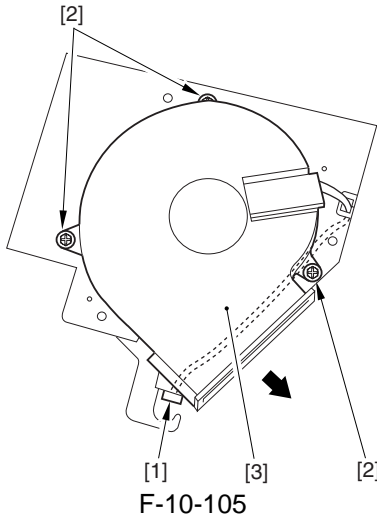

10.5.37 Pre-Transfer Charging Assembly Fan

10.5.37.1 Removing the Pre-Transfer Charging Assembly Fan (FM10)

- 1) Remove the process unit cover. (4 screws)
- 2) Remove the 2 screws [1], and disconnect the 2 connectors [2]; then, detach the fan motor [3].

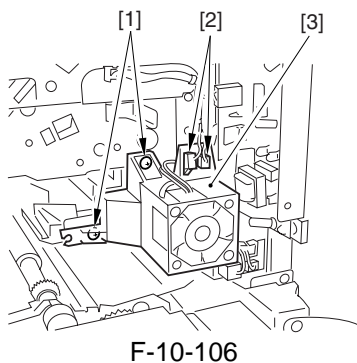

- 3) Disconnect the connector [1], and remove the 2 screws [2]; then, detach the pre-transfer charging assembly fan [3].

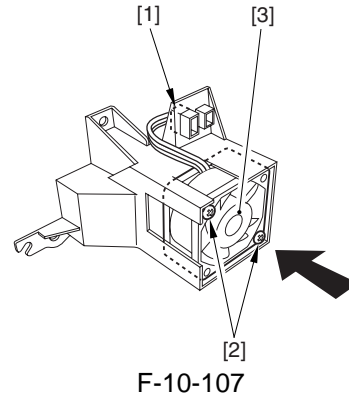

When mounting the fan, be sure that the direction of air current is as indicated by the arrow.

10.5.38 Power Supply Cooling Fan 1

10.5.38.1 Removing the Power Supply Cooling Fan 1 (FM11)

- 1) Remove the left lower cover. (4 screw)
- 2) Remove the power supply unit.
- 3) Remove the 3 screws [1], and detach the fan mounting base [2].

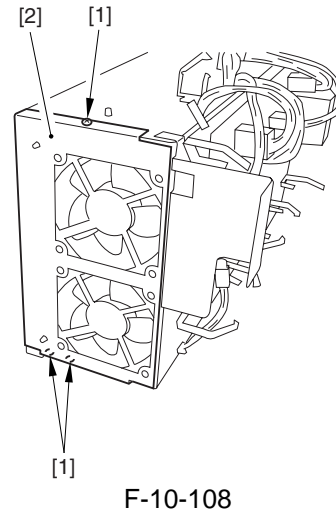

- 4) Remove the 2 screws [1], and disconnect the connector [2]; then, detach the power supply cooling fan [3].

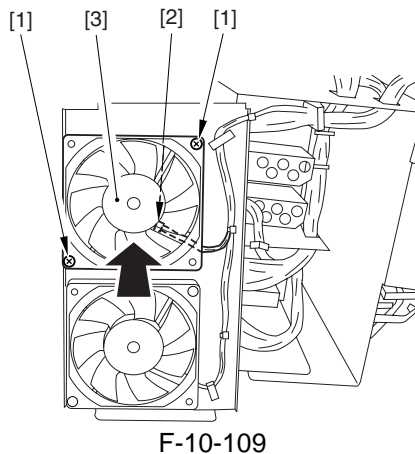

When mounting the fan, be sure that the direction of air current is as indicated by the arrow.

10.5.39 Power Supply Cooling Fan 2

10.5.39.1 Removing the Power Supply Cooling Fan 2 (FM12)

- 1) Remove the fan mounting base.
- 2) Remove the 2 screws [1], and disconnect the connector [2]; then, detach the power supply cooling fan 2 [3].

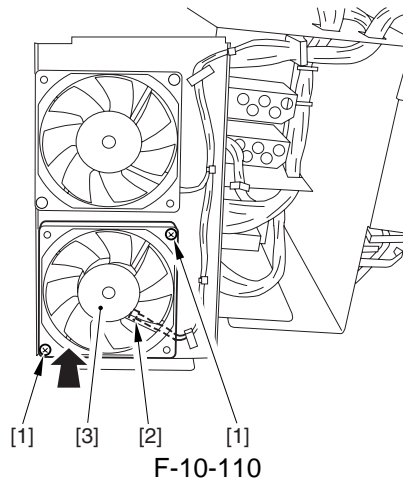

When mounting the fan, be sure that the direction of air current is as indicated by the arrow.

10.5.40 Separation Fan

10.5.40.1 Removing the Separation Fan (FM13)

- 1) Slide out the fixing/feeder unit.
- 2) Remove the 4 screws [1], and detach the fixing/feeding lower cover (1) [2] and the fixing/feeding lower cover (2) [3].

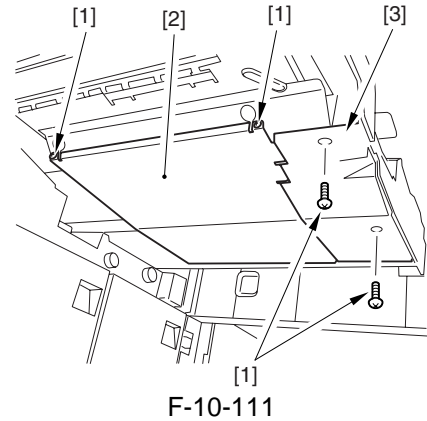

- 3) Disconnect the connector [1], and remove the heater 3 screws [2]; then, detach the separation fan [3].

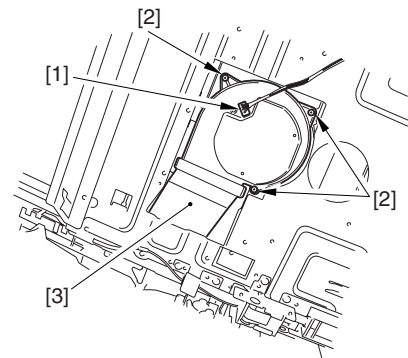

10.5.41 Developing Fan

10.5.41.1 Removing the Developing Fan (FM15)

- 1) Remove the primary charging assembly.
- 2) Disconnect the connector [1], and remove the 2 screws [2]; then, detach the fan unit [3].

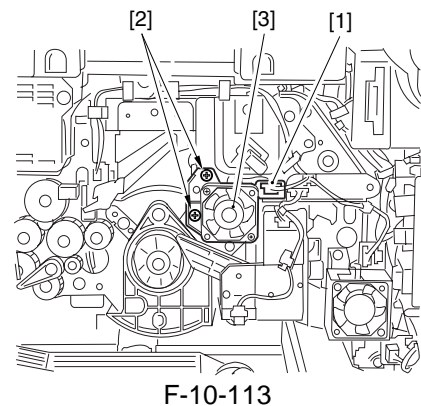

- 3) Remove the 2 screws [1], and detach the developing assembly fan [2].

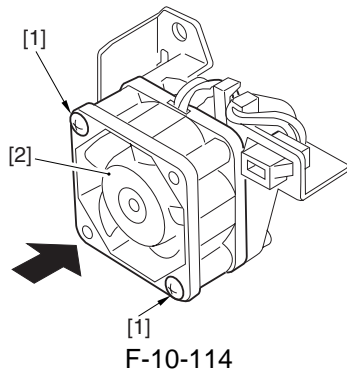

⚠
When mounting the fan, be sure that the direction of air current is as indicated by the arrow.

10.5.42 Delivery Anti-Adhesion Fan

10.5.42.1 Removing the Delivery Anti-Adhesion Fan (FM17)

- 1) Remove the left lower cover. (4 screws)
- 2) Disconnect the connector [1], and remove the 2 screws [2]; then, detach the fan unit [3].

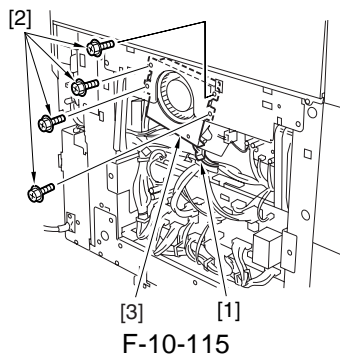

- 3) Remove the 2 screws [1], and detach the fan [2].

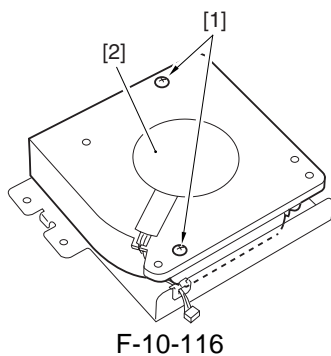

10.5.43 Duplex Feed Fan

10.5.43.1 Removing the Duplex Feed Fan (FM19)

- 1) Remove the duplex unit cover. (4 screws, 3 knobs)
- 2) Disconnect the connector [1], and remove the 3 screws [2]; then, detach the duplex feed fan unit [3].

At this time, keep in mind that the shift assembly [4] will also come off.

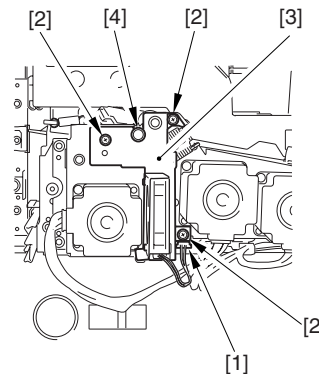

- 3) Remove the 2 screws [1], and detach the duplex feed fan [2].

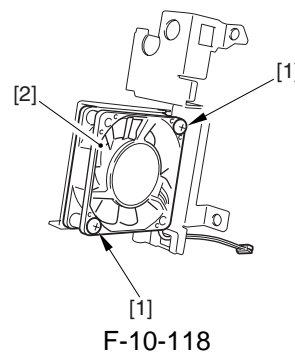

⚠
When mounting the fan, be sure that the direction of air current is as indicated by the arrow.

10.5.44 Separation Heat Discharge Fan

10.5.44.1 Removing the Separation Heat Discharge Fan (FM20)

- 1) Remove the rear cover.
- 2) Disconnect the connector, and remove the 2 screws [2]; then, detach the separation heat discharge fan [3].

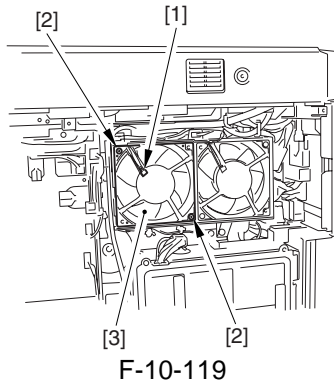

10.5.45 Reader Heat Discharge Fan 2

10.5.45.1 Removing the Reader Heat Discharge Fan 2

- 1) Remove the upper rear cover.
- 2) Remove the reader heat discharge fan 2 unit [1].
 - 1 connector [2]
 - 2 screws [3]

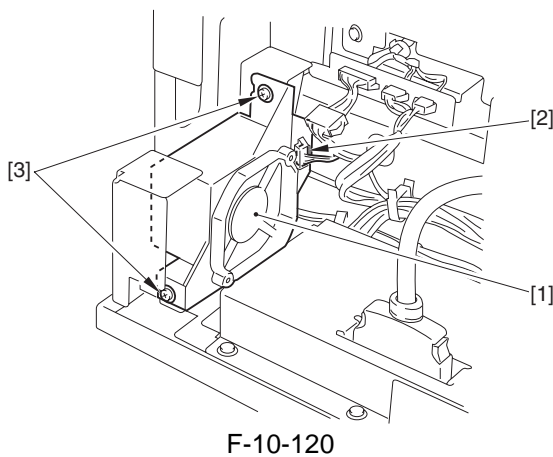

- 3) Remove the reader heat discharge fan 2 [1].
 - 2 screws [2]
 - 1 connector [3]

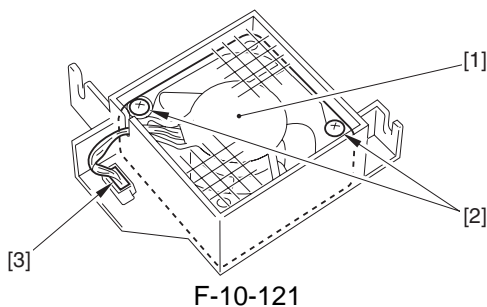

10.5.46 Fixing Inlet Sensor Motor

10.5.46.1 Before Starting the Work

- 1) Open the front cover, and slide out the fixing/feeding unit.
- 2) Remove the fixing assembly.

10.5.46.2 Removing the Fixing Inlet Sensor Lifter Motor

- 1) Remove the blocking cover [1].
 - 2 screws [2]

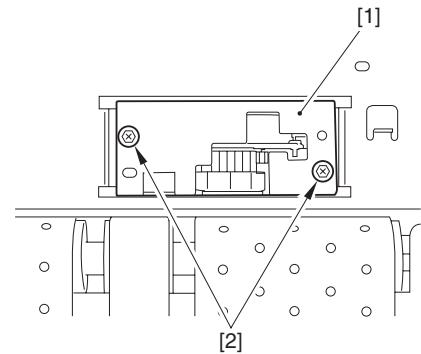

- 2) Remove the fixing inlet sensor lifter motor assembly [1].
 - 1 connector [2]
 - 1 screw [3]

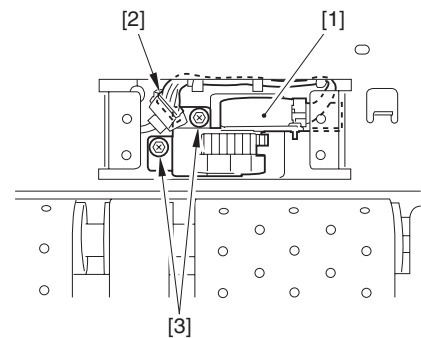

- 3) Remove the fixing inlet sensor lifter motor [1].
 - 2 screws [2]

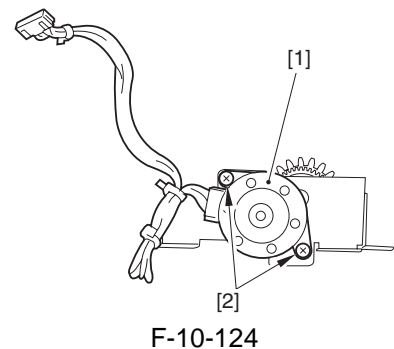

Chapter 11

MEAP

Contents

11.1 MEAP	11-1
11.1.1 Overview	11-1
11.1.2 MEAP Counter	11-1
11.1.3 Construction of the MEAP Platform	11-2

11.1 MEAP

11.1.1 Overview

The term MEAP stands for Multifunctional Embedded Application Platform, and is used to generically refer to a platform for software built into MFPs and peripheral equipment. The architecture is based on Java (J2ME, i.e., Java 2 Platform Micro Edition), and is designed to enable the execution of Java applications.

A MEAP application behaves independently from its host printer's system software, and may be installed or uninstalled using SMS (Service Management Service), which is an interface that runs as part of the browser on a PC. As long as the device supports MEAP, most MEAP applications may be added to the device in the field.

11.1.2 MEAP Counter

In addition to the commonly found print counters, a device that supports MEAP is equipped with a counter mechanism used to keep track of which functions are used as well as how often they are used for individual MEAP applications that are installed. The MEAP counter readings may be checked by making the following selections on the device control panel: Counter Check Key>MEAP Counter Check. A device may possess the following MEAP counters, and which counter to use and, therefore, to display all depend on the application in question.

A counter reading may be of a type that is forced to increase as a job is expected or of a type that is increased when the application sends instructions; or, it may be of a type that increases independently of the host device, thus increasing solely in response to the application being run; specifics are as follows:

T-11-1

Type	Count item
forced	total 1
	total (black-and-white small)
	total (black-and-white large)
	total (black-and-white 1)
	scan (total 1)
	black-and-white scan (total 1)
	black-and-white scan (total 1)
in response to instructions from application	black-and-white scan 1
	black-and-white scan 2
	black-and-white scan 3
	black-and-white scan 4
application-independent	free 1
	free 2
	free 3
	free 4
	free 5
	free 6
	free 7
	free 8
	free 9
	free 10
	free 11
	free 12

MEMO:

forced: the device forces the counter to increase its reading in response to execution of a job.

in response to instructions from application: the counter increases its reading only in response to instructions from the application.

application independent: the counter operates according to the specifications of the application.

11.1.3 Construction of the MEAP Platform

In addition to the installation of the system software, language file, and RUI, a printer equipped with MEAP functions calls for the installation of MEAP content, which offers functions (system services) needed to run MEAP applications and class libraries needed by the MEAP applications to control the device. It is important that the version of the system software be fully compatible with the version of the MEAP content, calling for special care. (In the case of a mismatch, the device will not be able to run the MEAP application.) For version information, refer to the Service Information bulletin that is released in conjunction with the system software.

The following shows the components of a MEAP application:

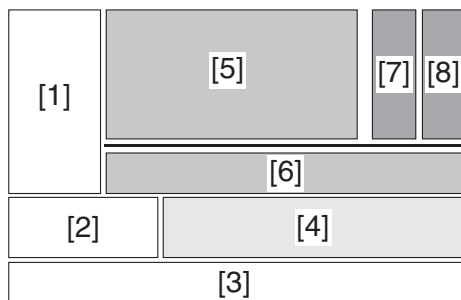

F-11-1

- [1] User Interface Control Bock
installed as part of the system software
- [2] Device Control Block
installed as part of the system software
- [3] Operating System
installed as part of the system software
- [4] Java VM
installed as part of the system software
- [5] MEAP System Services (includes SDL/SSO)
installed as part of MEAP content
- [6] Device Control Class Library
installed as part of MEAP content
- [7] internally developed application
- [8] externally developed application

Chapter 12

RDS

Contents

12.1 RDS.....	12- 1
12.1.1 Application operation mode.....	12- 1
12.1.2 Service Center URL and Port Specification	12- 1
12.1.3 Communication test.....	12- 1
12.1.4 Communication log.....	12- 1
12.1.5 Detailed Communication log.....	12- 1
12.1.6 SOAP communication function.....	12- 1
12.1.7 Resend at SOAP transmission error	12- 2
12.1.8 e-RDS setting screen	12- 3
12.1.9 Sleep operation.....	12- 5
12.1.10 Network Setting (Maintenance)	12- 5
12.1.11 e-RDS Setting (Maintenance).....	12- 6
12.1.12 Trouble shoot.....	12- 6
12.1.13 Error message.....	12- 7

12.1 RDS

12.1.1 Application operation mode

Serviceman selects the operation mode of OFF/ON by the setting in e-RDS setting screen of the service mode. (Menu Screen: E-RDS)

- OFF (default): e-RDS doesn't operate.
- ON: e-RDS operates every function.

12.1.2 Service Center URL and Port Specification

The URL and the port number of the equipment information destination can be specified as follows.

- Default (specified beforehand)
- Specified by the service mode. (Menu Screen: RGW-ADR, RGW-PORT)

12.1.3 Communication test

Serviceman can distinguish the communication status with the UGW by executing the communication test in the service mode (Menu Screen: COM-TEST), and referring to the communication log
Error information is displayed in the latest communication log at communication error.

12.1.4 Communication log

The list of the log of the communication error (proxy server error etc.)(For 30) can be displayed in display panel in the service mode. (Menu Screen: COM-LOG)

12.1.5 Detailed Communication log

Detailed information of the error in the communication log can be displayed in display panel. (Log List Screen: Each error)

12.1.6 SOAP communication function

The following processing is achieved by the SOAP communication (SSL client communication).
e-RDS does the host authentication by using the CA*1 certificate of the VeriSign Co..

When the host certificate or the CA certificate is expired, e-RDS doesn't connect to UGW.

*1: CA: Certificate Authority: Organization that issues electronic certificate used by electronic commerce etc

- (1) Communication test:
 - Do the communication test
- (2) Regularly collect the following data, and transmit it.
 - Copy Counter
 - Service mode counter
 - Parts counter
 - Mode Counter
 - ROM version
 - Scheduling information
 - Application log

- (3) When jam or alarm/service call error is detected from the device, e-RDS transmits to UGW.
 - Transmission of alert code(Counter information is transmitted at the same time.)
 When the state of the device changes, e-RDS sends the alert code list.
 The main alert codes used are Toner LOW/OUT, Jam, and Door open.
 When recovering from an error, e-RDS transmits data that shows the recovering from an error again.
 - Transmission of Jam log (Counter information is transmitted at the same time.)
 - Transmission of Alarm log (Counter information is transmitted at the same time.)
 - Transmission of Service Call (Error code) log (Counter information is transmitted at the same time.)
- (4) Change of the device scheduling information
 - Scheduling information can be changed by the instruction from UGW.

List of Transmissions:

Content of transmission	Transmission timing
Communication test	When Service mode of device is executed
Copy counter collection/transmission	Every 6 hours
Service mode counter collection/transmission	Every 6 hours
Mode counter collection/transmission	Every 6 hours
Parts counter collection/transmission	Every 6 hours
ROM version transmission	Every 6 hours
Application log	When the log file size exceeds 10kbytes
Transmission of alert code	When the state of the device is changed.
Jam	When Jam occurs
Alarm	When Alarm occurs
Error	When Error occurs
Confirmation whether there is processing that e-RDS executes	Every 6 hours

12.1.7 Resend at SOAP transmission error

When SOAP send error is generated by the trouble on UGW side etc. at the transmission of an alert code, the latest three batches of data that failed in the transmission are stored in HDD, and e-RDS resends it at prescribed intervals.

12.1.8 e-RDS setting screen

The e-RDS setting screen is in the service mode screen.

When the tab above is selected on any e-RDS setting screen, it changes to the mid item screen. Moreover, it returns to previous screen when reset key is pressed.

Menu Screen

The screenshot shows a menu screen with several tabs at the top: Display, I/O, Adjust, Function, Option, Test, and Counter. The main content area displays the following settings:

Item	Value	Range
TONER-S		
STRD-POS		
CARD	0	{ 1 ~ 2001 }
E-RDS	0	{ 0 ~ 1 }
RGW-PORT	443	{ 1 ~ 65535 }
COM-TEST		
COM-LOG		
RGW-ADR	https://a01.ugwdevice.net/ugw/agenti	

At the bottom of the screen, there are four navigation buttons: a left arrow, a right arrow, a +/- sign, and an OK button with a small arrow pointing down.

F-12-1

Setting screen of e-RDS. The form and the initial value of each setting item are as follows.

Item(meaning)	Explanation
E-RDS (Embedded-RDS)	Turning OFF/ON e-RDS. 0:OFF / 1:ON Counter information and error information are transmitted to the host at ON. Initial value: 0: OFF
RGW-ADR (RDS-Gateway ADDRESS)	URL of the host (When the input area is selected (touched), shift to the keyboard screen) Initial value: URL of an actual host. Length: 129 characters (NULL is contained)
RGW-PORT (RDS-Gateway PORT)	Port Number of the host Initial value: 443 Range of available number: 1-65535
COM-TEST (Communication Test)	Execution of Communication test Communication test starts when you select (touch) this and press the [OK] key. e-RDS tries the connection with the host, and displays the result by "OK!" or "NG!". (NG: No Good, the communication test is failed)
COM-LOG (Communication Log)	The result of communication test When this is selected (touched), and the blank rectangle on right side is selected, it switches to "Log list screen".

Log list screen

Display	I/O	Adjust	Function	Option	Test	Counter
<COM-TEST>		< 1 / 4 >		< READY >		
No.	DATE	TIME	CODE	Information		
01	2005 0129	1837	0500 0003	SUSPEND: Communicati		
02	2005 0129	1836	0500 0003	SUSPEND: Communicati		
03	2005 0129	1806	0500 0003	SUSPEND: Communicati		
04	2005 0129	1805	0500 0003	SUSPEND: Communicati		
05	2005 0129	1758	8000 2046	*Server certificate		
06	2005 0129	1750	0500 0003	SUSPEND: Communicati		
07	2005 0129	1743	0500 0003	SUSPEND: Communicati		
08	2005 0129	1722	0500 0003	SUSPEND: Communicati		
←		→		+/-		OK ↵

F-12-2

History list of communication test error (error generation date, error code and error information) is displayed.

When the each line is selected (touched), it shifts to "Log detailed screen".

It shifts to "Menu screen" by the [Function] > [INSTALL].

The list screen changes by a right arrow or a left arrow.

Maximum log number: 30

Notes: Only the first part of error information is displayed.

Log detailed screen



F-12-3

Detailed information of individual communication test error is displayed.

Refer to the displayed message to "Error message list".

It shifts to "Log list screen" by the [OK] button pressing.

Maximum length of error information: 128 characters (not include NULL)

12.1.9 Sleep operation

When there is a method that should be transmitted while e-RDS is operating (ON), e-RDS wakes from the state of sleep and begins transmitting.

12.1.10 Network Setting (Maintenance)

You should do the network setting of Device appropriately before the e-RDS setting.

A. Display the Additional Functions screen.

- Press [Additional Functions (*)] key.
- Input ID code.

B. Display the TCP/IP Settings screen.

- Select (touch) [System Settings] > [Network Settings] > [TCP/IP Settings] on the Touch Panel Display.

C. Setting of items related to IP address

- Select (touch) [IP Address Settings] => IP Address Settings screen is displayed.
- Set each items such as IP Address, Subnet Mask, Gateway Addresses, and DHCP, etc.
- Return to the TCP/IP Settings screen by pushing the [OK] button after the setting ends.

D. DNS Settings

- Select (touch) [DNS Settings] => DNS Settings screen is displayed.
- Set necessary items.
- Return to the TCP/IP Settings screen by pushing the [OK] button after the setting ends.

E. Proxy Settings

- Select (touch) [Proxy Settings] (Press Down arrow button until [Proxy Settings] is displayed on the TCP/IP Settings screen.) => Proxy Settings screen is displayed.
- Set necessary items.
- Return to the TCP/IP Settings screen by pushing the [OK] button after the setting ends.

F. Display the normal screen.

- Press [Additional Functions (*)] key pressing or press [Done] button to a necessary frequency.

12.1.11 e-RDS Setting (Maintenance)

A. Display the Menu screen of e-RDS from the service mode.

A-1. Shift to the service mode

- Press [Additional Functions (*)] key.
- Press 2 and 8 of the numeric keys at the same time.
- Press [Additional Functions (*)] key. => SERVICE MODE LEVEL1

A-2. Initialize e-RDS

- Select (touch) [COPIER] > [Function] > [CLEAR] > [ERDS-DAT] on the Touch Panel Display.

A-3. Display Menu screen of e-RDS

- Select (touch) [COPIER] > [Function] > [INSTALL] => Menu screen

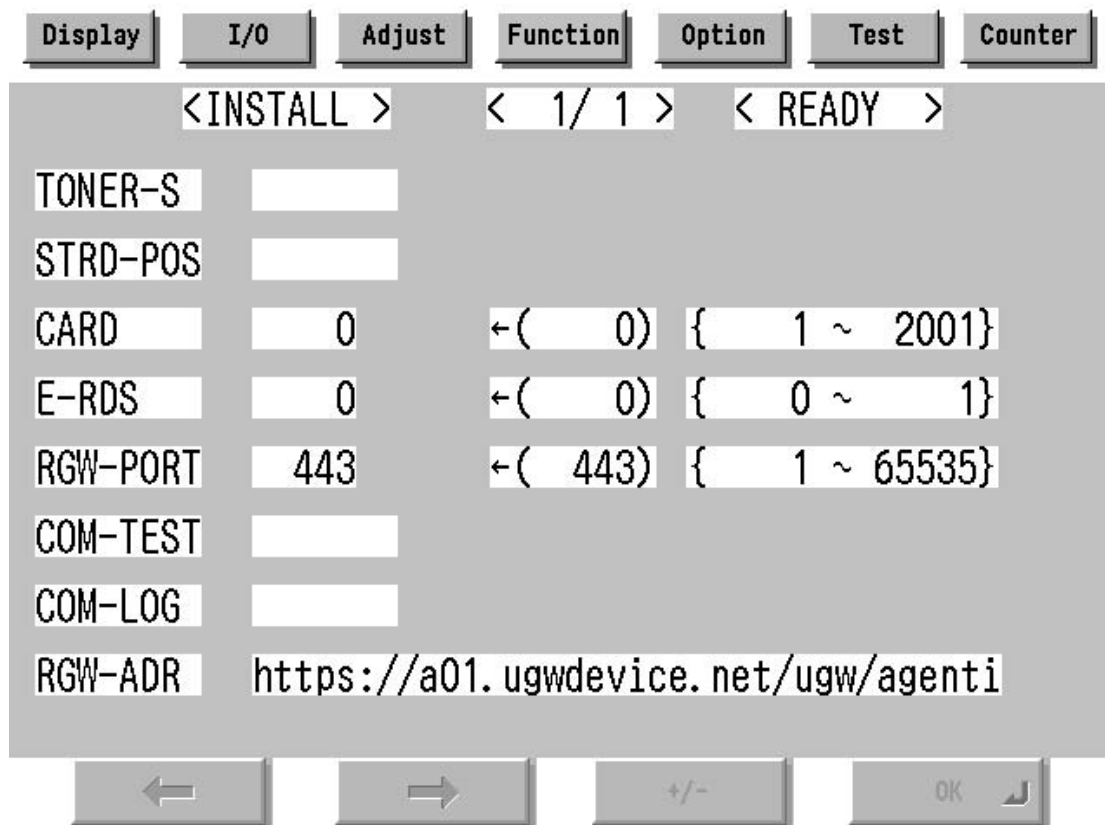

F-12-4

B. Set 1 in [E-RDS].

C. Input the URL of UGW in [RGW-ADR]. (Select the input area to shift to the keyboard screen, and Input URL.)

D. Input the port number of UGW in [RGW-PORT].

E. Select [COM-TEST] and push [OK] button to start the communication test with UGW.

F. While the result is "NG!", repeat to correct the setting and try [COM-TEST] until the result becomes "OK!". You need checking the setting of the network of the device and the connection of the network if necessary.

Notes: In the environment with the proxy server, you should set the proxy server. Refer to the proxy setting in the network guide of the device for details.

12.1.12 Trouble shoot

1-1

Q. There is no setting item.

A. Confirm the network setting.

Confirm the model

1-2

Q. The communication test fails.

A. Confirm the firmware version.

Confirm the network setting.

Confirm the communication test result.

12.1.13 Error message

Error information displayed in "Log list screen" or "Log detailed screen" is as follows.

Notes: Only the first part of error information is displayed in "Log list screen". Maximum length of error information in "Log detailed screen": 128 characters (not include NULL)

When the communication test is not completed end e-RDS is 1 (ON), following string is displayed:
"SUSPEND: Communication test is not performed."

Moreover, when it fails in the event waiting in the device and either of a Jam notification, an Alarm notification, and a Service call notification or an Alert notification is specified, following string is displayed.

"Event Registration is Failed."

In other cases error information is displayed in the form of the following.

"[*] [Error string]: [Method name] [Server side detailed error]"

The enclosed character string by [] is replaced as follows.

[*]:

*(asterisk) is added to the head of the string only at the communication test.

[Error string]:

As for number 1 and 2 of the following Error string lists, only the Error string is displayed. Besides, it is displayed as "[*] [Error string]: [Method name] [Server side detailed error]". ([Server side detailed error] might not go out.)

	Error string	Cause	Counter Measure
1	SUSPEND: Communication test is not performed	The e-RDS is started (the device is rebooted) when e-RDS is ON and communication test isn't done.	Complete the communication test.
2	Event Registration is Failed.	The device failed event processing.	Turn OFF/ON of the device main switch. Or, replace the system software of the device (upgrade).
3	URL Scheme error (not https)	The header of registered URL of UGW is not https.	Change the header on URL of UGW to https
4	Server connection error	Communication failure of TCP/IP occurred. Or IP address of the device isn't set.	Check the network connection.
5	URL server specified is illegal	Illegal URL (other than UGW) is specified.	Correct URL.
6	Proxy connection error	The e-RDS cannot connect it with the proxy server.	Check and correct the proxy server address etc.
7	Proxy authentication error	The e-RDS fails the authentication to proxy.	Check and correct username and password to log in proxy.
8	Server certificate error	- The certificate is not installed in The device. - The certificate that The user is using is not registered in The device or The server.	Register the root certificate in the device or register the VeriSign certificate in the server.
9	Server certificate expired	- Expired certificate is registered in the device or the server. - The date of the device is outside the time limit of the certificate.	- Register the root certificate in expiration date in the device or register the VeriSign certificate in the server. - Set an accurate date to the device.
10	Unknown error	Other communication error occurs.	After waiting for a while, try again.
11	Server response error (NULL)	UGW returns the error but communication to UGW is succeeded. If (NULL) is displayed after the message, the error occurs in the HTTPS communication.	After waiting for a while, try again.

	Error string	Cause	Counter Measure
12	Server response error (Hexadecimal)	UGW returns the error but communication to UGW is succeeded. (Hexadecimal) displayed after the message is error code that UGW returns. [server side detailed error] is added at the end of error information only at this error.	After waiting for a while, try again.
13	Device internal error	Device internal error such as the memory cannot be taken occurs.	Turn OFF/ON of the device main switch. Or, replace the system software of the device (upgrade).
14	Server schedule is invalid	Illegal schedule transmission information is set in UGW. (Ex: Every 30 minutes were set to UGW but the right interval in e-RDS is 1 hour.)	Correct the schedule transmission information setting in UGW. (Ex: every 1 hour)
15	Server response time out	There was no reply from UGW in predetermined time. (The congestion of the network etc.) It is the timeout at HTTPS level.	After waiting for a while, try again.
16	Service not found	The URL of UGW is illegal, and UGW is inaccessible.	Check and correct the URL of UGW.
17	E-RDS switch is set OFF	You execute the communication test while the E-RDS switch is OFF.	Turn ON E-RDS switch, and execute the communication test.
18	Server schedule is not exist	The e-RDS receives empty schedule data from UGW.	Check setting file. (Call the help desk of UGW.)
19	Network is not ready, try later	You execute the communication when the connection to the network has not been established. (The network connection might not be established from the start-up of the device for 60 seconds.)	Confirm that the network connection has been established. Moreover, execute again after enough waiting.
20	URL error	Illegal URL (Syntax error etc.)	Correct URL.

[Method name]:

T-12-1

	Method name	Meaning
1	postServiceModeCount	Account counter acquisition phase
2	postModeCount	Mode counter acquisition phase
3	postPartsCount	Parts counter acquisition phase
4	postFirmwareInfo	ROM version acquisition phase
5	getOperationList	Check/acquisition phase whether the information file for me is in UGW.
6	postOperationOutcome	
7	postConfiguration	Phase in which E-RDS configuration is transmitted to UGW
8	postGlobalClickCount	Counter acquisition phase
9	postJamLog	Jam notification acquisition phase
10	postServiceCallLog	Error notification acquisition phase
11	postAlert	Alert notification acquisition phase
12	postDebugLog	Log acquisition phase
13	getConfiguration	Information acquisition phase (Schedule transmission etc.)
14	communicationTest	Communication test phase

[Server side detailed error]:

Detailed error information returned from UGW is displayed for "Server response error". However, only the first 128 characters are displayed by the entire error information. Nothing is displayed here at other errors.

Maintenance & Inspection

Contents

13.1 Periodically Replaced Parts	13- 1
13.1.1 Overview	13- 1
13.1.2 Machine Proper	13- 1
13.2 Durables and Consumables.....	13- 1
13.2.1 Overview	13- 1
13.2.2 Machine Proper.....	13- 2
13.3 Scheduled Servicing Basic Procedure	13- 4
13.3.1 Scheduled Servicing Basic Procedure	13- 4
13.3.2 Scheduled Servicing Chart.....	13- 6
13.3.3 Scheduled Maintenance Work Procedure	13- 8
13.3.4 Points to Note About Schedule Servicing	13- 12

13.1 Periodically Replaced Parts

13.1.1 Overview

Some parts of the machine must be replaced on a periodical basis to ensure a specific level of machine performance. (They are likely to affect the performance once they fail even in the absence of external change or damage.)

Whenever possible, plan their replacement so that it will coincide with a scheduled service visit.



The values indicated are estimates only and are subject to change according to the site environment and usage habit.

- Checking the Timing of Replacement

You can check the timing of replacement in service mode:

COPIER > COUNTER > PRDC-1

13.1.2 Machine Proper

T-13-1

As of Nov 2005

No.	Parts name	Parts No.	Q'ty	Life (pages)	Remarks
1	Pre-transfer/transfer/separation charging wire	FB4-3687-000	AR	500,000*	if high temperature/humidity, 250,000 prints
2	Primary charging wire	FB4-3687-000	AR	500,000*	if high temperature/humidity, 250,000 prints if normal temperature/low humidity, 400,000
3	Primary grid wire	FY1-0883-000	AR	500,000*	
4	Main thermistor	FG6-7748-020	1	500,000	
5	Sub thermistor	FH7-7464-000	1	500,000	
6	Thermal switch unit	FG6-7745-000	1	1,000,000	
7	Ozone filter (drum)	FB6-0776-000	1	1,000,000	
8	Ozone filter (separation)	FB6-0397-000	1	1,000,000	
9	Ozone filter (fixing)	FC7-3082-000	1	1,000,000	
10	Side seal (front)	FL2-5152-000	1	500,000	
11	Side seal (rear)	FL2-5153-000	1	500,000	

The values above are estimates only, and are subject to change based on future data.

* Old type (full plated type) may not be used.

After replacing the charging wire, be sure to execute wire cleaning in service mode: COPIER > FUNCTION > CLEANING > WIRE-CLN.

* After the work, be sure to move the cleaning holder manually toward the front before putting the charging assembly back into the machine.

13.2 Durables and Consumables

13.2.1 Overview

Some parts of the machine may have to be replaced once or more over the warranty period of the product because of deterioration or damage. Replace them when they have failed.

- Checking the Timing of Replacement

You can check the timing of replacement in service mode:

- Main Machine

COPIER > COUNTER > DRBL-1

- Accessory

COPIER > COUNTER > DRBL-2

13.2.2 Machine Proper

T-13-2

As of Nov 2005

No.	Parts name	Parts No.	Q'ty	Life (pages)	Remarks
1	Developing cylinder	FB6-2370-020	1	1,000,000	
2	Developing assembly roll	FS5-6579-000	2	1,000,000	
3	Cleaner separation claw	FB4-8018-000	3	500,000	if high temperature/humidity, 250,000 prints
4	Cleaning blade	FB6-2720-000	1	1,000,000	use both edges, each for 500,000 prints; upon replacement, apply toner
5	Primary charging assembly	FG6-7313-000	1	1,000,000	
6	Transfer/separation charging assembly	FG6-8733-020	1	1,000,000	
7	Pre-transfer charging assembly	FG6-8740-000	1	1,000,000	
8	Primary charging wire cleaner 1	FF5-6883-000	2	500,000	if high temperature/humidity, 250,000 prints
9	Primary charging wire cleaner 2	FF5-6884-000	2	500,000	if high temperature/humidity, 250,000 prints
10	Transfer charging wire cleaner 1	FF5-6883-000	1	500,000	if high temperature/humidity, 250,000 prints
11	Transfer charging wire cleaner 2	FF5-6884-000	1	500,000	if high temperature/humidity, 250,000 prints
12	Separation charging wire cleaner	FF5-7891-020	1	500,000	if high temperature/humidity, 250,000 prints
13	Pre-transfer charging wire cleaner	FF5-9552-000	1	500,000	if high temperature/humidity, 250,000 prints
14	Pre-transfer charging assembly scraper	FF6-1031-000	1	1,000,000	
15	Fixing upper roller	FB5-6930-000	1	500,000	
16	Fixing lower roller	FB6-2374-000	1	500,000	
17	Fixing web	FY1-1157-000	1	500,000	
18	Insulating bush (front/rear)	FB5-6934-000	2	500,000	simultaneously with fixing upper roller
19	Fixing roller bearing	XG9-0421-000	2	1,000,000	
20	Fixing pressure roller bearing	XG9-0447-000	2	1,000,000	
21	Delivery upper separation claw	FB5-3625-000	6	500,000	
22	Delivery lower separation claw	FA2-9037-000	2	1,000,000	
23	Pickup roller (deck, cassette)	FF5-7829-000 (front) FF5-7830-000 (rear)	8	500,000	actual number of prints (2 pc. for each paper source) actual number may be checked in service mode* left deck: LD-PU-RL right deck: RD-PU-RL cassette 3: C3-PU-RL cassette 4: C4-PU-RL

As of Nov 2005

No.	Parts name	Parts No.	Q'ty	Life (pages)	Remarks
24	Feeding roller (deck, cassette)	FB6-0615-000	8	500,000	actual number of prints (2 pc. for each paper source) actual number may be checked in service mode* left deck: LD-FD-RL right deck: RD-FD-RL cassette 3: C3-FD-RL cassette 4: C4-FD-RL
25	Separation roller (deck, cassette)	FB5-6586-000	4	500,000	actual number of prints (1 pc. for each paper source) actual number may be checked in service mode* left deck: LD-SP-RL right deck: RD-SP-RL cassette 3: C3-SP-RL cassette 4: C4-SP-RL
26	Pickup roller (manual feed tray)	FF5-7829-030 (front) FF5-7830-000 (rear)	2	120,000	actual number of prints actual number may be checked in service mode* M-PU-RL
27	Feeding roller (manual feed tray)	FB4-2035-000	2	120,000	actual number of prints actual number may be checked in service mode* M-FD-RL
28	Separation roller (manual feed tray)	FB2-7545-000	1	120,000	actual number of prints actual number may be checked in service mode* M-SP-RL
29	Cleaner side scraper (font)	FB5-6868-000	1	1,000,000	
30	Cleaner side scarper (rear)	FB5-6869-000	1	1,000,000	
31	Developing Cylinder Clutch	FH6-5015-020	1	1,000,000	
32	Developing Cylinder Decelerating Clutch	FH6-5017-020	1	1,000,000	

*: Use the following service mode item: COPIER > COUNTER > DRBL-1.

13.3 Scheduled Servicing Basic Procedure

13.3.1 Scheduled Servicing Basic Procedure



1. As a rule, perform schedule servicing every 500,000 prints.
2. Before setting out for a visit, check the service book, and take parts for which replacement is expected.
3. If cleaned with alcohol, each charging wire must be checked to make sure that it is fully dry (solvent) before putting it back in the machine.
4. If left alone for a long time in an area subject to dust, humidity, or oil smoke, the power plug can collect dust, which will absorb moisture to suffer an insulation fault, turning into a possible source of fire. Be sure to disconnect it on a periodical basis, and clean it and the area around the power outlet using a dry cloth.

T-13-3

As of Nov 2005			
No.	Step	Work	Remarks
1	Report to the person in charge.	Check the general condition.	
2	Record the counter reading.	Check the faulty output.	
3	Make test prints.	a. image density b. soiling of white background c. character clarity d. lead edge margin e. fixing, registration (for displacement), back (for soiling)	Standard (simplexing) lead edge: $4.0 \pm 1.5 / -1.0$ mm left/right: 2.5 ± 1.5 mm trail edge: 2.5 ± 1.5 mm
4	Clean the charging assemblies: - charging wire (primary, pre-transfer, transfer/separation) - grid wire (primary charging assembly) - charging assembly shielding plate - roller electrode		Dry wipe with lint-free paper, and clean with alcohol.

⚠ Points to Note When Cleaning/Replacing the Charging Wire or Replacing the Charging Wire Cleaner

After the following, check to make sure that the charging wire is in the middle of the charging wire cleaner; failure to observe this is likely to cause image faults:

- a. cleaning the charging wire
- b. replacing the charging wire
- c. moving the charging wire cleaner by hand
- d. replacing the charging wire cleaner



F-13-1

Correct

Wrong

T-13-4

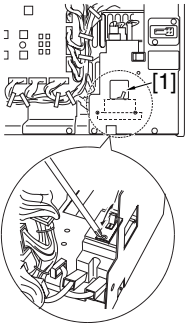
No.	Step	Work	Remarks
5	Clean the optical assembly: - No. 1/2/3 mirror - dust-blocking glass - scanning lamp reflecting plate - standard white plate		Use a blower brush. If dirt resists removal, use alcohol.
6	Check the optical system: - scanner cable - scanner rail	Check the area around the cable. Clean the sliding area, and apply silicone oil (FY9-6011).	Check the scanner cable only at the first 250,000 prints.
7	Dispose of the waste toner, and check the case.	If the case is half full with waste toner, dispose of the waste toner in a vinyl bag. Or, replace the case itself.	
8	Clean the filters. - ozone filter - dust filter		Remove the dust from the filter surface.
9	Clean the developing assembly. - developing assembly roll	Clean the developing assembly roll.	
10	Clean the pickup /transport assembly. - transfer guide (upper, lower) plate - registration roller (upper, lower) - transport belt - transport rollers - scanner sensor (prism)		Use an air blower, or dry wipe. (Do not use solvent.)
11	Clean the fixing/delivery assembly. - separation claw (upper, lower) - transport rollers - inlet guide - web (check) - web oil receptacle - thermistor - sub thermistor - thermal switch		
12	Clean the cleaner assembly. - side scraper		
13	Clean the duplexing assembly. - duplexing horizontal registration sensor		
14	Clean the copyboard glass.		
15	Make test prints.		
16	Make sample prints.		
17	Press the leakage breaker test switch to see the breaker operates normally. Thereafter, turn off the power switch, and shift the lever to ON position; then, turn the power switch back on.	Press the test switch while the power switch is in ON position and, in addition, the lever [1] of the leakage breaker is also in ON position. If normal, the breaker will go off to cut the power. (If you are replacing it, pay attention to its orientation.) If you have replaced the leakage breaker, be sure to check the breaker after replacement.	
⚠			
Check to see that the grounding is proper. Otherwise, the leakage breaker may fail to go on in the event of a leak.			
18	Put sample prints in order, and clean up the area around the machine.		
19	Record the most recent counter reading.		
20	Update the service book, and report to the person in charge.	Record the history of checks made on the leakage breaker.	

13.3.2 Scheduled Servicing Chart



Do not use solvents other than those indicated.

T-13-5

Unit name	Location	Maintenance intervals			Remarks
		upon installation	every 500,000 prints	every 1,000,000 prints	
Externals/controls	copyboard glass		clean		
	ozone filter (FM2, FM8, FM20)		clean	replace	Remove the dust from the filter surface.
	dust filter (FM1, FM3, FM10, FM501, FM502 (other than iR7086); front cover)		clean		Remove the dust from the filter surface.
Scanner	scanner cable		inspect adjust		
	scanner rail		clean lubricate		silicone oil S-20 (FY9-6011)
Optical assembly	No. 1 to No. 3 mirrors		clean		
	Dust-proof glass		clean		
	Reflecting plate		clean		
	Standard white plate		clean		
Charging assembly	charging wire (primary)	clean		replace	If high temperature/ humidity, every 250,000 prints.
	charging wire (transfer/separation)	clean		replace	If high temperature/ humidity, every 250,000 prints.
	charging wire (pre-transfer)	clean		replace	If high temperature/ humidity, every 250,000 prints. If normal temperature/low humidity, every 400,000 prints.
	grid wire (primary)	clean		replace	
	charging assembly shielding plates	clean		clean	If high temperature/ humidity, every 250,000 prints.
	roller electrode	clean		clean	If high temperature/ humidity, every 250,000 prints.
	pre-transfer exposure LED	clean		clean	200 V machine only
Photosensitive drum	photosensitive drum		clean		Use alcohol and drum cleaning powder (CK- 0429).

Unit name	Location	Maintenance intervals			Remarks
		upon installation	every 500,000 prints	every 1,000,000 prints	
	electrode of stop ring for drum heater			clean lubricate	Clean the following using alcohol, and apply FY9-6008 on the charge collecting brush: - electrode of slip ring - wall surface of protrusion on electrode - charge collecting brush
Developing assembly	developing cylinder	inspect			
Cleaner	developing roll		clean		
	side scraper		clean		
	toner receptacle (rear, front)		clean		
Fixing assembly	toner supply mouth		clean		
	magnet roller plate		clean		
	inlet guide		clean		
	web	inspect			Take up at time of installation.
Optical sensor	oil receptacle		clean		
	thermistor		replace		
	sub thermistor		replace		
	thermal switch			replace	
	sensor		clean		If high temperature/humidity, every 250,000 prints.
	reflecting prism		clean		If high temperature/humidity, every 250,000 prints.
Waste toner	waste toner case		inspect		Inspect/remove.
Waste case	Transfer guide		clean		
Pickup/transfer assembly	registration roller (upper, lower)		clean		
	transport belt		clean		
	delivery upper separation claw		replace		
	delivery lower separation claw		replace		
	transport rollers		clean		
	Duplexing assembly	duplexing horizontal registration sensor		clean	
	duplexing rubber roller		clean		

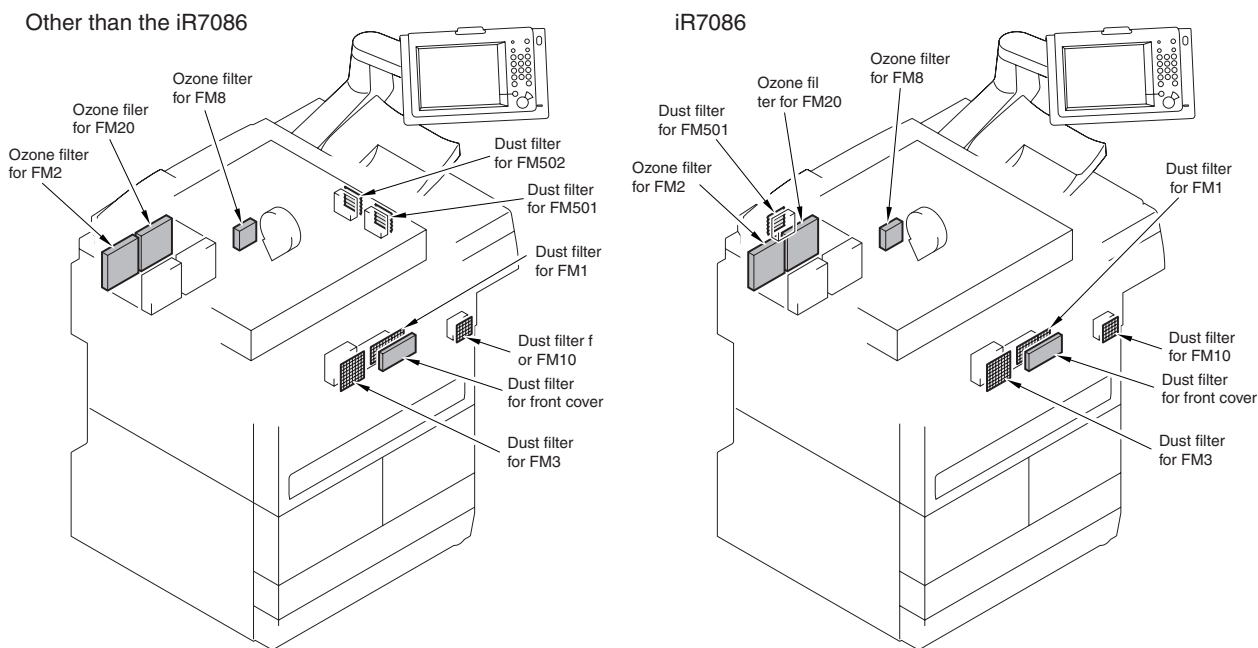

F-13-2

13.3.3 Scheduled Maintenance Work Procedure

Perform the following to service the area around the drum as part of scheduled maintenance:

Work 1

- a. cleaning the side scraper assembly
- b. cleaning the toner receptacle



Do not rotate the magnet roller drive assembly during the work. Doing so could cause waste toner to drop from the cleaner assembly.

- 1) Slide out the process unit.



Be sure to place paper over the fixing/transport unit.

- 2) Take out the photosensitive drum.
- 3) Remove the cleaning blade assembly.
- 4) Move the waste toner collecting in front of the magnet roller [1] and the scraper [2] using a piece of paper [3] in the direction of the feedscrew (rear).

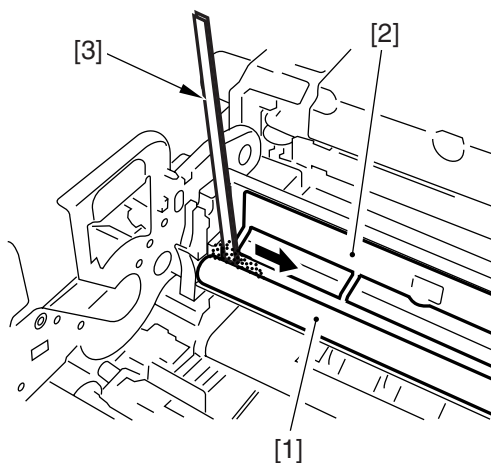

F-13-3

- 5) Release the 2 locks [1] of the slide rail, and slide the fixing/transport unit [2] farther toward the front.

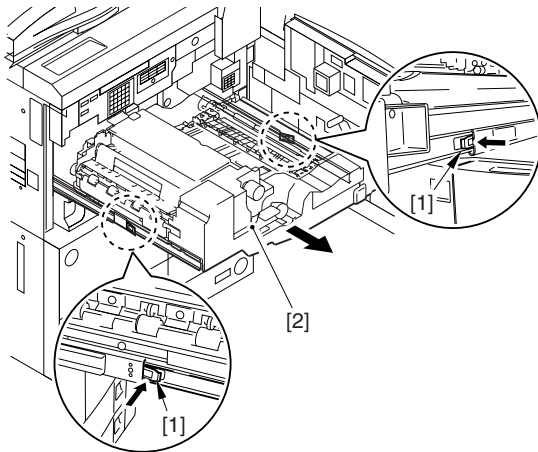

F-13-4

- 6) With the cleaner assembly [1] slid halfway out, remove the screw [2] (1 pc. each), and detach the 2 toner receptacle fixing plates [3].
7) Remove the front toner receptacle [4], and remove the toner from the front toner receptacle.

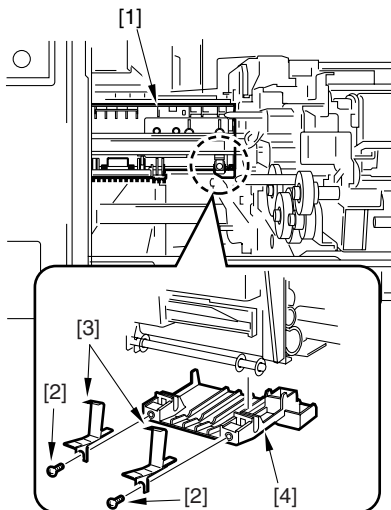

F-13-5

- 8) Slide the cleaner assembly [1] fully out, and remove the screw [2] (1 pc. each); then, detach the 2 toner receptacle fixing plates [3].

- 9) Remove the rear toner receptacle [4], and remove the toner from the rear toner receptacle.

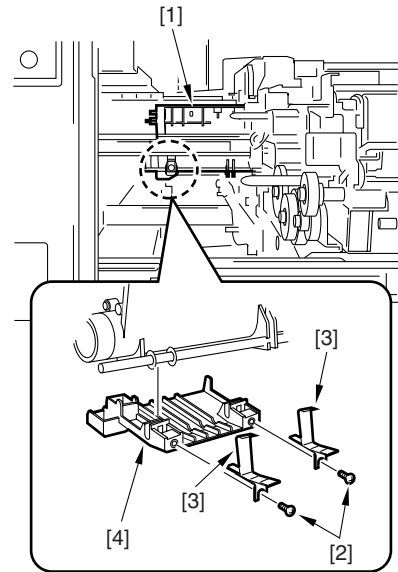

F-13-6

Work 2

- a. cleaning the photosensitive drum
- b. removing the toner from the magnet roller assembly
- c. turning over/replacing the cleaning blade



Do not rotate the magnet during the work. Otherwise, waste toner could drop from the cleaner assembly.

- 1) Slide out the process unit.



Be sure to place paper over the fixing/transport unit.

- 2) Remove the photosensitive drum.
- 3) Moisten lint-free paper [1] with 5 to 10 cc of alcohol [2]; then, collect 0.2 to 0.3 g of drum cleaning powder (CK-0429) [3] with the lint-free paper.

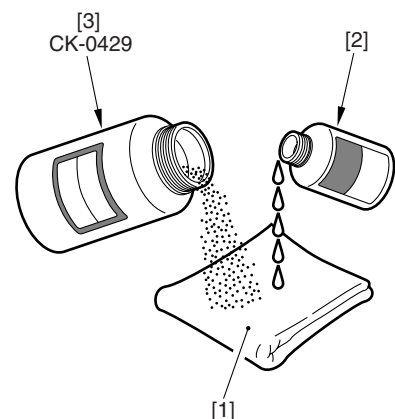

F-13-7

- 4) While forcing the lint-free paper against the photosensitive drum, wipe it as if to rub it from the front to the rear and then from the rear to the front.

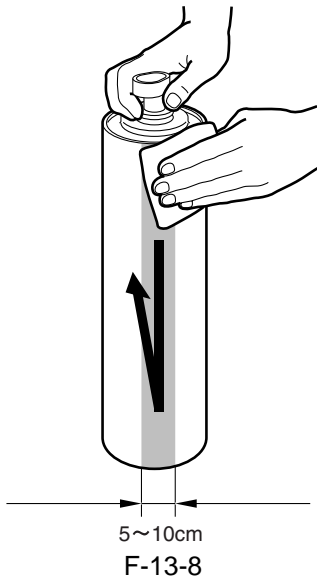

- Rub it over a width of 5 to 10 cm in drum peripheral direction.
- The drum life is not likely to be affected if the back-and-forth strokes of the lint-free paper over a single area is limited to 15 to 20 times.

- 5) When alcohol has evaporated, dry wipe the surface with lint-free paper. If the surface cleaned with the lint-free paper is uneven, go back to step 4), and repeat the work by increasing the number of back-and-forth strokes.
- 6) Rotate the drum an equivalent of the width over which its surface has been cleaned, and repeat steps 3) through 5) until the entire surface of the drum has been cleaned.
- 7) Remove the cleaning blade assembly.
- 8) Insert a ruler [3] between the magnet roller [1] and the scraper [2]; then, move it back and forth from the rear to the front and then from the front to the rear to break any cakes of waste toner.
- 9) Rotate the magnet roller [1] to see that the coating of waste toner is even.
- If the following is noted, repeat step 8):
- the surface of the magnet roller is a clearly recognizable lined coating of toner.
 - there are dents in parts of the surface.
 - there is a cake of toner.

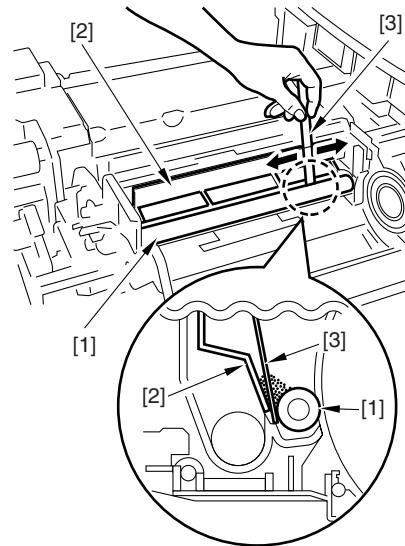

- 10) Remove the cleaning blade from the cleaning blade assembly.
- 11) Turn over or replace the cleaning blade [7]; then, match and butt it against the rear of the blade retaining plate [8].

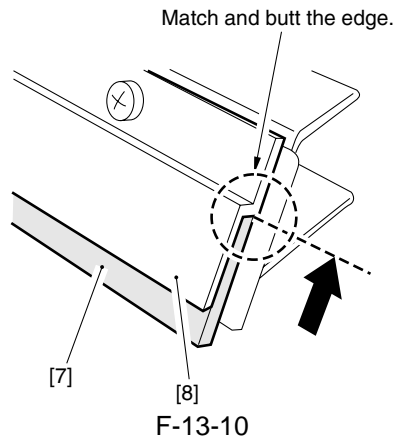

When butting the blade, force it down with your fingers, making sure there is no gap.

- 12) Tighten the following screws temporarily in the order indicated:
- temporarily tighten screws from 1 through 5

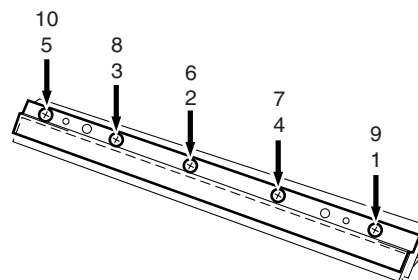



Keep the blade using the plate, and tighten the screws.

- fully tighten screws 6 through 10.

13) Apply toner to the edge of the cleaning blade where the blade comes into contact with the photosensitive drum, and mount the blade:

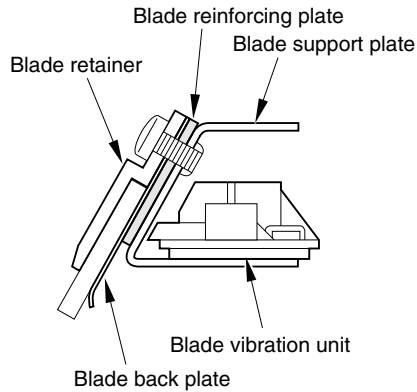

F-13-12



When mounting the cleaning blade, be sure to put the blade reinforcing plate between the blade support plate and the blade back plate.



After mounting the cleaning blade, turn the drum. If the cleaning blade fails to catch the toner, repeat the foregoing steps. If tightening the screws for a second time fails to correct the fault, replace the cleaning blade.

13.3.4 Points to Note About Schedule Servicing



- Make a thorough check to see that there is no melting, thermal deformation, cracking, or discoloration (yellowish) caused by leakage in the block (front, rear). If any abnormal condition is noted, replace it with a new one as soon as possible.
- Be sure to check and clean all the way, including the inner side of the block (front, rear).
- Never use a cloth with any metal particles.
- Do not use a moist cloth for areas other than those for which doing so is specifically mentioned. If alcohol has been used, be sure it has dried completely before putting the part back into the machine.
- Whenever possible, perform scheduled servicing and replacement at the indicated intervals.

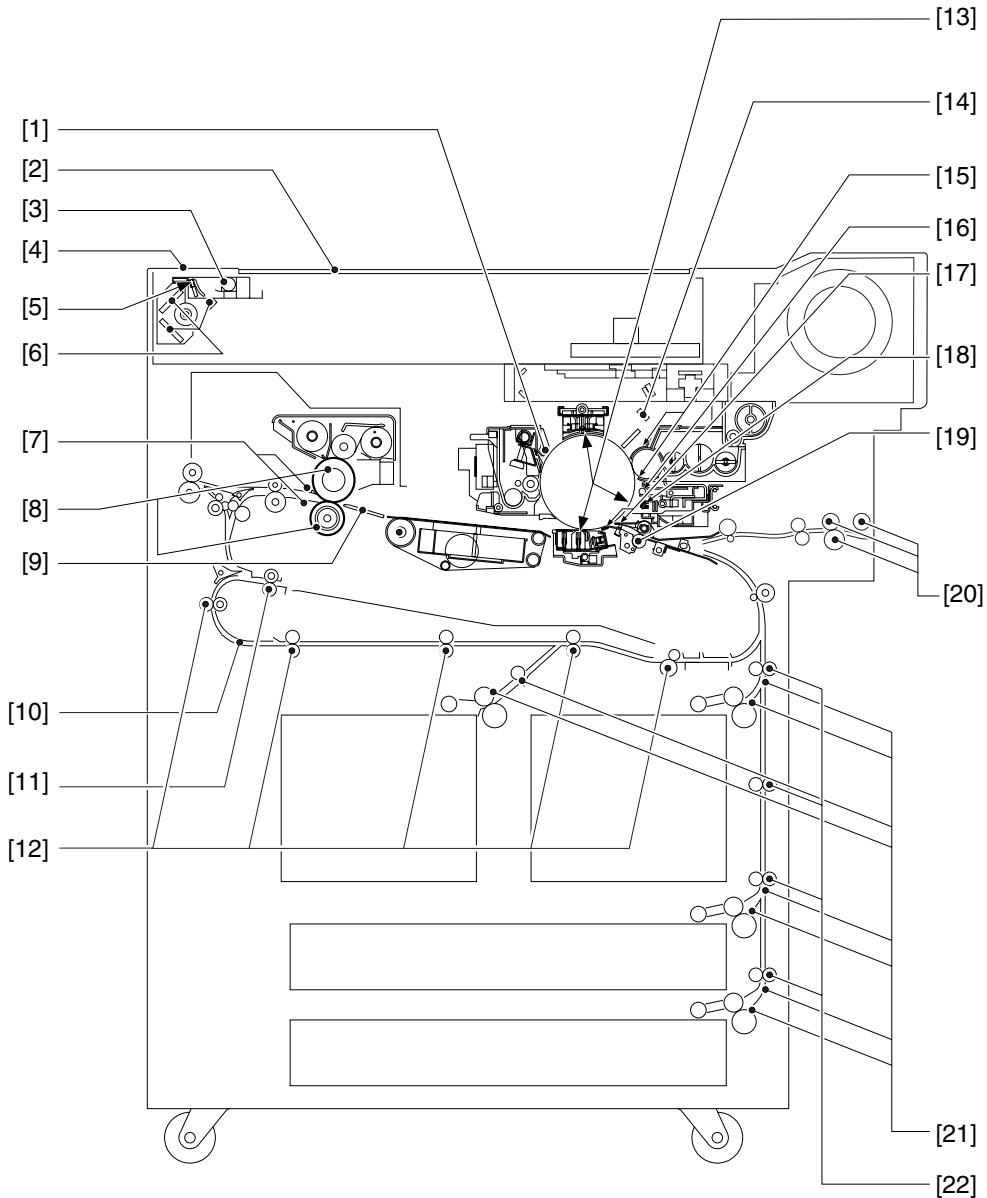

F-13-13

T-13-6

Item	Tool/solvent	Remarks	
[1]	pre-exposure lamp	alcohol	cleaning
[2]	copyboard glass	alcohol	cleaning
[3]	scanning lamp	lint-free paper	dry wiping
[4]	standard white plate	lint-free paper	dry wiping
[5]	reflecting plate	blower brush	cleaning
[6]	No. 1 through No. 3 mirrors	blower brush or lint-free paper	cleaning or blowing; if dirt persists, dry wiping with lint-free paper
[7]	separation claw	solvent (#160) and lint-free paper	cleaning
[8]	upper roller lower roller	Cleaning oil lint-free paper	cleaning
[9]	paper guide	solvent (#160) and lint-free paper	cleaning
[10]	transport assembly	moist cloth*1	cleaning
[11]	re-pickup assembly reversing roller	alcohol and lint-free paper	cleaning
[12]	re-pickup assembly pickup roller registration roller	alcohol and lint-free paper	cleaning
[13]	- primary charging assembly - transfer/separation charging assembly - pre-transfer charging assembly	alcohol and lint-free paper	dry wiping; then, cleaning with lint-free paper moistened with alcohol
[14]	dust-blocking glass	lint-free paper	cleaning
[15]	developing assembly base	moist cloth*1	cleaning
[16]	dust-collecting roller		dispose of toner from dust-collecting roller
[17]	transfer guide (upper/lower)	alcohol and lint-free paper	dry wiping; then, cleaning with lint-free paper with alcohol
[18]	pre-transfer exposure lamp	alcohol and lint-free paper	dry wiping; then, cleaning with lint-free paper with alcohol
[19]	registration roller	alcohol and lint-free paper	cleaning
[20]	manual feeder tray pickup roller transport roller	alcohol and lint-free paper	cleaning
[21]	prints (pickup sensor) (transport sensor) (vertical path sensor)	blower brush or lint-free paper	- cleaning or blowing - if dirt persists, dry wiping with lint-free paper - do not use solvent (alcohol)
[22]	vertical path roller	alcohol and lint-free paper	cleaning

*1 Be sure that no droplets of water remain.

Standards & Adjustments

Contents

14.1 Image Adjustment Basic Procedure	14- 1
14.1.1 Making Pre-Checks	14- 1
14.1.2 Making Checks on the Printer Side (Checking the Images)	14- 1
14.1.3 Making Checks on the Printer Side (Checking the Density Slope).....	14- 2
14.1.4 Making Checks on the Printer Side (Checking the Solid Black Density)	14- 3
14.1.5 Making Checks on the Printer Side (Checking for fogging).....	14- 4
14.1.6 Making Checks on the Printer Side (Checking Halftone Density).....	14- 4
14.1.7 Making Checks on the Reader Unit.....	14- 5
14.1.8 Potential Control System Conversion Table.....	14- 7
14.2 Image Adjustments.....	14- 11
14.2.1 Standards of Image Position.....	14- 11
14.2.2 Checking the Image Position	14- 11
14.2.3 Adjusting Side Registration	14- 11
14.2.4 Adjusting the Image Leading Edge Margin.....	14- 13
14.2.5 Adjusting the Left/Right Non-Image Width	14- 14
14.2.6 Adjusting the Leading Edge Non-Image Width.....	14- 14
14.3 Scanning System.....	14- 14
14.3.1 When Replacing Components of the Scanning System.....	14- 14
14.3.2 When Replacing Components of the Scanning System.....	14- 14
14.3.3 Adjusting the Position of the No. 1/No. 2 Mirror Base	14- 14
14.4 Laser Exposure System.....	14- 16
14.4.1 When Replacing the Laser Scanner Unit.....	14- 16
14.4.2 Checking the Laser Power	14- 16
14.5 Image Formation System	14- 17
14.5.1 Adjusting the Height of the Charging Wire	14- 17
14.6 Fixing System.....	14- 17
14.6.1 Adjusting the Lower Roller Pressure (nip)	14- 17
14.6.2 Points to Note When Mounting the Fixing Heater	14- 17
14.7 Electrical Components.....	14- 18
14.7.1 After Replacing the Hard Disk	14- 18
14.7.2 After Replacing the Main Controller.....	14- 18
14.7.3 After Replacing the DC Controller PCB	14- 20
14.7.4 After Replacing the Reader Controller PCB	14- 20
14.7.5 After Replacing the Reader Controller PCB	14- 20
14.7.6 After Replacing the HV-DC PCB.....	14- 21
14.7.7 When Replacing the Potential Sensor/Potential Control PCB.....	14- 21
14.7.8 Checking the Surface Potential Control System.....	14- 22
14.7.9 Checking the Environment Sensor	14- 24
14.8 Pickup/Feeding System.....	14- 25
14.8.1 Orientation of the Deck/Cassette Pickup Roller.....	14- 25
14.8.2 Orientation of the Deck/Cassette Separation Roller	14- 25
14.8.3 Orientation of the Feeding Roller of the Deck/Cassette Pickup Assembly	14- 25
14.8.4 Orientation of the Pickup Roller of the Manual Feed Tray/Side Paper	14- 25
14.8.5 Orientation of the Feeding Roller of the Manual Feed Tray.....	14- 26

14.8.6 Orientation of the Feeding Roller of the Side Paper Deck	14- 26
14.8.7 Adjusting the Pressure of the Deck/Cassette Separation Roller	14- 26
14.8.8 Adjusting the Pressure of the Pickup/Feeding Roller of the Manual	14- 26
14.8.9 Location of the solenoids	14- 27
14.8.10 Position of the Fixing Web Solenoid (SL2)	14- 27
14.8.11 Position of the Delivery Flapper Solenoid (SL3)	14- 27
14.8.12 Position the Fixing/Feeder Unit Locking Solenoid (SL4)	14- 27
14.8.13 Position of the Multifeder Latch Solenoid (SL6).....	14- 28
14.8.14 Position of the Deck (right) Pickup Solenoid (SL7).....	14- 28
14.8.15 Position of the Deck (Left) Pickup Solenoid (SL8).....	14- 28
14.8.16 Position of the Cassette 3/4 Pickup Solenoid (SL9/10)	14- 28
14.8.17 Position of the Side Paper Deck Pickup Roller Releasing Solenoid.....	14- 29
14.8.18 Fitting the Side Guide Timing Belt of the Manual Feed Tray Assembly.....	14- 29
14.8.19 Fitting the Drive Belt	14- 29

14.1 Image Adjustment Basic Procedure

14.1.1 Making Pre-Checks

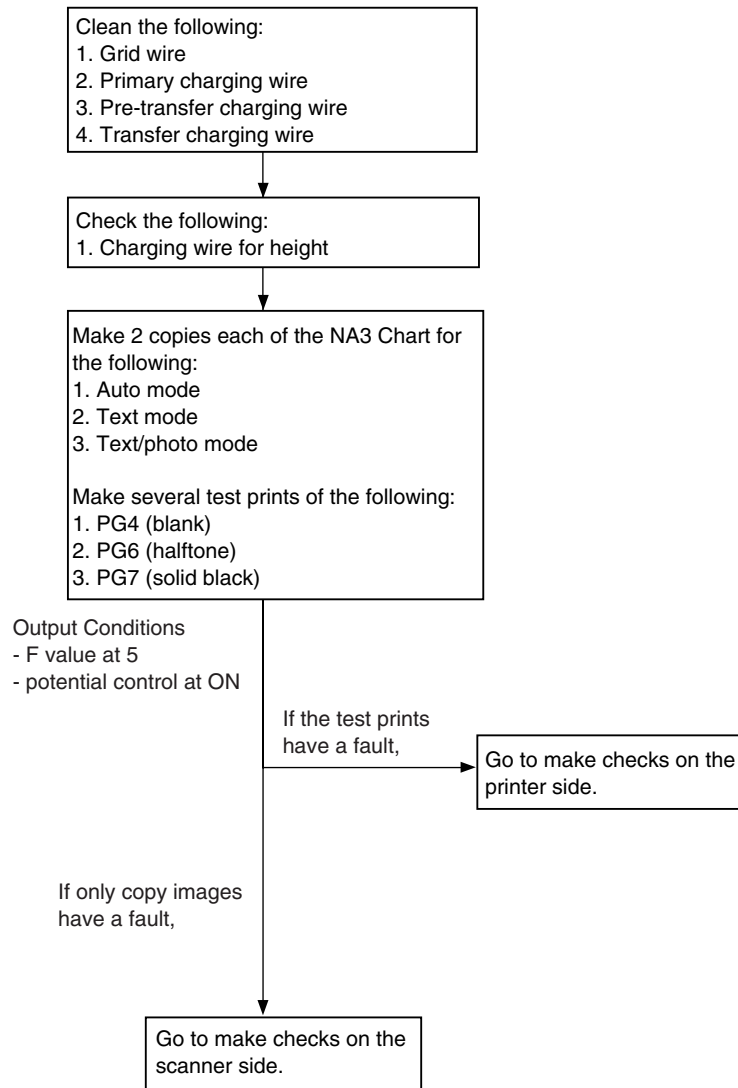

F-14-1

14.1.2 Making Checks on the Printer Side (Checking the Images)

- Use PG4, PG6, PG7

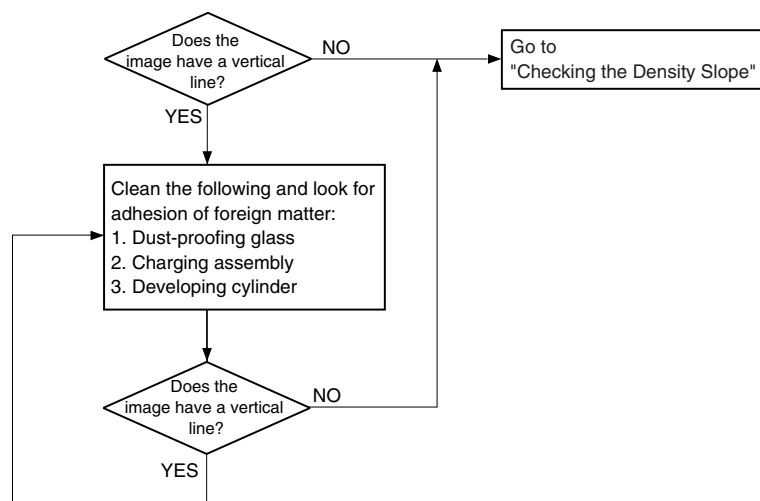

F-14-2

14.1.3 Making Checks on the Printer Side (Checking the Density Slope)

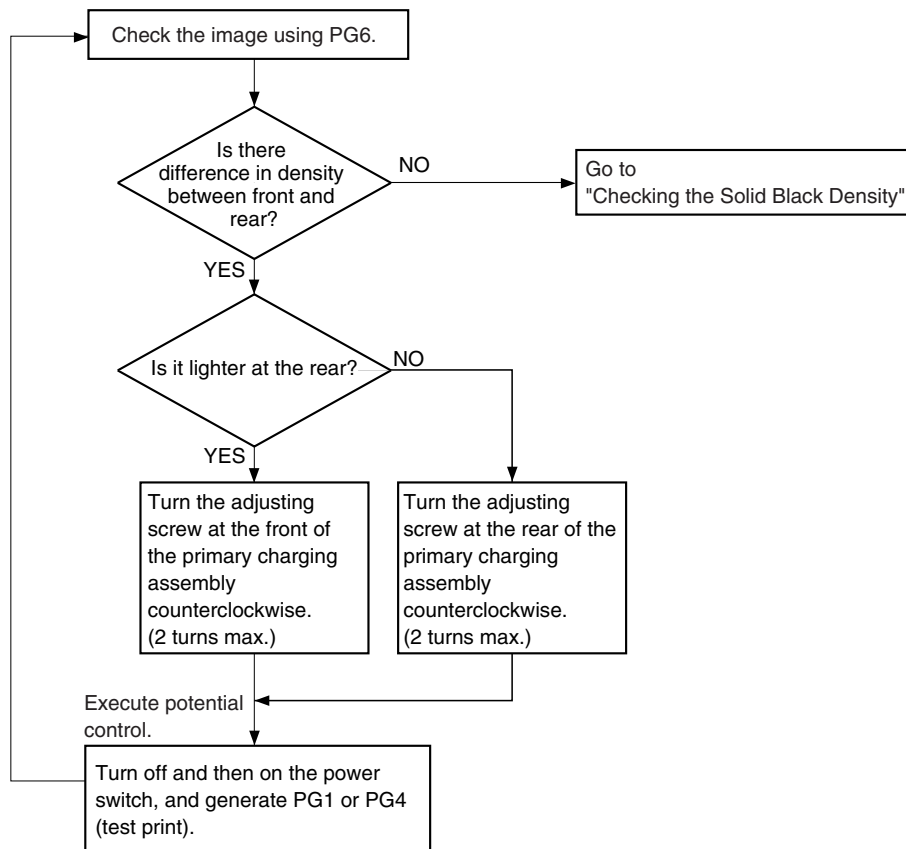

F-14-3



- 1) If the difference in density still exists after giving the adjusting screw 2 turns (one side; a full turn causes a change of about 0.7 mm), check the charging assembly, scanning lamp, and scanner for dirt.
- 2) When giving it a counterclockwise turn, be sure that the distance between wire and grid will not be 7.5 mm or less.

MEMO:

Moving the wire from the photosensitive drum causes the images to be darker; while moving it closer causes the images to be lighter.

14.1.4 Making Checks on the Printer Side (Checking the Solid Black Density)

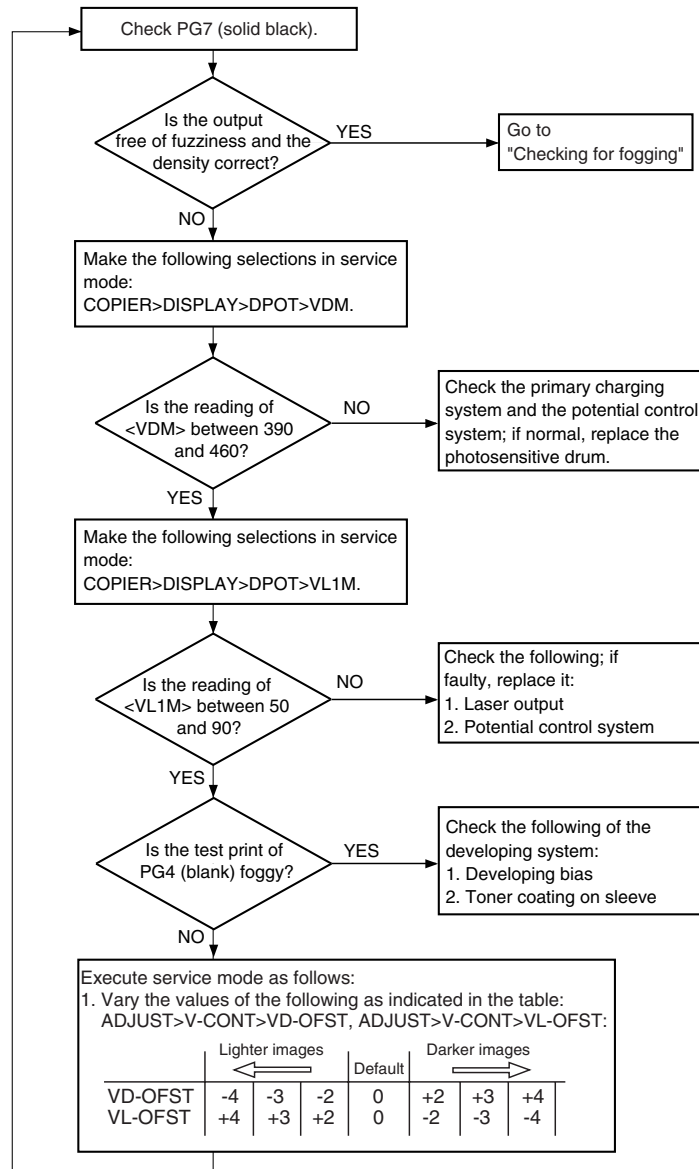

F-14-4

14.1.5 Making Checks on the Printer Side (Checking for fogging)

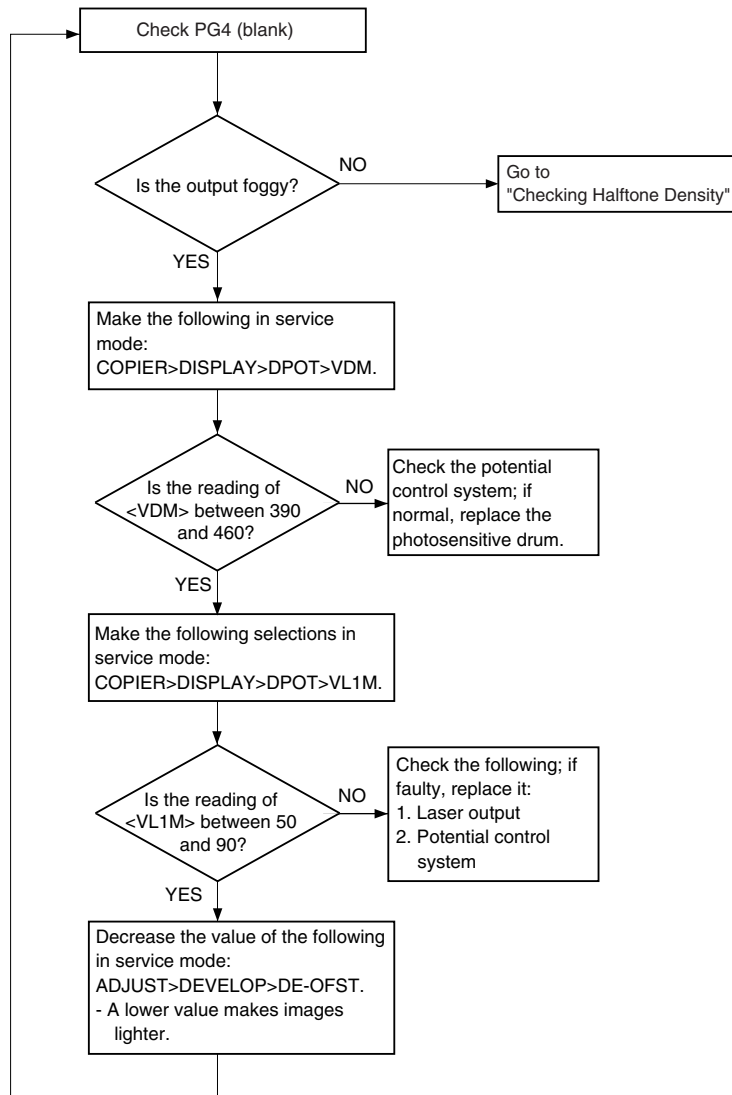

F-14-5

14.1.6 Making Checks on the Printer Side (Checking Halftone Density)

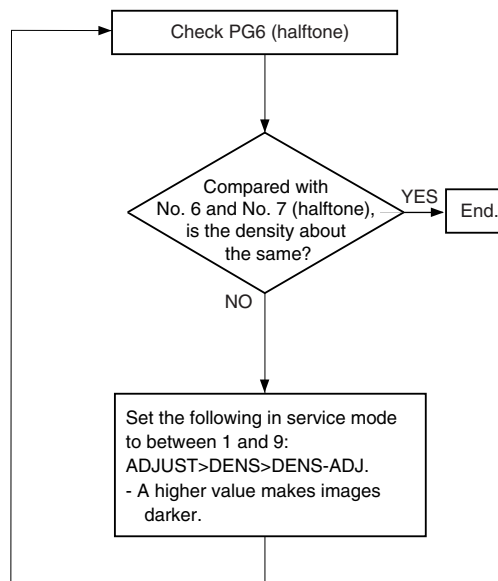

F-14-6

14.1.7 Making Checks on the Reader Unit

*: model w/ DADF-Q1 (non-Japanese model: iR7105/7095; Japanese model: iR7105/7095/7086N)
 **: model w/ DADF-M1 (non-Japanese model: iR7086)

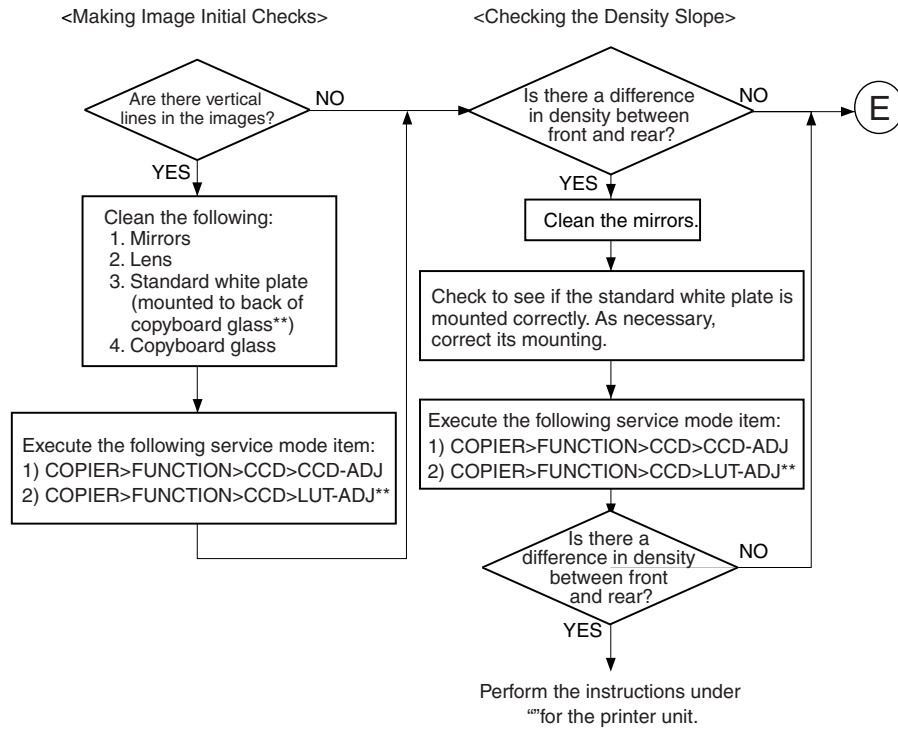

F-14-7

*: model w/ DADF-Q1 (non-Japanese model: iR7105/7095; Japanese model: iR7105/7095/7086N)
 **: model w/ DADF-M1 (non-Japanese model: iR7086)

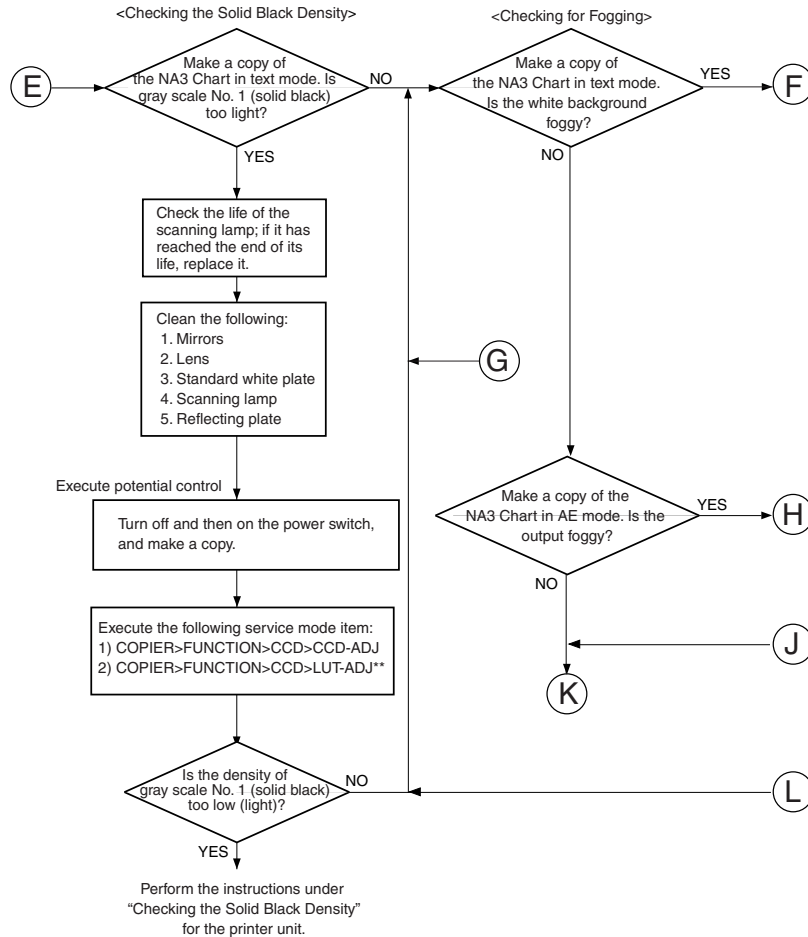

F-14-8

*: model w/ DADF-Q1 (non-Japanese model: iR7105/7095; Japanese model: iR7105/7095/7086N)
 **: model w/ DADF-M1 (non-Japanese model: iR7086)

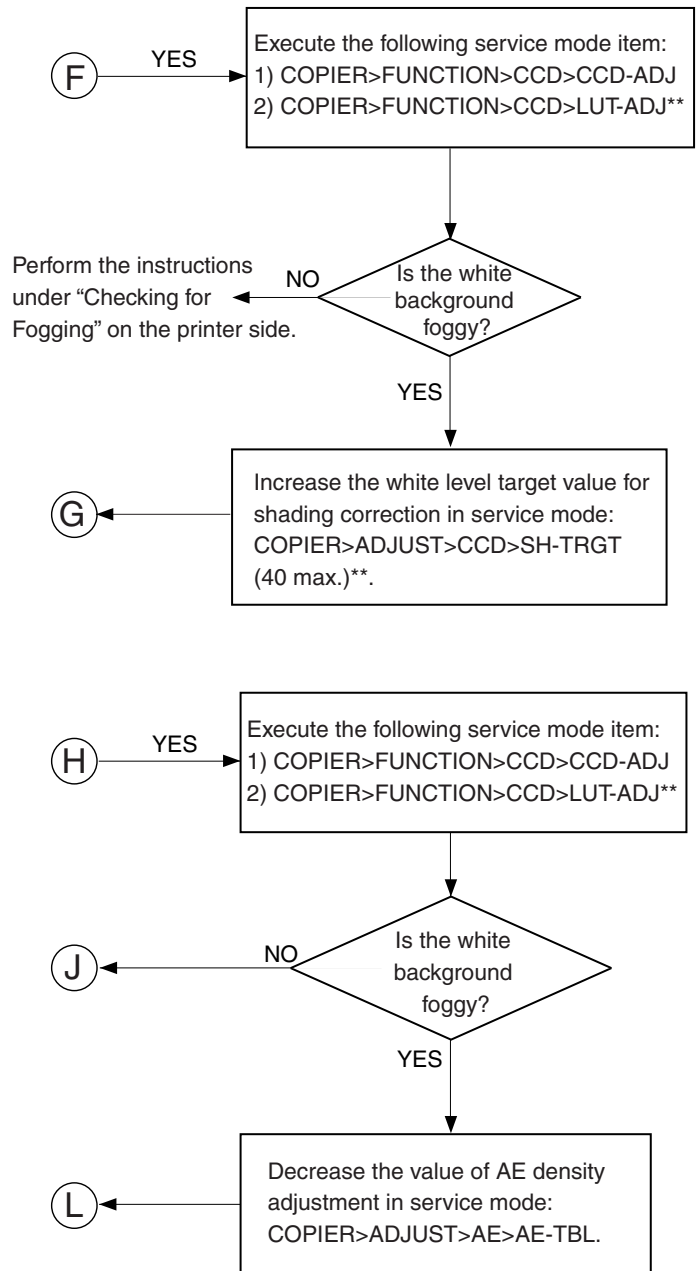

F-14-9

*: model w/ DADF-Q1 (non-Japanese model: iR7105/7095; Japanese model: iR7105/7095/7086N)

** : model w/ DADF-M1 (non-Japanese model: iR7086)

<Checking Halftone Density>

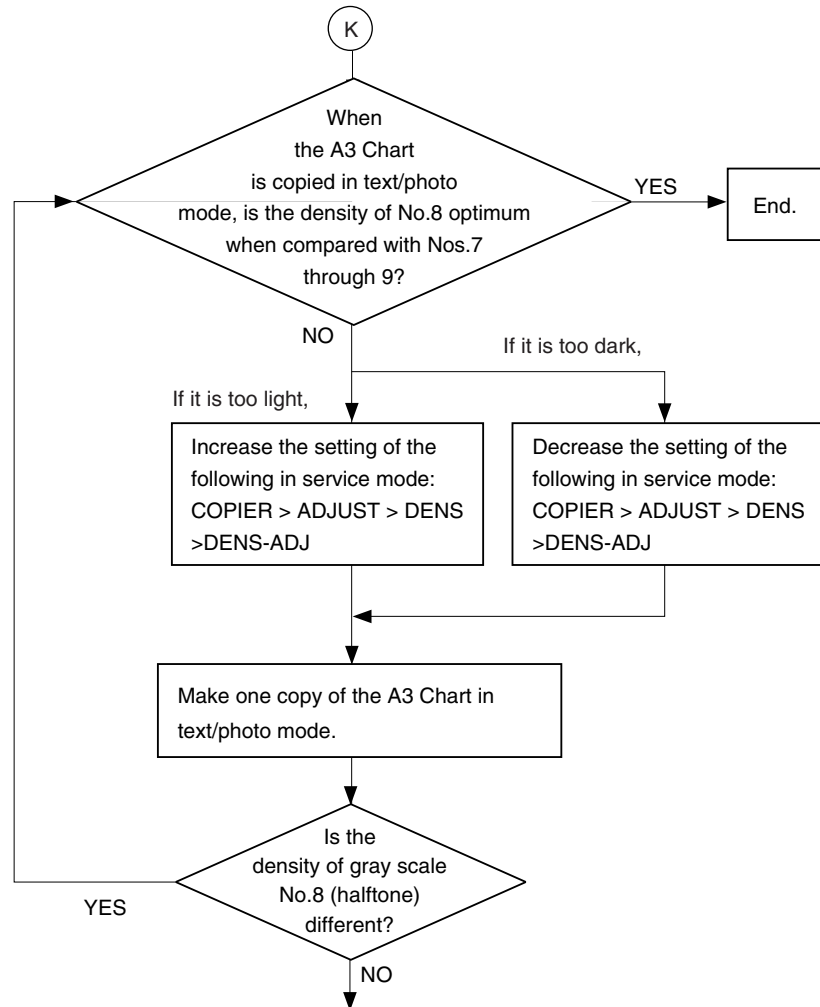

Go to "Checking the Solid Black Density" for the printer unit.

F-14-10

14.1.8 Potential Control System Conversion Table

T-14-1

Control [V]	Primary [uA]	Developing bias [V]	Pre-transfer [uA]	Transfer [uA]	Separation [uA]
3.00	1600	0	0	0	0
3.05	1590	3	+2	-4	+5
3.10	1580	7	+4	-8	+10
3.15	1570	11	+6	-12	+15
3.20	1560	15	+8	-16	+20
3.25	1550	18	+10	-20	+25
3.30	1540	22	+12	-24	+30
3.35	1530	26	+14	-28	+35
3.40	1520	30	+15	-32	+40
3.45	1510	33	+17	-36	+45
3.50	1500	37	+19	-40	+50
3.55	1490	41	+21	-44	+55
3.60	1480	45	+23	-48	+60
3.65	1470	48	+25	-52	+65
3.70	1460	52	+27	-56	+70

Control [V]	Primary [μ A]	Developing bias [V]	Pre-transfer [μ A]	Transfer [μ A]	Separation [μ A]
3.75	1450	56	+29	-60	+75
3.80	1440	60	+30	-65	+80
3.85	1430	63	+32	-69	+85
3.90	1420	67	+34	-73	+90
3.95	1410	71	+36	-77	+95
4.00	1400	75	+38	-81	+100
4.05	1390	78	+40	-85	+105
4.10	1380	82	+42	-89	+110
4.15	1370	86	+44	-93	+115
4.20	1360	90	+45	-97	+120
4.25	1350	93	+47	-101	+125
4.30	1340	97	+49	-105	+130
4.35	1330	101	+51	-109	+135
4.40	1320	105	+53	-113	+140
4.45	1310	108	+55	-117	+145
4.50	1300	112	+57	-121	+150
4.55	1290	116	+59	-125	+155
4.60	1280	119	+60	-129	+160
4.65	1270	123	+62	-134	+165
4.70	1260	127	+64	-138	+170
4.75	1250	131	+66	-142	+175
4.80	1240	134	+68	-146	+180
4.85	1230	138	+70	-150	+185
4.90	1220	142	+72	-154	+190
4.95	1210	146	+74	-158	+195
5.00	1200	150	+75	-162	+200
5.05	1190	153	+77	-166	+205
5.10	1180	157	+79	-170	+210
5.15	1170	161	+81	-174	+215
5.20	1160	165	+83	-178	+220
5.25	1150	168	+85	-182	+225
5.30	1140	172	+87	-186	+230
5.35	1130	176	+89	-190	+235
5.40	1120	180	+90	-195	+240
5.45	1110	183	+92	-199	+245
5.50	1100	187	+94	-203	+250
5.55	1090	191	+96	-207	+255
5.60	1080	195	+98	-211	+260
5.65	1070	198	+100	-215	+265
5.70	1060	202	+102	-219	+270
5.75	1050	206	+104	-223	+275
5.80	1040	210	+105	-227	+280
5.85	1030	213	+107	-231	+285
5.90	1020	217	+109	-235	+290
5.95	1010	221	+111	-239	+295
6.00	1000	225	+113	-243	+300
6.05	990	228	+115	-247	+305
6.10	980	232	+117	-251	+310
6.15	970	236	+119	-255	+315
6.20	960	240	+120	-260	+320
6.25	950	243	+122	-264	+325

Control [V]	Primary [uA]	Developing bias [V]	Pre-transfer [uA]	Transfer [uA]	Separation [uA]
6.30	940	247	+124	-268	+330
6.35	930	251	+126	-272	+335
6.40	920	255	+128	-276	+340
6.45	910	258	+130	-280	+345
6.50	900	262	+132	-284	+350
6.55	890	266	+134	-288	+355
6.60	880	269	+135	-292	+360
6.65	870	273	+137	-29	+365
6.70	860	277	+139	-300	+370
6.75	850	281	+141	-304	+375
6.80	840	285	+143	-308	+380
6.85	830	288	+145	-312	+385
6.90	820	292	+147	-316	+390
6.95	810	296	+149	-320	+395
7.00	800	300	+150	-325	+400
7.05	790	303	+152	-329	+405
7.10	780	307	+154	-333	+410
7.15	770	311	+156	-337	+415
7.20	760	315	+158	-341	+420
7.25	750	318	+160	-345	+425
7.30	740	322	+162	-349	+430
7.35	730	326	+164	-353	+435
7.40	720	330	+165	-357	+440
7.45	710	333	+167	-361	+445
7.50	700	337	+169	-365	+450
7.55	690	341	+171	-369	+455
7.60	680	345	+173	-373	+460
7.65	670	348	+175	-377	+465
7.70	660	352	+177	-381	+470
7.75	650	356	+179	-385	+475
7.80	640	360	+180	-390	+480
7.85	630	363	+182	-394	+485
7.90	620	367	+184	-398	+490
7.95	610	371	+186	-402	+495
8.00	600	375	+188	-406	+500
8.05	590	378	+190	-410	+505
8.10	580	382	+192	-414	+510
8.15	570	386	+194	-418	+515
8.20	560	390	+195	-422	+520
8.25	550	393	+197	-426	+525
8.30	540	397	+199	-430	+530
8.35	530	401	+201	-434	+535
8.40	520	405	+203	-438	+540
8.45	510	408	+205	-442	+545
8.50	500	412	+207	-446	+550
8.55	490	416	+209	-450	+555
8.60	480	419	+210	-454	+560
8.65	470	423	+212	-459	+565
8.70	460	427	+214	-463	+570
8.75	450	431	+216	-467	+575
8.80	440	434	+218	-471	+580

Control [V]	Primary [μ A]	Developing bias [V]	Pre-transfer [μ A]	Transfer [μ A]	Separation [μ A]
8.85	430	438	+220	-475	+585
8.90	420	442	+222	-479	+590
8.95	410	446	+224	-483	+595
9.00	400	450	+225	-487	+600
9.05	390	453	+227	-491	+605
9.10	380	457	+229	-495	+610
9.15	370	461	+231	-499	+615
9.20	360	465	+233	-503	+620
9.25	350	468	+235	-507	+625
9.30	340	472	+237	-511	+630
9.35	330	476	+239	-515	+635
9.40	320	480	+240	-520	+640
9.45	310	483	+242	-524	+645
9.50	300	487	+244	-528	+650
9.55	290	491	+246	-532	+655
9.60	280	495	+248	-536	+660
9.65	270	498	+250	-540	+665
9.70	260	502	+252	-544	+670
9.75	250	506	+254	-548	+675
9.80	240	510	+255	-552	+680
9.85	230	513	+257	-556	+685
9.90	220	517	+259	-560	+690
9.95	210	521	+261	-564	+695
10.00	200	525	+263	-568	+700
10.05	190	528	+265	-572	+705
10.10	180	532	+267	-576	+710
10.15	170	536	+269	-580	+715
10.20	160	540	+270	-585	+720
10.25	150	543	+272	-589	+725
10.30	140	547	+274	-593	+730
10.35	130	551	+276	-597	+735
10.40	120	555	+278	-601	+740
10.45	110	558	+280	-605	+745
10.50	100	562	+282	-609	+750
10.55	90	566	+284	-613	+755
10.60	80	570	+285	-617	+760
10.65	70	573	+287	-621	+765
10.70	60	577	+289	-625	+770
10.75	50	581	+291	-629	+775
10.80	40	585	+293	-633	+780
10.85	30	588	+295	-637	+785
10.90	20	592	+297	-641	+790
10.95	10	596	+299	-645	+795
11.00	0	600	+300	-650	+800

14.2 Image Adjustments

14.2.1 Standards of Image Position

The image margin/non-image width of a print made in direct must be as follows:

[Image Leading Edge Margin]

Single-Sided/Double-Sided

$L_f = 4.0 + 1.5 / -1.0$ mm [$4.0 + 1.5 / -1.0$ mm]



F-14-11

[Left/Right Image Margin]

Single-Sided/Double-Sided

$W_l = 2.5 \pm 1.5$ mm [$2.5 + 1.5 / -1.0$ mm]

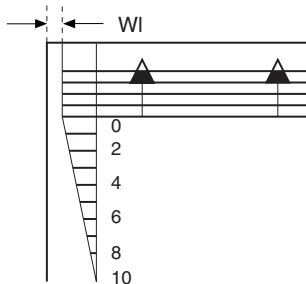

F-14-12

[Leading Edge Non-Image Width]

Single-Sided

$L_f = 4.0 + 1.5 / -1.0$ mm [$4.0 + 1.8 / -1.4$ mm]

Double-Sided

$L_f = 4.0 + 1.5 / -1.0$ mm [4.0 ± 1.8 mm]



F-14-13

[Left/Right Non-Image Width]

Single-Sided/Double-Sided

$W_l = 2.5 \pm 1.5$ mm [$2.5 + 1.5 / -1.8$ mm]

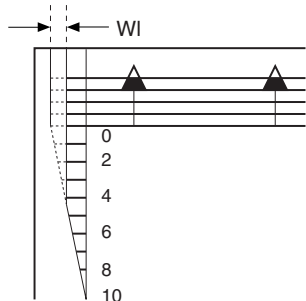

F-14-14

The information in brackets represents standards for the integrated configuration.

14.2.2 Checking the Image Position

Make prints using the following as the source of paper (10 prints each), and check to see that the image margin and the non-image width are as indicated:

- Each cassette
- Front deck (left, right)
- Manual feed tray
- Duplex feeding unit
- Side paper deck

If not as indicated, adjust the image position in the following order:

1. Adjusting the left/right image margin (registration)
2. Adjusting the image leading edge margin (registration)
3. Adjusting the left/right non-image width (CCD read start position)
4. Leading edge non-image width (scanner image leading edge position)

14.2.3 Adjusting Side Registration

<Cassette 3/4>

- 1) Press the release button of cassette 3/4, and slide out the cassette.
- 2) Shift down the cassette front cover [1] in the direction of the arrow.
 - 2 screws [2]

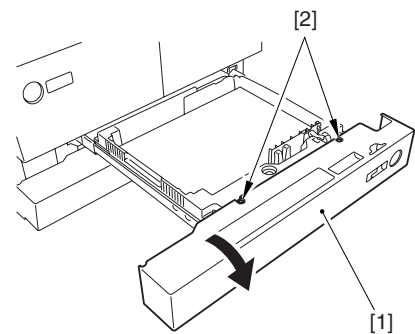

F-14-15

- 3) Loosen the 2 fixing screws [1] found on the right/left of the cassette.
- 4) Move the cassette case [2] to the front or the rear to make adjustments.
 - move it to the rear to decrease the horizontal registration (left margin).
 - move it to the front to increase the horizontal registration (left margin).

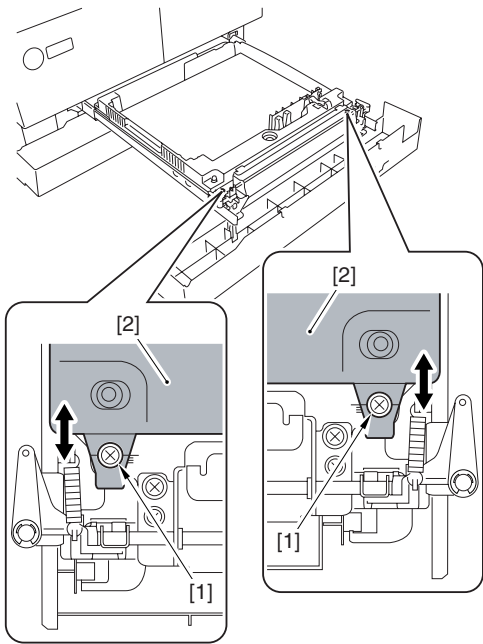

F-14-16

- 5) Check to make sure that the horizontal registration value (L; left margin) of the image made on paper from cassette 3/4 is 2.5 +/-1.5 mm.

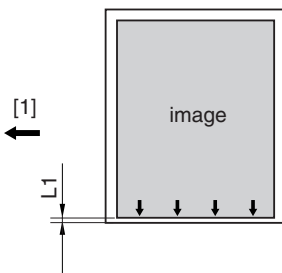

F-14-17

- [1] Paper movement

- 6) When done, tighten the 2 fixing screws loosened in step 3).
 7) Shift up the cassette front cover [1] in the direction of the arrow, and secure it in place using 2 screws [2].

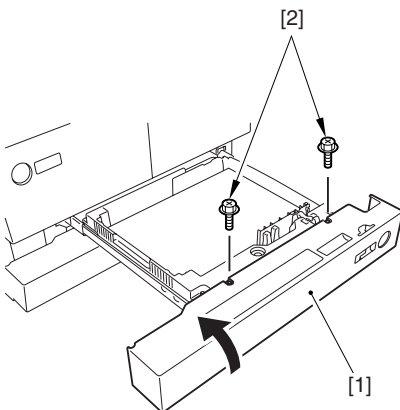

F-14-18

- 8) Put cassette 3/4 back inside the machine.
 9) When done, execute the following service mode items:

Cassette 3

COPIER > FUNCTION > CST > C3-STMTR
 COPIER > FUNCTION > CST > C3-A4R
 Register the paper width basic value for cassette 3.

9-1) Place STMTR paper in the cassette 3, and move the side guide plate to suit the STMTR width.

9-2) Select C3-STMTR in service mode to highlight, and press the OK key so that adjustment will be executed and the value will be registered automatically.

9-3) Likewise, repeat steps 9.1) and 9.2) for A4R.

Cassette 4

COPIER > FUNCTION > CST > C4-STMTR
 COPIER > FUNCTION > CST > C4-A4R
 Perform the work you performed for cassette 3.

<Front Deck Left/Right>

- 1) Press the release button of the front deck (left/right), and slide out the deck.
 2) Loosen the 4 screws [1].

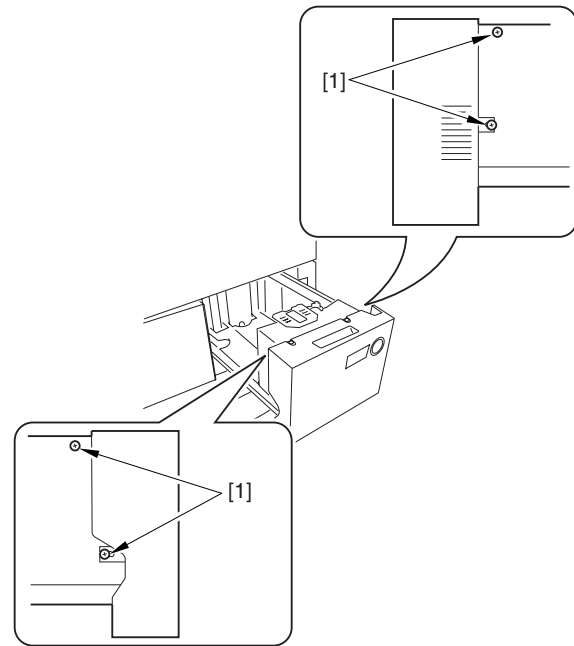

F-14-19

- 3) Move the cassette guide assembly (front) [1] to the front or the rear to make adjustments.
 - move the guide plate to the rear to decrease the horizontal registration (left margin).
 - move the guide plate to the front to increase the horizontal registration (left margin).

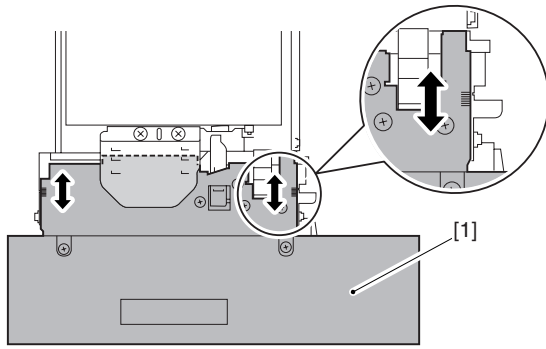

F-14-20

- 4) Check to see that the horizontal registration (L; left/right margin) of the images made on paper from the front deck (left/right) is 2.5 ± 1.5 mm.

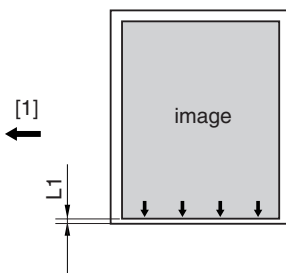

F-14-21

[1] Paper movement

- 5) Tighten the 4 screws you loosened in step 2).
6) Put the front deck (left/right) back in place.

<Manual Feeder Tray>

- 1) Move the side guide plate [1] to the center, and loosen the 2 manual feeder tray mounting screws [2]; then, adjust the position of the manual feeder tray.

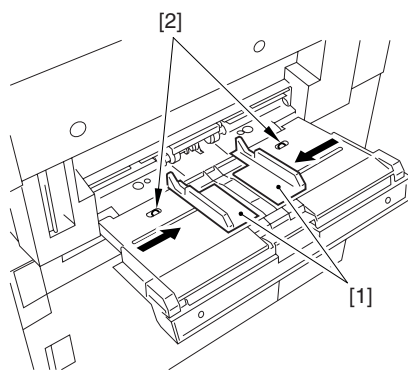

F-14-22

<Duplexing Transport Unit>

- 1) Make the following selections in service mode:
COPIER > ADJUST > FEED-ADJ > ADJ-REFER so that the image margin on the 2nd side will be as indicated.
- if the margin is too large, decrease the setting of ADJ-REFER (a change of 10 will decrease the margin by 1 mm).
- if the margin is too small, increase the setting of DJ-REFER (a change of 10 will increase the

margin by 1 mm).

$$W1 = 2.5 \pm 2.0 \text{ mm}$$

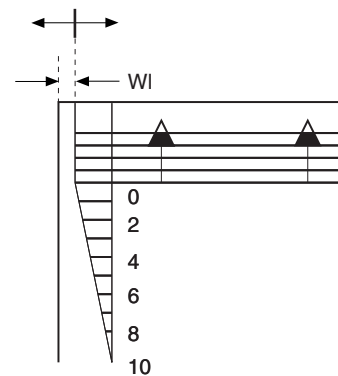

F-14-23

14.2.4 Adjusting the Image Leading Edge Margin

- 1) Make the following selections in service mode so that the image margin will be as indicated:
COPIER > ADJUST > FEED-ADJ > REGIST.
- if the margin is too large, increase the setting of REGIST (a change of 10 will decrease the margin by 1 mm).
- if the margin is too small, decrease the setting of REGIST (a change of 10 will increase the margin by 1 mm).

$$L_f = 4.0 \pm 1.5 / -1.0$$

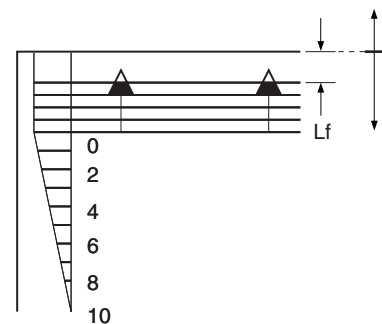

F-14-24

14.2.5 Adjusting the Left/Right Non-Image Width

1) Adjust the non-image width in service mode so that it is as indicated: COPIER > ADJUST > ADJ-XY > ADJ-Y.

[1] Edge of image

- Decreasing the ADJ-Y setting: A decrease by '10' will decrease the margin by 1 mm.

- Increasing the ADJ-Y setting: An increase by '10' will increase the non-image width by 1 mm.

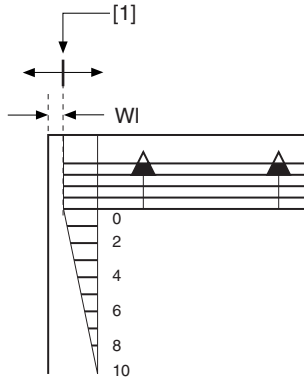

F-14-25

14.2.6 Adjusting the Leading Edge Non-Image Width

1) Adjust the non-image width in service mode so that it is as indicated: COPIER > ADJUST > ADJ-XY > ADJ-X.

[1] Image leading edge

- Decreasing the ADJ-X setting: A decrease by '10' will decrease the width by 1 mm.

- Increasing the ADJ-X setting: An increase by '10' will increase the width by 1 mm.



F-14-26

14.3 Scanning System

14.3.1 When Replacing Components of the Scanning System <iR7105/7095>

<Components>

CCD unit, copyboard glass, scanning lamp, standard white plate, inverter PCB

<Procedure>

Execute the following service mode item:

- 1) COPIER> FUNCTION> CCD> CCD-ADJ (shading correction based on the standard white plate)

14.3.2 When Replacing Components of the Scanning System <iR7086>

<Components>

CCD unit, copyboard glass, stream reading glass, scanning lamp, inverter PCB

<Procedure>

Execute the following service mode items:

- 1) COPIER> FUNCTION> CCD> CCD-ADJ (shading correction based on the standard white plate)
- 2) COPIER> FUNCTION> CCD> DF-WLVL1 (ADF white level; for copyboard mode)
- 3) COPIER> FUNCTION> CCD> DF-WLVL2 (ADF white level; for stream reading mode)

14.3.3 Adjusting the Position of the No. 1/ No. 2 Mirror Base

- 1) Arrange the mirror positioning tool (FY9-3009-040) so that it is ready for use in the machine (by changing the pin position; REAR).

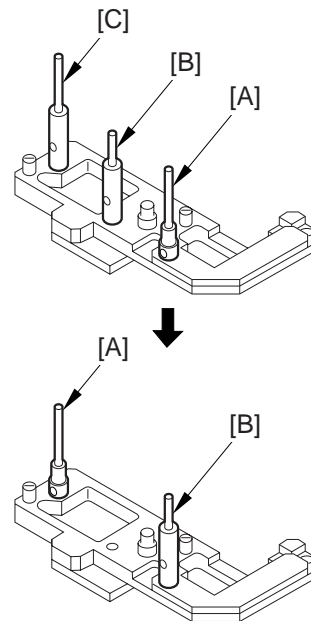

F-14-27

- 2) Arrange the mirror positioning tool so that it is ready for use in the machine (by changing the pin position; FRONT).

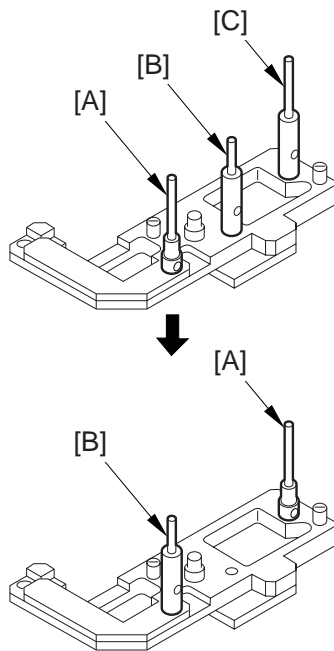

F-14-28

- 3) Fit the pins of the mirror positioning tool (front [2]; rear [3]) into the appropriate holes of the No. 1/No. 2 mirror base.

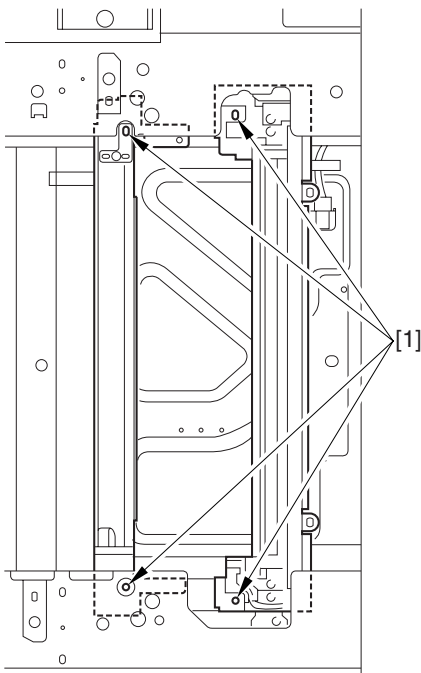

F-14-29

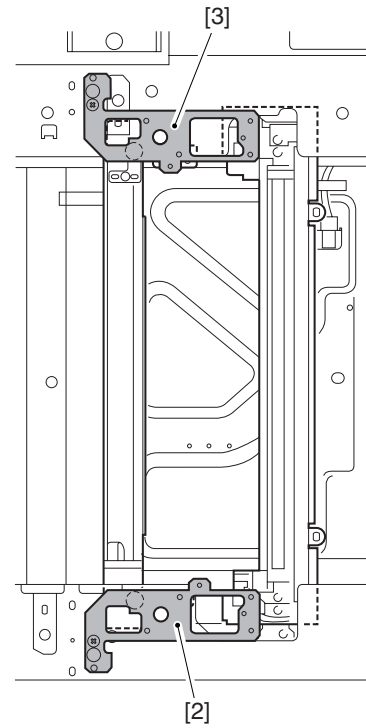

F-14-30

- 4) Secure the end of the cable that has temporarily been fixed in place on the hook of the reader unit frame.
- 5) Fully tighten the screws on the cable fixing plate both at the front and the rear.
- 6) Detach the mirror positioning tool (FRONT, REAR).
- 7) Put the detached parts back on by reversing the foregoing steps.

14.4 Laser Exposure System

14.4.1 When Replacing the Laser Scanner Unit

There is no special work in conjunction with the replacement of the laser scanner unit.

14.4.2 Checking the Laser Power

- 1) Check to make sure that the Data lamp in the control panel is OFF, and turn off the main power switch.
- 2) Disconnect the power plug from the power outlet.
- 3) Remove the copyboard glass.
- 4) Open the laser power checker slot cover [1].

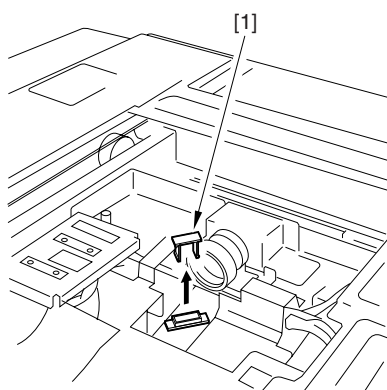

F-14-31

- 5) Shift the switch of the laser power checker (FY9-4008) to '2'.
- 6) While orienting the laser power checker so that its light-receiving face [1] is as shown, fit it in.

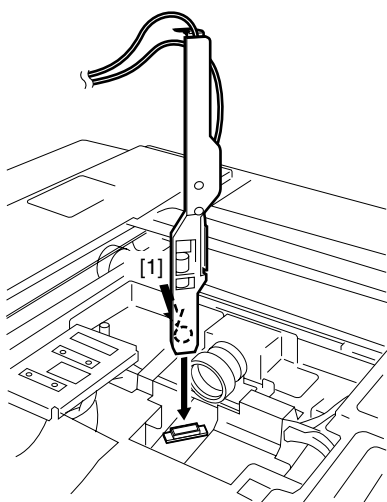

F-14-32

- 7) Connect the probe lines of the laser power checker to a digital multimeter.

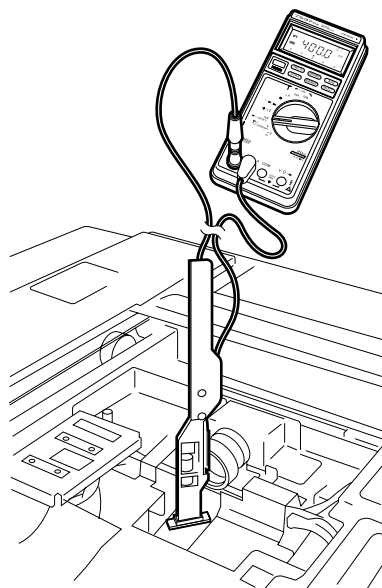

F-14-33

- 8) Connect the power plug to the power outlet, and turn on the main power switch.
- 9) Make the following selections in service mode: COPIER > FUNCTION > LASER.
- 10) Select <POWER-A>, and press the OK key.
- 11) Check to see that the reading of the digital multimeter is 9 to 11 mV, indicating that the power of the laser A is correct.
- 12) Select <POWER-B>, and press the OK key.
- 13) Check to see that the reading of the digital multimeter is 9 to 11 mV, indicating that the power of the laser B is correct.

14.5 Image Formation System

14.5.1 Adjusting the Height of the Charging Wire

T-14-2

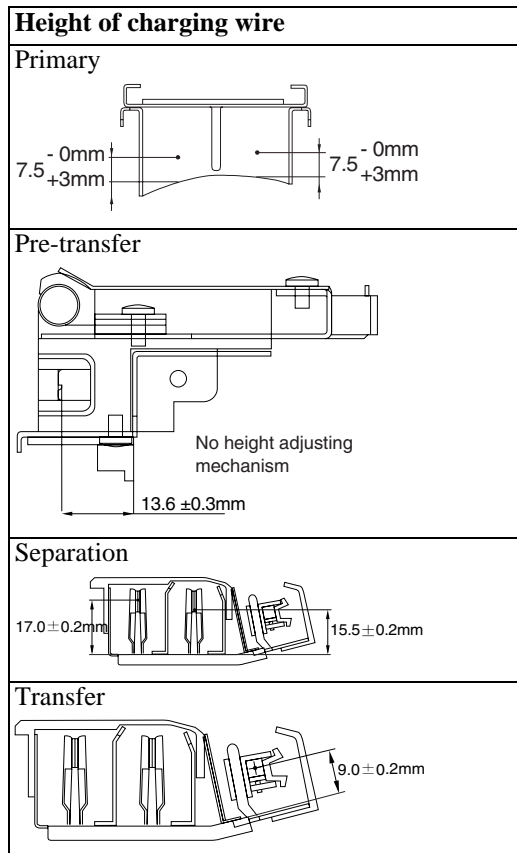

MEMO:

The height (position) of the primary and transfer charging wires may be adjusted by turning the screw found at the rear of the charging assembly. A full turn of the screw changes the position of the charging wire by about 0.7 mm.

14.6 Fixing System

14.6.1 Adjusting the Lower Roller Pressure (nip)

The nip width must be as indicated in figure; if not, adjust it using the pressure adjusting nut.

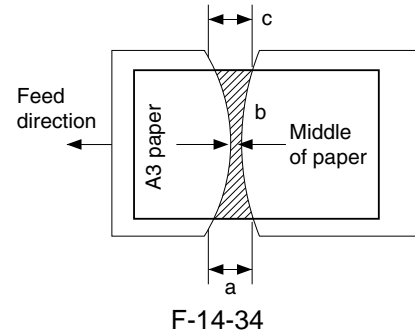

a and c are points 10 mm from both edges of paper.

T-14-3

Dimension	Measure with upper and lower rollers fully heated
b	200 V: 9.0 -/+ 0.5 mm, 208/230 V: 10.0 -/+ 0.5 mm
a-c	0.5 mm or less

a. Generating Output for Nip Width Measurement

Wait for 15 min after the copier ends its warm-up period; make 20 A4 copies, and measure the nip.

- 1) Place A3 copy paper in the manual feed tray.
- 2) Make the following selections in service mode to generate output:
COPIER > FUNCTION > FIXING > NIP-CHK.

The A3 paper will be picked up, and a copy like the one shown in figure will be delivered.

14.6.2 Points to Note When Mounting the Fixing Heater

1. Do not touch the heater surface.
2. For both heaters, mount so that the side with the longer heater harness is toward the front.
3. Viewing from the front of the fixing assembly, mount the main heater on the right (for 200V model, 1150 W; for 208V model, 1220 W; for 230V model, 1185 W) and the sub heater on the left (for 200V model, 565 W; for 208V model, 600 W; for 230V model, 645 W).
4. Viewing from the rear, connect the right side of the faston of the heater at the rear to the main heater, and connect the top side to the sub heater.

Height of the Fixing Inlet Guide

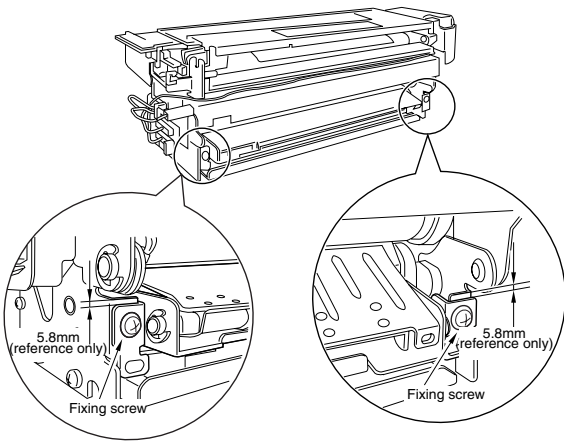

F-14-35



Do not loosen the fixing screw on the inlet guide, as you will have to adjust the position of the inlet guide if you remove the inlet guide base. If you must loosen it, be sure to adjust the position of the inlet guide afterward by referring to the index on the fixing assembly.

14.7 Electrical Components

14.7.1 After Replacing the Hard Disk

1) Formatting the HDD

Start up the machine in safe mode (i.e., turn on the main power while holding down the 2 and 8 keys).

Using the HD formatting function of the SST, execute full partition formatting. (For details, see the chapter on upgrading.)

2) Downloading the System Software

Using the SST, download the following: System, LANG, RUI, PS-FONT, OCR dictionary, SSL encryption key, SSL CA certificate, MEAP content.

3) Execute the following service mode item:

COPIER > FUNCTION > CLEAR > CA-KEY (Level 2)

4) Turn off and then on the power.

MEMO:

Execution of the following may delete the keys/certificates used for encrypted communications and the CA certificates used for authentication of external server certificates:

- replacement/formatting of the HDD
- replacement of the main controller PCB/initialization of the RAM

If a key/certificate for encrypted communications has been deleted, the control panel screen will indicate a message to the effect that the key has been corrupted; however, the key/certificate/CA certificate installed at time of shipment from the factory may be brought back by executing the following: COPI-

ER>FUNCTION>CLEAR>CA-KEY. If doing so has failed, use the SST to install the key/certificate/CA certificate, and execute CA-KEY once again.

⚠ Points to Note When Executing Service Mode Item CA-KEY

If the user has generated/added a key/certificate/CA certificate on his/her own, executing CA-KEY will also delete these files. Inform the user of this, and ask him/her to re-install them as necessary after the execution of CA-KEY.

14.7.2 After Replacing the Main Controller

⚠ Before Starting the Work (backing up the data)

If possible, perform the following:

- Using the SST, download the data stored in the RAM of the main controller.
- Print out the user mode/service mode data.

- If you are replacing the main controller PCB, be sure to physically transfer the following from the existing to the new PCB:

- [1] BootROM
- [2] HDD
- [3] image memory (DDR-SDRAM)
- [4] counter memory PCB

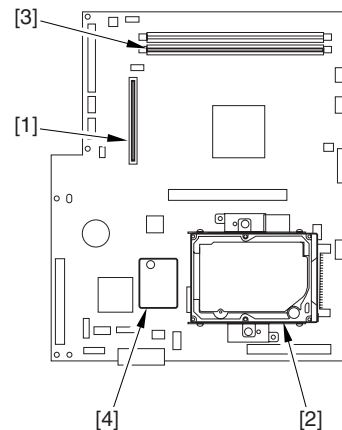

F-14-36

MEMO: Image memory (DDR-SDRAM)

The machine is equipped with the following image memory:

capacity: 1 GB

quantity: 1 pc.

Use one of the 2 slots. There is no optional memory for expansion.

- 1) Turn on the power. If there is a backup of the SRAM data (i.e., if downloaded using the SST), upload it.
- 2) Execute the following service mode item: COPIER > FUNCTION > CLEAR > CA-KEY (Level 2)

3) Turn off and then on the power.

MEMO:

Execution of the following may delete the keys/certificates used for encrypted communications and the CA certificates used for authentication of external server certificates:

- replacement/formatting of the HDD
- replacement of the main controller PCB/initialization of the RAM

If a key/certificate for encrypted communications has been deleted, the control panel screen will indicate a message to the effect that the key has been corrupted: however, the key/certificate/CA certificate installed at time of shipment from the factory may be

brought back by executing the following: COPIER>FUNCTION>CLEAR>CA-KEY. If doing so has failed, use the SST to install the key/certificate/CA certificate, and execute CA-KEY once again.

▲ Points to Note When Executing Service Mode Item CA-KEY

If the user has generated/added a key/certificate/CA certificate on his/her own, executing CA-KEY will also delete these files. Inform the user of this, and ask him/her to re-install them as necessary after the execution of CA-KEY.

▲ Points to Note When Fitting the Security Expansion Board

Whenever possible, do not replace the main controller PCB as part of the troubleshooting work conducted in relation to the installation of the security expansion board (option).

The machine checks the compatibility between the HDD and the main controller PCB when a security expansion board is installed. Replacement with a new board will cause the formatting of the HDD to start automatically, thus deleting all user data.

T-14-4

Data item deleted	Backup possibility
address data registered in the address book	Yes
settings made in user mode	Yes *1
settings stored in memory	Yes
license file for MEAP application	Yes
user authentication information stored using SDL (simple device login)	Yes
data stored using MEAP application	Yes *2
mode memory stored using copy function or Box function	No
data in Box	Yes *3
read mode settings stored using transmission function	No

Data item deleted	Backup possibility
files yet to be read (those selected for timer transmission or reserved for transmission)	No
forms stored for image synthesis	No
MEAP application	No
password for MEAP SMS (service management services); returns to factory default	No
job history information	No
user authentication information stored in relation to SSO (local device authentication)	Yes
key pairs and server certificates stored in conjunction with system control settings	No

*1: limited to those settings that may be exported using a remote UI or transmitted as part of machine information.

*2: limited to when the MEAP application in question offers a backup function.

*3: limited to data within the User Box.

When Replacing the Main Controller PCB

- Explain to the user that all user data will be deleted.

- As necessary, ask the user to make a backup of those data items that permit making of a backup.

- Explain to the user that the following data items do not permit making of a backup, and require remedial action:

<Suggestions for Remedial Action>

- for mode settings stored using the copy/Box function, ask the user to newly enter the settings.

- for read mode settings stored using the transmission function, ask the user to newly enter the settings.

- for files that are yet to be transmitted (i.e., files for selected timer transmission or reserved for transmission), ask the user to newly transmit them.

- for registered forms used in image synthesis, ask the user to newly enter them.

- for MEAP applications, ask the user to newly install them.

- for MEAP SMS (service management services) passwords, access the following: <http://<iR IP address>:8000/SMS>. (Use the factory password

"MeapSmsLogin" (case-sensitive) to log in and change the password.

- for job histories, if a record is needed, ask the user to store away the history using a remote UI. (However, there is no way of returning the history to the HDD.)

- for key pairs and server certificates, if the user has added any, ask for re-installation.

14.7.3 After Replacing the DC Controller PCB

▲ Before Starting the Work (backing up the data)

If possible, perform the following:

- Using the SST, download the data stored in the RAM of the DC controller.
- Print out the user mode/service mode data.

1) Turn on the power, and execute the following service mode:

COPIER > FUNCTION > CLEAR > DC-CON

2) If the data has been successfully downloaded using the SST as instructed in step 1) above, upload it.

3) Using the following service mode item, specify the order of connecting delivery accessories:

COPIER > OPTION > ACCPSD-D > ACC1 to ACC8

4) Set the values indicated on the service mode for their respective service mode items.

5) Set '0' for the following service mode item:

COPIER > OPTION > BODY > FIX-EXP (fixing smear repression mode)

6) Execute the following service mode item:

COPIER > FUNCTION > MISC-P > CL-ADJ
COPIER > FUNCTION > SENS-ADJ > OP-SENS (Level 2)

7) Enter the values indicated on the label attached to the new DC controller PCB for their respective service mode items:

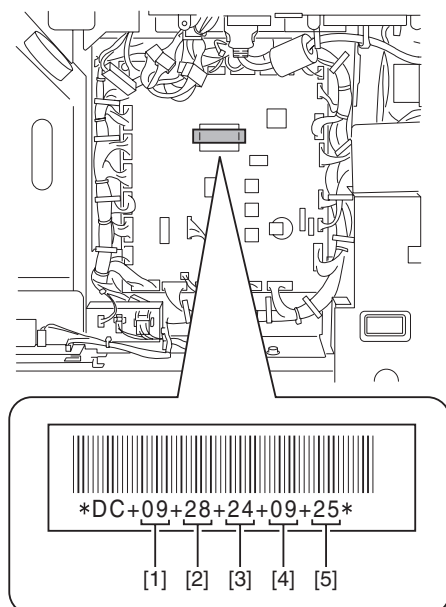

F-14-37

[1] COPIER > ADJUST > DEVELOP > D-HV-DE

[2] COPIER > ADJUST > HV-TR > D-HV-TR

[3] COPIER > ADJUST > HV-TR > D-PRE-TR

[4] COPIER > ADJUST > HV-SP > D-HV-SP

[5] COPIER > ADJUST > DEVELOP > OFF-SETDA

8) Turn off and then on the power.

14.7.4 After Replacing the Reader Controller PCB <iR7105/7095>

▲ Before Starting the Work (backing up the data)

If possible, perform the following:

- Using the SST, download the data stored in the RAM of the reader controller PCB.
- Print out the user mode/service mode data.

1) Turn on the power, and execute the following service mode item:

COPIER > FUNCTION > CLEAR > R-CON

2) If the data has successfully been downloaded using the SST before the replacement, upload the data.

3) Set the values indicated on the service label for their respective service mode items.

COPIER > ADJUST > ADJ-XY > ADJ-X (adjustment of image read start position in sub scanning direction; image lead edge)

COPIER > ADJUST > ADJ-XY > ADJ-Y (adjustment of image read start position in main scanning direction; horizontal registration)

COPIER > ADJUST > ADJ-XY > ADJ-S (adjustment of shading correction data measurement position)

COPIER > ADJUST > ADJ-XY > ADJ-Y-DF (adjustment of main scanning position for ADF stream reading)

COPIER > ADJUST > ADJ-XY > ADJ-Y-FX (adjustment of main scanning position for ADF fixed reading)

COPIER > ADJUST > ADJ-XY > ADJ-X-MG (fine-adjustment of magnification in sub scanning direction for copyboard reading)

4) Execute the following service mode item:

COPIER > FUNCTION > CCD > CCD-ADJ (shading correction based on standard white plate)

5) Turn off and then on the power.

14.7.5 After Replacing the Reader Controller PCB <iR7086>

▲ Before Starting the Work (backing up the data)

If possible, perform the following:

- Using the SST, download the data stored in the RAM of the reader controller PCB.
- Print out the user mode/service mode data.

1) Turn on the power, and execute the following service mode item:

COPIER > FUNCTION > CLEAR > R-CON

2) If the data has successfully been downloaded using the SST before the replacement, upload

the data.

3) Set the values indicated on the service label for their respective service mode items.

COPIER > ADJUST > ADJ-XY > ADJ-X (adjustment of image read start position in sub scanning direction; image lead edge)

COPIER > ADJUST > ADJ-XY > ADJ-Y (adjustment of image read start position in main scanning direction; horizontal registration)

COPIER > ADJUST > ADJ-XY > ADJ-S (adjustment of shading correction data measurement position)

COPIER > ADJUST > ADJ-XY > ADJ-Y-DF (adjustment of main scanning position for ADF stream reading)

COPIER > ADJUST > ADJ-XY > STRD-POS (adjustment of CCD read position for ADF stream reading)

COPIER > ADJUST > ADJ-XY > ADJ-X-MG (fine-adjustment of magnification in sub scanning direction for copyboard reading)

FEEDER > ADJUST > DOCST (adjustment of original stop position for ADF pickup)

FEEDER > ADJUST > LA-SPEED (adjustment of original transport speed for ADF stream reading)

4) Execute the following service mode items:

COPIER> FUNCTION> CCD> CCD-ADJ (shading correction based on standard white plate)

COPIER> FUNCTION> CCD> DF-WLVL1 (ADF white level adjustment; for copyboard reading)

COPIER> FUNCTION> CCD> DF-WLVL2 (ADF white level adjustment; for stream reading)

5) Turn off and then on the power.

MEMO:

In the case of the model with the DADF-M1 (outside Japan: iR7086), the ADF-related service mode data is stored in the RAM of the reader controller. As such, if you have initialized the RAM on the reader controller PCB or replaced the PCB, it is important that you newly enter service mode settings and execute appropriate adjustment items.

14.7.6 After Replacing the HV-DC PCB

1) Set the values (5 types) indicated on the label attached to the new HV-DC PCB for the respective service mode items:

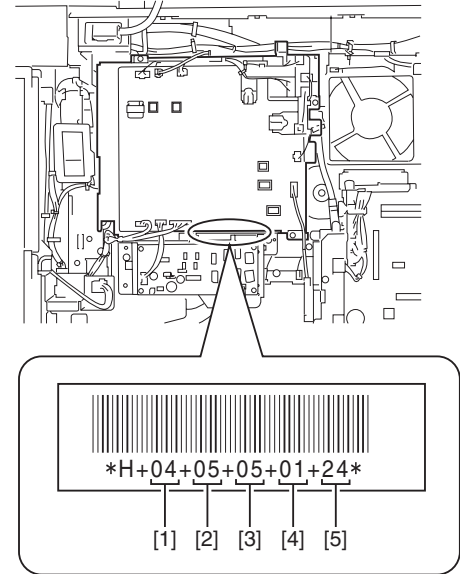

F-14-38

[1] COPIER > ADJUST > HV-TR > H-PRE-TR

[2] COPIER > ADJUST > HV-TR > HVT-TR

[3] COPIER > ADJUST > HV-SP > HVT-SP

[4] COPIER > ADJUST > DEVELOP > HVT-DE

[5] COPIER > ADJUST > DEVELOP > OFF-SETAC

2) Turn off and then on the power.

14.7.7 When Replacing the Potential Sensor/Potential Control PCB



The machine remains powered after the main power switch is turned off as long as the power plug is connected to the power outlet. Be sure to disconnect the power plug from the power outlet.

1) Turn off the power.

2) Remove the developing assembly, and slide out the process unit.

3) Disconnect the connector [1] of the potential sensor.

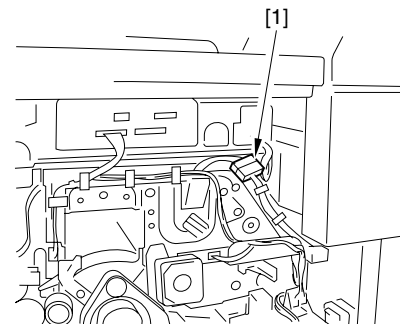

F-14-39

- 4) Remove the 2 screws [1], and detach the potential sensor support plate [2].

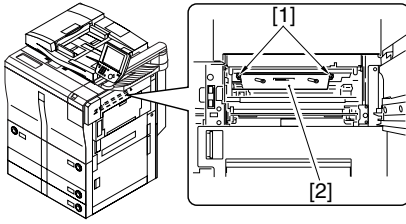

F-14-40

- 5) Put back the developing assembly and the process unit.
6) Connect the connector [1] of the potential sensor.

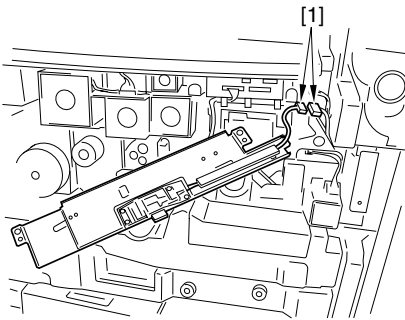

F-14-41

- 7) Fit the potential checker electrode (FY9-3041) [2] to the potential sensor [1].

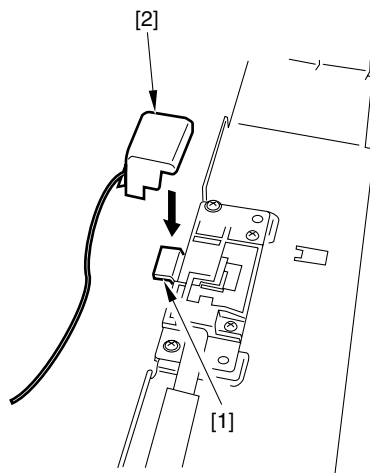

F-14-42



When fitting the checker electrode to the potential sensor, make sure that the magnet of the checker electrode will not come into contact with the potential sensor cover.

- 8) Connect the cable [1] of the potential sensor checker electrode to the frame assembly (GND) [2] of the machine.



Never bring the clip into contact with the sensor cover. Be sure to fit it fully away from the sensor window.

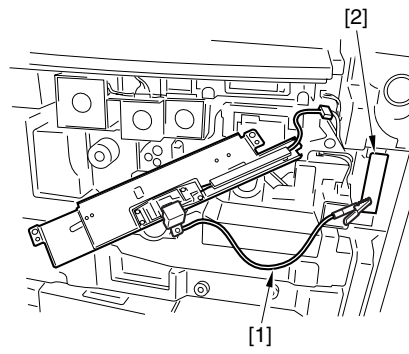

F-14-43

- 9) Fit the door switch actuator in the door switch assembly.
10) Turn on the power.
11) Execute the following service mode items:
COPIER > FUNCTION > DPC > OFST
12) Record the value of <OFST> on the service sheet.
13) Turn off the main power switch.
14) Detach the potential sensor checker electrode.
15) Put back the potential sensor support plate.
16) Turn on the power.

14.7.8 Checking the Surface Potential Control System

a. Outline

If image faults occur, it is important to find out whether the cause is in the latent static image formation block (including the photosensitive drum and the potential control system) or it is in the developing/transfer system, requiring a check on the surface potential. (You can check the surface potential in service mode.)

b. Disabling the Auto Control Mechanisms

As a way of checking the mechanisms used for corona current control, lamp intensity control, or developing bias control, you may disable the auto control mechanisms (hereafter, non-auto control mode).

As a first-aid measure when a fault exists in the auto control mechanism, you may use non-auto control mode; keep in mind that all outputs in non-auto control mode are fixed to standard values.

1. Procedure

- 1) Make the following selections in service mode, and enter '0':

COPIER > OPTION > BODY > PO-CNT.

- 2) Press the Reset key twice.



In non-auto control mode, all settings used for coronal current control, intensity control, developing bias control will be set to standard settings stored in ROM.

2. Making Use of Non-Auto Control Mode

If a fault occurs in images, use the mode to find out if the cause is on the input side or output side of the microprocessor on the DC controller PCB. In non-auto control mode, if the fault is corrected somewhat, you may suspect the potential measurement unit or the DC controller PCB.

c. Zero-Level Check

One way of finding out if the surface potential control circuit is good or not is to use a zero-level check.

MEMO:

A zero-level check is made to see if the microprocessor registers 0 V when the surface potential of the drum is 0 V.

Using the result of the check, you can find out if the microprocessor on the DC controller PCB or the measurement unit is good or not; a zero-level check may take either of the following two methods:

1. Method 1

- 1) Turn off the power switch.
- 2) Short the connectors J522-1 and -2 on the DC controller PCB with a jumper wire, and disconnect the connector J3 of the potential control PCB.

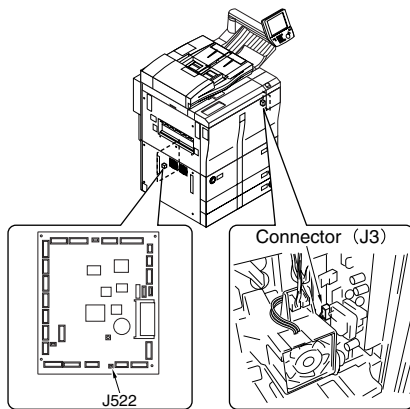

F-14-44

- 3) Fit the door switch actuator into the door switch assembly, and turn on the power switch.
- 4) Make the following selections in service mode, and check to see if the reading is between 0 and 30 during initial rotation: COPIER> DISPLAY> DPOT> DPOT-K.

MEMO:

If the reading is not as indicated, you may suspect a fault in the DC controller PCB.

- 5) Turn off the power switch, and detach the door switch actuator.
 - 6) Detach the jumper wire from the DC controller PCB.
 - 7) Connect the connector to J3 of the potential control PCB.
 - 8) Turn on the power switch.
- #### 2. Method 2
- 1) Turn off the power switch.

- 2) Remove the developing assembly, and slide out the process unit.
- 3) Disconnect the connector [1] of the potential sensor.

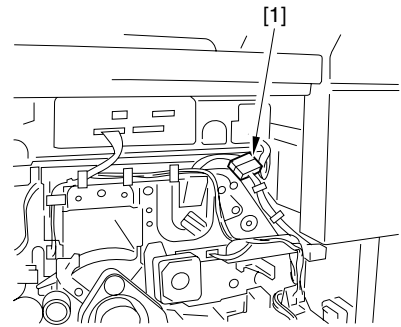

F-14-45

- 4) Remove the 2 screws [1], and detach the potential sensor support plate [2].

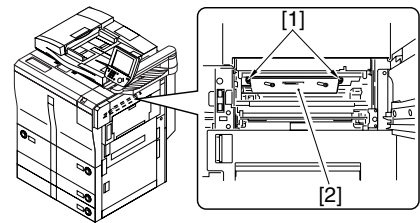

F-14-46

- 5) Put back the developing assembly and the process unit.
- 6) Connect the connector [1] of the potential sensor.

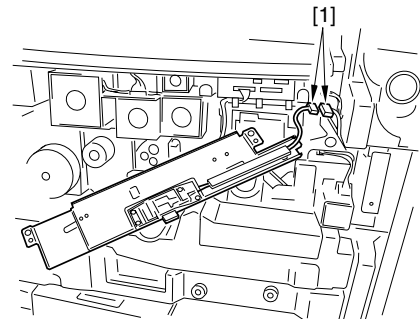

F-14-47

- 7) Fit the potential sensor checker electrode (FY9-3041) [2] to the potential sensor [1].



When fitting the checker electrode to the potential sensor, be sure that the magnet of the checker electrode will not come into contact with the potential sensor cover.

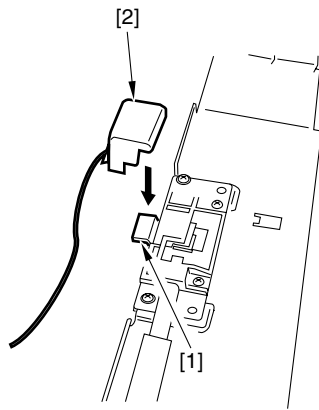

F-14-48

- 8) Connect the cable [1] of the potential sensor checker electrode to the frame (GND) [2] of the machine.



Never bring the clip into contact with the sensor cover. Be sure to keep it fully away from the sensor window.

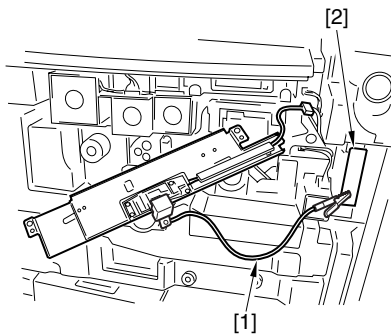

F-14-49

- 9) Fit the door switch actuator into the door switch assembly.
10) Turn on the power switch.



Once you have turned on the power switch, do not touch the potential sensor assembly.

- 11) Make the following selections in service mode, and check to make sure that the reading is between 0 and 30 during initial rotation:
COPIER> DISPLAY> DPOT> DPOT-K.

MEMO:

1. If the reading is as indicated in Method 1 but is not in Method 2, suspect dirt on the sensor or a fault in the potential measurement unit.
2. If the reading is as indicated in both Method 1 and Method 2, assume that the signal path and the operation from the potential sensor unit to the microprocessor on the DC controller PCB are normal.

- 12) Turn off the power switch.
13) Remove the potential sensor checker electrode.

- 14) Mount the potential sensor support plate.
15) Turn on the power switch.

14.7.9 Checking the Environment Sensor

- 1) Checking the Environment Sensor

Make the following selections in service mode, and check and record the temperature/humidity indicated on the screen in the control panel: COPIER > DISPLAY > ANALOG.

Data A

'TEMP' deg C data A1

'HUM' % data A2

- 2) Press the Rest key twice to turn off the power switch.

- 3) Remove the environment sensor, and fit the environment sensor jig (FY9-3014) in its place.

- 4) Turn on the power switch, and leave the machine alone for 5 min.

- 5) Make the following selections in service mode, and check and record the temperature/humidity indicated on the screen in the control panel: COPIER > DISPLAY > ANALOG:

Data B

'TEMP' deg C data B1

'HUM' % data B2

- 6) Compare data A and data B.

- difference between data A 1 and data B1 is 0 -/+ 5

- difference between data A2 and data B2 is 0 -/+ 20

If the difference between data A and data B is outside the range, replace the environment sensor.

- 7) Press the Reset key twice, and turn off the power switch.

- 8) Detach the environment sensor jig, and fit the environment sensor.

- 9) Put back all covers.



The environment sensor jig (FY9-3014) is precisely adjusted at the factory.

Be sure to keep it in an air-tight case with a drying agent.

14.8 Pickup/Feeding System

14.8.1 Orientation of the Deck/Cassette Pickup Roller

The deck/cassette pickup roller may be mounted by reversing the steps used to remove it; however, keep the following in mind:

- The pickup rollers used at the front and the rear of the machine are not interchangeable.
- The collar of the pickup roller used at the front of the machine is gold-colored.

When mounting the pickup roller [1] to the pickup assembly, be sure that the round marking [2] found on the side of the roller and the round marking [3] on the collar (gold-colored) are toward the front of the machine.

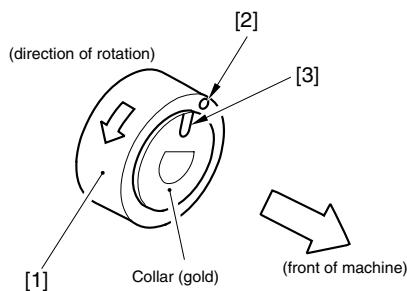

F-14-50

- The collar of the pickup roller used at the rear is silver-colored. When mounting the pickup roller [4] to the pickup assembly, be sure that the round marking [5] on the side of the roller and the round marking [6] on the collar (silver-colored) are toward the rear of the machine.

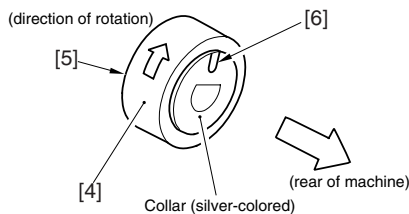

F-14-51

14.8.2 Orientation of the Deck/Cassette Separation Roller

When replacing the separation roller, be sure that it is oriented as shown

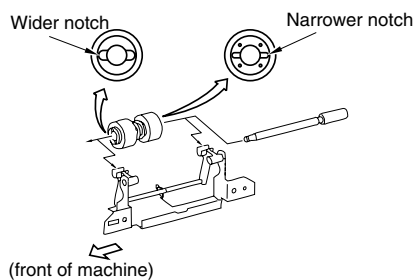

F-14-52

14.8.3 Orientation of the Feeding Roller of the Deck/Cassette Pickup Assembly

When mounting the feeding roller assembly to the deck/cassette pickup assembly, be sure that the belt pulley [2] is to the front of the machine. When mounting the feeding roller [3] to the feeding roller shaft [4], be sure that the round marking [5] is toward the front of the machine.

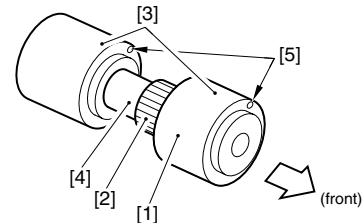

F-14-53

14.8.4 Orientation of the Pickup Roller of the Manual Feed Tray/Side Paper

The pickup roller may be mounted by reversing the steps used to remove it; however, keep the following in mind:

- The pickup rollers used at the front and the rear of the machine are not interchangeable.
- The collar of the pickup roller used at the front of the machine is silver-colored.

When mounting the pickup roller [1] to the pickup assembly, be sure that the round marking [2] of the color (silver-colored) is toward the front of the machine.

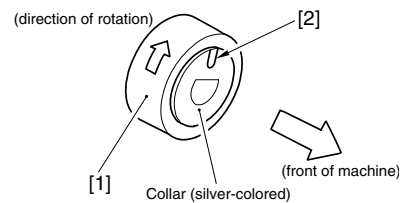

F-14-54

[1] Pickup roller

[2] Marking (collar)

- The collar of the pickup roller used at the rear of the machine is gold-colored.

When mounting the pickup roller [4] to the pickup assembly, be sure that the round marking [5] on the side of the roller and the round marking [6] on the collar (gold-colored) are toward the rear of the machine.

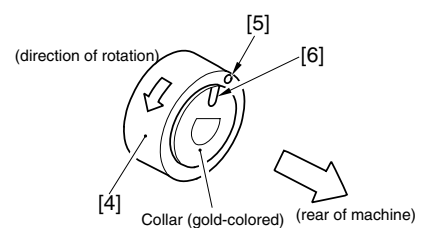

F-14-55

[4] Pickup roller

[5] Marking (roller)

[6] Marking (collar)

14.8.5 Orientation of the Feeding Roller of the Manual Feed Tray

When mounting the feeding roller assembly [1] to the manual feed tray pickup assembly, be sure that the belt pulley [2] is toward the front of the machine. When mounting the feeding roller [3] to the feeding roller shaft [4], be sure that the round marking [5] is toward the front of the machine.

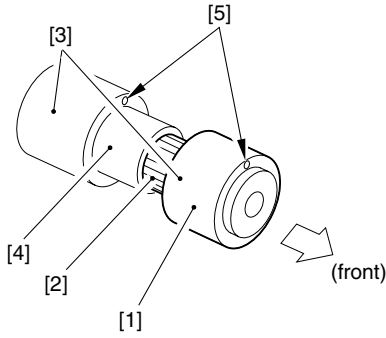

F-14-56

14.8.6 Orientation of the Feeding Roller of the Side Paper Deck

When mounting the feeding roller assembly [1] to the side paper deck pickup assembly, be sure that the belt pulley [2] is toward the front of the machine. When mounting the feeding roller [3] to the feeding roller shaft [4], be sure that the round marking [5] is toward the rear of the machine.

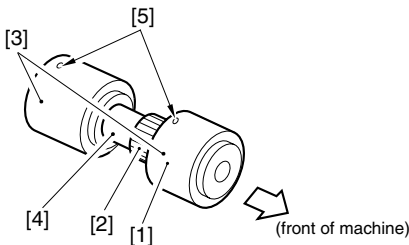

F-14-57

14.8.7 Adjusting the Pressure of the Deck/Cassette Separation Roller

If double feeding or pickup failure occurs during pickup, adjust the position of the pressure spring of the separation roller.

- If double feeding occurs, move the hook of the spring in the direction of arrow B.
- If pickup failure occurs, move the hook of the spring in the direction of A.

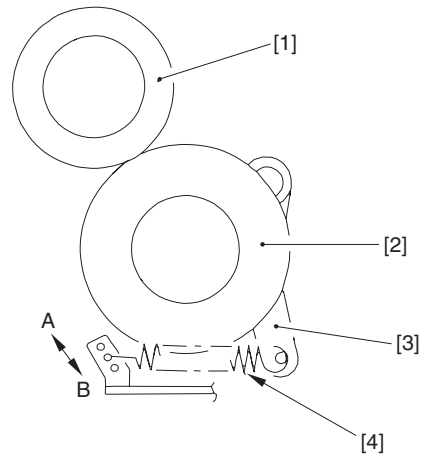

F-14-58
T-14-5

- [1] Feeding roller
- [2] Separation roller
- [3] Locking lever
- [4] Pressure spring

14.8.8 Adjusting the Pressure of the Pickup/Feeding Roller of the Manual

If double feeding or pickup failure occurs during pickup, adjust the position of the pressure spring of the separation roller.

- If double feeding occurs, move the hook of the spring in the direction of arrow A.
- If pickup failure occurs, move the hook of the spring in the direction of B.

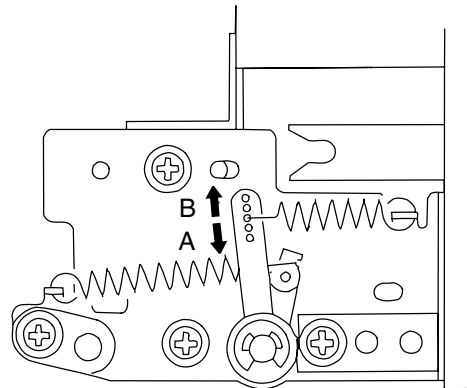

F-14-59

14.8.9 Location of the solenoids

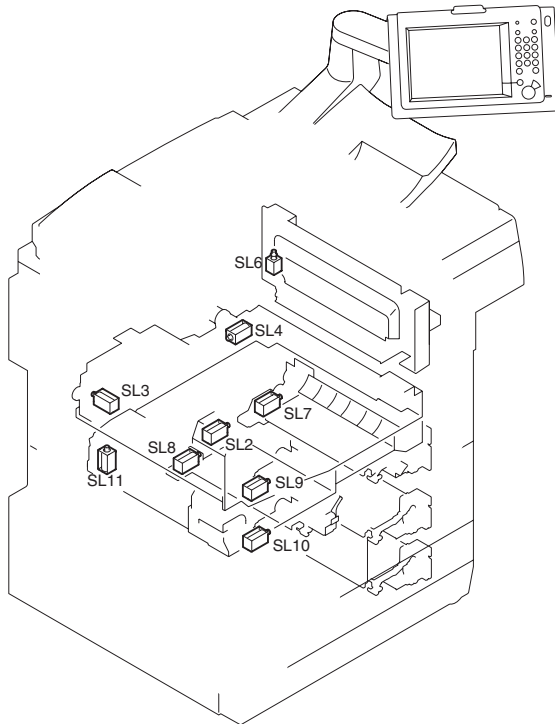

F-14-60

- SL2 : Fixing web solenoid
- SL3 : Delivery flapper solenoid
- SL4 : Fixing/feeder unit locking solenoid
- SL6 : Manual feed pickup latch solenoid
- SL7 : Deck (right) pickup solenoid
- SL8 : Deck (left) pickup solenoid
- SL9 : Cassette 3 pickup solenoid
- SL10: Cassette 4 pickup solenoid
- SL11: Reversing flapper solenoid

14.8.10 Position of the Fixing Web Solenoid (SL2)

a. If the Fixing Web Is New

Use the position of the solenoid [1] using the screw [2] so that the travel of the drive lever is 8.2 mm.

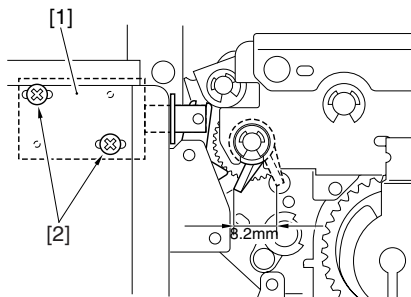

F-14-61

b. If the Fixing Web Is Not New

Before removing the solenoid, check the position [A] of the drive lever when the solenoid [1] is ON. After replacing the solenoid, make adjustments using the screw [2] so that the position of the drive lever is the same (when the solenoid is ON).

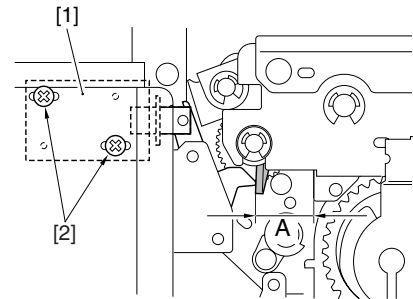

F-14-62

14.8.11 Position of the Delivery Flapper Solenoid (SL3)

Use the screw [2] to adjust the position of the solenoid [1] so that the drive lever is fully pushed when the solenoid is ON (i.e., when the steel core is drawn).

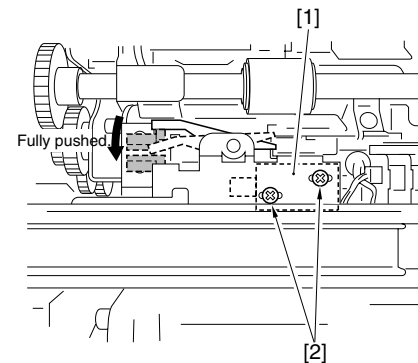

F-14-63

14.8.12 Position the Fixing/Feeder Unit Locking Solenoid (SL4)

Use the screw [3] to adjust the position of the solenoid [1] so that the locking lever [2] is 10.5 +/- 0.5 mm away from the frame when the solenoid is ON (i.e., when the steel core is drawn).

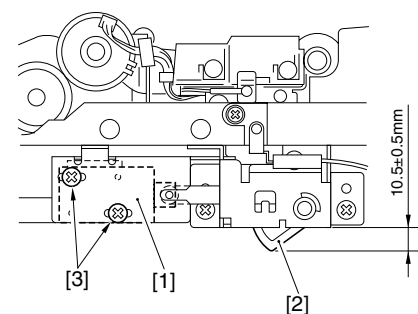

F-14-64

14.8.13 Position of the Multifeeder Latch Solenoid (SL6)

Slide the solenoid in the direction of A so that the gap between the shutter [1] and the shutter plate [2] is 0.4 ± 0.2 mm when the solenoid is drawn.

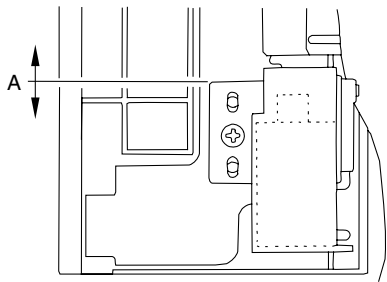

F-14-65

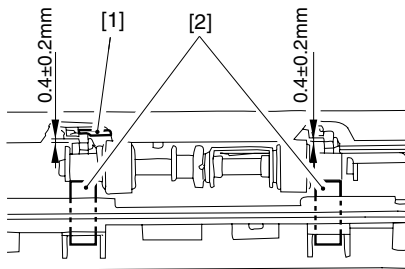

F-14-66

14.8.14 Position of the Deck (right) Pickup Solenoid (SL7)

Use the screw [3] so that the distance from the pickup unit bottom of each cassette holder and the bushing bottom edge of the A roller support plate is 34.0 ± 0.5 mm when the plunger of the pickup roller releasing solenoid is drawn (as occurring when [1] and [2] are operated as shown). (After adjustment, make sure that the distance between the paper face and the A roller is 2.5 ± 0.5 mm when the A roller is in UP position.)

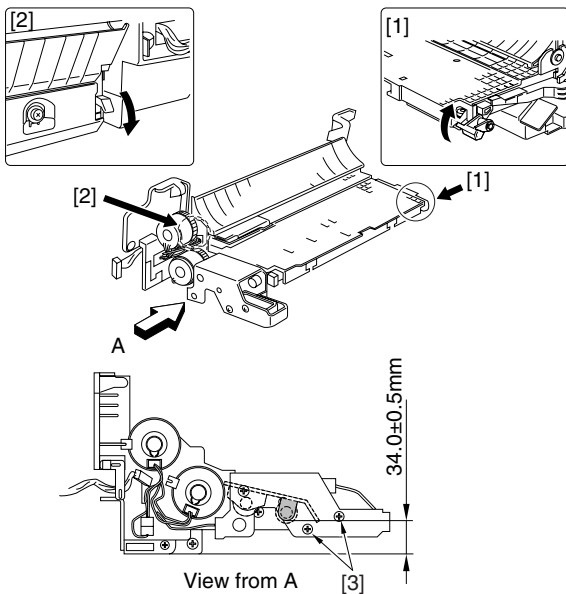

F-14-67

14.8.15 Position of the Deck (Left) Pickup Solenoid (SL8)

Use the screw [3] so that the distance from the pickup unit bottom face to the bushing bottom edge of the A roller support plate is 49.5 ± 0.5 mm when the plunger of the pickup releasing solenoid is drawn (as occurring when [1] and [2] are operated as shown). (After adjustment, make sure that the distance between the paper face and the A roller is 2.5 ± 0.5 mm when the A roller is in UP position.)

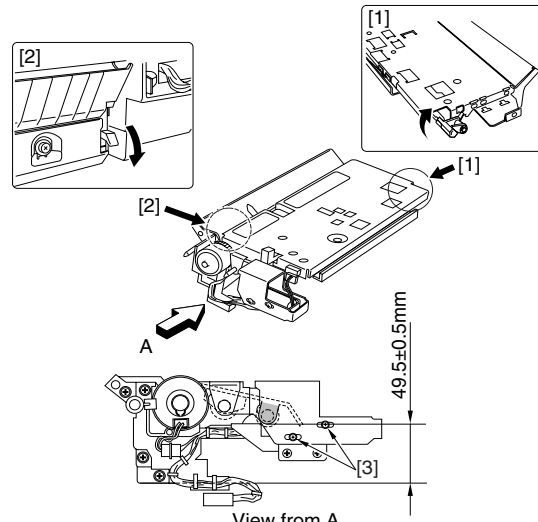

F-14-68

14.8.16 Position of the Cassette 3/4 Pickup Solenoid (SL9/10)

Use the screw [3] so that the distance from the pickup unit bottom face of each cassette holder and the bushing bottom edge of the A roller support plate is 35.5 ± 0.5 mm when the plunger of the pickup roller releasing solenoid is drawn (as occurring when [1] and [2] are operated as shown). (After adjustment, make sure that the distance between the paper face and the A roller is 2.5 ± 0.5 mm when the A roller is in UP position.)

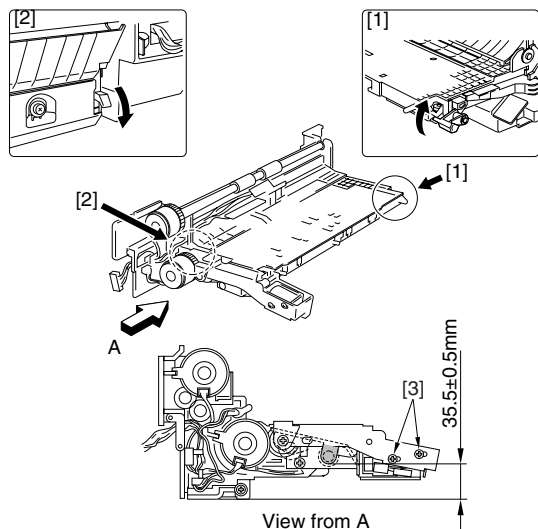

F-14-69

14.8.17 Position of the Side Paper Deck Pickup Roller Releasing Solenoid

Before removing the deck pickup roller releasing solenoid [1] from the support plate, make mental notes of the positions of the 2 fixing screws [2] of the solenoid with reference to the index on the support plate. (Or, mark the position of the solenoid on the support plate with a scribe.)

If you are replacing the solenoid on its own, you must secure it in its initial position.

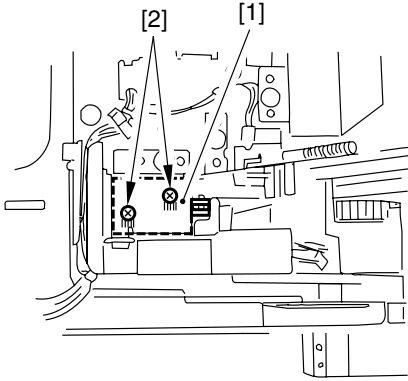

F-14-70

14.8.18 Fitting the Side Guide Timing Belt of the Manual Feed Tray Assembly

Butt the rack plate [1] of the manual feed tray against section A (open state).

Move the slide volume [2] in the direction of B, and fit the timing belt [3] to the pulley [4].

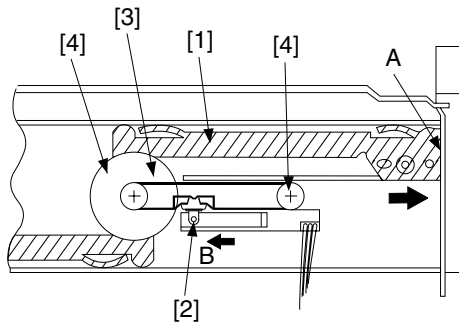

F-14-71

14.8.19 Fitting the Drive Belt

Fit the drive belt to the pulleys and rollers as follows:

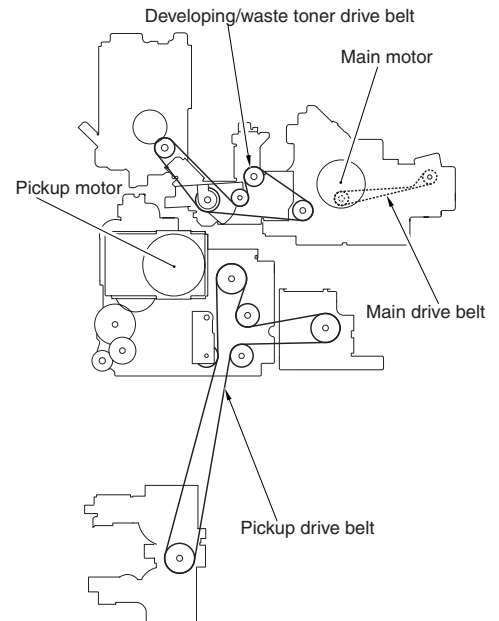

F-14-72

Correcting Faulty Images

Contents

15.1 Making Initial Checks	15- 1
15.1.1 Checking the Side of Installation	15- 1
15.1.2 Checking the Originals	15- 1
15.1.3 Checking the Copyboard Cover, Copyboard Glass, and Standard White Plate	15- 1
15.1.4 Checking the Charging Assemblies	15- 1
15.1.5 Checking the Develop Unit	15- 1
15.1.6 Checking the Paper	15- 1
15.1.7 Checking the Periodically Replaced Parts	15- 1
15.1.8 Others	15- 2
15.2 Outline of Electrical Components	15- 3
15.2.1 Clutch/Solenoid	15- 3
15.2.1.1 Clutches	15- 3
15.2.1.2 Solenoids	15- 4
15.2.2 Motor	15- 5
15.2.2.1 Motors	15- 5
15.2.3 Fan	15- 7
15.2.3.1 Fans	15- 7
15.2.3.2 Fans	15- 8
15.2.4 Sensor	15- 10
15.2.4.1 Sensor (reader) <iR7105/7095>	15- 10
15.2.4.2 Sensor (reader) <iR7086>	15- 11
15.2.4.3 Sensor 1	15- 12
15.2.4.4 Sensor 2	15- 17
15.2.5 Switch	15- 18
15.2.5.1 Switches	15- 18
15.2.6 Lamps, Heaters, and Others	15- 19
15.2.6.1 Heaters, Lamps, and Others	15- 19
15.2.7 PCBs	15- 21
15.2.7.1 PCBs	15- 21
15.2.8 Variable Resistors (VR), Light-Emitting Diodes (LED), and Check Pins by PCB	15- 23
15.2.8.1 Variable Resistors (VR), Light-Emitting Diodes (LED), and Check Pins by PCB	15- 23
15.2.8.2 Main controller PCB	15- 23
15.2.8.3 DC controller PCB	15- 24

15.1 Making Initial Checks

15.1.1 Checking the Side of Installation

Check the site of installation against the following requirements:

- a. The voltage of the power supply must be as rated (-/+ 10%). The power plug must remain connected day and night.
- b. The site must not be subject to high temperature/humidity (near a water faucet, water boiler, humidifier). The machine must not be installed in a cold place or in an area near a source of fire or subject to dust.
- c. The site must not be subject to ammonium gas.
- d. The site must not be subject to direct rays of the sun. As necessary, curtains must be provided.
- e. The site must be well ventilated.
- f. The machine must be kept level.
- g. The machine must remain powered throughout the night.

15.1.2 Checking the Originals

Check the originals to find out whether the problem is caused by the originals used or is in the machine:

- a. The copy density setting is optimum at 5 -/+ 1.
- b. If the original has a reddish background, copies can suffer poor contrast.

MEMO:

Red sheets, slips, and the like.

-
- c. The density of the original can have the following effects:

MEMO:

if the original is a diazo copy or is rather transparent, copies can be mistaken as being "foggy."
if the original is prepared in pencil, copies can be mistaken as being "too light."

15.1.3 Checking the Copyboard Cover, Copyboard Glass, and Standard White Plate

Check the copyboard cover, copyboard glass, and standard white plate for dirt or scratches. If dirt is found, clean it with a solution of mild detergent or alcohol; if a scratch is found, on the other hand, replace it.

15.1.4 Checking the Charging Assemblies

- a. Check the charging assemblies for dirt and a faulty charging wire.
- b. Clean the charging wire and the shielding plate of the charging assemblies. (If dirt cannot be removed, replace it.)
- c. Check the type and height of the charging wire.
- d. Check to make sure that the charging assemblies are firmly fitted.
- e. Check the charging wire spring for rusting.
- f. Check the charging wire cleaning pad (of each charging assembly) for displacement.

15.1.5 Checking the Develop Unit

- a. Check to make sure that the rolls on both ends of the developing assembly are in contact with the drum.
- b. Check to make user that the surface of the developing cylinder is coated with an even layer of toner.
- c. Check the connectors between the developing assembly and the machine for connection.
- d. Check to make sure that <DEV-SLOW> of the following in service mode in '2': COPIER > OPTION > BODY.

15.1.6 Checking the Paper

- a. Check to see if the paper is a type recommended by Canon.
- b. Check to see if the paper is moist. Try paper fresh out of package.

15.1.7 Checking the Periodically Replaced Parts

Check with the Periodical Servicing Chart and the Periodically Replaced Parts Table, and replace those parts that have reached the end of their lives.

15.1.8 Others

In winter, bringing a machine from a cold to warm place can cause the inside of the machine to develop condensation, leading to various problems.

MEMO:

- a. Condensation in the scanning system (glass, mirrors, lenses) will produce darker images.
- b. Condensation in the charging system will cause electrical leakage.
- c. Condensation on the pickup/feeding guide will cause feeding faults.

If condensation is found, dry wipe the part or leave the machine alone and powered for 60 min.



If the density is uneven (different between front and rear) or the image is too light or is foggy, perform the "Image Adjustment Basic Procedure" in advance.

15.2 Outline of Electrical Components

15.2.1 Clutch/Solenoid

15.2.1.1 Clutches

1. Reader Unit

The reader unit does not use clutches.

2. Printer Unit

T-15-1

Notation	Parts Name.	Parts No.	PART-CHK	Connector No.	
				no-stacking driver PCB	DC controller PCB
CL1	Magnet roller drive clutch	FH7-5840	CL>1		J504
CL2	Registration clutch	FH6-5013	CL>2		J509
CL3	Registration brake clutch	FH6-5014	CL>3		J509
CL4	Development 1 clutch	FH6-5015	CL>4		J512
CL5	Pre-registration clutch	FH6-5016	CL>5		J513
CL6	Pre-registration brake clutch	FH6-5014	CL>6		J513
CL7	Manual feed tray pickup roller clutch	FH6-5043	CL>7		J513
CL8	Vertical path 1 clutch	FH6-5014	CL>8		J511
CL9	Vertical path 2 clutch	FH6-5043	CL>9		J514
CL10	Deck (right) pickup clutch	FH6-5043	CL>10		J511
CL11	Deck (left) pickup clutch	FH6-5043	CL>11		J518
CL12	Cassette 3 pickup clutch	FH6-5043	CL>12		J515
CL13	Vertical path 3 clutch	FH6-5014	CL>13		J515
CL14	Cassette 4 pickup clutch	FH6-5043	CL>14		J517
CL15	Vertical path 4 clutch	FH6-5014	CL>15		J517
CL16	Lower feeder middle clutch	FH6-5014	CL>16	J3603	J519
CL17	Lower feeder right clutch	FH6-5014	CL>17	J3603	J519
CL18	Manual feed tray pulling clutch	FH6-5043	CL>18		J513
CL19	Deck (left) feeding clutch	FH6-5014	CL>19	J3603	J519
CL20	Developing cylinder deceleration clutch	FH6-5017	CL>20		J516
CL21	Delivery speed switching clutch	FH7-5844	CL>21		J508
CL22	Manual feed tray feeding roller clutch	FH6-5043	CL>22		J510
CL23	Sub hopper transport clutch	FH7-5840	CL>23		J511

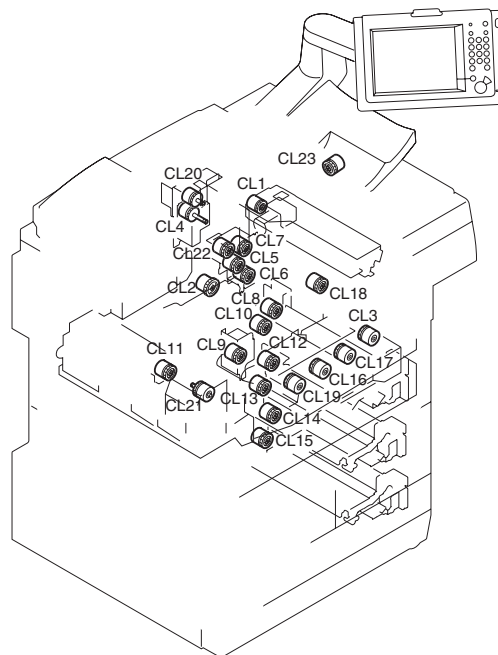

F-15-1

15.2.1.2 Solenoids

1. Reader Unit

The reader unit does not use solenoids.

2. Printer Unit

T-15-2

Notation	Parts Name	Parts No.	PART-CHK	Connector No.	
				no-stacking driver PCB	DC controller PCB
SL2	Fixing web solenoid	FK2-0034	SL>2		J508
SL3	Delivery flapper solenoid	FH7-5837	SL>3		J508
SL4	Fixing/feeder unit locking solenoid	FH7-5845	SL>4		J509
SL6	Manual feed pickup solenoid	FH7-5838	SL>6		J510
SL7	Deck (right) pickup solenoid	FK2-0126	SL>7		J511
SL8	Deck (left) pickup solenoid	FK2-0126	SL>8		J518
SL9	Cassette 3 pickup solenoid	FH7-5702	SL>9		J515
SL10	Cassette 4 pickup solenoid	FH7-5702	SL>10		J517
SL11	Reversing flapper solenoid	FH7-5837	SL>11	J3604	J519

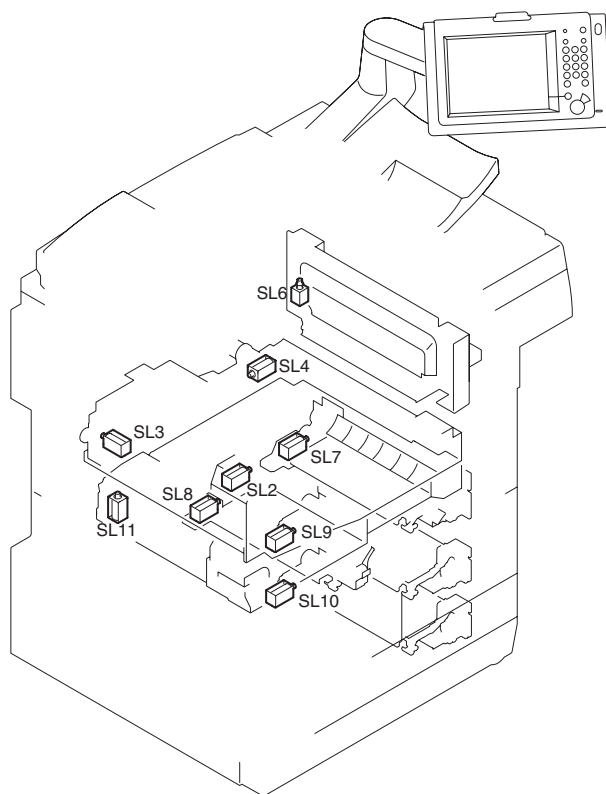

F-15-2

15.2.2 Motor

15.2.2.1 Motors

1. Reader Unit

T-15-3

Notation	Parts Name	Description	Parts No.	E code
M501	Scanner motor	drives the No. 1/No. 2 mirror base	FK2-1182	E202

T-15-4

Notation	Connector No.	
	I/F PCB	Reader controller PCB
M501	J306	J205

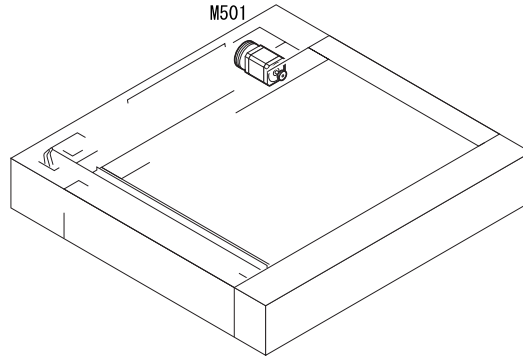

F-15-3

2. Printer Unit

Notation	Parts Name	Description	Parts No.	PART-CHK	E code
M0	Drum motor	drives components associated with the photosensitive drum	FH6-1934	MTR>0	E012
M1	Main motor	drives major components of the printer unit	FH6-1935	MTR>1	E010
M2	Pickup motor	drives the pickup assembly	FH6-1936	MTR>2	E015
M3	Fixing motor	drives the fixing assembly	FH6-1937	MTR>3	E014
M4	Polygon motor	drives the laser scanner	FM2-5449 (Laser scanner unit)	MTR>4	E110
M7	Pre-transfer charging wire cleaner motor	drives the pre-transfer wire cleaner	FH5-1138	MTR>7	
M8	Primary charging wire cleaner motor	drives the primary wire cleaner	FH5-1138	MTR>8	
M9	Transfer/separation charging wire cleaner motor	drives the transfer separation charging wire cleaner	FH5-1138	MTR>9	
M10/20	Vibration motor	drives the cleaning blade	FH5-1141	MTR>10/20	
M11	Duplex reversal motor	drives the reversing roller, lower feeding middle roller, lower feeding right motor	FH6-1939	MTR>11	
M12	Duplex feeder motor (left)	drives the U-turn roller 1, 2	FH6-1940	MTR>12	
M13	Deck (right) lifter motor	drives the Lifter of the deck (right)	FK2-0017	MTR>13	
M14	Deck (left) lifter motor	drives the Lifter of the deck (left)	FK2-0017	MTR>14	
M15	Horizontal registration motor	drives the horizontal registration sensor	FH6-1542	MTR>15	E051
M16	Cassette 3 lifter motor	drives the lifter of the cassette 3	FH6-1960	MTR>16	
M17	Cassette 4 lifter motor	drives the lifter of the cassette 4	FH6-1960	MTR>17	
M18	Buffer motor	supplies toner to the developing assembly	FH6-1543	MTR>18	
M19	Duplex feeder motor (right)	drives the Pre-confluence roller	FH6-1940	MTR>19	

Notation	Parts Name	Description	Parts No.	PART-CHK	E code
M21	Fixing inlet sensor lift motor	drives ascent/descent of the fixing inlet sensor	FH6-1542	MTR>21	
M22	Sub hopper motor	supplies toner to the buffer unit	FH6-1543	MTR>22	
M23	Toner bottle rotation motor	supplies toner to the sub hopper	FK2-0015	MTR>23	

Notation	Connector No.		
	no-stacking feeding driver PCB	Interface PCB	DC controller PCB
M0			J512
M1			J514
M2			J513
M3			J508
M4			J506
M7			J504
M8			J502
M9			J509
M10/20			J529
M11	J3607		J519
M12	J3607		J519
M13			J514
M14			J514
M15	J3603		J519
M16			J516
M17			J516
M18			J504
M19	J3608		J519
M21			J508
M22			J511
M23			J512
M501		J306	

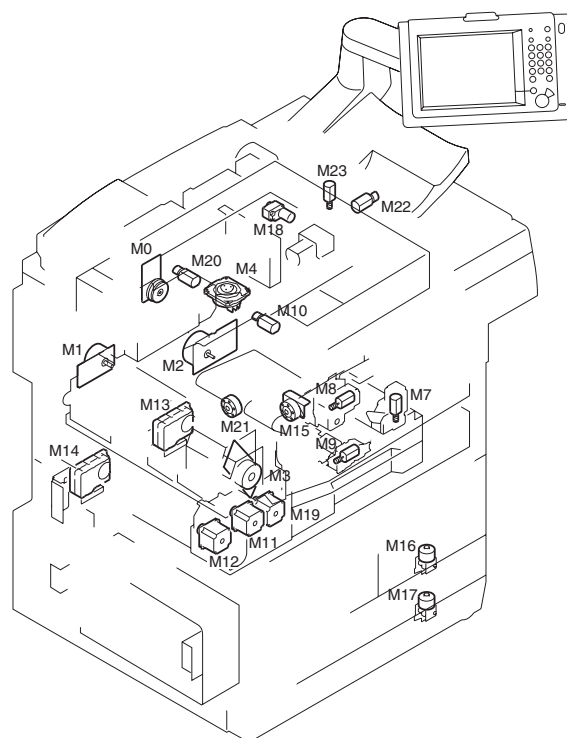

F-15-4

15.2.3 Fan

15.2.3.1 Fans <iR7086>

1. Reader Unit

T-15-5

Notation	Parts Name	Description	Parts No.	Connector No.		E/Alarm code
				Interface PCB	Reader controller PCB	
FM501	Reader cooling fan1	cools the reader assembly	FK2-0636	J313	J205	33-0003

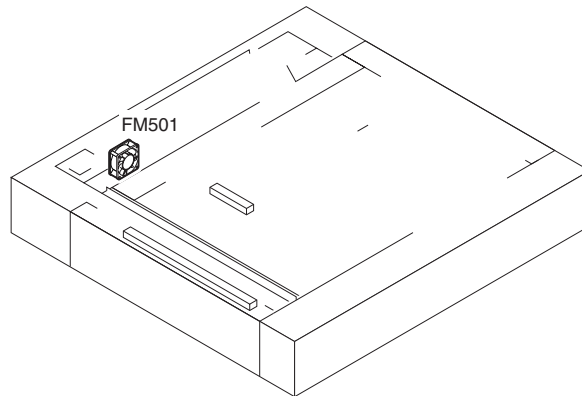

F-15-5

2. Printer Unit

T-15-6

Notation	Parts Name	Description	Parts No.	E code	Alarm code
FM1	polygon mirror cooling fan	cools the laser scanner motor; thermally insulates the unit from the fixing assembly; prevents soiling of the wire of the primary charging assembly	FH6-1941	E111-1111	-
FM2	fixing heat discharge fan	discharges heat from around the fixing assembly	FH6-1545	E805-0001	-
FM3	laser cooling fan	cools the laser scanner unit	FH6-1546	E121-0001	-
FM6	de-curling fan	cools paper	FH6-1548	-	33-0001
FM8	drum fan	draws out the ozone and stray toner from around the drum; cools the area	FH6-1550	E820-0000	-
FM10	pre-transfer charging assembly fan	discharges the ozone from around the pre-transfer charging assembly	FH6-1547	E823-0000	-
FM11	power supply cooling fan 1	cools the DC power supply PCB	FH6-1546	E804-0000	-
FM12	power supply cooling fan 2	cools the DC power supply PCB	FH6-1546	E804-0000	-
FM13	separation fan	helps separate paper from the drum	FH6-1942	E830-0000	-
FM15	developing fan	cools the developing assembly	FH6-1547	-	33-0006
FM16	system fan	cools the PCBs inside the system box	FH6-1878	-	00-0804
FM17	delivery anti-adhesion fan	cools paper being delivered	FH6-1877	-	33-0007
FM18	scanner heat discharge fan 2	discharges heat from around the laser scanner unit	FH6-1740	E121-0003	-
FM19	duplexing transport fan	cools the duplexing transport motor	FH6-1878	-	33-0009
FM20	separation heat discharge fan	discharges heat from around the separation assembly; improves separation	FH6-1545	E805-0002	-
FM21	scanner heat discharge fan 1	discharges heat from around the laser scanner unit	FH6-1547	E121-0001	-

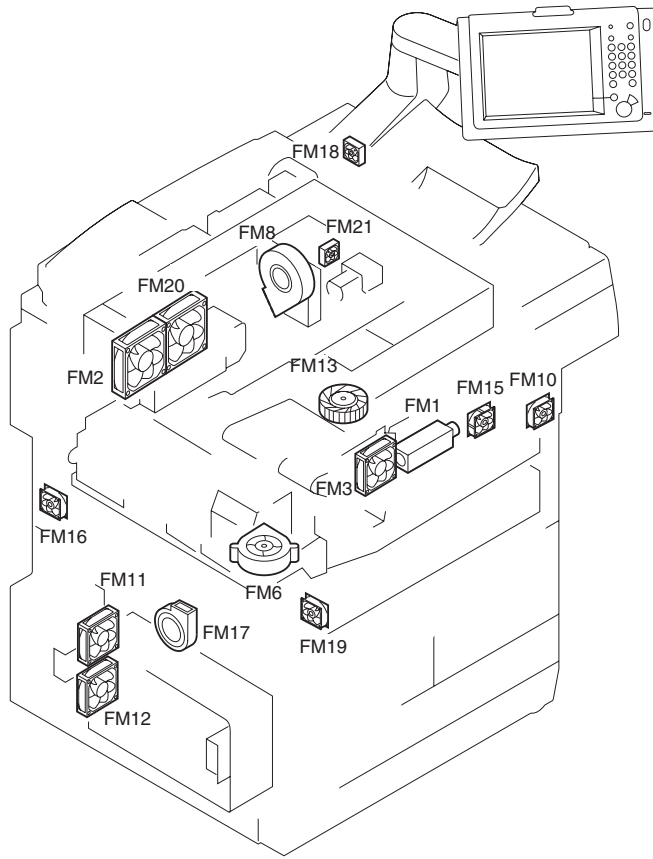

F-15-6

15.2.3.2 Fans <iR7105/7095>

1. Reader Unit

T-15-7

Notation	Parts Name	Description	Parts No.	Connector No.		
				Interface PCB	Reader controller PCB	E/Alarm code
FM501	Reader cooling fan1	cools the reader assembly	FK2-1188	J311	J205	33-0003
FM502	Reader cooling fan2	cools the reader assembly	FK2-1189	J311	J205	33-0004

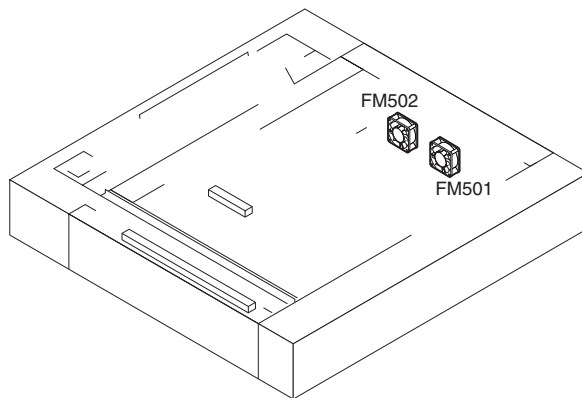

F-15-7

2. Printer Unit

T-15-8

Notation	Parts Name	Description	Parts No.	E code	Alarm code
FM1	polygon mirror cooling fan	cools the laser scanner motor; thermally insulates the unit from the fixing assembly; prevents soiling of the wire of the primary charging assembly	FH6-1941	E111-1111	-
FM2	fixing heat discharge fan	discharges heat from around the fixing assembly	FH6-1545	E805-0001	-
FM3	laser cooling fan	cools the laser scanner unit	FH6-1546	E121-0001	-
FM6	de-curling fan	cools paper	FH6-1548	-	33-0001
FM8	drum fan	draws out the ozone and stray toner from around the drum; cools the area	FH6-1550	E820-0000	-
FM10	pre-transfer charging assembly fan	discharges the ozone from around the pre-transfer charging assembly	FH6-1547	E823-0000	-
FM11	power supply cooling fan 1	cools the DC power supply PCB	FH6-1546	E804-0000	-
FM12	power supply cooling fan 2	cools the DC power supply PCB	FH6-1546	E804-0000	-
FM13	separation fan	helps separate paper from the drum	FH6-1942	E830-0000	-
FM15	developing fan	cools the developing assembly	FH6-1547	-	33-0006
FM16	system fan	cools the PCBs inside the system box	FH6-1878	-	00-0804
FM17	delivery anti-adhesion fan	cools paper being delivered	FH6-1877	-	33-0007
FM18	scanner heat discharge fan 2	discharges heat from around the laser scanner unit	FH6-1740	E121-0003	-
FM19	duplexing transport fan	cools the duplexing transport motor	FH6-1878	-	33-0009
FM20	separation heat discharge fan	discharges heat from around the separation assembly; improves separation	FH6-1545	E805-0002	-
FM21	scanner heat discharge fan 1	discharges heat from around the laser scanner unit	FH6-1547	E121-0001	-

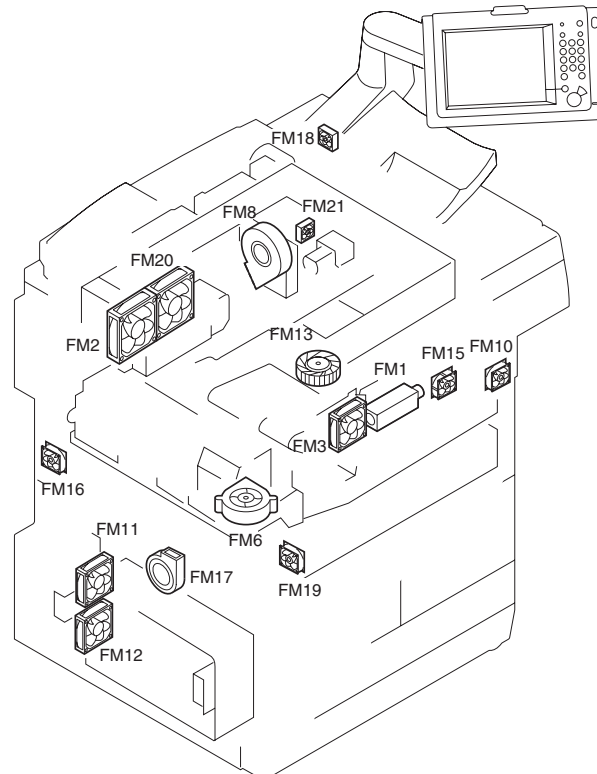

F-15-8

15.2.4 Sensor

15.2.4.1 Sensor (reader) <iR7105/7095>

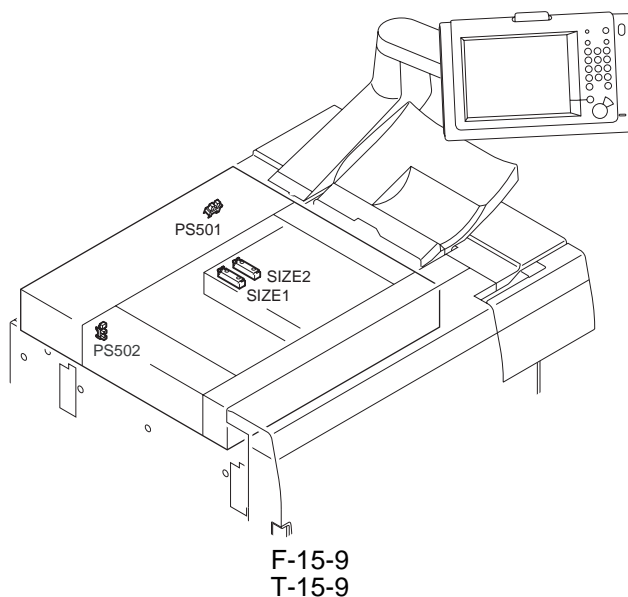

Notation	Name	Description	Parts No.	I/O (RCON)		Connector No.	
						Interface PCB	Reader controller PCB
PS501	ADF open/closed 1 sensor	detects the state (open/closed) of the ADF	FK2-0149	P006-7	0:ADF close	J301/302	J205
PS502	Scanner HP sensor	detects scanner home position	FK2-0149	P006-5	0:HP	J305/303	J202
SIZE1	Original size sensor 1	detects the original size (A/B, sub scanning direction)	FK2-0238				J206
SIZE2	Original size sensor 2	detects the original size (inch, sub scanning direction)	FK2-0238				J207

15.2.4.2 Sensor (reader) <iR7086>

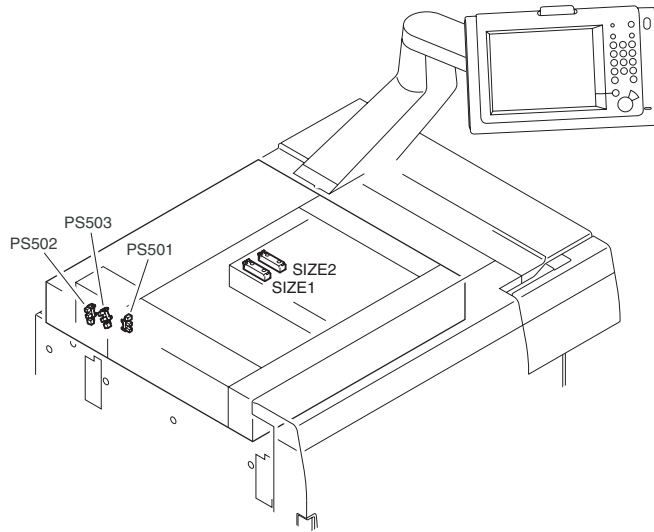

F-15-10
T-15-10

Notation	Name	Description	Parts No.	I/O (RCON)		Connector No.	
						Interface PCB	Reader controller PCB
PS501	ADF open/closed 1 sensor	detects the state (open/closed) of the ADF	FK2-0149	P006-6	1:HP	J310/307	J203
PS502	Scanner HP sensor	detects scanner home position	FK2-0149	P006-4	1:ADF close	J310/308	J202
PS503	ADF open/closed 2 sensor	detects the timing of original size	FK2-0149	6-59-11	1:ADF close	J310/308	J202
SIZE1	Original size sensor 1	detects the original size (A/B, sub scanning direction)	FK2-0238				J207
SIZE2	Original size sensor 2	detects the original size (inch, sub scanning direction)	FK2-0238				J208

15.2.4.3 Sensor 1

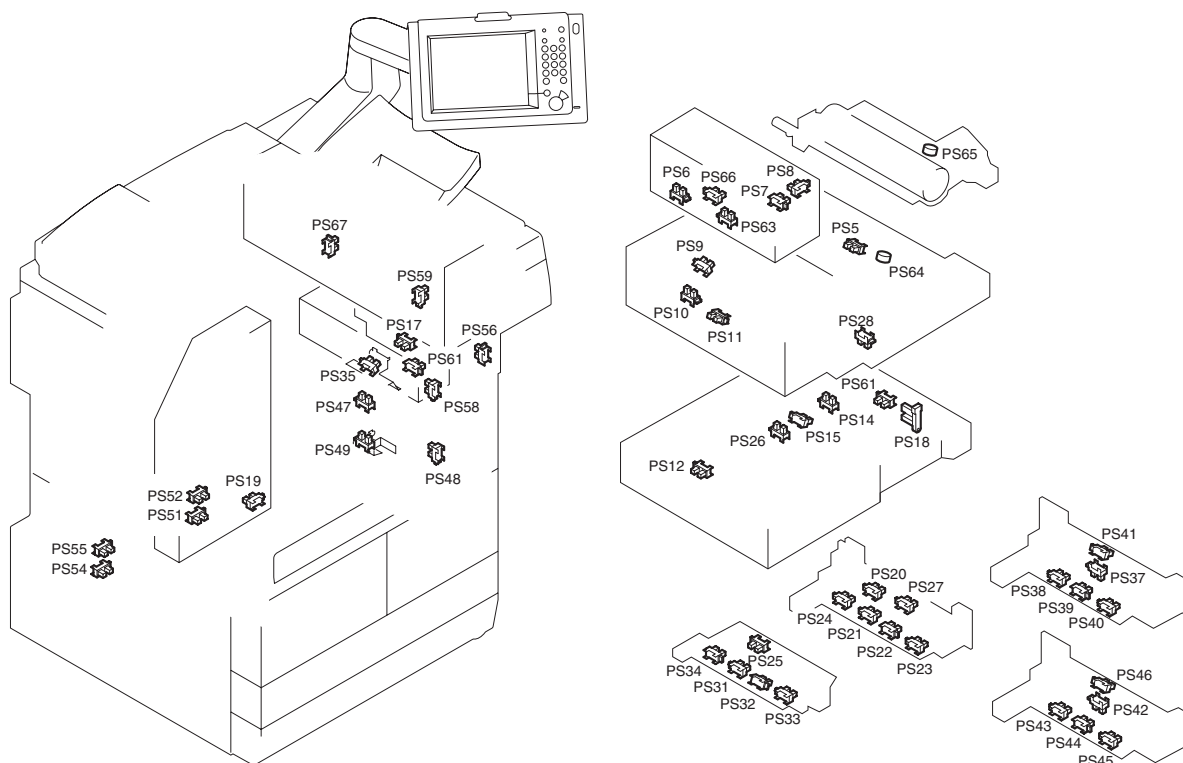
F-15-11
T-15-11

Notation	Name	Description	Parts No.	I/O (DCON)	
PS5	Registration sensor	detects the registration paper	FK2-0149	P002-11	1:paper present
PS6	Claw jam sensor	detects fixing claw jam	FK2-0149	P002-15	1:presence
PS7	No web sensor	detects fixing web length	FK2-0149	P003-3	1:no web
PS8	Web length warning sensor	detects no web alert	FK2-0149	P003-4	1:alert
PS9	Internal delivery sensor	detects the internal delivery	FK2-0149	P002-12	1:paper present
PS10	External delivery sensor	detects the external delivery	FK2-0149	P002-13	1:paper present
PS11	Fixing/feeding outlet sensor	detects the fixing/feeding outlet paper	FK2-0149	P002-14	1:paper present
PS12	Duplex reversal sensor	detects the duplex reversal paper	FK2-0149	P002-1	1:paper present
PS14	Pre-confluence reversal sensor	detects pre-confluence reversal paper	FK2-0149	P002-3	1:paper present
PS15	Post-confluence sensor	detects post-confluence paper	FK2-0149	P002-4	1:paper present
PS17	Multi tray paper sensor	detects paper on the multi tray	FK2-0149	P004-12	1:paper present
PS18	Horizontal registration sensor	detects HP of the horizontal registration guide	FH7-7196-020	-	-
PS19	Waste toner full sensor	detects the waste toner full	FK2-0149	P003-7	1:full

Notation	Name	Description	Parts No.	I/O (DCON)	
PS20	Right deck pickup sensor	detects the right deck paper pick up	FG6-8605	P003-8	1:paper present
PS21	Right deck lifter sensor	detects the right deck lifter	FK2-0149	P004-0	1:detects lifter
PS22	Deck right paper sensor	detects the paper in the right deck	FK2-0149	P004-8	1:paper present
PS23	Deck right open/closed sensor	detects the right deck open/closed	FK2-0149	P005-4	1:closed
PS24	Deck right limit sensor	detects the right deck limit	FK2-0149	P004-14	1:limit
PS25	Left deck pickup sensor	detects the left deck paper pick up	FG6-8605	P003-9	1:paper present
PS26	Left deck feed sensor	detects the left deck re-try	FG6-8605	P003-15	1:paper present
PS27	Right deck feed sensor	detects the right deck re-try	FG6-8605	P003-14	1:paper present
PS28	Fixing transport unit release lever sensor	detects fixing transport unit release	FK2-0149	P005-14	1:release
PS31	Left deck lifter sensor	detects the left deck lifter	FK2-0149	P004-1	1:detects lifter
PS32	Deck left paper sensor	detects the left deck lifter	FK2-0149	-	-
PS33	Deck left open/closed sensor	detects the left deck open/closed	FK2-0149	P005-5	1:closed
PS34	Deck left limit sensor	detects the left deck limit	FK2-0149	P004-15	1:limit
PS35	Multifeeder pickup sensor	detects the multifeeder re-try	FK2-0149	P002-10	1:paper present
PS37	Cassette 3 pickup sensor	detects paper in the cassette 3	FG6-8605	P003-10	1:paper present
PS38	Cassette 3 open/closed sensor	detects the cassette 3 lifter	FK2-0149	P004-2	1:detects lifter
PS39	Cassette 3 paper sensor	detects paper in the cassette 3	FK2-0149	P004-10	1:paper present
PS40	Cassette 3 open/closed sensor	detects the cassette 3 open/closed	FK2-0149	P005-6	1:closed
PS41	Vertical path 3 sensor	detects the vertical path 3 paper	FG6-8605	P003-12	1:paper present
PS42	Cassette 4 pickup sensor	detects the cassette 4 paper pick up	FG6-8605	P003-11	1:paper present
PS43	Cassette 3 lifter sensor	detects the cassette 4 lifter	FK2-0149	P004-3	1:detects lifter
PS44	Cassette 4 paper sensor	detects the paper in the cassette 4	FK2-0149	P004-11	1:paper present
PS45	Cassette 4 open/closed sensor	detects the cassette 4 open/closed	FK2-0149	P005-7	1:closed
PS46	Vertical path 4 sensor	detects the vertical path 4 paper	FG6-8605	P003-13	1:paper present
PS47	Vertical path 1 sensor	detects the vertical path 1 paper	FK2-0149	P002-8	1:paper present
PS48	Lower right cover open/closed sensor	detects the lower right cover open/closed	FK2-0149	P005-9	1:closed
PS49	Vertical path 2 sensor	detects the vertical path 2 paper	FK2-0149	P002-9	1:paper present

Notation	Name	Description	Parts No.	I/O (DCON)	
PS51	Right deck paper level middle sensor	detects the right deck level (middle)	FK2-0149	P004-4	1:paper present
PS52	Right deck paper level upper sensor	detects the right deck level (upper)	FK2-0149	P004-5	1:paper present
PS54	Left deck paper level middle sensor	detects the left deck level (middle)	FK2-0149	P004-6	1:paper present
PS55	Left deck paper level upper sensor	detects the left deck level (upper)	FK2-0149	P004-7	1:paper present
PS56	Manual feeder tray cover open/closed sensor	detects manual feeder tray cover open/closed	FK2-0149	P005-10	1:closed
PS58	Upper right cover open/closed sensor	detects the upper right cover open/closed	FK2-0149	P005-8	1:closed
PS59	Bottle cover open/closed sensor	detects the toner bottle cover open/closed	FK2-0149	P005-12	1:closed
PS60	Image write start sensor	detects the laser write start	FK2-0149	P002-5	1:paper present
PS61	Duplex outlet sensor	detects the duplex outlet	FK2-0149	P002-2	1:paper present
PS63	Fixing inlet sensor	detects the fixing inlet	FK2-0149	P002-7	1:paper present
PS64	Double feeding sensor (transmission)	detects double feeding (transmission)	FK2-0999	-	-
PS65	Double feeding sensor (reception)	detects double feeding (reception)	FK2-0999	-	-
PS66	Fixing inlet HP sensor	detects remaining paper on fixing inlet guide	FK2-0149	P002-6	1:HP
PS67	Toner bottle sensor	detects the toner bottle	FK2-0149	P003-5	1:detects bottle
PS68	Multiple curling prevention sensor	detects paper at multiple curling roller	FK2-0149	P002-0	1:paper present

T-15-12

Notation	Name	Connector No.				JAM
		Double feeding detection PCB (transmission)	Double feeding detection PCB (reception)	No-stacking feeder driver PCB	DC controller PCB	
PS5	Registration sensor				J509	xx09
PS6	Claw jam sensor				J508	
PS7	No web sensor				J508	
PS8	Web length warning sensor				J508	
PS9	Internal delivery sensor				J508	xx0B
PS10	External delivery sensor				J508	xx0C
PS11	Fixing/feeding outlet sensor				J508	xx0D
PS12	Duplex reversal sensor			J3605/ J3602	J519	xx0F
PS14	Pre-confluence reversal sensor			J3602/ J3602	J519	xx11
PS15	Post-confluence sensor			J3603/ J3602	J519	xx12
PS17	Multi tray paper sensor				J510	

Notation	Name	Connector No.				JAM
		Double feeding detection PCB (transmission)	Double feeding detection PCB (reception)	No-stacking feeder driver PCB	DC controller PCB	
PS18	Horizontal registration sensor			J3603/ J3602	J519	
PS19	Waste toner full sensor				J513	
PS20	Right deck pickup sensor				J511	xx01
PS21	Right deck lifter sensor				J511	
PS22	Deck right paper sensor				J511	
PS23	Deck right open/closed sensor				J511	
PS24	Deck right limit sensor				J511	
PS25	Left deck pickup sensor				J518	xx02
PS26	Left deck feed sensor			J3602/ J3602	J519	xx13
PS27	Right deck feed sensor				J511	xx14
PS28	Fixing transport unit release lever sensor				J509	
PS31	Left deck lifter sensor				J518	
PS32	Deck left paper sensor				J518	
PS33	Deck left open/closed sensor				J518	
PS34	Deck left limit sensor				J518	
PS35	Multifeeder pickup sensor				J510	xx19
PS37	Cassette 3 pickup sensor				J515	xx03
PS38	Cassette 3 open/closed sensor				J515	
PS39	Cassette 3 paper sensor				J515	
PS40	Cassette 3 open/closed sensor				J515	
PS41	Vertical path 3 sensor				J515	xx07
PS42	Cassette 4 pickup sensor				J517	xx04
PS43	Cassette 3 lifter sensor				J517	
PS44	Cassette 4 paper sensor				J517	
PS45	Cassette 4 open/closed sensor				J517	
PS46	Vertical path 4 sensor				J517	xx08
PS47	Vertical path 1 sensor				J502	xx05
PS48	Lower right cover open/closed sensor				J516	
PS49	Vertical path 2 sensor				J516	xx06
PS51	Right deck paper level middle sensor				J513	
PS52	Right deck paper level upper sensor				J513	
PS54	Left deck paper level middle sensor				J514	
PS55	Left deck paper level upper sensor				J514	
PS56	Manual feeder tray cover open/closed sensor				J502	

Notation	Name	Connector No.				JAM
		Double feeding detection PCB (transmission)	Double feeding detection PCB (reception)	No-stacking feeder driver PCB	DC controller PCB	
PS58	Upper right cover open/closed sensor				J502	
PS59	Bottle cover open/closed sensor				J512	
PS60	Image write start sensor				J503	xx18
PS61	Duplex outlet sensor			J3605/ J3602	J519	xx10
PS63	Fixing inlet sensor				J508	xx1A
PS64	Double feeding sensor (transmission)	J2703/J2702			J509	
PS65	Double feeding sensor (reception)		J2704/J2706		J550	xx0A
PS66	Fixing inlet HP sensor				J508	
PS67	Toner bottle sensor				J512	
PS68	Multiple curling prevention sensor				J510	xx16

15.2.4.4 Sensor 2

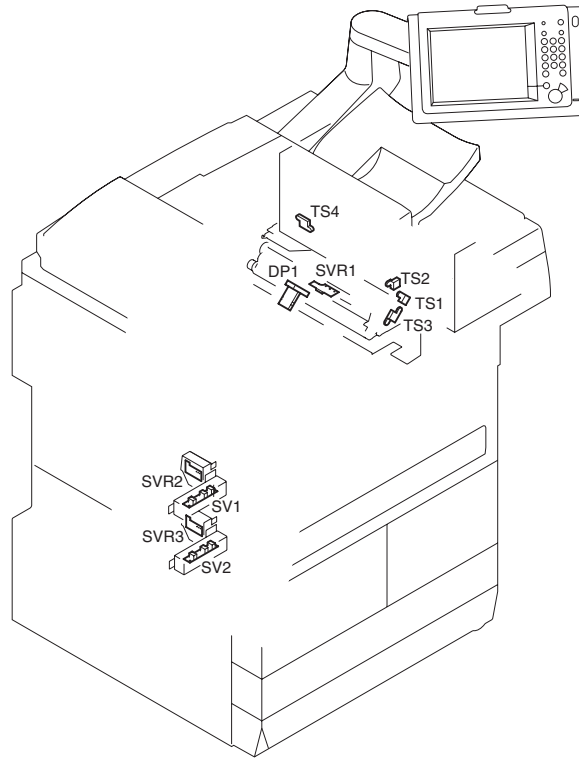
F-15-12
T-15-13

Notation	Name	Description	Parts No.	Connector No.	
				Potential measurement PCB	DC controller PCB
SV1	Cassette 3 paper length sensor	detects cassette 3 paper length	FG5-8221		J513
SV2	Cassette 4 paper length sensor	detects cassette 4 paper length	FG5-8221		J514
SVR1	Manual feed tray paper width detecting volume	detects manual feed tray paper width	FG5-1958		J510
SVR2	Cassette 3 paper width detecting volume	detects cassette 3 paper width	FG5-1957		J513
SVR3	Cassette 4 paper width detecting volume	detects cassette 4 paper width	FG5-1957		J514
TS1	hopper toner level sensor	detects the level of toner remaining inside the hopper	FK2-0158		J504
TS2	hopper toner lower limit sensor	detects the lower limit of toner remaining inside the hopper	FK2-0158		J504
TS3	developing assembly toner sensor	detects the level of toner remaining inside the developing assembly	FK2-0158		J504
TS4	sub hopper toner level sensor	detects the level of toner remaining inside the sub hopper	FK2-0158		J511
DP1	Potential sensor	measures potential voltage of Photosensitive drum	FG3-4067	J1,J2/J3	J502

15.2.5 Switch

15.2.5.1 Switches

1. Reader Unit

The reader unit does not have any switch.

2. Printer Unit

T-15-14

Notation	Parts Name	Description	Parts No.	E code
SW1	Main switch	turns on/off the main power	FK2-0140	
SW2	Front cover switch	detects the front cover	FH7-6253	
SW3	Drum heater switch	turns on/off the drum heater	WC1-5179	
MSW2	Waste toner lock detection switch	detects the state (locked/unlocked) of the waste toner screw	WC4-5029	E013-0000
MSW5	Manual feed tray cover open/closed detecting switch	detects the state (open/closed) of the manual feed tray	WC4-5153	
MSW7	Front cover open/closed detecting switch	detects the front cover	WC4-0153	
MSW8	Cartridge motor drive switch	detects drive of the cartridge motor	WC4-0241	

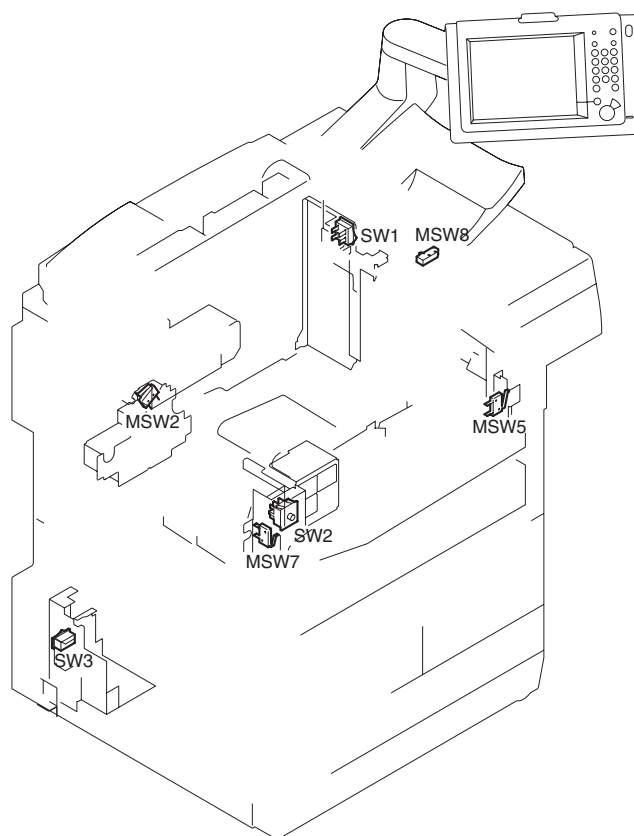

F-15-13

15.2.6 Lamps, Heaters, and Others

15.2.6.1 Heaters, Lamps, and Others

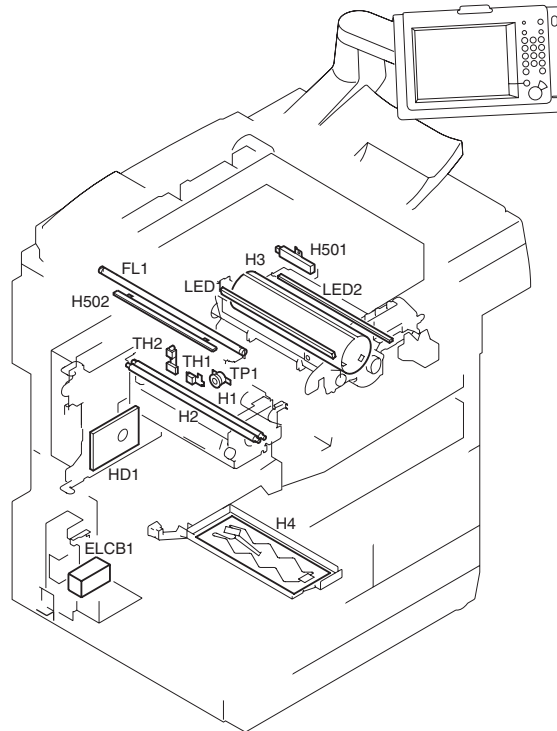

F-15-14
T-15-15

Notation	Parts Name	Description	Parts No.	PART-CHK	E code
H1	Fixing main heater	main heater (controls the fixing roller temperature)	FH7-4707(100V)*1		E000, E001, E002, E003, E004
			FH7-4719(200V)*2		
			FH7-4708(208V)*3		
			FH7-4720(230V)*4		
			FH7-4709(230V)*5		
H2	Fixing sub heater	sub heater (controls the fixing roller temperature)	FH7-4710(100V)*1		
			FH7-4723(200V)*2		
			FH7-4711(208V)*3		
			FH7-4724(230V)*4		
			F14-4712(230V)*5		
H3	Drum heater	prevents condensation on the drum	FH7-4713(100V)*1		
			FH7-4714(200/208V)		
			FH7-4715(230V)		
H4	Cassette heater	prevents absorption of moisture by paper inside the cassette	FH7-4584(100V)		
			FH7-4585(230V)		
H501	Lens heater	prevents condensation on the lens	FK2-0226(100V) FK2-0228(230V)		
H502	Mirror heater	prevents condensation on the mirror	FK2-0227(100V) FK2-0229(230V)		
TH1	fixing main thermistor	performs fixing temperature control, detects error	FH7-7553		E000, E001, E002, E003
TH2	fixing sub thermistor	performs fixing temperature control, detects error	FH7-7464		E000, E001, E002, E003

Notation	Parts Name	Description	Parts No.	PART-CHK	E code
TP1	fixing thermal switch	serves as a safety mechanism for the fixing assembly	FH7-6333		
ELCB1	Leakage breaker	Leakage breaker	FK2-0014(100V)		
			FH7-7626(200V)		
HD1	Hard disk	holds programs, images	WM2-5225		E602, E609, E610
LED1	pre-exposure lamp (LED)	removes residual charges from the surface of the photosensitive drum	FK2-1003		
LED2	Pre-transfer exposure lamp (LED)	removes residual charges from the surface of the photosensitive drum	FK2-1004		
LA1	scanning lamp	illuminates originals	FK2-1250	MISC-R>SCANLAMP	E225

T-15-16

Notation	Main controller PCB	Inverter PCB	Reader controller PCB	Relay PCB	AC driver PCB	DC controller PCB
H1					J6	J505
H2					J6	J505
H3					J5	J505
H4					J5	J505
H501				J1733	J5	
H502				J1733	J5	
TH1						J508
TH2						J508
TP1					J6	J505
ELCB1					J1	
HD1	J1003/J1004					
LED1						J504
LED2						J504
LA1		J602/601	J203			

15.2.7 PCBs

15.2.7.1 PCBs

1. Reader Unit

T-15-17

Notation	Parts Name	Parts No.	Description
[1]	Interface PCB	FM2-4820	communicates with the printer unit, ADF
[2]	Reader controller PCB	FM2-4819	controls the reader unit
[3]	CCD/AP PCB	FM2-4742 (CCD unit)	performs analog image processing
[4]	Inverter PCB	FK2-1251	drives the scanning lamp

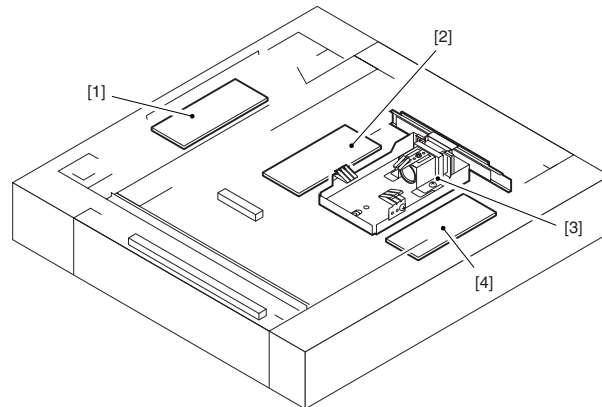

F-15-15

2. Printer Unit

T-15-18

Notation	Parts Name	Parts No.	Description
[1]	Fixing assembly inlet sensor (up/down) driver PCB	FM2-5066	Controls the fixing inlet sensor ascent/descent
[2]	ARCNET PCB	FM2-4884	Controls network communications
[3]	Video PCB	FM2-4354	Executes pixel/line conversion
[4]	Reader I/F PCB	FM2-3796	Converts communication signals
[5]	Main controller PCB	FM2-5423	Controls the system
[6]	DC controller PCB	FM2-4355	Controls the printer unit
[7]	Laser driver PCB 1	FM2-5449 (Laser scanner unit)	Drives the laser diode
[8]	Laser driver PCB 2	FM2-4394	Controls the laser intensity
[9]	DC power supply PCB	FK2-0967 (100V), FG6-8608 (200V), FG6-8600 (208V), FG6-7238 (230V)	Supplies DC power
[10]	HV-DC PCB	FM2-4351	Generates high-voltage DC components
[11]	HV-AC PCB	FG6-7249	Generates high-voltage AC components
[12]	All-day power supply PCB	FK2-0968 (100V), FM2-4366 (200V)	Supplies DC power
[13]	Relay PCB	FM2-4361	Distributes DC power supply
[14]	Double feeding detection PCB (reception)	FK2-0959 (standard if US)	Detects double-feeding of paper (receiving)
[15]	Double feeding detection PCB (transmission)	FK2-0960 (standard if US)	Detects double-feeding of paper (transmitting)

Notation	Parts Name	Parts No.	Description
[16]	Drum heater control PCB	FM2-4360 (100V), FM2-4359 (200V)	Drives the drum heater
[17]	BD PCB	FM2-5449 (Laser scanner unit)	Detects the laser beam
[18]	Potential control PCB	FG3-4067 (potential sensor unit)	Controls the drum surface potential
[19]	AC driver PCB	FM2-5063 (100V), FM2-5064 (200V)	Drive the fixing heater
[20]	Environment sensor PCB	FH7-7426	Detects the machine outside temperature/humidity
[21]	No-stacking feeding driver PCB	FG6-8585	Drives the duplex/feeder unit
[22]	Cassette 3 paper level detection PCB	FG6-1941	Detects the level of paper in the cassette 3
[23]	Cassette 4 paper level detection PCB	FG6-1941	Detects the level of paper in the cassette 4
[24]	Controls panel LED PCB	FM2-5463	Controls the LED indications
[25]	Controls panel CPU PCB	FM2-5461	Controls the control panel
[26]	Control panel key PCB	FM2-5462	Controls panel key inputs and LED indications
[27]	Control panel inverter PCB	FK2-1646	controls the back-light activation of the LCD

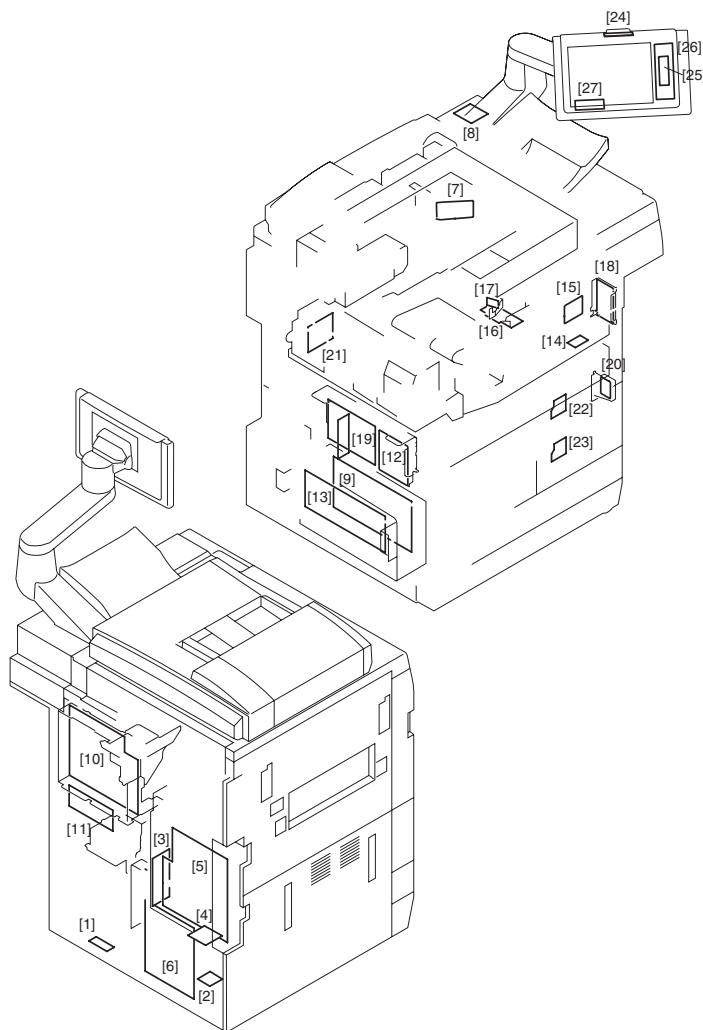

F-15-16

15.2.8 Variable Resistors (VR), Light-Emitting Diodes (LED), and Check Pins by PCB

15.2.8.1 Variable Resistors (VR), Light-Emitting Diodes (LED), and Check Pins by PCB

Of the variable VRs, LEDs, and switches used in the machine, those needed when servicing in the field are discussed.



1. Some LEDs emit dim light even when OFF because of leakage current; this is a normal condition, and must be kept in mind.
2. VRs that may be used in the field



VRs that must not be used in the field



Do not touch the VRs and check pins not discussed herein. They are exclusively for use at the factory, and require special tools and high precision.

15.2.8.2 Main controller PCB

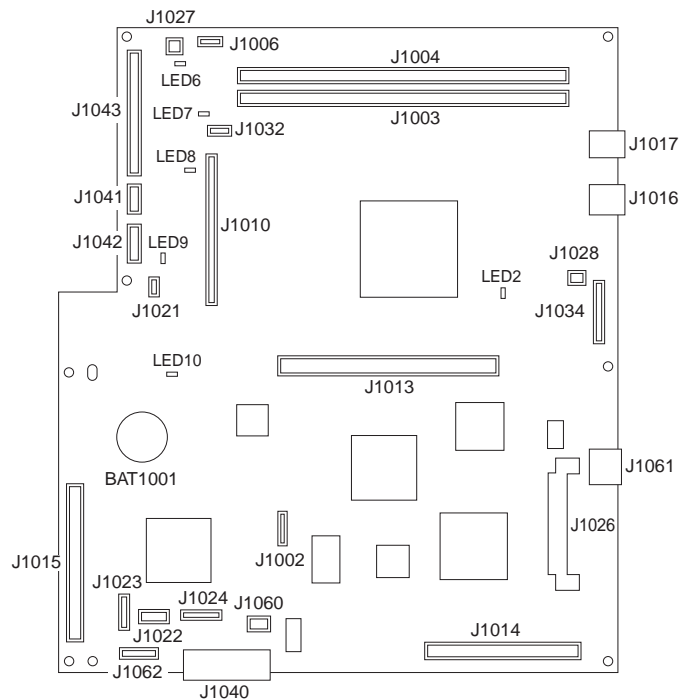

F-15-17

Notation	Condition of activation
LED2	after booting
LED6	while +3.3 V (non-all night) is being supplied
LED7	while +3.3 V (non-all night) is being supplied
LED8	while +5 V (non-all night) is being supplied
LED9	while +3.3 V (all night) is being supplied
LED10	while in sleep mode (sleep 3)

15.2.8.3 DC controller PCB

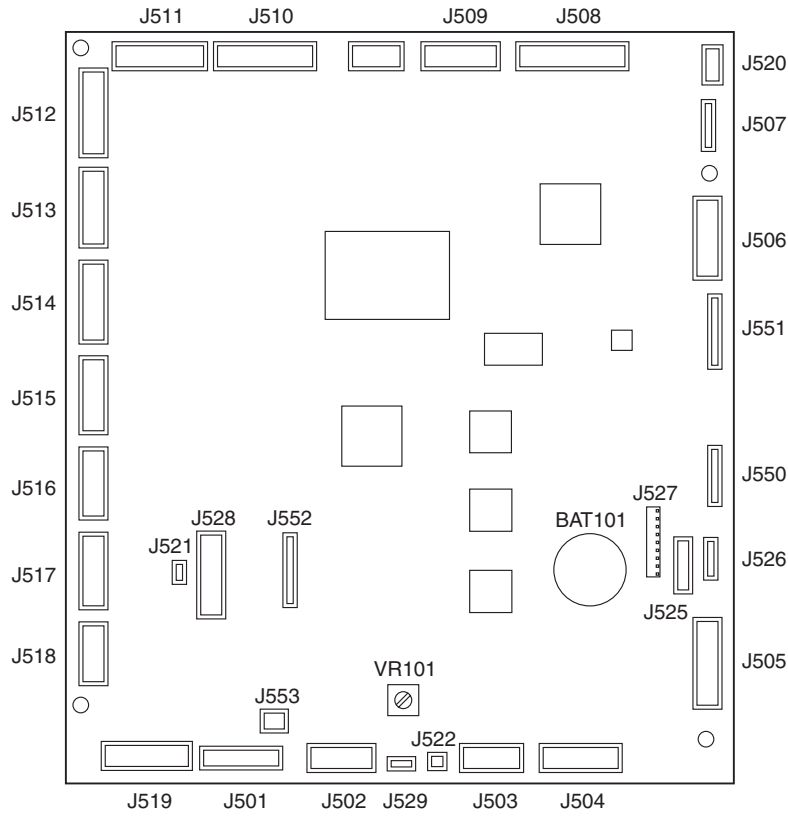

F-15-18

Self-Diagnosis

Contents

16.1 Error Code Table	16- 1
16.1.1 Error Code Table	16- 1
16.2 Error Code Details	16- 3
16.2.1 Error Code Details	16- 3
16.2.2 Detail in E602	16- 15
16.3 Jam Code.....	16- 18
16.3.1 Jam Code (printer).....	16- 18
16.3.2 Jam Code (DADF-Q1) <iR7105/7095>	16- 18
16.3.3 Jam Code (DADF-M1) <iR7086>.....	16- 22
16.4 Alarm Code.....	16- 24
16.4.1 Alarm Code.....	16- 24

16.1 Error Code Table

16.1.1 Error Code Table

T-16-1

Code	Description
*: model equipped with DADF-Q1 (outside Japan, iR7105/7095; inside Japan: iR7105/7095/7086).	
**: model equipped with DADF-M1 (outside Japan: iR7086).	
E000	The fixing unit has overheated. After correcting the fault, be sure to reset the error. (COPIER>FUNCTION>CLEAR>ERR)
E001	The fixing unit has overheated. After correcting the fault, be sure to reset the error. (COPIER>FUNCTION>CLEAR>ERR)
E002	The fixing unit has overheated. After correcting the error, be sure to reset the error. (COPIER>FUNCTION>CLEAR>ERR)
E003	The fixing unit temperature is abnormally low. After correcting the fault, be sure to reset the error. (COPIER>FUNCTION>CLEAR>ERR)
E004	The fixing unit has a fault. (protective circuit ON) After correcting the fault, be sure to reset the error. (COPIER>FUNCTION>CLEAR>ERR)
E005	The fixing web has run out. After correcting the fault, be sure to reset the error. (COPIER>FUNCTION>CLEAR>ERR)
E010	The main motor rotation is faulty.
E012	The drum motor rotation is faulty.
E013	The waste toner feedscrew is stuck. (clogged with waste toner) After correcting the fault, be sure to reset the error. (COPIER>FUNCTION>CLEAR>ERR)
E014	The fixing motor rotation is faulty.
E015	The pickup motor rotation is faulty.
E019	The waste toner case is full.
E020	The developing assembly is out of toner. The buffer motor rotation is faulty. The toner feed motor (sub hopper) rotation is faulty. After correcting the fault, be sure to reset the error. (COPIER>FUNCTION>CLEAR>ERR)
E025	The toner bottle motor rotation is faulty.
E032	The copy data controller/NE controller counter fails to operate.
E043	The rotation of the pickup motor of the side paper deck is faulty.
E051	The horizontal registration HP detection has an error.
E065	The high-voltage output has a fault. (primary charging assembly)
0000	A fault (leak) is detected when high voltage is supplied to the primary charging assembly.
E067	The high-voltage output has a fault.
0000	A fault is detected at the same time in 2 of the following: primary high voltage, pre-transfer high voltage, transfer high voltage, separation high voltage.
E068	The high-voltage output has a fault. (separation charging assembly)
0000	A fault (leak) has been detected while the separation charging assembly is being supplied with high voltage.
E069	The transfer high voltage has an error.
0000	A fault (leak) has been detected while the transfer charging assembly is being supplied with high voltage.
E102	A read error has occurred in relation to the laser scanner unit EEPROM data.
0001	The correction data cannot be read from the EEPROM of the laser scanner unit.
E110	The laser scanner motor rotation has a fault.
E111	The laser scanner motor cooling fan rotation has a fault.
E121	A fault exists in the rotation of the following: laser scanner unit cooling fan, reader heat discharge fan 1, reader heat discharge fan 2.
E197	The laser scanner motor communication has a fault.
E202	The scanner HP detection mechanism has a fault.
E225	The intensity of the scanning lamp is inadequate. (The lamp is exhausted.)
E227	The reader unit power supply (24 V) has a fault.

Code	Description
*: model equipped with DADF-Q1 (outside Japan, iR7105/7095; inside Japan: iR7105/7095/7086).	
** : model equipped with DADF-M1 (outside Japan: iR7086).	
E240 **	A fault exists in the communication between the main controller and the DC controller.
E248	A fault exists in the following: main controller SRAM, reader controller EEPROM.
E251	The inverter cooling fan rotation is faulty.
E302	Shading operation is faulty.
E315	The image data codec has a fault.
E351	An error has occurred in the main controller communication.
E400 **	An ADF communication error has occurred.
E402 *	The ADF belt motor rotation is faulty.
E404 *	The ADF delivery motor rotation is faulty.
E405 *	The ADF separation motor rotation is faulty.
E410 *	The ADF pickup motor rotation is faulty.
E413 **	The ADF shift motor rotation is faulty.
E420 *	An ADF EEPROM read error has occurred.
E490	The ADF is of the wrong type.
E602	The HDD has an error.
E604	The time memory (DDR-SDRAM) is faulty or inadequate.
E609	The HDD temperature is abnormally low.
E610	The HDD encryption key is faulty.
E711	An error has occurred in the communication between the pickup/delivery accessory and the printer unit.
E712	An error exists in the communication between the ADF and the reader unit.
E717	An error exists in the communication with the NE controller. After correcting the fault, be sure to reset the error. (COPIER>FUNCTION>CLEAR>ERR)
E719	An error has occurred in the communication with the coin vendor/card reader. After correcting the fault, be sure to reset the error. (COPIER>FUNCTION>CLEAR>ERR)
E730	A PDL-related error has occurred.
E732	An error has occurred in the communication between the reader unit and the main controller.
E733	An error has occurred in the communication between the reader unit and the main controller.
E740	An error exists in the LAN controller.
E743	A fault exists in the communication between the main controller and the reader controller.
E744	An error exists in the language file/boot ROM.
E746	An unsupported optional board has been detected.
E749	Restart in accordance with a change of the product configuration
E800	The auto power-off circuit has an error.
E804	The rotation of the following is faulty: power supply cooling fan 1, power supply cooling fan 2, controller cooling fan.
E805	The fixing heat discharge fan rotation is faulty.
E820	The drum fan rotation is faulty.
E823	The pre-transfer charging assembly fan rotation is faulty.
E840	An HP detection error has occurred in relation to the fixing inlet sensor (fixing wrap jam detection).
E850	There is a fault in the double-feeding detection unit.

16.2 Error Code Details

16.2.1 Error Code Details

T-16-2

Code	Description	Remedial action
*: model equipped with DADF-Q1 (outside Japan, iR7105/7095; inside Japan: iR7105/7095/7086). **: model equipped with DADF-M1 (outside Japan: iR7086).		
E000	The fixing unit has overheated. After correcting the fault, be sure to reset the error. (COPIER>FUNCTION>CLEAR>ERR)	
0000	The reading of the main thermistor is less than 70 deg C 3.5 min after power-on.	Check the mounting/soiling of the main thermistor. Replace the fixing heater. Replace the main thermistor. Replace the AC driver PCB. Replace the DC controller PCB.
0010	The power has been turned off and then on without resetting the error.	Reset the error. (COPIER>FUNCTION>CLEAR>ERR)
E001	The fixing unit has overheated. After correcting the fault, be sure to reset the error. (COPIER>FUNCTION>CLEAR>ERR)	
0001	The reading of the main thermistor or the sub thermistor is 230 deg C or more for 2 sec. (hardware detection)	Replace the AC driver PCB. Replace the DC controller PCB.
0002	The reading of the main thermistor or the sub thermistor is 230 deg C or more for 2 sec or more. (software detection)	Check the mounting/soiling of the main thermistor. Replace the main thermistor. Replace the sub thermistor. Replace the AC driver PCB. Replace the DC controller PCB.
0003	The difference in the readings of the main thermistor and the sub thermistor is 50 deg C for 1 sec. (main thermistor reading>sub thermistor reading)	Check the mounting/soiling of the main thermistor. Replace the main thermistor. Replace the AC driver PCB. Replace the DC controller PCB.
0004	The difference in the readings of the main thermistor and the sub thermistor is 50 deg C for 1 sec or more. (main thermistor reading>/=sub thermistor reading)	
0010	The power has been turned off and then on without resetting the error.	Reset the error. (COPIER>FUNCTION>CLEAR>ERR)
E002	The fixing unit has overheated. After correcting the error, be sure to reset the error. (COPIER>FUNCTION>CLEAR>ERR)	
0000	The reading of the main thermistor has exceeded 70 deg C, but does not reach 100 deg C within 2.5 sec thereafter.	Disconnect and then connect J508 of the DC controller PCB. Disconnect and then connect
0001	The reading of the main thermistor has exceeded 100 deg C, but does not reach 150 deg C within 2.5 min thereafter.	the connectors of the fixing unit. Check the wiring between the main/sub thermistor and the DC controller. Check the mounting/soiling of the main thermistor. Replace the fixing heater. Replace the AC driver PCB. Replace the DC controller PCB.
0010	The power has been turned on without resetting the error.	Reset the error. (COPIER>FUNCTION>CLEAR>ERR)
E003	The fixing unit temperature is abnormally low. After correcting the fault, be sure to reset the error. (COPIER>FUNCTION>CLEAR>ERR)	

Code	Description	Remedial action
*: model equipped with DADF-Q1 (outside Japan, iR7105/7095; inside Japan: iR7105/7095/7086). **: model equipped with DADF-M1 (outside Japan: iR7086).		
0000	The reading of the main thermistor has exceeded 100 deg C, but is 70 deg C or less for 2 sec thereafter.	Disconnect and then connect J508 of the DC controller PCB. Disconnect and then connect the connectors of the fixing unit. Check the wiring between the main/sub thermistor and the DC controller PCB. Check the mounting/soiling of the main thermistor. Replace the fixing heater. Replace the AC driver PCB. Replace the DC controller PCB.
E004	The fixing unit has a fault. (protective circuit ON) After correcting the fault, be sure to reset the error. (COPIER>FUNCTION>CLEAR>ERR)	
0000	While the sub heater is on, the SSR for the heater drive has a short-circuit for 5 sec or more.	Replace the AC driver PCB. Replace the DC controller PCB.
0001	While the main heater is on, the SSR for the heater drive has a short-circuit for 5 sec or more.	
E005	The fixing web has run out. After correcting the fault, be sure to reset the error. (COPIER>FUNCTION>CLEAR>ERR)	
0000	The absence of the fixing web has been detected for 5 sec or more.	Check the position of the fixing web detecting lever. Replace the fixing web. Replace the fixing web length sensor. Replace the DC controller PCB. If you have replaced the fixing web, be sure to reset the counter: - COPIER>COUNTER>MISC>FIX-WEB - COPIER>COUNTER>DRBL-1>FX-WEB
0010	The power has been turned off and then on without resetting the error.	Reset the error. (COPIER>FUNCTION>CLEAR>ERR)
E010	The main motor rotation is faulty.	
0000	After the main motor has gone on, the FG signal of the motor is not detected for 2 sec or more.	Disconnect and then connect J611 and J612 of the main motor. Disconnect and then connect J514 of the DC controller PCB. Disconnect and then connect J1720 of the relay PCB. Replace the main motor. Replace the relay PCB. Replace the DC controller PCB.
E012	The drum motor rotation is faulty.	
0000	After the drum motor has gone on, the PLL lock signal of the motor is not detected for 2 sec or more.	Disconnect and then connect J1721 of the relay PCB. Disconnect and then connect J512 of the DC controller PCB. Disconnect and then connect J601 and J602 of the drum motor. Replace the drum motor. Replace the DC controller PCB.
E013	The waste toner feedscrew is stuck. (clogged with waste toner) After correcting the fault, be sure to reset the error. (COPIER>FUNCTION>CLEAR>ERR)	

Code	Description	Remedial action
*: model equipped with DADF-Q1 (outside Japan, iR7105/7095; inside Japan: iR7105/7095/7086). **: model equipped with DADF-M1 (outside Japan: iR7086).		
0000	The waste toner feedscrew is stuck for 4 sec or more.	Detach and then attach the waste toner pipe. Replace the waste toner pipe. Replace the waste toner feedscrew detecting switch. Replace the DC controller PCB.
0010	The power has been turned off and then on without resetting the error.	Reset the error. (COPIER>FUNCTION>CLEAR>ERR)
E014	The fixing motor rotation is faulty.	
0000	After the fixing motor has gone on, the PLL signal of the motor is not detected for 2 sec or more.	Disconnect and then connect J651 and J652 of the fixing motor. Replace the fixing motor. Replace the relay PCB. Replace the DC controller PCB.
E015	The pickup motor rotation is faulty.	
0000	The pickup motor has gone on, but the FG signal of the motor is not detected for 2 sec or more.	Disconnect and then connect J621 and J622 of the pickup motor. Replace the pickup motor. Replace the relay PCB. Replace the DC controller PCB.
E019	The waste toner case is full.	
0000	After the waste toner case has become full, 50,000 prints (A4) or more have been made without disposing of the waste toner.	Dispose of the waste toner. Check the operation of the waste toner bottle base. Disconnect and then connect J514 of the DC controller PCB. Replace the waste toner case full sensor. Replace the DC controller PCB.
E020	The developing assembly is out of toner. The buffer motor rotation is faulty. The toner feed motor (sub hopper) rotation is faulty. After correcting the fault, be sure to reset the error. (COPIER>FUNCTION>CLEAR>ERR)	
0001	The absence of toner inside the developing assembly is detected of 120 sec or more even when toner supply operation has been executed for the assembly.	Disconnect and then connect the connector (J504, J512) of the DC controller PCB. Replace the developing cylinder clutch (CL4). Replace the buffer motor (M18). Replace the magnet roller drive clutch (CL1).
0002	The absence of toner in the buffer is detected for 60 sec even after toner supply operation for the buffer has been executed and when there is toner inside the hopper.	Disconnect and connect the connector (J504, J511) of the DC controller PCB. Replace the buffer motor (M18). Replace the following: magenta roller drive clutch (CL1), toner
0003	The absence of toner inside the buffer is detected for 210 sec or more even when there is toner inside the sub hopper and after toner supply operation of that buffer following the replacement of the toner bottle.	transport motor (sub hopper; M22), toner transport clutch (sub hopper; CL23), buffer inside toner sensor (TS1), buffer inside toner lower limit sensor (TS2).
0004	The absence of toner inside the buffer is detected for 150 sec or more even when there is toner inside the buffer and after toner supply operation has been executed for the buffer following the replacement of the toner bottle.	

Code	Description	Remedial action
*: model equipped with DADF-Q1 (outside Japan, iR7105/7095; inside Japan: iR7105/7095/7086). **: model equipped with DADF-M1 (outside Japan: iR7086).		
0005	When installation mode (COPIER>FUNCTION>INSTALL>TONER-S) is executed, the developing assembly inside toner sensor does not detect the presence of toner.	Disconnect and then connect the connector (J504) of the DC controller PCB. Replace the developing assembly inside toner sensor (TS3).
0006	When installation mode (COPIER>FUNCTION>INSTALL>TONER-S) is executed, the developing assembly inside toner sensor detects the presence of toner, but it does not detect the presence for 600 sec or more thereafter.	
0007	When installing mode (COVER>FUNCTION>INSTALL>TONER-S) is executed, the buffer inside toner sensor does not detect the presence of toner for 60 sec or more.	Disconnect and connect the connector (J504, J511) of the DC controller PCB. Replace the toner transport motor (sub hopper; M22), toner transport clutch (sub hopper; CL23), buffer inside toner sensor (TS1).
0008	When the toner feed motor (sub hopper) is driven, a fault is detected for 3 sec or more for the motor.	Disconnect and connect the connector (J511) of the DC controller PCB. Replace the toner feed motor (sub hopper; M22).
0009	There is a fault in the rotation of the buffer motor.	Disconnect and then connect the connector (J504) of the DC controller PCB. Replace the buffer motor (M18).
0010	The power has been turned off and then on without resetting the error.	Reset the error. (COPIER>FUNCTION>CLEAR>ERR)
E025	The toner bottle motor rotation is faulty.	
0000	A toner bottle motor error (over-current) is detected for 10 sec for a second time. MEMO: The 1st detection of the error will cause the machine to indicate the message "Shake and Replace the Toner Container."	Disconnect and then connect J512 of the DC controller PCB.
0001	The toner bottle motor is not connected.	
E032	The copy data controller/NE controller counter fails to operate.	
0001	An open circuit of the counter signal has been detected.	Disconnect and then connect J1022 of the main controller PCB. Replace the copy data controller/NE controller. Replace the main controller PCB.
E043	The rotation of the pickup motor of the side paper deck is faulty.	
0000	The side paper deck pickup motor has gone on, but the PLL lock signal is not detected for 2 sec or more (1st detection). MEMO: For the 2nd and subsequent detection, the machine will indicate "E043" on the screen offering a choice of sources of paper.	Disconnect and then connect J101 and J106 of the side paper deck driver PCB. Replace the pickup motor. Replace the side paper deck driver PCB. Replace the DC controller PCB.
E051	The horizontal registration HP detection has an error.	

Code	Description	Remedial action
*: model equipped with DADF-Q1 (outside Japan, iR7105/7095; inside Japan: iR7105/7095/7086). **: model equipped with DADF-M1 (outside Japan: iR7086).		
0001	After the start of horizontal registration HP detection, the HP sensor is not off within 5 sec (i.e., not leaving home position). MEMO: If an error is detected in the course of horizontal registration HP detection at power-on, the machine will indicate the presence of a jam.	At the start of horizontal registration detection in the course of printing, the horizontal registration detection operation for downstream paper does not end within 5 sec.
0002	After the start of horizontal registration HP detection, the home position is not detected within 5 sec. MEMO: If an error is detected in the course of horizontal registration HP detection at power-on, the machine will indicate the presence of a jam.	
0003	Replace the horizontal registration HP sensor. Replace the horizontal registration motor. Replace the stackless transport driver PCB. Replace the DC controller PCB.	
E065	The high-voltage output has a fault. (primary charging assembly)	
0000	A fault (leak) is detected when high voltage is supplied to the primary charging assembly.	Remove and then mount the primary charging assembly. Check for soiling. Disconnect and then connect T601, J723, and J731 of the HV-DC PCB. Replace the HV-DC PCB.
E067	The high-voltage output has a fault.	
0000	A fault is detected at the same time in 2 of the following: primary high voltage, pre-transfer high voltage, transfer high voltage, separation high voltage.	Remove and mount the primary charging assembly. Remove and mount the pre-transfer charging assembly. Remove and mount the transfer/separation charging assembly. Disconnect and then connect J721, J723, J731, and J734 of the HV-DC PCB. Replace the HV-DC PCB. Replace the HV-AC PCB.
E068	The high-voltage output has a fault. (separation charging assembly)	
0000	A fault (leak) has been detected while the separation charging assembly is being supplied with high voltage.	Remove and mount the transfer/separation charging assembly. Disconnect and then connect J7233 and J734 of the HV-DC PCB. Disconnect and then connect J741 and J742 of the HV-AC PCB. Replace the HV-AC PCB. Replace the transfer/separation charging assembly. Replace the pre-transfer charging assembly.
E069	The transfer high voltage has an error.	
0000	A fault (leak) has been detected while the transfer charging assembly is being supplied with high voltage.	Remove and mount the transfer/separation charging assembly. Check for soiling. Disconnect and then connect T701 and J723 of the HV-DC PCB. Replace the HV-DC PCB. Replace the pre-transfer charging assembly.
E102	A read error has occurred in relation to the laser scanner unit EEPROM data.	

Code	Description	Remedial action
*: model equipped with DADF-Q1 (outside Japan, iR7105/7095; inside Japan: iR7105/7095/7086). **: model equipped with DADF-M1 (outside Japan: iR7086).		
0001	The correction data cannot be read from the EEPROM of the laser scanner unit.	Disconnect and then connect the connector of the video PCB. Disconnect and then connect the DC controller PCB. Replace the laser scanner unit.
E110	The laser scanner motor rotation has a fault.	
0000	After the laser scanner motor has gone on, the PLL lock signal of the motor is not detected for 15 sec or more.	Check to see if all covers have been attached to the primary charging assembly. Disconnect and then connect J764 of the laser scanner motor drive PCB (in the laser scanner unit). Disconnect and then connect J1401 of the video PCB. Disconnect and then connect J506 of the DC controller PCB. Replace the laser scanner unit. Replace the video PCB. Replace the DC controller PCB.
E111	The laser scanner motor cooling fan rotation has a fault.	
0000	After the laser scanner motor cooling fan has gone on, the fan stop signal is detected for 5 sec or more.	Disconnect and then connect J503 of the DC controller PCB. Replace the laser scanner motor cooling fan. Replace the DC controller PCB.
E121	A fault exists in the rotation of the following: laser scanner unit cooling fan, reader heat discharge fan 1, reader heat discharge fan 2.	
0001	The laser scanner unit cooling fan has a fault. After the laser scanner unit cooling fan has gone on, the fan stop signal is detected for 5 sec or more.	Disconnect and then connect J503 of the DC controller PCB. Replace the laser scanner unit cooling fan. Replace the DC controller PCB.
0002	The reader heat discharge fan 1 has a fault. After the reader heat discharge fan 1 has gone on, the fan stop signal is detected for 5 sec or more.	Connect and then disconnect J512 of the DC controller PCB. Replace the reader heat discharge fan 1. Replace the DC controller PCB.
0003	The reader heat discharge fan 2 has a fault. After the reader heat discharge fan 2 has gone on, the fan stop signal is detected for 5 sec or more.	Disconnect and then connect J521 of the DC controller PCB. Replace the reader heat discharge fan 2. Replace the DC controller PCB.
E197	The laser scanner motor communication has a fault.	
0000	The communication with the laser control IC is not normal.	Replace the laser scanner unit. Replace the video PCB.
E202	The scanner HP detection mechanism has a fault.	
0001	While HP positioning is under way, the forward trip fails.	Disconnect and then connect the connector of the scanner HP sensor. Replace the scanner HP sensor. Replace the scanner motor. Replace the reader controller PCB.
0002	While HP positioning is under way, the reverse trip fails.	
E225	The intensity of the scanning lamp is inadequate. (The lamp is exhausted.)	
0001	At time of shading, the intensity of light is below the standard level.	Disconnect and then connect the connector of the scanning lamp. Replace the scanning lamp. Replace the inverter PCB. Replace the reader controller PCB.
** 0002	In ADF mode, the intensity of light is below the standard level between sheets.	

Code	Description	Remedial action
*: model equipped with DADF-Q1 (outside Japan, iR7105/7095; inside Japan: iR7105/7095/7086).		
**: model equipped with DADF-M1 (outside Japan: iR7086).		
E227	The reader unit power supply (24 V) has a fault.	
0001	At power-on, the 24V port is off.	Disconnect and then connect the reader power supply connector. Replace the power supply.
0002	At the start of a job, the 24V port is off.	
0003	At the end of a job, the 24V port is off.	
0004	While a load is driven, the 24V port is off.	
E240 **	A fault exists in the communication between the main controller and the DC controller.	
0000	A fault has occurred in the communication between the CPUs of the main controller and the DC controller.	Disconnect and then connect the connector. Replace the DC controller PCB. Replace the main controller PCB.
E248	A fault exists in the following: main controller SRAM, reader controller EEPROM.	
0000	At start-up, an SRAM check error has occurred.	Replace the main controller PCB.
0001	An error has occurred at time of power-on (EEPROM).	Replace the reader controller PCB.
0002	An error has occurred during write operation (EEPROM).	
0003	A read error has occurred after write operation (EEPROM).	
E251	The inverter cooling fan rotation is faulty.	
0000	After the inverter cooling fan has gone on, the fan stop signal is detected for 5 sec or more.	Disconnect and then connect J1110 of the reader controller PCB. Replace the inverter cooling fan. Replace the reader controller PCB.
E302	Shading operation is faulty.	
0000	In the course of shading operation, the processing does not end within the reader controller.	Disconnect and then connect J1107 and J1108 of the reader controller PCB. Replace the reader controller PCB.
E315	The image data codec has a fault.	
0007	A JBIG encoder error has occurred.	Replace the main controller PCB.
000d	A JBIG decoding error has occurred.	Replace the DDR-SDRAM. Replace the HDD. Replace the main controller PCB.
000e	An error has occurred in the course of software decoding.	
0100	An overrun error has occurred.	Replace the main controller PCB.
0200	the open I/F relay PCB has detected an error (no recovery after a retry).	Replace the open I/F relay PCB (relay PCB between the main controller and PS controller).
0300	Cubic time-out	Turn off and then back on he power.
0400	Shift Device A time-out	Replace the main controller PCB.
0401	Shift Device B time-out	
E351	An error has occurred in the main controller communication.	
0000	At start-up, a main controller communication error has occurred.	Replace the main controller PCB.
E400 **	An ADF communication error has occurred.	
0001	A check sum error has occurred.	Disconnect and then connect the connector. Replace the reader controller PCB. Replace the ADF controller PCB.
0002	A reception status error has occurred.	
0003	A reception interrupt error has occurred.	
E402 *	The ADF belt motor rotation is faulty.	

Code	Description	Remedial action
*: model equipped with DADF-Q1 (outside Japan, iR7105/7095; inside Japan: iR7105/7095/7086). **: model equipped with DADF-M1 (outside Japan: iR7086).		
0000	While the belt motor drive signal is on, no lock signal occurs for 100 msec.	Disconnect and then connect the cable between the belt motor driver PCB and the ADF controller PCB. Replace the belt motor clock sensor. Replace the belt motor clock sensor. Replace the belt motor. Replace the belt motor driver PCB. Replace the ADF controller PCB.
E404 *	The ADF delivery motor rotation is faulty.	
0000	When the delivery motor drive signal is on, no clock signal occurs for 200 msec.	Replace the delivery motor. Replace the delivery motor clock sensor. Replace the ADF controller PCB.
E405 *	The ADF separation motor rotation is faulty.	
0000	When the separation motor drive signal is on, no clock signal occurs for 200 msec.	Replace the separation motor. Replace the separation motor clock sensor. Replace the ADF controller PCB.
E410 *	The ADF pickup motor rotation is faulty.	
0000	No signal occurs from the following sensors within 2 sec after the pickup motor is driven: - pickup roller height sensor 1 (PI8), pickup roller height sensor 2 (PI9) - pickup roller HP sensor (PI7)	Replace the pickup motor. Replace the pickup roller height sensor (PI8). Replace the pickup roller height sensor 2 (PI9). Replace the pickup roller HP sensor (PI7). Replace the ADF controller PCB.
E413 **	The ADF shift motor rotation is faulty.	
0001	The shift motor HP sensor is open.	Disconnect and then connect the connector. Replace the shift motor HP sensor. Replace the shift motor.
0002	Shift motor HP sensor is closed.	
E420 *	An ADF EEPROM read error has occurred.	
0000	At power-on, an attempt to read the EEPROM backup data fails. Or, data that has been read has a fault.	Replace the ADF controller PCB.
E490	The ADF is of the wrong type.	
0001	The ADF is of the wrong type.	Replace the ADF.
E602	The HDD has an error.	
E604	The time memory (DDR-SDRAM) is faulty or inadequate.	
0000	A DDR-SDRAM (1 GB) of adequate capacity is not detected.	Replace the DDR-SDRAM.
E609	The HDD temperature is abnormally low.	
0008	At start-up, the HDD does not reach a specific temperature within a specific time.	Replace the HDD.
0009	When returning from sleep mode, the HDD does not reach a specific temperature within a specific time.	
E610	The HDD encryption key is faulty.	
0001	The memory is missing.	Install the security board.
0002	The memory is inadequate.	Replace the DDR-SDRAM with one for the model in question (1 GB).
0101	An attempt to initialize the key storage area of the memory has failed.	Turn off and then on the power. Replace the main controller PCB.

Code	Description	Remedial action
*: model equipped with DADF-Q1 (outside Japan, iR7105/7095; inside Japan: iR7105/7095/7086). **: model equipped with DADF-M1 (outside Japan: iR7086).		
0102	An error has occurred while the encryption processing area is being initialized.	Turn off and then on the power. Replace the security board.
0201	An error has occurred in the encryption processing area.	
0202	An error has occurred in the encryption processing area.	
0301	An attempt to create an encryption key has failed.	
0302	A fault exists in the encryption key.	Turn off and then on the power. Replace the main controller PCB.
0303	A fault exists in the encryption key.	
0401	An error has been detected during coding.	Turn off and then on the power. Replace the security board.
0402	A fault has been detected in decoding.	
0501	An error exists in the file management information in the image storage area.	
E711	An error has occurred in the communication between the pickup/delivery accessory and the printer unit.	
0001	The communication controller has detected a fault.	Turn off and then back on the power. (Turn off the machine and its delivery accessories; then, turn back on all accessories and then the machine.) Connect the communication cables and terminals between the machine and the delivery accessories once again. Replace the accessories controller PCB. Replace the transceiver PCB.
E712	An error exists in the communication between the ADF and the reader unit.	
0001	As much as 5 sec or more has passed without recovery after communication stopped between the reader controller and the ADF controller.	Disconnect and then connect the connectors between the reader unit and the ADF. Replace the reader controller PCB. Replace the ADF controller PCB.
E717	An error exists in the communication with the NE controller. After correcting the fault, be sure to reset the error. (COPIER>FUNCTION>CLEAR>ERR)	
0001	The NE controller that has been connected before power-off is not recognized at power-on.	Disconnect and then connect the main controller PCB. Install the NE controller. Replace the NE controller.
0002	An error that cannot be reset (e.g., cable break) has been detected in the communication.	
E719	An error has occurred in the communication with the coin vendor/card reader. After correcting the fault, be sure to reset the error. (COPIER>FUNCTION>CLEAR>ERR)	
0001	The coin vendor that was connected before power-off is not recognized at power-on.	Disconnect and then connect the connector of the main controller PCB. Install the coin vendor. Replace the coin vendor.
0002	In the communication with the coin vendor, an error that cannot be reset has occurred (e.g., cable break).	
0003	In the communication with the coin vendor, a communication error has occurred during acquisition of unit price information.	
0011	The card reader that was connected before power-off is not recognized at power-on.	Disconnect and then connect the connector of the main controller PCB. Install the card reader. Replace the card reader.
0012	In the communication with the card reader, an error that cannot be reset has occurred (e.g., cable break).	
E730	A PDL-related error has occurred.	

Code	Description	Remedial action
*: model equipped with DADF-Q1 (outside Japan, iR7105/7095; inside Japan: iR7105/7095/7086). **: model equipped with DADF-M1 (outside Japan: iR7086).		
1001	An initialization error has occurred at the start of a job.	Reset the PDL mechanism. Turn off and then on the power.
100A	An error has occurred in the communication with an external controller.	
9004	A fault has been detected in the cable connection with an external controller.	Turn off and then on the power. Replace the external controller relay PCB. Replace the external controller.
9005	A fault has been detected in the cable connection with an external controller.	
A006	The PDL mechanism does not respond.	Reset the PDL mechanism. Turn off and then on the power. Reinstall the system software. Replace the main controller.
A007	At start-up, the version of the machine control software and that of the PDL control software do not match.	Reset the PDL mechanism. Turn off and then on the power. Execute full formatting of the HDD, and reinstall the system software.
B013	The font data is corrupted at start-up.	Turn off and then on the power. Reinstall the system software. Execute full formatting of the HDD, and reinstall the system software.
E732	An error has occurred in the communication between the reader unit and the main controller.	
0001	An error has occurred in the communication between the reader unit and the main controller.	Disconnect and connect the connectors of the read communication cable. Check the power supply of the reader unit (to see if initialization occurs at power-on). Replace the reader controller PCB. Reap the reader I/F PCB. Replace the main controller PCB.
0010	A fault has been detected in the reader sync signal detection mechanism.	
E733	An error has occurred in the communication between the reader unit and the main controller.	
0000	An error has occurred in the communication between the reader unit and the main controller.	Disconnect and then connect the connector. Check the power supply of the DC controller (to see if initialization occurs at time of start-up). Replace the DC controller PCB. Replace the main controller PCB.
0001	An attempt to communicate with the DC controller fails.	
0010	A fault has occurred in the printer engine sync signal detection mechanism.	
E740	An error exists in the LAN controller.	
0002	An illegal MAC address has been detected at start-up.	Replace the main controller PCB.
E743	A fault exists in the communication between the main controller and the reader controller.	
0000	The reader controller has detected an error in the communication between the main controller and the reader controller.	Disconnect and then connect the connectors of the reader communications cable. Replace the reader controller PCB. Replace the main controller PCB.
E744	An error exists in the language file/boot ROM.	

Code	Description	Remedial action
*: model equipped with DADF-Q1 (outside Japan, iR7105/7095; inside Japan: iR7105/7095/7086). **: model equipped with DADF-M1 (outside Japan: iR7086).		
0001	The version of the language file on the HDD and that of bootable do not match.	Update the version of the language file (Language), or install the appropriate file.
0002	The language file on the HDD is too large.	
0003	There is no language to which a switchover is made as described in the Config file on the HDD.	
0004	An attempt to switch over to the language described in the Config file on the HDD fails.	
1000	The connected boot ROM is not one designed for the model in question.	Replace the boot ROM.
2000	An illegal engine ID has been detected.	Reinstall the system software.
E746	An unsupported optional board has been detected.	
0003	The option board that has been detected is one designed for a different model.	Replace it with one for the model in question.
E749	Restart in accordance with a change of the product configuration	
0001	A boot ROM designed for a different model has been fitted in place (as when installing an PDL option).	There is no need for remedial action. Nevertheless, the fact will remain as part of the error history.
E800	The auto power-off circuit has an error.	
	An open circuit has been detected for 3 sec or more in the auto power-off circuit.	Turn off and then on the power. Disconnect and then connect J505 of the DC controller PCB. Disconnect and then connect J1719 of the relay PCB. Replace the relay PCB. Replace the DC controller PCB.
E804	The rotation of the following is faulty: power supply cooling fan 1, power supply cooling fan 2, controller cooling fan.	
0001	The fan stop signal has been detected for 5 sec or more after the power supply cooling fan 1 has gone on.	Disconnect and then connect J505 of the DC controller PCB. Replace the power supply cooling fan 1. Replace the DC controller PCB.
0002	The fan stop signal has been detected for 5 sec or more after the power supply cooling fan 2 has gone on.	Disconnect and then connect J505 of the DC controller PCB. Replace the power supply cooling fan 2. Replace the DC controller PCB.
0004	The fan stop signal of the controller cooling fan has been detected continuously for 16 sec.	Disconnect and then connect J1028 of the main controller PCB. Replace the controller cooling fan. Replace the main controller PCB.
E805	The fixing heat discharge fan rotation is faulty.	
0002	The fan stop signal has been detected for 5 sec or more after the fixing heat discharge fan has gone on.	Disconnect and then connect J503 of the DC controller PCB. Replace the fixing heat discharge fan. Replace the DC controller PCB.
E820	The drum fan rotation is faulty.	
0000	The fan stop signal has been detected for 5 sec or more after the drum fan has gone on.	Disconnect and then connect J512 of the DC controller PCB. Replace the drum fan. Replace the DC controller PCB.
E823	The pre-transfer charging assembly fan rotation is faulty.	

Code	Description	Remedial action
*: model equipped with DADF-Q1 (outside Japan, iR7105/7095; inside Japan: iR7105/7095/7086). **: model equipped with DADF-M1 (outside Japan: iR7086).		
0000	The fan stop signal has been detected for 5 sec or more after the pre-transfer charging assembly fan has gone on.	Disconnect and then connect J504 of the DC controller PCB. Replace the pre-transfer charging assembly fan. Replace the DC controller PCB.
E840	An HP detection error has occurred in relation to the fixing inlet sensor (fixing wrap jam detection).	
0000	The home position is not detected when the sensor is moved up/down (i.e., the sensor has not gone on).	Disconnect and then connect J508, J552, and J553 of the DC controller PCB.
0001	The home position is not detected when the sensor is moved up/down (i.e., the sensor has not gone off).	Disconnect and then connect J4001 and J4002 of the fixing inlet sensor ascent/descent motor driver PCB; as necessary, replace the fixing inlet sensor ascent/descent motor. Replace the fixing inlet sensor ascent/descent motor driver PCB.
E850	There is a fault in the double-feeding detection unit.	
0000	The double-feeding sensor (reception) fails to attain an ultrasonic signal of a specific level.	Remove paper lint from the surface of the double-feeding sensor (reception). Remount the double-feeding sensor (transmission, reception). Disconnect and then connect J509 and J550 of the DC controller PCB. Replace the double-feeding sensor (transmission, reception). Replace the double-feeding sensor PCB (transmission, reception).

16.2.2 Detail in E602

<E602-XXYY>

XX= "00"

T-16-3

XX	YY	Description	Action to take
	01	The HDD cannot be recognized.	<ul style="list-style-type: none"> - Turn off the power, and check the HDD cable. Thereafter, turn off the power. - Turn on the power, and listen for a sound from the HDD or touch the HDD, to see if the HDD is rotating. - Replace the HDD, and reinstall the system software. - Replace the main controller PCB.
	02	There is no system software for the main CPU. At time of start-up, no start-up partition (BOOTDEV) is found.	<ul style="list-style-type: none"> - Start up in safe mode, and perform full formatting using the SST and reinstall the system software; then, turn off and then on the power. - Replace the HDD, and reinstall the system software.
00	03	An interrupt has been detected while data is being written to the boot device.	<p>Take action according to the type of error code screen: <error code screen is black-and-white></p> <ul style="list-style-type: none"> - Turn off the power, and turn on the power while holding down the 1 and 9 keys. <p>In response, the machine will automatically start to repair the sector in which the write operation has been interrupted. (The screen changes to solid black.) While repairs are being made, the progress of processing will be indicated on the screen, turning white at its end. When done, turn off and then back on the power.</p> <ul style="list-style-type: none"> - Start up in safe mode, and perform full formatting using the SST and reinstall the system software; then, turn off and the back on the power. - Replace the HDD, and reinstall the system software. <p><error core screen is normal (spanner mark)></p> <ul style="list-style-type: none"> - Set CHK-TYPE=0, and execute HD-CHECK; then, turn off and then back on the power. - Start up in safe mode, and execute full formatting using the SST and reinstall the system software; then, turn off and back on the power. - Replace the HDD, and reinstall the system software.
	06	No system software is found for the sub CPU.	<ul style="list-style-type: none"> - Start up in safe mode, and perform full formatting using the SST and reinstall the system software; then, turn off and then back on the power. - Replace the HDD, and reinstall the system software.
	12	A file used by the Web browser to make references is damaged, or has been deleted.	<ul style="list-style-type: none"> - Reinstall the content of the Web browser. - Replace the HDD, and reinstall the system software.

XX= "01" to "FF"

T-16-4

XX				YY					
XX	CHK - TYP E	Partition	Description	Occurrence at time of start-up			Occurrence during normal execution		
				03	05	00,0 1,02, 04	11,2 1	13,2 5	10,12, 14,22, 23,24
				Action			Action		
01	1	FSTDEV	compressed image data (e.g., Box)	*1	*5	*9	*10	*11	*12
02		IMG_MNG	file management table, profile						
03		FSTCDEV	job archiving (changing)						
04	2	APL_GEN	general-purpose data						
05		TMP_GEN	general-purpose data (temporary file)						
06		TMP_FAX	not used						
07		TMP_PSS	for PDL spool (temporary file)						
08	3	PDLDEV	PDL-related file						
09	4	BOOTDEV	firmware (system, MEAP, key, certificate, PDF dictionary, RUI, content, voice dictionary)						
10	5	APL_MEAP	MEAP application						
11	6	APL_SEN D	address book, filter						
12	7	APL_KEEP	for non-initialization data storage						
13	8	APL_LOG	system log						
FF	0	not specified	check for and recovery of HDD full-fault sectors	*4	*7				

YY	Description	Action
*1	The ongoing write operation is interrupted (at start-up).	- Set the partition number in question for CHK-TYPE, and execute HD-CLEAR; then, turn off and then back on the power. - Enter CHK-TYPE in question (for the partition), and execute HD-CLEAR; then, turn off and then back on the power.
*2		- Ask the user to download the address book data using a remote UI. - Set the partition number in question for CHK-TYPE, and execute HD-CLEAR; then, turn off and then back on the power. - Start download mode, and perform full formatting using the SST and reinstall the system software; then turn off and then back on the power.
*3		The recovery operation for the boot partition is not possible without the use of the SST in save mode. - Set CHK-TYPE=0, and execute HD-CHECK; then, turn off and then back on the power. - Start download mode, and perform full formatting using the SST and reinstall the system software; then, turn off and then back on the power.
*4		- Set CHK-TYPE=0, and execute HD-CHECK; then, turn off and then back on the power. - Set CHK-TYPE=1, 2, 3, 5, and execute HD-CLEAR; then, turn off and then back on the power.

	YY	Description	Action
*5	05	A file system error has occurred.	- Enter CHK-TYPE in question (for the partition), and execute HD-CLEAR; then, turn off and then back on the power. - Replace the HDD, and reinstall the system software.
*6			The machine is designed so that execution of HD-CLEAR is not possible in service mode (so as to prevent loss of information, e.g., address book, filter information). - Ask the user to download the address book data using a remote UI. - In service mode, start download mode, and execute full formatting using the SST and reinstall the system software; then, turn off and then back on the power.
*7			- Set CHK-TYPE=1, 2, 3, 5, and execute HD-CLEAR; then, turn off and then back on the power. - Replace the HDD, and reinstall the system software.
*8			The recovery operation for the boot partition is not possible without the use of the SST in save mode. - Start up in safe mode, and execute full formatting using the SST and reinstall the system software; then, turn off and back on the power. - Replace the HDD, and reinstall the system software.
*9	00 01 02 04	The HDD has poor contact, or a system error has occurred.	- Check the cable and the power cord. - Start up in safe mode, and execute full formatting using the SST and reinstall the system software; then, turn off and back on the power. - Replace the HDD, and reinstall the system software.
*10	11 21	The HDD has poor contact.	- Check the cable and the power cord. - Replace the HDD, and reinstall the system software.
*11	13 25	The ongoing write operation has been interrupted.	There is a strong possibility of damage in the file data (e.g., Box) stored on the HDD. - Set the partition number in question for CHK-TYPE, and execute HD-CHECK; then, turn off and back on the power. - Set the partition number in question for CHK-TYPE, and execute HD-CLEAR; then, turn off and back on the power. (In the case of BOOTDEV, BOOTDEV2 or APL_SEND, execute reformatting using the SST, and reinstall the system software.) - Replace the HDD, and reinstall the system software.
*12	10 12 14 22 23 24	A system error or a packet error has been detected.	- Start up in safe mode, and perform full formatting using the SST and reinstall the system software; then, turn off and back on the power. - Replace the HDD, and reinstall the system software.

16.3 Jam Code

16.3.1 Jam Code (printer)

T-16-5

Code	Jam type	Sensor type	Sensor No.
01xx	delay jam	See the table	
02xx	stationary jam		
0Axx	power-on residual jam		
0Bxx	door open jam		
0C00	double-feeding	double-feeding sensor (reception)	PS65

Code	Sensor type	Sensor No.	Code	Sensor type	Sensor No.
xx01	right deck pickup sensor	PS20	xx0F	duplexing reversal sensor	PS12
xx02	left deck pickup sensor	PS25	xx10	duplexing outlet sensor	PS61
xx03	cassette 3 pickup sensor	PS37	xx11	pre-confluence sensor	PS14
xx04	cassette 4 pickup sensor	PS42	xx12	post-confluence sensor	PS15
xx05	vertical path 1 paper sensor	PS47	xx13	left deck feed sensor	PS26
xx06	vertical path 2 paper sensor	PS49	xx14	right deck feed sensor	PS27
xx07	vertical path 3 paper sensor	PS41	xx15	side paper deck feed sensor	PS106
xx08	vertical path 4 paper sensor	PS46	xx16	multifeeder curl-removal sensor	PS68
xx09	registration roller sensor	PS5	xx17	side paper deck pickup sensor	PS101
xx0A	fixing claw jam sensor	PS65	xx18	image write start sensor	PS60
xx0B	inside delivery sensor	PS9	xx19	manual feeder feed sensor	PS35
xx0C	outside delivery sensor	PS10	xx1A	fixing inlet sensor	PS63
xx0D	fixing feed unit outlet sensor	PS11			

16.3.2 Jam Code (DADF-Q1)

<iR7105/7095>

T-16-6

Code	Sensor type	Sensor No.	Description
0001	separation delay	S4	At time of separation, the separation sensor does not detect the original after it has been moved a specific distance (221 mm) following the start of the separation motor.
0002	pickup delay	S4,S2	At time of separation, the pre-registration roller sensor does not detect the original after it has been moved a specific distance (93 mm) following the detection of its lead edge by the separation sensor.
0003	pickup stationary 1	S3	At time of pickup, the post-registration sensor does not detect the original after it has been moved a specific distance (40 mm) following the start of the reversal motor.
0004	pickup stationary 2	S2	At time of pickup, the pre-registration roller sensor detects the original after it has been moved a specific distance (330 mm if small; 660 mm if large) following the start of the reversal motor.
0005	reversal delay	S1	At time of reversal, the reversal sensor does not detect the original after it has been moved a specific distance (104 mm) from the platen roller.
0006	reversal stationary	S1	At time of reversal, the reversal sensor detects the original after it has been moved a specific distance (original length x 1.5 mm) following arching operation.
0007	delivery delay	PI13	At time of delivery, the delivery sensor does not detect the original after it has been moved a specific distance (631 mm - original length) following the start of the belt motor.

Code	Sensor type	Sensor No.	Description
0008	delivery stationary 1	PI13,S9	At time of delivery, the manual feeder registration roller sensor detects the original after it has been moved a specific distance (original length + 100 mm) following the activation of the delivery sensor.
0009	delivery stationary 2	PI13,S9	At time of delivery, the delivery sensor detects the original after it has been moved a specific distance (original length + 100 mm) following the deactivation of the manual feeder registration roller sensor.
0010	pre-reversal delay 1	S3	At time of pre-reversal, the post-registration roller sensor does not detect the original after it has been moved a specific distance (50 mm) following the activation of the reversal motor.
0011	pre-reversal delay 2	S1,S3	At time of pre-reversal, the reversal sensor does not detect the original after it has been moved a specific distance (100 mm) after the post-registration roller sensor has gone on.
0012	pre-reversal delay 3	PI4	At time of pre-reversal, the reversal sensor does not detect the original when it has been moved over a specific distance (100 mm) after the reversal motor has stopped.
0013	pre-reversal stationary 1	S1,S4	At time of reversal, the separation sensor has detected the original when it has been moved over a specific distance (169 mm) after the reversal sensor has gone on.
0014	pre-reversal stationary 2	S2,S4	At time of pre-reversal, the pre-registration sensor has detected the original when it has been moved over a specific distance (120 mm) after its trail edge has moved past the separation pull-off roller.
0015	pre-reversal stationary 3	S2,S3	At time of pre-reversal, the post-registration roller sensor detects the original after it has been moved a specific distance (50 mm) following the passage of the trail edge of the original for the pre-registration roller sensor.
0016	pre-reversal stationary 4	S1,S3	At time of pre-reversal, the reversal sensor detects the original after it has been moved a specific distance (100 mm) following the passage of the trail edge of the original from the pre-registration roller sensor.
0017	pre-reversal pickup delay	S1	At time of pre-reversal pickup, the reversal sensor does not detect the original after it has been moved a specific distance (100 mm) following the start of the reversal sensor.
0018	pre-reversal pickup stationary 1	S1,PI4	At time of pre-reveal, the pre-reversal sensor has detected the original when it has been moved over a specific distance after the reversal sensor has detected its lead edge.
0019	pre-reversal pickup stationary 2	S1,PI4	At time of pre-reversal pickup, the reversal sensor detects the original after it has been moved a specific distance following the detection of its trail edge by the pre-reversal sensor.
0020	reversal pickup delay	S2	At time of reversal, the pre-registration roller sensor does not detect the original after it has been moved a specific distance (197 mm) following the end of arching operation.
0021	reversal pickup stationary	S2	At time of reversal, the pre-registration roller sensor detects the original after it has been moved a specific distance (original length X 1.5 mm) following the start of the pre-registration roller sensor.
0022	pickup lead edge skew	S4,S5	At time of separation, there is a discrepancy of an equivalent of 10 mm in the timing of detecting the lead edge between the separation sensor and the skew sensor.
0023	pickup trail edge skew	S4,S5	At time of pickup, there is a discrepancy of an equivalent of 10 mm in the timing of detecting the trail edge between the separation sensor and the skew sensor.
0024	pickup fault 1	S1	At time of pickup, the reversal sensor detects an original before it moves past the pre-registration roller sensor.

Code	Sensor type	Sensor No.	Description
0025	pickup fault 2	S3,S2	At time of pickup, the post-registration sensor detects an original before the start of the reversal motor. At time of pickup, the pre-registration roller sensor does not detect the original after it has been moved a specific distance. At time of pre-reversal, the pre-registration roller sensor detects an original before the start of the reversal motor. At time of reversal, the pre-registration roller sensor does not detect the original while its trail edge is moving past the reversal sensor.
0026	reversal pickup trail edge skew	S4,S5	At time of pre-reversal, there is a discrepancy of an equivalent of 10 mm in the timing of detecting the trail edge between the separation sensor and the skew sensor.
0027	reversal pickup fault 1	PI4	At time of reversal, the pre-reversal sensor detects the original during a wait for the activation of the pre-registration roller sensor.
0030	manual feed registration delay	S9	At time of arching operation in manual feed mode, the manual feeder registration roller sensor does not detect an original within a specific period of time (1 sec) from the start of the delivery motor.
0031	manual feed registration delay	S1	At time of pickup from the manual feeder, the reversal sensor does not detect the original after it has been moved a specific distance (638 mm) following the start of the belt motor.
0032	manual feeder reversal stationary	S1	At time of pickup from the manual feeder (platen roller), the reversal sensor does not detect the original after it has been moved a specific distance (50 mm) following the start of the belt motor.
0033	manual feed delivery delay	PI13	At time of manual feed delivery, the delivery sensor does not detect the original after it has been moved a specific distance (621 mm - original length).
0034	manual feed delivery stationary	PI13	At time of manual feed delivery, the delivery sensor detects the original after it has been moved a specific distance (original length x 1.5) following the activation of the delivery sensor.
0043	1st sheet pickup stationary 1	S3	The 1st sheet is identified as a pickup delivery 1 jam (0003).
0044	1st sheet pickup stationary 2	S2	The 1st sheet is identified as a pickup stationary 2 jam (0004).
0045	1st sheet reversal delay	S1	The 1st sheet is identified as a reversal delay jam (0005).
0046	1st sheet reversal stationary	S1	The 1st sheet is identified as a reversal stationary jam (0006).
0047	1st sheet delivery delay	PI13	The 1st sheet is identified as a delivery delay jam (0007).
0048	1st sheet delivery stationary 1	PI13,S9	The 1st sheet is identified as a delivery delay jam (0008).
0049	1st sheet delivery stationary 2	PI13,S9	The 1st sheet is identified as a delivery stationary 2 jam (0009).
0050	1st sheet pre-reversal delay 1	S3	The 1st sheet is identified as a pre-reversal delay 1 jam (0010).
0051	1st sheet pre-reversal delay 2	S1,S3	The 1st sheet is identified as a pre-reversal delay 2 jam (0011).
0052	1st sheet pre-reversal delay 3	PI4	The 1st sheet is identified as a pre-reversal delay 3 jam (0012).
0053	1st sheet pre-reversal stationary 1	S1,S4	The 1st sheet is identified as a pre-reversal stationary 1 jam (0013).
0054	1st sheet pre-reversal stationary 2	S2,S4	The 1st sheet is identified as a pre-reversal stationary 2 jam (0014).
0055	1st sheet pre-reversal stationary 3	S2,S3	The 1st sheet is identified as a pre-reversal stationary 3 jam (0015).
0056	1st sheet pre-reversal stationary 4	S1,S3	The 1st sheet is identified as a pre-reversal stationary 4 jam (0016).

Code	Sensor type	Sensor No.	Description
0057	1st sheet pre-reversal pickup delay	S1	The 1st sheet is identified as a pre-reversal pickup delay jam (0017).
0058	1st sheet pre-reversal pickup stationary 1	S1,PI4	The 1st sheet is identified as a pre-reversal pickup stationary 1 jam (0018).
0059	1st sheet pre-reversal pickup stationary 2	S1,PI4	The 1st sheet is identified as a pre-reversal pickup stationary 2 jam (0019).
0060	1st sheet reversal pickup delay	S2	The 1st sheet is identified as a reversal pickup delay (0020).
0061	1st sheet reversal pickup stationary	S2	The 1st sheet is identified as a reversal pickup stationary jam (0021).
0062	1st sheet pickup lead edge skew	S4,S5	The 1st sheet is identified as a pickup lead edge skew jam (0022).
0063	1st sheet pickup trail edge skew	S4,S5	The 1st sheet is identified as a pickup trail edge skew jam (0023).
0064	1st sheet pickup fault 1	S1	A pickup NG1 condition (0024) has occurred on the 1st sheet.
0065	1st sheet pickup fault 2	S3,S2	A pickup NG1 condition (0025) has occurred on the 1st sheet.
0066	1st sheet reversal pickup trail edge skew	S4,S5	A reversal pickup trail edge skew condition (0026) has occurred on the 1st sheet.
0067	1st sheet reversal pickup NG1	PI4	The 1st sheet is identified as a reversal pickup fault 1 jam (0027).
0071	timing fault 1	-	The software control mechanism has failed.
0072	timing fault 2	-	In copyboard mode, an original has been read and moved to and stopped at the right side of the platen roller; however, the preceding original has not been delayed.
0073	illegal size	S3	At time of LDR stream reading, the post-registration sensor detects the original after it has been moved a specific distance (30 mm) from the wait position.
0074	manual feed original size error	S9,S1	At time of manual feed, the reversal sensor detects an original while the manual registration roller sensor also detects an original.
0075	image lead edge position error	S7	At time of stream reading, no change has occurred in the read position in response to a request for a change.
0076	1st sheet image lead edge position error	S7	The 1st sheet is identified as having an image lead edge position error (0075).
0077	belt speed setting error	PI1	The speed setting of the belt motor is below the minimum speed (100 mm/sec) or above the maximum speed (700 mm/sec).
0078	belt speed switch-over error	PI1	When the belt motor speed is switched over, the belt motor is not moving at a constant speed.
0079	belt status error	PI1	At time of switch-over, the state is not any of the following: acceleration, constant speed rotation, deceleration.
0080	image lead edge output timing error	S2,S3,SW3 01	At time of stream reading, the image lead edge signal is generated in the course of acceleration while a move is made from the wait position to the image lead edge position.
0081	reversal speed setting error	PI5	The speed setting of the reversal motor is below the minimum speed (100 mm/sec) or above the maximum speed (700 mm/sec).
0082	reversal speed switch-over error	PI5	At time of switching over the reversal motor speed, the reversal motor is not rotating at a constant speed.
0083	reversal status error	PI5	At time of switch-over, the state of the reversal motor is not any of the following: acceleration, constant speed, deceleration.
0084	last original error	PI1	A belt motor error occurs while the last original is being discharged by the platen roller or being moved.

Code	Sensor type	Sensor No.	Description
0085	error	PI1,PI2,PI11	A motor error other than an IPC communication or pickup error has occurred. (less than 3 times)
0090	ADF open	PI10	The ADF is identified as being open.
0091	user DF open	PI10	The ADF is identified as being open while the machine is operating.
0092	cover open	PI3,PI6	The cover is identified as being open.
0093	user cover open	PI3,PI6	The cover (front or rear) is identified as being open while the machine is operating.
0094	initial stationary	PI4,PI12,PI13,S1,S2,S3,S4,S5,S9	At the start of operation, a sensor inside the paper path detects an original.
0095	cycle fault	S6	The pickup signal has been received for a specific period of time (2 sec) in the absence of a detected original.
0096	residual original	S1	The reversal sensor detects an original while the belt motor is moved for a specific distance before the start of a left pickup job.
0097	manual feeder residual original	S1,S9	At time of manual feed pickup, the reversal sensor detects an original while the manual feeder registration roller sensor also detects an original.
0098	power-down	-	A drop occurs in the voltage supplied by the host machine while the machine is operating.

16.3.3 Jam Code (DADF-M1)

<iR7086>

T-16-7

Code	Sensor	Notation	Description
0001	post-separation sensor	PI7	The post-separation sensor does not detect paper when paper has been moved 452 mm after the start of separation.
0002	post-separation sensor	PI7	- The separation sensor detects paper when paper has been moved 500 mm (if extra-length, +200 mm) -45.5 mm after registration pickup. - the sensor goes on (paper with hole) before paper has been fed 12 mm after the detection of the trailing edge; the separation sensor detects paper after paper has been fed 50 mm from when the separation sensor has gone on.
0003	registration sensor	PI1	The registration sensor does not detect paper a feed length of 134.8 mm after the post-separation sensor has gone on.
0004	registration sensor	PI1	The read sensor goes off before the registration sensor goes off.
0005	read sensor	PI8	- The read sensor does not detect paper a feed length of 364.2 mm (182.1 x 2) from the point of registration. - The read sensor does not detect paper a feed length of 157.4 mm (78.7 x 2) from the point of No. 2 registration.
0006	read sensor	PI8	- The read sensor detects paper a feed length of 500 mm (if extra-length, +200 mm) after the start of feed, resumed after a temporary stop for reading. - At time of LTRR/LGL identification in mix mode, the read sensor detects paper a feed length of 514 mm after the start of feed from the edging wait point.
0007	delivery reversal sensor	PI9	If not in high-speed duplexing mode, the delivery sensor does not detect paper when paper is moved 132.1 mm after it has reached the leading edge lower stream roller with reference to the activation of the read sensor.
0008	delivery reversal sensor	PI9	The delivery sensor detects paper a feed length of 161.9 mm after the trailing edge read end point.
0042	post-separation sensor	PI7	1st sheet, post-separation sensor, stationary
0043	registration sensor	PI1	1st sheet, registration sensor, non arrival

Code	Sensor	Notation	Description
0044	registration sensor	PI1	1st sheet, registration sensor, stationary
0045	read sensor	PI8	1st sheet, read sensor, non arrival
0046	read sensor	PI8	1st sheet, read sensor, stationary
0047	delivery reversal sensor	PI9	1st sheet, delivery sensor, non arrival
0048	delivery reversal sensor	PI9	1st sheet, delivery sensor, stationary
0071	TIMING NG	-	fault in software timing
0073	TIMING NG	-	fault in shift motor
0090	ADF open/closed sensor 1	PS502	The ADF has been opened while in operation.
0091	ADF open/closed sensor 1	PS502	The ADF has been opened while in operating (paper wait).
0092	DF cover open/closed sensor	PI6	The cover has been opened while in operation (drive system in operation).
0093	DF cover open/closed sensor	PI6	The cover has been opened while in operation (paper wait).
0094	registration sensor, separation sensor, feed sensor, delivery reversal sensor	PI1, PI7, PI8, PI9	Paper has been detected in the path while the 1st sheet is being picked up.
0095	original set sensor, DF cover open/closed sensor, ADF open/closed sensor 1	PI5, PI6, PS502	With no paper in the tray or while the tray is open, the start of pickup operation is detected.

16.4 Alarm Code

16.4.1 Alarm Code

T-16-8

EE	Location	fff	Alarm
00	error code indication	0804	system fan alarm (detail code: 0004)
02	reader unit (scanner system)	0003	dust detection small 1
		0004	dust detection small 2
		0005	dust detection small 3
		0006	dust detection small 4
		0007	dust detection small 5
		0008	dust detection small 6
		0009	dust detection small 7
		0010	dust detection large 1
		0011	dust detection large 2
		0012	dust detection large 3
		0013	dust detection large 4
		0014	dust detection large 5
		0015	dust detection large 6
		0016	dust detection large 7
		0017	small position stream read disable
		0018	large position stream read disable
		0019	scanner lamp intensity too low
04	pickup/transport system	0001	right deck lifter
		0002	left deck lifter alarm
		0003	cassette 3 lifter alarm
		0004	cassette 4 lifter alarm
		0007	manual feeder tray lifter alarm
		0008	side paper deck lifter alarm
		0011	right deck retry alarm
		0012	left deck retry alarm
		0013	cassette 3 retry alarm
		0014	cassette 4 retry alarm
		0017	manual feeder retry alarm
		0018	side paper deck retry alarm
		0019	right deck pickup sensor low intensity alarm
		0020	left deck pickup sensor low intensity alarm
		0021	cassette 3 pickup sensor low intensity alarm
		0022	cassette 4 pickup sensor low intensity alarm
		0023	right deck pull-off sensor low intensity alarm
0024	left deck pull-off sensor low intensity alarm		
0025	cassette 3 pull-off sensor low intensity alarm		
0026	cassette 4 pull-off sensor low intensity alarm		
0027	side paper deck pickup sensor low intensity alarm		
0028	side paper deck pull-off sensor low intensity alarm		
30	high-voltage system	0001	primary charging assembly leakage
		0002	transfer charging assembly leakage
		0003	separation charging assembly leakage
32	potential control system	0001	potential control VD alarm
		0002	potential control VL alarm

EE	Location	fff	Alarm
33	fan system	0001	delivery assembly curl-removing fan alarm
		0006	developing assembly fan alarm
		0007	delivery anti-adhesion fan alarm
61	stapler system (sorter/finisher)	0001	no staple
62	saddle stitcher system	0001	no switch
65	puncher system (sorter/finisher)	0001	punch case full

Service Mode

Contents

17.1 Outline	17- 1
17.1.1 Service mode screen configuration	17- 1
17.1.2 Entering or selecting service modes	17- 2
17.1.3 Exiting service modes	17- 2
17.1.4 Backing Up Service Mode	17- 2
17.1.5 Initial screen	17- 3
17.1.6 Main/intermediate item screen	17- 3
17.1.7 Sub-item screen	17- 3
17.2 DISPLAY (Status Display Mode)	17- 4
17.2.1 COPIER	17- 4
17.2.1.1 COPIER Items	17- 4
17.2.2 FEEDER	17- 13
17.2.2.1 FEEDER Items	17- 13
17.3 I/O (I/O Display Mode)	17- 14
17.3.1 Overview	17- 14
17.3.2 <DC-CON>	17- 15
17.3.3 <R-CON>	17- 22
17.3.4 <R-CON>	17- 24
17.3.5 <FEEDER>	17- 25
17.3.6 <FEEDER>	17- 28
17.3.7 <SORTER>	17- 29
17.3.8 <MN-CONT>	17- 38
17.4 ADJUST (Adjustment Mode)	17- 39
17.4.1 COPIER	17- 39
17.4.1.1 COPIER Items	17- 39
17.4.2 FEEDER	17- 46
17.4.2.1 FEEDER Items	17- 46
17.4.3 SORTER	17- 46
17.4.3.1 SORTER Items	17- 46
17.5 FUNCTION (Operation/Inspection Mode)	17- 47
17.5.1 COPIER	17- 47
17.5.1.1 COPIER Items	17- 47
17.5.2 FEEDER	17- 57
17.5.2.1 FEEDER Items	17- 57
17.5.3 SORTER	17- 59
17.5.3.1 SORTER Items	17- 59
17.6 OPTION (Machine Settings Mode)	17- 60
17.6.1 COPIER	17- 60
17.6.1.1 COPIER Items	17- 60
17.6.1.2 Soft Counter Specifications	17- 77
17.6.2 FEEDER	17- 86
17.6.2.1 FEEDER Items	17- 86
17.6.3 SORTER	17- 86
17.6.3.1 SORTER Items	17- 86

17.6.4 BOARD.....	17- 87
17.6.4.1 BOARD Items	17- 87
17.7 TEST (Test Print Mode)	17- 88
17.7.1 COPIER.....	17- 88
17.7.1.1 COPIER Items	17- 88
17.8 COUNTER (Counter Mode)	17- 89
17.8.1 COPIER.....	17- 89
17.8.1.1 COPIER Items	17- 89

17.1 Outline

17.1.1 Service mode screen configuration

As shown below, the service modes use three screen levels: initial screen -> main/intermediate item screen -> sub-item screen.

One set of modes are used for normal maintenance (Level 1 modes), and another set are used for troubleshooting (Level 2 modes).

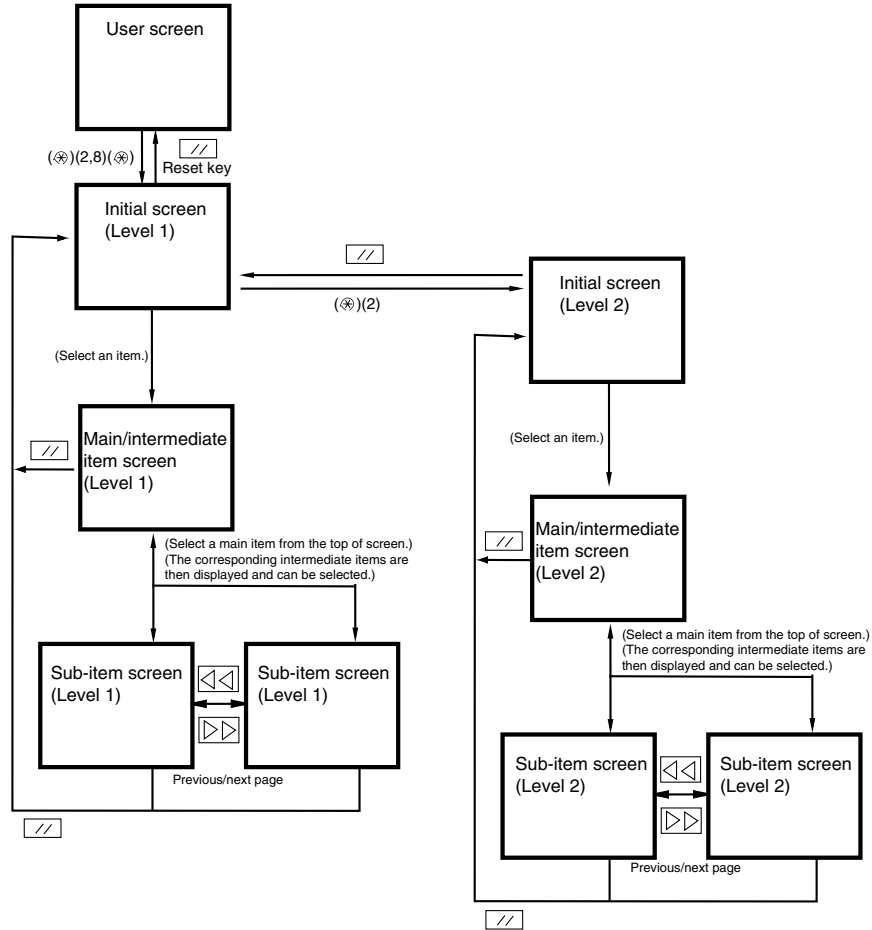

F-17-1

The copier has the 7 service modes listed below.

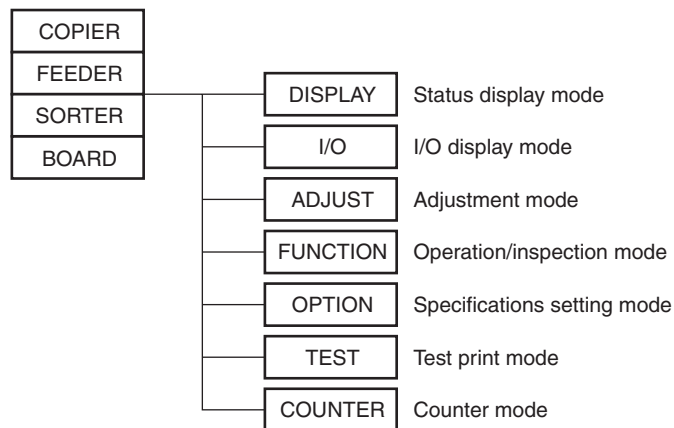

F-17-2

17.1.2 Entering or selecting service modes



To execute a copier operation using a service mode, remove the cable from the external controller or the cable from the network before entering the desired mode. Take care when using the FUNCTION (operation/inspection mode) mode, as the copier may malfunction and be damaged if a print job is received from outside while an operation is executing with this mode in effect.

- 1) Press the asterisk key (\star) on the operation panel.
- 2) Press 2 and 8 simultaneously on the numeric keypad.
- 3) Press the asterisk key (\star) on the operation panel.
The initial screen (see below) now appears.

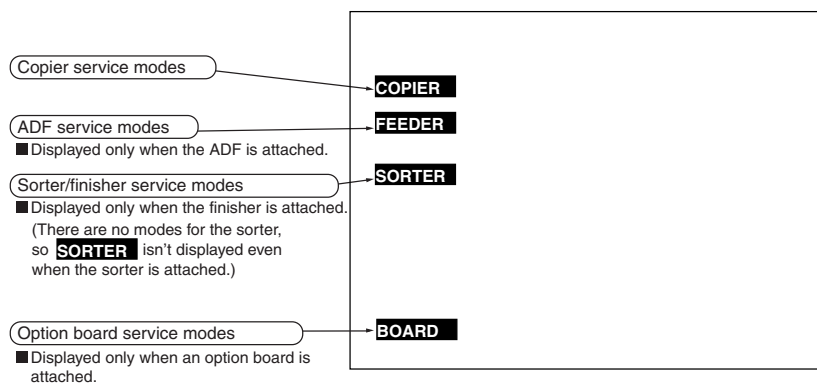

F-17-3

17.1.3 Exiting service modes

When the reset key is pressed once, the display returns to the service mode initial screen.

When the reset key is pressed twice, the service modes are exited, and the display returns to the user screen (standard screen).



When using the ADJUST, FUNCTION or OPTION service mode, be sure to turn the main power switch ON/OFF after exiting the mode.

17.1.4 Backing Up Service Mode

At time of shipment from the factory, each machine is adjusted, and the adjustment values are recorded on the Service sheet [1] (attached to the cover of the Service Book case behind the front cover).

If you have replaced the reader controller PCB, DC controller PCB (or if you have cleared the RAM of these), the ADJUST and OPTION settings will be replaced by default settings.

If you have made adjustments in the field and changed service mode settings, be sure to print out the Service sheet and store it away (COPIER>FUNCTION>MISC-P>LBL-PRNT). If the label lacks items, use its margin.

You can also print out a complete list of service mode settings: COPIER>ADJUST/OPTION/COUNTER; COPIER>FUNCTION>MISC-P>P-PRINT.

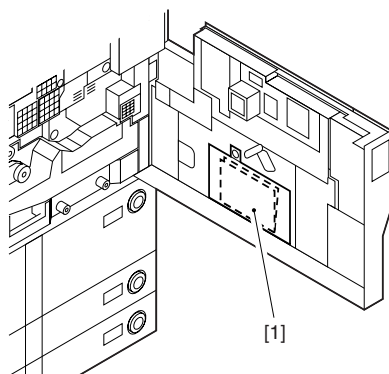

F-17-4

17.1.5 Initial screen

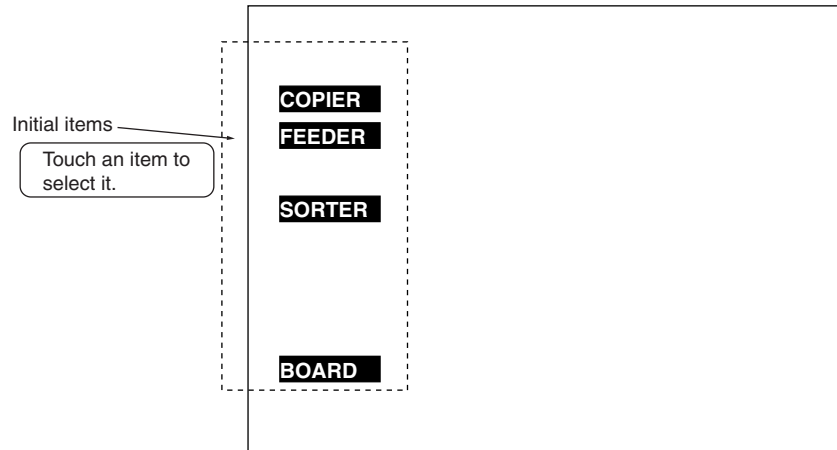

F-17-5

17.1.6 Main/intermediate item screen

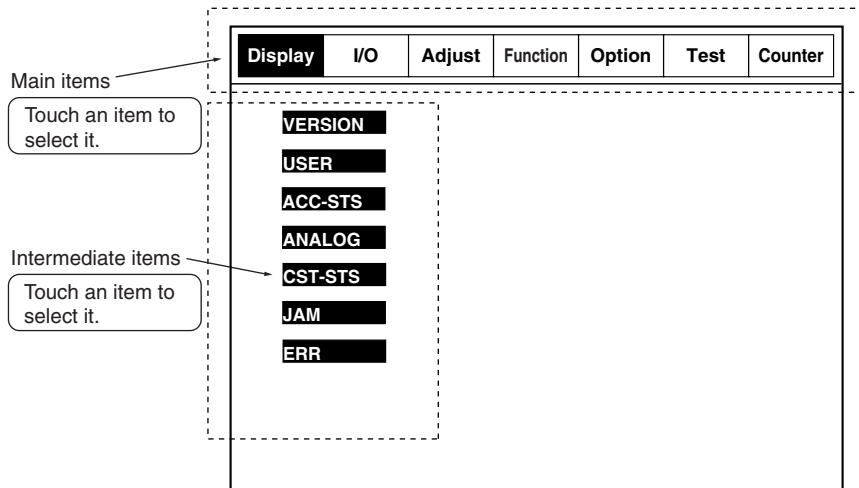

F-17-6

17.1.7 Sub-item screen

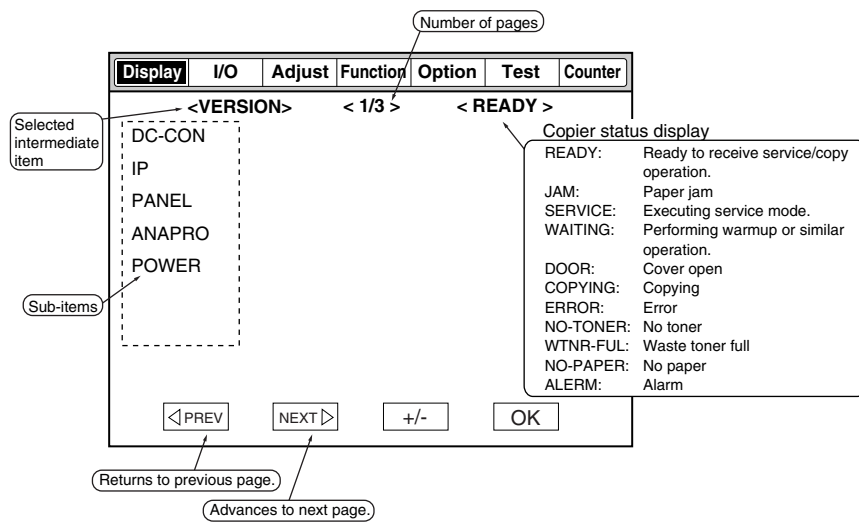

F-17-7

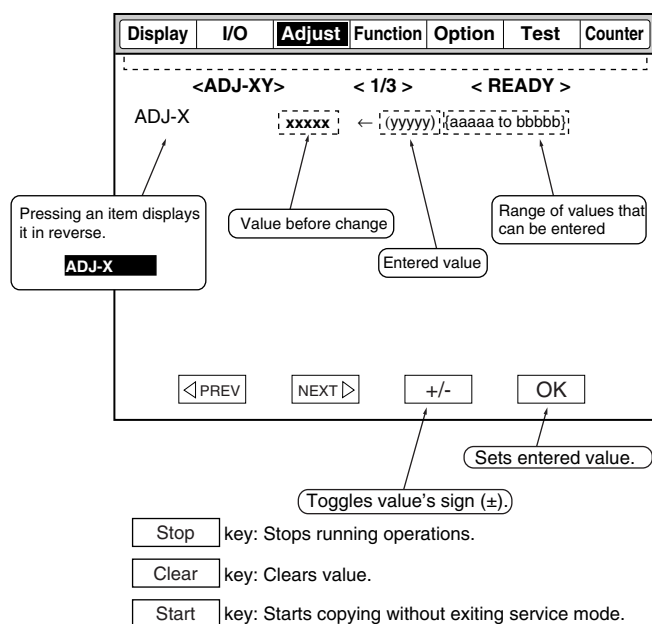

F-17-8

17.2 DISPLAY (Status Display Mode)

17.2.1 COPIER

17.2.1.1 COPIER Items

<VERSION>

T-17-1

COPIER > DISPLAY > VERSION		
Sub item	Description	Level
Use it to indicate the ROM version of a specific PCB (host machine, accessory).		
- EX: <R-CON XX.YY>XX, where XX indicates a version number while YY indicates an R&D control No.		
- In the absence of a PCB, the indication will be <-,>.		
DC-CON	indicates the ROM version of the DC controller PCB	1
R-CON	indicates the ROM version of the reader controller PCB	1
PANEL	indicates the ROM version of the control panel CPU PCB	1
FEEDER	indicates the ROM version of the ADF controller PCB	1
SORTER	indicates the ROM version of the finisher controller PCB (master CPU)	1
NIB	indicates the version of the network software	1
MN-CONT	indicates the ROM version of the main controller PCB	1
RIP1	not used	1
DIAG-DVC	indicates the ROM version of the self-diagnostic device	1
RUI	indicates the version of the remote user interface	1
PUNCH	indicates the version of the punch unit (inside the finisher)	1
LANG-EN	indicates the version of the English language file	1
LANG-FR	indicates the version of the French language file	1
LANG-DE	indicates the version of the German language file	1
LANG-IT	indicates the version of the Italian language file	1
LANG-JP	indicates the version of the Japanese language file	1

COPIER > DISPLAY > VERSION		
Sub item	Description	Level
Use it to indicate the ROM version of a specific PCB (host machine, accessory). - EX: <R-CON XX.YY>XX, where XX indicates a version number while YY indicates an R&D control No. - In the absence of a PCB, the indication will be <.,->.		
TRIM-VER	indicates the version of the trimmer	1
MEAP	indicates the version of the MEAP content	1
OCR-CN	indicates the OCR version of the Chinese language (simplified)	1
OCR-JP	indicates the OCR version of the Japanese language	1
OCR-KR	indicates the OCR version of the Korean language file	1
OCR-TW	indicates the OCR version of the Chinese language (classical)	1
BOOTROM	indicates the version of the boot ROM format: xx.yy_z, where z indicates the type of boot ROM	1
TTS-JA	indicates the version of the audio dictionary of the Japanese language	1
TTS-EN	indicates the version of the audio dictionary of the English language	1
WEB-BRWS	indicates the version of the Web browser	1
FN-INS	indicates the ROM version of the cover inserter for the finisher	1
STK-IF	indicates the version of the ROM of the relay PCB for the stacker	1
STACK	indicates the version of the ROM for the stacker	1
BND-IF	for future use	1
BND-MSTR	for future use	1
BND-SLAV	for future use	1
BND-TRIM	for future use	1
BND-INS	for future use	1
LANG-CS	indicates the version of the Czech language file	2
LANG-DA	indicates the version of the Danish language file	2
LANG-EL	indicates the version of the Greek language file	2
LANG-ES	indicates the version of the Spanish language file	2
LANG-ET	indicates the version of the Estonian language file	2
LANG-FI	indicates the version of the Finnish language file	2
LANG-HU	indicates the version of the Hungarian language file	2
LANG-KO	indicates the version of the Korean language file	2
LANG-NL	indicates the version of the Dutch language file	2
LANG-NO	indicates the version of the Norwegian language file	2
LANG-PL	indicates the version of the Polish language file	2
LANG-PT	indicates the version of the Portuguese language file	2
LANG-RU	indicates the version of the Russian language file	2

COPIER > DISPLAY > VERSION		
Sub item	Description	Level
Use it to indicate the ROM version of a specific PCB (host machine, accessory). - EX: <R-CON XX.YY>XX, where XX indicates a version number while YY indicates an R&D control No. - In the absence of a PCB, the indication will be <.->.		
LANG-SL	indicates the version of the Slovenian language file	2
LANG-SV	indicates the version of the Swedish language file	2
LANG-TW	indicates the version of the Chinese language file (simplified)	2
LANG-ZH	indicates the version of the Chinese language file (classical)	2
LANG-BU	indicates the version of the Bulgarian language file	2
LANG-CR	indicates the version of the Croatian language file	2
LANG-RM	indicates the version of the Romanian language file	2
LANG-SK	indicates the version of the Slovakian language file	2
LANG-TK	indicates the version of the Turkish language file	2

<ACC-ST>

T-17-2

COPIER > DISPLAY > ACC-ST		
Sub item	Description	Level
FEEDER	Use it to indicate the connection of the ADF. 0: not connected; 1: connected	1
SORTER	Use it to indicate the connection of a finisher and the puncher. <sorter type> 0: none 1: finisher 2: saddle finisher 3: saddle finisher + inserter 4: saddle finisher + paper folding unit 5: saddle finisher + inserter + paper folding unit 6: stacker <punch type> 0: none; 1: 2-hole; 2: 2-hole/3-hole; 3: 4-hole (FRN); 4: 4-hole (SWE)	1
DECK	Use it to indicate the connection of a paper deck. 0: not connected; 1: connected (small); 2: connected (large)	1
CARD	Use it indicates the connection of a card reader. 0: card reader connected, but card not inserted 1: card reader not connected, or card reader connected and card inserted ('1' if ready for copying; '0' if not ready for copying)	1
DATA-CON	Use it to indicate the connection of a copy data controller. 0: not connected; 1: connected	1
RAM	Use it to indicate the capacity of the memory mounted on the main controller PCB. 1024 MB	1
COINROBO	Use it to indicate the connection of a coin vendor. 0: not connected; 1: connected	1

COPIER > DISPLAY > ACC-ST5		
Sub item	Description	Level
NIB	Use it to indicate the connection of a network board. 0: connected 1: Ethernet board connected 2: TokenRing board connected 3: Ethernet board and TokenRing board connected	1
PS/PCL	not used	1
RIP1	not used	1
NETWARE	Use it to indicate installation of NetWare. 0: not installed; 1: installed	1
SEND	Use it to indicate addition of the SEND function. 0: SEND function not added; 1: SEND function added	1
TRIM-CN	Use it to indicate the connection of a trimmer. 0: not connected; 1: connected	1
PDL-FNC1/2	Use it to indicate the state (enabled/disabled) of the PDL function: 0000 0000 0000 0000 - 1111 1111 1111 1111 (0: OFF, 1: ON) for PDL-FNC1, b31 thorough b16 for PDL-FNC2, b15 thorough b0 b31: BDL, b30: PS, b29: PCL, b28: PDF, b27: LIPS, b26: N201, b25: I5577, b24: ESC/P, b23: HPGL, b22: HPGL2, b21: IMAGING, b20: KS, b19 through b0: for future use	1
HDD	Use it to indicate the model name of the HDD.	1
OVLP-UNT	Use it to indicate the connection of a double-feeding detection unit. 0: not connected; 1: connected	1
PCI1/2/3	Use it to indicate the board name of PC1/2/3. if not connected: - (hyphen) if connected: board name <board name> Voice Board: voice guidance board 3DES Board: security expansion board	1
USBH-SPD	Use it to indicate the connection of the USB device.	2

<ANALOG>

T-17-3

COPIER > DISPLAY > ANALOG		
Sub item	Description	Level
TEMP	machine inside temperature (environment sensor); unit: deg C	1
HUM	machine inside humidity (environment sensor); unit: %RH	1
ABS-HUM	water content (environment sensor); unit: g	1
FIX-C	fixing roller surface temperature (main thermistor); unit: deg C	1
FIX-E	fixing roller edge surface temperature (sub thermistor); unit: deg C	1

<CST-ST5>

T-17-4

COPIER > DISPLAY > CST-ST5		
Sub item	Description	Level
WIDTH-C3	indicates the paper width of cassette3 in terms of paper size; unit: mm	2
WIDTH-C4	indicates the paper width of cassette 4 in terms of paper size; unit: mm	2
WIDTH-MF	indicates the paper width size of the manual feeder tray; unit: mm	2

<JAM>

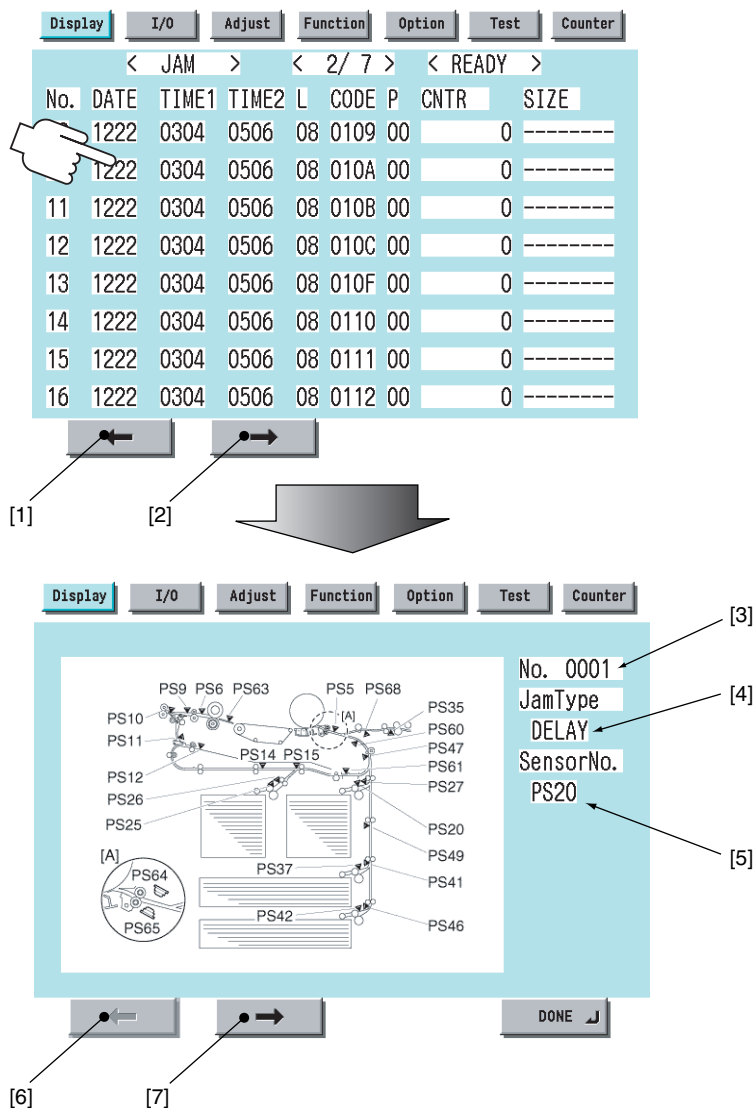

F-17-9

A touch on any Jam Indication screen will bring up the Detail screen of the jam in question.

- [1] to previous page
- [2] to next page
- [3] number indicating order of jam occurrence
- [4] type of jam
- [5] sensor in question
- [6] to previous jam screen
- [7] to next jam screen

No.: number indicating the order of jam occurrence; 1 through 50 (the higher the number, the older the jam)

- DATE: date of jam occurrence
- TIEM1: time of jam occurrence
- TIEM1: time of jam recovery
- L: location of jam

Code	Location
00	host machine
01	feeder
02	finisher / paper folding unit / insertion unit / panch unit / trimmer
51	stacker
61	for future use

CODE: jam code
P: source of paper

Code	Description
01	right deck
02	left deck
03	cassette 3
04	cassette 4
07	side paper deck
08	manual feeder tray
09	duplexing assembly
0A	inserter for finisher (upper)
0B	inserter for finisher (lower)
60	for future use
61	for future use

CNTR: reading of soft counter for source of paper
SIZE: paper size



The jam detail screen can only display jam codes that occur in the units shown below.

- Main unit
- ADF
- Paper deck
- Finisher

When a jam occurs in other units, the jam detail screen is not displayed, but you can specify a jam occurrence location (unit) using the jam-processing screen (in animation) displayed in the user screen.



Measures for a jam (when both of a finisher and stacker are installed)

A finisher and stacker share some jam codes.

For such jam codes, the jam detail screen always displays finisher information (illustrations, sensor numbers), but the jam might be actually occurring in the stacker.

Be sure to check the display of "location, category" ("L") in the jam history screen to specify the unit where the jam occurs.

<ERR>

Display	I/O	Adjust	Function	Option	Test	Counter
< ERR > < 2/ 7 > < READY >						
No.	DATE	TIME1	TIME2	CODE	DTL	L P
09	0102	0304	0506	E0708	090A	0C 0D
10	----	----	----	----	----	-- --
11	0102	0304	0506	E0708	090A	0C 0D
12	0102	0304	0506	E0708	090A	0C 0D
13	0102	0304	0506	E0708	090A	0C 0D
14	0102	0304	0506	E0708	090A	0C 0D
15	0102	0304	0506	E0708	090A	0C 0D
16	0102	0304	0506	E0708	090A	0C 0D

F-17-10

No.: number indicating order of error occurrence (the higher the number, the older the error)

DATE: date of error occurrence

TIME1: time of error occurrence

TIME2: time of error recovery

CODE: error code

DTL: detail code (if none, '0000')

L: location grouping

Code	Location grouping
00	main controller
01	DADF
02	finisher
04	reader unit
05	Printer unit
06	PDL board
41	trimmer
51	stacker
61	for future use

P: not used

<HV-STES>

T-17-5

COPIER > DISPLAY > HV-STES		
Sub item	Description	Level
PRIMARY	level of primary charging current in relation to the photosensitive drum resistance detection control mechanism (APVC) (uA)	1
PRI-GRID	grid voltage of primary charging (V)	1
PRE-TR	level of pre-transfer charging current (uA)	1
TR	setting of transfer current of the job executed last (uA)	1
SP	level of separation charging current (uA)	1
BIAS	developing bias setting of the job executed last (V)	1

<CCD>

T-17-6

COPIER > DISPLAY > CCD		
*: model equipped with DADF-Q1 (outside Japan: iR7105/7095; inside Japan: All model).		
**: model equipped with DADF-M1 (outside Japan: iR7086).		
Sub item	Description	Description
TARGET-G	shading target value of green for the CCD	2
GAIN	gain level adjustment value for the CCD	2
GAIN-OG	gain level adjustment value for green of the odd-number bits of the CCD	2
GAIN-OR *	gain level adjustment value for red of the odd-number bits of the CCD	2
GAIN-EG	gain level adjustment value for green of the even-number bits of the CCD	2
GAIN-ER *	gain level adjustment value for red of the even-number bits of the CCD	2

<DPOT>

T-17-7

COPIER > DISPLAY > DPOT		
Notes: Except DPOT-K, the value indicated is in relation to the most recent potential control.		
Sub item	Description	Level
DPOT-K	photopositive drum surface potential (real-time indication) range: 0 to 600	1
VL1T	light area potential target value (for copier) range: 0 to 600	1
VL1M	light area potential measurement value (for copier) range: 0 to 600; approx. optimum: VL1T +/-6 V	1
VDT	dark area potential target value (for copier) range: 0 to 600	1
VDM	dark area potential measurement value (for copier) range: 0 to 600; approx. optimum: VDT +/-6 V	1
VG-K	primary charging grid voltage (for copier) range: 0 to 900	1
VL1M-P	light area potential measurement level (for printer) range: 0 to 600; approx. optimum: VL1T-P +/-6 V	1
VL1T-P	light area potential target value (for printer) range: 0 to 600	1
BIAS-P	developing bias voltage (for printer) range: 0 to 600	1
BIAS-C	developing bias voltage (for copier) range: 0 to 600	1
LPOWE R-P	laser power value (for printer) range: 0 to 255	1
LPOWE R-C	laser power value (for copier) range: 0 to 255	1
VDM-P	dark area potential measurement (for printer) range: 0 to 600; approx. optimum: VDT-P +/-6 V	1
VDT-P	dark area potential target value (for printer) range: 0 to 600	1
VDT-S	dark area potential target value (OHT, heavy paper, tracing paper) range: 0 to 600	1
VDM-S	dark area potential measurement value (OHT, heavy paper, tracing paper) range: 0 to 600; approx. optimum: VDT-S +/-6 V	1
VLT-S	light area potential target value (OHT, heavy paper, tracing paper) range: 0 to 600	1
VLM-S	light are potential measurement value (OHT, heavy paper, tracing paper) approx. optimum: VLT-S +/-6 V	1
VG-K-P	primary charging grid voltage (for printer) range: 0 to 900	2
VG-K-S	primary charging grid voltage (OHT, heavy paper, tracing paper) range: 0 to 900	2
LPOWE R-S	laser power level (OHT, heavy paper, tracing paper) range: 0 to 255	2
BIAS-S	developing bias voltage (OHT, heavy paper, tracing paper) range: 0 to 600	2

<SENSOR>

T-17-8

COPIER > DISPLAY > SENSOR		
Sub item	Description	Level
DOC-SZ	indicates the size of the original detected by the original size sensor	2

<ALARM-2>

No.	DATE	TIME1	TIME2	CODE	DTL	CNTR
01	---	---	---	---	---	---
02	---	---	---	---	---	---
03	---	---	---	---	---	---
04	---	---	---	---	---	---
05	---	---	---	---	---	---
06	---	---	---	---	---	---
07	---	---	---	---	---	---
08	---	---	---	---	---	---

No.: number indicating order of alarm occurrence (the higher the number, the older the alarm)
DATE: date of alarm occurrence
TIME1: time of alarm occurrence
TIME2: time of alarm recovery
CODE: code of alarm location
DTL: detail code of alarm
CNTR: total counter reading at time of alarm occurrence

<ENVRNT>

Indicates the history of changes with reference to the monitor output of the environment sensor and the fixing thermistor (main); machine inside temperature (deg C), humidity (%), fixing roller surface (middle portion) temperature (deg C).

The intervals at which data is collected may be changed in service mode: COPIER > OPTION > BODY > ENVP-INT.

No.	DATE	TIME	D+deg C	E+%	F+deg C
001	0101	0000	D000	E000	F000
002	0201	0000	D000	E000	F000
003	0301	0000	D000	E000	F000
004	0401	0000	D000	E000	F000
005	0501	0000	D000	E000	F000
006	0601	0000	D000	E000	F000
007	0701	0000	D000	E000	F000
008	0801	0000	D000	E000	F000

F-17-11

Item	Description
No.	number indicating data collection (the higher the number, the older the data)
DATE	date of data collection
TIME	time of data collection
D+deg C	machine inside temperature
E+%	machine inside humidity
F+deg C	fixing roller surface (middle portion) temperature

17.2.2 FEEDER

17.2.2.1 FEEDER Items

T-17-9

FEEDER > DISPLAY		
*: model equipped with DADF-Q1 (outside Japan: iR7105/7095; inside Japan: All model).		
**: model equipped with DADF-M1 (outside Japan: iR7086).		
Sub item	Description	Level
FEEDSIZE	indicates the size of the original detected by the ADF	1
TRY-WIDE **	indicates the distance moved by the original width detecting slider (for detection of the width of paper; 0.1 mm)	1
SPSN-LMN **	post-separation sensor light intensity indicates the manual adjustment value (light voltage) of the post-separation sensor optimum range 179 or less	1
SPSN-RCV **	post-separation sensor light reception amount indicates the light reception voltage of the post-separation sensor after manual adjustment optimum range paper present: 154 or less paper absent: 179 or more	1
RDSN-LMN **	read sensor light emission amount indicates the manual adjustment value (light emission voltage) of the reader sensor optimum range 179 or less	1
RDSN-RCV **	read sensor light reception amount indicates the light reception voltage of the read sensor after manual adjustment optimum range paper present: 154 or less paper absent: 179 or more	1
DRSN-LMN **	delivery reversal sensor light intensity indicates the manual adjustment value (light emission voltage) of the delivery reversal sensor optimum range 905 or less	1
DRSN-RCV **	delivery reversal sensor light reception amount indicates the light reception voltage of the delivery reversal sensor after manual adjustment optimum range paper present: 154 or less paper absent: 179 or more	1

17.3 I/O (I/O Display Mode)

17.3.1 Overview

The following screen appears in response to: COPIER>I/O DISPLAY.

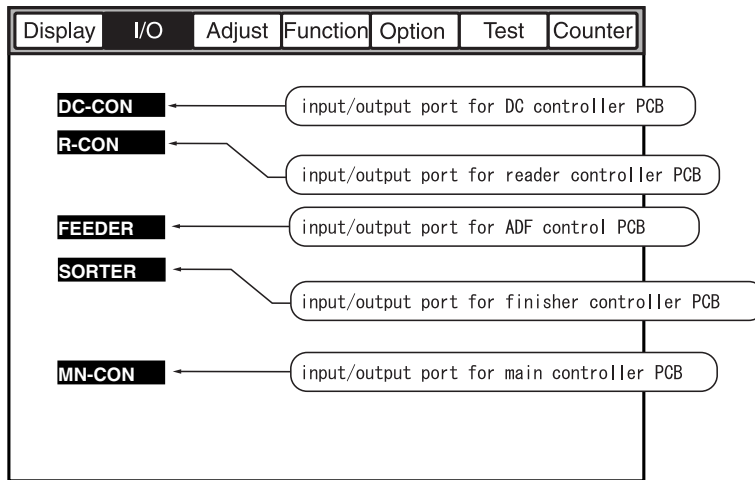

F-17-12

<Guide to Screen>

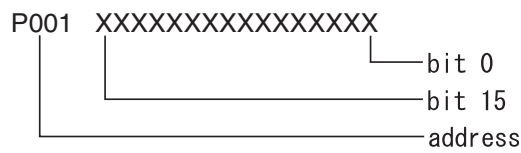

F-17-13

17.3.2 <DC-CON>

T-17-10

Addresses	Bit	Description	Notation	Remarks
P001	0	laser scanner motor cooling fan stop detection signal	FM1	
	1	fixing heat discharge fan stop detection signal	FM2	1: off
	2	laser scanner fan stop detection signal	FM3	1: off
	3	not used	-	
	4	curl-removing fan stop detection signal	FM6	1: off
	5	bottle motor error detection signal	M23	1: error
	6	drum suction fan stop detection signal	FM8	1: off
	7	pre-transfer charging assembly fan stop signal	FM10	1: off
	8	power supply cooling fan 1 stop detection signal	FM11	1: off
	9	power supply cooling fan 2 stop detection signal	FM12	1: off
	10	separation fan stop detection signal	FM13	1: off
	11	laser scanner motor lock detection signal	M4	0: constant speed
	12	delivery anti-adhesion fan stop detection signal	FM17	1: off
	13	developing fan stop detection signal	FM15	1: off
	14	reader heat discharge fan 1 stop detection signal	FM21	1: off
15	reader heat discharge fan 2 stop detection signal	FM18	1: off	
P002	0	manual feed curl-removal sensor	PS68	1: paper present
	1	duplexing reversal sensor	PS12	1: paper present
	2	duplexing outlet sensor	PS61	1: paper present
	3	pre-confluence sensor	PS14	1: paper present
	4	post-confluence sensor	PS15	1: paper present
	5	image write start sensor	PS60	1: paper present
	6	fixing inlet HP sensor	PS66	1: HP
	7	fixing inlet sensor	PS63	1: paper present
	8	vertical path 1 paper sensor	PS47	1: paper present
	9	vertical path 2 paper sensor	PS49	1: paper present
	10	manual feeder transport sensor	PS35	1: paper present
	11	registration roller sensor	PS5	1: paper present
	12	inside delivery sensor	PS9	1: paper present
	13	outside delivery sensor	PS10	1: paper present
	14	fixing transport outlet sensor	PS11	1: paper present
15	claw jam sensor	PS6	1: paper present	

Addresses	Bit	Description	Notation	Remarks
P003	0	buffer inside toner sensor	TS1	0: toner absent
	1	buffer inside toner lower limit sensor	TS2	0: toner absent
	2	developing assembly inside toner sensor	TS3	0: toner absent
	3	fixing web length sensor	PS7	1: no web
	4	fixing web length warning sensor	PS8	1: no web alert
	5	toner bottle sensor	PS67	1: present
	6	waste toner feedscrew lock detecting switch	MSW2	0: waste toner clog
	7	waste toner full sensor	PS19	1: waste toner case full
	8	right deck pickup sensor	PS20	1: paper present
	9	left deck pickup sensor	PS25	1: paper present
	10	cassette 3 pickup sensor	PS37	1: paper present
	11	cassette 4 pickup sensor	PS42	1: paper present
	12	vertical path 3 paper sensor	PS41	1: paper present
	13	vertical path 4 paper sensor	PS46	1: paper present
	14	right deck pull-off sensor	PS27	1: paper present
15	left deck pull-off sensor	PS26	1: paper present	
P004	0	right deck lifter sensor	PS21	1: paper present
	1	left deck lifter sensor	PS31	1: paper present
	2	cassette 3 lifter sensor	PS38	1: paper present
	3	cassette 4 lifter sensor	PS43	1: paper present
	4	right deck paper level middle sensor	PS51	1: paper present
	5	right deck paper level upper sensor	PS52	1: paper present
	6	left deck paper level middle sensor	PS54	1: paper present
	7	left deck paper level upper sensor	PS55	1: paper present
	8	right deck paper sensor	PS22	1: paper present
	9	left deck paper sensor	PS32	1: paper present
	10	cassette 3 paper sensor	PS39	1: paper present
	11	cassette 4 paper sensor	PS44	1: paper present
	12	manual feeder tray paper sensor	PS17	1: paper present
	13	fixing inlet sensor lift motor driver PCB connection detection	PCB34	1: connected
	14	right deck limit sensor	PS24	1: limit
15	left deck limit sensor	PS34	1: limit	
P005	0	cassette 3 paper length sensor	SV1	
	1	cassette 3 paper length sensor	SV1	
	2	cassette 4 paper length sensor	SV2	
	3	cassette 4 paper length sensor	SV2	
	4	right deck open/closed sensor	PS23	1: closed
	5	left deck open/closed sensor	PS33	1: closed
	6	cassette 3 open/closed sensor	PS40	1: closed
	7	cassette 4 open/closed sensor	PS45	1: closed
	8	upper right cover open/closed sensor	PS58	1: closed
	9	lower right cover open/closed sensor	PS48	1: closed
	10	manual feeder tray cover open/closed sensor	PS56	1: closed
	11	front cover open/closed detection	MSW7	1: closed
	12	bottle cover open/closed sensor	PS59	1: closed
	13	through path tray detection		0: present
	14	fixing transport unit release lever sensor	PS28	1: released
15	not used		1: error	

Addresses	Bit	Description	Notation	Remarks
P006	0	drum motor lock detection	M0	0: constant speed
	1	laser scanner motor lock detection	M4	0: constant speed
	2	fixing motor lock detection	M3	0: constant speed
	3	primary charging error detection	PCB11	1: error
	4	transfer charging error detection	PCB11	1: error
	5	transfer charging error detection	PCB11	1: error
	6	buffer motor error detection	M18	1: error
	7	bottle motor error detection	M23	1: error
	8	sub hopper motor error detection	M22	1: error
	9	separation heat discharge fan stop detection	FM20	1: off
	10	right door fan stop detection	FM23	1: off
	11	duplexing transport fan stop detection	FM19	1: off
	12	sub hopper inside toner sensor	TS4	0: toner absent
	13	AC relay shut-off open circuit detection		1: normal
	14	overcurrent notification (24 V)	PCB14	1: overcurrent
15	overcurrent notification (38 V)	PCB14	1: overcurrent	
P007	0	primary charging wire cleanser drive	M8	1: to rear
	1	primary charging wire cleaner drive	M8	1: to front
	2	pre-transfer charging wire cleaner drive	M7	1: to front
	3	pre-transfer charging wire cleaner drive	M7	1: to rear
	4	transfer/separation charging wire cleaner drive	M9	1: to rear
	5	transfer/separation charging wire cleaner drive	M9	1: to front
	6	fixing motor brake signal	M3	1: brake
	7	sub hopper motor drive	M22	1: ON
	8	drum motor drive	M0	0: ON
	9	main motor drive	M1	0: ON
	10	pickup motor drive	M2	0: ON
	11	fixing motor drive	M3	0: ON
	12	laser scanner motor drive	M4	0: ON
	13	bottle motor drive	M23	1: ON
	14	buffer motor drive	M18	1: ON
15	laser scanner motor speed switchover	M4	0: high-speed	
P008	0	fixing main heater drive	H1	1: ON
	1	fixing sub heater drive	H2	1: ON
	2	cassette heater drive	H4	0: ON
	3	drum heater drive	H3	1: ON
	4	drum heater half-wave/full-wave	H3	0: half-wave
	5	separation heat discharge fan full speed	FM20	0: ON
	6	bottle motor drive	M23	0: ON
	7	separation heat discharge fan half speed	FM20	0: off
	8	laser scanner motor cooling fan full speed	FM1	1: ON
	9	laser scanner motor cooling fan half speed	FM1	1: ON
	10	laser scanner cooling fan full speed	FM3	1: ON
	11	laser scanner cooling fan half speed	FM3	1: ON
	12	pre-transfer charging assembly fan full speed	FM10	1: ON
	13	pre-transfer charging assembly fan half speed	FM10	1: ON
	14	not used		
15	duplexing transport fan full speed	FM19	0: ON	

Addresses	Bit	Description	Notation	Remarks
P009	0	vibration motor 1	M10	1: ON
	1	vibration motor 2	M20	1: ON
	2	separation fan full speed	FM13	1: ON
	3	not used		
	4	curl-removing fan full speed	FM6	1: ON
	5	developing fan full speed	FM15	1: ON
	6	developing fan half speed	FM15	1: ON
	7	not used		
	8	fixing heat discharge fan full speed	FM2	1: ON
	9	fixing heat discharge fan half speed	FM2	1: ON
	10	not used		
	11	delivery anti-adhesion fan full speed	FM17	1: ON
	12	drum suction fan full speed	FM8	1: ON
	13	drum suction fan half speed	FM8	1: ON
	14	power supply cooling fan 1/2 full speed	FM11/12	1: ON
15	power supply cooling fan 1/2 half speed	FM11/12	1: ON	
P010	0	left deck transport clutch	CL19	1: ON
	1	lower transport right clutch	CL17	1: ON
	2	lower transport middle clutch	CL16	1: ON
	3	developing cylinder clutch	CL4	1: ON
	4	developing cylinder deceleration clutch	CL20	1: ON
	5	left deck pickup solenoid	SL8	1: ON
	6	cassette 3 pickup solenoid	SL9	1: ON
P011	7	cassette 4 pickup solenoid	SL10	1: ON
	0	delivery flapper solenoid	SL3	1: ON
	1	reversal flapper solenoid	SL11	1: ON
	2-5	not used		
	6	for R&D		
P012	7	for R&D		
	0	not used		
	1	right deck pickup clutch	CL10	1: ON
	2	left deck pickup clutch	CL11	1: ON
	3	cassette 3 pickup clutch	CL12	1: ON
	4	cassette 4 pickup clutch	CL14	1: ON
	5	vertical path 1 clutch	CL8	1: ON
	6	vertical path 2 clutch	CL9	1: ON
P013	7	vertical path 3 clutch	CL13	1: ON
	0	vertical path 4 clutch	CL15	1: ON
	1	manual feeder tray pickup clutch	CL7	1: ON
	2	manual feeder tray transport clutch	CL18	1: ON
	3	pre-registration clutch	CL5	1: ON
	4	speed switchover delivery clutch	CL21	1: reversal; 0: straight
	5	multifeeder transport clutch	CL22	1: ON
	6	DDI command		
	7	DDI command		

Addresses	Bit	Description	Notation	Remarks
P014	0	buffer inside magnet roller drive clutch	CL1	1: ON
	1	sub hopper inside toner feed clutch	CL23	1: ON
	2	right deck pickup solenoid	SL7	1: ON
	3	manual feed pickup latch solenoid (return)	SL6	1: ON
	4	manual feed latch solenoid (pull)	SL6	1: ON
	5	double-feeding detection PCB (reception) power supply	PCB33	0: power supplied
	6	reader heat discharge fan 1 full speed	FM21	1: ON
	7	reader heat discharge fan 1 half speed	FM21	1: ON
P015	0	video PCB manual reset	PCB3	0: reset
	1	reader heat discharge fan 2 full speed	FM18	1: ON
	2	reader heat discharge fan 2 half speed	FM18	1: ON
	3	fixing web solenoid	SL2	1: ON
	4	fixing transport unit lock solenoid (return)	SL4	0: ON
	5	fixing transport unit lock solenoid (pull)	SL4	1: ON
	6	pre-exposure lamp	LED1	1: ON
	7	for factory check		
P016	0	potential sensor	PCB19	1: ON
	1	high-voltage DC output	HVT	0: high-voltage output on
	2	developing AC output	HVT	0: ON
	3	pre-transfer charging AC bias/separation AC bias	HVT	0: ON
	4	paper transport guide bias	PCB11	0: ON
	5	paper transport guide bias switchover	PCB11	0: 200V 1: 600V
	6	waste toner case full reset	MSW2	0: reset
	7	main power shut-off	SW1	1: shut-off
P017	0-5	DDI command		
	6	double-feeding detection PCB (reception) connection detection	PCB33	1: connected
	7	bottle motor connection detection	PCB23	0: connected
P018	0-2	DDI command		
	3	not used		
	4	right deck lifter motor drive	M13	1: ON
	5	left deck lifter motor drive	M14	1: ON
	6	cassette 3 lifter motor drive	M16	1: ON
	7	cassette 4 lifter motor drive	M17	1: ON
	P019	0	DDI command	
1		DDI command		
2		not used		
3		not used		
4		relay ON		
5		not used		
6		not used		
7		PTOP output		
P020	0	LED2		
	1	LED1		
	2-7	not used		

Addresses	Bit	Description	Notation	Remarks
P021	0	for check		
	1	download control (reserved)		
	2	horizontal registration sensor		
	3	clock signal		
	4-7	not used		
P022	0	model switchover 1		
	1	model switchover 0		
	2	registration clutch brake		
	3	registration roller clutch		
	4	model switchover 2		
	5	relay SNS		
	6	not used		
	7	not used		
P023	0-7	factory mode		
P024	0-5	factory mode		
	6	not used		
	7	not used		
P025	0	optical sensor off 7		
	1	optical sensor off 6		
	2	optical sensor off 5		
	3	optical sensor off 4		
	4	optical sensor off 3		
	5	optical sensor off 2		
	6	optical sensor off 1		
	7	optical sensor off 0		
P026	0	side paper deck LED		
	1	side paper deck pickup roller release solenoid		
	2	side paper deck pull-off clutch		
	3	side paper deck pickup clutch		
	4	side paper deck pickup motor		
	5	side paper deck lifter motor		
	6	side paper deck lifter up/down		
	7	side paper deck open solenoid		
	8	side paper deck chip select		(H: CL, etc.; L: SNR)
	9	side paper deck latch IC control		(on only at power-on)
	10	side paper deck sensor switchover		(L: pickup; H: pull-out)
	11	side paper deck sensor LED		(H: force off; L: on)
	12	side paper deck speed switchover 1		
	13	side paper deck speed switchover 2		
	14	not used		
15	not used			

Addresses	Bit	Description	Notation	Remarks
P027	0	side paper deck open switch		L: OPEN
	1	side paper deck paper present		H: prevented
	2	side paper deck pickup position sensor		H: ON
	3	side paper deck pickup sensor on		H: ON
	4	side paper deck pull-off sensor on		H: ON
	5	side paper deck pickup solenoid		H: ON
	6	side paper deck motor clock detection		H: detected
	7	side paper deck paper supply position sensor		H: ON
	8	side paper deck paper level detection		H: detected
	9	side paper deck lifter lower limit detection		H: detected
	10	side paper deck installation detection		H: installed
	11	side paper deck state detection		H: closed
	12	side paper deck lifter motor overcurrent detection		H: detected
	13	not used		
	14	side paper deck connection detection		H: detected
15	side paper deck connection detection		L: detected	
P028-P029		not used		
P030	0	sub SSR error		H: shorted
	1	main SSR error	E004	H: shorted
	2	fixing thermistor 2 error detection		H: error
	3	fixing thermistor 1 error detection	E001	H: error
	4	fixing thermistor 2 open circuit detection		H: released
	5	fixing thermistor 1 open circuit detection		H: released
	6	fixing motor zero-cross error		H: error
	7	not used		
	8	released by sub SSR		H: released
	9	released by main SSR		H: released
	10	released by error in fixing thermistor 2		H: released
	11	released by error in fixing thermistor 1		H: released
	12	released by open circuit fixing thermistor 2		H: released
	13	released by open circuit in fixing thermistor 1		H: released
	14	not used		
15	not used			

17.3.3 <R-CON> <iR7105 / iR7095>

shading RAM chip select

T-17-11

Address	Bit	Description	Remarks
P001	0	reader heat discharge fan 1 stop detection	1: off
	1	reader heat discharge fan 1	1: ON
	2	reader heat discharge fan 2 stop detection	1: off
	3	reader heat discharge fan 2	1: ON
	4	not used	
	5	DDI-S command signal	
	6	DDI-S command signal	
	7	DDI-S command signal	
P002	0	xenon lamp control signal	0: ON
	1	power supply monitor (24V system)	1: 24V
	2	power supply monitor (13V system)	1: 13V
	3	not used	
	4	scanner motor control signal	1: ON
	5	sub scanning detection signal	0: ON
	6	sub scanning detection signal	0: ON
	7	main scanning detection signal	0: ON
P003	0	DDI-S command signal	
	1	ADF serial communication (TxD)	
	2	DDI-S command signal	
	3	ADF serial communication (RxD)	
	4	start-up check LED	
	5	DDI-S command signal	
	6	not used	
	7	not used	
P004	0	DDI-S command signal	
	1	DDI-S command signal	
	2	reader start-up signal	
	3	CPU operation mode setup	
	4	not used	
	5	not used	
	6	scanner motor reference voltage	
	7	not used	
P005	0	PC I/F	
	1	PC I/F	
	2	DDI-S command signal	
	3	DDI-S command signal	
	4	not used	
	5	not used	
	6	not used	
	7	not used	

Address	Bit	Description	Remarks
P006	0	not used	
	1	for factory mode	
	2	original size detection control signal	1: ON
	3	main scanning detection signal	0: ON
	4	image lead edge signal	0: ON
	5	scanner home position signal	0: HPdetected
	6	not used	
P007	7	copyboard closed detection signal	0: closed
	0	address bus	
	1	address bus	
	2	address bus	
	3	not used	
	4	download start	
	5	ADF reset signal	
P008	6	ADF mode setup	
	7	DDI-S command signal	
	0	not used	
	1	CCD on/off control signal	1: ON
	2	wait signal	
	3	write signal (Low)	
	4	write signal (High)	
P009	5	read signal	
	6	not used	
	7	CPU clock	
	0	not used	
	1	shading RAM chip select	
	2	work RAM chip select	
	3	ASIC RAM chip select	
P009	4	Flash ROM chip select	
	5	not used	
	6	not used	
	7	not used	

17.3.4 <R-CON>

<iR7086>

T-17-12

Address	bit	Description	Remarks
P001	0	delivery motor clock	
	1	DDIS IF(OPTO0-)	0: operation prohibited
	2	DDIS IF(SPRDY)	0: operation enabled
	3	DDIS IF(OPTI0)	0: active
	4	ADF pickup motor clock	
	5	fan power supply on signal	1: ON
	6	ADF read motor clock	
	7	size sensor on	1: ON
P002	0	shift motor clock	
	1	24V power supply monitor	0: normal
	2-3	not used	
	4	scanner motor clock	
	5	13V power supply monitor	0: normal
	6	Canon Denshi switchover	0: Cannon Denshi
	7	DDIS IF(SCPRDY)	0: operation enabled
P003	0	DDIS serial communication (TxD)	-
	1	ADF serial communication (TxD)	-
	2	DDIS serial communication (RxD)	-
	3	ADF serial communication (RxD)	-
	4	LED control	1: ON
	5	ADF serial communication (STACK)	-
	6-7	not used	
P004	0	original size detection 0	0: original present
	1	original size detection 1	0: original present
	2	original size detection 2	0: original present
	3	original size detection 3	0: original present
	4	DF connection detection	-
	5	DDIS IF(SRTS)	0: reception ready
	6	scanner motor Vref output	-
	7	not used	-
P005	0	PC connection IF (TxD)	-
	1	PC connection IF (RxD)	-
	2	fan lock detection signal	0: enabled
	3	DDIS IF(SCTS)	0: reception ready
	4-7	not used	
P006	0	not used	-
	1	PCB check terminal	1: normal
	2	DDIS IF(OPTI1)	0: active
	3	DDIS IF(OPTO1)	0: active
	4	ADF sensor interrupt input	0: active
	5	copyboard open/closed sensor interrupt input 0	1: copyboard closed
	6	HP sensor interrupt input	1: HP
	7	not used	-

Address	bit	Description	Remarks
P007	0	address bus 16	-
	1	address bus 17	-
	2	address bus 18	-
	3-4	not used	-
	5	ADF pickup motor lock interrupt input	
	6	ADF read motor lock interrupt input	
	7	ADF delivery reversal motor lock interrupt input	
P008	0	lamp on signal	1: ON
	1	CCD drive on signal	1: ON
	2	wait sign	0: wait
	3	L light signal	0: active
	4	H light signal	0: active
	5	read signal	0: active
	6	ADF serial communication (LOAD)	0: enabled
	7	CPU clock output	-
P009	0	not used	
	1	shading RAM chip select	0: selected
	2	work RAM chip select	0: selected
	3	ASIC register select	0: selected
	4	ROM chip select	0: selected
	5-7	not used	

17.3.5 <FEEDER> <iR7105 / iR7095>

T-17-13

Address	bit	Description	Notation	Remarks
P001	0	image lead edge signal		1: image lead edge
	1	pre-registration sensor	S2	1: original present
	2	OSC		
	3	not used		
	4	not used		
	5	delivery motor clock	PI11	during output, alternately between '0' and '1'
	6	delivery motor PWM signal	M5	0: output present
	7	not used		
P002	0	belt motor phase A		during output, alternately between '0' and '1'
	1	belt motor phase B		during output, alternately between '0' and '1'
	2	belt motor phase A*		during output, alternately between '0' and '1'
	3	belt motor phase B*		during output, alternately between '0' and '1'
	4	separation motor PWM signal	M4	0: output present
	5	reversal motor phase A		during output, alternately between '0' and '1'
	6	separation motor reference Ref		
	7	reversal motor phase B		during output, alternately between '0' and '1'
P003	0	TxD0		
	1	not used		
	2	RxD0		
	3	not used		
	4	SCK0		
	5	EEPROM chip select		1: EEPROM selected
	6	not used		
	7	not used		

Addresses	bit	Description	Notation	Remarks
P004	0	not used		
	1	not used		
	2	original sensor	S6	0: original present
	3	original trail edge sensor	S7	1: original present
	4	24VP down detection		1: 17 V or less
	5	24VL down detection		1: 17 V or less
	6	13V down detection		1: 10 V or less
	7	manual feeder registration roller sensor	S9	1: original present
P005	0-2	not used		
	3	A/D conversion trigger		
	4-7	not used		
P006	0	DA load signal		1: transmit
	1	PICK1		
	2	PICK0		
	3	PICKSTBY		
	4	separation sensor	S4	0: original present
	5	sheet-to-sheet sensor		
	6	belt motor clock		
	7	post-registration roller sensor	S3	1: original present
P007	0	ADF open/closed detection	PI10	1: closed
	1	pre-reversal sensor	PI4	1: original present
	2	left cover rear sensor (rear)	PI3	1: closed
	3	not used		
	4	skew sensor	S5	1: original present
	5	separation clock		during output, alternately '0' and '1'
	6	reversal sensor	S1	1: original present
	7	reversal slave clock		during output, alternately '0' and '1'
P008	0	pickup roller HP sensor	PI7	1: HP
	1	pickup roller height position sensor 1	PI8	1: paper present
	2	pickup roller height position sensor 2	PI9	1: paper present
	3	left cover front sensor (front side)	PI6	1: closed
	4	not used		
	5	not used		
	6	delivery sensor	PI13	1: original present
	7	manual feeder original sensor	PI12	1: original present
P009	0	tray LED		1: ON
	1	reversal flapper solenoid	SL1	1: ON
	2	shutter solenoid	SL2	0: plunger pulled
	3	shutter solenoid		0: plunger returned
	4	belt motor fan ON signal	FM1	0: ON
	5	pre-reversal flapper solenoid	SL3	1: ON
	6	separation clutch	CL1	1: ON
	7	solenoid timer		0: 100msec
P010	0	pickup motor phase A		
	1	pickup motor phase B		
	2	pickup motor phase A*		
	3	pickup motor phase B*		
	4	not used		
	5	not used		
	6	not used		
	7	not used		

Addresses	bit	Description	Notation	Remarks
P011	0	delivery flapper solenoid	SL4	0: plunger pulled
	1	delivery flapper solenoid	SL4	0: plunger returned
	2	not used		
	3	sensor power supply (+5R) ON/OFF		1: 5V ON
	4-7	not used		
P012	0	7-segment LED (D)		
	1	7-segment LED (E)		
	2	7-segment LED (C)		
	3	7-segment LED (G)		
	4	7-segment LED (B)		
	5	7-segment LED (F)		
	6	7-segment LED (A)		
	7	not used		
P013	0	original width detecting switch (SW1)		
	1	original width detecting switch (SW2)		
	2	original width detecting switch (SW3)		
	3	original width detecting switch (SW4)		
	4	original width detecting switch (SW5)		
	5	push switch (SW2)		0: pressed
	6	push switch (SW3)		0: pressed
	7	push switch (SW4)		0: pressed
P014	0	DIP switch (DIPSW1)		0: ON
	1	DIP switch (DIPSW2)		0: ON
	2	DIP switch (DIPSW3)		0: ON
	3	DIP switch (DIPSW4)		0: ON
	4	DIP switch (DIPSW5)		0: ON
	5	DIP switch (DIPSW6)		0: ON
	6	DIP switch (DIPSW7)		0: ON
	7	DIP switch (DIPSW8)		0: ON
P015		separation clock F/V		hereafter, analog port
P016		delivery clock F/V		
P017		original sensor AD		
P018		original sensor AD		
P019		reversal motor current adjustment		
P020		belt motor power supply adjustment		
P021		original sensor adjustment		
P022		original trail edge sensor adjustment		
P023		separation sensor adjustment		
P024		skew sensor adjustment		
P025		pre-registration roller sensor adjustment		
P026		post-registration roller sensor adjustment		
P027		reversal sensor adjustment		
P028		manual feeder registration roller sensor adjustment		
P029		sensor Ref voltage adjustment		
P030		separation motor current limit adjustment		

17.3.6 <FEEDER>

<iR7086>

T-17-14

Address	bit	Description	Remarks
P001	0	read sensor	0: paper present
	1	registration sensor	1: paper present
	2	delivery reversal sensor	0: paper present
	3	ADF cover open/closed sensor	0: ADF open
	4-7	not used	
P002	0	delivery reversal motor current setting 1	
	1	delivery reversal motor current setting 2	
	2	release motor current setting 1	
	3	release motor current setting 2	
	4	stamp solenoid drive	1: ON
	5	clutch drive	1: ON
	6	original detection LED	1: on
	7	fan motor drive	1: ON
P003	0	pickup motor current setting CUT	
	1	pickup motor current setting CUT	
	2	locking motor current setting	
	3	transport motor mode setting	
	4	transport motor current setting 1	
	5	transport motor current setting 2	
	6	pickup motor current setting 1	
	7	pickup motor current setting 2	
P004	0	ADF cover closed/open sensor	0: ADF cover open
	1-6	not used	
	7	stamp present/absent	0: stamp present
P005	0	not used	
	1	release H sensor	1: released
	2	delivery reversal sensor	0: paper present
	3	post-separation sensor	0: paper present
	4	LGL sensor	1: paper present
	5	AB/inch sensor	1: AB
	6	not used	
	7	original placement sensor	0: paper present
P006	0-7	for R&D	
P007	0-7	for R&D	
P008	0-7	for R&D	
P009	0-7	for R&D	
P010	0-7	for R&D	
P011	0-7	for R&D	

17.3.7 <SORTER>

T-17-15

Address	Bit	Description	Remarks
P001	0	shift transport motor FG	
	1	buffer motor FG	
	2	punch motor FG	
	3	inlet motor FG	
	4	punch RX interrupt	
	5	punch TX interrupt	
	6	trimmer RX interrupt	
	7	trimmer TX interrupt	
	8	stack delivery clock	
	9	pre-buffer transport motor FG	
	10	not used	
	11	folding motor FG	
	12	saddle press motor encoder clock	
	13	saddle feed motor FG	
	14	saddle butting motor encoder clock	
15	saddle folding encoder clock		
P002	0	inserter output	
	1	download output	
	2	inserter input	
	3	download input	
	4	inserter reset	
	5	inserter mode	
	6	not used	
	7	not used	
	8	horizontal registration sensor	
	9	buffer No. 2 sensor	
	10	buffer sensor	
	11	dust sensor	
	12	not used	
	13	lower path sensor	
	14	sample tray ISA/paper surface	
15	stack tray ISA/paper surface		
P003	0	paper folding unit output	
	1	paper folding unit input	
	2	not used	
	3	power supply remote output	1: ON
	4-7	not used	
	8	ASIC0 chip select	
	9	ASIC1 chip select	
	10	ASIC reset output	0: Reset
	11	SST download mode	
	12	ASIC0 interrupt 1	
	13	ASIC1 interrupt	
	14	sample tray idle movement detection	
15	ASIC0 interrupt 2		

Address	Bit	Description	Remarks
P004	0-3	address bus	
	4	not used	
	5	delivery motor FG	
	6	ARCNET-INT	
	7	stack tray idle movement detection	
	8	download hard latch command	
	9	download hard latch input	
	10	download latch release	
	11	light signal (lower order)	
	12	light signal (upper order)	
	13	read signal	
	14	not used	
	15	clock output	
P005	0	check LED	1: on
	1	SRAM chip select	0: selected
	2	not used	
	3	ROM chip select	0: selected
	4	ARCNET chip select	0: selected
5-15	not used		
P006	0	swing motor speed setting (High)	
	1	swing motor speed setting (Middle)	
	2	swing motor speed setting (Low)	
	3	swing motor on*	0: ON
	4	knurled belt shift motor phase A	
	5	knurled belt shift motor phase B	
	6	knurled belt shift motor current switchover	
	7	not used	
	8	upper guide motor phase A	
	9	upper guide motor phase B	
	10	upper guide motor current switchover	
	11	not used	
	12	assist motor clock	
	13	assist motor CW	1: CCW
	14	assist motor current switchover 1	
15	assist motor current switchover 2		
P007	0	stack delivery motor clock	
	1	stack delivery motor CW	1: CCW
	2	stack delivery motor current switchover 1	
	3	stack delivery motor current switchover 2	
	4	conveyer motor phase A	
	5	conveyer motor phase B	
	6	conveyor motor current switchover	
7-15	not used		
P008	0-15	not used	
P009	0-8	not used	
	9	upper guide HP sensor	1: HP
	10	knurled belt shift HP sensor	1: HP
	11	stack delivery motor 8FG	
	12	assist motor 8FG	
	13	saddle sub tray sensor	
	14	conveyer paper sensor 2	1: paper present
15	conveyer paper sensor 1	1: paper present	

Address	Bit	Description	Remarks
P010	0	LED4 (for indication of presence of paper)	1: ON
	1	not used	
	2	saddle butting motor CCW	1: CW
	3	saddle butting motor CW	1: CCW
	4	saddle butting transport motor PWM	0: ON
	5	saddle folding transport motor PWM	0: ON
	6	saddle folding transport motor CCW	1: CW
	7	saddle folding transport motor CW	1: CCW
	8	saddle alignment motor phase A	
	9	saddle alignment motor phase B	
	10	saddle alignment motor current	1: retained
	11	saddle press motor PWM	0: ON
	12	saddle alignment motor phase A*	
	13	saddle alignment motor phase B*	
	14	not used	
15	not used		
P011	0	saddle press motor CCW	1: CW
	1	saddle press motor CW	1: CCW
	2	not used	
	3	not used	
	4	saddle stapler motor CCW	1: CCW
	5	saddle stapler motor CW	1: CW
	6-12	not used	
	13	LED1	1: ON
	14	not used	
15	not used		
P012	0-11	not used	
	12	saddle press motor clock sensor	
	13	saddle transport motor FG	
	14	SDL butting motor lock sensor	
	15	saddle folding motor clock sensor	
P013	0-7	not used	
	8	saddle press HP sensor	1: HP
	9	saddle press intermediate sensor	
	10	saddle lead edge stopper HP sensor	1: HP
	11	saddle alignment HP sensor	1: HP
	12	saddle lead edge path sensor	1: paper present
	13	saddle staple detection 2	1: staple present
	14	saddle staple detection 2	1: staple present
15	saddle stapler HP sensor	1: HP	

Address	Bit	Description	Remarks
P014	0	rear alignment motor clock	
	1	rear alignment motor CW	
	2	rear alignment motor current switchover	
	3	not used	
	4	front alignment motor clock	
	5	front alignment motor CW	
	6	front alignment motor current switchover IH	
	7	not used	
	8	front bin shift motor phase A	
	9	front bin shift motor phase B	
	10	front bin shift motor current switchover	
	11	not used	
	12	trail edge motor phase A	
	13	trail edge motor phase B	
	14	trail edge motor alignment switchover	
15	handling tray solenoid		
P015	0	paddle lift motor phase A	
	1	paddle lift motor phase B	
	2	paddle lift motor current switchover	
	3	power-down (host standby mode)	
	4-7	not used	
	8	paddle rotation motor clock	
	9	paddle rotation motor CW	
	10	paddle rotation motor current switchover	
	11	not used	
	12	tray motor A	
	13	tray motor B	
	14	tray motor ON	
	15	check LED	1: on
	P016	0-7	not used
8		check SW8	
9		check SW7	
10		check SW6	
11		check SW5	
12		check SW4	
13		check SW3	
14		check SW2	
15		check SW1	
P017	0-2	not used	
	3	paddle lift HP sensor	1: HP
	4	shutter HP sensor	0: HP
	5	swing guide closed detection	0: Close
	6	swing guide open detention	1: HP
	7	tray HP sensor	1: HP
	8	paddle rotation HP sensor	1: HP
	9	swing motor clock sensor	
	10	rear alignment motor HP sensor	1: HP
	11	bin \$ sensor 2	
	12	handling tray paper sensor	0: paper present
	13	assist HP sensor	1: HP
	14	bin sensor 1	0: HP (bin HP)
15	front alignment HP sensor	1: HP	

Address	Bit	Description	Remarks
P018	0-3	not used	
	4	saddle lead edge stopper motor phase A	
	5	saddle lead edge stopper motor phase B	
	6	saddle lead edge stopper current	1: retained
	7	not used	
	8	saddle flapper solenoid 1	1: ON
	9	saddle flapper solenoid 2	1: ON
	10-15	not used	
P019	0	saddle pull-in roller shift motor phase A	
	1	saddle pull-in roller shift motor phase B	
	2	saddle pull-in roller shift motor current switchover	1: retained
	3	not used	
	4	saddle roller guide motor phase A	
	5	saddle roller guide motor phase B	
	6	saddle roller guide motor current switchover	1: retained
	7	not used	
	8	saddle transport motor clock	
	9	saddle transport motor CW	
	10	saddle transport motor current	
	11	saddle transport motor current	
	12	motor off signal	1: ON
13-15	not used		
P020	0-15	not used	
P021	0-7	not used	
	8	saddle butting HP sensor	1: HP
	9	saddle vertical path sensor	1: paper present
	10	saddle pull-in roller HP sensor	1: HP
	11	saddle roller guide HP sensor	1: HP
	12	saddle stack delivery sensor	0: paper present
	13	saddle small sensor	0: paper present
	14	saddle inlet sensor	1: paper present
15	saddle roller guide HP sensor passage detection	1: HP passed	
P022	0	buffer motor clock	
	1	buffer motor CW	1: CCW
	2	buffer motor current switchover 1	
	3	buffer motor current switchover 2	
	4	trimmer remote signal	0: ON
	5	trimmer output spare	
	6	Z-fold roller drive motor clock	
	7	Z-fold drive motor ON	1: ON
	8	pre-buffer transport motor clock	
	9	pre-buffer transport motor CW	1: CCW
	10	pre-buffer transport motor current switchover 1	
	11	pre-buffer transport motor current switchover 2	
	12	inserter detachment	0: detached
	13	paper folding unit detachment	0: detached
	14	saddle detachment	1: detached
15	not used		

Address	Bit	Description	Remarks
P023	0	shift transport motor clock	
	1	shift transport motor CW	1: CCW
	2	shift transport motor current switchover 1	
	3	shift transport motor current switchover 2	
	4	not used	
	5	fan on signal	1: ON
	6	Z-fold release solenoid	1: ON
	7	Z-fold lock solenoid	1: ON
	8	Z-fold inlet flapper solenoid	1: ON
	9	Z-fold B4 No. 1 solenoid	1: ON
	10	A-fold B4 No. 2 solenoid	1: ON
	11	motor standby	1: operating
	12	inlet transport motor clock	
	13	inlet transport motor CW	1: CCW
	14	inlet transport motor ON signal	
15	inlet transport motor current switchover		
P024	0	lower delivery sensor	1: paper present
	1	buffer No. 2 sensor	0: paper present
	2	horizontal registration sensor	0: paper present
	3	buffer path sensor	0: paper present
	4	shift unit trail edge sensor	1: paper present
	5	inlet sensor	1: paper present
	6	upper delivery sensor	1: paper present
	7	lower path sensor	0: paper present
	8	Z-fold path residual paper sensor 1	1: paper present
	9	Z-fold path residual paper sensor 2	1: paper present
	10	Z-fold path residual paper sensor 3	1: paper present
	11	Z-fold transport path paper sensor 1	1: paper present
	12	Z-fold transport path paper sensor 2	1: paper present
	13	Z-fold transport path paper sensor 3	1: paper present
	14	Z-fold transport path paper sensor 4	1: paper present
15	horizontal registration HP sensor	1: HP	
P025	0	stapler HP sensor	0: HP
	1	punch motor HP detection	1: HP
	2	punch front detection	1: rear; 0: front
	3	shift roller unit HP sensor	1: HP
	4	transport roller HP sensor	1: HP
	5	trail edge HP	1: HP
	6	professional puncher standby	
	7	professional puncher PUNCHENABLE signal	
	8	professional puncher PAERCOMACK signal	
	9	professional puncher PAPEREXIT signal	
	10	professional puncher door open	
	11	professional puncher connection detection	
	12	professional puncher connection detection	0: connected
	13	trimmer connection detection	0: connected
	14	not used	
15	not used		

Address	Bit	Description	Remarks
P026	0	paper surface sensor A/D input selector 1	
	1	paper surface sensor A/D input selector 2	
	2	paper surface sensor A/D input selector 3	
	3	not used	
	4	lower tray motor clock	
	5	lower tray motor CW	1: CW
	6	lower tray motor current switchover 1	
	7	lower tray motor current switchover 2	
	8	upper tray motor clock (sample tray)	
	9	upper tray motor CW (sample tray)	1: CW
	10	upper tray motor current switchover 1	
	11	upper tray motor current switchover 2	
	12	sub tray lifter solenoid	0: ON
	13	not used	
	14	stapler motor ON	
15	stapler motor direction switchover		
P027	0	stapler shift motor clock	
	1	stapler shift motor CW	1: CW
	2	stapler shift motor current switchover	
	3	stapler shift motor current switchover	
	4	lower tray detachment	0: detached
	5	not used	
	6	inserter CONFIGSET	
	7	inserter FEEDREQ	
	8	7-segment DOT	1: on
	9	7-segment G	1: on
	10	7-segment F	1: on
	11	7-segment e	1: on
	12	7-segment d	1: on
	13	7-segment c	1: on
	14	7-segment b	1: on
15	7-segment a	1: on	
P028	0	upper tray area sensor 1	1: light blocked
	1	upper tray area sensor 2	1: light blocked
	2	upper tray area sensor 3	1: light blocked
	3	upper tray area sensor 4	1: light blocked
	4	lower tray position sensor 1	1: light blocked
	5	lower tray position sensor 2	1: light blocked
	6	lower tray position sensor 3	1: light blocked
	7	lower tray position sensor 4	1: light blocked
	8	lower tray sensor	0: paper present
	9	lower tray paper surface sensor	0: paper present
	10	lower tray ISA sensor	0: paper present
	11	upper tray sensor	0: paper present
	12	upper tray paper surface sensor	0: paper present
	13	upper tray ISA sensor	0: paper present
	14	rib guide safety detection	1: detected
15	tray approach switch	0: detected	

Address	Bit	Description	Remarks
P029	0	upper tray paper sensor	1: paper present
	1	lower tray paper sensor	1: paper present
	2	waste staple case full detection 1	1: not set/full
	3	puncher unit detection	0: present
	4	stapling position 1	1: OK
	5	stapling position 2	1: OK
	6	stapling position 3	1: OK
	7	stapling position 4	1: OK
	8	stapler slide HP	
	9	stapler 24V down detection	1: 24V OFF
	10	READY detection	1: Ready
	11	staple absent detection	0: staple absent
	12	inserter SENSON	
	13	inserter serial error	
	14	inserter connector detection	1: connected
15	not used		
P030	0	assist roller shift solenoid 1	1: ON
	1	upper path switchover solenoid	1: ON
	2	punch PWM	
	3	saddle path switching solenoid	1: ON
	4	delivery motor clock	
	5	delivery motor CW/CCW	1: CCW
	6	delivery motor current switchover 1	
	7	delivery motor current switchover 2	
	8	horizontal registration shift motor clock (1-2 phase)	
	9	horizontal registration motor CW/CCW	1: CCW
	10	horizontal registration shift motor current switchover 1	
	11	horizontal registration shift motor current switchover 2	
	12	transport roller shift motor phase A	
	13	transport roller shift motor phase B	
	14	transport roller shift motor current switchover 1	
15	transport roller shift motor current switchover 2		
P031	0	horizontal registration detection motor phase A	
	1	horizontal registration detection motor phase B	
	2	horizontal registration detection motor current switchover 1	
	3	horizontal registration detection motor current switchover 2	
	4	horizontal registration detection motor phase A*	
	5	horizontal registration detection motor phase B*	
	6	buffer path switchover solenoid	1: ON
	7	not used	
	8	punch motor on signal	PCH-M-CW
	9	punch motor direction switchover	PCH-M-CCW
	10	5V power-down	0: power-down
	11	not used	
	12	professional puncher MACHINEON	
	13	professional puncher PAPERLATCH	
	14	professional puncher PAPERENTRY	
15	professional puncher PAPEREXITACK		

Address	Bit	Description	Remarks
P032	0	check SW8	
	1	check SW7	
	2	check SW6	
	3	check SW5	
	4	check SW4	
	5	check SW3	
	6	check SW2	
	7	check SW1	
	8	puncher check 2	
	9	puncher check 1	
	10	puncher check 0	
	11	for adjustment 0	
	12	for adjustment 1	
	13	for adjustment 2	
	14	for adjustment 3	
15	for adjustment 4		
P033	0	push switch (for ENTER)	not used
	1	push switch (for +)	0: pushed
	2	push switch (for -)	0: pushed
	3	fold transport motor FG	
	4	pre-buffer transport FG	
	5	door 24V power-down detection	1: power-down
	6	punch 2-hole/3-hole detection	1: 3-hole; 0: 2-hole
	7	punch waste case set detection	1: set
	8	front door open detection	0: open
	9	punch fan error	1: error
	10	upper cover open detection	0: open
	11	power supply fan error	1: error
	12	Z-fold path set detection	1: present
	13	Z-fold unit upper cover open detection	0: open
	14	folding unit connection detection	0: connected
15	saddle unit connection detection	0: connected	
P045		horizontal registration sensor	analog output
P046		buffer No. 2 sensor	
P047		buffer sensor	
P048		waste sensor	
P049		not used	
P050		lower path sensor	
P051		sample tray ISA/paper surface	
P052		stack tray ISA/paper surface	
P053		not used	
P054		punch waste case full sensor adjustment	
P055		sample tray ISA sensor adjustment	
P056		buffer path 2 adjustment	
P057		horizontal registration sensor adjustment	
P058		buffer path sensor adjustment	
P059		swing guide adjustment	
P060		lower path sensor adjustment	
P061-P063		not used	
P064		stack tray ISA sensor adjustment	
P065-P067		not used	

17.3.8 <MN-CONT>

Address	Bit	Description	Remarks
P001	0-15	for R&D	
P002	0-3	reader multi-purpose signal	
	3	reader power signal	
	4	printer start-up signal	
	5-7	printer multi-purpose signal	
	8	reader start-up signal	
	9	printer power signal	
	10-15	for R&D	
P003	0-5	for R&D	
	6	not used	
	7-15	for R&D	
P004	0-15	for R&D	
P005	0-9	for R&D	
	10	control panel connection (for MFP model)	0: connected
	11	control panel connection (for printer model)	0: connected
	12-15	for R&D	
P006-P016		not used	

17.4 ADJUST (Adjustment Mode)

17.4.1 COPIER

17.4.1.1 COPIER Items

<AE>

T-17-16

COPIER > ADJUST > AE		
Sub item	Description	Level
AE-TBL	Use it to adjust the character density for image density adjustment. range: 1 to 9 A higher setting will increase the density of characters. A lower setting will decrease the density of characters.  Be sure to enter the value indicated on the service label if you have initialized the RAM on the reader controller PCB.	1

<ADJ-XY>

T-17-17

COPIER > ADJUST > ADJ-XY		
*: model equipped with DADF-Q1 (outside Japan: iR7105/7095; inside Japan: All model).		
**: model equipped with DADF-M1 (outside Japan: iR7086).		
Sub item	Description	Level
Use it to adjust the image read start position.  Be sure to enter the value indicated on the service label if you have replaced the reader controller PCB or initialized the RAM.		
ADJ-X	Use it to adjust the image read start position (image lead edge) in sub scanning direction. range: 1 to 423 * / 1 to 2970 ** An increase by '1' will shift the image read start position by 0.1 mm toward the trail edge.	1
ADJ-Y	Use it to adjust the image read start position (horizontal registration) in main scanning direction. range: 1 to 423 * / 0 to 1000 ** An increase by '1' will shift the image read start position by 0.1 mm toward the front.	1
ADJ-S	Use it to adjust the shading correction data measurement position. range: 20 to 500 * / 0 to 4 ** A change by '1' will increase the image read start position by 0.1 toward the front.	1
ADJ-Y-DF	main scanning position adjustment or ADF stream reading range: 1 to 423 * / 0 to 1000 ** A change by '1' will increase the image read start position by 0.1 toward the front.	1
STRD-POS **	Use it to adjust the CCD read position for ADF stream reading mode. range: 1 to 200	1
ADJ-Y-FX *	Use it to adjust the main scanning position for ADF fixed reading mode. range: 1 to 423 A change by '1' will shift the image read start position by 0.1 mm toward the front.	1
ADJ-X-MG	Use it to fine-adjust the sub scanning magnification for copyboard mode. range: -50 to +50 (unit: 0.01%)	1

<CCD>

T-17-18

COPIER > ADJUST > CCD		
*: model equipped with DADF-Q1 (outside Japan: iR7105/7095; inside Japan: All model).		
**: model equipped with DADF-M1 (outside Japan: iR7086).		
Sub item	Description	Level
CCD, shading-related adjustment		
SH-TRGT	Use it to enter the white level target value for shading correction.	1
	Procedure Execute the following: COPIER > FUNCTION > CCD > CCD-ADJ, LUT-ADJ (LUT-ADJ2). Thereafter, if an image fault occurs, enter the value indicated on the service label. range: 1 to 2043	
DFTAR-G **	Use it to enter the shading target value for green for ADF mode.	1
	Procedure Execute the following: COPIER > FUNCTION > CCD > DF-WLVL1/DF-WLVL2. Thereafter, if an image fault occurs, enter the value indicated on the service label. range: 0 to 2047	

<LASER>





T-17-19

COPIER > ADJUST > LASER		
Sub item	Description	Level
Laser output adjustment		
PVE-OFST	Use it to adjust the laser A/C emission position.	1
	range: -300 to 300 A higher setting will cause a move toward the rear. A lower setting will cause a move toward the front. The laser B emission position moves in keeping with laser A, while the laser D emission position moves in keeping with laser C.	
LA-PWR-A	Use it to enter the laser A power adjustment value.	1
	range: 0 to 255	
LA-PWR-B	Use it to enter the laser B power adjustment value.	1
	range: 0 to 255	
LA-PWR-C	Use it to enter the laser C power adjustment value.	1
	range: 0 to 255	
LA-PWR-D	Use it to enter the laser D power adjustment value.	1
	range: 0 to 255	

<DEVELOP>

T-17-20

COPIER > ADJUST > DEVELOP		
Notes:		
At times, the value indicated for the following items may differ before and after input (maximum of +/-3). The fact has to do with how the indication values are computed, and will not affect the operation of the machine.		
Sub item	Description	Level
DE-DC	Use it to enter the developing DC bias output value for when an image is being formed.	1
	range: 0 to 600	
DE-NO-DC	Use it to enter the developing DC bias output value for when no image is being formed.	1
	range: 0 to 600	

COPIER > ADJUST > DEVELOP		
Notes: At times, the value indicated for the following items may differ before and after input (maximum of +/-3). The fact has to do with how the indication values are computed, and will not affect the operation of the machine.		
Sub item	Description	Level
HVT-DE	Use it to enter the offset value for the developing high-voltage output of the high-voltage unit. range: -50 to 50	1
	 Be sure to enter the value indicated on the label attached to the new unit if you have replace the high-voltage unit. Be sure to enter the value indicated on the service label if you have replaced the DC controller PCB or initialized the RAM.	
D-HV-DE	Use it to enter the offset value for the developing high-voltage of the DC controller PCB. range: -100 to 100	1
	 Be sure to enter the value indicated on the label attached to the new PCB if you have replaced the DC controller PCB. Be sure to enter the value indicated on the service label if you have initialized the RAM on the DC controller PCB.	
OFFSET DA	Use it to enter the high-voltage D/A output offset value for the developing AC bias. range: -100 to 100	1
	 Be sure to enter the value indicated on the label attached to the new PCB if you have replaced the DC controller PCB. Be sure to enter the value indicated on the service label if you have initialized the RAM on the DC controller PCB.	
OFFSET AC	Use it to adjust the offset value of the developing AC bias. range: -120 to 120	1
	 Be sure to enter the value indicated on the label attached to the new unit if you have replace the high-voltage unit. Be sure to enter the value indicated on the service label if you have replaced the DC controller PCB or initialized the RAM.	

<DENS>

T-17-21

COPIER > ADJUST > DENS		
Sub item	Description	Level
DENS-ADJ	Use it to correct the image density.	1
	Correct the F-value table if fogging occurs or a faint image occurs in a high-density area. A higher setting will reduce faint images. A lower setting will reduce fogging. range: 1 to 9  Be sure to enter the value indicated on the service label if you have replaced the DC controller PCB or initialized the RAM.	

<BLANK>

T-17-22

COPIER > ADJUST > BLANK		
Sub item	Description	Level
 Be sure to enter the value indicated on the service label if you have replaced the DC controller PCB or initialized the RAM.		
BLANK-T	Use it to enter the image lead edge non-image width adjustment value.	1
	range: 0 to 2362 A higher setting will increase the non-image width.	
BLANK-B	Use it to enter the image trail edge non-image width adjustment value.	1
	range: 0 to 2362 A higher setting will increase the non-image width. Notes: If you have changed BLANK-B and BLANK-TE, the higher setting will be given priority.	
BLANK-TE	Use it to enter a value of the non-image width in image main scanning direction (left, right).	1
	range: 10 to 50 Notes: If you have changed BLANK-B and BLANK-TE, the higher setting will be given priority.	

<V-CONT>

T-17-23

COPIER > ADJUST > V-CONT		
Sub item	Description	Level
 Enter the value indicated on the service label if you have replaced the DC controller PCB, initialized the RAM, or replaced the potential sensor (EPOTOFST only).		
EPOTOFST	Use it to enter the offset value of the potential sensor.	1
	range: 0 to 30	
VL-OFST	Use it to enter the offset value of the potential control light area target potential.	1
	range: -50 to 50	
VD-OFST	Use it to enter the offset value of the potential control dark area target potential.	1
	range: -50 to 50	
DE-OFST	Use it to enter the offset value for potential control VDC.	1
	range: -50 to 50	
OHP-OFST	Use it to enter the offset value of transparency potential control.	1
	range: -50 to 50	
VD-OFS-O	Use it to enter the offset value of the dark area target potential for transparency potential control.	1
	range: -50 to 50	







<HV-PRI>

T-17-24

COPIER > ADJUST > HV-PRI		
Sub item	Description	Level
GRID	Use it to enter the adjustment value for the primary charging assembly grid current.	1
	range: 400 to 900  Use it to enter the value indicated on the service label if you have replaced the DC controller PCB or initialized the RAM.	





<HV-TR>

T-17-25

COPIER > ADJUST > HV-TR		
Sub item	Description	Level
Notes: At times, the indicated value for the fogging items may differ before and after input (maximum of +/-3). The fact has to do with the way indicated values are computed, and will not affect the operation of the machine.		
TR-N1	Use it to enter the output adjustment value of the transfer charging current. (simplex mode, plain paper; or 1st side of double-sided print) range: -650 to 0  Be sure to enter the value indicated on the service label if you have replaced the DC controller PCB or initialized the RAM.	1
TR-N2	Use it to enter the output adjustment value of the transfer charging current. (plain paper, 2nd side of double-sided print) range: -650 to 0  Be sure to enter the value indicated on the service label if you have replaced the DC controller PCB or initialized the RAM.	1
PRE-TR	Use it to enter the output adjustment value of the pre-transfer charging current. range: 0 to 300  Be sure to enter the value indicated on the service label if you have replaced the DC controller PCB or initialized the RAM.	1
HVT-TR	Use it to enter the offset value of the transfer high-voltage output for the high-voltage unit. range: -100 to 100  Be sure to enter the value indicated on the label attached to the new unit if you have replace the high-voltage unit. Be sure to enter the value indicated on the service label if you have replaced the DC controller PCB or initialized the RAM.	1
H-PRE-TR	Use it to enter the offset voltage of the pre-transfer output for the high-voltage unit. range: -100 to 100  Be sure to enter the value indicated on the label attached to the new unit if you have replace the high-voltage unit. Be sure to enter the value indicated on the service label if you have replaced the DC controller PCB or initialized the RAM.	1
D-PRE-TR	Use it to enter the offset value of the pre-transfer high-voltage output or the DC controller PCB. range: -100 to 100  Be sure to enter the value indicated on the label attached to the new PCB if you have replaced the DC controller PCB. Be sure to enter the value indicated on the service label if you have initialized the RAM on the DC controller PCB.	1
D-HV-TR	Use it to enter the offset value of the transfer high-voltage output for the DC controller PCB. range: -100 to 100  Be sure to enter the value indicated on the label attached to the new PCB if you have replaced the DC controller PCB. Be sure to enter the value indicated on the service label if you have initialized the RAM on the DC controller PCB.	1

<HV-SP>

T-17-26

COPIER > ADJUST > HV-SP		
Sub item	Description	Level
Notes: At times, the indicated value for the following items may differ before and after input (maximum of +/-3). The fact has to do with the way indicated values are computed, and will not affect the operation of the machine.		
SP-N1	Use it to enter the output adjustment value of the separation charging current. (plain paper, simplex mode; or, 1st side of double-sided print) range: 0 to 800	1
	 Be sure to enter the value indicated on the service label if you have replaced the DC controller PCB or initialized the RAM.	
SP-N2	Use it to enter the output adjustment value of the separation charging current. (plain paper, 2nd side of double-sided print) range: 0 to 800	1
	 Be sure to enter the value indicated on the service label if you have replaced the DC controller PCB or initialized the RAM.	
HVT-SP	Use it to enter the offset value of the separation high-voltage output for the high-voltage unit. range: -100 to 100	1
	 Be sure to enter the value indicated on the label attached to the new unit if you have replaced the high-voltage unit. Be sure to enter the value indicated on the service label if you have replaced the DC controller PCB or initialized the RAM.	
D-HV-SP	Use it to enter the offset value of the separation high-voltage output for the DC controller PCB. range: -100 to 100	1
	 Be sure to enter the value indicated on the label attached to the new PCB if you have replaced the DC controller PCB. Be sure to enter the value indicated on the service label if you have initialized the RAM on the DC controller PCB.	

<FEED-ADJ>

T-17-27

COPIER > ADJUST > FEED-ADJ		
Sub item	Description	Level
REGIST	Use it to adjust the timing at which the registration roller clutch goes on. A higher setting will delay the timing at which the registration roller clutch goes on, thus decreasing the lead edge margin. range: -100 to 100 (unit: 0.1 mm)	1
ADJ-REFE	Use it to adjust the horizontal registration for re-pickup. Increase the value if the image is displaced to the front. range: -100 to 100 (unit: 01 mm)	1
	 Be sure to enter the value indicated on the service label if you have replaced the DC controller PCB or initialized the RAM.	

<CST-ADJ>

T-17-28

COPIER > ADJUST > CST-ADJ		
Sub item	Description	Level
Use it to make adjustments related to the cassette/manual feeder tray.		
 Be sure to enter the value indicated on the service label if you have replaced the DC controller PCB or initialized the RAM. Be sure to execute FUNCTION>CST if you have replaced the paper width detecting VR. (C-3STMTR/A4R, C4-STMTR/A4R, MF-A4R/A6R/A4)		
C3-STMTR	Use it to enter the paper width basic value for cassette 3. (STMTR)	1
	range: 0 to 255	
C3-A4R	Use it to enter the paper width basic value for cassette 3. (A4R)	1
	range: 0 to 255	
C4-STMTR	Use it to enter the paper width basic value for cassette 4. (STMTR).	1
	range: 0 to 255	
C4-A4R	Use it to enter the paper width basic value for cassette 4. (A4R)	1
	range: 0 to 255	
MF-A4R	Use it to enter the paper width basic value for the manual feeder tray. (A4R)	1
	range: 0 to 255	
MF-A6R	Use it to enter the paper width basic value for the manual feeder tray. (A6R)	1
	range: 0 to 255	
MF-A4	Use it to enter the paper width bias value for the manual feeder tray. (A4)	1
	range: 0 to 255	
C3-LVOL	Use it to enter the capacity of cassette 3. (50 sheets)	1
	range: 0 to 255	
C3-HVOL	Use it to enter the capacity of cassette 3. (250 sheets)	1
	range: 0 to 255	
C4-LVOL	Use it to enter the capacity of cassette 4. (50 sheets)	1
	range: 0 to 255	
C4-HVOL	Use it to enter the capacity of cassette 4. (250 sheets)	1
	range: 0 to 255	

<EXP-LED>

T-17-29

COPIER > ADJUST > EXP-LED		
Sub item	Description	Level
PRE-TR	Use it to enter the output adjustment value of the pre-transfer exposure.	1
	range: 20 to 80	

17.4.2 FEEDER

17.4.2.1 FEEDER Items

<ADJUST>

T-17-30

FEEDER > ADJUST		
*: model equipped with DADF-Q1 (outside Japan: iR7105/7095; inside Japan: All model).		
**: model equipped with DADF-M1 (outside Japan: iR7086).		
Sub item	Description	Level
DOCST	Use it to adjust the original stop position for ADF mode (pickup from the original tray).	1
	range: -30 to 30 (unit: 0.5 mm) A higher value decreases the lead edge margin. <Procedure> 1) Place the original in the original tray. 2) Select the item, and enter the appropriate value; then, press the OK key. 3) Press the OK key so that the original will be picked up. 4) Open the ADF, and check the original stop position. 5) Press the OK key so that the original is delivered.	
DOCST-M *	Use it to adjust the original stop position for ADF mode (pickup from the manual feeder tray).	1
	range: -30 to 30 (unit: 0.5 mm) Use the same procedure used for FEEDER > ADJUST > DOCST.	
LA-SPEED	Use it to adjust the original transport speed for ADF stream reading mode.	1
	A higher setting will increase the speed. range: -30 to 30 (unit: 0.1%)	
STRD-S *	Use it to adjust the scanner stop position for stream reading mode (small-size).	1
	range: -25 to 25 (unit: 0.1 mm)	
STRD-L *	Use it to adjust the scanner stop position for stream reading mode (large-size).	1
	range: -25 to 25 (unit: 0.1 mm)	
RVM-SPD *	Use it to adjust the speed of the reversal motor.	2
	A higher setting will increase the speed. range: -30 to 30 (unit: 0.1%)	

17.4.3 SORTER

17.4.3.1 SORTER Items

T-17-31

SORTER > ADJUST		
Sub item	Description	Level
PNCH-HLE	Not used	1
PNCH-Y	Use it to adjust the punch hole position (rear/front).	1
	range: -5 to 5 (unit: 0.45 mm)	

17.5 FUNCTION (Operation/Inspection Mode)

17.5.1 COPIER

17.5.1.1 COPIER Items

<INSTALL>

T-17-32

COPIER > FUNCTION > INSTALL		
Sub item	Description	Level
TONER-S	Use it to stir the toner inside the developing assembly at time of installation.	1
	Procedure 1) Select the item to highlight. 2) The message "Check the Developer" appears. Check to make sure that the connector of the developing assembly is connected. 3) Press the OK key to start the operation. The machine will stop automatically when a specific count has been taken. Notes: The message "Check the Developer" is used to prevent disconnection of the connector that could otherwise occur when mounting the developing assembly.	
CARD	Use it to make card reader settings as part of installation work.	1
	Procedure Enter a number between 1 and 2001, and press the OK key. (As many as 1000 cards may be used starting with the one bearing the number you enter.) At this time, the machine initializes the card control information (group ID and ID number).	
E-RDS	Use it to make E-RDS settings (embedded RDS).	1
	Range 0: disable RDS (off); 1: enable RDS (transmit all counter information)	
RGW-PORT	Use it to set the port number for the server used by E-RDS.	1
	range: 1 to 65535	
COM-TEST	Use it to check the connection to the server used for E-RDS.	1
	1) Select the item to highlight, and press the OK key. 2) Check the result expressed in OK or NG.	
COM-LOG	Use it to indicate the details of the result of a test executed on the communication with the server used for E-RDS.	1
	Procedure 1) Select the item to highlight, and press an information item. history particulars: calendar, date, time, error code, error details (128 characters max.)	
RGW-ADR	Use it to specify the URL of the server used for E-RDS.	1
	Procedure 1) Select the item to highlight, and press an information item. 2) When the URL input screen appears, press the OK key. (default: https://a01.ugwdevice.net/ugw/agentif010)	

<CCD>

T-17-33

COPIER > FUNCTION > CCD		
*: model equipped with DADF-Q1 (outside Japan: iR7105/7095; inside Japan: All model). **: model equipped with DADF-M1 (outside Japan: iR7086).		
Sub item	Description	Level
CCD-ADJ	Use it to execute CCD auto adjustment. <Procedure> 1) Place 10 or more sheets of paper on the copyboard glass. (Make sure the paper is the whitest of all used by the user but is not one for color printing). 2) Select 'CCD-ADJ' to highlight, and press the OK key. 3) See that auto adjustment takes place (about 15 sec), during which 'ACTIVE' appears in the upper right of the screen. 4) See that the LED (scanning lamp) goes on twice in the course of the adjustment and the screen indicates 'OK!' to end the adjustment. 5) All items under COPIER > ADJUST > CCD will be updated. Print out a service sheet for future reference.	1
LUT-ADJ*	Use it to execute CCD gain abridged correction. <Procedure> 1) Select the item, and press the OK key so that auto adjustment takes place. 2) See that adjustment ends automatically. 3) The items under COPIER>ADJUST>LAMP, COPIER>ADJUST>CCD in service mode are updated. Print out a service sheet for future reference.	1
DF-WLVL1** DF-WLVL2**	Use it to adjust the ADF white level. <Procedure> 1) Place paper on the copyboard glass, and execute DF-WLVL1. (Make sure that the paper is a type used by the user.) -> The machine will read the white level used for copyboard mode (i.e., checks the transmissivity of the copyboard glass). 2) Place paper in the ADF, and execute DF-WLVL2. (Make sure that the paper is a type used by the user.) -> The machine reads the white level used for ADF stream reading mode (i.e., to check the transmissivity of the stream reading glass). Be sure to execute the foregoing always in combination in the correct order, i.e., DF-WLVL1 and then DF-WLVL2.	1
LUT-ADJ2*	Use it to fine-adjust the CCD gain. Use it if the difference, if any, in density cannot be corrected using LUT-ADJ (CCD gain abridged correction). <Procedure> 1) Place the 10-gradation chart (D-10 Test Sheet) on the copyboard glass. 2) Select the item, and press the OK key so that auto adjustment takes place. 3) See that the machine ends the adjustment automatically. 4) The items under COPIER > ADJUST > LAMP, COPIER > ADJUST > CCD are updated. Print out a service sheet for future reference.	2

<LASER>

T-17-34

COPIER > FUNCTION > LASER		
Sub item	Description	Level
POWER-A/B/C/D	Use it to turn on the laser (A, B, C, D). <Procedure> 1) Select the item, and press the OK key. 2) See that the laser goes on, and 'STRWT' -> 'ACTIVE' appears. 3) See that the laser goes off in about 60 sec automatically and 'OK!' appears.	1

<DPC>

T-17-35

COPIER > FUNCTION > DPC		
Sub item	Description	Level
OFST	Use it to adjust the offset of the potential sensor.	1
	Do not execute this item on its own. It is part of a series of operations performed when replacing the potential sensor unit. <Procedure> 1) Select the item, and press the OK key so that offset adjustment takes place. 2) See that the machine ends the adjustment automatically.	

<CST>

T-17-36

COPIER > FUNCTION > CST		
Sub item	Description	Level
Use it to execute size auto adjustment of the cassette/manual feeder tray.		
C3-STMTR C3-A4R C4-STMTR C4-A4R	Use it to register the paper width basic value for cassette 3/4. STMTR width: 139.5 mm; A4R width: 210 mm	1
	<Procedure> 1) Place paper in the cassette, and adjust the side guide plate to suit the width of the paper. 2) Select the item, and press the OK key. The value will be registered at the end of the adjustment. Notes: If fine-adjustment is needed after registration of the basic value, use ADJUST > CST-ADJ > C3-STMTR, C3-A4R, CR-STMTR, C4-A4R.	
MF-A4R MF-A6R MF-A4	Use it to register the paper width basic value of the manual feeder tray. A4R width: 210 mm; A6R width: 105 mm; A4 width: 297 mm	1
	<Procedure> 1) Place paper in the manual feeder tray, and adjust the guide to suit the width of the paper. 2) Select the item, and press the OK key. The value will be registered at the end of the adjustment. Notes: If fine-adjustment is needed after registration of the basic value, use ADJUST > CST > ADJ > MF-A4R, MF-A6R, MF-A4.	

<CLEANING>

T-17-37

COPIER > FUNCTION > CLEANING		
Sub item	Description	Level
WIRE-CLN	Use it to execute auto cleaning of the charging wire.	1
	Execute the item after replacing the primary charging wire or the transfer charging wire. <Procedure> 1) Select the item, and press the OK key so that wire cleaning starts (5 trips). 2) See that the machine stops automatically when cleaning is done.	

<FIXING>

T-17-38

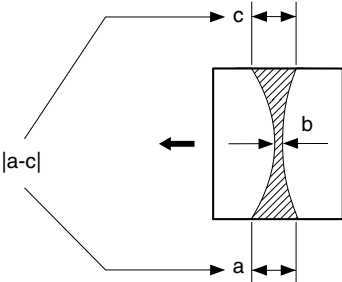
COPIER > FUNCTION > FIXING		
Sub item	Description	Level
NIP-CHK	Use it to adjust the fixing nip width.	1
	Make test prints for measurement of the fixing nip width. <Procedure> 1) Make about 20 A4 prints using the test sheet. 2) Place A4 paper in the manual feeder tray. 3) Select the item, and press the OK key. The paper will be stopped at the fixing nip area, and then discharged in about 20 sec. 4) Measure the nip. (The points of reference are 10 mm from the edges of the paper.)  $b = 200V: 9.0\text{mm} \pm 0.5\text{mm}$ $208/230V: 10.0\text{mm} \pm 0.5\text{mm}$ $ a-c = 0.5\text{mm}$ or less	

<PANEL>

T-17-39

COPIER > FUNCTION > PANEL		
Sub item	Description	Level
LCD-CHK	Use it to check for missing dots.	1
	<Procedure> 1) Select the item, and press the OK key so that the LCD will go on in the following sequence: white, black, red, green, blue. 2) Press the stop key to stop the operation.	
LED-CHK	Use it to check the activation of the LEDs on the control panel.	1
	Use it to check the activation of the LEDs on the control panel. 1) Select the item, and press the OK key so that the LEDs will go on in sequence. 2) Select LED-OFF to stop the operation.	
LED-OFF	Use it to check the activation of the LEDs on the control panel (to stop).	1
	<Procedure> 1) Select the item to stop LED-CHK operation.	
KEY-CHK	Use it to check key inputs.	1
	<Procedure> 1) Select the item so that the number/name of a specific input key appears. 2) Press a key to check. If normal, the corresponding character will appear on the LCD. (See the table.) 3) Select the item once again to stop the operation.	
TOUCHCHK	Use it to adjust the coordinates of the LCD.	1
	Execute this item if you have replaced the control panel so that specific points on the LCD will match specific coordinates. <Procedure> 1) Select the item, and press the OK key. 2) Press the 9 +s that appear in sequence on the LCD.	

<Input Key Names and Screen Indications>

Key	Indications	Key	Indications	Key	Indications
0 to 9,#,*	0 to 9,#,*	Initial Setup/ Register	USER	Authenticate	ID
Reset	RESET	Start	START	Help	?
Stop	STOP	Clear	CLEAR	Check Counter	BILL

<PART-CHK>

T-17-40

COPIER > FUNCTION > PART-CHK		
Sub item	Description	Level
CL	Use it to specify the clutch whose operation you want to check. (settings: 1 to 21)	1
	<Procedure> 1) Select the item. 2) Type in the appropriate number using the keypad. 3) Press the OK key.	
CL-ON	Use it to start a check on the operation of a clutch.	1
	<Procedure> 1) Select the item, and press the OK key so that the clutch repeatedly goes on and off as follows: on for 05 sec -> off for 10 sec -> on for 0.5 sec -> off for 10 sec -> on for 0.5 speed -> off	
MTR	Use it to select a motor whose operation you want to check. (settings: 1 to 13)	1
	<Procedure> 1) Select the item. 2) Type in the appropriate number using the keypad. 3) Press the OK key.	
MTR-ON	Use it to start a check on the operation of a motor.	1
	<Procedure> 1) Select the item, and press the OK key. - on for 20 sec -> off - if buffer motor or duplexing horizontal registration motor, on for 10 sec -> off - if shift tray motor, stops at front/rear HP - if vibration motor (M10/M20), repeats on and off at intervals of about 5 sec	
SL	Use it to select the operation of a solenoid.	1
	<Procedure> 1) Select the item. 2) Enter the appropriate number using the keypad. 3) Press the OK key.	
SL-ON	Use it to start a check on the operation of a solenoid.	1
	<Procedure> 1) Select the item, and press the OK key. on for 0.5 sec -> off for 5 sec -> on for 0.5 sec -> off for 5 sec, on for 0.5 sec -> of	

<Clutch>

Code	Name	Code	Name	Code	Name
1	manual feeder tray pickup clutch (CL7)	8	deck (left) pickup clutch (CL11)	15	registration brake clutch (CL3)
2	cassette 3 pickup clutch (CL12)	9	vertical path 2 clutch (CL9)	16	manual feeder tray transport clutch (CL18)
3	vertical path 3 clutch (CL13)	10	pre-registration clutch (CL5)	17	buffer inside magnet roller drive clutch (CL1)
4	cassette 4 pickup clutch (CL14)	11	lower transport middle clutch (CL16)	18	developing cylinder clutch (CL4)
5	vertical path 4 clutch (CL15)	12	lower transport right clutch (CL17)	19	registration roller clutch (CL2)
6	deck (right) pickup clutch (CL10)	13	deck (left) transport clutch (CL19)	20	side paper deck transport clutch (CL101)
7	vertical path 1 clutch (CL8)	14	delivery speed switchover clutch (CL21)	21	side paper deck pickup clutch (CL102)

<Motor>

Code	Name	Code	Name
1	drum motor (M0)	8	horizontal registration motor (M15)
2	main motor (M1)	9	duplexing reversal motor (M11)
3	pickup motor (M2)	10	duplexing transport motor (M12)
4	fixing motor (M3)	11	deck main motor (M101)
5	laser scanner motor (M4)	12	vibration motor1 (M10)
6	sub hopper inside toner feed motor (M22)	13	vibration motor2 (M20)
7	buffer motor (M18)		

<Solenoid>

Code	Name	Code	Name
1	deck (right) pickup solenoid (SL7)	7	delivery flapper solenoid (SL3)
2	deck (left) pickup solenoid (SL8)	8	reversal flapper solenoid (SL11)
3	deck 3 pickup solenoid (SL9)	9	fixing web solenoid (SL2)
4	cassette 4 pickup solenoid (SL10)	10	fixing feed unit lock solenoid (SL4) lock
5	manual feed pickup clutch solenoid (SL6) (The manual feeder pickup roller moves up.)	11	fixing transport unit lock solenoid (SL4) unlock
		12	not used
6	manual feeder pickup clutch solenoid (SL6) (The manual feeder pickup roller moves down.)	13	side paper deck pickup solenoid
		14	not used

<CLEAR>

T-17-41

COPIER > FUNCTION > CLEAR		
*: model equipped with DADF-Q1 (outside Japan: iR7105/7095; inside Japan: All model).		
**: model equipped with DADF-M1 (outside Japan: iR7086).		
Sub item	Description	Level
ERR	Use it to reset an error code.	1
	<Procedure> 1) Select the item, and press the OK key. 2) Turn off and then on the main power.	
DC-CON	Use it to initialize the RAM on the DC controller PCB.	1
	The RAM will be initialized when the main power is turned off and then back on. <Procedure> 1) Print out the particulars of service mode by making the following selections: COPIER > FUNCTION > MISC-P > P-PRINT. 2) Select the item, and press the OK key. 3) Turn off and then back on the main power. 4) As necessary, enter the data printed out using P-PRINT.	
R-CON	Use it to initialize the RAM on the reader controller PCB.	1
	<Procedure> 1) Print out the particulars of service mode by making the following selections: COPIER>FUNCTION>MISC-P>P-PRINT. 2) Select the item, and press the OK key. 3) Turn off and then back on the main power. 4) As necessary, enter the data printed using P-PRINT.	
JAM-HIST	Use it to reset the jam history.	1
	The jam history will be reset when the OK key is pressed. <Procedure> 1) Select the item, and press the OK key.	
ERR-HIST	Use it to reset the error code history.	1
	The error code history will be reset when the OK key is pressed. <Procedure> 1) Select the item, and press the OK key.	
PWD-CLR	Use it to reset the password for 'system administrator' set in user mode.	1
	The password will be reset when the OK key is pressed. <Procedure> 1) Select the item, and press the OK key.	
ADRS-BK	Use it to reset the address book data.	1
	The address book data will be reset when the main power is turned off and then back on. <Procedure> 1) Select the item, and press the OK key. 2) Turn off and then back on the main power switch.	
CNT-MCON	Use it to reset the service counter controlled by the main controller PCB.	1
	The counter will be reset when the OK key is pressed. <Procedure> 1) Select the item, and press the OK key.	
CNT-DCON	Use it to reset the service counter controlled by the DC controller PCB.	1
	The counter will be reset when the OK key is pressed. <Procedure> 1) Select the item, and press the OK key.	
OPTION**	Use it to initialize the RAM on the reader controller PCB. (items under COPIER>OPTION only)	1
	The RAM will be initialized when the OK key is pressed. <Procedure> 1) Select the item, and press the OK key.	

COPIER > FUNCTION > CLEAR		
*: model equipped with DADF-Q1 (outside Japan: iR7105/7095; inside Japan: All model).		
**: model equipped with DADF-M1 (outside Japan: iR7086).		
Sub item	Description	Level
MMI	Use it to reset user mode settings. - backup data for copier control panel (user settings) - backup data for common settings (user settings) - various backup data (user settings)	1
	The settings will be reset when the main power is turned off and then back on. <Procedure> 1) Select the item, and press the OK key. 2) Turn off and then back on the power.	
MN-CON	Use it to initialize the RAM on the main controller PCB. <Procedure> 1) Print out the particulars of service mode by making the following selections: COPIER > FUNCTION > MISC-P > P-PRINT. 2) Select the item, and press the OK key. 3) Turn off and then back on the main power. 4) As necessary, enter the data printed out using P-PRINT.	1
CARD	Use it to reset the data related to the card ID (group). The data will be reset when the main power is turned off and then back on. <Procedure> 1) Select the item, and press the OK key. 2) Turns off and then back on the main power.	1
ALARM	Use it to reset the alarm log. The log will be reset when the main power is turned off and then back on. <Procedure> 1) Select the item, and press the OK key. 2) Turn off and then back on the main power.	1
SLT-CLR	Use it to reset the salutation setting. <Procedure> 1) Select the item, and press the OK key.	1
LANG-ERR	Use it to reset a language-related error. The error will be reset when the main power is turned off and then back on. <Procedure> 1) Select the item, and press the OK key. 2) Turn off and then back on the main power.(resets to the default language)	1
ERDS-DAT	Use it to reset the E-RDS-related settings. <Procedure> 1) Select the item, and press the OK key. 2) Turn off and then back on the main power.	1
SND-STUP	Use it to reset the transmission read settings. The settings will be reset when the main power is turned off and then back on. <Procedure> 1) Select the item, and press the OK key. 2) Turn off and then back on the main power.	2
CA-KEY	Use it to reset the CA certificate and key. The certificate and key will be reset when the main power is turned off and then back on. <Procedure> 1) Select the item, and press the OK key. 2) Turn off and then back on the main power.	2

<MISC-R>

T-17-42

COPIER > FUNCTION > MISC-R		
Sub item	Description	Level
SCANLAMP	Use it to turn on the scanning lamp.	1
	<Procedure> 1) Select the item. 2) Press the OK key so that the scanning lamp goes on and remains on for about 3 sec.	

<MISC-P>

T-17-43

COPIER > FUNCTION > MISC-P		
Sub item	Description	Level
P-PRINT	Use it to print out the settings of service mode.	1
	<Procedure> 1) Select the item. 2) Press the OK key to obtain a printout.	
KEY-HIST	Use it to print out control panel key inputs.	1
	<Procedure> 1) Select the item. 2) Press the OK key to obtain a printout.	
HIST-PRT	Use it to print out a jam and error history.	1
	<Procedure> 1) Select the item. 2) Press the OK key to obtain a printout.	
TRS-DATA	Use it to move data received in memory to a Box.	1
	<Procedure> 1) Select the item. 2) Press the OK key to move the data.	
USER-PRT	Use it to print out the settings of service mode.	1
	<Procedure> 1) Select the item. 2) Press the OK key to obtain a printout.	
LBL-PRNT	Use it to print out the service label.	1
	<Procedure>	
	1) Place A4/LTR paper in cassette 1. 2) Select the item. 3) Press the OK key to obtain a printout.	
PRE-EXP	Use it to check the activation of the pre-exposure lamp (LED).	1
	<Procedure>	
	1) Select the item to highlight. 2) Press the OK key so that individual operations take place for several seconds and end. (all LEDs ON) 3) Press the OK key to obtain a printout.	
ENV-PRT	Use it to print out the data on the history of changes that have taken place in the machine inside temperature/humidity and fixing temperature.	1
	<Procedure> 1) Select the item. 2) Press the OK key to obtain a printout.	
PJH-P-1	Use it to print out the data on the history of print jobs with details. (most recent 100 jobs)	1
	<Procedure> 1) Select the item. 2) Press the OK key to obtain a printout.	

COPIER > FUNCTION > MISC-P		
Sub item	Description	Level
PJH-P-2	Use it to print out the data on the history of print jobs with details. (all jobs)	1
	<Procedure> 1) Select the item. 2) Press the OK key to obtain a printout.	
P-TR-EXP	Use it to check the activation of the pre-transfer exposure lamp.	2
	<Procedure> 1) Select the item, and press the OK key so that the pre-transfer exposure lamp goes on. 2) See that the lamp goes on and remains on for several seconds and then goes off automatically.	
CL-ADJ	Use it to adjust the timing at which a clutch goes on and off.	2

<SENS-ADJ>

T-17-44

COPIER > FUNCTION > SENS-ADJ		
Sub item	Description	Level
OP-SENS	Use it to execute automatic adjustment of the optical sensor.	2
	1) Place paper in all decks and cassettes. 2) Select the item, and press the OK key. 3) See that 'ACTIVE' is indicated, with the result (OK/NG) indicated for the sensors that have been checked in sequence.	

<SYSTEM>

T-17-45

COPIER > FUNCTION > SYSTEM		
Sub item	Description	Level
DOWNL OAD	Use it to switch over to download mode.	1
	<Procedure> 1) Select the item. 2) Press the OK key to switch to the Download mode screen.	
CHK-TYPE	Use it to specify the partition (No.) for which HD-CHECK, HD-CLEAR will be executed.	1
	<Procedure> 1) Select the item. 2) Type in the number of the partition using the keypad, and press the OK key. 0: entire HDD* 1: FSTDEV (compression image data), IMG_MNG (file control table, profile), FSTCDEV (job archiving) 2: AP_GEN (general-purpose data, TMP_GEN (temporary file), TMP_PSS (for PDL spooling) 3: PDLDEV (PDL-related file) 4: BOOTDEV (various firmware such as system software and content)* 5: APL_MEAP (MEAP application) 6: APL_SEND (address book, filter) 7: not used 8: APL_KEEP (non-initialization; for storage) *: HD-CLEAR will not initialize the HDD. If necessary, use the SST/USB memory in safe mode.	
HD-CHECK	Use it to check and recover the partition selected by CHK-TYPE.	1
	<Procedure> 1) Select the item. 2) Press the OK key. 3) See the result (1: OK; 2: NG (hardware); 3: NG (software); recovery/alternative sector).	

COPIER > FUNCTION > SYSTEM		
Sub item	Description	Level
HD-CLEAR	Use it to initialize the partition selected using CHK-TYPE.	1
	<Procedure> 1) Select the item. 2) Press the OK key. 3) Turn off and then on the main power so that initialization starts. Do not turn off the power while initialization is under way.	
DEBUG-1	Use it to set the type of log to store/timing of storage to the HDD.	2
	settings 0 to 3 (default: 0) Use this item when troubleshooting a fault. Be sure to change the setting as instructed by the QA Support department.	
DEBUG-2	Use it to print out logs stored on the HDD.	2
	<Procedure> 1) Select the item. 2) Press the OK key. 3) See that the log is printed. (about 2 sheets of A4) Use this time when troubleshooting a fault. Be sure to change the setting as instructed by the QA Support department.	

17.5.2 FEEDER

17.5.2.1 FEEDER Items

T-17-46

FEEDER > FUNCTION		
*: model equipped with DADF-Q1 (outside Japan: iR7105/7095; inside Japan: All model).		
**: model equipped with DADF-M1 (outside Japan: iR7086).		
Sub item	Description	Level
SENS-INT	Use it to adjust the sensitivity of the various sensors of the ADF.	1
	Be sure to clean the sensors before executing the item. Procedure 1) Select the item, and press the OK key. 2) See that the adjustment ends automatically.	
BLT-CLN *	Use it to clean the separation belt of the ADF.	1
	<Procedure> 1) Select the time, and press the OK key. 2) See that the separation belt goes on. Press the Stop key to stop the operation.	
REG-CLN *	Use it to clean the registration roller of the ADF.	1
	<Procedure> 1) Select the item, and press the OK key. 2) See that the registration roller rotates. Press the Stop key to stop the operation.	
MTR-CHK **	Use it to check the ADF motor on its own.	1
	<Procedure> 1) Select the item. 2) Type in the number of a specific part using the keypad. 3) Press the OK key. 4) Press MTR-ON to check the operation. No. and Part 0: pickup motor 1: transport motor	
TRY-A4 **	Use it to execute auto adjustment on paper width detection reference point 1 for the original pickup tray of the ADF. (A4)	1
TRY-A5R **	Use it to execute auto adjustment on paper width detection reference point 2 for the original pickup tray of the ADF. (A5R)	1

FEEDER > FUNCTION		
*: model equipped with DADF-Q1 (outside Japan: iR7105/7095; inside Japan: All model).		
**: model equipped with DADF-M1 (outside Japan: iR7086).		
Sub item	Description	Level
TRY-LTR **	Use it to execute auto adjustment on paper width detection reference point 1 for the original pickup tray of the ADF. (LTR)	1
TRY-LTRR **	Use it to execute auto adjustment on paper width detection reference point 2 for the original pickup tray of the ADF. (LTRR)	1
FEED-CHK **	Use it to check paper passage for the ADF on its own. <Procedure> 1) Select the item. 2) Type in the number of a specific paper passage mode using the keypad. 3) Press the OK key. 4) Press FEED-ON to check the operation. No. and Paper Passage Mode 0: simplex pickup delivery operation 1: duplex pickup delivery operation 2: simplex pickup delivery operation w/ stamp 3: duplex pickup delivery operation w/ stamp	1
CL-CHK **	Use it to check the ADF clutch on its own. <Procedure> 1) Select the item 2) Type in the number of a specific part using the keypad. 3) Press the OK key. 4) Press CL-ON to check the operation. No. and Part 0: pickup clutch	1
CL-ON **	Use it to start the operation of the clutch. <Procedure> 1) Select the item, and press the OK to start the operation of the clutch. 2) Press the OK key to stop the operation. (It will stop automatically in about 2 sec. But the indication will not change to 'STOP' until the OK key is pressed once again.)	1
FAN-CHK **	Use it to check the operation of the clutch on its own. <Procedure> 1) Select the item. 2) Type in the number of a specific part using the keypad. 3) Press the OK key. 4) Press FAN-ON to check the operation. No. and Part 0, 1: cooling fan	1
FAN-ON **	Use it to start fan operation. <Procedure> 1) Select the item, and press the OK key to start fan operation. 2) Press the OK key to stop the operation. (The operation will stop automatically in about 5 sec, but the indication will not change to 'STOP' until the OK key is pressed once again.)	1
SL-CHK **	Use it to check the ADF solenoid on its own. <Procedure> 1) Select the item. 2) Type in the number of a specific part using the keypad. 3) Press the OK key. 4) Press SL-ON to check the operation. No. and Part 0: locking solenoid 1: stamp solenoid	1

FEEDER > FUNCTION		
*: model equipped with DADF-Q1 (outside Japan: iR7105/7095; inside Japan: All model).		
**: model equipped with DADF-M1 (outside Japan: iR7086).		
Sub item	Description	Level
SL-ON **	Use it to start the operation of the solenoid.	1
	<Procedure> 1) Select the item, and press the OK key to start the motor operation. 2) Press the OK key to stop the operation. (The operation will stop automatically in about 5 sec, but the indication will not change to 'STOP' until the OK key is pressed once again.)	
MTR-ON **	Use it to start motor operation.	1
	<Procedure> 1) Select the item, and press the OK key so that the motor will start. 2) Press the OK key to stop the operation. (The operation will stop automatically in about 5 sec, but the indication will not change to 'STOP' until the OK key is pressed once again.)	
ROLL-CLN **	Use it to clean the ADF roller.	1
	<Procedure> 1) Select the item so that the roller starts to rotate. 2) While the roller is rotating, clean it by pressing lint-free paper (moistened with alcohol) against it. 3) Select ROLL-CLN to highlight, and press the OK key so that the roller will stop.	
FEED-ON **	Use it to check the passage of paper on the ADF on its own.	1
	<Procedure> 1) Select the item, and press the OK key so that paper movement starts according to the operation mode selected using FEED-CHK.	

17.5.3 SORTER

17.5.3.1 SORTER Items

T-17-47

SORTER > FUNCTION		
Sub item	Description	Level
PCH-STUP	Use it to setup up a high-accuracy puncher. (non-Japanese model only)	1
	Use it to adjust the horizontal registration position when installing a high-accuracy puncher. Procedure 1) Select the item, and press the OK key. 2) See that the machine turns out a blank print.	

17.6 OPTION (Machine Settings Mode)

17.6.1 COPIER

17.6.1.1 COPIER Items

<BODY>

T-17-48

COPIER > OPTION > BODY		
*: model equipped with DADF-Q1 (outside Japan: iR7105/7095; inside Japan: All model).		
**: model equipped with DADF-M1 (outside Japan: iR7086).		
Sub item	Description	Level
PO-CNT	Use it to enable/disable the potential control mechanism.	1
	settings 0: off; 1: on (default)	
TRNSG-SW	Use it to select an appropriate transfer guide bias control mode.	1
	settings	
	0: absolute moisture content (if 22 g or higher, 200 V; otherwise, 600 V)	
	1: fixed to 600 V	
	2: fixed to 200 V	
MODEL-SZ	Use it to switch over the display of default magnifications and ADF original size detection.	1
	settings	
	0: AB (6R5E) (default) 1: INCH (5R4E)	
	2: A (3R3E) 3: AB/INCH (6R5E)	
FIX-TEMP	Use it to set the down sequence start temperature for heavy paper.	1
	settings 0: 194 deg C; 1: 189 deg C (default); 2: 184 deg C	
FUZZY	Use it to enable/disable the fuzzy control mechanism and make environment settings.	1
	Affects the charging current level for pre-transfer, transfer, and separation.	
	- if set to '1' thorough '3', the mechanism will be free of the environment sensor readings.	
	settings	
	0: fuzzy control on (default)	
CNT-W/PR	Use it to enable/disable the density variation mode mechanism for a printing session (PDL input).	1
	settings	
	0: correct target value to enable density variation during printing (default)	
	1: disable density variation during printing	
CONFIG	Use it to select multiple firmware items on the hard disk for changing settings (country/area, language, destination, paper size series).	1
	<Procedure>	
	1) Select <CONFIG>.	
	2) Select the item to change.	
	3) Press the +/- key. (Each press changes the setting.)	
	4) Have all settings for all items, and press the OK key.	
	5) Turn off and then back on the main power switch.	
	XXYYZZAA	
	XX: country (e.g., JP=Japan)	
	YY: language (e.g., ja=Japanese)	
ZZ: destination (e.g., 00=Canon)		
AA: paper size series (00=AB; 01=inch; 02=A; 03=inch/AB)		
TR-SP-C1	Use it to change the transfer/separation output settings for pickup from the right deck.	1
	settings 0: plain paper (default); 1: recycled paper; 2: tracing paper	

COPIER > OPTION > BODY		
*: model equipped with DADF-Q1 (outside Japan: iR7105/7095; inside Japan: All model).		
**: model equipped with DADF-M1 (outside Japan: iR7086).		
Sub item	Description	Level
TR-SP-C2	Use it to change the transfer/separation output setting for pickup from the left deck.	1
	settings 0: plain paper (default); 1: recycled paper; 2: tracing paper	
TR-SP-C3	Use it to change the transfer/separation output setting for cassette 3.	1
	settings 0: plain paper (default); 1: recycled paper; 2: tracing paper	
TR-SP-C4	Use it to change the transfer/separation output setting for pickup from cassette 4.	1
	settings 0: plain paper (default); 1: recycled paper; 2: tracing paper	
TR-SP-MF	Use it to change the transfer/separation output setting for pickup from the manual feeder tray.	1
	settings 0: plain paper (default); 1: recycled paper; 2: tracing paper	
TR-SP-DK	Use it to change the transfer/separation output setting for pickup from the side paper deck.	1
	settings 0: plain paper (default); 1: recycled paper; 2: tracing paper	
DEV-SLOW	Use it to enable/disable the developing cylinder speed variation mechanism.	1
	settings 0: change to suit environment; 1: high speed; 2: low speed (default)	
W/SCNR	Use it to indicate the presence/absence of a reader unit.	1
	settings 0: printer model (w/o reader); 1: copier model (w/ reader) If the reader unit is detected at start-up, '1' will be set automatically.	
STPL-SFT	Use it to enable/disable offset stacking in stapler mode.	1
	settings 0: use offset stacking in stapler mode (default) 1: do not use offset stacking in stapler mode The foregoing choice is valid only when 1-point stapling is used.	
DFDST-L1	Use it to adjust the dust detection level when the ADF is in use. (sheet-to-sheet correction)	1
	A higher setting will make the mechanism more sensitive, detecting finer particles of dust. settings: 0 to 255	
DFDST-L2	Use it to adjust the dust detection level when the ADF is in use. (post-job detection)	1
	A higher setting will make the mechanism more sensitive, detecting finer particles of dust. settings: 0 to 255	
CCD-LUT *	Use it to indicate whether or not to use data for CCD gain correction.	1
	Indicates whether or not to use the data collected by COPIER > FUNCTION > CCD > LUT-ADJ2. settings 0: do not use; 1: use (1-point correction); 2: use (3-point correction)	
ENVP-INT	Use it to set the intervals at which the history data is collected on the machine inside temperature/fixing temperature.	1
	settings: 0 to 480 (unit: min) If '0', the history data is not collected.	
BASE-SW	Use it to switch from the MEAP full model to the base model.	1
	settings 0: off (base model); 1: on (full model)	
SC-L-CNT	Use it to set the threshold for identifying large size paper for the scan counter.	1
	settings 0: B4 (default); 1: LTR	

COPIER > OPTION > BODY		
*: model equipped with DADF-Q1 (outside Japan: iR7105/7095; inside Japan: All model).		
**: model equipped with DADF-M1 (outside Japan: iR7086).		
Sub item	Description	Level
LDAP-ADD	Use it to indicate whether or not to add a LDAP search switch.	1
	Indicates whether or not to add 'Object Class' and 'SrchnamRow' (Search Name Row) to the pull-down list showing the normal set of conditions (name, group, organization unit, e-mail) settings 0: do not add; 1: add The addresses to be searched are limited to e-mail addresses.	
ACFRQNY	Use it to set the developing AC bias frequency (remedy for retransfer/fogging; for plain paper).	1
	Varies the developing AC bias frequency to adjust the level of fogging. - if retransfer is too noticeable, decrease the setting (i.e., increase the level of fogging). - if fogging is too noticeable, increase the setting. settings: -5: 2.0KHz -4: 2.1KHz -3: 2.2KHz -2 :2.3KHz -1: 2.4KHz 0: 2.5KHz (default) 1: 2.6KHz 2: 2.7KHz 3: 2.8KHz 4: 2.9KHz 5: 3.0KHz The foregoing settings are valid only if '0' is set for the following: COPIER > OPTION > BODY > TR-SP-C1/C2/C3/C4/MF/DK.	
CNT-TMG	Use it to switch over the counter increment specifications when a delivery accessory is in use.	1
	settings 0: increase count upon delivery of paper from delivery accessory (default); 1: increase count upon delivery of paper from host machine	
ACFRQR	Use it to set the developing AC bias frequency (remedy for retransfer/fogging; for recycled paper).	1
	Varies the developing AC bias frequency to adjust the level of fogging. - if retransfer is too noticeable, decrease the setting (i.e., increase the level of fogging). - if fogging is too noticeable, increase the settings. settings -5: 2.0KHz -4: 2.1KHz -3: 2.2KHz -2 :2.3KHz -1: 2.4KHz 0: 2.5KHz (default) 1: 2.6KHz 2: 2.7KHz 3: 2.8KHz 4: 2.9KHz 5: 3.0KHz The foregoing settings are valid only when '0' is set for the fogging: COPIER > OPTION > BODY > TR-SP-C1/C2/C3/C4/MF/DK.	
ACFRQT	Use it to set the developing AC bias frequency (remedy for retransfer/fogging; for heavy paper).	1
	Varies the developing AC bias frequency to adjust the level of following. - if retransfer is too noticeable, decrease the setting (i.e., increase the level of fogging). - if fogging is too noticeable, increase the setting. settings -5: 2.0KHz -4: 2.1KHz -3: 2.2KHz -2 :2.3KHz -1: 2.4KHz 0: 2.5KHz (default) 1: 2.6KHz 2: 2.7KHz 3: 2.8KHz 4: 2.9KHz 5: 3.0KHz The foregoing settings are valid only when '0' is set for the following: COPIER > OPTION > BODY > TR-SP-C1/C2/C3/C4/MF/DK.	
K-DOT	Use it to select an appropriate retransfer remedial mode.	1
	Selects a mode in which minute dots are formed over the entire surface of the print (outside the image) as a remedy for retransfer. A higher setting will decrease the level of retransfer. settings 0: off (default); 1: 1-dot/75% frequency; 2: 1-dot/100% frequency; 3: 1 to 1.5-dot/100% frequency; 4: 1.5-dot/75% frequency This item is valid only when a type of paper other than heavy paper has been selected.	
FIX-EXP	Use it to select an appropriate fixing smear remedial mode.	1
	Selects VD down control mode to limit smearing occurring at time of fixing. Be sure to set it to '0' if you have replaced the DC controller or initialized the RAM. settings 0: off; 1: use of developing assembly 90 to 10,000 prints/VD down control to suit moisture content (default); 2: VD down control to suit use of developing assembly (0 to 10,000 prints); 3: specific level VD down control	

COPIER > OPTION > BODY		
*: model equipped with DADF-Q1 (outside Japan: iR7105/7095; inside Japan: All model).		
**: model equipped with DADF-M1 (outside Japan: iR7086).		
Sub item	Description	Level
OVLP-MD	Use it to enable/disable double-feeding detection mechanism.	1
	0: disable; 1: enable	
ABC-MODE *	Use it to switch over original background processing. (digital ABC setting switchover)	1
	A higher setting (between 1 and 3) will limit the background more. settings -1: limits removal of background density (for photo original or originals with complex elements) 0: off (no idle rotation) 1: remove background 1 2: remove background 2 3: remove background 3	
IDL-MODE	Use it to enable/disable the mechanism that computes the scan area based on the selected paper size.	2
	settings 0: OFF (disable idle rotation) 1: use auto control by environment sensor 2: start idle rotation when fixing roller temperature is 100 deg C 3: start idle rotation when main power switch goes on	
SCANSLCT	Use it to enable/disable computation of the scan area with reference to selected paper size.	2
	settings 0: off (determine scan area based on original detection; default) 1: on (determine scan area based on paper size)	
OHP-TEMP	Use it to switch over the transparency mode temperature control setting.	2
	Decreases the fixing temperature to facilitate separation of transparencies from the fixing roller. 0: 198 deg C (default); 1: 1983 deg C; 3: 183 deg C	
OHP-CNT	Use it to enable/disable the transparency mode potential control mechanism.	2
	settings 0: use the target value obtained from transparency mode (default) 1: do not execute potential control during transparency mode	
FIX-TMP1	Use it to select a start temperature for plain paper down sequence.	2
	If the user places priority on image quality, set it to '0'; on speed, to '2'. settings: 0: 183 deg C; 1:178 deg C (default); 2: 173 deg C	
TRSW-P-B	Use it to enable/disable the transfer current output correction mechanism for the trail edge of paper.	2
	settings 0: on; 1: off (default)	
SP-MODE	Use it to enable/disable the separation current output correction control mechanism.	2
	settings 0: standard mode (default); 1: low-voltage mode	
FTMP-DWN	Use it to select an appropriate stacking performance enhancement mode.	2
	Decreases the fixing temperature to improve the performance of stacking in the finisher. settings 0: off (default); 1: -5 deg C; 2: -10 deg C; 3: -15 deg C	

COPIER > OPTION > BODY		
*: model equipped with DADF-Q1 (outside Japan: iR7105/7095; inside Japan: All model).		
**: model equipped with DADF-M1 (outside Japan: iR7086).		
Sub item	Description	Level
DRUM-CLN	Use it to select an appropriate drum cleaning performance enhancement mode (stop sequence). - use it if cleaning faults occur. - during copying, stops the rotation of the drum for 1 sec when the setting is reached, recovering the cleaning performance of the cleaning blade. - the higher the setting (0 to 3), the more effective it is. settings 0: if single-sided, 1,000 prints; if double-sided, 500 prints (default) 1: if single-sided, 500 prints; if double-sided, 250 prints 2: if single-sided, 250 prints; if double-sided, 125 prints 3: at absolute moisture content of 9 g or more, if single-sided, passage of 1,000 prints/if double-sided, of 500 prints at absolute moisture content of less than 9 g, if single-sided, passage of 250 prints/if double-sided, of 125 prints 4: off (do not stop drum rotation)	2
DRM-IDL	Use it to set the drum idle rotation mode executed at power-on. Enable it if a smear occurs or the density drops immediately after power-on. - rotates the photosensitive drum idly to prevent adhesion of toner to the drum. settings 0: off (do not execute idle rotation; default) 1: rotate drum idly for 30 sec if absolute moisture content is 18 g or more 2: rotate drum idly for 2 min if absolute moisture content is 18 g or more 3: rotate drum for 30 sec regardless of environment 4: rotate drum for 2 min regardless of environment	2
SENS-CNF	Use it to set up the original sensor. settings 0: AB; 1: inch	2
RAW-DATA	Use it to set the reception image troubleshooting mode. Isolates faults occurring in reception images between received image data and image processing. settings 0: normal operation (default); 1: print out without image processing	2
SHARP	Use it to change the image sharpness level. A higher setting will make the images sharper. settings 1 to 5 (default: 3)	2
FDW-DLV	Use it to switch over face-down delivery for multiple printing (to ensure proper stacking). settings 0: normal (if 1 original, face-down for all) 1: if 1 original, face-up delivery for 1 set, but face-down delivery for multiple sets (default)	2
COTDPC-D	Use it to set toner save mode. settings 0: off (do not use toner save mode; default) 1: about -10%; 2: about -20%; 3: about -30%	2
RMT-LANG	Use it to switch over languages for the remote UI. To switch over, use the +/- key to select an appropriate language.	2
IFAX-LIM	Use it to limit the number of output characters for i-fax reception. settings 0 (no limit) to 999 (default: 500)	2
DF-BLINE	black line remedial processing for DF stream reading Use it to enable/disable use of a remedy against black lines caused by dust on the platen roller. setting 0: do not use (default); 1: use	2

COPIER > OPTION > BODY		
*: model equipped with DADF-Q1 (outside Japan: iR7105/7095; inside Japan: All model).		
**: model equipped with DADF-M1 (outside Japan: iR7086).		
Sub item	Description	Level
THICK-PR	Use it to set potential control for heavy paper mode.	2
	settings 0: use the value determined at time of potential control for plain paper mode (default) 1: use the value determined at time of potential control for transparency mode	
TEMP-TBL	Use it to select an appropriate fixing temperature.	2
	settings - if 200V model 0: 183 deg C 1: 193 deg C 2: 178 deg C 3: 173 deg C 4: 168 deg C - if 208V/230V model 0: 193 deg C 1: 198 deg C 2: 188 deg C 3: 183 deg C 4: 178 deg C	
DRM-H-SW	Use it to enable/disable the continuous drum heater off mode.	2
	settings 0: continuous drum heater on (default) 1: check environment temperature every 2 hr, and turn off drum heater if absolute moisture content is 9 g or less	
DEV-IDLR	Use it to set the forced developing assembly idle rotation mode. (before execution of black band sequence at power-on)	2
	settings 0: if 2,000 prints or more made on previous day and, in addition, absolute moisture content is 16 g or more (default); 1: at all times	
BK-BD-1 to BK-BD-12	Use it to set the month-based black band sequence mode (January to December).	2
	settings 0: do not execute if absolute moisture content is less than 9 g; if 9 g or more, execute every 200 prints (default); 1: execute every 60 prints; 2: execute every 20 prints; 3: execute every 6 prints	
PAPER-TY	Use it to set the fixing temperature/pre-transfer assembly control mechanism to suit paper type (inside/outside Japan).	2
	0: control to suit destination (A, AB, inch, AB/inch) 1: assume use of paper for Japan; 2: assume use of paper for outside Japan	
SMTPTXPN	Use it to change the SMTP transmission port number.	2
	settings 0 to 6535 (default: 25)	
SMTPRXPN	Use it to change the SMTP transmission port number.	2
	settings 0 to 65535 (default: 25)	
POP3PN	Use it to change the POP reception port number.	2
	settings 0 to 6535 (default: 110)	
RUI-DSP	Use it to set the copier function option switch of the remote UI (for compliance with disability laws).	2
	settings 0: do not show copier screen for remote UI (default); 1: display	
ORG-LGL	Use it to set special paper sizes (not recognized when the ADF is in use).	2
	settings: * 0: Legal-R (default); 1: Bolivian Officio-R; 2: Argentine Officio-R; 3: Argentine Legal-R; 4: Mexican Officio-R ** 0: Legal-R; 1: Foolscap-R; 2: Officio-R; 3: Folio-R; 4: Australian Foolscap-R; 5: Ecuadorian Officio-R; 6: Bolivian Office-R; 7: Argentine Officio-R; 8: Argentine Legal-R; 9: Government Legal-R; 10: Mexican-R	

COPIER > OPTION > BODY		
*: model equipped with DADF-Q1 (outside Japan: iR7105/7095; inside Japan: All model).		
**: model equipped with DADF-M1 (outside Japan: iR7086).		
Sub item	Description	Level
ORG-LTR	Use it to select special paper sizes (not recognized when the ADF is in use).	2
	settings * 0: Letter (default); 1: Executive; 2: Korean Government; 3: Argentine Letter; 4: Government Letter ** 0: Letter (default); 1: Executive; 2: Argentine Letter; 3: Government Letter	
ORG-B5 **	Use it to set a special paper size (not recognized when the ADF is in use).	2
	settings 0: B5 (delay); 1: Korean Government	
UI-COPY	Use it to enable/disable display of the copier screen on the control panel.	2
	settings 0: do not display; 1: display (default)	
UI-BOX	Use it to enable/disable display of the box screen on the control panel.	2
	settings 0: do not display; 1: display (default)	
UI-SEND	Use it to enable/disable display of the transmission screen on the control panel.	2
	settings 0: do not display; 1: display (default)	
UI-FAX	not used	2
UI-EXT	Use it to enable/disable display of the extension screen on the control panel.	2
	settings 0: do not display; 1: display (default)	
NW-SPEED	Use it to select an appropriate data transmission speed for service when connected to a network.	2
	settings 0: auto (default); 1: 100Base-TX; 2: 10Base-T	
TRY-CHG	Use it to switch over the tray control mechanism for a tray full condition.	2
	settings: 0: delivers to priority tray (default); 1: delivers to tray used for previous job	
STS-PORT	Use it to turn off/on the TOT sync type command communication port.	2
	Turns on/off the inquiry/response (sync) type command communication port for TUF over TCP/IP. settings 0: off (default); 1: on	
CMD-PORT	Use it to turn on/off the TOT async type status communication port.	2
	Turns off/on the async status communication port for TUIF over TCP/IP. settings 0: off (default); 1: on	
MODELS Z2	Use it to make global support settings for copyboard original size detection.	2
	settings 0: normal; 1: inch/AB mix detection	
SZDT-SW	Use it to switch between means of copyboard original size detection (CCD -> photosensor).	2
	settings 0: disable; 1: enable	
NS-CMD5	Use it to set restrictions on the use of CRAM-MD5 authentication for SMTP authentication.	2
	settings 0: depend on SMTP server (default); 1: disable	
NS-GSAPI	Use it to set restrictions on the use of GSSAPI authentication on SMTP authentication.	2
	settings 0: depend on SMTP server (default); 1: disable	

COPIER > OPTION > BODY		
*: model equipped with DADF-Q1 (outside Japan: iR7105/7095; inside Japan: All model).		
**: model equipped with DADF-M1 (outside Japan: iR7086).		
Sub item	Description	Level
NS-NTLM	Use it to set restrictions on the use of NTLM authentication for SMTP authentication.	2
	settings 0: depend on SMTP server (default); 1: disable	
NS-PLNWS	Use it to set restrictions on the use of PLAIN/LOGIN authentication for SMTP authentication.	2
	Use it to set restrictions on the use of PLAIN/LOGIN (plain text authentication for SMTP authentication) in an environment in which communication packets are encrypted. settings 0: depend on SMTP server (default); 1: disable	
NS-PLN	Use it to set restrictions on PLAIN/LOGIN authentication (plain text authentication) for SMTP authentication.	2
	Use it to set restrictions on the use of PLAIN/LOGIN (plain text authentication for SMTP authentication) in an environment in which communication packets are not encrypted. 0: depend on SMTP server (default); 1: disable	
NS-LGN	Use it to set restrictions on the use of LOGIN authentication for SMTP authentication.	2
	settings 0: depend on SMTP server (default); 1: disable	
MEAP-PN	Use it to change the HTTP port number for MEAP applications.	2
	settings 0 to 65535 (default: 8000)	
SPECK-SW *	Use it to switch between the timing of white plate dust detection.	2
	settings 0: normal timing; 1: for each job	
SVMD-ENT	Use it to switch between methods of starting service mode.	2
	settings 0: user mode key -> 2 and 8 at same time -> user mode key (default) 1: user mode key -> 4 and 9 at same time -> user mode key	
DA-CNCT	Use it to set WPGW(Workplace Gateway) connection.	2
	settings 0: off (default); 1: on	
CHNG-STTS	Use it to set the ToT status connection port number.	2
	Changes the port number for status connection in a TUIF over TCP/IP environment. settings 1 to 65535 (default: 20010)	
CHNG-CMD	Use it to set the ToT command connection port number.	2
	Use it to set the port number for the command connection in an TUIF over TCP/IP environment. settings 1 to 65535 (default: 20000)	
MEAP-DSP	Use it to prohibit a switch-over from the MEAP screen to the Native screen.	2
	settings 0: off (shift to Native screen; default); 1: on (do not shift to Native screen)	
ANIM-SW	Use it to prohibit display of the Error/Jam screen while a MEAP application is in operation.	2
	settings 0: off (display warning screen; default); 1: on (do not display warning screen)	
MEAP-SSL	Use it to set the HTTPS port for MEAP.	2
	settings 0 to 65535 (default: 8443)	
KSIZE-SW	Use it to support Chinese paper (K size).	2
	settings 0: support (default); 1: do not support	

COPIER > OPTION > BODY		
*: model equipped with DADF-Q1 (outside Japan: iR7105/7095; inside Japan: All model).		
**: model equipped with DADF-M1 (outside Japan: iR7086).		
Sub item	Description	Level
LPD-PORT	Use it to set the LPD port number.	2
	settings 1 to 65535 (default: 515)	
DFDST-L3 *	Use it to adjust the dust detection level when the ADF is in use (sheet-to-sheet correction; large-size paper).	2
	A higher setting will make the mechanism more sensitive, detecting finer particles of dust. settings: 0 to 255	
DFDST-L4 *	Use it to adjust the dust detection level when the ADF is in use (post-job detection; large-size paper)	2
	A higher setting will make the mechanism more sensitive, detecting finer particles of dust. settings: 0 to 255	
ORG-A4R	Use it to set a special paper size not recognized when the ADF is in use.	2
	settings 0: A4R (default); 1: Folio-R	
ORG-FLSC *	Use it to set a specific paper size not recognized when the ADF is in use.	2
	settings 0: Foolscap-R (default); 1: Officio-R; 2: Folio-R; 3: Australian Foolscap-R; 4: Ecuadorian Officio-R; 5: Argentine Officio-R; 7: Argentine Legal-R; 8: Government Legal-R; 10: Mexican Officio-R	
PDF-RDCT	Use it to enable/disable reduction for transmission (PDF transmission).	2
	Use it to enable/disable reduction of images received in fax mode (by converting into PDF for e-mail or file transmission). settings 0: do not reduced for transmission (default); 1: reduce for transmission	
REBOOT SW	enables/disables the rebooting mechanism in conjunction with E240	2
	settings: 0: reboot (default); 1: do not reboot	

<USER>

T-17-49

COPIER > OPTION > USER		
*: model equipped with DADF-Q1 (outside Japan: iR7105/7095; inside Japan: All model).		
**: model equipped with DADF-M1 (outside Japan: iR7086).		
Sub item	Description	Level
COPY-LIM	Use it to change the upper limit for the number of copies.	1
	settings 1 to 9999 prints (default: 9999)	
SLEEP	Use it to enable/disable the sleep function.	1
	settings 0: off; 1: on (default) The sleep function depends on the timer set in user mode.	
WEB-DISP	Use it to enable/disable the indication of a fixing web length warning message.	1
	settings 0: off (do not indicate warning; default); 1: on (indicate warning) If set to '0', the message will be limited to the service mode screen.	
W-TONER	Use it to turn off/on the waste toner case full message.	1
	settings 0: off (do not indicate message; default); 1: on (indicate message) If set to '0', the warning message will be limited to the service mode screen.	

COPIER > OPTION > USER		
*: model equipped with DADF-Q1 (outside Japan: iR7105/7095; inside Japan: All model).		
**: model equipped with DADF-M1 (outside Japan: iR7086).		
Sub item	Description	Level
COUNTE R1	Use it to set soft counter 1 for the user mode screen.	1
	settings 101: total 1 (fixed)	
COUNTE R2 to COUNTE R6	Use it to set soft counters 2 through 6 for the user mode screen.	1
	settings 0 to 999 For a list of settings, see the "Soft Counter Specifications" found later.	
CONTRO L	enables/disables the charging mechanism (PDL job)	1
	settings 0: do not restrict (default); 1: restrict	
B4-L- CNT	For soft counters 1 through 6, use it to specify whether B4 should be counted as large-size or small-size.	1
	settings 0: small size (default); 1: large size	
COPY- JOB	Use it to prohibit reservation of a copy job when a card reader/coin robot is in use.	1
	settings 0: enable reservation (default); 1: disable reservation	
TAB- ROT	Use it to enable/disable rotation of images by 180 deg for PDL printing (if tab paper is used for landscape orientation).	1
	settings 0: do not rotate; 1: rotate	
PR- PSESW	Use it to enable/disable display of the print pause function switch.	1
	settings 0: do not display (default); 1: display	
IDPRN- SW	Use it to switch between job types that initiate increases in group counters.	1
	settings 0: for print category, Box Print, Report Print, End Local Print, PDL Print for copy category, Copy (default) 1: for print category, Report Print, Send Local Print, PDL Print for copy category, Copy, Box Print	
CNT-SW	Use it to switch between charge counter default indication items.	1
	settings 0: 101 (total 1; default) 1: 102 (total 2), 202 (copy total 2), 127 (total A2) 2: 101 (total 1), 104 (total small), 103 (total large), 501 (scan total 1)	
TAB- ACC	Use it to enable/disable auto cassette switchover in response to the absence of tab paper (index paper).	1
	settings 0: do not switch between cassettes (default); 1: switch between cassettes	
BCNT- AST	Use it to switch between job types that initiate an increase in the box print count for the NE controller.	1
	settings 0: count as PDL job (default); 1: count as copy job	
DOC- REM *	Use it to enable/disable the indication of the Remove Original message.	1
	Normally, when an original is placed in the ADF and the Start button is pressed without opening and then closing the copyboard cover after an original has been read from the copyboard, the machine will indicate a message asking for the removal of the original. Use it to enable/disable the indication of the message. settings 0: do not indicate (default); 1: indicate	

COPIER > OPTION > USER		
*: model equipped with DADF-Q1 (outside Japan: iR7105/7095; inside Japan: All model).		
**: model equipped with DADF-M1 (outside Japan: iR7086).		
Sub item	Description	Level
TRAY-SEL	Use it to select the delivery tray. (finisher)	1
	Use it to select the target of delivery for the following: multiple originals, copy count at 1, sort selected, special tray A and B. settings 0: use sample tray (default); 1: use tray B	
LDAP-SW	Use it to switch cover search conditions for the LDAP server.	1
	settings 0: 'includes next'; 1: 'does not include next'; 2: 'is identical to'; 3: 'is not identical to'; 4: 'begins with' (default); 5: 'ends with'	
FROM-OF	Use it to enable/disable the deletion of 'from address' for mail transmissions.	1
	settings 0: do not delete (default); 1: delete	
SPEAKER	Use it to enable/disable display of the speaker/headset switch for user mode.	1
	Enables/disables display of the speaker/headset switch for user mode. settings 0: do not display (default); 1: display	
FILE-OF	Use it to enable/disable transmission to a file address.	1
	Enables/disables transmission to a file address by prohibiting input of a file address from the address book. settings 0: do not prohibit (default); 1: prohibit If a file address has already been registered, the address may be used even after selecting '1'; be sure to remove it manually.	
MAIL-OF	Use it to enable/disable transmission to an e-mail address.	1
	Enables/disables transmission to an e-mail address by prohibiting input of an e-mail address from the address book. settings 0: do not prohibit (default); 1: prohibit If an e-mail address has already been registered, the address may be used even after selecting '1'; be sure to remove it manually.	
IFAX-OF	Use it to enable/disable transmission to an i-fax address.	1
	Enables/disables transmission to an i-fax address by prohibiting input of an i-fax address from the address book. settings 0: do not prohibit (default); 1: prohibit If an i-fax address has already been registered, the address may be used even after '1' has been selected; be sure to delete it manually.	
LDAP-DEF	Use it to change the LDAP server search condition default settings.	1
	Use it to change the default conditions for the search attributes specified at time of making an LDAP server detail search. settings 0: 'name' 'default'; 1: 'e-mail'; 2: 'fax'; 3: 'group'; 4: 'group unit'; 5: user setting 1; 6: user setting 2	
ENCR-SW	Use it to enable/disable the HDD encryption function.	1
	Enables/disables the encryption function when the security expansion kit (encryption) and the iR security kit (HDD deletion) are used in combination. The performance will be higher than the use in combination. 0: do no use encryption; 1: use encryption (default)	
SIZE-DET	Use it to enable/disable the original size detection function.	2
	The machine is designed so that the scanning lamp goes on for detection of the size of the original when the copyboard cover is opened and then closed; if the user finds its light to be too intense, set it to '0'. settings 0: off; 1: on (default)	

COPIER > OPTION > USER		
*: model equipped with DADF-Q1 (outside Japan: iR7105/7095; inside Japan: All model).		
**: model equipped with DADF-M1 (outside Japan: iR7086).		
Sub item	Description	Level
DATE-DSP	Use it to switch between date notations.	2
	settings 0: YYMM/DD; 1: DD/MM/YY; 2: MM/DD/YY	
MB-CCV	Use it to set restrictions on the individuals permitted the use of mail box control card.	2
	settings 0: do not restrict (default); 1: restrict	
PR-D-SEL	Use it to set the density for printing (PDL input).	2
	settings 0: (light) <->4 (standard; default) <-> 8 (dark)	
TRY-STP	Use it to set the output interrupt mode used in response to a tray full condition.	2
	settings 0: normal mode (suspend when finisher tray becomes full; default); 1: suspend in relation to height	
MF-LG-ST	Use it to set extra length mode key.	2
	settings 0: normal (default); 1: indicate extra length key on supported mode screen	
SPECK-DP	Use it to enable/disable display of a warning message in response to the result of dust detection for stream reading.	2
	settings 0: do not indicate; 1: indicate (default)	
CNT-DISP	Use it to enable/disable the indication of a serial number in response to a press on the counter check mode.	2
	settings 0: indicate (default); 1: do not indicate	
PH-D-SEL	Use it to specify the number of lines for photo mode.	2
	settings 0: 141 lines (default); 1: 134 lines	
OP-SZ-DT	Use it to enable/disable the original size detection function in reference to the opening of the copyboard cover.	2
	The machine may be set so that it detects the size of an original with the copyboard cover open (e.g., for a book). settings 0: off (default); 1: on If set to '1', the machine executes original size detection in response to a press on the Start key.	
NW-SCAN	Use it to enable/disable the network scan function.	2
	settings 0: do not permit; 1: permit This choice is not available on a Japanese model. For a non-Japanese PS/PCL model, the settings is fixed to '1'.	
INS-C/S	Use it to expand the inserter function.	2
	settings 0: support only cover (default); 1: support multi-inserter (cover + interleaf)	
TBIC-RNK	Use it to enable/disable halftone uneven density reduction mode.	2
	settings 1 to 5 (default: 2)	
HDCR-DSP	Use it to switch between HDD deletion modes.	2
	settings 1: once using 0s (default); 2: once using random data; 3: 3 times using random data	
BCK-CVR	Use it to enable/disable the back cover function.	2
	settings 0: off; 1: on	

COPIER > OPTION > USER		
*: model equipped with DADF-Q1 (outside Japan: iR7105/7095; inside Japan: All model).		
**: model equipped with DADF-M1 (outside Japan: iR7086).		
Sub item	Description	Level
JOB- INVL	Use it to set job intervals for an interrupt.	2
	settings 0: continue with next job immediately for interrupt (default) 1: start next job after delivery of last sheet of interrupt 2: start next job after last sheet of all jobs	
LGSW- DSP	Use it to enable/disable display of 'enable/disable log indication' for user mode.	2
	settings 0: do not display (default); 1: display	
PCL- COPY	Use it to set PCL command COPIES Meru/Pinatubo/Hood compatibility.	2
	settings 0: control on page basis according to COPIES command set on each page (default) 1: Meru/Pinatubo/Hood compatibility mode; 2 through 65535: for future expansion	
PRJOB- CP	Use it to make CCV count pulse settings for reception and report output.	2
	settings 0: do not generate count pulse (default); 1: generate count pulse	
DPT-ID-7	Use it to enable/disable group ID registration and 7-character authentication input.	2
	settings 0: normal (default); 1: 7-character input	
RUI-RJT	Use it to cut the HTTP port in response to 3 attempts at illegal authentication from a remote UI.	2
	settings 0: disable (default); 1: enable	
CTM-S06	Use it to enable/disable deletion of the password from an export file with a file transmission address.	2
	settings 0: do not delete (default); 1: delete	
FREG- SW	Use it to enable/disable display of the free area of the MEAP counter (SPEED).	2
	settings 0: do not display (default); 1: display	
IFAX- SZL	Use it to set restrictions on transmission sizes for i-fax transmission.	2
	settings 0: set restrictions; 1: do not set restrictions (only if not through server; default)	
IFAX- PGD	Use it to enable/disable page division for transmission in i-fax simple mode (when the data exceeds the upper limit for transmission size).	2
	settings 0: do not permit (default); 1: permit	
MEAPSA FE	Use it to switch to MEAP safe mode.	2
	settings 0: normal mode (default); 1: safe mode If it is set to '1', the notation "MPSF" will appear at the top of the screen.	
TRAY- FLL	Use it to set the notification mechanism used in response to a tray full condition.	2
	settings 0: issue when all available trays are full 1: when special trays are full	
PRNT- POS	Use it to specify whether or not to suspend subsequent jobs when the ongoing job is cancelled in the presence of an error.	2
	Enables/disables suspension of subsequent jobs when a job cancel (e.g., #037) has occurred because of an error (other than a service call) during PDL printing. settings 0: do not suspend; 1: suspend	

COPIER > OPTION > USER		
*: model equipped with DADF-Q1 (outside Japan: iR7105/7095; inside Japan: All model).		
**: model equipped with DADF-M1 (outside Japan: iR7086).		
Sub item	Description	Level
AFN-PSWD	Use it to set restrictions on access in user mode.	2
	settings 0: off (shift to user mode scan without requiring password; default) 1: on (shift to user mode scan after password match)	
PTJAM-RC	Use it to set the PDL jam recovery switch.	2
	settings 0: off (do not execute recovery); 1: on (execute recovery; default)	
SLP-SLCT	Use it to set the switch designed to switch between existing network-based applications.	2
	settings 0: do not use (default); 1: use When it is set to '1', a shift to sleep mode 3 (1w sleep) will not occur.	
PS-MODE	Use it to make PS compatible settings.	2
	settings 0: no compatibility (default) 1: PS type 3 Halftone command compatible (dither growth reversed); 2 to 65535: for future expansion	
CNCT-RLZ	Use it to enable/disable the connection serialization function.	2
	settings 0: off; 1: on	
DOM-ADD	Use it to set the transmission target domain input complementary switch for mail transmission.	2
	Use it to enable/disable combination of the address entered for transmission with a domain (e.g., @xxx.co.jp) set in user mode. settings 0: do not combine (default); 1: combine <when sending mail to aaaa@xxxx.co.jp> 1) Set 'xxxx.co.jp' in the domain in user mode; then, set '1' for the item. 2) At time of transmission, type 'aaaa' so that the address will read 'aaaa@xxxx.co.jp'.	

<CST>

T-17-50

COPIER > OPTION > CST		
Sub item	Description	Sub item
P-SZ-C1/C2	Use it to select the size of the paper used in the front deck (C1: right deck; C2: left deck).	1
	settings 6: A4 (default); 15: B5; 18: LTR	
U1-NAME to U4-NAME	Use it to enable/disable indication of the paper name when paper of a particular size group (U1 through U4) is detected.	2
	settings 0: indicate 'U1, U2, U3, U4' on touch panel (default) 1: indicate paper name set in service mode (CST-UI, U2, USE, U4)	
CST-U1	Use it to specify the name of paper used in a paper size group (U1).	2
	When any of the following special size papers is set for U1, the paper may be used as a special size paper for U1 (universal cassette). settings 22: K-LGL; 31: Government LETTER (default)	
CST-U2	Use it to specify the name of paper used in a paper size group (U2).	2
	When any of the following special size papers is set for U2, the paper may be used as a special size paper for U2 (universal cassette). settings 24: Foolscap (default); 26: Officio; 27: Ecuadorian Officio; 33: Argentine Legal; 36: Argentina Officio; 37: Mexican Officio	

COPIER > OPTION > CST		
Sub item	Description	Sub item
CST-U3	Use it to specify the name of paper in a paper size group (U3).	2
	When any of the special size papers is specified for U3, the paper may be used as a special size paper for U3 (universal cassette). settings 25: Australian Foolscap; 34: Government Legal (default); 35: Folio	
CST-U4	Use it to specify the image of paper used in a paper size group (U4).	2
	When any of the following special size papers is set for U4, the paper may be used as a special size paper for U4 (universal cassette). settings 18: LTR (default); 29: Argentine Letter	

<ACC>

T-17-51

COPIER > OPTION > ACC		
Sub item	Description	Level
COIN	Use it to set the coin vendor mechanism.	1
	settings 0: coin vendor not used (default); 1: coin vendor used; 2: remote counter	
DK-P	Use it to specify the size of the paper in the side paper deck (small).	1
	settings 0: A4 (default); 1: B5; 2: LTR	
PD-SIZE	Use it to specify the size of the paper in the side paper deck (large).	1
	settings 0: as set in user mode (default); 22: Korean Government; 23: Korean Government-R; 24: Foolscap; 25: Australian Foolscap; 26: Officio; 27: Ecuadorian Officio; 28: Bolivian Officio; 29: Argentine Letter; 30: Argentine Letter-R; 31: Government Letter; 32: Government Letter-R; 33: Argentine Legal; 34: Government Legal; 35: Folio; 36: Argentine Officio; 37: Mexican Officio This mode item is indicated only when a large paper deck is connected.	
TRM-CTR	Use it to enable/disable display of the message for replacement of the trimmer blade on the user screen	1
	settings 0: do not display (default); 1: display	
TRM-CTRH	enabling/disabling display of the trimmer blade replacement message on the user screen	1
	settings 0: do not display (default); 1: display	
BND-CTR	for future use	1
BND-CTRH	for future use	1
CC-SPSW	Use it to change the I/F support level for the control card (CC IV/CC V).	2
	settings 0: do not support (default); 1: support (priority on speed); 2: support (control by priority on upper limit) If set to '1', suspension of printing may not be accurate based on the upper limit owing to the priority given to the maintenance of performance of the printer engine. If set to '2', suspension of printing is possible based on the upper limit, but the printer engine performance may drop depending on which source of paper is selected.	

<INT-FACE>

T-17-52

COPIER > OPTION > INT-FACE		
Sub item	Description	Level
IMG-CONT	Use it to indicate the connection of a PS print server unit.	1
	settings 0: PS print server unit not connected (default); 3: PS print server unit connected	
AP-OPT	Use it to enable/disable printing from a PS print server unit application (PrintME).	2
	settings 0: permit printing by specific account; 1: permit printing by all accounts (default); 2: do not permit printing (permit only specific group ID)	
AP-ACCNT	Use it to set a group ID for printing (job) from a PS print server unit application (PrintMe).	2
	settings 0 to 9999999 (default: 0)	
AP-CODE	Use it set the path for printing (CPCA) from a PS print server unit application (PrintMe).	2
	settings 0 to 9999999 (default: 0)	
NWCT-TM	Use it to set the time-out length in a network environment.	2
	settings 1 to 5 (unit: min; default: 5)	

<LCNS-TR>

T-17-53

COPIER > OPTION > LCNS-TR		
Indication EX: ST-XXXX 1<-(0) [0 to 0] [1] [2] [1] status indication; 0: not installed (default); 1: installed [2] invalidation execution; 0: invalidation execution (accepts only 0) <Invalidation Transfer> 1) Select SET-XXXX, and type in '0'; then press the OK key. 2) See that TR-XXXX indicates a license number (24 characters) for transfer.		
Sub item	Description	Level
ST-SEND	for the SEND function in relation to transfer invalidation, indicates the installation status/ executes transfer invalidation	2
TR-SEND	for the SEND function in relation to transfer invalidation, obtains a transfer license key	2
ST-ENPDF	for the SEND encryption PDF transmission function in relation to transfer invalidation, indicates installation status/ executes transfer invalidation	2
TR-ENPDF	for the SEND encryption PDF transmission function in relation to transfer invalidation, obtains a transfer license	2
ST-SPDF	for the SEND searchable PDF transmission function in relation to transfer invalidation, indicates installation status/ executes transfer invalidation	2
TR-SPDF	for the SEND searchable PDF transmission function in relation to transfer invalidation, obtains a transfer license key	2
ST-EXPDF	for the PDF expansion kit (encryption PDF + searchable PDF, compound function) in relation to transfer invalidation, indicates installation status/ executes transfer invalidation	2
TR-EXPDF	for the PDF expansion kit (encryption PDF + searchable PDF, compound function) in relation to transfer invalidation, obtains a transfer license key	2
ST-LIPS	for LIPS in relation to transfer invalidation, indicates installation status/ executes transfer invalidation	2
TR-LIPS	for LIPS in relation to transfer invalidation, obtains a transfer license key	2
ST-PDFDR	for PDF direct in relation to transfer invalidation, indicates installation status/ executes transfer invalidation	2
TR-PDFDR	for PDF direct in relation to transfer invalidation, obtains a transfer license key	2
ST-SCR	for encryption secure print in relation to transfer invalidation, indicates installation status/ executes transfer invalidation	2

COPIER > OPTION > LCNS-TR		
Indication EX: ST-XXXX 1<-(0) [0 to 0] [1] [2] [1] status indication; 0: not installed (default); 1: installed [2] invalidation execution; 0: invalidation execution (accepts only 0) <Invalidation Transfer> 1) Select SET-XXXX, and type in '0'; then press the OK key. 2) See that TR-XXXX indicates a license number (24 characters) for transfer.		
Sub item	Description	Level
TR-SCR	for encryption secure print in relation to transfer invalidation, obtains a transfer license key	2
ST-HDCLR	for HDD encryption/full deletion in relation to transfer invalidation, indicates invalidation status/executes transfer invalidation	2
TR-HDCLR	for HDD encryption/full deletion in relation to transfer invalidation, obtains a transfer license key	2
ST-BRDIM	for BarDIMM in relation to transfer invalidation, obtains a transfer license	2
TR-BRDIM	for BarDIMM in relation to transfer invalidation, obtains a transfer license key	2
ST-VNC	for VNC in relation to transfer invalidation, indicates installation status/executes transfer invalidation	2
TR-VNC	for VNC in relation to transfer invalidation, obtains a transfer license key	2
ST-WEB	for the Web browser in relation to transfer invalidation, indicates installation status/executes transfer invalidation	2
TR-WEB	for the Web browser in relation to transfer invalidation, obtains a transfer license key	2
ST-TRSND	for the trial SEND function in relation to transfer invalidation, indicates installation status/executes transfer invalidation	2
TR-TRSND	for the trial SEND function in relation to transfer invalidation, obtains a transfer license key	2
ST-WTMRK	for the background print function in relation to transfer invalidation, indicates installation status/executes transfer invalidation	2
TR-WTMRK	for the background print function in relation to transfer invalidation, obtains a transfer license key	2

<ACCPST-D>

T-17-54

COPIER > OPTION > ACCPST-D		
Sub item	Description	Level
ACC1 to ACC8	Use it to set the order of connection of ARCNET accessories (delivery system). Sets the order of connection of delivery accessories connected to the ARCNET network, starting from the host machine moving upstream. Be sure to use the item at time of installation or when you have replaced the DC controller PCB or initialized the RAM; otherwise, the break in the ARCNET network between the host machine and accessories will prevent the use of accessories. <Procedure> 1) Of ACC1 through ACC8, select the item for which the name of the accessory in question is indicated. 2) Check to find out the position of the accessory with reference to the host machine, and type in the number indicating its order. 3) Press the OK key. 4) Turn off and then back on the host machine and the accessory in the correct sequence. settings 0 to 99	1

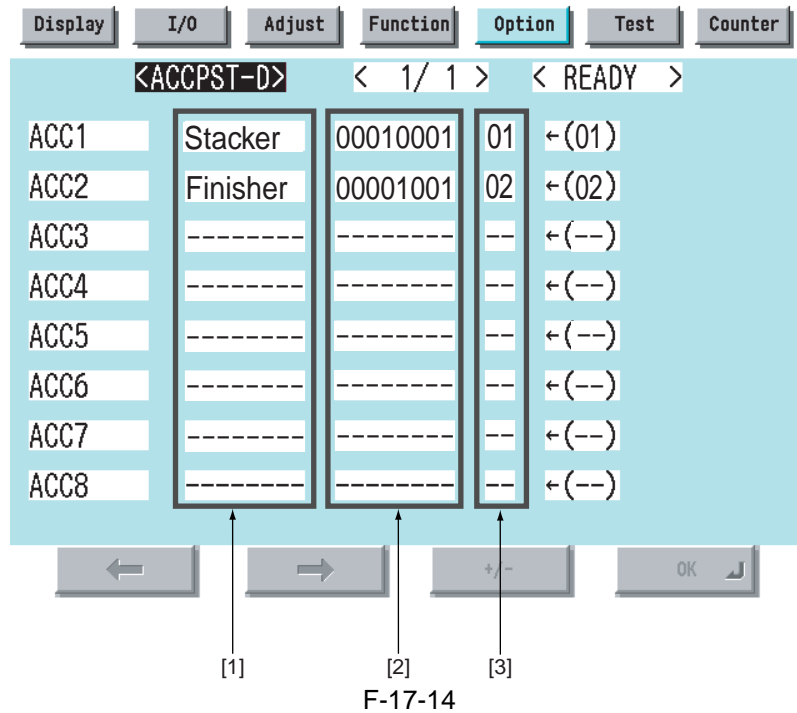

- [1] Names of connected accessories
 [2] IDs of connected accessories (unique, 8-character)
 [3] Order of connection

17.6.1.2 Soft Counter Specifications

T-17-55

No.	Counter description	Support
101	total 1	yes
102	total 2	yes
103	total (large)	yes
104	total (small)	yes
105	total (full color 1)	
106	total (full color 2)	
108	total (black-and-white 1)	yes
109	total (black-and-white 2)	yes
110	total (mono color; large)	
111	total (mono color; small)	
112	total (black-and-white; large)	yes
113	total (black-and-white: small)	yes
114	total 1 (double-sided)	yes
115	total 2 (double-sided)	yes
116	large (double-sided)	yes
117	small (double-sided)	yes
118	total (mono color 1)	
119	total (mono color 2)	
120	total (full color; large)	
121	total (full color; small)	
122	total (full color + mono color; large)	
123	total (full color + mono color; small)	
124	total (full color + mono color 2)	
125	total (full color + mono color 1)	
126	total A1	yes
127	total A2	yes

No.	Counter description	Support
128	total A (large)	yes
129	total A (small)	yes
130	total A (full color 1)	
131	total A (full color 2)	
132	total A (black-and-white 1)	yes
133	total A (black-and-white 2)	yes
134	total A (mono color; large)	
135	total A (mono color; small)	
136	total A (black-and-white; large)	yes
137	total A (black-and-white; small)	yes
138	total A1 (double-sided)	
139	total A2 (double-sided)	
140	large A (double-sided)	
141	small A (double-sided)	
142	total A (mono color 1)	
143	total A (mono color 2)	
144	total A (full color; large)	
145	total A (full color; small)	
146	total A (full color + mono color; large)	
147	total A (full color + mono color; small)	
148	total A (full color + mono color 2)	
149	total A (full color + mono color 1)	
150	total B1	yes
151	total B2	yes
152	total B (large)	yes
153	total B (small)	yes
154	total B (full color 1)	
155	total B (full color 2)	
156	total B (black-and-white 1)	yes
157	total B (black-and-white 2)	yes
158	total B (mono color; large)	
159	total B (mono color; small)	
160	total B (black-and-white; large)	yes
161	total B (black-and-white; small)	yes
162	total B1 (double-sided)	
163	total B2 (double-sided)	
164	large B (double-sided)	
165	small B (double-sided)	
166	total B (mono color 1)	
167	total B (mono color 2)	
168	total B (full color; large)	
169	total B (full color; small)	
170	total B (full color + mono color; large)	
171	total B (full color + mono color; small)	
172	total B (full color + mono color 2)	
173	total B (full color + mono color 1)	

T-17-56

No.	Counter description	Support
201	copy (total 1)	yes
202	copy (total 2)	yes
203	copy (large)	yes
204	copy (small)	yes
205	copy A (total 1)	yes
206	copy A (total 2)	yes
207	copy A (large)	yes
208	copy A (small)	yes
209	local copy (total 1)	yes
210	local copy (total 2)	yes
211	local copy (large)	yes
212	local copy (small)	yes
213	remote copy (total 1)	yes
214	remote copy (total 2)	yes
215	remote copy (large)	yes
216	remote copy (small)	yes
217	copy (full color 1)	
218	copy (full color 2)	
219	copy (mono color 1)	
220	copy (mono color 2)	
221	copy (black-and-white 1)	yes
222	copy (black-and-white 2)	yes
223	copy (full color; large)	
224	copy (full color; small)	
225	copy (mono color; large)	
226	copy (mono color; small)	
227	copy (black-and-white; large)	yes
228	copy (black-and-white; small)	yes
229	copy (full color + mono color; large)	
230	copy (full color + mono color; small)	
231	copy (full color + mono color; 2)	
232	copy (full color + mono color; 1)	
233	copy (full color; large; double-sided)	
234	copy (full color; small; double-sided)	
235	copy (mono color; large; double-sided)	
236	copy (mono color; small; double-sided)	
237	copy (black-and-white; large; double-sided)	
238	copy (black-and-white; small; double-sided)	
245	copy A (full color 1)	
246	copy A (full color 2)	
247	copy A (mono color 1)	
248	copy A (mono color 2)	
249	copy A (black-and-white 1)	yes
250	copy A (black-and-white 2)	yes
251	copy A (full color; large)	
252	copy A (full color; small)	
253	copy A (mono color; large)	
254	copy A (mono color; small)	
255	copy A (black-and-white; large)	yes
256	copy A (black-and-white; small)	yes

No.	Counter description	Support
257	copy A (full color + mono color; large)	
258	copy A (full color + mono color; small)	
259	copy A (full color + mono color 2)	
260	copy A (full color + mono color 1)	
261	copy A (full color; large; double-sided)	
262	copy A (full color; small; double-sided)	
263	copy A (mono color; large; double-sided)	
264	copy A (mono color; small; double-sided)	
265	copy A (black-and-white; large; double-sided)	
266	copy A (black-and-white; small; double-sided)	
273	local copy (full color 1)	
274	local copy (full color 2)	
275	local copy (mono color 1)	
276	local copy (mono color 2)	
277	local copy (black-and-white 1)	yes
278	local copy (black-and-white 2)	yes
279	local copy (full color; large)	
280	local copy (full color; small)	
281	local copy (mono color; large)	
282	local copy (mono color; small)	
283	local copy (black-and-white; large)	yes
284	local copy (black-and-white; small)	yes
285	local copy (full color + mono color; large)	
286	local copy (full color + mono color; small)	
287	local copy (full color + mono color 2)	
288	local copy (full color + mono color 1)	
289	local copy (full color; large; double-sided)	
290	local copy (full color; small; double-sided)	
291	local copy (mono color; large; double-sided)	
292	local copy (mono color; small; double-sided)	
293	local copy (black-and-white; large; double-sided)	
294	local copy (black-and-white; small; double-sided)	

T-17-57

No.	Counter description	Support
002	remote copy (full color 1)	
003	remote copy (full color 2)	
004	remote copy (mono color 1)	
005	remote copy (mono color 2)	
006	remote copy (black-and-white 1)	yes
007	remote copy (black-and-white 2)	yes
008	remote copy (full color; large)	
009	remote copy (full color; small)	
010	remote copy (mono color; large)	
011	remote copy (mono color; small)	
012	remote copy (black-and-white; large)	yes
013	remote copy (black-and-white; small)	yes
014	remote copy (full color + mono color; large)	
015	remote copy (full color + mono color; small)	
016	remote copy (full color + mono color 2)	
017	remote copy (full color + mono color 1)	
018	remote copy (full color; large; double-sided)	

No.	Counter description	Support
019	remote copy (full color; small; double-sided)	
020	remote copy (mono color; large; double-sided)	
021	remote copy (mono color; small; double-sided)	
022	remote copy (black-and-white; large; double-sided)	
023	remote copy (black-and-white; small; double-sided)	

T-17-58

No.	Counter description	Support
301	print (total 1)	yes
302	print (total 2)	yes
303	print (large)	yes
304	print (small)	yes
305	print A (total 1)	yes
306	print A (total 2)	yes
307	print A (large)	yes
308	print A (small)	yes
309	print (full color 1)	
310	print (full color 2)	
311	print (mono color 1)	
312	print (mono color 2)	
313	print (black-and-white 1)	yes
314	print (black-and-white 2)	yes
315	print (full color; large)	
316	print (full color; small)	
317	print (mono color; large)	
318	print (mono color; small)	
319	print (black-and-white; large)	yes
320	print (black-and-white; small)	yes
321	print (full color + mono color; large)	
322	print (full color + mono color; small)	
323	print (full color + mono color; 2)	
324	print (full color + mono color; 1)	
325	print (full color; large; double-sided)	
326	print (full color; small; double-sided)	
327	print (mono color; large; double-sided)	
328	print (mono color; small; double-sided)	
329	print (black-and-white; large; double-sided)	
330	print (black-and-white; small; double-sided)	
331	PDL print (total 1)	yes
332	PDL print (total 2)	yes
333	PDL print (large)	yes
334	PDL print (small)	yes
335	PDL print (full color 1)	
336	PDL print (full color 2)	
339	PDL print (black-and-white 1)	yes
340	PDL print (black-and-white 2)	yes
341	PDL print (full color; large)	
342	PDL print (full color; small)	
345	PDL print (black-and-white; large)	yes
346	PDL print (black-and-white; small)	yes
351	PDL print (full color; large; double-sided)	
352	PDL print (full color; small double-sided)	

No.	Counter description	Support
355	PDL print (black-and-white; large; double-sided)	
356	PDL print (black-and-white; small; double-sided)	

T-17-59

No.	Counter description	Support
401	copy + print (full color; large)	
402	copy + print (full color; small)	
403	copy + print (black-and-white; large)	
404	copy + print (black-and-white; small)	
405	copy + print (black-and-white 2)	
406	copy + print (black-and-white 1)	
407	copy + print (full color + mono color; large)	
408	copy + print (full color + mono color; small)	
409	copy + print (full color + mono color; 2)	
410	copy + print (full color + mono color; 1)	
411	copy + print (large)	
412	copy + print (small)	
413	copy + print (2)	
414	copy + print (1)	
415	copy + print (mono color; large)	
416	copy + print (mono color; small)	
417	copy + print (full color; large; double-sided)	
418	copy + print (full color; small; double-sided)	
419	copy + print (mono color; large; double-sided)	
420	copy + print (mono color; small; double-sided)	
421	copy + print (black-and-white; large; double-sided)	
422	copy + print (black-and-white; small; double-sided)	

T-17-60

No.	Counter description	Support
501	scan (total 1)	yes
502	scan (total 2)	yes
503	scan (large)	yes
504	scan (small)	yes
505	black-and-white scan (total 1)	yes
506	black-and-white scan (total 2)	yes
507	black-and-white scan (large)	yes
508	black-and-white scan (small)	yes
509	color scan (total 1)	
510	color scan (total 2)	
511	color scan (large)	
512	color scan (small)	

T-17-61

No.	Counter description	Support
601	box print (total 1)	yes
602	box print (total 2)	yes
603	box print (large)	yes
604	box print (small)	yes
605	box print (full color 1)	
606	box print (full color 2)	
607	box print (mono color 1)	
608	box print (mono color 2)	
609	box print (black-and-white 1)	yes

No.	Counter description	Support
610	box print (black-and-white 2)	yes
611	box print (full color; large)	
612	box print (full color; small)	
613	box print (mono color; large)	
614	box print (mono color; small)	
615	box print (black-and-white; large)	yes
616	box print (black-and-white; small)	yes
617	box print (full color + mono color; large)	
618	box print (full color + mono color; small)	
619	box print (full color + mono color 2)	
620	box print (full color + mono color 1)	
621	box print (full color; large; double-sided)	
622	box print (full color; small; double-sided)	
623	box print (mono color; large; double-sided)	
624	box print (mono color; small; double-sided)	
625	box print (black-and-white; large; double-sided)	
626	box print (black-and-white; small; double-sided)	

T-17-62

No.	Counter description	Support
701	reception print (total 1)	yes
702	reception print (total 2)	yes
703	reception print (large)	yes
704	reception print (small)	yes
705	reception print (full color 1)	
706	reception print (full color 2)	
707	reception print (grayscale 1)	
708	reception print (grayscale 2)	
709	reception print (black-and-white 1)	yes
710	reception print (black-and-white 2)	yes
711	reception print (full color; large)	
712	reception print (full color; small)	
713	reception print (grayscale; large)	
714	reception print (grayscale; small)	
715	reception print (black-and-white; large)	yes
716	reception print (black-and-white; small)	yes
717	reception print (full color + grayscale; large)	
718	reception print (full color + grayscale; small)	
719	reception print (full color + grayscale 2)	
720	reception print (full color + grayscale 1)	
721	reception print (full color; large; double-sided)	
722	reception print (full color; small; double-sided)	
723	reception print (grayscale; large; double-sided)	
724	reception print (grayscale; small; double-sided)	
725	reception print (black-and-white; large; double-sided)	
726	reception print (black-and-white; small; double-sided)	

T-17-63

No.	Counter description	Support
801	report print (total 1)	yes
802	report print (total 2)	yes
803	report print (large)	yes
804	report print (small)	yes
805	report print (full color 1)	
806	report print (full color 2)	
807	report print (grayscale 1)	
808	report print (grayscale 2)	
809	report print (black-and-white 1)	yes
810	report print (black-and-white 2)	yes
811	report print (full color; large)	
812	report print (full color; small)	
813	report print (grayscale; large)	
814	report print (grayscale; small)	
815	report print (black-and-white; large)	yes
816	report print (black-and-white; small)	yes
817	report print (full color + grayscale; large)	
818	report print (full color + ray scale; small)	
819	report print (full color + grayscale 2)	
820	report print (full color + grayscale 1)	
821	report print (full color; large; double-sided)	
822	report print (full color; small; double-sided)	
823	report print (grayscale; large; double-sided)	
824	report print (grayscale; small; double-sided)	
825	report print (black-and-white; large; double-sided)	
826	report print (black-and-white; small; double-sided)	

T-17-64

No.	Counter description	Support
901	copy scan total 1 (color)	
902	copy scan total 1 (black-and-white)	
903	copy scan total 2 (color)	
904	copy scan total 2 (black-and-white)	
905	copy scan total 3 (color)	
906	copy scan total 3 (black-and-white)	
907	copy scan total 4 (color)	
908	copy scan total 4 (black-and-white)	
909	local copy scan (color)	
910	local copy scan (black-and-white)	
911	remote copy scan (color)	
912	remote copy scan (black-and-white)	
913	transmission scan total 1 (color)	
914	transmission scan total 1 (black-and-white)	
915	transmission scan total 2 (color)	
916	transmission scan total 2 (black-and-white)	yes
917	transmission scan total 3 (color)	
918	transmission scan total 3 (black-and-white)	yes
919	transmission scan total 4 (color)	
920	transmission scan total 4 (black-and-white)	
921	transmission scan total 5 (color)	
922	transmission scan total 5 (black-and-white)	yes

No.	Counter description	Support
929	transmission scan total 6 (color)	
930	transmission scan total 6 (black-and-white)	yes
931	transmission scan total 7 (color)	
932	transmission scan total 7 (black-and-white)	
933	transmission scan total 8 (color)	
934	transmission scan total 8 (black-and-white)	
935	universal transmission scan total (color)	
936	universal transmission scan total (black-and-white)	
937	box scan (color)	
938	box scan (black-and-white)	
939	remote san (color)	
940	remote scan (black-and-white)	yes
941	transmission scan /fax (color)	
942	transmission scan/fax (black-and-white)	
943	transmission scan/i-fax (color)	
944	transmission scan/i-fax (black-and-white)	
945	transmission scan/e-mail (color)	
946	transmission scan/e-mail (black-and-white)	
947	transmission scan/FTP (color)	
948	transmission scan/FTP (black-and-white)	
949	transmission scan/SMB (color)	
950	transmission scan/SMB (black-and-white)	
951	transmission scan/IPX (color)	
952	transmission scan/IPX (black-and-white)	
953	transmission scan/database (color)	
954	transmission scan/database (black-and-white)	
955	transmission scan/local print (color)	
956	transmission scan/local print (black-and-white)	
957	transmission scan/box (color)	
958	transmission scan/box (black-and-white)	

17.6.2 FEEDER

17.6.2.1 FEEDER Items

T-17-65

FEEDER > OPTION		
*: model equipped with DADF-Q1 (outside Japan: iR7105/7095; inside Japan: All model).		
**: model equipped with DADF-M1 (outside Japan: iR7086).		
Sub item	Description	Level
DOC-F-SW *	Use it to enable/disable stream reading mode.	1
	settings 0: stream reading (default); 1: stream reading for small size only; 2: fixed reading	
SIZE-SW	Use it to enable/disable the mixed original detection mechanism (AB and inch).	1
	settings 0: on (disable detection; default); 1: off (enable detection)	
SLW-SPRT *	Use it to decrease the separation speed for original pickup.	1
	settings 0: normal mode (default); 1: deceleration mode	
LS-DBL **	Use it to enable/disable ADF high-speed duplexing mode.	1
	settings 0: on (high-speed duplexing mode; default); 1: off (low-speed duplexing mode)	
STAMP-SW **	Use it to indicate the installation of a stamp.	1
	settings 0: stamp not installed; 1: stamp installed (default)	
HS-DBL *	Use it to enable/disable ADF high-speed reversal mode.	1
	settings	
	0: off (normal mode; default); 1: on (high-speed duplexing mode) If an increase in productivity is desired in ADF duplexing mode, set it to '1'.	

17.6.3 SORTER

17.6.3.1 SORTER Items

T-17-66

SORTER > OPTION		
Sub item	Description	Level
BLNK-SW	Use it to set the margin width for the left and right sides of the crease when the saddle stitcher is used.	1
	settings 0: normal width (5 mm); 1: large width (10 mm); 2: no margin (default)	
MD-SPRTN	Use it to enable/disable bare-minimum (regression) mode.	1
	settings 0: normal operation (default); 1: enable bare-minimum operation (no stapling, alignment)	
SDL-PRS	Use it to specify saddle stitcher press operation.	1
	settings 0: enable pressing (one-way; default); 1: disable pressing; 2: enable pressing (both ways)	
BUFF-SW	Use it to enable/disable buffer operation of the finisher.	1
	settings 0: enable buffer operation (fault); 1: disable buffer operation The use of paper with a low friction coefficient (e.g., coated paper) tends to cause displacement in the buffer assembly. If such is the case, set it to '1' (a drop in productivity, however, will be a trade-off).	
TRY-EJCT	Use it to switch over delivery operation for the stack tray of the finisher.	1
	settings 0: normal operation (default); 1: delivery for thin paper The use of thin paper (i.e., paper with little body) can cause poor stacking. If such is the case, set it to '1'.	

SORTER > OPTION		
Sub item	Description	Level
PN-SKEW	Use it to increase the accuracy of punch hole positioning (in the direction of horizontal registration).	1
	settings 0: normal mode (default); 1: hole position enhancement mode If an increase in the accuracy of punch hole positioning is desired when the puncher unit is in use, set it to '1'. standard: +/-1.0 mm -> +/-0.5 mm A trade-off will be a drop in productivity (100 -> about 80 ppm).	
CNTR-OUT	Use it to set the delivery center position for the stacker.	2
	settings 0: disable center position delivery (default); 1: enable center position delivery This mode item is valid when a stacker is connected.	

17.6.4 BOARD

17.6.4.1 BOARD Items

T-17-67

BOARD > OPTION		
Sub item	Description	Level
FONTDL	Use it to enable/disable display of the service setup screen for fonts listed by the PS kanji font downloader.	1
	settings 0: disable display (default); 1: enable display	
MENU-1 to MENU-4	Use it to enable/disable display of levels 1 thorough 4 for the printer setup menu.	2
	settings 0: disable display (default); 1: enable display	

17.7 TEST (Test Print Mode)

17.7.1 COPIER

17.7.1.1 COPIER Items

<PG>

T-17-68

COPIER > TEST > PG		
Sub item	Description	Level
TYPE	Use it to select a type of test print.	1
	<Procedure> 1) Select the item, and type in the number of the test print you want. 2) Press the Start key so that test printing starts. 3) When done, put back the value to '0'. settings: 0 to 50 0: image from CCD (normal print); 1: grid; 2: 17-gradation (error diffusion); 3: 17-gradation (dither screen); 4: blank; 5: halftone 80H (error diffusion); 6: halftone 80 H (dither screen); 7: solid black; 8: horizontal lines (space: 27 dots; line width: 40 dots); 9: horizontal lines (space: 50 dots; line width: 60 dots); 10: horizontal lines (space: 3 dots; line width: 2 dots); 11: halftone 60 H (error diffusion); 12: halftone 60 H (dither screen); 13: halftone 30 H (error diffusion); 14: halftone 30 H (dither screen); 31: 1200-dpi vertical lines (space: 21 dots; line width: 8 dots); 32: 1200-dpi horizontal lines (space: 21 dots; line width: 8 dots); 33: for check on displacement of image in main scanning direction	
TXPH	Use it to set the image mode for test printing.	1
	settings: 0 to 4 0: text (default); 1: photo; 2: auto; 3: text/photo/map; 4: film print	
PG-PICK	Use it to select the source of paper for test printing.	1
	settings: 1 to 8 1: right deck (default); 2: left deck; 3: cassette 3; 4: cassette 4; 5: side paper deck; 6: manual feeder tray; 7 to 8: not used;	
2-SIDE	Use it to set the output mode for test printing.	1
	settings: 0: simplexing; 1: duplexing	
PG-QTY	Use it to set a copy count for test printing.	1
	setting: 1 to 999 (default: 1)	

<NETWORK>

T-17-69

COPIER > TEST > NETWORK		
Sub item	Description	Level
PING	Use it to issue the PING command.	1
	Use it to check the connection between the machine and the network (TCP/IP only). Use it to check the connection to the network at time of installation or when suspecting a fault in the connection to the network.	

17.8 COUNTER (Counter Mode)

17.8.1 COPIER

17.8.1.1 COPIER Items

<TOTAL>

T-17-70

COPIER > COUNTER > TOTAL		
Sub item	Description	Level
SERVIC E1	total counter 1 for service	1
SERVIC E2	total counter 2 for service large size: increase by 2; small size: increase by 1	1
COPY	total copy counter	1
PDL-PRT	PDL print counter A blank sheet will not be counted. The counter reading may be reset.	1
FAX-PRT	fax reception printer counter A blank sheet will not be counted. The counter reading may be reset.	1
RMT-PRT	remote print counter A blank sheet will not be counted. The counter reading may be reset.	1
BOX-PRT	box print counter A blank sheet will not be counted. The counter reading may be reset.	1
RPT-PRT	report print counter A blank sheet will not be counted. The counter reading may be reset.	1
2-SIDE	double-sided copy/printer counter A blank sheet will not be counted. The counter reading may be reset.	1
SCAN	scan counter A blank sheet will not be counted. The counter reading may be reset.	1

<SCANNER>

T-17-71

COPIER > COUNTER > SCANNER		
Sub item	Description	Level
SC-TTL	scanner total scan counter	1
SC-STRM	ADF stream reading counter	1
SC-NRM	ADF fixed reading counter	1

<PICK-UP>

T-17-72

COPIER > COUNTER > PICK-UP		
Sub item	Description	Level
C1	right deck pickup total counter	1
C2	left deck pickup total counter	1
C3/C4	cassette 3/4 pickup total counter	1
MF	manual feeder tray pickup total counter	1
DK	side paper deck pickup total counter	1
2-SIDE	duplexing pickup total counter	1

<FEEDER>

T-17-73

COPIER > COUNTER > FEEDER		
Sub item	Description	Level
FEED	ADF original pickup total counter	1
L-FEED	large-size original ADF pickup total counter	1
S-FEED	small-size original ADF pickup total counter	1
TTL-MF	ADF manual feeder pickup total counter	1
DFOP-CNT	ADF hinge operation (open/close) counter	1

<JAM>

T-17-74

COPIER > COUNTER > JAM		
Sub item	Description	Level
TOTAL	total jam counter	1
FEEDER	ADF total jam counter	1
SORTER	finisher total jam counter	1
2-SIDE	duplexing unit jam counter	1
MF	manual feeder pickup jam counter	1
C1	right deck pickup jam counter	1
C2	left deck pickup jam counter	1
C3/C4	cassette 3/4 pickup jam counter	1
DK	side paper deck jam counter	1

<MISC>

T-17-75

COPIER > COUNTER > MISC		
Sub item	Description	Level
FIX-WEB	fixing web counter	1
	Be sure to reset it after replacing the fixing web.	
WST-TNR	waste toner counter	1
	Be sure to reset it after replacing the waste toner.	
R-PD-SEN	right deck pickup sensor	1
L-PD-SEN	left deck pickup sensor	1
C3-SEN	cassette 3 pickup sensor	1
C4-SEN	cassette 4 pickup sensor	1
SDPD-SEN	side paper deck sensor	1
RK-F-SEN	right deck pull-off sensor	1
LK-F-SEN	left deck pull-off sensor	1
VPT3-SEN	vertical path 3 sensor	1
VPT4-SEN	vertical path 4 sensor	1
SP-F-SEN	side paper deck transport sensor	1

<PRDC-1>

T-17-76

COPIER > COUNTER > PRDC-1		
Sub item	Description	Level
PRM-WIRE	primary charging wire counter	1
PRM-GRID	primary grid wire counter	1
PO-WIRE	pre-transfer charging counter	1
TR-WIRE	pre-transfer charging counter	1
SP-WIRE	separation charging wire counter	1
FIX-TH1	fixing main thermistor (TH1) counter	1
FIX-TH2	fixing sub thermistor (TH2) counter	1
FX-TSW	fixing thermal switch (TP1) counter	1
OZ-FIL1	ozone filter counter	1
OZ-FIL2	ozone filter counter	1
OZ-FIL3	ozone filter counter	1

<DRBL-1>

T-17-77

COPIER > COUNTER > DRBL-1		
*: model equipped with DADF-Q1 (outside Japan: iR7105/7095; inside Japan: All model).		
**: model equipped with DADF-M1 (outside Japan: iR7086).		
Sub item	Description	Level
SCN-LMP *	not used	1
PRM-UNIT	primary charging assembly counter	1
PRM-CLN	primary charging wire cleaner counter	1
PO-UNIT	pre-transfer charging assembly counter	1
PO-CLN	pre-transfer charging wire cleaner counter	1
PO-SCRPR	pre-transfer charging assembly scraper counter	1
TR-CLN	pre-transfer charging wire cleaner counter	1
T/S-UNIT	transfer/separation charging assembly counter	1
SP-CLN	separation charging wire cleaner counter	1
CLN-BLD	cleaning blade counter	1
SP-CLAW	cleaner separation claw counter	1
BS-SL-F	drum cleaner assembly side seal (front) counter	1
BS-SL-R	drum cleaner assembly side seal (rear) counter	1
DVG-CYL	developing cylinder counter	1
DVG-ROLL	developing roll counter	1
DEV-1CL	developing cylinder clutch counter	1
C3/C4/ LD/RD/ M-PU-RL	cassette 3/cassette 4/left deck/right deck/manual feeder tray pickup roller counter	1

COPIER > COUNTER > DRBL-1		
*: model equipped with DADF-Q1 (outside Japan: iR7105/7095; inside Japan: All model). **: model equipped with DADF-M1 (outside Japan: iR7086).		
C3/C4/ LD/RD/ M-SP-RL	cassette 3/cassette 4/left deck/right deck/manual feeder tray separation roller counter	1
C3/C4/ LD/RD/ M-FD-RL	cassette 3/cassette 4/left deck/right deck/manual feeder tray feeder roller counter	1
FX-UP- RL	fixing upper roller counter	1
FX-LW- RL	fixing lower roller (pressure roller) counter	1
FX-IN-BS	fixing heat insulating bush counter	1
FIX-WEB	fixing web counter	1
FX-BRG- U	fixing upper bearing counter	1
FX-BRG- L	fixing lower bearing counter	1
DLV- UCLW	delivery upper separation claw counter	1
DLV- LCLW	delivery lower separation claw counter	1

<DRBL-2>

T-17-78

COPIER > COUNTER > DRBL-2		
*: model equipped with DADF-Q1 (outside Japan: iR7105/7095; inside Japan: All model). **: model equipped with DADF-M1 (outside Japan: iR7086).		
Sub item	Description	Level
DF-PU-RL	pickup roller counter (ADF)	1
	regardless of the selected read mode (single-sided/double-sided) or paper size (small-size/ large-size), the count is increased by 1 for each original	
DF-SP-PL **	separation plate counter (ADF)	1
DF-SP-PD **	separation pad counter (ADF)	1
DF-FD-RL	transport roller counter (ADF)	1
	single-sided mode: increase by 1 per original read double-sided mode: increase by 3 per original read (for passage of face, back, and idle) no distinction between large side and small size	
DF-SP-BL *	separation belt counter (ADF)	1
DF-F-BLT *	transport belt counter (ADF)	1
LNT-TAPI/ 2/3/4/5 **	dust removing sheet A/B/C/D/E counter (ADF)	1
STAMP **	stamp counter (ADF)	1
DF-HNG-L *	hinge (left) counter (ADF)	1
	increase by 1 per opening/closing of the copyboard	
DF-HNG-R *	hinge (right counter; DF)	1
	increase by 1 per opening/closing of the copyboard cover	
DF-SP-M *	separation motor counter (ADF)	1
DF-DL-RL *	delivery roller counter (ADF)	1
DF-DL-M *	delivery motor counter (ADF)	1

COPIER > COUNTER > DRBL-2		
*: model equipped with DADF-Q1 (outside Japan: iR7105/7095; inside Japan: All model).		
**: model equipped with DADF-M1 (outside Japan: iR7086).		
Sub item	Description	Level
DF-TRL-U *	turn roller unit counter (ADF)	1
	turn roller unit counter (ADF) single-sided mode: increase by 1 per original read double-sided mode: increase by 3 per original read (for passage of face, back, and idle) no distinction between large size and small size	
PD-PU-RL	pickup roller counter (side paper deck)	1
PD-SP-RL	separation roller counter (side paper deck)	1
PD-PU-CL	pickup clutch counter (side paper deck)	1
PD-FD-RL	transport roller counter (side paper deck)	1
PD-PL-CL	pull-off clutch counter (side paper deck)	1
PD-PU-MR	pickup motor counter (side paper deck)	1
PD-PU-SL	pickup solenoid counter (side paper deck)	1
NON-SORT	static eliminator counter (finisher upper delivery slot)	1
FIN-STPR	stapler counter (finisher)	1
SDL-STPL	side stapler counter (finisher)	1
PUNCH	punch unit counter (inside finisher)	1
SORT-2	knurled belt counter (finisher)	1
STCK	stack delivery upper roller counter (finisher)	1
DL-STC-L	static eliminator counter (delivery guide inside finisher)	1
DL-STC-R	static eliminator counter (delivery roller inside finisher)	1
STK-STC	stack discharge roller static eliminator counter (finisher)	1
SDL-STC1	inlet stack eliminator counter (finisher saddle transport upper guide)	1
SDL-STC2	static eliminator counter (finisher transport upper guide)	1
FLAP-STC	flapper static eliminator counter (finisher saddle transport upper guide)	1
SDL-RL	shift roller counter (finisher)	1
PF-STC-L	paper stack eliminator counter (paper folding unit left guide)	1
PF-STC-R	paper static eliminator counter (paper folding unit right guide)	1
IS-P-RL1	pickup roller counter (inserter upper tray for finisher)	1
IS-S-RL1	separation roller counter (inserter upper tray for finisher)	1
IS-F-RL1	transport roller counter (inserter upper tray for finisher)	1
IS-TQLM1	torque limiter counter (inserter upper tray for finisher)	1
IS-P-RL2	separation roller counter (inserter lower tray for finisher)	1
IS-S-RL2	transport roller counter (inserter lower tray for finisher)	1
IS-F-RL2	transport roller counter (inserter lower tray for finisher)	1
IS-TQLM2	torque limiter counter (inserter lower tray for finisher)	1
IS-P-RL3	for future use	1
IS-S-RL3	for future use	1
IS-F-RL3	for future use	1
IS-TQLM3	for future use	1
IS-P-RL4	for future use	1
IS-S-RL4	for future use	1
IS-F-RL4	for future use	1
IS-TQLM4	for future use	1
BND-STC1	for future use	1
BND-STC2	for future use	1
SWBK-RL	for future use	1
ALMT-MTR	for future use	1

COPIER > COUNTER > DRBL-2		
*: model equipped with DADF-Q1 (outside Japan: iR7105/7095; inside Japan: All model).		
**: model equipped with DADF-M1 (outside Japan: iR7086).		
Sub item	Description	Level
ST-DT-VR	for future use	1
GRIP-MTR	for future use	1
HEATER	for future use	1
BND-COLL	for future use	1
SNS-ARM1	for future use	1
SNS-ARM2	for future use	1
SNS-ARM3	for future use	1
BND-CUT	for future use	1
CUT-HLDR	for future use	1
TRM-CUT1	trimming upper blade counter (trimmer)	1
TRM-CUT2	trimming lower blade counter (trimmer)	1
TRM-BLT	flat belt counter (trimmer)	1
STK-STC1	static eliminating brush counter (stacker sample tray outlet)	1
STK-STC2	static eliminating brush counter (stacker stacking assembly outlet)	1
STK-STC3	static eliminating brush counter (stacker inlet)	1
STK-STC4	static eliminating brush counter (stacker downstream outlet)	1
PNCH-RL ***	aligning idle roller assembly counter (professional puncher)	1
PN-BP-RL ***	bypass roller kit counter (professional puncher)	1
PN-DR-RL ***	roller energy drive counter (professional puncher)	1
PNCH-BLT ***	aligning belt counter (professional puncher)	1
PNCH-SL ***	back gauge solenoid counter (professional puncher)	1

<H-DRBL-1>

Counters for Durables (used as reference after a long period of use of the host machine, i.e., at 6,000,000 prints)

T-17-79

COPIER > COUNTER > H-DRBL-1		
Sub item	Description	Level
DEV-U	developing assembly counter	1
PT-DRM	photosensitive drum counter	1
DRM-DR-U	drum drive counter	1
D-CLW-AM	reciprocating arm counter	1
BRUSH-U	power supply brush unit counter	1
O-DLV-RL	outside delivery roller counter	1
D-CLW-CL	delivery separation claw reciprocating one-way counter	1
D-CLW-GR	delivery separation claw reciprocating gear counter	1

COPIER > COUNTER > H-DRBL-1		
Sub item	Description	Level
RV-RL	reversal rubber roller counter	1
I-DLV-RL	inside delivery roller counter	1
REG-RL	registration upper roller counter	1
REG-COL	registration lower color counter	1
RD-FD-SH	roller B shaft (right deck) right deck counter	1
LD-FD-SH	roller B shaft (left deck) left deck counter	1
REV-GD	reversing guide counter	1
FLP-SL	flapper solenoid duplexing unit counter	1
RV-G-SL	reversing guide solenoid (SL11) duplexing unit counter	1
RD-PU-SL	right deck pickup solenoid (SL7) right deck counter	1
PU-DR-U	pickup main drive (except pickup motor) counter	1
PR-RG-RL	sponge roller (pre-registration roller) counter	1
PU-D-GR	pickup drive gear counter	1
M-DR-PT	multifeeder door hinge counter	1
DLV-S-AM	delivery sensor lever counter	1
DLV-UP-U	delivery roller guide (delivery upper unit) counter	1
LD-PU-1W	transport roller shaft one-way left deck counter	1
RD-PU-CL	right deck pickup clutch (CL10) right deck counter	1
LD-PU-CL	left deck pickup clutch (CL11) left deck counter	1
V-FD-RL	vertical path drive shaft (roller) counter	1
DUP-F-RL	duplexing sponge roller duplexing unit counter	1
DUP-D-GR	pulley gear 2 duplexing unit counter	1
WEB-SL	web solenoid (SL2) counter	1
CL-DR-U	cleaner drive assembly counter	1
DEV-DR-U	development drive assembly counter	1
PU-D-BLT	pickup drive timing belt counter	1
M-D-BLT	main drive timing belt counter	1

<H-DRBL-2>

Counters for Durables (used as reference after a long period of use of the host machine, i.e., 12,000,000 prints)

T-17-80

COPIER > COUNTER > H-DRBL-2		
Sub item	Description	Level
P-KIT	AP kit counter	1
CRG-D-U	toner cartridge drive unit counter	1
X-FD-U	fixing unit counter	1
RD-U	right deck unit right deck counter	1
LD-U	left deck unit left deck counter	1
C-PU-U	cassette pickup unit counter	1
V-FD-SNS	vertical path sensor base counter	1
V-FD-RL	vertical path roller counter	1
V-P-SNS1	paper detection base counter	1
PRG-V-GD	pre-registration vertical path guide counter	1
V-P-SNS2	vertical path paper sensor 2 counter	1
DUP-U	duplexing unit counter	1
FX-PS-PL	fixing positioning plate counter	1
VFD-SH-U	vertical path drive shaft unit counter	1
DRM-SFT	drum shaft unit counter	1
GEAR-U	90-T gear unit counter	1
V-FD-D-U	vertical path drive unit counter	1
L-PU-D-U	left pickup drive unit left deck counter	1
C-PU-D-U	cassette pickup drive unit counter	1
R-LFT-DR	right deck lifter drive unit counter	1
L-LFT-DR	left deck lifter drive assembly counter	1
MLT-DR-U	multifeeder pickup drive unit counter	1
MN-DR-U	main drive unit counter	1
AR-FIL1	air filter counter	1
AR-FIL2	air filter 2 counter	1
AR-FIL3	air filter 3 counter	1
AR-FIL4	air filter 4 counter	1
DRM-FAN	drum suction fan counter	1
W-T-PIPE	waste toner pipe counter	1
BUSH-1	bushing 1 counter	1
BUSH-2	bushing 2 counter	1
BUSH-3	bushing 3 counter	1
BUSH-4	bushing 4 counter	1
BUSH-5	bushing 5 counter	1

Upgrading

Contents

18.1 Outline	18- 1
18.1.1 Overview of Upgrading Work	18- 1
18.1.2 Outline of the Functions and Operations	18- 2
18.1.3 Points to Note at Time of Downloading	18- 4
18.2 Making Preparations	18- 5
18.2.1 Installing the System Software (System CD -> SST).....	18- 5
18.2.2 Copying the System Software (SST -> USB).....	18- 5
18.2.3 Making Connections (SST in use)	18- 7
18.2.4 Making Connections (USB device in use)	18- 7
18.3 Formatting the HDD	18- 9
18.3.1 Formatting the HDD for All Partition	18- 9
18.3.2 Formatting the HDD for Selected Partitions	18- 10
18.3.3 Formatting the Partitions	18- 10
18.4 Downloading System Software.....	18- 12
18.4.1 Downloading the System Software (ALL).....	18- 12
18.4.1.1 Outline	18- 12
18.4.1.2 Downloading Procedure	18- 12
18.4.2 Downloading the System Software (Single).....	18- 13
18.4.2.1 Downloading Procedure	18- 13
18.4.3 Uploading and Downloading Backup Data.....	18- 15
18.4.3.1 Outline	18- 15
18.4.3.2 Uploading Procedure	18- 16
18.4.3.3 Downloading Procedure	18- 17
18.4.4 Version Upgrade using USB.....	18- 18
18.4.4.1 Overview of Menus and Functions.....	18- 18
18.4.4.2 Points to Note	18- 18
18.4.4.3 Downloading/Writing the System Software (auto).....	18- 19
18.4.4.4 Downloading the System Software (auto or selective)	18- 19
18.4.4.5 Downloading the System Software (overwriting).....	18- 20
18.4.4.6 Formatting the HDD	18- 21
18.4.4.7 Other Functions.....	18- 22

18.1 Outline

18.1.1 Overview of Upgrading Work

The machine and its system software options may be upgraded as follows:

- downloading from a PC to which the Service Support Tool (SST) has been installed
- downloading from a USB device
- replacing the DIMM-ROM

T-18-1

Machine	System software type	Upgrading tool			SST display		Remarks
		SST	USB	Other	Product name	System software name	
Host Machine	main controller	yes	yes	-	iR7105	SYSTEM	
	language module	yes	yes	-		LANGUAGE	
	remote UI content	yes	yes	-		RUI	
	boot program	yes	yes	replacing the DIMM-ROM		BOOT	
	MEAP library	yes	yes	-		MEAPCONT	
	voice dictionary	yes	yes	-		TTS	used when adding the Voice Guidance Kit (optional)
	Web browser	yes	yes	-		BROWSER	used when adding the Web Browser Kit (optional)
	DC controller	yes	yes	-		DCON	
	reader controller (DADF-Q1 model)	yes	yes	-		RCON	DADF-Q1 model outside Japan: iR7105/7095 inside Japan: iR7105i/7095i/7086N
	reader controller (DADF-M1 model)	yes	yes	-		iR5570	RCON
OCR dictionary	yes	yes	-	iRYYY Y	SDICT	used when adding the Searchable PDF Kit (optional)	
encryption communication key/certificate/CA certificate	yes	yes	-		KEY	used for SSL communication/e-RDS communication	
ADF (DADF-Q1)	ADF controller	yes	-	-	ADFY4	CPU	requires a special service tool (downloader PCB; FY9-2034)
Finisher	finisher controller	yes	yes	-	FIN_V	FIN_CON	
Insertter	insertter	yes	yes	-	FIN_V	INSRTR	
Trimmer	trimmer	-	-	special software (PC in use)	-	-	- special software supplied together with the system software - calls for a PC possessing an RS232C interface

Machine	System software type	Upgrading tool			SST display		Remarks
		SST	USB	Other	Product name	System software name	
Professional Puncher	professional puncher	-	-	HyperTerminal (PC in use)	-	-	- non-Japanese model only - special software supplied together with the system software - calls for a PC possessing an RS232C interface - HyperTerminal comes standard with Windows
Hi-Capacity Stacker	stacker controller	yes	yes	-	HSTK_A1	STK	
	network controller	yes	yes	-	HSTK_A1	OP_CON	

18.1.2 Outline of the Functions and Operations

When connected to a PC (to which the SST and system software have been installed) and USB device (to which system software has been copied), the machine provides the following functions:

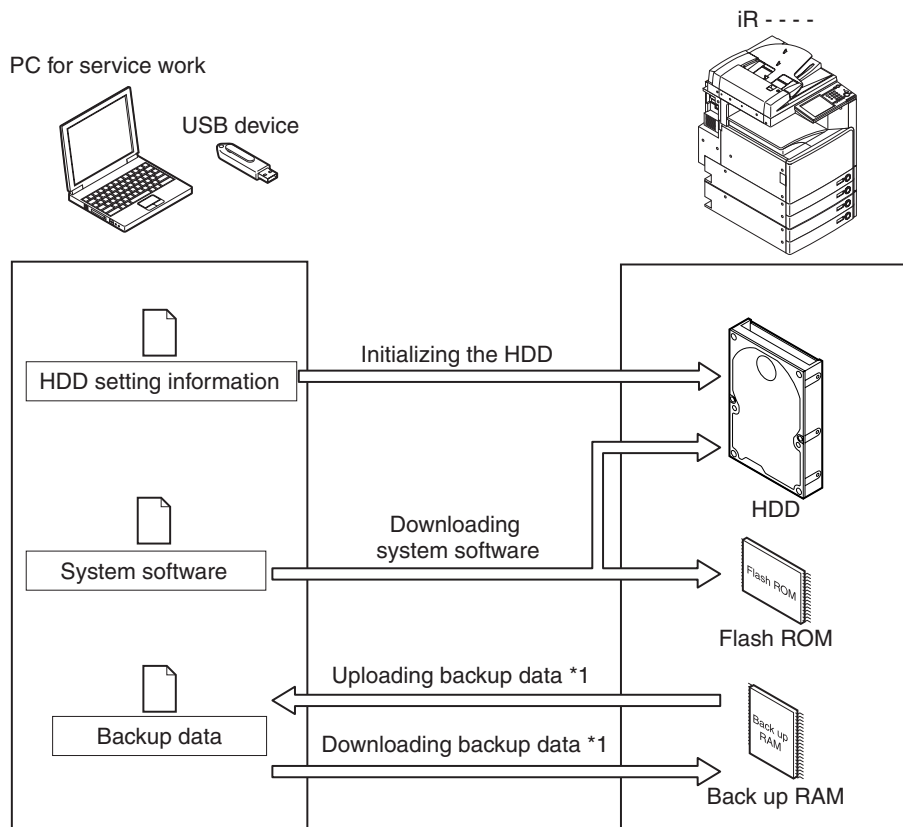

F-18-1

*1: Not when USB is in use.

To use these functions, the machine must be in download mode, which may be either of the following:

- Normal Mode (download mode B)

Turn on the main power while holding down the keys 1+7; then, make the following selections in service mode: COPIER > FUNCTION > SYSTEM > DOWNLOAD.

- Safe Mode (download mode A)

Turn on the main power while holding down the keys 2+8.

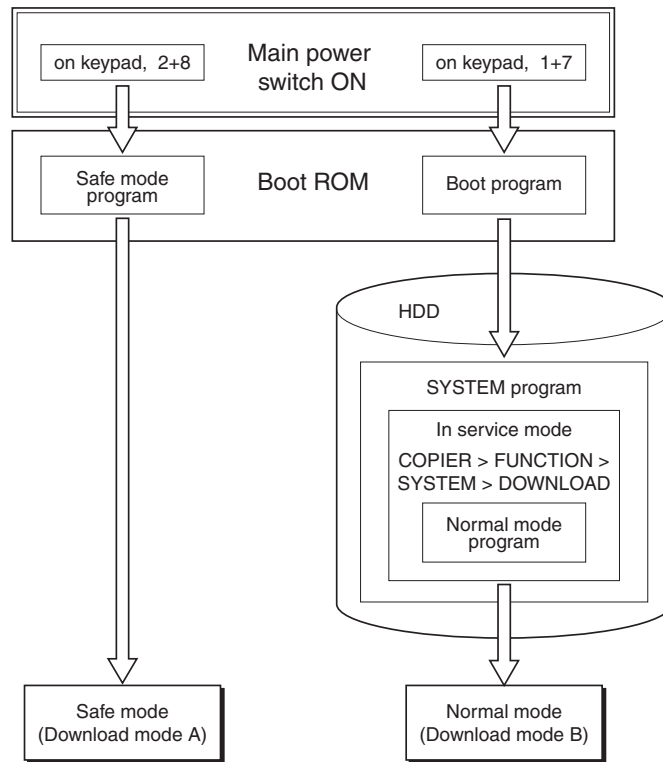

F-18-2



Use safe mode for the following:
 - after replacing the HDD
 - when the system fails to start up normally

The following shows combinations of download modes and functions:

T-18-2

Function	Download mode	
	Normal mode (download mode B)	Safe mode (download mode A)
Formatting the HDD	- -	All BOOTDEV
Downloading the system software *1	System Language RUI Boot Dcon Rcon SDICT MEAPCONT KEY TTS BROWSER FIN_CON INSRTR STK OP_CON	System Language RUI Boot Dcon Rcon SDICT MEAPCONT KEY TTS BROWSER FIN_CON INSRTR STK OP_CON
Uploading/downloading of backup data *2	- - SramRCON SramDCON	SramImg Meapback - -

*1: Not all software to download may be selected for downloading while USB is in use.
 *2: Not when USB device is in use.

Installing the System Software

When downloaded, the system software is stored in the temporary storage area of the HDD. At the end of downloading, the main power switch must be turned off and then back on, thus restarting the machine and writing the system software to both system area and flash ROM from the temporary storage area. When the main power switch is turned off and then back on once again, the machine will start up using the new system software.

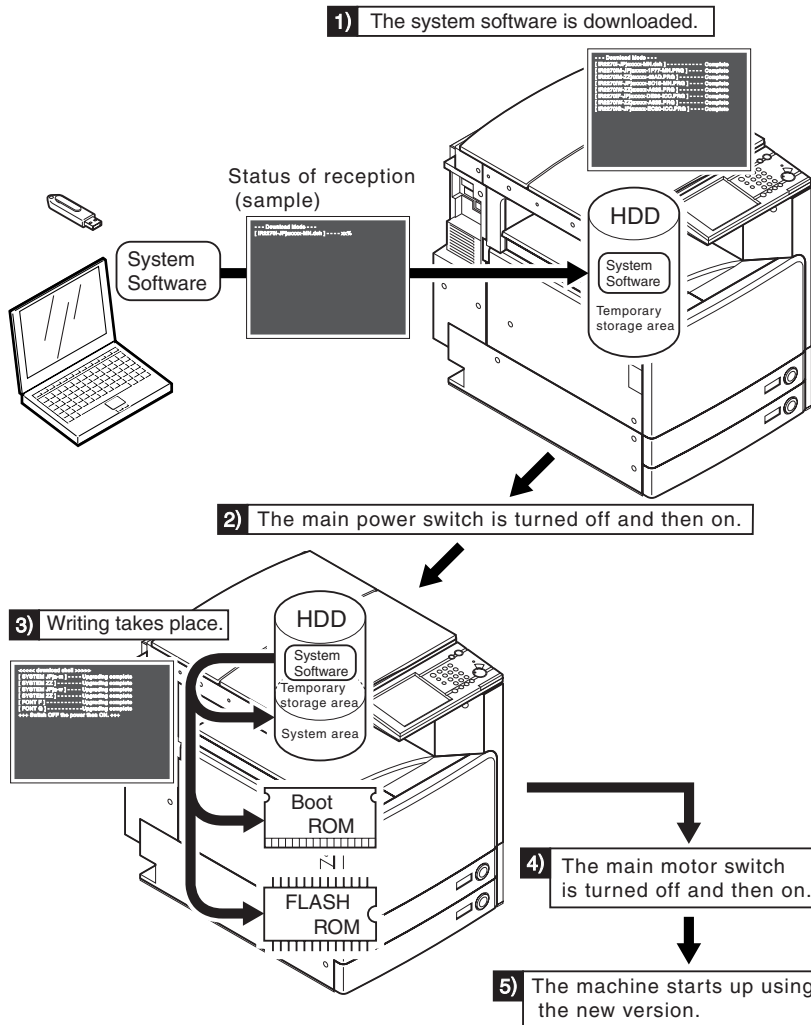

F-18-3

18.1.3 Points to Note at Time of Downloading

⚠ Do Not Turn Off the Power During Download/Write Operation

Do not turn off the power while the system software is being downloaded/written. Otherwise, the machine may fail to start up when its power is turned back on. (If such is the case, execute HDD formatting, and download the system software. In the case of a boot ROM, replace the DIMM-ROM.)

⚠ Points to Note About Upgrading the DC Controller/Reader Controller

The DC controller/reader controller may be downloaded in either in normal mode or in safe mode. If done in safe mode, however, the controller version information cannot be obtained, causing the data retained by the SST to be written over. It is a good idea, therefore, to use normal mode (so that the software will not be replaced with software of a previous version).

18.2 Making Preparations

18.2.1 Installing the System Software (System CD -> SST)

Here, you will be copying the system software found on the System CD to the SST.

[Preparatory Work]

Requirements

- PC to which the SST (version 3.21 or later) has been installed
- System CD

[Installing the System Software]

- 1) Turn on the PC.
- 2) Set the System CD in the PC.
- 3) Start up the SST.
- 4) Click [Register Firmware].

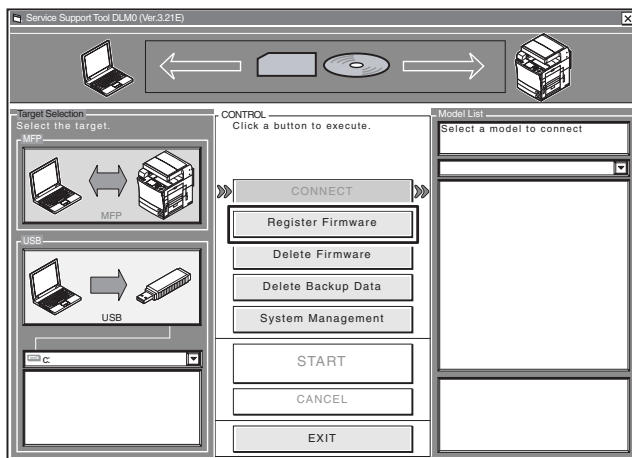

F-18-4

- 5) Select the drive in which the System CD has been set, and click [SEARCH].

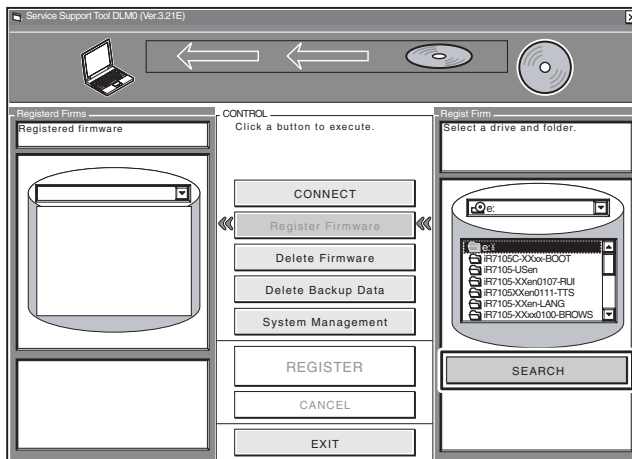

F-18-5

- 6) A list of system software found on the System CD appears. Remove the check marks from the folders and software files you do not need, and click [REGISTER].

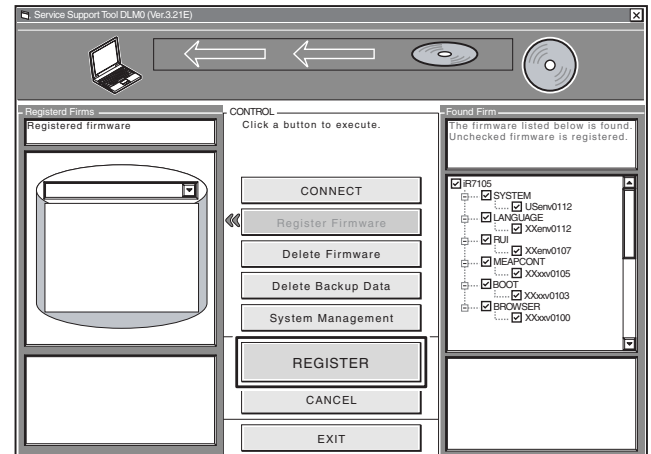

F-18-6

- 7) When a message has appeared to indicate that the system software has been installed, click [OK].

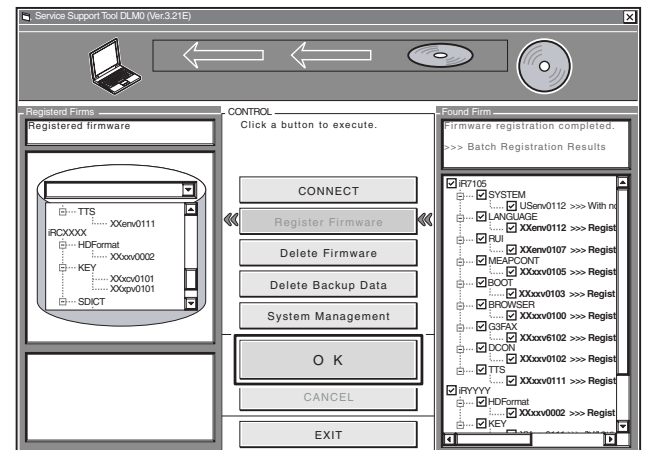

F-18-7

18.2.2 Copying the System Software (SST -> USB)

Here, you will be copying the system software from the SST to a USB device.

[Preparatory Work]

Requirements

- PC to which the SST (version 3.21 or later) has been installed
- USB device *

*: USB Requirements

Interface	USB 1.1 or higher (USB 2.0 recommended)
Capacity	1 GB or more recommended (A set of system software is in excess of 512 MB.)
Format	FAT (FAT16), FAT32 (It must not be NTFS or HFS.) single partition (There must not be multiple partitions.)



You will not be able to use a security-protected USB device. Be sure to remove the protection before use.

[Copying the System Software]

- 1) Start up the PC.
- 2) Connect the USB device to the USB port of the PC.
- 3) Start up the SST.
- 4) Click the USB icon on the Target Selection screen.

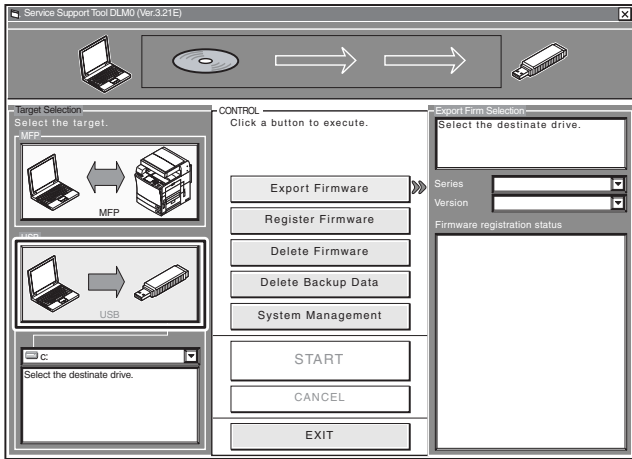

F-18-8

- 5) Select the drive to which the USB device has been connected.

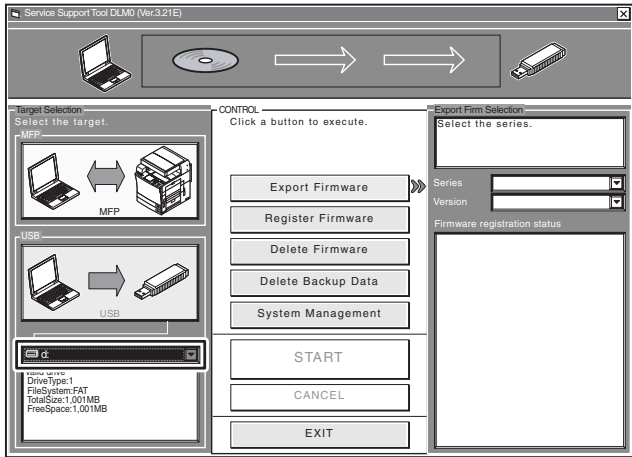

F-18-9

- 6) Select the appropriate series and version of the system software you want to copy.

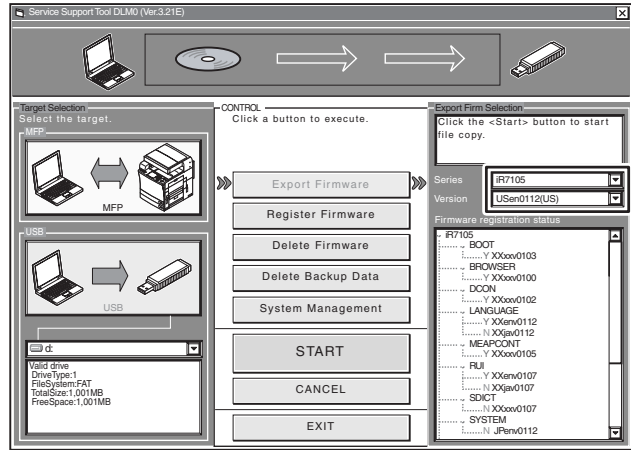

F-18-10

MEMO:

The notations that appear in the column under "Firmware registration status" mean the following:
Y: exists in the SST.
N: does not exist in the SST.

- 7) Click [START] so that copying to the USB device starts.

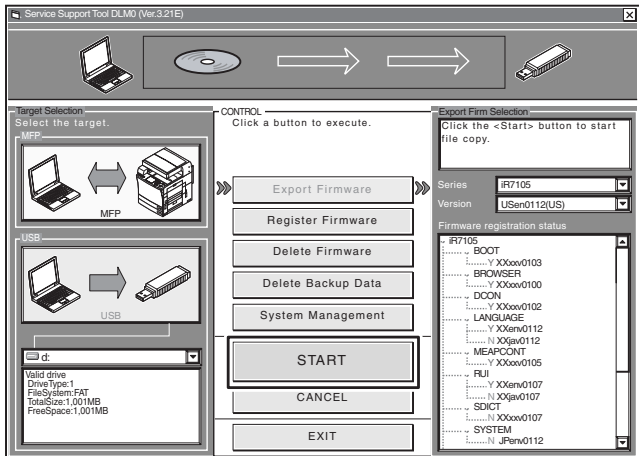

F-18-11

- 8) When done, click [OK].

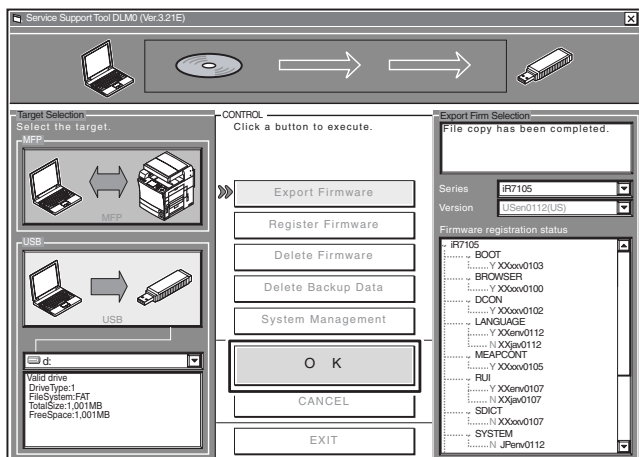

F-18-12

18.2.3 Making Connections (SST in use)

[Requirements]

- PC to which the SST (version 3.21 or later) has been installed and the system software has been copied
- twisted-pair cross cable
 - 10Base-T: Category 3 or 5
 - 100Base-TX: Category 5

[Procedure]

- 1) Start up the PC.
- 2) Check the network settings of the PC.
 - 2-1) Start the command prompt, and type in "IPCONFIG," and press the Return key.
 - 2-2) Check to be sure that the network settings appearing on the screen are as follows; if not, change the PC network settings:
 - IP address: 172.16.1.160**
 - Subnet mask: 255.255.255.0**
 - Default gateway: any**



Do not use the following IP addresses:

- 172.16.1.0
- 172.16.1.100
- 172.16.1.255

- 3) Check to make sure that the Execute/Memory lamp on the control panel is off; then, turn off the main power switch.
 - 3-1) Hold down the power switch on the control panel for 3 sec or more.
 - 3-2) Go through the shut-down instructions appearing on the control panel screen so that the main power switch may be turned off.
 - 3-3) Turn off the main power switch.
- 4) Connect the PC to the machine with a cross cable.

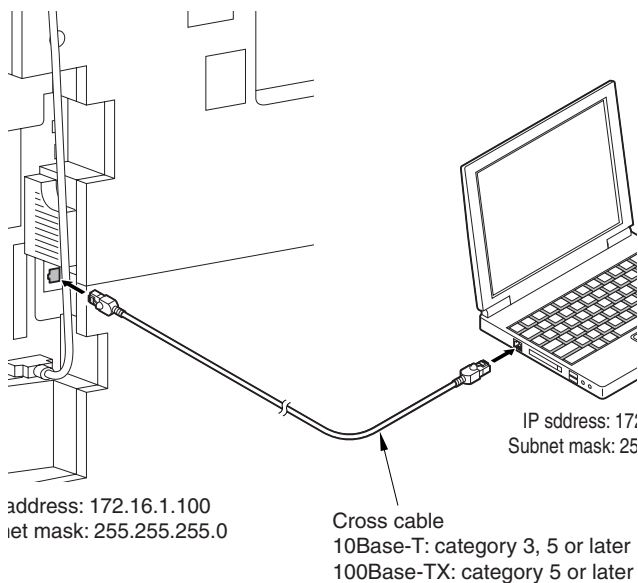

F-18-13

- 5) Set the machine to the appropriate mode:

- Normal Mode

Turn on the main power switch while holding down the keys 1 and 7.

When the machine has started, make the following selections in service mode:

COPIER > FUNCTION > SYSTEM > DOWNLOAD; then, click [OK].

- Safe Mode

Turn on the main power switch while holding down the keys 2 and 8. In response, the machine will start up in safe mode.

18.2.4 Making Connections (USB device in use)

[Requirements]

- USB device to which the system software has been copied.

[Procedure]

- 1) Check to make sure that the Execute/Memory on the control panel is off; then, turn off the main power switch as follows:
 - 1-1) Hold down the control panel power switch for 3 sec or more.
 - 1-2) Go through the shut-down instructions.
 - 1-3) Turn off the main power switch.
- 2) Connect the USB device [2] to the USB port [1].

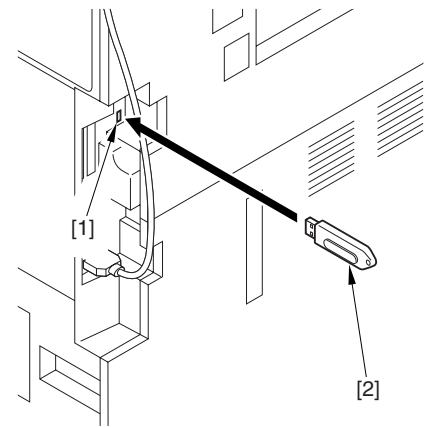

F-18-14

- 3) If a network cable is connected to the machine, disconnect it.
- 4) Set the machine to the appropriate download mode:

- Normal Mode

Turn on the main power switch while holding down the keys 1 and 7.

When the machine has started up, make the following selections in service mode, and press [OK]:

COPIER > FUNCTION > SYSTEM > DOWNLOAD.

- Safe Mode

Turn on the main power switch while holding down the keys 2 and 8 so that the machine will start up in safe mode.

-
- 5) See the following menu appearing on the control panel screen, indicating that the machine has recognized the presence of a USB device.

```
[[[[[ download Menu (USB) ]]]]]]]]]]]]]]
-----
[1]: Upgrade (Auto)
[2]: Upgrade (w Confirmation)
[3]: Upgrade (Overwrite all)
[4]: Format HDD
[5]: Backup
[6]: Restore former version
[7]: Clear downloaded files

[Stop]: Shutdown
```

F-18-15



The machine may not recognize certain types of USB device or USB device from certain manufacturers. The machine looks for a USB device for a maximum of 60 sec after its main power is turned on, not indicating the menu if it fails to detect one. (If such is the case, obtain an appropriate USB device.)



The SST cannot be run while the USB device is in use. (The machine will not communicate with the SST when it detects the presence of a USB device.)

18.3 Formatting the HDD

18.3.1 Formatting the HDD for All Partition

When formatting the HDD for all partition, there will be partitions on the HDD and all these partitions will be formatted (initialized) and the main controller will be made ready for use.

All the information needed to set up the partition is found in the partition settings file (on the SST, 'HD-Format' in the folder 'iRYYYY').

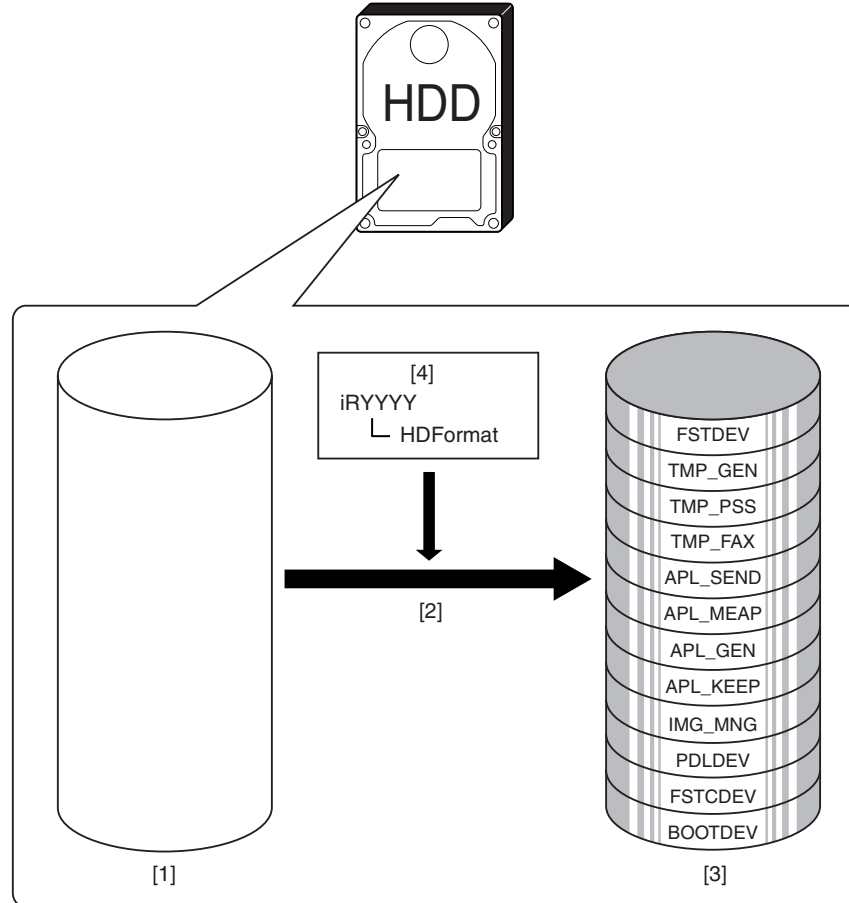

F-18-16

- [1] HDD (service part; without partitions)
- [2] Formatting for full partition (only in safe mode)
- [3] HDD after formatting
- [4] Partition settings information file

18.3.2 Formatting the HDD for Selected Partitions

When formatting the HDD for selected partitions, only those selected partitions will be initialized.

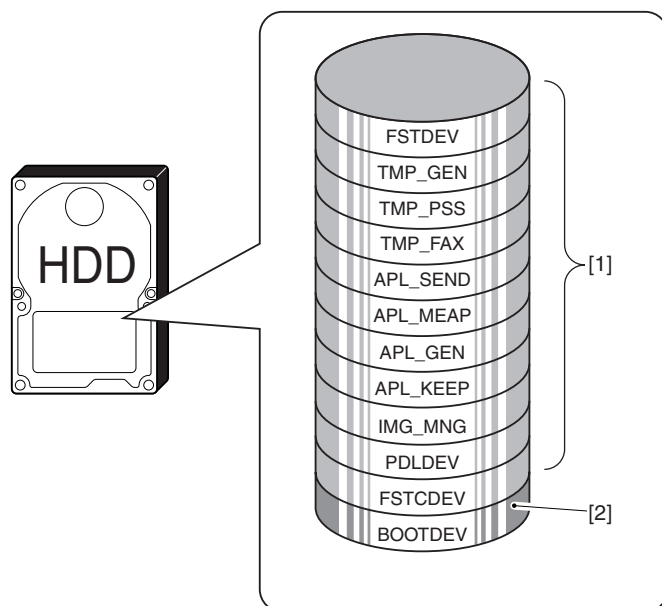

F-18-17

[1] Formatting not possible

[2] Formatting possible in safe mode

MEMO:

Partition-based formatting is possible in service mode (COPIER > FUNCTION > SYSTEM > HD-CLEAR), with the exception of BOOTDEV.

18.3.3 Formatting the Partitions

- 1) Start up the SST.
- 2) Select the model [1] and the type of system software [2] ('Single'); then, check the network settings, and click [START].

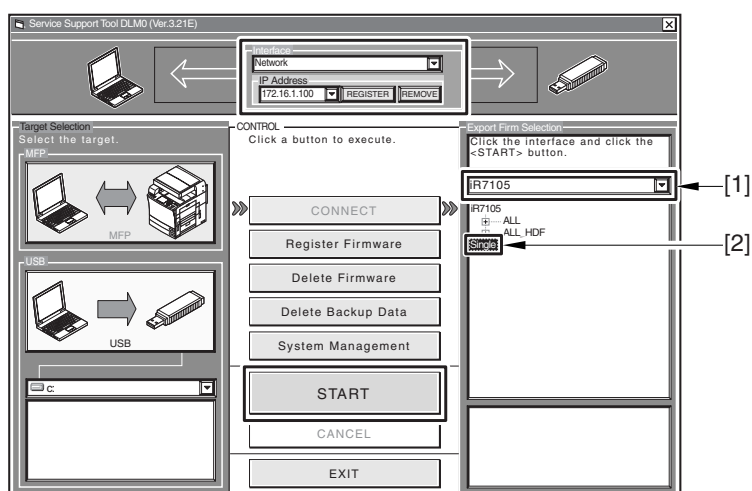

F-18-18

3) Click [Format HDD].

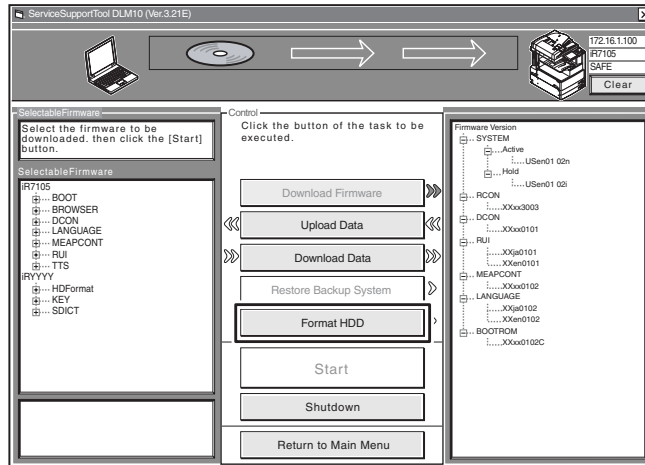

F-18-19

4) Specify BOOTDEV partition or full partition (ALL), and click [Start].

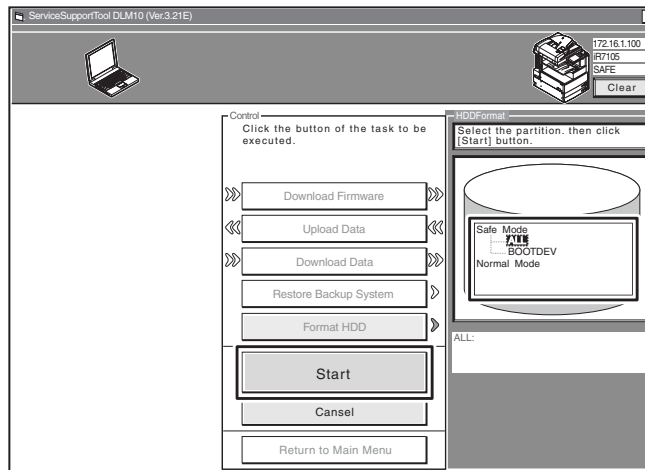

F-18-20

5) Click [Execute Formatting].

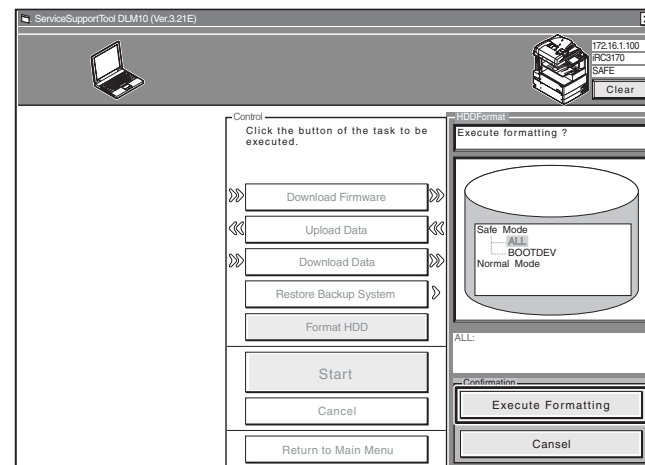

F-18-21

6) When formatting has ended, click [OK] to return to the Menu screen.

7) Move on to download the system software.



Whenever you have executed HDD formatting, be sure to download the system software; otherwise, an error (E602) will occur when the main power is turned on.

18.4 Downloading System Software

18.4.1 Downloading the System Software (ALL)

18.4.1.1 Outline

You can collectively download various system software files at one time. The groups of system software files that may be downloaded in a batch are identified in the batch download information file, which is found on the System CD. Copy the file to the SST to enable the batch downloading mechanism.

<Batch Download Information File>

ALL: for downloading in normal mode
 Use it to collectively download all system software files that are found.
 Use it as when upgrading the system software.

ALL_HDF: for downloading in safe mode
 Use it to collectively download system software files other than the following:

- BOOT
- DCON
- RCON

Use it when reinstalling the system software as after formatting the HDD.
 The foregoing 3 system software files may be downloaded using different steps.

18.4.1.2 Downloading Procedure

Here, the discussions are in reference to batch downloading in safe mode.

- 1) Start up the SST.
- 2) Select the model [1] and the batch download information file [2] ('ALL_HDF').

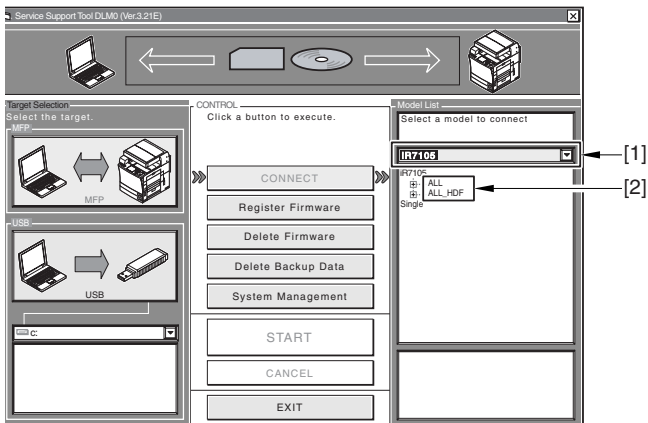

F-18-22

- 3) Make sure of the network settings, and click [Start Batch Download].

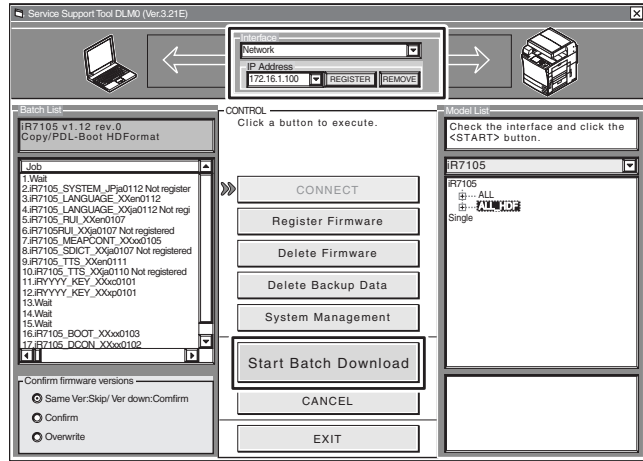

F-18-23

- 4) Click [Resume].

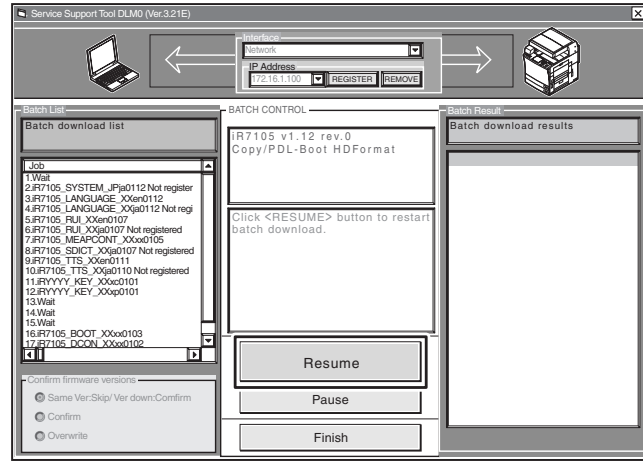

F-18-24

MEMO:
 Refer to the Batch Download List screen [1] for the progress of downloading.

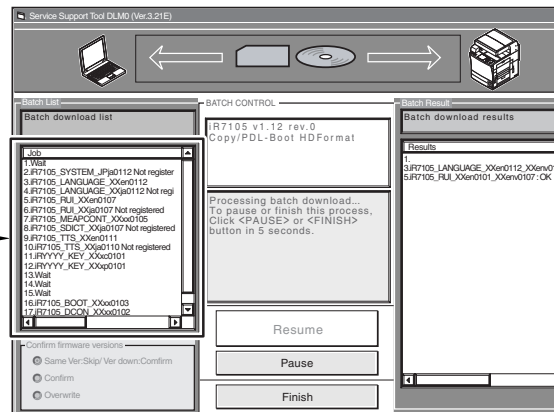

F-18-25

- The Download End screen appears for the system software files to be stored on the HDD. To stop downloading, click [Finish]; if you want to download BOOT, DCON, and RCON, on the other hand, click [Resume], and go to the next step.

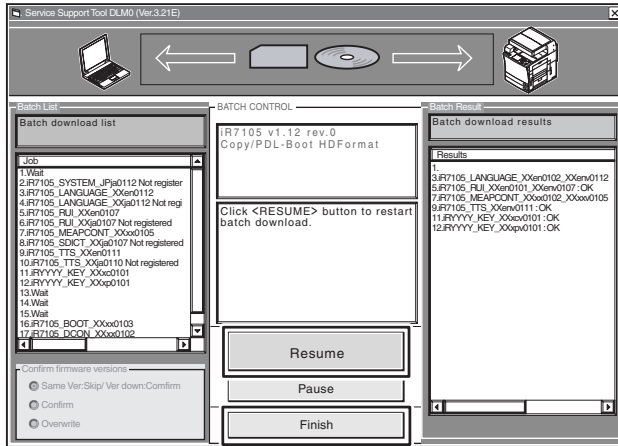

F-18-26

- Turn off the machine's main power switch, and start it up in normal mode (turn on the main power switch while holding down the 1 and 7 keys; then, start download mode in service mode). Click [Resume].

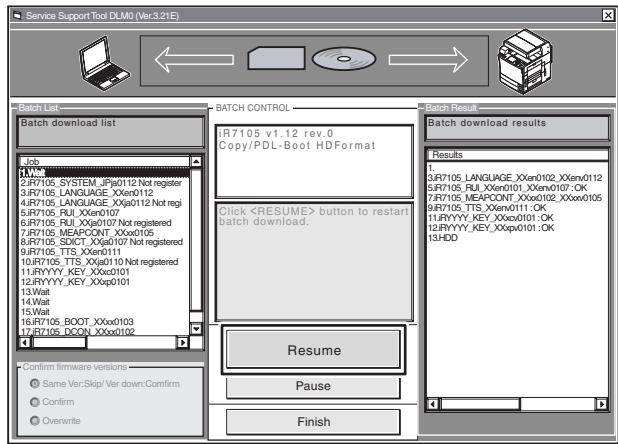

F-18-27

- Click [Resume] to start downloading BOOT, DCON, and RCON.

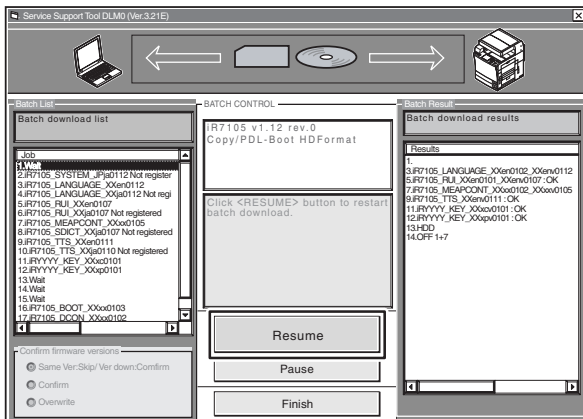

F-18-28

- Click [OK].

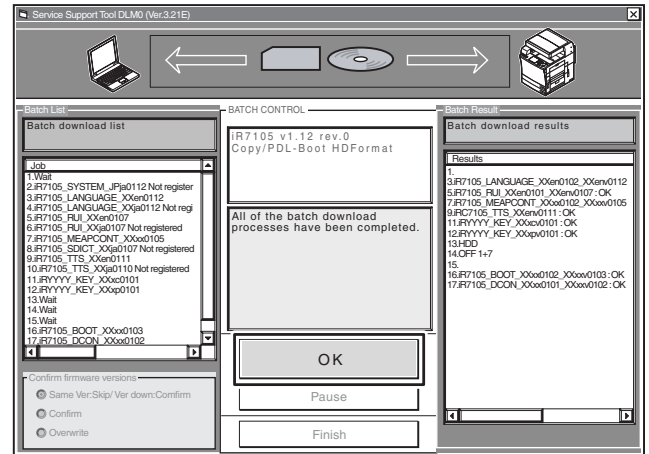

F-18-29

Turning Off the Power

Do not turn off the power while downloading or writing is under way; otherwise, the machine may fail to start up. If such is the case, execute HDD formatting, and download the system software once gain.

18.4.2 Downloading the System Software (Single)

18.4.2.1 Downloading Procedure

Here is the downloading procedure of the SYSTEM as a sample.

- Start up the SST.
- Select the model [1] and the type of system software [2] ('Single'); then, check the network settings, and click [START].

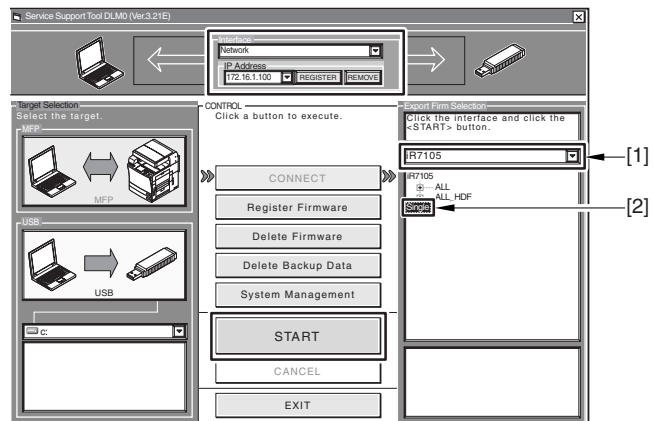

F-18-30

3) Select the version of the System software you want to download, and click [Start].

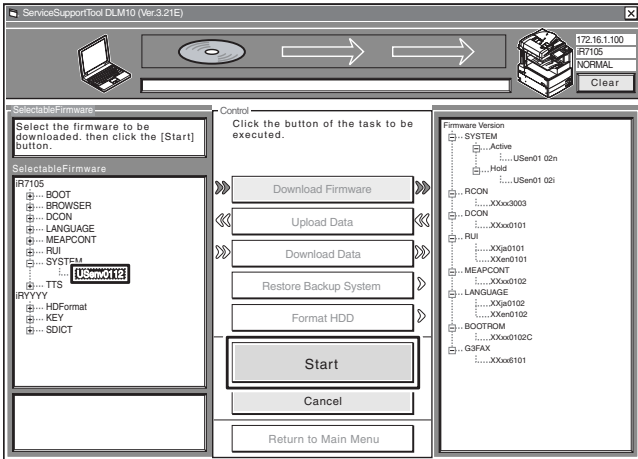

F-18-31

4) When downloading has ended, click [OK] to go back to the previous screen.

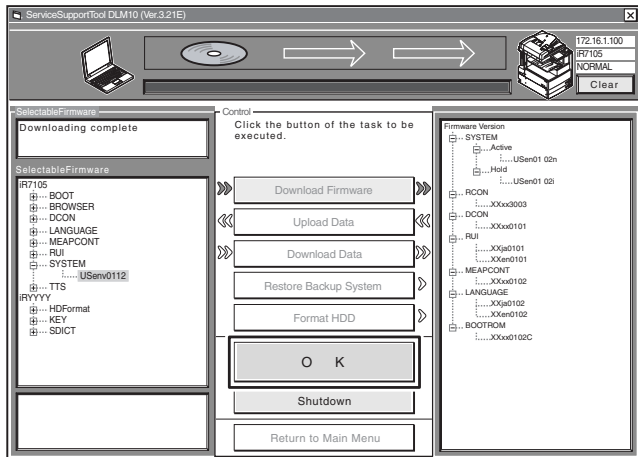

F-18-32

5) Start up the machine. The subsequent procedure differs depending on the download mode.

If the machine is in normal mode.

5-1) Click [Shutdown].

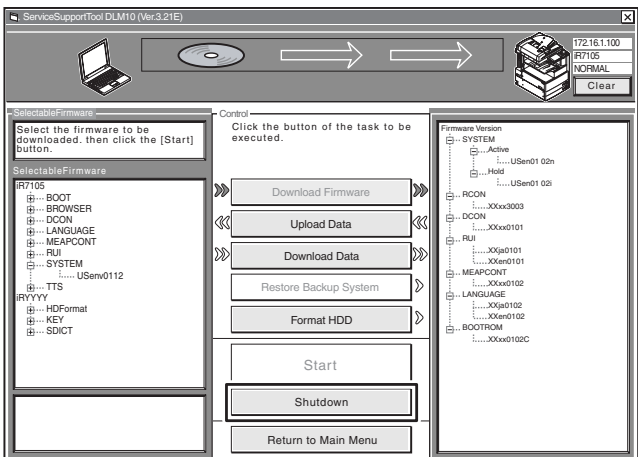

F-18-33

5-2) Click [Start Shutdown] so that the machine starts the shut-down sequence.

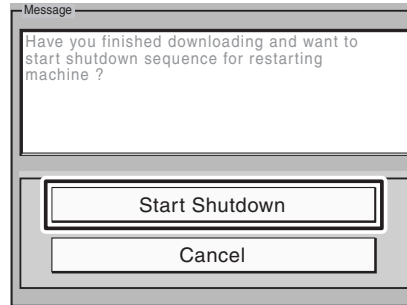

F-18-34

5-3) Click [OK], and turn off and then back on the machine's main power switch.

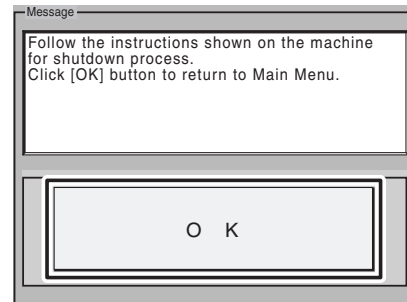

F-18-35

If the machine is in safe mode.

5-1) Turn off and then back on the machine's main power switch.

6) When the machine starts up, it will write the system software to its HDD and flash ROM while showing the progress of writing on the control panel screen. When done, it will indicate a message asking you to turn off and then back on the power. In response, turn off and then back on the main power.

⚠ Turning Off the Power

Do not turn off the machine's power while downloading or writing is under way; otherwise, the machine may fail to start up. If such is the case, execute HDD formatting, and download the system software once again.

MEMO:

You can remove the downloaded system software before it is written to the HDD or flash ROM. To do so, go through the following before restarting the machine:

- 1) Click [Clear] [1].

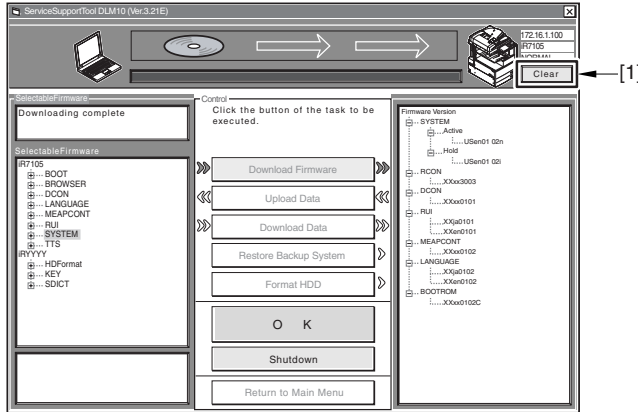

F-18-36

- 2) Click [Execute Clear] so that the system software that has been stored in the temporary storage area of the HDD will be removed.

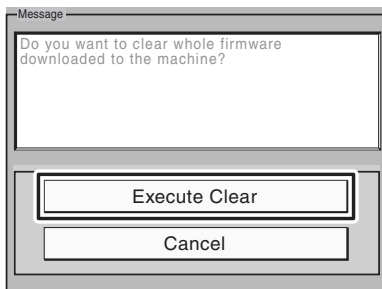

F-18-37

- 3) Click [OK].



F-18-38

MEMO:

When a connection is made, the upper right area of the SST screen will indicate the following device information [1]:

- IP address
- product name
- download mode

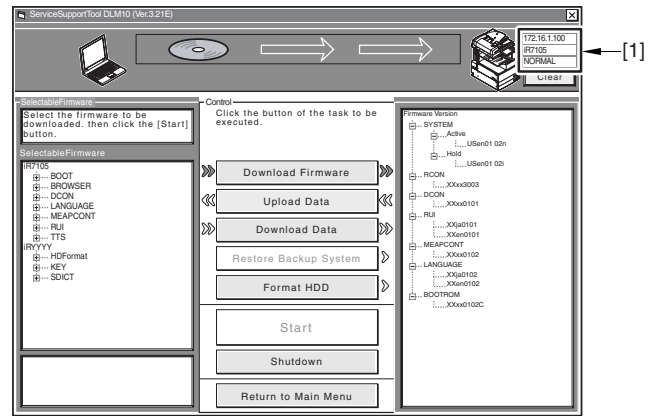

F-18-39

18.4.3 Uploading and Downloading Backup Data

18.4.3.1 Outline

The file SramImg is data stored in the SRAM of the Main controller PCB.

The file MeapBack is a MEAP application and its data stored on the HDD.

The file SramDCON is data stored in the SRAM of the DC controller PCB.

The file SramRCON is data stored in the EEPROM of the reader controller PCB.

Backup data	File to select for downloading
Main controller PCB backup	SramImg.bin (may be uploaded/downloaded in safe mode)
MEAP application	MeapBack.bin (may be uploaded/downloaded in safe mode)
For R&D	Sublog.txt (do not select this file)
Reader controller PCB backup	SramRCON (may be uploaded/downloaded in normal mode)
DC controller PCB backup	SramDCON (may be uploaded/downloaded in normal mode)

⚠ Points to Note When Uploading/Downloading MeapBack

If you need to re-install the system software to correct a fault, you may upload MeapBack and then download it back after formatting the HDD (by temporarily putting aside the MEAP application).

- 1) Upload MeapBack.
- 2) Execute HDD all format.
- 3) Re-install the system software.

At this time, be sure that the system software is the same as that existed before formatting the HDD. Otherwise, you will not be able to download MeapBack you have uploaded.

- 4) Download MeapBack.

You will not be able to download MeapBack you have uploaded unless you are downloading it to the

machine you have uploaded it from.

MEMO:

- If you are planning to replace the Main controller PCB, you can upload the SramImg file in advance, and download it after replacement so that the service mode and other settings may be inherited.
- If you are planning to replace the DC controller PCB, you can upload the SramDCON file in advance, and download it after replacement so that the service mode and other settings may be inherited.
- If you are planning to replace the DC controller PCB, you can upload the SramDCON file in advance, and download it after replacement so that the service mode and other settings may be inherited.

18.4.3.2 Uploading Procedure



- When uploading the data, do not select 'Sublog.txt'.
- The machine must be in normal mode for uploading/downloading SramDCON or SramRCON.
- The machine must be in safe mode when uploading/downloading SramImg or MeapBack.

[In the Case of MeapBack]

- 1) Start up the SST.
- 2) Select the model [1] and the type of system software [2] ('Single'); then, check the network settings, and click [START].

3) Click [Upload Data].

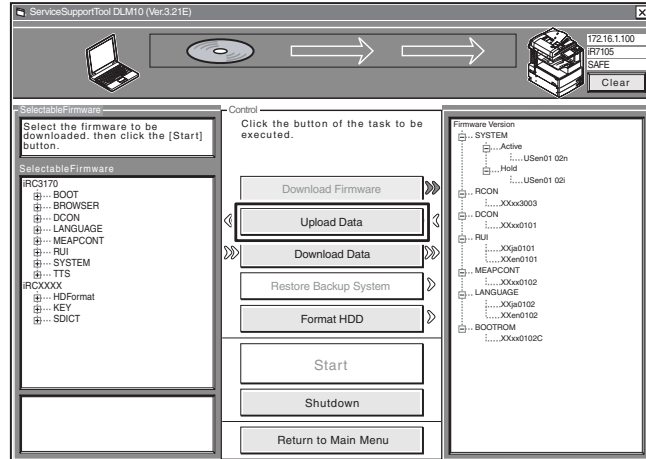

F-18-41

4) Select 'MeapBack.bin', and click [Start].

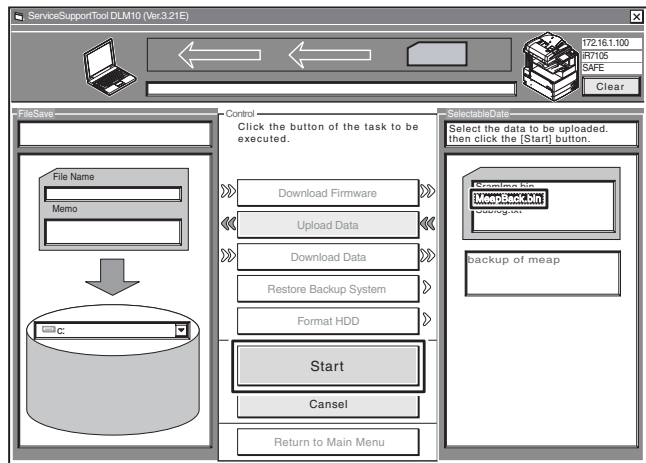

F-18-42

5) Type in the name of the file to store and, as necessary, a brief description; then, click [Save].

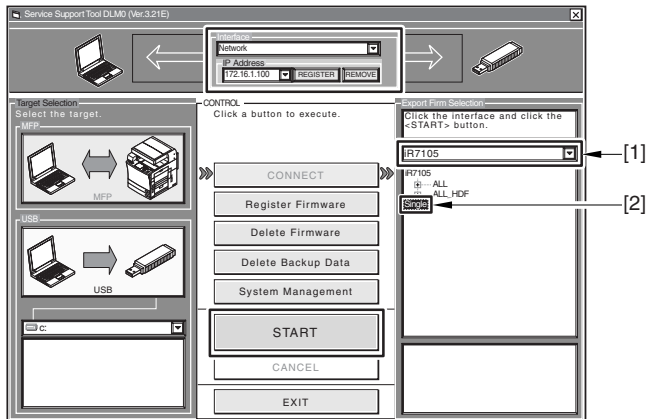

F-18-40

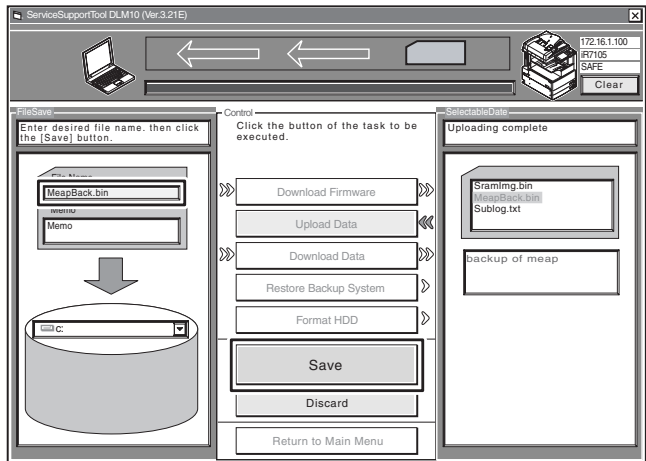

F-18-43

6) Click [OK].



The file SramImg, SramRCON, SramDCON, or MeapBack may only be downloaded to their source machine.

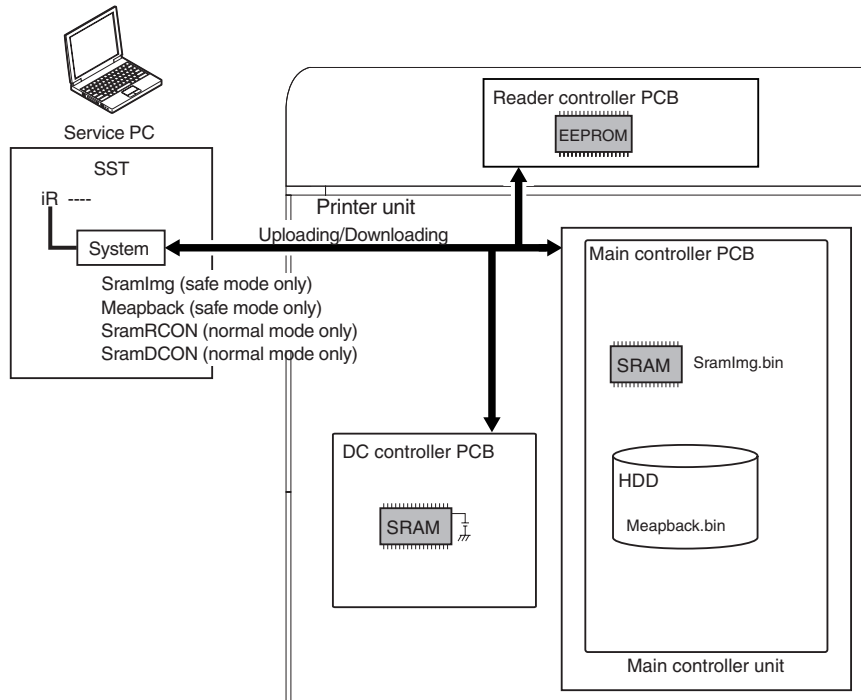

F-18-44

18.4.3.3 Downloading Procedure



- The machine must be in normal mode for uploading/downloading the file SramDCON or SramRCON.
- The machine must be in safe mode for uploading/downloading the file SramImg or MeapBack.

[In the Case of MeapBack]

- 1) Start up the SST.
- 2) Select the model [1] and the type of system software [2] ('Single'); then, check the network settings, and click [START].

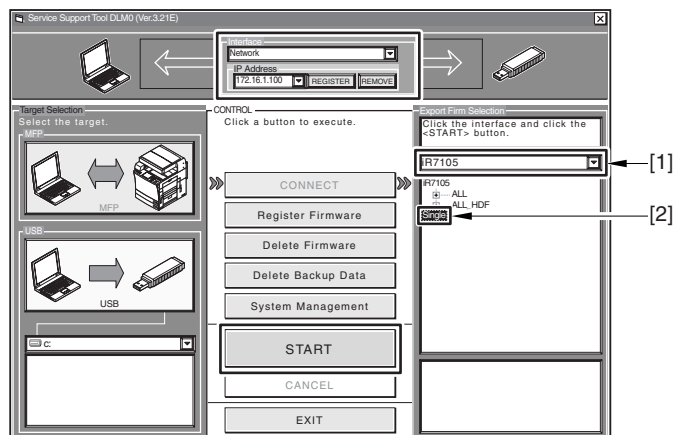

F-18-45

3) Click [Download Data].

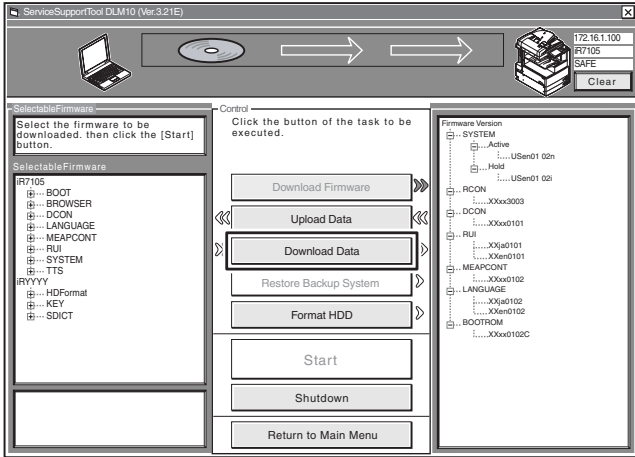

F-18-46

4) Select the data to download, and click [Start].

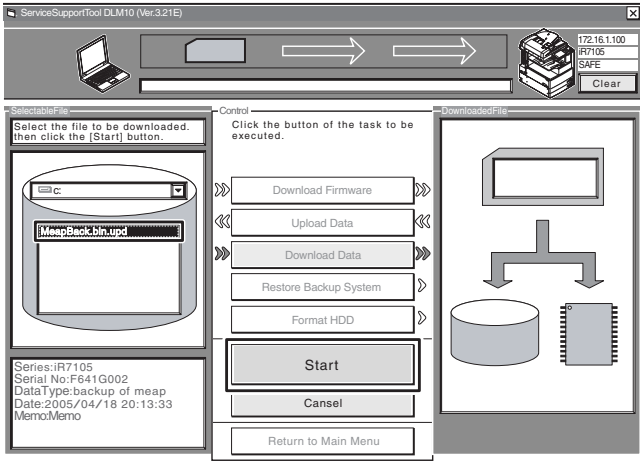

F-18-47

5) When downloading has ended, click [OK] to return to the previous screen.

18.4.4 Version Upgrade using USB

18.4.4.1 Overview of Menus and Functions

```

[[[[[ download Menu (USB) ]]]]]]]]]]
-----
[1]: Upgrade (Auto)
[2]: Upgrade (w Confirmation)
[3]: Upgrade (Overwrite all)
[4]: Format HDD
[5]: Backup
[6]: Restore former version
[7]: Clear downloaded files

[Stop]: Shutdown
    
```

F-18-48

Downloading the System Software

[1]: Upgrade (Auto)

Use it to download/write the system software. (auto)

[2]: Upgrade (w Confirmation)

Use it to download the system software. (auto or selective)

[3]: Upgrade (Overwrite all)

Use it to download the system software. (overwrite)

Formatting the HDD (only in safe mode)

[4]: Format HDD (in the presence of BOOTDEV)

Use it to format the HDD for BOOTDEV partition.

[4]: Format HDD (ALL) (in the absence of BOOTDEV)

Use it to format the HDD for full partition.

Other Functions

[5]: Backup

Do not use it. (for use by R&D only)

[6]: Restore former version (in the presence of a backup of the system software)

Use it to restore the backup of the system software.

[7]: Clear downloaded files

Use it to remove the system software immediately before downloading (before writing).

[Stop]: Shutdown (in normal mode)

Use it to execute shut-down instructions.

To select/execute a function, use the keys on the control panel.

18.4.4.2 Points to Note

⚠ Turning Off the Power

Do not turn off the machine while downloading or writing is under way. Doing so could prevent the machine from starting up. If this is the case, execute HDD formatting (menu [4]), and download the system software. If the machine fails to start up because of failed downloading of BOOT the DIMM ROM must be replaced.

⚠ Downgrading

Be sure that the system software in the USB device is of the latest version.

The following collection of the system software do not permit collection of version information. As such, they necessarily overwrite the system software on the HDD:

- KEY (in both normal and safe mode)
- TTS (in both normal and safe mode)
- BROWSER (in both normal and safe mode)
- DCON (in safe mode only)
- RCON (in safe mode only)

The following is recommended for normal downloading (i.e., downloading of the system software, not after HDD replacement or formatting):

- download mode: normal
- download menu: [1]: Upgrade (Auto)

```

[[[[[ download Menu (USB) ]]]]]]]]]]]
-----
[1]: Upgrade (Auto)
[2]: Upgrade (w Confirmation)
[3]: Upgrade (Overwrite all)
[4]: Format HDD
[5]: Backup
[6]: Restore former version
[7]: Clear downloaded files

[2] has been selected. Execute?
- (OK):0 / (CANCEL):The other keys -

```

F-18-53

MEMO:

If the system software in the USB device is found to be of the same or older version, a message will appear asking you if you want to overwrite. Go through the instructions on the control panel, and press the appropriate key.

[0]: overwrite / other than [0]: do not overwrite

```

Copying files from USB-dev.
[Warning] Same version or old version.
-----
[BOOT XXxx] Same OVERWRITE?
-- (YES) :0 / (NO) :The other keys--

```

F-18-54

5) While downloading is under way, the control panel screen shows its progress. At the end of downloading, a message will appear asking you to press a key. Press the appropriate key. If the machine is in normal mode, it starts the shutdown instructions.

```

Copying files from USB-dev.
[!R7105-XXen0111-5822-TTS.lst] OK.
[!RYYYY-XXxc0101-1776-KEY.dsh] OK.
[!RYYYY-XXxc0101-F4D1-KEY.dat] OK.
[!RYYYY-XXxc0101-405C-KEY.lst] OK.
[!RYYYY-XXxc0101-17AC-KEY.dsh] OK.
[!RYYYY-XXxp0101-96D0-KEY.dat] OK.
[!RYYYY-XXxp0101-0564-KEY.lst] OK.
[!R7105-XXxx0102-5C64-DCON.ird] OK.
[!R7105-XXxx0102-B1B1-DCON.prg] OK.
[!R7105-XXxx0102-DCON.ift] OK.
File transfer has been completed.

---Please hit any key---

```

F-18-55

6) When a message appears asking you to turn off the power, turn off the main power switch, remove the USB device, and turn on the main power switch.

7) Upon start-up, the machine starts to write the system software to the system area of the HDD or the flash ROM. At the end of writing to the HDD, a message will appear asking you to turn off and then back on the power. Turn off and then back on the main power switch.

```

<<<<<<<<<< download-shell >>>>>>>>
[KEY xp] ... Upgrading complete
[KEY xc] ... Upgrading complete
[TTS en] ... Upgrading complete
+++ Switch OFF the power then ON. +++

```

F-18-56

18.4.4.5 Downloading the System Software (overwriting)

[3]: Upgrade (Overwrite all)

The system software in the USB device will overwrite the software on the HDD regardless of the version of the latter. Unlike menu item [1], however, the machine will not restart on its own at the end of downloading. When the power is turned off and then back on manually, the machine starts writing the system software.

<Procedure>

- 1) If the machine is on, go through the HDD shutdown instructions, and turn off the main power.
 - 2) Connect the USB device to the USB port.
 - 3) Put the machine in download mode (normal or safe).
 - 4) Go through the instructions on the control panel, and press the appropriate key.
- [3] -> [0]: execute download / other than [0]: go back to Menu screen

```

[[[[[ download Menu (USB) ]]]]]]]]]]]
-----
[1]: Upgrade (Auto)
[2]: Upgrade (w Confirmation)
[3]: Upgrade (Overwrite all)
[4]: Format HDD
[5]: Backup
[6]: Restore former version
[7]: Clear downloaded files

[3] has been selected. Execute?
- (OK):0 / (CANCEL):The other keys -

```

F-18-57

5) While downloading is under way, the control panel screen shows its progress. At the end of downloading, a message will appear asking you to press a key. Press the appropriate key. If the machine is in normal mode, the shut-down sequence will start.

```

Copying files from USB-dev
[iR7105-XXen0111-5822-TTS.lst] OK
[iRYYYY-XXxc0101-1776-KEY.dsh] OK
[iRYYYY-XXxc0101-F4D1-KEY.dat] OK
[iRYYYY-XXxc0101-405C-KEY.lst] OK
[iRYYYY-XXxp0101-17AC-KEY.dsh] OK
[iRYYYY-XXxp0101-96D0-KEY.dat] OK
[iRYYYY-XXxp0101-0564-KEY.lst] OK
[iR7105-XXxx0102-5C64-DCON.ird] OK
[iR7105-XXxx0102-B1B1-DCON.prg] OK
[iR7105-XXxx0102-DCON.ift] OK
File transfer has been completed.

---Please hit any key---
```

F-18-58

- 6) When a message appears asking you to turn off the power, turn off the main power, remove the USB device, and turn the main power switch back on.
- 7) Upon start-up, the machine starts writing the system software to the system area of the HDD or the flash ROM. At the end of writing, a message will appear asking you to turn off and then back on the power. Turn off and then on the main switch.

```

<<<<<<<<< download-shell >>>>>>>>>
[KEY xp] ...Upgrading complete
[KEY xc] ...Upgrading complete
[TTS en] ...Upgrading complete
+++ Switch OFF the power then ON. +++
```

F-18-59

18.4.4.6 Formatting the HDD

! This function is available only when the machine is in safe mode.

[4]: Format HDD (in the presence of BOOTDEV)

Use it to format the HDD for BOOTDEV partition.

[4]: Format HDD (ALL) (in the absence of BOOTDEV, as when replacing with new HDD)

Use it to format the HDD for full partition.

<Procedure>

Go through the following to format the HDD for BOOTDEV partition:

- 1) If the machine is on, go through the HDD shut-down instructions, and turn off the main power.
- 2) Connect the USB device to the USB port.

- 3) Start up the machine in safe mode.
- 4) Follow the instructions on the control panel, and press the appropriate key.

[4] -> [0]: go to Partition Selection screen / other than [0]: go back to Menu screen

```

[[[[[ download Menu (USB) ]]]]]]]]]]
-----
[1]: Upgrade (Auto)
[2]: Upgrade (w Confirmation)
[3]: Upgrade (Overwrite all)
[4]: Format HDD
[5]: Backup
[6]: Restore former version
[7]: Clear downloaded files

[4] has been selected. Execute?
- (OK):0 / (CANCEL):The other keys -
```

F-18-60

- 5) Go through the instructions on the control panel, and press the appropriate key.

[1] -> [0]: execute BOOTDEV formatting / other than [0]: go back to Menu screen
[C]: go back to Menu screen

```

[[[[[ Format HDD Manu (USB) ]]]]]]]]]]
-----
[1]: BOOTDEV
[C]: Return to Main Menu

[1] has been selected. Execute?
- (OK):0 / (CANCEL):The other keys -
```

F-18-61

- 6) At the end of formatting, a message will appear asking you to press a key. Press any key to go back to the Men screen.

```

[[[[[ Format HDD Manu (USB) ]]]]]]]]]]
-----
[1]: BOOTDEV
[C]: Return to Main Menu

[1] has been selected. Execute?
- (OK):0 / (CANCEL):The other keys -

Formatting BOOTDEV ... OK
Formatting HDD ... Complete

---Please hit any key---
```

F-18-62

- 7) Start downloading the system software. For instructions, see "Downloading the System Software."

18.4.4.7 Other Functions

[5]: Backup



This function is for R&D purposes only. Do not use it.

[6]: Restore former version (in the presence of backup of system software)

Use it to restore the backup of the system software while saving the system software that is current as a backup.

<Procedure>

- 1) If the machine is on, go through the HDD shut-down instructions, and turn off the main power.
- 2) Connect the USB device to the USB port.
- 3) Put the machine in download mode (normal or safe).
- 4) Go through the instructions on the control panel, and press the appropriate key.

[6] -> [0]: initialize / other than [0]: go back to Menu screen

After execution, a message will appear asking you to turn off and then on the power.

```

[[[[[ download Menu (USB) ]]]]]]]]]]
-----
[1]: Upgrade (Auto)
[2]: Upgrade (w Confirmation)
[3]: Upgrade (Overwrite all)
[4]: Format HDD
[5]: Backup
[6]: Restore former version
[7]: Clear downloaded files

[6] has been selected. Execute?
- (OK):0 / (CANCEL):The other keys -
Restore former version...Complete.
+++ Switch OFF the power then ON. +++

```

F-18-63

- 5) Turn off the main power switch, remove the USB memory, and turn on the main power switch.

[7]: Clear downloaded files

Use it to remove the system software files that have been saved in the temporary storage area of the HDD. Use it if you want to remove the files without writing them to the HDD after downloading (menu [2] and [3]).

<Procedure>

- 1) When you have downloaded the system software using menu item [2] or [3], go to step 2) without turning off and then on the power. (If you already have turned off the power, start up the machine in safe mode.)
- 2) Go through the instructions on the control panel, and press an appropriate key.

[7] -> 10: execute / other than [0]: go back to Menu screen

Upon execution, the Menu screen will return.

```

[[[[[ download Menu (USB) ]]]]]]]]]]
-----
[1]: Upgrade (Auto)
[2]: Upgrade (w Confirmation)
[3]: Upgrade (Overwrite all)
[4]: Format HDD
[5]: Backup
[6]: Restore former version
[7]: Clear downloaded files

[7] has been selected. Execute?
- (OK):0 / (CANCEL):The other keys -

```

F-18-64

[Stop]: Shutdown (in normal mode only)

Use it to start up the shut-down sequence.

<Procedure>

- 1) Go through the instructions on the control panel, and press an appropriate key.

[Stop]->[0]: execute/ other than [0]: go to Menu screen

The shut-down sequence will be executed, and a message will appear asking you to turn off the power.

```

[[[[[ download Menu (USB) ]]]]]]]]]]
-----
[1]: Upgrade (Auto)
[2]: Upgrade (w Confirmation)
[3]: Upgrade (Overwrite all)
[4]: Format HDD
[5]: Backup
[6]: Restore former version
[7]: Clear downloaded files

[Stop]:Shutdown

[Shutdown] Execute?
- (OK):0 / (CANCEL):The other keys -

```

F-18-65

- 2) Turn off the main power switch, and remove the USB device.

Service Tools

Contents

19.1 Service Tools	19-1
19.1.1 Special Tools Table	19-1
19.1.2 Solvents/Oils	19-2

19.1 Service Tools

19.1.1 Special Tools Table

You will need the following tools in addition to the standard tools set to service the copier.

T-19-1

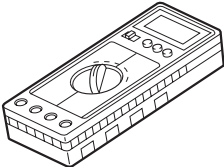
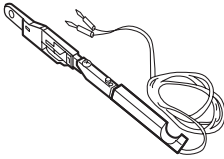
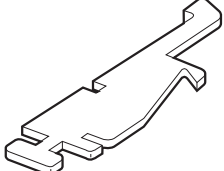
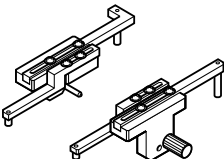
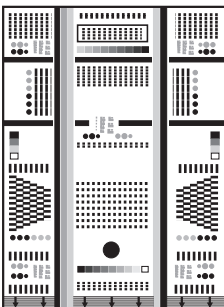
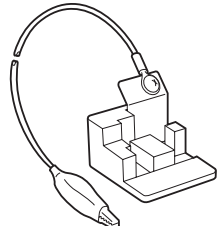
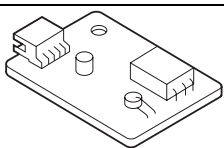
No.	Tool name	Tool No.	Shape	Rank*	Remarks
1	Digital multimeter	FY9-2002		A	For adjusting the laser intensity together with the laser power checker (for electrical checks).
2	Laser power checker	FY9-4008		A	For adjusting the light intensity together with the digital multimeter.
3	Door switch	TKN-0093		A	
4	Mirror positioning tool (front, rear)	FY9-3040		B	For adjusting the distance between No. 1 and No. 2 mirrors.
5	NA-3 test sheet	FY9-9196		A	For adjusting images and making checks.
6	Potential sensor tester electrode	FY9-3041		B	For checking the zero level of the surface potential sensor.
7	Environment sensor meter sensor	FY9-3014		B	For checking the environment sensor.

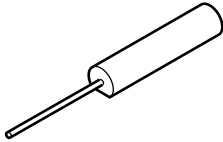
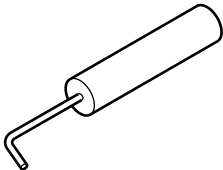
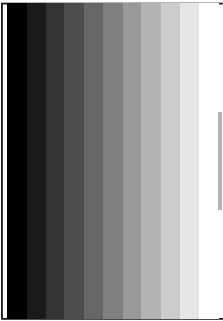
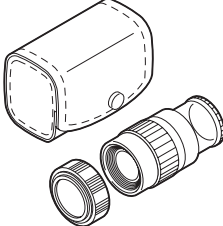
No.	Tool name	Tool No.	Shape	Rank*	Remarks
8	Tester extension pin	FY9-3038		A	For making electrical checks (attachment to the meter).
9	Tester extension pin (L-tipped)	FY9-3039		A	For making electrical checks (attachment to the meter).
10	D-10 Test Sheet	FY9-9129-000		B	For adjusting images.
11	Loupe	CK-0056-000		B	For checking images.

***Rank:**

A: Each service person is expected to carry one.

B: Each five or so service persons is expected to carry one.

C: Each workshop is expected to carry one.

19.1.2 Solvents/Oils

T-19-2

No.	Name	Uses	Composition	Remarks
1	Alcohol	Cleaning; e.g., glass, plastic, rubber (external covers)	Hydrocarbon of the fluorine family, alcohol, surface activating agent, water	- Do not bring near fire. - Procure locally. - IPA (isopropyl alcohol)
2	Solvent	Cleaning; e.g., metal areas; removing oil or toner.	Hydrocarbon of fluorine family, hydrocarbon of chlorine family, alcohol	- Do not bring near fire. - Procure locally.
3	Heat-resisting grease	Lubricating; e.g., fixing drive parts.	Lithium soap of mineral family, molybdenum disulfide	- CK-0427 (500 g/can)
4	Lubricant		Mineral oil (paraffin family)	- CK-0524 (100 cc)
5	Lubricant	Lubricating; e.g., friction parts.	Silicone oil	- CK-0551 (20 g)
6	Drum cleaning powder	Cleaning; e/g., photosensitive drum.	Selenium oxide	- CK-0429
7	Lubricant	Lubricating; e.g., scanner rail.	Silicone oil	- FY9-6011 (50 cc)
8	Conducting grease	Drum heater contact	Fluorine poly ethyl, Poly tetra fluorine ethylene	- FY9-6008 (10 g)

APPENDIX

General Timing Chart
Single-Sided Copy

A4, 2 Originals, Single-Sided Copy

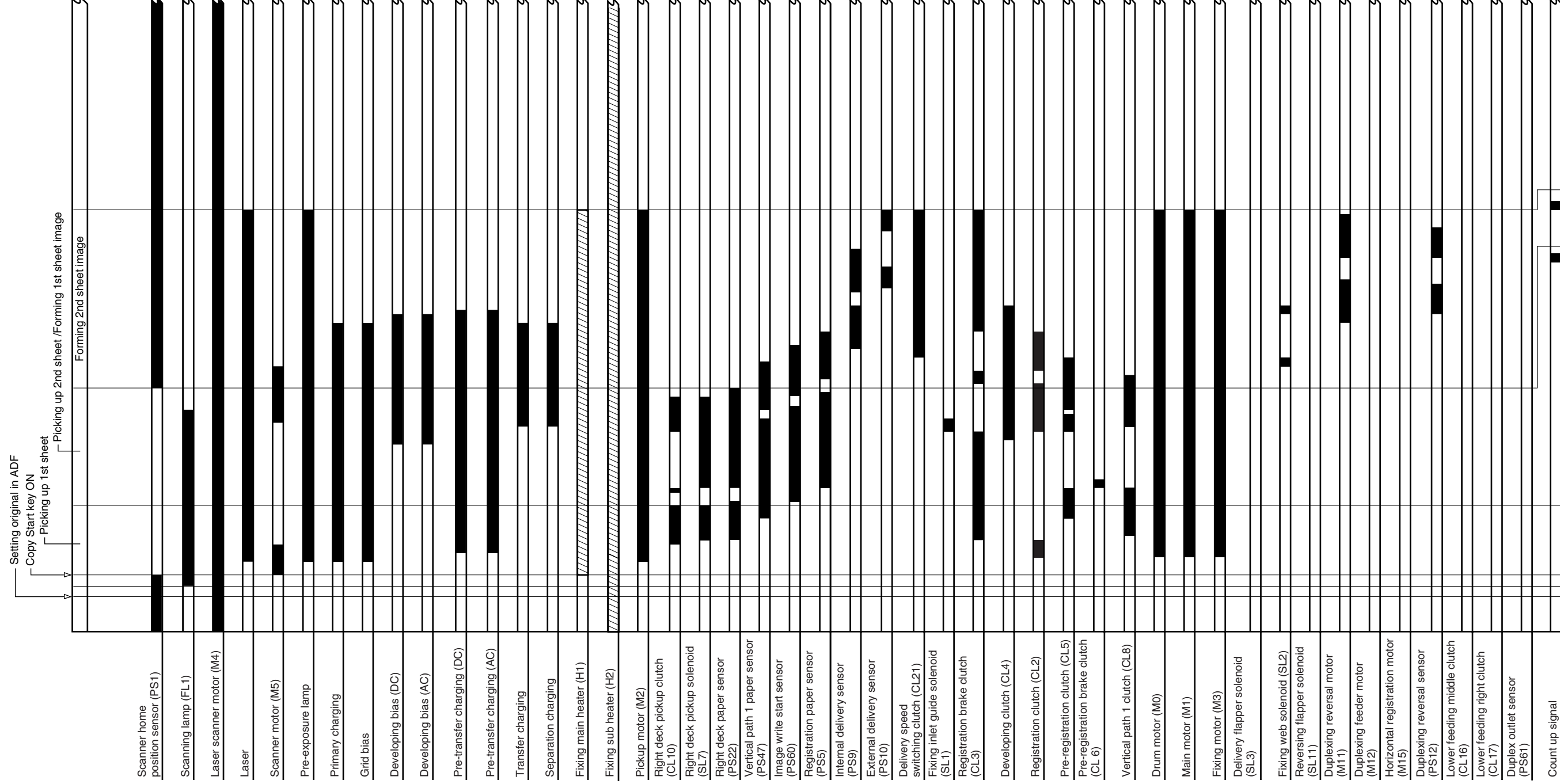

A4, 4 Originals, Double-Sided Copy

	Picking 1st sheet	Picking up 2nd sheet	Copying on 1st sheet face	Copying on 2nd sheet face	Copying on 1st sheet back	Copying on 2nd sheet back
Scanner home position sensor (PS1)						
Scanning lamp (FL1)						
Laser scanner motor (M4)						
Laser						
Scanner motor (M5)						
Pre-exposure lamp						
Primary charging						
Grid bias						
Developing bias (DC)						
Developing bias (AC)						
Pre-transfer charging (DC)						
Pre-transfer charging (AC)						
Transfer charging						
Separation charging						
Fixing main heater (H1)						
Fixing sub heater (H2)						
Pickup motor (M2)						
Right deck pickup clutch (CL10)						
Right deck pickup solenoid (SL7)						
Right deck paper sensor (PS22)						
Vertical path 1 paper sensor (PS47)						
Image write start sensor (PS60)						
Registration paper sensor (PS5)						
Internal delivery sensor (PS9)						
External delivery sensor (PS10)						
Delivery speed switching clutch (CL21)						
Fixing inlet guide solenoid (SL1)						
Registration brake clutch (CL3)						
Developing clutch (CL4)						
Registration clutch (CL2)						
Pre-registration clutch (CL5)						
Pre-registration brake clutch (CL6)						
Vertical path 1 clutch (CL8)						
Drum motor (M0)						
Main motor (M1)						
Fixing motor (M3)						
Delivery flapper solenoid (SL3)						
Fixing web solenoid (SL2)						
Reversing flapper solenoid (SL11)						
Duplexing reversal motor (M11)						
Duplexing feeder motor (M12)						
Horizontal registration motor (M15)						
Duplexing reversal sensor (PS12)						
Lower feeding middle clutch (CL16)						
Lower feeding right clutch (CL17)						
Duplex outlet sensor (PS61)						
Count up signal						

F-1-2

Signal Names

List of Signals/Abbreviations

The following is a list of the signals and abbreviations used in this chapter and the circuit diagrams.

MEMO:

The abbreviations in parentheses are electrical signals, but are analog signals, which cannot be expressed in terms of '1' or '0'. Others are digital signals, which may be expressed in terms of '1' or '0'.

T-2-1

AFTER_JOIN_PS	Post-confluence sensor detection signal
BUFFER_CL	Hopper internal magnet roller drive clutch drive command
BUFFER_MOTOR (-)	Hopper internal toner feeder motor drive command 2
BUFFER_MOTOR (+)	Hopper internal toner feeder motor drive command 1
BUFFER_NG	Hopper internal toner lower limit sensor detection signal
BUFFER_WARNING	Hopper internal toner sensor detection signal
C3_FEED_CL_ON	Cassette 3 pickup clutch drive command
C3_FEED_PS	Cassette 3 pickup sensor detection signal
C3_LENGTH	Cassette 3 paper length sensor detection signal
C3_LIFT_PS	Cassette 3 lifter sensor detection signal
C3_LIFTER_MOTOR	Cassette 3 lifter motor drive command
C3_OPEN_PS	Cassette 3 open/closed sensor detection signal
C3_PAPER_PS	Cassette 3 paper sensor detection signal
C3_PICKUP_SL	Cassette 3 pickup solenoid drive command
C3_PLEVER_VR	Cassette 3 paper level detection signal
C3VR	Cassette 3 paper width volume detection signal
C4_FEED_CL_ON	Cassette 4 pickup clutch drive command
C4_FEED_PS	Cassette 4 pickup sensor detection signal
C4_LENGTH	Cassette 4 paper length sensor detection signal
C4_LIFT_PS	Cassette 4 lifter sensor detection signal
C4_LIFTER_MOTOR	Cassette 4 lifter motor drive command
C4_OPEN_PS	Cassette 4 open/closed sensor detection signal
C4_PAPER_PS	Cassette 4 paper sensor detection signal
C4_PICKUP_SL_ON	Cassette 4 pickup solenoid drive command
C4_PLEVER_VR	Cassette 4 paper level detection signal
C4VR	Cassette 4 paper width volume detection signal
CARTRIGE_DETECT	Cartridge detecting switch detection signal
CARTRIGE_MOTORCART RIGE_	Cartridge internal toner feeder motor drive command
MOTOR+	Cartridge internal toner feeder motor drive command

CARTRIGE_OPEN_PS	Toner cartridge cover open/closed sensor detection signal
CLEW_PS	Fixing claw jam sensor detection signal
CURL_FAN_STOP	De-curling fan lock detection signal
DCP_FAN1_STOP	Power supply cooling fan 1 lock detection signal
DCP_FAN2_STOP	Power supply cooling fan 2 lock detection signal
DECK_PULL_PS	Front deck (left) feeding sensor detection signal
DEV_FAN_STOP	Developing fan lock detection signal
DEV_SLEEVE_CL_ON	Developing cylinder deceleration clutch drive command
DEV1_SLEEVE_CL_ON	Developing clutch drive command
DEVELOP_IS	Developing assembly internal toner sensor detection signal
DOCUMENT_TOP	Image leading edge sensor detection signal
DRUN_FAN_STOP	Drum fan lock detection signal
DRUN_MOTOR_LOCK	Drum motor lock detection signal
DRUN_MOTOR_ON	Drum motor drive command
DUP-INV_PS	Duplexing reversal sensor detection signal
EXHAUST_FAN_STOP	Fixing assembly heat discharge fan lock detection signal
EXIT_DEL_PS	External delivery sensor detection signal
EXIT_FAN1_LOCK	Delivery adhesion-proofing fan lock detection signal
FEED_MOTOR_FG	Pickup motor frequency signal
FEED_MOTOR_ON	Pickup motor drive command
FIXEXIT_DEL_PS	Fixing feeding unit outlet sensor detection signal
FL_TH	Scanning lamp thermal sensor detection signal
FLAP_SL	Delivery flapper solenoid drive command
FREAD_FAN_STOP	Stream reading fan lock detection signal
FRONT_DR_OPEN	Front cover open/closed detecting switch detection signal
FRONT_JOIN_PS	Pre-confluence sensor detection signal
FUSE_M_LOCK	Fixing motor lock detection signal
FUSE_M_ON	Fixing motor drive command
GLASS_PS	Copyboard glass sensor detection signal
INT_DEL_PS	Internal delivery sensor detection signal
INV_FAN_STOP	Inverter cooling fan lock detection signal
INV_GUIDE_SL	Reversing flapper solenoid drive command
KAKIKOMI_PS	Image write start sensor detection signal
LASER1_FAN_STOP	Scanner cooling fan lock detection signal
LASER2_FAN_STOP	Laser driver cooling fan lock detection signal
LDECK_FEED_CL	Deck (left) pickup clutch drive command
LDECK_FEED_PS	Front deck (left) pickup sensor detection signal
LDECK_LIFT_MOTOR	Deck (left) lifter motor drive command
LDECK_LIFT_PS	Front deck (left) lifter sensor detection signal
LDECK_LIMIT_PS	Front deck (left) limit sensor detection signal
LDECK_OPEN_PS	Front deck (left) open/closed sensor detection signal

LDECK_PAPER_PS	Front deck (left) paper sensor detection signal
LDECK_PICKUP_SL	Deck (left) pickup solenoid drive command
LDECK_PLEVEL_M	Front deck (left) paper level middle sensor detection signal
LDECK_PLEVEL_U	Front deck (left) paper level high sensor detection signal
LDECK_PULL_CL	Deck (left) feeding clutch drive command
LOCK	System fan lock detection signal
LOCK	Duplex feed fan lock detection signal
LOW_DR_OPEN	Lower right cover open/closed sensor detection signal
LOWPASS_C_CL	Lower feeding middle clutch drive command
LOWPASS_R_CL	Lower feeding right clutch drive command
MAIN_MOTOR_FG	Main motor frequency signal
MAIN_MOTOR_ON	Main motor drive command
MAIN_TENP	Fixing main thermistor detection signal
MLT_CURL_ENTRY	Manual feed sensor detection signal
MLT_DR_OPEN	Manual feed tray cover open/closed sensor detection signal
MLT_FEED_CL	Manual feed tray pickup clutch drive command
MLT_PAPER_PS	Manual feed tray paper sensor detection signal
MLT_PICKUP_SL_BACK	Manual feed pickup clutch solenoid drive command
MLT_PICKUP_SL_PULL	Manual feed pickup clutch solenoid drive command
MLT_PULL_CL	Manual feed tray feeding clutch drive command
MLT_VOLUME	Manual feed tray paper width volume detection signal
MOTOR_ON	Vibration motor drive command
MUTI DOOR OPEN	Manual feed tray cover open/closed detecting sensor detection signal
OPT_HP1	Scanner home position sensor detection signal
OPT_MOTOR_FAN_STOP	Scanner moter cooling fan lock detection signal
ORI_SIZE_ON/OFF	Original size sensor ON/OFF detection signal
ORI_SIZE1	Original size sensor detection signal 1
ORI_SIZE2	Original size sensor detection signal 2
ORI_SIZE3	Original size sensor detection signal 3
ORI_SIZE4	Original size sensor detection signal 4
PATH1_CL_ON	Vertical path 1 clutch drive command
PATH1_PS	Vertical path 1 paper sensor detection signal
PATH2_CL_ON	Vertical path 2 clutch drive command
PATH2_PS	Vertical path 2 paper sensor detection signal
PATH3_CL_ON	Vertical path 3 clutch drive command
PATH3_PS	Vertical path 3 paper sensor detection signal
PATH4_CL_ON	Vertical path 4 clutch drive command
PATH4_PS	Vertical path 4 paper sensor detection signal
POST_FAN_STOP	Pre-transfer charging fan lock detection signal

POST_M.C_BK	Pre-transfer charging wire cleaning motor drive command (reverse)
POST_M.C_FW	Pre-transfer charging wire cleaning motor drive command (forward)
POTENTIAL_ON	Potential sensor detection signal
POTENTIAL_SIG	Potential sensor detection signal
PRESSING_PLATE_OPEN	Copyboard cover open/closed sensor detection signal
PRIM_FAN_STOP	Primary charging assembly fan lock detection signal
PRIMARY_V.C_BK	Primary charging wire cleaning motor drive command (reverse)
PRIMARY_V.C_FW	Primary charging wire cleaning motor drive command (forward)
PRIREGI_BRAKE_CL_ON	Pre-registration brake clutch drive command
PRIREGI_CL_ON	Pre-registration clutch drive command
RDECK_FEED_CL	Deck (right) pickup clutch drive command
RDECK_FEED_PS	Front deck (right) pickup sensor detection signal
RDECK_LIFT_MOTOR (24VU)	Deck (right) lifter motor drive command
RDECK_LIFTER_PS	Front deck (right) lifter sensor detection signal
RDECK_LIMIT_PS	Front deck (right) limit sensor detection signal
RDECK_OPEN_PS	Front deck (right) open/closed sensor detection signal
RDECK_PAPER_PS	Front deck (right) paper sensor detection signal
RDECK_PICKUP_SL_ON	Deck (right) pickup solenoid drive command
RDECK_PLEVEL_M	Front deck (right) paper level middle sensor detection signal
RDECK_PLEVEL_U	Front deck (right) paper level high sensor detection signal
RDECK_PULL_PS	Front deck (right) feeding sensor detection signal
REGI_BRAKE_CL	Registration brake clutch drive command
REGIST_CL	Registration clutch drive command
REGIST_PS	Registration paper sensor detection signal
REVER_OPEN_PS	Fixing/feeding unit releasing lever sensor detection signal
RUP_DR_OPEN	Upper right cover open/closed sensor detection signal
SEP_EXHAUST_FAN_STOP	Scanner motor cooling fan lock detection signal
SIDE_REGI_PS	Horizontal registration sensor detection signal
SPEED_DEL_CL	Delivery speed switching clutch drive command
STOP	Separation fan lock detection signal
SUB_TEMP	Fixing sub thermistor detection signal
T/S_W.C_OUT1	Transfer/separation charging wire cleaning motor drive command 1
T/S_W.C_OUT2	Transfer/separation charging wire cleaning motor drive command 2
THERN_HUM_SENSOR	Environment sensor detection signal
UNITLOCK_SL_BACK	Fixing feeding unit locking solenoid drive command (back)
UNITLOCK_SL_PULL	Fixing feeding unit locking solenoid drive command (pull)
U-TURN_PS	Duplex outlet sensor detection signal

VASIE_TONER_PACKED_DTC	Waste toner clog detecting switch detection signal
WASTE_TONER_OVER_PS	Waste toner case full sensor detection signal
WEB_LESS	Fixing cleaning belt sensor detection signal
WEB_SL	Fixing cleaning belt solenoid drive command
WEB_WARNING	Fixing cleaning belt warning sensor detection signal

General Circuit Diagram

General Circuit Diagram (1/20)

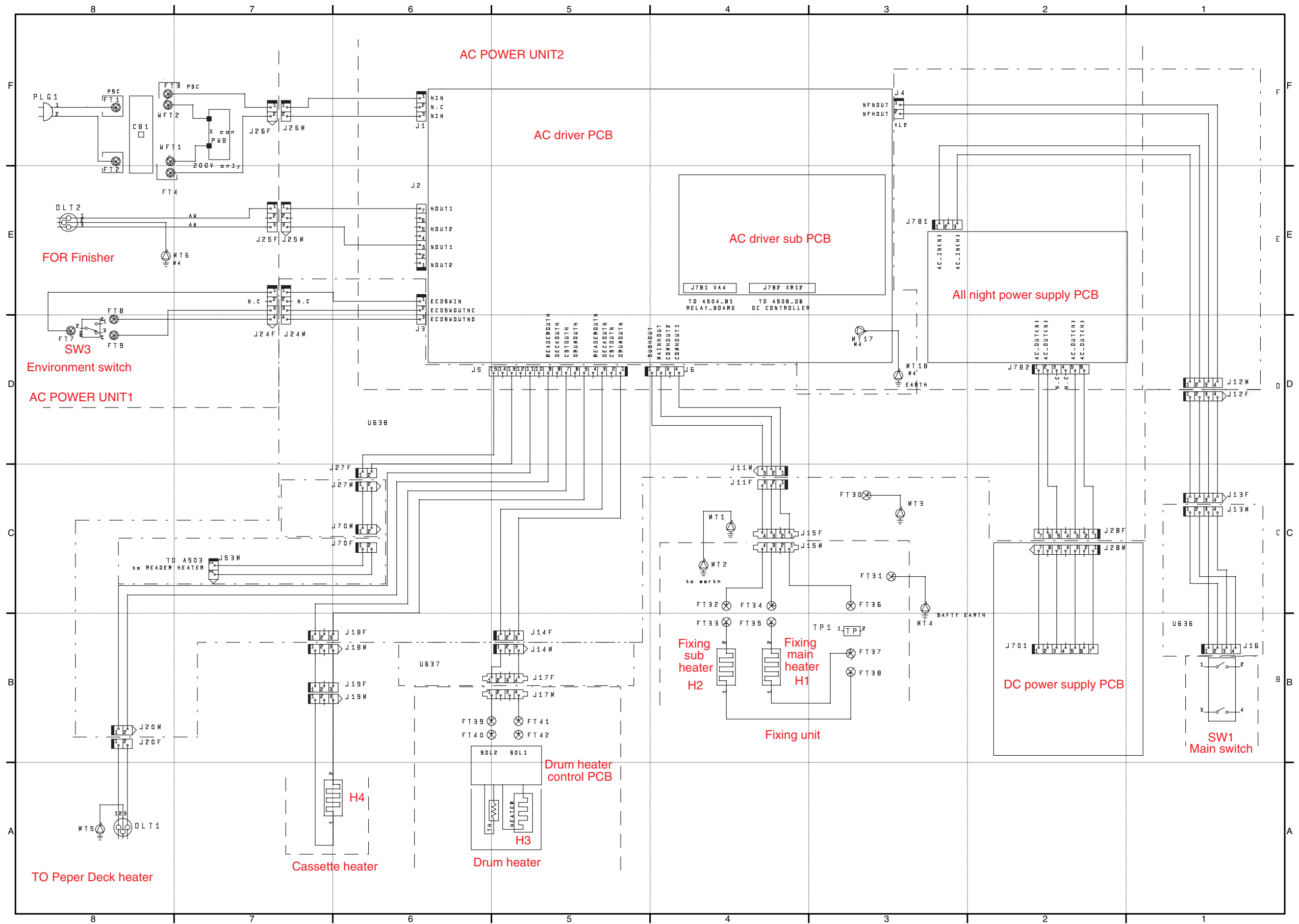

(1/20)

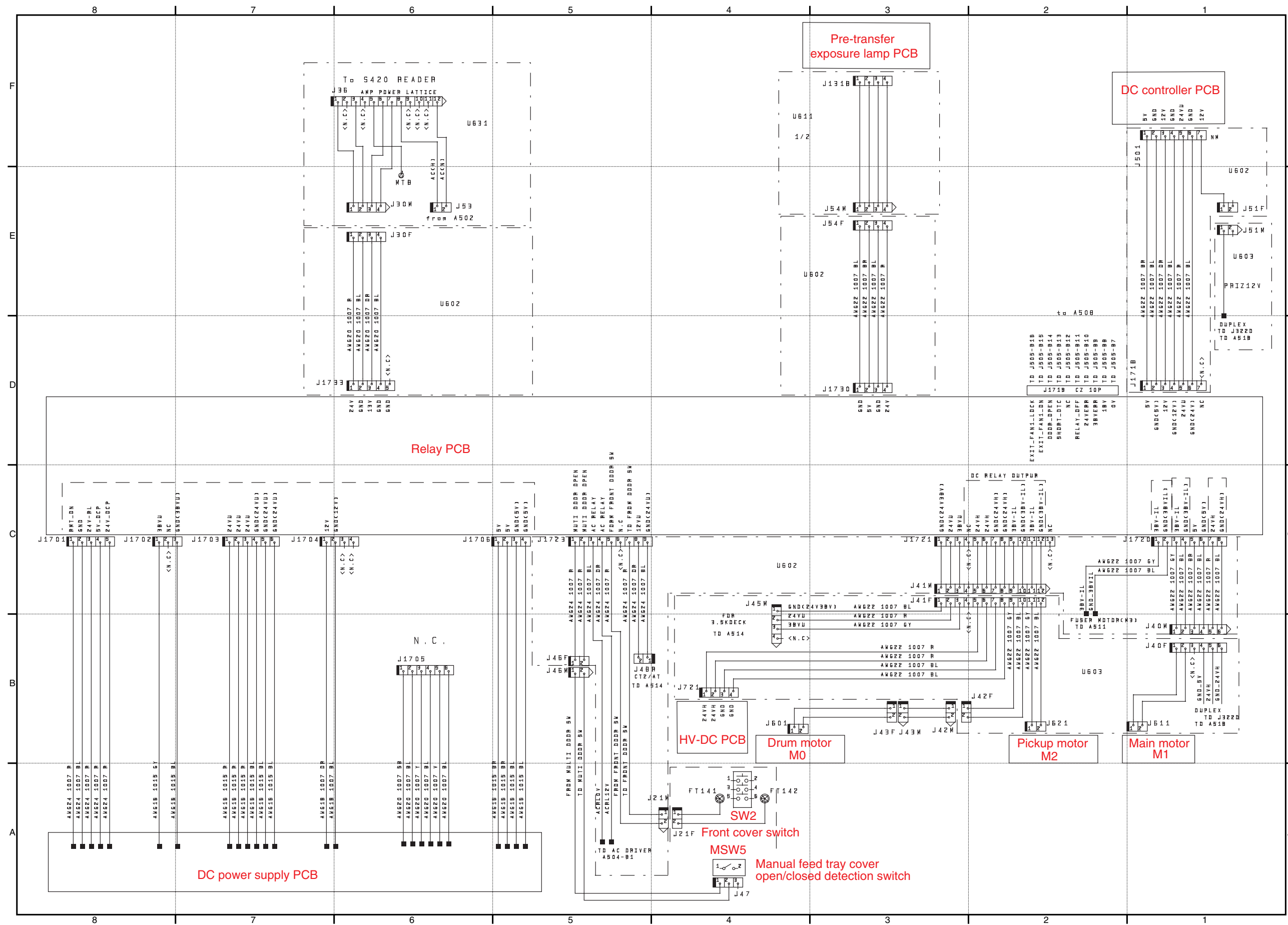

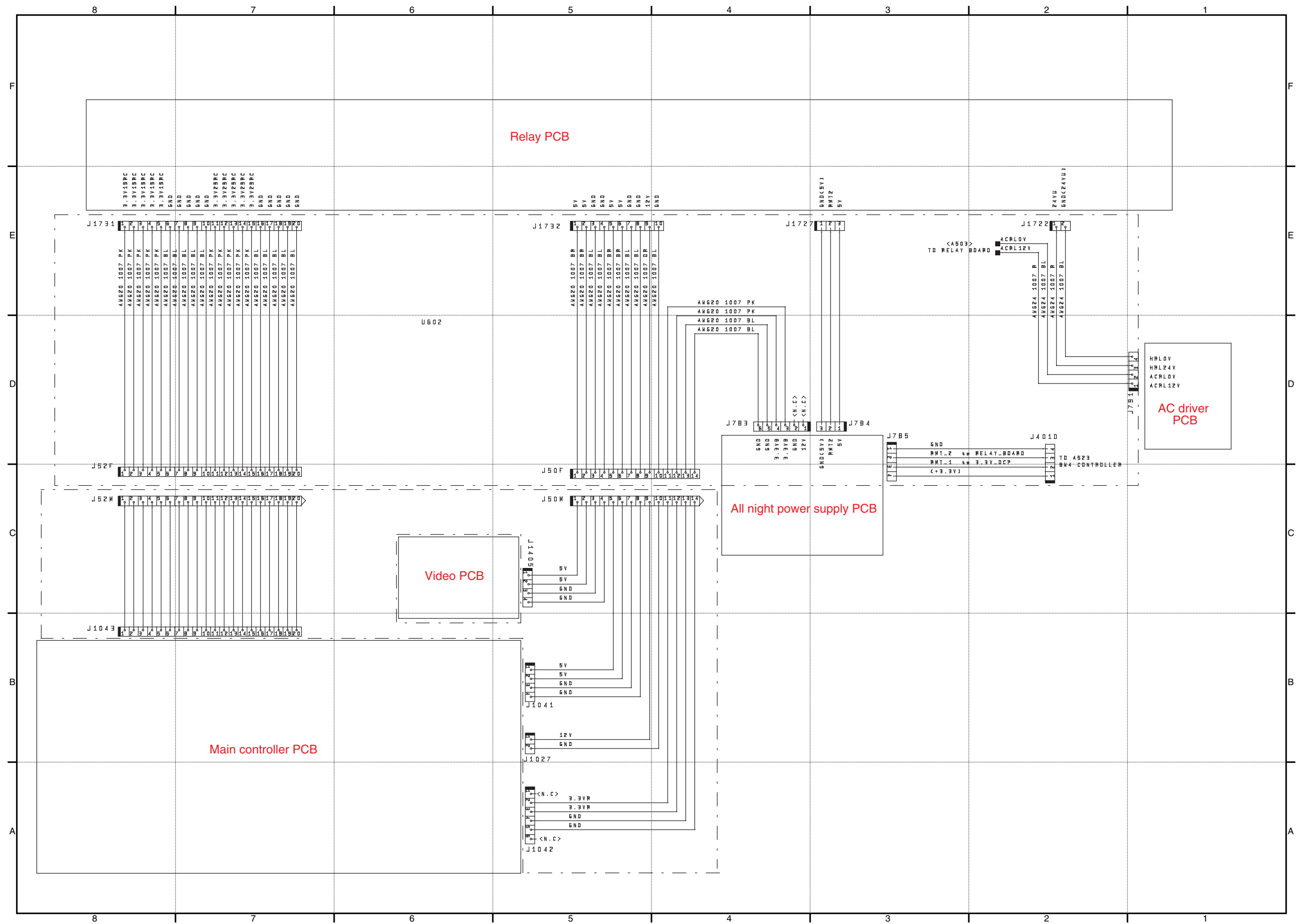

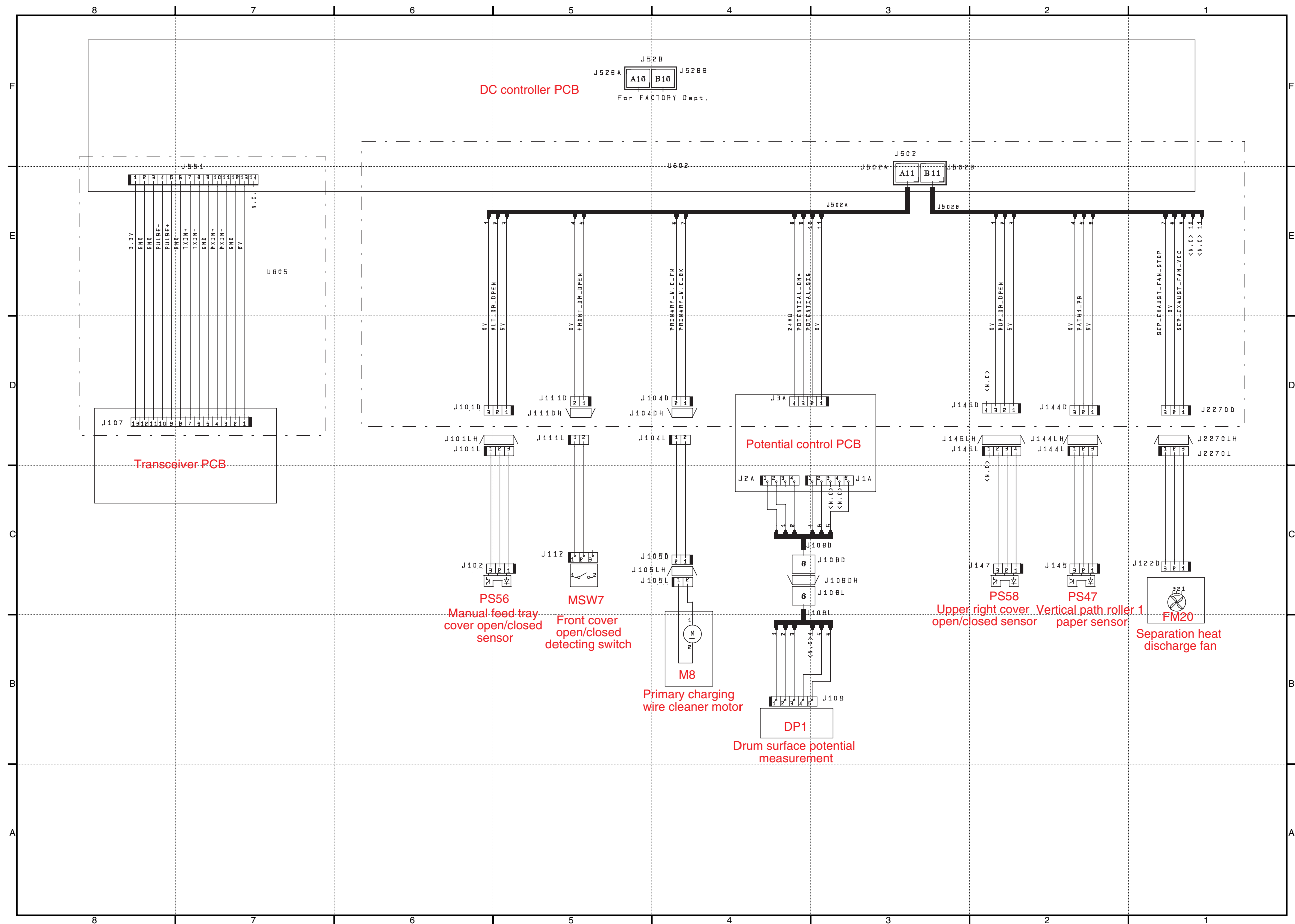

F-2-4

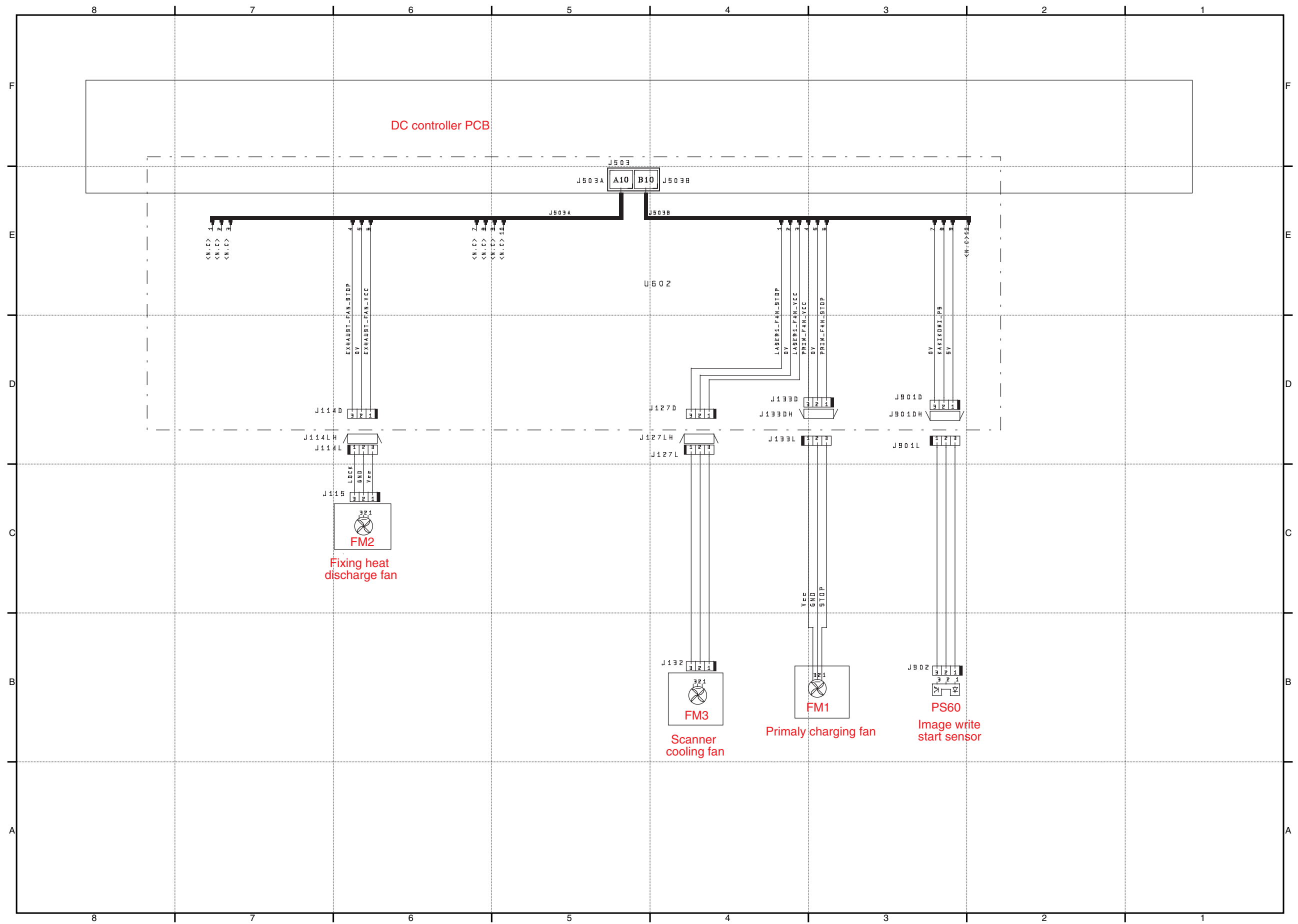

F-2-5

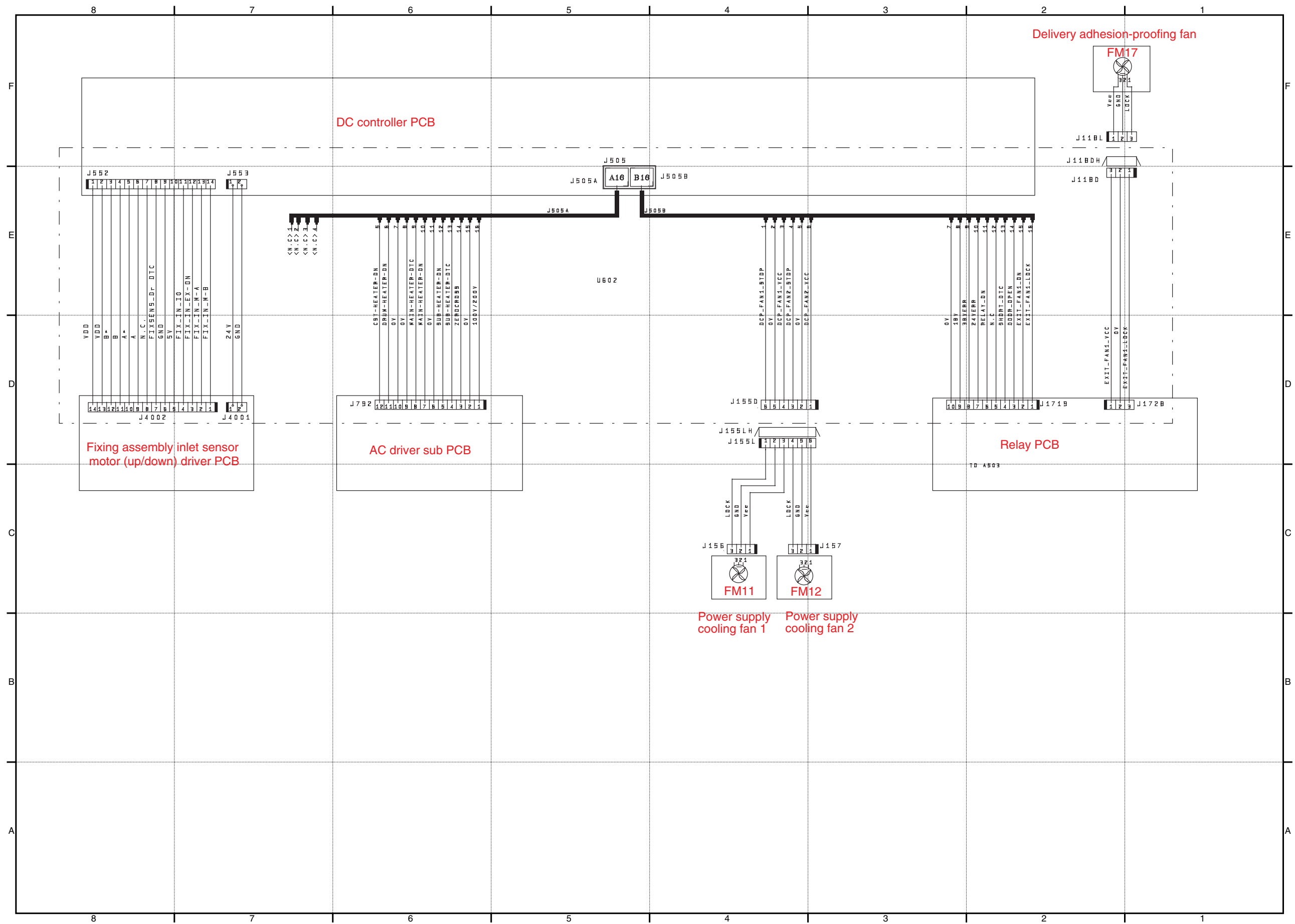

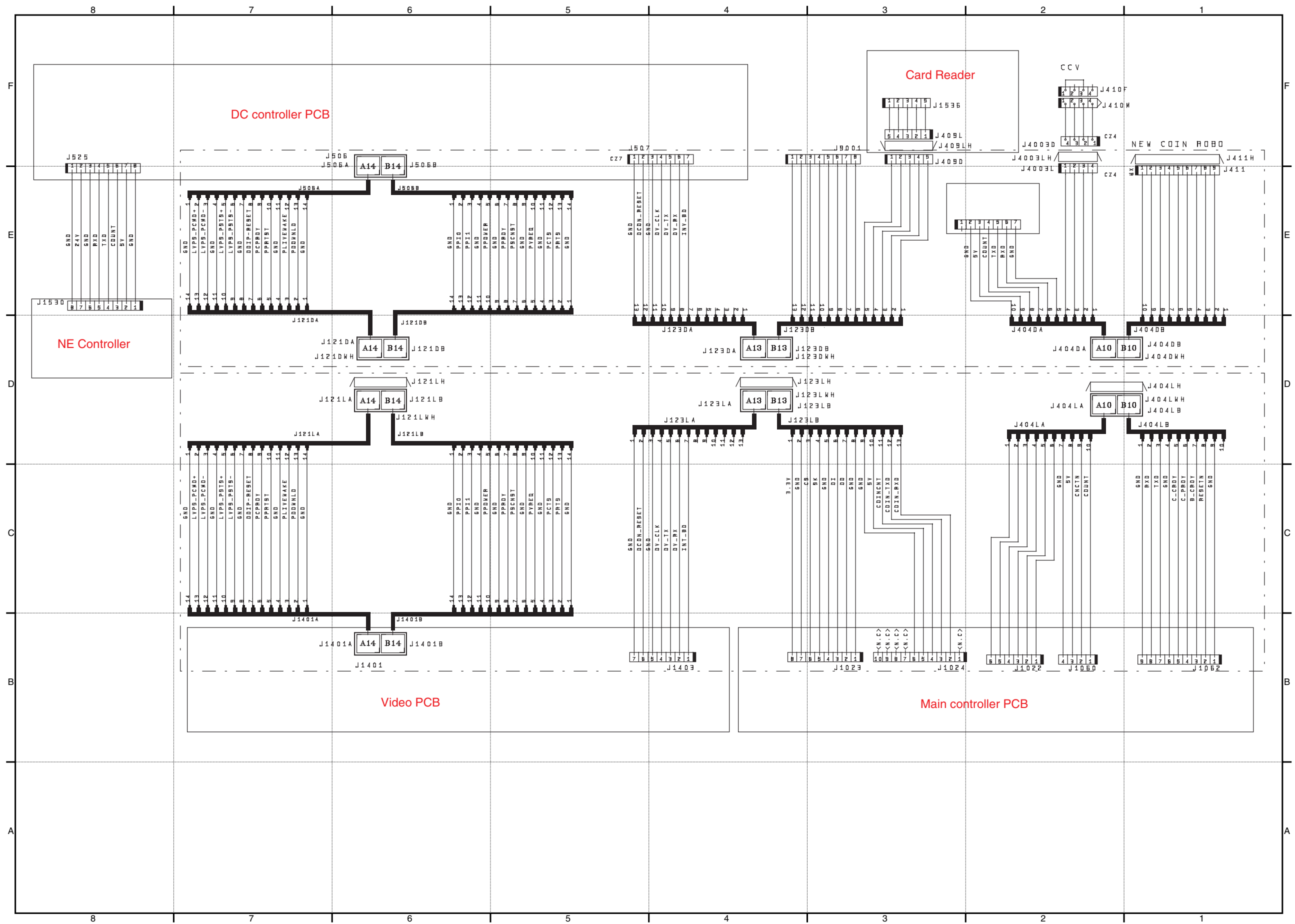

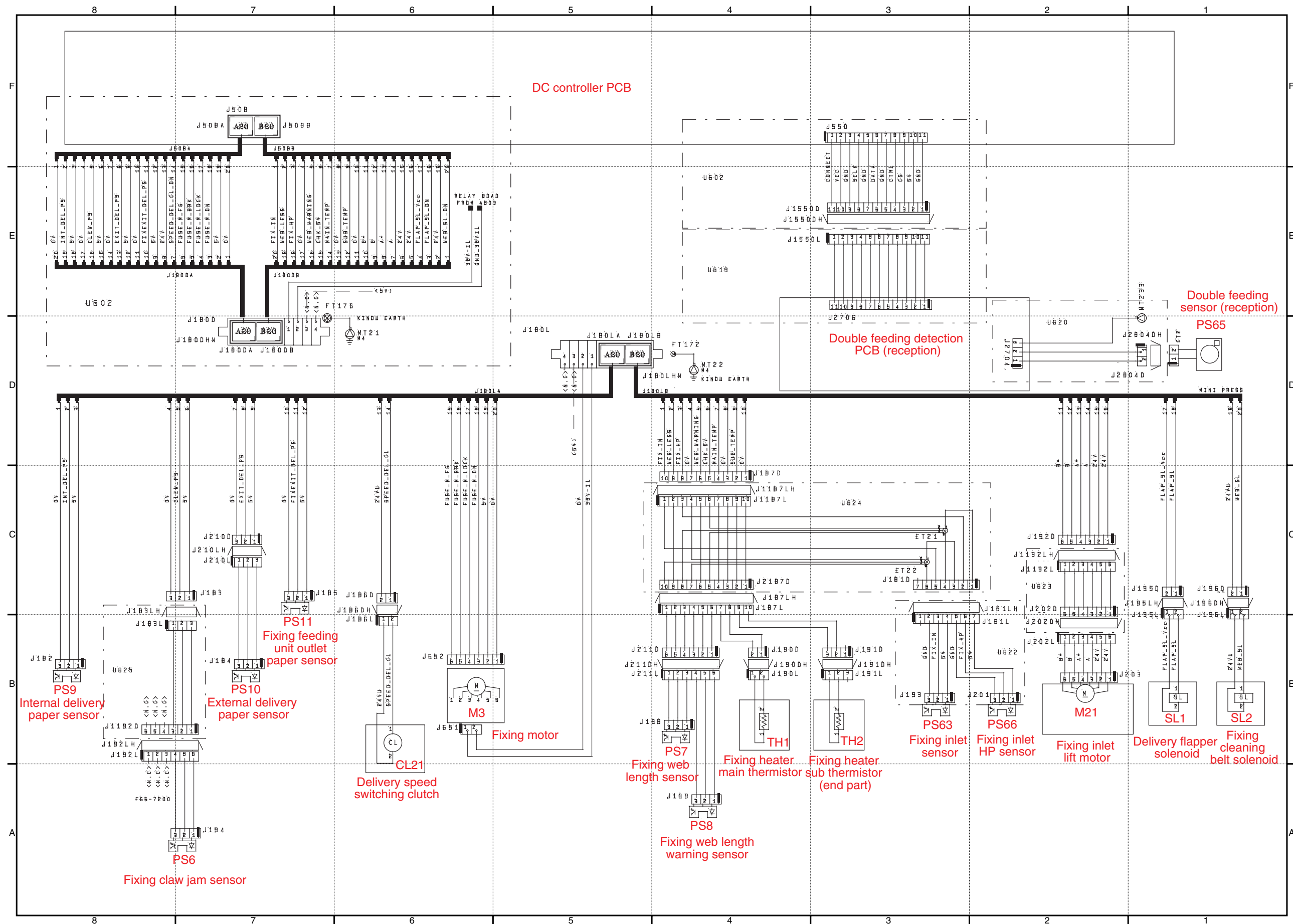

F-2-10

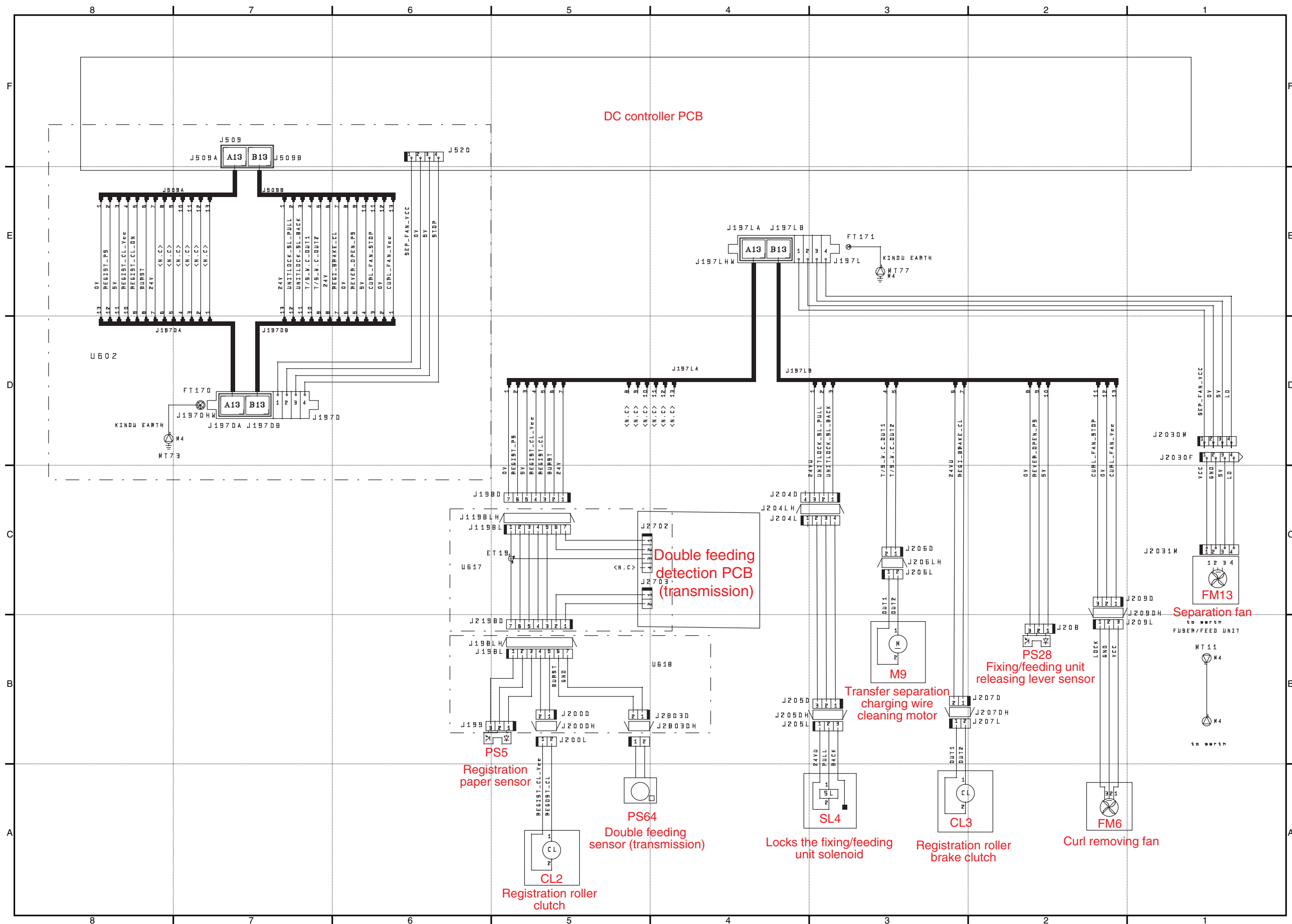

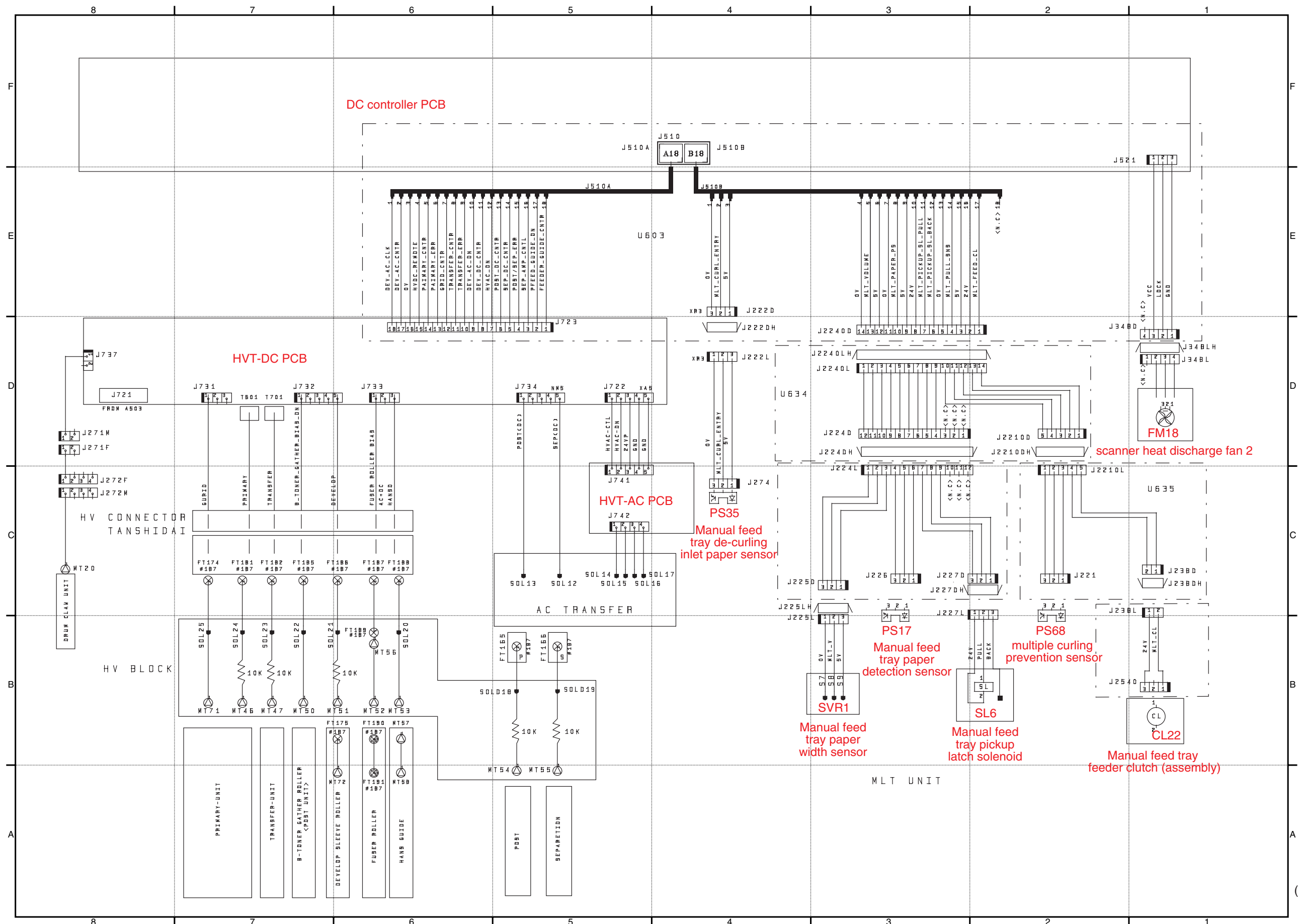

F-2-12

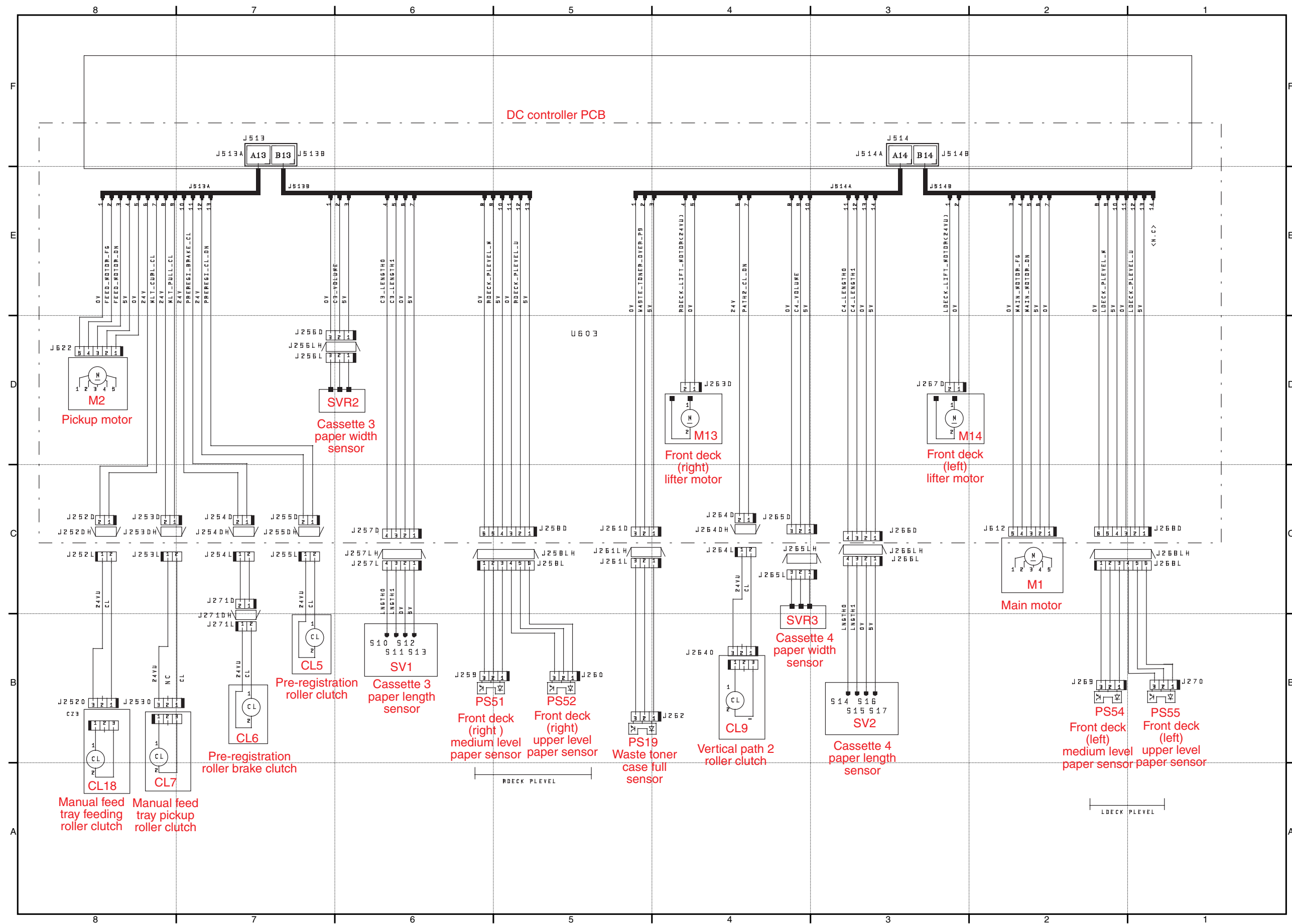

F-2-14

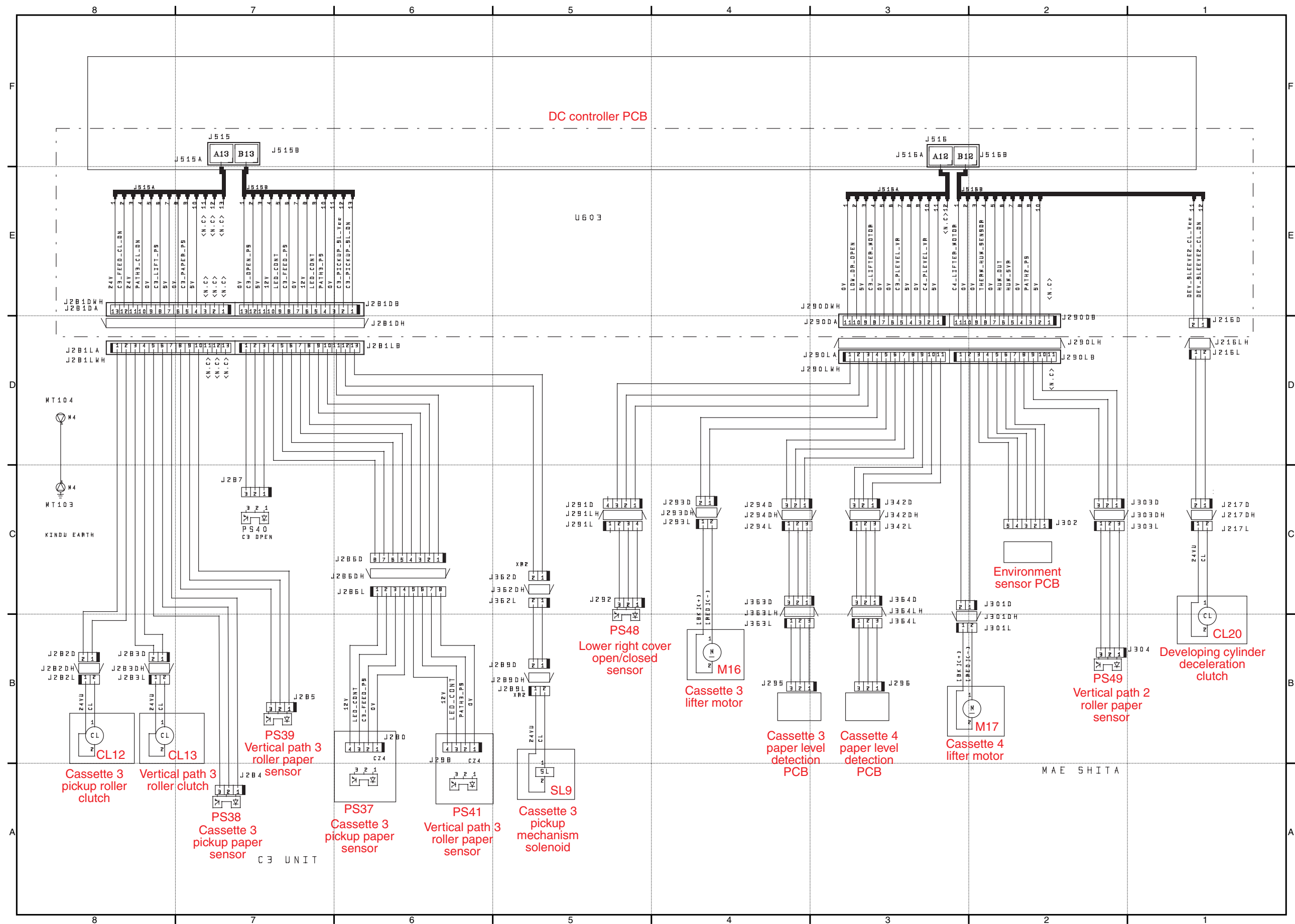

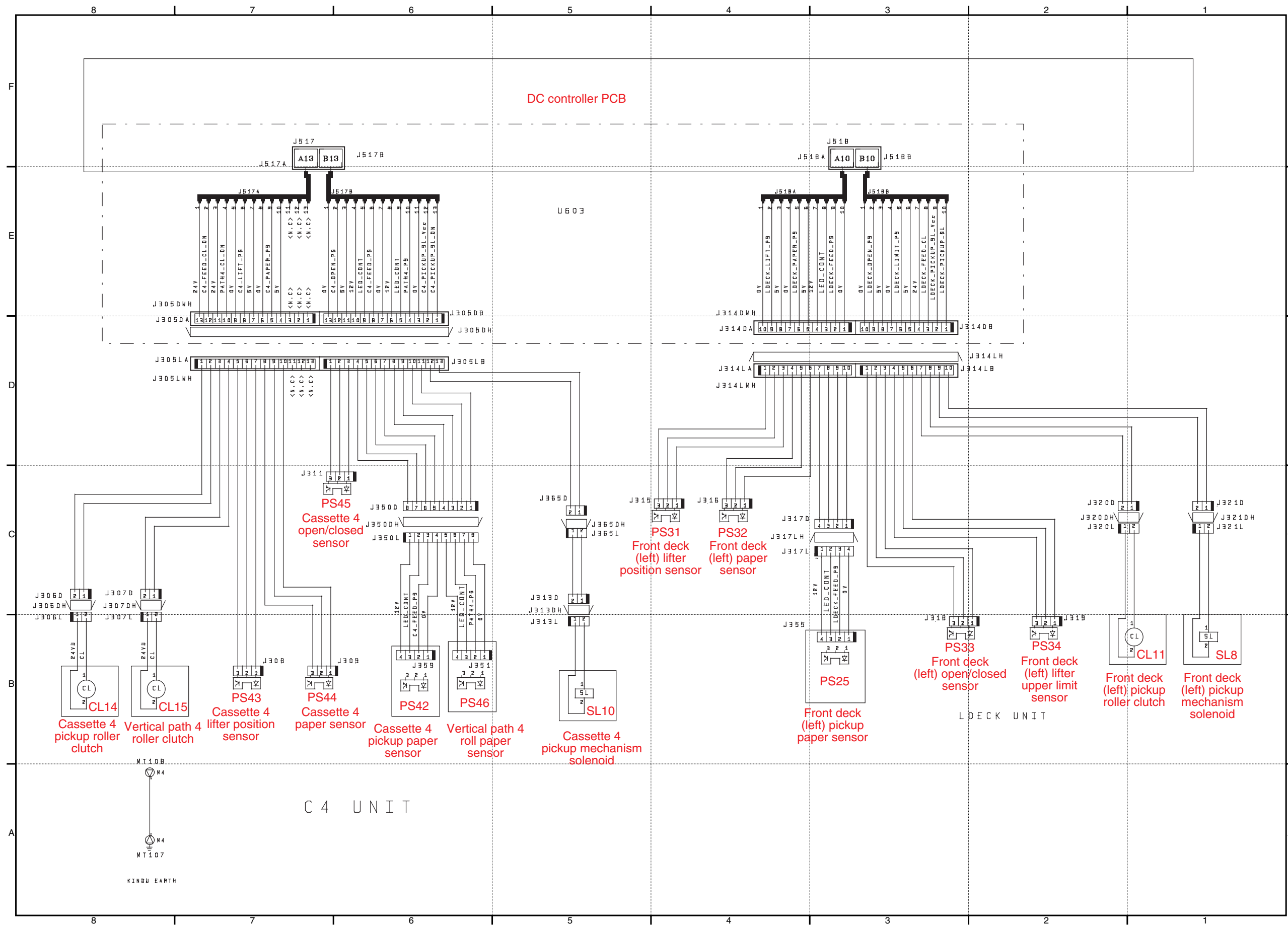

F-2-16

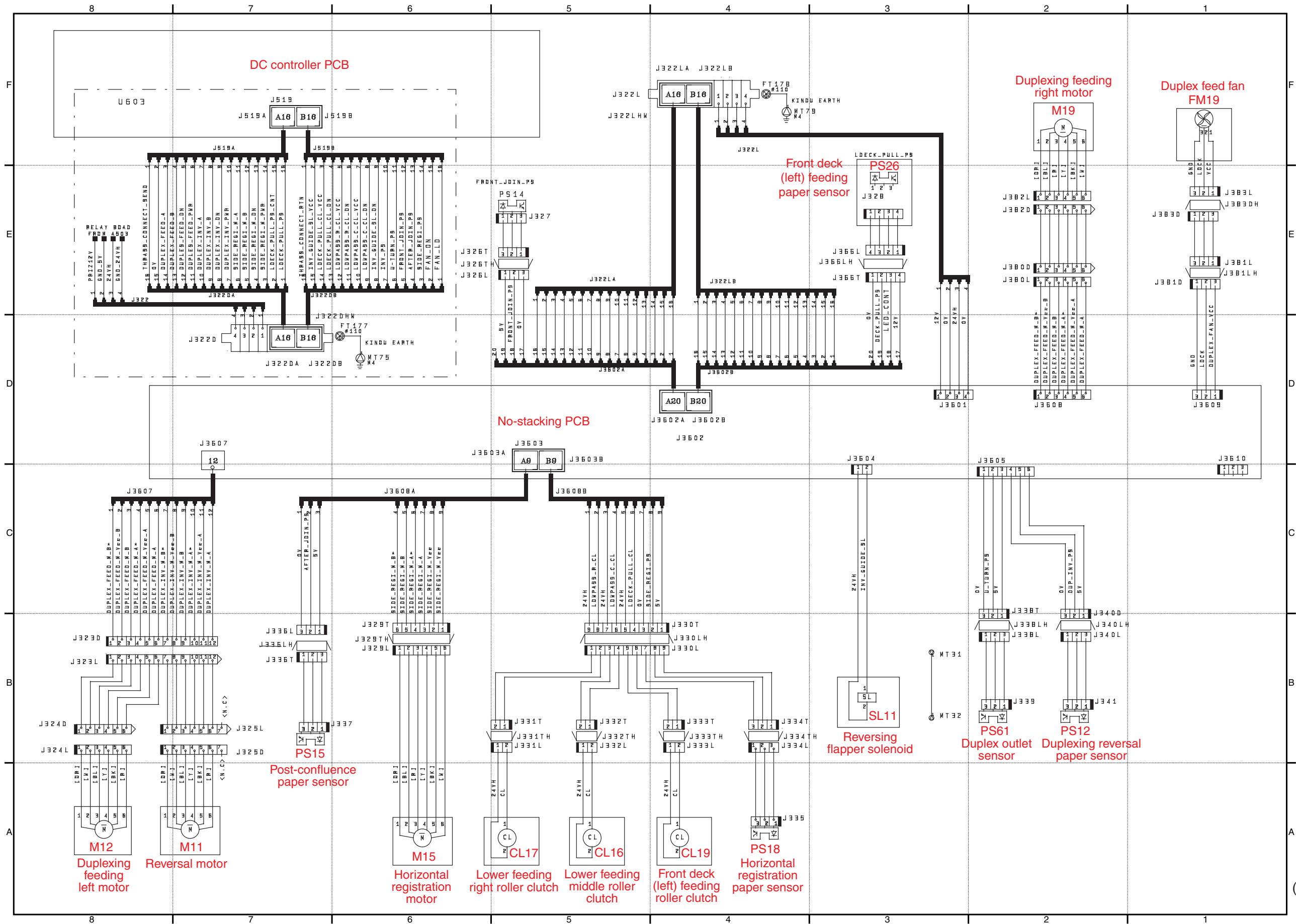

F-2-17

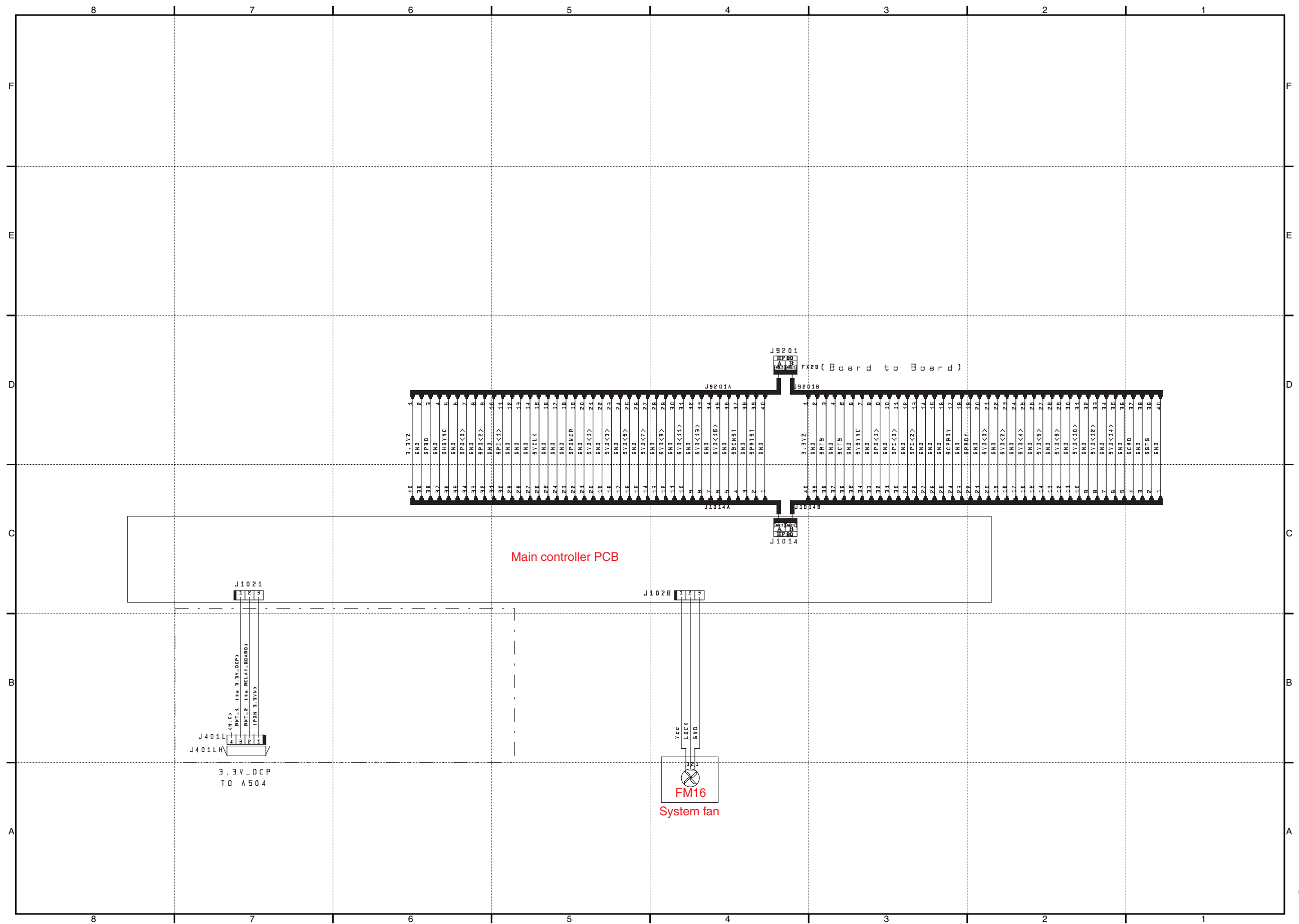

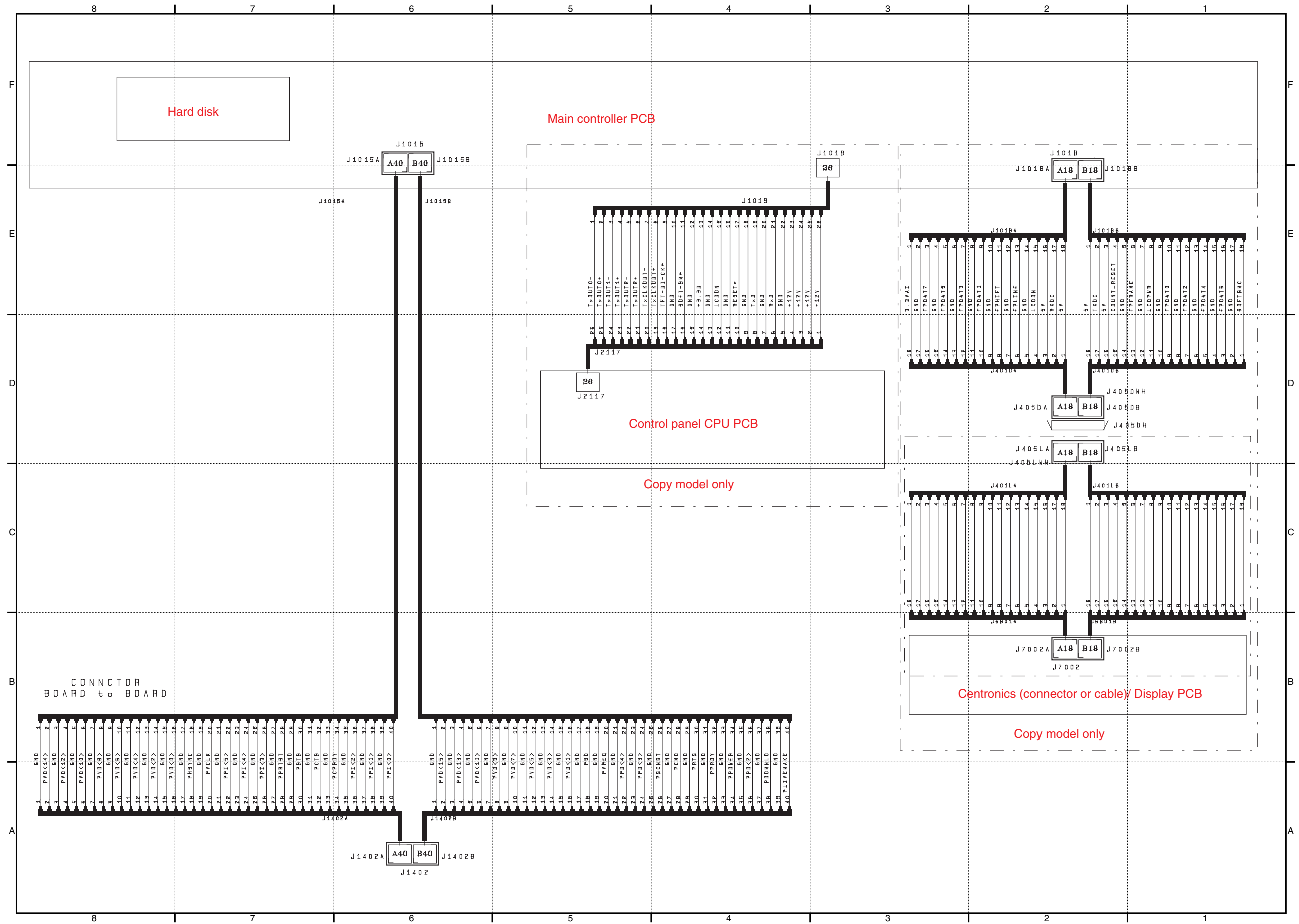

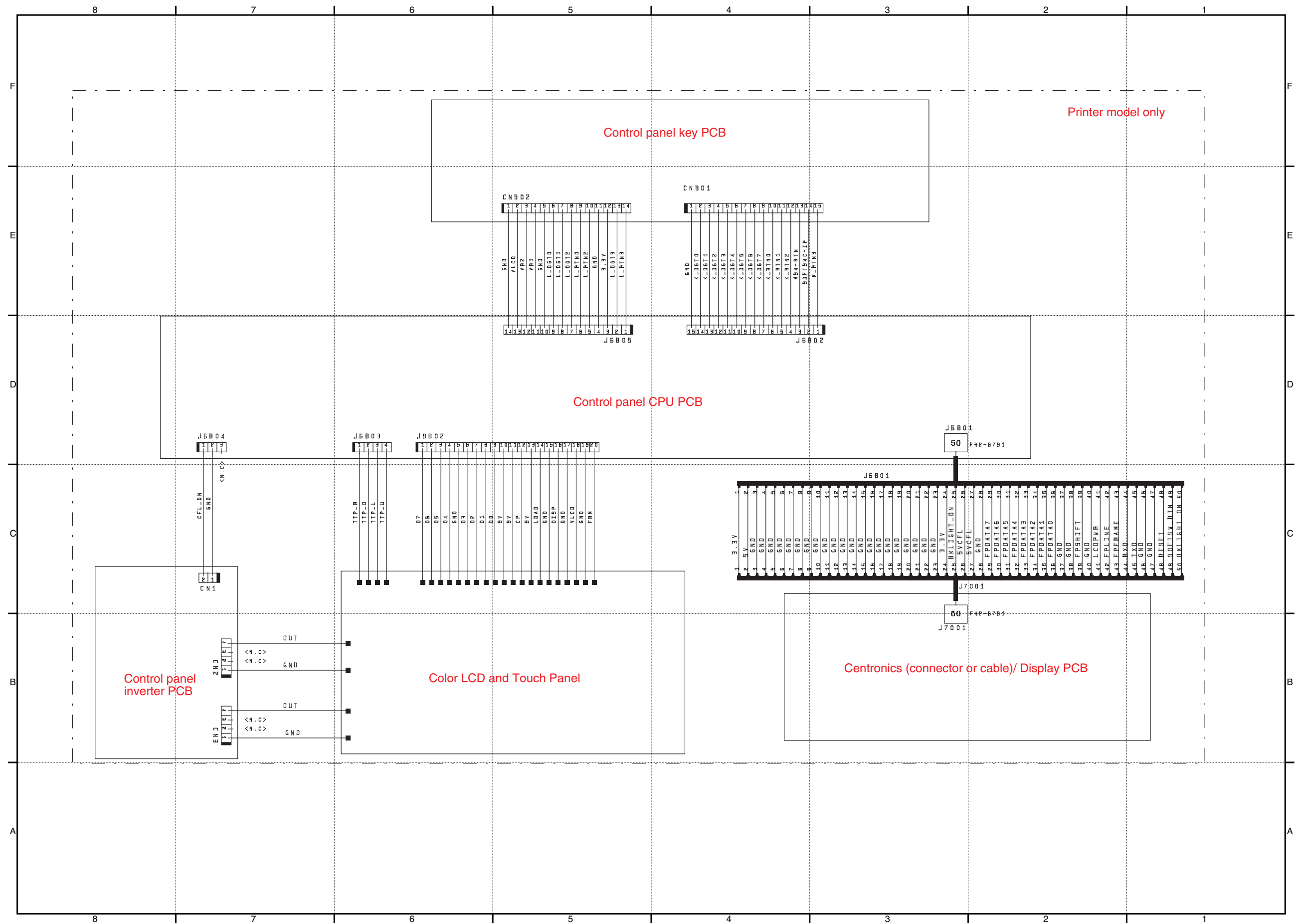

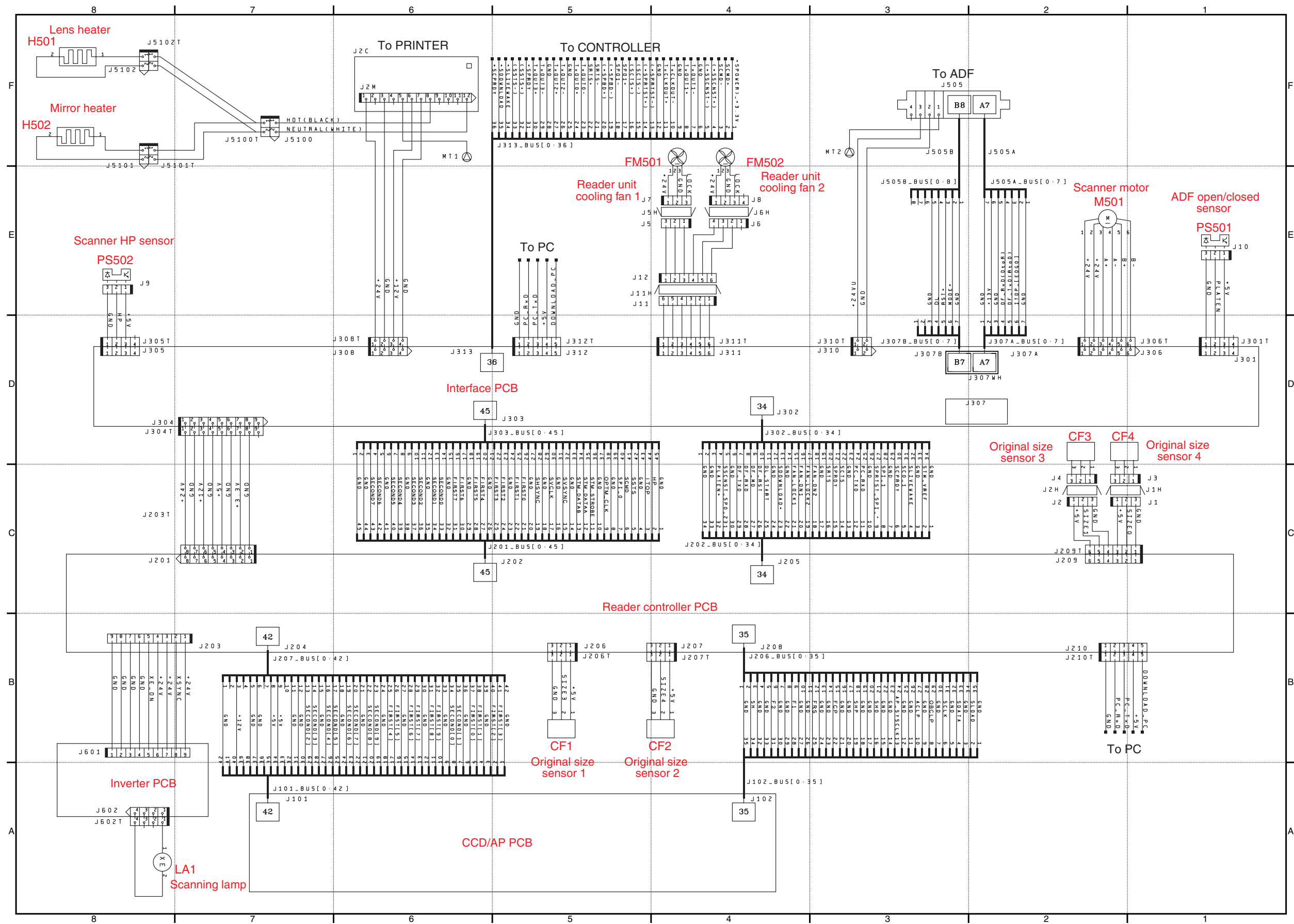

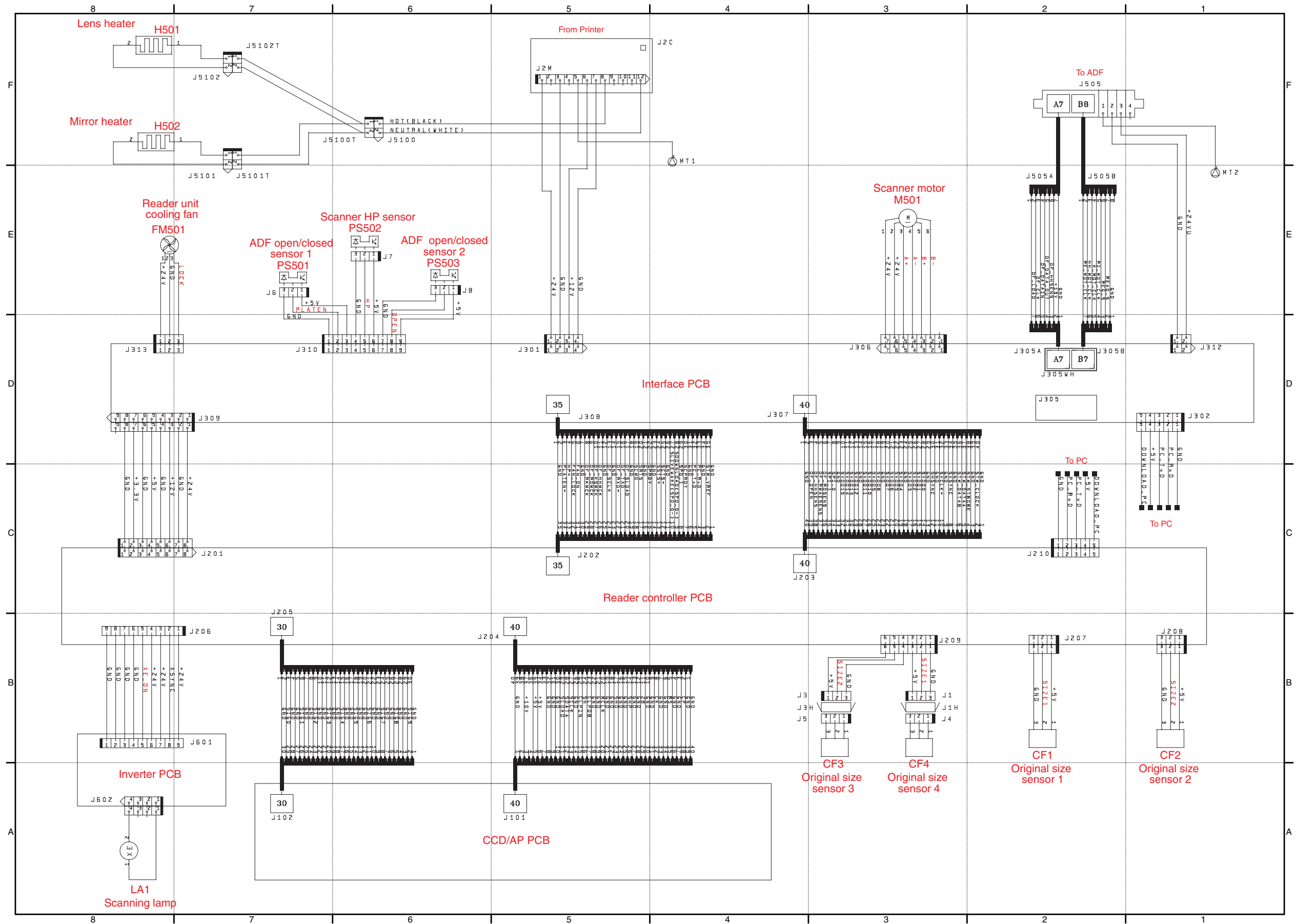

F-2-22

Canon