

PARTS CATALOG

Color imageRUNNER C1022 Series

Cassette Feeding Unit-AB1



Canon

DU7-3218-000

SEPTEMBER 2008
REV. 0

PREFACE

This Parts Catalog contains listings of parts used

Diagrams are provided with the listings to aid the service technician in identifying clearly, the item to be ordered.

Whenever ordering parts, consult this Parts Catalog for all of the information pertaining to each item. Be sure to include, in the Parts Request, the full item description, the item part number, and the quantity.

COPYRIGHT (C) 1999 CANON INC.

Use of this manual should be strictly supervised to avoid disclosure of confidential information.

Contents

NUMERICAL INDEX

C2110/1022/1021 Series(Numerical Index)..... 1-1

C2110/1022/1021 Series(Parts Catalog)

A1	ASSEMBLY LOCATION DIAGRAM	2-1
A2	OPTION PARTS CATALOG LIST	2-3
001	ACCESSORIES	2-4
100	EXTERNAL COVERS, PANELS, ETC.	2-6
101	FRONT COVER ASSEMBLY	2-8
102	INTERNAL COMPONENTS 1	2-10
103	INTERNAL COMPONENTS 2	2-12
104	INTERNAL COMPONENTS 3	2-14
105	INTERNAL COMPONENTS 4	2-17
106	INTERNAL COMPONENTS 5	2-19
107	INTERNAL COMPONENTS 6	2-22
130	CONTROL PANEL ASSEMBLY	2-24
160	AUTO DOCUMENT FEEDER ASS'Y	2-27
161	ADF PAPER FEED ASSEMBLY	2-30
260	PAPER PICK-UP DRIVE ASS'Y	2-33
265	DUPLEXING FEED DRIVE ASS'Y	2-35
270	DEV. ESTRANGEMENT DRIVE ASS'Y	2-37
280	FIXING DRIVE ASSEMBLY	2-39
300	CASSETTE	2-41
310	PAPER PICK-UP ASSEMBLY	2-43
315	MULTI PURPOSE TRAY ASS'Y	2-45
330	ELECT. TRANSPORT BELT ASS'Y	2-47
331	REVERSE ASSEMBLY	2-49
400	READER ASSEMBLY	2-53
810	FIXING ASS'Y	2-55
900	CONTROLLER BOX ASSEMBLY	2-58
ZZA	MECHANICAL STANDARD PARTS (HOW TO USE)	2-61
ZZB	MECHANICAL STANDARD PARTS (SCREWS)	2-62
ZZC	MECHANICAL STANDARD PARTS (BOLTS)	2-69
ZZD	MECHANICAL STANDARD PARTS (NUTS)	2-70
ZZE	MECHANICAL STANDARD PARTS (WASHERS)	2-71
ZZF	MECHANICAL STANDARD PARTS (RETAINING RINGS)	2-74
ZZG	MECHANICAL STANDARD PARTS (PINS)	2-77
ZZH	MECHANICAL STANDARD PARTS (SPACERS)	2-78

NUMERICAL INDEX

C2110/1022/1021 Series(Numerical Index)

PARTS NUMBER	FIGURE & KEY NO.	PARTS NUMBER	FIGURE & KEY NO.	PARTS NUMBER	FIGURE & KEY NO
FC5-5256-000	101 - 4	FC7-6132-000	100 - 8	FC7-6850-000	900 - 2
FC7-6008-000	104 - 1	FC7-6133-000	100 - 9	FC7-6852-000	107 - 24
FC7-6009-000	105 - 1	FC7-6137-000	331 - 32	FC7-6855-000	900 - 2
FC7-6011-000	100 - 1	FC7-6141-000	101 - 1	FC7-6857-000	900 - 9
FC7-6012-000	101 - 2	FC7-6142-000	105 - 11	FC7-6862-000	107 - 1
FC7-6013-000	315 - 1	FC7-6145-000	106 - 1	FC7-6867-000	900 - 9
FC7-6014-000	100 - 19	FC7-6147-000	100 - 10	FC7-6868-000	100 - 10
FC7-6015-000	100 - 2	FC7-6148-000	106 - 2	FC7-6869-000	100 - 3
FC7-6016-000	100 - 3	FC7-6149-000	300 - 6	FC7-6870-000	100 - 5
FC7-6017-000	100 - 20	FC7-6153-000	106 - 3	FC7-6912-000	101 - 6
FC7-6018-000	100 - 4	FC7-6156-000	105 - 12	FC7-7090-000	130 - 2
FC7-6019-000	100 - 5	FC7-6165-000	104 - 6	FC7-7091-000	130 - 1
FC7-6027-000	400 - 23	FC7-6167-000	105 - 13	FC7-7093-000	130 - 6
FC7-6029-000	105 - 2	FC7-6168-000	105 - 14	FC7-7095-000	130 - 1
FC7-6030-000	105 - 3	FC7-6180-000	160 - 1	FC7-7099-000	130 - 1
FC7-6031-000	105 - 4	FC7-6182-000	161 - 4	FC7-7126-000	130 - 1
FC7-6032-000	105 - 5	FC7-6189-000	160 - 9	FC7-7127-000	130 - 1
FC7-6033-000	105 - 6	FC7-6200-000	161 - 8	FC7-7128-000	130 - 1
FC7-6034-000	105 - 7	FC7-6222-000	400 - 10	FC7-7129-000	130 - 1
FC7-6035-000	105 - 8	FC7-6223-000	400 - 11	FC7-7130-000	130 - 1
FC7-6036-000	105 - 9	FC7-6224-000	400 - 12	FC7-7132-000	130 - 6
FC7-6037-000	400 - 24	FC7-6228-000	400 - 13	FC7-7133-000	130 - 6
FC7-6043-000	161 - 1	FC7-6240-000	400 - 1	FC8-0533-000	130 - 6
FC7-6047-000	400 - 8	FC7-6246-000	400 - 14	FC8-0540-000	130 - 2
FC7-6048-000	400 - 9	FC7-6254-000	400 - 15	FC8-0541-000	130 - 2
FC7-6052-000	161 - 2	FC7-6257-000	400 - 16	FC8-0553-000	160 - 15
FC7-6057-000	331 - 4	FC7-6262-000	160 - 2	FC8-0554-000	160 - 15
FC7-6058-000	331 - 5	FC7-6263-000	160 - 3	FC8-0555-000	160 - 15
FC7-6060-000	331 - 26	FC7-6264-000	160 - 4	FC8-0556-000	160 - 15
FC7-6068-000	331 - 6	FC7-6265-000	160 - 6	FC8-0557-000	400 - 1
FC7-6069-000	331 - 7	FC7-6266-000	160 - 5	FC8-0558-000	400 - 1
FC7-6074-000	331 - 17	FC7-6278-000	161 - 5	FC8-0559-000	400 - 1
FC7-6075-000	331 - 18	FC7-6281-000	161 - 23	FC8-0563-000	400 - 2
FC7-6078-000	331 - 3	FC7-6284-000	161 - 24	FC8-0564-000	400 - 2
FC7-6080-000	331 - 19	FC7-6287-000	161 - 25	FC8-0565-000	400 - 2
FC7-6081-000	331 - 20	FC7-6288-000	161 - 26	FC8-0569-000	400 - 2
FC7-6082-000	331 - 8	FC7-6289-000	161 - 6	FC8-0576-000	160 - 16
FC7-6091-000	331 - 9	FC7-6295-000	160 - 25	FC8-0577-000	160 - 16
FC7-6098-000	331 - 10	FC7-6296-000	160 - 12	FC8-0578-000	160 - 16
FC7-6101-000	331 - 11	FC7-6297-000	160 - 26	FC8-0579-000	300 - 26
FC7-6106-000	331 - 12	FC7-6298-000	160 - 27	FC8-0580-000	331 - 14
FC7-6107-000	331 - 13	FC7-6299-000	160 - 28	FC8-0581-000	100 - 18
FC7-6108-000	331 - 22	FC7-6300-000	160 - 29	FC8-0584-000	100 - 17
FC7-6109-000	331 - 23	FC7-6310-000	160 - 18	FC8-0594-000	300 - 27
FC7-6117-000	331 - 28	FC7-6320-000	160 - 19	FC8-3601-000	160 - 17
FC7-6118-000	331 - 29	FC7-6321-000	160 - 20	FC8-3602-000	101 - 1
FC7-6125-000	331 - 1	FC7-6827-000	100 - 11	FC8-3603-000	101 - 1
FC7-6126-000	331 - 2	FC7-6828-000	100 - 12	FC8-3604-000	101 - 1
FC7-6127-000	100 - 6	FC7-6832-000	100 - 13	FC8-3605-000	101 - 1
FC7-6128-000	331 - 30	FC7-6833-000	100 - 14	FC8-3607-000	101 - 1
FC7-6129-000	331 - 31	FC7-6845-000	100 - 15	FC8-3609-000	101 - 1
FC7-6130-000	100 - 7	FC7-6846-000	100 - 16	FC8-3610-000	101 - 1

NUMERICAL INDEX

C2110/1022/1021 Series(Numerical Index)

PARTS NUMBER	FIGURE & KEY NO.	PARTS NUMBER	FIGURE & KEY NO.	PARTS NUMBER	FIGURE & KEY NO
FC8-3614-000	101 - 1	FM3-1334-000	160 - 11	FM3-5024-000	900 - 5
FC8-3615-000	101 - 1	FM3-1339-000	160 - 21	FU5-3570-000	331 - 37
FC8-3616-000	101 - 1	FM3-1342-000	161 - 14	FU5-3576-000	400 - 18
FC8-3616-000	101 - 1	FM3-1343-000	161 - 3	FU6-2998-000	161 - 28
FC8-3617-000	101 - 1	FM3-1346-000	331 - 16	FU6-2999-000	161 - 29
FC8-3618-000	101 - 1	FM3-1347-000	331 - 25	FU7-0641-000	331 - 15
FC8-3621-000	101 - 1	FM3-1348-000	331 - 21	FU7-0642-000	331 - 43
FC8-3625-000	101 - 1	FM3-1351-000	400 - 7	FU7-0646-000	331 - 38
FC8-3633-000	130 - 7	FM3-1353-000	400 - 4	FU7-0648-000	331 - 39
FC8-3634-000	130 - 7	FM3-1356-000	400 -	FU7-0650-000	331 - 27
FC8-3635-000	130 - 7	FM3-1360-000	101 -	FU7-0667-000	161 - 17
FC8-3636-000	130 - 7	FM3-1366-000	300 -	FU7-0668-000	161 - 18
FC8-3637-000	130 - 7	FM3-1367-000	106 - 4	FU7-0669-000	161 - 19
FC9-4409-000	130 - 8	FM3-1368-000	106 - 4	FU7-0671-000	161 - 20
FH2-7078-000	106 - 35	FM3-1369-000	106 - 4	FU7-0672-000	160 - 22
FH2-7080-000	106 - 35	FM3-1370-000	310 -	FU7-0676-000	161 - 21
FH2-7082-000	106 - 35	FM3-1373-000	280 -	FU7-0678-000	161 - 22
FK2-5274-000	001 - 3	FM3-1378-000	103 - 26	FU7-2009-000	400 - 19
FK2-5275-000	001 - 1	FM3-1651-000	130 -	FU7-2015-000	161 - 30
FK2-5282-000	400 - 3	FM3-2909-000	107 - 10	FU7-2016-000	160 - 13
FK2-5283-000	107 - 3	FM3-2911-000	105 - 16	FU7-2021-000	161 - 31
FK2-5284-000	107 - 4	FM3-2912-000	161 - 16	FU7-2022-000	161 - 32
FK2-5285-000	900 - 6	FM3-2913-000	130 - 4	HC1-0586-000	160 - 23
FK2-5294-000	161 - 7	FM3-2914-000	130 - 5	HC1-0586-000	161 - 33
FK2-5296-000	107 - 6	FM3-2915-000	105 - 15	HC1-0586-000	400 - 20
FK2-5320-000	106 - 35	FM3-2916-000	900 - 5	HK1-0544-000	001 - 1
FK2-5321-000	001 - 2	FM3-2917-000	900 - 3	HK1-0547-000	001 - 1
FK2-7778-000	001 - 4	FM3-2918-000	900 - 3	HK1-0550-000	001 - 1
FK2-7779-000	001 - 4	FM3-2919-000	900 - 3	HK1-0559-000	001 - 1
FK2-7780-000	001 - 4	FM3-2934-000	105 - 17	HU1-1022-000	160 - 24
FK2-7781-000	001 - 4	FM3-2942-000	900 - 10	HU1-1022-000	161 - 27
FK2-7782-000	001 - 4	FM3-2945-000	900 - 7	NPN	001 -
FK2-7783-000	001 - 4	FM3-2946-000	900 - 8	NPN	100 -
FK2-7784-000	001 - 4	FM3-2947-000	107 - 16	NPN	102 -
FK2-7786-000	001 - 4	FM3-2948-000	107 - 14	NPN	103 -
FK2-7787-000	001 - 4	FM3-2949-000	107 - 15	NPN	104 -
FK2-7789-000	001 - 4	FM3-2959-000	105 - 10	NPN	105 -
FL2-6637-000	160 - 10	FM3-2970-000	106 - 36	NPN	106 -
FL2-6647-000	161 - 9	FM3-2974-000	130 - 4	NPN	107 -
FL2-6649-000	161 - 10	FM3-3818-000	130 -	NPN	330 -
FL2-6660-000	331 - 33	FM3-3819-000	130 -	NPN	331 -
FL2-6664-000	331 - 34	FM3-3820-000	130 -	NPN	900 -
FL2-6665-000	161 - 13	FM3-3821-000	130 -	RC1-6229-030	810 - 1
FL2-6668-000	400 - 17	FM3-3822-000	130 -	RC1-6230-020	810 - 2
FM2-2765-000	107 - 9	FM3-3824-000	130 -	RC1-6234-020	810 - 3
FM2-7753-000	107 - 9	FM3-3825-000	130 -	RC1-6235-000	810 - 4
FM3-1328-000	160 -	FM3-3997-000	331 - 42	RC1-6237-000	810 - 5
FM3-1329-000	160 - 7	FM3-4008-000	900 - 4	RC1-6245-000	810 - 6
FM3-1330-000	161 -	FM3-4009-000	900 - 4	RC1-6254-020	810 - 7
FM3-1331-000	160 - 8	FM3-5021-000	900 - 5	RC1-6257-000	810 - 8
FM3-1332-000	161 - 11	FM3-5022-000	900 - 5	RC1-6258-000	810 - 9
FM3-1333-000	161 - 12	FM3-5023-000	900 - 5	RC1-6259-000	810 - 10

NUMERICAL INDEX

C2110/1022/1021 Series(Numerical Index)

PARTS NUMBER	FIGURE & KEY NO.	PARTS NUMBER	FIGURE & KEY NO.	PARTS NUMBER	FIGURE & KEY NO
RC1-6260-000	810 - 11	RC1-6612-000	106 - 33	RC1-6875-000	102 - 20
RC1-6261-000	810 - 12	RC1-6629-000	102 - 6	RC1-7544-000	103 - 17
RC1-6262-000	810 - 13	RC1-6631-000	102 - 7	RC1-7545-000	103 - 18
RC1-6263-000	810 - 14	RC1-6632-000	102 - 8	RC1-7547-000	102 - 21
RC1-6264-000	810 - 15	RC1-6633-000	102 - 9	RC1-7548-000	102 - 22
RC1-6265-000	810 - 16	RC1-6634-000	102 - 10	RC1-7549-000	102 - 30
RC1-6266-000	810 - 17	RC1-6636-000	102 - 11	RC1-7552-000	104 - 30
RC1-6267-000	810 - 18	RC1-6638-000	104 - 10	RC1-7554-010	104 - 31
RC1-6268-000	810 - 19	RC1-6639-000	104 - 11	RC1-7555-010	104 - 32
RC1-6269-000	810 - 20	RC1-6640-020	102 - 12	RC1-7562-000	104 - 33
RC1-6270-000	810 - 21	RC1-6641-000	102 - 13	RC1-7563-000	104 - 34
RC1-6275-000	810 - 22	RC1-6643-020	102 - 14	RC1-7566-000	104 - 5
RC1-6276-000	810 - 23	RC1-6645-010	104 - 12	RC1-7570-000	300 - 17
RC1-6277-000	810 - 24	RC1-6646-000	104 - 13	RC1-7572-000	810 - 34
RC1-6281-020	810 - 25	RC1-6650-000	104 - 15	RC1-7573-000	810 - 35
RC1-6285-000	810 - 26	RC1-6651-000	103 - 12	RC1-7574-000	810 - 36
RC1-6303-000	810 - 27	RC1-6652-000	106 - 5	RC1-7575-000	810 - 37
RC1-6308-000	810 - 28	RC1-6653-000	106 - 6	RC1-7576-000	103 - 19
RC1-6381-000	315 - 3	RC1-6668-000	103 - 13	RC1-7583-000	102 - 23
RC1-6382-000	315 - 4	RC1-6670-000	104 - 14	RC1-7591-000	104 - 36
RC1-6405-000	104 - 7	RC1-6673-020	104 - 16	RC1-7592-000	104 - 37
RC1-6420-000	104 - 43	RC1-6674-000	104 - 17	RC1-7594-000	102 - 24
RC1-6461-000	300 - 1	RC1-6675-000	104 - 22	RC1-7597-000	103 - 20
RC1-6465-000	300 - 5	RC1-6676-000	104 - 18	RC1-7598-000	103 - 21
RC1-6492-000	300 - 7	RC1-6677-000	102 - 15	RC1-7599-000	107 - 12
RC1-6493-000	300 - 8	RC1-6679-000	102 - 16	RC1-7601-000	300 - 18
RC1-6494-000	300 - 9	RC1-6680-000	104 - 19	RC1-7602-000	300 - 19
RC1-6495-000	300 - 10	RC1-6681-000	106 - 7	RC1-7606-000	810 - 51
RC1-6498-000	300 - 11	RC1-6682-000	103 - 14	RC1-7618-000	102 - 25
RC1-6499-000	104 - 8	RC1-6683-000	104 - 21	RC1-7632-000	810 - 45
RC1-6501-000	106 - 25	RC1-6684-000	104 - 20	RC1-7644-000	300 - 4
RC1-6502-000	104 - 9	RC1-6701-000	102 - 17	RC1-7645-000	300 - 2
RC1-6540-020	300 - 12	RC1-6702-000	102 - 18	RC1-7649-000	300 - 3
RC1-6571-000	102 - 2	RC1-6744-000	104 - 23	RC1-7960-000	102 - 26
RC1-6573-000	102 - 3	RC1-6771-020	103 - 15	RC2-0062-000	101 - 5
RC1-6574-000	102 - 4	RC1-6772-000	106 - 8	RC2-1606-000	300 - 14
RC1-6575-000	102 - 5	RC1-6773-000	106 - 9	RC2-1646-000	810 - 50
RC1-6579-000	103 - 1	RC1-6776-000	104 - 24	RC2-1647-000	810 - 52
RC1-6580-000	103 - 2	RC1-6777-000	104 - 25	RC2-2737-000	100 - 21
RC1-6581-000	103 - 3	RC1-6780-020	300 - 13	RC2-2745-000	104 - 3
RC1-6582-000	103 - 4	RC1-6786-000	104 - 26	RK2-0939-000	104 - 41
RC1-6583-000	103 - 5	RC1-6787-000	300 - 15	RK2-0948-000	331 - 40
RC1-6584-000	103 - 6	RC1-6788-000	300 - 16	RK2-0954-000	101 - 3
RC1-6589-000	103 - 7	RC1-6795-000	104 - 27	RK2-0954-000	102 - 27
RC1-6593-000	103 - 8	RC1-6823-000	103 - 16	RK2-0966-000	106 - 29
RC1-6594-000	103 - 9	RC1-6824-020	102 - 19	RK2-0967-000	106 - 30
RC1-6594-000	270 - 1	RC1-6825-000	106 - 10	RK2-0969-000	107 - 5
RC1-6596-000	103 - 10	RC1-6833-020	104 - 28	RK2-0970-000	107 - 13
RC1-6605-000	103 - 11	RC1-6839-000	810 - 29	RL1-1064-000	104 - 39
RC1-6607-000	107 - 18	RC1-6840-000	810 - 30	RL1-1067-000	104 - 40
RC1-6609-000	310 - 2	RC1-6841-000	810 - 31	RL1-1068-000	104 - 38
RC1-6611-000	106 - 32	RC1-6843-000	810 - 33	RL1-1069-000	104 - 2

NUMERICAL INDEX

C2110/1022/1021 Series(Numerical Index)

PARTS NUMBER	FIGURE & KEY NO.	PARTS NUMBER	FIGURE & KEY NO.	PARTS NUMBER	FIGURE & KEY NO
RL1-1074-000	300 - 20	RU5-0328-000	300 - 21		
RM1-2576-000	106 - 26	VS1-7173-005	900 - 11		
RM1-2578-100	107 - 7	VS1-7173-007	900 - 12		
RM1-2581-000	106 - 11	VS1-7177-002	106 - 21		
RM1-2585-000	103 - 22	VS1-7177-002	331 - 36		
RM1-2586-000	810 - 42	VS1-7177-003	106 - 28		
RM1-2594-000	106 - 31	VS1-7177-003	107 - 11		
RM1-2595-000	106 - 12	VS1-7177-004	106 - 22		
RM1-2597-000	106 - 13	VS1-7177-004	107 - 21		
RM1-2601-000	810 - 47	VS1-7177-004	331 - 41		
RM1-2603-000	104 - 42	VS1-7177-004	400 - 21		
RM1-2605-000	106 - 14	VS1-7177-009	107 - 23		
RM1-2608-000	106 - 15	VS1-7207-003	400 - 22		
RM1-2609-000	106 - 27	VS1-7207-005	107 - 17		
RM1-2610-000	106 - 16	VS1-7207-006	107 - 19		
RM1-2611-000	106 - 17	VS1-7207-009	331 - 35		
RM1-2613-000	106 - 18	VS1-7258-007	106 - 23		
RM1-2614-000	106 - 19	VS1-7258-014	104 - 29		
RM1-2619-000	280 - 1	VS1-7507-010	107 - 20		
RM1-2627-000	103 - 23	WA7-4997-000	900 - 1		
RM1-2632-000	107 - 8	WA7-4998-000	900 - 1		
RM1-2640-000	106 - 20	WA7-5065-000	900 - 1		
RM1-2666-050	810 - 43	WG8-5696-000	161 - 15		
RM1-2667-100	810 - 44	WG8-5696-000	331 - 24		
RM1-2677-000	102 - 28	WG8-5696-000	400 - 5		
RM1-2679-020	260 -	WG8-5696-000	810 - 32		
RM1-2683-020	102 - 29	WP2-5214-000	106 - 34		
RM1-2687-000	270 -	XA9-0476-000	107 - 22		
RM1-2689-000	103 - 25	XA9-0476-000	160 - 14		
RM1-2699-000	310 - 4	XA9-0476-000	400 - 6		
RM1-2702-000	310 - 3	XA9-0685-000	105 - 18		
RM1-2704-000	310 - 6	XA9-1449-000	103 - 28		
RM1-2706-030	300 - 22	XA9-1449-000	106 - 24		
RM1-2707-000	300 - 23	XA9-1449-000	810 - 38		
RM1-2708-000	300 - 24	XA9-1671-000	100 - 22		
RM1-2709-000	300 - 25	XA9-1671-000	102 - 1		
RM1-2710-000	315 - 2	XA9-1671-000	103 - 27		
RM1-2711-040	315 -	XA9-1671-000	104 - 4		
RM1-2718-030	330 - 1	XA9-1671-000	106 - 37		
RM1-2719-000	330 - 2	XA9-1671-000	107 - 2		
RM1-2720-000	265 -	XA9-1671-000	310 - 5		
RM1-2741-000	310 - 1	XA9-1671-000	330 - 3		
RM1-2744-050	810 - 43	XA9-1671-000	331 - 44		
RM1-2746-000	810 - 46	XD2-1100-242	810 - 40		
RM1-2747-030	810 - 48	XD9-0233-010	104 - 35		
RM1-2748-000	810 - 49	XD9-0234-000	810 - 39		
RM1-2751-000	103 - 24	XG9-0572-000	810 - 41		
RM1-4300-000	810 -				
RM1-4301-000	810 - 43				
RM1-4348-020	810 -				
RM1-4349-000	810 -				
RM1-4352-000	330 - 4				

C2110/1022/1021 Catalog)

Series(Parts

iR C2110F

100V F15-1114-000 CRF

FAX model

iR C2110N

100V F15-1115-000 DKC

iR C1021i

230V AU F15-1144-000 CTP

FAX model

230V EUR F15-1194-000 CRE

iR C1021

230V AU F15-1145-000 CTN

Color imageRUNNER C1022i

120V UL F15-1134-000 CTM

FAX model

Color imageRUNNER C1022

120V UL F15-1135-000 CRB

Contents

A1	ASSEMBLY LOCATION DIAGRAM	2-1
A2	OPTION PARTS CATALOG LIST	2-3
001	ACCESSORIES	2-4
100	EXTERNAL COVERS, PANELS, ETC.	2-6
101	FRONT COVER ASSEMBLY	2-8
102	INTERNAL COMPONENTS 1	2-10
103	INTERNAL COMPONENTS 2	2-12
104	INTERNAL COMPONENTS 3	2-14
105	INTERNAL COMPONENTS 4	2-17
106	INTERNAL COMPONENTS 5	2-19
107	INTERNAL COMPONENTS 6	2-22
130	CONTROL PANEL ASSEMBLY	2-24
160	AUTO DOCUMENT FEEDER ASS'Y	2-27
161	ADF PAPER FEED ASSEMBLY	2-30
260	PAPER PICK-UP DRIVE ASS'Y	2-33
265	DUPLEXING FEED DRIVE ASS'Y	2-35
270	DEV. ESTRANGEMENT DRIVE ASS'Y	2-37
280	FIXING DRIVE ASSEMBLY	2-39
300	CASSETTE	2-41
310	PAPER PICK-UP ASSEMBLY	2-43
315	MULTI PURPOSE TRAY ASS'Y	2-45
330	ELECT. TRANSPORT BELT ASS'Y	2-47
331	REVERSE ASSEMBLY	2-49
400	READER ASSEMBLY	2-53
810	FIXING ASS'Y	2-55
900	CONTROLLER BOX ASSEMBLY	2-58
ZZA	MECHANICAL STANDARD PARTS (HOW TO USE)	2-61
ZZB	MECHANICAL STANDARD PARTS (SCREWS)	2-62
ZZC	MECHANICAL STANDARD PARTS (BOLTS)	2-69
ZZD	MECHANICAL STANDARD PARTS (NUTS)	2-70
ZZE	MECHANICAL STANDARD PARTS (WASHERS)	2-71
ZZF	MECHANICAL STANDARD PARTS (RETAINING RINGS)	2-74
ZZG	MECHANICAL STANDARD PARTS (PINS)	2-77
ZZH	MECHANICAL STANDARD PARTS (SPACERS)	2-78

FIGURE A1 ASSEMBLY LOCATION DIAGRAM

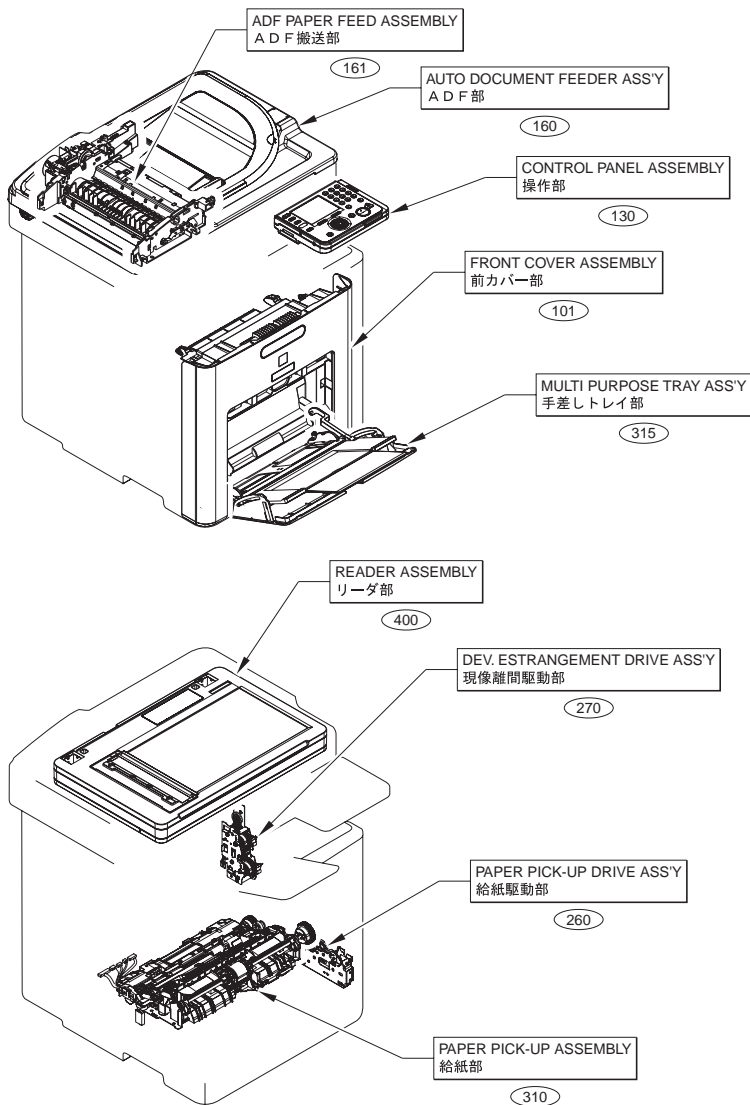

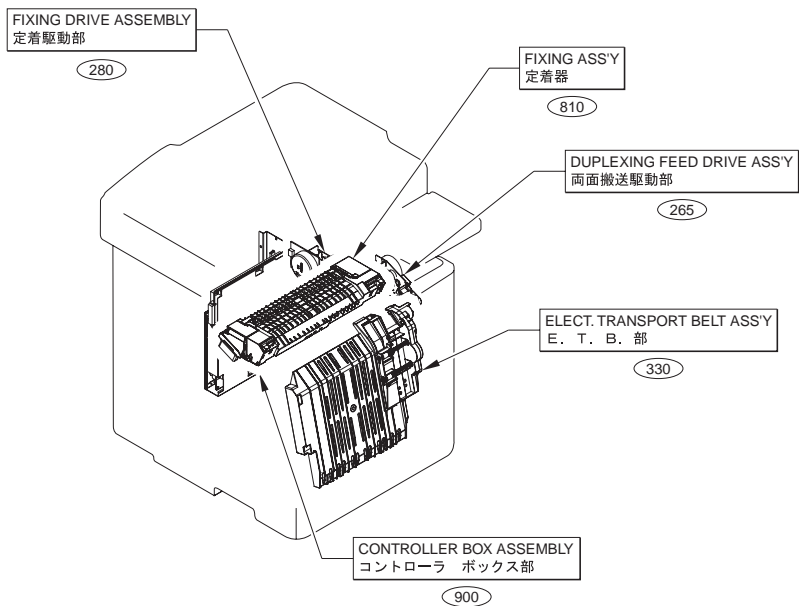
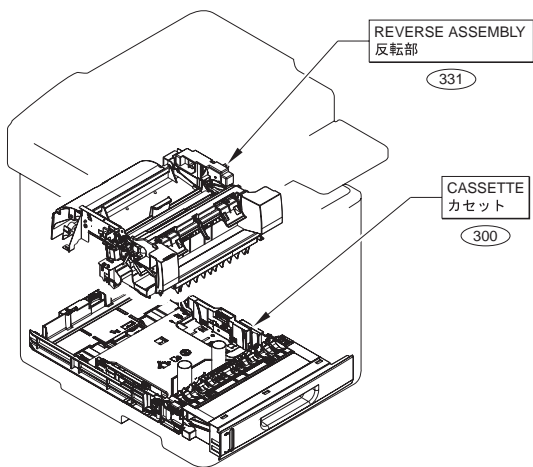

FIGURE A2

OPTION PARTS CATALOG LIST

This is the table of the machine's options whose parts catalog is issued.
本機のオプションで、パーツカタログが発行されている機種の一覧である。

No.	Model Name(English)	Model Name(Japanese)
1	Card Reader-E1	カードリーダー・E1
2	Card Reader Attachment-F1	カードリーダー取り付けキット・F1
3	Super G3 FAX Board-AB1	スーパーG3 FAXボード・AB1
4	HAND SET-J1	ハンドセット・J1
5	Cassette Feeding Unit-AB1	1段カセットベディスタル・AB1

FIGURE 001 ACCESSORIES

JP,GB,US,CA,LTN

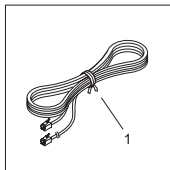

AU

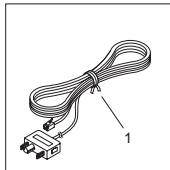

FR

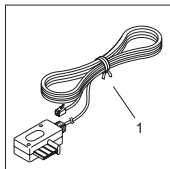

IT

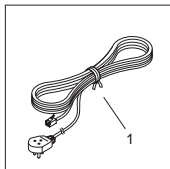

DE

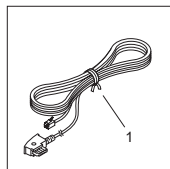

100V

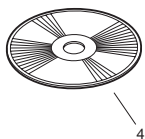
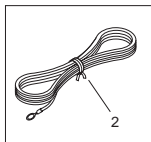

FIGURE & KEY NO.	PARTS NUMBER	RANK	Q'TY	DESCRIPTION	SERIAL NUMBER/REMARKS	SVC
Fig.001	NPN		RF	ACCESSORIES		
1	FK2-5275-000		1	CORD, MODULAR	JP,GB,US,CA,LTN	
1	HK1-0559-000		1	MODULAR CORD	AU	
1	HK1-0547-000		1	MODULAR CORD	FR	
1	HK1-0550-000		1	CORD, MODULAR	IT	
1	HK1-0544-000		1	MODULAR CORD	DE	
2	FK2-5321-000		1	WIRE, GROUNDING	100V	
4	FK2-7786-000		1	CD-ROM, USER SOFTWARE	English,French,Spanish	
4	FK2-7784-000		1	CD-ROM, PCL SOFTWARE	English,French,Italian,German,Spanish	
4	FK2-7779-000		1	CD-ROM, UFR11 LT/FAX SOFTWARE	English	
4	FK2-7787-000		1	CD-ROM, UFR11 LT/FAX SOFTWARE	English,French,Spanish	
4	FK2-7789-000		1	CD-ROM, UFR11 LT/FAX SOFTWARE	French,Italian,German,Spanish	
4	FK2-7783-000		1	CD-ROM, LIPS LX/FAX SOFTWARE	Japanese	
4	FK2-7782-000		1	CD-ROM, CARPS2/FAX SOFTWARE	Japanese	

FIGURE 100
EXTERNAL COVERS, PANELS, ETC.

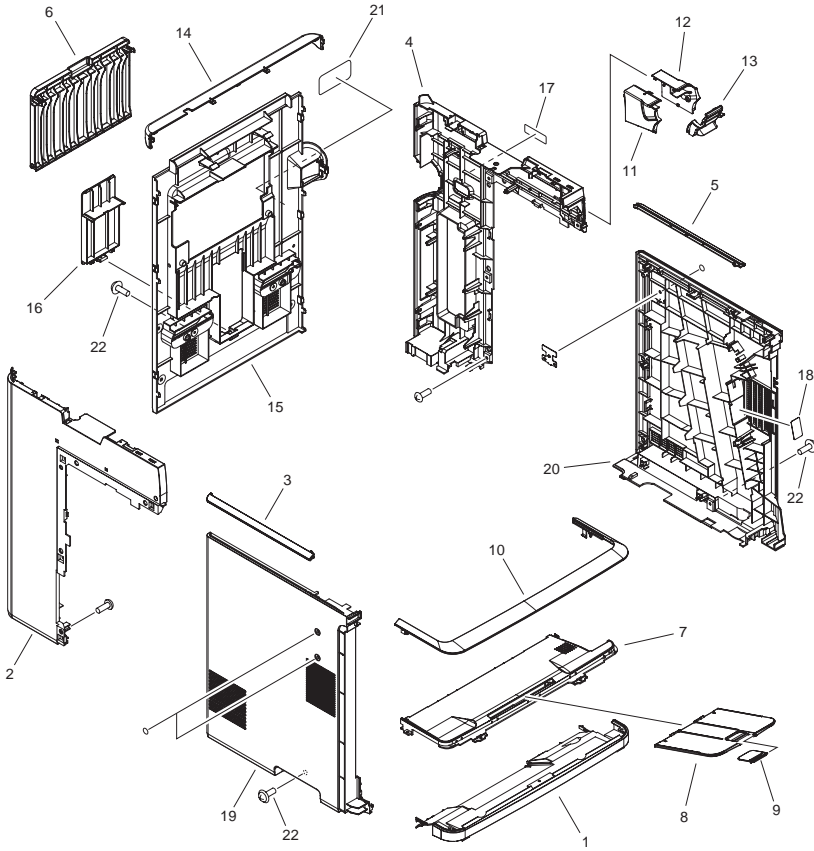
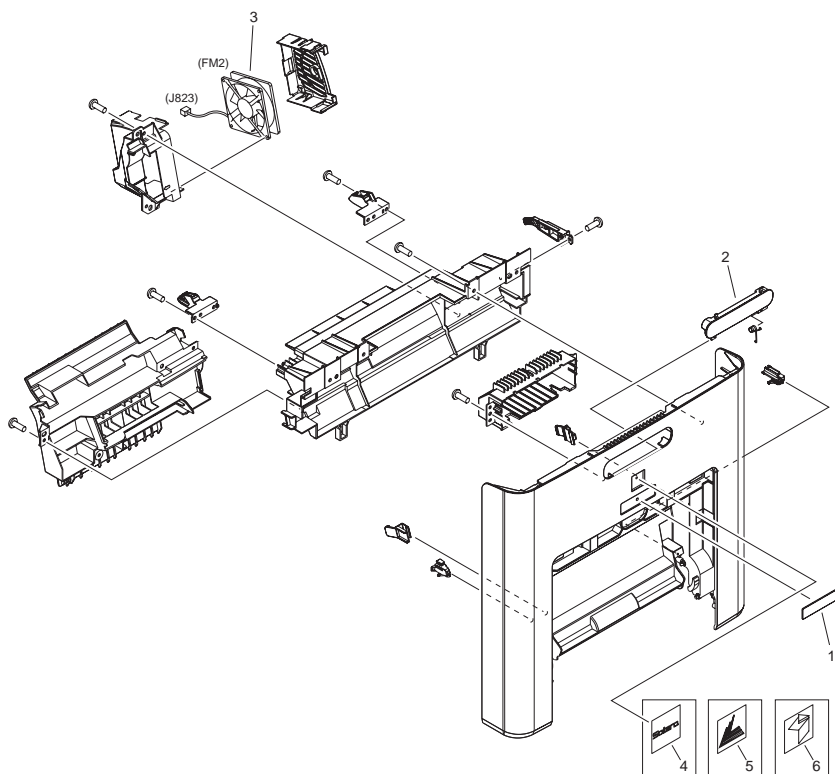

FIGURE & KEY NO.	PARTS NUMBER	RANK	Q'TY	DESCRIPTION	SERIAL NUMBER/REMARKS	SVC
Fig.100	NPN		RF	EXTERNAL COVERS, PANELS, ETC.		
1	FC7-6011-000		1	COVER, FRONT UPPER, 1		
2	FC7-6015-000		1	COVER, LEFT, REAR		
3	FC7-6016-000		1	COVER, LEFT, UPPER		
4	FC7-6018-000		1	COVER, RIGHT, REAR		
5	FC7-6019-000		1	COVER, RIGHT, UPPER		
6	FC7-6127-000		1	COVER, JAM CLEARING		
7	FC7-6130-000		1	COVER, PAPER DELIVERY TRAY		
8	FC7-6132-000		1	TRAY, PAPER DELIVERY EXPANSION		
9	FC7-6133-000		1	STOPPER, PAPER DELIVERY		
10	FC7-6147-000		1	COVER, FRONT UPPER, 2		
11	FC7-6827-000		1	COVER, PANEL STAND, LEFT		
12	FC7-6828-000		1	COVER, PANEL STAND, RIGHT		
13	FC7-6832-000		1	COVER, PANEL STAND, FRONT		
14	FC7-6833-000		1	COVER, READER HINGE		
15	FC7-6845-000		1	COVER, REAR		
16	FC7-6846-000		1	COVER, OPTION RAM		
17	FC8-0584-000		1	LABEL, MAIN POWER SUPPLY		
18	FC8-0581-000		1	LABEL, HIGH TMP. CAUTION		
19	FC7-6014-000		1	COVER, LEFT		
20	FC7-6017-000		1	COVER, RIGHT		
21	RC2-2737-000		1	LABEL, GROUNDING CAUTION	JP	
22	XA9-1671-000		AR	SCREW, D, M3X8		

FIGURE 101 FRONT COVER ASSEMBLY



NOTE : This assembly does not include the part shown with key No. 1.
注 : このユニットにKey No. 1の部品は含まれません。

FIGURE & KEY NO.	PARTS NUMBER	RANK	Q'TY	DESCRIPTION	SERIAL NUMBER/REMARKS	SVC
Fig.101	FM3-1360-000		1	FRONT COVER ASSEMBLY		
1	FC7-6141-000		1	PLATE, NAME	SEE NOTE Color imageRUNNER C1022	
1	FC8-3602-000		1	PLATE, NAME	SEE NOTE Color imageRUNNER C1022i	
1	FC8-3617-000		1	PLATE, NAME	SEE NOTE iR C1021	
1	FC8-3618-000		1	PLATE, NAME	SEE NOTE iR C1021i	
1	FC8-3621-000		1	PLATE, NAME	SEE NOTE iR C2110F	
1	FC8-3625-000		1	PLATE, NAME	SEE NOTE iR C2110N	
2	FC7-6012-000		1	COVER, HANDLE		
3	RK2-0954-000		1	FAN	FM2	
4	FC5-5256-000		1	EMBLEM		
5	RC2-0062-000		1	EMBLEM		
6	FC7-6912-000		1	EMBLEM		

FIGURE 102 INTERNAL COMPONENTS 1

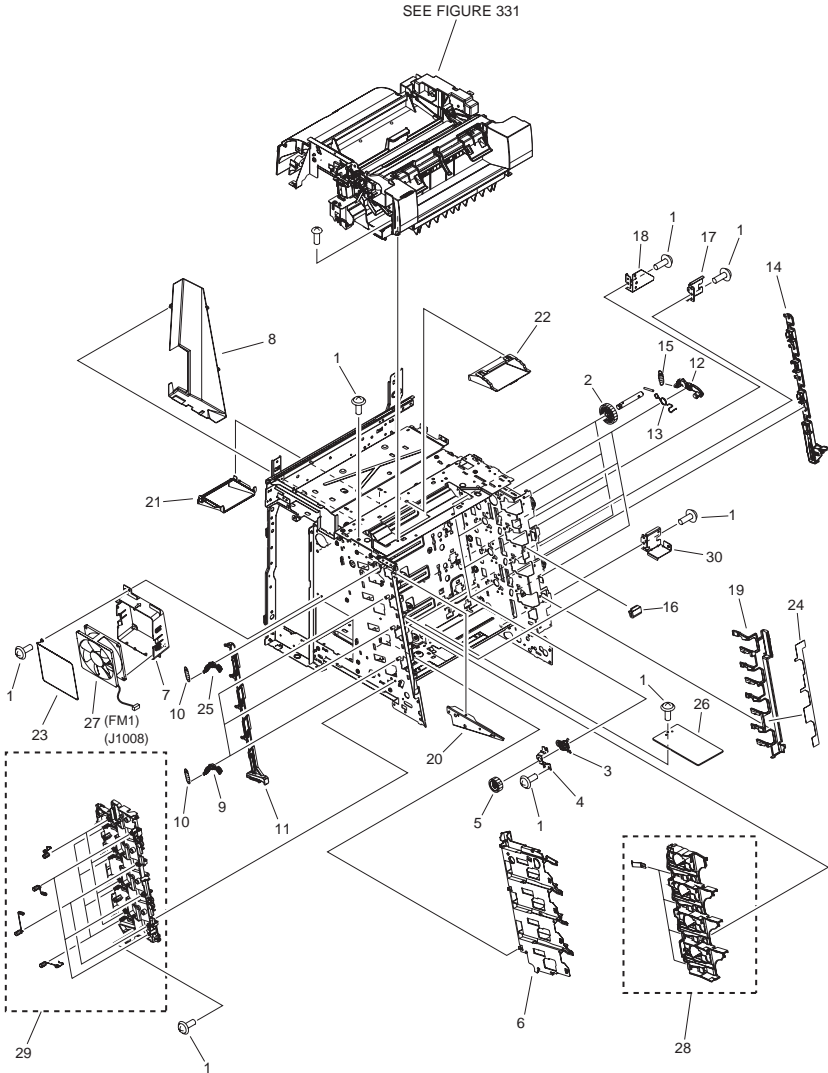

FIGURE & KEY NO.	PARTS NUMBER	RANK	Q'TY	DESCRIPTION	SERIAL NUMBER/REMARKS	SVC
Fig.102	NPN		RF	INTERNAL COMPONENTS 1		
1	XA9-1671-000		AR	SCREW, D, M3X8		
2	RC1-6571-000		4	GEAR, 58T		
3	RC1-6573-000		4	BUSHING		
4	RC1-6574-000		4	BASE, DEV. OUTPUT GEAR		
5	RC1-6575-000		4	GEAR, 29T		
6	RC1-6629-000		1	GUIDE, CARTRIDGE, LEFT		
7	RC1-6631-000		1	HOLDER, FAN		
8	RC1-6632-000		1	DUCT, FAN		
9	RC1-6633-000		3	LEVER, LOCK, LEFT		
10	RC1-6634-000		4	SPRING, TENSION		
11	RC1-6636-000		1	LEVER, LOCK SLIDE, LEFT		
12	RC1-6640-020		4	LEVER, LOCK, RIGHT		
13	RC1-6641-000		4	SPRING, GROUNDING		
14	RC1-6643-020		1	LEVER, LOCK SLIDE, RIGHT		
15	RC1-6677-000		4	SPRING, TENSION		
16	RC1-6679-000		2	COVER, LOCK CLAW		
17	RC1-6701-000		1	SUPPORT, RIGHT LOWER, REAR		
18	RC1-6702-000		1	BRACKET, RIGHT REAR		
19	RC1-6824-020		1	COVER, SIDE PLATE, RIGHT		
20	RC1-6875-000		1	PLATE, REINFORCEMENT, LEFT		
21	RC1-7547-000		1	DUCT, 2		
22	RC1-7548-000		1	DUCT, 3		
23	RC1-7583-000		1	SPRING, GROUNDING		
24	RC1-7594-000		1	LABEL, CARTRIDGE POSITIONING		
25	RC1-7618-000		1	LEVER, LOCK, LEFT UPPER		
26	RC1-7960-000		1	COVER, BASE		
27	RK2-0954-000		1	FAN	FM1	
28	RM1-2677-000		1	CARTRIDGE GUIDE RIGHT ASSY		
29	RM1-2683-020		1	CONTACT HOLDER ASS'Y		
30	RC1-7549-000		1	CROSSMEMBER, RIGHT LOWER, FR.		

FIGURE 103 INTERNAL COMPONENTS 2

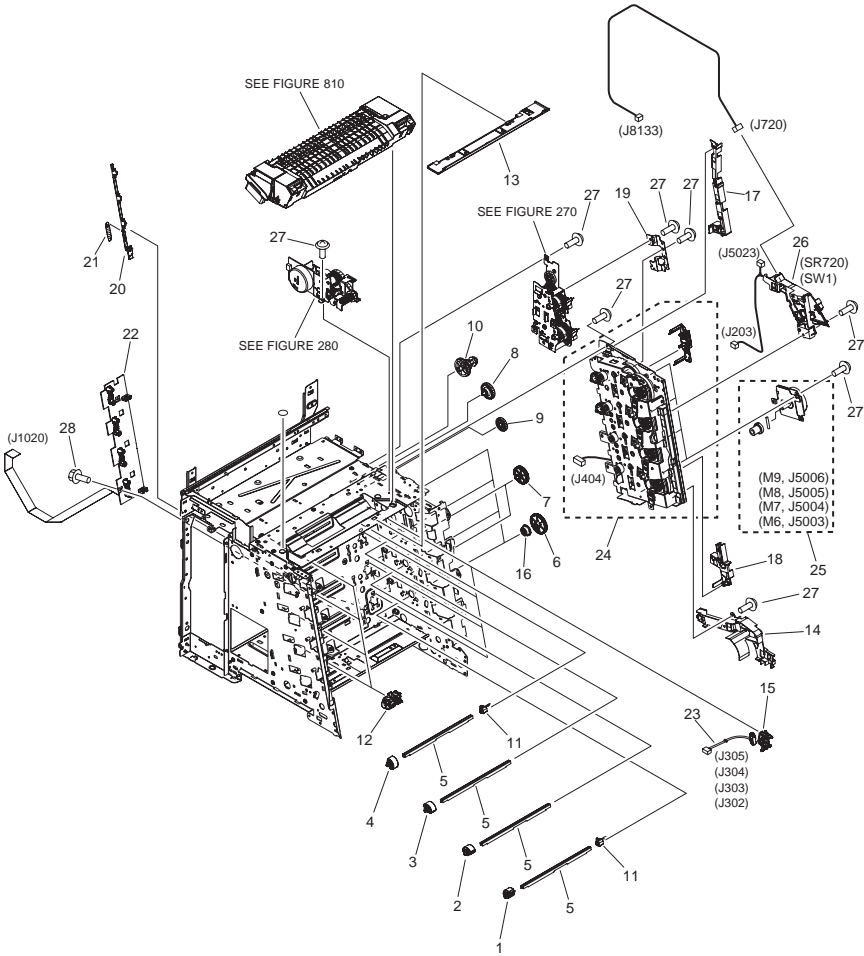

FIGURE & KEY NO.	PARTS NUMBER	RANK	Q'TY	DESCRIPTION	SERIAL NUMBER/REMARKS	SVC
Fig.103	NPN		RF	INTERNAL COMPONENTS 2		
1	RC1-6579-000		1	CAM, DEV.ESTRANGEMENT, 1		
2	RC1-6580-000		1	CAM, DEV.ESTRANGEMENT, 2		
3	RC1-6581-000		1	CAM, DEV.ESTRANGEMENT, 3		
4	RC1-6582-000		1	CAM, DEV.ESTRANGEMENT, 4		
5	RC1-6583-000		4	SHAFT, DEV.ESTRANGEMENT		
6	RC1-6584-000		4	CAM/GEAR, 48T		
7	RC1-6589-000		2	GEAR, 41T		
8	RC1-6593-000		1	GEAR, 19T/30T		
9	RC1-6594-000		1	GEAR, 31T		
10	RC1-6596-000		1	GEAR, 17T/41T		
11	RC1-6605-000		2	FLAG, DEV.ESTRANGEMENT		
12	RC1-6651-000		4	COVER, SHUTTER, LEFT		
13	RC1-6668-000		1	COVER, CROSSMEMBER, UPPER		
14	RC1-6682-000		1	GUIDE, CABLE, RIGHT, 1		
15	RC1-6771-020		4	HOLDER, TONER CARTRIDGE		
16	RC1-6823-000		4	BUSHING		
17	RC1-7544-000		1	GUIDE, CABLE, RIGHT, 3		
18	RC1-7545-000		1	GUIDE, CABLE, RIGHT, 4		
19	RC1-7576-000		1	CROSSMEMBER, DRIVE SIDE PLATE		
20	RC1-7597-000		1	LEVER, SENSING		
21	RC1-7598-000		1	SPRING, TENSION		
22	RM1-2585-000		1	CARTRIDGE SENSOR PCB ASSY		
23	RM1-2627-000		4	CABLE, TAG MEMORY		
24	RM1-2751-000		1	MAIN DRIVE ASSY		
25	RM1-2689-000		4	DRIVE MOTOR ASSY		
26	FM3-1378-000		1	INTERLOCK SWITCH ASSEMBLY	SW1,SR720	
27	XA9-1671-000		AR	SCREW, D, M3X8		
28	XA9-1449-000		3	SCREW, RS, M3X8		

FIGURE 104
INTERNAL COMPONENTS 3

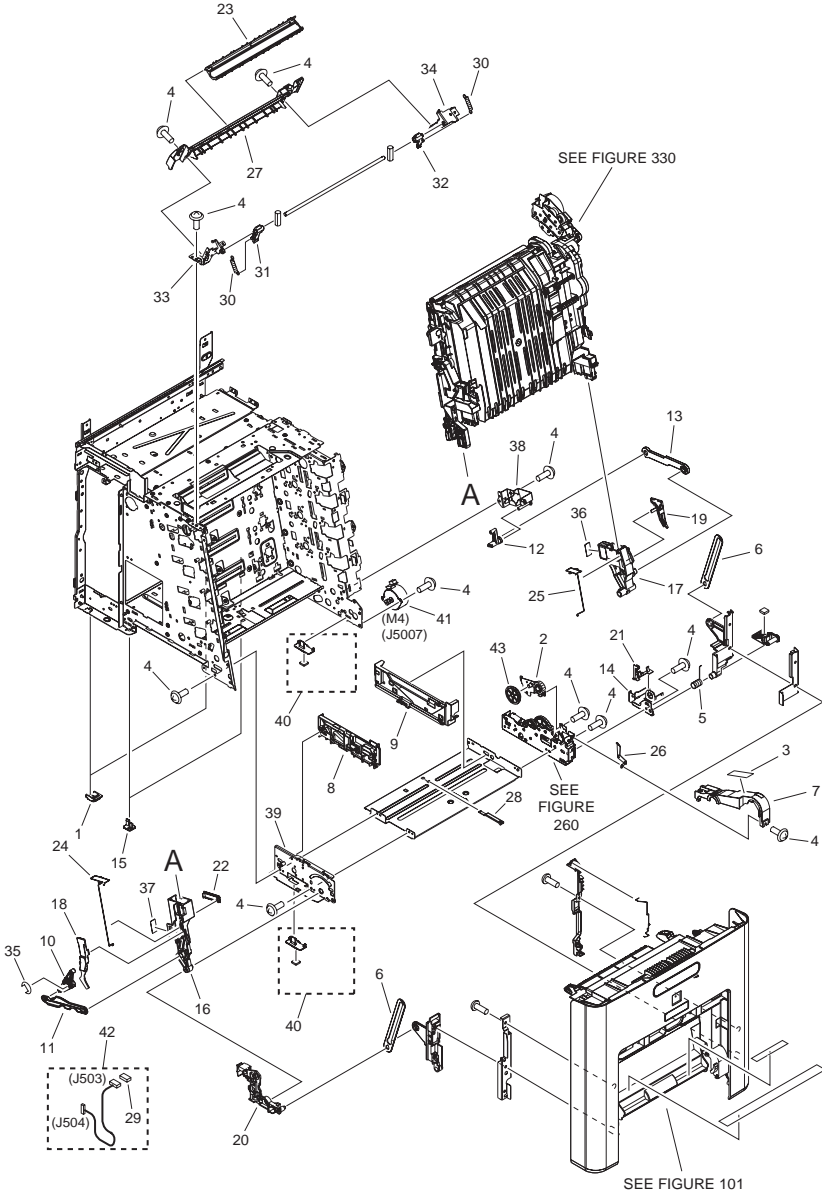

FIGURE & KEY NO.	PARTS NUMBER	RANK	Q'TY	DESCRIPTION	SERIAL NUMBER/REMARKS	SVC
Fig.104	NPN		RF	INTERNAL COMPONENTS 3		
1	FC7-6008-000		2	FOOT, REAR		
2	RL1-1069-000		1	PLATE, GEAR, 3		
3	RC2-2745-000		1	LABEL, JAM CLEARING		
4	XA9-1671-000		AR	SCREW, D, M3X8		
5	RC1-7566-000		1	SPRING, COMPRESSION		
6	FC7-6165-000		2	ARM		
7	RC1-6405-000		1	COVER, GEAR		
8	RC1-6499-000		1	GUIDE, CASSETTE FRONT, LEFT		
9	RC1-6502-000		1	GUIDE, CASSETTE FRONT, RIGHT		
10	RC1-6638-000		1	CAM, SLIDE, LEFT		
11	RC1-6639-000		1	ROD, LINK, LEFT		
12	RC1-6645-010		1	CAM, SLIDE, RIGHT		
13	RC1-6646-000		1	ROD, LINK, RIGHT		
14	RC1-6670-000		1	MOUNT, HINGE, RIGHT		
15	RC1-6650-000		2	FOOT, REAR		
16	RC1-6673-020		1	HOLDER, E.T.B., LEFT		
17	RC1-6674-000		1	HOLDER, E.T.B., RIGHT		
18	RC1-6676-000		1	COVER, E.T.B. HOLDER, LEFT		
19	RC1-6680-000		1	COVER, E.T.B. HOLDER, RIGHT		
20	RC1-6684-000		1	MOUNT, HINGE, LEFT		
21	RC1-6683-000		1	GUIDE, CABLE, RIGHT 2		
22	RC1-6675-000		1	COVER, CONNECTOR		
23	RC1-6744-000		1	GUIDE, DUPLEXING EXTERNAL		
24	RC1-6776-000		1	SPRING, GROUNDING		
25	RC1-6777-000		1	SPRING, GROUNDING		
26	RC1-6786-000		1	PLATE, GROUNDING		
27	RC1-6795-000		1	COVER, GUIDE CROSSMEMBER		
28	RC1-6833-020		1	PLATE, PLATE LOCK RELEASE, MD.		
29	VS1-7258-014		1	CONNECTOR, DRAWER		
30	RC1-7552-000		2	SPRING, TENSION		
31	RC1-7554-010		1	LATCH, LEFT		

FIGURE & KEY NO.	PARTS NUMBER	RANK	Q'TY	DESCRIPTION	SERIAL NUMBER/REMARKS	SVC
32	RC1-7555-010		1	LATCH, RIGHT		
33	RC1-7562-000		1	HOLDER, TOGGLE, LEFT		
34	RC1-7563-000		1	HOLDER, TOGGLE, RIGHT		
35	XD9-0233-010		1	RING, E		
36	RC1-7591-000		1	LABEL, POSITIONING, RIGHT		
37	RC1-7592-000		1	LABEL, POSITIONING, LEFT		
38	RL1-1068-000		1	SUPPORT, RACK		
39	RL1-1064-000		1	BASE, LEFT FRONT		
40	RL1-1067-000		2	FOOT RUBBER ASS'Y, FRONT		
41	RK2-0939-000		1	MOTOR, DC24V, 9W	M4	
42	RM1-2603-000		1	CABLE, SENSOR		
43	RC1-6420-000		1	GEAR, 26T/34T		

FIGURE 105 INTERNAL COMPONENTS 4

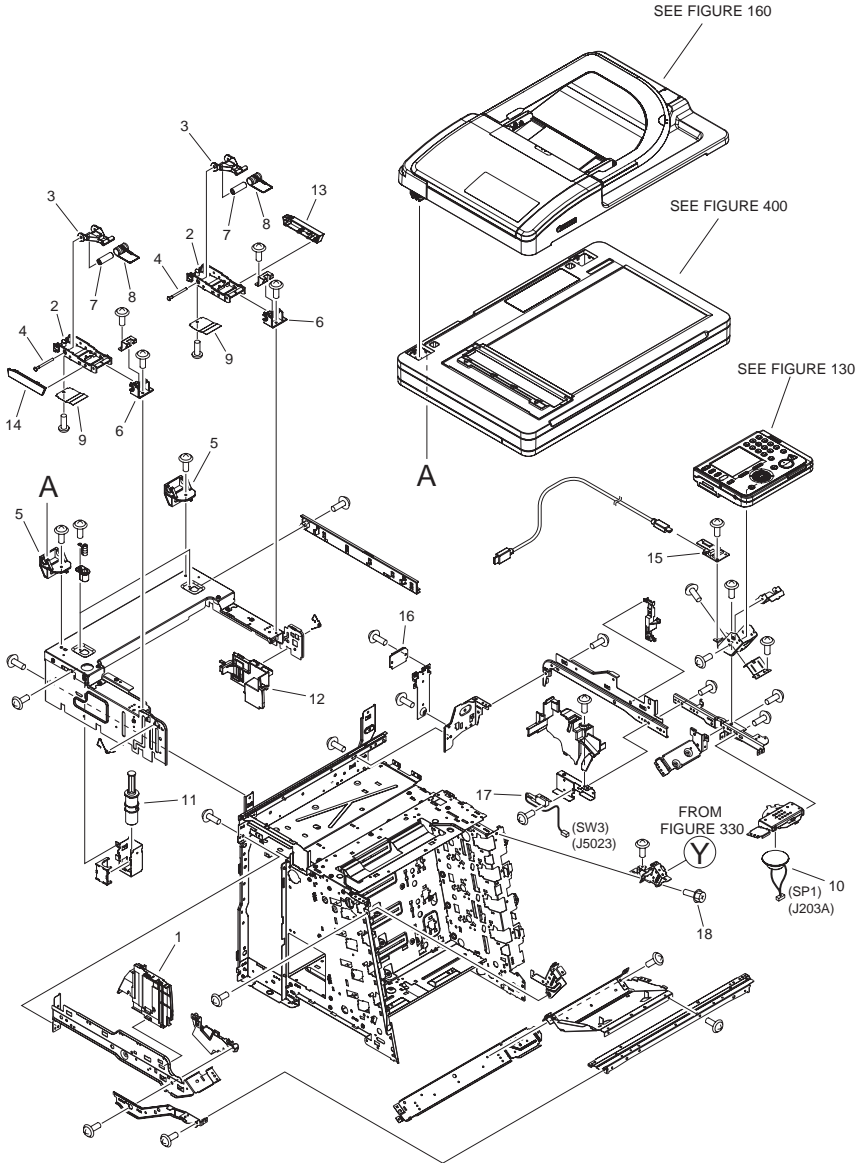

FIGURE & KEY NO.	PARTS NUMBER	RANK	Q'TY	DESCRIPTION	SERIAL NUMBER/REMARKS	SVC
Fig.105	NPN		RF	INTERNAL COMPONENTS 4		
1	FC7-6009-000		1	COVER, INNER, LEFT		
2	FC7-6029-000		2	LINK, 1		
3	FC7-6030-000		2	LINK, 2		
4	FC7-6031-000		2	SHAFT, LINK		
5	FC7-6032-000		2	HINGE, READER		
6	FC7-6033-000		2	BUSHING		
7	FC7-6034-000		2	ROLLER, LINK		
8	FC7-6035-000		2	SPRING, TORSION		
9	FC7-6036-000		2	STOPPER, LINK		
10	FM3-2959-000		1	SPEAKER UNIT	SP1	
11	FC7-6142-000		1	DAMPER UNIT, AIR		
12	FC7-6156-000		1	COVER, INNER, RIGHT		
13	FC7-6167-000		1	COVER, LINK, RIGHT		
14	FC7-6168-000		1	COVER, LINK, LEFT		
15	FM3-2915-000		1	CONNECTING PCB ASSEMBLY		
16	FM3-2911-000		1	CCD CONNECTING PCB ASSEMBLY		
17	FM3-2934-000		1	CABLE, SWITCH	SW3	
18	XA9-0685-000		1	SCREW, M4X6 SWCH		

FIGURE & KEY NO.	PARTS NUMBER	RANK	Q'TY	DESCRIPTION	SERIAL NUMBER/REMARKS	SVC
Fig.106	NPN		RF	INTERNAL COMPONENTS 5		
1	FC7-6145-000		1	SWITCH, POWER SUPPLY		
2	FC7-6148-000		1	COVER, POWER SUPPLY		
3	FC7-6153-000		1	ROD, POWER SUPPLY SWITCH		
4	FM3-1367-000		1	POWER SUPPLY PCB ASS'Y	100V	
4	FM3-1368-000		1	POWER SUPPLY PCB ASS'Y	120V	
4	FM3-1369-000		1	POWER SUPPLY PCB ASS'Y	230V	
5	RC1-6652-000		1	HOLDER, DRAWER CONNECTOR		
6	RC1-6653-000		1	HOLDER, DRAWER		
7	RC1-6681-000		1	GUIDE, CABLE, LEFT		
8	RC1-6772-000		1	GUIDE, FLEXIBLE FLAT CABLE, 1		
9	RC1-6773-000		1	GUIDE, FLEXIBLE FLAT CABLE, 2		
10	RC1-6825-000		1	GUARD, CABLE		
11	RM1-2581-000		1	DRIVER PCB ASS'Y		
12	RM1-2595-000		1	CABLE, ENVIRONMENT SENSOR		
13	RM1-2597-000		1	FIXING UNIT CABLE ASS'Y		
14	RM1-2605-000		1	CABLE, DRIVE POWER		
15	RM1-2608-000		1	CABLE, E.T.B.		
16	RM1-2610-000		1	CABLE, DRUM MOTOR		
17	RM1-2611-000		1	CABLE, SOLENOID		
18	RM1-2613-000		1	CABLE		
19	RM1-2614-000		1	CABLE, DRUM MOTOR		
20	RM1-2640-000		1	SCANNER ASS'Y		
21	VS1-7177-002		2	CONNECTOR, SNAP TIGHT, BK		
22	VS1-7177-004		1	CONNECTOR, SNAP TIGHT, BK		
23	VS1-7258-007		2	CONNECTOR, DRAWER		
24	XA9-1449-000		AR	SCREW, RS, M3X8		
25	RC1-6501-000		1	GUIDE, CASSETTE REAR, LEFT		
26	RM1-2576-000		1	CASSETTE SENSOR PCB ASS'Y		
27	RM1-2609-000		1	CABLE, DUPLEXING DOCKING		
28	VS1-7177-003		1	CONNECTOR, SNAP TIGHT, BK		
29	RK2-0966-000		1	CABLE, SCANNER FLAT		

FIGURE & KEY NO.	PARTS NUMBER	RANK	Q'TY	DESCRIPTION	SERIAL NUMBER/REMARKS	SVC
30	RK2-0967-000		1	CABLE, SCANNER FLAT		
31	RM1-2594-000		1	CABLE, SCANNER		
32	RC1-6611-000		1	COVER, PAPER SENSOR		
33	RC1-6612-000		1	COVER, REGISTRATION SENSOR		
34	WP2-5214-000		1	SENSOR UNIT, TEMPERATURE		
35	FH2-7078-000		1	CORD, POWER SUPPLY	100V JP	
35	FK2-5320-000		1	CORD, POWER SUPPLY	120V UL	
35	FH2-7080-000		1	CORD, POWER SUPPLY	230V ASIA, EUR	
35	FH2-7082-000		1	CORD, POWER SUPPLY	230V AU	
36	FM3-2970-000		1	MAIN SWITCH ASSEMBLY	SW4	
37	XA9-1671-000		AR	SCREW, D, M3X8		

FIGURE 107 INTERNAL COMPONENTS 6

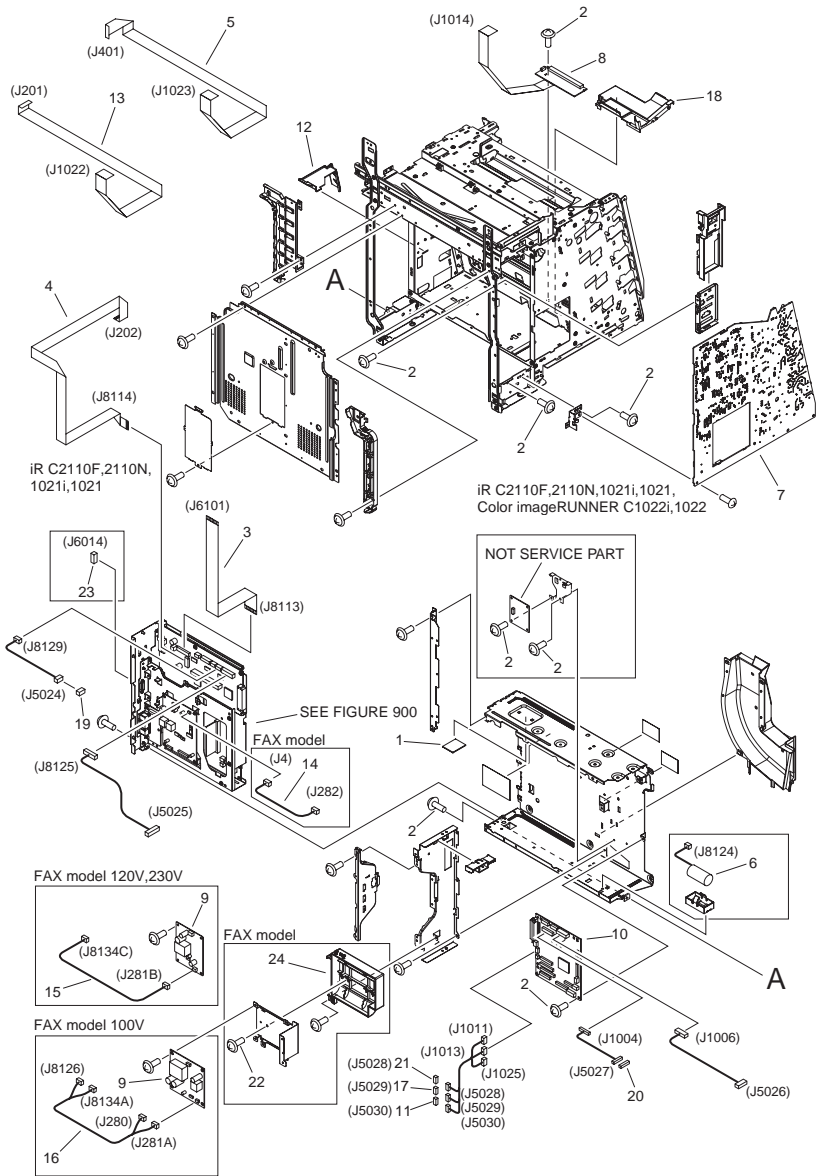
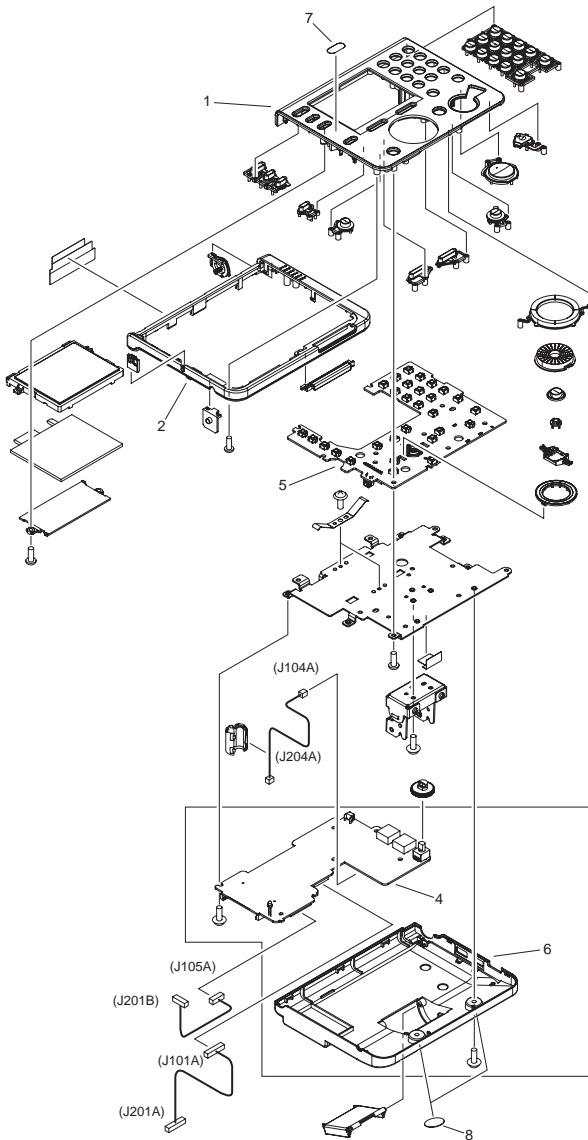

FIGURE & KEY NO.	PARTS NUMBER	RANK	Q'TY	DESCRIPTION	SERIAL NUMBER/REMARKS	SVC
Fig.107	NPN		RF	INTERNAL COMPONENTS 6		
1	FC7-6862-000		1	SPACER		
2	XA9-1671-000		9	SCREW, D, M3X8		
3	FK2-5283-000		1	CABLE, FLAT, 1		
4	FK2-5284-000		1	CABLE, FLAT, 2		
5	RK2-0969-000		1	CABLE, DRIVE FLAT, 1		
6	FK2-5296-000		1	BATTERY, NI-MH		
7	RM1-2578-100		1	HIGH-VOLTAGE PCB ASS'Y		
8	RM1-2632-000		1	RELAY PCB ASS'Y		
9	FM2-7753-000		1	PSEUDO CI PCB ASSEMBLY	FAX model 100V	
9	FM2-2765-000		1	PSEUDO CI PCB ASSEMBLY	FAX model 120V,230V	
10	FM3-2909-000		1	DC CONTROLLER PCB ASSY		
11	VS1-7177-003		1	CONNECTOR, SNAP TIGHT, BK		
12	RC1-7599-000		1	SHIELD, PCB		
13	RK2-0970-000		1	CABLE, DRIVE FLAT, 2		
14	FM3-2948-000		1	CABLE, PSEUDO CI/OFF HOOK	FAX model	
15	FM3-2949-000		1	CABLE, OFF HOOK	FAX model 120V,230V	
16	FM3-2947-000		1	CABLE, FAX	FAX model 100V	
17	VS1-7207-005		1	CONNECTOR, SNAP TIGHT		
18	RC1-6607-000		1	COVER, CONNECTOR		
19	VS1-7207-006		1	CONNECTOR, SNAP TIGHT		
20	VS1-7507-010		1	CONNECTOR, SNAP TIGHT		
21	VS1-7177-004		1	CONNECTOR, SNAP TIGHT, BK		
22	XA9-0476-000		2	SCREW,TP M3X8	FAX model	
23	VS1-7177-009		1	CONNECTOR, SNAP TIGHT	iR C2110F,2110N,1021i,1021	
24	FC7-6852-000		1	COVER, PSEUDO CI	FAX model	

FIGURE 130 CONTROL PANEL ASSEMBLY



NOTE : This assembly does not include the part shown with key No. 7.
 注 : このユニットにKey No. 7の部品は含まれません。

FIGURE & KEY NO.	PARTS NUMBER	RANK	Q'TY	DESCRIPTION	SERIAL NUMBER/REMARKS	SVC
Fig.130	FM3-3820-000		1	CONTROL PANEL ASSEMBLY	iR C2110F,2110N	
Fig.130	FM3-3821-000		1	CONTROL PANEL ASSEMBLY	iR C1021i AU,1021,Color imageRUNNER C1022i,1022	
Fig.130	FM3-3822-000		1	CONTROL PANEL ASSEMBLY	iR C1021i EUR	
1	FC7-7091-000		1	PANEL, CONTROL	iR C2110F,2110N	
1	FC7-7095-000		1	PANEL, CONTROL	iR C1021i AU,1021,Color imageRUNNER C1022i,1022	
1	FC7-7099-000		1	PANEL, CONTROL	iR C1021i EUR	
2	FC7-7090-000		1	COVER, CONTROL	JP	
2	FC8-0540-000		1	COVER, CONTROL	UL,AU,ASIA	
2	FC8-0541-000		1	COVER, CONTROL	EUR	
4	FM3-2913-000		1	CONTROL PANEL PCB ASSEMBLY		
5	FM3-2914-000		1	CONTROL PANEL JOG PCB ASS'Y		
6	FC7-7132-000		1	COVER, CONTROL PANEL, LOWER	iR C1021i AU,1021,Color imageRUNNER C1022i,1022	
6	FC7-7133-000		1	COVER, CONTROL PANEL, LOWER	iR C2110F,2110N,1021i EUR	
7	FC8-3634-000		1	LABEL, CUSTOMIZE	SEE NOTE iR C2110F,2110N	

FIGURE & KEY NO.	PARTS NUMBER	R A N K	Q'TY	DESCRIPTION	SERIAL NUMBER/ REMARKS	S V C
7	FC8-3633-000		1	LABEL, CUSTOMIZE	SEE NOTE iR C1021i AU,1021,Color imageRUNNER C1022i,1022	
7	FC8-3635-000		1	LABEL, CUSTOMIZE	SEE NOTE iR C1021i EUR	
8	FC9-4409-000		2	SHEET, ELES. PREVENTION, REAR		

FIGURE 160 AUTO DOCUMENT FEEDER ASS'Y

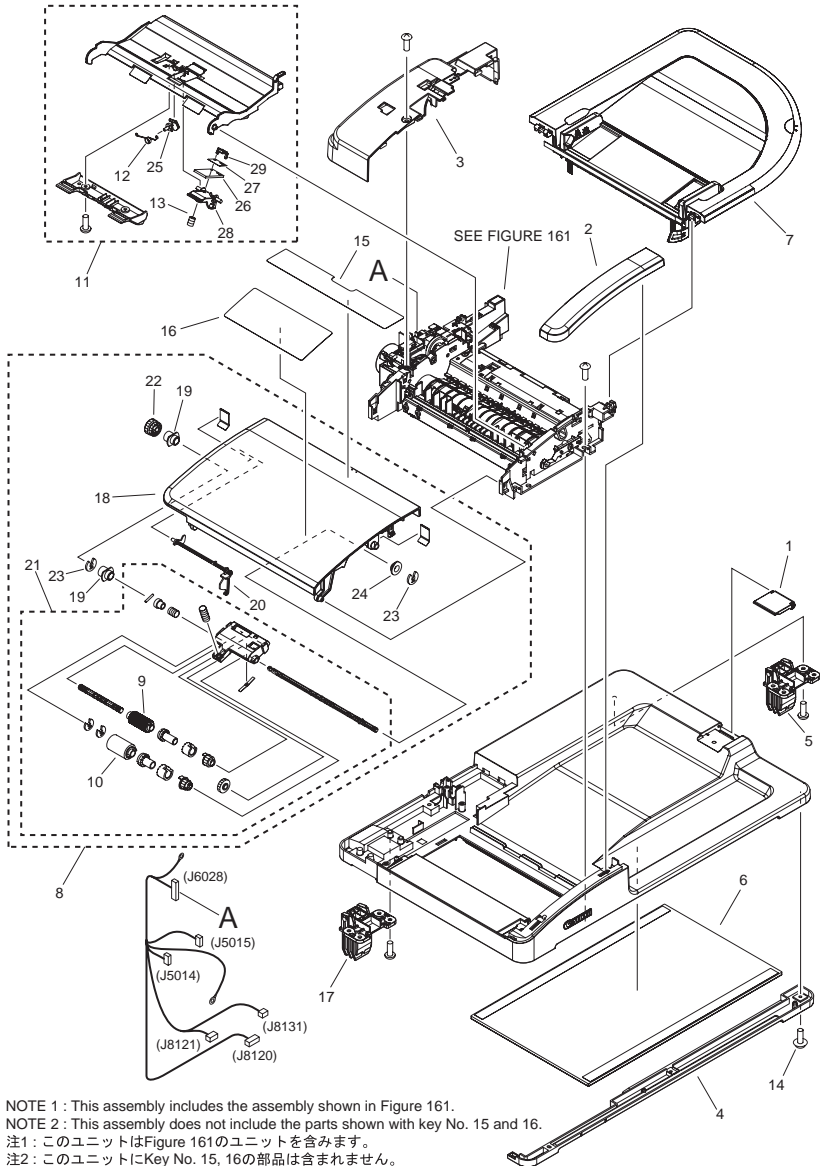

NOTE 1 : This assembly includes the assembly shown in Figure 161.

NOTE 2 : This assembly does not include the parts shown with key No. 15 and 16.

注1 : このユニットはFigure 161のユニットを含みます。

注2 : このユニットにKey No. 15, 16の部品は含まれません。

FIGURE & KEY NO.	PARTS NUMBER	R A N K	Q'TY	DESCRIPTION	SERIAL NUMBER/ REMARKS	S V C
Fig.160	FM3-1328-000		1	AUTO DOCUMENT FEEDER ASS'Y	SEE NOTE 1	
1	FC7-6180-000		1	STOPPER, PAPER DELIVERY		
2	FC7-6262-000		1	PANEL, FRONT		
3	FC7-6263-000		1	PANEL, REAR		
4	FC7-6264-000		1	PANEL, LOWER		
5	FC7-6266-000		1	CASE, HINGE		
6	FC7-6265-000		1	SHEET, WHITE		
7	FM3-1329-000		1	DOCUMENT TRAY ASSEMBLY		
8	FM3-1331-000		1	OPEN/CLOSE PANEL ASSEMBLY		
9	FC7-6189-000		1	ROLLER, PICK-UP		
10	FL2-6637-000		1	ROLLER, SEPARATION		
11	FM3-1334-000		1	UPPER GUIDE ASSEMBLY		
12	FC7-6296-000		1	SPRING, TORSION		
13	FU7-2016-000		1	SPRING, COMPRESSION		
14	XA9-0476-000		3	SCREW,TP M3X8		
15	FC8-0553-000		1	LABEL, DOCUMENT SIZE	SEE NOTE 2 AB SIZE	
15	FC8-0554-000		1	LABEL, DOCUMENT SIZE	SEE NOTE 2 INCH/A SIZE	
15	FC8-0555-000		1	LABEL, DOCUMENT SIZE	SEE NOTE 2 A SIZE	
15	FC8-0556-000		1	LABEL, DOCUMENT SIZE	SEE NOTE 2 INCH/AB SIZE	
16	FC8-0576-000		1	LABEL, GLASS CLEANING	SEE NOTE 2 UL	
16	FC8-0577-000		1	LABEL, GLASS CLEANING	SEE NOTE 2 EUR	
16	FC8-0578-000		1	LABEL, GLASS CLEANING	SEE NOTE 2 JP,AU,ASIA	
17	FC8-3601-000		1	HINGE, LEFT		
18	FC7-6310-000		1	PANEL, OPEN/CLOSE		
19	FC7-6320-000		2	BUSHING		
20	FC7-6321-000		1	FLAG, DOCUMENT SCANNER		
21	FM3-1339-000		1	SEPARATION ROLLER ASSEMBLY		
22	FU7-0672-000		1	GEAR, 24T		
23	HC1-0586-000		2	RETAINING RING (E-TYRE)		
24	HU1-1022-000		1	BUSHING		
25	FC7-6295-000		1	STOPPER, DOCUMENT		

FIGURE & KEY NO.	PARTS NUMBER	R A N K	Q'TY	DESCRIPTION	SERIAL NUMBER/ REMARKS	S V C
26	FC7-6297-000		1	PAD, SEPARATION		
27	FC7-6298-000		1	SHEET, SEPARATION PAD		
28	FC7-6299-000		1	HOLDER, SEPARATION PAD		
29	FC7-6300-000		1	CLAMP, SEPARATION PAD		

FIGURE 161 ADF PAPER FEED ASSEMBLY

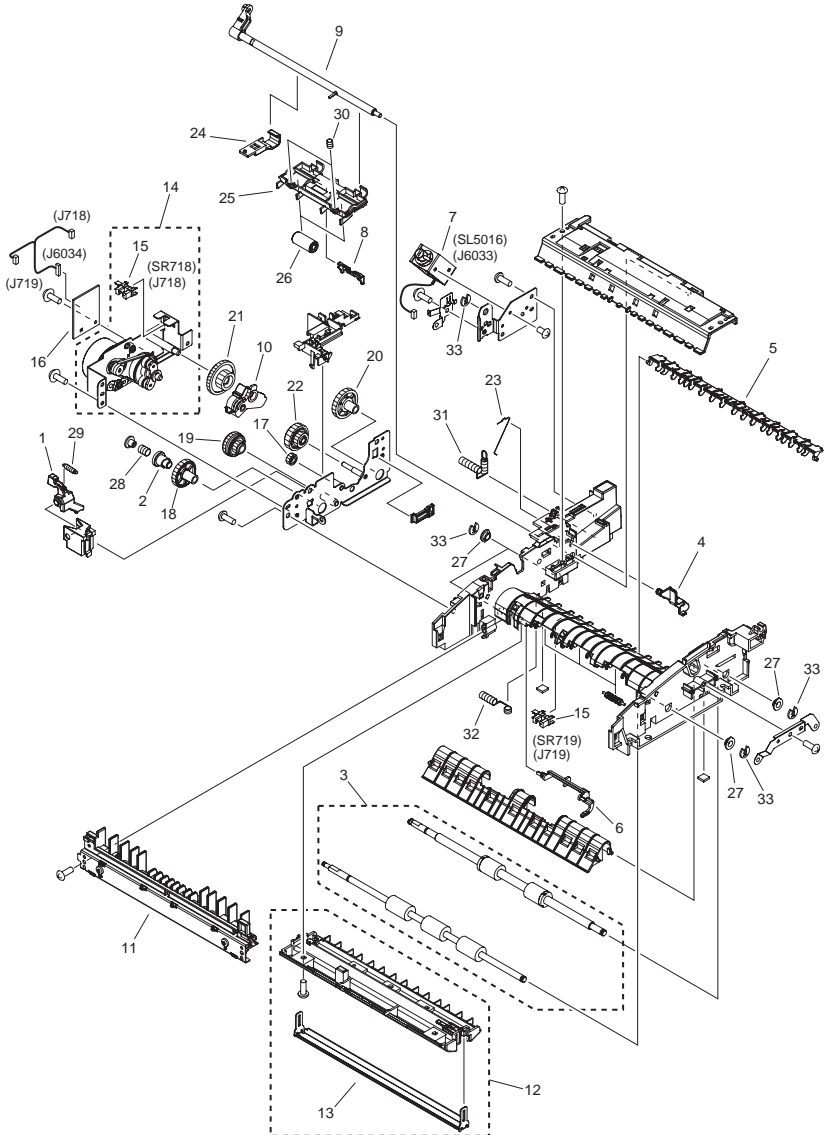

NOTE : This assembly is included in the assembly shown in Figure 160.
 注 : このユニットはFigure 160のユニットに含まれます。

FIGURE & KEY NO.	PARTS NUMBER	R A N K	Q'TY	DESCRIPTION	SERIAL NUMBER/ REMARKS	S V C
Fig.161	FM3-1330-000		1	ADF PAPER FEED ASSEMBLY	SEE NOTE	
1	FC7-6043-000		1	LEVER, DRIVE RELEASE		
2	FC7-6052-000		1	RATCHET, PAPER FEED ROLLER		
3	FM3-1343-000		1	PAPER FEED ROLLER UNIT		
4	FC7-6182-000		1	LEVER, ROLLER RELEASE		
5	FC7-6278-000		1	FLAPPER, PAPER DELIVERY		
6	FC7-6289-000		1	LEVER, DEVELOPER SLIDER		
7	FK2-5294-000		1	SOLENOID	SL5016	
8	FC7-6200-000		1	PLATE, PAPER DELIVERY DOWN		
9	FL2-6647-000		1	SHAFT, PAPER DELIVERY ROLLER		
10	FL2-6649-000		1	ARM, SEPARATION SWING		
11	FM3-1332-000		1	PAPER FEED GUIDE ASSEMBLY		
12	FM3-1333-000		1	LOWER GUIDE ASSEMBLY		
13	FL2-6665-000		1	PLATE, WHITE SHEET		
14	FM3-1342-000		1	DRIVE SUB PLATE ASSEMBLY		
15	WG8-5696-000		2	PHOTO INTERRUPTER, TLP1243	SR718,SR719	
16	FM3-2912-000		1	ADF CONNECTING PCB ASSEMBLY		
17	FU7-0667-000		1	GEAR, 20T		
18	FU7-0668-000		1	GEAR, 54T		
19	FU7-0669-000		1	GEAR, 46T/23T		
20	FU7-0671-000		1	GEAR, 36T		
21	FU7-0676-000		1	GEAR, 21T/42T		
22	FU7-0678-000		1	GEAR, 51T/17T		
23	FC7-6281-000		1	SPRING, ARM		
24	FC7-6284-000		1	CLAMP, DELIVERY ROLLER SHAFT		
25	FC7-6287-000		1	HOLDER, PAPER DELIVERY ROLLER		
26	FC7-6288-000		2	ROLLER, PAPER DELIVERY		
27	HU1-1022-000		4	BUSHING		
28	FU6-2998-000		1	SPRING, COMPRESSION		
29	FU6-2999-000		1	SPRING, TENSION		
30	FU7-2015-000		2	SPRING, COMPRESSION		
31	FU7-2021-000		1	SPRING, COMPRESSION		

FIGURE & KEY NO.	PARTS NUMBER	R A N K	Q'TY	DESCRIPTION	SERIAL NUMBER/ REMARKS	S V C
32	FU7-2022-000		1	SPRING, GROUNDING		
33	HC1-0586-000		5	RETAINING RING		

FIGURE 260
PAPER PICK-UP DRIVE ASS'Y

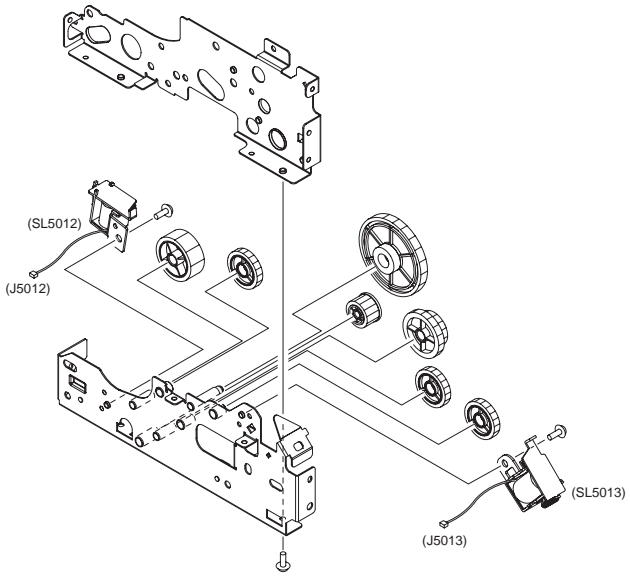

FIGURE & KEY NO.	PARTS NUMBER	R A N K	Q'TY	DESCRIPTION	SERIAL NUMBER/ REMARKS	S V C
Fig.260	RM1-2679-020		1	PAPER PICK-UP DRIVE ASS'Y		

FIGURE & KEY NO.	PARTS NUMBER	R A N K	Q'TY	DESCRIPTION	SERIAL NUMBER/ REMARKS	S V C
Fig.265	RM1-2720-000		1	DUPLEXING FEED DRIVE ASS'Y		

FIGURE 270
DEV. ESTRANGEMENT DRIVE ASS'Y

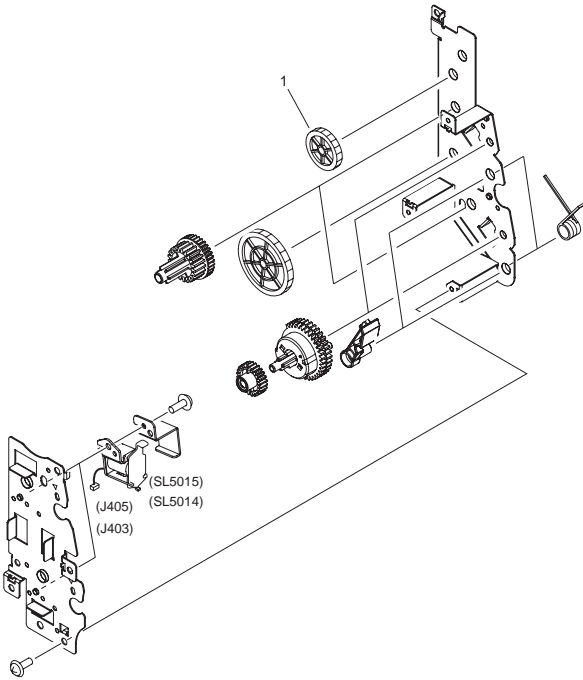

FIGURE & KEY NO.	PARTS NUMBER	RANK	Q'TY	DESCRIPTION	SERIAL NUMBER/REMARKS	SVC
Fig.270	RM1-2687-000		1	DEV. ESTRANGEMENT DRIVE ASS'Y		
1	RC1-6594-000		1	GEAR, 31T		

FIGURE 280 FIXING DRIVE ASSEMBLY

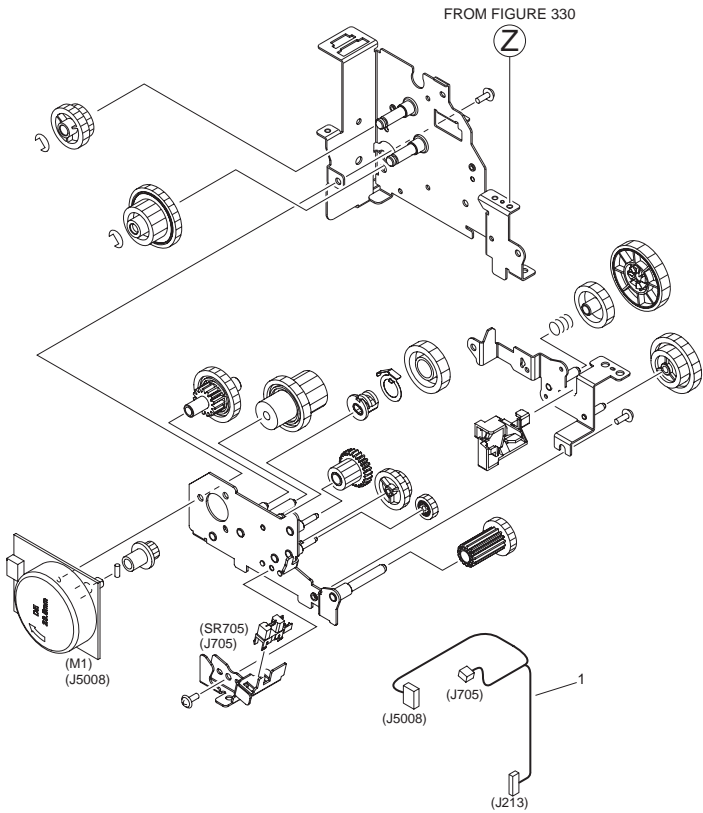
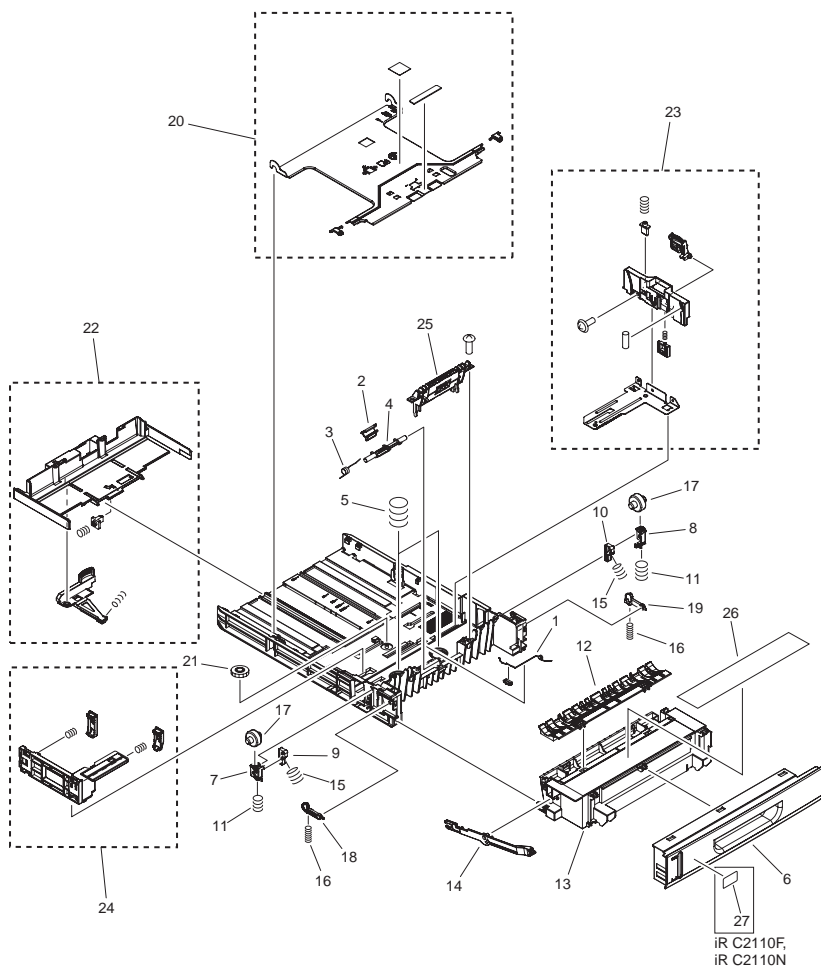

FIGURE & KEY NO.	PARTS NUMBER	RANK	Q'TY	DESCRIPTION	SERIAL NUMBER/REMARKS	SVC
Fig.280	FM3-1373-000		1	FIXING DRIVE ASSEMBLY		
1	RM1-2619-000		1	CABLE, FIXING DRIVE		

FIGURE 300 CASSETTE



NOTE : This assembly does not include the part shown with key No. 27.
 注 : このユニットにKey No. 27の部品は含まれません。

FIGURE & KEY NO.	PARTS NUMBER	RANK	Q'TY	DESCRIPTION	SERIAL NUMBER/REMARKS	SVC
Fig.300	FM3-1366-000		1	CASSETTE		
1	RC1-6461-000		1	SPRING, GROUNDING		
2	RC1-7645-000		1	LOCK, PAPER LIFTING PLATE, 2		
3	RC1-7649-000		1	SPRING, COMPRESSION		
4	RC1-7644-000		1	LOCK, PAPER LIFTING PLATE, 1		
5	RC1-6465-000		2	SPRING, COMPRESSION		
6	FC7-6149-000		1	PANEL, CASSETTE, FRONT		
7	RC1-6492-000		1	CAM, LEFT		
8	RC1-6493-000		1	CAM, RIGHT		
9	RC1-6494-000		1	RACK, LEFT		
10	RC1-6495-000		1	RACK, RIGHT		
11	RC1-6498-000		2	SPRING, COMPRESSION		
12	RC1-6540-020		1	GUIDE, CASSETTE PAPER		
13	RC1-6780-020		1	FRAME, CASSETTE, FRONT		
14	RC2-1606-000		1	ARM, REMNANT INDICATION		
15	RC1-6787-000		2	SPRING, COMPRESSION		
16	RC1-6788-000		2	SPRING, COMPRESSION		
17	RC1-7570-000		2	ROLLER, CAM		
18	RC1-7601-000		1	STOPPER, CASSETTE, LEFT		
19	RC1-7602-000		1	STOPPER, CASSETTE, RIGHT		
20	RL1-1074-000		1	PLATE, PAPER LIFTING		
21	RU5-0328-000		1	GEAR, 10T		
22	RM1-2706-030		1	BACK END LIMIT ASS'Y		
23	RM1-2707-000		1	PAPER SIDE END RIGHT ASS'Y		
24	RM1-2708-000		1	PAPER SIDE END LEFT ASS'Y		
25	RM1-2709-000		1	SEPARATION HOLDER ASS'Y		
26	FC8-0579-000		1	LABEL, CONTROL PANEL		
27	FC8-0594-000		1	LABEL, CASSETTE SIZE	SEE NOTE iR C2110F,2110N	

FIGURE 310
PAPER PICK-UP ASSEMBLY

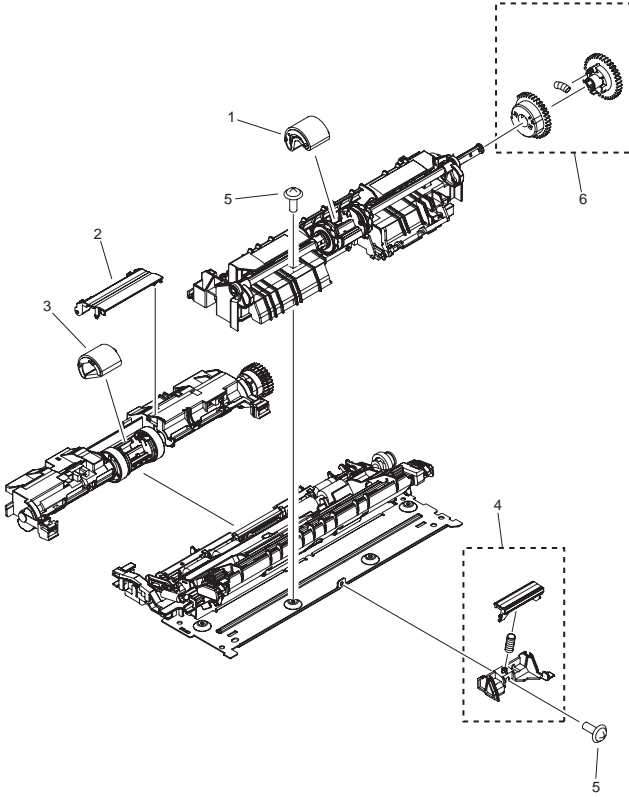

FIGURE & KEY NO.	PARTS NUMBER	RANK	Q'TY	DESCRIPTION	SERIAL NUMBER/REMARKS	SVC
Fig.310	FM3-1370-000		1	PAPER PICK-UP ASSEMBLY		
1	RM1-2741-000		1	M.P. PICK-UP ROLLER ASS'Y		
2	RC1-6609-000		1	COVER, CASSETTE ROLLER		
3	RM1-2702-000		1	CST. PICK-UP ROLLER ASS'Y		
4	RM1-2699-000		1	MULTI-PURPOSE SEP. PAD ASS'Y		
5	XA9-1671-000		5	SCREW, D, M3X8		
6	RM1-2704-000		1	M.P. PAPER PICK-UP GEAR ASS'Y		

FIGURE 315
MULTI PURPOSE TRAY ASS'Y

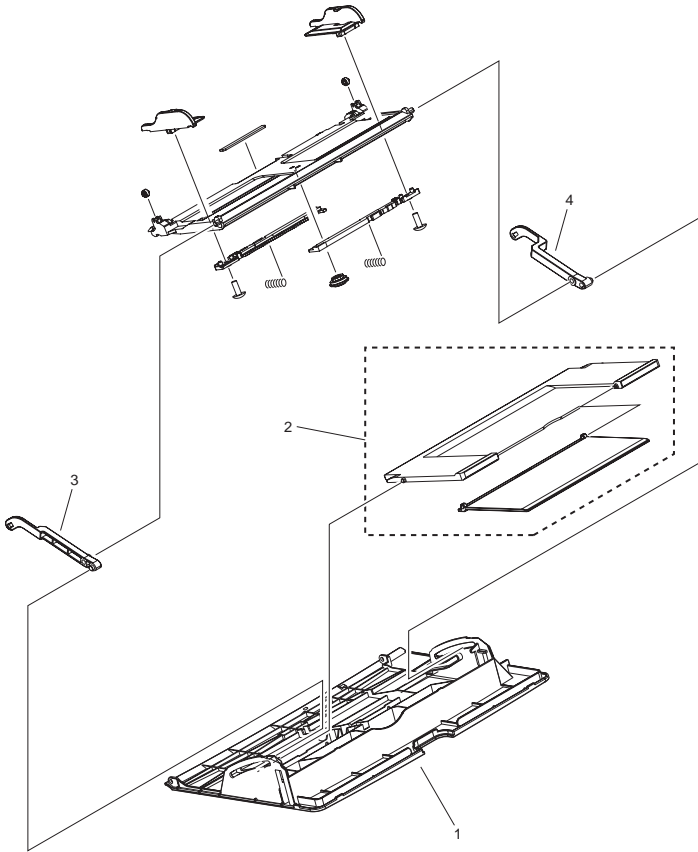

FIGURE & KEY NO.	PARTS NUMBER	RANK	Q'TY	DESCRIPTION	SERIAL NUMBER/REMARKS	SVC
Fig.315	RM1-2711-040		1	MULTI PURPOSE TRAY ASS'Y		
1	FC7-6013-000		1	COVER, MULTI FEED		
2	RM1-2710-000		1	M.P. EXTENSION TRAY ASS'Y		
3	RC1-6381-000		1	LINK, M.P. HINGE, LEFT		
4	RC1-6382-000		1	LINK, M.P. HINGE, RIGHT		

FIGURE 330 ELECT. TRANSPORT BELT ASS'Y

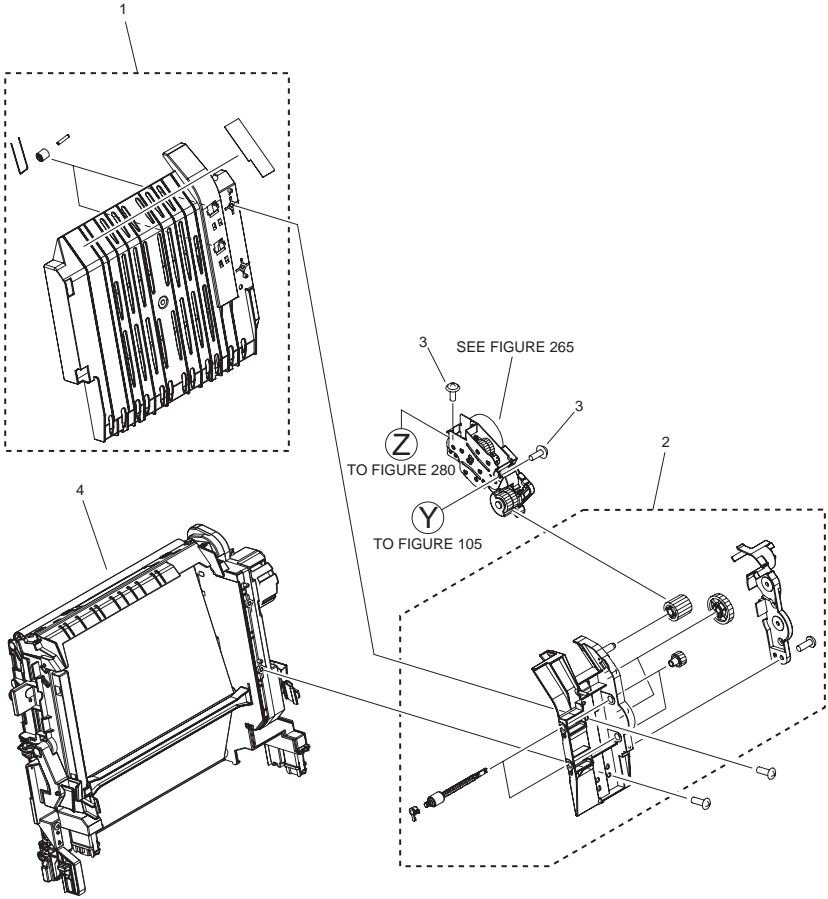
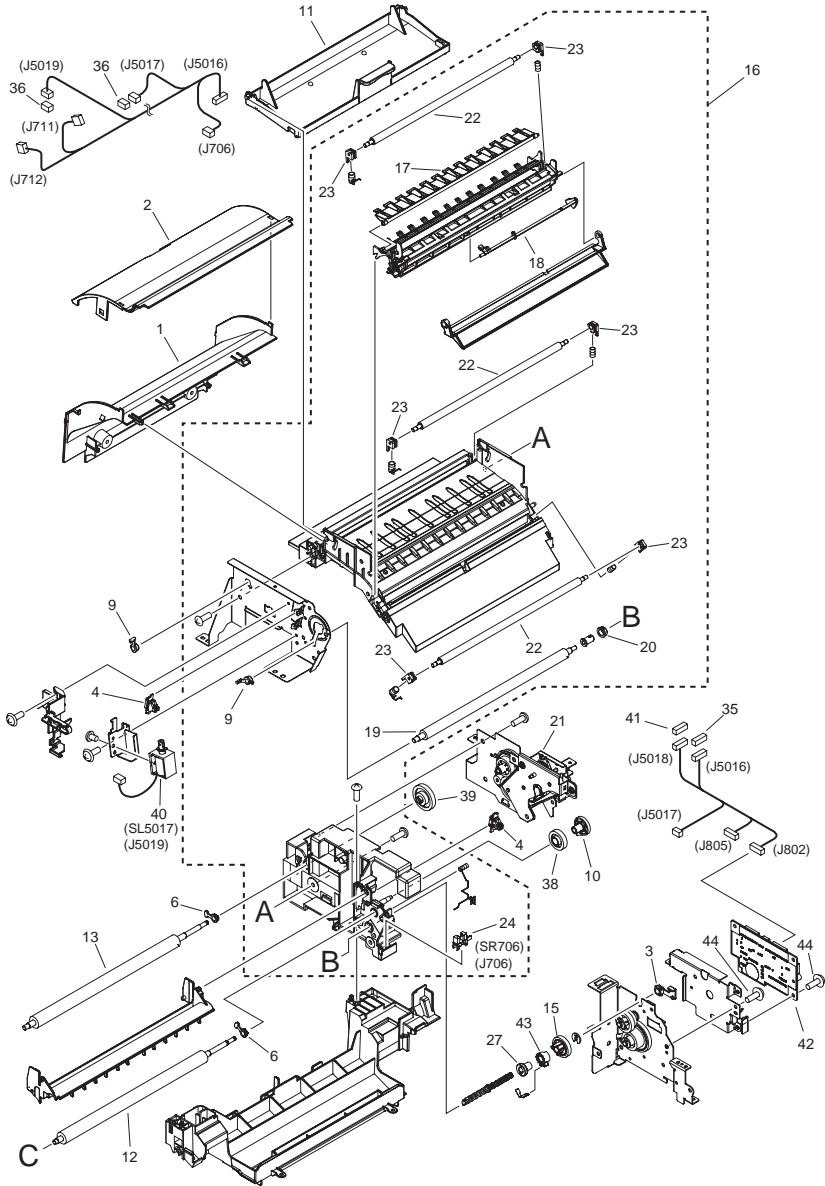

FIGURE & KEY NO.	PARTS NUMBER	RANK	Q'TY	DESCRIPTION	SERIAL NUMBER/REMARKS	SVC
Fig.330	NPN		RF	ELECT. TRANSPORT BELT ASS'Y		
1	RM1-2718-030		1	DUPLEXING PAPER FEED ASS'Y		
2	RM1-2719-000		1	PAPER FEED GUIDE ASSEMBLY		
3	XA9-1671-000		3	SCREW, D. M3X8		
4	RM1-4352-000		1	ELECT. TRANSPORT BELT ASS'Y		

FIGURE 331 REVERSE ASSEMBLY



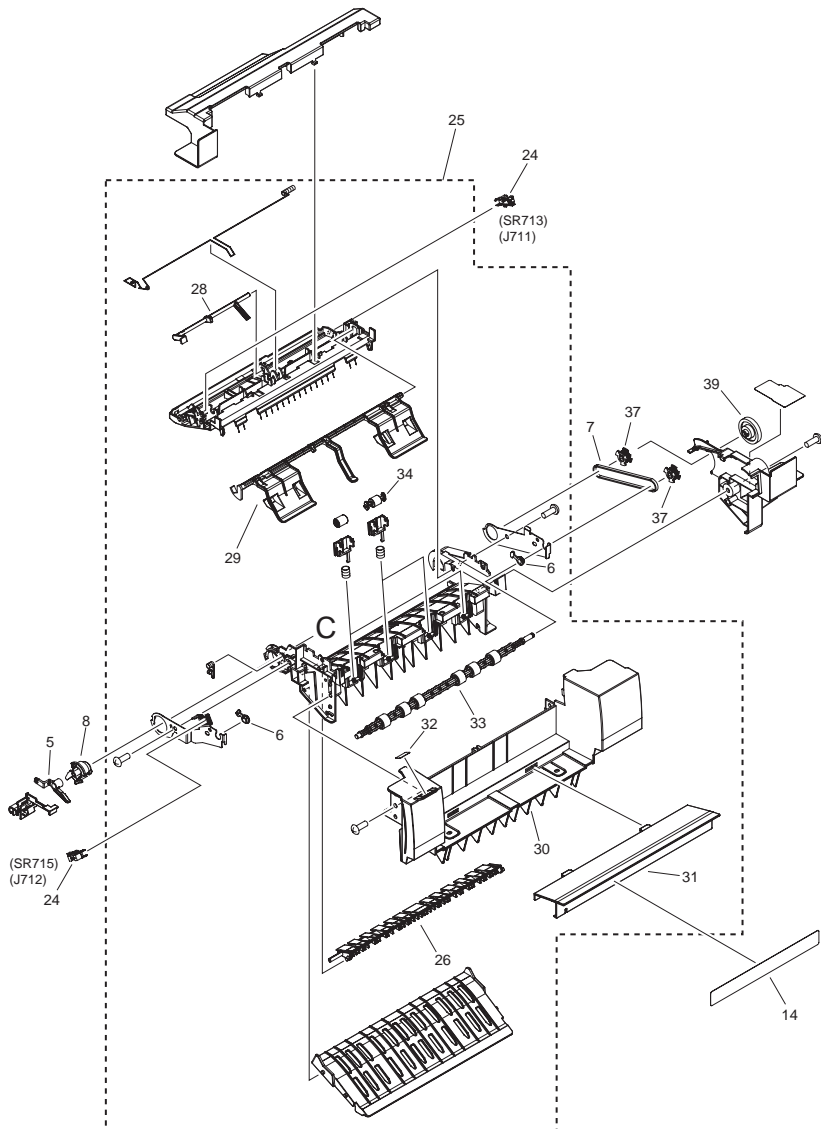
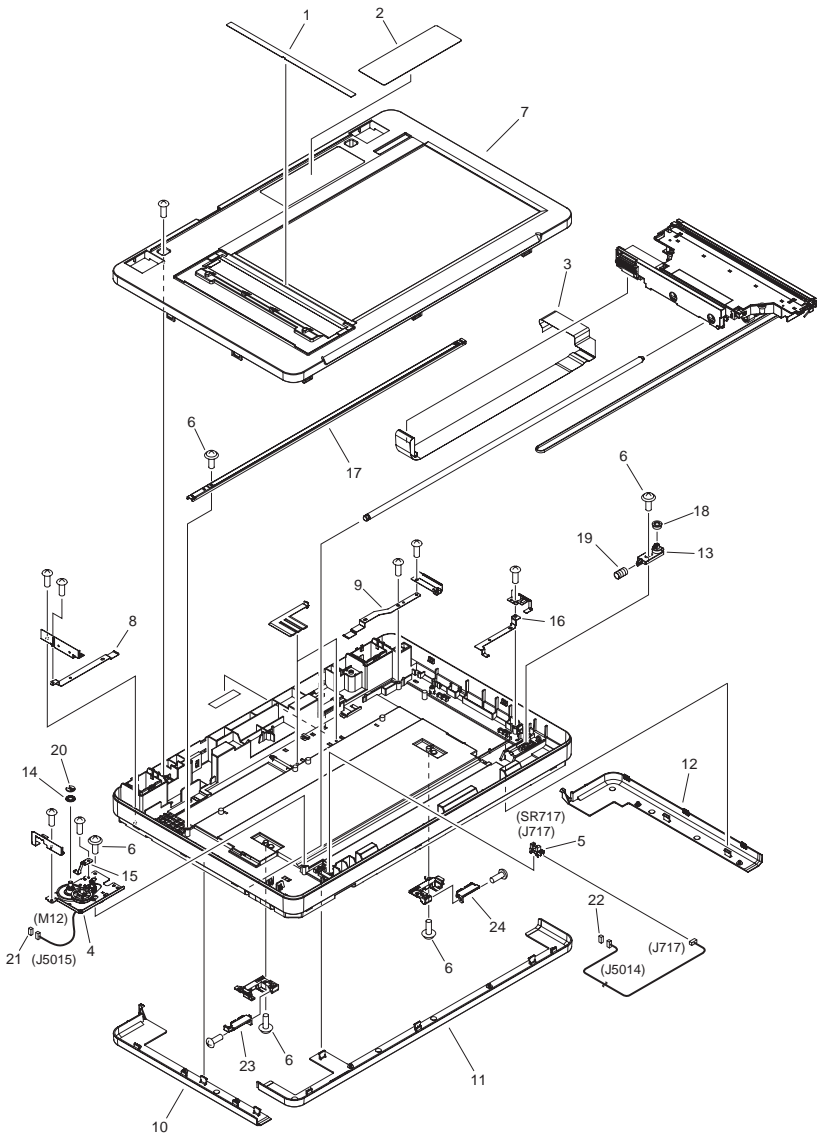

FIGURE & KEY NO.	PARTS NUMBER	RANK	Q'TY	DESCRIPTION	SERIAL NUMBER/REMARKS	SVC
Fig.331	NPN		RF	REVERSE ASSEMBLY		
1	FC7-6125-000		1	GUIDE, REVERSE, REAR		
2	FC7-6126-000		1	GUIDE, REVERSE, REAR UPPER		
3	FC7-6078-000		1	BUSHING		
4	FC7-6057-000		2	BLOCK, BRAKE		
5	FC7-6058-000		1	LEVER, DOCUMENT SCANNER		
6	FC7-6068-000		4	BUSHING		
7	FC7-6069-000		1	BELT, TIMING		
8	FC7-6082-000		1	HINGE, GUIDE, FRONT		
9	FC7-6091-000		2	BUSHING		
10	FC7-6098-000		1	STOPPER, GEAR		
11	FC7-6101-000		1	GUIDE, REVERSE, UPPER		
12	FC7-6106-000		1	ROLLER, INTERMEDIATE, 2		
13	FC7-6107-000		1	ROLLER, REVERSE		
14	FC8-0580-000		1	LABEL, HIGH TMP. CAUTION		
15	FU7-0641-000		1	GEAR, 28T		
16	FM3-1346-000		1	GUIDE BASE ASSEMBLY		
17	FC7-6074-000		1	FLAPPER, REVERSE		
18	FC7-6075-000		1	FLAG, REVERSE SENSOR		
19	FC7-6080-000		1	ROLLER, INTERMEDIATE, 1		
20	FC7-6081-000		1	BUSHING		
21	FM3-1348-000		1	REVERSE DRIVE ASSEMBLY		
22	FC7-6108-000		3	ROLLER, DELIVERY FOLLOWER		
23	FC7-6109-000		6	BUSHING		
24	WG8-5696-000		3	PHOTO INTERRUPTER, TLP1243	SR706,SR713,SR715	
25	FM3-1347-000		1	FR. PAPER DELIVERY GUIDE ASSY		
26	FC7-6060-000		1	FLAPPER, DUPLEXING		
27	FU7-0650-000		1	GEAR, 12T		
28	FC7-6117-000		1	FLAG, PAPER DELIVERY SENSOR		
29	FC7-6118-000		1	LEVER, PAPER DELIVERY		
30	FC7-6128-000		1	COVER, PAPER DELIVERY GUIDE		
31	FC7-6129-000		1	TRAY, PAPER DELIVERY GRADIENT		

FIGURE & KEY NO.	PARTS NUMBER	RANK	Q'TY	DESCRIPTION	SERIAL NUMBER/REMARKS	SVC
32	FC7-6137-000		1	LABEL, DELIVERY GUIDE COVER	SL5017	
33	FL2-6660-000		1	ROLLER, PAPER DELIVERY		
34	FL2-6664-000		2	ROLLER, PAPER FEED		
35	VS1-7207-009		1	CONNECTOR, SNAP TIGHT		
36	VS1-7177-002		2	CONNECTOR, SNAP TIGHT, BK		
37	FU5-3570-000		2	PULLEY, 22T		
38	FU7-0646-000		1	GEAR, 26T		
39	FU7-0648-000		2	GEAR, 35T		
40	RK2-0948-000		1	SOLENOID		
41	VS1-7177-004		1	CONNECTOR, SNAP TIGHT, BK		
42	FM3-3997-000		1	DUPLEXING PCB ASSEMBLY		
43	FU7-0642-000		1	GEAR, 12T		
44	XA9-1671-000		AR	SCREW, D, M3X8		

FIGURE 400 READER ASSEMBLY



NOTE : This assembly does not include the parts shown with key No. 1, 2, 23 and 24.
 注 : このユニットにKey No. 1, 2, 23, 24の部品は含まれません。

FIGURE & KEY NO.	PARTS NUMBER	RANK	Q'TY	DESCRIPTION	SERIAL NUMBER/REMARKS	SVC
Fig.400	FM3-1356-000		1	READER ASSEMBLY		
1	FC7-6240-000		1	LABEL, LENGTH SIZE	SEE NOTE INCH/A SIZE	
1	FC8-0557-000		1	LABEL, LENGTH SIZE	SEE NOTE AB SIZE	
1	FC8-0558-000		1	LABEL, LENGTH SIZE	SEE NOTE A SIZE	
1	FC8-0559-000		1	LABEL, LENGTH SIZE	SEE NOTE INCH/AB SIZE	
2	FC8-0563-000		1	LABEL, COPY PROHIBITION	SEE NOTE Japanese	
2	FC8-0564-000		1	LABEL, COPY PROHIBITION	SEE NOTE US English	
2	FC8-0565-000		1	LABEL, COPY PROHIBITION	SEE NOTE UK English	
2	FC8-0569-000		1	LABEL, COPY PROHIBITION	SEE NOTE US English,French,German,Spanish,Italian,Russian	
3	FK2-5282-000		1	CABLE, FLAT		
4	FM3-1353-000		1	MOTOR ASSEMBLY	M12	
5	WG8-5696-000		1	PHOTO INTERRUPTER, TLP1243	SR717	
6	XA9-0476-000		10	SCREW,TP M3X8		
7	FM3-1351-000		1	TOP COVER ASSEMBLY		
8	FC7-6047-000		1	PLATE, READER GROUNDING, LEFT		
9	FC7-6048-000		1	PLATE, READER GROUNDING, RIGHT		
10	FC7-6222-000		1	PANEL, LEFT LOWER		
11	FC7-6223-000		1	PANEL, FRONT LOWER		
12	FC7-6224-000		1	PANEL, RIGHT LOWER		
13	FC7-6228-000		1	HOLDER, PULLEY		
14	FC7-6246-000		1	STOPPER, BELT		
15	FC7-6254-000		1	PLATE, MOTOR GROUNDING		
16	FC7-6257-000		1	PLATE, GROUNDING		
17	FL2-6668-000		1	RAIL, OPTICAL		
18	FU5-3576-000		1	PULLEY, 18T		
19	FU7-2009-000		1	SPRING, TENSION		
20	HC1-0586-000		1	RETAINING RING (E-TYRE)		
21	VS1-7177-004		1	CONNECTOR, SNAP TIGHT, BK		
22	VS1-7207-003		1	CONNECTOR, SNAP TIGHT, BK		
23	FC7-6027-000		1	CLAMP, READER SHAFT, LEFT	SEE NOTE	
24	FC7-6037-000		1	CLAMP, READER SHAFT, RIGHT	SEE NOTE	

FIGURE 810
FIXING ASS'Y

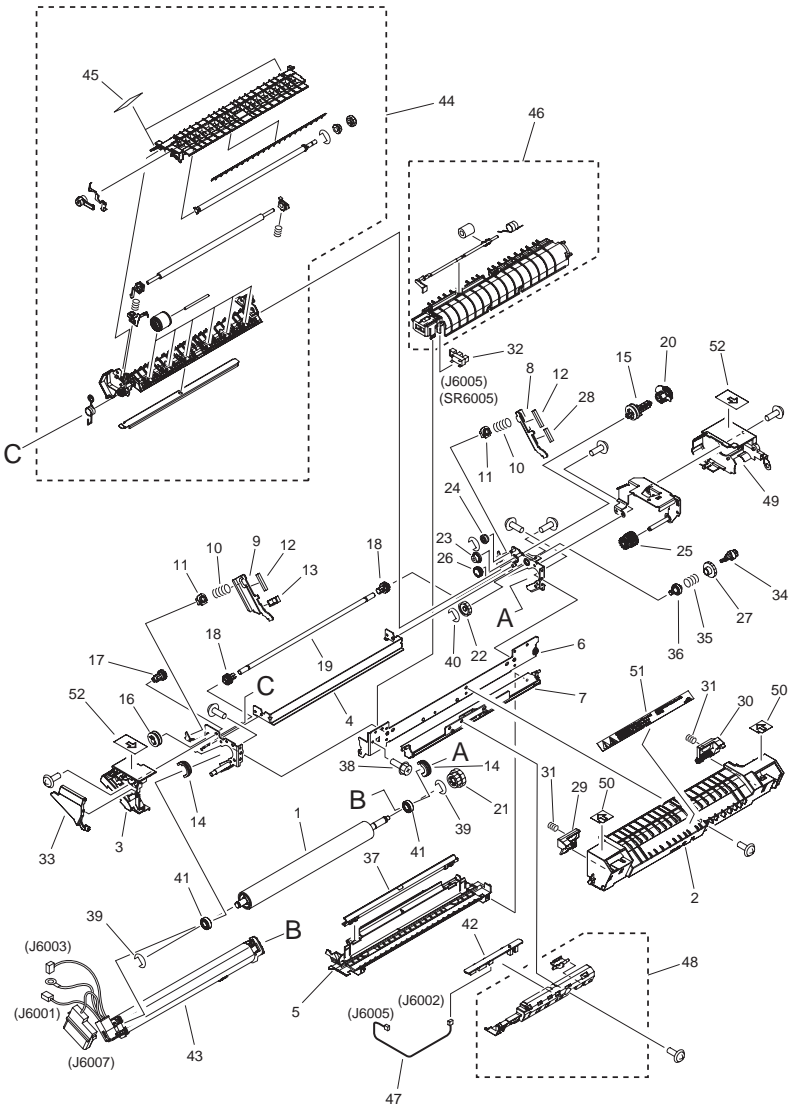

FIGURE & KEY NO.	PARTS NUMBER	R A N K	Q'TY	DESCRIPTION	SERIAL NUMBER/ REMARKS	S V C
Fig.810	RM1-4300-000		1	FIXING ASS'Y	100V	
Fig.810	RM1-4348-020		1	FIXING ASS'Y	120V	
Fig.810	RM1-4349-000		1	FIXING ASS'Y	230V	
1	RC1-6229-030		1	ROLLER, PRESSURE		
2	RC1-6230-020		1	COVER, PRE-FIXING		
3	RC1-6234-020		1	COVER, FIXING, LEFT		
4	RC1-6235-000		1	CROSSMEMBER, FIXING, REAR		
5	RC1-6237-000		1	COVER, FIXING, LOWER		
6	RC1-6245-000		1	PLATE, FIXING BASE		
7	RC1-6254-020		1	GUIDE, FIXING ENTRANCE		
8	RC1-6257-000		1	PLATE, SLEEVE PRESSURE, RIGHT		
9	RC1-6258-000		1	PLATE, SLEEVE PRESSURE, LEFT		
10	RC1-6259-000		2	SPRING, COMPRESSION		
11	RC1-6260-000		2	HOLDER, PRESSURE SPRING		
12	RC1-6261-000		2	SLIDER, CAM, 1		
13	RC1-6262-000		1	GUIDE, CABLE		
14	RC1-6263-000		2	BUSHING		
15	RC1-6264-000		1	CAM, ESTRANGEMENT, RIGHT		
16	RC1-6265-000		1	CAM, ESTRANGEMENT, LEFT		
17	RC1-6266-000		1	GEAR, 15T		
18	RC1-6267-000		2	GEAR, 15T		
19	RC1-6268-000		1	SHAFT, CAM		
20	RC1-6269-000		1	GEAR, 21T		
21	RC1-6270-000		1	GEAR, 23T/23T		
22	RC1-6275-000		1	GEAR, 31T		
23	RC1-6276-000		1	GEAR, 23T/14T		
24	RC1-6277-000		1	GEAR, 14T/17T		
25	RC1-6281-020		1	GEAR, 22T/15T		
26	RC1-6285-000		1	GEAR, 15T		
27	RC1-6303-000		1	GEAR, 25T		
28	RC1-6308-000		1	SLIDER, CAM, 2		
29	RC1-6839-000		1	LOCK, FIXING, LEFT		

FIGURE & KEY NO.	PARTS NUMBER	RANK	QTY	DESCRIPTION	SERIAL NUMBER/REMARKS	SVC
30	RC1-6840-000		1	LOCK, FIXING, RIGHT		
31	RC1-6841-000		2	SPRING, COMPRESSION		
32	WG8-5696-000		1	PHOTO INTERRUPTER, TLP1243	SR6005	
33	RC1-6843-000		1	COVER		
34	RC1-7572-000		1	RATCHET		
35	RC1-7573-000		1	SPRING, COMPRESSION		
36	RC1-7574-000		1	HOLDER, SPRING		
37	RC1-7575-000		1	COVER, SHAFT		
38	XA9-1449-000		1	SCREW, RS, M3X8		
39	XD9-0234-000		2	RING, E		
40	XD2-1100-242		1	WASHER, RETAINING		
41	XG9-0572-000		2	BEARING, BALL		
42	RM1-2586-000		1	RELAY PCB ASS'Y		
43	RM1-4301-000		1	FIXING FILM GUIDE ASS'Y	100V	
43	RM1-2666-050		1	FIXING FILM GUIDE ASS'Y	120V	
43	RM1-2744-050		1	FIXING FILM GUIDE ASS'Y	230V	
44	RM1-2667-100		1	PAPER DELIVERY GUIDE ASS'Y		
45	RC1-7632-000		2	LABEL, OPEN/CLOSE GUIDE		
46	RM1-2746-000		1	HEAT INSULATING COVER ASS'Y		
47	RM1-2601-000		1	CABLE, FIXING DC		
48	RM1-2747-030		1	LOOP SENSOR HOLDER ASS'Y		
49	RM1-2748-000		1	FIXING RIGHT COVER ASS'Y		
50	RC2-1646-000		2	LABEL, FIXING, 1		
51	RC1-7606-000		1	LABEL, HIGH TMP. CAUTION		
52	RC2-1647-000		2	LABEL, FIXING, 2		

FIGURE 900 CONTROLLER BOX ASSEMBLY

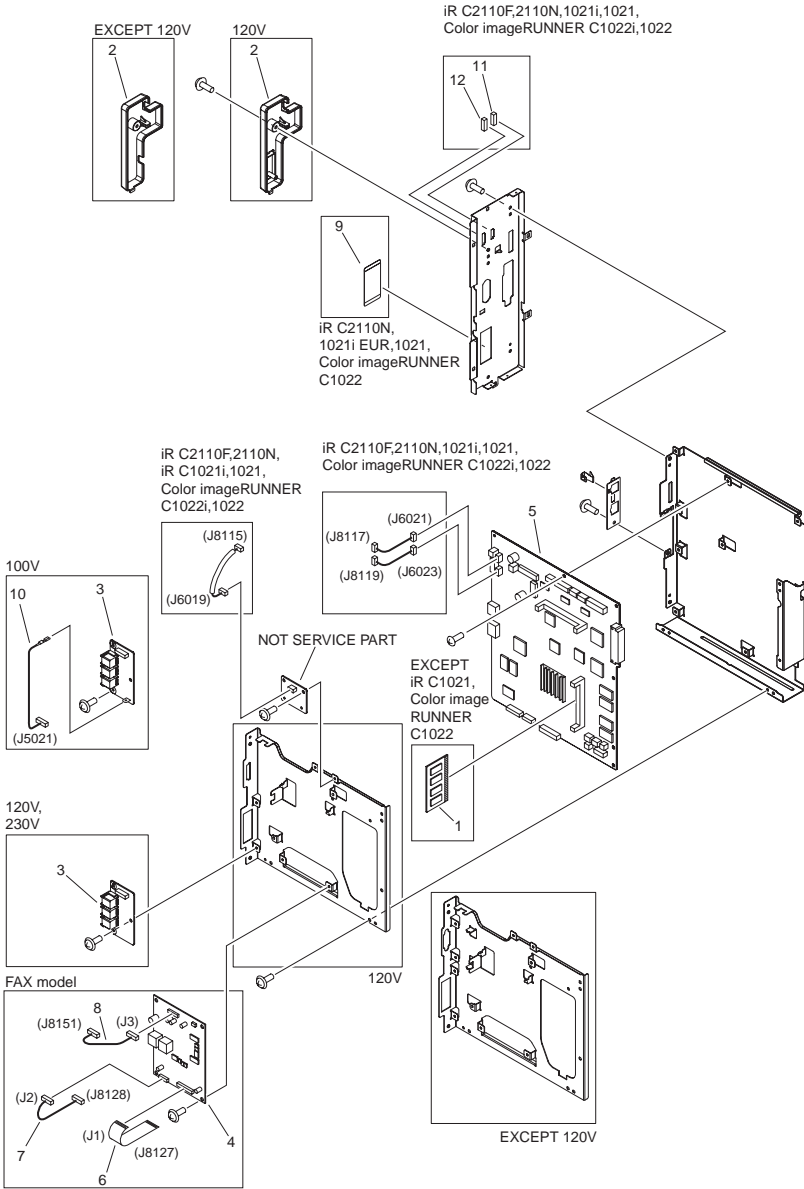

FIGURE & KEY NO.	PARTS NUMBER	RANK	Q'TY	DESCRIPTION	SERIAL NUMBER/REMARKS	SVC
Fig.900	NPN		RF	CONTROLLER BOX ASSEMBLY		
1	WA7-4997-000		1	DIMM, SMD-N51226NP-D	iR C2110F,2110N,1021i,Color imageRUNNER C1022i	
2	FC7-6850-000		1	COVER, OPTION CONNECTOR	120V	
2	FC7-6855-000		1	COVER, OPTION CONNECTOR	EXCEPT 120V	
3	FM3-2918-000		1	MODULAR PCB ASSEMBLY	100V	
3	FM3-2917-000		1	MODULAR PCB ASSEMBLY	120V	
3	FM3-2919-000		1	MODULAR PCB ASSEMBLY	230V	
4	FM3-4009-000		1	NCU PCB ASSEMBLY	FAX model AU	
4	FM3-4008-000		1	NCU PCB ASSEMBLY	FAX model EXCEPT AU	
5	FM3-2916-000		1	MAIN CONTROLLER PCB ASSEMBLY	iR C2110F,2110N,1021i,102 1,Color imageRUNNER C1022i,1022	
6	FK2-5285-000		1	CABLE, FLAT, 3	FAX model	
7	FM3-2945-000		1	CABLE, NCU	FAX model	
8	FM3-2946-000		1	CABLE, MODULAR JACK	FAX model	
9	FC7-6867-000		1	SHEET, BLANKING	iR C2110N,1021i EUR,1021,Color imageRUNNER C1022	
10	FM3-2942-000		1	CABLE, ARRESTER	100V	
11	VS1-7173-005		1	CONNECTOR, SNAP TIGHT	iR C2110F,2110N,1021i,102 1,Color imageRUNNER C1022i,1022	

FIGURE & KEY NO.	PARTS NUMBER	R A N K	Q'TY	DESCRIPTION	SERIAL NUMBER/ REMARKS	S V C
12	VS1-7173-007		1	CONNECTOR, SNAP TIGHT	iR C2110F,2110N,1021i,102 1,Color imageRUNNER C1022i,1022	

FIGURE ZZA

MECHANICAL STANDARD PARTS (HOW TO USE)

Mechanical standard parts

機械標準部品

About a mechanical standard parts

A Mechanical standard parts is a mechanical part which not parts peculiar to a product. They are parts which are common to a Canon product and are used, such as a screw and a washer. The Fig No. and parts number of the mechanical standard parts are not listed in the product parts catalog. Refer to the parts catalog of mechanical standard parts when checking the parts number for screw or washer etc. and identify them by part shape or size.

機械標準部品とは

機械標準部品とは、製品特有の部品ではなく、ねじやワッシャなどキヤノン製品共通で使用されている機械部品（メカ部品）のことです。製品のパーツカタログには、機械標準部品のFig No.や部品番号は記載していません。ねじや、ワッシャ等の部品番号を調べるときは、機械標準部品のパーツカタログを参照し、部品の形状や大きさから判断し、使用している部品を調べてください。

Material and surface treatment of a mechanical standard parts

Material and surface treatment of mechanical standard parts are assigned commonly for each part. Refer to the Table 1 for the parts which material and surface treatment are assigned as numbers.

機械標準部品の材料および表面処理

機械標準部品の材料および表面処理については、各種部品共通で決められています。材料および表面処理が番号で決められている部品については、表1を参照してください。

Table 1 Material and Surface treatment
表1 材料および表面処理

No. 番号	Material 材料	Surface treatment 表面処理	Color 色
1	Stainless steel ステンレス	Stainless steel black coloring (BC4) ステンレス黒着色(BC4)	Black 黒
2		not to be given なし	White 白
3	Brass 黄銅	Regular nickel plating (NL) 普通ニッケルメッキ(NL)	White 白
4		Black nickel plating (BN) 黒色ニッケルメッキ(BN)	Black 黒
5	Steel 鋼	White zinc trivalent chromate treating (ZC3) 白色亜鉛3価クロメート(ZC3)	White 白
6		Regular nickel chromium plating (NC) 普通ニッケルクロムメッキ(NC)	White 白
7		Regular nickel plating (NL) 普通ニッケルメッキ(NL)	White 白
8		Iron and steel phosphating (P1) 鉄鋼磷酸塩処理(P1)	Black 黒
9		Black zinc trivalent chromate treating (BZ3) 黒色亜鉛3価クロメート(BZ3)	Black 黒

FIGURE ZZB MECHANICAL STANDARD PARTS (SCREWS)

1. Screws ねじ

How to read Parts Numbers
部品番号の見方

Screws
ねじ

XB1-2400-609

Type No.
類別番号
Normal designation (d)
ねじの呼び(d)
Length (L)
ねじの長さ(L)
Material and Surface treatment
材料および表面処理

XB1-2 expresses Binding head machine screw.
XB1-2は、バインドねじを表す
40 expresses M4.0.
40は、M4.0を表す
0-60 expresses a length of 6.0mm.
0-60は、6.0mmの長さを表す
9 expresses Steel (Black zinc trivalent chromate
treating) from Table 1.
9は、表1より鋼(黒色亜鉛3価クロメート)を表す

1-1. Cross Recessed Head Screws for Precision Equipments 精密機器用十字穴付き小ねじ

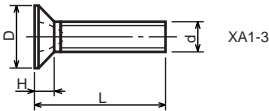
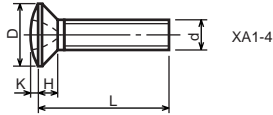
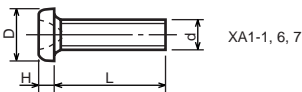

Type No. 類別番号	Type 類別	Head size (mm) 頭部寸法 (mm)							
		M1.4	M1.6	M1.7	M2	M2.5	M2.6		
XA1-1	Pan head Class 1 なべ1種	D	XA1-1	2	2.4	2.5	3	3.8	4
		H	XA1-1	0.5	0.55	0.5	0.6	0.9	0.8
XA1-3	Countersunk head Class 1 さら1種	D	XA1-3	2	2.4	2.5	3	3.8	4
		H	XA1-3	0.48	0.55	0.58	0.73	0.85	0.93
XA1-4	Oval countersunk head Class 1 丸さら1種	D	XA1-4	2	2.4	2.5	3	3.8	4
		H + K	XA1-4	0.68	0.8	0.88	1	1.25	1.3
XA1-6	Pan head Class 3 なべ3種	D	XA1-6	2.5	2.8	3	3.5	4.3	4.5
		H	XA1-6	0.8	0.85	0.9	1	1.3	1.2
XA1-7	Pan head Class 2 なべ2種	D	XA1-7	2.5	2.8	3	3.5	4.3	4.5
		H	XA1-7	0.5	0.55	0.5	0.6	0.9	0.8

1-2. Precision Tapping Screws
精密用タッピンねじ

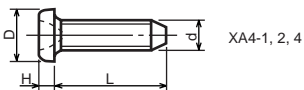

XA4-1, 2, 4

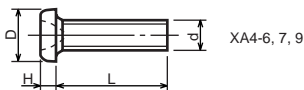

XA4-6, 7, 9

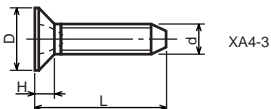

XA4-3



XA4-8

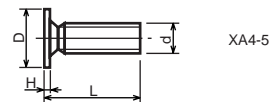

XA4-5

Type No. 類別番号	Type 類別	Head size (mm) 頭部寸法 (mm)						
		M1.4	M1.6	M1.7	M2	M2.5	M2.6	
XA4-1	With tapered end pan head Class 1 絞りなべ1種	D XA4-1	2	2.4	2.5	3	3.8	4
		H XA4-1	0.5	0.55	0.5	0.6	0.9	0.8
XA4-2	With tapered end pan head Class 3 絞りなべ3種	D XA4-2	2.5	2.8	3	3.5	4.3	4.5
		H XA4-2	0.8	0.85	0.9	1	1.3	1.2
XA4-3	With tapered end countersunk head 絞りさら	D XA4-3	2	2.4	2.5	3	3.8	4
		H XA4-3	0.48	0.55	0.58	0.73	0.85	0.93
XA4-4	With tapered end pan head Class 2 絞りなべ2種	D XA4-4	2.5	2.8	3	3.5	4.3	4.5
		H XA4-4	0.5	0.55	0.5	0.6	0.9	0.8
XA4-5	With parallel end ultra thin head ストレート超薄頭	D XA4-5	2.5	2.8	3	-	-	-
		H XA4-5	0.2	0.2	0.2	-	-	-
XA4-6	With parallel end pan head Class 1 ストレートなべ1種	D XA4-6	2	2.4	2.5	3	3.8	4
		H XA4-6	0.5	0.55	0.5	0.6	0.9	0.8
XA4-7	With parallel end pan head Class 3 ストレートなべ3種	D XA4-7	2.5	2.8	3	3.5	4.3	4.5
		H XA4-7	0.8	0.85	0.9	1	1.3	1.2
XA4-8	With parallel end countersunk head ストレートさら	D XA4-8	2	2.4	2.5	3	3.8	4
		H XA4-8	0.48	0.55	0.58	0.73	0.85	0.93
XA4-9	With parallel end pan head Class 2 ストレートなべ2種	D XA4-9	2.5	2.8	3	3.5	4.3	4.5
		H XA4-9	0.5	0.55	0.5	0.6	0.9	0.8

1-3. Cross Recessed Head Screws
一般用十字穴付き小ねじ

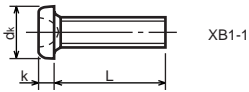

XB1-1

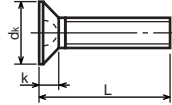

XB1-3

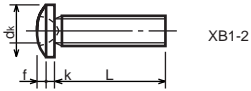

XB1-2

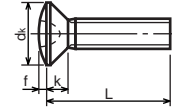

XB1-4

Type No. 類別番号	Type 類別
XB1-1	Pan head なべ
XB1-2	Binding head バインド
XB1-3	Countersunk head ざら
XB1-4	Oval countersunk head 丸ざら

		Head size (mm) 頭部寸法 (mm)					
		M2	M2.5	M2.6	M3	M4	M5
dk	XB1-1	3.5	4.5	4.5	5.5	7	9
k	XB1-1	1.3	1.7	1.7	2	2.6	3.3
dk	XB1-2	4.3	5.3	5.5	6.3	8.3	10.3
k+f	XB1-2	1.2	1.5	1.6	1.9	2.5	3.1
dk	XB1-3	4	5	-	6	8	10
k	XB1-3	1.2	1.45	-	1.75	2.3	2.8
dk	XB1-4	4	5	-	6	8	10
k+f	XB1-4	1.6	2	-	2.45	3.2	4
Screw part length ねじ部長さ b		8	12	12	12	16	20

1-4. Cross Recessed Head Screws with Captive Washer

座金組込み十字穴付き小ねじ

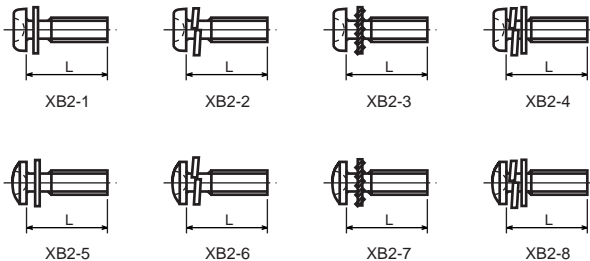

Type No. 類別番号	Type 類別
XB2-1	Pan head + Plain washer (circular bright) なべねじ+平座金
XB2-2	Pan head + Spring washer なべねじ+ばね座金
XB2-3	Pan head + Toothed lock washer なべねじ+歯付座金
XB2-4	Pan head + Spring washer and plain washer (circular bright) なべねじ+(ばね+平)座金
XB2-5	Binding head + Plain washer (circular bright) バインドねじ+平座金
XB2-6	Binding head + Spring washer バインドねじ+ばね座金
XB2-7	Binding head + Toothed lock washer バインドねじ+歯付座金
XB2-8	Binding head + Spring washer and plain washer (circular bright) バインドねじ+(ばね+平)座金

1-5. Hexagon Head Tapping Screws for Metallic Materials
 金属用六角タッピンねじ

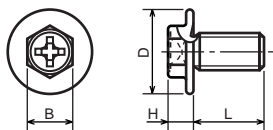

Type No. 類別番号	Type 類別	Head size (mm) 頭部寸法 (mm)		
		M3	M4	
XB3-6	For metallic materials 金属用タッピン	D	8	10
		B	5.5	5.5
XB3-7	For metallic materials with clawed 金属用タッピン-つめ付き	H XB3-6	3.1	3.1
		H XB3-7	3.2	3.2

1-6. Special Tapping Screws
 特殊タッピンねじ

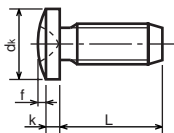

Type No. 類別番号	Type 類別	Head size (mm) 頭部寸法 (mm)		
		M3	M4	
XB4-5	Binding head バインド	d _k	6.3	8.3
		k	1.3	1.7
		k+f	1.9	2.5

1-7. General Head Tapping Screws
 一般用タッピンねじ

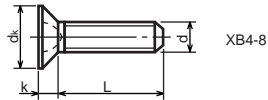
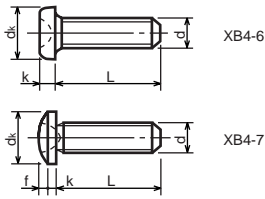

Type No. 類別番号	Type 類別
XB4-6	Pan head なべ
XB4-7	Binding head バインド
XB4-8	Countersunk head さら

		Head size (mm) 頭部寸法 (mm)					
		M2	M2.5	M2.6	M3	M4	M5
dk	XB4-6	3.5	4.5	4.5	5.5	7	9
k	XB4-6	1.3	1.7	1.7	2	2.6	3.3
dk	XB4-7	4.3	5.3	5.5	6.3	8.3	10.3
k+f	XB4-7	1.2	1.5	1.6	1.9	2.5	3.1
dk	XB4-8	4	5	5.2	6	8	10
k	XB4-8	1.2	1.45	1.5	1.75	2.3	2.8

1-8. Tapping Screws for Metallic Materials
 金属用タッピンねじ

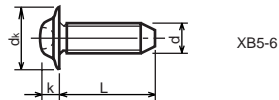
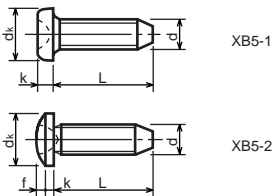

Type No. 類別番号	Type 類別
XB5-1	Pan head なべ
XB5-2	Binding head バインド
XB5-6	Flanged pan head つば付きなべ

		Head size (mm) 頭部寸法 (mm)				
		M2.5	M2.6	M3	M4	M5
dk	XB5-1	4.5	4.5	5.5	7	9
k	XB5-1	1.7	1.7	2	2.6	3.3
dk	XB5-2	5.5	5.5	6.3	8.3	10.3
k+f	XB5-2	1.6	1.6	1.9	2.5	3.1
dk	XB5-6	6.5	6.5	8	10	12
k	XB5-6	2.1	2.1	1.75	3.2	4

1-9. Hexagon Socket Set Screws

六角穴付き止めねじ

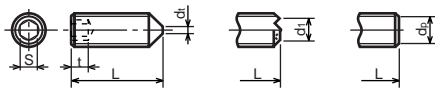

XB6-1

XB6-2

XB6-3

Type No. 類別番号	Type 類別
XB6-1	Cone point とがり先
XB6-2	Double point ダブルポイント
XB6-3	Flat point 平先

	Head size (mm) 頭部寸法 (mm)						
	M1.6 M1.7	M2	M2.5 M2.6	M3	M5	M5	M6
S	0.7	0.9	1.3	1.5	2	2.5	3
t	1.5	1.7	2	2	2.5	3	3.5
d _{t max} XB6-1	0.4	0.5	0.65	0.75	1	1.25	1.5
d _{l max} XB6-2	-	1.2	1.5	1.7	2.2	2.8	3.3
d _{l min} XB6-2	-	1	1.2	1.4	1.9	2.4	2.9
d _{p max} XB6-3	0.8	1	1.5	2	2.5	3.5	4
d _{p min} XB6-3	0.55	0.75	1.25	1.75	2.25	3.2	3.7

1-10. Flanged Pan Head Machine Screws

つば付きなべ小ねじ

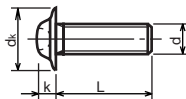

Type No. 類別番号	Type 類別
XB6-7	Flanged pan head つば付きなべ

	Head size (mm) 頭部寸法 (mm)				
	M2	M2.5 M2.6	M3	M5	M5
d _k	5	6.5	8	10	12
k	1.7	2.1	2.5	3.2	4

FIGURE ZZC MECHANICAL STANDARD PARTS (BOLTS)

2. Bolts (Socket head cap screw) ボルト

How to read Parts Numbers
部品番号の見方

Bolt (Socket head cap screw)
ボルト

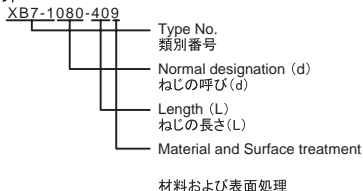

XB7-1 expresses Hexagon socket head cap screws.
XB7-1は、六角穴付きボルトを表す

080 expresses M8.0.
080は、M8.0を表す

40 expresses a length of 40mm.
40は、40mmの長さを表す

9 expresses Steel (Black zinc trivalent chromate treating) from Table 1.

9は、表1より鋼(黒色亜鉛3価クロメート)を表す

2-1. Hexagon socket head cap screws 六角穴付きボルト

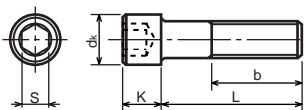

Type No. 類別番号	Type 類別
XB7-1	Hexagon socket head cap screws 六角穴付きボルト

	Head size (mm) 頭部寸法 (mm)						
	M3	M4	M5	M6	M8	M10	M12
S	2.5	3	4	5	6	8	10
d_k	5.5	7	8.5	10	13	16	18
K	3	4	5	6	8	10	12
Screw part length b_{max} ねじ部長さ b_{max}	18	20	22	24	28	32	36

FIGURE ZZD MECHANICAL STANDARD PARTS (NUTS)

3. Nuts ナット

How to read Parts Numbers
部品番号の見方

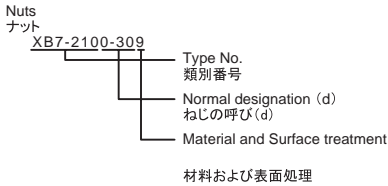

XB7-210 expresses Hexagon nut class 1.
XB7-210は、六角ナット1種を表す

0-30 expresses M3.0.
0-30は、M3.0を表す

9 expresses Steel (Black zinc trivalent chromate treating) from Table 1.

9は、表1より鋼(黒色亜鉛3価クロメート)を表す

3-1. Hexagon Nuts and Hexagon Thin Nuts 六角ナット

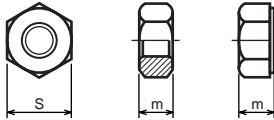

Type No. 類別番号	Type 類別
XB7-210	Hexagon nut Class 1 六角ナット-1種
XB7-220	Hexagon nut Class 3 六角ナット-3種
XB7-230	Hexagon nut Style 1 double chamfered 六角ナット-スタイル1-両面とり
XB7-231	Hexagon nut Style 1 washer faced 六角ナット-スタイル1-座付き
XB7-240	Hexagon nut Style 2 double chamfered 六角ナット-スタイル2-両面とり
XB7-241	Hexagon nut Style 2 washer faced 六角ナット-スタイル2-座付き
XB7-250	Hexagon nut 六角ナット
XB7-260	Hexagon thin nut double chamfered 六角低ナット-両面とり
XB7-270	Hexagon thin nut not chamfered 六角低ナット-面とり無し

	Head size (mm) 頭部寸法 (mm)						
	M2	M2.5	M3	M4	M5	M6	M8
S	4	5	5.5	7	8	10	13
m XB7-210	1.6	2	2.4	3.2	4	5	6.5
m XB7-220	1.2	1.6	1.8	2.4	3.2	3.6	5
m XB7-230, 231	1.6	2	2.4	3.2	4.7	5.2	6.8
m XB7-240, 241	-	-	-	-	5.1	5.7	7.5
m XB7-250	-	-	-	-	5.6	6.1	7.9
m XB7-260	1.2	1.6	1.8	2.2	2.7	3.2	4
m XB7-270	1.2	1.6	1.8	2.2	2.7	3.2	4

FIGURE ZZE MECHANICAL STANDARD PARTS (WASHERS)

4. Washers ワッシャ

How to read Parts Numbers
部品番号の見方

Washers (XD1-1)
ワッシャ (XD1-1)

XD1-1102-625

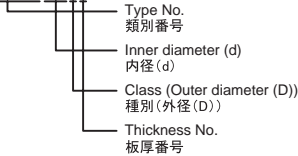

XD1-110 expresses copper material washer.
XD1-110は、銅材のワッシャを表す

2-6 expresses a inner diameter of 2.6 mm.
2-6は、2.6mmの内径を表す

2 expresses a outer diameter of 4.4 mm from Table 2.
2は、表2より4.4mmの外径を表す

5 expresses a thickness of 0.5 mm from Table 3.
5は、表3より0.5mmの板厚を表す

Table 2 表2

d (mm)	D (mm)		
	Class 1 1種	Class 2 2種	Class 3 3種
1.5	-	2.6	3.2
1.8	2.7	3.1	3.7
2.1	3.2	3.6	4.2
2.3	3.6	4	4.6
2.6	4	4.4	5
3.1	4.6	5	5.6
3.6	5.4	5.8	6.4
4.1	5.7	6.6	8
4.6	6.4	7.4	9
5.2	7.2	8.2	10
5.7	7.8	9	11
6.2	8.5	9.8	12
6.7	9.2	10.5	13
7.2	10	11.4	14
7.7	10.6	12.2	15
8.2	11.4	13	16
8.7	12	13.8	17
9.2	12.8	14.6	18
9.7	13.5	15.4	19
10.2	14.3	15.6	20

Table 3 表3

Thickness No. 板厚番号	t (mm)
0	0.05
1	0.1
2	0.2
3	0.3
4	0.4
5	0.5
6	0.6
7	0.7
8	0.8
9	1

Plain washers, Spring lock washers, Toothed lock washers (XD1-2, 3, 4)
平座金、ばね座金、歯付き座金 (XD1-2, 3, 4)

XD1-2100-307

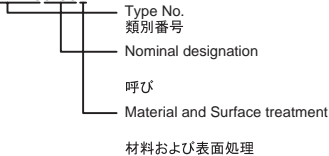

XD1-210 expresses plain washer.
XD1-210は、平座金を表す

0-30 expresses a 030 of nominal designation.
(See Table 4)

0-30は、呼び030を表す (表4参照)

7 expresses Steel (Regular nickel chromium plating)
from Table 1.

7は、表1より鋼 (普通ニッケルメッキ) を表す

4-1. Washers
ワッシャ

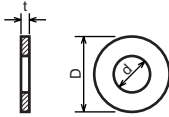

Type No. 類別番号	Type 類別
XD1-110	Washer - Copper material ワッシャ 銅
XD1-120	Washer - Stainless steel material ワッシャ ステンレス

4-2. Plain Washers
平座金

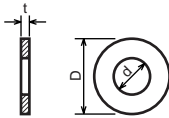

Type No. 類別番号	Type 類別
XD1-210	Regular type grade A 並形—等級A
XD1-120	Washer - Stainless steel material ワッシャ ステンレス

Table 4 表4

Nominal designation 呼び	d (mm)	D (mm)	t (mm)
020	2.2	5	0.3
025	2.7	6.5	0.5
026	2.8	6.5	0.5
030	3.2	7	0.5
040	4.3	9	0.8
050	5.3	10	1
060	6.4	12.5	1.6
080	8.4	17	1.6
100	10.5	21	2
120	13	24	2.5

4-3. Spring Lock Washers
ばね座金

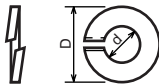

Type No. 類別番号	Type 類別
XD1-310	No.2 2号

Table 4 表4

Nominal designation 呼び	d (mm)	D (mm)
020	2.1	4.4
025	2.6	5.2
026	2.7	6.5
030	3.1	5.3
040	4.1	5.9
050	5.1	9.2
060	6.1	12.2
080	8.2	15.4
100	10.2	18.4
120	12.2	21.5

4-4. Toothed Lock Washers
歯付き座金

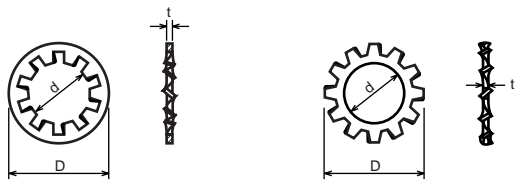

Type No. 類別番号	Type 類別
XD1-410	Internal tooth type 内歯形
XD1-420	External tooth type 外歯形

Table 4 表4

Nominal designation 呼び	d (mm)	D (mm)	t (mm)	No. of Int. tooth 内歯数	No. of Ext. tooth 外歯数
020	2.2	4.8	0.3	7	-
025	2.7	5.7	0.3	7	-
026	2.8	5.8	0.3	7	-
030	3.2	6.5	0.45	8	8
040	4.3	8.5	0.45	8	9
050	5.3	10	0.6	8	10
060	6.4	11	0.6	9	12
080	8.4	15	0.8	9	12

FIGURE ZZF MECHANICAL STANDARD PARTS (RETAINING RINGS)

5. Retaining Rings

止め輪

How to read Parts Numbers

部品番号の見方

Retaining Rings

止め輪

XD2-1100-202

Type No.

類別番号

Nominal designation

呼び

Material and Surface treatment

材料および表面処理

XD2-110 expresses retaining ring-E type (Type1).
XD2-110は、E形止め輪(1種)を表す

0-20 expresses a 020 of nominal designation.

(See Table 5)

0-20は、呼び020を表す(表5参照)

2 expresses Stainless steel (Surface treatment is not to be given) from Table 1.

2は、表1よりステンレス(表面処理なし)を表す

5-1. Retaining Rings - E type

E形止め輪

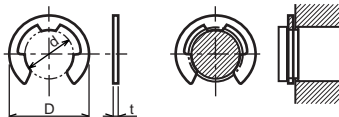

Type No. 類別番号	Type 類別
XD2-110	Retaining ring - E type (Type 1) E形止め輪(1種)
XD2-120	Retaining ring - E type (Type 2) E形止め輪(2種)

Table 5 表5

Type 種類	Nominal designation 呼び	d (mm)	D (mm)	t (mm)
Type 1 1種	007	0.65	2	0.2
	010	0.95	2.8	0.2
	013	1.25	3.3	0.3
	017	1.65	4.2	0.4
	020	1.95	4.6	0.5
	024	2.35	6	0.6
	028	2.74	6.5	0.6
	032	3.14	7.2	0.6
	037	3.64	8	0.7
	040	3.93	10	0.7
	042	4.13	10	0.7
	050	4.93	11	0.7
	058	5.73	12	0.7
	060	5.93	12.7	0.9
	064	6.32	13.5	0.9
	074	7.31	15	0.9
080	7.91	16.5	1	
Type 2 2種	008	0.8	2	0.2
	012	1.2	3	0.3
	015	1.5	4	0.4
	020	2	5	0.4
	025	2.5	6	0.4
	030	3	7	0.6
	040	4	9	0.6
	050	5	11	0.6
	060	6	12	0.8
	070	7	14	0.8
	080	8	16	0.8
	090	9	18	0.8
	100	10	20	1

5-2. Grip Rings
グリップ止め輪

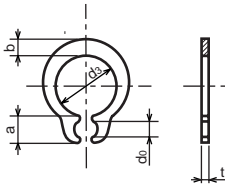

Type No. 類別番号	Type 類別
XD2-210	Grip ring グリップ止め輪

Table 5 表5

Nominal designation 呼び	d ₃ (mm)	t (mm)	b (mm)	a (mm)	d ₀ (mm)
020	1.9	0.5	1	1.8	0.8
025	2.35	0.5	1.2	1.9	0.9
030	2.85	0.6	1.4	1.9	0.9
035	3.3	0.6	1.6	2	0.9
040	3.8	0.8	1.8	2.8	1.2
045	4.25	0.8	2	2.9	1.3
050	4.75	0.8	2.2	2.9	1.3
060	5.7	1	2.4	3.1	1.4
070	6.7	1	2.7	3.3	1.4
080	7.7	1	3	3.5	1.4
090	8.65	1.2	3.3	4.7	1.5
100	9.65	1.2	3.5	4.7	2

5-3. Toothed Retaining Rings
歯付き形止め輪

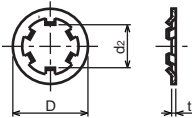

Type No. 類別番号	Type 類別
XD2-230	Toothed retaining ring 歯付き形止め輪

Table 5 表5

Nominal designation 呼び	d ₂ (mm)	D (mm)	t (mm)	No of teeth 歯数
015	1.4	5.2	0.25	3
020	1.9	6	0.25	3
024	2.3	6.4	0.25	3
030	2.8	8	0.25	4
040	3.8	9	0.25	4
050	4.8	10	0.25	5
060	5.8	11	0.25	5
080	7.8	13	0.25	5
100	9.8	15.4	0.25	6

5-4. Retaining Rings - C Type

C形止め輪

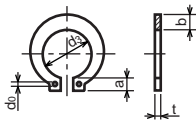

Type No. 類別番号	Type 類別
XD2-310	Retaining ring - C type for shaft C形止め輪 軸用

Table 5 表5

Nominal designation 呼び	d ₂ (mm)	t (mm)	b (mm)	a (mm)	d ₀ (mm)
010	9.3	1	1.6	3	1.2
012	11.1	1	1.8	3.2	1.5
014	12.9	1	2	3.4	1.7
015	13.8	1	2.1	3.5	1.7
016	14.7	1	2.2	3.6	1.7
017	15.7	1	2.2	3.7	1.7
018	16.5	1.2	2.6	3.8	1.7
020	18.5	1.2	2.7	3.9	2
022	20.5	1.2	2.7	4.1	2
025	23.2	1.2	3.1	4.3	2
028	25.9	1.5	3.1	4.6	2
030	27.9	1.5	3.5	4.8	2
032	29.6	1.5	3.5	5	2.5
035	32.2	1.5	4	5.4	2.5

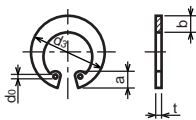

Type No. 類別番号	Type 類別
XD2-320	Retaining ring - C type for hole C形止め輪 穴用

Table 5 表5

Nominal designation 呼び	d ₂ (mm)	t (mm)	b (mm)	a (mm)	d ₀ (mm)
010	10.7	1	1.8	3.1	1.2
011	11.8	1	1.8	3.2	1.2
012	13	1	1.8	3.3	1.5
014	15.1	1	2	3.6	1.7
016	17.3	1	2	3.7	1.7
018	19.5	1	2.5	4	1.7
019	20.5	1	2.5	4	2
020	21.5	1	2.5	4	2
022	23.5	1	2.5	4.1	2
025	26.9	1.2	3	4.4	2
028	30.1	1.2	3	4.6	2
030	32.1	1.2	3	4.7	2
032	34.4	1.2	3.5	5.2	2.5
035	37.8	1.5	3.5	5.2	2.5
037	39.8	1.5	3.5	5.2	2.5
040	43.5	1.8	4	5.7	2.5
042	45.5	1.8	4	5.8	2.5
045	48.5	1.8	4.5	5.9	2.5
047	50.5	1.8	4.5	6.1	2.5
050	54.2	2	4.5	6.5	2.5
052	56.2	2	5.1	6.5	2.5
055	59.2	2	5.1	6.5	2.5
060	64.2	2	5.1	6.8	2.5
062	66.2	2	5.5	6.9	2.5
068	72.5	2.5	6	7.4	2.5
072	76.5	2.5	6.6	7.4	2.5
075	79.5	2.5	6.6	7.8	2.5
080	85.5	2.5	7	8	2.5
085	90.5	3	7	8	3
090	95.5	3	7.6	8.3	3
095	100.5	3	8	8.5	3

FIGURE ZZG MECHANICAL STANDARD PARTS (PINS)

6. Pins ピン

How to read Parts Numbers
部品番号の見方

Pins ピン

XD3-1200-122

Type No.
類別番号
Nominal diameter (d)
呼び径 (d)
Length (L)
長さ (L)
Material and Surface treatment
材料および表面処理

XD3-1 expresses spring pins for general use.
XD3-1は、スプリングピン(一般用)を表す
20 expresses a nominal diameter of 2.0 mm.
20は、2.0mmの呼び径を表す
0-12 expresses a length of 12 mm.
0-12は、12mmの長さを表す
2 expresses Stainless steel (Surface treatment is not to be given) from Table 1.
2は、表1よりステンレス(表面処理なし)を表す

6-1. Springs Pins スプリングピン

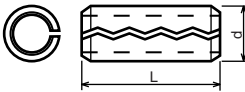

Type No. 類別番号	Type 類別
XD3-0	Spring pin for light load スプリングピン(軽荷重用)
XD3-1	Spring pin for general use スプリングピン(一般用)

6-2. Parallel Pins 平行ピン

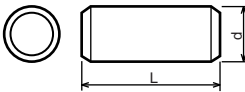

Type No. 類別番号	Type 類別
XD3-2	Parallel pin (h7 hard) 平行ピン(h7硬質)
XD3-4	Parallel pin (m6 soft) 平行ピン(m6軟質)

6-3. Taper Pins テーパピン

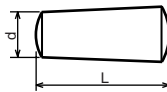

Type No. 類別番号	Type 類別
XD3-3	Taper pin テーパピン

FIGURE ZZH MECHANICAL STANDARD PARTS (SPACERS)

7. Spacers スペーサ

How to read Parts Numbers
部品番号の見方

Spacers
スペーサ

XZ1-1301-005

Type No.
類別番号

Nominal diameter (d)
呼び径 (d)

Length (L)
長さ (L)

Material and Surface treatment
材料および表面処理

XZ1-1 expresses spacers.
XZ1-1は、スペーサを表す

30 expresses a nominal diameter of 3.0 mm.
30は、3.0mmの呼び径を表す

1-00 expresses a length of 10 mm.
1-00は、10mmの長さを表す

5 expresses Steel (White zinc trivalent chromate
treating) from Table 1.
5は、表1より鋼(白色亜鉛3価クロメート)を表す

7-1. Spacers スペーサ

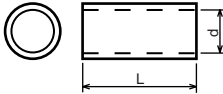

Type No. 類別番号	Type 類別
XZ1-1	Spacers スペーサ

Prepared by
OIP HFE Promotion Center
CANON INC.

Canon

Canon

Cassette Feeding Unit-AB1/AC1

PARTS CATALOG



Canon

SEPTEMBER 2008
REV. 0

PREFACE

This Parts Catalog contains listings of parts used

Diagrams are provided with the listings to aid the service technician in identifying clearly, the item to be ordered.

Whenever ordering parts, consult this Parts Catalog for all of the information pertaining to each item. Be sure to include, in the Parts Request, the full item description, the item part number, and the quantity.

COPYRIGHT (C) 1999 CANON INC.

Use of this manual should be strictly supervised to avoid disclosure of confidential information.

Contents

NUMERICAL INDEX

Cassette Feeding Unit- AB1/AC1(Numerical Index) 1-1

Cassette Feeding Unit- AB1/AC1(Parts Catalog)

RA	ASSEMBLY LOCATION DIAGRAM	2-1
R11	INTERNAL COMPONENTS	2-2
R30	CASSETTE	2-5
R40	PAPER PICK-UP FRAME ASS'Y	2-7

NUMERICAL INDEX

Cassette Feeding Unit- AB1/AC1(Numerical Index)

PARTS NUMBER	FIGURE & KEY NO.	PARTS NUMBER	FIGURE & KEY NO.	PARTS NUMBER	FIGURE & KEY NO
FC7-7069-000	R11 - 36	RC1-6925-000	R40 - 8		
FC7-7070-000	R11 - 30	RC1-6926-000	R40 - 9		
FC7-7077-000	R30 - 26	RC1-6928-000	R40 - 10		
FC7-7079-000	R11 - 21	RC1-6932-000	R11 - 17		
FC7-7080-000	R11 - 39	RC1-6933-000	R11 - 37		
FC7-7081-000	R11 - 22	RC1-6936-000	R11 - 31		
FC7-7082-000	R11 - 41	RC1-6937-000	R11 - 32		
FC7-7083-000	R11 - 23	RC1-6938-000	R11 - 18		
FC7-7084-000	R30 - 27	RC1-6938-000	R40 - 11		
FC7-7087-000	R11 - 43	RC1-6940-000	R11 - 19		
FC7-7088-000	R11 - 44	RC1-6943-000	R30 - 10		
FC7-7089-000	R11 - 45	RC1-6950-000	R40 - 12		
FC7-7124-000	R30 - 28	RC1-6951-000	R40 - 13		
FC7-7135-000	R30 - 29	RC1-6952-000	R40 - 14		
FC7-7136-000	R30 - 30	RC1-6953-000	R40 - 15		
FM3-1657-000	R30 -	RC1-6954-000	R40 - 16		
FM3-3829-000	R40 -	RC1-6955-000	R40 - 17		
FM3-3830-000	R40 - 23	RC1-6956-000	R11 - 33		
NPN	R11 -	RC1-6957-000	R11 - 38		
RC1-2182-000	R40 - 1	RC1-6960-000	R11 - 34		
RC1-2192-000	R40 - 2	RC1-6962-000	R11 - 25		
RC1-3507-000	R30 - 1	RC1-6964-000	R11 - 26		
RC1-3508-000	R30 - 2	RC1-6972-000	R40 - 18		
RC1-4216-000	R30 - 3	RC1-6973-000	R40 - 19		
RC1-4273-000	R30 - 4	RC2-1708-000	R30 - 15		
RC1-4274-000	R30 - 5	RK2-0946-000	R11 - 1		
RC1-4275-000	R30 - 6	RM1-2583-000	R11 - 3		
RC1-4276-000	R30 - 7	RM1-2622-000	R11 - 4		
RC1-4278-000	R30 - 8	RM1-2625-000	R40 - 21		
RC1-4285-000	R30 - 9	RM1-2727-000	R40 - 22		
RC1-6701-000	R11 - 28	RM1-2730-000	R11 - 40		
RC1-6880-000	R30 - 11	RM1-2731-000	R11 - 35		
RC1-6881-000	R30 - 12	RM1-2733-000	R30 - 23		
RC1-6891-000	R30 - 13	RM1-2734-000	R30 - 24		
RC1-6892-000	R11 - 29	RM1-2735-020	R30 - 25		
RC1-6898-020	R11 - 5	RM1-2736-000	R30 - 16		
RC1-6899-000	R11 - 6	RM1-2737-000	R30 - 14		
RC1-6900-000	R11 - 7	RU5-0426-010	R30 - 17		
RC1-6904-000	R11 - 8	RU5-2327-000	R30 - 18		
RC1-6905-000	R11 - 9	RU5-2431-000	R30 - 19		
RC1-6906-000	R11 - 10	RU5-2432-000	R30 - 20		
RC1-6908-000	R11 - 11	RU5-2433-000	R30 - 21		
RC1-6910-000	R11 - 12	RU5-2436-000	R30 - 22		
RC1-6912-000	R11 - 13	VS1-7257-007	R11 - 20		
RC1-6913-000	R11 - 14	WG8-5696-000	R40 - 20		
RC1-6915-000	R11 - 15	XA9-1449-000	R11 - 2		
RC1-6919-000	R11 - 16	XA9-1671-000	R11 - 27		
RC1-6920-000	R40 - 3	XD3-2200-162	R11 - 24		
RC1-6921-000	R40 - 4	XZ9-0624-000	R11 - 42		
RC1-6922-020	R40 - 5				
RC1-6923-000	R40 - 6				
RC1-6924-000	R40 - 7				

Cassette Feeding Unit- AB1/AC1(Parts Catalog)

Cassette Feeding Unit-AB1

F27-3901-000 DCS

Cassette Feeding Unit-AC1

F27-3901-000 DEN

E

Contents

RA	ASSEMBLY LOCATION DIAGRAM	2-1
R11	INTERNAL COMPONENTS	2-2
R30	CASSETTE	2-5
R40	PAPER PICK-UP FRAME ASS'Y	2-7

FIGURE RA ASSEMBLY LOCATION DIAGRAM

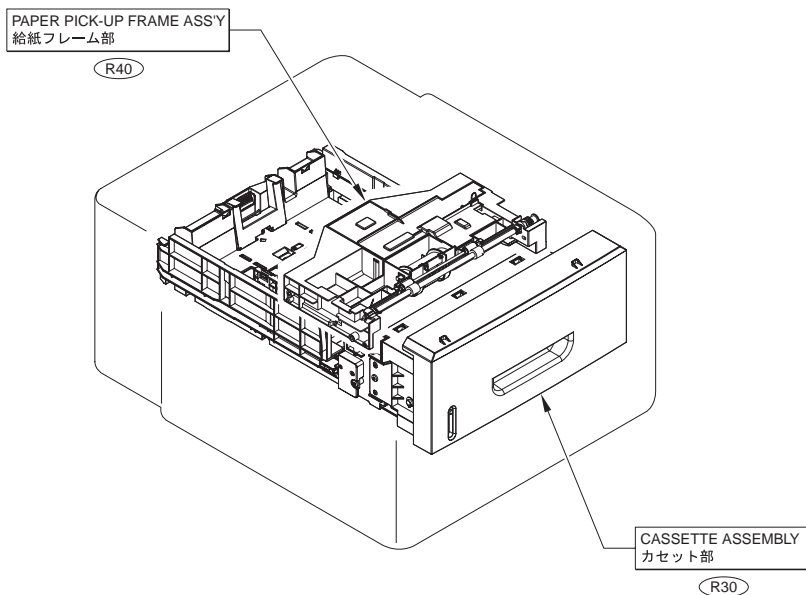

FIGURE R11 INTERNAL COMPONENTS

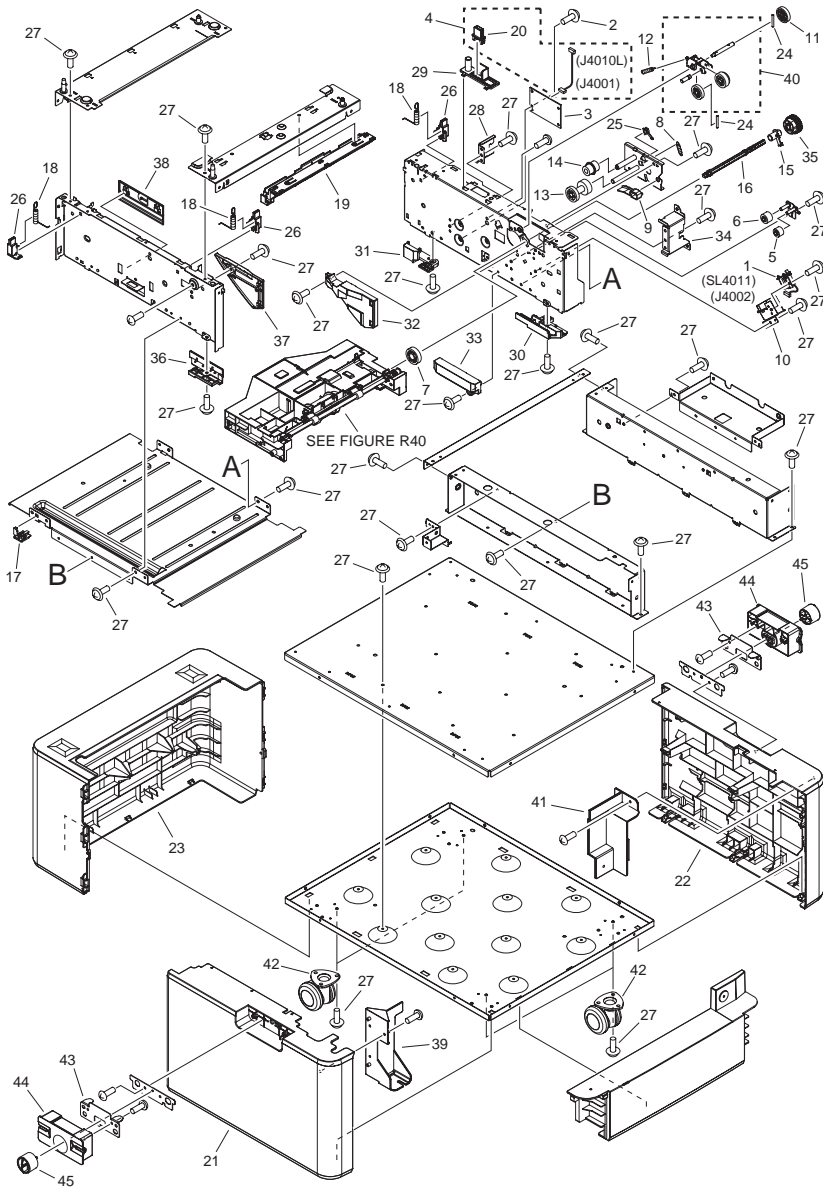

FIGURE & KEY NO.	PARTS NUMBER	R A N K	Q'TY	DESCRIPTION	SERIAL NUMBER/ REMARKS	S V C
Fig.R11	NPN		RF	INTERNAL COMPONENTS		
1	RK2-0946-000		1	SOLENOID	SL4011	
2	XA9-1449-000		2	SCREW, RS, M3X8		
3	RM1-2583-000		1	OPTION CASSETTE PCB ASSY		
4	RM1-2622-000		1	CABLE, OPTION		
5	RC1-6898-020		1	GEAR, 17T		
6	RC1-6899-000		1	GEAR, 19T		
7	RC1-6900-000		1	GEAR, 34T		
8	RC1-6904-000		1	SPRING, TENSION		
9	RC1-6905-000		1	ARM, PICK-UP GEAR STOPPER		
10	RC1-6906-000		1	MOUNT, SOLENOID		
11	RC1-6908-000		1	GEAR, 49T		
12	RC1-6910-000		1	SPRING, TENSION		
13	RC1-6912-000		1	GEAR, 23T/31T		
14	RC1-6913-000		1	GEAR, 15T/31T		
15	RC1-6915-000		1	BUSHING		
16	RC1-6919-000		1	SHAFT, PAPER PICK-UP DRIVE		
17	RC1-6932-000		1	GUIDE, CASSETTE, LEFT REAR		
18	RC1-6938-000		3	SPRING, GROUNDING		
19	RC1-6940-000		1	GUIDE, PAPER		
20	VS1-7257-007		1	CONNECTOR, DRAWER		
21	FC7-7079-000		1	COVER, LEFT		
22	FC7-7081-000		1	COVER, RIGHT		
23	FC7-7083-000		1	COVER, REAR		
24	XD3-2200-162		2	PIN ,PARALLEL		
25	RC1-6962-000		1	BUSHING		
26	RC1-6964-000		3	GUIDE, GROUNDING SPRING		
27	XA9-1671-000		AR	SCREW, D, M3X8		
28	RC1-6701-000		1	SUPPORT, RIGHT LOWER, REAR		
29	RC1-6892-000		1	HOLDER, DRAWER CONNECTOR		
30	FC7-7070-000		1	GUIDE, CASSETTE FRONT, RIGHT		
31	RC1-6936-000		1	GUIDE, CASSETTE, RIGHT REAR		

FIGURE & KEY NO.	PARTS NUMBER	R A N K	Q'TY	DESCRIPTION	SERIAL NUMBER/ REMARKS	S V C
32	RC1-6937-000		1	GUIDE, LIFTER PLATE, RIGHT		
33	RC1-6956-000		1	GUIDE, CASSETTE, RIGHT CENTER		
34	RC1-6960-000		1	STAY, REINFORCEMENT, FRONT		
35	RM1-2731-000		1	PICK-UP GEAR ASS'Y		
36	FC7-7069-000		1	GUIDE, CASSETTE FRONT, LEFT		
37	RC1-6933-000		1	GUIDE, LIFTER PLATE, LEFT		
38	RC1-6957-000		1	GUIDE, CASSETTE, LEFT CENTER		
39	FC7-7080-000		1	COVER, LEFT FRONT		
40	RM1-2730-000		1	SWING GEAR ASS'Y		
41	FC7-7082-000		1	COVER, RIGHT FRONT		
42	XZ9-0624-000		4	CASTER		
43	FC7-7087-000		2	PLATE, FIXED		
44	FC7-7088-000		2	COVER, BLANKING		
45	FC7-7089-000		2	SCREW, FIXED, M3X20.6		

FIGURE R30 CASSETTE

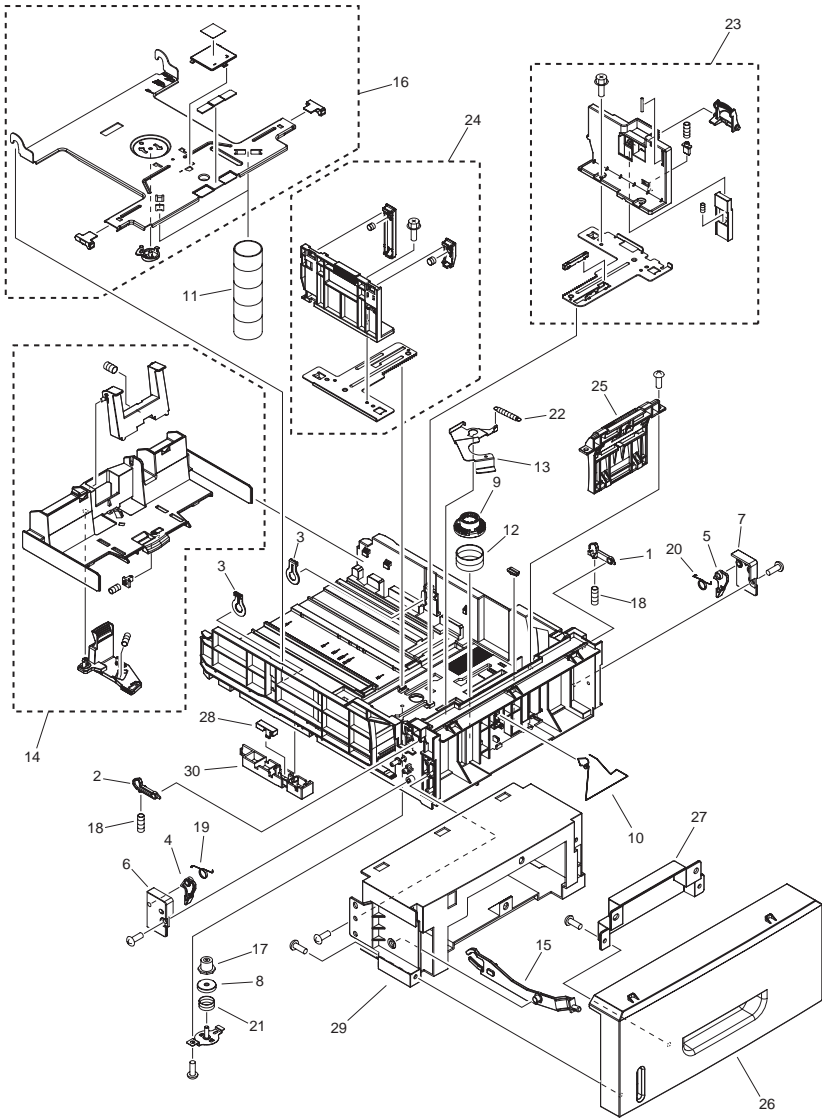

FIGURE & KEY NO.	PARTS NUMBER	R A N K	Q'TY	DESCRIPTION	SERIAL NUMBER/ REMARKS	S V C
Fig.R30	FM3-1657-000		RF	CASSETTE		
1	RC1-3507-000		1	STOPPER, CASSETTE, RIGHT		
2	RC1-3508-000		1	STOPPER, CASSETTE, LEFT		
3	RC1-4216-000		2	CAP, HINGE		
4	RC1-4273-000		1	STOPPER, LEFT		
5	RC1-4274-000		1	STOPPER, RIGHT		
6	RC1-4275-000		1	COVER, CAM, LEFT		
7	RC1-4276-000		1	COVER, CAM, RIGHT		
8	RC1-4278-000		1	FLANGE		
9	RC1-4285-000		1	BASE, CASSETTE LIFT SPRING		
10	RC1-6943-000		1	SPRING, GROUNDING		
11	RC1-6880-000		2	SPRING, COMPRESSION		
12	RC1-6881-000		1	SPRING, COMPRESSION		
13	RC1-6891-000		1	ARM, SPRING LOCK		
14	RM1-2737-000		1	BACK END LIMIT PLATE ASS'Y		
15	RC2-1708-000		1	ARM, REMNANT INDICATION		
16	RM1-2736-000		1	LIFTER PLATE ASS'Y		
17	RU5-0426-010		1	GEAR, 10T		
18	RU5-2327-000		2	SPRING, COMPRESSION		
19	RU5-2431-000		1	SPRING, TORSION		
20	RU5-2432-000		1	SPRING, TORSION		
21	RU5-2433-000		1	SPRING, COMPRESSION		
22	RU5-2436-000		1	SPRING, TENSION		
23	RM1-2733-000		1	PAPER SIDE END RIGHT ASS'Y		
24	RM1-2734-000		1	PAPER SIDE END LEFT ASS'Y		
25	RM1-2735-020		1	SEPARATION PAD HOLDER ASS'Y		
26	FC7-7077-000		1	COVER, CASSETTE, FRONT		
27	FC7-7084-000		1	COVER, CASSETTE FRONT, SMALL		
28	FC7-7124-000		1	STOPPER		
29	FC7-7135-000		1	FRAME, CASSETTE, FRONT		
30	FC7-7136-000		1	STOPPER, CASSETTE		

FIGURE R40 PAPER PICK-UP FRAME ASS'Y

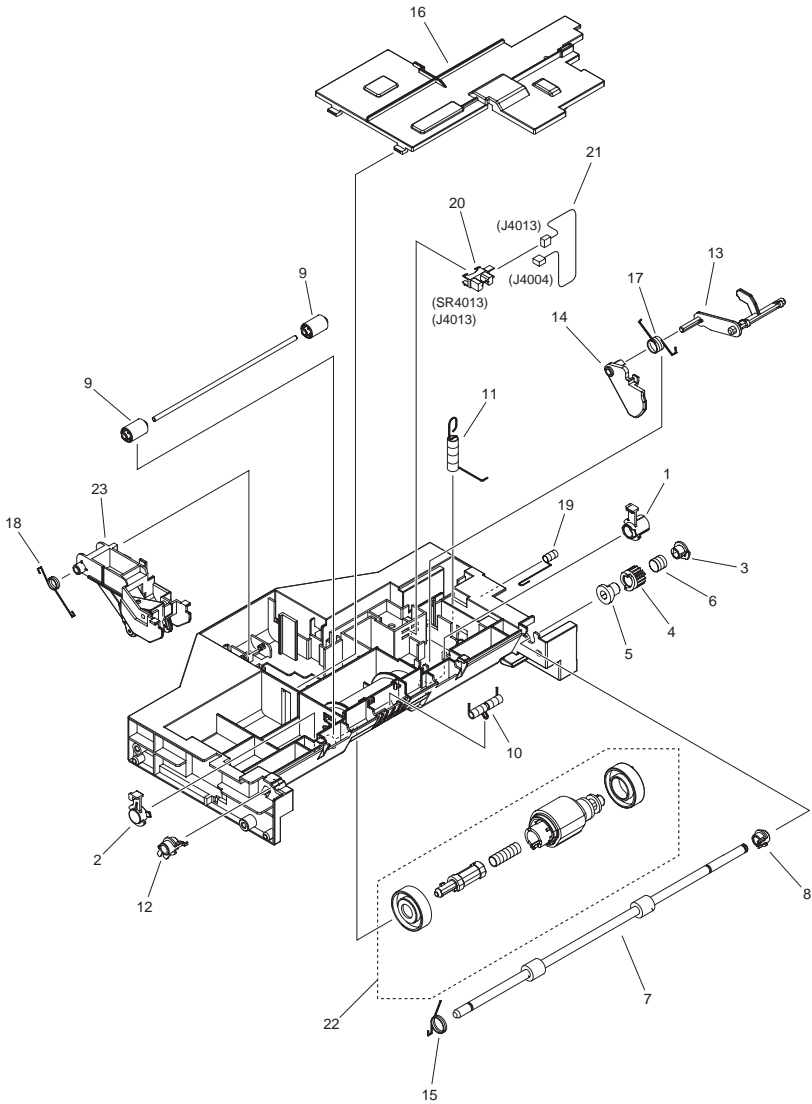

FIGURE & KEY NO.	PARTS NUMBER	R A N K	Q'TY	DESCRIPTION	SERIAL NUMBER/ REMARKS	S V C
Fig.R40	FM3-3829-000		RF	PAPER PICK-UP FRAME ASS'Y		
1	RC1-2182-000		1	BUSHING		
2	RC1-2192-000		1	BUSHING		
3	RC1-6920-000		1	COLLAR, ONE-WAY CLUTCH GEAR		
4	RC1-6921-000		1	GEAR, 15T		
5	RC1-6922-020		1	CLUTCH, ONE-WAY		
6	RC1-6923-000		1	SPRING, COMPRESSION		
7	RC1-6924-000		1	ROLLER, PAPER FEED		
8	RC1-6925-000		1	BUSHING		
9	RC1-6926-000		2	ROLLER, PAPER FEED		
10	RC1-6928-000		1	SPRING, TORSION		
11	RC1-6938-000		1	SPRING, GROUNDING		
12	RC1-6950-000		1	BUSHING		
13	RC1-6951-000		1	ARM, PAPER SENSOR, 1		
14	RC1-6952-000		1	ARM, PAPER SENSOR, 2		
15	RC1-6953-000		1	SPRING, TORSION		
16	RC1-6954-000		1	COVER, MEDIA SENSOR		
17	RC1-6955-000		1	SPRING, TORSION		
18	RC1-6972-000		1	SPRING, TORSION		
19	RC1-6973-000		1	SPRING, GROUNDING		
20	WG8-5696-000		1	PHOTO INTERRUPTER, TLP1243	SR4013	
21	RM1-2625-000		1	CABLE, OPTION SENSOR		
22	RM1-2727-000		1	PAPER PICK-UP ROLLER ASS'Y		
23	FM3-3830-000		1	MEDIA GUIDE ASSEMBLY		

Canon