

imageRUNNER ADVANCE DX C477iF/C477iFZ

PARTS CATALOG



Canon

August 25, 2020
Rev. 0

Index

SNL	Product Code No. /Serial No.
A1A	ASSEMBLY LOCATION DIAGRAM (IR-ADV DX C477iFZ)
A1B	ASSEMBLY LOCATION DIAGRAM (IR-ADV DX C477iF)
A1E	ASSEMBLY LOCATION DIAGRAM (IR-ADV DX C477iZ)
A1F	ASSEMBLY LOCATION DIAGRAM (IR-ADV DX C477i)
A2	OPTION PARTS CATALOG LIST
001A	ACCESSORIES
100A	EXTERNAL COVERS, PANELS, ETC. (FINISHER model)
100B	EXTERNAL COVERS, PANELS, ETC. (MODEL WITHOUT FINISHER)
101	INTERNAL COMPONENTS 1
102A	INTERNAL COMPONENTS 2 (FINISHER model)
102B	INTERNAL COMPONENTS 2 (MODEL WITHOUT FINISHER)
103	INTERNAL COMPONENTS 3
104A	INTERNAL COMPONENTS 4
105	INTERNAL COMPONENTS 5
106A	INTERNAL COMPONENTS 6 (IR-ADV DX C477iFZ)
106B	INTERNAL COMPONENTS 6 (IR-ADV DX C477iF)
106E	INTERNAL COMPONENTS 6 (IR-ADV DX C477iZ)
106F	INTERNAL COMPONENTS 6 (IR-ADV DX C477i)
107A	INTERNAL COMPONENTS 7 (FINISHER model)
107B	INTERNAL COMPONENTS 7 (MODEL WITHOUT FINISHER)
130	CONTROL PANEL ASSEMBLY
350	FINISHER ASSEMBLY (FINISHER model)
351	STAPLE ASSEMBLY (FINISHER model)
900	CONTROLLER BOX ASSEMBLY
B01	ADF MAINTENANCE KIT
B10	READER/ADF ASSEMBLY
B11	AUTO DOCUMENT FEEDER ASS'Y SET
B12	PAPER PICK-UP COVER ASS'Y
D10	READER ASSEMBLY
T20	FAX ASSEMBLY (FAX model)
T21	SPEAKER ASSEMBLY (FAX model)
ZZA	MECHANICAL STANDARD PARTS (HOW TO USE)
ZZB	MECHANICAL STANDARD PARTS (SCREWS)
ZZC	MECHANICAL STANDARD PARTS (BOLTS)
ZZD	MECHANICAL STANDARD PARTS (NUTS)
ZZE	MECHANICAL STANDARD PARTS (RETAINING RINGS)

Figure SNL Product Code No./Serial No.

	Product Code No.	Model Name	Remarks	Serial No.
1	F17-8731-000	imageRUNNER ADVANCE DX C477iFZ	FINISHER model FAX model	2PD
2	F17-8735-000	imageRUNNER ADVANCE DX C477iF	MODEL WITHOUT FINISHER FAX model	2PB
3	F17-8791-000	imageRUNNER ADVANCE DX C477iZ	FINISHER model	2PF
4	F17-8795-000	imageRUNNER ADVANCE DX C477i	MODEL WITHOUT FINISHER	28Q

	中オーダー	製品名	備考	シリアル No.
1	F17-8731-000	imageRUNNER ADVANCE DX C477iFZ	FINISHER model FAX model	2PD
2	F17-8735-000	imageRUNNER ADVANCE DX C477iF	MODEL WITHOUT FINISHER FAX model	2PB
3	F17-8791-000	imageRUNNER ADVANCE DX C477iZ	FINISHER model	2PF
4	F17-8795-000	imageRUNNER ADVANCE DX C477i	MODEL WITHOUT FINISHER	28Q

FIGURE & KEY NO.	PART NUMBER	RANK	QTY	DESCRIPTION	SERIAL NUMBER /REMARKS
SNL	NPN		RF	Product Code No./Serial No.	
1	F17-8731-000		1	imageRUNNER ADVANCE DX C477iFZ	2PD FINISHER model FAX model
1	F17-8791-000		1	imageRUNNER ADVANCE DX C477iZ	2PF FINISHER model
2	F17-8795-000		1	imageRUNNER ADVANCE DX C477i	28Q MODEL WITHOUT FINISHER
2	F17-8735-000		1	imageRUNNER ADVANCE DX C477iF	2PB MODEL WITHOUT FINISHER FAX model

Figure A1A ASSEMBLY LOCATION DIAGRAM (IR-ADV DX C477iFZ)

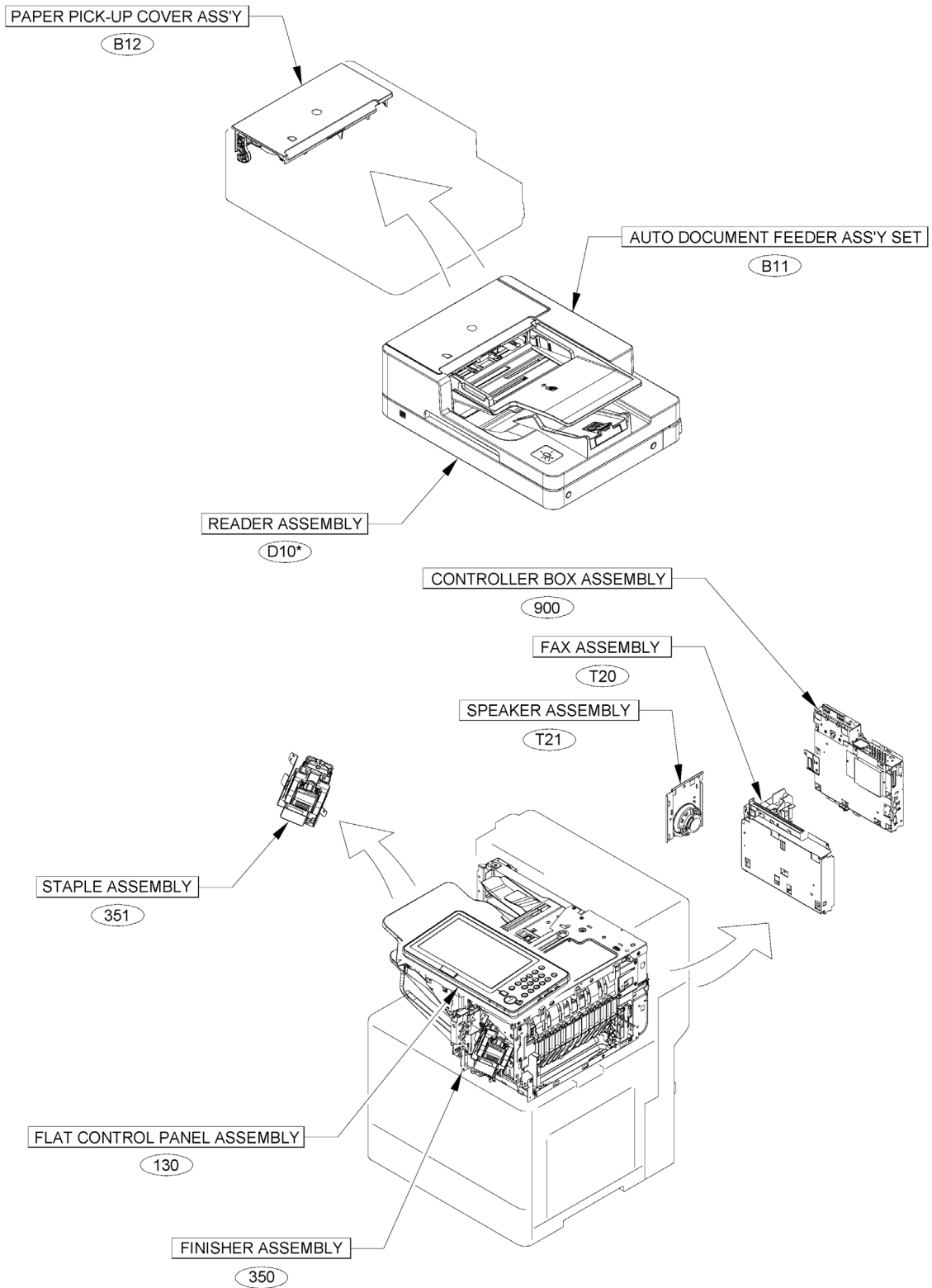

Figure A1B ASSEMBLY LOCATION DIAGRAM (IR-ADV DX C477iF)

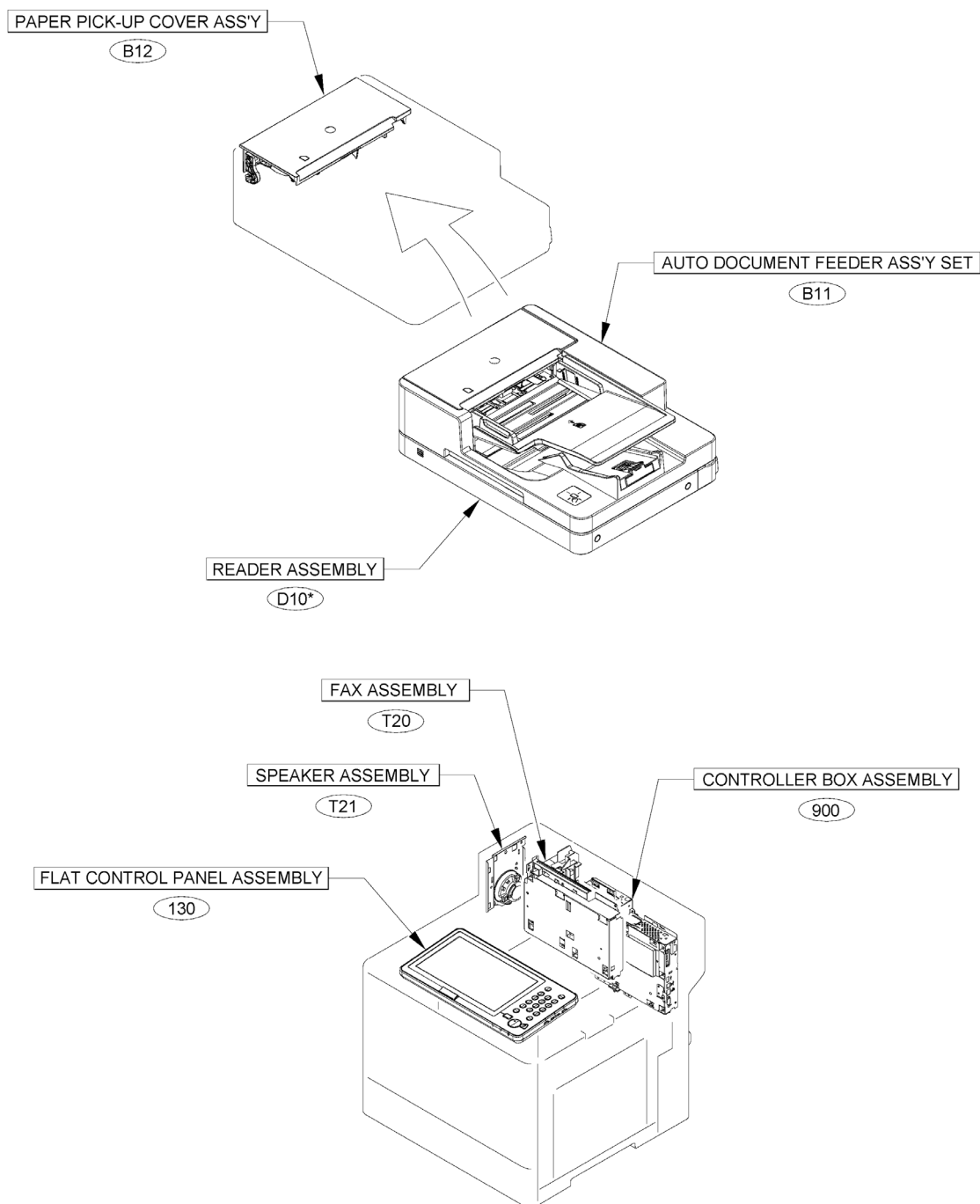

Figure A1E ASSEMBLY LOCATION DIAGRAM (IR-ADV DX C477iZ)

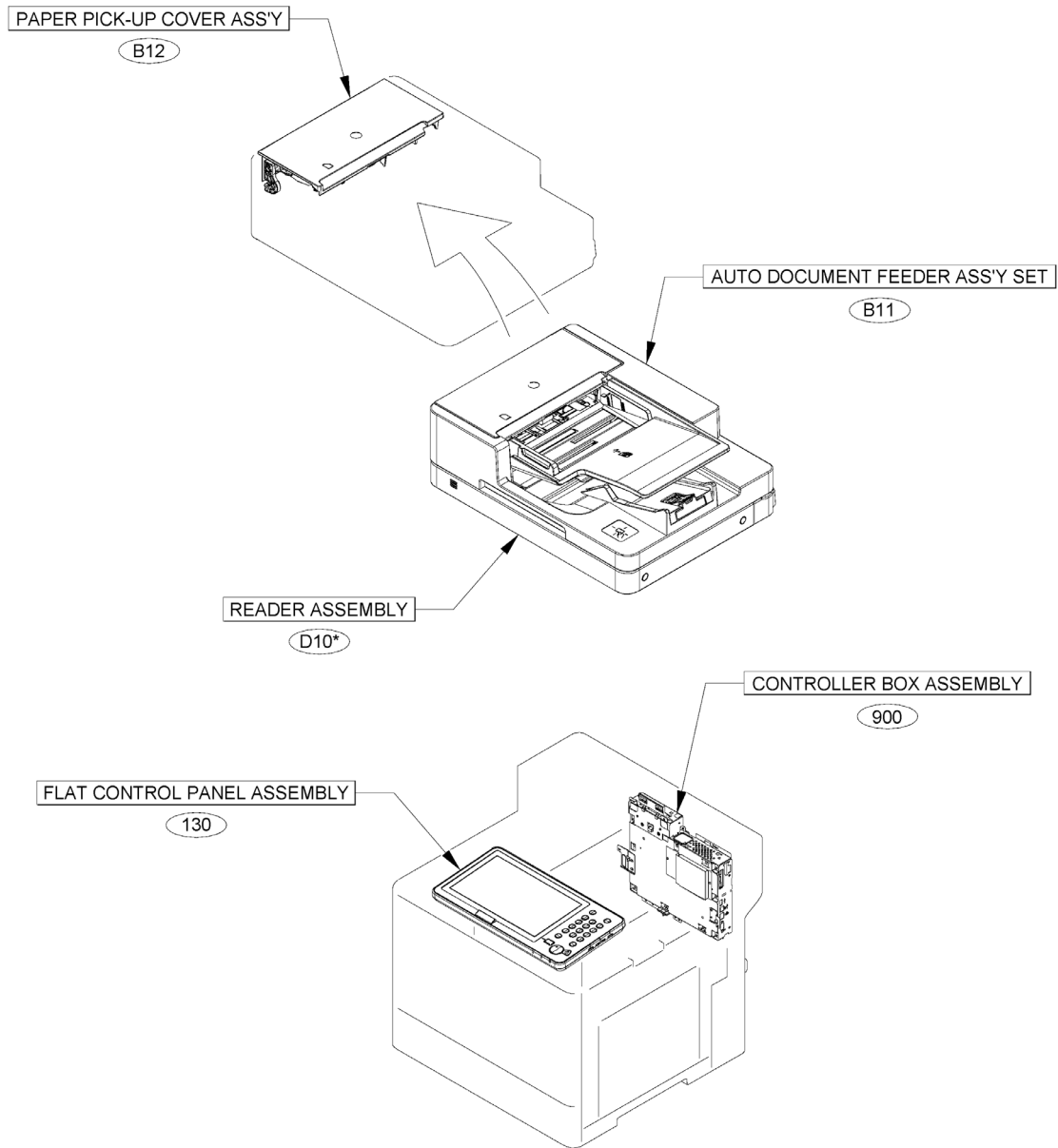

Figure A1F ASSEMBLY LOCATION DIAGRAM (IR-ADV DX C477i)

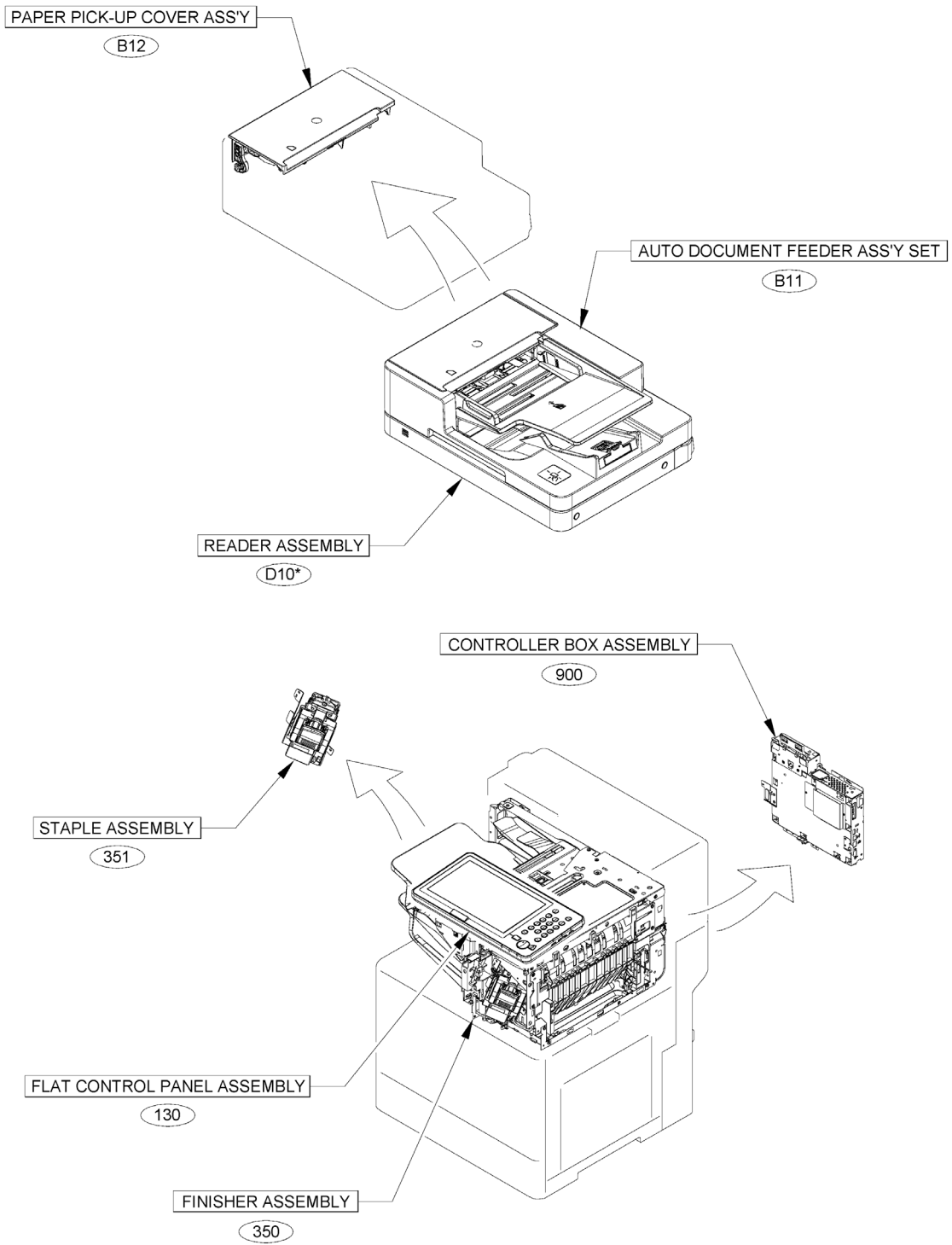

Figure A2 OPTION PARTS CATALOG LIST

This is the table of the machine's options whose parts catalog is issued.
 本機のオプションで、パーツカタログが発行されている機種の一覧である。

No.	Model Name(English)	Model Name(Japanese)
1	ADF Access Handle-A1	(日本仕向けなし)
2	NFC Kit-E1	(日本仕向けなし)
3	Cassette Feeding Unit-AS1/AT1	(日本仕向けなし)
4	Cassette Module-AJ1	(日本仕向けなし)
5	Copy Card Reader Attachment-B5	(日本仕向けなし)
6	Super G3 FAX Board-AT1	(日本仕向けなし)
7	Copy Control Interface Kit-A1	(日本仕向けなし)
8	IC Card Reader Box-D1	(日本仕向けなし)
9	Copy Card Reader-F1	(日本仕向けなし)
10	Connection Kit-A1 for Bluetooth LE	(日本仕向けなし)

Figure 001A ACCESSORIES

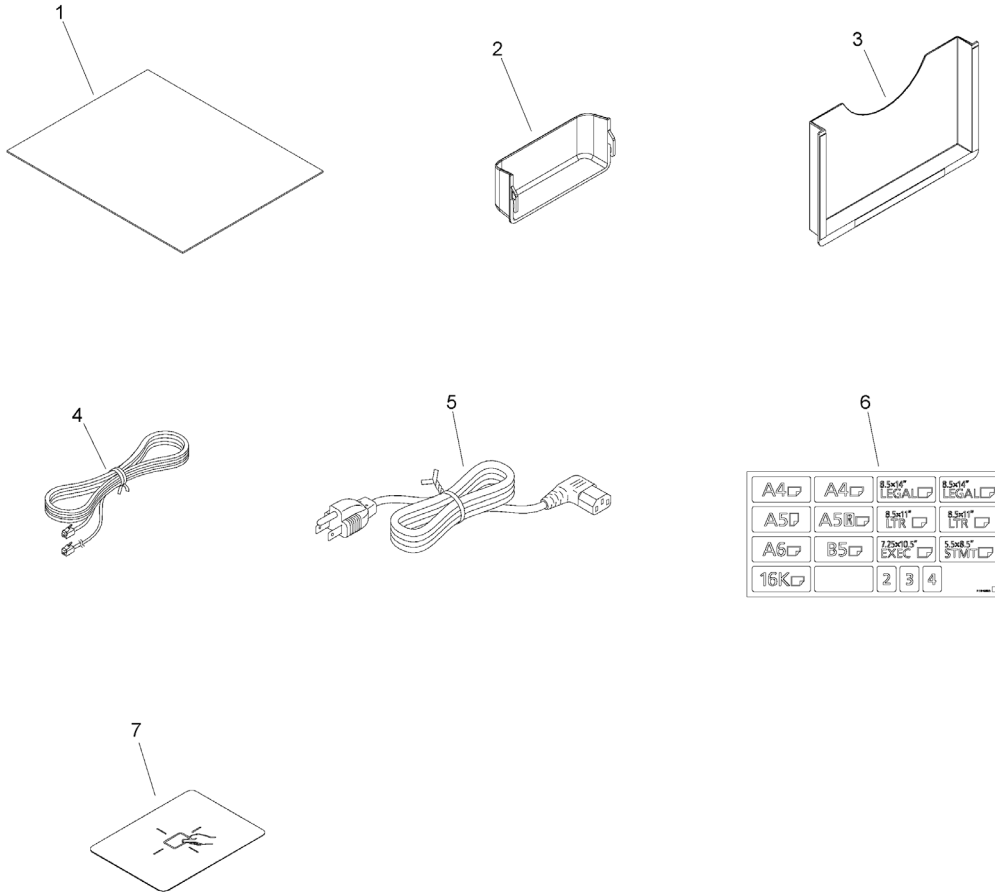

FIGURE & KEY NO.	PART NUMBER	RANK	QTY	DESCRIPTION	SERIAL NUMBER /REMARKS
001A	NPN		RF	ACCESSORIES	
1	FE2-A001-000		1	CLOTH, CLEANING	
2	FE2-H874-000		1	BOX, CLEANING CLOTH STOCK	
3	FE4-3758-000		1	HOLDER, SERVICE BOOK	
4	FK2-5275-000		1	CORD, MODULAR	
5	FK4-5598-000		1	CORD, POWER	
6	FE8-6065-000		1	LABEL, CASSETTE	
7	FL4-0487-000		1	LABEL, CARD READER	

Figure 100A EXTERNAL COVERS, PANELS, ETC. (FINISHER model)

NOTE 1 : Several kinds of labels are attached on the board for the parts of Key No. 33.

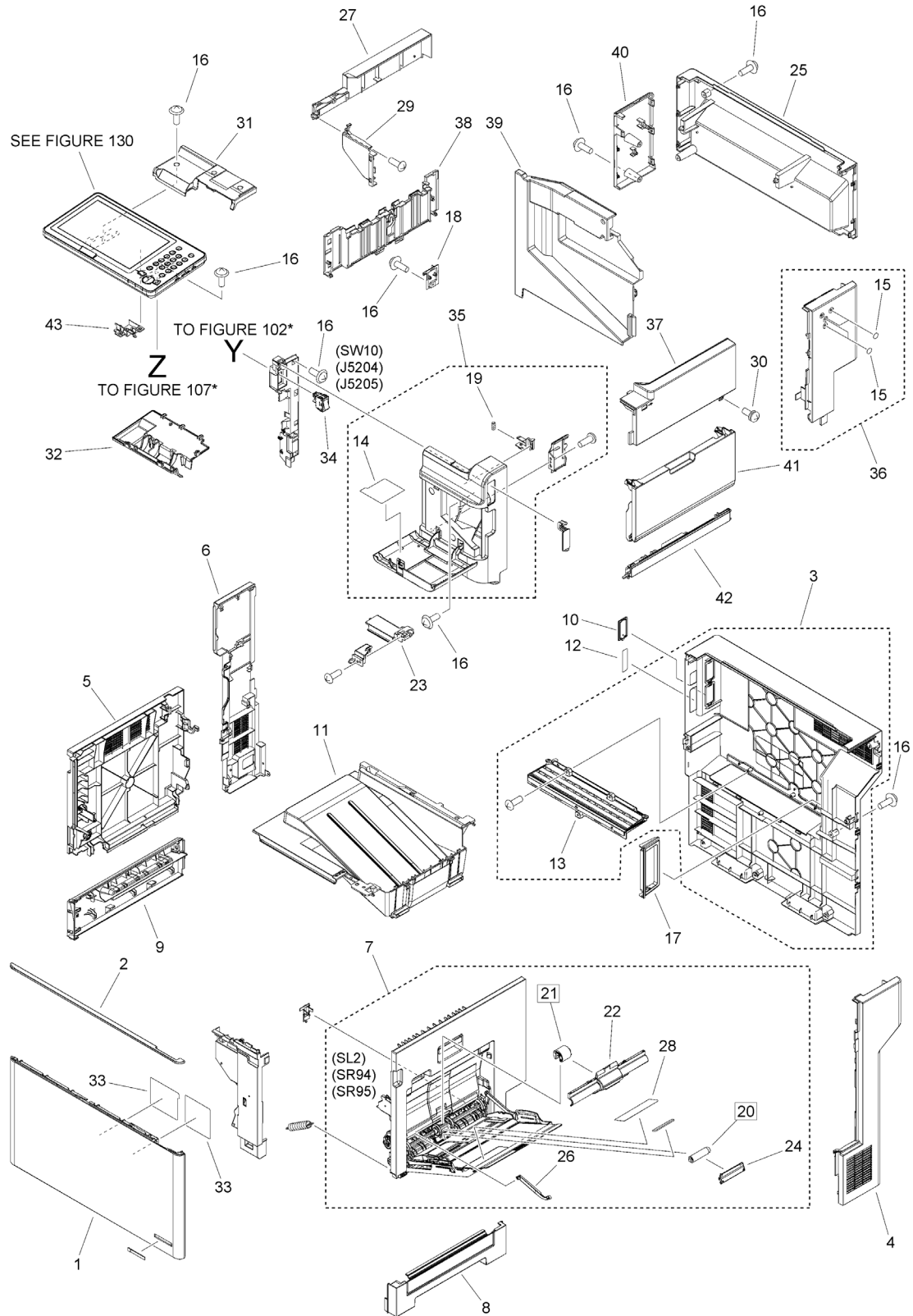

FIGURE & KEY NO.	PART NUMBER	RANK	QTY	DESCRIPTION	SERIAL NUMBER /REMARKS
100A	NPN		RF	EXTERNAL COVERS, PANELS, ETC.	FINISHER model
1	FM1-Z048-000		1	FRONT DOOR ASS'Y	
2	FE2-A627-000		1	DOOR, FRONT, UPPER	
3	FM1-Y780-000		1	REAR COVER ASSEMBLY	
4	FE2-A640-000		1	COVER, RIGHT REAR	
5	FL1-5586-000		1	DOOR, LEFT	
6	FE2-A634-000		1	COVER, LEFT REAR	
7	FM1-U440-000		1	RIGHT DOOR ASS'Y	SL2, SR94, SR95
8	FM1-U437-000		1	RIGHT HANDLE ASS'Y	
9	FM1-U435-000		1	LEFT HANDLE ASS'Y	
10	FE3-9088-000		1	COVER, FAX CONNECTOR	
11	FM1-U434-000		1	FACE-DOWN TRAY ASS'Y	
12	FE8-4239-000		1	LABEL, FAX	
13	FM1-V752-000		1	COVER, LOUVER, REAR	
14	FE3-7418-000		1	LABEL, CONTROL	
15	FC6-4513-000		4	SEAL	
16	XA9-1671-000		15	SCREW, D, M3X8	
17	FE8-6098-000		1	PANEL, INTERFACE, REAR	
18	FE8-6129-000		1	COVER, 2 BIN, REAR	
19	FE8-6054-000		1	SPRING, COMPRESSION	
20	RL2-0079-000		1	ROLLER, MULTI-PURPOSE SEP.	[DP]
21	RL2-0034-000		1	ROLLER, MULTI-PURPOSE	[DP]
22	RC4-7318-000		1	MP ROLLER COVER	
23	FE2-A649-000		1	COVER, FACE-DOWN TRAY	
24	RC4-0548-000		1	GUIDE, NIP	
25	FE2-A680-000		1	COVER, REAR	
26	RC4-7316-000		1	MULTI-PURPOSE ARM, LEFT	
27	FE2-A692-000		1	COVER, JOG, LEFT	
28	FE2-C050-000		1	LABEL, MULTI PAPER PICK-UP	
29	FE2-A693-000		1	COVER, JOG, FRONT	
30	XA9-1451-000		1	SCREW,W/WASHER,M3X10,ZC3	
31	FE2-E422-000		1	COVER, CONTROL PANEL, UPPER	
32	FL4-0619-000		1	COVER, CONNECTOR	
33	FL1-5593-010		1	LABEL, SERVICE	SEE NOTE
34	FK3-2835-000		1	SWITCH, MAIN POWER SUPPLY	SW10
35	FM1-X616-000		1	STAPLE COVER ASS'Y	
36	FL1-6372-000		1	COVER, RIGHT, REAR	
37	FE2-E426-000		1	COVER, RIGHT, UPPER	
38	RM2-1057-000		1	STACKING WALL ASS'Y	
39	FE2-A679-000		1	COVER, INNER, REAR	
40	FE2-A681-000		1	COVER, LEFT	
41	FM1-U456-000		1	RIGHT DOOR ASS'Y	
42	FE8-6122-000		1	COVER, FINISHER, RIGHT LOWER	
43	FE2-D432-000		1	HOLDER, CABLE	

Figure 100B EXTERNAL COVERS, PANELS, ETC. (MODEL WITHOUT FINISHER)

NOTE 1 : Several kinds of labels are attached on the board for the parts of Key No. 32.

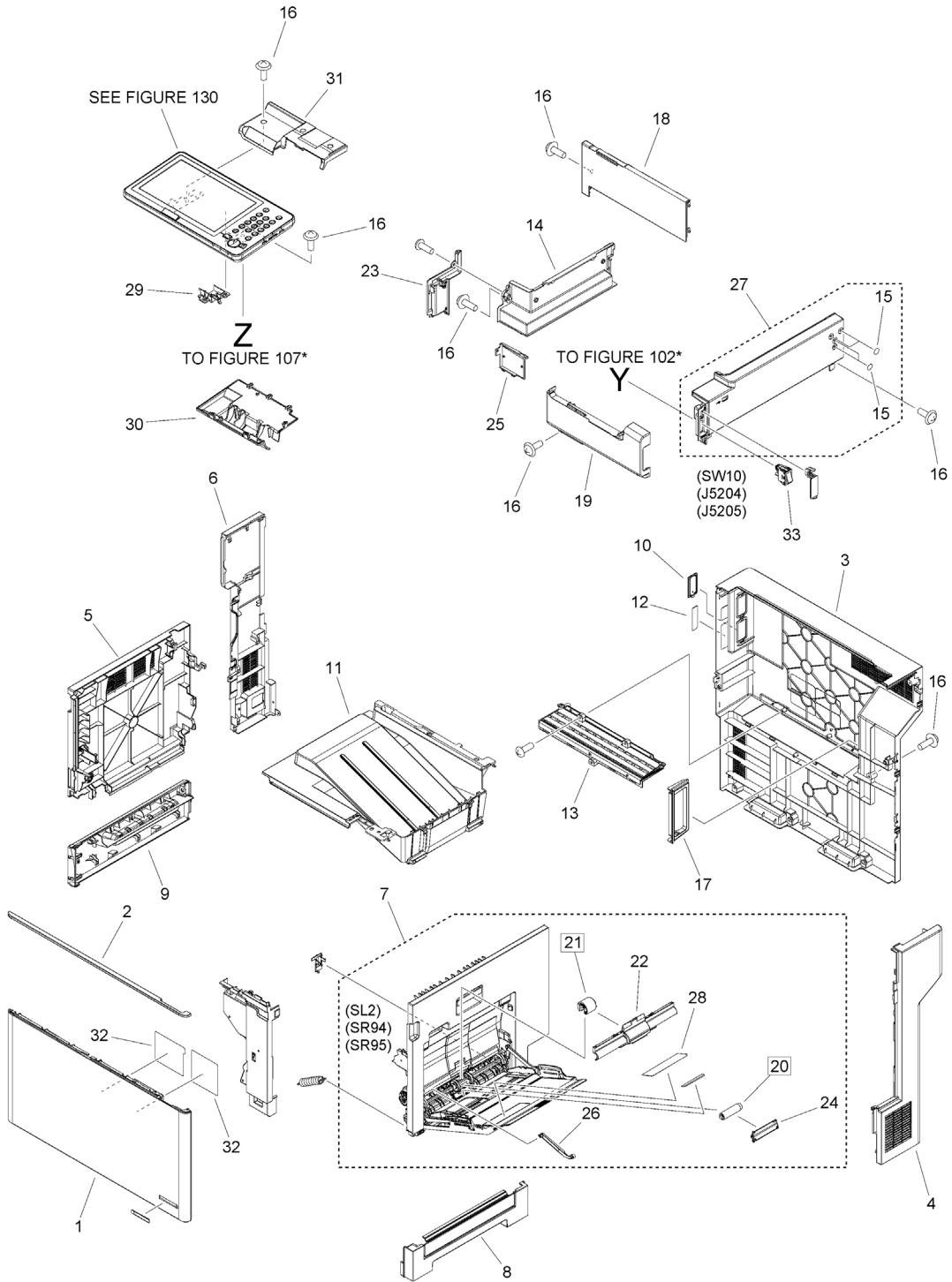

FIGURE & KEY NO.	PART NUMBER	RANK	QTY	DESCRIPTION	SERIAL NUMBER /REMARKS
100B	NPN		RF	EXTERNAL COVERS, PANELS, ETC.	MODEL WITHOUT FINISHER
1	FM1-Z048-000		1	FRONT DOOR ASS'Y	
2	FE2-A627-000		1	DOOR, FRONT, UPPER	
3	FL1-6533-000		1	COVER, REAR	
4	FE2-A640-000		1	COVER, RIGHT REAR	
5	FL1-5586-000		1	DOOR, LEFT	
6	FE2-A634-000		1	COVER, LEFT REAR	
7	FM1-U440-000		1	RIGHT DOOR ASS'Y	SL2, SR94, SR95
8	FM1-U437-000		1	RIGHT HANDLE ASS'Y	
9	FM1-U435-000		1	LEFT HANDLE ASS'Y	
10	FE3-9088-000		1	COVER, FAX CONNECTOR	
11	FM1-U434-000		1	FACE-DOWN TRAY ASS'Y	
12	FE8-4239-000		1	LABEL, FAX	
13	FM1-V752-000		1	COVER, LOUVER, REAR	
14	FE2-A644-010		1	COVER, FACE-DOWN INNER	
15	FC6-4513-000		4	SEAL	
16	XA9-1671-000		15	SCREW, D, M3X8	
17	FE8-6098-000		1	PANEL, INTERFACE, REAR	
18	FE2-A645-000		1	COVER, FACE-DOWN INNER, REAR	
19	FE2-E423-000		1	COVER, FRONT, UPPER	
20	RL2-0079-000		1	ROLLER, MULTI-PURPOSE SEP.	[DP]
21	RL2-0034-000		1	ROLLER, MULTI-PURPOSE	[DP]
22	RC4-7318-000		1	MP ROLLER COVER	
23	FE2-A648-000		1	COVER, FRONT, LEFT	
24	RC4-0548-000		1	GUIDE, NIP	
25	FE2-B029-000		1	COVER, FACE-DOWN INNER SUB	
26	RC4-7316-000		1	MULTI-PURPOSE ARM, LEFT	
27	FL4-0744-000		1	COVER, RIGHT, UPPER	
28	FE2-C050-000		1	LABEL, MULTI PAPER PICK-UP	
29	FE2-D432-000		1	HOLDER, CABLE	
30	FE2-E422-000		1	COVER, CONTROL PANEL, UPPER	
31	FL4-0619-000		1	COVER, CONNECTOR	
32	FL1-5593-010		1	LABEL, SERVICE	SEE NOTE
33	FK3-2835-000		1	SWITCH, MAIN POWER SUPPLY	SW10

Figure 101 INTERNAL COMPONENTS 1

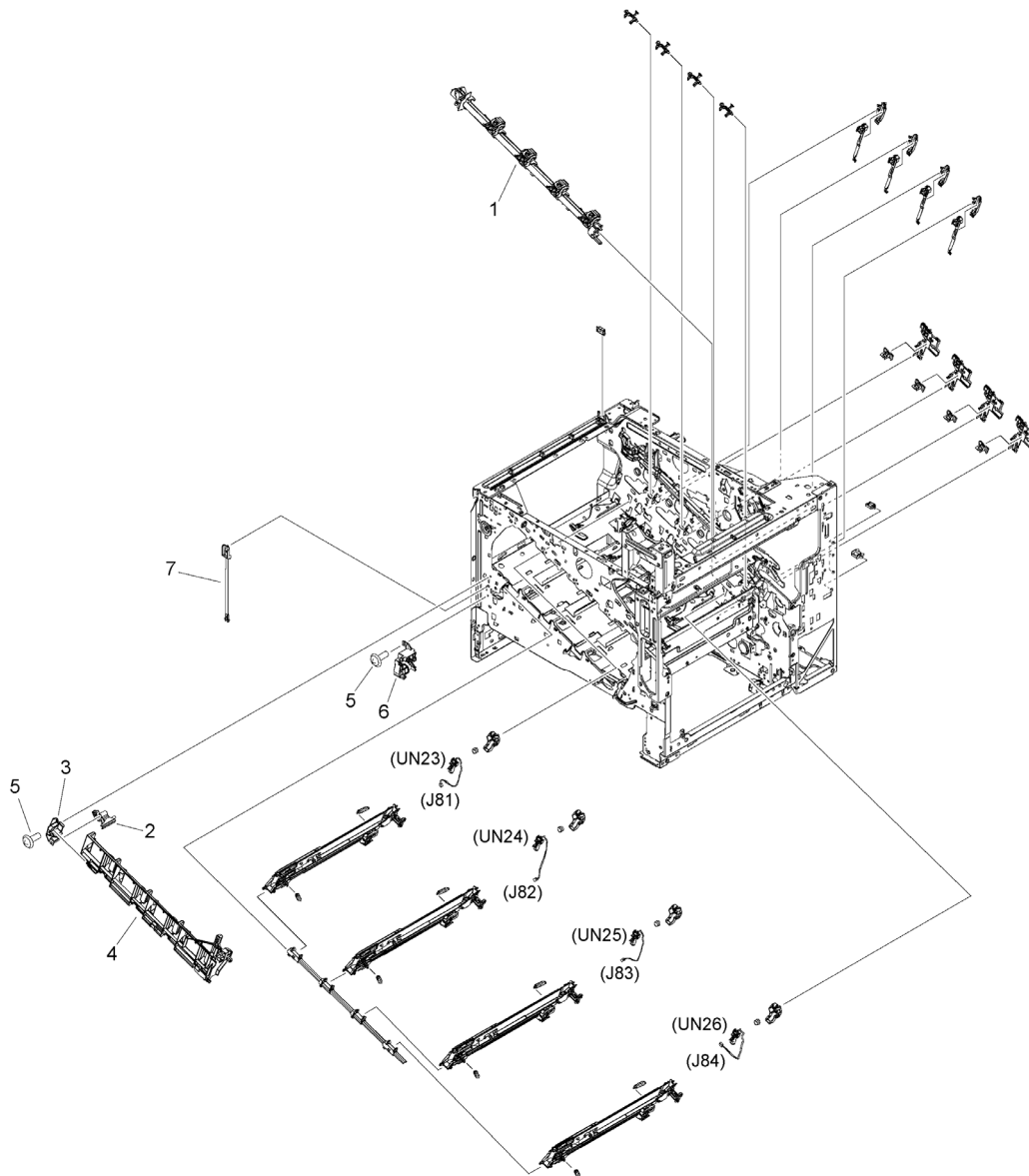

FIGURE & KEY NO.	PART NUMBER	RANK	QTY	DESCRIPTION	SERIAL NUMBER /REMARKS
101	NPN		RF	INTERNAL COMPONENTS 1	
1	RM2-6620-000		1	TONER CARRY ASS'Y	
2	RC4-6519-000		1	LEVER, DETECT	
3	RC4-6540-000		1	HINGE, INNER DOOR	
4	FL1-5587-000		1	DOOR, INNER	
5	XA9-1671-000		15	SCREW, D, M3X8	
6	RC4-6585-000		1	HINGE, FRONT COVER, LEFT	
7	RC4-6588-000		1	BAND, COVER, FRONT	

Figure 102A INTERNAL COMPONENTS 2 (FINISHER model)

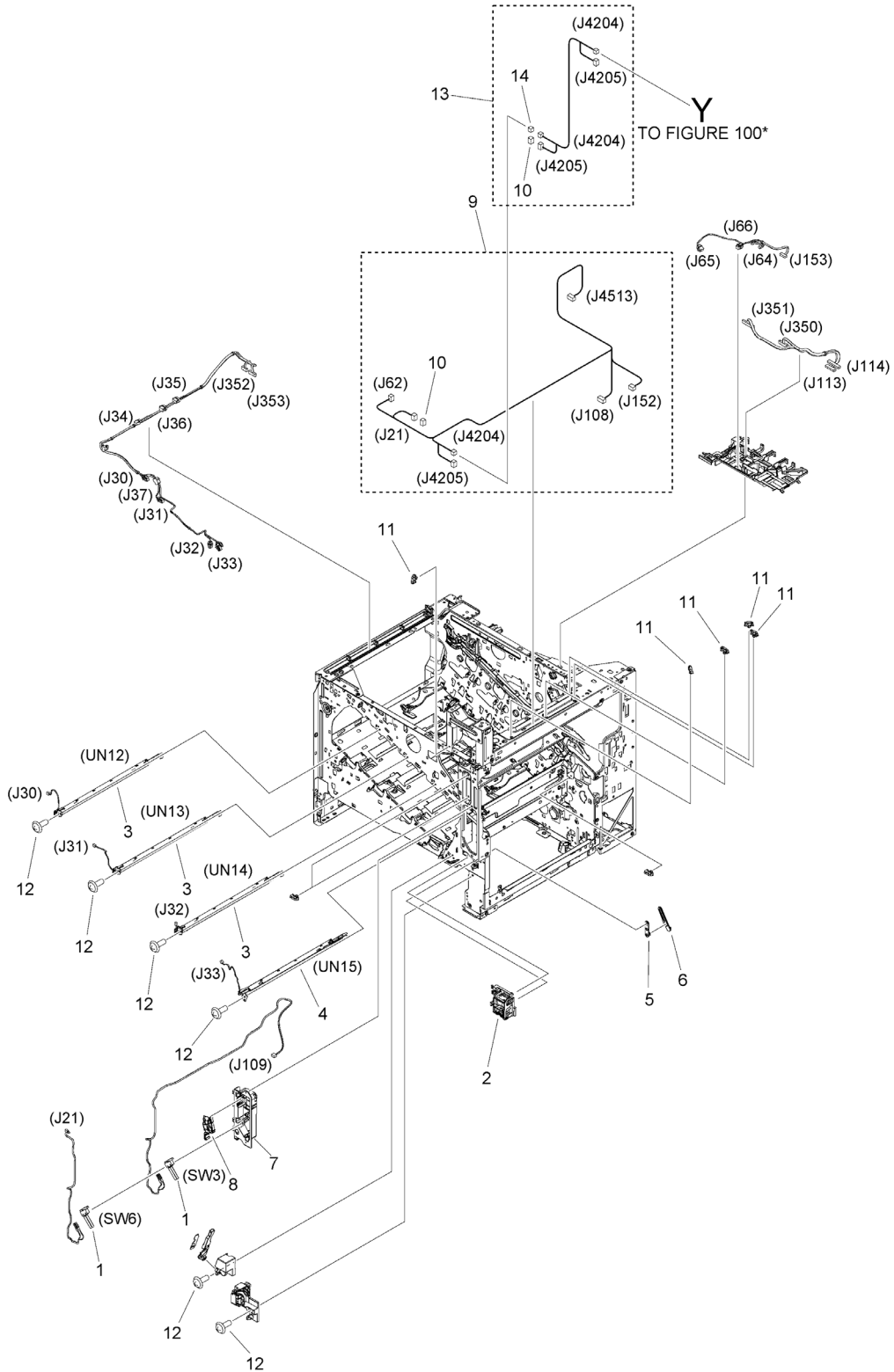

FIGURE & KEY NO.	PART NUMBER	RANK	QTY	DESCRIPTION	SERIAL NUMBER /REMARKS
102A	NPN		RF	INTERNAL COMPONENTS 2	FINISHER model
1	RK2-0535-000		2	MICROSWITCH	SW3, SW6
2	RC4-6492-000		1	HOLDER, SWITCH	
3	RM3-7046-000		3	PRE-EXPOSURE PCB ASS'Y	UN12, UN13, UN14
4	RM3-7047-000		1	PRE-EXPOSURE PCB ASS'Y	UN15
5	RC4-9411-000		1	STRAP, DOOR, FRONT	
6	RC4-9422-000		1	STRAP, DOOR, FRONT	
7	RC4-6533-000		1	HOLDER, DOOR LINK	
8	RM2-6648-000		1	DOOR LINK LEVER ASS'Y	
9	FM2-F922-000		1	CABLE, TOP R	
10	VS1-7440-003		2	CONNECTOR, SNAP TIGHT	
11	WT2-6493-000		5	CLAMP, CABLE	
12	XA9-1671-000		15	SCREW, D, M3X8	
13	FM2-F927-000		1	CABLE, MAIN SWITCH	
14	VS1-7440-002		1	CONNECTOR, SNAP TIGHT	

Figure 102B INTERNAL COMPONENTS 2 (MODEL WITHOUT FINISHER)

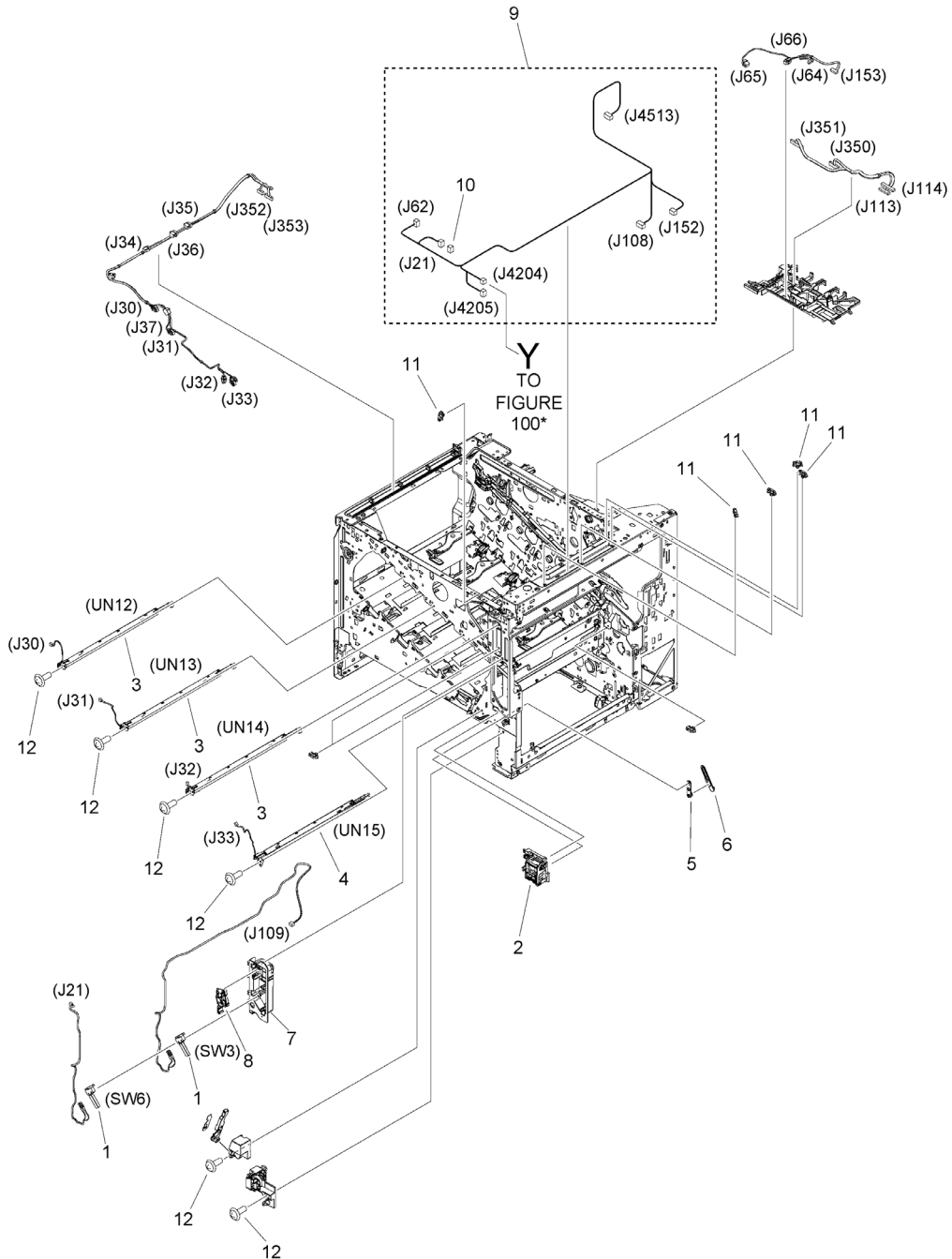

FIGURE & KEY NO.	PART NUMBER	RANK	QTY	DESCRIPTION	SERIAL NUMBER /REMARKS
102B	NPN		RF	INTERNAL COMPONENTS 2	MODEL WITHOUT FINISHER
1	RK2-0535-000		2	MICROSWITCH	SW3, SW6
2	RC4-6492-000		1	HOLDER, SWITCH	
3	RM3-7046-000		3	PRE-EXPOSURE PCB ASS'Y	UN12, UN13, UN14
4	RM3-7047-000		1	PRE-EXPOSURE PCB ASS'Y	UN15
5	RC4-9411-000		1	STRAP, DOOR, FRONT	
6	RC4-9422-000		1	STRAP, DOOR, FRONT	
7	RC4-6533-000		1	HOLDER, DOOR LINK	
8	RM2-6648-000		1	DOOR LINK LEVER ASS'Y	
9	FM2-F922-000		1	CABLE, TOP R	
10	VS1-7440-003		1	CONNECTOR, SNAP TIGHT	
11	WT2-6493-000		5	CLAMP, CABLE	
12	XA9-1671-000		15	SCREW, D, M3X8	

Figure 103 INTERNAL COMPONENTS 3

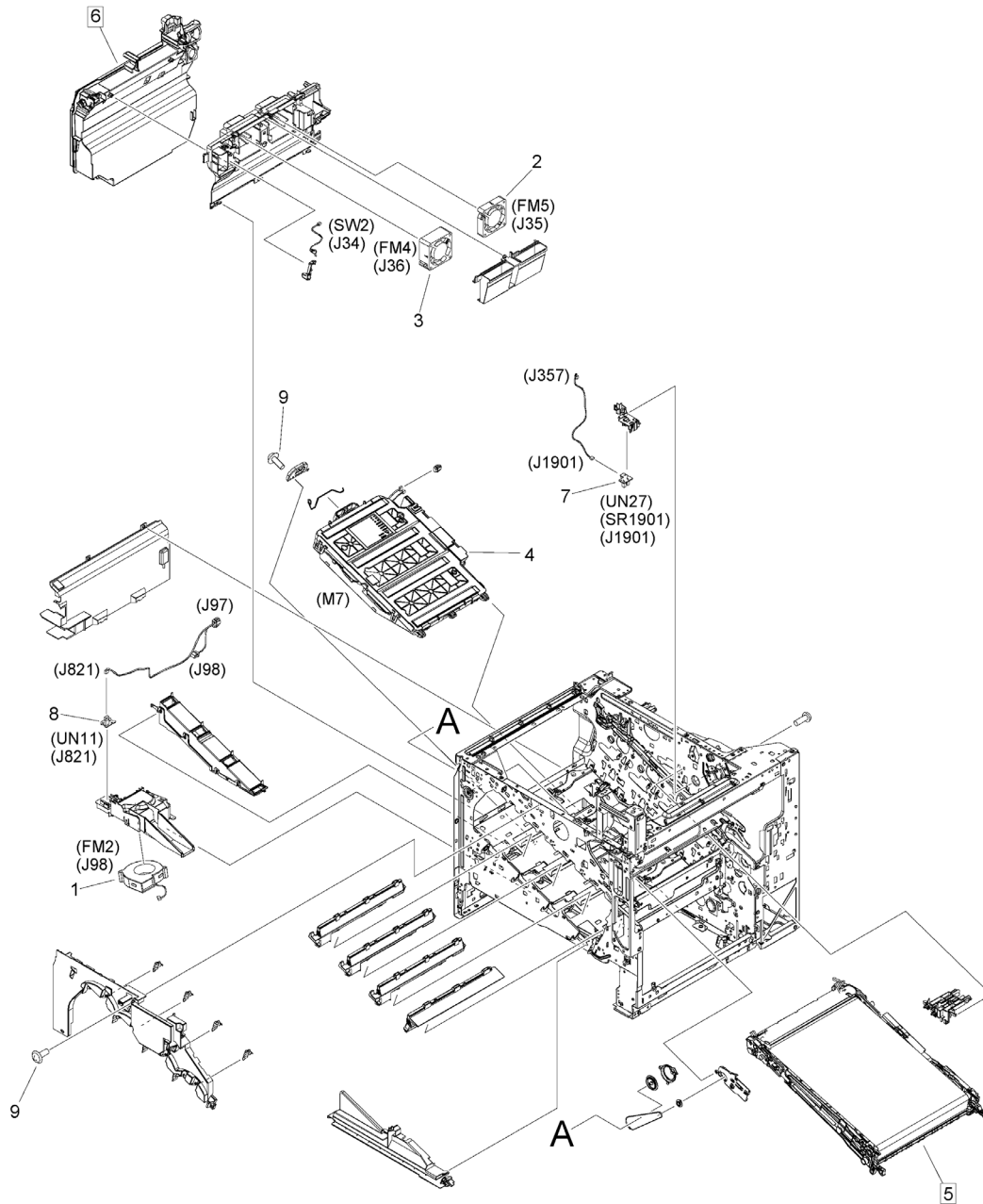

FIGURE & KEY NO.	PART NUMBER	RANK	QTY	DESCRIPTION	SERIAL NUMBER /REMARKS
103	NPN		RF	INTERNAL COMPONENTS 3	
1	RK2-6124-010		1	FAN	FM2
2	RK2-7949-000		1	FAN	FM5
3	RK2-7951-000		1	FAN	FM4
4	RM2-1237-000		1	SCANNER ASS'Y	M7
5	FM1-W273-010		1	I.T. BELT UNIT, TB-206	[DP]
6	FM1-W271-010		1	WASTE TONER BOX ASS'Y, WT-206	[DP]
7	RM2-7157-000		1	ESTRANGEMENT DETECT PCB ASS'Y	UN27, SR1901
8	RM2-8440-000		1	ENVIRONMENT SENSOR PCB ASS'Y	UN11
9	XA9-1671-000		15	SCREW, D, M3X8	

Figure 104A INTERNAL COMPONENTS 4

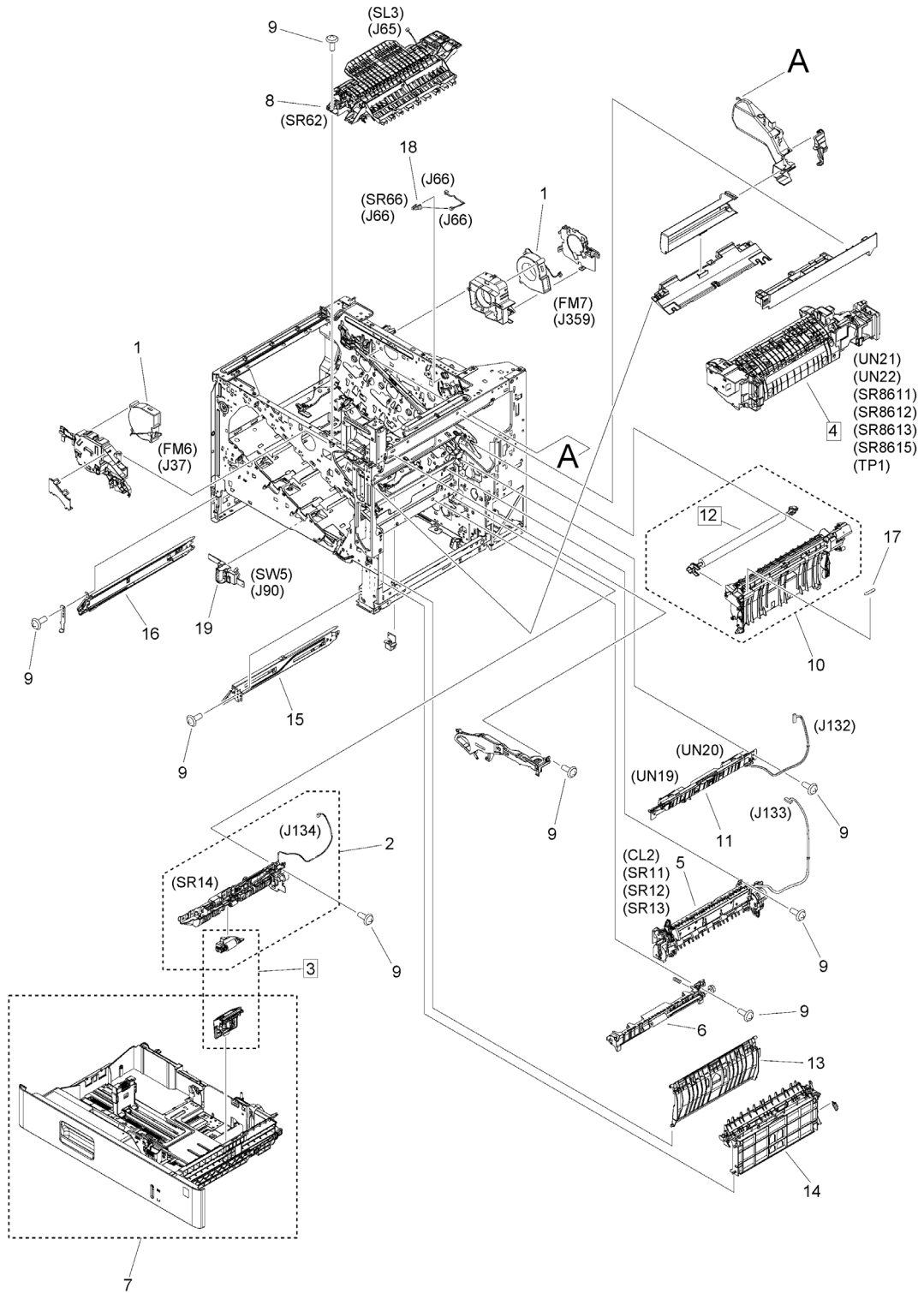

FIGURE & KEY NO.	PART NUMBER	RANK	QTY	DESCRIPTION	SERIAL NUMBER /REMARKS
104A	NPN		RF	INTERNAL COMPONENTS 4	
1	RK2-6124-010		2	FAN	FM6, FM7
2	RM2-6556-000		1	PAPER PICK-UP ASS'Y	SR14
3	FM1-W269-010		1	ROLLER KIT, CR-206	[DP]
4	FM1-W274-010		1	FIXING ASS'Y, FX-206	UN21, UN22, SR8611, SR8612, SR8613, SR8615, TP1 [DP]
5	FM1-U429-000		1	REGISTRATION ASS'Y	CL2, SR11, SR12, SR13
6	RM2-6684-000		1	FEED ROLLER ASS'Y	
7	FM1-U438-000		1	CASSETTE ASS'Y	
8	RM2-6621-000		1	PAPER DELIVERY ASS'Y	SL3, SR62
9	XA9-1671-000		15	SCREW, D, M3X8	
10	RM2-6682-000		1	SECONDARY TRANSFER ASS'Y	
11	RM2-7160-000		1	DENSITY DETECT ASS'Y	UN19, UN20
12	FM1-W270-010		1	2ND TRANSFR. ROLLER, TR-206	[DP]
13	RM2-6650-000		1	GUIDE ASS'Y	
14	RM2-6651-000		1	UPPER GUIDE ASS'Y	
15	RM2-0048-000		1	CASSETTE RAIL ASS'Y, RIGHT	
16	RM2-5151-000		1	CASSETTE RAIL ASS'Y, LEFT	
17	FE2-C460-000		1	LABEL, SECONDARY TRANSFER	
18	WG8-5935-000		1	IC, PHOTO INTERRUPTER	SR66
19	RM2-1946-000		1	SIZE DETECT SWITCH ASS'Y	SW5

Figure 105 INTERNAL COMPONENTS 5

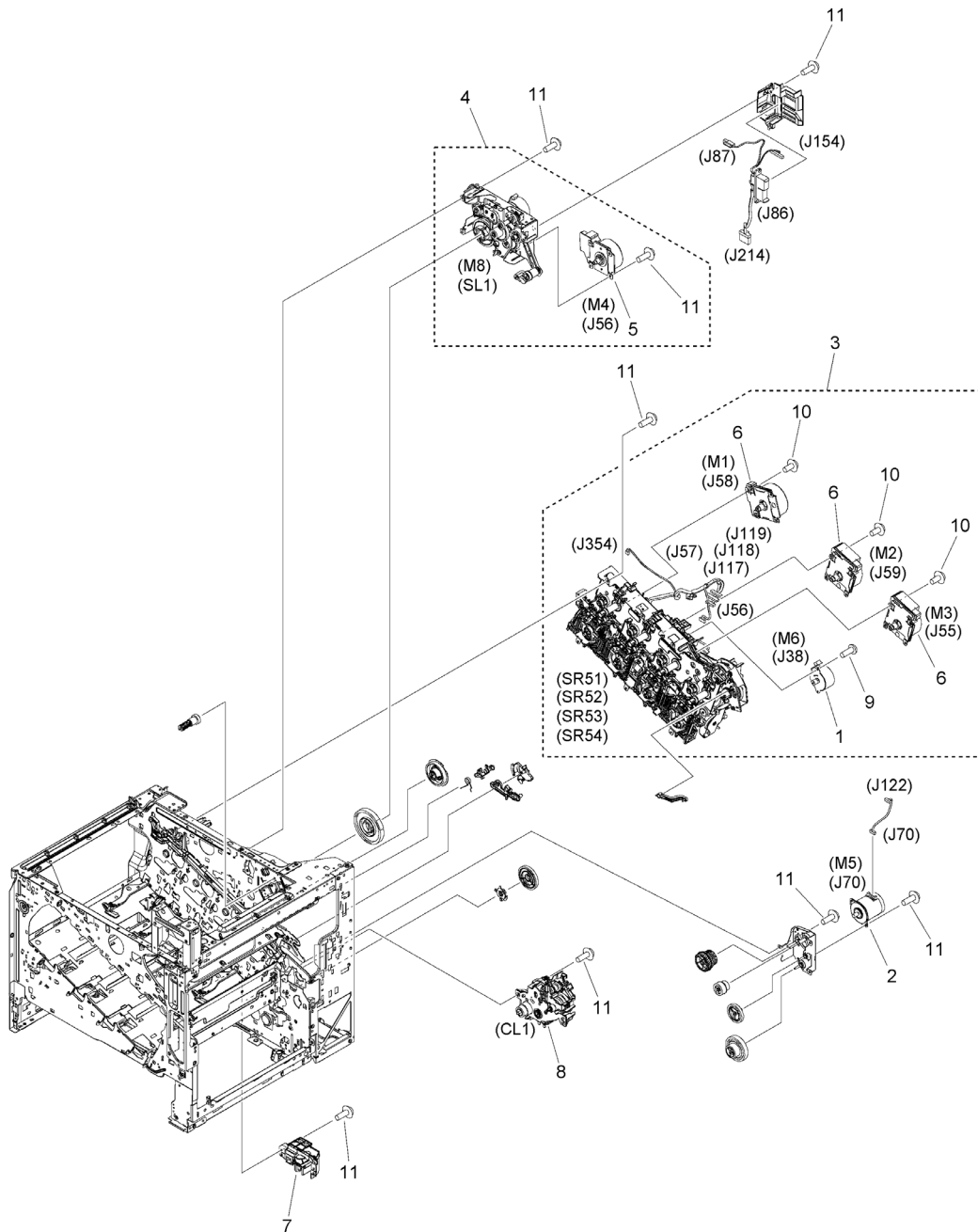

FIGURE & KEY NO.	PART NUMBER	RANK	QTY	DESCRIPTION	SERIAL NUMBER /REMARKS
105	NPN		RF	INTERNAL COMPONENTS 5	
1	RK2-6027-000		1	MOTOR, STEPPING	M6
2	RK2-7757-000		1	MOTOR, STEPPING	M5
3	RM2-1927-000		1	MAIN DRIVE ASS'Y	SR51, SR52, SR53, SR54
4	RM2-1934-000		1	FIXING DRIVE ASS'Y	M8, SL1
5	RM2-1955-000		1	FIXING MOTOR ASS'Y	M4
6	RM2-1956-000		3	DRUM MOTOR ASS'Y	M1, M2, M3
7	RM2-5147-000		1	AUTO CLOSE ASS'Y	
8	RM2-6669-000		1	LIFTER DRIVE ASS'Y	CL1
9	XA9-1833-000		2	SCREW, D, M3X6	
10	XA9-1670-000		12	SCREW, D, M3X6	
11	XA9-1671-000		15	SCREW, D, M3X8	

Figure 106A INTERNAL COMPONENTS 6 (IR-ADV DX C477iFZ)

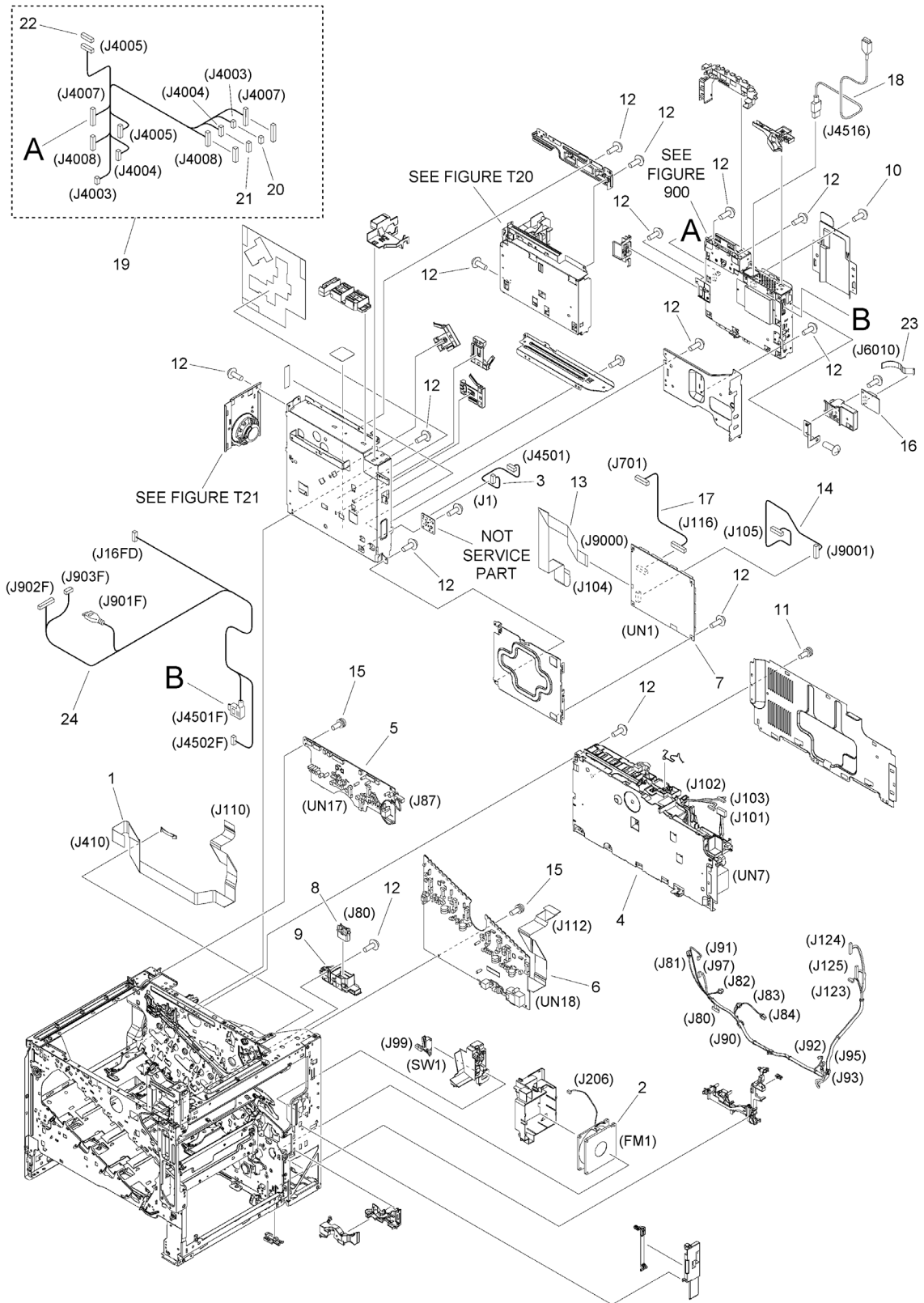

FIGURE & KEY NO.	PART NUMBER	RANK	QTY	DESCRIPTION	SERIAL NUMBER /REMARKS
106A	NPN		RF	INTERNAL COMPONENTS 6	IR-ADV DX C477IFZ
1	RK2-7768-000		1	CABLE, FLEXIBLE FLAT	
2	RK2-2416-010		1	FAN	FM1
3	FM2-F928-000		1	CABLE, SIGNAL	
4	FM1-U443-000		1	POWER SUPPLY PCB ASS'Y	UN7
5	RM2-8424-000		1	UP.H.V. POWER SUPPLY PCB ASS'Y	UN17
6	RM3-7006-000		1	LW.H.V. POWER SUPPLY PCB ASS'Y	UN18
7	FM2-J844-000		1	DC CONTROLLER PCB ASS'Y	UN1
8	VS1-7258-012		1	CONNECTOR	
9	RC4-6497-000		1	HOLDER, DRAWER CONNECTOR	
10	XA9-1435-000		1	SCREW, ROUND, M3X6	
11	XA9-1420-000		1	SCREW, W/WASHER, M3X8	
12	XA9-1671-000		15	SCREW, D, M3X8	
13	FK4-5505-000		1	CABLE, FLAT	
14	FM2-F925-000		1	CABLE, CONT DCC IF	
15	XA9-1831-000		3	SCREW, W/WASHER D, M3X8	
16	QM7-4472-000		1	WIRELESS LAN BOARD ASS'Y	
17	FM2-F923-000		1	CABLE, POUT OP	
18	FK4-5487-000		1	CABLE, USB	
19	FM2-P909-000		1	CABLE, READER	
20	VS1-7177-004		1	CONNECTOR, SNAP TIGHT, BK	
21	VS1-7504-006		1	CONNECTOR, SNAP TIGHT	
22	VS1-7504-010		1	CONNECTOR, SNAP TIGHT	
23	FK4-6272-000		1	CABLE, FLEXIBLE FLAT, WIFI	
24	FM2-P941-000		1	UI CABLE UNIT, FINISHER	
25	VS1-8412-011		1	CONNECTOR	
26	VS1-8412-023		1	CONNECTOR	

Figure 106B INTERNAL COMPONENTS 6 (IR-ADV DX C477iF)

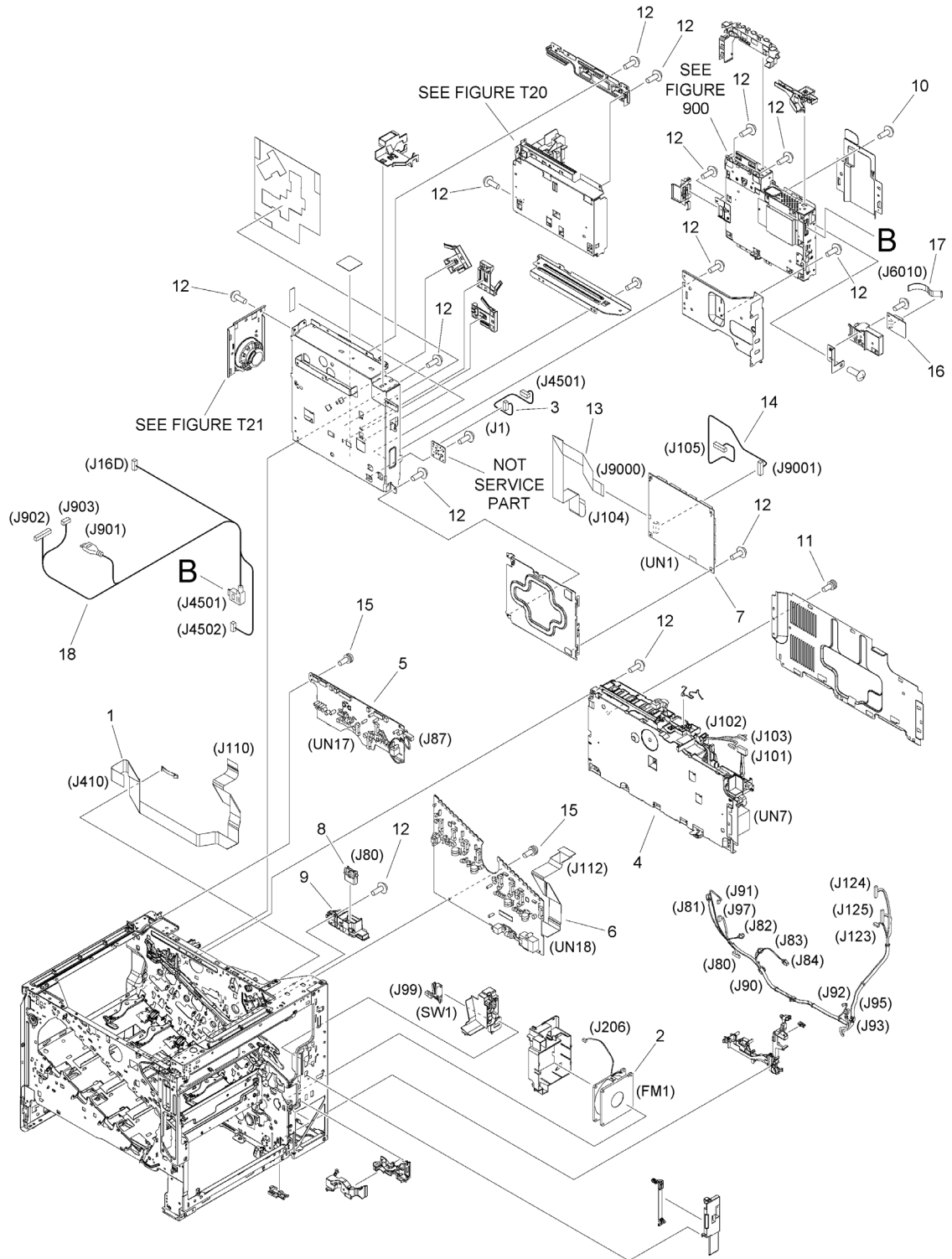

FIGURE & KEY NO.	PART NUMBER	RANK	QTY	DESCRIPTION	SERIAL NUMBER /REMARKS
106B	NPN		RF	INTERNAL COMPONENTS 6	IR-ADV DX C477IF
1	RK2-7768-000		1	CABLE, FLEXIBLE FLAT	
2	RK2-2416-010		1	FAN	FM1
3	FM2-F928-000		1	CABLE, SIGNAL	
4	FM1-U443-000		1	POWER SUPPLY PCB ASS'Y	UN7
5	RM2-8424-000		1	UP.H.V. POWER SUPPLY PCB ASS'Y	UN17
6	RM3-7006-000		1	LW.H.V. POWER SUPPLY PCB ASS'Y	UN18
7	FM2-J844-000		1	DC CONTROLLER PCB ASS'Y	UN1
8	VS1-7258-012		1	CONNECTOR	
9	RC4-6497-000		1	HOLDER, DRAWER CONNECTOR	
10	XA9-1435-000		1	SCREW, ROUND, M3X6	
11	XA9-1420-000		1	SCREW, W/WASHER, M3X8	
12	XA9-1671-000		15	SCREW, D, M3X8	
13	FK4-5505-000		1	CABLE, FLAT	
14	FM2-F925-000		1	CABLE, CONT DCC IF	
15	XA9-1831-000		3	SCREW, W/WASHER D, M3X8	
16	QM7-4472-000		1	WIRELESS LAN BOARD ASS'Y	
17	FK4-6272-000		1	CABLE, FLEXIBLE FLAT, WIFI	
18	FM2-P940-000		1	UI CABLE UNIT	

FIGURE & KEY NO.	PART NUMBER	RANK	QTY	DESCRIPTION	SERIAL NUMBER /REMARKS
106E	NPN		RF	INTERNAL COMPONENTS 6	IR-ADV DX C477iZ
1	RK2-7768-000		1	CABLE, FLEXIBLE FLAT	
2	RK2-2416-010		1	FAN	FM1
3	FM2-F928-000		1	CABLE, SIGNAL	
4	FM1-U444-000		1	POWER SUPPLY PCB ASS'Y	UN8
5	RM2-8424-000		1	UP.H.V. POWER SUPPLY PCB ASS'Y	UN17
6	RM3-7006-000		1	LW.H.V. POWER SUPPLY PCB ASS'Y	UN18
7	FM2-J844-000		1	DC CONTROLLER PCB ASS'Y	UN1
8	VS1-7258-012		1	CONNECTOR	
9	RC4-6497-000		1	HOLDER, DRAWER CONNECTOR	
10	XA9-1435-000		1	SCREW, ROUND, M3X6	
11	XA9-1420-000		1	SCREW, W/WASHER, M3X8	
12	XA9-1671-000		15	SCREW, D, M3X8	
13	FK4-5505-000		1	CABLE, FLAT	
14	FM2-F925-000		1	CABLE, CONT DCC IF	
15	XA9-1831-000		3	SCREW, W/WASHER D, M3X8	
16	QM7-4472-000		1	WIRELESS LAN BOARD ASS'Y	
17	FM2-F923-000		1	CABLE, POUT OP	
18	FK4-5487-000		1	CABLE, USB	
19	FM2-P909-000		1	CABLE, READER	
20	VS1-7177-004		1	CONNECTOR, SNAP TIGHT, BK	
21	VS1-7504-006		1	CONNECTOR, SNAP TIGHT	
22	VS1-7504-010		1	CONNECTOR, SNAP TIGHT	
23	FK4-6272-000		1	CABLE, FLEXIBLE FLAT, WIFI	
24	FM2-P941-000		1	UI CABLE UNIT, FINISHER	
25	VS1-8412-011		1	CONNECTOR	
26	VS1-8412-023		1	CONNECTOR	

FIGURE & KEY NO.	PART NUMBER	RANK	QTY	DESCRIPTION	SERIAL NUMBER /REMARKS
106F	NPN		RF	INTERNAL COMPONENTS 6	IR-ADV DX C477i
1	RK2-7768-000		1	CABLE, FLEXIBLE FLAT	
2	RK2-2416-010		1	FAN	FM1
3	FM2-F928-000		1	CABLE, SIGNAL	
4	FM1-U444-000		1	POWER SUPPLY PCB ASSY	UN8
5	RM2-8424-000		1	UP.H.V. POWER SUPPLY PCB ASS'Y	UN17
6	RM3-7006-000		1	LW.H.V. POWER SUPPLY PCB ASS'Y	UN18
7	FM2-J844-000		1	DC CONTROLLER PCB ASS'Y	UN1
8	VS1-7258-012		1	CONNECTOR	
9	RC4-6497-000		1	HOLDER, DRAWER CONNECTOR	
10	XA9-1435-000		1	SCREW, ROUND, M3X6	
11	XA9-1420-000		1	SCREW, W/WASHER, M3X8	
12	XA9-1671-000		15	SCREW, D, M3X8	
13	FK4-5505-000		1	CABLE, FLAT	
14	FM2-F925-000		1	CABLE, CONT DCC IF	
15	XA9-1831-000		3	SCREW, W/WASHER D, M3X8	
16	QM7-4472-000		1	WIRELESS LAN BOARD ASS'Y	
17	FK4-6272-000		1	CABLE, FLEXIBLE FLAT, WIFI	
18	FM2-P940-000		1	UI CABLE UNIT	

Figure 107A INTERNAL COMPONENTS 7 (FINISHER model)

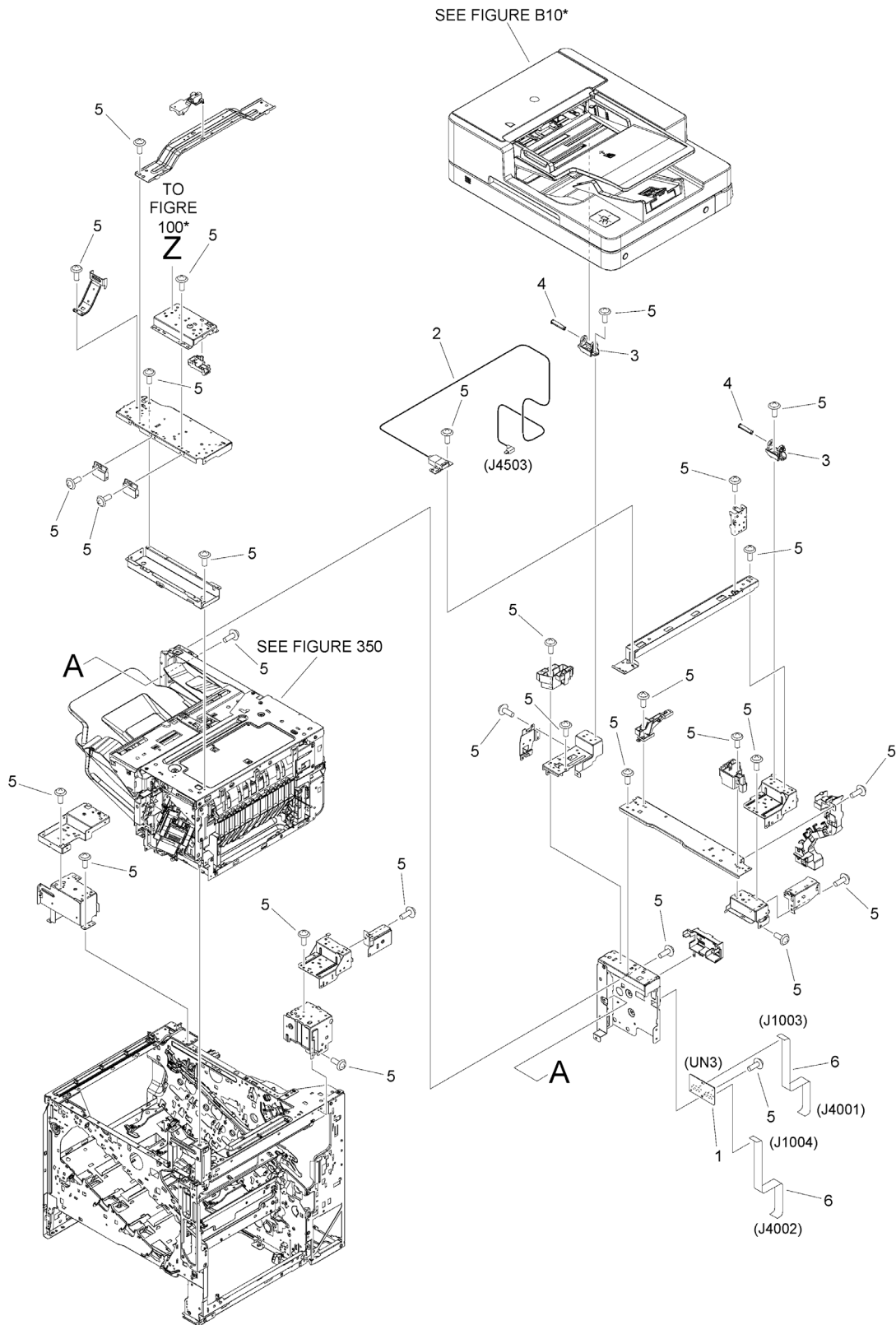

FIGURE & KEY NO.	PART NUMBER	RANK	QTY	DESCRIPTION	SERIAL NUMBER /REMARKS
107A	NPN		RF	INTERNAL COMPONENTS 7	FINISHER model
1	FM2-F883-000		1	READER RELAY PCB ASS'Y	UN3
2	FK4-5481-000		1	CABLE, USB	
3	FE8-2110-000		2	HINGE, READER	
4	FE8-2405-000		2	SHAFT, READER HINGE	
5	XA9-1671-000		15	SCREW, D, M3X8	
6	FK4-5726-000		2	CABLE, FLAT	

Figure 107B INTERNAL COMPONENTS 7 (MODEL WITHOUT FINISHER)

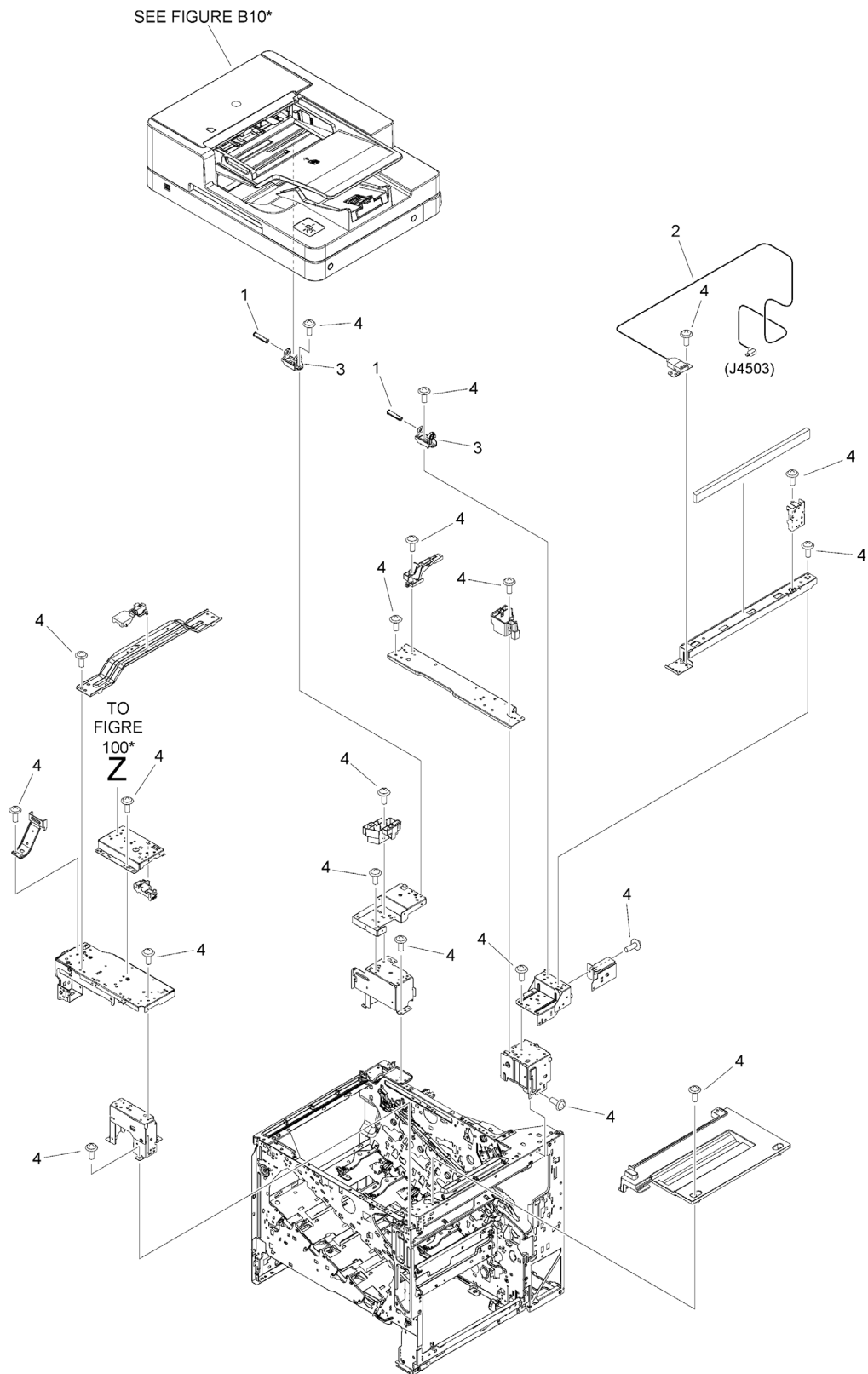

FIGURE & KEY NO.	PART NUMBER	RANK	QTY	DESCRIPTION	SERIAL NUMBER /REMARKS
107B	NPN		RF	INTERNAL COMPONENTS 7	MODEL WITHOUT FINISHER
1	FE8-2405-000		2	SHAFT, READER HINGE	
2	FK4-5483-000		1	CABLE, USB	
3	FE8-2110-000		2	HINGE, READER	
4	XA9-1671-000		15	SCREW, D, M3X8	

Figure 130 CONTROL PANEL ASSEMBLY

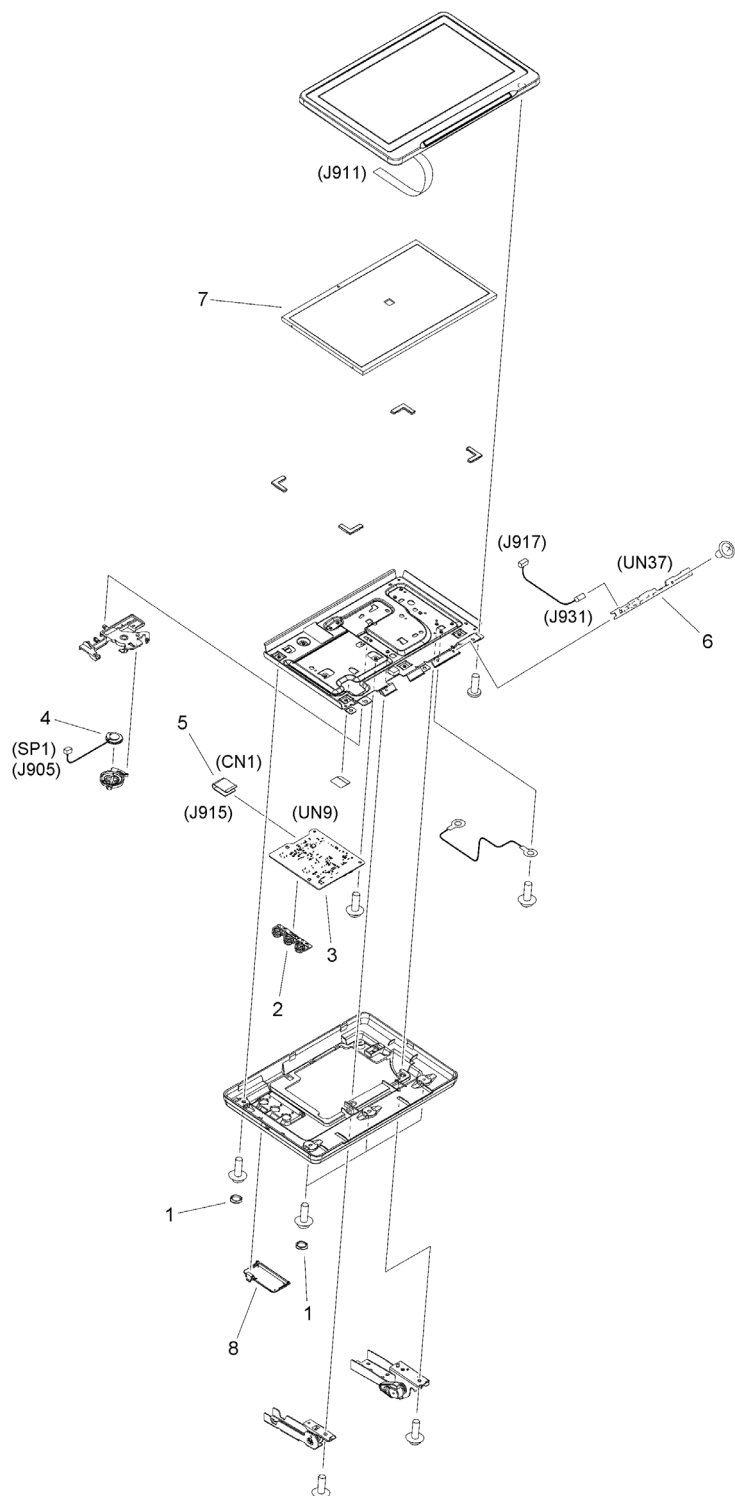

FIGURE & KEY NO.	PART NUMBER	RANK	QTY	DESCRIPTION	SERIAL NUMBER /REMARKS
130	FM1-X148-000		1	CONTROL PANEL ASSEMBLY	
1	FE3-9169-000		4	CAP	
2	FE8-7637-000		1	KEY TOP, SWITCH	
3	FM2-K897-000		1	CONTROL PANEL MAIN PCB ASS'Y	UN9
4	FK4-2377-000		1	SPEAKER	SP1
5	FK4-4895-000		1	CABLE, FLAT	
6	FM2-A912-000		1	CONTROL PANEL LED PCB ASSEMBLY	UN37
7	FK4-6830-000		1	LCD UNIT	
8	FE8-7628-000		1	COVER, SWITCH	

Figure 350 FINISHER ASSEMBLY (FINISHER model)

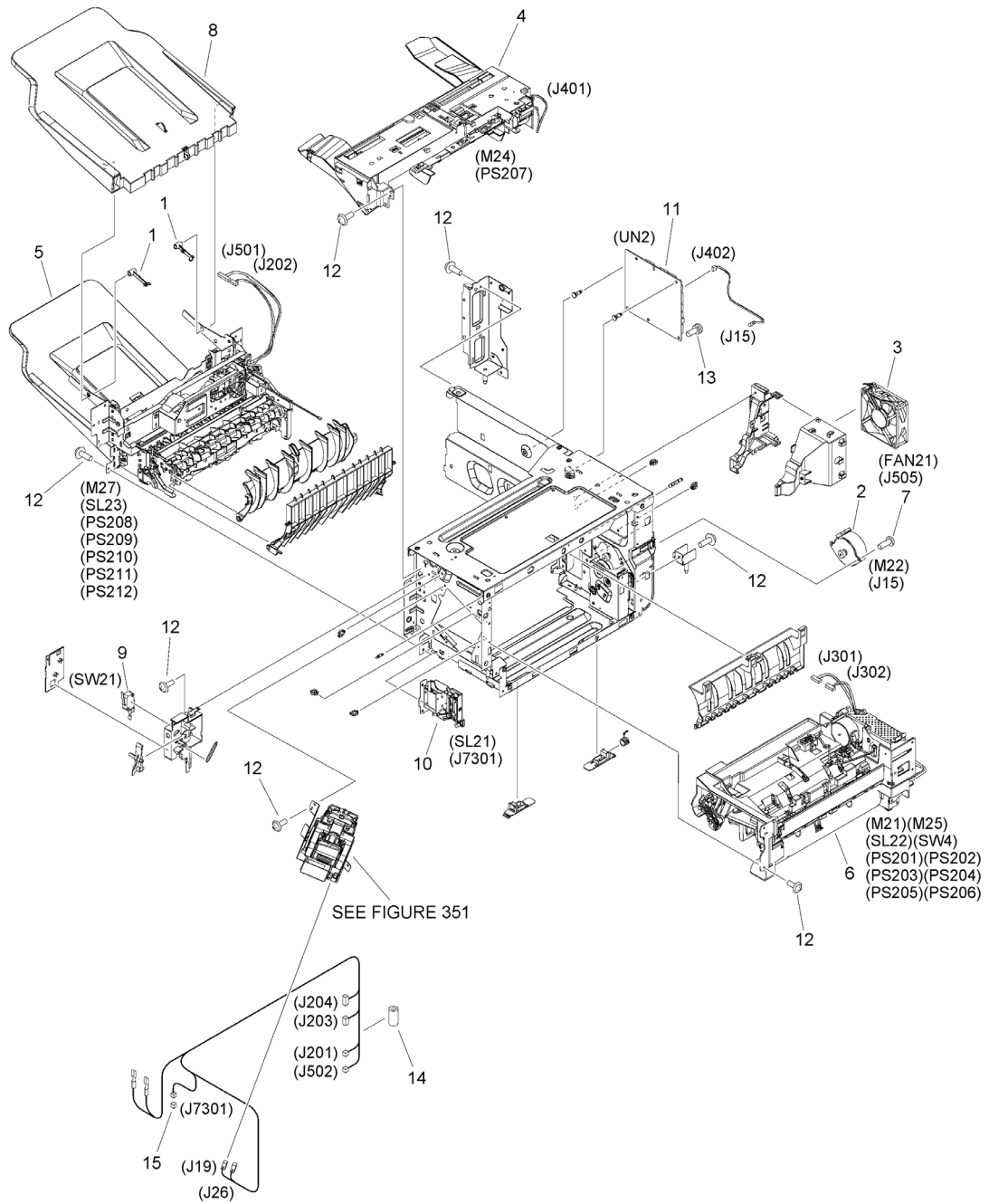

FIGURE & KEY NO.	PART NUMBER	RANK	QTY	DESCRIPTION	SERIAL NUMBER /REMARKS
350	NPN		RF	FINISHER ASSEMBLY	FINISHER model
1	RC5-0353-000		2	PIN, TRAY FIXED	
2	RK2-8149-000		1	MOTOR, STEPPING, DC	M22
3	RK2-8153-000		1	FAN	FAN21
4	RM2-1066-000		1	JOG ASS'Y	M24, PS207
5	FM1-W268-000		1	LOWER PAPER FEED ASS'Y	M27, SL23, PS208, PS209, PS210, PS211, PS212
6	RM2-6810-000		1	UPPER PAPER FEED ASS'Y	M21, M25, SL22, SW4, PS201, PS202, PS203, PS204, PS205, PS206
7	XA9-1833-000		2	SCREW, D, M3X6	
8	FM1-R145-000		1	TRAY ASS'Y	
9	WC4-5171-000		1	MICROSWITCH	SW21
10	RM2-1040-010		1	SOLENOID ASS'Y	SL21
11	FM2-F842-000		1	FINISHER CONTROLLER PCB ASS'Y	UN2
12	XA9-1671-000		15	SCREW, D, M3X8	
13	XA9-1503-000		2	SCREW, TAP, M3X6	
14	WE8-6817-000		1	CORE, FERRITE	
15	VS1-7177-002		1	CONNECTOR, SNAP TIGHT, BK	

Figure 351 STAPLE ASSEMBLY (FINISHER model)

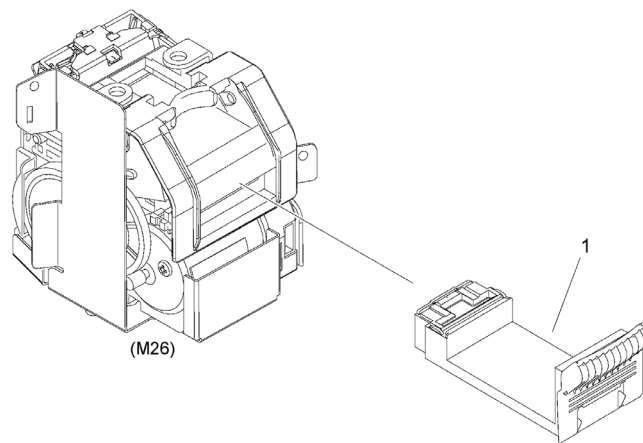

FIGURE & KEY NO.	PART NUMBER	R A N K	QTY	DESCRIPTION	SERIAL NUMBER /REMARKS
351	FM1-U026-000		1	STAPLE ASSEMBLY	M26 FINISHER model
1	FE8-1031-000		1	CASE, STAPLE CARTRIDGE	

Figure 900 CONTROLLER BOX ASSEMBLY

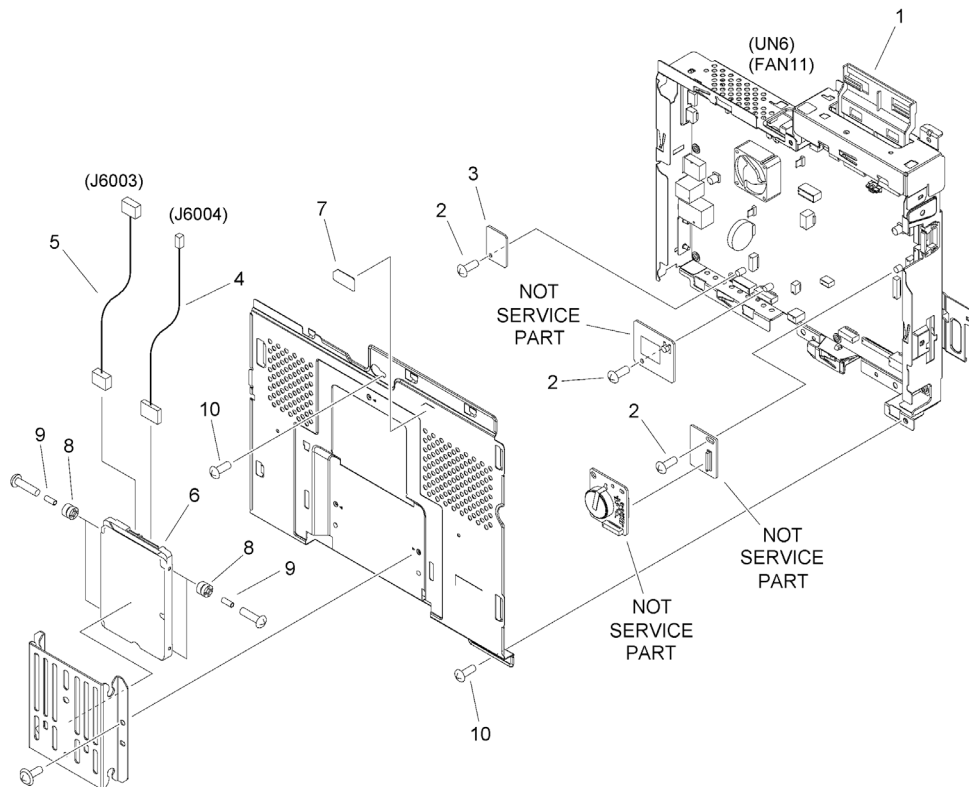

FIGURE & KEY NO.	PART NUMBER	RANK	QTY	DESCRIPTION	SERIAL NUMBER /REMARKS
900	NPN		RF	CONTROLLER BOX ASSEMBLY	
1	FM2-B597-000		1	MAIN CONTROLLER PCB ASSEMBLY	UN6, FAN11
2	XA9-1979-000		3	SCREW, MACH. PAN HEAD, M3X4	
3	FM1-M981-000		1	TPM PCB ASSEMBLY	
4	FK4-3811-000		1	CABLE, SATA POWER	
5	FK4-3810-000		1	CABLE, SATA SIGNAL	
6	FK4-1550-010		1	HARD DISK DRIVE, MQ01ABF032	
7	FU8-8257-000		1	LABEL, CAUTION	
8	XH9-0149-000		4	DAMPER, CUSHION	
9	XZ1-1301-005		4	SPACER	
10	XA9-1435-000		2	SCREW, ROUND, M3X6	

Figure B01 ADF MAINTENANCE KIT

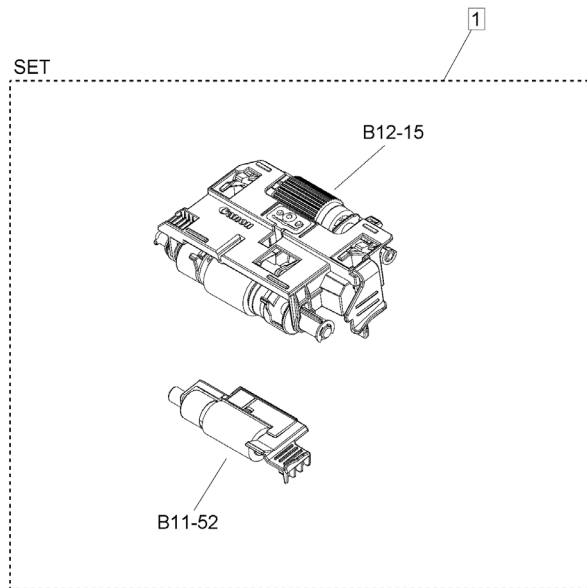

FIGURE & KEY NO.	PART NUMBER	R A N K	QTY	DESCRIPTION	SERIAL NUMBER /REMARKS
B01	NPN		RF	ADF MAINTENANCE KIT	
1	FM2-B058-000		1	ADF MAINTENANCE KIT, DR-208	[DP]

Figure B10 READER/ADF ASSEMBLY

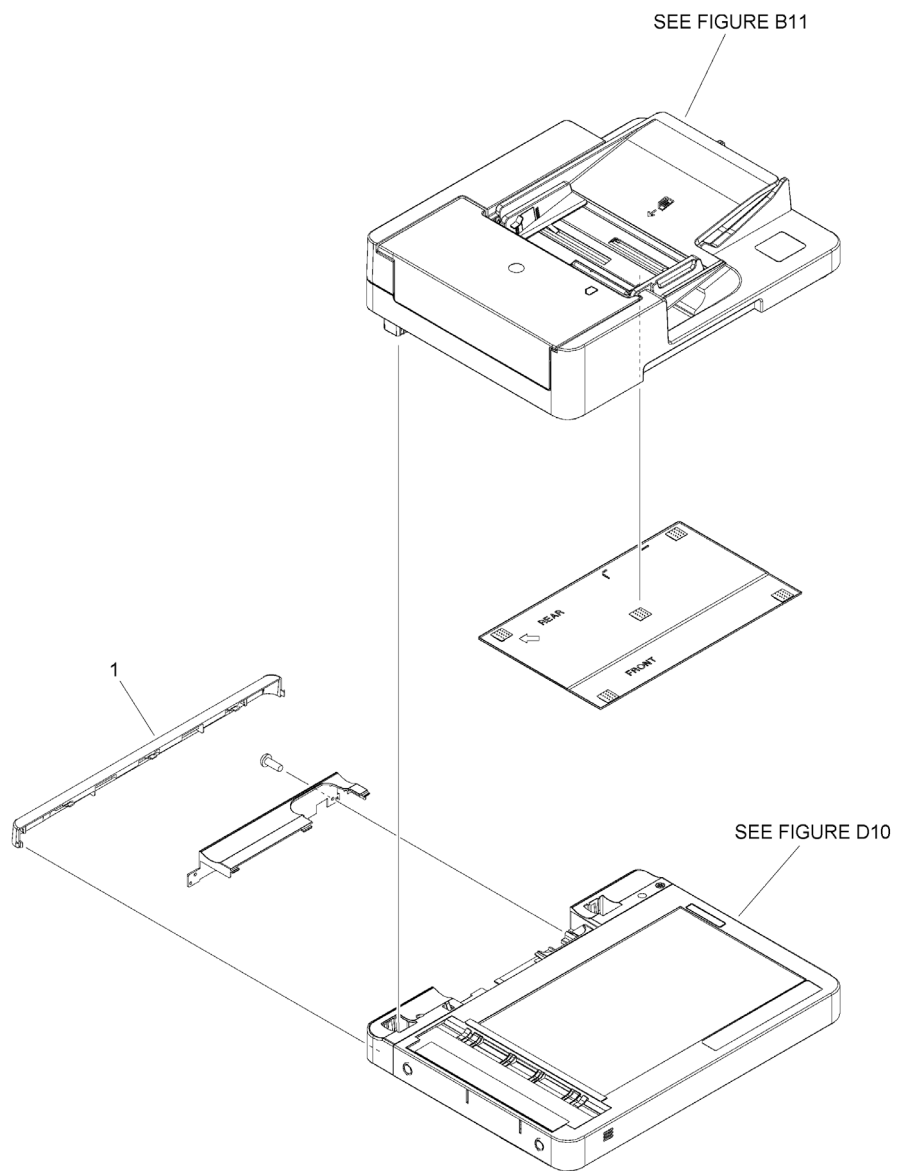

FIGURE & KEY NO.	PART NUMBER	R A N K	QTY	DESCRIPTION	SERIAL NUMBER /REMARKS
B10	NPN		RF	READER/ADF ASSEMBLY	
1	FE8-2109-010		1	COVER, READER REAR, 2	

Figure B11 (1/3)AUTO DOCUMENT FEEDER ASS'Y SET

NOTE : This assembly does not include the part shown with key No. 32.

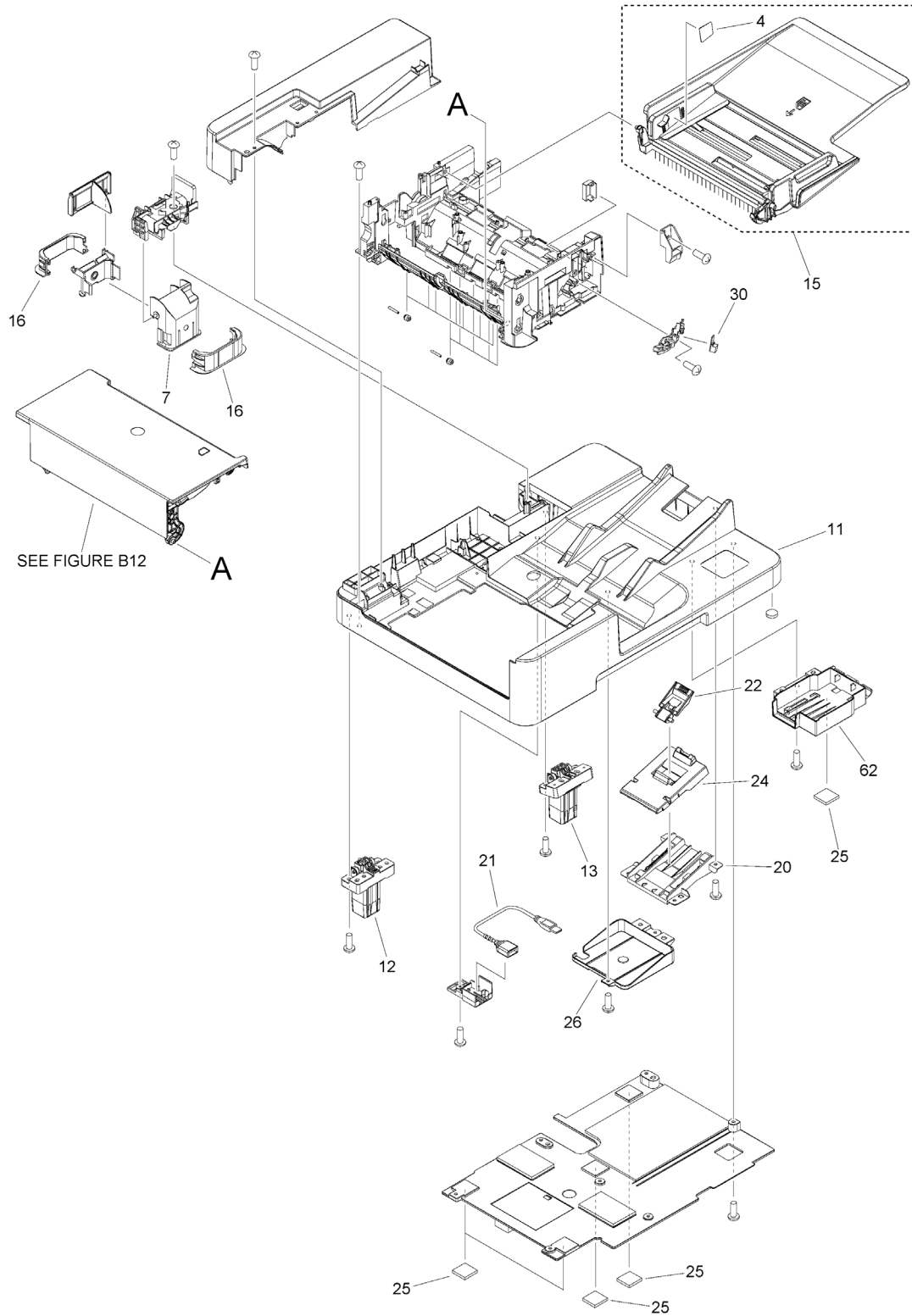

Figure B11 (2/3)AUTO DOCUMENT FEEDER ASS'Y SET

NOTE : This assembly does not include the part shown with key No. 32.

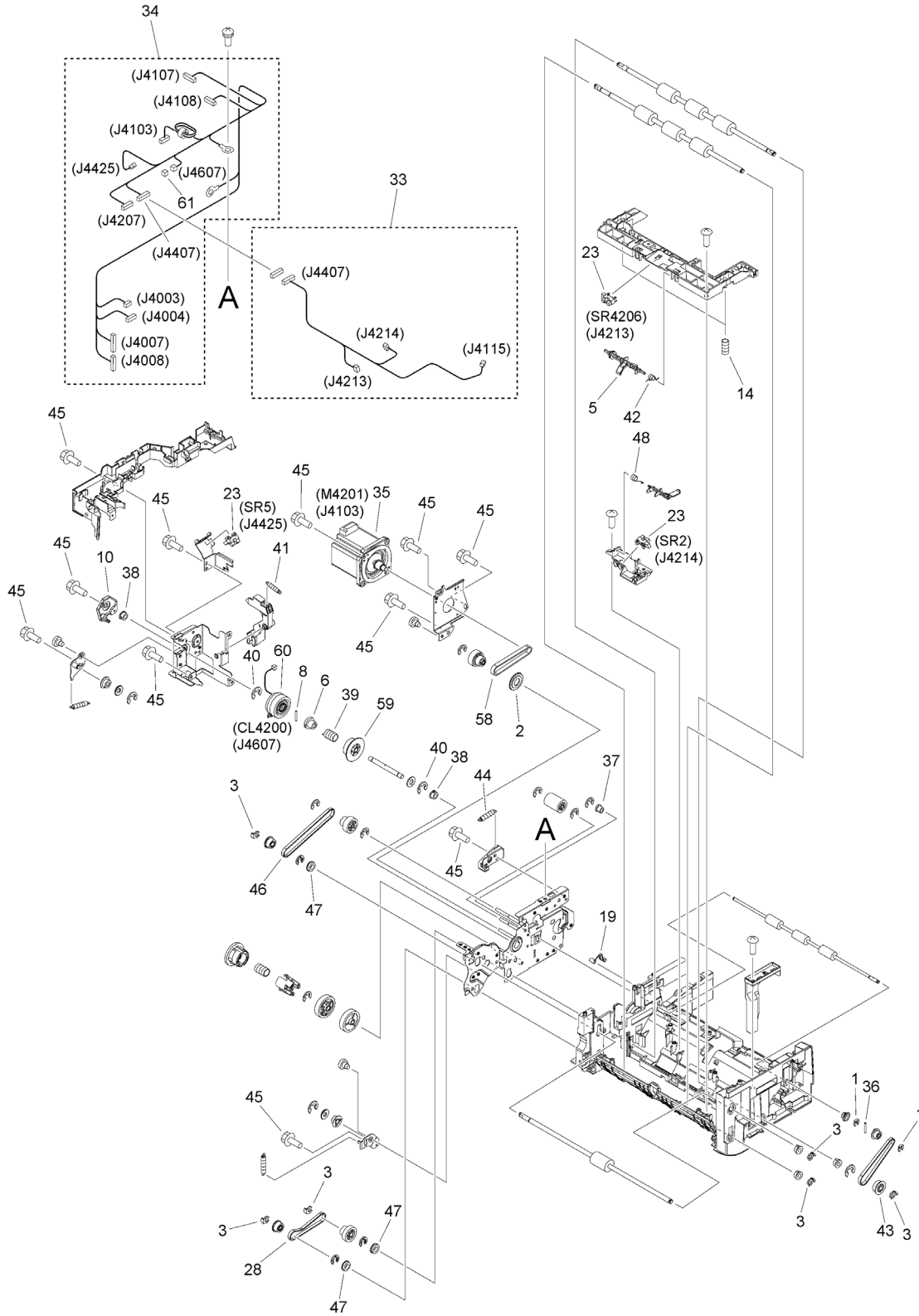

Figure B11 (3/3) AUTO DOCUMENT FEEDER ASS'Y SET

NOTE : This assembly does not include the part shown with key No. 32.

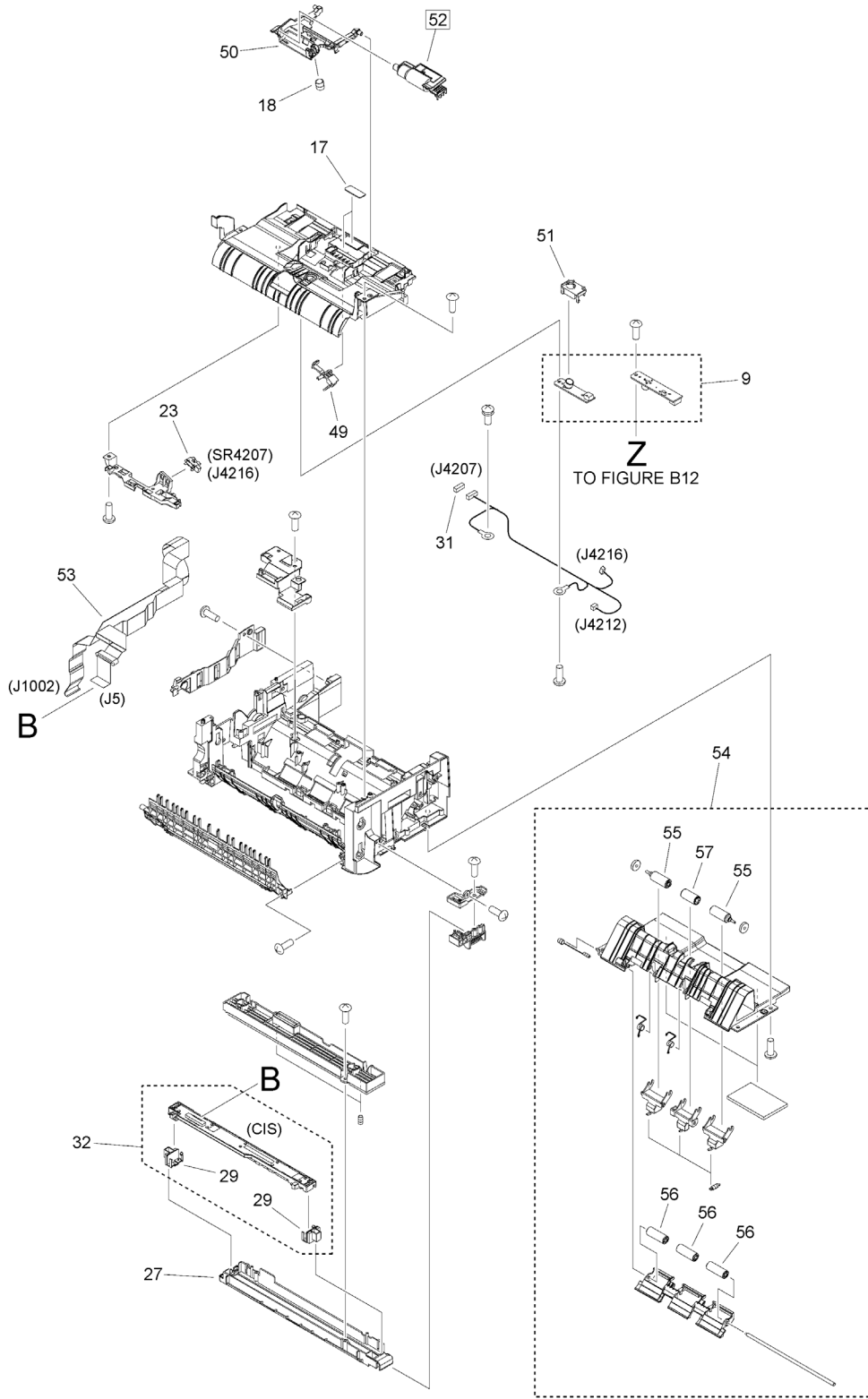

FIGURE & KEY NO.	PART NUMBER	RANK	QTY	DESCRIPTION	SERIAL NUMBER /REMARKS
B11	FM2-B175-000		1	AUTO DOCUMENT FEEDER ASS'Y SET	SEE NOTE
1	FC0-1271-000		2	CLIP	
2	FC8-5484-000		1	FLANGE, PULLEY	
3	FC5-4424-000		6	CLIP	
4	FE2-J168-000		1	LABEL, DOCUMENT MAXIMUM LOAD	
5	FE2-D778-000		1	LEVER, READ SENSOR	
6	FE2-D574-000		1	JOINT, PICK-UP	
7	FE4-5746-000		1	GUIDE, CABLE, FRONT	
8	XD9-0334-000		1	PIN, DOWEL	
9	FM1-K086-010		1	DOUBLE FEED DETECTION KIT	
10	FE2-D732-000		1	STOPPER, CLUTCH ROTATION	
11	FE2-D759-000		1	FRAME, BASE	
12	FE2-E037-000		1	HINGE, ADF, LEFT	
13	FE2-E038-000		1	HINGE, ADF, RIGHT	
14	FE2-D656-000		2	SPRING, COMPRESSION	
15	FM1-W651-000		1	DOCUMENT TRAY ASSEMBLY	
16	FE8-2334-000		2	GUIDE, CABLE, LOWER	
17	FE8-3713-000		2	PAD, PICK-UP	
18	FE2-D826-000		1	SPRING, COMPRESSION	
19	FE2-D545-000		1	SPRING, TORSION	
20	FE2-D750-000		1	HOLDER, EXTENSION TRAY	
21	FK4-3808-000		1	CABLE, USB	
22	FE2-D751-000		1	STOPPER	
23	WG8-5935-000		4	IC, PHOTO INTERRUPTER	SR2, SR5, SR4206, SR4207
24	FE2-D752-000		1	TRAY, EXTENSION	
25	FL0-5178-000		5	CUSHION	
26	FE2-D754-000		1	COVER, CABLE	
27	FL1-7786-000		1	HOLDER, CONTACT IMAGE SENSOR	
28	XF2-1611-040		1	BELT, TIMING	
29	FL1-6459-000		2	SPACER, CONTACT IMAGE SENSOR	RANK B
29	FL1-7791-000		2	SPACER, CONTACT IMAGE SENSOR	RANK C
29	FL1-7792-000		2	SPACER, CONTACT IMAGE SENSOR	RANK A
30	FM0-0294-000		1	EJECT LIGHT LED PCB ASS'Y	
31	VS1-7177-006		1	CONNECTOR, SNAP TIGHT, BK	
32	FM2-B174-000		1	CONTACT IMAGE SENSOR ASS'Y SET	CIS SEE NOTE
33	FM2-P907-000		1	CABLE, ADF PASS SENSOR	
34	FM2-P904-000		1	CABLE, ADF MAIN	
35	FM1-W686-000		1	MOTOR ASS'Y	M4201
36	XD9-0352-000		1	PIN	
37	FS1-1528-000		1	BUSHING, PL	
38	FS5-1805-000		2	BUSHING	
39	FE2-D575-000		1	SPRING, CLUTCH	
40	XD9-0394-000		2	RING, E	

FIGURE & KEY NO.	PART NUMBER	RANK	QTY	DESCRIPTION	SERIAL NUMBER /REMARKS
41	FE2-D726-000		1	SPRING, TENSION	
42	FE2-E057-000		1	SPRING, TORSION	
43	FE2-D698-000		1	PULLEY, 27T	
44	FE2-D737-000		1	SPRING, TENSION	
45	XA9-1386-000		15	SCREW,RS,M3X8	
46	XF2-1607-840		1	BELT, TIMING	
47	XG9-0520-000		3	BEARING, BALL, MF106ZZS	
48	FE2-D782-000		1	SPRING, TORSION	
49	FE2-D824-000		1	FLAG, REMNANT DETECT	
50	FE2-D827-000		1	HOLDER, ROLLER	
51	FE4-1947-000		1	COVER, SENSOR	
52	FM1-W655-000		1	SEPARATION ROLLER ASSEMBLY	[DP]
53	FK4-6663-000		1	CABLE, FLEXIBLE FLAT, LASER	
54	FM1-W659-000		1	LEAD 2 OUTER GUIDE ASSEMBLY	
55	FC8-6316-010		2	ROLLER, DELIVERY	
56	FE2-D649-000		3	ROLLER, READ	
57	FE2-D660-000		1	ROLLER, PAPER DELIVERY	
58	XF2-1608-260		1	BELT, TIMING	
59	FE2-D693-000		1	GEAR, 22	
60	FK4-6674-000		1	CLUTCH, ELECTROMAGNETIC	CL4200
61	VS1-7177-002		1	CONNECTOR, SNAP TIGHT, BK	
62	FE4-5735-010		1	COVER, CARD READER	

Figure B12 PAPER PICK-UP COVER ASS'Y

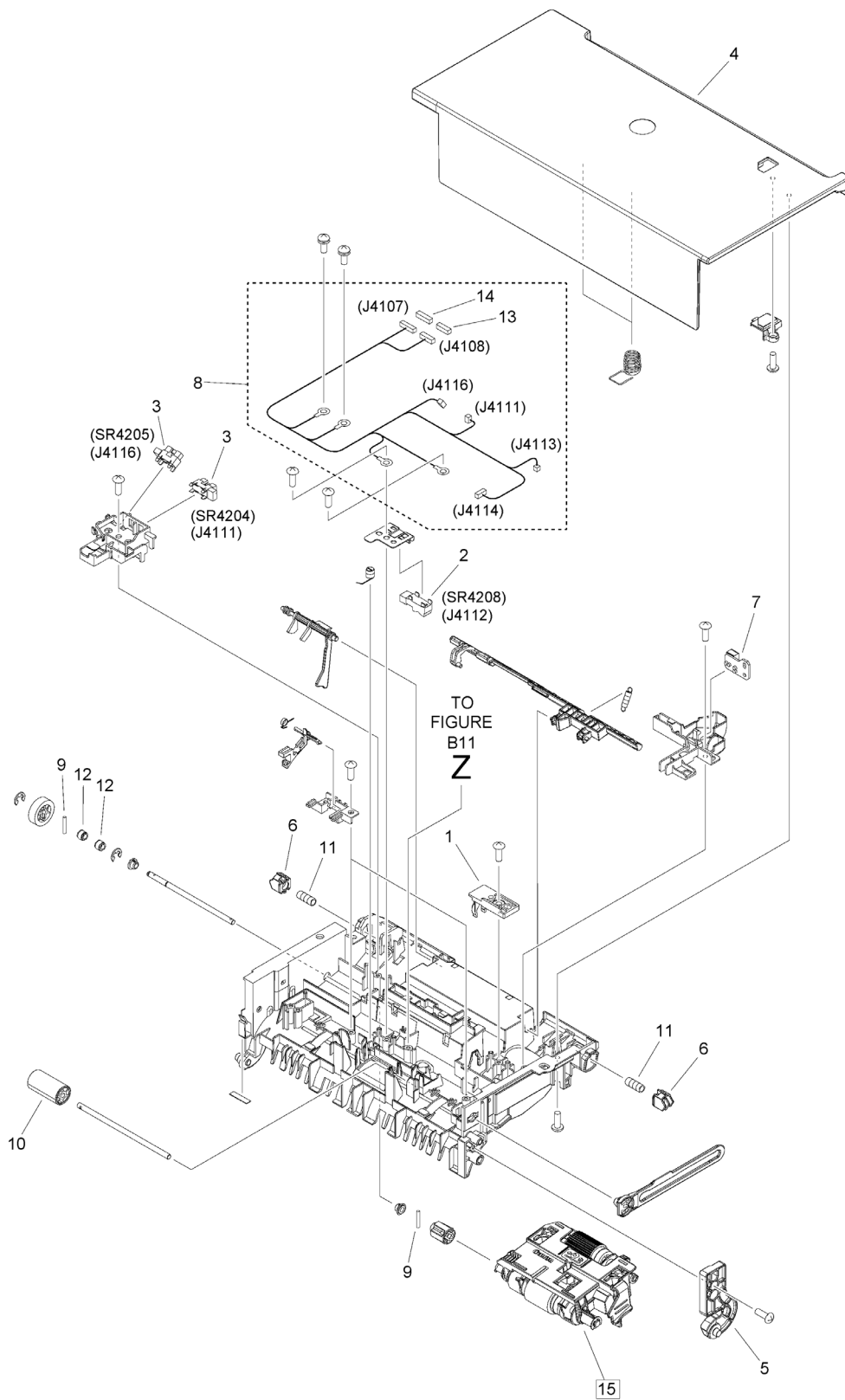

FIGURE & KEY NO.	PART NUMBER	RANK	QTY	DESCRIPTION	SERIAL NUMBER /REMARKS
B12	NPN		RF	PAPER PICK-UP COVER ASS'Y	
1	FE8-2386-000		1	HOLDER, PICK	
2	WG8-6233-000		1	PHOTO-INTERRUPTER	SR4208
3	WG8-5935-000		2	IC, PHOTO INTERRUPTER	SR4204, SR4205
4	FL4-4284-000		1	COVER, PAPER PICK-UP	
5	FE2-F453-000		1	LEVER, STOP	
6	FE2-D543-000		2	LATCH	
7	FM1-K827-000		1	LED PCB ASSEMBLY	
8	FM2-P905-000		1	CABLE, ADF COVER	
9	XD9-0352-000		2	PIN	
10	FC5-4324-000		1	ROLLER, REGISTRATION, 2	
11	FU2-1808-000		2	SPRING, COMPRESSION	
12	FE2-E018-000		2	ROLLER, PRESSURE	
13	VS1-7177-007		1	CONNECTOR, 7P, FEMALE, BK	
14	VS1-7177-009		1	CONNECTOR, WIRE TO WIRE, 9P	
15	FM1-W677-000		1	ADF PAPER PICK-UP ASSEMBLY	[DP]

Figure D10 READER ASSEMBLY

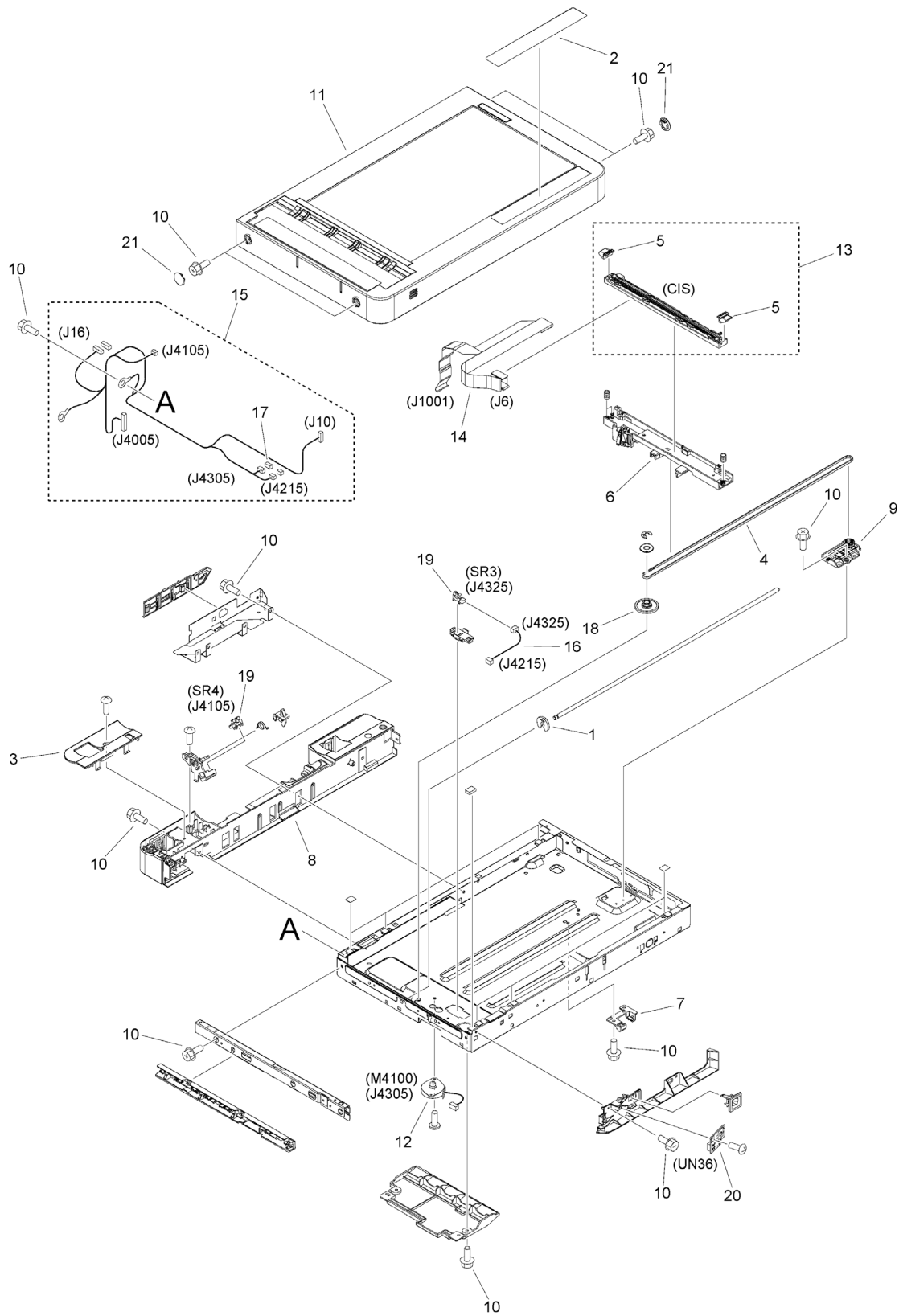

FIGURE & KEY NO.	PART NUMBER	RANK	QTY	DESCRIPTION	SERIAL NUMBER /REMARKS
D10	NPN		RF	READER ASSEMBLY	
1	FE3-7699-000		1	RING, C,EXTERNAL	
2	FE2-E522-000		1	LABEL, COPY INHIBITED	US English
2	FE2-E523-000		1	LABEL, COPY INHIBITED	Canadian French, Portuguese, Spanish
2	FE2-E524-000		1	LABEL, COPY INHIBITED	UK English, French, German, Italian
3	FE8-2093-000		1	COVER, READER REAR, UP.	
4	FE8-2361-000		1	BELT, TIMING, COGGED	
5	FE2-D705-000		2	SPACER, CONTACT IMAGE SENSOR	RANK B
5	FE2-D706-000		2	SPACER, CONTACT IMAGE SENSOR	RANK C
5	FE2-D707-000		2	SPACER, CONTACT IMAGE SENSOR	RANK A
6	FM1-Y667-000		1	CIS HOLDER ASSEMBLY	
7	FC0-5557-000		1	BUSHING	
8	FE8-2098-010		1	COVER, READER REAR, 1	
9	FM1-Y190-000		1	IDLER PULLEY HOLDER ASSEMBLY	
10	XA9-1386-000		15	SCREW,RS,M3X8	
11	FM1-W504-000		1	READER COVER UNIT, TOP	
12	FK3-3035-000		1	MOTOR, STEPPING	M4100
13	FM2-B173-000		1	CONTACT IMAGE SENSOR ASSEMBLY	CIS
14	FK4-6675-000		1	CABLE, FLAT	
15	FM1-W894-010		1	CABLE, READER	
16	FM1-C987-010		1	CABLE, HOME POSITION SENSOR	
17	VS1-7177-004		1	CONNECTOR, SNAP TIGHT, BK	
18	FU9-0581-000		1	GEAR, 85T/20T	
19	WG8-5935-000		2	IC, PHOTO INTERRUPTER	SR3, SR4
20	FM1-W896-000		1	INTERFACE SENSOR PCB ASSEMBLY	UN36
21	FE2-K423-000		4	CAP	

Figure T20 FAX ASSEMBLY (FAX model)

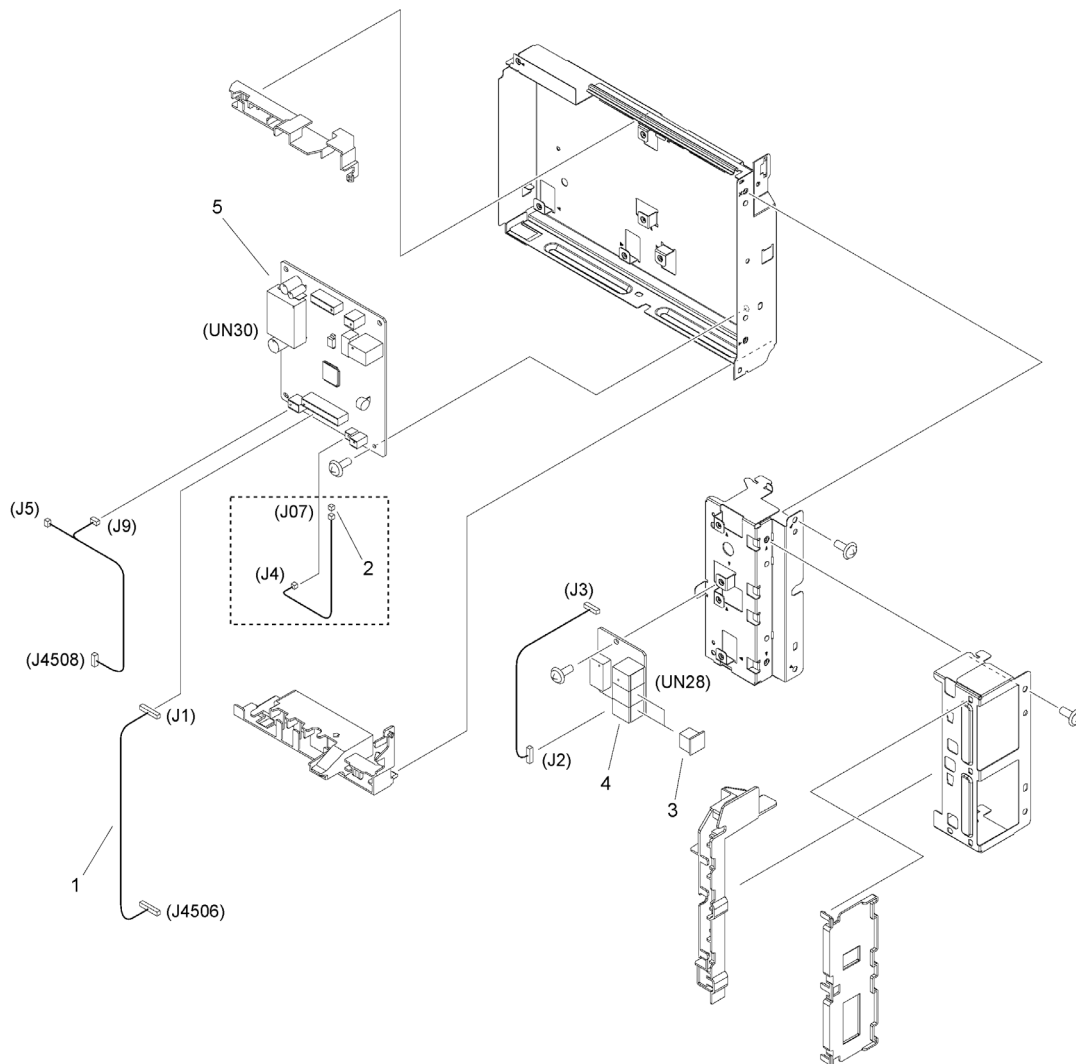

FIGURE & KEY NO.	PART NUMBER	RANK	QTY	DESCRIPTION	SERIAL NUMBER /REMARKS
T20	NPN		RF	FAX ASSEMBLY	FAX model
1	FM1-W903-000		1	CABLE, FAX SIGNAL	
2	VS1-7177-002		1	CONNECTOR, SNAP TIGHT, BK	
3	WT8-5076-000		2	SPACER,MODULAR	
4	FM4-2476-000		1	MODULAR PCB ASSEMBLY	UN28
5	FM1-W902-000		1	1 LINE PCB ASSEMBLY	UN30

Figure T21 SPEAKER ASSEMBLY (FAX model)

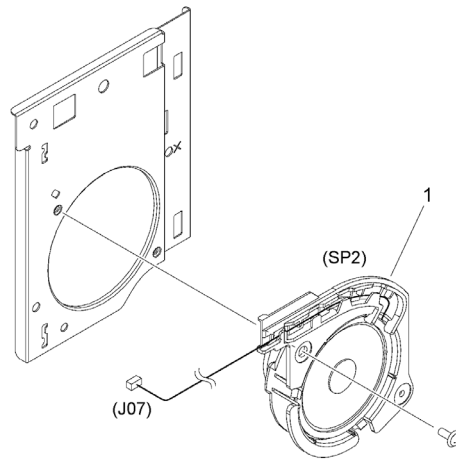

FIGURE & KEY NO.	PART NUMBER	R A N K	QTY	DESCRIPTION	SERIAL NUMBER /REMARKS
T21	NPN		RF	SPEAKER ASSEMBLY	FAX model
1	FM0-0059-010		1	SPEAKER	SP2

Figure ZZA MECHANICAL STANDARD PARTS (HOW TO USE)

Mechanical standard parts 機械標準部品

About a mechanical standard parts

A Mechanical standard parts is a mechanical part which not parts peculiar to a product.
They are parts which are common to a Canon product and are used, such as a screw and a washer.
The Fig No. and parts number of the mechanical standard parts are not listed in the product parts catalog.
Refer to the parts catalog of mechanical standard parts when checking the parts number for screw or washer etc. and identify them by part shape or size.

機械標準部品とは

機械標準部品とは、製品特有の部品ではなく、ねじやワッシャなどキヤノン製品共通で使用されている機械部品（メカ部品）のことです。
製品のパーツカタログには、機械標準部品のFig No.や部品番号は記載していません。
ねじや、ワッシャ等の部品番号を調べるときは、機械標準部品のパーツカタログを参照し、部品の形状や大きさから判断し、使用している部品を調べてください。

Material and surface treatment of a mechanical standard parts

Material and surface treatment of mechanical standard parts are assigned commonly for each part.
Refer to the Table 1 for the parts which material and surface treatment are assigned as numbers.

機械標準部品の材料および表面処理

機械標準部品の材料および表面処理については、各種部品共通で決められています。
材料および表面処理が番号で決められている部品については、表1を参照してください。

Table 1 Material and Surface treatment
表1 材料および表面処理

No. 番号	Material 材料	Surface treatment 表面処理	Color 色
1	Stainless steel ステンレス	Stainless steel black coloring (BC4) ステンレス黒着色(BC4)	Black 黒
2		not to be given なし	White 白
3	Brass 黄銅	Regular nickel plating (NL) 普通ニッケルメッキ(NL)	White 白
4		Black nickel plating (BN) 黒色ニッケルメッキ(BN)	Black 黒
5	Steel 鋼	White zinc trivalent chromate treating (ZC3) 白色亜鉛3価クロメート(ZC3)	White 白
6		Regular nickel chromium plating (NC) 普通ニッケルクロムメッキ(NC)	White 白
7		Regular nickel plating (NL) 普通ニッケルメッキ(NL)	White 白
8		Iron and steel phosphating (P1) 鉄鋼燐酸塩処理(P1)	Black 黒
9		Black zinc trivalent chromate treating (BZ3) 黒色亜鉛3価クロメート(BZ3)	Black 黒

Figure ZZB (1/7)MECHANICAL STANDARD PARTS (SCREWS)

1. Screws
ねじ

How to read Parts Numbers
部品番号の見方

Screws
ねじ

XB1-2400-609

Type No.
類別番号
Normal designation (d)
ねじの呼び (d)
Length (L)
ねじの長さ (L)
Material and Surface treatment
材料および表面処理

XB1-2 expresses Binding head machine screw.
XB1-2は、バインドねじを表す
40 expresses M4.0.
40は、M4.0を表す
0-60 expresses a length of 6.0mm.
0-60は、6.0mmの長さを表す
9 expresses Steel (Black zinc trivalent chromate
treating) from Table 1.
9は、表1より鋼 (黒色亜鉛3価クロメート) を表す

1-1. Cross Recessed Head Screws for Precision Equipments
精密機器用十字穴付き小ねじ

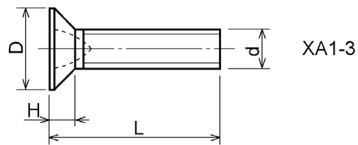
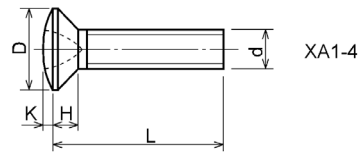
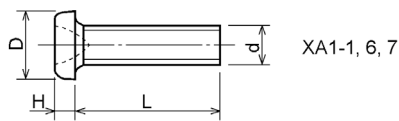

Type No. 類別番号	Type 類別	Head size (mm) 頭部寸法 (mm)						
		M1.4	M1.6	M1.7	M2	M2.5	M2.6	
XA1-1	Pan head Class 1 なべ1種	D	2	2.4	2.5	3	3.8	4
		H	0.5	0.55	0.5	0.6	0.9	0.8
XA1-3	Countersunk head Class 1 さら1種	D	2	2.4	2.5	3	3.8	4
		H	0.48	0.55	0.58	0.73	0.85	0.93
XA1-4	Oval countersunk head Class 1 丸さら1種	D	2	2.4	2.5	3	3.8	4
		H + K	0.68	0.8	0.88	1	1.25	1.3
XA1-6	Pan head Class 3 なべ3種	D	2.5	2.8	3	3.5	4.3	4.5
		H	0.8	0.85	0.9	1	1.3	1.2
XA1-7	Pan head Class 2 なべ2種	D	2.5	2.8	3	3.5	4.3	4.5
		H	0.5	0.55	0.5	0.6	0.9	0.8

Figure ZZB (2/7) MECHANICAL STANDARD PARTS (SCREWS)

1-2. Precision Tapping Screws
精密用タッピンねじ

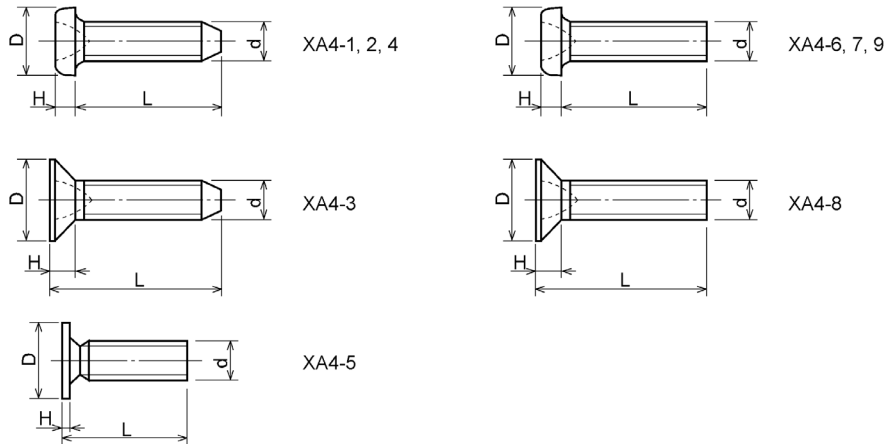

Type No. 類別番号	Type 類別	Head size (mm) 頭部寸法 (mm)						
		M1.4	M1.6	M1.7	M2	M2.5	M2.6	
XA4-1	With tapered end pan head Class 1 絞り-なべ1種	D XA4-1	2	2.4	2.5	3	3.8	4
		H XA4-1	0.5	0.55	0.5	0.6	0.9	0.8
XA4-2	With tapered end pan head Class 3 絞り-なべ3種	D XA4-2	2.5	2.8	3	3.5	4.3	4.5
		H XA4-2	0.8	0.85	0.9	1	1.3	1.2
XA4-3	With tapered end countersunk head 絞り-さら	D XA4-3	2	2.4	2.5	3	3.8	4
		H XA4-3	0.48	0.55	0.58	0.73	0.85	0.93
XA4-4	With tapered end pan head Class 2 絞り-なべ2種	D XA4-4	2.5	2.8	3	3.5	4.3	4.5
		H XA4-4	0.5	0.55	0.5	0.6	0.9	0.8
XA4-5	With parallel end ultra thin head ストレート-超薄頭	D XA4-5	2.5	2.8	3	-	-	-
		H XA4-5	0.2	0.2	0.2	-	-	-
XA4-6	With parallel end pan head Class 1 ストレート-なべ1種	D XA4-6	2	2.4	2.5	3	3.8	4
		H XA4-6	0.5	0.55	0.5	0.6	0.9	0.8
XA4-7	With parallel end pan head Class 3 ストレート-なべ3種	D XA4-7	2.5	2.8	3	3.5	4.3	4.5
		H XA4-7	0.8	0.85	0.9	1	1.3	1.2
XA4-8	With parallel end countersunk head ストレート-さら	D XA4-8	2	2.4	2.5	3	3.8	4
		H XA4-8	0.48	0.55	0.58	0.73	0.85	0.93
XA4-9	With parallel end pan head Class 2 ストレート-なべ2種	D XA4-9	2.5	2.8	3	3.5	4.3	4.5
		H XA4-9	0.5	0.55	0.5	0.6	0.9	0.8

Figure ZZB (3/7) MECHANICAL STANDARD PARTS (SCREWS)

1-3. Cross Recessed Head Screws
一般用十字穴付き小ねじ

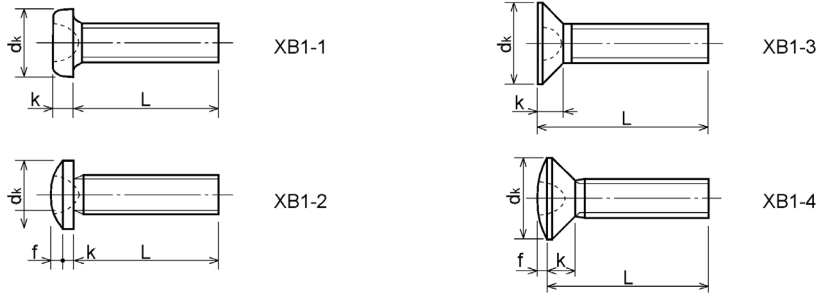

Type No. 類別番号	Type 類別
XB1-1	Pan head なべ
XB1-2	Binding head バインド
XB1-3	Countersunk head さら
XB1-4	Oval countersunk head 丸さら

		Head size (mm) 頭部寸法 (mm)					
		M2	M2.5	M2.6	M3	M4	M5
d_k	XB1-1	3.5	4.5	4.5	5.5	7	9
k	XB1-1	1.3	1.7	1.7	2	2.6	3.3
d_k	XB1-2	4.3	5.3	5.5	6.3	8.3	10.3
$k+f$	XB1-2	1.2	1.5	1.6	1.9	2.5	3.1
d_k	XB1-3	4	5	-	6	8	10
k	XB1-3	1.2	1.45	-	1.75	2.3	2.8
d_k	XB1-4	4	5	-	6	8	10
$k+f$	XB1-4	1.6	2	-	2.45	3.2	4
Screw part length ねじ部長さ b		8	12	12	12	16	20

Figure ZZB (4/7) MECHANICAL STANDARD PARTS (SCREWS)

1-4. Cross Recessed Head Screws with Captive Washer
座金組込み十字穴付き小ねじ

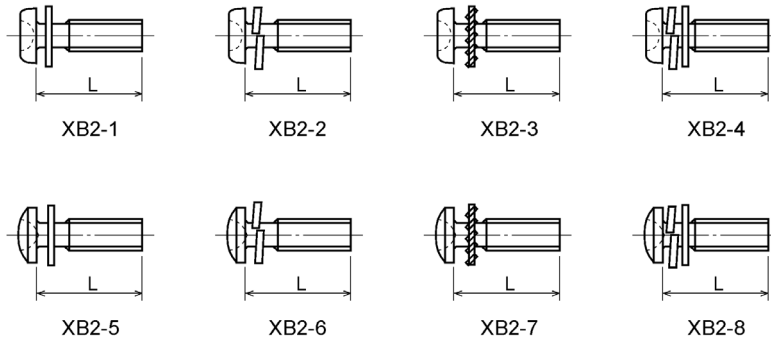

Type No. 類別番号	Type 類別
XB2-1	Pan head + Plain washer (circular bright) なべねじ+平座金
XB2-2	Pan head + Spring washer なべねじ+ばね座金
XB2-3	Pan head + Toothed lock washer なべねじ+歯付座金
XB2-4	Pan head + Spring washer and plain washer (circular bright) なべねじ+(ばね+平)座金
XB2-5	Binding head + Plain washer (circular bright) バインドねじ+平座金
XB2-6	Binding head + Spring washer バインドねじ+ばね座金
XB2-7	Binding head + Toothed lock washer バインドねじ+歯付座金
XB2-8	Binding head + Spring washer and plain washer (circular bright) バインドねじ+(ばね+平)座金

Figure ZZB (5/7) MECHANICAL STANDARD PARTS (SCREWS)

1-5. Hexagon Head Tapping Screws for Matallic Materials
 金属用六角タッピンねじ

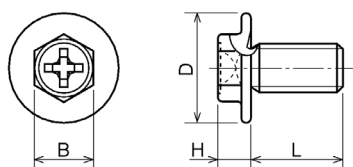

Type No. 類別番号	Type 類別	Head size (mm) 頭部寸法 (mm)		
		M3	M4	
XB3-6	For metallic materials 金属用タッピン	D	8	10
		B	5.5	5.5
XB3-7	For metallic materials with clawed 金属用タッピン-つめ付き	H XB3-6	3.1	3.1
		H XB3-7	3.2	3.2

1-6. Special Tapping Screws
 特殊タッピンねじ

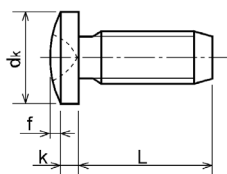

Type No. 類別番号	Type 類別	Head size (mm) 頭部寸法 (mm)		
		M3	M4	
XB4-5	Binding head バインド	dk	6.3	8.3
		k	1.3	1.7
		k+f	1.9	2.5

Figure ZZB (6/7) MECHANICAL STANDARD PARTS (SCREWS)

1-7. General Head Tapping Screws
一般用タッピンねじ

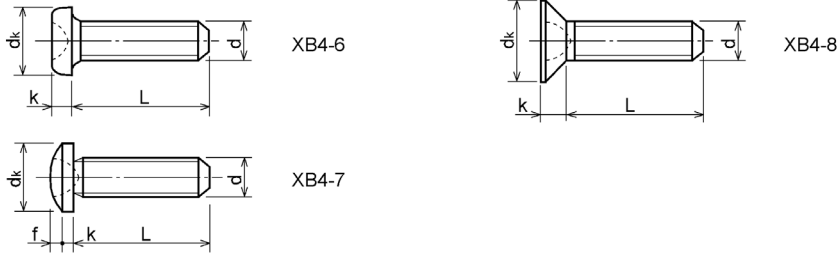

Type No. 類別番号	Type 類別	Head size (mm) 頭部寸法 (mm)						
		M2	M2.5	M2.6	M3	M4	M5	
XB4-6	Pan head なべ	dk XB4-6	3.5	4.5	4.5	5.5	7	9
		k XB4-6	1.3	1.7	1.7	2	2.6	3.3
XB4-7	Binding head バインド	dk XB4-7	4.3	5.3	5.5	6.3	8.3	10.3
		k+f XB4-7	1.2	1.5	1.6	1.9	2.5	3.1
XB4-8	Countersunk head さら	dk XB4-8	4	5	5.2	6	8	10
		k XB4-8	1.2	1.45	1.5	1.75	2.3	2.8

1-8. Tapping Screws for Metallic Materials
金属用タッピンねじ

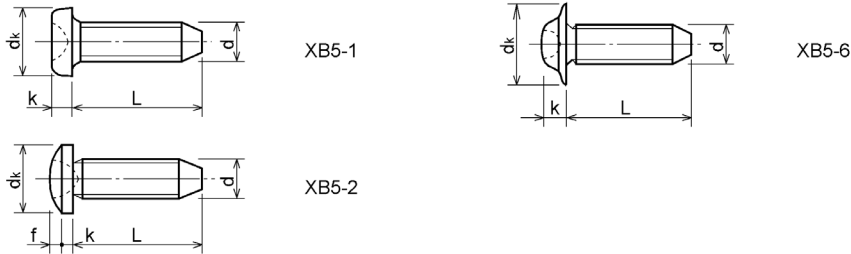

Type No. 類別番号	Type 類別	Head size (mm) 頭部寸法 (mm)					
		M2.5	M2.6	M3	M4	M5	
XB5-1	Pan head なべ	dk XB5-1	4.5	4.5	5.5	7	9
		k XB5-1	1.7	1.7	2	2.6	3.3
XB5-2	Binding head バインド	dk XB5-2	5.5	5.5	6.3	8.3	10.3
		k+f XB5-2	1.6	1.6	1.9	2.5	3.1
XB5-6	Flanged pan head つば付きなべ	dk XB5-6	6.5	6.5	8	10	12
		k XB5-6	2.1	2.1	1.75	3.2	4

Figure ZZB (7/7) MECHANICAL STANDARD PARTS (SCREWS)

1-9. Hexagon Socket Set Screws
六角穴付き止めねじ

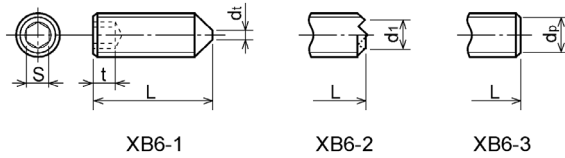

Type No. 類別番号	Type 類別	Head size (mm) 頭部寸法 (mm)						
		M1.6 M1.7	M2	M2.5 M2.6	M3	M5	M5	M6
	S	0.7	0.9	1.3	1.5	2	2.5	3
	t	1.5	1.7	2	2	2.5	3	3.5
	dt max XB6-1	0.4	0.5	0.65	0.75	1	1.25	1.5
	d1 max XB6-2	-	1.2	1.5	1.7	2.2	2.8	3.3
	d1 min XB6-2	-	1	1.2	1.4	1.9	2.4	2.9
	dp max XB6-3	0.8	1	1.5	2	2.5	3.5	4
	dp min XB6-3	0.55	0.75	1.25	1.75	2.25	3.2	3.7

1-10. Flanged Pan Head Machine Screws
つば付きなべ小ねじ

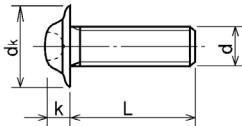

Type No. 類別番号	Type 類別	Head size (mm) 頭部寸法 (mm)				
		M2	M2.5 M2.6	M3	M5	M5
	dk	5	6.5	8	10	12
	k	1.7	2.1	2.5	3.2	4

Figure ZZC MECHANICAL STANDARD PARTS (BOLTS)

2. Bolts (Socket head cap screw)
ボルト

How to read Parts Numbers
部品番号の見方

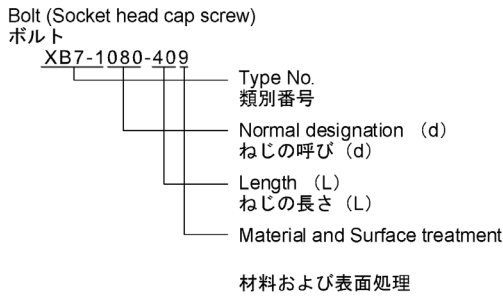

XB7-1 expresses Hexagon socket head cap screws.
XB7-1は、六角穴付きボルトを表す

080 expresses M8.0.
080は、M8.0を表す

40 expresses a length of 40mm.
40は、40mmの長さを表す

9 expresses Steel (Black zinc trivalent chromate treating) from Table 1.
9は、表1より鋼（黒色亜鉛3価クロメート）を表す

2-1. Hexagon socket head cap screws
六角穴付きボルト

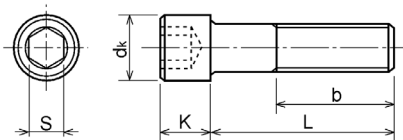

Type No. 類別番号	Type 類別
XB7-1	Hexagon socket head cap screws 六角穴付きボルト

	Head size (mm) 頭部寸法 (mm)						
	M3	M4	M5	M6	M8	M10	M12
S	2.5	3	4	5	6	8	10
dk	5.5	7	8.5	10	13	16	18
K	3	4	5	6	8	10	12
Screw part length ねじ部長さ b_{max}	18	20	22	24	28	32	36

Figure ZZD MECHANICAL STANDARD PARTS (NUTS)

3. Nuts
ナット

How to read Parts Numbers
部品番号の見方

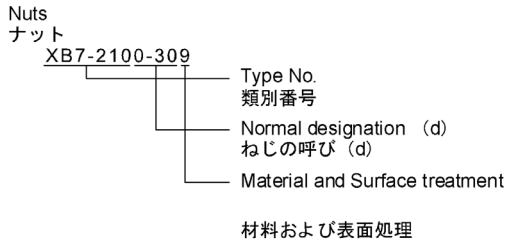

XB7-210 expresses Hexagon nut class 1.
XB7-210は、六角ナット1種を表す

0-30 expresses M3.0.
0-30は、M3.0を表す

9 expresses Steel (Black zinc trivalent chromate treating) from Table 1.
9は、表1より鋼（黒色亜鉛3価クロメート）を表す

3-1. Hexagon Nuts and Hexagon Thin Nuts
六角ナット

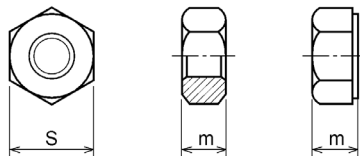

Type No. 類別番号	Type 類別
XB7-210	Hexagon nut Class 1 六角ナット-1種
XB7-220	Hexagon nut Class 3 六角ナット-3種
XB7-230	Hexagon nut Style 1 double chamfered 六角ナット-スタイル1-両面とり
XB7-231	Hexagon nut Style 1 washer faced 六角ナット-スタイル1-座付き
XB7-240	Hexagon nut Style 2 double chamfered 六角ナット-スタイル2-両面とり
XB7-241	Hexagon nut Style 2 washer faced 六角ナット-スタイル2-座付き
XB7-250	Hexagon nut 六角ナット
XB7-260	Hexagon thin nut double chamfered 六角低ナット-両面とり
XB7-270	Hexagon thin nut not chamfered 六角低ナット-面とり無し

	Head size (mm) 頭部寸法 (mm)						
	M2	M2.5	M3	M4	M5	M6	M8
S	4	5	5.5	7	8	10	13
m XB7-210	1.6	2	2.4	3.2	4	5	6.5
m XB7-220	1.2	1.6	1.8	2.4	3.2	3.6	5
m XB7-230, 231	1.6	2	2.4	3.2	4.7	5.2	6.8
m XB7-240, 241	-	-	-	-	5.1	5.7	7.5
m XB7-250	-	-	-	-	5.6	6.1	7.9
m XB7-260	1.2	1.6	1.8	2.2	2.7	3.2	4
m XB7-270	1.2	1.6	1.8	2.2	2.7	3.2	4

Figure ZZE (1/3)MECHANICAL STANDARD PARTS (RETAINING RINGS)

5. Retaining Rings
止め輪

How to read Parts Numbers
部品番号の見方

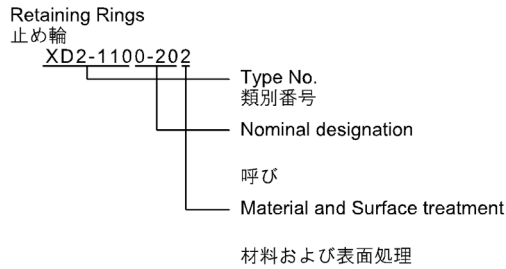

XD2-110 expresses retaining ring-E type (Type1).
XD2-110は、E形止め輪（1種）を表す

0-20 expresses a 020 of nominal designation.
(See Table 5)
0-20は、呼び020を表す（表5参照）

2 expresses Stainless steel (Surface treatment is not to be given) from Table 1.
2は、表1よりステンレス（表面処理なし）を表す

5-1. Retaining Rings - E type
E形止め輪

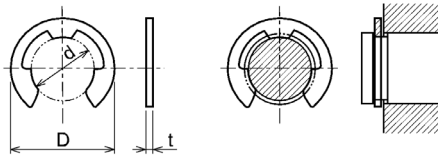

Type No. 類別番号	Type 類別
XD2-110	Retaining ring - E type (Type 1) E形止め輪（1種）
XD2-120	Retaining ring - E type (Type 2) E形止め輪（2種）

Table 5 表5

Type 種類	Nominal designation 呼び	d (mm)	D (mm)	t (mm)
Type 1 1種	007	0.65	2	0.2
	010	0.95	2.8	0.2
	013	1.25	3.3	0.3
	017	1.65	4.2	0.4
	020	1.95	4.6	0.5
	024	2.35	6	0.6
	028	2.74	6.5	0.6
	032	3.14	7.2	0.6
	037	3.64	8	0.7
	040	3.93	10	0.7
	042	4.13	10	0.7
	050	4.93	11	0.7
	058	5.73	12	0.7
	060	5.93	12.7	0.9
064	6.32	13.5	0.9	
074	7.31	15	0.9	
080	7.91	16.5	1	
Type 2 2種	008	0.8	2	0.2
	012	1.2	3	0.3
	015	1.5	4	0.4
	020	2	5	0.4
	025	2.5	6	0.4
	030	3	7	0.6
	040	4	9	0.6
	050	5	11	0.6
	060	6	12	0.8
	070	7	14	0.8
	080	8	16	0.8
	090	9	18	0.8
100	10	20	1	

Figure ZZE (2/3)MECHANICAL STANDARD PARTS (RETAINING RINGS)

5-2. Grip Rings
グリップ止め輪

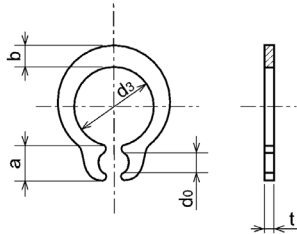

Table 5 表5

Nominal designation 呼び	d_3 (mm)	t (mm)	b (mm)	a (mm)	d_o (mm)
020	1.9	0.5	1	1.8	0.8
025	2.35	0.5	1.2	1.9	0.9
030	2.85	0.6	1.4	1.9	0.9
035	3.3	0.6	1.6	2	0.9
040	3.8	0.8	1.8	2.8	1.2
045	4.25	0.8	2	2.9	1.3
050	4.75	0.8	2.2	2.9	1.3
060	5.7	1	2.4	3.1	1.4
070	6.7	1	2.7	3.3	1.4
080	7.7	1	3	3.5	1.4
090	8.65	1.2	3.3	4.7	1.5
100	9.65	1.2	3.5	4.7	2

Type No. 類別番号	Type 類別
XD2-210	Grip ring グリップ止め輪

5-3. Toothed Retaining Rings
歯付き形止め輪

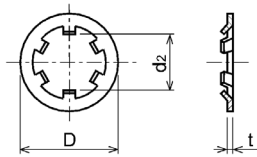

Table 5 表5

Nominal designation 呼び	d_z (mm)	D (mm)	t (mm)	No of teeth 歯数
015	1.4	5.2	0.25	3
020	1.9	6	0.25	3
024	2.3	6.4	0.25	3
030	2.8	8	0.25	4
040	3.8	9	0.25	4
050	4.8	10	0.25	5
060	5.8	11	0.25	5
080	7.8	13	0.25	5
100	9.8	15.4	0.25	6

Type No. 類別番号	Type 類別
XD2-230	Toothed retaining ring 歯付き形止め輪

Figure ZZE (3/3)MECHANICAL STANDARD PARTS (RETAINING RINGS)

5-4. Retaining Rings - C Type
C形止め輪

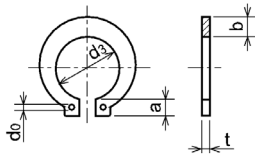

Type No. 類別番号	Type 類別
XD2-310	Retaining ring - C type for shaft C形止め輪 軸用

Table 5 表5

Nominal designation 呼び	d ₃ (mm)	t (mm)	b (mm)	a (mm)	d ₀ (mm)
010	9.3	1	1.6	3	1.2
012	11.1	1	1.8	3.2	1.5
014	12.9	1	2	3.4	1.7
015	13.8	1	2.1	3.5	1.7
016	14.7	1	2.2	3.6	1.7
017	15.7	1	2.2	3.7	1.7
018	16.5	1.2	2.6	3.8	1.7
020	18.5	1.2	2.7	3.9	2
022	20.5	1.2	2.7	4.1	2
025	23.2	1.2	3.1	4.3	2
028	25.9	1.5	3.1	4.6	2
030	27.9	1.5	3.5	4.8	2
032	29.6	1.5	3.5	5	2.5
035	32.2	1.5	4	5.4	2.5

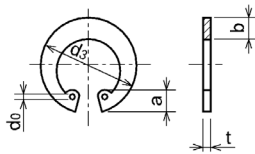

Type No. 類別番号	Type 類別
XD2-320	Retaining ring - C type for hole C形止め輪 穴用

Table 5 表5

Nominal designation 呼び	d ₃ (mm)	t (mm)	b (mm)	a (mm)	d ₀ (mm)
010	10.7	1	1.8	3.1	1.2
011	11.8	1	1.8	3.2	1.2
012	13	1	1.8	3.3	1.5
014	15.1	1	2	3.6	1.7
016	17.3	1	2	3.7	1.7
018	19.5	1	2.5	4	1.7
019	20.5	1	2.5	4	2
020	21.5	1	2.5	4	2
022	23.5	1	2.5	4.1	2
025	26.9	1.2	3	4.4	2
028	30.1	1.2	3	4.6	2
030	32.1	1.2	3	4.7	2
032	34.4	1.2	3.5	5.2	2.5
035	37.8	1.5	3.5	5.2	2.5
037	39.8	1.5	3.5	5.2	2.5
040	43.5	1.8	4	5.7	2.5
042	45.5	1.8	4	5.8	2.5
045	48.5	1.8	4.5	5.9	2.5
047	50.5	1.8	4.5	6.1	2.5
050	54.2	2	4.5	6.5	2.5
052	56.2	2	5.1	6.5	2.5
055	59.2	2	5.1	6.5	2.5
060	64.2	2	5.1	6.8	2.5
062	66.2	2	5.5	6.9	2.5
068	72.5	2.5	6	7.4	2.5
072	76.5	2.5	6.6	7.4	2.5
075	79.5	2.5	6.6	7.8	2.5
080	85.5	2.5	7	8	2.5
085	90.5	3	7	8	3
090	95.5	3	7.6	8.3	3
095	100.5	3	8	8.5	3