

imageRUNNER ADVANCE DX 6000i

PARTS CATALOG



Canon

March 27, 2020
Rev. 0

Index

SNL	Product Code No./Serial No.
A1B	ASSEMBLY LOCATION DIAGRAM
A2	OPTION PARTS CATALOG LIST
001B	ACCESSORIES (MODEL WITHOUT GOVERNMENT)
001D	ACCESSORIES (GOVERNMENT model)
100B	EXTERNAL COVERS, PANELS, ETC.
101	INTERNAL COMPONENTS 1
102C	INTERNAL COMPONENTS 2
103B	INTERNAL COMPONENTS 3
104	INTERNAL COMPONENTS 4
105	INTERNAL COMPONENTS 5
106B	MACHINE REAR PLATE 1
107B	MACHINE REAR PLATE 2
108	MACHINE REAR PLATE 3
109	MACHINE REAR PLATE 4
111	RIGHT DOOR ASSEMBLY
112	RIGHT INNER DOOR ASSEMBLY
113	RIGHT LOWER DOOR ASSEMBLY
114	RIGHT OUTER DOOR ASSEMBLY
115	FRONT COVER ASSEMBLY
130	CONTROL PANEL ASSEMBLY
140B	POWER CORD TERMINAL ASS'Y
250	MAIN DRIVE ASSEMBLY
260	PAPER PICK-UP DRIVE ASS'Y, UP.
261	PAPER PICK-UP DRIVE ASS'Y, LW.
262	DUPLEXING REG. DRIVE ASSEMBLY
270	SHUTTER DRIVE MOUNT ASSEMBLY
271	SET ON DRIVE ASSEMBLY
280	FIXING DRIVE ASSEMBLY
281	FIXING DELIVERY DRIVE ASSEMBLY
290	LIFTER DRIVE MOUNT ASSEMBLY
310	PAPER PICK-UP ASSEMBLY, 1
311	PAPER PICK-UP ASSEMBLY, 2
313	PRE-REG. GUIDE ASSEMBLY
315	MULTI PAPER PICK-UP TRAY ASS'Y
316	MULTI PAPER PICK-UP ASSEMBLY
350	FIRST PAPER DELIVERY ASSEMBLY
351	2ND/3RD PAPER DELIVERY ASS'Y
352	SECOND PAPER DELIVERY ASSEMBLY
353	THIRD PAPER DELIVERY ASSEMBLY

Index

460	LASER SCANNER ASSEMBLY
530B	INTER. TRANSFER BELT ASS'Y
535	TRANSFER CLEANER ASSEMBLY
600	PROCESS-KIT FRAME ASSEMBLY
620	SET ON HOPPER ASS'Y, BLACK
626B	BOTTLE FRONT INNER DOOR ASS'Y
627	BOTTLE BASE ASSEMBLY, BLACK
640	DEVELOPING ASSEMBLY
770	CONTAINER, WASTE TONER, WT-202
771	WASTE TONER DRIVE DETECT ASS'Y
810B	FIXING ASSEMBLY (120V)
811	SHUTTER ASSEMBLY
812	DELIVERY GUIDE ASSEMBLY, LOWER
900	CONTROLLER BOX ASSEMBLY
910	POWER SUPPLY ASSEMBLY
930	MAIN CONTROLLER PCB ASSEMBLY
931	RISER PCB ASSEMBLY
962A	PAPER FEED DRIVER PCB ASSEMBLY
B01	ATTACHMENT PARTS
B02	ADF MAINTENANCE KIT, DR-205
B11C	INTERNAL COMPONENTS 1
B12C	INTERNAL COMPONENTS 2
B13	INTERNAL COMPONENTS 3
B14	INTERNAL COMPONENTS 4
B15	DOCUMENT TRAY ASSEMBLY
B16	OPEN/CLOSE COVER ASSEMBLY
B17	BASE FRAME ASSEMBLY
B40	PLATEN GUIDE ASS'Y
B90	DF DRIVER PCB ASSEMBLY
D11B	READER ASSEMBLY
H30A	CASSETTE ASSEMBLY (SMALL) (WITHOUT GOVERNMENT)
H30C	CASSETTE ASSEMBLY (SMALL) (GOVERNMENT model)
H31A	CASSETTE ASSEMBLY (LARGE) (WITHOUT GOVERNMENT)
H31C	CASSETTE ASSEMBLY (LARGE) (GOVERNMENT model)
ZZA	MECHANICAL STANDARD PARTS (HOW TO USE)
ZZB	MECHANICAL STANDARD PARTS (SCREWS)
ZZC	MECHANICAL STANDARD PARTS (BOLTS)
ZZD	MECHANICAL STANDARD PARTS (NUTS)
ZZE	MECHANICAL STANDARD PARTS (RETAINING RINGS)

Figure SNL Product Code No./Serial No.

	Product Code No.	Model Name	Remarks	Serial No.
1	F81-1631-000	imageRUNNER ADVANCE DX 6000i	MODEL WITHOUT GOVERNMENT	3BX
2	F81-1633-000	imageRUNNER ADVANCE DX 6000i	GOVERNMENT model	3BY

	中オーダー	製品名	備考	シリアル No.
1	F81-1631-000	imageRUNNER ADVANCE DX 6000i	MODEL WITHOUT GOVERNMENT	3BX
2	F81-1633-000	imageRUNNER ADVANCE DX 6000i	GOVERNMENT model	3BY

FIGURE & KEY NO.	PART NUMBER	RANK	QTY	DESCRIPTION	SERIAL NUMBER /REMARKS
SNL	NPN		RF	Product Code No./Serial No.	
1	F81-1631-000		1	imageRUNNER ADVANCE DX 6000i	3BX MODEL WITHOUT GOVERNMENT
2	F81-1633-000		1	imageRUNNER ADVANCE DX 6000i	3BY GOVERNMENT model

Figure A1B (1/6) ASSEMBLY LOCATION DIAGRAM

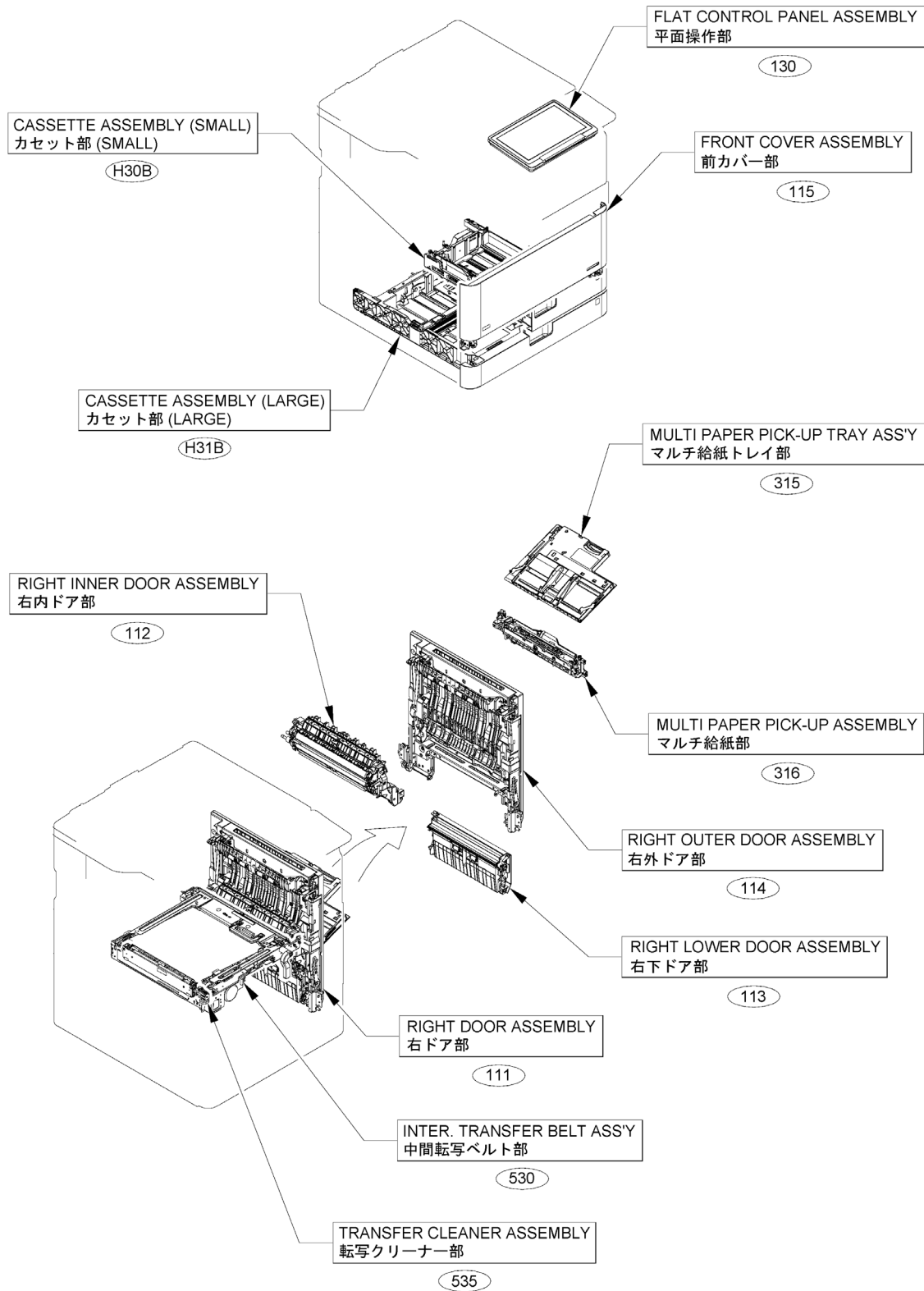

Figure A1B (2/6) ASSEMBLY LOCATION DIAGRAM

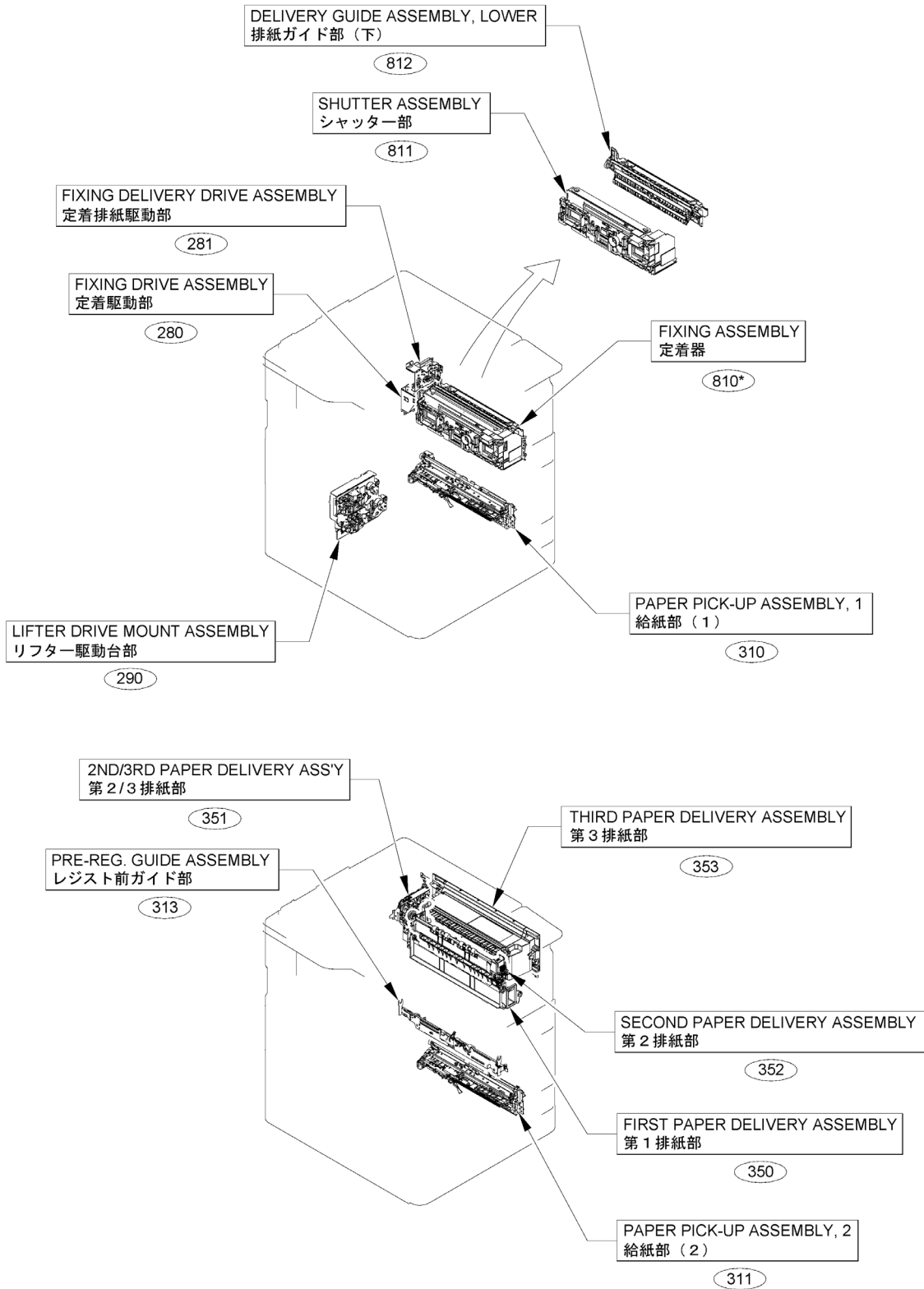

Figure A1B (3/6) ASSEMBLY LOCATION DIAGRAM

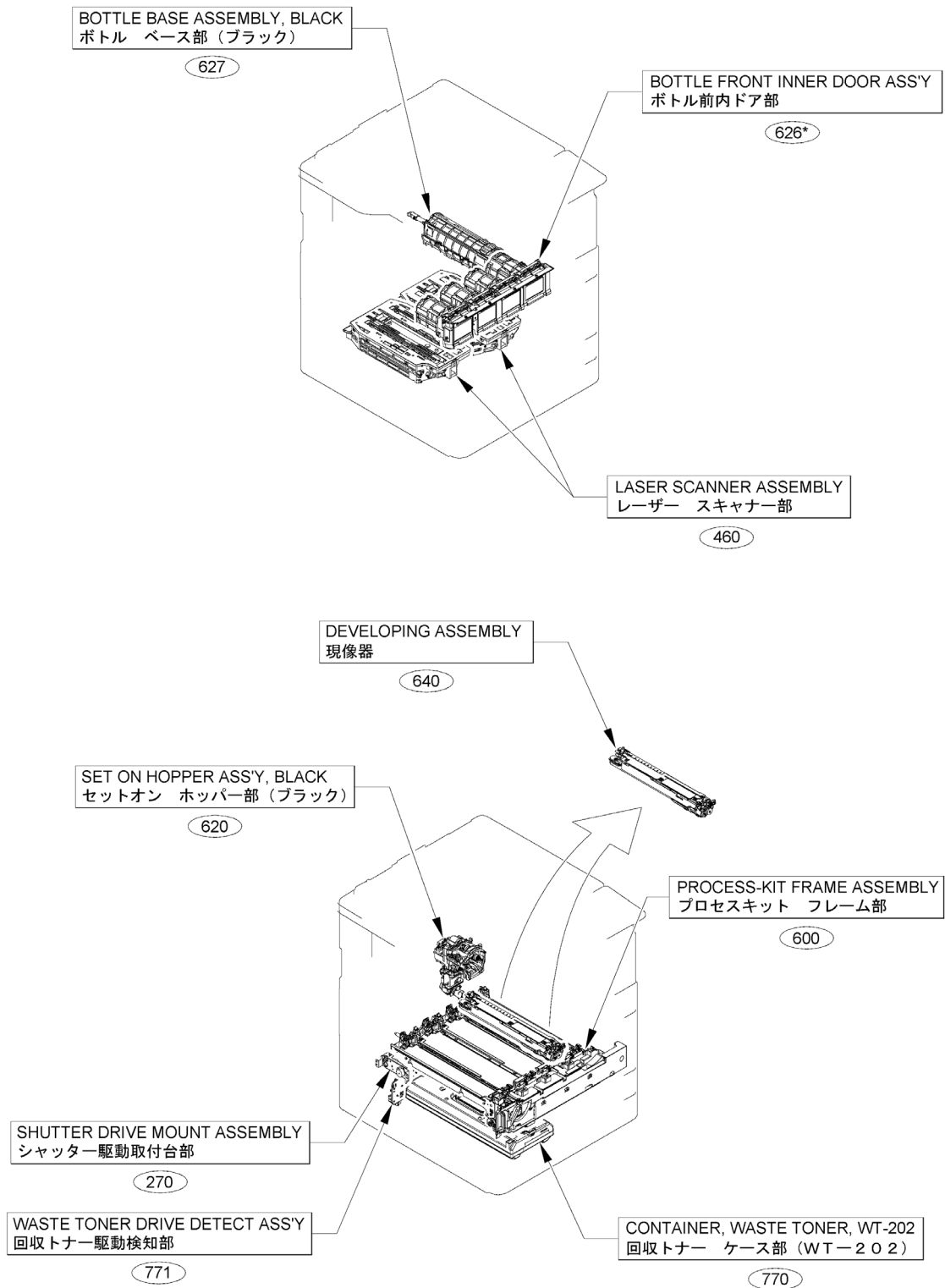

Figure A1B (4/6) ASSEMBLY LOCATION DIAGRAM

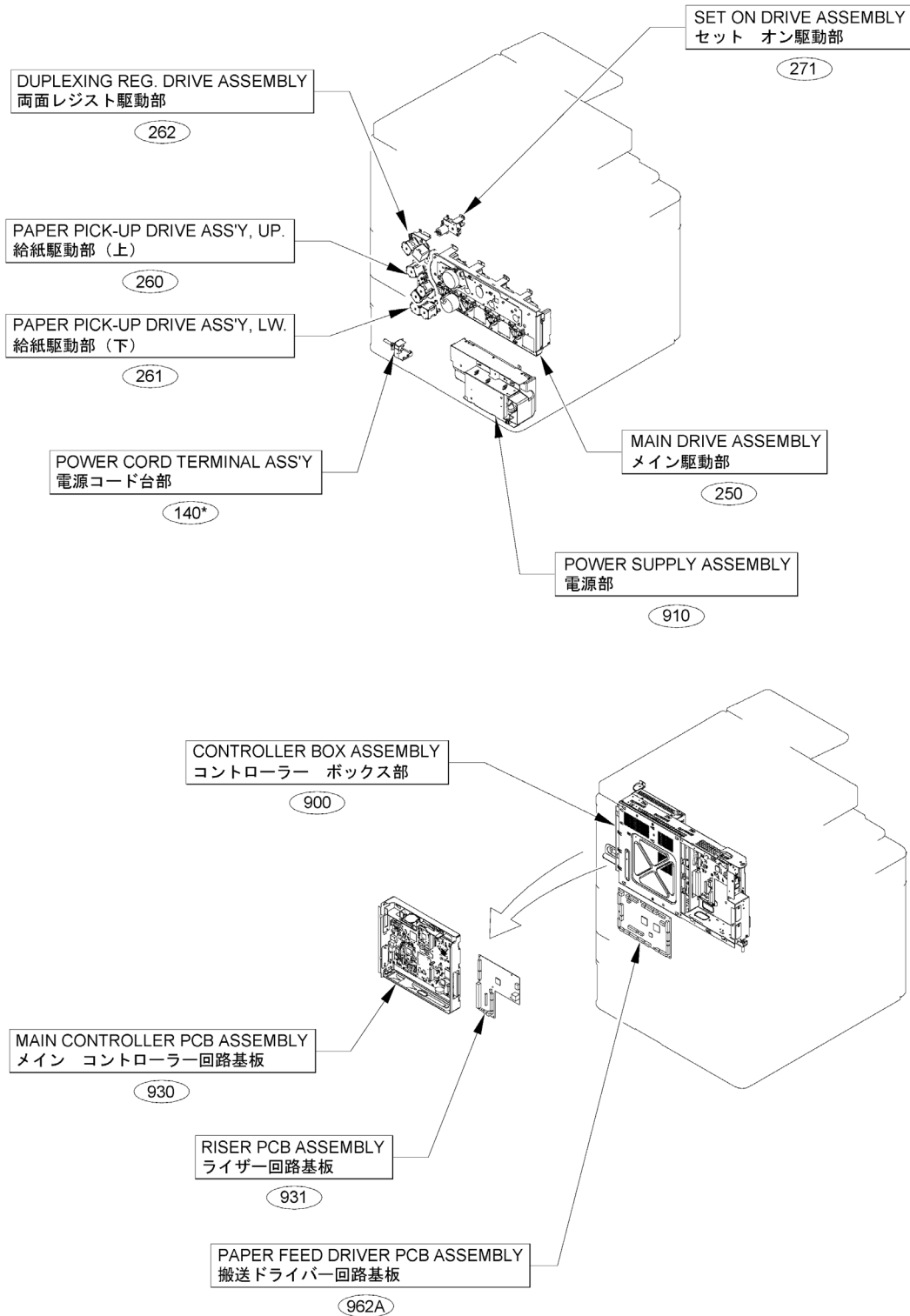

Figure A1B (5/6) ASSEMBLY LOCATION DIAGRAM

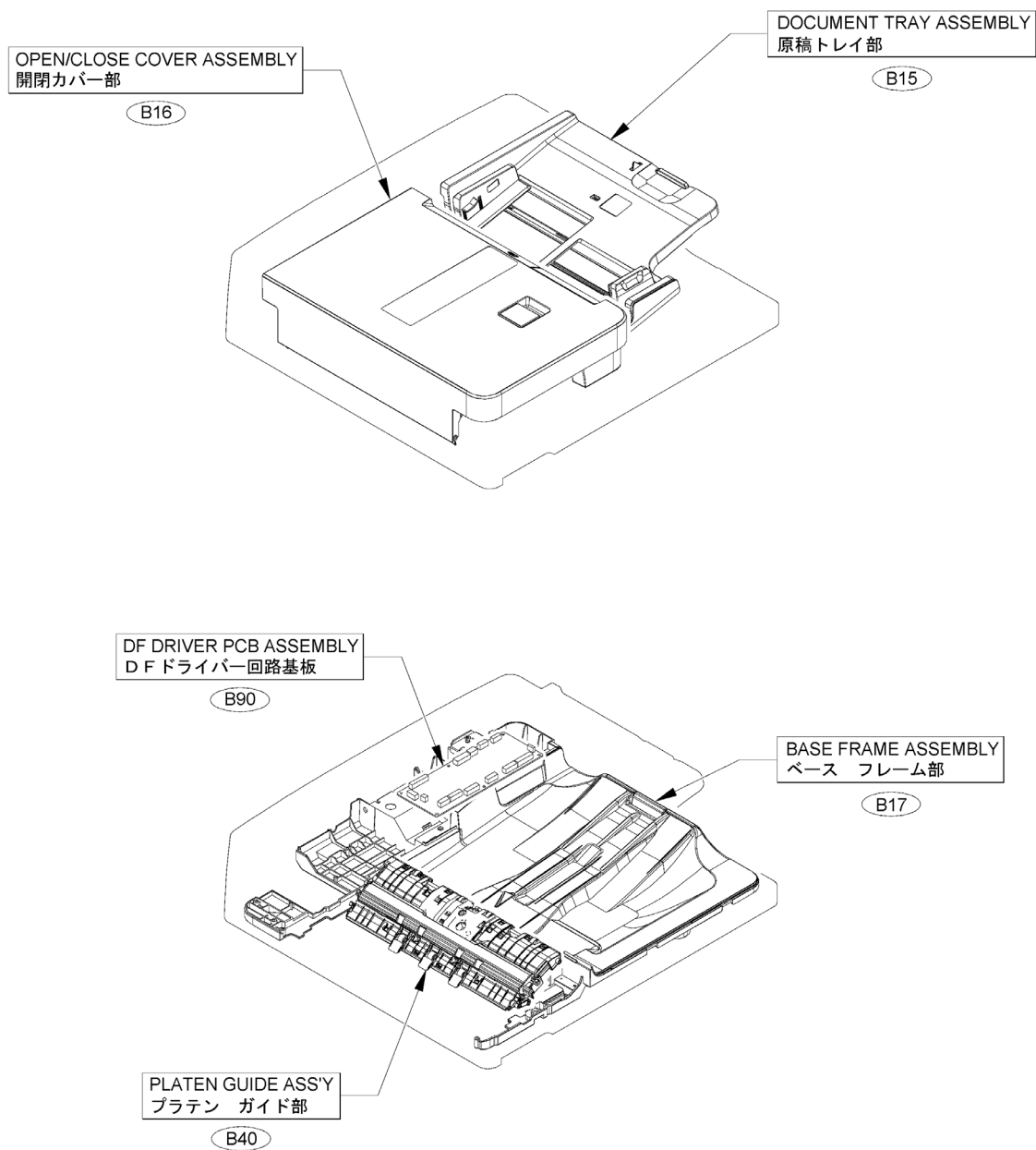

Figure A1B (6/6) ASSEMBLY LOCATION DIAGRAM

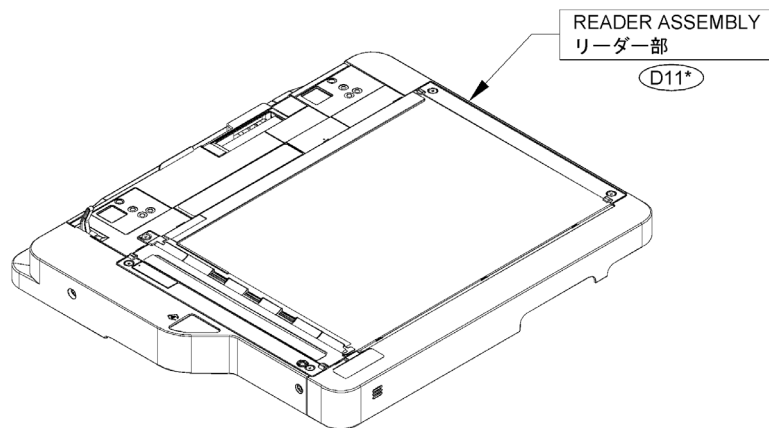

Figure A2 OPTION PARTS CATALOG LIST

This is the table of the machine's options whose parts catalog is issued.
 本機オプションで、パーツカタログが発行されている機種の一覧である。

No.	Model Name(English)	Model Name(Japanese)
1	Platen Cover-Y2	原稿台カバー・Y 2
2	Stamp Ink Cartridge-C1	スタンプインクカートリッジ・C 1
3	ADF Access Handle-A1	A D Fアクセスハンドル・A 1
4	(JAPAN ONLY)	プリンタカバー・M 1
5	NFC Kit-E1	N F Cキット・E 1
6	Paper Deck Unit-F1	ペーパーデッキユニット・F 1
7	Cassette Feeding Unit-AM1	2段カセットペディスタル・AM 1
8	High Capacity Cassette Feeding Unit-A1	大容量カセットペディスタル・A 1
9	Tab Feeding Attachment-F1	インデックス紙アタッチメント・F 1
10	Copy Tray-J2	コピートレイ・J 2
11	Inner 2way Tray-J1	インナー2ウェイトレイ・J 1
12	Staple Finisher-Y1/Booklet Finisher-Y1	ステイプルフィニッシャー・Y 1 ／中綴じフィニッシャー・Y 1
13	Inner Finisher-H1	インナーフィニッシャー・H 1
14	2/3 Hole, 2/4 Hole, 4 Hole Puncher Unit-A1	2／3穴、2／4穴、 4穴パンチャーユニット・A 1
15	Inner 2/3 Hole, 2/4 Hole, 4 Hole Puncher-B1	インナー2／3穴、2／4穴、 4穴パンチャー・B 1
16	Buffer Pass Unit-L1	バッファパスユニット・L 1
17	Staple Cartridge-Y1	ステイプル・Y 1
18	Reader Heater Unit-J5	リーダーヒーターキット・J 5
19	Cassette Heater Unit-41	(日本仕向なし)
20	Paper Deck Heater Unit-C1	ペーパーデッキヒーターユニット・C 1
21	Utility Tray-B1	ユーティリティートレイ・B 1
22	Copy Card Reader Attachment-B7	コピーカードリーダー取付けキット・B 7
23	Numeric Keypad-A1	テンキー・A 1
24	Super G3 FAX Board-AS1	(日本仕向なし)
25	Super G3 FAX Board-AS2	(日本仕向なし)
26	Super G3 2nd Line Fax Board-AS1	(日本仕向なし)
27	Super G3 2nd Line Fax Board-AS2	(日本仕向なし)
28	Super G3 3rd/4th Line Fax Board-AS1	G 3回線増設キット(3・4回線)・AS 1
29	Super G3 3rd/4th Line Fax Board-AS2	(日本仕向なし)
30	(JAPAN ONLY)	G 3回線増設キット(2回線)・BA 1
31	(JAPAN ONLY)	ハンドセット・G 2
32	Voice Guidance Kit-G1	(日本仕向なし)
33	Voice Operation Kit-D1	音声操作キット・D 1
34	(JAPAN ONLY)	i R-A D V課金装置接続キット・A 3
35	Serial Interface Kit-K3	(日本仕向なし)
36	Copy Control Interface Kit-A1	(日本仕向なし)
37	2.5inch/1TB HDD-P1/250GB HDD-N1	オプションHDD(2.5inch/1TB)・ P 1 / (2.5inch/250GB)・N 1
38	HDD Mirroring Kit-J1	HDDミラーリングキット・J 1
39	IC Card Reader Box for Numeric Keypad-A1	テンキー用ICカードリーダーボックス・A 1
40	Copy Card Reader-F1	コピーカードリーダー・F 1
41	Connection Kit-A2 for Bluetooth LE	拡張キット・A 2 for Bluetooth LE
42	Option Attachment kit for Reader-A2	リーダー用オプション取付けキット・A 2

Figure 001B ACCESSORIES (MODEL WITHOUT GOVERNMENT)

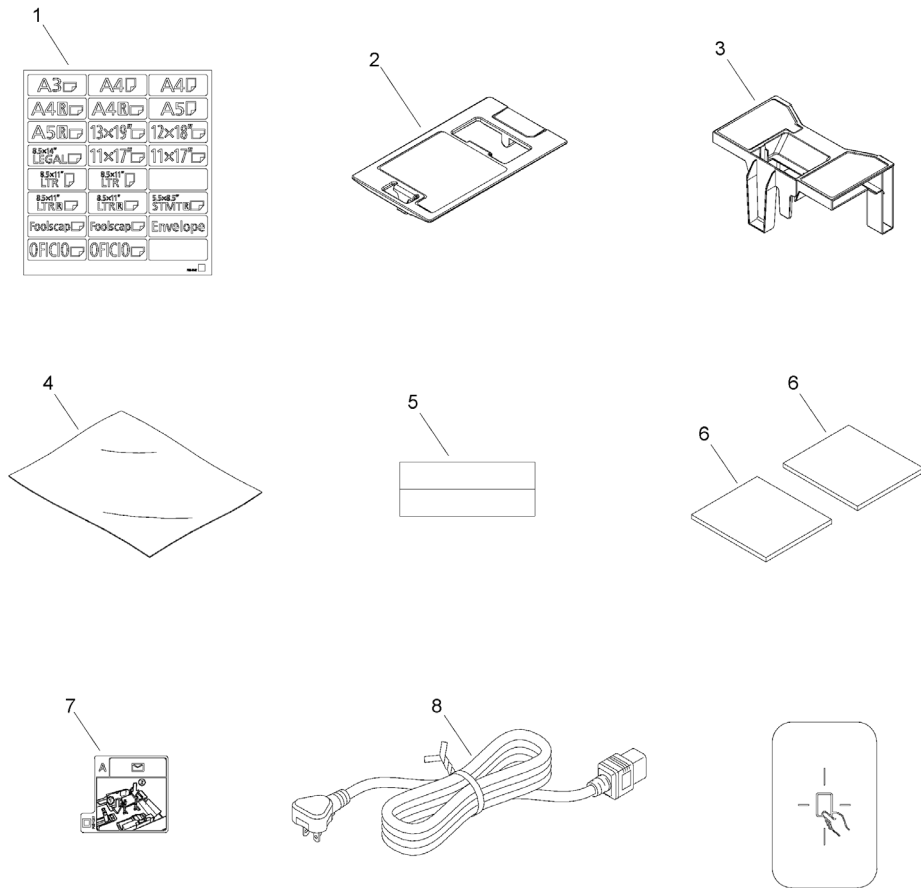

FIGURE & KEY NO.	PART NUMBER	RANK	QTY	DESCRIPTION	SERIAL NUMBER /REMARKS
001B	NPN		RF	ACCESSORIES	MODEL WITHOUT GOVERNMENT
1	FE8-9142-000		1	LABEL, PAPER SIZE	
2	FL0-4625-000		1	ENVELOPE VERTICAL FEED ASS'Y	
3	FL0-2305-000		1	ENVELOPE HORIZONTAL FEED ASS'Y	
4	FE2-D452-000		1	CLOTH, CLEANING	
5	FE8-5468-000		1	TAPE, DUPLEXING	
6	FE8-5466-000		2	CUSHION, BASE	
7	FU2-1377-000		1	LABEL, ENVELOPE KIT	
8	FK3-2053-000		1	CORD, POWER SUPPLY, 120V	

Figure 001D ACCESSORIES (GOVERNMENT model)

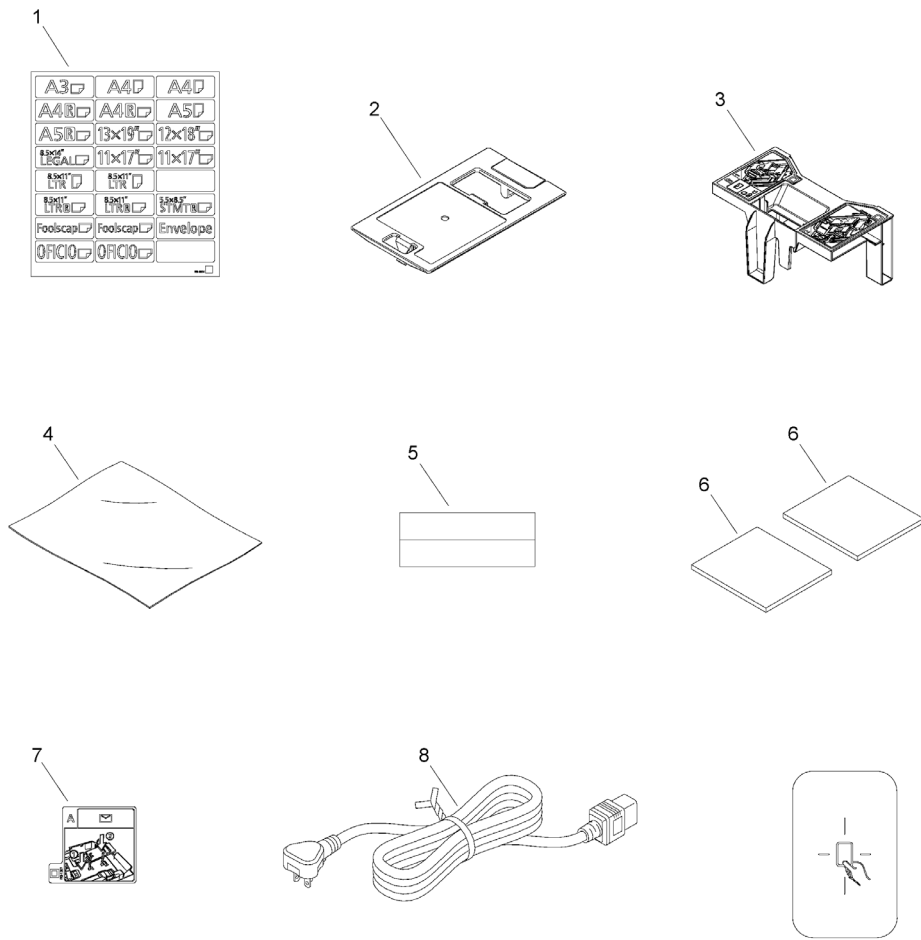

FIGURE & KEY NO.	PART NUMBER	RANK	QTY	DESCRIPTION	SERIAL NUMBER /REMARKS
001D	NPN		RF	ACCESSORIES	GOVERNMENT model
1	FE8-8834-000		1	LABEL, PAPER SIZE	
2	FL0-3261-000		1	PLATE, LIFTING	
3	FL1-0490-000		1	ENVELOPE HORIZONTAL FEED ASS'Y	
4	FE2-A001-000		1	CLOTH, CLEANING	
5	FE4-7895-000		1	TAPE, DUPLEXING	
6	FE4-7896-000		2	CUSHION	
7	FE8-1367-000		1	LABEL, ENVELOPE KIT	
8	FK3-2053-000		1	CORD, POWER SUPPLY, 120V	

Figure 100B (1/2)EXTERNAL COVERS, PANELS, ETC.

NOTE : Several kinds of labels are attached on the board for the parts of Key No. 33.

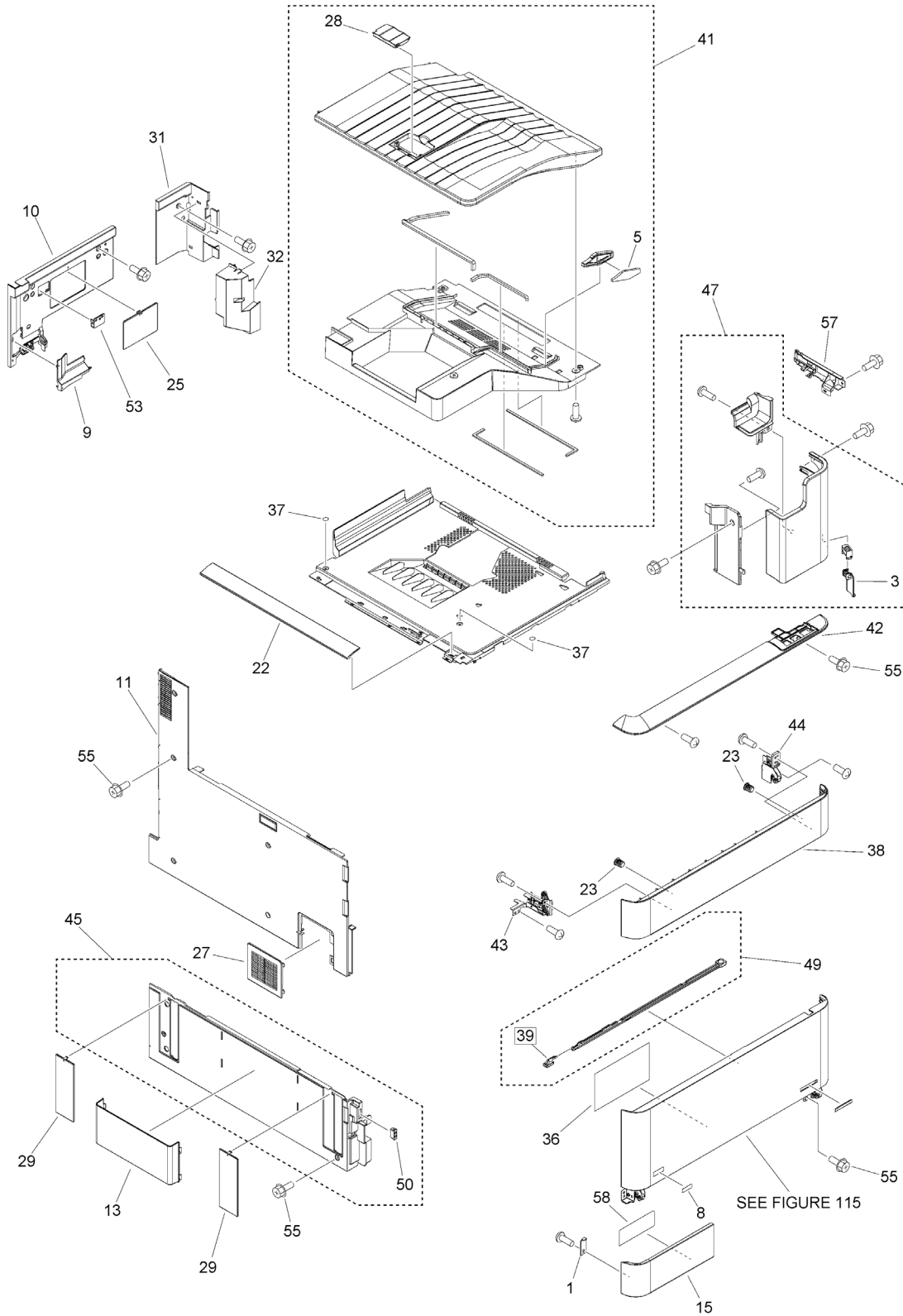

Figure 100B (2/2) EXTERNAL COVERS, PANELS, ETC.

NOTE : Several kinds of labels are attached on the board for the parts of Key No. 33.

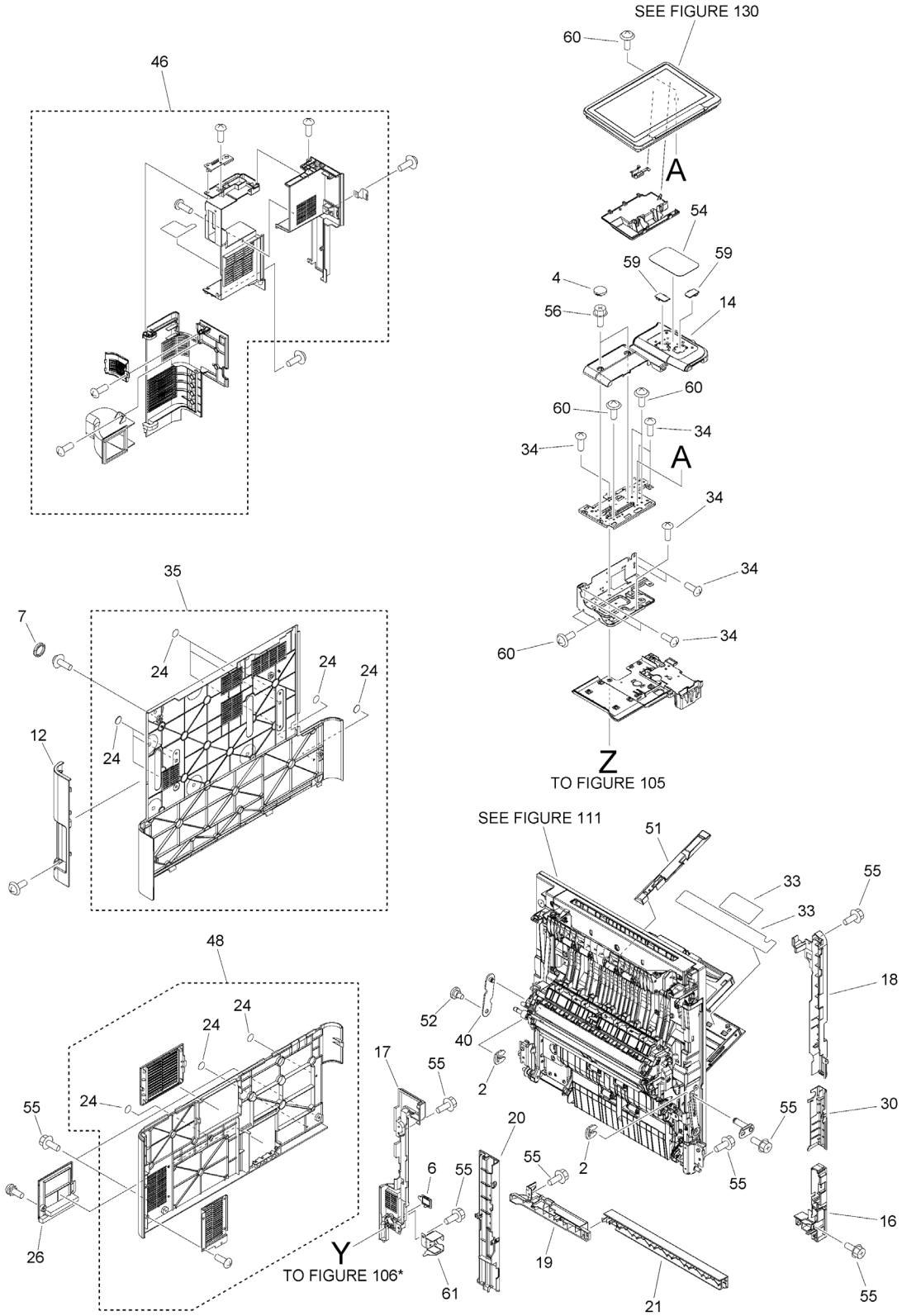

FIGURE & KEY NO.	PART NUMBER	RANK	QTY	DESCRIPTION	SERIAL NUMBER /REMARKS
100B	NPN		RF	EXTERNAL COVERS, PANELS, ETC.	
1	FC6-1844-000		1	PLATE, MAGNET, B	
2	FC6-3002-000		2	RING, RESIN, RETAINING	
3	FC8-4000-000		1	COVER, MAIN SWITCH	
4	FE3-9169-000		2	CAP	
5	FC8-5086-000		1	FILTER, AIR	
6	FE3-9087-000		1	COVER, ENV. HEATER SWITCH	
7	FE3-9178-000		1	CAP	
8	FE4-1818-000		1	LABEL, TONER	
9	FE4-1987-000		1	COVER, INNER DELIVERY, LF REAR	
10	FE4-2009-000		1	COVER, INNER,DELV. REAR	
11	FE4-2010-000		1	COVER, LEFT UPPER	
12	FE4-2808-000		1	COVER, REAR UPPER, LEFT	
13	FE4-2809-000		1	HOLDER, SERVICE BOOK	
14	FE2-J022-000		1	COVER, ARM, UPPER	
15	FE4-3610-000		1	COVER, WASTE TONER ASSEMBLY	
16	FE4-3815-000		1	COVER, RIGHT, FRONT	
17	FE4-3816-000		1	COVER, RIGHT REAR	
18	FE4-3817-000		1	COVER, RIGHT FRONT, UPPER	
19	FE4-3818-000		1	COVER, RIGHT REAR, LOWER	
20	FE4-3849-000		1	COVER, HANDLE, RIGHT REAR	
21	FE4-4156-000		1	COVER, LOWER RIGHT	
22	FL1-1988-000		1	COVER, BELT, LEFT UPPER	
23	FE4-4819-000		2	CATCH, MAGNET, METAL	
24	FE4-5428-000		11	SEAL	
25	FE4-7420-000		1	COVER, BIAS PCB	
26	FL1-6629-000		1	COVER, CONNECTOR	
27	FE4-7477-000		1	COVER, DUCT, LEFT	
28	FE4-7487-000		1	STOPPER, PUSHING	
29	FE4-7494-000		2	COVER, HANDLE, LEFT	
30	FE4-7495-000		1	COVER, RIGHT FRONT HANDLE, MD.	
31	FE4-9267-000		1	COVER,INNER DELIVERY,RT. REAR	
32	FE4-9268-000		1	COVER, INNER DELIVERY SENSOR	
33	FE2-C324-000		1	LABEL, MULTIPLE	SEE NOTE
34	XA9-0893-000		8	SCREW, M4X8	
35	FL0-4181-010		1	COVER, REAR UPPER	
36	FL4-3303-000		1	LABEL, SERVICE	GOVERNMENT model
36	FL4-3455-000		1	LABEL, SERVICE	MODEL WITHOUT GOVERNMENT
37	FL0-7516-000		2	SEAL, BLANKING	
38	FL1-0394-000		1	COVER, TONER	
39	FL1-6298-000		1	PAD, GLASS CLEANING	[DP] MODEL WITHOUT GOVERNMENT

FIGURE & KEY NO.	PART NUMBER	RANK	QTY	DESCRIPTION	SERIAL NUMBER /REMARKS
39	FL2-9476-010		1	PAD, GLASS CLEANING	[DP] GOVERNMENT model
40	FL2-9530-010		1	STOPPER, RIGHT DOOR, 2	
41	FM1-G221-000		1	INNER LOWER COVER ASSEMBLY	
42	FM1-G231-000		1	FRONT UPPER COVER ASSEMBLY	
43	FM1-G344-000		1	TONER COVER HINGE MOUNT ASS'Y	
44	FM1-G352-000		1	TONER COVER HINGE ASS'Y, RIGHT	
45	FM1-G373-000		1	COVER ASSEMBLY, LEFT LOWER	
46	FM1-G601-000		1	RIGHT REAR UP. COVER ASSEMBLY	
47	FM1-Z399-000		1	RIGHT FRONT UP. COVER ASSEMBLY	
48	FM1-G643-000		1	REAR LOWER COVER ASSEMBLY	
49	FM1-U651-000		1	GLASS CLEANING ROD ASSEMBLY	MODEL WITHOUT GOVERNMENT
49	FM3-5968-030		1	GLASS CLEANING ROD ASSEMBLY	GOVERNMENT model
50	XZ9-0603-000		1	CATCH, MAGNET	
51	FE4-4841-000		1	COVER,MULTI PAPER PICK-UP WIRE	
52	FU2-2390-000		1	SCREW, STEPPED, M4	
53	FE4-7425-000		1	SUPPORT, PAPER DELIVERY TRAY	
54	FL1-3902-000		1	SHEET_COVER_ADHESIVE_PC(R)	
55	XA9-0732-010		15	SCREW,RS,M4X8	
56	XA9-1386-000		2	SCREW,RS,M3X8	
57	FL4-3302-000		1	COVER, USB	
58	FE4-3035-000		1	LABEL, OPERATOR CAUTION	
59	FE8-6989-000		2	COVER, 10 KEY	
60	XA9-2050-000		8	SCREW, SELF-TAPPING, M3	
61	FC0-5054-000		1	COVER, PLUG	

FIGURE & KEY NO.	PART NUMBER	RANK	QTY	DESCRIPTION	SERIAL NUMBER /REMARKS
101	NPN		RF	INTERNAL COMPONENTS 1	
1	FC6-1844-000		1	PLATE, MAGNET, B	
2	XZ9-0603-000		2	CATCH, MAGNET	
3	FC8-4202-000		1	LINK, MOVABLE	
4	FM2-H971-000		1	CABLE, WASTE TONER	
5	FE4-3608-000		1	COVER, WASTE TONER CASE	
6	FK2-7291-000		1	FAN	FM9
7	FM1-G618-000		1	MAIN SWITCH ASSEMBLY	SW1
8	FM1-V528-000		1	DRAWER ASSEMBLY	
9	FM1-V529-000		1	INTERLOCK SWITCH ASSEMBLY	SW3
10	FM2-J815-000		1	DRIVER PCB ASSEMBLY, FRONT	UN3
11	FE8-1304-000		1	ROLLER, RAIL	
12	FM1-K250-000		1	AUTO SIZE DETECT ASSEMBLY	SW9
13	FM1-N636-000		1	PATT. READ SHUTTER DRIVE ASS'Y	SL1
14	XA9-2011-000		2	SCREW, MACH., TRUSS HEAD, M4X36	
15	WG8-5783-000		2	IC, PHOTO-INTERRUPTER, LG248NL1A	PS17, PS18
16	FM1-G358-000		1	SHUTTER ASSEMBLY	
17	FM2-A156-000		1	COVER, I.T.B., FRONT	
18	XA9-0732-010		15	SCREW, RS, M4X8	
19	FM2-H969-000		1	CABLE, LOAD	
20	FE2-K587-000		1	SHEET, BLANKING	

Figure 102C INTERNAL COMPONENTS 2

NOTE : Several kinds of labels are attached on the board for the parts of Key No. 2 and 7.

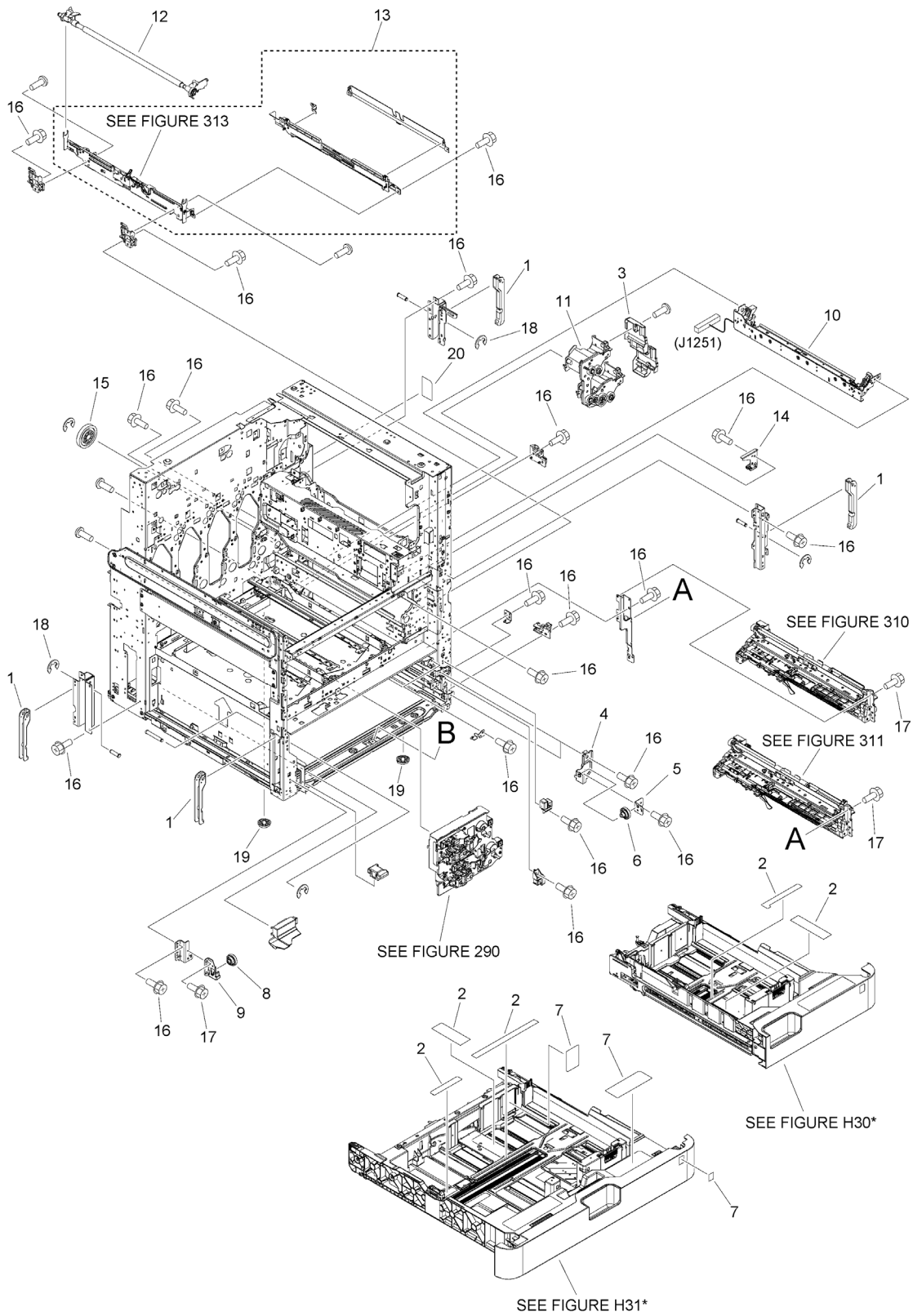

FIGURE & KEY NO.	PART NUMBER	RANK	QTY	DESCRIPTION	SERIAL NUMBER /REMARKS
102C	NPN		RF	INTERNAL COMPONENTS 2	
1	FB2-8094-020		4	KNOB, 1	
2	FE2-C320-000		1	LABEL, ENVELOPE	SEE NOTE GOVERNMENT model
2	FE8-7384-000		1	LABEL, ENVELOPE	SEE NOTE MODEL WITHOUT GOVERNMENT
3	FE4-4151-000		1	COVER, PAPER PICK-UP CABLE	
4	FE4-4624-000		2	SUPPORT, CST. ROLLER, RIGHT 1	
5	FE4-4625-000		2	SUPPORT, CST. ROLLER, RIGHT 2	
6	FE8-1304-000		2	ROLLER, RAIL	
7	FE8-1364-000		1	LABEL, MULTIPLE	SEE NOTE GOVERNMENT model
7	FE8-4838-000		1	LABEL, MULTIPLE	SEE NOTE MODEL WITHOUT GOVERNMENT
8	FE8-1713-000		1	ROLLER, RAIL	
9	FL1-0489-000		1	SUPPORT, CASSETTE ROLLER, LEFT	
10	FM2-A059-000		1	PHOTO SENSOR UNIT, REG. PATCH	
11	FM1-G580-000		1	PAPER PICK-UP DRIVE ASSEMBLY	
12	FM1-H146-000		1	REGISTRATION ROLLER ASSEMBLY	
13	FM1-V453-000		1	PRE-REG. GUIDE ASSEMBLY SET	
14	FM3-8916-000		1	DRAWING LINK ASSY, FRONT	
15	FU2-2267-000		1	GEAR, 36T	
16	XA9-0732-010		15	SCREW,RS,M4X8	
17	XA9-1386-000		9	SCREW,RS,M3X8	
18	XD9-0396-000		2	RING, E	
19	XH9-0136-000		2	FOOT, RUBBER	
20	FE2-C349-000		1	LABEL, DRIVE ASSEMBLY CAUTION	

Figure 103B INTERNAL COMPONENTS 3

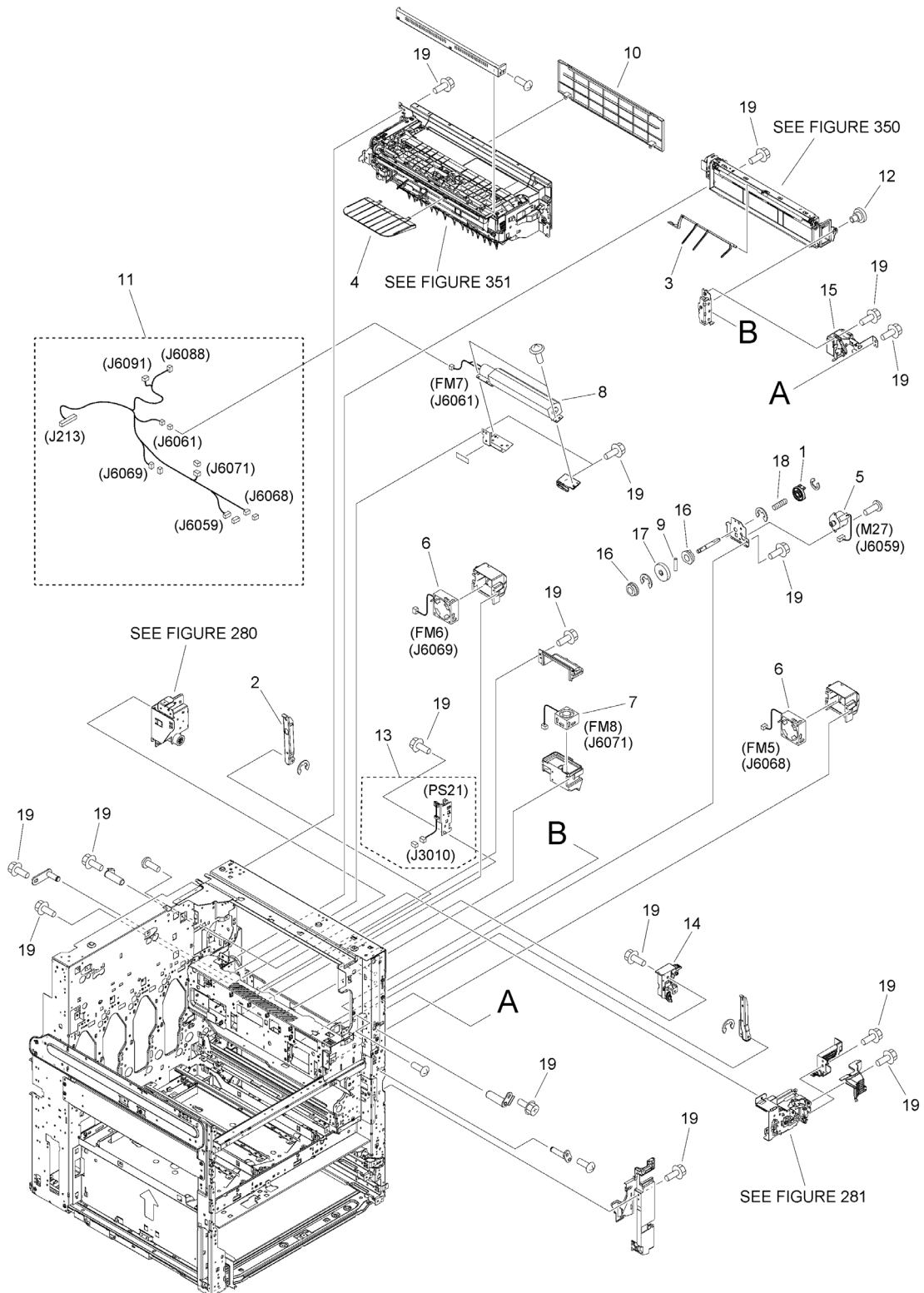

FIGURE & KEY NO.	PART NUMBER	RANK	QTY	DESCRIPTION	SERIAL NUMBER /REMARKS
103B	NPN		RF	INTERNAL COMPONENTS 3	
1	FC6-9556-000		1	COUPLING, FAN SHUTTER	
2	FC8-4909-010		1	RAIL, FIXING, REAR	
3	FE4-1985-000		1	LEVER, FULL DETECT	
4	FE4-7497-000		1	GUIDE, REVERSE BACK END	
5	FK2-2069-000		1	MOTOR, STEPPING, DC	M27
6	FK2-3679-000		2	FAN	FM5, FM6
7	FK2-7290-000		1	FAN	FM8
8	FK2-7362-010		1	FAN	FM7
9	XD9-0288-000		1	PIN, DOWEL	
10	FL0-5270-010		1	COVER, PAPER DELIVERY BLANKING	
11	FM2-H976-000		1	CABLE, SIDE END COOLING FAN	
12	FU2-2390-000		1	SCREW, STEPPED, M4	
13	FM1-G228-000		1	OPEN/CLOSE SENSOR ASSEMBLY	PS21
14	FM1-K437-000		1	PAPER DELIVERY DOOR HOOK ASS'Y	
15	FM3-6008-000		1	SUPPORT, TOGGLE, FRONT	
16	FS1-1508-000		2	BUSHING	
17	FU7-0318-000		1	GEAR, 50T	
18	FU7-2530-000		1	SPRING	
19	XA9-0732-010		15	SCREW,RS,M4X8	

Figure 104 INTERNAL COMPONENTS 4

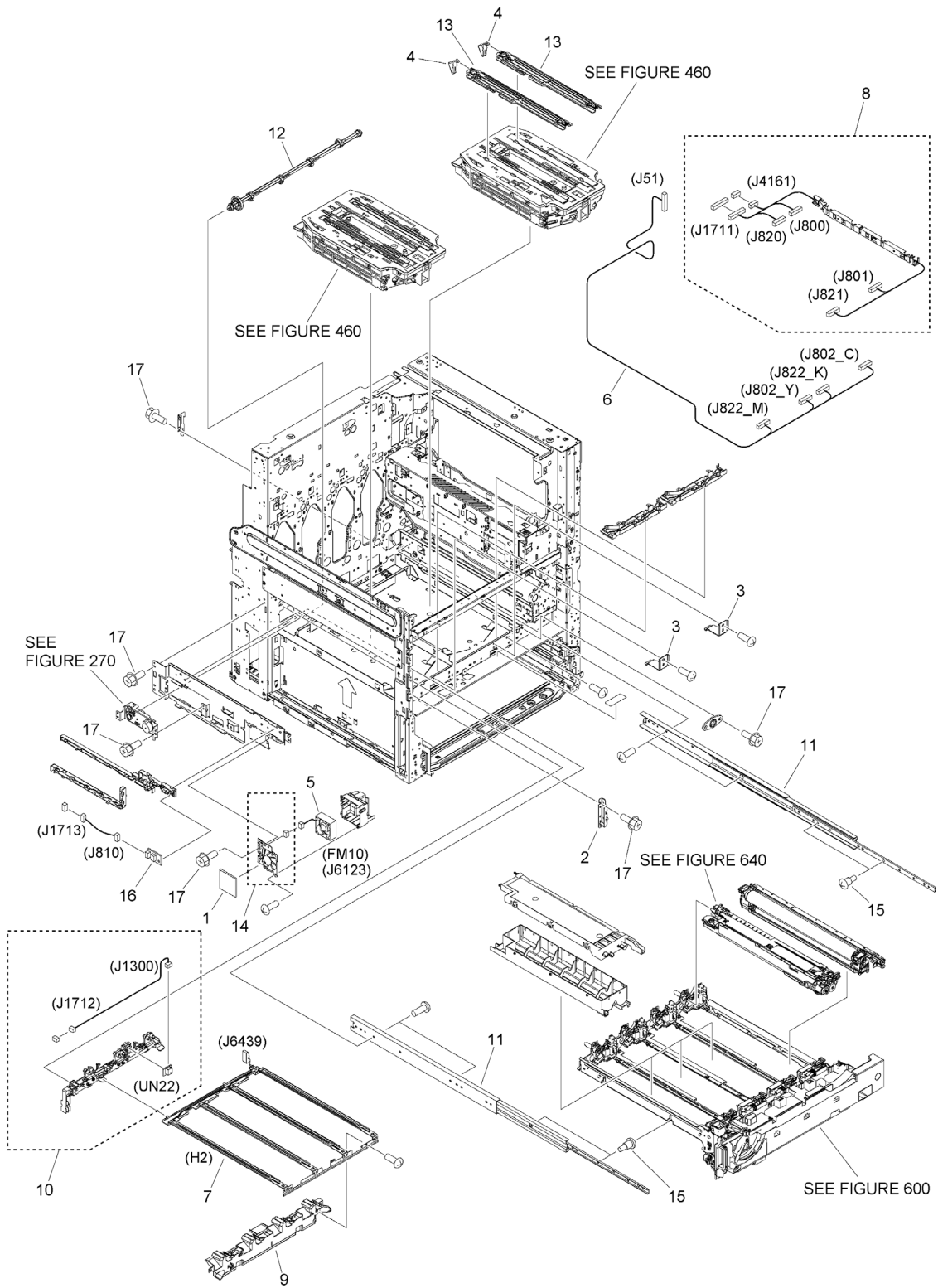

FIGURE & KEY NO.	PART NUMBER	RANK	QTY	DESCRIPTION	SERIAL NUMBER /REMARKS
104	NPN		RF	INTERNAL COMPONENTS 4	
1	FC6-4023-000		1	FILTER, AIR	
2	FC8-4014-000		1	CROSSMEMBER, PROCESS KIT FRAME	
3	FC8-5009-010		2	SPRING	
4	FC8-5013-000		2	SPRING, LEAF	
5	FK2-3679-000		1	FAN	FM10
6	FK4-1102-000		1	CABLE, COAXIAL	
7	FK4-1110-000		1	HEATER, DRUM	H2
8	FM2-A219-000		1	LASER SCANNER CABLE UNIT	
9	FM1-G597-000		1	IMAGING FRONT DUCT ASSEMBLY	
10	FM1-G603-000		1	IMAGING H.V. CONTACT ASS'Y, CL	UN22
11	FM1-G610-000		2	RAIL CROSSMEMBER ASS'Y	
12	FM3-5927-020		1	SHUTTER CAM SHAFT ASSEMBLY	
13	FM3-5966-010		2	DUST-PROOF SHUTTER ASSEMBLY	
14	FM3-8896-010		1	FILTER HOLDER ASSEMBLY	
15	FU5-9447-000		4	SCREW, STEPPED, M4X6.3	
16	WP2-5410-000		1	SENSOR, HUMIDITY	
17	XA9-0732-010		12	SCREW,RS,M4X8	

Figure 105 INTERNAL COMPONENTS 5

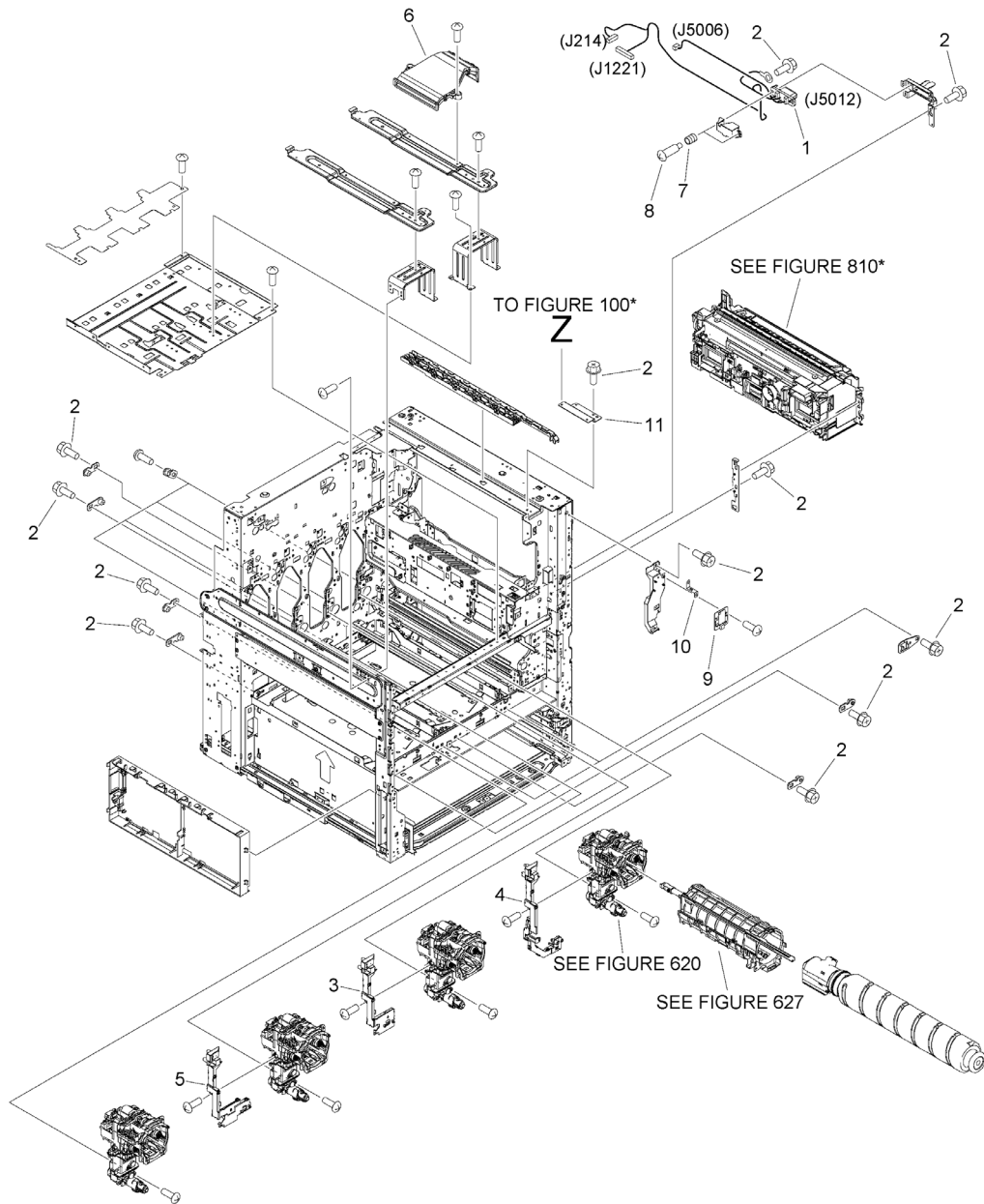

FIGURE & KEY NO.	PART NUMBER	RANK	QTY	DESCRIPTION	SERIAL NUMBER /REMARKS
105	NPN		RF	INTERNAL COMPONENTS 5	
1	FM2-H977-000		1	CABLE, FIXING DRAWER, 2	
2	XA9-0732-010		15	SCREW,RS,M4X8	
3	FM1-G317-000		1	HIGH VOLTAGE CONNECTING ASS'Y	
4	FM1-G323-000		1	CONNECTING HOLDER ASSEMBLY	
5	FM1-G341-000		1	HIGH VOLTAGE CONNECTING ASS'Y	
6	FM1-K164-000		1	INNER EXHAUST DUCT ASSEMBLY	
7	FS5-2964-000		2	SPRING, COMPRESSION	
8	FS5-9758-020		2	SCREW, STEPPED, M3	
9	FM1-P046-000		1	WIRELESS NETWORK PCB ASSEMBLY	
10	FE2-J020-000		1	SPRING, LEAF GROUNDING	
11	FE2-J049-000		1	PLATE, REINFORCEMENT	

Figure 106B MACHINE REAR PLATE 1

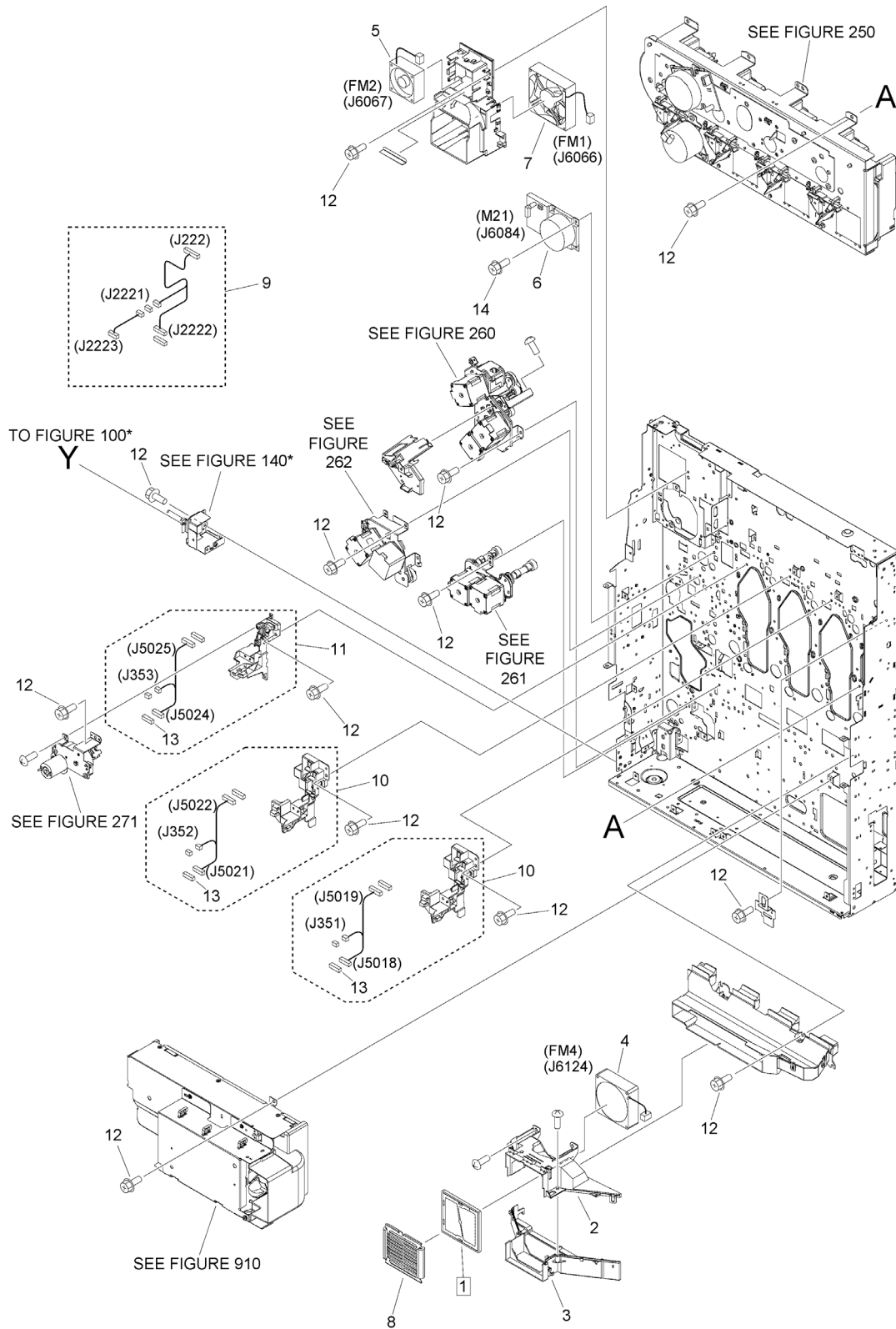

FIGURE & KEY NO.	PART NUMBER	RANK	QTY	DESCRIPTION	SERIAL NUMBER /REMARKS
106B	NPN		RF	MACHINE REAR PLATE 1	A/ INCH SIZE
1	FM1-P236-000		1	TONER FILTER ASSEMBLY	[DP]
2	FC8-4079-000		1	COVER, REAR DUCT, UPPER	
3	FC8-4080-000		1	COVER, REAR DUCT, LOWER	
4	FK2-0360-000		1	FAN	FM4
5	FK2-3679-000		1	FAN	FM2
6	FK2-7302-000		1	MOTOR, DC	M21
7	FL0-8154-000		1	FAN	FM1
8	FL3-3585-000		1	PLATE, FAN PROTECTIVE, REAR	
9	FM2-H980-000		1	CABLE, CASSETTE MOTOR	
10	FM1-G346-000		2	IMAGING H.V.CONTACT ASSEMBLY	
11	FM1-G347-000		1	SET ON DRIVE BLACK MOUNT ASS'Y	
12	XA9-0732-010		15	SCREW,RS,M4X8	
13	VS1-8412-007		4	CONNECTOR, SNAP TIGHT, BL	
14	XA9-1386-000		3	SCREW,RS,M3X8	

Figure 107B MACHINE REAR PLATE 2

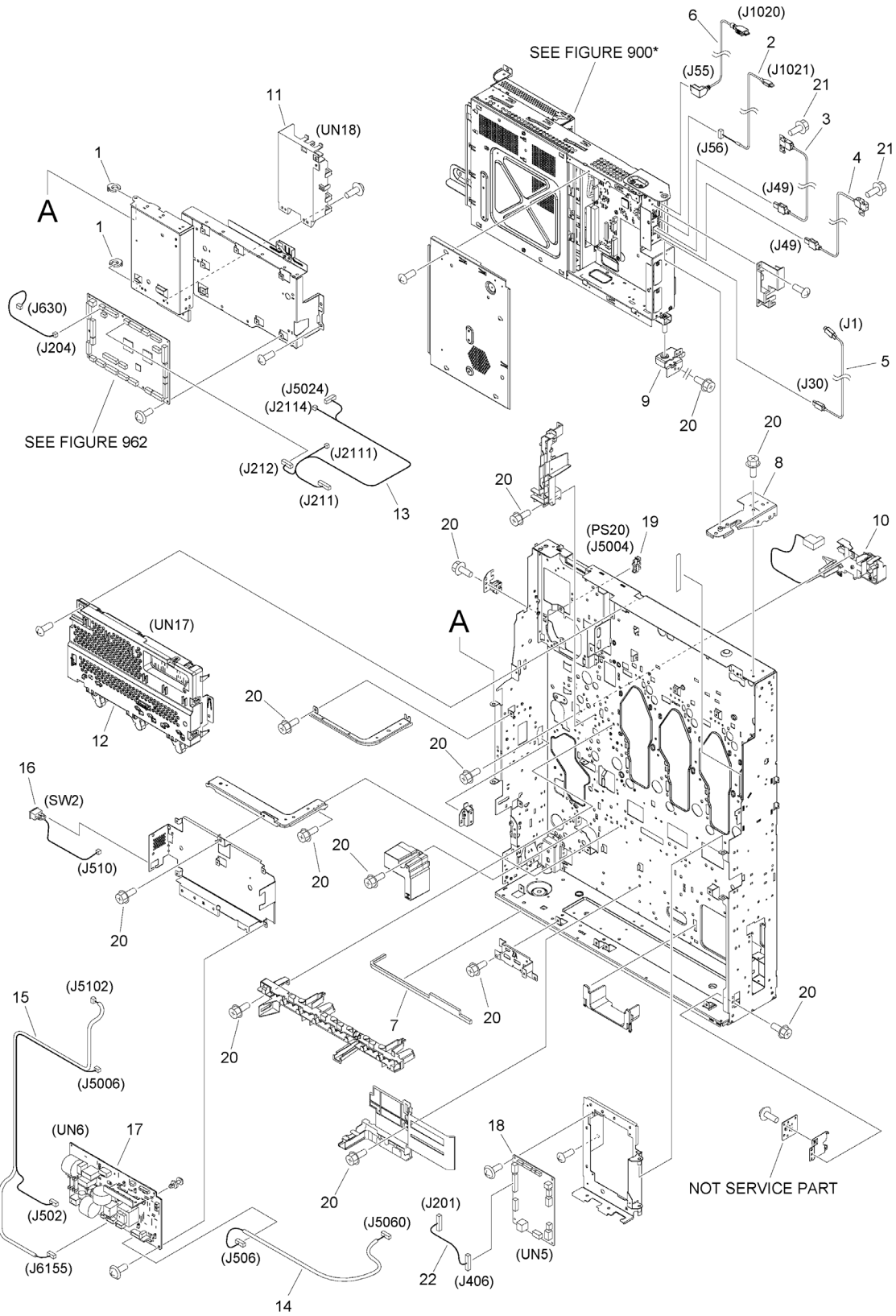

FIGURE & KEY NO.	PART NUMBER	RANK	QTY	DESCRIPTION	SERIAL NUMBER /REMARKS
107B	NPN		RF	MACHINE REAR PLATE 2	
1	FC5-4424-000		2	CLIP	
2	FK4-6913-000		1	CABLE, USB	
3	FK4-3254-000		1	CABLE, USB	
4	FK4-6915-000		1	CABLE, USB	
5	FK4-3256-010		1	CABLE, USB	
6	FK4-6914-000		1	CABLE, USER INTERFACE	
7	FL1-6343-000		1	SEAL, BASE PLATE	
8	FL2-9531-000		1	HINGE, CONTROLLER BOX, UPPER	
9	FL3-1197-000		1	HINGE, CONTROLLER BOX, LOWER	
10	FM1-G558-000		1	H.V. CONTACT ASS'Y	
11	FM1-G628-000		1	POWER SUPPLY ASS'Y	UN18
12	FM1-Z207-000		1	HIGH VOLTAGE POWER SUPPLY UNIT	UN17
13	FM2-R832-000		1	CABLE, TONER HOPPER	
14	FM2-H974-000		1	CABLE, AC HEATER	
15	FM2-R847-000		1	CABLE, FIXING READER HEATER	
16	FM2-H986-000		1	CABLE, ENVIRONMENT SWITCH	SW2
17	FM2-J810-000		1	AC DRIVER PCB ASSEMBLY	UN6
18	FM2-R851-000		1	RELAY PCB ASSEMBLY	UN5
19	WG8-5783-000		1	IC,PHOTO-INTERRUPTER,LG248NL1A	PS20
20	XA9-0732-010		15	SCREW,RS,M4X8	
21	XA9-1386-000		4	SCREW,RS,M3X8	
22	FM2-H990-000		1	CABLE, FEED POWER SUPPLY	

Figure 108 MACHINE REAR PLATE 3

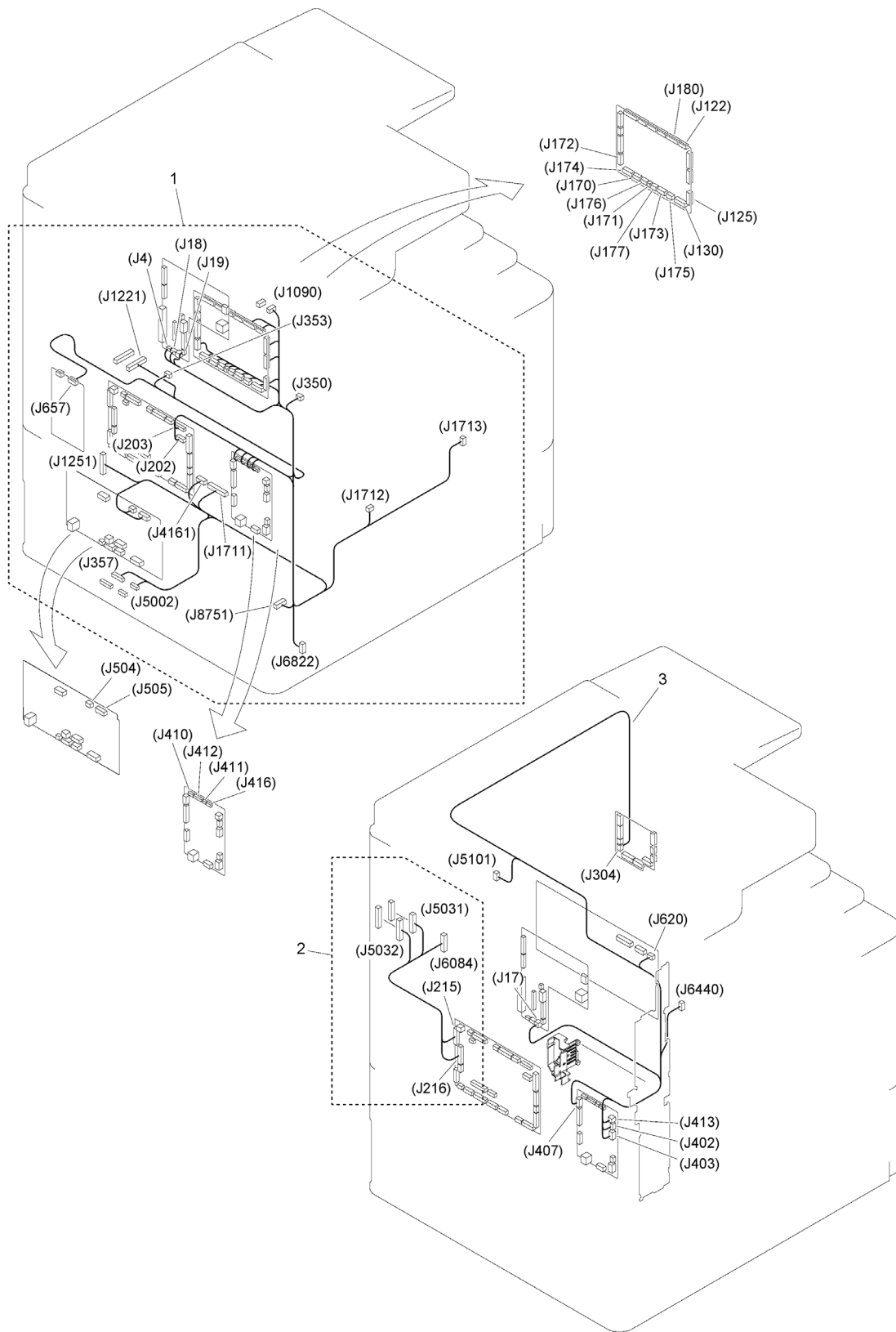

FIGURE & KEY NO.	PART NUMBER	R A N K	QTY	DESCRIPTION	SERIAL NUMBER /REMARKS
108	NPN		RF	MACHINE REAR PLATE 3	
1	FM2-R829-000		1	CABLE, MAIN	
2	FM2-H967-000		1	CABLE, PAPER FEED MAIN	
3	FM2-R848-000		1	CABLE, DC POWER SUPPLY MAIN	

Figure 109 MACHINE REAR PLATE 4

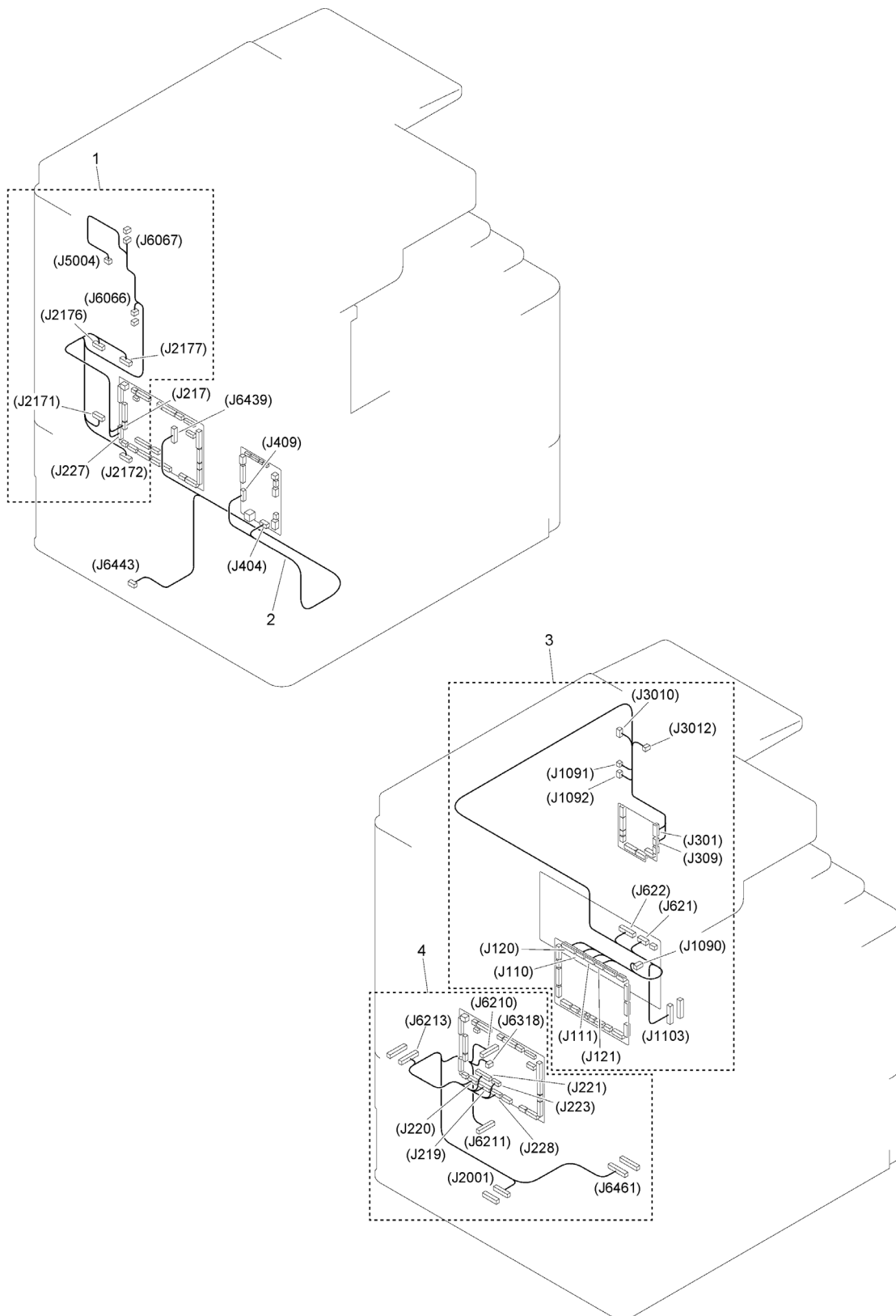

FIGURE & KEY NO.	PART NUMBER	RANK	QTY	DESCRIPTION	SERIAL NUMBER /REMARKS
109	NPN		RF	MACHINE REAR PLATE 4	
1	FM2-H978-000		1	CABLE, PAPER FEED MAIN	
2	FM2-R827-000		1	CABLE, DC POWER SUPPLY MAIN, 2	
3	FM2-H985-000		1	CABLE, MAIN, UPPER	
4	FM2-J855-000		1	PAPER FEED CABLE ASS'Y, LOWER	

Figure 111 RIGHT DOOR ASSEMBLY

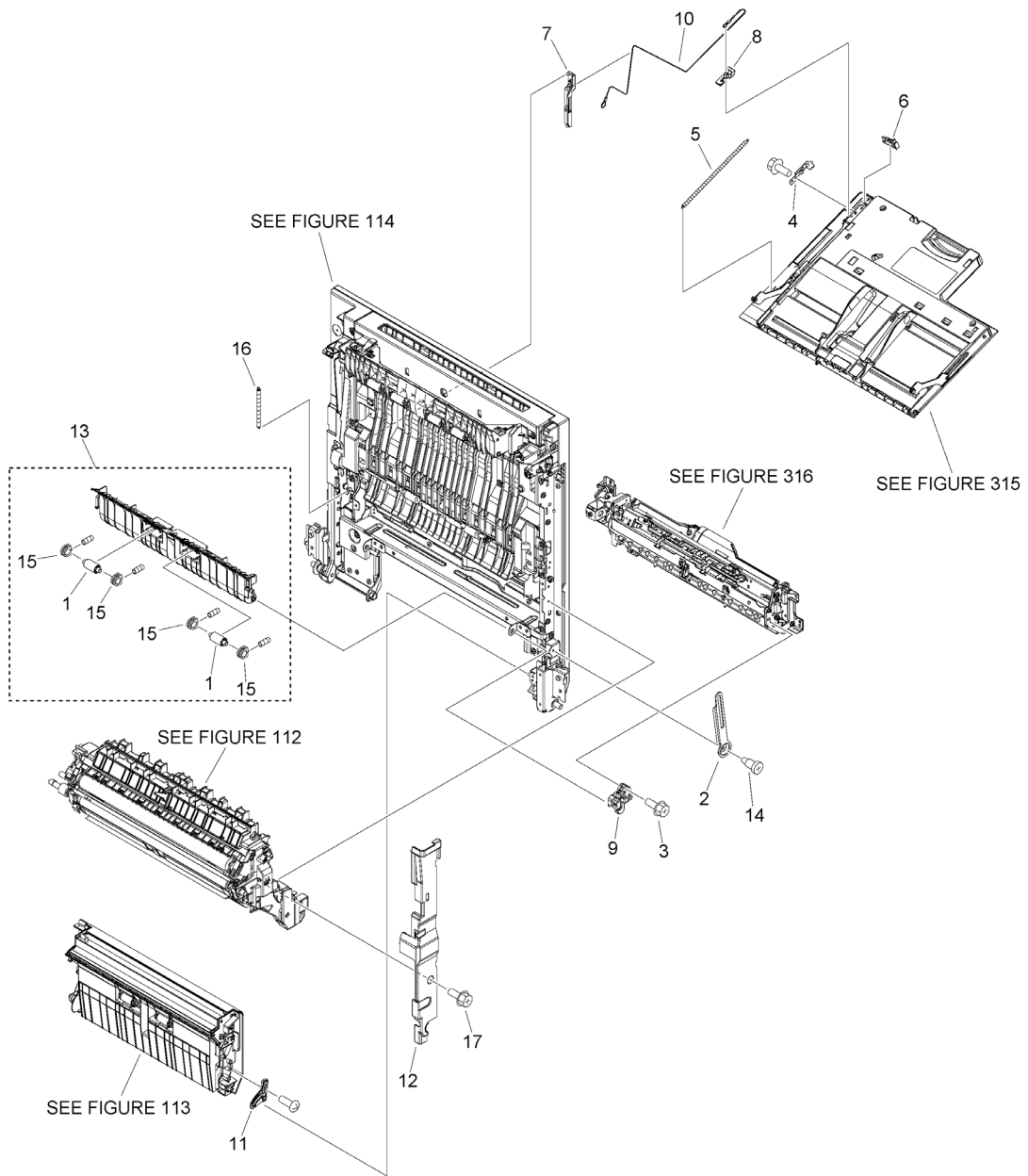

FIGURE & KEY NO.	PART NUMBER	RANK	QTY	DESCRIPTION	SERIAL NUMBER /REMARKS
111	NPN		RF	RIGHT DOOR ASSEMBLY	
1	FC0-7610-010		2	ROLLER, DRIVEN ROLLER	
2	FC8-4820-000		1	STOPPER, RIGHT DOOR, F	
3	XA9-1386-000		1	SCREW,RS,M3X8	
4	FE4-4849-000		1	SUPPORT, WIRE, 2	
5	FE4-4851-000		1	SPRING, TENSION	
6	FE4-4853-000		1	STOPPER, WIRE	
7	FE4-4855-000		1	COVER, MULTI PULLEY	
8	FE4-4872-000		1	HOOK, MULTI WIRE	
9	FE4-4882-000		1	STOPPER, MULTI CROSSING GUIDE	
10	FE4-5152-000		1	WIRE, MULTI TRAY	
11	FE8-1312-000		1	STOPPER, DOOR	
12	FE8-2449-000		1	COVER, RIGHT DOOR INNER, F	
13	FM1-G579-010		1	MULTI GUIDE ASSEMBLY	
14	FU2-2390-000		1	SCREW, STEPPED, M4	
15	FU2-1731-000		4	BUSHING	
16	FU7-2480-000		1	SPRING	
17	XA9-0732-010		6	SCREW,RS,M4X8	

Figure 112 RIGHT INNER DOOR ASSEMBLY

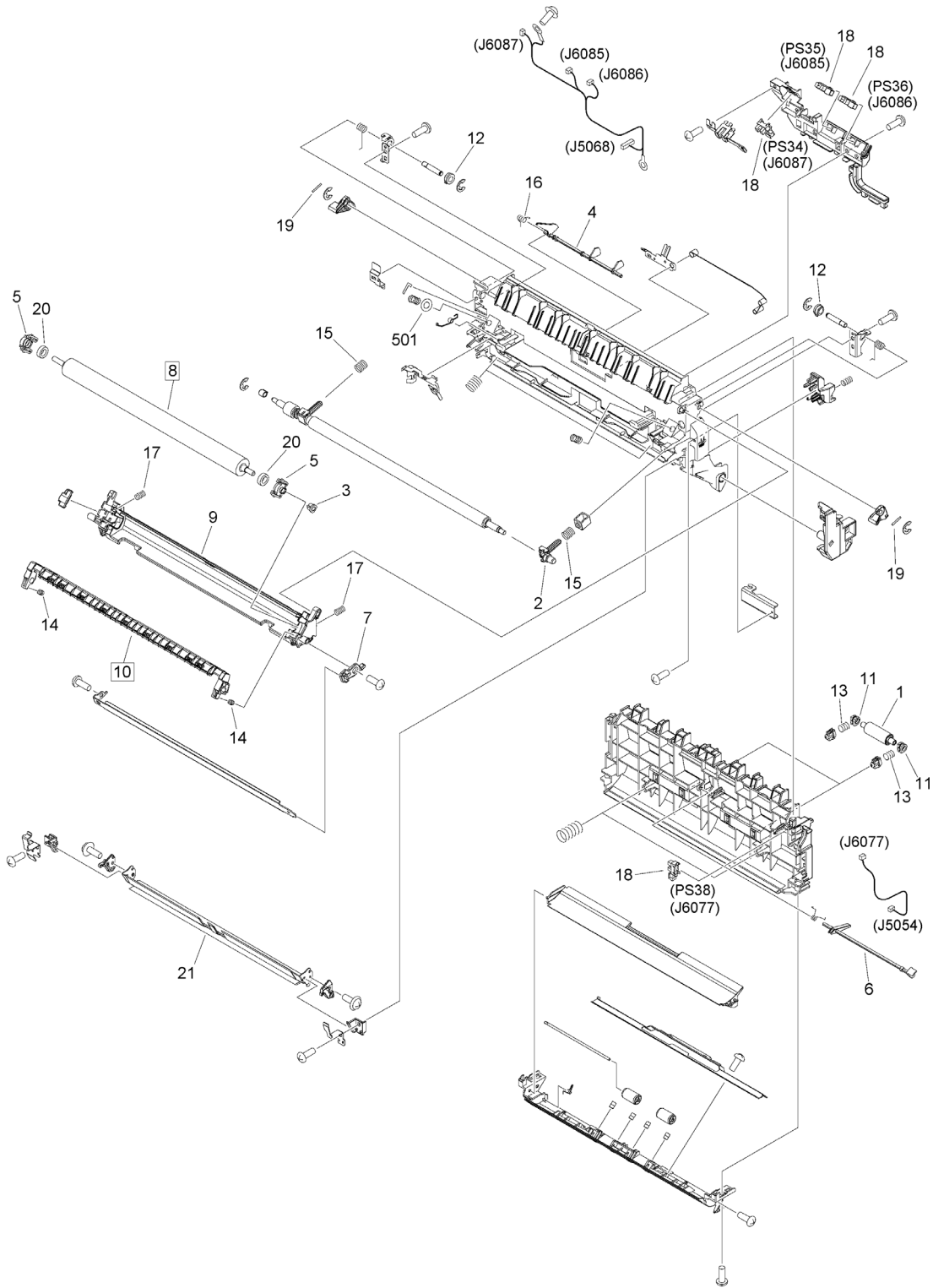

FIGURE & KEY NO.	PART NUMBER	RANK	QTY	DESCRIPTION	SERIAL NUMBER /REMARKS
112	FM1-G550-020		1	RIGHT INNER DOOR ASSEMBLY	
1	FB6-4873-000		2	ROLLER, PAPER FEED	
2	FC0-0220-000		1	BUSHING	
3	FC8-4884-000		1	BUSHING	
4	FC8-5303-000		1	LEVER, LOOP SENSOR	
5	FC8-5313-000		2	HOLDER, 2ND TRNSFR. BUSHING	
6	FC8-5314-000		1	LEVER, DUPLEXING SENSOR	
7	FC9-7955-000		1	SUPPORT, OUTER GUIDE	
8	FE4-8322-000		1	ROLLER, 2ND TRNSFR. OUTER	[DP]
9	FL0-7279-000		1	HOLDER, TRANSFER OUTER	
10	FM3-8893-000		1	TRANSFER SEP. GUIDE ASSEMBLY	[DP]
11	FU2-1731-000		4	BUSHING	
12	FU5-1457-000		2	BUSHING	
13	FU7-2521-000		4	SPRING	
14	FU7-2524-000		2	SPRING	
15	FU7-2525-000		2	SPRING	
16	FU7-2526-000		1	SPRING	
17	FU8-2925-000		2	SPRING, COMPRESSION	
18	WG8-5783-000		4	IC,PHOTO-INTERRUPTER,LG248NL1A	PS34, PS35, PS36, PS38
19	XD9-0291-000		2	PIN, PARALLEL	
20	XG9-0795-000		2	BEARING, BALL, L-1060ZZHPOP25L	
21	FL0-4415-000		1	GUIDE, PRE-REG. DOOR SIDE	
501	XD1-1108-225		1	WASHER,COP	

Figure 113 RIGHT LOWER DOOR ASSEMBLY

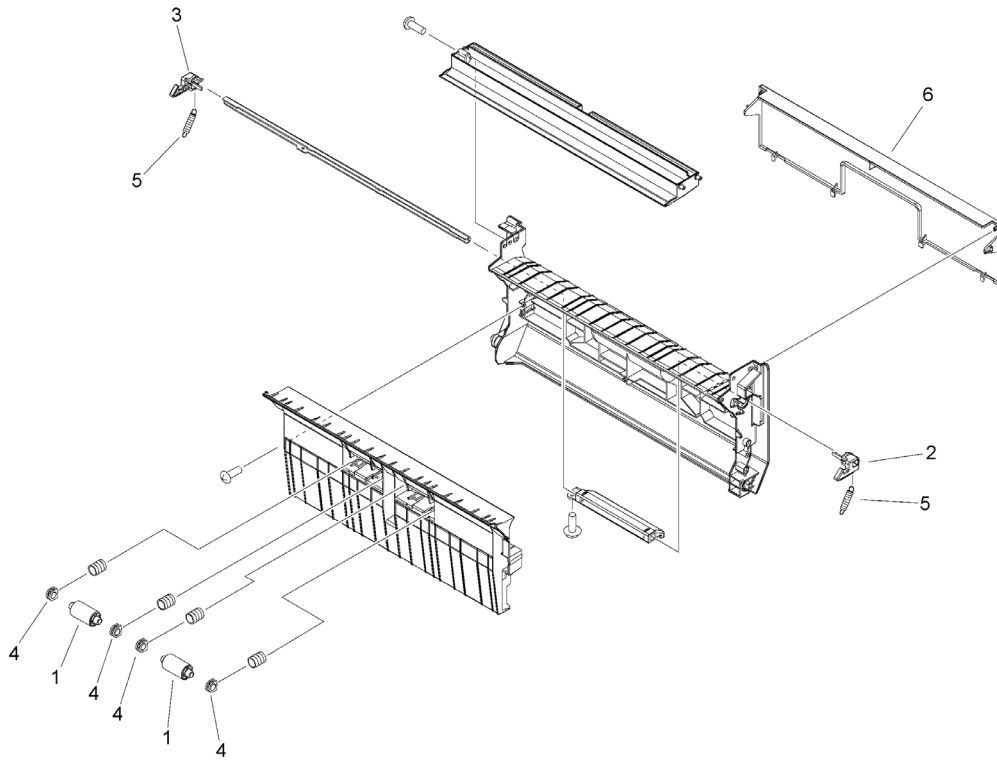

FIGURE & KEY NO.	PART NUMBER	RANK	QTY	DESCRIPTION	SERIAL NUMBER /REMARKS
113	FM1-G583-000		1	RIGHT LOWER DOOR ASSEMBLY	
1	FC0-7610-010		2	ROLLER, DRIVEN ROLLER	
2	FC8-4859-000		1	HOOK, RIGHT LOWER DOOR, F	
3	FC8-4860-000		1	HOOK, RIGHT LOWER DOOR	
4	FU2-1731-000		4	BUSHING	
5	FU7-2519-000		2	SPRING	
6	FE4-3782-000		1	COVER, DECK PATH	

FIGURE & KEY NO.	PART NUMBER	RANK	QTY	DESCRIPTION	SERIAL NUMBER /REMARKS
114	FM1-G549-020		1	RIGHT OUTER DOOR ASSEMBLY	
1	FC0-4876-000		1	ARM, SLIDE, F	
2	FC0-5077-000		1	ROLLER, DUPLEXING FEEDER	
3	FE2-B762-000		1	WIRE, DAMPER	
4	FC8-4854-020		1	LEVER, TOGGLE, F	
5	FE4-2006-010		1	GUIDE, FIRST DELIVERY OPPOSED	
6	FU2-2390-000		1	SCREW, STEPPED, M4	
7	FU2-1731-000		8	BUSHING	
8	FU5-1033-000		3	BUSHING	
9	FU5-1457-000		1	BUSHING	
10	FU5-3016-000		1	PULLEY, 24T	
11	FU6-1020-000		4	BUSHING	
12	FU7-2478-000		2	SPRING	
13	FU8-0202-000		1	GEAR, 15T	
14	FU8-0203-000		1	GEAR, 22T	
15	VS1-8412-003		1	CONNECTOR, SNAP TIGHT, BL	
16	WG8-5783-000		1	IC,PHOTO-INTERRUPTER,LG248NL1A	PS19
17	XA9-0732-010		59	SCREW,RS,M4X8	
18	XD9-0288-000		1	PIN, DOWEL	
19	XD9-0292-000		3	PIN, PARALLEL	
20	XF2-4118-340		1	BELT, TIMING	
21	XG9-0497-000		1	BEARING, BALL, MR106ZZ,	
22	FC8-4855-000		1	LEVER, TOGGLE, R	
23	FE4-9274-000		4	ROLLER, DRIVEN	
24	FM1-E937-000		1	CABLE, DOOR, RIGHT	
25	FM1-M839-000		1	RELAY PCB ASSEMBLY	UN61

Figure 115 FRONT COVER ASSEMBLY

NOTE : This assembly does not include the part shown with key No. 6.

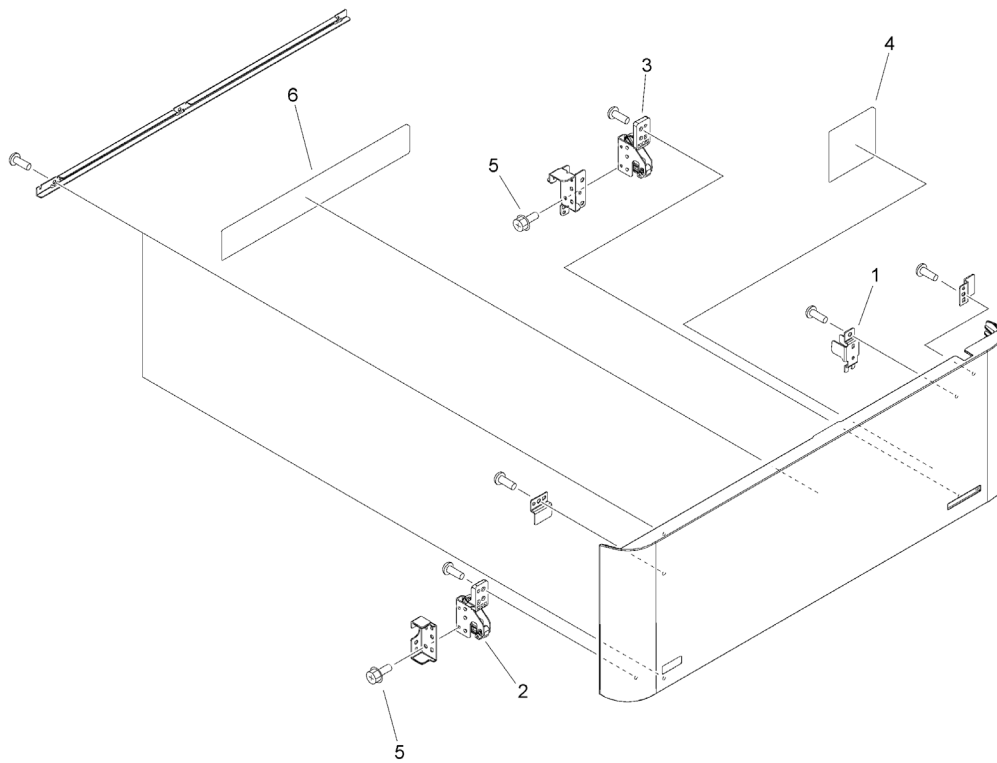

FIGURE & KEY NO.	PART NUMBER	RANK	QTY	DESCRIPTION	SERIAL NUMBER /REMARKS
115	FM1-Z401-000		1	FRONT COVER ASSEMBLY	
1	FC8-4155-000		1	PLATE,F DOOR OPEN/CLOSE DETECT	
2	FM3-6064-010		1	HINGE ASSEMBLY, 2	
3	FM3-8934-000		1	HINGE ASSEMBLY	
4	FU6-8646-000		1	LABEL, LASER CAUTION	
5	XA9-1386-000		4	SCREW,RS,M3X8	
6	FE2-K762-000		1	LABEL, CLN ROD OPERATION	SEE NOTE

Figure 130 CONTROL PANEL ASSEMBLY

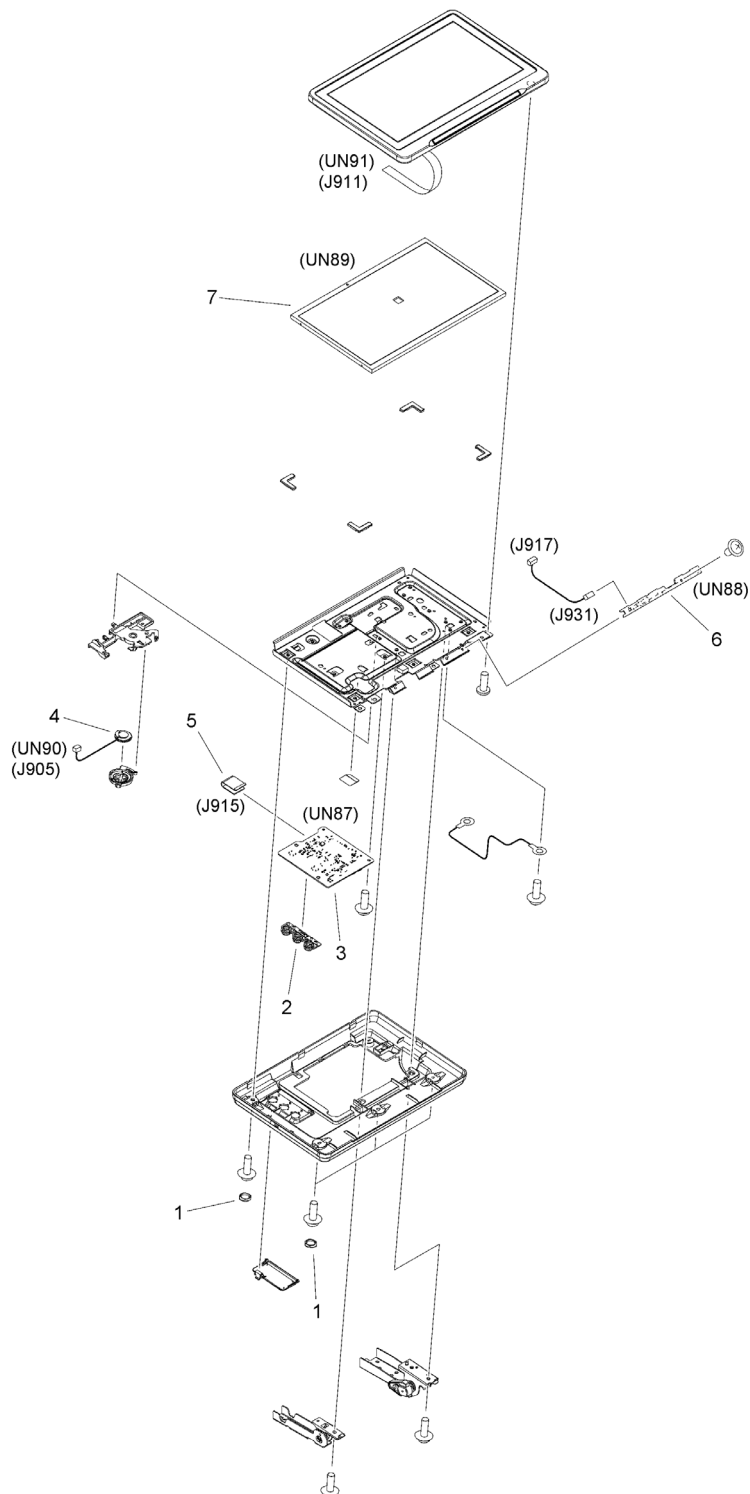

FIGURE & KEY NO.	PART NUMBER	RANK	QTY	DESCRIPTION	SERIAL NUMBER /REMARKS
130	FM1-X148-000		1	CONTROL PANEL ASSEMBLY	
1	FE3-9169-000		4	CAP	
2	FE8-7637-000		1	KEY TOP, SWITCH	
3	FM2-K897-000		1	CONTROL PANEL MAIN PCB ASS'Y	UN87
4	FK4-2377-000		1	SPEAKER	UN90
5	FK4-4895-000		1	CABLE, FLAT	
6	FM2-A912-000		1	CONTROL PANEL LED PCB ASSEMBLY	UN88
7	FK4-2375-000		1	LCD UNIT	UN89

Figure 140B POWER CORD TERMINAL ASS'Y

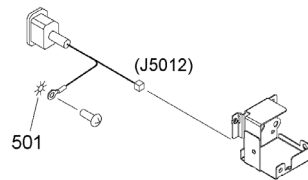

FIGURE & KEY NO.	PART NUMBER	R A N K	QTY	DESCRIPTION	SERIAL NUMBER /REMARKS
140B	FM1-G624-000		1	POWER CORD TERMINAL ASS'Y	
501	XD1-4200-502		1	LOCK WASHER (SUS)	

Figure 250 MAIN DRIVE ASSEMBLY

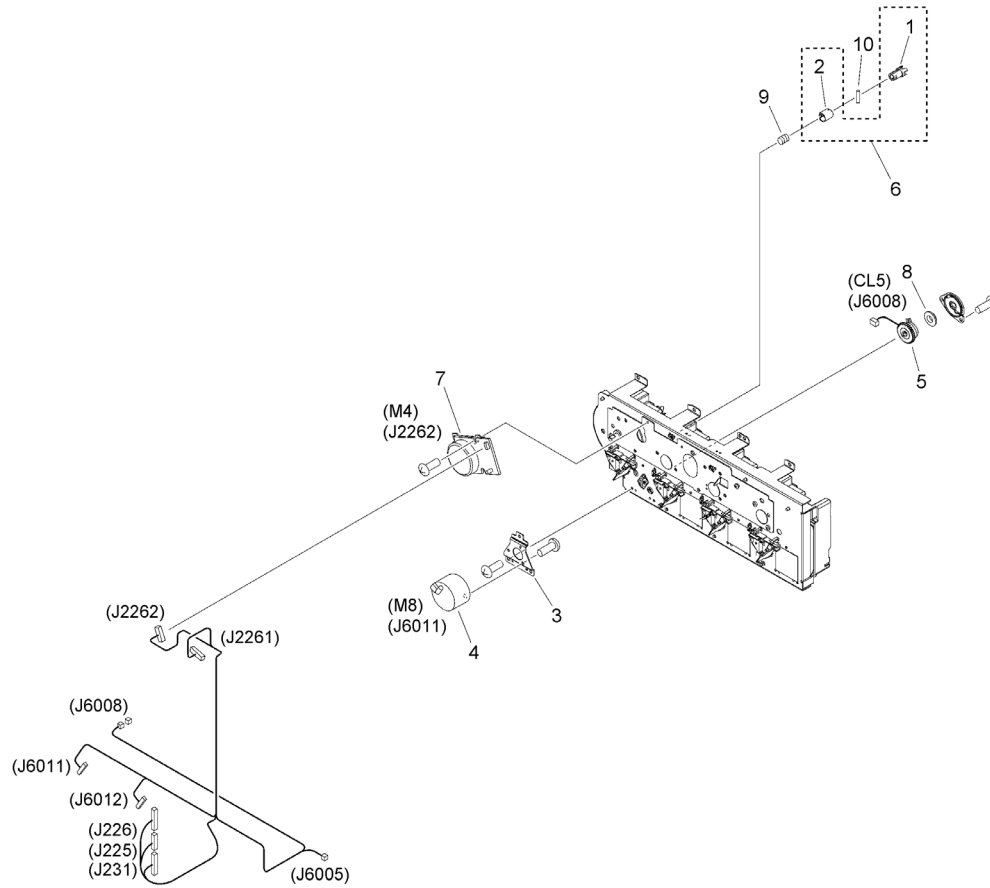

FIGURE & KEY NO.	PART NUMBER	RANK	QTY	DESCRIPTION	SERIAL NUMBER /REMARKS
250	FM2-A086-000		1	MAIN DRIVE ASSEMBLY	
1	FC8-4170-000		1	COUPLING, DEVELOPMENT	
2	FC8-4171-010		1	CAP, COUPLING	
3	FC8-5323-000		1	PLATE, MOTOR MOUNTING	
4	FK2-7303-000		1	MOTOR, DC	M8
5	FK2-7371-000		1	CLUTCH, ELECTROMAGNETIC	CL5
6	FM4-8387-010		1	COUPLING SET(2)	
7	FK4-1109-000		1	BRUSHLESS MOTOR BK	M4
8	FU5-1448-000		1	BUSHING	
9	FU6-2636-000		1	SPRING, COMPRESSION	
10	XD9-0325-000		1	PIN, PARALLEL	

Figure 260 PAPER PICK-UP DRIVE ASS'Y, UP.

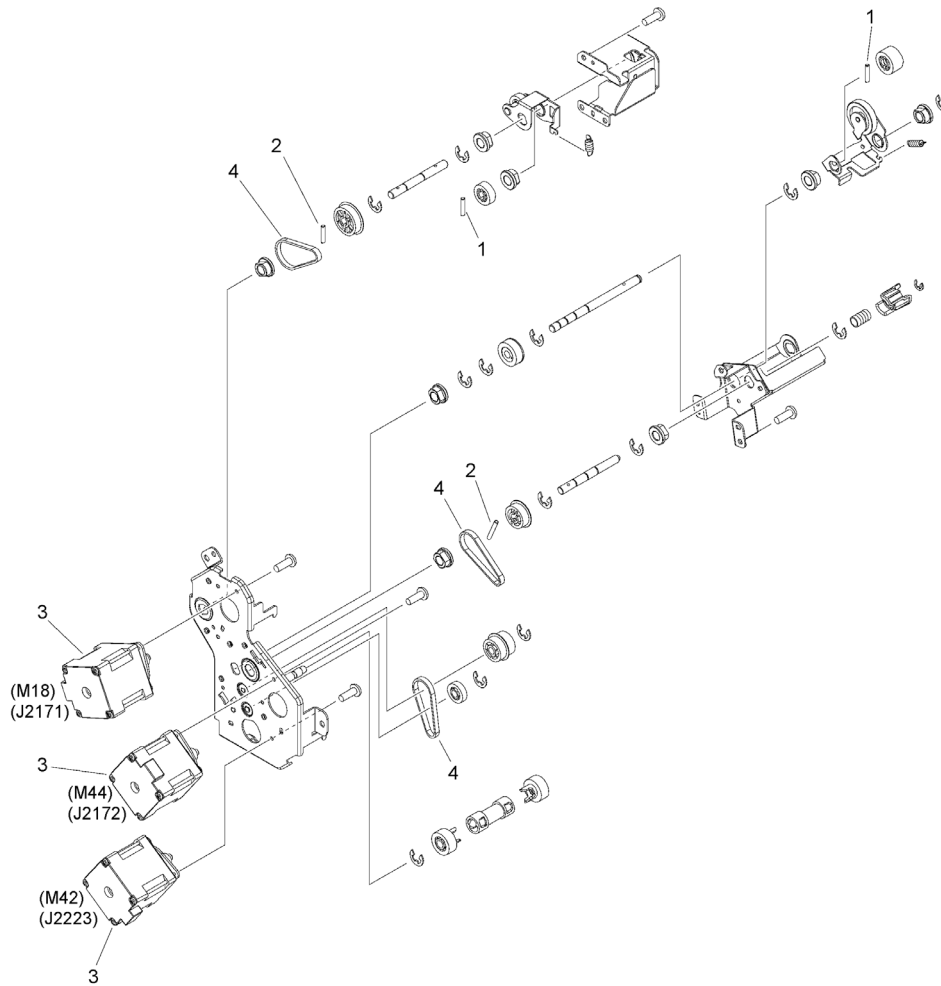

FIGURE & KEY NO.	PART NUMBER	RANK	QTY	DESCRIPTION	SERIAL NUMBER /REMARKS
260	FM1-G577-010		1	PAPER PICK-UP DRIVE ASSY, UP.	
1	XD9-0288-000		2	PIN, DOWEL	
2	XD9-0290-000		2	PIN, PARALLEL	
3	FM1-H189-010		3	MOTOR ASSEMBLY	M18, M42, M44
4	XF2-1605-740		1	BELT, TIMING	

Figure 261 PAPER PICK-UP DRIVE ASS'Y, LW.

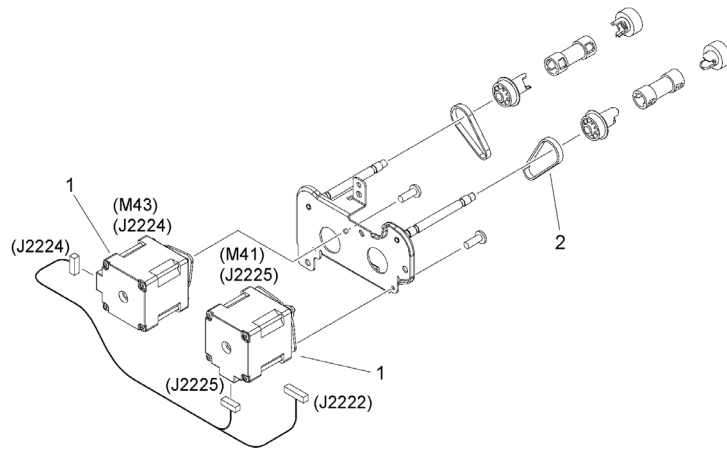

FIGURE & KEY NO.	PART NUMBER	R A N K	QTY	DESCRIPTION	SERIAL NUMBER /REMARKS
261	FM1-G578-010		1	PAPER PICK-UP DRIVE ASSY, LW.	
1	FM1-H189-010		2	MOTOR ASSEMBLY	M41, M43
2	XF2-1605-740		1	BELT, TIMING	

Figure 262 DUPLEXING REG. DRIVE ASSEMBLY

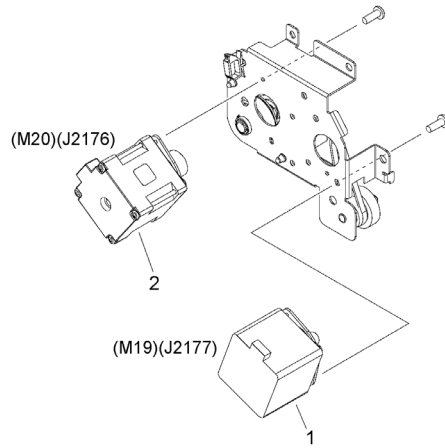

FIGURE & KEY NO.	PART NUMBER	R A N K	QTY	DESCRIPTION	SERIAL NUMBER /REMARKS
262	FM1-G552-010		1	DUPLEXING REG. DRIVE ASSEMBLY	
1	FK2-7586-010		1	MOTOR, STEPPING	M19
2	FM1-H135-010		1	MOTOR ASS'Y	M20

Figure 270 SHUTTER DRIVE MOUNT ASSEMBLY

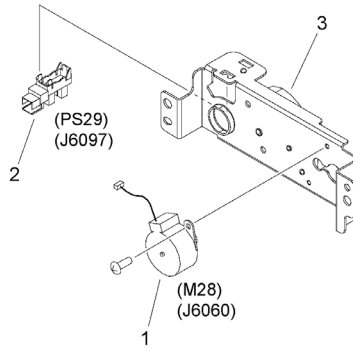

FIGURE & KEY NO.	PART NUMBER	RANK	QTY	DESCRIPTION	SERIAL NUMBER /REMARKS
270	NPN		RF	SHUTTER DRIVE MOUNT ASSEMBLY	
1	FK2-2069-000		1	MOTOR, STEPPING, DC	M28
2	WG8-5783-000		1	IC,PHOTO-INTERRUPTER,LG248NL1A	PS29
3	FM3-6109-000		1	DRIVE MOUNT BASE ASSEMBLY	

Figure 271 SET ON DRIVE ASSEMBLY

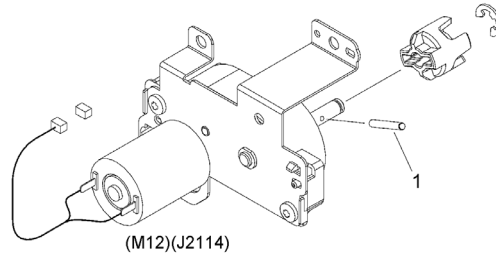

FIGURE & KEY NO.	PART NUMBER	R A N K	QTY	DESCRIPTION	SERIAL NUMBER /REMARKS
271	FM1-G328-010		1	SET ON DRIVE ASSEMBLY	M12
1	XD9-0290-000		1	PIN, PARALLEL	

Figure 280 FIXING DRIVE ASSEMBLY

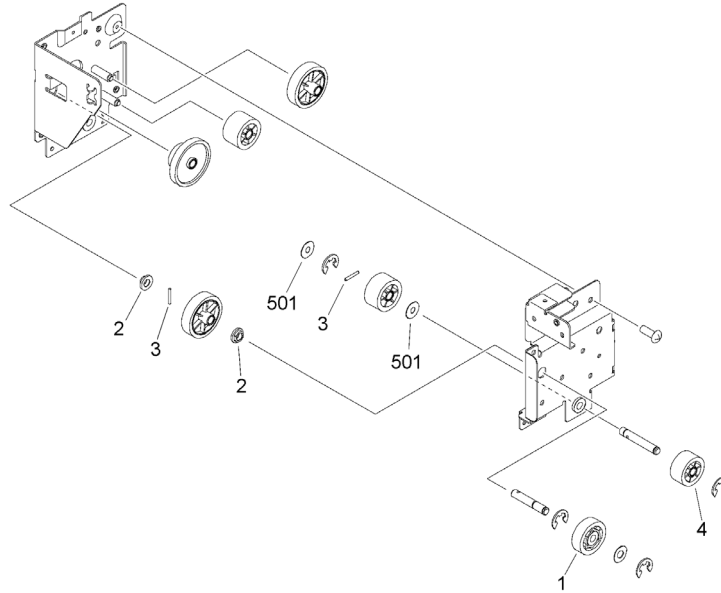

FIGURE & KEY NO.	PART NUMBER	RANK	QTY	DESCRIPTION	SERIAL NUMBER /REMARKS
280	FM1-G513-000		1	FIXING DRIVE ASSEMBLY	
1	FL3-1198-000		1	GEAR ASSEMBLY	
2	FU5-1173-000		2	BUSHING	
3	XD9-0290-000		2	PIN, PARALLEL	
4	FL0-4346-000		1	GEAR, 21T	
501	XD1-1106-215		2	WASHER,COP	

Figure 281 FIXING DELIVERY DRIVE ASSEMBLY

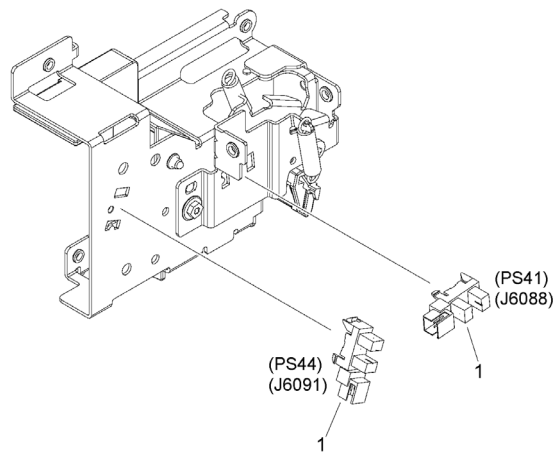

FIGURE & KEY NO.	PART NUMBER	RANK	QTY	DESCRIPTION	SERIAL NUMBER /REMARKS
281	FM1-G222-000		1	FIXING DELIVERY DRIVE ASSEMBLY	
1	WG8-5783-000		2	IC,PHOTO-INTERRUPTER,LG248NL1A	PS41, PS44

Figure 290 LIFTER DRIVE MOUNT ASSEMBLY

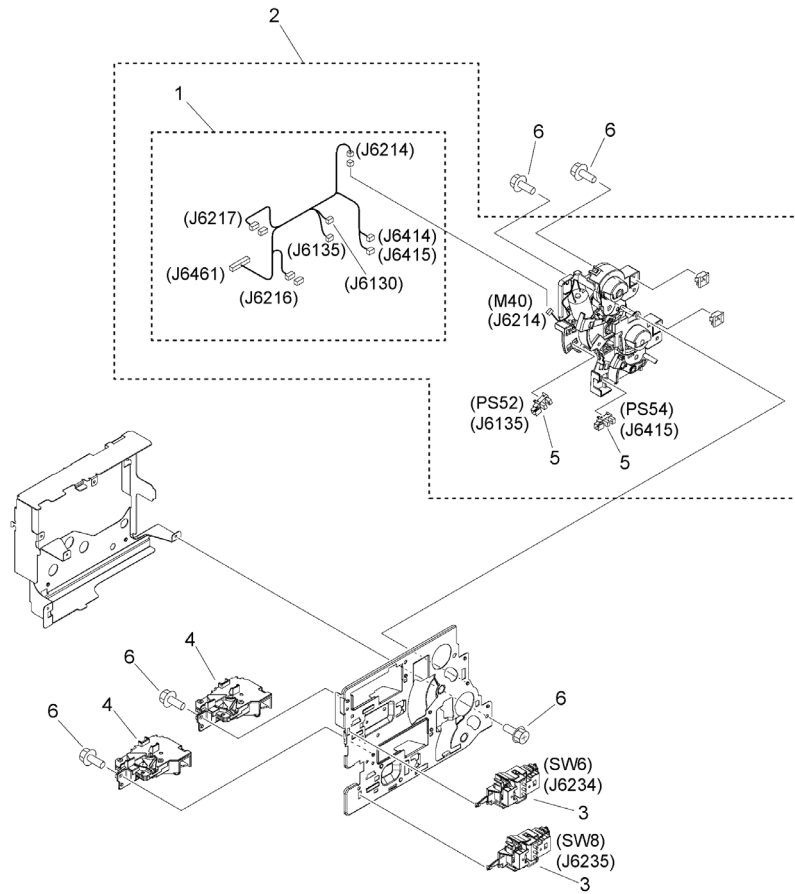

FIGURE & KEY NO.	PART NUMBER	R A N K	QTY	DESCRIPTION	SERIAL NUMBER /REMARKS
290	NPN		1	LIFTER DRIVE MOUNT ASSEMBLY	
1	FM2-J951-000		1	CABLE, LIFTER	
2	FM1-V487-000		1	LIFTER DRIVE ASSEMBLY	M40
3	FM1-K250-000		2	AUTO SIZE DETECT ASSEMBLY	SW6, SW8
4	FM1-M019-000		2	CASSETTE AUTO CLOSE ASSEMBLY	
5	WG8-5783-000		2	IC,PHOTO-INTERRUPTER,LG248NL1A	PS52, PS54
6	XA9-1386-000		13	SCREW,RS,M3X8	

Figure 310 PAPER PICK-UP ASSEMBLY, 1

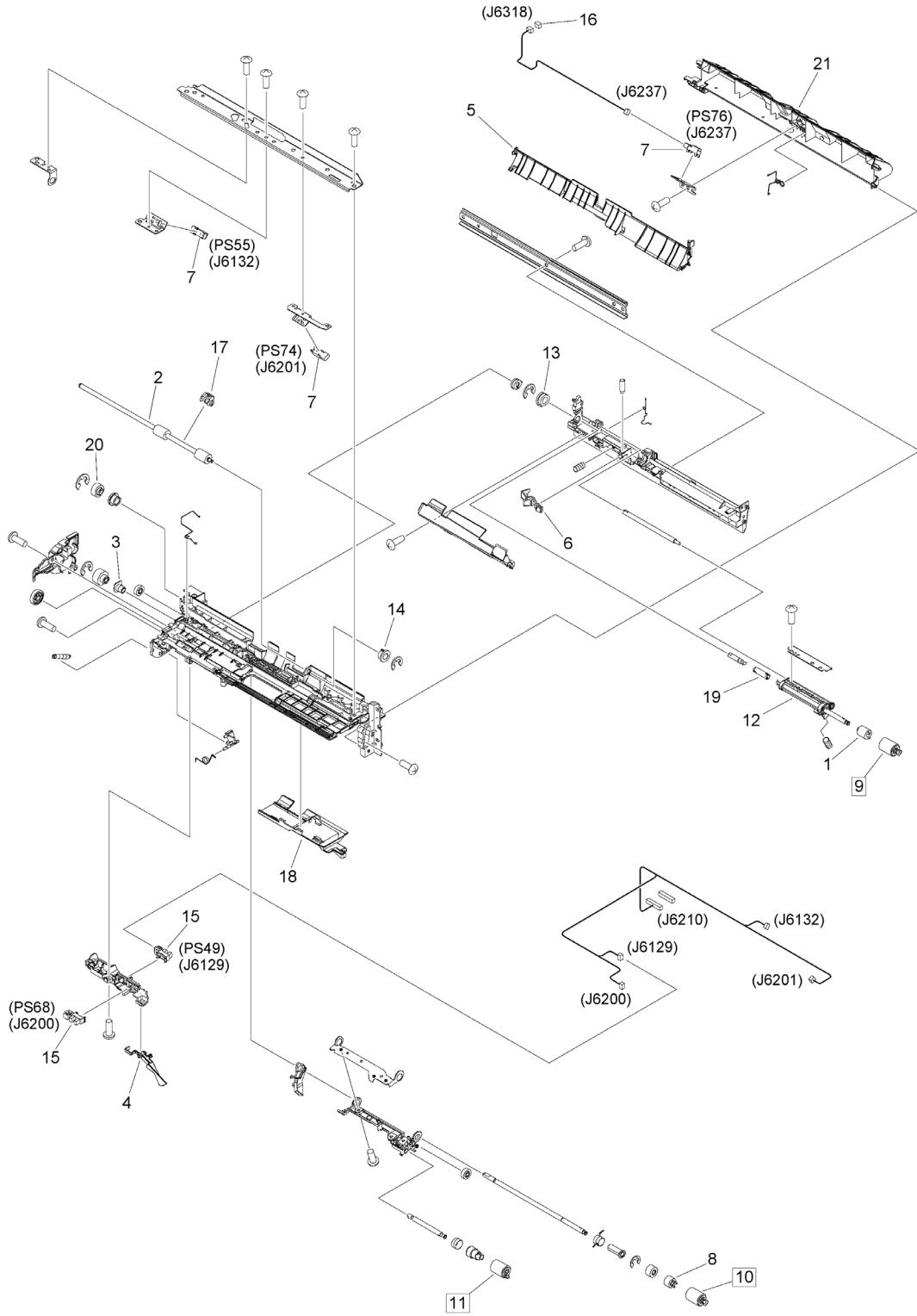

FIGURE & KEY NO.	PART NUMBER	RANK	QTY	DESCRIPTION	SERIAL NUMBER /REMARKS
310	FM2-A205-000		1	PAPER PICK-UP ASSEMBLY, 1	
1	FE4-9853-000		1	LIMITER, TORQUE	
2	FE4-4426-000		1	ROLLER, EXTRACTION	
3	FE4-4536-000		1	BUSHING	
4	FE4-4564-000		1	LEVER, PAPER YES/NO DETECT	
5	FE4-4560-000		1	GUIDE, VERTICAL PATH, UPPER	
6	FE8-1330-010		1	LEVER, ESTRANGEMENT	
7	WG8-6233-000		3	PHOTO-SENSOR, KUA0055C	PS55, PS74, PS76
8	FL0-1515-000		1	ONE-WAY CLUTCH ASSEMBLY	
9	FL0-1674-000		1	ROLLER, SEPARATION	[DP]
10	FL4-0763-000		1	ROLLER, PAPER FEED	[DP]
11	FL4-0762-000		1	ROLLER, PAPER PICK-UP	[DP]
12	FL0-4772-000		1	HOLDER, SEPARATION ROLLER	
13	FS1-1508-000		1	BUSHING	
14	FU5-1442-000		1	BUSHING	
15	WG8-5783-000		2	IC,PHOTO-INTERRUPTER,LG248NL1A	PS49, PS68
16	VS1-8412-003		1	CONNECTOR, SNAP TIGHT, BL	
17	FE8-8918-000		1	GUIDE, EXTRACTION OPTION	
18	FE4-4545-000		1	GUIDE, SLIDE	
19	FE4-5061-010		1	COUPLING, JOINT	
20	FL0-4776-000		1	GEAR, 19T	
21	FE4-4544-000		1	GUIDE, VERTICAL PATH, LOWER	

Figure 311 PAPER PICK-UP ASSEMBLY, 2

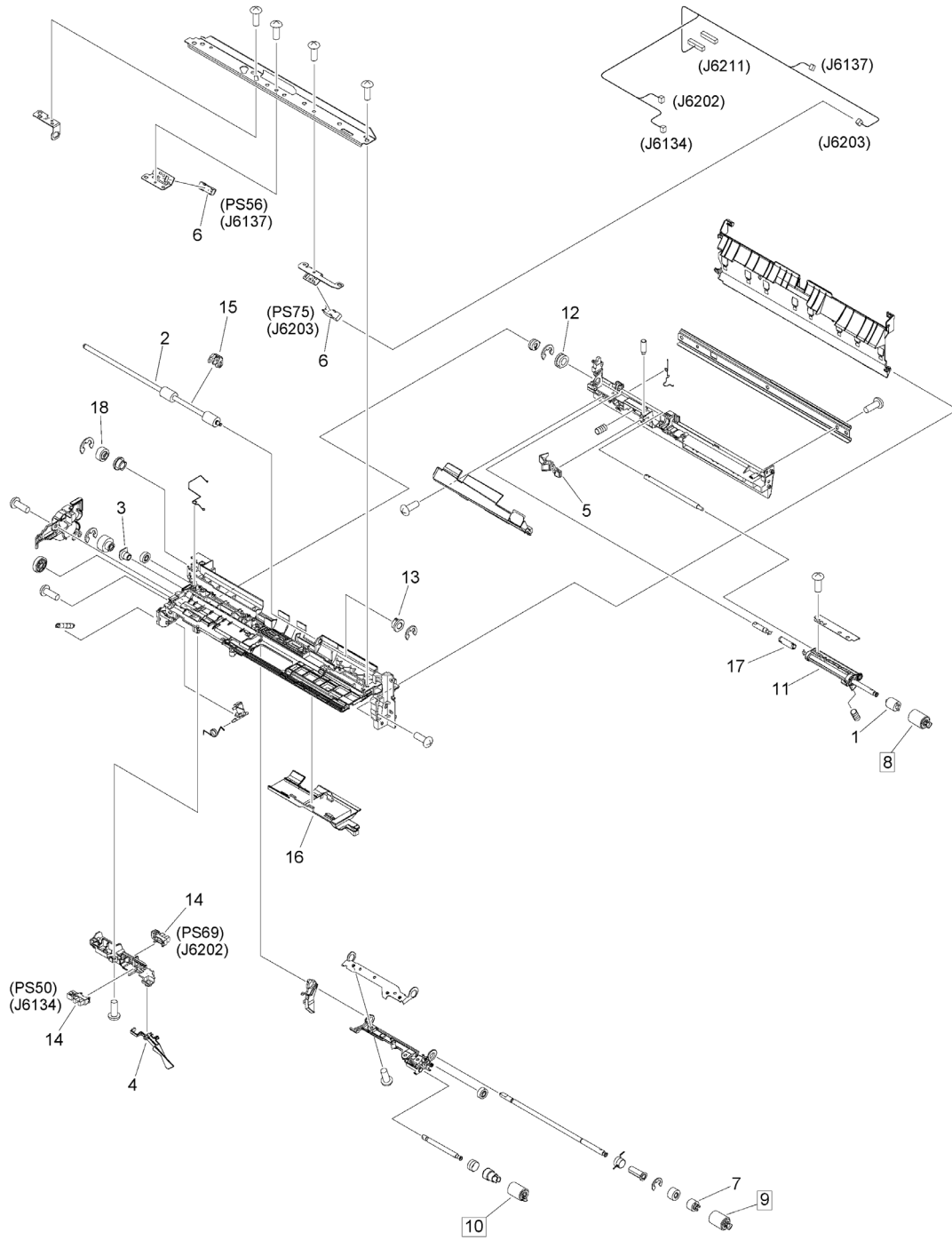

FIGURE & KEY NO.	PART NUMBER	RANK	QTY	DESCRIPTION	SERIAL NUMBER /REMARKS
311	FM2-A206-000		1	PAPER PICK-UP ASSEMBLY, 2	
1	FE4-9853-000		1	LIMITTER, TORQUE	
2	FE4-4426-000		1	ROLLER, EXTRACTION	
3	FE4-4536-000		1	BUSHING	
4	FE4-4564-000		1	LEVER, PAPER YES/NO DETECT	
5	FE8-1330-010		1	LEVER, ESTRANGEMENT	
6	WG8-6233-000		2	PHOTO-SENSOR, KUA0055C	PS56, PS75
7	FL0-1515-000		1	ONE-WAY CLUTCH ASSEMBLY	
8	FL0-1674-000		1	ROLLER, SEPARATION	[DP]
9	FL4-0763-000		1	ROLLER, PAPER FEED	[DP]
10	FL4-0762-000		1	ROLLER, PAPER PICK-UP	[DP]
11	FL0-4772-000		1	HOLDER, SEPARATION ROLLER	
12	FS1-1508-000		1	BUSHING	
13	FU5-1442-000		1	BUSHING	
14	WG8-5783-000		2	IC,PHOTO-INTERRUPTER,LG248NL1A	PS50, PS69
15	FE8-8918-000		1	GUIDE, EXTRACTION OPTION	
16	FE4-4545-000		1	GUIDE, SLIDE	
17	FE4-5061-010		1	COUPLING, JOINT	
18	FL0-4776-000		1	GEAR, 19T	

Figure 313 PRE-REG. GUIDE ASSEMBLY

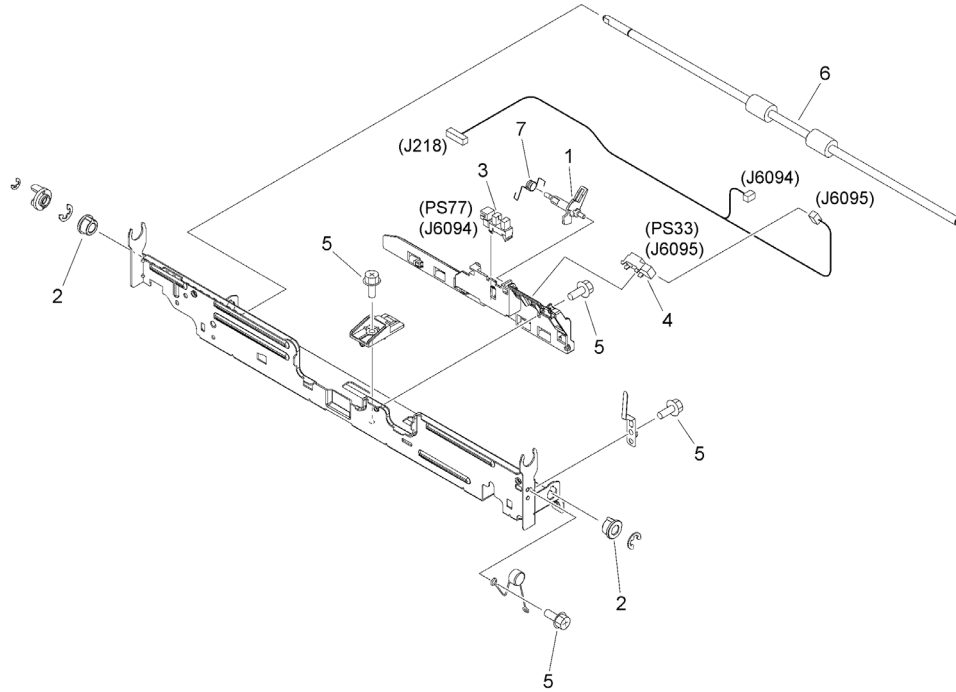

FIGURE & KEY NO.	PART NUMBER	RANK	QTY	DESCRIPTION	SERIAL NUMBER /REMARKS
313	NPN		1	PRE-REG. GUIDE ASSEMBLY	
1	FE4-8307-010		1	FLAG, REG. SENSOR	
2	FS5-1943-000		2	BUSHING	
3	WG8-5783-000		1	IC,PHOTO-INTERRUPTER,LG248NL1A	PS77
4	WG8-6233-000		1	IC,PHOTO-INTERRUPTER	PS33
5	XA9-1386-000		4	SCREW,RS,M3X8	
6	FL0-4417-000		1	ROLLER, PRE-REGISTRATION	
7	FU2-1271-000		1	SPRING, TORSION	

Figure 315 MULTI PAPER PICK-UP TRAY ASS'Y

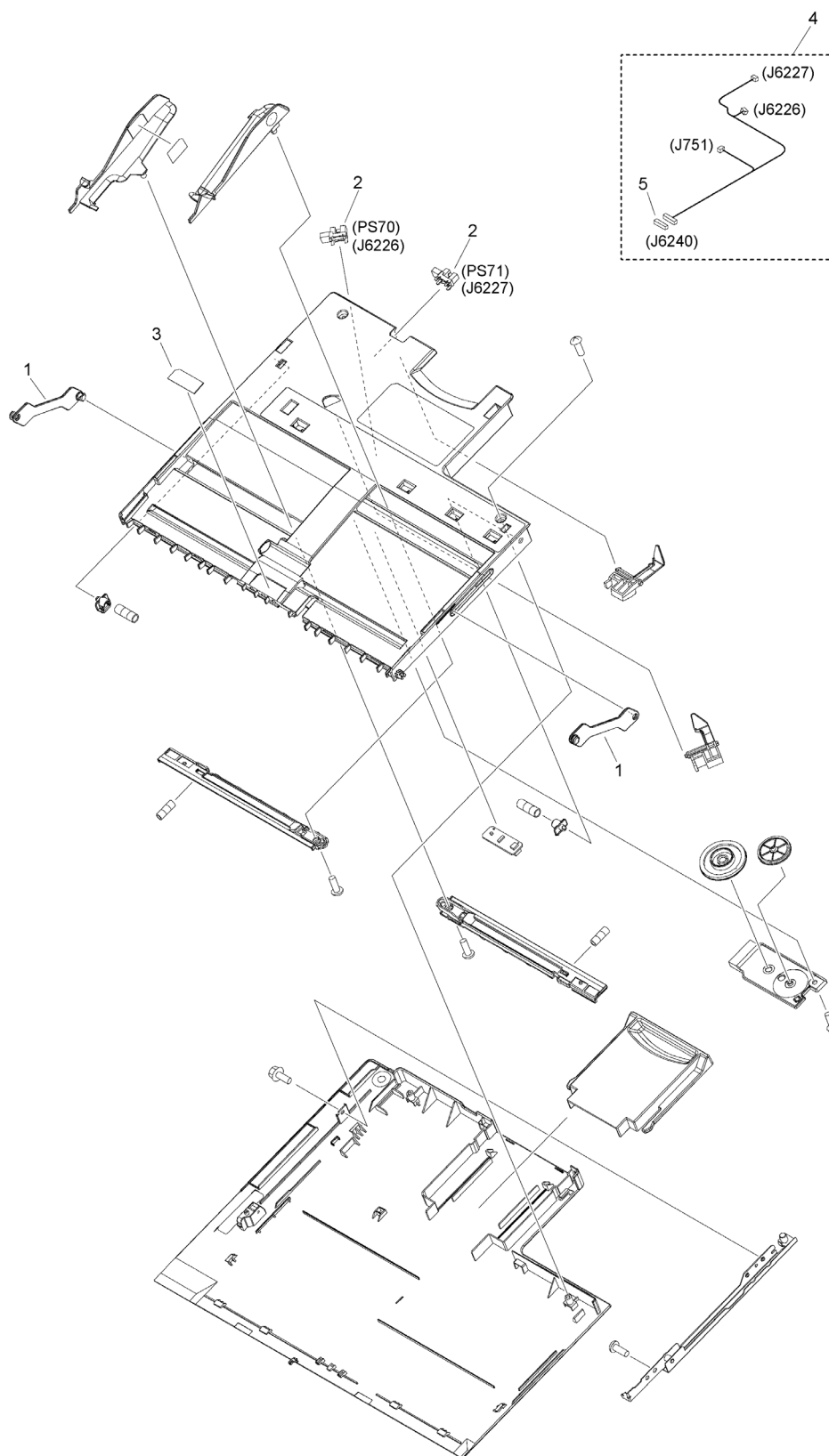

FIGURE & KEY NO.	PART NUMBER	RANK	QTY	DESCRIPTION	SERIAL NUMBER /REMARKS
315	FM1-N385-010		1	MULTI PAPER PICK-UP TRAY ASS'Y	
1	FE4-4880-000		2	LINK, MULTI TRAY	
2	WG8-5935-000		2	IC, PHOTO INTERRUPTER	PS70, PS71
3	FL0-5121-000		1	SHEET, SEPARATION	
4	FM1-E939-010		1	CABLE, MULTI	
5	VS1-7177-009		1	CONNECTOR, WIRE TO WIRE, 9P	

Figure 316 (1/2)MULTI PAPER PICK-UP ASSEMBLY

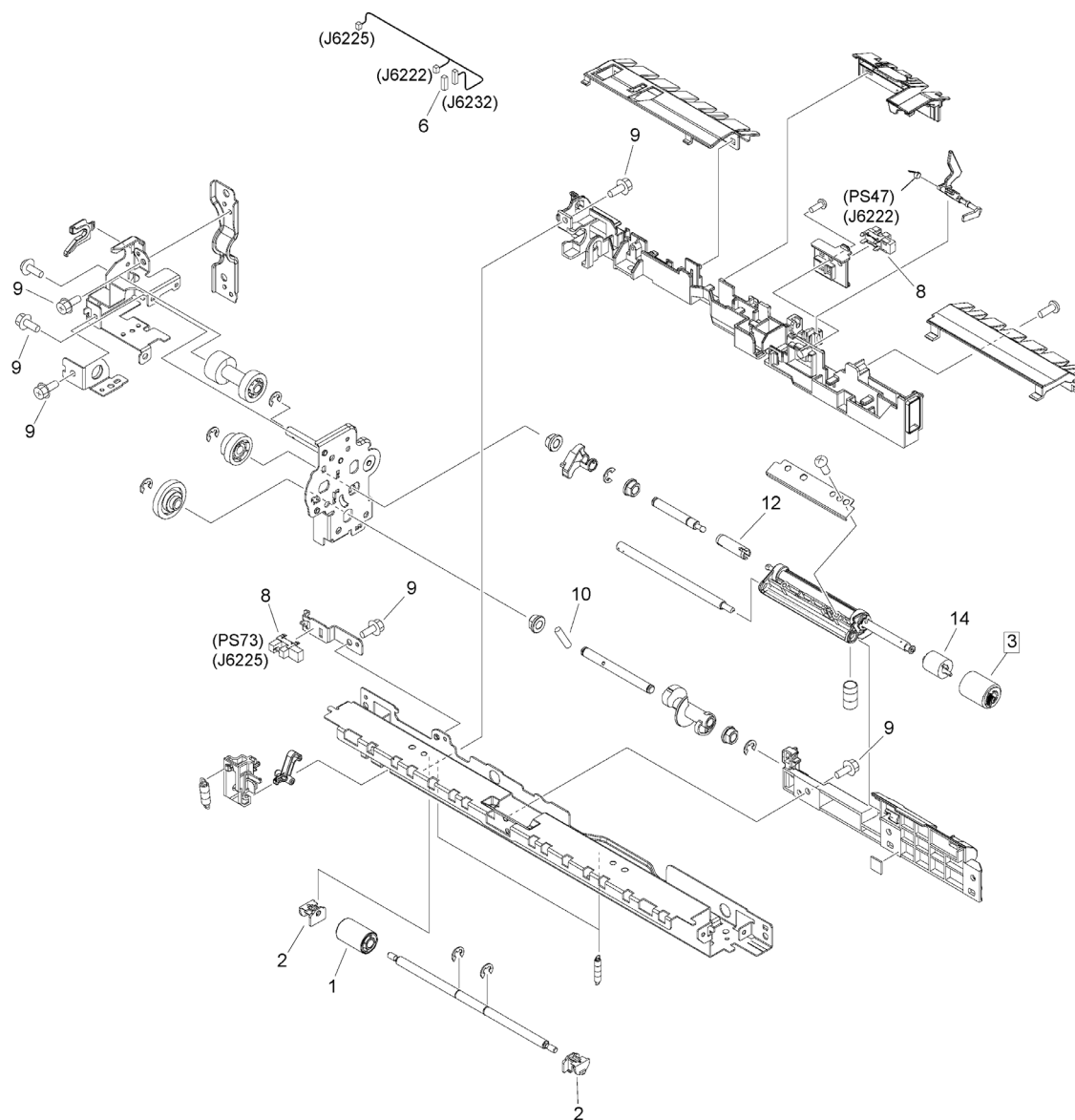

Figure 316 (2/2) MULTI PAPER PICK-UP ASSEMBLY

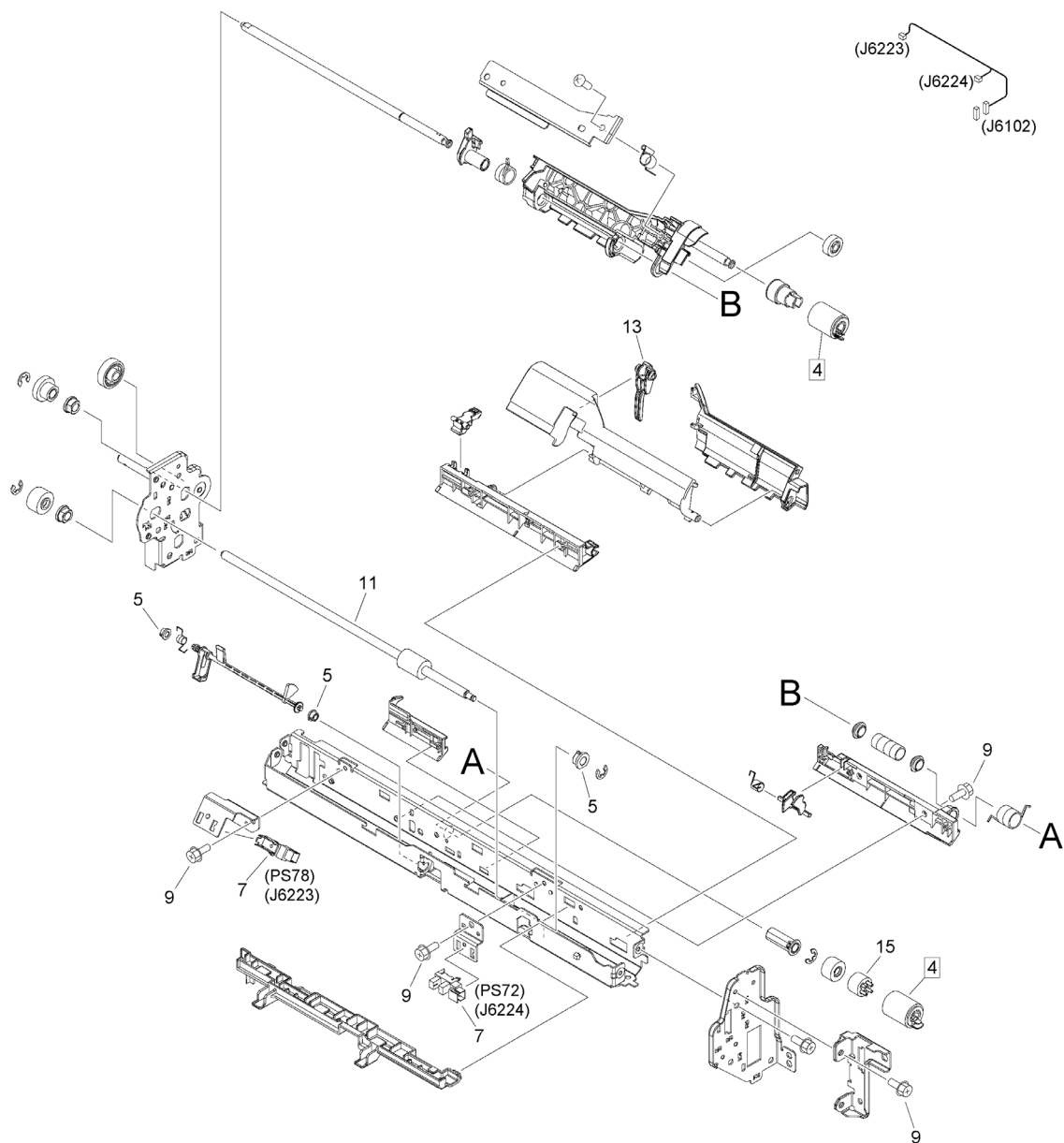

FIGURE & KEY NO.	PART NUMBER	RANK	QTY	DESCRIPTION	SERIAL NUMBER /REMARKS
316	FM2-A212-000		1	MULTI PAPER PICK-UP ASSEMBLY	
1	FE3-9593-000		1	ROLLER, REGISTRATION DRIVEN	
2	FE4-1049-000		2	BUSHING	
3	FL0-1674-000		1	ROLLER, SEPARATION	[DP]
4	FL4-0762-000		2	ROLLER, PAPER PICK-UP	[DP]
5	FU5-1442-000		3	BUSHING	
6	VS1-7177-007		1	CONNECTOR, 7P, FEMALE, BK	
7	WG8-5783-000		2	IC,PHOTO-INTERRUPTER,LG248NL1A	PS72, PS78
8	WG8-5935-000		2	IC, PHOTO INTERRUPTER	PS47, PS73
9	XA9-1386-000		28	SCREW,RS,M3X8	
10	XD9-0289-000		1	PIN, PARALLEL	
11	FE4-5020-000		1	ROLLER, MULTI EXTRACTION	
12	FE4-5061-010		1	COUPLING, JOINT	
13	FE4-5153-000		1	SHUTTER, PAPER PICK-UP	
14	FE4-5133-000		1	LIMITER, TORQUE	
15	FL0-5118-000		1	CLUTCH, ONE-WAY	

Figure 350 FIRST PAPER DELIVERY ASSEMBLY

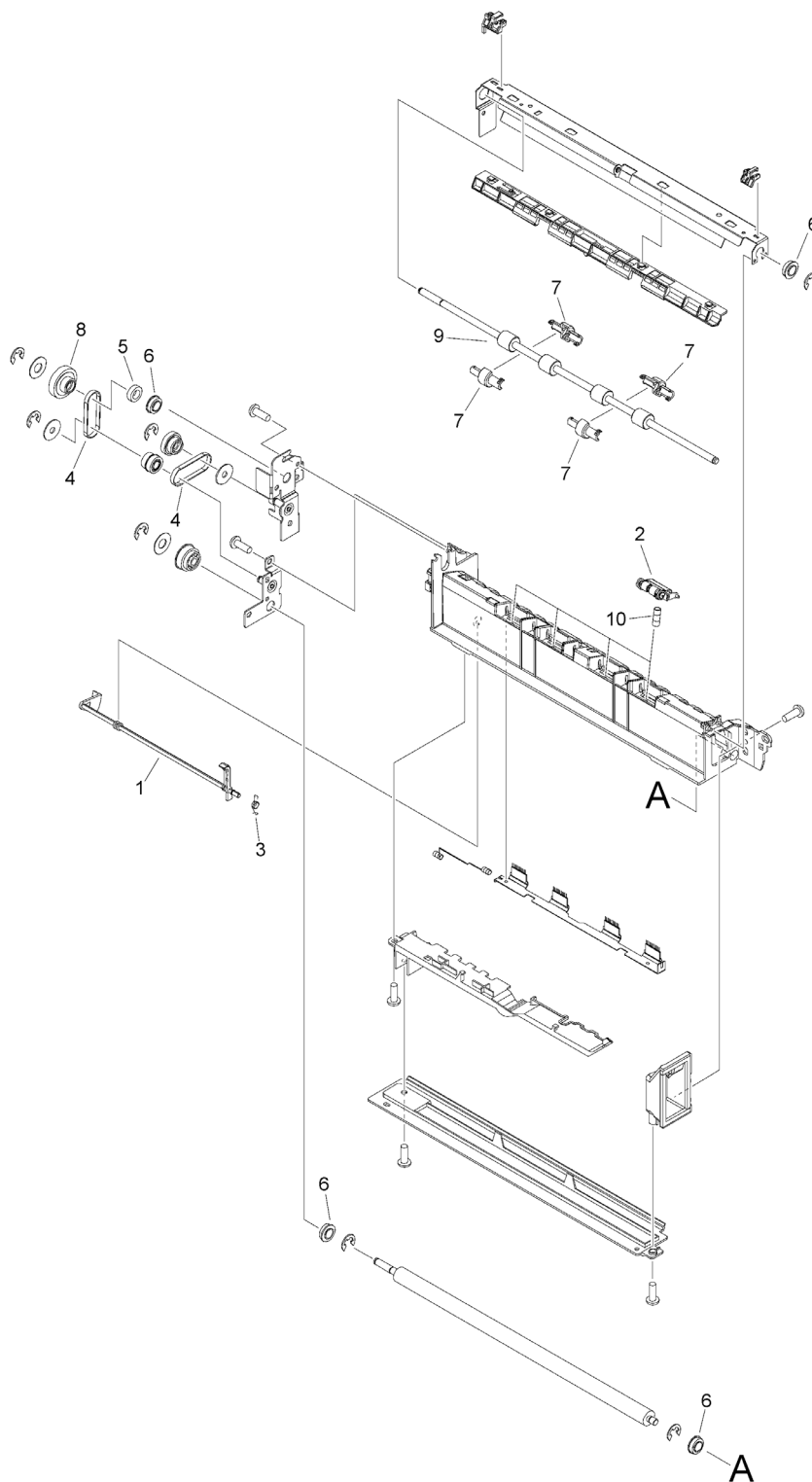

FIGURE & KEY NO.	PART NUMBER	R A N K	QTY	DESCRIPTION	SERIAL NUMBER /REMARKS
350	FM1-G218-010		1	FIRST PAPER DELIVERY ASSEMBLY	
1	FE4-1984-000		1	FLAG, 1ST DELIVERY SENSOR	
2	FM1-G226-000		4	PAPER DELIVERY ROLLER ASSEMBLY	
3	FU5-2068-030		1	SPRING, TORSION	
4	XF2-1605-640		2	BELT, TIMING	
5	XG9-0497-000		1	BEARING, BALL, MR106ZZ,	
6	XG9-0778-000		4	BEARING, BALL, MF106ZZ-1	
7	FE4-1991-000		4	ROLLER, REFORM	
8	FL0-4022-000		1	GEAR, 25T/PULLEY, 25T	
9	FL0-4033-000		1	ROLLER, SECOND PAPER DELIVERY	
10	FU2-1649-000		4	SPRING, COMPRESSION	

Figure 351 2ND/3RD PAPER DELIVERY ASS'Y

NOTE : This assembly includes the assemblies shown in Figure 352 and 353.

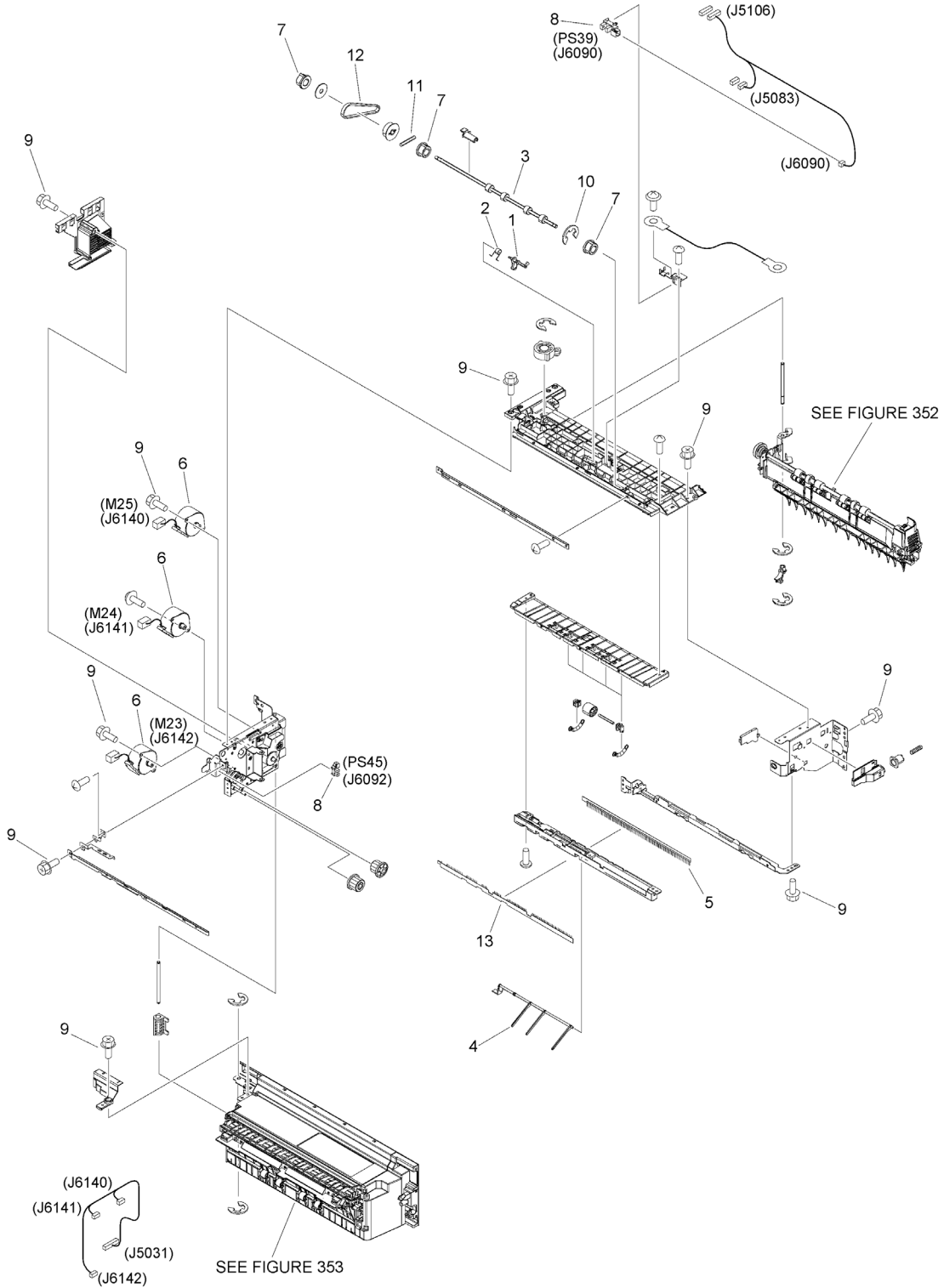

FIGURE & KEY NO.	PART NUMBER	RANK	QTY	DESCRIPTION	SERIAL NUMBER /REMARKS
351	FM1-G219-040		1	2ND/3RD PAPER DELIVERY ASS'Y	SEE NOTE
1	FC5-0987-000		1	FLAG, REVERSE SENSOR	
2	FC5-0988-000		1	SPRING, TORSION	
3	FC5-0989-020		1	ROLLER, REVERSE	
4	FC8-4752-000		1	LEVER,2ND DELIVERY FULL DETECT	
5	FE3-8288-000		1	ELIMINATOR, STATIC CHARGE	
6	FK2-7304-000		3	MOTOR	M23, M24, M25
7	FS5-1943-000		3	BUSHING	
8	WG8-5783-000		2	IC,PHOTO-INTERRUPTER,LG248NL1A	PS39, PS45
9	XA9-1386-000		16	SCREW,RS,M3X8	
10	XD9-0395-000		1	RING, E	
11	XD9-0289-000		1	PIN, PARALLEL	
12	XF2-1607-640		1	BELT, TIMING	
13	FE3-8286-000		1	ELIMINATOR, STATIC CHARGE	

Figure 352 SECOND PAPER DELIVERY ASSEMBLY

NOTE : This assembly is included in the assembly shown in Figure 351.

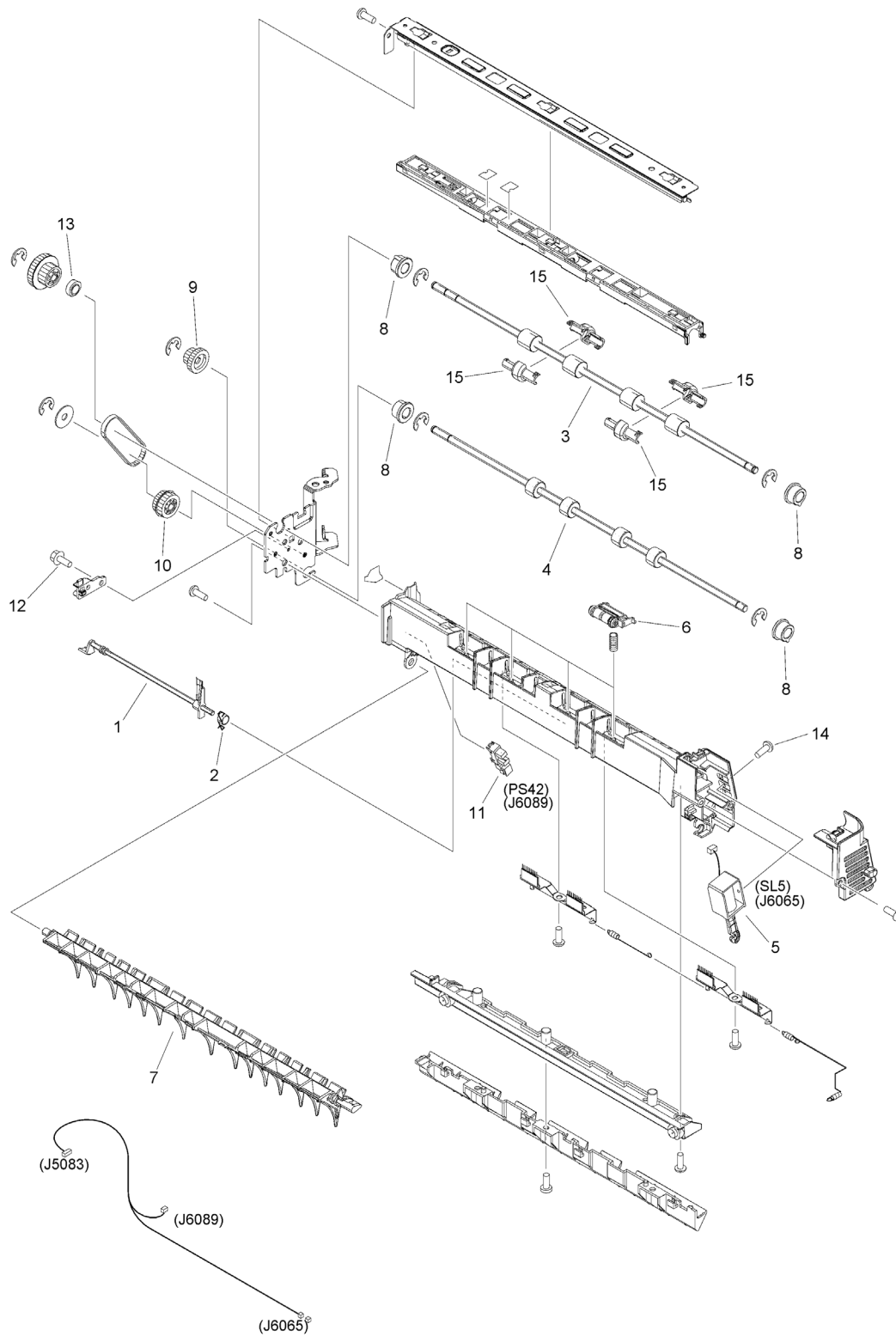

FIGURE & KEY NO.	PART NUMBER	RANK	QTY	DESCRIPTION	SERIAL NUMBER /REMARKS
352	FM1-G224-020		1	SECOND PAPER DELIVERY ASSEMBLY	SEE NOTE
1	FC5-0996-000		1	FLAG, 2ND DELIVERY SENSOR	
2	FC5-0997-000		1	SPRING, TORSION	
3	FC8-4782-000		1	ROLLER, SECOND PAPER DELIVERY	
4	FC8-4789-000		1	ROLLER, SECOND VERTICAL PATH	
5	FL0-4029-000		1	SOLENOID	SL5
6	FM1-G226-000		4	PAPER DELIVERY ROLLER ASSEMBLY	
7	FM1-N629-000		1	FLAPPER ASSEMBLY	
8	FS5-1943-000		4	BUSHING	
9	FU5-0076-000		1	GEAR, 24T	
10	FU5-3020-000		1	GEAR, 24T/PULLEY, 30T	
11	WG8-5783-000		1	IC,PHOTO-INTERRUPTER,LG248NL1A	PS42
12	XA9-1386-000		1	SCREW,RS,M3X8	
13	XG9-0704-000		1	BEARING, BALL, MR106ZZ	
14	XA9-2008-000		1	SCREW,M3X4	
15	FE4-1991-000		4	ROLLER, REFORM	

Figure 353 THIRD PAPER DELIVERY ASSEMBLY

NOTE : This assembly is included in the assembly shown in Figure 351.

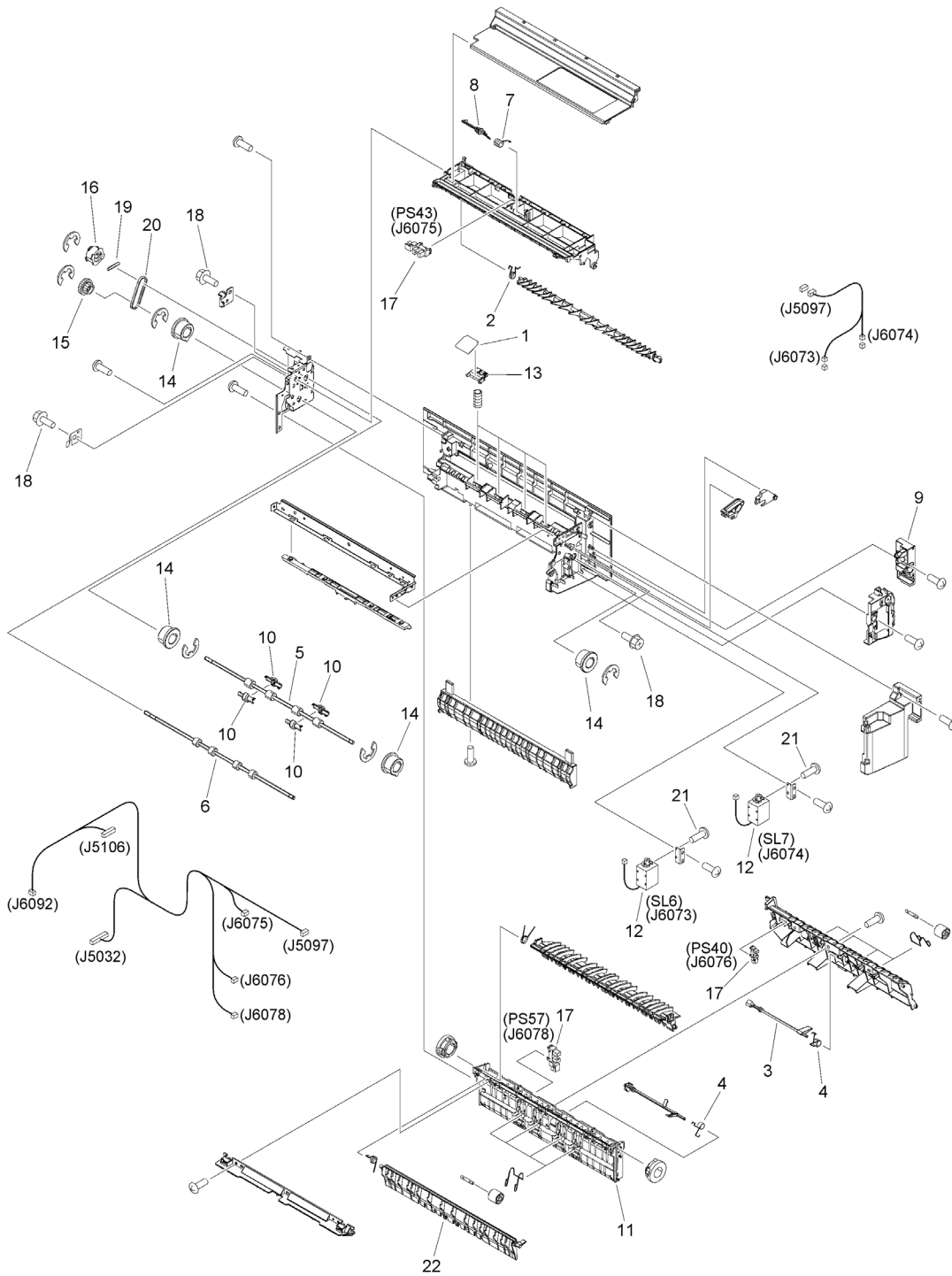

FIGURE & KEY NO.	PART NUMBER	RANK	QTY	DESCRIPTION	SERIAL NUMBER /REMARKS
353	FM1-G230-030		1	THIRD PAPER DELIVERY ASSEMBLY	SEE NOTE
1	FC0-4875-000		4	SHEET, ROLLER HOLDER	
2	FC5-0977-000		1	SPRING, TORSION	
3	FC5-1005-000		1	FLAG, DUPLEX ENTRANCE SENSOR	
4	FC5-1006-000		2	SPRING, TORSION	
5	FC5-1020-020		1	ROLLER, 3RD DELIVERY	
6	FC8-4783-000		1	ROLLER, DUPLEXING ENTRANCE	
7	FC8-5111-000		1	SPRING	
8	FC8-5112-000		1	FLAG, THIRD DELIVERY SENSOR	
9	FC8-5120-000		1	HOOK, 2ND/3RD PAPER DELIVERY	
10	FC9-8621-000		4	ROLLER, REFORM	
11	FL0-7191-010		1	GUIDE, 2ND DEL. ENTRANCE INNER	
12	FL3-1169-000		2	SOLENOID	SL6, SL7
13	FM4-9344-010		4	PAPER DELIVERY ROLLER ASSEMBLY	
14	FS5-1943-000		4	BUSHING	
15	FU5-3018-000		1	PULLEY, 30T/GEAR, 35T	
16	FU5-3021-000		1	PULLEY, 30T	
17	WG8-5783-000		3	IC,PHOTO-INTERRUPTER,LG248NL1A	PS40, PS43, PS57
18	XA9-1386-000		4	SCREW,RS,M3X8	
19	XD9-0289-000		1	PIN, PARALLEL	
20	XF2-4107-240		1	BELT, TIMING	
21	XA9-2008-000		4	SCREW,M3X4	
22	FC0-4857-000		1	FLAPPER, 2ND DELIVERY ENTRANCE	

Figure 460 LASER SCANNER ASSEMBLY

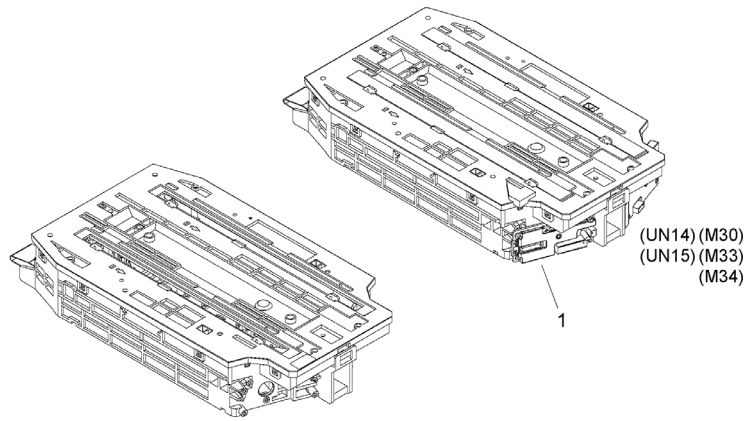

FIGURE & KEY NO.	PART NUMBER	R A N K	QTY	DESCRIPTION	SERIAL NUMBER /REMARKS
460	NPN		RF	LASER SCANNER ASSEMBLY	
1	FM1-G395-000		1	LASER SCANNER ASSEMBLY	UN14, UN15, M30, M33, M34

Figure 530B (1/4) INTER. TRANSFER BELT ASS'Y

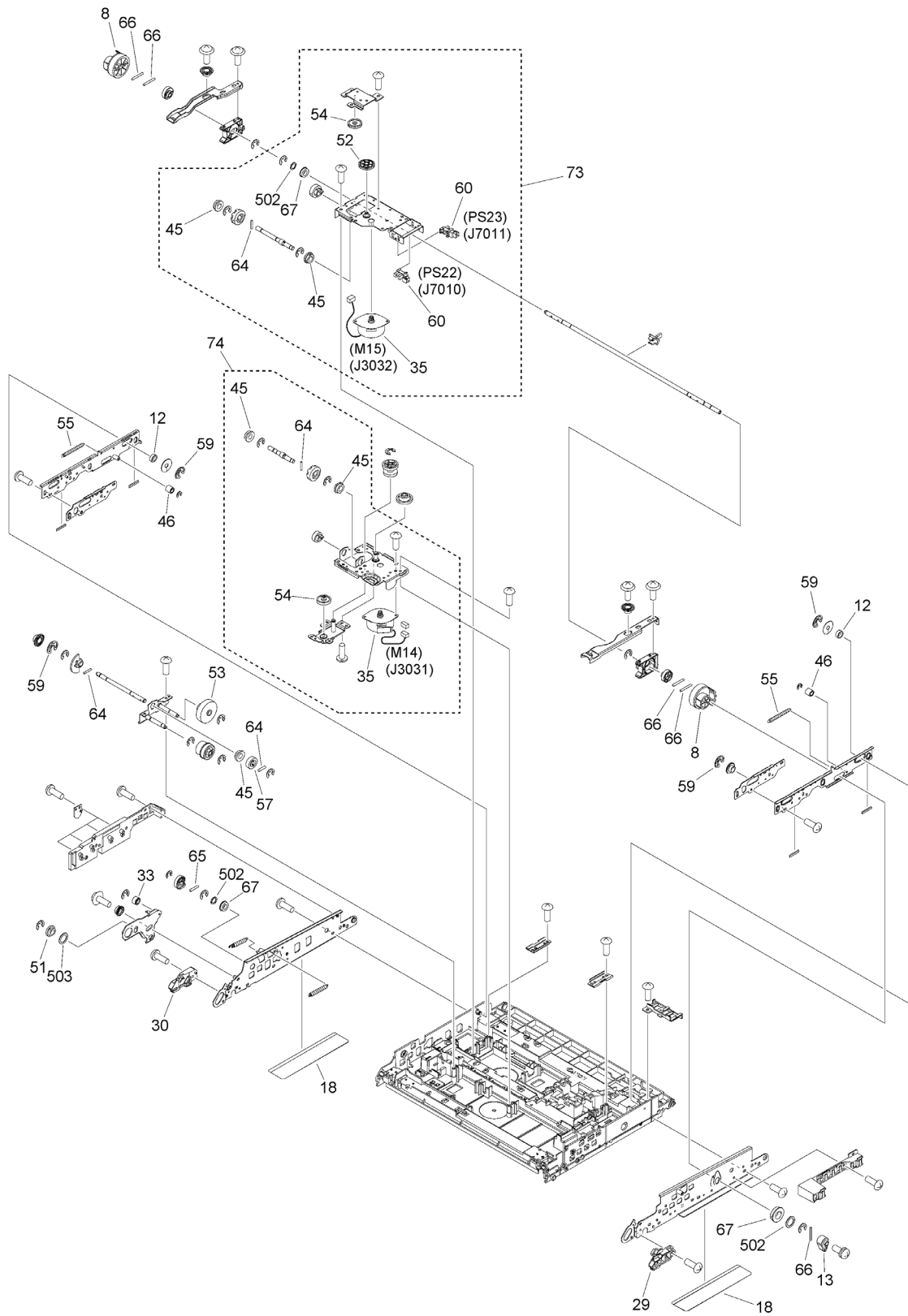

Figure 530B (2/4) INTER. TRANSFER BELT ASS'Y

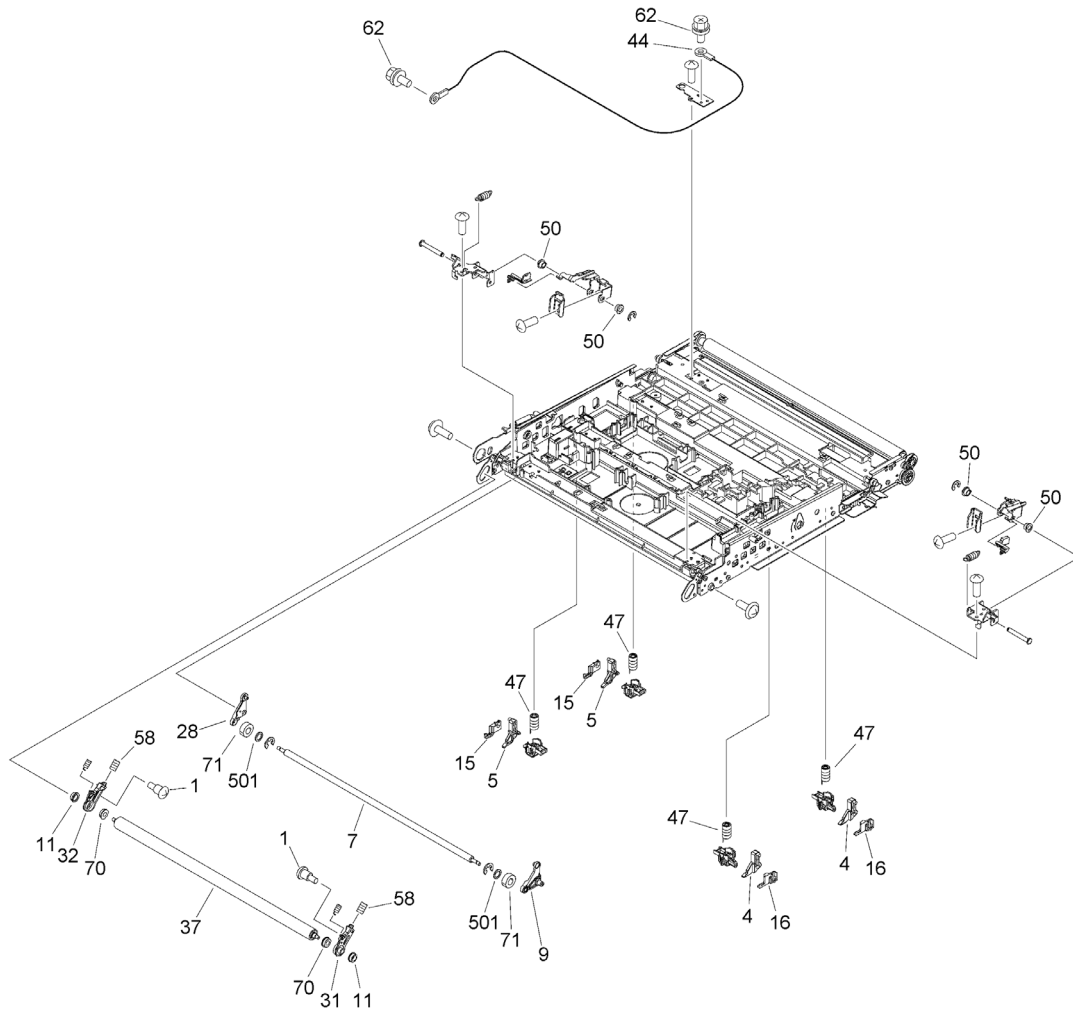

Figure 530B (3/4) INTER. TRANSFER BELT ASS'Y

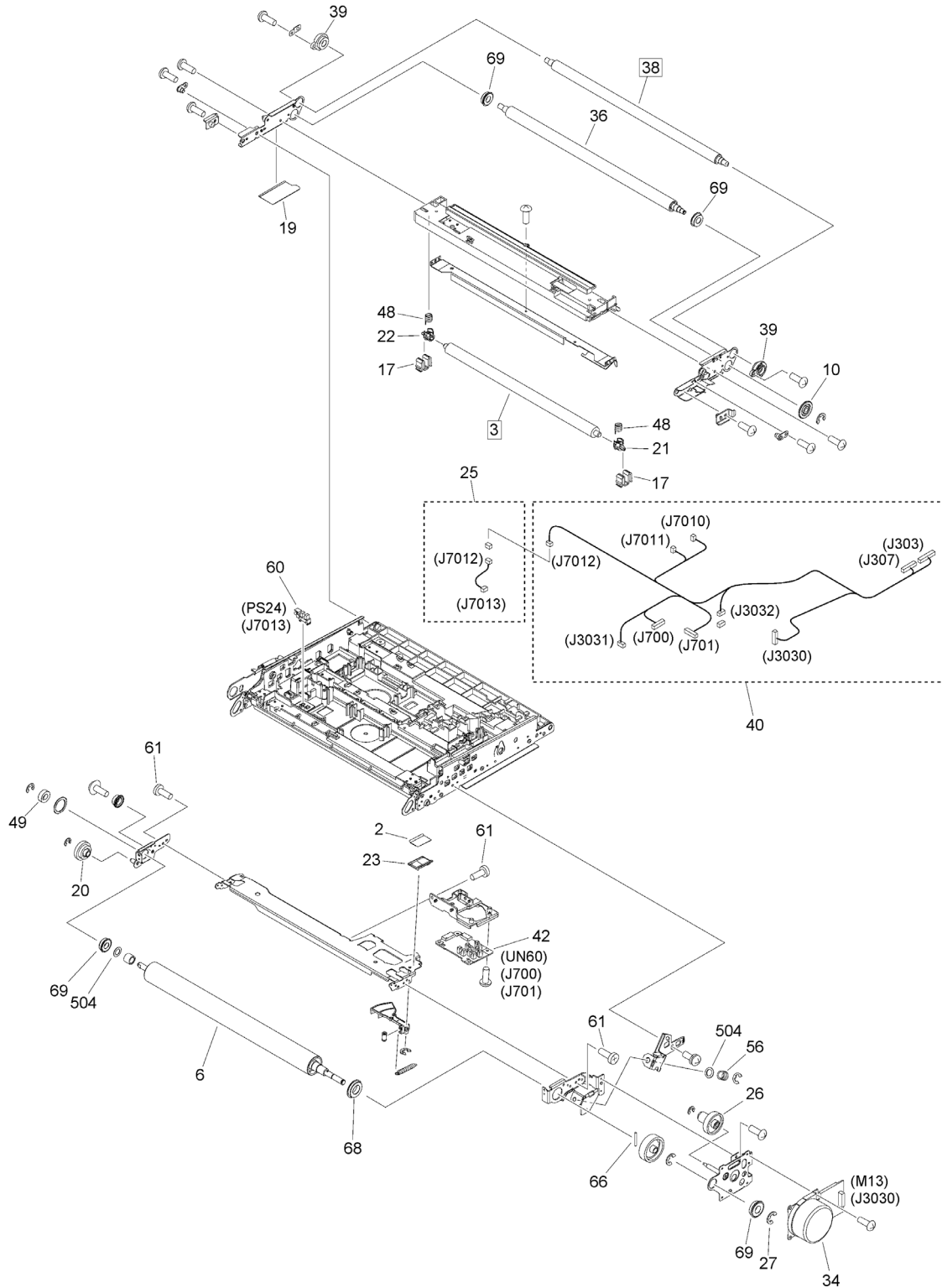

Figure 530B (4/4) INTER. TRANSFER BELT ASS'Y

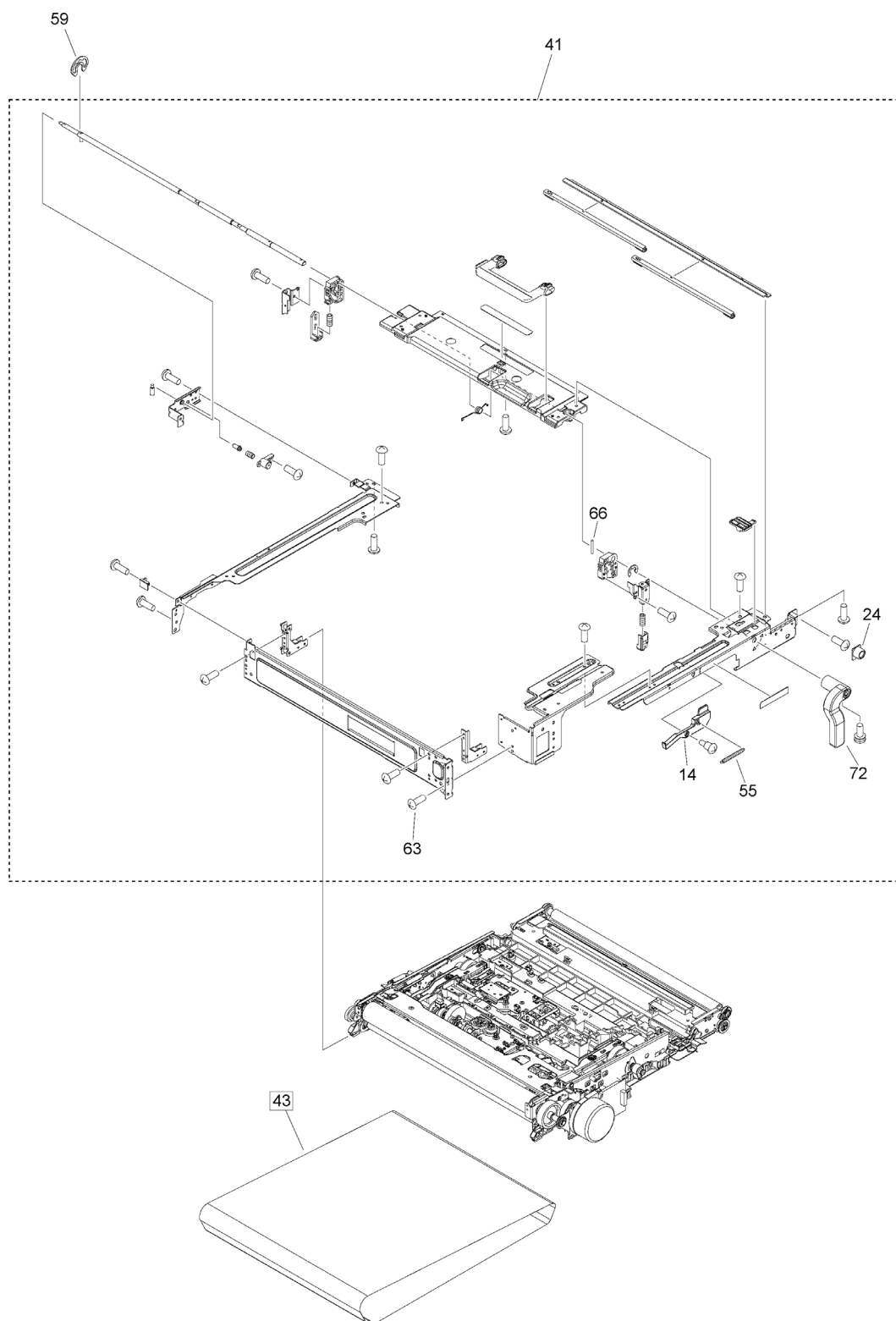

FIGURE & KEY NO.	PART NUMBER	RANK	QTY	DESCRIPTION	SERIAL NUMBER /REMARKS
530B	NPN		RF	INTER. TRANSFER BELT ASS'Y	
1	FU2-2387-000		2	SCREW, M3X2.2	
2	FC0-0253-000		1	PLATE, BELT RETAINING	GOVERNMENT model
2	FL4-3667-000		1	PLATE, BELT RETAINING	MODEL WITHOUT GOVERNMENT
3	FE8-3974-000		1	ROLLER, PRIMARY TRANSFER	[DP]
4	FC0-5043-000		2	ARM, DESORPTION, FRONT	
5	FC0-5044-000		2	ARM, DESORPTION, REAR	
6	FC8-4403-000		1	ROLLER, DRIVE	
7	FC8-4406-000		1	ROLLER, 1ST TRNSFR. AUXILIARY	
8	FC8-4414-000		2	CAM, DESORPTION	
9	FE4-2193-000		1	PLATE, DESORPTION ARM AUX., FR.	
10	FC8-4449-000		1	FLANGE	
11	FC8-4455-000		2	ROLLER, TENSION SLIDER	
12	FC8-4456-000		2	ROLLER, DESORPTION SLIDE	
13	FC8-4490-000		1	CAM, LOCK	
14	FC8-4491-000		1	ARM, LOCK	
15	FC8-4492-010		2	STOPPER, 1ST TRNSFR. BUSHING, R	
16	FC8-4493-010		2	STOPPER, 1ST TRNSFR. BUSHING, F	
17	FC8-4494-000		2	STOPPER, BLACK	
18	FC9-7915-000		2	SHEET, BELT RETAINING, B	GOVERNMENT model
18	FL4-3668-000		2	SHEET, BELT RETAINING, B	MODEL WITHOUT GOVERNMENT
19	FC9-7916-000		1	SHEET, BELT RETAINING, C	GOVERNMENT model
19	FL4-3669-000		1	SHEET, BELT RETAINING, C	MODEL WITHOUT GOVERNMENT
20	FU2-1126-000		1	GEAR, 28T/28T	
21	FE4-2116-000		1	BUSHING, PRIMARY TRANSFER, FR.	
22	FE4-2117-000		1	BUSHING, PRIMARY TRANSFER, RR.	
23	FL3-4847-010		1	GUIDE, BELT	
24	FC0-3759-000		1	CAP, SCREW	
25	FM1-E934-000		1	CABLE, I.T.B. RELAY	
26	FL0-4161-000		1	GEAR, 65T/19T	
27	XD9-0396-000		1	RETAINING RING (E-TYPE)	
28	FE4-2194-000		1	PLATE, DESORPTION ARM AUX., REAR	
29	FE4-2203-000		1	ARM, TRANSFER, FRONT	
30	FE4-2204-000		1	ARM, TRANSFER, REAR	
31	FE4-2219-000		1	BUSHING, FRONT	
32	FE4-2220-000		1	BUSHING, REAR	
33	FE4-2222-000		1	ROLLER	
34	FK2-7300-000		1	MOTOR, DC	M13
35	FK2-7365-000		2	MOTOR	M14, M15

FIGURE & KEY NO.	PART NUMBER	RANK	QTY	DESCRIPTION	SERIAL NUMBER /REMARKS
36	FL0-4162-000		1	ROLLER, IDLER	
37	FL0-4163-000		1	ROLLER, TENSION	
38	FL0-4164-000		1	ROLLER, 2ND TRNSFR. INNER	[DP]
39	FL3-1109-000		2	HOLDER, 2ND TRNSFR. BUSHING	
40	FM2-H968-000		1	CABLE, I.T.B.	
41	FM1-G312-000		1	TRANSFER OUTER FRAME ASSEMBLY	
42	FM1-M838-000		1	DISPLACEMENT SENSOR PCB ASS'Y	UN60
43	FM1-N265-010		1	BELT, INTER TRANSFER	[DP]
44	FM2-R840-000		1	CABLE,PRIMARY TRANSFER H.V. CK	
45	FS1-1508-000		5	BUSHING	
46	FS5-6948-000		2	COLLAR, RAIL	
47	FU2-1136-000		4	SPRING, COMPRESSION	GOVERNMENT model
47	FU2-3402-000		4	SPRING, COMPRESSION	MODEL WITHOUT GOVERNMENT
48	FU2-1137-000		2	SPRING, COMPRESSION	GOVERNMENT model
48	FU2-3403-000		2	SPRING, COMPRESSION	MODEL WITHOUT GOVERNMENT
49	FU3-0267-000		1	GEAR, 18T	
50	FU5-1442-000		4	BUSHING	
51	FU5-1447-000		1	BUSHING	
52	FU6-0147-000		1	GEAR, 48T	
53	FU6-0272-000		1	GEAR, 15T/45T	
54	FU6-0686-000		2	GEAR, 11T/43T	
55	FU7-2451-000		3	SPRING	
56	FU7-2462-000		1	SPRING	
57	FU8-0499-000		1	GEAR, 22T	
58	FU8-2926-000		2	SPRING, TENSION	
59	FB6-6088-000		5	RING, RETAINING	
60	WG8-5783-000		3	IC,PHOTO-INTERRUPTER,LG248NL1A	PS22, PS23, PS24
61	XA9-2018-000		6	SCREW,M3,L6	
62	XA9-2003-000		2	SCREW, W/WASHER, M3X6	
63	XA9-2008-000		4	SCREW,M3X4	
64	XD9-0288-000		4	PIN, DOWEL	
65	XD9-0289-000		1	PIN, PARALLEL	
66	XD9-0291-000		7	PIN, PARALLEL	
67	XG9-0520-000		3	BEARING, BALL, MF106ZZS	
68	XG9-0731-000		1	BEARING, BALL, 6801ZZ	
69	XG9-0794-000		4	BEARING, BALL, LNR-1680KKR	
70	XG9-0797-000		2	BEARING, BALL, LF-1260ZZRPOP25	
71	XG9-0861-000		2	BEARING, BALL, L-840ZZHPOP25L	
72	FC8-4394-000		1	LEVER	
73	FM1-N263-000		1	DESORPTION DRIVE ASSEMBLY	
74	FM1-H223-000		1	STEPPING DRIVE ASSEMBLY	

FIGURE & KEY NO.	PART NUMBER	R A N K	QTY	DESCRIPTION	SERIAL NUMBER /REMARKS
501	XD1-1104-115		2	WASHER,COP	
502	XD1-1106-215		3	WASHER,COP	
503	XD1-1109-215		1	WASHER,COP	
504	XD1-1208-225		2	WASHER, PLAIN	

Figure 535 TRANSFER CLEANER ASSEMBLY

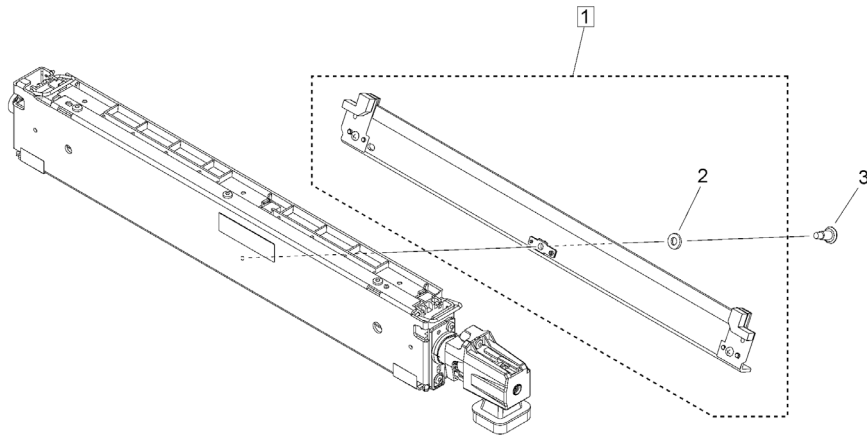

FIGURE & KEY NO.	PART NUMBER	RANK	QTY	DESCRIPTION	SERIAL NUMBER /REMARKS
535	FM1-G370-010		1	TRANSFER CLEANER ASSEMBLY	
1	FM4-7246-010		1	BLADE, TRANSFER CLEANING	[DP]
2	FS5-6957-000		1	WASHER,WAVE	
3	FU5-9737-000		1	SCREW, STEPPED, M4X6.5	

Figure 600 (1/2) PROCESS-KIT FRAME ASSEMBLY

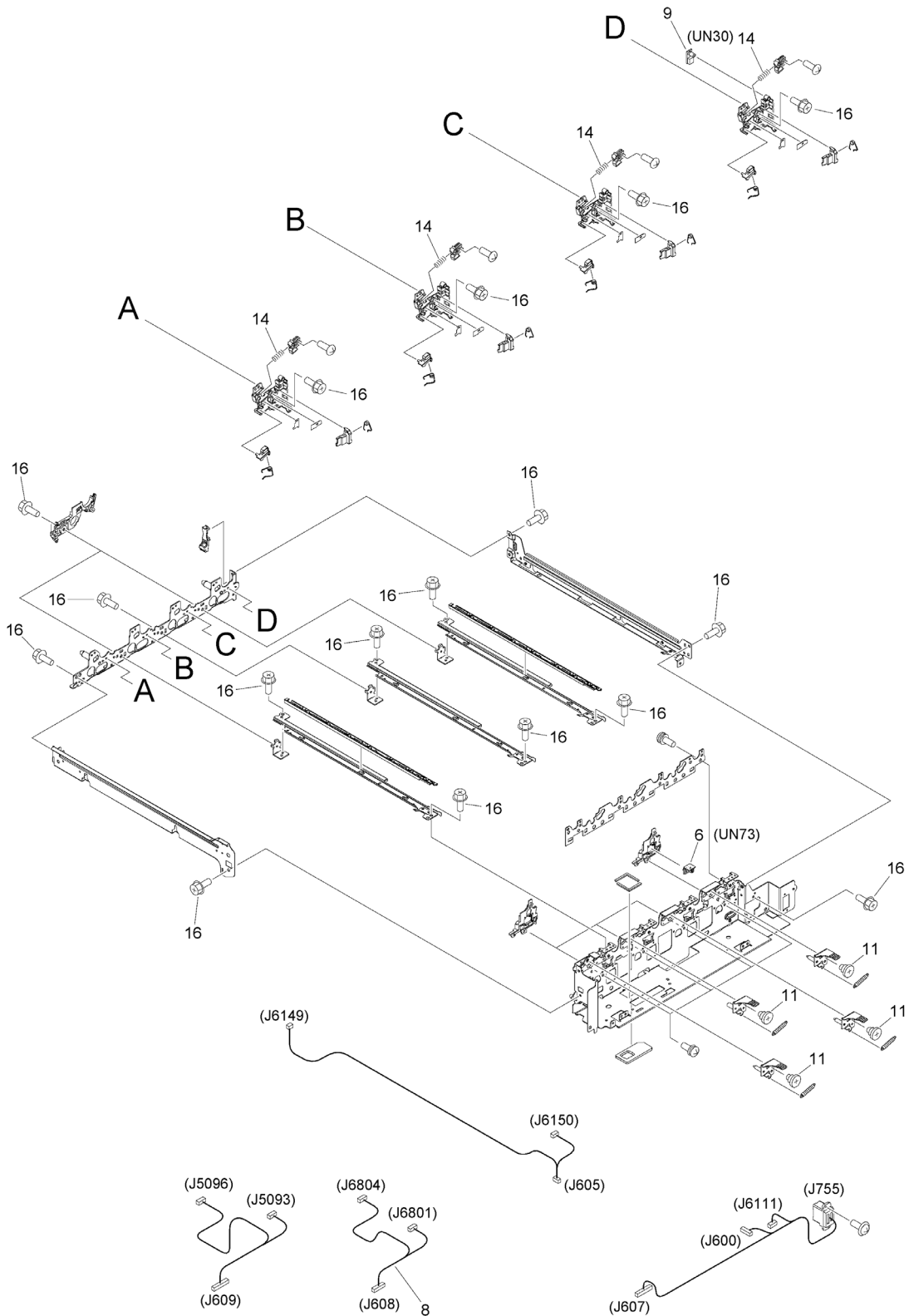

Figure 600 (2/2) PROCESS-KIT FRAME ASSEMBLY

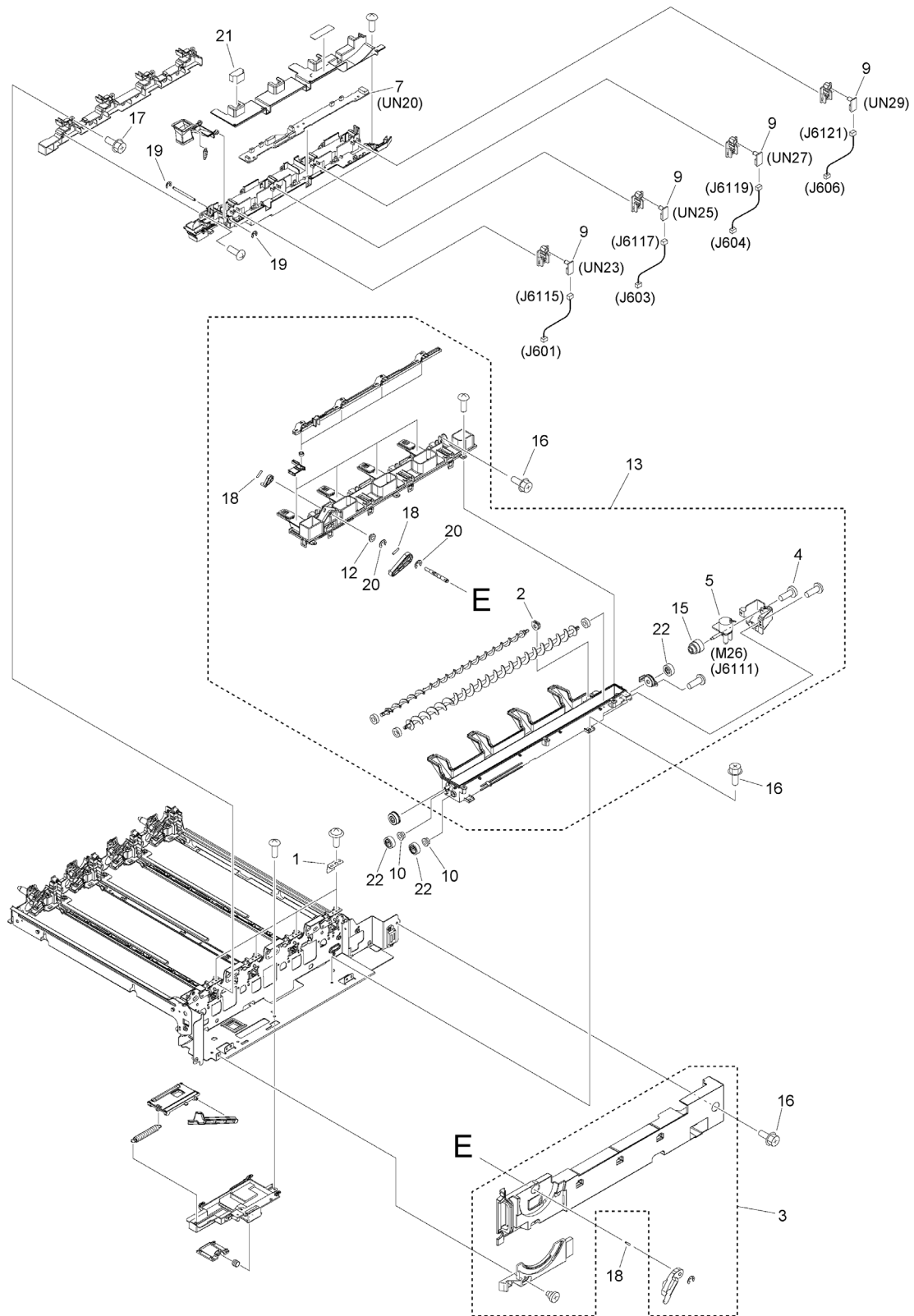

FIGURE & KEY NO.	PART NUMBER	RANK	QTY	DESCRIPTION	SERIAL NUMBER /REMARKS
600	FM2-A080-000		1	PROCESS-KIT FRAME ASSEMBLY	
1	FC8-3921-000		4	PLATE, DRUM GROUNDING	
2	FC8-4573-000		1	BUSHING	
3	FM1-W438-000		1	PROCESS FRONT COVER ASS'Y SET	
4	XA9-2018-000		2	SCREW,M3,L6	
5	FM1-G365-010		1	FEED MOTOR DRIVE ASSEMBLY	M26
6	FM1-V982-000		1	DRUM CONTACT PCB ASS'Y	UN73
7	FM1-V983-010		1	CONNECTING PCB ASSEMBLY	UN20
8	FM2-R835-000		1	CABLE, DRUM IC	
9	FM3-7945-000		5	LED PCB ASSEMBLY	UN23, U25, UN27, UN29, UN30
10	FS1-1205-000		2	BUSHING	
11	FS5-9360-020		4	SCREW,STEPPED,M4	
12	FU5-1447-000		1	BUSHING	
13	FM1-G364-000		1	FEED CASE ASSEMBLY	
14	FU7-2470-000		4	SPRING	
15	FU8-0209-000		1	GEAR, 16T/36T	
16	XA9-0732-010		24	SCREW,RS,M4X8	
17	XA9-1386-000		4	SCREW,RS,M3X8	
18	XD9-0288-000		3	PIN, DOWEL	
19	XD9-0134-000		2	RING, E	
20	XD9-0395-000		2	RING, E	
21	FE4-3589-000		1	SHEET, PROTECTION	
22	FU2-1192-000		3	GEAR, 19T	

Figure 620 SET ON HOPPER ASS' Y, BLACK

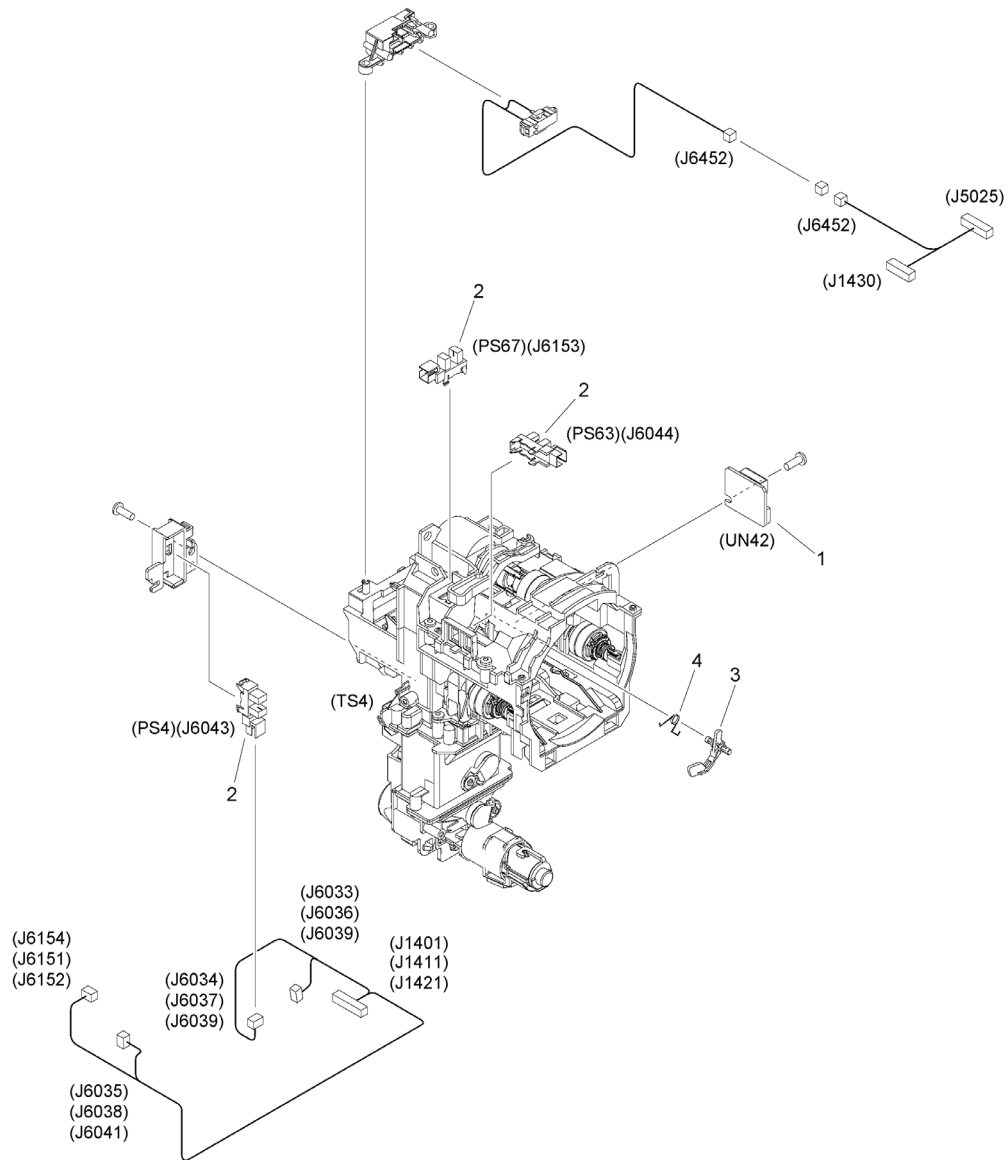

FIGURE & KEY NO.	PART NUMBER	RANK	QTY	DESCRIPTION	SERIAL NUMBER /REMARKS
620	FM1-G327-010		1	SET ON HOPPER ASS'Y, BLACK	TS4
1	FM3-7948-000		1	TONER SENSOR RELAY PCB ASS'Y	UN42
2	WG8-5783-000		3	IC,PHOTO-INTERRUPTER,LG248NL1A	PS4, PS63, PS67
3	FC0-5760-000		1	FLAG, BOTTLE SENSOR	
4	FU9-2035-000		1	SPRING, BOTTLE SENSOR FLAG	

Figure 626B BOTTLE FRONT INNER DOOR ASS'Y

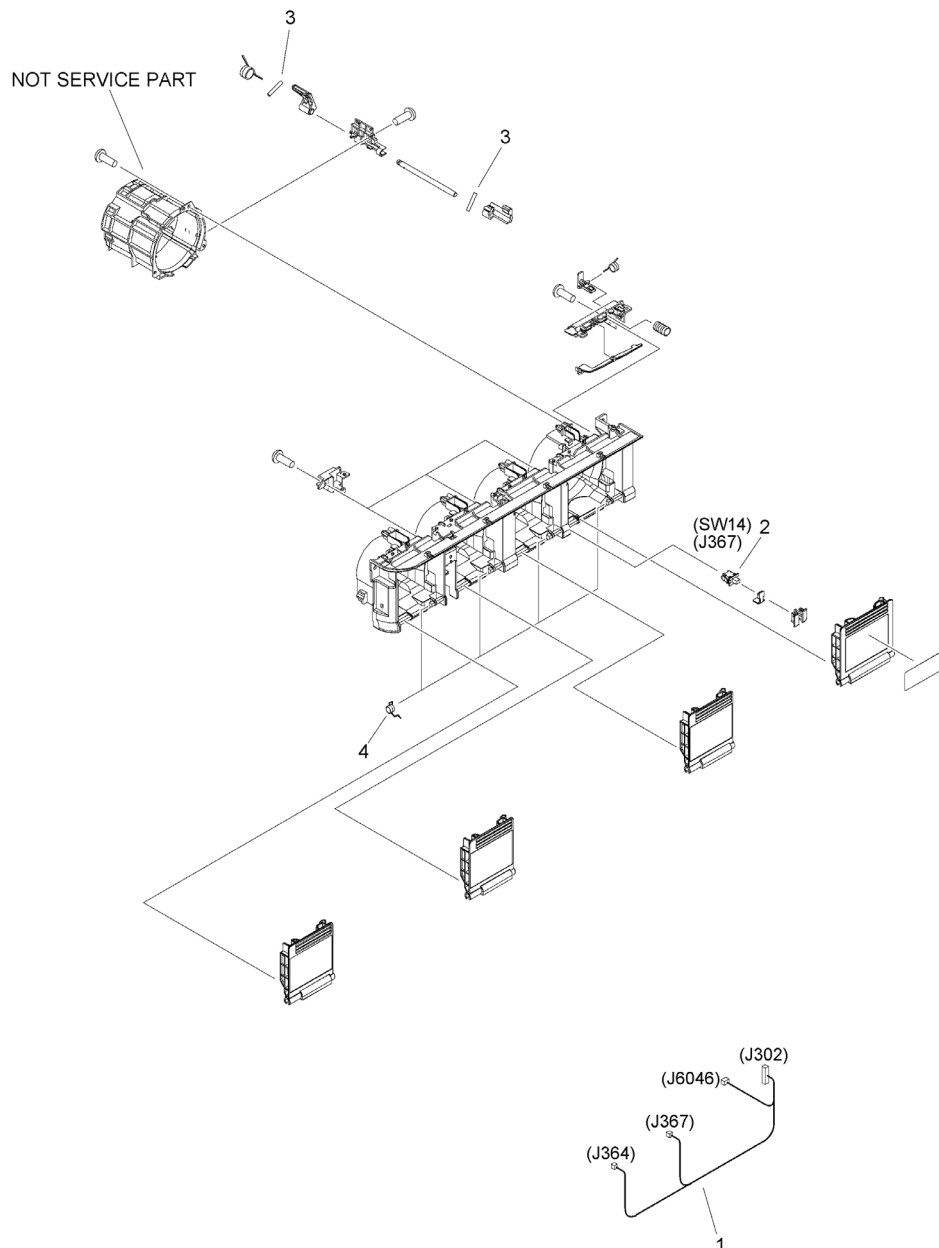

FIGURE & KEY NO.	PART NUMBER	RANK	QTY	DESCRIPTION	SERIAL NUMBER /REMARKS
626B	NPN		1	BOTTLE FRONT INNER DOOR ASS'Y	
1	FM2-R833-000		1	CABLE, SET ON DOOR SENSOR	
2	WC2-5806-000		1	SWITCH, PUSH	SW14
3	XD9-0289-000		2	PIN, PARALLEL	
4	FC8-4687-000		4	SPRING, TORSION	

Figure 627 BOTTLE BASE ASSEMBLY, BLACK

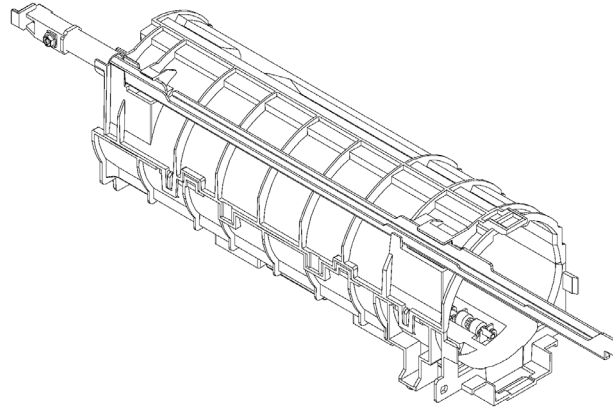

FIGURE & KEY NO.	PART NUMBER	R A N K	QTY	DESCRIPTION	SERIAL NUMBER /REMARKS
627	FM1-G349-010		1	BOTTLE BASE ASSEMBLY, BLACK	

Figure 640 DEVELOPING ASSEMBLY

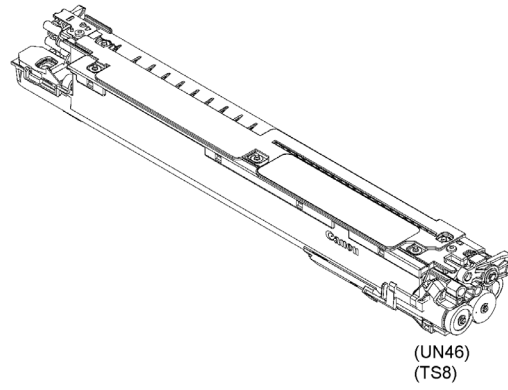

FIGURE & KEY NO.	PART NUMBER	R A N K	QTY	DESCRIPTION	SERIAL NUMBER /REMARKS
640	FM1-N373-010		1	DEVELOPING ASSEMBLY, BK	UN46, TS8 [DP]

Figure 770 CONTAINER, WASTE TONER, WT-202

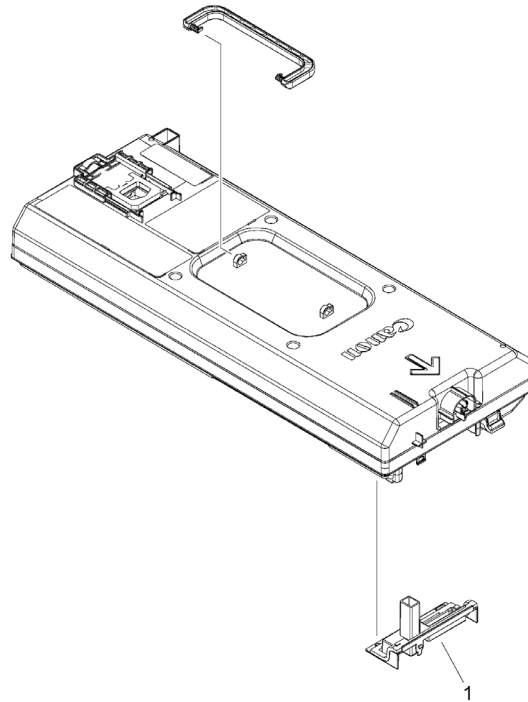

FIGURE & KEY NO.	PART NUMBER	R A N K	QTY	DESCRIPTION	SERIAL NUMBER /REMARKS
770	FM1-A606-050		1	CONTAINER, WASTE TONER, WT-202	[DP]
1	FLO-7007-000		1	WINDOW, WASTE TONER CASE	

Figure 771 WASTE TONER DRIVE DETECT ASS'Y

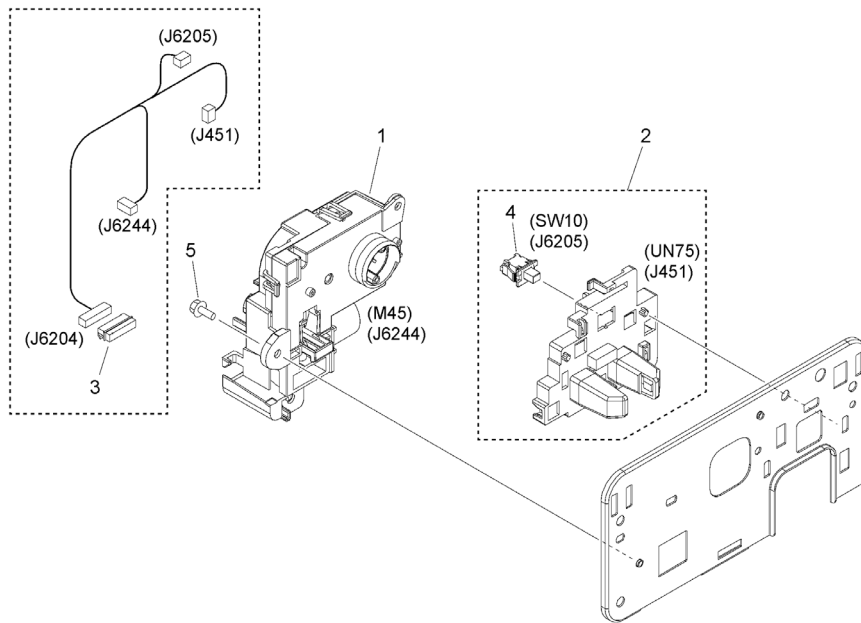

FIGURE & KEY NO.	PART NUMBER	RANK	QTY	DESCRIPTION	SERIAL NUMBER /REMARKS
771	FM1-G366-000		1	WASTE TONER DRIVE DETECT ASS'Y	
1	FM1-G361-010		1	WASTE TONER DRIVE ASSEMBLY	M45
2	FM1-G362-010		1	WASTE TONER DETECT ASSEMBLY	UN75
3	VS1-7177-009		1	CONNECTOR, WIRE TO WIRE, 9P	
4	WC2-5803-000		1	SWITCH	SW10
5	XA9-1386-000		2	SCREW,RS,M3X8	

Figure 810B (1/2)FIXING ASSEMBLY (120V)

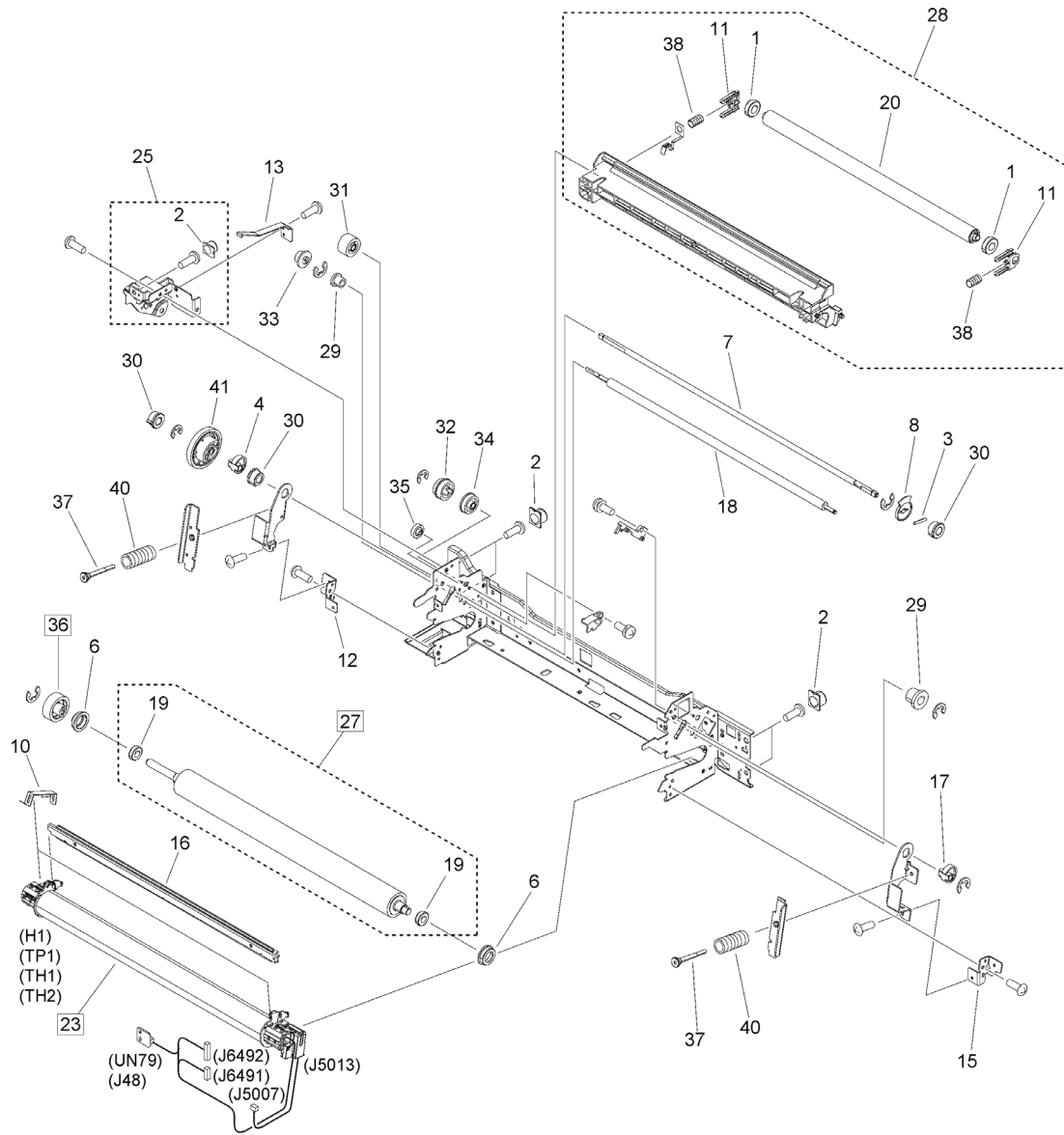

Figure 810B (2/2)FIXING ASSEMBLY (120V)

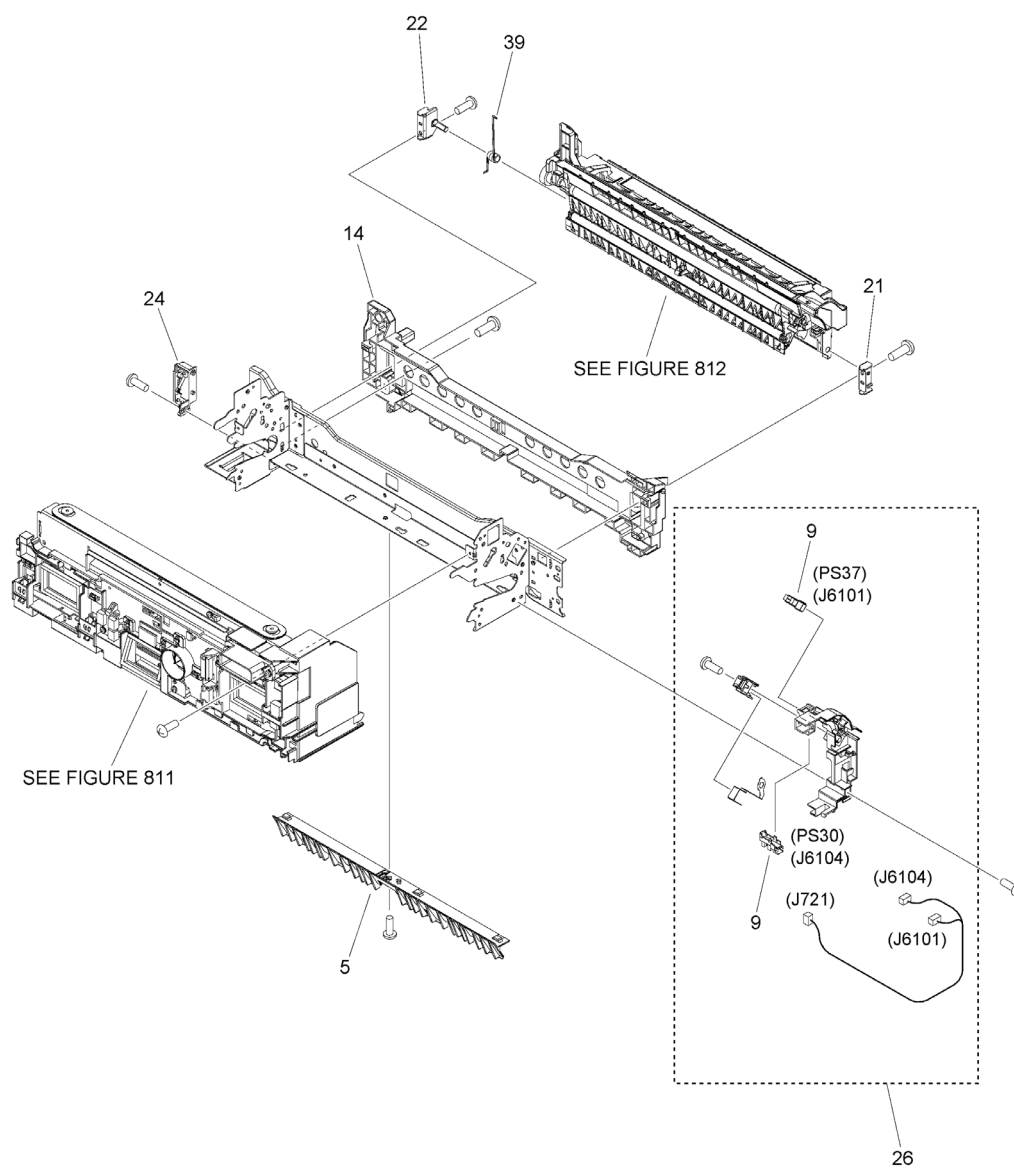

FIGURE & KEY NO.	PART NUMBER	RANK	QTY	DESCRIPTION	SERIAL NUMBER /REMARKS
810B	NPN		1	FIXING ASSEMBLY	120V
1	FA9-4077-000		2	BUSHING	
2	FC0-3759-000		5	CAP,SCREW	
3	XD9-0289-000		1	PIN, PARALLEL	
4	FC0-4925-000		1	CAM, PRESSURE RELEASE	
5	FC0-4934-010		1	GUIDE, FIXING ENTRANCE	
6	FC5-7182-000		2	HOUSING,BEARING	
7	FC6-9269-000		1	SHAFT	
8	FC6-9272-000		1	FLAG, PRESSURE RELEASE SENSOR	
9	WG8-5783-000		2	IC,PHOTO-INTERRUPTER,LG248NL1A	PS30, PS37
10	FE8-6575-000		2	SPRING, LEAF	
11	FC6-9472-000		2	HOLDER, BUSHING	
12	FC7-2392-000		1	MOUNT, PRESSURE	
13	FC7-4834-010		1	STOPPER, PRESSURE RELEASE	
14	FC8-5027-010		1	HANDLE, FIXING DRAWER	
15	FC8-5031-000		1	MOUNT, PRESSURE, FRONT	
16	FC8-5043-030		1	GUIDE, FIXING SEPARATION	
17	FC8-5068-000		1	CAM, PRESSURE RELEASE	
18	FE4-3689-000		1	ROLLER, INNER PAPER DELIVERY	
19	XG9-0875-000		2	BEARING, BALL, NS P0 16MM	
20	FL1-5523-000		1	ROLLER, SLEEVE	
21	FL2-9554-000		1	PLATE, GUIDE HINGE, FRONT	
22	FL3-1145-000		1	PLATE, GUIDE HINGE, REAR	
23	FM2-A667-000		1	FILM ASSEMBLY	UN79, H1, TH1, TH2, TP1 [DP]
24	FM1-G663-000		1	PRESSURE ROLLER CONTACT ASS'Y	
25	FM1-H216-000		1	PRESSURE RELEASE PLATE ASS'Y	
26	FM1-H217-000		1	SENSOR HOLDER ASSEMBLY	
27	FM1-N252-000		1	PRESSURE ROLLER KIT	[DP]
28	FM3-5955-000		1	GUIDE, FIXING DELIVERY, UPPER	
29	FS1-1528-000		2	BUSHING, PL	
30	FS5-1943-000		3	BUSHING	
31	FU2-1246-000		1	GEAR, 19T	
32	FU2-1247-000		1	GEAR, 33T/17T	
33	FU2-1248-000		1	GEAR, 15T	
34	FU2-1249-000		1	GEAR, 32T	
35	FU2-1250-000		1	GEAR, 23T	
36	FU2-1252-000		1	GEAR, 27T	[DP]
37	FU6-0028-000		2	SCREW	
38	FU6-2644-000		2	SPRING, COMPRESSION	
39	FU8-2279-000		1	SPRING	
40	FU8-2921-000		2	SPRING, COMPRESSION	
41	FU9-0513-000		1	GEAR, 46T	

Figure 811 SHUTTER ASSEMBLY

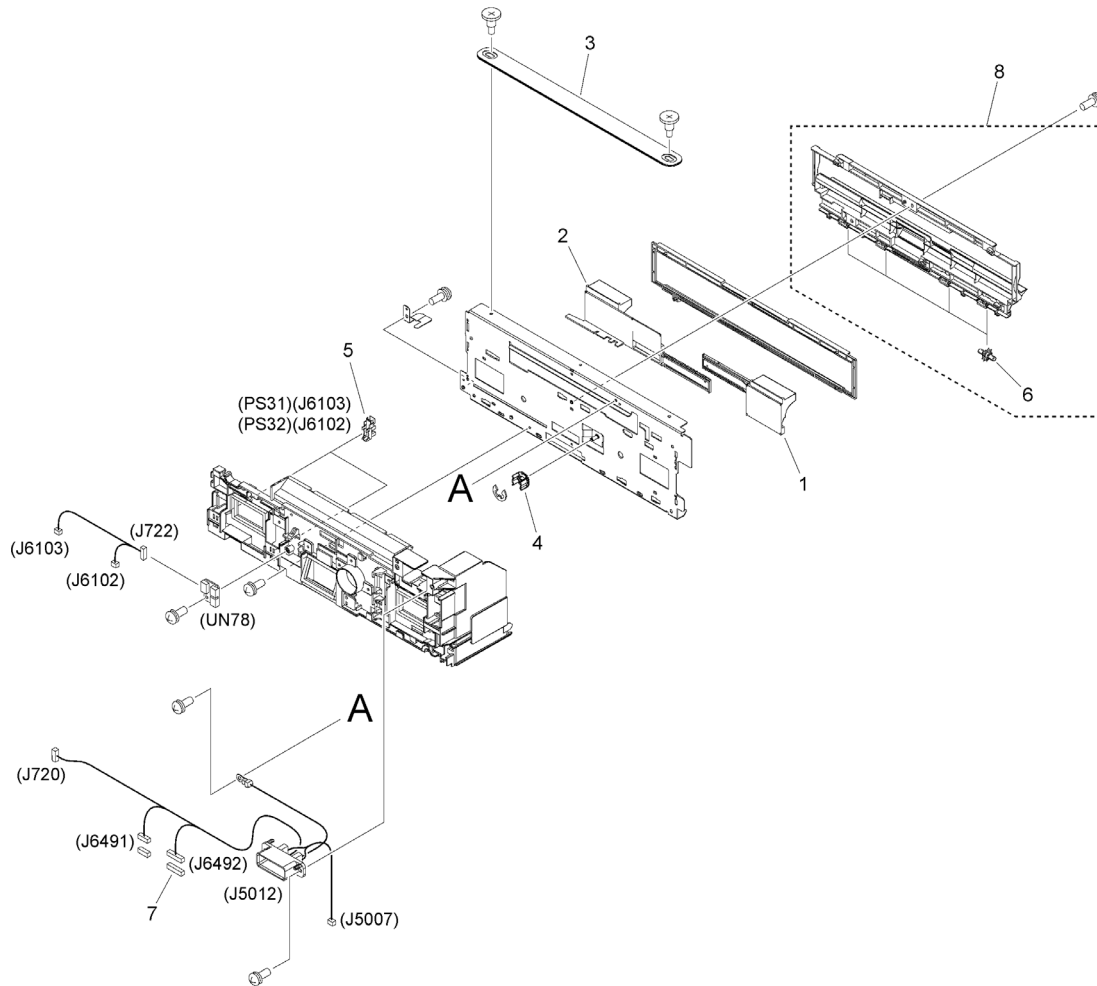

FIGURE & KEY NO.	PART NUMBER	RANK	QTY	DESCRIPTION	SERIAL NUMBER /REMARKS
811	FM1-G662-010		1	SHUTTER ASSEMBLY	UN78
1	FC8-5047-000		1	SHUTTER, F	
2	FC8-5048-000		1	SHUTTER, R	
3	FL0-4511-000		1	HANDLE, FIXING	
4	FU7-0270-000		1	PINION, SHUTTER	
5	WG8-5783-000		2	IC,PHOTO-INTERRUPTER,LG248NL1A	PS31, PS32
6	FC7-2471-000		4	ROWEL	
7	VS1-7177-012		1	CONNECTOR, SNAP TIGHT, BK	
8	FM1-U496-000		1	SHUTTER COVER ASSEMBLY	

Figure 812 DELIVERY GUIDE ASSEMBLY, LOWER

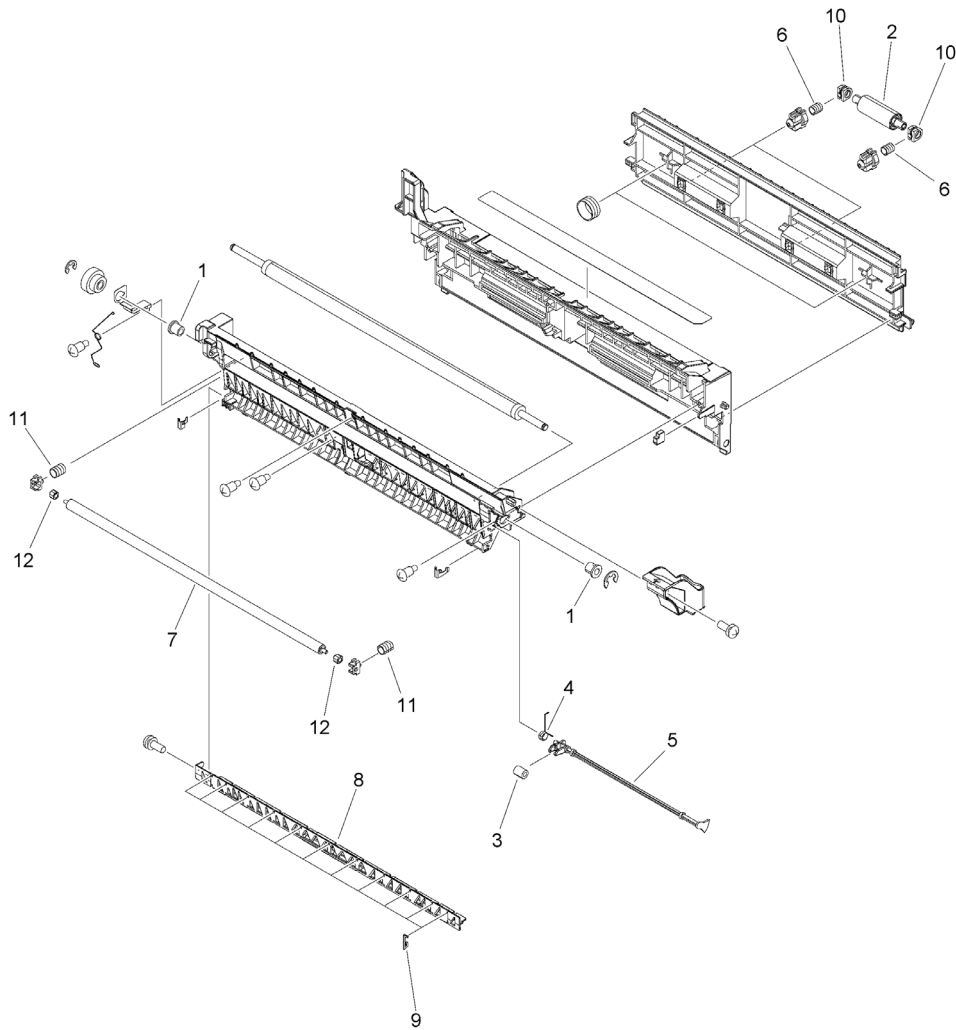

FIGURE & KEY NO.	PART NUMBER	RANK	QTY	DESCRIPTION	SERIAL NUMBER /REMARKS
812	FM1-G658-000		1	DELIVERY GUIDE ASSEMBLY, LOWER	
1	FA9-4041-005		2	BUSHING	
2	FB6-4873-000		2	ROLLER, PAPER FEED	
3	FB6-7002-000		1	ROLLER, PAPER SENSOR	
4	FC6-9309-000		1	SPRING, TORSION	
5	FC6-9473-000		1	FLAG, PAPER DELIVERY SENSOR	
6	FU7-2521-000		4	SPRING	
7	FC7-2395-000		1	ROLLER, PAPER DELIVERY	
8	FC7-6978-000		1	GUIDE, INNER PAPER DELIVERY	
9	FE4-3706-000		11	RIB	
10	FU5-1035-000		4	BUSHING	
11	FU5-2683-000		2	SPRING	
12	FU6-1269-000		2	BUSHING	

Figure 900 CONTROLLER BOX ASSEMBLY

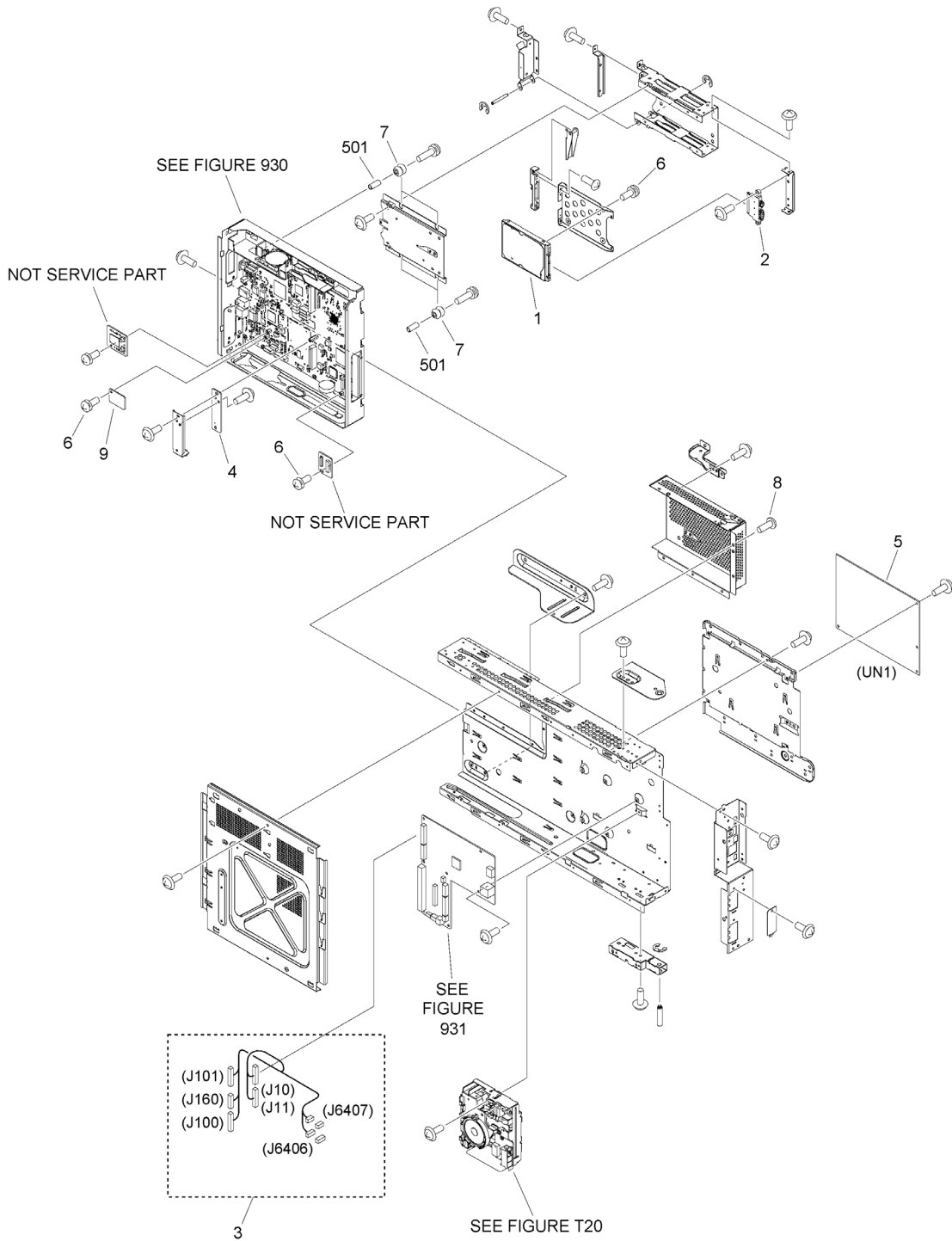

FIGURE & KEY NO.	PART NUMBER	RANK	QTY	DESCRIPTION	SERIAL NUMBER /REMARKS
900	NPN		1	CONTROLLER BOX ASSEMBLY	
1	FK4-1550-010		1	HARD DISK DRIVE, MQ01ABF032	
2	FK4-2497-000		1	CABLE, HARD DISK DRIVE, 1	
3	FM2-H992-000		1	CABLE, INTERFACE	
4	FM1-T849-000		1	BYPASS PCB ASSEMBLY	
5	FM2-R839-000		1	DC CONTROLLER PCB ASSEMBLY	UN1
6	XA9-1979-000		4	SCREW, MACH. PAN HEAD, M3X4	
7	XH9-0149-000		4	DAMPER, CUSHION	
8	XA9-2008-000		6	SCREW,M3X4	
9	FM1-M981-000		1	TPM PCB ASSEMBLY	
501	XZ1-1301-005		4	SPACER	

Figure 910 POWER SUPPLY ASSEMBLY

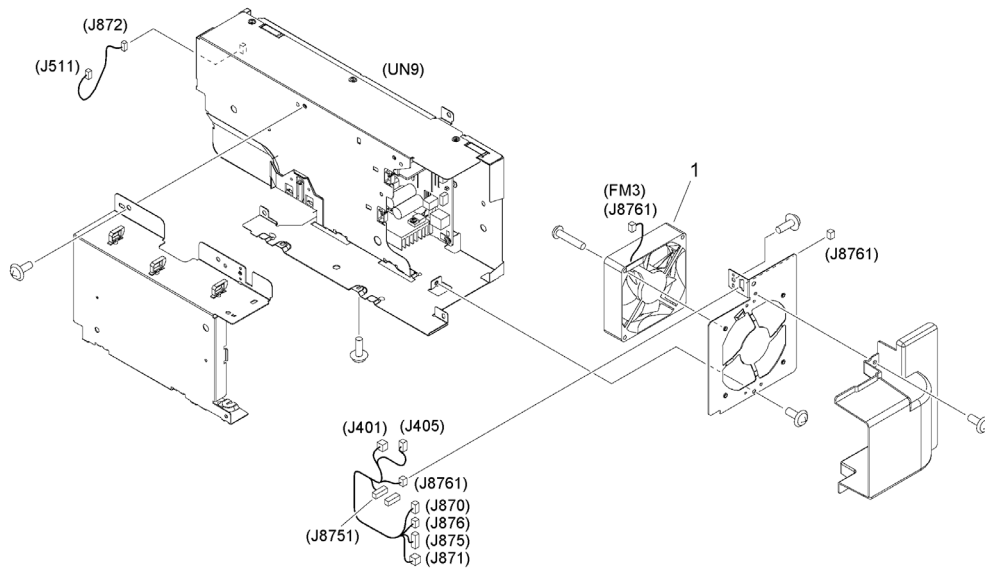

FIGURE & KEY NO.	PART NUMBER	R A N K	QTY	DESCRIPTION	SERIAL NUMBER /REMARKS
910	FM1-V290-010		1	POWER SUPPLY ASSEMBLY	UN9
1	FL0-8154-000		1	FAN	FM3

Figure 930 MAIN CONTROLLER PCB ASSEMBLY

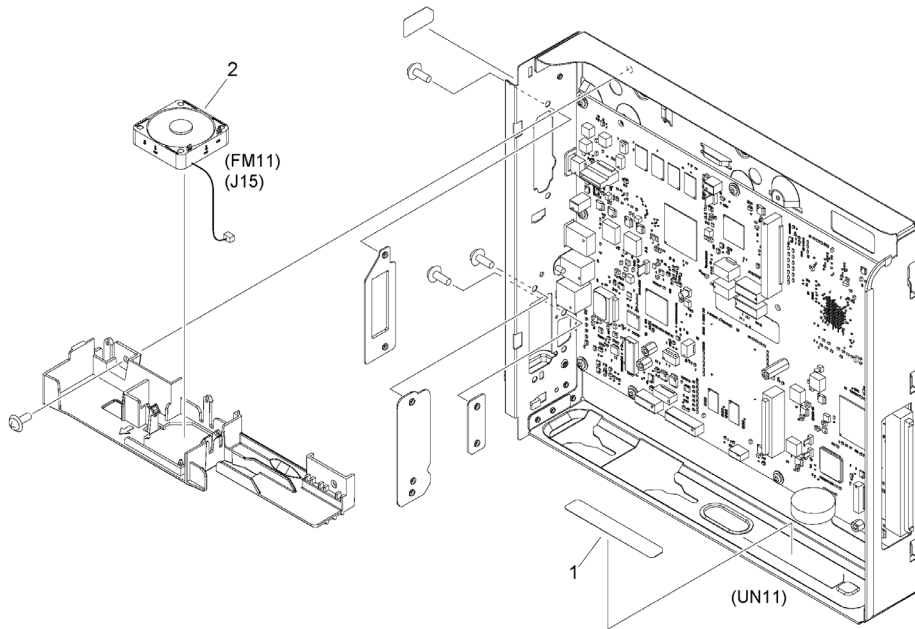

FIGURE & KEY NO.	PART NUMBER	R A N K	QTY	DESCRIPTION	SERIAL NUMBER /REMARKS
930	FM2-A300-000		1	MAIN CONTROLLER PCB ASSEMBLY	UN11
1	FC0-5049-000		1	LABEL, MEMORY CAUTION	
2	FK4-3886-000		1	FAN	FM11

Figure 931 RISER PCB ASSEMBLY

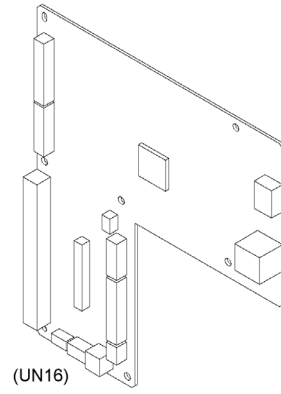

FIGURE & KEY NO.	PART NUMBER	R A N K	QTY	DESCRIPTION	SERIAL NUMBER /REMARKS
931	FM2-J818-000		1	RISER PCB ASSEMBLY	UN16

Figure 962A PAPER FEED DRIVER PCB ASSEMBLY

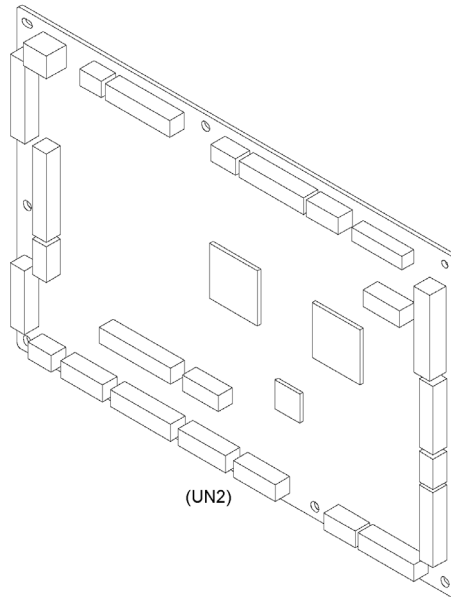

FIGURE & KEY NO.	PART NUMBER	R A N K	QTY	DESCRIPTION	SERIAL NUMBER /REMARKS
962A	FM2-J814-000		1	PAPER FEED DRIVER PCB ASSEMBLY	UN2

Figure B01 ATTACHMENT PARTS

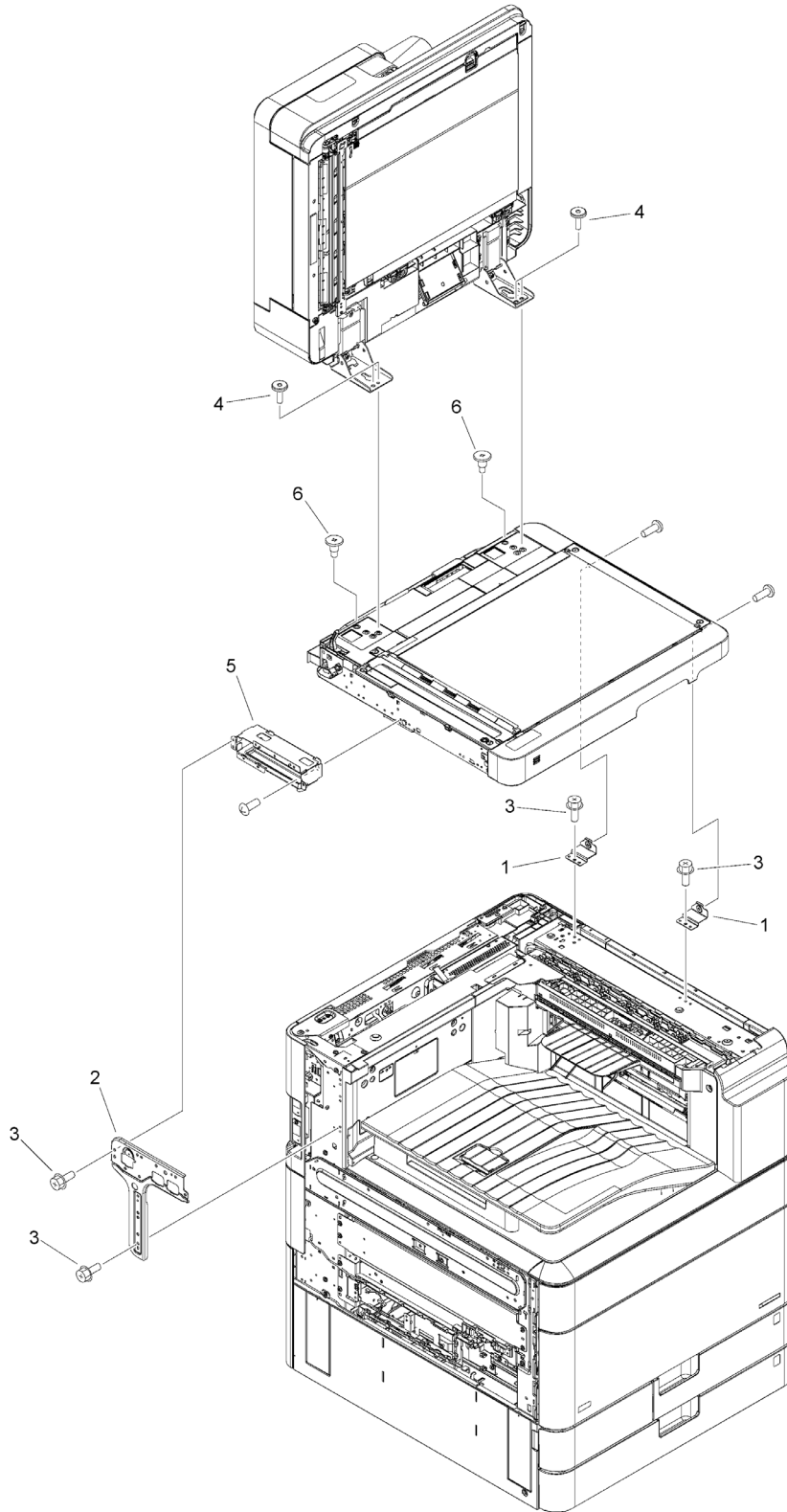

FIGURE & KEY NO.	PART NUMBER	RANK	QTY	DESCRIPTION	SERIAL NUMBER /REMARKS
B01	NPN		RF	ATTACHMENT PARTS	
1	FE2-J134-000		2	PLATE, READER MOUNTING, 1	
2	FE2-J132-000		1	PLATE, READER MOUNTING, 2	
3	XA9-0732-010		15	SCREW,RS,M4X8	
4	FE2-F750-000		4	SCREW, FIXED, M4	
5	FE2-J133-000		1	PLATE, READER MOUNTING, 1	
6	FE2-F749-000		2	SCREW, STEPPED, M5X6	

Figure B02 ADF MAINTENANCE KIT, DR-205

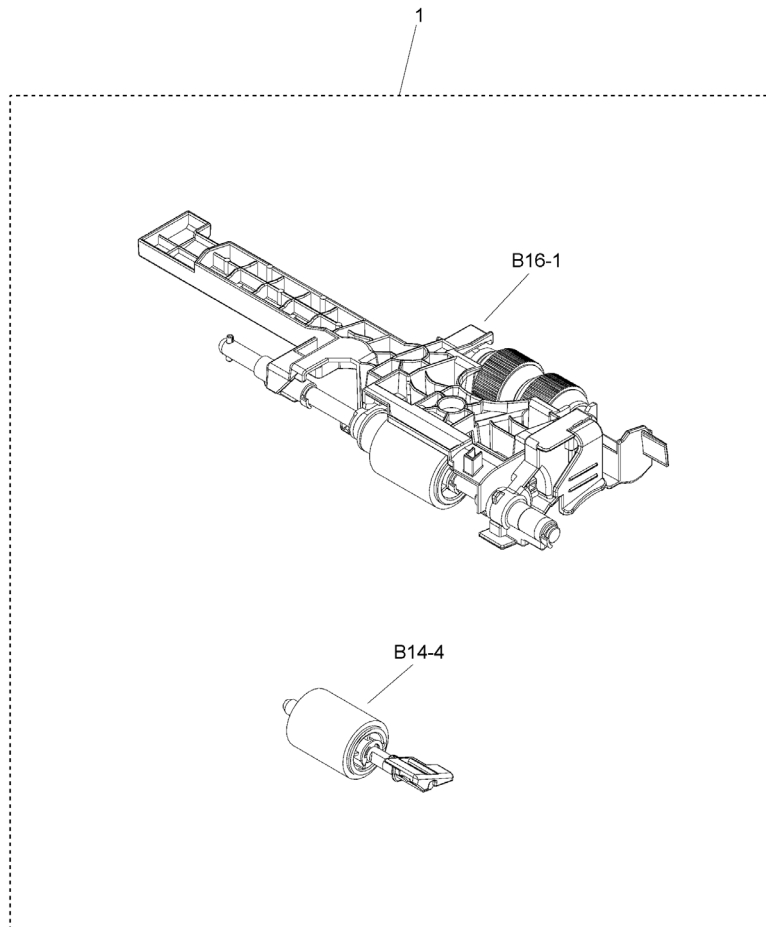

FIGURE & KEY NO.	PART NUMBER	R A N K	QTY	DESCRIPTION	SERIAL NUMBER /REMARKS
B02	NPN		RF	ADF MAINTENANCE KIT	
1	FM2-A273-000		1	ADF MAINTENANCE KIT, DR-205	

Figure B11C INTERNAL COMPONENTS 1

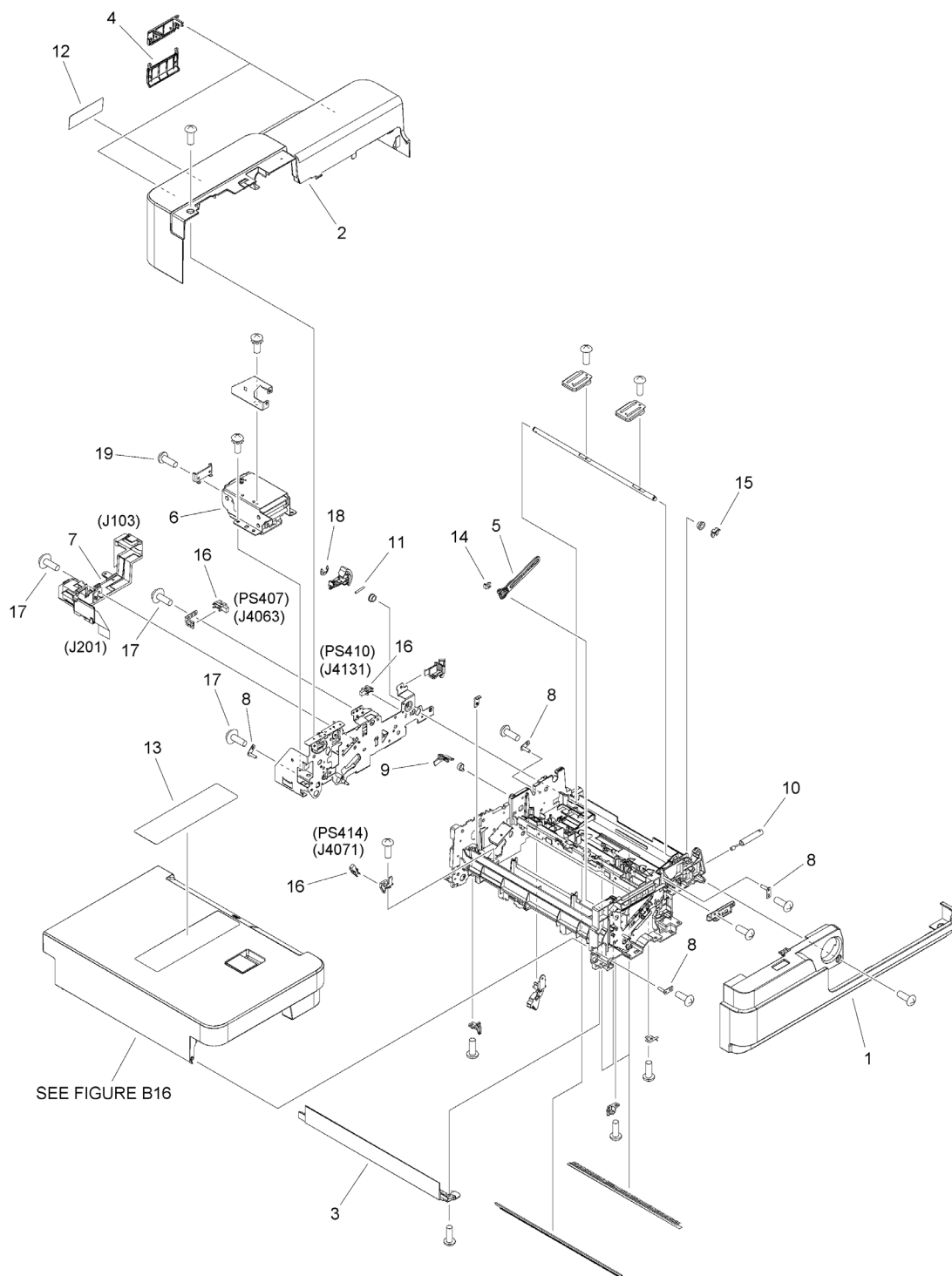

FIGURE & KEY NO.	PART NUMBER	RANK	QTY	DESCRIPTION	SERIAL NUMBER /REMARKS
B11C	NPN		RF	INTERNAL COMPONENTS 1	
1	FM1-U274-000		1	FRONT COVER ASSEMBLY	
2	FM1-U272-000		1	REAR COVER ASSEMBLY	
3	FE8-9895-000		1	COVER, LEFT, LOWER	
4	FE2-A749-000		2	COVER, HINGE 2	
5	FE8-9253-000		1	STOPPER, OPEN/CLOSE	
6	FE8-9880-000		1	HINGE, LEFT	
7	FM2-A274-000		1	FLAT CABLE UNIT	
8	FL1-2829-000		4	SHAFT, OPEN/CLOSE	
9	FE8-9257-000		1	FLAG, OPEN/CLOSE SENSOR	
10	FE2-D485-000		1	DAMPER UNIT, OIL	
11	XD9-0359-000		1	PIN, PARALLEL	
12	FE2-A717-000		1	LABEL, CAUTION	GOVERNMENT model
12	FE2-C909-000		1	LABEL, CAUTION	MODEL WITHOUT GOVERNMENT
13	FE2-C419-000		1	LABEL, PROHIBITION DOCUMENT	MODEL WITHOUT GOVERNMENT
13	FE2-H797-000		1	LABEL, PROHIBITION DOCUMENT	GOVERNMENT model
14	FE8-5515-000		1	CLIP	
15	FC5-4425-000		1	CLIP	
16	WG8-5935-000		3	IC, PHOTO INTERRUPTER	PS407, PS410, PS414
17	XA9-1671-000		15	SCREW, D, M3X8	
18	XD9-0395-000		1	RETAINING RING (E-TYPE)	
19	XA9-2014-000		1	SCREW, MACH. TRUSS HEAD, M4X6	

Figure B12C INTERNAL COMPONENTS 2

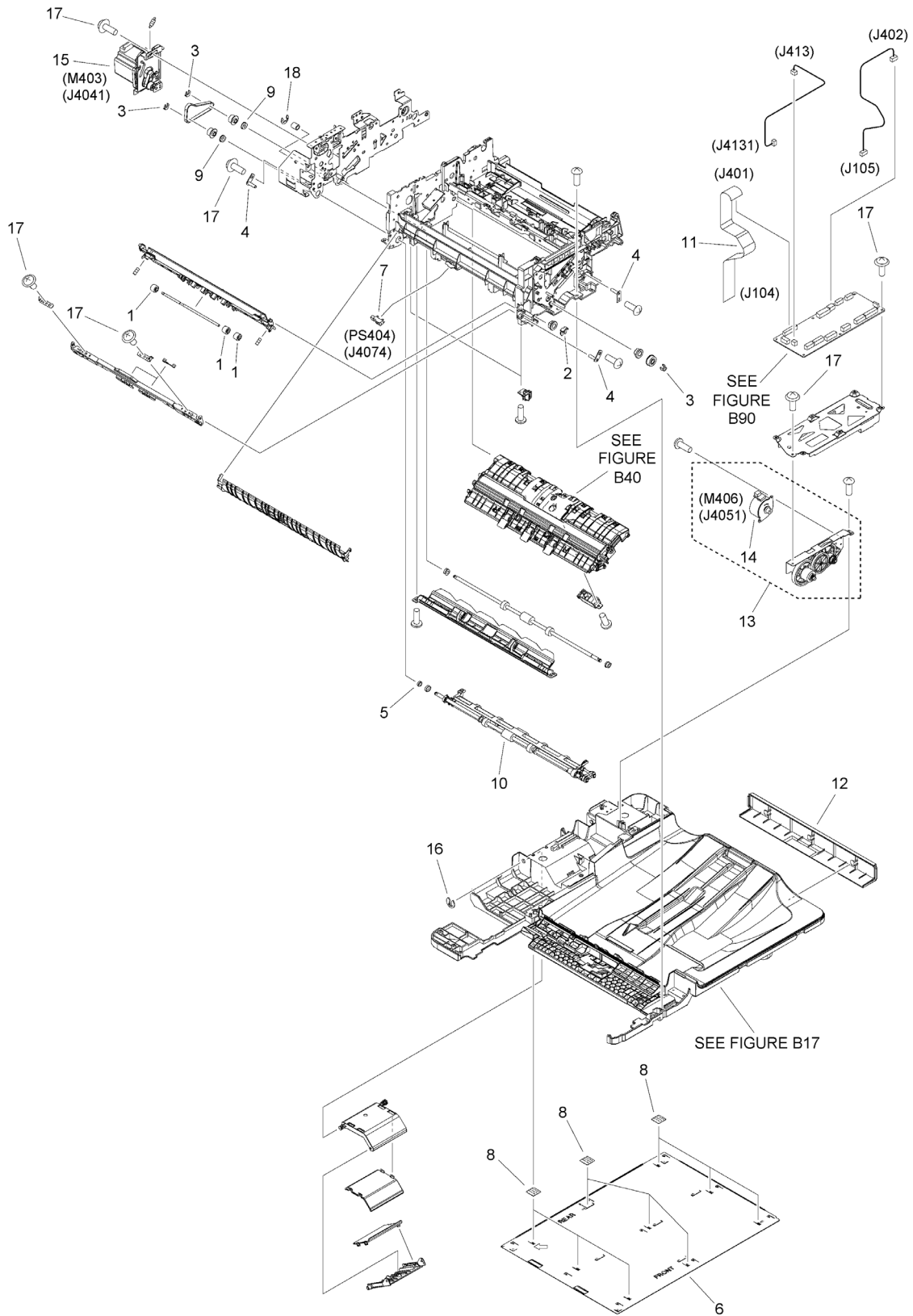

FIGURE & KEY NO.	PART NUMBER	RANK	QTY	DESCRIPTION	SERIAL NUMBER /REMARKS
B12C	NPN		RF	INTERNAL COMPONENTS 2	
1	FC0-1296-000		3	ROLLER	
2	FC5-4425-000		1	CLIP	
3	FE8-5515-000		3	CLIP	
4	FL1-2829-000		3	SHAFT, OPEN/CLOSE	
5	FE8-5380-000		1	ROLLER, DESORPTION SLIDE	
6	FE3-5529-010		1	PANEL, COPYBOARD	
7	WG8-6233-000		1	PHOTO-INTERRUPTER	PS404
8	FE8-5725-000		9	SPONGE, SHEET, WHITE	
9	XG9-0805-000		2	BEARING, BALL, LF-1260ZZR	
10	FM1-U342-000		1	PLATEN ROLLER ASS'Y	
11	FK4-3337-000		1	CABLE, FLAT	
12	FE8-9900-000		1	COVER, RIGHT	
13	FM1-U405-000		1	LIFTER DRIVE ASSEMBLY	
14	FK4-3336-000		1	MOTOR, STEPPING, DC	M406
15	FM1-U404-000		1	MOTOR ASS'Y	M403
16	FE8-5516-000		1	RING, RETAINING	
17	XA9-1671-000		15	SCREW, D, M3X8	
18	XD9-0395-000		1	RETAINING RING (E-TYPE)	

FIGURE & KEY NO.	PART NUMBER	RANK	QTY	DESCRIPTION	SERIAL NUMBER /REMARKS
B13	NPN		RF	INTERNAL COMPONENTS 3	
1	FC5-4425-000		2	CLIP	
2	FE8-5162-000		5	CLIP	
3	FE8-5515-000		3	CLIP	
4	FE8-5156-000		1	DIAL, JAM CLEARING	
5	FL1-5310-000		1	PULLEY, 34T	
6	FL1-5503-000		1	GLASS, READER	
7	FM1-T962-000		2	MOTOR ASS'Y	M401, M404
8	FM1-U403-000		1	PAPER PICK-UP MOTOR ASS'Y	
9	FK4-3336-000		1	MOTOR, STEPPING, DC	M405
10	WG8-5935-000		1	IC, PHOTO INTERRUPTER	PS408
11	FM1-W515-000		1	MOTOR ASS'Y	M402
12	XD9-0395-000		5	RETAINING RING (E-TYPE)	
13	XD9-0328-000		2	PIN, PARALLEL	
14	XG9-0497-000		4	BEARING, BALL, MR106ZZ,	
15	XG9-0805-000		2	BEARING, BALL, LF-1260ZZR	
16	XA9-2014-000		1	SCREW, MACH. TRUSS HEAD, M4X6	
17	XA9-1671-000		15	SCREW, D, M3X8	

Figure B14 INTERNAL COMPONENTS 4

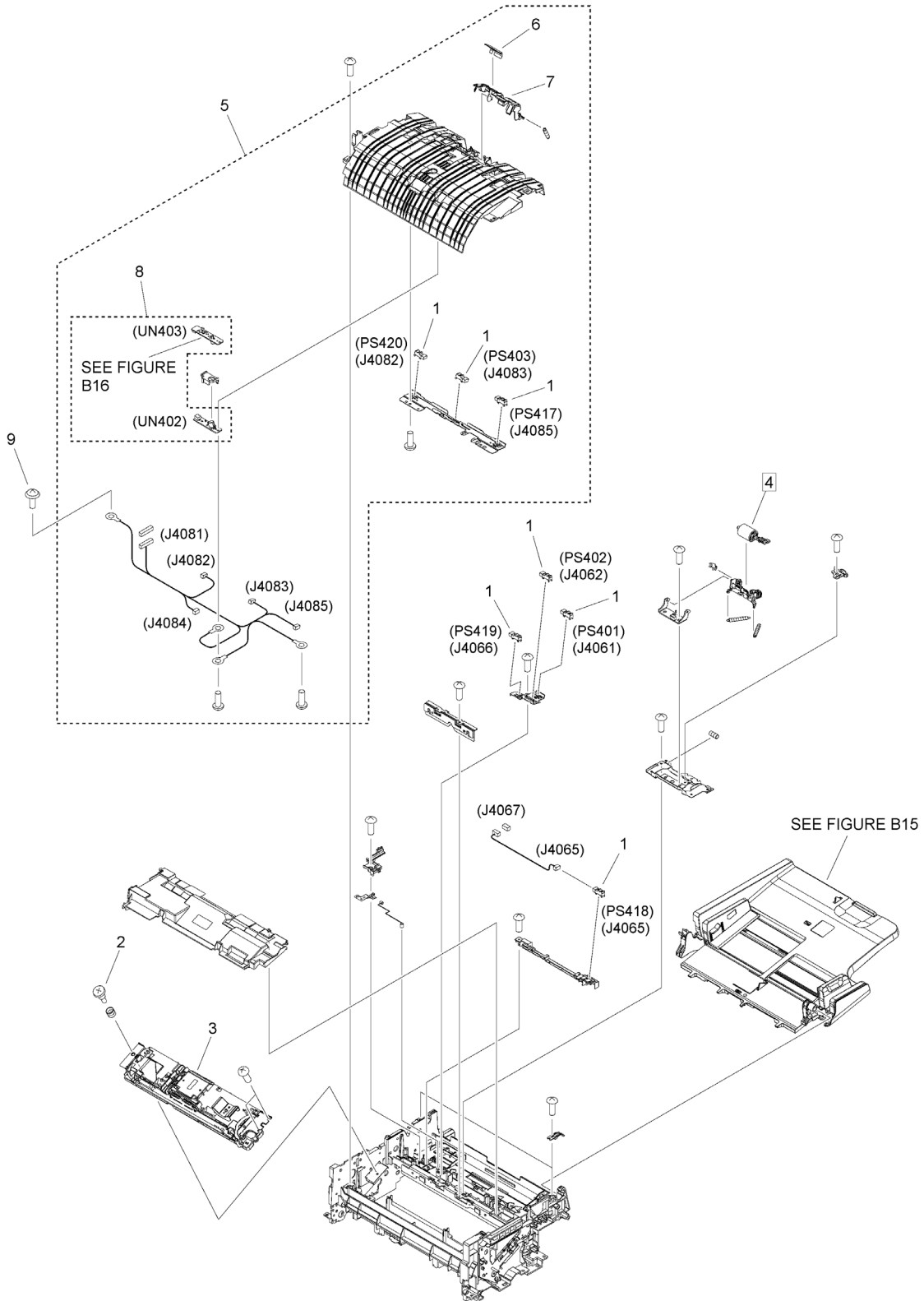
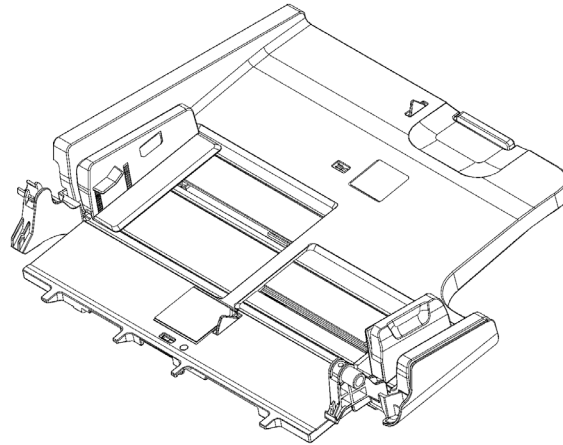

FIGURE & KEY NO.	PART NUMBER	RANK	QTY	DESCRIPTION	SERIAL NUMBER /REMARKS
B14	NPN		RF	INTERNAL COMPONENTS 4	
1	WG8-6233-000		7	PHOTO-INTERRUPTER	PS401, PS402, PS403, PS417, PS418, PS419, PS420
2	FS5-9284-020		1	SCREW, STEPPED	
3	FM2-A693-000		1	SCANNER UNIT	
4	FM1-T423-000		1	SEPARATION ROLLER UNIT	[DP]
5	FM1-T424-000		1	LOWER EXTRACTION GUIDE ASS'Y	
6	FL1-4610-000		1	PAD, SEPARATION	
7	FL4-0117-000		1	GUIDE, SEPARATION	
8	FM1-K086-010		1	DOUBLE FEED DETECTION KIT	UN402, UN403
9	XA9-1671-000		1	SCREW, D, M3X8	

Figure B15 DOCUMENT TRAY ASSEMBLY



(LED402)(VR401)(PS409)(PS411)(PS412)(PS413)(PS415)

FIGURE & KEY NO.	PART NUMBER	R A N K	QTY	DESCRIPTION	SERIAL NUMBER /REMARKS
B15	FM1-T421-000		1	DOCUMENT TRAY ASSEMBLY	LED402, VR401, PS409, PS411, PS412, PS413, PS415

Figure B16 OPEN/CLOSE COVER ASSEMBLY

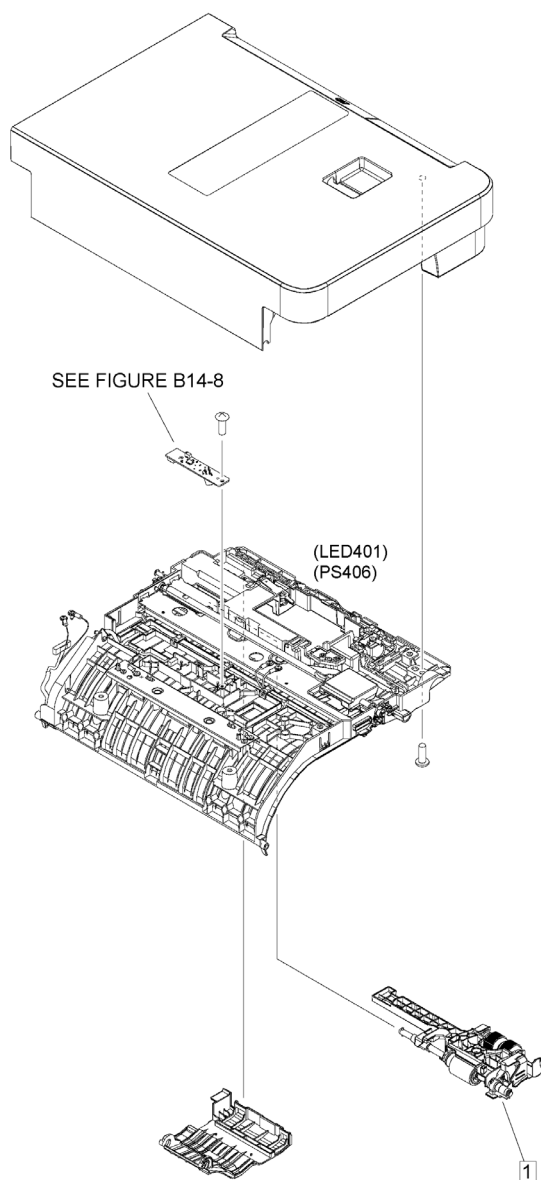

FIGURE & KEY NO.	PART NUMBER	RANK	QTY	DESCRIPTION	SERIAL NUMBER /REMARKS
B16	FM1-T420-000		1	OPEN/CLOSE COVER ASSEMBLY	LED401, PS406
1	FM1-T417-000		1	PAPER PICK-UP ROLLER ASSEMBLY	[DP]

Figure B17 BASE FRAME ASSEMBLY

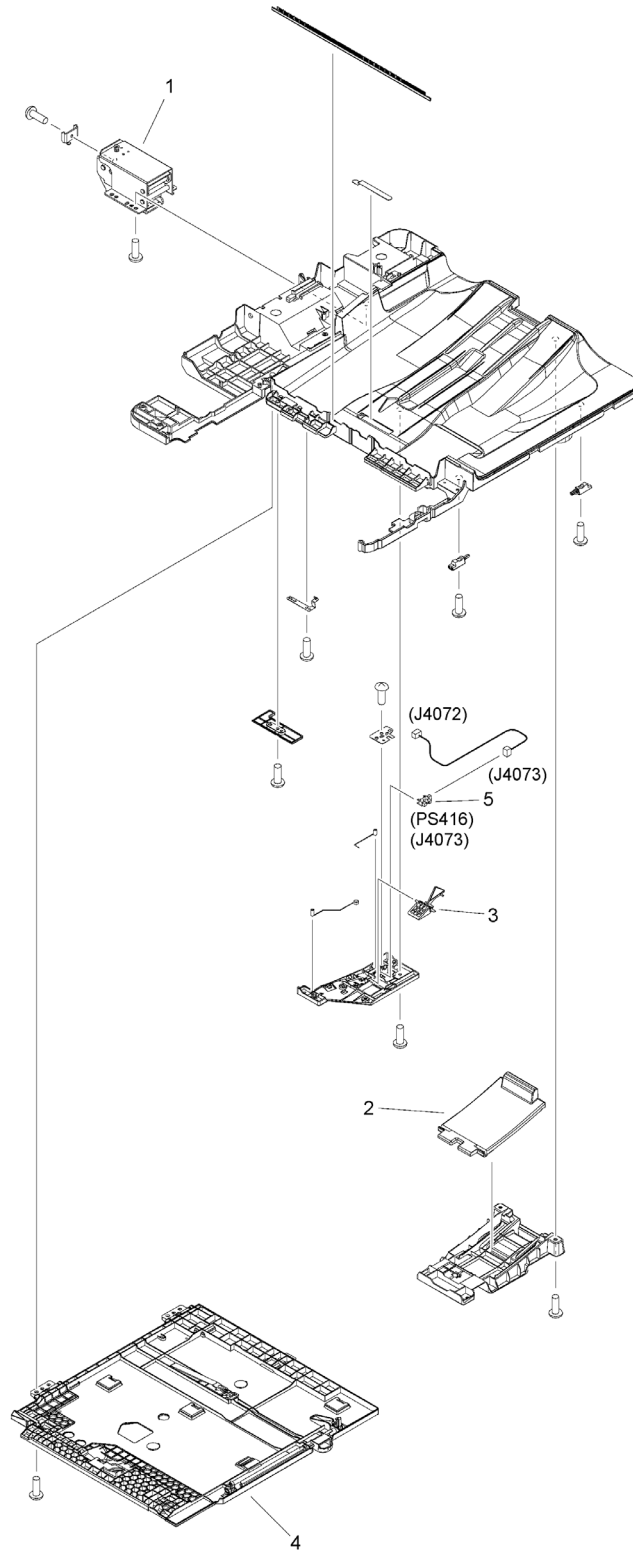

FIGURE & KEY NO.	PART NUMBER	RANK	QTY	DESCRIPTION	SERIAL NUMBER /REMARKS
B17	NPN		RF	BASE FRAME ASSEMBLY	
1	FE8-9881-000		1	HINGE, RIGHT	
2	FE2-A477-000		1	TRAY, PAPER DELIVERY EXTENSION	
3	FE8-9893-000		1	FLAG, PAPER DELIVERY SENSOR	
4	FM1-U273-000		1	WHITE PLATE SUPPORT ASSEMBLY	
5	WG8-5935-000		1	IC, PHOTO INTERRUPTER	PS416

Figure B40 PLATEN GUIDE ASS'Y

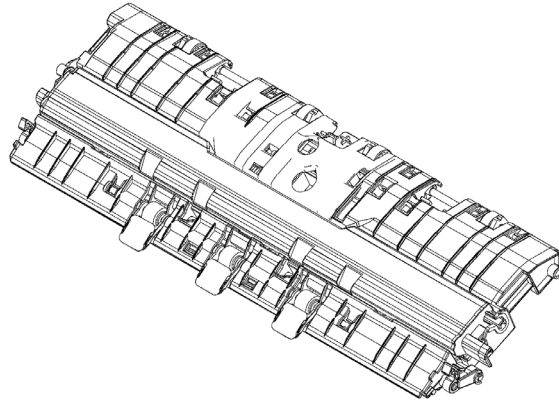

FIGURE & KEY NO.	PART NUMBER	R A N K	QTY	DESCRIPTION	SERIAL NUMBER /REMARKS
B40	FM1-U343-000		1	PLATEN GUIDE ASSY	

Figure B90 DF DRIVER PCB ASSEMBLY

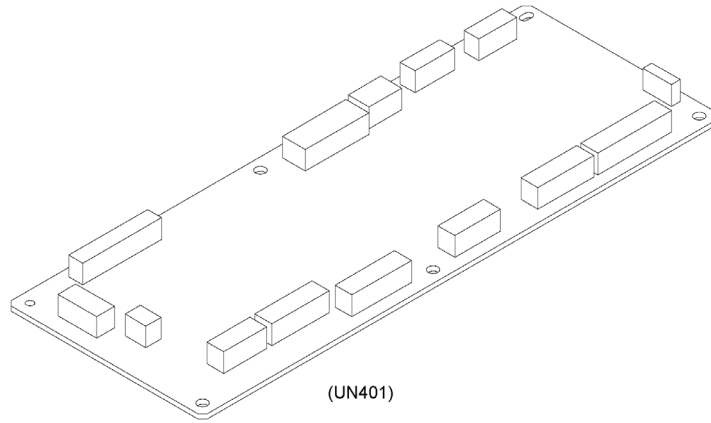

FIGURE & KEY NO.	PART NUMBER	R A N K	QTY	DESCRIPTION	SERIAL NUMBER /REMARKS
B90	FM1-T957-000		1	DF DRIVER PCB ASSEMBLY	UN401

Figure D11B READER ASSEMBLY

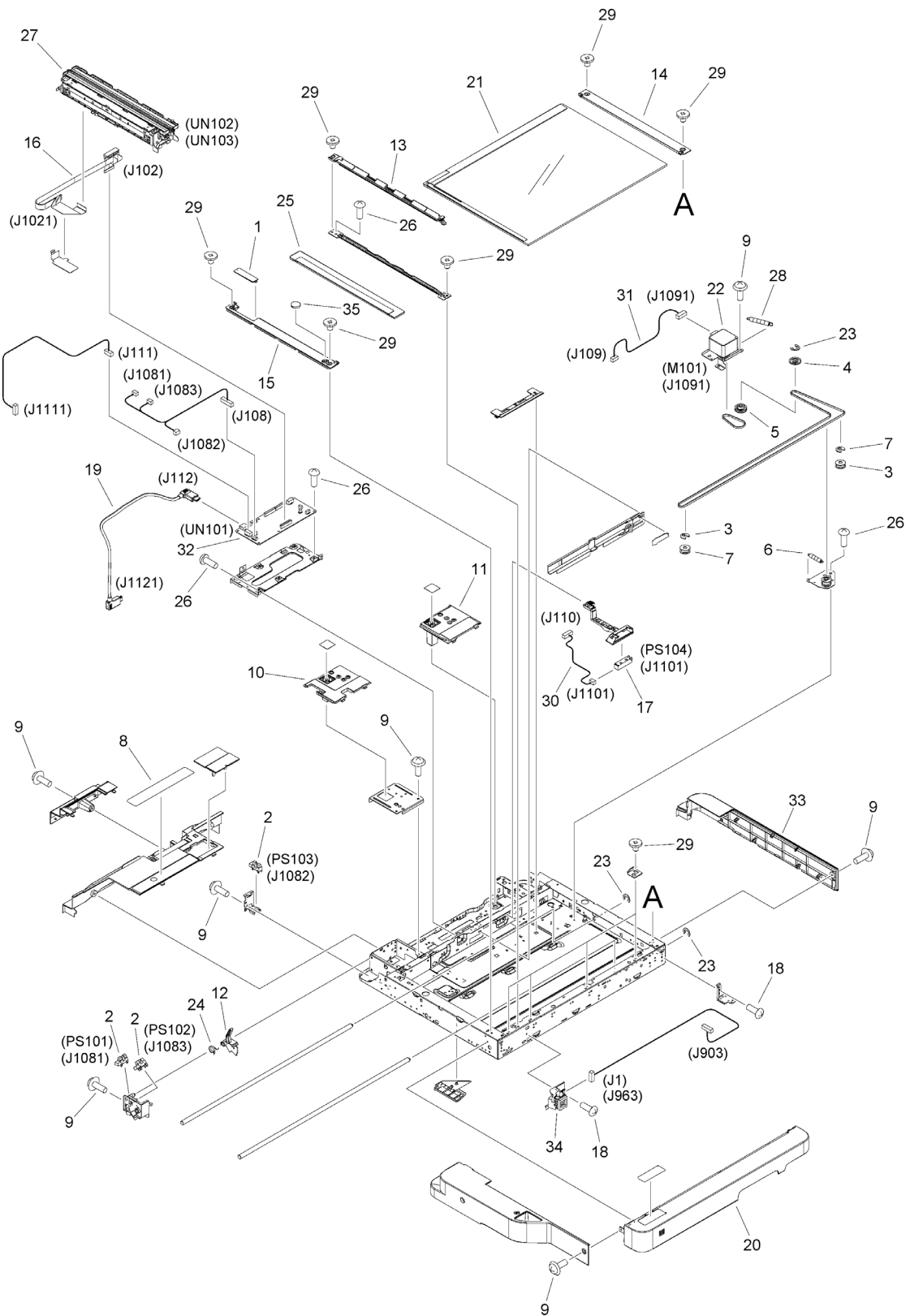

FIGURE & KEY NO.	PART NUMBER	RANK	QTY	DESCRIPTION	SERIAL NUMBER /REMARKS
D11B	NPN		RF	READER ASSEMBLY	
1	FE2-A111-000		1	COVER, READER, LEFT UPPER	MODEL WITHOUT GOVERNMENT
1	FE2-H715-000		1	COVER, READER, LEFT UPPER	GOVERNMENT model
2	WG8-5935-000		3	IC, PHOTO INTERRUPTER	PS101, PS102, PS103
3	FE8-5627-000		2	PULLEY	
4	FE8-5626-000		1	PULLEY	
5	FL0-0825-000		1	PULLEY, 24T/41T	
6	FU2-2214-000		1	SPRING, TENSION	
7	FE8-5516-000		2	RING, RETAINING	
8	FE8-4672-000		1	LABEL, COPY INHIBITED	MODEL WITHOUT GOVERNMENT English
8	FE8-6152-000		1	LABEL, COPY INHIBITED	GOVERNMENT model English
8	FE8-6153-000		1	LABEL, COPY INHIBITED	GOVERNMENT model French
8	FE8-6158-000		1	LABEL, COPY INHIBITED	MODEL WITHOUT GOVERNMENT French
9	XA9-2050-000		15	SCREW, SELF-TAPPING, M3	
10	FE2-A113-000		1	COVER, HINGE LOWER, LEFT	
11	FE2-A114-000		1	COVER, HINGE LOWER, RIGHT	
12	FE8-5215-000		1	FLAG, OPEN/CLOSE SENSOR	
13	FE8-9350-000		1	COVER, GLASS SUPPORT	
14	FE8-5747-000		1	COVER, GLASS RETAINING	
15	FE2-A110-000		1	COVER, GLASS RETAINING, LEFT	
16	FK4-3319-000		1	CABLE, FLAT	
17	FK4-4384-000		1	IC, PHOTO SENSOR,DOCUMENT SIZE	PS104
18	XA9-0893-000		2	SCREW, M4X8	
19	FK4-2334-000		1	CABLE, INTERFACE	
20	FE2-A105-000		1	COVER, READER, FRONT	
21	FL1-5546-000		1	GLASS, COPYBOARD	
22	FM1-T727-000		1	MOTOR ASS'Y	M101
23	XD9-0395-000		3	RETAINING RING (E-TYPE)	
24	FU2-2215-000		1	SPRING, TORSION	
25	FL1-5083-000		1	GLASS, READER	
26	XA9-1116-030		13	SCREW,M3X5	
27	FM2-A692-000		1	SCANNER UNIT	UN102, UN103
28	FU2-2200-000		1	SPRING, TENSION	
29	XA9-1415-000		10	SCREW, FLAT HEAD, M4	
30	FM1-T947-000		1	CABLE, SIZE SENSING	

FIGURE & KEY NO.	PART NUMBER	RANK	QTY	DESCRIPTION	SERIAL NUMBER /REMARKS
31	FM1-T941-000		1	CABLE, OPTICAL MOTOR	
32	FM1-T937-000		1	READER CONTROLLER PCB ASSEMBLY	UN101
33	FE2-J032-000		1	COVER, RIGHT	
34	FM1-U011-000		1	MOTION SENSOR UNIT	
35	FE3-9178-000		1	CAP	

Figure H30A CASSETTE ASSEMBLY (SMALL) (WITHOUT GOVERNMENT)

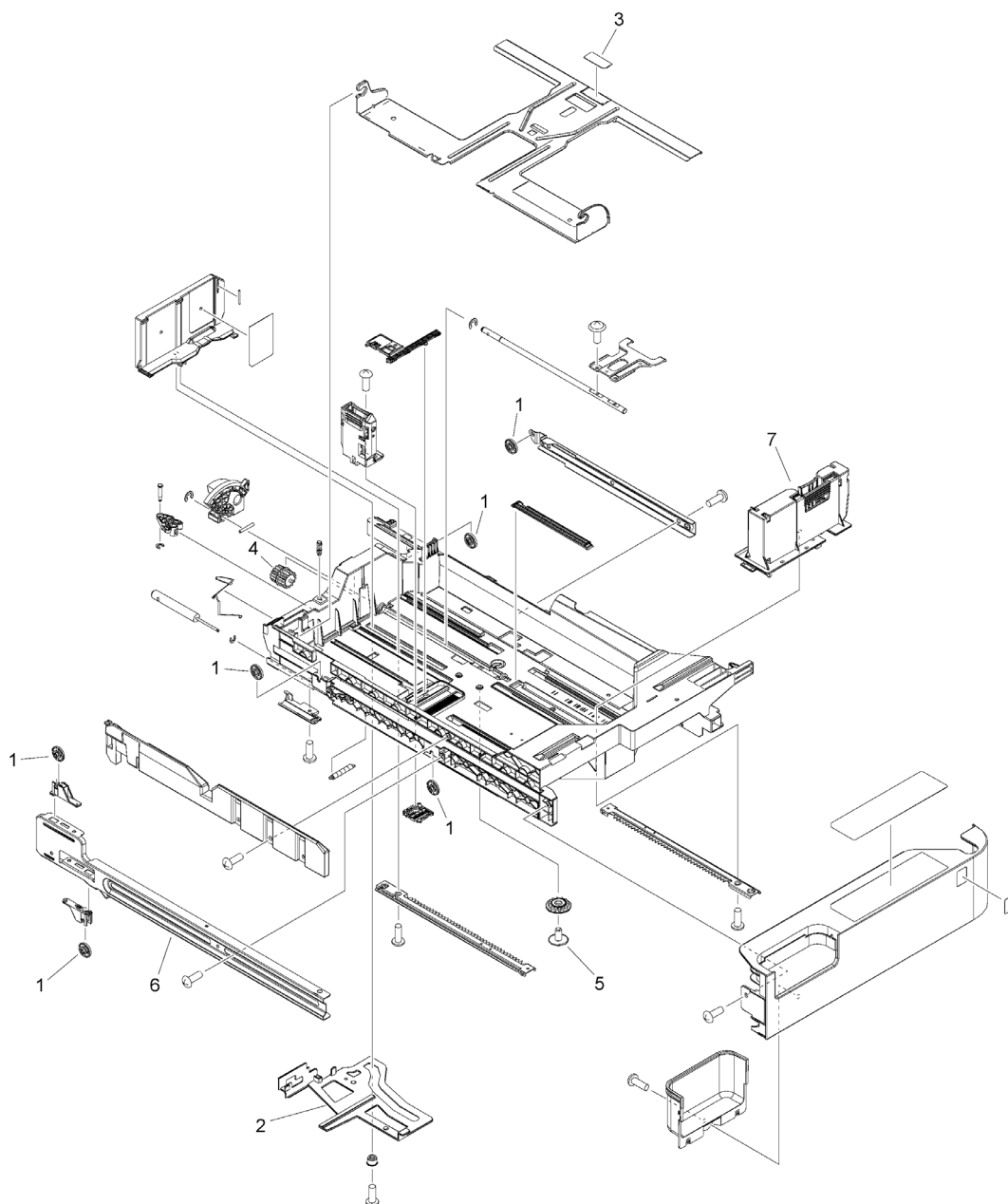

FIGURE & KEY NO.	PART NUMBER	RANK	QTY	DESCRIPTION	SERIAL NUMBER /REMARKS
H30A	FM2-A296-000		1	CASSETTE ASSEMBLY	SMALL WITHOUT GOVERNMENT
1	FE3-1528-010		6	ROLLER, CASSETTE	
2	FE3-1613-010		1	LINK, SIZE DETECT	
3	FL0-4008-000		1	SHEET, SEPARATION	
4	RC1-9396-000		1	GEAR, 14T	
5	FE8-0315-000		1	SCREW, B, M4X8	
6	FE4-4678-000		1	SUPPORT, CASSETTE RAIL	
7	FM1-B240-000		1	SIDE END PLATE ASSEMBLY, FRONT	

Figure H30C CASSETTE ASSEMBLY (SMALL) (GOVERNMENT model)

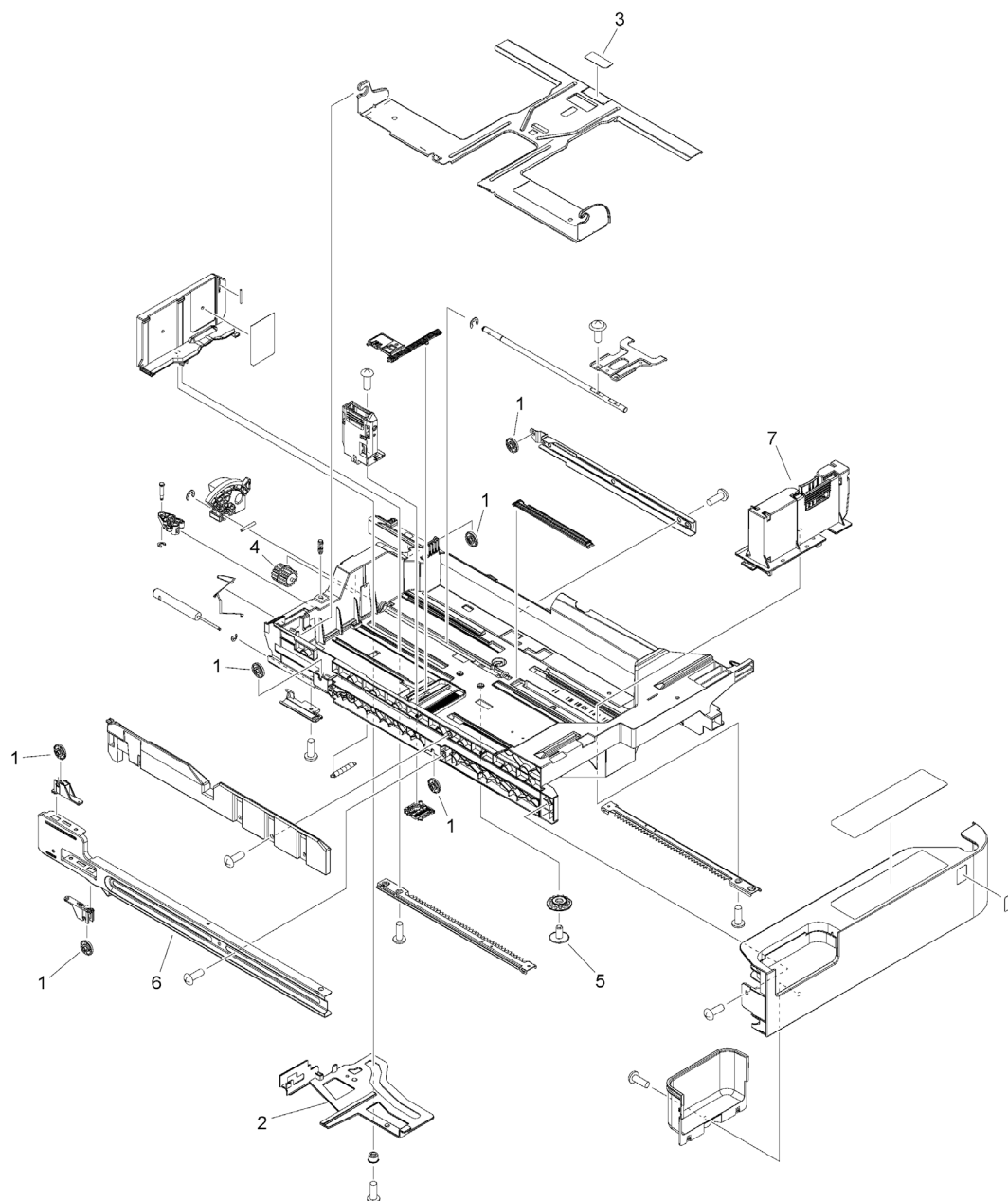

FIGURE & KEY NO.	PART NUMBER	RANK	QTY	DESCRIPTION	SERIAL NUMBER /REMARKS
H30C	FM1-G581-010		1	CASSETTE ASSEMBLY	SMALL GOVERNMENT model
1	FE3-1528-010		6	ROLLER, CASSETTE	
2	FE8-1308-000		1	LINK, SIZE DETECT	
3	FL3-6526-000		1	SHEET, SEPARATION	
4	RC1-9396-000		1	GEAR, 14T	
5	FE8-0315-000		1	SCREW, B, M4X8	
6	FE4-4678-000		1	SUPPORT, CASSETTE RAIL	
7	FM1-B545-010		1	SIDE END PLATE ASSEMBLY, FRONT	

Figure H31A CASSETTE ASSEMBLY (LARGE) (WITHOUT GOVERNMENT)

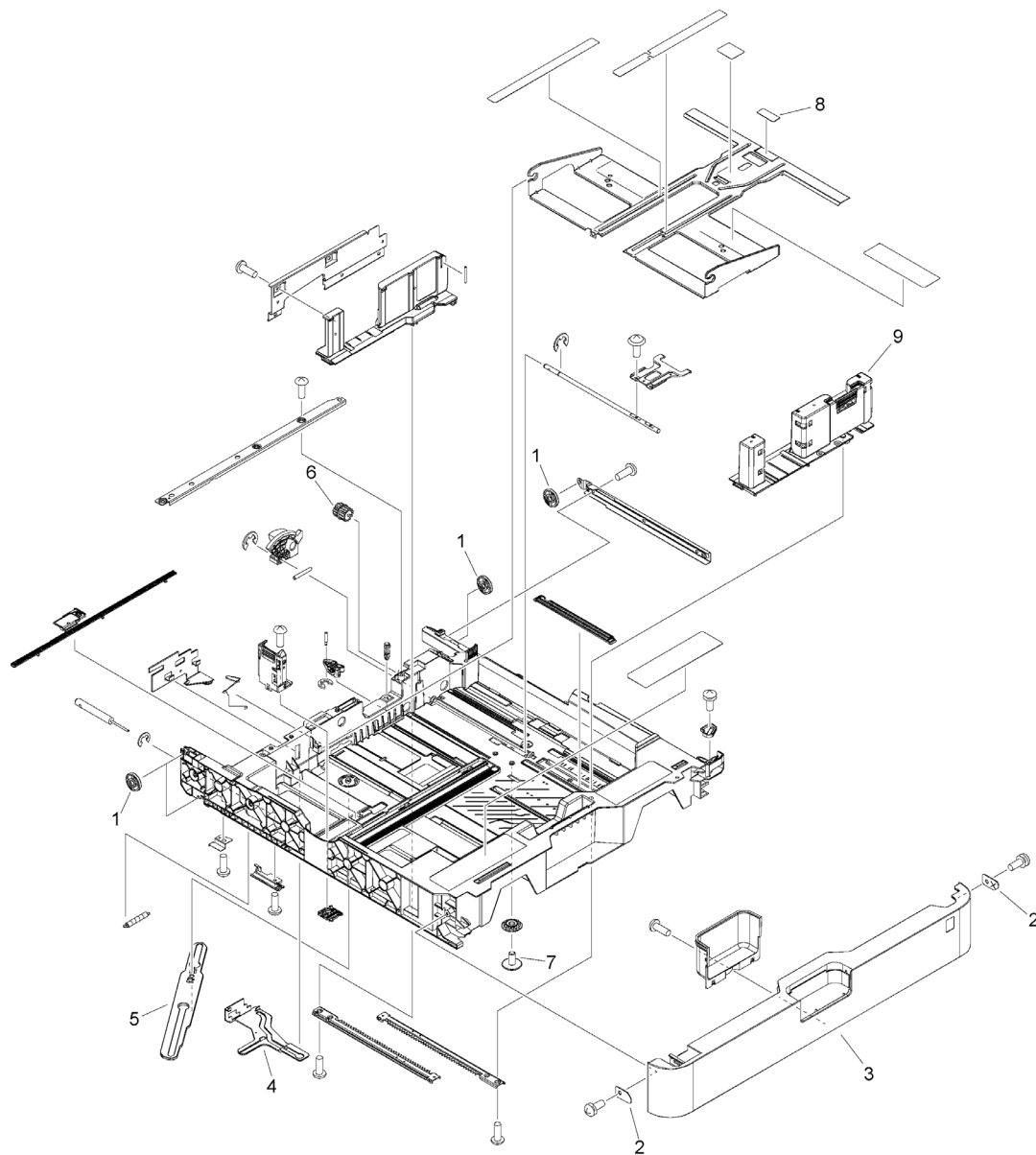

FIGURE & KEY NO.	PART NUMBER	RANK	QTY	DESCRIPTION	SERIAL NUMBER /REMARKS
H31A	FM2-A297-000		1	CASSETTE ASSEMBLY	LARGE WITHOUT GOVERNMENT
1	FE3-1528-010		4	ROLLER, CASSETTE	
2	FE2-F661-000		2	WASHER	
3	FE4-4603-000		1	COVER, CASSETTE FRONT	
4	FE3-1525-020		1	LINK, SIZE DETECT	
5	FE3-1526-000		1	ARM, BACK END DETECT	
6	RC1-9396-000		1	GEAR, 14T	
7	FE8-0315-000		1	SCREW, B, M4X8	
8	FL0-4008-000		1	SHEET, SEPARATION	
9	FM1-B243-000		1	SIDE END PLATE ASSEMBLY, FRONT	

Figure H31C CASSETTE ASSEMBLY (LARGE) (GOVERNMENT model)

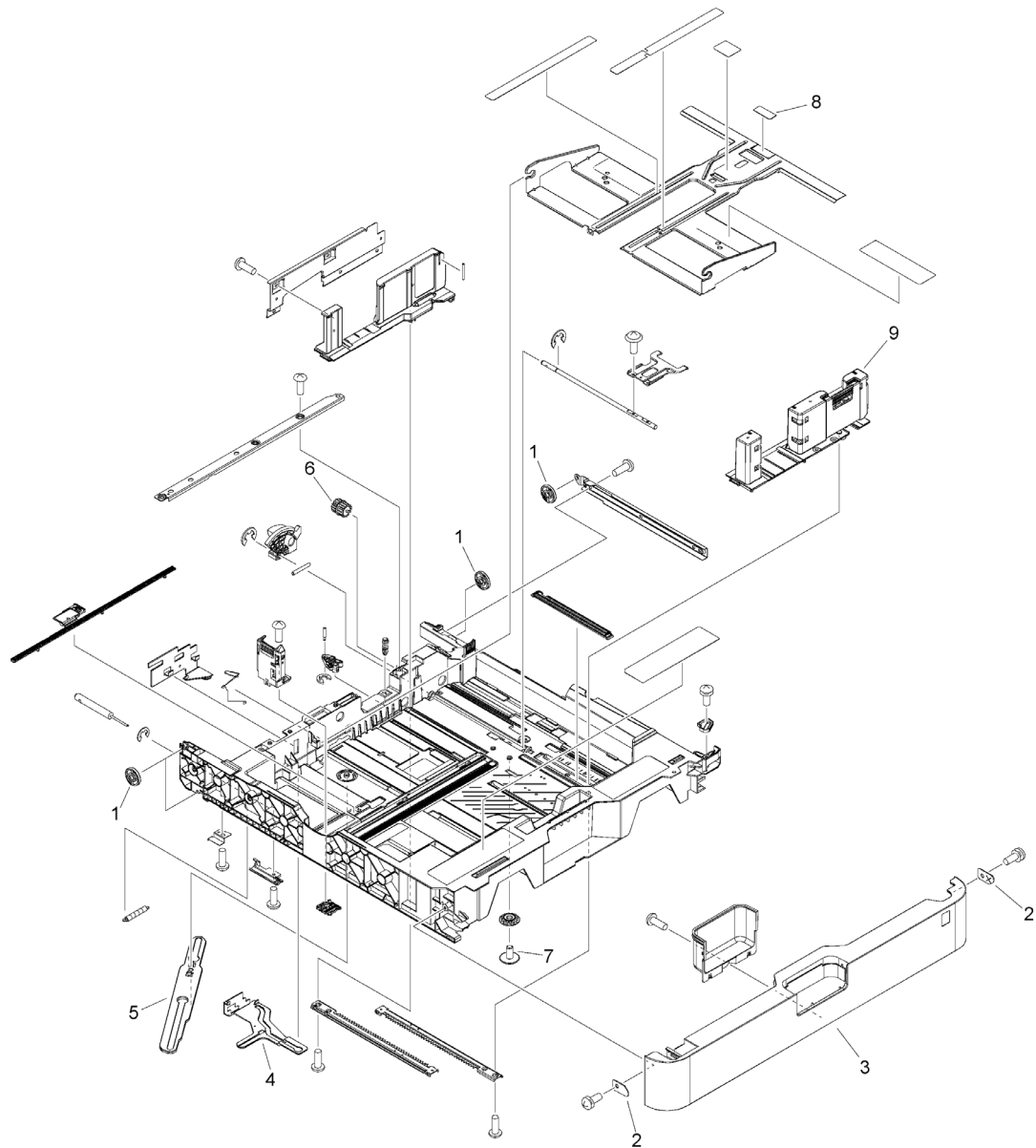

FIGURE & KEY NO.	PART NUMBER	RANK	QTY	DESCRIPTION	SERIAL NUMBER /REMARKS
H31C	FM1-G582-020		1	CASSETTE ASSEMBLY	LARGE GOVERNMENT model
1	FE3-1528-010		4	ROLLER, CASSETTE	
2	FE2-F661-000		2	WASHER	
3	FE4-4603-000		1	COVER, CASSETTE FRONT	
4	FE8-1306-000		1	LINK, SIZE DETECT	
5	FE8-1307-000		1	ARM, BACK END DETECT	
6	RC1-9396-000		1	GEAR, 14T	
7	FE8-0315-000		1	SCREW, B, M4X8	
8	FL3-6526-000		1	SHEET, SEPARATION	
9	FM1-M025-000		1	SIDE END PLATE ASSEMBLY, FRONT	

Figure ZZA MECHANICAL STANDARD PARTS (HOW TO USE)

Mechanical standard parts 機械標準部品

About a mechanical standard parts

A Mechanical standard parts is a mechanical part which not parts peculiar to a product.
They are parts which are common to a Canon product and are used, such as a screw and a washer.
The Fig No. and parts number of the mechanical standard parts are not listed in the product parts catalog.
Refer to the parts catalog of mechanical standard parts when checking the parts number for screw or washer etc. and identify them by part shape or size.

機械標準部品とは

機械標準部品とは、製品特有の部品ではなく、ねじやワッシャなどキヤノン製品共通で使用されている機械部品（メカ部品）のことです。
製品のパーツカタログには、機械標準部品のFig No.や部品番号は記載していません。
ねじや、ワッシャ等の部品番号を調べるときは、機械標準部品のパーツカタログを参照し、部品の形状や大きさから判断し、使用している部品を調べてください。

Material and surface treatment of a mechanical standard parts

Material and surface treatment of mechanical standard parts are assigned commonly for each part.
Refer to the Table 1 for the parts which material and surface treatment are assigned as numbers.

機械標準部品の材料および表面処理

機械標準部品の材料および表面処理については、各種部品共通で決められています。
材料および表面処理が番号で決められている部品については、表1を参照してください。

Table 1 Material and Surface treatment
表1 材料および表面処理

No. 番号	Material 材料	Surface treatment 表面処理	Color 色
1	Stainless steel ステンレス	Stainless steel black coloring (BC4) ステンレス黒着色(BC4)	Black 黒
2		not to be given なし	White 白
3	Brass 黄銅	Regular nickel plating (NL) 普通ニッケルメッキ(NL)	White 白
4		Black nickel plating (BN) 黒色ニッケルメッキ(BN)	Black 黒
5	Steel 鋼	White zinc trivalent chromate treating (ZC3) 白色亜鉛3価クロメート(ZC3)	White 白
6		Regular nickel chromium plating (NC) 普通ニッケルクロムメッキ(NC)	White 白
7		Regular nickel plating (NL) 普通ニッケルメッキ(NL)	White 白
8		Iron and steel phosphating (P1) 鉄鋼燐酸塩処理(P1)	Black 黒
9		Black zinc trivalent chromate treating (BZ3) 黒色亜鉛3価クロメート(BZ3)	Black 黒

Figure ZZB (1/7)MECHANICAL STANDARD PARTS (SCREWS)

1. Screws
ねじ

How to read Parts Numbers
部品番号の見方

Screws
ねじ

XB1-2400-609

Type No.
類別番号
Normal designation (d)
ねじの呼び (d)
Length (L)
ねじの長さ (L)
Material and Surface treatment
材料および表面処理

XB1-2 expresses Binding head machine screw.
XB1-2は、バインドねじを表す
40 expresses M4.0.
40は、M4.0を表す
0-60 expresses a length of 6.0mm.
0-60は、6.0mmの長さを表す
9 expresses Steel (Black zinc trivalent chromate
treating) from Table 1.
9は、表1より鋼 (黒色亜鉛3価クロメート) を表す

1-1. Cross Recessed Head Screws for Precision Equipments
精密機器用十字穴付き小ねじ

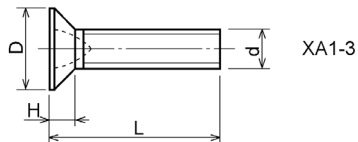
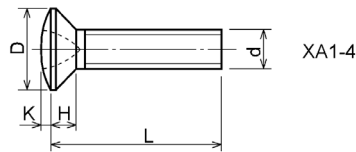
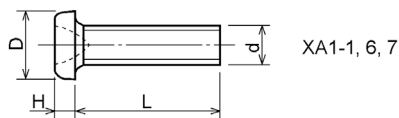

Type No. 類別番号	Type 類別	Head size (mm) 頭部寸法 (mm)						
		M1.4	M1.6	M1.7	M2	M2.5	M2.6	
XA1-1	Pan head Class 1 なべ1種	D	2	2.4	2.5	3	3.8	4
		H	0.5	0.55	0.5	0.6	0.9	0.8
XA1-3	Countersunk head Class 1 さら1種	D	2	2.4	2.5	3	3.8	4
		H	0.48	0.55	0.58	0.73	0.85	0.93
XA1-4	Oval countersunk head Class 1 丸さら1種	D	2	2.4	2.5	3	3.8	4
		H + K	0.68	0.8	0.88	1	1.25	1.3
XA1-6	Pan head Class 3 なべ3種	D	2.5	2.8	3	3.5	4.3	4.5
		H	0.8	0.85	0.9	1	1.3	1.2
XA1-7	Pan head Class 2 なべ2種	D	2.5	2.8	3	3.5	4.3	4.5
		H	0.5	0.55	0.5	0.6	0.9	0.8

Figure ZZB (2/7) MECHANICAL STANDARD PARTS (SCREWS)

1-2. Precision Tapping Screws
精密用タッピンねじ

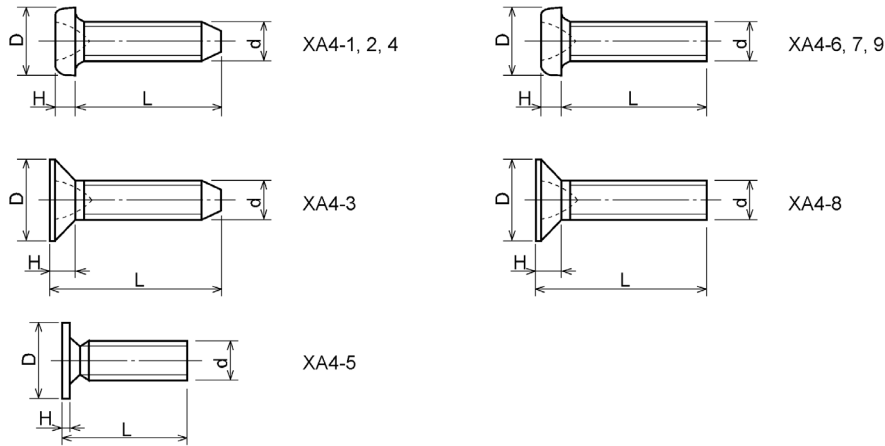

Type No. 類別番号	Type 類別	Head size (mm) 頭部寸法 (mm)						
		M1.4	M1.6	M1.7	M2	M2.5	M2.6	
XA4-1	With tapered end pan head Class 1 絞り-なべ1種	D XA4-1	2	2.4	2.5	3	3.8	4
		H XA4-1	0.5	0.55	0.5	0.6	0.9	0.8
XA4-2	With tapered end pan head Class 3 絞り-なべ3種	D XA4-2	2.5	2.8	3	3.5	4.3	4.5
		H XA4-2	0.8	0.85	0.9	1	1.3	1.2
XA4-3	With tapered end countersunk head 絞り-さら	D XA4-3	2	2.4	2.5	3	3.8	4
		H XA4-3	0.48	0.55	0.58	0.73	0.85	0.93
XA4-4	With tapered end pan head Class 2 絞り-なべ2種	D XA4-4	2.5	2.8	3	3.5	4.3	4.5
		H XA4-4	0.5	0.55	0.5	0.6	0.9	0.8
XA4-5	With parallel end ultra thin head ストレート-超薄頭	D XA4-5	2.5	2.8	3	-	-	-
		H XA4-5	0.2	0.2	0.2	-	-	-
XA4-6	With parallel end pan head Class 1 ストレート-なべ1種	D XA4-6	2	2.4	2.5	3	3.8	4
		H XA4-6	0.5	0.55	0.5	0.6	0.9	0.8
XA4-7	With parallel end pan head Class 3 ストレート-なべ3種	D XA4-7	2.5	2.8	3	3.5	4.3	4.5
		H XA4-7	0.8	0.85	0.9	1	1.3	1.2
XA4-8	With parallel end countersunk head ストレート-さら	D XA4-8	2	2.4	2.5	3	3.8	4
		H XA4-8	0.48	0.55	0.58	0.73	0.85	0.93
XA4-9	With parallel end pan head Class 2 ストレート-なべ2種	D XA4-9	2.5	2.8	3	3.5	4.3	4.5
		H XA4-9	0.5	0.55	0.5	0.6	0.9	0.8

Figure ZZB (3/7)MECHANICAL STANDARD PARTS (SCREWS)

1-3. Cross Recessed Head Screws
一般用十字穴付き小ねじ

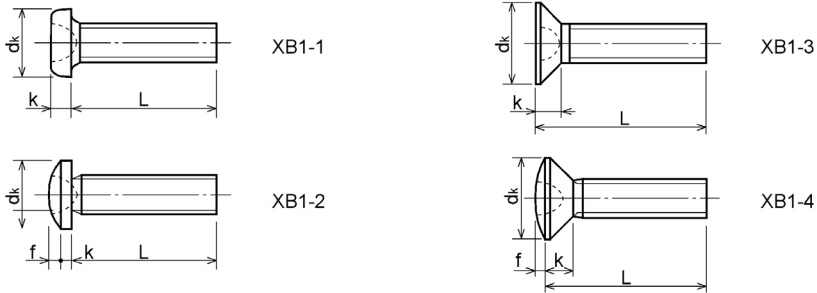

Type No. 類別番号	Type 類別
XB1-1	Pan head なべ
XB1-2	Binding head バインド
XB1-3	Countersunk head さら
XB1-4	Oval countersunk head 丸さら

		Head size (mm) 頭部寸法 (mm)					
		M2	M2.5	M2.6	M3	M4	M5
dk	XB1-1	3.5	4.5	4.5	5.5	7	9
k	XB1-1	1.3	1.7	1.7	2	2.6	3.3
dk	XB1-2	4.3	5.3	5.5	6.3	8.3	10.3
k+f	XB1-2	1.2	1.5	1.6	1.9	2.5	3.1
dk	XB1-3	4	5	-	6	8	10
k	XB1-3	1.2	1.45	-	1.75	2.3	2.8
dk	XB1-4	4	5	-	6	8	10
k+f	XB1-4	1.6	2	-	2.45	3.2	4
Screw part length ねじ部長さ b		8	12	12	12	16	20

Figure ZZB (4/7) MECHANICAL STANDARD PARTS (SCREWS)

1-4. Cross Recessed Head Screws with Captive Washer
座金組込み十字穴付き小ねじ

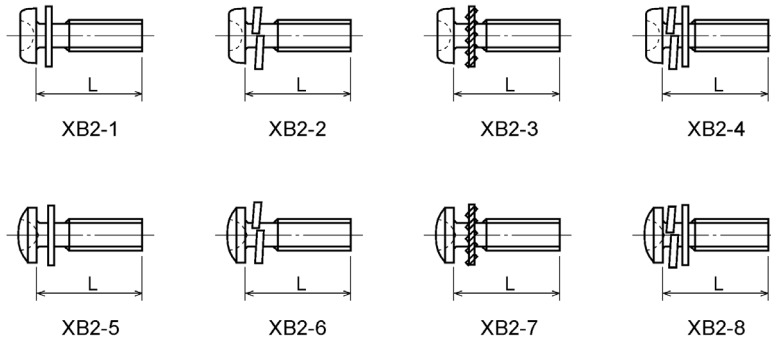

Type No. 類別番号	Type 類別
XB2-1	Pan head + Plain washer (circular bright) なべねじ+平座金
XB2-2	Pan head + Spring washer なべねじ+ばね座金
XB2-3	Pan head + Toothed lock washer なべねじ+歯付座金
XB2-4	Pan head + Spring washer and plain washer (circular bright) なべねじ+(ばね+平)座金
XB2-5	Binding head + Plain washer (circular bright) バインドねじ+平座金
XB2-6	Binding head + Spring washer バインドねじ+ばね座金
XB2-7	Binding head + Toothed lock washer バインドねじ+歯付座金
XB2-8	Binding head + Spring washer and plain washer (circular bright) バインドねじ+(ばね+平)座金

Figure ZZB (5/7) MECHANICAL STANDARD PARTS (SCREWS)

1-5. Hexagon Head Tapping Screws for Matallic Materials
 金属用六角タッピンねじ

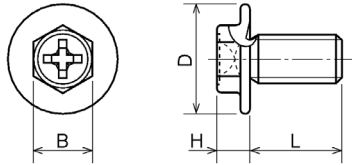

Type No. 類別番号	Type 類別	Head size (mm) 頭部寸法 (mm)		
		M3	M4	
XB3-6	For metallic materials 金属用タッピン	D	8	10
		B	5.5	5.5
XB3-7	For metallic materials with clawed 金属用タッピン-つめ付き	H XB3-6	3.1	3.1
		H XB3-7	3.2	3.2

1-6. Special Tapping Screws
 特殊タッピンねじ

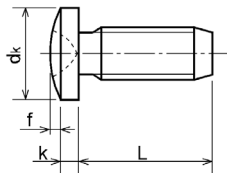

Type No. 類別番号	Type 類別	Head size (mm) 頭部寸法 (mm)		
		M3	M4	
XB4-5	Binding head バインド	dk	6.3	8.3
		k	1.3	1.7
		k+f	1.9	2.5

Figure ZZB (6/7) MECHANICAL STANDARD PARTS (SCREWS)

1-7. General Head Tapping Screws
一般用タッピンねじ

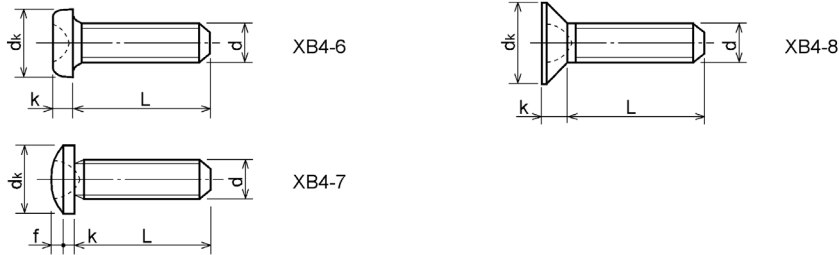

Type No. 類別番号	Type 類別	Head size (mm) 頭部寸法 (mm)						
		M2	M2.5	M2.6	M3	M4	M5	
XB4-6	Pan head なべ	dk XB4-6	3.5	4.5	4.5	5.5	7	9
		k XB4-6	1.3	1.7	1.7	2	2.6	3.3
XB4-7	Binding head バインド	dk XB4-7	4.3	5.3	5.5	6.3	8.3	10.3
		k+f XB4-7	1.2	1.5	1.6	1.9	2.5	3.1
XB4-8	Countersunk head さら	dk XB4-8	4	5	5.2	6	8	10
		k XB4-8	1.2	1.45	1.5	1.75	2.3	2.8

1-8. Tapping Screws for Metallic Materials
金属用タッピンねじ

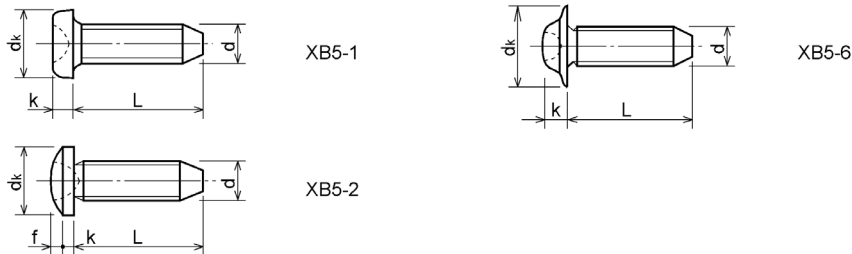

Type No. 類別番号	Type 類別	Head size (mm) 頭部寸法 (mm)					
		M2.5	M2.6	M3	M4	M5	
XB5-1	Pan head なべ	dk XB5-1	4.5	4.5	5.5	7	9
		k XB5-1	1.7	1.7	2	2.6	3.3
XB5-2	Binding head バインド	dk XB5-2	5.5	5.5	6.3	8.3	10.3
		k+f XB5-2	1.6	1.6	1.9	2.5	3.1
XB5-6	Flanged pan head つば付きなべ	dk XB5-6	6.5	6.5	8	10	12
		k XB5-6	2.1	2.1	1.75	3.2	4

Figure ZZB (7/7) MECHANICAL STANDARD PARTS (SCREWS)

1-9. Hexagon Socket Set Screws
六角穴付き止めねじ

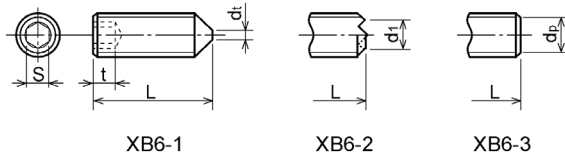

Type No. 類別番号	Type 類別	Head size (mm) 頭部寸法 (mm)						
		M1.6 M1.7	M2	M2.5 M2.6	M3	M5	M5	M6
	S	0.7	0.9	1.3	1.5	2	2.5	3
	t	1.5	1.7	2	2	2.5	3	3.5
	dt max XB6-1	0.4	0.5	0.65	0.75	1	1.25	1.5
	d1 max XB6-2	-	1.2	1.5	1.7	2.2	2.8	3.3
	d1 min XB6-2	-	1	1.2	1.4	1.9	2.4	2.9
	dp max XB6-3	0.8	1	1.5	2	2.5	3.5	4
	dp min XB6-3	0.55	0.75	1.25	1.75	2.25	3.2	3.7

1-10. Flanged Pan Head Machine Screws
つば付きなべ小ねじ

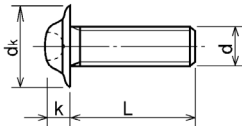

Type No. 類別番号	Type 類別	Head size (mm) 頭部寸法 (mm)				
		M2	M2.5 M2.6	M3	M5	M5
	dk	5	6.5	8	10	12
	k	1.7	2.1	2.5	3.2	4

Figure ZZC MECHANICAL STANDARD PARTS (BOLTS)

2. Bolts (Socket head cap screw)
ボルト

How to read Parts Numbers
部品番号の見方

Bolt (Socket head cap screw)
ボルト

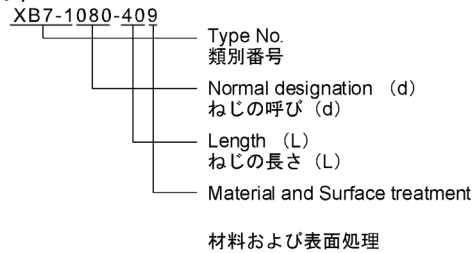

XB7-1 expresses Hexagon socket head cap screws.
XB7-1は、六角穴付きボルトを表す

080 expresses M8.0.
080は、M8.0を表す

40 expresses a length of 40mm.
40は、40mmの長さを表す

9 expresses Steel (Black zinc trivalent chromate treating) from Table 1.
9は、表1より鋼（黒色亜鉛3価クロメート）を表す

2-1. Hexagon socket head cap screws
六角穴付きボルト

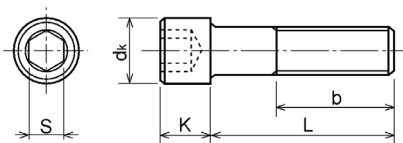

Type No. 類別番号	Type 類別
XB7-1	Hexagon socket head cap screws 六角穴付きボルト

	Head size (mm) 頭部寸法 (mm)						
	M3	M4	M5	M6	M8	M10	M12
S	2.5	3	4	5	6	8	10
dk	5.5	7	8.5	10	13	16	18
K	3	4	5	6	8	10	12
Screw part length ねじ部長さ b_{max}	18	20	22	24	28	32	36

Figure ZZD MECHANICAL STANDARD PARTS (NUTS)

3. Nuts
ナット

How to read Parts Numbers
部品番号の見方

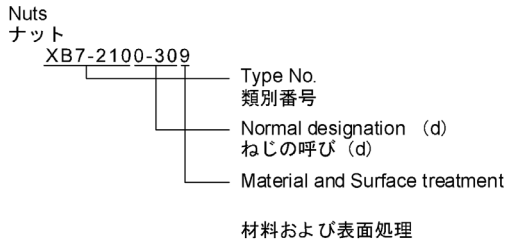

XB7-210 expresses Hexagon nut class 1.
XB7-210は、六角ナット1種を表す

0-30 expresses M3.0.
0-30は、M3.0を表す

9 expresses Steel (Black zinc trivalent chromate treating) from Table 1.
9は、表1より鋼（黒色亜鉛3価クロメート）を表す

3-1. Hexagon Nuts and Hexagon Thin Nuts
六角ナット

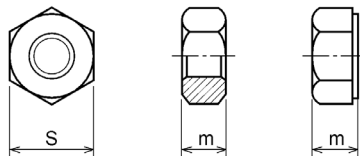

Type No. 類別番号	Type 類別
XB7-210	Hexagon nut Class 1 六角ナット-1種
XB7-220	Hexagon nut Class 3 六角ナット-3種
XB7-230	Hexagon nut Style 1 double chamfered 六角ナット-スタイル1-両面とり
XB7-231	Hexagon nut Style 1 washer faced 六角ナット-スタイル1-座付き
XB7-240	Hexagon nut Style 2 double chamfered 六角ナット-スタイル2-両面とり
XB7-241	Hexagon nut Style 2 washer faced 六角ナット-スタイル2-座付き
XB7-250	Hexagon nut 六角ナット
XB7-260	Hexagon thin nut double chamfered 六角低ナット-両面とり
XB7-270	Hexagon thin nut not chamfered 六角低ナット-面とり無し

	Head size (mm) 頭部寸法 (mm)						
	M2	M2.5	M3	M4	M5	M6	M8
S	4	5	5.5	7	8	10	13
m XB7-210	1.6	2	2.4	3.2	4	5	6.5
m XB7-220	1.2	1.6	1.8	2.4	3.2	3.6	5
m XB7-230, 231	1.6	2	2.4	3.2	4.7	5.2	6.8
m XB7-240, 241	-	-	-	-	5.1	5.7	7.5
m XB7-250	-	-	-	-	5.6	6.1	7.9
m XB7-260	1.2	1.6	1.8	2.2	2.7	3.2	4
m XB7-270	1.2	1.6	1.8	2.2	2.7	3.2	4

Figure ZZE (1/3)MECHANICAL STANDARD PARTS (RETAINING RINGS)

5. Retaining Rings
止め輪

How to read Parts Numbers
部品番号の見方

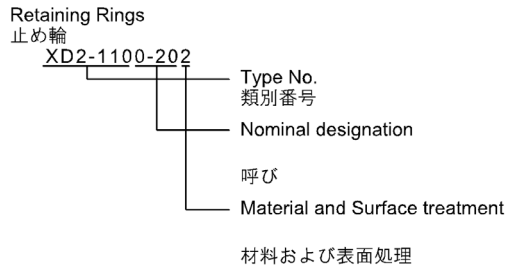

XD2-110 expresses retaining ring-E type (Type1).
XD2-110は、E形止め輪（1種）を表す

0-20 expresses a 020 of nominal designation.
(See Table 5)
0-20は、呼び020を表す（表5参照）

2 expresses Stainless steel (Surface treatment is not to be given) from Table 1.
2は、表1よりステンレス（表面処理なし）を表す

5-1. Retaining Rings - E type
E形止め輪

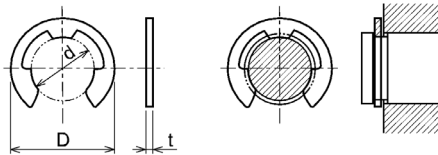

Type No. 類別番号	Type 類別
XD2-110	Retaining ring - E type (Type 1) E形止め輪（1種）
XD2-120	Retaining ring - E type (Type 2) E形止め輪（2種）

Table 5 表5

Type 種類	Nominal designation 呼び	d (mm)	D (mm)	t (mm)
Type 1 1種	007	0.65	2	0.2
	010	0.95	2.8	0.2
	013	1.25	3.3	0.3
	017	1.65	4.2	0.4
	020	1.95	4.6	0.5
	024	2.35	6	0.6
	028	2.74	6.5	0.6
	032	3.14	7.2	0.6
	037	3.64	8	0.7
	040	3.93	10	0.7
	042	4.13	10	0.7
	050	4.93	11	0.7
	058	5.73	12	0.7
	060	5.93	12.7	0.9
064	6.32	13.5	0.9	
074	7.31	15	0.9	
080	7.91	16.5	1	
Type 2 2種	008	0.8	2	0.2
	012	1.2	3	0.3
	015	1.5	4	0.4
	020	2	5	0.4
	025	2.5	6	0.4
	030	3	7	0.6
	040	4	9	0.6
	050	5	11	0.6
	060	6	12	0.8
	070	7	14	0.8
	080	8	16	0.8
	090	9	18	0.8
	100	10	20	1

Figure ZZE (2/3)MECHANICAL STANDARD PARTS (RETAINING RINGS)

5-2. Grip Rings
グリップ止め輪

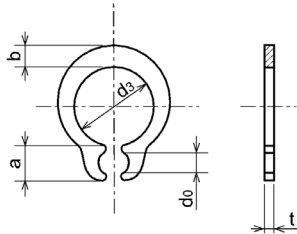

Table 5 表5

Nominal designation 呼び	d_3 (mm)	t (mm)	b (mm)	a (mm)	d_o (mm)
020	1.9	0.5	1	1.8	0.8
025	2.35	0.5	1.2	1.9	0.9
030	2.85	0.6	1.4	1.9	0.9
035	3.3	0.6	1.6	2	0.9
040	3.8	0.8	1.8	2.8	1.2
045	4.25	0.8	2	2.9	1.3
050	4.75	0.8	2.2	2.9	1.3
060	5.7	1	2.4	3.1	1.4
070	6.7	1	2.7	3.3	1.4
080	7.7	1	3	3.5	1.4
090	8.65	1.2	3.3	4.7	1.5
100	9.65	1.2	3.5	4.7	2

Type No. 類別番号	Type 類別
XD2-210	Grip ring グリップ止め輪

5-3. Toothed Retaining Rings
歯付き形止め輪

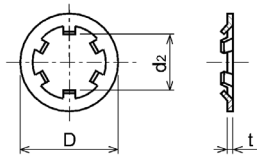

Table 5 表5

Nominal designation 呼び	d_z (mm)	D (mm)	t (mm)	No of teeth 歯数
015	1.4	5.2	0.25	3
020	1.9	6	0.25	3
024	2.3	6.4	0.25	3
030	2.8	8	0.25	4
040	3.8	9	0.25	4
050	4.8	10	0.25	5
060	5.8	11	0.25	5
080	7.8	13	0.25	5
100	9.8	15.4	0.25	6

Type No. 類別番号	Type 類別
XD2-230	Toothed retaining ring 歯付き形止め輪

Figure ZZE (3/3)MECHANICAL STANDARD PARTS (RETAINING RINGS)

5-4. Retaining Rings - C Type
C形止め輪

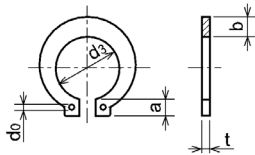

Type No. 類別番号	Type 類別
XD2-310	Retaining ring - C type for shaft C形止め輪 軸用

Table 5 表5

Nominal designation 呼び	d ₃ (mm)	t (mm)	b (mm)	a (mm)	d ₀ (mm)
010	9.3	1	1.6	3	1.2
012	11.1	1	1.8	3.2	1.5
014	12.9	1	2	3.4	1.7
015	13.8	1	2.1	3.5	1.7
016	14.7	1	2.2	3.6	1.7
017	15.7	1	2.2	3.7	1.7
018	16.5	1.2	2.6	3.8	1.7
020	18.5	1.2	2.7	3.9	2
022	20.5	1.2	2.7	4.1	2
025	23.2	1.2	3.1	4.3	2
028	25.9	1.5	3.1	4.6	2
030	27.9	1.5	3.5	4.8	2
032	29.6	1.5	3.5	5	2.5
035	32.2	1.5	4	5.4	2.5

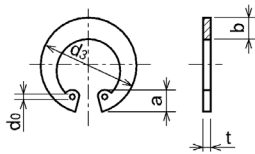

Type No. 類別番号	Type 類別
XD2-320	Retaining ring - C type for hole C形止め輪 穴用

Table 5 表5

Nominal designation 呼び	d ₃ (mm)	t (mm)	b (mm)	a (mm)	d ₀ (mm)
010	10.7	1	1.8	3.1	1.2
011	11.8	1	1.8	3.2	1.2
012	13	1	1.8	3.3	1.5
014	15.1	1	2	3.6	1.7
016	17.3	1	2	3.7	1.7
018	19.5	1	2.5	4	1.7
019	20.5	1	2.5	4	2
020	21.5	1	2.5	4	2
022	23.5	1	2.5	4.1	2
025	26.9	1.2	3	4.4	2
028	30.1	1.2	3	4.6	2
030	32.1	1.2	3	4.7	2
032	34.4	1.2	3.5	5.2	2.5
035	37.8	1.5	3.5	5.2	2.5
037	39.8	1.5	3.5	5.2	2.5
040	43.5	1.8	4	5.7	2.5
042	45.5	1.8	4	5.8	2.5
045	48.5	1.8	4.5	5.9	2.5
047	50.5	1.8	4.5	6.1	2.5
050	54.2	2	4.5	6.5	2.5
052	56.2	2	5.1	6.5	2.5
055	59.2	2	5.1	6.5	2.5
060	64.2	2	5.1	6.8	2.5
062	66.2	2	5.5	6.9	2.5
068	72.5	2.5	6	7.4	2.5
072	76.5	2.5	6.6	7.4	2.5
075	79.5	2.5	6.6	7.8	2.5
080	85.5	2.5	7	8	2.5
085	90.5	3	7	8	3
090	95.5	3	7.6	8.3	3
095	100.5	3	8	8.5	3