

# imagePROGRAF iPF670

## SERVICE MANUAL



# Canon

February 27, 2017  
Rev. 3



## Application

This manual has been issued by Canon Inc. for qualified persons to learn technical theory, installation, maintenance, and repair of products. This manual covers all localities where the products are sold. For this reason, there may be information in this manual that does not apply to your locality.

## Corrections

This manual may contain technical inaccuracies or typographical errors due to improvements or changes in products. When changes occur in applicable products or in the contents of this manual, Canon will release technical information as the need arises. In the event of major changes in the contents of this manual over a long or short period, Canon will issue a new edition of this manual.

The following paragraph does not apply to any countries where such provisions are inconsistent with local law.

## Trademarks

The product names and company names used in this manual are the registered trademarks of the individual companies.

## Copyright

This manual is copyrighted with all rights reserved. Under the copyright laws, this manual may not be copied, reproduced or translated into another language, in whole or in part, without the written consent of Canon Inc.

***COPYRIGHT © 2001 CANON INC.***

*Printed in Japan*

## Caution









Use of this manual should be strictly supervised to avoid disclosure of confidential information.

---

# Symbols Used

---



This documentation uses the following symbols to indicate special information:

Symbol	Description
	Indicates an item of a non-specific nature, possibly classified as Note, Caution, or Warning.
	Indicates an item requiring care to avoid electric shocks.
	Indicates an item requiring care to avoid combustion (fire).
	Indicates an item prohibiting disassembly to avoid electric shocks or problems.
	Indicates an item requiring disconnection of the power plug from the electric outlet.
 Memo	Indicates an item intended to provide notes assisting the understanding of the topic in question.
 REF.	Indicates an item of reference assisting the understanding of the topic in question.
	Provides a description of a service mode.
	Provides a description of the nature of an error indication.



The following rules apply throughout this Service Manual:

1. Each chapter contains sections explaining the purpose of specific functions and the relationship between electrical and mechanical systems with reference to the timing of operation.

In the diagrams,  represents the path of mechanical drive; where a signal name accompanies the symbol, the arrow  indicates the direction of the electric signal.

The expression "turn on the power" means flipping on the power switch, closing the front door, and closing the delivery unit door, which results in supplying the machine with power.

2. In the digital circuits, '1' is used to indicate that the voltage level of a given signal is "High", while '0' is used to indicate "Low". (The voltage value, however, differs from circuit to circuit.) In addition, the asterisk (\*) as in "DRMD\*" indicates that the DRMD signal goes on when '0'.

In practically all cases, the internal mechanisms of a microprocessor cannot be checked in the field. Therefore, the operations of the microprocessors used in the machines are not discussed: they are explained in terms of from sensors to the input of the DC controller PCB and from the output of the DC controller PCB to the loads.

The descriptions in this Service Manual are subject to change without notice for product improvement or other purposes, and major changes will be communicated in the form of Service Information bulletins.

All service persons are expected to have a good understanding of the contents of this Service Manual and all relevant Service Information bulletins and be able to identify and isolate faults in the machine."



# Contents

## Chapter 1 PRODUCT DESCRIPTION

1.1 Product Overview .....	1- 1
1.1.1 Product Overview .....	1- 1
1.2 Features .....	1- 2
1.2.1 Features .....	1- 2
1.2.2 Printhead .....	1- 2
1.2.3 Ink Tank .....	1- 2
1.2.4 Cutter .....	1- 2
1.2.5 Roll Holder .....	1- 3
1.2.6 Stand (ST-26) .....	1- 4
1.2.7 Stand (ST-27) .....	1- 6
1.2.8 Consumables .....	1- 9
1.3 Product Specifications .....	1- 10
1.3.1 Product Specifications .....	1- 10
1.4 Detailed Specifications .....	1- 11
1.4.1 Interface Specifications .....	1- 11
1.5 Names and Functions of Components .....	1- 13
1.5.1 Front .....	1- 13
1.5.2 Side .....	1- 14
1.5.3 Top Cover (Inside) .....	1- 15
1.5.4 Roll Unit Cover (Inside) .....	1- 16
1.5.5 Carriage .....	1- 16
1.5.6 Ink Tank Cover (Inside) .....	1- 17
1.5.7 Stand (ST-26) .....	1- 18
1.5.8 Stand (ST-27) .....	1- 19
1.6 Basic Operation .....	1- 20
1.6.1 Operation Panel .....	1- 20
1.6.2 Display .....	1- 21
1.6.3 Menu .....	1- 22
1.7 Safety and Precautions .....	1- 42
1.7.1 Safety Precautions .....	1- 42
1.7.1.1 Moving Parts .....	1- 42
1.7.1.2 Adhesion of Ink .....	1- 43
1.7.1.3 Electric Parts .....	1- 44
1.7.2 Other Precautions .....	1- 45
1.7.2.1 Printhead .....	1- 45
1.7.2.2 Ink Tank .....	1- 46
1.7.2.3 Handling the Printer .....	1- 46
1.7.3 Precautions When Servicing Printer .....	1- 48
1.7.3.1 Notes on the Data Stored in the Printer .....	1- 48
1.7.3.2 Confirming the Firmware Version .....	1- 48
1.7.3.3 Precautions against Static Electricity .....	1- 48
1.7.3.4 Precautions for Disassembly/Reassembly .....	1- 48
1.7.3.5 Self-diagnostic Feature .....	1- 48
1.7.3.6 Disposing of the Lithium Battery .....	1- 49

## Chapter 2 TECHNICAL REFERENCE

2.1 Basic Operation Outline .....	2- 1
2.1.1 Printer Diagram .....	2- 1
2.1.2 Print Signal Sequence .....	2- 2

2.1.3 Print Driving .....	2- 3
2.2 Firmware .....	2- 5
2.2.1 Operation Sequence at Power-on.....	2- 5
2.2.2 Operation Sequence at Power-off.....	2- 6
2.2.3 Print Position Adjustment Function .....	2- 7
2.2.4 Head Management .....	2- 7
2.2.5 Printhead Overheating Protection Control .....	2- 7
2.2.6 Pause between Pages.....	2- 7
2.2.7 White Raster Skip .....	2- 7
2.2.8 Sleep Mode.....	2- 7
2.2.9 Shut Down Mode .....	2- 7
2.3 Printer Mechanical System.....	2- 8
2.3.1 Outline.....	2- 8
2.3.1.1 Outline.....	2- 8
2.3.2 Ink Passage .....	2- 9
2.3.2.1 Ink Passage .....	2- 9
2.3.2.2 Ink Tank Unit.....	2- 10
2.3.2.3 Carriage Unit.....	2- 12
2.3.2.4 Printhead.....	2- 16
2.3.2.5 Purge Unit.....	2- 17
2.3.2.6 Maintenance Cartridge.....	2- 22
2.3.2.7 Air Flow .....	2- 23
2.3.3 Paper Path.....	2- 25
2.3.3.1 Outline.....	2- 25
2.3.3.2 Paper Path .....	2- 26
2.3.3.3 Cutter Unit.....	2- 28
2.4 Printer Electrical System .....	2- 29
2.4.1 Outline.....	2- 29
2.4.1.1 Overview .....	2- 29
2.4.2 Main Controller.....	2- 31
2.4.2.1 Main controller PCB components .....	2- 31
2.4.2.2 Connectors and Pin Arrangement of Main controller PCB.....	2- 32
2.4.3 Carriage Relay PCB.....	2- 39
2.4.3.1 Carriage PCB components .....	2- 39
2.4.3.2 Connectors and Pin Arrangement of Carriage PCB .....	2- 40
2.4.4 Maintenance Cartridge Relay PCB .....	2- 44
2.4.4.1 Maintenance cartridge relay PCB components.....	2- 44
2.4.5 Power Supply.....	2- 45
2.4.5.1 Power supply block diagram .....	2- 45
2.4.5.2 Connectors and Pin Arrangement of Power supply PCB.....	2- 46
2.5 Detection Functions with Sensors .....	2- 47
2.5.1 Covers.....	2- 47
2.5.2 Ink passage system .....	2- 48
2.5.3 Carriage system.....	2- 51
2.5.4 Paper path system .....	2- 53
2.5.5 Others .....	2- 55
 Chapter 3 INSTALLATION	
3.1 Transporting the Printer.....	3- 1
3.1.1 Transporting the Printer .....	3- 1
3.1.1.1 Transporting the Printer .....	3- 1
3.1.2 Reinstalling the Printer.....	3- 4
3.1.2.1 Reinstalling the Printer.....	3- 4
 Chapter 4 DISASSEMBLY/REASSEMBLY	
4.1 Service Parts .....	4- 1

---

4.1.1 Service Parts .....	4- 1
4.2 Disassembly/Reassembly.....	4- 2
4.2.1 Disassembly/Reassembly .....	4- 2
4.3 Points to Note on Disassembly and Reassembly .....	4- 2
4.3.1 Note: Items that should never be disassembled.....	4- 2
4.3.2 Moving the carriage manually.....	4- 2
4.3.3 Units requiring draining of ink .....	4- 3
4.3.4 External Covers .....	4- 4
4.3.5 Drive Unit.....	4- 13
4.3.6 Cutter .....	4- 17
4.3.7 Carriage Unit .....	4- 19
4.3.8 Purge Unit.....	4- 26
4.3.9 Ink Tank Unit .....	4- 30
4.3.10 Ink Tube Unit .....	4- 34
4.3.11 Waste Ink Collection Unit.....	4- 38
4.3.12 Multi Sensor.....	4- 43
4.3.13 Linear Encoder .....	4- 44
4.3.14 Head Management Sensor.....	4- 49
4.3.15 PCBs.....	4- 50
4.3.16 Opening the Cap/Moving the Wiper Unit .....	4- 51
4.3.17 Opening/Closing the Ink Supply Valve/Subtank Air Passage Valve.....	4- 53
4.3.18 Draining the ink.....	4- 54
4.4 Applying the Grease .....	4- 55
4.4.1 Applying the Grease .....	4- 55
4.5 Adjustment and Setup Items .....	4- 59
4.5.1 Adjustment Item List.....	4- 59
4.5.2 Procedure after Replacing the Carriage Unit or Multi Sensor .....	4- 59
4.5.3 Procedure after Replacing the Feed Roller or Feed Roller Encoder .....	4- 59
4.5.4 Procedure after Replacing the Head Management Sensor.....	4- 59

## Chapter 5 MAINTENANCE

5.1 Periodic Replacement Parts .....	5- 1
5.1.1 Periodic Replacement Parts.....	5- 1
5.2 Consumable Parts .....	5- 1
5.2.1 Consumable Parts.....	5- 1
5.3 Periodic Maintenance .....	5- 3
5.3.1 Periodic Maintenance .....	5- 3

## Chapter 6 TROUBLESHOOTING

6.1 Troubleshooting.....	6- 1
6.1.1 Outline .....	6- 1
6.1.1.1 Outline of Troubleshooting.....	6- 1
6.2 Error Code .....	6- 2
6.2.1 Outline .....	6- 2
6.2.1.1 Outline.....	6- 2
6.2.2 Warning/Error/Service Call Error .....	6- 3
6.2.2.1 Code Table .....	6- 3
6.3 Service Software .....	6- 35
6.3.1 L Printer Service Tool .....	6- 35
6.4 Firmware Update Tool .....	6- 40
6.4.1 imagePROGRAF Firmware Update Tool .....	6- 40
6.5 Service Tools.....	6- 42
6.5.1 Tool List.....	6- 42

Chapter 7 SERVICE MODE

7.1 Service Mode .....	7- 1
7.1.1 Service Mode Operation .....	7- 1
7.1.2 Map of the Service Mode .....	7- 2
7.1.3 Details of Service Mode .....	7- 10
7.1.4 e-Maintenance/imageWARE Remote .....	7- 28
7.1.5 Viewing PRINT INF .....	7- 38
7.2 Special Mode.....	7- 53
7.2.1 Special Modes for Servicing .....	7- 53

---

## Chapter 1 PRODUCT DESCRIPTION

---





---

# Contents

1.1 Product Overview .....	1-1
1.1.1 Product Overview .....	1-1
1.2 Features .....	1-2
1.2.1 Features .....	1-2
1.2.2 Printhead .....	1-2
1.2.3 Ink Tank .....	1-2
1.2.4 Cutter .....	1-2
1.2.5 Roll Holder .....	1-3
1.2.6 Stand (ST-26) .....	1-4
1.2.7 Stand (ST-27) .....	1-6
1.2.8 Consumables .....	1-9
1.3 Product Specifications .....	1-10
1.3.1 Product Specifications .....	1-10
1.4 Detailed Specifications .....	1-11
1.4.1 Interface Specifications .....	1-11
1.5 Names and Functions of Components .....	1-13
1.5.1 Front .....	1-13
1.5.2 Side .....	1-14
1.5.3 Top Cover (Inside) .....	1-15
1.5.4 Roll Unit Cover (Inside) .....	1-16
1.5.5 Carriage .....	1-16
1.5.6 Ink Tank Cover (Inside) .....	1-17
1.5.7 Stand (ST-26) .....	1-18
1.5.8 Stand (ST-27) .....	1-19
1.6 Basic Operation .....	1-20
1.6.1 Operation Panel .....	1-20
1.6.2 Display .....	1-21
1.6.3 Menu .....	1-22
1.7 Safety and Precautions .....	1-42
1.7.1 Safety Precautions .....	1-42
1.7.1.1 Moving Parts .....	1-42
1.7.1.2 Adhesion of Ink .....	1-43
1.7.1.3 Electric Parts .....	1-44
1.7.2 Other Precautions .....	1-45
1.7.2.1 Printhead .....	1-45
1.7.2.2 Ink Tank .....	1-46
1.7.2.3 Handling the Printer .....	1-46
1.7.3 Precautions When Servicing Printer .....	1-48
1.7.3.1 Notes on the Data Stored in the Printer .....	1-48
1.7.3.2 Confirming the Firmware Version .....	1-48
1.7.3.3 Precautions against Static Electricity .....	1-48
1.7.3.4 Precautions for Disassembly/Reassembly .....	1-48
1.7.3.5 Self-diagnostic Feature .....	1-48
1.7.3.6 Disposing of the Lithium Battery .....	1-49



## 1.1 Product Overview

### 1.1.1 Product Overview

This printer is capable of printing on A4- to A1-size cut sheets and its maximum print width is 24 inches. This printer is a desktop large-format printer five-colors (dye- and pigment-based colors) printer that can be used to print CAD and office documents as well as handy POP and posters.

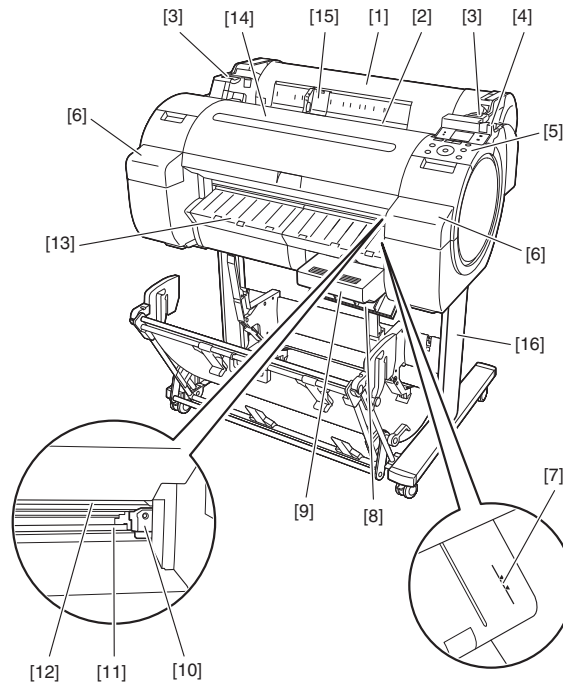

F-1-1

- |                                 |                           |
|---------------------------------|---------------------------|
| [1] Roll media cover            | [9] Maintenance cartridge |
| [2] Media loading slot          | [10] Cutter unit          |
| [3] Roll media temporary table  | [11] Cutter rail          |
| [4] Release lever               | [12] Paper eject slot     |
| [5] Operation panel             | [13] Output guide         |
| [6] Ink tank cover              | [14] Upper cover          |
| [7] Media alignment line        | [15] Width guide          |
| [8] Maintenance cartridge cover | [16] Stand                |

## 1.2 Features

### 1.2.1 Features

- High resolutions of 2,400 x 1,200 dpi maximum, coupled with the exceptionally light-fast, water-proof and ozone-proof five-color pigment inks of Y, M, C, PBK and MBK, deliver high-quality photographic picture quality.
- Black ink suitable for the selected media type is automatically selected from two types of black ink, "black ink" for vivid and glossy printing and "matte black ink" for matte and high-quality printing.
- A 160-by-128-dot-large LCD
- One-inch wide printhead having 2,560 nozzles per color, which are as many as the those of the existing models. High-density printhead technology "FINE" that can satisfy both of beautiful and fast printing requirements of a high order is employed for accurate ejection of ultrasmall 4-pl drops of ink to the target positions. Prints with 2,400 x 1,200 dpi resolution can be made at a high speed.
- Imaging processor "L-COA" incorporated for high-speed image data processing. High-speed processing of 5-color, 12-bit large-size images and printer control for high-accuracy operation of high-density head can be performed with a single chip.
- Standard support for 10Base-T/100Base-TX/1000Base-T and USB 2.0 Hi-Speed.
- Borderless printing on and auto cutting of roll media.
- All operations such as loading the roll media and cut sheet and replacing the ink tank can be carried out at the front (top) of the printer.
- The printer can be installed with its back in touch with the wall, requiring no installation space at the back of the printer.
- A subtank mounted at the ink port allows you to replace the ink tank during printing.
- The pressure of suction from the borderless printing ink catch groove changes automatically with the media size, preventing shift of media edges and staining of the backside of the media.
- A printhead having nozzles (I-shaped nozzle) with a new shape reduces ink mist, ensuring superfine printing.
- Compatibility with e-maintenance/imageWARE Remote allows centralized management of customers' printer information.
- The newly designed operation panel allows you to operate the printer intuitively.

Functional enhancements new to this model include:

- The processing ability of the printed data will enhance by improvement of throughput.

### 1.2.2 Printhead

The printhead that mounts on the carriage is an integrated six-color disposable printhead. It has 5,120 nozzles for MBK and 2,560 nozzles for each additional color arranged in a staggered pattern. If print quality remains unimproved even after a specified cleaning operation, replace the printhead.

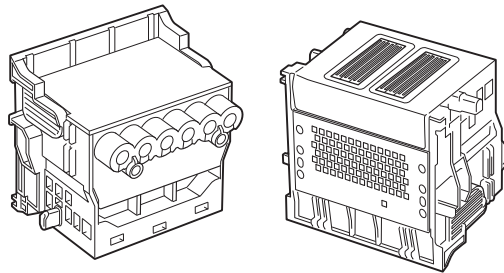

F-1-2

### 1.2.3 Ink Tank

The ink tank is disposable.

There are four dye-based ink colors (black, cyan, magenta, and yellow) and one pigment-based ink color (matte black).

This printer features a mechanism by which only the correct color ink tank will fit in the given slot.

When the message that ink tank is empty is displayed, replace the ink tank with a new one.

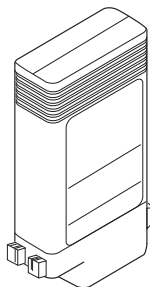

F-1-3

### 1.2.4 Cutter

The cutter attached to the cutter unit is a round cutter.

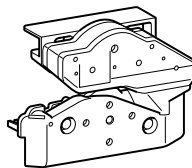

F-1-4

### 1.2.5 Roll Holder

The roller holder accepts paper tubes having inside diameters of both 2 and 3 inches. It is furnished with attachments for 2- and 3-inch diameter paper tubes. The roll holder clamps the paper tube of a roll not exceeding 150 mm in outside diameter from the inside.

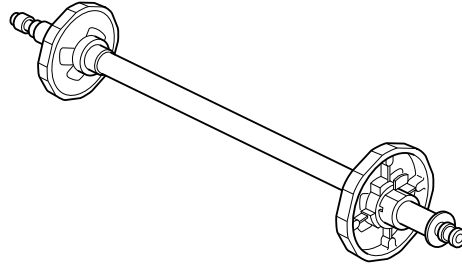

F-1-5

[2-inch paper tube attachment]

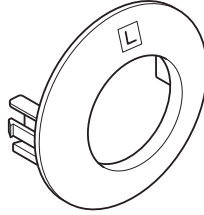

F-1-6

[3-inch paper tube attachment R]

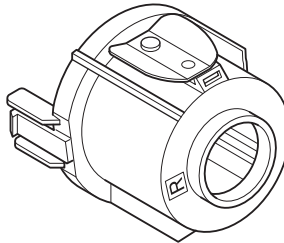

F-1-7

[3-inch paper tube attachment L]

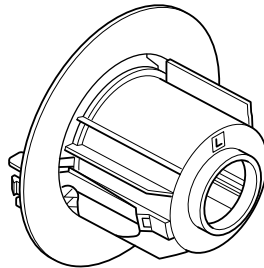

F-1-8

### 1.2.6 Stand (ST-26)

The stand [1] is equipped with casters so that the printer can be easily moved. The output stacker [2] included with stand can use by the two ways of the regular position or extended position.

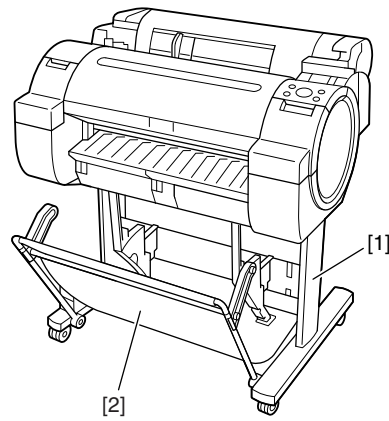

F-1-9

---

**MEMO:**  
- When delivering the printing to the output stacker: Use the position [A].  
- When not using the output stacker or moving the printer: Use the position [B]. When moving the printer, raise the auxiliary rod to the position of extended position. The output stacker may touch the floor and be soiled or damaged.

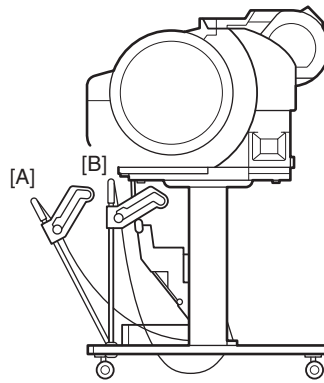

F-1-10

---

[Regular position]

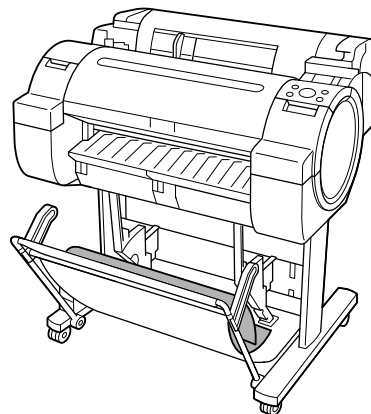

F-1-11

[Extended position]

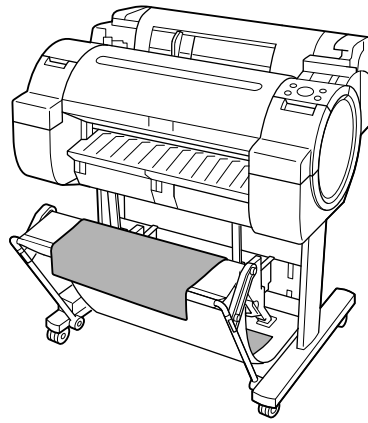

F-1-12

- Changing from the regular position to extended position.

1) Raise the auxiliary rod [1] to the position [A] of the illustration to change to the extended position.

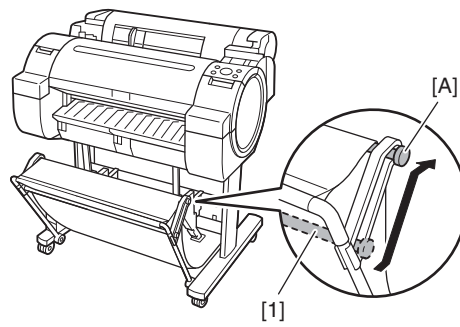

F-1-13

2) Pull out the switching stopper [1] when using roll paper that is A1 size or has a width of 24 inches.

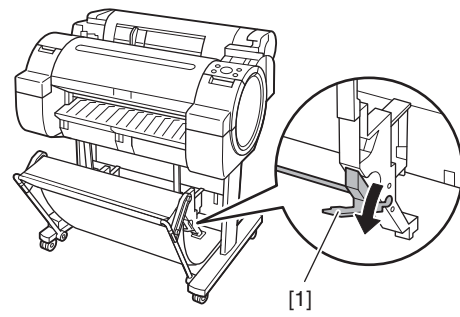

F-1-14

### 1.2.7 Stand (ST-27)

The stand [1] is equipped with casters so that the printer can be easily moved. The output stacker [2] included with stand can use by the three ways of the regular position or two extended positions.

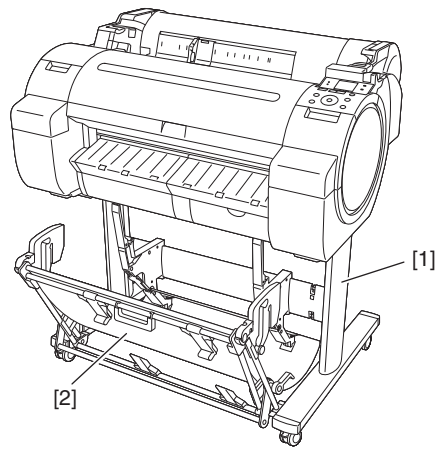

F-1-15

---

**MEMO:**  
- When delivering the printing to the output stacker: Use the position [A].  
- When not using the output stacker or moving the printer: Use the position [B]. When moving the printer, raise the auxiliary rod to the position of extended position. The output stacker may touch the floor and be soiled or damaged.

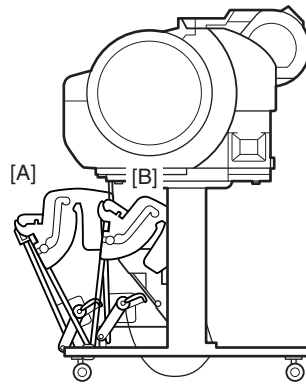

F-1-16

---

[Regular position]

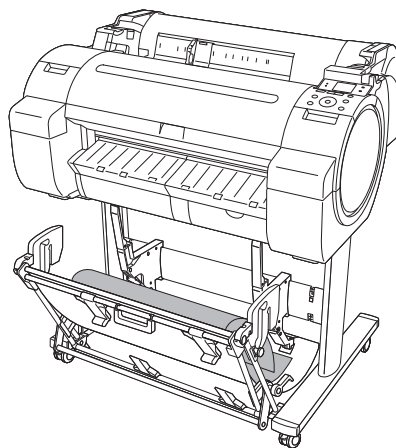

F-1-17



[Extended position A]

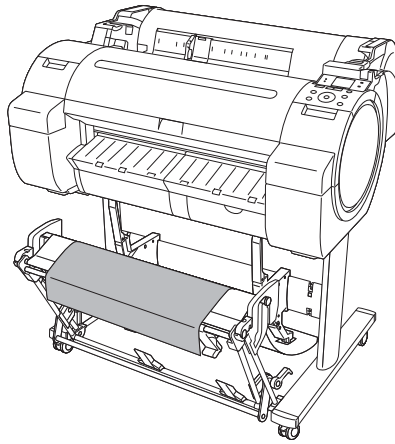

F-1-18

- Changing from the regular position to extended position A.

1) Raise the auxiliary rod [1] to the position [A] of the illustration to change to the extended position A.

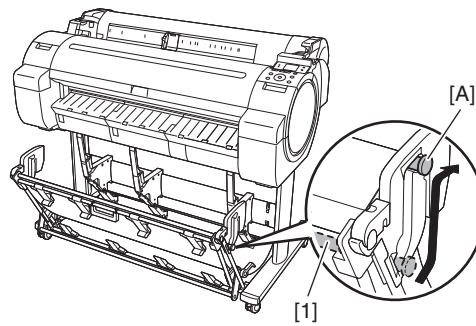

F-1-19

2) Pull out the switching stopper [1] when using roll paper that is A1 size or has a width of 24 inches.

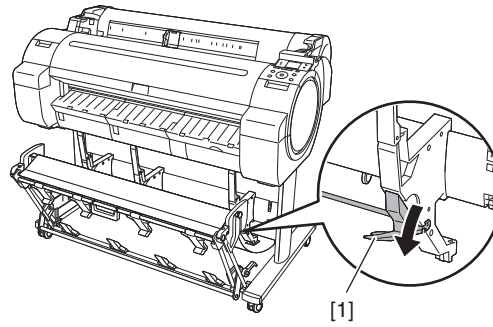

F-1-20

[Extended position B]

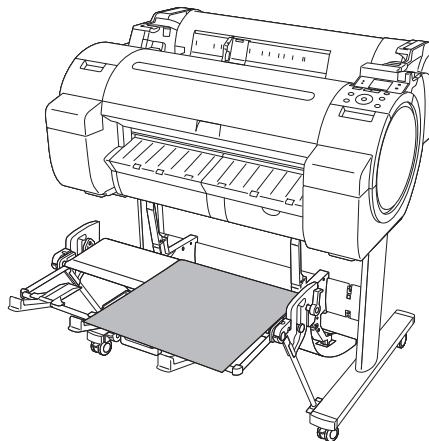

F-1-21

- Changing from the regular position to extended position B.

1) Grasp the output stacker handle [1] to set the guide as shown in the following illustration.

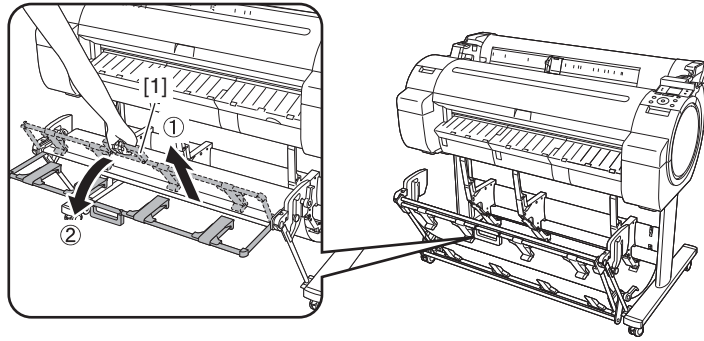

F-1-22

2) Open the output stacker ejection guides [1] toward the front.

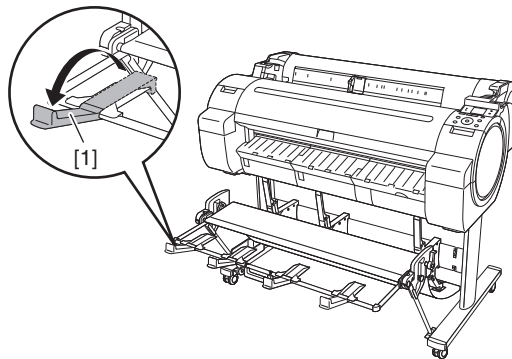

F-1-23

- Changing from the extended position B to regular position.

1) Close the output stacker ejection guides [1] and pull the output stacker release lever [2] forward to release the lock, and then grasp the output stacker handle [3] to return the guide.

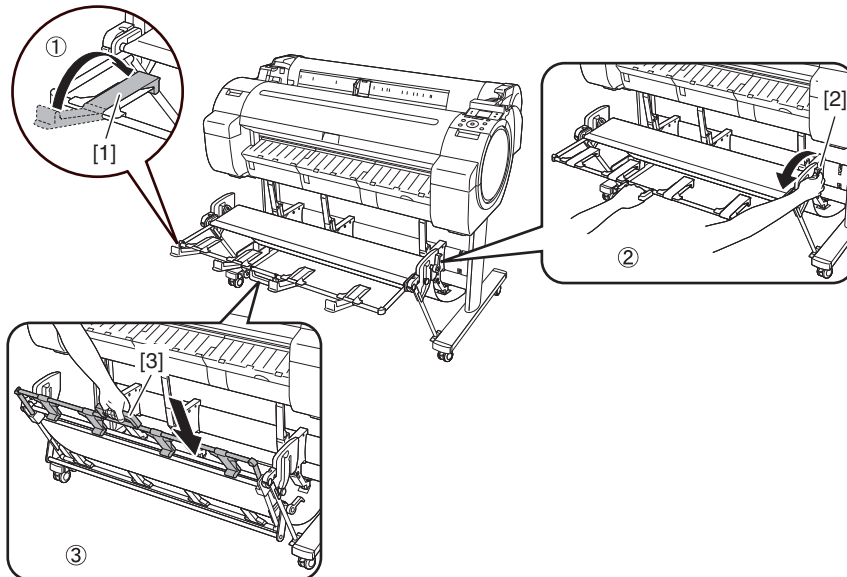

F-1-24

## 1.2.8 Consumables

### Printhead

The consumable printhead is the same as that supplied with the printer.

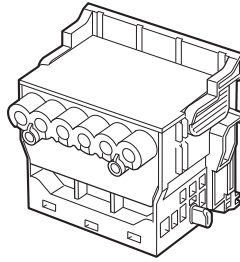

F-1-25

### Ink Tanks

The consumable ink tanks are available in five colors (matte black, black, cyan, magenta and yellow). They are the same as those supplied with the printer. The ink tank that can be used with this printer is labeled "J".

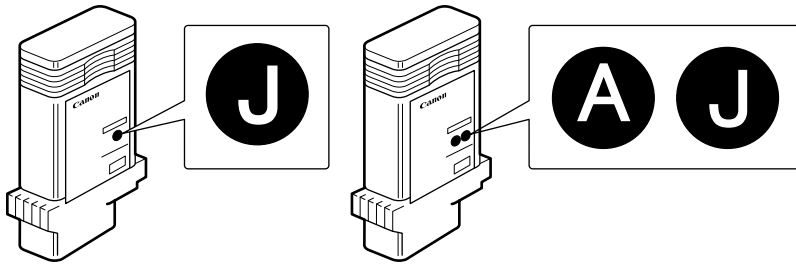

F-1-26

---

### MEMO:

You can also use ink tanks other than magenta ink tank that are simply labeled "A".

---

### Maintenance Cartridge

The consumable maintenance cartridge is the same as that supplied with the printer.

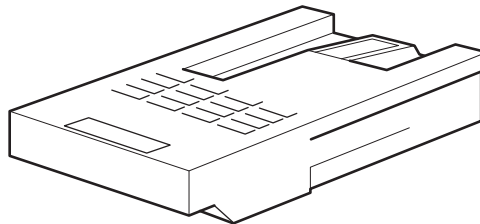

F-1-27

## 1.3 Product Specifications

### 1.3.1 Product Specifications

<b>Type</b>	Bubble jet large-sized paper printer (stand model)
<b>Feeding system</b>	Roll media: manual feed from top Cut sheet: manual feed from top
<b>Feeding capacity</b>	- Roll media: 1 roll media (Outer diameter of roll: 150 mm or less/Inner diameter of paper tube: 2 or 3 inches) - Cut sheet: 1 sheet
<b>Delivery method</b>	Forward delivery, face up
<b>Sheet delivery capability</b>	Stacking to the output stacker of the stand - 1 sheet: when using in the regular position - approximate 20 sheets: when using in the extended position (However, it has the following restrictions.) when using in the extended position/extended position A: paper length A0/36"X48" or A1/24"X36" size plain paper or recycled paper when using in the extended position B: paper length A1/36"X24" or A2/24"X18" size plain paper or recycled paper
<b>Cutter</b>	Automatic cross-cutter (round blade)
<b>Type of media</b>	Roll Media: Plain Paper, Plain Paper (High Quality), Plain Paper (High Grade), Coated Paper, Heavyweight Coated Paper, Premium Matte Paper, Premium Glossy Paper 200, Premium Semi-Glossy Paper 200, Premium Glossy Paper 280, Premium Semi-Glossy Paper 280, Back Light Film, Economy Bond Paper, Universal Bond Paper, Matte Coated Paper 170gsm, Premium RC Photo Luster, Durable Backlit Film, High Resolution Coated Paper, Matte Coated Paper 90gsm, Glossy Photographic Paper 190gsm, Glossy Photographic Paper 240gsm, Satin Photographic Paper 240gsm, Glossy Photographic Paper 270gsm, Satin Photographic Paper 270gsm, HW Glossy Photo Paper, HW Satin Photo Paper, Commercial Proofing Paper, Standard Paper1569B 80g, Standard Paper1570B 90g, Matt Coated Paper 9171, Matt Coated Paper 7215, Matt Coated Paper 140g, Opaque Paper White, Hi Res Graphic Paper, Hi Res Barrier Paper, Photo Realistic Paper 210g, Photo paper Pearl 260g, Glossy Proofing Paper 195g, Semiglossy Proofing Paper 195g, Semiglossy Proofing Paper 255g  Cut Paper: Plain Paper, Plain Paper (High Quality), Plain Paper (High Grade), Coated Paper, Premium Matte Paper, Premium Glossy Paper 280, Premium Semi-Glossy Paper 280, High Resolution Paper, Matte Photo Paper, Glossy Photo Paper GP-501, Photo Paper Plus Glossy 2, Photo Paper Pro Platinum, Photo Paper Plus Semi-Gloss, Universal Bond Paper, Premium RC Photo Luster, High Resolution Coated Paper, Matt Coated Paper 7215, Matt Coated Paper 140g
<b>Supported thickness</b>	0.07mm to 0.8mm
<b>Media size (Roll media)</b>	Width: 254.0mm (10") to 609.6mm (24") Length: 203.2mm (8") to 18m (709") *1 Outer diameter of roll :150mm or less *1: The maximum amount of length may vary by the using operating system or the applications.
<b>Media size (Cut sheet)</b>	Width: 203.2mm (8") to 609.6mm (24") Length: 279.4mm (11") to 1600mm (63") *1 *1: The maximum amount of length may vary by the using operating system or the applications.
<b>Printable area (Roll media)</b>	Internal area, excluding a 3-mm top, bottom and left and right margins. Borderless printing: 0 mm from the leading edge, trailing edge, and left and right edges. * The printable area may vary with each type of paper media used.  Width of media allowing borderless printing: 24"(609.6mm), A1(594.0mm), B2(515.0mm), 17"(431.8mm), A2(420.0mm), 14"(355.6mm), 300mm, A3(297.0mm), B4(257.0mm), 10"(254mm)
<b>Printable area (Cut sheet)</b>	Internal area, excluding a 3-mm top margin, a 23-mm bottom margin and 3-mm left and right margins. * The printable area may vary with each type of paper media used.
<b>Printing recommendation area (Roll media)</b>	Internal area, excluding a 20-mm top margin, a 5-mm bottom margin and 5-mm left and right margins.
<b>Printing recommendation area (Cut sheet)</b>	Internal area, excluding a 20-mm top margin, a 23-mm bottom margin and 5-mm left and right margins.
<b>Memory</b>	256MB Increase of memory: none
<b>Firmware</b>	Flash ROM (update from USB or Ethernet) - Printer description language GARO (Graphic Arts language with Raster Operation), HP-GL/2, HP-RTL
<b>Interface</b>	USB2.0 Hi-Speed Network (10Base-T/100Base-TX/1000Base-T)

<b>Operation panel</b>	LCD (160 X 128 dots), 13 keys, 5 LEDs - Panel language English - Message language English, German, French, Italian, Spanish, Chinese, Korean, Russian and Japanese
<b>Printhead/Ink Tank type</b>	Printhead and separate ink tanks
<b>Printhead</b>	PF-04 Structure: Integrated six-color assembly Number of nozzles: 5,120 for MBK, 2,560 for other each color
<b>Ink tank</b>	[PFI-107/8107] MBK, BK, C, M, Y Ink type: Pigment ink (MBK) Dye ink (BK, C, M, Y) Ink tank capacity: [PFI-107/8107] 130 ml (Ink tanks supplied with the printer contain 90 ml of each color.)
<b>Detection functions (Cover system)</b>	Upper cover open/closed detection: Yes Ink tank cover open/closed detection: Yes
<b>Detection functions (Ink passage system)</b>	Ink tank presence/absence detection: Yes Remaining ink level detection (dot count and electrode): Yes Maintenance cartridge presence/absence detection: Yes Used ink tank full detection: Yes Ink supply Valve open/closed detection: Yes
<b>Detection functions (Carriage system)</b>	Printhead presence/absence detection: Yes Carriage position detection: Yes Carriage home position detection: Yes Printhead temperature detection: Yes Printhead height detection: Yes Non-discharging nozzle detection: Yes Non-discharging nozzle backup feature: Yes Ambient temperature/humidity detection: Yes
<b>Detection functions (Paper path system)</b>	Paper presence/absence detection: Yes Paper width detection: Yes Skew detection: Yes Paper leading edge and trailing edge detection: Yes Release lever position detection: Yes Remaining roll media detection: Yes Feed roller rotation detection: Yes Roll holder rotation detection: Yes Cutter position detection: Yes
<b>Operating noise</b>	Operating: Approx. 47dB (A) or less Standby: Approx. 35dB (A) or less
<b>Operating environment</b>	Temperature: 15 to 30 degrees centigrade Humidity: 10% to 80%RH without dew condensation
<b>Print quality guaranteed environment</b>	Temperature: 15 to 30 degrees centigrade Humidity: 10% to 80%RH
<b>Power supply</b>	100-240 VAC (50/60 Hz)
<b>Power consumption (Maximum)</b>	During printing: Max. 140 W
<b>Power consumption</b>	In power save (sleep) mode: 5W or less During standby: 0.5W or less
<b>Printer unit dimensions (WxDxH)</b>	997mm(W) x 698mm(D) x 507mm(H) (printer alone) 997mm(W) x 870mm(D) x 1062mm(H) (with ST-26 or ST-27 stand and opening the output stacker) 997mm(W) x 1100mm(D) x 1062mm(H) (with ST-27 stand and setting to the extended position B)
<b>Weight</b>	Approx. 43kg (printer alone) Approx. 54kg (with ST-26 or ST-27 stand and without printhead and ink tank)
<b>Package dimensions (WxDxH) / Weight</b>	1127mm x 830mm x 773mm (printer alone, with the palette), approx. 72kg 1073mm x 766mm x 263mm (ST-26 stand), approx. 15kg 1083mm x 766mm x 350mm (ST-27 stand alone), approx. 19kg For US model: 1127mm x 830mm x 1058mm (with the stand and the palette), approx. 89kg

## 1.4 Detailed Specifications

### 1.4.1 Interface Specifications

#### a. USB (standard)

- (1) Interface type  
USB 2.0 Hi-Speed (Full speed (12 Mbps/sec), High speed (480 Mbps/sec))
- (2) Data transfer system  
Control transfer  
Bulk transfer
- (3) Signal level  
Compliant with the USB standard.
- (4) Interface cable  
Twisted-pair shielded cable, 5.0 m max.  
Compliant with the USB standard.  
Wire materials: AWG No.28, data wire pair (AWF: American Wire Gauge)  
AWG No.20 to No.28, power distribution wire pair
- (5) Interface connector  
Printer side: Series B receptacle compliant with USB standard

Cable side: Series B plug compliant with USB standard

**b. Network (standard)**

- (1) Interface type  
Interface compliant with IEEE802.3
- (2) Data transfer system  
IEEE802.0 10Base-T, IEEE802.3u 100Base-TX/Auto-Negotiation, IEEE802.3ab 1000Base-T/Auto-Negotiation, IEEE802.3x Full Duplex
- (3) Interface cable  
Category 5 (UTP or FTP) cable, 100 m or shorter  
Compliant with ANSI/EIA/TIA-568A or ANSI/EIA/TIA-568B
- (4) Interface connector  
Printer side: Compliant with IEEE802.3, ANSI X3.263, ISO/IEC60603-7
- (5) Protocol  
IPX/SPX (Netware4.2(J), 5.1(J), 6.0(J)), SNMP, TCP/IP(IPv4/IPv6), AppleTalk, HTTP

## 1.5 Names and Functions of Components

### 1.5.1 Front

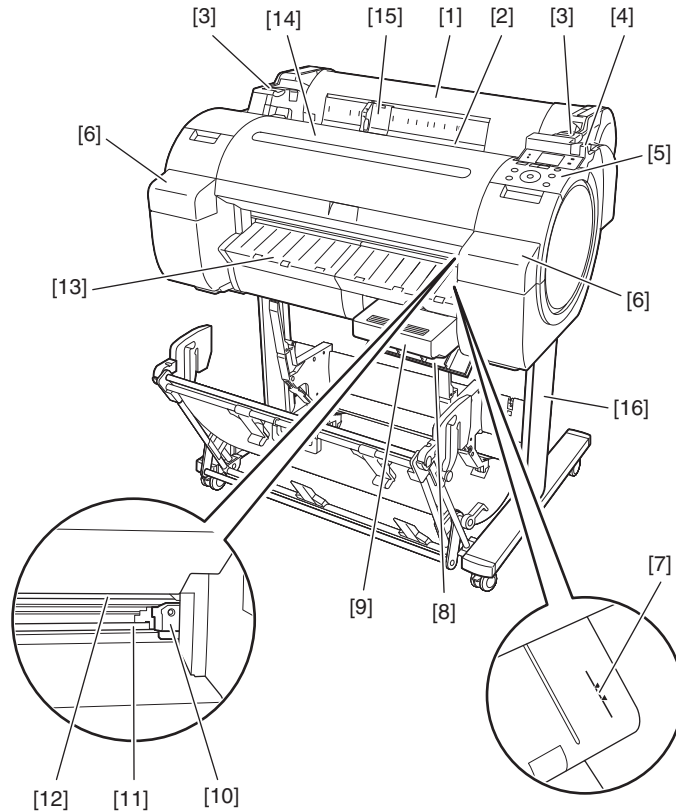

F-1-28

- [1] Roll media cover  
Open this cover, and then load roll media.
- [2] Media loading slot  
Insert media in this slot to load it.
- [3] Roll media temporary table  
When loading roll media, place the roll holder here and then insert the media in the roll holder slot.
- [4] Release lever  
When releasing the paper retainer, press this lever backward.
- [5] Operation panel  
Use this panel to operate the printer or check the printer status.
- [6] Ink tank cover  
Open this cover to replace the ink tank.
- [7] Media alignment line  
This orange line is used to align media.
- [8] Maintenance cartridge cover  
Open this cover to replace the maintenance cartridge.
- [9] Maintenance cartridge  
This cartridge absorbs the ink used for maintenance. (Replace it when it becomes full of ink.)
- [10] Cutter unit  
This cutter with a round blade is used to cut roll media automatically.
- [11] Cutter rail  
The cutter unit moves on this rail to cut media.
- [12] Paper eject slot  
All printouts are ejected from this slot.
- [13] Output guide  
A printout is ejected along this guide.
- [14] Upper cover  
Open this cover to install the printhead or remove the media jammed inside the printer.
- [15] Width guide  
When loading cassette paper, move this guide according to the paper size.
- [16] Stand  
Install the printer on this stand. This stand has casters for easy relocation.

1.5.2 Side

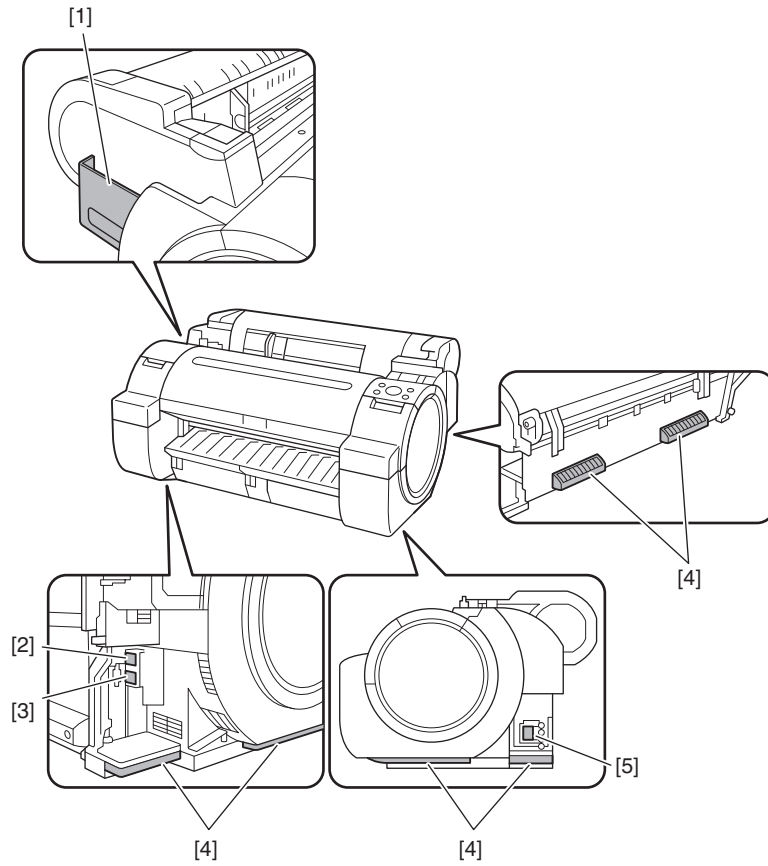

F-1-29

[1] Manual pocket

Store the printer manual in this pocket.

[2] Ethernet connector

Connect the Ethernet cable to this connector. The lamp lights when the Ethernet cable is connected properly and the printer is ready to communicate accordingly.

[3] USB port

Connect the USB cable to this port. This port is compatible with the high-speed USB.

[4] Carrying handles

Three carrying handles provided at the left, right, and back allows three persons to carry the printer.

[5] Power receptacle

Plug the power cord into this receptacle.



## 1.5.3 Top Cover (Inside)

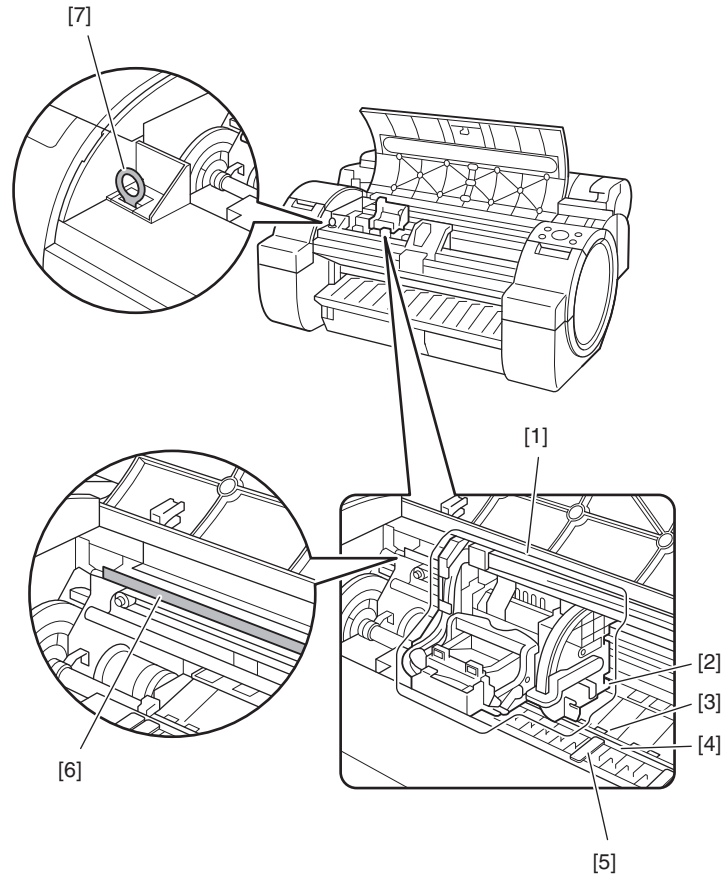

F-1-30

## [1] Carriage

The carriage moves the printhead. It is an important component used for printing.

## [2] Carriage shaft

The carriage moves on this shaft.

## [3] Paper retainer

This is an important component used to feed paper. It retains paper.

## [4] Platen

The printhead moves on this component to perform printing. Suction holes are provided on the platen surface to prevent media from floating.

## [5] Borderless printing ink catch groove

Ink flowed out of the paper edges enter in this groove during borderless printing.

## [6] Linear scale

This is an important component used to detect the carriage position. Never touch it when cleaning the parts or removing jammed media inside the upper cover.

## [7] Cleaner brush

Use this brush to remove paper dust off the platen when cleaning the parts inside the upper cover.

### 1.5.4 Roll Unit Cover (Inside)

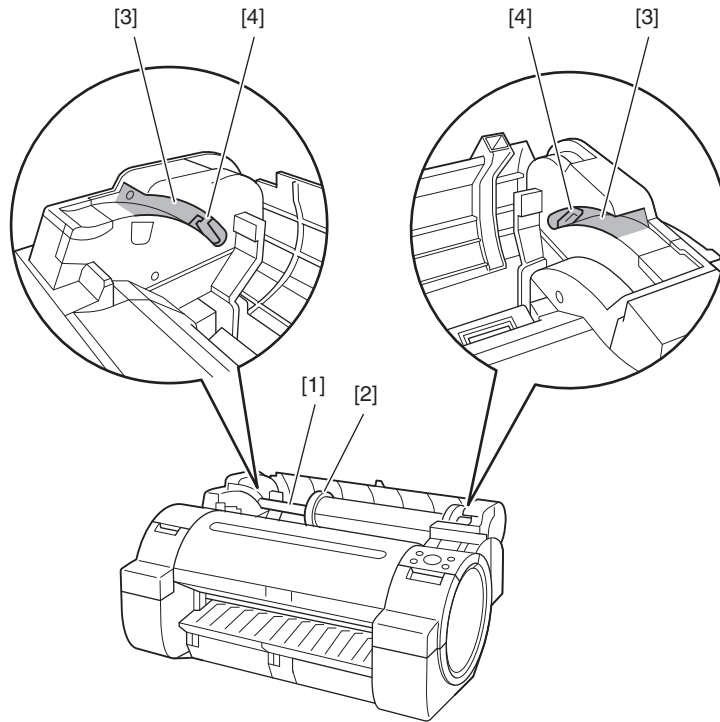

F-1-31

- [1] Roll holder  
Load roll media in this holder.
- [2] Holder stopper  
Use this part to secure roll media to the roll holder.
- [3] Slide guide  
Move the roll holder along this guide.
- [4] Roll holder slot  
Fit the roll holder in this slot.

### 1.5.5 Carriage

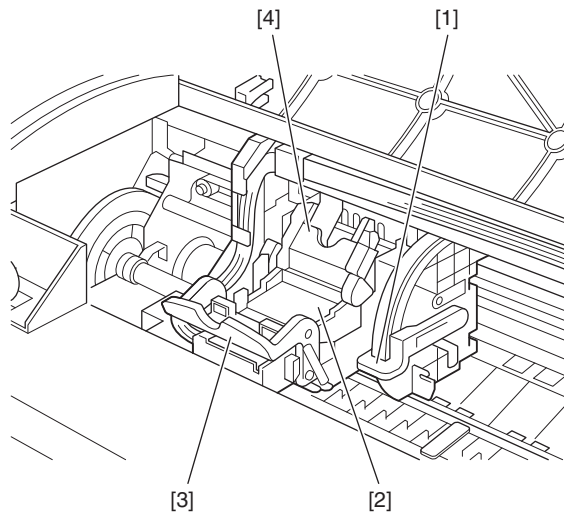

F-1-32

- [1] Slant adjusting lever  
This lever is used to fine adjust slant of rules lines.
- [2] Printhead  
The printhead has nozzles. It is an important component used to perform printing.
- [3] Printhead fixer lever  
This lever is used to lock the printhead fixer cover.
- [4] Printhead fixer cover  
This cover is used to secure the printhead.

## 1.5.6 Ink Tank Cover (Inside)

[Left Ink Tank Unit]

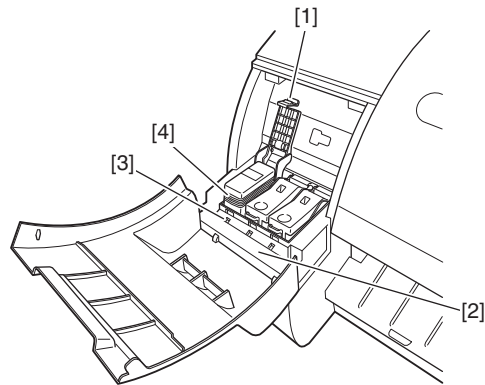

F-1-33

[Right Ink Tank Unit]

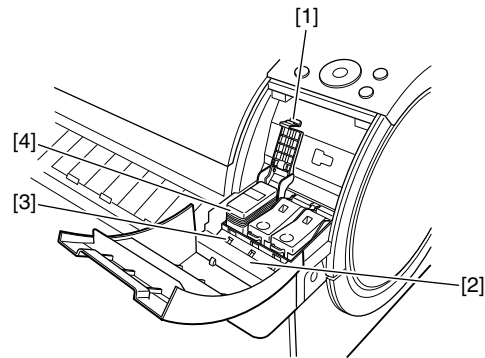

F-1-34

[1] Ink tank lock lever

This lever is used to protect and lock the ink tank. Open/close this lever when replacing the ink tank.

[2] Ink color label

Load each ink tank according to the label color and name.

[3] Ink tank lamp (red)

When the ink tank is opened, the ink tank lamp illuminates as follows:

- Stays lit

The ink tank is loaded properly.

- Not lit

No ink tank is loaded or the remaining ink detection function is disabled.

- Blinking slow

Only a small amount of ink remains in the ink tank.

- Blinking fast

No ink remains in the ink tank.

[4] Ink tank

This is a cartridge containing ink of each color.

1.5.7 Stand (ST-26)

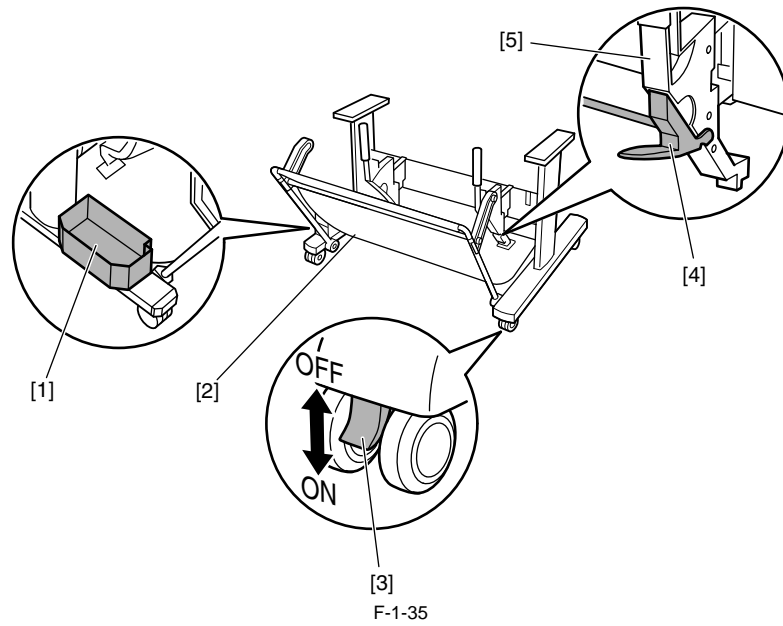

[1] Accessory pocket

Store the printer accessories.

[2] Output stacker

Ejected printouts are collected in this output stacker.

[3] Lockable caster

This caster can be locked.

When relocating the printer, be sure to unlock all four casters. Moving the printer with the casters locked can damage the floor.

[4] Switching stopper

Pull out this stopper when using the output stacker at the extended position.

[5] Paper guide

This guide is used to lead the ejected printout to the output stacker.

F-1-35

## 1.5.8 Stand (ST-27)

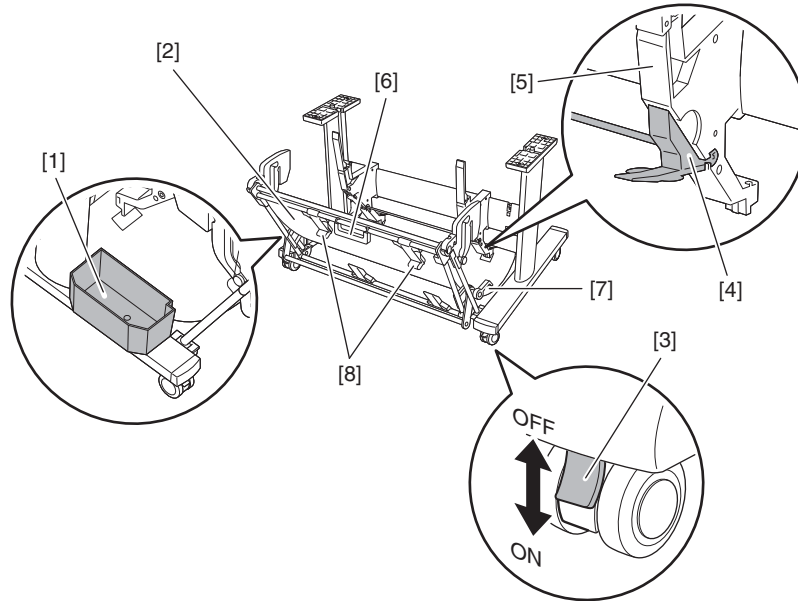

F-1-36

## [1] Accessory pocket

Store the printer accessories.

## [2] Output stacker

Ejected printouts are collected in this output stacker.

## [3] Lockable caster

This caster can be locked.

When relocating the printer, be sure to unlock all four casters. Moving the printer with the casters locked can damage the floor.

## [4] Switching stopper

Pull out depending on the paper size when using the output stacker in the extended position A.

## [5] Paper guide

This guide is used to lead the ejected printout to the output stacker.

## [6] Output stacker handle

This handle is grasped and supports the sliding output stacker when putting the output stacker into extended position B and returning it to the regular position.

## [7] Output stacker release lever

Pull this lever towards you to release extended position B.

## [8] Output stacker ejection guide

This guide supports the paper that is output when using the output stacker in extended position B.

## 1.6 Basic Operation

### 1.6.1 Operation Panel

This section explains the functions of the buttons and the meanings of the LEDs on the operation panel.

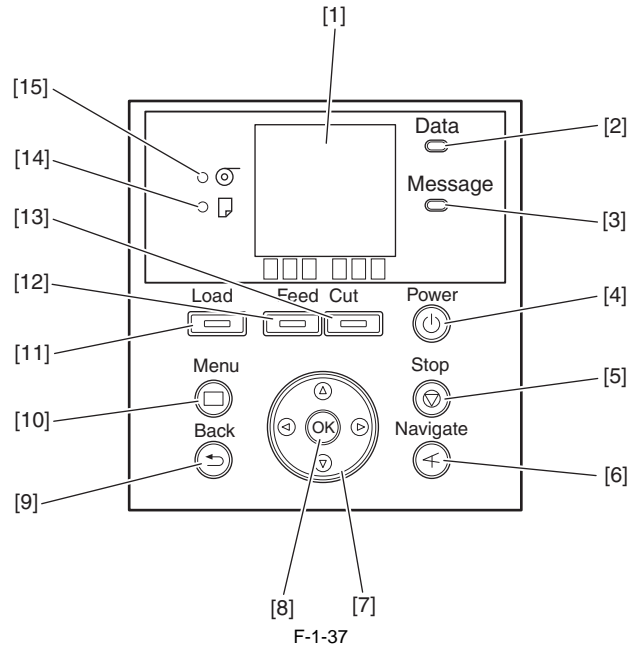

#### [1] Display

Printer menus, statuses, and messages are shown on this display.

#### [2] Data reception lamp (green)

- Blinking: When the printer is making prints, this lamp indicates that a print job is being received or processed. When the printer is not making prints, this lamp indicates that the print job is suspended or the firmware data is being received.

- Not lit: This lamp indicates that there is no print job.

#### [3] Message lamp (orange)

- Stays lit: A warning message is being displayed.

- Blinking: An error message is being displayed.

- Not lit: The printer is normal or not powered.

#### [4] [Power] button (green)

Use this button to turn on or off the printer.

When the printer is powered or in the sleep mode, the [Power] button lamp stays lit.

#### [5] [Stop] button

Use this button to stop execution of a job or drying ink.

#### [6] [Navi] button

Use this key to confirm the procedures for loading/unloading media, replacing an ink tank, and replacing the printhead.

#### [7] Direction buttons

- ◀ button: Pressing this button on the [tab selection screen] moves the tab. When a menu requiring you to enter a value is selected, pressing this button allows you to move to the left-hand digit.

- ▲ button: Pressing this button in a menu displays the upper item or setting value.

- ▶ button: Pressing this button on the [tab selection screen] moves the tab. When a menu requiring you to enter a value is selected, pressing this button allows you to move to the right-hand digit.

- ▼ button: Pressing this button in a menu displays the lower item or setting value.

#### [8] [OK] button

Pressing this button on the [tab selection screen] displays the menu for the displayed tab.

In the menu for a tab, pressing this button at the item preceded by [+ ] allows you to move to the bottom layer of menu items, where you can execute a menu item or set values. Also press this button when a message asking you to press the [OK] button is shown on the display.

#### [9] [Back] button

Pressing this button displays the preceding screen.

#### [10] [Menu] button

Pressing this button displays the [tab selection screen] screen.

#### [11] [Media Change] button

Press this button when loading/replacing media.

#### [12] [Media Feed] button

When roll media is loaded, pressing this button allows you to change the media position.

#### [13] [Media Cut] button

When roll media is loaded, pressing this button cuts the media.

#### [14] [Cut Sheet] lamp (green)

This lamp stays lit when cut sheet is selected as a media type.

#### [15] [Roll Media] lamp (green)

This lamp stays lit when roll media is selected as a media type.

#### MEMO:

When the printer is in the sleep mode, pressing any button other than the [Power] button wakes up the printer.

## 1.6.2 Display

When the printer starts, the [tab selection screen] appears on the display.

There are four types of tabs on which the relevant printer status, menu, and error information are displayed.

The tab appears as the icon to the top field of display. The tab moves by ◀ key or ▶ key.

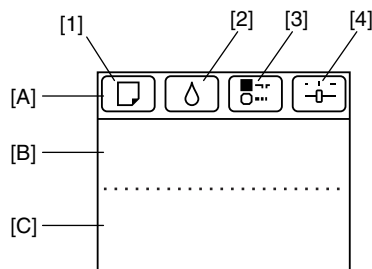

F-1-38

### [1] Media tab

This tab shows the printer status and menu related to media. When this tab is shown in reverse video, pressing the [OK] button displays the [Media] menu.

-[A] Top field of display: Shows the media icon in reverse video.

-[B] Middle field of display: Shows the printer status and a menu name.

-[C] Bottom field of display: Shows the media type in the first row and the media size in the second row.

### [2] Ink tab

This tab shows the printer status and menu related to ink. When this tab is shown in reverse video, pressing the [OK] button displays the [Ink] menu.

-[A] Top field of display: Shows the ink icon in reverse video.

-[B] Middle field of display: Shows the printer status and a menu name.

-[C] Bottom field of display: Shows the remaining ink levels of the ink tanks loaded in the printer.

### [3] Job tab

This tab shows the printer status and menu related to the print job. When this tab is shown in reverse video, pressing the [OK] button displays the [Job] menu.

-[A] Top field of display: Shows the job icon in reverse video.

-[B] Middle field of display: Shows the printer status and a menu name.

### [4] Setup/Adjustment tab

This tab shows the printer status and menu related to setup/adjustment. When this tab is shown in reverse video, pressing the [OK] button displays the [Setup/Adjustment] menu.

-[A] Top field of display: Shows the setup/adjustment icon in reverse video.

-[B] Middle field of display: Shows the printer status and a menu name.

-[C] Bottom field of display: Shows the remaining ink level of the maintenance cartridge.

### 1.6.3 Menu

The printer has a Main menu which includes a menu related to maintenance such as adjustment of ink ejection position of each nozzle and head cleaning, a menu related to printing settings such as auto cutting and ink drying time, and a menu related to parameters such as a message language.

#### 1. Menu Operation

##### a) Displaying menu on each tab

Press the ◀ key or ▶ key on the [Tab Selection] screen to select a tab, and press the [OK] key.  
A menu associated with each tab is displayed.

Press the ▲ key or ▼ key to select a menu and press the [OK] key.  
The menu is selected and menu items are displayed.

Select a menu with [+] on the left side and press the [OK] key to navigate to lower level menus.

##### b) Setting menu items

Press the ▲ key or ▼ key to select an item to set and press the [OK] key.

The item is checked on the left side check box to confirm that it is set.

After 2 seconds, the menu that is one level above is displayed.

##### c) Setting numeric value for a menu item

Proceed as follows to set a numeric value for an item such as network settings.

1. Press the ◀ key or ▶ key to move the underscore to the field you want to enter a numeric value.
2. Press the ▲ key or ▼ key to enter a numeric value.
3. Repeat steps 1 and 2 and press the [OK] key when finished.



## 2. Main Menu

The structure and settings of the main menu is as follows. The asterisk mark "\*" is default setting.

### [Paper Menu]

First Level	Second Level	Third Level	Fourth Level	Fifth Level
[Load Paper]	[Roll Paper]			
	[Cut Sheet]			
[Eject Paper]				
[Chg. Paper Type]	[Roll Paper]	(The paper type is displayed here.)		
	[Cut Sheet]	(The paper type is displayed here.)		
[Chg. Paper Size]	[Cut Sheet Size]	(The size of paper is displayed here.)		
		[CustomPaperSize]	(Set the length)	
	[Roll Length]*1	(Set the length)		
[ManageRemainRoll]	[Off]*			
	[On]			
[Pap. Detail Set]	(The paper type is displayed here.)	[Head Height]	[Automatic]*	
			[Highest]	
			[High]	
			[Standard]	
			[Low]	
			[Lowest]	
		[Crooked Chk Lv.]	[High Accuracy]	
			[Standard]*	
			[Loose]	
			[Off]	
		[Cutting Mode]	[Automatic]	
			[Eject]*	
			[Manual]	
		[Cut Speed]	[Fast]	
			[Standard]	
			[Slow]*	
		[Trim Edge First]	[Automatic]*	
			[Off]	
			[On (Preset Len)]	
			[On (Input Length)]	
			[Manual]	
		[CutDustReduct.]	[Off]*	
			[On]	
		[VacuumStrngth]	[Automatic]*	
			[Strongest]	
			[Strong]	
			[Standard]	
			[Weak]	
			[Weakest]	

First Level	Second Level	Third Level	Fourth Level	Fifth Level
[Paper Details]	(The paper type is displayed here.)	[Scan Wait Time]	[Dry time]	[Off]*
				[1 sec.]
				[3 sec.]
				[5 sec.]
				[7 sec.]
			[9 sec.]	
			[Area]*16	[Entire area]*
			[Leading edge]	
			[Roll DryingTime]	[Off]*
				[30 sec.]
		[1 min.]		
		[3 min.]		
		[5 min.]		
		[10 min.]		
		[30 min.]		
		[60 min.]		
		[NearEnd RollMrgn]	[3mm]*	
			[20mm]	
		[NearEnd Sht Mrgn]	[3mm]*	
			[20mm]	
[BordlessOversize]	[Standard]*			
	[Reduced]			
[Width Detection]	[Off]			
	[On]*			
[Return Defaults]				
[Pap. Detail Print]				
[Keep Paper Type]	[Off]*			
	[On]			

**[Ink Menu]**

First Level	Second Level	Third Level	Fourth Level	Fifth Level
[Rep. Ink Tank]				
[Head Cleaning A]				

**[Job Menu]**

First Level	Second Level	Third Level	Fourth Level	Fifth Level
[Print Job]*14	(Job List is displayed here.)	(Select Print Job.)	[Delete] [Preempt Jobs]*3	
[Stored Job]*14	(Mailbox List is displayed here.)	(Enter a password if one has been set.)	[Job List] [Print Job List]	[Print] [Delete]
[Job Log]	(Choose from information about the latest three print jobs.)	[Document Name] [User Name] [Page Count] [Job Status] [Print Start Time] [Print End Time] [Print Time] [Output Img. Size] [Media Type] [Paper Consumed] [Paper Length] [Paper Width] [Interface] [Ink Consumed] [Print settings] [Head Height] [Temp./Humidity] [Adjustment reg.]	[OK] [CANCELED] [yyyymm/dd hh:mm:ss] [yyyymm/dd hh:mm:ss] [xxxsec.] (The image size is displayed) [USB] [Network] (Indicates the ink color.)	[xxx.xxx ml]
[Print Job Log]				
[Pause Print]	[Off]* [On]			

## [Set./Adj. Menu]

First Level	Second Level	Third Level	Fourth Level	Fifth Level		
[Test Print]	[Nozzle Check]					
	[Status Print]					
	[Interface Print]					
	[GL2 Set Print]					
	[Pap. Detail Print]					
	[Print Job Log]					
	[Menu Map]					
	[Color Palette]					
[Adjust Printer]	[Head Posi. Adj.]	[Auto(Standard)]				
		[Auto(Advanced)]				
		[Manual]*4				
	[Head Inc. Adj.]					
	[Feed Priority]	[Adj. Priority]				[Automatic]*
						[Print Quality]
						[Print Length]
		[Adj. Quality]*5				[Auto(GenuinePpr)]
						[Auto(OtherPaper)]
						[Manual]
	[Adjust Length]*6				[AdjustmentPrint]	[A:High]
						[B:Standard/Draft]
		[Change Settings]	[A:High]			
			[B:Standard/Draft]			
[Maintenance]	[Head Cleaning]	[Head Cleaning A]				
		[Head Cleaning B]				
	[Nozzle Check]					
	[Replace P.head]					
	[Repl. maint cart]					
	[Head Info]	The "ProductName" and "s/n" and "Days elapsed" and "Count [Mdot]" are displayed here.				
[GL2 Replot]						
[GL2 Buffer Clear]						

First Level	Second Level	Third Level	Fourth Level	Fifth Level	Sixth Level	
[GL2 Settings]	[Quality Manager]	[Color Mode]	[Monochrome]			
			[Color (CAD) 1]*			
			[Color (CAD) 2]			
			[Color (CAD) 3]			
			[Color (CAD) 4]			
			[Color (CAD) 5]			
		[Print Quality]	[Draft]			
			[Standard]*			
			[High]			
		[Input Resolution]	[600dpi]*			
			[300dpi]			
		[Print (Economy)]	[Off]*			
			[On]			
		[Paper Manager]	[Paper Source]	[Automatic]*		
	[Roll Paper]					
	[Cut Sheet]					
	[Margin]		[3mm(Standard)]*			
			[5mm]			
	[Oversize]		[Off]			
			[On]*			
	[Conserve Paper]		[Off]*			
			[On]			
	[Auto Rotate]		[Off]*			
			[On]			
	[Enlarge/Reduce]		[Off]*			
			[Specify scaling]			
			[Fit to paper]			
	[Print centered]		[Off]*			
			[On]			
	[Standard cut]		[Off]*			
			[On]			
	[Nesting]*14		[Use Nesting]	[Off]*		
				[On]		
		[Nesting WaitTime]*7	[xx min.]			
		[Cut Lines]*7	[Off]*			
			[On]			

First Level	Second Level	Third Level	Fourth Level	Fifth Level	Sixth Level		
[GL2 Settings]	[Line&Pen Manager]	[Enable merge]	[Off]*				
			[On]				
		[Pen Setup]	[Select Palette]	[Software]*			
				[Palette A]			
				[Palette B]			
				[Factory]			
			[Define Palette]	[Palette A] (Choose a pen number.)	[Width] (Indicates the Width value.)		
					[Color] 0-255		
				[Line Attributes]-[No Setting]/[Circle Setting]			
				[Palette B] (Choose a pen number.) (Indicates Width, Color, and Line Attributes.)	(Specify the values of Width, Color, and Line Attributes.)		
				[Factory] (Choose a pen number.) (Indicates Width, Color, and Line Attributes.)			
				[Reset Palette]	[All Palette]		
			[Palette A]				
			[Palette B]				
		[Smoothing]	[Software]*				
				[Smooth]			
		[ThickenFineLines]	[Off]*				
			[On]				
		[AdjustFaintLines]	[Off]				
			[On]*				
		[Ln Wdth correct]	[Black/gray]	(Set the correcting value of line width.)			
			[Color]	(Set the correcting value of line width.)			
		[ProcessingOption]	[Warning]	[Off]*			
				[On]			
			[On-the-Fly]*14	[Off]*			
				[On]			
			[Detect img size]	[Off]*			
[Command priority]							
	[Detected size]						
[GL2 Set Print]							

First Level	Second Level	Third Level	Fourth Level	Fifth Level	Sixth Level	Seventh Level		
[Interface Setup]	[EOP Timer]*12	[10 sec.]						
		[30 sec.]						
		[1 min.]						
		[2 min.]						
		[5 min.]						
		[10 min.]*						
		[30 min.]						
		[60 min.]						
	[TCP/IP]*12	[IPv4]	[IPv4 Mode]	[Automatic]				
				[Manual]*				
			[Protocol]*8	[DHCP]	[On]*			
					[Off]			
				[BOOTP]	[On]			
					[Off]*			
			[RARP]	[On]				
				[Off]*				
			[IPv4 Settings]*13	[IP Address]	(Set the Address.)			
				[Subnet Mask]	(Set the Address.)			
				[Default G/W]	(Set the Address.)			
			[DNS Settings]*13	[DNS Dync update]	[On]			
				[Off]*				
		[Pri. DNS SrvAddr]		(Set the Address.)				
		[Sec. DNS SrvAddr]		(Set the Address.)				
		[DNS Host Name]		(Set the DNS host name.)				
		[DNS Domain Name]		(Set the DNS domain name.)				
		[IPv6]	[IPv6 Support]	[Supported]				
				[Not Supported]*				
			[IPv6 StatelessAddrs]*17	[Use]*				
				[Do Not Use]				
			[DHCPv6]*17	[Use]				
	[Do Not Use]*							
	[DNS Settings]*13*17 (Choose whether if using the DNS Settings of IPv4.)		[DNS Dync update]	[Statefull Addr]	[On]			
					[Off]*			
			[Stateless Addr]	[On]				
				[Off]*				
[Pri. DNS SrvAddr]			(Set the Address.)					
[Sec. DNS SrvAddr]		(Set the Address.)						
[DNS Host Name]	(Set the DNS host name.)							
[DNS Domain Name]	(Set the DNS domain name.)							

First Level	Second Level	Third Level	Fourth Level	Fifth Level	
[Interface Setup]	[Ethernet Driver]*12	[Auto Detect]	[On]* [Off]		
		[Comm.Mode]*10	[Half Duplex]* [Full Duplex]		
		[Ethernet Type]*10	[10Base-T]* [100Base-TX] [1000Base-T]		
		[Spanning Tree]	[Not Use]* [Use]		
		[MAC Address]	(The MAC address is displayed here.)		
		[Interface Print]*12			
	[Return Defaults]*12				
[System Setup]	[Sleep Timer]	[5 min.]*			
		[10 min.]			
		[15 min.]			
		[20 min.]			
		[30 min.]			
		[40 min.]			
		[50 min.]			
		[60 min.]			
		[210 min.]			
	[Shut Down Timer]	[Off]			
		[5 min.]			
		[10 min]			
		[30 min]			
		[1 hour]			
		[4 hours]			
	[Buzzer]	[Off]			
		[On]*			
		[Contrast Adj.]			-4,-3,-2,-1,0*,+1,+2,+3,+4
	[Date & Time]*12	[Date]	[yyyy/mm/dd]*11	[Time]	[hh:mm]
	[Date Format]	[yyyy/mm/dd]*			
		[dd/mm/yyyy]			
		[mm/dd/yyyy]			
	[Language]	[English]			
[Japanese]					
[Francais]					
[Italiano]					
[Deutsch]					
[Espanol]					
[Portuguese]					
[Russian]					
[Chinese] (simplified)					
[Korean]					



First Level	Second Level	Third Level	Fourth Level	Fifth Level
[System Setup]	[Time Zone]*12	[0:London(GMT)]		
		[+1:Paris,Rome]		
		[+2:Athens,Cairo]		
		[+3:Moscow]		
		[+4:Eerevan,Baku]		
		[+5:Islamabad]		
		[+6:Dacca]		
		[+7:Bangkok]		
		[+8:Hong Kong]		
		[+9:Tokyo,Seoul]		
		[+10:Canberra]		
		[+11NewCaledonia]		
		[+12:Wellington]		
		[-12:Eniwetok]		
		[-11:Midway is.]		
		[-10Hawaii(AHST)]		
		[-9:Alaska(AKST)]		
		[-8:Oregon (PST)]		
		[-7:Arizona(MST)]		
		[-6:Texas(CST)]		
	[-5:NewYork(EST)]			
	[-4:Santiago]			
	[-3:Buenos Aires]			
	[-2:CenterAtlantic]			
	[-1:Cape Verde]			
	[Length Unit]	[meter]*		
		[feet/inch]		
	[Detect Mismatch]	[Pause]		
		[Warning]		
		[None]*		
	[Paper Size Basis]	[Roll Selection 1]	[ISO A3 (297mm)]*	
			[300mm Roll]	
		[Roll Selection 2]	[10in. (254mm)]*	
[JIS B4 (257mm)]				
[Keep Paper Size]	[Off]*			
	[On]			
[TrimEdge Reload]	[Automatic]			
	[Off]*			
	[On]			
[Rep.P.head Print]	[Off]			
	[On]*			

First Level	Second Level	Third Level	Fourth Level	Fifth Level
[System Setup]	[Nozzle Check]	[Frequency]	[Standard]*	
			[1 page]	
			[10 pages]	
			[Off]	
		[Warning]	[Off]*	
		[On]		
		[Use USB]*12	[Use]*	
		[Do Not Use]		
	[Use Ethernet]*12	[Use]*		
	[Do Not Use]			
	[Use RemoteUI]*12	[Use]*		
	[Do Not Use]			
	[Reset PaprSetngs]*12			
	[Show Job Log]*12	[Off]		
	[On]*			
[Prep.MovePrinter]				
[Admin. Menu]*12	[Chg.Admin.Pswd]*13	(The screen for setting the password is displayed)		
	[Init.Admin.Pswd]*13			
[Printer Info]	[Paper Info]			
	[Ink Info]			
	[Head Info]			
	[System Info]			
	[Error Log]			
	[Use Situation]	[Tot. Print Area]		
	[Duty Counter]			

- \*1: Available only if ManageRemainRoll is On.
- \*2: Available only if Width Detection is set to Off.
- \*3: Print Anyway is displayed when a job being held is selected.
- \*4: Available after Auto(Advanced) in Head Posi. Adj. has been used once.
- \*5: Available when you have specified Feed Priority > Adj. Priority > Automatic or Print Quality.
- \*6: Available when you have specified Feed Priority > Adj. Priority > Automatic or Print Length.
- \*7: Available only if Use Nesting is set to On.
- \*8: Not shown if you have set IPv4 Mode to Manual.
- \*10: Not shown if you have set Auto Detect to On.
- \*11: Follows the setting in Date Format.
- \*12: Viewing and configuration is possible for administrators, and only viewing for other users.
- \*13: Viewing and configuration is possible for administrators only.
- \*16: Leading edge is not available as a setting option in the Paper Detailed Settings dialog box of the printer driver.
- \*17: Not displayed if IPv6 Support is Not Supported.

**3. Main menu during printing**

The structure of the main menu during printing is as follows.

First Level	Second Level	Third Level	Fourth Level	Fifth Level
[Adj. Fine Feed]				
[Printer Info]	[Paper Info]			
	[Ink Info]			
	[Head Info]			
	[System Info]			
	[Error Log]			
	[Other Counter]			

#### 4. Main Menu Settings

Main menu items are described in the following tables.

##### [Paper Menu]

Setting Item		Description/Instructions
[Load Paper]		Select and load either cut sheet or roll media.
[Eject Paper]		Remove currently loaded paper.
[Chg. Paper Type]		Change currently set paper type.
[Chg. Paper Size]		Change currently set paper size.
[ManageRemainRoll]		Choose On to print a barcode at the end of a roll before you remove it. The printed barcode can be used in managing the amount of roll paper left. Choose Off if you prefer not to print the barcode.
[Pap. Detail Set] (The paper type is displayed here.)	[Head Height]	Adjust the Printhead height.
	[Crooked Chk Lv.]	If you print on the paper that has an irregular width, choose Loose for a higher skew detection threshold, or choose Off to disable skew detection. However, if paper is loaded askew when detection is Off, note that paper jams or Platen soiling may occur.
	[Cutting Mode]	Select whether to use standard round blade cutter or not. Select [Automatic] to cut paper after printing. Select [Manual] to print a line at the cut position after printing without cutting. Select [Eject] to prevent the printout from dropping until the ink dries after printing.
	[Cut Speed]	Choose the cutting speed. If you use adhesive paper, choosing Slow helps prevent adhesive from sticking to the cutter and keeps the cutter sharp.
	[Trim Edge First]	If a roll is loaded, the end of the paper will be cut.
	[CutDustReduct.]	Choose On to reduce the amount of debris generated when cutting film and similar media by printing a line at the cut position. This option reduces the amount of debris given off after cutting. It also helps prevent adhesive from sticking to the cutter and keeps the cutter sharp if you use adhesive paper.
	[VacuumStrngth]	Specify the level of suction that holds paper against the Platen.
	[Scan Wait Time]	Specify the time to wait for the ink to dry between each scan in bidirectional printing, in consideration of how quickly the ink dries. Note that printing will take longer if you specify a wait time.
	[Roll DryingTime]	Specify the time to wait for the ink to dry for each sheet.
	[NearEnd RollMrgn]	Specify the minimum margin at the leading edge of roll paper to ensure better printing quality at the leading edge. Note that if you choose 3mm, it may lower the printing quality at the leading edge and affect feeding accuracy. The printed surface may be scratched, and ink may adhere to the leading edge. It may also cause the Platen to become soiled.
	[NearEnd Sht Mrgn]	Specify a margin at the leading edge of sheets to ensure better printing quality at the leading edge. Note that if you choose 3mm, it may lower the printing quality at the leading edge and affect feeding accuracy. The printed surface may be scratched, and ink may adhere to the leading edge.
	[BordlessOversize]	Select the margin during borderless printing.
	[Width Detection]	Set to print from desired position such as when printing inside a frame. Select [Off] to disable paper width and skew detection. If paper is loaded askew, paper may jam or platen soiling may occur.
[Return Defaults]	Choose OK to restore Paper Details to the factory default values.	
[Pap. Detail Print]		Print the paper settings set with [Paper Details].
[Keep Paper Type]		Select [On] to continue using the same type of paper.

**[Ink Menu]**

Setting Item	Description/Instructions
[Rep. Ink Tank]	When replacing the Ink Tank, choose Yes and follow the instructions on the screen.
[Head Cleaning A]	Specify Printhead cleaning options. Execute Head Cleaning A if printing is faint, oddly colored, or contains foreign substances.

**[Job Menu]**

Setting Item			Description/Instructions	
[Print Job]	[Job List]	(Select Print Job.)	[Delete]	Delete the current job or queued jobs.
			[Preempt Jobs]	Print the job first after the current print job is finished printing.
[Stored Job]	[Mailbox List]	(Enter a password if one has been set.)	[Job List]- [Print]	Print a saved job.
			[Job List]- [Delete]	Delete a saved job.
			[Print Job List]	Print a list of saved jobs.
[Job Log]	(Choose from information about the latest three print jobs.)	[Document Name]		Display the name of the document in the most recently printed job.
		[User Name]		Display the name of the user who has transmitted the job.
		[Page Count]		Display the number of sheets of the job.
		[Job Status]		Display the result of processing of the job.
		[Print Start Time]		Display the time at which the job started printing.
		[Print End Time]		Display the time at which the job finished printing.
		[Print Time]		Display the time spent printing the job.
		[Output Img. Size]		Display the image size in the print job.
		[Media Type]		Display the type of the paper used for printing the job.
		[Paper Consumed]		Display the consumption of paper.
		[Paper Length]		Display the length of paper.
		[Paper Width]		Display the width of paper.
		[Interface]		Display the interface of the job.
		[Ink Consumed]		Display the amount of ink consumed for printing the job.
	[Print Settings]		Display the job print settings.	
	[Head Height]		Display the head height when jobs were printed.	
	[Temp./Humidity]		Display the temperature and humidity when jobs were printed.	
	[Adjustment reg.]		Display the adjustment conditions applied to jobs.	
[Print Job Log]				Print the print job information such as paper type, size, and ink consumption. Ink consumption is the approximate amount of ink used to print one sheet.
[Pause Print]				Select [On] to stop printing.

## [Set./Adj. Menu]

Setting Item		Description/Instructions		
[Test Print]	[Nozzle Check]	Print a nozzle check pattern.		
	[Status Print]	Print the printer information.		
	[Interface Print]	Print the interface settings.		
	[GL2 Set Print]	Print the GL2 settings.		
	[Pap. Detail Print]	Print the paper settings set with [Paper Details].		
	[Print Job Log]	Print print job information such as paper type, size, and ink consumption. Ink consumption is the approximate amount of ink used to print one sheet.		
	[Menu Map]	Print the menu list.		
	[Color Palette]	Print the GL2 color list.		
[Adjust Printer]	[Head Posi. Adj.]	[Auto(Standard)]	Print and read a test pattern for the automatic adjustment of Printhead alignment relative to the printing direction.	
		[Auto(Advanced)]	Print and read a test pattern for the automatic adjustment of Printhead alignment relative to the nozzle and printing direction.	
		[Manual]	Print a test pattern for adjustment of Printhead alignment relative to the printing direction. Enter the adjustment value manually based on the resulting pattern.	
	[Head Inc. Adj.]	Print an adjustment pattern for adjusting the inclination of the printhead.		
	[Feed Priority]	[Adj. Priority]	[Automatic]	Set the priority feed precision. Normally select [Automatic]. Select [Print Quality] to print at high quality. Select [Print Quality] to reduce horizontal streaks. Select [Print Length] to accurately control the feed amount. However, selecting [Print Length] may cause colors to become slightly uneven in the carriage scan direction.
			[Print Quality]	
			[Print Length]	
		[Adj. Quality]	[Auto(GenuinePpr)]	Set when using paper described in the paper reference guide. A pattern to adjust the paper feed amount is printed, and the feed amount is automatically adjusted from the printed result.
			[Auto(OtherPaper)]	Set when using paper not described in the paper reference guide. A pattern to adjust the paper feed amount is printed, and the feed amount is automatically adjusted from the printed result. This takes longer than [Auto (GenuinePpr)] to print and consumes more ink.
			[Manual]	Select for paper that cannot be adjusted by [Auto(GenuinePpr)] or [Auto(OtherPaper)], such as highly transparent paper. Print a pattern to adjust the paper feed amount according to the type of paper.
		[Adjust Length]	[AdjustmentPrint]-[A:High]/[B:Standard/Draft]	Print a test pattern for adjustment relative to paper stretching or shrinkage, after which you can enter the amount of adjustment.
[Change Settings]-[A:High]/[B:Standard/Draft]	Display when [Print Length] is selected as [Adj. Priority] for [Feed Priority]. Adjust the expansion rate of the currently loaded paper. Enter the result adjusted with [AdjustmentPrint] or the difference with your own measurement in %. Increase the adjustment value to increase the feed amount for paper that tends to expand, and reduce it for paper that tends to shrink.			
[Maintenance]	[Head Cleaning]	Specify Printhead cleaning options. Choose Head Cleaning A if printing is faint, oddly colored, or contains foreign substances. Choose Head Cleaning B if no ink is printed at all, or if printing is not improved by Head Cleaning A.		
	[Nozzle Check]	Print a nozzle check pattern.		
	[Replace P.head]	Not displayed during a warning message that the remaining Maintenance Cartridge capacity is low. When replacing the Printhead, choose Yes and follow the instructions on the screen.		
	[Repl. maint cart]	When exchanging the maintenance cartridge, choose Yes and follow the instructions on the screen.		
	[Head Info]	Display the Printhead informations.		
[GL2 Replot]	Print again the last data printed on the GL2.			
[GL2 Buffer Clear]	Delete the print data of the replot buffer.			

Setting Item			Description/Instructions	
[GL2 Settings]	[Quality Manager]	[Color Mode]	[Monochrome 1]	Print by the monochrome.
			[Color (CAD) 1]	Print by the standard color.
			[Color (CAD) 2]	Print by the bright color.
			[Color (CAD) 3]	Print by the color emulated the Canon iPF500/iPF600/iPF700/iPF510/iPF610/iPF710/iPF605/iPF720/iPF810/iPF820.
			[Color (CAD) 4]	Print by the color emulated the HP Designjet 500/800.
			[Color (CAD) 5]	Print by the color emulated the HP Designjet 1000.
		[Print Quality]		Select the print quality.
		[Input Resolution]		Choose the printer input resolution from between [600dpi] and [300dpi].
		[Print (Economy)]		Print with a lower grade of print than normal, but with less ink consumption. Select [ON] to economize on inks.
		[Paper Manager]	[Paper Source]	Select how to feed paper for printing on the HP-GL/2.
			[Margin]	Set the top/bottom and left/right margins of the paper. For cut-sheet, the trailing edge margin is 23mm. However, if the leading edge margin is set with [Paper Details], that value has priority.
			[Oversize]	Set the positions of the margins. Select [On] to adds the margins to the outer edge of the rendering region set by the [Detect img size] function. (This corresponds to the case where the [PaperSizeProcess 1] function in the old menu is set to Off) Select [Off] to sets the margins inside the rendering region taking the size set by the [Detect img size] function as the rendering region. Areas that overlap with the margin are not printed. (This corresponds to the case where the [PageSizeProcess 1] function in the old menu is set to On)
			[Conserve Paper]	Print by economizing on paper.
		[Auto Rotate]	If a document has its long side shorter than the roll width, the page rotates by 90 degrees automatically to economize on paper. If a document contains horizontally long data such that it has its long side longer than the roll width and its short side shorter than the roll width, the page rotates 90 degrees to print within the boundaries of the paper. HP RTL cannot rotate. In case of HP RTL image, the image may be truncated or a blank paper may be ejected because the image cannot be rotated even if the paper size is rotated by 90 degrees. In that case, set [Auto Rotate] to [Off].	
		[Enlarge/Reduce]	Set the enlargement or reduction. Select [Off] to enlargement and reduction are not executed. Select [Specify scaling] to prints at the specified magnification. You can specify the magnification in the range of 25 to 400%. Select [Fit to paper] to print at enlargement or reduction ratio to fit the paper size.	
		[Print centered]	Set the printing position on the paper. Select [On] when printing on roll paper, prints in the center of the width of the roll paper. When printing on cut paper, prints in the center of the paper. Select [Off] to print at the top left of the paper.	
		[Standard cut]	Select [On] to print depending on the standard paper size.	
		[Nesting]	[Use Nesting]	Select [On] to print pages when they are tiled fully to the roll width, instead of printing them one by one.
			[Nesting WaitTime]	Set the time to elapse before printing.
			[Cut Lines]	Select [On] to print perforated lines between pages.

Setting Item		Description/Instructions	
[GL2 Settings]	[Line&Pen Manager]	[Enable merge]	When lines overlap, set whether to merge or overwrite the colors of the overlapping lines. Select [Off] to overwrite with the line printed later. Select [On] to merge all overlapping colors.
	[Pen Setup]	[Select Palette]	Select the value related to pen from [Software], [Palette A], [Palette B], or [Factory]. Select [Software] to print according to the application side instruction. Select [Palette A] or [Palette B] to print with value set by [Define Palette].
		[Define Palette]	Set [Width], [Color], and [Line Attributes] for the palette's [Pen Number]. Select [Factory] to check the value when [Factory] is selected for [Select Palette]. For [Line Attributes], select the shape of line end and joint between lines as [No Setting] or [Circle Setting].
		[Reset Palette]	Return the [Define Palette] settings to factory settings.
	[Smoothing]	Choose whether to draw an arc with a smooth curve or with a polygon.	
	[ThickenFineLines]	Select [On] to print thin lines clearly.	
	[AdjustFaintLines]	If thin lines print in a tint of color varied from other patterns, selecting [Off] may provide the print result as intended, though the thin lines may print, interrupted, depending on the color.	
	[Ln Wdth correct]	Correct the width of lines. (The basic line width is set using the [Pen Setup] function) Select [Black/gray] to correct the width of lines where all of the RGB values are the same (except when R=G=B=255). The setting value can be set in the range of -20 to +20, with the setting value given in units of correction of 0.025mm. When set to -20, lines become 0.5mm thinner, and when set to +20, lines become 0.5mm thicker. Select [Color] to correct the width of lines that are not [Black/gray]. The setting value can be set in the range of -20 to +20 with the setting value given in units of correction of 0.025mm. When set to -20 lines become 0.5mm thinner, and when set to +20 lines become 0.5mm thicker	
	[Detect img size]	Set the method for selecting the rendering region. Select [Off] to use the value from the PS command in the input data. If there are no PS commands, prints using the maximum size (maximum roll paper width X (maximum roll paper width X 1.5)). This reduces the printing time compared with the cases where [Command priority] or [Detected size] are set because the data analysis finishes in a shorter period of time.	
	[ProcessingOption]	[Warning]	Select [On] to display warnings during GL2.
[On-the-Fly]		In printing data consisting solely of HP RTL, if the data is slow to print, select [On] to expedite the time at which the data starts printing. Verify the print result to make sure that images are not chipped in this case.	
[GL2 Set Print]		Print the GL2 settings.	



Setting Item			Description/Instructions		
[Interface Setup]	[EOP Timer]		Specify the timeout period before cancellation of print jobs that cannot be received by the printer.		
	[TCP/IP]	[IPv4]	[IPv4 Mode]	Choose whether the printer IP address is configured automatically or a static IP address is entered manually.	
			[Protocol]	[DHCP]/ [BOOTP]/ [RARP]	Specify the protocol used to configure the IP address automatically.
			[IPv4 Settings]	[IP Address]/ [Subnet Mask]/ [Default G/W]	Specify the printer network information when using a static IP address. Enter the IP address assigned to the printer, as well as the network subnet mask and default gateway.
			[DNS Settings]	[DNS Dync update]	Specify whether DNS server registration is updated automatically.
				[Pri. DNS SrvAddr]/[Sec. DNS SrvAddr]	Specify the DNS server address.
				[DNS Host Name]	Specify the DNS host name.
				[DNS Domain Name]	Specify the DNS domain name.
		[IPv6]	[IPv6 Support]	Set whether to support IPv6 connection.	
			[IPv6 StatelessAddrs]	Set whether to use IPv6 stateless address.	
			[DHCPv6]	Set whether to use DHCPv6 setting.	
	[DNS Settings]		[DNS Dync update]-[Statefull Addr]/[Stateless Addr]	Specify whether DNS server registration is updated automatically.	
			[Pri. DNS SrvAddr]/[Sec. DNS SrvAddr]	Specify the DNS server address.	
			[DNS Host Name]	Specify the DNS host name.	
		[DNS Domain Name]	Specify the DNS domain name.		
	[Ethernet Driver]*12	[Auto Detect]		Specify the communication method. To apply your changes, choose Register Setting. Choose On for automatic configuration of the LAN communication protocol. Choose Off to use settings values of Comm.Mode and Ethernet Type.	
		[Comm.Mode]		Choose the LAN communication method.	
		[Ethernet Type]		Choose the LAN transfer rate.	
		[Spanning Tree]		Choose whether spanning-tree packets are supported over the LAN.	
		[MAC Address]		Display the MAC address.	
	[Interface Print]			Print the interface settings.	
	[Return Defaults]			Select [OK] to return the [Interface Setup] settings to factory default.	

Setting Item		Description/Instructions
[System Setup]	[Sleep Timer]	Specify the period before the printer enters Sleep mode.
	[Shut Down Timer]	Specify the period the printer shuts down after entering Sleep mode.
	[Buzzer]	Set the buzzer. Choose On for the buzzer to sound once for warnings and three times for errors.
	[Contrast Adj.]	Adjust the Display Screen contrast level.
	[Date & Time] [Date]	Set the current date.
	[Time]	Set the current time. This can be set only when [Date] is set.
	[Date Format]	Specify the date format.
	[Language]	Specify the language used on the Display Screen.
	[Time Zone]	Specify the time zone. Time zone options indicate a main city in this time zone and the difference from Greenwich Mean Time.
	[Length Unit]	Choose the unit of measurement when roll length is displayed. You can switch the unit displayed for the remaining paper amount.
	[Detect Mismatch]	Set the printing behavior when the paper type and size set with the printer menu does not match the paper type and size set with the printer driver. Select [Pause] to pause printing. Select [Warning] to print a warning and continue printing. Select [None] to continue printing without displaying a warning.
	[Paper Size Basis] [RollSelection 1]	When the size of roll paper is detected, select which roll width to use if the roll width is between [ISO A3 (297mm)] and [300mm Roll].
	[RollSelection 2]	When the size of roll paper is detected, select which roll width to use if the roll width is between [10inch (254mm)] and [JIS B4 (257mm)].
	[Keep Paper Size]	Select [On] to give priority to paper size. If the margin set with the printer driver is less than the margin set with the printer menu, the margin set with the printer menu has priority and text and images extending beyond the margins are truncated. Select [Off] to give priority to margin settings. If the margins set with the printer driver and the margins set with the printer menu are different, the larger settings are used for printing.
	[TrimEdge Reload]	Select whether cut the leading edge of the paper when the paper at the standby position has loaded. Cut it when the roller trace at the standby position attract attention. Choose On to cut it everytime when the paper at the standby position has loaded. Choose Automatic to cut it when the paper at the standby position during two days or more has loaded.
	[Rep.P.head Print]	Select [On] to automatically perform [Adjust Detail] after replacing the Printhead.
	[Nozzle Check]	Set with [Frequency] the timing to check for nozzle clogging after printing. Select [Standard] to adjust the checking timing according to the nozzle usage. Select [1 page] or [10 pages] to check every one page or 10 pages. Select [On] for [Warning] to display a warning when the print head nozzle is clogged while printing.
	[Use USB]	Select [Off] to disable the function of the USB connection.
	[Use Ethernet]	Select [Off] to disable the function of the ethernet connection.
	[Use RemoteUI]	Select [Off] to disable access from RemoteUI and enable setting only from the operation panel.
	[Reset PaprSetngs]	Restore settings that you have changed with Media Configuration Tool to the factory default values.

Setting Item		Description/Instructions
[System Setup]	[Show Job Log]	Selecting off prevents display of the log in Job Menu > Job Log. Additionally, the log is not printed if you choose Job Menu > Print Job Log. Note that because job logs are not collected, the Status Monitor accounting functions will not work correctly.
[Prep.MovePrinter]		Select when moving the printer. Follow the instruction on the screen and perform the necessary process. This is not displayed when displaying a warning message about the amount remaining maintenance cartridge.
[Admin. Menu]	[Chg.Admin.Pswd]	Set a password to restrict displaying/setting of menus as follows. Allowed value is from 0 to 9999999. - Allow only administrator to display/set [IPv4] [Change Password] [Init.Admin.Pswd] - Allow administrator to display/set and non-administrator to display only [Interface Setup] (exclude [IPv4]) [Date & Time] [Date Format] [Time Zone] [Use RemoteUI] [Reset PaprSetngs] [Save: Shared Box]
	[Init.Admin.Pswd]	Press [OK] to return the [Administrator Menu] password to factory default.
[Printer Info]	[Paper Info]	Display the currently set paper type, size and printer settings.
	[Ink Info]	Display ink levels and maintenance cartridge capacity.
	[Head Info]	Display the Printhead information.
	[System Info]	Display the firmware version, serial number, and interface information.
	[Error Log]	Display the most recent error messages (up to 5).
	[Use Situation]	Display the total area and duty counter printed.

## 1.7 Safety and Precautions

### 1.7.1 Safety Precautions

#### 1.7.1.1 Moving Parts

Moving parts of the printer include the carriage unit driven by the carriage motor, the carriage belt, the ink tube, the flexible cable, the feed roller driven by the feed motor, the pinch roller, and the purge unit driven by the purge motor. To prevent accidents, the upper cover of the printer is locked during printing. If the top cover is opened in the online/offline mode, the carriage motor, feed motor, and other driving power supplies are turned off.

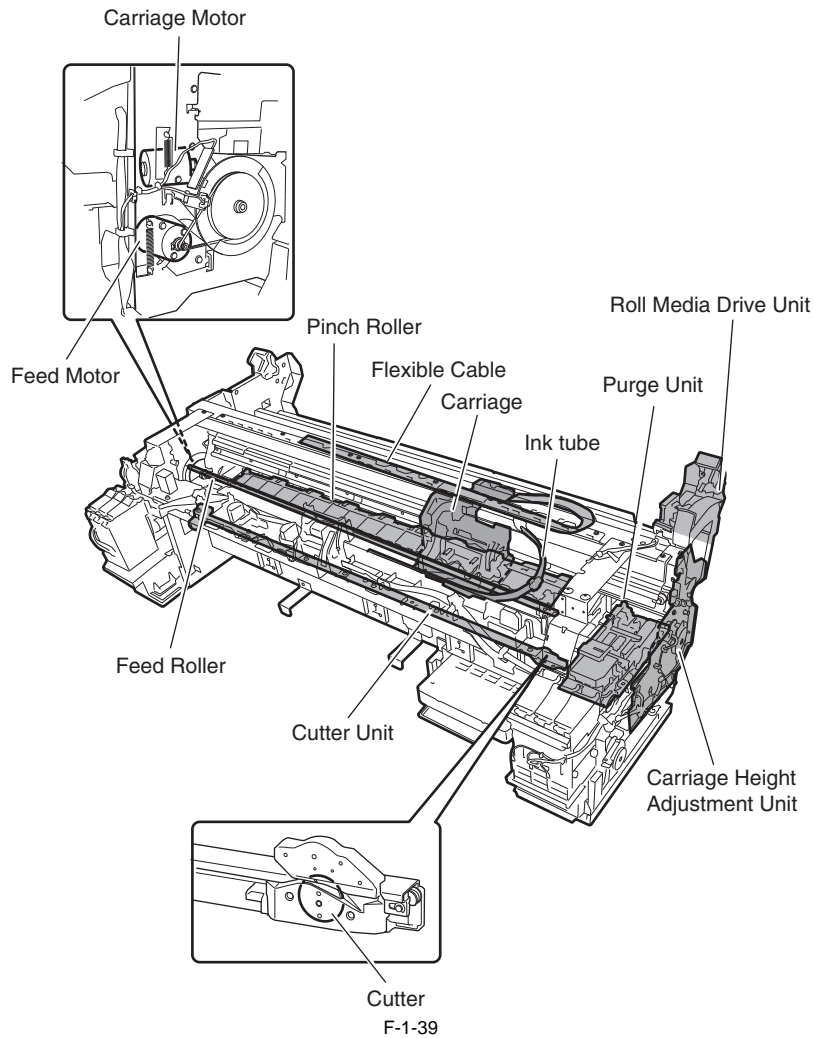

### 1.7.1.2 Adhesion of Ink

#### (1) Ink passages

Be careful not to touch the ink passages of the printer to prevent the printer, workbench, and clothes from being stained with ink. The ink flows through the ink tank unit, carriage unit, purge unit, maintenance cartridge, and the ink tubes that relay ink to individual units.

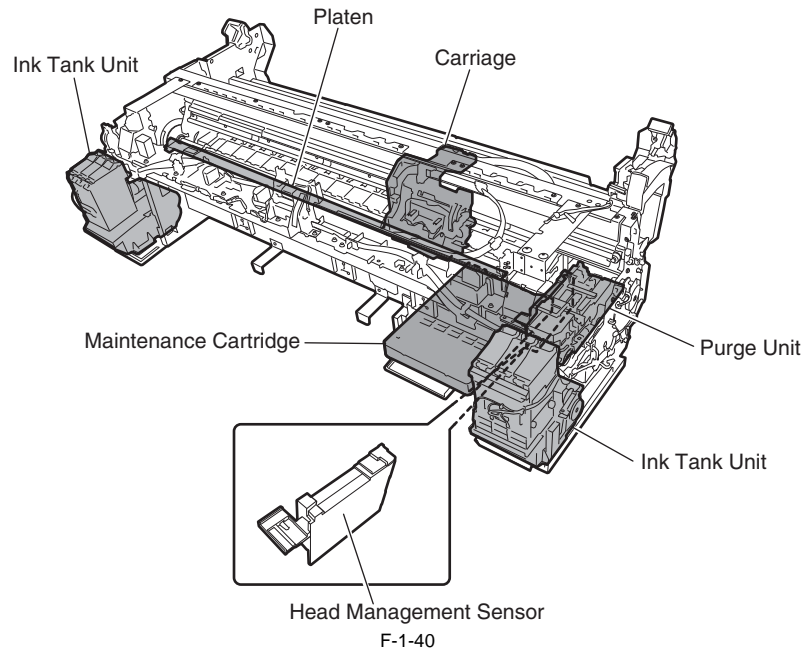

- Although the ink is not harmful to the human body, it contains organic solvents. Ink may contaminate the surrounding parts. Carry out the work with due caution. If your hands are stained with ink, wash them with a plenty of water. Be careful not to allow the ink to get into your mouth or eyes.
- If the ink gets into your eyes, flush them with water well and see a doctor.
- In case of accidental ingestion of a large quantity of ink, see a doctor immediately.
- It is also effective to use gloves to prevent ink from adhering when working.
- Since this ink contains pigment, stains will not come out of clothing.

#### (2) Ink Mist

Since the printhead prints by squirting ink onto the media, a minute amount of ink mist is generated in the printing unit during printing. The generated ink mist is collected in the printer by the airflow. However, uncollected ink mist may stain the platen, carriage unit, exterior, and purge unit. These stains may soil the print media or hands and clothes when servicing the printer. Wipe them off carefully with a soft, well-wrung cloth.

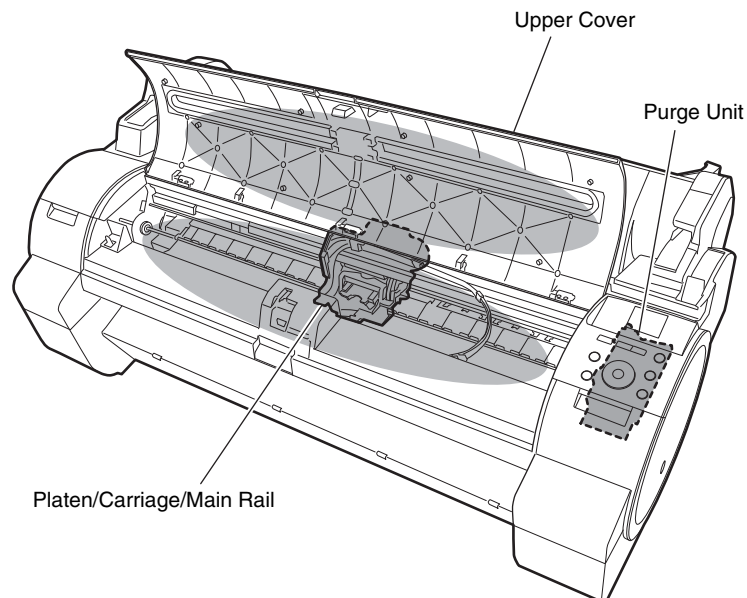

### 1.7.1.3 Electric Parts

The electric parts of the printer are activated when the printer is connected to the AC power supply.

At the rear and left/right side of the printer are the main controller, power supply and interface connector. The carriage PCB is incorporated in the carriage unit, and the operation panel is on the upper right top cover.

When serving the printer with the cover removed, be extremely careful to avoid electric shock and shorting electrical devices.

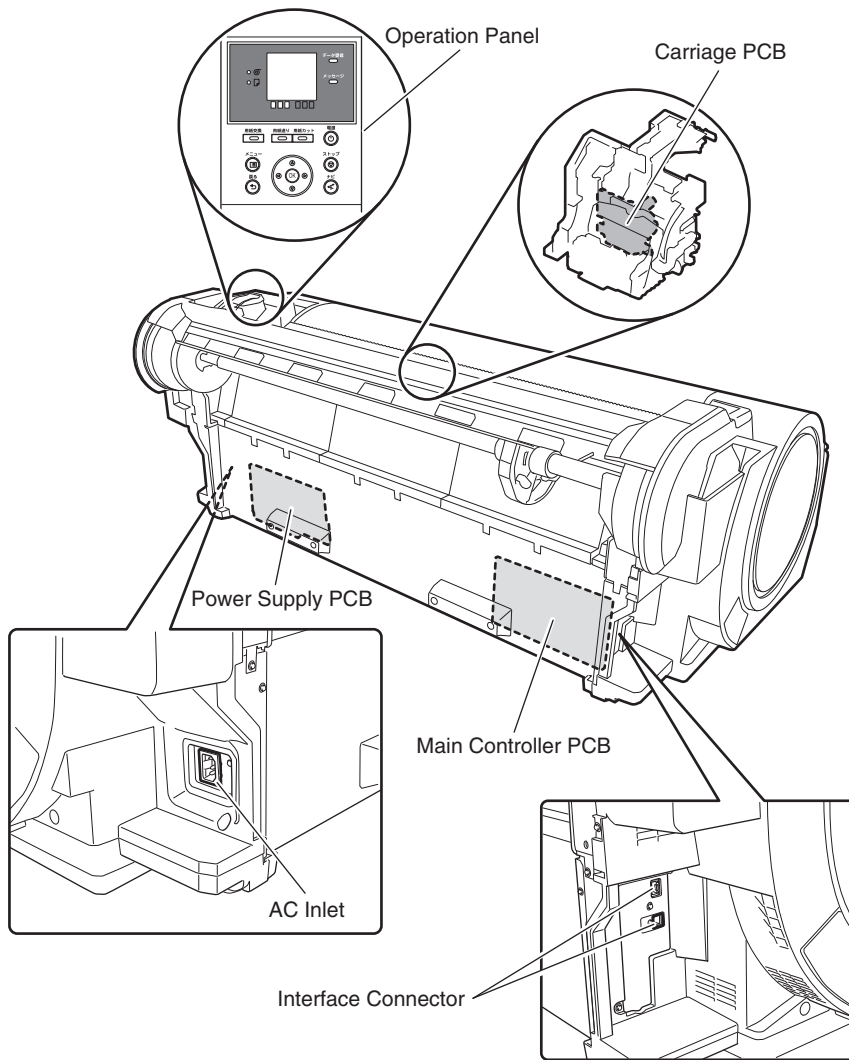

F-1-42

## 1.7.2 Other Precautions

### 1.7.2.1 Printhead

#### 1. How to Handle the Printhead

Do not open the printhead package until you are ready to install the head.

When installing the printhead in the printer, hold the knob and then remove the protective cap 1 and protective cap 2 in that order.

Do not reattach the protective cap to the printhead because the cap may damage the nozzles.

To prevent the nozzles from getting clogged with foreign matter or dried ink, install the printhead immediately after you remove the protective caps.

Also make sure to press down the locking lever of the printhead until you feel a click.

In addition, to prevent clogging of the nozzles with foreign matter and improper supply of ink, never touch the nozzles or ink port, or wipe it with tissue paper or anything else.

Do not touch Electrical contact.

Also, never attempt to disassemble/reassemble the printhead or wash it with water.

#### MEMO:

If the nozzles are clogged or an ink suction problem occurs, white lines can appear on the printout a constant frequency or color dulling can occur. If this problem is not resolved by cleaning operations, replace the printhead with a new one.

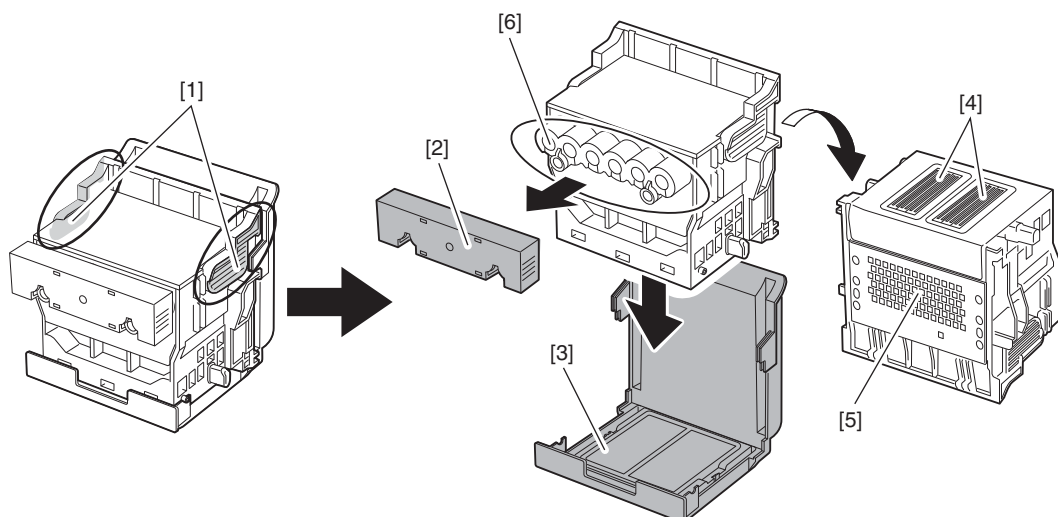

F-1-43

- |                      |                        |
|----------------------|------------------------|
| [1] Knob             | [4] Nozzles            |
| [2] Protective cap 1 | [5] Electrical contact |
| [3] Protective cap 2 | [6] Ink port           |

#### 2. Capping

The printer will perform the capping operation when printing has ended or during standby due to an error, in order to protect the printhead and avoid ink leakage. If the power cord is accidentally unplugged, turn off the Power button, reconnect the power cord, and then turn on the Power button. Confirm that the printer starts up properly and enters to the "Online" or "Offline" status, and then power off the printer using the Power button.



Improper "capping operation" may cause clogged nozzles due to dried ink or ink leakage from the printhead.

#### 3. When the printer is not used for a long time

Keep the printhead installed in the printer even when it is not used for an extended period of time.



If the printhead is left uninstalled, a printing failure may arise from closed nozzles due to depositing of foreign matter or dried ink when it is reinstalled. Even if the head remains installed, the nozzle may dry out and cause a printing failure if the ink is drained for transport.

#### 4. Conductivity of Ink

The ink used in this printer is electrically conductive. If ink leaks into the mechanical unit, wipe clean with a soft, well-wrung damp cloth. If ink leaks onto electrical units, wipe them completely using tissue paper. If you cannot remove ink completely, replace the electrical units with new ones.



If electrical units are powered with ink leaked onto them, the units may damage. Never connect the power cord when ink has leaked onto the electrical units.

### 1.7.2.2 Ink Tank

#### 1. Unpacking the Ink Tank

Do not unpack the ink tank until you are ready to install it.

When installing the ink tank, be sure to shake it slowly 1 to 2 times before unpacking it. Otherwise, the ink ingredients may precipitate and degrade the print quality. To prevent foreign matter from entering the ink port, install the unpacked ink tank in the printer immediately.

#### 2. Handling the Ink Tank

To prevent foreign matter from entering the ink flow path and causing ink suction and printing problems, never touch the ink port and contacts of the ink tank.

When you press down the ink tank cover, the needle enters the ink port, allowing ink to flow between the printer and ink tank.

Do not raise or lower the ink tank cover except when replacing the ink tank.

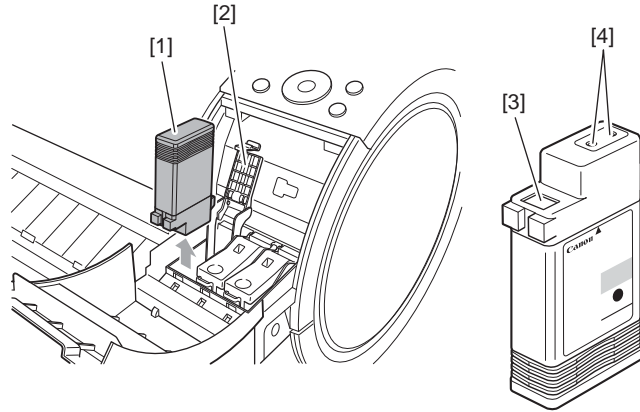

F-1-44

- [1] Ink tank
- [2] Ink tank lock lever
- [3] Contacts
- [4] Ink port

### 1.7.2.3 Handling the Printer

#### 1. Precautions against Static Electricity

Certain clothing may generate static electricity, causing an electrical charge to build up on your body. Such a charge can damage electrical devices or change their electrical characteristics.

In particular, never touch the printhead contacts.

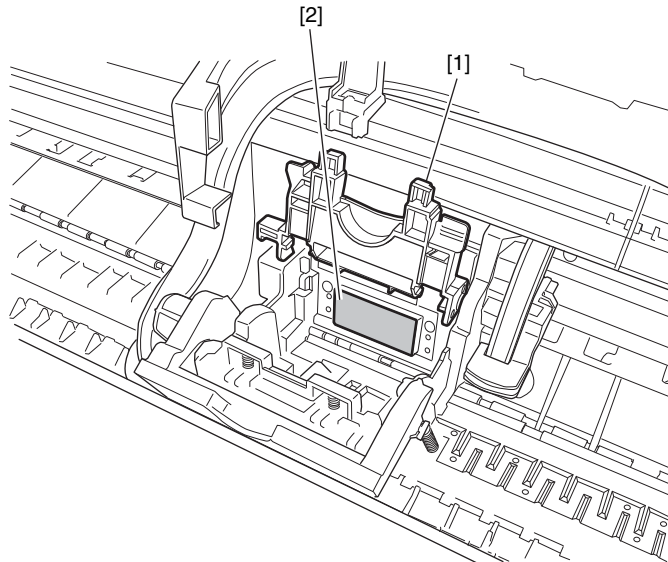

F-1-45

- [1] Carriage unit
- [2] Printhead contacts

#### 2. Fixing the Carriage

After completion of printing, the carriage is mechanically locked by the lock pin in the purge unit at the same moment the printhead is capped.



### 3. Contact of Linear Scale/Carriage Shaft

Do not touch the linear scale and carriage shaft when the upper cover is opened, for maintenance. Touching the linear scale and carriage shaft might cause abnormal movement of the carriage and produce defective prints.

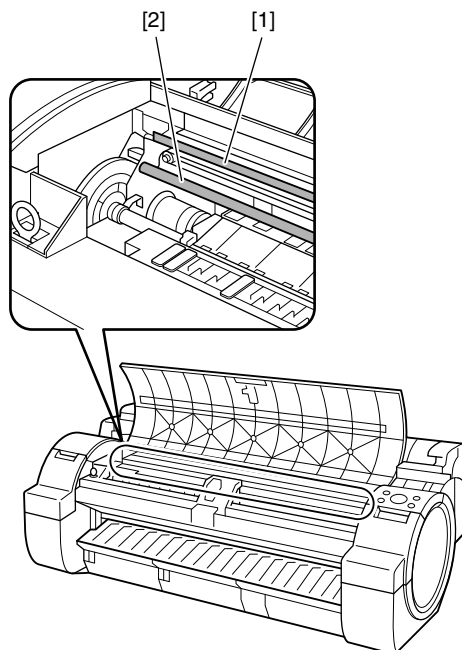

F-1-46

- [1] Linear Scale
- [2] Carriage Shaft



Don't apply the grease to the linear scale and carriage shaft. It may cause abnormal operations and defective prints.

### 4. Replacing the maintenance cartridge

When the maintenance cartridge detects that the tank is full, the "Repl. Maint. C" error appears. In this case the maintenance cartridge must be replaced. The printer will not operate until the error is cancelled. Be careful that the waste ink does not splash when you remove the used maintenance cartridge from the printer.

#### MEMO:

This printer has an EEPROM in the maintenance cartridge and the maintenance cartridge status is controlled by the main controller PCB which reads and writes the contents of that EEPROM. Therefore, initializing the counter information will not be needed when the maintenance cartridge is replaced.

### 5. Refilling the ink

After draining the ink from the printer according to the automatic or manual ink draining procedure for disassemble, reassemble, or transport/ship the printer, refill the ink as soon as possible upon completion of those tasks. Dried remaining ink on the surface of some components, may cause damage or abnormal operations.

### 1.7.3 Precautions When Servicing Printer

#### 1.7.3.1 Notes on the Data Stored in the Printer

This printer counts the print length, number of ink tank replacements, carriage driving time, number of cleaning operations, number of cutter operations, and so on and stores them in the main controller's EEPROM as a COUNTER in Service mode.

COUNTER provides important information about the printer usage status.

You can check this information by printing it in the service mode or displaying it on the display.

Follow the precautions below when servicing the printer.

(1) Repairing/replacing the PCB

When replacing the main controller, follow the specified replacement procedure.

For the main controller replacement procedure, see "DISASSEMBLY/REASSEMBLY" > "Points to Note on Disassembly and Reassembly" > "PCBs".

(2) After replacing the carriage unit

The information about the carriage driving time resides in the carriage unit. After replacing the carriage unit, select [INITIALIZE] > [CARRIAGE] in the service mode to initialize the information about the carriage driving time.

(3) After replacing the purge unit

The information about the number of cleanings resides in the purge unit. After replacing the purge unit, select [INITIALIZE] > [PURGE] in the service mode to initialize (clear) the information about the number of cleanings.

(4) On replacement of supplies

After supplies have been replaced, execute [INITIALIZE] > [PARTS COUNTER] > [PARTS xx] in service mode to initialize (clear) the parts counter information.

For the consumable parts, see "MAINTENANCE" > "Periodic Replacement Parts".

---



You cannot check the counter information once it is initialized (cleared). Be careful not to initialize the counter information before checking it.

You cannot modify the counter information from the operation panel.

---

#### 1.7.3.2 Confirming the Firmware Version

Firmware has been downloaded to the main controller.

When you have replaced the main controller, check that the firmware is the latest version. If not, update it to the latest version.

---

**Reference:**

For instruction on how to update the main controller, refer to "TROUBLESHOOTING" > "Version Up".

---

#### 1.7.3.3 Precautions against Static Electricity

Certain clothing may generate static electricity, causing an electrical charge to build up on your body. Such a charge can damage electrical devices.

To prevent this, discharge any static buildup by touching a grounded metal fitting before you start disassembling the printer.

#### 1.7.3.4 Precautions for Disassembly/Reassembly

The precautions for disassembly/reassembly are described in "DISASSEMBLY/REASSEMBLY".

#### 1.7.3.5 Self-diagnostic Feature

The printer has a self-diagnostic feature to analyze hardware problems.

The self-diagnosis result is shown on the display and indicated by lamps.

For detailed information, see "ERROR CODE".

---

### 1.7.3.6 Disposing of the Lithium Battery

The main controller PCB of this printer is equipped with a lithium battery to back up various data.

---



Risk of explosion if battery is replaced by an incorrect type.  
Dispose of used batteries according to the instructions.

"For CA, USA Only  
Included battery contains Perchlorate Material-special handling may apply. See  
<http://www.dtsc.ca.gov/hazardouswaste/perchlorate/> for detail."

---

#### **Achtung:**

Die Lithiumbatterie darf nur durch das Originalersatzteil (Parts Katalog) ersetzt werden;  
ansonsten besteht Brand-/Explosionsgefahr.  
Lithiumbatterien niemals aufladen, demontieren oder durch Verbrennen entsorgen;  
bei der Entsorgung die örtlichen Entsorgungsvorschriften beachten (Schadstoffe; Sondermüll).

---



警告

如果更換不正確之電池型式會有爆炸的風險

請依製造商說明書處理用過之電池

---



---

## Chapter 2 TECHNICAL REFERENCE

---



# Contents

2.1 Basic Operation Outline .....	2-1
2.1.1 Printer Diagram .....	2-1
2.1.2 Print Signal Sequence .....	2-2
2.1.3 Print Driving .....	2-3
2.2 Firmware .....	2-5
2.2.1 Operation Sequence at Power-on .....	2-5
2.2.2 Operation Sequence at Power-off .....	2-6
2.2.3 Print Position Adjustment Function .....	2-7
2.2.4 Head Management .....	2-7
2.2.5 Printhead Overheating Protection Control .....	2-7
2.2.6 Pause between Pages .....	2-7
2.2.7 White Raster Skip .....	2-7
2.2.8 Sleep Mode .....	2-7
2.2.9 Shut Down Mode .....	2-7
2.3 Printer Mechanical System .....	2-8
2.3.1 Outline .....	2-8
2.3.1.1 Outline .....	2-8
2.3.2 Ink Passage .....	2-9
2.3.2.1 Ink Passage .....	2-9
2.3.2.1.1 Overview of Ink Passage .....	2-9
2.3.2.2 Ink Tank Unit .....	2-10
2.3.2.2.1 Structure of Ink Tank Unit .....	2-10
2.3.2.3 Carriage Unit .....	2-12
2.3.2.3.1 Functions of Carriage Unit .....	2-12
2.3.2.3.2 Structure of Carriage Unit .....	2-13
2.3.2.4 Printhead .....	2-16
2.3.2.4.1 Structure of Printhead .....	2-16
2.3.2.5 Purge Unit .....	2-17
2.3.2.5.1 Functions of Purge Unit .....	2-17
2.3.2.5.2 Structure of Purge Unit .....	2-20
2.3.2.6 Maintenance Cartridge .....	2-22
2.3.2.6.1 Maintenance Cartridge .....	2-22
2.3.2.7 Air Flow .....	2-23
2.3.2.7.1 Air Flow .....	2-23
2.3.3 Paper Path .....	2-25
2.3.3.1 Outline .....	2-25
2.3.3.1.1 Overview of Paper Path .....	2-25
2.3.3.2 Paper Path .....	2-26
2.3.3.2.1 Structure of Feed Roller Unit .....	2-26
2.3.3.3 Cutter Unit .....	2-28
2.3.3.3.1 Structure of Cutter Unit .....	2-28
2.4 Printer Electrical System .....	2-29
2.4.1 Outline .....	2-29
2.4.1.1 Overview .....	2-29
2.4.2 Main Controller .....	2-31
2.4.2.1 Main controller PCB components .....	2-31
2.4.2.2 Connectors and Pin Arrangement of Main controller PCB .....	2-32
2.4.3 Carriage Relay PCB .....	2-39
2.4.3.1 Carriage PCB components .....	2-39
2.4.3.2 Connectors and Pin Arrangement of Carriage PCB .....	2-40
2.4.4 Maintenance Cartridge Relay PCB .....	2-44
2.4.4.1 Maintenance cartridge relay PCB components .....	2-44
2.4.5 Power Supply .....	2-45

2.4.5.1 Power supply block diagram .....	2-45
2.4.5.2 Connectors and Pin Arrangement of Power supply PCB.....	2-46
<b>2.5 Detection Functions with Sensors .....</b>	<b>2-47</b>
2.5.1 Covers.....	2-47
2.5.2 Ink passage system .....	2-48
2.5.3 Carriage system.....	2-51
2.5.4 Paper path system.....	2-53
2.5.5 Others .....	2-55



## 2.1 Basic Operation Outline

### 2.1.1 Printer Diagram

Shown below is a printer diagram.

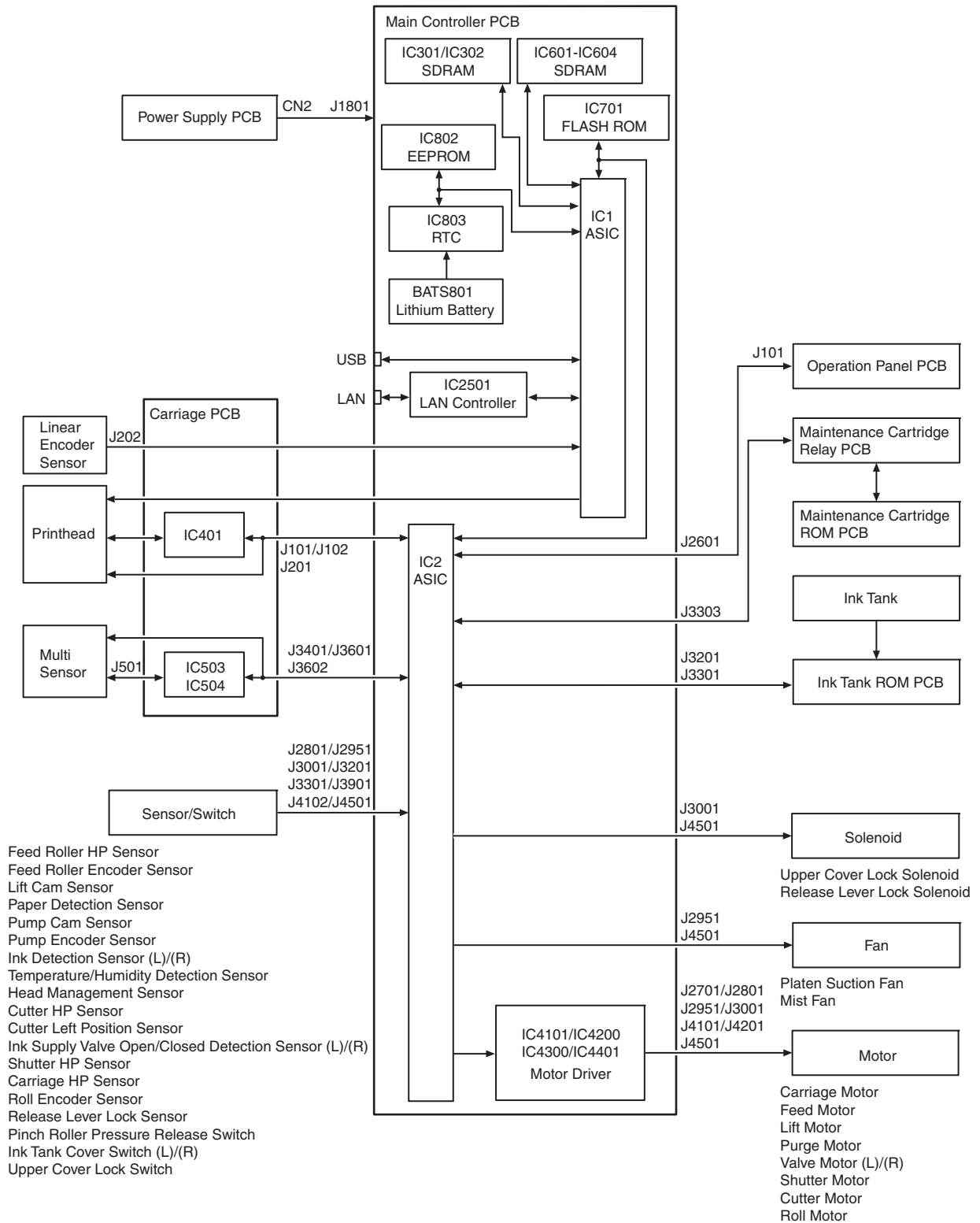

F-2-1

### 2.1.2 Print Signal Sequence

The signal sequence from when the printer receives the print signals until printing starts is shown in the following figure.

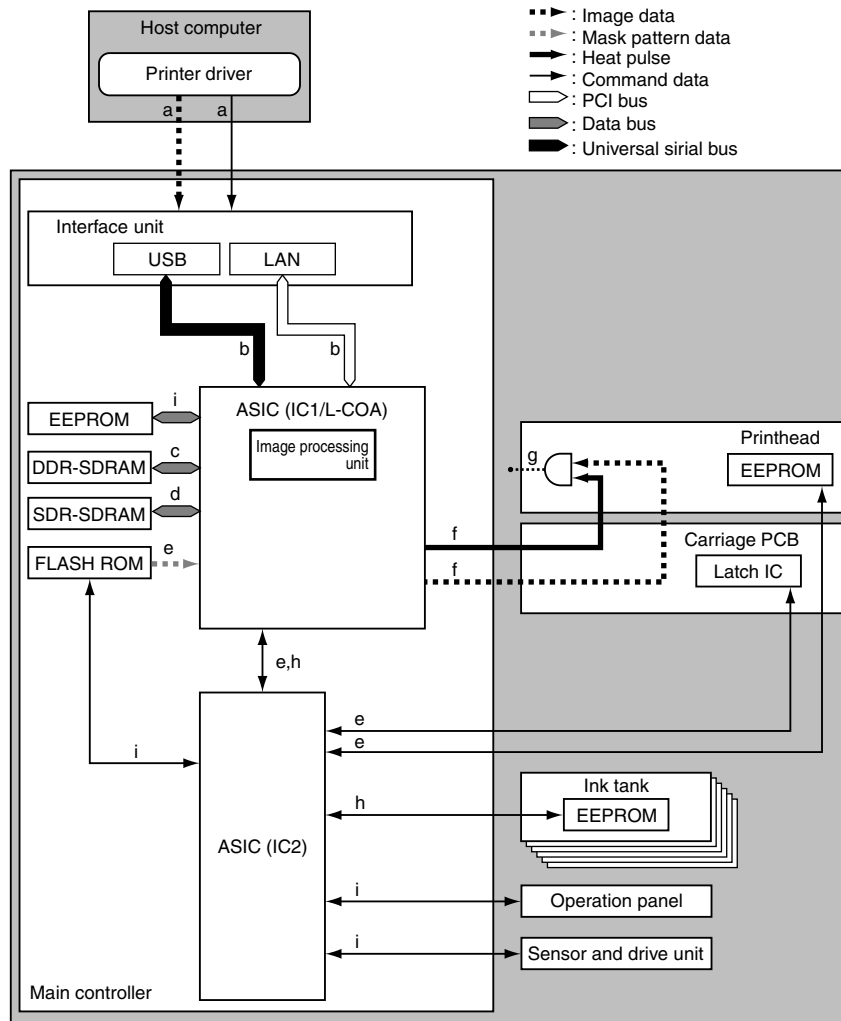

F-2-2

a) The printer driver on the host computer transmits print data, including command data, to the printer after compressing the image data, without resolution, color and 12-color binarization conversion.

To achieve high-quality image output, the image processing table data used for image data color conversion and binarization conversion are generated as command data to meet the Media Type and other specifications of the printer driver.

b) This printer receives print data from the individual interfaces on the main controller, transmitting the received print data to ASIC (IC1).

c) The main controller decompresses the print data transmitted to the ASIC and gets it through resolution, color and 5-color binarization conversion while loading the data into DDR-SDRAM from time to time.

It also converts the print data to 5-color binary equivalents of image and command data.

d) The ASIC (IC1) generates image data synthesized with mask data within the ASIC in sync with the discharge time while loading the data into DDR-SDRAM from time to time.

e) The ASIC (IC2) collects printhead information from EEPROM mounted on the printheads and the printer temperature from the latch IC on the carriage board and transmit them to the ASIC (IC1).

The ASIC (IC1) also receives mask pattern data from the firmware installed in flash ROM.

f) The ASIC (IC1) converts the image data synthesized with the mask pattern to data associated with the printhead information and the printer temperature, transmitting the data to the printheads as a print signal. It transmits heat pulses to the printheads at the same time to optimize head driving.

g) The printheads convert the received print signal from a serial signal to a parallel signal for each row of nozzles and then the signal is composed with the heat pulses to perform the printing.

h) The ASIC (IC1) controls the general aspects of image processing and print drive control by detecting the status of the individual printer components with reference to the adjustment values stored in EEPROM. SDR-SDRAM is used as work memory.

i) The ASIC (IC2) controls the general aspects of drive control by controlling button actuations and message displays on the basis of the firmware installed in flash ROM.

### 2.1.3 Print Driving

Print and control signals are transferred via the carriage PCB to the printheads to discharge inks from the nozzle assembly at printing. Each printhead has 12 trains of nozzles arranged in a zigzag pattern.

This printer uses one printhead.

(In installed state, from left to right, C, M, Y, MBK, MBK, BK)

Print signals directed at each nozzle train are even-numbered nozzle data (Hx-x-DATA-x-EV) and odd-numbered nozzle data (Hx-x-DATA-x-OD). These are transferred in timing with a data transfer clock (Hx-CLK) and data latch pulses (Hx-LT).

The Heat Enable (Hx-x-HE-x) drive control signal enables inks to be discharged from the nozzles.

#### 1. Print drive control

Each train of nozzles in a printhead has 2,560 nozzles.

Ink discharge nozzles are selected split in 40-, 20- or 10-nozzle blocks according to the Block Enable information in the even-numbered nozzle data and odd-numbered nozzle data.

Each selected block of nozzles is impressed with a Heat Enable signal generated with variable pulse widths according to the head rank, head temperature and printer temperature for optimized ink discharges. The nozzles are driven by heater boards in the nozzles to discharge inks. Optimal nozzle blocks are selected according to the print path.

The diagram below illustrates the relationship between a 40-block nozzle and nozzles driven.

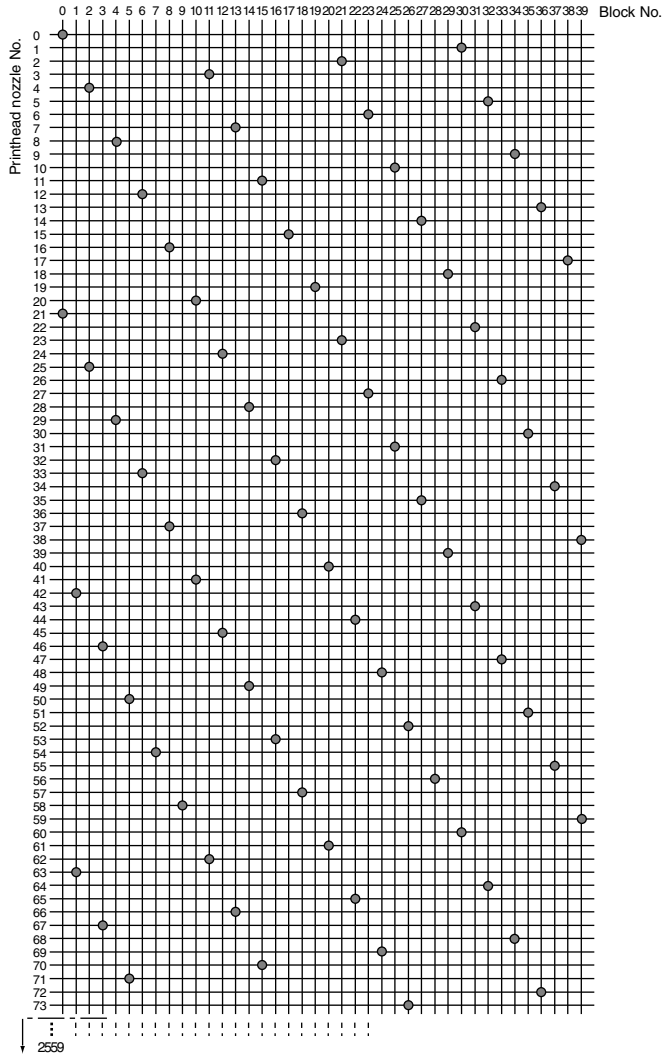

F-2-3

**2. Print drive timing**

Each printhead houses 12 trains of nozzles, which share the same data transfer clock (Hx-CLK) and data latch pulses (Hx-LT). Even-numbered nozzle data (Hx-x-DATA-x-EV), odd-numbered nozzle data (Hx-x-DATA-x-OD) and the Heat Enable (Hx-x-HE-x) signal are generated for each nozzle train and controlled individually.

Printing is carried out in two ways through reciprocating motion of the carriage.

An encoder sensor mounted on the carriage generates a 150-dpi-pitched linear scale detection signal (ENCODER\_A) and a signal (ENCODER\_B) shifted 120 degrees in phase. The direction of carriage motion is detected from the status of the ENCODER\_B signal relative to the leading edge of the ENCODER\_A signal. The printhead is driven using a 2400-dpi timing signal (internal signal), which is generated by dividing the ENCODER\_A signal detected at the 150 dpi timing into 16 equal sections.

Printing in the forward direction is triggered at the leading edge of the detection signal (ENCODER\_A).

Printing in the backward direction is carried out the same way as printing in the forward direction but at the trailing edge of the detection signal (ENCODER\_A), when the order of heated nozzles is reversed depending on the sequence of transfer of even-numbered nozzle data and odd-numbered nozzle data.

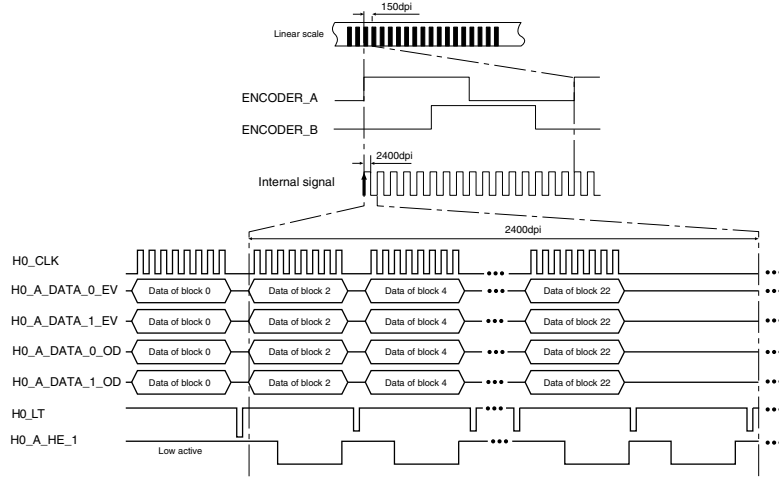

F-2-4

## 2.2 Firmware

### 2.2.1 Operation Sequence at Power-on

The sequence of printer operations, from power-on to transition to online mode, is flowcharted below. The printer takes less than 1 minute to initialize itself(\*).  
 \* Excluding the times spent supplying inks and cleaning the printhead after leaving the printer for extended periods of time.

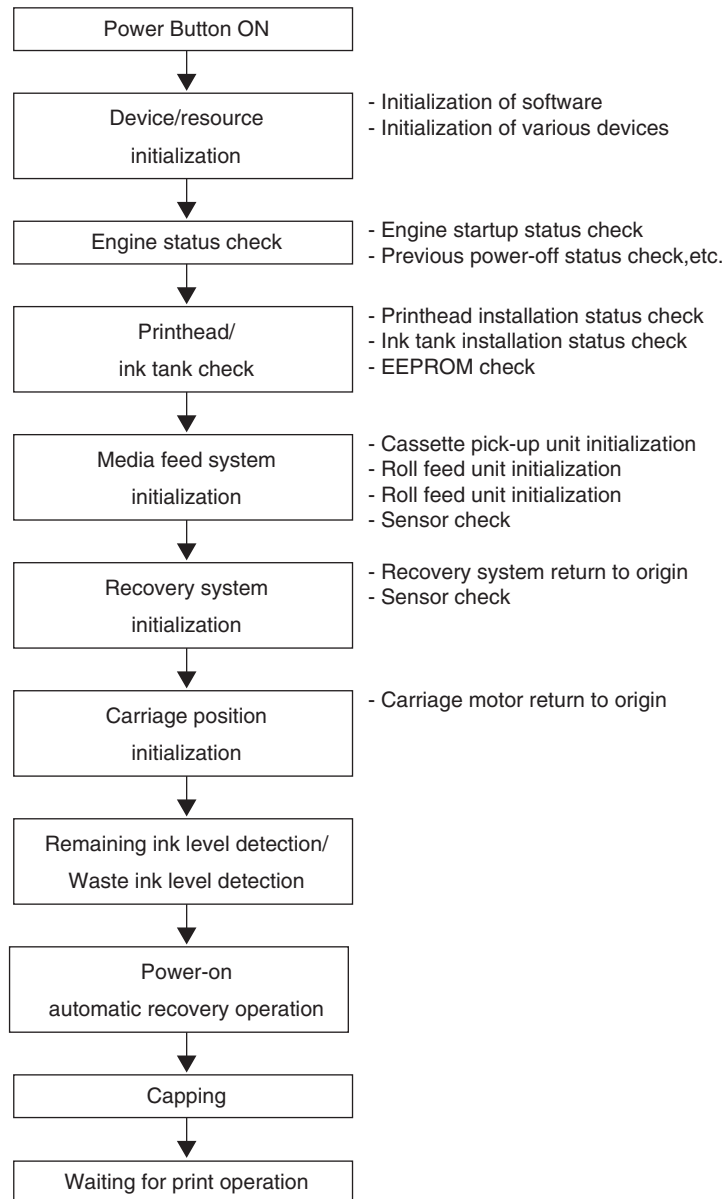

F-2-5

### 2.2.2 Operation Sequence at Power-off

Turning off the power switch cuts off the drive voltage supply, launching a firmware power-off sequence as shown below.

If the power cord is disconnected from the wall outlet or the upper cover or any other cover is opened, the printer cancels the ongoing operation and shuts down immediately. Since printhead capping may or may not have been carried out properly, reconnect the power cord to the wall out and turn on the power switch. Making sure that the printer has entered online mode, turn off the power switch.

#### 1. Power-off sequence

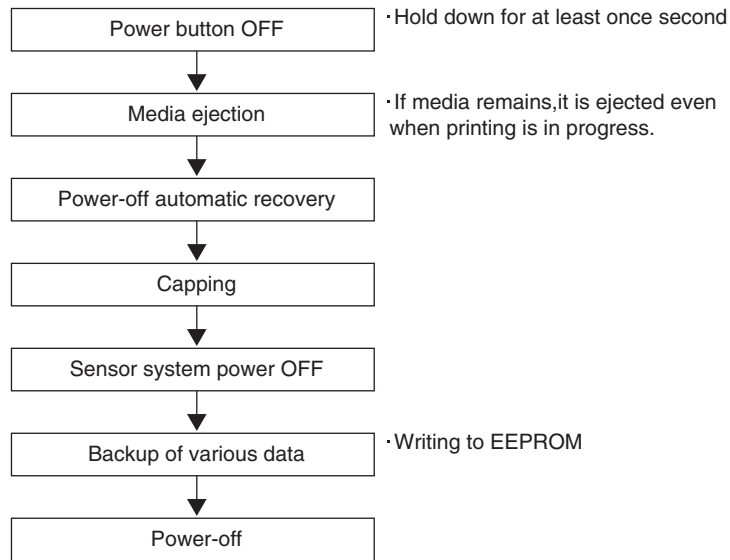

F-2-6

### 2.2.3 Print Position Adjustment Function

This printer supports a print position adjustment for the vertical and horizontal print positions, the bidirectional print position of the printhead mounted on the carriage, and the feedrate.

There are two adjustment modes for the print: automatic adjustment, in which print position adjustment patterns printed are detected by the multi sensor attached to the lower left part of the carriage, and manual adjustment, in which print position adjustment patterns that are slightly modified from one another are printed, so that visually verified adjustment values can be set from the operation panel.

To execute the print position adjustments, 10-inches size or larger roll media or two sheets of A4/LTR-size or larger cut sheet are needed. However, in case of A2-size or larger cut sheet, one sheet is needed.

The print position adjustment function is executed by the following menu.

[Set./Adj. Menu]

First Level	Second Level	Third Level	Fourth Level	Fifth Level	
[Adjust Printer]	[Head Posi. Adj.]	[Auto(Standard)]			
		[Auto(Advanced)]			
		[Manual]*4			
		[Head Inc. Adj.]			
		[Feed Priority]	[Adj. Priority]	[Automatic]*	
				[Print Quality]	
				[Print Length]	
			[Adj. Quality]*5	[Auto(GenuinePpr)]	
				[Auto(OtherPaper)]	
				[Manual]	
			[Adjust Length]*6	[AdjustmentPrint]	[A:High]
					[B:Standard/Draft]
			[Change Settings]	[A:High]	
				[B:Standard/Draft]	

### 2.2.4 Head Management

This printer supports a nozzle check function to spot non-discharging nozzles in the printhead.

When the printer detects a non-discharging nozzle, it starts cleaning the printhead automatically to correct its discharge failure. If cleaning does not work, the printer backs up the non-discharging nozzle with an alternative nozzle automatically to ensure unfailling print performance.

Detection timings (automatic):

Power-on, carriage cover open detection, print start (check timing variable by selecting Nozzle Check from the system menu).

### 2.2.5 Printhead Overheating Protection Control

When an abnormal temperature rise in the printhead is detected, overheating protection control launches.

Overheating could occur in the printhead after a period of print operations without the nozzles being filled with inks.

Overheating protection control is implemented on the basis of the temperature detected by the head temperature sensor for each nozzle. When an abnormal temperature is detected in any nozzle train, overheating protection control is exerted at one of two levels according to that temperature.

Protection level 1:

If the head temperature sensor (DI sensor) detects a temperature higher than the protection temperature, it halts the carriage temporarily at the scan end position in the direction of travel according to the carriage scan status.

Printing resumes when the printhead radiates naturally to cool down below a predetermined temperature or when 30 seconds or longer have elapsed since the detection of the higher temperature.

Protection level 2:

If the head temperature sensor (DI sensor) detects a temperature higher than the abnormal temperature, the printer shuts down the print operation immediately, moving the carriage to the home position for capping, with an error indication on the display.

### 2.2.6 Pause between Pages

An inter-page function is available to prevent ink rubbing, which keeps paper just printed hanging above the platen and waiting for a predetermined period of time before delivery.

The wait time is user-programmable from the print driver. This feature is particularly useful on paper that takes time to dry after printing, such as film.

### 2.2.7 White Raster Skip

This printer supports a white raster skip function to bypass carriage scanning in a consecutive sequence of voids in print data, for added throughput.

### 2.2.8 Sleep Mode

The printer has sleep mode to reduce its standby power requirement.

The printer transitions to sleep mode automatically when it has been left idle or no print data has been received for a predetermined period of time while the printer is online or offline.

The printer exits sleep mode when any operation panel key is activated or print data is received from the host computer.

The time to transition to sleep mode is variable from the operation panel (Default: 5minutes).

### 2.2.9 Shut Down Mode

The power supply of printer turns off automatically to reduce the power consumption when the sleep mode is continued for a predetermined period of time.

The time to transition to shut down mode can be changed by the operation panel (Default: 8 hours).

## 2.3 Printer Mechanical System

### 2.3.1 Outline

#### 2.3.1.1 Outline

The printer mechanism can be broadly divided into two major components: the ink passage and paper path.

The ink passage consists of the ink tank unit, the carriage unit having the printhead, the purge unit, the maintenance cartridge, and the tube unit which are used to supply, circulate, and suck ink.

The paper path consists of the feed roller unit to support one type of media feeding, transport, and ejection.

This section provides an overview of these mechanical components.

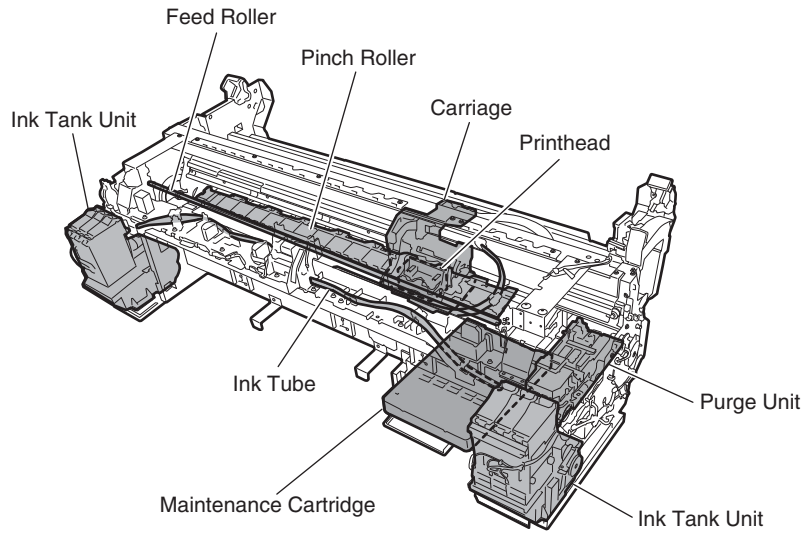



## 2.3.2 Ink Passage

### 2.3.2.1 Ink Passage

#### 2.3.2.1.1 Overview of Ink Passage

The ink passage houses the ink tank, printhead, caps, maintenance jet tray, maintenance cartridge, waste ink collector, ink tubes interconnecting the mechanical units, suction pump driven mainly for sucking inks and so on. Its functions include supplying, circulating and sucking inks.

The ink passage (per color) is schematically shown below, along with the ink flow.

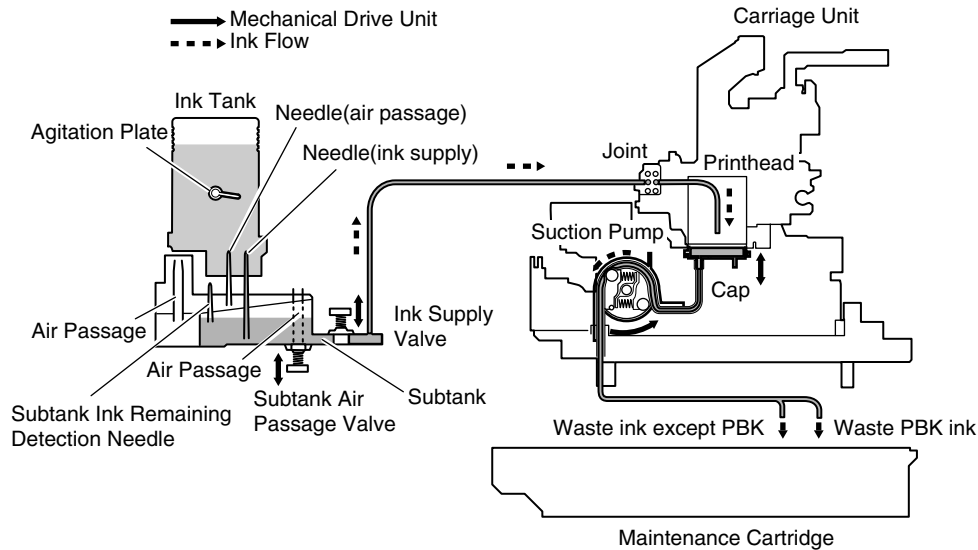

F-2-8

#### a) Supplying inks from the ink tanks to the ink supply valve assembly

The ink tanks each contain ink to feed the printhead.

The ink is supplied from the ink tanks to the sub tanks first, then to the ink supply valves.

Air is discharged through the air passage to keep the internal pressure of the ink tanks and sub tanks constant.

#### b) Supplying inks from the ink supply valves to the printhead

The ink stored in an ink tank flows to the printhead when the suction pump is driven with the ink supply valve opened and the head capped.

The ink sucked from the caps flows to the maintenance cartridge.

#### c) Supplying inks while printing

The ink supply valves and sub tank air passage valves are kept open while printing, so that inks is constantly flowing to the printhead under the negative pressure of the nozzle assembly which is caused by the discharging inks.

Furthermore, waste inks sucked in the cleaning operation and inks from the maintenance jet tray flow into the maintenance cartridge.



If all of ink passages are opened (no ink tank is installed, the ink supply valve is opened, the sub tank air passage valve is opened, and the printhead fixer lever is opened) when the ink tube is being filled with ink, the ink in the ink tube may reverse-flow due to the fluid level difference and ink may leak from the hollow needle of the ink tank.

Do not open all of the ink passages at the same time when the ink tube is being filled with ink.

#### d) Agitation of ink in the ink tank

Ink in the ink tank and the sub tank are agitated to prevent precipitation of pigment-based ink in the ink tank and sub tank.

This function is implemented by reverse-flowing ink to the ink tank and sub tank by opening and closing the ink supply valve and sub tank air passage valve in succession. Inside the ink tank is provided with an agitation plate to assist agitation of ink. (The agitation plate is also provided in the dye ink tank.)

- Operation timing: When a new ink tank is installed or when 168 hours have lapsed since the previous agitation (the agitation is performed irrespective of the condition whether the printer is printing or cleaning its printhead.)

- Ink supply valve opening/closing count: 30 times (every 30 seconds)

If 336 or more hours have lapsed, the ink valve opening/closing count and the time until the next agitation are changed according to the length of the time lapsed.

### 2.3.2.2 Ink Tank Unit

#### 2.3.2.2.1 Structure of Ink Tank Unit

##### a) Ink tank

Each ink tank contains 130 ml of ink (the starter ink tank supplied with the printer contains 90 ml of ink) for each color. The amount of ink is memorized in the EEPROM mounted to the ink tank.

The amount of the ink remaining in the ink tank is detected as a dot count according to the data memorized in the EEPROM.

When the electrodes mounted to the hollow needle detect a con-conductive state, a message appears on the display to indicate that the ink is nearly empty. If the dot count reaches the prescribed value, the ink tank is considered to be empty.

##### b) Ink port

When the ink tank lock lever is pressed down, the hollow needle enters the ink port (covered with a rubber plug), establishing an ink passage between the printer and ink tank.

##### c) Air passage

When the ink tank lever of the printer is pressed down, the hollow needle enters the air passage (covered with a rubber plug) and thus the internal pressure of the ink tank is released, maintaining the internal pressure constant.

##### d) Notches for preventing incorrect insertion

The ink tanks have notches for preventing incorrect location. Wrong ink tanks cannot be installed in place due to these notches.

The ink tank lock lever can lowered to start ink supply only when the ink tank has been installed in place.

##### e) Agitation plate

The agitation plate assists the ink agitation which is performed to prevent precipitation of ink.

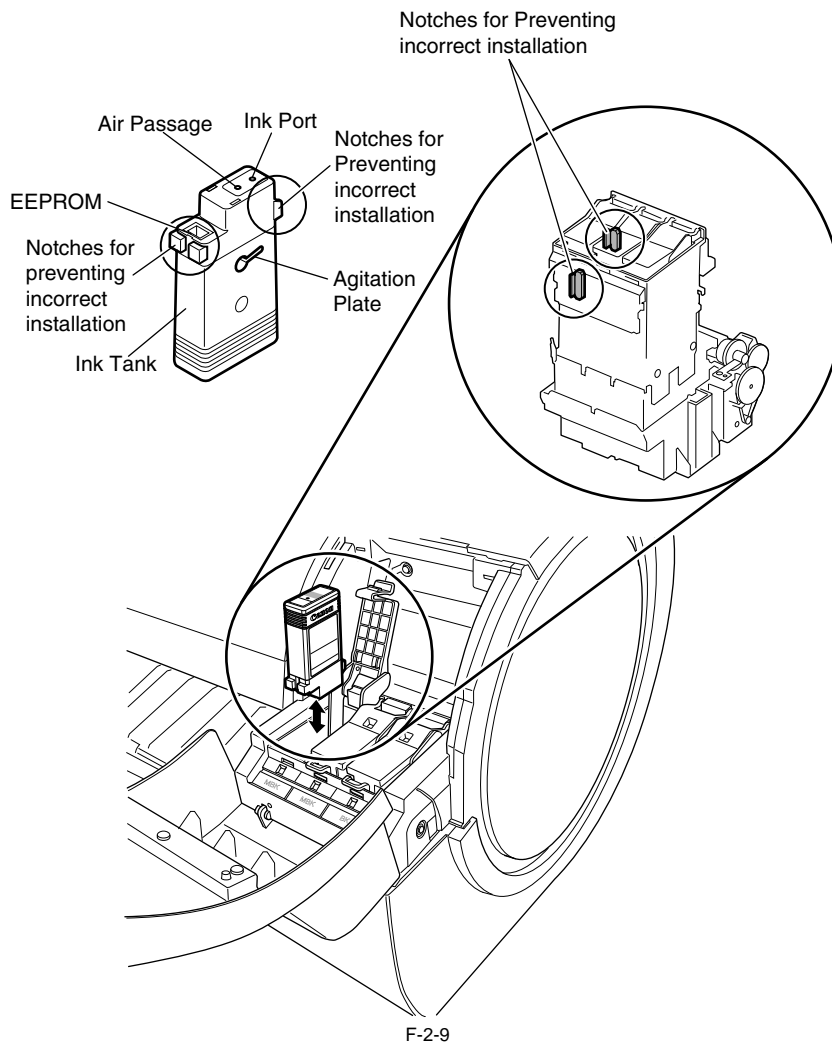

**f) Subtank**

The subtank installed under each ink tank complements the work of the ink tank, agitating the ink in the tank.

If the ink tank runs out of the ink while printing, the ink stored in the subtank is available, allowing the ink tank to be replaced without having to stop printing.

**g) Ink supply valve**

The ink supply valve is located between the ink tank and ink tube to prevent ink leakage from occurring when the ink tube on the ink tank side is opened during replacement of the ink tank.

The ink supply valve is opened and closed by the valve open/close mechanism which is driven by the valve motor.

The ink tank unit (Left/Right) consist of tank bases each of which contains ink tanks for three colors and the ink tubes for three colors.

Ink supply valves for all colors are opened and closed at the same time.

**h) Subtank air passage valve**

The subtank air passage valves keep the internal pressure of the subtank adequately.

The subtank air passage valve is opened and closed by the valve open/close mechanism which is driven by the valve motor.

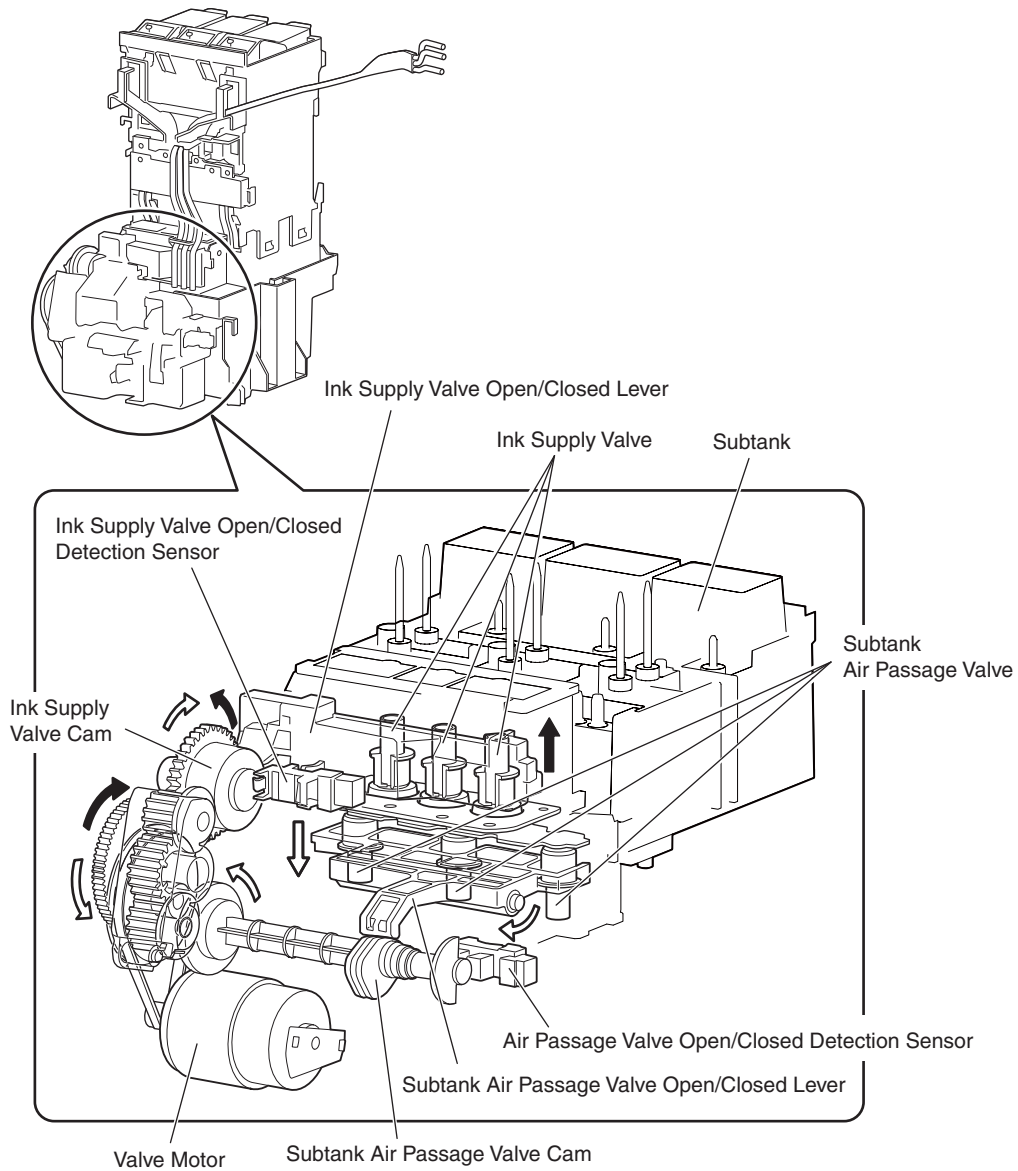

F-2-10

### 2.3.2.3 Carriage Unit

#### 2.3.2.3.1 Functions of Carriage Unit

##### a) Printhead mounting function

The carriage mechanically locks the printhead and transmits the print signals to the printhead via the carriage PCB.

##### b) Control function

The carriage incorporates a carriage PCB that relays the signal from the main controller, a linear encoder that generates a print timing signal based on the detected carriage position, and a multi sensor that detects the media width and skewing to adjust the registration and height. The carriage PCB and main controller PCB are connected with a flexible cable.

##### c) Carriage drive function

The carriage motor moves the carriage back and forth on the platen via the carriage belt.

##### d) Printhead maintenance function

The printer performs the printhead cleaning operation such as printhead wiping and suction at the home position of the carriage.

##### e) Nozzle check function

The printer detects a non-discharging nozzle using the head management sensor attached to the maintenance jet tray by discharging ink with the carriage stopped at the maintenance jet tray.

##### f) Media thickness adjustment function

If the gap between the printhead face and the media increases due to the difference in media thickness, cockling, curling, and so on, more ink mist is generated. In reverse, if the gap decreases, the head can touch the media surface more frequently.

To maintain the proper gap, the remote lifter is driven to adjust the head height automatically according to the selected media type, media supply method, printing conditions (borderless/priority print type), environmental conditions (temperature/humidity), and the result of measurement by the multi sensor.

The relationship between media types and head heights (from the platen) is summarized in the table below. Note that the head height is adjusted with priority given to the media gap measured by the multi sensor.

Head height (mm)	Media type (Value in parentheses:mm)*1
1.0	(select by the user when using the plain paper)
1.3	Photo paper, Synthetic paper, Backlit film
1.8	Plain paper, Coated paper
2	Heavyweight coated paper
2.2	Premium matte paper, Special
2.6	Special (at the low humidity or high humidity)

\*1: Roll media, borderless printing, standard mode except for line document

##### g) Paper leading edge detection function/paper width detection function/skewing detection function

The leading edge, width, and skewing of the paper fed to the platen is detected by the multi sensor mounted at the lower left of the carriage.

##### h) Auto printing position adjustment function

The adjustment pattern printed on paper is read by the multi sensor mounted at the lower left of the carriage, thus adjusting the printing timings of each printhead automatically.

##### i) Remaining roll media detection function

The amount of the remaining roll paper can be detected using the multi sensor mounted at the lower left of the carriage by printing a barcode at delivery of the roll media.

##### j) Internal temperature detection function

The internal temperature around the printhead is detected using the thermistor mounted on the carriage PCB.

### 2.3.2.3.2 Structure of Carriage Unit

#### a) Printhead mounting unit

The printhead is secured to the carriage by the printhead fixer lever.

When the printhead is secured to the carriage, the signal contact of the carriage PCB touches the signal contact point of the printhead, allowing print signals to be transmitted.

The ink passage from the ink tank is connected to the printhead through the ink tube and joint.

#### b) Ink port

Ink is supplied to the printhead via an ink tube, which is connected to ink joints, and runs between the tube guides to reach the carriage and follow its movement.

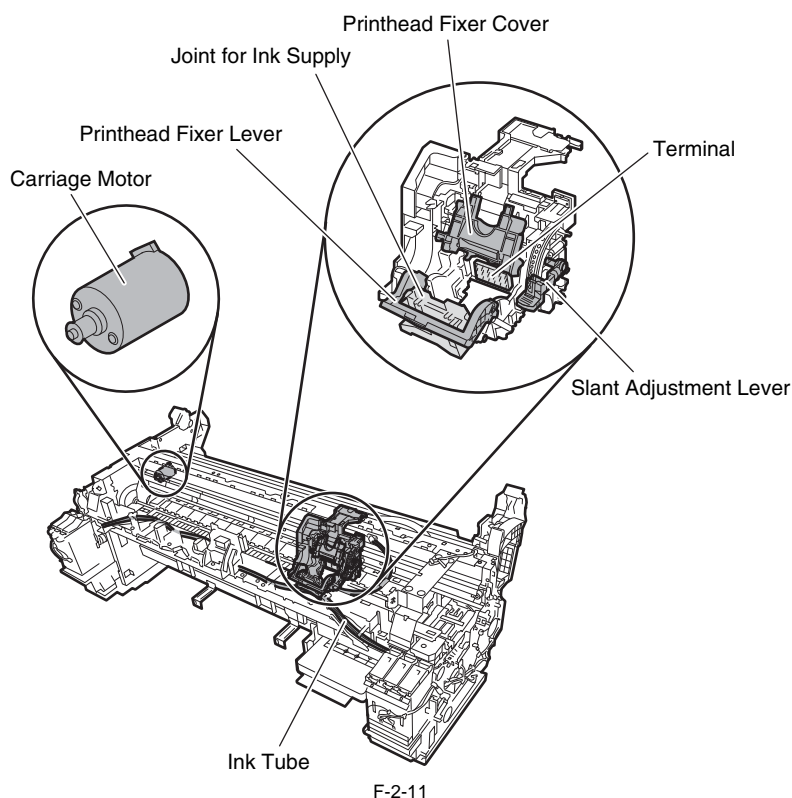

#### c) Control unit

The carriage PCB is connected to the main controller PCB with a flexible cable. The flexible cable moves in conjunction with the carriage.

A photo-coupler-type encoder is mounted at the top of the rear of the carriage to detect the slit on the linear scale during carriage movement, thus controlling the print timing.

#### d) Carriage drive

Mechanical misregistrations in the vertical/horizontal and bidirectional print positions of the printhead mounted can be corrected by selecting Adjust Printer from the main menu to shift the print timing.

A DC-operated carriage motor drives the carriage reciprocally on the platen by way of the carriage belt.

The carriage home position, or the capping position, is detected by the sensor flag on the right side of the carriage and the photointerrupter-based carriage HP sensor on the right side of the printer. When the linear scale position is set as a reference home position for use in subsequent position control operations, the carriage motor is driven by a control signal generated from the main controller PCB.

#### e) Printhead maintenance unit

This printer cleans the printhead with the carriage halted at its home position.

Wiping takes place through the rotation of the motor.

Wiper blades mounted on the carriage wipe the printhead while the carriage is halted at its home position.

Wet wiping is carried out for added wiping removal performance, whereby the wiper blades are moistened with glycerin as they are pressed against an absorber impregnated with glycerin.

Maintenance jet ejection is carried out on the cap, at the maintenance jet tray.

A suction operation is carried out by a suction cap in the purge unit.

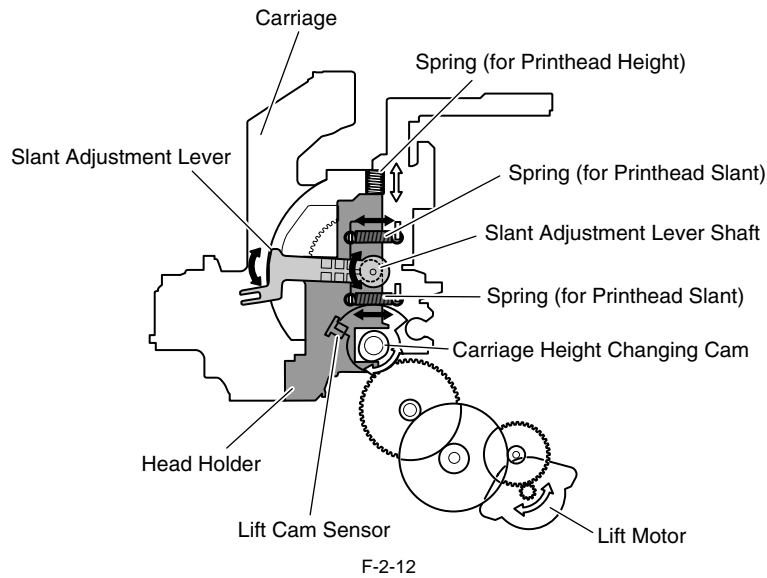

F-2-12

**f) Carriage height adjustment unit**

The head height is adjusted with the carriage halted at its home position.

The lift motor is driven to rotate the carriage height changing cam within the carriage, in sync with which the lift cams on both sides of the carriage move the head holder up and down, thereby varying the separation between the face of the printhead and the paper.

The printhead height is detected from the lift cam sensor within the carriage and the distance of rotation of the lift motor.

**g) Slant adjustment unit**

The tilting of the head is adjusted with the slant adjustment lever.

The point where the slant adjustment lever axis touches the head holder is offset from the fulcrum of the lever axis. Therefore, the printhead is tilted by moving the slant adjustment lever and moving the position on the right side of the head holder back or forward.

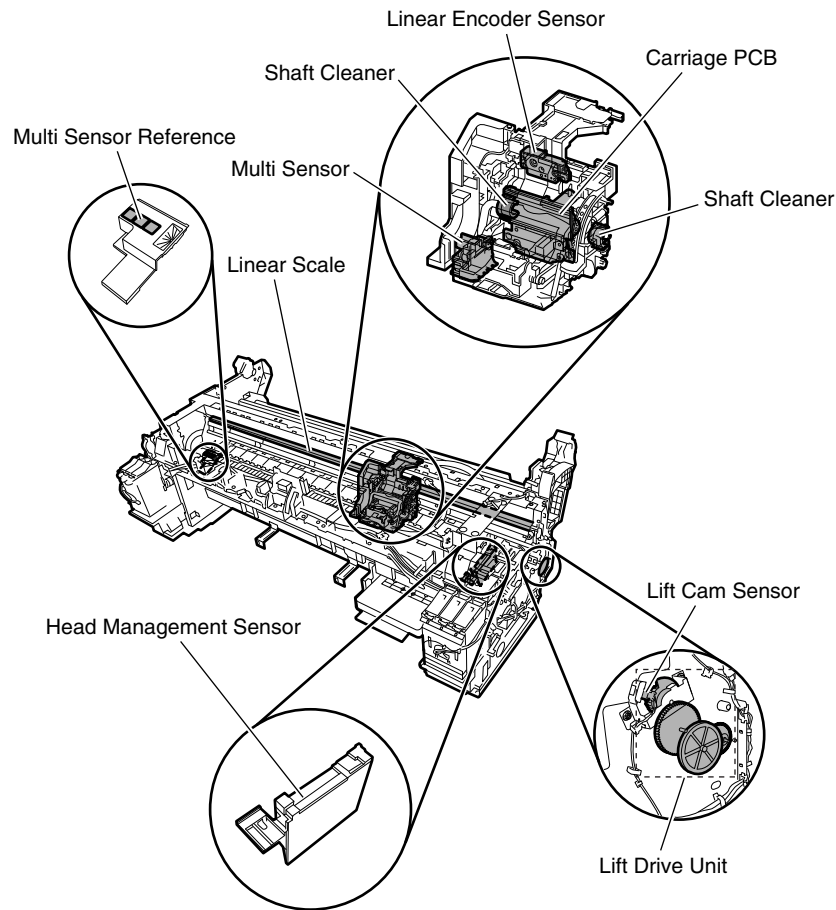

F-2-13

**h) Multi Sensor**

A photo reflective type multi sensor consists of three red LEDs, one red/blue/green LED array, and three light receiving sensors and is used for media end, skew, and width adjustment, registration adjustment, head height adjustment, and print position adjustment.

The multi sensor reference has three white plates attached to it, so that a reference value can be calculated during carriage height measurement by measuring the intensity of light reflected upon the white plates.

(Service mode: SERVICE MODE>ADJUST>GAP CALIB.)

**i) Shaft cleaner units**

The shaft cleaners mounted at the left and right of the carriage are used to clean the carriage and apply oil to the shaft.

**j) Internal temperature detection**

A thermistor for measuring the internal temperature is mounted on the carriage PCB on the rear of the head holder.

**2.3.2.4 Printhead**

**2.3.2.4.1 Structure of Printhead**

A printhead incorporates six nozzle arrays. Each nozzle can be controlled individually so that a six-color discharge action can be performed by a single printhead.

**a) Nozzle arrays**

A total of 2560 nozzles are arranged in a two-column staggered pattern.

In each column, 1280 nozzles are arranged in a staggered pattern at intervals of 600 dpi, forming a 2560-nozzle arranged at intervals of 1200 dpi.

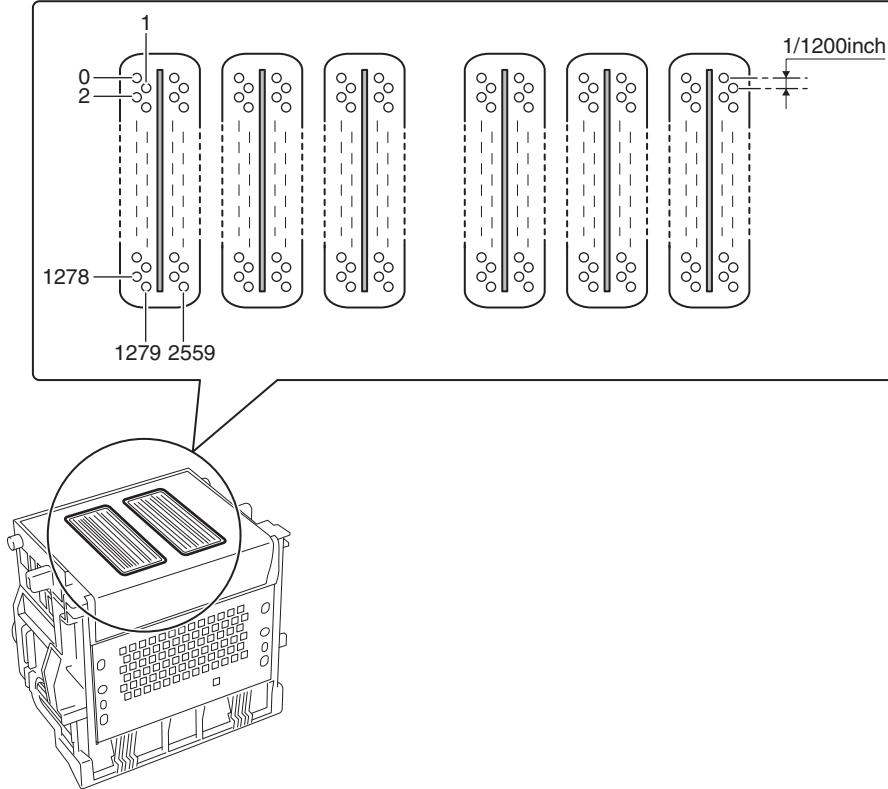

F-2-14

**b) Nozzle structure**

Ink supplied from the ink tank is filtered by a mesh ink filter, and the supplied to the nozzles.

Ink is supplied from the shared ink chamber to the nozzles. When the head driving current is applied to the nozzle heater, ink boils and form bubbles so that ink droplets are discharged from the nozzles.

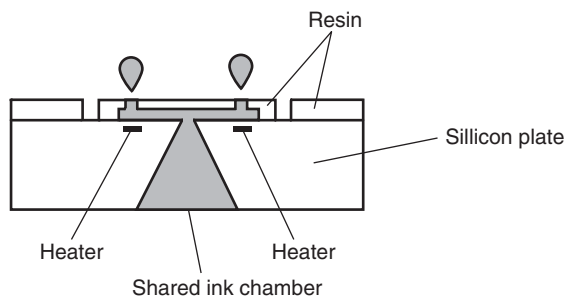

F-2-15



### 2.3.2.5 Purge Unit

#### 2.3.2.5.1 Functions of Purge Unit

To maintain high print quality, the purge unit performs maintenance of the nozzles of the printhead. The purge unit supports a capping function, cleaning function, and ink supply function.

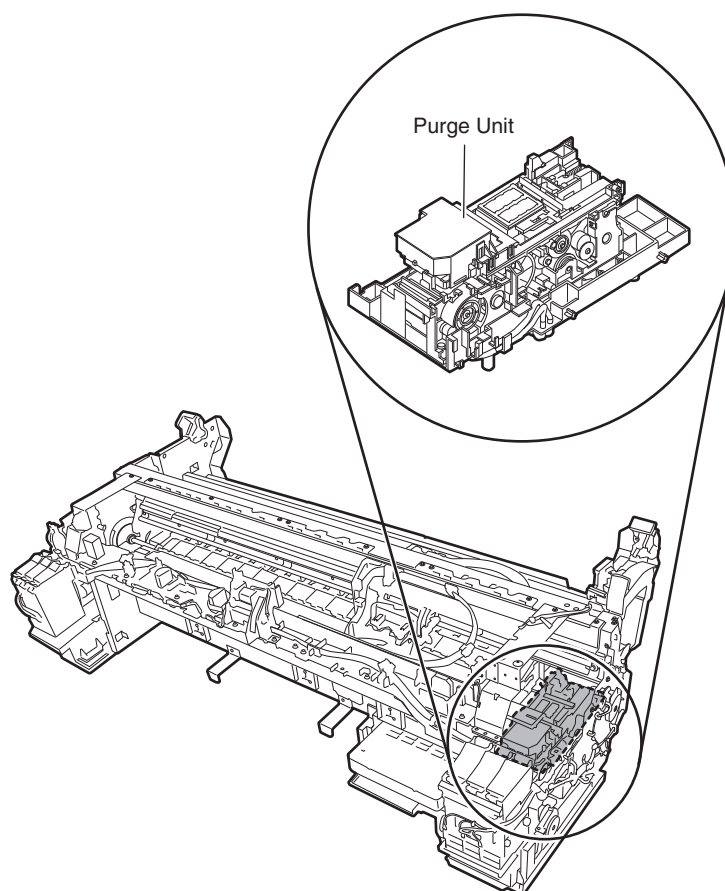

F-2-16

##### a) Capping function

The capping function presses the cap of the purge unit against the face plate on the nozzle section of the printhead to prevent nozzle drying and dust adhesion. Capping is performed when printing is complete, at the start of the suction operation, and when switching to the standby state due to an error. The capping function also establishes the ink passage between the printhead and purge unit.

##### b) Cleaning function

The cleaning function restores the printhead to the state where ink can be easily discharged from nozzles. This function includes the following three types of operations.

###### - Wiping operation

This operation is performed to remove paper fibers and dried ink from the face plate.

###### - Pumping operation

This operation is performed to remove ink from the nozzles and fill the nozzles with fresh ink.

###### - Maintenance jet operation

This operation is performed to spray ink from the nozzles to the cap, the maintenance jet ink groove of the platen to remove bubbles in the nozzles and dust and other foreign particles.

##### c) Ink supply function

The suction pump of the purge unit operates together with the ink supply valve to supply ink to the printhead during the initial filling and ink level adjustment.

Details of the cleaning function are shown in the table below.

<b>Cleaning mode</b>	<b>Name of Service mode or PRINT INF (Name of Main Menu)</b>	<b>Operation</b>	<b>Description of cleaning</b>
Cleaning 1	CLN-A-1/CLN-M-1 (Head Cleaning A)	Normal cleaning	Removes dried ink from nozzles, thick ink accumulated on the face, and paper particles.
Cleaning 2	CLN-A-2	Ink level adjustment and cleaning	Adjust the ink level in the head by suction, and then performs normal cleaning.
Cleaning 3	CLN-A-3	Initial filling ink	Fills the empty tube (during initial installation) with ink, and then performs normal cleaning.
Cleaning 4	CLN-M-4 (Replace P.head)	Ink drainage for head replacement	Drains ink to replace the head (drains only the ink in the head).
Cleaning 5	CLN-M-5 (Move Printer)	Ink drainage for secondary transport	Drains ink from the head and tube for secondary transport.
Cleaning 6	CLN-A-6/CLN-M-6 (Head Cleaning B)	Normal (strong) cleaning	Performs suction stronger than when adjusting the ink filling amount in the head or normal cleaning to unclog nozzles.
Cleaning 7	CLN-A-7	Aging	Performs idle ejection after replacement of the head.
Cleaning 10	CLN-A-10 (Move Printer)	Ink filling after secondary transport	Fills the empty tube (during installation after secondary transport) with ink, and performs normal cleaning.
Cleaning 11	CLN-A-11	Ink filling after head replacement	Performs normal cleaning after head replacement and ink filling.
Cleaning 15	CLN-A-15	Dot count suction	Performs suction to remove ink adhered to dried nozzles and thick ink accumulated on the face when the dot count reaches the prescribed value.
Cleaning 16	CLN-A-16	Precipitated ink agitation	Performs the agitation (ink supply valve open/close) operation to prevent the ink ingredient from precipitating.
Cleaning 17	CLN-A-17	Cleaning (weak)	Performs cleaning weaker than normal cleaning to unclog nozzles.

Cleaning operation timings are as follows.

Printer status		Cleaning operation	Ink consumption (typ.)*1		
Standby	The following times elapsed since the last section of Cleaning 2, 3, 6, 10. - Color: At least 720 hours - Black: At least 3840 to 11520 hours		Cleaning 6 (Normal (strong) Cleaning)	5g	
	At initial installation and 96 hours elapsed since the last session of Cleaning 16		Cleaning 16 (Precipitated ink agitation)	-	
	1 hour elapsed capped with a specified number of dots discharged per chip completed after last wiping		Wiping + Idle ejection	0.013g	
Power-on	At initial installation		Cleaning 3 (initial filling ink)	50g	
	Both heads and inks available	The print operation has completed.	The following times elapsed since the last section of Cleaning 2, 3, 6, 10. - Color: At least 720 hours - Black: At least 3840 to 11520 hours	Cleaning 6 (Normal (strong) Cleaning)	5g
			At least 96 hours elapsed since the last session of Cleaning 16	Cleaning 16 (Precipitated ink agitation)	-
			At least 1 hour elapsed capped with a specified number of dots discharged per chip completed after last wiping	Wiping + Idle ejection	0.013g
		Print operation aborted (uncapped) and CR error occurring	Up to 72 hours elapsed after an abort	Cleaning 1 (Normal Cleaning)	1g
			Over 72 hours elapsed after an abort	Cleaning 6 (Normal (strong) Cleaning)	5g
		Print operation aborted (uncapped) and no CR error occurring		Cleaning 11 (ink filling after head replacement)	10g
No heads are available		Cleaning 10 (ink filling on secondary transport)	60g		
Power off	Specified number of dots discharged per chip completed since the last session of wiping		Wiping + Idle ejection	0.013g	
Before the start of printing	Less than 168 hours elapsed capped		Idle ejection	0.013g	
	Before printing in the wake of an error occurrence		Cleaning 1 (Normal Cleaning)	1g	
Printing	Before scanning while printing		Idle ejection (+Wiping)	-(0.013g)	
After the end of printing	A specified number of dots (color) discharged per chip since the last session of Cleaning 2, 3, 6 or 1		Cleaning 6 (Normal (strong) Cleaning)	5g	
	A specified number of dots discharged per chip after the last session of wiping		Wiping + Idle ejection	0.013g	
	3 minutes elapsed since the last session of capping		Wiping + Idle ejection	0.013g	
	0.5 to 3 hours elapsed uncapped since the last session of Cleaning 1, 2, 3, 6 or 10		Idle ejection	MBK:0.5g(X2)	
When the Head Cleaning menu choice is executed	Manual Cleaning (Head Cleaning A)		Cleaning 1 (Normal Cleaning)	1g	
	Manual cleaning (Head cleaning B)		Cleaning 6 (Normal (strong) Cleaning)	5g	
When the Replace Printhead menu choice is executed	After and before head replacement		Cleaning 4 (ink drainage for head replacement) + Cleaning 11 (ink filling after head replacement)	20g	
When the Move Printer menu choice is executed	After the Move Printer menu choice is executed		Cleaning 5 (ink drainage for secondary transport)	10g	
	After power-on at secondary installation		After power-on at secondary installation	60g	

\*1: Quantities of ink consumption by nozzle train

### 2.3.2.5.2 Structure of Purge Unit

#### a) Cap unit

The cap unit is used to cap the printhead nozzles during capping and cleaning. The portion that touches the face plate is made from rubber. Two caps are arranged for the printhead (six arrays of nozzles) installed in the carriage.

During cleaning, the caps used for both suction and capping are used to suck ink from the printhead using the suction pump.

During capping, the caps are raised by the purge motor to cover the printhead when the carriage has moved to the home position, thus protecting the nozzles.

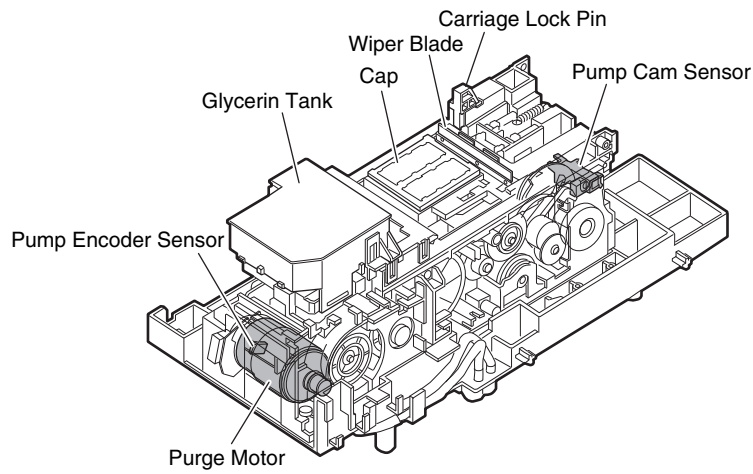

F-2-17

**b) Wiper unit**

The wiper unit operated by the purge motor wipes the printhead face.

The printer is provided with a pair of wiper blades for better wiping performance.

The wiping operation is performed by a "slide wipe" method by which the purge motor rotates (in the normal direction) to slide the wiper blade via the wiper cam.

It is performed by a constant-speed movement toward the front of the printer as viewed from the printer front.

The wiper blade, which is positioned at right angles to the printhead, wipes the entire printhead face, and then the narrow blade is used to wipe the nozzle arrays.

After wiping, the wiper blades are cleaned before they are set at the wiping position so that the maximum wiping performance is obtained.

During the wiper blade cleaning, the ink removed from the head is rubbed off by the ink scraper. Absorbent material soaked with glycerin is pressed against the wiper blades to enhance the wiping performance. The amount of glycerin used (tank capacity: 50 ml) is managed by counting the number of times the wiper blade is pressed against the absorbent material. When this count reaches the specified values, either a replacement warning (continued print available) or replacement required indication (service call error) is issued.

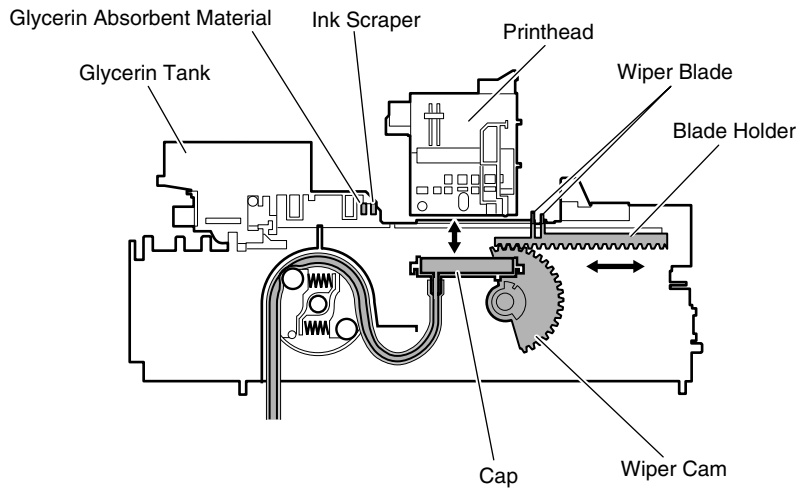

F-2-18

**c) Pump unit**

This printer uses tube pumps (suction pumps) that press on the ink tubes using rollers to produce negative pressure, thus sucking ink.

Two rollers are used to press on a single tube one after another to control the amount of ink sucked.

The roller rotation timing is detected by the pump cam sensor, and the amount of rotation is controlled by the driving of the purge motor.

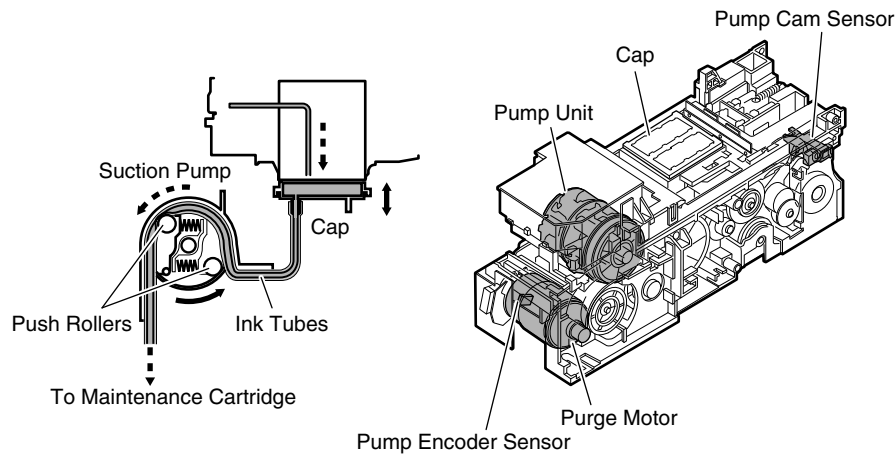

F-2-19

### 2.3.2.6 Maintenance Cartridge

#### 2.3.2.6.1 Maintenance Cartridge

**a) Maintenance cartridge**

The maintenance cartridge can store waste ink.

**b) Detection of waste ink in maintenance cartridge**

The quantity of waste ink in the maintenance cartridge is measured by counting dots.

When the quantity of the waste ink reaches approximately 80% of the cartridge capacity, the warning message "Check maint cartridge capacity" is displayed to tell that the maintenance cartridge is nearly full.

Printing may continue even when the warning message is displayed.

When the quantity of the waste ink reaches approximately 100% of the cartridge capacity, a replacement prompt error message is displayed, telling that the maintenance cartridge is full.

When the printer determines that the maintenance cartridge is full, it shuts down even while it is printing.

The printer will remain inoperable until the maintenance cartridge is replaced.

---

**MEMO:**  
The maintenance cartridge houses EEPROM, so that main controller PCB can control the status of the maintenance cartridge by writing to and reading from the EEPROM content.  
There is no need to initialize the counter information, therefore, when the maintenance cartridge is replaced.

---

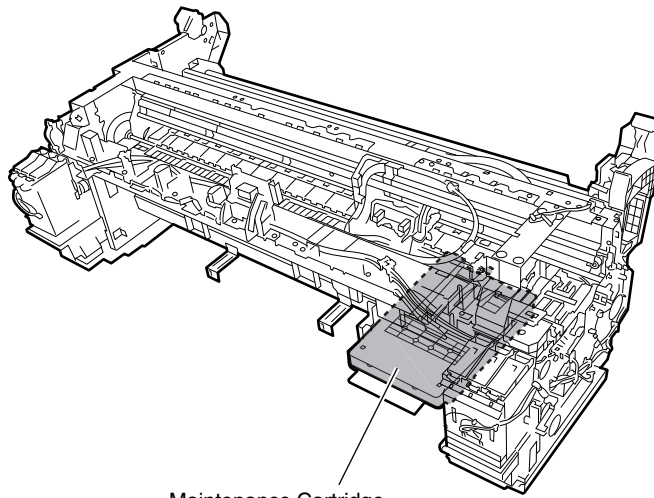

Maintenance Cartridge

F-2-20

### 2.3.2.7 Air Flow

#### 2.3.2.7.1 Air Flow

This printer is equipped with a mist fan to collect the ink mist and a suction fan to suck the media to the platen. The ink floating in air or spattered from the media during printing passes through the suction port because of the air flow inside the printer and is collected inside the mist fan and mist exhaust duct. There is a duct below the platen and the ink mist in the duct is collected in the platen suction duct by the platen suction fan.

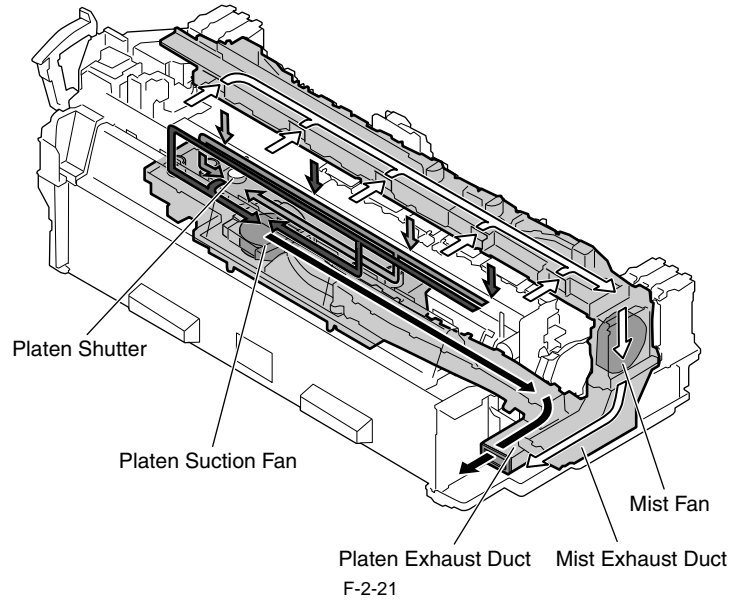

There are two ducts below the platen and each is connected to the platen suction fan. One comes from the borderless printing ink receiving grooves and the other comes from the suction port.

The duct from the borderless printing ink receiving grooves has a shutter unit in front of the platen suction fan. This controls the suction pressure from the borderless printing ink receiving grooves according to the paper size and number of print passes with the shutter opening amount of the shutter unit in order to prevent ink flowing and smearing at the edge of paper during borderless printing.

The shutter position (opening) is detected by the shutter HP sensor and the rotation of the shutter motor.

The shutter is controlled at the following six positions.

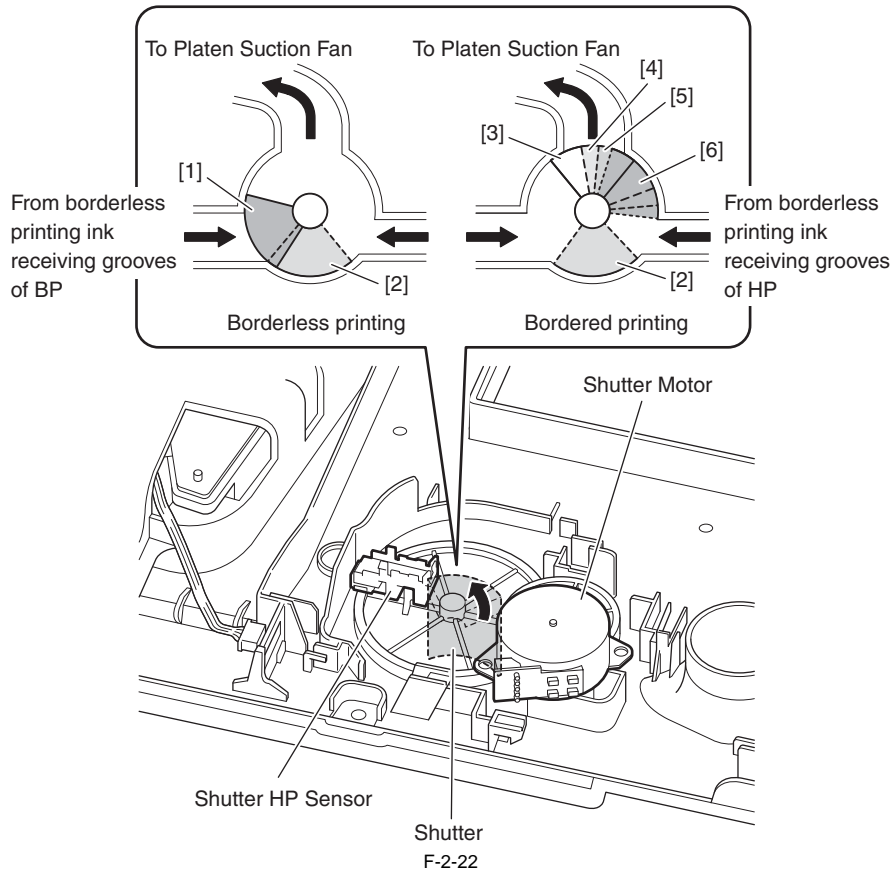

Shutter position	Shutter opening	During borderless printing	During bordered printing
[1]	Only HP side open	Yes (17 inch or shorter media)	
[2]	Fully open	Yes (B2 or larger media)	Yes
[3]	Fully close		Yes
[4]	1/4 open		Yes
[5]	1/2 open		Yes
[6]	3/4 open		Yes



## 2.3.3 Paper Path

### 2.3.3.1 Outline

#### 2.3.3.1.1 Overview of Paper Path

The paper pass comprises an roll unit, a feed roller, a pinch roller pressure drive unit that pressurizes and depressurizes the pinch roller, a roll holder drive unit that drives the roll holder and sensors that detect the transport status of paper to feed paper in one way, and transport and eject the paper.

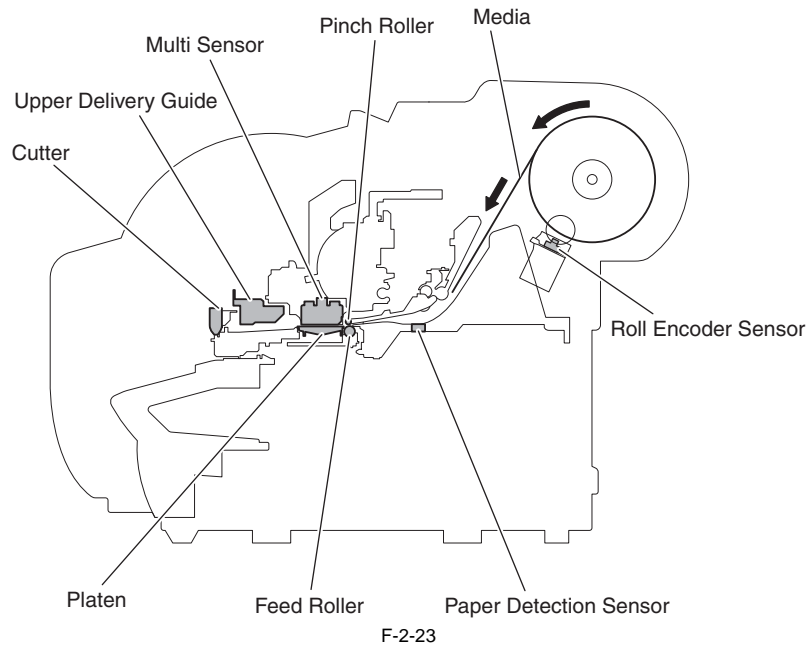

### 2.3.3.2 Paper Path

#### 2.3.3.2.1 Structure of Feed Roller Unit

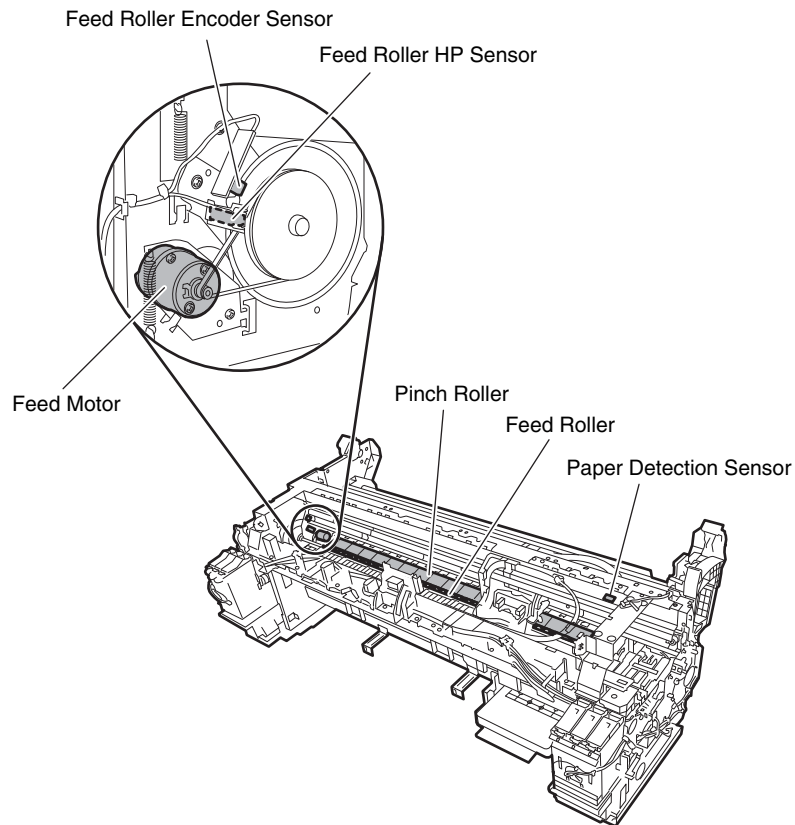

F-2-24

##### a) Feed roller Unit

The feed roller unit consists of media feeding mechanisms such as feed rollers driven by the feed motor and the pinch roller unit operating in conjunction with the feed rollers. While being held flat on the platen, media is fed horizontally under the printhead.

##### b) Detection Unit

The feed roller unit has a sensor that detects the media feed status and a sensor that detects the status of the mechanisms that constitute the paper path.

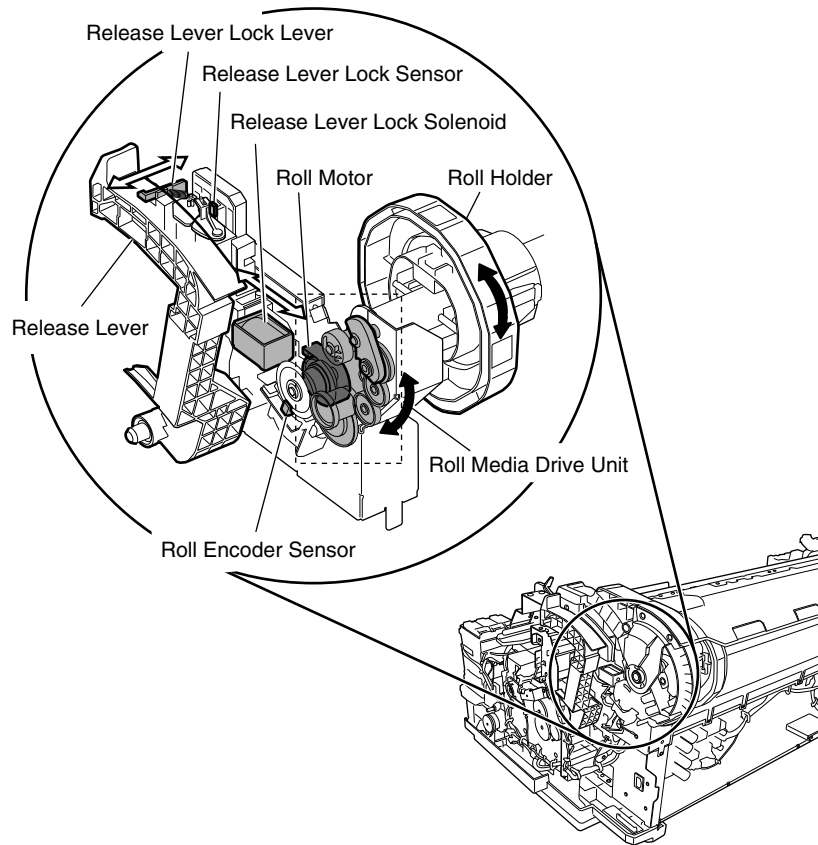

F-2-25

**c) Roll media drive unit**

The paper feed unit has a roll media drive unit to prevent sagging and skewing of media when feeding a roll media. The roll media drive unit feeds/rewinds the roll media by rotating the roll holder with the forward/reverse rotation of the roll motor.

The roll encoder sensor of the roll media drive unit detects the rotation of the roll holder during roll media feed, and assumes the end of roll media is reached when the roll holder stops rotating.

**d) Release lever unit**

The release lever is used to release the pinch roller pressure when setting the media or fixing jam.

The release lever lock solenoid turns ON and locks the release lever with the release lever lock lever so that the pinch roller pressure cannot be released while printing.

The release lever lock status is detected with the release lever lock sensor.

### 2.3.3.3 Cutter Unit

#### 2.3.3.3.1 Structure of Cutter Unit

When a roll media is used, the cutter unit cuts the leading end of the roll on loading and also cuts the roller on paper ejection. Whether cutting takes place or not depends on the relevant printer driver setting in the main menu. The cutter in the cutter unit stands by at the cutter home position, except when a roll media is cut. Power imparted from the cutter motor to the cutter via a circular belt drives it to travel from right to left for cutting.

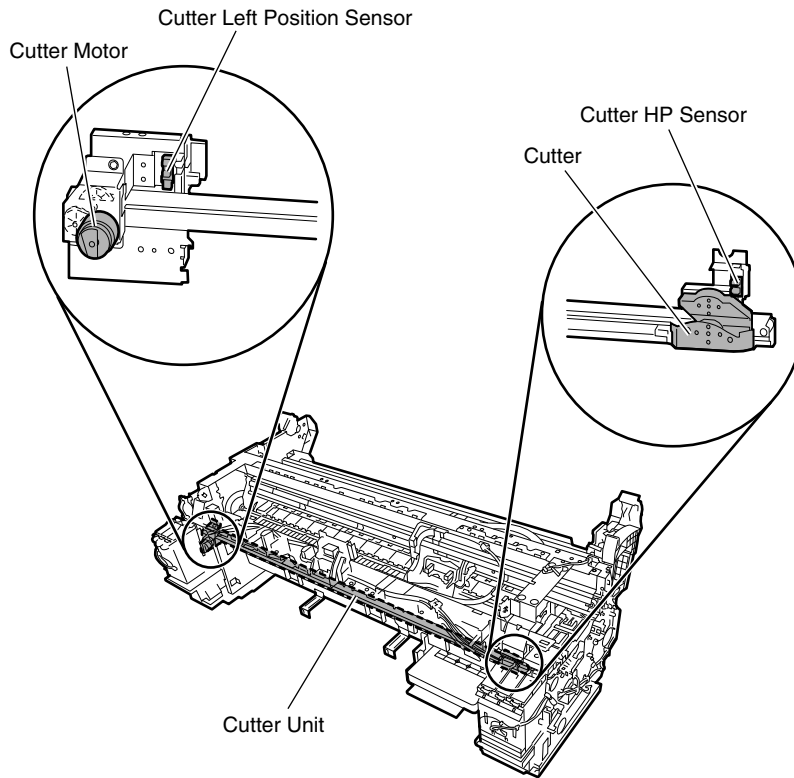

F-2-26

---

## 2.4 Printer Electrical System

---

### 2.4.1 Outline

#### 2.4.1.1 Overview

The printer electrical system consists of the main controller PCB and power supply PCB which are mounted on the rear side of the printer, the carriage PCB and printhead which are mounted in the carriage, and other electrical components such as the operation panel, sensors, and motors. The main controller PCB manages the image data processing and the entire electrical system, and controls relay PCBs and driver functions.

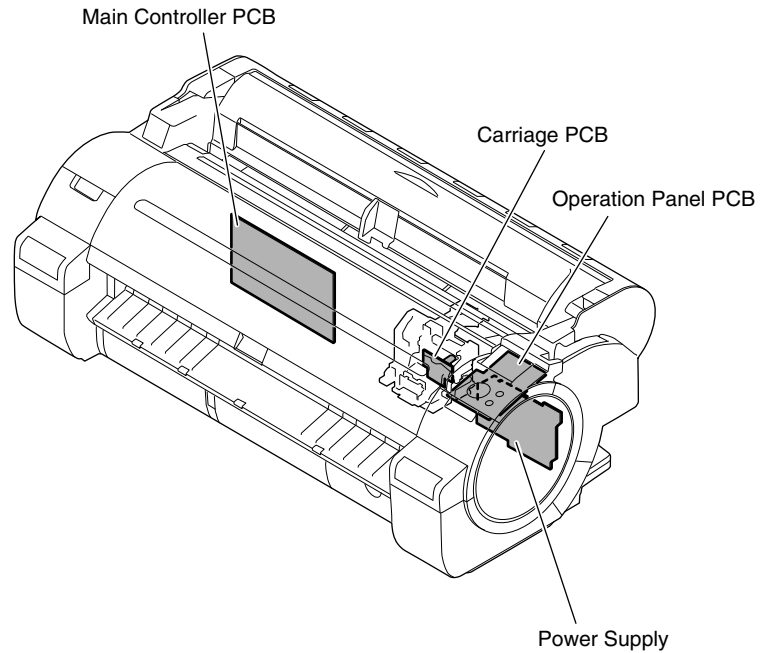

F-2-27

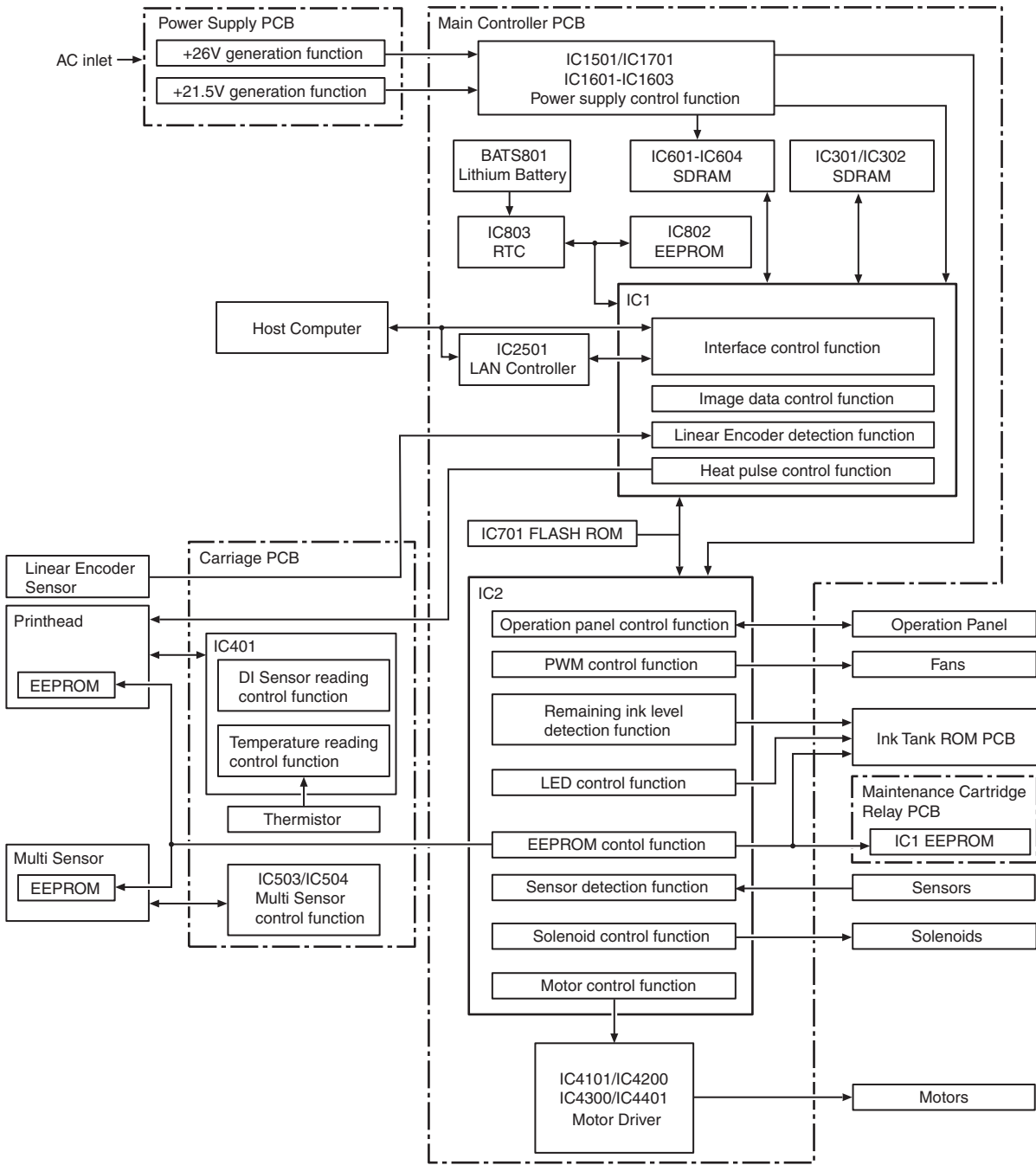

F-2-28

## 2.4.2 Main Controller

### 2.4.2.1 Main controller PCB components

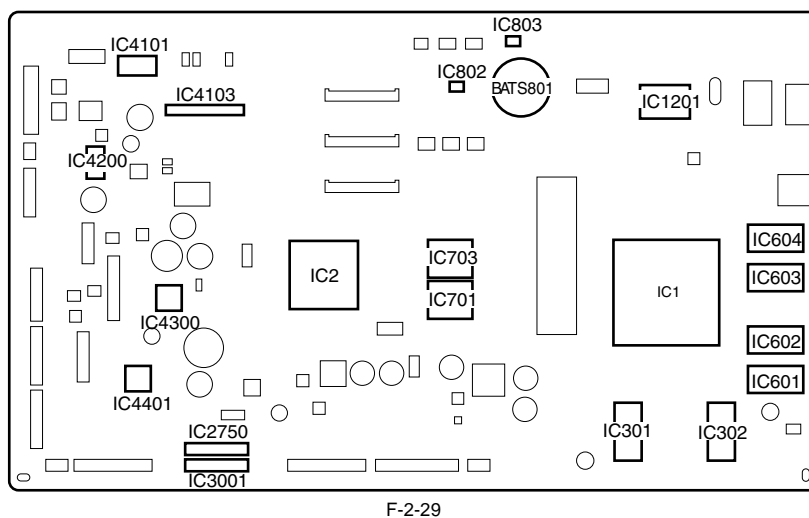

#### a) ASIC (IC1/IC2)

The ASIC (IC1/IC2) with a 32/16-bit internal bus is driven in sync with the 165/66 MHz external clock. It supports the following functions:

##### Image processing unit

This unit converts the RGB multi-value image data or CMYK multi-value data received from the host computer through the interface connector to the binary image data for the ink colors used.

##### DMA controller

This controller control DMA transfer of the data transferred through the input interfaces as well as DMA transfer of the data stored in the DIMM.

##### Image data generation/output function

This function generates image data for color printing from the received image data and the mask pattern (corresponding to print mode) stored in the FLASH ROM, and stored the generated image data in DIMM. It also outputs the generated image data to the carriage PCB.

##### Interrupt controller

This controller receives and processes internal interrupts and external interrupts from the USB, image processing unit, and expansion card slot.

##### Timer function

Even when the printer is turned off, the timer function is held on using the RTC(IC803) and lithium battery(BATS801) to assist the cleaning function. When the power cord is plugged to the outlet, power is supplied to the RTC and therefore the lithium battery power is not consumed.

##### Heat Enable signal control function

This function uses the pulse width to perform variable control of the time of application of the Heat Enable signal to the nozzle heater board for each printhead nozzle array.

##### Linear scale count function

This function reads the linear scale when the carriage moves, thus generating the ink discharge timing. It also counts the linear scale timing cycle using the reference clock to measure the carriage moving speed.

##### Dot count function

This function controls the discharge dots used as the information for Heat Enable signal control, maintenance jet control, cleaning control, and remaining ink level for each nozzle array.

##### Operation panel control function

This function controls serial communication with the operation panel.

##### PWM control function

This function controls driving of the suction fan and mist fan as well as the temperature of the printhead.

##### Remaining ink level detection function

This function detects the remaining level of each color of ink based on the signal received from the hollow needle mounted in the ink tank unit.

##### LED control function

This function controls the LEDs on the ink tank unit.

##### I/O port function

This function controls input signals from sensors.

##### Power ON/OFF control function

This function controls turning on/off of the drive power (26 V and 21.5 V) supplied from the power supply PCB.

##### Head DI sensor read control function

This function controls read operation by the head DI sensor.

##### Multi sensor control function

This function controls the LED, adjusts the gain, and controls obtainment of the reading for the multi sensor.

##### EEPROM control function

This function controls the EEPROMs of individual ink tanks, the maintenance cartridge EEPROM, the EEPROM on the maintenance cartridge relay PCB, and the head EEPROM in addition to the on-board EEPROM.

##### Motor control function

This function controls the carriage motor, feed motor, valve motor (L)/(R), shutter motor, purge motor, lift motor, roll motor and cutter motor based on the input signals from sensors.

**b) Driver IC (IC4101/4103)**

This IC generates a carriage motor control signal based on the control signal from the ASIC.

**c) Driver IC (IC4200)**

This IC generates a feed motor control signal based on the control signal from the ASIC.

**d) Driver IC (IC4300)**

This IC generates purge motor and cutter motor control signals based on the control signal from the ASIC.

**e) Driver IC (IC4401)**

This IC generates roll motor and valve motor (L)/(R) control signals based on the control signal from the ASIC.

**f) Driver IC (IC2750)**

This IC generates a shutter motor control signal based on the control signal from the ASIC.

**g) Driver IC (IC3001)**

This IC generates a lift motor control signal based on the control signal from the ASIC.

**h) DIMMs (IC301, IC302, IC601, IC602, IC603, IC604)**

The DIMM comprising a 512-MB DDR-SDRAM (IC301/IC302) and 256-MB SDR-SDRAM (IC601/IC602/IC603/IC604) is connected to the 32-bit data bus to be used as a work area.

During print data reception, it is also used as an image buffer.

It cannot be expanded.

**i) FLASH ROM (IC701/IC703)**

A 128-MB/64-MB flash ROM (IC701/IC703) is connected to the 8-bit data bus to store the printer control program.

**j) EEPROM (IC802)**

The 256-KB EEPROM stores various setting values, adjustment values, log data, counter values related to the user/servicing.

**MEMO:**

After replacement of the main controller PCB, the printer must be started up in the service mode to copy over the setting and adjustment values to the new PCB properly (the service mode will be switched to the PCB replacement mode automatically).

**2.4.2.2 Connectors and Pin Arrangement of Main controller PCB**

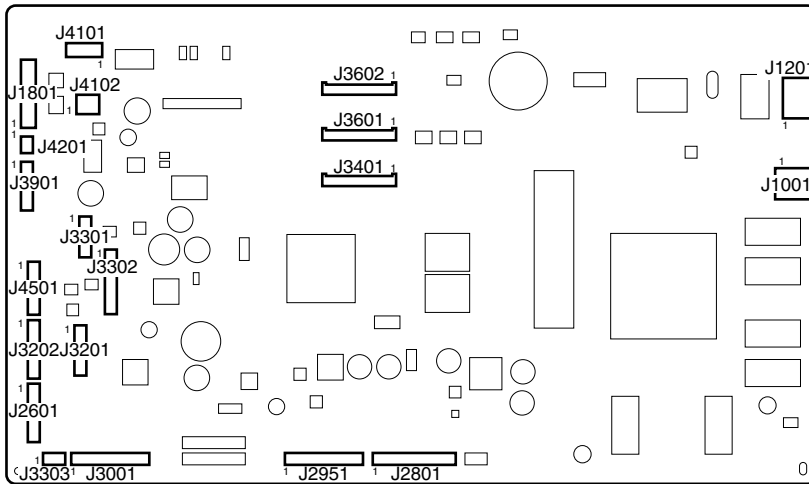

F-2-30

T-2-1

J1001 (USB)			
Pin Number	Signal name	IN/OUT	Function
1	VBUS	IN	USB VBUS(+5V)
2	D-	IN/OUT	USB data (-)
3	D+	IN/OUT	USB data (+)
4	GND	-	USB GND
5	GND	-	GND (Connector shell)
6	GND	-	GND (Connector shell)

T-2-2

J1201 (Network)			
Pin Number	Signal name	IN/OUT	Function
1	TX+	OUT	Ethernet data TX line (+)
2	TX-	OUT	Ethernet data TX line (-)
3	RX+	IN	Ethernet data RX line (+)
4	-	-	Not used



<b>J1201 (Network)</b>			
<b>Pin Number</b>	<b>Signal name</b>	<b>IN/OUT</b>	<b>Function</b>
5	-	-	Not used
6	RX-	IN	Ethernet data RX line (-)
7	-	-	Not used
8	-	-	Not used
9	GREEN_LED_C	OUT	Link LED (green:100Mb/s) cathode terminal
10	GREEN_LED_A	OUT	Link LED (green:100Mb/s) anode terminal
11	YELLOW_LED_C	OUT	Link LED (yellow:10Mb/s) cathode terminal
12	YELLOW_LED_A	OUT	Link LED (yellow:10Mb/s) anode terminal

T-2-3

<b>J1801 (Connect to Power supply)</b>			
<b>Pin Number</b>	<b>Signal name</b>	<b>IN/OUT</b>	<b>Function</b>
1	PW_CONT	OUT	Normal/power saving switch signal
2	VM(+32V)	IN	Power supply (+32V)
3	VM(+32V)	IN	Power supply (+32V)
4	VMGND	-	GND
5	VMGND	-	GND
6	VH(+32V)	IN	Power supply (+32V)
7	VH(+32V)	IN	Power supply (+32V)
8	VHGND	-	GND
9	VHGND	-	GND
10	PW_ENB(VH_ENB)	OUT	VH power supply ON/OFF signal

T-2-4

<b>J2601 (Connect to Operation panel)</b>			
<b>Pin Number</b>	<b>Signal name</b>	<b>IN/OUT</b>	<b>Function</b>
1	POWER_ON	IN	Power switch signal
2	GND	-	GND
3	+5.1V	OUT	Power supply (+5.1V)
4	BUZZER	OUT	Buzzer control signal
5	PDO	OUT	Panel IC control signal
6	+5.1V	OUT	Power supply (+5.1V)
7	PDI	OUT	Panel IC data signal
8	EX_HDD_LED	-	N.C
9	PRESET*	OUT	Panel IC reset signal
10	GND	-	GND
11	PCK	OUT	Panel IC clock signal
12	PANEL5V_ON	OUT	LED backlight power supply (+5V)
13	PCS*	OUT	Panel chip select signal

T-2-5

<b>J2801 (Purge motor, Pump encoder sensor, Pump cam sensor, Paper detection sensor, Lift cam sensor, Carriage HP sensor, Pinch roller pressure release switch)</b>			
<b>Pin Number</b>	<b>Signal name</b>	<b>IN/OUT</b>	<b>Function</b>
1	PUMPM_OUTA	OUT	Purge motor drive signal A
2	PUMPM_OUTB	OUT	Purge motor drive signal B
3	PUMP_ENCB	IN	Pump encoder sensor output signal B
4	SNS5V_FU1	OUT	Power supply (+5V)
5	PUMP_ENCA	IN	Pump encoder sensor output signal A
6	GND	-	GND
7	SNS3V_FU1	OUT	Power supply (+3.3V)
8	GND	-	GND
9	PUMP_HP_SNS*	IN	Pump cam sensor output signal
10	GND	-	GND
11	LFPE(MEDIA)_SNS*	IN	Paper detection sensor output signal
12	MEDIA5V	OUT	Power supply (+5V)
13	SNS3V_FU1	OUT	Power supply (+3.3V)
14	GND	-	GND
15	LIFT_HP_SNS*	IN	Lift cam sensor output signal
16	SNS3V_FU1	OUT	Power supply (+3.3V)
17	GND	-	GND
18	CR_HP_SNS*	IN	Carriage HP sensor output signal
19	RELEASE_LEV_OPEN_SNS*	IN	Pinch roller pressure release switch output signal
20	GND	-	GND

T-2-6

<b>J2951 (Head management sensor, Shutter HP sensor, Shutter motor, Platen suction fan)</b>			
Pin Number	Signal name	IN/OUT	Function
1	APCHK	IN	Head management sensor unit LED current output detection signal
2	FUTO_MONITOR(N.C.)	-	N.C
3	GND	-	GND
4	FUTO_CLMP*	OUT	Head management sensor unit clamp signal
5	FUTO_ON*	OUT	Head management sensor unit LED ON/OFF signal
6	SNS5V	OUT	Power supply (+5V)
7	FUTO_CMP*	IN	Head management sensor unit light shading detection signal
8	SNS3V_FU1	OUT	Power supply (+3.3V)
9	GND	-	GND
10	HUSOKU_HP_SNS*	IN	Shutter HP sensor output signal
11	VM_26V	OUT	Power supply (+26V)
12	HUSOKUM_OUTA	OUT	Shutter motor drive signal A
13	HUSOKUM_OUTAX	OUT	Shutter motor drive signal AX
14	HUSOKUM_OUTB	OUT	Shutter motor drive signal B
15	HUSOKUM_OUTBX	OUT	Shutter motor drive signal BX
16	FAN_VM(26.5V)	OUT	Power supply (+26.5V)
17	PLATEN_FAN_LOCK*	IN	Platen suction fan lock signal
18	PLATEN_FAN_PWM	OUT	Platen suction fan PWM control signal
19	GND	-	GND

T-2-7

<b>J3001 (Lift motor, Roll motor, Roll encoder sensor, Release lever lock sensor, Release lever lock solenoid)</b>			
Pin Number	Signal name	IN/OUT	Function
1	VM_26V(26.5V)	OUT	Power supply (+26.5V)
2	LIFTM0_A	OUT	Lift motor drive signal A
3	LIFTM2_AX_N0	OUT	Lift motor drive signal AX
4	LIFTM1_B	OUT	Lift motor drive signal B
5	LIFTM3_BX_N0	OUT	Lift motor drive signal BX
6	TP_ROLL_TRNSM_AP	OUT	Roll motor drive signal AP
7	TP_ROLL_TRNSM_AM	OUT	Roll motor drive signal AM
8	TP_ROLL_TRNSM_BP	OUT	Roll motor drive signal BP
9	TP_ROLL_TRNSM_BM	OUT	Roll motor drive signal BM
10	GND	-	GND
11	ROLL_KEI_ENCA	IN	Roll encoder sensor output signal A
12	SNS5V_FU1	OUT	Power supply (+5V)
13	ROLL_KEI_ENCB	IN	Roll encoder sensor output signal B
14	SNS3V_FU2	OUT	Power supply (+3.3V)
15	GND	-	GND
16	RELEASE_LEV_MEM_SNS*	IN	Release lever lock sensor output signal
17	VM_26V	OUT	Power supply (+26.5V)
18	RELEASE_LEV_LOCK_SOL*	OUT	Release lever lock solenoid drive signal

T-2-8

<b>J3201 (Ink detection sensor (R), Ink tank cover switch (R), Cutter HP sensor)</b>			
Pin Number	Signal name	IN/OUT	Function
1	GND	-	GND
2	INK_SNS3	IN	Ink detection sensor output signal 3
3	INK_SNS4	IN	Ink detection sensor output signal 4
4	INK_SNS5	IN	Ink detection sensor output signal 5
5	INK_SNS9	IN	Ink detection sensor output signal 9
6	INK_SNS10	IN	Ink detection sensor output signal 10
7	INK_SNS11	IN	Ink detection sensor output signal 11
8	TANK_COVER_SW_R*	IN	Ink tank cover switch (R) output signal
9	GND	-	GND
10	SNS3V_FU1	OUT	Power supply (+3.3V)
11	GND	-	GND
12	CUTTER_R_SNS*	OUT	Cutter HP sensor output signal

T-2-9

<b>J3202 (Ink supply valve open/closed detection sensor (R), Air passage valve open/closed detection sensor (R), valve motor (R), Ink tank ROM PCB (R))</b>			
Pin Number	Signal name	IN/OUT	Function
1	SNS3V_FU1	OUT	Power supply (+3.3V)

<b>J3202 (Ink supply valve open/closed detection sensor (R), Air passage valve open/closed detection sensor (R), valve motor (R), Ink tank ROM PCB (R))</b>			
Pin Number	Signal name	IN/OUT	Function
2	GND	-	GND
3	SUPPLY_BEN_R_SNS*	IN	Ink supply valve open/closed detection sensor (R) output signal
4	SNS3V_FU1	OUT	Power supply (+3.3V)
5	GND	-	GND
6	TAIKI_BEN_R_SNS*	OUT	Air passage valve open/closed detection sensor (R) output signal
7	INKBEN_R_OUTB	OUT	Valve motor (R) drive signal B
8	INKBEN_R_OUTA	OUT	Valve motor (R) drive signal A
9	TANK_DAT3	IN/OUT	Ink tank data signal 3
10	TANK_DAT4	IN/OUT	Ink tank data signal 4
11	TANK_3V	OUT	Power supply (+3.3V)
12	TANK_DAT5	IN/OUT	Ink tank data signal 5
13	GND	-	GND
14	TANK_CLK	OUT	Ink tank clock signal

T-2-10

<b>J3301 (Ink detection sensor (L), Ink tank cover switch (L))</b>			
Pin Number	Signal name	IN/OUT	Function
1	GND	-	GND
2	INK_SNS0	IN	Ink detection sensor output signal 0
3	INK_SNS1	IN	Ink detection sensor output signal 1
4	INK_SNS2	IN	Ink detection sensor output signal 2
5	INK_SNS6	IN	Ink detection sensor output signal 6
6	INK_SNS7	IN	Ink detection sensor output signal 7
7	INK_SNS8	IN	Ink detection sensor output signal 8
8	TANK_COVER_SW_L*	IN	Ink tank cover switch (L) output signal
9	GND	-	GND

T-2-11

<b>J3302 (Ink supply valve open/closed detection sensor (L), Air passage valve open/closed detection sensor (L), Valve motor (L), Ink tank ROM PCB (L))</b>			
Pin Number	Signal name	IN/OUT	Function
1	SNS3V_FU1	OUT	Power supply (+3.3V)
2	GND	-	GND
3	SUPPLY_BEN_L_SNS*	IN	Ink supply valve open/closed detection sensor (L) output signal
4	SNS3V_FU1	OUT	Power supply (+3.3V)
5	GND	-	GND
6	TAIKI_BEN_L_SNS*	OUT	Air passage valve open/closed detection sensor (L) output signal
7	INKBEN_L_OUTB	OUT	Valve motor (L) drive signal B
8	INKBEN_L_OUTA	OUT	Valve motor (L) drive signal A
9	TANK_DAT3	IN/OUT	Ink tank data signal 3
10	TANK_DAT4	IN/OUT	Ink tank data signal 4
11	TANK_3V	OUT	Power supply (+3.3V)
12	TANK_DAT5	IN/OUT	Ink tank data signal 5
13	GND	-	GND
14	TANK_CLK	OUT	Ink tank clock signal
15	N.C.	-	N.C.

T-2-12

<b>J3303 (Connect to Maintenance cartridge relay PCB)</b>			
Pin Number	Signal name	IN/OUT	Function
1	MENT_ROM_SDA	IN/OUT	Maintenance cartridge rom control signal (data)
2	MENT_ROM_SCL	IN/OUT	Maintenance cartridge rom control signal (clock)
3	GND	-	GND
4	TANK_3V	OUT	Power supply (+3.3V)

T-2-13

<b>J3401 (Connect to Carriage PCB J201)</b>			
Pin Number	Signal name	IN/OUT	Function
1	VHGND	-	GND
2	VHGND	-	GND
3	VHGND	-	GND
4	VHGND	-	GND
5	VH_MONI1	IN	VH control signal
6	VH	OUT	Power supply (+21.5V)

<b>J3401 (Connect to Carriage PCB J201)</b>			
<b>Pin Number</b>	<b>Signal name</b>	<b>IN/OUT</b>	<b>Function</b>
7	VH	OUT	Power supply (+21.5V)
8	VHGND	-	GND
9	H3V	OUT	Power supply (+3V)
10	H3V	OUT	Power supply (+3V)
11	VHGND	-	GND
12	H5V	OUT	Power supply (+5V)
13	H5V	OUT	Power supply (+5V)
14	VH	OUT	Power supply (+21.5V)
15	VH	OUT	Power supply (+21.5V)
16	VH	OUT	Power supply (+21.5V)
17	VH	OUT	Power supply (+21.5V)
18	VH	OUT	Power supply (+21.5V)
19	VH	OUT	Power supply (+21.5V)
20	VH	OUT	Power supply (+21.5V)
21	VH	OUT	Power supply (+21.5V)
22	VHGND	-	GND
23	VH	OUT	Power supply (+21.5V)
24	VH	OUT	Power supply (+21.5V)
25	VH	OUT	Power supply (+21.5V)

T-2-14

<b>J3601 (Connect to Carriage PCB J101)</b>			
<b>Pin Number</b>	<b>Signal name</b>	<b>IN/OUT</b>	<b>Function</b>
1	FFC_SLANT_DET_SNS2*	IN	FFC disconnection detection signal 2
2	GAP_SNS2	IN	Multi sensor head height (GAP) detection signal 2
3	GAP_SNS1	IN	Multi sensor head height (GAP) detection signal 1
4	EDGE_SNS	IN	Multi sensor paper edge detection signal
5	GND	-	GND
6	VH_DIS	OUT	VH select signal
7	GND	-	GND
8	ENCODER_A	IN	Carriage encoder output signal A
9	ENCODER_B	IN	Carriage encoder output signal B
10	GND	-	GND
11	H1-B-DATA-3-EV	OUT	Even head data signal 3(B)
12	GND	-	GND
13	H1-B-HE-3*	OUT	Head heat enable signal 3(B)
14	GND	-	GND
15	H1-C-DATA-4-EV	OUT	Even head data signal 4(C)
16	GND	-	GND
17	H1-C-DATA-5-EV	OUT	Even head data signal 5(C)
18	GND	-	GND
19	H1-C-HE-5*	OUT	Head heat enable signal 5(C)
20	GND	-	GND
21	H1-C-DATA-5-OD	OUT	Odd head data signal 5(C)
22	GND	-	GND
23	H1-D-DATA-7-OD	OUT	Odd head data signal 7(D)
24	GND	-	GND
25	H1-D-DATA-6-OD	OUT	Odd head data signal 6(D)
26	GND	-	GND
27	H1-D-HE-6*	OUT	Head heat enable signal 6(D)
28	GND	-	GND
29	H1-D-DATA-6-EV	OUT	Even head data signal 6(D)
30	GND	-	GND
31	H1-D-DATA-7-EV	OUT	Even head data signal 7(D)
32	GND	-	GND
33	H1-D-HE-7*	OUT	Head heat enable signal 7(D)
34	GND	-	GND
35	H1-E-DATA-8-EV	OUT	Even head data signal 8(E)
36	GND	-	GND
37	H1-E-DATA-9-EV	OUT	Even head data signal 9(E)
38	GND	-	GND
39	H1-E-HE-9*	OUT	Head heat enable signal 9(E)
40	GND	-	GND
41	H1-F-DATA-10-EV	OUT	Even head data signal 10(F)
42	GND	-	GND

<b>J3601 (Connect to Carriage PCB J101)</b>			
<b>Pin Number</b>	<b>Signal name</b>	<b>IN/OUT</b>	<b>Function</b>
43	H1-F-DATA-11-EV	OUT	Even head data signal 11(F)
44	GND	-	GND
45	H1-F-HE-11*	OUT	Head heat enable signal 11(F)
46	GND	-	GND
47	H1-F-DATA-11-OD	OUT	Odd head data signal 11(F)
48	GND	-	GND
49	IO-ASIC-SDA	IN/OUT	Head ROM control signal (data)
50	FFC-SLANT-DET-SNS1*	IN	FFC disconnection detection signal 1

T-2-15

<b>J3602 (Connect to Carriage PCB J102)</b>			
<b>Pin Number</b>	<b>Signal name</b>	<b>IN/OUT</b>	<b>Function</b>
1	FFC_SLANT_DET_SNS4*	IN	FFC disconnection detection signal 4
2	H1-DSOUT1	IN	Head temperature output 1
3	H1-DSOUT2	IN	Head temperature output 2
4	COLOR_SNS	IN	Multi sensor density detection signal
5	GND	-	GND
6	H1-DLD_LICC2	OUT	Head analogue switch latch signal
7	H1-DATA_LICC2	OUT	Head analogue switch data signal
8	H1-DASLK_LICC2	OUT	Head analogue switch clock signal
9	H-DASH_LICC2	OUT	Analogue switch A/D trigger signal
10	GND	-	GND
11	H1-C-DATA-4-OD	OUT	Odd head data signal 4(C)
12	GND	-	GND
13	H1-C-HE-4*	OUT	Head heat enable signal 4(C)
14	GND	-	GND
15	H1-B-DATA-3-OD	OUT	Odd head data signal 3(B)
16	GND	-	GND
17	H1-B-DATA-2-OD	OUT	Odd head data signal 2(B)
18	GND	-	GND
19	H1-B-HE-2*	OUT	Head heat enable signal 2(B)
20	GND	-	GND
21	H1-A-DATA-1-OD	OUT	Odd head data signal 1(A)
22	GND	-	GND
23	H1-A-DATA-0-OD	OUT	Odd head data signal 0(A)
24	GND	-	GND
25	H1-A-HE-0*	OUT	Head heat enable signal 0(A)
26	GND	-	GND
27	H1-A-DATA-0-EV	OUT	Even head data signal 0(A)
28	GND	-	GND
29	H1-A-DATA-1-EV	OUT	Even head data signal 1(A)
30	GND	-	GND
31	H1-A-HE-1*	OUT	Head heat enable signal 1(A)
32	GND	-	GND
33	H1-B-DATA-2-EV	OUT	Even head data signal 2(B)
34	GND	-	GND
35	H1-LT*	OUT	Head latch signal
36	GND	-	GND
37	H1-CLK	OUT	Head clock signal
38	GND	-	GND
39	H1-E-HE-8*	OUT	Head heat enable signal 8(E)
40	GND	-	GND
41	H1-F-DATA-10-OD	OUT	Odd head data signal 10(F)
42	GND	-	GND
43	H1-F-HE-10*	OUT	Head heat enable signal 10(F)
44	GND	-	GND
45	H1-E-DATA-9-OD	OUT	Odd head data signal 9(E)
46	GND	-	GND
47	H1-E-DATA-8-OD	OUT	Odd head data signal 8(E)
48	GND	-	GND
49	IO-ASIC_SCL	IN/OUT	Head ROM control signal (clock)
50	FFC_SLANT_DET_SES3*	IN	FFC disconnection detection signal 3

T-2-16

<b>J3901 (Feed roller encoder sensor, Feed roller HP sensor, Temperature/humidity detection sensor)</b>			
Pin Number	Signal name	IN/OUT	Function
1	GND	-	GND
2	LF_ENCA	IN	Feed roller encoder sensor output signal A
3	SNS5V_FU1	OUT	Power supply (+5V)
4	LF_ENCB	IN	Feed roller encoder sensor output signal B
5	SNS3V_FU1	OUT	Power supply (+3.3V)
6	GND	-	GND
7	LF_HP_SNS*	IN	Feed roller HP sensor output signal
8	BACKUP_3V	OUT	Power supply (+5V)
9	RH2_OUT	IN	Temperature/humidity detection sensor output signal
10	GND	-	GND
11	TH2_OUT	IN	Thermistor output signal

T-2-17

<b>J4101 (Carriage motor)</b>			
Pin Number	Signal name	IN/OUT	Function
1	CR_HWP	IN	Carriage motor hole device W-phase + signal
2	CR_HWM	IN	Carriage motor hole device W-phase - signal
3	CR_W	OUT	Carriage motor W-phase drive signal
4	CR_HVM	IN	Carriage motor hole device V-phase - signal
5	CR_U	OUT	Carriage motor U-phase drive signal
6	GND	-	GND
7	CR_V	OUT	Carriage motor V-phase drive signal
8	SNS5V		Power supply (+5V)
9	N.C.	-	N.C
10	CR_HVP	IN	Carriage motor hole device V-phase + signal
11	CR_HUM	IN	Carriage motor hole device U-phase - signal
12	CR_HUP	IN	Carriage motor hole device U-phase + signal

T-2-18

<b>J4102 (Upper cover lock switch)</b>			
Pin Number	Signal name	IN/OUT	Function
1	VM	OUT	Power supply (+32V)
2	CR_VM	IN	Upper cover lock switch output signal

T-2-19

<b>J4201 (Feed motor)</b>			
Pin Number	Signal name	IN/OUT	Function
1	LF_OUTB(LF_AP)	OUT	Feed motor driver signal B
2	LF_OUTA(LF_AM)	OUT	Feed motor driver signal A

T-2-20

<b>J4501 (Upper cover lock solenoid, Cutter left position sensor, Cutter motor, Mist fan)</b>			
Pin Number	Signal name	IN/OUT	Function
1	VM_26V(26.5V)	OUT	Power supply (+26.5V)
2	DCOVER_SOL	OUT	Upper cover lock solenoid drive signal
3	SNS3V_FU1	OUT	Power supply (+3.3V)
4	GND	-	GND
5	CUTTER_L_SNS*	OUT	Cutter left position sensor signal
6	CUTTERM_OUTB	OUT	Cutter motor driver signal B
7	CUTTERM_OUTA	OUT	Cutter motor driver signal A
8	MIST_FAN_VM(26.5V)	OUT	Power supply (+26V)
9	MIST_FAN_LOCK*	OUT	Mist fan drive signal
10	N.C.(MIST_FAN_PWM)	-	N.C
11	GND	-	GND
12	N.C.	-	N.C

## 2.4.3 Carriage Relay PCB

### 2.4.3.1 Carriage PCB components

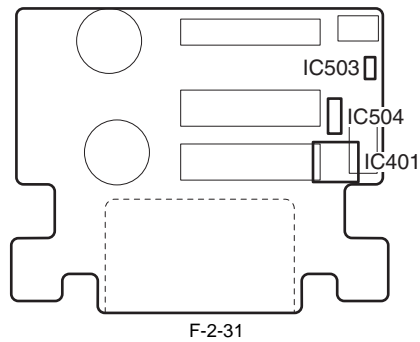

#### a) Latch ICs (IC401)

##### **DI sensor reading control function**

This function obtains the DI sensor value in the printhead and head rank for each color and sends it to the main controller PCB based on the control signals from the main controller.

##### **Environmental temperature reading control**

This function sends the environmental temperature detected by the thermistor on the board based to the main controller PCB based on the control signals from the main controller PCB.

##### **Image data relay function**

This function relays the image data from the main controller PCB to the printhead. The function for processing image data is not supported.

#### b) Multi sensor control ICs (IC503 and IC504)

These ICs are used to generate the multi sensor LED control signal and adjust the gain.

## 2.4.3.2 Connectors and Pin Arrangement of Carriage PCB

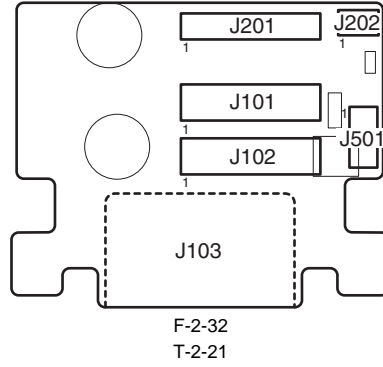

<b>J101 (Connect to Main controller PCB J3601)</b>			
<b>Pin Number</b>	<b>Signal name</b>	<b>IN/OUT</b>	<b>Function</b>
1	FFC-SLANT-DET-SNS1*	OUT	FFC disconnection detection signal 1
2	IO-ASIC-SDA	IN/OUT	Head ROM control signal (data)
3	GND	-	GND
4	H1-F-DATA-11-OD	IN	Odd head data signal 11(F)
5	GND	-	GND
6	H1-F-HE-11*	IN	Head heat enable signal 11(F)
7	GND	-	GND
8	H1-F-DATA-11-EV	IN	Even head data signal 11(F)
9	GND	-	GND
10	H1-F-DATA-10-EV	IN	Even head data signal 10(F)
11	GND	-	GND
12	H1-E-HE-9*	IN	Head heat enable signal 9(E)
13	GND	-	GND
14	H1-E-DATA-9-EV	IN	Even head data signal 9(E)
15	GND	-	GND
16	H1-E-DATA-8-EV	IN	Even head data signal 8(E)
17	GND	-	GND
18	H1-D-HE-7*	IN	Head heat enable signal 7(D)
19	GND	-	GND
20	H1-D-DATA-7-EV	IN	Even head data signal 7(D)
21	GND	-	GND
22	H1-D-DATA-6-EV	IN	Even head data signal 6(D)
23	GND	-	GND
24	H1-D-HE-6*	IN	Head heat enable signal 6(D)
25	GND	-	GND
26	H1-D-DATA-6-OD	IN	Odd head data signal 6(D)
27	GND	-	GND
28	H1-D-DATA-7-OD	IN	Odd head data signal 7(D)
29	GND	-	GND
30	H1-C-DATA-5-OD	IN	Odd head data signal 5(C)
31	GND	-	GND
32	H1-C-HE-5*	IN	Head heat enable signal 5(C)
33	GND	-	GND
34	H1-C-DATA-5-EV	IN	Even head data signal 5(C)
35	GND	-	GND
36	H1-C-DATA-4-EV	IN	Even head data signal 4(C)
37	GND	-	GND
38	H1-B-HE-3*	IN	Head heat enable signal 3(B)
39	GND	-	GND
40	H1-B-DATA-3-EV	IN	Even head data signal 3(B)
41	GND	-	GND
42	ENCODER_B	OUT	Carriage encoder output signal B
43	ENCODER_A	OUT	Carriage encoder output signal A
44	GND	-	GND
45	VH_DIS	IN	VH select signal
46	GAP_FAR_SNS	OUT	Multi sensor head height (FAR) detection signal
47	GAP_NEAR_SNS	OUT	Multi sensor head height (NEAR) detection signal
48	GND	-	GND
49	COLOR_SNS	OUT	Multi sensor density detection signal



<b>J101 (Connect to Main controller PCB J3601)</b>			
<b>Pin Number</b>	<b>Signal name</b>	<b>IN/OUT</b>	<b>Function</b>
50	FFC_SLANT_DET_SNS2*	OUT	FFC disconnection detection signal 2

T-2-22

<b>J102 (Connect to Main controller PCB J3602)</b>			
<b>Pin Number</b>	<b>Signal name</b>	<b>IN/OUT</b>	<b>Function</b>
1	FFC_SLANT_DET_SES3*	OUT	FFC disconnection detection signal 3
2	IO-ASIC_SCL	IN/OUT	Head ROM control signal (clock)
3	GND	-	GND
4	H1-E-DATA-8-OD	IN	Odd head data signal 8(E)
5	GND	-	GND
6	H1-E-DATA-9-OD	IN	Odd head data signal 9(E)
7	GND	-	GND
8	H1-F-HE-10*	IN	Head heat enable signal 10(F)
9	GND	-	GND
10	H1-F-DATA-10-OD	IN	Odd head data signal 10(F)
11	GND	-	GND
12	H1-E-HE-8*	IN	Head heat enable signal 8(E)
13	GND	-	GND
14	H1-CLK	IN	Head clock signal
15	GND	-	GND
16	H1-LT*	IN	Head latch signal
17	GND	-	GND
18	H1-B-DATA-2-EV	IN	Even head data signal 2(B)
19	GND	-	GND
20	H1-A-HE-1*	IN	Head heat enable signal 1(A)
21	GND	-	GND
22	H1-A-DATA-1-EV	IN	Even head data signal 1(A)
23	GND	-	GND
24	H1-A-DATA-0-EV	IN	Even head data signal 0(A)
25	GND	-	GND
26	H1-A-HE-0*	IN	Head heat enable signal 0(A)
27	GND	-	GND
28	H1-A-DATA-0-OD	IN	Odd head data signal 0(A)
29	GND	-	GND
30	H1-A-DATA-1-OD	IN	Odd head data signal 1(A)
31	GND	-	GND
32	H1-B-HE-2*	IN	Head heat enable signal 2(B)
33	GND	-	GND
34	H1-B-DATA-2-OD	IN	Odd head data signal 2(B)
35	GND	-	GND
36	H1-B-DATA-3-OD	IN	Odd head data signal 3(B)
37	GND	-	GND
38	H1-C-HE-4*	IN	Head heat enable signal 4(C)
39	GND	-	GND
40	H1-C-DATA-4-OD	IN	Odd head data signal 4(C)
41	GND	-	GND
42	H1-DASLK_LICC2	IN	Head analogue switch clock signal
43	H1-DLD_LICC2	IN	Head analogue switch latch signal
44	H1-DATA_LICC2	IN	Head analogue switch data signal
45	H-DASH_LICC2	IN	Analogue switch A/D trigger signal
46	GND	-	GND
47	H1-DSOUT1	OUT	Head temperature output 1
48	H1-DSOUT2	OUT	Head temperature output 2
49	EDGE_SNS	OUT	Multi sensor paper edge detection signal
50	FFC_SLANT_DET_SNS4*	OUT	FFC disconnection detection signal 4

T-2-23

<b>J103 (Printhead)</b>			
<b>Pin Number</b>	<b>Signal name</b>	<b>IN/OUT</b>	<b>Function</b>
1	VH2	OUT	Power supply
2	VH2	OUT	Power supply
3	VH2	OUT	Power supply
4	VHT12	OUT	Head Transistor drive Power supply
5	H1-F-DATA-10-EV	OUT	Even head data signal 10(F)

J103 (Printhead)			
Pin Number	Signal name	IN/OUT	Function
6	IO_ASIC_SDA	IN/OUT	EEPROMcontrol signal (data)
7	IO_ASIC_SCL	OUT	EEPROMcontrol signal (clock)
8	H3V_1	OUT	Power supply (+3V)
9	H1-C-DIA1	IN	Head DI sensor signal 1(C)
10	/H1-A-HE-1	OUT	Head heat enable signal 8(E)
11	VH1	OUT	Power supply
12	VH1	OUT	Power supply
13	VH1	OUT	Power supply
14	VH2	OUT	Power supply
15	VH2	OUT	Power supply
16	H1-E-DATA-9-OD	OUT	Odd head data signal 9(E)
17	/H1-F-HE-11	OUT	Head heat enable signal 11(F)
18	H1-E-DIA1	IN	Head DI sensor signal 1(E)
19	H1-D-DIA1	IN	Head DI sensor signal 1(D)
20	H3V_1	OUT	Power supply
21	H3V_1	OUT	Power supply
22	H1-B-DATA-3-EV	OUT	Even head data signal 3(B)
23	H1-A-DATA-0-EV	OUT	Even head data signal 0(A)
24	/H1-B-HE-2	OUT	Head heat enable signal 2(B)
25	VH1	OUT	Power supply
26	VH1	OUT	Power supply
27	H1-D-DIA2	IN	Head DI sensor signal 2(D)
28	/H1-E-HE-8	OUT	Head heat enable signal 8(E)
29	H1-E-DIA2	IN	Head DI sensor signal 2(E)
30	H1-F-DIA2	IN	Head DI sensor signal 2(F)
31	/H1-E-HE-9	OUT	Head heat enable signal 9(E)
32	H1-D-DATA-7-EV	OUT	Even head data signal 7(D)
33	/H1-D-HE-6	OUT	Head heat enable signal 6(D)
34	H1-C-DATA-5-OD	OUT	Odd head data signal 5(C)
35	H1-C-DATA-4-EV	OUT	Even head data signal 4(C)
36	H1-A-DATA-1-EV	OUT	Even head data signal 1(A)
37	H1-A-DIA2	IN	Head DI sensor signal 2(A)
38	H1-B-DIA2	IN	Head DI sensor signal 2(B)
39	/H1-C-HE-4	OUT	Head heat enable signal 4(C)
40	H1-D-DATA-7-OD	OUT	Odd head data signal 7(D)
41	H1-E-DATA-8-OD	OUT	Odd head data signal 8(E)
42	/H1-F-HE-10	OUT	Head heat enable signal 10(F)
43	H1-F-DATA-11-EV	OUT	Even head data signal 11(F)
44	H1-E-DATA-8-EV	OUT	Even head data signal 8(F)
45	H1-D-DATA-6-EV	OUT	Even head data signal 6(D)
46	H1-C-DIA2	IN	Head DI sensor signal 2(C)
47	H1-C-DATA-5-EV	OUT	Even head data signal 5(C)
48	H1-B-DIA1	IN	Head DI sensor signal 1(B)
49	/H1-A-HE-0	OUT	Head heat enable signal 0(A)
50	H1-B-DATA-2-OD	OUT	Odd head data signal 2(B)
51	H1-B-DATA-3-OD	OUT	Odd head data signal 3(B)
52	H1-C-DATA-4-OD	OUT	Odd head data signal 4(C)
53	GND	-	GND
54	GND	-	GND
55	GND	-	GND
56	H1-F-DATA-11-OD	OUT	Odd head data signal 11(F)
57	H1-E-DATA-9-EV	OUT	Even head data signal 9(E)
58	GND	-	GND
59	H1-D-DATA-6-OD	OUT	Odd head data signal 6(D)
60	/H1-C-HE-5	OUT	Head heat enable signal 5(C)
61	/H1-B-HE-3	OUT	Head heat enable signal 3(B)
62	H1-A-DIA1	IN	Head DI sensor signal 1(A)
63	H1-A-DATA-1-OD	OUT	Odd head data signal 1(A)
64	GND	-	GND
65	GND	-	GND
66	GND	-	GND
67	GND	-	GND
68	H1-F-DATA-10-OD	OUT	Odd head data signal 10(F)
69	H1-F-DIA1	IN	Head DI sensor signal 1(F)
70	/H1-D-HE-7	OUT	Head heat enable signal 7(D)

<b>J103 (Printhead)</b>			
Pin Number	Signal name	IN/OUT	Function
71	GND	-	GND
72	H1_CLK	OUT	Head data clock signal
73	/H1_LT	OUT	Head data latch signal
74	H1-B-DATA-2-EV	OUT	Even head data signal 2(B)
75	H1-A-DATA-0-OD	OUT	Odd head data signal 0(A)
76	GND	-	GND
77	GND	-	GND
78	GND	-	GND

T-2-24

<b>J201 (Connect to Carriage PCB J3401)</b>			
Pin Number	Signal name	IN/OUT	Function
1	VHGND	-	GND
2	VHGND	-	GND
3	VHGND	-	GND
4	VHGND	-	GND
5	VH	IN	Power supply (+21.5V)
6	VH	IN	Power supply (+21.5V)
7	VH	IN	Power supply (+21.5V)
8	VH	IN	Power supply (+21.5V)
9	VH	IN	Power supply (+21.5V)
10	VH	IN	Power supply (+21.5V)
11	VH	IN	Power supply (+21.5V)
12	VH	IN	Power supply (+21.5V)
13	+24V_HV_SW	IN	Power supply (+24V)
14	SNS5V	IN	Power supply (+5V)
15	GND	-	GND
16	+3.3V_H1	IN	Power supply (+3.3V)
17	+3.3V_H1	IN	Power supply (+3.3V)
18	VH_SW1_ON	IN	VH control signal
19	21V_H1_VHT	IN	Power supply (+21V)
20	+5V_VM_IC	IN	Power supply (+5V)
21	GND	-	GND
22	VHGND	-	GND
23	VHGND	-	GND
24	VHGND	-	GND
25	VHGND	-	GND

T-2-25

<b>J202 (Linear encoder sensor)</b>			
Pin Number	Signal name	IN/OUT	Function
1	ENCODER_B	IN	Carriage encoder output signal B
2	GND	-	GND
3	ENCODER_A	IN	Carriage encoder output signal A
4	SNS5V	OUT	Power supply (+5V)

T-2-26

<b>J501 (Multi sensor)</b>			
Pin Number	Signal name	IN/OUT	Function
1	SNS3.3V	OUT	Power supply (+3.3V)
2	GND	-	GND
3	IO-ASIC_SCL	IN/OUT	Head ROM control signal (clock)
4	IO-ASIC_SDA	IN/OUT	Head ROM control signal (data)
5	GAP_SNS1	IN	Multi sensor head height (GAP) detection signal 1
6	GAP_SNS2	IN	Multi sensor head height (GAP) detection signal 2
7	COLOR_SNS	IN	Multi sensor density detection signal
8	EDGE_SNS	IN	Multi sensor paper edge detection signal
9	GND	-	GND
10	SNS5V	OUT	Power supply (+5V)
11	THERMISTOR	-	N.C
12	GND	-	GND

## 2.4.4 Maintenance Cartridge Relay PCB

### 2.4.4.1 Maintenance cartridge relay PCB components

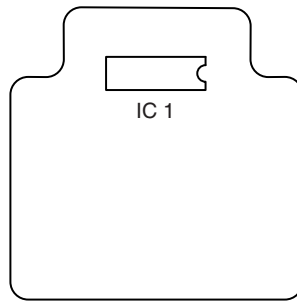

F-2-33

#### a) EEPROM (IC1)

The 256-KB EEPROM stores all information written to the EEPROM on the main controller PCB.

## 2.4.5 Power Supply

### 2.4.5.1 Power supply block diagram

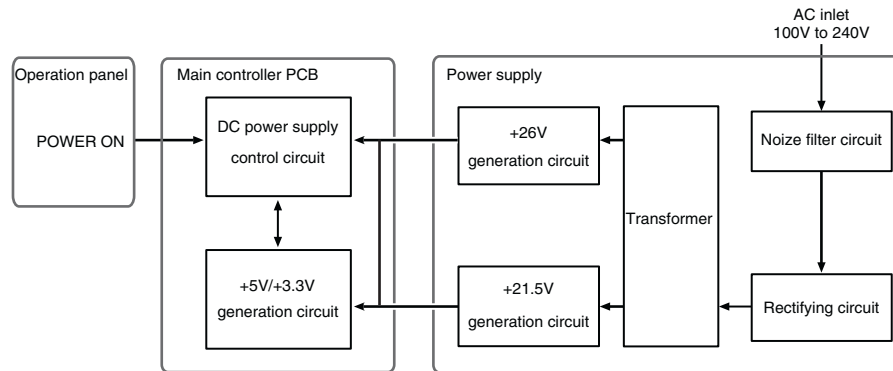

F-2-34

The power supply converts AC voltages ranging from 100 V to 240 V from the AC inlet to DC voltages for driving the ICs, motor, and others.

The voltage generator circuits include the +26 V generation circuit for driving motors, fans, and sensors and a +21.5 V generator circuit for driving sensors, heads, logic circuits, and others.

When the power is turned off, +26 V and +21.5 V are reduced to about 12 V and 9 V respectively (power save mode).

Power ON/OFF operation is controlled by the main controller PCB.

## 2.4.5.2 Connectors and Pin Arrangement of Power supply PCB

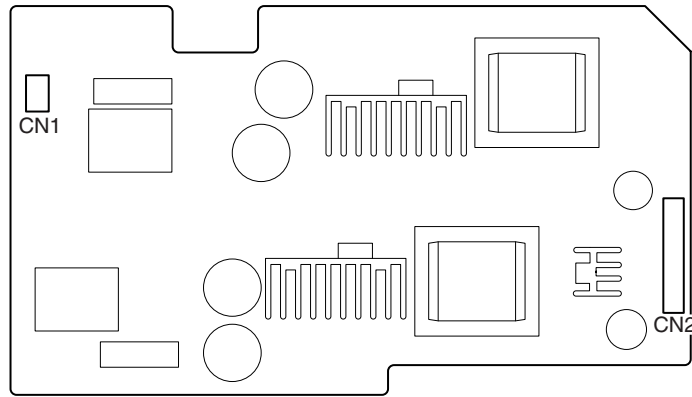

F-2-35  
T-2-27

CN1			
Pin Number	Signal name	IN/OUT	Function
1	AC(H)	-	Power supply (AC120V or AC230V)
2	AC(N)	-	Power supply (AC120V or AC230V)

T-2-28

CN2 (Connect to Main controller PCB)			
Pin Number	Signal name	IN/OUT	Function
1	PW_CONT	IN	Normal/power saving switch signal
2	VM(+32V)	OUT	Power supply (+32V)
3	VM(+32V)	OUT	Power supply (+32V)
4	VMGND	-	GND
5	VMGND	-	GND
6	VH(+32V)	OUT	Power supply (+32V)
7	VH(+32V)	OUT	Power supply (+32V)
8	VHGND	-	GND
9	VHGND	-	GND
10	VM_UNIT_PW_ENB	IN	VH power supply ON/OFF signal

## 2.5 Detection Functions with Sensors

### 2.5.1 Covers

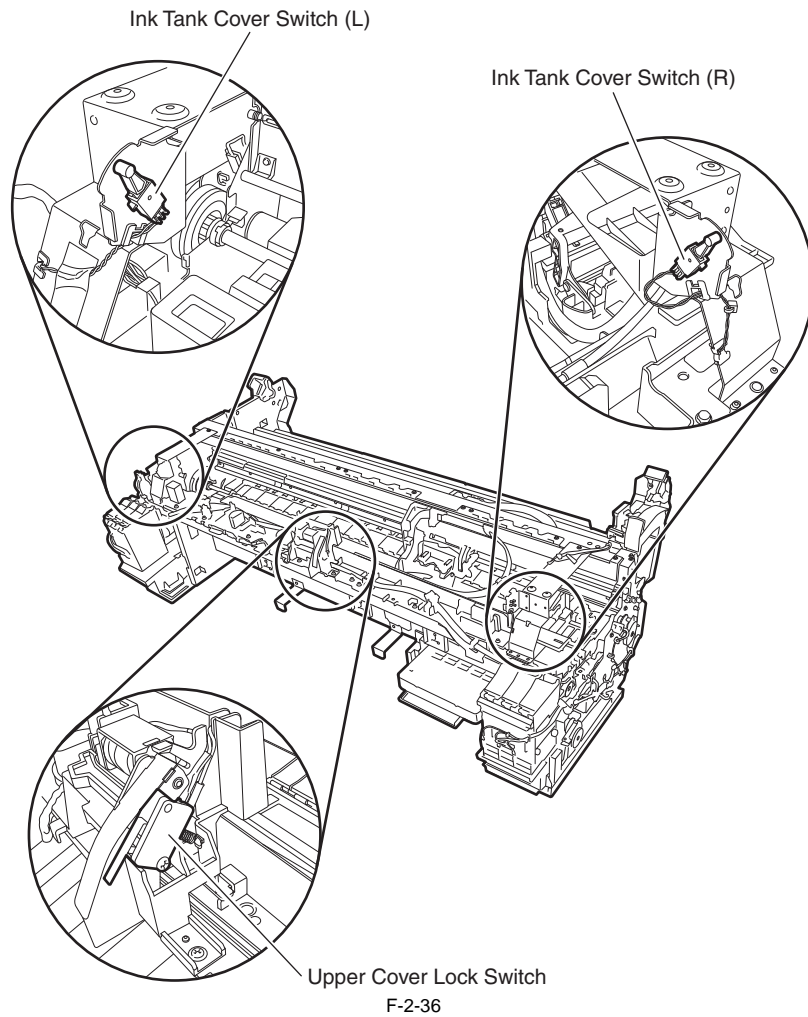

#### Upper cover lock switch

The microswitch-based upper cover lock switch detects the open/closed states of the upper cover. When the upper cover close, the switch is pressed to detect the closed state of the upper cover.

#### Ink tank cover switch (L)/(R)

The microswitch-based ink tank cover switches detect the open/closed states of left and right ink tank cover. When an ink tank cover closes, the switch is pressed to detect the closed state of the ink tank cover.

2.5.2 Ink passage system

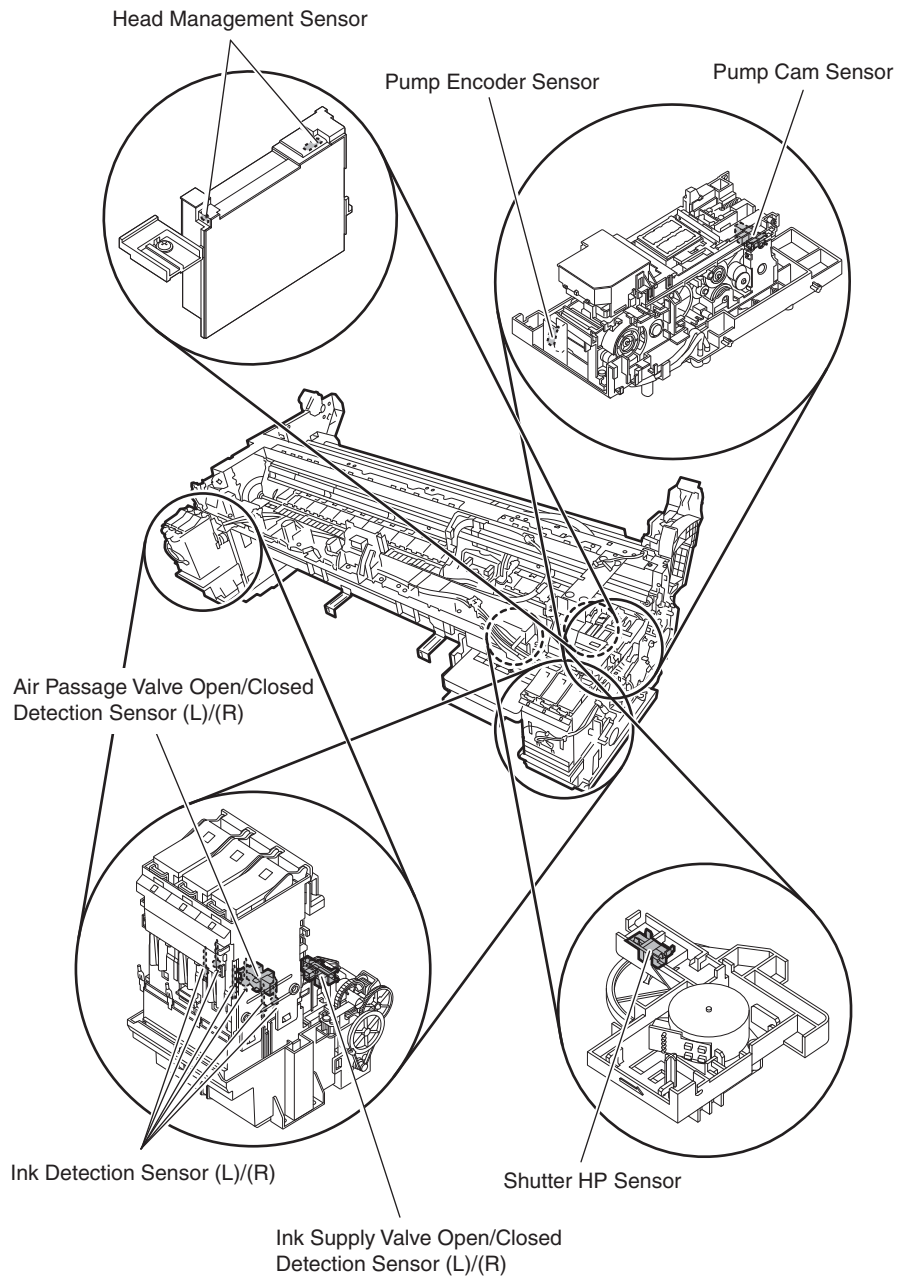



**Pump cam sensor**

The photo-interrupter-type pump cam sensor detects that the sensor light is shielded or unshielded by the rotary cam. The sensor detects the purge unit capping and wiping states with the combination of the state detected by the pump cam and the state of pump motor rotation control performed by the pump encoder.

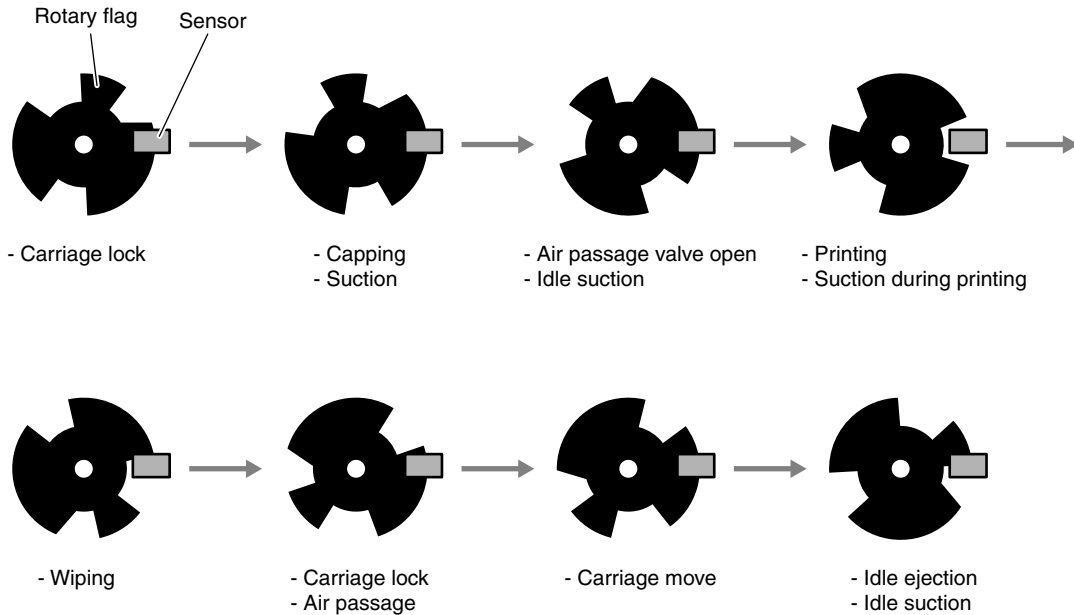

F-2-38

**Pump encoder sensor**

The pump encoder is a photo-interruptive type sensor. It reads the slits on the pump motor's encoder film to control the amount of pump motor rotation.

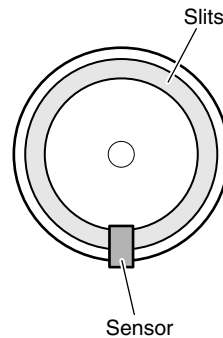

F-2-39

**Ink supply valve open/closed detection sensor (L)/(R)**

The photo-interrupter-type ink supply valve open/closed detection sensor detect the valve cam state.

When the link that operates in conjunction with the ink supply valve cam shields light, this sensor detects that the ink supply valve has been opened.

**Air passage valve open/closed detection sensor (L)/(R)**

The photo-interrupter-type air passage valve open/closed detection sensor detect the valve cam state.

When the link that operates in conjunction with the subtank air passage valve cam shields light, this sensor detects that the subtank air passage valve has been opened.

**Ink detection sensor (L)/(R)**

Presence of absence of ink in the ink tank is detected according to whether the two hollow needles are electrically connected.

When the ink level in the ink tank lowers below the wall around the hollow needle at the air passage, this hollow needle is electrically disconnected from the hollow needle located on the ink supply side, thus detecting that the printer has run out of ink.

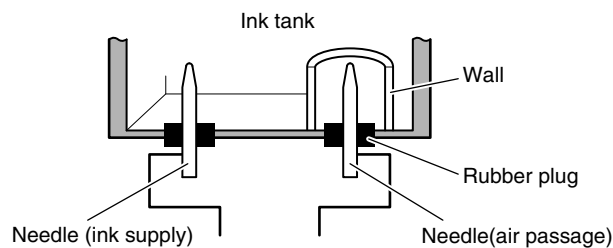

F-2-40

**Shutter HP sensor**

The photointerrupter-type sensor detects the presence of the shutter at the home position.

**Head management sensor**

The photo-transmission-type sensor detects that the printhead is discharging ink.

The carriage moves to and stops at the detection positions for individual nozzle arrays. When the carriage is at a stop, nozzles discharge ink on after another. The sensor detects each nozzle due to the voltage change caused when ink discharged from the nozzle blocks the sensor light.

Non-discharging nozzle detection is carried out at the following timings:

- After the execution of Cleaning 1, Cleaning 2, Cleaning 3, Cleaning 6 or Cleaning 10
- After the number of copies that has been set by the user menu choice Nozzle Check Frequency have been printed

If more than a specified number of non-discharging nozzles have been located in one session of non-discharging nozzle detection, the normal cleaning sequence is launched before a second session of non-discharging nozzle detection is conducted. If more than a specified number of non-discharging nozzles are located in the second session of non-discharging nozzle detection, the normal (High) cleaning session is launched before a third session of non-discharging nozzle detection is conducted.

If there are at least 320 non-discharging nozzles out of 2560 nozzles as the result of non-discharging nozzle detection, printing is canceled after displaying a message to replace the head.

However, if service mode: [SERVICE MODE] > [SETTING] > [HEAD DOT INF] is [ON], the following message appears.

If there are at least 30 nozzles unable to correct the non-discharging state and the number of non-discharging nozzles is less than 100 out of 2,560 nozzles as the result of non-discharging nozzle detection, printing can continue after displaying a message to check the printing. Also, if the number of non-discharging nozzles is at least 100 but less than 320 nozzles, printing can continue after displaying a message to check the head. And if there are at least 320 non-discharging nozzles, printing is canceled after displaying a message to replace the head.

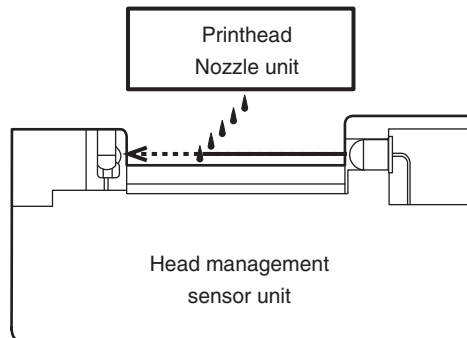

F-2-41

### 2.5.3 Carriage system

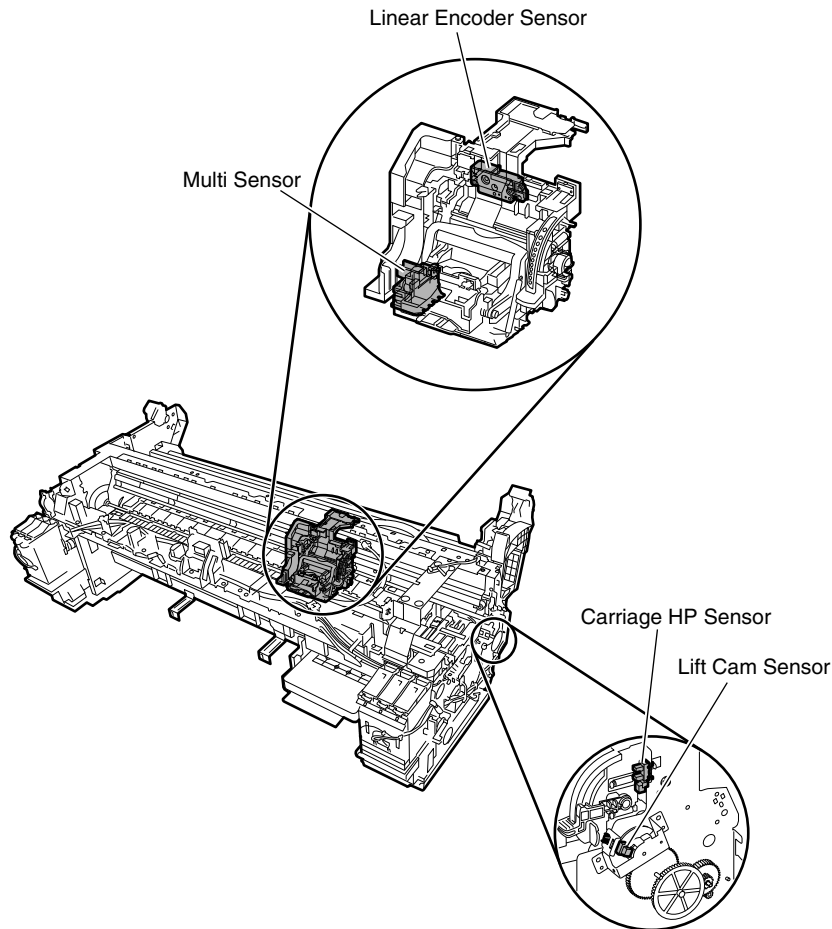

F-2-42

#### Carriage HP sensor

The photointerrupter-based carriage HP sensor detects the home position of the carriage. Installed on the right side plate of the printer, the sensor detects an edge of the carriage home position on the carriage unit under carriage movement control. The printer establishes the carriage home position from the position at which its edge is detected as a reference position.

#### Linear encoder sensor

Mounted on the back of the carriage, the linear encoder detects the position of the carriage from a slit in the linear scale during its movement.

#### Lift cam sensor

A photointerrupter-based sensor. After the sensor light is shielded by the flag, the lift motor is driven by a predetermined number of pulses to regulate the separation between the printheads and platen automatically.

#### Ambient temperature sensor

The thermostat-based ambient temperature sensor mounted on the carriage PCB detects the ambient temperature to which the carriage is exposed. The resistance of the thermistor that varies as a function of temperature changes in the printer is transmitted to the main controller via the carriage PCB. The ambient temperature is used to help calibrate the head temperature sensor and detect abnormal ambient temperatures.

#### Head temperature sensor

The head temperature sensor detects the temperature of the printhead. The printhead temperature is transmitted to the main controller via the carriage PCB. The printhead temperature is used to help control the head drive and detect abnormal printhead temperatures.

#### Printhead contact detection

The printhead contact detects the status of printhead installation by electrical means. The contact detects the status of contact from voltage changes in the flexible cables on the carriage side that come into contact with two terminals of the printhead with remote contact surfaces, the power terminals and GND terminal.

**Multi sensor**

A photo reflective type multi sensor consists of three red LEDs, one red/blue/green LED array, and three light receiving sensors and is used for media end, skew, and width adjustment, registration adjustment, head height adjustment, and print position adjustment.

Media leading edge detection, head height (GAP) detection, and print density detection are performed by independent LED and sensor.

A clear film media detection (regular reflection) LED and a non-clear film media detection (diffused reflection) LED are used for end of media detection.

The head height is detected by receiving the reflection of red LED from the media with two sensors in a light receiving sensor and calculating the difference in measurements.

The print density is detected by receiving the reflection of red/blue/green LED array from the media and determining the density of the printed surface.

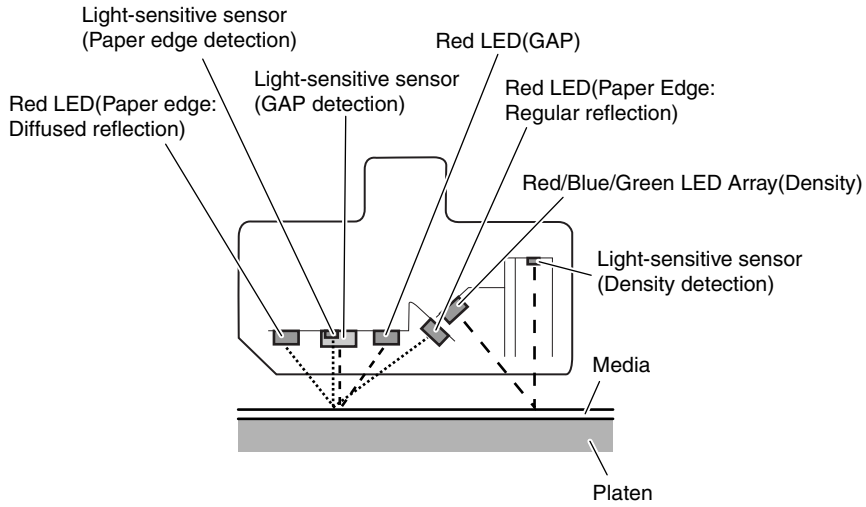

F-2-43



Service mode: After SERVICE MODE > ADJUST > GAP CALIB. has been carried out, pass paper to make sure that it is detected properly.

## 2.5.4 Paper path system

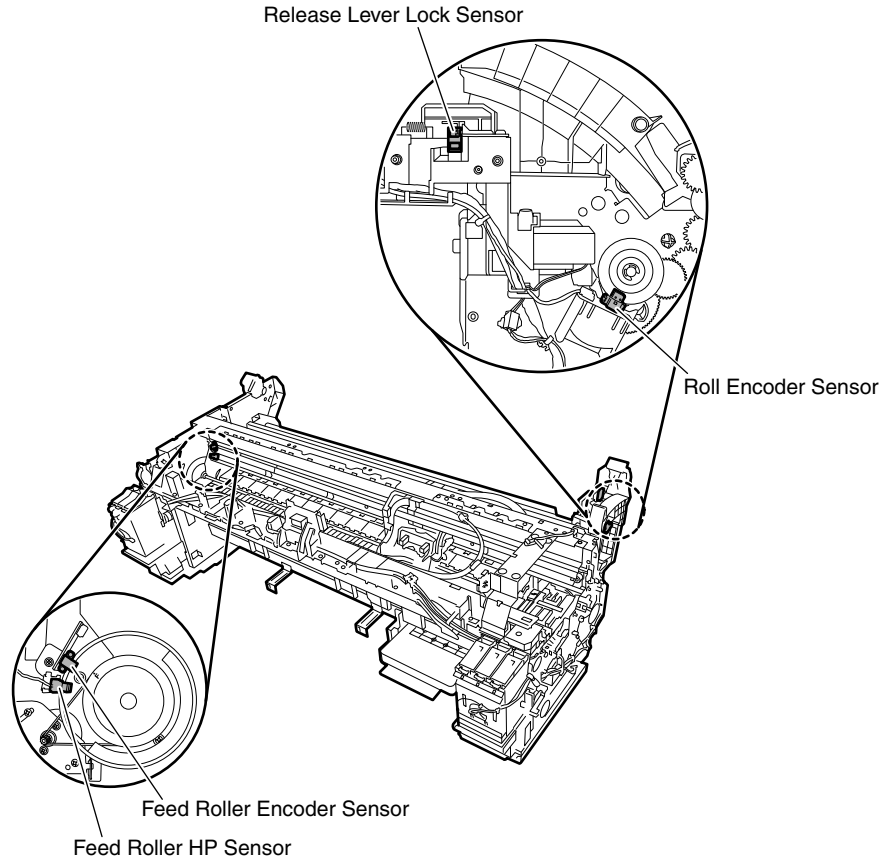

F-2-44

### Feed roller HP sensor

The feed roller HP sensor detects a reference white (transmitted) to black (shielded) transition from the encoder at power on and sets a home position for correcting the eccentricity of the feed roller.

### Feed roller encoder sensor

The feed roller encoder sensor detects the rate of paper transport per revolution of the feed roller from slits in the encoder during driving.

### Release lever lock sensor

A photointerrupter type sensor. This sensor detects the release lever lock status when the release lever solenoid turns ON and the sensor flag shields the sensor light.

### Roll encoder sensor

A photointerrupter type sensor. This sensor detects the rotation of the roll holder by reading the encoder film at the roll media drive unit.

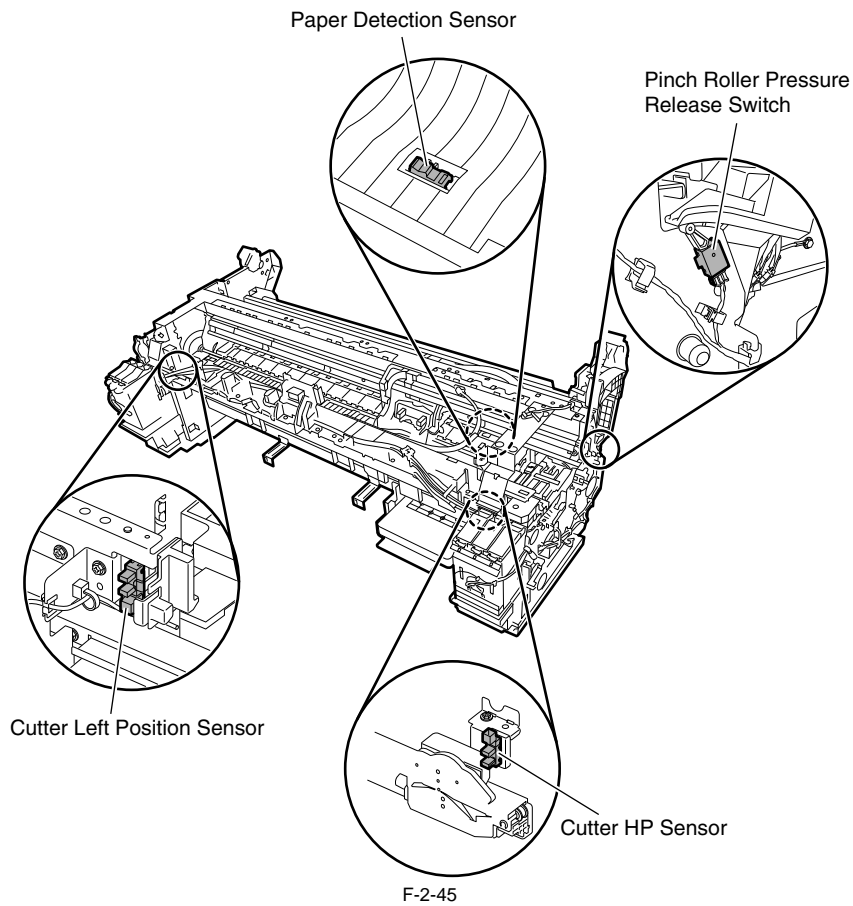

**Paper detection sensor**

A photoreflexive type sensor. When a media is fed from the manual feed unit and roll feed unit, this sensor detects the presence of media by receiving the light reflected from the media.

**Cutter HP sensor**

The photointerrupter-type sensor detects the presence of the cutter at the home (rightmost) position.

**Cutter left position sensor**

The photointerrupter-type sensor detects the presence of the cutter at the leftmost position.

**Pinch roller pressure release switch**

A micro switch type pinch roller pressure release switch detects the application/release of pinch roller pressure. The pinch roller pressure release switch is depressed when the media release lever is set and detects the pressure of the pinch roller.

### 2.5.5 Others

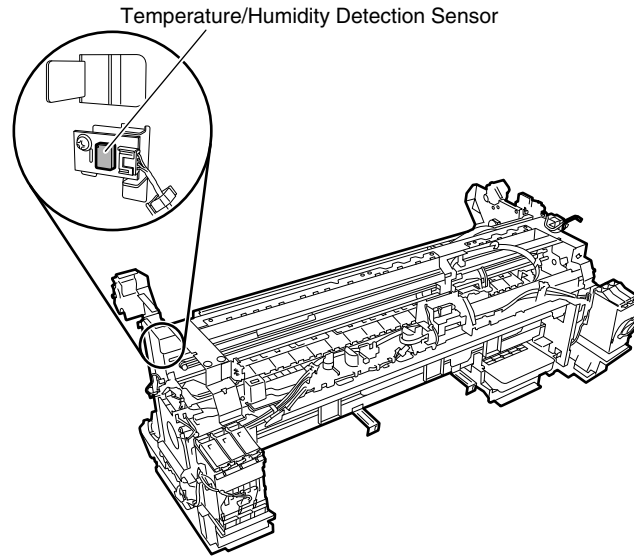

F-2-46

**Temperature/humidity detection sensor**

The temperature/humidity detection sensor detects the temperature and relative humidity around the printer to implement head height adjustment, maintenance jet control, waste ink evaporation calculation and suction fan control on the basis of the temperature and relative humidity thus measured.





---

## Chapter 3 INSTALLATION

---



# Contents

3.1 Transporting the Printer .....	3-1
3.1.1 Transporting the Printer .....	3-1
3.1.1.1 Transporting the Printer .....	3-1
3.1.2 Reinstalling the Printer .....	3-4
3.1.2.1 Reinstalling the Printer .....	3-4



## 3.1 Transporting the Printer

### 3.1.1 Transporting the Printer

#### 3.1.1.1 Transporting the Printer

Do not remove the printhead once they are installed, as this may cause the nozzles to dry out or accumulate foreign matter. Also the head must be capped and stay in the carriage while transporting the printer. In spite of this precaution, shocks incurred during transportation can still damage the printhead. Print the "Nozzle Check" before moving the printer, print the "Nozzle Check" after installing in a new location, and compare the two printouts. If any deterioration is evident in the output quality, replace the printhead with new ones.

This subsection describes how to transport the printer.

When moving the printer to another place on the same floor of the building, move it slowly so that it does not receive any shocks. Follow the steps shown in "1. Moving the printer on the same floor with no difference in grade".

When moving it elsewhere, follow the steps shown in "2. How to transport the printer to a different floor".



- When lifting or moving the printer, be sure to hold the left and right and rear carrying handles of the printer. The printer may be unsteady if you hold it at other positions, which poses a risk of injury from dropping the printer.

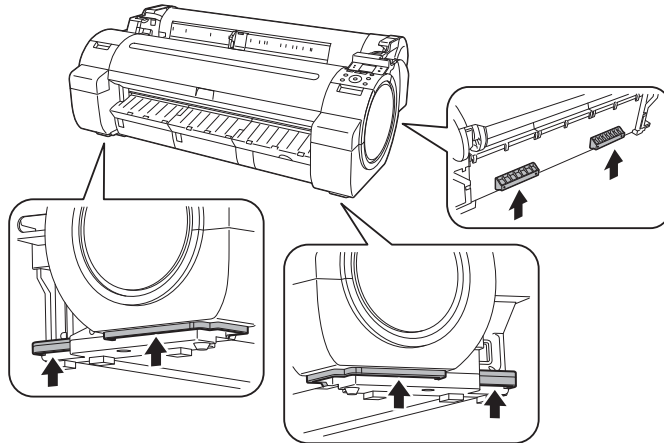

F-3-1

- The printer main unit weights approximately 43kg. When moving the printer, have at least three people hold it from left and right and rear side taking care not to hurt their back.

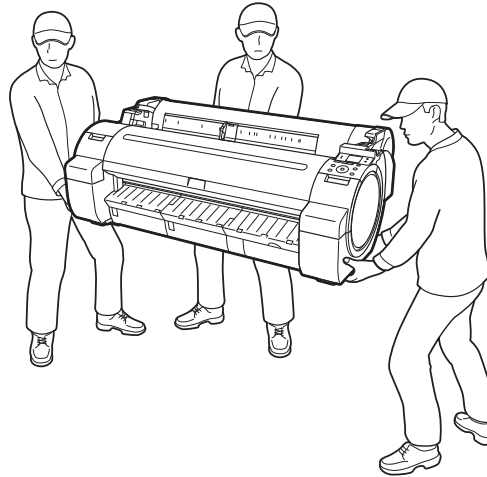

F-3-2

**1. Moving the printer on the same floor with no difference in grade**

Item	Description
[Prep. MovePrinter] on the Main menu	This need not be performed.
Allowed tilting angle	Do not tilt.
Ink consumption	No ink is consumed.
Ink tank	It may be installed or removed.
Separation of printer and stand	They do not need to be separated.
Maintenance cartridge	Install. There is no need to open a new maintenance cartridge.
Replacement of consumable parts	There is no need to replace consumable parts.
Service support	No service support is necessary.

**Transportation procedure**

- 1) Turn off the [Power] button, and check that the heads are capped and carriage is locked.
- 2) Remove the roll holder from the roll unit.
- 3) Remove the interface cable and power cord from the printer.
- 4) Unlock the casters on the stand.
- 5) Hold the printer carrying handle at the bottom, and then slowly move the printer.



- If the printer is subjected to strong vibrations when it is moved, it can cause ink leakage or damage to the printhead. Be sure to move the printer slowly and carefully.
- Do not incline the printer during transportation. The internal ink may leak and the surrounding area may be stained.

**2. Moving the printer on floor where there is difference in grade, or transporting by truck or plane or ship or others, or transporting in low temperature environment such as below freezing**

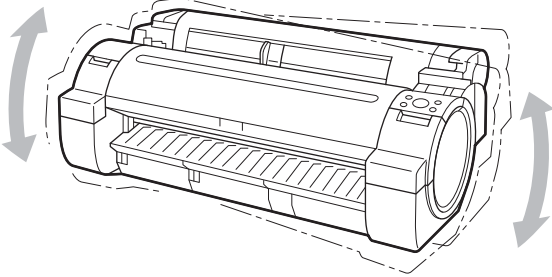
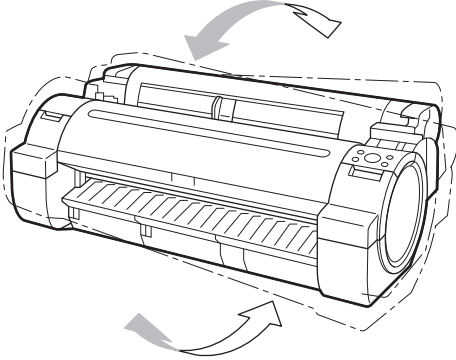
Item	Description
[Prep. MovePrinter] on the Main menu	Perform [Limited].
Allowed tilting angle	Lengthwise: -30 to +30 degrees 
	Rotation: -30 to +30 degrees 
Separation of printer and stand	They do not need to be separated.
Maintenance cartridge	Install. There is no need to open a new maintenance cartridge. However, if there is a message instructing to replace the maintenance cartridge or check the remaining ink, replace with new maintenance cartridge before transporting.
Replacement of consumable parts	There is no need to replace consumable parts.
Service support	No service support is necessary.

**Transportation procedure**

- 1) Turn on the [Power] button on the printer.
- 2) Remove the roll holder from the roll unit.
- 3) Enter the Main menu, and then select "Set./Adj. Menu" > "Prep.MovePrinter". Follow the instructions in the messages, and remove all of the ink tanks. Put the removed ink tanks in the plastic bag with the ink supply part upward and close the opening.



- "Prep.MovePrinter" cannot be selected when "MTCart Full Soon" is displayed. In this case, replace the maintenance cartridge first.
- If the consumable parts counter is checked and a message to replace consumable parts appear, check the consumable parts counter from service mode and replace the necessary consumable parts. After replacing the consumable parts and resetting the counter of service mode, perform the steps again. Refer to "SERVICE MODE" > "Details of Service Mode" > "PARTS CNT." and "MAINTENANCE" > "Consumable Parts" > "Consumable Parts".
- Never disconnect the power cord while the "Prep.MovePrinter" operation is in progress since this can cancel the operation. "Ink Filling" is performed when the power is turned back on after canceling so repeat "Prep.MovePrinter" from the beginning.
- Check that used ink is no longer leaking after removing the maintenance cartridge. If it is leaking, install the maintenance cartridge and wait until leaking stops.

- 4) Once the "Prep.MovePrinter" operation is completed, turn off the [Power] button.
  - 5) Open the upper cover, check that the heads are capped and carriage is locked.
  - 6) Close the upper cover.
  - 7) Disconnect the interface cable and power cord from the printer.
  - 8) Attach the cushioning materials and tape.
  - 9) If the printer is mounted on a stand, remove the printer from the stand.
  - 10) Pack the printer into the packing box, and then put the roll media, ink tank and stand in another packing box for moving.
- Use the original packing material for the printer and stand. If it is not available, pack them with a sufficient amount of cushioning materials.

### 3. Transportation procedure when the printer is not operating properly



To prevent the waste ink from leaking, remove the maintenance cartridge after draining the ink. Package the removed maintenance cartridge so that the waste ink does not leak from it.

- 1) Make sure that the printer is turned off.
- 2) Disconnect the interface cable and power cord from the printer.
- 3) Remove the roll holder from the roll unit.
- 4) While referring to "DISASSEMBLY/REASSEMBLY" > "Draining the Ink" > "Manual Ink Drainage", drain the ink from the printer.
- 5) While referring to "INSTALLATION" > "Transporting the Printer" > "Transporting the Printer" > "4. Manual Capping", perform the capping and lock of the carriage operations.
- 6) Remove the maintenance cartridge, and then package it so that the waste ink does not leak from it.



Check that used ink is no longer leaking after removing the maintenance cartridge. If it is leaking, install the maintenance cartridge and wait until leaking stops.

- 7) Attach all external covers.
  - 8) Attach the cushioning materials and tape.
  - 9) If the printer is mounted on a stand, remove the printer from the stand.
  - 10) Pack the printer into the packing box, and then put the roll media, ink tank and stand in another packing box for moving.
- Use the original packing material for the printer and stand. If it is not available, pack them with a sufficient amount of cushioning materials.

### 4. Manual capping

When transporting the printer, cap the Printhead to protect the nozzles from drying out and to keep them clean. Follow the procedures described below:

- 1) While referring to "DISASSEMBLY/REASSEMBLY" > "Points to Note on Disassembly and Reassembly" > "Opening the Cap/Releasing the Carriage Lock Pin/Moving the Wiper Unit manually", open all caps.
- 2) Move the carriage to the home position.
- 3) While referring to "DISASSEMBLY/REASSEMBLY" > "Points to Note on Disassembly and Reassembly" > "Opening the Cap/Releasing the Carriage Lock Pin/Moving the Wiper Unit manually", perform the capping.



Manual capping is an emergency measure when the printer does not operate. Manual capping can damage the printhead.

### 3.1.2 Reinstalling the Printer

#### 3.1.2.1 Reinstalling the Printer

##### 1. Installing the printer on the same floor

If ink has not been drained from the printer when moving it to another place on the same floor, then an operation check (Test Print) needs to be performed after the printer is moved to a new location.

##### 2. Installing the printer on a different floor

If ink has been drained when transporting the printer to a different floor, follow the installation procedure below. It is nearly identical to the procedure when installing for the first time.

- 1) Remove the cushioning materials and tape.
- 2) Connect the power cord and interface cable.
- 3) Turn on the power and following the instruction in the message to install the ink tank. The ink is filled.
- 4) After the ink has been filled, load the media, and perform the operation check.



---

## Chapter 4 DISASSEMBLY/REASSEMBLY

---



---

# Contents

4.1 Service Parts .....	4-1
4.1.1 Service Parts .....	4-1
4.2 Disassembly/Reassembly.....	4-2
4.2.1 Disassembly/Reassembly .....	4-2
4.3 Points to Note on Disassembly and Reassembly .....	4-2
4.3.1 Note: Items that should never be disassembled.....	4-2
4.3.2 Moving the carriage manually.....	4-2
4.3.3 Units requiring draining of ink .....	4-3
4.3.4 External Covers .....	4-4
4.3.5 Drive Unit.....	4-13
4.3.6 Cutter.....	4-17
4.3.7 Carriage Unit .....	4-19
4.3.8 Purge Unit.....	4-26
4.3.9 Ink Tank Unit .....	4-30
4.3.10 Ink Tube Unit .....	4-34
4.3.11 Waste Ink Collection Unit.....	4-38
4.3.12 Multi Sensor.....	4-43
4.3.13 Linear Encoder .....	4-44
4.3.14 Head Management Sensor.....	4-49
4.3.15 PCBs.....	4-50
4.3.16 Opening the Cap/Moving the Wiper Unit .....	4-51
4.3.17 Opening/Closing the Ink Supply Valve/Subtank Air Passage Valve.....	4-53
4.3.18 Draining the ink.....	4-54
4.4 Applying the Grease .....	4-55
4.4.1 Applying the Grease .....	4-55
4.5 Adjustment and Setup Items .....	4-59
4.5.1 Adjustment Item List.....	4-59
4.5.2 Procedure after Replacing the Carriage Unit or Multi Sensor .....	4-59
4.5.3 Procedure after Replacing the Feed Roller or Feed Roller Encoder .....	4-59
4.5.4 Procedure after Replacing the Head Management Sensor.....	4-59



---

## 4.1 Service Parts

---

### 4.1.1 Service Parts

The service parts indicated below require careful handling.

1. Keep all packages with the warning not to turn over.

Pay careful attention to all individually packaged service part (carriage unit, purge unit, ink tank unit, and other parts) boxes marked "This side up" and handle appropriately.



F-4-1

## 4.2 Disassembly/Reassembly

---

### 4.2.1 Disassembly/Reassembly

For the procedure for disassembly/reassembly of the components excluding the major components, refer to the parts catalog. Illustrations in the parts catalog are assigned illustration numbers according to the order in which parts are disassembled.

## 4.3 Points to Note on Disassembly and Reassembly

---

### 4.3.1 Note: Items that should never be disassembled

---



Assemblies that should never be removed after initial factory adjustments, are indicated by the presence of red screws. Under no circumstance should these red screws be loosened or removed. Removing these screws will render the printer out of alignment forever.



F-4-2

---

### 4.3.2 Moving the carriage manually

Hold the handle [1] when moving the carriage.

---



Move the carriage as required during assembly and disassembly to prevent the carriage from contacting the parts to be removed. You cannot move the carriage when capping has been performed. Refer to DISASSEMBLY/REASSEMBLY > Points to Notes on Disassembly and Reassembly > Opening the caps and moving the wiper unit to remove the caps, and then move the carriage.

---

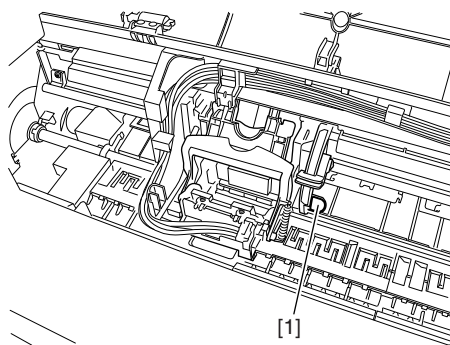

F-4-3

---

### 4.3.3 Units requiring draining of ink

When disassembling the following units, drain the ink completely, to prevent ink leakage. For ink drain instructions, refer to **DISASSEMBLY/REASSEMBLY > Points to Notes on Disassembly and Reassembly > Draining the ink.**

[1] Carriage unit

Refer to DISASSEMBLY/REASSEMBLY > Points to Notes on Disassembly and Reassembly > Carriage unit.

[2] Ink tube unit

Refer to DISASSEMBLY/REASSEMBLY > Points to Notes on Disassembly and Reassembly > Ink tube unit.

[3] Ink tank unit

Refer to DISASSEMBLY/REASSEMBLY > Points to Notes on Disassembly and Reassembly > Ink tank unit.

### 4.3.4 External Covers

#### a) Operation Panel

##### Removing the Operation Panel

- 1) To remove the operation panel, open the upper cover [1] and right tank cover [2], and then release two hooks [3] using a flat head screwdriver.
- 2) Remove the cable from the cable guide, and then remove the ground wire [5] by pushing the hook [4] from the backside of the operation unit and disconnect the connector [6], and then remove the operation panel [7].

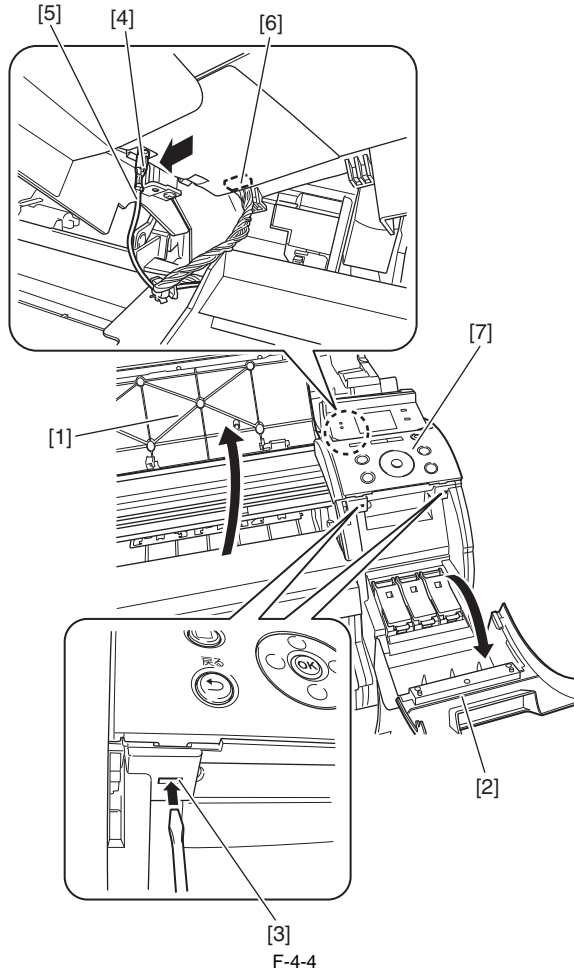

#### b) Upper Left Cover

##### Removing the Upper Left Cover

- 1) To remove the upper left cover [4], open the upper cover [1] and left tank cover [2], and then release two hooks [3] by using a flat head screwdriver.

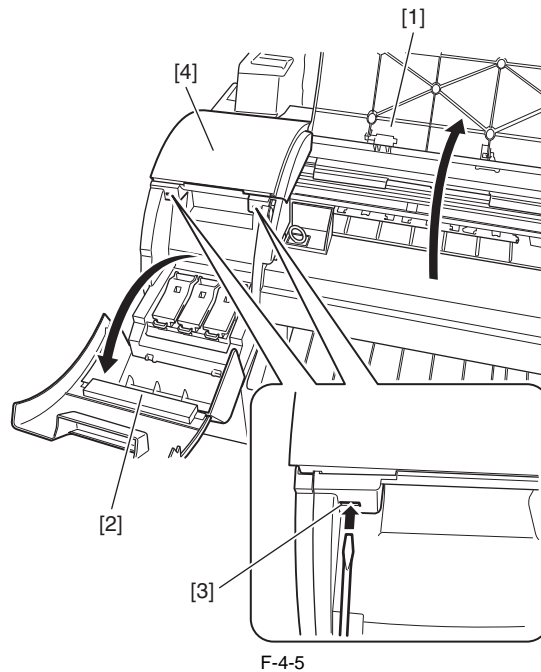



**c) Right Cover**

## Removing the Right Cover

- 1) To remove the right cover, remove the operation panel.
- 2) Remove six screws [1], release two hooks [2], and then remove the right cover [3].

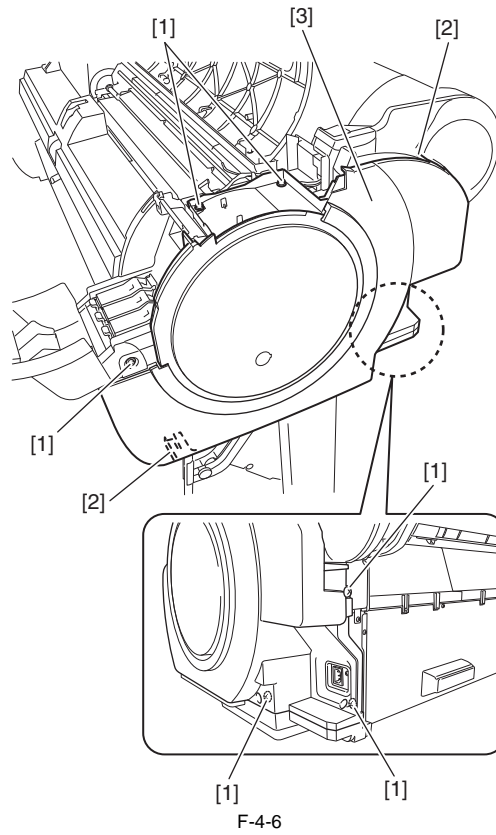
**d) Left Cover**

## Removing the Left Cover

- 1) To remove the left, remove the upper left cover.
- 2) Remove six screws [1], release two hooks [2], and then remove the left cover [3].

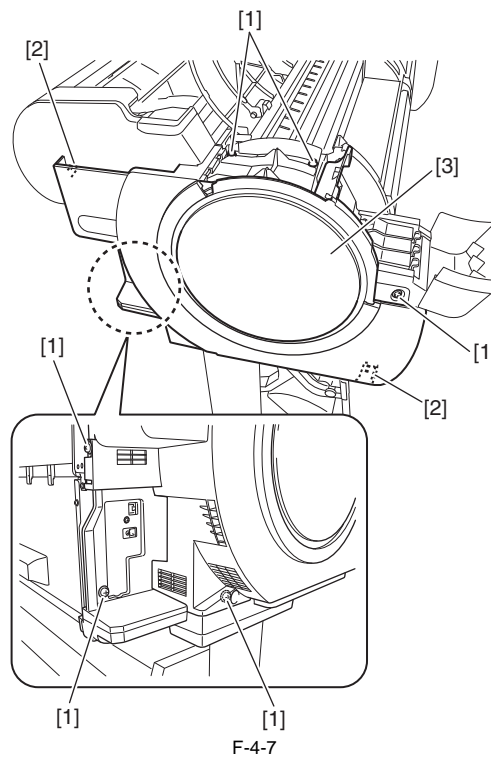

**e) Front Cover**

**Removing the Front Cover**

1) To remove the front cover [5], open the upper cover [1] to remove the cleaner brush [2], remove two screws [3], and then release three hooks [4] by using the flat head screwdriver.

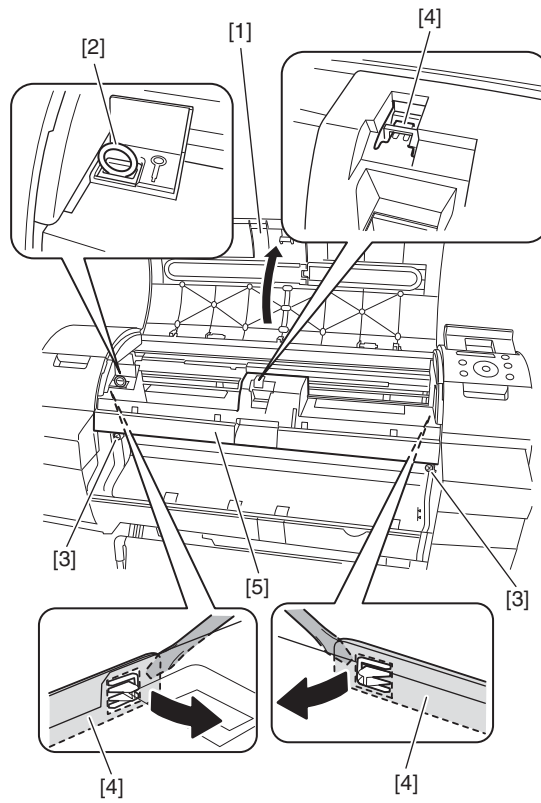

F-4-8

**f) Output Guide**

**Removing the Output Guide**

1) To remove the output guide, open the maintenance cartridge cover [1] to remove the maintenance cartridge [2], and then remove the face cover [3] by inserting a flat head screwdriver in the slit.

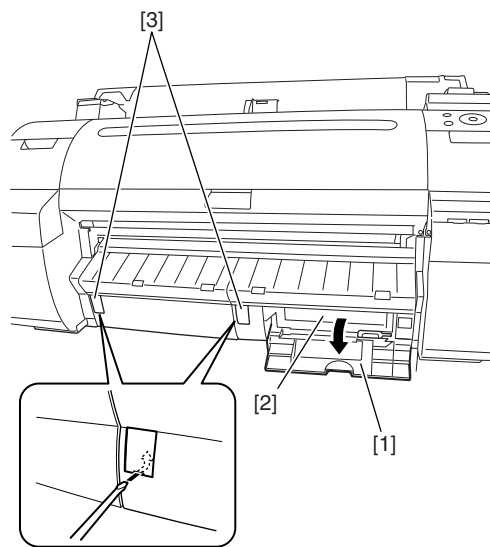

F-4-9

2) Remove two screws [1], and then the output guide (right) [2].

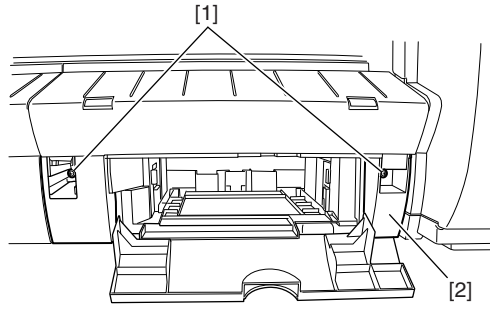

F-4-10

3) Remove one screw [1], release two hooks [2], and then remove the output guide (middle)/left [3].

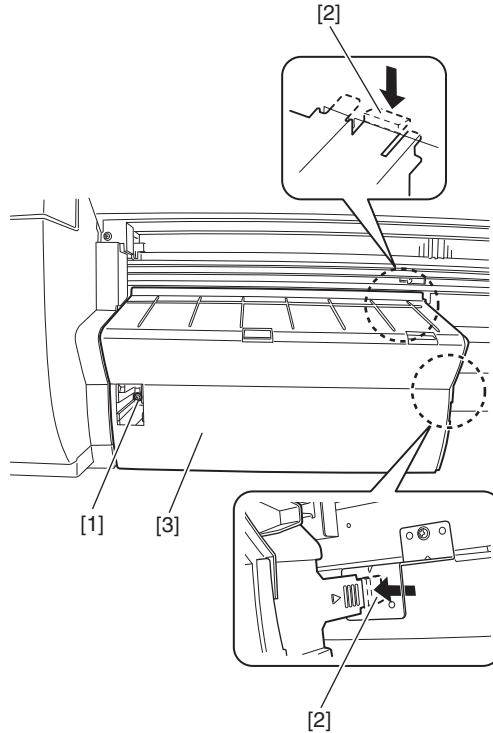

F-4-11

**g) Left/Right Ink Tank Cover**

Removing the Left/Right Ink Tank Cover

1) To remove the left/right ink tank cover [2], remove the left/right cover, and then one screw [1].

<Left Ink Tank Cover>

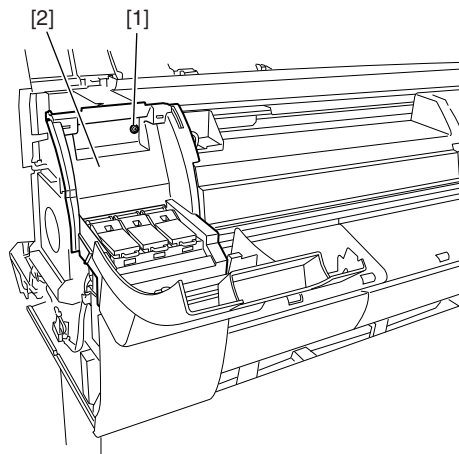

F-4-12

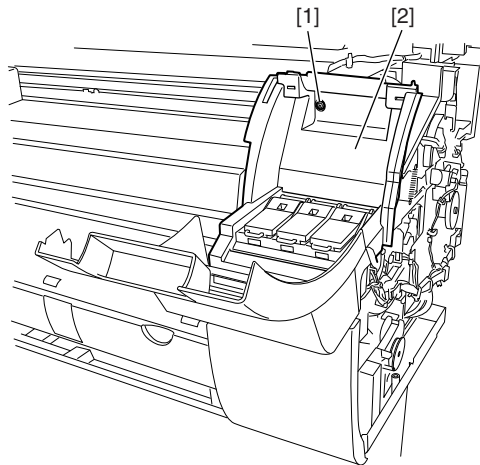

F-4-13

**h) Upper Cover**

**Removing the Upper Cover**

1) To remove the upper cover [1], remove the upper left cover, and then slide the upper cover [1] to the left to remove it from the hinge [2].

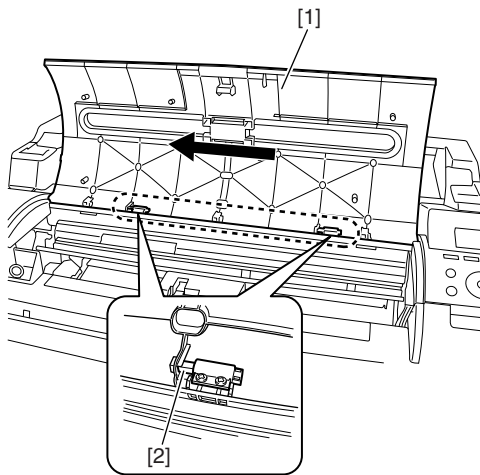

F-4-14

**i) Rear Upper Cover**

**Removing the Rear Upper Cover**

1) To remove the rear upper cover [3], remove the left/right cover and upper cover, open the roll cover [1], and then remove eight screws [2].

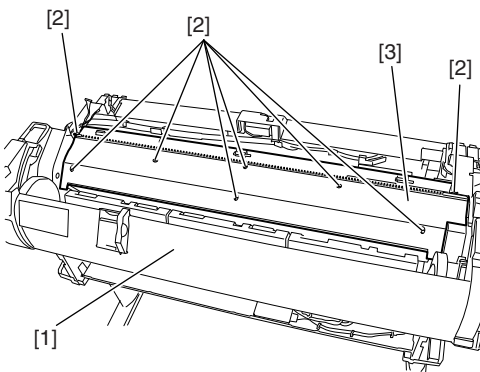

F-4-15

**MEMO:**

The rear upper cover [1] and upper cover [2] can be removed together.

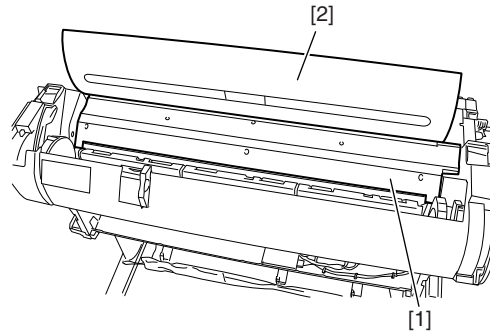

F-4-16

**j) Rear Cover**

Removing the Rear Cover

1) To remove the rear cover [2], remove ten screws [1].

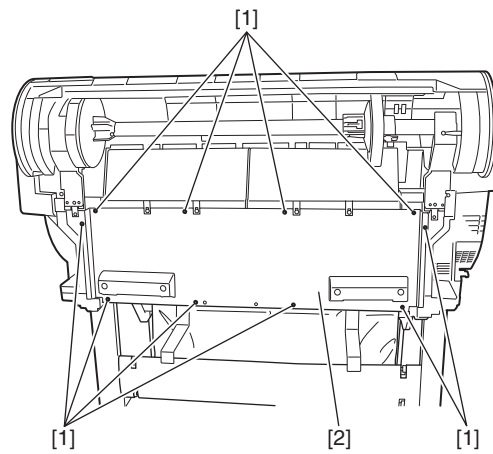

F-4-17

**k) Roll Feed Unit**

Removing the Roll Feed Unit

**MEMO:**

Open/close the roll cover as needed.

- 1) To remove the roll feed unit, remove the roll holder, and then remove the left/right cover and rear upper cover.
- 2) Remove four screws [1] and one connector [2], and then the feed guide [3].

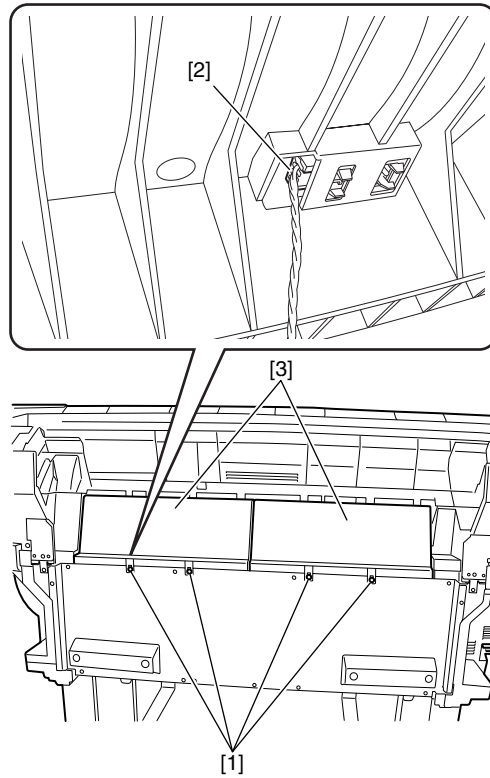

F-4-18

- 3) Remove four screws [1], and then the left and right roll lower inner covers [2].

<Left roll lower inner cover >

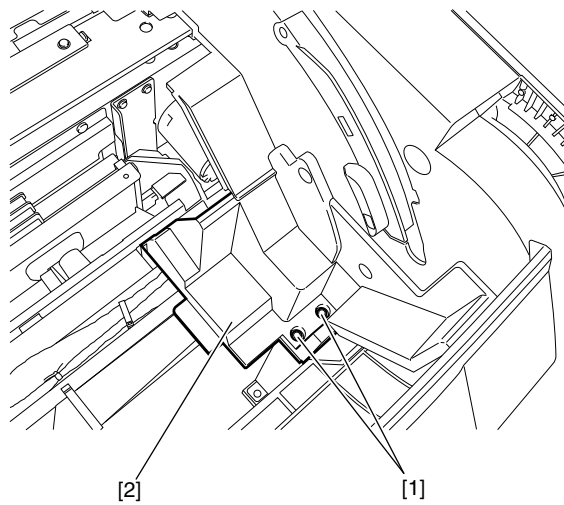

F-4-19

<Right roll lower inner cover >

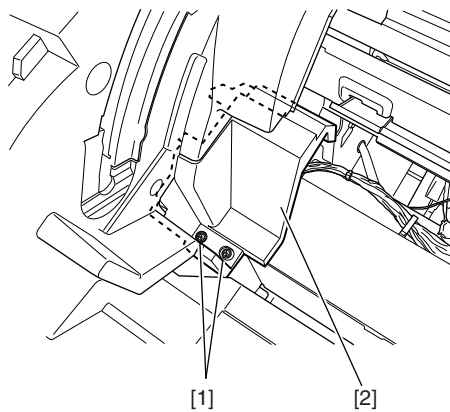

F-4-20

4) Remove three screws [1], and then remove the left roll cover [2].

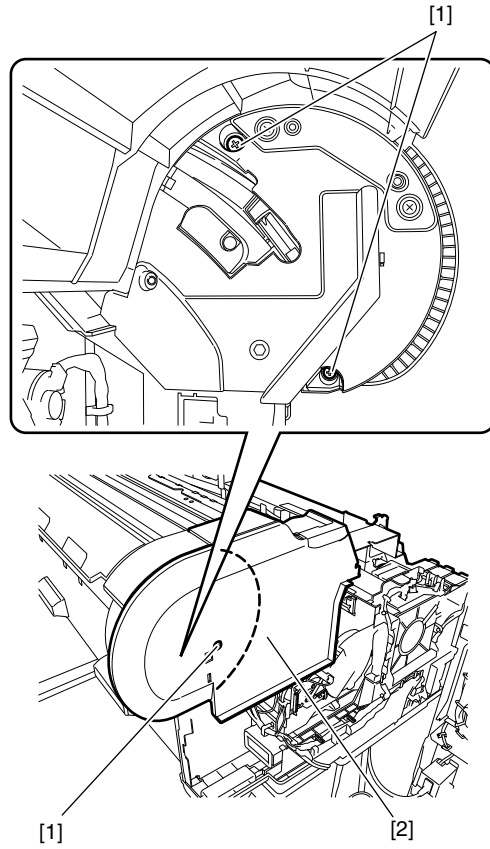

F-4-21

5) Remove seven screws [1] and three connectors [2], and then remove the cable from the cable guide to remove the roll feed unit [3].

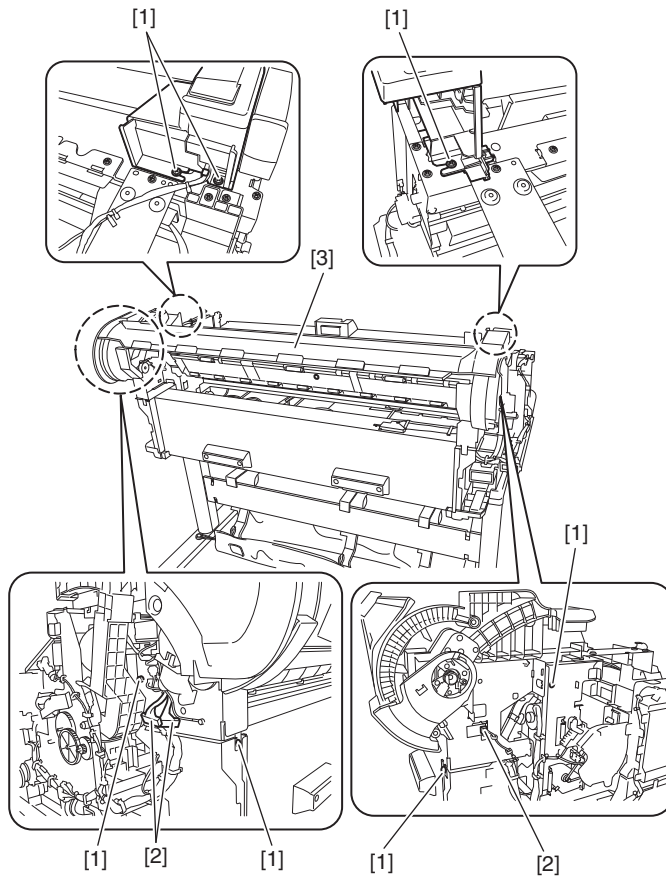

F-4-22

**1) Release Lever**

**Removing the Release Lever**

1) To remove the release lever, remove five screws [1] and four connectors [2], and then remove the cable from the cable guide to remove the right side plate unit [3].

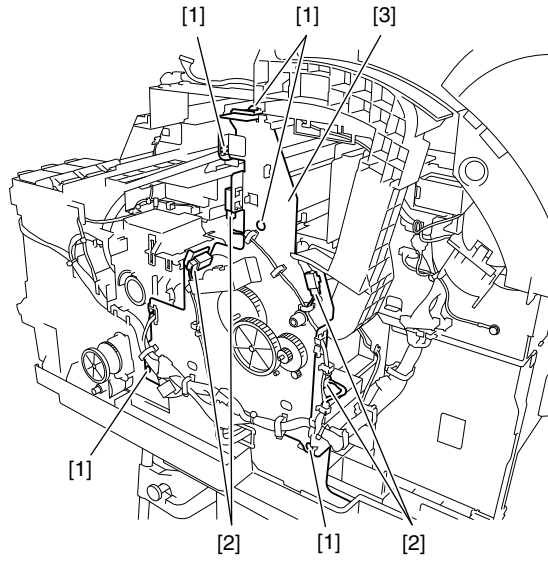

F-4-23

2) Remove one spring [1], and then the release lever [2]. Keep the pinch roller pressurized to enable phase adjustment at the time of release lever reinstallation.

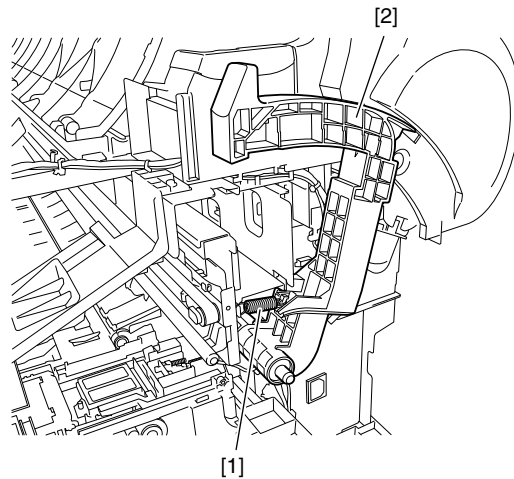

F-4-24

**Precautions about Reinstallation of Release Lever**

When reinstalling the release lever, align the notch [1] on the gear portion of the release lever with the protrusion [2] on the gear portion of the pinch roller.

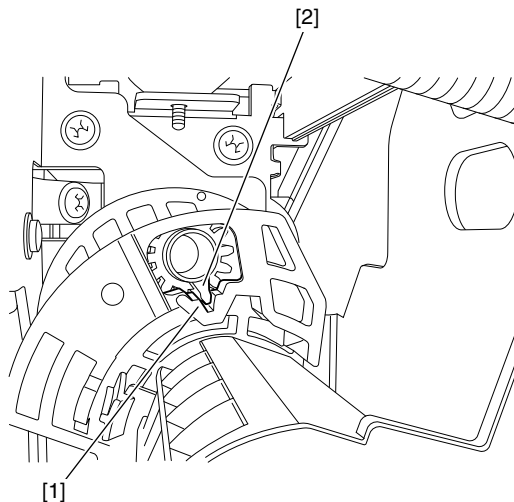

F-4-25



### 4.3.5 Drive Unit

#### a) Feed Motor

Removing the Feed Motor

- 1) Remove the left cover.
- 2) Remove one spring [1], two screws [2], and one connector [3], and then remove the belt [4] from the motor pulley and remove the cable from the cable guide to remove the feed motor [5].

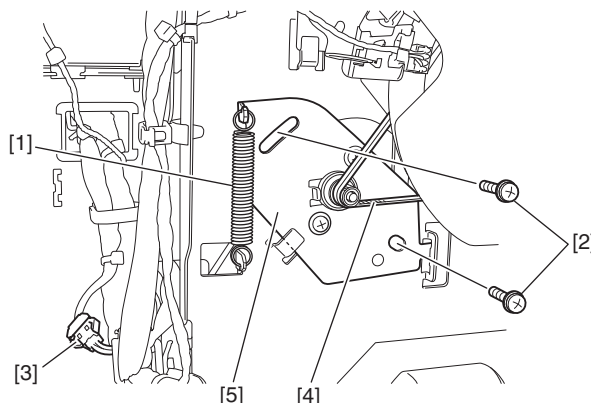

F-4-26

#### Precautions about Reinstallation of Feed Motor

Put the timing belt on the pulley in the feed motor drive unit, tighten the screw [1] temporarily, install the spring [2], and then tighten the screw [1] to secure the feed motor.

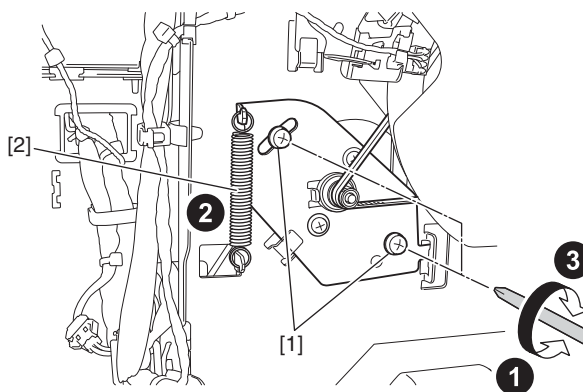

F-4-27

#### b) Action to take after replacing the feed roller encoder and feed roller

This printer as shipped has the feed roller eccentricity (that is, variations in the rate of paper feed from rotation to rotation) corrected for enhanced media feed accuracy. When the feed roller HP sensor or feed roller encoder and feed roller pertaining to the correction of eccentricity variations has been replaced, therefore, they should require adjustment.

Execute service mode under the following conditions to launch automatic adjustment:

Service mode: SERVICE MODE > ADJUST > PRINT PATTERN > LF TUNING

- Media type: Glossy photo paper

- Media size (width): 24 inches

If adjustment cannot be done properly by selecting "SERVICE MODE > ADJUST > PRINT PATTERN > LF TUNING" (auto adjustment), carry out manual adjustment.

Service mode: SERVICE MODE > ADJUST > PRINT PATTERN > LF TUNING2

- Media type: Gloss photo paper

- Media size (width): 24 inches

Check the printed pattern and enter values for adjustment.

**c) Carriage Motor**

Removing the Carriage Motor

- 1) Move the carriage onto the platen. Refer to "Disassembly/Reassembly > Points to Note on Disassembly and Reassembly > Opening the Cap/Moving the Wiper Unit".
- 2) Remove the left/right cover.
- 3) Remove one screw [1], and then remove the carriage upper cover [2].

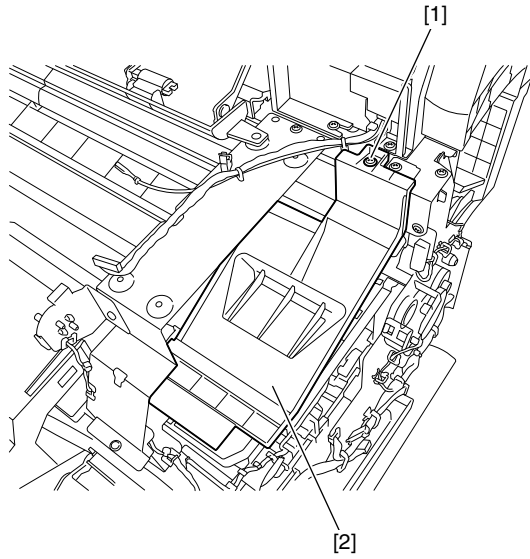

F-4-28

- 4) Remove one screw [1], pulley retainer [2] and spring [3] to loosen the carriage belt [4]. Remove the belt from the pulley unit [5], and then the pulley unit [5].

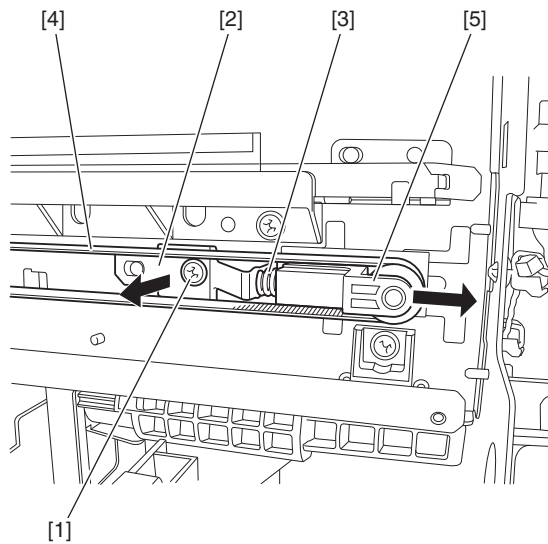

F-4-29

5) Remove the belt [1] from the pulley [5], and then remove two screws [2] and disconnect one connector [3] to remove the carriage motor [4].

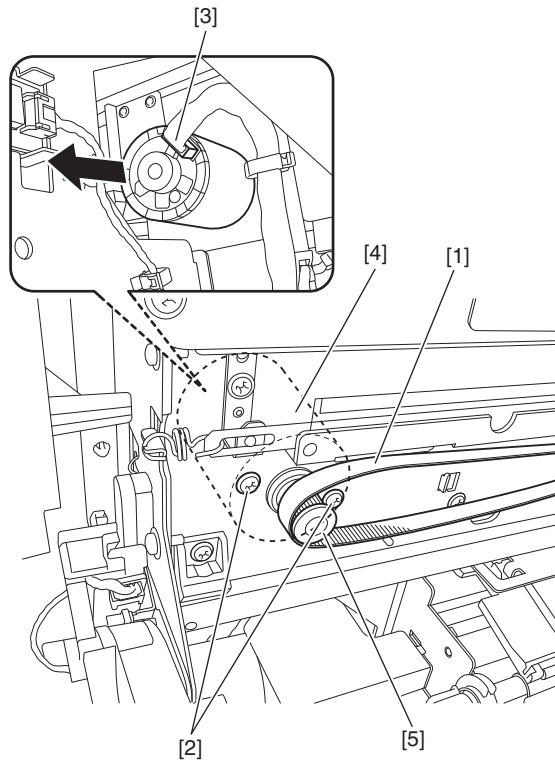

F-4-30

#### Precautions about Reinstallation of Carriage Motor

- Reinstall the carriage belt [1] carefully so that it is not twisted. After reinstalling it, check whether the carriage moves on the platen smoothly.

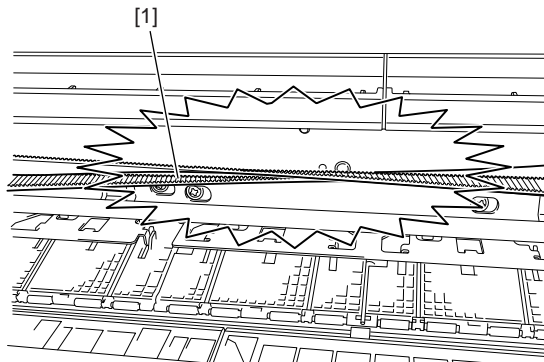

F-4-31

- Reinstall the pulley retainer [1] in such a manner that it fits in the notch [2] on the side plate.

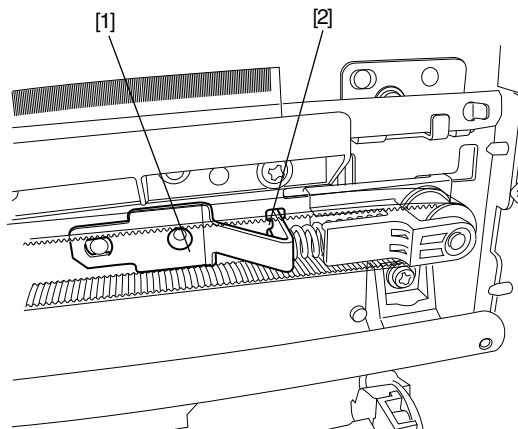

F-4-32

#### d) Action to take after removing or replacing the carriage motor

After the carriage and carriage motor and carriage belt and linear encoder sensor has been removed or replaced, execute the following service mode.  
Service mode: SERVICE MODE > ADJUST > CR MOTOR COG

e) **Shutter Motor**

Removing the Shutter Motor

- 1) Remove the output guide (right).
- 2) Disconnect one connector [1]. While releasing the hook [3] by pressing the protrusion [2], turn the shutter motor unit [4] slightly in the clockwise direction. Remove the shutter motor unit [4] with it lifted.

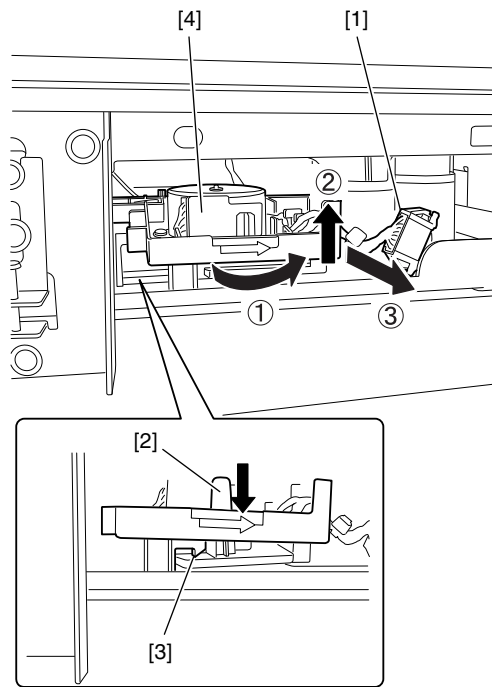

F-4-33

### 4.3.6 Cutter

#### a) Cutter

##### Removing the Cutter

- 1) Perform service mode: [SERVICE MODE] > [REPLACE] > [CUTTER] and then choose [YES] to move the cutter to the replacement place.
- 2) Remove two screws [1] by using the hex key wrench of 1.5mm diameter to remove the cutter [2].

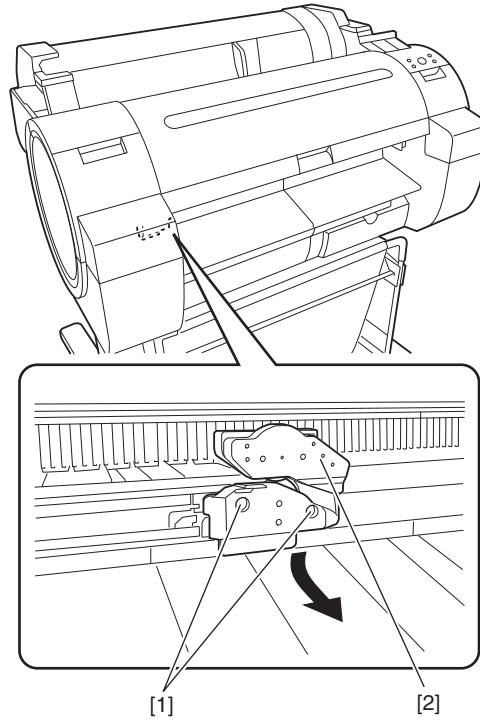

F-4-34

#### MEMO:

After replacing the cutter, press the [OK] key to return the cutter to the home position. Then, choose [CLR COUNTER CT-1] > [YES] that displayed on the LCD to initialize the parts counter information.

#### Removing the Cutter Rail Unit

- 1) Drain ink. Refer to "Draining Ink" in "Precautions about Disassembly/Reassembly" in "Disassembly/Reassembly".
- 2) To remove the cutter rail unit, remove the left/right ink tank cover, left/right ink tank unit, and mist fan.
- 3) Remove two screws [1] and disconnect one connector [2] and remove the cable from the cable guide, and then remove the cutter unit [3].

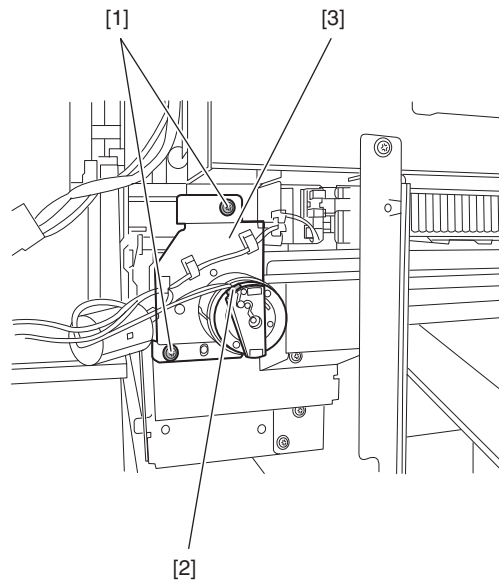

F-4-35

4) Remove one screw [1], move the cutter rail unit [2] to the left to release it from two protrusion [3], and then remove it rightward.

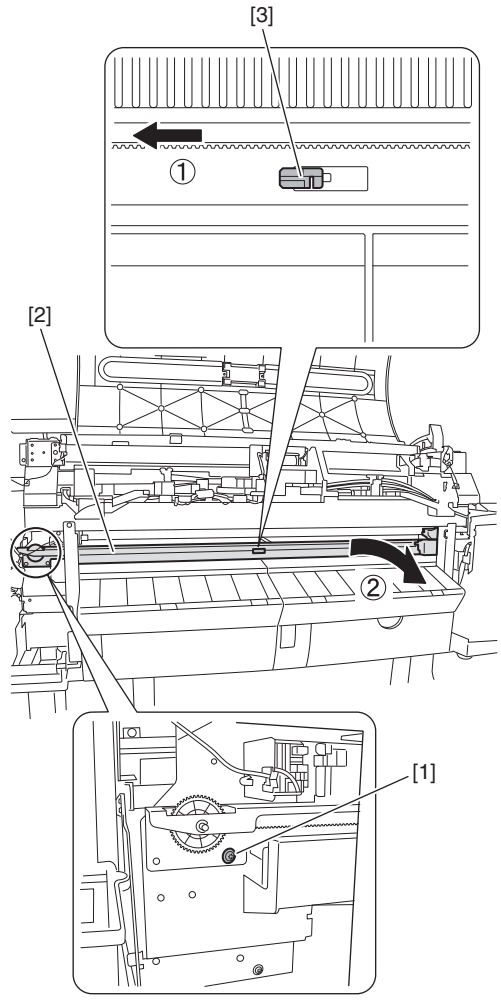

F-4-36

### 4.3.7 Carriage Unit

#### a) Carriage Unit

##### Removing the Carriage Unit

- 1) Drain ink. Refer to "Draining Ink" in "Precautions about Disassembly/Reassembly" in "Disassembly/Reassembly".
- 2) Unlock the carriage unit. Refer to "Disassembly/Reassembly > Points to Note on Disassembly and Reassembly > Opening the Cap/Moving the Wiper Unit".
- 3) Remove the rear upper cover, front cover, and rear cover.
- 4) Move the carriage to the position where there is a notch [1] at the front of the platen as shown in the figure.

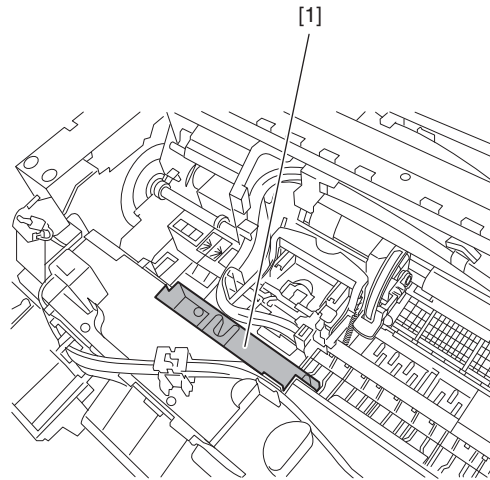

F-4-37

- 5) Remove the printhead.

- 6) Open the tube guide [1] an angle of 90 degrees frontward, and then remove the tube guide [1] together with the ink tube from the carriage. Remove the ink tube [2] from the carriage guide, and then remove one spring [3] and two hooks [4] to remove the joint base [5] together with the printhead fixer lever.

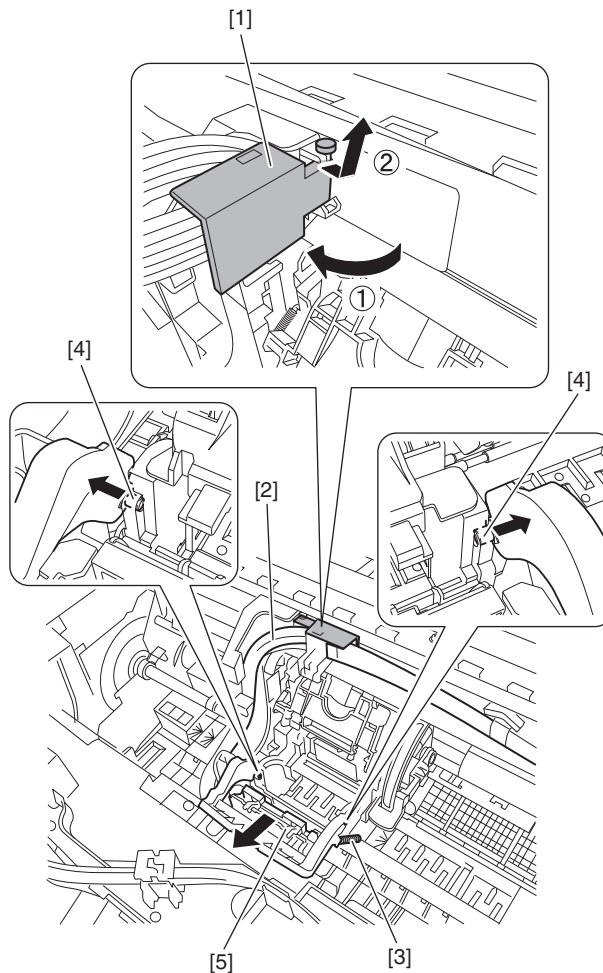

F-4-38



- Remove the joint carefully so that ink does not spout.
- Put a plastic bag or the like on the ink tube joint to prevent ink from spouting.

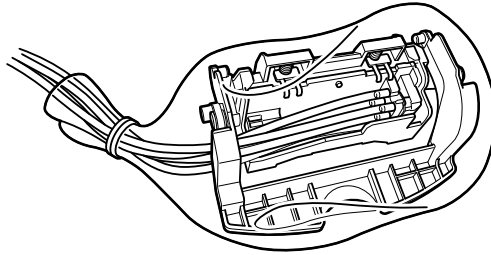

F-4-39

- 7) Move the carriage to the HP side on the platen.
- 8) Release the hook [1], and then remove the flexible cable guide [2] by sliding it to the left.

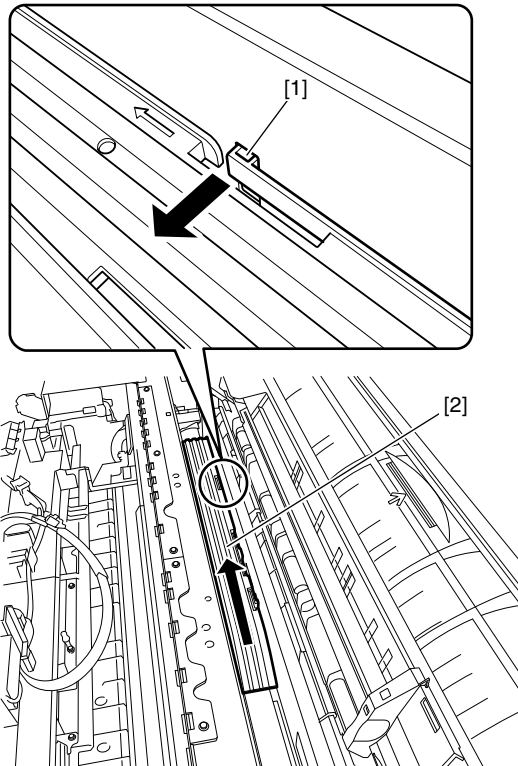

F-4-40

- 9) Remove two screws [1], and then remove the feed guide (left) [2].

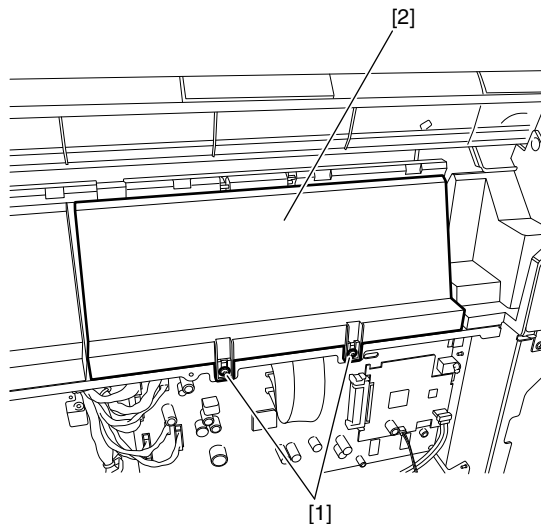

F-4-41



10) Remove two screws [1], and then remove the left roll lower inner cover [2].

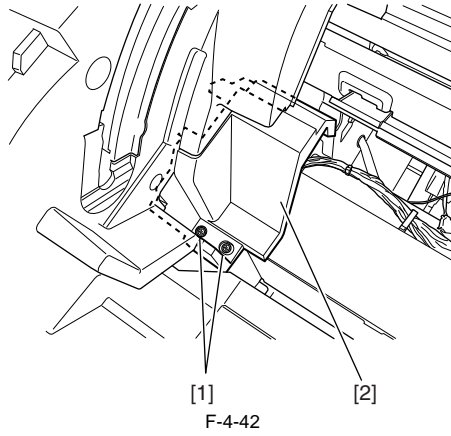

F-4-42

11) Disconnect three flexible cable connectors [1] from the main controller PCB.

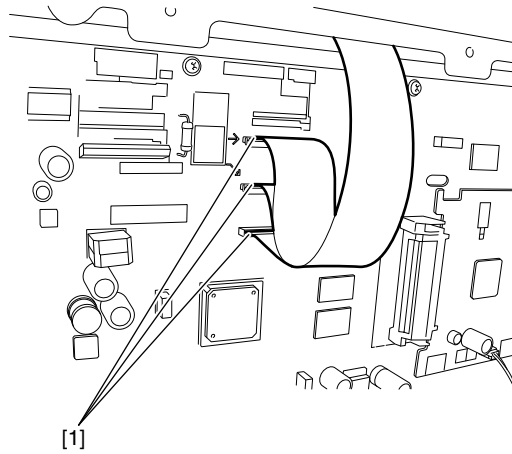

F-4-43

12) Release the hook [1], and then remove the flexible cable guide [2].

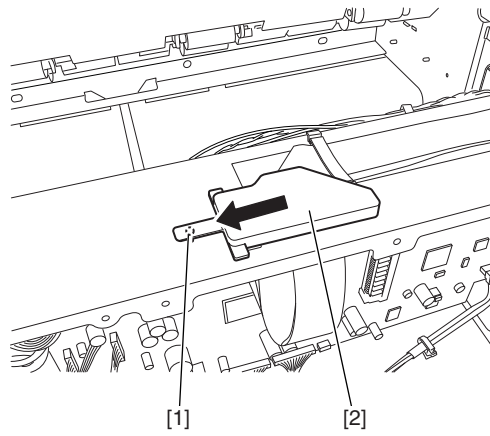

F-4-44

13) Release two hooks [1], and then remove the flexible cable [4] from the flexible cable retainer [2] and flexible guide [3].

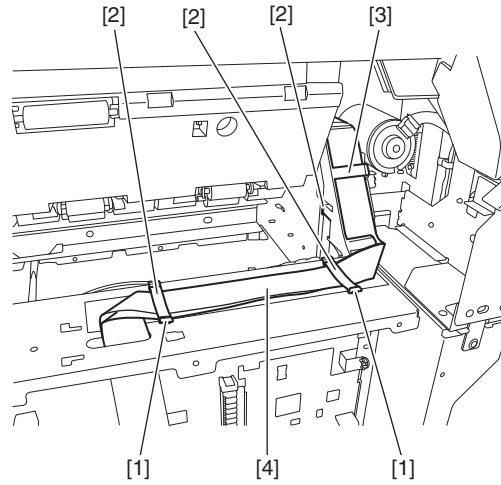

F-4-45

14) While releasing the hook with the guide [1] lifted, slide the flexible cable retainer [2] to remove it.

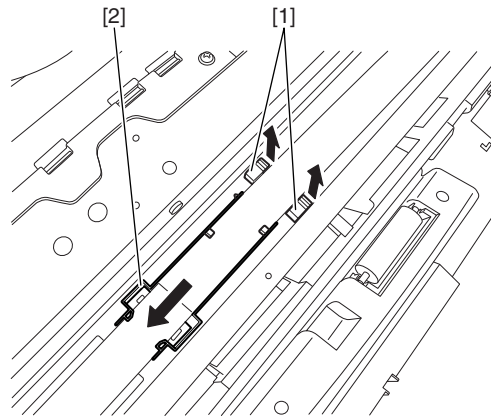

F-4-46

15) Remove one screw [1], and then remove the carriage upper cover [2].

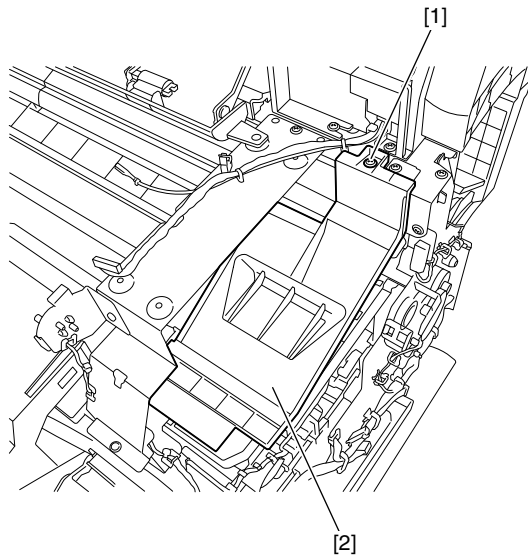

F-4-47

16) Remove one screw [1], the pulley retainer [2], and spring [3] to loosen the carriage belt [4]. Remove the belt [4] from the pulley unit [5], and then remove the pulley unit [5].

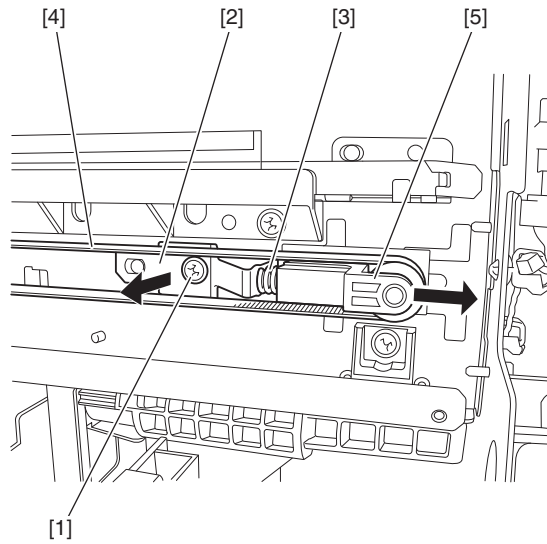

F-4-48

17) Remove the carriage belt [1] from the carriage motor pulley [2].

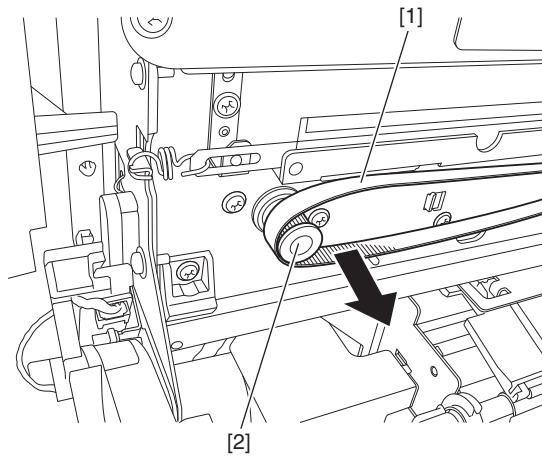

F-4-49

18) Remove five screws [1] and disconnect four connectors [2], and then remove the cable from the cable guide to remove the right side plate unit [3].

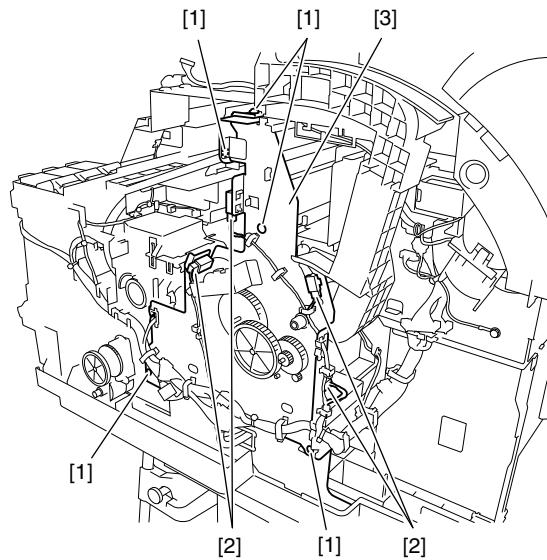

F-4-50

19) Remove the carriage unit [1] from the right side of the printer.

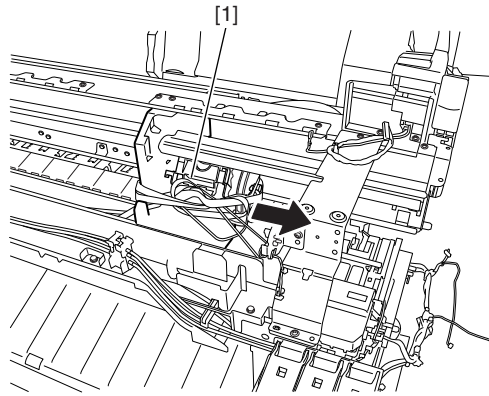

F-4-51

Precautions about Reinstallation of Carriage Unit

- When replacing the carriage unit, see "4.4.1 Applying the Grease" and follow the direction.
- Make sure that the linear scale [1] is in the detection zone of the linear encoder sensor [2].

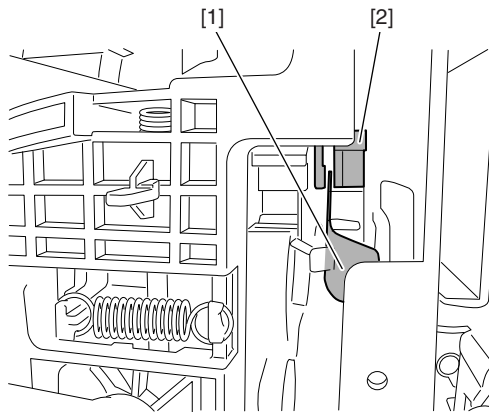

F-4-52

- Reinstall the carriage belt [1] carefully so that it is not twisted. After reinstalling it, check whether the carriage moves on the platen smoothly.

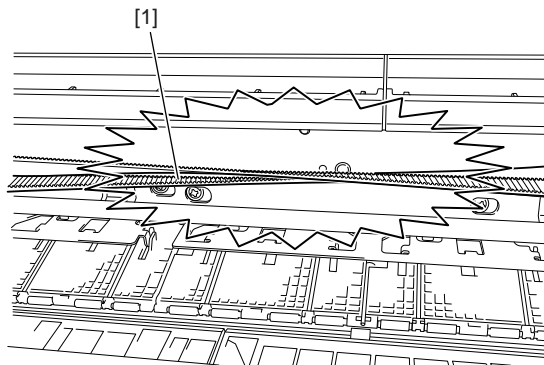

F-4-53

- Reinstall the pulley retainer [1] in such a manner that it fits in the notch [2] on the side plate.

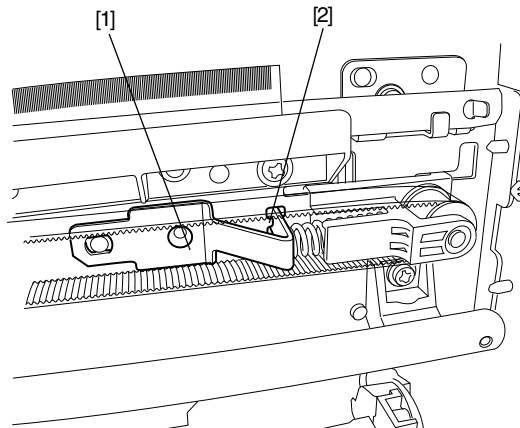

F-4-54

- The phase of the carriage height adjuster is automatically adjusted as the motor turns, requiring no on-site adjustment.

#### Precautions about Reinstallation of Carriage Belt

- When reinstalling the carriage belt, push it deeply into the belt holder of the carriage.

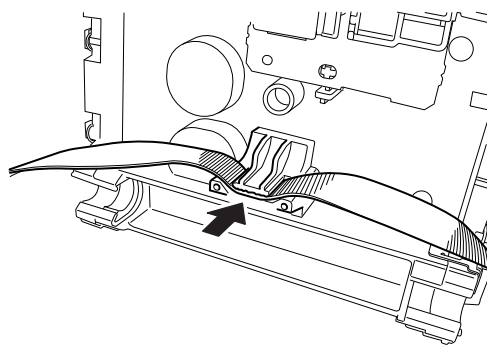

F-4-55

#### b) Action following the replacement of the carriage unit/multi sensor

Because the distance between the multi sensor (in the carriage unit) and the nozzles (in the printhead) is varied from one unit to another, the printer as shipped has its optical axis corrected to adjust the image write position. When the carriage unit or multisensor has been replaced or disassembled and reassembled, they require adjustment.

Execute service mode under the following conditions:

\* The multi sensor reference plate(QL2-6891: MOUNT, MULTI SENSOR REFERENCE) must be replaced at the same time whenever the carriage or the multi sensor is being replaced.

- 1) Carry out the following service mode without media loading.
  - Service mode : SERVICE MODE > ADJUST > GAP CALIB.
- 2) Load the following media.
  - Media type : Photo glossy paper
  - Media size : Media having a width equal too larger than that of A2-size paper
- 3) Carry out the following service mode.
  - Service mode : SERVICE MODE > ADJUST > PRINT PATTERN > OPTICAL AXIS

- After the carriage unit or carriage motor or carriage belt or linear encoder sensor have been removed or replaced, execute the following service mode.

Service mode: SERVICE MODE > ADJUST > CR MOTOR COG

#### c) Precautions against handling the carriage shaft



The carriage shaft is functionally important part. Therefore, be sure to note the following points.

- Do not touch the shaft.
- Do not allow the shaft to get scratched or marked.
- Do not apply the grease to the shaft.

### 4.3.8 Purge Unit

#### a) Purge Unit

##### Removing the Purge Unit

- 1) Unlock the carriage unit, and then move the carriage onto the platen. Refer to "Disassembly/Reassembly > Points to Note on Disassembly and Reassembly > Opening the Cap/Moving the Wiper Unit".
- 2) Remove the right cover.
- 3) Remove five screws [1] and disconnect five connectors [2], and then remove the cable from the cable guide to remove the right side plate unit [3].

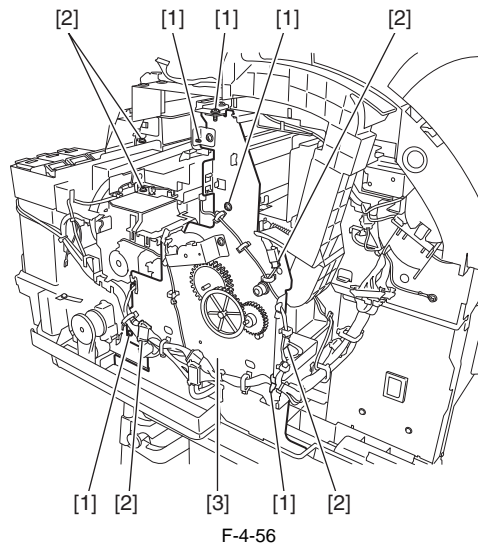

- 4) Remove two screws [1] and two waste ink tubes [2], the cable from the cable guide, and then remove the purge unit [3].

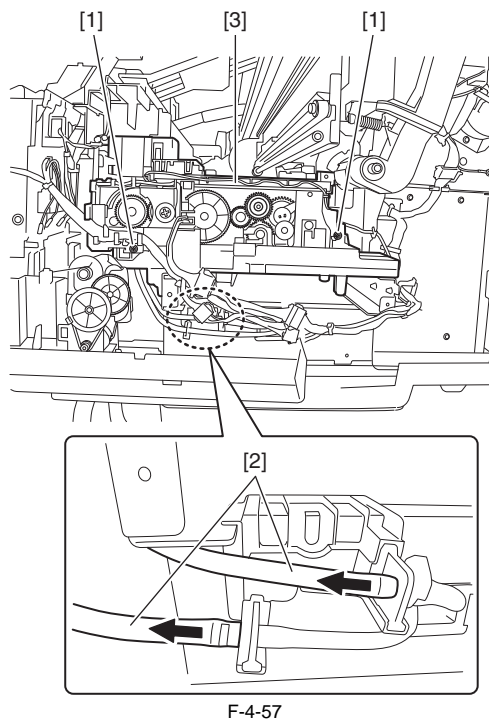

Remove the waste ink tubes carefully so that ink does not spout.

### Precautions about Reinstallation of Purge Unit

- When installing the waste ink tubes, attach the tube that painted the white mark [1] to the near edge (i.e.; the length of the tube is the shorter) to the left joint [2].

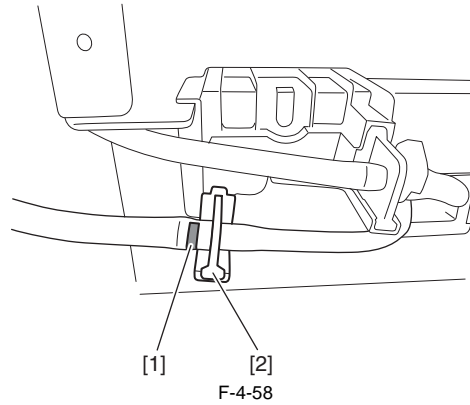

- When installing the waste ink tubes, attach the tubes surely until end of the joint. And check that the tubes are not buckled.

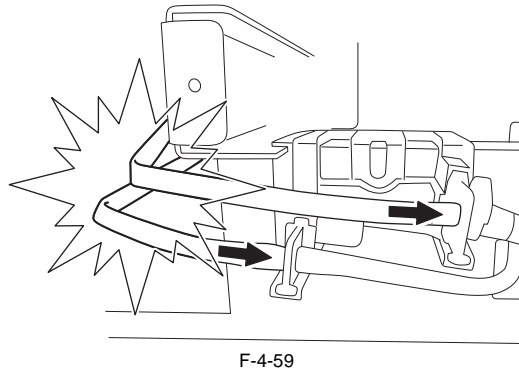

### b) Drain ink tube joint (CL)

#### Removing the drain ink tube joint (CL)

- 1) Open the maintenance cartridge cover [1] to remove the maintenance cartridge [2], and then remove the face cover [3] by inserting a flat head screwdriver in the slit.

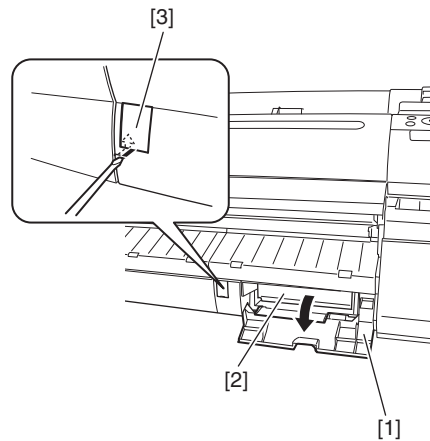

- 2) Remove two screws [1], and then remove the output guide (right) [2].

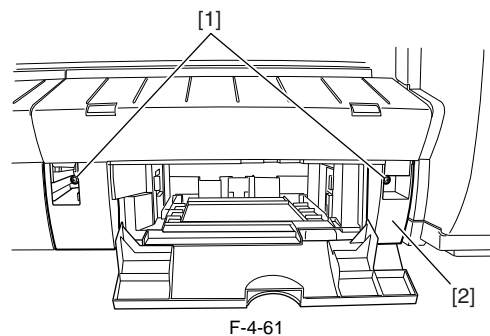

3) Remove ten screws [1], and then remove the rear cover [2].

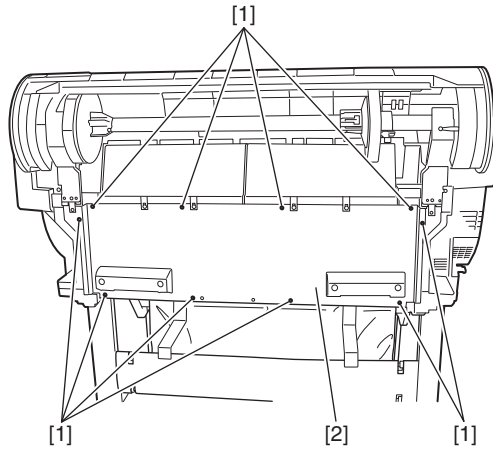

F-4-62

4) Disconnect the connector [1].

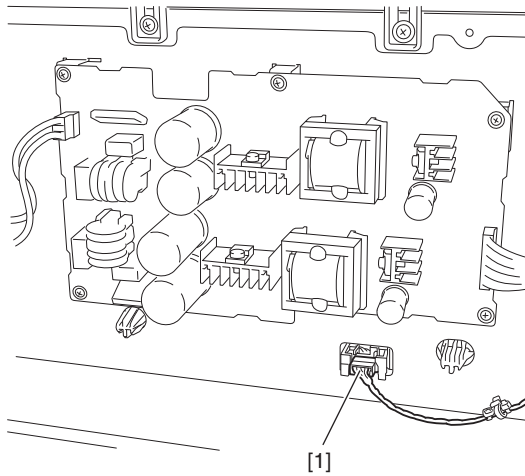

F-4-63

5) Remove two screws [1], and then remove the maintenance cartridge holder unit [2].

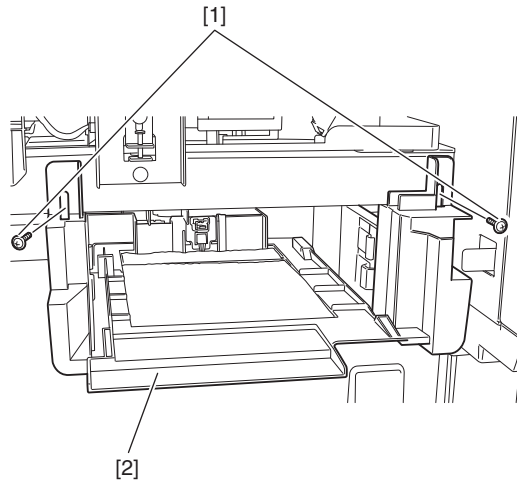

F-4-64



6) Remove three screws [1] and drain ink tube [2], and then remove the drain ink tube joint (CL) [3].

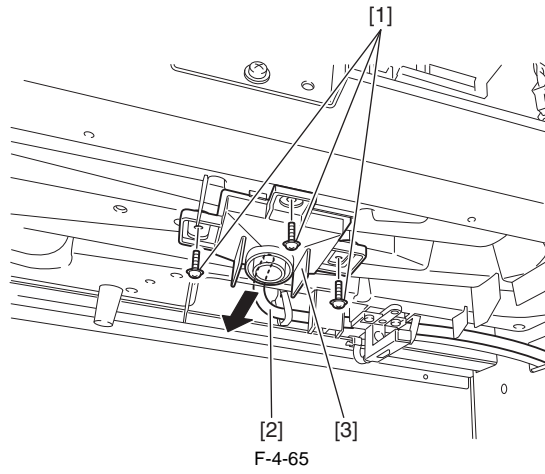

When removing the drain ink tube joint (CL) and the drain ink tube, be careful so that the ink do not spout or drip.

Precautions about Reinstallation of drain ink tube joint (CL)

- When attaching the drain ink tube joint (CL), insert the drain ink tube [1] firmly to the joint.

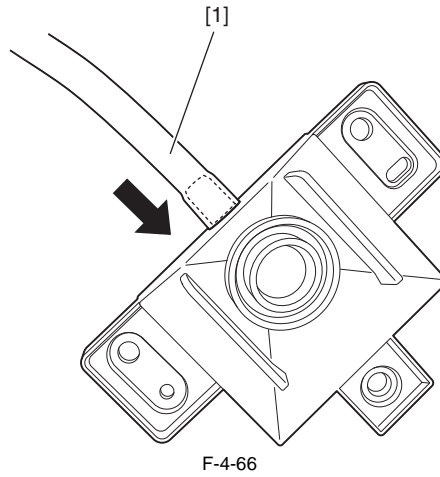

### 4.3.9 Ink Tank Unit

#### a) Ink Tank Unit

Removing the Right Ink Tank Unit

- 1) Perform ink drainage. Refer to "Disassembly/Reassembly > Points to Note on Disassembly and Reassembly > Draining the ink".
- 2) Remove the right cover, right ink tank cover, and front cover.
- 3) Remove four screws [1] and disconnect two connectors [2], and then remove the cable from the cable guide.
- 4) Remove the joint [3] between the ink tube unit and ink tank unit carefully, the ink tube from the guide, and then remove the right ink tank unit [4].

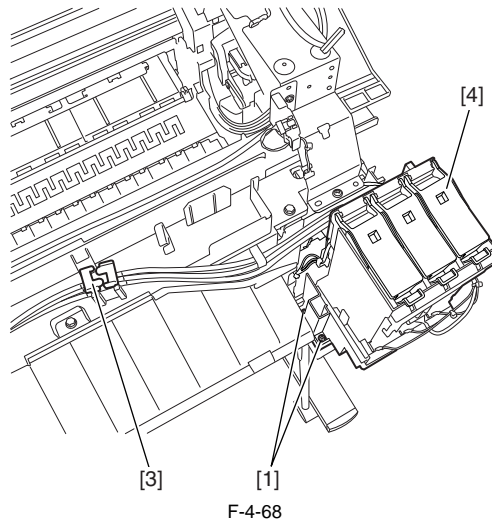
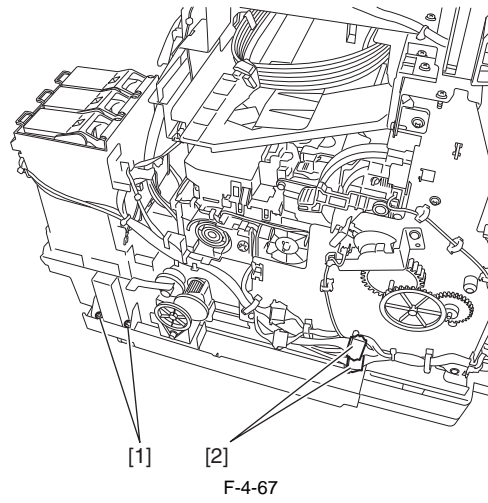



- Remove the joint carefully so that ink does not spout.
- Put a plastic bag or the like on the ink tube joint to prevent ink from spouting.

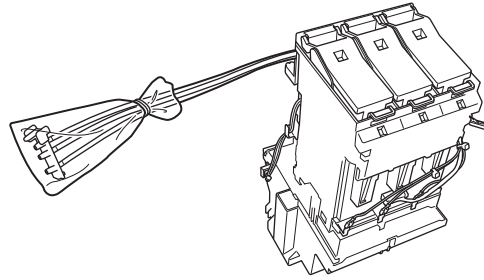

F-4-69

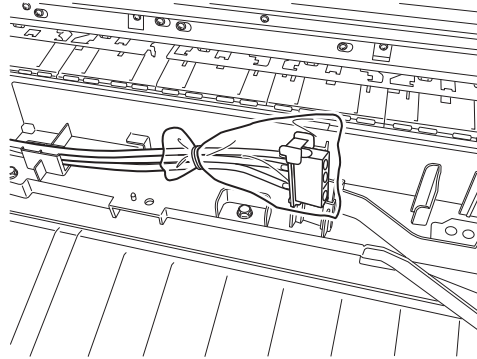

F-4-70

Removing the Left Ink Tank Unit

- 1) Perform ink drainage. Refer to "Disassembly/Reassembly > Points to Note on Disassembly and Reassembly > Draining the ink".
- 2) Remove the left cover, left ink tank cover, and front cover.
- 3) Remove four screws [1] and disconnect two connectors [2], and then remove the cable from the cable guide.
- 4) Remove the joint [3] between the ink tube unit and ink tank unit carefully, the ink tube from the guide, and then remove the left ink tank unit [4].

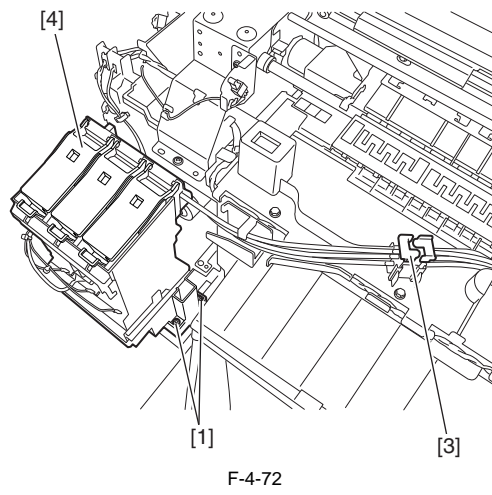
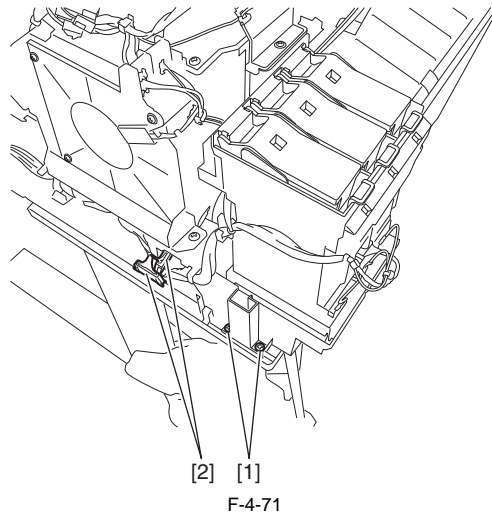



- Remove the joint carefully so that ink does not spout.
- Put a plastic bag or the like on the ink tube joint to prevent ink from spouting.

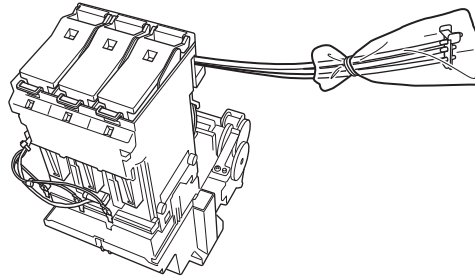

F-4-73

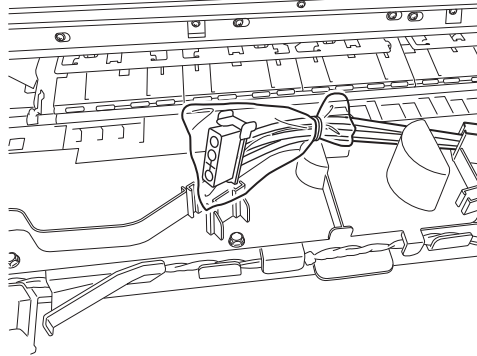

F-4-74

#### b) Valve Motor Unit

Removing the Valve Motor Unit

- 1) Remove the ink tank unit.
- 2) Remove three screws [1] and disconnect three connectors [2], and then remove the cable from the cable guide to remove the valve unit [4] while pressing down the protrusion [3].

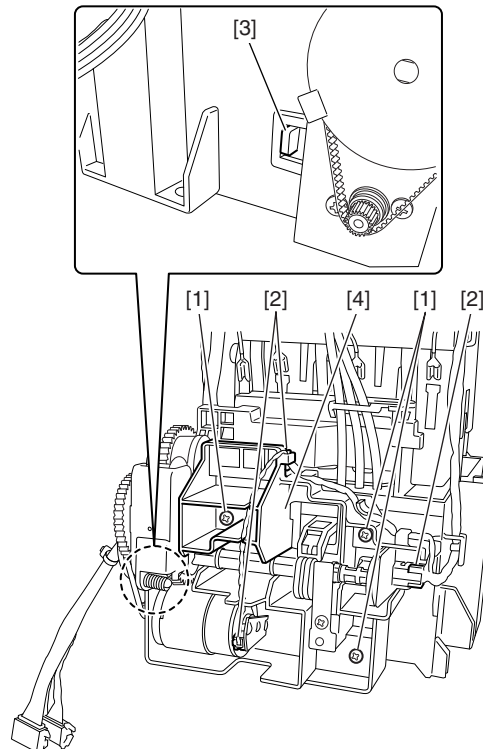

F-4-75

### 4.3.10 Ink Tube Unit

#### a) Ink Tube Unit

Removing the Ink Tube Unit

- 1) Perform ink drainage. Refer to "Disassembly/Reassembly > Points to Note on Disassembly and Reassembly > Draining the ink".
- 2) Unlock the carriage unit. Refer to "Disassembly/Reassembly > Points to Note on Disassembly and Reassembly > Opening the Cap/Moving the Wiper Unit".
- 3) Remove the front cover.
- 4) Move the carriage to the position where there is a notch [1] at the front of the platen as shown below.

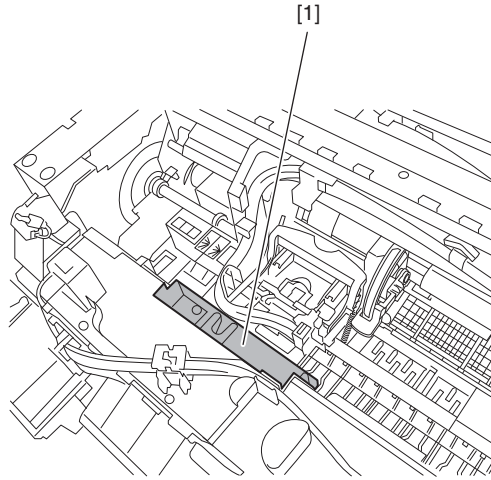

F-4-76

5) Remove the printhead.

6) Open the tube guide [1] an angle of 90 degrees frontward, and then remove the tube guide [1] together with the ink tube.

Remove the ink tube [2] from the carriage guide and one spring [3], release two hooks [4], and then remove the joint base [5] together with the printhead fixer lever.

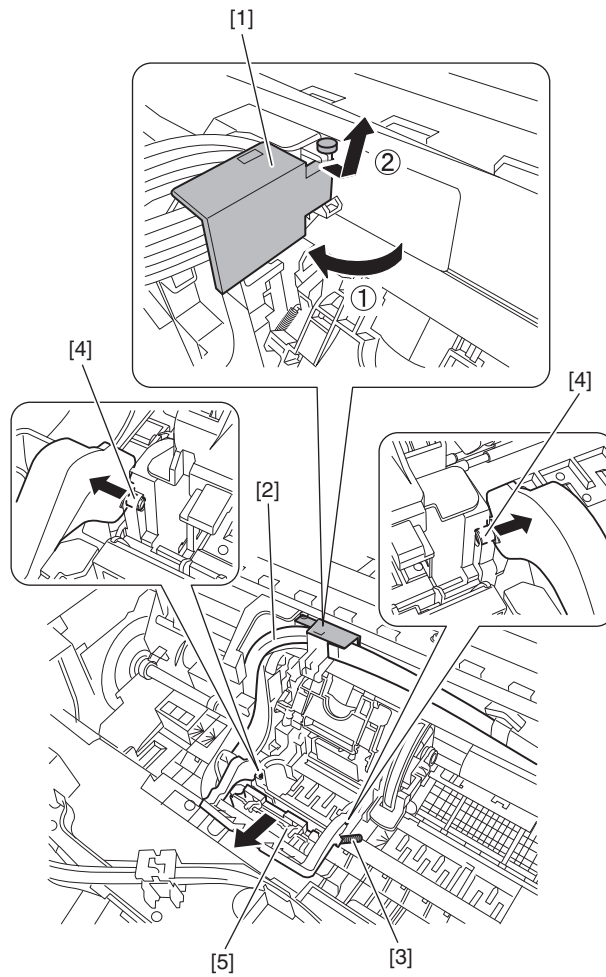

F-4-77



- Remove the joint carefully so that ink does not spout.
- Put a plastic bag or the like on the ink tube joint to prevent ink from spouting.

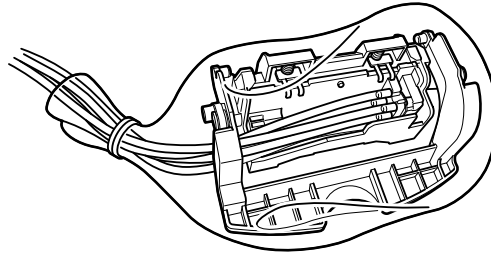

F-4-78

- 7) Remove two screws [1] and disconnect two connectors [2], and then remove the solenoid base [3].

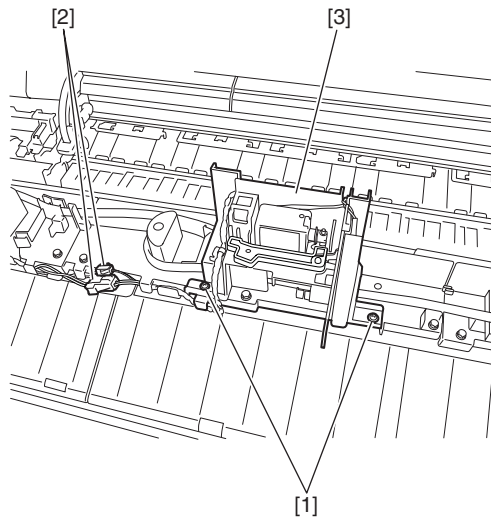

F-4-79

- 8) Remove two joint [1] between the ink tube unit [2] and ink tank unit carefully, and then remove the ink tube unit [2] from the guide.

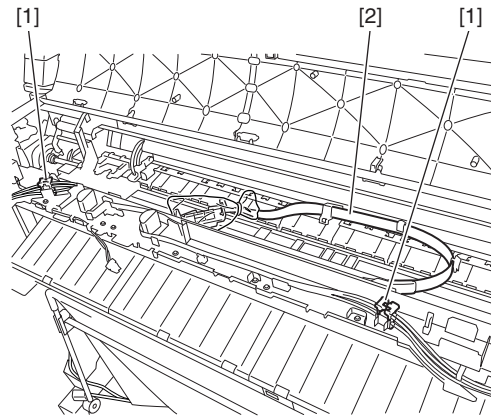

F-4-80



- Remove the joint carefully so that ink does not spout.
- Put a plastic bag or the like on the ink tube joint to prevent ink from spouting.

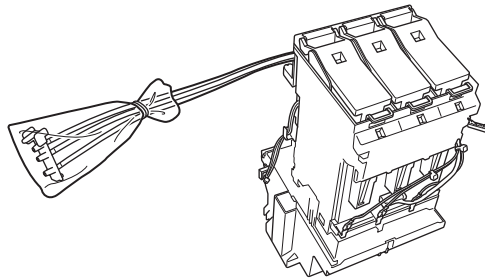

F-4-81

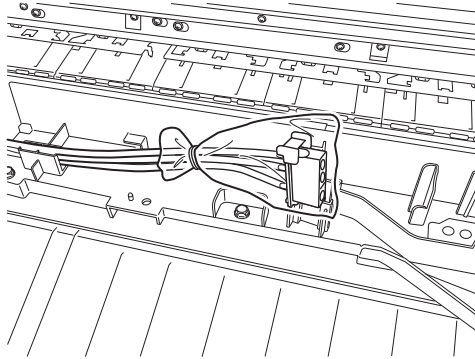

F-4-82

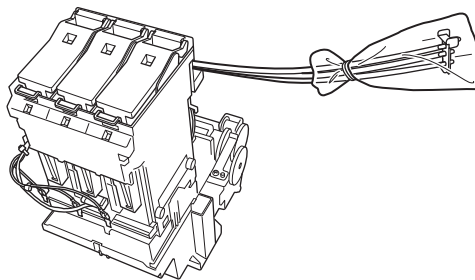

F-4-83

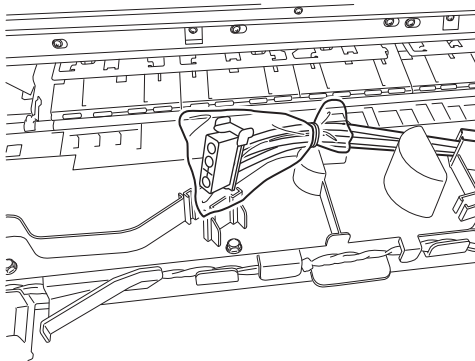

F-4-84



**Precautions about Reinstallation of Ink Tube Unit**

- Insert the ink tube and joint deeply into the guide.
- When installing the ink tube unit, align marking [1] on the ink tube unit to the right end of guide [2] and the left end of tape [3] to within 4mm from the left end of tube guide [4].

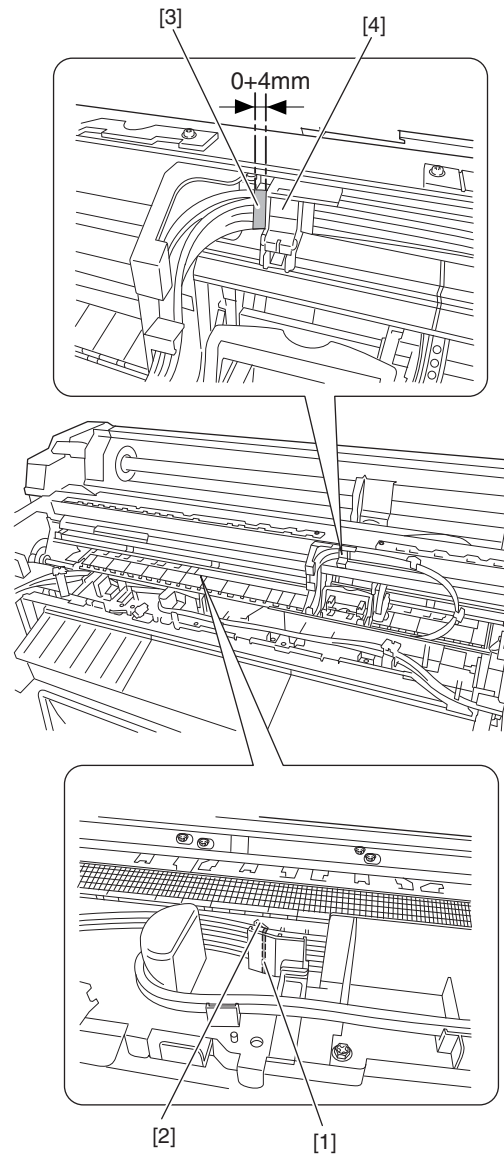

F-4-85



After detaching the joint of the ink tube unit, the joint might become easy to come off by the ink that has adhered to it. In that case, please wash the joint by alcohol and remove the adhering ink.

### 4.3.11 Waste Ink Collection Unit

When disassembling the waste ink collection unit, pay attention to the ink leaking from the disassembled parts. Put the parts of the disassembled waste ink collection unit in a plastic bag or the like with care given to the ink leaking from the portion [A] enclosed in a circle. The service parts packing box may include a plastic bag for packing replacement parts. Use it for putting consumable parts of the waste ink collection unit.

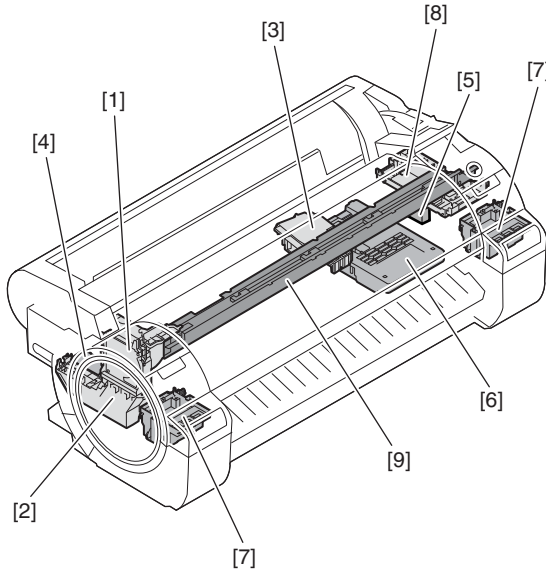

F-4-86

No	Name	Q'ty	Part number	Consumables	Service Mode (PARTS xx)
[1]	Mist Fan	1	QM4-2798	Yes	Mi-1
[2]	Mist Exhaust Duct	1	QM4-2797	Yes	Mi-1
[3]	Platen Suction Fan	1	QM4-2817		
[4]	Platen Exhaust Duct	1	QM4-2753	Yes	WF-2
[5]	Head Management Sensor	1	QM4-2767	Yes	HMa-1
[6]	Maintenance Cartridge	1	-		
[7]	Ink Tank Unit Waste Ink Tray	1	QM4-2873/ QM4-2876		
[8]	Purge Unit Waste Ink Tray	1	-		
[9]	Front Duct	1	-		

[1] Mist Fan

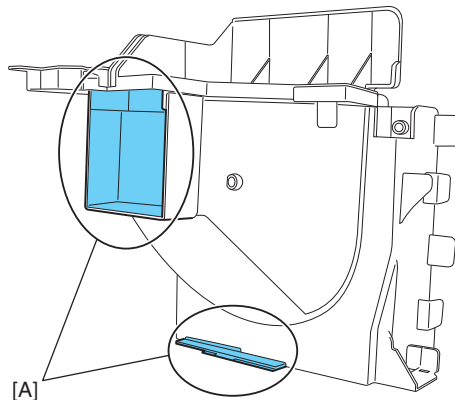

F-4-87

[2] Mist Exhaust Duct

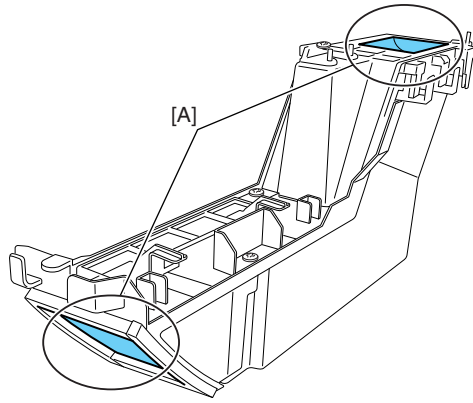

F-4-88

[3] Platen Suction Fan

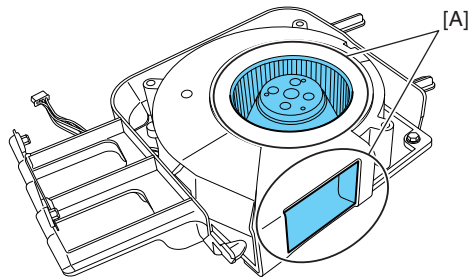

F-4-89

[4] Platen Exhaust Duct

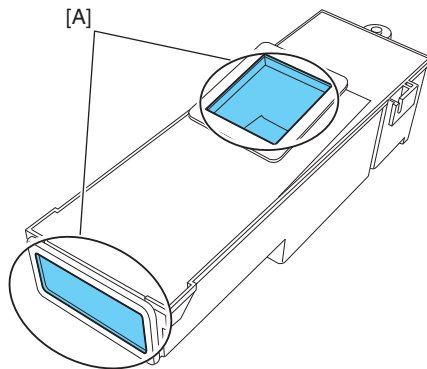

F-4-90

[5] Head Management Sensor

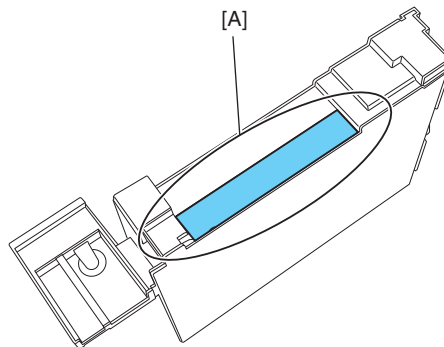

F-4-91

**a) Mist Fan**

Removing the Mist Fan

1) Remove the rear upper cover and front cover and left ink tank cover.

2) Remove two screws [1] and disconnect the connector [2], and then remove the cable from the cable guide to remove the support plate [3].

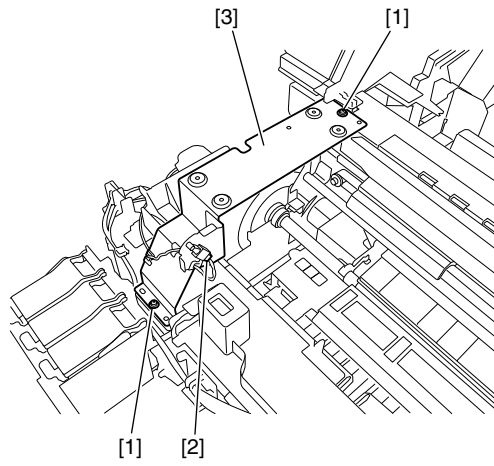

F-4-92

3) Remove four screws [1] and disconnect three connectors [2], and then remove the cable from the cable guide to remove the mist fan [3].

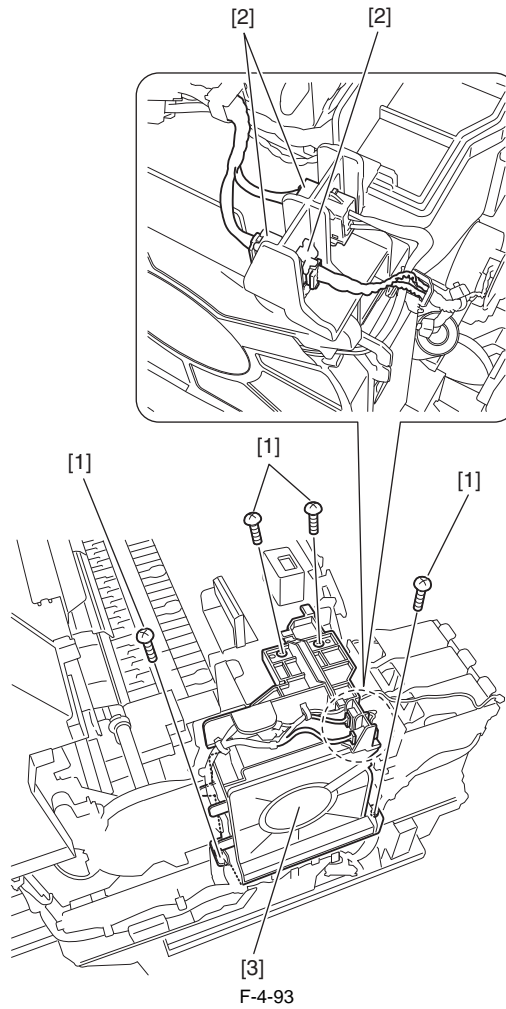

F-4-93

**b) Mist Exhaust Duct**

Removing the Mist Exhaust Duct

1) Remove the mist fan.

2) Remove one screw [1], and then remove the cable from the cable guide to remove the mist exhaust duct [2].

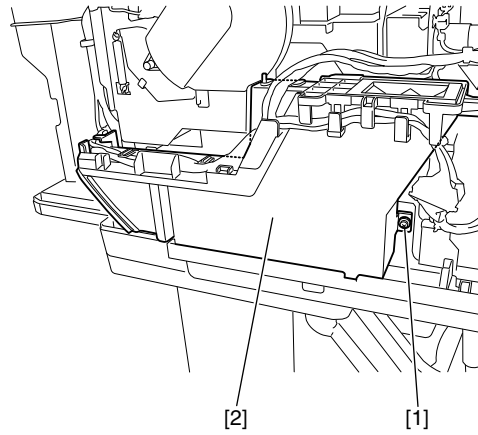

F-4-94

**MEMO:**

The mist fan [1] and mist exhaust duct [2] can be removed together.

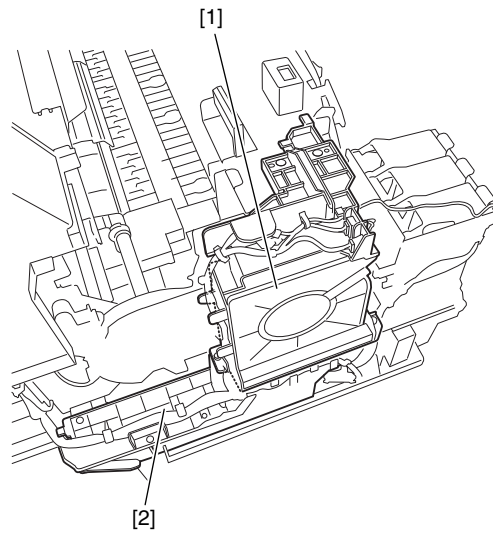

F-4-95

**Precautions about Reinstallation of Mist Exhaust Duct**

Make sure that the protrusion [1] on the mist exhaust duct fits in the notch [2] on the side plate.

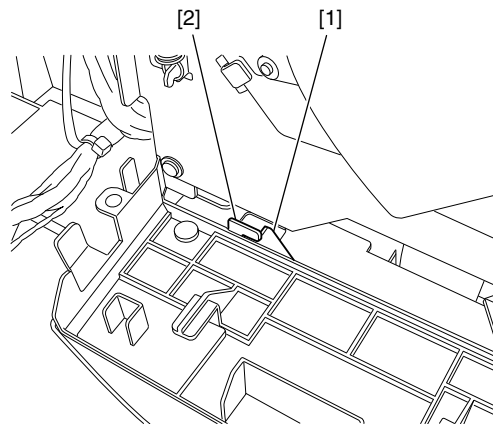

F-4-96

**c) Platen Suction Fan**

Removing the Platen Suction Fan

- 1) Remove the output guide (right)/(middle).
- 2) Remove one screw [1] and disconnect one connector [2] to remove the platen suction fan [3].

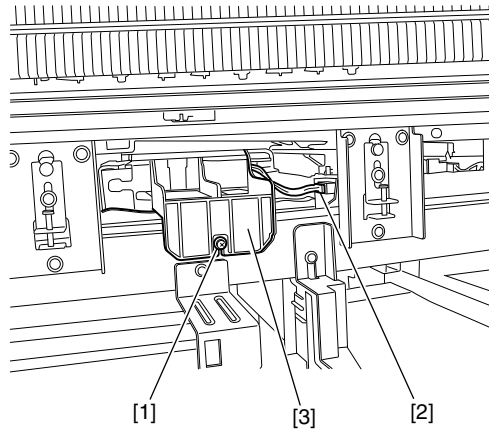

F-4-97

- 3) After drawing out the platen suction fan [1], turn it up side down immediately so that ink does not drip off.

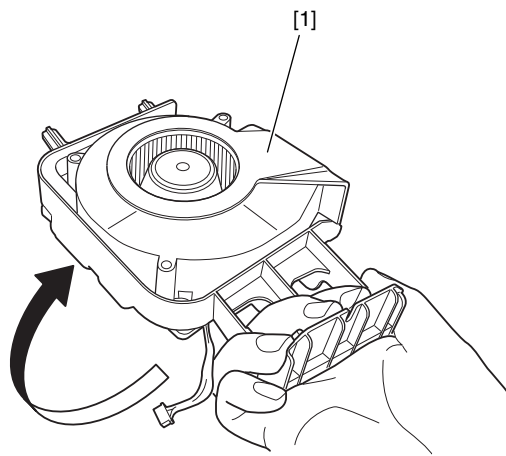

F-4-98

**d) Platen Exhaust Duct**

Removing the Platen Exhaust Duct

- 1) Remove the mist exhaust duct and left ink tank unit.
- 2) Remove one screw [1], and then the platen exhaust duct [2].

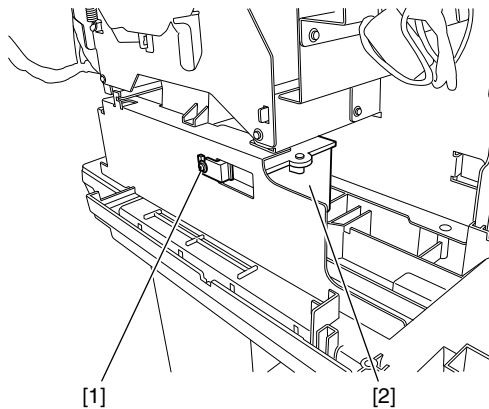

F-4-99

### 4.3.12 Multi Sensor

#### a) Removing the Multi Sensor

- 1) Unlock the carriage unit, and then move the carriage onto the platen. Refer to "Disassembly/Reassembly > Points to Note on Disassembly and Reassembly > Opening the Cap/Moving the Wiper Unit".
- 2) Remove the printhead to protect it.
- 3) Remove one screw [1] and disconnect one connector [2], and then the multi sensor [3].

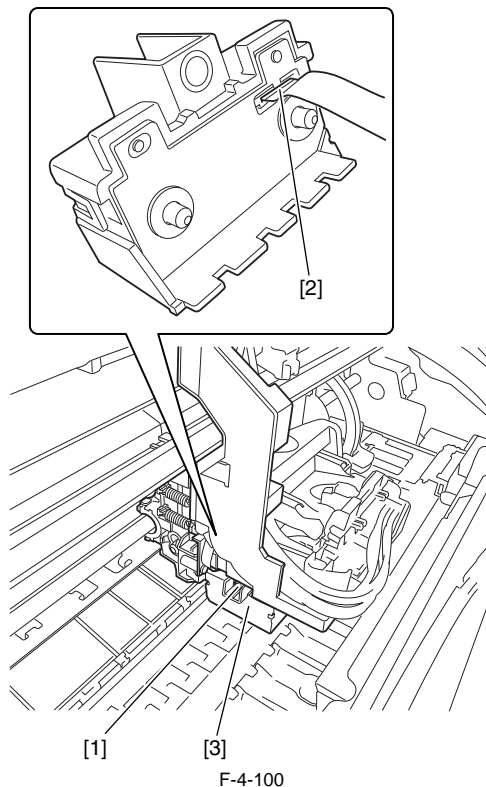

#### b) Removing the Multi Sensor Reference Plate

- 1) Remove one screw [1], and then remove the multi sensor reference plate [2].

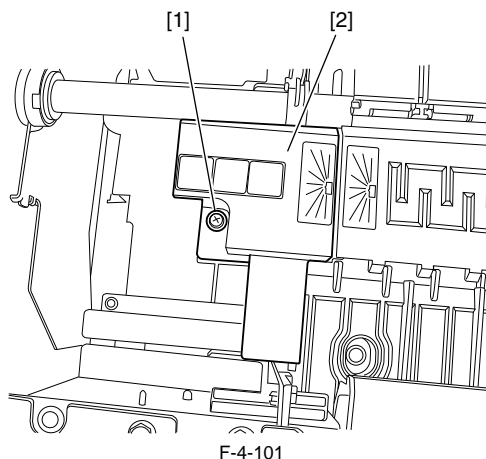

Do not touch the white sheets of the multi sensor reference plate.

#### c) Action following the replacement of the carriage unit/multi sensor

Because the distance between the multi sensor (in the carriage unit) and the nozzles (in the printhead) is varied from one unit to another, the printer as shipped has its optical axis corrected to adjust the image write position. When the carriage unit or multi sensor has been replaced or disassembled and reassembled, they require adjustment.

Execute service mode under the following conditions:

\* The multi sensor reference plate(QL2-6891: MOUNT, MULTI SENSOR REFERENCE) must be replaced at the same time whenever the carriage or the multi sensor is being replaced.

- 1) Carry out the following service mode without media loading.
  - Service mode : SERVICE MODE > ADJUST > GAP CALIB.
- 2) Load the following media.
  - Media type : Photo glossy paper
  - Media size : Media having a width equal to or larger than that of A2-size paper
- 3) Carry out the following service mode.
  - Service mode : SERVICE MODE > ADJUST > PRINT PATTERN > OPTICAL AXIS

### 4.3.13 Linear Encoder

#### a) Linear Encoder

Removing the Linear Encoder Sensor

- 1) Remove the carriage unit.
- 2) Remove two screws [1], and then remove the linear encoder sensor cover [2].

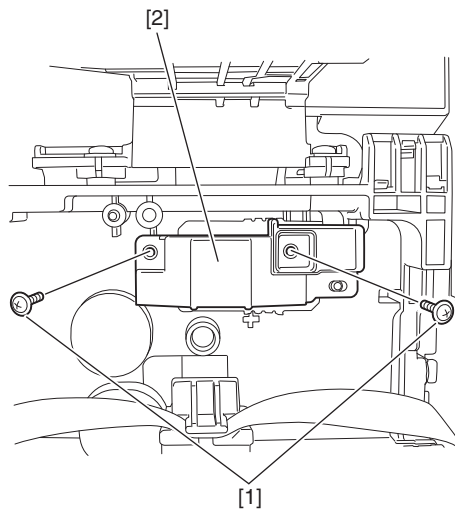

F-4-102

- 3) Remove two screws [1] and disconnect one connector [2], and then remove the linear encoder sensor [3].

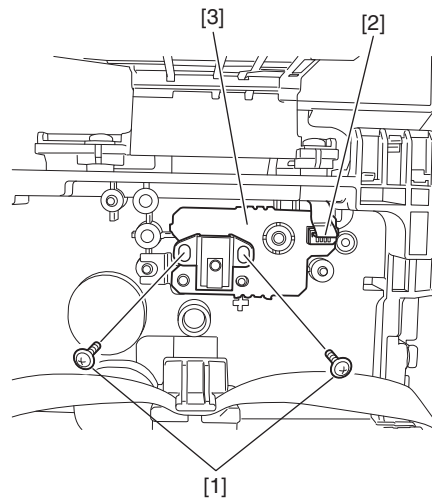

F-4-103

#### Removing the Linear Scale

- 1) Unlock the carriage unit, and then move the carriage unit [1] on the platen. Refer to "Disassembly/Reassembly > Points to Note on Disassembly and Reassembly > Opening the Cap/Moving the Wiper Unit".

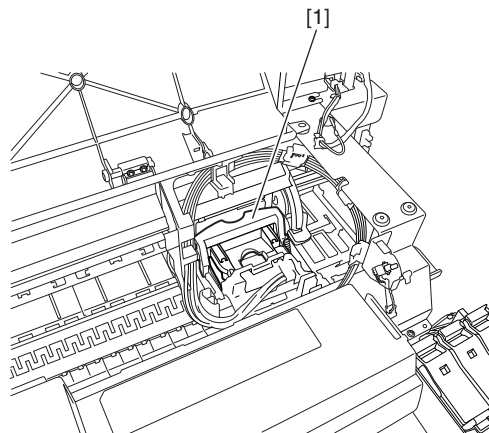

F-4-104

**MEMO:**  
When removing or installing the linear scale, move the carriage unit to the HP side on top of the platen to prevent the linear scale from touching the linear encoder sensor.



- 2) Remove the left/right cover and left/right ink tank cover.
- 3) Remove one screw [1], and then remove the carriage upper cover [2].

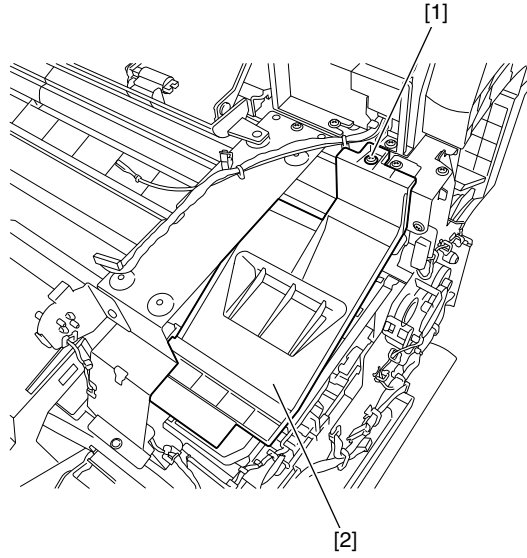

F-4-105

- 4) Remove the spring [1], release the notch from the protrusion [2] on the side plate, and then remove the linear scale [3] from the left side.

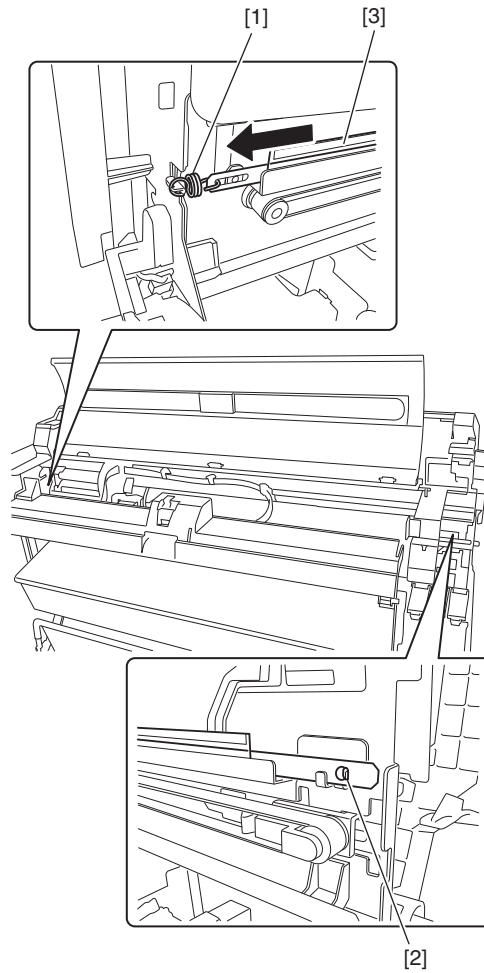

F-4-106

Precaution about Reinstallation of Linear Encoder Sensor/Linear Scale

- When removing or installing the linear scale, move the carriage unit to the HP side on top of the platen to prevent the linear scale from touching the linear encoder sensor.
- Reinstall the linear scale in such a manner that the "R" mark on the linear scale is on the right side of the printer and the "L" mark is on the left side of the printer when viewed from the front of the printer.

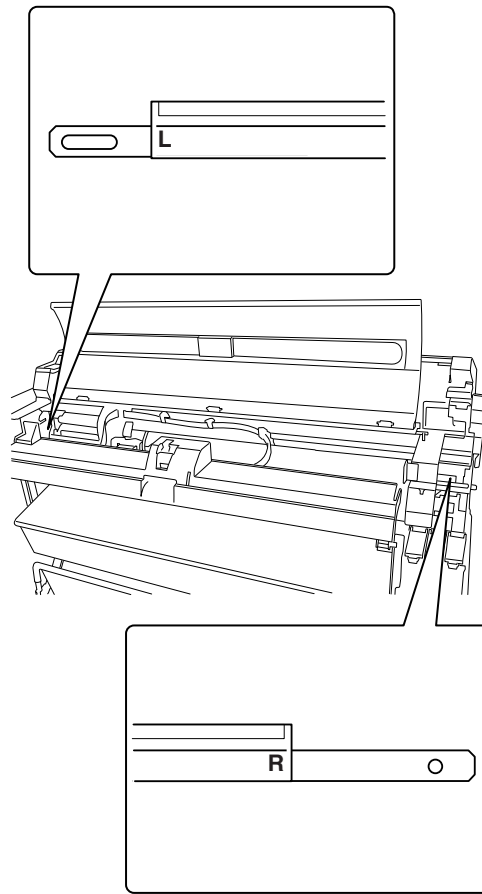

F-4-107

- Reinstall the linear scale in such a manner that it passes through the notch in the guide [1] and the notch [2] on the side plate.

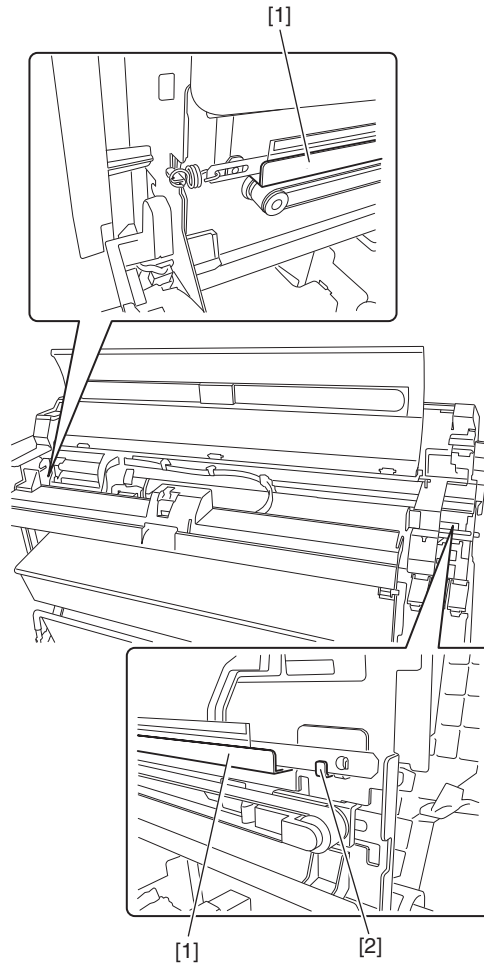

F-4-108

- Never touch the detection part [1] of the linear scale.

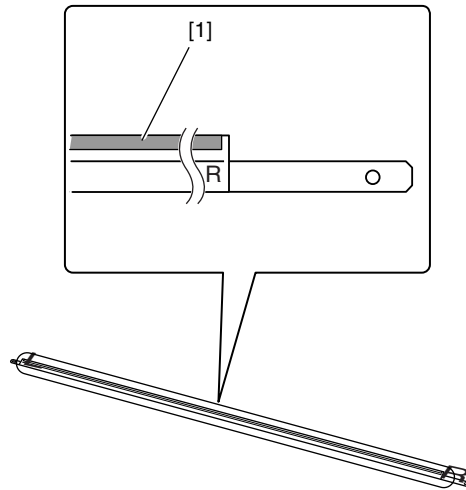

F-4-109

- Make sure that the linear scale [1] is in the detection zone of the linear encoder sensor [2].

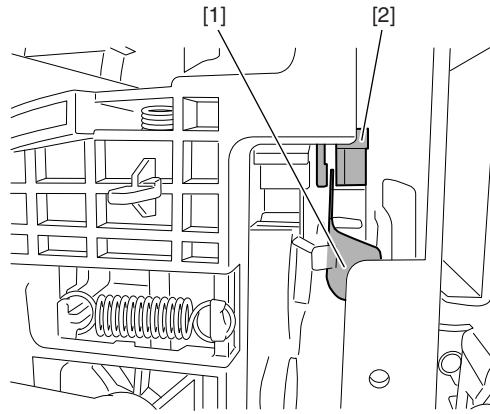

F-4-110

**b) Action to take after removing or replacing the linear encoder sensor**

After the carriage and carriage motor and carriage belt and linear encoder sensor has been removed or replaced, execute the following service mode.  
Service mode: SERVICE MODE > ADJUST > CR MOTOR COG

### 4.3.14 Head Management Sensor

#### a) Head Management Sensor

Removing the Head Management Sensor

- 1) Remove the purge unit.
- 2) Remove one screw [1] and one disconnect connector [2], release one protrusion [3], and then remove the head management sensor [4].

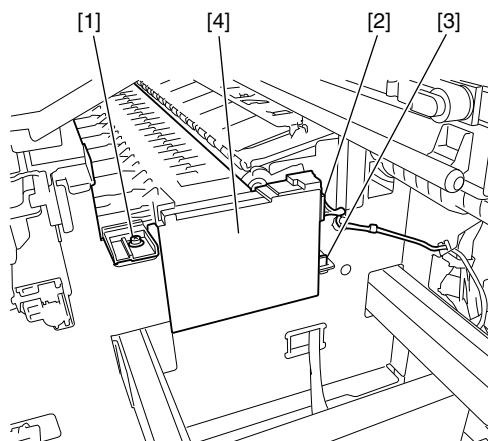

F-4-111

#### b) Procedure after replacing the head management sensor

Since the distance between the head management sensor and the carriage unit varies among printers, the optical axis is factory-adjusted to adjust the non-discharging detection position. When you have replaced the head management sensor or performed assembly/reassembly of surrounding parts that can change the distance between the head management sensor and the carriage unit, readjustment is required. Perform the readjustment in the service mode.

Service mode : SERVICE MODE > ADJUST > NOZZLE CHK POS.

### 4.3.15 PCBs

Do not replace the main controller PCB and the maintenance cartridge relay PCB (ROM board) at the same time.

Both PCBs hold vital information, such as settings and a carriage drive time. Before either PCB is replaced, such information is temporarily saved through internal communication with the other PCB and is automatically written to the new PCB when it is installed. For this reason, the two PCBs cannot be replaced at the same time. To replace both PCBs, work in order of (a) > (b).

When the main controller PCB and maintenance cartridge relay PCB have been replaced with service parts, check that the latest version of firmware is installed in them.

If not, upgrade the firmware to the latest version.

---

#### Reference:

For instruction on how to update the main controller, refer to "TROUBLESHOOTING" > "Version Up".

---

#### a) Replacing the maintenance cartridge relay PCB (ROM board)

- 1) Turn off the power and disconnect the power plug.
- 2) Replace the maintenance cartridge relay PCB.
- 3) Reconnect the power plug and turn on the power while pressing the [Load] and [Navigate] keys. (Start the printer in PCB replacement mode.)
- 4) Release the key, but not before making sure that "Initializing" appears on the display. (The message lamp lights when printer enters PCB replacement mode.)
- 5) Wait until "REPLACE MODE" appears on the display.
- 6) Select MC BOARD and press the [OK] key.
- 7) Turn off the power, but not before making sure that "Power off" appears on the display.
- 8) Turn on the power.
- 9) Check the firmware version. If the firmware is not the latest version, upgrade the firmware to the latest version.

#### b) Replacing the main controller PCB

- 1) Turn off the power and disconnect the power plug.
- 2) Replace the main controller PCB.
- 3) Reconnect the power plug and turn on the power while pressing the [Load] and [Navigate] keys. (Start the printer in PCB replacement mode.)
- 4) Release the key, but not before making sure that "Initializing" appears on the display. (The message lamp lights when printer enters PCB replacement mode.)
- 5) Wait until "REPLACE MODE" appears on the display.
- 6) Select CPU BOARD and press the [OK] key.
- 7) Turn off the power, but not before making sure that "Power off" appears on the display.
- 8) Turn on the power.
- 9) Check the firmware version. If the firmware is not the latest version, upgrade the firmware to the latest version.

### 4.3.16 Opening the Cap/Moving the Wiper Unit

#### a) Opening the Cap/Releasing the Carriage Lock Pin by service mode

After entering the service mode, execute the following mode.

Service mode: SERVICE MODE > FUNCTION > CR UNLOCK

#### b) Opening the Cap/Releasing the Carriage Lock Pin/Moving the Wiper Unit manually

1) Insert a flat head screwdriver in the slit on the left cover [1].

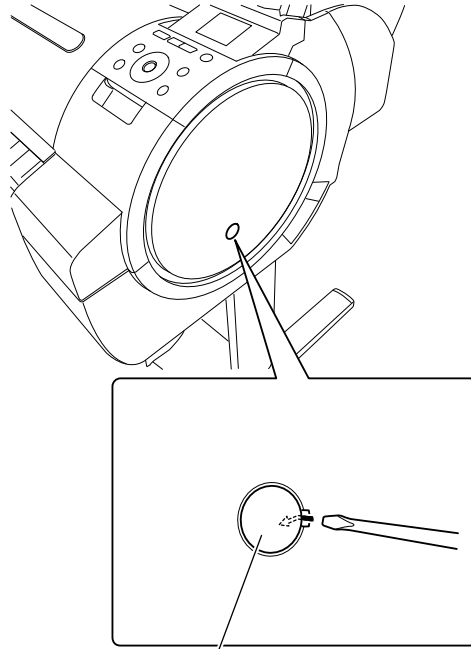

[1]

F-4-112

2) Insert a Phillips screw driver in the "+" groove on the purge unit and turn it counterclockwise. The cap and carriage lock pin lower, allowing the carriage to move. Also, the wiper unit can move.

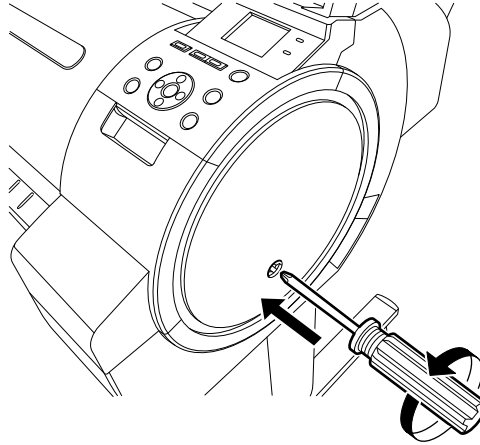

F-4-113

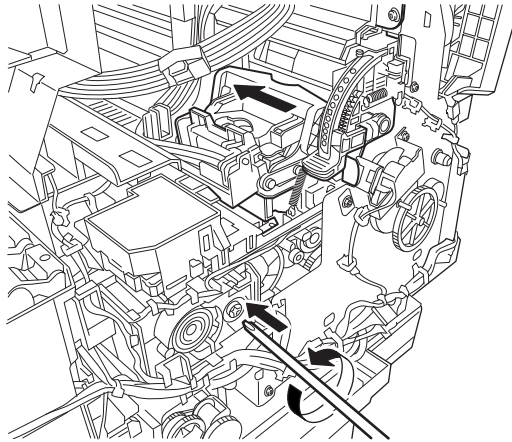

F-4-114

**MEMO:** Turning the screwdriver continuously repeats the vertical movement of the cap and carriage lock pin and the to-and-fro movement of the wiper unit. Visually check that the cap has been opened and the carriage lock pin has been released.

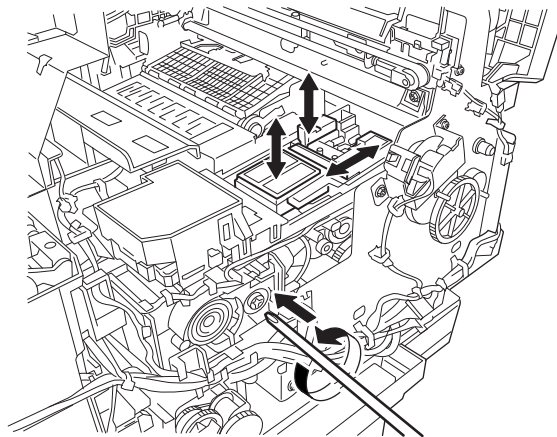

F-4-115



### 4.3.17 Opening/Closing the Ink Supply Valve/Subtank Air Passage Valve

#### a) Opening/Closing the Ink Supply Valve/Subtank Air Passage Valve

- 1) Remove the ink tank cover.
- 2) Open the ink supply valve and the subtank air passage valve with moving the lever [1] in the arrow direction.

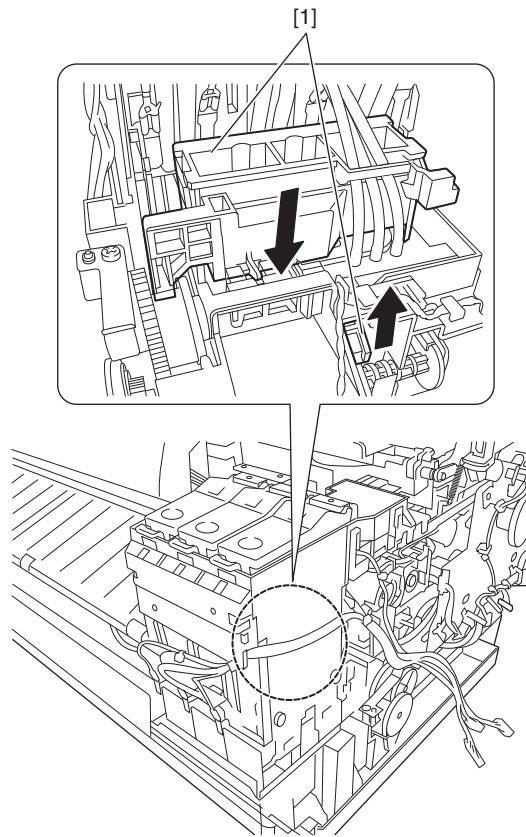

F-4-116



- If the printhead fixer lever is released with the ink supply valve and subtank air passage valve to an ink tube open while the tube is filled with an ink, the ink in the tube could flow backward to the ink tank unit, leaking through the hollow needle in the ink tank.
- If the valve remains open, as on occurrence of the valve open/close error, remove the valve motor unit and (see Disassembly/Reassembly > Points to Note on Disassembly/Reassembly > Ink Tank Unit) and close the ink supply valve.

### 4.3.18 Draining the ink

There are two ways to drain the ink passage of inks: automatic and manual.

---



Be sure to drain the ink from the ink passage to prevent ink leakage before disassembling any component of the ink passage or reshipping the printer.

---

#### 1. Automatic Ink Drain

Execute Automatic Ink Drain by selecting "Set./Adj. Menu" > "Prep.MovePrinter" from the main menu.

---



Execute Automatic Ink Drain once again if the printer shuts down due to a power failure or any other trouble before the operation completes.

---

#### 2. Manual Ink Drain

Drain the ink passage of inks manually if any electrical component in the printer fails or firmware malfunctions or if the printer fails to be powered on.

- 1) Remove left/right cover, left/right ink tank cover. See "Disassembly/Reassembly > Points to Note on Disassembly/Reassembly > External Covers".
  - 2) Remove the ink tanks.
  - 3) Move the carriage to above the platen. See "Disassembly/Reassembly > Points to Note on Disassembly/Reassembly > Opening the caps and moving the wiper unit".
  - 4) Release the printhead fixer lever.
  - 5) Open the ink supply valve/subtank air passage valve to allow the inks to flow into the ink tank unit waste ink tray.
- 

#### MEMO:

When supplying the ink to the printer after the manual ink drainage, return the printer to the normal condition, and then turn ON the power supply without the printhead installed. And according to the message, execute the installation of the printhead.

---

## 4.4 Applying the Grease

### 4.4.1 Applying the Grease

Some parts require application of grease when replaced. Apply the grease(special tool) listed below. Smear the grease lightly and evenly with a flat brush or the like.

For the printer disassembly/reassembly method, refer to "DISASSEMBLY/REASSEMBLY" and "parts catalog".



Do not apply the grease to locations in which not designated grease may cause poor print quality. Take particular care that grease do not get onto the wiper, cap, carriage shaft and the linear scale.

No.	Location	Grease	Quantity	Remarks
1	Joint Base Rib	FLOIL G-5000H	Approx. 8-20mg	
2	Shaft Cleaner	EU-1	Soaks enough.	
3	Upper Cover Hinge Catch	FLOIL G-5000H	Approx. 8-20mg	
	Roll Cover Slide Guide	FLOIL G-5000H	Approx. 8-20mg	
4	Contact between Pinch Roller Release Shaft and Pinch Roller	FLOIL G-5000H	Approx. 8-20mg	
	Pinch Roller Pressure Release Gear	FLOIL G-5000H	Approx. 8-20mg	
	Protrusion of Release Lever	FLOIL G-5000H	Approx. 8-20mg	Be careful not to apply the grease to the edge face of protrusions.
	Bushing of Feed Roller	FLOIL G-5000H	Approx. 8-20mg	

#### 1. Joint Base Rib [1]

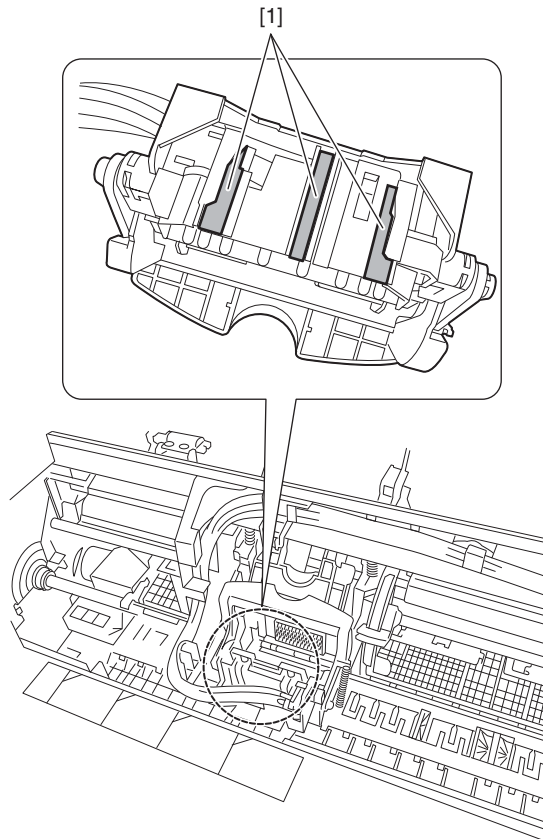

F-4-117

2. Shaft Cleaner [1]

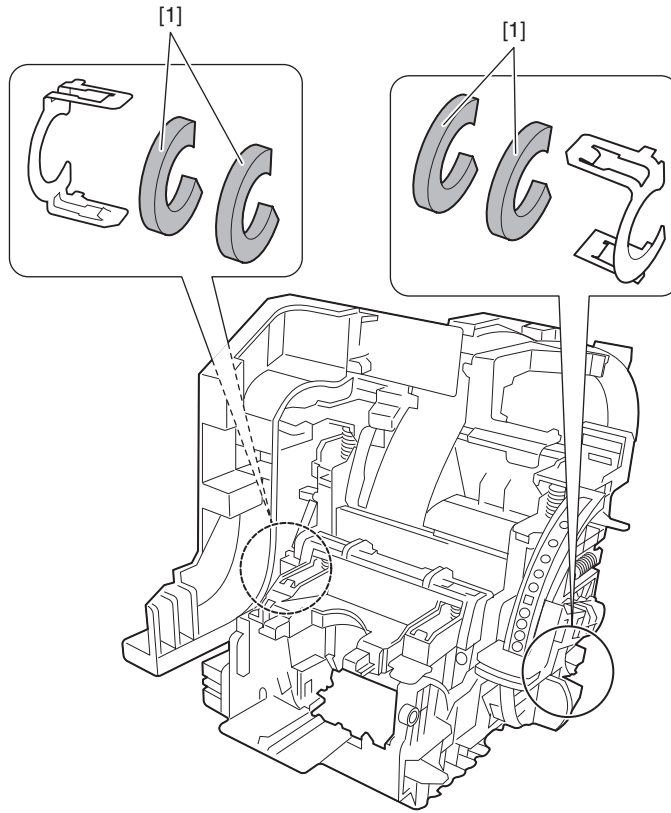

F-4-118

3. Upper Cover Hinge Catch [1] / Roll Cover Slide Guide [2]

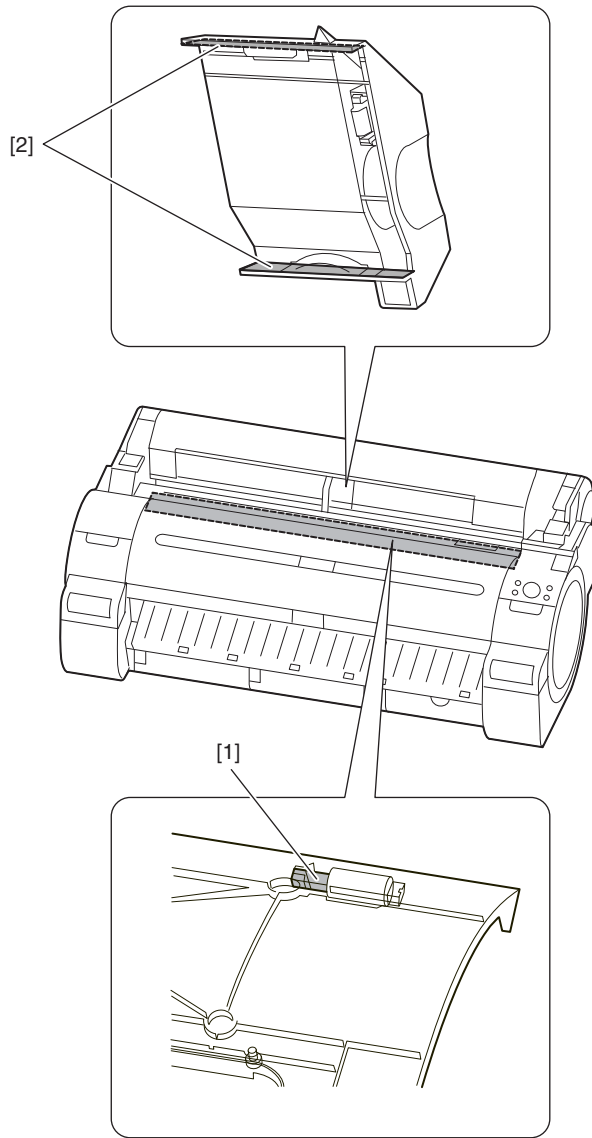

F-4-119

4. Contact between Pinch Roller Release Shaft and Pinch Roller [1] / Pinch Roller Pressure Release Gear [2] / Protrusion of Release lever [3] / Bushing of Feed Roller [4]

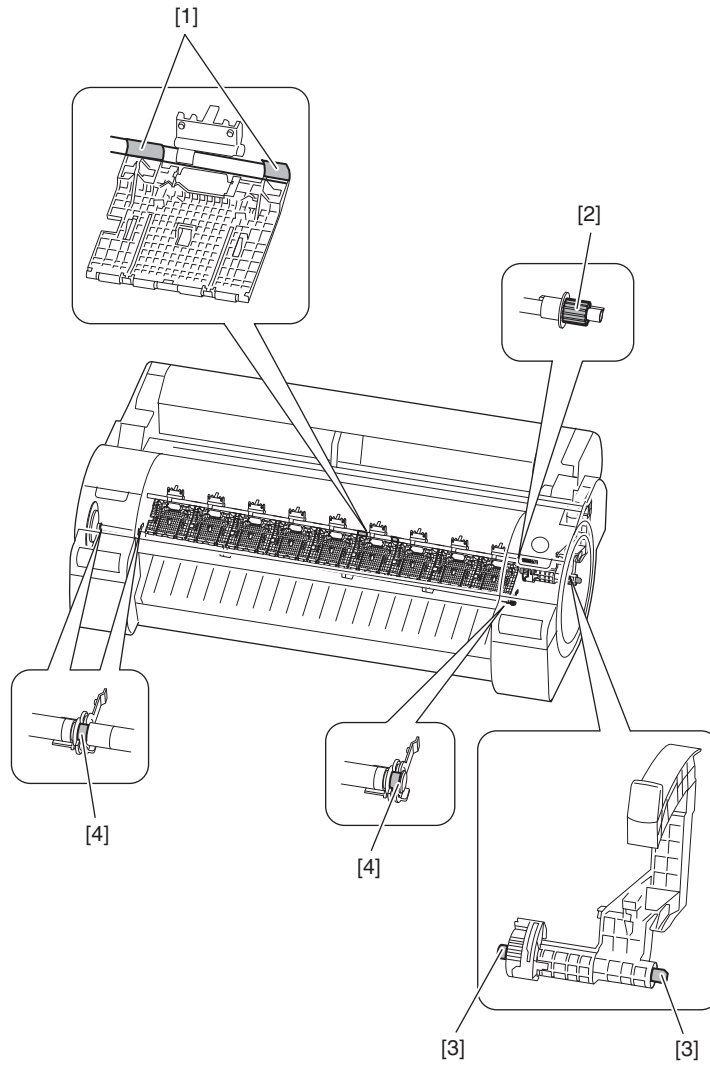

F-4-120

## 4.5 Adjustment and Setup Items

### 4.5.1 Adjustment Item List

The following adjustment procedures need to be performed when parts have been replaced or removed and then reinstalled:

Adjustment item	Adjustment timing
Multi sensor recalibration	Multi sensor replacement/removal
	Carriage unit replacement/removal
Adjusting feed roller eccentricity	Feed roller
	Feed roller encoder
Head management sensor recalibration	Head management sensor replacement/removal
	Carriage unit replacement/removal
Carriage motor recalibration	Carriage unit replacement/removal
	Carriage motor replacement/removal
	Carriage belt replacement/removal

### 4.5.2 Procedure after Replacing the Carriage Unit or Multi Sensor

#### a) Note on replacing the carriage unit and the multi sensor

- The multi sensor reference plate(QL2-6891: MOUNT, MULTI SENSOR REFERENCE) must be replaced at the same time whenever the carriage or the multi sensor is being replaced.

#### b) Multi Sensor Recalibration

Because the distance between the multi sensor (in the carriage unit) and the nozzles (in each printhead) is varied from one unit to another, the printer has its optical axis corrected and paper gap adjustment sensor gain and calibration adjusted prior to shipment. When the carriage unit or multi sensor has been replaced, they should require adjustment.

Execute service mode under the following conditions to launch automatic adjustment:

- 1) Carry out the following service mode without media loading.
  - Service mode : SERVICE MODE > ADJUST > GAP CALIB.
- 2) Load the following media.
  - Media type : Photo glossy paper
  - Media size : Media having a width equal too larger than that of A2-size paper
- 3) Carry out the following service mode.
  - Service mode : SERVICE MODE > ADJUST > PRINT PATTERN > OPTICAL AXIS

#### c) Carriage Motor Adjustment

- After the carriage and carriage motor and carriage belt and linear encoder sensor has been removed or replaced, execute the following service mode.  
Service mode: SERVICE MODE > ADJUST > CR MOTOR COG

### 4.5.3 Procedure after Replacing the Feed Roller or Feed Roller Encoder

Feed roller eccentricity is factory-adjusted (correction of variation in the paper feed amount per rotation). It is necessary to adjust feed roller eccentricity after replacing the feed roller or feed roller encoder.

In the service mode, perform automatic adjustment of feed roller eccentricity.

Service mode : SERVICE MODE > ADJUST > PRINT PATTERN > LF TUNING  
- Media type: Photo glossy paper  
- Media size (width): 24 inches

If adjustment cannot be done properly by selecting "SERVICE MODE > ADJUST > PRINT PATTERN > LF TUNING" (auto adjustment), carry out manual adjustment.

Service mode : SERVICE MODE > ADJUST > PRINT PATTERN > LF TUNING2  
- Media type: Photo glossy paper  
- Media size (width): 24 inches  
Check the printed pattern and enter values for adjustment.

### 4.5.4 Procedure after Replacing the Head Management Sensor

Since the distance between the head management sensor and the carriage unit varies among printers, the optical axis is factory-adjusted to adjust the non-discharging detection position. When you have replaced the head management sensor or performed assembly/reassembly of surrounding parts that can change the distance between the head management sensor and the carriage unit, readjustment is required. Perform the readjustment in the service mode.

Service mode : SERVICE MODE > ADJUST > NOZZLE CHK POS.





---

## Chapter 5 MAINTENANCE

---



# Contents

5.1 Periodic Replacement Parts .....	5-1
5.1.1 Periodic Replacement Parts .....	5-1
5.2 Consumable Parts .....	5-1
5.2.1 Consumable Parts .....	5-1
5.3 Periodic Maintenance .....	5-3
5.3.1 Periodic Maintenance .....	5-3



## 5.1 Periodic Replacement Parts

### 5.1.1 Periodic Replacement Parts

Level	Periodic Replacement Part
User	None
Service Personnel	None

## 5.2 Consumable Parts

### 5.2.1 Consumable Parts

Counter name *1	Name	Parts number	Qty	Life sheets/A0 *2	Warning level thresholds			Panel message *3		Count contents	Reference page of "Points to Note on Disassembly and Reassembly"
					Level1	Level2	Unit	Level1	Level2		
CR1	CARRIAGE UNIT	QM4-2880	1	28000	11228571	12476190	(X210) mm	W: Level1	W: Level2	Carriage scan distances	"Carriage Unit" > "Removing the Carriage Unit"
CR2	FLEXIBLE CABLE UNIT	QM3-4614	1	54000	6030000	6700000	times	W: Level1	W: Level2	Carriage scan times	
CR3	CARRIAGE UNIT	QM4-2880	1	28000	14850000	16500000	(X1,000,000) dots	W: Level1	W: Level2	Total ink discharge quantity	"Linear Encoder" >
	SCALE, LINEAR	QC4-9427	1								"Removing the Linear Encoder"
CR4	CARRIAGE UNIT	QM4-2880	1	28000	54000	60000	times	W: Level1	W: Level2	Number of carriage height changing cam rotation	Carriage Unit > "Removing the Carriage Unit"
CR5	MULTI SENSOR UNIT	QM4-3668	1	30000	14850000	16500000	(X1,000,000) dots	W: Level1	W: Level2	Total ink discharge quantity	"Multi Sensor" > "Removing the Multi Sensor"
SP1	INK TUBE UNIT	QM4-2865	1	35000	3960000	4400000	times	W: Level1	E144-4047	Carriage scan times	"Ink Tube Unit" > "Removing the Ink Tube Unit"
PG1	PURGE UNIT	QM4-3670	1	50000	45000	50000	times	W: Level1	E141-4046	Number of suction pump rotation	"Purge Unit" > "Removing the Purge Unit"
	JOINT, TUBE, COLOR	QC4-8861	1								"Purge Unit" > "Removing the Waste Ink Tube Joint (CL)"
Hma1	HEAD MANAGEMENT SENSOR UNIT	QM4-2767	1	100000	30.35	31.29	ml	W: Level1	E194-404A	Ink discharge quantity to head management sensor	"Head Management Sensor" > "Removing the Head Management Sensor"
MT1	MOTOR, DC	QK1-5068	1	480000	13500	15000	hours	- *4	- *4	Carriage scan hours	"Drive Unit" > "Removing the Carriage Motor"
PL1	MOTOR, DC	QK1-0447	1	45000	700.20	778	hours	- *4	- *4	Media feed hours	"Drive Unit" > "Removing the Feed Motor"
Mi1	FAN UNIT	QM4-2798	1	31000	34.97	38.85	ml	W: Level1	E146-4001	Mist collection quantity	"Waste Ink Collection Unit" > "Removing the Mist Fan"
	MIST FAN DUCT UNIT	QM4-2797	1								"Waste Ink Collection Unit" > "Removing the Mist Exhaust Duct"
CT1	CUTTER	QM4-2881	1	100000	90000	100000	times	W: Level1	W: Level2	Cut times (cut operation to the forward direction)	"Cutter" > "Removing the Cutter"
WF1	M/C HOLDER UNIT	QM4-2785	1	- (when the error occurring)	254.21	282.45	ml	W: Level1	E146-4001	Waste ink quantity by suction operation that has been executed during detachment of the maintenance cartridge	"Purge Unit" > "Removing the Waste Ink Tube Joint (CL)"
WF2	WASTE INK BOX UNIT	QM4-2753	1	77000	42.53	47.25	ml	W: Level1	E146-4001	Mist collection quantity by platen fan	"Waste Ink Collection Unit" > "Removing the Platen Exhaust Duct"

\*1: The counter name is the name of "SERVICE MODE > COUNTER > PARTS CNT. > COUNTER XX-X".

\*2: The exchange timing varies by the print mode and operating condition and others. (Print condition: coated paper/ print mode of photo and illustration/ each color 12.5% duty X 4(total 50% duty))

- \*3: When displaying the message of "W: Level1" or "W: Level2", the printer continues to operate. And when displaying the error code, the printer stops to operate.
- \*4: The operation panel do not display the message, but the condition is printed in the "PRINT INF".

**- Maintenance Kit**

Kit name	Parts number	Counter name	Name
MAINTENANCE KIT (CR/Mi)	QY6-1535	CR1/CR2/CR4/CR5	CARRIAGE UNIT
		CR3	SCALE, LINEAR
		Mi1	FAN UNIT

---



After supplies have been replaced, execute [INITIALIZE] > [PARTS COUNTER] > [PARTS xx] in service mode to initialize (clear) the parts counter information.

---

## 5.3 Periodic Maintenance

### 5.3.1 Periodic Maintenance

Level	Periodic maintenance
User	Cleaning of ink mist and other substances (about once each month)
Service personnel	None

#### a) Printer cleaning

To keep up with print quality and prevent troubles, clean the printer about once each month.

- 1) Turn off the printer power.
- 2) Remove the power cord and interface cable.
- 3) Wipe the external surfaces of the printer with a cloth moistened with water and then wrung tight and then dry them finally with a dry cloth.

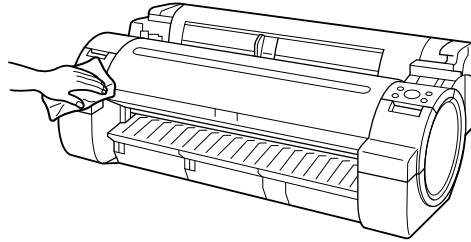

F-5-1



- Be sure to turn off the printer power and pull out the power cord from the outlet. If the power is accidentally turned on, contact with moving internal parts can result in injury.
- Do not use flammable solvents, such as thinner and benzene, on the printer. Solvents coming into contact with any electrical parts inside the printer could result in fires or electrical shock hazards.

- 4) Open the Upper Cover.

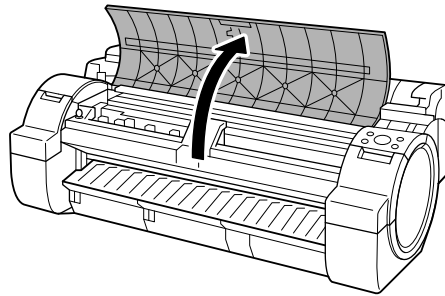

F-5-2

5) If paper dust has accumulated in the suction holes [1] on the Platen, the borderless printing ink grooves [2], use the included Cleaning Brush [3] to wipe it away.

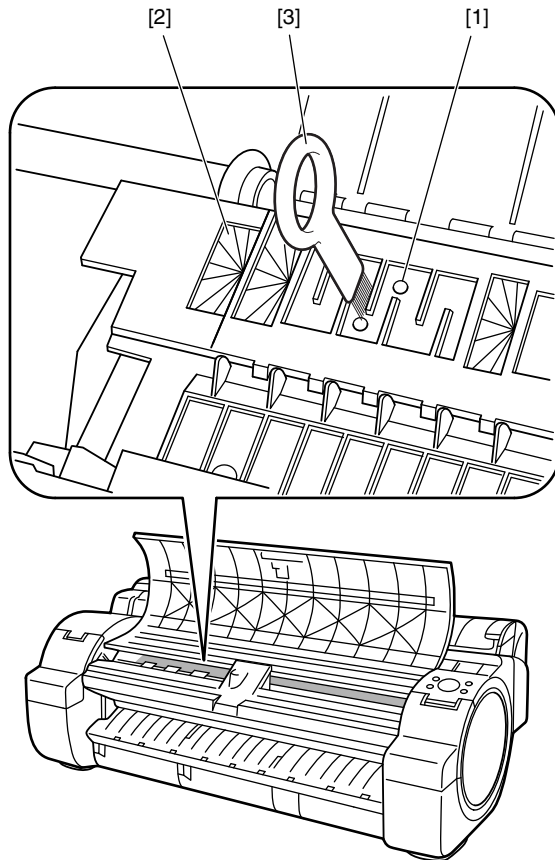

F-5-3

**MEMO:**  
If the Cleaning Brush is dirty, rinse it in water.

6) Using a damp cloth that you have wrung out completely, wipe inside the Upper Cover to clean it. Wipe away any ink residue on all over the Platen [1], the Pinch Roller Unit [2], the Borderless Printing Ink Grooves [3], the Output Guide [4], and so on.

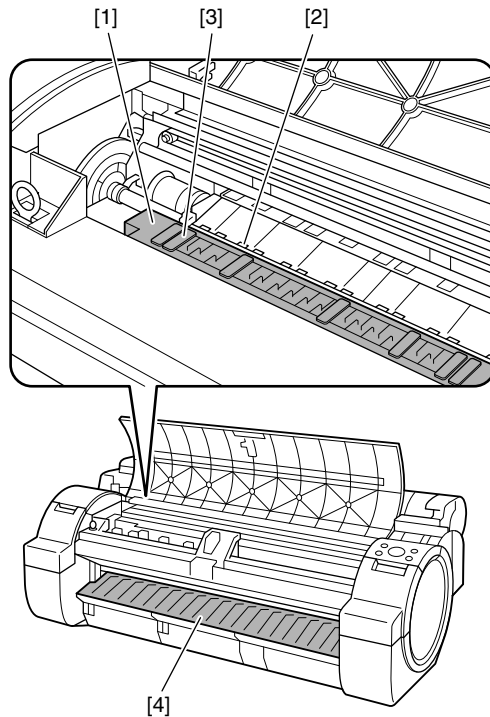

F-5-4





- Do not dry the interiors of the upper cover with a dry cloth. Electrostatic charges could make the internal components susceptible to dirt, resulting in degraded print quality.
- Do not use flammable solvents, such as thinner and benzene, on the printer. Solvents coming into contact with any electrical parts inside the printer could result in fires or electrical shock hazards.
- Do not touch linear scale [1] and carriage shaft [2].

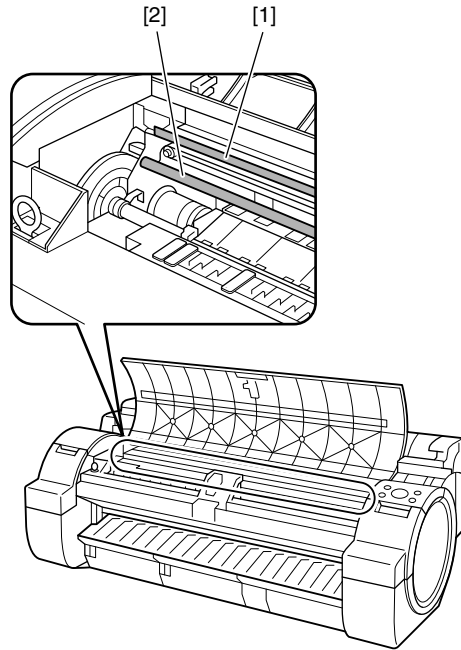

F-5-5

**MEMO:**

When cleaning between the Platen and Output Guide, use a damp cloth that you have wrung out completely to wipe over the ejection slot and along grooves.

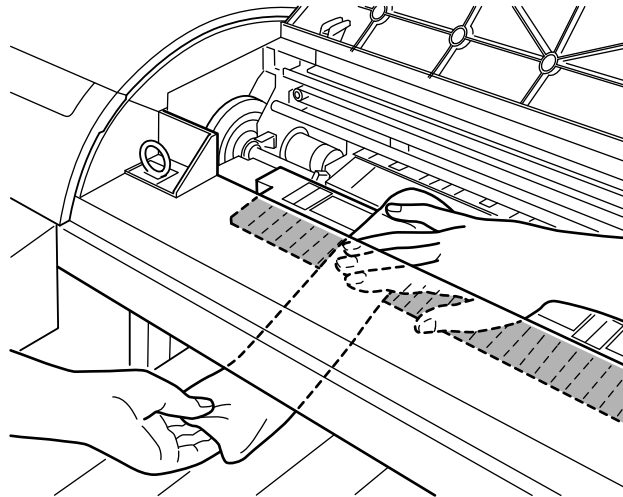

F-5-6

7) Close the upper cover.



---

## Chapter 6 TROUBLESHOOTING

---



---

# Contents

6.1 Troubleshooting .....	6-1
6.1.1 Outline .....	6-1
6.1.1.1 Outline of Troubleshooting .....	6-1
6.2 Error Code .....	6-2
6.2.1 Outline .....	6-2
6.2.1.1 Outline .....	6-2
6.2.2 Warning/Error/Service Call Error .....	6-3
6.2.2.1 Code Table .....	6-3
6.3 Service Software .....	6-35
6.3.1 L Printer Service Tool .....	6-35
6.4 Firmware Update Tool .....	6-40
6.4.1 imagePROGRAF Firmware Update Tool .....	6-40
6.5 Service Tools .....	6-42
6.5.1 Tool List .....	6-42



---

## 6.1 Troubleshooting

---

### 6.1.1 Outline

#### 6.1.1.1 Outline of Troubleshooting

##### 1. Outline

Troubles subject to troubleshooting are classified into those shown on the display (warning, error, and service call) and those not shown on the display.

The code of warning and error is shown by combining alphanumeric characters of eight digits and four digits.

The code of service call error is shown by the initial character of "E" and combining alphanumeric characters of three digits and four digits.

No code number is displayed when a warning occurs. Selecting [SERVICE MODE] > [DISPLAY] > [WARNING] in service mode allows you to check the warning log.

##### 2. Precautions for Troubleshooting

1) Check the environmental conditions and the media used for printing.

2) Before performing troubleshooting, make sure that all connectors and cables are connected properly.

3) When servicing the printer with the external cover removed and the AC power supplied, be extremely careful to avoid electric shock and shorting electrical devices.

4) In the following sections, the troubleshooting steps are described such that the component related to the most probable cause of the problem will be repaired or replaced first, being followed by components with less problem probability. If multiple components have the same problem probability, the steps are described beginning with the easiest one.

After performing each step, check to see if the problem has been resolved by making test prints. If the problem persists, proceed to the next step.

5) After completion of the troubleshooting, check that all connectors and cables have been reconnected and screws have been tightened firmly.

6) Whenever you have performed replacement or repair services, make test prints to check whether the problem has been resolved.

7) When connecting with the printer by using the LAN cable at the service working, be sure to enter the service mode to recognize the printer correctly.

## 6.2 Error Code

### 6.2.1 Outline

#### 6.2.1.1 Outline

The printer indicates errors using the display and LEDs.

If an error occurs during printing, the printer status is also displayed on the status monitor of the printer driver.

The following three types of errors are displayed on the display:

- Warning

Status where the print operation can be continued without remedying the cause of the problem. This can, however, adversely affect the printing results.

- Error

Status where the print operation is stopped, and the regular operation cannot be recovered until the cause of the problem is remedied.

- Service call error

When a service call error occurs, the error is not cleared and the error indication remains on the operation panel even if the printer is powered off and on again.

(Occurrence of the service call error is indicated again at power-on.)

This measure is taken to prevent user's recovery of the service call error and damages to the printer.

Service call errors can be cleared, however, by starting up the printer in the service mode.

The codes of warning and error and service call error are common in all models.

Note that some of the warnings, errors, and service call error described in the following tables may not appear in this printer.

In addition, the message that appears on the screen may not be the same as what is described in the table.

The first 4 digits of Warning and Error code show the following description.

The first 2 digits of code	Description
01xxxxx-xxx	Warning
03xxxxx-xxx	Error

The next 2 digits of code	Description
xx01xxxx-xxxx	Jam-related
xx03xxxx-xxxx	Cover-related
xx06xxxx-xxxx	Media-related
xx13xxxx-xxxx	Controller-related
xx1Axxxx-xxxx	HDD-related
xx32xxxx-xxxx	Media-related
xx34xxxx-xxxx	PDL-related
xx80xxxx-xxxx	Printhead-related
xx81xxxx-xxxx	Inktank-related
xx83xxxx-xxxx	Inktank-related
xx84xxxx-xxxx	Maintenance cartridge-related
xx86xxxx-xxxx	Print-related
xx87xxxx-xxxx	Cutter-related
xx89xxxx-xxxx	Media take-up unit-related
xx8Bxxxx-xxxx	Stacker-related
xx90xxxx-xxxx	Version up-related



## 6.2.2 Warning/Error/Service Call Error

## 6.2.2.1 Code Table

Code (last 4 digits)	Panel display (Large LCD)	Panel display (Small LCD)	Explanation/Detection sequence	Remedial Action
-	Sheet printing is selected, but a roll is loaded.		Paper mismatch (cut sheet) Print data having a cut sheet print specification has been received with media take-up unit use being selected.	Printing on cut sheet is not functional with a media take-up unit in use.
-	Media Type not compatible with cassette. Check Media Type.  Stop: Stop Printing	Media Check Please Cancel Cas Cannot Feed Please Check	Paper mismatch (cut sheet) Cassette pickup has been specified for paper that does not support cassette pickup.	Check the cassette pick-up setting/ paper type.
-	Regular printing is selected, but a roll is loaded.  Press OK, remove the roll, and load sheets.		Paper mismatch (cut sheet) Print data having a manual feed print specification has been received at the completion of roll paper pickup.	Check the cassette pick-up setting/ paper type.
-	PapR Type Mismatch	PapRTyp Mismatch	Paper mismatch (type) (1) Mismatch following the selection of any of the following menu choices: - [Warning Indication] has been selected for [Paper Mismatch Detection]. - [ON] has been selected for [Paper Error Skip]. (2) On forced printing following a mismatch resulting from the selection of the following menu option: - [Pause] has been selected for [Paper Mismatch Detection].	This is a warning and allows continued printing.
-		Paper Mismatch	Paper mismatch (both type and size) (1) Mismatch following the selection of any of the following menu choices: - [Warning Indication] has been selected for [Paper Mismatch Detection]. - [ON] has been selected for [Paper Error Skip]. (2) On forced printing following a mismatch resulting from the selection of the following menu option: - [Pause] has been selected for [Paper Mismatch Detection].	This is a warning and allows continued printing.
-	PapR Size Mismatch	PapRSiz Mismatch	Paper mismatch (size) (1) Mismatch following the selection of any of the following menu choices: - [Warning Indication] has been selected for [Paper Mismatch Detection]. - [ON] has been selected for [Paper Error Skip]. (2) On forced printing following a mismatch resulting from the selection of the following menu option: - [Pause] has been selected for [Paper Mismatch Detection].	This is a warning and allows continued printing.
-	Cannot print as specified.  Lift the release lever and replace paper with XXX (vertical) or larger		Paper mismatch (size) When performing internal printing, paper loaded is smaller than the size specified for each print purpose.  [XXX]: appropriate paper size	Replace the paper with appropriate one.
-	Sheet printing is selected.  Press Load/Eject and load sheets.		Paper mismatch (cut sheet) No cassette paper has been loaded when data having a cut sheet specification is received. (Paper type /size not determined)	Load cut sheet.
-	Sheet printing is selected.		Paper mismatch (cut sheet) No cassette paper has been loaded when data having a cut sheet specification is received. (Paper type /size not determined)	Load cut sheet.
-	Paper Pos Wrong	Paper Pos Wrong	Invalid paper loading position Paper is invalidly positioned on the platen.	
-	Turn on the media take-up unit.		Printing has started with the media take-up unit setting of [Use] and with the media take-up unit switched off.	Switch on the media take-up unit.  *A measure for a third-party media take-up unit that is not connected to the main unit.

Code (last 4 digits)	Panel display (Large LCD)	Panel display (Small LCD)	Explanation/Detection sequence	Remedial Action
-	Media take-up unit ready. Online: Print Stop: Stop Printing		Media take-up unit use has been set to [Do not use] at the start of printing when the media take-up unit is active.	1. Press the [Online] button to set the media take-up unit use setting to force [Use] and print. 2. Press the [Stop] key to cancel printing.
-	End of paper feed. Cannot feed paper more.	Feed Limit..	Forced feed limit Paper being manually fed in the return direction (back-feeding) has reached the pinch roller position.	The message clears automatically 2 seconds later. Check the Paper detection sensor/ Media sensor sensor (I/O mode).
-	Close Ink Tank Cover		Ink tank cover open while printing On a model having a subtank, the ink tank cover opened while printing. (Printing is allowed to continue.)	The message clears when the ink tank cover is closed. Check the sensor (I/O mode).
-	The roll feed unit is loose. Push it all the way in.		The roll unit has been pulled out during standby or printing on the lower roll paper or cut sheet A3 or less.	Close the roll unit.
-	Prepare for parts replacement. Call for service.	W Level 1 Consumables Low	Durable parts replacement due soon Any of the parts counters has reached warning level 1.	Check the parts counter and prepare the target unit or Refresh Service Kit. Initialize the parts counter for the target unit after the replacement.
-	Parts replacement time has passed. Call for service.	W Level 2 Repl Consumables	Durable parts replacement due soon Any of the parts counters has reached warning level 2.	
1000 to 100C	Ink Level: Check Not much ink is left. Prepare to replace the ink.	Ink Lvl: Chk XX	Ink tank near-empty (continued use allowed) The remaining volume of ink is diminishing (below the pin check level). (XX: Target color display)  Last 2 digits of error code: 00:Bk, 01:Y, 02:M, 03:C, 04:PM, 05:PC, 06:MBk1, 07:MBk2, 08:GY, 09:PGY, 0A:R, 0B:B, 0C:G	1. Replace the tank (continued usage allowed). 2. If the problem persists after the tank has been replaced, the remaining ink detection system is at fault. (Replace the supply unit or check catching wire or connection status of harness.)
100F	End of paper feed. Cannot feed paper any more.	End of paper feed.	The limit of forced paper feeding. The media reached to a pinchroller at feeding backfeed media manually. (not an error or a failure)	The message is cleared automatically after displaying for 2sec. Confirmation of Paper detection sensor/ Media sensor sensor (I/O mode)
1010	Problem with Printhead L/R Chk printing results Check printed document.	CheckPrintout:LR Check Printout	Head non-ejection warning (Check printout/ possible to continue printing)  See 280C for detection criteria.	1. Check image quality. (Unless there are problems with the image quality, there is no need to replace the printhead.) 2. Replace the printhead.
1012	Problem with Printhead R Chk printing results	CheckPrintout:R	Printhead R non-ejection warning (double-head model) (Check printout/ possible to continue printing)  See 280C for detection criteria.	
1013	Problem with Printhead L Chk printing results	CheckPrintout:L	Printhead L non-ejection warning (double-head model) (Check printout/ possible to continue printing)  See 280C for detection criteria.	
1015	This type of paper is not compatible with HP-GL/2.	GL2: Unsup. papr GL2: Incompatible paper type Press Online Starts printing	HP-GL2 error: out of the scope of paper support [Warning Indication] or [Pause] have been selected for [Paper Mismatch Detection].  The paper that is being fed does not support HP-GL/2 printing; that is, a paper type that does not have a required print mode has been set.	When [Warning Indication] is selected Replace with appropriate paper.  When [Pause] is selected 1. Press the [Online] button to force printing. Caution) Due to use of image process table (LUT) defined for HP-GL/2 compatible paper different from the specified paper, you might have a problem in quality of image. 2. Press the [Stop] button to cancel printing.
1021	Papr Type Mismatch	MediaType Mismatch	Paper mismatch (type) With [Warning Indication] is selected for [Paper Mismatch Detection], the type of loaded paper mismatches the specified type. Or, with [Pause] is selected for [Paper Mismatch Detection], the [Online] button was pressed to execute forced printing.	Continued printing is allowed. Check driver setting. Replace with appropriate paper.
1022	Papr Type Mismatch	MediaType Mismatch	Paper mismatch (type) With [Warning Indication] is selected for [Paper Mismatch Detection], the type of loaded paper mismatches the specified type. Or, with [Pause] is selected for [Paper Mismatch Detection], the [Online] button was pressed to execute forced printing.	Continued printing is allowed. Check driver setting. Replace with appropriate paper.

Code (last 4 digits)	Panel display (Large LCD)	Panel display (Small LCD)	Explanation/Detection sequence	Remedial Action
1030	GARO W1221	GARO W1221	(Image mode)Unknown command A character that is located within bounds of a group character or end parameter character but that is not defined as a command has been detected during Image mode command decoding.	1. Identify the model. 2. If the error has occurred with RIP, try with the printer driver. 3. Try in an alternative environment (I/F, PC).
1031	GARO W1222	GARO W1222	(Image mode) Invalid parameter count (no parameters) A numeric field has not been identified as being numeric during Image mode command decoding.	
1032	GARO W1223	GARO W1223	(Image mode) Required item missing A character out of bounds has been detected where a group or end parameter character ought to exist, during Image mode command decoding.	
1034	GARO W1225	GARO W1225	(Image mode)Other warning A character other than <ESC> has been detected right after the image mode analysis module entered Image mode or when the decoding of a single command ended.	
1035	GARO W1231	GARO W1231	(Setup mode)Unknown command A command character string other than RESET, SET, OPCMT0 and OPCMT2 has been detected in a PJI command.	
1036	GARO W1232	GARO W1232	(Setup mode)Invalid parameter count Too many or too few parameters have been detected during Setup mode command decoding.	1. Retransmit. 2. Check with a different interface choice. 3. Try by printing other data. 4. With RIP, print from the print driver. Supplement: If this error occurs, the print result would appear blank.
1037	GARO W1233	GARO W1233	(Setup mode) Required item missing The exit parameter is missing in the EnterGAROMode command and the UniversalExitLanguage command used in Setup mode.	
1038	GARO W1234	GARO W1234	(Setup mode)Data out of bounds A character string that is not defined as an environmental variable has been detected. An unknown environmental variable has been detected. A character string that is not defined as an environmental variable value has been detected. The value of an unknown environmental variable has been detected.	
1039	GARO W1235	GARO W1235	(Setup mode) Other warning A character string other than the @PJI prefix has been detected while the analysis module was idle.	
103A	GARO W1226	GARO W1226	(Image mode) Image processing table error No image processing table is being transmitted, a required image processing table is unavailable, or an image processing table contains a value out of bounds.	
1040	GL2: W0501 The memory is full.	GL2: W0501	HP/GL2 error; Insufficient memory capacity The size of drawing data exceeds the processing capacity.	1. Reduce the size of rendering data. 2. Replace with HP RTL data for manipulation with On The Fly*.  *: On The Fly: The method to transmit data in sequence from paper. The software that generates HP-GL/2 data has this option to specify. Select this option to save the memory usage of the printer.
1041	GL2: W0502 The parameter is out of range.	GL2: W0502	HP/GL2 error; invalid parameter Data having an invalid number of types of parameters that follow the command has been detected.	Verify the data and fix it.
1043	GL2: W0504 This command is not supported.	GL2: W0504	HP/GL2 error; Invalid command A command that is not defined in HP-GL/2 or HP RTL is included.	Verify the data and fix it.
1047	GL2: W0903 The memory is full.	GL2: W0904	HP/GL2 error; replot buffer overflow Data storage buffers have run short.	1. Reduce the size of rendering data. 2. Replace with HP RTL data for manipulation with On The Fly*.  *: On The Fly: The method to transmit data in sequence from paper. The software that generates HP-GL/2 data has this option to specify. Select this option to save the memory usage of the printer.

Code (last 4 digits)	Panel display (Large LCD)	Panel display (Small LCD)	Explanation/Detection sequence	Remedial Action
1048	GL2: W0904 The memory is full.	GL2: W0903	HP/GL2 error; polygon buffer overflow The size of drawing data exceeds the processing capacity.	1. Reduce the size of rendering data. 2. Replace with HP RTL data for manipulation with On The Fly*.  *: On The Fly: The method to transmit data in sequence from paper. The software that generates HP-GL/2 data has this option to specify. Select this option to save the memory usage of the printer.
1049	Before borderless printing, move the blue platen switch.		When print data with borderless printing specification has been received, platen shutter was closed.	Open the platen shutter.
1050	Blue platen switch is dirty. Please clean the switch.		Cleaning of platen shutter is necessary.  When reading the platen shutter in multisensor, borderless printing data has been received in unstable output condition.	Clean the platen shutter.
1051	Paper Too Small		Paper mismatch (size) Size clip warning With [Warning Indication] selected for [Paper Mismatch Detection] in the menu settings, the size of paper loaded is smaller than that of specified from driver.	Continued printing allowed. Check driver settings. Replace with appropriate paper.
1052	Borderless printing not possible. Check supported paper.		Borderless printing not available (unsupported size)  With [Warning Indication] selected for [Paper Mismatch Detection] in the menu settings, borderless printing data is received, but roll paper not supporting borderless printing has been loaded.	Replace with appropriate paper.
1053	Paper position not suitable for borderless printing.		Borderless printing not available (physical) With [Warning Indication] selected for [Paper Mismatch Detection] in the menu settings, borderless printing data is received, but roll paper loaded is more than 1mm off the predefined position for the pre-ejection opening at the counter-HP side.	Reload/ replace the roll paper.
1053	Borderless printing not possible. Check pap. pos. or spacer			Reload/ replace the roll paper. Check the borderless spacer.
1054	PapWidth Mismatch		Paper mismatch (size) With [Warning Indication] selected for [Paper Mismatch Detection] in the menu settings, the width of roll paper loaded and that of specified by data do not match.	Continued printing allowed. Check driver settings. Replace with appropriate paper.
1056 to 1062	Move the blue platen switch No.XX to the right.		The multisensor detected that the platen shutter used for pre-ejection was closed. Detection timing: -At paper loading -At start of first printing (after upper cover is opened and closed, or recovery from sleep mode, or the power is turned on with paper loaded)  The following list shows the last 2 digits of error codes and the corresponding messages. 56:No.2, 57:No.3, 58:No.459:No.5, 5A:No.6, 5B:No.75C:No.8, 5D:No.9, 5E:No.105F:No.11, 60:No.12, 61:No.13, 62:No.14	Move the platen shutter relevant to the message to the right, to open it.
1100	Prepare for maint cart replacement.	MTCart Full Soon	Maintenance cartridge near-full (continued usage allowed) Near-full has been detected from the dot count and the usage period (drying time).  <Maintenance cartridge detection timings> The presence of a maintenance cartridge is detected at the following timings: 1. Before printing/during printing (twice per second)/at the end of printing/ between pages 2. Before a recovery operation/during a recovery operation (twice per second)/ before opening of the ink supply valve 3. When the cartridge is removed and inserted following the occurrence of an error or warning.	Prepare a maintenance cartridge.
1101	Replace part soon.	Mist Full Soon	Mist count near-full Waste ink near-full has been detected from the dot count.	Check the parts counter and replace the target unit or Refresh Service Kit. Initialize the parts counter for the target unit after the replacement.

Code (last 4 digits)	Panel display (Large LCD)	Panel display (Small LCD)	Explanation/Detection sequence	Remedial Action
1400 to 140C	No ink left. Press OK and replace ink tank.		Ink tank empty (continued use allowed) The ink tank has run out of ink, but a certain volume of ink is reserved in the subtank. (The reserved volume of ink is put to use after the remaining ink falls below the pin check level.) Displayed only on models having a subtank. (XX: Display applicable colors) Last 2 digits: 00:Bk, 01:Y, 02:M, 03:C, 04:PM, 05:PC, 06:MBk1, 07:MBk2, 08:GY, 09:PGY, 0A:R, 0B:B, 0C:G	1. Replace the tank. 2. Failure of remaining ink detection system. (Replace the supply unit /check the bundled wires.)
	Ink tank is empty. Replace the ink tank.			
1410 to 141C	No ink tank loaded. Check ink tank.		Ink tank not installed (continued use allowed) The ink tank is not installed but a sufficient volume of ink is left in the subtank. Displayed only on models having a subtank. This occurs in cases such as when the ink tank cover is opened during printing, and the ink tank is removed. (XX: Displays applicable colors) Last 2 digits: 10:Bk, 11:Y, 12:M, 13:C, 14:PM, 15:PC, 16:MBk1, 17:MBk2, 18:GY, 19:PGY, 1A:R, 1B:B, 1C:G	1. Mount the tank. 2. Failure of remaining ink detection system. (Replace the supply unit /check the bundled wires.)
200A	Paper size not detected. Press Load/Eject and reload the paper.	Paper Please Reload Size Undetected	Paper size detection failure Cannot detect the paper width (poorly positioned paper).	
	Paper size not detected. Reload paper.			
	Paper size not detected. Press OK and reload the paper.			
200B	Paper size not detected. Reload paper.	Paper Please Reload Size Undetected	Paper size detection failure Paper is invalidly positioned on the platen.	
200C	Paper size not detected. Press Load/Eject and reload the paper.	Paper Please Reload Size Undetected	Paper size detection failure Cannot detect the leading edge of the paper. The leading edge of paper has been located by coarse detection but not by a second round of fine detection (up to 300 mm) (semi-transparent paper). (This is the message when the release lever operation is not necessary.)	
	Paper size not detected. Reload paper.			
	Paper size not detected. Lift the release lever and reload the paper.	Paper Size Undetected Press Online Key and Reload	Paper size detection failure Cannot detect the leading edge of the paper. The leading edge of paper has been located by coarse detection but not by a second round of fine detection (up to 300 mm) (semi-transparent paper).	
200D	Paper size not detected. Press Load/Eject and reload the paper.	Paper Please Reload Size Undetected	Paper size detection failure Cannot detect the trailing edge of the paper. -Cannot detect the trailing edge of the cut sheet loaded after they have been fed 50 mm. -Cannot locate the trailing edge of the paper that has been found by coarse detection.	1. Check to see if roll paper are not loaded in the cut sheet mode. 2. Load cut sheet.
	Leading edge detection error. Lift the release lever and align leading edge with orange line.			
	Paper size not detected. Lift the release lever and reload the paper.			
	Paper size not detected. Reload paper.			
200E	This paper cannot be used. Check supported paper sizes.	Paper Size Please Check Paper Too Small	Paper is too small The width and length of paper detected are shorter than the supported size (1.5% margin).	1. Check paper conditions (soiling, tear-offs, residual paper chips, residual trimming cuts, folds)/size. 2. Has the paper been fed successfully (without slippage under a load or any influence)? 3. Has the LF adjustment value set correctly? 4. Hasn't the loaded paper shrunk to below its margin in the particular environment?
	This paper cannot be used. Check supported paper sizes. Load/Eject: Change Paper	Paper Size Please Check Paper Too Small Press Online Key		

Code (last 4 digits)	Panel display (Large LCD)	Panel display (Small LCD)	Explanation/Detection sequence	Remedial Action
200F	This paper cannot be used. Check supported paper sizes.	Paper Size Please Check Paper Too Large	Paper mismatch (size) Paper is too large -The width and length of paper detected are longer than the supported size (1.5% margin).	1. Check paper conditions (soiling, tear-offs, residual paper chips, residual trimming cuts, folds)/size. 2. Has the paper been fed successfully (without slippage under a load or any influence)? 3. Has the LF adjustment value set correctly? 4. Hasn't the loaded paper shrunk to below its margin in the particular environment?
	This paper cannot be used. Check supported paper sizes. Load/Eject: Change Paper	Paper Too Large Please Check Press Online Key and Reload	-Cannot detect the leading edge of paper even when the paper has been fed by 1300 mm for roll paper and by the size mentioned above for cut sheet. -Cannot detect the width of paper even when the paper is fed by the size mentioned above.	
2010	Paper loaded askew. Press Load/Eject and reload the paper.	Paper Askew Please Reload Paper Skew	Skew (skewed right)  Paper is determined skewed as its edge is read by the multisensor.	Reload the paper.
	Paper loaded askew. Reload the paper.	Paper Loaded Crooked Press Online Key and Reload		
	Paper loaded askew. Lift the release lever.	Paper loaded askew. Remove paper		
	Paper loaded askew. Lift the release lever and reload the paper.			
	Paper loaded askew. Press OK and reload the paper.			
	Paper loaded askew Lift the release lever.			
2015	Cannot cut paper. Press Load/Eject and reload the paper.	<When small LCD 1> Cutting Error Please Cut Paper	Cutting failure/jam detected due to a cutting failure An idle cutter unit or a cutter blade that is too blunt to cut sheet has been detected by the paper leading edge detection sequence.	
	Cannot cut paper. Reload the paper.	<When small LCD 2> Press (upper arrow) Key to Release Paper		
	Cannot cut paper. Lift the release lever and reload the paper.			
	Paper cutting failed. Lift the release lever.			
2016	No sheets. Press Load/Eject and reload the paper.	Sheets Please Load Sheet Not Loaded	Paper loosened out of position while printing The trailing edge of paper has been detected at least 20 mm shorter than the length of cut forms detected.	Reload the paper.
	No sheets. Lift the release lever and reload the sheets.			
	The paper is too small. Check paper size.			
	Sheet removed. Lift the release lever.			
	Paper jam. Press Load/Eject and reload the paper.	Paper Jam Press (upper arrow) Key	Jam while picking up, ejecting or printing on paper (A sequence of removing jams with the pinch roller released is required) Virtually all recovery errors that could occur in connection with paper pickup are handled.	1. Open and close the release lever to reload the paper. 2. Remove the paper once and then refeed it.
	Paper jam. Manually rewind roll all the way.	Paper Jam Press (upper arrow) Key Paper Eject Err Remove Paper		
	Paper jam. Manually rewind roll all the way and press OK.			
	Cannot feed paper Lift the release lever and reload paper.			
	Cannot feed paper. Reload the paper.			
	Cannot feed paper. Press Load/Eject and reload the paper.			

Code (last 4 digits)	Panel display (Large LCD)	Panel display (Small LCD)	Explanation/Detection sequence	Remedial Action
2017	Paper size not detected. Lift the release lever and reload the paper.	Paper Please Reload Size Undetected Press (upper arrow) Key	Paper (right) side detection error 1. Multisensor error on light quantity adjustment 2. The read reference paper edge is 5 mm or more apart from its theoretical position. 3. Cannot locate the edge of reference paper.	
	Paper size is undetected. Reload paper.	PapR Size Undetected Press Online Key and Reload		
	Paper size not detected. Press Load/Eject and reload the paper.			
	Paper size not detected. Lift the release lever.			
	Could not detect paper size. Push release lever back, then pull out the cut sheet.			
	Could not detect paper size. Press OK, then Insert roll paper straight into feed slot..			
2018	Paper size not detected. Lift the release lever and reload the paper.	PapR Size Undetected Press Online Key and Reload	Paper (left) side detection error The non-reference edge of paper has been located by coarse detection but not by a second round of fine detection.	
	Paper size not detected. Reload paper.			
	Paper size not detected. Press Load/Eject and reload the paper.	Paper Please Reload Size Undetected Press (upper arrow) Key		
	Paper size not detected. Lift release lever.			
	Could not detect paper size. Push release lever back, then pull out the cut sheet.			
	Could not detect paper size. Press OK, then insert roll paper straight into feed slot.			
2019	Cannot cut paper. Lift the release lever and reload the paper.		Cutting failure/jam detected due to a cutting failure An idle cutter unit or a cutter blade that is too blunt to cut sheet has been detected by the paper leading edge detection sequence. Or, cutter unit home position detection was failed.	
	Cannot cut paper. Reload the paper.			
	Paper cutting failed. Lift the release lever.			
	Paper cutting failed. Remove the paper after cutting at the top of feed slot. Push the release lever back.			
201A	Paper not aligned with right guide. Press OK and then reload the roll paper.		When loading cut sheet, paper (right) side detection was failed.	The error is cleared by releasing the release lever. After that, load paper to the correct position.
	Paper not aligned with right guide. Push the release lever back, then reload the paper.			
201B	Roll paper is not securely in contact with roll holder. Press OK, then re-attach the roll paper.		When loading roll paper, paper (right) side detection was failed.	Paper is ejected automatically, and by pressing the [OK] button the error is cleared. After that, load paper to the correct position.

Code (last 4 digits)	Panel display (Large LCD)	Panel display (Small LCD)	Explanation/Detection sequence	Remedial Action
201C	Paper jam Push the release lever back.		While printing, paper width was detected to have fluctuated beyond the predefined value. Failure of detecting right edge of the paper (cut paper, in printing).	By releasing the release lever, move to the loading sequence, and load paper to the correct position.
201D	Paper jam Remove the paper after cutting at the top of feed slot. Push the release lever back.		While printing, paper width was detected to have fluctuated beyond the predefined value. Failure of detecting right edge of the paper (cut paper, in printing).	1. Cut the paper near the feed slot, and remove the paper. 2. Release the release lever, and load the paper to the correct position.
201E	Media Type not compatible with cassette. Check Media Type. Stop: Stop Printing	Media Check Please Cancel Cas Cannot Feed Please Check	Paper mismatch (cut sheet) Cassette pickup has been specified for paper that does not support cassette pickup.	Check the cassette pick-up setting/paper type.
2405	Borderless printing not possible. Lift the release lever and reload the paper.  Online: Print  Bordless Printing not possible. Lift release lever and reload the paper.  Bordless Printing not possible. Lift release lever and reload the paper Online: Not bordrlss Stop: Stop Printing  Paper position not suitable for borderless printing  Borderless printing not possible. Check roll position. Online: Print Load/Eject: Change Paper  Borderless printing not possible. Check roll width and spacers. Online: Print Load/Eject: Change Paper	Roll Paper Chk Check Width/Spcer Borderless Prtng Not Possible	Invalid paper loading position (borderless printing) The position at which paper is loaded is unfit for borderless printing. Data with a borderless print specification has been received while the left or right edge of roll paper was off the center of the borderless print idle ejection port at the completion of roll paper pickup.	Reload the roll paper. Check spacers
2406	Borderless printing not possible. Check paper size setting. Online: Print Load/Eject: Change Paper  Borderless printing not possible. Check supported paper.	Check Supported Paper. No Borderless w/ This Roll Paper	Borderless print data not printable (logic) Borderless print data was received at the start of printing and one or more of the following requirements are met at the same time: -A feeder slot other than one for roll paper has been specified in the data. -A paper type that does not support borderless printing has been set on the data. -Banner printing has been specified on the data at the same time. -A paper size that does not support borderless printing has been specified in a job for which paper had already been fed.	Reset the driver and RIP.
2407	Borderless printing not possible. Paper stretched or shrank. Confirm usage cond. of the paper.		It occurs when all of the following conditions are met at start of printing. -Borderless printing data has been received. -Roll paper has been loaded, and its paper width and edge position recognized at loading are within the supported range of borderless printing. -As a result of right/left side edge detection after start of print processing, it was detected as beyond the supported range of borderless printing.	Reset /replace the roll paper. Confirm and explain usage environment.
2408	Borderless printing not possible. Check supported paper.  Bordless Printing not possible. Lift release lever and reload the paper.		At the start of borderless printing, roll paper whose size doesn't support borderless printing has been loaded.	Replace with appropriate paper.



Code (last 4 digits)	Panel display (Large LCD)	Panel display (Small LCD)	Explanation/Detection sequence	Remedial Action
2409	Paper position is not suitable for borderless printing. Check paper position. Print to normal printing. Stop printing.		Invalid paper loading position (suspended job/ borderless printing) All of the following conditions were met. -Borderless printing data has been received. -Roll paper whose paper loading position is not suitable for borderless printing has been loaded. -The right or left edge of roll paper is more than 1mm off the prescribed position of the pre-ejection opening.	Reload/ replace the roll paper. Check roll paper. 1) Select "Normal printing. (No borderless printing)" and enforce printing. Borderless print setting is ignored. Print with default margin. Default margin depends on selected feeding trays and media type. 2) Select "Stop printing" or press "stop button" to stop printing. 3) Select "replace printing" or release releasing lever.
240A	Borderless printing is not possible. Check supported paper. Check paper position. Print to normal printing. Stop printing.		Borderless printing is not possible (suspended job/ unsupported size). All of the following conditions are met. -Borderless printing data has been received. -Roll paper not supporting borderless printing has been loaded.	
2500 to 250C	Ink tank is empty. Press OK and replace ink tank. No ink left. Replace ink tank.	No Ink Left (lower arrow)	Ink tank empty (continued use not allowed) The ink tank has run out of ink. (The reserved volume of ink is put to use after the remaining ink falls below the pin check level.) (In the small LCD, the lower arrow points to the color in question.)  The last 2 digits signify applicable colors. 00:Bk, 01:Y, 02:M, 03:C, 04:PM, 05:PC, 06:MBk1, 07:MBk2, 08:GY, 09:PGY, 0A:R, 0B:B, 0C:G	1. Replace the tank. 2. If the problem persists after the tank has been replaced, the remaining ink detection system is at fault (replace the supply unit or check the bundled wires).
2510 to 251C	Ink level is unknown. Check ink level. Press Online to start printing.	Online Key Press To Print Ink Lvl Unknown Press Online	Remaining ink level unknown (continued use allowed) The level of ink remaining in the tank is detected when the tank cover is closed. Consumption has exceeded the original ink capacity (mismatch detected). Refill ink may have been used. (In the small LCD, the lower arrow points to the color in question.)  The last 2 digits signify applicable colors. 10:Bk, 11:Y, 12:M, 13:C, 14:PM, 15:PC, 16:MBk1, 17:MBk2, 18:GY, 19:PGY, 1A:R, 1B:B, 1C:G	Replace the ink tank.
2520 to 252C	No ink tank loaded. Press OK and check ink tank. No ink tank loaded. Check ink tank.	Ink Tank Check XX No Ink Tank Check Ink Tank	Ink tank not installed (continued use not allowed) On a model that is furnished with a subtank, this error is indicated if the subtank has run out of ink and the state of an ink tank not being installed is detected.  The last 2 digits signify applicable colors. 20:Bk, 21:Y, 22:M, 23:C, 24:PM, 25:PC, 26:MBk1, 27:MBk2, 28:GY, 29:PGY, 2A:R, 2B:B, 2C:G	1. Remove and then reinstall the tank. 2. Replace the tank. 3. Failure of remaining ink detection system. (Replace the supply unit /check the bundled wires.)
2540 to 254C	Ink tank error. Press OK and replace ink tank. Wrong ink tank. Replace ink tank. Wrong ink tank. Press OK and replace ink tank.	Ink Tank Replace BK Ink Tank Error Repl. Ink Tank	Ink tank ID error The type of ink tank is wrong.  The last 2 digits signify applicable colors. 40:Bk, 41:Y, 42:M, 43:C, 44:PM, 45:PC, 46:MBk1, 47:MBk2, 48:GY, 49:PGY, 4A:R, 4B:B, 4C:G	1. Replace the tank. 2. Failure of remaining ink detection system. (Replace the supply unit /check the bundled wires.)
2560 to 256C	Ink tank error. Press OK and replace ink tank.	Ink Tank Replace BK Ink Tank Error Repl. Ink Tank	Ink tank EEPROM error There is an error in tank EEPROM.  The last 2 digits signify applicable colors. 60:Bk, 61:Y, 62:M, 63:C, 64:PM, 65:PC, 66:MBk1, 67:MBk2, 68:GY, 69:PGY, 6A:R, 6B:B, 6C:G	1. Replace the tank. 2. Failure of remaining ink detection system. (Replace the supply unit /check the bundled wires.)

Code (last 4 digits)	Panel display (Large LCD)	Panel display (Small LCD)	Explanation/Detection sequence	Remedial Action
2570 to 257C	Ink insufficient. Press OK and replace ink tank.		Ink tank short on ink A suction operation was attempted, but there is not enough ink left in the tank for the operation (iPF8000 series, iPF9000 series).  Reference) About 5 mL to 40 mL of ink may have been left in the tank when this warning occurs. 70:Bk, 71:Y, 72:M, 73:C, 74:PM, 75:PC, 76:MBk1, 77:MBk2, 78:GY, 79:PGY, 7A:R, 7B:B, 7C:G	1. Replace the tank. 2. Failure of remaining ink detection system. (Replace the supply unit /check the bundled wires.)
2580 to 258C	Ink insufficient. Press OK and replace ink tank.  Ink insufficient. Replace ink tank.	Not Enough Ink (lower arrow) Replace ink tank or Online to print	Ink tank short on ink A suction operation was attempted, but there is not enough ink left in the tank for the operation. (In the small LCD, the lower arrow points to the color in question.)  Reference) About 5 mL to 40 mL of ink may have been left in the tank when this warning occurs. 80:Bk, 81:Y, 82:M, 83:C, 84:PM, 85:PC, 86:MBk1, 87:MBk2, 88:GY, 89:PGY, 8A:R, 8B:B, 8C:G	1. Replace the ink. 2. Failure of remaining ink detection system. (Replace the supply unit /check the bundled wires.)
2590 to 259C (*1)	Ink insufficient. Press OK and replace ink tank.  Ink insufficient. Replace ink tank.	Not Enough Ink (lower arrow) Replace ink tank or Online to print	Ink tank short on ink A print operation was attempted, but there is not enough ink left in the tank for the operation. (In the small LCD, the lower arrow points to the color in question.)  Reference) About 5 mL to 40 mL of ink may have been left in the tank when this warning occurs. 90:Bk, 91:Y, 92:M, 93:C, 94:PM, 95:PC, 96:MBk1, 97:MBk2, 98:GY, 99:PGY, 9A:R, 9B:B, 9C:G (*1) 259C: 03810208-259C	1. Replace the ink. 2. Failure of remaining ink detection system. (Replace the supply unit /check the bundled wires.)
259C (*2) to 25A8	Ink insufficient. Press OK and replace ink tank.  Ink insufficient. Press OK and replace ink tank.	Ink insufficient Press (lower arrow) key. Replace ink tank or start printing online.	Ink insufficient in ink tank. The amount of ink left in the ink tank is insufficient for printing. (In the small LCD, the lower arrow points to the correspondence color.)  Reference) There are the cases that about 5ml to 40ml ink is left in a ink tank at warning occurs. 9C:Bk, 9D:C, 9E:M, 9F:Y, A0:PC, A1:PM, A2:MBk1, A3:MBk2, A4:GY, A5:PGY, A6:R, A7:G, A8:B (*2) 259C: 03810104-259C	1. Replace ink tank 2. Failure of detecting the ink amount left in the ink tank. (Replace the supply unit /check the bundled wires.)
25B7	Close the ink tank cover. Unable to detect ink level correctly.  Unable to detect ink level correctly.		The remaining ink falls below the pin check level while ink tank cover is open.	Close the ink tank cover.  Note) It does not recover if the cover is open when replacing the ink tank with a valid one.  If removing the ink tank with lower ink remains (LIR) than Supply Pin in this situation, an error is detected. Also when keeping printing in this situation, if empty sub tank corresponding to the ink tank with LIR is detected, the error shifts from ink tank with LIR to empty sub tank.
260E	Hardware error. 03130031-260E  Turn off printer, wait, then turn on again.	Power On Again Gap Detect Err	Gap detection failure Carriage gap calibration has not been carried out, or gap detection is disabled by corrupt calibration data.	1. Check to see if the multisensor reference plate (white patch for batch correction) is not soiled and perform GAP CALIB (if soiled, adjust the part after replacing it). 2. Replace the multisensor and perform GAP CALIB. 3. Replace the carriage unit and perform GAP CALIB.
260F	Gap error.  Turn off printer.	Power On Again Gap Error	Gap reference plane error Request to replace an abnormal reference plane sheet (only in Service mode).	Check the multisensor reference plate (for soiling and faulty mounting).
2618	Hardware error. 03130031-2618  Turn off printer, wait, then turn on again.		Vh voltage error	

Code (last 4 digits)	Panel display (Large LCD)	Panel display (Small LCD)	Explanation/Detection sequence	Remedial Action
2800	No printhead Install printhead.	Printhead Please Check No Printhead Check Printhead	Printhead [X] non-existing  [X]: Double-head model : The R-head does not exist. Single-head model: The head does not exist.	1. Check the status of the printhead mounted. 2. Mount the long flexible cable and check the status of the cable being locked.
2801	Printhead error Open top cover and replace the printhead.	Printhead Please Replace Printhead Error Replace Printhead	Printhead [X] DI correction failure  [X]: Double-head model: R head DI correction failure Single-head model: Head DI correction failure	Replace the printhead.
2802	Printhead error Open top cover and replace the printhead.	Printhead Please Replace Printhead Error Replace Printhead	An invalid printhead has been mounted in [X].  [X]: Double-head model: Invalid head mounted on the R-side Single-head model: Invalid head mounted	Replace with a valid printhead. (An error has occurred but the printhead itself is not damaged, so communication has been maintained properly.)
2803	Printhead error Open top cover and replace the printhead.	Printhead Please Replace Printhead Error Replace Printhead	Printhead [X] EEPROM error  [X]: Double-head model: R head EEPROM error Single-head model: Head EEPROM error	Replace the printhead.
2804	PHeads: wrong pos. Open top cover and check the printhead positions.	Printhead Check Printhead L/R Heads Revrstd Check Printheads	Printheads mounted in L/R opposite positions L printhead is mounted on R side.	Replace with a valid printhead. (An error has occurred but the printhead itself is not damaged, so communication has been maintained properly.) The L/R printheads cannot be interchanged.
2805	Printhead error.  Open top cover and replace the printhead.		The specified time has been passed in lower printhead temperature than the specified temperature.	1. Acclimate to room temperature. 2. Replace the printhead. 3. Replace the main controller PCB. 4. Replace the CR board.
2807	PHeads: wrong pos. Open top cover and check the printhead positions.	Printhead Check Printhead L/R Heads Revrstd Check Printheads	Printhead mounted in L/R opposite positions. R printhead is mounted on L side.	Replace with a valid printhead. (An error has occurred but the printhead itself is not damaged, so communication has been maintained properly.) The L/R printheads cannot be interchanged.
2808	No left printhead Install left printhead.	Printhead Left Chk L Printhead No Left Printhead Chk L Printhead	Printhead L non-existing	1. Check the status of the printhead mounted. 2. Mount the long flexible cable and check the status of the cable being locked.
2809	Left printhead error Open top cover and replace the left printhead.	Printhead Left Replace Printhead Left Printhead Err Replace Printhead	Printhead L DI correction failure	Replace the printhead.
280A	Left printhead error Open top cover and replace the left printhead.	Printhead Left Replace Printhead Left Printhead Err Replace Printhead	Invalid printhead L has been mounted.	Replace with a valid printhead. (An error has occurred but the printhead itself is not damaged, so communication has been maintained properly.)
280B	Left printhead error Open top cover and replace the left printhead.	Printhead Left Replace Printhead Left Printhead Err Replace Printhead	Printhead L EEPROM error	Replace the printhead.
280C 280D 280E	PHead needs cleaning. Press Online to clear error.  The printhead requires cleaning.  The printhead requires cleaning. Online=Print Stop=Stop Printing  Execute printhead cleaning. If this message is still displayed, replace the printhead.	Printhead (R) Check Nozzles Online Key Press To Print	Printhead R non-ejection warning (Check printhead) Printing paused/ continued printing allowed  The level of error is decided as shown in the table below, based on the number of non-ejecting nozzles per color (per chip) and the number of nozzles unable to back up.  Depending on the firmware version, the specifications vary as shown in the table below.	1. Check image quality. (Unless there are problems with the image quality, there is no need to replace the printhead.) 2. Replace the printhead.

## 1. Initial firmware

	No. of nozzles impossible to back up	
	Less than 30	30 or over

No. of non-ejecting nozzles 1 color (per chip)	more than 0, less than 100	---	Check printout
	more than 100, less than 200	---	Check head
	200 or over	Check head	Check head

2. Running change firmware

The specifications have been changed from the versions shown below.  
 iPF500/600/5000/700: Ver.1.33, iPF510/610/710/8000/9000: Ver.1.36  
 iPF8100/9100/8000S/9000S: Ver.1.37, iPF810/820/6000S: Ver.1.03  
 iPF605/6200: Ver.1.02, iPF5100/6100: Ver.1.38, iPF720:Ver.1.10

You can choose A:(default setting) or B:(if you want to use automatic stop) from Service mode.

A: (default setting)	No. of non-ejecting nozzles 1 color (per chip)	more than 0, less than 320	---	
		320 or over	Head replacement	
B: (If you want to use automatic stop)			No. of nozzles impossible to back up	
			less than 30	30 or over
	No. of non-ejecting nozzles 1 color (per chip)	more than 0, less than 100	---	Check printout
		more than 100, less than 320	---	Check printhead
320 or over		Replace printhead	Replace printhead	

3. iPF650/750 series, iPF6300/6350/8300 and later model

You can choose A:(default setting) or B:(if you want to use automatic stop) from User mode.

A (Default setting)	No. of non-ejecting nozzles 1 color (per chip)	more than 0, less than 320	---	
		320 or over	Head replacement	
B (if you want to use automatic stop)			No. of nozzles impossible to back up	
			less than 30	30 or over
	No. of non-ejecting nozzles 1 color (per chip)	more than 0, less than 100	---	Check printout
		more than 100, less than 320	---	Check printhead
320 or over		Replace printhead	Replace printhead	

	Error code	Applicable printhead
Check printout	1010	LR or single-head model
	1012	R printhead
	1013	L printhead
Check printhead	280C	LR or single-head model
	280D	R printhead
	280E	L printhead
Replace printhead	2827	LR or single-head model
	2828	R printhead
	2829	L printhead

Code (last 4 digits)	Panel display (Large LCD)	Panel display (Small LCD)	Explanation/Detection sequence	Remedial Action
2811	Printhead error Open top cover and replace the left printhead.  Wrong printhead.  Open top cover and replace the printhead.	Printhead Replace Printhead Printhead Err Replace Printhead	Incompatible printhead version	Replace with a valid printhead. (An error has occurred but the printhead itself is not damaged, so communication has been maintained properly.)
2812	Right printhead error Open top cover and replace the right printhead.	Printhead Right Replace Printhead Right Printhead Err Replace Printhead	Incompatible printhead R version	Replace with a valid printhead. (An error has occurred but the printhead itself is not damaged, so communication has been maintained properly.)
2813	Left printhead error Open top cover and replace the left printhead.	Printhead Left Replace Printhead Left Printhead Err Replace Printhead	Incompatible printhead L version	Replace with a valid printhead. (An error has occurred but the printhead itself is not damaged, so communication has been maintained properly.)

Code (last 4 digits)	Panel display (Large LCD)	Panel display (Small LCD)	Explanation/Detection sequence	Remedial Action
2816	Maintenance cartridge problem. Replace the maintenance cartridge. Maintenance cartridge problem. Hold base of maint cart firmly. Keep it level during removal	Maint Cartridge Replace Cart Maint Cart Error Replace Cart	Maintenance cartridge EEPROM error Communication is enabled but the information is corrupted.  <Maintenance cartridge detection timings> The presence of a maintenance cartridge is detected at the following timings: 1. Before printing/during printing (twice per second)/at the end of printing/ between pages 2. Before a recovery operation/during a recovery operation (twice per second)/ before opening of the ink supply valve 3. When the cartridge is removed and inserted following the occurrence of an error or warning.	Replace the maintenance cartridge.
2817	Maintenance cartridge problem. Replace the maintenance cartridge. Wrong maintenance cartridge. Hold base of maint cart firmly. Keep it level during removal	Maint Cartridge Replace Cart Maint Cart Error Replace Cart	Maintenance cartridge ID error A maintenance cartridge for another model has been mounted.  <Maintenance cartridge detection timings> The presence of a maintenance cartridge is detected at the following timings: 1. Before printing/during printing (twice per second)/at the end of printing/ between pages 2. Before a recovery operation/during a recovery operation (twice per second)/ before opening of the ink supply valve 3. When the cartridge is removed and inserted following the occurrence of an error or warning.	Replace the maintenance cartridge. (The maintenance cartridge was capable of normal communication when the error occurred.)
2818	No maintenance cartridge. Check the maintenance cartridge. Insert new maint cart and push in fully	Maint Cartridge Load Cartridge No Maint Cart Load Cartridge	Maintenance cartridge not found Cannot communicate, or cannot detect a maintenance cartridge.  <Maintenance cartridge detection timings> The presence of a maintenance cartridge is detected at the following timings: 1. Before printing/during printing (twice per second)/at the end of printing/ between pages 2. Before a recovery operation/during a recovery operation (twice per second)/ before opening of the ink supply valve 3. When the cartridge is removed and inserted following the occurrence of an error or warning.	Remove and reinstall, or replace the maintenance cartridge.
2819	Maintenance cartridge full. Replace the maintenance cartridge. Maintenance cartridge full. Hold base of maint cart firmly. Keep it level during removal	Maint Cartridge Replace Cart Maint Cart Error Replace Cart	Maintenance cartridge full Maintenance cartridge full is detected from the dot count and the usage period (drying time).  <Maintenance cartridge detection timings> The presence of a maintenance cartridge is detected at the following timings: 1. Before printing/during printing (twice per second)/at the end of printing/ between pages 2. Before a recovery operation/during a recovery operation (twice per second)/ before opening of the ink supply valve 3. When the cartridge is removed and inserted following the occurrence of an error or warning.	Replace the maintenance cartridge.  Reference) The absorber may appear whitish or weigh light, depending on the usage conditions.
281A	Prepare for maint cart replacement.	MTCart Full Soon	Maintenance cartridge near-full (continued usage allowed) Near-full has been detected from the dot count and the usage period (drying time).  <Maintenance cartridge detection timings> The presence of a maintenance cartridge is detected at the following timings: 1. Before printing/during printing (twice per second)/at the end of printing/ between pages 2. Before a recovery operation/during a recovery operation (twice per second)/ before opening of the ink supply valve 3. When the cartridge is removed and inserted following the occurrence of an error or warning.	Prepare a maintenance cartridge.

Code (last 4 digits)	Panel display (Large LCD)	Panel display (Small LCD)	Explanation/Detection sequence	Remedial Action
281B	No Maintenance Cartridge capacity. Replace the maintenance cartridge.  No Maintenance Cartridge capacity. Hold base of maint cart firmly. Keep it level during removal	Maint Cartridge Replace Cart Maint Cart Error Replace Cart	The maintenance cartridge before cleaning does not have an enough capacity (reusable). Near-full has been detected from the dot count and the usage period (drying time).  <Maintenance cartridge detection timings> The presence of a maintenance cartridge is detected at the following timings: 1. Before printing/during printing (twice per second)/at the end of printing/ between pages 2. Before a recovery operation/during a recovery operation (twice per second)/ before opening of the ink supply valve 3. When the cartridge is removed and inserted following the occurrence of an error or warning.	Replace the maintenance cartridge. The maintenance cartridge can be put to reuse after the end of cleaning.  Reference) The absorber may appear whitish or weigh light, depending on the usage conditions.
2820	Cannot adjust printhead.  Press Online to clear the error and readjust printhead.	Online Key and recalibrate Printhead Adj Err Please Readjust	Head registration unadjustable The adjustment value has gone out of bounds during automatic head adjustment.	Check the nozzle check pattern
2821	Cannot adjust band.  Press Online to clear the error and readjust the band.  Cannot adjust paper feed.  Press OK to clear the error and readjust printhead.	Online Key and recalibrate Band Adj Error Please Readjust	LF unadjustable A detected value has gone out of bounds while performing automatic band adjustment.	1. Adjustment is not possible with transparent/semi-transparent paper. Replace with paper having similar substrate and perform automatic band adjustment or manual adjustment. 2. Make detailed band adjustment (automatic). 3. Check the nozzle check pattern. 4. Initialize the system settings/paper preferences and then add additional paper and perform automatic band adjustment (detailed). If the paper preferences are initialized, all the paper setting would be reset to their factory defaults.
2822	Cannot adjust eccentric.  Press Online to clear the error.  Cannot adjust eccentric.	OnlineKey: Press To Clear Error Eccent Adj Error	Eccentricity uncorrectable (which does not occur when in User mode) A detected value has gone out of bounds while making adjustment.	1. Check the paper type: Replace with photo glossy paper (UF120). 2. Check the paper for soiling, tear and other defects. Having run LF tuning, update the additional paper.
2823	Hardware error. 03010000-2823  Turn off printer, wait, then turn on again.	Power On Again Invalid Head Chk	Head check error	
2824	Cannot adjust optic axis.  Press Online to clear the error.  Cannot adjust optic axis.	OnlineKey: Press To Clear Error Optic Axis Adj Error	Optical axis unadjustable (which does not occur when in User mode) An adjustment pattern has not been printed. The optical axis deviates from the correct position by +/-3 mm or more.	Check the paper (paper type check).
2825	This type of media is not compatible with HP-GL/2.		Paper type not compatible with HP-GL/2 has been specified.	Check the paper.
2826	LFNG XXX XXX XXX XXX press OK key (XXXX is a measured value.)		When executing LF unevenness auto diagnostic processing, the multisensor read value has gone outside the predefined scope (Service mode only).	Check the paper. Check the multisensor.

Code (last 4 digits)	Panel display (Large LCD)	Panel display (Small LCD)	Explanation/Detection sequence	Remedial Action
2827 2828 2829	Execute printhead cleaning. If this message is still displayed, replace Printhead.  Execute printhead cleaning. If this message is still displayed, replace Printhead. [Stop: Stop Printing  Execute printhead cleaning. If this message is still displayed, replace printhead . Printing stopped. [OK]		Printhead non-discharge error (Replace printhead/ continued printing not allowed)  At start of printing the number of non-ejecting nozzles is more than 320 per color (1 chip). 2827: Both L and R, or single printhead model 2828: R printhead 2829: L printhead  * For the detailed head non-ejection errors, see section 280C. (If Setting of SERVICE MODE > SETTING >HEAD WARNING is off, the error code is 280E.)	1. Execute cleaning. 2. Replace printhead.
282A	CR MOTOR TUNING ERROR :PRESS OK		Carriage motor identification processing (rotation adjustment) failed (for Service mode)	Error is cleared by OK button. 1. Check installation of carriage or carriage belt. 2. Clean the carriage main rail (Do not oil it.) 3. Replace the carriage motor.
282B	CR VIBRATION ERROR :PRESS OK		When processing carriage motor identification (rotation adjustment), carriage vibration has been detected (for Service mode).	Error is cleared by OK button. 1. Check installation of carriage or carriage belt. 2. Clean the carriage main rail (Do not oil it.) 3. Replace the carriage motor.
282D	Left printhead error.  Turn off printer, wait, then turn on again.		Printhead error detected (L head only). Displayed when an abnormal temperature rise of printhead has been detected to prompt you to restart.	After restarting, replace the printhead L.
282E	!Printhead error Turn off printer, wait, then turn on again.		Temperature rising detected by particular ink pre-injection before printing was judged abnormal.	1. Replace the printhead. 2. Replace the main controller PCB.
2830	Left printhead error.  Open top cover and replace the left printhead.		Printhead error detected (L head only). Displayed when restarting after detection of error 282D to prompt you to replace printhead L.	Replace the printhead L.
2832	Hardware error 03130031-2832 Turn off printer, wait, then turn on again.		VHT leak detection error of right printhead or of a single printhead, in case of VHT exceeds rated value or falls below the rated value.	iPF6300/6400 Series iPF8300/8400/9400 Series Replace right or left printhead.
2833	Hardware error 03130031-2833 Turn off printer, wait, then turn on again.		VHT leak detection error of left printhead, in case of VHT exceeds rated value or falls below the rated value.	
2834	!Unknown printhead. Open top cover and re-install printhead.		Printhead contact failure is detected after the printhead installation.	1. Remove and reinstall the printhead. 2. Replace the printhead. 3. Replace the carriage unit. 4. Replace the main controller PCB.
2835	!Cannot recognize print head R. Open the top cover and re-insert the printhead R.		Printhead contact failure is detected after the printhead installation.	1. Remove and reinstall the printhead. 2. Replace the printhead. 3. Replace the carriage unit. 4. Replace the main controller PCB.
2836	!Cannot recognize print head L. Open the top cover and re-insert the printhead L.		Printhead contact failure is detected after the printhead installation.	1. Remove and reinstall the printhead. 2. Replace the printhead. 3. Replace the carriage unit. 4. Replace the main controller PCB.
2901	Mail box nearly full. Delete unwanted data  The mail box is nearly full. Delete unwanted jobs.		The available size of the permanent area of the hard disk space has fallen to less than 1 GB.	Reorganize data.
2902	Mail box full. Now printing without saving data.		The hard disk has run out of free space, disabling copy printing or error recovery.	Reorganize data.

Code (last 4 digits)	Panel display (Large LCD)	Panel display (Small LCD)	Explanation/Detection sequence	Remedial Action
2905	Mail box full. Delete unwanted data on your computer to resume printing. Press Stop to cancel printing.		A job save has been executed when the available size of the permanent area of the hard disk space was lost. Cancel the job.	Reorganize data.
	The mail box is full. Delete unwanted data from your computer to continue.			
2906	Mail box full. Cannot save. Delete unwanted data on your computer to resume printing. Press Stop to cancel printing.		The 101st job has been received when 100 jobs are already saved in the permanent area of the hard disk space.	Reorganize data.
	Too many jobs for mail box. Delete unwanted data from your computer to continue.			
2907	Mail box full. Delete unwanted data		100 jobs are already saved in the permanent area of the hard disk space (Warning).	Reorganize data.
	Maximum jobs stored. Delete unwanted data.			
2908	Hard disk error.  Press OK to reformat		HDD format error	1. Format as instructed by the on-panel message. 2. Replace the HDD.
	Hard disk error. Press OK to format HDD and restart the printer (Takes 40 min). This deletes all HDD data. (cannot be canceled)			
	Hard disk error. Will format HDD and restart the printer (Takes 40 min). This deletes all HDD data (cannot be canceled)			
2909	File read error.		HDD file error	Restart the printer. (The file in error is deleted, but the printer will recover normally when it is restarted.)
	Turn off printer, wait a while, and turn it on again. Invalid files will be deleted.			
290A	Hardware error. 03130031-290A Turn off printer, wait, then turn on again.		HDD not connected. HDD was not detected at startup.	Connect the HDD/ Check the harness. Replace the HDD.
2918		Power On Again Cassette Sensor Detection Error	Cassette detection sensor detection failure (cassette presence/absence sensor) No cassette has been detected during cassette pickup.	1. Check to see if the cassette itself is properly loaded. 2. Check and replace the sensor (I/O mode).
291A	Roll sensor cannot detect.  Turn on printer again.	Power On Again Roll Sensor Detection Error	Roll sensor detection failure Could not detect the roll unit.	1. Check the roll unit, and remove, install or replace the roll unit. 2. Check I/O mode (roll unit detection).
291B	Hardware error. 03130031-291B  Turn off printer, wait, then turn on again.	Power On Again Lift Motion Timeout	Lift shift timeout A lift operation has been executed, but no sensor has been detected or a sensor has remained detected.	1. Switch off the printer, then back on. 2. The carriage cannot travel to the lift drive position. 3. The lift drive cam is not engaged. 4. Faulty lift drive sensor 5. Faulty lift drive motor
291D	Hardware error. 03130031-291D  Turn off printer, wait, then turn on again.	Power On Again Hardware Err 1 03130031-291D	Spur cam sensor detection failure	Check the spur cam sensor in I/O mode. -If OK, check the lifter drive system. -If NG, replace the sensor.



Code (last 4 digits)	Panel display (Large LCD)	Panel display (Small LCD)	Explanation/Detection sequence	Remedial Action
2920	Media Take-up error. Check the paper. Press Online to clear error.		Cannot take up paper An error check has been made on paper after the paper had been fed 1850 mm, but the media take-up unit was not driven at all in that interval (up to about 3700 mm [when run immediately after the start of detection]).	1. Check to see if the media take-up unit is switched on with the lock lever down. 2. Check the connection between the main unit and the media take-up unit. 3. Check to see if the wait roller is properly set. 4. Check to see if the media take-up detection sensor is shielded by paper when it is presented. 5. Faulty media take-up detection sensor 6. Faulty Media take-up motor
	Media Take-up error. Check the paper.			
	Media take-up unit ready. Online: Print Stop: Stop Printing		Media take-up unit use has been set to [Do not use] at the start of printing when the media take-up unit is active. The media take-up unit settings are checked only when executing external printing.	Press the [Online] button to set the media take-up unit use setting to force [Use] and print.
2921	Rewinding error. Check for jam at indicated position. Press Online to clear error.		Continued rewinding error The media take-up unit has continued rewinding for 10 seconds, with the media take-up paper detection sensor turned on, at printer power-on and at the start of printing.	1. Check to see if any obstacle is placed at the media take-up paper detection sensor position. 2. Faulty media take-up paper detection sensor 3. Faulty media take-up button 4. Faulty media take-up motor
	Rewinding error. Check for jam at indicated position.			
2930	Cutting Mode not Automatic. Remove stacker and print again or cancel and change settings.  Print again Cancel		Stacker is not ready. - The power supply is not supplied to the stacker. - The distance between the stacker and printer is not appropriate. - The stacker is not joined. - Stacker initial error	Continue or stop the print. If the preparation of the stacker isn't performed, the error occurs again.
2931	Cutting Mode not Automatic. Remove stacker and print again or cancel and change settings.  Print again Cancel		When the stacker is usable condition, the printing has been started at the setting of cut-off or outline print or eject or manual mode.	Print again after separating the distance between the stacker and printer enough, or cancel print.
2E00		Load Roll Media	Paper mismatch (roll paper) No roll paper have been fed when a job with a roll paper specification is received.	Load roll paper.
2E01	Roll printing is selected.  Press Load/Eject and load a roll.	Roll Selected Load Roll	Paper mismatch (roll paper) Roll Paper have not been fed when an internal print job having a roll paper specification started (during internal printing).	Load roll paper.
	Roll printing is selected.			
2E02	Sheet printing is selected.  Press Load/Eject and load sheets.	Front paper feed slot is selected.  Press Load/Eject and load a sheet.	Paper mismatch (cut sheet) No cassette paper has been loaded when data having a cut sheet specification is received.	Load cut sheet.
	Manual printing is selected.			
	Top paper feed slot is selected.  Press OK and load a sheet.			
	Top paper feed slot is selected.  Press Load/Eject and load a sheet.			
	Front paper feed slot is selected.  Press OK and load a sheet.			
	Front paper feed slot is selected.  Press Load/Eject and load a sheet.			
	Front paper feed slot is selected.			

Code (last 4 digits)	Panel display (Large LCD)	Panel display (Small LCD)	Explanation/Detection sequence	Remedial Action
2E03		Load Papr in Cas Press Online.	Paper mismatch (cut sheet) Not cut sheet have been loaded in cassettes when data having a cassette specification is received.	Feed paper as instructed by the on-screen guidance.
2E04	Manual(Front) (Paper type) (Paper size) Load Paper Stop Printing	Load Front Tray	Paper mismatch (cut sheet) No manually fed paper has been fed when a job having a front paper feed specification is received.	Feed paper manually from the front as instructed by the on-screen guidance.
2E05	Manual(Top) (Paper type) (Paper size) Load Paper Stop Printing	Load Top Tray	Paper mismatch (cut sheet) No manually fed paper has been fed when a job having a top paper feed specification is received.	Feed paper manually from the top as instructed by the on-screen guidance.
	Sheet printing is selected.		Paper mismatch (cut sheet) Not cut sheet have been loaded in cassettes when data having a cassette specification is received.(When paper type/ size is not determined)	Load cut sheet.
2E08	Wrong paper size. Check paper size setting on computer.  Online: Print Stop: Stop Printing	PaprSiz Mismatch Pnt:PressOnline Loaded Papr Diff From Spfd Size	Paper mismatch (size) (roll paper) The width of data and that of the actually loaded paper do not match.	Check the paper that is actually loaded on the printer and the paper size setting of the driver.
	Wrong paper size. Check paper size setting in driver.  Online: Print Stop: Stop Printing	Driver: Chk Papr Size Setting Loaded Papr Diff From Spfd Size		
	PaprWidth Mismatch			
2E09	Insufficient paper for job Online: Print Stop: Stop Printing Load/Eject: Change Paper	Roll Paper Please Replace Paper Level Low Replace Paper	Short on roll paper All of the following conditions have been met at the start of printing: -[ON] has been selected for [Remaining Roll Paper Detection]. -Among the paper size settings coded in the print data, the paper length exceeds the remaining length of roll paper.	Replace the roll paper.
2E0A	Roll printing is selected, but sheets are loaded.	Sheets Loaded Press (lower arrow) To Eject Roll Selected Load Roll	Paper mismatch (roll paper) Print data having a roll paper print specification has been received at the completion of manual feed paper pickup.	Check the paper that is actually loaded on the paper and the paper feed setting of the driver.
	Press Load/Eject and remove the sheets.			
	Roll printing is selected, but manual paper is loaded.			
	Roll printing is selected, but sheets are loaded.  Press OK, remove the sheets, and load a roll.			
	Roll printing is selected, but sheets are loaded.  OK:Eject Sheets Stop:Stop Printing			
Roll printing is selected, but sheets are loaded.				
2E0B	Cassette printing is selected.  Press Load/Eject and remove manually loaded sheets.	Sheets Loaded Press (lower arrow) To Eject Cassette Selectd Load Papr in Cas	Paper mismatch (cut sheet) Print data having a cassette print specification has been received at the completion of manual feed paper pickup.	Check the paper that is actually loaded on the paper and the paper feed setting of the driver.

Code (last 4 digits)	Panel display (Large LCD)	Panel display (Small LCD)	Explanation/Detection sequence	Remedial Action
2E0C	Manual printing is selected, but a roll is loaded.  Press Load/Eject and remove the roll.  Sheet printing is selected, but a roll is loaded. Stop Printing  Sheet printing is selected, but a roll is loaded.	Tray Selected Press OK	Paper mismatch (cut sheet) 1. Print data having a manual feed print specification has been received at the completion of roll paper pickup. 2. Print data having a manual feed print specification has been received when there is roll paper printout. 3. Cut sheet data has been received when the media take-up unit is in use.	Check the paper that is actually loaded on the paper and the paper feed setting of the driver.
2E0E	No Roll Feed Unit.  Turn printer off and install roll feed unit.	Roll P Unit Please Check Power On Again	Roll paper unit not installed The unit has received print data having a roll paper print specification when it had started without a roll unit being connected to it.	1. Check the roll unit, and remove, install or replace the roll unit. 2. Check I/O mode (roll unit detection).
2E0F	Top cover is open.  Turn off printer, wait a while, and turn it on again.	Top Cover Please Close Top Cover Open Close Top Cover	The top cover is abnormally open.	Check the cover. Check the sensor (I/O mode).
2E10	Ink tank cover is open.  Turn off printer, wait a while, and turn it on again.	Ink Tank Cover Close Please Tank Cover Open Close Please	Ink tank cover error open (continued use allowed) The ink tank cover opened while performing any operation, such as printing and suctioning.	Close the ink tank cover. Check the sensor (I/O mode).
2E11	Carriage Cover is open.		Carriage cover open error A carriage cover open has been detected.	Close the carriage cover. Check the sensor (I/O mode).
2E12	Rel lever is in wrong position. Turn off printer, wait, then turn on again.		Faulty release lever The state of the release lever up (released) has been detected.	Push down the release lever. Check the sensor.
2E14	Wrong paper size. Check paper size setting on computer.  Online: Print Stop: Stop Printing  Wrong paper size. Check paper size setting in driver.  Online: Print Stop: Stop Printing	Paprsiz Mismatch Pmnt:PressOnline Loaded Papr Diff From Spfd Size  Driver: Chk Papr Size Setting Loaded Papr Diff From Spfd Size	Paper mismatch (size or width) The paper size specified for the [Print to meet the paper width] setting of the driver on receiving print data and the width of the roll paper actually fed did not match.	Check the paper that is actually loaded on the printer and the paper size setting of the driver.

Code (last 4 digits)	Panel display (Large LCD)	Panel display (Small LCD)	Explanation/Detection sequence	Remedial Action
2E15	Wrong paper type. Stop: Stop Printing Load/Eject: Change Paper	Paper mismatch Press (lower arrow) To Replace (Paper Type) (Paper Size)	Paper mismatch (type) (on adjustment) The second and subsequent sheets of paper have been fed as a paper type different from the first sheet when LF adjustment was made with cut sheet.	Equalize the paper types for the first and second sheets with each other in adjustment printing.
	Wrong paper type. Replace paper in cassette.	Loaded Paper Check Type Switch Paper In Cassette		
	Wrong paper type. Lift the release lever and reload the paper. Stop: Stop Printing	Loaded Paper Check Type Press (lower arrow) Key and Reload		
	Wrong paper type. Lift the release lever and reload the paper.			
	Wrong paper type. Lift the release lever and reload the paper.			
	Paper mismatch Make sure media type and paper size match for the adjustment print.			
	Wrong paper type. Check paper type setting in driver. Online: Print Stop: Stop Printing	Driver: Chk Papr Type Setting Chk Paper Type Press Online	Paper mismatch (type) At the start of printing, paper type specified in the job and the type of paper actually loaded do not match, and [Stop] has been selected for [Paper Mismatch Detection].	Check the paper that is actually loaded on the printer and the driver paper type setting.
	Wrong paper type. This type of media is not compatible with HP-GL/2.	PapTyp Mismatch Prnt:PressOnline		
Wrong paper feed slot for this paper type. Press Load/Eject and reload the paper.	Paper Feed Slot SpdfdPapR NotFit Press (lower arrow) Key and Reload	Paper mismatch (type) A paper type that cannot be fed from the specified feeder slot has been specified.	Check the feeder slot/cassette pick-up setting.	
Wrong paper feed slot for this paper type.				
2E16	Wrong paper type. Check paper type setting on computer. Online: Print Stop: Stop Printing	Paper Mismatch Prnt:PressOnline Check Paper Press Online	Paper mismatch (type) The data type defined in the data and the type of actually loaded paper do not match. Following the transmission of data in the GARO format, all of the following conditions have been met at the start of printing: -The paper type that has been set in the job and the type of actually fed paper do not match. -[Stop] has been selected for [Paper Mismatch Detection].	Check the paper that is actually loaded on the printer and the driver paper type setting.
	Wrong paper type and size. Check paper type and size setting on computer. Online: Print Stop: Stop Printing			
	Wrong paper type and size. Check paper type and size setting in driver. Online: Print Stop: Stop Printing			
2E17	No cassette detected. Check the cassette.	Cassette Undetected Check Cassette Press Online	Cassette not installed	1. Check to see if the cassette itself is properly loaded. 2. Check and replace sensor (I/O mode).
2E18	Cannot load. Press Load/Eject and reload the paper.	Remove paper Cannot Feed Press (upper arrow) Key	Paper not fed as far as the platen	
2E19	Cannot load. Press Load/Eject and reload the paper.	Remove paper Cannot Feed Press (upper arrow) Key	Feeding error LF out of synchronization for cut sheet	Refeed the paper.
2E1A	Cannot load. Press Load/Eject and reload the paper.	Remove paper Cannot Feed Press (upper arrow) Key	Feeding error LF out of synchronization for cut sheet	Refeed the paper.

Code (last 4 digits)	Panel display (Large LCD)	Panel display (Small LCD)	Explanation/Detection sequence	Remedial Action
2E1B	The roll is empty. Load/Eject: Change Paper	Roll Paper Please Replace Paper Not Loaded Press (upper arrow) Key	No roll paper available (trailing edge of roll paper detected) -Trailing edge of paper has been detected by paper sensor in a roll paper operation. -LF out of synchronization on roll paper. (Detected the spool no longer rotating.)	1. Replace the roll paper. 2. Check paper sensor R (I/O mode). 3. Is the paper fed successfully (under a negative load or any other influence)?
	The roll is empty. Lift the release lever and replace the roll.			
	The roll is empty.			
	The roll is empty. Lift the release lever and replace the roll.			
	Out of roll paper. Push the release lever back, then replace the roll.			
2E1C	Paper jam. Press Load/Eject and reload the paper.	Paper Jam Press (upper arrow) Key	Jam while ejecting paper (A sequence of removing jams with the pinch roller released is required) A jam has been detected while ejecting paper.	1. Open and close the release lever to reload the paper. 2. Remove the paper once
2E1D	Cannot load. Press Load/Eject and reload the paper.	Remove paper Cannot Feed Press (upper arrow) Key	Feeding error LF out of synchronization for cut sheet	Refeed the paper.
2E1F	Cannot print as specified. Press Load/Eject and replace paper with A2/ 16.6"x23.4" (vertical) or larger	Paper Mismatch ReplcPap:Press (lower arrow)	Paper mismatch (size) The second and subsequent sheets of paper have been fed as a paper size different from the first sheet when adjustment was made with cut sheet.	Check the paper that is actually loaded on the printer and the paper size setting of the driver.
	Cannot print as specified. Press Load/Eject and replace roll with 10 in. wide or larger roll.	Need A3 Vertical or Larger Press (lower arrow) Key and Reload	The paper size setting in effect at the start of an internal print session has fallen below the minimum size specified for that internal print session.  [XXX x YYY]: Required minimum size	
	Cannot print as specified. Lift the release lever and replace paper with [ XXX ] (vertical) or larger.		The second and subsequent sheets of paper have been fed as a paper size different from the first sheet when adjustment was made with cut sheet. [XXX x YYY]: Required minimum size	
	Cannot print as specified. Lift the release lever and replace roll with 10 in. wide or larger roll			
	Cannot print as specified. Replace paper with [XXX] (vertical) or larger.			
	The paper is too small. Replace paper with [XXX] (vertical) or larger.			
	The paper is too small. Replace roll with 10 in. wide or larger roll.			
	Cannot print as specified. Lift the release lever and replace paper with [XXX] (vertical) or larger.			
	Cannot print as specified. Lift the release lever and replace roll with 10 in. wide or larger roll.			
	Wrong paper type. Lift the release lever and reload the paper.  Stop: Stop Printing			
Wrong paper. Lift the release lever and replace the paper.				
Paper mismatch Make sure media type and paper size match for the adjustment print.				

Code (last 4 digits)	Panel display (Large LCD)	Panel display (Small LCD)	Explanation/Detection sequence	Remedial Action		
2E21	Hardware error. 03130000-2E21 Turn off printer, wait, then turn on again.	Power On Again IEEE 1394 Error Restart Printer	IEEE1394 interface error Any error has been detected while initializing IEEE1394 at startup.	1. Restart the printer. 2. Remove and reinsert the IEEE1394 board and then restart the printer. 3. Replace the IEEE1394 board.		
2E22	Media Type not compatible with cassette. Check Media Type.  Stop: Stop Printing	Media Check Please Cancel Cas Cannot Feed Please Check	Paper mismatch (cut sheet) Cassette pickup has been specified for paper that does not support cassette pickup.	Check the cassette pick-up setting/ paper type.		
2E23	Hardware error. 03130031-2E23 Turn off printer, wait, then turn on again.	Power On Again Hardware Err 1 03130031-2E23	Cutter unit failure At startup or completion of paper jam handling, when attempting to get the cutter which is in other position than HP back to HP, the home position sensor timed out without response.	1. Remove paper slip (foreign matter) attached to the cutter home position sensor. 2. Check the cutter driving circuit and the cutter unit. When FU3902 blows out on PF510/ 5100/610, -Replace the main controller PCB When FU2802 blows out on iPF6300 series/ 6400 series -Replace the main controller PCB.		
2E24	Roll feed unit err Turn off printer and check roll feed unit	Power On Again Roll Feed Unit Error	Faulty roll paper unit Failed to detect the cam in the roll unit while no paper was loaded.	Check the roll cam sensor (I/O mode).		
2E25	Cannot detect papr Remove paper and press Load/Eject.	Can't DetectPapr  Remove Paper Press Online	Jam while picking up, ejecting or printing on paper (JAM2)  After loading of roll paper or cut sheet was loaded successfully, Paper detection sensor/ Media sensor sensor detected no paper(JAM2).			
	Cannot feed paper. Remove paper and press Load/Eject.	Remove paper Press Online				
	Cannot detect papr Remove paper and press OK.					
2E27	Cannot load. Press Load/Eject and reload the paper.	Remove paper Cannot Feed Press (upper arrow) Key	Feeding error (nip release required) LF out of synchronization (feed motor won't rotate) has been detected.			
	Cannot feed paper Lift the release lever and reload paper.					
	Cannot feed paper. Reload the paper.					
	Paper jam.  Press Load/Eject and reload the paper.	Paper Jam Press (upper arrow) Key			Jam while picking up, ejecting or printing on paper (A sequence of removing jams with the pinch roller released is required)(JAM1) Virtually all recovery errors that could occur in connection with paper pickup are handled.	1. Open and close the release lever to reload the paper. 2. Remove the paper once and then refeed it.
	Paper jam. Lift the release lever.					
	Paper jam. Push the release lever back.					
Paper jam. Manually rewind roll all the way.						
Paper jam. Manually rewind roll all the way and press OK.						
2E30	The paper is too small.		Paper mismatch (size) With [Pause] selected for [Paper Mismatch Detection] in the menu setting, paper size for the paper loaded was smaller than the size specified by data.	Continued printing allowed. Check driver setting Replace with appropriate paper.		
2E31	Insufficient paper for job		All of the following conditions have been met at the start of external printing: -[ON] has been selected for [Remaining Roll Paper Detection]. -Among the paper size settings coded in the print data, the paper length exceeds the remaining length of roll paper. -Automatic roll feed to another roll paper slot which is not the current feeding path, out of the 2 slots the printer has, is not available.	Replace the roll paper.		

Code (last 4 digits)	Panel display (Large LCD)	Panel display (Small LCD)	Explanation/Detection sequence	Remedial Action
2E32	Insufficient paper for job		All of the following conditions have been met at the start of external printing: -[ON] has been selected for [Remaining Roll Paper Detection]. -Among the paper size settings coded in the print data, the paper length exceeds the remaining length of roll paper. -Automatic roll feed to another roll paper slot which is not the current feeding path, out of the 2 slots the printer has, is not available.	Replace the roll paper.
2E33	Roll Paper (Paper type) (Paper size) Load Roll Paper Stop Printing		Paper mismatch (roll paper) No roll paper has been fed when a job with a roll paper specification is received.	Load roll paper. 1. Select "load a roll" and follow instruction on the panel. 2. Select "stop printing," or stop printing by pressing stop button. 3. Release the release lever and load the paper.
	Roll 1 (Upper) (Paper type) (Paper size) Press Load/Eject and load a roll.		Paper mismatch (roll paper) No roll paper has been fed when a job with a roll paper specification is received. When paper has not been loaded on either upper or lower slot, and the feeding slot is set to [Automatic] in the job setting, an error of upper roll occurs.	
2E34	Roll 2 (Lower) (Paper type) (Paper size) Press Load/Eject and load a roll.		Paper mismatch (roll paper) No roll paper has been fed when a job with a roll paper specification is received. When no paper has been loaded on either upper or lower slot, and the feeding slot is set to [Automatic] in the job setting, an error of upper roll (2E33) occurs.	Load roll paper.
	Roll 2 (Lower) is selected.  Press Load/Eject and load a roll.		Paper mismatch (roll paper) No roll paper has been fed when a job with a roll paper specification is received. When no paper has been loaded on either upper or lower slot, and the feeding slot is set to [Automatic] in the job setting, an error of upper roll (2E33) occurs. * This is a message that appears when paper type/ size specification does not exist due to HPGL format etc.	
2E35	Roll printing is selected.		Paper mismatch (roll paper) No roll paper has been fed when performing internal printing.	Load roll paper.
	Roll printing is selected.  Press Load/Eject and load a roll.			
2E36	Roll printing is selected.  Press Load/Eject and load a roll.		Paper mismatch (roll paper) (lower) No roll paper was fed when internal printing with the specified roll paper (lower) was started.	Load roll paper.
2E37	Roll printing is selected.		Paper mismatch (roll paper) (Upper) No roll paper has been fed when a job with roll paper specification is received.	Load roll paper. 1. Select "load a roll" and follow instruction on the panel. 2. Select "stop printing," or stop printing by pressing stop button. 3. Release the release lever and load the paper. (This step 3 is only for 800/8000/9000 series.)
	Roll 1 (Upper) is selected.  Press Load/Eject and load a roll.		Paper mismatch (roll paper) No roll paper was fed when the job specified with upper roll paper was received.	
2E38	Roll 2 (Lower) is selected.  Press Load/Eject and load a roll.		Paper mismatch (roll paper)(Lower) No roll paper has been fed when a job with lower roll paper specification is received.	Load roll paper.
2E39	The Roll 2 (Lower) is empty. Lift the release lever and replace the roll.		No roll paper available (trailing edge of roll paper detected) -Detected that cut sheet sized paper has been fed at the roll paper feeding slot. -The trailing edge of paper was detected by the Paper detection sensor/ Media sensor sensor during operation in which roll paper was used. -The spool stopped rotating during paper loading or printing (XX: Upper roll paper/ Lower roll paper)	1. Replace the roll paper -Check paper sensor R (I/O mode). 2. Is the paper fed successfully (under a negative load or any other influence)?
	The roll (XX) is empty. Press OK.			
2E3A	Roll1 jammed. Manually rewind the roll all the way and press OK.		During upper roll paper feeding operation, the paper was fed with the roll feed sensor detecting the paper, but the paper detection sensor/ media sensor sensor could not detect the paper and the operation timed out.	Manually rewind the paper and reload.
	Roll1 (Uppr) jammed. Manually rewind the roll all the way and press OK.			

Code (last 4 digits)	Panel display (Large LCD)	Panel display (Small LCD)	Explanation/Detection sequence	Remedial Action
2E3B	Roll 2 (Lwr) jammed. Manually rewind the roll all the way and press OK.		During lower roll paper feeding operation, the paper was fed with the roll feed sensor detecting the paper, but the paper detection sensor/ media sensor sensor could not detect the paper and the operation timed out.	Manually rewind the paper and reload.
2E3C	Paper jam. Lift the release lever.		During operations with cut sheet, the state of the paper detection sensor/ media sensor sensor has become invalid.	Reload the paper.
2E3D	Roll 1 (upper) jam Lift the release lever.		During operations with upper roll paper, the paper was fed with the roll paper detection sensor and the roll feeding sensor detecting the paper, but the state of the paper detection sensor/ media sensor sensor became invalid.	Reload the paper.
2E3E	Roll 2 (lower) jam Lift the release lever.		During operations with lower roll paper, the paper was fed with the roll paper detection sensor and the roll feeding sensor detecting the paper, but the state of the paper detection sensor/ media sensor sensor became invalid.	Reload the paper.
2E3F	Paper jam. Lift the release lever.		When either upper or lower roll paper is in operation, the states of the roll paper detection sensor, roll feeding sensor, and paper detection sensor/ media sensor sensor became invalid.	Reload the paper.
2E40	Cannot print as selected. Another roll is in use. [Stop]: Stop printing		Print data having lower roll paper specification has been received while upper roll printout remains.	Remove the printout of upper roll, and print again.
2E41	Cannot print as selected. Another roll is in use. [Stop]: Stop printing		Print data having upper roll paper specification has been received while lower roll printout remains.	Remove the printout of lower roll, and print again.
2E42	Media Type Mismatch		Paper mismatch (type/ restart printing of suspended job) It occurs when all of the following conditions are met: -[Stop] selected for [Paper Mismatch Detection] in menu settings. -[Change Paper] button was pressed for suspended jobs from host. -The paper type that has been set in the job and the type of actually fed paper do not match.	Continued printing allowed. Replace with appropriate paper.
2E45	Media Type Mismatch		Paper mismatch (type/ restart printing of suspended job) It occurs when all of the following conditions are met: -[Stop] selected for [Paper Mismatch Detection] in menu settings. -The paper width that has been set with data and the paper width of actually fed paper do not match.	Continued printing allowed. Check the driver settings. Replace with appropriate paper.
2E47	Cutter Position Error		Cut Failure The cutter is not at home position when restart from jam. Also paper feeding was detected.	Check around the cutter unit.
2F11	CR error Call for Service.	Power On Again CR Error	An operation order has been issued while the carriage suffered a hardware error.	
2F12	LF error Call for Service.	Power On Again LF Error	LF error -An operation order has been received while the LF suffered a hardware error. -The target position could not be reached within a predicted operation time +3 seconds during an LF operation. -The sensor could not be detected during an LF operation involving sensor detection.	1. Replace the feed roller encoder sensor. 2. Replace the feed motor. <Supplement> -If the carriage travels heavily near the stop position, a mechanical load error may be suspected. -If any other symptom is observed, a feeding sensor may be at fault.
2F13	Hardware error. 03130031-2F13 Turn off printer, wait, then turn on again.	Power On Again Hardware Err 1 03130031-2F13	A/D converter external trigger output stop (Hardware error 1)	
2F14	Hardware error. 03130031-2F14 Turn off printer, wait, then turn on again.	Power On Again Hardware Err 2	ASIC register not writable (Hardware error 2) Could not write to the ASIC register on the main controller PCB.	Replace the main controller PCB.



Code (last 4 digits)	Panel display (Large LCD)	Panel display (Small LCD)	Explanation/Detection sequence	Remedial Action
2F16	Hardware error. 03130031-2F16 Turn off printer, wait, then turn on again.	Power On Again Mist Fan Error	Mist fan error The rotation of the mist fan is not detectable.	1. Check the bundled wires in the mist fan drive circuit. 2. Replace the mist fan unit. 3. Replace the main controller PCB.
2F17	Hardware error. 03130031-2F17 Turn off printer, wait, then turn on again.	Power On Again Platen Fan Lock  Power On Again Platen Fan Err	Platen fan lock detection error The lock signal has been supplied continuously for 3 seconds or longer, 10 seconds after the platen fan started rotating.	1. Check the bundled wires in the platen suction fan drive circuit. 2. Replace the platen suction fan unit. 3. Replace the main controller PCB.
2F1F	Hardware error. 03130031-2F1F Turn off printer, wait, then turn on again.	Power On Again Purge Motor Sensor Error	Purge sensor error (recovery purge motor HP detection error) The recovery system has been driven but no sensor interrupt occurs. The recovery system has been driven to close the cap, but the cap has not been capped successfully.	
2F20	Hardware error. 03130031-2F20  Turn off printer, wait, then turn on again.	Power On Again Motor Cam Pos Error	Cap motor cam positioning error The recovery system has been driven but no sensor interrupt occurs. The recovery system has been driven to close the cap, but the cap has not been capped successfully.	
2F21	Rel lever is in wrong position.  Turn off printer, wait, then turn on again.		Pinch roller open detected with the pinch roller locked.	1. Restart with the pinch roller closed. 2. Check the sensor in I/O DISPLAY in Service mode (Check the pinch roller pressure release detection SW/ the release lever lock sensor.)
2F22	Hardware error. 03130031-2F22 Turn off printer, wait, then turn on again.	Power On Again Pump Motion Timeout	Pump shift timeout The target position could not be reached within a predicted operation time +3 seconds during pump operation or no sensor has been detected during a pump operation involving sensor detection.	<Supplement> -If the carriage travels heavily towards the stop position: A mechanical load error may be suspected. -Otherwise: The sensor in the purge unit may be at fault.
2F23	Hardware error. 03130031-2F23 Turn off printer, wait, then turn on again.	Power On Again Pump Motion Error	Purge motor error A PWM duty of 100% has lasted for 200 msec in a pump operation.	<Supplement> -If the motor could not be run at all or has resulted in an error after moving by a slight distance: A. A mechanical load error may be suspected. B. The motor or drive circuit may be at fault. -If the carriage has run more or less out of control and resulted in an error: A. The encoder sensor may be at fault.
2F24	Cannot cut paper. Lift the release lever and reload the paper.	Cutting Error Please Cut Papr Press (upper arrow) Key to Release Paper	Cutter shift timeout The cutter failed to reach the home position in time during a cutting operation	
2F24	Hardware error. 03130031-2F24 Turn off printer, wait, then turn on again.	Power On Again Cutter Timeout	Cutter shift timeout error No sensor has been detected during a cutter operation involving sensor detection.	
2F25	Hardware error. 03130031-2F25 Turn off printer, wait, then turn on again.	Power On Again CR Position Err Restart Printer	Carriage motor HP not detectable Detected only for the wide format. For the narrow format, the carriage motor HP can be detected when the carriage hits the wall in a full scan following the detection of the HP.	Check the carriage HP sensor in I/O mode. <Supplement> -If the motor could not be run at all: A. A mechanical load error may be suspected. B. The motor or drive circuit may be at fault. -If the carriage has resulted in an error after moving at a constant speed: A. The carriage HP sensor may be at fault. -If the carriage has run more or less out of control and resulted in an error: A. The encoder sensor may be at fault.
2F26	Hardware error. 03130031-2F26 Turn off printer, wait, then turn on again.	Power On Again Carriage Motion Error	Carriage operation disabled -A PWM duty of 100% has lasted for 200 msec in a carriage operation -A collision has been detected in a carriage operation (with the speed predicted from the PWM output value having a deviation of 25 ips or more from the actual speed).	<Supplement> -If the motor could not be run at all or has resulted in an error after moving by a slight distance: A. A mechanical load error may be suspected. B. The motor or drive circuit may be at fault. -If the carriage has run more or less out of control and resulted in an error: A. encoder sensor may be at fault.

Code (last 4 digits)	Panel display (Large LCD)	Panel display (Small LCD)	Explanation/Detection sequence	Remedial Action
2F27	Hardware error. 03130031-2F27 Turn off printer, wait, then turn on again.	Power On Again Carriage Timeout Restart Printer	Carriage shift timeout The target position could not be reached within a predicted operation time +3 seconds during carriage operation.	<Supplement> -If the carriage travels heavily towards the stop position, a mechanical load error may be suspected.
2F28	Hardware error. 03130031-2F28 Turn off printer, wait, then turn on again.	Power On Again Lift Motion Timeout	Lift shift timeout A lift operation has been executed, but no sensor has been detected or a sensor has remained detected.	1. Switch off the printer, then back on. 2. The carriage cannot travel to the lift drive position. 3. The lift drive cam is not engaged. 4. Faulty lift drive sensor 5. Faulty lift drive motor
2F29	Hardware error. 03030000-2F29 Turn off printer, wait, then turn on again.	Power On Again LF Feed Timeout Restart Printer	LF feeding motor timeout (cut sheet) -The target position could not be reached within a predicted operation time +3 seconds during an LF operation. -The sensor could not be detected during an LF operation involving sensor detection.	1. Replace the feed roller encoder sensor. 2. Replace the feed motor. <Supplement> -If the carriage travels heavily near the stop position, a mechanical load error may be suspected. -If any other symptom is observed, a feeding sensor may be at fault.
2F2A	Hardware error. 03130031-2F2A Turn off printer, wait, then turn on again.	Power On Again LF Position Err Restart Printer	Cannot detect the LF home position The LF home position could not be detected on LF homing during initialization.	1. Check the sensor (I/O mode check). 2. Replace the feed roller encoder sensor. 3. Replace the encoder film. 4. Replace the feed motor/belt/ adjust the belt tension. 5. Replace the long flexible cable. <Supplement> -If the motor could not be run at all: A. A mechanical load error may be suspected. B. The motor or drive circuit may be at fault. -If the carriage has resulted in an error after moving at a constant speed: The feed roller HP sensor may be at fault. -If the carriage has run more or less out of control and resulted in an error, the encoder sensor may be at fault. When FU2802 blows out on iPF6300/ 6400 series -Replace the main controller PCB.
2F2B	Hardware error. 03130031-2F2B Turn off printer, wait, then turn on again.	Power On Again LF Motion Error	LF operation failure (LF operation disabled) A pump duty of 100% has lasted for 200 msec during LF operation.	1. Replace the feed roller encoder sensor. 2. Replace the feed motor. <Supplement> -If the motor could not be run at all or has resulted in an error after moving by a slight distance: A. A mechanical load error may be suspected. B. The motor or drive circuit may be at fault. -If the carriage has run more or less out of control and resulted in an error, the encoder sensor may be at fault. When FU2802 blows out on iPF6300/ 6400 Series -Replace the main controller PCB.
2F2C	Hardware error. 03130031-2F2C Turn off printer, wait, then turn on again.	Power On Again Hardware Err 1 03130031-2F2C	Cassette shift timeout -The target position could not be reached within a predicted operation time + 3 seconds during cassette operation. -No sensor has been detected during a pump operation involving sensor detection.	<Supplement> -If the carriage travels heavily near the stop position, a mechanical load error may be suspected. -Otherwise, the cassette unit sensor may be at fault.
2F2D	Cassette not working. Turn off printer, wait, then turn on again.	Power On Again Cassette Motion Error	Cassette operation disabled A PWM duty of 100% has lasted for 200 msec in a cassette operation.	1. Check the cassette motor and the drive circuit. 2. Check the cassette encoder sensor.
2F2E	Hardware error. 03130031-2F2E Turn off printer, wait, then turn on again.	Power On Again Roll Motion Timeout	Roll shift timeout No sensor has been detected during a roll operation involving sensor detection.	

Code (last 4 digits)	Panel display (Large LCD)	Panel display (Small LCD)	Explanation/Detection sequence	Remedial Action
2F2F	Hardware error. 03800500-2F2F Turn off printer, wait, then turn on again.	Power On Again Eject. Detect Err	Non-ejection detection error As a result of nozzle checking made by the head management sensor unit: 1. All 640 nozzles in a nozzle line are non-discharging. 2. At least 50 nozzles have been found mismatched in a nozzle line of 640 nozzles since the last session of detection.	1. Check whether any foreign matter such as paper slip exists on the head management sensor optical axis. 2. Light interception due to ink accumulation.-> Remove the ink/ Replace the unit. 3. Check the head management sensor's connector connection 4. If Service mode nozzle check pattern printing is no problem, replace the head management sensor unit.  Reference 1) As for the detection condition 1. above, in the iPF650/750, iPF6300/6350, and iPF8300 series or later, the error codes are broken up into 2F40,2F41,2F42,2F43,2F44, and 2F47 depending on the non-ejection conditions.  Reference 2) Error 2F2F,2F40,2F41,2F42,2F43,2F44, and 2F47 are detected in the following order. 1. Determines signal level (2F47) of head management sensor 2. Determines complete non-ejection of all colors (2F40) 3. Determines multiple mismatches (2F2F) 4. Determines complete non-ejection of a single color (2F41) 5. Determines complete non-ejection of one line (2F42) 6. Determines complete non-ejection of 640 nozzles (2F43) 7. Determines non-ejection of more than 320 nozzles (2F44)  Reference 3) The amount of change (between non-ejecting and ejecting nozzle counts) from the last session of nozzle checking is defined as the amount of mismatch.
2F30	Hardware error. 03800500-2F30 Turn off printer, wait, then turn on again.	Power On Again Eject. Detect Err	Non-ejection detecting position error No detectable region has been found during non-ejection position adjustment.	
2F32	Multi-sensor error Turn off printer, wait a while, then turn it on again.	Power On Again Multi-sensor Err	Faulty multisensor Light quantity adjustment of multisensor failed. Or, outside light entered during multisensor light quantity adjustment.	1. Retry the adjustment with the effect of outside light, such as that of the afternoon sun, being removed. 2. Check the position at which the multisensor is installed. 3. Replace the multisensor.
2F33	Use another paper. Press Online to clear the error.	Paper Type Please Change Can't Adj Paper Chg Paper Type	Unadjustable because of transparent paper Paper are unidentifiable on automatic adjustment (transparent/semi-transparent paper).	Change to appropriate paper.
2F34	Cannot calibrate. Press OK and try calibration again.  Cannot calibrate. Try calibration again.	Press OK and recalibrate Calibration Err Recalibrate	Color calibration error The adjustment value has gone out of bounds during calibration.	1. Check to see if the loaded paper permit calibration. 2. Check calibrated printed matter for soiling and other defects. 3. Check the nozzle pattern
2F35	Calibration There is a problem with the multi-sensor. Press OK to cancel calibration.  Calibration There is a problem with the multi-sensor. Cancel calibration.	Calibration multi-sensor err Press OK to cancel	Faulty multisensor (on calibration) A failure to calibrate has been detected from the parts counter.	1. Check the parts counter in service mode and replace the multisensor unit. 2. Initialize the counter for the replacement unit mounted. (It is recommended to estimate the usage status of other units coming to the end of their service life and replace them as needed.)
2F37	ERROR E173-2F37 Call for service.	ERROR E173-2F37 Call For Service	Linear scale error No signal is available from the carriage encoder when the printhead is driven.	
2F38	Top cover is open. Turn off printer, wait a while, and turn it on again.	Ink Tank Cover Close Please Tank Cover Open Close Please	The top cover is abnormally open.	Check the cover. Check the sensor (I/O mode).

Code (last 4 digits)	Panel display (Large LCD)	Panel display (Small LCD)	Explanation/Detection sequence	Remedial Action
2F3A	Hardware error. 03130031-2F3A Turn off printer, wait, then turn on again.	Power On Again Valve Motor Err	Ink Supply Valve Open/Closed motor timeout error	1. Replace the ink supply unit. 2. Replace the main controller PCB.
2F3B	Hardware error. 03130031-2F3B Turn off printer, wait, then turn on again.	Power On Again Hardware Err 1 03130031-2F3B	CS communication error An irrecoverable communication error has occurred communicating between the CS chip mounted on the ink tank and the main unit.	1. Remove and insert the ink tank, or replace the ink tank. 2. Check bundled wires in the ink tank unit and the main controller PCB. 3. Replace the main controller PCB.
2F3C	Hardware error. 03130031-2F3C Turn off printer, wait, then turn on again.		LF nip sensor error. When executing nip automatic operation, one of the following conditions is met. -The sensor detected nip closed after the nip completed opening operation. -The sensor detected nip open after the nip completed closing operation.	Check the lift cam sensor/ pressure release switch (I/O mode)
2F3D	Hardware error. 03130031-2F3D Turn off printer, wait, then turn on again.		HP pre-ejection pump motor overload error	Replace the HP maintenance jet tray unit.
2F3E	Hardware error. 03130031-2F3E Turn off printer, wait, then turn on again.		HP pre-ejection pump motor shift timeout	Replace the HP maintenance jet tray unit.
2F3F	Hardware error. 03130031-2F3F Turn off printer, wait, then turn on again.		An error other than overload error or shift timeout error has been detected for the HP pre-ejection pump motor.	Replace the HP maintenance jet tray unit.
2F40	Hardware error. 03800500-2F40 Turn off printer, wait, then turn on again.		When the result of non-ejection detection is as follows. When non-ejection has been detected for all nozzles of all colors -The error code assuming a problem in the supply system/ purge system/ main controller PCB (electric).	
2F41	Hardware error. 03800500-2F41 Turn off printer, wait, then turn on again.		When the result of non-ejection detection is as follows: Complete non-ejection of nozzles in 1 to 5 chip(s). (A line EVEN/ A line ODD/ B line EVEN/ B line ODD Total of 2560 nozzles x 1 to 5 chip(s) complete non-ejection) -Error code assuming a problem in the ink supply system/ purge system.	
2F42	Hardware error. 03800500-2F42 Turn off printer, wait, then turn on again.		When the result of non-ejection detection is as follows: Complete non-ejection of one line in 1 chip. (In either A line or B line, a complete non-ejection of 1280 nozzles) -Error code assuming broken flexible cable or contact failure (heat enable line).	
2F43	Hardware error. 03800500-2F43 Turn off printer, wait, then turn on again.		When the result of non-ejection detection is as follows: Complete non-ejection (640 nozzles) of EVEN line or ODD line. -Error code assuming broken flexible cable or contact failure (data line).	
2F44	Hardware error. 03800500-2F44 Turn off printer, wait, then turn on again.		When the result of non-ejection detection is as follows: More than half of 640 nozzles in EVEN line or ODD line have non-ejection (more than 320 nozzles). -Error code assuming a head failure such as broken heater board of head.	
2F46	Hardware error. 03130031-2F46 Turn off printer, wait, then turn on again.	Only for iPF750 series	The shutter HP sensor did not respond at startup and at switching of platen shutter at printing.	Check the platen shutter HP sensor (I/O Display). Check/ replace the platen shutter drive unit or sensor

Code (last 4 digits)	Panel display (Large LCD)	Panel display (Small LCD)	Explanation/Detection sequence	Remedial Action
2F47	Hardware error. 3800500-2F47 Turn off printer, wait, then turn on again.	Only for iPF750 series	The optical axis of the head management sensor unit has been intercepted for some reasons.  The amount of LED luminescence and the level of detection signal of diode light receiving sensitivity has gone beyond the predefined range. (determines the level of APCCHK)(It's not a problem of printhead or ink supply system.)	1. Check whether any foreign matter such as paper slip exists on the head management sensor optical axis. 2. Light interception due to ink accumulation.-> Remove the ink/ Replace the unit. 3. Check connection of the head management sensor's connector. 4. Main controller PCB (Check the fuse/ Replace the PCB.) 5. A large amount of ink mist has been attached to optical element. 6. Replace the head management sensor.
2F48	Hardware error. 03130031-2F48 Turn off printer, wait, then turn on again.		VHT (heater drive power supply for printhead) error VHT has gone below or above the rating.	iPF6300 series 1. Replace the printhead. 2. Replace the main controller PCB. iPF8300 series 1. Replace the printhead. 2. Replace the CR relay board. 3. Check/ replace the long flexible cable. 4. Replace the main controller PCB.
2F49 2F50 2F51	Hardware error. 03130031-xxxx Turn off printer, wait, then turn on again.		Printhead short-circuited detected. Prior to VH power on, it has been detected that the printhead had been damaged due to paper jam etc, and ink went inside the terminal area causing near short-circuit. 2F49: L side printhead 2F50: R side printhead 2F51: LR both printhead	iPF6300 series 1. Replace the printhead 2. Replace the main controller PCB. iPF8300 series 1. Replace the printhead 2. Replace the CR relay board 3. Check/ replace the long flexible cable. 4. Replace the main controller PCB.
2F4A	Hardware error. 03130031-2F4A Turn off printer, wait, then turn on again.	iPF6300/830 or newer	main controller PCB error.	Replace the main controller PCB.
2F4D	Hardware error. 03130031-2F4D Turn off printer, wait, then turn on again.	Left printhead only.  Possible to occur on iPFX400 or newer models.	VHT leak detection error of left printhead, in case of VHT exceeds rated value or falls below the rated value.	For iPF6400 series, 1. Replace the printhead. 2. Replace the main controller PCB. For iPF8400/9400 series, 1. Replace the printhead. 2. Replace the CR relay board. 3. Check and replace the long flexible cable printed circuit. 4. Replace the main controller PCB.
2F4E	Hardware error. 03130031-2F4E Turn off printer, wait, then turn on again.	Right printhead or a single printhead  Possible to occur on iPFX400 or newer models.	VHT leak detection error of right printhead, in case of VHT exceeds rated value or falls below the rated value.	
2F4F	Hardware error. 03130031-2F4F Turn off printer, wait, then turn on again.	Possible to occur on iPFX400 or newer models.	VHT leak detection error of right and left printhead or a single printhead, in case of VHT exceeds rated value or falls below the rated value.	
2F52	Hardware error. 03130031-2F52 Turn off printer, wait, then turn on again.		Detected that a carriage unit of a legacy model has been mounted (iPF8300/6300/6350 only).	Replace with an appropriate carriage unit. 1. Replace with an appropriate carriage unit. 2. Replace the printhead. 3. Replace the main controller PCB.
2F53	Hardware error. 03130031-2F53. Turn off printer, wait, then turn on again.		Supply valve motor error of the left ink tank. Drove supply valve motor. The movement was not detected.	iPF8400/9400 Series 1. Replace the left ink tank unit. 2. Replace the main controller PCB.
2F54	Hardware error. 03130031-2F54. Turn off printer, wait, then turn on again.		Supply valve motor error of the right ink tank. Drove supply valve motor. The movement was not detected.	iPF8400/9400 Series 1. Replace the right ink tank unit. 2. Replace the main controller PCB.
2F60	!Spectrophotometer Unit not connected. Turn off power and attach Spectrophotometer Unit.		Spectrophotometer unit won't return signals.	1. Install spectrophotometer unit. 2. Replace signal line. 3. Replace connection. 4. Replace spectrophotometer unit PCB.
2F61	Hardware error 038A0002-2F61 Turn off printer, wait a while, then turn it on again.		UART communication error. (Data transfer volume in consistency, checksum error etc.)	1. Replace signal line. 2. Replace connection. 3. Replace spectrophotometer unit PCB
2F62	Hardware error 038A0002-2F62 Turn off printer, wait a while, then turn it on again.		When transmitting specified pulses to spectrophotometer carriage motor, the spectrophotometer carriage unit won't respond to spectrophotometer carriage HP sensor.	1. Replace spectrophotometer unit PCB. 2. Replace lines around spectrophotometer carriage unit. 3. Replace spectrophotometer carriage motor.

Code (last 4 digits)	Panel display (Large LCD)	Panel display (Small LCD)	Explanation/Detection sequence	Remedial Action
2F63	Hardware error 038A0002-2F63 Turn off printer, wait a while, then turn it on again.		The spectrophotometer up-down unit upper detection sensor won't respond when a predefined pulse is sent to the spectrophotometer up-down unit motor.	1. Replace spectrophotometer up-down unit motor. 2. Replace spectrophotometer up-down unit upper detection sensor. 3. Re-install delivery guide. 4. Replace the spectrophotometer unit PCB.
2F65	Hardware error 038A0002-2F65 Turn off printer, wait a while, then turn it on again.		When a predefined pulse is sent to the spectrophotometer up-down unit motor, the spectrophotometer up-down unit lower detection sensor in spectrophotometer unit won't respond.	1. Replace spectrophotometer up-down unit motor. 2. Replace spectrophotometer up-down unit lower detection sensor. 3. Re-install delivery guide. 4. Replace the spectrophotometer unit PCB.
2F66	Hardware error 038A0002-2F66 Turn off printer, wait a while, then turn it on again.		Media dry fan won't return signals.	1. Replace fan 2. Replace signal lines 3. Replace the spectrophotometer unit PCB.
2F67	Hardware error 038A0002-2F67 Turn off printer, wait a while, then turn it on again.		Embedded FlashROM read/ write error	Replace the spectrophotometer unit PCB.
2F68	Hardware error 038A0002-2F68 Turn off printer, wait a while, then turn it on again.		Spectrophotometer EEPROM read/write error	Replace the spectrophotometer unit PCB.
2F69	Hardware error 038A0002-2F69 Turn off printer, wait a while, then turn it on again.		Write/read error at RAM check	Replace the spectrophotometer unit PCB.
2F6A	Hardware error 038A0002-2F6A Turn off printer, wait a while, then turn it on again.		Firmware update failed.	1. Update firmware again 2. Replace the spectrophotometer unit PCB.
2F6B	Hardware error 038A0002-2F6B Turn off printer, wait a while, then turn it on again.		Initialization after power on of CPU at spectrophotometer unit side failed.	Replace the spectrophotometer unit PCB.
2F6C	Hardware error. 03130031-2F6C. Turn off printer, wait, then turn on again.		Failed self-testing.	Replace the spectrophotometer unit PCB.
2F70	Hardware error. 03130031-2F70. Turn off printer, wait, then turn on again.		Indication at ink priming error in both subtanks.	For iPF6400 Series, 1. Replace both of the inktank units. 2. Replace the main controller PCB.
2F71	Hardware error. 03130031-2F71. Turn off printer, wait, then turn on again.	Call for Service. HW1 error 03130031-2F71	Indication at ink priming error in the left subtank.	For iPF6400 Series, 1. Replace the left inktank unit. 2. Replace the main controller PCB.
2F72	Hardware error. 03130031-2F72. Turn off printer, wait, then turn on again.	Call for Service. HW1 error 03130031-2F72	Indication at ink priming error in the right subtank.	For iPF6400 Series, 1. Replace the right subtank 2. Replace the main controller PCB.
2F80	!Spectrophotometer sensor is not mounted. Please check if the sensor is mounted properly and press OK.		Spectrophotometer sensor won't return signals.	1. Install Spectrophotometer sensor. 2. Check cables. 3. Replace spectrophotometer sensor. 4. Replace the spectrophotometer unit PCB.
2F81	! Spectrophotometer Unit Calibration white tile error. Clean the tile then mount it and press OK.		After white calibration, the spectrophotometer sensor returned a value other than predetermined value.	1. Clean white tile. 2. Mount white tile. 3. Replace spectrophotometer sensor.
2F82	! Delivery guide of SP unit is not mounted. Check if the guide is mounted properly and press OK.		While the spectrophotometer up-down unit upper detection sensor and spectrophotometer top cover open/closed detection sensor are detecting, the interlock switch remains OFF.	1. Mount delivery guide. 2. Replace the spectrophotometer unit PCB. 3. Replace spectrophotometer up-down unit upper detection sensor.
2F83	!Backing plate error in the spectrophotometer unit. Clean the backing plate. Install the backing plate to the unit. Then press [OK].		No signal returned from backing plate. The signal from the backing plate is beyond threshold.	1. Clean the backing plate. 2. Replace the spectrophotometer unit PCB. 3. Replace the spectrophotometer sensor.
2F85	! SP unit up and down cover is open. Close it and press OK		Spectrophotometer top cover open/closed detection sensor won't respond.	1. Close spectrophotometer top cover. 2. Replace spectrophotometer top cover open/closed detection sensor. 3. Replace the spectrophotometer unit PCB.

Code (last 4 digits)	Panel display (Large LCD)	Panel display (Small LCD)	Explanation/Detection sequence	Remedial Action
2F86	! SP unit cover is open. Close it and then press OK.		Spectrophotometer cover open/closed detection sensor won't respond.	1. Close spectrophotometer cover. 2. Replace cover sensor. 3. Replace the spectrophotometer unit PCB.
2F87	! Colorimetric readout error. Please press OK and execute color measuring again.		When executing color measuring, the spectrophotometer sensor returned a value other than predetermined value was returned.	1. Operate paper feed adjustment. 2. Change the patch size to large. 3. Printer support (In case of printing failure). 4. Replace spectrophotometer sensor
2F88	! Colorimetric readout error. Please press OK and execute color measuring again.		When reading the positioning bar, a value other than predetermined value was returned.	1. Operate paper feed adjustment. 2. Printer support (In case of printing failure). 3. Replace spectrophotometer sensor.
2F89	! Colorimetric readout error. Please press OK and execute color measuring again		1) No shifting amount detected from the positioning bar reading value. 2) Position shifting exceeded the threshold value. 3) Skew exceeded the threshold value.	1. Operate paper feed adjustment. 2. Printer support (In case of printing failure). 3. Replace spectrophotometer sensor
2F90			Detected 3V of abnormal power out from the printhead. (Latch up current flows at head logic and temporarily the print head falls into abnormal state ; it is possible to recover by power on and off.)	
2FA0	!!It is recommended to clean the white calibration board to prevent it from possible dirt.		Inform the calibration timing of the spectrophotometer sensor.	Calibrate the spectrophotometer sensor.
4001	ERROR E146-4001 Call for service.	ERROR E146-4001 Call For Service	Borderless/flow pre-ejection/mist recovery count full	Check the parts counter and replace the target unit or Refresh Service Kit. Initialize the parts counter for the target unit after the replacement.
401A	ERROR E602-401A Call for service.		HDD failure Failed to read and write to and from the HDD.	1. Restart in service mode. 2. Remove and install HDD 3. Replace HDD. Switch on service mode after the replacement.
401B	ERROR E602-401B Call for service.		Poor HDD connection The HDD and the HDD controller are not indefinable.	1. Restart in service mode. 2. Remove and install HDD 3. Replace HDD. Switch on service4. Replace HDD controller or the main controller PCB. Restart after the replacement.
401C	ERROR E198-401C Call for service.	ERROR E198-401C Call For Service	Faulty RTC Any error other than the two errors mentioned below has been detected while initializing the RTC at startup.	1. Restart the printer in service mode. 2. Replace the main controller PCB.
401D	ERROR E198-401D Call for service.	ERROR E198-401D Call For Service	RTC low battery error A battery error has been detected while initializing the RTC at startup.	1. Restart the printer in service mode. 2. Check the RTC battery. 3. Replace the main controller PCB.
401E	ERROR E198-401E Call for service.	ERROR E198-401E Call For Service	RTC clock stop The RTC has been detected idle while initializing the RTC at startup.	1. Restart the printer in service mode. 2. Replace the main controller PCB.
4027	Hardware error. 03130031-4027 Turn off printer, wait, then turn on again.	Power On Again Lift Motion Timeout	Lift shift timeout error A lift operation has been executed, but no sensor has been detected or a sensor has remained detected.	1. Switch off the printer, then back on. 2. The carriage cannot travel to the lift drive position. 3. The lift drive cam is not engaged. 4. Faulty lift drive sensor 5. Faulty lift drive motor 6. Replace the main controller PCB.
4034	ERROR E196-4034 Call for service.	ERROR E196-4034 Call For Service	Multisensor unit version error A different version of multisensor is installed. This would not occur in an ordinary user environment.	Replace the multisensor unit.
4037	ERROR E173-4037 Call for service.	ERROR E173-4037 Call For Service	Linear scale error No signal is available from the carriage encoder when the printhead is driven.	
403E	ERROR E161-403E Call for service.	ERROR E161-403E Call For Service	Head abnormal temperature rise (printhead 1 (R), or A model) Either of the two Di sensors maintained for each printhead chip (color-specific) has been detected at 120 degrees C or higher or -10 degrees C or lower.	
403F	ERROR E161-403F Call for service.	ERROR E161-403F Call For Service	Head abnormal temperature rise (printhead 2 (L)) Either of the two Di sensors maintained for each printhead chip (color-specific) has been detected at 120 degrees C or higher or -10 degrees C or lower.	

Code (last 4 digits)	Panel display (Large LCD)	Panel display (Small LCD)	Explanation/Detection sequence	Remedial Action
4040	ERROR E196-4040 Call for service.	ERROR E196-4040 Call For Service	Checksum error The checksum of a file transmitted on execution of the firmware update is unmatched.	1. Start in download mode to upgrade the firmware. 2. Restart the printer in service mode to clear the error. 3. Replace the main controller PCB.
4041	ERROR E196-4041 Call for service.	ERROR E196-4041 Call For Service	Flash erase error Failed to erase flash ROM on execution of the firmware update.	1. Start in download mode to upgrade the firmware. 2. Restart the printer in service mode to clear the error. 3. Replace the main controller PCB.
4042	ERROR E196-4042 Call for service.	ERROR E196-4042 Call For Service	Flash write error Failed to write flash ROM on execution of the firmware update.	1. Start in download mode to upgrade the firmware. 2. Restart the printer in service mode to clear the error. 3. Replace the main controller PCB.
4042	Unknown file. Check file format. Turn off printer, wait a while, then turn it on again.		MIT data transfer failure Failed to write MIT data on its transmission.	1. Execute "Initialize Paper Type" from the system settings. (Note: All paper information will be reset to its factory defaults and additional Paper deleted.) 2. Upgrade the firmware in download mode. 3. Replace the main controller PCB.
4043	ERROR E196-4043 Call for service.	ERROR E196-4043 Call For Service	Firmware update failure error Failed to allocate a work area on RAM on firmware update.	1. Start in download mode to upgrade the firmware. 2. Restart the printer in service mode to clear the error. 3. Replace the main controller PCB.
4044	ERROR E196-4044 Call for service.	ERROR E196-4044 Call For Service	EEPROM size error Size information about the firmware data transmitted on firmware update and the size of actually transmitted data do not match.	1. Start in download mode to upgrade the firmware. 2. Restart the printer in service mode to clear the error. 3. Check the firmware transfer environment (IF changes, PC). 4. Replace the main controller PCB.
4045	ERROR E196-4045 Call for service.	ERROR E196-4045 Call For Service	Engine EEPROM write error An EEPROM read/write failure has been detected in the engine portion of the firmware.	1. Start in download mode to upgrade the firmware. 2. Restart the printer in service mode to clear the error. 3. Replace the main controller PCB.
4046	ERROR E141-4046 Call for service.	ERROR E141-4046 Call For Service	Recovery part revolutions reaching 50,000 cycles or more Recovery part operations have reached a predetermined count.	Check the parts counter and replace required parts. (Replacement of the parts coming to the end of their useful lives is recommended.) Initialize the counter for the replacement unit mounted. The iPF5000/500/600 have a counter problem fixed. Identify the firmware version and start in download mode to upgrade the firmware to Ver.1.13 or later from any earlier release.
4047	ERROR E144-4047 Call for service.	ERROR E144-4047 Call For Service	Carriage count error Supply part operations have reached a predetermined count.	Check the parts counter and replace the target unit or Refresh Service Kit. Initialize the parts counter for the target unit after the replacement.
4048	ERROR E144-4048 Call for service.	ERROR E144-4048 Call For Service	Non-discharging nozzles on initial filling An unallowable number of non-discharging nozzles have been detected at the completion of initial filling.	
4049	Unknown file. Check file format. Turn off printer, wait a while, then turn it on again.	Cannot update firmware Power On Again	Wrong transfer ROM data model Files for a different model have been transferred on firmware update.	1. Restart the printer in service mode to clear the error (this error won't occur when FUT is used). 2. Start in download mode to upgrade the firmware. 3. Replace the main controller PCB.
404A	ERROR E194-404A Call for service.	ERROR E194-404A Call For Service	Non-ejection count error A non-ejection part operation counter has reached a specified limit.	Check the parts counter and replace the target unit or Refresh Service Kit. Initialize the parts counter for the target unit after the replacement.
404B	ERROR E199-404B Call for service.	ERROR E199-404B Call For Service	Temperature/humidity sensor error When temperature 0 and humidity 0% are detected, the detection mechanism is considered failed and an error message is displayed.	1. Restart the printer in service mode to clear the error. 2. Identify the firmware version and update the firmware to the last release if it is earlier than Ver.1.31 (firmware defect). 3. Remove and reinsert the temperature/humidity sensor PCB connector 4. Replace the temperature/humidity sensor PCB.



Code (last 4 digits)	Panel display (Large LCD)	Panel display (Small LCD)	Explanation/Detection sequence	Remedial Action
404C	ERROR E196-404C Call for service.	ERROR E196-404C Call For Service	Serial number information mismatch A mismatch has been detected between the serial number information stored in the EEPROM on the main controller PCB and that stored in the EEPROM on the MTC relay PCB at startup.	1. Check to see if the correct PCB is mounted, since a PCB of the wrong model may have been mistakenly mounted during servicing. 2. Invoke service mode to implement PCB replacement.
404D	ERROR E196-404D Call for service.	ERROR E196-404D Call For Service	Machine ID information mismatch A mismatch has been detected between the model ID information stored in the EEPROM on the main controller PCB and that stored in the EEPROM on the MTC relay PCB at startup.	1. Check to see if the correct PCB is mounted, since a PCB of the wrong model may have been mistakenly mounted during servicing. 2. Invoke service mode to implement PCB replacement.
404E	ERROR E196-404E Call for service.	ERROR E196-404E Call for service.	An EEPROM read/ write error has been detected in the controller portion of the firmware.	1. Start in download mode to upgrade the firmware. 2. Start in service mode to clear the error. 3. Replace the main controller PCB.
404F	ERROR E144-404F Call for service.		Pump revolutions full The number of HP pre-ejection pump revolution has reached the defined value.	Clear the counter in service mode after having replaced the HP pre-ejection tray unit.
4050	Error E161-4050 Call for service. For iPF6000, 03800500-4050.	Error! E161-4050 Call for service.	Non-ejection detection error The timing of "ink priming sequence" is following. -At installation of a new model printer -At reinstallation after the second transportation. -At replacement of the printhead	
405A	Error E602-405A Call for service.		Incorrect capacity HDD model is connected.	Replace HDD
405B	Error E602-405B Call for service.		Mismatched HDD model is connected.	Replace HDD
4061	!The paper loaded askew. Remove the paper.		Position detection of askew loaded paper.	

## 6.3 Service Software

### 6.3.1 L Printer Service Tool

#### a) Function of L Printer Service Tool

- This tool has the following function.
- Updating the firmware of printer
  - Color check of multi sensor
  - Displaying the printer information

#### Connection method with the computer:

USB, Network

b) Screen description

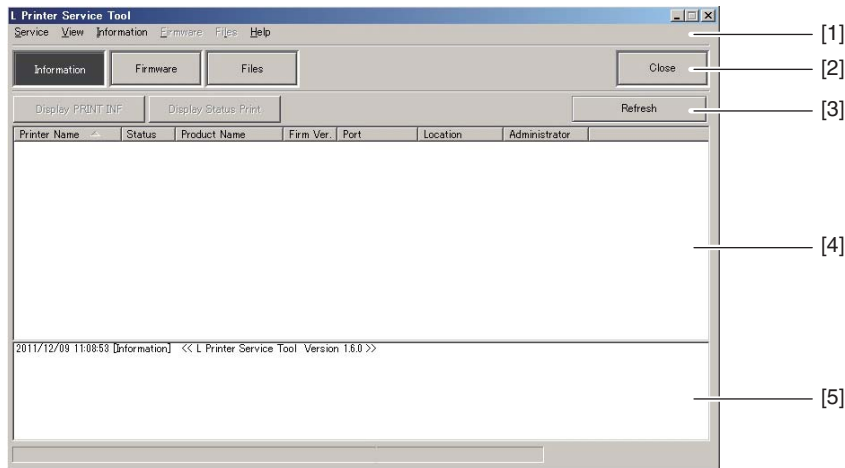

F-6-1

[1] Main menu

Choose the menu to execute.

[2] Main menu button

Choose the menu to execute between the [Information] and the [Firmware] and the [Files].

[3] Sub menu button

The sub menu button is displayed according to the menu chosen by main menu or main menu button.

[4] Printer information area

The information of the printer connected with computer is shown according to the chose menu.

[5] Message area

The message of executed menu is shown. And the message is saved as the text file when choosing the "[Service]-[Save Message]" of the main menu.

c) Operation

1) Showing the information of the printer

The data of PRINT INF or status print is shown.

(1) Choose the [Information] of the main menu button or the "[Service]-[Information]" of the main menu.

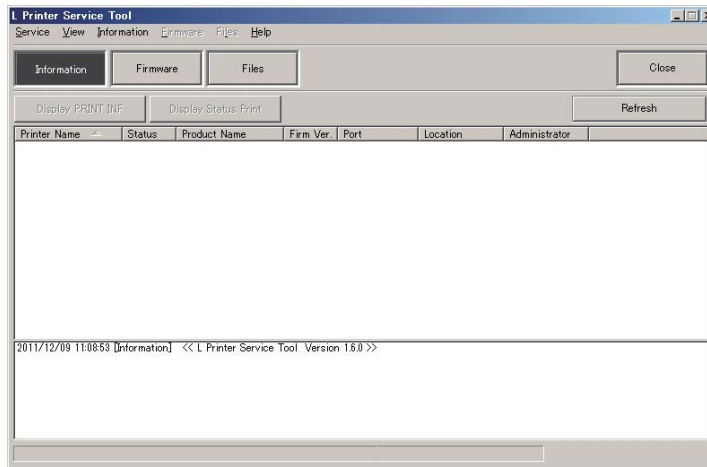

F-6-2

(2) Choose the printer from the list shown to the printer information area.

**MEMO:**

- The list is refreshed when choosing the [Refresh] of the sub menu button or the "[View]-[Refresh]" of the main menu.
- The printer is searched according to the setting of the [Specify Search Range] dialogue box after choosing the "[View]-[Specify Search Range]" of the main menu to display the dialogue box. The five IP addresses at the maximum can register when searching by the IP address.

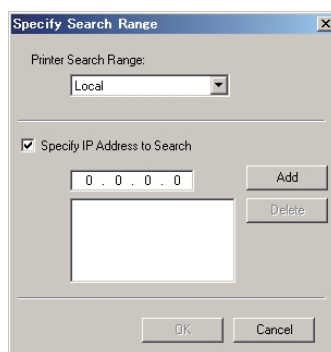

F-6-3

- (3)-1 Choose the [Display PRINT INF] of the sub menu button or the "[Information]-[Display PRINT INF]" of the main menu when showing the PRINT INF.
- The data of PRINT INF is shown by the appointed application software.

- (3)-2 Choose the [Display Status Print] of the sub menu button or the "[Information]-[Display Status Print]" of the main menu when showing the Status Print.
- The data of Status Print is shown by the appointed application software.

- (3)-3 Choose the [Color Check] of the sub menu button or the "[Information]-[Color Check]" of the main menu when executing the color check.

- This mode judges the OK or NG by checking the color check data that measured by the multi sensor.

- Before executing the color check, need the following media to set to the printer.

Roll media of more than 10 inch width, or cut sheet of more than A4-size.

Paper type: Glossy Photo Paper 170gsm

- When executing the color check, the paper type that selected by the dialogue box must match with the paper type that set to the printer so that the check can execute correctly.

**MEMO:**

- The application software used to show the data and the folder used to store the files can change by the "[Service]-[Setup]" of the main menu.

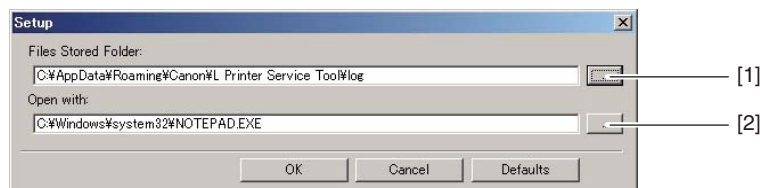

F-6-4

[1] This menu can change the folder used to store the file.

[2] This menu can change the application software (NotePad or WordPad) used to show the data.

- The printer name can add by the "[Service]-[Add Printer]" of the main menu.

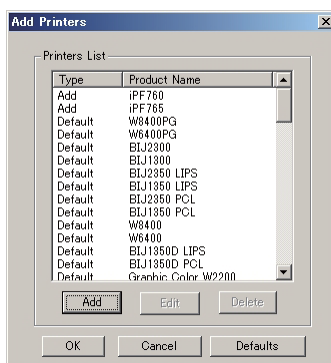

F-6-5

2) Updating the firmware of the printer

The firmware of printer can update according to the following procedure.

- (1) Choose the [Firmware] of the main menu button or the "[Service]-[Firmware]" of the main menu.

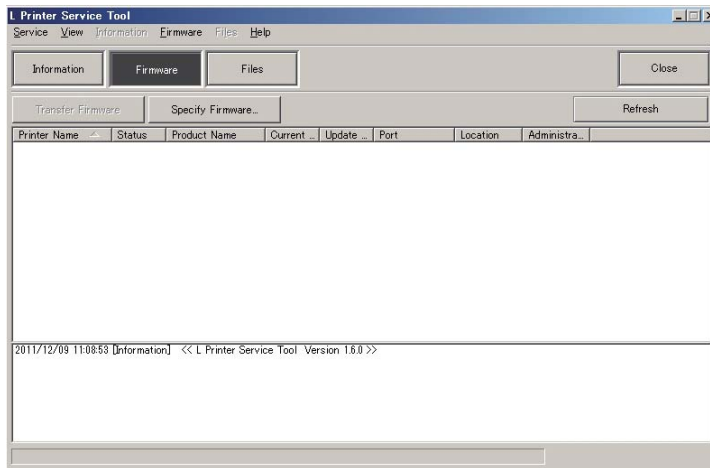

F-6-6

- (2) Choose the printer to update from the list of the printer shown to the printer information area.

**MEMO:**

- The printer list is refreshed when choosing the [Refresh] of the sub menu button or the "[View]-[Refresh]" of the main menu.
- The printer is searched according to the setting of the [Specify Search Range] dialogue box after choosing the "[View]-[Specify Search Range]" of the main menu to display the dialogue box. The five IP addresses at the maximum can register when searching by the IP address.

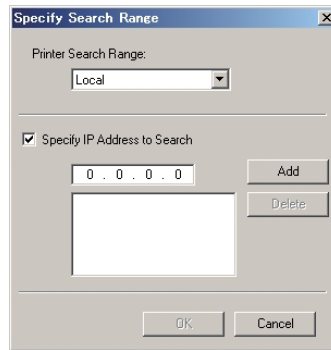

F-6-7

- (3) Choose the [Specify Firmware] of the sub menu button or the "[Firmware]-[Specify Firmware]" of the main menu. Specify the folder stored the file by the [Specify Firmware Folder] of the [Specify Firmware] dialogue box or specify the file (.jdl file) by the [Specify Firmware File] of the dialogue box.

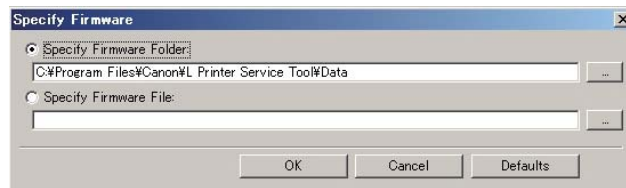

F-6-8

- (4) Make sure that the printer is the online mode or the download mode. The firmware of the printer is updated when choosing the [Transfer Firmware] of the sub menu button or the "[Firmware]-[Transfer Firmware]" of the main menu.

**MEMO:** The Printer becomes the force transfer mode when choosing the "[Firmware]-[Force Transfer Mode]" of the main menu. Thereby, you can choose the [Transfer Firmware] without concerning the status of the printer. And when transferring an incorrect file, as it may destroy the printer firmware, please take extra care.

### 3) Managing the information of the printer

The list of the PRINT INF or the status print gotten according to the procedure of "1) Showing the information of the printer" can manage.

(1) Choose the [Files] of the main menu button or the "[Service]-[Files]" of the main menu.

- The list of the PRINT INF or the status print gotten so far is shown in the printer information area.

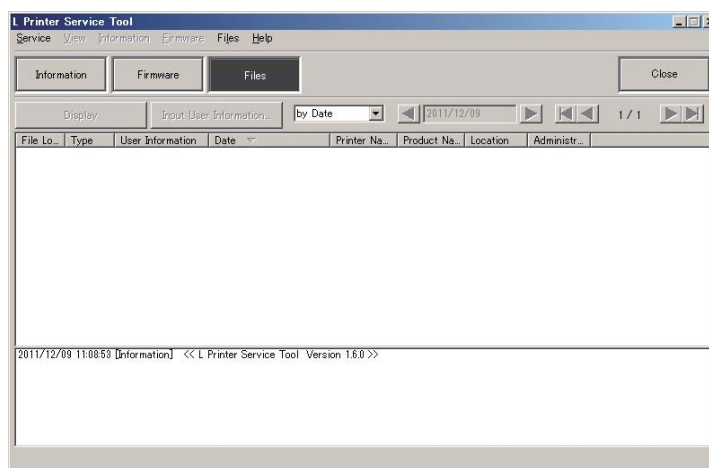

F-6-9

(2) Choose the [Display] of the sub menu button or the "[Files]-[Display]" of the main menu after selecting the list that want to show in the printer information area. The multiple selection from the lists is possible.

- The data of the selected PRINT INF or status print is shown.

#### MEMO:

- The user information can set to the list after choosing the [Input User Information] of the sub menu button or the "[Files]-[Input User Information]" of the main menu. The input of max 511 characters is possible.

- In case of deleting the list, choose the "[Files]-[Delete Files]" of main menu after selecting the list which want to delete from the printer information area.

## 6.4 Firmware Update Tool

### 6.4.1 imagePROGRAF Firmware Update Tool

#### a) Function of imagePROGRAF Firmware Update Tool

This tool has the following function.  
 - Updating the firmware of printer

**Connection method with the computer:**  
 USB, Network

#### b) Operation

- 1) Make sure that the printer is the online mode.
- 2) Exit all other running programs.
- 3) Start the imagePROGRAF Firmware Update Tool.
- 4) According to the internet connection state of the computer, specify in the [Update Method Selection] dialogue box as shown in the followings.
- 4)-1 In case the computer is connected to the internet, select the [Connect to the internet to get the latest information], and then click [Next].

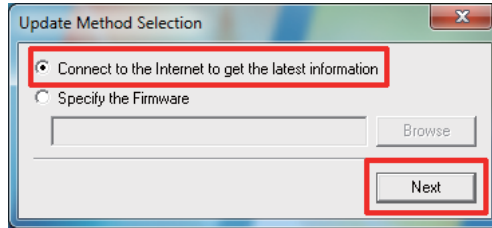

F-6-10

- 4)-2 In case the computer is not connected to the internet, select the [Specify the Firmware] and specify the firmware data that downloaded manually, and then click the [Next].

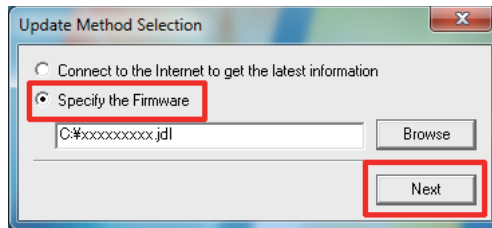

F-6-11

- 5) The [Update Possible] is displayed in the [Status] field of the printers that a newer firmware is available.

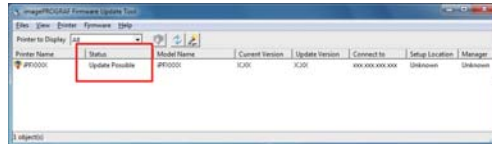

F-6-12

**MEMO:**

The overwriting the same firmware version or the firmware downgrade can not execute.

- 6) Click the printer to update the firmware of to select it, and then click the [Start Update] icon.

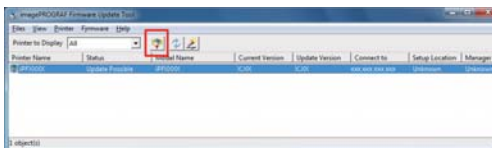

F-6-13

7) Click [Yes] in the [Update Confirmation] dialogue box.

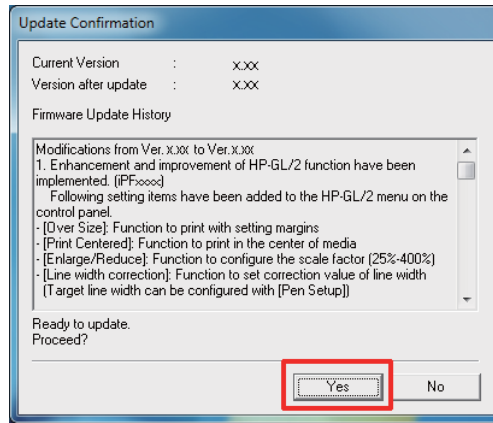

F-6-14

8) The firmware data is transferred to the printer.

9) After the firmware data transference has completed, the [Finish Update] dialogue box is displayed. Click the [OK].  
- When the firmware has been overwritten, the printer restarts.

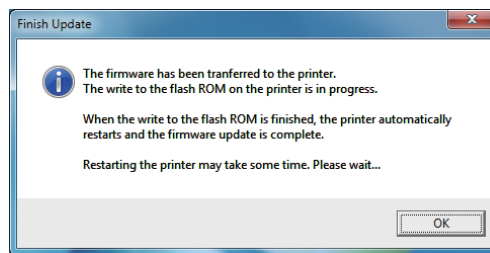

F-6-15

## 6.5 Service Tools

---

### 6.5.1 Tool List

T-6-1

General-purpose tools	Application
Long phillips scerewdriver	Inserting and removing screw
Phillips scerewdriver	Inserting and removing screw
Flat-head scerewdriver	Removing the E-ring
Needle-nose pliers	Inserting and removing the spring parts
Hex key wrench	Inserting and removing hexagonal screws
Flat brush	Applying grease

T-6-2

Special-purpose tools	Application
Cover Switch Tool (QY9-0103)	Pressing the cover switch
Grease FLOIL G-5000H (FY9-6022)	Applying to specified locations
EU-1 (FY9-6028)	Soaking or applying to specified locations
Syringe (CK-0541)	Draining ink manually
Lint free paper (CK-0336)	Wiping off ink
Rubber gloves (QC1-5547)	Preventing ink stains
Penlight (CK-0327)	Assisting the manual cappings



---

## Chapter 7 SERVICE MODE

---



---

# Contents

7.1 Service Mode.....	7-1
7.1.1 Service Mode Operation.....	7-1
7.1.2 Map of the Service Mode.....	7-2
7.1.3 Details of Service Mode.....	7-10
7.1.4 e-Maintenance/imageWARE Remote.....	7-28
7.1.5 Viewing PRINT INF .....	7-38
7.2 Special Mode .....	7-53
7.2.1 Special Modes for Servicing .....	7-53



---

## 7.1 Service Mode

---

### 7.1.1 Service Mode Operation

#### a) How to enter the Service mode

Enter service mode according to the following procedure:

- 1) Turn off the printer power.
- 2) Turn on the power while pressing the [Load] key and [Navigate] key.
  - \* Keep pressing the above keys until "Initializing" is displayed.
- 3) "S" appears at the top right of the display.
- 4) Press the ◀ key or ▶ key to choose the [Set./Adj. Menu] and press the [OK] key.  
"SERVICE MODE" appears in the menu list and the MESSAGE LED flashes.
- 5) Press the ▲ key or ▼ key to choose "SERVICE MODE" and press the [OK] key.
  - \* Service mode is added to the [Set./Adj. Menu]. Service mode can be entered even when an error occurs (an error message is displayed) by turning off the power once and then pressing the above keys.

#### b) How to exit the Service mode

Turn off the printer.

#### c) Key operation in the service mode

- Selecting menus and parameters: ◀ or ▶ key
- Going to the next lower-level menu: ▼ key
- Going to the previous higher-level menu: ▲ key
- Determining a selected menu or parameter: [OK] key

### 7.1.2 Map of the Service Mode

The hierarchy of menus and parameters in the Service Mode is as shown below.

First Level	Second Level	Third Level	Fourth Level	Fifth Level	Sixth Level	
DISPLAY	PRINT INF	YES/NO	: Select YES to print			
	SYSTEM	S/N				
		TYPE				
		LF TYPE				
		TMP				
		RH				
		SIZE LF				
		SIZE LF				
		SIZE CR				
		SIZE CR				
		AFTER INST				
		HEAD	S/N			
			LOT			
	INK	C				
		---				
		BK				
	WARNING	01				
		---				
		20				
	ERROR	01				
---						
20						
JAM	01					
	---					
	05					
	INK CHECK	000000				
I/O DISPLAY	I/O DISPLAY 1					
	I/O DISPLAY 2					
	I/O DISPLAY 3					

First Level	Second Level	Third Level	Fourth Level	Fifth Level	Sixth Level	
ADJUST	PRINT PATTERN	NOZZLE 1	: Press the [OK] button to execute			
		OPTICAL AXIS	: Press the [OK] button to execute			
		LF TUNING				
		LF TUNING 2				
	HEAD ADJ.	MANUAL HEAD ADJ	DETAIL	: Press the [OK] button to execute		
			BASIC	: Press the [OK] button to execute		
		ADJ. SETTING	A	A-1	: Adjustment value entry	
			---			
				A-24	: Adjustment value entry	
			---			
			F	F-1	: Adjustment value entry	
			SAVE SETTINGS	YES/NO		
			RESET SETTINGS	YES/NO		
		NOZZLE CHK POS.	YES/NO			
	GAP CALIB.	YES/NO				
	CHANGE LF TYPE	0/1				
	CR REG	EXECUTE	YES/NO			
		RESET	YES/NO			
	CR MOTOR COG	YES/NO				
	MARGIN ADJ	TOP MARGIN ADJ	-5.0 to 5.0			
BTM MARGIN ADJ		-5.0 to 5.0				
PRINT PATTERN		YES/NO				

First Level	Second Level	Third Level	Fourth Level	Fifth Level	
FUNCTION	CR UNLOCK	YES/NO			
	CR LOCK	YES/NO			
	PG CHECK	YES/NO			
	CR AUTO SCAN	YES/NO			
	CR SCAN COUNT	1		: Press the [OK] button to set	
		---			
		30		: Press the [OK] button to set	
	CR SCAN SIZE	1		: Press the [OK] button to set	
		---			
		5		: Press the [OK] button to set	
	CR SCAN SPEED	1		: Press the [OK] button to set	
		---			
		5		: Press the [OK] button to set	
	STIRRING CHECK	YES/NO			
	OPT SENS OUTPUT	YES		OUTPUT0	
		---			
		NO		OUTPUT6	
	NOZZLE CHK	YES/NO			
	NOZZLE INF	C			
		---			
		BK			
	MEMORY CHK	DDR		YES/NO	
		EEP		YES/NO	
HEAD CNT CHK	YES/NO				
CR ERR CHK	YES/NO				
HEAD CHK	temp		: Display the value.		
	AD Di0		: Display the value.		
	AD Di1		: Display the value.		
	AD Vh		: Display the value.		
REPLACE	CUTTER	YES/NO			



First Level	Second Level	Third Level	Fourth Level	Fifth Level	
COUNTER	PRINTER	LIFE TTL			
		LIFE ROLL			
		LIFE CUTSHEET			
		LIFE A			
		---			
		LIFE F			
		POWER ON			
		W-INK			
		CUTTER			
		WIPE			
		SLEEP ON			
		CARRIAGE	PRINT		
			DRIVE		
	CR COUNT				
	CR DIST.				
	PRINT COUNT				
	PURGE	CLN-A-1			
		CLN-A-2			
		CLN-A-3			
		CLN-A-6			
		CLN-A-7			
		CLN-A-10			
		CLN-A-11			
		CLN-A-15			
		CLN-A-16			
		CLN-A-17			
		CLN-A-TTL			
		CLN-M-1			
		CLN-M-4			
		CLN-M-5			
		CLN-M-6			
		CLN-M-TTL			
		CLEAR	CLR-INK CONSUME		
	CLR-MTC EXC.				
	CLR-HEAD EXC.				
	CLR CR-1 EXC.				
	CLR CR-2 EXC.				
	CLR CR-3 EXC.				
	CLR CR-4 EXC.				
	CLR CR-5 EXC.				
	CLR SP-1 EXC.				
	CLR PG-1 EXC.				
	CLR HM <sub>a</sub> -1 EXC.				
	CLR MT-1 EXC.				
	CLR PL-1 EXC.				
	CLR Mi-1 EXC.				
	CLR CT-1 EXC.				
CLR WF-1 EXC.					
CLR WF-2 EXC.					
CLR-FACTORY CNT.					

First Level	Second Level	Third Level	Fourth Level	Fifth Level		
COUNTER	EXCHANGE	MTC EXC.				
		HEAD EXC.				
		BOARD EXC.(M/B)				
		CR-1 EXC.				
		CR-2 EXC.				
		CR-3 EXC.				
		CR-4 EXC.				
		CR-5 EXC.				
		SP-1 EXC.				
		PG-1 EXC.				
		HMa-1 EXC.				
		MT-1 EXC.				
		PL-1 EXC.				
		Mi-1 EXC.				
		CT-1 EXC.				
		WF-1 EXC.				
		WF-2 EXC.				
		DETAIL-CNT	MOVE PRINTER	N-INK CHK(C)		
				---		
				N-INK CHK(BK)		
	MEDIACONFIG-CNT					
	INK-USE1	INK-USE1(C)	---			
			INK-USE1(BK)			
			INK-USE1(TTL)			
			N-INK-USE1(C)			
			---			
			N-INK-USE1(BK)			
			N-INK-USE1(TTL)			
			---			
	INK-USE2	INK-USE2(C)	---			
			INK-USE2(BK)			
			INK-USE2(TTL)			
			N-INK-USE2(C)			
			---			
			N-INK-USE2(BK)			
	INK-EXC	INK-EXC(C)	---			
			INK-EXC(BK)			
			INK-EXC(TTL)			
			N-INK-EXC(C)			
			---			
			N-INK-EXC(BK)			
			N-INK-EXC(TTL)			

First Level	Second Level	Third Level	Fourth Level	Fifth Level	
COUNTER	MEDIA 1	NAME			
		TTL			
		TTL			
		ROLL			
		ROLL			
		CUTSHEET			
		CUTSHEET			
		---			
	MEDIA 7	NAME			
		TTL			
		TTL			
		ROLL			
		ROLL			
		CUTSHEET			
		CUTSHEET			
		MEDIA OTHER	NAME		
	TTL				
	TTL				
	ROLL				
	ROLL				
	CUTSHEET				
	CUTSHEET				
	MEDIASIZE1 ROLL		P-SQ 24-36		
		P-SQ 24-36			
		P-SQ 17-24			
		P-SQ 17-24			
		P-SQ -17			
		P-SQ -17			
		P-CNT 24-36			
		P-CNT 17-24			
		P-CNT -17			
		MEDIASIZE2 ROLL	D-SQ 24-36		
			D-SQ 24-36		
			D-SQ 17-24		
	D-SQ 17-24				
	D-SQ -17				
	D-SQ -17				
	D-CNT 24-36				
	D-CNT 17-24				
	D-CNT -17				

First Level	Second Level	Third Level	Fourth Level	Fifth Level	
COUNTER	MEDIASIZE1 CUT	P-SQ 24-36			
		P-SQ 24-36			
		P-SQ 17-24			
		P-SQ 17-24			
		P-SQ -17			
		P-SQ -17			
		P-CNT 24-36			
		P-CNT 17-24			
		P-CNT -17			
		MEDIASIZE2 CUT			D-SQ 24-36
	D-SQ 24-36				
	D-SQ 17-24				
	D-SQ 17-24				
	D-SQ -17				
	D-SQ -17				
	D-CNT 24-36				
	D-CNT 17-24				
	D-CNT -17				
	HEAD DOT CNT. 1	C			
	---				
	BK				
	TTL				
	HEAD DOT CNT. 2	C			
	---				
	BK				
	TTL				
	PARTS CNT.	COUNTER CR-1			OK/W1/W2/E
					1:00
					2:00
					3:00
					4:00
		---			
COUNTER WF-2		OK/W1/W2/E			
		1:00			
		2:00			
		3:00			
	4:00				

First Level	Second Level	Third Level	Fourth Level	Fifth Level	Sixth Level	
SETTING	Pth	ON/OFF				
	RTC	DATE	yyyy/mm/dd			
		TIME	hh:mm			
	PV AUTO JUDGE	ON/OFF				
	NETWORK	CERTIFICATE	CA-CERTIFICATE	VALIDITY	yyyy/mm/dd	
	E-RDS	E-RDS SWITCH	ON/OFF			
		UGW-ADDRESS	https://XXX			
		UGW-PORT	XXXXXX			
		COM-TEST	YES			
		COM-LOG				
	HEAD DOT INF	ON/OFF				
	TSC	TTL PRINT AREA	ON/OFF			
		INK CONSUMED	ON/OFF			
		DUTY CNT	ON/OFF			
		DISPLAY DECIMAL	TTL PRINT AREA		ON/OFF	
			INK CONSUMED		ON/OFF	
			DUTY CNT		ON/OFF	
		UNIT	TTL PRINT AREA		LENGTH UNIT	
					A4	
					LETTER	
			DUTY CNT		LENGTH UNIT	
				A4		
				LETTER		
INITIALIZE	WARNIG	: Press the [OK] button to clear				
	ERROR	: Press the [OK] button to clear				
	JAM	: Press the [OK] button to clear				
	ADJUST	: Press the [OK] button to clear				
	W-INK	: Press the [OK] button to clear				
	CARRIAGE	: Press the [OK] button to clear				
	PURGE	: Press the [OK] button to clear				
	INK-USE CNT	: Press the [OK] button to clear				
	W-INK-CHG CNT	: Press the [OK] button to clear				
	HEAD-CHG CNT	: Press the [OK] button to clear				
	PARTS-CHG CNT	PARTS CR ALL	: Press the [OK] button to clear			
		---				
	PARTS WF-2	PARTS WF-2	: Press the [OK] button to clear			
		---				
	PARTS COUNTER	PARTS CR ALL	: Press the [OK] button to clear			
		---				
	PARTS WF-2	PARTS WF-2	: Press the [OK] button to clear			
		---				
	USER SETTEING	YES/NO				
	CA-KEY	YES/NO				
ERDS-DAT	YES/NO					
JOB LOG	: Press the [OK] button to clear					

### 7.1.3 Details of Service Mode

This section provides details of the Service mode menu.

#### a) DISPLAY

Displays and prints the printer information.

##### 1) PRINF INF

Prints adjustment values in the User menu, [DISPLAY] and [COUNTER] parameters on A4-size or larger paper. When roll media is used, the layout is optimized according to the media width.

##### 2) SYSTEM

Displays the printer information shown below.

Display	Description	Unit
S/N	Serial number of printer	-
TYPE	Type setting on main controller PCB * iPF671/670 is represented by 24".	-
LF TYPE	Feed roller type: 0 or 1	-
TMP	Ambient temperature	centigrade degrees
RH	Ambient humidity	%
SIZE LF	Detected size of loaded media (feed direction) 0 is always detected for the roll media.	mm/inch
SIZE CR	Detected size of loaded media (carriage scan direction)	mm/inch
AFTER INST.	Number of days since initial installation	Days

##### 3) HEAD

Displays the following EEPROM information of the printhead.

Display	Description
S/N	Serial number of printhead
LOT	Lot number of printhead

##### 4) INK

Displays the numbers of days passed since installation of the following ink tanks.

Display	Description	Unit
BK	Number of days passed since the BK ink tank was installed	Days
MBK	Number of days passed since the MBK ink tank was installed	Days
MBK2	Number of days passed since the MBK2 ink tank was installed	Days
C	Number of days passed since the C ink tank was installed	Days
M	Number of days passed since the M ink tank was installed	Days
Y	Number of days passed since the Y ink tank was installed	Days

##### 5) WARNING

Displays the warning history (up to 20 events). The newest event has the smallest history number.

##### 6) ERROR

Displays the error history (up to 20 events). The newest event has the smallest history number.

7) JAM

Displays log of jams that have occurred (up to five events). The newest event has the smallest history number.

Indicates the date and time of jam and error code. "0000" is displayed if there is no log.

```

0 1      M M / D D   H H : M M
X X X X - X X X X
    
```

F-7-1

Press the ▼ key to display detail information.

Press the ◀ key or ▶ key to navigate among detail information display 1 to 4.

Detail information display 1

```

J A M   0 1
1 : X X X X X X X X X
      1 2 3 4 5 6 7 8 9
    
```

F-7-2

Detail information display 2

```

J A M   0 1
2 : X X X X X X X X X
      10
    
```

F-7-3

Detail information display 3

```

J A M   0 1
3 : X X X X
      11
    
```

F-7-4

Detail information display 4

```

J A M   0 1
4 : X X X X X X X X
      12
    
```

F-7-5

Display	Description	LCD display contents
1	Jam type	1:Carriage error, 2:Jam, 3:Feed failure (delay), 4:Cut failure, 0:Unknown
2	Media	1:Roll media, 2:Cut sheet, 0:Unknown
3	Jam timing	1:Feed, 2:Print, 3:Eject, 0:Unknown
4	Media width detection	1:ON, 2:OFF, 0:Unknown
5	Head height	SL:1.0mm, L:1.3mm, M1:1.8mm, M2:2.0mm, M3:2.2mm, 0:Unknown
6	Platen shutter position	1:Fully close, 2:HP side only open, 3:1/4 open, 4:1/2 open, 5:3/4 open, 6:Fully open, 0:Unknown
7	Cut mode setting	1:User cut, 2:Eject cut, 3:Auto cut, 0:Unknown
8	Environment	Display Media Information Tool's environment settings A to F according to Temperature/Humidity Detection Sensor, 0:Unknown
9	Borderless printing setting	1:Bordered printing, 2:Borderless printing, 0:Unknown
10	Print mode	Display print mode, 0:Unknown
11	Media siz	Display media size, 0:Unknown
12	Media name	Display media name, 0:Unknown

8) INK CHECK

Displays the number of times the remaining ink level detection function was turned off, to accommodate refilled ink cartridges in the order of C, M, Y, MBK, MBK2 and BK.

0: Never

1: Executed at least once

**b) I/O DISPLAY**

The status of each sensor and switch is shown in the display.

Sensor and switch status is shown in the display.

ON: 1

OFF or not used: 0

Screen 1

I / O	D I S P L A Y	1	(Upper row)
0 0 0 0 0 0 0 0 0 0 0 0 0 0 0			(Lower row)
1 2 3 4 5 6 7 8 9 10 11 12 13 14 15 16			(Display position)

F-7-6

Screen 2

I / O	D I S P L A Y	2	(Upper row)
0 0 0 0 0 0 0 0 0 0 0 0 0 0 0			(Lower row)
17 18 19 20 21 22 23 24 25 26 27 28 29 30 31 32			(Display position)

F-7-7

Screen 3

I / O	D I S P L A Y	3	(Upper row)
0 0 0 0 0 0 0 0 0 0 0 0 0 0 0			(Lower row)
33 34 35 36 37 38 39 40 41 42 43 44 45 46 47 48			(Display position)

F-7-8



Screen 1, Screen 2 and Screen 3 are selectable with the ◀ and ▶ keys.  
These screens display the associated sensor status as listed in the table below.

Display position	Sensor name	LCD display contents
1	Pump cam sensor	0:Sensor ON, 1:Sensor OFF
2	Ink supply valve open/closed detection sensor (R)	0:Sensor OFF, 1:Sensor ON
3	(Not Used)	-
4	(Not Used)	-
5	(Not Used)	-
6	Lift cam sensor	0:Sensor ON, 1:Sensor OFF
7	Feed roller HP sensor	0:Sensor ON, 1:Sensor OFF
8	Upper cover lock switch	0:Cover close, 1:Cover open
9	(Not Used)	0:Cover open, 1:Cover close
10	Ink tank cover switch (R)	0:Cover open, 1:Cover close
11	Ink tank cover switch (L)	0:Cover open, 1:Cover close
12	(Not Used)	-
13	(Not Used)	-
14	(Not Used)	-
15	(Not Used)	-
16	(Not Used)	-
17	(Not Used)	-
18	(Not Used)	-
19	(Not Used)	-
20	Cutter HP sensor	0:Sensor ON, 1:Sensor OFF
21	Cutter left position sensor	0:Sensor ON, 1:Sensor OFF
22	Carriage HP sensor	0:Sensor ON, 1:Sensor OFF
23	(Not Used)	-
24	Paper detection sensor	0:Media loaded, 1:No media
25	(Not Used)	-
26	(Not Used)	-
27	(Not Used)	-
28	(Not Used)	-
29	(Not Used)	-
30	Ink supply valve open/closed detection sensor (L)	0:Sensor OFF, 1:Sensor ON
31	(Not Used)	-
32	(Not Used)	-
33	Release lever lock sensor	0:Sensor ON, 1:Sensor OFF
34	Pinch roller pressure release switch	0:Released, 1:Pressured
35	Shutter HP sensor	0:Sensor OFF, 1:Sensor ON
36	(Not Used)	-
37	(Not Used)	-
38	(Not Used)	-
39	(Not Used)	-
40	(Not Used)	-
41	Flexible cable connection detection (J3601 pin no.50)	0:Connect, 1:Disconnect
42	Flexible cable connection detection (J3601 pin no.1)	0:Connect, 1:Disconnect
43	Flexible cable connection detection (J3602 pin no.50)	0:Connect, 1:Disconnect
44	Flexible cable connection detection (J3602 pin no.1)	0:Connect, 1:Disconnect
45	(Not Used)	-
46	(Not Used)	-
47	(Not Used)	-
48	(Not Used)	-

**c) ADJUST**

Performs adjustments and prints the adjustment and check patterns necessary for adjusting the printer parts.

1) PRINT PATTERN

Display	Description
NOZZLE 1	Prints the nozzle check pattern by single direction/ single pass without using the non-discharging back up. It is used to check for the non-discharging nozzles. - Media size: A4 - Media type: any
OPTICAL AXIS	Prints the pattern and adjusts the optical axis of the multi sensor. For details, refer to "Disassembly/Reassembly" > "Adjustment and Setup Items" > "Procedure after replacing the carriage unit or multi sensor". - Media type: photo glossy paper
LF TUNING	Carry out automatic correction of eccentricity of the feed roller. For more details, refer to "Disassembly/Reassembly" > "Adjustment and Setup Items" > "Procedure after Replacing the Feed Roller or Feed Roller Encoder". - Media type: Photo glossy paper - Media size (width): 24 inches
LF TUNING 2	Carry out manual correction of eccentricity of the feed roller. For more details, refer to "Disassembly/Reassembly" > "Adjustment and Setup Items" > "Procedure after Replacing the Feed Roller or Feed Roller Encoder". - Media type: Photo glossy paper - Media size (width): 24 inches

2) HEAD ADJ.

Set or initialize the registration adjustment values of each printheads.

Display		Description
MANUAL HEAD ADJ	DETAIL	Prints the detail patterns for the manual head adjustment. After printing, the mode will change to [ADJ. SETTING]. Check the printed patterns and input the set values.
	BASIC	Prints the basic patterns for the manual head adjustment. After printing, the mode will change to [ADJ. SETTING]. Check the printed patterns and input the set values.
ADJ. SETTING	A to F	This mode is to input the registration adjustment values. It is possible to return the values to the former one by printing the status print before changing the value.
	A-1 to F-1	
	SAVE SETTINGS	Save the registration adjustment values that has been input.
RESET SETTINGS		Initialize the registration adjustment values (to 0).

3) NOZZLE CHK POS.

This mode is for adjusting the optical axis of the head management sensor. For details, refer to "Disassembly/Reassembly" > "Adjustment and Setup Items" > "Procedure after replacing the head management sensor".

4) GAP CLIB.

This mode measures the gap between the printhead and media by using the multi sensor and corrects the calibration value.

5) CHANGE LF TYPE

Change the type of the feed roller.

- 0: Old feed roller
- 1: New feed roller

## 6) CR REG

Executes automatic head adjustment.

Make this adjustment if the registration remains partially misregistered after user-mode head adjustment.

EXECUTE: Execute automatic head adjustment.

RESET: Reset the registration adjustment value (0).

- Applicable media size is A2 (17inch) or larger.
- Applicable media type is photo glossy paper

If an error message appears when performing CR REG, check the following.

Replace the multi sensor if the error reoccurs after checking and performing CR REG again.

<CHECK>

1. Check for non-discharging of the printhead and dirty media, and replace the printhead and/or media if necessary.

2. Perform [Head Cleaning A].

3. Perform [Head Posi. Adj.]-[Auto].

## 7) CR MOTOR COG

Adjust the carriage motor rotation.

Perform in the following cases:

- When removing/attaching or replacing the carriage or carriage belt.
- When replacing the carriage motor or linear encoder sensor.
- When there is excessive load on the carriage (such as when jamming)

If the following error message appears when performing CR MOTOR COG, check that carriage and carriage belt are installed properly and clean the carriage shaft.

If the error still occurs, replace the carriage motor.

C R V I B R A T I O N
E R R O R

F-7-9

## 8) MARGIN ADJ

This mode is to perform the fine adjustment of the leading and trailing edge margin.

Display	Description
TOP MARGIN ADJ	Set the fine adjustment value of leading edge margin. Range: -5.0 to 5.0mm (in 0.1mm increments)
BTM MARGIN ADJ	Set the fine adjustment value of trailing edge margin. Range: -5.0 to 5.0mm (in 0.1mm increments)
PRINT PATTERN	Print the pattern for checking the margin. After adjusting the margin, make sure of the margin by printing the pattern.

**d) FUNCTION**

1) CR UNLOCK

Unlocks the carriage.

When CR UNLOCK is performed, the carriage lock pin is lowered and the carriage can be moved.

2) CR LOCK

Locks the carriage.

When CR LOCK is performed, the carriage lock pin is raised and the carriage is locked.

3) PG CHECK

Initializes the purge unit.

4) CR AUTO SCAN

The carriage scans.

When CR AUTO SCAN is performed, the carriage scans with the count, width, and speed set with CR SCAN COUNT/CR SCAN SIZE/CR SCAN SPEED.

5) CR SCAN COUNT

Sets the number of scans (1 to 30) to be performed with CR AUTO SCAN.

Default: 1

6) CR SCAN SIZE

Sets the scan width to be performed with CR AUTO SCAN.

1:A4, 2:A3, 3:A2, 4:24inch, 5:36inch

Default: 5

7) CR SCAN SPEED

Sets the speed of the scan to be performed with CR AUTO SCAN.

1:12.5, 2:25, 3:33.3, 4:40, 5:50 (Unit: inch/sec)

Default: 1

**MEMO:**

The settings made with CR SCAN COUNT, CR SCAN SIZE, CR SCAN SPEED are reset to default when the power is reset.

8) STIRRING CHECK

Agitates the ink tank.

9) OPT SENS OUTPUT

Displays the values (analog value) multi sensor detected from the media.

You can confirm the amount of margin the media has with the values read with the multi sensor and the status of the multi sensor by comparing the values with the threshold.

Press the ◀ key or ▶ key to navigate among OUTPUT 0 to 6 windows.

OUTPUT 0

O U T P U T 0													
X	X	X	X	X	X	X	X	X	X	X	X	X	X
1	1	1	2	2	2	3	3	3	4	4	4	5	5

F-7-10

OUTPUT 1

O U T P U T 1													
X	X	X	X	X	X	X	X	X	X	X	X	X	X
6	6	6	7	7	7	8	8	8	9	9	9	10	10

F-7-11

OUTPUT 2

O U T P U T 2													
X	X	X	X	X	X	X	X	X	X	X	X	X	X
11	11	11	12	12	12	13	13	13	14	14	14	15	15

F-7-12

OUTPUT 3

O U T P U T 3													
X	X	X	X	X	X	X	X	X	X	X	X	X	X
16	16	16	17	17	17	18	18	18	19	19	19	20	20

F-7-13

## OUTPUT 4

O U T P U T 4														
X	X	X	X	X	X	X	X	X	X	X	X	X	X	X
21	21	21	22	22	22	23	23	23	24	24	24	25	25	25

F-7-14

## OUTPUT 5

O U T P U T 5														
X	X	X	X	X	X	X	X	X	X	X	X	X	X	X
26	26	26	27	27	27	28	28	28	29	29	29	30	30	30

F-7-15

## OUTPUT 6

O U T P U T 6														
X	X	X	X	X	X	X	X	X	X	X	X	X	X	X
31	31	31	32	32	32	33	33	33	34	34	34	35	35	35

F-7-16

Display position	Description
1	Media edge (diffuse reflection) media output (including outside light)
2	Media edge (diffuse reflection) outside light output (when LED is OFF)
3	Media edge (diffuse reflection) platen output (excluding outside light)
4	Media edge (diffuse reflection) gain
5	Media edge (diffuse reflection) current value (Unit: X10mA)
6	Media edge (regular reflection) media output (including outside light)
7	Media edge (regular reflection) outside light output (when LED is OFF)
8	Media edge (regular reflection) platen output (excluding outside light)
9	Media edge (regular reflection) gain
10	Media edge (regular reflection) current value (Unit: X10mA)
11	GAP1 media output (including outside light)
12	GAP1 outside light output (when LED is OFF)
13	GAP1 platen output (excluding outside light)
14	GAP1 gain
15	GAP1 current value (Unit: X10mA)
16	GAP2 media output (including outside light)
17	GAP2 outside light output (when LED is OFF)
18	GAP2 platen output (excluding outside light)
19	GAP2 gain
20	GAP2 current value (Unit: X10mA)
21	Density (red) media output (including outside light)
22	Density (red) outside light output (when LED is OFF)
23	Density (red) platen output (excluding outside light)
24	Density (red) gain
25	Density (red) current value (Unit: X10mA)
26	Density (green) media output
27	Density (green) outside light output (including outside light)
28	Density (green) platen output (excluding outside light)
29	Density (green) gain
30	Density (green) current value (Unit: X10mA)
31	Density (blue) media output (including outside light)
32	Density (blue) outside light output (when LED is OFF)
33	Density (blue) platen output (excluding outside light)
34	Density (blue) gain
35	Density (blue) current value (Unit: X10mA)

**MEMO:**

- Displays all "?" if "GAP CALIB" is not performed.
- If the value exceeds 1000, 999 is displayed.

## 1. Checking "OUTPUT 0" and "OUTPUT 1" when media (excluding clear film) is fed

[Check 1]

Check whether the multi sensor performance has degraded or whether the media is compatible with the multi sensor.

When "Media edge (diffuse reflection) gain" and "Media edge (diffuse reflection) current value" are maximum values and "Media edge (diffuse reflection) media output" is 186 or less, an error occurs.

Maximum value of "Media edge (diffuse reflection)" gain: 255

Maximum value of "Media edge (diffuse reflection)" current value: 320

When the multi sensor and media are normal, the following values are displayed:

	Media edge (diffuse reflection) gain	Media edge (diffuse reflection) current value	Media edge (diffuse reflection) media output
Plain paper	About 10-35	About 200	About 500-600
Glossy paper	About 8-25		
Tracing paper	About 30-100		

[Check 2]

Check whether the multi sensor performance has degraded or whether the media is compatible with the multi sensor.

When the difference between "Media edge (diffuse reflection) gain" and "Media edge (diffuse reflection) platen output" is 100 or less, an error occurs.

When the multi sensor and media are normal, the difference is about 300-600.

[Check 3]

Check the effect of external diffuse light.

When the difference between "Media edge (diffuse reflection) external light output" and "Media edge (diffuse reflection) platen output" is 500 or more, the effect of diffuse light is judged as being great.

When the effect is normal, the difference is about 50-300.

[Check 4]

Check whether the media is compatible.

When the result of "Media edge (regular reflection) gain"x"Media edge (regular reflection) current value" is five times as large as the result of "Media edge (diffuse reflection) gain"x"Media edge (diffuse reflection) current value", the media is judged as being incompatible with the multi sensor.

If the media is compatible, the result is about 0.5 to 1.5 times for plain/glossy paper; about 1-3 times for tracing paper.

[Check 5]

Check whether the media is compatible.

When the result of "Media edge (diffuse reflection) gain"x"Media edge (diffuse reflection) current value" is in one of the following, the media may be incompatible with the multi sensor.

- Nine or more times as large as that of plain paper (normally, 2000-7000)
- Ten or more times as large as that of glossy paper (normally, 1600-5000)
- Three or more times as large as that of tracing paper (normally, 6000-20000)

## 2. Checking "OUTPUT 0" when clear film is fed

[Check 1]

Check whether the multi sensor performance has degraded or whether the media is compatible.

When the "Media edge (regular reflection) gain" and "Media edge (regular reflection) current value" are maximum values and "Media edge (regular reflection) media output" is 186 or less, an error occurs.

Maximum value of "media edge (regular reflection)" gain: 255

Maximum value of "media edge (regular reflection)" current value: 320

When the multi sensor and media are normal, the following values are displayed:

	Media edge (regular reflection) gain	Media edge (regular reflection) current value	Media edge (regular reflection) media output
Clear film	About 10-60	About 200	About 500-600

[Check 2]

Check whether the multi sensor performance has degraded or whether the media is compatible.

When the difference between "Media edge (regular reflection) gain" and "Media edge (regular reflection) platen output" is 100 or less, an error occurs.

When the multi sensor and media are normal, the difference is about 250-500.

[Check 3]

Check the effect of external diffuse light.

When the difference between "Media edge (regular reflection) external light output" and "Media edge (regular reflection) platen output" is 500 or more, the effect of diffuse light is judged as being great.

When the effect is normal, the difference is about 50-300.

## 3. Checking "OUTPUT 2/OUTPUT 3" and "OUTPUT 4/OUTPUT 5/OUTPUT 6"

[Check 1]

Check whether the multi sensor performance has degraded or whether the media is compatible.

When "GAP gain" and "GAP current value" are maximum values and "GAP media output" is 93 or less, an error occurs.

Maximum value of "GAP gain": 255

Maximum value of "GAP current value": 320

When the multi sensor and media are normal, "GAP gain" is about 30-250; "GAP current value" is about 200.

[Check 2]

Check whether the multi sensor performance has degraded or whether the media is compatible.

When "Density gain" and "Density current value" are maximum values and "Density media output" is 168 or less, an error occurs.

Maximum value of "Density gain": 255

Maximum value of "Density current value": 245

When the multi sensor performance and media are normal, "Density gain" is about 5-100; "Density current value" is about 200.

#### 10) NOZZLE CHECK

Checks for non-discharging nozzle with head management sensor.

#### 11) NOZZLE INF

Displays the result of non-discharging nozzle check performed with "NOZZLE CHECK" by nozzle row of each ink color.

- Press the ◀ key or ▶ key to switch the ink color.

- AE:A-EVEN row, AO:A-ODD row, BE:B-EVEN row, BO:B-ODD row

C	A E	: O K	A O	: O K
	B E	: O K	B O	: O K

F-7-17

#### 12) MEMORY CHK

Display	Description
DDR	Checks the DDR-SDRAM mounted on the Main Controller PCB.
EEP	Checks the EEPROM.

#### 13) HEAD CNT CHK

Confirms the contact status of the printhead.

#### 14) CR ERR CHK

This mode performs the self diagnosis about the drive state of the carriage unit.

Perform in case the drive state of the carriage unit is abnormal. it can guess the failure cause of the carriage unit as shown in the followings.

- Carriage motor failure

- Linear encoder sensor failure

- Linear scale failure or overload state

\* When performing this mode, open and close the upper cover by following the instructions on the screen.

After displaying the following screen, press the [OK] key to start the self diagnosis, and then the diagnosis result is displayed.

If the failure is found, check and replace the corresponding parts or surrounding parts.

C R	H P	S N S	O K
P R E S S	O K	K E Y	

F-7-18

- Normal

C R	C H E C K	O K
C H E C K	E N D	

F-7-19

- Carriage motor failure

C R	M O T O R	E R R
C H E C K	E N D	

F-7-20

- Linear encoder sensor failure

C R	E N C	S E N S	E R R
C H E C K	E N D		

F-7-21

- Linear scale failure or overload state

E N C	o r	O V E R L O A D
C H E C K	E N D	

F-7-22

15) HEAD CHK

Perform in case the printhead is abnormal. It can guess whether the failure cause is the printhead or not.

**MEMO:**

As the printhead and thermistor are high temperature after printing immediately, perform this mode after 5 minutes or more printing is completed.

Display the value (analogue) detected by the printhead, the thermistor on the carriage PCB, DI sensor (Di0/Di1) and head Vh. Check whether the detection value is normal or not to judge the abnormal part.

Press the ◀/▶ key to select the item, and then press the ▼ key to display the detection value.

- temp

2 5	1 2 6	- 2 7	T	3 0
- 1 5	2 5	1 2 7	t	2 8

Printhead temperature  
(centigrade degrees)

chipA chipB chipC  
chipD chipE chipF

T: Thermistor detection temperature  
mounted on the Carriage PCB  
(centigrade degrees)

t: Temperature/Humidity detection sensor  
detection temperature  
(centigrade degrees)

F-7-23

- AD Di0

2 5 5	1 2 7	1 0 2 3	D
1 0 2 3	6 3	1 2 7	0

Head DI sensor (Di0) detection analogue value

F-7-24

- AD Di1

2 5 5	1 2 7	1 0 2 3	D
1 0 2 3	6 3	1 2 7	1

Head DI sensor (Di1) detection analogue value

F-7-25

- AD Vh

1 0 2 3	V
	h

Head VH detection analogue value

F-7-26

<CHECK>

Judge the failure part by comparing the temperature of the printhead and the value detected by thermistor on the carriage PCB.

T-7-1

PrintHead temperature (Centigrade degree)*	Thermistor temperature (Centigrade degree)*	Judgement
22 to 28	22 to 28	Normal
	21 or less, 29 or more	The part except for the printhead may have a failure. (Carriage PCB, flexible cable, main controller PCB)
21 or less, 29 or more	22 to 28	The printhead may have a failure.
	21 or less, 29 or more	The printhead or the carriage PCB or the flexible cable or the main controller PCB may have a failure.

\*: Adequate temperature ranges when the surrounding temperature (temperature/humidity sensor detection value) of the printer is 25 degrees centigrade. For example, when the surrounding temperature is 30 degrees centigrade, above temperatures rise each 5 degrees centigrade.

e) REPLACE

1) CUTTER

This mode is for replacing the cutter.

f) COUNTER

Displays the life (operation frequency and time) of each unit, print counts for each media type, and else.

The count values can be printed from [PRINT INF].



## 1) PRINTER: Counters related to product life

Display	Description	Unit
LIFE TTL	Cumulative number of printed media (equivalent of A4)	sheets
LIFE ROLL	Cumulative number of printed roll media (equivalent of A4)	sheets
LIFE CUTSHEET	Cumulative number of printed cut sheets (equivalent to A4)	sheets
LIFE A-F	Cumulative number of printed media for environments A to F	sheets
POWER ON	Cumulative power-on time (excluding the sleep time)	Hours
W-INK	Remaining capacity of the maintenance cartridge	%
CUTTER	Number of cutting operations (count as 1 by moving back and forth)	Times
WIPE	Number of wiping operations	Times
SLEEP ON	Cumulative sleep-on time	Hours

## 2) CARRIAGE: Counters related to carriage unit

Display	Description	Unit
PRINT	Cumulative printing time	Hours
DRIVE	Cumulative carriage moving time	Hours
CR COUNT	Cumulative carriage scan count (count as 1 by moving back and forth)	Times
CR DIST.	Cumulative carriage scan distance (count as 1 by moving 210mm)	Times
PRINT COUNT	Cumulative print end count (count as 1 by capping)	Times

## 3) PURGE: Counters related to purge unit

Display	Description	Unit
CLN-A-1	Cumulative number of automatic cleaning 1 (normal suction) operations	Times
CLN-A-2	Cumulative number of automatic cleaning 2 (ink level adjusting) operations	Times
CLN-A-3	Cumulative number of automatic cleaning 3 (initial filling) operations	Times
CLN-A-6	Cumulative number of automatic cleaning 6 (strong normal suction) operations	Times
CLN-A-7	Cumulative number of automatic cleaning 7 (aging) operations	Times
CLN-A-10	Cumulative number of automatic cleaning 10 (ink filling after secondary transportation) operations	Times
CLN-A-11	Cumulative number of automatic cleaning 11 (ink filling after head replacement) operations	Times
CLN-A-15	Cumulative number of automatic cleaning 15 (dot count small suction) operations	Times
CLN-A-16	Cumulative number of automatic cleaning 16 (sedimented ink agitation) operations	Times
CLN-A-17	Cumulative number of automatic cleaning 17 (small suction) operations	Times
CLN-A-TTL	Total number of automatic cleaning operations	Times
CLN-M-1	Cumulative number of manual cleaning 1 (normal suction) operations	Times
CLN-M-4	Cumulative number of manual cleaning 4 (ink draining from head after head replacement) operations	Times
CLN-M-5	Cumulative number of manual cleaning 5 (ink draining from head and tube before transportation ) operations	Times
CLN-M-6	Cumulative number of manual cleaning 6 (normal strong suction) operations	Times
CLN-M-TTL	Total number of manual cleaning operations	Times

## 4) CLEAR: Counters related to counter initialization

Display	Description	Unit
CLR-INK CONSUME	Cumulative count of ink section consumption amount clearing	Times
CLR-MTC EXC.	Cumulative count of maintenance cartridge replacement count clearing	Times
CLR-HEAD EXC.	Cumulative count of printhead replacement count clearing	Times
CLR-UNIT CR-1 EXC.	Cumulative count of unit CR-1(carriage unit bushing) replacement count clearing	Times
CLR-UNIT CR-2 EXC.	Cumulative count of unit CR-2(flexible cable unit) replacement count clearing	Times
CLR-UNIT CR-3 EXC.	Cumulative count of unit CR-3(linear encoder sensor/linear scale/shaft cleaner) replacement count clearing	Times
CLR-UNIT CR-4 EXC.	Cumulative count of unit CR-4(carriage height changing cam) replacement count clearing	Times
CLR-UNIT CR-5 EXC.	Cumulative count of unit CR-5(multi sensor) replacement count clearing	Times
CLR-UNIT SP-1 EXC.	Cumulative count of unit SP-1(ink tube unit) replacement count clearing	Times
CLR-UNIT PG-1 EXC.	Cumulative count of unit PG-1(purge unit) replacement count clearing	Times
CLR-UNIT HMa-1 EXC.	Cumulative count of unit HMa-1(head management sensor) replacement count clearing	Times
CLR-UNIT MT-1 EXC.	Cumulative count of unit MT-1(carriage motor) replacement count clearing	Times
CLR-UNIT PL-1 EXC.	Cumulative count of unit PL-1(feed motor) replacement count clearing	Times
CLR-UNIT Mi-1 EXC.	Cumulative count of unit Mi-1(mist fan/mist exhaust duct) replacement count clearing	Times
CLR-UNIT CT-1 EXC.	Cumulative count of unit CT-1(cutter) replacement count clearing	Times
CLR-UNIT WF-1 EXC.	Cumulative count of unit WF-1(ink absorber under the maintenance cartridge unit) replacement count clearing	Times
CLR-UNIT WF-2 EXC.	Cumulative count of unit WF-2(platen exhaust duct) replacement count clearing	Times
CLR-FACTORY CNT.	For factory	Times

## 5) EXCHANGE: Counters related to parts replacement

Display	Description	Unit
MTC EXC.	Maintenance cartridge replacement count	Times
HEAD EXC.	Printhead replacement count	Times
BOARD EXC.(M/B)	Main controller PCB replacement count	Times
CR-1 EXC.	CR-1(carriage unit bushing) replacement count (Count of executing [INITIALIZE] > [PARTS COUNTER] > [PARTS CR-1])	Times
CR-2 EXC.	CR-2(flexible cable unit) replacement count (Count of executing [INITIALIZE] > [PARTS COUNTER] > [PARTS CR-2])	Times
CR-3 EXC.	CR-3(linear encoder sensor/linear scale/shaft cleaner) replacement count (Count of executing [INITIALIZE] > [PARTS COUNTER] > [PARTS CR-3])	Times
CR-4 EXC.	CR-4(carriage height changing cam) replacement count (Count of executing [INITIALIZE] > [PARTS COUNTER] > [PARTS CR-4])	Times
CR-5 EXC.	CR-5(multi sensor) replacement count (Count of executing [INITIALIZE] > [PARTS COUNTER] > [PARTS CR-5])	Times
SP-1 EXC.	SP-1(ink tube unit) replacement count (Count of executing [INITIALIZE] > [PARTS COUNTER] > [PARTS SP-1])	Times
PG-1 EXC.	PG-1(purge unit) replacement count (Count of executing [INITIALIZE] > [PARTS COUNTER] > [PARTS PG-1])	Times
HMa-1 EXC.	HMa-1(head management sensor) replacement count (Count of executing [INITIALIZE] > [PARTS COUNTER] > [PARTS HMa-1])	Times
MT-1 EXC.	MT-1(carriage motor) replacement count (Count of executing [INITIALIZE] > [PARTS COUNTER] > [PARTS MT-1])	Times
PL-1 EXC.	PL-1(feed motor) replacement count (Count of executing [INITIALIZE] > [PARTS COUNTER] > [PARTS PL-1])	Times
Mi-1 EXC.	Mi-1(mist fan/mist exhaust duct) replacement count (Count of executing [INITIALIZE] > [PARTS COUNTER] > [PARTS Mi-1])	Times
CT-1 EXC.	CT-1(cutter) replacement count (Count of executing [INITIALIZE] > [PARTS COUNTER] > [PARTS CT-1])	Times
WF-1 EXC.	WF-1(ink absorber under the maintenance cartridge unit) replacement count (Count of executing [INITIALIZE] > [PARTS COUNTER] > [PARTS WF-1])	Times
WF-2 EXC.	WF-2(platen exhaust duct) replacement count (Count of executing [INITIALIZE] > [PARTS COUNTER] > [PARTS WF-2])	Times

## 6) DETAIL-CNT: Other counters

Display	Description	Unit
MOVE PRINTER	A(B,C,D) A: Number of times "Prep.MovePrinter" on Main menu is executed. B: Number of times "Limited" (Level1) C: Number of times "Standard" (Level2) D: Level of "Prep.MovePrinter" that executed at previous time	Times
N-INKCHK(XX)	XX: Ink color Count of turning off the ink remaining level detection for each color	Times
MEDIACONFIG-CNT	Count of media registered by media editor	Times

## 7) INK-USE1: Counters related to ink consumption

Display	Description	Unit
INK-USE1(XX)	XX: Ink color Cumulative consumption amount of generic ink	ml
INK-USE1(TTL)	Total amount of cumulative consumption of generic ink	ml
N-INK-USE1(XX)	XX: Ink color Cumulative consumption amount of refilled ink	ml
N-INK-USE1(TTL)	Total amount of cumulative consumption of refilled ink	ml

## 8) INK-USE2: Counters related to ink consumption

Display	Description	Unit
INK-USE2(XX)	XX: Ink color Consumption amount of generic ink of the currently installed ink tank.	ml
INK-USE2(TTL)	Total consumption amount of generic ink of the currently installed ink tanks	ml
N-INK-USE2(XX)	XX: Ink color Consumption amount of refilled ink of the currently installed ink tank	ml
N-INK-USE2(TTL)	Total consumption amount of refilled ink of the currently installed ink tanks	ml

## 9) INK-EXC: Counters related to ink tank replacement

Display	Description	Unit
INK-EXC(XX)	XX: Ink color Cumulative count of generic ink tank replacement	ml
INK-EXC(TTL)	Total amount of cumulative count of generic ink tank replacement	ml
N-INK-EXC(XX)	XX: Ink color Cumulative count of refilled ink tank replacement	ml
N-INK-EXC(TTL)	Total amount of cumulative count of refilled ink tank replacement	ml

## 10) MEDIA x (x: 1 to 7): Counters related to media

One to seven media types are displayed individually in order with large cumulative print area.

Display	Description	Unit
NAME	Media type	-
TTL	Total amount of cumulative print area of roll media and cut sheet (metric)	Sq.m
TTL	Total amount of cumulative print area of roll media and cut sheet (inch)	Sq.f
ROLL	Cumulative print area of roll media (metric)	Sq.m
ROLL	Cumulative print area of roll media (inch)	Sq.f
CUT SHEET	Cumulative print area of cut sheet (metric)	Sq.m
CUT SHEET	Cumulative print area of cut sheet (inch)	Sq.f

## 11) MEDIA OTHER: Counters related to media

Displays the total amount of cumulative print area of the other media type than the above-mentioned

Display	Description	Unit
NAME	Media type	-
TTL	Total amount of cumulative print area of roll media and cut sheet (metric)	Sq.m
TTL	Total amount of cumulative print area of roll media and cut sheet (inch)	Sq.f
ROLL	Cumulative print area of roll media (metric)	Sq.m
ROLL	Cumulative print area of roll media (inch)	Sq.f
CUT SHEET	Cumulative print area of cut sheet (metric)	Sq.m
CUT SHEET	Cumulative print area of cut sheet (inch)	Sq.f

## 12) MEDIASIZE1 ROLL: Counters related to roll media printing

Display	Description	Unit
P-SQ 24-36	Cumulative print area of paper equal to or larger than 24 inches but less than 36 inches (physical size)	Sq.m/Sq.f
P-SQ 17-24	Cumulative print area of paper equal to or larger than 17 inches but less than 24 inches (physical size)	Sq.m/Sq.f
P-SQ -17	Cumulative print area of paper less than 17 inches (physical size)	Sq.m/Sq.f
P-CNT 24-36	Cumulative number of sheets of A4-equivalent paper equal to or larger than 24 inches but less than 36 inches (physical size)	sheets
P-CNT 17-24	Cumulative number of sheets of A4-equivalent paper equal to or larger than 17 inches but less than 24 inches (physical size)	sheets
P-CNT -17	Cumulative number of sheets of A4-equivalent paper less than 17 inches (physical size)	sheets

## 13) MEDIASIZE2 ROLL: Counters related to roll media printing

Display	Description	Unit
D-SQ 24-36	Cumulative print area of paper equal to or larger than 24 inches but less than 36 inches (data size)	Sq.m/Sq.f
D-SQ 17-24	Cumulative print area of paper equal to or larger than 17 inches but less than 24 inches (data size)	Sq.m/Sq.f
D-SQ -17	Cumulative print area of paper less than 17 inches (data size)	Sq.m/Sq.f
D-CNT 24-36	Cumulative number of sheets of A4-equivalent paper equal to or larger than 24 inches but less than 36 inches (data size)	sheets
D-CNT 17-24	Cumulative number of sheets of A4-equivalent paper equal to or larger than 17 inches but less than 24 inches (data size)	sheets
D-CNT -17	Cumulative number of sheets of A4-equivalent paper less than 17 inches (data size)	sheets

## 14) MEDIASIZE1 CUT: Counters related to cut sheet printing

Display	Description	Unit
P-SQ 24-36	Cumulative print area of paper equal to or larger than 24 inches but less than 36 inches (physical size)	Sq.m/Sq.f
P-SQ 17-24	Cumulative print area of paper equal to or larger than 17 inches but less than 24 inches (physical size)	Sq.m/Sq.f
P-SQ -17	Cumulative print area of paper less than 17 inches (physical size)	Sq.m/Sq.f
P-CNT 24-36	Cumulative number of sheets of A4-equivalent paper equal to or larger than 24 inches but less than 36 inches (physical size)	sheets
P-CNT 17-24	Cumulative number of sheets of A4-equivalent paper equal to or larger than 17 inches but less than 24 inches (physical size)	sheets
P-CNT -17	Cumulative number of sheets of A4-equivalent paper less than 17 inches (physical size)	sheets

## 15) MEDIASIZE2 CUT: Counters related to cut sheet printing

Display	Description	Unit
D-SQ 24-36	Cumulative print area of paper equal to or larger than 24 inches but less than 36 inches (data size)	Sq.m/Sq.f
D-SQ 17-24	Cumulative print area of paper equal to or larger than 17 inches but less than 24 inches (data size)	Sq.m/Sq.f
D-SQ -17	Cumulative print area of paper less than 17 inches (data size)	Sq.m/Sq.f
D-CNT 24-36	Cumulative number of sheets of A4-equivalent paper equal to or larger than 24 inches but less than 36 inches (data size)	sheets
D-CNT 17-24	Cumulative number of sheets of A4-equivalent paper equal to or larger than 17 inches but less than 24 inches (data size)	sheets
D-CNT -17	Cumulative number of sheets of A4-equivalent paper less than 17 inches (data size)	sheets

## 16) HEAD DOT CNT.1: Counter related to dot count

Display	Description	Unit
XX	XX: Ink color Dot counts of each colors of the currently installed printhead	(x 1,000,000) dots
TTL	Total dot counts of each colors of the currently installed printhead	(x 1,000,000) dots

## 17) HEAD DOT CNT.2: Counter related to dot count

Display	Description	Unit
XX	XX: Ink color Cumulative dot counts of each colors	(x 1,000,000) dots
TTL	Total cumulative dot counts of each colors	(x 1,000,000) dots

18) PARTS CNT. : Counter related to consumable parts

```

C O U N T E R   C R - 1
a a                               b b b b b
    
```

F-7-27

The displays are selectable with the ◀ and ▶ keys.  
Counter of the consumable part (current)

```

C O U N T E R   C R - 1
1 :                               x x x x x
    
```

F-7-28

Life of the consumable part

```

C O U N T E R   C R - 1
2 :                               x x x x x
    
```

F-7-29

Use rate until part replacement

```

C O U N T E R   C R - 1
3 :                               x x x %
    
```

F-7-30

Counter of the consumable part (accumulate)

```

C O U N T E R   C R - 1
4 :                               x x x x x
    
```

F-7-31

Display	Description	Unit
COUNTER xx-x	xx-x: Unit number of consumable parts (For detail, refer to "Maintenance and Inspection" > "Consumable Parts")  Display the status (aa) and the days passed since the counter (bbbb) resetting. - Status OK: Use rate (until part replacement) of all consumable parts included in each unit are below 90%. W1: Use rate (until part replacement) of either of the consumable parts included in each unit has reached 90% or more. W2: Use rate (until part replacement) of either of the consumable parts included in each unit has reached 100%, but no need to stop the printer. E : Use rate (until part replacement) of either of the consumable parts included in each unit has reached 100%, and the printer needs to be stopped.	Days
1:	Unit number of consumable parts Counter of the consumable part (current)	
2:	Life of the consumable part	
3:	Use rate until part replacement	%
4:	Counter of the consumable part (accumulate)	

**g) SETTING**

Make various settings.

## 1) Pth

Turn on or off the head pulse rank control function.

Default: OFF

## 2) RTC

Set RTC (real time clock) after replacing the lithium battery on the main controller PCB.

Display		Description
DATE	yyyy/mm/dd	Set date
TIME	hh:mm	Set time

## 3) PV AUTO JUDGE

Sets ink saver mode.

Default: OFF

## 4) NETWORK

See "e-maintenance/imageWARE Remote" for detail.

## 5) E-RDS

See "e-maintenance/imageWARE Remote" for detail.

## 6) HEAD DOT INF

Select whether to display the message as the result of non-discharging nozzle detection or not.

Default: ON

Number of non-discharging nozzle (nozzle/2,560-nozzles)	ON	OFF
0-99	Displays a message to check the printing.	-
100-319	Displays a message to check the head.	-
320 or more	Displays a message to replace the head.	-

## 7) TSC

Make indication settings about TSC.

T-7-2

Display		Description
TTL PRINT AREA		Select whether to display the total printing area or not (Default: ON)
INK CONSUMED		Select whether to display the amount of ink consumption or not (Default: OFF)
DUTY CNT		Select whether to display the Duty counter or not (Default: ON)
DISPLAY DECIMAL	TTL PRINT AREA	Select whether to display the decimal fraction of total printing area or not (Default: ON)
	INK CONSUMED	Select whether to display the decimal fraction of amount of ink consumption or not (Default: ON)
	DUTY CNT	Select whether to display the decimal fraction of Duty counter or not (Default: ON)
UNIT	TTL PRINT AREA	Set the unit of total printing area Setting value: LENGTH UNIT* (default)/A4/LETTER *: The setting is in accord with [Lenght Unit] in the Main menu.
	DUTY CNT	Set the unit of Duty counter Setting value: LENGTH UNIT*/A4 (default)/LETTER *: The setting is in accord with [Lenght Unit] in the Main menu.

**h) INITIALIZE**

Clear the [DISPLAY] histories, [ADJUST] settings, [COUNTER] values, and other parameters.

Display		Description
WARNING		Initialize the history of WARNING. (All displayed contents of [DISPLAY] > [WARNING] will be initialized.)
ERROR		Initialize the history of ERROR. (All displayed contents of [DISPLAY] > [ERROR] will be initialized.)
JAM		Initialize the history of JAM. (All displayed contents of [DISPLAY] > [JAM] will be initialized.)
ADJUST		Initialize the value of band adjustment (by user) and head adjustment. The automatically adjusted value will not be initialized.
W-INK		Initialize the remaining capacity (%) of the maintenance cartridge. (Clear [COUNTER] > [PRINTER] > [W-INK])
CARRIAGE		Initialize the counter related to carriage unit. (Clear [COUNTER] > [CARRIAGE])
PURGE		Initialize the counter related to purge unit. (Clear [COUNTER] > [PURGE])
INK-USE CNT		Initialize the consumption amount of ink. (Clear [COUNTER] > [INK-USE2], and count up [COUNTER] > [CLEAR] > [CLR-INK CONSUME])
W-INK-CHG CNT		Initialize the maintenance cartridge replacement frequency. (Clear [COUNTER] > [EXCHANGE] > [MTC EXC.], and count up [COUNTER] > [CLEAR] > [CLR-MTC EXC.]
HEAD-CHG CNT		Initialize the printhead replacement frequency. (Clear [COUNTER] > [EXCHANGE] > [HEAD EXC.], and count up [COUNTER] > [CLEAR] > [CLR-HEAD EXC.]
PARTS-CHG CNT	PARTS xx-x	xx-x: Unit number of consumable parts (For details, refer to "Maintenance and Inspection" > "Consumable Parts") Initialize the consumable part replacement frequency. (Clear [COUNTER] > [EXCHANGE] > [xx-x EXC], and count up [COUNTER] > [CLEAR] > [CLR xx-x EXC.]
PARTS COUNTER	PARTS xx-x	xx-x: Unit number of consumable parts (For details, refer to "Maintenance and Inspection" > "Consumable Parts") Initialize the counter amount of the consumable parts. (Clear [COUNTER] > [PARTS CNT.] > [COUNTER xx-x]) * After replacing the consumable part, be sure to execute this menu.
USER SETTING		Initializes the user menu. Same as executing the following mode in the user menu. -[Set./Adj. Menu]-[System Setup]-[Reset PaprSetngs] -[Set./Adj. Menu]-[Interface Setup]-[Return Defaults]
CA-KEY		See "e-maintenance/imageWARE Remote" for detail.
ERDS-DAT		See "e-maintenance/imageWARE Remote" for detail.
JOB LOG		Initialize the history of JOB LOG.

## 7.1.4 e-Maintenance/imageWARE Remote

### 1. Overview

The e-Maintenance/imageWARE Remote system allows a customer's device information and status to be monitored via the Internet on a server called the UGW (Universal Gateway) Server.

The following device information/ statuses can be monitored.

- Service mode counters
- Parts counters
- Mode counters
- Firmware information
- Service call errors log
- Jam log
- Alarm log
- Alert change statuses (Toner/ ink low/ out, etc.)

Device monitor information above is sent by the e-RDS (embedded Remote Diagnostic System), which is embedded in the devices.

Further, as the above is all customer information, https SOAP protocol is used for communication between the UGW and the device, providing enhanced security (SSL client communication)

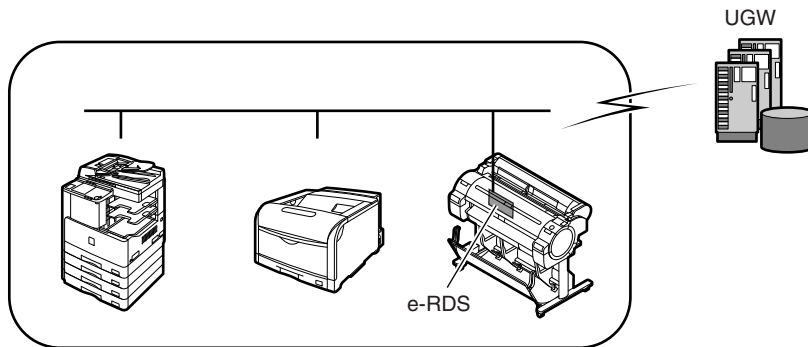

F-7-32

### 2. Feature and benefits

Device (e-RDS) embedded with network module can realize a front-end processing of the e-Maintenance/imageWARE Remote system without attaching an extra hardware equipment.

The e-Maintenance/imageWARE Remote system can be implemented without imposing a burden on the users.

### 3. Settings procedures

#### 3.1 Advance preparations

To monitor the device with e-Maintenance/imageWARE Remote, the following settings are required.

##### 1) Advance confirmation

Check with the UGW administrator whether the printer to be connected to the e-Maintenance/imageWARE remotely has been registered in the UGW.

##### 2) Advance preparations

Interview the user's system administrator in advance to find out the following information about the network.

###### Information item -1

###### IP address setting methods

Check whether automatic setting or manual setting is to be used, and confirm the information below.

- Automatic setting: (DHCP, RARP, BOOTP) (ON/OFF selection)
- or
- Manual setting: IP address, subnet mask and gateway address to be set

###### Information item -2

Is there a DNS server in use?

If there is a DNS server in use, find out the following.

- Primary DNS server address
- Secondary DNS server address (optional)

###### Information item -3

Is there a proxy server?

If there is a proxy server in use, find out the following.

- Proxy server address
- Port number connected to proxy server

###### Information item -4

Is proxy server authentication required?

If proxy server authentication is required, find out the following.

- User name and password required for proxy authentication

#### 3) Network settings

Make the network settings based on the information obtained in "2) Advance preparations."

Network settings are made in user mode. Therefore, it is assumed that the user has already set it. However, there are a few cautions as described below, and if necessary, there may be cases in which the service technicians do it after obtaining an approval from user.

##### Caution point -1

###### Proxy server settings

Proxy server settings cannot be made in "Remote UI". Enter from the operation panel menu. In addition, the operation panel menu items for proxy server only appear when e-RDS functions are enabled. Therefore, when you make proxy server settings, turn the "E-RDS SWITCH" setting to "ON" as described in later sections beforehand.

##### Caution point -2

Validate the settings (restart the printer)



The server address settings are activated only after you restart the printer. Make sure you always restart the printer after changing server address settings.

(1) How to enter Proxy server address

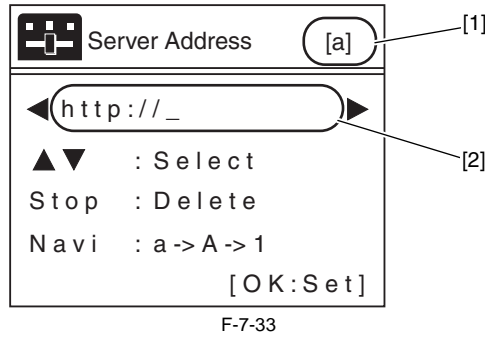

- [1] Display to show enter mode
  - a: Small alphabet letter
  - A: Capital alphabet letter
  - 1: Numerical character
- [2] URL entry field (128 one-byte characters)

- Following symbols exist in each enter mode. (When you press the ▲ key, characters on the right hand side will appear.)
  - [a] Small alphabet letter mode: [Symbol] abcdefghijklmnopqrstuvwxyz
  - [A] Capital alphabet letter mode: [Symbol] ABCDEFGHIJKLMNOPQRSTUVWXYZ
  - [1] Numerical character mode: [Symbol] 1234567890

- [Symbol] appears in the following order.

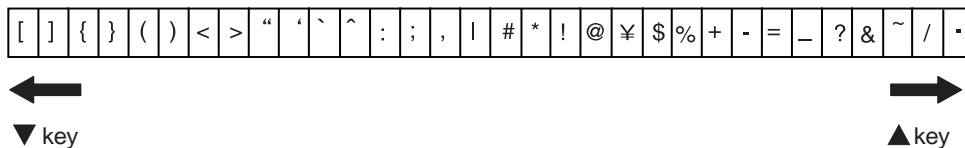

F-7-34

- Within the URL entry field, you can use the ▲ or ▼ key to select a character, and the ◀ or ▶ key to move the cursor.
- The Stop key has the Delete function when there is a character at the cursor position. (The character at the position of the cursor is deleted, moving all following characters one position toward freed place.)  
If there is no character at the cursor position, it has the Backspace function. (The character at the left of the cursor is deleted, moving the cursor.)
- When you move the cursor to a position of a character and press the ▲ or ▼ key, you can insert characters. (The character at the cursor position is moved to the right, and a new character is inserted.)
- You can select the enter mode with the Navi key. (The default setting is small alphabet letter.)

(2) How to enter port number

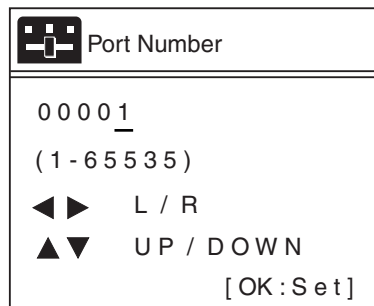

F-7-35

- Possible to set between 1 and 65535 (The default display is 1).
- The top digit can be selected between 0 and 6. Other digits can be selected between 0 and 9.
- When OK key is pressed, and the value is over 65535, it is fixed on 65535.
- When OK key is pressed, and the value is 0, it is fixed on 1.

(3) How to enter user name

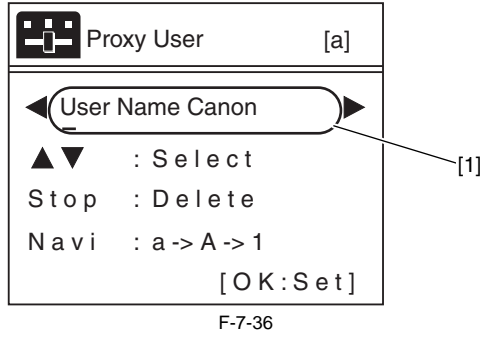

[1] Entry filed (24 one-byte characters)

- It is the same as the entering method of proxy server address.

(4) How to enter password

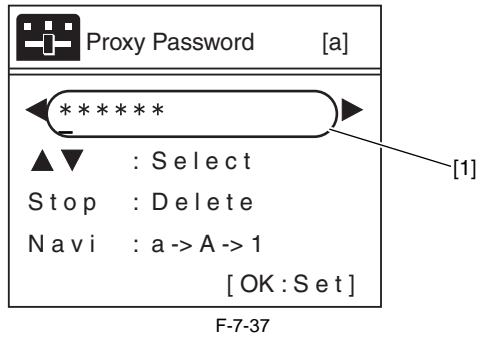

[1] Entry filed (24 one-byte characters)

- If a password has already been set, when you press the ▲ or ▼ key at any cursor position, all the "\*" will disappear and the first letter will be entered as the first character.
- Entered characters are visible until you press OK key. Once entering into the menu again, they will be changed to "\*".
- Other information is the same as the entering method of proxy server address.

**3.2 e-RDS settings**

- 1) Enter the service mode.
  - Turn off the printer power.
  - Turn on the power while pressing the [Load] key and [Navigate] key.
    - \* Keep pressing the above keys until "Initializing" is displayed.
  - "S" appears at the top right of the display.
  - Press the ◀ or ▶ key to choose the [Set./Adj. Menu] and press the [OK] key.
    - \* "SERVICE MODE" appears in the menu list and the MESSAGE LED flashes.
  - Press the ▲ key or ▼ key to choose "SERVICE MODE" and press the [OK] key.

2) Set the following e-RDS setting items No.1-4.  
 (If the result of the communication test (COM-TEST) is "NG", execute setting items No.5-6 to solve the problem.)

No.	Item	Type	Description
1	E-RDS SWITCH	2 bytes	OFF : Disable/ ON : Enable e-Maintenance/ imageWARE Remote system to send device information, meter data, and error statuses to the UGW. Default value is OFF (not in use)
2	UGW-ADDRESS	129 bytes (NULL included, SJIS not allowed)	The UGW address by default : https://a01---. The complete address is not provided in this document for security reason.
3	UGW-PORT	4 bytes	The UGW Port Number by default : 443 Validation : 1-65535
4	COM-TEST		To perform Communication test with UGW and set "OK!"/ "NG!" as the result.
5	COM-LOG		Detailed communication data log Switches to display time when error occurred, error code, and error data up to now. Max 30 loggings retained. Max 128 characters (not containing NULL) for Error information.
6	ERDS-DAT		Initialize e-RDS setting data

## 3.3 Service Mode Menu Tree

First Level	Second Level	Third Level	Fourth Level	Fifth Level	Sixth Level	
DISPLAY						
I/O DISPLAY						
ADJUST						
FUNCTION						
REPLACE						
COUNTER						
SETTEING	Pth					
	RTC					
	PV AUTO JUDGE					
	NETWORK	CERTIFICATE	CA-CERTIFICATE	VALIDITY:*1	yyyy/mm/dd	
	E-RDS	E-RDS SWITCH:*1		ON/OFF		
		UGW-ADDRESS:*1		http://XXX		
		UGW-PORT:*1		XXXXX		
		COM-TEST:*1		YES		
		COM-LOG:*1				
	HEAD DOT INF					
INITIALIZE	WARNING					
	ERROR					
	JAM					
	ADJUST					
	W-INK					
	CARRIAGE					
	PURGE					
	INK-USE CNT					
	W-INK-CHG CNT					
	HEAD-CHG CNT					
	HDD BOX PASS					
	PARTS-CHG CNT					
	PARTS COUNTER					
	USER SETTEING					
	CA-KEY:*1	YES/NO				
ERDS-DAT:*1	YES/NO					
JOB LOG	YES/NO					

- \* Press ► key to move to the next menu of the same layer, and press ▼ key to move to the menu of one layer deeper.  
 \* The menus shown in '\*1' are the e-RDS-related menus.

## 3.4 e-RDS Related Setting Details

## 1) e-RDS's Operation Mode [E-RDS SWITCH]

In service mode, referring to the "Service Mode Menu Tree", go to [E-RDS SWITCH] menu using ► key and ▼ key.

(1) Choose between [ON] or [OFF] using the ◀ and ▶ keys.

```

E - R D S   S W I T C H
O F F

```

F-7-38

(2) Press [OK] key to determine the operation mode and go back to the previous screen.

```

E - R D S   S W I T C H
= O N

```

F-7-39

- When the operation mode is determined, "=" will be displayed.
- OFF: When it is set to [OFF], e-RDS is not used. Default value is OFF.
- ON: When it is set to [ON], e-RDS is used.

**2) UGW Address [UGW-ADDRESS] and UGW port [UGW-PORT]**

Usually, the default values set in advance are used for the setting value of [UGW-ADDRESS] and [UGW-PORT]. Unless there is a special instruction, the default value should not be changed. If it should be changed, the communication with UGW may have an error. If [UGW-ADDRESS] and [UGW-PORT] are changed, the new setting will be enabled after power OFF/ON.

Therefore, usually, the setup is not necessary.

\* If you change under a special instruction, perform the following procedure.

**(1) Setting address for UGW**

- In service mode, referring to the "Service Mode Menu Tree", go to [UGW-ADDRESS] menu using **▶** key and **▼** key.

```

E - R D S
  U G W   A D D R E S S
  
```

F-7-40

- Press **▼** key to enter the Setup Mode. (A character indicating the input mode (in the upper right corner of the screen) and the cursor are displayed.)  
Enter UGW address (URL).

```

U G W - A D D R E S S      : a
h t t p : / /
  
```

F-7-41

Display to indicate an input mode

A: Alphabet capital letter

a: Alphabet small letter

1: Numerical character

- The cursor is shown at the first letter.

- Use **▲** and **▼** keys to select characters to enter.

- Press [Back] key to cancel what you entered and go back to the previous screen.

- Press [OK] key to determine what you entered and go back to the previous screen.

**(2) Setting up the GW Port Number**

- In service mode, referring to the "Service Mode Menu Tree", go to [UGW-PORT] menu using **▶** key and **▼** key.

```

E - R D S
  U G W   P O R T
  
```

F-7-42

- Press **▼** key to enter the Setup Mode. (A cursor is displayed.)  
Enter a port number.

```

U G W - P O R T
                                0 0 0 0 0
  
```

F-7-43

- Use **▲** and **▼** keys to select characters to enter.

- Press [Back] key to cancel what you entered and go back to the previous screen.

- Press [OK] key to determine what you entered and go back to the previous screen.

\* The actual setting value of UGW address [UGW-ADDRESS] and UGW port [UGW-PORT] are categorized as confidential information, so they are not described in this manual.

**3) Communication Test [COM-TEST]**

(1) In service mode, referring to the "Service Mode Menu Tree", go to [COM-TEST] menu using **▶** key and **▼** key.

```

C O M - T E S T
  Y E S
  
```

F-7-44

(2) Press [OK] key to start the test. ("=" is displayed at the start of the test.)

```

C O M - T E S T
= Y E S
  
```

F-7-45

(3) During the communication test, "CHECK NOW" is displayed.

```

C O M - T E S T
  C H E C K   N O W . .
  
```

F-7-46

- Once the communication test is started, it cannot be cancelled.(Other operation won't be accepted until the result is obtained.)

(4) If the communication test was successful, "CHECK RSLT:OK" is displayed.

```

C O M - T E S T
C H E C K   R S L T : O K

```

F-7-47

- Press ▲ key to exit this operation mode and go back to the top of [COM-TEST] menu.

(5) If the communication test was failed, "CHECK RSLT:NG" is displayed.

```

C O M - T E S T
C H E C K   R S L T : N G

```

F-7-48

- Press ▲ key to exit this operation mode and go back to the top of [COM-TEST] menu.

- If you cannot obtain the result after 30 seconds from the start of a communication test, the test is considered failed and the same screen will appear.

\* When the communication test was successful, it is necessary to take the interval of 5 minutes before performing the next communication test.

#### 4) Communication Log [COM-LOG]

Communication Error Information/Detailed Communication Error Information can be displayed on the screen at the time of a communication error with the Service Center (including proxy server error). When a communication error occurs, you can refer to this information to study how to deal with the problem.

\* For the countermeasure corresponding to each Communication Error Information or Detailed Communication Error Information, see the list of error message in "4. Troubleshoot".

(1) In service mode, referring to the "Service Mode Menu Tree", go to [COM-LOG] menu using ► key and ▼ key.

```

E - R D S
C O M - L O G

```

F-7-49

(2) Press ▼ key, and communication error information is displayed. On the upper line of the LCD, a log number (01-30) and an error code are shown; on the bottom line, an occurrence date and time of the error is shown.

```

N o : 0 1      X X X X X X X X H
Y Y Y Y / M M / D D   H H : M M

```

F-7-50

- COM-LOG information can be saved up to 30 cases.

- Use Right and Left keys to change logs to display.

- Logs are displayed in the sequence of the time of occurrence. (Log number 1 is the latest log.)

- Press ▲ key to exit this operation mode and go back to the top of [COM-LOG] menu.

\* If the Communication Error Information is not saved, the screen below will appear.

```

C O M - L O G
N O   L O G

```

F-7-51

- Press ▲ key to exit the communication error information screen and go back to the top of [COM-LOG] menu.

(3) Press ▼ key to display the Detailed Communication Error Information (maximum 128 characters).

1st-32nd characters of Detailed Communication Error Information are shown.

```

X X X X X X X X X X X X X X X X
X X X X X X X X X X X X X X X X

```

F-7-52

33rd-64th characters of Detailed Communication Error Information are shown.

```

X X X X X X X X X X X X X X X X
X X X X X X X X X X X X X X X X

```

F-7-53

65th-96th characters of Detailed Communication Error Information are shown.

```
X X X X X X X X X X X X X X X X X
X X X X X X X X X X X X X X X X X
```

F-7-54

97th-128th characters of Detailed Communication Error Information are shown.

```
X X X X X X X X X X X X X X X X X
X X X X X X X X X X X X X X X X X
```

F-7-55

- Use ◀ and ▶ keys to move among Screen and Screen. (Detailed Communication Error Information can be made with maximum 128 characters, however, even if the information is made up with 1 to 96 characters, all Screens are still displayed.)

- Press ▲ key to exit the Detailed Communication Error Information screen and go back to the Communication Error Information screen.

\* If Detailed Communication Error Information does not exist, the screen below will appear.

```
N O   E R R O R   D E T A I L
```

F-7-56

- Press ▲ key to exit the Detailed Communication Error Information screen and go back to the Communication Error Information screen.

**5) Initializing the e-RDS setting [ERDS-DAT]**

Usually, the setup is not necessary.

Use this procedure when you want to reset the e-RDS settings to the factory default.

(1) In service mode, referring to the "Service Mode Menu Tree", go to [ERDS-DAT] menu using ▶ key and ▼ key.

```
E - R D S   D A T
N O
```

F-7-57

(2) Choose between YES/NO using ◀ and ▶ keys, and press [OK] key to set.

```
E - R D S   D A T
= Y E S
```

F-7-58

- Press [OK] key, and "=" will appear and the initializing process will begin.

[NO]: Do not initialize the e-RDS setting. Default value is [NO].

[YES]: Initialize the e-RDS setting.

**6) Displaying the CA Certificate Information [VALIDITY]**

For the secure communication between the device (e-RDS) and the UGW, an authentication technology from a certification authority is used. A license has been issued from the certification authority. For this reason, the devices are shipped with the CA (Certificate Authority) certificate enabled in advance to prove the license obtained.

Therefore, usually, the setup is not necessary.

To confirm that this CA certificate is valid or how long it will be valid, you can display the expiration date of the CA certificate information.

(1) In service mode, referring to the "Service Mode Menu Tree", go to [VALIDITY] menu using ▶ key and ▼ key.

```
C A - C E R T I F I C A T E
V A L I D I T Y
```

F-7-59

(2) Press ▼ key, and the expiration date of the CA certificate will be displayed.

```
V A L I D I T Y
Y Y Y Y / M M / D D
```

F-7-60

- Press ▲ key to exit the CA certificate expiration date display screen and go back to the top of [VALIDITY] menu.

\* If the CA certificate is deleted, the screen below will appear.

```

V A L I D I T Y
N O T   I N S T A L L E D
  
```

F-7-61

- Press ▲ key to exit the CA certificate expiration date display screen and go back to the top of [VALIDITY] menu.

### 7) Deleting the CA Certificate [CA-KEY]

For the secure communication between the device (e-RDS) and the UGW, an authentication technology from a certification authority is used. A license has been issued from the certification authority. For this reason, the devices are shipped with the CA (Certificate Authority) certificate enabled in advance to prove the license obtained.

The device (e-RDS) uses this CA certificate to communicate with the UGW, thus CA must not be deleted.

Therefore, usually, the setup is not necessary.

\* If you delete the CA certificate under a special instruction, perform the following procedure.

(1) In service mode, referring to the "Service Mode Menu Tree", go to [CA-KEY] menu using ► key and ▼ key.

```

C A - K E Y
N O
  
```

F-7-62

(2) Choose between YES/NO using ◀ and ▶ keys, and press [OK] key to set.

```

C A - K E Y
= Y E S
  
```

F-7-63

- Press [OK] key, and "=" will appear and the initializing process will begin.

[NO]: Do not delete the CA certificate. Default value is [NO].

[YES]: Delete the CA certificate.

## 4. FAQ

No.	Question	Answer
Q1	Registration information of the device (E-RDS) is once deleted from the UGW server, and is re-registered after that. If a communication test is not carried out, then device information on UGW becomes invalid.	When registration of the device (e-RDS) is deleted from the UGW, the status will be changed to the communication test not completed because related information has lost from a database. Therefore, device information will also become invalid if that condition persists for seven days without carrying out the communication test. Hence, to avoid the invalid condition, carry out the communication test.
Q2	The communication test with the UGW server results NG!	The communication test might become NG in the following cases. - 1. Name resolution was failed due to an incorrect host name or DNS server has been halted. - 2. Network cable is blocked off. Network cable is broken. - 3. Proxy server settings are not correct.
Q3	Could you describe the timing of data transmitting from the device (e-RDS) to the UGW, and what data size is sent to the UGW?	The schedule of data transmitting, and the start time are determined by settings in the UGW side. The timing is once per 16 hours by default, and counter data size is maximum 1400 bytes.
Q4	Can I turn the device power off during the device (e-RDS) operation?	While operating the device (e-RDS), the power of the printer and network equipment such as HUB must be ON. If power OFF is needed, do not leave it OFF for a long time. An error such as "Device is busy, try later" could occur if the power supply of network equipment is made prolonged OFF.

## 5. Troubleshooting

No.	Condition detected	Action
1	The communication test has failed.	Check network conditions such as proxy server settings and so on. - Check the communication log from COM-LOG. -> Execute "Remedy" in the "Error message list". - Check whether RGW-ADDRESS or RGW-PORT settings have changed.



## 6. Error message list

Details of the errors and their remedies are as described below.  
(The meaning of server indicates the UGW in this section)

No.	Error Code	Error Message	Cause	Remedy
1	0500 0003	SUSPEND: Communication test is not performed	E-RDS has been booted up (device reboot) with E-RDS SWITCH = ON but the communication test had not yet been performed.	Perform the communication test [COMTEST] in service mode.
2	8600 0002 8600 0003 8600 0101 8600 0201 8600 0305 8600 0401 8600 0403 8600 0414 8600 0415	Event Registration is Failed	Event Registration is Failed Processing (event processing) within the device has failed.	Turn the device OFF/ ON. If the error persists, replace the device system software (firmware). (Upgrade)
3	8xxx 2001	URL Scheme error (not https)	The header of the URL of the registered UGW is not in https format. A "https://" input error.	Check that the value of UGW-ADR has been entered correctly as https://a01---
4	8xxx 200A	Server connection error	An UGW connection error. Displayed in the event of a TCP/IP communication fault.	Check the network-related settings according to "No.1: Communication test is not performed" in "Troubleshooting".
5	8xxx 2002	URL server specified is illegal	A URL different to that specified by the UGW has been set. An URL address setting error.	Check that the value of UGW-ADR has been entered correctly as https://a01---
6	8xxx 2014	Proxy connection error	Cannot connect to proxy server. Displayed when unable to connect to proxy server.	Check proxy server address and re-enter if necessary.
7	8xxx 201E	Proxy authentication error	Displayed when the authentication to the proxy server has failed.	Check the user name and password required in order to login to the proxy, and re-enter if necessary.
8	8xxx 2028	Server certificate error	Device's route certificate is unavailable.	Reinstall the latest device system software (firmware). (Upgrade)
9	8xxx 2046	Server certificate expired	The route certificate registered with the device has expired.	Check that the device time and date are correctly set. If the device time and date are correct, upgrade to the latest system software (firmware).
10	8xxx 2058	Unknown error	Some other kind of communication error has occurred.	Try again after a period of time. If the same error occurs again, check the UGW status with the UGW administrator.
11	8xxx 2063	SOAP Fault	SOAP communication error has occurred.	Check that the value of UGW-PORT is 443.
12	8xxx 0101	Server response error (NULL)	A UGW response error (when UGW error code processing has failed). A HTTPS communication error.	Try again after a period of time. If the same error persists, check the UGW status with the UGW administrator.
13	8xxx 2004	Server response error (Hexadecimal) [Error detailed in the UGW]:*1	A UGW response error. Displayed when communication with UGW has been successful, but an error of some sort has prevented UGW from responding.	Check an error code (hexadecimal) returned from the UGW, then retry after a period of time.
14	xxxx xxxx	Device internal error	An internal device error. An error due to the device side.	Switch the device OFF/ ON. Or, replace the device system software. (Upgrade)
15	8xxx 0201 8xxx 0202 8xxx 0203 8xxx 0204 8xxx 0206	Server schedule is invalid	During the communication test, there has been some kind of error in the schedule values passed from UGW.	When the error occurs, report the details to the support department. Then, after the UGW side has responded, retry the communication test.
16	8xxx 2047	Server response time out	UGW response time out. Due to network congestion, etc., the response from UGW does not come within the specified time.	If this error occurs when the communication test is being run, wait some time and rerun the test.
17	8xxx 2048	Server not found	There is a mistake in the UGW URL, and UGW cannot be accessed.	Check that the value of Service mode > E-RDS/RGW-ADR is https://a01---
18	84xx 0003	E-RDS switch is set OFF	E-RDS is disabled.	Set E-RDS SWITCH = ON, and run COM-TEST in service mode.
19	0xxx 0003	Server schedule is not exist	Server schedule does not exist. Blank schedule data has been received from UGW.	Check the device settings status with the UGW administrator.
20	8xxx 2003	Network is not ready, try later	Network-related settings have not been made for the device.	Make network-related settings properly for the device (printer).
21	8xxx 2052	URL error	A URL setting error. Non-URL text string entered in URL field.	Check that the value of UGW-ADR is https://a01---
22	8xxx 2015	Proxy address resolution error	A proxy server address resolution error.	Check that the proxy server name is correct.
23	8xxx 2029	Server certificate verify error	The server certificate verification (URL check) error.	Check that the value of UGW-ADR is https://a01---
24	8xxx 200B	Server address resolution error	UGW address resolution has failed.	Check that the value of UGW-ADR is https:// a01---

\*1:[Hexadecimal] indicates an error code returned from the UGW in hexadecimal.

## 7. Service cautions

After performing the following service actions, it is necessary to perform the resetting of the e-RDS.  
Failure to do so will result that the counter transmitting value to the UGW may become unusual.

- System software (firmware) upgrade
- After replacing the main controller board, the following settings in service mode must not be changed unless there are specific instructions to do so. Changing these values will cause error in communication with the UGW.

(Initial values)

UGW-PORT: 443

UGW-ADDRESS: https://a01---

### 7.1.5 Viewing PRINT INF

#### a) PRINT INF item detail

The details of each PRINT INF item displayed when performing [SERVICE MODE] > [DISPLAY] > [PRINTINF] are as follows:

Print item		Print content	Printed value
SYSTEM	S/N	Serial number of printer	characters/numerals of 8-byte
	TYPE	Type setting on main controller PCB	24, 36
	LF TYPE	Feed roller type	0: old type roller 1: new type roller
	TMP	Ambient temperature	Unit: Centigrade degree
	RH	Ambient humidity	Unit: %
	SIZE LF	Detected size of loaded media (feed direction)	mm (0 is always detected for the roll media.)
	SIZE CR	Detected size of loaded media (carriage scan direction)	mm
	AFTER INST.	Number of days since initial installation	Unit: Day(s)
HEAD	S/N	Serial number of printhead	characters/numerals (8 digits)
	LOT	Lot number of printhead	characters/numerals (8 digits)
INK	(The ink color is indicated)	Number of days passed since the ink tank was installed	Unit: Days
WARNING	01-20	Warning history (up to 20 events)	Number: Lowest is the most recent Date: mm/dd Time: mm/ss Code: Last 4 digits Cumulative number of printed media (equivalent of A4)
ERROR	01-20	Error history (up to 20 events)	Number: Lowest is the most recent Date: mm/dd Time: mm/ss Code: Last 4 digits Cumulative number of printed media (equivalent of A4)

Print item		Print content	Printed value
JAM	01-05	JAM log (5 records)	Number: Lowest is the most recent Date: mm/dd Time: mm/ss Jam code
	01	Jam type	1: CR error 2: Jam 3: Feed failure (delay) 4: Cut failure *: Unknown
	02	Media format	1: Roll media 2: Cut sheet *: Unknown
	03	Jam timing	1: Feed 2: Print 3: Eject *: Unknown
	04	Width detection OFF mode	1: ON 2: OFF *: Unknown
	05	Head height	0: SL (1.0mm) 1: L (1.3mm) 2: M1 (1.8mm) 3: M2 (2.0mm) 4: M3 (2.2mm) 5: H (2.6mm) *: Unknown
	06	Platen shutter position	1: Fully close 2: Only HP side open 3: 1/4 open 4: 1/2 open 5: 3/4 open 6: Fully open *: Unknown
	07	Cut mode	1: User cut 2: Eject cut 3: Auto cut *: Unknown
	08	Media passing environment	0: A(temperature 15 to 25 degrees centigrade/humidity 40 to 60%) 1: B(temperature 25 to 30 degrees centigrade/humidity 40 to 60%) 2: C(temperature 15 to 30 degrees centigrade/humidity 10 to 40%) 3: D(temperature 15 to 30 degrees centigrade/humidity 60 to 80%) 4: E(temperature 15 to 30 degrees centigrade/humidity 0 to 10%, or 15 degrees centigrade or less and 30 degrees centigrade or more/humidity 0 to 50%[low humidity is out of guarantee.]) 5: F(temperature 15 to 30 degrees centigrade/humidity 80 to 100%, or 15 degrees centigrade or less and 30 degrees centigrade or more/humidity 50 to 100%[high humidity is out of guarantee.]) *: Unknown
	09	Borderless/Bordered	1: Bordered printing 2: Borderless printing *: Unknown
	10	Print mode label No.	Display print mode *: Unknown
	11	Media size	Display size *: Unknown
12	Media type	Display media name *: Unknown	
INK CHK	(The ink color is indicated)	Refill log Print whether disable remaining ink detection was previously set	0: Disable remaining ink detection was never set 1: Disable remaining ink detection was set at least once

Print item		Print content	Printed value
COUNTER	PRINTER	LIFE-TTL	Total amount of cumulative number of sheets Unit: sheets (A4-equivalent paper)
		LIFE-ROLL	Cumulative number of sheets of roll media Unit: sheets (A4-equivalent paper)
		LIFE-CUTSHEET	Cumulative number of sheets of cut sheet Unit: sheets (A4-equivalent paper)
		LIFE A-F	Cumulative number of sheets of each environment Unit: sheets (A4-equivalent paper)
		POWER ON	Cumulative power-on time Unit: hours
		SLEEP ON	Cumulative sleep-on time Unit: hours
		CUTTER	Number of cutting operations Unit: times
		WIPE	Number of wiping operations Unit: times
		W-INK	Remaining capacity of the maintenance cartridge Unit: %
		PDL	Cumulative number of printed media according to PDL GAR0: xx sheets HP-GL/2: xx sheets
	CARRIAGE	PRINT	Cumulative printing time Unit: hours
		DRIVE	Cumulative carriage moving time Unit: hours
		CR-COUNT	Cumulative carriage scan count (count as 1 by moving back and forth) Unit: times
		CR-DIST.	Cumulative carriage scan distance (count as 1 by moving 210mm) Unit: times
		PRINT-COUNT	Cumulative print end count (count as 1 by capping) Unit: times
	PURGE	CLN-A	Cumulative number of automatic cleaning operations
		1	Cumulative number of automatic cleaning 1 (normal suction) operations Unit: times
		2	Cumulative number of automatic cleaning 2 (ink level adjusting) operations
		3	Cumulative number of automatic cleaning 3 (initial filling) operations
		6	Cumulative number of automatic cleaning 6 (strong normal suction) operations
		7	Cumulative number of automatic cleaning 7 (aging) operations
		8	Cumulative number of automatic cleaning 8 (flashing) operations
		10	Cumulative number of automatic cleaning 10 (ink filling after secondary transportation) operations
		11	Cumulative number of automatic cleaning 11 (ink filling after head replacement) operations
		15	Cumulative number of automatic cleaning 15 (dot count small suction) operations
		16	Cumulative number of automatic cleaning 16 (sedimented ink agitation) operations
		17	Cumulative number of automatic cleaning 17 (small suction) operations
		TTL	Total number of automatic cleaning operations
		CLN-M	Cumulative number of manual cleaning 1 operations
		1	Cumulative number of manual cleaning 1 (normal suction) operations Unit: times
		4	Cumulative number of manual cleaning 4 (ink draining from head after head replacement) operations
		5	Cumulative number of manual cleaning 5 (ink draining from head and tube before transportation ) operations
		6	Cumulative number of manual cleaning 6 (normal strong suction) operations
TTL		Total number of manual cleaning operations	

Print item		Print content	Printed value
COUNTER	CLEAR	INK CONSUME	Cumulative count of ink section consumption amount clearing
		MTC EXC.	Cumulative count of maintenance cartridge replacement count clearing
		HEAD EXC.	Cumulative count of printhead replacement count clearing
		PARTS CR1 EXC.	Cumulative count of unit CR-1(carriage unit bushing) replacement count clearing
		PARTS CR2 EXC.	Cumulative count of unit CR-2(flexible cable unit) replacement count clearing
		PARTS CR3 EXC.	Cumulative count of unit CR-3(linear encoder sensor/linear scale/shaft cleaner) replacement count clearing
		PARTS CR4 EXC.	Cumulative count of unit CR-4(carriage height changing cam) replacement count clearing
		PARTS CR5 EXC.	Cumulative count of unit CR-5(multi sensor) replacement count clearing
		PARTS SP1 EXC.	Cumulative count of unit SP-1(ink tube unit) replacement count clearing
		PARTS PG1 EXC.	Cumulative count of unit PG-1(purge unit) replacement count clearing
		PARTS HMa1 EXC.	Cumulative count of unit HMa-1(head management sensor) replacement count clearing
		PARTS MT1 EXC.	Cumulative count of unit MT-1(carriage motor) replacement count clearing
		PARTS PL1 EXC.	Cumulative count of unit PL-1(feed motor) replacement count clearing
		PARTS Mi1 EXC.	Cumulative count of unit Mi-1(mist fan/mist exhaust duct) replacement count clearing
		PARTS CT1 EXC.	Cumulative count of unit CT-1(cutter) replacement count clearing
		PARTS WF1 EXC.	Cumulative count of unit WF-1(ink absorber under the maintenance cartridge unit) replacement count clearing
PARTS WF2 EXC.	Cumulative count of unit WF-2(platen exhaust duct) replacement count clearing		
FACTORY CNT.	For factory		

Print item		Print content	Printed value	
COUNTER	EXCHANGE	MTC EXC.	Maintenance cartridge replacement count	Unit: times
		HEAD EXC.	Printhead replacement count	
		BOARD EXC.(M/B)	Main controller PCB replacement count	
		PARTS CR1 EXC.	CR-1(carriage unit bushing) replacement count	
		PARTS CR2 EXC.	CR-2(flexible cable unit) replacement count	
		PARTS CR3 EXC.	CR-3(linear encoder sensor/linear scale/shaft cleaner) replacement count	
		PARTS CR4 EXC.	CR-4(carriage height changing cam) replacement count	
		PARTS CR5 EXC.	CR-5(multi sensor) replacement count	
		PARTS SP1 EXC.	SP-1(ink tube unit) replacement count	
		PARTS PG1 EXC.	PG-1(purge unit) replacement count	
		PARTS HMa1 EXC.	HMa-1(head management sensor) replacement count	
		PARTS MT1 EXC.	MT-1(carriage motor) replacement count	
		PARTS PL1 EXC.	PL-1(feed motor) replacement count	
		PARTS Mi1 EXC.	Mi-1(mist fan/mist exhaust duct) replacement count	
		PARTS CT1 EXC.	CT-1(cutter) replacement count	
		PARTS WF1 EXC.	WF-1(ink absorber under the maintenance cartridge unit) replacement count	
		PARTS WF2 EXC.	WF-2(platen exhaust duct) replacement count	
		DETAIL-CNT	MOVE PRINTER	
MEDIACONF IG-CNT	Count of media registered by media editor			
N-INKCHK (The ink color is indicated)	Count of turning off the ink remaining level detection for each color			

Print item		Print content		Printed value
COUNTER	INK-USE1	INK (The ink color is indicated)	Cumulative consumption amount of generic ink	Unit: ml
		TTL	Total amount of the cumulative consumption of generic ink	
		LINK (The ink color is indicated)	Cumulative consumption amount of generic large ink	
		TTL	Total amount of the cumulative consumption of generic large ink	
		SINK (The ink color is indicated)	Cumulative consumption amount of generic small ink	
		TTL	Total amount of the cumulative consumption of generic small ink	
		NINK (The ink color is indicated)	Cumulative consumption amount of refilled ink	
		TTL	Total amount of the cumulative consumption of refilled ink	
	INK-USE2	INK (The ink color is indicated)	Consumption amount of generic ink of the currently installed ink tank.	Unit: ml
		TTL	Total consumption amount of generic ink of the currently installed ink tanks	
		NINK (The ink color is indicated)	Consumption amount of refilled ink of the currently installed ink tank	
		TTL	Total consumption amount of refilled ink of the currently installed ink tanks	
INK-EXC	INK (The ink color is indicated)	Cumulative count of generic ink tank replacement	Unit: times	
	TTL	Total amount of the cumulative count of generic ink tank replacement		
	NINK (The ink color is indicated)	Cumulative count of refilled ink tank replacement		
	TTL	Total amount of the cumulative count of refilled ink tank replacement		

Print item			Print content	Printed value
COUNTER	MEDIA 1-7	NAME	Media type	
		TTL	Total amount of cumulative print area of roll media and cut sheet	Unit: square/meter, square/feet
		ROLL	Cumulative print area of roll media	
		CUTSHEET	Cumulative print area of cut sheet	
	MEDIA OTHER	NAME	OTHER	OTHER
		TTL	Total amount of cumulative print area of roll media and cut sheet	Unit: square/meter, square/feet
		ROLL	Cumulative print area of roll media	
		CUTSHEET	Cumulative print area of cut sheet	
	MEDIA SIZE1 ROLL P-SQ/P-CNT	36-44	Cumulative print area of roll media equal to or larger than 36 inches but less than 44 inches (physical size)	Unit: square/meter, square/feet, sheets (equivalent of A4)
		24-36	Cumulative print area of roll media equal to or larger than 24 inches but less than 36 inches (physical size)	
		17-24	Cumulative print area of roll media equal to or larger than 17 inches but less than 24 inches (physical size)	
		0-17	Cumulative print area of roll media less than 17 inches (physical size)	
	MEDIA SIZE2 ROLL D-SQ/D-CNT	36-44	Cumulative print area of roll media equal to or larger than 36 inches but less than 44 inches (data size)	Unit: square/meter, square/feet, sheets (equivalent of A4)
		24-36	Cumulative print area of roll media equal to or larger than 24 inches but less than 36 inches (data size)	
		17-24	Cumulative print area of roll media equal to or larger than 17 inches but less than 24 inches (data size)	
		0-17	Cumulative print area of roll media less than 17 inches (data size)	
	MEDIA SIZE1 CUT P-SQ/P-CNT	36-44	Cumulative print area of cut sheet equal to or larger than 36 inches but less than 44 inches (physical size)	Unit: square/meter, square/feet, sheets (equivalent of A4)
		24-36	Cumulative print area of cut sheet equal to or larger than 24 inches but less than 36 inches (physical size)	
		17-24	Cumulative print area of cut sheet equal to or larger than 17 inches but less than 24 inches (physical size)	
		0-17	Cumulative print area of cut sheet less than 17 inches (physical size)	
	MEDIA SIZE2 CUT D-SQ/D-CNT	36-44	Cumulative print area of cut sheet equal to or larger than 36 inches but less than 44 inches (data size)	Unit: square/meter, square/feet, sheets (equivalent of A4)
		24-36	Cumulative print area of cut sheet equal to or larger than 24 inches but less than 36 inches (data size)	
		17-24	Cumulative print area of cut sheet equal to or larger than 17 inches but less than 24 inches (data size)	
		0-17	Cumulative print area of cut sheet less than 17 inches (data size)	
HEAD DOT CNT.1	(The ink color is indicated)	Dot counts of each colors of the currently installed printhead	Unit: (x 1,000,000) dots	
	TTL	Total dot counts of each colors of the currently installed printhead		
HEAD DOT CNT.2	(The ink color is indicated)	Cumulative dot counts of each colors	Unit: (x 1,000,000) dots	
	TTL	Total cumulative dot counts of each colors		



Print item	Print content	Printed value	
HEAD INF.1 [Installed head]	01	Date & time installed (last 4 times)	YY/MM/DD Display order: Installed date (last) -> Installed date (2nd to last) -> Installed date (3rd to last) -> Installed date (initial)
	02	Removal date & time (last 3 times)	YY/MM/DD Display order: Last -> 2nd to last -> 3rd to last
	03	Main unit serial No. (last 3 times)	Display order: Last -> 2nd to last -> 3rd to last
	04	CLN_A (auto) count	Unit: Times
	05	CLN_A (manual) count	
	06	Cleaning B (auto/left cap) count	
	07	Cleaning B (auto/right cap) count	
	08	CLN_B (manual) count	
	09	Head replacement ink drain count	
	10	Secondary transport ink drain count	
	11	Secondary transport ink fill count	
	12	Ink filling after head replacement count	
	13	Recovery suction	
	14	Number of sheets printed	Unit: Sheets (A4 equivalent sheets)
	15	Error log	YY/MM/DD xxxx (last 4 digits) 01: Last, 02: 2nd to last, 03: 3rd to last, ..., 20: 20th to last
	16	Refill tank usage log (per chip)	A: x, B: x, C: x, D: x, E: x, F: x
	17	Firmware version (last 3)	XX.XX YY/MM/DD Display order: Last -> 2nd to last -> 3rd to last
	18	Head highest temperature (per chip)	A: xxx, B: xxx, C: xxx, D: xxx, E: xxx, F: xxx
	19	Number of non-discharging nozzles (per nozzle row) chip A row A, chip A row B to chip F row A, chip F row B	AA: xxx, AB: xxx, BA: xxx, BB: xxx, CA: xxx, CB: xxx, DA: xxx, DB: xxx, EA: xxx, EB: xxx, FA: xxx, FB: xxx
	20	EEPROM format Ver (oldest version)	
	21	EEPROM format Ver (latest version)	
HEAD INF.2 [Head installed 2nd to last]	01	Date & time installed (last 4 times)	YY/MM/DD Display order: Installed date (last) -> Installed date (2nd to last) -> Installed date (3rd to last) -> Installed date (initial)
	02	Removal date & time (last 3 times)	YY/MM/DD Display order: Last -> 2nd to last -> 3rd to last
	03	Main unit serial No. (last 3 times)	Display order: Last -> 2nd to last -> 3rd to last
	04	CLN_A (auto) count	Unit: Times
	05	CLN_A (manual) count	
	06	Cleaning B (auto/left cap) count	
	07	Cleaning B (auto/right cap) count	
	08	CLN_B (manual) count	
	09	Head replacement ink drain count	
	10	Secondary transport ink drain count	
	11	Secondary transport ink fill count	
	12	Ink filling after head replacement count	
	13	Recovery suction	
	14	Number of sheets printed	Unit: Sheets (A4 equivalent sheets)
	15	Error log	YY/MM/DD xxxx (last 4 digits) 01: Last, 02: 2nd to last, 03: 3rd to last, ..., 20: 20th to last
	16	Refill tank usage log (per chip)	A: x, B: x, C: x, D: x, E: x, F: x
	17	Firmware version (last 3)	XX.XX YY/MM/DD Display order: Last -> 2nd to last -> 3rd to last
	18	Head highest temperature (per chip)	A: xxx, B: xxx, C: xxx, D: xxx, E: xxx, F: xxx
	19	Number of non-discharging nozzles (per nozzle row) chip A row A, chip A row B to chip F row A, chip F row B	AA: xxx, AB: xxx, BA: xxx, BB: xxx, CA: xxx, CB: xxx, DA: xxx, DB: xxx, EA: xxx, EB: xxx, FA: xxx, FB: xxx
	20	EEPROM format Ver (oldest version)	
	21	EEPROM format Ver (latest version)	

Print item	Print content	Printed value	
PARTS CNT.	[Value of each parts counter]	Status	OK/W1/W2/E
		Number of days after set	Unit: Days
		Count	
		Life threshold	
		Usage	Unit: %
		Cumulative count	
COGFF	CONDITION	Cogging FF result	0: Disabled 1: Enabled 2: Check required 3: Adjust reuired
	PITCHERR-F	Pitch deviation in the forward path (FWD)	-400 to 400 (1/100000 mm)
	PITCHRR-B	Pitch deviation of the return path (BWD)	
	PARAM0-F	Parameters 1	REF: Motor error (6 digits) PHASE: Phase (3 digits) AMP: Amplitude (3 digits) RATE: Decay rate (3 digits)
	PARAM0-B	Parameters 2	REF: Motor error (6 digits) PHASE: Phase (3 digits) AMP: Amplitude (3 digits) RATE: Decay rate (3 digits)
	PARAM1-F	Parameters 1	REF: Motor error (6 digits) PHASE: Phase (3 digits) AMP: Amplitude (3 digits) RATE: Decay rate (3 digits)
	PARAM1-B	Parameters 2	REF: Motor error (6 digits) PHASE: Phase (3 digits) AMP: Amplitude (3 digits) RATE: Decay rate (3 digits)
LF/SCALE ADJUSTMENT VALUE	MEDIA	Type of paper that printed "PRINT INF"	
	LF-A	User LF adjustment value A of the above MEDIA (standard)	LF adjustment value (up to 4 decimal places)
	LF-B	User LF adjustment value B of the above media (low pass)	
	SCALE-A	User scale adjustment value A of the above media (fine scale)	Scale adjustment value (integer)
	SCALE-B	User scale adjustment value B of the above media (fast scale)	
PV AUTO JUDGE		Ink reduction mode	ON (NORMAL/LOW only when ON)/OFF *: NORMAL: normal mode, LOW: ink saving mode
		Inrush number of times	Inrush number of times (0 to 254) *: Times that swiched from NORMAL (normal mode) to LOW (ink saving mode)
MULTI SENSOR	UNIT	Multi sensor version	
	DATA	Multi sensor data	

Print item		Print content	Printed value	
CRREG	HRZ A	Adjustment value of the horizontal registration A and B and C ink droplet landing position		
	HRZ B			
	HRZ C			
	VRT LATEST CALC POINTS	As to the listed value, the number of effective value from the first		
	VRT a	Adjustment value when performing the vertical registration a and b and c average adjustment value calculation		
	VRT b			
VRT c				
JOB LOG	No	Job history (up to 5 events)	Number: Lowest is the most recent	
	M	Print mode		
	HEAD	Head height		
	TEMP&HUM	Temperature and humidity		
	MEDIA TYPE	Media type		
	DATE	Date		
	TIME	Time		
	R	Registration condition	A: The GAP used for printing and GAP of internal registration adjustment value is a match. B: The GAP used for printing and GAP of internal registration adjustment value is a mismatch. C: No registration adjustment value	
	GAP	Gap information	Distance between head and media	
	JOB NAME	Job name		
ADJUST LOG	No	No: Adjustment history (up to 5 events, lowest is the most recent) D: Advanced registration history E: Expansion registration history	The history of D and E are each most recent one only.	
	ADJ. TYPE	Adjustment type	manual: Manual adjustment auto(d): Detail auto(s): Basic auto(e): Extension	
	HEAD	Head height	xx(y,Z) xx= A: automatic panel setting, H: fixed panel setting, AE: adjustment error occurred (automatic), HE: adjustment error occurred (fixed), (y,z)=0: SLOW, 1: LO, 2: M1, 3: M2, 4: M3, 5: H1 y: GAP1 z: GAP2	
	TEMP&HUM	Temperature and humidity		
	MEDIA TYPE	Media type		
	DATE	Date		
	TIME	Time		
	GAP1	1st kind GAP		
	GAP2	2nd kind GAP		
	DUTY	UNIT: m2	A(xxx)	A: Cumulative print area of Duty A B: Cumulative print area of Duty B C: Cumulative print area of Duty C D: Cumulative print area of Duty D E: Cumulative print area of Duty E TTL: Cumulative print area of all Duty xxx: Counter number of e-Maintenance/imageWARE Remote
B(xxx)				
C(xxx)				
D(xxx)				
E(xxx)				
TTL(xxx)				
UNIT: sq.f		A(xxx)		
		B(xxx)		
		C(xxx)		
		D(xxx)		
		E(xxx)		
		TTL(xxx)		
UNIT: A4 Sheet		A(xxx)		
		B(xxx)		
		C(xxx)		
		D(xxx)		
		E(xxx)		
		TTL(xxx)		
UNIT: Letter Sheet		A(xxx)		
		B(xxx)		
	C(xxx)			
	D(xxx)			
	E(xxx)			
	TTL(xxx)			

**b) Layout**

PRINT INF layout is shown below.

```

1/5
Canon imagePROGRAF iPFxxx PRINT INF
Firm:xx.xx Boot:xx.xx MIT(DBF):x.xx MIT(DB):x.xx
S/N:xxxxxxxx Date:yyyy/mm/dd
SYSTEM
S/N:xxxxxxxx TYPE:12 -LF:1 TMP:xx RH:xx SIZE-LF:xxxxx.x -CR:xxxxx.x AFTER INST:xxxx x
HEAD INK
S/N:xxxxxxxx LOT:xxxxxxxx C:xxxxxx M:xxxxxx Y:xxxxxx MBK:xxxxxx MBK2:xxxxxx BK:xxxxxx
WARNING
01:MM/DD HH:MM xxxx 02:MM/DD HH:MM xxxx
03:MM/DD HH:MM xxxx 04:MM/DD HH:MM xxxx
05:MM/DD HH:MM xxxx 06:MM/DD HH:MM xxxx
07:MM/DD HH:MM xxxx 08:MM/DD HH:MM xxxx
09:MM/DD HH:MM xxxx 10:MM/DD HH:MM xxxx
11:MM/DD HH:MM xxxx 12:MM/DD HH:MM xxxx
13:MM/DD HH:MM xxxx 14:MM/DD HH:MM xxxx
15:MM/DD HH:MM xxxx 16:MM/DD HH:MM xxxx
17:MM/DD HH:MM xxxx 18:MM/DD HH:MM xxxx
19:MM/DD HH:MM xxxx 20:MM/DD HH:MM xxxx
ERROR
01:MM/DD HH:MM xxxx 02:MM/DD HH:MM xxxx
03:MM/DD HH:MM xxxx 04:MM/DD HH:MM xxxx
05:MM/DD HH:MM xxxx 06:MM/DD HH:MM xxxx
07:MM/DD HH:MM xxxx 08:MM/DD HH:MM xxxx
09:MM/DD HH:MM xxxx 10:MM/DD HH:MM xxxx
11:MM/DD HH:MM xxxx 12:MM/DD HH:MM xxxx
13:MM/DD HH:MM xxxx 14:MM/DD HH:MM xxxx
15:MM/DD HH:MM xxxx 16:MM/DD HH:MM xxxx
17:MM/DD HH:MM xxxx 18:MM/DD HH:MM xxxx
19:MM/DD HH:MM xxxx 20:MM/DD HH:MM xxxx
JAM
01:MM/DD HH:MM xxxx xxxxxxxx
01:x 02:x 03:x 04:x 05:xx 06:x 07:x 08:x
09:x 10:xxx 11:media_sizexxxxxx 12:media_namexxxxxx
02:MM/DD HH:MM xxxx xxxxxxxx
01:x 02:x 03:x 04:x 05:xx 06:x 07:x 08:x
09:x 10:xxx 11:media_sizexxxxxx 12:media_namexxxxxx
03:MM/DD HH:MM xxxx xxxxxxxx
01:x 02:x 03:x 04:x 05:xx 06:x 07:x 08:x
09:x 10:xxx 11:media_sizexxxxxx 12:media_namexxxxxx
04:MM/DD HH:MM xxxx xxxxxxxx
01:x 02:x 03:x 04:x 05:xx 06:x 07:x 08:x
09:x 10:xxx 11:media_sizexxxxxx 12:media_namexxxxxx
05:MM/DD HH:MM xxxx xxxxxxxx
01:x 02:x 03:x 04:x 05:xx 06:x 07:x 08:x
09:x 10:xxx 11:media_sizexxxxxx 12:media_namexxxxxx

```

```

2/5
Canon imagePROGRAF iPFxxx PRINT INF
Firm:xx.xx Boot:xx.xx MIT(DBF):x.xx MIT(DB):x.xx
S/N:xxxxxxx Date:yyyy/mm/dd
INK CHECK
C:x M:x Y:x MBK:x MBK2:x BK:x
COUNTER
PRINTER
LIFE-TTL:xxxxxx LIFE-ROLL:xxxxxx LIFE-CUTSHEET:xxxxxx
LIFE A:xxxxxx B:xxxxxx C:xxxxxx D:xxxxxx E:xxxxxx F:xxxxxx
POWER-ON:xxxxxx SLEEP-ON:xxxxxx CUTTER:xxxxxx WIPE:xxxxxx W-INK:xxxxxx
PDL: GARO:xxxxxx HP-GL/2:xxxxxx
CARRIAGE
PRINT:xxxxxx DRIVE:xxxxxx CR-COUNT:xxxxxx CR-DIST.:xxxxxx PRINT-COUNT:xxxxxx
PURGE
CLN-A : 1:xxxxx 2:xxxxx 3:xx 6:xxxx 7:xxx 10:xxx 11:xxx 15:xxx 16:xxxxx 17:xxxxx TTL:xxxxxx
CLN-M : 1:xxxxx 4:xxx 5:xx 6:xxxxx TTL:xxxxx
CLEAR
INK CONSUME:xxx MTC EXC.:xxx HEAD EXC.:xxx
PARTS CR1 EXC.:xx PARTS CR2 EXC.:xx PARTS CR3 EXC.:xx PARTS CR4 EXC.:xx PARTS CR5 EXC.:xx
PARTS SP1 EXC.:xx PARTS PG1 EXC.:xx PARTS HMa1 EXC.:xx PARTS MT1 EXC.:xx PARTS PL1 EXC.:xx
PARTS Mi1 EXC.:xx PARTS CT1 EXC.:xx PARTS WF1 EXC.:xx PARTS WF2 EXC.:xx
FACTORY CNT.:xx
EXCHANGE
MTC EXC.:xxx HEAD EXC.:xxx BOARD EXC.(M/B):xx
PARTS CR1 EXC.:xx PARTS CR2 EXC.:xx PARTS CR3 EXC.:xx PARTS CR4 EXC.:xx PARTS CR5 EXC.:xx
PARTS SP1 EXC.:xx PARTS PG1 EXC.:xx PARTS HMa1 EXC.:xx PARTS MT1 EXC.:xx PARTS PL1 EXC.:xx
PARTS Mi1 EXC.:xx PARTS CT1 EXC.:xx PARTS WF1 EXC.:xx PARTS WF2 EXC.:xx
DETAIL-CNT
MOVE PRINTER:xxx MEDIACONFIG-CNT:xxx
N-INKCHK: C:xxxx M:xxxx Y:xxxx MBK:xxxx MBK2:xxxx BK:xxxx
INK-USE1
INK C:xxxx.xml M:xxxx.xml Y:xxxx.xml MBK:xxxx.xml MBK2:xxxx.xml BK:xxxx.xml
TTL:xxxxxx.xml
NINK C:xxxx.xml M:xxxx.xml Y:xxxx.xml MBK:xxxx.xml MBK2:xxxx.xml BK:xxxx.xml
TTL:xxxxxx.xml
INK-USE2
INK C:xxxx.xml M:xxxx.xml Y:xxxx.xml MBK:xxxx.xml MBK2:xxxx.xml BK:xxxx.xml
TTL:xxxxxx.xml
NINK C:xxxx.xml M:xxxx.xml Y:xxxx.xml MBK:xxxx.xml MBK2:xxxx.xml BK:xxxx.xml
TTL:xxxxxx.xml
INK-EXC
INK C:xxx M:xxx Y:xxx MBK:xxx MBK2:xxx BK:xxx
TTL:xxxxx
NINK C:xxx M:xxx Y:xxx MBK:xxx MBK2:xxx BK:xxx
TTL:xxxxx

```

3/5

Canon imagePROGRAF iPFxxx PRINT IN F

Firm:xx.xx Boot:xx.xx MIT(DBF):x.xx MIT(DB):x.x x

S/N:xxxxxxxx Date:yyyy/mm/d d

MEDIA 1

NAME : xxxxxxxxxxxxxxxxxxxxxxxxxxxxxxxxxxxx  
TTL : xxxxxxx.x m2 xxxxxxx.x sq.f  
ROLL : xxxxxxx.x m2 xxxxxxx.x sq.f  
CUTSHEET : xxxxxxx.x m2 xxxxxxx.x sq.f

MEDIA 2

NAME : xxxxxxxxxxxxxxxxxxxxxxxxxxxxxxxxxxxx x  
TTL : xxxxxxx.x m2 xxxxxxx.x sq.f  
ROLL : xxxxxxx.x m2 xxxxxxx.x sq.f  
CUTSHEET : xxxxxxx.x m2 xxxxxxx.x sq.f

MEDIA 3

NAME : xxxxxxxxxxxxxxxxxxxxxxxxxxxxxxxxxxxx  
TTL : xxxxxxx.x m2 xxxxxxx.x sq.f  
ROLL : xxxxxxx.x m2 xxxxxxx.x sq.f  
CUTSHEET : xxxxxxx.x m2 xxxxxxx.x sq.f

MEDIA 4

NAME : xxxxxxxxxxxxxxxxxxxxxxxxxxxxxxxxxxxx x  
TTL : xxxxxxx.x m2 xxxxxxx.x sq.f  
ROLL : xxxxxxx.x m2 xxxxxxx.x sq.f  
CUTSHEET : xxxxxxx.x m2 xxxxxxx.x sq.f

MEDIA 5

NAME : xxxxxxxxxxxxxxxxxxxxxxxxxxxxxxxxxxxx  
TTL : xxxxxxx.x m2 xxxxxxx.x sq.f  
ROLL : xxxxxxx.x m2 xxxxxxx.x sq.f  
CUTSHEET : xxxxxxx.x m2 xxxxxxx.x sq.f

MEDIA 6

NAME : xxxxxxxxxxxxxxxxxxxxxxxxxxxxxxxxxxxx x  
TTL : xxxxxxx.x m2 xxxxxxx.x sq.f  
ROLL : xxxxxxx.x m2 xxxxxxx.x sq.f  
CUTSHEET : xxxxxxx.x m2 xxxxxxx.x sq.f

MEDIA 7

NAME : xxxxxxxxxxxxxxxxxxxxxxxxxxxxxxxxxxxx  
TTL : xxxxxxx.x m2 xxxxxxx.x sq.f  
ROLL : xxxxxxx.x m2 xxxxxxx.x sq.f  
CUTSHEET : xxxxxxx.x m2 xxxxxxx.x sq.f

MEDIA OTHE R

NAME : xxxxxxxxxxxxxxxxxxxxxxxxxxxxxxxxxxxx x  
TTL : xxxxxxx.x m2 xxxxxxx.x sq.f  
ROLL : xxxxxxx.x m2 xxxxxxx.x sq.f  
CUTSHEET : xxxxxxx.x m2 xxxxxxx.x sq.f

MEDIA SIZE1 ROLL P-SQ/P-CN T

36-44: xxxxxxx.x m2 xxxxxxx.x sq.f 0  
24-36: xxxxxxx.x m2 xxxxxxx.x sq.f 0  
17-24: xxxxxxx.x m2 xxxxxxx.x sq.f 0  
0-17: xxxxxxx.x m2 xxxxxxx.x sq.f 0

MEDIA SIZE2 ROLL D-SQ/D-CN T

36-44: xxxxxxx.x m2 xxxxxxx.x sq.f 0  
24-36: xxxxxxx.x m2 xxxxxxx.x sq.f 0  
17-24: xxxxxxx.x m2 xxxxxxx.x sq.f 0  
0-17: xxxxxxx.x m2 xxxxxxx.x sq.f 0

MEDIA SIZE1 CUT P-SQ/P-CN T

36-44: xxxxxxx.x m2 xxxxxxx.x sq.f 0  
24-36: xxxxxxx.x m2 xxxxxxx.x sq.f 0  
17-24: xxxxxxx.x m2 xxxxxxx.x sq.f 0  
0-17: xxxxxxx.x m2 xxxxxxx.x sq.f 0

MEDIA SIZE2 CUT D-SQ/D-CN T

36-44: xxxxxxx.x m2 xxxxxxx.x sq.f 0  
24-36: xxxxxxx.x m2 xxxxxxx.x sq.f 0  
17-24: xxxxxxx.x m2 xxxxxxx.x sq.f 0  
0-17: xxxxxxx.x m2 xxxxxxx.x sq.f 0

4/5

Canon imagePROGRAF iPFxxx PRINT IN F

Firm:xx.xx Boot:xx.xx MIT(DBF):x.xx MIT(DB):x.x x

S/N:xxxxxxx Date:yyyy/mm/d

HEAD DOT CNT. 1

C:xxxxxxxx M:xxxxxxxx Y:xxxxxxxx MBK:xxxxxxxx MBK2:xxxxxxxx BK:xxxxxxxx x  
TTL:xxxxxxxxxxxxxx x

HEAD DOT CNT. 2

C:xxxxxxxx M:xxxxxxxx Y:xxxxxxxx MBK:xxxxxxxx MBK2:xxxxxxxx BK:xxxxxxxx x  
TTL:xxxxxxxxxxxxxx x

HEAD INF. 1

1:YY/MM/DD YY/MM/DD YY/MM/DD YY/MM/DD 2:YY/MM/DD YY/MM/DD YY/MM/D D

3:xxxxxxxx xxxxxxxx xxxxxxx x

4:xxxxx 5:xxxxx 6:xxxxx 7:xxxxx 8:xxx 9:xxx 10:xxx 11:xxx 12:xx x

13:xxxxxxxx 19:1

14: 1:YY/MM/DD xxxxxxxx-xxxx 2:YY/MM/DD xxxxxxxx-xxxx 3:YY/MM/DD xxxxxxxx-xxx x

4:YY/MM/DD xxxxxxxx-xxxx 5:YY/MM/DD xxxxxxxx-xxxx 6:YY/MM/DD xxxxxxxx-xxx x

7:YY/MM/DD xxxxxxxx-xxxx 8:YY/MM/DD xxxxxxxx-xxxx 9:YY/MM/DD xxxxxxxx-xxx x

10:YY/MM/DD xxxxxxxx-xxxx 11:YY/MM/DD xxxxxxxx-xxxx 12:YY/MM/DD xxxxxxxx-xxx x

13:YY/MM/DD xxxxxxxx-xxxx 14:YY/MM/DD xxxxxxxx-xxxx 15:YY/MM/DD xxxxxxxx-xxx x

16:YY/MM/DD xxxxxxxx-xxxx 17:YY/MM/DD xxxxxxxx-xxxx 18:YY/MM/DD xxxxxxxx-xxx x

19:YY/MM/DD xxxxxxxx-xxxx 20:YY/MM/DD xxxxxxxx-xxx x

15:A:x B:x C:x D:x E:x F: x

16:XX.XX YY/MM/DD XX.XX YY/MM/DD XX.XX YY/MM/D D

17:A:xxx B:xxx C:xxx D:xxx E:xxx F:xx x

18:AA:xxx AB:xxx BA:xxx BB:xxx CA:xxx CB:xxx DA:xxx DB:xxx EA:xxx EB:xxx FA:xxx FB:xx x

HEAD INF. 2

1:YY/MM/DD YY/MM/DD YY/MM/DD YY/MM/DD 2:YY/MM/DD YY/MM/DD YY/MM/D D

3:xxxxxxxx xxxxxxxx xxxxxxx x

4:xxxxx 5:xxxxx 6:xxxxx 7:xxxxx 8:xxx 9:xxx 10:xxx 11:xxx 12:xx x

13:xxxxxxxx 19:1

14: 1:YY/MM/DD xxxxxxxx-xxxx 2:YY/MM/DD xxxxxxxx-xxxx 3:YY/MM/DD xxxxxxxx-xxx x

4:YY/MM/DD xxxxxxxx-xxxx 5:YY/MM/DD xxxxxxxx-xxxx 6:YY/MM/DD xxxxxxxx-xxx x

7:YY/MM/DD xxxxxxxx-xxxx 8:YY/MM/DD xxxxxxxx-xxxx 9:YY/MM/DD xxxxxxxx-xxx x

10:YY/MM/DD xxxxxxxx-xxxx 11:YY/MM/DD xxxxxxxx-xxxx 12:YY/MM/DD xxxxxxxx-xxx x

13:YY/MM/DD xxxxxxxx-xxxx 14:YY/MM/DD xxxxxxxx-xxxx 15:YY/MM/DD xxxxxxxx-xxx x

16:YY/MM/DD xxxxxxxx-xxxx 17:YY/MM/DD xxxxxxxx-xxxx 18:YY/MM/DD xxxxxxxx-xxx x

19:YY/MM/DD xxxxxxxx-xxxx 20:YY/MM/DD xxxxxxxx-xxx x

15:A:x B:x C:x D:x E:x F: x

16:XX.XX YY/MM/DD XX.XX YY/MM/DD XX.XX YY/MM/D D

17:A:xxx B:xxx C:xxx D:xxx E:xxx F:xx x

18:AA:xxx AB:xxx BA:xxx BB:xxx CA:xxx CB:xxx DA:xxx DB:xxx EA:xxx EB:xxx FA:xxx FB:xx x

5/5

Canon imagePROGRAF iPFxxx PRINT IN F

Firm:xx.xx Boot:xx.xx MIT(DBF):x.xx MIT(DB):x.x x

S/N:xxxxxxx Date:yyyy/mm/d d

## PARTS CNT .

PARTS CR1 : OK	0	0.0	0.0	0%	0.0
PARTS CR2 : OK	0	0.0	0.0	0%	0.0
PARTS CR3 : OK	0	0.0	0.0	0%	0.0
PARTS CR4 : OK	0	0.0	0.0	0%	0.0
PARTS CR5 : OK	0	0.0	0.0	0%	0.0
PARTS SP1 : OK	0	0	0	0%	0
PARTS PG1 : OK	0	0	0	0%	0
PARTS HMa1 : OK	0	0	0	0%	0
PARTS MT1 : OK	0	0	0	0%	0
PARTS PL1 : OK	0	0	0	0%	0
PARTS Mi1 : OK	0	0	0	0%	0
PARTS CT1 : OK	0	0	0	0%	0
PARTS WF1 : OK	0	0	0	0%	0
PARTS WF2 : OK	0	0	0	0%	0

## COGFF

CONDITION : 0

PARAM0-F : REF: xxxxxx xxxxxx xxxxxx xxxxxx PHASE: xxx xxx xxx xx x

AMP: xxx xxx xxx xxx RATE: xxx xxx xxx xx x

PARAM0-B : REF: xxxxxx xxxxxx xxxxxx xxxxxx PHASE: xxx xxx xxx xx x

AMP: xxx xxx xxx xxx RATE: xxx xxx xxx xx x

## LF-A

ROLL LARGE : XXX.XXXX MIDDLE : XXX.XXXX SMALL : XXX.XXXX SMALLER : XXX.XXX X

CUT LARGE : XXX.XXXX MIDDLE : XXX.XXXX SMALL : XXX.XXXX SMALLER : XXX.XXX X

## LF-B

ROLL LARGE : XXX.XXXX MIDDLE : XXX.XXXX SMALL : XXX.XXXX SMALLER : XXX.XXX X

CUT LARGE : XXX.XXXX MIDDLE : XXX.XXXX SMALL : XXX.XXXX SMALLER : XXX.XXX X

## SCALE-A

ROLL LARGE : XXX MIDDLE : XXX SMALL : XXX SMALLER : XX X

CUT LARGE : XXX MIDDLE : XXX SMALL : XXX SMALLER : XX X

## SCALE-B

ROLL LARGE : XXX MIDDLE : XXX SMALL : XXX SMALLER : XX X

CUT LARGE : XXX MIDDLE : XXX SMALL : XXX SMALLER : XX X

PV AUTO JUDGE : ON(NORMAL) , 0



---

## 7.2 Special Mode

---

### 7.2.1 Special Modes for Servicing

This printer supports the following special modes in addition to the service mode:

- PCB replacement mode
- Download mode
- Counter display mode

#### 1. PCB replacement mode

This mode is used when replacing the main PCB or MC relay PCB.

By executing this mode,

- Backup data of the settings and counter values stored in the MC relay PCB are moved to the new main PCB.
- The data such as the settings and counter values are copied to the MC relay PCB.

##### a) Entering the PCB replacement mode

Follow the same procedure as that for entering the service mode.

(With the [Load] button and [Navigate] button pressed down, turn on the [Power] button.)

When the printer starts up, compare the serial number memorized in the main PCB's EEPROM with that memorized in the MC relay PCB's EEPROM. If they do not match, or no serial number is memorized in either EEPROM, enter the PCB replacement mode.

##### b) Procedure

Select "CPU BOARD" or "MC BOARD" using the [◀] and [▶] buttons, and then press the [OK] button to determine it.

##### - CPU BOARD

Select this after replacing the main PCB.

The data in the MC relay PCB is copied to the main PCB.

##### - MC BOARD

Select this before replacing the MC relay PCB.

The data in the main controller PCB is copied to the MC relay PCB.

##### c) Exiting the PCB replacement mode

Turning off the [Power] button of the printer allows you to exit the PCB replacement mode.

For details on how to replace the PCB, see DISASSEMBLY/REASSEMBLY > Points to Note on Disassembly and Reassembly > PCBs.

#### 2. Download mode

Use this mode only when updating the firmware without performing initialization.

This mode can update the firmware even if the printhead and ink tanks have not been installed to the printer.

---

#### Reference:

For instruction on how to update the main controller, refer to "TROUBLESHOOTING" > "Version Up".

---

#### a) Entering the download mode

1) Turning off the [Power] button of the printer.

2) With the [Stop] and [Navigate] buttons pressed down, turn on the [Power] button of the printer.

\* Keep pressing the above buttons until "Initializing" appears on the display.

#### b) Procedure

When "Download Mode/Send Firmware" is shown on the display, transfer the firmware.

When downloading of the firmware is completed, the printer is turned off automatically.

#### 3. Counter display mode

Use this mode to view only printer counter information.

##### a) Invoking counter display mode

1) Press the [MENU] button to keep [Printer Info] > [System Info] selected.

2) Press the [▲] button while holding down the [MENU] button + [OK] button to invoke counter display mode.

##### b) How to view counter display mode

- S/N: Unit serial number

- CNT: Number of copies printed in A4 terms (unit: copies)



---

## Appendix

---



1 General Circuit Diagram  
 General Circuit Diagram (1/6)

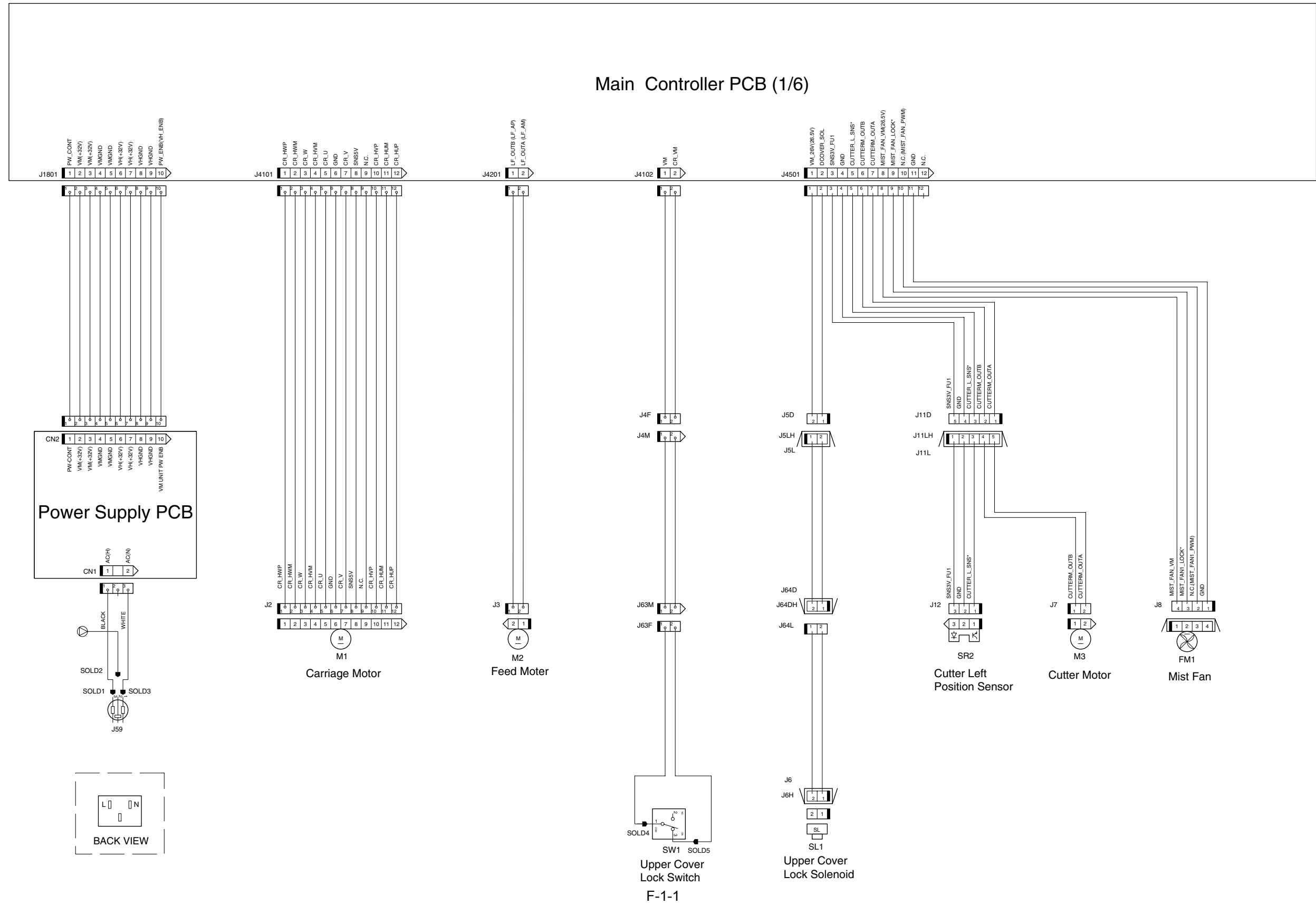

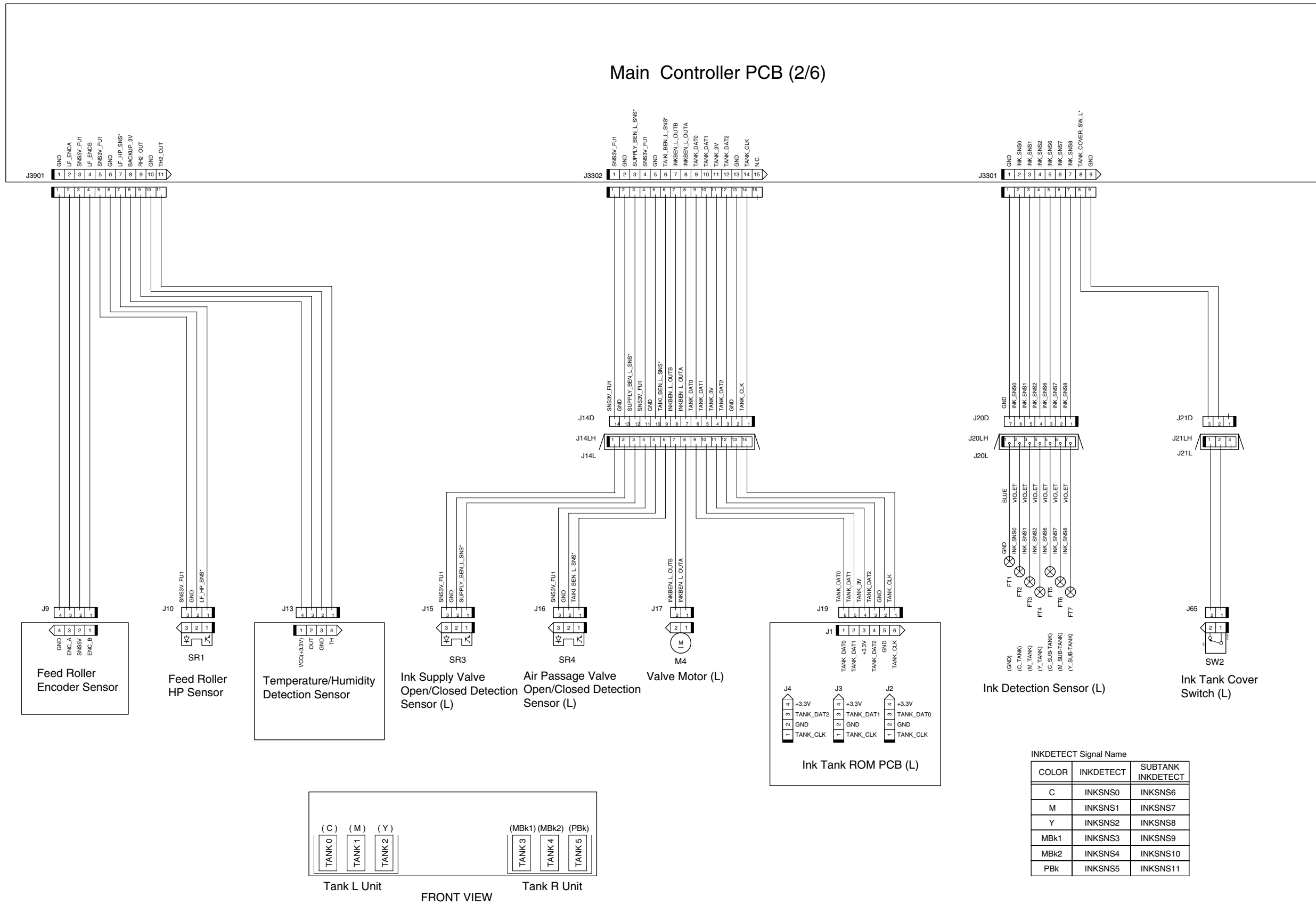

F-1-2

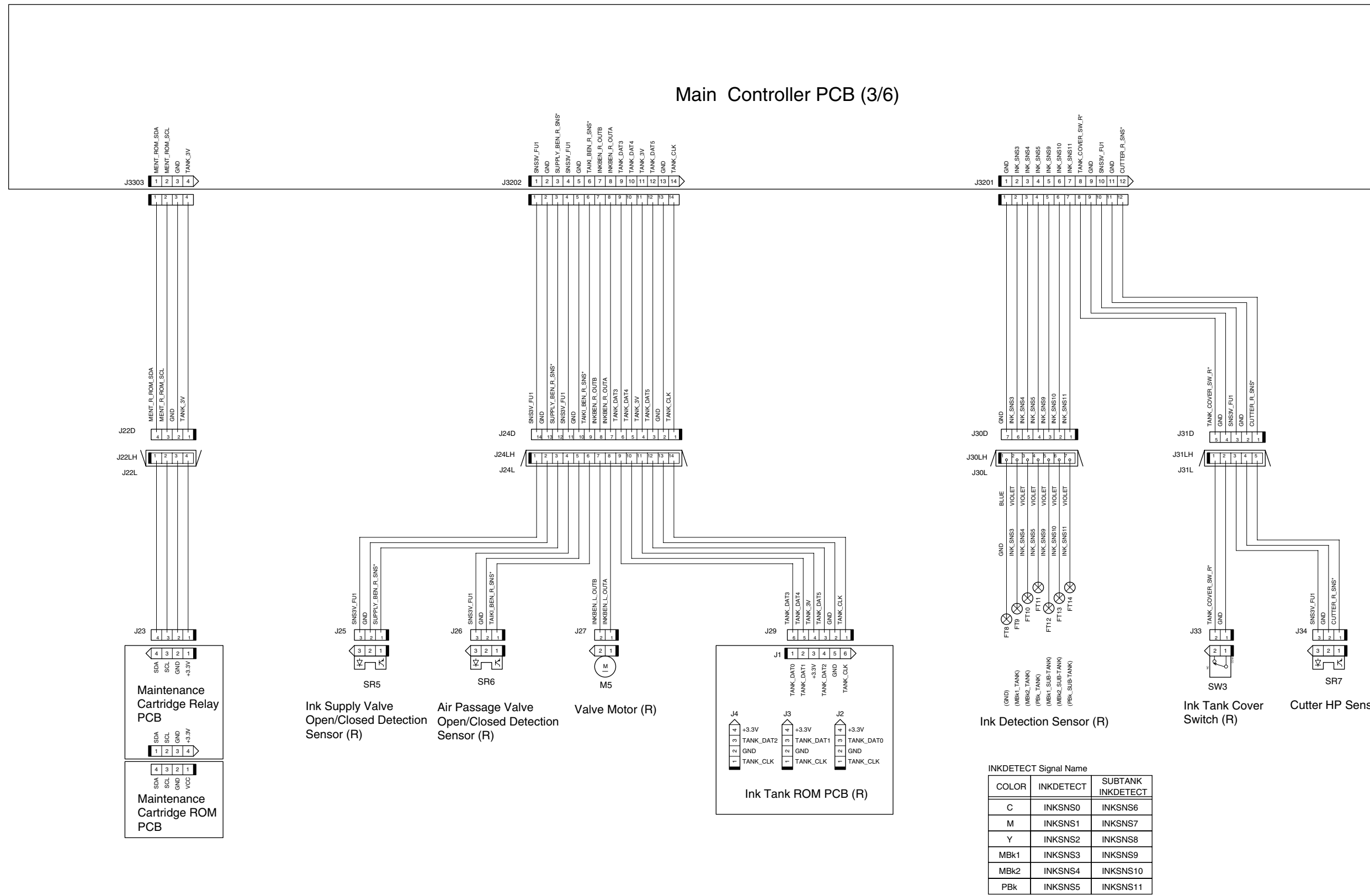

Main Controller PCB (4/6)

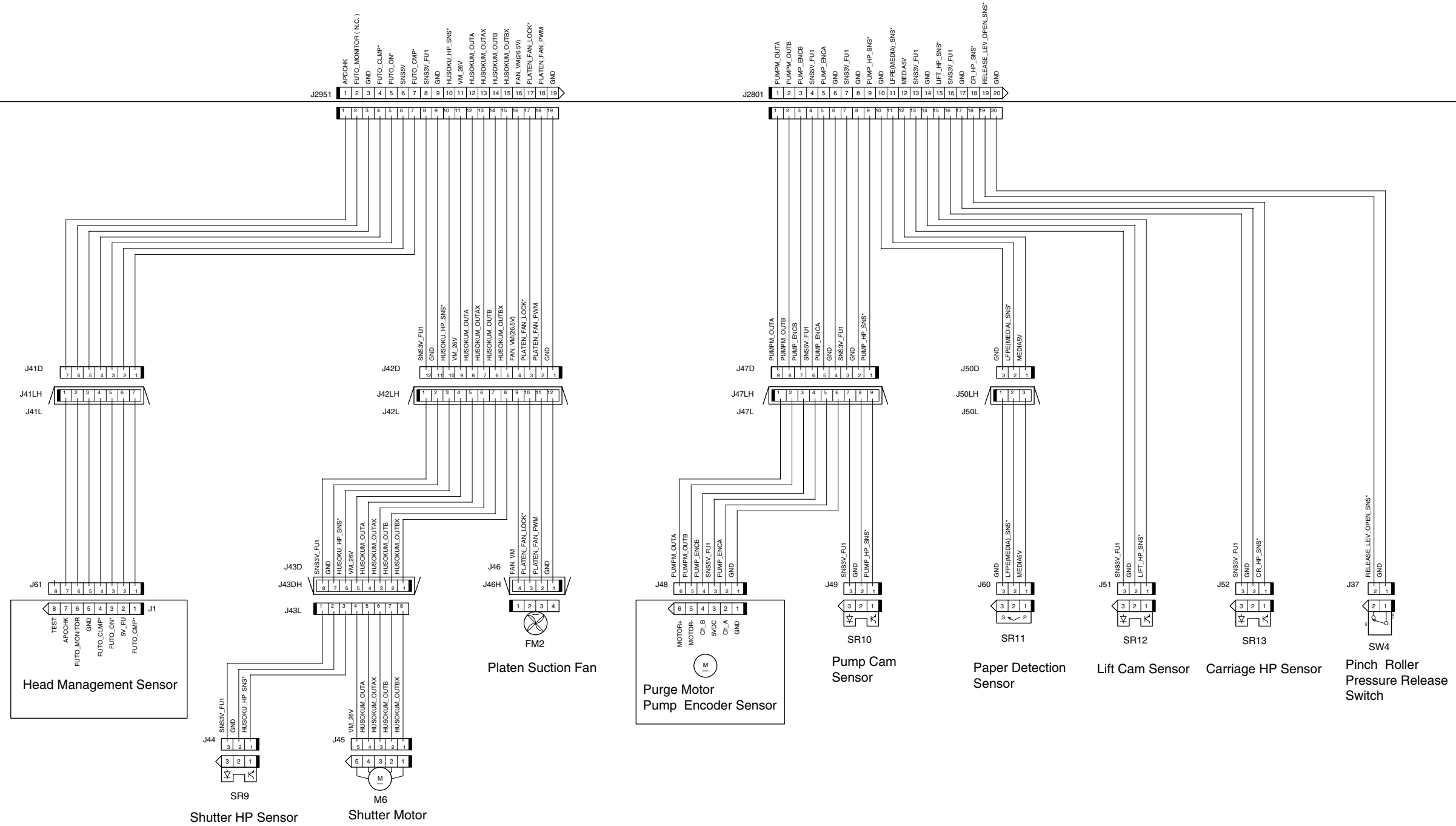



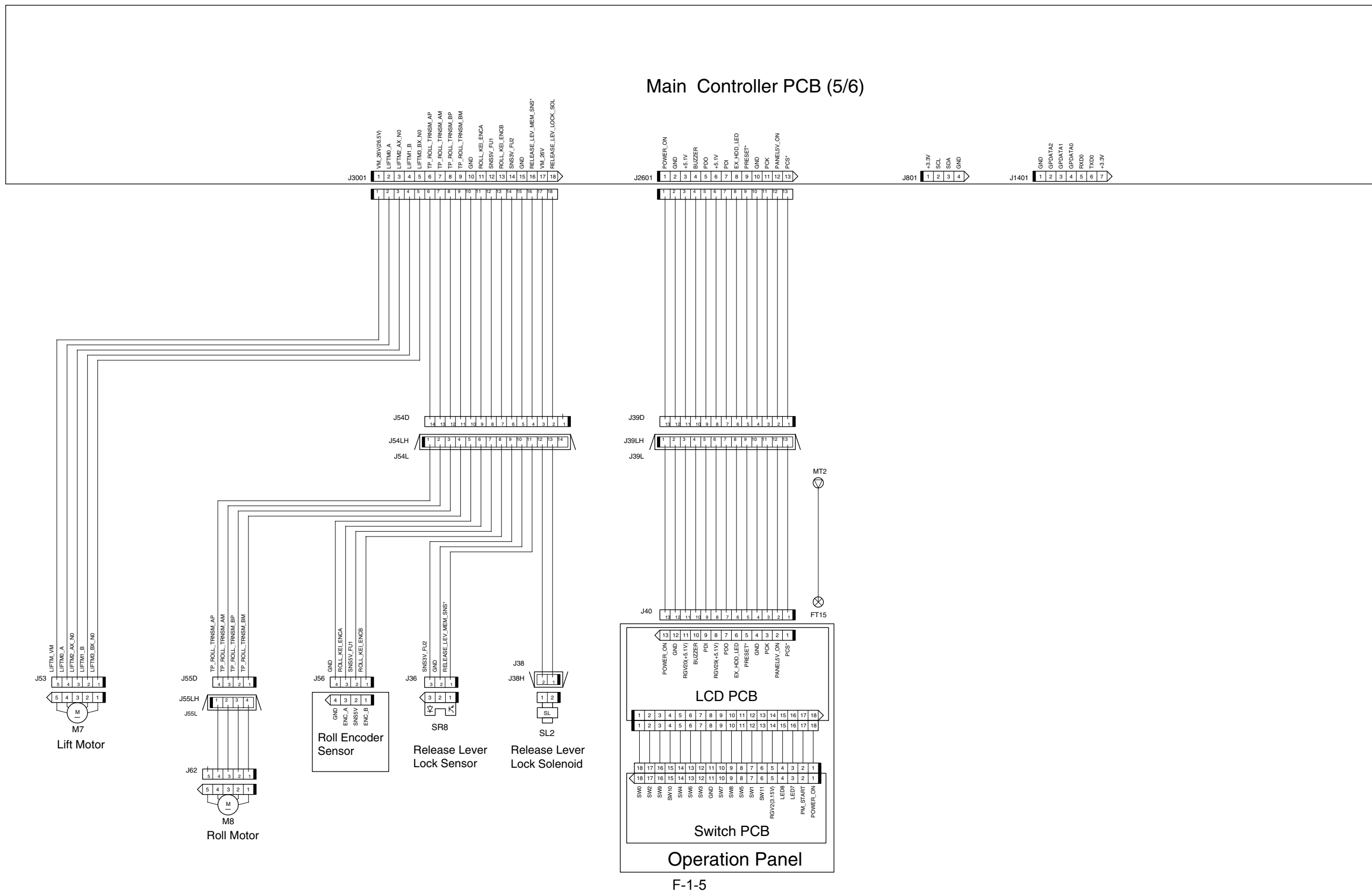

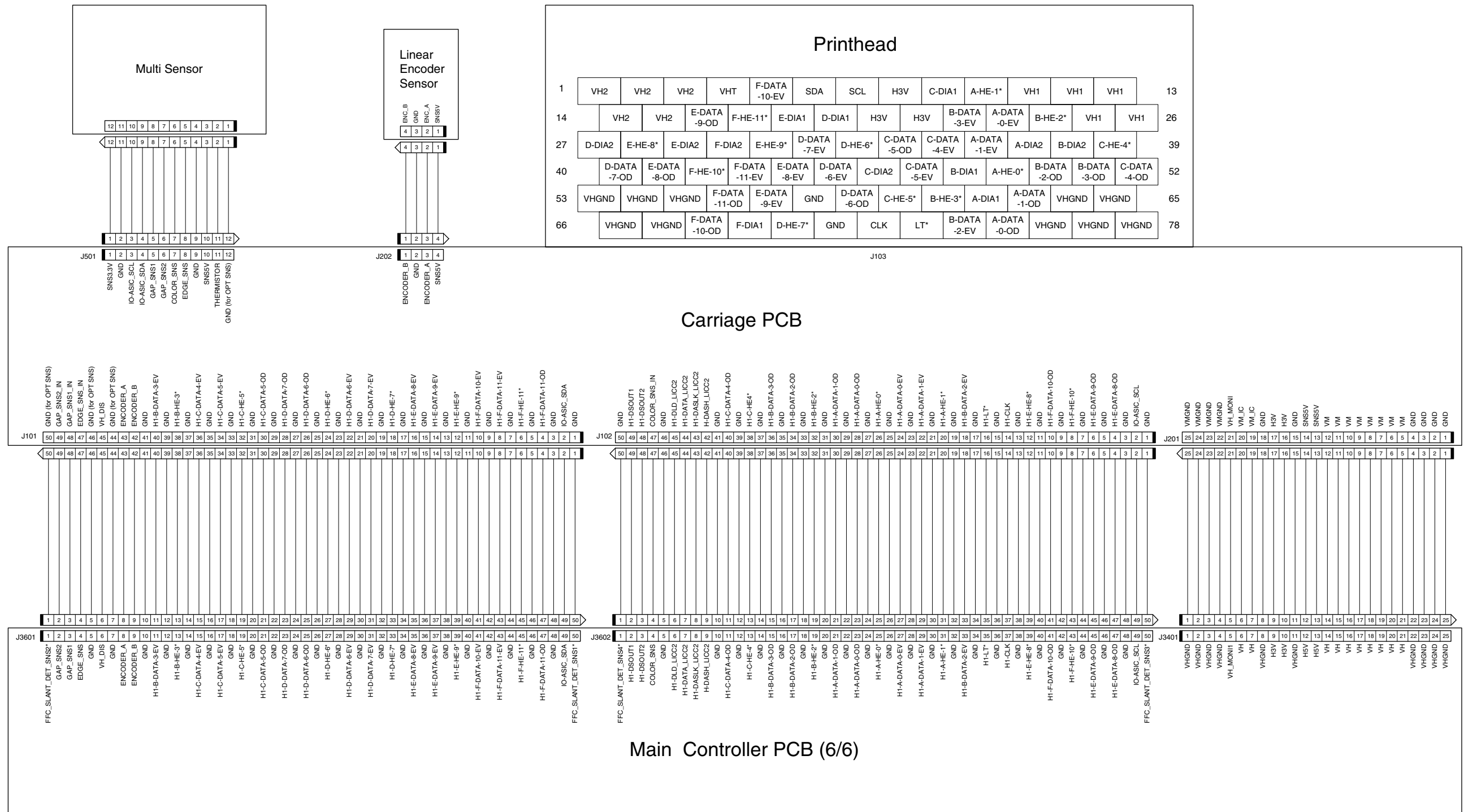

Feb 27 2017

**Canon**