

Service manual PRISMAsync V3.1.0.0 for imagePRESS C7010VPS/C7011VPS series

PRISMAsync

Revision 11

Contents

Chapter 1

Preface.....5
 Preface.....6

Chapter 2

Introduction.....9
 Introduction.....10
 Features.....11

Chapter 3

Installation.....13
 Passwords.....14
 Installation sequence.....15
 Verify site conditions.....16
 Unpacking the PRISMAsync.....17
 Mount the PRISMAsync supports/pedestals.....18
 Assembling the Operator panel.....20
 Connecting the PRISMAsync.....21
 Completing installation and starting up.....27

Chapter 4

Using the PRISMAsync.....31
 The operator panel.....32
 'System' Settings.....35
 Maintenance and Service Mode.....38
 'Colour adjustments'43
 'Media' management.....47
 Operator maintenance.....50

Chapter 5

Starting, shutting down, and restarting.....53
 Turn on the system.....54
 Turn off the system.....55
 Restarting the system.....56
 Restarting the copier only.....57
 Restarting copier after error in copier.....60

Chapter 6

The Settings Editor.....61
 The Settings Editor.....62

Chapter 7

Service procedures	65
Service procedures.....	66
Overview Service procedures.....	71
Accessing internal components.....	73
Replacing GPU board.....	75
Replacing DDI board.....	77
Replacing AUX control board.....	78
Replacing DDR3 modules.....	80
Replacing Hard Disk Drives.....	82
Replacing Ethernet board.....	84
Replacing Base controller.....	86
Connect Harness 22W01.....	89
Chapter 8	
System software	93
System software	94
Preparation of the 'USB'-stick.....	95
Re-Installation of the system software.....	103
Installing patches.....	106
Installing a license.....	108
Installing the printer driver.....	109
Configure the machine for the USA.....	110
Handling of 11504 MRE.....	112
Chapter 9	
Troubleshooting	113
Troubleshooting.....	114
Checking external connections.....	115
Checking internal components.....	116
Comprehensive system inspection.....	117
Diagnose LED's.....	119
Error messages and conditions.....	122
Beep codes PRISMAsync.....	127
Chapter 10	
Appendix A: Specifications	129
Hardware features.....	130
Connectivity.....	131
Chapter 11	
Appendix B: Parts overview	133
Overview of the service parts.....	134
Chapter 12	
Appendix C: Tips & Tricks	137
How to check if DDR memory is defect or missing.....	138
How to print transparencies with best quality.....	140

How to improve black density on the print.....	141
Strange colors after editing CMYK curves.....	142
Omapp does not work.....	143
Chapter 13	
Appendix D: System overview.....	145
System overview.....	146
Chapter 14	
Appendix E: How to make a datadump file.....	147
How to make a datadump file.....	148
Chapter 15	
Appendix F: How to make a tracelog.....	151
How to make a tracelog.....	152
Chapter 16	
Appendix G: Important media printer adjustments.....	155
Important media printer adjustments.....	156
Chapter 17	
Appendix H: Engine reports.....	167
Engine reports.....	168
Chapter 18	
Appendix I: The Trapping editor.....	173
The Trapping editor.....	174

Chapter 1

Preface

Preface

Application

This manual has been issued for qualified persons to learn technical theory, installation, maintenance, and repair of products.

This Service Manual is written for world-wide markets.

As such it may contain information relating to accessories or licensed functionality not supported by Canon U.S.A., Inc. as of the date of the manual publication.

Corrections

This manual may contain technical inaccuracies or typographical errors due to improvements or changes in products. When changes occur in applicable products or in the contents of this manual, Océ will release technical information as the need arises. In the event of major changes in the contents of this manual over a long or short period, Océ will issue a new edition of this manual.

The following paragraph does not apply to any countries where such provisions are inconsistent with local law.

Trademarks

The product names and company names used in this manual are the registered trademarks of the individual companies.

Copyright

This manual is copyrighted with all rights reserved. Under the copyright laws, this manual may not be copied, reproduced or translated into another language, in whole or in part, without the written consent of Océ.

Safety and emissions compliance

The imagePRESS Server has been certified to meet or surpass the following government standards:

Safety approvals: EMI/EMC approvals:

- UL 60950-1 (TUV/CU mark)
- FCC Class B
- CSA 22.2 #60950-1
- VCCI Class B
- EN 60950-1 (TUV/GS mark)
- EN 55022 Class B CB scheme IEC 60950-1

- EN55024 AS/NZS CISPR22: 2004 Class B

CAUTION:

- All parts inside the PRISMAsync have a fire safety class V2 or higher.
It is therefore forbidden to store objects or paper (USB-key, reports etc.) inside the PRISMAsync controller

Points to notice when handling the Lithium Battery**CAUTION:**

- RISK OF EXPLOSION IF BATTERY IS REPLACED BY AN INCORRECT TYPE.
DISPOSE OF USED BATTERIES ACCORDING TO THE INSTRUCTIONS.

CAUTION:

- WENN MIT DEM FALSCHEN TYP AUSGEWECHSELT, BESTEHT EXPLOSIONSGEFAHR.
GEBRAUCHTE BATTERIEN GEMASS DER ANLEITUNG BESEITIGEN.

Chapter 2

Introduction

Introduction

This Service manual describes the service aspects of the Canon imagePRESS C7010VPS and C7011VPS series.

The PRISMAsync colour controller sets the tone for all colour print production on Canon imagePRESS C7010VPS/C7011VPS series printers. High processing power, professional colour management, ease of use and superb media handling all ensure consistent output at every stage. The PRISMAsync colour controller uses the latest Adobe RIP and colour management technologies.

Features

The PRISMAsync has a lot of features like:

- Harmonized workflow for cutsheet production systems. Both black & white and colour.
- Clear task split between prepress and print operation.
- Job submission from a user's desktop via Océ Printer Family Driver or Océ PRISMAprepare software.
- Media driven operation by using a detailed media catalogue.
- High speed colour calibration allowing you to calibrate for all media and halftone screening in one go.
- Basic or professional colour management depending on access rights of users. Simple colour presets for inexperienced operators and users.
- Automated workflows allowing users to define their own templates.
- Last minute colour correction buttons to apply last-minute correction to brightness and contrast when copying and printing.
- Both 1200x1200 dpi and 600x600 dpi support.
- Intuitive time schedule.
- Support of 17 languages.
- Extensive colour libraries. Pantone and Pantone Goe libraries are available in the controller as a default along with HKS libraries.
- Support for IPDS.
- Native Adobe PDF interpreter APPE support
- Device links
- Named Colour Profiles
- JDF/JMF connector
- eRDS support.
- DocBox
- VDP-support
- In-RIP Trapping for APPE
- Automatic restore of settings and jobs after installation

Chapter 3

Installation

Passwords

When servicing the PRISMAsync or making adjustments you often will need a password for a specific task. See the list below for an overview of the default passwords, used in the PRISMAsync.

- Enter Service Mode: 675756
- System Administrator: 71617000
- Key Operator: 13524
- Engine maintenance: 12345
- OMApp (On remote PC): 1836671

Resetting the passwords

It could occur that the password for the System Administrator, Key Operator, Engine maintenance or Omapp application is lost. In that case a service technician has to reset the password.

Take the following steps to reset the passwords:

1. Open the Settings Editor (See *'The Settings Editor' on page 62*) on a remote PC connected to the network of the customer.
2. Browse to 'Configuration' -> 'Security'. Click on 'Reset the system administrator password'.
3. Enter the Service password (675756)
4. Confirm your choice. Now the System Administrator password is reset to the factory default. (71617000)
5. You can use this password for entering the new passwords.

Installation sequence

This chapter describes the installation sequence for the PRISMAsync controller. Please stick to this sequence since it will make the job as easy as possible. Installation problems are easier to avoid and diagnose. See list below which outlines the recommended installation procedure for connecting the PRISMAsync to the copier.

Because the PRISMAsync is connected to the customer's network, coordinate your installation with the network administrator at the customer site, so he can take care for the presence of a working network connection.

Note:

Please note that the PRISMAsync has to be connected to the copier for entering Service Mode.

Follow the steps below for installation:

1. Verify site conditions.
2. Unpack the PRISMAsync controller.
3. Mount the PRISMAsync supports
4. Assemble the Operator panel
5. Connect the PRISMAsync to the copier
6. Connect the PRISMAsync to the network
7. Bundle the cables with a tiwrap
8. Complete the installation

Verify site conditions

Introduction

Before installing the PRISMAsync, check the site conditions.

Copier

- Is the copier configured for use with the PRISMAsync? For the proper settings, see the documentation that comes with the copier.
- Is space available for the PRISMAsync behind the copier? The PRISMAsync is placed behind the copier. Be sure that there is enough room for servicing either the copier or the PRISMAsync. You may need to move the copier away from the wall so that interface connectors are accessible.
- Check if the interface cables between copier and PRISMAsync are present. 2 data cables (length 3m) must be delivered together with the copier. 1 Ethernet cross cable is delivered with the PRISMAsync.

Power & Network

- Is a dedicated, grounded electrical outlet for the PRISMAsync available near the copier?
 - Locate the grounded electrical outlet that will supply power to the PRISMAsync. Do not run the PRISMAsync and the copier on the same circuit.
 - Do not plug the PRISMAsync into a switchable wall outlet. This can result in the PRISMAsync being turned off accidentally.
 - Do not plug the PRISMAsync into a circuit with heating or refrigeration equipment (including water coolers).
 - Do not pull on the cable when unplugging the PRISMAsync. Pull the plug instead.
- Make sure that there is a working cabled network connection available at installation time.

A wireless network will not work on the PRISMAsync
- Contact the Network Administrator for the following settings:
 - The Hostname of the system
 - Static IP-address or DHCP
 - Subnet mask, Gateway, DNS-server

Environment

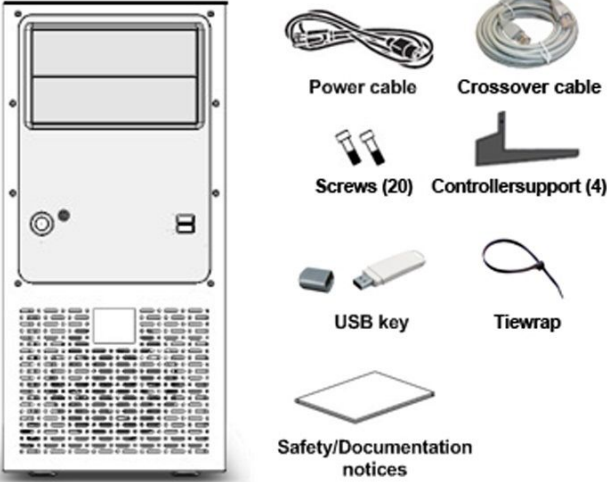
- A networked computer (PC or Mac OS) must be available close to the copier.

Unpacking the PRISMAsync

Introduction

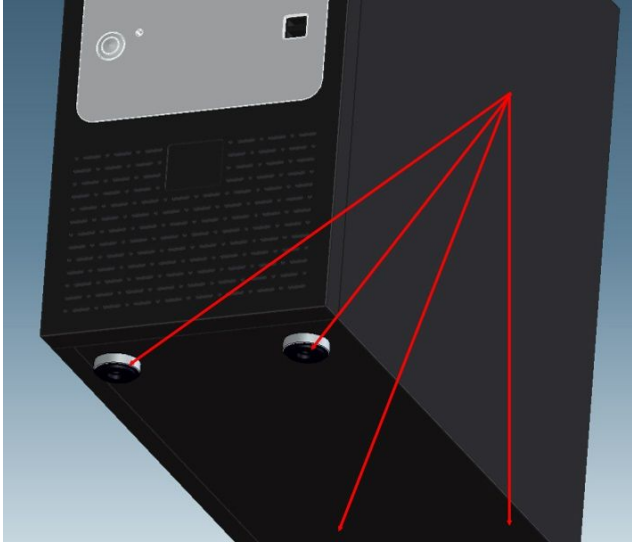
The PRISMAsync is assembled and shipped from the factory with the software pre-installed. The interface cables (2 data cables and 1 Ethernet cross cable) are delivered with the copier and the PRISMAsync. The network cable is not included.

Unpack the PRISMAsync

Step	Action
1	Open the box and carefully lift the PRISMAsync out of the box Save the original box and packing material in case the PRISMAsync needs to be transported at a later date.
2	<p>Check the contents of the box</p>  <p>Fig. PRISMAsync shipping contents</p>
3	<p>Give the Safety Notice and User Documentation notice to the customer.</p> <p>Let the customer know where he can find the documentation in order to take full advantage of the PRISMAsync.</p>

Mount the PRISMAsync supports/pedestals

The PRISMAsync comes with 4 supports. These supports have to be mounted in the place of the original supports. The probability that dust enters the controller is less, if these supports are mounted.

Step	Action
1	<p data-bbox="354 444 795 475">Remove all 4 existing controller supports</p>  <p>The diagram shows a top-down view of a dark-colored rectangular device. At the top edge, there is a grey rectangular component with a circular icon and a small square. Below this, the device's surface is covered with a grid of small, illegible text. In the bottom-left corner, there are two circular supports. In the bottom-right corner, there are two more circular supports. Four red lines originate from a single point in the upper-right quadrant and extend to the centers of each of the four circular supports, indicating their locations for removal.</p>

Step	Action
2	<p data-bbox="413 202 992 232">Mount the new supports using the Bolt-HEX M3x16</p>  <p>The image shows a 3D CAD model of a server rack. The rack is black with a silver front panel. A black pedestal is being attached to the bottom of the rack. Two red lines point to the mounting points on the pedestal where the bolts should be inserted. The background is a light blue gradient.</p>

Assembling the Operator panel

Before connecting the PRISMAsync to the engine it is necessary to assemble the Operator panel. For the assembly instructions refer to Assembly of the Operator panel in the Service manual of the copier.

Connecting the PRISMAsync

You are now ready to make the following connections:

- Operator console
- Copier interface connections
- Operator Attention Light
- Network cable connection
- Power cable connection

Please follow standard ESD precautions when handling components.

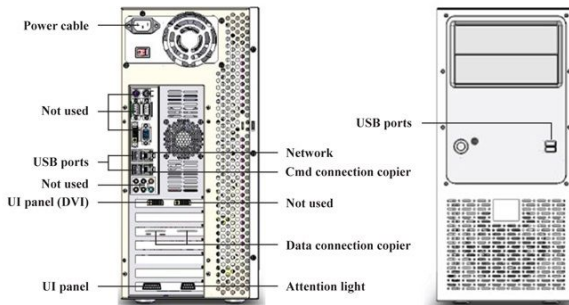


Fig. : PRISMAsync connections

Connect the operator console

Step	Action
1	The cables needed for the connections come with the copier.
2	Open the backside of the monitor.
3	Connect the DVI-cable to the backside of the Operator panel. Connect the other side to the left DVI port on the backside of the PRISMAsync.
4	Connect the 15-pins D-sub connector to the connector on the backside of the PRISMAsync. Connect the other side to the backside of the operator panel.
5	Connect a 'USB' cable to the backside of the operator panel. Connect the other side to the backside of the PRISMAsync
6	Close the backside of the operator panel.

Connect to the copier

Step	Action
1	Connect one side of the Ethernet crossover-cable to the lower RJ45 connector on the backside of the PRISMAsync (Command/Status). Connect the other side to the RJ45 connector on the backside of the copier.
2	<p>Locate the two copier interface cables, and identify the keyed and un-keyed connector ends on each cable. Each cable has one keyed connector and one un-keyed connector.</p> <div data-bbox="366 578 807 955" style="text-align: center;"> <p>The diagram shows two copier interface cables. Each cable has a standard RJ45 Ethernet connector at the top. Below the RJ45 connector is a different type of connector. The one on the left is labeled 'Unkeyed' and has a simple rectangular shape. The one on the right is labeled 'Keyed' and has a notch on its top edge, which is designed to fit into a corresponding port on the copier.</p> </div> <p>Fig.: Copier interface cable connections</p>
3	Connect the cables to the interface ports on the copier.
4	<p>Connect the other ends to their corresponding ports on the PRISMAsync.</p> <p>Each cable connector is designed to fit only one way when properly oriented.</p> <p>If a cable connector does not fit into an interface port, change the orientation of the cable. Do not force a connection that is mis-keyed. Doing so may permanently damage the port or the cable</p>

Connect the Operator Attention Light

Step	Action
1	Mount the Operator Attention Light to the backside of the copier

Step	Action
2	Connect the cable with the 9-pins D-sub connector to the connector on the backside of the PRISMAsync.
3	Connect the other side of the cable to the connector attached to the Attention Light

Connect to the network

Step	Action
1	Connect one side of a straight-through Ethernet cable to the upper RJ45 connector on the backside of the PRISMAsync.
2	Connect the other side of the Ethernet cable to the Ethernet wall-outlet

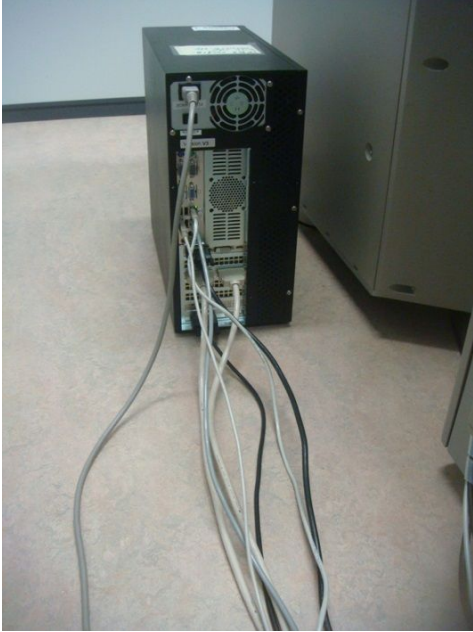
Connect the power


Step	Action
1	Connect recessed end of the power cable to the power connector on the back of the PRISMAsync.
2	Connect the other end of the power cable to a wall outlet.

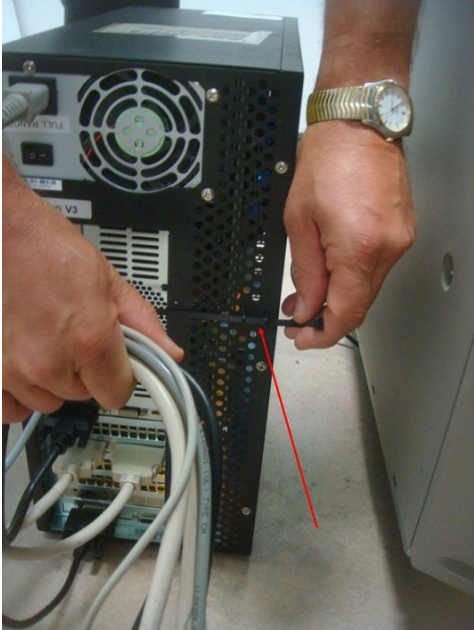

Bundle the cables with a Tiewrap

The PRISMAsync will be delivered with a releasable tie-wrap.

This tie-wrap is used to regulate and fix all data cables to the PRISMAsync. The power cord is not fixed with the tie-wrap.

Step	Action
1	<p>Take all data cables (no power cable) and guide them neatly next to each other.</p> 

Step	Action
2	<p data-bbox="359 203 1164 265">Lead the bundle of cables in a kind of loop going upwards and next downwards. Take care that there is not too much tension on the connectors.</p>  A photograph showing a person's hand holding a bundle of several white and grey cables. The cables are plugged into the back of a black server rack. The rack has a fan and a label that says "Version 1.3". The cables are arranged in a loop, going up and then down, as described in the text.

Step	Action
3	<p data-bbox="299 202 1091 334">Run the Tiewrap through the two eyes at the rear-side of the controller as shown and lead the bundle in a curve along the rear side of the controller downwards. Fasten the cable tie without drawing the cables too tight. NOTE: the Tiewrap is a releasable type so it is reusable.</p> <div data-bbox="299 353 769 984">A close-up photograph showing a person's hands working on a server rack. The person is wearing a gold watch. They are using a black cable tie to secure a bundle of white cables. A red arrow points to the cable tie. The server rack has a fan and various ports visible.</div> <div data-bbox="807 353 1097 738">A photograph of a server rack with several white cables bundled together and secured by a black cable tie. The server rack has a fan and various ports visible.</div>

Completing installation and starting up

To finish the installation of the PRISMAsync make sure to do the following:

Step	Action
1	Open the front doors of the copier. If they are closed, an error will occur after switching on the copier
2	Power on the copier.
3	Power on the PRISMAsync. To power on the PRISMAsync, switch the On/Off switch on the backside to the On-position. If the PRISMAsync does not start automatically, press the On/Off button on the front side of the PRISMAsync. The PRISMAsync will start up. This may take a while. Please wait until the panel displays a splash screen with the printer type.
4	Note the Host name which is located above the PRISMAsync logo on the display. This name is automatically generated and can be changed (See following steps).
5	Wake up the system by pressing the button on the panel with the “Moon” symbol on it.
6	Set the UI language. <ul style="list-style-type: none"> ■ On the panel, touch “System” -> “Setup” ■ Select the desired language
7	Complete the installation of the copier. The PRISMAsync server has to run for installing the copier since you need it for entering Service Mode of the copier.
8	Change the settings (e.g. TCP/IP, Hostname) of the system. Contact the customer for the appropriate settings. <ul style="list-style-type: none"> ■ You need the key operator PIN (13524) to make changes in the settings. ■ On the panel, touch “System” -> “Setup” -> “Local key operator settings” ■ Touch the button of the group that contains the setting you want to change. (e.g. Connectivity for network settings) ■ Touch the required setting and enter the desired value. ■ Touch “OK”

Step	Action
9	If the PRISMAsync came with no licenses, please install them now. Refer to <i>Installing a license</i> on page 108.
10	<p>Perform any required system software upgrades.</p> <p>Check if the version of the PRISMAsync software is compatible with the version of the firmware of the copier. If not, either upgrade the firmware of the copier or the software of the PRISMAsync.</p> <p>Before updating the PRISMAsync, please take care that you always make a backup of the settings. This backup also contains the licenses installed on your PRISMAsync .</p> <p>Updates for the system software may be available from a USB key. Patches are available via download from an ftp-server and may need to be installed after installation. (See System Updates)</p>
11	When the PRISMAsync is installed and all the appropriate settings are made, always make a backup of these settings. See: "Service Mode" in <i>Maintenance and Service Mode</i> on page 38
12	<p>Set the country/region in Service Mode. This is needed to display the billing counters correct.</p> <p>To set the country/Region do the following:</p> <ol style="list-style-type: none"> Go to Service Mode Select COPIER>OPTION>BODY>CONFIG Select language with +/- key (e.g. CN for China or JP for Japan) Press OK Restart the system to activate the setting
13	<p>Set the billing counters that have to be displayed on the Operator Panel.</p> <ol style="list-style-type: none"> Go to Service Mode Select COPIER>OPTION>USER 11. Make the following settings: <ul style="list-style-type: none"> - CNT_SW o - Counter1 112 Total (Black/Large) - Counter2 113 Total (Black/Small) - Counter3 122 Total (Full Color + Single Color/Large) - Counter4 123 Total (Full Color + Single Color/Small) - Counter5 102 Total 2 - Counter6 o - Counter7 o - Counter8 o

Step	Action
14	<p>Assist the customer with the installation of the printer-driver on 1 workstation.</p> <p>The printer driver can be found by using the Settings Editor.</p> <ul style="list-style-type: none"> ■ On your PC open an Internet browser (e.g. Microsoft Explorer) ■ In the Address bar enter <code>http://<hostname></code> or IP-address ■ A window with the Settings Editor will open. Go to the "Support" tab ■ Touch 'Software'. At the bottom of the page you will find the drivers which can be downloaded to your computer ■ Install the driver needed (Windows, Mac OS) ■ Make some test prints with the driver.
15	<p>Ask the customer to make sure that all media (CD's and/or USB sticks) shipped with the PRISMAsync are stored in a safe location.</p>
<p>CAUTION</p> <ul style="list-style-type: none"> ■ Do not store any media or paper (USB keys or reports) inside the PRISMAsync because of fire-hazard. 	

Chapter 4

Using the PRISMAsync

The operator panel

The operator panel helps you to carry out print jobs, copy jobs and scan jobs. This section describes the main components of the operator panel.

Note:

- You can clean the screen of the operator panel with a 50% mix of water and isopropyl alcohol. Use a lint-free cloth. Always put the cleaner onto the cloth and not directly on the screen.



Fig. Operator panel

The components of the operator panel

1. Sleep mode key

Depending on whether the copier is currently active or in the sleep mode

- Put the machine in to sleep mode, or
- Wake up the machine from the sleep mode
- shut down the printer and the controller
- Startup the controller after a shutdown

2. Stop key

Stop the printer

- After a set, or
- As soon as possible

3. Paper tray key

Get direct access to the tray section on the operator panel to do the following:

- Check the content of all paper trays.
- Load a new media type into a paper tray.
- Change the media type which is available in one of the paper trays.
- Create a tracelog on a USB stick. If an 11504 error is displayed, insert a USB stick and press this key to create a tracelog on the stick.

4. USB port

Used for:

- Connect spectrophotometer for calibration
- 'USB'-stick for software installation
- 'USB'-stick for backup/Restore
- 'USB'-stick to scan to and/or print from.
- 'USB'-stick to store log-files
- 'USB'-stick for installation of patches and licenses

5. Schedule button

Access the 'Schedule' view to manage the jobs in the schedule.

6. Jobs button

Access all functions to print, copy and scan documents.

- Manage or change the settings of jobs in the lists of Waiting jobs, Scheduled jobs and Printed jobs.
- Carry out copy jobs and scan jobs.

7. Paper tray button

Get direct access to the tray section on the operator panel to do the following:

- Check the content of all paper trays.
- Load a new media type into a paper tray.
- Change the media type which is available in one of the paper trays.

8. System button

Access the System section to do the following, for example:

- Check the status of the toner, staples and other supplies.
- Read the counters
- Start maintenance.
- Set up the preferred work flows.
- Change a number of default system settings.
- Adjust the brightness and contrast of the LCD panel.
- Shut down the printer.

- View the content of the Media catalogue or add temporary media to the Media catalogue.

9. Dashboard

The dashboard displays information about the system status such as:

- Information about the current printing process.
- Information about operator intervention that is required soon.
- Information about errors.
- Information about the status of the toner reservoir and staple cartridges.

10. Status LED

This LED describes the status of the system.

- **Green:**
The machine is busy printing. No operator attention required
- **Orange:**
The machine will stop soon, e.g. because an output location is almost full or more paper is required.
- **Red:**
The machine has stopped, e.g. because a required media type is not available or an error has occurred. Operator attention is required.

'System' Settings

In the 'Setup' tab of the 'System' section some important settings can be made regarding 'System' 'Setup'.

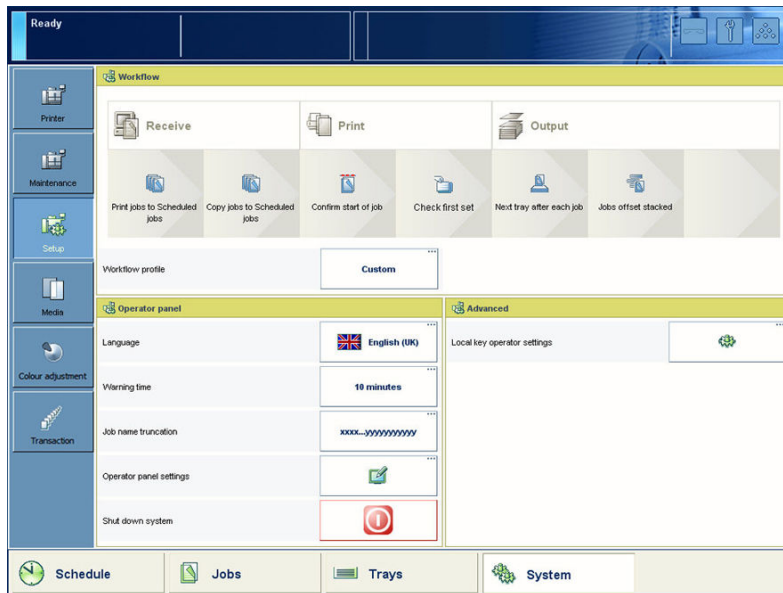


Fig. System settings screen

- **'Workflow profile'**
Select a workflow profile or manually define the settings that match your needs.
- **'Language'**
'Change language' of the operator panel.
- **'Warning time'**
Define the moment when the 'System' warns you about an action that is required soon, for example 10 minutes in advance. The warning is displayed in the dashboard and indicated through the operator attention light.
- **'Job name truncation'**
Define the way the 'System' shortens the job name when the job name is too long to display fully.
- **'Operator panel settings'**
Adjust the brightness and contrast of the screen of the operator panel.
- **'Shut down system'**

'Shut down' the printer and the controller in a controlled way.

The advanced section displays the following button.

- **'Local key operator settings'**

Get direct access to a number of important key operator settings in the Settings Editor on the PRISMAsync controller.

Local access to settings of the Settings Editor

The Settings Editor application on the PRISMAsync controller is a web based application that allows key operators and 'System' administrators to adapt the 'System' completely to the situation in an organisation and production environment. The Settings Editor allows key operators and 'System' administrators to manage settings with regard to network configuration, system preferences, job preferences and media, for example.

For convenience reasons, a subset of frequently used settings is accessible through the operator panel.

These settings are grouped in logical groups.

Note:

- You need the key operator PIN (13524), Service Password (675756) or the 'System' Administrator PIN (71617000) to make changes in this section.

1. About

- 'Serial number' (read only)
- 'Version of printer software' (read only)
- 'Upgrade software (from USB)'
With this option you can install a patch on the PRISMAsync controller.
- Upgrade software (from server)
With this option you can install a patch that is stored on a remote server. If there is a patch available it will be downloaded and installed

2. Software licenses

- 'Upload' license
When you have a new license to activate a new feature on the printer, you can upload the license file through this section. After uploading the license file, the feature becomes active

3. 'Logging'

- 'Save the datadump file'
When an error occurs, you can create a datadump file. The datadump file is a .zip file that contains detailed technical information about the 'System'.

- 'Save the trace file'
The 'System' can also store trace log files in .zip files. These contain an even more detailed and technical description of occurrences in the 'System'.
- 'Print the configuration report'
The configuration report contains information about the configuration of your printing 'System', for example information about the 'System' configuration, controller configuration or network settings.

4. 'Connectivity'

The 'Connectivity' section contains the main settings to integrate the printer into a network. After you adapted the network settings, you can test the connection from here. A more detailed description of the settings can be found in the Settings Editor Document.

- 'MAC address' (read-only)
- 'Host name'
- 'Link speed and connection type'
- 'Primary DNS suffix'
- 'DNS suffix follows domain'
- 'Test the TCP/IP connection'
- 'DHCP enabled'
- 'TCP/IP address'
- 'Subnet mask'
- 'Default gateway'
- DNS 1
- DNS 2
- WINS 1
- WINS 2
- 'IPv6 enabled'
- 'IPv6 DHCP enabled'
- 'IPv6 TCP/IP address'
- 'IPv6 link local address'
- 'IPv6 prefix length'
- 'IPv6 gateway'
- IPv6 DNS 1
- IPv6 DNS 2

5. 'System settings'

- 'Date and time'
- 'System of measurement'
- 'Time zone'

Maintenance and Service Mode

The maintenance section displays the following information.

- **'Counters'**

This section has two columns. The first column displays the different billing counters that represent the total number of prints that have been made since the machine was installed. The second column displays the same counters. This column however can be reset to “0”. You can, for example, reset the day counters at the beginning of a working day.

In Service Mode you can select which counters to display. In total 8 counters are selectable.

Furthermore the maintenance section gives access to the following functions.

- **'Start maintenance'**

From the maintenance section you can start the maintenance procedures.

- **'Go to the service mode'**

In service mode you can diagnose the printer.

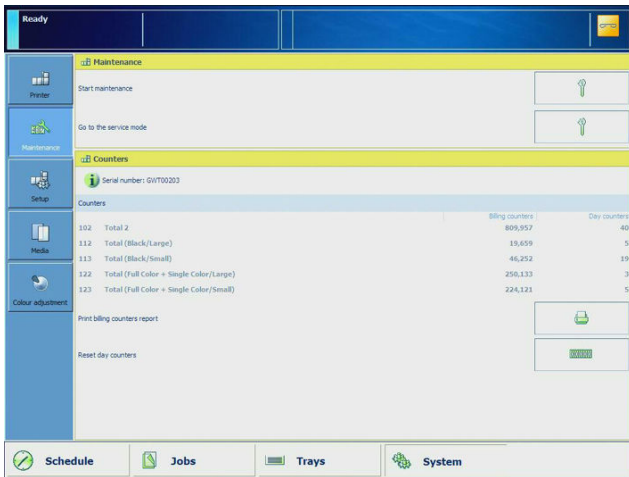


Fig. Service and maintenance

Maintenance mode

When you push the maintenance button you will enter a mode in which you can perform some adjustments to the system. All the adjustments are guided by a wizard to make your job easier. A password is required to enter the maintenance mode. (Default: 12345)

1. **Stacker: Replace flip rings**

A wizard to help you replace the four flip rings of the HCS-F1

2. Auto colour mismatch correction

You can automatically correct colour mismatching that occurs in the output. The Auto colour mismatch correction aligns the position of the four different colours.

3. 'Clean the clean roller (main unit)'

If dirt or stripes appear on printed output, clean the roller inside of the main unit. The procedure takes approximately one minute to finish

4. 'Clean the corona wires'

If stripes appear on printed output or random parts of the printed image are missing, clean the corona assembly wires inside the main unit.. The procedure takes approximately 35 seconds to finish.

5. 'Clean the rollers of the ADF'

If your originals have black stripes or appear dirty after transporting them through the feeder, clean the rollers of the feeder. The procedure takes approximately 20 seconds to finish.

6. Printer maintenance

Trained operators are allowed to perform more complicated maintenance actions themselves without the need of a service technician. For this an application exists, that is called Operator Maintenance Application (Abbr. OMAApp). The operator can use a web browser to gain access to the PRISMAsync OMAApp. From this web browser he can start different maintenance actions like replacing and cleaning of parts. The application is password protected to avoid improper use.

Since the application is started from a remote PC you must be sure that the system is not in use, so it is safe to start the maintenance. For that reason the system has to be put in an Advanced Operator Mode which has to be done by this 'Printer Maintenance' button.

7. 'Perfect Binder adjustments'

With this option you can adjust perfect binder settings. The settings are:

- a. Cover position
- b. glue amount.

8. Refresh the fixing roller

When paper with a longer width is used after copying or printing 100 or more sheets of paper with a shorter width (for example, when you use A3 paper after A4R paper), gloss lines may appear on both edges in the feeding direction. In addition, patches of uneven gloss may appear in the high density areas of the printed heavy paper or coated paper. In this case, the lines and patches of uneven gloss may be reduced by refreshing the fixing roller and cleaning its surface.

Service mode

When you touch the 'Go to the service mode' button, the Service Mode is entered. The system will ask for the PIN. Enter the PIN (675756). The following screen is displayed

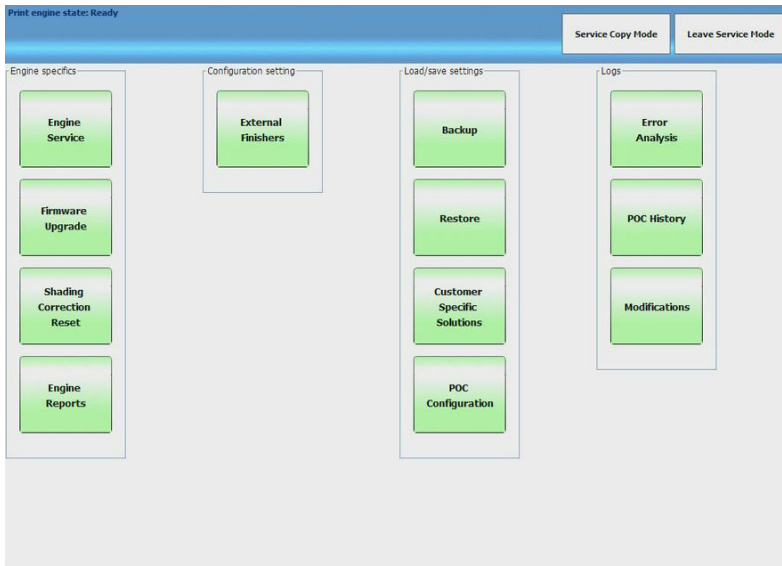


Fig. SDS entry screen.

1. Service Copy Mode

This button is used to temporarily switch back to Normal mode. Printing and scanning is possible in this mode. You can re-enter SDS without the need of the PIN.

2. Leave Service Mode

Leave the Service mode and return to the Normal User Mode
The following screen will show up.



Fig. Leave Service Mode

If you temporarily want to leave the Service Mode, please press "Leave Service Mode".
If this is the end of the service visit please press "End of service visit". In this way a new snapshot is made in the datadump file, making it easier to analyse these files.

3. Engine Service

Enter the Service mode. All service functionality is available.

4. Firmware Upgrade

With this button you can start the upgrade procedure of the firmware of the copier. A USB-stick containing the firmware should be available.

The upgrade is done from this USB-stick and not via the SST-tool.

5. Shading Correction Reset

Reset the values as measured during a shading correction calibration to 0. Typically used before performing a shading correction.

6. Engine Reports

In the service mode a sorted list of all durables and periodically replaceable parts of the engine and accessories can be generated and displayed on the LUI. The list is sorted by lifetime. Doing so is the easiest way for the Field Service Technician to get an overview of the status of all parts. For a more detailed description see the appendix

7. External Finishers

If there are External finishers (booklet maker or ringbinder) connected to the copier then you have to set parameters to make the connection work properly.

For a description of these parameters see the Service Manual of the copier.

8. Backup

Make a backup of the PRISMAsync settings. Insert a USB-stick into the USB-port on the operator panel. The system will point to this stick. After accepting the pathname the settings are written to this USB stick. The filename will contain the time of the backup. Always perform the backup, before servicing the PRISMAsync.

9. Restore

Restore the settings that were written on the USB-stick during a backup procedure. Insert the USB-stick into the USB-port on the operator panel. The system will ask for a filename. After selecting the correct file, the settings are restored to the PRISMAsync. When restoring is ready the PRISMAsync will reboot automatically.

10. Customer Specific Solutions

For some customers it is possible that specific solutions for their system are made.

In this screen you can disable or enable these solutions.

11. POC Configuration

In the POC configuration screen you can determine which Key Operator (Printer Operator Care) actions the customer is allowed to do with respect to the High Capacity Stacker F1.

If it is enabled then a wizard will show up guiding the customer through the actions.

12. Error Analysis

An overview of the most recent errors is presented on the screen.

13. POC history

The most recent Key Operator Maintenance actions are presented on the screen

14. Modifications

An overview of the modifications on the system is presented on the screen. You can view/register modifications for the copier, the scanner and the PRISMAsync controller.

When touching the Engine Service button the following screen will show up:

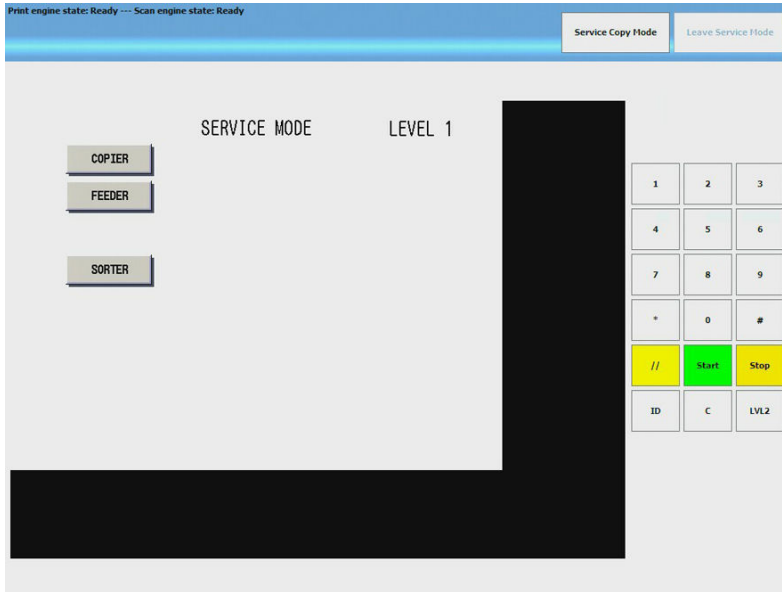


Fig. Service screen

This is the copier service screen. A description of the Service Mode can be found in the Service Manual of the copier.

'Colour adjustments'

In the 'System' tab there is a dedicated section called 'Colour adjustments' in which colour aspects can be adjusted. In this section you can perform the **Colour calibrations** and **edit the CMYK curves**.

Calibrations

Due to external environmental circumstances, like temperature and humidity, consumables and print quality change over time. These changes effect the colour quality of the printed documents. Although the printer performs automatic adjustments on a regular basis, you are advised to calibrate the printer configuration regularly. The calibration procedure consists of 3 steps. Always perform these steps in the given order.

- **Shading correction**

The Shading correction procedure corrects slight density unevenness that occurs in the halftone density area of the printed image. The Shading correction assures consistent colour planes over the whole print.

- **Auto gradation adjustment**

The Auto gradation adjustment procedure is a precise calibration of the gradation, density and colour settings of the printer. A test print is used to scan and to correct the irregularities automatically. In this part you can choose between:

- **1. Full adjustment**

This option does the auto gradation adjustment by printing sheets and measuring them, either automatically or vi the glass platen.

- **2. Quick adjustment**

The measurement is done without printing any paper but is considered to be less accurate than the Full adjustment. We advise not to use this adjustment.

- **Media family calibration**

The Media family is a group of media that uses the same output profile. The controller provides by default the media families coated and uncoated. An expert can create a new media family for a specific group of media. A media family refers to 1 colour profile per halftone: 'Normal', 'Fine' and 'Error diffusion'. The controller has to be calibrated for each media family and halftone.

The shading correction and media family calibration are executed by using an I1 photo spectrometer. The PRISMAsync supports both UV- and non-UV meters.

The customer can set alert timers for the shading and Autogradation calibration in the Settings Editor.

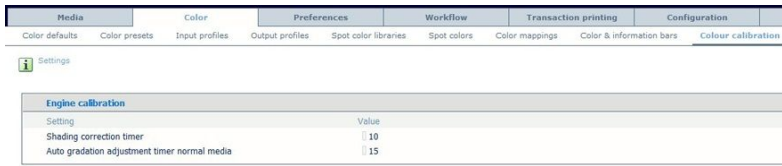


Fig. Set calibration interval

These alert timers generate a warning on the screen if a calibration is due.



Fig. Calibration warning

In the Color adjustment tab is displayed which calibration has to be executed as a result of reaching the interval.

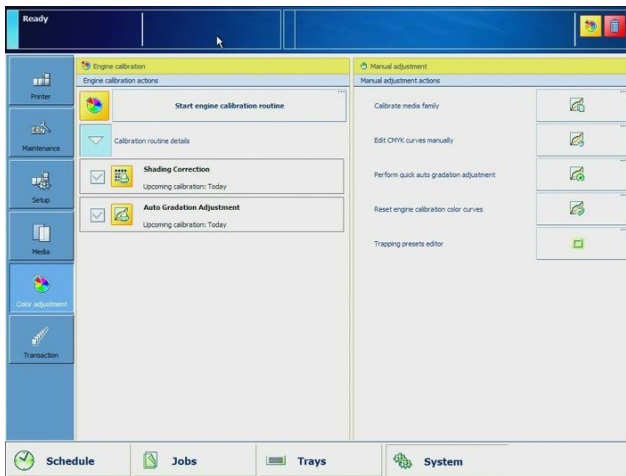


Fig. Calibration Screen

In the left part of the screen the calibration parts that are due are checked. By pressing the “Start engine calibration routine” button these checked parts are executed. It is possible to (un)check parts manually, thus overriding the current setting.

In the right part of the screen you can start the Media family calibration. In most cases this calibration does not have to be done very often.

Edit CMYK curves

With this option you can adjust the CMYK curves per media family and halftone. The settings are applied for all new jobs. It is also possible to edit the CMYK curve for a spe-

cific job. This can be done in the properties field of the job. Other jobs will remain unaffected.

You can make adjustments separately for C, M, Y and K.

Note

- When editing the CMYK curves on a system level (not in the properties of the job) you have to do the adjustment for all halftones of the media family. Very often images and fonts are printed with a different halftone. If you only change the curve for one halftone differences in color will occur.
This is not applicable for changing the curve on a job level.

Quick Auto gradation

The Auto gradation adjustment procedure is a precise calibration of the gradation, density and colour settings of the printer.

The measurement is done without printing any paper but is considered to be less accurate than the Full adjustment. We advise not to use this adjustment.

Reset engine calibration curves

It is possible to reset the actual calibration curves. In the dialog you have to select the curve to delete. After deletion you have to perform the calibration again to get the best image quality.

Trapping presets editor

From V3.1 on, In-RIP trapping is implemented in the PRISMAsync. It is only applicable for the PDF print path (APPE) in document printing mode (Not transaction). It is set on job level.

Trapping is a digital compensation for color-to-color mis-registration in the print engine. It typically tries to reduce the white gaps resulting from this mis-registration.

Trapping can generate artificial edges between adjacent objects, so trapping should be used with care.

.

Trapping in the PRISMAsync:

1. Trapping control & editor on Operator panel
2. Trapping control in Automated Workflow
3. Trapping control in PRISMAprepare & PRISMAccess

4. Using Adobe in-RIP trapping technology, editable trapping settings are in line with settings of Adobe Creative Suite
5. Set of trap parameters can be saved as trap pre-set on Operator panel; default trap pre-set delivered from factory for easy application
6. Trap settings are shown on printed job ticket, color configuration report & selectable for information bar
7. Factory default: trapping disabled

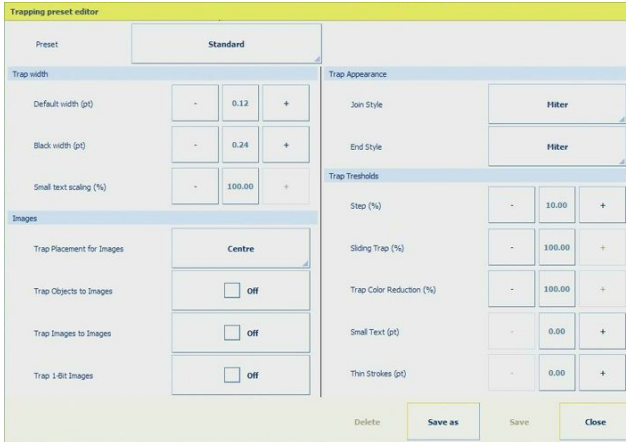


Fig. Trapping Preset Editor

See the appendix for a description of the presets.

'Media' management

The PRISMAsync uses a 'Media' catalogue in which all the possible media that are used, are defined. Definition of these new paper types is done in the **Settings Editor**. On the Operator Panel you can gain access to the catalogue via the **'System' -> 'Media'** tab.

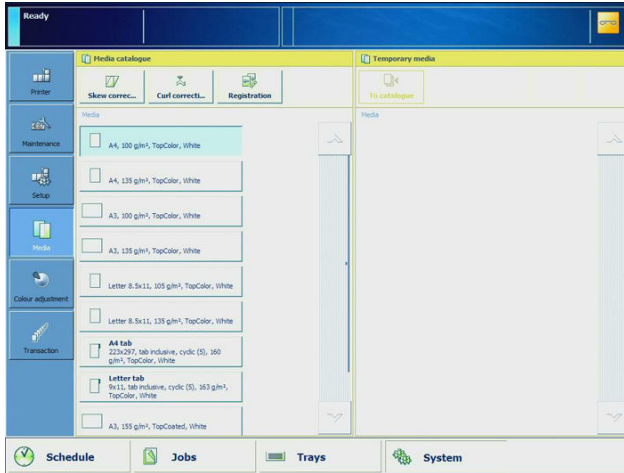


Fig. Media management

In this section you can also make the following adjustments

- **Skew and Rectangle**
Select a specific media that you want to adjust. Select the Skew Correction adjustment. A wizard will start, guiding you through the adjustment.

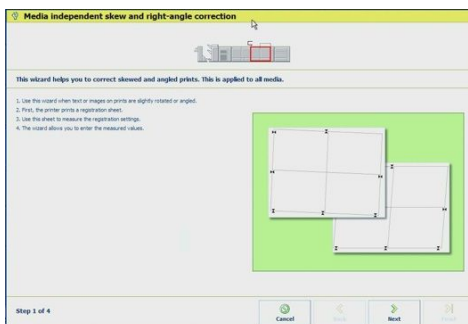


Fig. Skew correction

- **'Curl correction'**

Select a specific media that you want to adjust. Select the Curl correction adjustment. A screen will pop up in which you can enter the values. Descriptive images tell you if these values need to be positive or negative.

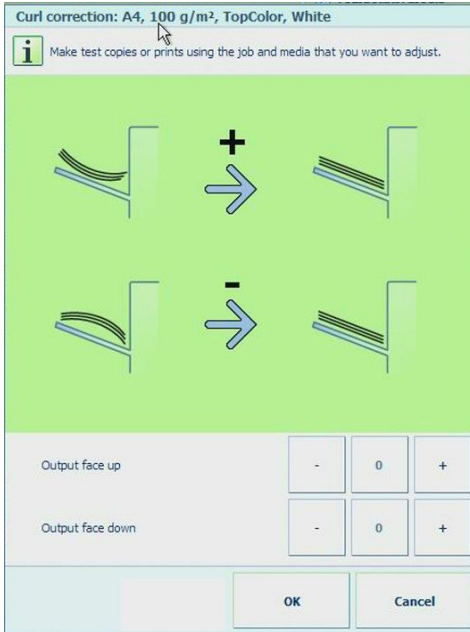


Fig. Curl correction

■ 'Registration'

Select a specific media that you want to adjust. Select the Registration correction adjustment.

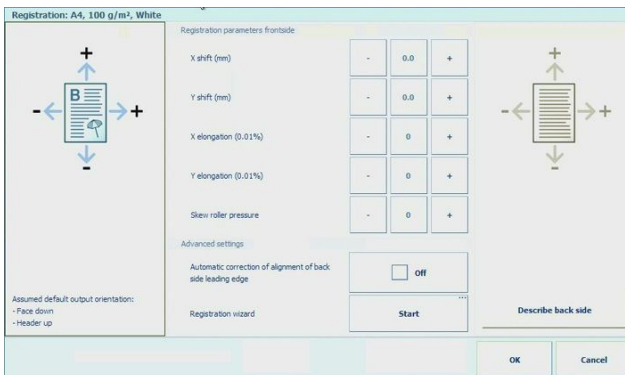


Fig. Registration correction

You can select a wizard to guide you through the process. For more experienced users it is possible to enter the values manually.

1. Repeat the procedures for each paper type you want to adjust.
2. The calculated values can be checked in the Settings Editor.

Operator maintenance

Trained operators are allowed to perform more complicated maintenance actions themselves without the need of a service technician. For this an application exists, that is called **Operator Maintenance Application (Abbr. omapp)**. The operator can use a web browser to gain access to the PRISMAsync omapp. From this web browser he can start different maintenance actions like replacing and cleaning of parts. The application is password protected to avoid improper use. Since the application is started from a remote PC you must be sure that the system is not in use, so it is save to start the maintenance. For that reason the system has to be put in an Advanced Operator Mode which can be done by the **'Engine Maintenance'** button in the **Maintenance Mode** section. Follow the steps below to use the **Operator Maintenance Application**:

1. Select 'Engine Maintenance' out of the options. The following windows is displayed:

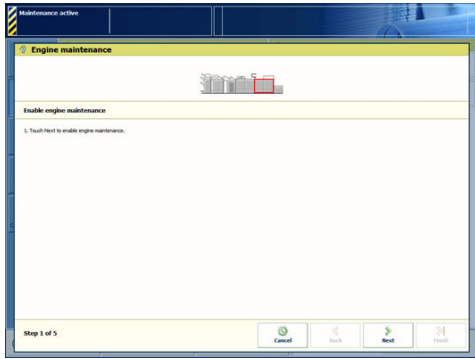


Fig. Operator maintenance screen 1

2. Click 'Next'. After a few seconds the following screen is displayed

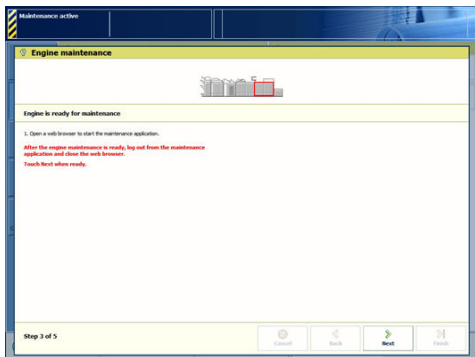


Fig. Operator maintenance screen 2

3. It is now save to start the omapp from a remote PC. Open a webbrowser and in the address bar enter the ip-address or DNS-name of the printer followed by the word “omapp” (**http://systemname/omapp**). Take care that this is case-sensitive.
4. On the PC the application will start. Enter the password for the application (default: 1836671).
5. When ready, log out from the application and close the web browser.
6. On the Operator Panel click 'Next'.
7. On the Operator Panel click 'Finish' to exit the wizard for engine maintenance.

Chapter 5

Starting, shutting down, and restarting

Turn on the system

You are advised to turn on the system in the following order.

1. The optional equipment (Paper and finishing modules)
2. The copier
3. The controller



Note:

If you turn on the controller first, the omapp feature will not work!

Turn on the copier

1. Turn on the optional equipment.
2. Put the main power switch on top of the main unit in the 'I' position.
3. If required, wait until the controller is ready.
4. Press the Sleep button (Moon) at the right-hand side of the operator panel.

Turn on the controller

Use one of the following options to turn on the controller.

1. Press the Sleep button at the right-hand side of the operator panel if the system was shut down from the operator panel.
2. Press the on/off button of the controller



Note:

The controller needs some time to start up. In the beginning the screen will be black. Please be patient until the flash screen appears.

Turn off the system

Turn off the system

Note:

Leave the power switch of the main unit in the 'I' position. When you shut down, the power switch will automatically switch to the 'O' position.

If you switch off the power of the copier, the PRISMAsync will generate the error 11506.

How to turn off the printer

1. Touch 'System' -> 'Setup' -> 'Shut down system'.
The operator panel displays the message 'Are you sure you want to shut down?'.
2. Touch 'Yes'.
A message indicates when the shut down will begin. The shut down can take a maximum of 60 minutes.

Note:

Using the 'Shut down now' option can damage the printer. Use the 'Shut down now' option only to turn the printer off and on within 10 minutes.

3. Turn off the optional equipment.

Restarting the system

Restarting the system

You can restart the system via the Settings Editor or via the operator panel. In both cases only the PRISMAsync will be restarted.

How to restart via the Settings Editor.

1. On a PC open the Settings Editor
2. Go to 'Support' -> 'Troubleshooting'
3. Select 'Restart the system'

How to restart via the operator panel

1. Touch 'System' -> 'Setup' -> 'Shut down system'.
The operator panel displays the message 'Are you sure you want to shut down?'.
2. Touch 'Restart'.

Restarting the copier only

If the copier is switched off with the power switch an errorcode (11506 Connection lost) will arise. As a result the PRISMAsync has to be restarted too, which will take a long time. When you are servicing the copier this is a very time-consuming situation. That is why, starting from V2.1, a solution is implemented to overcome this situation. In the following part, 2 situations are described how to restart the copier only.

Restart copier in Service Mode

- 1. In Service Mode, switch off the copier. The following screen will be displayed:

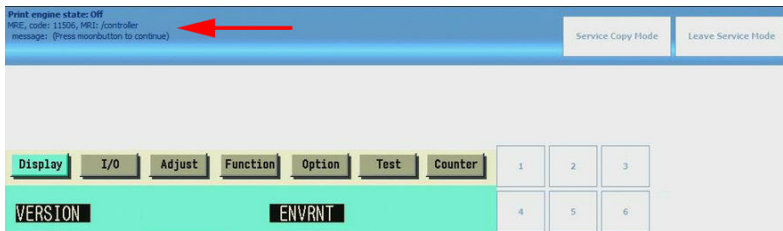


Fig. Error 11506 in Service Screen

In the bar the error code 11506 is shown and the message to Press the moonbutton to continue.

- 2. Press the “moon-button”.
After this the error will be reset. If you do not press this button and you will switch to normal user mode the error screen will be displayed.
- 3. Of course the Service screen will not function now because the copier is off. You might get the following screen.

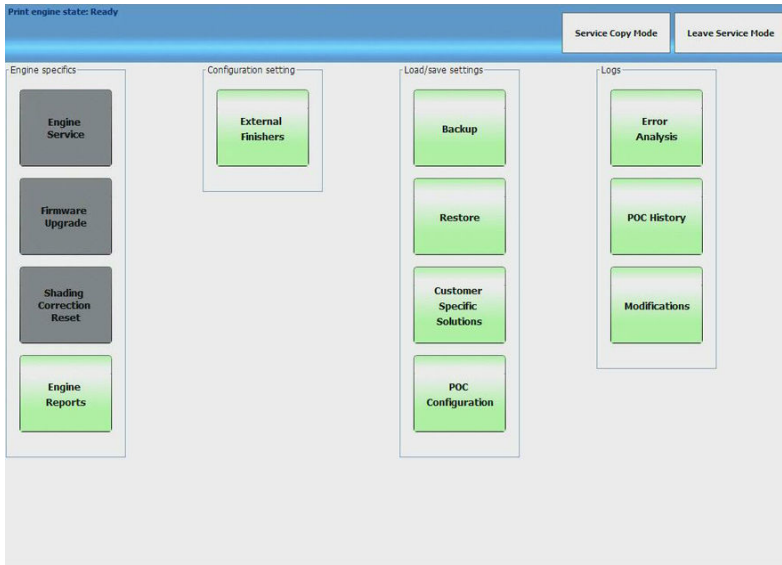


Fig. Service Screen when copier is off

- 4. Switch on the copier. After a few seconds the buttons will turn green again.

Restart copier in Normal Mode

1. In Normal mode switch off the copier with the power switch. The following screen will appear.

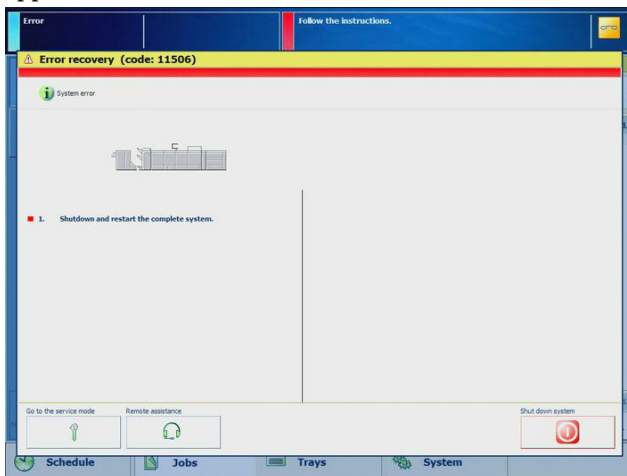


Fig. Error 11506 in Normal mode

2. Press 'Go to the service mode'

3. The next screen will appear.



Fig. 11506 in Service screen and engine off

4. Press the “moon-button” to reset the error.
5. From this point on you have the same situation as previously described (Restart copier in Service Mode).

Restarting copier after error in copier

From V2.2 on it is possible to restart the copier without restarting the PRISMAsync. This is useful if an error occurred in the copier resulting in an E-code. If this happens the following screen will pop-up (example):

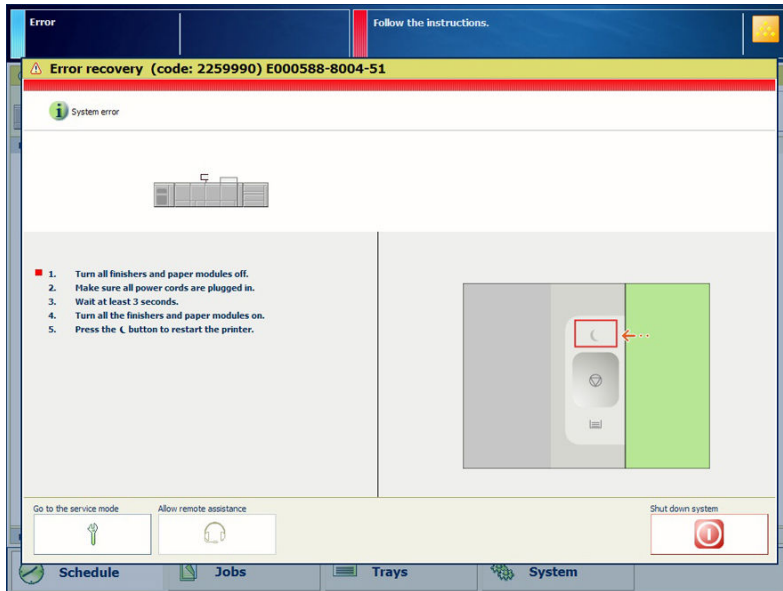


Fig: Restart engine only

The customer has to follow the steps indicated at the left side of the screen.

1. Turn all finishers and paper modules off
2. Check if power cords are plugged in
3. Wait at least 3 seconds
4. Turn all finishers and paper modules on
5. Press the moon-button to restart the printer.



Note:

The copier will restart without restarting the PRISMAsync.

Chapter 6

The Settings Editor

The Settings Editor

The Settings Editor is a web-based application and therefore accessible via an Internet browser.

The Settings Editor enables you to manage settings or to display information in the following areas.

- 'Media'
- 'Colour'
- 'Preferences'
- 'Workflow'
- Transaction Printing (only with IPDS-license)
- 'Configuration'
- 'Support'

Accessing the Settings Editor

Before using the Settings Editor make sure that you have the following information:

- The IP-address or hostname of the controller
- The Service- or Key Operator password. (675756 resp. 13524)

There are 2 ways to get access to the Settings Editor:

- Via a remote PC connected to the client network
- Via a laptop directly connected to the PRISMAsync controller

Access via client network

To get access to the Settings Editor do the following:

- Be sure the PC and the PRISMAsync are connected to the client network
- On the PC open an Internet browser (eg. Microsoft Explorer)
- In the address bar, enter the IP-address or the Hostname of the PRISMAsync. As a result the Settings Editor will open. It is now possible to make changes in the above listed areas.

Access via direct connection to PRISMAsync

Sometimes you can not access the Settings Editor via the client network. In this case it is better to connect a PC/laptop directly to the PRISMAsync controller.

Follow these steps:

1. Disconnect the cross-over Ethernet cable from the copier and connect it to the Ethernet port on your laptop.
2. Set the IP-address of your laptop to 134.188.254.101
3. Set the Subnet mask of your laptop to 255.255.255.0
4. On the laptop open an Internet browser (eg. Microsoft Explorer)
5. In the address bar, enter **http://134.188.254.11**
6. The Settings Editor will open in your Internet browser.

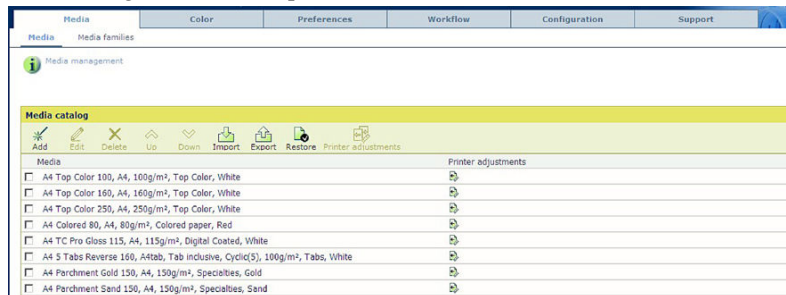


Fig. Settings Editor



Note:

See the appendix for : *Important media printer adjustments* on page 156

Chapter 7

Service procedures

Service procedures

In general the PRISMAsync controller does not require regular service or maintenance. Use the procedures in this chapter to inspect and/or replace major hardware components.

Hardware versions

There are multiple version of PRISMAsync controllers in the field numbered from V1 to V4 (Or A4).

- **Version 1**

The initial version of the PRISMAsync.

- **Version 2**

This version has a new motherboard compared to Version 1.

- **Version 3**

Differences with the previous versions:

- o New ErP compliant motherboard
 - o New PBA AUX control board. Old boards not supported anymore.
 - o NVIDIA GTS450 GPU Graphic Board not longer supported
 - o No DVD player
 - o There are 2 different sub-versions of this controller in the field. These have different GPU boards installed:
 - Version 3 with N550GTX-TI GPU (1070006840)
 - Version 3 with GTX650 GPU (1070026100)
- The N550GTX GPU will not be delivered anymore.

- **Version 4**

This version is also known as A4. Differences with the previous versions:

- o More RAM-memory. This version has four memory modules of 4Gb on board.
- o A new BIOS of the motherboard

Identification of controller version

You can identify the version of the controller on the outside by the following characteristics:

- **Version 1 and Version 2**

- o DVD player
- o No sticker at the bottom with the partnumber/codenummer
- o o Red Océ Tag mounted on the front



Fig. Océ Red Tag

Version 3

- No DVD player anymore
- On the sticker at the bottom of the controller the Océ partnumber/codenummer is printed (1070006840 or 1070026100)
- Red Océ Tag mounted on the front

Version 4

- No DVD player present
- On the sticker at the bottom of the controller the Océ partnumber/codenummer is printed (1070033079)
- PRISMAsync logo mounted on the front



Fig. PRISMAsync logo

- Standard delivered with pedestal (is service part and can be mounted on older versions too.)

Compatibility issues

When exchanging parts the technician has to be aware of the controller version that is concerned. In the following list the compatibility issues are mentioned.

- Controller version 3 is **only** compatible with Version 2 system software.
- Controller version 2 is compatible with Release 2 system software. This means that you can upgrade the version 2 PRISMAsync with Version 2 software.
- Automatic loading of DDI firmware depending on XPe or W7 platform.
- Old PBA AUX board from version 2 controller (1060111070) is not compatible with version 3 or higher controller. If you have to exchange the Base controller from a version 2 controller with a higher version you also need a new PBA AUX control board.
- A new PBA AUX control board (1070005457) can be used in a version 2 controller.
- Controller version 4 is only compatible with Version 3 system software
- If you install Version 3 software on a version 3 controller you will not have the same performance as on a V4 controller.
- 4GB memory modules are not supported for V1, V2 or V3 controllers.
- 2 GB memory is not supported for V4 controller.
- The Graphical board MSI- 550GTX (1060131773) is not supported on a V4 controller.

In the table below you can find an overview of the compatibility.

Item	Description	V1		V2		V3	V4
		V1.x WinXP	V2.x Win7	V1.x WinXP	V2.x Win7	V2.x Win7	V3.x Win7
1060118890	CABLE, USB 2.0 CT2-4P HDR-10P 0,3M.	v	v	v	v	v	v
1060069477	DATA-CABLE,RJ45-RJ45 CRSVR SFTP 2.8M	v	v	v	v	v	v
1060130444	HARNESS,22W01	n/a	n/a	n/a	n/a	v	v
1060099125	PBA,DDI IF BOARD	v	v	v	v	v	v

Item	Description	V1		V2		V3	V4
1060111070	PBAP,AUX_CON- TROL	v	v	v	v		
1070005457	PBAP,AUX_CON- TROL	v	v	v	v	v	v
1060131771	VHE-CTRL- MB950 V2 IN- DUSTRIAL CONTROLLER (GPU 1060115734 or 1060131773 in- cluded)	v	v	v	v	n/a	n/a
1070006840	VHE-CTRL- MB950 V3 IN- DUSTRIAL CONTROLLER (GPU 1060131773 in- cluded)	n/a	n/a	n/a	n/a	v	v (1)
1070026100	VHE-CTRL- MB950 V3 IN- DUSTRIAL CONTROLLER (GPU 1070026086 in- cluded)	n/a	n/a	n/a	n/a	V2.2	v (1)
1070033079	VHE-CTRL- MB950 V4 IN- DUSTRIAL CONTROLLER	n/a	n/a	n/a	n/a	n/a	v
1060120116	MEMORY MODULE 2GB DDR3	v	v	v	v	v	n/a
1070037688	4GB DDR3 DIMM, SPARE PART	n/a	n/a	n/a	n/a	n/a	v
1070026086	GPU, SPARE PART		V2.2		V2.2	V2.2	v

Item	Description	V1		V2		V3	V4
1060131773	MSI N550GTX-TI PCI-E X16 GRAPHIC BOARD	v	v	v	v	v	
1060115734	NVIDIA GTS450 PCI-E X16 GRAPHIC BOARD	v	v	v	v		
1060127337	USER INTER-FACE PANEL TYPE 4	v	v	v	v	v	v
1070003522	USER INTER-FACE PANEL TYPE 4	v	v	v	v	v	v
1060118980	SIGNAL LAMP ASSY	v	v	v	v	v	v

V2.2	--> SW Version V2.x or higher is mandatory for hardware configuration support
v (1)	--> see release notes for performance limitation of specific features
	Not Supported

Overview Service procedures

Introduction

The following chapters describe the servicing of the following components:

- Boards, cables
- DIMM's
- Fan
- Power supply
- Hard disk drive

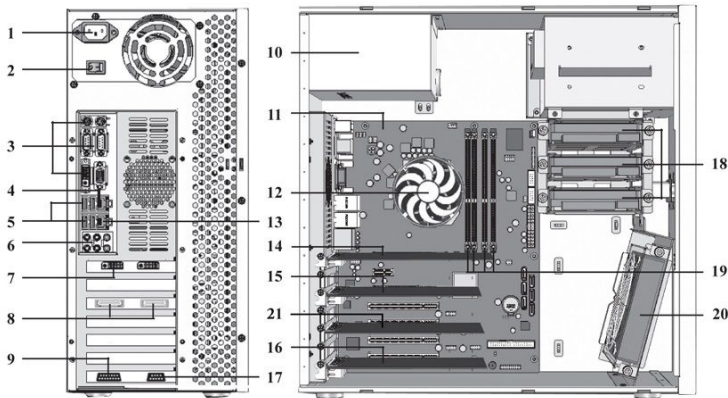


Fig. Hardware component overview

1	Power connector	12	CPU cooler
2	On/Off switch	13	CMD connection copier
3	Not used	14	Graphics board (GPU)
4	Network connection	15	DDI Interface board
5	USB ports	16	AUX control board
6	Not Used	17	Attention light connection
7	UI panel (DVI)	18	Hard Disk Drives (250GB)
8	Data connections copier	19	DIMMS
9	UI panel	20	System fan
10	Power supply	21	Network card (IPDS)

11	Motherboard		
----	-------------	--	--

Accessing internal components

This section describes how to open the PRISMAsync controller to gain access to the internal components.

1. Shutdown the 'System'

If the 'System' is in sleep mode then touch the **On/Off** button to shutdown the 'System'. If the 'System' is not in sleep-mode then touch the 'System' tab followed by the 'Setup' tab. In this screen touch the **On/Off** button. In the next screen touch 'Shut down'. The 'System' will 'Shut down'.

Note:

Do not switch off the power button of the copier. It will switch off automatically. You can also touch the moon-button when the system is not in sleep mode.

2. Remove all cables from the back of the PRISMAsync controller.

If you have wrapped the cables then release the tie-wrap.

3. Remove the left side cover of the PRISMAsync controller.

To remove the side cover, remove the 3 screws at the right side on the back of the PRISMAsync controller. Then shift the cover to the back to let it come off.

4. Open the cable ties attached to the middle bracket

These ties are re-usable and are meant for keeping the cable bundles in place and to avoid them from making contact with the fan.

5. **Loosen the 2 spring screws to remove the middle bracket.** Rotate the bracket a little in counter clockwise direction to get it out of the PRISMAsync. Be careful with the fixings that hold the PCB boards on their position.

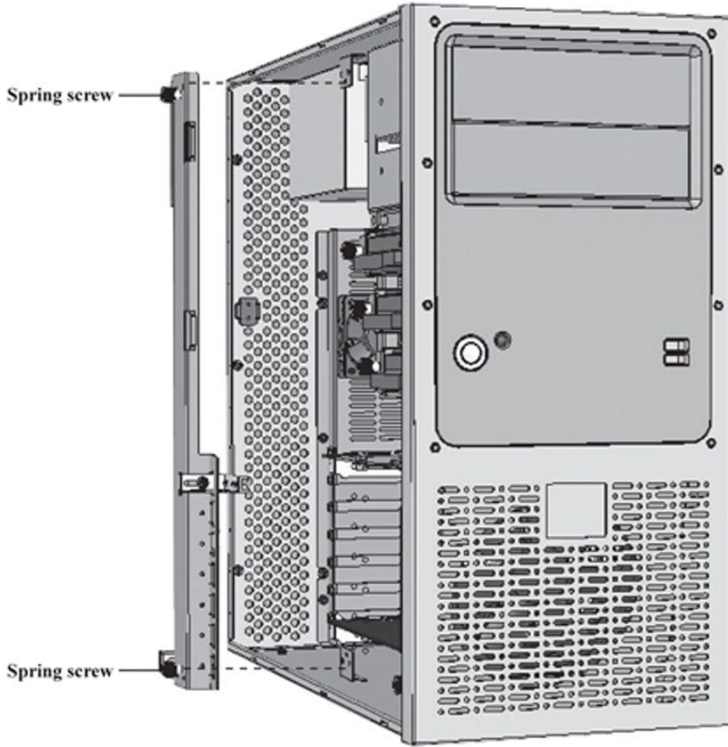


Fig. Remove the bracket from the PRISMAsync

Replacing GPU board

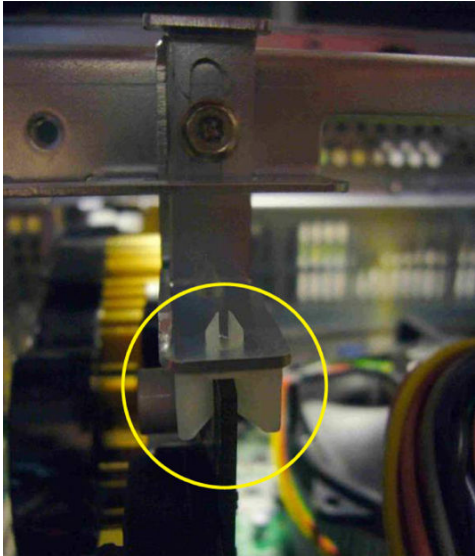
Note:

When servicing components of the PRISMAsync always wear a grounded strap around your wrist, to avoid electrostatic discharge that will harm your equipment.

Note:

When replacing the GPU board, please check the compatibility matrix. It might be possible that you have to re-install the software of the PRISMAsync after exchanging the GPU.

Step	Action
1	Remove side cover and middle bracket. Follow the instructions as described in ‘Accessing internal components’ on page 73
2	Unplug the power connector of the board.
3	Remove the screw of the metal PCI bracket. Use a small Philips screwdriver to remove the screw used to mount the bracket to the backside of the PRISMAsync.
4	Firmly press the PCI-E lock-mechanism to unlock the board. The lock-mechanism is located at the bottom right side of the PCI-E connector on the motherboard. Pressing it down will lift the board out of the connector.
5	Take the board out of the PRISMAsync.
6	Place the new board in the PCI-E connector. Firmly press the board in the PCI-E 1 connector (the upper). Check that the lock mechanism is closed.
7	Fix the graphic board. Fix the board with a single screw on the PCI bracket side with a Philips screwdriver.
8	Plug the power connector to the board.

Step	Action
9	<p>Re-install middle bracket and side cover.</p> <p>Take care that the fixing on the middle bracket is in position. It should fit exactly on the GPU-board.</p>  <p>Fig. Fixing of the PCI board</p>
10	<p>Re-install software if needed</p> <p>GPU-boards might change quite often over time. Check if the replaced GPU board is the same as the new one. If not, it is possible that the system software needs to be re-installed because of a new driver that is needed for this GPU.</p> <p>If you installed a new GPU board in a V2/V3 controller, the system software of the PRISMAsync has to be upgraded to V2.2 or higher.</p>

Replacing DDI board

Note:

When servicing components of the PRISMAsync always wear a grounded strap around your wrist, to avoid electrostatic discharge that will harm your equipment.

The DDI board handles the interfacing between the copier and the PRISMAsync. Only replace the board if you have checked the cables connected to the board.

Step	Action
1	Remove side cover and middle bracket. Follow the instructions as described in <i>'Accessing internal components'</i> on page 73.
2	Unplug the power connector and internal connectors of the board.
3	Remove the screw of the metal PCI bracket. Use a small Philips screwdriver to remove the screw used to mount the bracket to the backside of the PRISMAsync.
4	Remove the PCI card from it's slot Hold the PCI card by the two top corners. Pull it straight out of the socket.
5	Take the board out of the PRISMAsync.
6	Unpack the new board.
7	Place the board in the PCI-E connector. Firmly press the board in the PCI-E connector. Use the PCI-E 3 port.
8	Fix the DDI board. Fix the board with a single screw on the PCI bracket side with a Philips screwdriver.
9	Plug the internal connectors to the board.
10	Re-install middle bracket and side cover. Take care that the fixing on the middle bracket is in position. It should fit exactly on the DDI-board.



Replacing AUX control board

Note:

When servicing components of the PRISMAsync always wear a grounded strap around your wrist, to avoid electrostatic discharge that will harm your equipment.

The AUX control board supplies power to the operator panel and controls the Operator Attention Light.

Step	Action
1	Remove side cover and middle bracket. Follow the instructions as described in <i>'Accessing internal components'</i> on page 73 'Accessing internal components'.
2	Unplug the power connector and internal connectors of the board.
3	Remove the screw of the metal PCI bracket. Use a small Philips screwdriver to remove the screw used to mount the bracket to the backside of the PRISMAsync
4	Remove the PCI card from it's slot Hold the PCI card by the two top corners. Pull it straight out of the socket.
5	Take the board out of the PRISMAsync.
6	Unpack the new board.

Step	Action
7	<p>Connect the USB-wire connector</p> <p>The USB wire connector (white side) must be connected to the Auxiliary Board. Because of the space between Board and controller box, it's advised to do this before inserting the board into the PCI connector.</p>  <p>Fig. AUX board USB connector</p> <p>.</p> <p>Connect the other side of the connector to the nearest available USB pin header of the motherboard.</p>  <p>Fig. AUX to Motherboard USC connector</p>
8	<p>Place the board in the PCI connector. Firmly press the board in the PCI connector. Use the PCI 4 port. It is the lowest PCI connector on the Motherboard.</p>
9	<p>Fix the AUX control board. Fix the board with a single screw on the PCI bracket side with a Philips screwdriver</p>
10	<p>Plug the internal connectors to the board. See 'Connect Harness 22 W01' on page 89</p>
11	<p>Re-install middle bracket and side cover. Take care that the fixing on the middle bracket is in position. It should fit exactly on the AUX control board.</p>

Replacing DDR3 modules

Note:

When servicing components of the PRISMAsync always wear a grounded strap around your wrist, to avoid electrostatic discharge that will harm your equipment.

The MB950 board supports four DDR3 memory socket for a maximum total memory of 16GB in DDR3 DIMM memory type.

On delivery the PRISMAsync is equipped with a certain amount of memory depending on the version of the controller.

- **Version 1, 2 and 3**
2 x 2GB DDR3 memory modules, mounted in DIMM1 and DIMM3 slot
- **Version 4**
4 x 4GB DDR3 memory modules.

Note:

Do not install 4GB memory modules in Version 1 thru 3 controllers. The effect on the performance will be limited

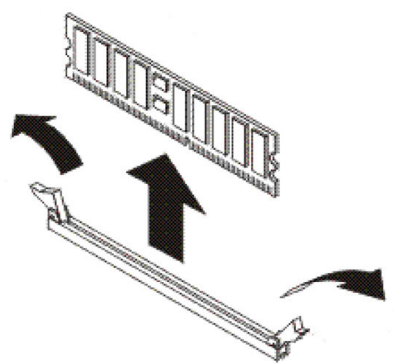
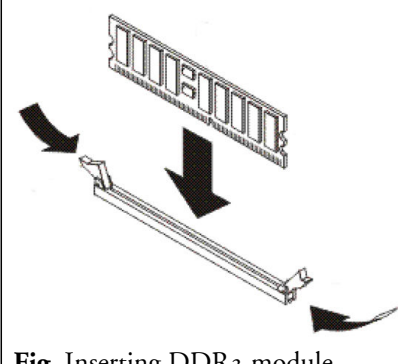
Note:

Only install 4GB (not 2GB) modules in the Version 4 controller.

Note:

Do not install mixed memory modules (2GB and 4 GB). This might lead to unspecified behavior.

Step	Action
1	Remove side cover and middle bracket. Follow the instructions as described in <i>'Accessing internal components'</i> on page 73.
2	Open the clips by pressing them outward. Firmly press on the clips on the left and the right side of the connector. The DDR3 module will be lifted out of the connector.
3	Align the DDR3 module with memory slot.

Step	Action
4	<p data-bbox="359 205 774 232">Push DDR3 module in memory slot</p> <p data-bbox="359 238 1166 333">Gently push the DDR3 module in an upright position until the clips of the slot close, to hold the DDR3 module in place when the DDR3 module touches the bottom of the slot.</p> <div data-bbox="359 347 753 711"></div> <p data-bbox="359 724 693 751">Fig. Removing DDR3 module</p> <div data-bbox="766 347 1160 711"></div> <p data-bbox="774 697 1096 724">Fig. Inserting DDR3 module</p>
5	<p data-bbox="359 769 825 797">Re-install middle bracket and side cover.</p>

Replacing Hard Disk Drives

Note:

When servicing components of the PRISMAsync always wear a grounded strap around your wrist, to avoid electrostatic discharge that will harm your equipment.

The PRISMAsync is equipped with 3 x 250GB 3.5” SATA II HDD @ 7200rpm Hard Disk Drives. One of the drives is used for the System software. The other 2 drives are for data. Please check the table below for connections and purpose.

HDD # (position)	Connector	Purpose
0 (top)	SATA J18	System disk
1 (middle)	SATA J24	Data
2 (bottom)	SATA J16	Data

Note:

After replacement of the HDD's you will have to re-install the system software.

Note:

Always exchange all 3 drives at once.

Note:

The 2 data drives are Raid0 configured. This means that if 1 disk has crashes, all the data will be lost.

Step	Action
1	Remove side cover. Follow the instructions as described in <i>'Accessing internal components'</i> on page 73.
2	Unplug the connectors. Unplug the power and the SATA connectors on the HDD.
3	Remove the 2 screws on the front side.
4	Slide the HDD outward.
5	Insert the new HDD until it clicks into position.
6	Fix the HDD with the 2 screws

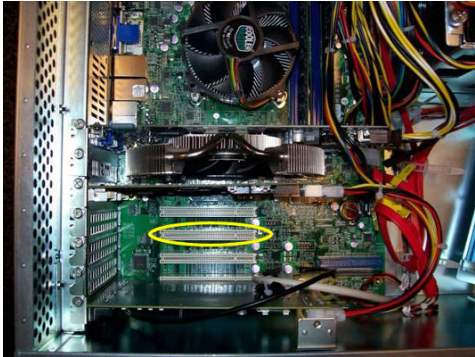
Step	Action
7	Plug the connectors. Plug the power and the SATA connector on the HDD.
8	Repeat steps 2 thru 7 for the other 2 HDD's
9	Re-install middle bracket and side cover.
10	Re-install the system software. See <i>'Re-Installation of the system software'</i> on page 103 .

Replacing Ethernet board

Note:

When servicing components of the PRISMAsync always wear a grounded strap around your wrist, to avoid electrostatic discharge that will harm your equipment.

The extra Ethernet board (Intel PRO/1000 GT Desktop Adapter) is needed when IPDS functionality is enabled (Extra license). The board is needed for the Codishell tool to analyze IPDS-problems. It can also be used to connect the laptop to the PRISMAsync.

Step	Action
1	<p>Remove side cover and middle bracket. Follow the instructions as described in <i>'Accessing internal components'</i> on page 73.</p>
2	<p>Unpack the new board.</p>
3	<p>Remove the fifth PCI metal bracket (starting from the CPU). Use a Philips screwdriver to remove the bracket..</p>
4	<p>Place the board in the PCI connector. Firmly press the board in the PCI connector.</p>  <p>Fig: Location of extra network card.</p>
5	<p>Fix the Ethernet board. Fix the board with a single screw on the PCI bracket side with a Philips screwdriver.</p>
6	<p>Re-install middle bracket and side cover. Take care that the fixing on the middle bracket is in position. It should fit exactly on the Ethernet board.</p>

Step	Action
7	Re-install system software If the Ethernet board is mounted for the first time (no replacement) there will be no driver installed for it. Therefore you have to re-install the PRISMAsync software.

Replacing Base controller

Note:

When servicing components of the PRISMAsync always wear a grounded strap around your wrist, to avoid electrostatic discharge that will harm your equipment.

If it is clear that an error can only be solved by replacing the motherboard a new base controller can be ordered as a service part. This controller has all the hardware in it without the extra boards that are added to make it a PRISMAsync controller (DDI board, AUX Control Board, Ethernet Board, 22W1 Harness).

In the field, multiple different hardware versions of the PRISMAsync exist. To determine which controller you are working on please check "Identification of controller version".

There are 2 ways to determine which version you are working on:

If the new controller (V4/A4) is a replacement for an older Version controller the following rules apply:

Perform the following actions to exchange the controllers:

Exchanging Version 1/Version 2 to Version 4

- The AUX Control board of the V1/V2 controller is not compatible with the V4 controller. In this case a new AUX control board must be ordered.
- The Version 4 controller is not compatible with V1.x or V2.x PRISMAsync software. After exchange you will have to install V3.x software or higher.
- The Harness 22W01 must be ordered with the V4 controller. See instructions for installation of this harness.

Exchanging Version 3 to Version 4

- Software Version V3.1 must be installed.



Note:

See also: "Hardware versions" on page 66.

Step	Action
1	<p>Remove side cover and middle bracket.</p> <p>Follow the instructions as described in <i>'Accessing internal components'</i> on page 73.</p>

Step	Action
2	<p>Remove extra boards</p> <p>Remove the following boards:</p> <ul style="list-style-type: none"> ■ DDI board (See: ‘Replacing DDI board’ on page 77) ■ AUX Control board (See: ‘Replacing AUX control board’ on page 78) <p>Check if you need a newer version of the AUX control board. (See conditions above) If so, you do not have to remove the board.</p> <ul style="list-style-type: none"> ■ Additional Ethernet board (IPDS) (See: ‘Replacing Ethernet board’ on page 84) ■ (Optional) HDD’s. (See: ‘Replacing Hard Disk Drives’ on page 82) <p>If HDD’s are still working and the PRISMAsync software version is V3.1 or higher you can exchange the hard disks. In this case all settings and jobs will be saved and no new system software installation is needed.</p>
3	<p>Remove harness 22W01</p> <p>If you are replacing a V3 controller you need to remove the harness 22W01. This is needed for the new controller. In V1/V2 controllers this harness is not present and needs to be ordered separately.</p>
4	<p>Remove the connections at the backside of the PRISMAsync</p>
5	<p>Unpack the base controller</p>
6	<p>Remove side cover and middle bracket.</p> <p>Follow the instructions as described in ‘Accessing internal components’ on page 73.</p>
7	<p>Insert previously removed boards</p> <p>Insert the following boards:</p> <ul style="list-style-type: none"> ■ DDI board (See: ‘Replacing DDI board’ on page 77) ■ AUX Control board (See: ‘Replacing AUX control board’ on page 78) <p>Re-use the old board if possible, otherwise insert the new board. Be aware that you have to connect the 22W01 harness too.</p> <ul style="list-style-type: none"> ■ Additional Ethernet board (IPDS) (See: ‘Replacing Ethernet board’ on page 84) ■ (Optional) HDD’s. <p>(See: ‘Replacing Hard Disk Drives’ on page 82) See conditions above if it is possible to re-use the HDD’s.</p>
8	<p>Connect Harness 22W01</p> <p>See Connect Harness 22W01</p>


Step	Action
9	Re-install middle bracket and side cover. Take care that the fixing on the middle bracket is in position. It should fit exactly on the boards.
10	Mount the supports/pedestals See: <i>Mount the PRISMAsync supports/pedestals</i> on page 18
11	Connect the cables at the backside of the controller See: <i>Connecting the PRISMAsync</i> on page 21
12	Install system software In case that the hard disks were not exchanged, you have to install V _{3.x} PRISMAsync software because the V ₄ controller does not work with earlier versions.
13	Restore a backup If you have a backup of the system before it crashed you can restore it now. All settings will be restored except the licenses because they belong to the “old” controller.
14	Rehost and install licenses Since the MAC-address of the PRISMAsync controller has changed it is necessary to re-host the licences. Please contact your local service organization for the new licenses.

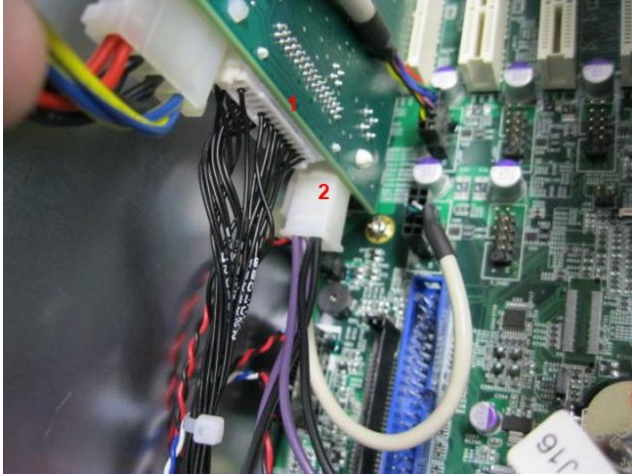
Connect Harness 22W01

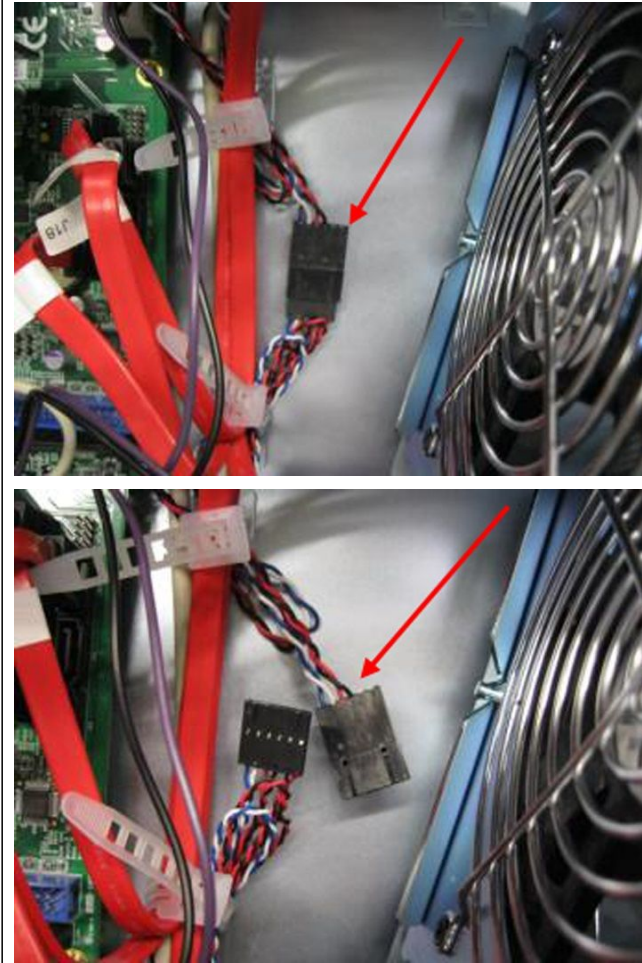
The harness 22W01 was introduced with the Version 3 controller. It must be assembled because of power regulations.

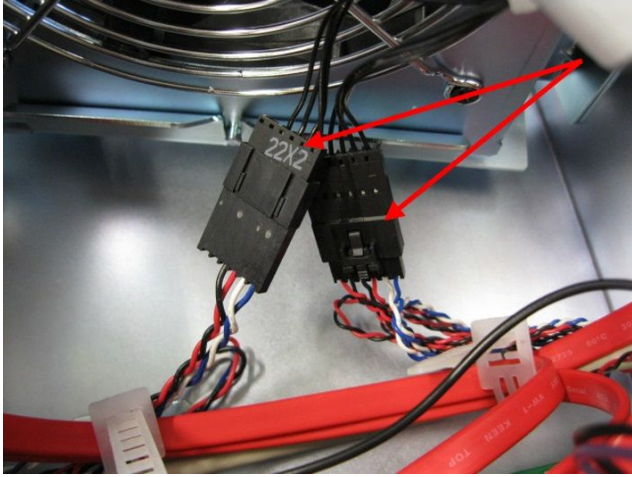
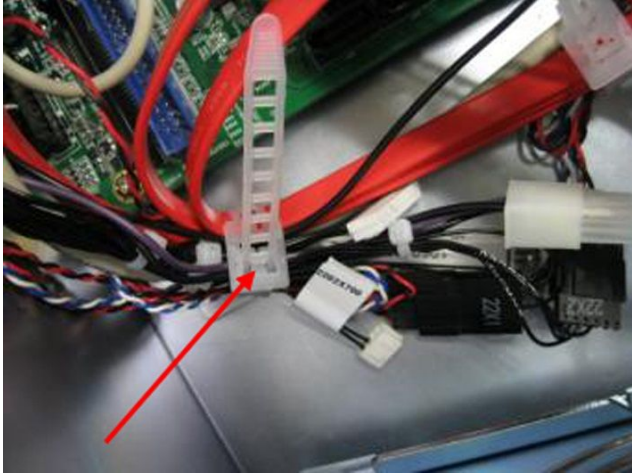


Fig. Harness 22W01

Step	Action
1	<p data-bbox="413 911 1122 975">Be sure the AUX control board is mounted correctly in the PRIS-MAsync</p>  <p data-bbox="413 1297 803 1332">Fig. Connected AUX control board</p>

Step	Action
2	<p data-bbox="354 202 860 232">Connect the harness to the AUX control board</p>  <p data-bbox="354 724 1028 820">Fig. Connect harness to AUX board 1. Connect harness 22W1 to the AUX board. 2. Connect standby powersupply connector to the AUX board</p>

Step	Action
3	<p data-bbox="404 196 1173 236">Disconnect the On/Off motherboard cable</p>  <p data-bbox="404 1201 1173 1252">Fig. Disconnect On/Off Motherboard cable</p>

Step	Action
4	<p data-bbox="354 202 908 232">Connect the harness 22W01 to On/Off connectors</p>  <p data-bbox="354 724 829 755">Fig. Connect harness to On/Off connectors</p>
5	<p data-bbox="354 771 1097 866">Fasten the harness Fasten the harness 22W01 with the bundle holder. Make sure no cables or connectors can touch the fan.</p>  <p data-bbox="354 1357 561 1388">Fig. Fasten harness</p>

Chapter 8

System software

System software

The PRISMAsync is pre-installed with a system software version. You can check the version as follows:

1. Open the **Settings Editor** and browse to “**Support**” -> **'About'**”. In the field 'Version of the printer main software' the version is given.
2. In the **'System'** section of the 'Setup' Setup tab on the Operator panel, touch “**Local key operator settings**””. In the section 'About'you will find the version number.

In some cases it is necessary to re-install the system software:

1. **A newer version of the software is available.**
If a new version of the software is available you can obtain this via your Service channel.
2. **The currently installed software seems to be corrupt.**
If the current software reacts in an undefined way and it is obvious that there is no hardware defect, re-installing the software might be a solution.
3. **After replacement of the HDDs.**
If the HDDs drives have been replaced it is necessary to re-install the software.

Preparation of the 'USB'-stick

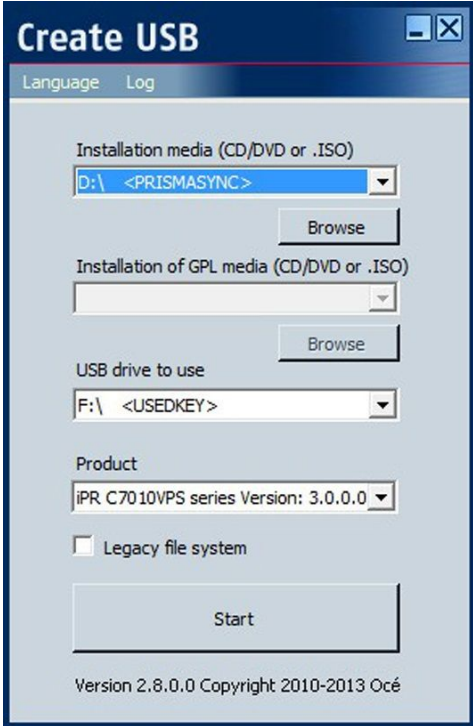
For installation of the PRISMAsync software you need a pre-programmed 'USB'-stick. This chapter describes how to prepare the stick. You will need the following:

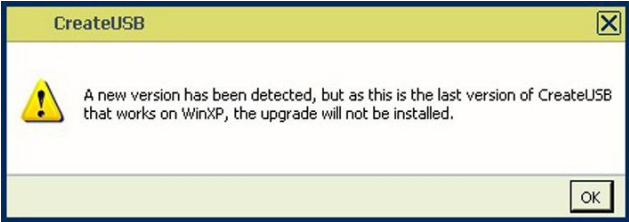
- A 4GB 'USB' stick (available via the normal service channel)
- An image of the PRISMAsync software (available via ftp-site or your service channel)
- A 'USB' creation tool called Create 'USB' (available via ftp-site or your service channel or in the PRISMAsync iso-file).
- A PC or laptop


Follow the steps below, depending on the Operating System your laptop is running on.

Windows XP

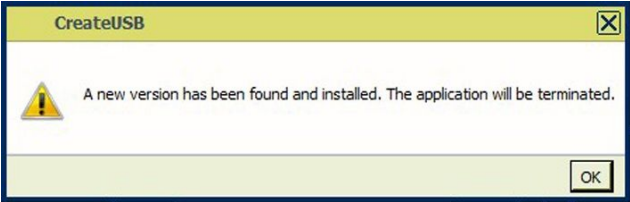
Step	Action
1	Start the CreateUSB Tool From your Start Menu select the Create USB Tool. Do not select an iso-image yet.
2	Check the version of the tool On the bottom of the window check the version of the tool. The latest version is 2.8.0.0. If your version is lower the tool has to be upgraded. Otherwise no upgrade is necessary and you can continue at step 7.
3	Uninstall the old version of the CreateUSB Tool. From the start menu select Océ_>CreateUSB->UnInstall
4	Obtain the latest USBCreate Tool a. Mount the PRISMAsync image with a mounting tool or b. burn the image on a DVD or c. Obtain it via your regular Service Channel (downloadable)
5	Copy or extract the CREATEUSB folder from the mounted drive or DVD to your laptop
6	Execute the Setup Run (double-click) the CREATEUSBSETUP_WINXP.EXE. Check that the version is 2.8.0.0.
7	Insert the 'USB' stick into the 'USB' port on your PC

Step	Action
8	<p>Start the CreateUSB tool</p> <p>The following screen will pop-up (Depending on the version of the USB Create Tool that is installed).</p>  <p>Fig. Create USB Tool V2.8.o.o The USB is detected automatically. If not, please select the correct port.</p>

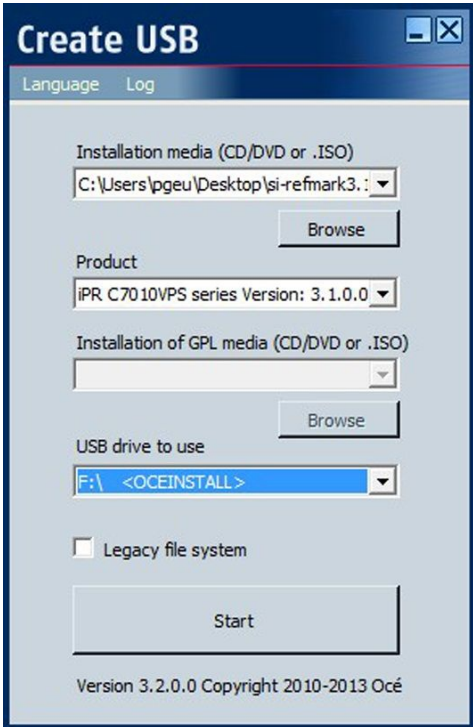
Step	Action
9	<p>Make the settings as described in the image above.</p> <p>Installation media: Browse to the directory where the iso-image is located.</p> <p>Installation of GPL media: If the software contains a GPL part (Open source software) delivered as a separate image, select this image here. If there is no GPL part this box is greyed out.</p> <p>'USB' drive to use: Select the 'USB' drive that the software has to be written to.</p> <p>Product: Select the correct product.</p> <p>Legacy file system: On some PC's it is impossible to create a USB stick because the anti-virus program on this PC intervenes with the tool. In these cases check the "Legacy file system". This creates a FAT-partition instead of NTFS.</p> <p>After you selected the iso-file a window might pop-up.</p>  <p>Fig. Last version of CreateUSB Tool</p> <p>The tool has detected that a newer version is in the iso-image but this is a version that runs on WIN7 systems. The version 2.8.o.o is the last version for Windows XP and it will no longer update itself.</p>
10	<p>Press OK</p> <p>The programming will start and the iso-image is programmed to the stick. Please wait until the CreateUSB tool indicates that the USB-stick is ejected and the process is ready.</p>

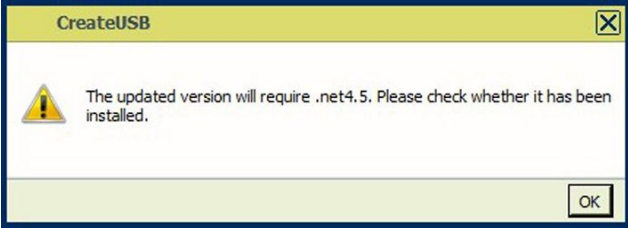
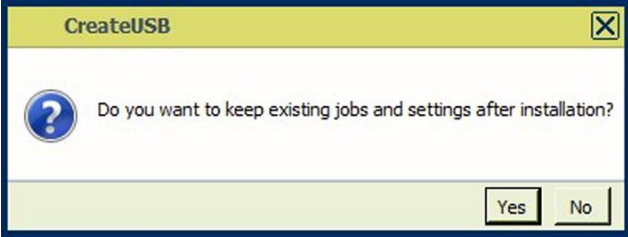
Step	Action
11	<p>Remove the USB-stick from your PC</p> <p>The USB-stick is ready for use. The name of the stick is OCEIN-STALL.</p> <p>.</p> <p>NOTE:</p> <p>If you accidentally did an automatic update of the CreateUSB tool, please uninstall it since it will not work on your Windows XP system. The following screen will be displayed:</p>  <p>Fig. Create USB not valid.</p>

Windows Vista and later

Step	Action
1	<p>Check that .NET 4.5 is installed</p> <p>Check that .NET 4.5 is installed on your laptop. If this is not the case the tool will not work. Install the .NET 4.5 framework.</p>
2	<p>Insert USB key and start CreateUSB Tool Fill in the fields in the tool. Once the iso-file is filled in the tool will start to check if a newer version is available in the image-file. . If so it will install this version overwriting the old one. The following dialog will pop-up.</p>  <p>Fig. New Create USB Tool installed</p>

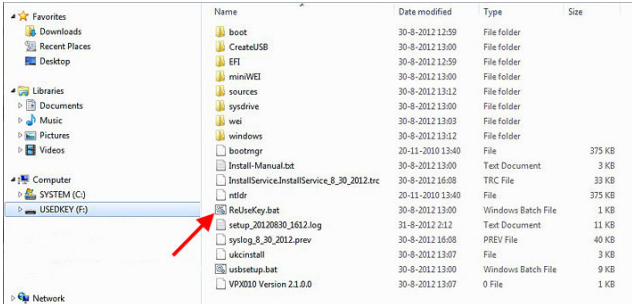
Step	Action
3	

Step	Action
	<p>Restart the Create USB Tool Restart the tool and make the settings as described below.</p>  <p>Fig. Create USB Tool V3.2.o.o.</p> <p>Installation media: Browse to the directory where the iso-image is located.</p> <p>Installation of GPL media: If the software contains a GPL part (Open source software) delivered as a separate image, select this image here. If there is no GPL part this box is greyed out.</p> <p>USB drive to use: Select the USB drive that the software has to be written to. Product: Select the correct product.</p> <p>Legacy file system: On some PC's it is impossible to create a USB stick because the anti-virus program on this PC intervenes with the tool. In these cases check the "Legacy file system". This creates a FAT-partition instead of NTFS.</p> <p>A new window will pop-up.</p>

Step	Action
	 <p>Fig. .NET 4.5 needed</p> <p>Check that you have the .NET 4.5 framework installed, and press OK if it is installed. Otherwise Exit the CreateUSB tool and install the .NET 4.5 version. If you don't do this the tool will not work.</p>
4	<p>Press OK to start the programming process After pressing OK the following window will pop-up.</p>  <p>Fig. Save Jobs and Settings</p> <p>This functionality is introduced with V3.1. If you select “Yes” all the settings and jobs will be restored automatically after the installation is done. This will make the backup/Restore procedure after installation unnecessary.</p> <p>Note: This will not work when you are upgrading an V2.x system to an V3.x system. Once V3.x is installed it will work for re-installations and upgrades.</p> <p>After making the selection, the process will start and the iso-image is programmed to the stick. Please wait until the CreateUSB tool indicates that the USB-stick is ejected and the process is ready</p>
5	<p>Remove the USB-stick from your PC The USB-stick is ready for use. The name of the stick is OCEINSTALL</p>

Making a USB-stick re-usable

It is possible to re-use the USB-stick after an installation. You can check if a USB-stick is ready or not. A USB stick that is ready for installation is called “OCEINSTALL”. When it is used, the name is “USED_KEY”. Please take the following steps to re-use the stick.

Step	Action																																																																												
1	Enter the USB-stick on a USB-port on your computer.																																																																												
2	Open the Explorer																																																																												
3	Check the name of the USB-stick																																																																												
4	<p>Make the USB-stick ready for re-use (if needed) If the name of the USB-stick is “USED_KEY”, open the contents of the stick in your explorer. In the list you will find a file called “ReUseKey.bat”. Double-click this file.</p>  <p>The screenshot shows a Windows Explorer window with the left sidebar displaying 'USEDKEY (F:)' selected. The main pane shows a list of files and folders with columns for Name, Date modified, Type, and Size. A red arrow points to the file 'ReUseKey.bat' in the list.</p> <table border="1"> <thead> <tr> <th>Name</th> <th>Date modified</th> <th>Type</th> <th>Size</th> </tr> </thead> <tbody> <tr><td>boot</td><td>30-8-2012 12:59</td><td>File folder</td><td></td></tr> <tr><td>CreateUSB</td><td>30-8-2012 13:00</td><td>File folder</td><td></td></tr> <tr><td>EFI</td><td>30-8-2012 12:59</td><td>File folder</td><td></td></tr> <tr><td>minint64</td><td>30-8-2012 13:00</td><td>File folder</td><td></td></tr> <tr><td>sources</td><td>30-8-2012 13:12</td><td>File folder</td><td></td></tr> <tr><td>sysdrive</td><td>30-8-2012 13:00</td><td>File folder</td><td></td></tr> <tr><td>wei</td><td>30-8-2012 13:03</td><td>File folder</td><td></td></tr> <tr><td>windows</td><td>30-8-2012 13:12</td><td>File folder</td><td></td></tr> <tr><td>bootmgr</td><td>20-11-2010 13:40</td><td>File</td><td>375 KB</td></tr> <tr><td>Install-Manual.txt</td><td>30-8-2012 13:00</td><td>Text Document</td><td>3 KB</td></tr> <tr><td>InstallService.InstallService_8_30_2012.trc</td><td>30-8-2012 16:08</td><td>TRC File</td><td>33 KB</td></tr> <tr><td>ntldr</td><td>20-11-2010 13:40</td><td>File</td><td>375 KB</td></tr> <tr><td>ReUseKey.bat</td><td>30-8-2012 13:00</td><td>Windows Batch File</td><td>1 KB</td></tr> <tr><td>setup_20120830_1612.log</td><td>31-8-2012 2:12</td><td>Text Document</td><td>11 KB</td></tr> <tr><td>syslog_8_30_2012.prev</td><td>30-8-2012 16:08</td><td>PREV File</td><td>40 KB</td></tr> <tr><td>ukcinatll</td><td>30-8-2012 13:07</td><td>File</td><td>3 KB</td></tr> <tr><td>usbsetup.bat</td><td>30-8-2012 13:00</td><td>Windows Batch File</td><td>9 KB</td></tr> <tr><td>VFD010 Version 2.1.0.0</td><td>30-8-2012 13:07</td><td>0 File</td><td>1 KB</td></tr> </tbody> </table>	Name	Date modified	Type	Size	boot	30-8-2012 12:59	File folder		CreateUSB	30-8-2012 13:00	File folder		EFI	30-8-2012 12:59	File folder		minint64	30-8-2012 13:00	File folder		sources	30-8-2012 13:12	File folder		sysdrive	30-8-2012 13:00	File folder		wei	30-8-2012 13:03	File folder		windows	30-8-2012 13:12	File folder		bootmgr	20-11-2010 13:40	File	375 KB	Install-Manual.txt	30-8-2012 13:00	Text Document	3 KB	InstallService.InstallService_8_30_2012.trc	30-8-2012 16:08	TRC File	33 KB	ntldr	20-11-2010 13:40	File	375 KB	ReUseKey.bat	30-8-2012 13:00	Windows Batch File	1 KB	setup_20120830_1612.log	31-8-2012 2:12	Text Document	11 KB	syslog_8_30_2012.prev	30-8-2012 16:08	PREV File	40 KB	ukcinatll	30-8-2012 13:07	File	3 KB	usbsetup.bat	30-8-2012 13:00	Windows Batch File	9 KB	VFD010 Version 2.1.0.0	30-8-2012 13:07	0 File	1 KB
Name	Date modified	Type	Size																																																																										
boot	30-8-2012 12:59	File folder																																																																											
CreateUSB	30-8-2012 13:00	File folder																																																																											
EFI	30-8-2012 12:59	File folder																																																																											
minint64	30-8-2012 13:00	File folder																																																																											
sources	30-8-2012 13:12	File folder																																																																											
sysdrive	30-8-2012 13:00	File folder																																																																											
wei	30-8-2012 13:03	File folder																																																																											
windows	30-8-2012 13:12	File folder																																																																											
bootmgr	20-11-2010 13:40	File	375 KB																																																																										
Install-Manual.txt	30-8-2012 13:00	Text Document	3 KB																																																																										
InstallService.InstallService_8_30_2012.trc	30-8-2012 16:08	TRC File	33 KB																																																																										
ntldr	20-11-2010 13:40	File	375 KB																																																																										
ReUseKey.bat	30-8-2012 13:00	Windows Batch File	1 KB																																																																										
setup_20120830_1612.log	31-8-2012 2:12	Text Document	11 KB																																																																										
syslog_8_30_2012.prev	30-8-2012 16:08	PREV File	40 KB																																																																										
ukcinatll	30-8-2012 13:07	File	3 KB																																																																										
usbsetup.bat	30-8-2012 13:00	Windows Batch File	9 KB																																																																										
VFD010 Version 2.1.0.0	30-8-2012 13:07	0 File	1 KB																																																																										
5	<p>Check the name of the USB-stick In your explorer please check the name of the stick. It should be “OCEINSTALL”. If the name did not change it might be needed that you remove the stick and insert it again.</p>																																																																												
6	<p>Your USB-stick is ready for use again. Be aware that if you made the setting to "keep existing jobs and settings" that the re-newed stick has the same functionality. If you did not select this option at initial creation then the re-newed stick will not have it neither.</p>																																																																												

Re-Installation of the system software

For installation of the PRISMAsync controller software you need a bootable USB-stick with the software installed on it. Preparation of this stick is described in *Preparation of the 'USB'-stick* on page 95.

■ **Note 1**

If the USB stick was programmed with the setting to save all settings and jobs it is in principle not necessary to create a backup and restore. For safety reasons we advise to make a backup. When the controller or the hard disks have to be exchanged you will lose all settings.

■ **Note 2**

Before upgrading always print the configuration page so you have the Network-settings to your disposal.

■ **Note 3**

Please check the release notes for pre-requisites for the new version. It is possible that the new version requires an update of the engine firmware too.

■ **Note 4**

It is possible to upgrade directly only in the following situations:

V2.1.0.0 -> V3.1.0.0

V2.2.0.0 -> V3.1.0.0

The installation process will take approximately 30 minutes to complete.

Take the following steps to re-install the software.



Note:

If the system software seems to be corrupt or the HDD drives have been replaced it is not possible to execute steps 1 and 2.

1. Print a configuration page

Print this page for checking purposes.

2. Make a backup of the settings and licenses (See Notes)

To make a backup do the following:

- Insert a USB stick into the left side of the Operator panel.

It is not allowed to use the USB-stick with the system software on it. It will become unusable.

In the 'System' section of the 'Maintenance' tab on the Operator panel, touch 'Go to service mode'. See also **Service mode** in '*Maintenance and Service Mode*' on page 38.

In the first screen touch the '**Backup**' button. The system will detect the USB stick and will ask to confirm the location and filename. After confirmation, the settings are copied to the USB stick. When ready, please remove the USB-stick.

3. Switch off the copier

When you upgrade from V1.x to V2.x it is necessary to switch off the copier. V2.x is not able to communicate with the copier firmware that belongs to a V1.x system.

Unpredictable results will arise when you try to connect a V2.x PRISMAsync controller to an older version of copier firmware.

4. Insert the USB-stick that contains the system software into a USB-port

Be sure to insert the USB-stick while the PRISMAsync is switched on. The Operating System has to recognize the stick and install the driver.

5. Switch off the system

On the Operator Panel touch the "Shutdown system" button in the Setup tab of the System section.

Another possibility is to press the "Moon" button and select "Shutdown".

6. Switch on the PRISMAsync

Press the "Moon-button" to switch on the PRISMAsync. The PRISMAsync will boot from the stick. This can take a few minutes because the system is checking the contents of the USB-stick. A text will be displayed telling you that it is checking the USB-stick. After some time the PRISMAsync will reboot again and the process will start. Status messages are displayed on the Operator panel. The PRISMAsync will reboot a few times during installation. Do not switch off the controller during the installation process. At the end of the process the PRISMAsync will switch off. The total process will take approx. 30 minutes. When the PRISMAsync is off, remove the USB-stick.

If the installation did not start, switch the PRISMAsync off and on again.

7. Switch on the PRISMAsync

Press the "Moon-button" to switch on the PRISMAsync. The new system software is installed. The controller will probably reboot again. In this step the firmware of the DDI board is upgraded in case there is a newer DDI firmware package available.

When the DDI software is installed the PRISMAsync controller will switch off. If it was not needed to upgrade the firmware the controller will stay on.

8. Install the copier firmware

Please check the Service Manual for PRISMAsync series for the steps to take.

9. Restart the PRISMAsync and the copier

When the installation of the copier firmware is ready you have to restart the PRISMAsync and the copier. On the Operator Panel touch the "Moon" button, and select "Shutdown".

Wait until the whole system is off. . First start the copier with the power switch the “Moon” button to start the PRISMAsync. After this the Plug&Play procedure will start in which the PRISMAsync will recognize the correct copier type. Finally the PRISMAsync will reboot again to complete the installation.

10. Restore the system settings and licenses

If you had decided, (during USB key creation) not to save the settings and the jobs you have to follow this procedure. Follow the procedure also if you installed a new controller or hard disks.

To restore the settings and licenses do the following:

- Insert the USB stick you used to backup the settings, into the left side of the Operator panel. In the System section of the Maintenance tab on the Operator panel, touch 'Go to service mode'. See also **Service mode** in '*Maintenance and Service Mode*' on [page 38](#). In the first screen touch the 'Restore' button. The system will detect the USB stick and will ask to confirm the location and filename. After confirmation, the settings are copied to the PRISMAsync. When all the settings are copied, the PRISMAsync will automatically reboot. When ready, please remove the USB-stick. If you were not able to make a backup of the settings before installation, please use the last backup file you have created.

11. If necessary install patches.

It is possible that there are patches belonging to the new installed system software. Install these patches now. See next chapter.

12. Make a new backup of settings



Note:

The USB-stick you used to install the software on the PRISMAsync can be used again. To do this, open the USB-stick in your explorer. You will find a file called “ReUseKey.bat”. Double-click the file to execute it. When ready, the USB-stick can be used to perform a new installation. The name of the USB-stick is called “OCEINSTALL”.



Note:

If you installed the software because the controller was exchanged you have to re-host the license because the original license that was stored in the back-up is not valid.

Installing patches

Sometimes a patch for the system software of the PRISMAsync will be released. This patch will resolve 1 or more problems, but does not require a complete re-installation of the software.

The patch is released in an EXE-format. Do not change the filename of the patch, because it will become unusable.

There are 4 methods to install a patch:

- The patch resides on a PC/laptop. The upgrade is done via the Settings Editor.
- The patch resides on a USB stick. This stick is entered into the PRISMAsync and the upgrade is done via the Operator Panel.
- The patch resides on a remote server. The patch is downloaded from the server and installed on the controller via the Settings Editor. (License Remote Service needed)
- The patch resides on a remote server. The patch is downloaded from the server and installed on the controller via the Operator Panel. (License Remote Service needed)

To install a patch from a PC via the Settings Editor take the following steps:

1. Be sure the patch is installed on your PC/laptop

2. Browse to the software upgrade section

In your web browser open the Settings Editor and browse to "Support -> Software". Select the "Upload upgrade package 1" option. Depending on the new software version, sometimes 3 packages must be uploaded. It is recommended to finish and remove your jobs before you perform the upgrade.

3. Select the location of the patch

In the next window browse to the location of the patch, and select "Upload".

4. Select "OK"

5. If needed repeat this for the other packages

6. Start the upgrade.

The packages are uploaded to the PRISMAsync but they are not installed yet. Select "Start upgrade" in the Settings Editor. In the next window select "Start".

7. Select "OK"

A window will pop-up saying, you have to restart the controller after upgrade. Press "OK" until the installation starts.

8. Restart the PRISMAsync and the copier

To install a patch with a USB stick via the Operator Panel take the following steps:

1. Copy the patch to a USB stick

2. Start the install patches procedure

On the Operator Panel in the System section of the Setup tab choose 'Local key operator settings'. In the next window choose 'About -> Upgrade software (from USB)'. The system will ask you for the location of the USB-stick and the filename.

3. Select the patch-file.

In the next window browse to the location where the EXE-file with the patch resides. Select the file and select "Upgrade" on the Operator Panel.

4. Wait until the installation finishes.

When the installation has finished the message 'Installation successful' is shown.

5. Restart the PRISMAsync and the copier.

To install a patch from a Remote Server via the Settings Editor take the following steps:

1. In the Settings Editor browse to the software upgrade section

In your web browser open the Settings Editor and browse to "Support -> Software". Select the "Upgrade the software by downloading from server" option. The System Administrator or Service password is needed for this functionality.

2. Press the Upgrade button

In the next window press the "Upgrade the software (download from server)" button.

3. Select "OK"

A window pops-up saying that you need to restart the system for changes to take effect. Select "OK". The system will check if a new software version is available.

4. Select "OK"**5. Restart the PRISMAsync and the copier.**

To install a patch from a Remote Server via the Operator Panel take the following steps:

1. Start the install patches procedure

On the Operator Panel in the System section of the Setup tab choose 'Local key operator settings'. In the next window choose 'About -> Upgrade software (from Server)'. Press "Upgrade". The System Administrator or Service password is needed for this functionality.

2. Select the patch-file.

The system will check the remote server for patches. When found it will start upgrading.

3. Restart the PRISMAsync and the copier.

When the installation has finished you will be asked to restart the system.

Installing a license

For a lot of the functionality to work, the PRISMAsync will need licenses. These licenses are generated by the configuration centre, and delivered in a license-file. This license file has to be uploaded to the PRISMAsync.

To install the licenses there are 2 possibilities:

1. On the Operator panel

- Copy the license file to a 'USB'-stick
- Insert the 'USB'-stick into a 'USB' port on the PRISMAsync. You can use any port, but for convenience it is best to use the port on the operator panel.
- In the '**System**' section of the '**Setup**' tab choose '**Local key operator settings**' .
- In the next window choose '**Software licenses -> upload license**'. The 'System' will ask you for the location of the 'USB'-stick and the filename.
- Choose the correct file and touch '**Start**' .
- When the file is uploaded, restart the PRISMAsync.
- Make a backup of the settings

2. In the Settings Editor

- Locate the license file on your PC
- On your PC open the Settings Editor (See *'The Settings Editor' on page 62*).
- Browse to 'Support' -> '**Software**' .
- Click '**Upload license file**' (You will need the Key Operator or 'System' Administrator password).
- Browse to the License file on your PC.
- Start the upload of the license file.
- When the file is uploaded, restart the PRISMAsync and the copier.
- Make a backup of the settings

Installing the printer driver

After a release of new PRISMAsync software, most of the time a new printer driver is released. This driver can be obtained in 2 ways:

1. Via the support section on the Océ website.

Download the driver from the website and install it according to the standard installation instruction of printer drivers of your Operating System

2. Download it via the Settings Editor.

It is possible to obtain the printer driver via the **Settings Editor**. Open a web browser and browse to your system. Go to the tab '**Support**' > '**Software**'. Here you will find an item to download the printer driver. You will need the Key operator PIN or System Administrator password for this. After entering the PIN, a window will pop up, asking you to select the appropriate driver. Click on the needed item. The driver will be downloaded to your system. Now you can install it according to the standard installation instruction of printer drivers of your Operating System.

Configure the machine for the USA

After installing the controller software the system is ready for use in ROW (Rest of the World). To make the installation ready for use in the US the following additional steps need to be performed:

1. In the Settings editor

- 'Preferences'-'>'System settings'-'>'Regional settings'-'>Region->USA
- 'Preferences'-'>'System settings'-'>'System of measurement'-'>'Imperial'
- 'Preferences'> 'Print job defaults'> 'Separator sheet' > Letter 28 lb
- 'Preferences'> 'Print job defaults'> Front Cover > Letter 28 lb
- 'Preferences'> 'Print job defaults'> Back Cover > Letter 28 lb
- 'Preferences'> 'Print job defaults'> 'Banner' > Letter 28 lb
- 'Preferences'> 'Print job defaults'> 'Calibration media' > Tabloid 28 lb
- 'Preferences'> PostScript> Media > Letter 28 lb
- 'Preferences'>PDF>Media>Letter 28 lb
- Colour> Colour defaults> Device CMYK input profile> US Web Coated SWOP
- Colour> Colour presets> Photographic content> Device CMYK input profile> US Web Coated SWOP

2. On the Operator panel

- Change the language on the Operator panel to English-US

3. On the application PC

- Change in the Control panel the regional setting to English-US

4. In the UPD Printer driver

- Printing 'Preferences'-'>paper letter-28

5. Entering 'media:' weights

When using “Imperial” as measurement system, then all media weights have to be entered according to the following table.

	Bond Ledger	Offset Text	Cover	Tag	Index	Points	*Caliper (inches)	millimeters	Metric (grams/sq meter)
Equivalent Weight	18	40	22	37	33	3.2	.0032	0.081	60.2 gsm
	18	45	24	41	37	3.6	.0036	0.092	67.72 gsm
	20	50	28	46	42	3.8	.0038	0.097	75.2 gsm
	24	60	33	56	50	4.8	.0048	0.12	90.3 gsm
	28	70	39	64	58	5.8	.0058	0.147	105.35 gsm
	29	73	40	62	60	6	.0060	0.152	109.11 gsm
	31	81	45	73	66	6.1	.0061	0.155	116.63 gsm
	35	90	48	80	74	6.2	.0062	0.157	131.66 gsm
	36	90	50	82	75	6.8	.0068	0.173	135.45 gsm
	39	100	54	90	81	7.2	.0072	0.183	146.73 gsm
	40	100	56	93	83	7.3	.0073	0.185	150.5 gsm
	42	110	60	100	90	7.4	.0074	0.188	161.78 gsm
	44	110	61	102	92	7.6	.0076	0.193	165.55 gsm
	47	120	65	108	97	8	.0078	0.198	176.83 gsm
	53	135	74	122	110	9	.0085	0.216	199.41 gsm
	54	137	75	125	113	9	.009	0.229	203.17 gsm
	58	146	80	134	120	9.5	.0092	0.234	218.22 gsm
65	165	90	150	135	10	.0095	0.241	244.56 gsm	
67	170	93	156	140	10.5	.010	0.25	252.08 gsm	
72	183	100	166	150	11	.011	0.289	270.9 gsm	
76	192	105	175	158	13	.013	0.33	285.95 gsm	
82	208	114	189	170	14	.014	0.356	308.52 gsm	
87	220	120	200	180	15	.015	0.38	312 gsm	
				552					999 gsm

Fig: Tabel media weights

Media weights up to 161.78 grams/square meter must be entered in Bond and media with a higher media weight must be entered as index.

Handling of 11504 MRE

The 11504 error indicates a software error in the PRISMAsync from which it can not restore. On the display a yellow triangle is displayed asking you to press the panel to restart the PRISMAsync.

In most of the cases, rebooting the system will solve the problem, however it might happen that the 11504 is persistent and occurs again after reboot. In this case the following actions can be taken:

- For analysis by R&D you can insert a 'USB'-key in the PRISMAsync and press the tray button on the right side of the panel when the error is active (Yellow triangle on the screen)
- During rebooting
- During rebooting the stop-button and the tray-button on the right side of the operator panel will start flashing simultaneously. When this happens press both buttons for a few seconds. All the jobs in the queue will be removed, so if a job in the scheduled queue causes the 11504 it is removed and the system will reboot correct.
- After a **Third** consecutive occurrence of the error caused by the fact that the PRISMAsync does not startup correctly, the Hansiplast procedure will start

NOTE:

- If the 11504 or 11561 error occurs at the first start after an installation or a software upgrade check the version of printer firmware and PRISMAsync software. Probably there is a mismatch between the versions.

Hansiplast procedure

Hansiplast is the name of a procedure that is started after 3 consecutive 11504 crashes of the PRISMAsync because it is not possible to start up completely (e.g. the software has become corrupt).

An image of the software is present on the PRISMAsync and during the Hansiplast procedure this image is restored. This restore is equivalent to a new installation of the software, hence all jobs will be lost.

The display will show that Windows is installing. The total procedure will take approximately 1 hour to complete.

Notes:

1. Do not switch off the PRISMAsync during this procedure because then you have to manually re-install the software.
2. After completion the settings will be restored just like when you do a manual restore after a backup.

Chapter 9

Troubleshooting

Troubleshooting

The PRISMAsync is part of a copier/printer system. Problems with respect to the PRISMAsync are always in one of these 3 areas:

- Inside the PRISMAsync,
- In the interface between the PRISMAsync and the copier,
- In the interface between the PRISMAsync and the networked computers.

This chapter does not try to describe the possible problems that exist in the networked computers or the network itself.

The following paragraphs describe the checks you can perform to locate and fix obvious problems. Always check internal and external connections first before replacing any components. A lot of the problems are caused by bad connections.

Notes:

1. If an error code is displayed on the operator panel, please check the list with error codes in '*Error messages and conditions*' on page 122'.
2. Check that the network of the customer is functioning. If this is not the case direct these problems to the appropriate service department or the network administrator.
3. Check that the problems are not caused by trying to print a specific job. If other jobs are printed correct, then focus on the problematic job.

Checking external connections

Before opening the PRISMAsync first check the external connections. Check the following:

1. Power cable is connected to the PRISMAsync and the wall outlet.
2. Power is present on the wall outlet.
3. Network cable is connected and status LED is blinking.
4. Crossover Ethernet cable (lower network port) is connected to the copier.
5. Crossover Ethernet cable and normal Ethernet cable (upper network port) are not exchanged.
6. Both data cables are connected correctly to PRISMAsync and copier.
7. USB cable to operator panel is connected.
8. DVI cable to operator panel is properly connected (Left DVI port).
9. 15-pin D-sub cable to operator panel is connected.
10. 9-pin D-sub cable to Operator attention light is connected
11. Cables in the backside of the Operator panel are connected (Remove the cover on the backside of the operator panel).

Checking internal components

When checking the internal components the PRISMAsync has to be opened. Please check '[Accessing internal components](#)' on page 73',
Please follow standard ESD precautions when handling components.

Make the following checks.

1. No strange objects are inside the PRISMAsync.
2. Look for obvious loose boards. Reseat each board including DDR₃ modules.
3. Look for obvious loose connectors. Reseat each connector firmly.
4. Be sure that HDD's are connected to the right SATA port. See '[Replacing Hard Disk Drives](#)' on page 82

Comprehensive system inspection

If none of the previous checks did help you might have to do a component by component inspection. A comprehensive inspection allows you to verify that each hardware component is properly installed and configured, and helps you avoid replacing expensive components unnecessarily.

Component	Actions
External connectors	<ul style="list-style-type: none"> ■ See ‘<i>Checking external connections</i>’ on page 115’ ■ Cables, cable connectors, and mating connectors appear undamaged.
Internal components	<ul style="list-style-type: none"> ■ All replaceable parts are: <ul style="list-style-type: none"> – Present – Properly aligned – Installed securely – Installed on the appropriate site – The correct part for the system – Appear undamaged ■ Chassis and contents have not been tampered with. ■ Chassis does not contain any foreign objects.
Motherboard	<ul style="list-style-type: none"> ■ Motherboard, including components and traces, appear undamaged, and no foreign objects are evident ■ CPU is present, well-seated, and appears undamaged. ■ CPU cooling assembly is well-aligned and firmly attached. ■ Each fan (including fan cable) is well-positioned (not upside down), installed in the correct connector (CPU_FAN₁), and appears undamaged. ■ Boards required on the motherboard are present, well-seated, and in the correct slots. ■ Battery is installed.
DDR3 modules	<ul style="list-style-type: none"> ■ Each DIMM is well-seated. ■ Each DIMM is of the same brand and type. ■ Each DIMM is seated in the correct port. Pairs DIMM₁/DIMM₃ and DIMM₂/DIMM₄

Component	Actions
PCI boards	<ul style="list-style-type: none"> ■ Each board required is: <ul style="list-style-type: none"> - Present - Installed in the correct slot - Well-seated - Appears undamaged ■ Required cables (if applicable) are <ul style="list-style-type: none"> - Present - Firmly connected in the correct connectors - Appear undamaged
Power supply	<ul style="list-style-type: none"> ■ The power supply required is: <ul style="list-style-type: none"> - Present - Correctly installed - Appears undamaged ■ Cable connectors are: <ul style="list-style-type: none"> - Firmly connected - Appear undamaged - Installed in the correct devices
HDD's	<ul style="list-style-type: none"> ■ The HDDs required are: <ul style="list-style-type: none"> - Present - Correctly installed - Appear undamaged ■ HDD data cables are: <ul style="list-style-type: none"> - Present - Firmly connected in correct motherboard connectors: <ul style="list-style-type: none"> - HDD 0 (upper drive in bracket) to J18 - HDD 1 (middle drive in bracket) to J24 - HDD 2 (lower drive in bracket) to J16 - Appear undamaged
System fan	<ul style="list-style-type: none"> ■ The system fan is: <ul style="list-style-type: none"> - Present - Correctly installed - Appears undamaged ■ System fan cables are: <ul style="list-style-type: none"> - Present - Firmly connected in correct motherboard connector (SYS_FAN1) - Appears undamaged

Diagnose LED's

There are some LED's present on the outside and the inside of the PRISMAsync. These LED's might lead you to the cause of a problem. Always check these LED's first to get some first impression.

Network Status LED's

Next to each Ethernet connector there are 2 LED's indicating the network speed.

When data is transferred, the appropriate LED will blink to indicate network activity.

■ **No LED activity on upper Ethernet connector.**

There is no connection to the customer network. First checks to perform:

- Check if cables are connected correctly in PRISMAsync and wall outlet.
- Check if cable is not defect.
- Check if normal and crossover Ethernet cables are not exchanged.
- Check if the network is functioning.

■ **No LED activity on lower Ethernet connector.**

There is no connection between the copier and the PRISMAsync. First checks to perform:

- Check if cables are connected correctly in PRISMAsync and wall outlet
- Check if cable is not defect
- Check if normal and crossover Ethernet cables are not exchanged.

LED in power button

In the power on/off button on the front side of the PRISMAsync a LED is integrated. If the PRISMAsync is switched on this LED is shining blue.

If the LED stays off check the following:

- Does the PRISMAsync switch on? If so there is probably an open connection in the LED wiring.
- If the PRISMAsync cannot be switched on or off then there is either a problem with the wiring of the button or with the power supply.

LED's on AUX control board

On the AUX control board you can find some LED's. These LED's indicate the presence of power on the board. All LED's should be shining green. If one of the LED's is off, the board will not function.

Please first check the connectors and the cables before replacing the board.

The function of the LED's are

1. 3.3 Volt

2. 5 Volt
3. 12 Volt
4. 24 Volt

Note:

- The board is mounted upside down in the PRISMAsync, so it might be difficult to check the boards.

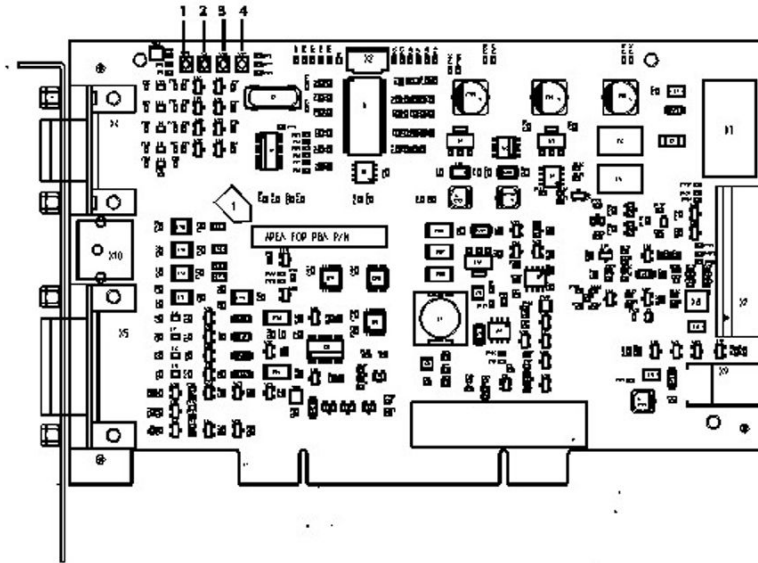


Fig. AUX control board

LED's on DDI board

On the DDI board you can find some LED's. Some of these LED's can be used to determine if the board or the cable is defect.

The following LED's are present:

1. 10 yellow LED's to signal the activity of the two SCSI interfaces. The LED's can be on or off.
2. Red LED that shines as long as the FPGA is not booted successfully. If it stays red then the board is defect and must be replaced.
3. Green LED that lights when the PLL clock generator is locked. If this LED is off the board or one of the cables might be defect or not well connected.
4. 8 LED's provided for debug and testing reasons (R&D functionality).

Note:

- The board is mounted upside down in the PRISMAsync, so it might be difficult to check the boards.

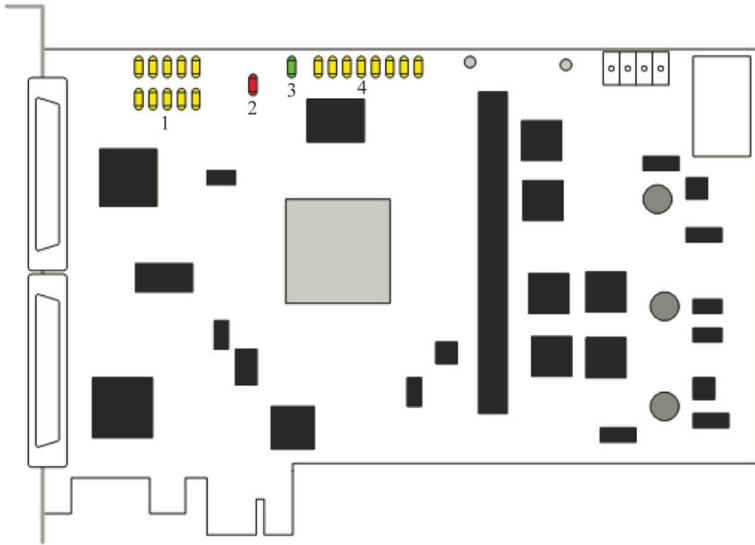


Fig: DDI Board

Error messages and conditions

The next table gives an overview of possible error situations of the PRISMAsync.

Effect	Check	Action
Blank screen	- Check 'USB' Cable	Disconnect/connect 'USB' cable on backside of PRISMAsync.
PRISMAsync cannot be switched on PRISMAsync cannot be switched off.	- Check Power supply - Check power button - Check connection with Operator panel	Replace power supply or Power button. Replace PBA-AUX. If that does not solve the problem replace the motherboard.
Excessive noise	- Check fans	Replace fan
Garbled prints or blank pages	- Check data cables	Replace data cable
Strange colours on operator panel or blank screen or stripes on screen or skewed image on screen or rolling screen	- Check DVI cable	Connect or replace DVI cable
“no signal” on operator panel	- Check DVI cable - Check GPU board	Replace cable or GPU board
Spectrometer not recognized	- Check meter	Try another 'USB' port. Probably 'USB' port on oper. panel defect.
Impossible to install via 'USB' port on operator panel	- Check 'USB' key	Try another 'USB' port. Probably 'USB' port on oper. panel defect.
Led on operator panel always off.	- Check cable - Check AUX cntrl board	Replace cable or AUX cntrl board
Operator panel dark and Attention light off.	- Check 12V on AUX board - Check power cable to AUX board - Check fuse on AUX board.	Connect power cable. Replace AUX board

Effect	Check	Action
“Press sleep button” during start up or Pressing Sleep-button has no effect.	- Check 3V3 connection on AUX board	Connect power cable. Replace AUX board
One of Attention lights always on		Replace AUX board
One or more of the attention lights always off.	- Check fuse on AUX board	Replace AUX board
Message “No OS found”	- Check cables to HDD	Replace HDD's
FPGA Led on DDI stays red	- Check cable to DDI board	Replace cable Replace DDI board
PLL lock led is off.	- Check cable to DDI board	Replace cable
1 of 4 diagnose Led's on AUX board is off.	- Check power supply to AUX	If no power on connector check the cable or power supply. Replace AUX board

In some cases the PRISMAsync controller will give an error code which is displayed on the operator panel screen. These MRE's (Machine Recoverable Errors) can only be recovered by rebooting the system. This is done by touching the Operator panel screen. If the problems persist please check the table below for a description of the error and the checks to make.

Error code	Problem	Action
11115	Incorrect installation Inconsistent configuration	Create new 'USB' key with system software. Re-install the software
11501	Message “No OS found”	Replace HDD's and re-install system software
11502	Message “HDD2 failure”	Replace HDD's
11504	Software failure	Reboot the system. Check in error history (Service Mode) the description. Contact your Service representative.

Error code	Problem	Action
11506	Lost logical command connection with engine	Check your Ethernet cross-over cable. Reboot the system.
11520	No Logical Command Connection with Print Engine	Check your Ethernet cross-over cable. Reboot the system.
11526	Lost Physical Command Connection with Print Engine	Check your Ethernet cross-over cable. Reboot the system.
11529	No Physical Connection with On/Off Controller	Check connection between operator panel and PRISMAsync.
11530	Lost Physical Connection with On/Off Controller	Check connection between operator panel and PRISMAsync
11531	SRA error	Reboot the PRISMAsync. Problem with IPDS.
11535	Software failure	Software failure in copier firmware. Reboot the system. Re-install the firmware. If problem persists contact your service representative.
11558	No VGA connection with UI Panel	Check connection between operator panel and PRISMAsync. Check GPU PCB.
11559	No-Lost Physical Connection With UI Panel	Check connection between operator panel and PRISMAsync.
11560	No-Lost Logical Connection with UI Panel	Check connection between operator panel and PRISMAsync.
11561	System error at the printer module. Invalid configuration.	Check the version of the printer firmware. Upgrade to the latest level.

Error code	Problem	Action
11563	No Logical Connection with On/Off Controller	Reboot the system. Check connection between Operator panel and PRISMAsync
11564	Lost Logical Connection with On/Off Controller	Reboot the system. Check connection between Operator panel and PRISMAsync
11570	Upgrading the touch screen failed	Reboot the system. Check connection between Operator panel and PRISMAsync
11571	Printer Interface board hardware failure	Check the DDI board in the PRISMAsync and the interface board in the copier.
11572	Scanner Interface board hardware failure	Check the interface board of the scanner.
11573	Printer Interface board software failure	Re-install the software of the PRISMAsync
11574	Scanner Interface board software failure	
11575	Engine boot failure	Check LED's and hardware of engine. This is not a PRISMAsync failure
2259990	Machine recoverable error in copier	Check the description that comes with this code. It describes where in the copier, the error occurred.
2259992	Machine recoverable error in scanner	Check the description that comes with this code. It describes where in the scanner, the error occurred.

Error code	Problem	Action
2279991	Operator recoverable error in copier	A normal error in the copier, like a paper jam. It also comes with a description to determine where the error occurred.
2279993	Operator recoverable error in scanner	A normal error in the scanner, like a paper jam. It also comes with a description to determine where the error occurred.

Beep codes PRISMAsync

In case the PRISMAsync will not start up or unknown errors (11504) keep coming up, it is possible that the PRISMAsync itself does some internal hardware checks. The result of this hardware check is given by a specific number of beeps during booting of the system. If you are not able to determine the error please reboot the system and check if beep-codes are given during startup.

Boot Block Beep Codes	
Number of Beeps	Description
1	Insert diskette in floppy drive A:
2	'AMIBOOT.ROM' file not found in root directory of diskette in A:
3	Base Memory Error
4	Flash Programming successful
5	Floppy read error
6	Keyboard controller BAT command failed
7	No Flash EPROM detected
8	Floppy controller failure
9	Boot Block BIOS checksum error
10	Flash Erase error
11	Flash Program error
12	'AMIBOOT.ROM' file size error
13	BIOS ROM image mismatch

Post BIOS Beep Codes	
Number of Beeps	Description
1	Memory refresh timer error
2	Parity error in base memory (first 64K block)

Post BIOS Beep Codes	
3	Base memory read/write test error
4	Motherboard timer not operational
5	Processor error
6	8042 Gate A20 test error (cannot switch to protected mode)
7	General exception error (processor exception interrupt error)
8	Display memory error (system video adapter)
9	AMIBIOS ROM checksum error
10	CMOS shutdown register read/write error
11	Cache memory test failed.

Troubleshooting Post BIOS Beep Codes	
Number of Beeps	Description
1,2 or 3	Reseat the memory, or replace with known good module
4-7, 9-11	<p>Fatal error indicating a serious problem with the system. Consult your service representative. Before declaring the motherboard beyond all hope, eliminate the possibility of interference by a malfunctioning add-in card. Remove all expansion cards except the video adapter.</p> <ul style="list-style-type: none"> ■ If beep codes are generated when all other expansion cards are absent, consult your service representative. ■ If beep codes are not generated when all other expansion cards are absent, one of the add-in cards is causing the malfunction. Insert the cards back into the system one at a time until the problem happens again. This will reveal the malfunctioning card.
8	If the system video adapter is an add-in card, replace or reseat the video adapter. If the video adapter is an integrated part of the system board, the board may be faulty.

Chapter 10

Appendix A: Specifications

Hardware features

- Intel Core i7 860 @ 2.8GHz – 8MB cache CPU
- 4 x 4GB DDR3 @ 1333MHz SDRAM non-ECC (Dual channel mode)
- 1 x 250GB 3.5" SATA II HDD @ 7200rpm (System disk)
- 2 x 250GB 3.5" SATA II HDD @ 7200rpm (2 x Data disk Raid0)
- ATX power supply, 600W, 80+ Bronze
- Dimensions (HxWxD): 42 cm (16.5 in.) x 20 cm (7.9 in.) x 43 cm (16.9 in.)
- Weight: 16 Kg.
- Power consumption: 100-240V, 10-5A, 50-60Hz

Important note:

All Hard Disk Drives and memory modules integrated in one system must all have:

- **the same brand, model for the Hard Disk Drives**
- **the same brand, model, organization and layout for the memory modules**

Connectivity

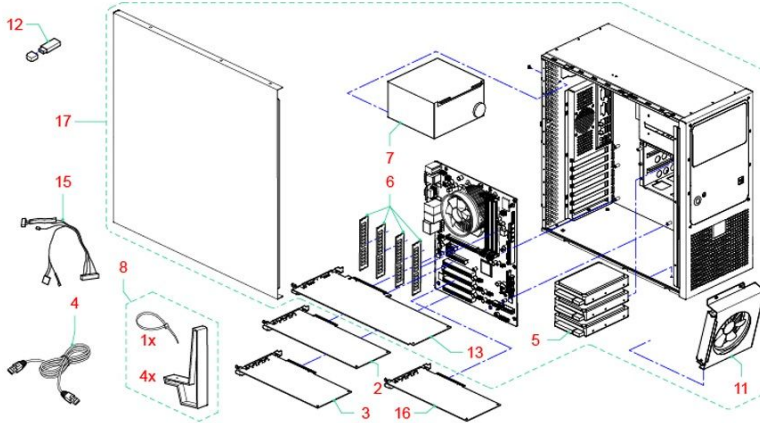
- 10/100/1000 Base T
- TCP/IP
 - lpr/lpd
 - 9100 socket
 - SMB
- IP-version: IPv4
IP-version: IPv6
- static/auto IP (BOOTP, DHCP)
- SNMP v1-v3 support
 - Host resources MIB
 - System group MIB
 - Printer MIB
 - Job MIB
 - Job Monitor MIB
- Embedded WebServer
 - WEB Settings Editor
 - Operator Maintenance Application

Chapter 11

Appendix B: Parts overview

Overview of the service parts

Illustration



Component - function table

No	Part
1	Not used
2	PBA DDI IF BOARD
3	PBAP AUX_CONTROL
4	DATA CABLE RJ45-RJ45 CRSVR SFTP 2.8M
5	HDD 3,5" SATA II 250GB 7200RPM (3X)
6	MEMORY MODULE 2GB DDR3 (2X) MEMORY MODULE 4GB DDR3 (4X) (Version 4 controller)
7	POWER SUPPLY 600W
8	PEDESTAL (4X) + TIEWRAP
9	Not used
10	Not used
11	SYSTEM FAN 120MM
12	USB KEY
13	PCI-E X16 GRAPHIC BOARD

No	Part
14	Not used
15	HARNESS 22W01
16	ETHERNET BOARD ROHS (IPDS)
17	INDUSTRIAL CONTROLLER iBase

For the part numbers please check the parts-catalog of the imagePRESS C7010VPS/C7011VPS series..

Chapter 12

Appendix C: Tips & Tricks

How to check if DDR memory is defect or missing

Description

- The controller responds in an uncontrolled way and is very slow in performance.
- A particular 11504 errors occur very frequently.
- Fails to install new software

Possible causes

Defect or missing memory DIMM.

Analysis

1. Check the configuration report. There you can find the amount of memory available in your system. This should be 4.0GB in the V1, V2 and V3 controller. The V4 controller has 16GB.

System memory	4.0 GB
Version of the PRISMAsync controller	14.9.1.18
Version of the PRISMAsync controller operating system	6.1.7601.0.Servi

Fig. Memory in Configuration report

Be sure that you create a new Configuration Report in the Settings Editor. The configuration Report that is visible on the screen might be older of age.

2. On the Operator Panel go to Service Mode. In the first screen select "Error Analysis". If you see multiple 11504 errors with the description described below, it is possible that a memory module is defect.

Description 11504: Can't allocate runlength block number xx (size 11366400)

3. If, during re-installation the screen below is shown, it is possible that a defect memory module causes this.

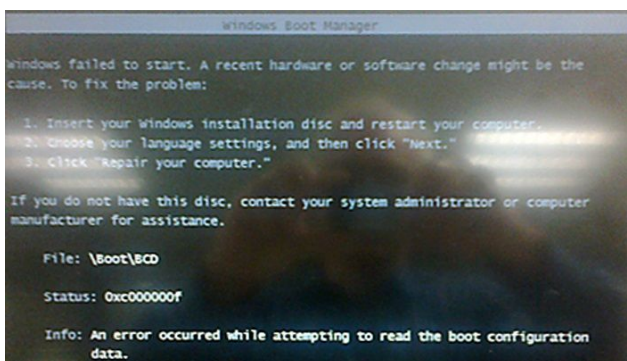


Fig. Unable to boot

4. Reboot the PRISMAsync. If during the boot sequence Beep codes are heard, count the number of beeps. Compare the number with the number given in the chapter *'Beep codes PRISMAsync'* on page 127. If the number of beeps is 1, 2 or 3 check the memory modules.

How to print transparencies with best quality

Description

Transparencies might cause image quality problems like darker areas etc. The copier and the PRISMAsync will make a difference between Text/Vector and Images. Different screens can be specified for these objects.

Solution

Some tips for improving Image Quality in these situations are:

1. Use the APPE engine for printing. This means
 - Use Hotfolder, Automated Workflow or PRISMAprepare.
 - Do not use the driver, since this creates Postscript.
2. Make sure a good calibrations was performed for both screenings (Normal and Fine) for all media families
3. Make the screening for text and images the same for 600 dpi printing (No screen jump will occur)
4. Make a new preset if you do not want to do this for all jobs

How to improve black density on the print

Description

On some media the density of black is too low.

Solution

There is a setting available to improve the Black density. It can be adjusted in the “Printer adjustment” section of the specified media.

1. In your browser open the Settings Editor and go to “Media”
2. Select the media and then select “Printer adjustment”.
3. In the “Advanced” section select “Gloss and Fine black adjustment”
4. Adjust the value to your need. You can change it between -2 and +2. These values are related to the Gloss-setting. However the Fine-Black setting will also change when you change the Gloss-Setting. The following relation exists:

Gloss	Fine Black
-2	2
-1	1
0	0
+1	0
+2	0

5. Please take care that this setting can only be used for Plain paper. (So not for coated, vellum etc.)

Strange colors after editing CMYK curves

Description

After editing the CMYK curves one might get strange effects with the colors. Colors that were the same before editing, now are different.

Solution

First thing you must know is that there is a big difference between editing the CMYK curves on a job-level and editing on system-level.

1. Job-Level

On the Operator Panel, select the job and open the properties (double-click). Select "Adjust Image". In the next window you can change the CMYK-curves. If you then print the job the result will be good, because the curve has been adjusted for this particular job and media.

2. System-Level

Changing the CMYK-curves on system level means that the curves will be changed for all the jobs to come. In the "Color Adjustment" section of the "System" tab you will find the "Edit CMYK curves manually". After selecting this, you are able to adjust the curves per media family. Very important however is that you do the changes for all halftones/screens. If you forget this, it is very well possible that you get differences in colors between text and images. This is caused by the fact that text is often printed with another halftone than images.

To overcome these differences you have to either edit the curve for all halftones or force the system to print text and images with the same halftone.

Omapp does not work

Description

When starting the Operator maintenance Application the user gets a network error and is unable to access the application.

Solution

1. The problem is caused by the fact that the PRISMAsync was turned on before the engine is turned on. To solve the problem, shut down the whole system and switch off the optionals. Then turn on the optionals, turn on the copier and finally turn on the PRISMAsync.

Chapter 13

Appendix D: System overview

System overview

Illustration

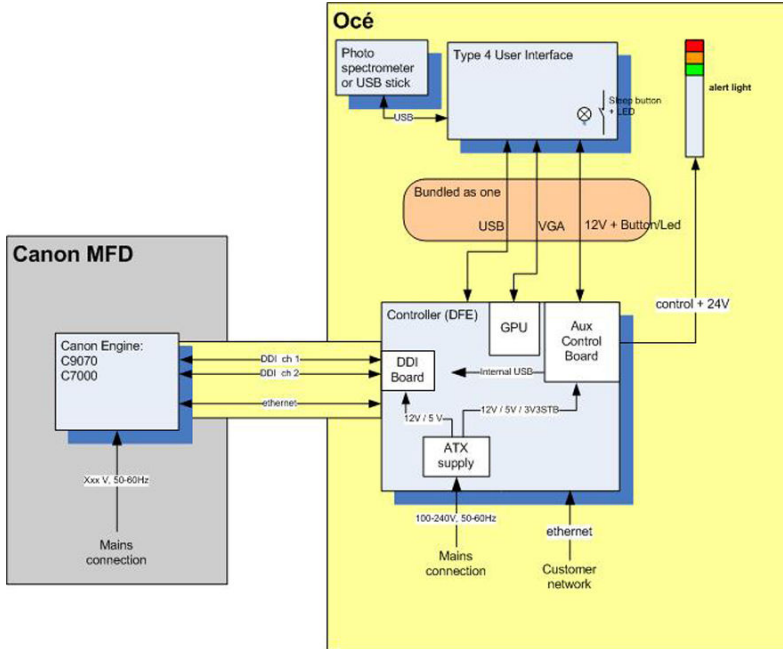


Fig. System overview

Chapter 14

Appendix E: How to make a datadump file

How to make a datadump file

Question

How to make a datadump file

Answer

A datadump contains all kinds of system information about counters, versions and errors. This information is very useful for analysis of the system behaviour. This datadump is generated from the Settings Editor. To do so take the following steps:

1. Open the Setting Editor by entering the name of your system in the address bar of your internet browser (e.g. Internet Explorer). In the example the system name is: ipc6010s-sns.

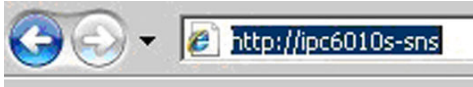


Fig. Enter DNS name

2. The following window is opened:

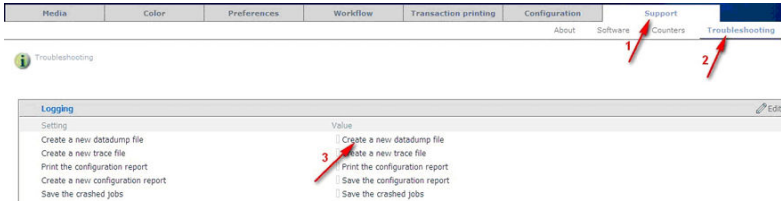


Fig. Select Datadump

Select the following steps:

- Select “Support”
- Select “Troubleshooting”
- Select “Create a new datadump file”

- To create the file you have to be logged in as “Key operator” or “System administrator”. Select the correct User and enter the password (13524 for 'Key operator' or 71617000 for 'System administrator'). Then click on “Login”.



Fig. Login as Key Operator

- In the next window select 'Create a new datadump file’. The name of the new file appears in the window. It is possible that a name was already present, but to be sure that you will get the most recent version it is recommended to execute this step.

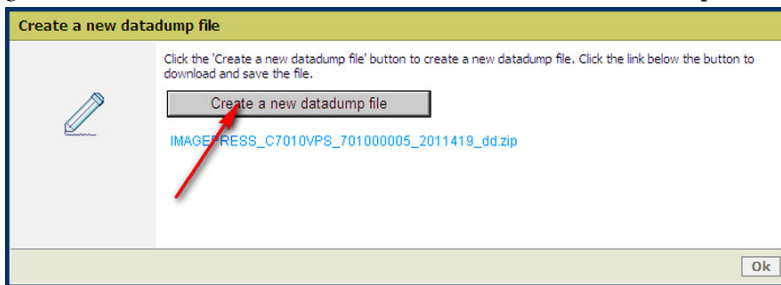


Fig. Create a Datadump

- The next step is to select the filename.

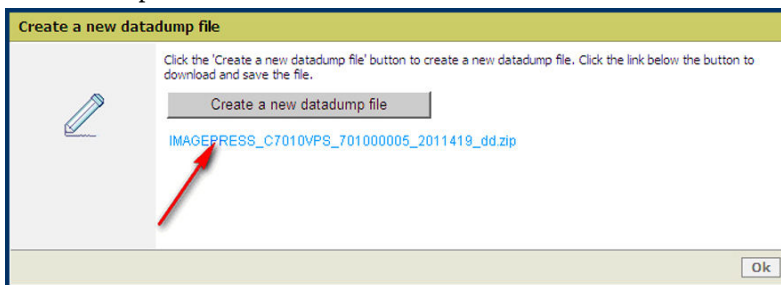


Fig. Select Datadump Filename

- In the next window choose “Save” and enter a filename and confirm your choice.

7. Finally close the window in the Settings Editor by clicking “OK”.

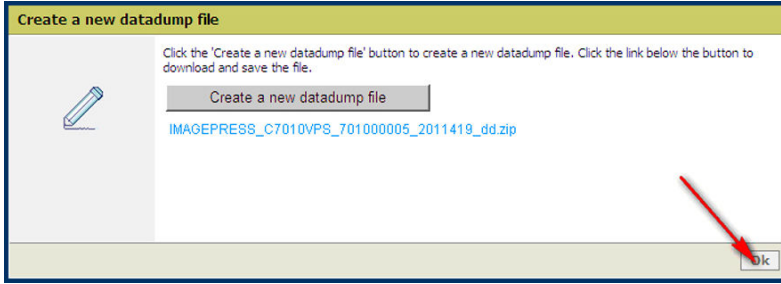


Fig. Select OK

Chapter 15

Appendix F: How to make a tracelog

How to make a tracelog

Question

How to make a datadump file

Answer

A tracelog gives very detailed system information about the data- and eventflow of the PRISMAsync software. This information is necessary for the analysis of the system behaviour and to determine the cause of the occurrence of errors.

The tracelog can be generated from the Settings Editor. The following steps are needed:

1. Open the Setting Editor by entering the name of your system in the address bar of your internet browser (e.g. Internet Explorer). In the example the system name is: **ipc6010s-sns**.



Fig. Enter DNS name

2. The following window is opened:

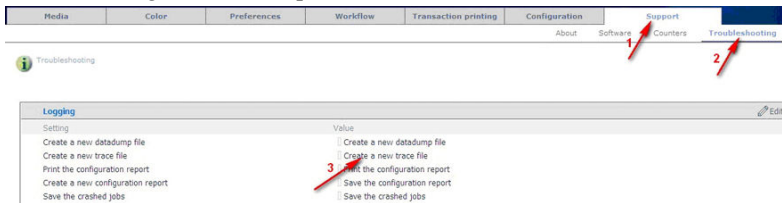


Fig. Select Tracelog

Select the following steps

- Select **“Support”**
- Select **“Troubleshooting”**
- Select **“Create a new trace file”**

- To create the file you have to be logged in as “**Key operator**” or “**System administrator**”. Select the correct User and enter the password. Then click on “**Login**”.



Fig. Login as Key Operator

- In the next dialog possibly a few filenames might be visible which were created in the past. To create a new file, please click on “**Create a new trace file**”. After a short while the new file is added at the top of the list. In the example you find tracelogs that are generated due to the occurrence of an error and normal logs. If an error does occur the errorcode will be present in the name of the tracelog (e.g. 11504).

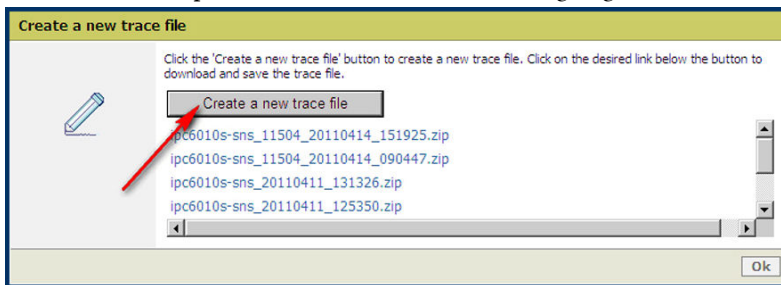


Fig. Create a Tracelog

- Next, click on the tracelog file that you want to download:

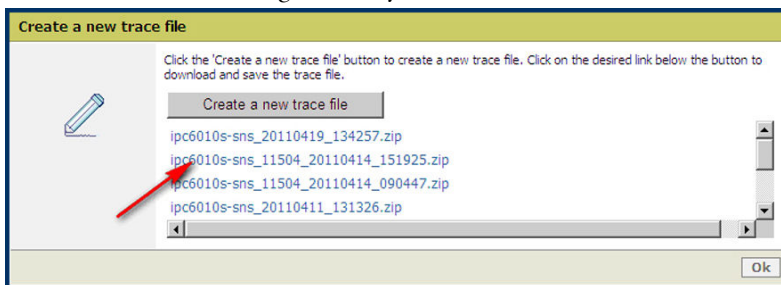


Fig. Select Tracelog Filename

- In the next window choose “**Save**” and enter a filename and confirm your choice.
- Repeat this procedure if you want to download more files. It is possible that more files are present with an errorcode in it. If you think these are interesting for analysis of the problem then download these too.

Finally close the window in the Settings Editor by clicking “OK”.

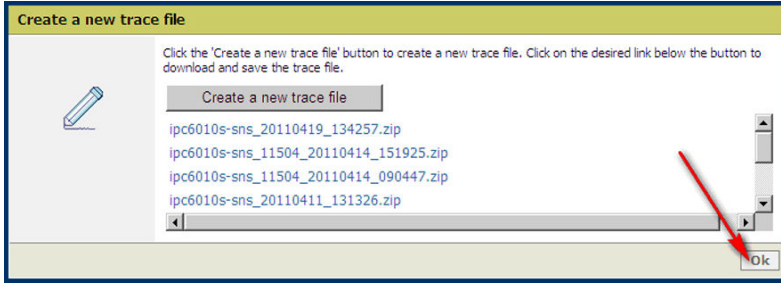


Fig. Select OK

Chapter 16

Appendix G: Important media printer adjustments

Important media printer adjustments

Introduction

In the table below some important media printer adjustments that are available in the Settings Editor are described.

General

Item	Setting	Objective	When/How
Saddle stitch position adjustment (mm)	Range: -2.00 to +2.00 mm, step 0,25 mm., default 0.0 mm	Move the stitch position towards the intended centre of the booklet. If necessary, perform the 'Saddle stitch fold position adjustment' to move the fold towards the intended centre too.	Change the value when the saddle stitch position is slightly offset from the paper center. - Increase: the saddle stitch position is shifted to the right of the printing side. - Decrease: the saddle stitch position is shifted to the left of the printing side.
Saddle stitch fold position adjustment (mm)	Range: -2.00 to +2.00 mm, step 0,25 mm., default 0.0 mm	When the saddle stitch function of the Saddle Finisher is used, the value is changed if the fold placement is not exactly on the centre of the paper.	- Increase the setting value to shift the fold placement to the right of the printing surface. - Decrease the setting value to shift the fold placement to the left of the printing surface
Punch hole position adjustment (mm)	Range: -2.0 to +2.0 mm, step 0.25 mm., default 0.0 mm	Use this function when the punch hole position is offset due to the paper type used.	- Increased values: the punch hole position is shifted to the bottom. - Decreased values: the punch hole position is shifted to the top.

Item	Setting	Objective	When/How
Saddle fold position adjustment (mm)	Range: -2.00 to +2.00 mm, step 0.25 mm, default 0.0 mm	When the saddle fold function of the Saddle Finisher is used, the value is changed if the fold placement is not exactly on the centre of the paper.	- Increase the setting value to shift the fold placement to the left. - Decrease the setting value to shift the fold placement to the right.

Advanced

Item	Setting	Objective	When/How
Face up curl correction	Range: -15 to +15, step 1, default 0	Adjust the paper curl level cause at the output of the system..	Increased values: higher curl correction level Decreased values: lower curl correction level
Face down curl correction	Range: -15 to +15, step 1, default 0	Adjust the paper curl level cause at the output of the system..	Increased values: higher curl correction level Decreased values: lower curl correction level
Gloss and fine black adjustment	Range: -2 to +2, step 1, default 0	Adjust the paper gloss. By changing the values, switch fixing temperatures and the paper feed methods either going through only the primary fixing unit or both primary and secondary fixing units. The fine black adjustment changes with this setting also.	Increased values: glossier Decreased values: less glossy Fine black adjustment is not valid for transparency, 1-sided coated paper, 2-sided coated paper and vellum paper.

Item	Setting	Objective	When/How
Paper separation fan level	Range: 1 to 7, step 1, default 4	Adjust the amount of air to improve the media separation in the input trays.	Decrease when high-density areas are not printed evenly, or when the curl is exceptionally high due to a lack of moisture, media characteristics and variable humidity of the environment. Increase the value when paper jams occur frequently, or in case of high temperature and humidity.
Paper separation from the ITB (Intermediate Transfer Belt)	Range: -5 to 5, step 1, default 0	Improve the separation of media from the ITB	
Image clear level adjustment ¹	Range: -10 to +10, step 1, default 0	If residual toner is attached on the paper, ITB cleaning may be insufficient. If this occurs, increase/decrease the value on a step-by-step basis until the symptom is improved.	Increased values: Higher ITB cleaning bias Decreased values: Lower ITB cleaning bias

Registration: Front

Item	Setting	Objective	When/How
X shift (0.1mm)	Value: -50.0 mm to +50.0 mm, step 0.1 mm, default 0.0 mm	To make adjustment to enable printing with correct alignment of paper and image	Incorrect image position with respect to the leading edge of paper in the feed direction.

Item	Setting	Objective	When/How
Y shift (0.1mm)	Value: -50.0 mm to +50.0 mm, step 0.1 mm, default 0.0 mm	To make adjustment to enable printing with correct alignment of paper and image	Incorrect image position with respect to the side edge of paper perpendicular to the feed direction.
X elongation (0.01%)	Value: -1.00 to +1.00%, step 0.01%, default 0.00%	To make adjustment (enlargement/reduction) of image size in feed direction	Incorrect image size/magnification in the feed direction.
Y elongation (0.01%)	Value: -1.00 to +1.00%, step 0.01%, default 0.00%	To make adjustment (enlargement/reduction) of image size perpendicular to feed direction	Incorrect image size/magnification perpendicular to the feed direction.
Skew roller pressure	Value: -2 to +2, step 1 default 0	If the printed image is skewed on a specific media only, such as thin paper the settings enables you to adjust the transferring position of this media. The skew correction rollers are located in the feeding unit of the printer. The rollers adjust the registered position of the fed media. When the value is too low, the image on the media may still be skewed. When the value is set too high or too low, a paper jam can occur.	Skew image position with respect to side edge of paper.

Item	Setting	Objective	When/How
Tail end white patch correction threshold	Level: -10 to +10	Improve the image quality on curled media or curl-prone media types in 2-sided printing when at the tail end of the media, white areas or fading appears. Fading in high-density area: choose negative values. White areas: choose positive values	Fading in highdensity area: choose negative values. White patch: choose positive values.
Tail end white patch correction amount (mm)	Level: -20 to +20	Improve the image quality on curled media or curl-prone media types in 2-sided printing when at the tail end of the media, white areas or fading appears. Depending on the media type and curl, the size of the area on the tail end of the media where white areas appear may differ. Use this setting to adjust the starting position to correct the area. The default position of the 'Tail end white patch correction' starts at 20 mm/0,8" from the tail edge of the media. To make the area bigger, decrease the value. To make the area smaller, increase the value.	Lower value: Increase the area Higher value: Decrease the area.

Item	Setting	Objective	When/How
Secondary transfer voltage	Range: -10 to +10 Increased values: Higher secondary transfer bias Decreased values: Lower secondary transfer bias	When image blurring occurs, adjust the voltage that transfers toner to the paper. This setting can affect the 'Image clear level adjustment' and 'Tail end white patch correction' settings. If necessary, readjust these settings too. Decrease the value when: 1) thin paper is used, 2) tiny white spots appear in low-density areas (when density in high-density areas is normal), 3) white spots appear in high-density areas and 4) the used paper has a rough surface (such as embossed paper) and white spots appear on the concave side. Increase the value when: 1) thick paper is used, 2) the density level in high-density areas and low-density areas is low, 3) uneven glossy areas occur in high-density images and 4) outlines in high-density images blur. Change this setting in small steps and check the output after each adjustment.	

Registration: Back

Item	Setting	Objective	When/How
X shift (0.1mm)	Value: -50.0 mm to +50.0 mm, step 0.1 mm, default 0.0 mm	To make adjustment to enable printing with correct alignment of paper and image	Incorrect image position with respect to the leading edge of paper in the feed direction.
Y shift (0.1mm)	Value: -50.0 mm to +50.0 mm, step 0.1 mm, default 0.0 mm	To make adjustment to enable printing with correct alignment of paper and image	Incorrect image position with respect to the side edge of paper perpendicular to the feed direction.
X elongation (0.01%)	Value: -1.00 to +1.00%, step 0.01%, default 0.00%	To make adjustment (enlargement/reduction) of image size in feed direction	Incorrect image size/magnification in the feed direction.
Y elongation (0.01%)	Value: -1.00 to +1.00%, step 0.01%, default 0.00%	To make adjustment (enlargement/reduction) of image size perpendicular to feed direction	Incorrect image size/magnification perpendicular to the feed direction.
Automatic correction of alignment of back side leading edge	On/Off, default On	To make automatic adjustment for change in length of media for backside image.	Incorrect image size/magnification for backside image in the feed direction.

Item	Setting	Objective	When/How
Skew roller pressure	Value: -2 to +2, step 1 default 0	If the printed image is skewed on a specific media only, such as thin paper the settings enables you to adjust the transferring position of this media. The skew correction rollers are located in the feeding unit of the printer. The rollers adjust the registered position of the fed media. When the value is too low, the image on the media may still be skewed. When the value is set too high or too low, a paper jam can occur.	Skew image position with respect to side edge of paper.
Tail end white patch correction threshold	Level: -10 to +10	Improve the image quality on curled media or curl-prone media types in 2-sided printing when at the tail end of the media, white areas or fading appears. Fading in high-density area: choose negative values. White areas: choose positive values	Fading in highdensity area: choose negative values. White patch: choose positive values.

Item	Setting	Objective	When/How
Tail end white patch correction amount (mm)	Level: -20 to +20	Improve the image quality on curled media or curl-prone media types in 2-sided printing when at the tail end of the media, white areas or fading appears. Depending on the media type and curl, the size of the area on the tail end of the media where white areas appear may differ. Use this setting to adjust the starting position to correct the area. The default position of the 'Tail end white patch correction' starts at 20 mm/0,8" from the tail edge of the media. To make the area bigger, decrease the value. To make the area smaller, increase the value.	Lower value: Increase the area Higher value: Decrease the area.

Item	Setting	Objective	When/How
Secondary transfer voltage	Range: -10 to +10 Increased values: Higher secondary transfer bias Decreased values: Lower secondary transfer bias	When image blurring occurs, adjust the voltage that transfers toner to the paper. This setting can affect the 'Image clear level adjustment' and 'Tail end white patch correction' settings. If necessary, readjust these settings too. Decrease the value when: 1) thin paper is used, 2) tiny white spots appear in low-density areas (when density in high-density areas is normal), 3) white spots appear in high-density areas and 4) the used paper has a rough surface (such as embossed paper) and white spots appear on the concave side. Increase the value when: 1) thick paper is used, 2) the density level in high-density areas and low-density areas is low, 3) uneven glossy areas occur in high-density images and 4) outlines in high-density images blur. Change this setting in small steps and check the output after each adjustment.	

Chapter 17

Appendix H: Engine reports

Engine reports

■ 1.

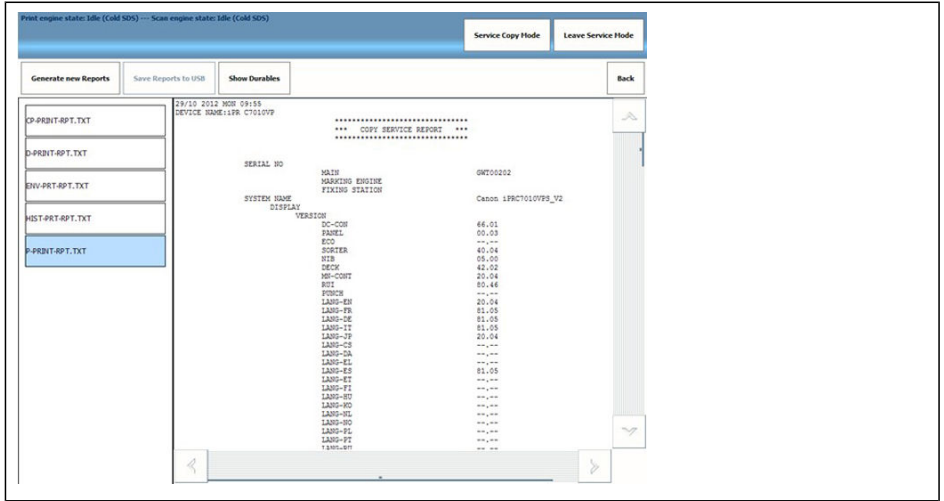
In the service mode a sorted list of all durables and periodically replaceable parts of the engine and accessories can be generated and displayed on the LUI. The list is sorted by lifetime. Doing so is the easiest way for the Field Service Technician to get an overview of the status of all parts.

The screenshot shows the engine reports interface. At the top, it displays 'Print engine status: Idle (GIM SDS)' and 'Scan engine status: Idle (GIM SDS)'. Below this are buttons for 'Service Copy Mode' and 'Leave Service Mode'. A navigation bar includes 'Generate new Reports', 'Save Reports to USB', 'Show Durables', and 'Back'. The main content area shows a table of parts with the following data:

Consumption Rate (%)	Part Code (with counter path)	Current Counter Value	Part Lifetime
188	COUNTER > CLEANING > PO-C-RL	282171	150000
188	COUNTER > CLEANING > 2TR-C-RL	282171	150000
128	COUNTER > DRBL-1 > ITB-VIEB	128131	100000
128	COUNTER > CLEANING > FXI-RPRL	128131	100000
128	COUNTER > CLEANING > FXI-RPCL	128131	100000
127	COUNTER > DRBL-1 > 2TR-BURL	765520	600000
127	COUNTER > DRBL-1 > ITB-CLN1	765520	600000
127	COUNTER > DRBL-1 > FX-LB-ST	765520	600000
112	COUNTER > PRDC-1 > PRM-W-Y	282171	250000
112	COUNTER > PRDC-1 > GR-PAD-Y	282171	250000
112	COUNTER > PRDC-1 > PRM-G-Y	282171	250000

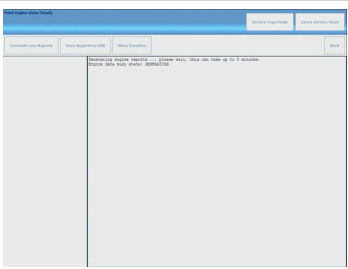
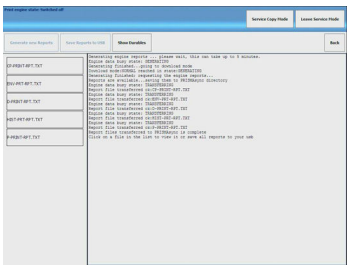
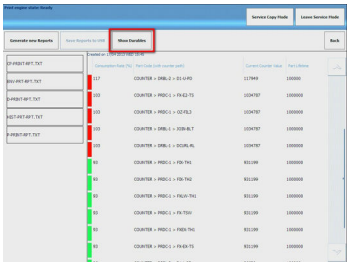
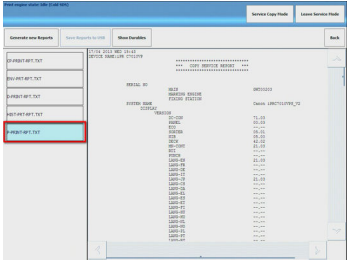
■ 2.

A digital version of the P-PRINT, CP-PRINT, D-PRINT, ENV-PRINT and the HIST-PRINT can be generated and displayed on the LUI. The prints can be stored on a USB stick when needed e.g. for escalation purposes.



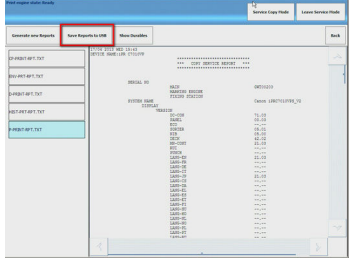
How to view & store engine reports

Step	Action	Remarks
1	Go to service mode.	
2	Press button -engine reports	
3	Click on -generate new reports- button	

Step	Action	Remarks
4	New reports will be generated	
5	By toggling -Show Durable- and -XX print- buttons the durables or the engine reports will be shown	
6		
7		

How to save reports

Step	Action	Remarks
1	Insert a USB key.	If no key is inserted, the button – Save Reports to USB- will be greyed-out.

Step	Action	Remarks
2	Click on one of the buttons to show the desired report	
3	Click on – Save Reports to USB- and all reports will be saved to the USB key	

Durable list

The durable list on the PRISMAsync Local User Interface is derived from the DRBL’s and PRDC as present on the P-print. The parts with the highest lifetime percentage are on top.

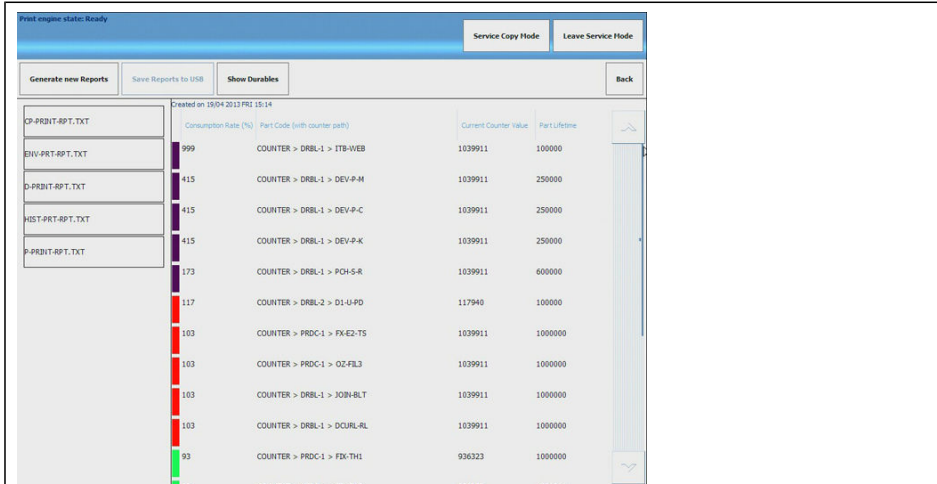
In service operations some parts are not actively monitored and thus counters are not reset. Part counters with a threshold of -o- (zero) will be ignored by PRISMAsync and not displayed on the LUI.

Advice

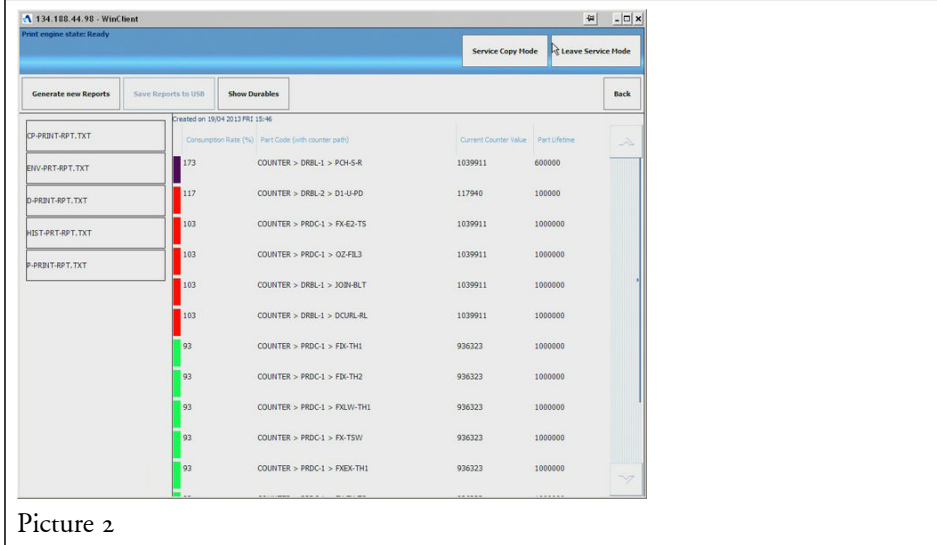
To have an accurate list of parts in the durable list it is advised to set the threshold value of -non actively monitored parts- in engine service mode to -o-.

Example:

In picture 1 the lifetime of ITB-WEB and DEV-P-X are displayed. Go to service mode > Copier> Counter> AVE-DRB1 and set the threshold to -o-. In picture 2 the ITB-WEB and DEV-P-X parts are no longer displayed. Result; a more accurate list.



Picture 1



Picture 2

Chapter 18

Appendix I: The Trapping editor

The Trapping editor

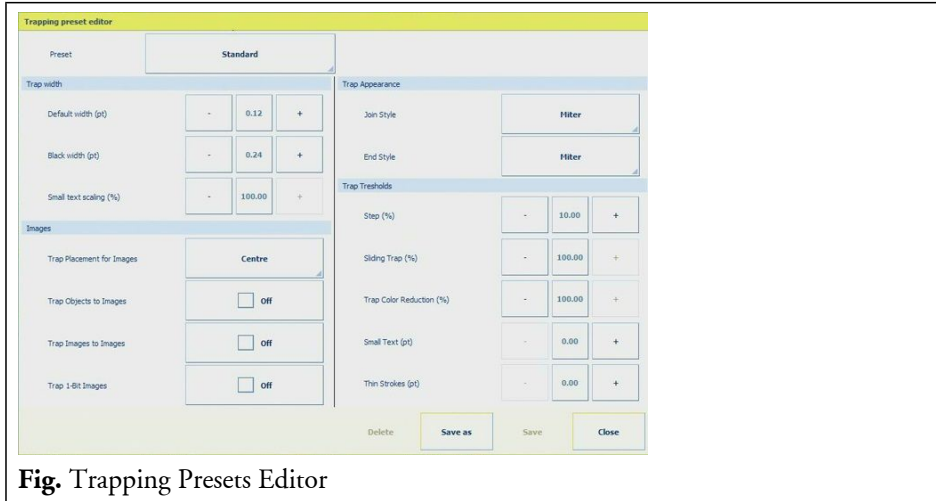


Fig. Trapping Presets Editor

Trap width

Trap width is the amount of overlap for each trap. Differences in paper characteristics, screen rulings, and printer conditions require different trap widths.

- **Default width:**
Specifies the trap width in points for trapping all colors except those involving solid black.
The default value is 0.25.
- **Black width:**
Indicates the distance that toners spread into solid black, or the holdback amount—the distance between black edges and underlying toners for trapping rich blacks. The default value is 0.5. This value is often set to be 1.5 to 2 times the value of the default trap width.

Trap Appearance

- **Join Style:**
A join is where two trap edges meet at a common endpoint. You can control the shape of the outside join of two trap segments and the intersection of three traps. Join Style Controls the shape of the outside join of two trap segments. Choose from Miter, Round, and Bevel. (Left to right)

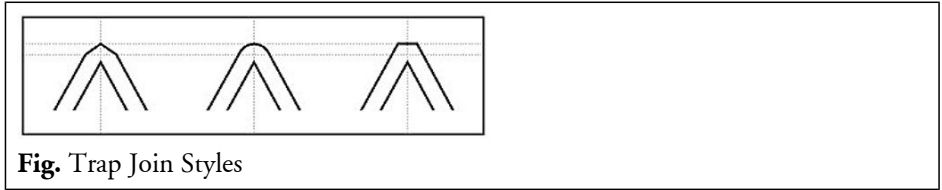
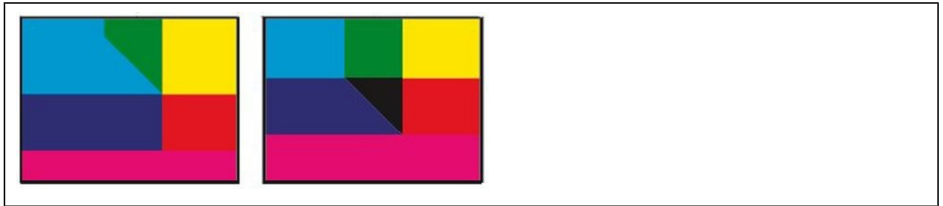


Fig. Trap Join Styles

- **End Style:**
 Controls the intersection of three-way traps. Miter (the default) shapes the end of the trap to keep it away from the intersecting object. Overlap affects the shape of the trap generated by the lightest neutral density object that intersects with two or more darker objects. The end of the lightest trap is wrapped around the point where the three objects intersect. In the example the left image shows the miter effect. The right image shows the overlap.



Trap thresholds

- **Step**
 Specifies the color change threshold at which the trapping engine creates a trap. Some jobs need only the most extreme color changes trapped, while others require traps for more subtle color changes. The Step value indicates the degree to which components (such as CMYK values) of abutting colors must vary before trapping occurs. To change how much the component toners in abutting colors can vary before causing those colors to trap, increase or decrease the value for Step. The default is 10%. For best results, use a value from 8% to 20%. Lower percentages increase sensitivity to color differences and result in more traps.
- **Sliding Trap**
 Determines when the trapping engine starts to straddle the centerline of the color boundary. The value refers to the proportion of the lighter color's neutral density value to a darker, abutting color's neutral density value. For example, setting the Sliding Trap value to 70% moves the point at which the trap begins to straddle the centerline to where the lighter color exceeds 70% of the darker color in neutral density (lighter color's neutral density divided by darker color's neutral density > 0.70). Colors of identical neutral density will always have their traps exactly straddle the centerline, unless the Sliding Trap is set to 100%.

- **Trap Color Reduction**
Indicates the degree to which components from abutting colors are used to reduce the trap color. This setting is useful for preventing certain abutting colors (such as pastels) from making an unsightly trap that is darker than either color. Specifying a Trap Color Reduction lower than 100% begins to lighten the color of the trap; a Trap Color Reduction value of 0% makes a trap with a neutral density equal to the neutral density of the darker color.

Images

- **Trap Placement for Images** Provides options for determining where the trap falls when you trap vector objects to bitmap images. All options except "Normal" create a visually consistent edge.
 - Center creates a trap that straddles the edge between objects and images.
 - Choke causes objects to overlap the abutting image.
 - Normal applies the same trapping rules as used elsewhere in the document. Trapping an object to a photograph with the "Normal" setting can result in noticeably uneven edges as the trap moves from one side of the edge to another.
 - Spread causes the bitmap image to overlap the abutting object.
- **Trap Objects To Images**
Ensures that vector objects (such as frames used as keylines) trap to images, using the Trap Placement settings. If vector objects don't overlap images in a trapping page range, consider turning this option off to speed trapping of that page range.
- **Trap Images To Images**
Turns on trapping along the boundary of overlapping or abutting bitmap images.
- **Trap 1-Bit Images**
Ensures that 1-bit images trap to abutting objects. This option doesn't use the Image Trap Placement settings, because 1-bit images use only one color. In most cases, leave this option selected. In some cases, such as with 1-bit images where pixels are widely spaced, selecting this option may darken the image and slow the trapping.