

imagePRESS C800/C700/C60 Series

Operator Maintenance Manual



Application

This manual has been issued by Canon Inc. for qualified persons to learn technical theory, installation, maintenance, and repair of products. This manual covers all localities where the products are sold. For this reason, there may be information in this manual that does not apply to your locality.

Corrections

This manual may contain technical inaccuracies or typographical errors due to improvements or changes in products. When changes occur in applicable products or in the contents of this manual, Canon will release technical information as the need arises. In the event of major changes in the contents of this manual over a long or short period, Canon will issue a new edition of this manual.

The following paragraph does not apply to any countries where such provisions are inconsistent with local law.

Trademarks

The product names and company names used in this manual are the registered trademarks of the individual companies.

Copyright

This manual is copyrighted with all rights reserved. Under the copyright laws, this manual may not be copied, reproduced or translated into another language, in whole or in part, without the consent of Canon Inc.



















Copyright CANON INC. 2014

Caution

Use of this manual should be strictly supervised to avoid disclosure of confidential information.



Explanation of Symbols

The following symbols are used throughout this Service Manual.

Symbols	Explanation	Symbols	Explanation
	Check.		Remove the claw.
	Check visually.		Insert the claw.
	Check a sound.		Push the part.
	Disconnect the connector.		Connect the power cable.
	Connect the connector.		Disconnect the power cable.
	Remove the cable/wire from the cable guide or wire saddle.		Turn on the power.
	Install the cable/wire to the cable guide or wire saddle.		Turn off the power.
	Remove the screw.		Loosen the screw.
	Install the screw.		Tighten the screw.

Symbols	Explanation	Symbols	Explanation
	Cleaning is needed.		Measurement is needed.

The following rules apply throughout this Service Manual:

- Each chapter contains sections explaining the purpose of specific functions and the relationship between electrical and mechanical systems with reference to the timing of operation.
In the diagrams,  represents the path of mechanical drive; where a signal name accompanies the symbol, the arrow  indicates the direction of the electric signal.
The expression "turn on the power" means flipping on the power switch, closing the front door, and closing the delivery unit door, which results in supplying the machine with power.
- In the digital circuits, '1' is used to indicate that the voltage level of a given signal is "High", while '0' is used to indicate "Low". (The voltage value, however, differs from circuit to circuit.) In addition, the asterisk (*) as in "DRMD*" indicates that the DRMD signal goes on when '0'.
In practically all cases, the internal mechanisms of a microprocessor cannot be checked in the field. Therefore, the operations of the microprocessors used in the machines are not discussed: they are explained in terms of from sensors to the input of the DC controller PCB and from the output of the DC controller PCB to the loads.

The descriptions in this Service Manual are subject to change without notice for product improvement or other purposes, and major changes will be communicated in the form of Service Information bulletins.

All service persons are expected to have a good understanding of the contents of this Service Manual and all relevant Service Information bulletins and be able to identify and isolate faults in the machine.

Contents

1 Initial Setup

Basic Operation	1-2
Operator Maintenance Mode and Replacement/Cleaning Mode	1-2
Login to Operator Maintenance Mode	1-3
Moving to Operator Maintenance Mode	1-3
Terminating Operator Maintenance mode	1-4
Auto-timeout Notification	1-4
Operator Maintenance Basic Screen	1-5
Display	1-5
Control Keys	1-5
Warning List Screen in Operator Maintenance Mode	1-6
Display	1-6
Control keys	1-6
Maintenance Log List Screen in Operator Maintenance Mode	1-7
Display	1-7
Control Keys	1-7
Replaceable Parts List Screen in Operator Maintenance Mode	1-8
Display	1-8
Control Keys	1-8
Cleanable Parts List Screen in Operator Maintenance Mode	1-9
Display	1-9
Control Keys	1-9
Detailed Information Screen	1-10
Display	1-10
Control Keys	1-10
Counter Operation Screen	1-11
Control key	1-11
Detailed Information Screen	1-12
Clearing the Counter	1-12
Procedure for Clearing the Counter of the Fixing Assembly	1-12
Procedure for Clearing the Counter of the Secondary Transfer Outer Roller / Fixing Refresh Roller	1-14
Replacement/Cleaning Mode	1-15

Moving to Replacement/Cleaning Mode	1-15
Terminating Replacement/Cleaning Mode	1-16
Adjustments/Settings	1-17
Adjustment/Maintenance Menu screen	1-17
Automatic Gradation Adjustment	1-18
Shading Correction	1-28
Automatic Color Tone Correction	1-31
Output Test Page	1-35
Management Setting Menu Screen	1-37
Changing Password	1-38
Initialization of the Password	1-38
Settings of Auto-Timeout Conditions	1-39
Display Log Menu Screen	1-40
Display of Log of JAM	1-41
Display of Log of ERR	1-42
Display of Log of ALARM-2	1-43

2 Procedure of Replacement/Cleaning

List of Operator Replaceable/Cleanable Parts	2-2
Replaceable Parts	2-2
Cleanable Parts	2-2
Transfer area	2-3
Replacing the Secondary Transfer Unit	2-3
Replacement procedure	2-3
Fixing area	2-7
Replacing the Fixing Assembly	2-7
Replacement procedure	2-7
Cleaning	2-13
Cleaning the Fixing Refresh Roller	2-13
Cleaning Procedure	2-13



Initial Setup

- Basic Operation
- Adjustments/Settings

Basic Operation

Operator Maintenance Mode and Replacement/Cleaning Mode

To use the functions provided in Operator Maintenance mode, log in (enter the password) to move to Operator Maintenance mode.

When replacing/cleaning the parts, move to Replacement/Cleaning mode in Operator Maintenance mode.

The figure below shows the relation between Operator Maintenance mode and Replacement/Cleaning mode.

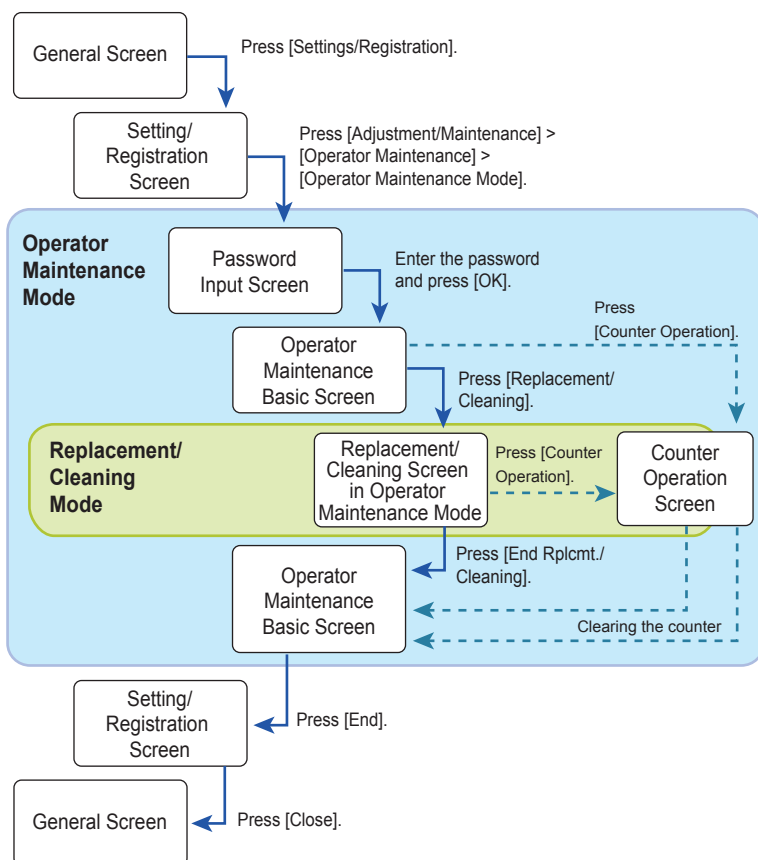

F-1-1

Login to Operator Maintenance Mode

Moving to Operator Maintenance Mode

To use the functions provided in Operator Maintenance mode, enter the password to move to Operator Maintenance mode.

1) Press [Settings/Registration] > [Adjustment/Maintenance] > [Operator Maintenance].

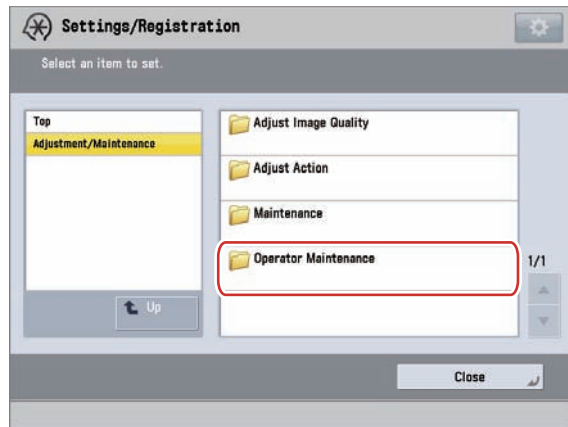

F-1-2

NOTE:

When the [Operator Maintenance] is not displayed, contact the service representative.

2) Press [Operator Maintenance Mode].

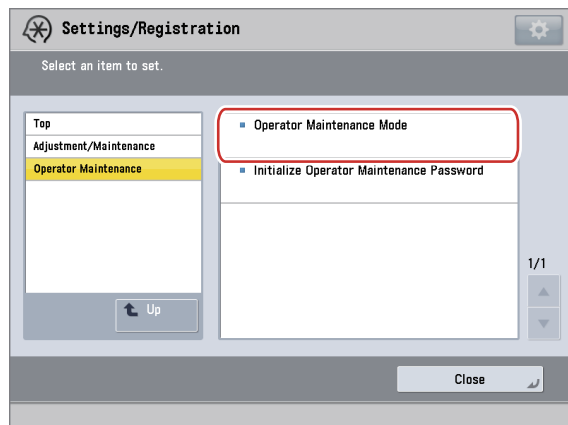

F-1-3

->Password input screen is shown.

3) Enter the password and press [OK].

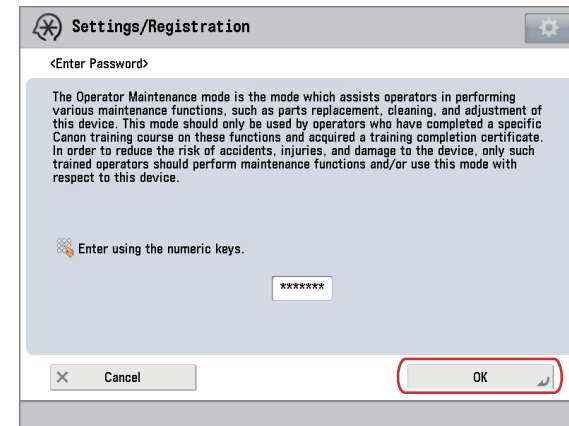

F-1-4

->When the entered password is successfully authenticated, operator maintenance basic screen is shown.

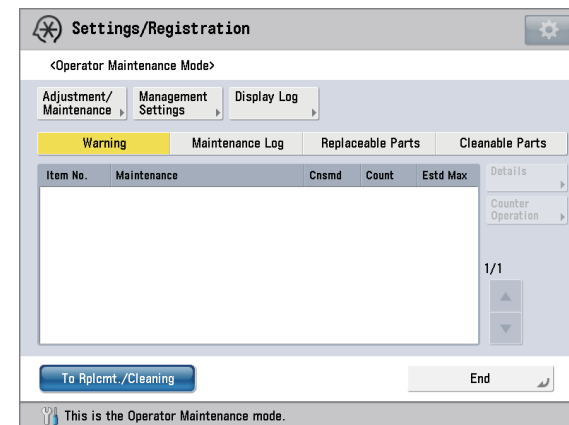

F-1-5

->When the password authentication fails, press [Cancel] to return to Operator Maintenance (Adjustment/Maintenance) screen.

NOTE:

Password can be changed with the following setting.
"Changing Password"(page 1-38).

Terminating Operator Maintenance mode

When all operator maintenance works are completed, terminate Operator Maintenance mode.

1) Press [End] in operator maintenance basic screen.

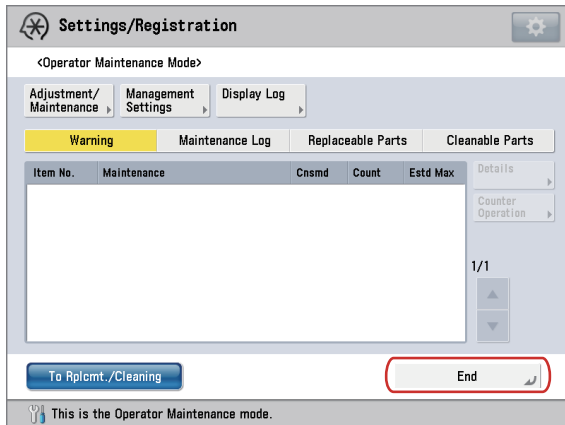

F-1-6

-> Operator maintenance mode is terminated to return to Operator Maintenance (Adjustment/Maintenance) screen.

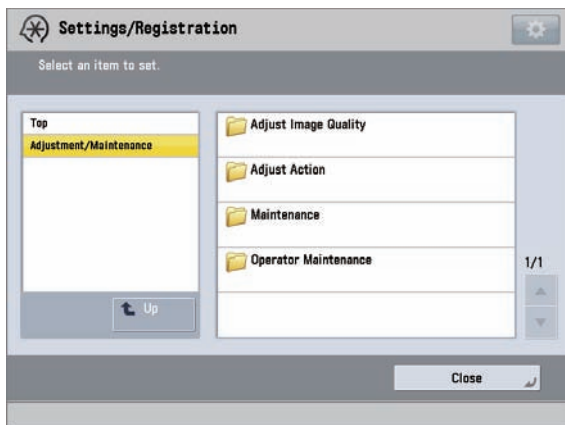

F-1-7

Auto-timeout Notification

When no operation is made for certain duration in Operator Maintenance mode, the password screen is redisplayed. This is called as auto-timeout notification.

Enter the password and press [OK] to return to Operator Maintenance mode.

The auto-timeout is not notified when performing adjustment/maintenance.

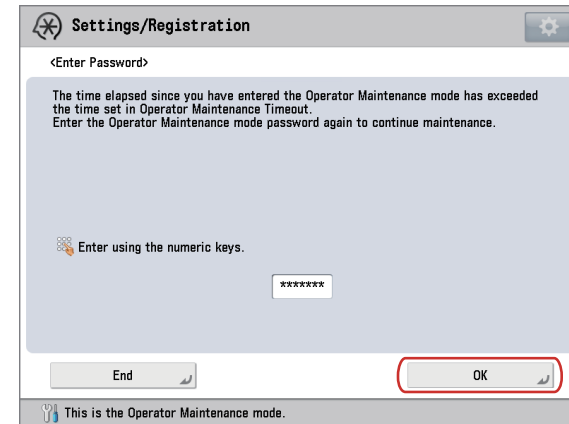

F-1-8

NOTE:

Auto-timeout conditions can be checked/changed with the following setting. "Settings of Auto-Timeout Conditions"(page 1-39).

Operator Maintenance Basic Screen

When moving to Operator Maintenance mode, operator maintenance basic screen is shown. This is the basic screen to perform operator maintenance works.

On operator maintenance screen, the lists of warning, maintenance log, replaceable parts and cleanable parts are shown. Each list shows the information on replacement/cleaning parts. Operators should follow the information shown in each list to perform the maintenance works such as parts adjustment/maintenance or parts replacement/cleaning.

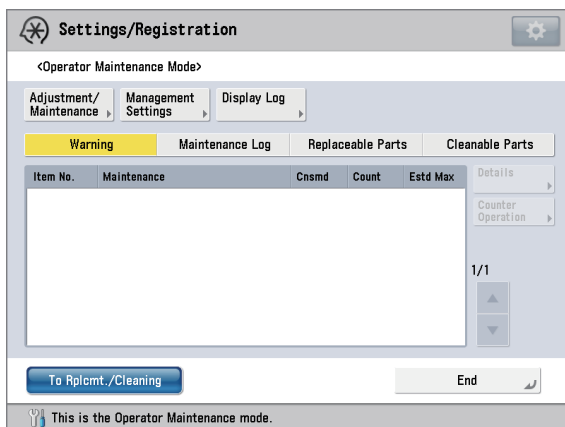

F-1-9

Display

Items	Contents
Warning	"Warning List Screen in Operator Maintenance Mode"(page 1-6).
Maintenance Log	"Maintenance Log List Screen in Operator Maintenance Mode"(page 1-7).
Replaceable Parts	"Replaceable Parts List Screen in Operator Maintenance Mode"(page 1-8).
Cleanable Parts	"Cleanable Parts List Screen in Operator Maintenance Mode"(page 1-9).
Status fields	Messages are shown in the status fields in Operator Maintenance mode.

T-1-1

NOTE: Setting of the parts shown in the lists
Only the parts with conditions set by your service representative will be shown in each list. Contact your service representative to change the condition setting.

Control Keys

Items	Contents
Adjustment/Maintenance	"Adjustment/Maintenance Menu screen"(page 1-17).
Management Settings	"Management Setting Menu Screen"(page 1-37).
Display Log	"Display Log Menu Screen"(page 1-40).
To Rplcmt./Cleaning	"Replacement/Cleaning Mode"(page 1-15).
End	Press [End] to move to Operator Maintenance (Adjustment/Maintenance) screen.

T-1-2

NOTE:
[Display Log] key is not shown by default. Contact your service representative to add this key on the screen.

Warning List Screen in Operator Maintenance Mode

When moving to Operator Maintenance mode, the warning list is shown on operator maintenance basic screen. To switch from the other screen display, press [Warning] and the warning list is displayed.

The parts in the warning status are listed here. The parts in the warnings status mean replacement/cleaning parts in shorter service life. The parts are listed in the descending order from higher to lower rates in the wear status.

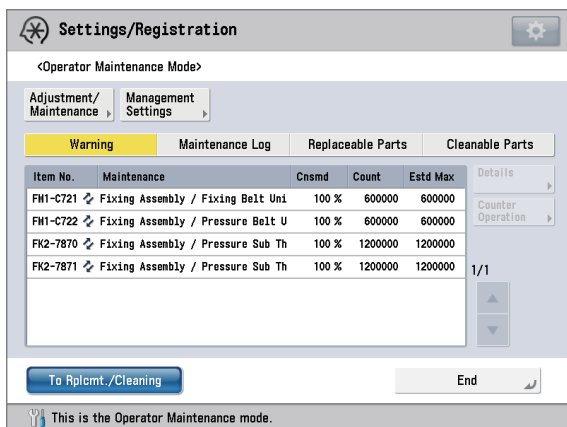

F-1-10

CAUTION:

This is the screen when logging in the Operator Maintenance mode, so any changes made during login are not reflected here.

Display

Items	Contents
Item No.	8 digits characters and/or numbers (format XXX-XXXX)
Replacement/ Cleaning Icons	Replacement icon
	Cleaning icon
Maintenance	Max. 54 single byte characters (overflow will be rounded)
Wear Status	0 to 999 %
Count	8 digit numbers
Recommended Value	8 digit numbers

T-1-3

NOTE:

In the warning list, the parts in 100% or more of the wear status rate are shown in the default setting. This setting can be changed to show the parts in 90% or more of the wear status rate. Contact your service representative to change this setting.

Control keys

Names of Key	Function
Details	Select a parts to enable [Details] key. Press this key to display the detailed information screen. "Detailed Information Screen"(page 1-10).
Counter Operation	Select a parts to enable [Counter Operation] key. Press this key to clear the counter. "Clearing the Counter"(page 1-12).

T-1-4

Maintenance Log List Screen in Operator Maintenance Mode

Press [Maintenance Log] in operator maintenance basic screen to show the maintenance log list.

In the maintenance log list, the maintenance works in replacing/cleaning parts are listed. A blank list is shown when no history found.

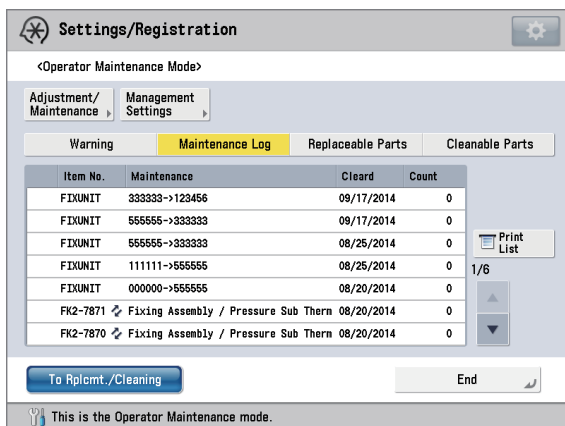

F-1-11

CAUTION:

This is the screen when [Maintenance Log] is pressed.

Display

Items	Contents
Item No.	8 digits in characters and numbers (format XXX-XXXX)
Replacement/ Cleaning Icons	Replacement icon
	Cleaning icon
Maintenance	Max. 34 single byte characters (overflow will be rounded)
Date of Counter Cleared	Year / Month / Day (For Japan) Month / Day / Year (For U.S.A.) Day / Month / Year (For Europe)
Count	8 digit numbers (the count when cleared)

T-1-5

NOTE:

The maintenance history for all replacement parts is shown in the maintenance log list regardless of the display/non-display setting.

"NOTE: Setting of the parts shown in the lists"(page 1-5).

Control Keys

Names of Key	Function
Print List	Press [Print List] to print the maintenance log report. This key is disabled (shaded) when A4 or larger size paper is not loaded or it is in Replacement/Cleaning mode.

T-1-6

CAUTION:

If [To Rplcmt./Cleaning] is pressed immediately after pressing [Print List], wait time of approx. 2 minutes is required in order to protect the device.

Replaceable Parts List Screen in Operator Maintenance Mode

Press [Replaceable Parts] on operator maintenance basic screen to show the replaceable parts list.

The replaceable parts are listed here together with each counter reading.

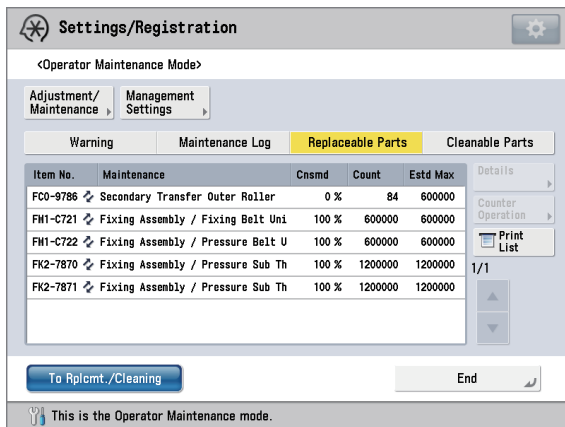

F-1-12

CAUTION:

This is the screen when logging in the Operator Maintenance mode, so any changes made during login are not reflected here.

Display

Items	Contents
Item No.	8 digit characters and/or numbers (format XXX-XXXX)
Replacement Icon	
Maintenance	Max. 34 single byte characters (overflow will be rounded)
Wear Status	0 to 999 %
Count	8 digit numbers
Recommended Value	8 digit numbers

T-1-7

Control Keys

Names of Key	Function
Details	Select a parts to enable [Details] key. Press this key to show the detailed information screen. "Detailed Information Screen"(page 1-10).
Counter Operation	Select a parts to enable [Counter Operation] key. Press this key to clear the counter. "Clearing the Counter"(page 1-12).
Print List	Press [Print List] to print the replacement parts list. This key is disabled (shaded) when A4 or larger size paper is not loaded or it is in Replacement/Cleaning mode.

T-1-8

CAUTION:

If [To Rplcmt./Cleaning] is pressed immediately after pressing [Print List], wait time of approx. 2 minutes is required in order to protect the device.

Cleanable Parts List Screen in Operator Maintenance Mode

Press [Cleanable Parts] in operator maintenance basic screen to show the cleanable parts list.

The cleanable parts are listed here together with each counter reading.

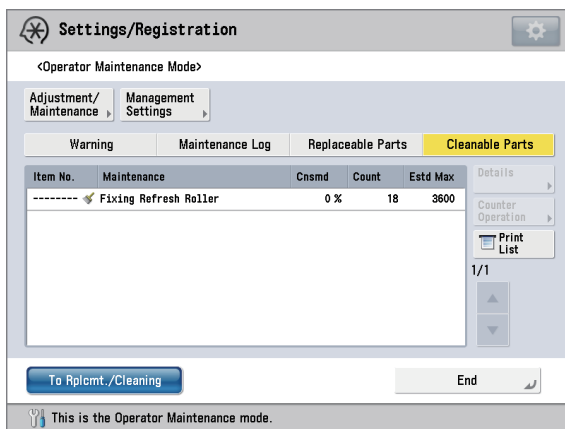

F-1-13

CAUTION:

This is the screen when logging in the Operator Maintenance mode, so any changes made during login are not reflected here.

Display

Items	Contents
Item No.	Non-display (format -----)
Cleaning Icon	
Maintenance	Max. 34 single byte characters (overflow will be rounded)
Wear Status	0 to 999 %
Count	8 digit numbers
Recommended Value	8 digit numbers

T-1-9

Control Keys

Names of Key	Function
Details	Select a parts to enable [Details] key. Press this key to show the detailed information screen "Detailed Information Screen"(page 1-10).
Counter Operation	Select a parts to enable [Counter Operation] key. Press this key to clear the counter. "Clearing the Counter"(page 1-12).
Print List	Press [Print List] to print the replacement parts list. This key is disabled (shaded) when A4 or larger size paper is not loaded or it is in Replacement/Cleaning mode.

T-1-10

CAUTION:

If [To Rplcmt./Cleaning] is pressed immediately after pressing [Print List], wait time of approx. 2 minutes is required in order to protect the device.

Detailed Information Screen

In the warning list / replacement parts list / cleaning parts list shown on operator maintenance basic screen, select a parts and press [Details] to display the detailed information screen for the selected replacement/cleaning parts.

Detailed information screen (for the replacement parts)

Items	Contents
ID	Alphanumeric 6 digit (Only the Fixing Assembly is displayed)
Item Number	Alphanumeric 8 digit (format XXX-XXXX)
Maintenance	Max. 54 single byte characters (overflow will be rounded)
Current count value	numeral 8 digit
Replacement/Cleanable suggested count value	numeral 8 digit
Current wear status	0 to 999 %
Remaining Days	XXX day
Times Number of replacement/cleanable (Total)	0 to 999 times

F-1-14

Detailed information screen (for the cleanable parts)

F-1-15

Display

Displayed items are in common on both replacement and cleanable detailed display.

Items	Contents
ID	Alphanumeric 6 digit (Only the Fixing Assembly is displayed)
Item Number	Alphanumeric 8 digit (format XXX-XXXX)
Maintenance	Max. 54 single byte characters (overflow will be rounded)
Current count value	numeral 8 digit
Replacement/Cleanable suggested count value	numeral 8 digit
Current wear status	0 to 999 %
Remaining Days	XXX day
Times Number of replacement/cleanable (Total)	0 to 999 times

T-1-11

Control Keys

Names of Key	Function
Close	Press [Close] to return the previous screen. (warning list / replacement parts list / cleaning parts list)

T-1-12

Counter Operation Screen

When pressing [Counter Operation] after selecting the parts of the Fixing Assembly in the Warning or Replaceable Parts screen, the Counter Operation screen of Fixing Assembly may be displayed.

The Fixing Assembly ID is displayed in the Counter Operation screen.

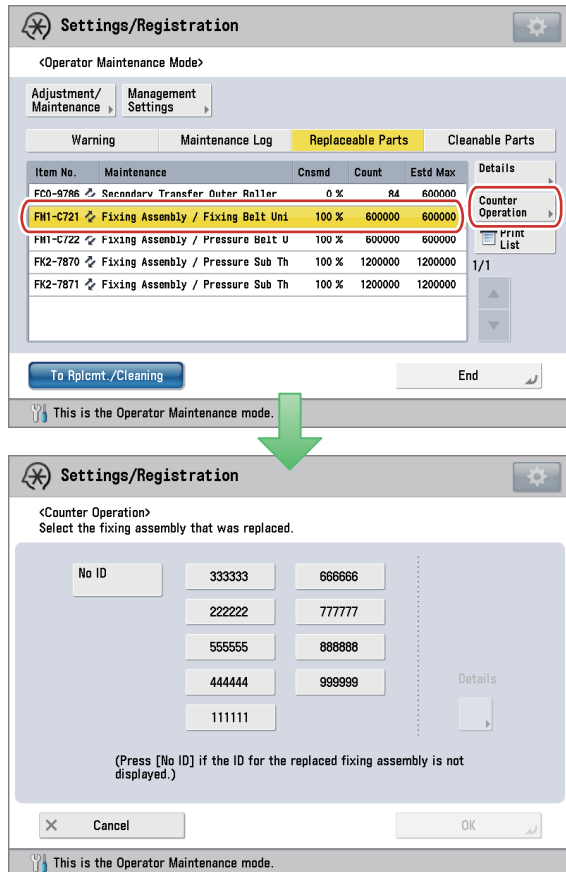

F-1-16

Control key

Items	Contents
ID	Up to 10 IDs can be displayed. IDs are registered by the service technician. IDs of Fixing Assemblies that are currently used are not displayed.
Details	The [Details] is activated when an ID is selected. Pressing this key will display the Details screen.
No ID	Select this key when the ID of the Fixing Assembly that has been replaced is not displayed.

T-1-13

Detailed Information Screen

On the Counter Operation screen, select an ID, and press the [Details]. The screen showing the details of the selected Fixing Assembly will appear.

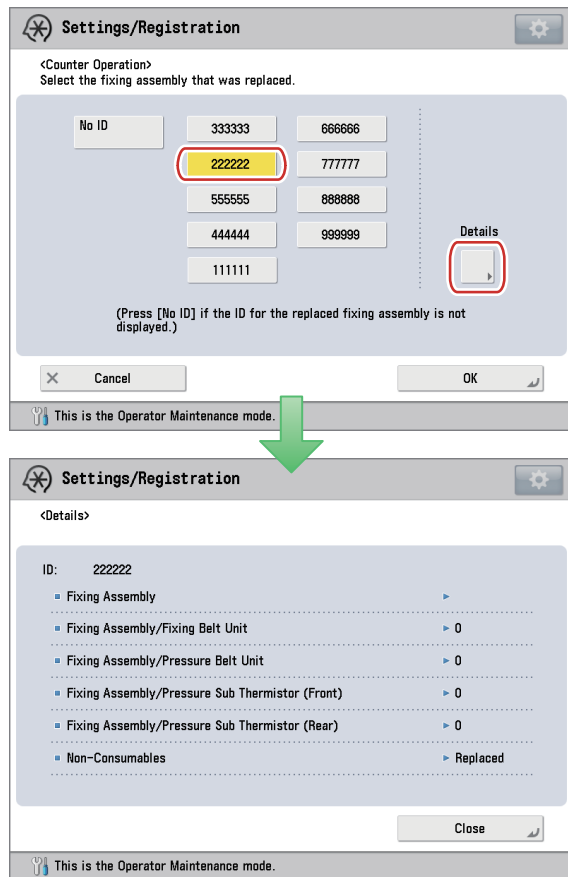

F-1-17

NOTE:

This information shows the state of the Fixing Assembly registered by the service technician.

Clearing the Counter

The counter of the part which has been replaced/cleaned needs to be cleared after replacing/cleaning the part.

Procedure for Clearing the Counter of the Fixing Assembly

- 1) Check the ID label for operator maintenance affixed to the Fixing Assembly, and write down the ID.

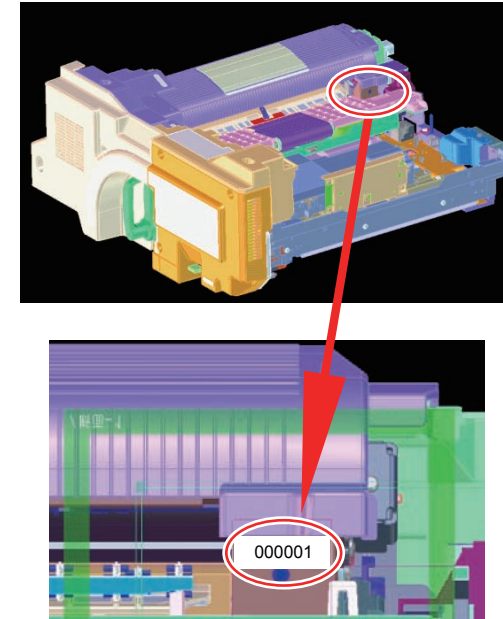

F-1-18

- 2) On the warning list screen or the replaceable parts list screen, select the part of the Fixing Assembly which has triggered the warning, and press [Counter Operation].

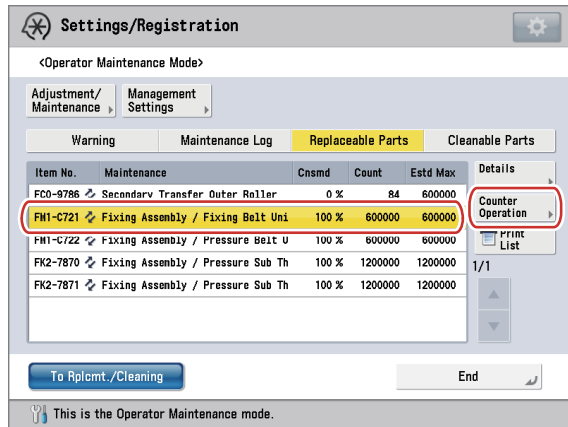

F-1-19

NOTE:

If the confirmation screen for clearing the counter appears, perform step 4.

- 3) Select the ID of the Fixing Assembly you wrote down in step 1, and press [OK].

NOTE:

If the ID of the Fixing Assembly you wrote down in step 1 is not displayed, select [No ID]. In addition, let the service technician know that the Fixing Assembly ID is not displayed.

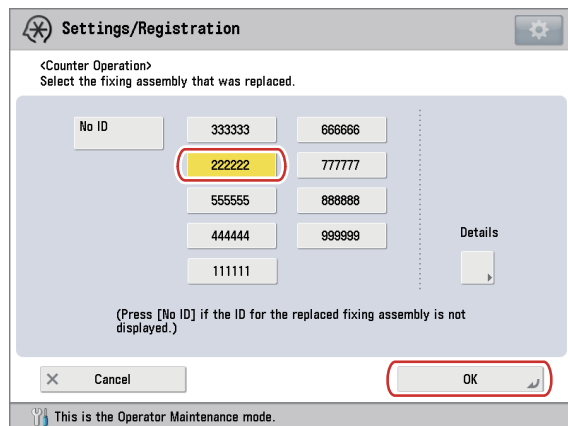

F-1-20

- > The confirmation screen for clearing the counter will appear.

- 4) Press [Yes].

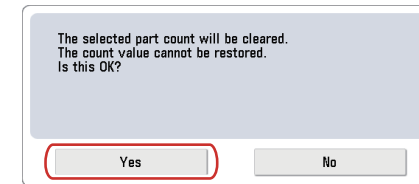

F-1-21

- > The count clear completion screen will appear.

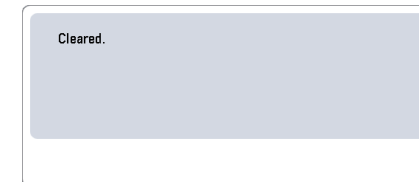

F-1-22

Count clear can be executed whether in the Replacement/Cleaning mode or not. If executing count clear in the Replacement/Cleaning mode, the message will be shown on the screen to confirm Replacement/Cleaning mode termination after clear.

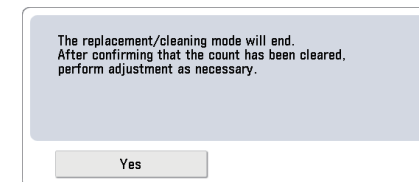

F-1-23

Procedure for Clearing the Counter of the Secondary Transfer Outer Roller / Fixing Refresh Roller

NOTE:

- When clearing the counter of the Secondary Transfer Outer Roller, perform 1-1.
- When clearing the counter of the Fixing Refresh Roller, perform 1-2.

1-1) In the Warning or Replaceable Parts screen, select [Secondary Transfer Outer Roller], and press [Counter Operation].

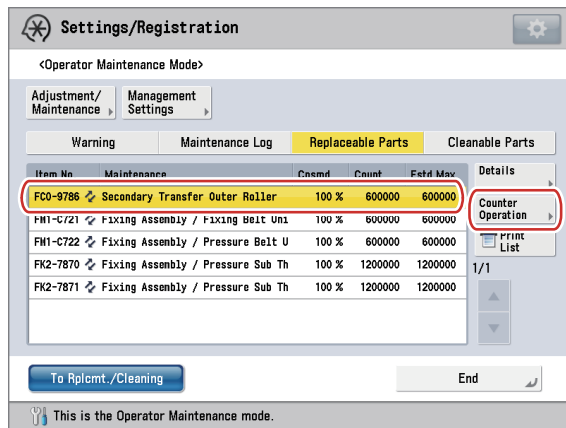

F-1-24

1-2) In the Warning or Cleanable Parts screen, select [Fixing Refresh Roller], and press [Counter Operation].

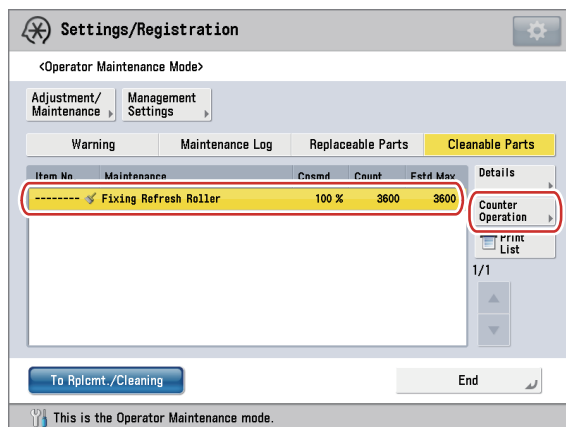

F-1-25

->The confirmation screen for clearing the counter will appear.

2) Press [Yes].

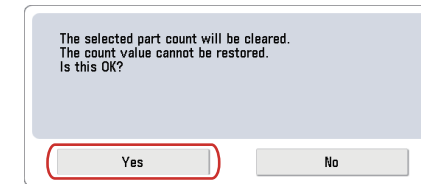

F-1-26

->The count clear completion screen will appear.

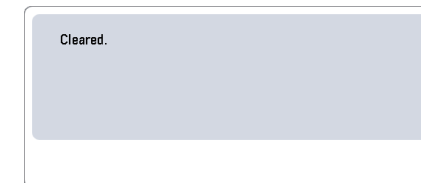

F-1-27

Count clear can be executed whether in the Replacement/Cleaning mode or not. If executing count clear in the Replacement/Cleaning mode, the message will be shown on the screen to confirm Replacement/Cleaning mode termination after clear.

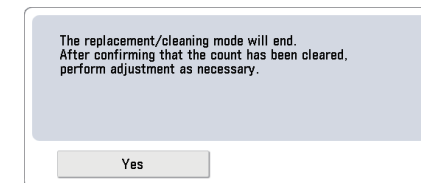

F-1-28

Replacement/Cleaning Mode

Moving to Replacement/Cleaning Mode

To replace or clean the parts, move from Operator Maintenance mode to Replacement/Cleaning Mode.

1) Press [To Rplcmt./Cleaning] in operator maintenance basic screen.

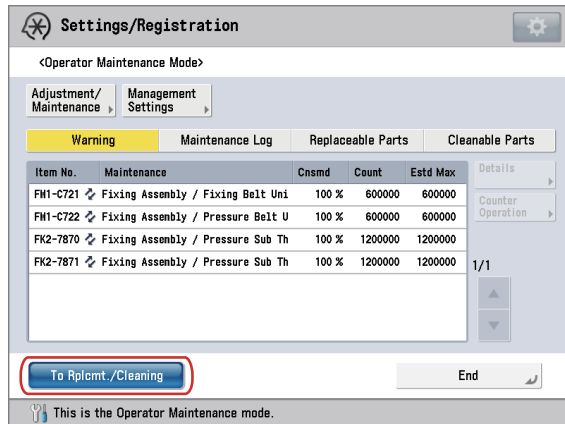

F-1-29

CAUTION:

- [To Rplcmt./Cleaning] is disabled when any start-up jobs or PDL jobs are executed in the control panel. End the jobs to enable [To Rplcmt./Cleaning].
- If [To Rplcmt./Cleaning] is pressed immediately after pressing [Print List], wait time of approx. 2 minutes is required in order to protect the device.

-> The message screen will be shown to confirm the mode to be switched to Replacement/Cleaning mode.

2) Press [Yes].

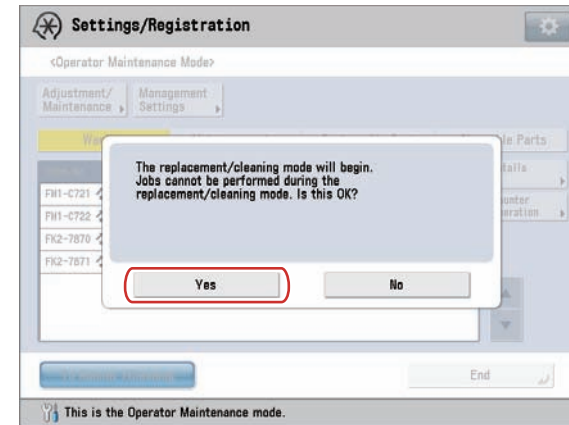

F-1-30

-> Move from Operator Maintenance mode to Replacement/Cleaning mode, and then replacement/cleaning mode screen in Operator Maintenance mode is shown.

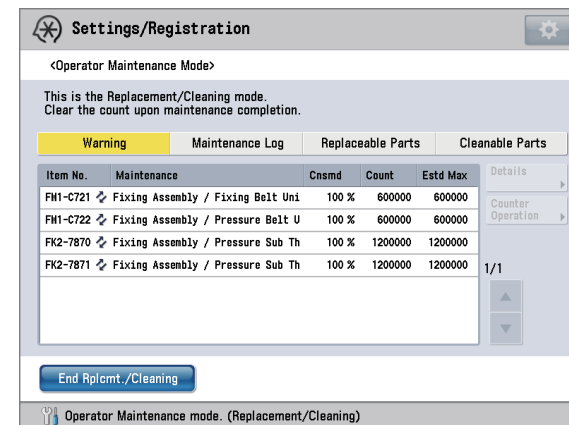

F-1-31

CAUTION:

Prohibitions in Replacement/Cleaning Mode.

- Moving to the other functions (including the system status/user mode)
- Power controls such as sleep or power saving.

Terminating Replacement/Cleaning Mode

After the replacement or cleaning of the target parts is finished, clear the counters, exit Replacement/Cleaning mode, and then return to Operator Maintenance mode.
(For clear the counter, refer to "Clearing the Counter"(page 1-12).)

->Close Replacement/Cleaning mode to return to Operator Maintenance mode. Then the operator maintenance basic screen is shown.

- 1) Press [End Rplcmt./Cleaning] on replacement/cleaning mode screen in Operator Maintenance mode.

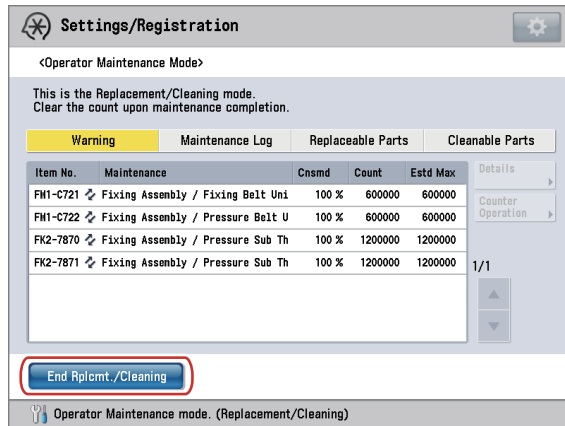

F-1-32

->The message will be shown on the screen to confirm Replacement/Cleaning mode termination.

- 2) Press [Yes].

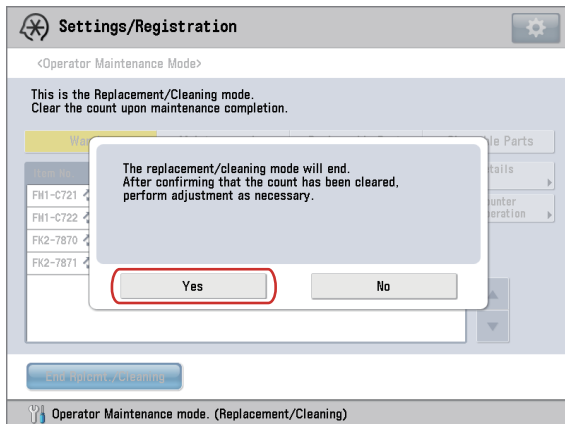

F-1-33

Adjustments/Settings

Adjustment/Maintenance Menu screen

Display adjustment/maintenance menu screen when executing parts adjustment or cleaning. Select adjustment or maintenance items needed in adjustment/maintenance operation screen.

1) In operator maintenance basic screen, press [Adjustment/Maintenance].

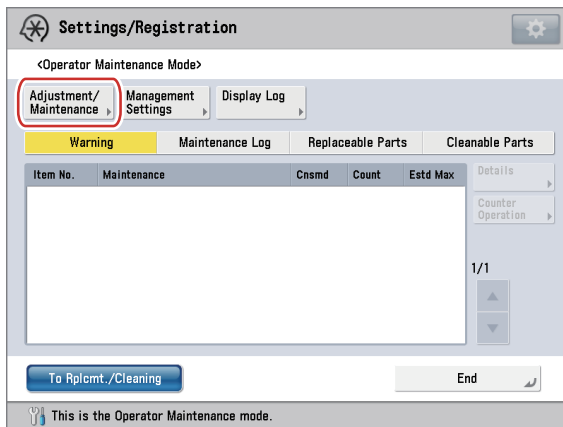

F-1-34

->Adjustment/maintenance screen is displayed.

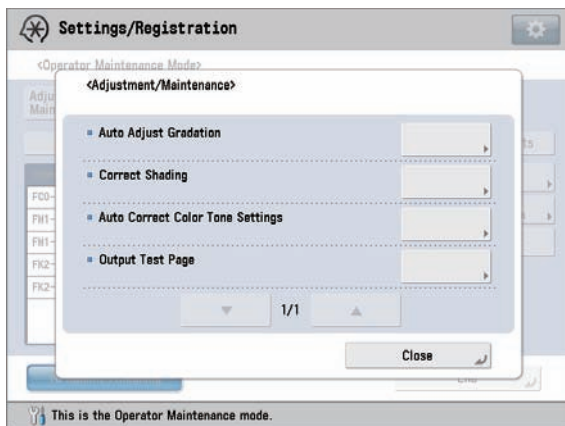

F-1-35

2) In adjustment maintenance menu screen, select adjustment or maintenance items needed and press the key.

-> The screen for executing item selected is displayed.

3) Execute adjustment/maintenance by following the indication on the each screen.

-> Back to adjustment/maintenance screen after adjustment/maintenance.

4) In adjustment/maintenance menu screen, press [Close] key.

-> Back to operator maintenance basic screen.

Automatic Gradation Adjustment

You can recalibrate the machine when you notice irregularities in the color of the copies or prints, such as when copies or prints turn out to be different from the original in gradation, density, or color.

The following two types of automatic gradation adjustments can be made:

- Quick Adjustment

This is a quick and simple adjustment that is made to the gradation, density, and color settings of the machine. Recalibrations are made internally without outputting any test pages.

- Full Adjustment

This is a precise recalibration that is made to the gradation, density, and color settings of the machine. The procedure involves making test pages and scanning them using the Duplex Color Image Reader Unit-H1 or the Auto Gradation Sensor-A1. Once this is complete, the machine automatically corrects the irregularities.

CAUTION:

- Make sure to perform this function in the stable room environment (i.e. temperature and humidity). The color may become unstable due to the rapid changes in room environment, especially soon after starting up an air conditioner during summer or winter season.
- It is recommended that you select [Full Adjust] when performing an automatic gradation adjustment. Select [Quick Adjust] for a quick, but less complete adjustment between regular full adjustment recalibrations.
- This machine adjusts the toner and print speed according to the paper type. To make effective adjustments, select the correct paper type.
- Make sure that you place the test pages properly. Accurate recalibrations of the gradation, density, and color settings of the machine cannot be made if the test pages are not scanned correctly.

NOTE:

Test pages are not counted as part of the copy or print total page counts.

Quick Adjustment

1) In Adjustment/Maintenance menu screen, press [Auto Adjust Gradation].

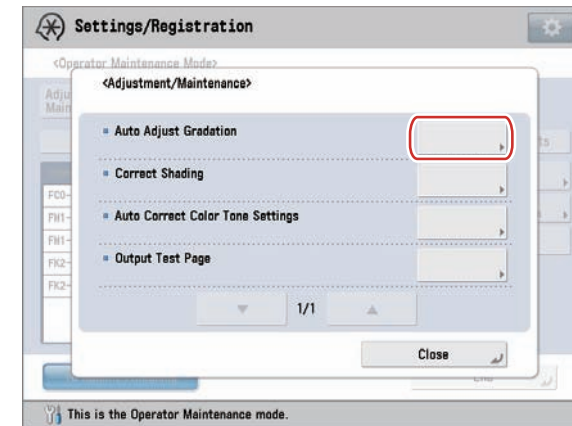

F-1-36

-> Automatic adjustment gradation screen is displayed.

2) In the Automatic adjustment gradation screen, press [Quick Adjust].

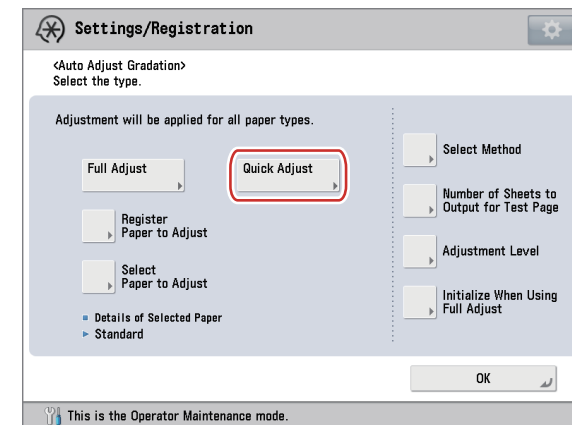

F-1-37

-> Quick adjustment screen is displayed.

3) In quick adjustment screen, press [Start].

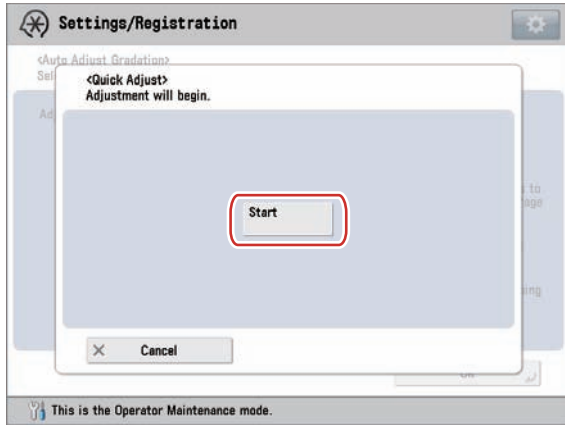

F-1-38

->Quick adjustment is executed. After the operation of quick adjustment, automatically back to Automatic adjustment gradation screen.

● Full Adjustment

You can select the following two types of procedure for automatic gradation adjustment (Full Adjustment):

- Use the Duplex Color Image Reader Unit-H1
In this procedure, you need to scan the printed test pages 3 times. You need to place test pages on the platen glass for scanning, but it takes shorter time for the adjustment in comparison to using the Auto Gradation Sensor-A1. The number of sheets required for the adjustment is 3 to 11 sheets of paper.
- Use the Auto Gradation Sensor-A1
In this procedure, the machine automatically performs the adjustment by printing test pages ten times. You do not need to set test pages for scanning, but it takes longer time for the adjustment in comparison to using the Duplex Color Image Reader Unit-H1. The number of sheets required for the adjustment is 10 to 42 sheets of paper.

NOTE:

If both the Duplex Color Image Reader Unit-H1 and the Auto Gradation Sensor-A1 are attached, select the automatic gradation adjustment method you use in [Select Method] beforehand.

- When Using the Duplex Color Image Reader Unit-H1 : [Use Scanner]
- When Using the Auto Gradation Sensor-A1 : [Do Not Use Scanner]

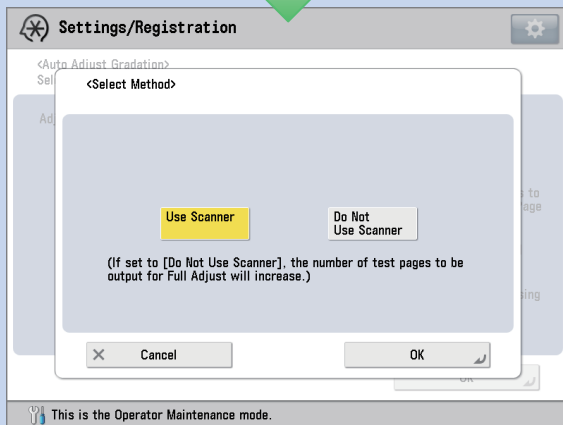
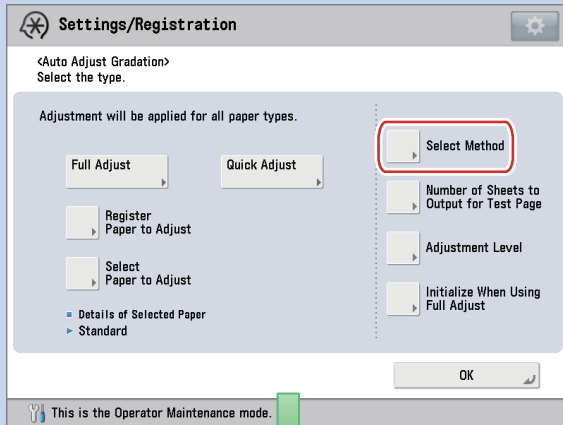

F-1-39

To perform this procedure, you must log in to this machine as an administrator.

NOTE:

Confirm that the following size and type of paper is set in the paper source before starting this procedure.

Item	When Using the Duplex Color Image Reader Unit-H1	When Using the Auto Gradation Sensor-A1
Size	<ul style="list-style-type: none"> • A3 • 11" x 17" 	<ul style="list-style-type: none"> • A3 • 11" x 17" • 12 5/8" x 17 11/16" • 12" x 18" • 13" x 19"
Basis Weight/Finish/Whiteness	Hammermill Color Copy Digital (28lb. (105 g/m ²))* or the paper type registered/selected as paper to adjust	

T-1-14

* The name of the paper is subject to change without notice. For more information, contact with service technician.

NOTE:

To improve the precision of the full adjustment, press [Number of Sheets to Output for Test Page] and increase the number of sheets to output for test page.

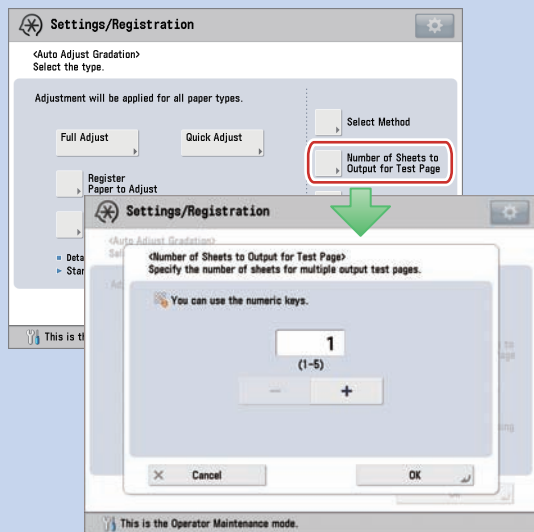

F-1-40

The following table shows the relationship between the setting value and actual number of sheets to output for test page.

- Number of sheets to output for test page when using the Duplex Color Image Reader Unit-H1

Setting Value	First Test Page	Second Test Page	Third Test Page	Total Test Pages
1	1 sheet	1 sheet	1 sheet	3 sheets
2	1 sheet	2 sheets	2 sheets	5 sheets
3	1 sheet	3 sheets	3 sheets	7 sheets
4	1 sheet	4 sheets	4 sheets	9 sheets
5	1 sheet	5 sheets	5 sheets	11 sheets

T-1-15

- Number of sheets to output for test page when using the Auto Gradation Sensor-A1

Setting Value	First Test Page	Second Test Page	Third Test Page	Forth Test Page	Total Test Pages
1	1 sheet	1 sheet	4 sheets	4 sheets	10 sheets
2	1 sheet	1 sheet	8 sheets	8 sheets	18 sheets
3	1 sheet	1 sheet	12 sheets	12 sheets	26 sheets
4	1 sheet	1 sheet	16 sheets	16 sheets	34 sheets
5	1 sheet	1 sheet	20 sheets	20 sheets	42 sheets

T-1-16

To perform this procedure, you must log in to this machine as an administrator.

- In Adjustment/Maintenance menu screen, press [Auto Adjust Gradation].

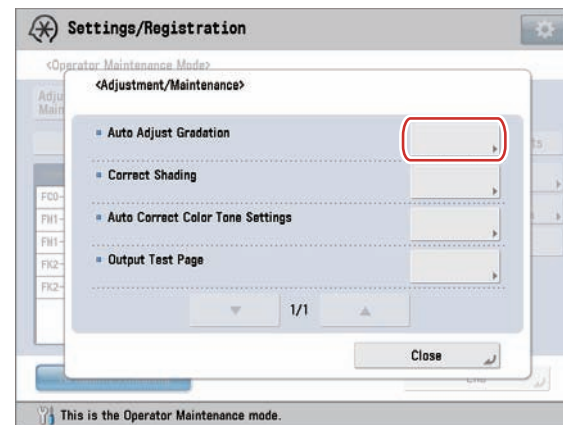

F-1-41

-> Automatic adjustment gradation screen is displayed.

- In the Automatic adjustment gradation screen, press [Full Adjust].

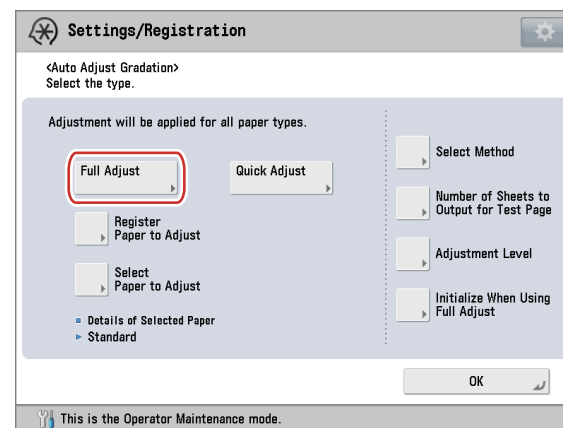

F-1-42

-> Select paper screen is displayed.

3) Select the paper and press [OK].

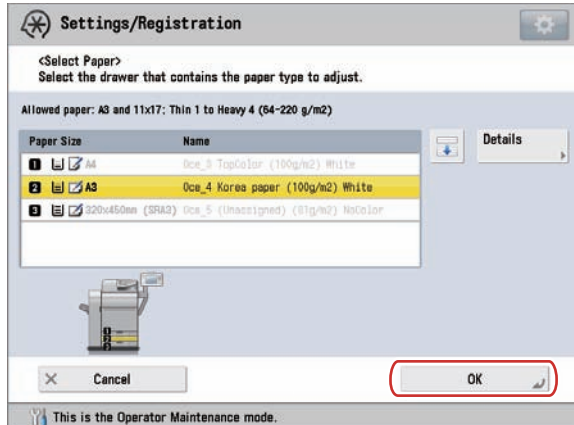

F-1-43

-> Full adjustment screen is displayed.

NOTE:

The following procedures are required when using the Duplex Color Image Reader Unit-H1 as an automatic gradation adjustment method. When using the Auto Gradation Sensor-A1, you do not need to scan test pages, and when you press [Start Printing], the machine prints test pages and perform full adjustment automatically.

4) In the full adjustment screen, press [Start Printing].

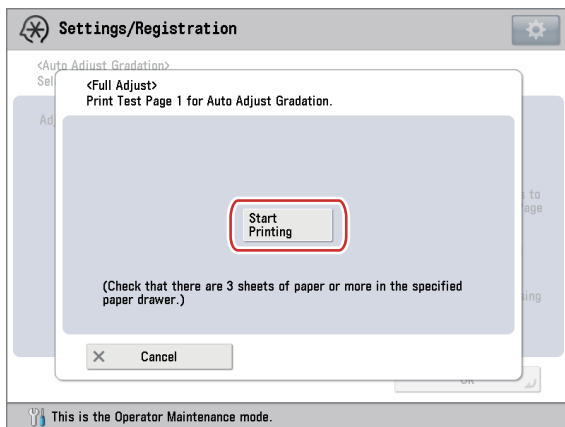

F-1-44

-> First test page is output.

5) Place the first test page on the platen glass -> press [Start Scanning].

Place the first test page face down on the platen glass, with the black bar along the left edge of the platen glass.

6) Remove the first test page from the platen glass -> press [Start Printing].

-> Second test page is output.

7) Place the second test page on the platen glass -> press [Start Scanning].

Place the second test page face down on the platen glass, with the black bar along the top back edge of the platen glass.

NOTE:

Make sure to place the last output if the multiple second test pages are output. To perform more precise full adjustment, you can increase the number of sheets for test pages in [Number of Sheets to Output for Test Page]. In this case, multiple second test pages are output.

8) Remove the second test page from the platen glass -> press [Start Printing].

-> Third test page is output.

9) Place the third test page on the platen glass -> press [Start Scanning].

Place the third test page face down on the platen glass, with the black bar along the top back edge of the platen glass.

NOTE:

Make sure to place the last output if the multiple third test pages are output. To perform more precise full adjustment, you can increase the number of sheets for test pages in [Number of Sheets to Output for Test Page]. In this case, multiple third test pages are output.

-> Full adjustment of gradation is executed based on the result of reading all test print.

After the normal termination of full adjustment, screen will automatically return to automatic gradation adjustment screen.

NOTE:

Pop-up error message prompting to retry is displayed at the abnormal termination of automatic gradation adjustment. When this message is displayed repeatedly, contact with service technician.

10) Remove the third test page from the platen glass.

● Registering Paper for Calibration

If you perform automatic gradation adjustment for a custom paper type, registering a custom paper type for calibration is required beforehand.

You can register paper for calibration in the following two types of procedure.

- Use the Duplex Color Image Reader Unit-H1
In this procedure, you need to scan the printed test pages 2 times, 1 time for base paper and 1 time for a custom paper type. You need to place test pages on the platen glass for scanning, but it takes shorter time for the adjustment in comparison to using the Auto Gradation Sensor-A1. The number of sheets required for the registration is 2 sheets of paper.
- Use the Auto Gradation Sensor-A1
In this procedure, the machine automatically performs the registration by printing test pages. You do not need to scan test pages, but it takes longer time for the registration in comparison to using the Duplex Color Image Reader Unit-H1. The number of sheets required for the adjustment is 4 sheets of paper. Two basis paper and two custom paper type to calibrate is output for test pages.

CAUTION:

- Make sure to register paper to adjust in the stable room environment (i.e. temperature and humidity).
- If the rapid changes in room environment occur after the registration of paper to adjust, accurate recalibrations of the gradation, density, and color settings of the machine cannot be made for paper already registered to adjust. In this case, register again that paper to adjust.
- Make sure to register paper whose finish and whiteness are equivalent to the Hammermill Color Copy Digital (28lb. (105 g/m²)) as paper to adjust. Accurate recalibrations of the gradation, density, and color settings of the machine may not be made if you register and use paper other than that condition as paper to adjust.
- To perform the procedure described in this section, you must log in to this machine as an administrator.
- If both the Duplex Color Image Reader Unit-H1 and the Auto Gradation Sensor-A1 are attached, select the automatic gradation adjustment method you use in [Select Method] beforehand.
 - When Using the Duplex Color Image Reader Unit-H1 : [Use Scanner]
 - When Using the Auto Gradation Sensor-A1 : [Do Not Use Scanner]

CAUTION:

Confirm that both paper to use as a basis and a custom paper type to register to adjust, described in the following table, are set in paper sources correctly before starting this procedure.

Item	When Using the Duplex Color Image Reader Unit-H1	When Using the Auto Gradation Sensor-A1
Size	<ul style="list-style-type: none"> • A3 • 11" x 17" 	<ul style="list-style-type: none"> • A3 • 11" x 17" • 12 5/8" x 17 11/16" • 12" x 18" • 13" x 19"
Basis Weight/Finish/Whiteness	Paper to use as a basis: <ul style="list-style-type: none"> • Hammermill Color Copy Digital (28lb. (105 g/m²))* • Thin 1, Plain 1, Plain 2 or Heavy 1 to Heavy 6/Uncoated that has the same whiteness of the Hammermill Color Copy Digital (28lb. (105 g/m²)) and that is already registered as paper to adjust • Custom paper type equivalent to the above basis weight/finish/whiteness and already registered as paper to adjust Custom paper type to register to adjust: Custom paper type equivalent to the basis weight/finish/whiteness of paper to use as a basis	

T-1-17

* The name of the paper is subject to change without notice. For more information, contact with service technician.

NOTE:

While you are registering the custom paper type as a paper to adjust, the paper type settings are protected and you cannot change the detailed information for custom type or delete the custom type in [Paper Type Management Settings] in [Preferences] (Settings/Registration).

1) In Adjustment/Maintenance menu screen, press [Auto Adjust Gradation].

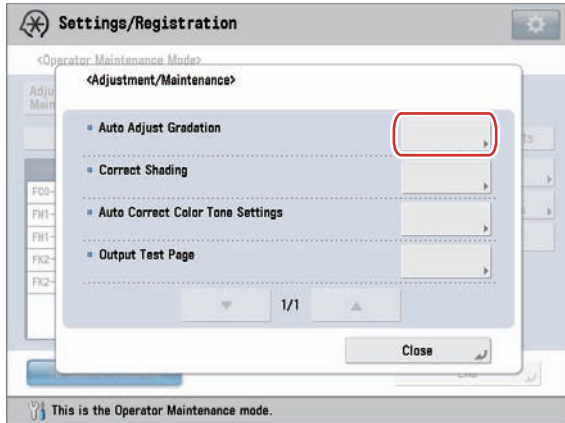

F-1-45

->Automatic adjustment gradation screen is displayed.

2) Press [Register Paper to Adjust].

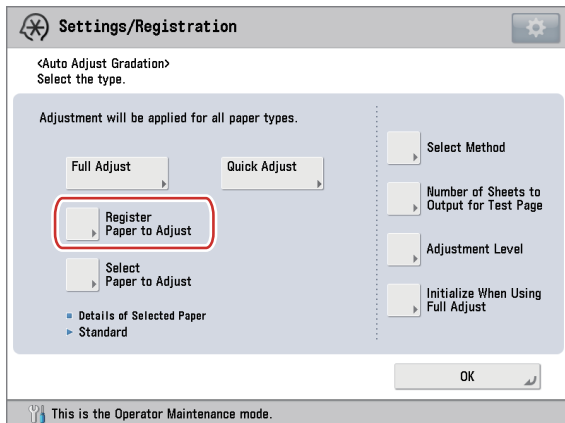

F-1-46

3) Select the destination for registering new paper to adjust -> press [Next].

NOTE:

You can register up to three type of paper to adjust and you can overwrite them. When overwriting, you cannot restore the paper settings previously registered.

4) Select the type for the paper to use as a basis -> press [Next].

5) Select the paper source contains the type of paper to use as a basis -> press [Next].

CAUTION:

This machine adjusts the toner and print speed according to the paper type. To make effective adjustments, select the correct paper type.

6) Press [Start Printing].

-> First test page is output.

NOTE:

If you are using the Auto Gradation Sensor-A1, steps 7 to 8 are not necessary. Proceed to step 9.

7) Place the first test page on the platen glass -> press [Start Scanning].

Place the first test page face down on the platen glass, with the black bar along the top back edge of the platen glass.

8) Remove the first test page from the platen glass.

9) Select the paper source that contains the custom paper type to adjust -> press [Next].

CAUTION:

This machine adjusts the toner and print speed according to the paper type. To make effective adjustments, select the correct paper type.

10) Press [Start Printing].

-> Second test page is output.

NOTE:

If you are using the Auto Gradation Sensor-A1, the following steps are not necessary.

11) Place the second test page on the platen glass -> press [Start Scanning].

Place the second test page face down on the platen glass, with the black bar along the top back edge of the platen glass.

12) Remove the second test page from the platen glass.

Selecting Paper for Calibration

You can select the type of paper for calibration.

CAUTION:

To perform the procedure described in this section, you must log in to this machine as an administrator.

1) In Adjustment/Maintenance menu screen, press [Auto Adjust Gradation].

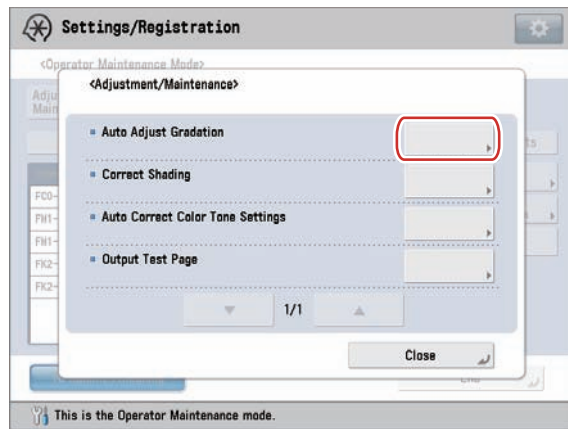

F-1-47

-> Automatic adjustment gradation screen is displayed.

2) Press [Select Paper to Adjust] -> select the type of paper to adjust -> press [OK].

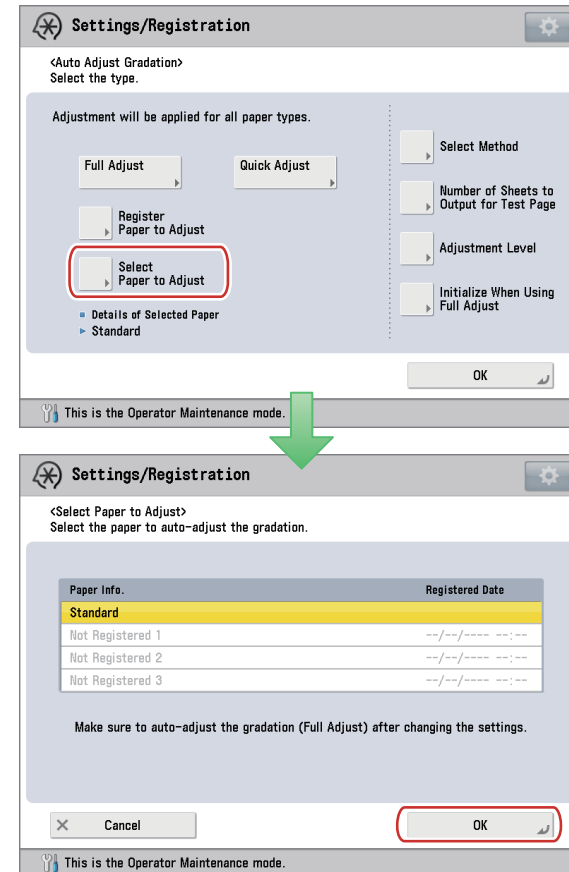

F-1-48

CAUTION:

- This machine adjusts the toner and print speed according to the paper type. To make effective adjustments, select the correct paper type.
- To perform the auto gradation adjustment to some custom paper type, select that custom paper type, which is registered in advance, for paper to adjust.

Changing Adjustment Level

You can change the adjustment level for auto gradation adjustment.

CAUTION:

To perform the procedure described in this section, you must log in to this machine as an administrator.

NOTE:

When you set [By Paper Type Group] for [Adjustment Level], you can select the paper type and make effective adjustments according to the paper type that you select from [Thin 1/Plain/Heavy 1-4], [Heavy 5], or [Heavy 6].

1) In Adjustment/Maintenance menu screen, press [Auto Adjust Gradation].

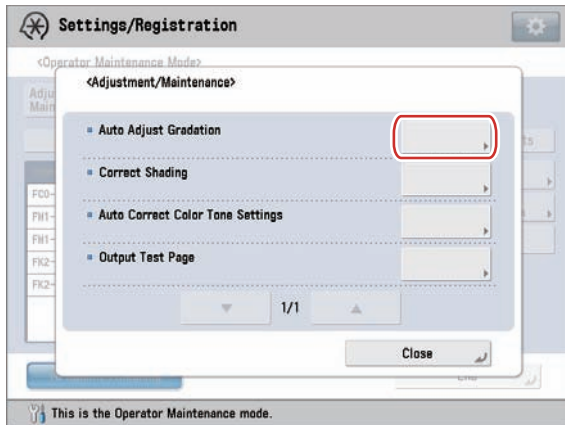

F-1-49

-> Automatic adjustment gradation screen is displayed.

2) Press [Adjustment Level] -> select the adjustment level -> press [OK].

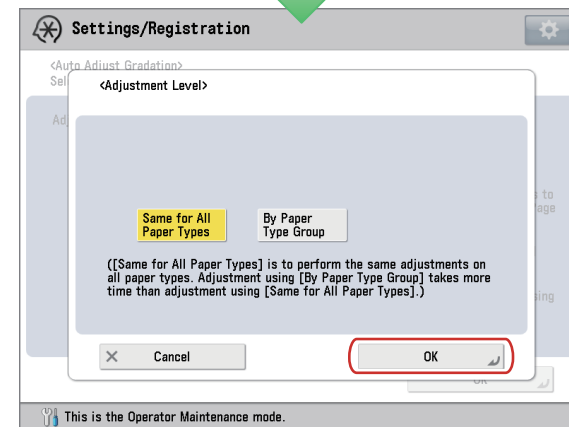
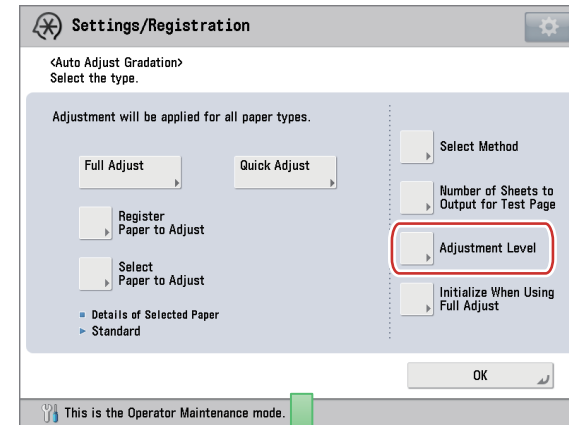

F-1-50

CAUTION:

After changing the settings, make sure to perform the automatic gradation adjustment first, and then perform the color balance adjustment as the color balance may become unstable.

● Initializing Standard Values for Calibration

If you perform automatic gradation adjustment but cannot adjust gradation, density, or color correctly, or scanned error message appears for the test page, set [Initialize When Using Full Adjust] to 'On', and then perform [Full Adjust].

1) In Adjustment/Maintenance menu screen, press [Auto Adjust Gradation].

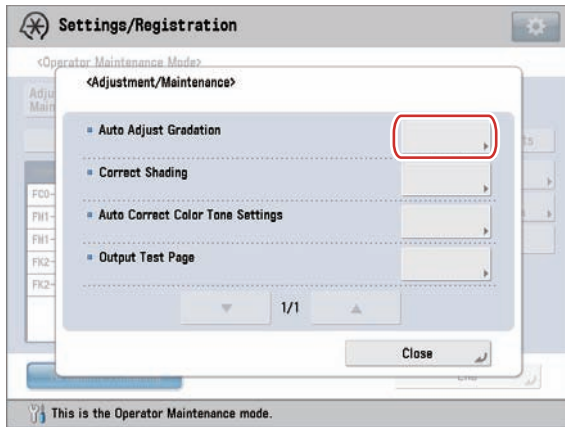

F-1-51

->Automatic adjustment gradation screen is displayed.

2) Press [Initialize When Using Full Adjust] -> [On] -> [OK].

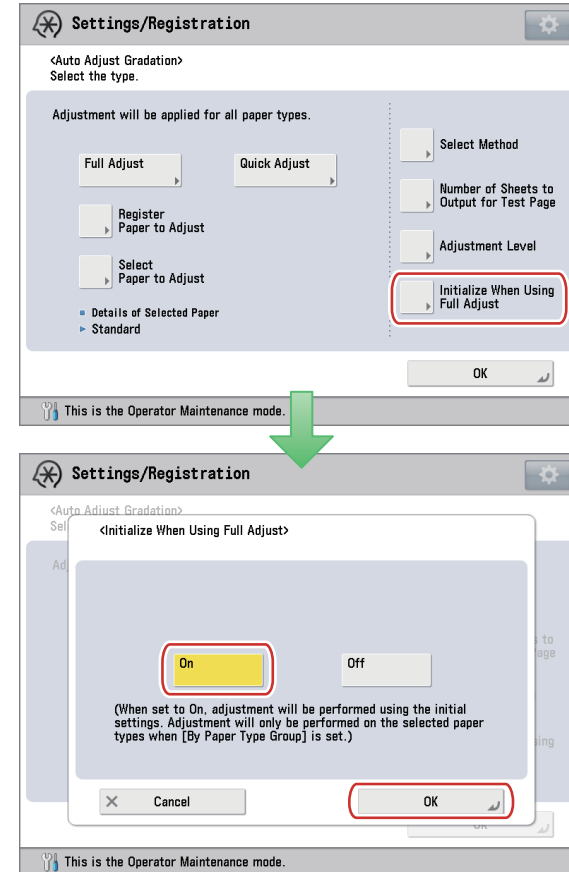

F-1-52

3) Perform Full Adjust by following steps 2 to 10 in "Full Adjustment".

Shading Correction

This mode enables you to correct the slightly uneven densities that occur in the halftone density area of a printed image.

The following three types of shading correction can be made:

- **Densitometer Correction**
This mode enables you to correct uneven densities by gauging the output results of the test page using a densitometer, and entering the displayed values for density adjustment.
- **Visual Correction**
This mode enables you to correct uneven densities by viewing the output results of the test page and adjusting the density manually. Select this mode to correct uneven densities if the densitometer is unavailable or the densitometer correction is unsatisfactory. Note that sufficient experience in detecting slightly uneven densities is required to manually adjust the density.

NOTE:

13" x 19", 12 5/8" x 17 16/11", 12" x 18", 11" x 17", or LTR plain paper can be used for test pages. Make sure that a sufficient supply of paper is loaded in the paper source before starting this procedure.

NOTE:

Other than the foregoing methods, shading correction can be performed by receiving data from the print server when installing the optional imagePRESS Server. For details, refer to the manual that comes with imagePRESS Server.

Densitometer Correction

1) In Adjustment/Maintenance menu screen, press [Correct Shading].

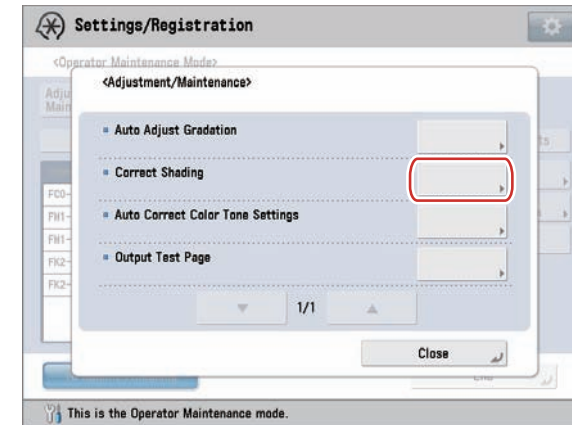

F-1-53

-> Shading correction screen is displayed.

2) Press [Densitometer Correction] -> [Start Printing].

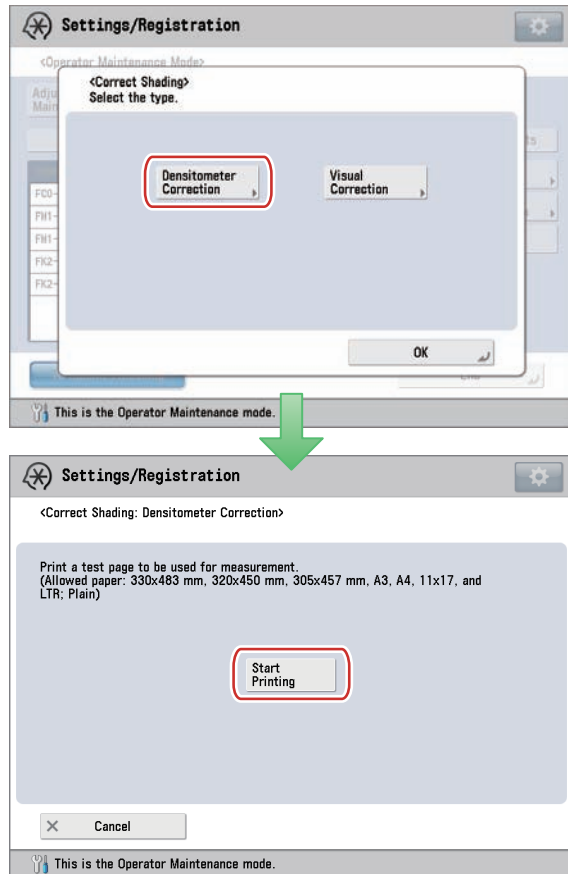

F-1-54

-> Test page 1 with marks from 0 to 8 is output.

NOTE:

The marks 0 and 8 may not be shown, depending on the paper width.

3) Gauge the mark on the output test page 1 using the densitometer.

4) Press [Fine Adjust] of the color you want to adjust.

5) Select the number -> enter the gauged density value from the test page -> press [OK].

NOTE:

- The density adjustment is performed based on all the density values of marks from 0 to 8. If all marks from 0 to 8 are shown on the test page, make sure to gauge and enter the density values for all imprinted marks.
- If the marks 0 and 8 are not shown on the test page, gauge and enter the density values for all the imprinted marks from 1 to 7 and make sure that the density values for the marks 0 and 8 are set to "0". If you enter the density values other than "0" for the marks 0 and 8, you cannot perform density adjustment precisely.

6) Press [Output Test Page] -> [Start Printing].

-> Test page 2 with marks from -7 to +6 after adjustment is output.

NOTE:

- The marks -7 and +6 may not be shown on the output test page 2, depending on the paper width.
- Although the mark -7 may be shown on the output test page 2, the numbers you can adjust values for are from -6 to +6. You cannot adjust values for -7.

7) View the output test page 2 and confirm that there is no uneven density.

8) Press [Store and Finish].

Visual Correction

1) In Adjustment/Maintenance menu screen, press [Correct Shading].

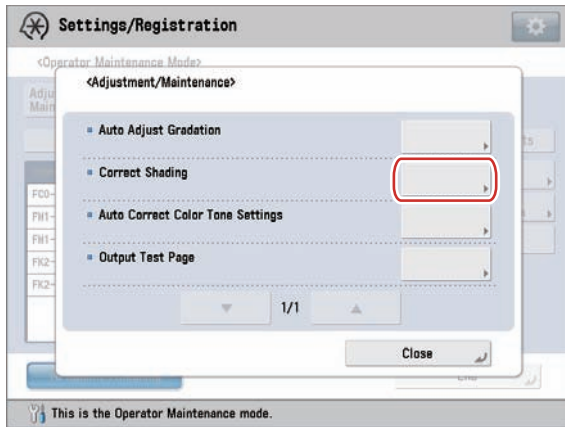

F-1-55

-> Shading correction screen is displayed.

2) Press [Visual Correction] -> [Output Test Page] -> [Start Printing].

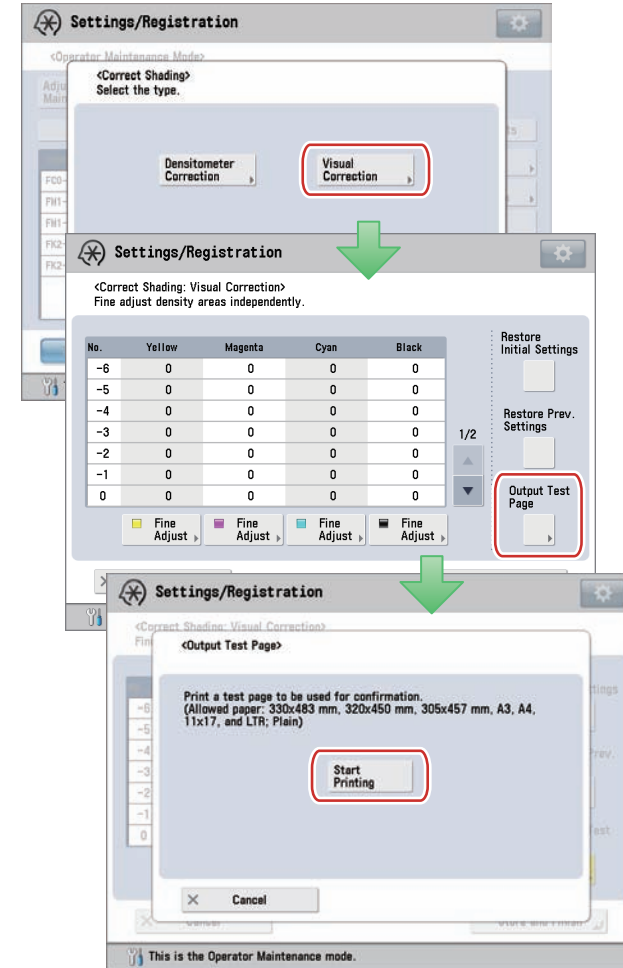

F-1-56

-> Test page 2 with marks from -7 to +6 is output.

NOTE:

- The marks -7 and +6 may not be shown on the output test page 2, depending on the paper width.
- Although the mark -7 may be shown on the output test page 2, the numbers you can adjust values for are from -6 to +6. You cannot adjust values for -7.

- 3) View the output test page -> press [Fine Adjust] of the color you want to adjust.
- 4) Select the number to adjust -> press [+] for a heavy density or [-] for a light density -> [OK].
- 5) Press [Output Test Page] -> [Start Printing].
-> Test page 2 with marks from -7 to +6 after adjustment is output.
- 6) View the output test page 2 and confirm that there is no uneven density.
- 7) Press [Store and Finish].
-> The display returns to the screen of step 1. Repeat steps for visual correction until the shading is improved.

■ Automatic Color Tone Correction

The hue of the image is automatically corrected by outputting a test page and reading it with the optional Duplex Color Image Reader Unit-H1.

CAUTION:

- Make sure to perform this function in the stable room environment (i.e. temperature and humidity). The color may become unstable due to the rapid changes in room environment, especially soon after starting up an air conditioner during summer or winter season.
- You can use this function only if the Duplex Color Image Reader Unit-H1 is attached.
- Make sure to perform "Automatic Gradation Adjustment (Full Adjust)" to correct gradation and density settings before starting "Auto Correct Color Tone" to correct color settings.
- This machine adjusts the toner and print speed according to the paper type. To make effective adjustments, select the correct paper type.
- Make sure that you place the test pages properly. Accurate recalibrations of the color settings of the machine cannot be made if the test pages are not scanned correctly.

NOTE:

Test pages are not counted as part of the copy or print total page counts.

Automatic Color Tone Correction

1) In Adjustment/Maintenance menu screen, press [Auto Correct Color Tone Settings].

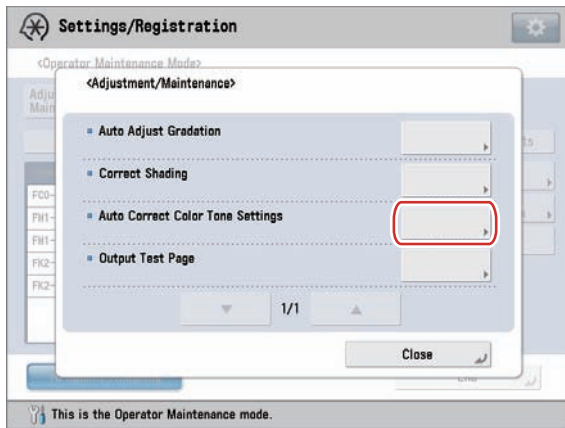

F-1-57

-> Automatic color tone correction screen is displayed.

2) Press [Auto Correct Color Tone].

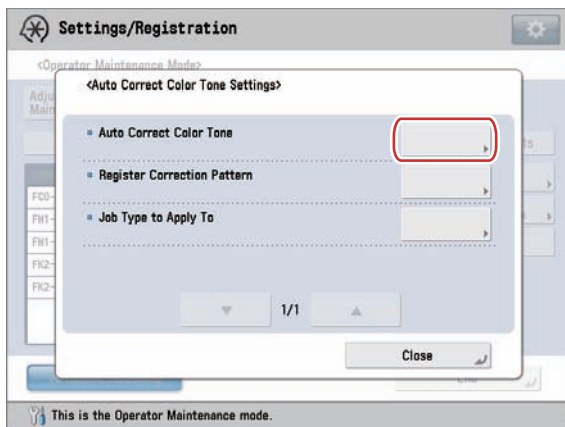

F-1-58

-> A screen for checking whether or not auto gradation adjustment (full adjustment) has been performed will appear.

3) Press [Yes].

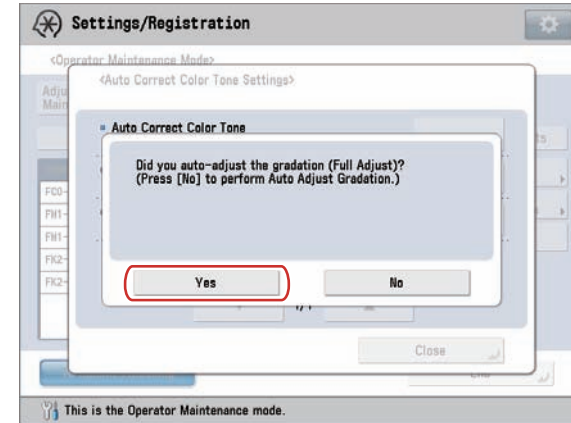

F-1-59

NOTE:

Press [No] to perform automatic gradation adjustment.

4) Press [Start Correcting].

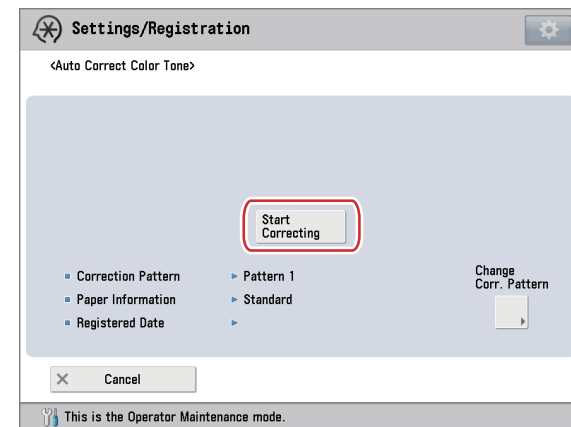

F-1-60

-> This procedure corrects color using the default correction pattern.

NOTE:

To correct color using the registered correction pattern, press [Change Corr. Pattern] -> select the registered correction pattern -> press [OK].

- 5) Select the paper source that contains Hammermill Color Copy Digital (28lb. (105 g/m²)) or paper to adjust -> press [OK].

CAUTION:

If you correct color tone using the registered correction pattern, you can only select the paper source that contains the same type of paper as you used for test page when registering the selected correction pattern.

NOTE:

The name of the paper is subject to change without notice. For more information, contact with service technician.

- 6) Press [Start Printing].
-> Test page is output.

- 7) Place the test page face down on the platen glass -> press [Start Scanning].
Place the test page face down, with the gray bar along the left edge of the platen glass.

- 8) Remove the test page from the platen glass.

● Registering Correction Pattern

You can create and register correction patterns for desired paper type.

CAUTION:

To perform the procedure described in this section, you must log in to this machine as an administrator.

- 1) In Adjustment/Maintenance menu screen, press [Auto Correct Color Tone Settings].

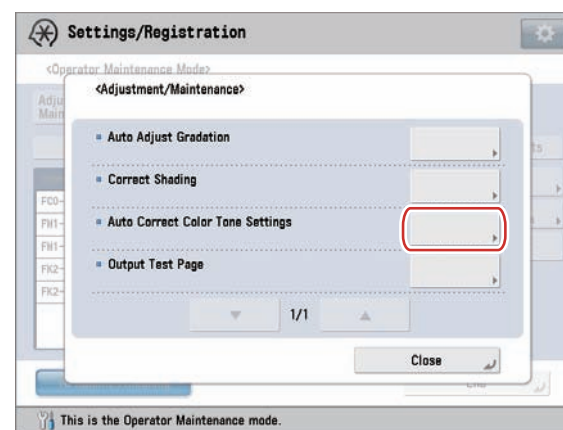

F-1-61

-> Automatic color tone correction screen is displayed.

- 2) Press [Register Correction Pattern].

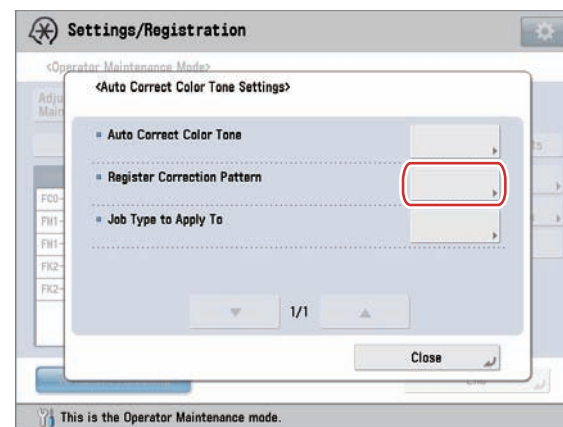

F-1-62

->A screen for checking whether or not auto gradation adjustment (full adjustment) has been performed will appear.

3) Press [Yes].

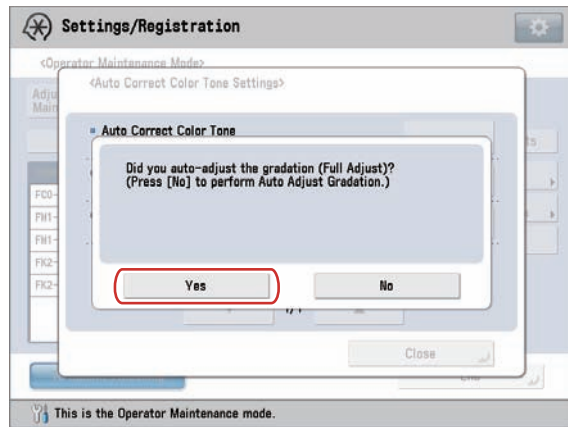

F-1-63

NOTE:

Press [No] to perform automatic gradation adjustment.

4) Select the registration destination for new correction pattern -> press [Next].

NOTE:

You can register up to four correction patterns and overwrite existing correction patterns. When you overwrite the correction pattern, the previous correction pattern is deleted.

5) Select paper type to use for test page -> press [Next].

You can select the paper type from the simple or detailed setting screen. For paper types that are not displayed on the simple setting screen, press [Detailed Settings] -> select the paper type from the detailed setting screen.

CAUTION:

- You can use the following paper size and paper type other than Hammermill Color Copy Digital (28lb. (105 g/m²))*

Size:

- A3, A4, 11" x 17", and LTR

Basis Weight/Finish/Whiteness:

- Thin 1, Plain 1, Plain 2 or Heavy 1 to Heavy 6/Uncoated that has the same whiteness of the Hammermill Color Copy Digital (28lb. (105 g/m²))
- Custom paper type whose basis weight/finish/whiteness is equivalent to above

* The name of the paper is subject to change without notice. For more information, contact with service technician.

- This machine adjusts the toner and print speed according to the paper type. To make effective adjustments, select the correct paper type.

NOTE:

- If paper type you want to use for test page for correction is not listed in the detailed settings screen, you can register paper type in the list.
- While you are registering the custom paper type as a correction pattern, the paper type settings are protected and you cannot change the detailed information for custom type or delete the custom type in [Paper Type Management Settings] in [Preferences] (Settings/Registration).

6) Select the paper source that contains the correct paper to use for the test page -> press [OK].

7) Press [Start Printing].
-> Test page is output.

8) Place the test page face down on the platen glass -> press [Start Scanning].
Place the test page face down on the platen glass, with the gray bar along the left edge of the platen glass.

9) Remove the test page from the platen glass.

Job Type to Apply

When performing [Auto Correct Color Tone], corrections of color tone are applied to copy/print jobs. Corrections can be applied separately for copy job or print job. If you do not want to change the color tone of either copy or print job, set [Off] for the job type you do not want to apply to in [Job Type to Apply To].

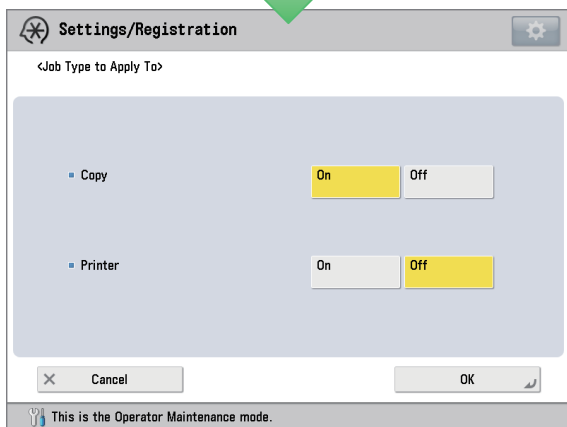
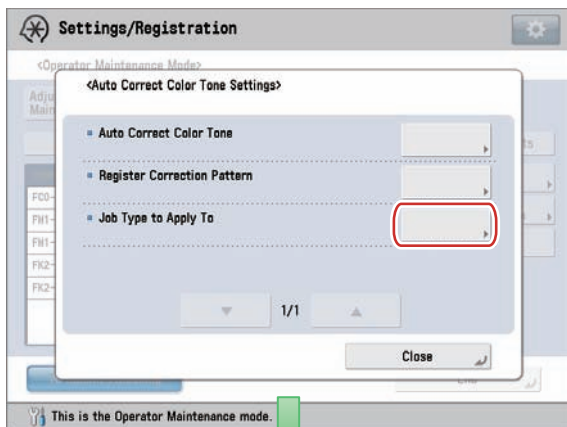

F-1-64

Output Test Page

Execute the output test page with the following procedure.

- 1) Press [Output Test Page] on Adjustment/Maintenance Menu screen.

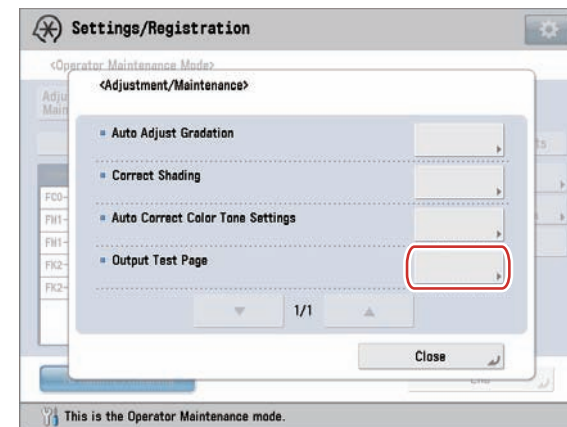

F-1-65

->Output Test Page: Image Type Selection screen is displayed.

- 2) Select the image type to be output, and press [Next].

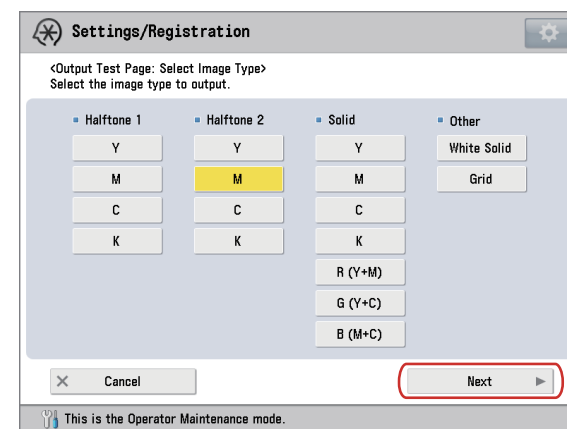

F-1-66

NOTE:

As for the setting items for the image type, multiple selections are possible.

->Output Test Page: Paper Selection screen is displayed.

3) Select a paper and press [OK].

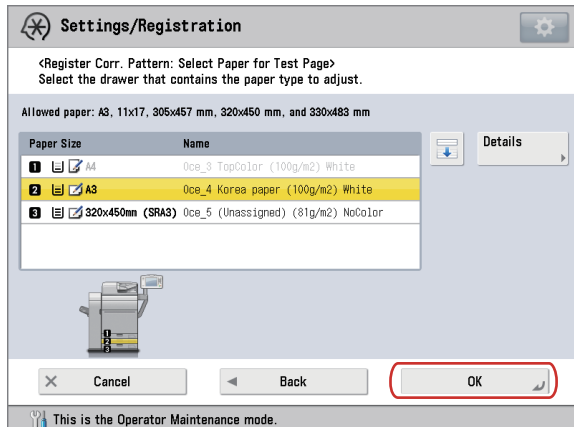

F-1-67

NOTE:

- Paper sizes to be used for test printing are A3, 11x17, 305 x 457 mm, 320 x 450 mm, 330 x 483 mm.
Plain paper is the recommended paper type.
- The duplexing mode is not available for the test print.

->When the test print completes normally, it automatically returns to Adjustment/Maintenance Menu screen.

By pressing [Back], Output Test Page: Select Image Type screen is displayed.

By pressing [Cancel], it returns to Adjustment/Cleaning Menu screen.

NOTE:

Pop-up error message prompting to retry is displayed at the abnormal termination.
When this message is displayed repeatedly, contact the service representative.

Management Setting Menu Screen

In order to change the password for the Operator Maintenance mode or the auto time-out conditions, display Management Setting Menu screen first.

On the Management Setting Menu screen, select the item intended to change.

1) Press [Management Settings] on Operator Maintenance Basic screen.

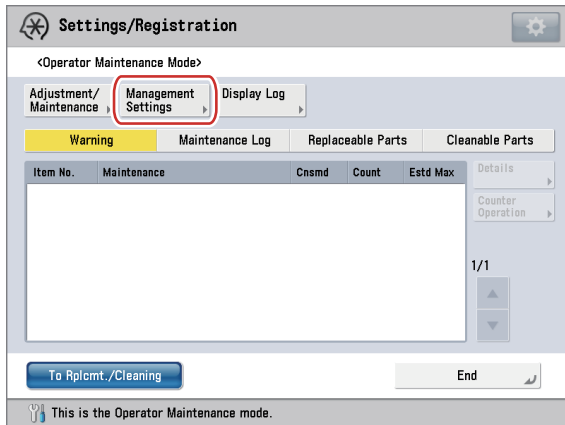

F-1-68

-> Management Setting Menu screen is displayed.

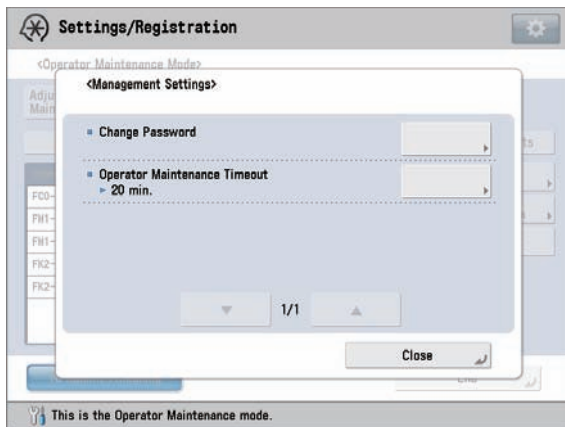

F-1-69

2) On Management Setting Menu screen, select the item intended to change and press the key.

-> The screen to change the selected item is displayed.

3) Change the settings by following the instruction on each screen.

-> When the setting change completes, it returns to Management Setting Menu screen.

4) Press [Close] on Management Setting Menu screen.

-> It returns to Operator Maintenance Basic screen.

Changing Password

The password to enter Operator Maintenance Mode can be changed.

1) Press [Change Password] on Management Setting Menu screen.

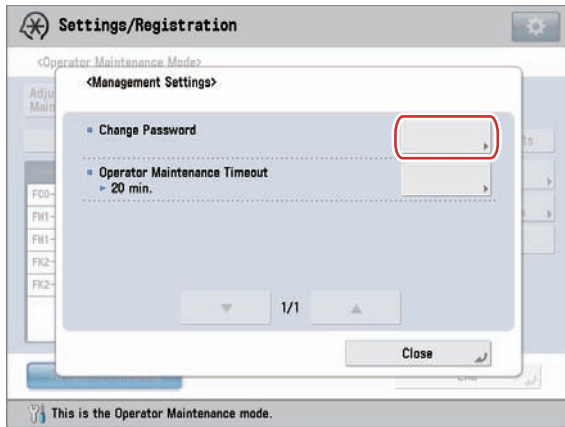

F-1-70

->Change Password screen is displayed.



F-1-71

2) Enter the password.

NOTE:

Only 7-digit numbers can be set for the password.

3) Press [Confirm], and reenter the password for confirmation.

4) Press [OK].

Initialization of the Password

It is possible to initialize the password for entering operator maintenance mode.

1) Press [Settings/Registration] > [Adjustment/Maintenance] > [Operator Maintenance].

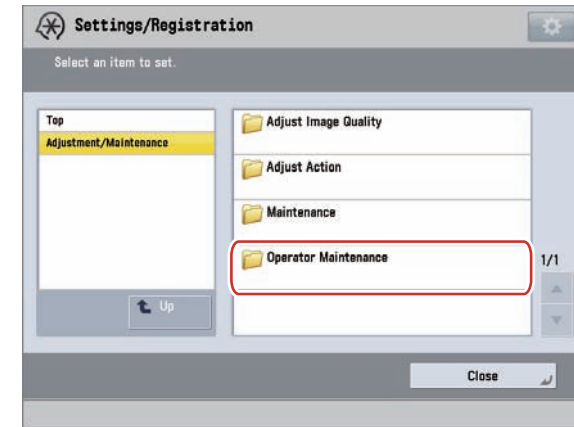

F-1-72

2) Press [Initialize Operator Maintenance Password].

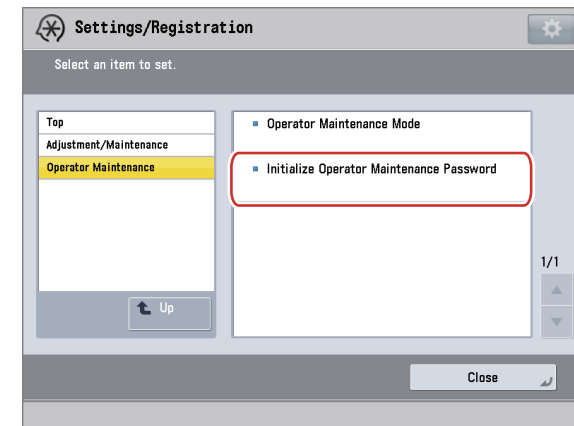

F-1-73

->The message screen for confirming initialization of the password will appear.

3) Press [Yes].

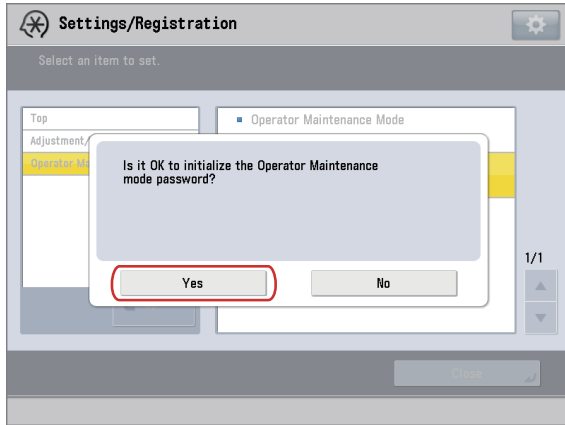

F-1-74

Settings of Auto-Timeout Conditions

The auto-timeout time of the Operator Maintenance mode can be changed.

Assignable values: 0 = Off, 5 mins, 10 mins, 20 mins, 30 mins, 1 hour, 90 mins, 2 hours

1) Press [Operator Maintenance Timeout] on the screen of control settings menu.

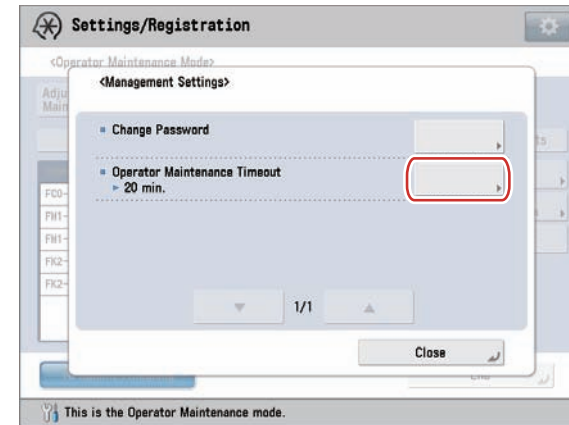

F-1-75

-> The screen of the settings of auto-timeout conditions is displayed.

2) Set the time of auto-timeout conditions, and Press [OK].

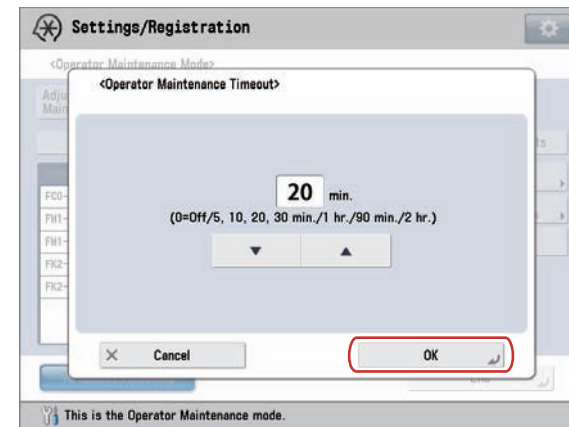

F-1-76

Display Log Menu Screen

Selects a target of the log to be displayed. The log of jam (JAM), error (ERR) and alarm (ALARM-2) can be displayed.

1) Press [Display Log] of the operator maintenance basic screen.

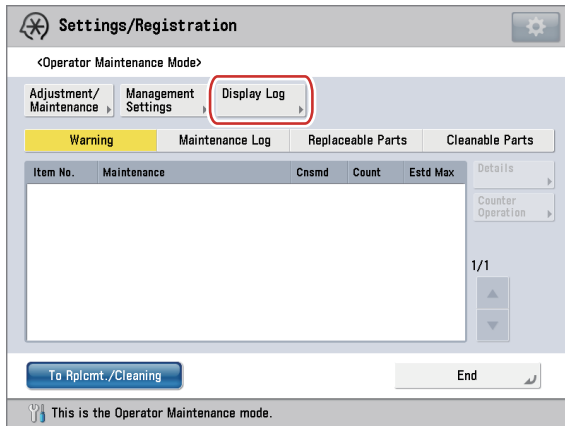

F-1-77

NOTE:

[Display Log] is not displayed in the normal setting, therefore this function cannot be used.

If [Display Log] needs to be displayed for the use of this function, contact a servicing person.

[Display Log] is not displayed in the Replacement/Cleaning mode, therefore this function cannot be used.

->The display log menu screen is displayed.

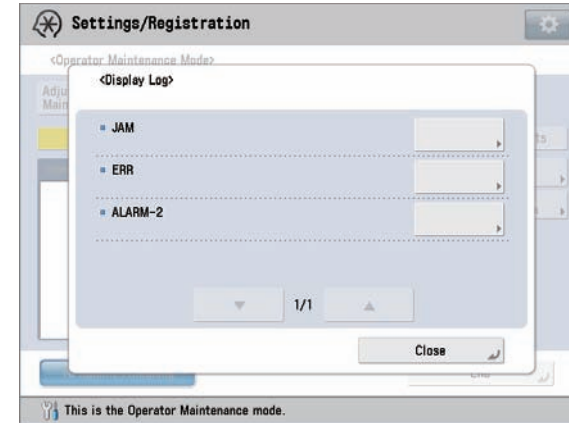

F-1-78

2) Select an item whose log needs to be displayed via the display log menu screen, and press the key.

->The display log screen of the selected item is displayed.

3) Confirm the log on each display log screen. After confirming them, press [Close].

->Return to the display log menu screen.

4) Press [Close] of the display log menu screen.

->Return to the operator maintenance basic screen.

Display of Log of JAM

The log of jam (JAM) is displayed.

NOTE:

This function cannot be used in the normal setting. If it needs to be available, contact a servicing person.

This function cannot be used in the Replacement/Cleaning mode.

1) Press [JAM] on the log display menu screen.

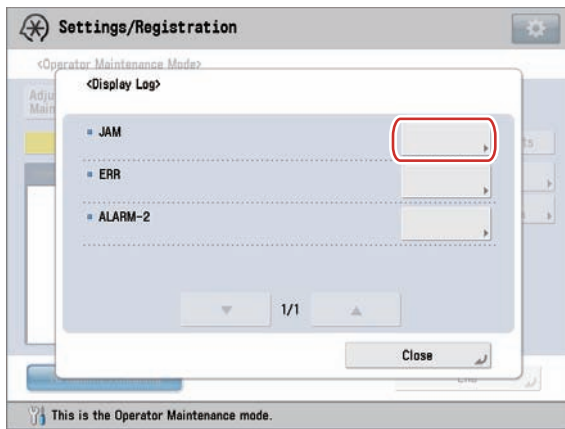

F-1-79

->The JAM screen is displayed.

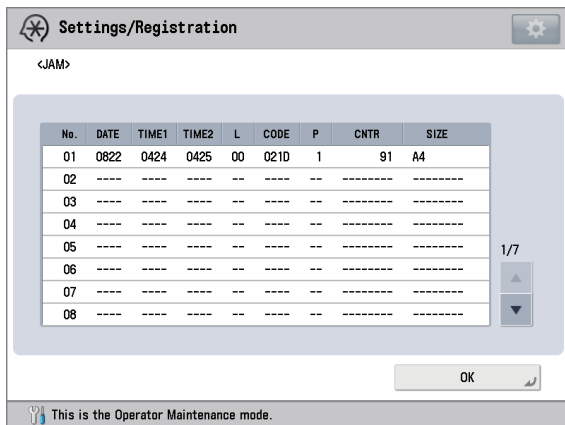

F-1-80

2) Confirm the log of jam (JAM).

3) After confirming the log, press [OK].

The contents of the display

Items	Contents
No.	Sequence of jam occurrence (the larger the number is, the older time jam occurred in) Maximum 50 cases
DATE	Date of jam occurrence (2 digits both for month and date)
TIME1	Time of jam occurrence (24-hr display)
TIME2	Time of jam recovery (24-hr display)
L	Category of occurrence
CODE	Jam code
P	Pickup position
CNTR	Pickup cassette soft counter
SIZE	Paper size

T-1-18

Display of Log of ERR

The log of error (ERR) is displayed.

NOTE:

This function cannot be used in the normal setting. If it needs to be available, contact a servicing person.

This function cannot be used in the Replacement/Cleaning mode.

1) Press [ERR] on the log display menu screen.



F-1-81

->The ERR screen is displayed.

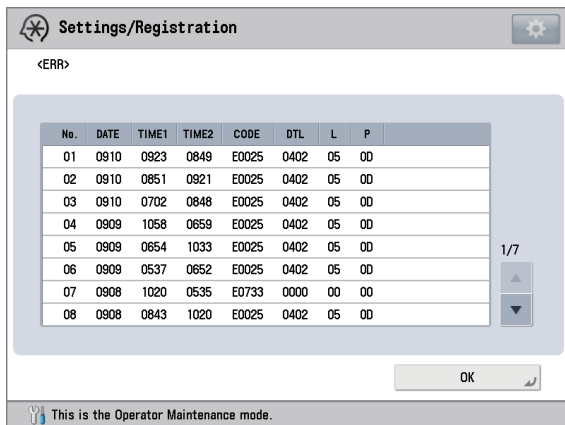

F-1-82

2) Confirm the log of error (ERR).

3) After confirming the log, press [OK].

The contents of the display

Items	Contents
No.	Sequence of error activation (the larger the number is, the older time err occurred in) Maximum 50 cases
DATE	Date of error occurrence (2 digits both for month and date)
TIME1	Time of error occurrence (24-hr display)
TIME2	Time of error recovery (24-hr display)
CODE	Error code
DTL	Detailed error code
L	Category of occurrence
P	Not used

T-1-19

Display of Log of ALARM-2

The log of alarm (ALARM-2) is displayed.

NOTE:

This function cannot be used in the normal setting. If it needs to be available, contact a servicing person.

This function cannot be used in the Replacement/Cleaning mode.

1) Press [ALARM-2] on the log display menu screen.

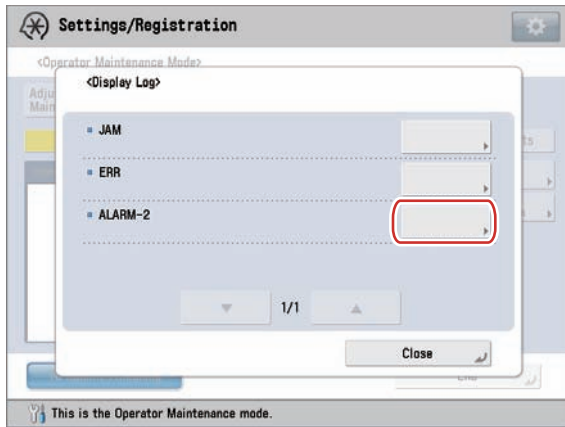

F-1-83

-> The ALARM-2 screen is displayed.

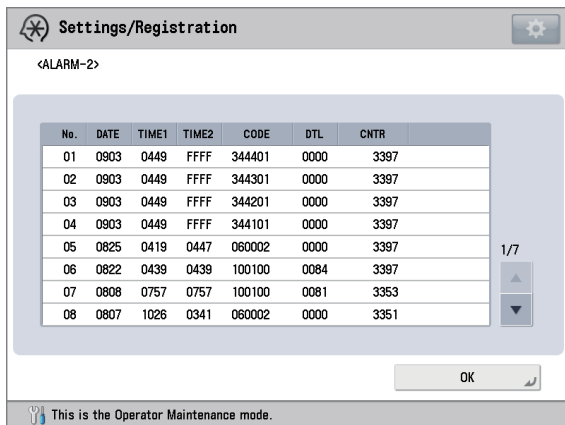

F-1-84

2) Confirm the log of alarm (ALARM-2).

3) After confirming the log, press [OK].

The contents of the display

Items	Contents
No.	Sequence of alarm activation (the larger the number is, the older time alarm occurred in) Maximum 50 cases
DATE	Date of alarm activation (2 digits both for month and date)
TIME1	Time of alarm activation (24-hr display)
TIME2	Time of alarm recovery (24-hr display)
CODE	Code of alarm activation location
DTL	Detailed alarm code
CNTR	Soft counter at the time of alarm activation

T-1-20

2

Procedure of Replacement/ Cleaning

- List of Operator Replaceable/Cleanable Parts
- Transfer area
- Fixing area
- Cleaning

List of Operator Replaceable/Cleanable Parts

The parts that need to be replaced/cleaned after a certain period of use, their estimated life (number of sheets) and the cleaning interval (number of seconds) are shown in the following table. Be sure to replace or clean the part in order to maintain the performance and functions of the host machine.

NOTE:

- The expected life is based on the median of the evaluation data. The actual life may be differed depending on the installation environment and/or the machine use. Please note that parts numbers are subject to change due to improvement or others.
- The number written in "Adjustment after replacement" indicates the adjustment order.

Replaceable Parts

As of November 2014													
Category	Part name	Part No.	Replacement interval (sheets)				Q'ty	Adjustment after replacement				Parts replaced by operator	Reference
			image PRESS C800	image PRESS C700	image PRESS C600	image PRESS C60		Auto Adjust Gradation	Correct Shading	Auto Correct Color Tone Settings	Output Test Page		
			Transfer area	Secondary Transfer Outer Roller	FC0-9786	900,000		750,000	600,000	600,000	1		
Fixing area	Fixing Assembly / Fixing Belt Unit	FM1-C721	600,000	500,000	400,000	400,000	1	1	2	3	4	Fixing Assembly	p. 2-7
	Fixing Assembly / Pressure Belt Unit	FM1-C722	600,000	500,000	400,000	400,000	1						
	Fixing Assembly / Pressure Sub Thermistor (Rear)	FK2-7870	1,200,000	1,000,000	600,000	600,000	1						
	Fixing Assembly / Pressure Sub Thermistor (Front)	FK2-7871	1,200,000	1,000,000	600,000	600,000	1						

T-2-1

Cleanable Parts

As of November 2014														
Category	Part name	Part No.	Cleaning interval (seconds)				Q'ty	Adjustment after replacement				Parts replaced by operator	Remarks	Reference
			image PRESS C800	image PRESS C700	image PRESS C600	image PRESS C60		Auto Adjust Gradation	Correct Shading	Auto Correct Color Tone Settings	Output Test Page			
			Cleaning	Fixing Refresh Roller	-	3,600		3,600	3,600	3,600	1			

T-2-2

Transfer area

Replacing the Secondary Transfer Unit



Replacement procedure

CAUTION:

Be sure not to touch the surface [A] of the Secondary Transfer Outer Roller when replacing

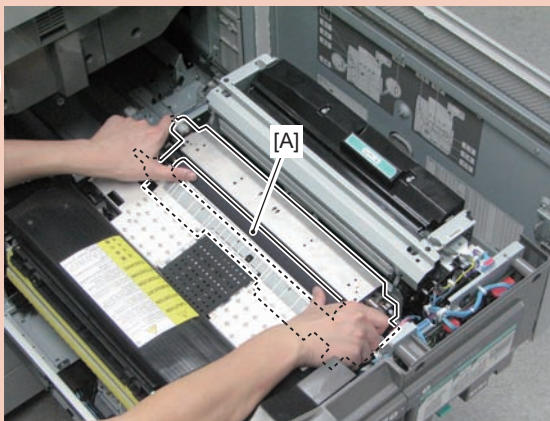

F-2-2

1) Open the Front Cover.

2) Turn over the lever [1] and pull out the Fixing Feed Unit [2].

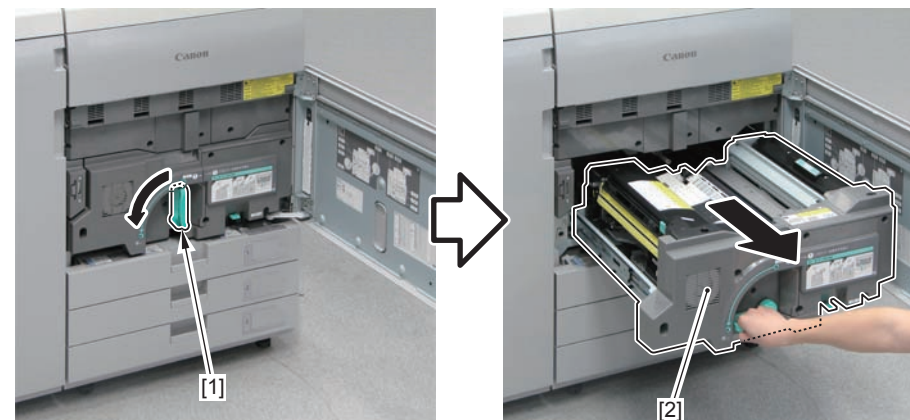

F-2-3

- 3) Press the 2 Release Springs [1] at both sides of the rail to release the locks, and further pull out the Fixing Feed Unit [2] until it stops.

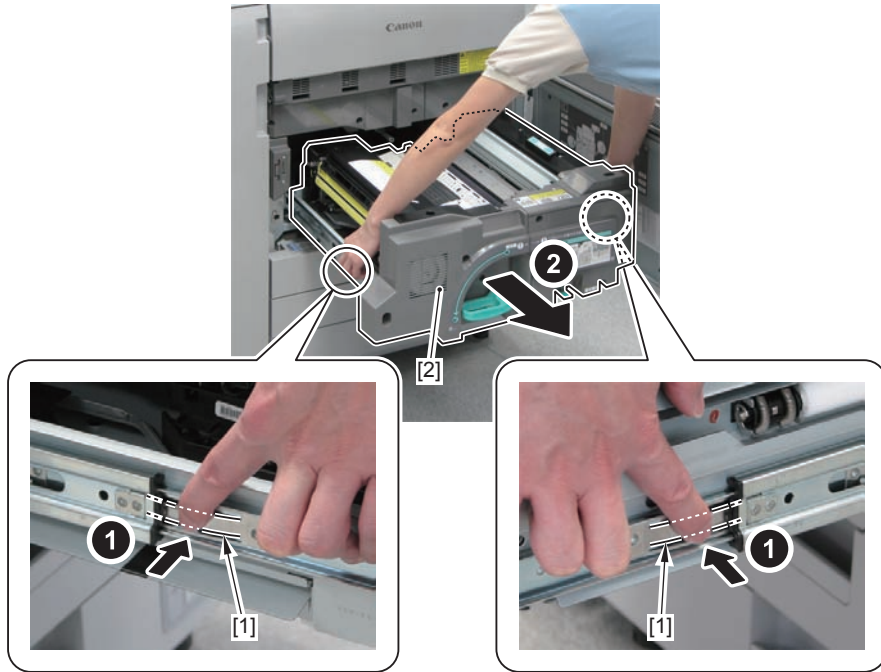

F-2-4

⚠ CAUTION:

Do not release the locks of the 2 Release Springs [3] at the rear on the rails of both sides.

Pulling out the Fixing Feed Unit [2] further than the trailing edge [A] of the Release Springs at the rear side may cause the unit to fall (when the red screw [4] securing the Fixing Feed Unit Rail has come off).

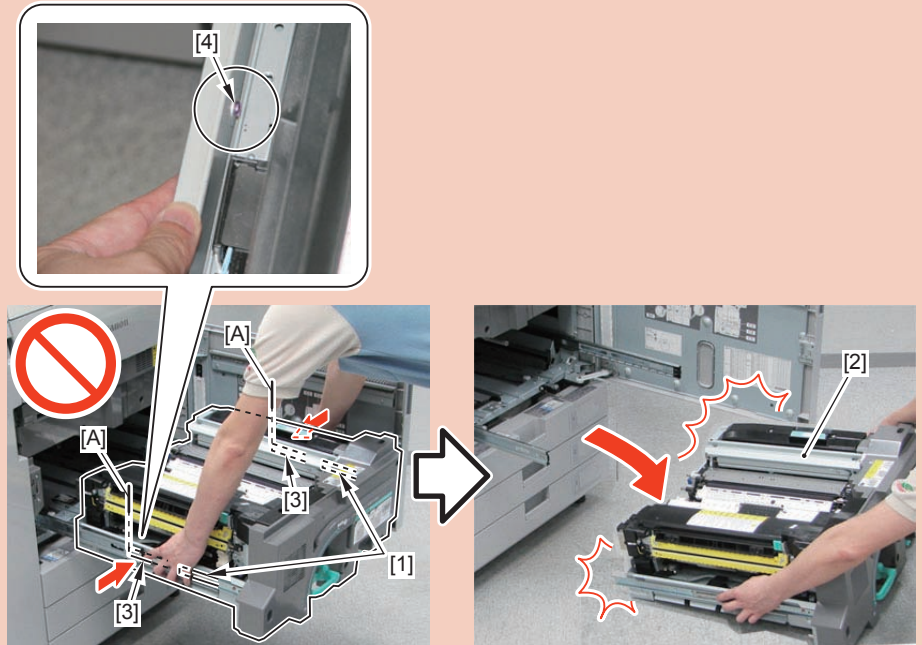

F-2-5

4) Remove the Fixing Feed Sub Cover [1].

- 1 Screw [2] (to loosen)
- 2 Hooks [3]

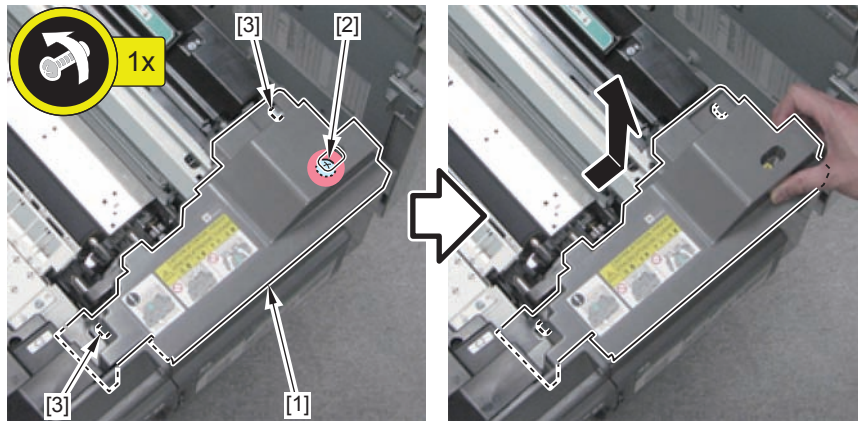

F-2-6

5) Remove the Secondary Transfer Unit [1].

- 2 Connectors [2]
- 2 Positioning Pins [3]

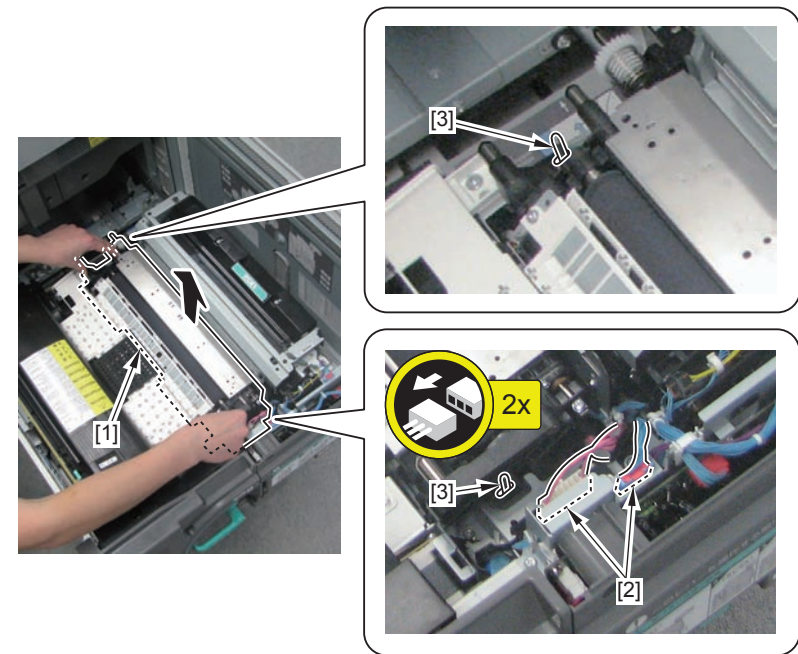

F-2-8

NOTE: How to install the Fixing Feed Sub Cover
Put the [A] part of the Fixing Feed Sub Cover under the Fixing Feed Front Left Cover [4].

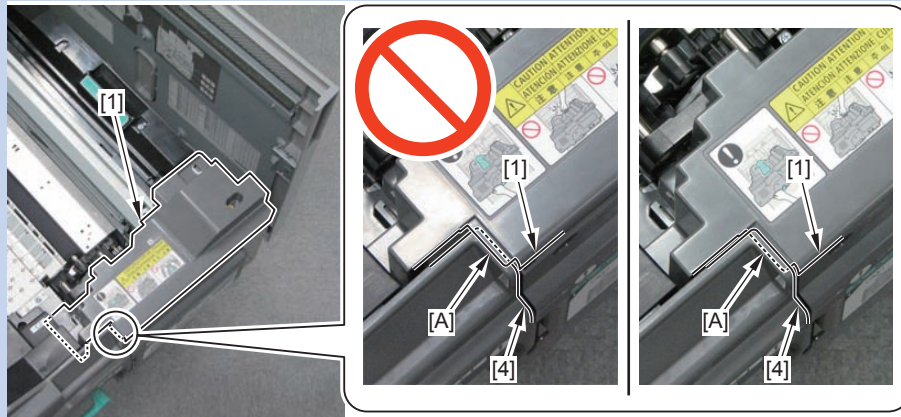

F-2-7

CAUTION:

When installing the Secondary Transfer Unit to the Fixing Feed Unit, be sure to do so after releasing the pressure applied on the Secondary Transfer Outer Roller.

(Otherwise, the Secondary Transfer Outer Roller may be deformed, or the ITB may be damaged.)

How to release the pressure applied on the Secondary Transfer Outer Roller

The pressure on the Secondary Transfer Outer Roller [3] can be released by turning the gear [1] and changing the direction of the cam [2]. Be sure to keep the Secondary Transfer Outer Roller lowered.

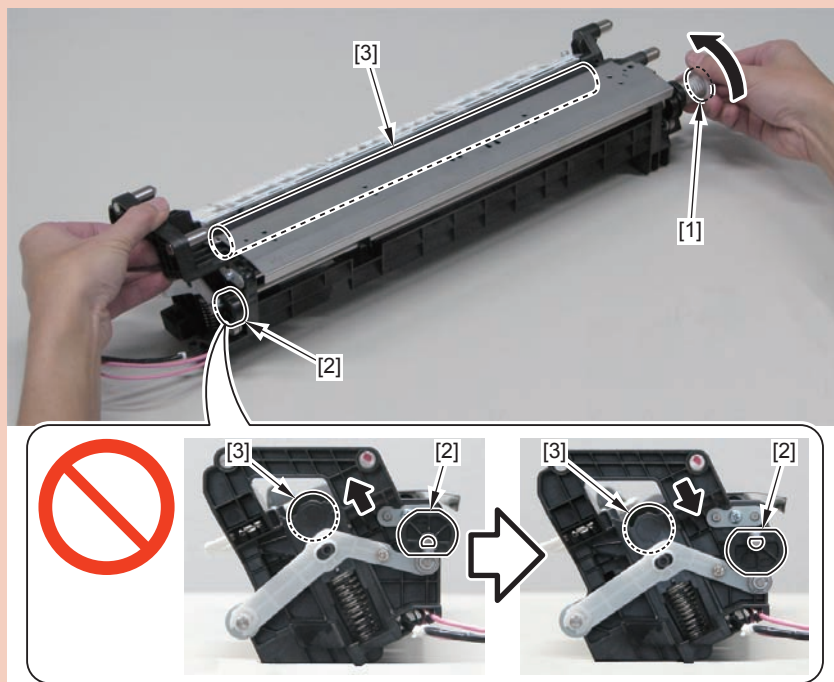

F-2-9

6) From the Adjustment/Maintenance menu, execute [Automatic Gradation Adjustment].
(Refer to page 1-18)

7) From the Adjustment/Maintenance menu, execute [Shading Correction].
(Refer to page 1-28)

8) From the Adjustment/Maintenance menu, execute [Automatic Color Tone Correction].
(Refer to page 1-31)

9) From the Adjustment/Maintenance menu, execute [Output Test Page].
(Refer to page 1-35)

Fixing area

Replacing the Fixing Assembly



F-2-10

Replacement procedure

CAUTION:

Because the Fixing Assembly [1] is hot, be sure to replace it after it is cooled down.

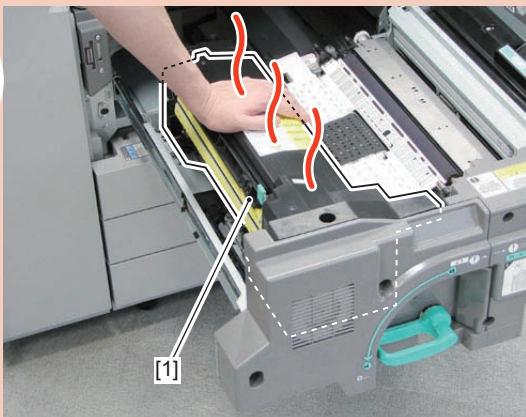

F-2-11

1) Open the Front Cover.

2) Turn over the lever [1] and pull out the Fixing Feed Unit [2].

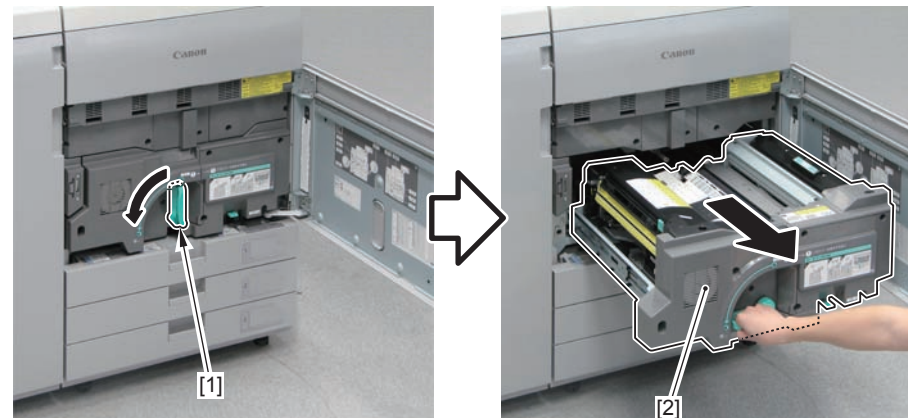

F-2-12

- 3) Press the 2 Release Springs [1] at both sides of the rail to release the locks, and further pull out the Fixing Feed Unit [2] until it stops.

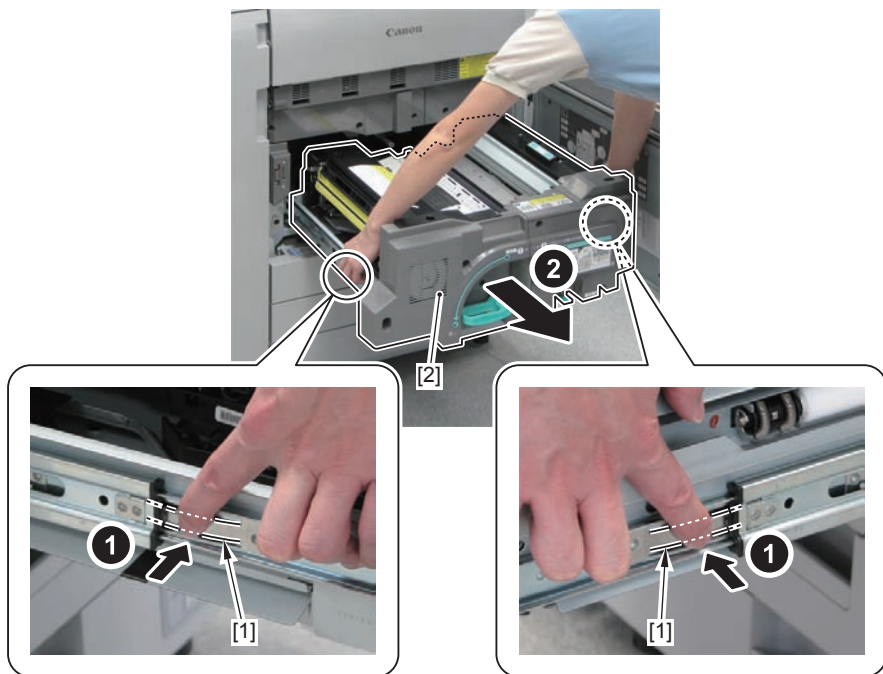

F-2-13

⚠ CAUTION:

Do not release the locks of the 2 Release Springs [3] at the rear on the rails of both sides.

Pulling out the Fixing Feed Unit [2] further than the trailing edge [A] of the Release Springs at the rear side may cause the unit to fall (when the red screw [4] securing the Fixing Feed Unit Rail has come off).

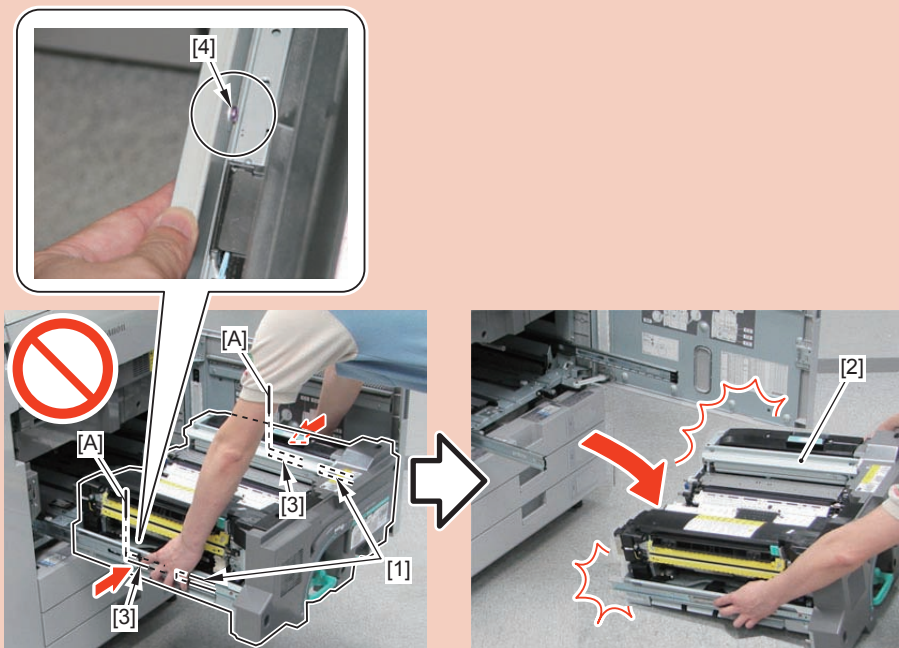

F-2-14

4) Remove the Fixing Upper Cover [1].

- 1 Screw [2]
- 2 Hooks [3]

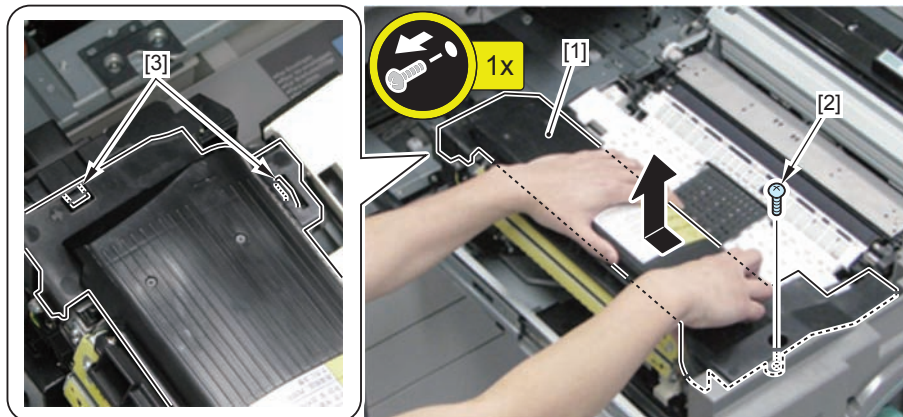

F-2-15

CAUTION:

Be sure to check that the 2 hooks [3] are hooked when installing the Fixing Upper Cover [1].

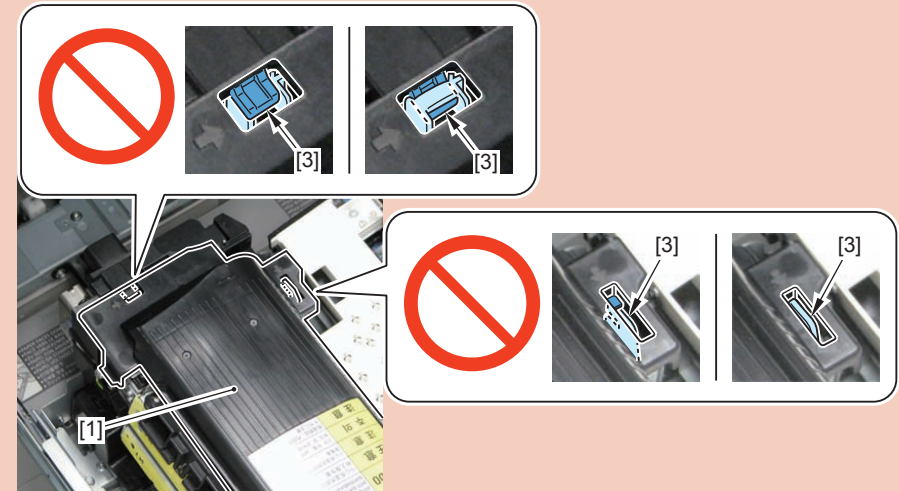

F-2-16

If the 2 hooks [3] are not hooked, the Fixing Upper Cover [1] may hit the duct [5] when storing the Fixing Feed Unit [4].

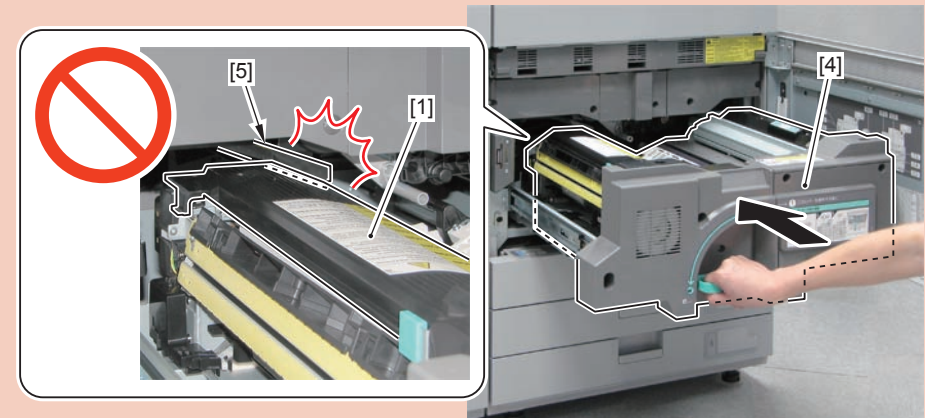

F-2-17

5) Disconnect the 4 connectors [1].

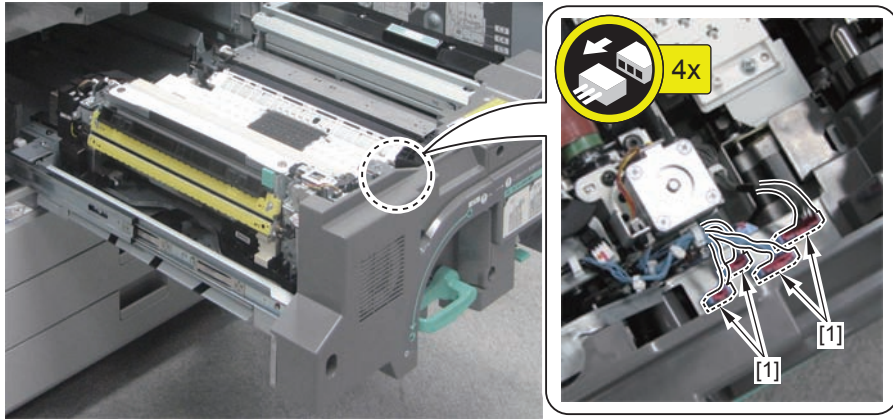

F-2-18

6) Loosen the screw [1], and remove 2 screws [2].

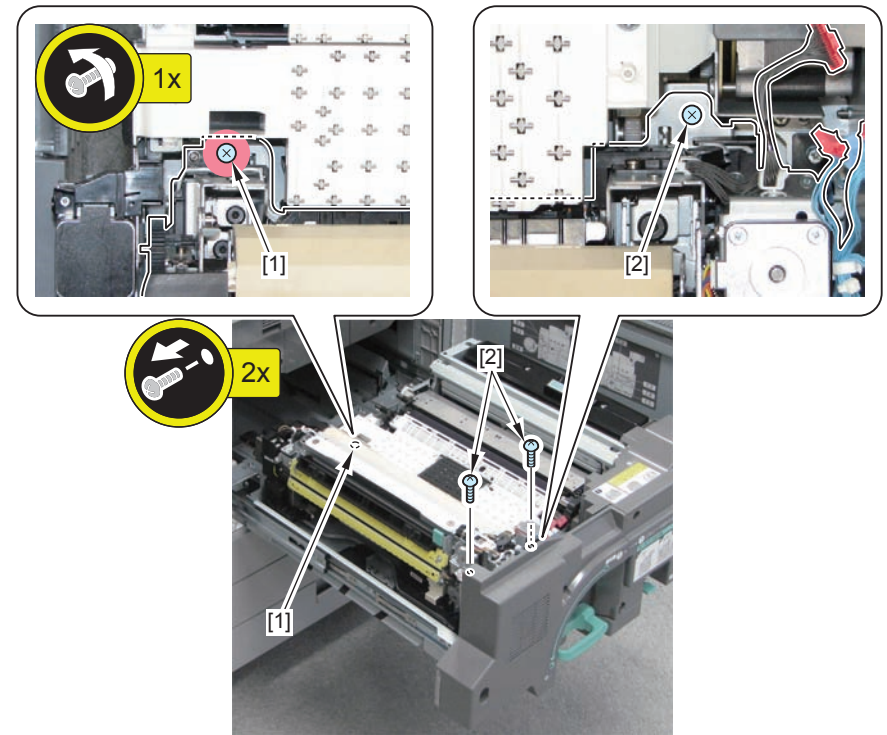

F-2-19

- 7) Hold the handle [1] and lift the front side of the Fixing Assembly [2], and place the connector [3] on the Feed Guide [4].
- 8) Lift the rear side, and remove the Fixing Assembly [2] while keeping the unit in a horizontal position.

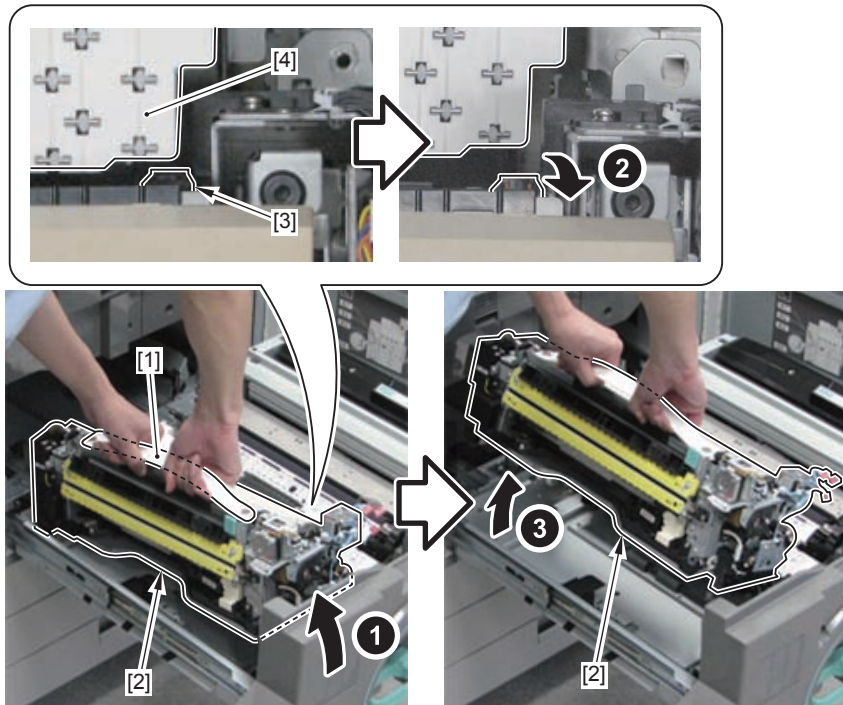

F-2-20

CAUTION:

- When installing/removing the Fixing Assembly [2], be careful not to hit the connector [3] with the Feed Guide [4].
- When installing/removing the Fixing Assembly [2], be careful not to hit the assembly with the Feed Guide [4] and the Feed Belt [6].

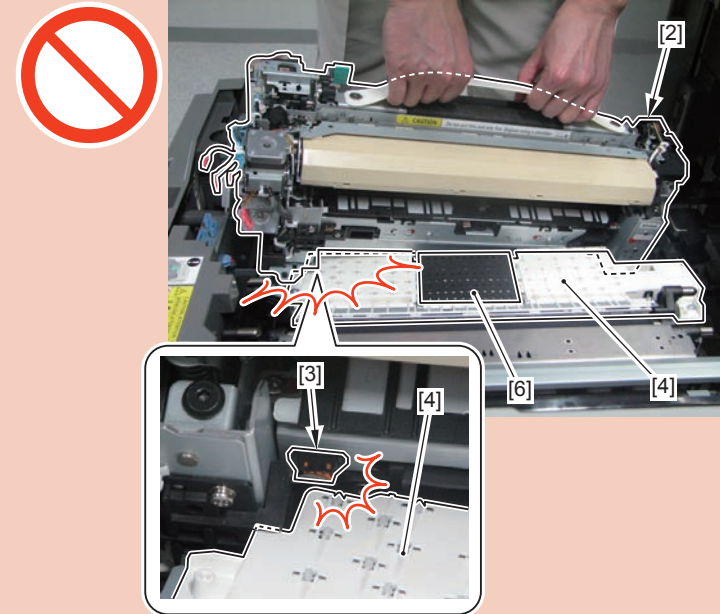

F-2-21

NOTE: How to install the Fixing Assembly

Be sure to hold the Fixing Assembly [1] horizontally and align the 2 holes [A] with the 2 Positioning Protrusions [B] of the Fixing Feed Unit to install the assembly.

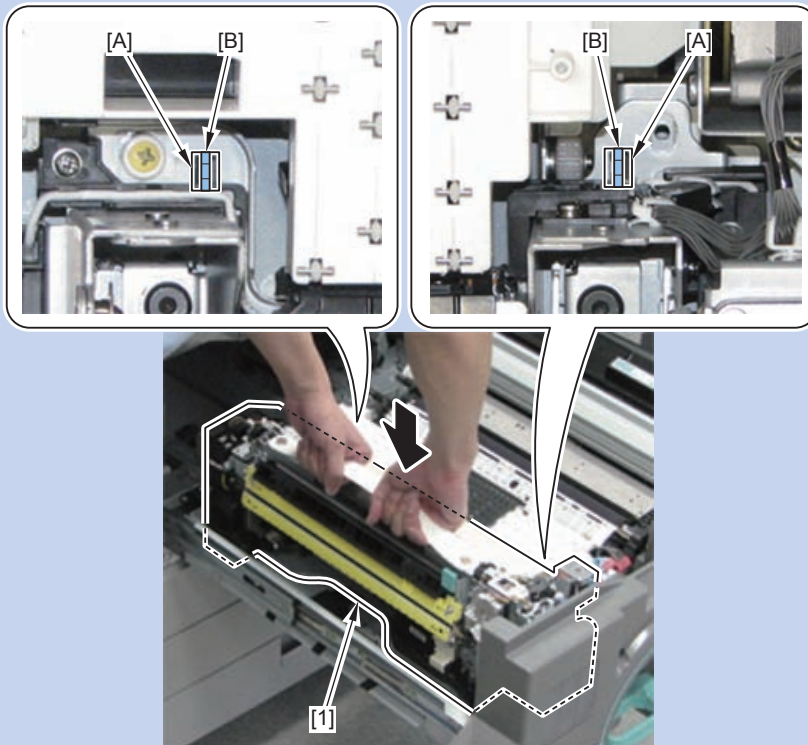

F-2-22

9) From the Adjustment/Maintenance menu, execute [Automatic Gradation Adjustment].

(Refer to page 1-18)

10) From the Adjustment/Maintenance menu, execute [Shading Correction].

(Refer to page 1-28)

11) From the Adjustment/Maintenance menu, execute [Automatic Color Tone Correction].

(Refer to page 1-31)

12) From the Adjustment/Maintenance menu, execute [Output Test Page].

(Refer to page 1-35)

Cleaning

Cleaning the Fixing Refresh Roller

Cleaning Procedure

CAUTION:

Because the Fixing Assembly [1] is hot, be sure to clean it after it is cooled down.

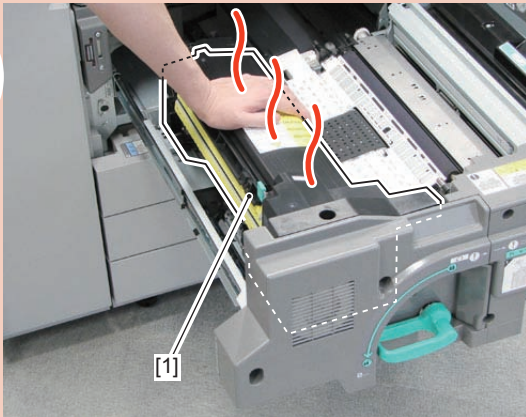

F-2-23

1) Open the Front Cover.

2) Turn over the lever [1] and pull out the Fixing Feed Unit [2].

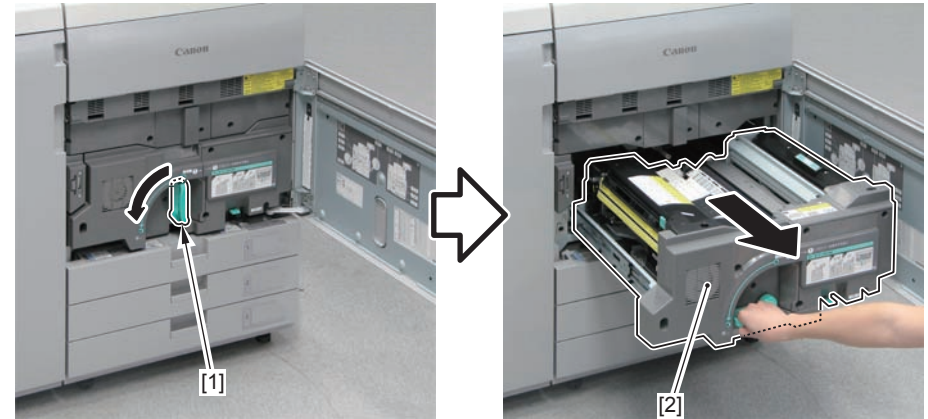

F-2-24

- 3) Press the 2 Release Springs [1] at both sides of the rail to release the locks, and further pull out the Fixing Feed Unit [2] until it stops.

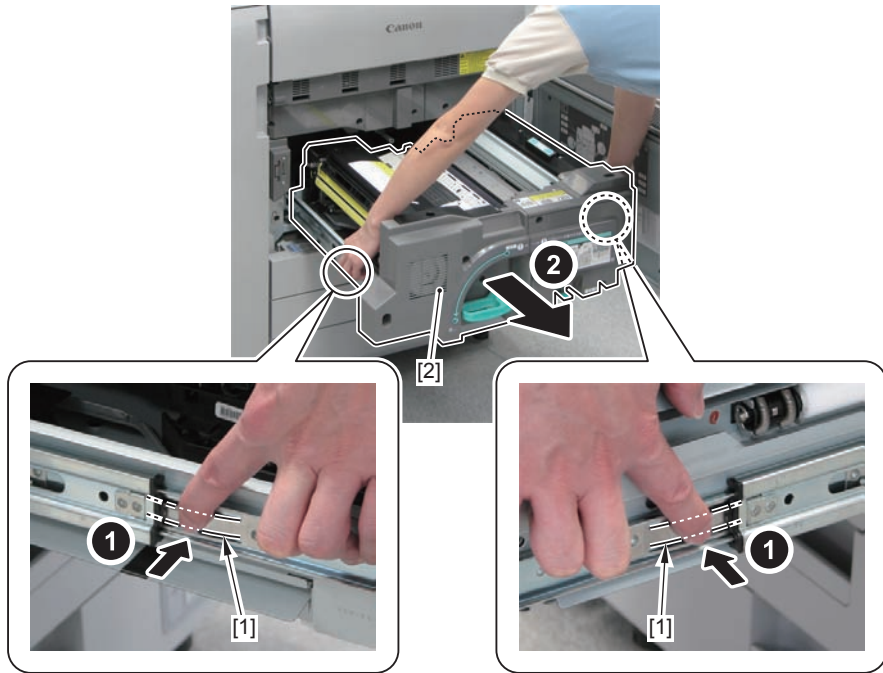

F-2-25

⚠ CAUTION:

Do not release the locks of the 2 Release Springs [3] at the rear on the rails of both sides.

Pulling out the Fixing Feed Unit [2] further than the trailing edge [A] of the Release Springs at the rear side may cause the unit to fall (when the red screw [4] securing the Fixing Feed Unit Rail has come off).

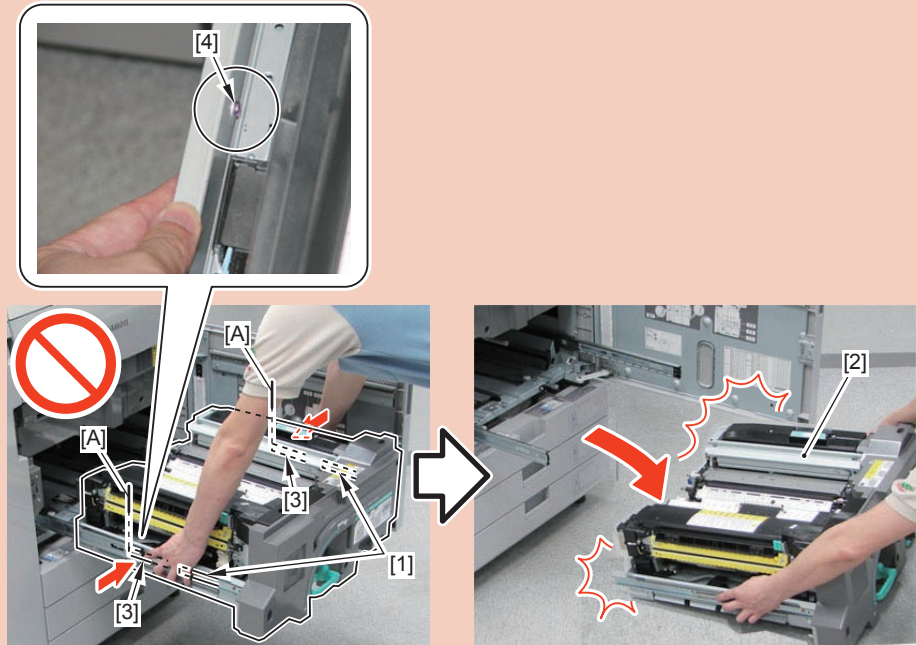

F-2-26

4) Remove the Fixing Upper Cover [1].

- 1 Screw [2]
- 2 Hooks [3]

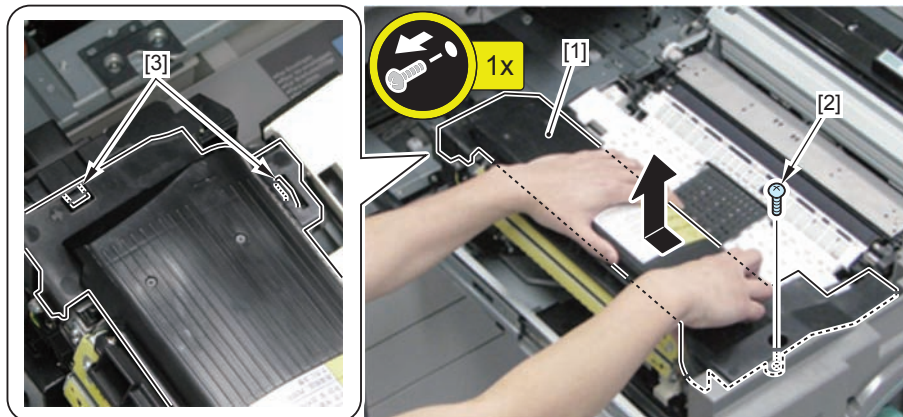

F-2-27

CAUTION:

Be sure to check that the 2 hooks [3] are hooked when installing the Fixing Upper Cover [1].

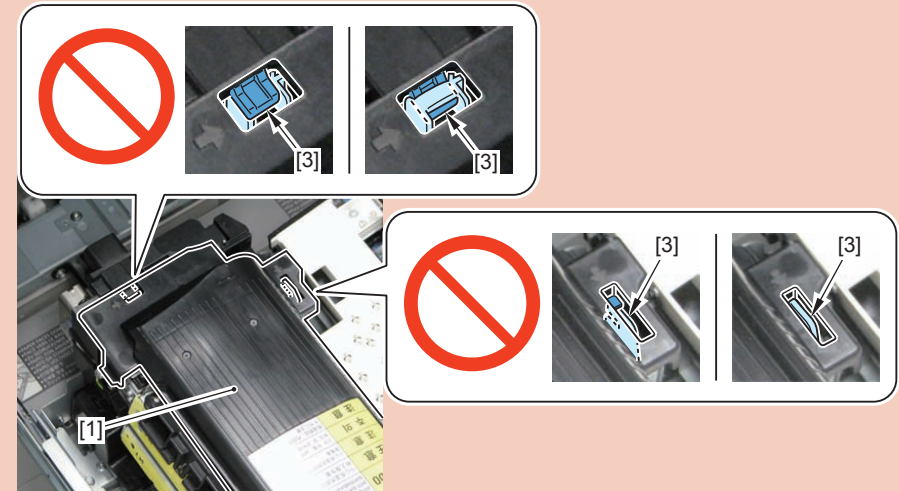

F-2-28

If the 2 hooks [3] are not hooked, the Fixing Upper Cover [1] may hit the duct [5] when storing the Fixing Feed Unit [4].

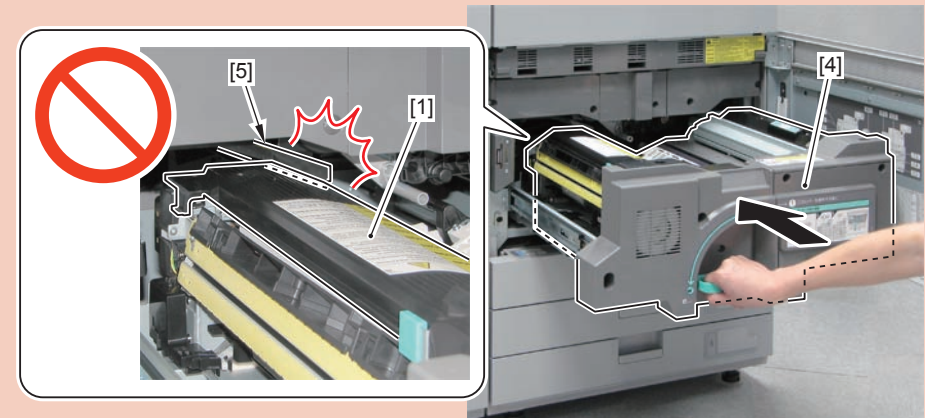

F-2-29

5) Hold the handle [1], and open the Inner Delivery Unit [2].

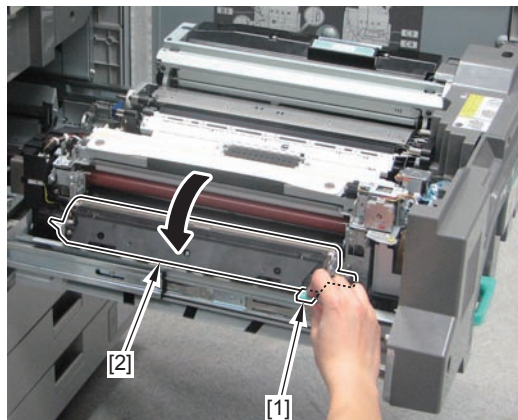

F-2-30

6) By rotating the Fixing Refresh Roller while holding its edge [A] (the area 1 cm from the two ends of the roller), clean its surface [B] with lint-free paper [1] moistened with alcohol.

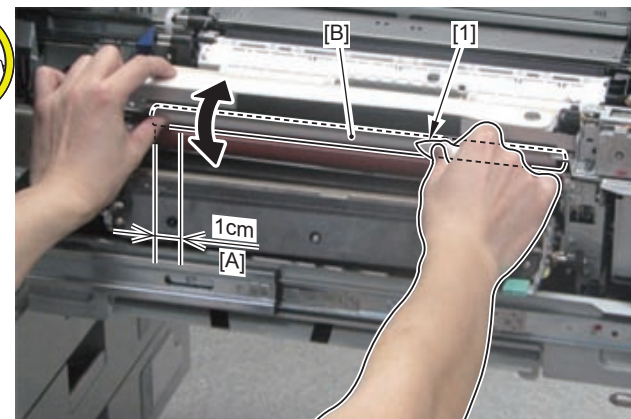

F-2-32

CAUTION:

Do not touch the surface [A] of the Fixing Belt and the surface [B] of the Pressure Belt.

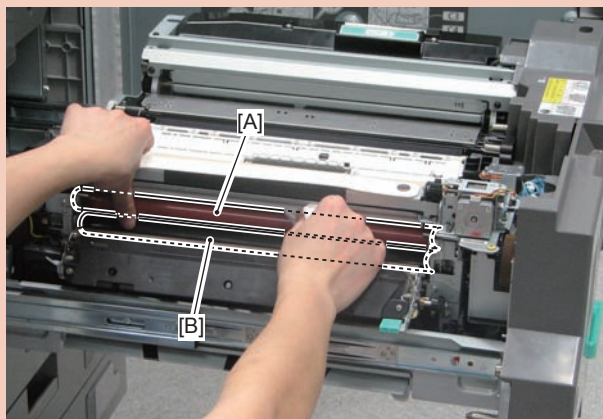

F-2-31

CAUTION:

Do not touch the center [A] of the surface of the Fixing Refresh Roller (any area other than the area 1 cm from the two ends of the roller [B]).

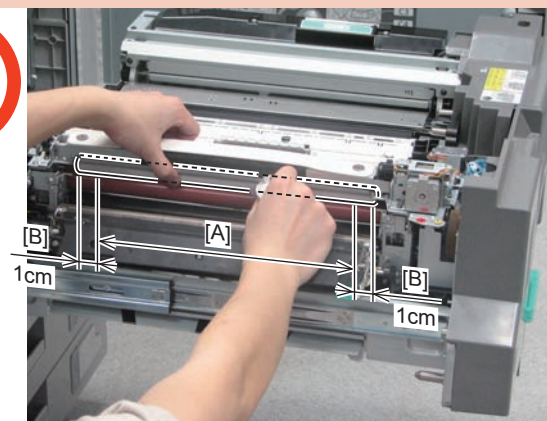

F-2-33

- 7) From the Adjustment/Maintenance menu, execute [Automatic Gradation Adjustment].
(Refer to page 1-18)
- 8) From the Adjustment/Maintenance menu, execute [Shading Correction].
(Refer to page 1-28)
- 9) From the Adjustment/Maintenance menu, execute [Automatic Color Tone Correction].
(Refer to page 1-31)
- 10) From the Adjustment/Maintenance menu, execute [Output Test Page].
(Refer to page 1-35)