

# DR-M140

# SERVICE MANUAL

FIRST EDITION

**Canon**

AUG. 2011

**MY8-13AR-000**

***COPYRIGHT © CANON ELECTRONICS INC. 2011***

Use of this manual should be strictly supervised to avoid disclosure of confidential information.

---

## PREFACE

---

This Service Manual describes necessary basic information for field service and maintenance for maintaining the product quality and functions of this machine.

### Contents

#### **Chapter 1: General description**

Product specifications, name of parts, operation method

#### **Chapter 2: Functions and operation**

Description of operation of machine system and electrical system by function

#### **Chapter 3: Disassembly and reassembly**

Disassembly method, reassembly method

#### **Chapter 4: Installation and maintenance**

Installation method, maintenance method

#### **Chapter 5: Troubleshooting**

Error display and troubleshooting

#### **Appendix: General diagram etc.**

Information in this manual is subject to change. Notification of such changes will be given in Service Information Bulletins.

Thoroughly read the information contained in this Service Manual and the Service Information Bulletins to gain a correct and deeper understanding of the machine. This is one way of fostering response for ensuring prolonged quality and function, and for investigating the cause of trouble during troubleshooting.

Quality Assurance Center  
Canon Electronics Inc.

# CONTENTS

---

## CHAPTER 1 GENERAL DESCRIPTION

---

I.	PRODUCT OUTLINE .....	1-1
	1. Features .....	1-1
	2. Main Specifications .....	1-2
	3. Precautions .....	1-5
II.	NAME OF PARTS.....	1-6
	1. Name of Parts .....	1-6
III.	USER OPERATION.....	1-7
	1. Placing Documents .....	1-7
	2. Scanning .....	1-8
	3. Clearing Paper Jams .....	1-10

---

## CHAPTER 2 FUNCTIONS & OPERATION

---

I.	OUTLINE .....	2-1
	1. Main Configuration .....	2-1
	2. Feed Path .....	2-2
	3. Motor Drive .....	2-3
	4. Electrical Circuits .....	2-4
	5. Timing Chart.....	2-5
II.	READING SYSTEM.....	2-6
	1. Reading Unit .....	2-6
	2. Shading.....	2-7
III.	FEED SYSTEM .....	2-8
	1. Feeding Mechanism.....	2-8
	2. Feed Error Detection .....	2-11
IV.	CONTROL SYSTEM .....	2-13
	1. Control Circuits .....	2-13
	2. Image Processing .....	2-15
V.	POWER SUPPLY .....	2-17
	1. Power Supply.....	2-17
VI.	LAYOUT OF ELECTRICAL COMPONENTS.....	2-18
	1. Layout of Electrical Components .....	2-18
VII.	PARTS LAYOUT ON EACH PCB .....	2-19
	1. Control PCB .....	2-19
	2. Operation PCB.....	2-20

3.	Document Sensor PCB.....	2-20
----	--------------------------	------

---

## CHAPTER 3 DISASSEMBLY & REASSEMBLY

---

I.	EXTERNAL PARTS .....	3-1
	1. Upper Cover.....	3-1
	2. Bottom Cover / Feed Tray.....	3-2
	3. Document Eject Tray.....	3-3
	4. Straight Path Tray .....	3-3
II.	BASE UNIT .....	3-4
	1. Control PCB .....	3-4
	2. Main Motor .....	3-5
	3. Feed Motor.....	3-6
	4. Registration Roller (Drive).....	3-7
	5. Straight Eject Roller (Drive).....	3-8
III.	UPPER UNIT .....	3-10
	1. Sensor PCBs .....	3-10
	2. Ultrasonic Drive PCB .....	3-10
	3. Follower Roller .....	3-11
	4. U-Turn Unit.....	3-12
	5. Upper Unit.....	3-13
IV.	READING UNIT .....	3-14
	1. Upper Reading Unit .....	3-14
	2. Upper Reading Guide .....	3-15
	3. Lower Reading Unit .....	3-15
	4. Lower Reading Guide .....	3-16

---

## CHAPTER 4 INSTALLATION & MAINTENANCE

---

I.	INSTALLATION.....	4-1
	1. System Requirements.....	4-1
	2. Checking the Accessories.....	4-1
	3. Removing the Packing Material .....	4-2
	4. Installing the Software.....	4-2
	5. Connecting to a Computer .....	4-3
	6. Power On .....	4-3

II.	PARTS TO BE REPLACED .....	4-4
1.	Periodically Replaced Parts .....	4-4
2.	Consumable Parts .....	4-4
3.	Major Parts List.....	4-5
III.	MAINTENANCE .....	4-6
1.	User Maintenance .....	4-6
2.	Service Maintenance.....	4-8

---

## CHAPTER 5 TROUBLESHOOTING

---

I.	ERROR DISPLAY .....	5-1
1.	Main Body.....	5-1
2.	Computer.....	5-1
II.	SERVICE MODE.....	5-2
1.	Outline .....	5-2
2.	How to Install.....	5-6
3.	How to Start and Finish .....	5-7
4.	Application Information.....	5-8
5.	Simulation Mode.....	5-9
A.	Main Menu.....	5-9
1.	Regist Adjustment .....	5-9
2.	Light Adjustment.....	5-11
3.	Max Document Size .....	5-12
4.	Sleep .....	5-13
5.	Counter.....	5-13
6.	Firm Load .....	5-15
B.	Dcon Check.....	5-16
1.	LED.....	5-16
2.	Sensors and Buttons .....	5-16
3.	Motor/Feed Test.....	5-18
C.	Get Status.....	5-19
1.	Last Error Logs .....	5-19
2.	Check Device .....	5-20
3.	Serial Number/Other .....	5-20
4.	Write Setting to Text .....	5-21
D.	Scan Check.....	5-22
1.	Scan Check.....	5-22
2.	Manual Shading .....	5-24
E.	Firm Load .....	5-24

1.	Firm Registration .....	5-25
2.	Firm Load .....	5-27
F.	Analog .....	5-28
1.	Analog .....	5-28
G.	Extended Setting .....	5-29
1.	Outline .....	5-29
2.	Registration Adjustment .....	5-30
3.	Scaling Rate Control.....	5-32
H.	Other Functions.....	5-35
1.	Mechanical Feed Mode .....	5-35
2.	Recovery of Log Files.....	5-35
III.	TROUBLESHOOTING LIST .....	5-37
1.	Operation Failures .....	5-37
2.	Image Failures.....	5-37
IV.	OPERATION TROUBLESHOOTING ....	5-38
1.	Power Does Not Come ON .....	5-38
2.	No Scanner is Found.....	5-39
3.	Scanning Does Not Start .....	5-39
4.	Scanner Does Not Feed Properly ....	5-40
5.	Scanning Speed is Slow .....	5-41
V.	IMAGE TROUBLESHOOTING.....	5-42
1.	All Black/All White/All Streaked .....	5-43
2.	Too Dark/Too Light.....	5-43
3.	Streaks in Image.....	5-44
4.	Image Slanted .....	5-44
5.	Wrong Image Size .....	5-45
6.	Text Cannot be Seen .....	5-45
7.	Moire in Image.....	5-46
IV.	AFTER REPLACING PARTS .....	5-47

---

## APPENDIX

---

I.	GENERAL CIRCUIT DIAGRAM.....	A-1
II.	LIST OF SPECIAL EQUIPMENT .....	A-2



---

# CHAPTER 1

---

## GENERAL DESCRIPTION

---

---

I. PRODUCT OUTLINE .....	1-1	III. USER OPERATION .....	1-7
II. NAME OF PARTS .....	1-6		

---





## I. PRODUCT OUTLINE

### 1. Features

- 1) High-speed machine with U-turn path  
This is upper and successor model for the DR-2580C.
- 2) Scanning speed (A4, 200dpi)  
B&W, Gray, and Color modes: 40ppm/80ipm
- 3) Improvement of reliability for the pickup and separation operations  
Drive for retard roller is improved.  
Outside diameter of feed roller is made larger.  
Skew sensor installed.
- 4) Automatic image processing  
Auto-color detection mode  
Auto-resolution mode  
Full-auto mode
- 5) Includes easy to user application software  
CaptureOnTouch/CapturePerfect

“Windows” is a trademark of Microsoft Corporation in the U.S. and other countries.

Other company names and product names mentioned in this document are registered trademarks or trademarks of the respective companies.

## 2. Main Specifications

No.	Item	Specifications
1	Type	Desktop type sheet-fed scanner
2	Dimensions *See details at following.	1) Tray closed: 313 (W) x 181 (D) x 93 (H) mm 2) Tray opened: 313 (W) x 250 (D) x 165 (H) mm
3	Weight	2.6kg (Main body only)
4	Power supply	AC adapter 1) Input: 100V-240VAC, 50/60Hz 2) Output: 24VDC, 2.0A
5	Power consumption	1) Operation: 25W same or less 2) Sleep mode: 1.9W same or less 3) Power switch OFF: 0.5W same or less
6	External interface	USB 2.0 (Hi-speed) *Hi-speed and Full-speed with USB 3.0 can work.
7	Expected product life (In-house information only)	One of the following two items, whichever comes first. 1) 5 years 2) 1,000,000 sheets (A4) *Replace parts if necessary.
8	Installation	By user.
9	Option	1) Flatbed scanner: FSU 101 2) Barcode module (software)
10	Consumable parts (Commercial goods)	1) Exchange roller kit *Roller unit and Retard roller *Replaced by user. Expected life is 200,000 sheets.
11	Bundle software	1) ISIS/TWAIN driver, CapturePerfect 3.1, CaptureOnTouch, eCopy PDF Pro Office 2) Others depend on Sales region
12	Sensor type, Density	1 line/4 parallel-CMOS contact image sensor, 600dpi
13	Sensor operation mode	600dpi or 300dpi
14	Effective reading width	219mm
15	Light source	3-color (RGB) LED, Single-side illumination
16	Background color	White
17	Image data memory	32MB *Used for the working memory together.

**Table 1-101a**

No.	Item	Specifications		
18	Output data to computer	1) Type: 8bit gray or 24bit color *It has converted always to JPEG compression. 2) Resolution: 600x600dpi, 400x400dpi, 300x300dpi, Gray→200x200dpi, 150x150dpi Color→200x400dpi, 150x300dpi		
19	Mode setting in driver	1) Binary: B&W, Error diffusion, ATE, ATE-II *ATE=Advanced Text Enhancement 2) Gray: 8bit 3) Color: 24bit *Auto-color detection mode can be available.		
20	Resolution setting in driver	600x600dpi, 400x400dpi, 300x300dpi, 200x200dpi, 150x150dpi *Auto-resolution mode can be available.		
21	Scanning speed (A4 size)	Mode	Resolution	Simplex/Duplex
		B&W (TIFF)	200dpi	40ppm/80ipm
			300dpi	40ppm/80ipm
			600dpi	20ppm/40ipm
		Gray (JPEG)	200dpi	40ppm/80ipm
			300dpi	40ppm/80ipm
			600dpi	20ppm/40ipm
		Color (JPEG)	200dpi	40ppm/80ipm
			300dpi	40ppm/80ipm
			600dpi	12ppm/24ipm
*Using computer for test. The numbers above may differ depending on the computer, settings and other conditions.				
22	Document feed path	U-turn path and Straight path *U-turn is available for document within 0.15mm thickness.		
23	Document size	1) Width: 50.8 to 216mm 2) Length: 54 to 356mm		
24	Document weight (Thickness)	1) Normal pickup: 27 to 128g/m <sup>2</sup> (0.04 to 0.15mm) 2) None separate/Straight path: 27 to 255g/m <sup>2</sup> (0.04 to 0.30mm) *Minimum size in normal (52x74mm): 127 to 209g/m <sup>2</sup> *Maximum size (LGL size: 216x356mm): 52 to 209g/m <sup>2</sup> *Maximum size (B5 size: 176x250mm): for 27g/m <sup>2</sup>		

Table 1-101b

No.	Item	Specifications
25	Special document	Post card, Plastic card, Business card, Folio, Long document and others are available. *Use straight path for post, plastic & business cards. *There are some limitations required.
26	Document storage	Pickup and Eject (U-turn path): 1) A4 or smaller: 50 sheets max. and 10mm height max. 2) A4 over: 40 sheets max. and 10mm height max.
27	Double feed detection	1) Length detection by registration sensor 2) Double feed detection by ultrasonic sensor
28	Operation/Indication	1) Button: Power, Start, Stop, Job Select, DFR 2) LED: Job No. (7-segment), Power, DFR, Separate 3) Lever: OPEN, Feed selection

**Table 1-101c**

◆ External dimensions (mm)

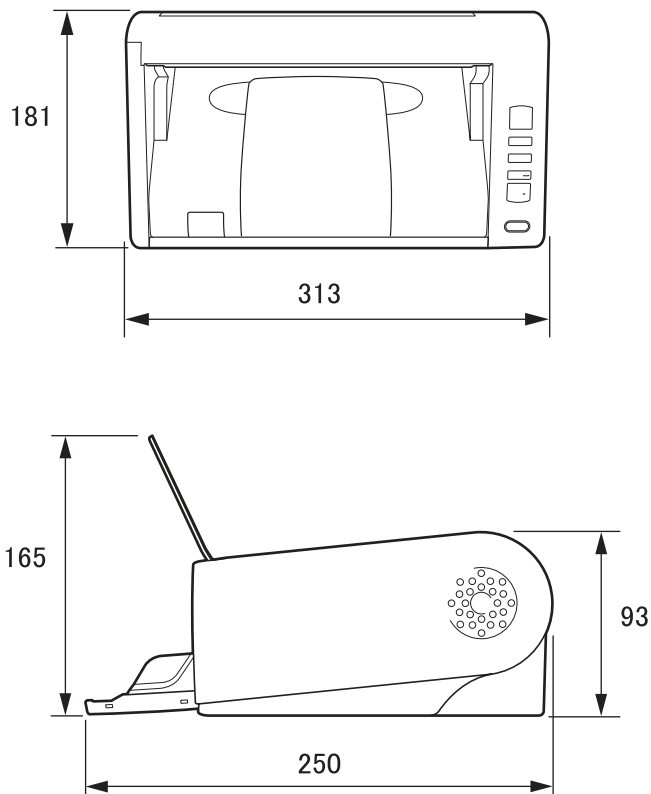

**Figure 1-101**

### 3. Precautions

This section describes items that require particular care, for example, regarding human safety.

These precautions must be observed. The user should be explained the items that relate to user safety and instructed to take appropriate actions.

#### 1) Power OFF in emergency

If such abnormal conditions as extraordinary noise, smoke, heat and odor occur, immediately unplug the power cord.

Be careful not to get clothing (ties, long hair, etc.) caught in this machine as it may cause injury. Should this occur, immediately unplug the power cord.

Do not insert fingers in the feed section while moving the rollers.

#### 2) Power OFF on disassembling

When disassembling and assembling are performed, unplug the power cord.

#### 3) Prohibition of modify

This machine must not arbitrarily be modified or remade. If it is, use may be forcibly suspended.

To change the specifications or disassemble and reassemble this machine, follow the instructions described in this manual and the service information.

#### 4) Electromagnetic wave interference

This machine complies with some standards regarding electromagnetic wave interference, such as VCCI and FCC. However, the user may have to take countermeasures if the machine causes electromagnetic wave interference.

#### 5) "User Manual"

Read each "User Manual" thoroughly prior to use of this machine.

#### 6) Disposal

Follow local regulations when disposing of the product and parts. This product is subject to the WEEE Directive in Europe.

## II. NAME OF PARTS

### 1. Names of Parts

#### ◆ Front View

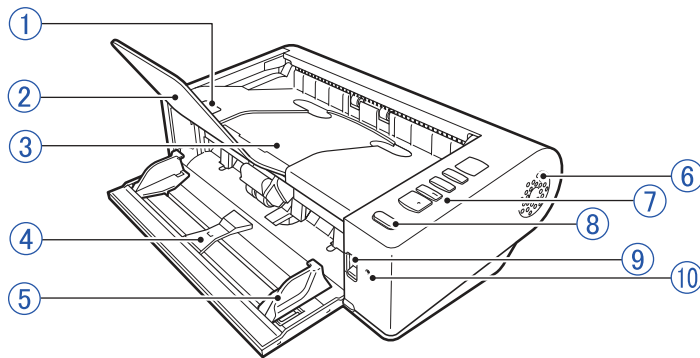

Figure 1-201

- |                                    |                          |
|------------------------------------|--------------------------|
| ① OPEN lever                       | ⑥ Ventilation holes      |
| ② Document eject extension support | ⑦ Operating panel        |
| ③ Document eject tray/Upper unit   | ⑧ Power button           |
| ④ Document feed tray               | ⑨ Feed selection lever   |
| ⑤ Document guides                  | ⑩ LED indicator (orange) |

#### ◆ Back View

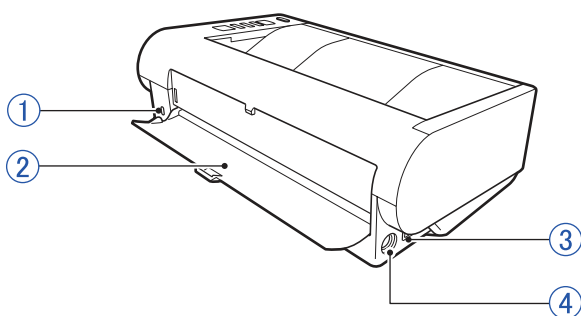

Figure 1-202

- ① Kensington slot
- ② Straight path tray
- ③ USB connector
- ④ Power connector

#### ◆ Operating Panel

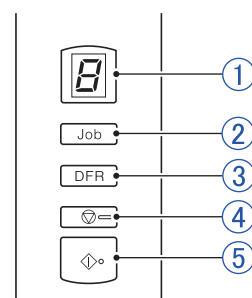

Figure 1-203

- ① Job No. indicator
- ② Job select button
- ③ DFR (Double Feed Release) button
- ④ Stop button
- ⑤ Start button

### III. USER OPERATION

This section shows how to scan several sheets of a regular paper document using the initial settings of CaptureOnTouch. For details on other operations, refer to the "User Manual" for this machine.

For installation and maintenance, refer to "CHAPTER 4 INSTALLATION & MAINTENANCE".

#### 1. Placing Documents

- 1) Change the feed and eject methods depending on types of documents. Open the document feed tray. Furthermore, open the document eject extension support if necessary.

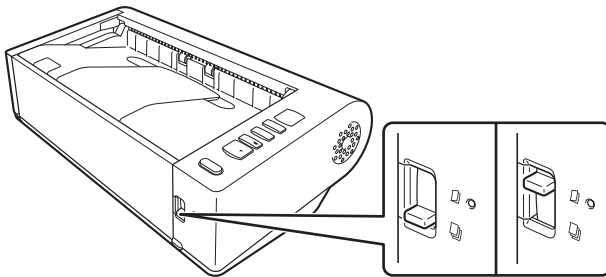

Figure 1-301

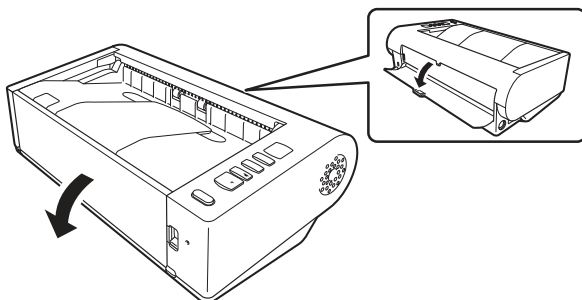

Figure 1-302

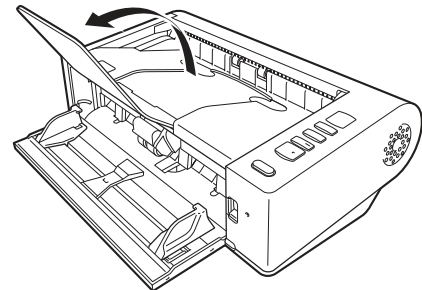

Figure 1-303

- 2) Place the document, and adjust the document guides to fit the document width.

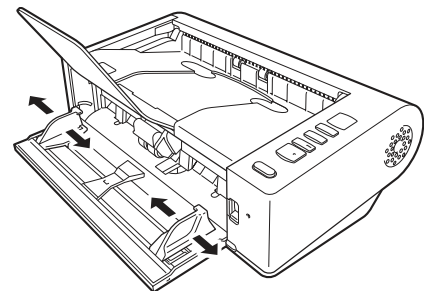

Figure 1-304

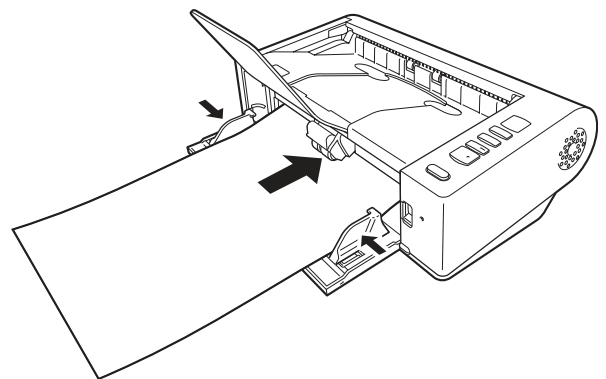

Figure 1-305

## 2. Scanning

This section describes how to scan using [Scan First] in CaptureOnTouch.

**Note:**CaptureOnTouch is TWAIN compatible application software.

- 1) Start CaptureOnTouch.  
Double-click the CaptureOnTouch icon in the task bar to start CaptureOnTouch.



Figure 1-306

- 2) When the main screen is displayed, click [Scan First].

**Note:**Since [Scan First] is enabled by default, this operation is not required.



Figure 1-307

- 3) Change the [Enable continuous scanning] and [Scans in the full auto mode] settings as needed.

**Note:**In this example, set [Enable continuous scanning: ON] and [Scans in the full auto mode: ON].

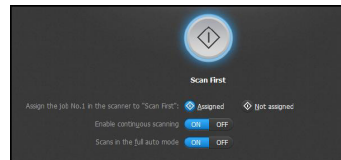

Figure 1-308

- 4) Click the Start button to start the scan.

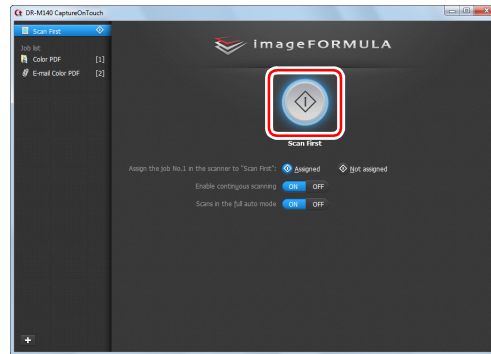

Figure 1-309



- The scanned image is displayed on the screen. Once you have finished, click the [Next step] button.

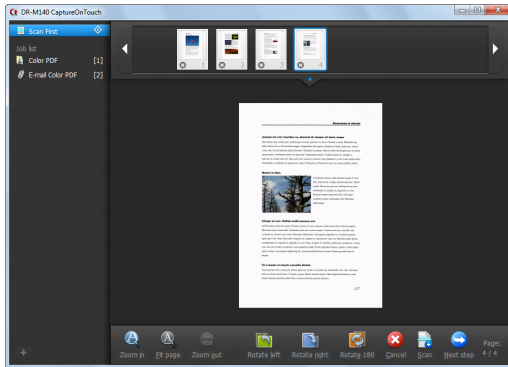

Figure 1-310

- The output settings are displayed. Configure the settings and click the buttons as needed.

**Note:** The button names vary depending on the output method.

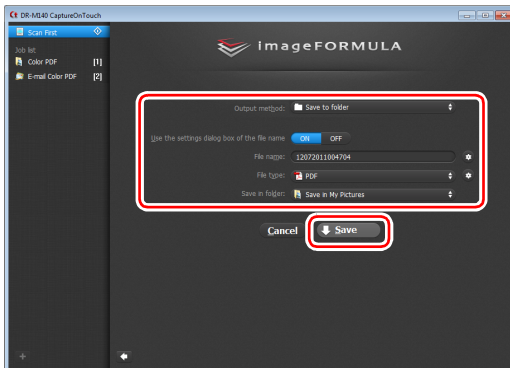

Figure 1-311

- When the output is complete, the finished screen is displayed.

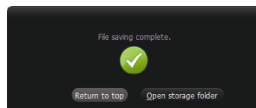

Figure 1-312

**Reference:** Scanner Settings Screen

You can display the settings on the screen by setting [Scans in the full auto mode: OFF] in the step 3. You can then open the advanced settings dialog box by setting [Use advanced settings dialog box: ON] and clicking the button on the right.

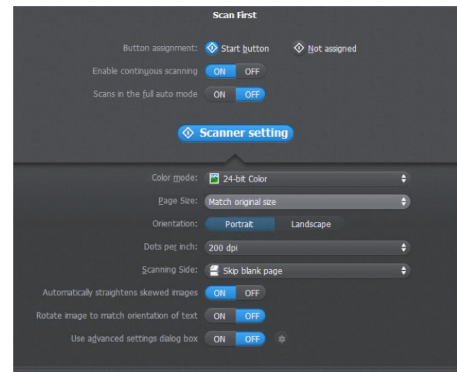

Figure 1-313

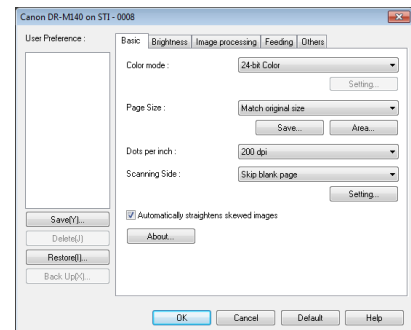

Figure 1-314

### 3. Clearing Paper Jams

- 1) Remove any remaining documents from the document feed tray.

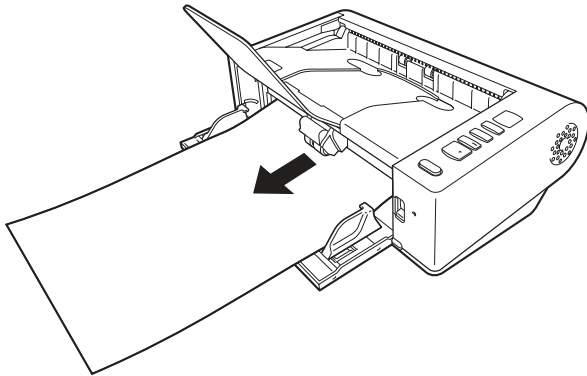

Figure 1-315

- 2) Pull up the OPEN lever and open the upper unit.

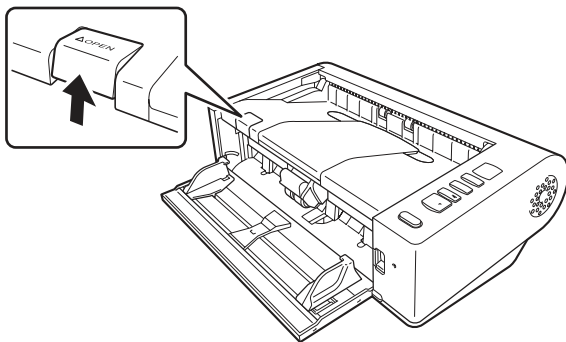

Figure 1-316

- 3) Remove any jammed documents.

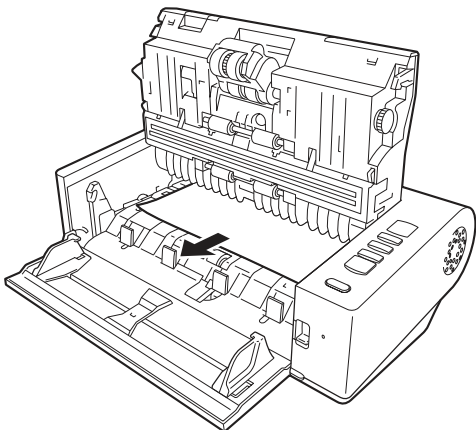

Figure 1-317

---

# CHAPTER 2

---

## FUNCTIONS & OPERATION

---

---

I. OUTLINE.....	2-1	V. POWER SUPPLY .....	2-17
II. READING SYSTEM .....	2-6	VI. LAYOUT OF ELECTRICAL COMPONENTS ...	2-18
III. FEED SYSTEM.....	2-8	VII. PARTS LAYOUT ON EACH PCB.....	2-19
IV. CONTROL SYSTEM .....	2-13		

---



## I. OUTLINE

### 1. Main Configuration

Figure 2-101 shows the main configuration of this machine.

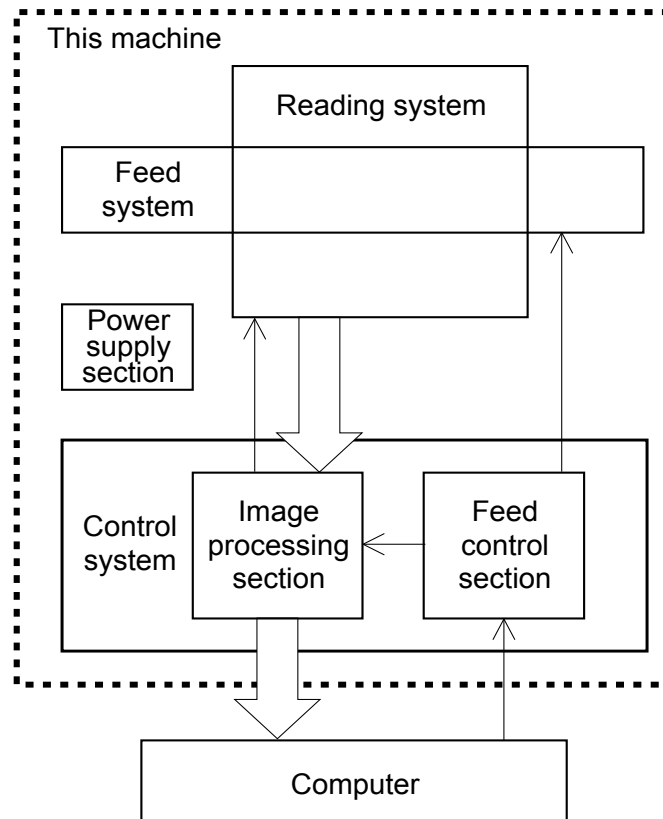

**Figure 2-101**

- 1) **Reading system**  
This system reads image data from image sensors.
  - 2) **Feed system**  
This system performs from document pickup to document ejection.
  - 3) **Control system**  
This system is comprised of an image processing section and a feed control section.
  - 4) **Power supply section**  
This section supplies DC power, converted from AC power with the AC adapter, to the control PCB of this machine.
- The image processing section controls the reading system, and processes the read image data. The computer also processes image data.
- The feed control section controls the feed system.

## 2. Feed Path

A sectional view of the feed path of this machine is shown below.

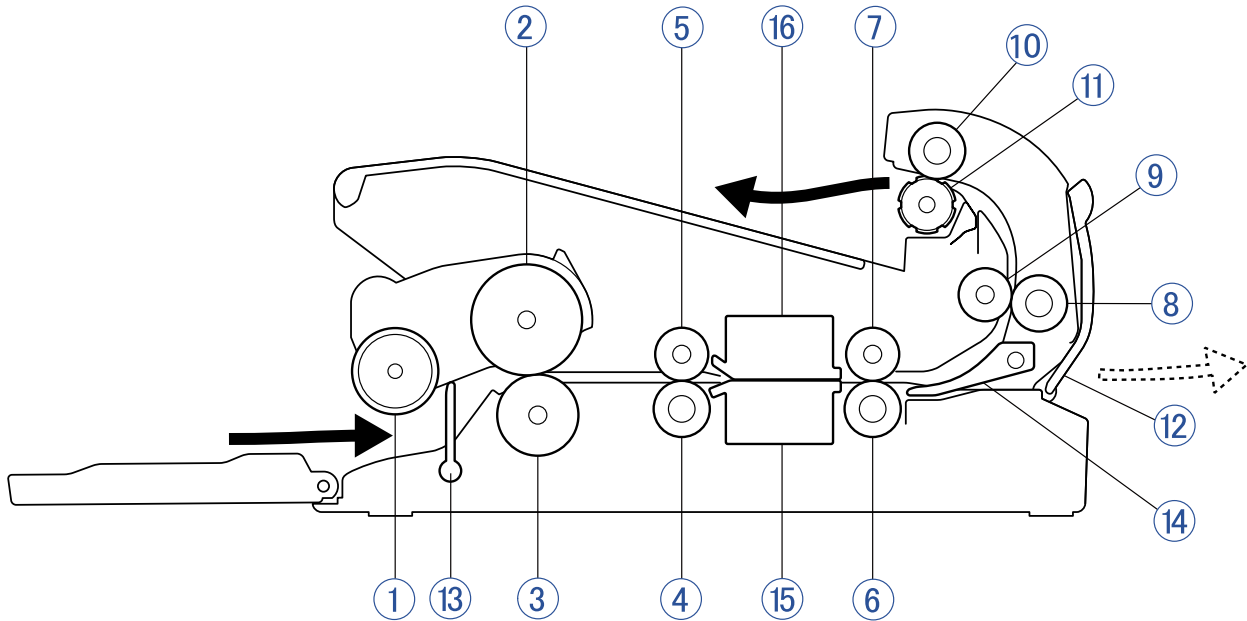

Figure 2-102

- |                                    |                            |
|------------------------------------|----------------------------|
| ① Pickup roller                    | ⑨ U-turn roller (follower) |
| ② Feed roller                      | ⑩ Eject roller (drive)     |
| ③ Retard roller                    | ⑪ Eject roller (follower)  |
| ④ Registration roller (drive)      | ⑫ Straight path tray       |
| ⑤ Registration roller (follower)   | ⑬ Stopper                  |
| ⑥ Straight eject roller (drive)    | ⑭ Flapper                  |
| ⑦ Straight eject roller (follower) | ⑮ Reading unit (lower)     |
| ⑧ U-turn roller (drive)            | ⑯ Reading unit (upper)     |

### 3. Motor Drive

This machine has a feed motor for picking up documents and a main motor for feeding documents.

Also, the document stopper of the pickup section is moved by the feed motor.

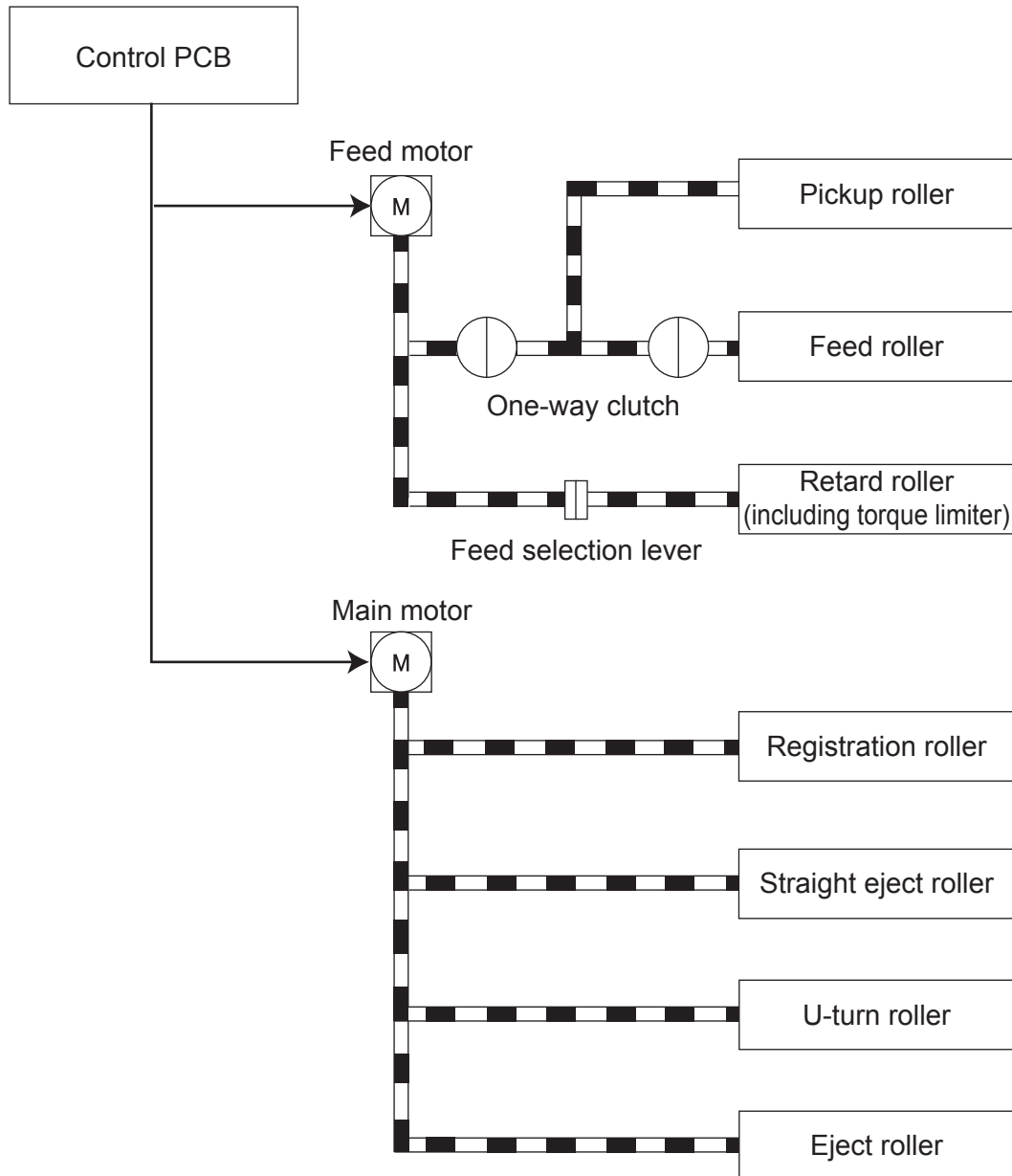

Figure 2-103

## 4. Electrical Circuits

An overview of the electrical circuits block diagram of this machine is shown below.

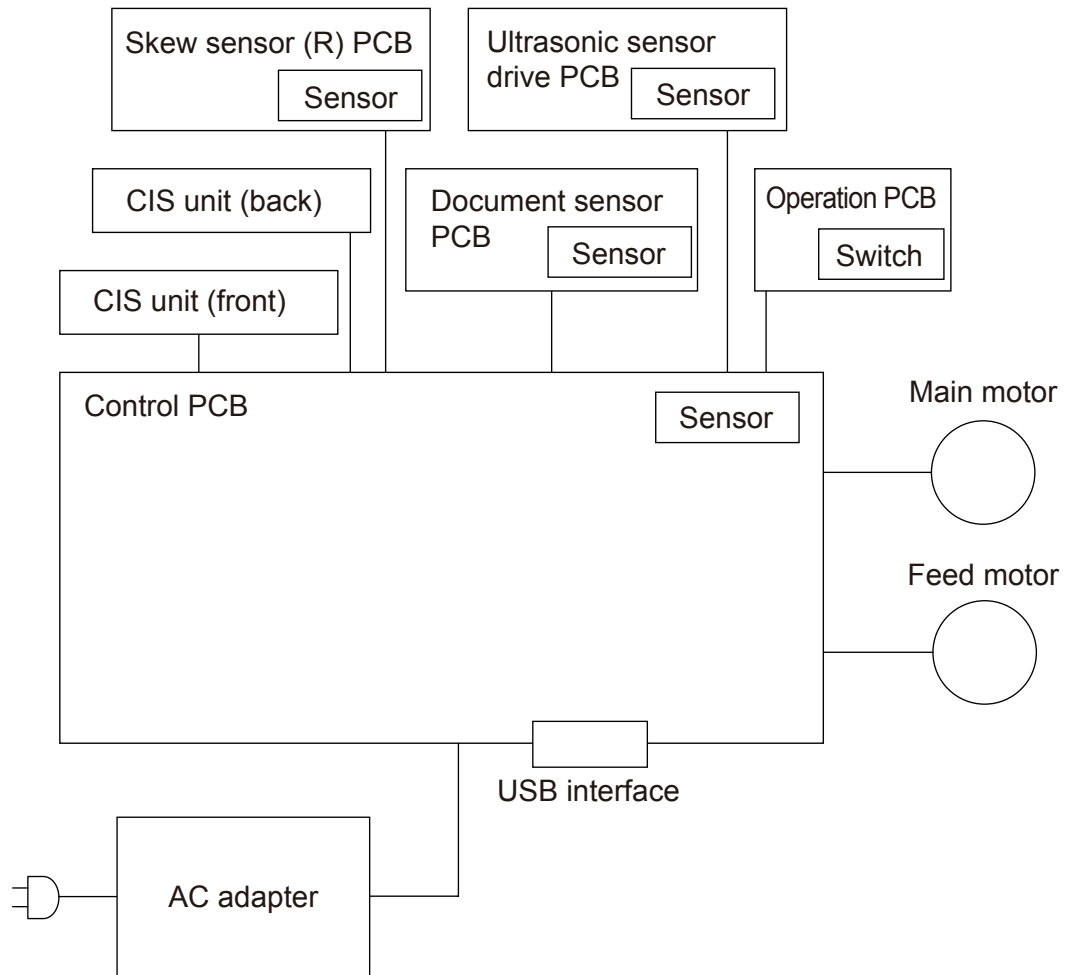

Figure 2-104



### 5. Timing Chart

The timing chart when you separately pickup 2 sheets of document without temporarily suspending the machine is shown below.

Once the machine starts scanning, it activates the feed motor and the main motor and feeds the document after the initial operation.

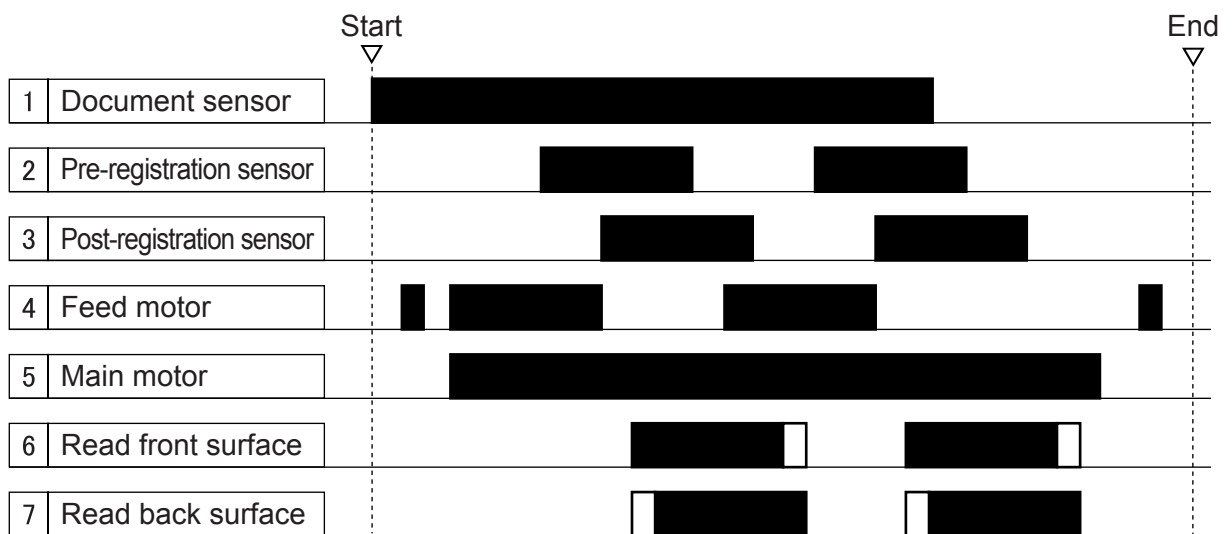
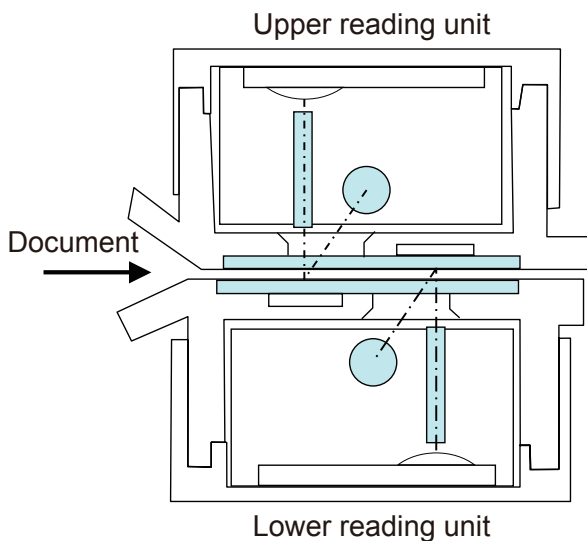

Figure 2-105

## II. READING SYSTEM

### 1. Reading Unit

The sectional view of the reading system is shown below. The upper and lower reading units have the same configuration but the different guide shapes.



**Figure 2-201**

The upper reading unit reads the front side of the documents and the lower reading unit reads the back side of the documents. This configuration enables the machine to read both front and back sides of a document using a single scan.

The read image data are sent to the image processing section of the control PCB.

To prevent reading speed from decreasing, the image data is divided into four and output in parallel.

The reading unit consists of CIS unit, guide, and case.

The CIS unit consists of CIS PCB, lens array, LED (R/G/B), light guide, and case.

The reading glass and white reference sheet are mounted on the guide.

Photosensitive pixels are mounted on the CIS PCB with a density of 600 dpi in a line. The effective reading width is 219mm, and the number of effective picture elements is 5184.

A set of three basic color LEDs, red, green, and blue (RGB), is mounted only on the one side. This single-side illumination causes a shadow on a document, which may effect on the image data quality.

In the binary or grayscale modes, image data are read with composite light generated by lighting the RGB LEDs at the same time. In the color mode, the LED is successively lit, and reads image data with each color. As documents are being fed at regular speed while image data are read, the reading positions of RGB are shifted slightly.

In the color dropout mode, only the LED of a designated color lights. In the color emphasis mode, the LED of a color other than a designated color lights.

## 2. Shading

This section explains the reading mechanism of the white reference sheet for determination of the shading correction value.

The sectional view of the reading unit is shown below.

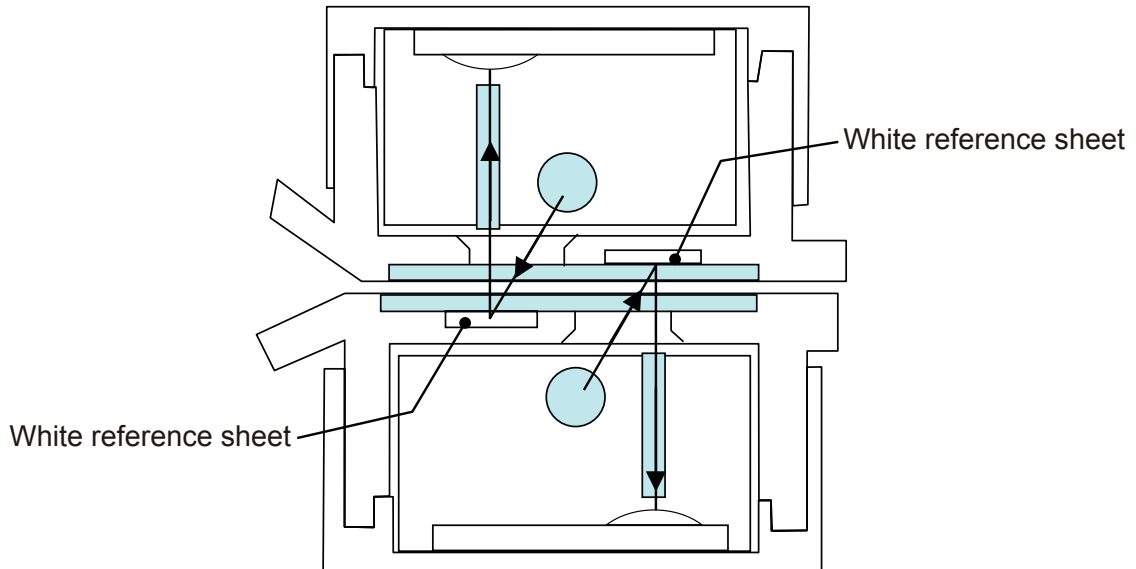

**Figure 2-202**

This machine can read the white reference data at the document reading position, unlike other scanners having the black background color, since its background color is white. Therefore, there is neither need to feed the shading sheet nor to move the internal white reference sheet or the reading units.

For example, when the lower reading unit reads the white reference data, the LED emitted from the lower unit is reflected from the white reference sheet on the upper unit to be input to the sensor on the CIS PCB.

Since the white reference sheet is placed under the reading glass, feeding document does not cause dirt on it. Note that executing shading while the reading

glass is dirty can cause poor images such as white lines occurring in the images.

When this machine is turned ON or starts scanning, it reads the white reference data to determine the shading correction value.

However, the slightly different optical paths to the light receiving element are used for the actual document and the white reference sheet. Therefore this machine needs fine adjustment of the shading correction value using the service mode and the shading sheet. This fine adjustment is necessary after replacing the reading unit or after replacing the control PCB recording the shading correction value.

### III. FEED SYSTEM

#### 1. Feeding Mechanism

The sectional view of the feed system is shown below.

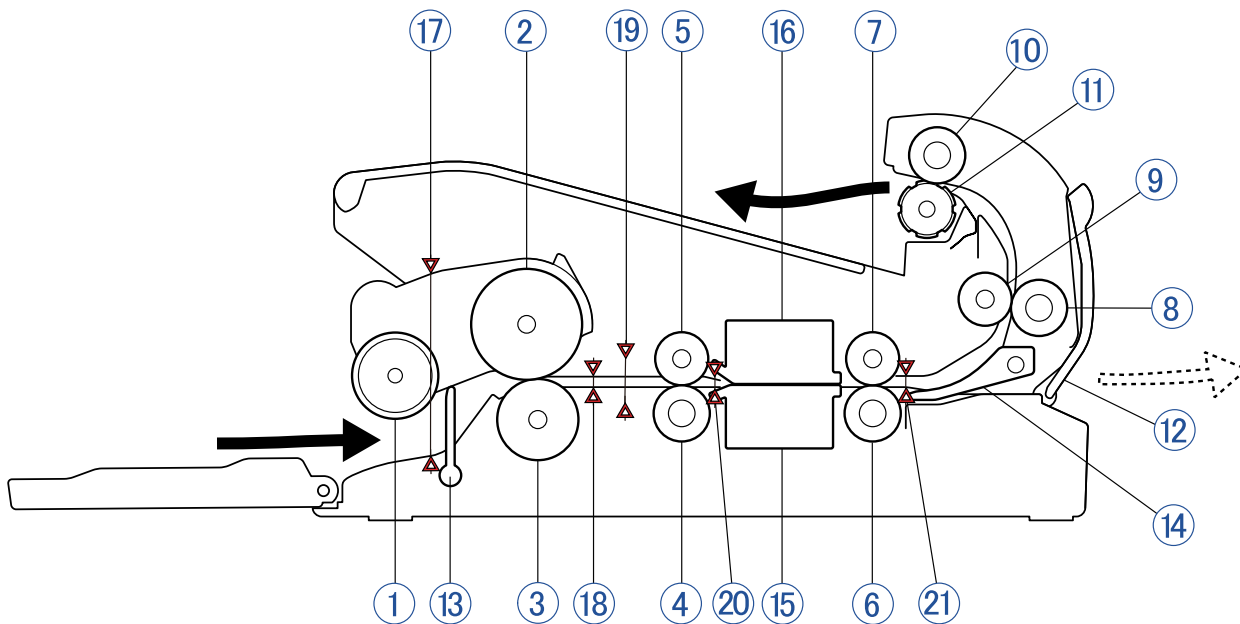

Figure 2-301

- |                                    |  |
|------------------------------------|--|
| ① Pickup roller                    | ⑪ Eject roller (follower)                      |
| ② Feed roller                      | ⑫ Straight path tray                           |
| ③ Retard roller                    | ⑬ Stopper                                      |
| ④ Registration roller (drive)      | ⑭ Flapper                                      |
| ⑤ Registration roller (follower)   | ⑮ Reading unit (lower)                         |
| ⑥ Straight eject roller (drive)    | ⑯ Reading unit (upper)                         |
| ⑦ Straight eject roller (follower) | ⑰ Document sensor detection point              |
| ⑧ U-turn roller (drive)            | ⑱ Pre-registration/skew sensor detection point |
| ⑨ U-turn roller (follower)         | ⑲ Ultrasonic sensor detection point            |
| ⑩ Eject roller (drive)             | ⑳ Post-registration sensor detection point     |
|                                    | ㉑ Eject sensor detection point                 |

1) Feed path

The feed path in this machine is horizontal in the reading unit, and has the two types of straight or U-turn in the eject section.

When feeding cards, use the straight path.

2) Drive

The pickup, feed, and retard rollers in the early stage are driven by the feed motor, and from the registration roller to the eject roller in the later stage are driven by the main motor. The scanning condition determines each drive speed.

Furthermore, the document stopper is driven by the feed motor.

3) Feed

The following figure shows a cross-sectional diagram of the feed section before starting the feed. The document stopper is standing up.

When a document is placed in the inlet, the leading edge of the document lines up at the document stopper. Once the machine starts scanning, the document is fed after the document stopper is lowered.

Misfeeds and double feeds have been reduced by increasing the diameter of the feed roller and making the retard roller movable up and down.

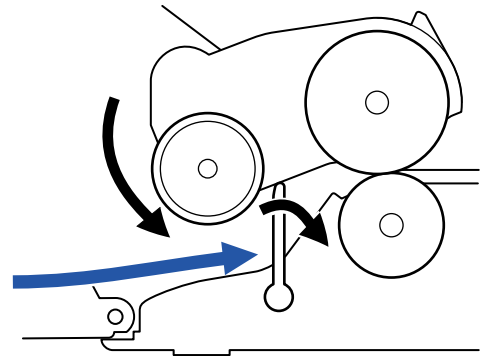

Figure 2-302

4) Separation

Separation of the documents is performed by the retard roller.

If the feed selection lever is set to normal (separate), though the retard roller is connected to the drive system, since the torque limiter is built into it, when the outside pressure on the roller exceeds the specified value into the feed direction, the roller begins to rotate in the same direction.

As shown in Figure 2-303-a, when overlapped documents enter into the clearance between the feed roller and the retard roller, the document in contact with the feed roller is fed in the direction entering the scanner and the document in contact with the retard roller does not enter the scanner because the retard roller rotates in the direction to return the document to the feeder.

As shown in Figure 2-303-b, once a single document remains, the feed roller and the document add torque on the retard roller. When this torque exceeds the retard roller torque, the retard roller rotates in the direction pushing the document into the scanner due to the torque limiter.

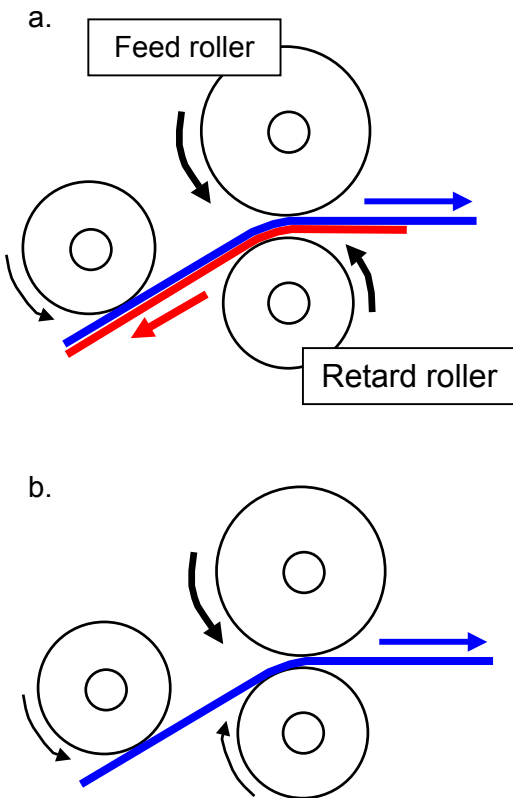

Figure 2-303

However, if the lever is in none separate feed, the retard roller is allowed to rotate freely, and the document is fed by the rotation of the feed roller.

5) Eject

This machine is equipped with both a U-turn path and a straight path. The selection is made by opening or closing the straight eject tray. This is what operates the flapper.

The difference is shown in the following figures.

a. U-turn path

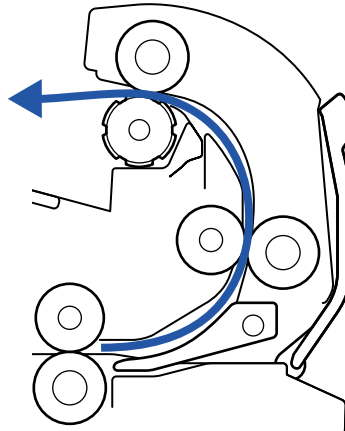

b. Straight path

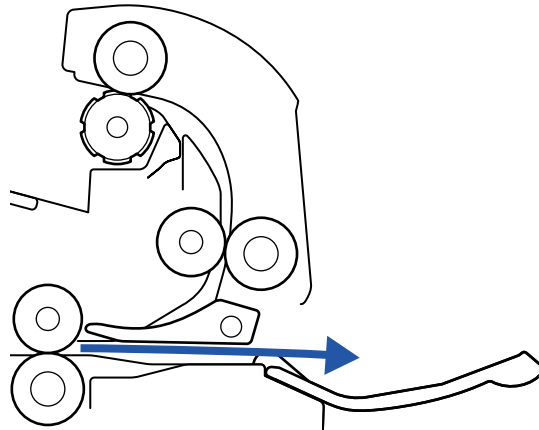

Figure 2-304

## 6) Sensor

The document sensor is mounted on the inlet, the registration sensor is mounted before and after the registration roller, and the eject sensor is mounted immediately after the straight eject roller. Furthermore, the ultrasonic sensor for double feed detection is mounted in front of the registration roller.

In addition, the skew sensors (R and L) are mounted in front of the registration roller in this device. This detects when the document is skewed. This makes it possible to both prevent damage to the document if it is skewed, and to detect documents that are held by staples.

## 2. Feed Error Detection

### 1) Paper Jam Detection

Paper jams are detected by the registration sensor and eject sensor. The types of the document jams are described as follows.

#### a) Pickup Delay Jam (Pickup Error)

The leading edge of the document was not detected by the registration sensor within the specified time after the machine starts scanning.

#### b) Early Reach Jam

The leading edge of the following document was detected after the trailing edge of the document was detected by the registration sensor before the document has been fed for a specified length.

#### c) Residual Jam

The trailing edge of the document was not detected even though the document has been fed for the maximum specified length after the leading edge of the document was detected by the registration sensor and eject sensor.

#### d) Fast Feed Jam

The trailing edge of the document was detected after the leading edge of the document was detected by the registration sensor before the document has been fed for the minimum specified length.

#### e) Non-removal Jam

The machine starts scanning while the document is detected by the registration sensor and eject sensor, and still remains inside this machine.

2) Double Feed Detection

There are 2 double feed detection methods: the document length detection by the registration sensor and the document overlapping detection by the ultrasonic sensor.

◆ Registration sensor

The registration sensor uses the first document length of the scanned batch as a reference to detect the document length. The 35 mm or more difference from the standard is interpreted as a double feed.

◆ Ultrasonic sensor

The ultrasonic drive sensor transmits the ultrasonic and the ultrasonic receive sensor receives the ultrasonic signal to gain a specific signal level. When overlapping documents are fed, the signal level is different from when properly feeding a single document. This machine interprets this difference as a double feed.

Note that since this level of difference occurs depending on the presence of a layer of air, a double feed will not be detected if the document is tightly adhered by static electricity or adhesive. Furthermore, "double feed" is judged if this level of difference is detected continuously for a specific amount of time. As a result, if the overlap between sheets is less than 50 mm when a document is being fed, it might not be judged as a "double feed" because the detection time is short. Furthermore, the ranges within 10mm from the leading and trailing edges are not judged.

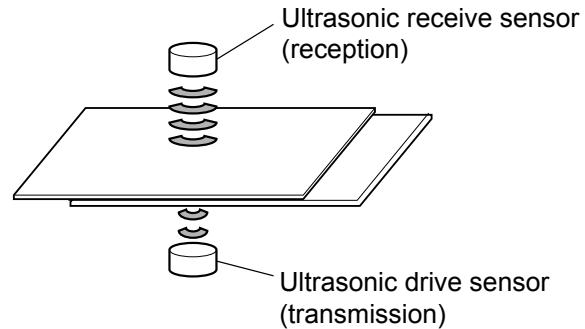

Figure 2-305

3) Skew Detection

Skewed documents are detected by the skew sensors (L and R). This makes it possible to both prevent damage to the document if it is skewed, and to detect documents that are held by staples.

If multiple A4 or LTR size documents are fed stapled together in a single location, the uppermost document will become skewed. This is detected by the skew sensor to prevent the documents from becoming damaged.

The following figure shows positions of the skew sensors.

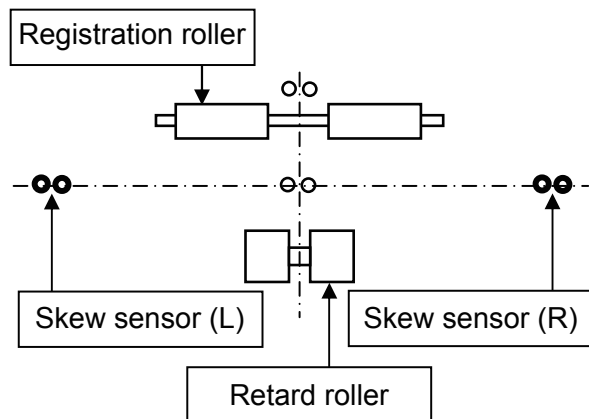

Figure 2-306



## IV. CONTROL SYSTEM

### 1. Control Circuits

The machine is controlled by the control

PCB. The block diagram and the function list of major ICs are shown below.

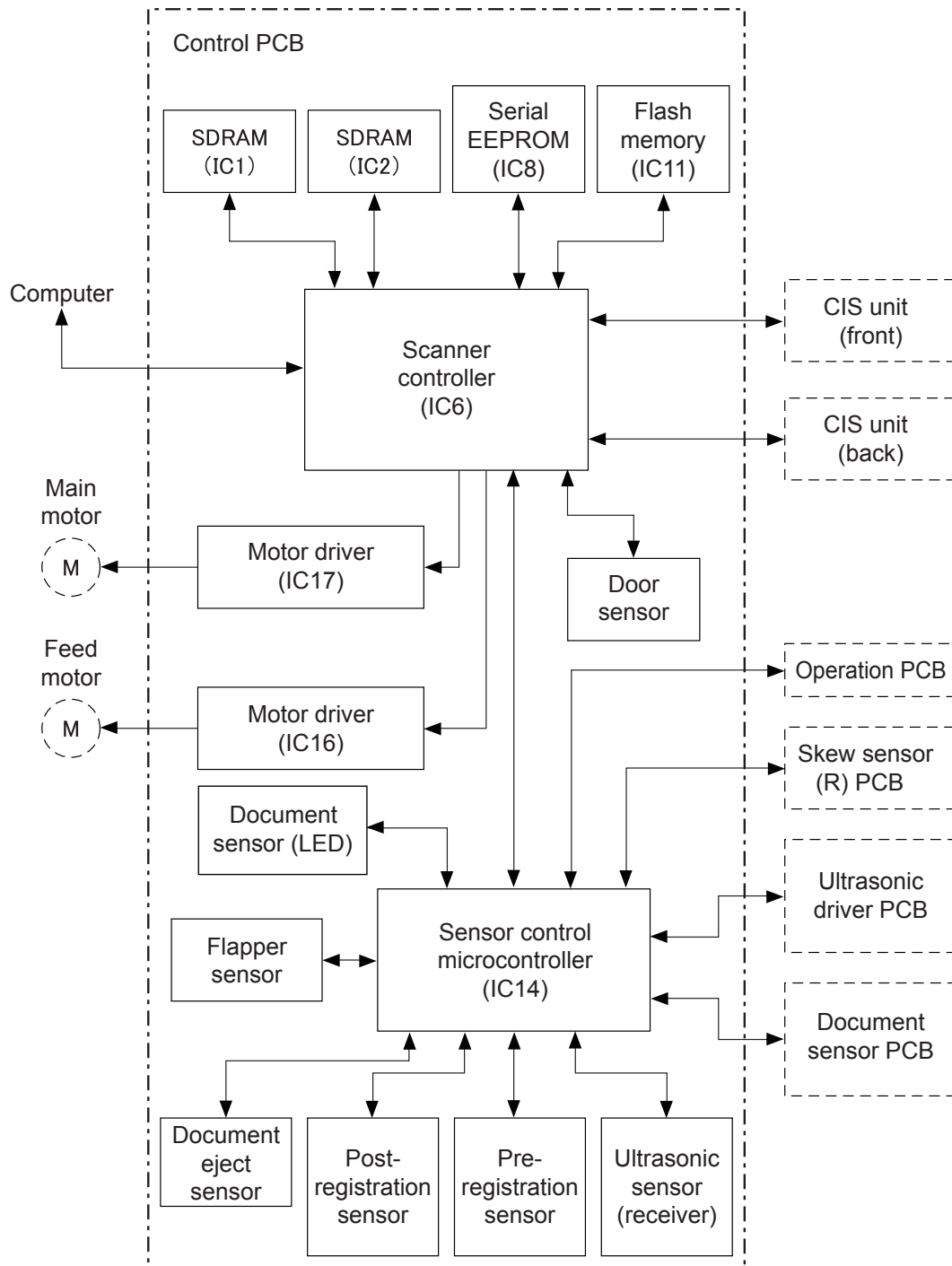

Figure 2-401

◆ Function list of major ICs

IC No.	Name	Function
IC1	SDRAM (128 Mbit)	Working memory for the scanner controller and for storing image data temporarily
IC2	SDRAM (128 Mbit)	Working memory for the scanner controller and for storing image data temporarily
IC6	Scanner controller	Overall scanner control
IC8	Serial EEPROM (2 kbit)	Saves the various setting data
IC11	Flash memory (16 Mbit)	Stores firmware
IC14	Sensor control microcontroller	Controls the ultrasonic sensor and other sensors for detecting documents
IC16	Motor driver	For driving the feed motor
IC17	Motor driver	For driving the main motor

Table 2-401

## 2. Image Processing

A block diagram of the image processing is shown below.

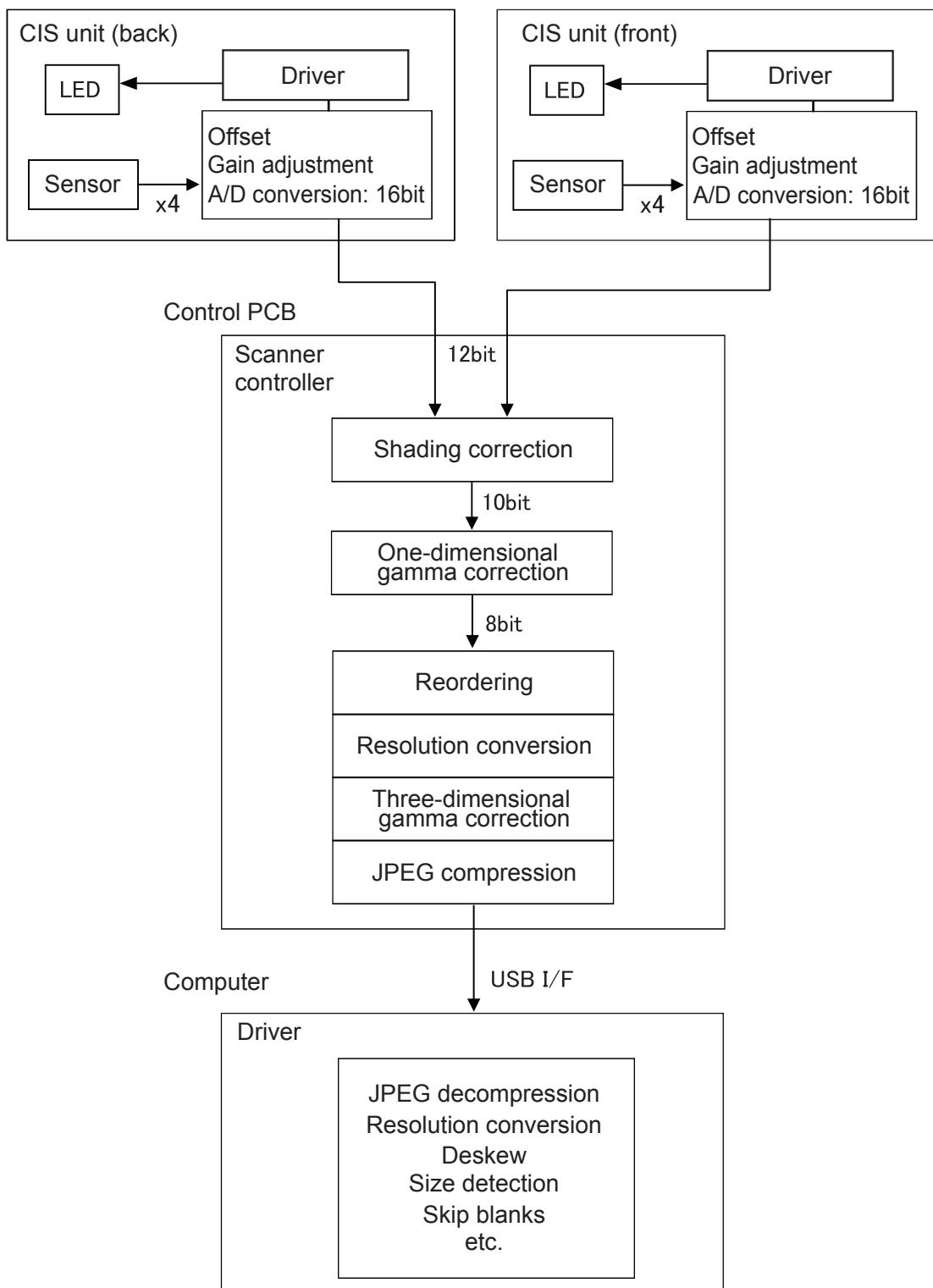

Figure 2-402

Analog signals proportionate to the density of each picture element are output as 4 parallel lines from the image sensor on the CIS unit to the analog processor. The analog processor carries out offset adjustment, gain adjustment, and A/D conversion. Analog signals are converted into 16 bit digital signals in the analog processor.

This image data is sent to the scanner controller on the control PCB where shading correction and one-dimensional gamma correction are performed, and the data is simultaneously converted into 8-bit data. After this, data reordering, resolution conversion, three-dimensional gamma correction, and JPEG compression are performed, and the data is output to the computer via the USB interface.

Inside the computer, the various image processing is executed according to the user settings by the driver for this machine. Whether to perform processing inside the machine or on the computer varies depending on the settings, even for the same processing, in consideration of the overall efficiency.

## V. POWER SUPPLY

### 1. Power Supply

The machine uses an AC adapter for its power supply. Its rated input voltage is 100-240 VAC, 50/60 Hz and whose output is 24 VDC. Use the AC adapter bundled with this machine. The power output from the AC adapter is input to the control PCB.

In case of excess voltage or current applied to the AC adapter output, the safety system cuts the power. In this case, unplug the AC plug. After removing the cause, plug it back.

The power switch for the machine is mounted on the operation PCB. When the switch is turned on, a DC/DC converter activates to generate each of the DC voltages and supply power to each of the

components.

When no documents have been fed or there has been no communication via this USB I/F for an extended period of time, the machine enters the sleep mode (Energy Star mode). When the machine is in the sleep mode, the electrical circuits enter a sleeping state. However, the CPU does not enter a sleeping state. This machine automatically returns from the sleep mode when it receives communication from a computer or when a key on the operation panel is pressed.

Furthermore, on the user setting screen, user can set the power to be turned OFF if no operations are performed for a long period of time (4 hours).

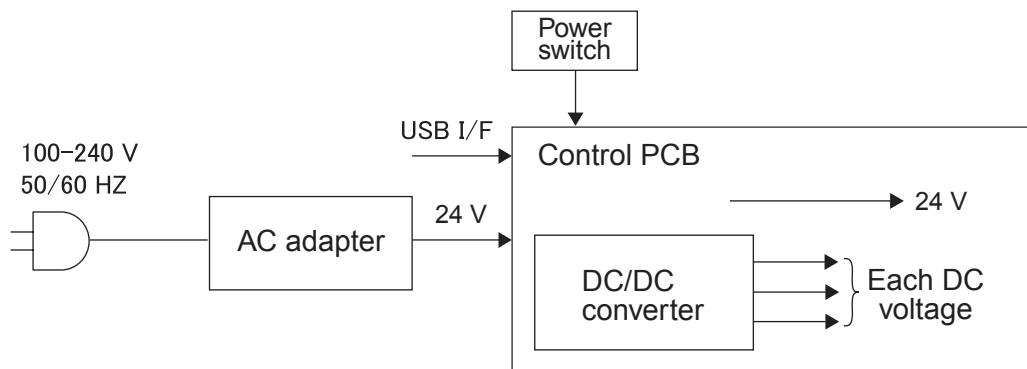

Figure 2-501

## VI. LAYOUT OF ELECTRICAL COMPONENTS

### 1. Layout of Electrical Components

For sensors etc. on the PCBs, refer to "VII.PARTS LAYOUT ON EACH PCB".

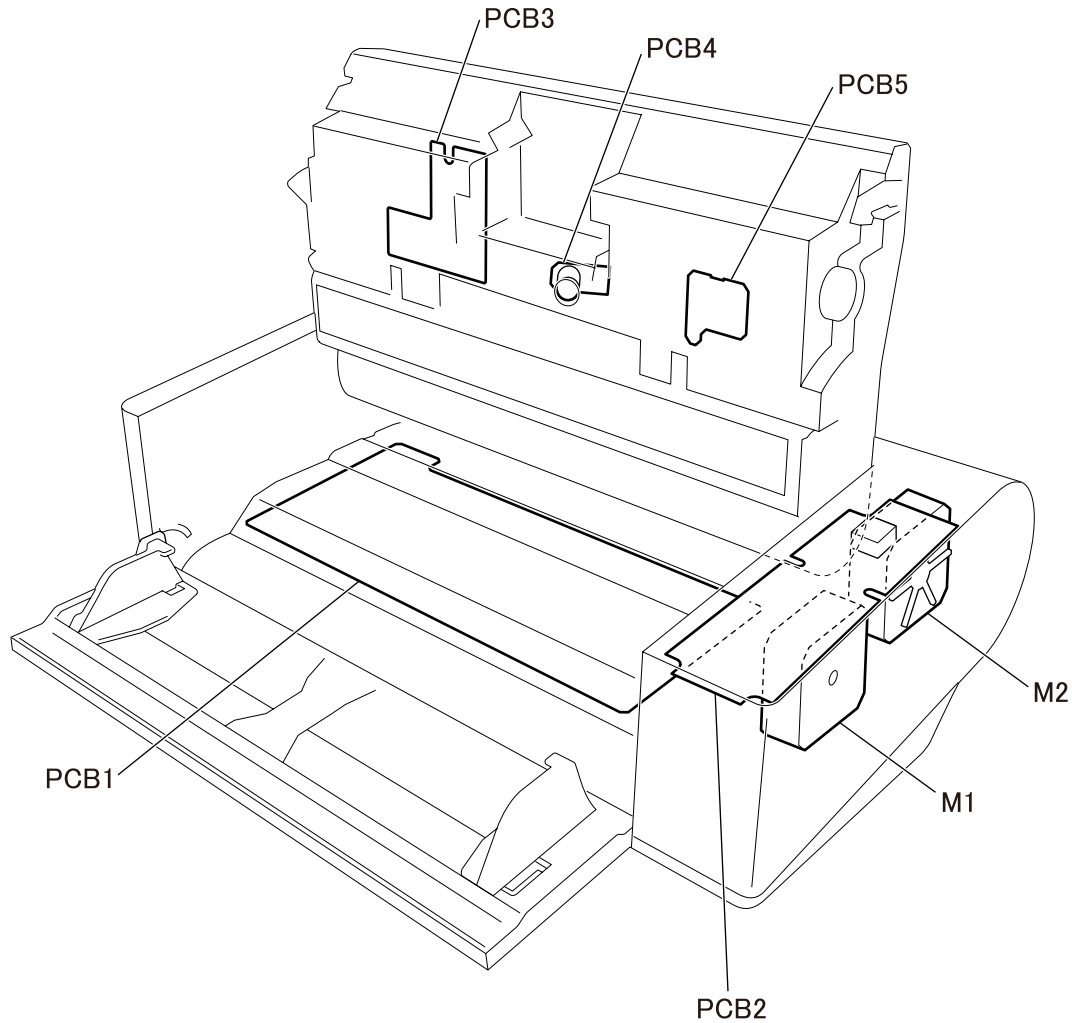

Figure 2-601

Category	Name	Location	Symbol
Motor	Feed motor	Base unit (right)	M1
	Main motor	Base unit (right)	M2
PCB	Control PCB	Base unit (lower)	PCB1
	Operation PCB	Base unit (right)	PCB2
	Document sensor PCB	Upper unit	PCB3
	Ultrasonic drive PCB	Upper unit	PCB4
	Skew sensor (R) PCB	Upper unit	PCB5

Table 2-601

## VII. PARTS LAYOUT ON EACH PCB

### 1. Control PCB

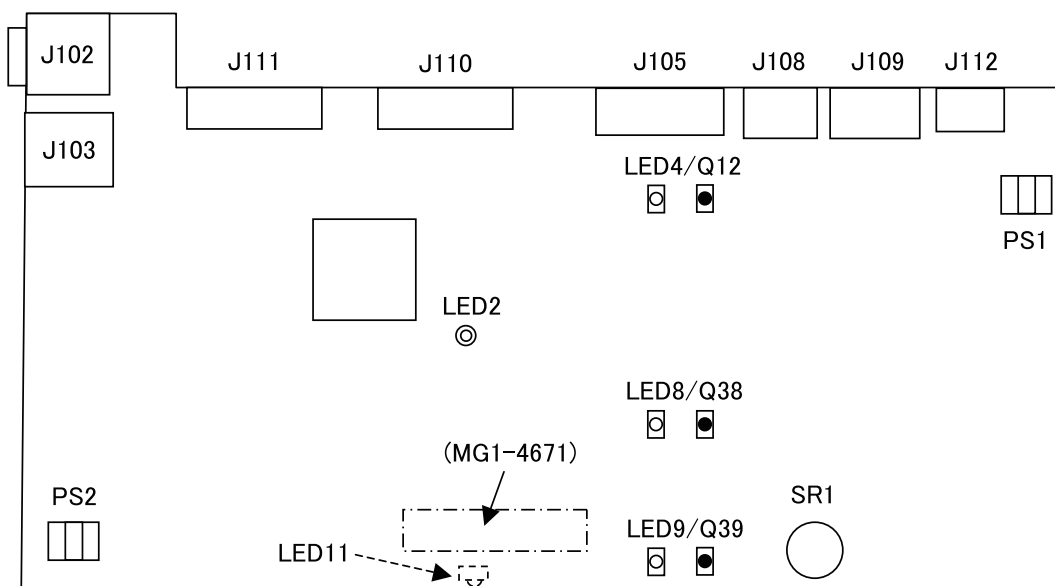

Figure 2-701

Connector		Details
J102	–	AC adapter
J103	–	USB interface
J105	13P	Document sensor PCB, etc.
J108	5P	Main motor
J109	6P	Feed motor
J110	20P	CIS unit (back)
J111	20P	CIS unit (front)
J112	10P	Operation PCB

Table 2-701

Symbol	Details
PS1	Flapper sensor
PS2	Door sensor
SR1	Ultrasonic sensor (receiver)
LED11	Back: Document sensor (transmitter)
LED9/Q39	Pre-registration sensor
LED8/Q38	Post-registration sensor
LED4/Q12	Eject sensor
LED2	Blinking 1 (slowly) ON: 500 msec, OFF: 500 msec (1 time/second) → CPU operation/DC power good
	Blinking 2 (quickly) ON: 250 msec, OFF: 250 msec (2 time/second) → Firmware fault
	Blinking 3 (intermittently) (ON: 125 msec, OFF: 125 msec) × 4 times, OFF: 1 sec → EPROM fault

Table 2-702

## 2. Operation PCB

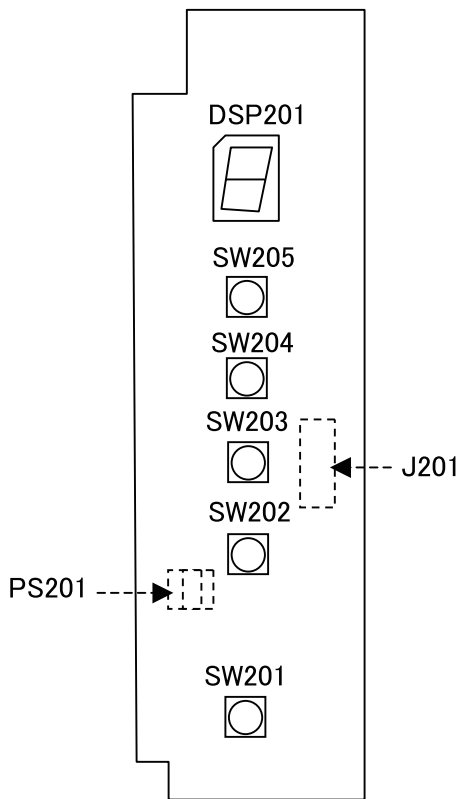

Figure 2-702

Symbol	Details
J201 (10P)	Back: Control PCB
PS201	Front: Separation sensor
DPS201	7 segments LED
SW201	Power switch
SW202	Start switch
SW203	Stop switch
SW204	DFR switch
SW205	JOB switch

Table 2-703

## 3. Document Sensor PCB

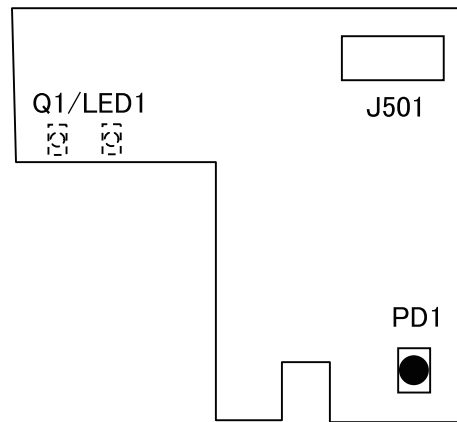

Figure 2-703

Symbol	Details
J501 (6P)	Control PCB
PD1	Document sensor (receiver)
Q1/LED1	Back: Skew sensor (L)

Table 2-704



---

# CHAPTER 3

---

## DISASSEMBLY & REASSEMBLY

---

The machine shown in the photographs of the figures in this chapter may be different from some mass-produced machines.

---

I. EXTERNAL PARTS.....	3-1	III. UPPER UNIT.....	3-10
II. BASE UNIT .....	3-4	IV. READING UNIT.....	3-14

---



## I. EXTERNAL PARTS

### 1. Upper Cover

- 1) Stand up the main body, insert a tool into the 2 holes ① on the left and right side of the bottom cover, and slightly lift up the front side of the upper cover ② to unhook the fitting parts.

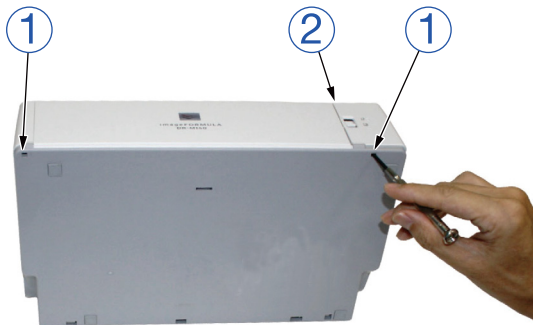

Figure 3-101

- 2) Return the main body to horizontal and open the straight path tray ①. Unhook the 2 pairs of fitting parts ② on the left and right side and remove the upper cover ③. Take care because there is a cable connected to the back of the control panel. Then, remove the connector ④.

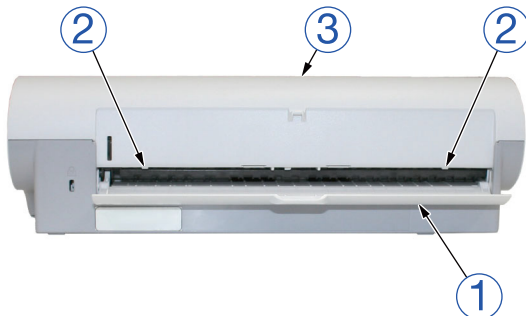

Figure 3-102

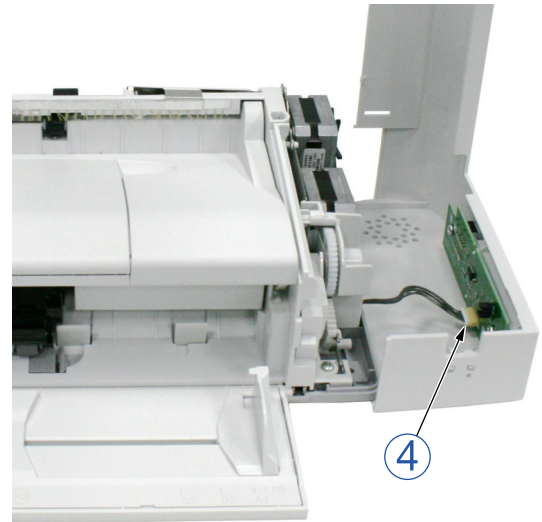

Figure 3-103

#### ◆ Notes on assembling

Connect the cable before attaching the upper cover. Do not get the cables caught in parts. Furthermore, align the position with the rear side bottom cover.

## 2. Bottom Cover / Feed Tray

- 1) Remove the upper cover.  
(Page 3-1)
- 2) Remove the 2 screws ① (M3, self-tapping). Then, unhook the fitting parts ③ after removing the screws ② (M3, self-tapping) on the inside of the retard roller cover, while lifting up the front side slightly and pulling it towards you. Remove the main body ④ after the rear side fitting parts come unhooked.



Figure 3-104

- 3) Remove the document feed tray ① from the bottom cover ②. The plate spring ③ can also be removed.



Figure 3-105

### ◆ Notes on assembling

Assemble the main body from the rear side, and insert the cables for the operation PCB in the cable guide, and ensure that the cables do not get caught in parts.

### 3. Document Eject Tray

- 1) Remove the roller unit and remove the screw ① (M3, self-tapping). Then, push down the hooks ② on the left and right to unhook the fitting parts, and pull the document eject tray out towards you.

**Note:** Once you have removed the document eject tray, the open/close lever inside and coil spring can also be removed. Furthermore, the document eject extension tray can also be removed.

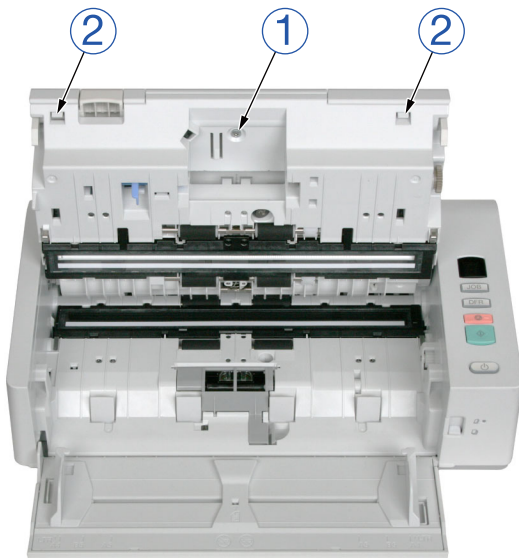

Figure 3-106

### 4. Straight Path Tray

- 1) Open the straight path tray ①, bend the tray with your fingers, and unhook the fitting parts ② on the right side in the figure below. Then, unhook the fitting parts ③ on the left side as well.

**Note:** Remove from the right side as shown in the figure below. Do not break the tray by bending it too much.



Figure 3-107

**Note:** To remove the tray without bending it, you should remove the upper unit first.

## II. BASE UNIT

### 1. Control PCB

1) Remove the bottom cover and the document feed tray.

[\(Page 3-2\)](#)

2) Remove the 2 screws ① (M3, self-tapping) and turn the control PCB ② (with mounting plate) upside-down. Then, remove the connected connectors.

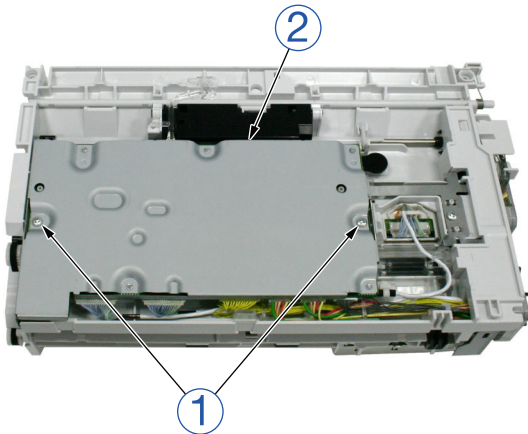

Figure 3-201

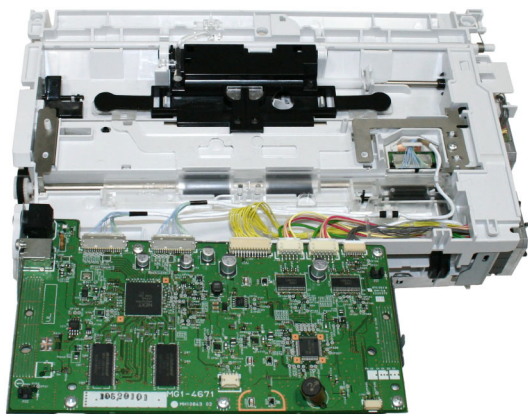

Figure 3-202

3) Remove the 6 screws ① (M3xL4) and remove the control PCB ② from the mounting plate.

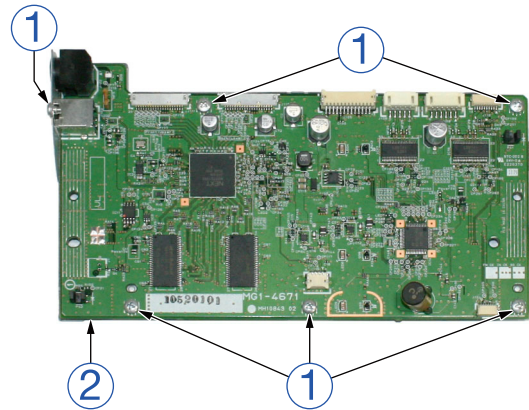

Figure 3-203

#### ◆ Notes on assembling

You should insert the connector straight and all the way in. Be careful when handling the reading unit connector because it is thin.

Furthermore, although the lengths of the upper and lower cables of the reading unit differ to suit the positions of the connectors, the connectors are the same, and you should not connect them incorrectly.

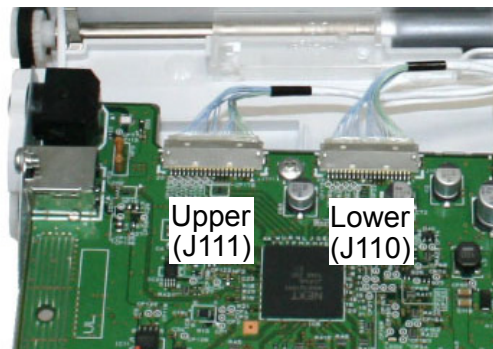

Figure 3-204

## 2. Main Motor

- 1) Remove the control PCB (with mounting plate).

[\(Page 3-4\)](#)

- 2) Remove the main motor cable ① from the cable holder, and remove it from the base unit.

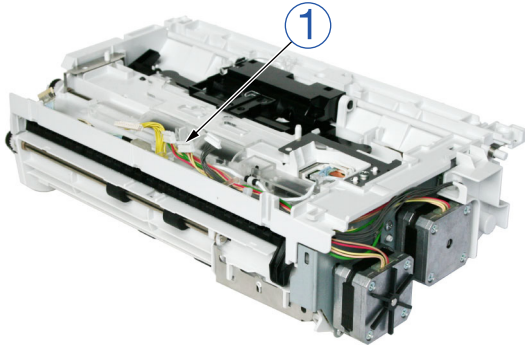

Figure 3-205

- 3) Remove the 2 screws ① (M3, self-tapping), and then remove the main motor ② (with belt).

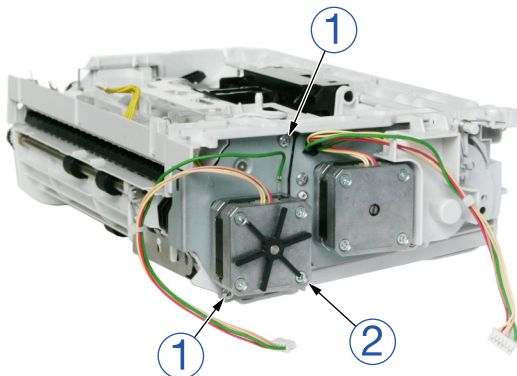

Figure 3-206

- 4) Remove the belt ① and gears ②.

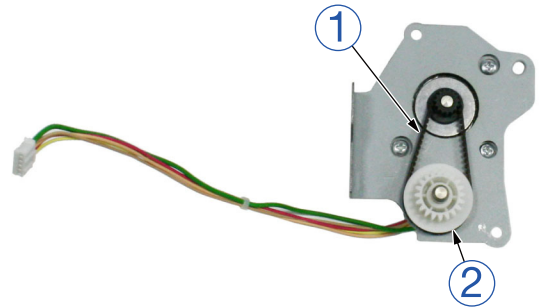

Figure 3-207

### ◆ Notes on assembling

Align the edge ① of the gear shaft with the hole in the base, and mount the motor while inserting the position setting pin ③ into the hole in the mounting plate so that the two edges ② of the grounding plate touch the inside of the motor mounting plate.

Do not get the cables caught in parts.

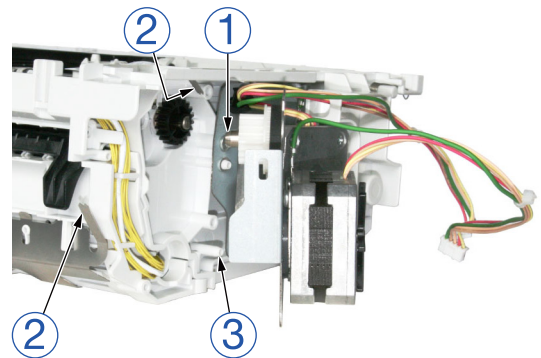

Figure 3-208

### 3. Feed Motor

- 1) Remove the control PCB (with mounting plate).  
(Page 3-4)
- 2) Remove the feed motor cable ① from the cable holder, and remove it from the base unit.

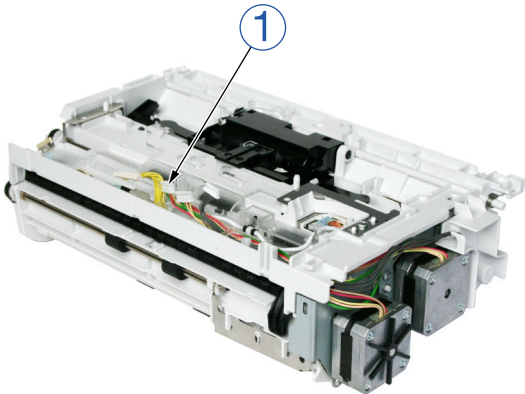

Figure 3-209

- 3) Unhook the 2 pairs of fitting parts ① and remove the cable guide ②.

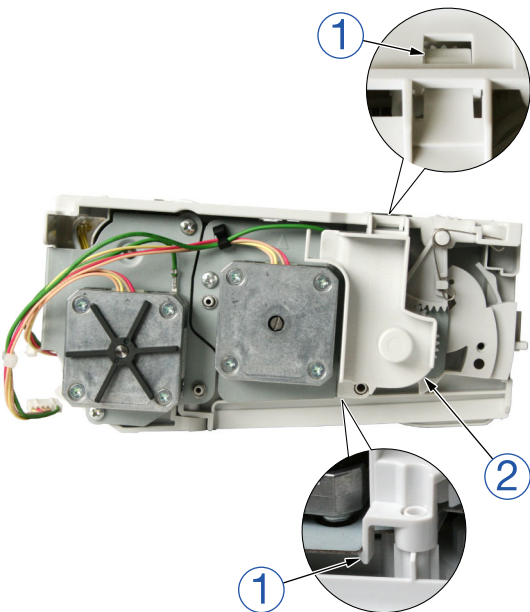

Figure 3-210

- 4) Unhook the fitting part at the edge of the gear ①, then remove the gear. Next, remove the 2 screws ② (M3, self-tapping), and remove the feed motor ④ (with belt) ensuring that it does not touch the stopper ③ gears.

**Note:** Be careful not to break the hook on the gear edge because it is thin.

**Note:** Once you have removed the feed motor, the retard roller drive units ⑤ can also be removed.

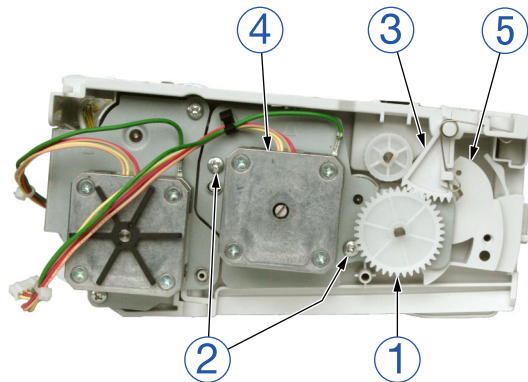

Figure 3-211

- 5) Remove the belt ① and gears ②.

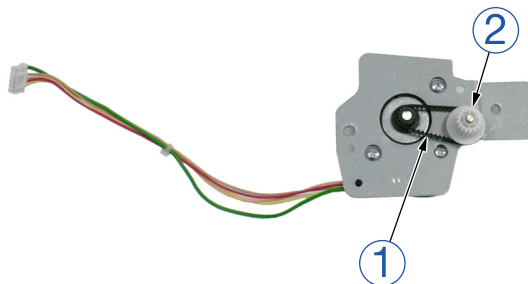
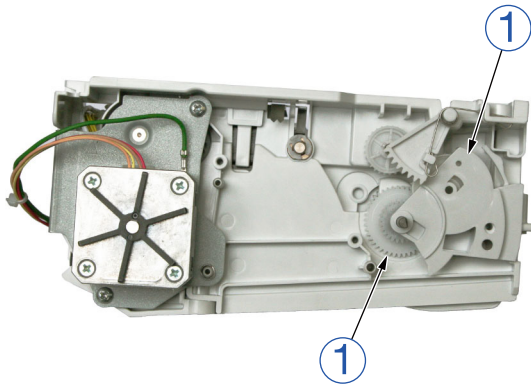

Figure 3-212



◆ **Notes on assembling**

Before assembling the motor, you should assemble the 2 retard roller drive units ① as shown in the figure below.

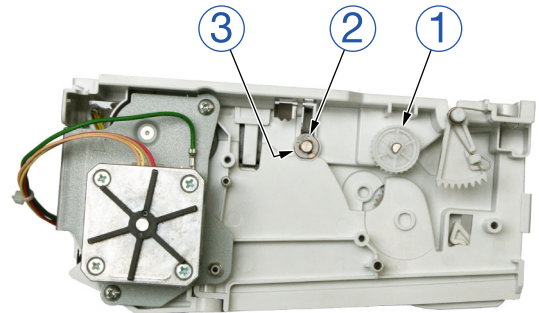

**Figure 3-213**

Next, align the holes in the motor mounting plate with the shaft of the retard roller drive unit and the positioning pins in the base, and assemble the motor while letting out the stopper gear. The edge of the grounding plate should touch the bottom side of the mounting plate.

**4. Registration Roller (Drive)**

- 1) Remove the feed motor (with belt).  
[\(Page 3-6\)](#)
- 2) Unhook the fitting part at the edge of the gear ①, then remove the gear. Remove the stopper ring ② and shaft ③.



**Figure 3-214**

- 3) Unhook the fitting part ① and remove the shaft ②. Remove the light guide ③. Next, unhook the 2 pairs of fitting parts ④ and then rotate the float unit ⑤ slightly and remove from the 2 pairs of fitting parts ⑥. The link shaft ⑦ also comes loose at the same time.

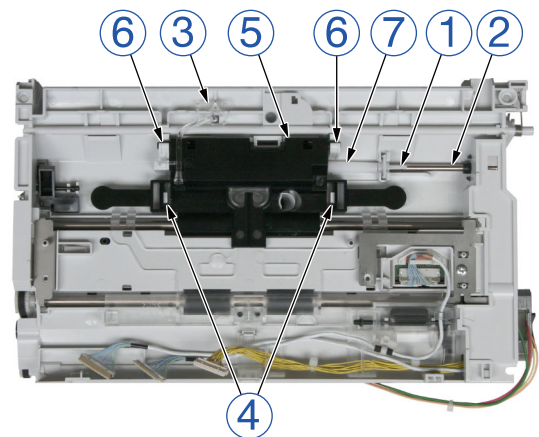

**Figure 3-215**

- 4) Remove the grounding plate ①. Remove the screw ② (M3, self-tapping) and remove the grounding plate ③. Next, remove the cable ④ from the cable guide. Then, unhook the 3 pairs of fitting parts ⑤ and remove the lower light guide ⑥.

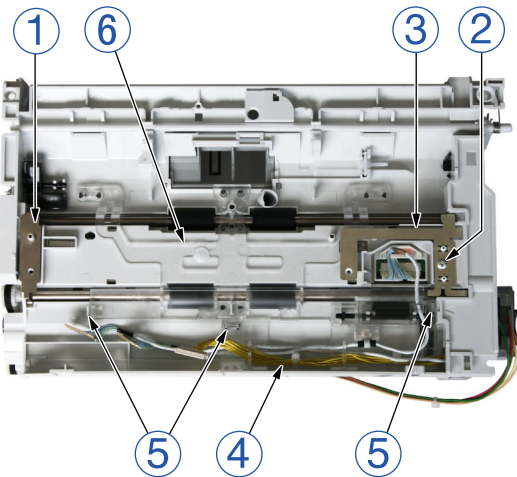

Figure 3-216

- 5) Loosen the screw ① (M3, self-tapping) and then remove the belt ②. Next, unhook the fitting part at the edge of the gear ③, and remove the gear and the bearing. Then, remove the registration roller ④.

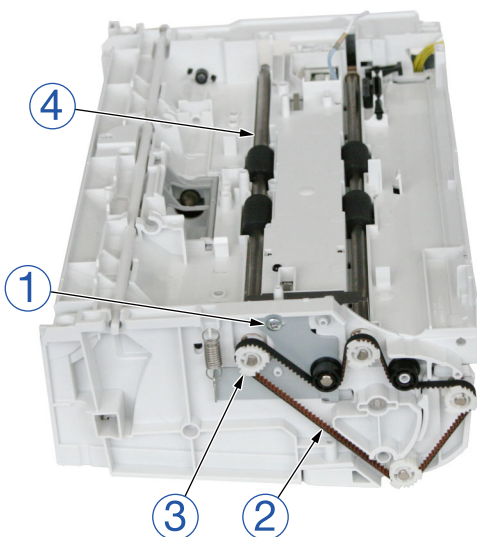

Figure 3-217

## 5. Straight Eject Roller (Drive)

- 1) Remove the feed motor (with belt).  
[\(Page 3-6\)](#)
- 2) Remove the lower light guide by referring to the section on the registration roller (drive).  
[\(Page 3-7\)](#)
- 3) Remove the main motor (with belt).  
[\(Page 3-5\)](#)
- 4) Unhook the fitting part at the edge of the gear ①, then remove the gear and bearing.

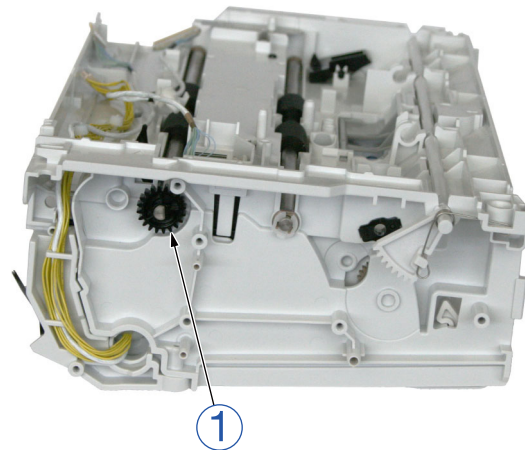

Figure 3-218

- 5) Loosen the screw ① (M3, self-tapping) and then remove the belt ②. Next, unhook the fitting part at the edge of the gear ③, and remove the gear and the bearing. Then, remove the straight eject roller ④.

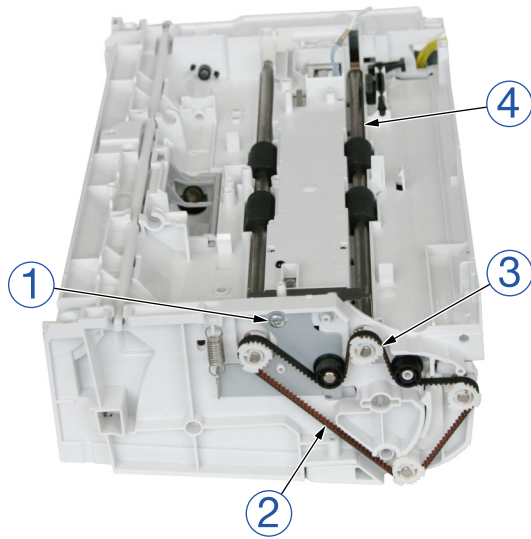

Figure 3-219

### III. UPPER UNIT

#### 1. Sensor PCBs

- 1) Remove the document eject tray.  
([Page 3-3](#))
- 2) Remove the open/close lever ① and spring. Disconnect the connector ② and unhook the 3 pairs of fitting parts ③, then remove the document sensor PCB ④. Then, disconnect the connector ⑤, unhook the 2 pairs of fitting parts ⑥, and remove the skew sensor (R) PCB ⑦.

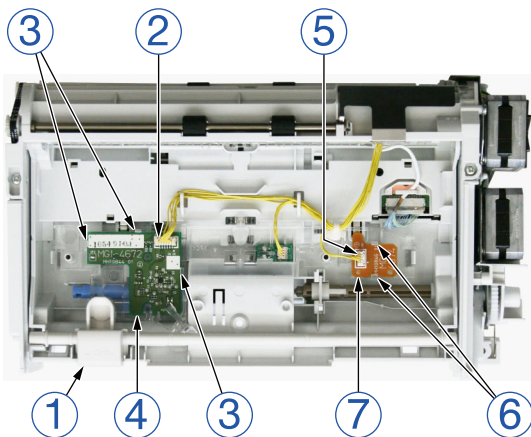

Figure 3-301

#### 2. Ultrasonic Drive PCB

- 1) Remove the sensor PCBs.  
([Page 3-10](#))
- 2) Remove the connector ① and the cable holder ② (reusable type), then unhook the 4 pairs of fitting parts ③ and remove the upper light guide ④.

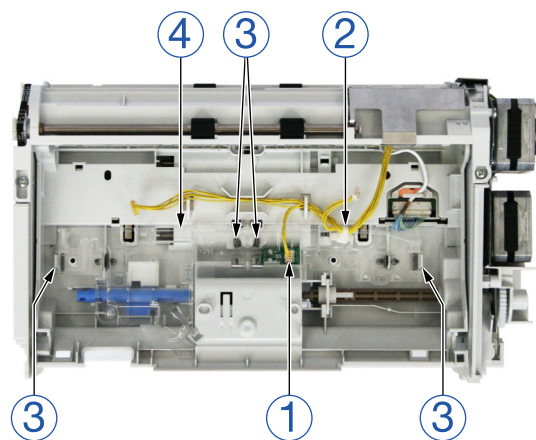

Figure 3-302

- 3) Remove the ultrasonic drive PCB ①.

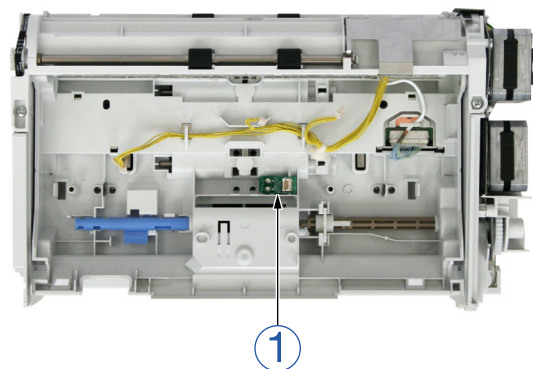

Figure 3-303

### 3. Follower Roller

**Note:** There are 3 sets of follower rollers.

In the figure below, ① is for the registration roller, ② is for straight path, and ③ is for U-turn.

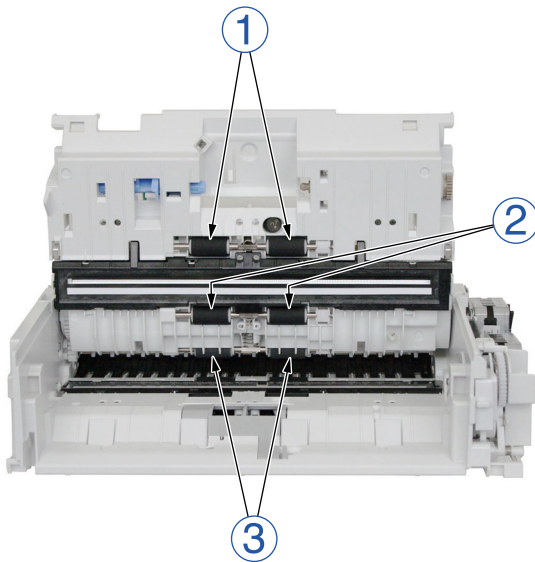

Figure 3-304

- 1) Remove the document eject tray.  
[\(Page 3-3\)](#)
- 2) To remove the follower roller for the registration roller, remove the upper light guide by referring to the procedure in "Ultrasonic Drive PCB".  
[\(Page 3-10\)](#)

- 3) If you unhook the 2 pairs of fitting parts ① on the target follower roller at the same time, follower roller on the back side (2 rollers ②, shaft ③, and stopper ④) and the spring ⑤ are removed.

**Note:** The figure below shows the follower roller for the registration roller. For the straight path and U-turn, the spring ⑥ is connected.

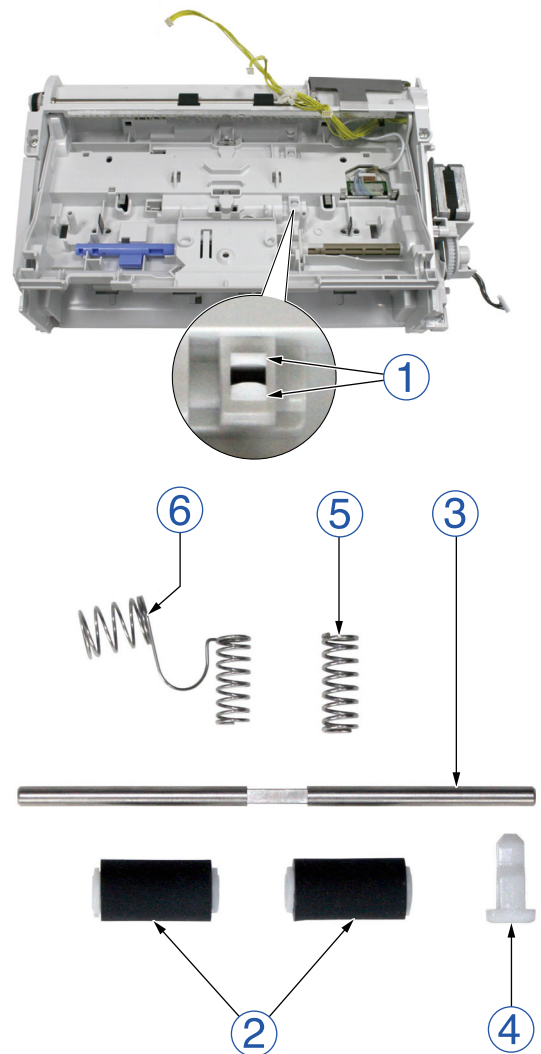
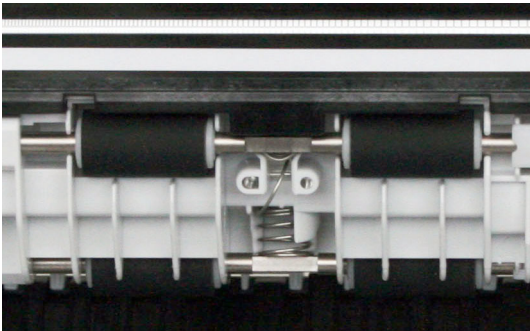

Figure 3-305

◆ **Notes on assembling**

The flat surface in the center of the shaft should touch the end surface of the spring. The figure below shows the state of the assembled spring for the straight path and U-turn path.



**Figure 3-306**

**4. U-Turn Unit**

- 1) Remove the bottom cover and the document feed tray.  
[\(Page 3-2\)](#)
- 2) Remove the main motor.  
[\(Page 3-5\)](#)
- 3) Loosen the screw ① (M3, self-tapping) and then remove the belt ②.

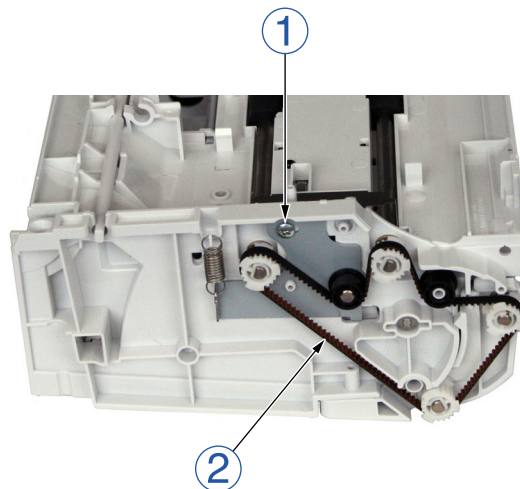

**Figure 3-307**

- 4) Remove the 2 screws ① (M3, self-tapping) while the upper unit is closed. Remove the cables ② from the cable holder, and remove the U-turn unit ③.

**Note:** Since the damper will come loose and the upper unit will close suddenly when the screws are removed, you should close the unit before performing the work.

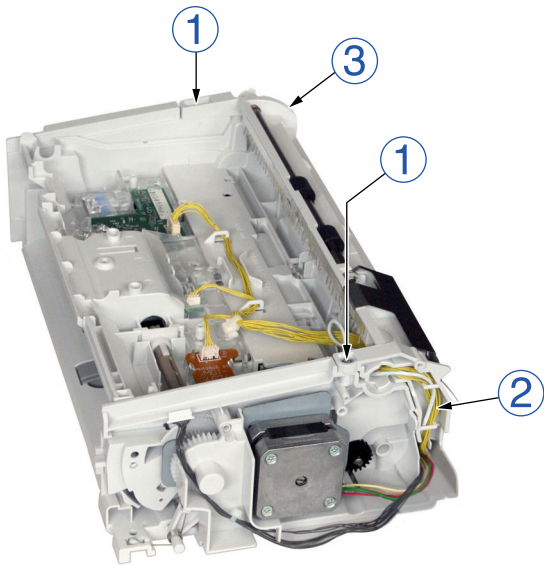

Figure 3-308

### 5. Upper Unit

- 1) Remove the bottom cover and the document feed tray.  
([Page 3-2](#))
- 2) Remove the document eject tray.  
([Page 3-3](#))
- 3) Remove the U-turn unit.  
([Page 3-12](#))
- 4) Detach the three connectors ① and cable holders, and move the cables outside of the upper unit ②. Then, remove the upper unit.

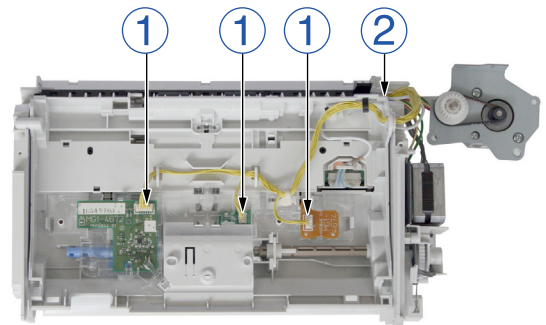

Figure 3-309

#### ◆ Notes on assembling

If the one-way gear for the damper comes off, look at the side with writing as shown in the figure below and insert the one-way gear onto the shaft while rotating to the left.



Figure 3-310

## IV. READING UNIT

**Note:**The shapes of the reading guides for the upper reading unit and the lower reading unit are different.

### 1. Upper Reading Unit

- 1) Open the upper unit, spread open the left and right hooks ① to unhook the fitting parts, and then pull the reading unit ② out.

**Note:**Do not pull it excessively because the cable is connected to it. Do not damage the hook.

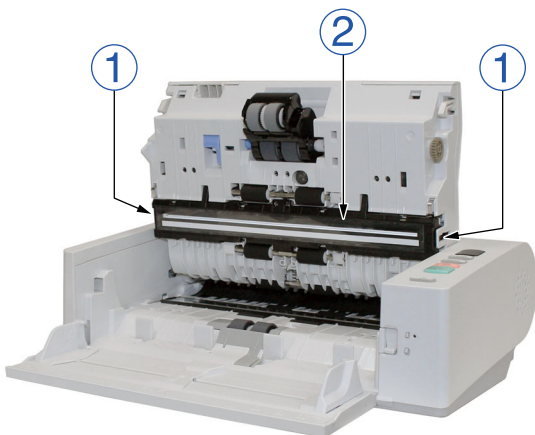

Figure 3-401

- 2) Remove the cable ① from the cable holder, then remove the connector and remove the reading unit ②.

**Note:**Take care when handling the leading end of the cable, which is split into thin cables. Care is also required for the thin connector.

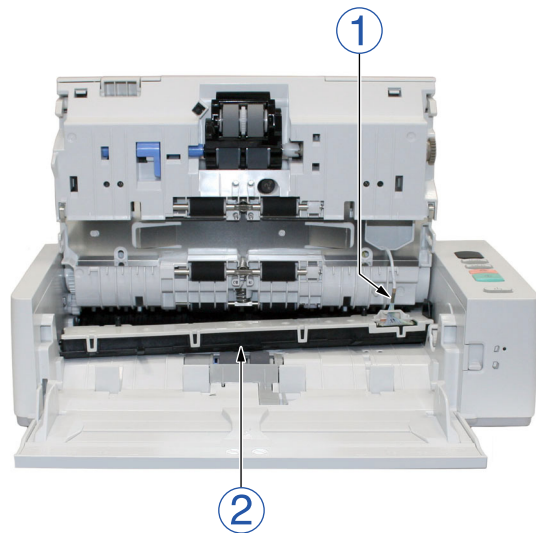

Figure 3-402

◆ **Notes on assembling**

You should insert the reading unit while pushing in the cable. Do not get the cables caught in parts.



## 2. Upper Reading Guide

**Note:**This component should not be disassembled unless necessary because once the component has been removed, there is a risk of dust getting inside the reading unit.

When disassembling, be careful with dusts and do not touch the inner surface of the glass or the surface of the lens array.

- 1) Remove the upper reading unit.  
(Page 3-14)
- 2) With the reading unit upside-down, unhook the 8 pairs (4x2) of fitting parts ① and remove the case ②. Then remove the CIS unit from the reading guide ③.

**Note:**Do not damage the hook. Do not drop the CIS unit.

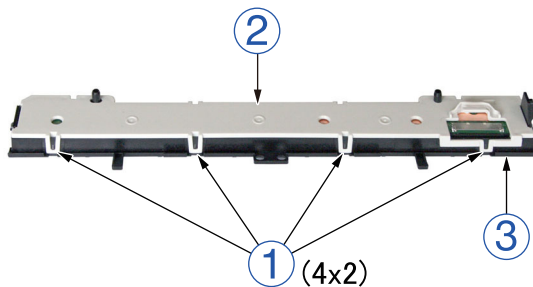

Figure 3-403

### ◆ Notes on assembling

Ensure that there is no dust or dirt on the CIS unit and reading glass.

There should not be any raised parts or gaps in any of the fitting parts.

## 3. Lower Reading Unit

- 1) Open the upper unit, spread open the left side hooks ① using a tool to unhook the fitting parts, and then lift up the end of the reading unit ②. Pull out the reading unit while unhooking the fitting parts on the opposite side.

**Note:**Do not pull it excessively because the cable is connected to it.

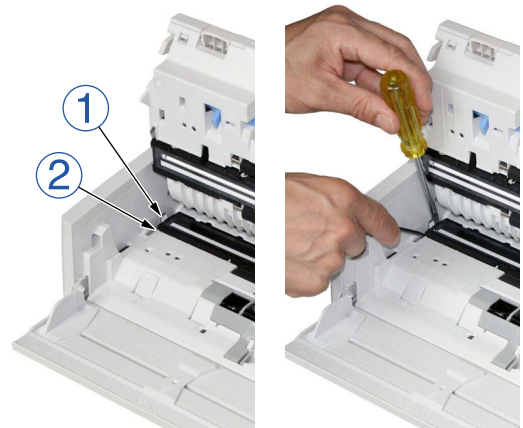

Figure 3-404

- 2) Remove the cable ① from the cable holder, then remove the connector and remove the reading unit ②.

**Note:**Take care when handling the leading end of the cable, which is split into thin cables. Care is also required for the thin connector.



Figure 3-405

◆ **Notes on assembling**

You should insert the reading unit while pushing in the cable. Do not get the cables caught in parts.

**4. Lower Reading Guide**

**Note:**This component should not be disassembled unless necessary because once the component has been removed, there is a risk of dust getting inside the reading unit.

When disassembling, be careful with dusts and do not touch the inner surface of the glass or the surface of the lens array.

- 1) Remove the lower reading unit.  
([Page 3-15](#))
- 2) With the reading unit upside-down, unhook the 8 pairs (4x2) of fitting parts ① and remove the case ②. Then remove the CIS unit from the reading guide ③.

**Note:**Do not damage the hook. Do not drop the CIS unit.

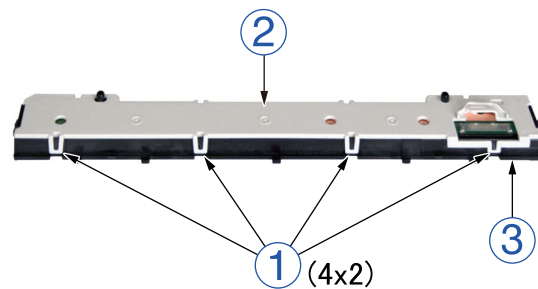

Figure 3-406

◆ **Notes on assembling**

Ensure that there is no dust or dirt on the CIS unit and reading glass.

There should not be any raised parts or gaps in any of the fitting parts.

---

# CHAPTER 4

---

## INSTALLATION & MAINTENANCE

---

---

I. INSTALLATION .....	4-1	III. MAINTENANCE .....	4-6
II. PARTS TO BE REPLACED .....	4-4		

---



## I. INSTALLATION

This machine is installed by the user. The user should be advised to install the scanner by reading the Setup Guide thoroughly. This section gives an overview of the procedure. For details, refer to the user manual.

### 1. System Requirements

The recommended system is as follows.

#### 1) Computer

CPU: Intel Core 2-Duo 1.66GHz or higher

Memory: 1GB or more

Hard disk: 3GB or more space

(For all software)

USB interface: Hi-speed USB 2.0

Monitor: Resolution 1024 x 768 (XGA) or higher

Optical drive: Able to read DVDs

#### 2) OS

Microsoft Windows XP

Microsoft Windows XP x64 Edition

Microsoft Windows Vista

(32/64 bit edition)

Microsoft Windows 7 (32/64 bit edition)

**Note:** For details on each version, refer to the "User Manual".

### 2. Checking the Accessories

Open the package, and take out the main body and its accessories.

- ① Main body
- ② USB cable
- ③ AC adapter
- ④ Power cord
- ⑤ Reference Guide  
(Basic operation edition)
- ⑥ Setup disk
- ⑦ Warranty, etc. (depends on the shipping region)

### 3. Removing the Packing Material

Remove all of the tape and protective material that is attached to the main body.

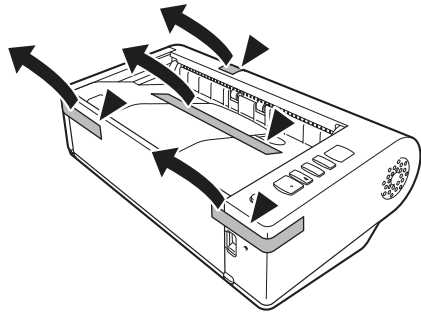

Figure 4-101

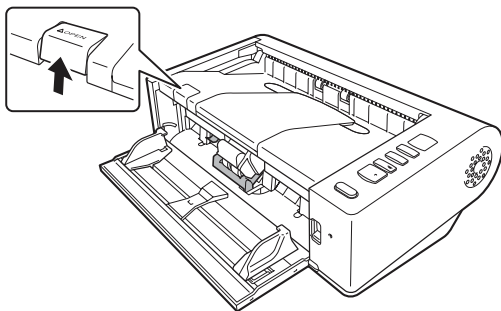

Figure 4-102

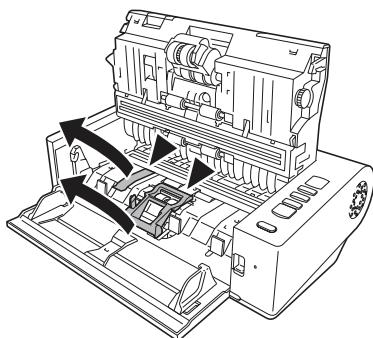

Figure 4-103

### 4. Installing the Software

Install the software from the included setup disk that is required in order to use the scanner.

**Note:** The software should be installed before connecting the machine to a computer.

The following shows an outline of the installation.

- 1) Login using an account with Administrator privileges.
- 2) Before installing the software, exit all other applications.
- 3) Load the setup disk into the DVD drive of the computer.
- 4) The setup menu starts automatically.
- 5) Click [Typical Installation].



Figure 4-104

Finish the installation by following the on-screen messages.

## 5. Connecting to a Computer

**Note:** Always use the power cord and AC adapter supplied with the machine.

- 1) Connect the power cord to the AC adapter.
- 2) Insert the plug from the AC adapter into the connector on the main body, and connect the power cord to the outlet.
- 3) Check that the power switch of the machine is off. If the power is on, turn it off.
- 4) Connect the machine and the computer using the included USB cable.

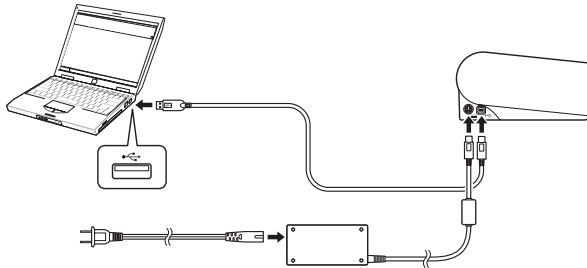

**Figure 4-105**

## 6. Power On

Press the power button. The power button lights when the power turns ON.

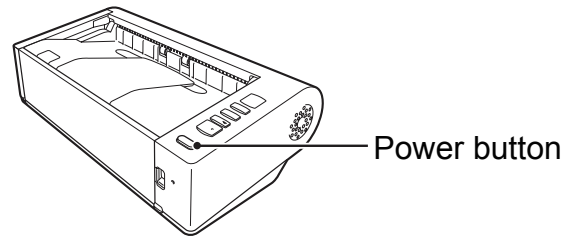

**Figure 4-106**

When you turn this machine connected to the computer ON, the plug-and-play function recognizes this machine, and the device driver is automatically installed.

The preparation is now complete. Check whether scanning is really performed. Refer to the "User Manual" for the details.

**Note:** To turn the power OFF, hold down the power button until the light goes off.

## II. PARTS TO BE REPLACED

### 1. Periodically Replaced Parts

This machine does not have any periodically replaced parts.

### 2. Consumable Parts

#### 1) Parts replaced by users

No.	Parts name	Parts number	Expected life	Remarks
1	Roller unit	MG1-4648-000	200,000 sheets	Because of the worn rollers, it is necessary to replace when the feed error are occurred after cleaning.
2	Retard roller	MG1-4650-000		

**Note:** The items above are assigned as service parts and an exchange roller kit is assigned as commercially available products for a set.

**Table 4-201**

#### 2) Replaced by service technicians

None



### 3. Major Parts List

The list below shows the major service parts, except for the parts replaced by users.

Refer to the "Parts Catalog" for the details.

No.	Parts name	Parts number	Q'ty	Remarks
1	Control PCB	MG1-4671-000	1	
2	Operation PCB	MG1-4673-000	1	
3	Upper Reading Unit	MG1-8313-000	1	Includes reading guide
4	Lower Reading Unit	MG1-8312-000	1	
5	Upper Reading Guide	MF1-4737-000	1	A reading glass attached
6	Lower Reading Guide	MF1-4738-000	1	A reading glass attached
7	Feed motor	MH7-1183-000	1	
8	Main motor	MH7-1182-000	1	
9	AC adapter	MG1-4558-000	1	Outside of China
10	AC adapter (China)	MG1-4565-000	1	China only

**Table 4-202**

### III. MAINTENANCE

#### 1. User Maintenance

Refer to the "User Manual" for the details.

1) List

[△:Clean, ●: Replace]

No.	No.	Location/Parts		Details
		As necessary	200,000 sheets	
1	Main body	△		Use a cloth slightly dampened with water and well wrung out to remove any dirt, and then use a clean, dry cloth to wipe the main body.
2	Reading glass	△		Use a soft, clean, and dry cloth to wipe off any dirt.
3	Roller unit	△	●	Use a cloth slightly dampened with water and well wrung out to remove any dirt, and then use a clean, dry cloth to wipe the main body. Note: Remove the roller unit/retard roller from the main body before cleaning.
4	Retard roller	△	●	
5	Other rollers	△		
6	Feed path	△		Use such as air blowers to remove any dust and paper particles that have accumulated on the feed path.

Table 4-301

2) Locations to be cleaned

- Reading glass

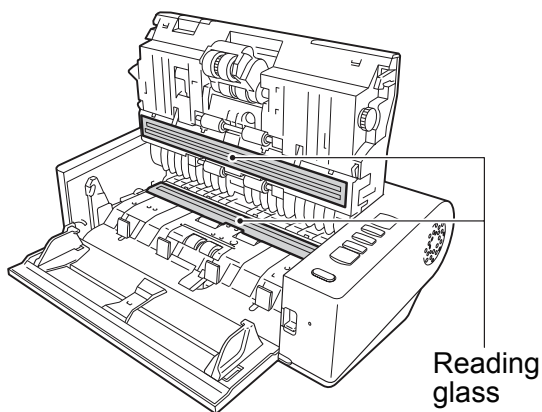

Figure 4-301

- Roller

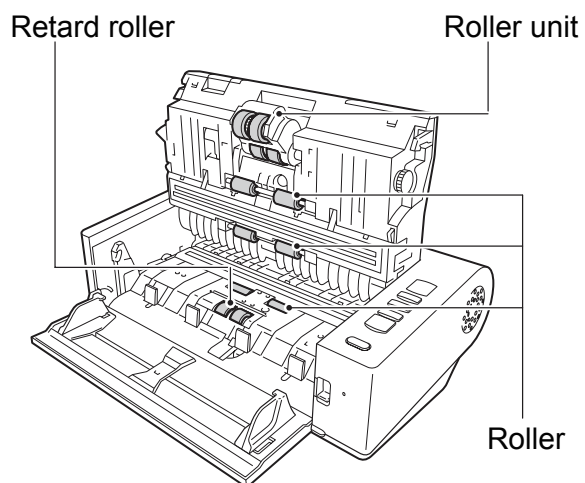

Figure 4-302

3) Replace Rollers Display

Once the number of sheets fed exceeds the guide for replacement of 200,000 sheets, a screen displaying the message [Replace Rollers] is displayed the next time the computer recognizes the machine.

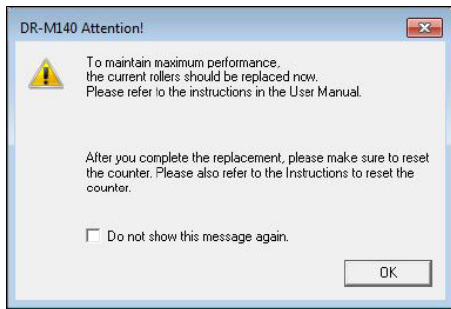

Figure 4-303

4) Method for Replacing Rollers

◆ Roller unit

Move the lever and remove the roller unit. Then assemble the new roller unit by aligning the fitting parts on the right side and lock into place using the lever.

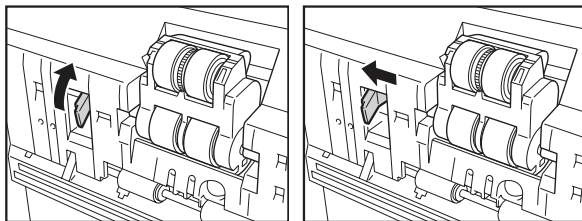

Figure 4-304

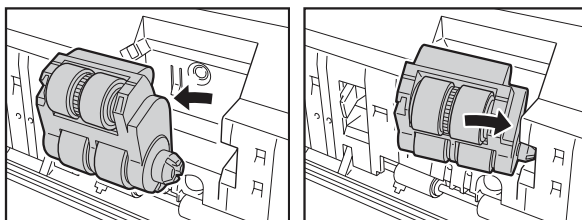

Figure 4-305

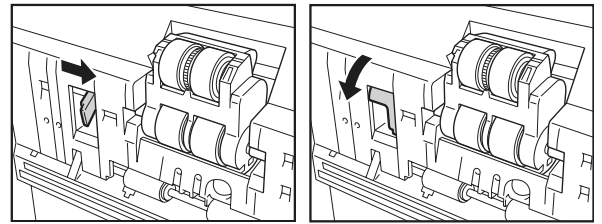

Figure 4-306

◆ Retard roller

Open the roller cover and remove the roller by pulling the lever. Then assemble the new roller by aligning the fitting parts on the right side.

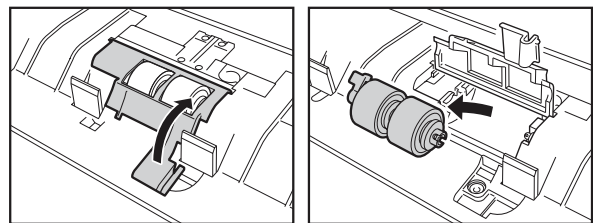

Figure 4-307

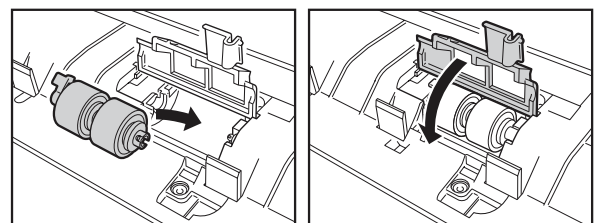

Figure 4-308

5) Resetting after replacement

The counters need to be reset after replacing the rollers. The following shows the method for doing this.

- Start Windows, and login with administrator privileges.
- Click the [Start] button on the computer, and then click [All Programs], [Canon DR-M140], and [Canon imageFORMULA Utility] in order.
- The [Canon imageFORMULA Utility] starts, and the screen is displayed.

- Select [Canon DR-M140 USB] and then click [Properties].

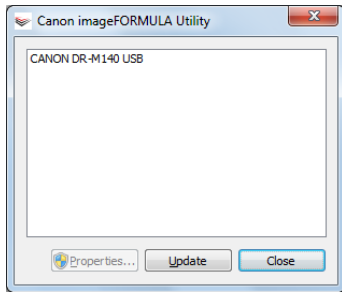

Figure 4-309

- On the next screen, click the [Maintenance] tab. Next, click [Reset].

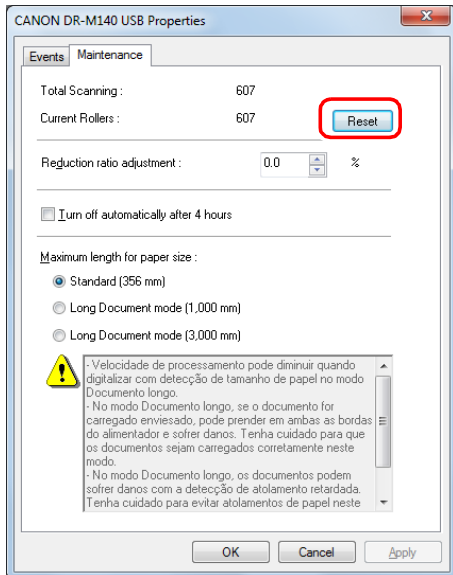

Figure 4-310

- Click [OK] and then close the property.

## 2. Service Maintenance

For this machine, no periodical maintenance item by the service technicians is specified.

However, when visiting a user, check whether the reading glasses and the rollers are dirty. If they are very dirty, instruct the user to follow the “user maintenance” procedures. Recommend the user to replace consumable parts if necessary. Furthermore, remove the cover, check that there is no paper dust or other foreign matter inside the main body, and then perform cleaning.

---

# CHAPTER 5

---

## TROUBLESHOOTING

---

---

I. ERROR DISPLAY .....	5-1	IV. OPERATION TROUBLESHOOTING .....	5-38
II. SERVICE MODE .....	5-2	V. IMAGE TROUBLESHOOTING .....	5-42
III. TROUBLESHOOTING LIST .....	5-37	VI. AFTER REPLACING PARTS .....	5-47

---



# I. ERROR DISPLAY

## 1. Main Body

When an error occurs, a symbol is displayed on the Job No. indicator on the operating panel. The details of this display are as follows.

◆ Job No. indicator





Display	Details
	The upper unit is open
	A paper jam has been detected
	A double feed was detected during scanning
	A skew was detected
	Other errors

Table 5-101

## 2. Computer

Error messages are displayed on the screen of the computer connected to the machine. Each of the different pieces of software (applications, drivers, OSs) have their own unique messages which they control.

There are many user-related messages, such as when the user performs an incorrect operation. Users should resolve problems according to the error messages.

The following shows an example of an error message when using CaptureOnTouch.

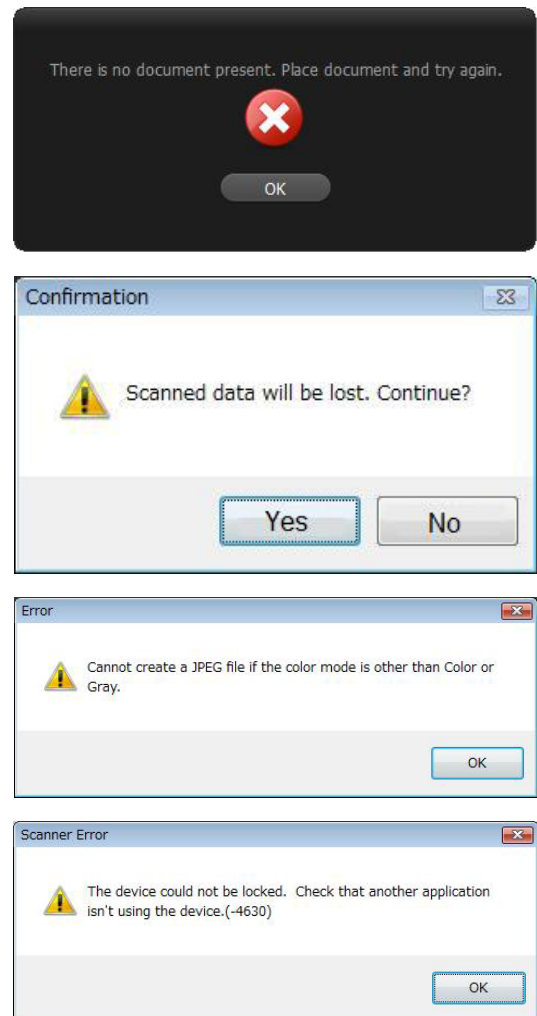

Figure 5-101

## II. SERVICE MODE

### 1. Outline

To execute the service mode, install the software (service tool) for the service mode, which is stored in the packaged setup disc or distributed for the service in the computer for servicing. This service tool is an integrated tool that consists of a common EXE file and product-specific DLL files.

The system requirements for the computer are equivalent to those indicated in the “User Manual”. The processing speed may drop if the CPU or memory capacity are not up to the specs.

When you select an operation button on the initial screen, the corresponding screen is displayed allowing you to execute each of the service modes.

The main screens are shown below.

● Initial screen

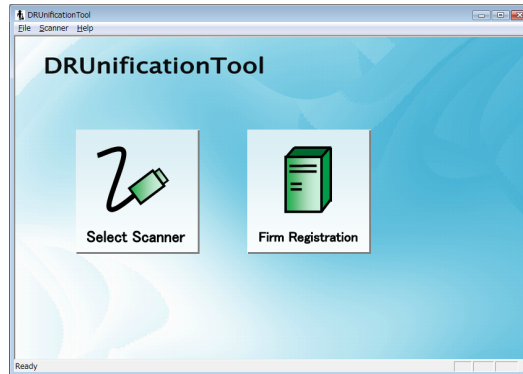

● Main Menu

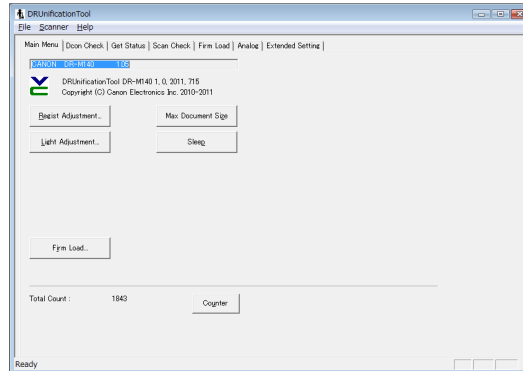

● Dcon Check

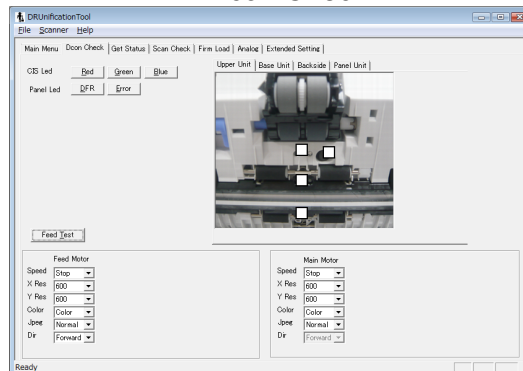
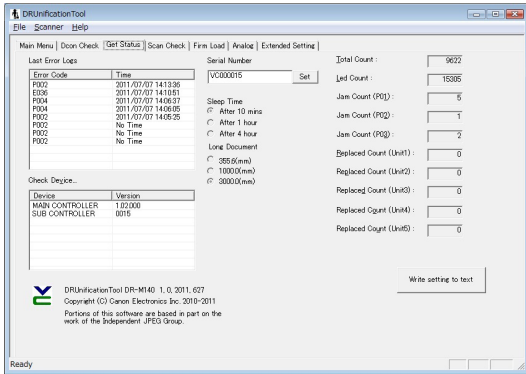

Figure 5-201



● Get Status



● Analog

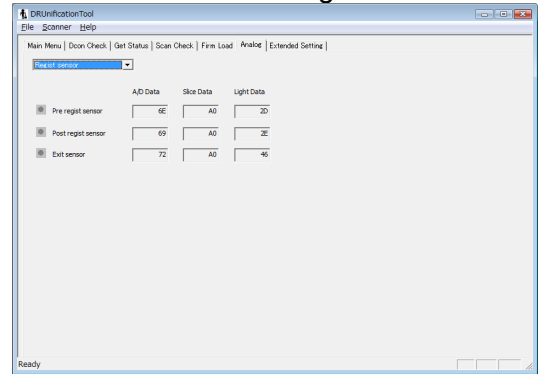

● Scan Check

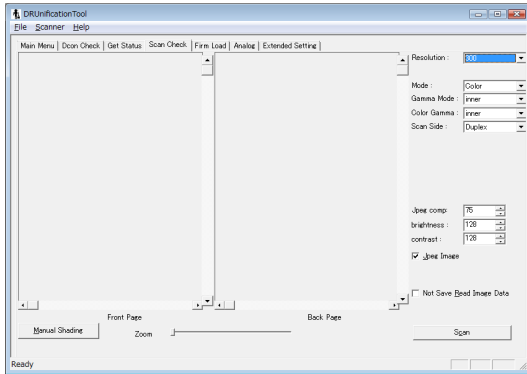

● Extended Setting

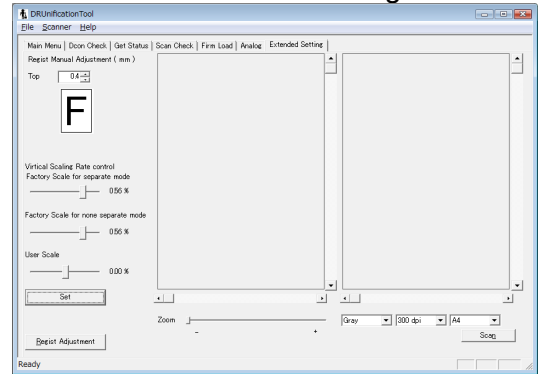

● Firm Load

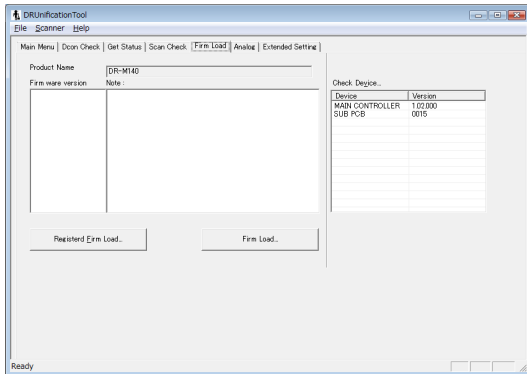

● Registration of Firm

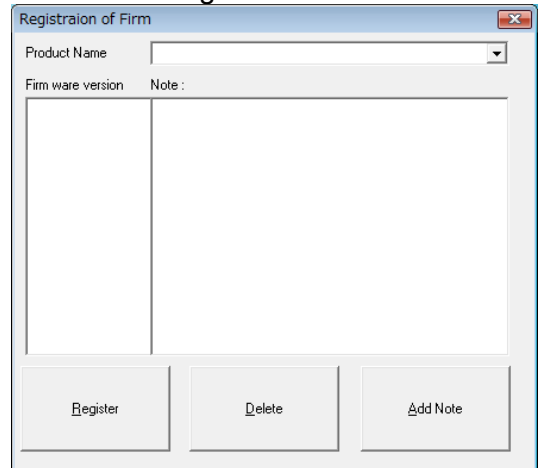

Figure 5-202

Figure 5-203

A list of the modes is show below.

No.	Component/display name	Function
1	Main Menu	
2	Regist Adjustment	Automatically adjusts the reading start position.
3	Light Adjustment	Automatic fine tunes the shading compensation value.
4	Max Document Size	Selects the long document mode.
5	Sleep	Selects the time before entering sleep mode.
6	Firm Load	Changes the general firmware.
7	Counter	Displays and changes counters such as the total scanning count and part replacement counters.
8	Dcon Check	
9	CIS Led	Checks the reading unit LED light.
10	Panel Led	Checks the operating panel LED light.
11	Upper Unit	Checks detection by the registration/eject/ultrasonic sensors.
12	Base Unit	Checks detection by the document/door/skew /separation sensors
13	Rear	Checks detection by the flapper sensor.
14	Panel Unit	Checks whether the operating panel keys are ON or OFF.
15	Feed Test	Checks the overall operation of feeding documents.
16	Feed Motor	Checks the operation of the feed motor.
17	Main Motor	Checks the operation of the main motor.
18	Get Status	
19	Last Error Logs	Displays up to the 8 most recent error codes that have occurred.
20	Check Device	Displays the internal firmware version.
21	Serial Number	Displays and sets the serial number of the main body.
22	Sleep Time	Displays the sleep time setting.
23	Long Document	Displays the long document mode (maximum length) setting.
24	Count	Displays the counters.
25	Write setting to text	Saves the above information on the computer.
26	Scan Check	
27	Front Page	Displays the scanned image (front surface).
28	Back Page	Displays the scanned image (back surface).
29	(Scanning Modes)	Selects the various scanning parameters.
30	Zoom	Enlarges the displayed image.
31	Scan	Executes a scan.
32	Manual Shading	Manually adjusts the shading correction value.

Table 5-201a

33	Firm Load	
34	Firmware version/Note:	Displays and selects the content of registered firmware.
35	Registered Firm Load	Changes the registered firmware.
36	Firm Load	Selects and changes unregistered firmware.
37	Check Device	Displays the current firmware version.
38	Analog	
39	Regist Sensor	Operates the registration sensors (pre and post) and displays data.
40	Door Open Sensor	Operates the door sensor and displays data.
41	Double Feed Sensor	Operates the ultrasonic sensor and displays data.
42	Document Sensor	Operates the document sensor and displays data.
43	Separation Sensor	Operates the separation sensor and displays data.
44	Flapper Sensor	Operates the flapper sensor and displays data.
45	Skew Sensor	Operates the skew sensor and displays data.
46	Extended Setting	
47	Regist Manual Adjustment	Manually adjusts the current registration adjustment value.
48	Virtual Scaling Rate control	Manually adjusts the reduction ratio in the feed direction.
49	(Scanning Modes)	Selects the various scanning parameters.
50	Zoom	Enlarges the displayed image.
51	Scan	Executes a scan.
52	Regist Adjustment	Automatically adjusts the reading start position.
53	Firm Registration	
54	Register	Registers firmware.
55	Delete	Deletes registered firmware.
56	Add Note	Adds remarks to the registered firmware.
57	Application information	Displays the service tool (EXE file) version.
58	Simulation mode	Executes simulated operation without connecting to the scanner.

Table 5-201b

## 2. How to Install

The following shows the procedure for installing the service tool from the setup disk. Never install it in the user's computer.

- 1) Turn ON the computer for servicing to start OS (Windows).
- 2) Install the setup disc packaged with this machine.
- 3) An installation screen for the user is displayed, but ignore this, right-click the [Start] button, and select "Explorer".
- 4) Copy the folder "\Driver\Tools" in the setup disc on any drive in the computer for servicing.

**Note:** Make sure to also install the driver for this machine onto the computer for servicing. You should also install CaptureOnTouch if necessary. Please refer to the "User Manual" on installation of the driver.

However, when checking a specification such as the scanning speed, the system requirements for a computer described in the "User Manual" should be satisfied.

**Note:** Keep the name of the folder and the password confidential from the user.

**Note:** If there is already a folder for another integrated tool, you can copy the files within the "Tools" folder for this product into that folder. However, you should copy by only overwriting with newer files. If you are not sure whether a file is newer or not, check the "Modified date" of each file before executing.

**Reference:** Folders and files

The files needed by the integrated tool should be saved in the same folder.

Although you can change the folder name to any name, you should not change the file names. There are 3 files needed for this machine as follows.

- DRUnificationTool.exe  
Executable file (EXE file)  
This is used in common for all products.
- DR-M140.dll  
Product-specific file (DLL file)
- DRUnificationTool.LOC  
Language localization file (Japanese/English)  
Only required for displaying Japanese.

The DLL files for other products for the integrated tool that are created in the future can be used by saving them in this folder.

When development started on this product, a new DLL file was created and the LOC file was updated.

Furthermore, the folders and files that are required are created in this folder when "Firm Registration" is executed. For details, refer to the "Firm Registration" section.

### 3. How to Start and Finish

◆ How to start

- 1) Start the computer for servicing.
- 2) If an icon of CaptureOnTouch is displayed on the task bar, click the icon to terminate it.

**Note:** Refer to the “User Manual” for the details of how to operate CaptureOnTouch.

- 3) Connect the USB cable and then turn on the machine.
- 4) Run the installed file “DRUnificationTool.exe”.

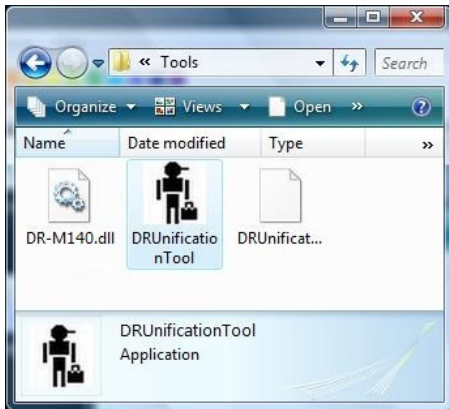

Figure 5-204

- 5) Password dialogue box appears, and enter six characters as “market” and select [OK].



Figure 5-205

- 6) The initial screen is displayed.

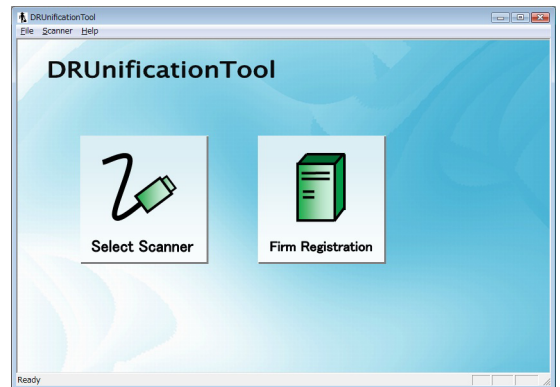
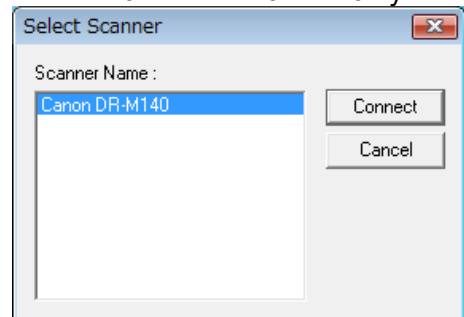

Figure 5-206

- 7) Select [Select Scanner] to run each service mode, or select [Firm Registration] to register firmware.
- 8) If you select [Select Scanner], the scanner selection screen is displayed to select the connected scanner.

● For DR-M140.DLL only



● When there are other DLLs

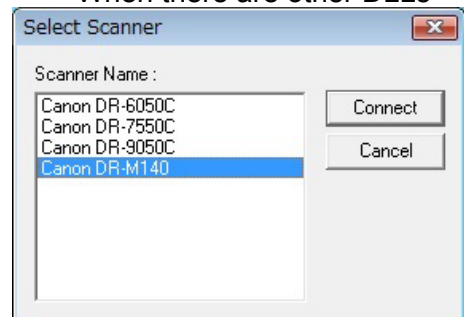

Figure 5-207

9) The main menu screen appears.

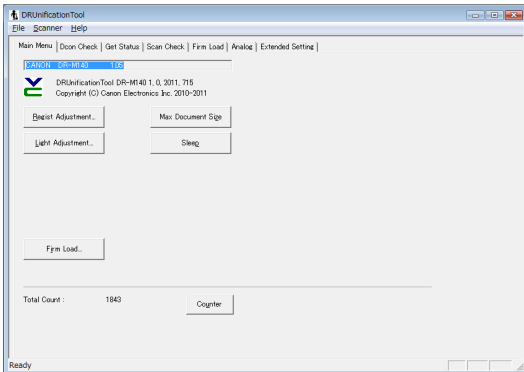

Figure 5-208

**Note:** Do not run any other application software such as CaptureOnTouch or turn off the machine while the service tool is running. If the tool becomes unresponsive, you should restart the computer.

◆ How to finish

Either select [⌘: Close] on the operation screen or select [Exit Application] from the [File] menu in the toolbar.

## 4. Application Information

This mode is used to check the detailed version of the service mode software (EXE file).

Select [Help] from the toolbar at the top of the screen and then select [Application information].



Figure 5-209

## 5. Simulation Mode

This mode is used to train service technicians about service mode without connecting to the scanner.

### ◆ Operation Procedure

- 1) Enter the 8 characters "training" as the password.
- 2) The screen is the same as in the real procedure, and can be operated in the same way except for some buttons that are grayed out.

**Note:**Note that you cannot execute operations that require communication with the scanner.

## A. Main Menu

### 1. Regist Adjustment

This mode performs adjustments on a reading-start position and reading-end position for feed direction automatically.

If the leading- and trailing-edge positions of a scanned image are improper, perform this adjustment.

Also run this mode after replacing or reassembling the reading unit or the registration detection related part, or after replacing the control PCB recording the adjustment data.

### ◆ Adjustment sheet

A sheet of ordinary white copier paper is required to execute this mode. The size is fixed at A4 or LTR. Since this can be obtained easily, it is not designated as a service tool.

Do not use paper where the outer shape is slanted, or that easily becomes jammed or feeds crookedly.

You can also use the shading sheet: TKM-0326/0332.

**Note:**Do not use an adjustment sheet where the edges have been made black using another DR scanner. The adjustment will not work properly.

### ◆ Operation Procedure

- 1) Clean feed path, roller, and reading glass.
- 2) Place a piece of the registration adjustment sheet. Make sure to set the document guides to fit the sheet to prevent skews.

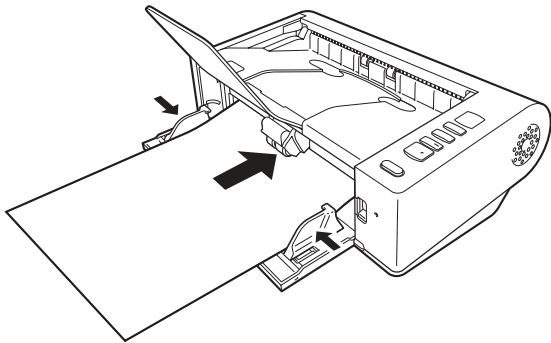

Figure 5-210

- 3) Select [Regist Adjustment] from the main menu screen.

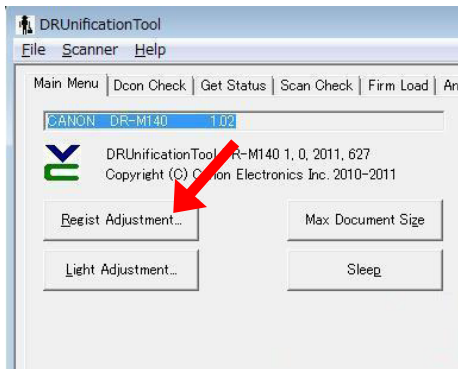

Figure 5-211

- 4) A screen is displayed to check the adjustment sheet. Check that the sheet is placed correctly and select [OK].

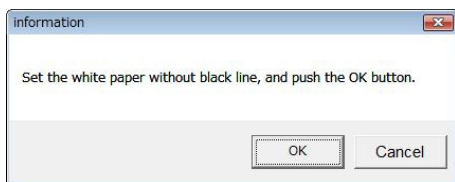

Figure 5-212

- 5) The adjustment proceeds automatically while the progress screens are displayed.

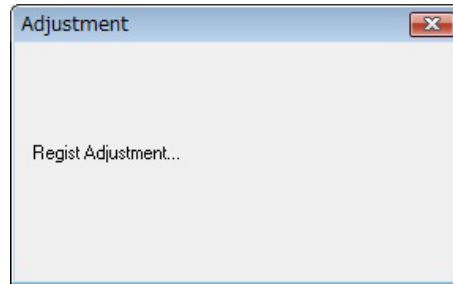

Figure 5-213

- 6) The sheet is fed. When finished, the progress screen disappears and the main menu screen returns.



## 2. Light Adjustment

This mode performs fine adjustments on the shading correction values since the reading point differs between the white reference sheet inside of the reading unit and the actual document.

If the scanned image quality is degraded, perform this adjustment. Also perform this adjustment after replacing the reading unit or after replacing the control PCB recording the adjustment data.

### ◆ Adjustment sheet

The shading sheet is required to execute this mode. Use TKM-0326 or TKM-0332, which is the same shading sheet as the one used for the DR-2010C/2510C or others. Do not use a sheet with any dirt or creases.

### ◆ Operation Procedure

- 1) Clean feed path, roller, and reading glass.
- 2) Set the feed selection lever to “none separate”.

Place a shading sheet to fit the width between the document guides.

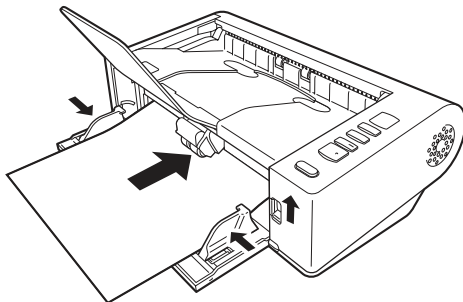

Figure 5-214

- 3) Select [Light Adjustment] from the main menu screen.

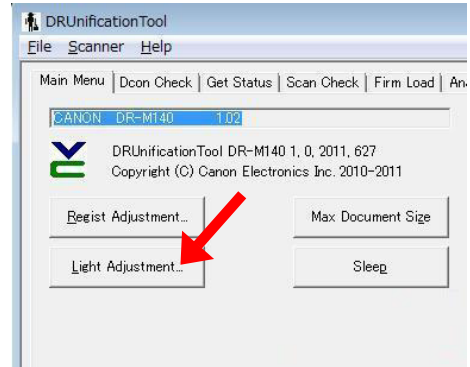

Figure 5-215

- 4) A screen is displayed to check the adjustment sheet. Check that the sheet is placed correctly and select [OK].

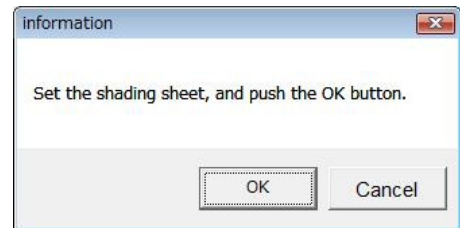

Figure 5-216

**Note:** If the feed selection lever is not set to the “none separate”, a confirmation screen is displayed. Set the lever to “none separate” and then select [OK] in the screen.

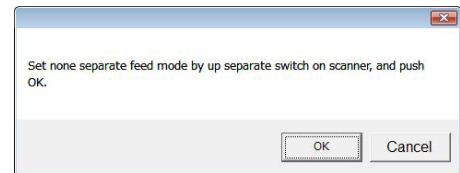

Figure 5-217

- 5) The adjustment starts automatically. The sheet is fed, and a progress screen is displayed.



Figure 5-218

- 6) Even after the sheet has been ejected, the data may be processed inside the machine. The progress screen disappears, and a warning screen is displayed. Do not turn OFF the machine or perform any operations until the warning screen disappears.

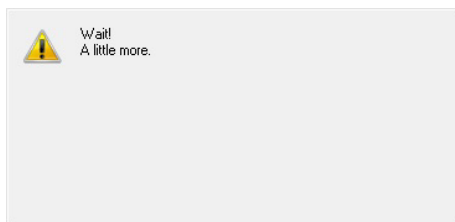

Figure 5-219

- 7) After the adjustment is complete, the warning screen disappears.

### 3. Max Document Size

This mode is used to set the long document mode. This is set to standard mode by factory default. This can be changed by user mode.

Select [Max Document Size] from the main menu screen to display the setting screen. To set the long document mode, change the setting to [1000.0(mm)] or [3000.0(mm)] and select the [OK] button.

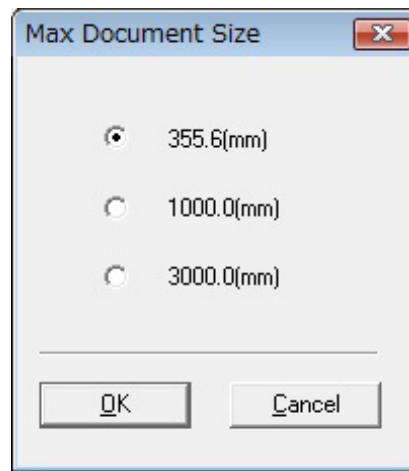

Figure 5-220

## 4. Sleep

This mode is used to change the time before entering sleep mode. This is set to [After 10 mins.] by factory default.

This setting can be changed depending on the user usage conditions. If you change this setting, notify the user that you are changing it.

Select [Sleep] from the main menu screen to display the setting screen. In addition to [After 10 mins.], you can also choose from [After 1 hour.] and [After 4 hour.]. Change the setting as necessary and select the [OK] button.

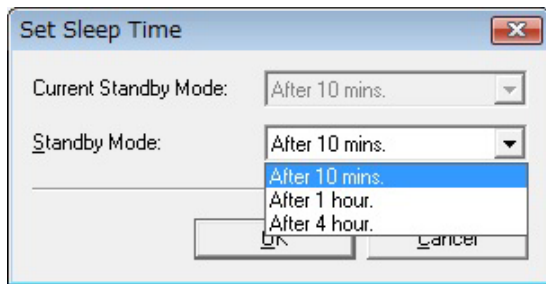

Figure 5-221

## 5. Counter

This mode is used to check the number of pages fed and the number of paper jams, and to record the number of sheets fed when changing consumable parts. These setting values can also be changed.

Select [Counter] from the main menu screen to display the change counter screen. The screen and list of items is shown below.

The value of the [Total Count] is displayed at the bottom of the main menu screen.

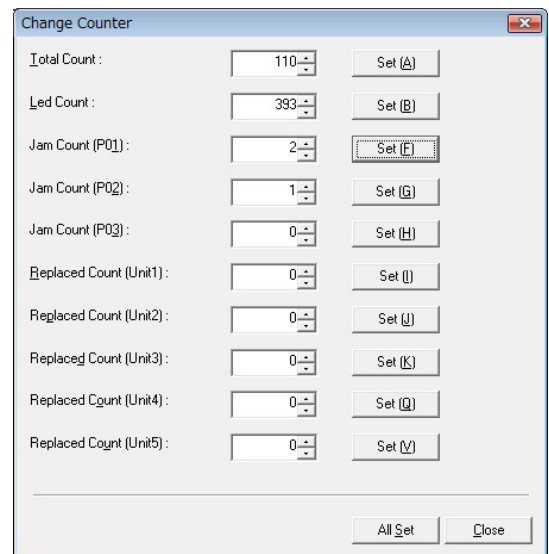

Figure 5-222

Display	Details
Total Count	Total number of sheets that have been fed.
LED Count	Total amount of time that the LED used by the reading unit (upper and lower) has been alight. Note that the units are in "seconds". 1000 hours = 3,600,000 seconds.
Jam Count (P01)	The number of paper jams in the pickup section. Error code P001.
Jam Count (P02)	The number of paper jams in the registration section. Error code P002/006/007.
Jam Count (P03)	The number of paper jams in the eject section. Error code P004.
Replaced Count (Unit1)	Number of feeds when replacing the user replaceable parts (rough guide to replacement of 200,000 sheets). This displays the total number of sheets fed when reset in user mode.
Replaced Count (Unit2)	Replaced Count (Unit2) to Replaced Count (Unit5) are used by the service technicians to manually input the total number of sheets fed when replacing a part to serve as a rough guide until the next replacement. The corresponding parts can be decided within each local region or by the service technicians as necessary.
Replaced Count (Unit3)	
Replaced Count (Unit4)	
Replaced Count (Unit5)	
Replaced Count (Unit5)	

Table 5-202

After changing the value, select the [Set] button or [All Set] button at the right side of each item to apply the changed value.

To close the screen, select [Close].

These values are changed when the control PCB is replaced. After the replacing the control PCB, the values need to be input. If you don't know the values before replacement, you can input estimated values.

If you replace the control PCB or change the [Total Count], then the counter for [Current Rollers] on the user maintenance screen is also updated. Since the [Replace Rollers] message may be displayed the next time the user turns the power on or the counter for the [Current Rollers] may take on an invalid value, you should check the counter for the [Current Rollers] after exiting

service mode and reset it if it is invalid.

**Note:**The count for the current rollers is the value that subtracted the total sheet fed count at the last reset from the current total sheet fed count.

## 6. Firm Load

Firmware is changed in this mode. For details, refer to service information provided when firmware is changed. Do not use this mode by mistake.

The same functionality as this mode is also available in “E. Firm Load”.

### ◆ Operation Procedure

- 1) Select [Firm Load] from the main menu screen.
- 2) The screen is displayed requiring the file in which software is stored to be selected.
- 3) Select and open the file.
- 4) It is loaded automatically and a progress screen is displayed.

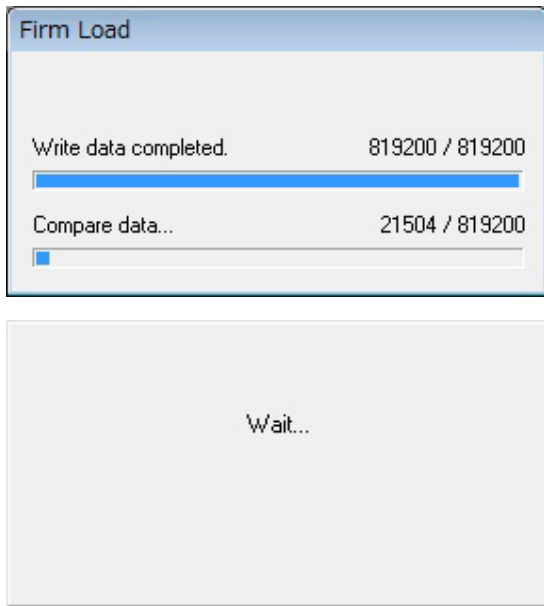

Figure 5-223

- 5) When finished, the progress screen disappears and the main menu screen returns.

When the firmware is changed, a reset is automatically executed internally.

- 6) Check that the version displayed on the main menu screen is correct.

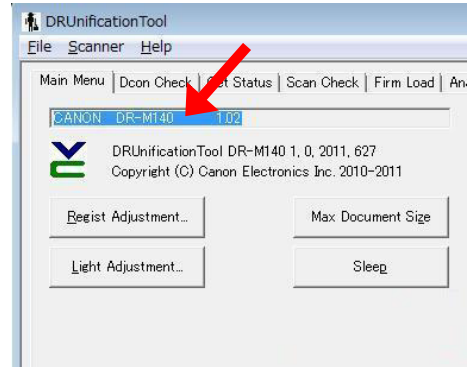

Figure 5-224

**Note:** Do not turn the power OFF including the USB cable is removed during loading. If the power is turned OFF, it returns to its original state when restarted, but this is not guaranteed.

## B. Dcon Check

### 1. LED

Checks the operation of each of the LEDs.

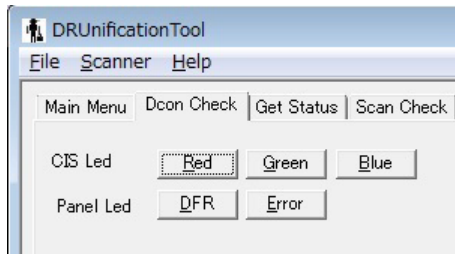

Figure 5-225

#### 1) CIS Led

Checks the reading unit LED light. Open the upper unit and press the corresponding button to light the LED. Press the button again to turn the LED off.

#### 2) Panel Led

Checks that the panel unit LED lights. Select [DFR] to light the DFR LED. Select [Error] to make the Job No. LEDs flash.

Select the buttons again to return to the original state.

### 2. Sensors and Buttons

Checks the operation of the sensors and buttons.

When the sensor detects its target, the corresponding mark lights.

The display screen is divided into “Upper Unit”, “Base Unit”, “Rear”, and “Panel Unit”. These are displayed by selecting the corresponding tabs.

#### 1) Upper Unit

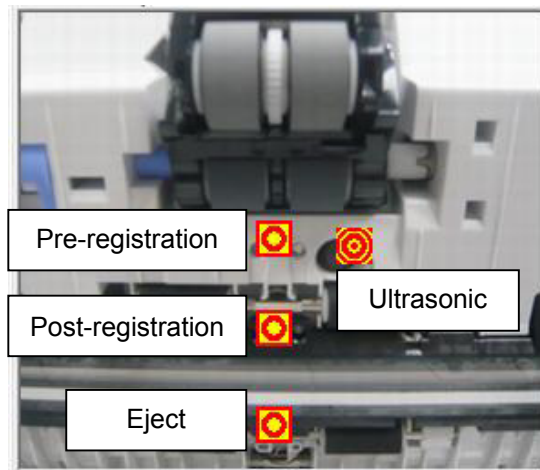

Figure 5-226

Open the upper unit, place the appropriate paper in the sensor area, and close the upper unit. The mark lights up when the paper is detected.

For the ultrasonic sensor, the double circle mark lights when there are two or more sheets of paper.

**Note:** Although the mark lights up if the upper unit is open, this does not confirm the correct operation. You should confirm the operation by actually moving the unit as described.

2) Base Unit

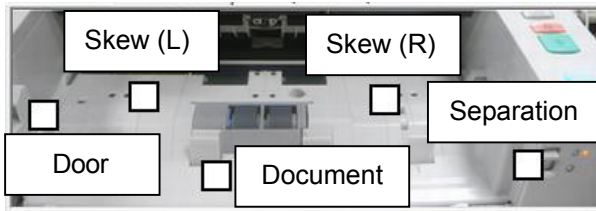

Figure 5-227

If you place paper on the document sensor, the document sensor lights up. If you open the upper unit, the door sensor lights up. If you put paper on the left or right skew sensors and close the upper unit, the skew sensor lights up. If you lift up the feed selection lever to select none separate, the separation sensor lights up. At this time, the LED beside the lever also lights up.

3) Rear

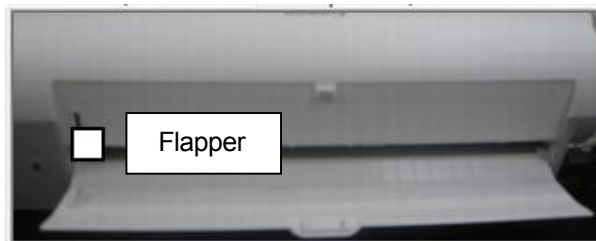

Figure 5-228

If you open the straight path tray, the flapper sensor lights up.

4) Panel Unit

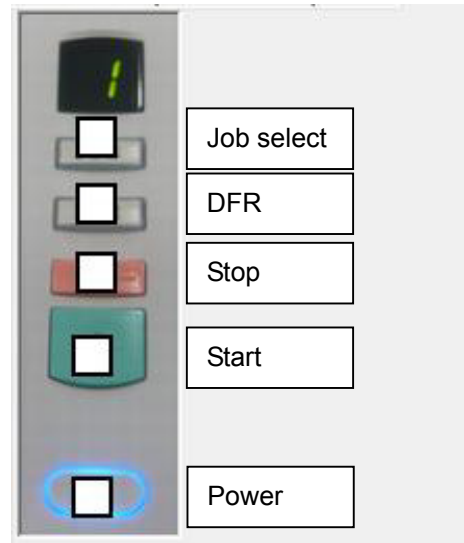

Figure 5-229

When a button on the panel unit is pressed, the corresponding mark lights.

### 3. Motor/Feed Test

This mode checks the operation of the feed motor and main motor, and checks the actual document feed operation.

The corresponding part of the screen and list of items is shown below.

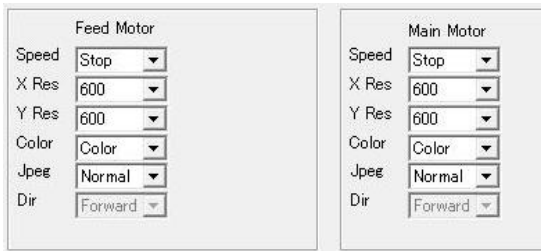

Figure 5-230

Message	Options
Speed	<u>Stop</u> /Start
X Res	100/200/300/400/ <u>600</u> (dpi)
Y Res	100/200/300/400/ <u>600</u> (dpi)
Color	Gray/ <u>Color</u>
Jpeg	<u>Normal</u> /HighQuality
Dir	<u>Forward</u>

**Note:**Initial values are underlined.

Table 5-203

◆ Operation Procedure

- 1) After selecting the operating conditions for the target motor, select [Start] to rotate the motor. Select [Stop] to stop the motor.

**Note:**The combination of X (horizontal) and Y (vertical) resolution should be a combination that actually exist in the driver. Otherwise, it will not operate correctly.

- 2) After setting the motor operation conditions and placing the appropriate paper, select [Feed Test] to start feeding. Select [Feed Test] again to stop the

motor.

**Note:**For the feed test, you should set the feed motor and main motor operation conditions the same. Otherwise, it will not operate correctly.



## C. Get Status

### 1. Last Error Logs

Displays the 8 most recent error codes and the time they occurred.

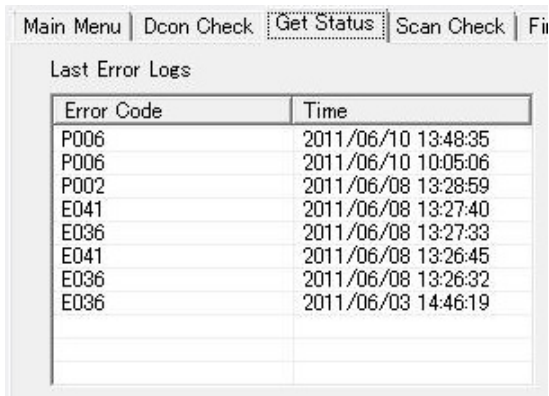

Error Code	Time
P006	2011/06/10 13:48:35
P006	2011/06/10 10:05:06
P002	2011/06/08 13:28:59
E041	2011/06/08 13:27:40
E036	2011/06/08 13:27:33
E041	2011/06/08 13:26:45
E036	2011/06/08 13:26:32
E036	2011/06/03 14:46:19

**Figure 5-231**

The details of the error codes are shown below. Note that since not all errors are displayed and the first detected error code is displayed, the details that are displayed may differ from the problem that you see occurring.

For example, if the front reading unit cable is not connected, E054 is not displayed but E036 and E041 are displayed as the error that are processed first.

**Note:** For errors during the mechanical feed mode, the time is not displayed because the computer is not connected.

Message	Details
E031	ASIC image sensor error
E036	ASIC image processing error
E041	Light adjustment error
E050	Patch cord error
E054	Front image sensor connection error
E055	Back image sensor connection error
E086	EEPROM write error
P001	Paper jam when entering pre-registration sensor
P002	Paper jam when leaving pre-registration sensor
P004	Paper jam at eject
P006	Paper jam when entering post-registration sensor
P007	Paper jam when leaving post-registration sensor
P050	Force stop from controller

**Table 5-204**

## 2. Check Device

This mode is used to check the versions of the main body firmware and internal devices of this machine.

Check Device...

Device	Version
MAIN CONTROLLER	1.06.000
SUB CONTROLLER	0014

Figure 5-232

## 3. Serial Number/Other

Displays the serial number, sleep time, long document, and counter information.

Serial Number	Total Count :	<input type="text" value="110"/>
<input type="text" value="ABC00001"/> <input type="button" value="Set"/>	Led Count :	<input type="text" value="402"/>
Sleep Time	Jam Count (P01) :	<input type="text" value="5"/>
<input checked="" type="radio"/> After 10 mins	Jam Count (P02) :	<input type="text" value="2"/>
<input type="radio"/> After 1 hour	Jam Count (P03) :	<input type="text" value="0"/>
<input type="radio"/> After 4 hour	Replaced Count (Unit1) :	<input type="text" value="0"/>
Long Document	Replaced Count (Unit2) :	<input type="text" value="0"/>
<input checked="" type="radio"/> 355.6(mm)	Replaced Count (Unit3) :	<input type="text" value="0"/>
<input type="radio"/> 1000.0(mm)	Replaced Count (Unit4) :	<input type="text" value="0"/>
<input type="radio"/> 3000.0(mm)	Replaced Count (Unit5) :	<input type="text" value="0"/>

Figure 5-233

Serial number data is saved on the control PCB. If this PCB is replaced, enter the serial number shown on the rating label at the main body and select “Set” on the right side.

#### 4. Write Setting to Text

You can save the displayed information to a text file by selecting [Write setting to text] at the bottom right of the screen.

##### ◆ Operation Procedure

- 1) Select [Write settings to text].
- 2) When the save screen is displayed, set the save location.
- 3) The information is saved.

The following shows some of the details in the file that is saved.

```

Error Code : Time
P006 : 2011/06/10 13:48:35
P006 : 2011/06/10 10:05:06
P002 : 2011/06/08 13:28:59
E041 : 2011/06/08 13:27:40
E036 : 2011/06/08 13:27:33
E041 : 2011/06/08 13:26:45
E036 : 2011/06/08 13:26:32
E036 : 2011/06/03 14:46:19

-----

Librally version :
DRUnificationTool DR-xxxx 1, 3, 2011.

-----

Device Name : Version
MAIN CONTROLLER : 1.06.000
SUB PCB : 0014

-----

Serial Number :
ABC00001

-----

Counter Name : Count
TotalCounter : 110
LedCounter : 402
P01JamCount : 5
P02JamCount : 2
P03JamCount : 0
Replace01Count : 0
Replace02Count : 0
Replace03Count : 0

```

**Figure 5-234**

**D. Scan Check**  
**1. Scan Check**

Allows you to perform actual scans in service mode. You can display and save the scanned images.

◆ Description of the screen

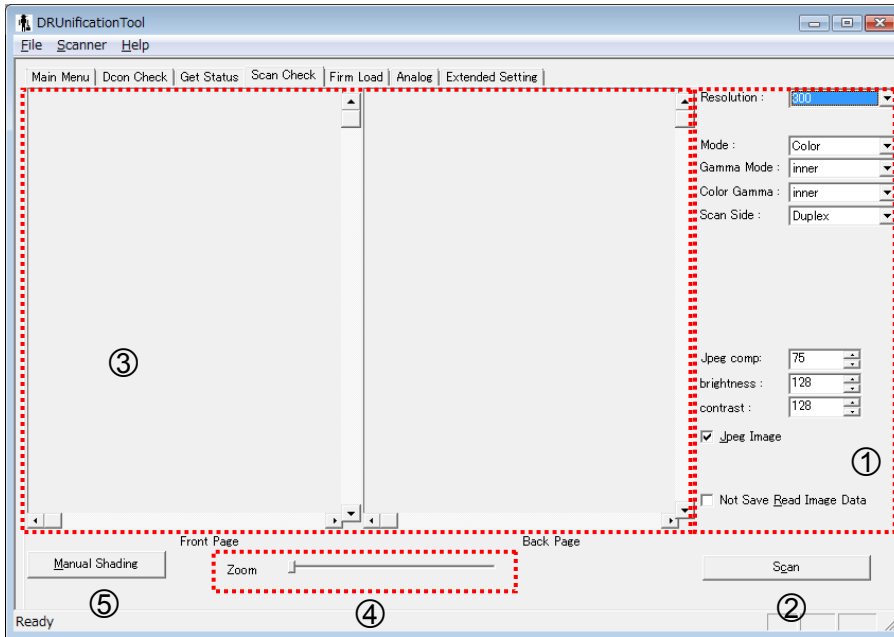

Figure 5-235

No.	Details
①	<b>Scanning Modes</b> * Resolution: 100 to 600 dpi * Mode: Color/Gray * Gamma Mode/Color Gamma: inner: Inner setting value download: Download value through: No adjustment * Scan Side: Simplex/Duplex * Jpeg comp/brightness/contrast * Jpeg Image * Not Save Read Image Data
②	<b>Scan</b> Click this button to begin the scan.

No.	Details
③	<b>Image display area</b> The scanned image is displayed. The left side is the front image and the right side is the back image. You can move the image using the scroll bars.
④	<b>Zoom</b> Enlarges the image in ③ above using a slide bar.
⑤	<b>Manual Shading</b> Used to change the shading correction value. This is not normally used. For details, refer to the other section.

Table 5-205

◆ Operation Procedure

- 1) Set the scan modes.
- 2) Place the document.
- 3) When the save screen is displayed, set the save location.
- 4) The document is scanned.
- 5) The data is saved and the image is displayed as well.

If you scanned multiple sheets, the last document image is displayed. However, if [Not Save Read Image Data] is selected, the image is neither saved nor displayed.

- 6) The completion screen is displayed when the document ends. Click [OK].



**Figure 5-237**

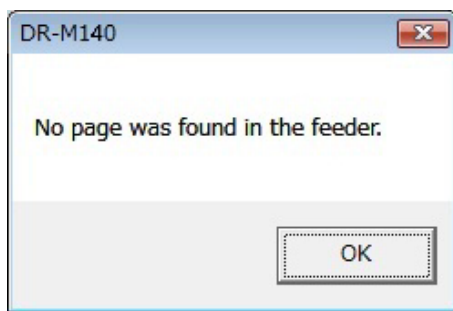

**Figure 5-236**

**Note:** If an error occurs in the scan modes, the following error screen is displayed. Select [OK] at the top of the screen to exit the scan. You should restart after exiting service mode.

Furthermore, if you become unable to perform operations while using service mode, you should reset the computer and scanner.

## 2. Manual Shading

This mode is used to change the color of the image depending on the user conditions even if regular automatic shading adjustment and light adjustment using the service tool are performed. You should not normally use this.

### ◆ Operation Procedure

- 1) Select [Manual Shading] to display the setting screen. The initial values are all "0".

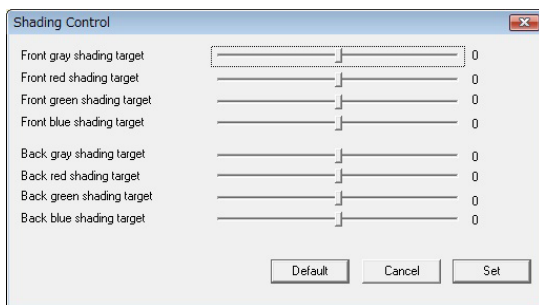

Figure 5-238

- 2) Set the adjustment value by moving the slide bar. The set values are displayed. The adjustable settings are gray, red, green, and blue for each of the front and back sides.
- 3) After setting, select [Set].  
Select [Initial Values] to return to [0].  
Select [Cancel] to return to the values before changing.
- 4) Actually scan a document and check the image.

## E. Firm Load

There are two methods for updating the firmware: One is to select and execute pre-registered firmware, and the other is to select and execute firmware saved on the computer. The methods using pre-registration makes it possible to store all of the firmware within the same folder and attach comments to firmware, and is easy to manage.

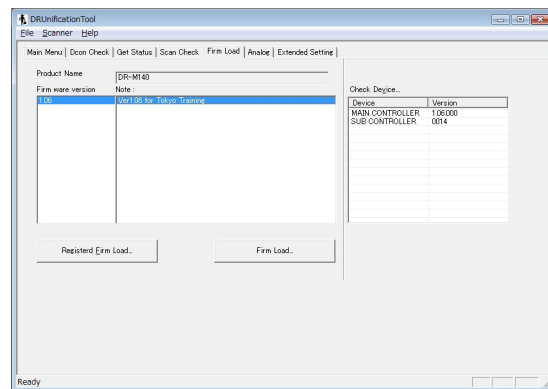

Figure 5-239

**Note:**For details on firmware updates, refer also to the separately issued service information.

## 1. Firm Registration

This mode saves scanner firmware on a computer for servicing in advance, making it possible to correctly perform actual firmware updates.

### ◆ Operation Procedure

- 1) On the initial screen, select [Firm Registration]. Or, select [Registration of Firm] from the scanner in the task bar of the initial screen or other screens.

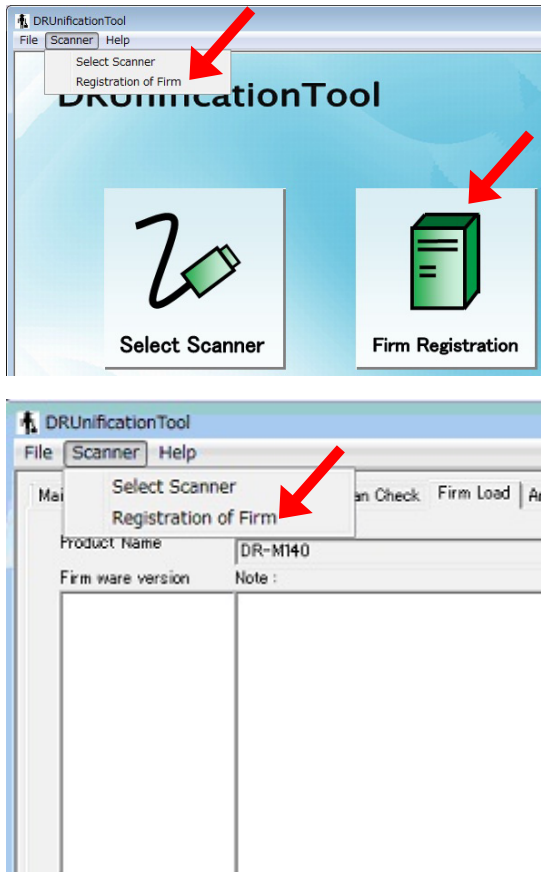

Figure 5-240

- 2) The following screen is displayed only if there are no firmware already registered. Select [OK].

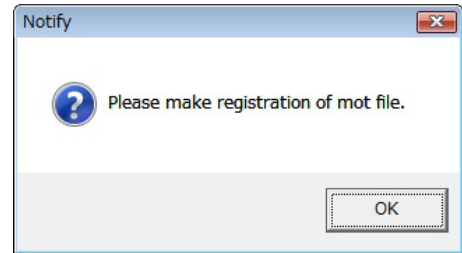

Figure 5-241

- 3) The firmware registration screen is displayed. Select [Register].

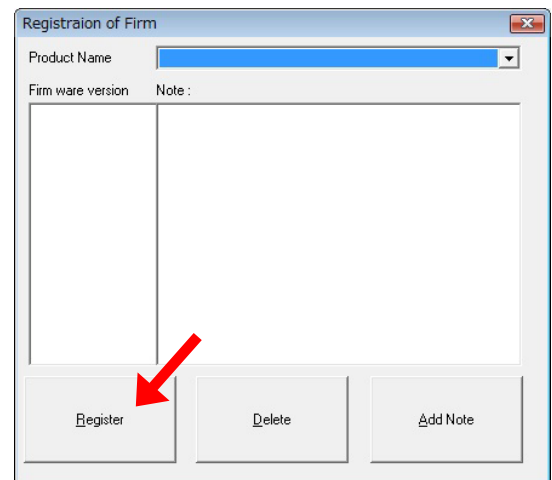

Figure 5-242

- 4) When the file selection screen is displayed, select the file.

**Note:**The file format is “mot”. The file name can be changed to anything.

- 5) The firmware is automatically registered. The “Product Name” and “Firmware version” are displayed on the firmware registration screen.

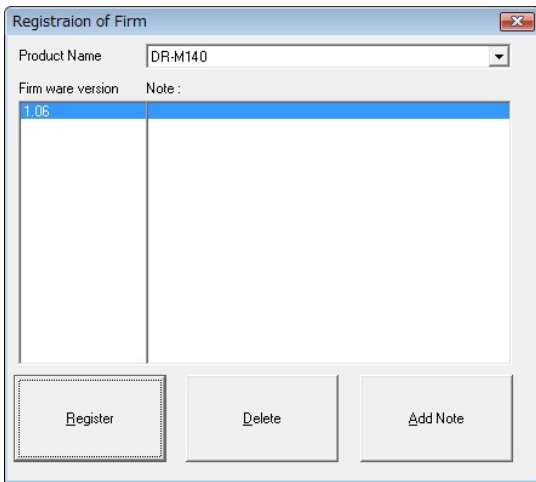

Figure 5-243

**Note:**The registered firmware is saved together within the service tool folder. Since the product name, version number, etc. are written in the “mot” file, the folder name is decided to match them. Furthermore, an “ini” file that contains the setting conditions is saved at the same time. The following shows an example of the folder.

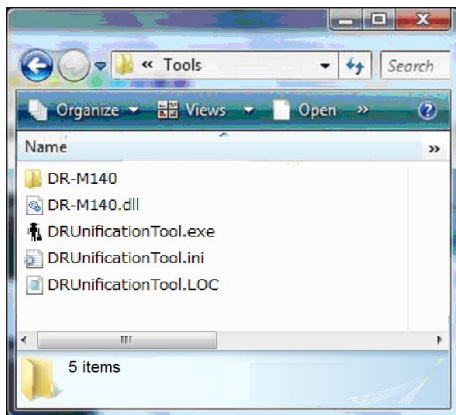

Figure 5-244

- 6) Select [Add Note] if necessary and enter any arbitrary information. After entering the information, select [OK].

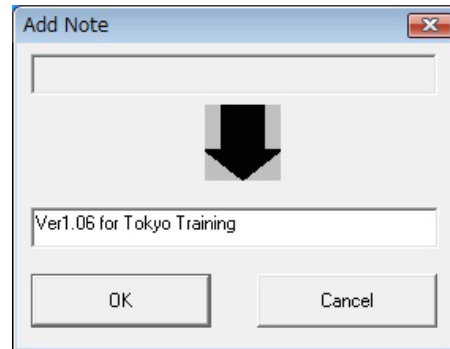

Figure 5-245

**Note:**To delete from the registration screen, select the target version and then select [Delete]. Note that the file is not deleted from the folder.

**Note:**The registered firmware is displayed in the [Firm Load] screen on the next restart or when returning from another screen.



## 2. Firm Load

The method for writing firmware varies depending on whether that firmware has already been registered or has not been registered. The operation procedures are shown below.

◆ For registered firmware

- 1) Select the version to write and then select [Registered Firm Load].

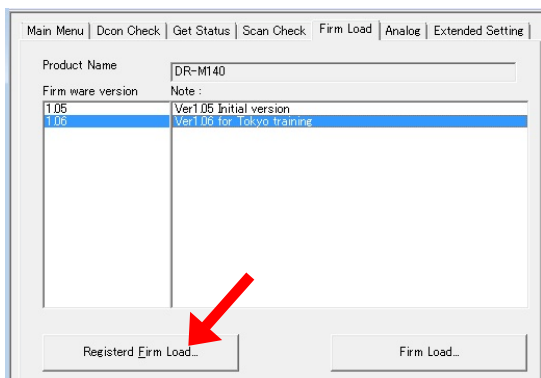

Figure 5-246

- 2) When the warning screen is displayed, click [OK].



Figure 5-247

- 3) Writing starts automatically and the progress screen is displayed.

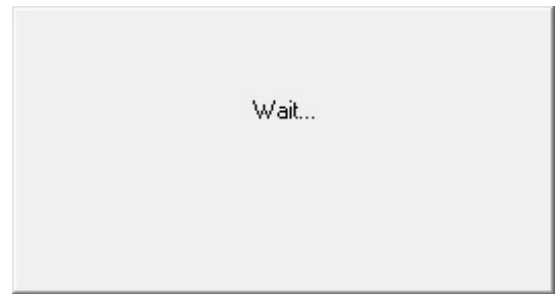
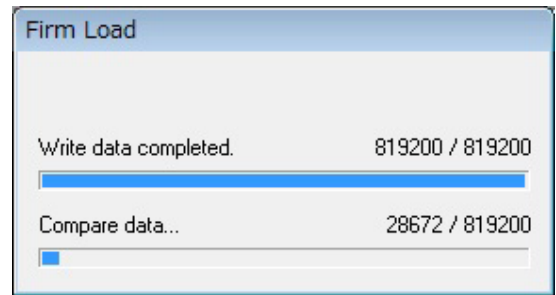

Figure 5-248

- 4) After the process is complete, the progress screen disappears. When the firmware is changed, a reset is automatically executed internally.
- 5) Check the version screen on the [Check Device] screen.

◆ For unregistered firmware

This mode has the same functionality as Firm Load in the “Main Menu” screen.

- 1) Select [Firm Load].

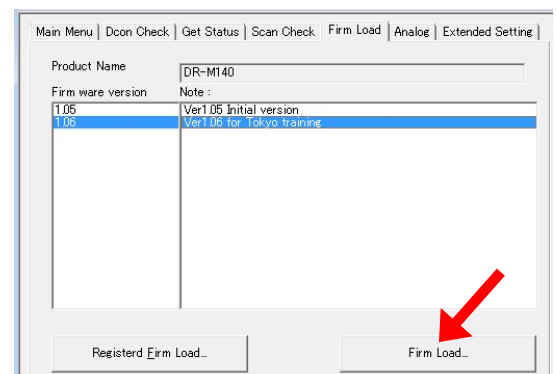

Figure 5-249

- 2) When the file selection screen is displayed, select the file.

3) Writing starts automatically and the progress screen is displayed.

The rest of the procedure is the same as in “For registered firmware”.

**Note:** This automatically detects whether the file is for the connected scanner and only executes writing if it is suitable.

## F. Analog

### 1. Analog

This mode is used to check the analog data from sensors. Note that checking the regular sensor operation is performed using “Dcon Check”.

Selecting the sensor is performed from the drop-down box. Furthermore, when a sensor is detected, a “red circle” lights on the left side.

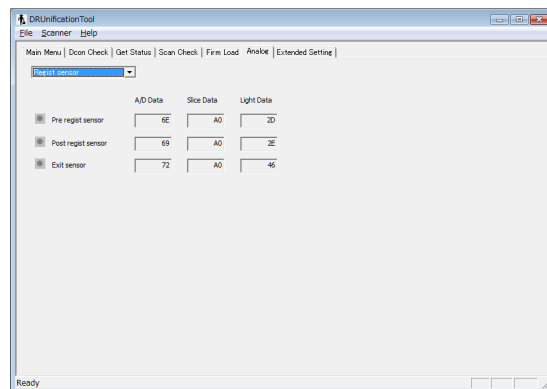

Figure 5-250

Options for the drop-down box are shown below.

- Registration sensor
- Door sensor
- Double feed sensor
- Document sensor
- Separation sensor
- Flapper sensor
- Skew sensor

## G. Extended Setting

### 1. Outline

This mode makes it possible to adjust the image scale parameter and reading-start position. It is used to correct changes due to

the friction of the roller or to perform fine adjustment of automatic adjustment. This mode should also be executed after replacing the control PCB that records the adjustment data.

#### ◆ Description of the screen

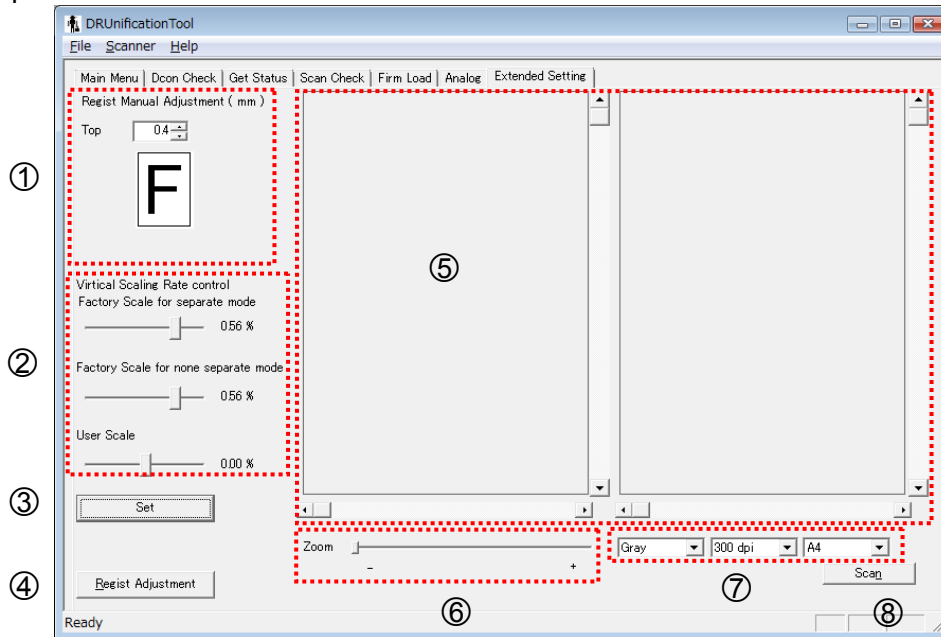

Figure 5-251

No.	Details
①	Regist Manual Adjustment Reading-start position adjustment value. Units are mm, and the setting range is ±5.0. The [+] direction delays the timing.
②	Virtual Scaling Rate control Feed direction scale parameter adjustment value. There are three types. Units are %, and the setting range is ±1.0 of the factory value, ±3.0 of the user value.
③	[Set] button Sets the adjustment values.

No.	Details
④	[Regist Adjustment] button Executes automatic registration adjustment.
⑤	Scan image The scanned image is displayed. The left side is the front image and the right side is the back image.
⑥	Zoom Enlarges the image in ⑤ above.
⑦	Scanning Modes Mode, resolution, and size.
⑧	[Scan] button Executes a scan.

Table 5-206

◆ Overview procedure

The following flow chart shows an overview of the procedure for adjusting the scale parameter when performing automatic or manual adjustment. Refer to each of the items for details.

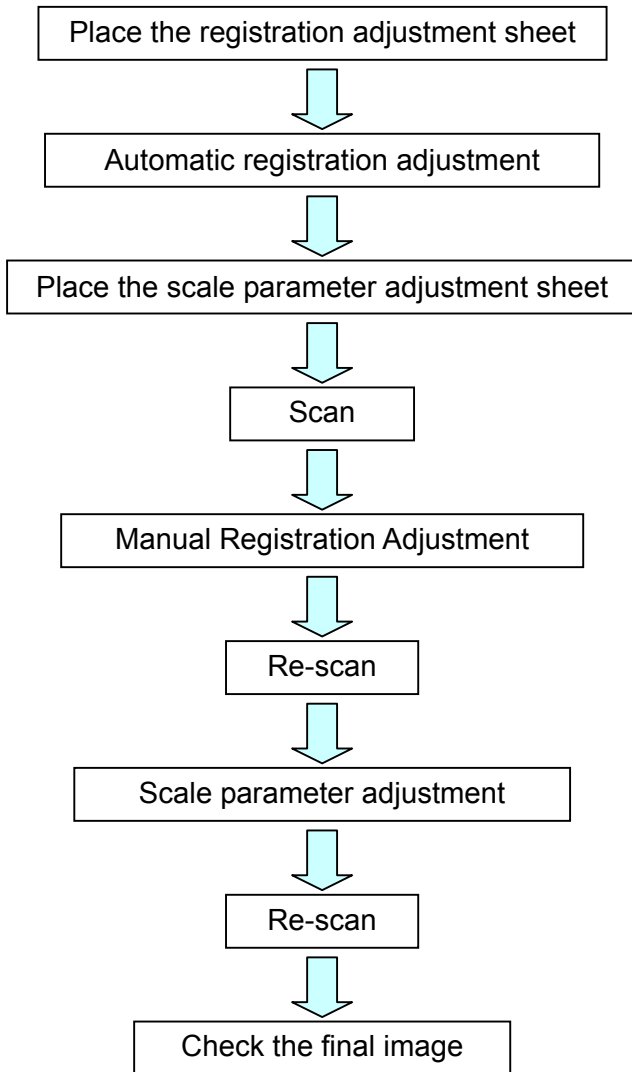

Figure 5-252

## 2. Registration Adjustment

You can execute both automatic and manual registration adjustment from the [Extended Setting] screen.

### a. Automatic Registration Adjustment

This automatic registration adjustment is the same as the automatic registration adjustment on the “Main Menu” screen, and operates with linked settings. The operation method is also the same, which is to place the registration adjustment sheet (white sheet) and then click the [Regist Adjustment] button at the bottom of the screen. The values that are set at that time are displayed.

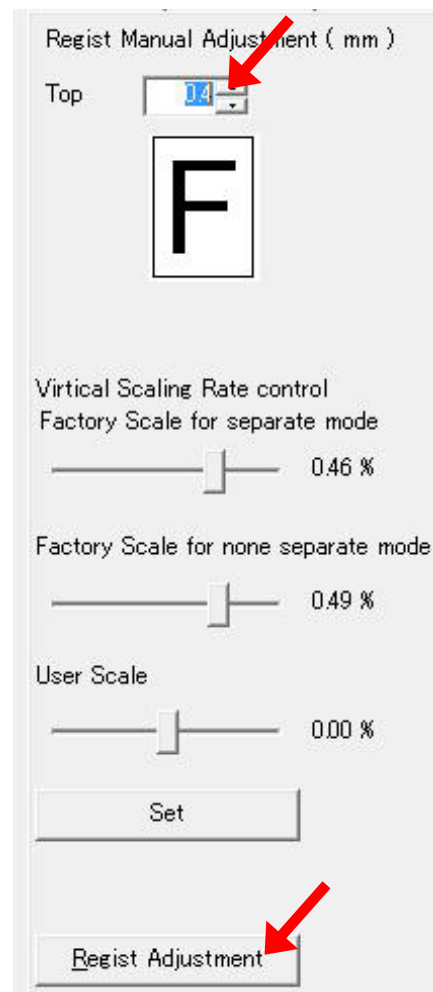

Figure 5-253

### b. Manual Registration Adjustment

Registration adjustment is normally performed in automatic mode. This manual adjustment is a mode that performs fine adjustment of the result of the automatic adjustment. Note that it does not reduce variations in the registration position.

#### ◆ Adjustment sheet

Use the same sheet as the scale parameter adjustment sheet. For details, refer to the “Scale Parameter Adjustment” section.

#### ◆ Operation Procedure

- 1) Place a single adjustment sheet and adjust the document guides. Place with the pattern surface at the front.
- 2) Set the scanning modes and select the [Scan] button.

**Note:** Set the resolution to [300 dpi] or [600 dpi], the size to match the sheet size you are using or set to [Auto Size], and the mode to either [Gray] or [Color].

Other settings are the setting values stored in the service tool.

- 3) Enlarge the image and check the leading edge position.
- 4) The value to adjust is changed by directly entering in the data box or by using the scroll arrows. This amount of additional change is added to the value previously set by the automatic adjustment.  
For example, if the value is already [0.4], then enter [-0.6] if you want to add 1mm to make the reading start 1mm earlier, or enter [1.4] if you want to subtract 1mm.

- 5) After setting, always select the [Set] button.

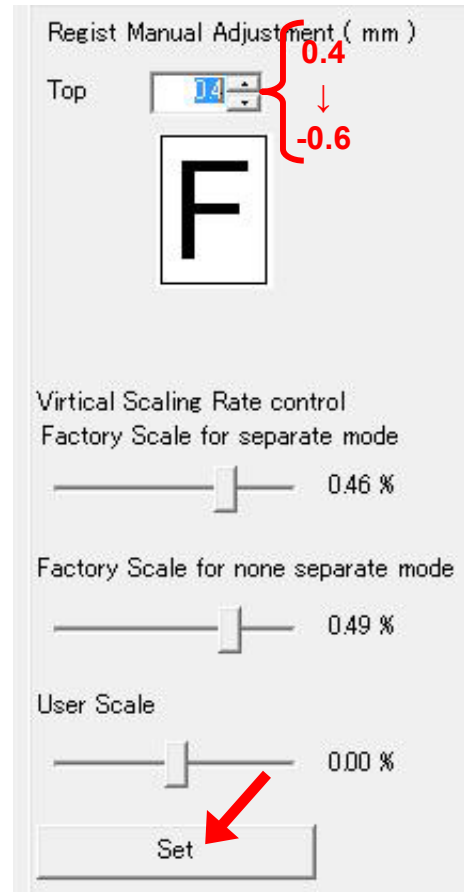

**Figure 5-254**

- 6) Scan the image again and check the position.

### 3. Scaling Rate Control

This mode adjusts the scale parameter to make the length of the image in the feed direction correct. It performs adjustment using the front side image. The same values are applied to the reverse side image as the front side.

If the image leading edge position is different, perform registration adjustment first.

◆ Types

There are three types of scale parameter adjustment.

- 1) Factory Scale for separate mode
- 2) Factory Scale for none separate mode
- 3) User Scale

Since the feed method differs between separate and none separate mode, a slight difference occurs in the scale parameter and the individual scale parameters are set when shipped from the factory.

Furthermore, there is a user scale parameter to enable the user to re-adjust after the product ships. The setting can be configured from the “Utility/USB Properties/Maintenance” user operating screen. That value is linked with the “User Scale” in this mode. Note that the user value is displayed to one decimal place with the value rounded.

◆ Adjustment sheet

Prepare a single sheet of A4 or LTR size paper printed with a pattern that makes the positions of the leading and trailing edges clear.

Service tool: You can use the TKM-0271 test sheet or a hand-made test sheet as

shown below.

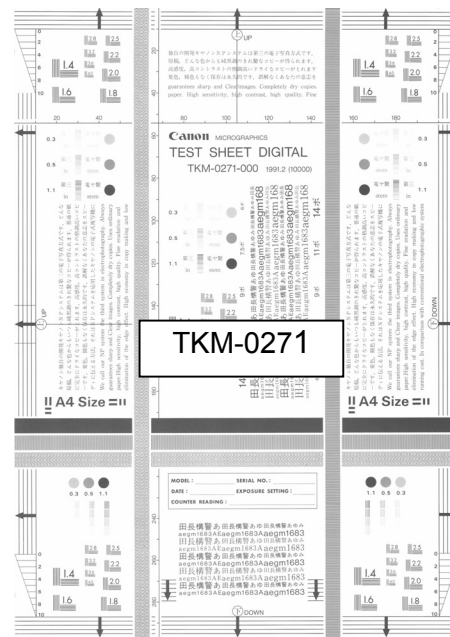

Figure 5-255

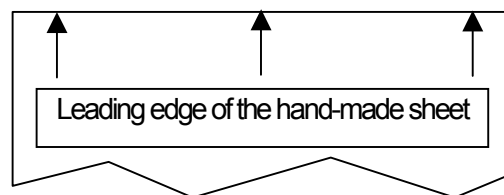

Figure 5-256

◆ Operation Procedure

**Note:** If you adjust the scale parameter after replacing the control PCB or want to set the scale parameter adjustment value that is displayed in the user operating screen to “0.0”, you should first set all three of the adjustment values to “0.00” and select the [Set] button.

- 1) Place a single adjustment sheet and adjust the document guides. Place with the pattern surface at the front.

- 2) Set the feed selection lever to “separate mode” or “none separate mode” as necessary.
- 3) Set the resolution, size and mode, and then select the [Scan] button.

**Note:** To set both “separate mode” and “none separate mode”, do this twice.

- 4) The scanned image is displayed. (Refer to Figure 5-257)
- 5) Use [Zoom] to enlarge the leading edge of the image and ensure that the position of the leading edge is correct. (Refer to Figure 5-258)

**Note:** If the position of the leading edge is incorrect or the image is skewed, perform the scan again.

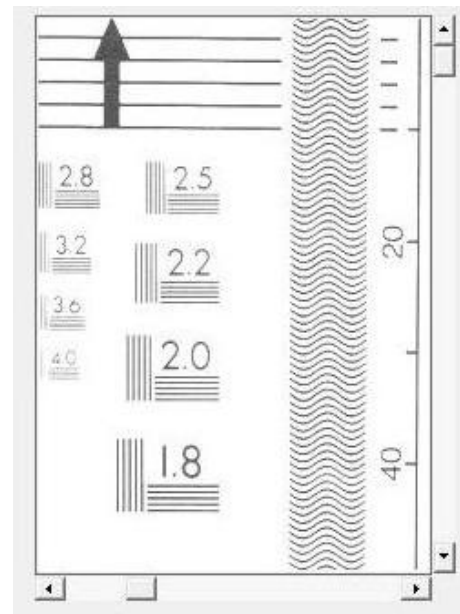

Figure 5-258

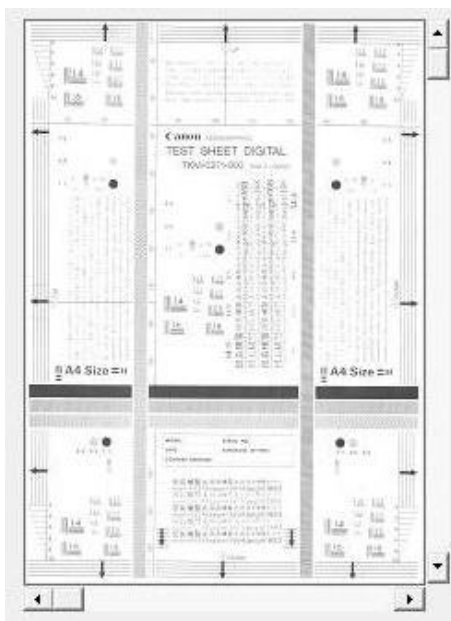

Figure 5-257

- 6) Check the trailing edge image next and set the adjustment values. For example, if you want to extend by 2.0mm with A4 size, then since  $2.0 \div 297 = 0.67\%$ , add “0.67” to the value. If the original value is “0.0”, set the setting value to “0.67”. After you have set the value, click the [Set] button.

In the below figure, [Factory Scale for separate mode] is set.

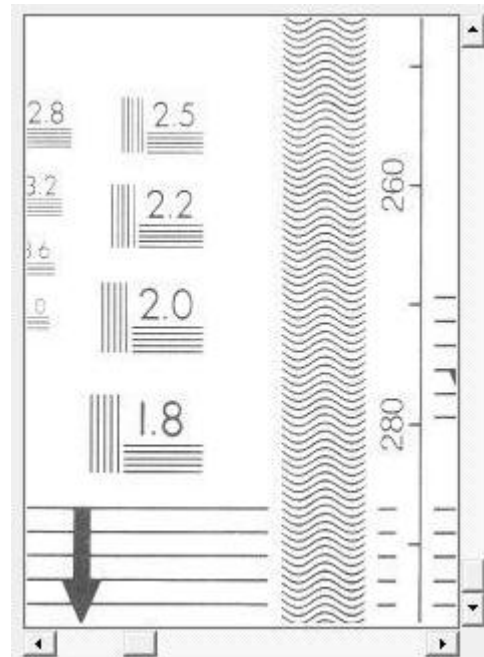
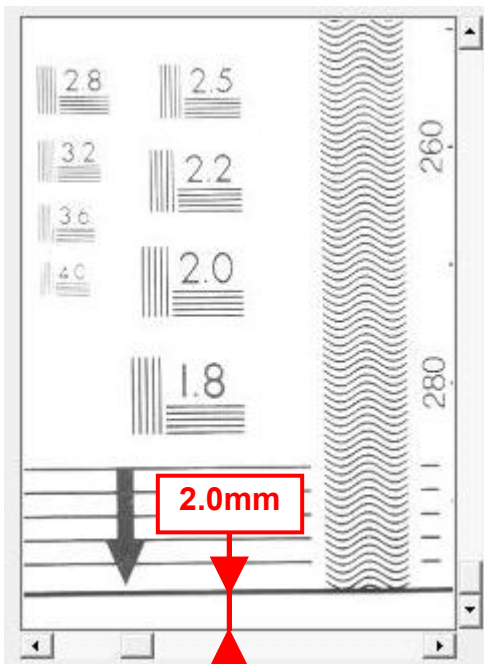

Figure 5-260

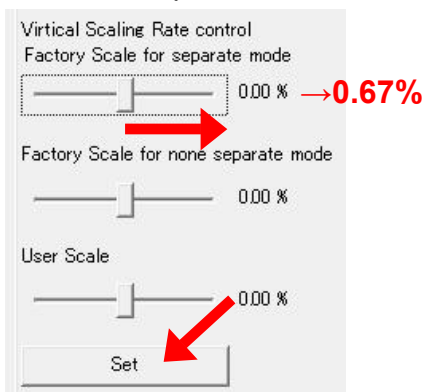

Figure 5-259

**Note:**The adjustment might not be enough using the factory adjustment value alone. If this happens, use the user adjustment value as well. Or, replace the rollers.

7) Place the adjustment sheet and scan again. Check the displayed image.

**Note:**Repeat the procedure again if the adjustments were not corrected properly.



## H. Other Functions

### 1. Mechanical Feed Mode

Although it is not part of the service mode using the service tool, this machine is equipped with a mechanical feed mode for checking the state of the feed transport without using a computer. You use this mode as necessary. Note that you should not disclose this mode to users. Press the buttons on the control panel in the following sequence to enter mechanical feed mode.

- ◆ Entering mechanical feed mode  
While holding down the Start button, press the power button, and after the lamp lights up and once the lamp starts flashing, immediately press the Stop button. When you enter this mode, a dot lights up in the bottom right of the Job No. indicator.
- ◆ Feeding paper  
While the machine is in this mode, place paper and press the Start button to begin feeding the paper.  
To feed again after finishing feeding one batch, press the Stop button once before pressing the Start button.
- ◆ How to finish  
Hold down the power button continuously until the lamp stops flashing. This is the same as turning the power off normally.

### 2. Recovery of Log Files

The software for this machine collects log files of user usage status information, and is equipped with a function for recovering these log files.

Since the log files are designed to be useful for resolving problems, the user may be asked to do the operation to recover the files.

The following gives an overview of the log files and the procedure for recovering them.

- ◆ Types of information
  - 1) User operations
  - 2) Error
  - 3) Settings
  - 4) Debugging (note that this excludes default settings)
  - 5) Latest information when recovering the files
- ◆ Recovery procedure (refer to Figure 5-261)
  - 1) Open the Advanced screen for the scanner, and click the [About] button.
  - 2) Click the [Log File Settings] button in the About screen.
  - 3) Click the [Execute] button in the Log File Settings screen.
  - 4) The Save Settings screen is displayed. Select the appropriate location to save the files.
  - 5) The files are saved with [xxx.dat] attached.

#### Note:[Full] Setting

On the Log File Settings screen, the type of log file can be set to [Full] or [Mini]. The default setting is [Mini]. If you need the [Full] information, set to [Full] and click the [OK] button. Then, perform the steps to reproduce the problem and

perform the recovery operation. Note that when set to [Full], the scanning speed may be reduced.

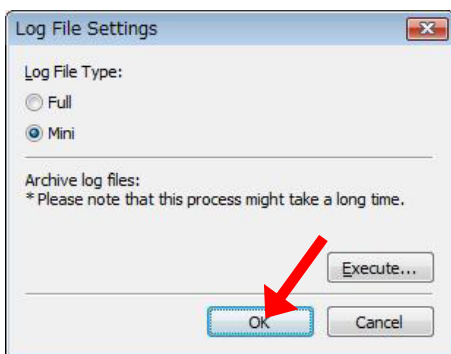
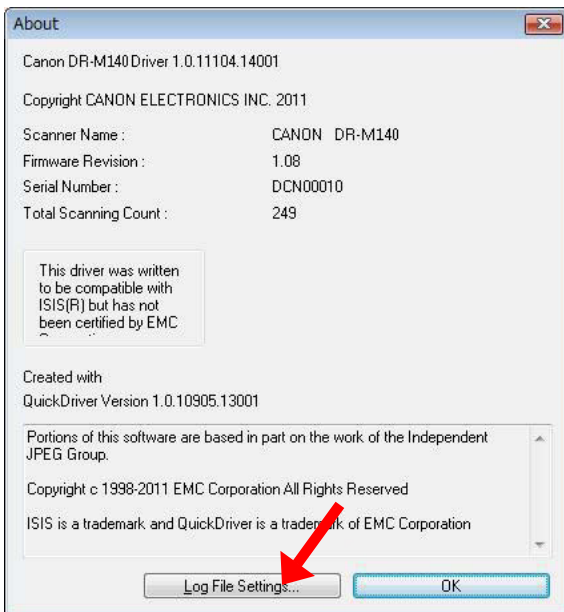
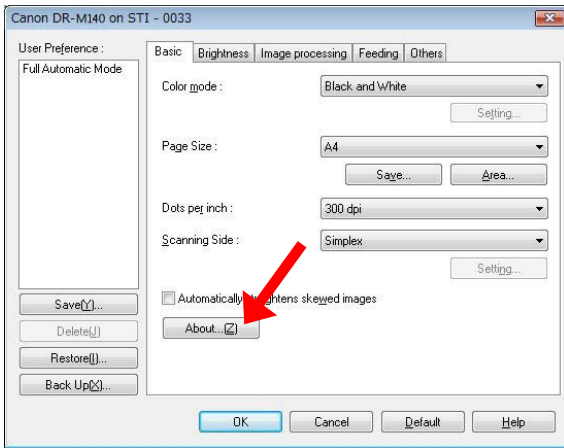

Figure 5-261

- ◆ Save location of log files
  - The original log files of the log files to send are saved on the user computer. The maximum size of the log files is approx. 200 MB. Once this limit is exceeded, old data is deleted. Data is also deleted after one year has passed.
  - For users who does not want to increase the disk usage, ask the users to delete these as necessary from the save locations shown below.

- 1) Windows XP
  - C:\Documents and Settings
  - \All Users\Application Data
  - \Canon Electronics\Scanner Drivers\log
- 2) Windows Vista/7
  - C:\ProgramData\Canon Electronics
  - \Scanner Drivers\log

**Reference: Displaying log files**

Although the content of the log files cannot be interpreted by generic software, it can be displayed in text format by using a dedicated application. Here is an example:

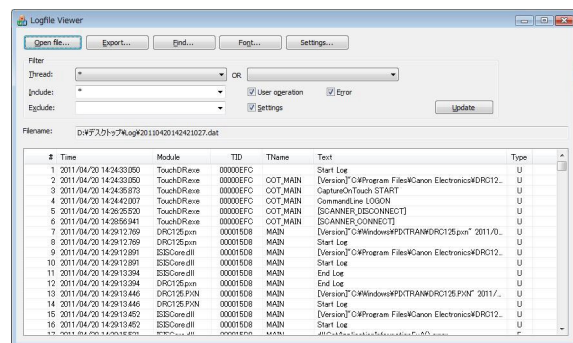

Figure 5-262

### III. TROUBLESHOOTING LIST

The lists below give the major failures conditions and their causes. Refer to the next section for details of the causes and the measures to be taken.

#### 1. Operation Failures

Note: Major causes of each failure are marked "X".

No.	Cause Failure	System/ Software	Hard- ware	Connec- tion	Dirt/ dust	Docu- ment	Settings
1	Power does not come ON.		X	X			
2	No scanner is found.	X		X			
3	Scanner does not start.	X	X	X			X
4	Scanning does not feed properly.		X		X	X	
5	Scanning speed is slow.	X					X

Table 5-301

#### 2. Image Failures

Note: Major causes of each failure are marked "X".

No.	Cause Failure	System/ Software	Hard- ware	Connec- tion	Dirt/ dust	Docu- ment	Settings
1	All black/all white/all streaked.	X	X		X		X
2	Too dark/too light.				X		X
3	Streaks in image.		X		X		
4	Image slanted.					X	X
5	Wrong image size.					X	X
6	Text cannot be seen.					X	X
7	Moire in image.					X	X

Table 3-302

## IV. OPERATION TROUBLESHOOTING

When an operation problem occurs, check the error message displayed on the display connected to a computer. Also perform an operation check on the sensors and motors using the service mode.

### 1. Power Does Not Come ON

The power indicator is not lit.

**Note:** Make sure to use the AC adapter and power cord supplied with the machine.

Cause/Faulty Locations	Step	Check Item	Result	Action
Connection of power cord	1	Is the power cord connected?	NO	Connect the connectors correctly.
AC power supply voltage	2	Is the power outlet supplying power at the rated voltage?	NO	Explain to the user that this is not a problem with the machine.
Connection of AC adapter	3	Is the AC adapter connected?	NO	Connect the connectors correctly.
Power button	4	Is the power button on?	NO	Turn the power button on.
Power cord	5	Does replacing the power cord fix the problem?	YES	Done.
AC adapter	6	Does replacing the AC adapter fix the problem?	YES	Done.
Control PCB Operation PCB	7	Is the cable connected?	NO	Connect the connectors correctly.
			YES	Replace the PCB.

Table 5-401

## 2. No Scanner is Found

**Note:** You should install the driver on the computer before connecting the scanner.

Cause/Faulty Locations	Step	Check Item	Result	Action
Power Supply	1	Is power supplied to the machine?	NO	Perform "1. Power Does Not Come ON".
Connection of the USB cable	2	Is the USB cable connected?	NO	Connect the connectors correctly.
Computer and interface card	3	Are the computer and interface card compatible?	NO	Use compatible equipment.

Table 5-402

## 3. Scanning Does Not Start

**Note:**The "cover open" and "no document" error messages may be displayed and scanning may not start due to sensor problems.

Cause/Faulty Locations	Step	Check Item	Result	Action
System	1	Was the problem solved by resetting the power of the scanner or restarting the computer?	YES	Done.
Software	2	Was the problem solved by reinstalling the scanner driver or application?	YES	Done.
Connection of the connector (control PCB)	3	Are the motor and sensor connectors connected correctly?	NO	Connect the connectors correctly.
Drive transmission system	4	Is the transmission system of the motors normal? Are parts such as gears and belts normal?	NO	Attach the parts correctly. Replace the parts.
Motors	5	Is the operation normal when you perform an operation check with the service mode?	NO	Check the cable connections. Replace the motors.
Sensors	6	Is the operation normal when you perform an operation check with the service mode?	NO	Check the attachment of sensors and sensor levers. Check the connections of sensor cables.
Each sensor PCB	7	Was the problem solved by replacing the PCB?	YES	Done.
Control PCB	8	Was the problem solved by replacing the control PCB?	YES	Done.

Table 5-403

### 4. Scanner Does Not Feed Properly

**Note:**A “paper jam” or “double-feed” error message may be displayed due to a sensor problem.

Cause/Faulty Locations	Step	Check Item	Result	Action
Document	1	Specified document? (thickness, size, fold or curl)	NO	Use documents compliant with the specified.
Placing documents	2	Are documents stuck together?	YES	Fan the documents well.
	3	Is the position of the document guide correct?	NO	Correct the position.
Feed selection lever	4	Is the lever set properly?	NO	Set the lever properly.
Rollers	5	Are the rollers attached correctly?	NO	Attach the rollers correctly.
	6	Are they dirty or deformed?	NO	Clean or replace the rollers.
Parts in feed path	7	Parts touching documents installed properly? (no float, slant or gaps)	NO	Attach the parts correctly.
	8	Is the surface touching documents smooth? (No scratches or burrs)	NO	Replace inferior parts.
Drive transmission system	9	Does an abnormal noise occur while feeding? Are any of the gears damaged or the belts loose?	YES	Attach the parts correctly. Replace inferior parts.
Motors	10	Is the operation normal when you perform an operation check with the service mode?	NO	Check the cable connections. Replace the motors.
Sensors	11	Is the operation normal when you perform an operation check with the service mode?	NO	Check the attachment of sensors and sensor levers. Check the connections of sensor cables.
Each sensor PCB	12	Was the problem solved by replacing the PCB?	YES	Done.
Control PCB	13	Was the problem solved by replacing the control PCB?	YES	Done.

**Table 5-404**

## 5. Scanning Speed is Slow

The basic speed of this machine is 40 ppm. (A4/200 dpi)

The speed is further reduced if high resolution, color settings, or special functions are selected.

If the scanning speed is still slow after taking the above into consideration, the cause may be as follows.

Cause/Faulty Locations	Step	Check Item	Result	Action
Insufficient computer memory	1	Is the memory sufficient?	NO	Increase the memory.
	2	Are other applications running?	YES	Close the other applications.
	3	Are resident applications such as a virus protection program running?	YES	Close the service-type applications.
	4	Is there insufficient hard disc space?	YES	Increase the hard disc space.
Hi-speed USB 2.0 not supported	5	Is the USB port supported?	NO	Use a computer that supports it.
	6	Is the USB cable supported?	NO	Use the included USB cable.
	7	Is the USB hub supported?	NO	Use a USB hub that supports it.
The log file setting is [Full]	8	Is the log file setting set to [Full]?	YES	Set to [Mini].

**Table 5-405**

## V. IMAGE TROUBLESHOOTING

### ◆ Image Sample

Document 	Normal (B&W) 	All black 	All white 	All streaked 
Too dark 	Too light 	Streaks 1 	Streaks 2 	Streaks 3 
Slanting 	Skew correction 	Wrong size 	Auto size 	Has shadows 
Original document (B) 	Missing leading edge 	Margin at leading edge 	Stretched 	Compressed 

Table 5-501



**Note:**The level of reproducing the image depends on types of documents and setup conditions. Changing setup conditions sometimes works.

### 1. All Black/All White/All Streaked

The image is all black, all white, or all streaked.

Cause/Faulty Locations	Step	Check Item	Result	Action
Placing documents	1	Is the document placed with the front/back around the right way?	NO	Place properly.
Setup of "Brightness"	2	"Brightness" setup properly?	NO	Change the setup. Change "Contrast" if necessary.
System	3	Was the problem solved by resetting the power of the scanner or restarting the computer?	YES	Done.
Reading Unit	4	Reading-related cables connected properly?	NO	Connect properly.
	5	Was the problem solved by replacing the reading unit?	YES	Done.
Control PCB	6	Was the problem solved by replacing the control PCB?	YES	Done.

Table 5-502

### 2. Too Dark/Too Light

The image cannot be seen properly because the brightness is inappropriate.

Cause/Faulty Locations	Step	Check Item	Result	Action
Setup of "Brightness"	1	"Brightness" setup properly? Normally middle value is fine, but this may need to be changed, depending on the document.	NO	Change the setup.
Setup of "Contrast"	2	"Contrast" setup properly?	NO	Change the setup.
Light Adjustment	3	Have you executed Light Adjustment?	NO	Execute the adjustment.

Table 5-503

### 3. Streaks in Image

Streaks in the feeding direction may appear in the image due to dirt on the reading glass. Dirt on the feeding rollers may also be transferred to the document.

When white streaks appear in the image, this is due to shading correction being performed when the reading glass is dirty.

Cause/Faulty Locations	Step	Check Item	Result	Action
Reading glass	1	Is the reading glass clean?	NO	Clean it. Replace the reading guide (reading glass) if it is damaged.
Roller	2	Is the surface clean?	NO	Clean or replace it.
Feed Unit	3	Is the feed path clean?	NO	Clean it.
CIS unit	4	Is the inside of the CIS unit clean?	NO	Clean or replace the reading unit.
Light Adjustment	5	Have you executed Light Adjustment?	NO	Execute the adjustment.

Table 5-504

### 4. Image Slanted

If the document is fed at an angle, the image will become slanted.

Cause/Faulty Locations	Step	Check Item	Result	Action
Placing documents	1	Is the document placed properly?	NO	Place properly.
	2	Are the document guides adjusted to fit the document width?	NO	Correct the position.
Setup of "Skew correction"	3	Was "Skew correction" set?	NO	Set it. You can correct the slant of an image using image processing.
Feeding documents	4	Are documents fed straight?	NO	Perform the checks in "IV. RESOLVING MALFUNCTIONS, 4.The Document Does Not Feed Properly".

Table 5-505

## 5. Wrong Image Size

There are margins around the image, or some of the image is missing.

**Note:** Set the paper size to “auto detection” when scanning batch of different size documents.

Cause/Faulty Locations	Step	Check Item	Result	Action
Setup of “Paper size”	1	Is the setup of “Paper size” correct?	NO	Change the setup.
Placing documents	2	Was the document placed in the correct position?	NO	Place the document in the correct position.
Setup of “Auto detection” for the paper size	3	Was “Auto detection” set?	NO	Set it.
Registration adjustment	4	Have you executed automatic registration adjustment or manual registration adjustment?	NO	Execute the adjustment.
Scale parameter adjustment	5	Have you executed scale parameter adjustment?	NO	Execute the adjustment.

**Table 5-506**

## 6. Text Cannot be Seen

When the background includes colors or patterns, text may be hidden by the background when scanning in black and white. There are special modes such as [Advanced Text Enhancement] etc. for solving this problem.

**Note:** The problem may not be fixed, depending on the type of document.

Cause/Faulty Locations	Step	Check Item	Result	Action
Setup of “Mode”	1	Was the problem solved by setting to “Color” or “Grayscale”?	YES	Done.
	2	Was the problem solved by setting to a special mode such as [Advanced Text Enhancement] etc.?	YES	Done.
Setup of “Brightness”	3	Was the problem solved by changing the setup of “Brightness”?	YES	Done.

**Table 5-507**

## 7. Moire in Image

The moire effect occur when photos from magazines, catalogs, etc. are scanned at a low resolution.

Cause/Faulty Locations	Step	Check Item	Result	Action
Setup of "Moire Reduction"	1	Is "Moire Reduction" set?	NO	Set it.
			YES	Increase the resolution. Set to "High Quality Moire Reduction".

Table 5-508

---

## VI. AFTER REPLACING PARTS

---

Some of the parts used in this machine require adjustments and settings after being replaced or disassembled and reassembled.

You should check the feed and images after replacing parts or reassembling and reassembling the machine.

◆ Control PCB

- 1) Execute [Regist Adjustment] and [Light Adjustment] in service mode.
- 2) Change the value in the [Counter] in service mode.
- 3) Execute the scale parameter adjustment in [Extended Setting] screen in service mode.

◆ Reading Unit

Execute [Regist Adjustment] and [Light Adjustment] in service mode.

◆ Registration Related Parts

If problems occur in the leading edge or trailing edge positions of images scanned after replacing or reassembling registration related parts, execute [Regist Adjustment] in service mode. Furthermore, execute the regist manual adjustment in [Extended Setting] screen if necessary.



---

---

# APPENDIX

---

---

I. GENERAL CIRCUIT DIAGRAM.....A-1	II. LIST OF SPECIAL EQUIPMENT .....A-2
------------------------------------	--

---





# I. GENERAL CIRCUIT DIAGRAM

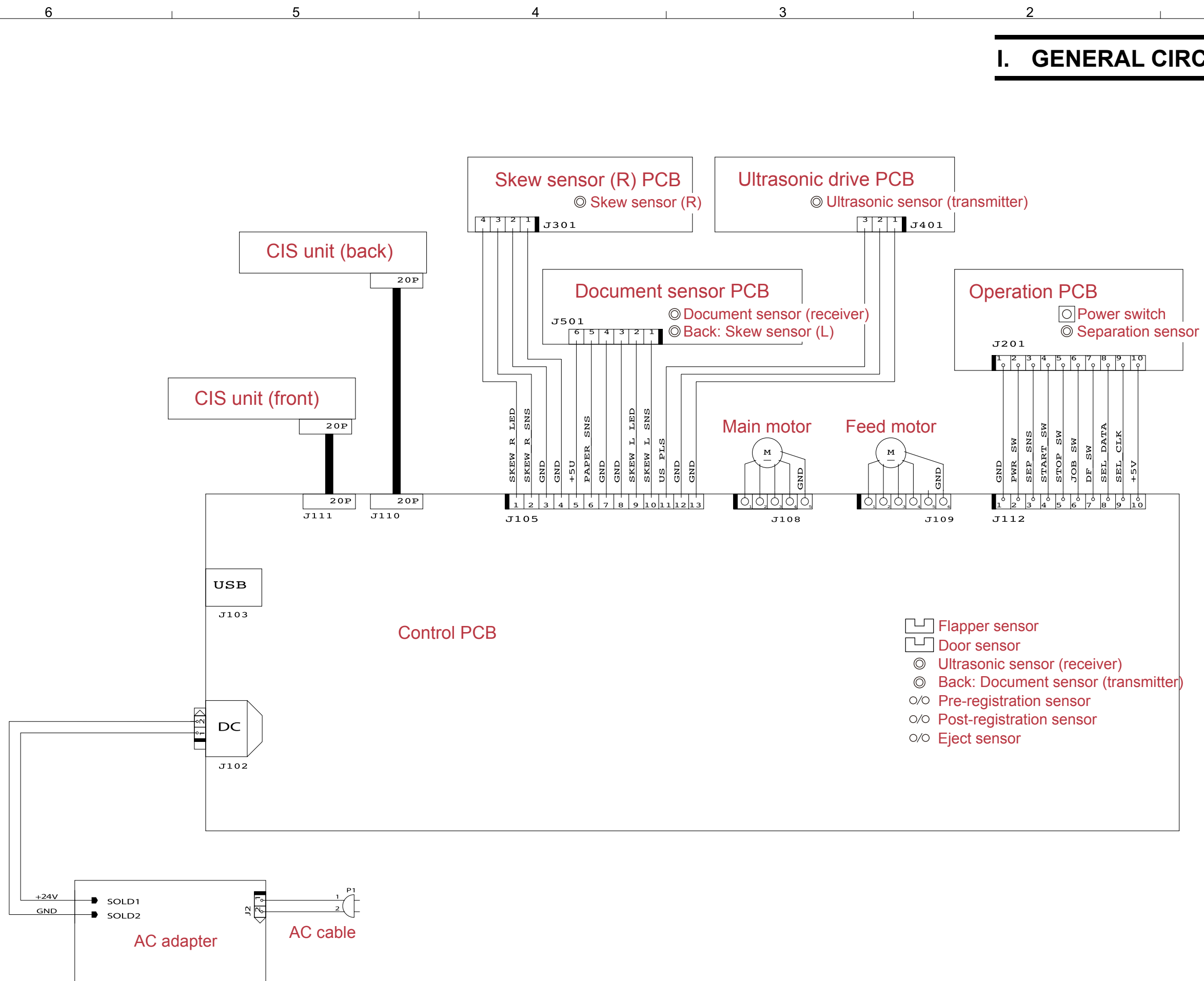



## II. LIST OF SPECIAL EQUIPMENT

The list of special tools needed for service works on this machine is the following.

Note that these are the same as used for other machines or are self-made.

No.	Tool name	Tool number	Rank	Usage/Remarks
1	Shading sheet	TKM-0326 TKM-0332	B	For the light adjustment 10 sheets/1 set
2	Scale parameter adjustment sheet	TKM-0271 or self-made	B	For the scale parameter adjustment Can also be created from copier paper by the service technician.
3	Test sheet	TKM-0271	A	For normal image display checking 10 sheets/1 set

**Table A-201**

**Note:** Rank notation:

A: Equipment that each service technician must carry.

B: Equipment that can be shared among a group of 5 service technicians.

C: Equipment that each workshop needs to have.



**Prepared by**

**Quality Assurance Center  
Canon Electronics Inc.**

**3-5-10 Shibakoen, Minato-ku  
Tokyo 105-0011, Japan**

**FIRST EDITION: AUG. 2011 (63999)**

**Canon**

0811SZ

*WWW.SERVICE-MANUAL.NET*