

# imageFORMULA DR-G2140 DR-G2110

# SERVICE MANUAL



# Canon

August 11, 2018  
Rev. 1

*COPYRIGHT © CANON ELECTRONICS INC. 2018*

Use of this manual should be strictly supervised to avoid disclosure of confidential information.

This Service Manual describes necessary basic information for field service and maintenance for maintaining the product quality and functions of this machine.

### **Contents**

#### **Chapter 1: General description**

Product specifications, name of parts, operation method

#### **Chapter 2: Functions and operation**

Description of operation of machine system and electrical system by function

#### **Chapter 3: Disassembly and reassembly**

Disassembly method, reassembly method

#### **Chapter 4: Installation and maintenance**

Installation method, maintenance method

#### **Chapter 5: Troubleshooting**

Error display and troubleshooting

#### **Appendix: General diagram etc.**

Information in this manual is subject to change. Notification of such changes will be given in Service Information Bulletins.

Thoroughly read the information contained in this Service Manual and the Service Information Bulletins to gain a correct and deeper understanding of the machine. This is one way of fostering response for ensuring prolonged quality and function, and for investigating the cause of trouble during troubleshooting.

Quality Assurance Center  
Canon Electronics Inc.

# CONTENTS

---

## CHAPTER 1 GENERAL DESCRIPTION

---

I. PRODUCT SPECIFICATIONS .....	1-1
1. Features .....	1-1
2. Specifications .....	1-2
3. Precautions .....	1-6
II. NAME OF PARTS .....	1-7
1. Front Side .....	1-7
2. Rear Side .....	1-8
3. Operation Panel .....	1-8
III. USER OPERATION .....	1-9
1. Preparation of Trays .....	1-9
2. Job Function .....	1-10
3. CaptureOnTouch .....	1-11
4. Paper Jam, Skew and Staple Detection Handling .....	1-13
5. User Mode .....	1-15

---

## CHAPTER 2 FUNCTIONS & OPERATION

---

I. OUTLINE .....	2-1
1. Basic Configuration .....	2-1
2. Feed Path .....	2-2
3. Motor Drive .....	2-3
4. List of Sensors .....	2-4
5. Electrical Circuits .....	2-6
6. Timing Chart .....	2-7
II. READING SYSTEM .....	2-10
1. Outline .....	2-10
2. Image Reading .....	2-11
3. Shading .....	2-12
III. FEED SYSTEM .....	2-13
1. Outline .....	2-13
2. Pickup Tray Elevation .....	2-14
3. Separation Mechanism .....	2-15
4. Feed Error Detection .....	2-16
5. Staple Detection .....	2-17
IV. CONTROL SYSTEM .....	2-18

1. Control PCB .....	2-18
2. Drive System Block Diagram .....	2-19
3. Image Processing Control .....	2-20
4. New Binarizing .....	2-21
5. Network Scanning .....	2-22
V. POWER SUPPLY .....	2-23
1. Power Supply .....	2-23
VI. OPTION .....	2-24
1. Imprinter .....	2-24
2. Flatbed Scanner Unit .....	2-25
VII. ELECTRICAL PARTS LAYOUT .....	2-26
1. Motor, Fan, Solenoid .....	2-26
2. PCB, Sensor, Unit .....	2-28
VIII. PARTS LAYOUT ON EACH PCB .....	2-30
1. Control PCB .....	2-30
2. Main Drive PCB .....	2-31
3. Sub-Drive PCB .....	2-32
4. Power PCB .....	2-33
5. Eject PCB .....	2-34

---

## CHAPTER 3 DISASSEMBLY & REASSEMBLY

---

I. REPLACED BY USERS .....	3-1
1. Pickup Roller .....	3-1
2. Feed Roller .....	3-1
3. Retard Roller .....	3-2
II. EXTERNAL COVERS .....	3-3
1. Control PCB Cover .....	3-3
2. Right Cover Assembly .....	3-3
3. Operation Panel .....	3-4
4. Left Cover Assembly .....	3-5
5. Top Cover .....	3-6
6. Pickup Tray Unit .....	3-7
7. Eject Tray Unit .....	3-7
8. Upper Front Cover .....	3-8
9. Rear Cover .....	3-9

III. UPPER UNIT-1 (MECHANICAL RELATION)	
.....	3-10
1. Pickup Unit .....	3-10
2. Pickup Roller Cover .....	3-11
3. Upper Entrance Guide.....	3-12
4. Pull-in Upper Roller .....	3-12
5. Registration Upper Roller .....	3-13
6. Reading Upper Roller .....	3-14
7. Platen Upper Roller .....	3-15
8. U-turn Upper Roller .....	3-16
9. Eject Follower Roller .....	3-16
10. Eject Tray Extension.....	3-17
11. Imprinter Cover .....	3-18
12. Eject Document Guide .....	3-18
13. Entire Upper Unit .....	3-19
IV. UPPER UNIT-2 (ELECTRICAL RELATION)	
.....	3-21
1. Main Drive PCB .....	3-21
2. Ultrasonic Sensor PCB.....	3-21
3. Feed Motor .....	3-22
4. Pickup Motor.....	3-23
5. Pickup Up/Down Motor.....	3-23
V. UPPER UNIT-3 (READING RELATION)..	3-24
1. Upper Reading Unit.....	3-24
2. Shading Motor .....	3-25
3. Upper Reading Glass Assembly .....	3-26
VI. BASE UNIT-1 (MECHANICAL RELATION)	
.....	3-27
1. Pickup Document Guide.....	3-27
2. Tray Drive Box.....	3-28
3. Blind Cover .....	3-29
4. Pickup Tray Plate .....	3-30
5. Lower Front Cover.....	3-30
6. Lower Entrance Guide.....	3-31
7. Right Belt .....	3-31
8. Left Front Belt.....	3-32
9. Left Rear Belt.....	3-32
10. Pull-in Lower Roller .....	3-33
11. Registration Lower Roller .....	3-33
12. Platen Lower Roller .....	3-34
13. Reading Lower Roller .....	3-35
14. Pre U-turn Lower Roller.....	3-36
15. U-turn Lower Roller (Middle) .....	3-37
16. U-turn Lower Roller (Rear) .....	3-37
17. Eject Drive Unit.....	3-38
18. Eject Drive Roller.....	3-38
VII. BASE UNIT-2 (ELECTRICAL RELATION)	
.....	3-39
1. Control PCB.....	3-39
2. Sub-Drive PCB .....	3-40
3. Staple PCB .....	3-40
4. Power PCB .....	3-41
5. Ultrasonic Drive PCB.....	3-42
6. Eject PCB .....	3-42
7. Document Sensor PCB .....	3-43
8. Main Motor.....	3-44
9. Tray Motor .....	3-45
10. Separation Motor.....	3-46
11. Eject Motor.....	3-46
12. Exhaust Fan .....	3-47
13. Cooling Fan .....	3-48
VIII. BASE UNIT-3 (READING RELATION) ..	3-49
1. Lower Reading Unit.....	3-49
2. Shading Motor .....	3-50
3. Lower Reading Glass Assembly.....	3-51

---

## CHAPTER 4 INSTALLATION & MAINTENANCE

---

I. INSTALLATION.....	4-1
1. Choosing Location.....	4-1
2. Unpacking And Installation .....	4-2
3. Imprinter Installation Procedure .....	4-8
II. PARTS REPLACEMENT .....	4-12
1. Periodically Replaced Parts .....	4-12
2. Consumable Goods (Commercial Goods)	
.....	4-14
3. Consumable Parts (Service Parts) .....	4-14
III. MAINTENANCE .....	4-15
1. User Maintenance .....	4-15

2. Service Maintenance .....	4-16
------------------------------	------

---

## CHAPTER 5 TROUBLESHOOTING

---

I. ERROR DISPLAY .....	5-1	9. Others .....	5-31
1. Main Body .....	5-1	D. Firmware.....	5-31
2. Computer .....	5-3	1. Firm Registration .....	5-32
II. SERVICE MODE .....	5-4	2. Firm Load.....	5-34
1. Outline.....	5-4	3. Network Firmware.....	5-35
2. Preparation .....	5-9	E. Analog.....	5-36
3. How to Start and Finish .....	5-10	1. Analog Sensor .....	5-36
4. Application Information .....	5-11	2. Write File.....	5-36
5. Simulation Mode .....	5-11	F. Scan Test.....	5-37
A. Information.....	5-12	1. Scan.....	5-37
1. Scanner Name.....	5-12	G. Imprinter .....	5-38
2. Background color.....	5-12	H. Network .....	5-39
3. Firmware version .....	5-13	1. Obtainment of Log Files.....	5-40
4. Error History.....	5-13	III. TROUBLESHOOTING LIST .....	5-42
5. Serial Number.....	5-14	1. Operation Failures .....	5-42
6. Sleep Mode.....	5-14	2. Image Failures .....	5-42
7. Auto Power OFF .....	5-15	IV. OPERATION TROUBLESHOOTING .....	5-43
8. Counter .....	5-15	1. Power Does Not Turn ON .....	5-43
9. Write File.....	5-17	2. No Scanner is Found .....	5-44
B. Adjustment.....	5-18	3. Scanning Does Not Start .....	5-45
1. All .....	5-19	4. Scanner Does Not Feed Properly .....	5-46
2. Scaling (Manual).....	5-20	5. Scanning Speed is Slow .....	5-47
3. Registration (Manual) .....	5-23	V. IMAGE TROUBLESHOOTING .....	5-48
4. Density (Auto).....	5-24	1. Completely Black, Completely White, All Streaks.....	5-49
5. Density (Manual) .....	5-25	2. Too Dark, Too Light .....	5-49
C. Motor / Sensor.....	5-26	3. Black Borders Around Image .....	5-50
1. CIS, LCD, Buzzer .....	5-26	4. Image Skews .....	5-50
2. Move .....	5-27	5. Streaks on Image.....	5-51
3. Position.....	5-27	6. Outer Areas of Image Disappear .....	5-51
4. CoverOpen .....	5-28	7. Wrong Image Size .....	5-52
5. Panel.....	5-29	8. Text Invisible.....	5-52
6. SD Card .....	5-29	VI. AFTER REPLACING PARTS .....	5-53
7. USB 3.1 .....	5-30		
8. Imprinter Door.....	5-30		

---

## APPENDIX

---

I. GENERAL DIAGRAM .....	A-1
II. LIST OF SPECIAL EQUIPMENT .....	A-2

---

# CHAPTER 1

---

## GENERAL DESCRIPTION

---

---

I. PRODUCT OUTLINE.....	1-1	III. USER OPERATION .....	1-9
II. NAME OF PARTS .....	1-7		

---





---

# I. PRODUCT SPECIFICATIONS

---

## 1. Features

- 1) Succeeding models of DR-G1130/G1100
  
- 2) 3 models suitable for each usage (Scanning speed at gray and color, 200dpi)
  - DR-G2140: A4 landscape 140 ppm/280 ipm, A3 85 ppm/170 ipm
  - DR-G2110: A4 landscape 110 ppm/220 ipm, A3 70 ppm/140 ipm
  - DR-G2090: A4 landscape 90 ppm/180 ipm, A3 60 ppm/120 ipm
  
- 3) High-durability
  - Expect life 16 million sheets (A4 copy paper)
  
- 4) High-speed USB interface
  - Support USB3.1 Gen1 (Super Speed)
  
- 5) Network scanning with wired LAN
  - Supported by DR-G2140/G2110 network models
  
- 6) New CIS unit and DR processor
  
- 7) New binary processing “Active thresholding”

“Windows” is a trademark of Microsoft Corporation in the U.S. and other countries.  
Other company names and product names mentioned in this document are registered trademarks or trademarks of the respective companies.

## 2. Specifications

### 1) Appearance/Installation

No.	Item	Specifications
1	Type of scanner	Desktop type sheet-fed scanner
2	Document path	U-turn path
3	Dimensions	Tray closed: 480(W)×569(D)×315(H)mm *See details at following.
4	Weight	25 kg (Main body only)
5	Power supply	1) 100V model: AC100V, 50/60Hz 2) 120V model: AC120V, 60Hz 3) 200V model: AC220-240V, 50/60Hz * Power PCB supports AC100 to 240V, 50/60Hz.
6	Power consumption	1) Maximum operation: 66.5W 2) Sleep mode: 3.5W 3) Power switch OFF: 0.2W
7	External interface	1) USB 3.1 (Standard B connector) USB 3.1 Gen1 Super-Speed/USB 2.0 Hi-Speed support 2) Wired LAN (RJ45 connector) 10Base-T/100Base-TX/1000Base-T support * Only one of above can be used at the same time. * The wired LAN is for the network model only.
8	Expected product life (In-house information only)	One of the following two items, whichever comes first. 1) 5 years 2) 16 million sheets (A4 copy paper) * Replace parts if necessary.
9	Installation	By service technicians *Need 2 or more persons for carry the machine.
10	Bundle software	ISIS/TWAIN driver, CaptureOnTouch V4 Pro, Driver setting tool, KOFAX SVRS
11	Consumable parts (Commercial goods)	1) Exchange roller kit (Pickup/ Feed/ Retard rollers) * Expected life 600,000 sheets 2) Separation pad (Separation cover with pad) * Expected life 6 million sheets
12	Type of scanner	1) Imprinter (Post type) 2) Flatbed scanner unit (FSU102、FSU201) * No use for wired LAN connection. 3) Carrier sheets (A4) 4) Cleaning sheets 5) White platen rollers

**Table 1-101**

## ◆ External dimensions (unit: mm)

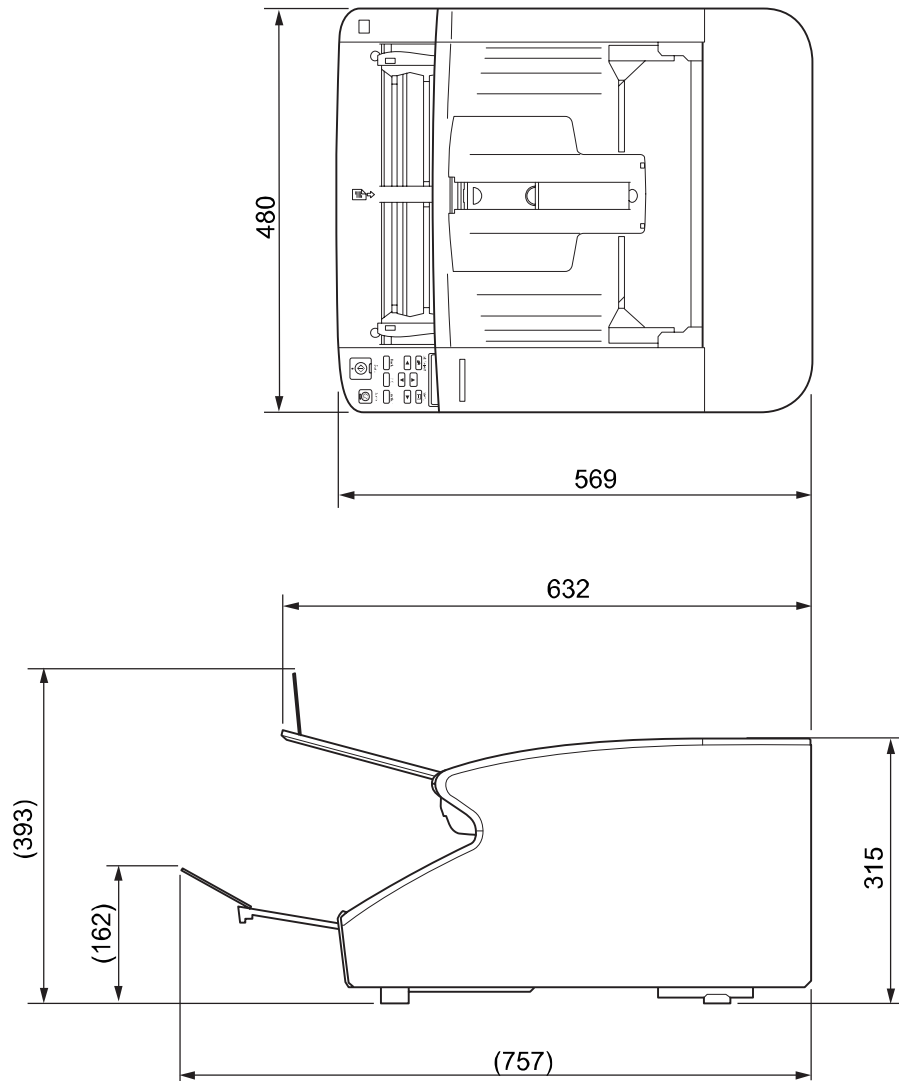

Figure 1-101

2) Functions

No.	Item	Specifications						
1	Sensor type	3 lines-CMOS contact image sensor (CIS), 600dpi						
2	Effective reading width	308mm						
3	Light source	3-color (RGB) LED, Both-side illumination						
4	Background color	Black (White as option.)						
5	Maximum scanning size	305 x 432 mm * 3,000 or 5,588 mm maximum at long document mode.						
6	Document size	1) Width: 50.8 to 305 mm 2) Length: 70 to 432 mm 3) Weight (Thickness) : 20 to 209 g/m <sup>2</sup> (0.04 to 0.25 mm) * There are some limitations for special document.						
7	Document storage (Pickup tray)	1) A4 or smaller: 500 sheets or 48 mm height maximum * 300 sheet maximum for DR-G2090. 2) A4 over: 200 sheets or 20 mm height maximum						
8	Double feed detection	1) Length detection by registration sensor 2) Double feed detection by ultrasonic sensor (one pair)						
9	Skew detection	Equipped						
10	Staple detection	Equipped						
11	Separation mode	1) Thin paper mode 2) Normal 3) High separation mode						
12	Mode setting in driver	1) Binary: B&W/Error diffusion/ATE/ATE-II/Active threshold 2) Gray (8-bit) 3) Color (24-bit)						
13	Resolution setting in driver	100x100dpi, 150x150dpi, 200x200dpi, 240x240dpi 300x300dpi, 400x400dpi, 600x600dpi						
14	Scanning speed	Auto-size and skew detections are ON, it may differ depending on the computer and function settings.						
			Model	Document	Mode	resolu- tion	Simplex (ppm)	Duplex (ipm)
		DR-G2140	A4 Landscape	Gray (JPEG)	200dpi	140	280	
					300dpi	140	280	
					600dpi	38	76	
				Color (JPEG)	200dpi	140	280	
					300dpi	140	280	
					600dpi	38	76	
			A4 Portrait (Refer.)	Gray (JPEG)	200dpi	110	220	
					300dpi	110	220	
					600dpi	30	60	
				Color (JPEG)	200dpi	110	220	
					300dpi	110	220	
					600dpi	30	60	

Table 1-102

No.	Item		Specifications				
14	(cont.)	DR-G2140	A3 (Refer.)	Gray (JPEG)	200dpi	85	170
					300dpi	80	160
					600dpi	22	44
				Color (JPEG)	200dpi	85	170
					300dpi	80	160
					600dpi	22	22
		DR-G2110	A4 Landscape	Gray (PEG)	200dpi	110	220
					300dpi	110	220
					600dpi	30	60
				Color (JPEG)	200dpi	110	220
					300dpi	110	220
					600dpi	30	60
			A4 Portrait (Refer.)	Gray (JPEG)	200dpi	90	180
					300dpi	90	180
					600dpi	25	50
				Color (JPEG)	200dpi	90	180
					300dpi	90	180
					600dpi	25	50
		A3 (Refer.)	Gray (JPEG)	200dpi	70	140	
				300dpi	70	140	
				600dpi	18	36	
			Color (JPEG)	200dpi	70	140	
				300dpi	70	140	
				600dpi	18	22	
		DR-G2090	A4 Landscape	Gray (JPEG)	200dpi	90	180
					300dpi	90	180
					600dpi	24	48
Color (JPEG)	200dpi			90	180		
	300dpi			90	180		
	600dpi			24	48		
A4 Portrait (Refer.)	Gray (JPEG)		200dpi	75	150		
			300dpi	75	150		
			600dpi	20	40		
	Color (JPEG)		200dpi	75	150		
			300dpi	75	150		
			600dpi	20	40		
A3 (Refer.)	Gray (JPEG)		200dpi	60	120		
			300dpi	60	120		
			600dpi	15	30		
	Color (JPEG)		200dpi	60	120		
			300dpi	60	120		
			600dpi	15	15		
15	Operation	1) LCD: Monochrome, Backlight, 5 lines 2) Button: Power button, other 11 operation buttons					

Table 1-103

### 3. Precautions

This section describes items that require particular care, for example, regarding human safety.

These precautions must be observed. The user should be explained the items that relate to user safety and instructed to take appropriate actions.

#### 1) Power OFF in emergency

If such abnormal conditions as extraordinary noise, smoke, heat and odor occur, immediately unplug the power cord.

Be careful not to get clothing (ties, long hair, etc.) caught in this machine as it may cause injury. Should this occur, immediately unplug the power cord. Do not insert fingers in the feed section while moving the rollers.

#### 2) Power OFF on disassembling

When disassembling and assembling are performed, unplug the power cord.

#### 3) Prohibition of modify

This machine must not arbitrarily be modified or remade. If it is, use of this machine may be forcibly suspended.

To change the specifications or disassemble and reassemble this machine, follow the instructions described in this manual and the service information.

#### 4) Electromagnetic wave interference

This machine complies with some standards regarding electromagnetic wave interference, such as VCCI and FCC. However, the user may have to take countermeasures if the machine causes electromagnetic wave interference.

#### 5) User Manual

Read each "User Manual" thoroughly prior to use of this machine.

#### 6) Disposal

Follow local regulations when disposing of the product and parts. This product is subject to the WEEE Directive in Europe.

#### 7) Movement

This machine weighs 25 kg. When lifting or moving this machine, 2 persons must hold it from both sides. Never lift it by one person.

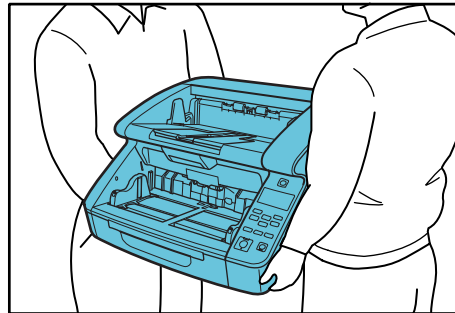

Figure 1-102

## II. NAME OF PARTS

### 1. Front Side

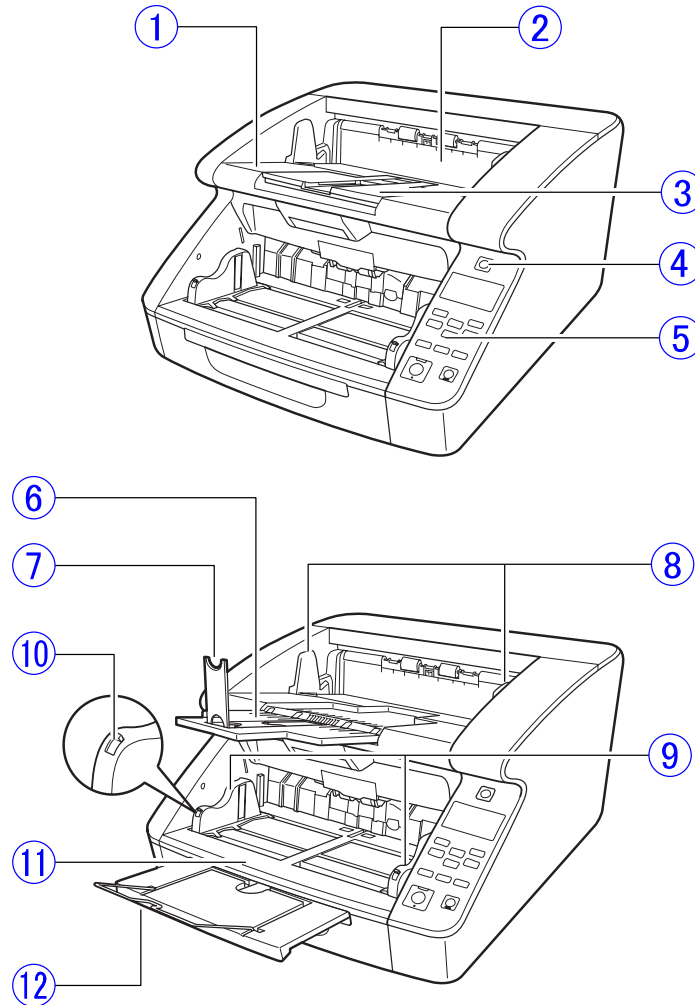

Figure 1-201

- |                                 |                                       |
|---------------------------------|---------------------------------------|
| ① Upper unit                    | ⑦ Document eject stopper              |
| ② Imprinter cover               | ⑧ Document eject guides               |
| ③ Document eject tray           | ⑨ Document feed guides                |
| ④ Power switch                  | ⑩ Document guide lock lever           |
| ⑤ Operation panel               | ⑪ Document feed tray (Pickup tray *)  |
| ⑥ Document eject tray extension | ⑫ Document feed tray extension & wire |

**Note:**In this manual, the “Document feed tray” may be mentioned as the “Pickup tray.”

## 2. Rear Side

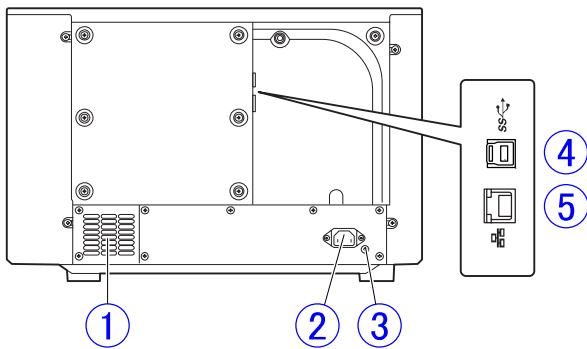

Figure 1-202

- ① Ventilation holes (Exhaust fan)
- ② Power connector
- ③ Grounding terminal
- ④ USB connector (Type B)
- ⑤ LAN connector (RJ-45)

## 3. Operation Panel

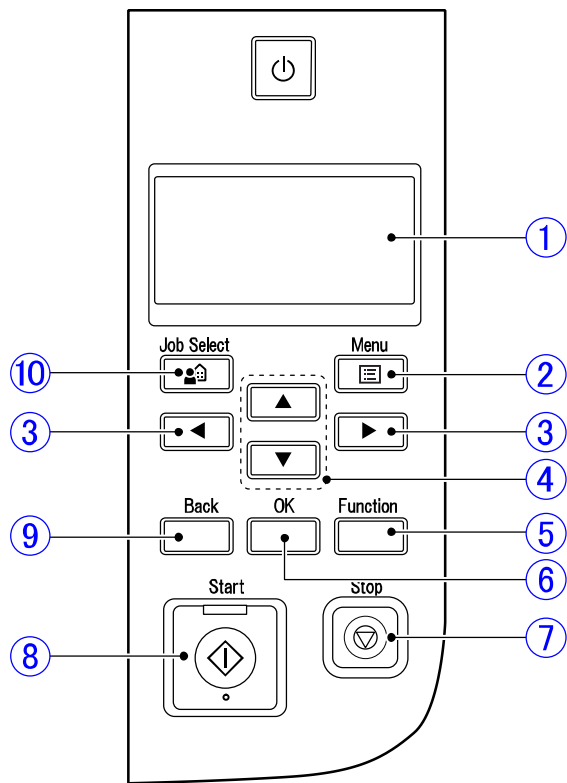

Figure 1-203

- ① Display panel
- ② Menu key
- ③ ◀▶ (left/right) keys
- ④ ▲▼ (up/down) keys
- ⑤ Function key
- ⑥ OK key
- ⑦ Stop key
- ⑧ Start key
- ⑨ Back key
- ⑩ Job key



## III. USER OPERATION

This section presents an outline of the user operations. Refer to the “User Manual” of this machine for details.

### 1. Preparation of Trays

Before scanning documents, prepare for the document feed tray and document eject tray according to the documents.

#### 1) Document feed tray

The height of the document feed tray can be adjusted according to the number of documents to be set and is set to the lowest position as the initial value. It is changed in user mode.

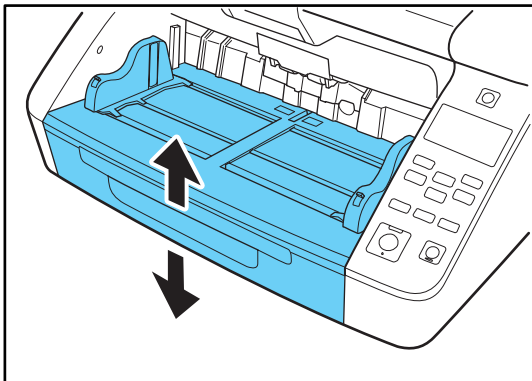

Figure 1-301

Adjust the position of the document feed guides according to the document width.

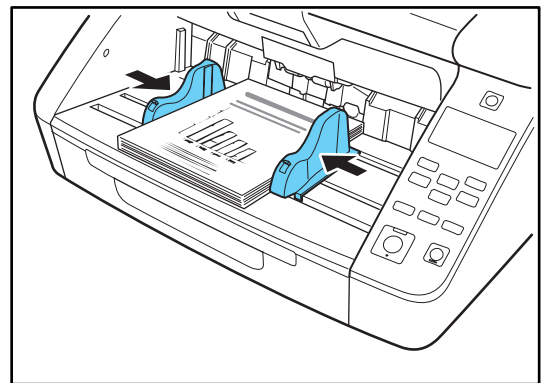

Figure 1-302

**Note:**The right and left positions can be changed by locking the document guides. Refer to the “User Manual” for details.

Pull out the tray extension according to the document length. Open the extension wire as required.

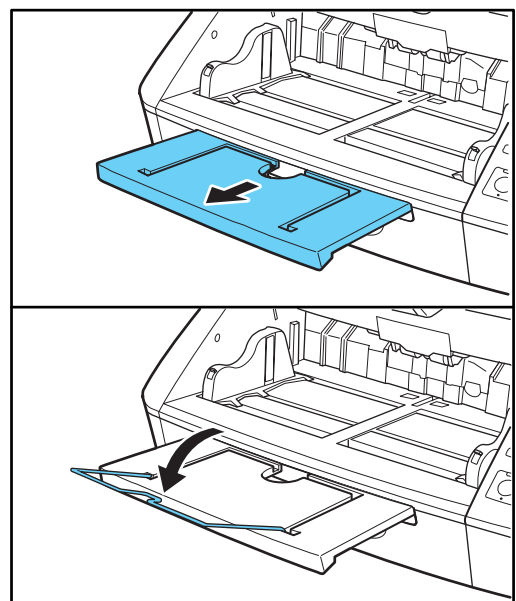

Figure 1-303

2) Document eject tray

Hold both document guides and adjust the positions according to the width of the document to be set.

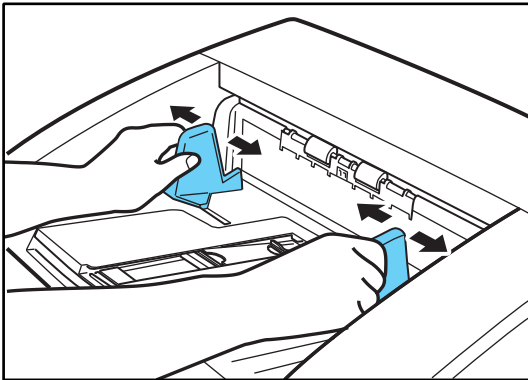

Figure 1-304

**Note:** The positions of the right and left document guides of the document eject tray can be changed independently of each other.

Open the document eject tray extension according to the document length. Raise the document eject stopper as necessary.

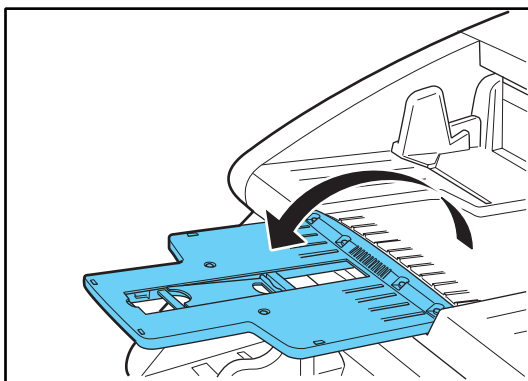

Figure 1-305

2. Job Function

The job function select and executes jobs (favorites) that have been registered with CaptureOnTouch by pressing the job key on the operation panel.

Refer to the “User Manual” for details.

1) Press the Job key on the operation panel.

**Note:** With USB connection, the Job selection screen is displayed. With LAN connection, the PC selection screen is displayed.

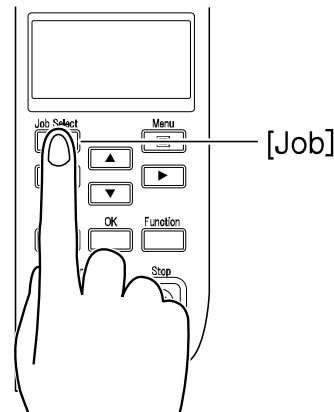

Figure 1-306

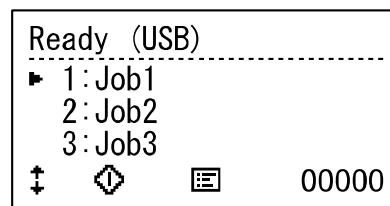

Figure 1-307 (USB)

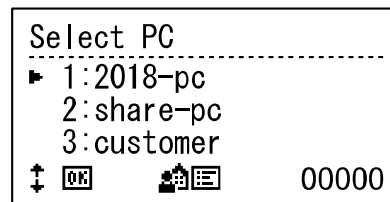
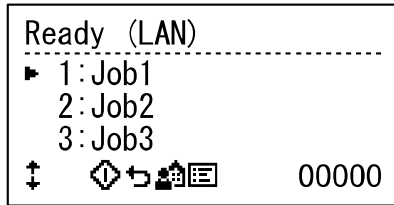

Figure 1-308 (LAN)

- 2) With LAN connection, at first press the ▲▼ keys to select a computer for connection.  
And press the OK key.



**Figure 1-309 (LAN)**

- 3) Press the ▲▼ keys to select the job. And then press the Start key.

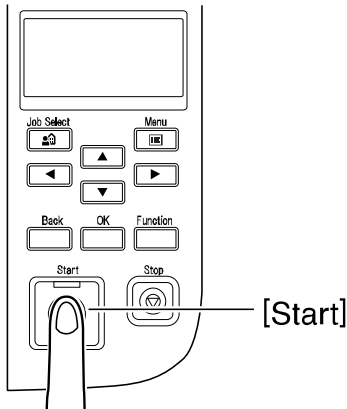

**Figure 1-310**

### 3. CaptureOnTouch

This section describes how to scan using the [Standard Scanning] in CaptureOnTouch.

**Note:** CaptureOnTouch is TWAIN compatible application software.

- 1) Click the CaptureOnTouch icon on the task bar.



**Figure 1-311**

- 2) Click the Select Scanner on the menu.

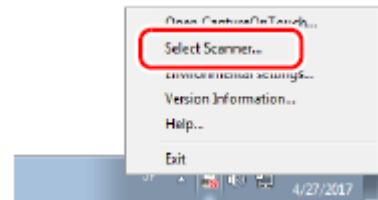

**Figure 1-312**

- 3) Select the scanner you are using and click the OK.

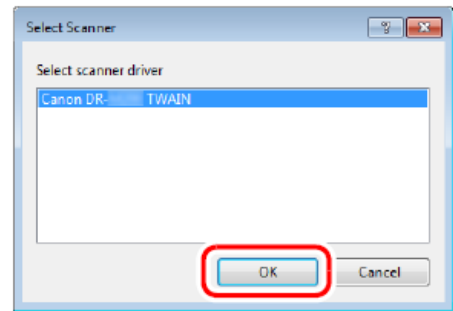

**Figure 1-313**

4) The main menu is displayed.

**Note:** There are two areas in the CaptureOn-Touch main screen, the Scanning Shortcut and the Standard Scanning.

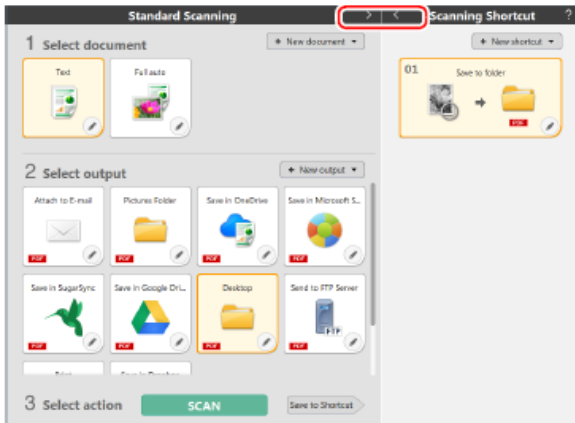

Figure 1-314

5) Place the document in the scanner.  
 6) Click the select document panel for the document to be scanned from the 1 Select document in the main screen.

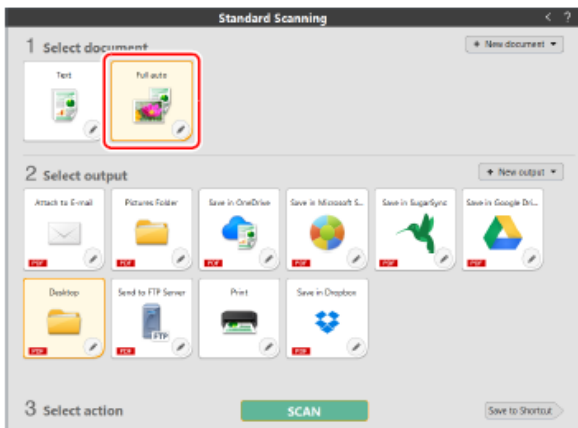

Figure 1-315

7) Click the output panel for the scan image application from the 2 Select output.

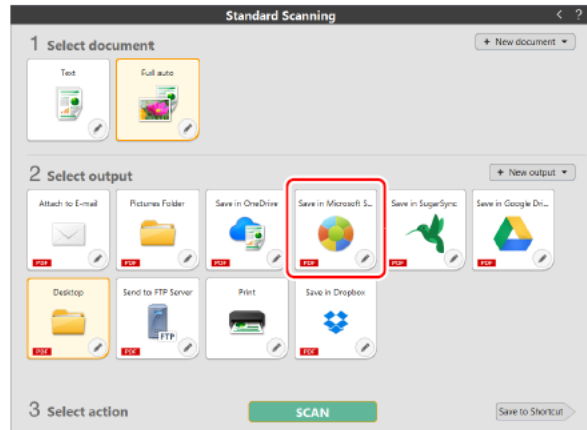

Figure 1-316

8) Click the Scan button. The scanning starts.

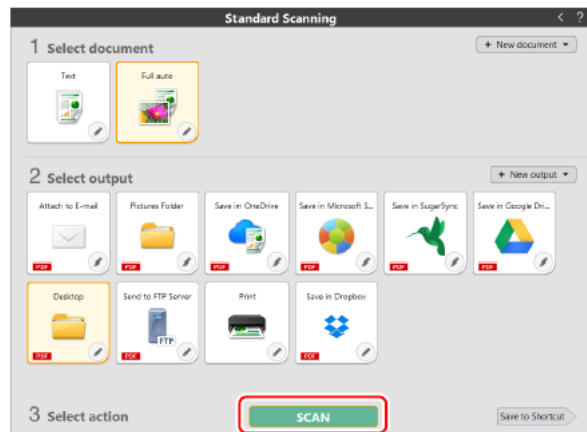

Figure 1-317

9) To check the scanned image, click the Finish button.

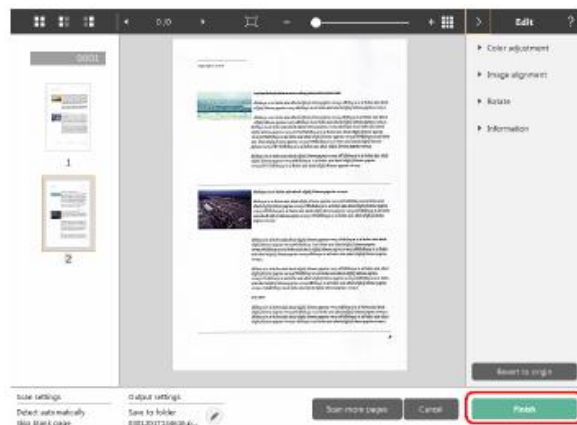
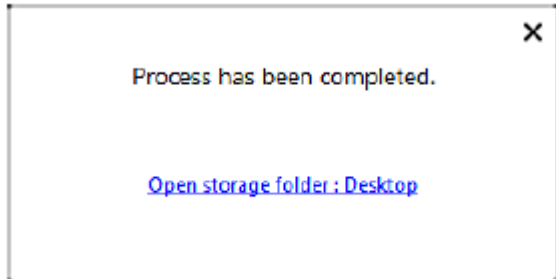

Figure 1-318

- 10) When the output has finished, a popup window will be displayed.

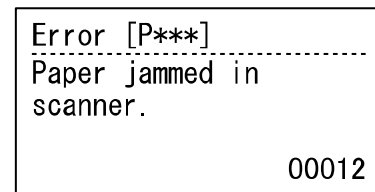

**Figure 1-319**

## 4. Paper Jam, Skew and Staple Detection Handling

If a feeding error occurs during scanning, the following message is displayed on the display panel and feeding stops.

**Note:** Refer to the “I. Error Display” in Chapter 5 for the details of error message and error code.



**Figure 1-320**

When the paper jam, skew, staple or double feed is detected, and any documents remaining in the eject tray or scanner must be removed.

**Note:** Be careful removing any documents remaining inside the scanner. Otherwise document could be damaged or unexpected injury from paper cuts may occur.

**Note:** Remove all documents remaining inside the scanner. Any torn paper remaining may cause paper jams or troubles.

- 1) Remove any documents remaining in the eject tray.
- 2) Pull and hold the open/close lever, and open the unit smoothly until it stops.

**Note:** When opening and closing the upper unit, be careful not to get your fingers caught.

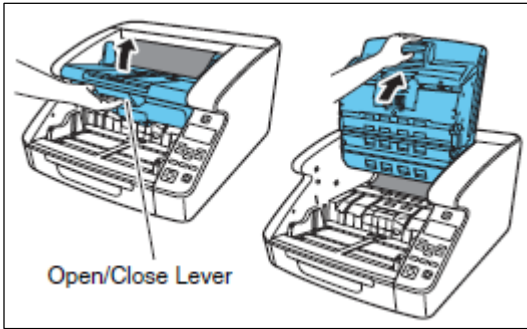
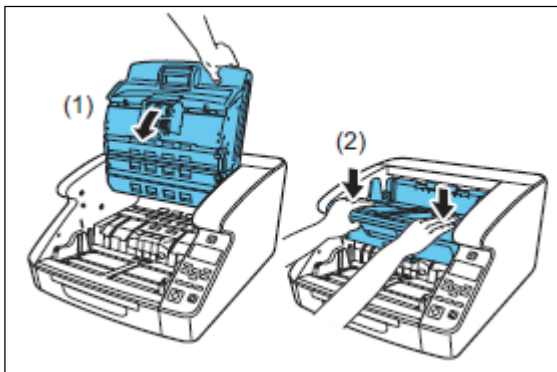

**Figure 1-321**

- 3) If any documents remain inside the scanner, remove them.

**Note:**Any document that is partially ejected on the eject tray, remove it with the upper unit slightly opened.

- 4) Smoothly close the upper unit (1). Further, press both ends of the upper unit to verify that it is securely closed (2).



**Figure 1-322**

- 5) Check the last saved image, and try scanning again.

**Note:**If the “Rapid recovery system” is set, a message is displayed in the display panel after paper removed.

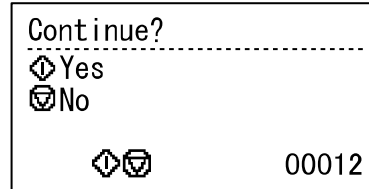

**Figure 1-323**

## 5. User Mode

This section describes the basic operation and the items in the user mode.

- 1) When the Menu key on the operation panel is pressed, the items in the user mode are displayed.

**Note:** The connection mode, USB or LAN is displayed beside of the title.

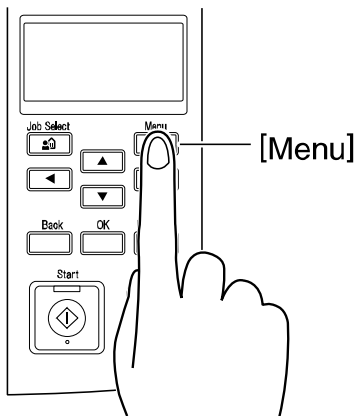

Figure 1-324

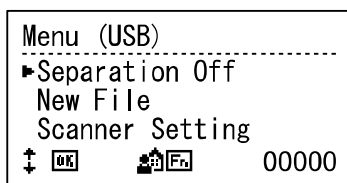

Figure 1-325

- 2) Press the ▲▼ keys to select a menu item.

**Note:** Refer to the next page for the details of the user mode items.

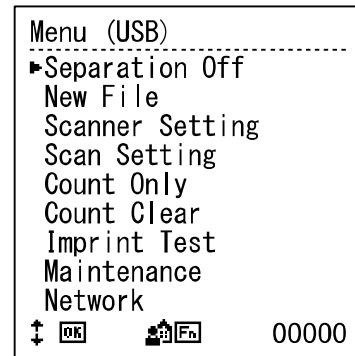

Figure 1-326

- 3) Press the OK key to enter the setting screen.

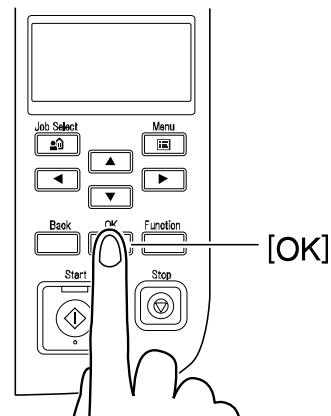

Figure 1-327

- 4) Press the ▲▼ and ◀▶ keys to select, and press the OK key to accept.

**Note:** If the item has a lower level to select, repeat this step,

- 5) Press the Menu key to return to the original screen.

◆ For each screen of the user mode, it is shown following. Refer to the “User Manual” for details.

1) Separation Off (S icon is displayed)

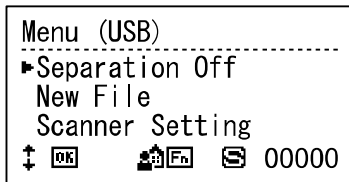

Figure 1-328

2) New File (N icon is displayed)

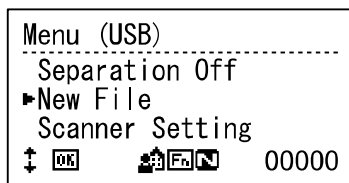

Figure 1-329

3) Scanning Setting

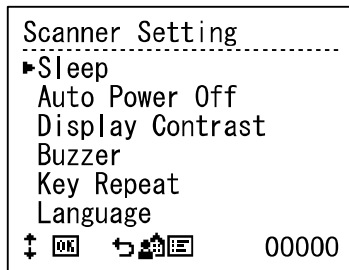

Figure 1-330

4) Scan Setting

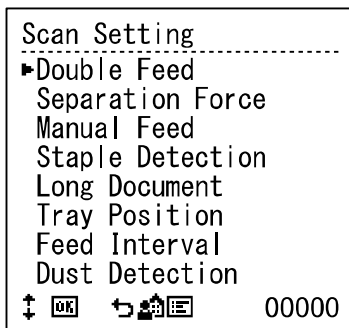

Figure 1-331

5) Count Only

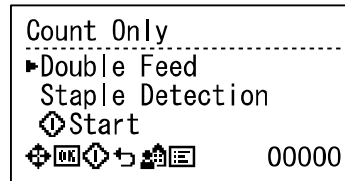

Figure 1-332

6) Count Clear

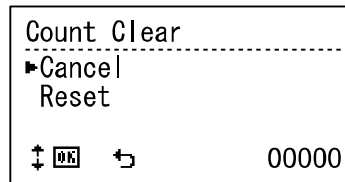

Figure 1-333

7) Imprint Test

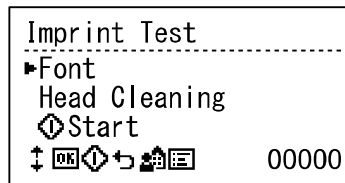

Figure 1-334

8) Maintenance

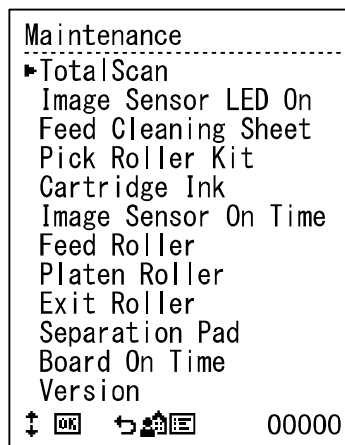

Figure 1-335

9) Network

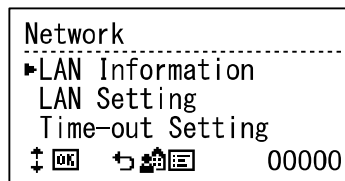

Figure 1-336



---

# CHAPTER 2

---

## FUNCTIONS & OPERATION

---

---

I. OUTLINE.....	2-1	V. POWER SUPPLY .....	2-24
II. READING SYSTEM .....	2-10	VI. OPTION.....	2-25
III. FEED SYSTEM.....	2-13	VII. ELECTRICAL PARTS LAYOUT .....	2-27
IV. CONTROL SYSTEM.....	2-19	VIII. PARTS LAYOUT ON EACH PCB.....	2-31

---



## I. OUTLINE

### 1. Basic Configuration

The configuration of this machine is shown below.

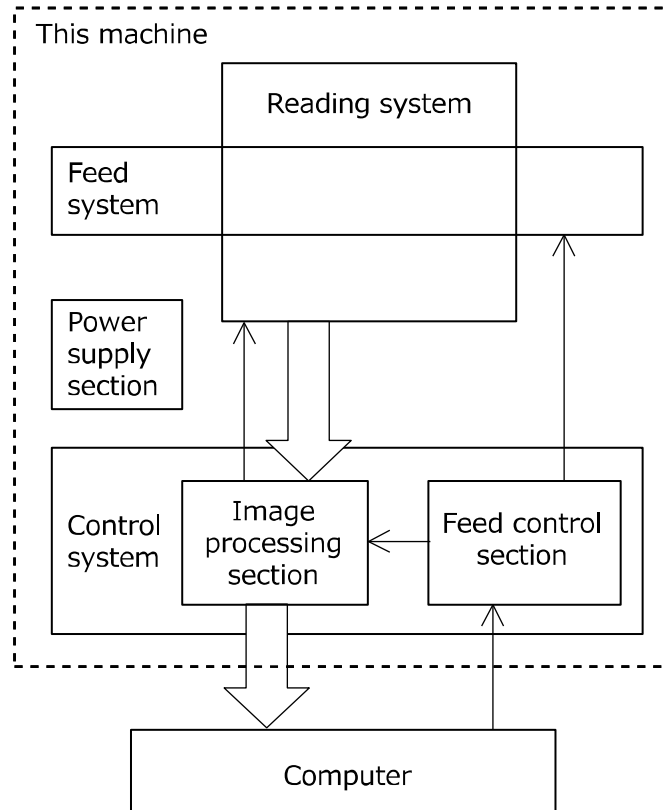
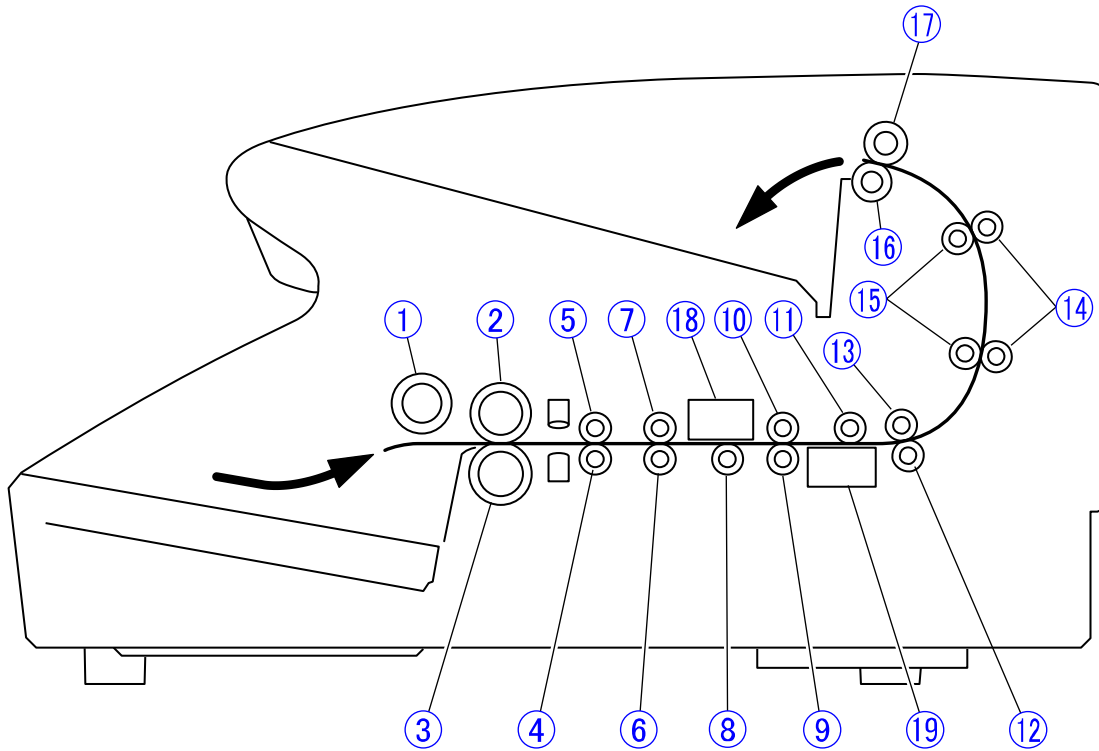

**Figure 2-101**

- |  |  |
|--|--|
| <p>1) Reading system<br/>This system reads image data from image sensors.</p>  | <p>The image processing section controls the reading system and processes the read image data.<br/>However, image data processing is also performed by the computer.</p> |
| <p>2) Feed system<br/>This system performs from document pickup to document ejection.</p>  | <p>The feed control section controls the feed system.</p>  |
| <p>3) Control system<br/>This system is comprised of an image processing section, a feed control section and a system control section.</p> | <p>4) Power supply section<br/>This section converts the AC power supplied from external into the DC power and supplies it to the internal PCB.</p>                      |

## 2. Roller Arrangement

A sectional view of the feed section is shown below.



**Figure 2-102**

- |                             |                                     |
|-----------------------------|-------------------------------------|
| ① Pickup roller             | ⑪ Platen upper roller               |
| ② Feed roller               | ⑫ Pre U-turn lower roller           |
| ③ Retard roller             | ⑬ Pre U-turn upper roller           |
| ④ Pull-in lower roller      | ⑭ U-turn lower roller (drive): 2    |
| ⑤ Pull-in upper roller      | ⑮ U-turn upper roller (follower): 2 |
| ⑥ Registration lower roller | ⑯ Eject follower roller             |
| ⑦ Registration upper roller | ⑰ Eject drive roller                |
| ⑧ Platen lower roller       | ⑱ Upper reading unit (front)        |
| ⑨ Reading lower roller      | ⑲ Lower reading unit (back)         |
| ⑩ Reading upper roller      |                                     |

### 3. Motor Drive

This machine has the following 9 motors. Additionally, it also has a cooling fan and an exhaust fan.

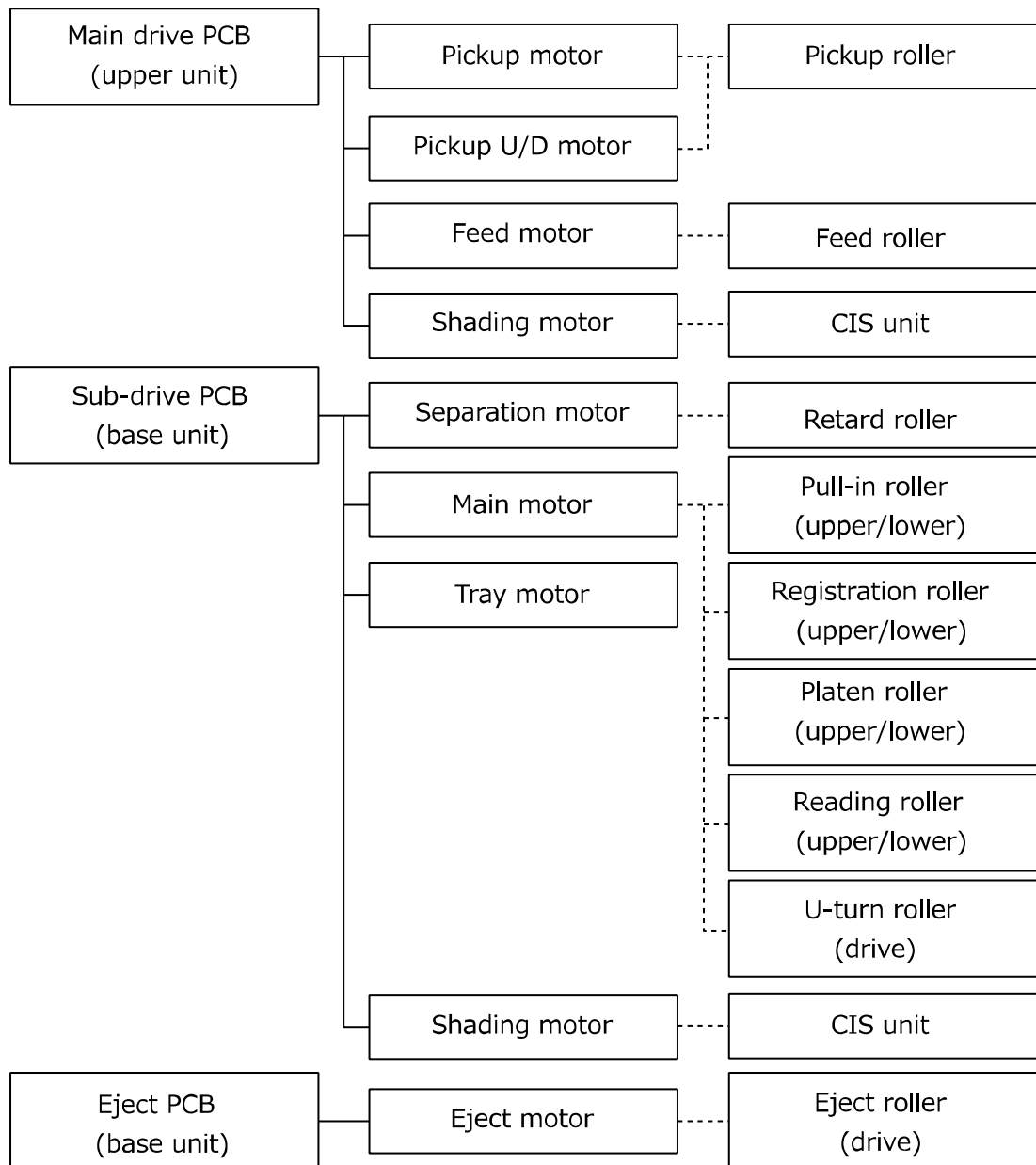

Figure 2-103

## 4. List of Sensors

This machine has the sensors. Its list and outline layout are shown below.

No.	Name	Functions and features
1	Document sensor (transmission)	Detects whether there is a document on the pickup tray. However, a signal is received by the light-receiving elements of the staple sensor (No.14).
2	Pickup sensor	Detects whether a document is in the pickup position.
3	Pickup roller sensor	Detect whether the pickup roller position.
4	Registration front sensor (left/right)	Detects whether there is a document in front of the pull-in roller and double feed sensor.
5	Registration middle sensor	Detects whether there is a document behind the pull-in roller.
6	Registration back sensor	Detects whether there is a document behind the registration roller.
7	Exit sensor	Detects whether there is a document in front of the eject roller.
8	Skew sensor (left/right)	Detects whether the document extends beyond edges horizontally.
9	Double feed sensor (transmission/reception)	Detects double feed of a document. A pair of ultrasonic sensor is mounted.
10	Door sensor	Detects whether the upper unit is open.
11	Imprinter door sensor	Detects whether the imprinter cover is open.
12	Shading sensor (front/back)	Detects the position of the CIS unit. In the detection state, the CIS unit is in the shading data reading position.
13	Tray home sensor	Detects the home position of the pickup tray.
14	Staple sensor	Detects buildup of documents bundled with staples. Consists of 4 light-receiving elements. The 4 LEDs on the opposite side light and the light from them is detected by the light-receiving elements.

**Table 2-101**

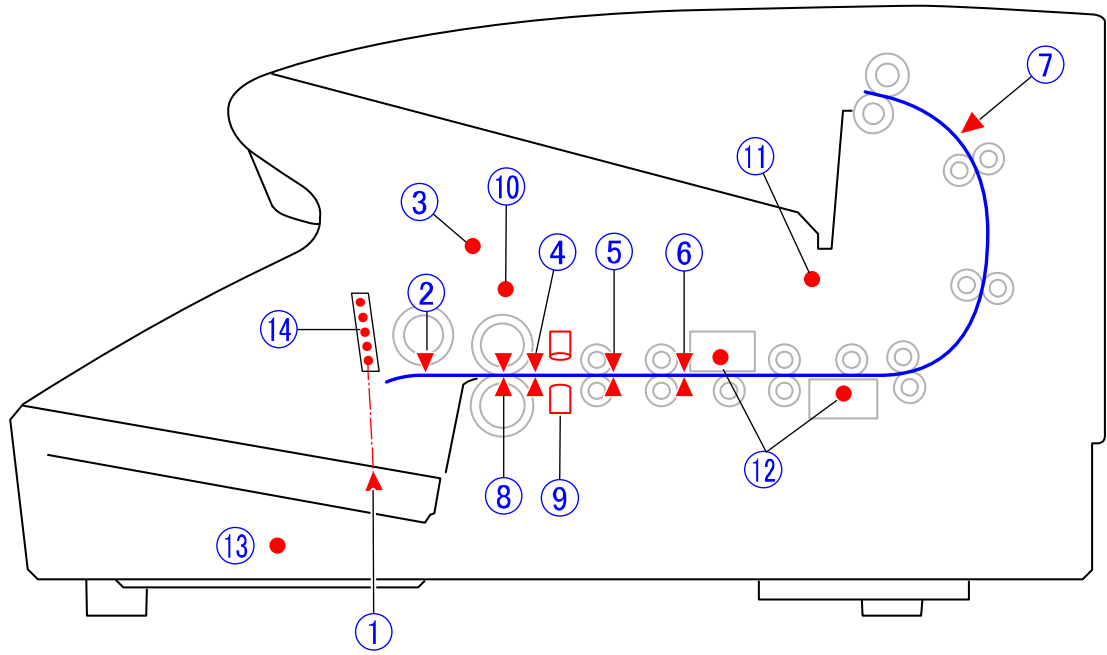

Figure 2-104

### 5. Electrical Circuits

An overview of the electrical circuits block diagram of this machine is shown below.

The control PCB, which is mounted on the rear side of the main body, controls the

entire electrical circuits. The main drive PCB is mounted in the upper unit and the sub-drive PCB is mounted at the right side of the main body.

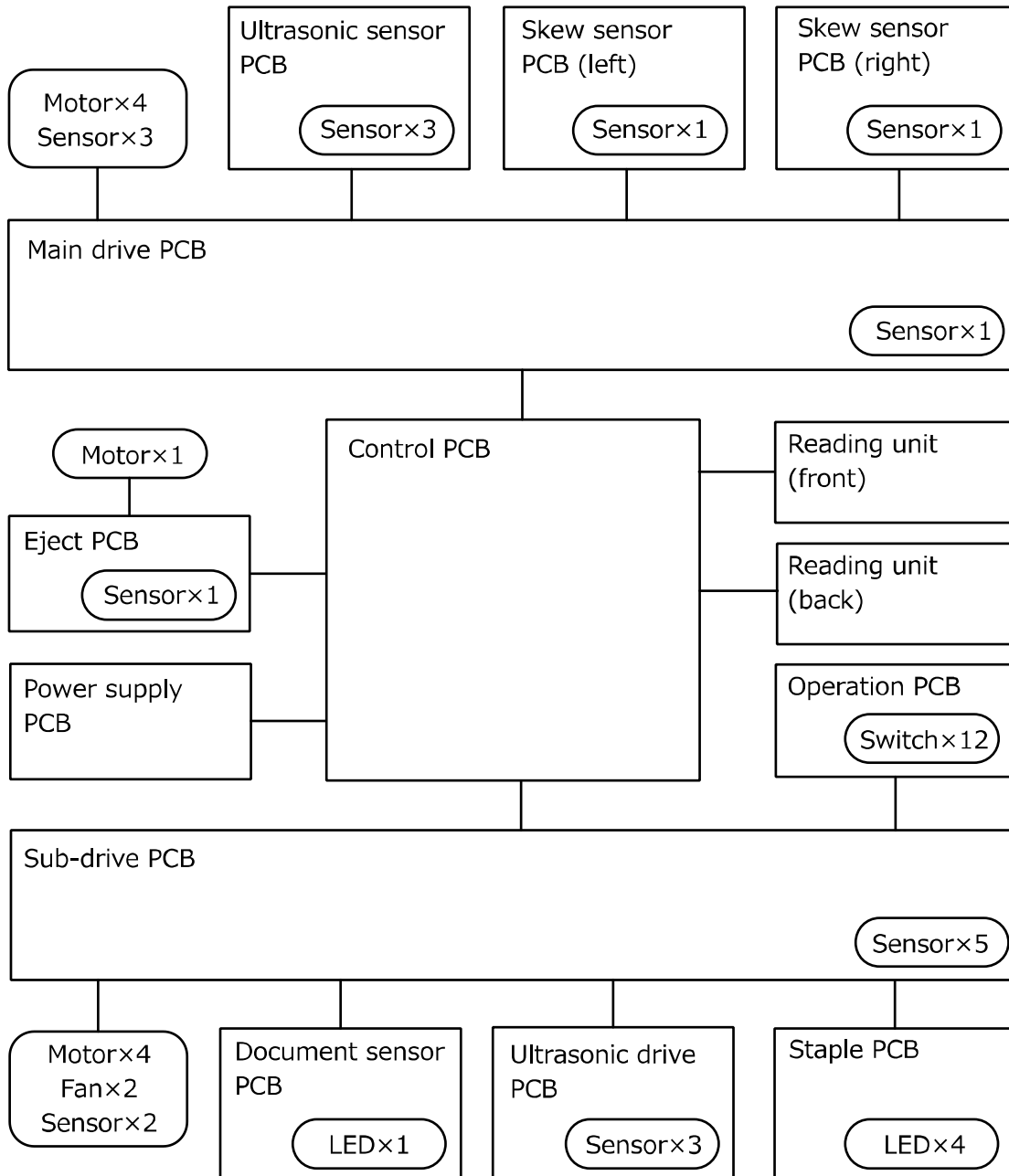

Figure 2-105



## 6. Timing Chart

The timing chart when 1 sheet of document is separately pickup is shown below.

Once the machine starts scanning, the pickup tray lifts. Thereafter each motor starts rotating to feed the document.

### 1) Separation mode: Normal

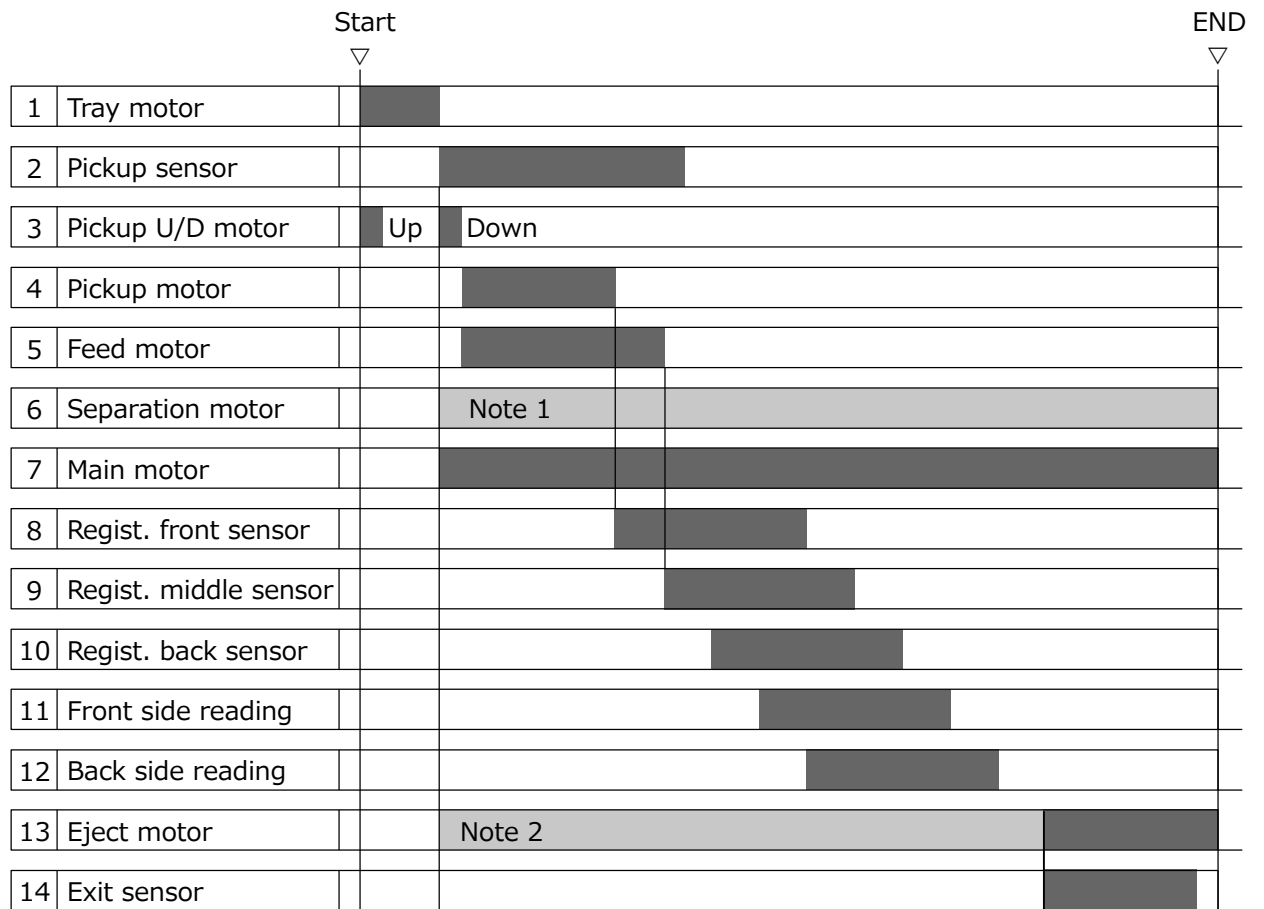

Figure 2-106

**Note 1:** The separation motor is energized to stay, but not to rotate.

**Note 2:** At a high speed feeding, the eject motor rotates slowly at a gray zone and fast at black zone. At a low speed feeding, it rotates slowly at a gray and black zone.

2) Separation mode: Thin paper

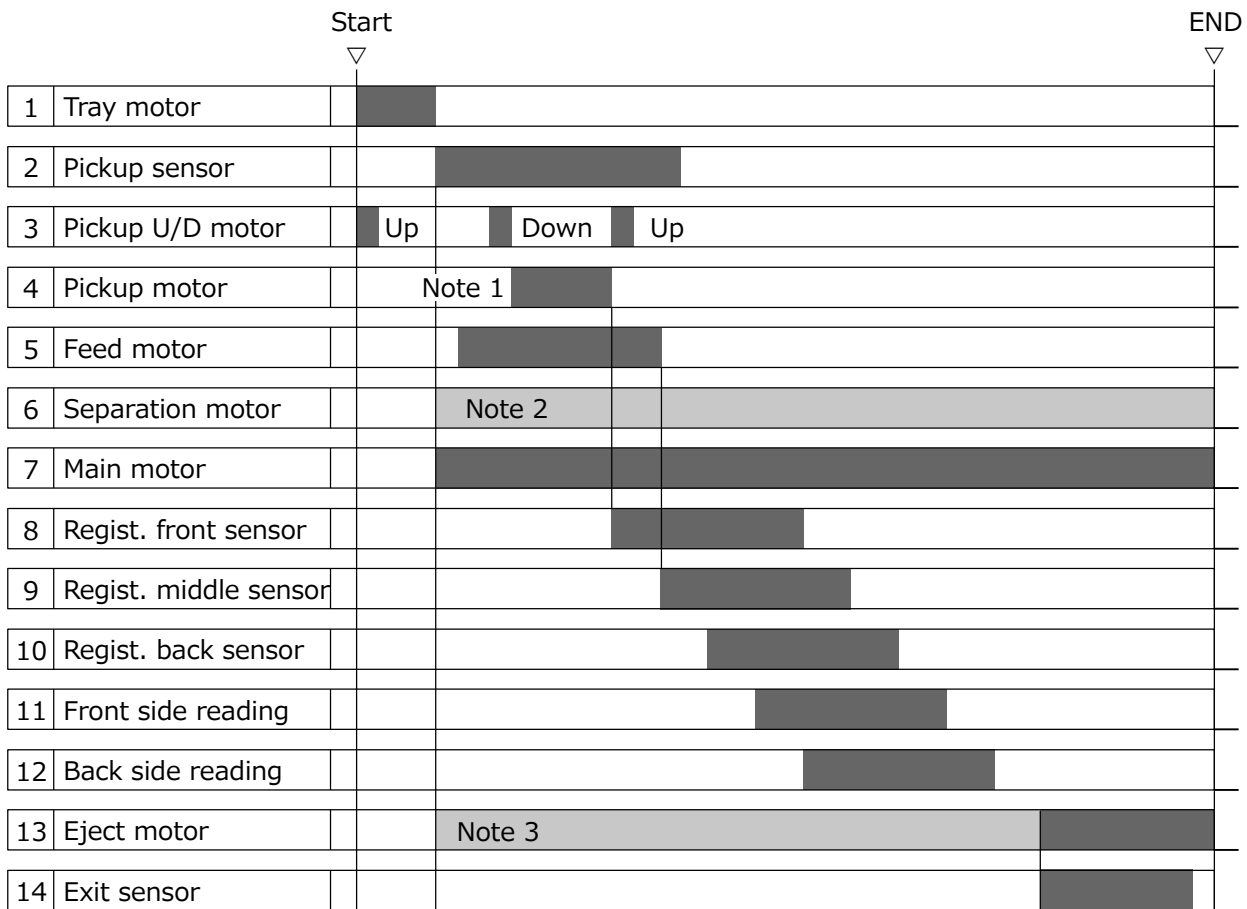

Figure 2-107

**Note 1:** The pickup motor rotates slower than ones at the separation mode “Normal” or “High”.

**Note 2:** The separation motor is energized to stay, but not to rotate.

**Note 3:** At a high speed feeding, the eject motor rotates slowly at a gray zone and fast at black zone. At a low speed feeding, it rotates slowly at a gray and black zone.

3) Separation mode: High

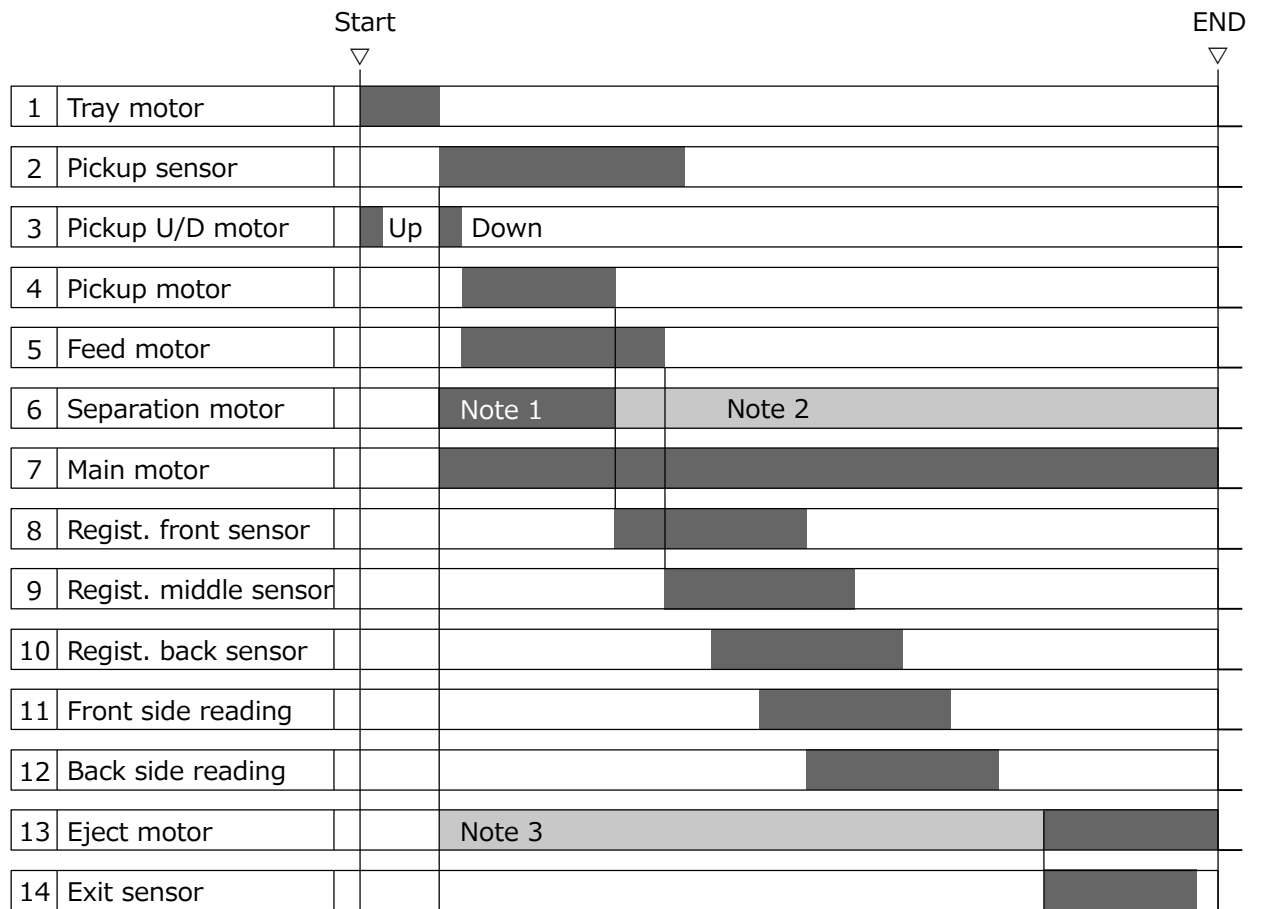

Figure 2-108

**Note 1:** The separation motor rotates with reverse direction till the registration front sensor detects next document.

**Note 2:** The separation motor is energized to stay, but not to rotate.

**Note 3:** At a high speed feeding, the eject motor rotates slowly at a gray zone and fast at black zone. At a low speed feeding, it rotates slowly at a gray and black zone.

## II. READING SYSTEM

### 1. Outline

A sectional view of the image reading section is shown below.

The upper reading unit reads the front side of the documents and the lower reading unit reads the back side of the documents. This configuration enables the unit to read

both the front and back sides of a document using a single scan.

The platen rollers are assembled as opposed by the reading units.

The image data read are sent to the image processing section of the control PCB.

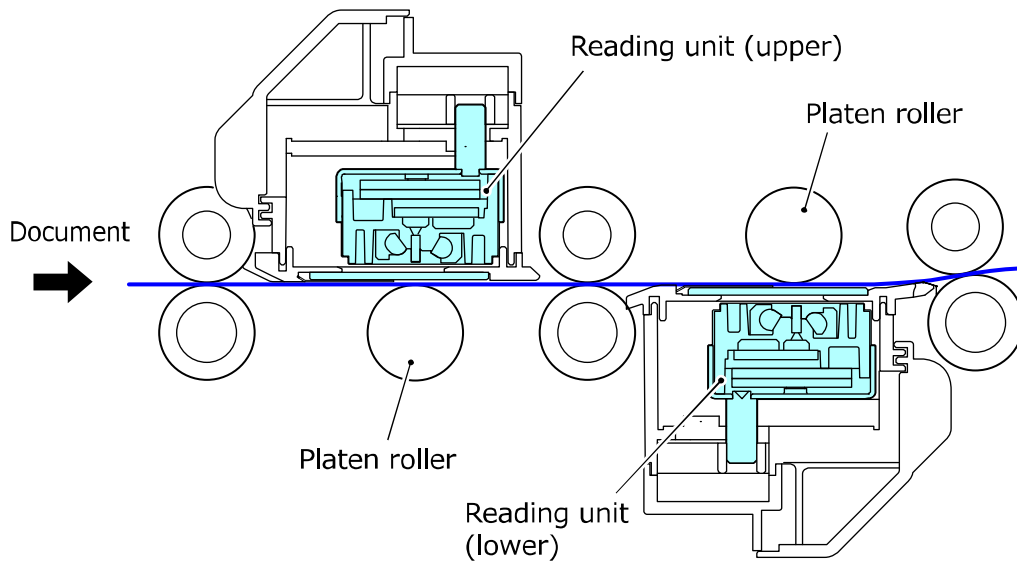

**Figure 2-201**

## 2. Image Reading

A sectional view of the lower image reading unit and the platen roller is shown below.

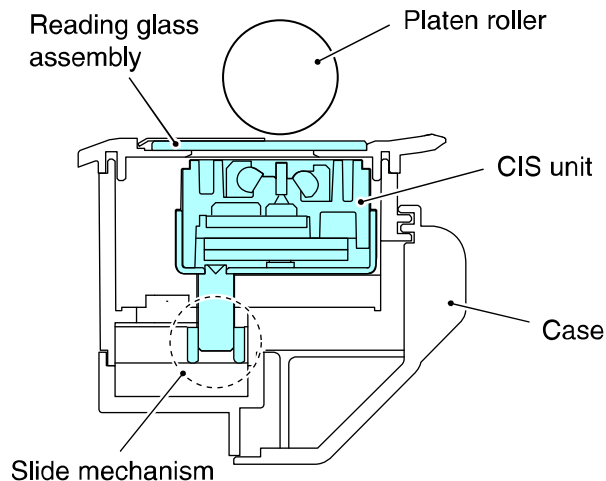

**Figure 2-202**

The reading unit consists of a CIS unit, a reading glass assembly, a case and a slide mechanism.

A CIS PCB in the CIS (Contact Image Sensor) unit has a light-receiving elements having an optical resolution of 600 dpi. This light-receiving element is a 3-line CMOS image sensor with color filters for R, G and B. The number of effective pixels of each line is 7,272 and its reading width is 308 mm.

As the 3-line type light-receiving element, it can light on the LEDs of the 3 colors at the same time for image reading, thus reducing color shift. In addition, it can prevent slow-down in reading in the color mode.

The 2 pairs of 3 colors (R/G/B) LEDs are assembled in each side of light guides.

The lights from the LEDs illuminate the document through the light guides and the reading glass. The lights reflected from the document enter the image sensors through the lens arrays. The image sensors convert the lights to analog signals.

The analog signals are processed in the CIS unit and transformed into digital signals. And then, they are sent to the control PCB.

As the platen roller is black, the background color becomes black. However, white platen rollers are set as the option. It makes the background color white.

### 3. Shading

The CIS unit and its slide mechanism are assembled inside the reading unit.

The CIS unit is positioned in the document reading position when the documents are read. Since the scanner needs to read the white reference on a surface of the reading glass when determining the shading correction value, it slides the CIS unit. The guide plate is assembled for protection of the white reference.

The position of the CIS unit when reading an image and white reference is shown below.

This slide plate is driven by the shading motor. Since the white reference is attached on a surface of the reading glass, the reflection distances during image reading and white reference reading can be made equal.

When the power is turned ON and when scanning starts, this machine slides the CIS unit and reads the white reference data to decide the shading correction value.

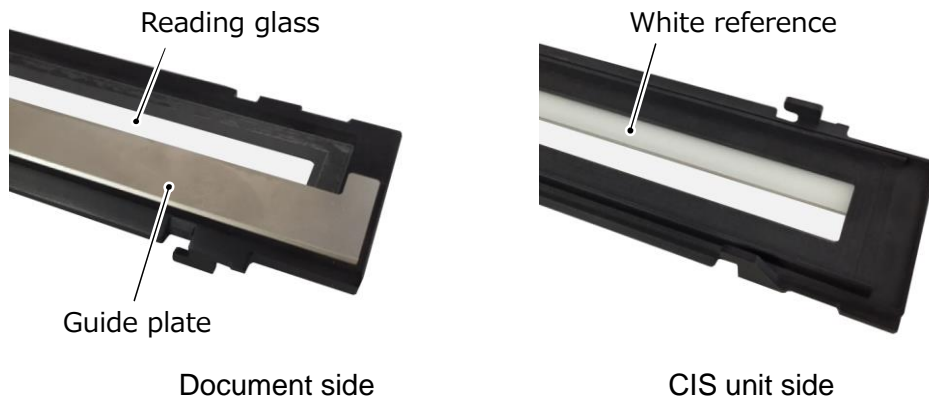

Figure 2-203

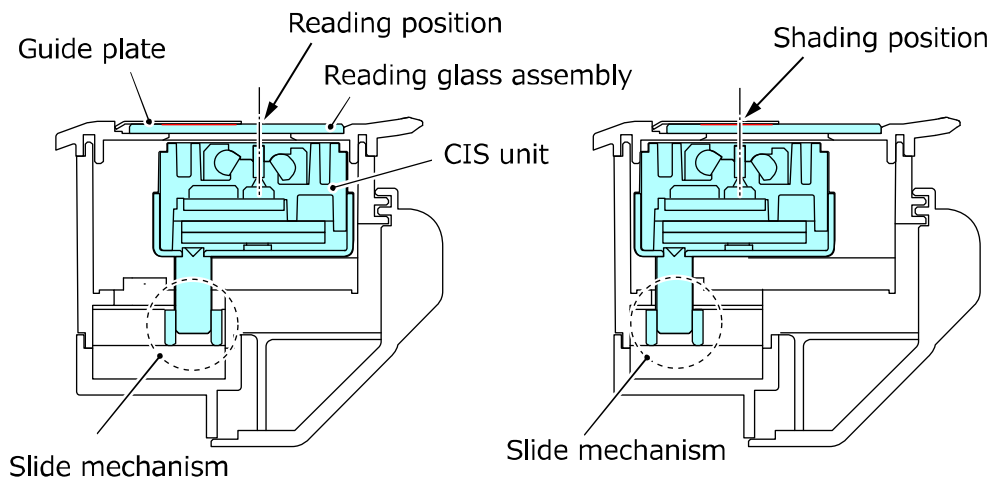

Figure 2-204

---

## III. FEED SYSTEM

---

### 1. Outline

The drive rollers are driven by each motor and rotated by transmission of gears and belts. In addition to a roller drive motor, a pickup tray elevation motor is assembled. The sensors for feed control are also mounted.

The main characteristics of the feed system of this machine are shown below.

- 1) Pickup tray elevation  
The elevation and the stop position of the pickup tray can be controlled. Thus, a large number of documents can be set and the standby position of the pickup tray can be selected.
- 2) Independent mechanism operation of the right and left document guides  
The document guides of the pickup tray can be slid together and independently of each other and the document guides of the eject tray can be slid independently. Thus, the reference position at which a document is loaded can be set arbitrarily.
- 3) Document separation  
Overlapped documents can be separated and fed one by one with the retard roller and feed roller. And 3 type of the separation mode (High/Normal/Thin paper) are available to adjust a kind of document.
- 4) Double feed detection  
This machine contains a pair of ultrasonic sensors. Therefore, the following two double feed detections are available: the document length detection by the registration front and back sensors, and the document overlapping detection by the ultrasonic sensor.
- 5) Eject speed control  
If documents are fed at a high speed and ejected at the same speed, alignment of the documents deteriorates. The speed when the trailing edge of the document is ejected is reduced and deterioration of alignment is prevented by controlling the number of revolutions of the eject motor.
- 6) Staple detection  
Feeding of stapled documents can be stopped by installing a dedicated sensor at the pickup inlet.
- 7) Skew detection  
Document that is skewed and attached a side end of feed path can be stopped by installing sensors at side end of the pickup inlet.

## 2. Pickup Tray Elevation

The maximum loading capacity of the DR-G2140 and DR-G2110 is 500 sheets of ordinary copy paper and that for the DR-G2090 is 300 sheets. To handle a large number of documents, the pickup tray of this machine can be elevated. A structural drawing is shown below.

There is a box unit with an elevating function under the pickup tray. The unit has 4 arms that support the pickup tray. When the arms turn sideways, the pickup tray is at the bottom position. When the arms are rotated clockwise by the drive of the tray motor, the pickup tray lifts. When they are rotated counterclockwise with erect arms, the pickup tray goes down.

A tray home sensor is mounted next to

the box unit. When part of the tray pad blocks light from this sensor, the fact that the pickup tray reaches the bottom (home position) can be detected. The fact that the pickup tray reaches the top (pickup position) can be detected with a pickup sensor mounted near the pickup roller.

If the pickup tray is at the bottom position suitable for the maximum loading capacity, waiting time until the pickup tray lifts to the pickup position increases when a few documents are scanned. Thus, it has a function that can set the standby position of the pickup tray at 3 levels: top, middle, and bottom. However, the DR-G2090 has 2 levels: top and bottom. The top or middle position is controlled with the number of input pulses from the home position to the tray motor.

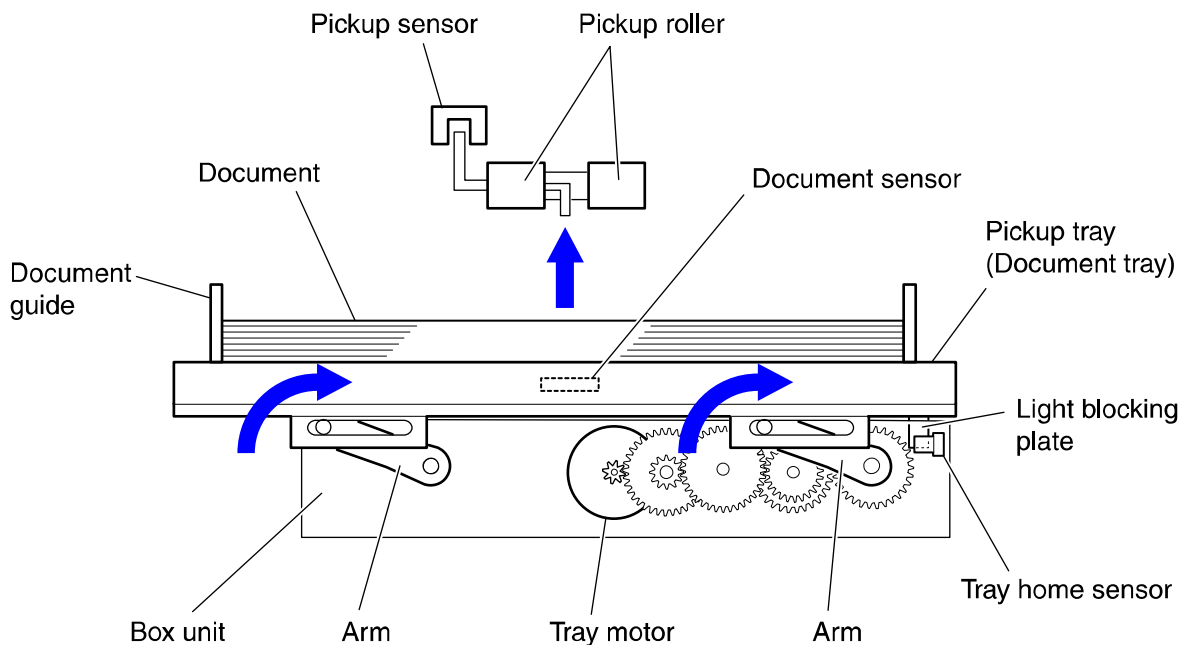

Figure 2-301



### 3. Separation Mechanism

The separation section consists the feed roller, separation pad and retard roller. A torque limiter is assembled in the retard roller.

When the overlapped documents have been fed, the overlapped documents are stopped at the separation pad, and if it does not effect, the retard roller separates the overlapped documents.

The configuration of the separation mechanism is shown below.

#### ◆ Separation pad separation (at Normal)

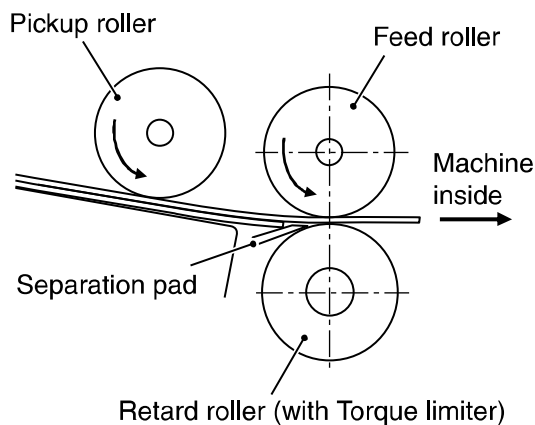

**Figure 2-302**

#### ◆ Retard roller separation (at Normal)

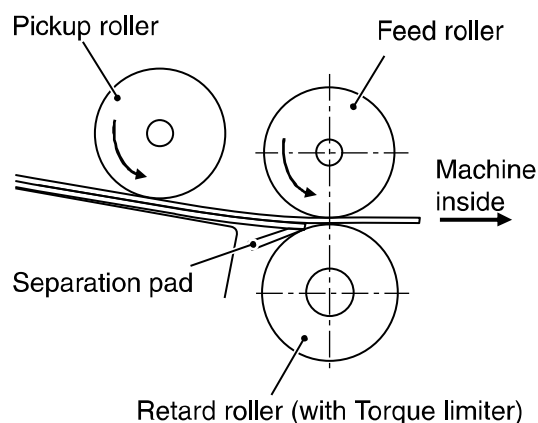

**Figure 2-303**

And 3 types of the separation mode are available to adjust a kind of document.

#### 1) Separation mode: Normal

This is good for the normal documents.

The pickup roller downs and feeds the documents with a normal rotation. And it stops rotations when the registration front sensor detects a document.

The feed roller rotates normally, and the retard roller stays without any rotation.

Therefore, the document only attaches the feed roller side is fed to inside if the overlapped documents reach at the retard roller.

If one sheet of document reaches the separation section, the retard roller rotates with a following direction of feed roller and document.

#### 2) Separation mode: Thin paper

This is good for the thin documents that are easy to be jammed.

The pickup roller downs and rotates with lower speed to feed the documents. And the pickup roller lifts and stop rotations when the registration front sensor detects a document. It avoids rushing to feed the documents.

Operations of the feed roller and retard roller are the same as ones of the Normal mode.

#### 3) Separation mode: High

This is good for the sticky document that are easy to be double feed.

Operations of the pickup roller and feed roller are the same as ones of the Normal mode.

The retard roller rotates with reverse direction till the registration front sensor detect a document. It makes a separation harder. When the registration front sensor detects a document, the retard roller rotates with a following direction of feed roller and document.

## 4. Feed Error Detection

### ◆ Jam Detection

Document jams are detected by the registration sensors. The types of the document jams are described as follows.

#### 1) Pickup Delay Jam (Pickup Error)

The leading edge of the document was not detected by the registration sensors within the specified time after the machine starts scanning.

#### 2) Early Reach Jam

The leading edge of the following document was detected after the trailing edge of the document was detected by the registration sensors before the document has been fed for a specified length.

#### 3) Residual Jam

The trailing edge of the document was not detected even though the document has been fed for the maximum specified length after the leading edge of the document was detected by the registration sensors.

#### 4) Fast Feed Jam

The trailing edge of the document was detected after the leading edge of the document was detected by the registration sensors before the document has been fed for the minimum specified length.

#### 5) Non-removal Jam

The machine starts scanning while the document is detected by the registration sensors and still remains inside this machine.

### ◆ Double Feed Detection

There are 2 double feed detection methods: the document length detection by the registration sensors and the document overlapping detection by the ultrasonic sensor.

The registration sensors uses the first document length of the scanned batch as a reference to detect the document length. The 35 mm or more difference from the standard is interpreted as a double feed.

The ultrasonic drive sensor transmits the ultrasonic and the ultrasonic receive sensor receives the ultrasonic signal to gain a specific signal level. When overlapping documents are fed, the signal level is different from when properly feeding a single document. This machine interprets this difference as a double feed.

**Note:** The double feed detection by ultrasonic may not work if the document overlapping width is 50 mm or less. Further, the machine does not execute the double feed detection for the area of 15 mm from the leading and trailing edges of the document.

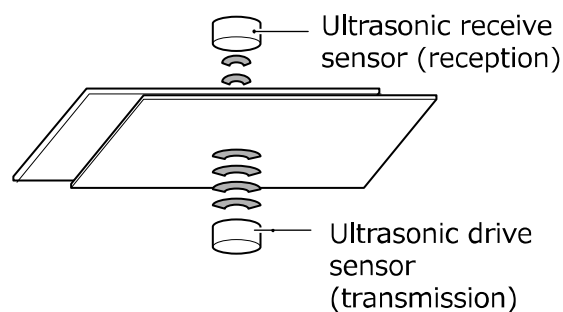

**Figure 2-304**

## 5. Staple Detection

In this unit, a staple detection mechanism is used which detects the jumping up of stapled documents.

This mechanism is designed not to detect the staple itself, but to detect the jumping up of the stapled documents when the stapled documents are picked up, and to stop the feeding. As such, it prevents stapled documents from being torn apart.

A stapled document jumping up due to the pickup roller, and the configuration of the staple detection are shown below.

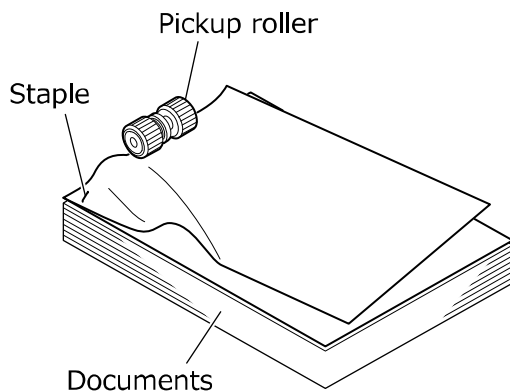

**Figure 2-305**

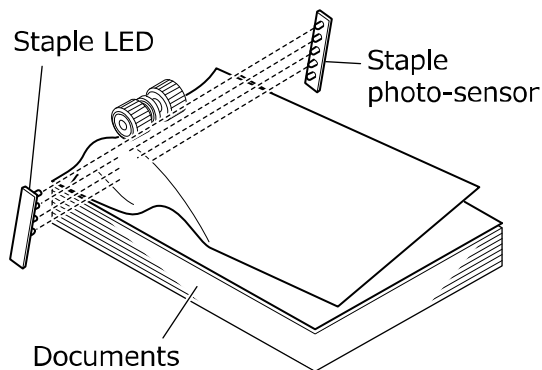

**Figure 2-306**

The staple detection mechanism consists of staple LEDs and a staple photo-sensor, arranged on both sides of the document pickup inlet. If there is no staple in the documents,

the light emitted from the staple LEDs is directly received by the photo-sensor. If the stapled documents jump up, the light gets blocked and the documents are found to be stapled, resulting in stopping the feeding.

The 4 staple LEDs are mounted on the staple LED PCB. The staple photo-sensor has 4 sensors that correspond to 4 LEDs on the staple LED, and is directly mounted on the sub-drive PCB.

**Note:** Because the documents do not jump up under the following conditions, the staple detection sensor will not work:

- When there are two or more stapled places.
- When the staple is not positioned at a corner.
- When the documents are smaller than A5.

Document curl must be 3 mm or less in height and the documents cannot be creased.

It is possible to change the level of detection accuracy with the user mode.

## IV. CONTROL SYSTEM

### 1. Control PCB

Control of this machine is performed by the control PCB. The block diagram associated with image is shown below.

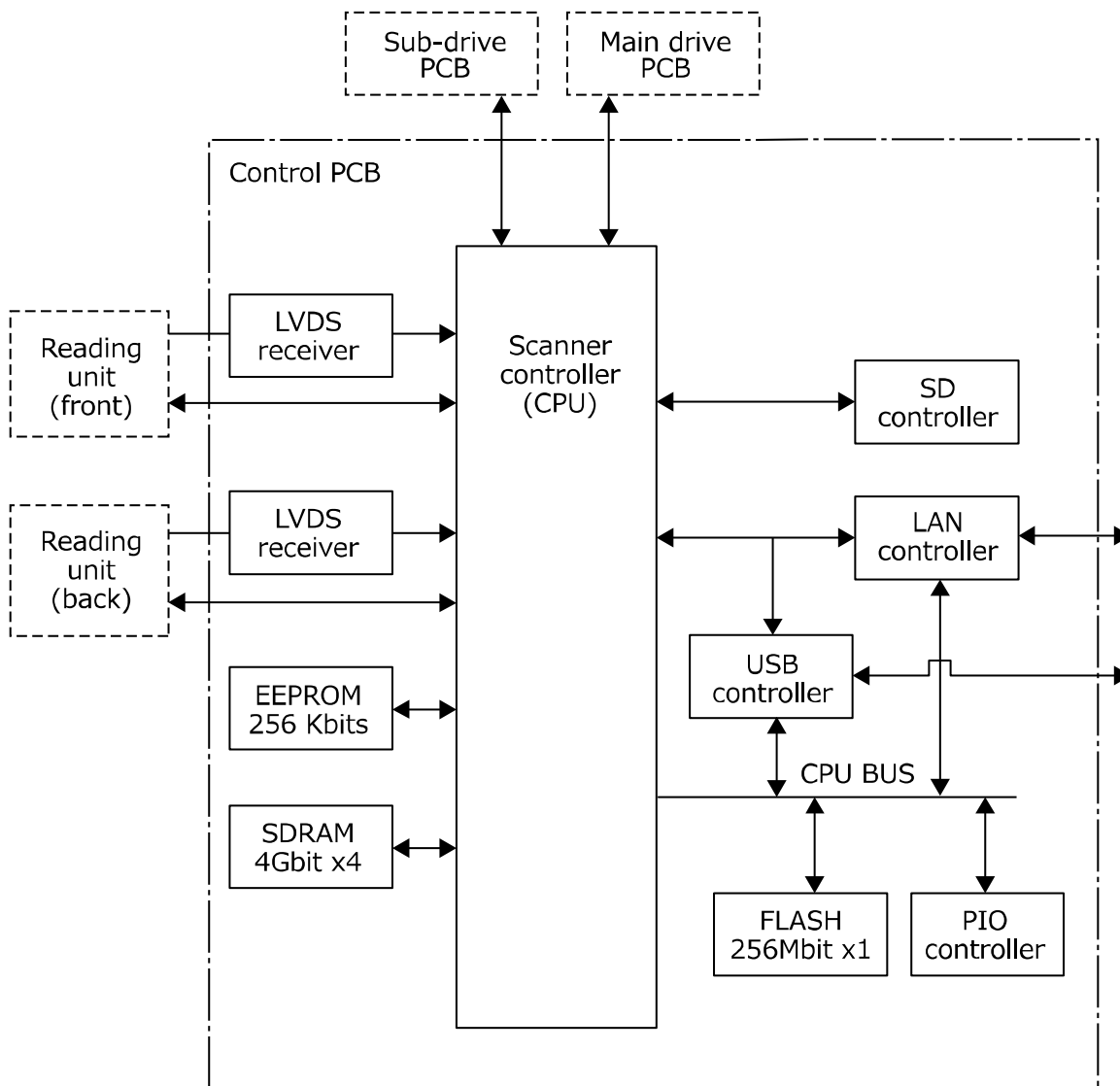

Figure 2-401

## 2. Drive System Block Diagram

The block diagram associated with motor control is shown below. It includes a solenoid and fan.

A control CPU is mounted on each PCB.

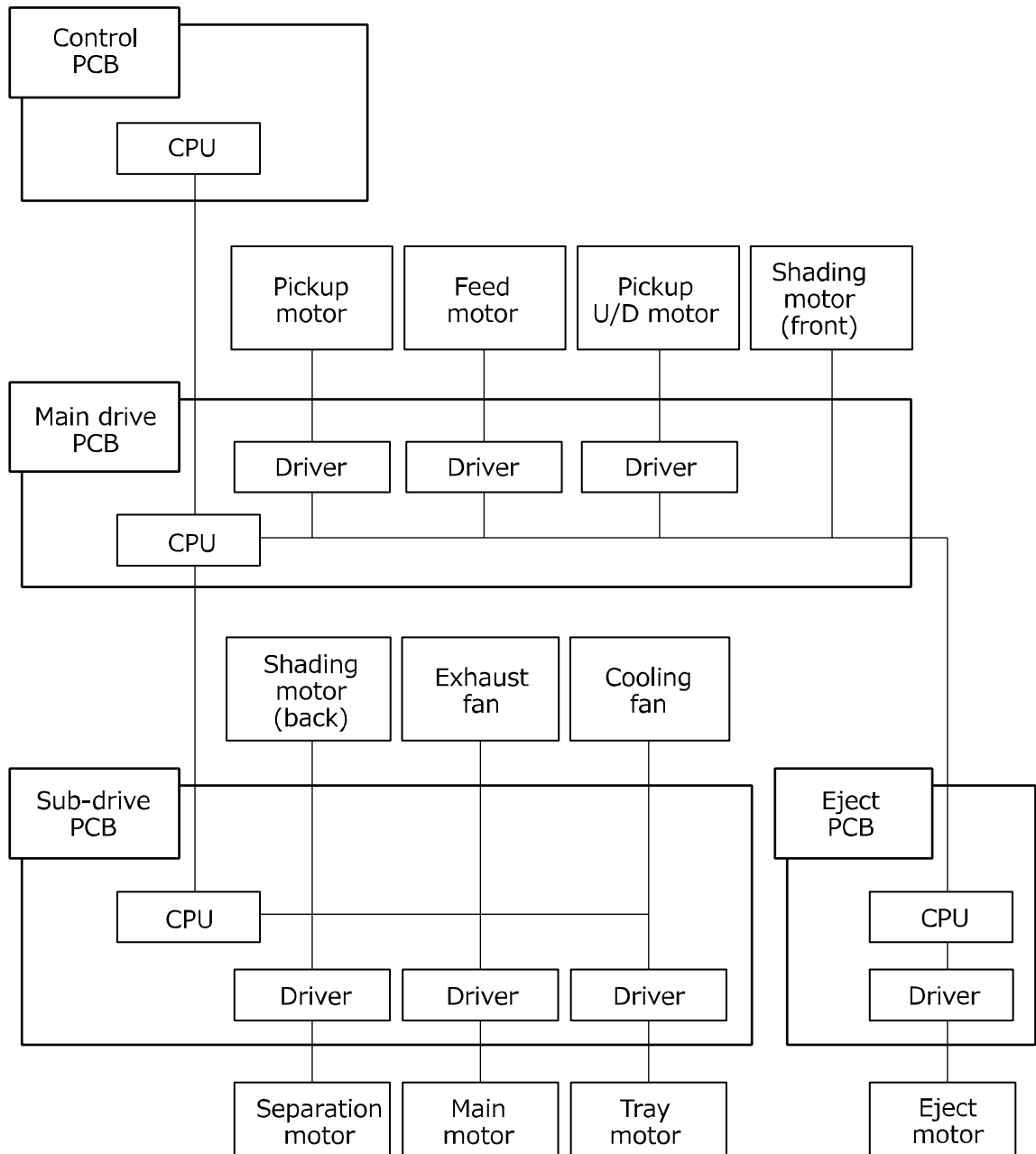

Figure 2-402

### 3. Image Processing Control

This machine performs main image processing using the hardware in the main body to speed up image processing.

The block diagram of the image processing in the main body is shown below.

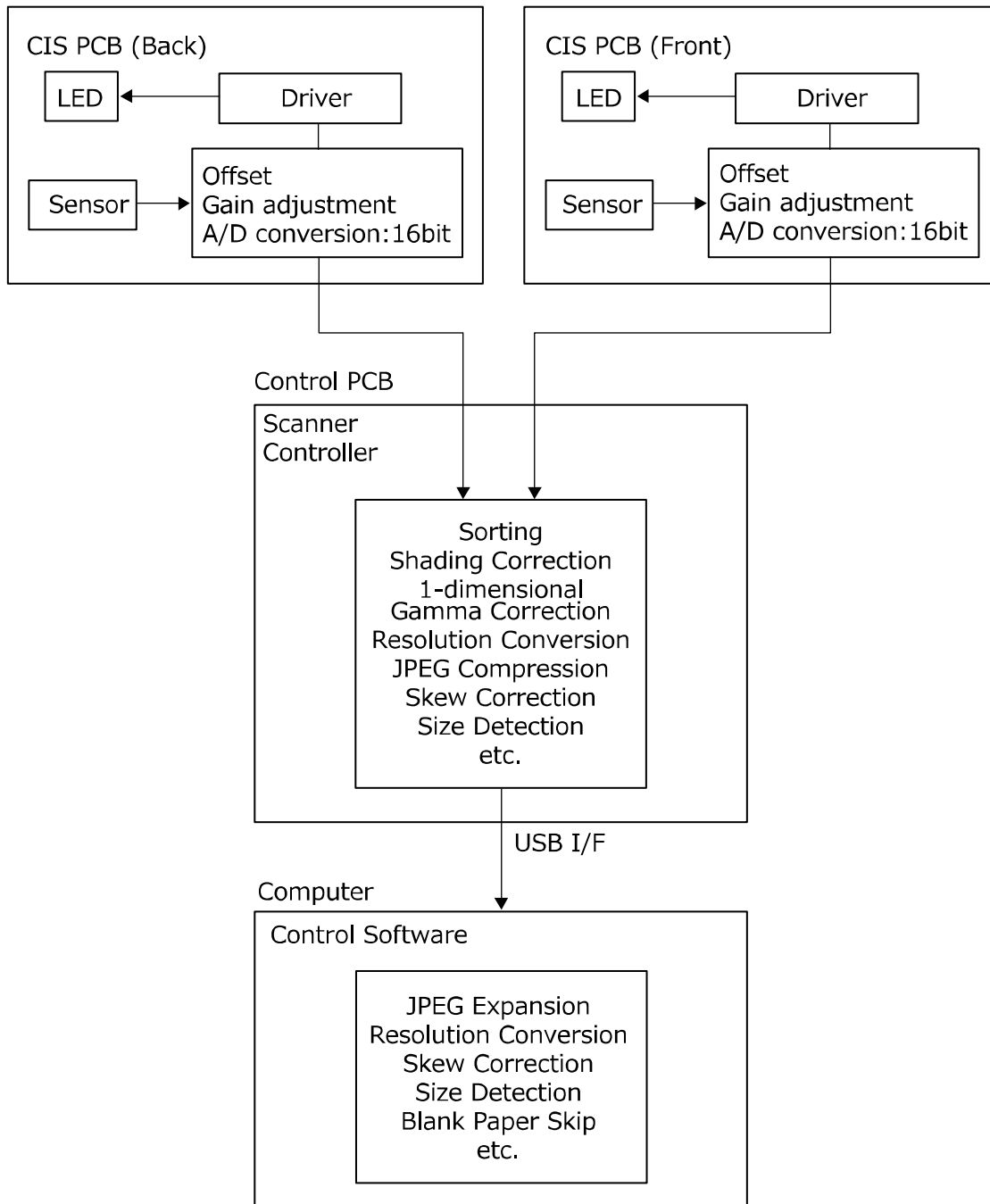

Figure 2-403

Analog signals proportionate to the density of each picture element are output as 9 parallel lines from the image sensor on the CIS PCB to the analog processor. The analog processor carries out offset adjustment, gain adjustment, and A/D conversion. Analog signals are converted into digital signals in the analog processor.

This image data is sent to the scanner controller on the control PCB where data re-ordering, shading correction, one-dimensional gamma correction, resolution conversion, and various image processing are performed, JPEG compressed data is output to the computer via the USB interface.

Inside the computer, the various image processing is executed according to the use settings by the driver for this machine.

In image processing done by scanner controller, depending on the reading setting, some of them are processed by driver.

## 4. New Binarizing

A new binarizing mode “Active Threshold” was added. In the past, binarizing mode, the ATE (Advanced Text Enhancement) or ATE II have been used for scanning the documents with light color text and non-uniform or uniformed background.

The Active Threshold is intended for batch processing various kind of documents at once, such as those with light color text or stains. For examples, users can batch process documents such as copy slip at once. Brightness-related properties are automatically adjusted based on the text and background of the whole image, enabling consistent reproduction of light color text and removal of background stains.

### Original Image

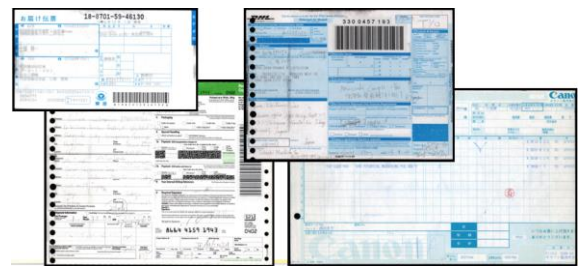

### Scanned Image

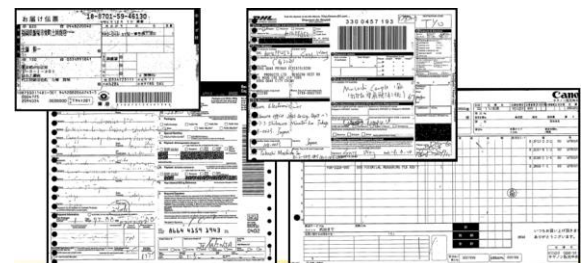

Figure 2-404

## 5. Network Scanning

The network scanning with wired LAN is supported by the DR-G2140/G2110 network models.

The scanner supports the DHCP. Therefore, the DHCP server in the network system provides IP address that can be automatically acquired, eliminating the need to specify an IP address for the scanner.

For the selection of computer or connections, refer to the “User manual” for details.

**Note:**When the scanner starts up, if both the USB cable and LAN cable are connected, the USB connection takes precedence.

**Note:**When the connection with wired LAN, the optional flatbed scanner unit cannot be used.



## V. POWER SUPPLY

### 1. Power Supply

A block diagram related the power supply of this machine is shown below.

The power supply PCB is common use into a 100 V system (for 100 V/120 V) and a 200 V system (for 220-240 V).

The power switch (button) mounted on the operation PCB.

When the power cord is connected, the AC power is supplied to the power PCB and then generated 5 VDC for control. In this state, the power switch is turned ON, and the FET (Field-Effect Transistor) is turned ON, then the control PCB starts working. And the control PCB orders that the power PCB generates 24 VDC, and it is supplied to the control PCB.

Furthermore, the DC/DC converter generates each of the DC voltages that are supplied to the components.

When no documents have been fed or there has been no communication with the computer for a period of time to be set, the machine enters the sleep mode. When the machine is in the sleep mode, the electrical circuits enter a sleeping state. However, the CPU does not enter a sleeping state. This machine automatically returns from the sleep mode when it receives communication from a computer or when a key on the operation panel is pressed or other any input.

And this machine has an auto power OFF function. When the auto power OFF function is set ON, the power supply automatically turns OFF after 4 hours without a scanning or other operation.

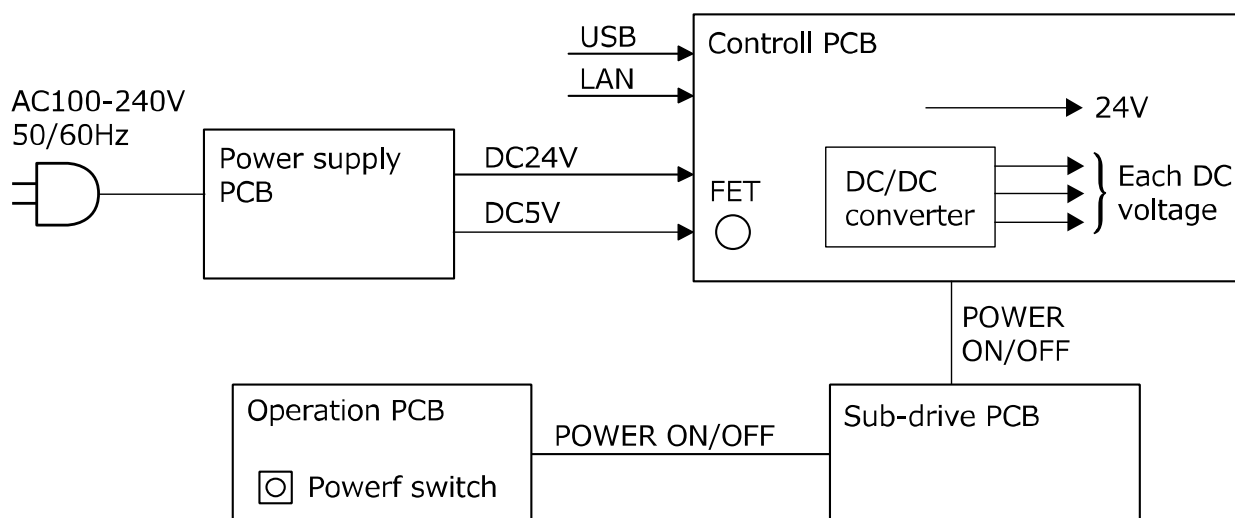

Figure 2-501

## VI. OPTION

### 1. Imprinter

Characters can be printed on the front side of the document by installing the imprinter in the scanner. This is a post-imprinter that prints after reading the document.

Ink cartridges made by Hewlett Packard are used.

Note: Comparing to the DR-G1130 series, a part of printing positions will be no use because the eject rollers has been changed.

The imprinter is installed by the service technician. Refer to “CHAPTER 4, INSTALLATION & MAINTENANCE” for details.

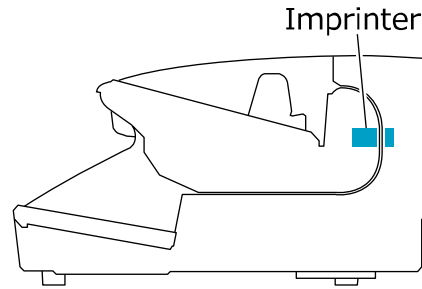

Figure 2-601

No.	Item	Description
1	Type	Post-imprinter
2	Form	Built in the main body
3	Printing surface	Front
4	Head movement	Manual
5	Printing density	12 nozzles/line, 96 dpi
6	Maximum number of characters	32 characters
7	Character font	Original (12 × 12 dots, 12 × 8 dots)
8	Character string	1) ASCII codes: 20H to 7FH (Alphanumeric characters, symbols) 2) Special: counter, time, date, arrow
9	Printing position	1) Horizontal: An example is shown below. 2) Vertical: 0 to 500 mm from the leading edge of the document
10	Printing orientation	0/90/180/270°

Table 2-601

◆ Printing positions: Distributes from the center (13 positions in total)

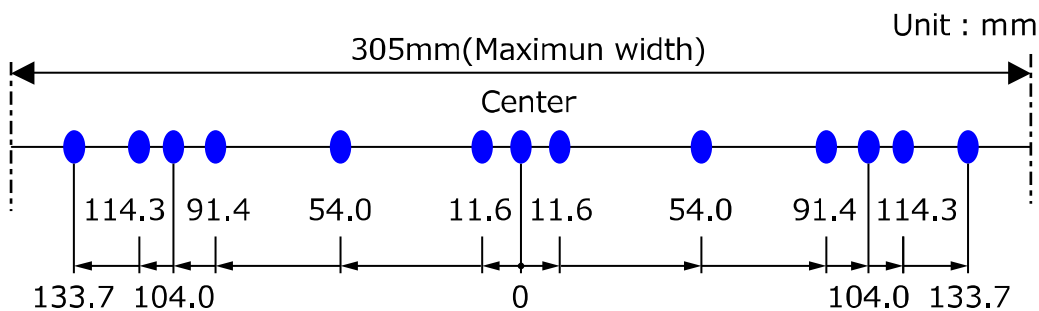

Figure 2-602

## 2. Flatbed Scanner Unit

The flatbed scanner unit FSU102 and FSU201 are option for the DR scanners, and the FSU102 supports A4/LTR size document and the FSU201 supports A3 size document.

**Note:** When the wired LAN connection is used, FSU102 and FSU201 cannot use for this machine.

## VII. ELECTRICAL PARTS LAYOUT

### 1. Motor, Fan, Solenoid

1) Base unit

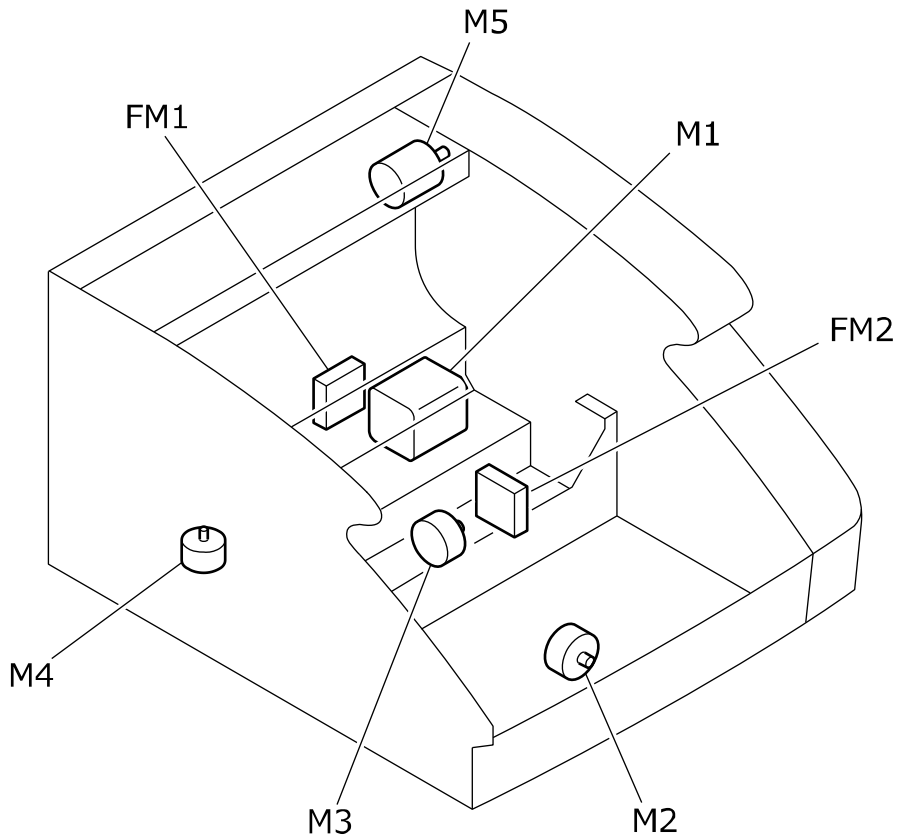

Figure 2-701

Name	Symbol	Remarks
Main motor	M1	
Tray motor	M2	
Separation motor	M3	
Shading motor (back)	M4	
Eject motor	M5	
Exhaust fan	FM1	
Cooling fan	FM2	

Table 2-701

2) Upper unit

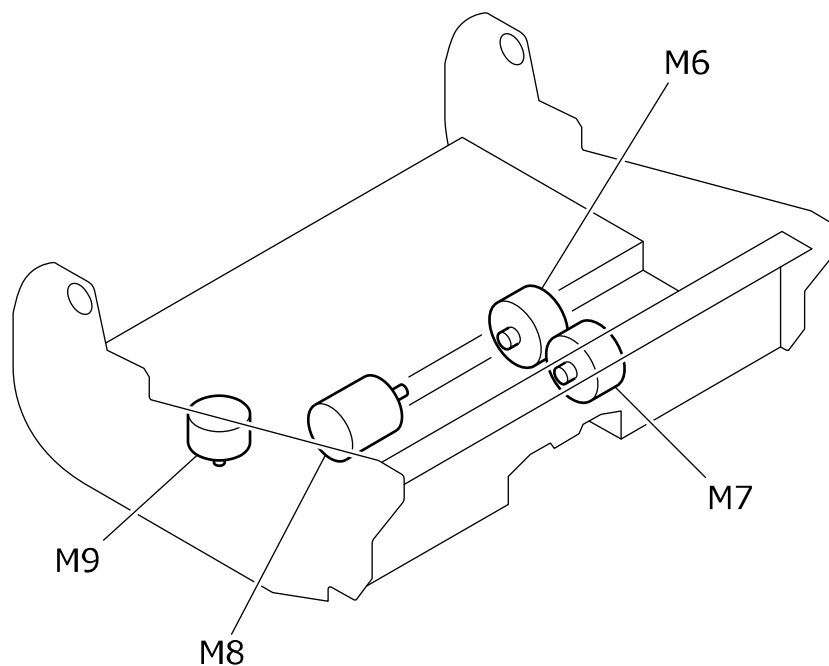

Figure 2-702

Name	Symbol	Remarks
Pickup motor	M6	
Pickup up/down motor	M7	
Feed motor	M8	
Shading motor (front)	M9	

Table 2-702

## 2. PCB, Sensor, Unit

### 1) Base unit

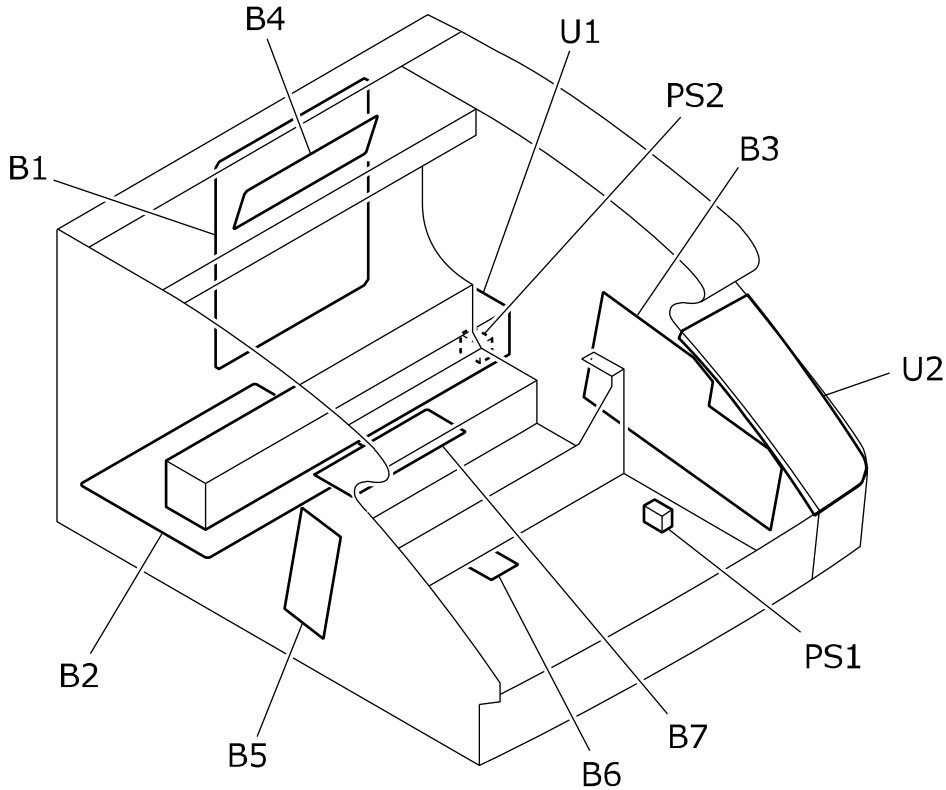

Figure 2-703

Name	Symbol	Remarks
Control PCB	B1	
Power PCB	B2	
Sub-drive PCB	B3	Staple sensor PD
Eject PCB	B4	Exit sensor LED/PD
Staple PCB	B5	Staple sensor LED
Document sensor PCB	B6	Document sensor LED
Ultrasonic drive PCB	B7	Ultrasonic sensor (transmit) Registration middle sensor LED/PD Registration back sensor LED/PD
Tray home sensor	PS1	
Shading sensor (back)	PS2	
Reading unit (back)	U1	
Operation panel unit	U2	Power switch, Operation keys

Table 2-703

## 2) Base unit

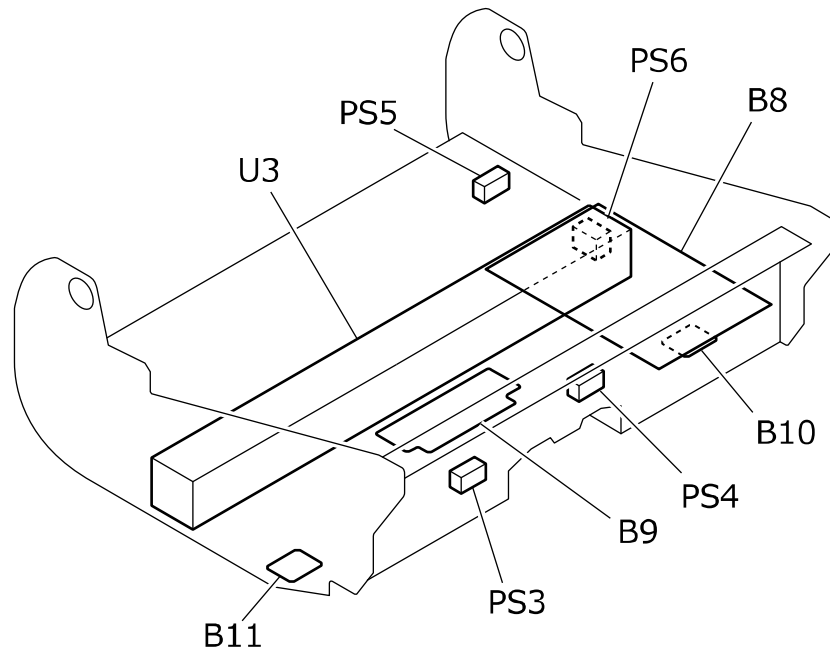

Figure 2-704

Name	Symbol	Remarks
Main drive PCB	B8	Door sensor LED/PS
Ultrasonic sensor PCB	B9	Ultrasonic sensor (receive) Registration front sensor PS
Skew sensor PCB (right)	B10	Skew sensor (right) PS
Skew sensor PCB (left)	B11	Skew sensor (left) PS
Pickup sensor	PS3	
Pickup up/down sensor	PS4	
Imprinter door sensor	PS5	
Shading sensor (front)	PS6	
Reading unit (front)	U3	

Table 2-704

## VIII. PARTS LAYOUT ON EACH PCB

### 1. Control PCB

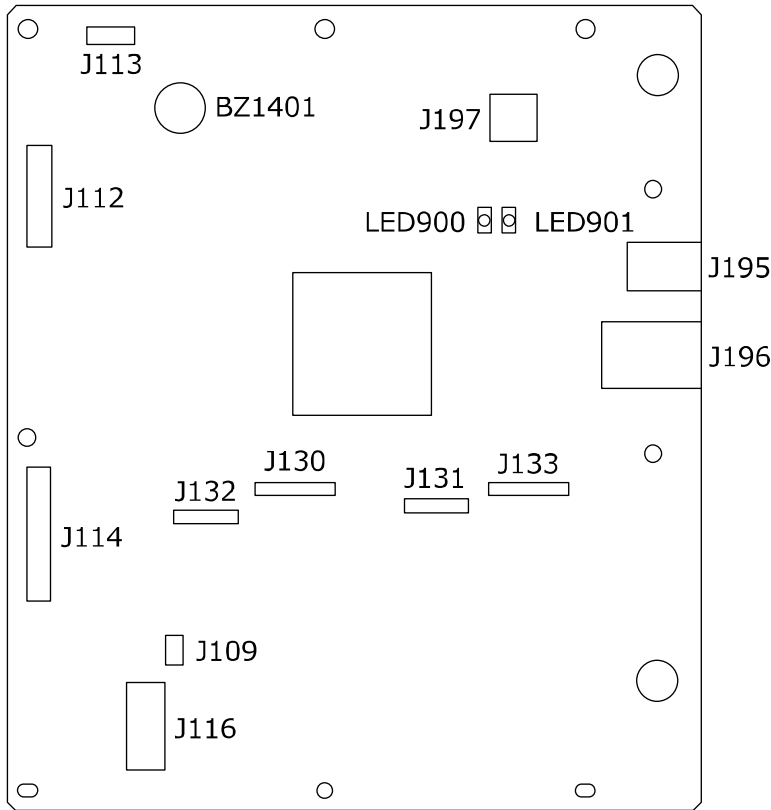

Figure 2-801

Connector		Description
J112	21P	Main drive PCB
J114	29P	Sub drive PCB
J109	3P	Power PCB
J116	5P	
J113	6P	Eject PCB
J130	20P	CIS PCB (back)
J132	14P	
J131	20P	CIS PCB (front)
J133	14P	

Table 2-801a

Connector		Description
J195	—	USB
J196	—	LAN (LAN model only)
J197	—	microSD

Table 2-801b

Symbol	Description
LED900	Lit: 24V OK
LED901	Flashing: CPU OK

Table 2-802



## 2. Main Drive PCB

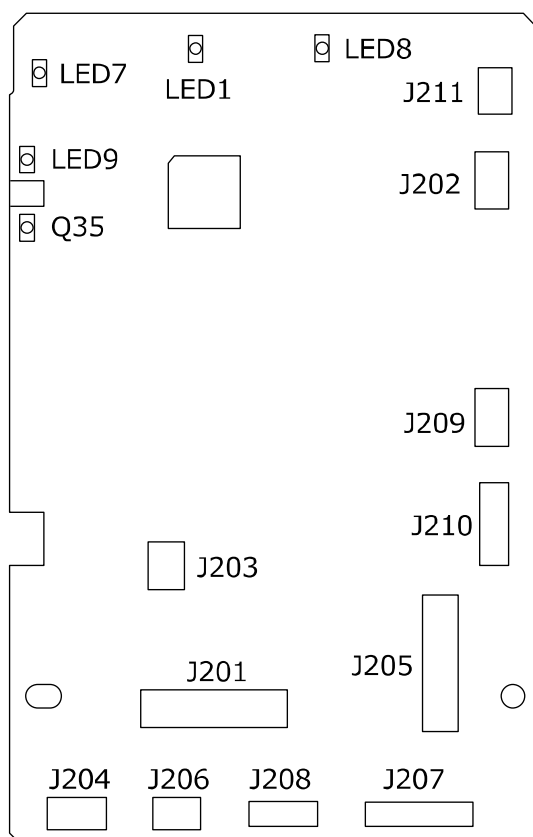

**Figure 2-802**

Connector		Description
J201	21P	Control PCB
J202	4P	Pickup up/down motor
J203	3P	Skew sensor PCB (right)
J204	4P	Imprinter door sensor
J205	11P	Skew sensor PCB (left) Pickup sensor Shading motor (front)
J206	3P	Shading sensor (front)
J207	10P	Ultrasonic sensor PCB
J208	6P	Imprinter (option)
J209	4P	Pickup motor
J210	12P	Feed motor
J211	3P	Pickup up/down sensor

**Table 2-803**

Symbol	Description
LED1	Lit: CPU OK
LED7	Flashing: 5VDC OK
LED8	Lit: 24VDC OK
LED9/Q35	Door sensor

**Table 2-804**

### 3. Sub-Drive PCB

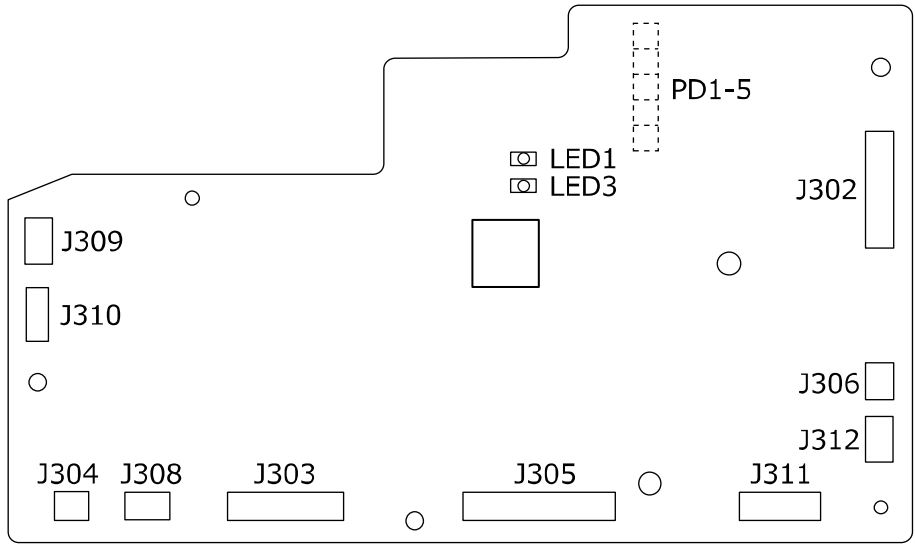

Figure 2-803

Connector	Description
J302	21P Operation PCB
J303	21P Ultrasonic drive PCB Staple PCB Shading motor (back)
J304	3P Shading motor (front)
J305	29P Control PCB
J306	3P Exhaust fan
J308	4P Separation motor
J309	4P Tray motor
J310	6P Document sensor PCB Tray home sensor
J311	6P Main motor
J312	4P Cooling fan

Table 2-805

Symbol	Description
LED1	Flashing: CPU OK
LED7	Lit: 24VDC OK
PD1 to 5	Staple/Document sensor (receive)

Table 2-806

## 4. Power PCB

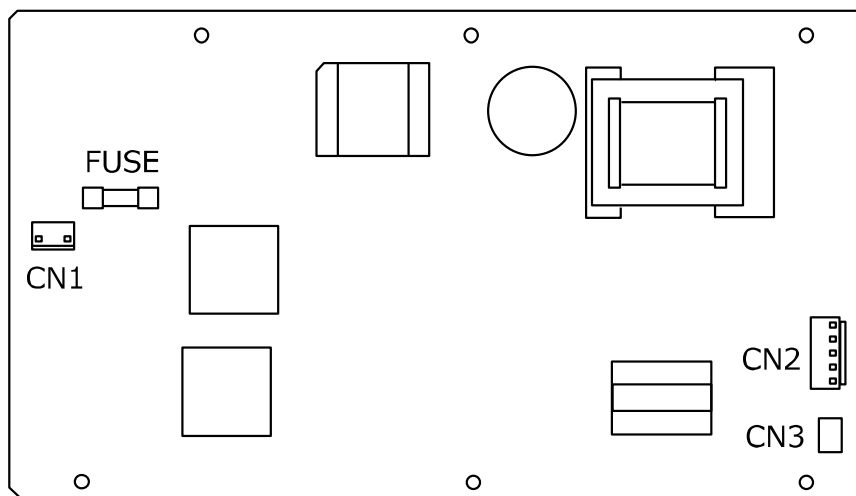

Figure 2-804

Connector		Description
CN1	3P	AC100 to 240V
CN2	5P	Control PCB
CN3	3P	Control PCB

Table 2-807

## 5. Eject PCB

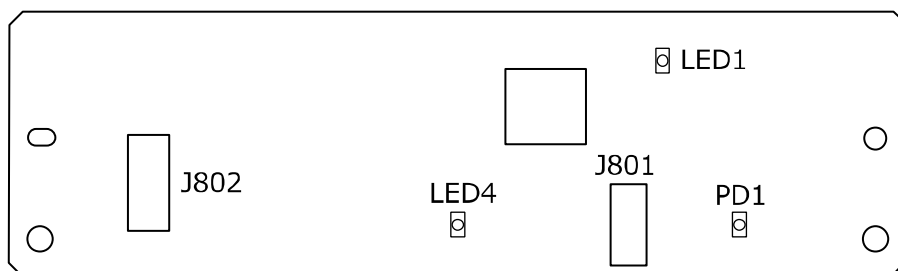

Figure 2-805

Connector		Description
J801	6P	Control PCB
J802	12P	Eject motor

Table 2-808

Symbol	Description
LED1	Flashing: CPU OK 5VDC OK
LED4/PD1	Exit sensor

Table 2-809

---

# CHAPTER 3

---

## DISASSEMBLY & REASSEMBLY

---

**Note:**

The machine shown in the photographs of the figures in this chapter may be different of part from mass-produced machines.

---

I. REPLACED BY USERS.....	3-1	V. UPPER UNIT-3 (READING).....	3-24
II. EXTERNAL COVERS .....	3-3	VI. BASE UNIT-1 (MECANICAL).....	3-27
III. UPPER UNIT-1 (MECHANICAL) .....	3-10	VII. BASE UNIT-2 (ELECTRICAL).....	3-39
IV. UPPER UNIT-2 (ELECTRICAL).....	3-21	VIII. BASE UNIT-3 (READING).....	3-49

---



## I. REPLACED BY USERS

### 1. Pickup Roller

- 1) Hold the roller cover as shown in the figure below and open it to the front.

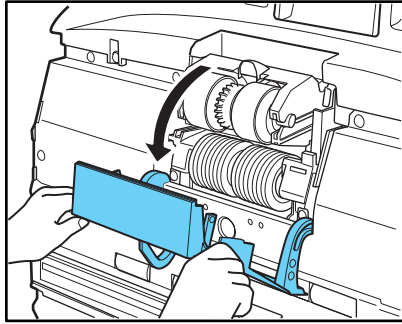

Figure 3-101

- 2) While opening the roller holder, remove the pickup roller.

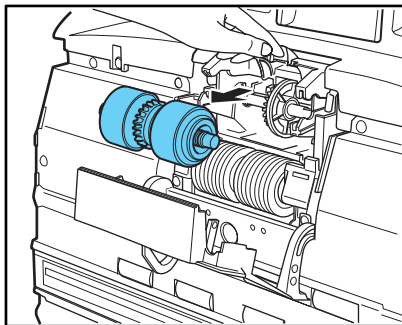
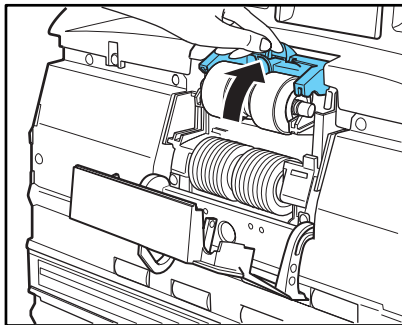

Figure 3-102

### 2. Feed Roller

- 1) Open the roller cover.
- 2) Open the roller lock lever to the front.

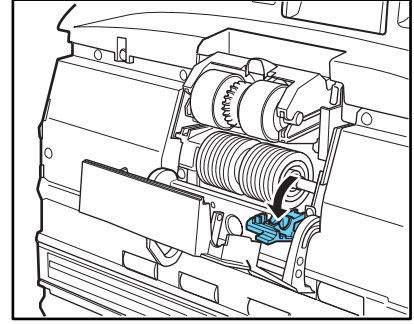

Figure 3-103

- 3) Slide the feed roller to the right and turn it to the front. Then, remove the feed roller.

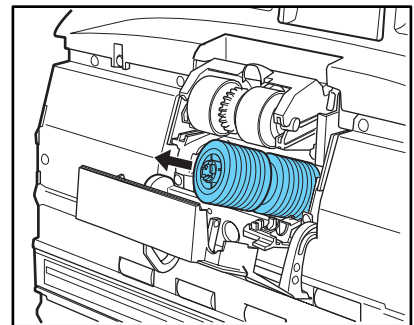
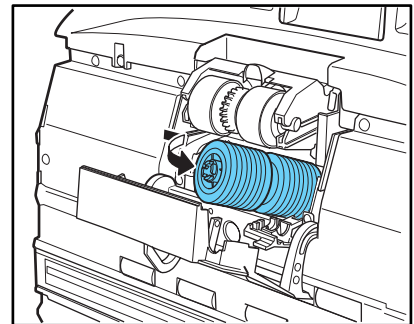
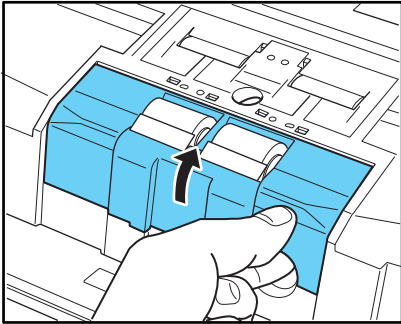

Figure 3-104

### 3. Retard Roller

- 1) Hold the roller cover with fingers and remove it.



**Figure 3-105**

**Note:** The roller cover itself is also user-replaced part as named “separation pad”.

- 2) Remove the roller lock lever from the retard roller. (①→②)

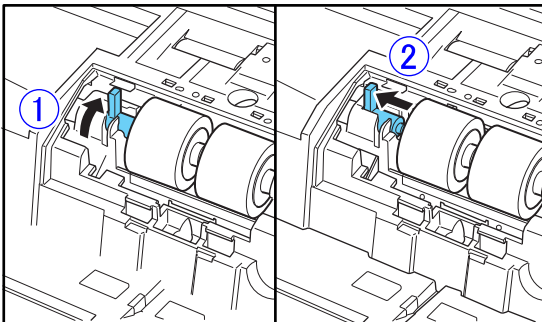

**Figure 3-106**

- 3) Remove the retard roller.

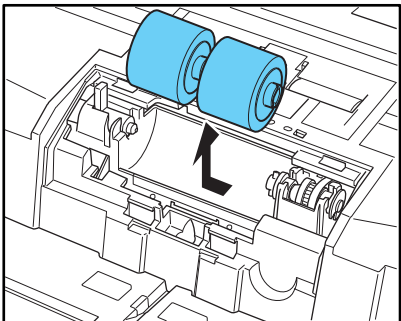

**Figure 3-107**



## II. EXTERNAL COVERS

### 1. Control PCB Cover

- 1) Remove 6 screws ① (M4-bind head, round tip) and remove the control PCB cover ②.

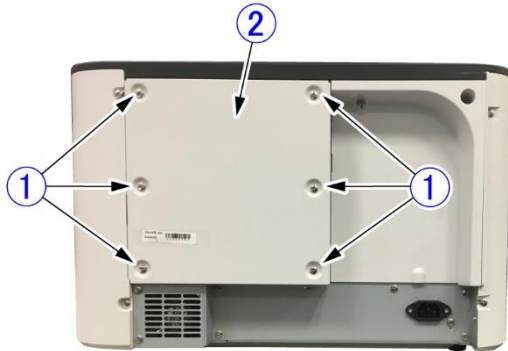

Figure 3-201

### 2. Right Cover Assembly

- 1) Remove 2 screws ① (M4-bind head, round tip).



Figure 3-202

- 2) Remove 4 screws ① (M4, self-tapping, black).

**Note:** With the upper unit open, remove 2 screws. And with document feed guides close, remove screw on front side.



Figure 3-203

- 3) Since there are bottom and front fitting parts, remove the rear fitting part, slide the right cover ① to the bottom and front and remove it from the main body.

**Note:** Do not pull it excessively because a cable is connected to the back side.



Figure 3-204

- 4) Remove the cable band with lock ① and connector with lock ② and remove the right cover assembly ③.

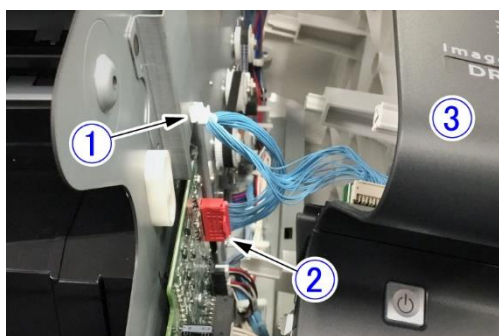

Figure 3-205

**Note:** The right cover assembly is composed of the right cover, right upper cover and operation panel. Remove them if necessary.

### 3. Operation Panel

- 1) Remove the right cover assembly.  
([Page 3-3](#))
- 2) Remove 2 screws ① (M3x8, self-tapping, black) and remove the operation panel ② and then the cable ③.

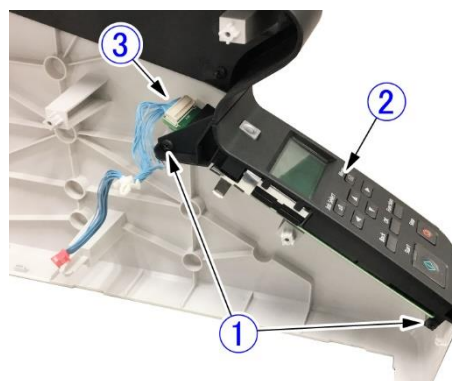

Figure 3-206

**Note:** Since the operation panel assembly is set as a single part, do not disassemble it.

#### 4. Left Cover Assembly

- 1) Remove 2 screws ① (M4-bind head, round tip).



Figure 3-207

- 2) Remove 4 screws ① (M4, self-tapping).

**Note:** With the upper unit open, remove 2 screws. And with document feed guides close, remove screw on front side.

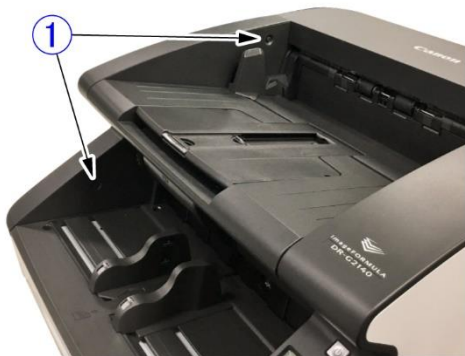

Figure 3-208

- 3) Since there are bottom and front fitting parts, remove the rear fitting part, slide the left cover assembly ① to the bottom and front and remove it from the main body.

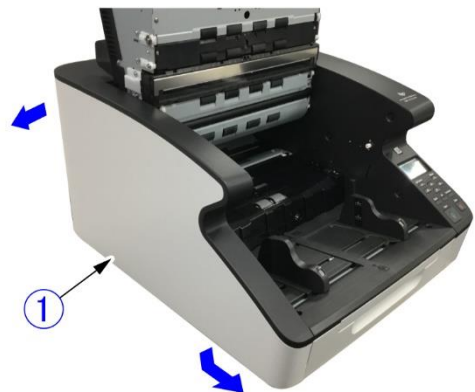

Figure 3-209

**Note:** The left cover assembly is composed of the left cover, left upper cover and left lower cover. Remove them if necessary.

## 5. Top Cover

- 1) Remove the control PCB cover.  
(Page 3-3)
- 2) Remove the right and left covers.  
(Page 3-3), (Page 3-5)
- 3) Remove the screw ① (M3-TP head, round tip). Then hang on your fingers under the cover at front/center②, and move to front/upper side to remove a fitting part inside. After that, while unhooking 2 pairs of the right and left fitting parts③④, remove the top cover⑤.

**Note:** Don't deform the static eliminator brush when you hang on your fingers under the cover.

### ◆ Notes on assembling

After assembling, push the cover to check the fitting part on front side is without any floating.



Figure 3-212

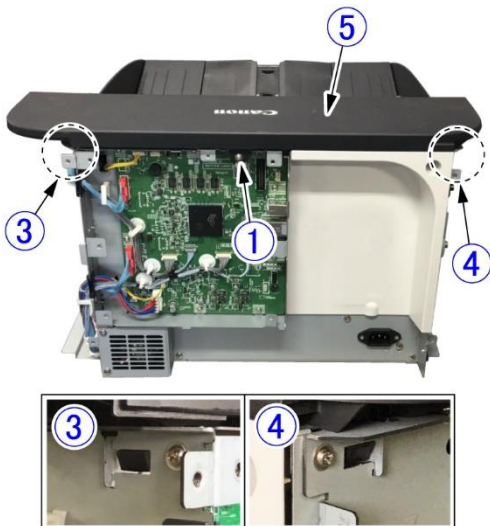

Figure 3-210



Figure 3-211

## 6. Pickup Tray Unit

**Note:** The shapes of the DR-G2090 pickup tray unit and the extension tray are slightly different from those shown below, but the procedure is the same.

- 1) Remove 4 screws ① (M4, stepped) and remove the pickup tray unit ②.

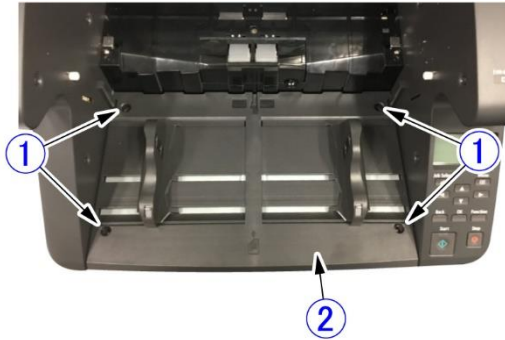

Figure 3-213

- 2) Remove the extension tray ①.

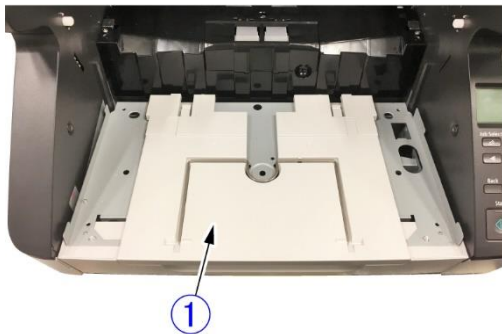

Figure 3-214

## 7. Eject Tray Unit

- 1) Unlock and open the imprinter cover. Refer to "Notes on assembling".
- 2) Open the upper unit, and remove 4 screws ① (2 on both sides, M3-TP head, round tip).

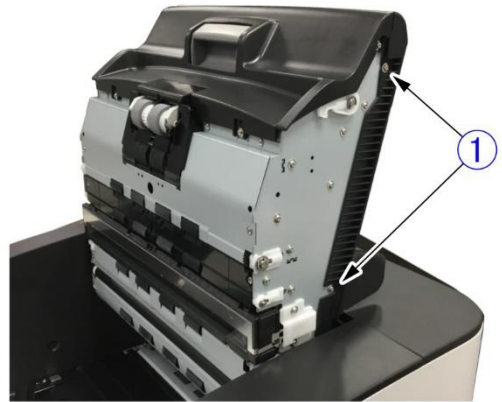

Figure 3-215

- 3) Close the upper unit and remove the eject tray unit ① while sliding it to the front side.



Figure 3-216

### ◆ Notes on assembling

Verify that the imprinter cover is opened before assembling. Because that you can see inside no damage with cables and others while assembling.



Figure 3-217

## 8. Upper Front Cover

- 1) Remove the eject tray unit.  
([Page 3-7](#))
- 2) Remove 6 screws ① (M3-TP head, round tip) and remove the upper front cover ②.

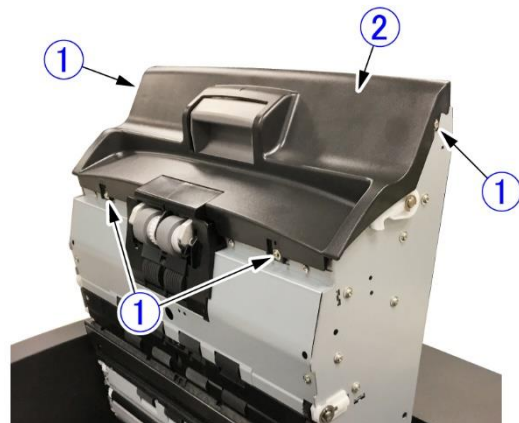
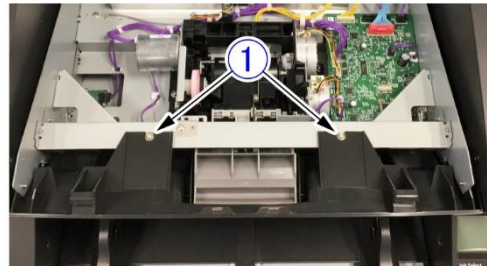

Figure 3-218

## 9. Rear Cover

- 1) Remove the control PCB cover.  
(Page 3-3)
  - 2) Remove all connectors connected to the control PCB①. And remove 3 locked cable bands ② then remove the cables from the cable holder③ while opened.
- Note:**Unlock 3 locked connectors and then remove them.

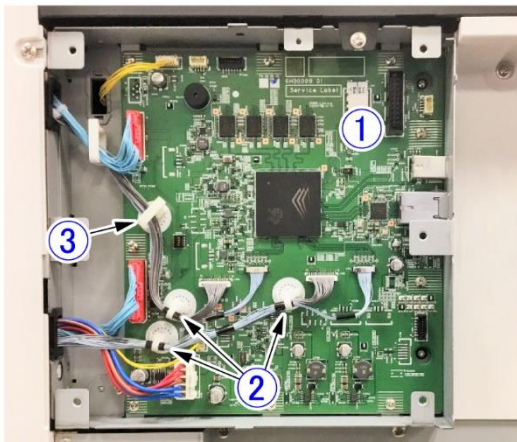

Figure 3-219

- 3) Remove 7 screws① (M3-TP head, round tip). And remove the mounting plate② (with control PCB) from bottom side, and unhook the hook③ on the upper right.

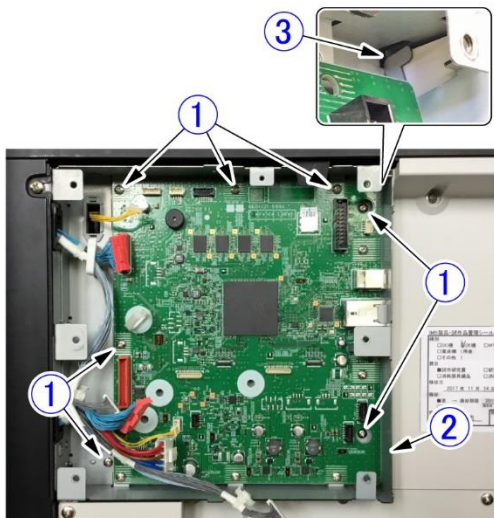

Figure 3-220

- 4) Remove 2 screws ① (M3-TP head, round tip). Rotate the upper side of the rear cover② to the front and while unhooking 2 pairs of the lower fitting parts③, remove the rear cover.

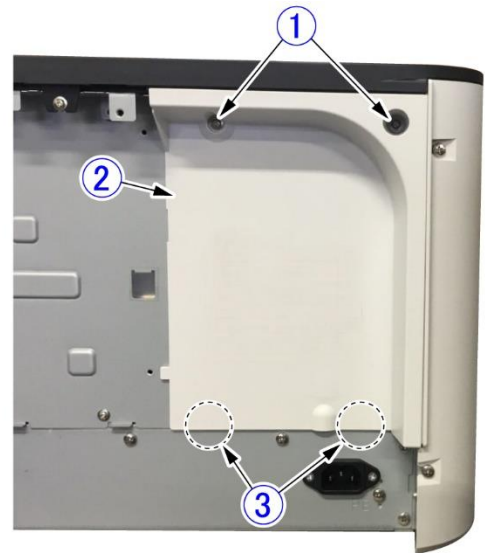

Figure 3-221

### ◆ Notes on assembling

Be sure not to break the lower hooks.

## III. UPPER UNIT-1 (MECHANICAL RELATION)

### 1. Pickup Unit

- 1) Remove the eject tray unit.  
(Page 3-7)
- 2) Remove the upper front cover.  
(Page 3-8)
- 3) Open the pickup roller cover, and remove 2 screws ① (M3x6, self-tapping) and the screw ② (M3-bind head, round tip) for pickup sensor position adjustment.

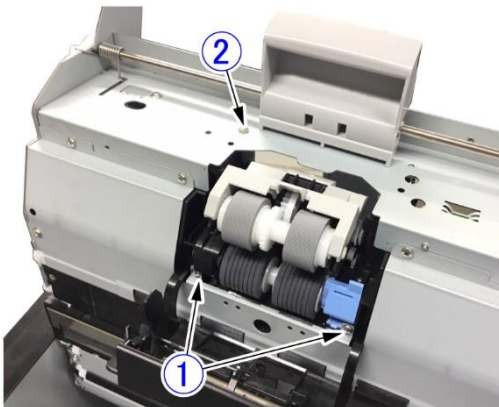

Figure 3-301

- 4) Remove the cables ① ② connected to the pickup motor and pickup sensor.

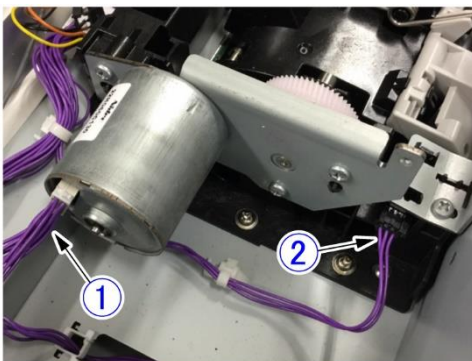

Figure 3-302

- 5) Remove 3 cables ① connected on the main drive PCB.

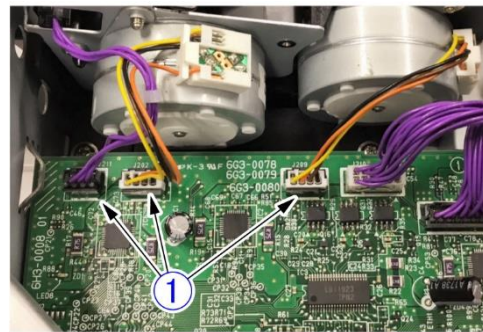

Figure 3-303

- 4) Remove the screw ① (M3-bind head, round tip) and remove the ground plate ②. Then, remove 4 screws ③ (M3-TP head, round tip) and remove the pickup unit ④.

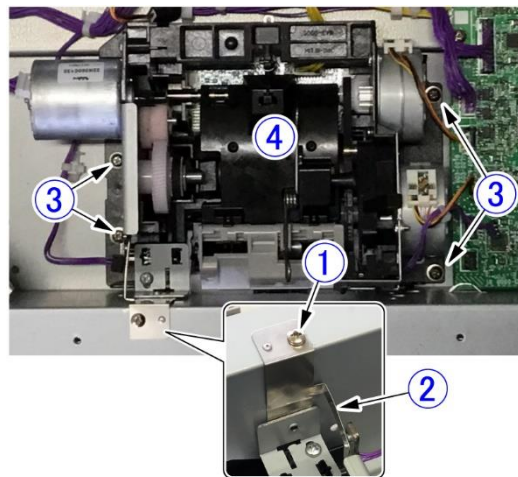

Figure 3-304

#### ◆ Notes on assembling

Finally, install the ground plate at the original position, and tighten the screw ② (M3-bind head, round tip) for pickup sensor position adjustment which was removed in step 3, to the extent that it does not become loose. If they are tightened excessively, the position of the pickup sensor



changes or the pickup sensor mounting plate deforms.

◆ **Adjustment after assembly**

If the pickup sensor malfunctions after assembly, adjust the position of the pickup sensor. Refer to “CHAPTER 5 TROUBLE-SHOOTING, VI. AFTER REPLACING PARTS” for details.

## 2. Pickup Roller Cover

- 1) Remove the pickup unit.  
[\(Page 3-10\)](#)
- 2) Unhook 2 pairs of the fitting parts① and remove the pickup roller cover②.

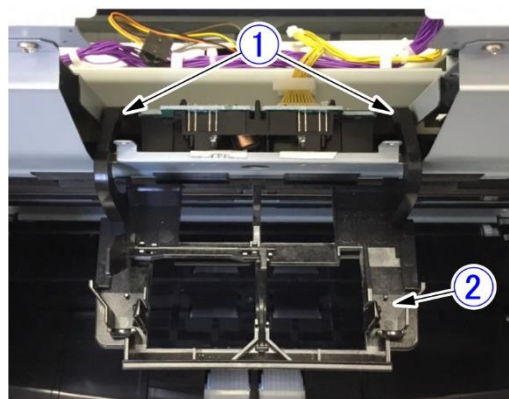

Figure 3-305

### 3. Upper Entrance Guide

- 1) Open the pickup roller cover.
- 2) Remove 2 screws ① (M3x6, self-tapping) and 6 screws ② (M3-bind head, round tip) and remove the upper entrance guide ③.

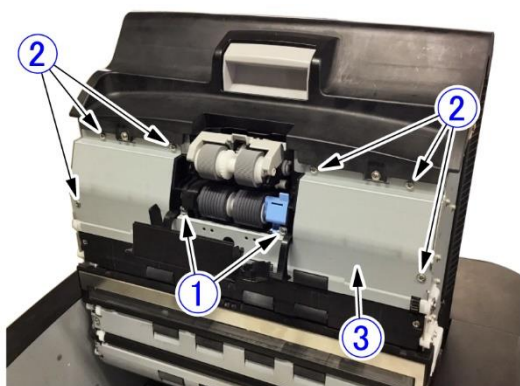

Figure 3-306

### 4. Pull-in Upper Roller

- 1) Remove the upper entrance guide. [\(Page 3-12\)](#)
- 2) Open the end of both bearing holders ① and while unhooking the fitting parts, remove the pull-in roller unit ②.

**Note:** Since the coil spring in the roller unit may be detached, do not lose it. The tension of this coil spring is harder than other holders' one. Do not mix them.

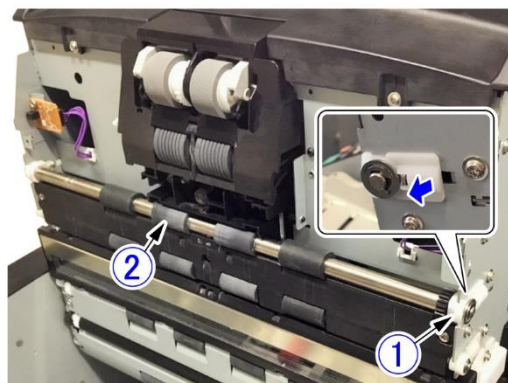

Figure 3-307

- 3) Remove 2 E-rings ① (1 on both sides) and remove the bearing holder ② from the pull-in upper roller ③.

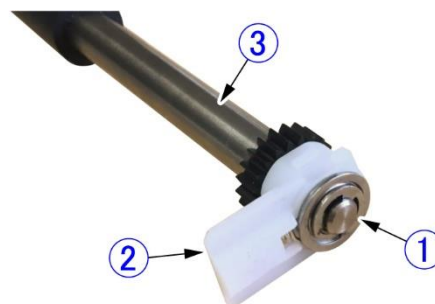

Figure 3-308

#### ◆ Notes on assembling

When mounting the coil spring in the bearing holder, set the position of the spring bending section ① as follows. Insert the end of the bending section between the ball bearing flange ② and the bearing holder.

Since the end of the bending section touches the outer area of the ball bearing, static electricity on the roller is discharged to the side plate.



Figure 3-309

Push the right and left bearing holders into the side plate at the same time. Insert the fitting part of the bearing holder into the hole of the side plate.

## 5. Registration Upper Roller

- 1) While holding the upper middle feed guide ①, remove 3 screws ② (M3, stepped 3.2) and remove the upper middle feed guide.

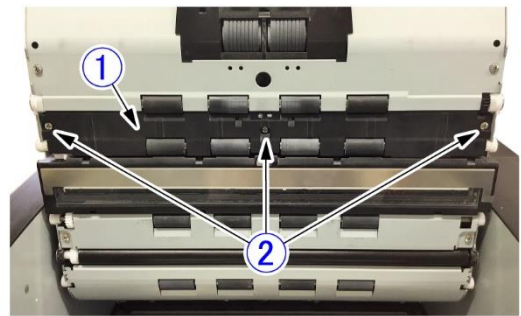

Figure 3-310

- 2) Open the end of both bearing holders ① and while unhooking the fitting parts, remove the registration upper roller unit ②.

**Note:** Since the coil spring in the roller unit may be detached, do not lose it.

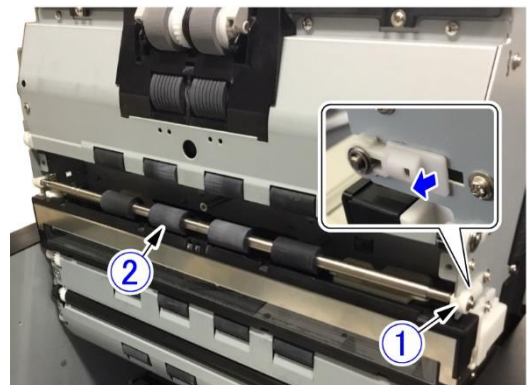

Figure 3-311

- 3) Remove 2 E-rings ① (1 on both sides) and remove the bearing holder ② from the registration upper roller ③.

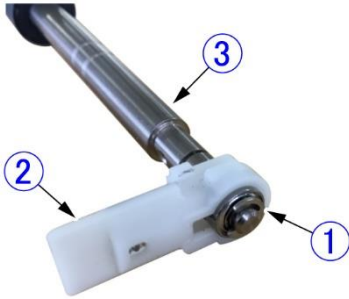

Figure 3-312

◆ **Notes on assembling**

When mounting the coil spring in the bearing holder, set the position of the spring bending section ① as follows. Insert the end of the bending section between the ball bearing flange ② and the bearing holder.

Since the end of the bending section touches the outer area of the ball bearing, static electricity on the roller is discharged to the side plate.



Figure 3-313

Push the right and left bearing holders into the side plate at the same time. Insert the fitting part of the bearing holder into the hole of the side plate.

**6. Reading Upper Roller**

- 1) While holding the upper rear feed guide ①, remove 2 screws ② (M3-bind head, round tip) and remove the upper rear feed guide.

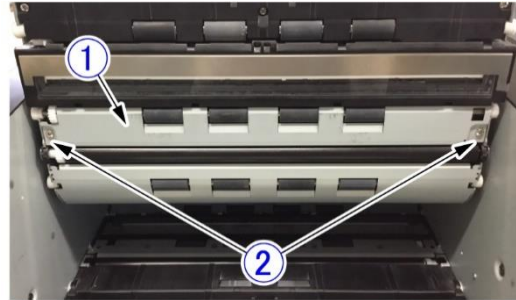

Figure 3-314

- 2) Open the end of both bearing holders ① and while unhooking the fitting parts, remove the reading upper roller unit ②.

**Note:** Since the coil spring in the roller unit may be detached, do not lose it.

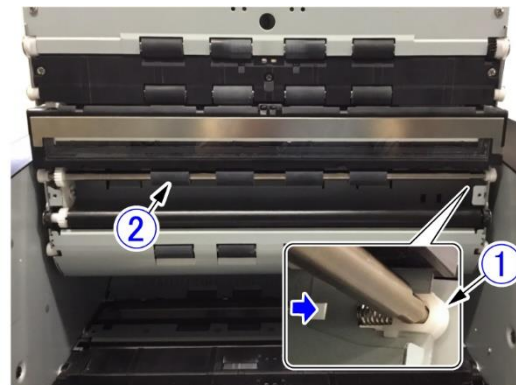

Figure 3-309

**Note:** This part is used the same roller as the "registration upper roller" and added a gear. Therefore, refer to "Registration Roller Upper" for details of the subsequent procedure and precautions.

## 7. Platen Upper Roller

- 1) Remove the reading upper roller.  
([Page 3-14](#))
- 2) While holding the platen upper roller ①, push the claw (marked arrow) of the right and left bearing holders from the inside with a tool with a thin tip, and remove the platen upper roller unit.

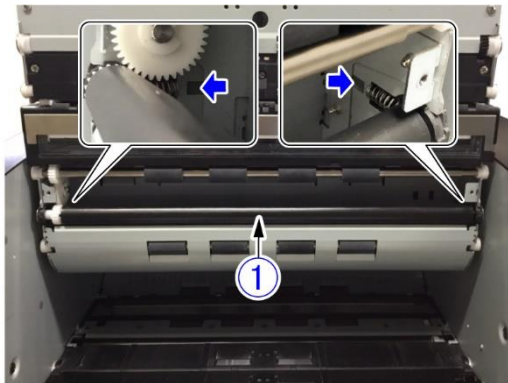

Figure 3-316

- 3) For the platen upper roller unit ①, remove 2 E-rings ② (1 on both sides) and remove the bearing holders ③. And remove gear ④ and pin ⑤ on the left side.

**Note:** Since the pin may be detached, do not lose it.

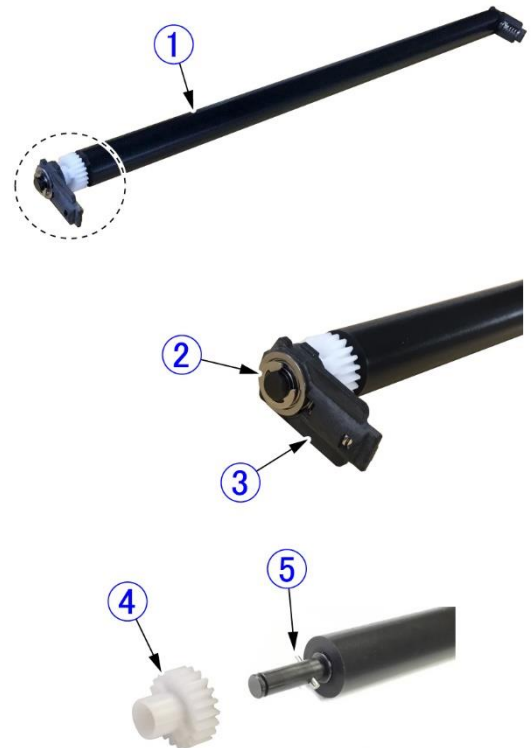

Figure 3-317

**Note:** Refer to “Pull-in upper roller” for details precautions.

([Page 3-12](#))

## 8. U-turn Upper Roller

There are pre U-turn upper roller and 2 U-turn upper rollers in U-turn section of the upper unit.

- 1) Remove the entire upper unit.  
[\(Page 3-19\)](#)
- 2) Remove 6 screws ① (3 on both sides, M3-TP head, round tip) and remove the U-turn guide ②.

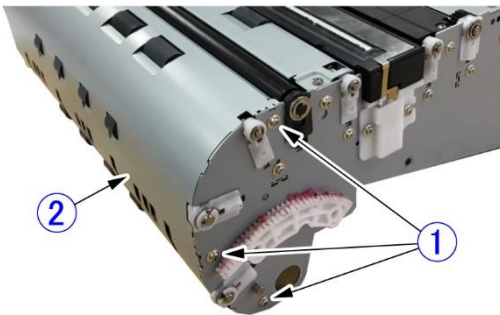

Figure 3-318

- 3) Open the end of both bearing holders ①, and while unhooking the fitting parts, remove the pre U-turn upper roller ② and 2 U-turn upper rollers ③.

**Note:**The roller with a wider roller rubber is a pre U-turn upper roller.

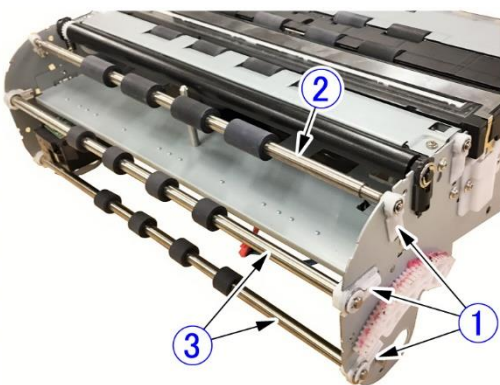

Figure 3-319

**Note:**Refer to “Pull-in Upper Roller” for details of the subsequent procedure and precautions.

[\(Page 3-12\)](#)

## 9. Eject Follower Roller

- 1) Remove the eject tray unit.  
[\(Page 3-7\)](#)
- 2) While unhooking 2 pairs of the fitting parts ① one at a time, pull out the eject follower roller ② upward.

**Note:**Since the fitting parts are secure, pull the roller out carefully to prevent damage to it.

Do not lose the coil springs ③.

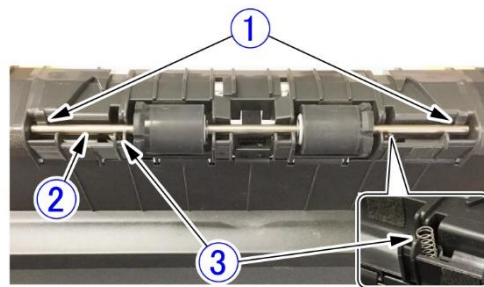

Figure 3-320

### ◆ Notes on assembling

Set the roller shaft with the D-cut shapes ① down, and assemble the roller during pushing coil springs.

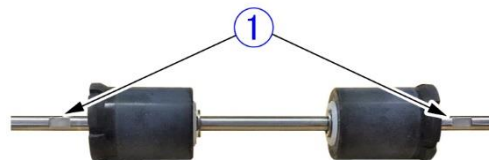

Figure 3-321

## 10. Eject Tray Extension

- 1) Remove 6 screws ① (M3x6, self-tapping). While unhooking 2 claws ②, slide the upper tray extension ③ to the front, unhook 2 claws ④ at the front, and remove the upper tray extension.

**Note:** Take care not to break the claws.

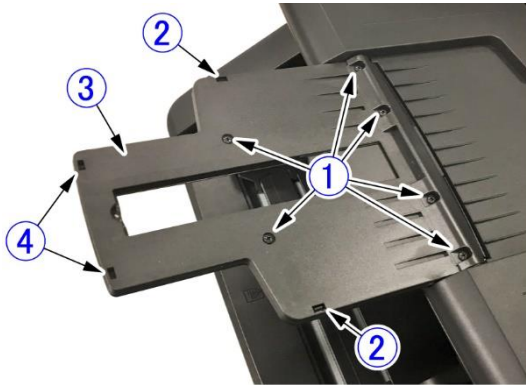

Figure 3-322

- 2) Remove the eject stopper ① and lower tray extension ②.

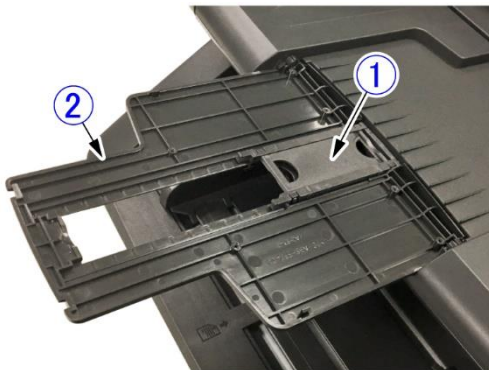

Figure 3-323

### ◆ Notes on assembling

To assemble the eject stopper ①, a rear depression ② should be upper side.

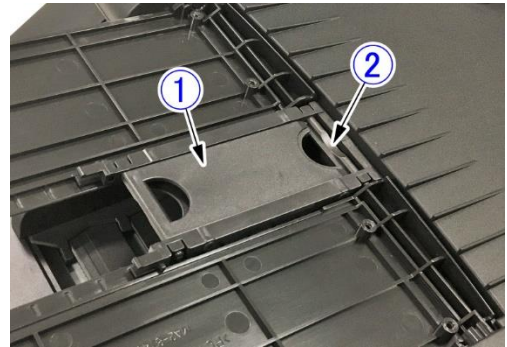

Figure 3-324

## 11. Imprinter Cover

- 1) Slide the eject document guides to sides.
- 2) Release a lock for the imprinter cover①.  
And then deflect the imprinter cover, and unhook right side boss② first, and left side boss③ next to remove the imprinter cover.

**Note:** Since the right boss is shorter, unhook the right one first.



Figure 3-325

## 12. Eject Document Guide

- 1) Remove the eject tray unit.  
([Page 3-7](#))
- 2) Remove 2 screws① (M3x6, self-tapping) and remove the cover②.

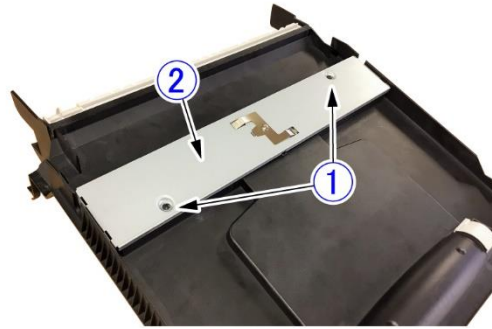

Figure 3-326

- 3) Remove 2 screws① (M3x6, self-tapping) and while holding the eject document guide on the back side, remove the guide plate②.

**Note:** The right eject document guide is different from the left one in shape, but the guide plates are the same parts.

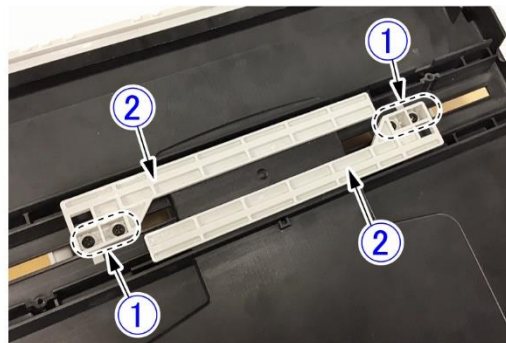

Figure 3-327

### ◆ Notes on assembling

Pay attention to the direction of the cover. If the direction of the cover is reversed, the screw positions are not aligned.



### 13. Entire Upper Unit

**Note:** You need to prepare space for placing the upper unit before remove it.

- 1) Remove the control PCB cover.  
(Page 3-3)
- 2) Remove the right and left covers.  
(Page 3-3), (Page 3-5)
- 3) Remove the eject tray unit.  
(Page 3-7)
- 4) Remove 3 cables ① and locked cable band on the control PCB. And open the cable holders to release the cables and pull them in to the upper unit.

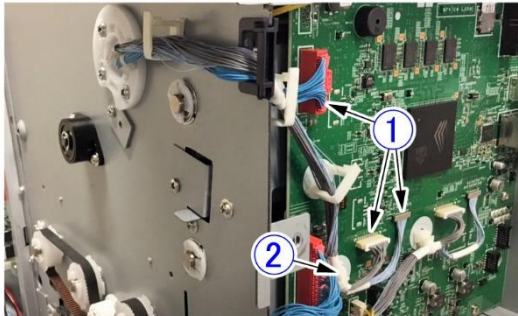

Figure 3-328

- 5) To prevent damage to the feed surface, put paper or a sheet ① on the feed surface of the base section, and close the upper unit.

**Note:** If the dampers are removed using the following procedure, the upper unit cannot be kept open, so be sure to close it.



Figure 3-329

- 6) Removing 6 screws ① (3 on both sides, M4-TP head, round tip) to remove the hinge ②, and remove 4 screws ③ (2 on both sides, M3-TP head, round tip) to remove the damper ④ (black) and damper ⑤ (white). Then remove right side screw ⑥ (M3-bind head, round tip) to remove the stopper plate ⑦, and remove left side screw ⑥ to remove the grounding plate ⑧.

**Note:** The right and left hinges are the same parts but the dampers are different parts.

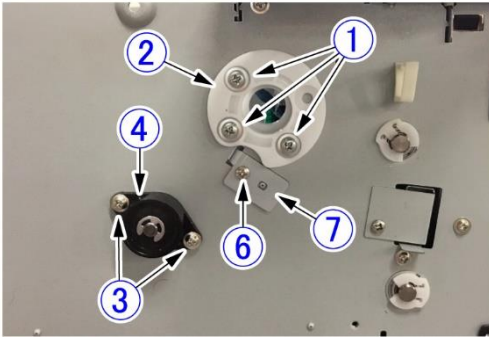

Figure 3-330 (right side)

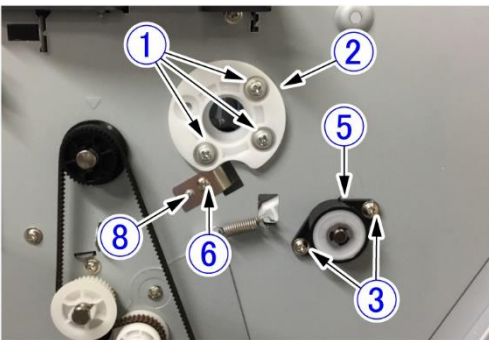

Figure 3-331 (left side)

7) Press the open/close button of the upper unit ①, lift the front side ② of the upper unit slightly, and hold rear side ③ with hand. Then, lift and pull it out to the front. Take care not to strike it to the side of the base unit and the feed surface.

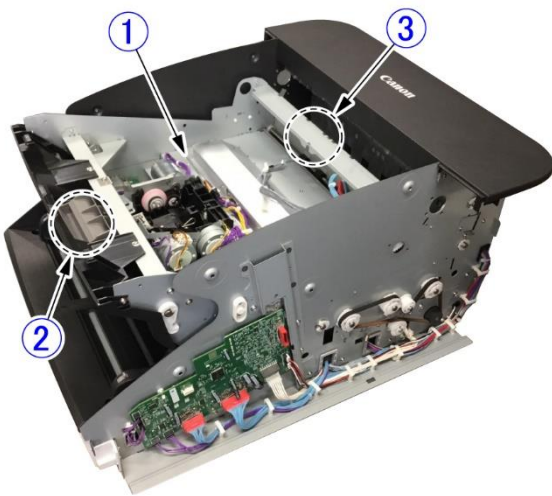

Figure 3-332

◆ **Notes on assembling**

- 1) After assembling the upper unit in the base unit, install the right and left hinges first. Then, install the right and left dampers, stopper plate and grounding plate.
- 2) The right and left dampers are different in the color of the end surfaces. The left side is white and the right side is black.



Figure 3-333

- 3) If grease is attached to your fingers or the outside surface, wipe it off.
- 4) After assembly, ensure that the upper unit is opened and closed correctly.

## IV. UPPER UNIT-2 (ELECTRICAL RELATION)

### 1. Main Drive PCB

- 1) Remove the eject tray unit.  
([Page 3-7](#))
- 2) Remove all the cables connected to the main drive PCB①.  
Remove 2 screws ② (M3-bind head, round tip), and while removing 2 pairs of fitting parts③ and the cable in the cable guide④, remove the main drive PCB.

**Note:** Unlock the locked connectors and then remove them.

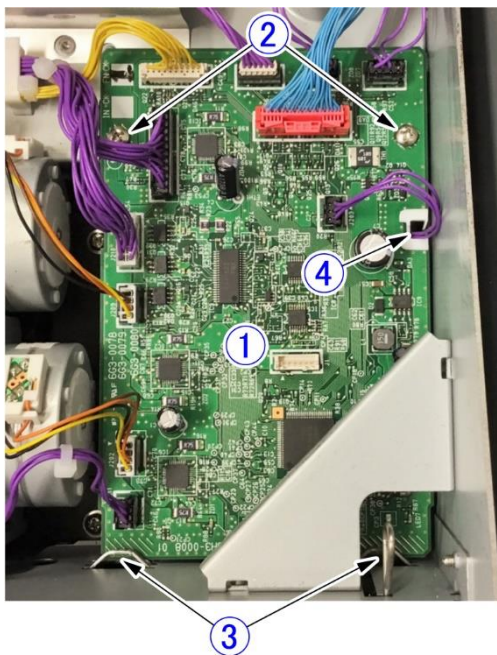

Figure 3-401

#### ◆ Notes on assembling

Do not forget to assemble the cable (for a skew sensor) that passes through the cable guide from the bottom.

### 2. Ultrasonic Sensor PCB

- 1) Remove the eject tray unit.  
([Page 3-7](#))
- 2) Open the cable holder①, and remove the cable② (for the ultrasonic sensor PCB) from the cable holder to provide extra length.

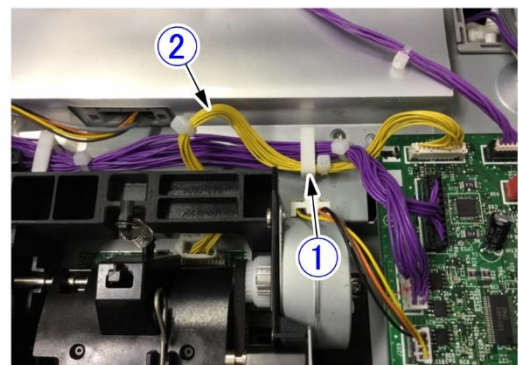

Figure 3-402

- 3) Remove the pull-in upper roller.  
([Page 3-12](#))

- 4) Remove 2 screws ① (M3-bind head, round tip), pull out the ultrasonic sensor PCB ② (with guide plate) and remove the cable ③ connected to the back side.

**Note:** Do not pull it excessively because the cable is connected to it.

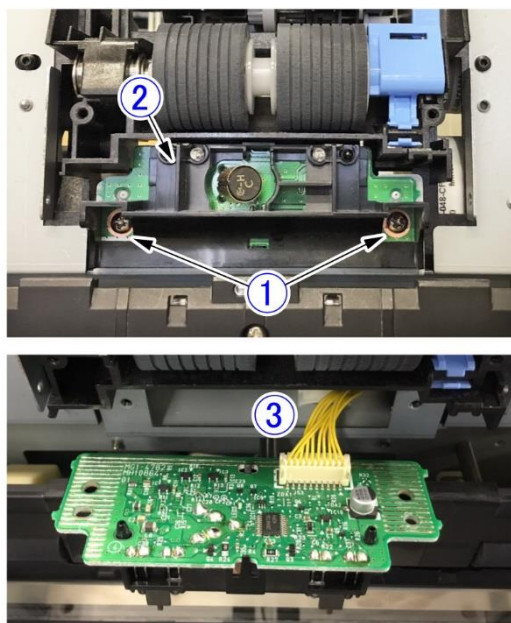

Figure 3-403

### 3. Feed Motor

- 1) Remove the pickup unit.  
([Page 3-10](#))
- 2) Remove 3 screws ① (M3x6, self-tapping) and while removing the belt ②, remove the motor unit ③ (including the mounting plate).

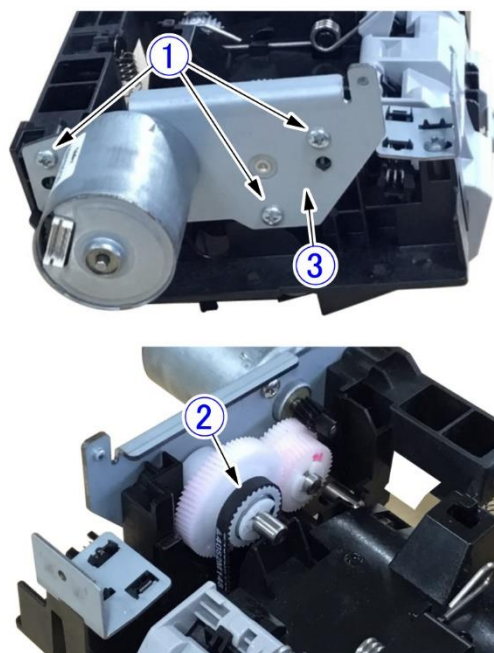

Figure 3-404

- 3) Remove 2 screws ① (M3-bind head, round tip) and remove the feed motor ②.

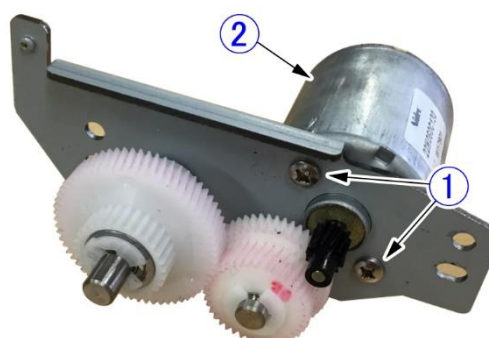

Figure 3-405

#### 4. Pickup Motor

- 1) Remove the pickup unit.  
(Page 3-10)
- 2) Go through the tool ① from opposite side, then remove 2 screws ② (M3-bind head, round tip) and remove the pickup motor ③.  
Note: Do not make any damage on the belt ④ by the tool.

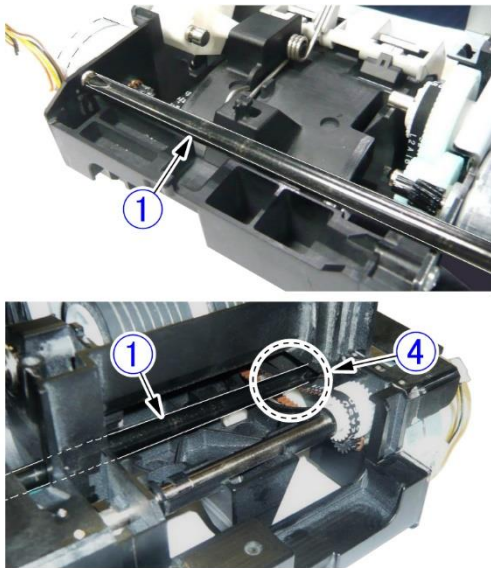

Figure 3-406

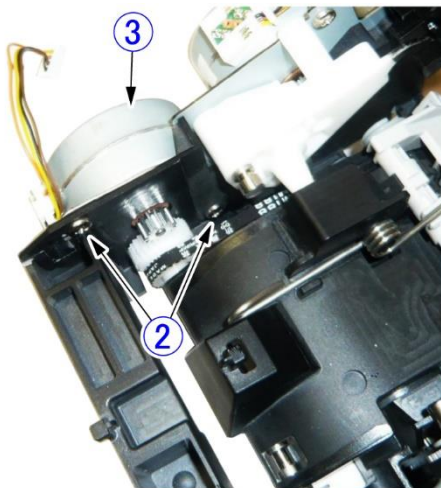

Figure 3-407

#### 5. Pickup Up/Down Motor

- 1) Remove the pickup unit.  
(Page 3-10).
- 2) Remove 2 screws ① (M3, self-tapping), and remove the motor unit ② (including mounting plate).

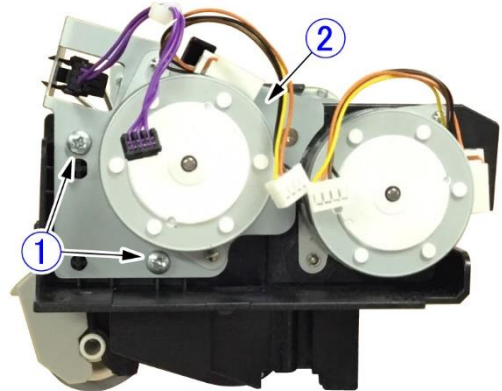

Figure 3-408

- 3) Remove 2 screws ① (M3,-bind head, round tip), and remove the pickup up/down motor ②.

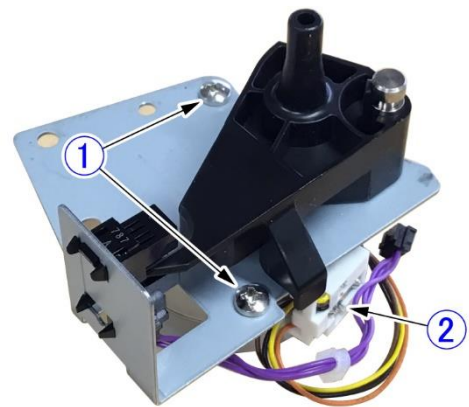

Figure 3-409

## V. UPPER UNIT-3 (READING RELATION)

### 1. Upper Reading Unit

1) Remove the eject tray unit.

[\(Page 3-7\)](#)

2) Remove the screw ① (M3-bind head, round tip) and remove the grounding cable ② and connector ③. And then remove the locked cable band ④, and connector ⑤.

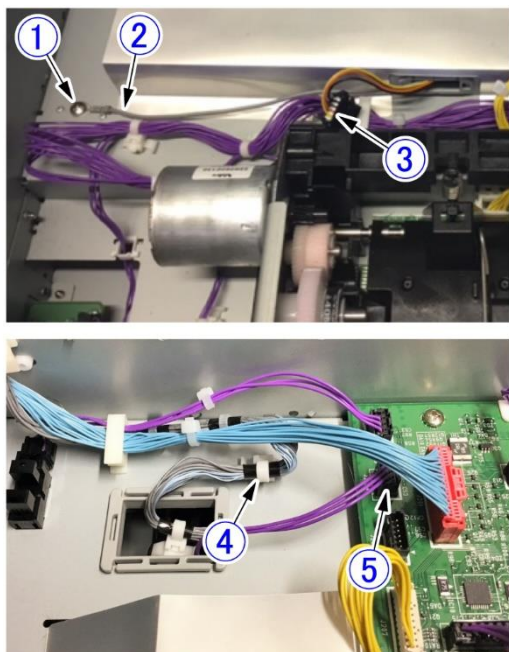

Figure 3-501

3) Remove the registration upper roller.

[\(Page 3-13\)](#)

4) Remove 4 screws ① (2 on both sides, M3-TP head, round tip). While holding the reading unit ②, remove the right and left guides ③.

**Note:** The right and left guides are the same one.

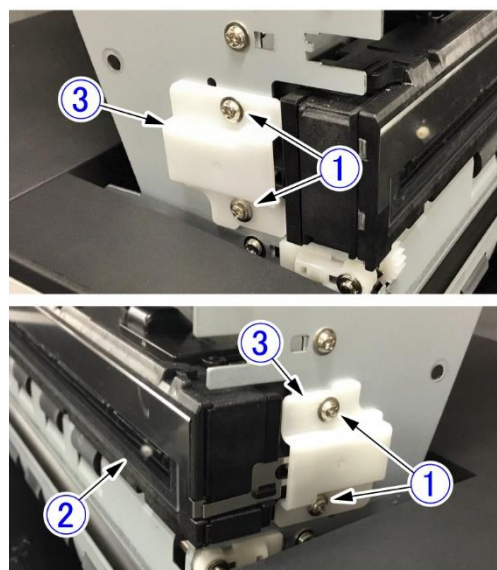

Figure 3-502

5) Slide the reading unit ① in front and hold it. Remove 2 fitting parts ② and remove the cover ③. And then remove the cable band with lock ④ and remove the connectors ⑤ and ⑥. And remove the reading unit with cables for the motor, grounding and sensor.

**Note:** Do not pull it excessively because a cable is connected.

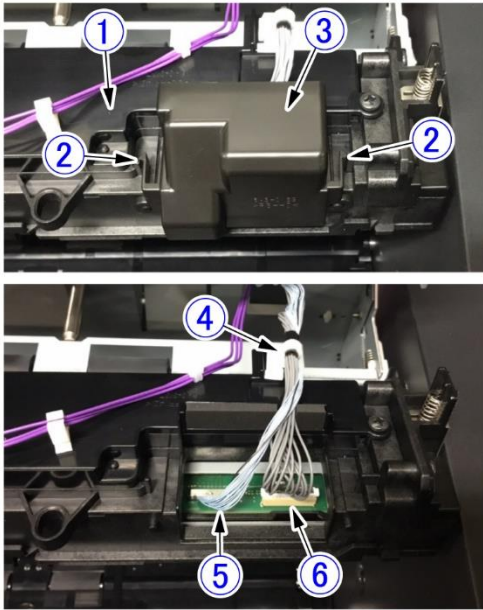

Figure 3-503

#### ◆ Notes on assembling

The cables connected to the CIS unit should be formed with extra because the CIS unit slides to get shading data.

Connect 2 cables to the CIS unit, and then insert the cable band with lock. And placed these cables in the groove of sponge packing and then assemble the cover.

Pass the motor, grounding and sensor cables through a hole before assembling the reading unit. Be careful not to allow these cables to be caught.

## 2. Shading Motor

- 1) Remove the upper reading unit.  
([Page 3-24](#))
- 2) Remove 2 screws ① (M3-bind head, round tip) and remove the shading motor ②.

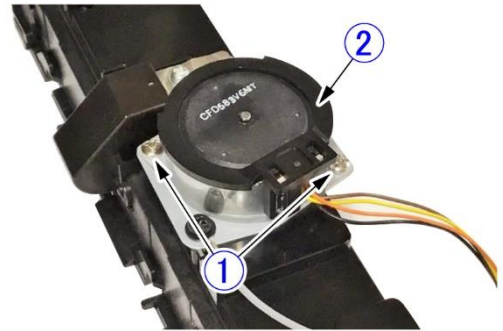

Figure 3-504

### 3. Upper Reading Glass Assembly

- 1) Clean the glass surface and the feed path to prevent dust from entering the reading unit.
- 2) While pushing the stopper① with a tool with a thin tip and unhooking the fitting parts, slide the upper reading glass assembly② until it stops and remove it.

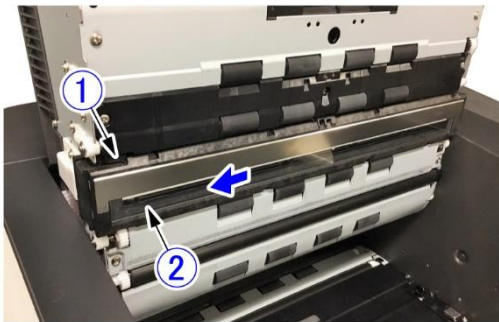

Figure 3-505

#### ◆ Notes on assembling

Do not touch the glass rear surface and the surface of the lens array of the reading unit with fingers. If they are dirty, clean them with a clean dry cloth.



## VI. BASE UNIT-1 (MECHANICAL RELATION)

### 1. Pickup Document Guide

**Note:**For the DR-G2090, some of parts are different shape but no change on disassembling method below.

- 1) Remove the pickup tray unit.  
(Page 3-7)
- 2) Remove 5 screws ① (M3x6, self-tapping) and remove the leaf spring ② and cover ③.

**Note:**Do not lose the leaf spring.

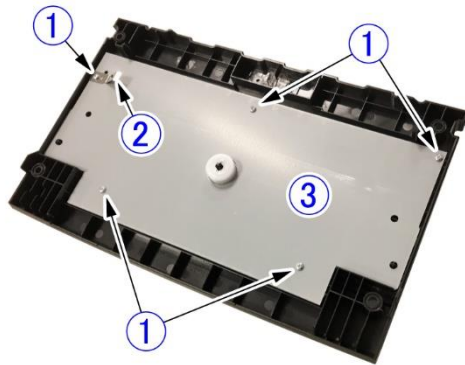

Figure 3-601

- 3) Remove 4 screws ① (2 on both sides, M3x6, self-tapping) and remove the pickup document guides ②, racks ③ and gear assembly ④.

**Note:**A lock lever ⑤ is built in the pickup document guide. The right pickup document guide, lock lever and rack are different from the left ones.

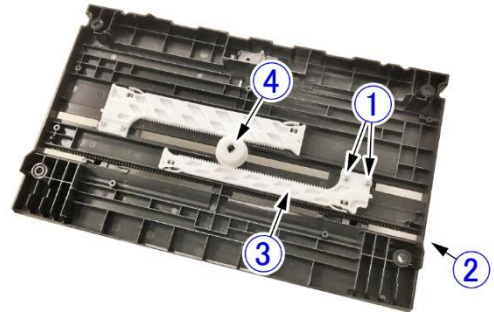

Figure 3-602

#### ◆ Notes on assembling

Keep the order of assembling parts as the right rack first, and gear assembly and then left rack.

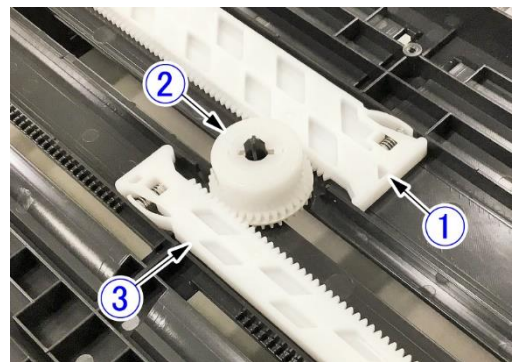

Figure 3-603

Verify that the pickup document guides work correctly after assembly.

Center the pickup document guides so that they are symmetrical.

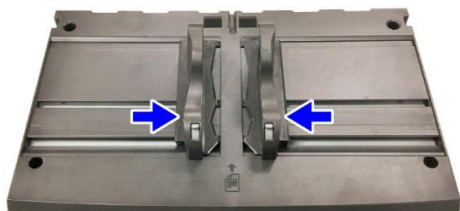

Figure 3-604

## 2. Tray Drive Box

**Note:** For the DR-G2090, there is a spacer on the center of the top surface but no change on disassembling method below.

- 1) Remove the right cover.  
([Page 3-3](#))
- 2) Remove the pickup tray unit.  
([Page 3-7](#))
- 3) Remove 2 connectors on the main drive PCB and locked cable band.

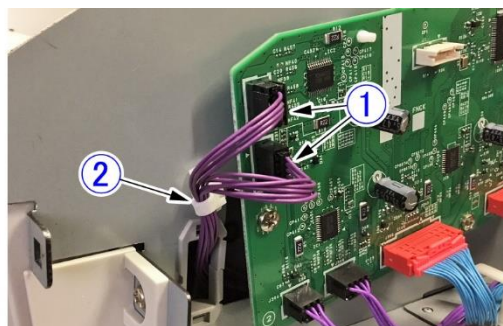

Figure 3-605

- 4) Remove 6 screws (M3-bind head, round tip) that are placed in the holes ①. Pick up the tray drive box ② slowly and remove it with the cables ③.

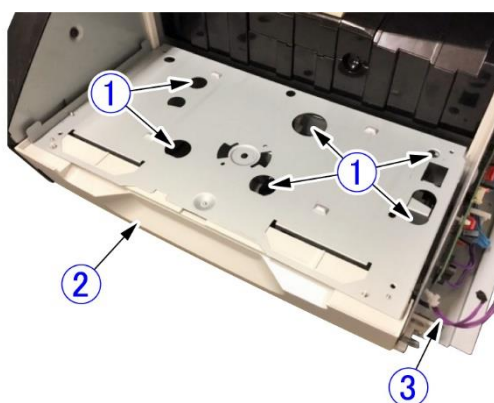

Figure 3-606

**◆ Notes on assembling**

There are 2 bosses for positioning at the bottom of the base unit. Insert the bosses into the holes at the bottom of the tray drive box. If the position is shifted, the screw hole position is shifted or lift occurs.

**3. Blind Cover**

- 1) Remove the tray drive box.  
[\(Page 3-28\)](#)
- 2) Turn the tray drive box over, remove 3 screws① (M3-TP head, round tip) and remove the blind cover②.

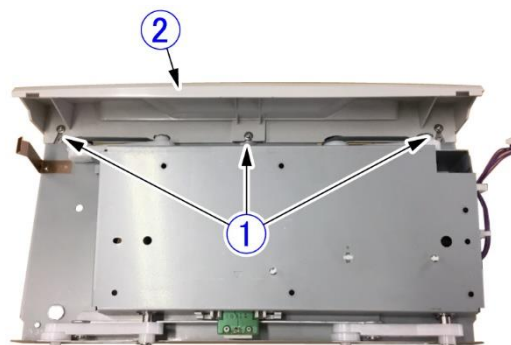
**Figure 3-607**

#### 4. Pickup Tray Plate

- 1) Remove the tray drive box and blind cover.  
([Page 3-29](#))
- 2) Remove 2 screws ① (M4, self-tapping), and remove the washer ② and flange ③ on each side. And remove the pickup tray plate ④ from 4 bosses ⑤.

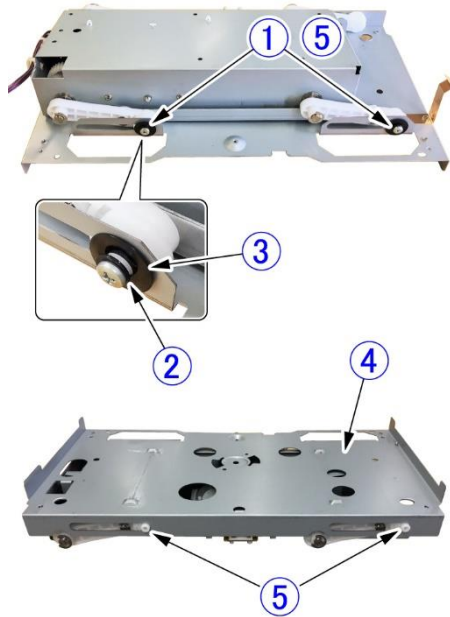

Figure 3-608

#### 5. Lower Front Cover

- 1) Remove the right and left covers.  
([Page 3-3](#)), ([Page 3-5](#))
- 2) Remove the tray drive box.  
([Page 3-28](#))
- 3) Remove 2 screws ① (M3-bind head, round tip) and screw ② (M3x12) and remove the lower front cover ③.

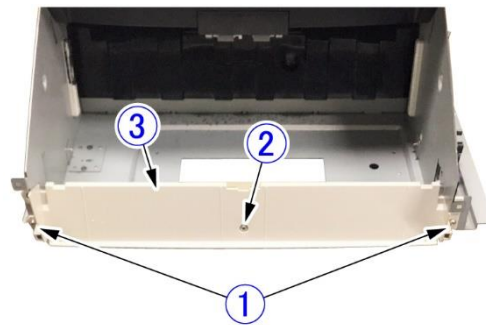

Figure 3-609

## 6. Lower Entrance Guide

- 1) Remove the roller cover. Remove 3 screws ① (M3, stepped 3.2) and remove the lower entrance guide ②.

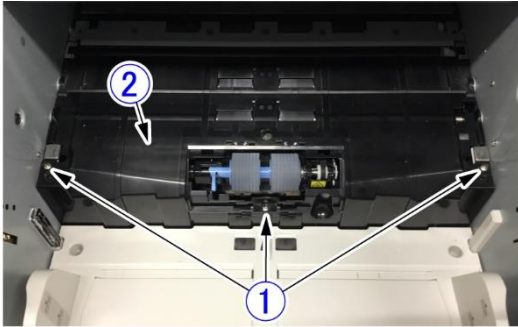

Figure 3-610

**Note:** Remove the light guides (total 3) if necessary. Do not damage fitting parts when removing them.

## 7. Right Belt

- 1) Remove the right cover. [\(Page 3-3\)](#)
- 2) Loosen the screw ② (M3-bind head, round tip) of the tension plate ①. And remove the belt ③.

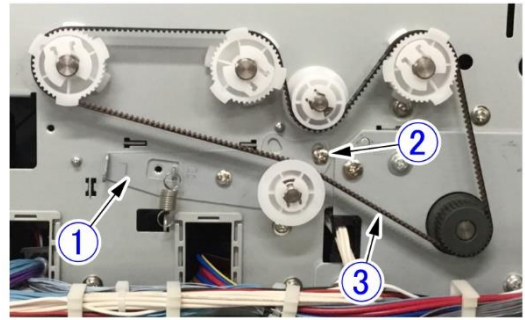

Figure 3-611

### ◆ Notes on assembling

First, assemble the belt to the pulleys, and then tighten the screw. The tension of the belt is fixed by a coil spring with the tension plate.

## 8. Left Front Belt

- 1) Remove the left cover.  
(Page 3-5)
- 2) Loosen the screw ② (M3-bind head, round tip) of the tension plate ①. And remove the coil spring ③ and the belt ④.

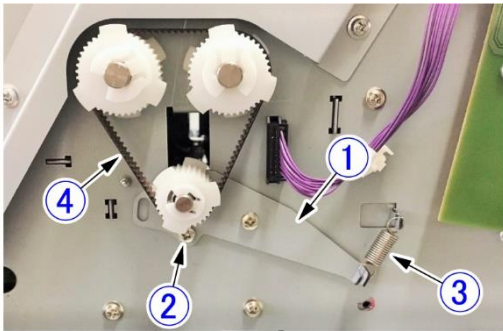

Figure 3-612

### ◆ Notes on assembling

First, assemble the belt to the pulleys, and then tighten the screw. The tension of the belt is fixed by a coil spring with the tension plate.

## 9. Left Rear Belt

- 1) Remove the left cover.  
(Page 3-5)
- 2) Loosen the screw ② (M3-bind head, round tip) of the tension plate ①. And remove the belt ③.

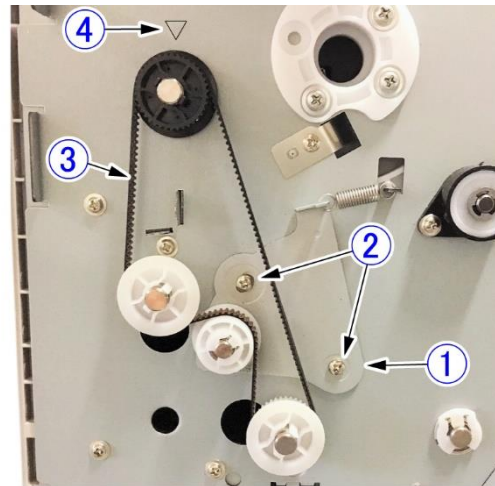

Figure 3-613

### ◆ Notes on assembling

Verify the orientation of the flange attached to the pulley. "∇" indicated by mark ④ in the above figure shows the position of the black pulley (the flange is inside).

First, assemble the belt to the pulleys, and then tighten the screw. The tension of the belt is fixed by a coil spring with the tension plate.

## 10. Pull-in Lower Roller

- 1) Remove the right and left covers.  
([Page 3-3](#)), ([Page 3-5](#))
- 2) Remove the lower entrance guide.  
([Page 3-31](#))
- 3) Remove the left front belt,  
([Page 3-32](#))
- 4) For the pull-in lower roller①, remove the stopper②, pulley③ and pin④ on the left side. And remove the stopper④ on the right side, and bearing⑤ on each side. And remove the roller.

**Note:** Do not lose the pin.

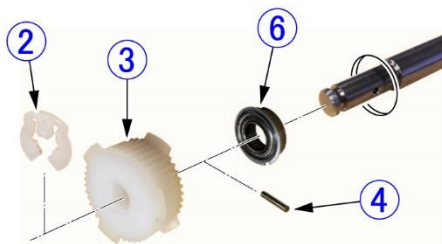
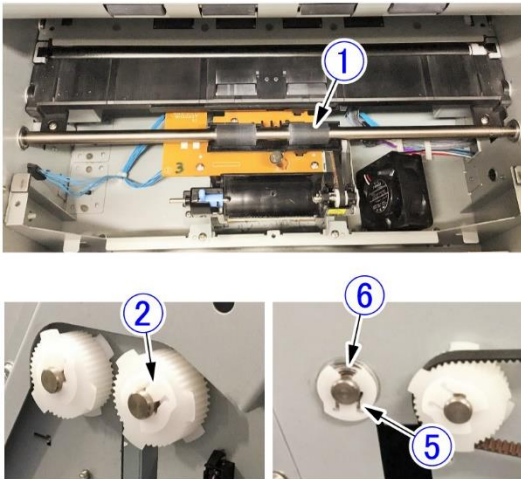

**Figure 3-614**

## 11. Registration Lower Roller

- 1) Remove the right and left covers.  
([Page 3-3](#)), ([Page 3-5](#))
- 2) Remove the right belt and left front belt.  
([Page 3-31](#)), ([Page 3-32](#))
- 3) Remove the lower entrance guide.  
([Page 3-31](#))
- 4) Remove 2 screws① (M3, stepped 3.2), and remove the lower feed guide②.

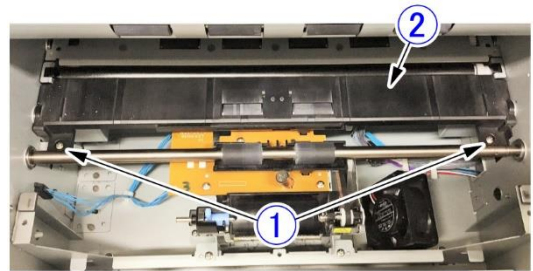

**Figure 3-615**

- 5) For the registration lower roller①, remove the stopper②, pulley③ and pin④ on each side. And remove the bearing⑤ on each side. And remove the roller.

**Note:** Do not lose the pin.

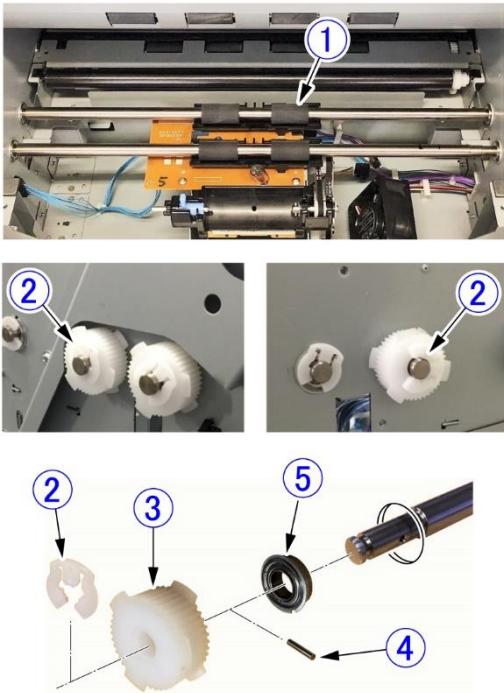

Figure 3-616

## 12. Platen Lower Roller

**Note:** You need a short screwdriver. Otherwise, you need to disassemble the entire upper unit at first.

- 1) Remove the right and left covers.  
([Page 3-3](#)), ([Page 3-5](#))
- 2) Remove the lower entrance guide.  
([Page 3-31](#))
- 3) Remove 2 screws ① (M3, stepped 3.2), and remove the lower feed guide ②.

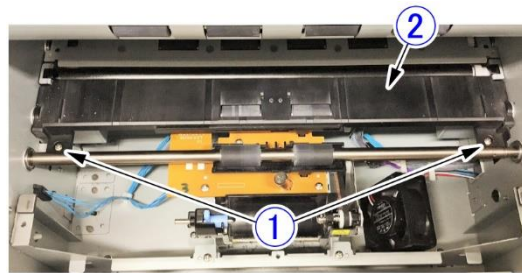

Figure 3-617

- 4) Remove 2 screws ① (M3-bind head, round tip) using a short screwdriver and remove the platen unit ②.

**Note:** The screwdriver may strike the upper unit and may not touch the screw vertically. Install and remove screws carefully. It is better to use a short screwdriver.



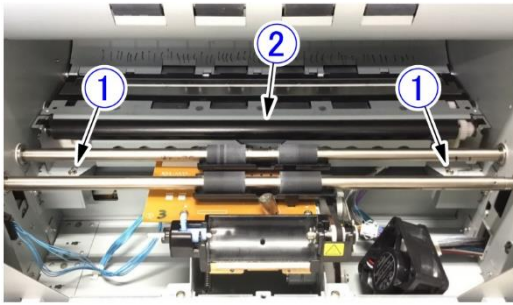

Figure 3-618

- 4) Remove the E-rings ① and bearing holder ② (including bearing) on each side and remove the platen lower roller ③. And then remove the gear ④ (including one-way clutch) and stopper ⑤.

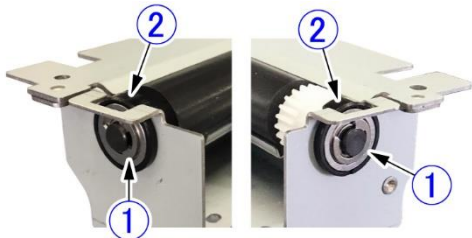

Figure 3-619

### 13. Reading Lower Roller

- 1) Remove the right and left covers. [\(Page 3-3\)](#), [\(Page 3-5\)](#)
- 2) Remove the right belt. [\(Page 3-31\)](#)
- 3) Remove the platen unit. [\(Page 3-34\)](#)
- 5) For the reading lower roller ①, remove the stopper ②, pulley ③ and pin ④ on the right side. And remove the stopper ⑤ on the left side, and bearing ⑥ on each side. And remove the roller.

**Note:** Do not lose the pin.

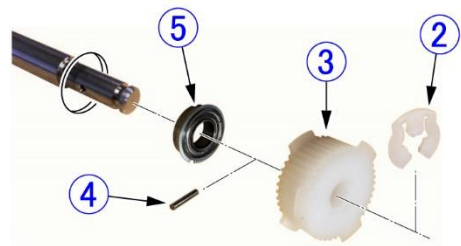
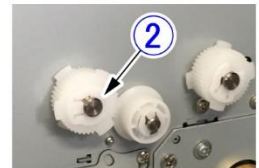
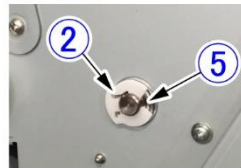

Figure 3-620

### 14. Pre U-turn Lower Roller

- 1) Remove the right and left covers.  
([Page 3-3](#)), ([Page 3-5](#))
- 2) Remove the right and left belts.  
([Page 3-31](#)), ([Page 3-32](#))
- 3) For the pre U-turn lower roller①, remove the stopper②, pulley③ and pin④ on the right side. And open the fitting parts to remove the pulley⑤ and pin⑥ on the left side, and bearing⑦ on each side.

**Note:** Do not lose the pin.

- 4) On the left side, move the shaft to the left hole (bigger one), and then pull out the pre U-turn lower roller① without any damage on the rubber roller sections.

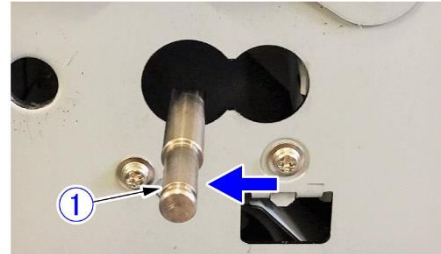

**Figure 3-622**

◆ **Notes on assembling**

Adjust and insert the rubber roller sections into the holes in the U-turn guide.

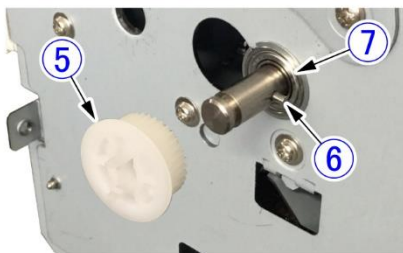
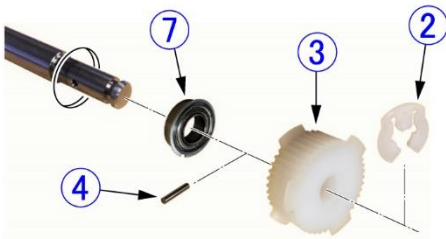
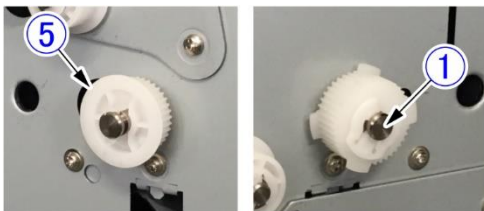

**Figure 3-621**

## 15. U-turn Lower Roller (Middle)

**Note:**This is the same parts as the U-turn lower roller (rear).

- 1) Remove the right and left covers.  
([Page 3-3](#)), ([Page 3-5](#))
- 2) Remove the left belt.  
([Page 3-32](#))
- 3) For the U-turn lower roller (middle) ①, open the fitting parts to remove the pulley ② and pin ③ on the left side. And remove the stopper ④ on the right side, and bearing ⑤ on each side.

**Note:**Do not lose the pin.

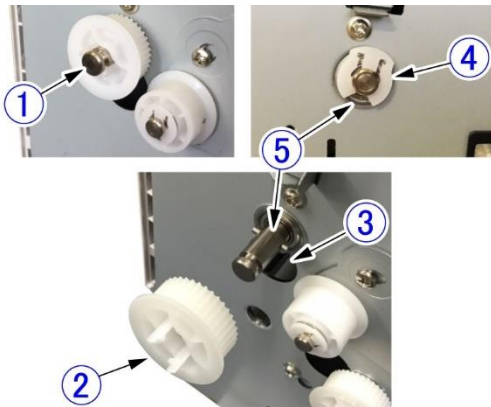

Figure 3-623

- 4) On the left side, move the shaft to the lower hole (bigger one), and then pull out the U-turn lower roller (middle) ① without any damage on the rubber roller sections.

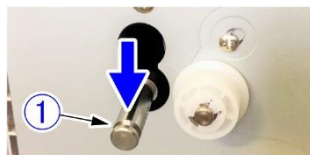

Figure 3-624

### ◆ Notes on assembling

Adjust and insert the rubber roller sections into the holes in the U-turn guide.

## 16. U-turn Lower Roller (Rear)

**Note:**This is the same parts as the U-turn lower roller (middle).

- 1) Remove the right and left covers.  
([Page 3-3](#)), ([Page 3-5](#))
- 2) Remove the eject drive unit.  
([Page 3-38](#))
- 3) For the U-turn lower roller (rear) ①, open the fitting parts to remove the pulley ② and pin ③ on the left side. And remove the stopper ④ on the right side, and bearing ⑤ on each side. And then pull out the U-turn lower roller (rear) from upper side without any damage on the rubber roller sections.

**Note:** Do not lose the pin.

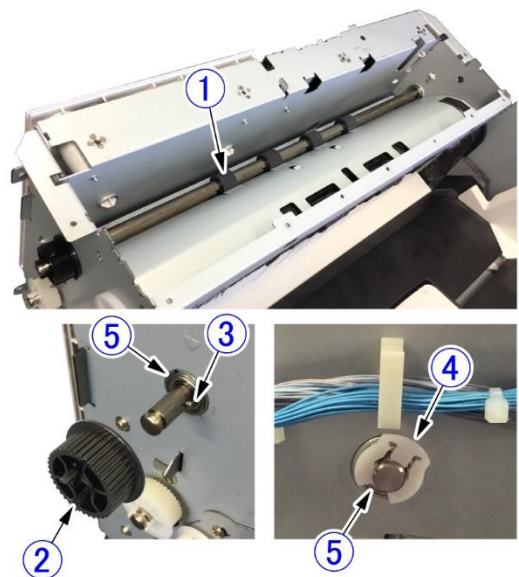

Figure 3-625

### ◆ Notes on assembling

Adjust and insert the rubber roller sections into the holes in the U-turn guide.

### 17. Eject Drive Unit

- 1) Remove the control PCB cover.  
(Page 3-3)
- 2) Remove the top cover.  
(Page 3-6)
- 3) Remove the connector ① connected to the control PCB and 6 screws ② (M3-bind head, round tip), and remove the eject drive unit ③.

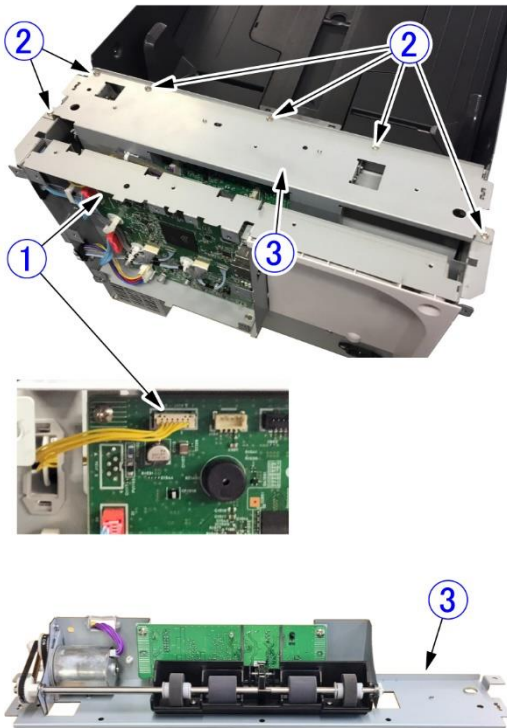

Figure 3-626

### 18. Eject Drive Roller

- 1) Remove the eject drive unit.  
(Page 3-38)
- 2) Loosen the screw ① (M3-bind head, round tip) of the tension plate. And remove the stopper ② and the belt ③.

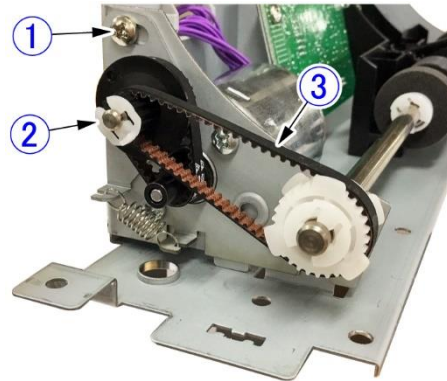

Figure 3-627

- 3) Open the fitting parts to remove the pulley ① and pin ②. And remove the stopper ③ and bearing ④ on each side. And while escaping the lever ⑤, remove the eject drive roller ⑥.

**Note:** Do not lose the pin.

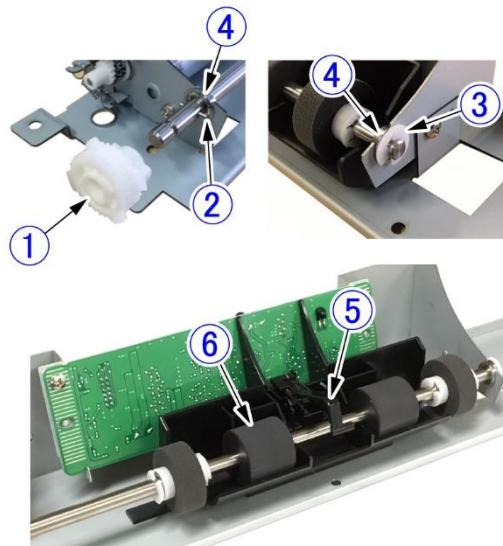

Figure 3-628

## VII. BASE UNIT-2 (ELECTRICAL RELATION)

### 1. Control PCB

1) Remove the control PCB cover.

[\(Page 3-3\)](#)

2) Remove all cables connected to the control PCB ① and remove 3 locked cable bands ②. Open the cable holder ③ and remove the cable.

**Note:** There are 3 connectors with lock. Release the lock and remove the connector.

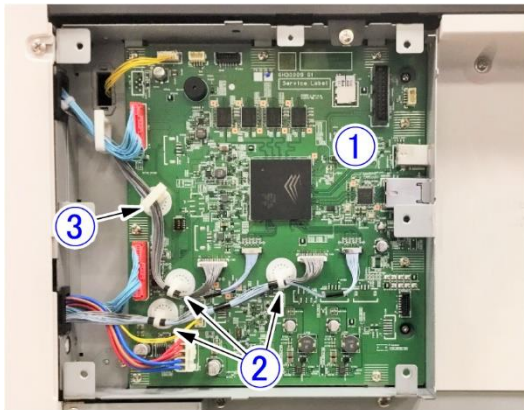

Figure 3-701

3) Remove 9 screws ① (M3-bind head, round tip) and remove the control PCB ②.

**Note:** Remove the cable holder, if necessary. It is not a component of the control PCB.

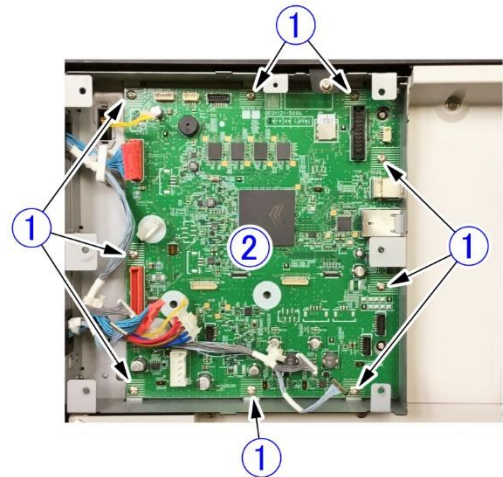

Figure 3-702

**Note:** Don't remove a micro SD card from the control PCB..

## 2. Sub-Drive PCB

- 1) Remove the right cover.  
([Page 3-3](#))
- 2) Remove all cables connected to the sub-drive PCB ①. And remove 4 screws ② (M3-bind head, round tip) and 2 screws ③ (M3, self-tapping), then remove the sub-drive PCB.

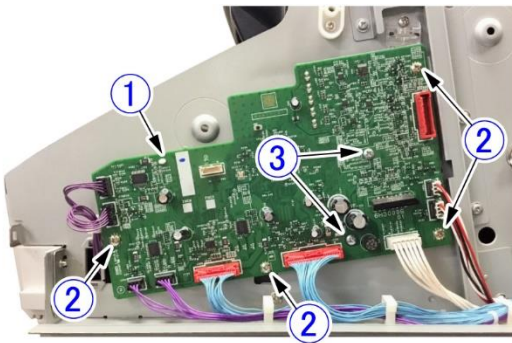

Figure 3-703

## 3. Staple PCB

- 1) Remove the left cover.  
([Page 3-5](#))
- 2) Remove 2 screws ① (M3, self-tapping) and remove the staple PCB ②. And then remove the cable ③.

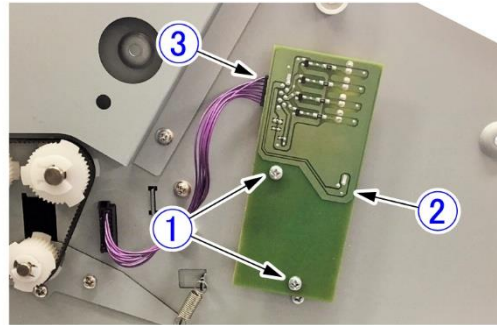

Figure 3-704

#### 4. Power PCB

- 1) Remove 8 screws ① (M4-bind head, round tip) and pull out the power PCB② (including the mounting plate).

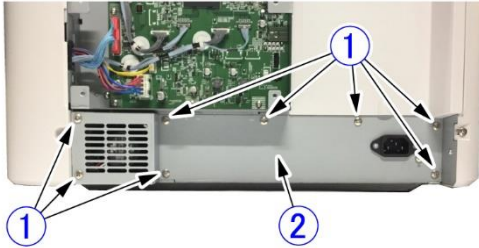

Figure 3-705

- 2) Remove the cable ① (with a connector lock) and cable ②, then remove the power PCB ③ (including the mounting plate).

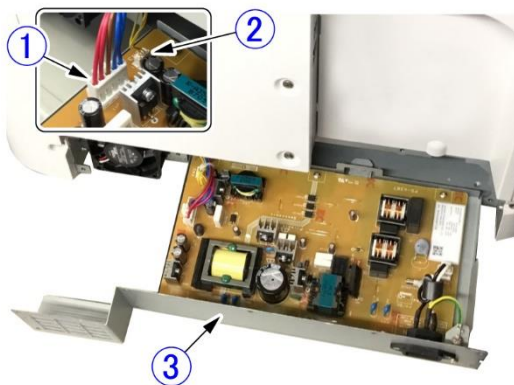

Figure 3-706

- 3) Remove 6 screws ① (M3-bind head, round tip) and cable ② (with connector lock), and then remove the power PCB ③.

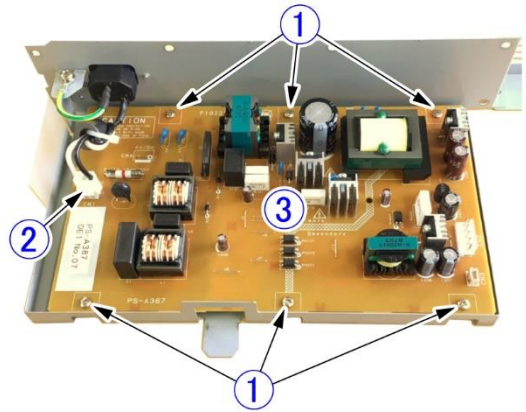

Figure 3-707

## 5. Ultrasonic Drive PCB

- 1) Remove the registration lower roller.  
([Page 3-33](#))
- 2) Remove 3 screws ① (M3-bind head, round tip) and remove the ultrasonic drive PCB ②. Then, remove the cable ③ on the back side.

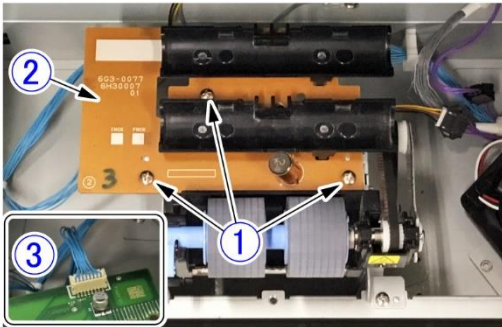

Figure 3-708

## 6. Eject PCB

- 1) Remove the eject drive unit.  
([Page 3-38](#))
- 2) Remove 2 cables ①. Then remove 2 screws ② (M3-bind head, round tip), and while unhooking 2 position setters ③, remove the eject PCB ④.

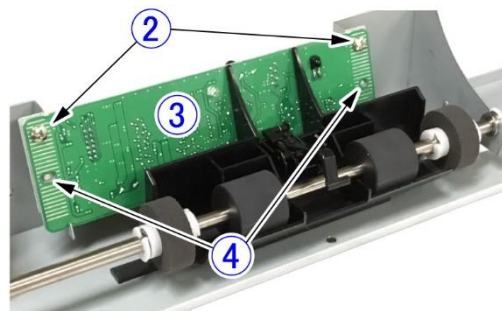
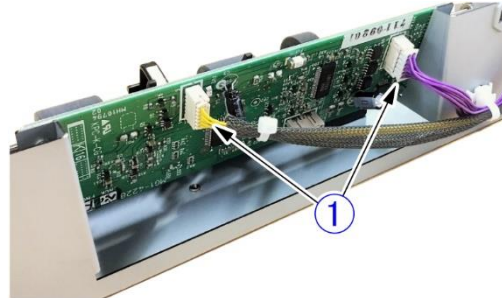

Figure 3-709



## 7. Document Sensor PCB

1) Remove the tray drive box and pickup tray plate.

[\(Page 3-30\)](#)

2) Remove the connector ①. And turn the gear ② by hand and lift the connecting plate ③.

**Note:** Grease is applied to the gears. Wipe grease off your fingers.

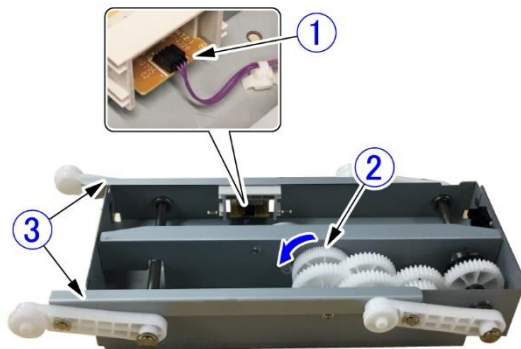

Figure 3-710

3) Then, unhook 2 pairs of the fitting parts ① and remove the sensor cover ② (including the PCB).

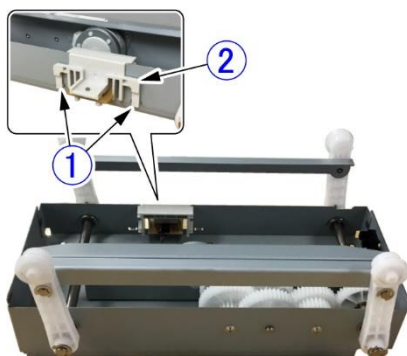

Figure 3-711

4) Unhook 2 pairs of the fitting parts ①, remove the document sensor PCB ②.

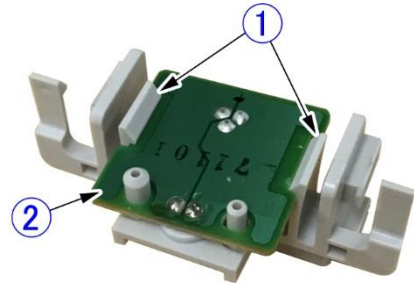

Figure 3-712

## 8. Main Motor

- 1) Remove the right cover and right belt.  
([Page 3-31](#))
- 2) Open 6 cable holders①, and move the cables ② away. And remove the connector③ and release the cable of the exhaust fan. And then remove 2 cable holders④.

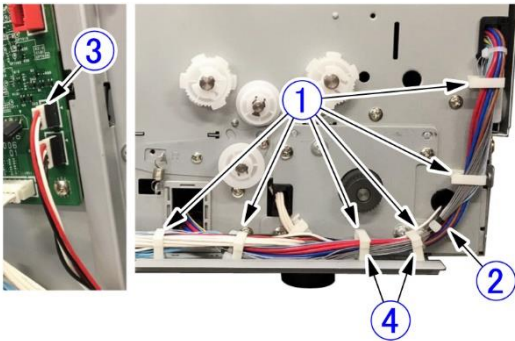

Figure 3-713

- 3) Remove the locked cable band① and 4 screws② (M4-bind head, round tip), and then slide the main motor unit③ in front and remove the cable④. Then, remove 2 screws⑤ (M4-TP head, round tip) and remove the main motor plate⑥.

**Note:** Handle the main motor carefully because it is heavy.

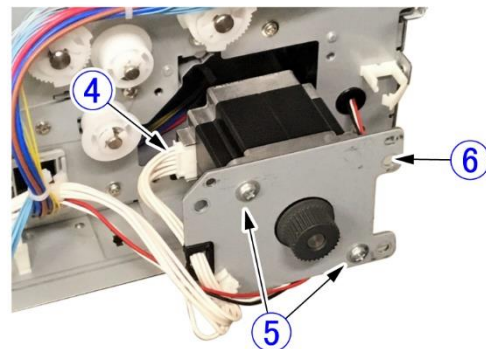
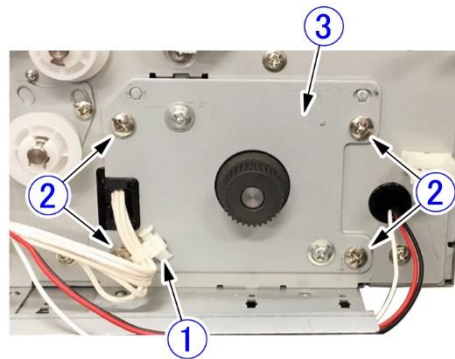

Figure 3-714

## 9. Tray Motor

- 1) Remove the tray drive box and pickup tray plate.

(Page 3-30)

- 2) Open the cable holder ① and remove the connector ②.

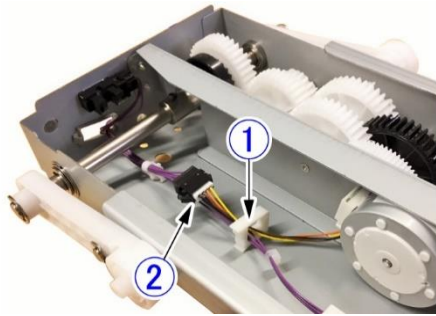

Figure 3-715

- 3) Remove 6 screws ① (M3-bind head, round tip) and remove the gear unit ②.

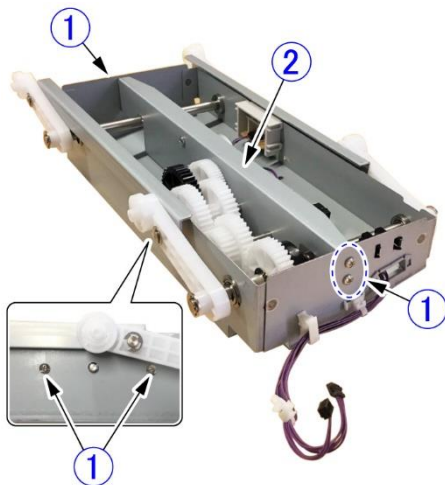

Figure 3-716

- 4) Remove 5 gears ① to ⑤. Then remove 2 screws ⑥ (M3-bind head, round tip) and remove the tray motor ⑦.

**Note:** Grease is applied to the gears. Wipe grease off your fingers and around area.

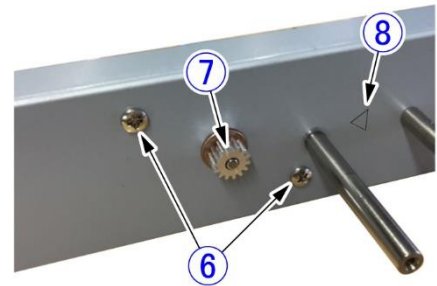
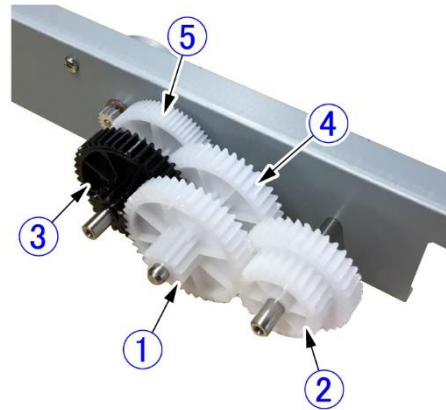

Figure 3-717

**Note:** "∇" ⑧ indicated in the above figure shows the motor cable position.

## 10. Separation Motor

- 1) Remove the registration lower roller.  
([Page 3-33](#))
- 2) Remove the cooling fan.  
([Page 3-48](#))
- 3) Remove 3 screws ① (M3-bind head, round tip) and 2 connectors ② and pull out the retard roller drive assembly ③.

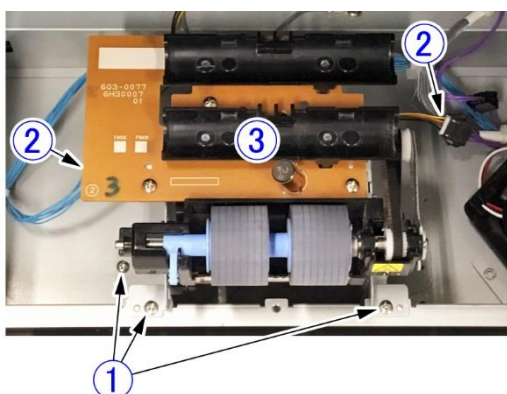

Figure 3-718

- 4) Remove 2 screws ① (M3-bind head, round tip) and remove the separation motor ②.

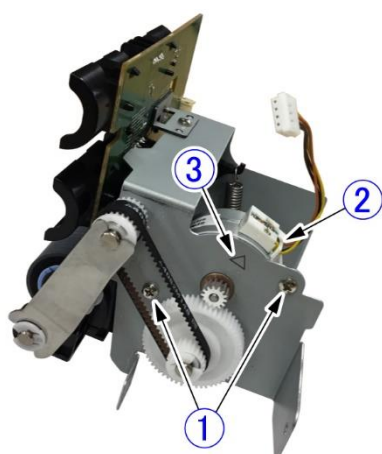

Figure 3-719

**Note:** "▽" ③ indicated in the above figure shows the motor cable position.

## 11. Eject Motor

- 1) Remove the eject drive unit.  
([Page 3-38](#))
- 2) Loosen the screw ① (M3x6, bind head) and remove the stopper ② and remove the belt ③. Then remove the pulley ④, belt ⑤ and coil spring ⑥.

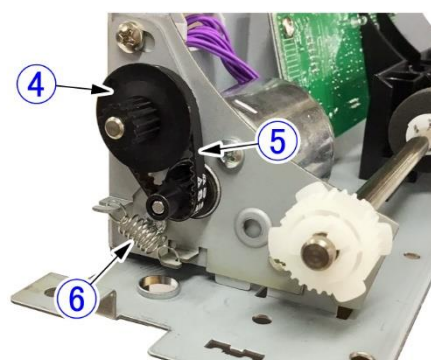
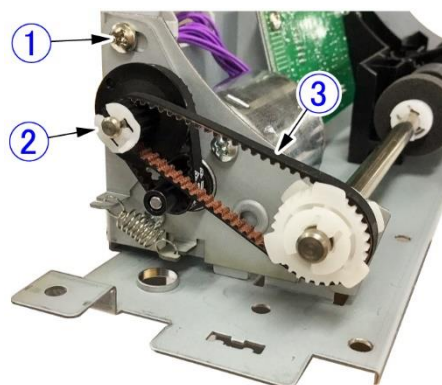

Figure 3-720

- 3) Remove 2 screws ① (M3-bind head, round tip) and the cable ②, and then remove eject motor ③ and 2 plates ④.

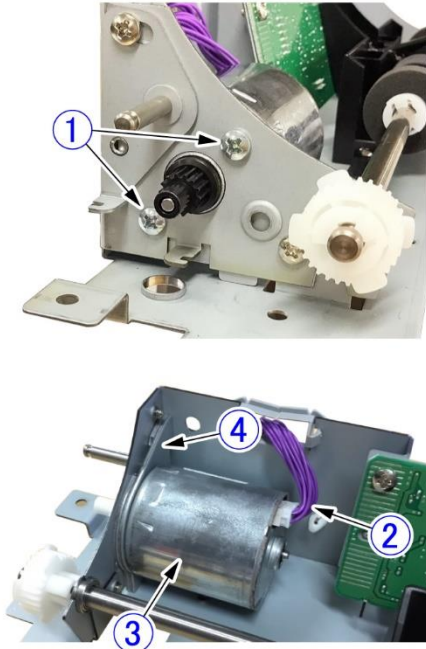

Figure 3-721

## 12. Exhaust Fan

- 1) Remove the right cover.  
(Page 3-3)
- 2) Remove the power PCB (including a mounting plate).  
(Page 3-41)
- 3) Remove the connector ① of the exhaust fan on the sub drive PCB, remove the cable from the cable holders. And remove the screw ② (M4x30) and remove the exhaust fan ③ with cable.

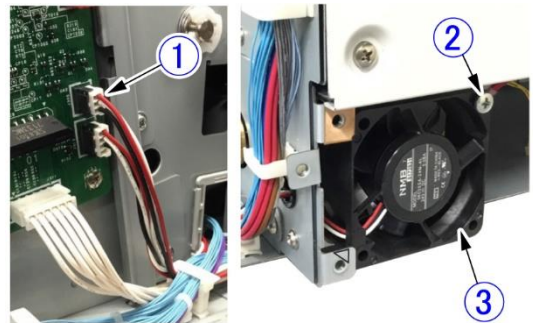

Figure 3-722

### ◆ Notes on assembling

Insert the projection ① of the main body into the upper left hole, and secure it with a screw.

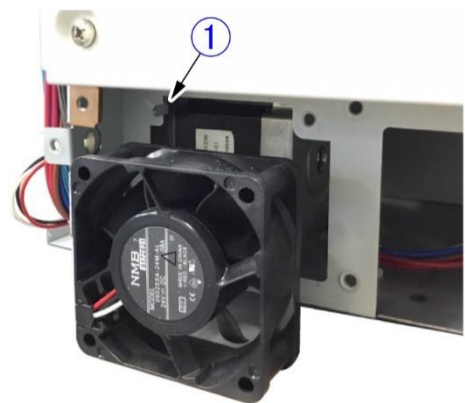

Figure 3-723

### 13. Cooling Fan

- 1) Remove the pull-in lower roller..  
([Page 3-3](#))
- 2) Remove the lower entrance guide.  
([Page 3-31](#))
- 3) Remove the connector① of the exhaust fan on the sub drive PCB, remove the cable from the cable holders②. And remove the screw ③ (M3-bind head, round tip) and remove the cooling fan④ (including mount plate).

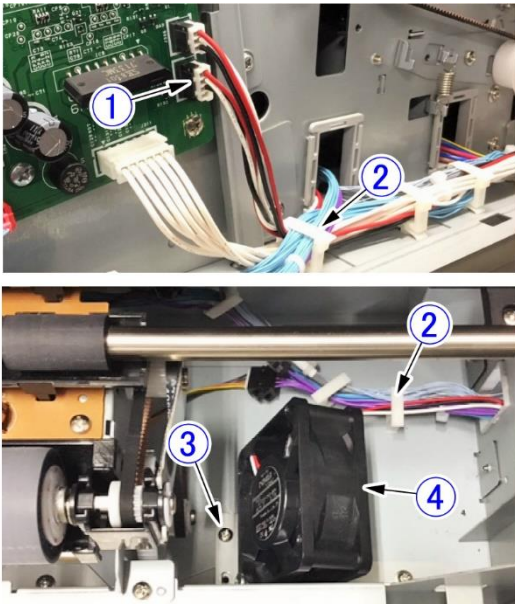

Figure 3-724

- 4) Remove the screw ① (M4x30) and remove the cooling fan②.

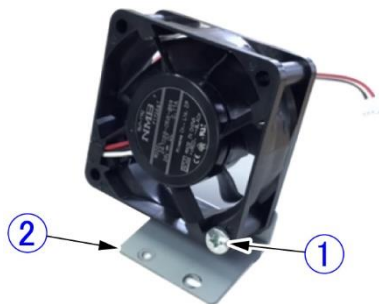

Figure 3-725

## VIII. BASE UNIT-3 (READING RELATION)

### 1. Lower Reading Unit

**Note:** A short screwdriver is required to remove this part. If it is not available, remove the entire upper unit.

- 1) Remove the registration lower roller.  
(Page 3-33)
- 2) Remove the reading lower roller.  
(Page 3-38)
- 3) Remove the screw ① (M3-bind head, round tip), and the grounding cable ② and relay connector ③. And open the cable holder ④, remove the relay connector ⑤, then remove the reading unit's cable ⑥ from the cable holder.

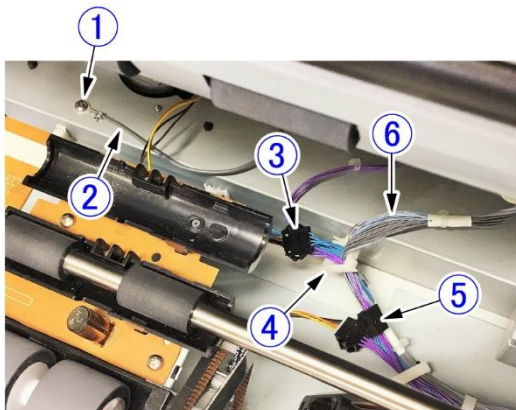

Figure 3-801

- 4) Remove 2 screws ① (M3, stepped 3.2) using the short screwdriver and lift the lower reading unit ③ slightly, and pull it out to the front, and then turn it to reverse.

**Note:** Do not pull it excessively because a cable is connected to the back side.

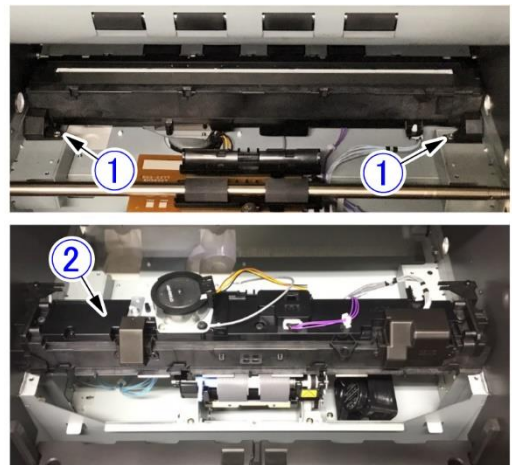

Figure 3-802

- 5) Remove 2 fitting parts ① and the cover ②. And then remove the cable band with lock ③ and remove the connectors ④ and ⑤. And remove the reading unit with cables for the motor, grounding and sensor.

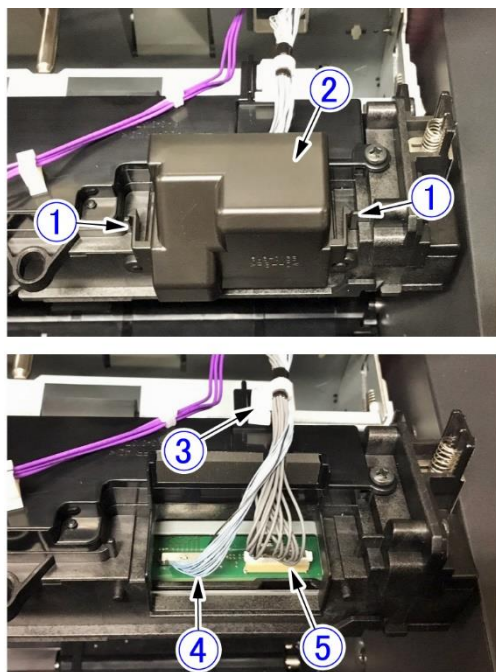

Figure 3-803

## 2. Shading Motor

- 1) Remove the lower reading unit.  
([Page 3-49](#))
- 2) Remove 2 screws ① (M3-bind head, round tip) and remove the shading motor ②.

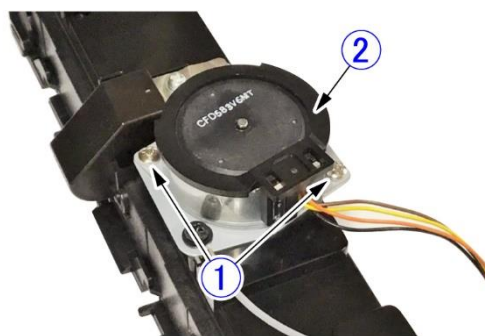

Figure 3-804

### ◆ Notes on assembling

The cables connected to the CIS unit should be formed with extra because the CIS unit slides to get shading data.

Connect 2 cables to the CIS unit, and then insert the cable band with lock. And placed these cables in the groove of sponge packing and then assemble the cover.

Pass the motor, grounding and sensor cables through a hole before assembling the reading unit. Be careful not to allow these cables to be caught.



### 3. Lower Reading Glass Assembly

- 1) Clean the glass surface and the feed path to prevent dust from entering the reading unit.
- 2) While pushing the stopper ① with a finger or tool with a thin and bent tip and unhooking the fitting parts, slide the lower reading glass assembly ② until it stops and remove it.

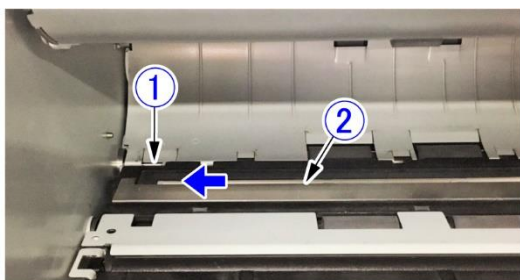

Figure 3-806

#### ◆ Notes on assembling

Do not touch the glass rear surface and the surface of the lens array of the reading unit with fingers. If they are dirty, clean them with a clean dry cloth.



---

# CHAPTER 4

---

## INSTALLATION & MAINTENANCE

---

---

I. INSTALLATION .....	4-1	III. MAINTENANCE .....	4-15
II. PARTS REPLACEMENT.....	4-12		

---



## I. INSTALLATION

### 1. Choosing Location

The following requirements should be met when installing this machine. The service technician should inspect the planned location before delivery.

You can refer the user manual or setup guide for details.

- Ensure to provide a carry-in route and a means of transporting this machine in the packing condition. The packing weight is approx. 30 kg, and the dimensions are approx. 600(W) × 680(D) × 450 (H) mm.
- There should be an enough space around this machine for operation, maintenance and ventilation.

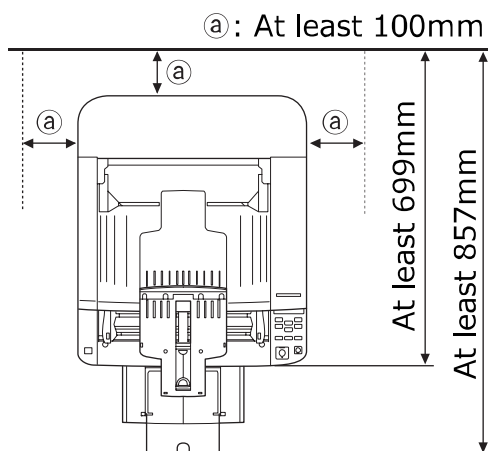

Figure 4-101

- This machine should not be exposed to open flames, dust, ammonia fumes, direct sunlight, vibration, or electromagnetic wave.
- \* If it has to be placed in a sunny place, the windows should be curtained to avoid direct sunlight.

- This machine should not be installed near water faucets, boilers, humidifiers, refrigerators, etc. and should not be put in a location where the temperature or humidity changes abruptly.
- Do not install this machine on a weak table or an inclined or unstable location. The weight of the main body is approx. 25 kg.
- The temperature should be between 10°C and 35°C and the relative humidity should be between 20% and 80%. However, since the performance is guaranteed at a temperature between 15°C and 27.5°C and a relative humidity between 25% and 75%, this machine should be installed in this range.
- The power supply must be able to be connected separately from a reference voltage receptacle.
  - \* If a ground wire must be connected, connect it to the correct location shown below.
    - 1) Ground terminal of the receptacle.
    - 2) Ground wire for which grounding work for office equipment is performed.

## 2. Unpacking And Installation

When metallic objects are brought from a cold room into a warm room, small drops of water may be formed on the surfaces. This phenomenon is called condensation and if the machine with condensation is used, vari-

ous problems may take place. Therefore, allow this machine at least one hour to adjust to room temperature before moving the machine from a cold room into a warm room and installing it.

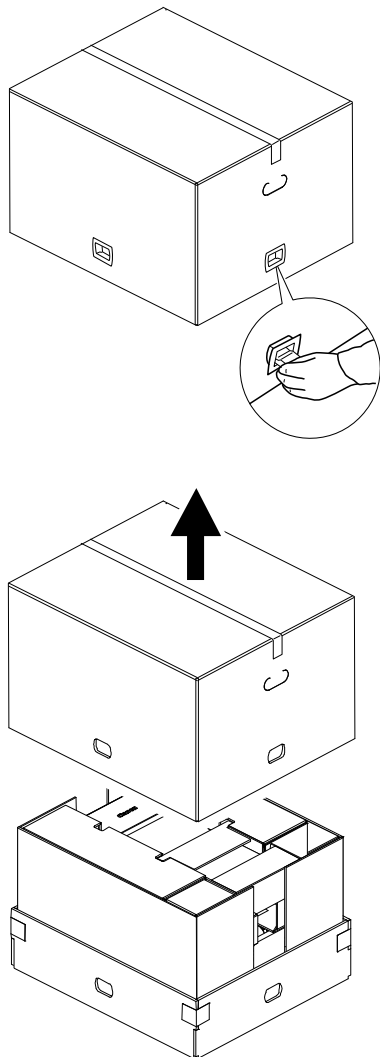
No.	Step	Details/Remarks
1	<p>Remove the box joints (4) and lift and remove the cardboard box. The packing weight is approx. 30 kg and the dimensions are approx. 600 (W) × 680 (D) × 450(H) mm.</p> <p><b>Note:</b> 1) Do not open the top of the cardboard box, but remove the entire cardboard box.</p>	

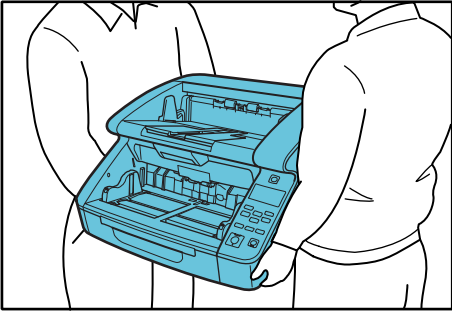
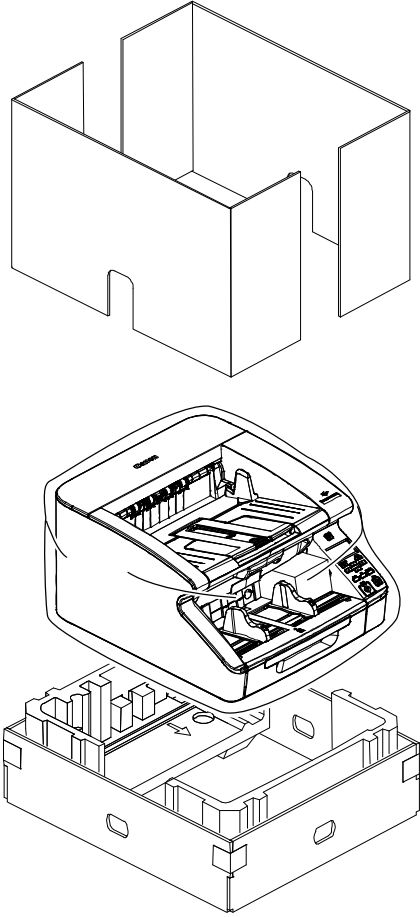

No.	Step	Details/Remarks
2	<p>Take out the packing and accessories.</p> <p>Check that the accessories are present.</p> <ul style="list-style-type: none"> <li>① Power cord</li> <li>② Ground cord (100V model only)</li> <li>③ USB cable</li> <li>④ Setup Guide</li> <li>⑤ Setup Disc</li> <li>⑥ Cleaning cloth</li> <li>⑦ Warranty card (a part of region only)</li> </ul>	

No.	Step	Details/Remarks
3	<p>Remove the side packing and take out the main body.</p> <p><b>Note:</b> The weight of the main body is approx. 25 kg. When taking the main body out or moving it, 2 persons must hold it from both sides. Use a cart, etc. when moving it.</p>  <p>When taking out the main body, lift the center with no pad with one hand, then support the rear side with the other hand because the center of gravity of the main body is at the rear side.</p>	
4	<p>Place the main body at the installation location.</p> <p><b>Note:</b></p> <ol style="list-style-type: none"> <li>1) Since it is heavy, place it on a flat, sturdy surface.</li> <li>2) Check if the covers show any signs of damage caused during transportation.</li> </ol>	

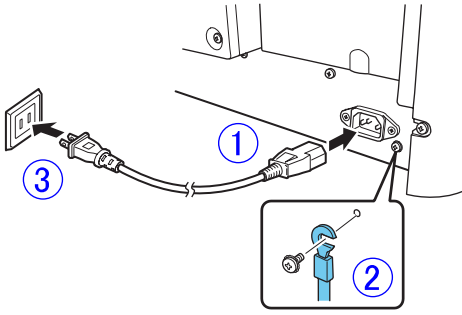
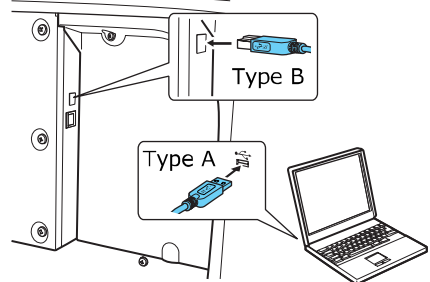

No.	Step	Details/Remarks
5	<p>Peel off all the tape securing each part.</p> <p><b>Note:</b></p> <ol style="list-style-type: none"> <li>1) Release the document guide lock ②, and then remove the protection pad ①,</li> <li>2) Open the upper unit, and then remove the protection sheet ③.</li> <li>3) Open the pickup roller cover ④, and then remove the fixing tape ⑤.</li> <li>4) Open the retard roller cover ⑥, and then remove the protection pad ⑦.</li> </ol>	

No.	Step	Details/Remarks
6	<p>Install software in the computer used for operation check as required.</p> <p><b>Note:</b> From Step No.6, refer to the User Manual or Setup Guide for details.</p> <ul style="list-style-type: none"> <li>◆ If it has already been installed in the computer for servicing, it does not need to be installed during installation.</li> <li>◆ If the service technician installs it in the user's computer, obtain the user's approval beforehand.</li> <li>◆ If the user installs it, ask the user to install it according to the "Setup Guide".</li> </ul> <p><b>Note:</b></p> <ol style="list-style-type: none"> <li>1) Ensure that the specification of computer and type of the operating system are correct.</li> <li>2) Do not connect the scanner to the computer before installing software.</li> <li>3) Be sure to log on with administrator privileges.</li> </ol>	<ol style="list-style-type: none"> <li>1) Insert the Setup Disc into the disc drive.                     <div data-bbox="826 405 1257 707" data-label="Image"> </div> </li> <li>2) The setup menu starts. Click [Typical Installation] or [Custom Installation].                     <div data-bbox="807 846 1273 1178" data-label="Image"> </div> </li> <li>3) Later on, perform operation according to the screen instructions.</li> <li>4) When all installation is completed, the installation completion screen is displayed. Click [Exit].                     <div data-bbox="807 1384 1273 1715" data-label="Image"> </div> </li> </ol>

No.	Step	Details/Remarks
7	<p>Connect the power cord and USB cable</p> <p><b>Note:</b></p> <p>1) Inhere, the installation and operation check will be done with the USB connection.</p> <p>2) This machine does not have a LAN cable, router and other goods related the LAN connection in the box. You need prepare separately.</p>	<p>◆Power cord</p> <ol style="list-style-type: none"> <li>1) Connect the supplied power cord to the power connector on the rear side of the main body. ①</li> <li>2) (100V model only) Connect the supplied grand cord. ②</li> <li>3) Insert the power plug in the receptacle. ③</li> </ol>  <p>◆USB cable</p> <ol style="list-style-type: none"> <li>1) Connect the supplied USB cable with the computer.</li> </ol> 
8	<p>Turn the power ON and make the computer recognize the scanner.</p>	<ol style="list-style-type: none"> <li>1) Press the power switch to turn this machine ON.</li> <li>2) Windows recognizes this machine as a new hardware and installs it automatically.</li> <li>3) When it was completed, The CaptureOnTouch icon appears on the taskbar as follows.</li> </ol> 
9	<p>Ensure that it operates correctly by using the supplied "CaptureOnTouch". Refer to the "User Manual" for details.</p>	

### 3. Imprinter Installation Procedure

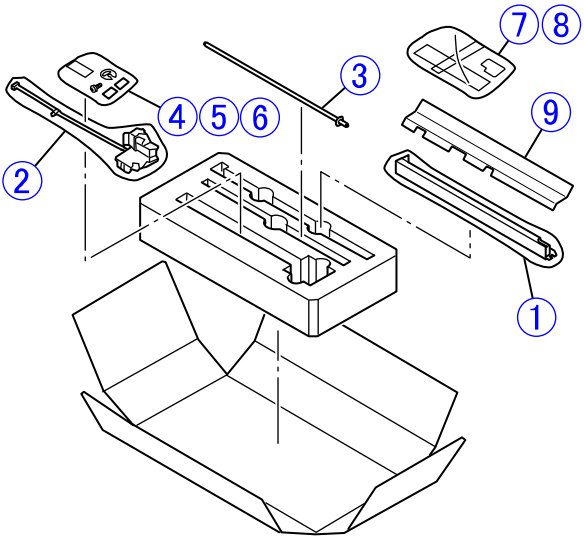
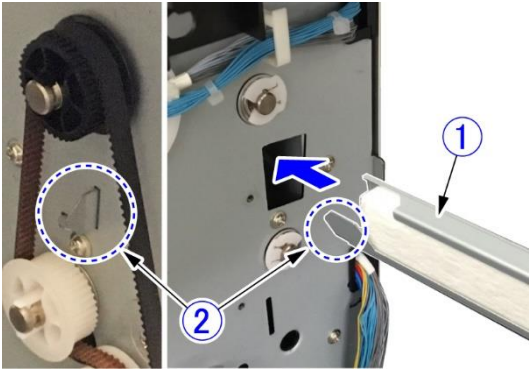
No.	Step	Details/Remarks
1	<p>Make sure that all parts are ready.</p> <ul style="list-style-type: none"> <li>① IP drain unit</li> <li>② IP carriage</li> <li>③ IP shaft</li> <li>④ Stopper plate (2 pcs.)</li> <li>⑤ Plastic retaining ring</li> <li>⑥ Screw (BH, M3x6)</li> <li>⑦ Caution label</li> <li>⑧ IP label</li> <li>⑨ Protection sheet</li> </ul> <p><b>Note:</b></p> <ul style="list-style-type: none"> <li>1) The stopper plate④ is for DR-G2140 series only and protection sheet⑨ is for DR-G1130 series only to use.</li> <li>2) Since the electrical contacts of the IP carriage are exposed, handle it carefully to avoid damage due to static electricity.</li> <li>3) The E-ring must be press-fitted on the one side of the IP shaft.</li> <li>4) Provide an ink cartridge for operation check. The ink cartridge is separately sold.</li> </ul>	
2	<p>Remove the right and left covers and the eject tray unit.</p> <p><b>Note:</b></p> <ul style="list-style-type: none"> <li>1) Refer to “CHAPTER 3, DISASSEMBLY &amp; REASSEMBLY” for details.</li> </ul>	
3	<p>Insert the IP drain unit① into the hole on the right side of this machine, in the direction of the arrow, as far as it will go. Be careful to orient the unit correctly. Place the inserted tip ② into the hole on the left side of this machine.</p>	 <p>Left side      Right side</p>

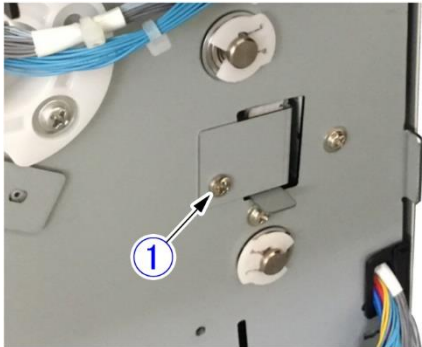
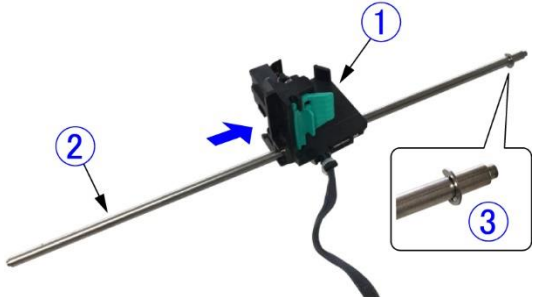
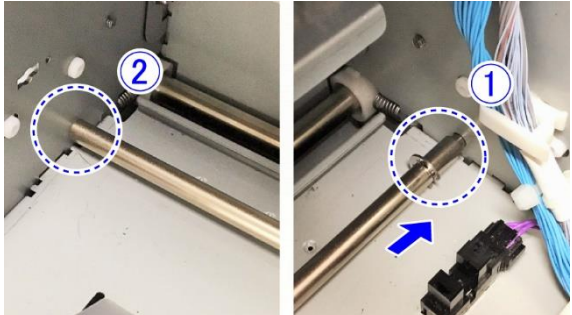
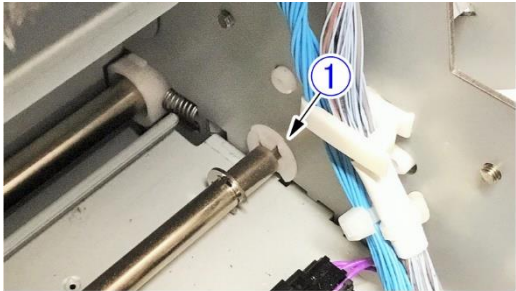
No.	Step	Details/Remarks
4	Secure the IP drain unit using the screw ① (BH, M3x6).	
5	Insert the IP shaft ② into the IP carriage ①.  Note: 1) Be careful to insert the IP shaft in the correct direction. The E-ring ③ of the IP shaft should be placed on the right side as the figure.	
6	Insert the right side (longer tip) of the IP shaft into the hole at the right side inside the main body. (①) And insert the left side (shorter tip) of the IP shaft into the hole at the left side. (②)	 <p style="text-align: center;">Left side                      Right side</p>
7	Attach the plastic retaining ring ① to the right end of the IP shaft to secure it.	

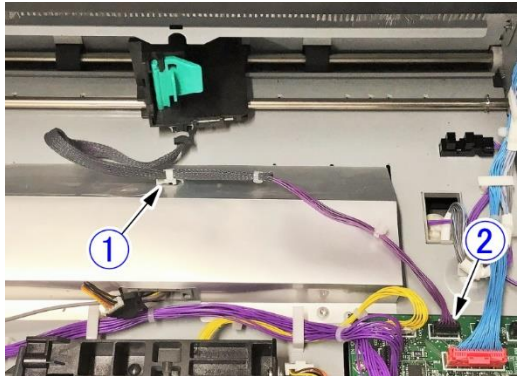
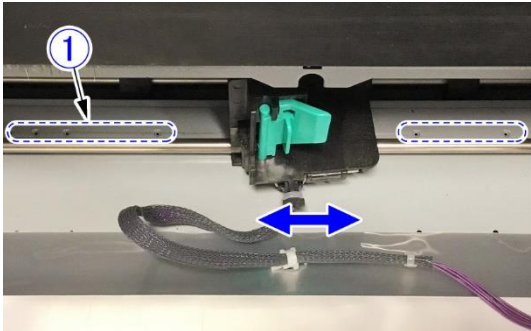
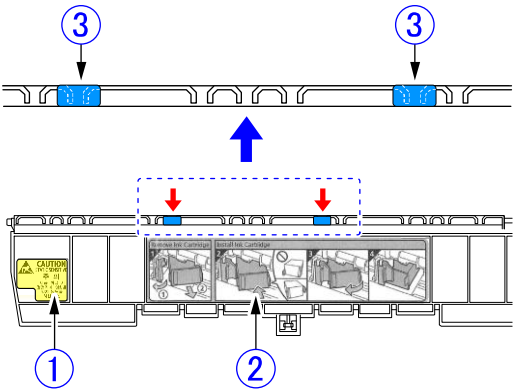
No.	Step	Details/Remarks
8	Insert the lock of the cable band ① into the hole of the cover, and connect the cable to the connector ② on the main drive PCB.	
9	Check that the IP carriage can move from side to side. On the base frame, there are small round dents ①. A projection in the bottom of the IP carriage is set in this dent to stop the position the IP carriage.  <b>Note:</b> 1) The cable should not hang the IP carriage.	
10	Install the eject try unit and right and left covers.  <b>Note:</b> 1) The eject try unit should be installed with the imprinter cover opened.	
11	Stick the caution label ① and IP label ② on the inside of imprinter cover. And stick the 2 stoppers ③ on each location in figure.  <b>Note:</b> 1) The labels should be set as seeing from the front of the main body. 2) The stoppers need to stick for the DR-G2140 series, not for the DR-G1130 series. 3) The stoppers should be block on the 5th and 9th grooves from the left side. These grooves could not use to stop. 4) The stoppers should be stick over the groove and touch the extrusion wall of the imprinter cover.	

No.	Step	Details/Remarks
12	Install an ink cartridge.	The ink cartridges are sold separately. Use the products made by Hewlett-Packard Company, with part numbers as follows: C6602R (Red), and C6602B (Blue)
13	<p>Close the imprinter cover and verify that it operates correctly. It can be verified without using a computer by using "Imprinter Test" in the user mode.</p> <p><b>Note:</b> 1) If the stop position of the IP carriage is wrong, the imprinter cover cannot be closed.</p>	

## II. PARTS REPLACEMENT

### 1. Periodically Replaced Parts

The parts assigned as a service parts and to be periodically replaced by service technician are listed below. And a layout of each part are shown in the figure following. Each number in this list and the layout figure are corresponding.

No.	Parts name	Parts number	Q'ty	Expected life	Remarks
1	Pull-in lower roller Bearing	6A3-0101 XG9-0714	1 2	8,000,000 sheets	<p>Because of the worn rollers, it is necessary to replace them when the document jams or the feed failures occur after the roller cleaning.</p> <p><b>Note:</b></p> <p>1) Because of expected life of electrical conductivity, replace the bearing at the same time.</p> <p>2) Platen roller upper and lower are the same.</p> <p>3) No.9 and No.11 rollers are the same one.</p>
2	Registration lower roller Bearing	6A3-0102 XG9-0714	1 2	8,000,000 sheets	
3	Platen roller *Note 2 Bearing	6A3-0100 MS2-9003	2 4	6,000,000 sheets	
4	Reading lower roller Bearing	6F3-0004 XG9-0714	1 2	8,000,000 sheets	
5	Pre U-turn lower roller Bearing	6A3-0104 XG9-0714	1 2	8,000,000 sheets	
6	U-turn lower roller (drive) Bearing	MA3-0166 XG9-0714	2 4	8,000,000 sheets	
7	Eject drive roller Bearing	6G3-0093 MS2-9010	1 2	6,000,000 sheets	
8	Pull-in upper roller Bearing	6F3-0055 MS2-9003	1 2	8,000,000 sheets	
9	Registration upper roller Bearing *Note 3	6A3-0106 MS2-9011	1 2	8,000,000 sheets	
10	Reading upper roller Bearing	6G3-0028 MS2-9011	1 2	8,000,000 sheets	
11	Pre U-turn upper roller Bearing *Note 3	6A3-0106 MS2-9011	1 2	8,000,000 sheets	
12	U-turn upper roller (follower) Bearing	MA3-0168 MS2-9003	2 4	8,000,000 sheets	
13	Eject follower roller *including bearings	6G3-0098	1	8,000,000 sheets	
14	Upper reading unit (front)	6R3-0002	1	1,000 hrs.	<p>Corresponds to LED life of 1000 hours.</p> <p>You can check how many hours LED lit using the service tool or user mode.</p>
15	Lower reading unit (back)	6R3-0003	1	1,000 hrs.	
16	White platen roller Bearing	3601C004* 3601C008* MS2-9003	1* 4	6,000,000 sheets	<p>Two rollers in set is assigned as option for commercial goods.</p> <p>Item code: 3601C004 CCN only 3601C008</p>

Table 4-201



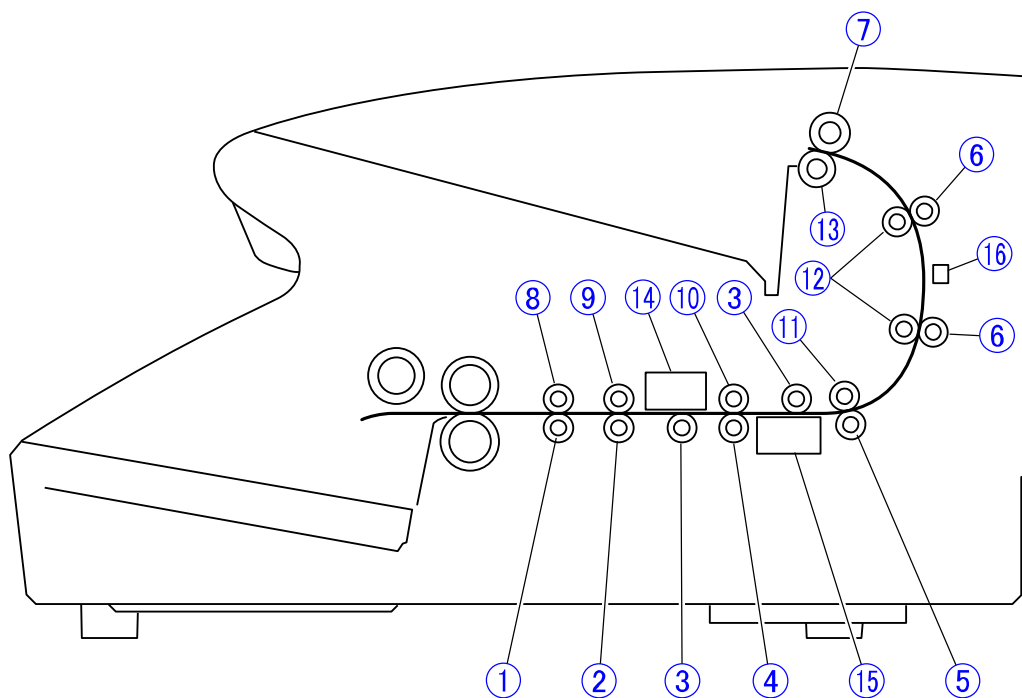

Figure 4-201

## 2. Consumable Goods (Commercial Goods)

The list below shows the consumable goods specified as commercial goods. The user replaces them.

No.	Item name	Item code	Expected life	Remarks
1	Exchange roller kit Pickup roller Feed roller Retard roller	3601C002 3601C003 for China only	600,000 sheets	Due to the worn rollers, it is replaced when the pickup failures or the document jams occur after cleaning.
2	Separation pad (cover)	3601C005 3601C006 for China only	6,000,000 sheets	Due to the worn pads, it is replaced when the pickup failures or the document jams occur after cleaning.
3	Ink cartridge: blue	3693A002	1,750,000 characters	For imprinter. Replace if ink runs out. The condition of expected life is 8×12 font, 32 characters/sheet, 100 sheets/batch, including preliminary application.
4	Ink cartridge: red	3693A003		

Table 4-202

## 3. Consumable Parts (Service Parts)

The list below shows the consumable parts that are specified as service parts and can be replaced by the service technician.

No.	Parts name	Parts number	Expected life	Remarks
1	IP pad unit	MG1-4311	6,000,000 sheets	When using an imprinter. Replace if ink is not absorbed and the document gets dirty.

Table 4-203

**Note:** Each individual part of the exchange roller kit and separation pad (separation cover) in the “2. Consumable Goods” is assigned as service parts too.

## III. MAINTENANCE

### 1. User Maintenance

A list is shown below. Refer to the "User Manual" for details.

[△: Cleaning, ●: Replace]

No.	Location/parts	Intervals		Details
		As required	Others	
1	Main body	△		Wipe the main body with a cloth dipped into water and wrung tightly, then wipe dry.
2	Pickup inlet/feed path	△		Using a blower, etc., remove remained dust and paper powder.
3	Pickup roller Feed roller Retard roller	△	● 600,000 sheets	Wipe the rollers with a cloth dipped into water and wrung tightly, then wipe dry. The expected life is 600,000 sheets. Refer to Note 2.
4	Separation pad (cover)		● 6,000,000 sheets	Wipe the rollers with a cloth dipped into water and wrung tightly, then wipe dry. The expected life is 6,000,000 sheets. Refer to Note 2.
5	Power plug	△		Remove dust on the connecting portion with the receptacle.
6	Reading glass	△		Wipe the reading glass with a cloth dipped into water and wrung tightly, then wipe dry.
7	Ink cartridge	△		Perform the Head Cleaning in the user mode. And clean the discharge outlet of the ink head with soft cloth or paper or a cotton swab. Refer to Note 3.
8	Parts to which ink is attached	△		Wipe these parts with a cloth dipped into water and wrung tightly, then wipe dry.

Table 4-301

**Note 1:** The supplied cleaning cloth is used to clean the reading glass and rollers.

**Note 2:** If the number of sheets fed with the roller exceeds 600,000 sheets, a replacement message is displayed on the operation panel LCD and computer screen. For the separation pad, it is displayed at exceeding 6,000,000 sheets.

**Note 3:** If lines or streaks appear in the printout, it can be corrected by performing the Head Cleaning. However, it does not improve printing, remove the ink cartridge and clean the print head.

## 2. Service Maintenance

A list is shown below. For details of replacement parts, refer to the above section, "II. PARTS REPLACEMENT".

[△: Cleaning, □: Adjust, ●: Replace]

No.	Location/parts	Intervals		Remarks
		At visiting	Others	
1	User maintenance items	△		Perform cleaning inside this machine as well.
2	Rollers Bearing		●	Expected life: 6,000,000 sheets Or 8,000,000 sheets
4	Reading unit		●	Expected life: 1,000 hours
6	Ink drain pad		●	Expected life: 6,000,000 sheets

**Table 4-302**

**Note 1:** If rollers or feed paths are very dirty, the user should be advised to perform "user maintenance".

**Note 2:** If necessary, make a request to replace the exchange roller kit and separation pad.

---

# CHAPTER 5

---

## TROUBLESHOOTING

---

---

I. ERROR DISPLAY .....	5-1	IV. OPERATION TROUBLESHOOTING .....	5-43
II. SERVICE MODE.....	5-4	V. IMAGE TROUBLESHOOTING.....	5-48
III. TROUBLESHOOTING LIST .....	5-42	VI. AFTER REPLACING PARTS .....	5-53

---



## I. ERROR DISPLAY

### 1. Main Body

When an error is occurred, “Message” and “Code” appear on the display panel of the main body.

The service call message is displayed the message as “Scanner hardware problem” and code as “Exxx”.

#### ◆ Display example

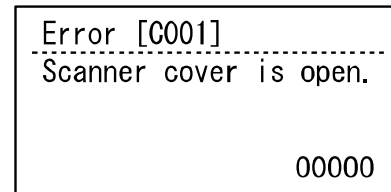

**Figure 5-101**

#### ◆ Errors associated with user operations

No.	Message	Code	Failure
1	Scanner cover is open.	C001	The upper unit is open.
2		C009	The imprinter cover is open.
3	A double paper-feed has occurred.	D002	A double feed was detected by the document length.
4		D004	A double feed was detected ultrasonically.
5	Imprinter Insert Error	H001	An imprinter voltage error was detected...
6		H004	An ink cartridge is not installed in the imprinter.
7	Staple was Detected.	J001	A stapled document has been detected.
8	A document was skewed.	J018	A skewed document was detected.
9	Dust was detected	J050	Dust was detected on the reading glass.
10	Paper jammed in scanner.	P000	A document has detected in a feed path before scanning.
11		P001	A document has jammed before entering the registration pre-sensor.
12		P002	A document has jammed before exiting from the registration pre-sensor.
13		P004	A document has jammed at the eject sensor.
14		P006	A document has jammed before entering the registration post-sensor.
15		P007	A document has jammed before exiting from the registration post-sensor.
16		P010	A document has jammed before entering the eject sensor.
17		P050	Feeding stopped due to other document jams.
18	The count does not match.	U001	The specified number of sheets was exceeded before the scan ended.
19		U002	The scan ended with a number of sheets less than the setting.

**Table 5-101**

## ◆ Service calls

If a communication error occurs between the motor or sensor and PCB, an error message and code “Exxx” appears.

If it appears, reset the main body and computer power. If the message still appears, check the error code, and then check the con-

nection of the related part, and if it is faulty, correct it. If there is no problem with connections, replace the related part.

For motors, check the connected drive transmission parts and operation check sensor as well.

Code	Parts/symptom
E011	Pickup up/down motor
E012	Feed motor
E020	Main motor
E021	Tray motor
E022	Separation motor
E024	Eject motor
E025	Pickup motor
E030	Exhaust fan
E032	Control PCB model error
E033	Shading motor (front)
E034	Shading motor (back)
E039	Cooling fan
E040	Sub-drive PCB (Man drive CPU judgment)
E041	Main drive PCB (Man drive CPU judgment)
E044	Ultrasonic drive PCB (Man drive CPU judgment)

Code	Parts/symptom
E046	Main drive PCB (Controller CPU judgment)
E048	Eject PCB (Man drive CPU judgment)
E049	Sub-drive PCB (Controller CPU judgment)
E054	Reading unit (front)
E055	Reading unit (back)
E086	Control EEPROM write error
E101	Pickup tray timeout error
E102	Pickup sensor timeout error
E103	Document sensor timeout error
E104	Shading move timeout error (front)
E105	Shading move timeout error (back)
E851	CIS data error
E860	Shading data timeout error

Table 5-102



## 2. Computer

The display connected to the computer shows error messages. Their contents differ depending on the software being used.

Each software (applications, drivers, OS) has own unique messages which they control. There are many user-related messages, such as when the user performs an incorrect operation. Users should resolve problems according to the error messages.

The following shows an example of an error message when using CaptureOnTouch.

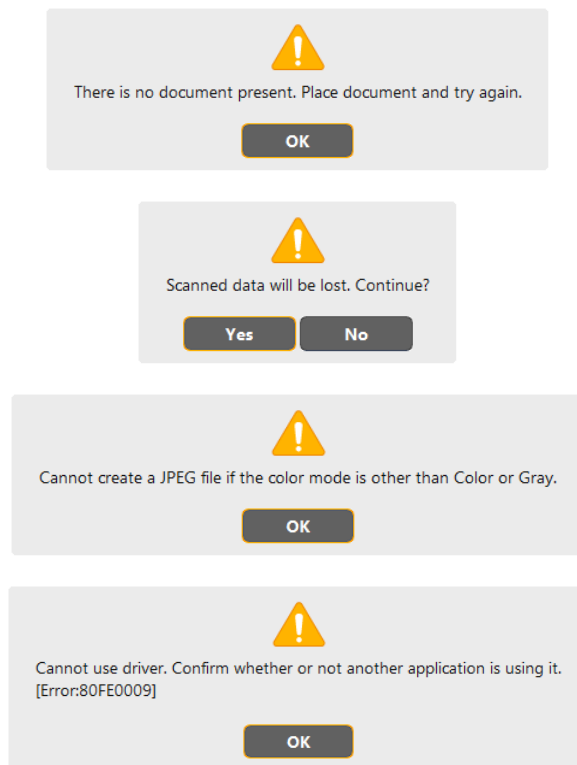

**Figure 5-102**

## II. SERVICE MODE

### 1. Outline

The service mode of this machine can be executed by installing the service mode software (service tool) supplied for servicing in the computer for servicing. This service tool is an integrated tool that consists of a common EXE file and DLL files for each product.

The system requirements for the computer to be used are the same as those described in the “User Manual.” The lower the CPU performance or memory capacity, may be the longer the processing time.

Each screen is shown below.

#### ● Initial screen

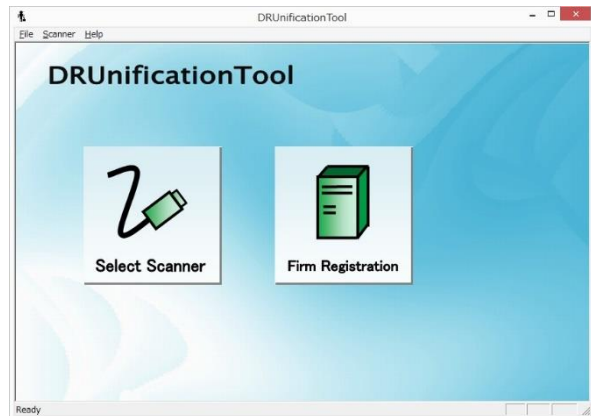

#### ● Information

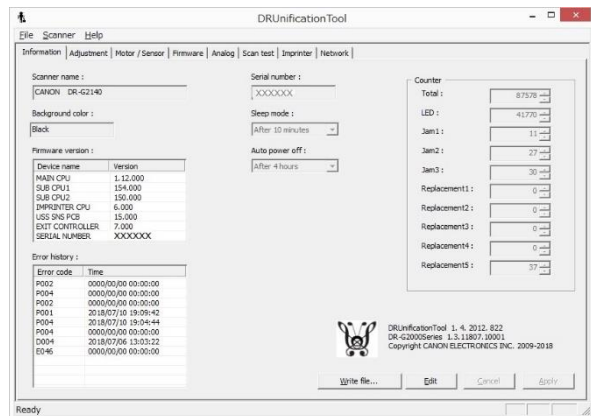

#### ● Adjustment

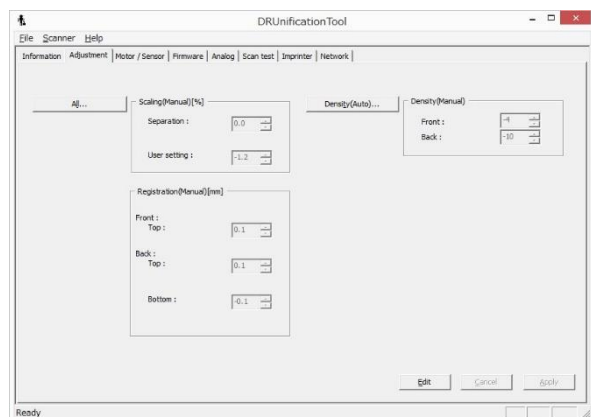
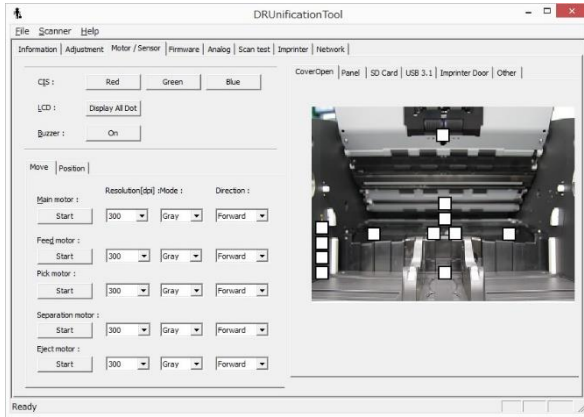
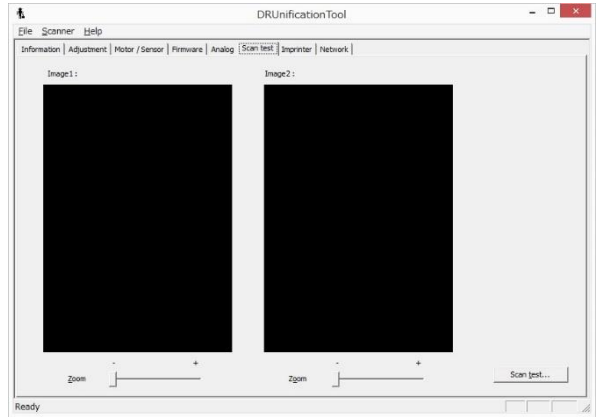

Figure 5-201

● Motor / Sensor



● Scan test



● Firmware

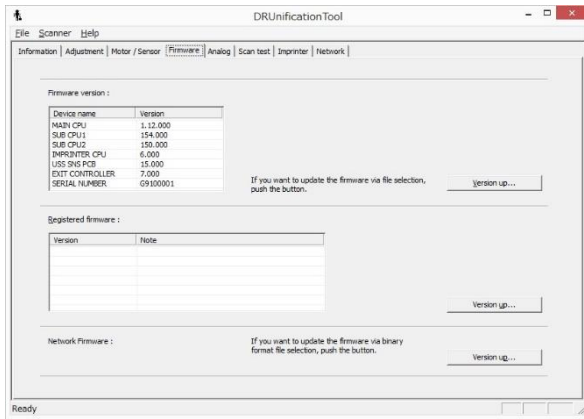

● Inprinter

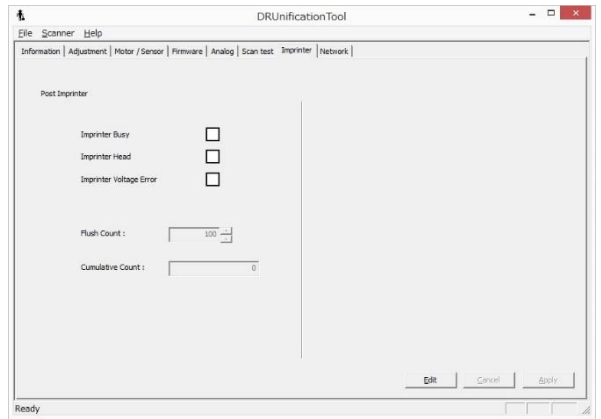

● Analog

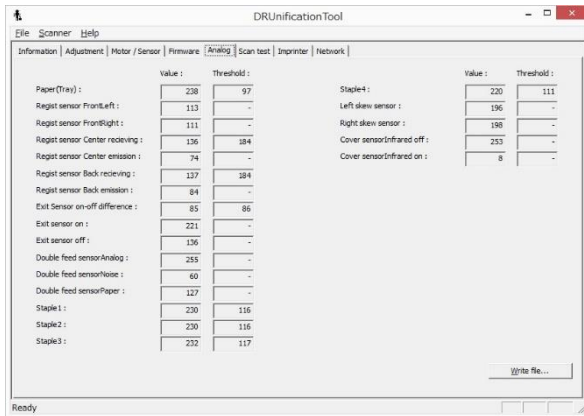

● Network

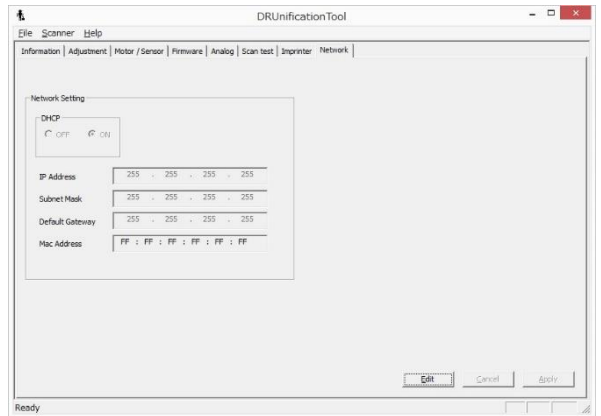

Figure 5-202

Figure 5-203

A list of items is shown below.

No.	Component/display name	Function
1	Information	
2	Scanner name	Display the scanner name.
3	Background color	Display the background color.
4	Firmware version	Display the current firmware version.
5	Error history	Display the latest error code up to 8.
6	Serial number	Display the serial number of the main body.
7	Sleep mode	Display the sleep mode selected.
8	Auto power off	Display the auto power off selected.
9	Counter	Display the counter for each item.
10	Write file	Save the above information on the text file.
11	Edit	Change the value and setting for the serial number, sleep mode, auto power off and counter.
12	Cancel	Cancel the changed value and setting.
13	Apply	Save the changed value and setting.
14	Adjustment	
15	All	Execute the automatic adjustment for the scaling and registration (reading position).
16	Scaling (Manual)	Display the manual adjustment value of the scaling.
17	Registration (Manual)	Display the manual adjustment value of the registration.
18	Density (Auto)	Execute the automatic adjustment for the density.
19	Density (Manual)	Display the manual adjustment value for the density.
20	Edit	Change the value for the manual adjustment.
21	Cancel	Cancel the changed value.
22	Apply	Save the changed value.
23	Motor / Sensor	
24	CIS	Check the LED in the reading unit.
25	LCD	Check the LCD in the operation panel.
26	Buzzer	Check the buzzer on the control PCB.
27	Move	Check the motor operation.
28	Position	Check the position of tray, CIS, pickup roller.
29	Cover Open	Check the sensor operation.
30	Panel	Check the key in the display panel.

**Table 5-201a**

No.	Component/display name	Function
31	SD Card	Check the connection of the SD card.
32	USB 3.1	Check the communication with USB Super Speed.
33	Imprinter Door	Check the imprinter door sensor.
34	Others	Check the exit sensor, double feed sensor, tray home sensor, door sensor and others.
35	Firmware	
36	Firmware version	Display the current firmware version.
37	Version up (upper one)	Update from unregistered firmware.
38	Registered firmware	Display and select the registered firmware.
39	Version up (middle one)	Update from registered firmware.
40	Network firmware	-----
41	Version up (lower one)	Update the network related firmware with the bin format only.
42	Analog	
43	(name of each sensor)	Display each value of analog data.
44	Write file	Save the above information on the text file.
45	Scan test	
46	Image 1	Display the scanned image (the second last one).
47	Image 2	Display the scanned image (the last one).
48	Zoom (Image 1)	Enlarge the image 1.
49	Zoom (Image 2)	Enlarge the image 2.
50	Scan test	Move the scanning screen and execute.
51	Imprinter	
52	Imprinter Busy	Check the operation of the imprinter.
53	Imprinter Head	Check the detection of the imprinter head.
54	Imprinter Voltage Error	Check the applied voltage to the imprinter.
55	Flush Count	Display the ink flushing count at once.
56	Cumulative Count	Display the total flush counts.
57	Edit	Change the value for the counts above.
58	Cancel	Cancel the changed value.
59	Apply	Save the changed value.

Table 5-201b

No.	Component/display name	Function
60	Network	
61	Network Setting	Display the network settings.
62	Edit	Change the value for the settings above.
63	Cancel	Cancel the changed value.
64	Apply	Save the changed value.
65	Firm Registration	
66	Register	Register the firmware.
67	Delete	Delete registered the firmware.
68	Add Note	Add notes to the registered firmware.
69	Application information	Display the version of the service tool (EXE file).
70	Simulation mode	A trial operation can be performed without connecting the scanner.

**Table 5-201c**

## 2. Preparation

In advance, you need to install the service tool and scanner driver for this products in the compute for servicing. Do not install the service tool in the user's computer.

You can get these data file in your marketing region or from data base system, for example the WISDOM for the service tool and the GDLS for the scanner driver.

**Note:**The scanner driver needs for the scanner device recognition and other service mode with the service tool.

### ◆ Folder and files of service tool

The files need for the service mode should be saved in the same folder. Although you can change the folder name to any name, but you cannot change the file names. In the holder of the service tool, there are 4 files as follows.

- DRUnificationTool.exe  
Executable file (EXE file)  
This is used in common for all products
- DR-G2000Series.dll  
Specific files for each product (DLL file)
- DRUnificationTool.LOC  
Language localization file (LOC file)  
Only required for displaying Japanese
- UnificationToolU.LOC  
Language localization file (LOC file)  
Only required for displaying Japanese



**Figure 5-204**

The DLL files for other products can be used by saving them in the same folder.

Furthermore, the folders and files for the firmware are created in this folder when “Firm Registration” is executed. For details, refer to the “Firm Registration” section.

### 3. How to Start and Finish

◆ How to start

- 1) Start the computer for servicing.
- 2) If an icon of CaptureOnTouch is displayed on the task bar, click the icon to terminate.

**Note:** Refer to the “User Manual” for the details of how to terminate CaptureOnTouch.

- 3) Connect the USB cable and then turn on the machine.
- 4) Start up the installed file “DRUnificationTool.exe”.
- 5) The password screen is displayed, so after inputting the 6 characters “market,” select [OK].



Figure 5-205

- 6) The initial screen is displayed.

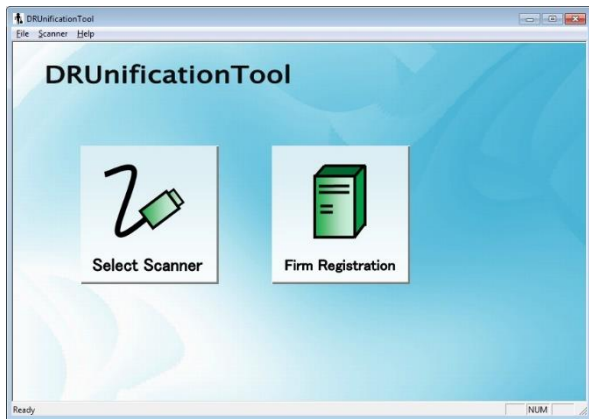

Figure 5-206

- 7) If you execute the service mode, select [Select Scanner] and if you register the firmware, select [Firm Registration].

- 8) When [Select Scanner] is selected, the scanner selection screen is displayed. Select the connected scanner.

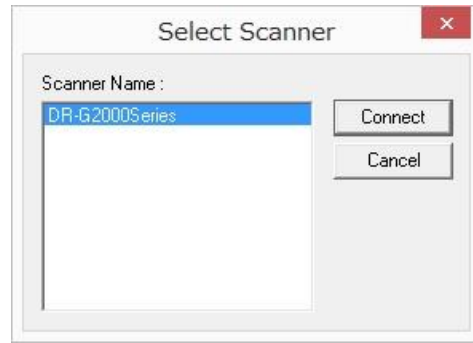

Figure 5-207

- 9) The “Information” screen is displayed.

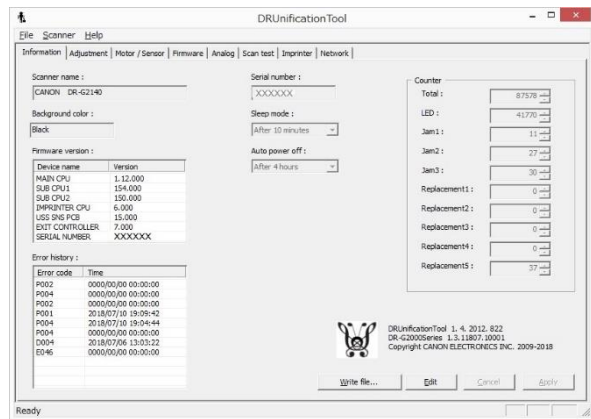

Figure 5-208

**Note:** Do not start up any other application software such as CaptureOnTouch or turn off the machine while the service tool is running. If the tool becomes unresponsive, you should restart the computer.

◆ How to finish

To finish the service tool, select [X:Close] on each operation screen or select [End Application] from [File] on the toolbar. However, if “Firmware version update” is performed, reset the power properly.



## 4. Application Information

This mode is used to check the detailed version of the service mode software (EXE file).

Select [Help] from the toolbar at the top of the screen and then select [Application information].

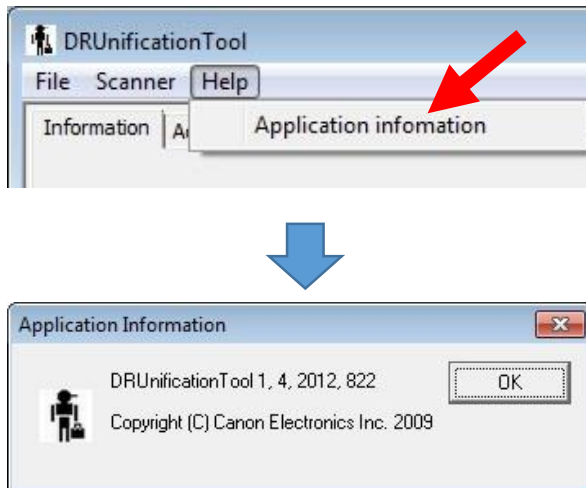

Figure 5-209

## 5. Simulation Mode

This mode is used to train service technicians about service mode without connecting to the scanner.

### ◆ Operation Procedure

- 1) Enter the 8 characters “training” as the password.



Figure 5-210

- 2) The screen is the same as in the real procedure, and can be operated in the same way except for some buttons that are grayed out.

**Note:** You cannot execute operations that require communication with the scanner.

## A. Information

(The numbers shown in figure are corresponding the item numbers following.)

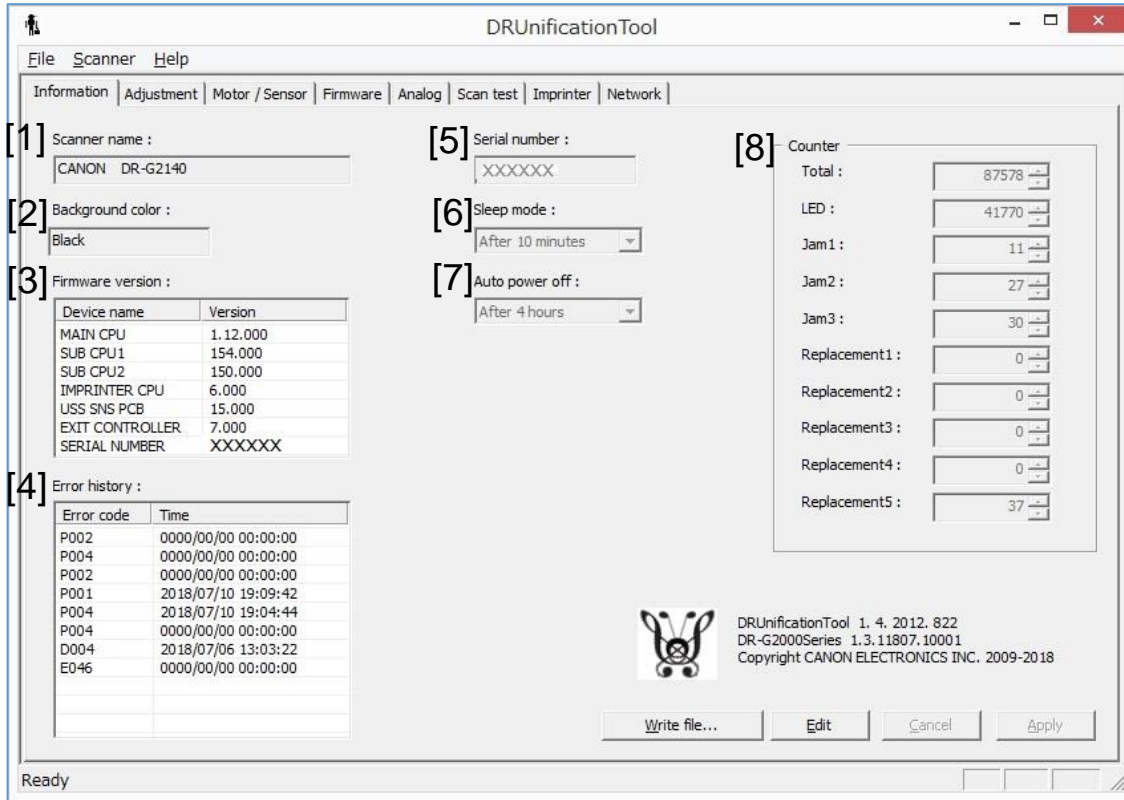

Figure 5-211

### 1. Scanner Name

This is used to check the scanner name.

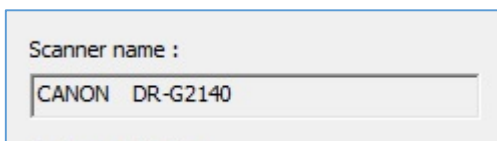

Figure 5-212

### 2. Background color

This is used to check the background color of the scanner.

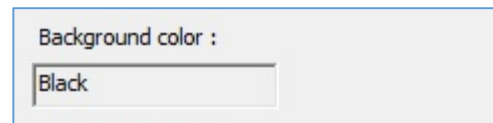

Figure 5-213

### 3. Firmware version

This is used to check the versions of the main body firmware and the internal devices of the scanner.

Also, it can be checked by the user mode “Maintenance” using the operation panel excepting the [SERIAL NUMBER].

Firmware version :	
Device name	Version
MAIN CPU	1.12.000
SUB CPU1	154.000
SUB CPU2	150.000
IMPRINTER CPU	6.000
USS SNS PCB	15.000
EXIT CONTROLLER	7.000
SERIAL NUMBER	XXXXXX

Figure 5-214

- [MAIN CPU]  
Control PCB firmware
- [SUB CPU1]  
Main drive PCB firmware
- [SUB CPU2]  
Sub drive PCB firmware
- [IMPRINTER CPU]  
Imprinter firmware
- [USS SNS PCB]  
USS sensor PCB firmware
- [EXIT CONTROLLER]  
Exit PCB firmware
- [SERIAL NUMBER]  
Special serial number for main body

**Note:**The [SERIAL NUMBER] above could not be changed in the market. If you replaced the control PCB to the service parts, this number does not display.

### 4. Error History

This is used to check the error code and occurrence time. Displays up to 8 errors.

Error history :	
Error code	Time
P002	0000/00/00 00:00:00
P004	0000/00/00 00:00:00
P002	0000/00/00 00:00:00
P001	2018/07/10 19:09:42
P004	2018/07/10 19:04:44
P004	0000/00/00 00:00:00
D004	2018/07/06 13:03:22
E046	0000/00/00 00:00:00

Figure 5-215

Refer to the “I. ERROR DISPLAY” to the contents of error code.

Note that not all errors are displayed. For example, errors occurred before scanning, cover open (C001/C009), and document remaining (P000), or error could not record, EEPROM writing error (E086) and others.

And only the first error code is displayed, such that the error indicated may differ from the observed error.

Also, while the computer is not connected or the computer does not control the time, occurrence time cannot be displayed.

## 5. Serial Number

This is used to check the serial number.

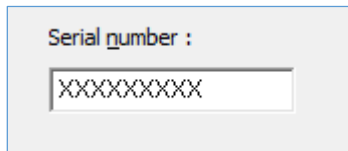

Figure 5-216

Serial number data is saved on the control PCB. When the control PCB is replaced, values are displayed validly by selecting the [Edit] button on the information screen.

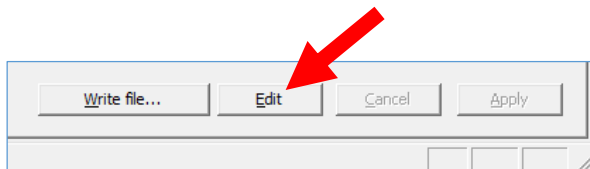

Figure 5-217

Enter the serial number shown on the rating label on the main body.

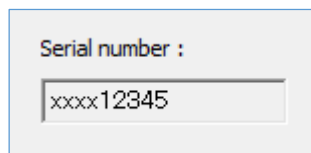

Figure 5-218

After entry, select the [Apply] button on the information screen and save the values.

If the [Cancel] button is selected on the information screen, the changed values are not saved.

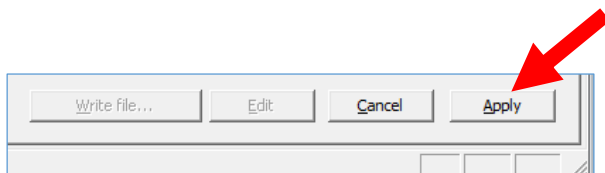

Figure 5-219

## 6. Sleep Mode

This is used to check and change the time before entering sleep mode. This is set to [After 10 minutes] by factory default.

Also, it can be checked by the user mode using the operation panel. If you change this setting, notify the user that you are changing it.

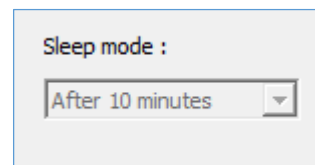

Figure 5-220

To change the sleep mode setting, select the [Edit] button in the information screen to enable selection and setting change.

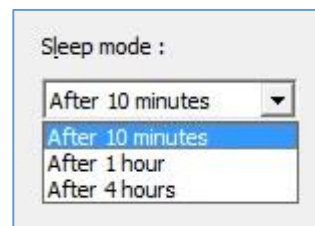

Figure 5-221

After selecting, be sure to select the [Apply] button on the information screen and save the setting.

If the [Cancel] button is selected on the information screen, the changed settings are not saved.

These button operations are the same as "Serial Number" and others.

## 7. Auto Power OFF

This is used to check and change setting of the power to turn off automatically when 4 hours of inactivity elapse since the last operation. This is set to [after 4 hours] by factory default.

Also, it can be checked by the user mode using the operation panel. If you change this setting, notify the user that you are changing it.

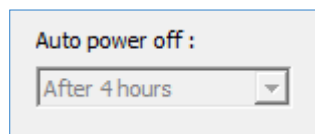

**Figure 5-222**

To change the Auto power off setting, select the [Edit] button on the information screen to enable selection and setting change.

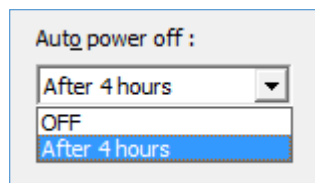

**Figure 5-223**

After selecting, be sure to select the [Apply] button on the information screen and save the settings.

If the [Cancel] button is selected on the information screen, the changed settings are not saved.

## 8. Counter

This is used to check and change the scanning count and the number of document jams.

Also, it can be checked by the user mode “Maintenance” using the operation panel. If you change this number notify the user that you are changing it.

**Note:** Do not change the value of each item by mistake. Change it only if necessary.

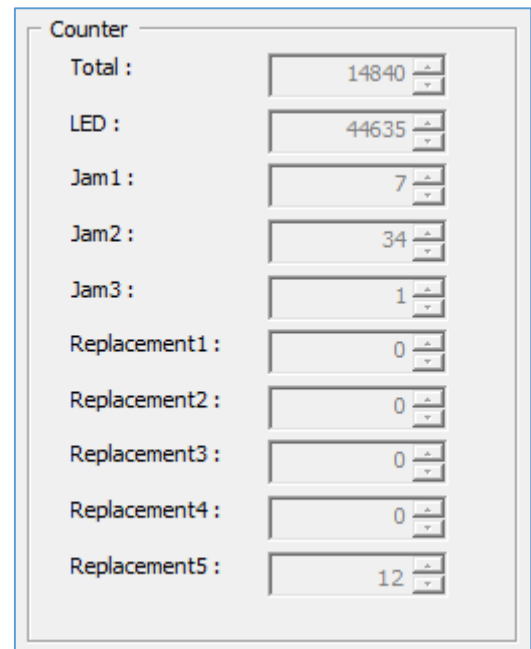

**Figure 5-224**

The list is shown below.

Display	Details
Total	Total number of sheets fed.
LED	Total lit time of the LED for the reading unit. This units is in "seconds". When you replaced, you have to input [0].
Jam 1	The number of paper jams in the pickup section. Error code P001.
Jam 2	The number of paper jams in the registration section. Error code P002/P006/P007.
Jam 3	Number of document jams in the eject section. Error code P004/P010.
Replacement 1	For user replaceable parts. [1] → Pick Roller Kit [2] → Separation pad It is displayed the total number of sheets fed when reset in user mode. When you replaced, you have to reset or input [Total].
Replacement 2	
Replacement 3	For service periodically replaced parts. [3] → Feeding rollers: expected life 8-million fed. [4] → Platen rollers & Exit drive roller: expected life 6-million fed. It is displayed the total number of sheets fed when you replaced the parts. When you replaced, you have to input [Total].
Replacement 4	
Replacement 5	Total operated time of the power PCB. This units is in "hours". When you replaced, you have to input [0].

**Table 5-202**

**Note:**In the user mode "Maintenance", it is displayed the number since the parts was replaced.

These values are changed when the control PCB is replaced. After the replacing the control PCB, input the same values as before the replacement. If you don't know the values before the replacement, input the estimated values.

When the "Edit" button on the information screen is selected, values are displayed validly and can be changed.

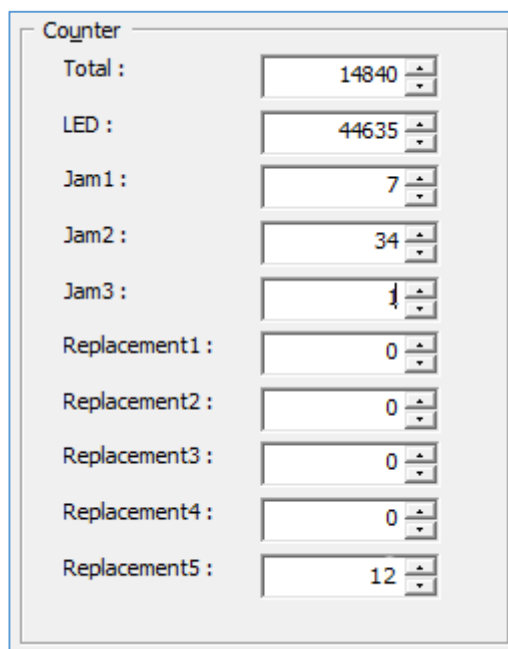

**Figure 5-225**

If the [Apply] button on the information screen is selected, the values are saved.

And if the [Cancel] button is selected, they are not saved.

## 9. Write File

This is used to output the data shown on the information screen as a text file.

When [Write file] on the lower right side of the screen is selected, displayed information can be saved in a text file.

### ◆ Operation Procedure

- 1) Select [Write file].

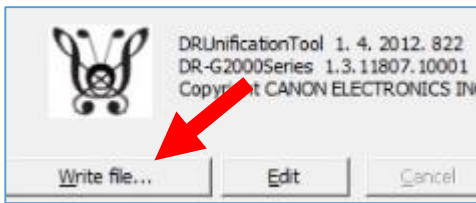

Figure 5-226

- 2) When the save screen is displayed, set the save location.

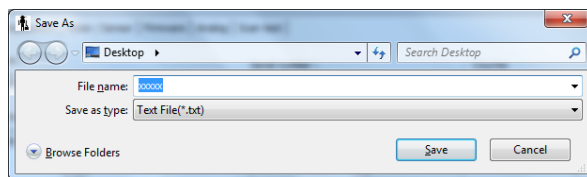

Figure 5-227

- 3) The information is saved.

It is shown below a part of example.

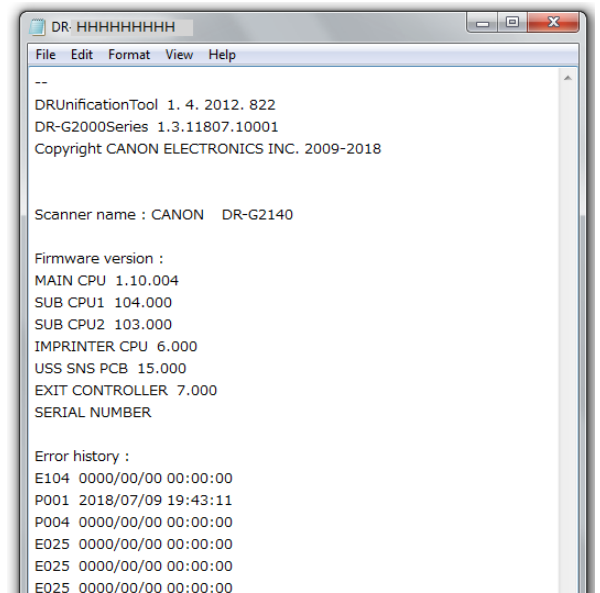

Figure 5-228

## B. Adjustment

(The numbers shown in figure are corresponding the item numbers following.)



**Figure 5-229**

Adjustment should follow this order. Adjust in the order of “Scaling” → “Registration” → “Density”. If previous adjustment results are fine as they are, an adjustment item can be omitted. However, making adjustments in the reverse order may have incorrect.



## 1. All

This is used to adjust the scaling and registration automatically in succession. The scaling is adjustment for image length with feeding direction, and registration is adjustment for reading-start position and reading-end position.

This adjustment also needs to execute if the reading unit or registration related parts have been replaced or reassembled, and if the control PCB has been replaced. The control PCB has recorded adjustment data.

Adjustment sheet and procedure are shown below.

### ◆ Adjustment sheet

Use an adjustment sheet: 6Y3-6001 (QT-52). It is printed on both sides with the same pattern.

**Note:** It can be used for black and white background both.

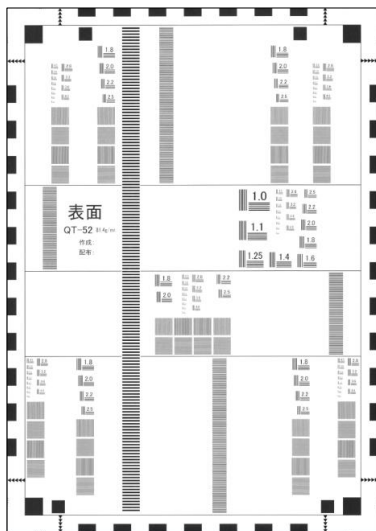

Figure 5-230

### ◆ Operation Procedure

- 1) Clean the feed path, roller, and scanning glass.
- 2) Place a single adjustment sheet in center with vertical direction like a figure below.

Make sure to set the document guides so they are fit with the adjustment sheet to prevent skews.

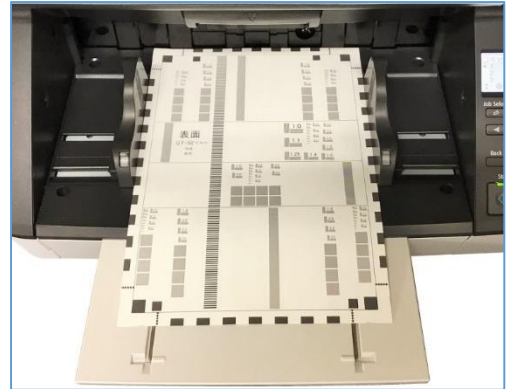

Figure 5-231

- 3) Select [All].

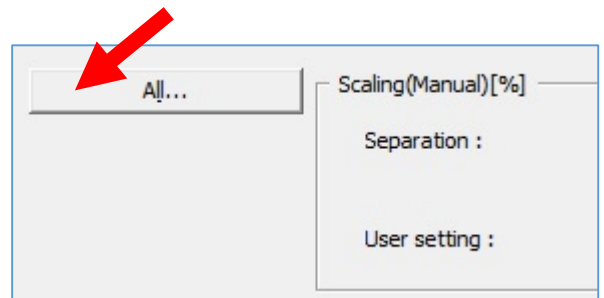

Figure 5-232

- 4) A progress screen appears, and the adjustment sheet is fed.

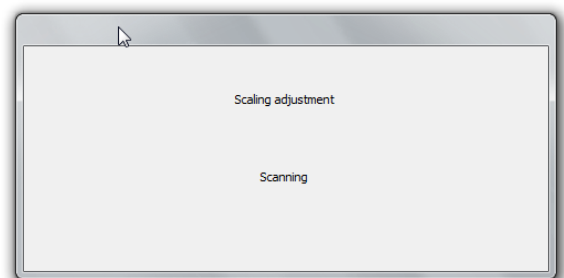

Figure 5-233

- 5) The adjustment sheet is ejected. The process is completed when the progress screen disappears.

## 2. Scaling (Manual)

Scaling adjustment is normally performed in automatic mode “All”. This manual adjustment is for manually adjusting the scale parameter of an image against the result of automatic mode. This adjustment will be End. with a front side image.

### ◆ Types

There are 2 types of scaling adjustment.

- 1) Factory setting at separation mode  
(Parameter range: -1.0 to 1.0)
- 2) User setting  
(Parameter range: -3.0 to 3.0)

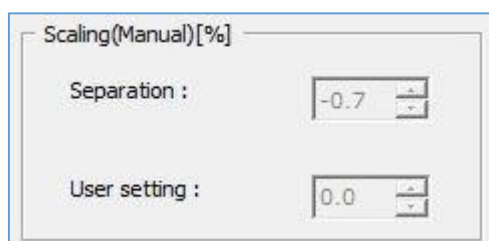

Figure 5-234

There is a user scale setting to enable the user to re-adjust after the factory shipping. The setting can be configured from the maintenance tab in “Canon imageFORMULA driver setting tool”. That value is linked with the “User setting” in this mode.

### ◆ Adjustment sheet

You can use a sheet that is printed any pattern to be judged a gap of position of the leading and trailing edges. Therefore you can use the test sheet; TKM-02711, adjustment sheet; 6Y3-6001 that is used for the automatic adjustment, or others.

### ◆ Operation Procedure

In this section, it is described using the adjustment sheet; 6Y3-6001 and for the factory setting at separation mode.

Also, this is a case that adjustment value is unknown and you need to judge it using the service tool. If you have known adjustment value, you can change value at first.

- 1) Clean the feed path, roller, and scanning glass.
- 2) Select the [Edit] button.

**Note:** If you adjust the scaling after replacing the control PCB or want to set the scale parameter that is displayed in the user operating screen to “0.0”, you should first set all two of the parameters to “0.0” and select the [Apply] button.

- 3) Place a single adjustment sheet in center with vertical direction and printed side should be up side like a figure below. Make sure to set the document guides so they are fit with the adjustment sheet to prevent skews.



Figure 5-235

4) Open [Scan test] tab.

**Note:** Refer to the section “F. Scan Test” for details of “Scantest”.

5) Select [Scan test] button, and set the scanning conditions, then start a scanning.

6) The scanned image is displayed on preview window of [image 1].

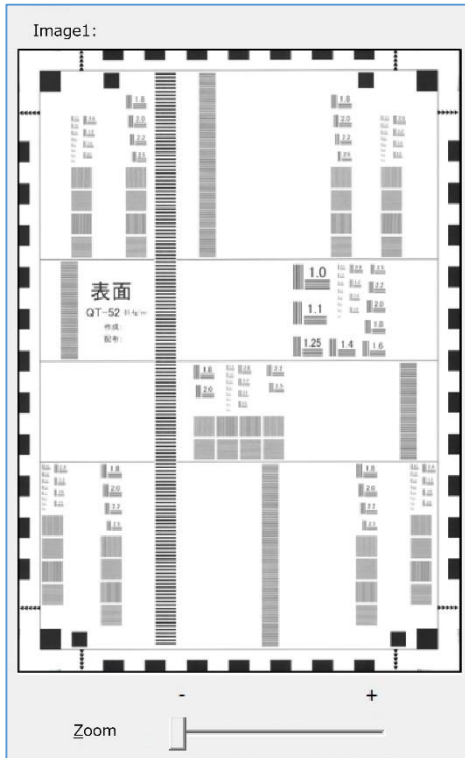

Figure 5-236

7) Moving slider to enlarge the image to check the leading edge is in correct position.

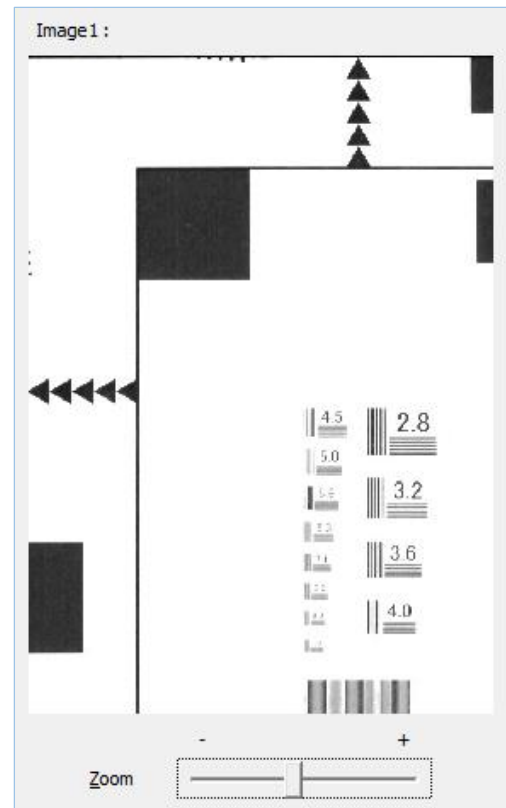

Figure 5-237

8) Then check the trailing edge image, and set the adjustment values. For example, if you want to extend by 1.0 mm with A4 size, then since  $-1.0 \div 297 \rightarrow -0.3\%$ , add “-0.3” to the setting value. If the original value is “-0.7”, set the setting value to  $(-0.7) + (-0.3) \rightarrow -1.0$ .

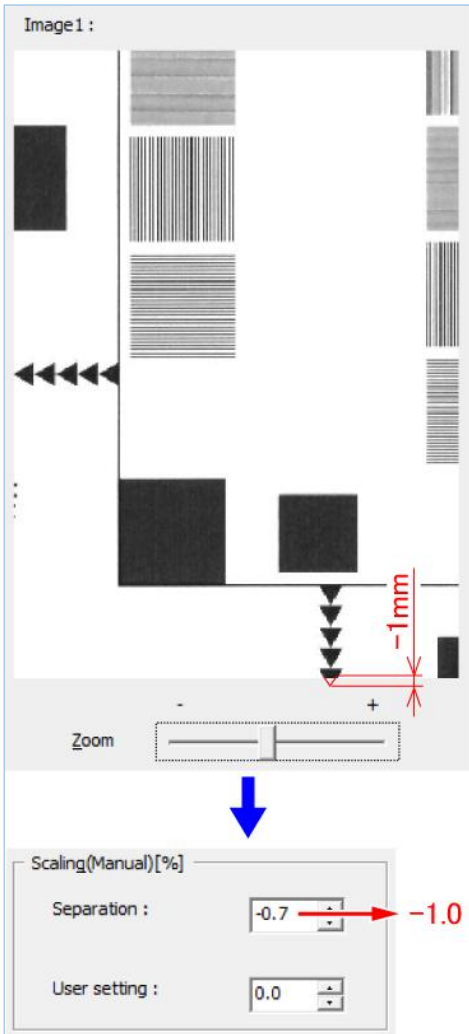

Figure 5-238

9) After you have set the value, click the [Apply] button.

10) Place the adjustment sheet and scan again. Check the displayed image.

**Note:** Repeat the procedure again if the adjustments were not corrected properly.

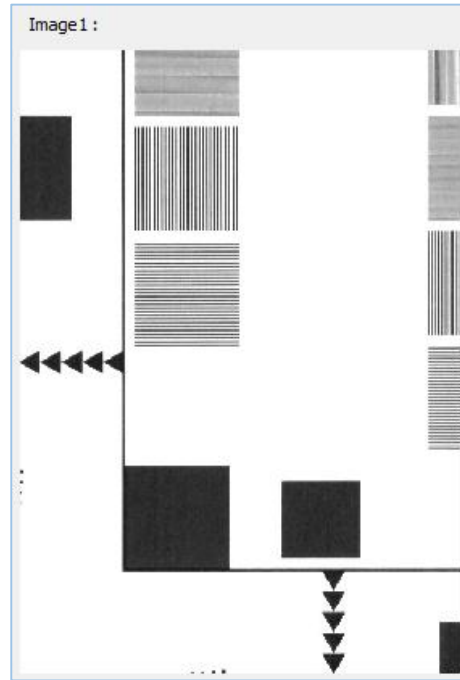

Figure 5-239

**Note:** The adjustment might not be enough using the factory adjustment value alone. If this happens, use the user adjustment value as well. Or, replace the rollers.

### 3. Registration (Manual)

Registration adjustment is normally performed in automatic mode [All]. This manual adjustment is a mode that performs fine adjustment of the result of the automatic adjustment. Note that it does not reduce variations in the registration position.

#### ◆ Adjustment sheet

You can use a sheet that is printed any pattern to be judged a gap of position of the leading and trailing edges. Therefore you can use the test sheet; TKM-0271, adjustment sheet; 6Y3-6001 that is used for the automatic adjustment, or others.

#### ◆ Operation Procedure

In this section, it is described a case that adjustment value is known ready.

- 1) Clean feed path, rollers, and scanning glass.
- 2) Place a single adjustment sheet in center and printed side should be set to adjustment side.  
Make sure to set the document guides so they are fit with the adjustment sheet to prevent skews.
- 3) Select the [Edit] button.
- 4) As for the value to adjust, the amount of additional change is added to the value previously set by the automatic adjustment. For example, add [1.0] mm to "Front: Top" if you want to make the reading start of the leading edge 1mm earlier on the front side, or add [-1.0] if you want to subtract 1mm.

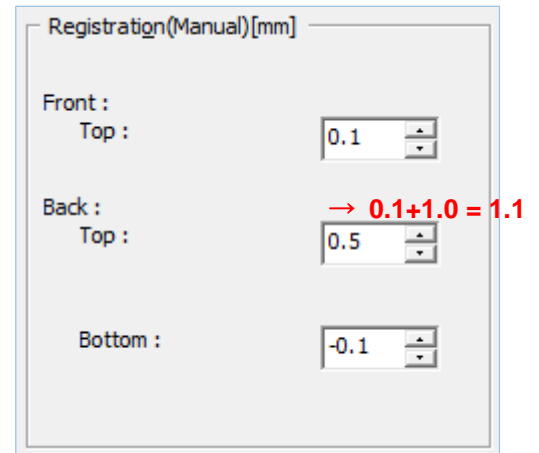

Figure 5-240

- 5) Input the value to adjust, and click the [Apply] button.
- 6) Open [Scan test] tab. And select [Scan test] button, and set the scanning conditions, then start a scanning.

**Note:**Refer to the section "F. Scan Test" for details of "Scantest".

- 7) The adjustment sheet is scanned.
- 8) Check the scanned image to be adjusted.

**Note:**Repeat the procedure again if the adjustments were not corrected properly.

## 4. Density (Auto)

This automatically adjusts the density of front and back images. It measures the average density of the adjustment sheet and derives the value to adjust by.

At first, a front side is adjusted, and then a back side is adjusted.

### ◆ Adjustment sheet

Use a special adjustment sheet; TKM-0347 (QT-28).



Figure 5-241

### ◆ Operation Procedure

- 1) Clean feed path, rollers, and scanning glass.
- 2) Place the color chart on the top edge and set the adjustment sheet with front side up. Make sure to set the document guides so they are fit with the adjustment sheet to prevent skews.



Figure 5-242

- 3) Select [Density (Auto)].

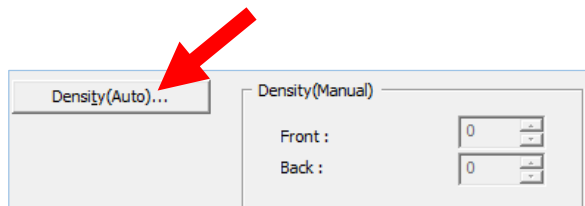

Figure 5-243

- 4) The adjustment sheet is fed. Once ejected a confirmation screen appears for “back-side” adjustment.

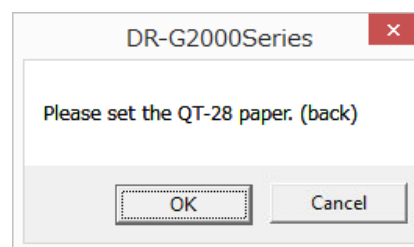

Figure 5-244

- 5) Set the same adjustment sheet with back side up, and select [OK].



Figure 5-245

- 6) The adjustment sheet is fed/ejected again. Adjustment is now completed, and the progress screen disappears.

- ◆ For market items, perform this adjustment for density faults (including differences in front and back densities), or after replacing the control PCB.

## 5. Density (Manual)

This is for manually changing values set at factory shipment or with [Density (Auto)].

The value set automatically is equivalent to the midrange value of [128] for the driver's brightness adjustment. Density of the midrange value [128] can be changed with this manual adjustment. Differences in front- and backside densities can also be adjusted.

### ◆ Operation Procedure

- 1) First, determine the amount by which to adjust from an actual scan image. The amount for adjustment by the driver is equivalent to the setting value of this mode.

Note: For example as a guide, to change the density of the driver's setting value [118] to the midrange value, based on an adjustment amount of  $118-128=-10$ , the setting values for this mode should be [-10].

- 2) Select [Edit].
- 3) Enter the setting value in the data box using the scroll arrows. Front- and backside setting values are independent. The figure below shows only the front side being changed from [0] to [-10]. The setting value can be in a range of  $\pm 20$ .

Note: The recommended range is  $\pm 10$

Exceeding this range may prevent image processing such as automatic size detection and B&W/color detection from running correctly.

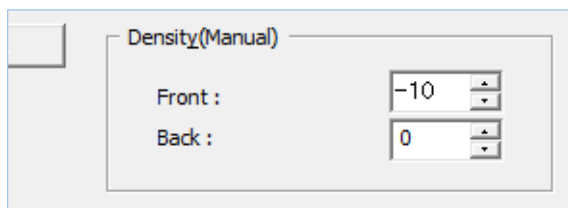

Figure 5-246

- 4) Input the adjustment value and select [Apply].
- 5) Check a scan image after making the change. Readjust as necessary.

Note: Make sure to check density of an image scanned under the same conditions as an actual scan. Don't use the [Scan Test] for checking density adjustment.

### ◆ Example of density adjustment results

- 1) Setting value [-10] → Darker

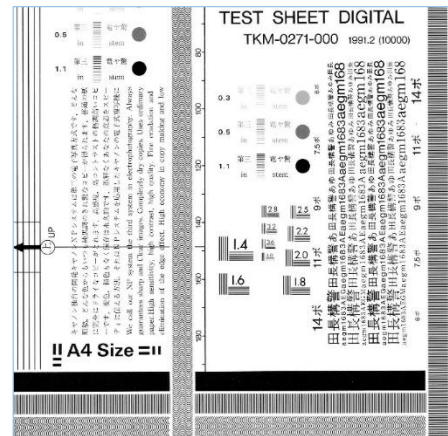

Figure 5-247

- 2) Setting value [10] → Lighter

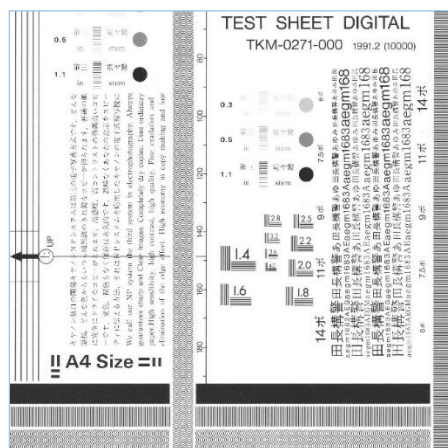

Figure 5-248

### C. Motor / Sensor

(The numbers shown in figure are corresponding the item numbers following.)



Figure 5-249

#### 1. CIS, LCD, Buzzer

This is used to check operation of the reading unit's LED, LCD panel and buzzer.

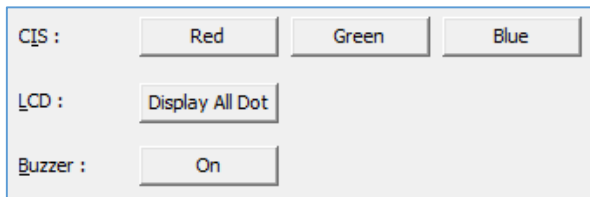

Figure 5-250

##### 1) CIS

Check a lighting of the reading unit's LED. Open the upper unit, and then select a corresponding button to turn on the LED. Select the button again to turn off the LED.

##### 2) LCD

Check a lighting of the operation panel's LCD. Select "Display All Dot" to turn on the all the dot for display. Selecting either again returns either LCD to all off.

When LCD is renewal like a door open, its display is back to normal.

##### 3) Buzzer

Check a sound of the buzzer. Select "On" button, the buzzer sounds 3 times buzzer. Select the button again, the button is released.

**Note:**The buzzer sounds, even the buzzer setting is set as "No buzzer".



## 2. Move

This is used to check operation of the motors.

It is shown the operation screen area and list of items below.

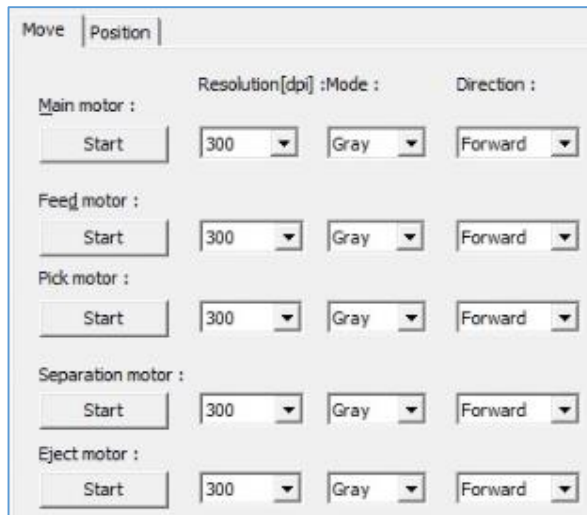

Figure 5-251

Display	Items
Resolution	300 / 600 (dpi)
Mode	Gray / Color
Direction	*Forward / Revers *Forward / Revers / Hold (Separation motor only) *Forward (Eject motor only)

Table 5-203

Select operating conditions for a motor, then select [Start] to run the motor. Select [Start] again to stop the motor.

## 3. Position

This is used to check operation of the motors.

It is shown the operation screen area and list of items below.



Figure 5-252

Display →Motor name	Items
TrayHP →Tray motor	TrayTop 100 paper 300 paper 500 paper
CIS Position →Shading motor	Shading Scan
Pick position →pickup up/down motor	PickOff PickHP PickBottom PickUp

Table 5-204

Select operating position for a motor, then select [Start] to run the motor. And motor stops.

### 4. CoverOpen

This is used to check operation of the sensors.

It is shown the display screen and list of items below.

When the sensor detected, its mark is lit. And when you move a cursor to close the mark, its sensor name appears.

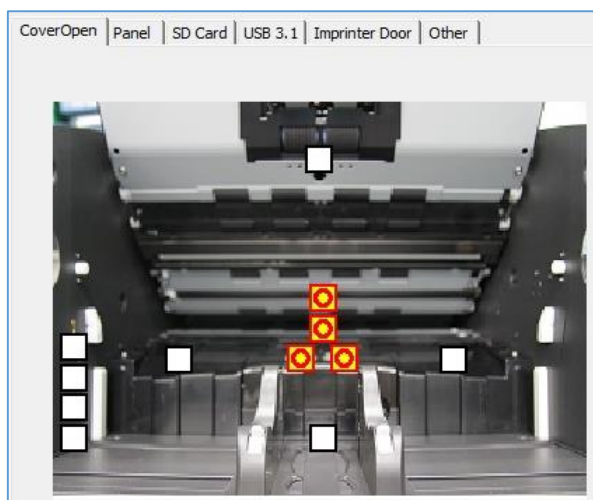

Figure 5-253



Figure 5-254

No.	Display → Formal sensor name
1	Paper (Tray) → Document sensor
2	Regist sensor L → Registration front sensor (left)
3	Regist sensor R → Registration front sensor (right)
4	Regist sensor Middle → Registration middle sensor
5	Regist sensor Back → Registration back sensor
6	Paper (Pick) → Pickup sensor
7	Deskew (L) → Skew sensor (left)
8	Deskew (R) → Skew sensor (right)
9	Staple 1, 2, 3, 4 → Staple sensor

Table 5-205

## 5. Panel

This is used to check operation of the buttons on the operation panel.

It is shown the display screen below.

When the button is turned on, its mark is lit. And when you move a cursor to close the mark, its sensor name appears.



Figure 5-255

## 6. SD Card

This is used to check operation of the micro SD card on the control PCB

It is shown the display screen below.

When the micro SD card is set and made communication, its mark is lit.



Figure 5-256

## 7. USB 3.1

This is used to check operation of the USB 3.1 communication.

It is shown the display screen below.

When the USB 3.1 communication is detected, its mark is lit. Note USB cable and computer should be conformed the USB 3.1 communication.



**Figure 5-257**

## 8. Imprinter Door

This is used to check operation of the imprinter door sensor.

It is shown the display screen below.

When the imprinter door sensor is detected, its mark is lit.



**Figure 5-258**

## 9. Others

This is used to check operation of the other sensors and functions.

It is shown the display screen and list of items below.

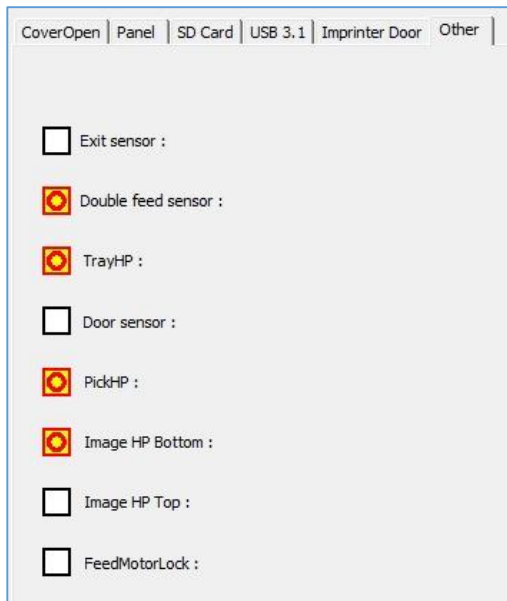

Figure 5-259

No.	Display →Formal sensor name
1	Exit sensor →Exit sensor
2	Double feed sensor →Double feed sensor
3	TrayHP →Tray home sensor
4	Door sensor →Door sensor
5	PickHP →Pickup roller sensor
6	Image HP Bottom →Shading sensor (back)
7	Image HP Top →Shading sensor (front)
8	FeedMotorLock →(This is not necessary in market)

Table 5-206

## D. Firmware

There are two methods for updating the firmware: One is to select and execute pre-registered firmware, and the other is to select and execute firmware saved on the computer. The methods using pre-registration makes it possible to store all of the firmware within the same folder and attach comments to firmware, and is easy to manage.

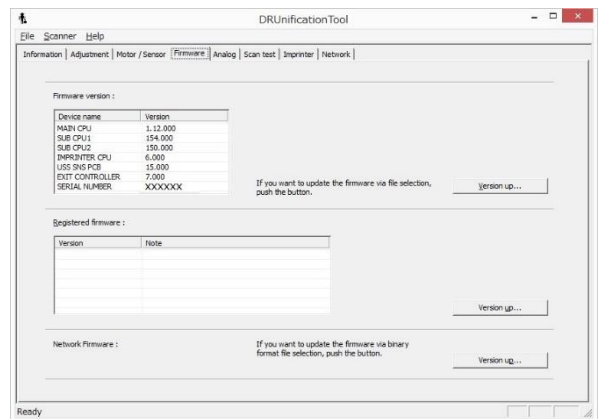

Figure 5-260

Note: For details on firmware updates, refer also to the separately issued service information.

## 1. Firm Registration

This is used to save scanner firmware on a computer for servicing in advance, making it possible to correctly perform actual firmware updates.

### ◆ Operation Procedure

- 1) On the initial screen, select [Firm Registration]. Or, select [Registration of Firm] from the scanner in the task bar of the initial screen or other screens.

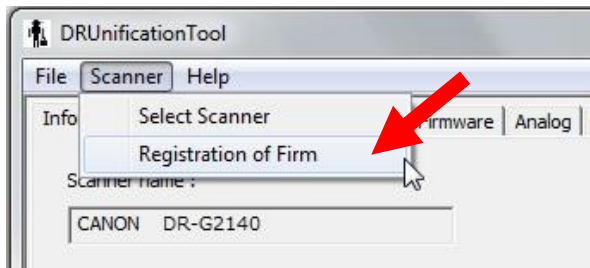
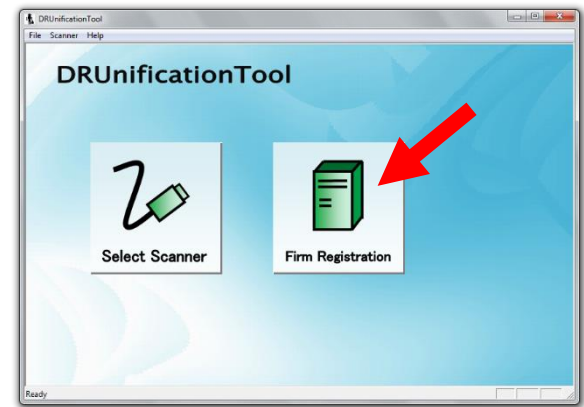

Figure 5-261

- 2) The following screen is displayed only if there are no firmwares already registered. Select [OK].

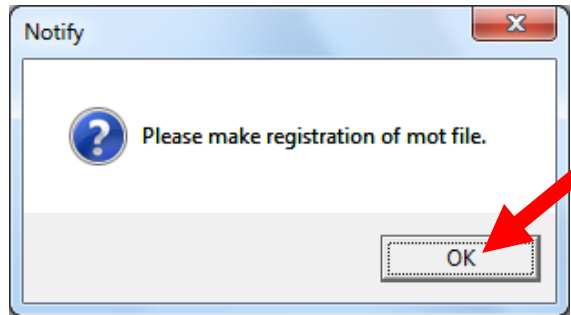

Figure 5-262

- 3) The firmware registration screen is displayed. Select [Register].

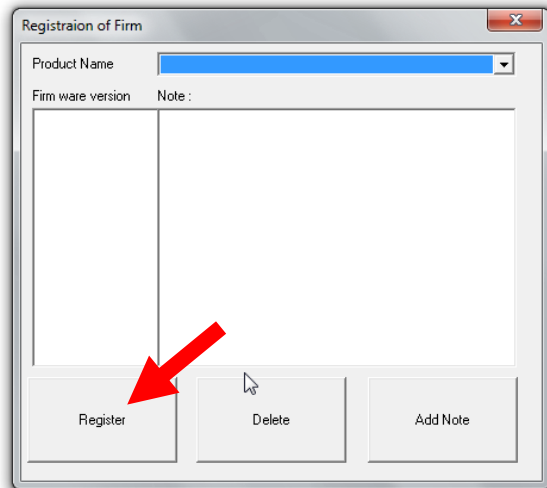

Figure 5-263

- 4) When the file selection screen is displayed, select the file.

Note: The file format is "mot". The file name can be changed to anything.

- 5) The firmware is automatically registered. The “Product Name” and “Firmware version” are displayed on the firmware registration screen.

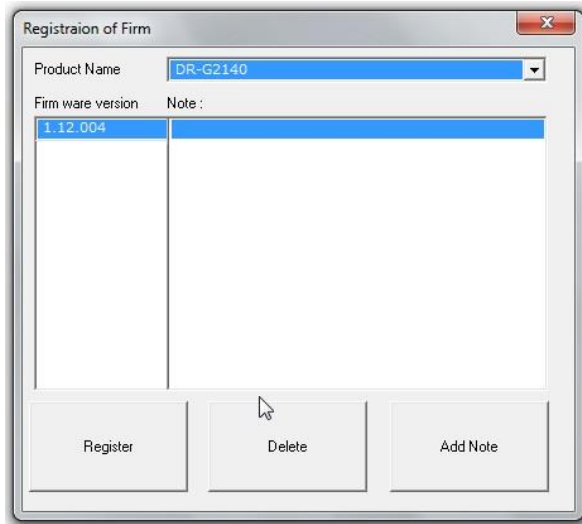

Figure 5-264

**Note:**The registered firmware is saved together within the service tool folder. Since the product name, version number, etc. are written in the “mot” file, the folder name is decided to match them. Furthermore, an “ini” file that contains the setting conditions is saved at the same time. The following shows an example of the folder.

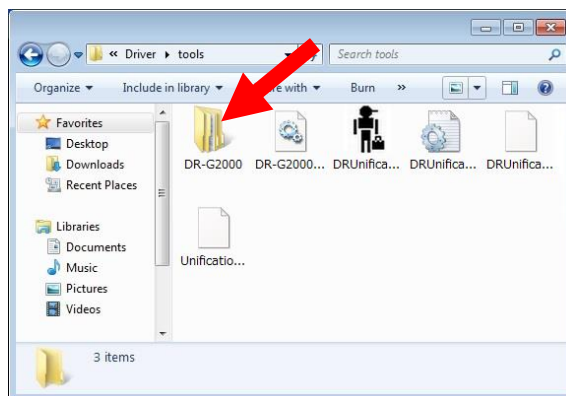

Figure 5-265

- 6) Select [Add Note] if necessary and enter any arbitrary information. After entering the information, select [OK].

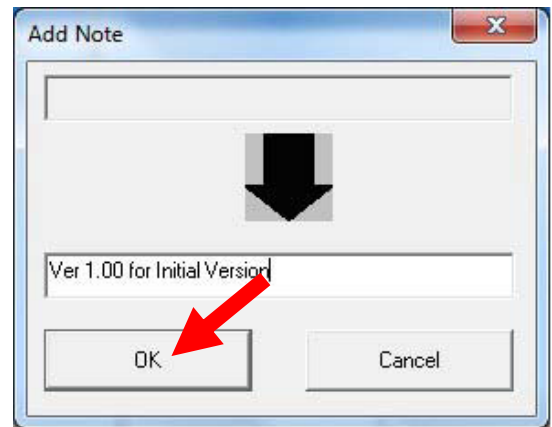

Figure 5-266

**Note:**To delete from the registration screen, select the target version and then select [Delete]. Note that the file is not deleted from the folder.

**Note:**The registered firmware is displayed in the “Firmware” screen on the next restart or when returning from another screen.

## 2. Firm Load

This method for writing firmware varies depending on whether that firmware has already been registered or has not been registered. The operation procedures are shown below.

**Note:** Do not remove the USB cable or turn the power OFF during loading. If the power is turned OFF, it returns to its original state when restarted, but this is not guaranteed.

- ◆ For registered firmware  
In this mode, the file saved in the service tool is selected and its version is upgraded.

- 1) Select the version to write and then select [Version up] in middle.

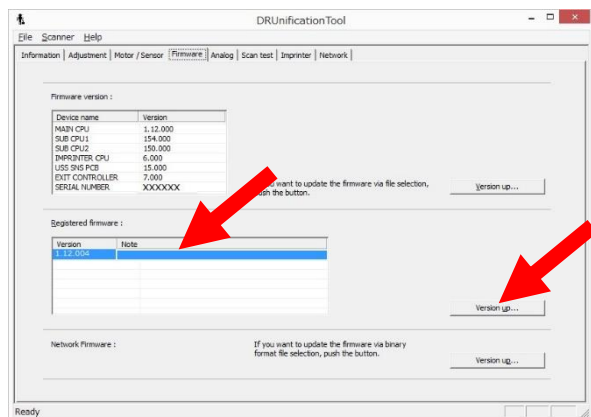

Figure 5-267

- 2) The confirmation screen is displayed. Select [OK].

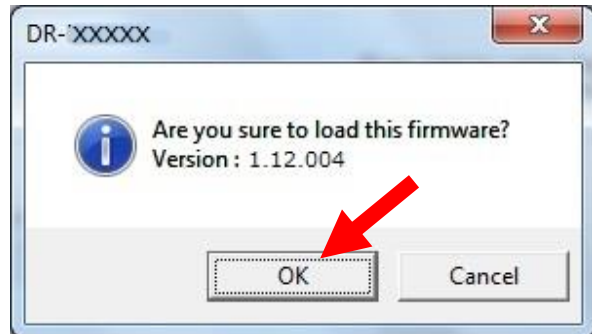

Figure 5-268

- 3) Writing starts automatically and the progress screen is displayed.

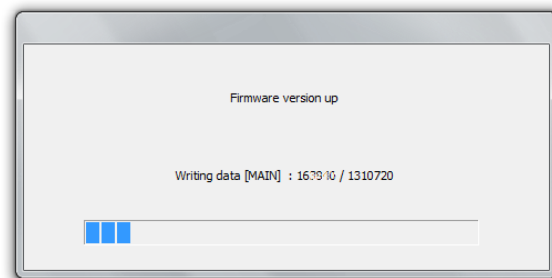

Figure 5-269

- 4) When finished, the progress disappears and the complete screen appears. Select [OK].

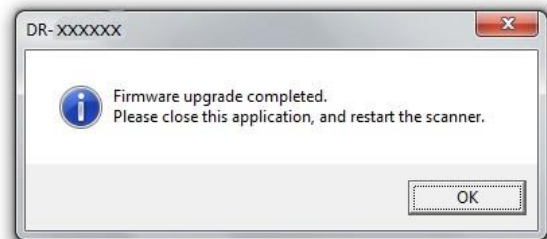

Figure 5-270



- After the firmware is upgraded, all tabs except the firmware disappear to prevent operation mistakes of the service tool.

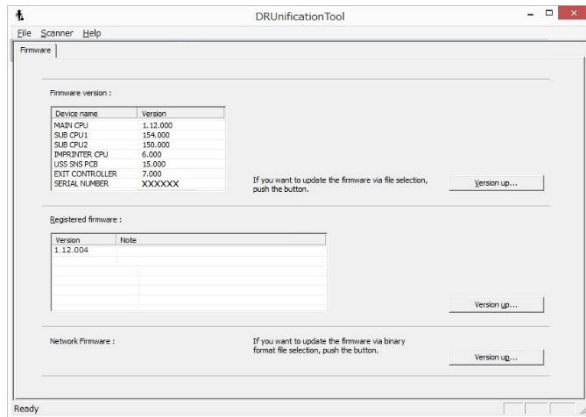

Figure 5-271

- Restart the service tool and scanner main body and then check the version number.

◆ For unregistered firmware

In this mode, the file saved in the software is selected and its version is upgraded.

- Select [Version up] in upper side.

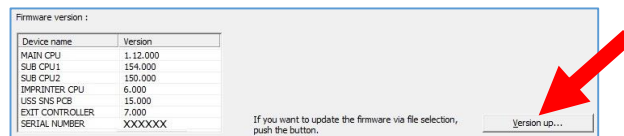

Figure 5-272

- When the file selection screen is displayed, select the file.
- Writing starts automatically and the progress screen is displayed. The rest of the procedure is the same as in “For registered firmware”.

**Note:**This automatically detects whether the file is for the connected scanner and only executes writing if it is suitable.

### 3. Network Firmware

This is used to upgrade the firmware for the network related. This file is supplied by “bin” format.

**Note:**Do not remove the USB cable or turn the power OFF during loading. If the power is turned OFF, it returns to its original state when restarted, but his is not guaranteed.

◆ Operation Procedure

- Select [Version up] in lower side.

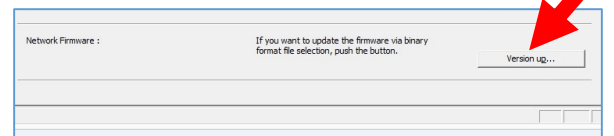

Figure 5-273

- When the file selection screen is displayed, select the file.
- Writing starts automatically and the progress screen is displayed. The rest of the procedure is the same as in “For registered firmware”.

**Note:**This automatically detects whether the file is for the connected scanner and only executes writing if it is suitable.

- Restart the service tool and scanner main body and then check the version number.

## E. Analog

(The numbers shown in figure are corresponding the item numbers following.)

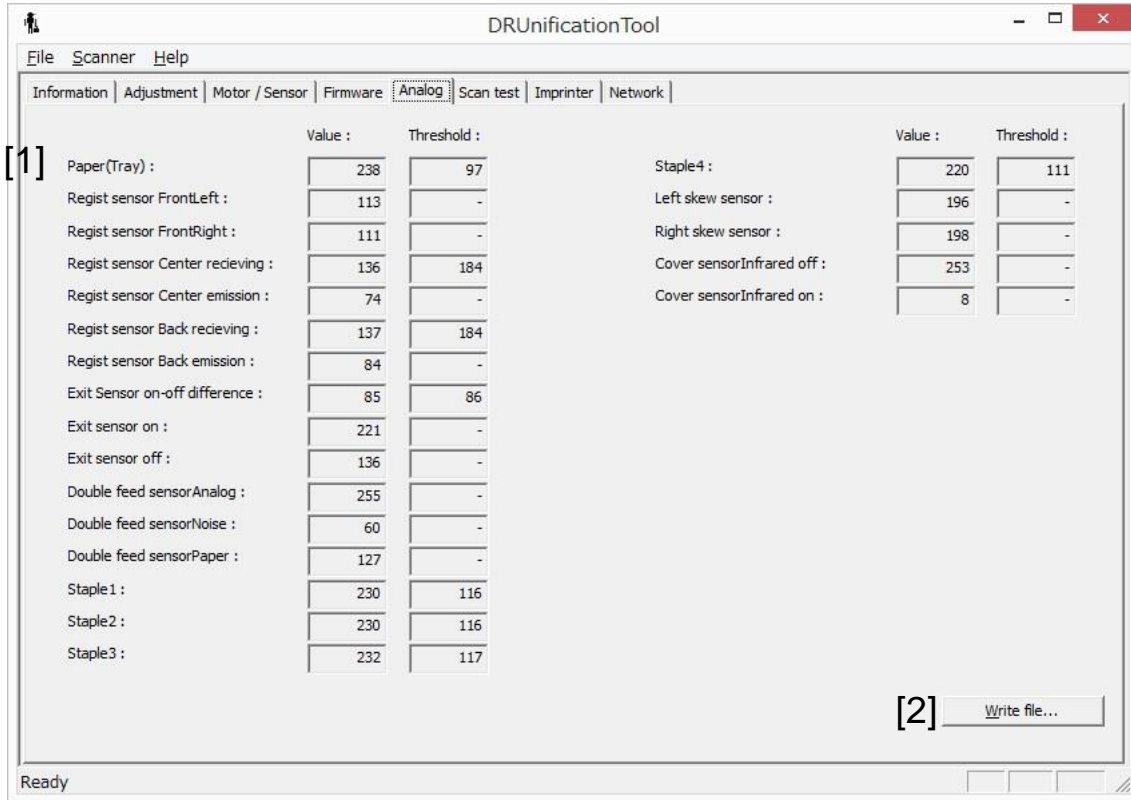

Figure 5-274

### 1. Analog Sensor

This is used to check analog data for the following sensors. However, sensor operation is normally checked using “Motor/Sensor”.

For threshold values shown on the right side of analog data, “-“ is displayed if there are no threshold values.

### 2. Write File

When [Write file] on the lower right side of the analog screen is selected, displayed information can be saved in a text file.

The operation procedure is the same as that in “A. Information, 9. Write File.”

## F. Scan Test

### 1. Scan

This is used to perform scans in service mode. Scanned images are displayed and saved.

#### ◆ Description of screen

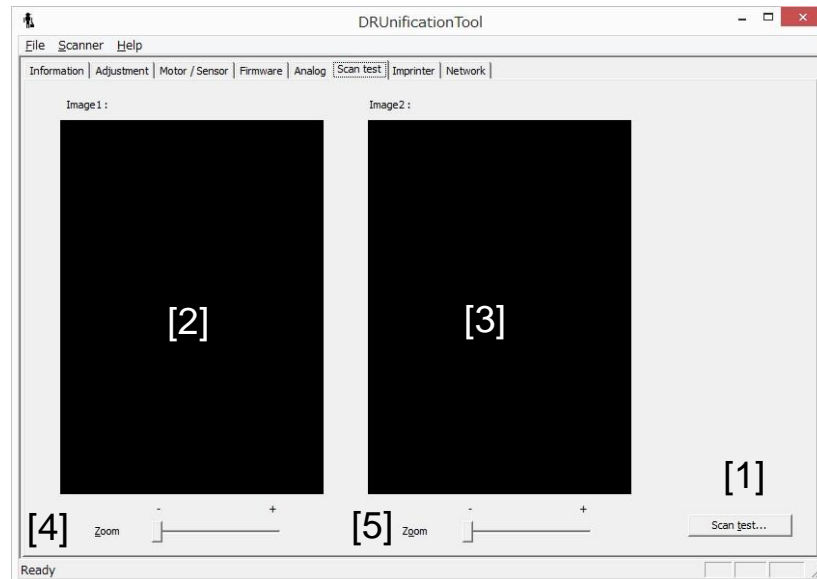

Figure 5-275

No.	Details
1	<b>Scan test</b> The scan setting dialog appears and scanning is carried out. Scanned images are saved.
2	<b>Image 1</b> If only one sheet is scanned, the scanned front image is displayed. If multiple sheets are scanned, the second last scanned image is displayed. Move the image by dragging the mouse.
3	<b>Image 2</b> In only one sheet is scanned, the scanned back image is displayed. If multiple sheets are scanned, the last scanned image is displayed. Move the image by dragging the mouse.
4	<b>Zoom (Image 1)</b> Enlarges the image in [2] above using a slide bar. They can be enlarged up to 10 times from the initial display state.
5	<b>Zoom (Image 2)</b> Enlarges the image in [3] above using a slide bar. They can be enlarged up to 10 times from the initial display state.

Table 5-207

◆ Operation Procedure

- 1) Place the document.
- 2) When the “Scan test” button is selected, a scanner setting dialog in the driver appears. Set the scanner properly and click the “OK” button.

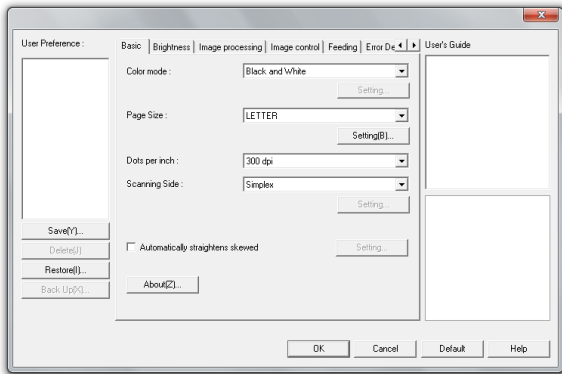

Figure 5-276

- 3) The screen for saving scanned images is displayed. Set a save location and click the “Save” button. The scanned image is saved in bitmap form.
- 4) The document is scanned.
- 5) The data is saved and the image is displayed as well. If only one sheet is scanned, the front surface is displayed in “Image 1” and back surface is displayed in “Image 2”.  
If multiple sheets are scanned, the last document image is displayed in “Image 2”, and the last scanned image but one is displayed in “Image 1”.

G. Imprinter

This is used to check status of the imprinter.

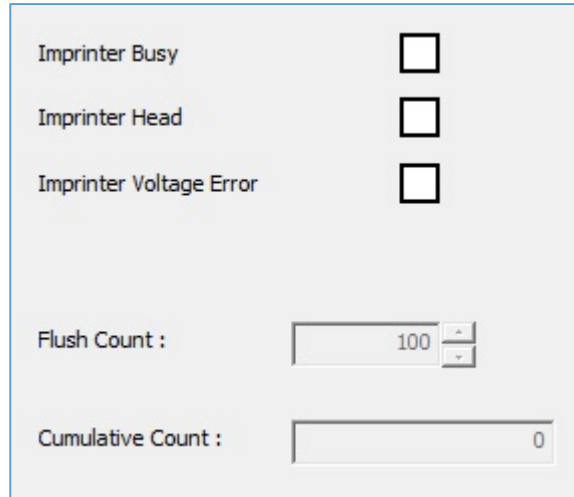

Figure 5-277

- ◆ Imprinter Busy  
While the imprinter is printing, the mark is lit.
- ◆ Imprinter Head  
While the imprinter head is detected, the mark is lit.
- ◆ Imprinter Voltage Error  
While the imprinter voltage error is detected, the mark is lit.
- ◆ Flush Count  
Display and set a count of the ink flushing at once.
- ◆ Cumulative Count  
Display and set a total count of the ink flushing.

**Note:**For the Flush count and cumulative count, you can change number when you select the “Edit” button in the right lower side.

## H. Network

This is used to check and set the network settings.

The screenshot shows a 'Network Setting' window. At the top, there is a 'DHCP' section with two radio buttons: 'OFF' (selected) and 'ON'. Below this are four input fields, each with a label on the left and a text box on the right containing a default value:

- IP Address:** 255 . 255 . 255 . 255
- Subnet Mask:** 255 . 255 . 255 . 255
- Default Gateway:** 255 . 255 . 255 . 255
- Mac Address:** FF : FF : FF : FF : FF : FF

**Figure 5-278**

- ◆ **DHCP**  
Display and set the setting of DHCP. If you get the IP address automatically using DHCP, turn it ON.
- ◆ **IP Address**  
Display the IP Address. When the DHCP setting is OFF, you can set it.
- ◆ **Subnet Mask**  
Display the subnet mask. When the DHCP setting is OFF, you can set it.
- ◆ **Default Gateway**  
Display the default gateway. When the DHCP setting is OFF, you can set it.
- ◆ **Mac Address**  
Display the Mac address of this main body.

**Note:**The “Mac Address” cannot be changed in the market.

**Note:**When you change the network settings, you have to inform the user.

## I. Other Function

### 1. Obtainment of Log Files

This is not function of the service tool. However, the software for this machine automatically collects log files of user usage status information, and it is equipped with a function for obtainment of the log files.

Since the log files are designed to be useful for resolving problems, the user may be asked to do the operation to obtain the files.

The following gives an overview of the log files and the procedure for recovering them.

◆ Use of software and select screen

- 1) CaptureOnTouch “Environmental Settings”
- 2) CapturePerfect “Version Information”
- 3) Scanner driver “About”
- 4) Canon imageFORMULA Driver Setting Tool “Diagnostic”

**Note:** Using the application software, you can get its application and driver’s logs. Using the driver, you can get driver’s log.

◆ Types of information

- 1) User operations
- 2) Error
- 3) Settings
- 4) Debugging  
(Note that this excludes default settings)
- 5) Latest information when recovering the files

The “Canon imageFORMULA Driver Setting Tool” is used for description following. The settings of this tool are valid while USB connection.

◆ Procedure

- 1) Start “Canon imageFORMULA Driver Setting tool” and open [Diagnostic] tab.

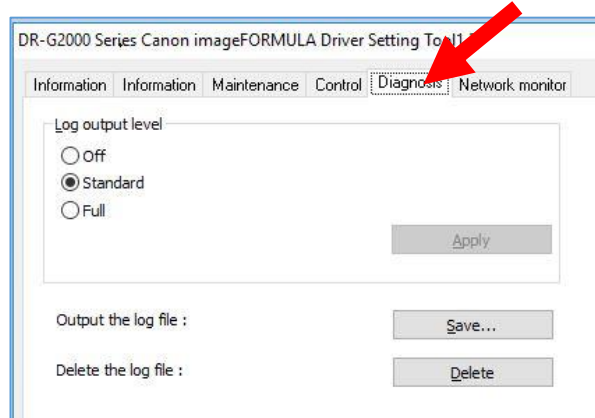

Figure 5-279

- 2) Click the [Save] button for the [Output the log file].

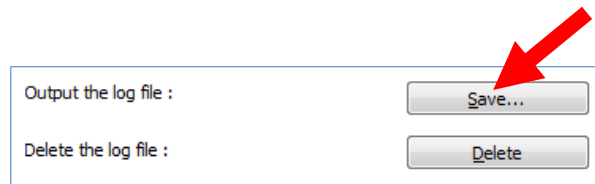

Figure 5-280

- 3) The Save Settings screen is displayed. Select the appropriate location to save the files.
- 4) The files are saved with [xxx.dat] attached.

◆ Log output level

Select [Standard] or [Full] of log file level.

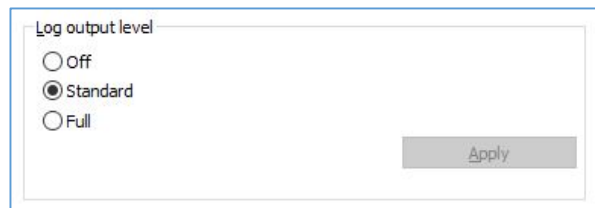

Figure 5-281

The default setting is [Standard]. If you need the [Full] information, set to [Full] and click the [Apply] button. Then, perform the steps to reproduce the problem and perform the obtainment operation. Note that when set to [Full], the scanning speed may be reduced.

Also, outputting log file may stop when you select [Off].

◆ Delete log file

The log files data of the past year are saved on the user computer. The maximum size of the log files is approx. 200 MB. Once this limit is exceeded, old data is deleted. When you delete the old log files data, follow the procedure below.

- 1) Start “Canon imageFORMULA driver setting tool” and open [Diagnosis] tab, then select [Delete] button for the [Delete the log file].

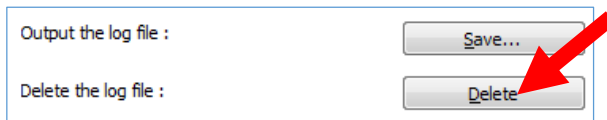

**Figure 5-282**

## III. TROUBLESHOOTING LIST

The lists below give the major failures conditions and their causes. Refer to the next section for details of the causes and the measures to be taken.

### 1. Operation Failures

Note: Major causes of each failure are marked "X".

No.	Cause Failure	System/ Soft- ware	Hard- ware	Connec- tion	Dirt/dust	Docu- ment	Settings
1	Power does not come ON		X	X			
2	No scanner is found	X	X	X			X
3	Scanner does not start	X	X	X			
4	Scanning does not feed properly		X		X	X	X
5	Scanning speed is slow	X					X

Table 5-301

### 2. Image Failures

Note: Major causes of each failure are marked "X".

No.	Cause Failure	System/ Soft- ware	Hard- ware	Connec- tion	Dirt/dust	Docu- ment	Settings
1	All black/all white/all streaked	X	X	X			X
2	Too dark/too light					X	X
3	Black Borders					X	X
4	Image slanted		X			X	X
5	Streaks in image		X		X		
6	Outer area disappear					X	X
7	Wrong image size					X	X
8	Text cannot be seen					X	X

Table 5-302



## IV. OPERATION TROUBLESHOOTING

When an operation problem occurs, check the error message displayed on the display connected to a computer. Also perform an operation check on the sensors and motors using the service mode.

### 1. Power Does Not Turn ON

The display panel is not lit.

**Note:** Make sure to use the power cord supplied with the machine.

Cause/Faulty Locations	Step	Check Item	Result	Action
AC power supply voltage	1	Is the power outlet supplying power at the rated voltage?	NO	Explain to the user that this is not a problem with the machine.
Connection of power cord	2	Is the power cord connected?	NO	Connect the power cord correctly.
Power cord	3	Does replacing the power cord fix the problem?	YES	End.
Operation panel Sub-drive PCB Control PCB Power PCB	4	Does the LED on the control PCB light when turn the power ON?	YES	Power is supplied. Check the Step 6.
			NO	Check the step 5.
	5	Is the cable connected?	YES	Check the step 6.
			NO	Connect the cable correctly.
6	Is the problem solved by replacing the PCB?	YES	End.	

**Table 5-401**

## 2. No Scanner is Found

**Note:** You should install the driver on the computer before connecting the scanner.

### 1) USB connection

Cause/Faulty Locations	Step	Check Item	Result	Action
Connection of the USB cable	1	Is the USB cable connected?	NO	Connect the USB cable correctly.
System	2	Does a resetting this machine and computer fix the problem?	YES	End.
USB cable	3	Is the USB cable compatible?	NO	Use the USB cable supplied.
USB HUB	4	Does a direct connection fix the problem?	YES	End. Connect directly or replace the USB HUB.
Control PCB	5	Does a replacing of the control PCB fix the problem?	YES	End.

**Table 5-402**

### 2) LAN connection

Cause/Faulty Locations	Step	Check Item	Result	Action
Connection of the LAN cable	1	Is the LAN cable connected?	NO	Connect the LAN cable correctly.
	2	Are the LAN and USB cables connected?	YES	Disconnect the USB cable and restart.
System	3	Does a resetting this machine and computer fix the problem?	YES	End.
IP address (Network setting)	4	Is the IP address correct?	NO	Contact user network administrator to be correct.
Device name (Scanner name)	5	Is the device name correct?	YES	Contact user network administrator to be correct.
Micro SD card	6	Is the micro SD card in the control PCB?	NO	Replace the control PCB.
Control PCB	7	Does a replacing of the control PCB fix the problem?	YES	End.

**Table 5-403**

**Note:** When the scanner is the LAN connection, the flatbed scanner cannot be used.

### 3. Scanning Does Not Start

**Note:** While error messages is displayed, scanning may not start. Clear the error.

Cause/Faulty Locations	Step	Check Item	Result	Action
System	1	Does a resetting this machine and computer fix the problem?	YES	End.
Software	2	Does a reinstalling the scanner driver and application fix the problem?	YES	End.
Connection of the connector	3	Are the motor and sensor connectors connected correctly?	NO	Connect the connectors correctly.
Drive transmission system	4	Is the transmission system of the motors normal? Are parts such as gears and belts normal?	NO	Attach the parts correctly. Replace the parts.
Motors	5	Is the operation normal when you perform an operation check with the service mode?	NO	Check the cable connections. Replace the parts.
Sensors	6	Is the operation normal when you perform an operation check with the service mode?	NO	Check the cable connection, and the attachment of sensors, sensor levers and light guide. Replace the parts.
Control PCB Main drive PCB Sub-drive PCB	7	Was the problem solved by replacing each PCB?	YES	End.

**Table 5-404**

## 4. Scanner Does Not Feed Properly

**Note:** A “paper jam” or “double-feed” error message may be displayed due to a sensor problem.

Cause/Faulty Locations	Step	Check Item	Result	Action
Document	1	Specified document? (thickness, size, fold or curl)	NO	Use documents compliant with the specified.
Placing documents	2	Are documents stuck together?	YES	Fan the documents well. Eliminate static electricity.
	3	Is the position of the document guide correct?	NO	Correct the position.
Pickup or feeding conditions	4	Is the setting of pickup or feeding is correct? (Separation force, thin paper, manual feeding mode settings)	NO	Correct the condition.
Rollers	5	Are the rollers attached correctly?	NO	Attach the rollers correctly.
	6	Are they dirty or deformed?	NO	Clean or replace the rollers.
Parts in feed path	7	Parts touching documents installed properly? (no float, slant or gaps)	NO	Attach the parts correctly.
	8	Is the surface touching documents smooth? (No scratches or burrs)	NO	Replace defect parts.
Drive transmission system	9	Does an abnormal noise occur while feeding? Is there any gear damage or belt loose?	YES	Attach the parts correctly. Replace defect part.
Motors	10	Is the operation normal when you perform an operation check with the service mode?	NO	Check the cable connections. Replace the parts.
Sensors	11	Is the operation normal when you perform an operation check with the service mode?	NO	Check the cable connection, and the attachment of sensors, sensor levers and light guide. Replace the parts.
Control PCB Main drive PCB Sub drive PCB	12	Was the problem solved by replacing the each PCB?	YES	End.

**Table 5-405**

## 5. Scanning Speed is Slow

The speed is further reduced if high resolution, color settings, or special functions are selected.

If the scanning speed is slow after taking these considerations, the cause may be as follows.

Cause/Faulty Locations	Step	Check Item	Result	Action
Insufficient computer memory	1	Is the memory sufficient?	NO	Increase the memory.
	2	Are other applications running?	YES	Close the other applications.
	3	Are resident applications such as a virus protection program running?	YES	Close the service-type applications.
	4	Is there insufficient hard disc space?	YES	Increase the hard disc space.
USB3.1 Gen1 and USB 2.0 not supported	5	Is the USB port of computer supported?	NO	Use a computer that supports it.
	6	Is the USB cable supported?	NO	Use the supplied USB cable.
	7	Is the USB HUB supported?	NO	Use a USB HUB that supports it.
The log file setting is [Full]	8	Is the log file setting set to [Full]?	YES	Set to [Standard].

**Table 5-406**

## V. IMAGE TROUBLESHOOTING

### ◆ Image Samples

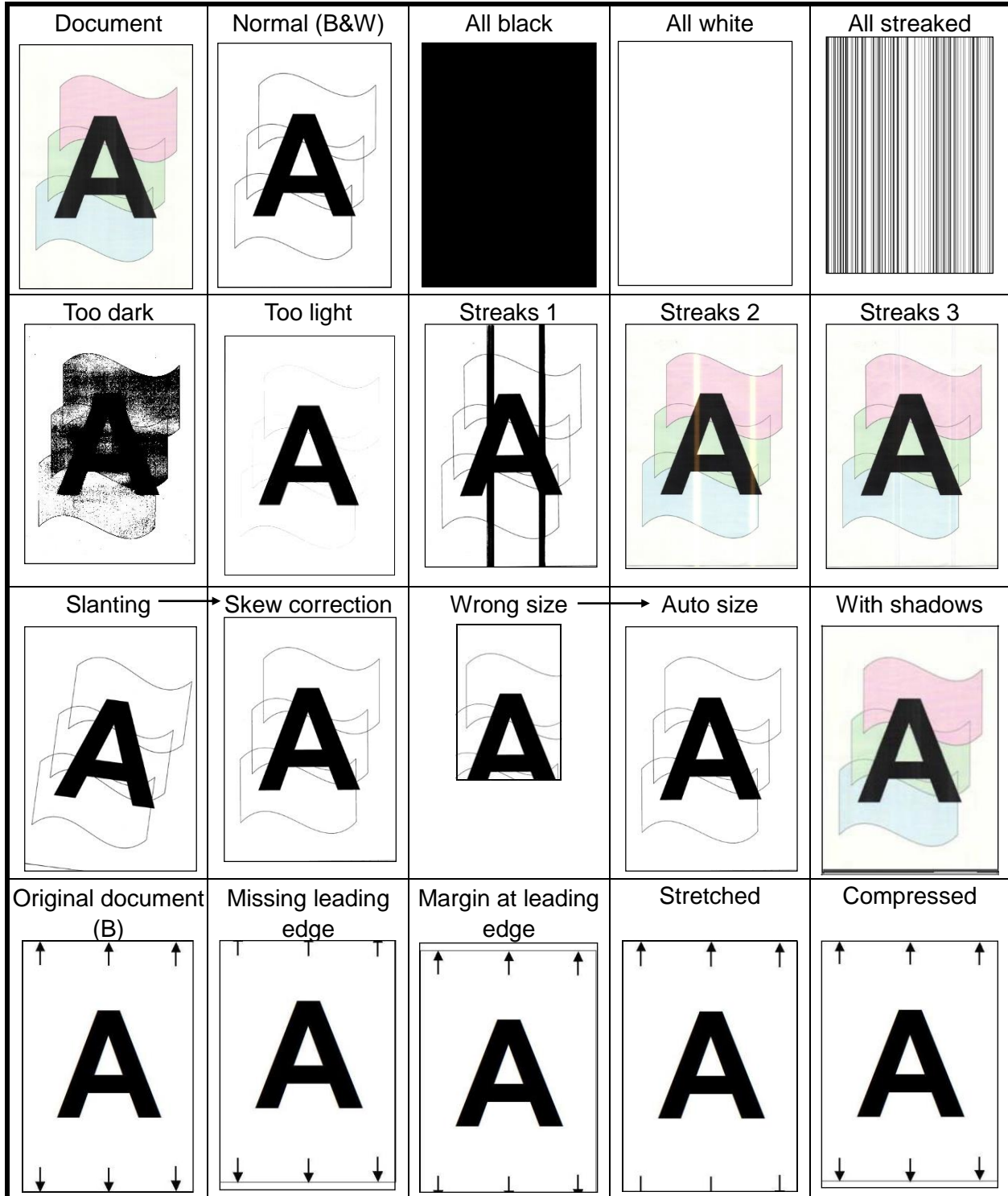

Figure 5-501

**Note:** There are times when, depending on the type of image and settings, document reproducibility becomes poor. In such case, the image may be improved by changing the settings.

## 1. Completely Black, Completely White, All Streaks

Completely Black, Completely White, or All Streaks are output.

Cause/Faulty Locations	Step	Check Item	Result	Action
"Brightness" setting	1	Is the "Brightness" setting appropriate?	NO	Change the setting. Also change "Contrast" if necessary.
System	2	Is the problem solved when the scanner power is reset and the computer is re-started?	YES	End.
Reading unit	3	Are the reading related cables connected properly?	NO	Connect them properly. Replace defect parts.
	4	Is the problem solved when the reading unit is replaced?	YES	End.
Control PCB	5	Is the problem solved when the control PCB is replaced?	YES	End.

**Table 5-502**

## 2. Too Dark, Too Light

Image does not look appropriate due to improper brightness.

Cause/Faulty Locations	Step	Check Item	Result	Action
"Brightness" setting	1	Is the "Brightness" properly set? The brightness should be set to middle in normal case but may be required to change according to the type of document.	NO	Change the setting.
"Contrast" setting	2	Is the "Contrast" properly set?	NO	Change the setting.
"Density adjustment"	3	Have you executed "Density adjustment" by service mode?	NO	Execute the adjustment.

**Table 5-503**

### 3. Black Borders Around Image

Black borders appear around the images.

Cause/Faulty Locations	Step	Check Item	Result	Action
"Page Size" setting	1	Is the "Page Size" properly set?	NO	Change the setting.
Document setting	2	Is the document set at the correct position?	NO	Set the document at the correct position.
Setting of "Auto-detection" for page size or "Border Removal"	3	Is "Auto-detection" or "Border Removal" set?	NO	Set the function. Black border can be removed by image processing.

**Table 5-504**

### 4. Image Skews

If the document skews when fed, the scanned image also skews.

Cause/Faulty Locations	Step	Check Item	Result	Action
Document setting	1	Is the document properly set?	NO	Properly set the document.
Document feeding	2	Is the document fed straight?	NO	Carry out check items listed in "IV. OPERATION TROUBLESHOOTING, 4. Documents Are Not Fed Properly."
"Deskew" setting	3	Is the "Deskew" set?	NO	Set the function. Slant can be corrected by image processing.

**Table 5-505**



## 5. Streaks on Image

If the reading glass surface is dirty, streaks appear on the scanned images in the feed direction. Dirt on the rollers may also be transferred to the documents.

On the other hand, white streaks appearing on the scanned images are caused by the execution of the shading correction while the inside of reading unit is dirty.

Cause/Faulty Locations	Step	Check Item	Result	Action
Reading glasses	1	Are the reading glasses clean?	NO	Clean the reading glasses. Replace the reading glass if scratches are found.
Roller	2	Are the surfaces clean?	NO	Clean or replace the roller.
Feed path	3	Is the feed path clean?	NO	Clean the feed path.
Reading unit inside	4	Is the reading unit inside clean?	NO	Clean or replace the reading unit.

Table 5-506

## 6. Outer Areas of Image Disappear

When scanning a document with black or deep color outer areas, selecting the “Auto-detection,” the “Deskew” or the “Border Removal” may cause the outer areas to disappear from the scanned image.

Cause/Faulty Locations	Step	Check Item	Result	Action
Document	1	Is there any black or deep color on the document outer areas?	YES	Disable the functions such as the “Auto-detection”.

Table 5-507

## 7. Wrong Image Size

There are margins around the image, or some of the image is missing.

**Note:** Set the paper size to “auto detection” when scanning batch of different size documents.

Cause/Faulty Locations	Step	Check Item	Result	Action
“Paper size” setting	1	Is the setting of “Paper size” correct?	NO	Change the setup.
Placing documents	2	Is the document placed in the correct position?	NO	Place the document in the correct position.
Setting of “Auto detection” for the paper size	3	Is the “Auto detection” set?	NO	Set it.
“Registration adjustment” “Scaling adjustment”	4	Have you executed automatic adjustment “All” by the service mode?	NO	Execute the adjustment.

**Table 5-508**

## 8. Text Invisible

When the background includes colors or patterns, text may be hidden by the background when scanning in black and white mode. A special mode called “ATE: Advanced Text Enhancement” and “Active Threshold” exists to solve this problem.

**Note:** The problem may not be fixed, depending on the type of document.

Cause/Faulty Locations	Step	Check Item	Result	Action
“Mode” setting	1	Is the problem solved when the “Color” or “Grayscale” is set?	YES	End.
	2	Is the problem solved when a special mode such as the “Advanced Text Enhancement” or “Active Threshold” is set?	YES	End.
“Brightness” setting	3	Is the problem solved when the “Brightness” setting is changed?	YES	End.

**Table 5-509**

## VI. AFTER REPLACING PARTS

Some of the parts used in this machine require adjustments and settings after being replaced or disassembled/reassembled. The related parts are shown below.

Check document feed and images after the replacement or disassembly/reassembly of the parts.

### 1) Control PCB

Perform adjustment "All" and "Density" in the service mode. Change the value for "Counter" and enter "serial number" in the Information tab.

### 2) Reading unit

Perform adjustment "All" and "Density" in the service mode.

### 3) Registration-related parts

When replacing or reassembling the ultrasonic sensor PCB and ultrasonic drive PCB on which a registration sensor is built, perform adjustment "All" in the service mode.

### 4) Periodically replaced parts (servicing)

When the periodically replaced parts, such as registration rollers and platen rollers, which are replaced by the service technician, are replaced, set the number of sheets fed at replacement by the "Counter" in the service mode.

### 5) Power PCB

When the power PCB replaced, set the number of hours at replacement by the "Counter" in the service mode.

### 6) Pickup sensor

When the pickup sensor is not properly installed, the pickup motion and feeding are not performed correctly.

Therefore, the adjustment of the pickup sensor position is required not only after replacing parts, but also when a malfunction occurs after changing the position of the pickup sensor.

For details, refer to following items.

#### ◆ Operation check

Select "Motor / Sensor" in the service mode and keep the operating condition of the pickup sensor visible. If the pickup sensor lights when the pickup tray is not lifted or if the sensor does not light when the pickup tray is at the top position, position adjustment is necessary.

#### ◆ Assembly verification

Verify that the pickup sensor and sensor mounting plate have been assembled correctly before position adjustment. Verify that the sensor cable is connected and that a positioning boss is inserted in the hole in the mounting plate.

◆ Adjustment procedure

- i) Remove the eject tray unit and upper front cover.
- ii) Loosen the fixing screw ①, rotate the adjusting screw ② and after moving the sensor mounting plate ③ on which the pickup sensor is mounted a little back and forth, fix the plate.

**Note:** The positioning boss ④ must be inserted into the hole in the sensor mounting plate.

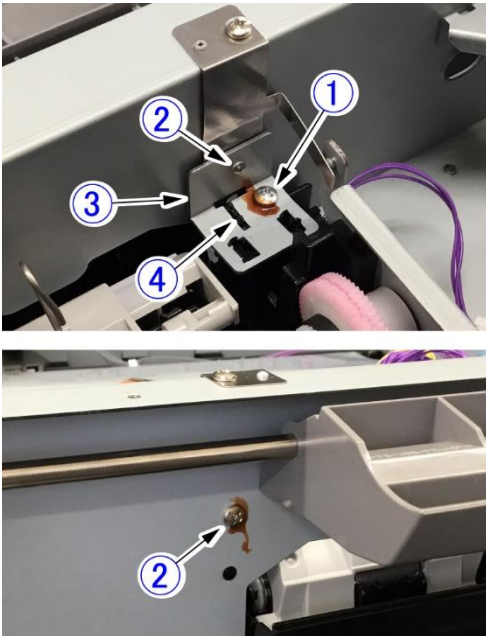

**Figure 5-601**

- iii) While feeding a sheet of paper, check the sensor and the feeding operation. If it is not corrected, retry the previous procedure.
- iv) If it is corrected, replace covers and check the operation again.

---

---

# APPENDIX

---

---

I.	GENERAL DIAGRAM .....	A-1
II.	LIST OF SPECIAL TOOLS.....	A-2

---









## II. LIST OF SPECIAL TOOLS

The list of special tools needed for servicing this machine are the following.  
However, adjustment sheet: 6Y3-6001 is a new tool, and others are existing ones.

No.	Tool name	Tool number	Rank	Usage/Remarks
1	Test sheet	TKM-0271	A	General image check 10 sheets/1 set
2	Density adjustment sheet	TKM-0347	B	For density adjustment 10 sheets/1 set
3	Adjustment sheet	6Y3-6001	B	For scaling and registration adjustment 10 sheets/1 set

**Figure A-201**

**Note:** Rank symbol

A: Equipment that each service technician must carry.

B: Equipment that can be shared among a group of 5 service technicians.

C: Equipment that each workshop needs to have.



**Prepared by**

**Quality Assurance Center  
Canon Electronics Inc.**

**3-5-10, Shibakoen, Minato-ku,  
Tokyo 105-0011, Japan**

**FIRST EDITION: AUG. 2018**

**Canon**