



SERVICE INFORMATION (IMS)

Issued by Quality Assurance Center, Canon Electronics Inc.

MODEL: DR-G1130/G1100

No. : DP31-1202E

DATE : December 6, 2012

- Major quality issues Quality upgrade/production efficiency
 Field quality problems Miscellaneous

LOCATION

SUBJECT DR-G1130/G1100 TECHNICAL INFORMATION

1. OUTLINE

This document provides supplemental technical information for the DR-G1130/G1100. These models are based on the DR-9050C/7550C/6050C and their succeeding ones, and their pickup/separation function and others are improved.

This information provides the items different from the DR-9050C about the service manual. For the items about the parts catalog, refer to another parts catalog: MY8-31AM-000. And for the other items, refer to the service manual and others for DR-9050C.

Also, the latest "Service tool" ver.1.6, and the "Product Guide" issued by IMS product planning dept. are distributed with this service information for your reference.

2. MERCHANDISE CODE (DESIGN NO.)

Items	DR-G1130		DR-G1100	
	8073B001xx	M11-11711	8074B001xx	M11-11811
100V	8073B001xx	M11-11711	8074B001xx	M11-11811
120V	8073B002xx	M11-11713	8074B001xx	M11-11813
220-240V	8073B003xx	M11-11714	8074B001xx	M11-11814
KR (Korea)	8073B005xx	M11-11716	8074B001xx	M11-11816
CN (China)	8073B004xx	M11-11719	8074B001xx	M11-11819
CME (Mid. East)	8073B006xx	M11-1171E	8074B001xx	M11-1181E
110V	8073B007xx	M11-11718	8074B001xx	M11-11818

3. MAIN PRODUCT IMPROVEMENTS

- 1) Improving the scanning speeds
(DR-G1130 at A4 portrait: 100ppm/200ipm, at A4 landscape: 130ppm/260ipm)
- 2) Improving the pickup/separation function
- 3) Improving the operating sounds
- 4) Corresponding the European standard Lot 6
- 5) Corresponding the new energy star program

4. APPEARANCE

It is almost the same. The color of the upper cover is changed to gray.

After here, described the main changed items based on the DR-9050C service manual.

The chapter numbers and tile names are conformed to the service manual.

Chapter 1: GENERAL DESCRIPTION

I. PRODUCT OUTLINE

2. Specifications

No.	Item	Specifications																												
1	Power supply rating	1) 100 V model: 100 VAC, 50/60 Hz, 97 W 2) 120 V model: 120 VAC, 60 Hz, 1.0 A 3) 200 V model: 220-240 VAC, 50/60 Hz, 0.6 A																												
2	Power consumption	1) Operating: 96.9W(100V), 95W(120V), 94.3W(220-240V) 2) Sleep mode: 1.6W(100V/120V), 1.7W(220-240V) 3) Power switch OFF: 0.3W																												
3	Sound level	1) Standby (Sound power level): 40 dB max. 2) Operating (Fast mode, sound power level): 69.5 dB max. 3) Operating (Fast mode, by-stander): 54 dB max.																												
4	Dimensions	1) Tray closed: 480 (W) x535 (D) x315 (H) mm 2) Tray opened: 480 (W) x723 (D) x390 (H) mm																												
5	Weight	22.8 kg (Main body only)																												
6	External interface	◆SCSI was deleted. 1) USB 2.0 (Hi-speed)																												
7	Expected product life (In-house information)	◆No changes One of the following two items, whichever comes first. 1) 5 years 2) Sheets fed: 14.4 millions sheets (A4 copy paper) *There are parts needed to replace.																												
8	Bundle software	◆Each software was updated. ISIS/TWAIN driver, CapturePerfect 3.1, Job Tool, Kofax VRS																												
9	Consumable parts (Commercial goods)	◆Each roller was changed, and Separation cover with pad was added. 1) Exchange roller kit (Pickup/Feed/Retard rollers) *Expected life 450,000 sheets 2) Separation cover with pad * Expected life 6,000,000 sheets																												
10	Scanning speed	600dpi is set as speed priority. Auto-size detection and deskew are set ON. The numbers may differ depending on the computer, the function settings and other conditions.																												
		<table border="1"> <thead> <tr> <th>Model</th> <th>Document Direction</th> <th>Mode (File format)</th> <th>Resolution</th> <th>Simplex (ppm)</th> <th>Duplex (ipm)</th> </tr> </thead> <tbody> <tr> <td rowspan="6">DR-G1130</td> <td rowspan="6">A4 Portrait</td> <td rowspan="3">B&W (TIFF)</td> <td>200dpi</td> <td>100</td> <td>200</td> </tr> <tr> <td>300dpi</td> <td>100</td> <td>200</td> </tr> <tr> <td>600dpi</td> <td>83</td> <td>83</td> </tr> <tr> <td rowspan="3">Gray (JPEG)</td> <td>200dpi</td> <td>100</td> <td>200</td> </tr> <tr> <td>300dpi</td> <td>100</td> <td>200</td> </tr> <tr> <td>300dpi</td> <td>100</td> <td>200</td> </tr> </tbody> </table>	Model	Document Direction	Mode (File format)	Resolution	Simplex (ppm)	Duplex (ipm)	DR-G1130	A4 Portrait	B&W (TIFF)	200dpi	100	200	300dpi	100	200	600dpi	83	83	Gray (JPEG)	200dpi	100	200	300dpi	100	200	300dpi	100	200
Model	Document Direction	Mode (File format)	Resolution	Simplex (ppm)	Duplex (ipm)																									
DR-G1130	A4 Portrait	B&W (TIFF)	200dpi	100	200																									
			300dpi	100	200																									
			600dpi	83	83																									
		Gray (JPEG)	200dpi	100	200																									
			300dpi	100	200																									
			300dpi	100	200																									

				600dpi	80	80
			Color (JPEG)	200dpi	100	200
				300dpi	100	170
				600dpi	45	45
		A4 Landscape	B&W (TIFF)	200dpi	130	260
				300dpi	130	260
			Gray (JPEG)	200dpi	130	260
				300dpi	130	260
			Color (JPEG)	200dpi	130	200
				300dpi	130	170
	DR-G1100	A4 Portrait	B&W (TIFF)	200dpi	75	150
				300dpi	75	150
				600dpi	75	83
			Gray (JPEG)	200dpi	75	150
				300dpi	75	150
				600dpi	75	80
			Color (JPEG)	200dpi	75	150
				300dpi	75	150
				600dpi	45	45
		A4 Landscape	B&W (TIFF)	200dpi	100	200
				300dpi	100	200
			Gray (JPEG)	200dpi	100	200
				300dpi	100	200
			Color (JPEG)	200dpi	100	200
				300dpi	100	170

Table 1-101

II. NAME OF PARTS

The SCSI connector and SCSI dipswitch were deleted.

No changes for other items refer to the user manual for the details.

III. USER OPERATION

Because of the specification changes, some operation screens and others are changed.

Refer to the user manual for the details. Only the user mode is shown below.

5. User Mode

The new "Items and display order" is shown below.

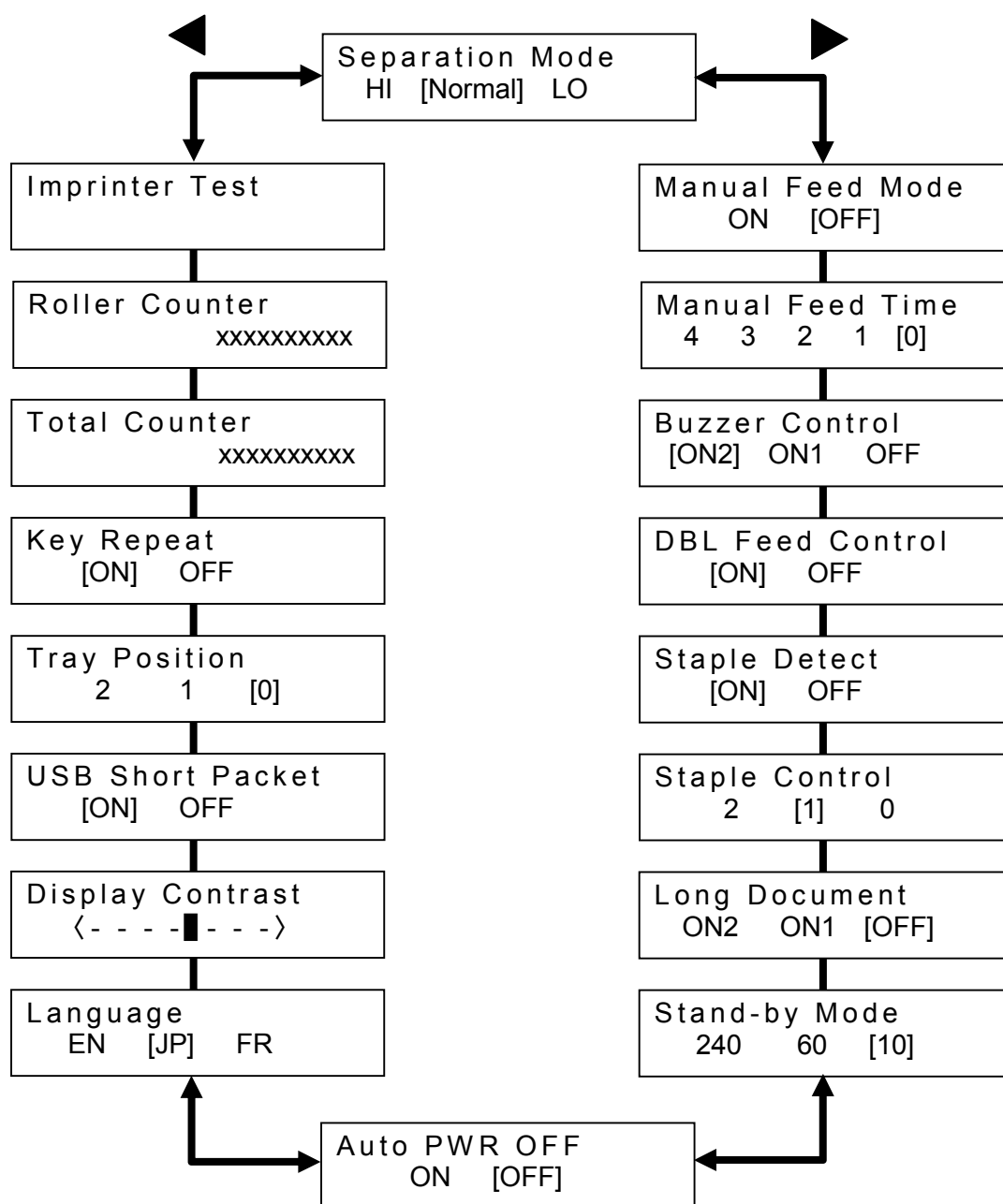

Fig. 1-301

Chapter 2: FUNCTIONS & OPERATION

At first, it is described for the basic items include the major changed items by products improvements and the explanation for the new pickup/separation part.

◆Product improvements

1. Improving the scanning speeds

The basic scanning speed for the DR-G1130 is improved to 100ppm/200ipm at A4 size with portrait, it was 90ppm/180ipm for the DR-9050C. And it is 130ppm/260ipm at A4 size with landscape.

Its cause is the making shorter the space between documents by the mechanical and software improvements.

The basic speed is the same for the DR-G1100 and DR-7550C.

2. Improving the pickup/separation function

Especially for the document to be hard to pickup and separate include soft thin paper and sticky gloss paper, the pickup unit includes the pickup and feed rollers in the upper unit, and the retard roller in the base part are changed to improve the pickup/ separation function. And then provided the 3 types for the separation mode by changing the driving method to be available the user selection by its documents.

3. Improving the operation sounds

To reduce the vibration and noise, the reinforcement plates are added to make the frame strength better, added the cover for the belt driving part, and improved the damper and mount plate for the main motor.

4. Corresponding the European standard Lot 6

The power PCB, the power switch and the software were changed to provide the auto power OFF function. It is available to select this function to be valid or invalid depend on the regional state.

5. Corresponding the new energy star program

The power PCB was improved its efficiency of voltage converter. And the power PCB is changed to the worldwide type, then the same power PCB can be used for the 100V and 200V series.

6. Others

It is not a improving, but the SCSI connection was deleted because of the market state.

◆New pickup/separation part

The figures of the new pickup/separation part are shown below.

The figures show the pickup tray is raised to pickup position. And each side view shows the pickup roller is up and down position.

The pickup up/down motor was used to up and down the pickup roller instead of the solenoid.

And also the separation pad made by rubber sheet was attached on the separation cover to prevent the document hitting the retard roller.

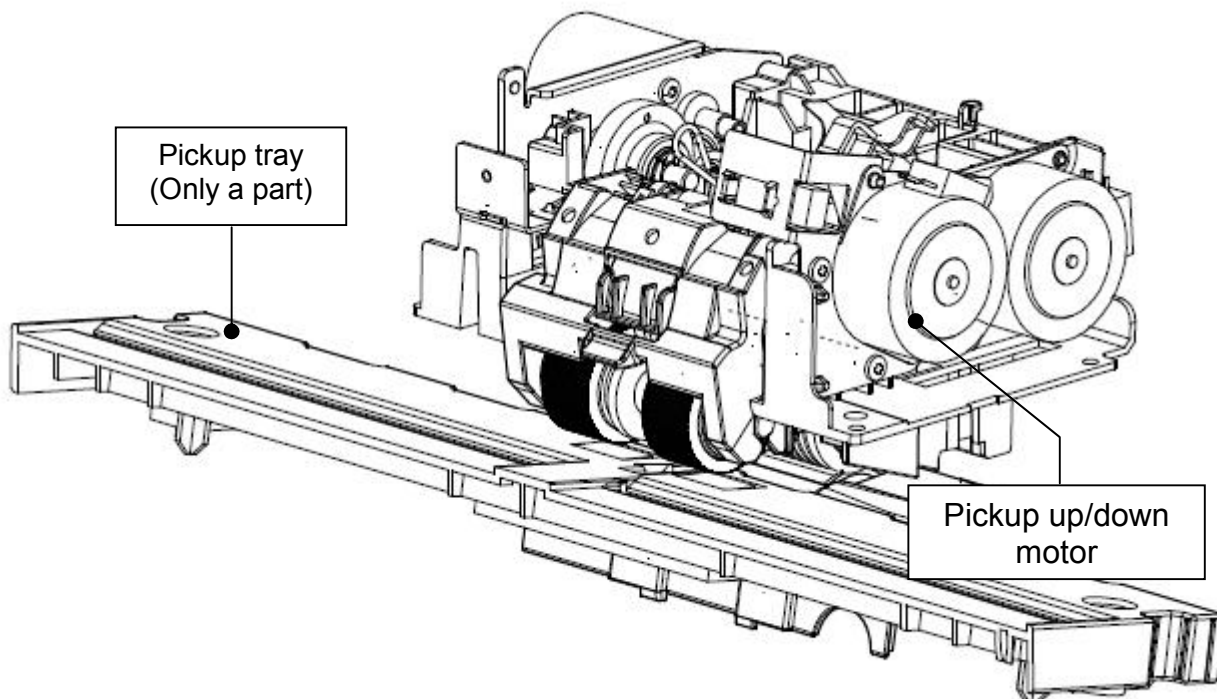
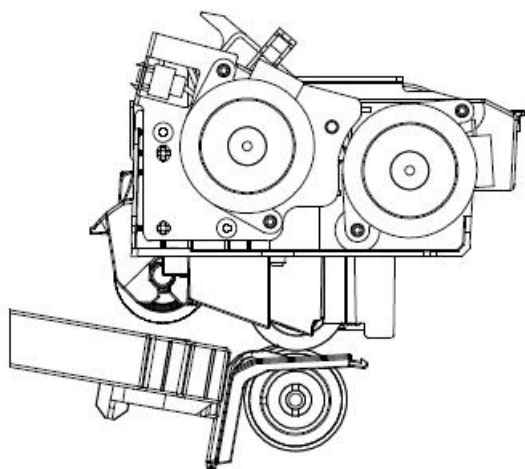

Fig. 2-001

◆Pickup roller : Upper position



◆Pickup roller: Lower position

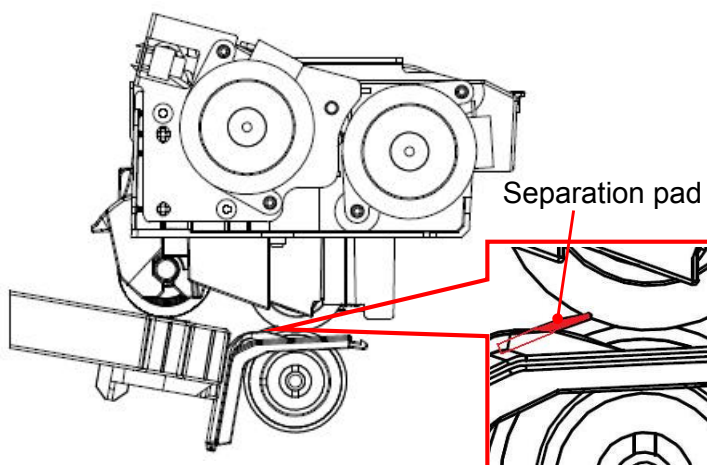

Fig. 2-002

I. OUTLINE

3. Motor Drive

The solenoid has been used to drive the pickup roller up and down for the DR-9050C. However, it was changed to the motor: pickup up/down motor for the DR-G1130/G1100. The expected life of the solenoid was 1.5 millions sheets, the changing to the motor could expanded to 14.4 millions sheets that is the same number of the product life.

The fan has been installed one for exhaust in the power PCB assembly area, and one more fan was installed for the retard roller shaft cooling. It is caused by changing the torque limiter in the retard roller. The limit force was increased and then temperature by friction between the torque limiter and retard roller shaft goes up.

4. Sensor

One sensor: pickup up/down sensor was added for control the position of the pickup up/down motor.

5. Electrical circuit

Refer to the "GENERAL DIAGRAM" in APPENDIX for the general electrical circuit includes additional motor and sensor above.

6. Timing Chart

Each timing chart for 3 separation modes is shown here.

At first, each feature is shown below.

Items	Object documents	Pickup roller	Retard roller
Normal	Normal	Keep down position Normal speed	Stay only (without rotation)
Low	Soft and thin Jam easily	Down position at pickup only Rotate slowly and not rush	The same as [Normal]
High	Sticky Double feed easily	The same as [Normal]	Rotate reverse and separate strongly

Note: At [Low], the scanning speeds (numbers of fed sheet per minute) go down because that the pickup roller rotating speeds go down.

Table 2-101

1) Separation mode: Normal

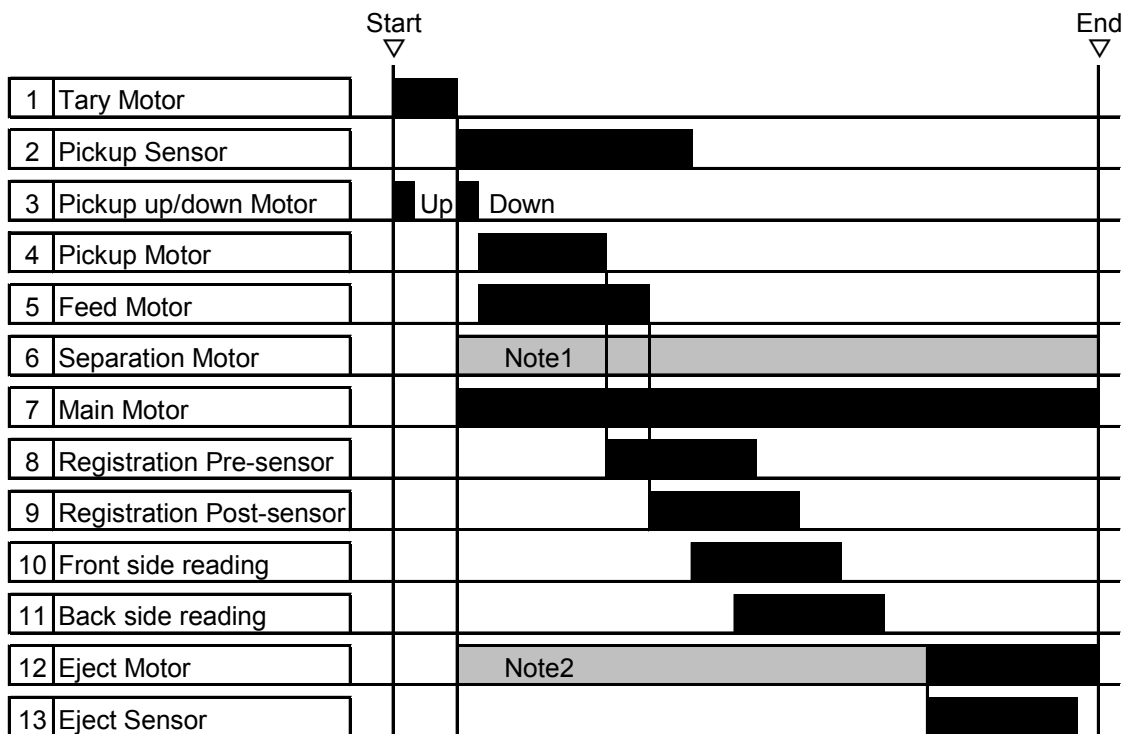

Note1: Separation motor supplies holding force only, not rotation.

Note2: Eject motor rotates low speed in gray zone and high speed in black zone for high speed scanning, and low speed in both zones for low speed scanning.

Fig. 2-101

2) Separation mode: Low

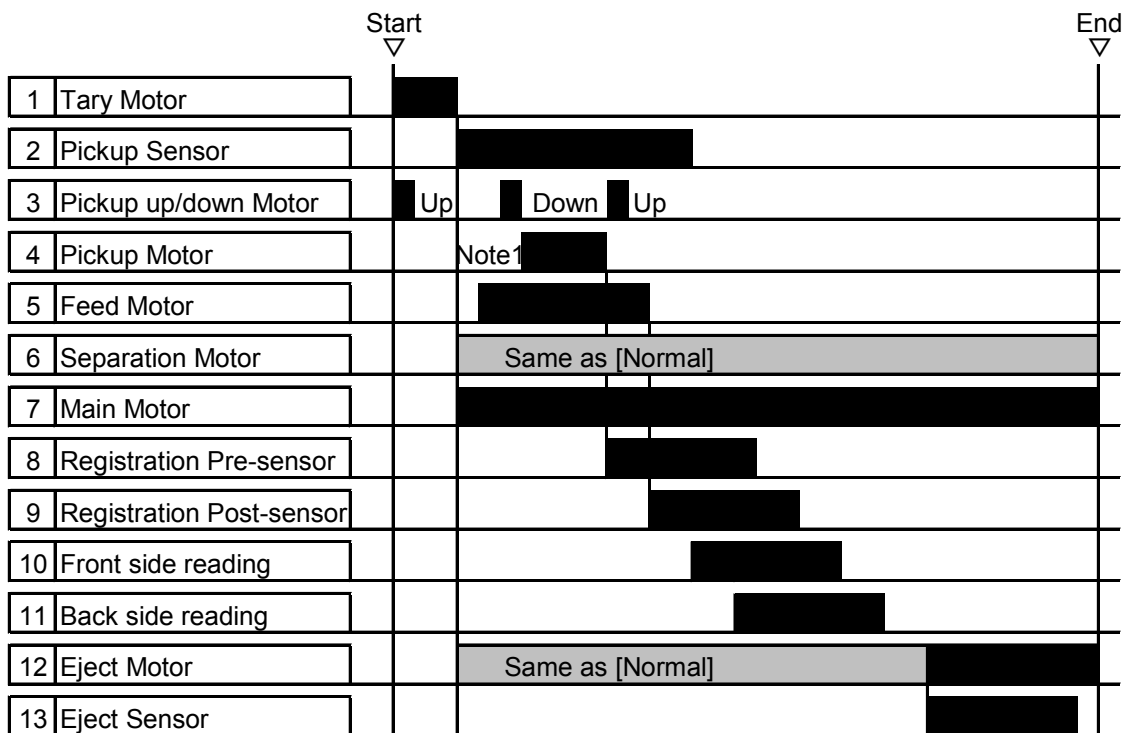

Note1: Pickup motor rotates lower speed than [Normal] and [Hi] ones.

Fig. 2-102

3) Separation mode: High

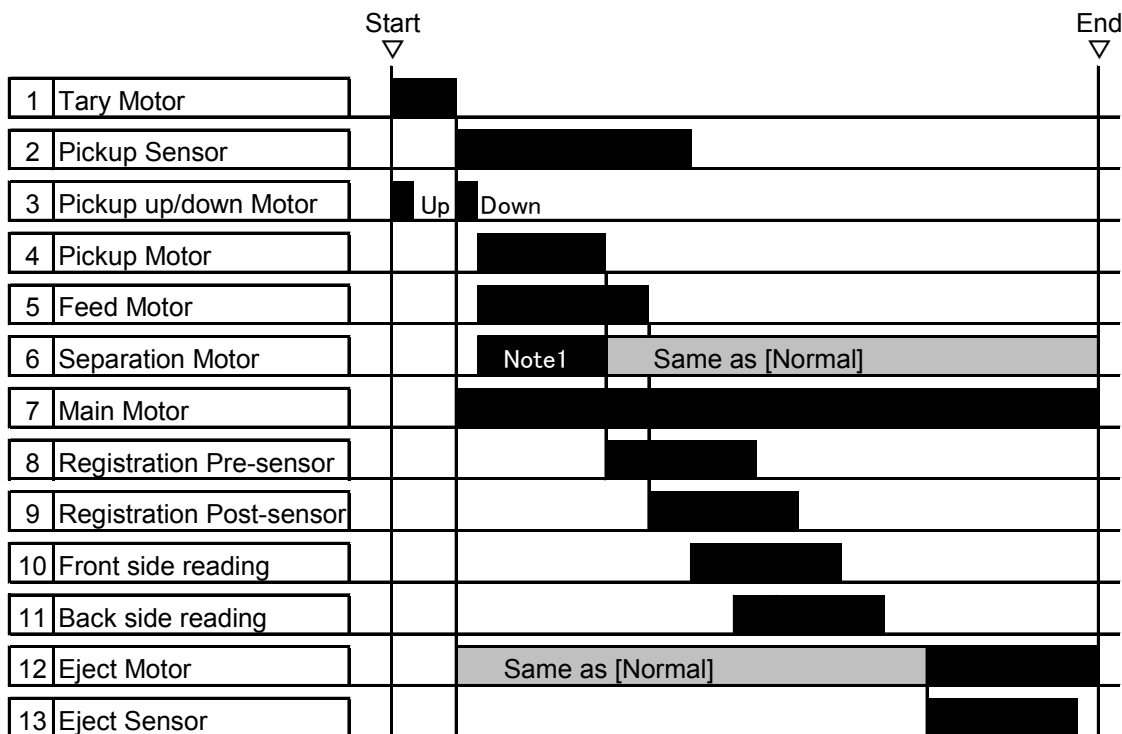

Note1: Separation motor rotates in reverse direction till the registration pre-sensor detects.

Fig. 2-103

II. READING SYSTEM

A part of slide mechanism for the shading was improved. Most of others are the same.

III. FEED SYSTEM

According to the above-mentioned, the three rollers: pickup/feed/retard rollers were changed, and the three types: normal/low/high for the separation mode were provided.

3. Separation Mechanism

The three types: normal/low/high for the separation mode were provided. Refer to above "I-6. Timing Chart" for each timing chart.

It is the same as the DR-9050C for the non-separation mode.

◆ 2 sheets into the separation area

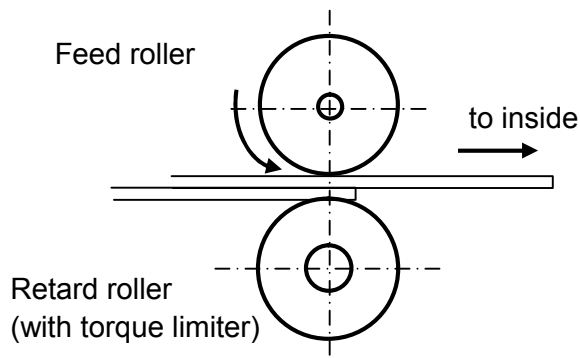

◆ 1 sheet into the separation area

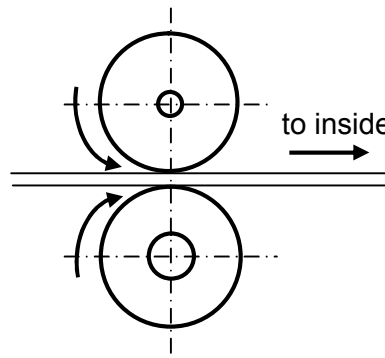

Fig. 2-301

1) Separation mode: Normal

It is used for the normal document.

The pickup roller rotates normally, pick the document up and it reaches to the separation area.

The feed roller rotates normally, and the retard roller is held without the rotation.

Therefore, if more than 2 sheets document reach to the separation area, only upper side one sheet attached to the feed roller is fed into the inside.

If one sheet document only, the retard roller rotates following the feed roller and document.

2) Separation mode: Low

It is used for the document that is soft and thin, and easy to occur the jam.

The pickup roller rotates slowly, and it is only down while the document is picked up and completed separation, then the document reaches the separation area. Therefore, the document isn't pushed by force.

The feed roller and retard roller are the same as the [Normal] mode.

3) Separation mode: High

It is used for the document that is sticky and easy to occur the double feed.

The pickup roller is the same as the [Normal] mode.

The feed roller rotates normally, and the retard roller rotates with reverse until the pre-registration sensor detects the document. Therefore, the document is separated by force.

After that, the retard roller will be the same as the [Normal] mode, and then it rotates following the feed roller and document.

IV. CONTROL SYSTEM

The control PCB was changed to the new one, and its function is almost the same.

The solenoid was changed to the motor for the control the up and down driving for the pickup roller.

And the image processing control is almost the same too. The bundle software: common driver and CapturePerfect 3.1 are changed corresponding this product.

V. POWER SUPPLY

1. Power Supply

At first, the power PCB assembly was changed to the common use for the 100V and 200V series.

And the power switch was connected to the staple PCB assembly.

The power ON/OFF control is changed corresponding the Lot 6 that is European standard. The AC power is supplied to the power PCB assembly, and the 5VDC for the control power is generated. In this state, if the power switch is turned on, the FET on the control PCB is turned on and the control PCB assembly then starts to work. And the 24VDC in the power PCB assembly is generated by the order from the control PCB assembly, and it is supplied. If the power switch is turned off, or the order from the control PCB assembly set the FET to be OFF, the power is turned off.

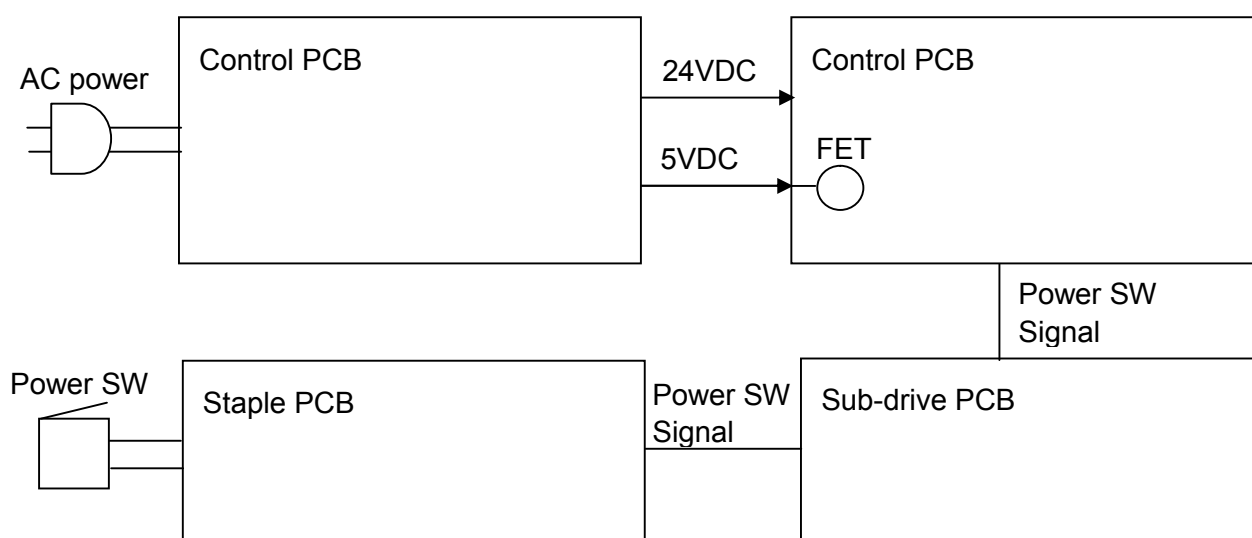

Fig. 2-501

VI. OPTION

The imprinter and the barcode module are the same for the DR-C9050C.

However, the patchcode decoder is the same on the function, but its PCB assembly and the cable are new ones because of the changing the connector. The parts numbers are shown in the parts catalog.

And also, the flatbed scanners: FSU101 and FSU201 can be used.

Chapter 3: DISASSEMBLY & ASSEMBLE

III. UPPER UNIT-1 (ELECTRICAL)

It is shown below for the major items only.

The photos may be different from some mass-produced machines.

I. USER REPLACEABLE PARTS

It may be changed on the shape, but the procedure for disassembly is the same.

Refer to the user manual for details.

II. EXTERNAL COVERS

The same.

1. Main Drive PCB

◆ some of cables were changed

◆ reinforced plate was added on frame

- 1) Remove the eject tray unit.
- 2) Remove all the cables connected to the main drive PCB [1]. (Total 10 cables excepting imprinter's one)

Remove 2 screws [2] (M3, bind-head) and while losing 2 pair of fitting parts [3] and the cable in the cable guide [4], remove the PCB.

Note: Don't hit the PCB to the reinforced plate on frame. Don't remove the reinforced plate to prevent from deforming of the frame.

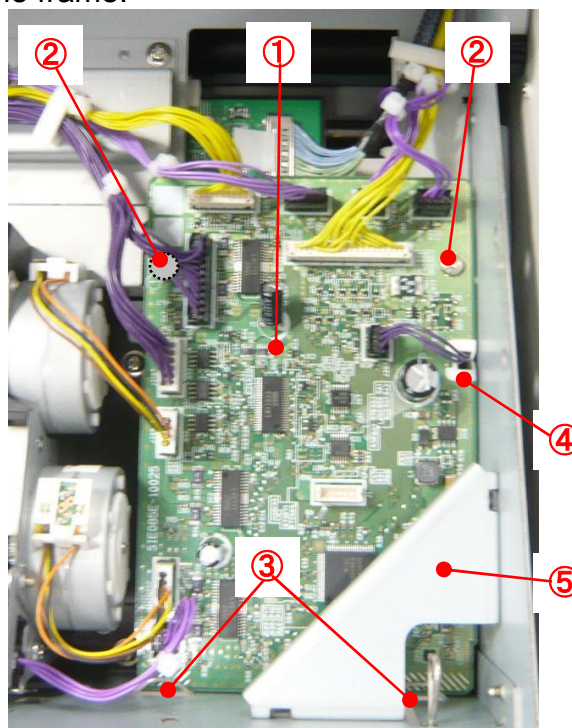

Fig. 3-301

⇒ Note on assembling

Do not forget to assemble the cable (for a skew sensor) that passes through the cable guide from the bottom.

2. Ultrasonic Sensor PCB

◆pickup unit was changed

- 1) Remove the eject tray unit.
- 2) Remove the cable [1] (for the ultrasonic) from the cable holder [2] to provide clearance.

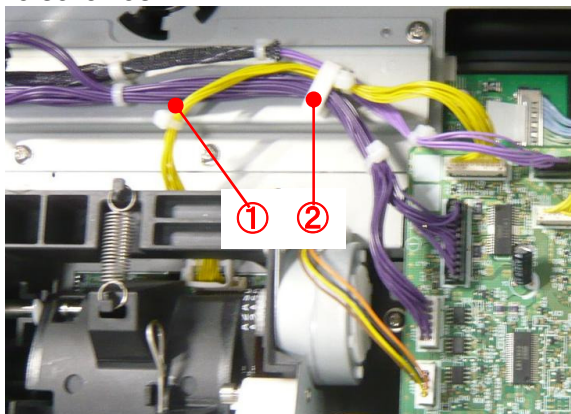

Fig. 3-302

- 3) Remove the inlet guide upper.
- 4) Remove the registration roller upper.
- 5) Remove 2 screws [1] (M3, bind-head), pull out the ultrasonic sensor PCB [2], and remove the cable [3] connected to the backside.

Note: Don't pull the PCB excessively because the cable is connected.

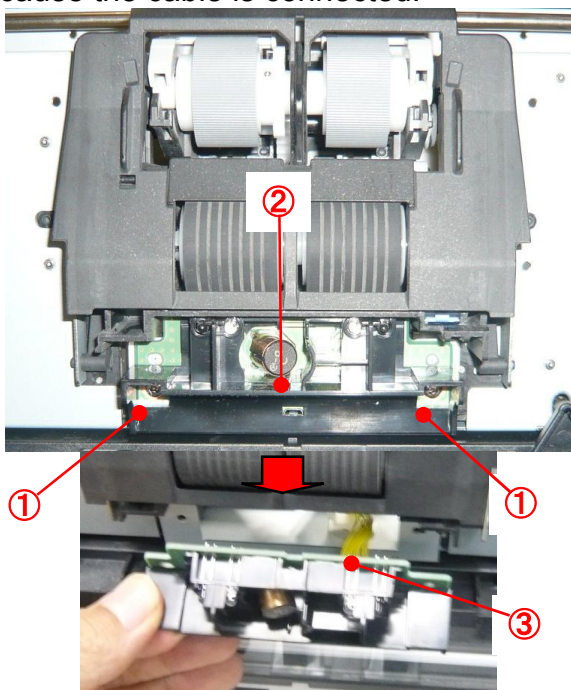

Fig. 3-303

3. Feed Motor

◆mounting plate was changed

- 1) Remove the pickup unit.

Note: Refer to the "VI. UPPER UNIT-2" for

the pickup unit. The same for the followings.

- 2) Remove 3 screws [1] (M3, self-tapping), and remove the motor unit [2] (including the mounting plate) while removing the belt.

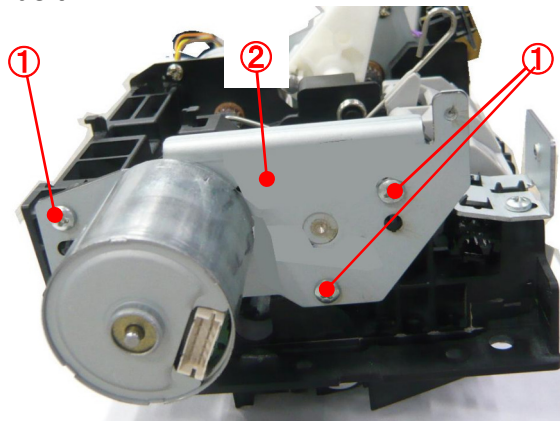

Fig. 3-304

- 3) Remove 2 screws [1] (M3x4, black), and remove the feed motor [2].

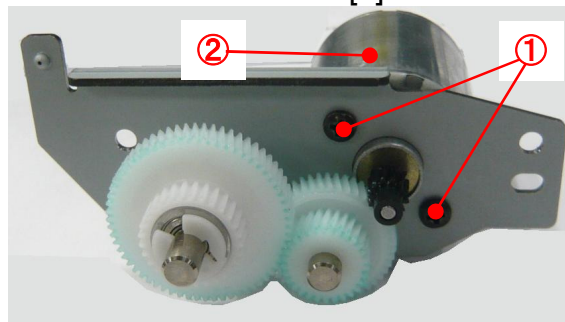

Fig. 3-305

4. Pickup Motor

◆procedures were changed

- 1) Remove the pickup unit.
- 2) Go through the tool from other side and remove 2 screws [1] (M3, bind-head), and then remove the pickup motor [2].

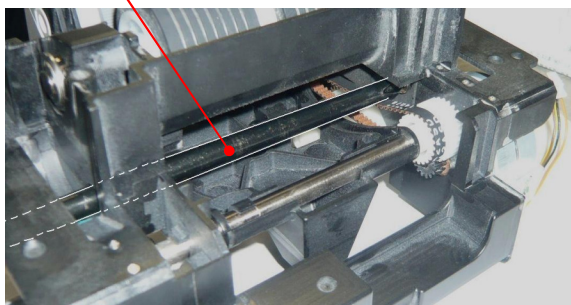
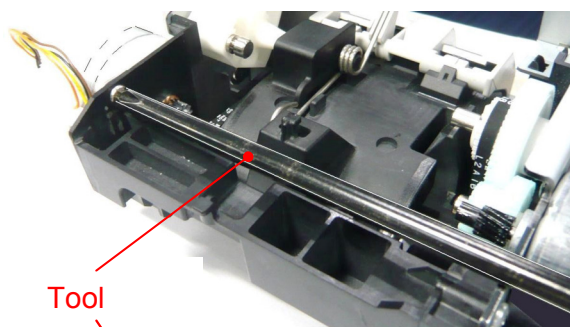
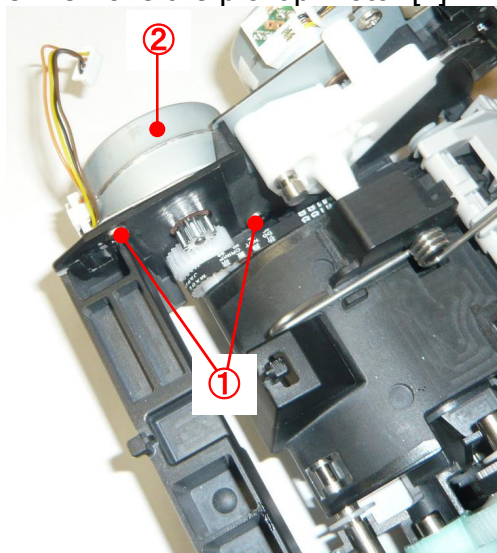

Fig. 3-306

5. Pickup Up/Down Motor

◆solenoid was changed to motor

◆procedures were changed

- 1) Remove the pickup motor.
- 2) Remove 2 screws [1] (M3, self-tapping), and remove the motor unit [2] (including the mounting plate).

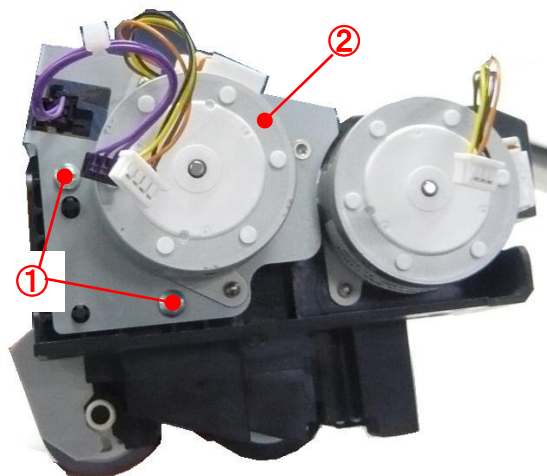

Fig. 3-307

- 3) Remove 2 screws [1] (M3, bind-head), and remove the pickup up/down motor [2].

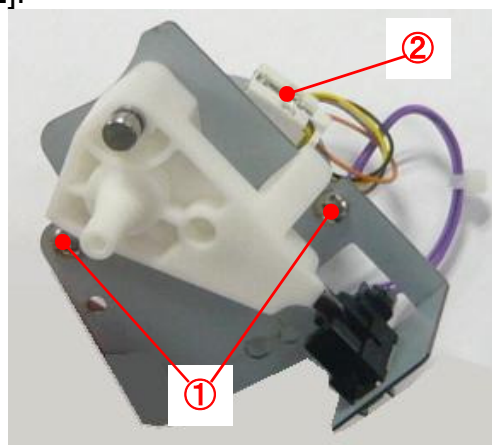

Fig. 3-308

IV. UPPER UNIT-2 (MECHANICAL)

1. Pickup Unit

◆procedures were changed

◆shapes of parts were changed

1) Remove the eject tray unit.

2) Remove the upper front cover.

3) Remove the ultrasonic sensor PCB.

Note: Because it may hit while removing the pickup unit.

4) Remove the screw [1] (M3, bind-head).

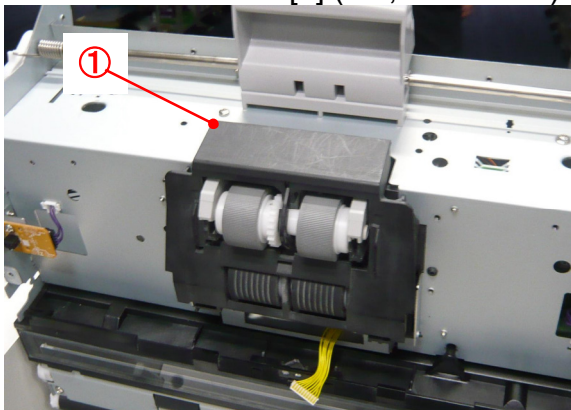

Fig. 3-401

5) Remove the screw [1] (M3, bind-head), and remove the grounding plate [2]. And remove 4 connectors [4] of the cables connected to the pickup unit [3], then remove 4 screws [5] (M3, TP-head).

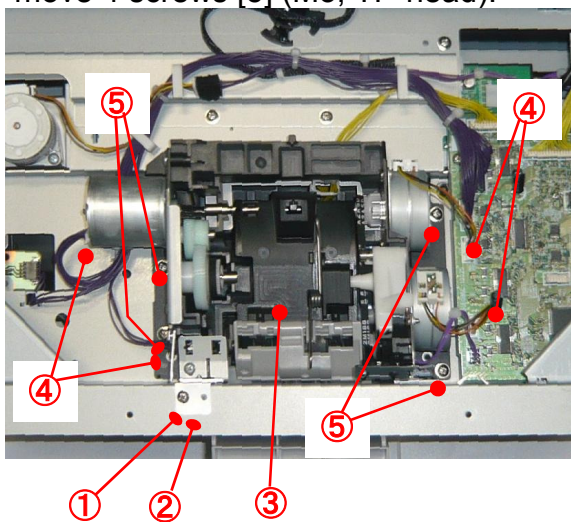

Fig. 3-402

6) Open the roller cover [1], and remove the pickup unit [2] from mounting area while tilting it.

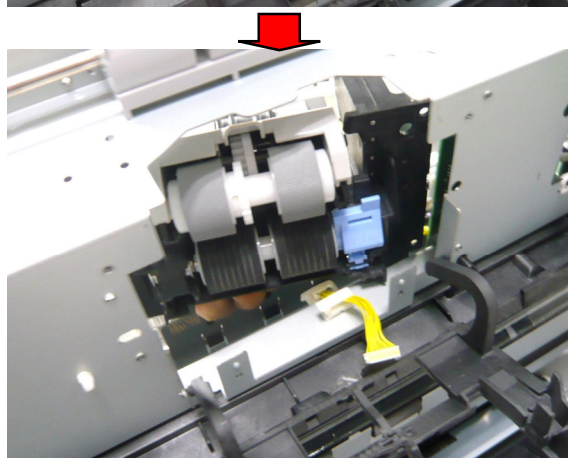
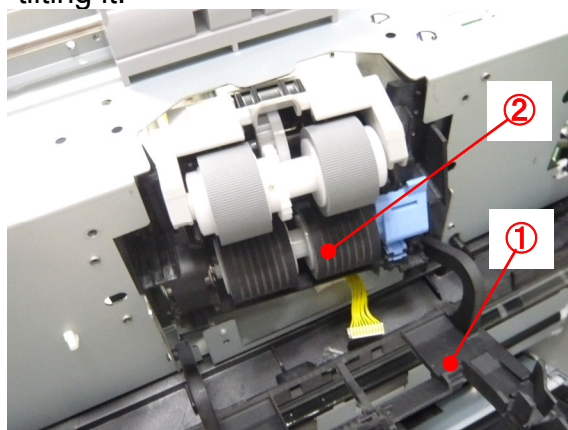

Fig. 3-403

◆Notes on assembling

1) The while of assembling the pickup unit, set the rear side [1] first, and then push the front side [2] in next. Don't pinch the cable [3].

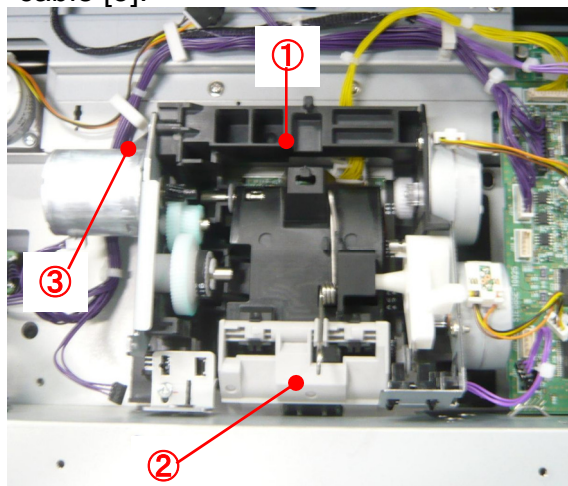

Fig. 3-404

2) Install the grounding plate at original position, and then set the screw for pickup sensor adjustment that was re-

moved in step 4, not to become loose the screw. If the screw is tightened excessively, the position of the pickup sensor may be changed.

- 3) If the pickup sensor malfunctions after assembly, adjust the position of the pickup sensor.

4. Registration Roller Upper-front

- ◆ same disassembling procedures
- ◆ name was changed (upper → upper-front)
- ◆ different one with reading roller upper

Note: The shapes are the same between the registration roller upper-front and the reading roller upper. However, the color of gear is different, the registration one is black and the reading one is white. And force of the spring in the bearing holder is different, the registration one is harder than the reading one.

V. UPPER UNIT-3 (READING)

1. Upper Reading Unit

◆connector was changed

- 1) Remove the eject tray unit.
- 2) Open the cable stoppers, and remove 3 cable connectors [1] on the reading unit.

Note: Pull the white tape to remove the face type connector marked "A".

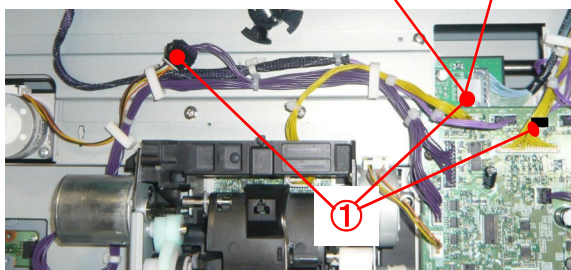
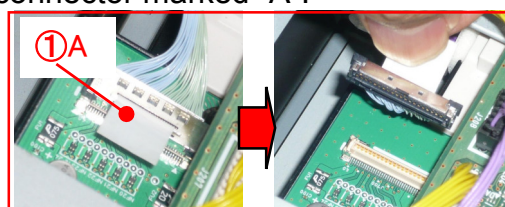

Fig. 3-501

- 3) The following procedures are the same.

◆Notes on assembling

For the face type connector that was removed in step 2, adjust the position with the connector on the PCB, and then push it down. The 2 positionings [1] on the PCB side should be outside of the connector with cable side.

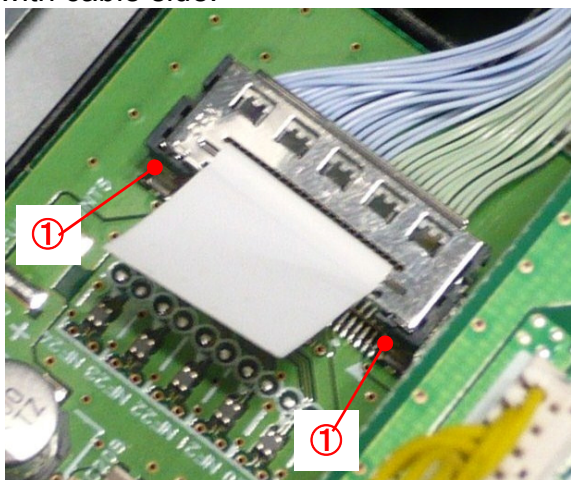

Fig. 3-502

VI. BASE UNIT-1 (ELECTRICAL)

1. Control PCB

◆connectors were changed

◆SCSI connector was deleted

- 1) Remove the control PCB cover.
- 2) Remove all 7 connectors connected with the control PCB [1], and remove the cable stopper [2] and 7 screws [3] (M3, bind-head).

While releasing the hook located at the upper right by pulling the bottom of the control PCB unit (including the mounting plate), remove it.

Note: The DC power supply connector marked "A" has a lock.

For the face type connector for the reading unit marked "B", refer to the items "Reading Unit Upper".

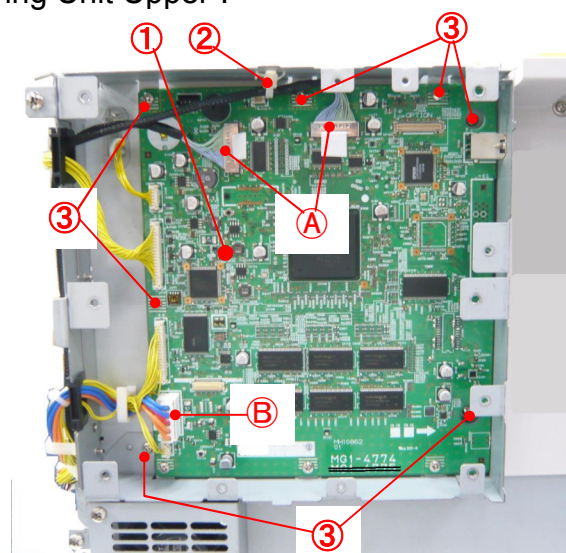

Fig. 3-601

- 3) Remove 4 screws [1] (M3, bind-head), and separate the mounting plate [2] and the control PCB [3].

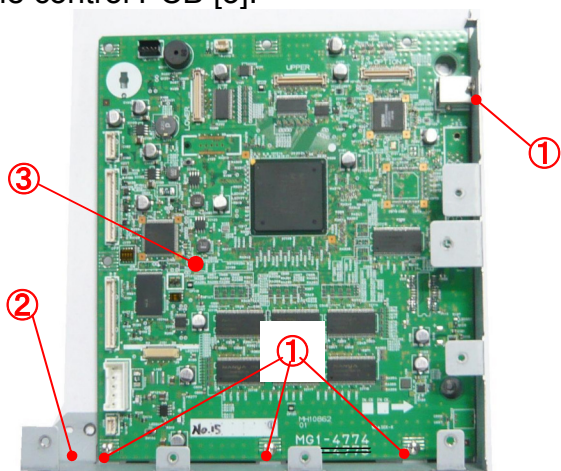

Fig. 3-602

◆Notes on assembling

Insert the hook at the upper right part of the mounting plate into the hole in the main body, and then assemble the control PCB (including the mounting plate).

3. Power Supply PCB
 - ◆power switch was deleted
 - ◆one cable was added

- 1) Remove 8 screws [1] (M4, bind-head), and then pull out the power supply PCB [2] (including the mounting plate).

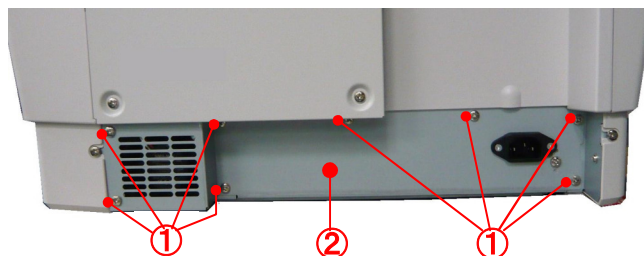

Fig. 3-603

- 2) Remove the connector [1] (with a lock) and the connector [2], and then remove the power supply PCB [3] (including the mounting plate).

Note: The grounding plate is assembled in the part marked "A".

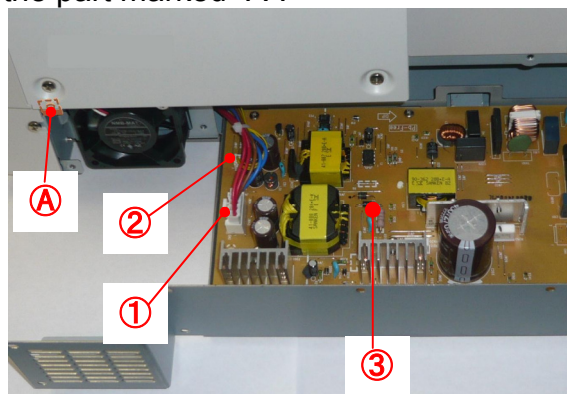

Fig. 3-604

- 3) Remove 6 screws [1] (M3, bind-head) and the connector [2] (with a lock), and then remove the power supply PCB [3].

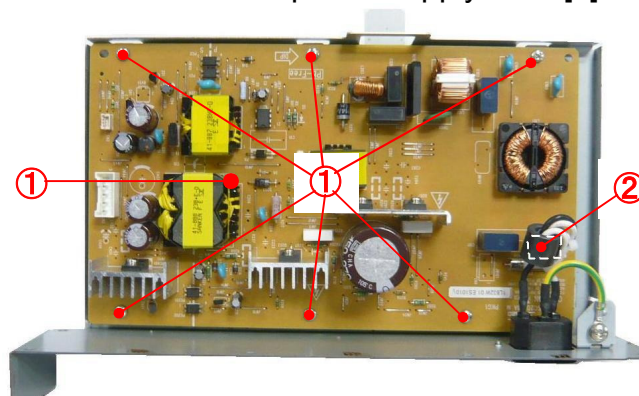

Fig. 3-605

7. Main Motor

- ◆procedures were changed
- ◆mounting plate was changed
- ◆belt cover was added

- 1) Remove the right cover.
- 2) Pull the cables out from the cable stoppers [1] to be able to remove the belt cover [2].

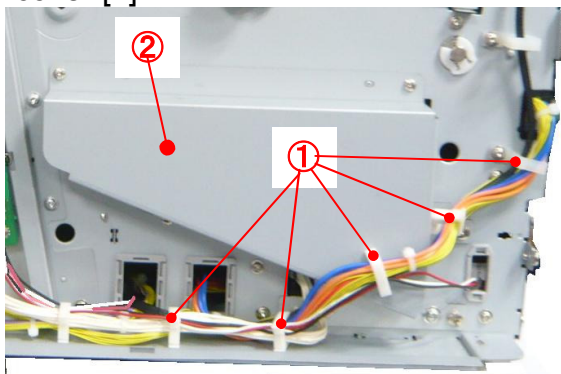

Fig. 3-606

- 3) Remove 3 screws [1] (M3, bind-head), and then remove the belt cover [2]. And Turn the cable stopper [3] 90 degrees to remove it.

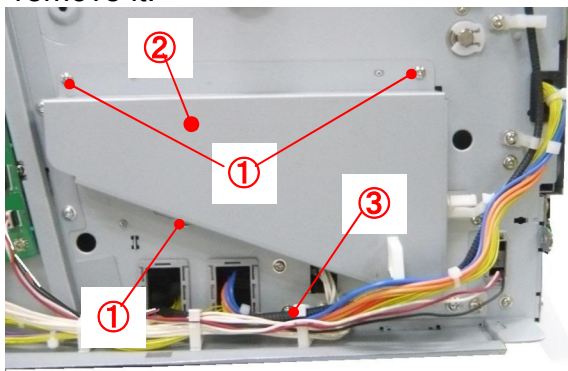

Fig. 3-607

- 4) Remove 3 screws [1] (M4, bind-head) to be loose the motor assembly [2]. And then remove the belt [3].

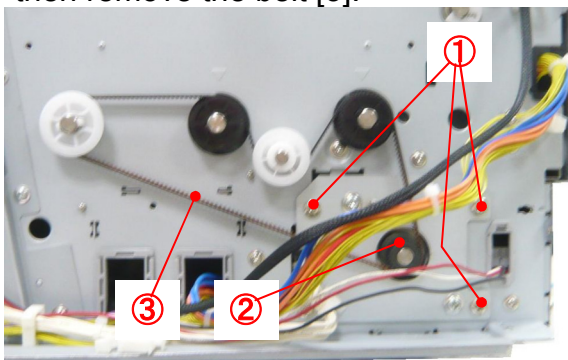

Fig. 3-608

- 5) Remove the screw [1] (M4, bind-head). The spacer [2] is assembled in the screw. Note: Don't lose the spacer. The motor assembly rotates on the screw by weight of itself.

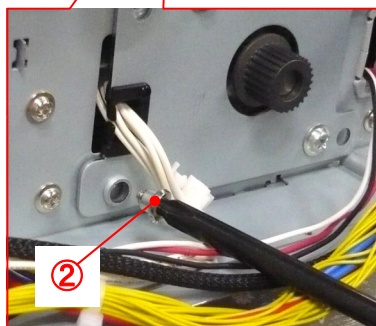
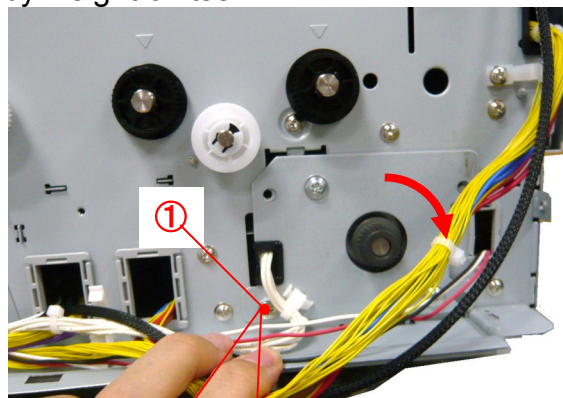

Fig. 3-609

- 6) Move the cables to pull the motor assembly out. Note: Take care handling because the motor is heavy.

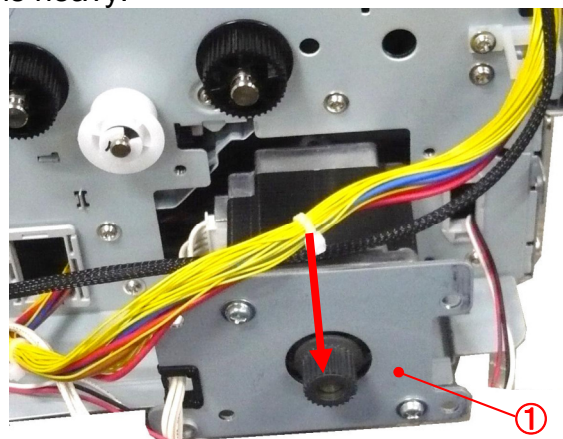

Fig. 3-610

- 7) Remove the connector [1] and 2 screws [2] (M4. bind-head), and then remove the main motor [3].

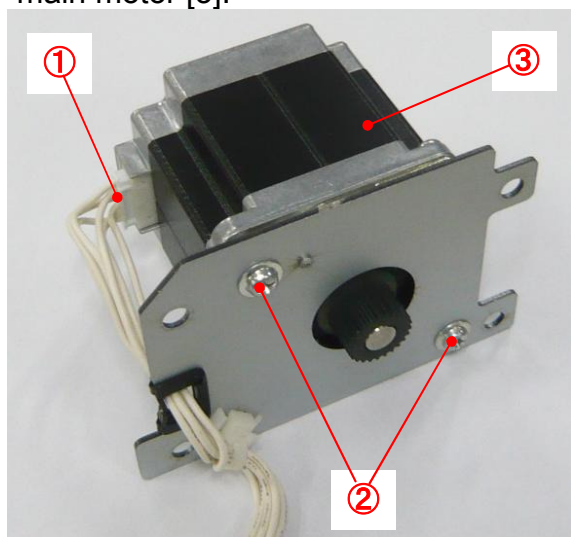

Fig. 3-611

◆Notes on assembling

Set the belt after tightening the screw that is shown in step 5 to get correct belt tension. And then tighten other 3 screws for the motor assembly.

A1. Power Switch

◆added on the left side

- 1) Remove the left cover.
- 2) Remove the screw [1] (M3, bind-head) and the connector [2], and then remove the power switch [3] (including the mounting plate).

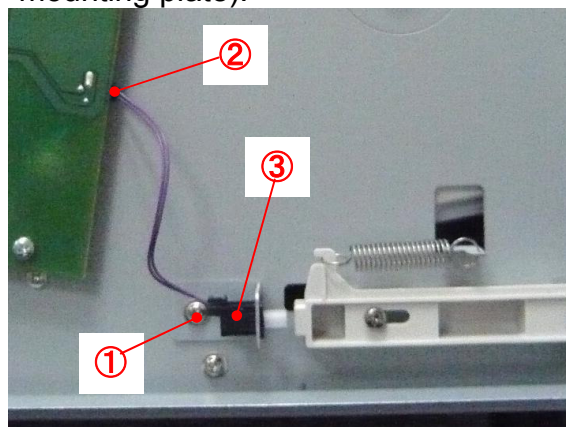

Fig. 3-612

- 3) While loosening 2 pairs of fitting parts [1], slide to front side and remove the power switch [2].

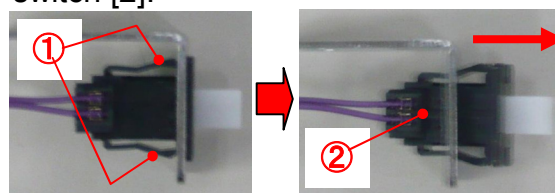

Fig. 3-613

◆Notes on assembling

Adjust the position of the mounting plate of power switch and the left side plate, and then tighten the screw.

A2. Cooling Fan

◆added by the separation unit

- 1) Remove the right cover.
- 2) Open the cable stopper [1], and then remove the cooling fan connector [2] (4 pins).



图 3-614

- 3) Remove the inlet guide lower.
- 4) Remove the screw [1] (M3, bind-head), and then remove the fan assembly [2] (including the mounting plate) with the cable together.

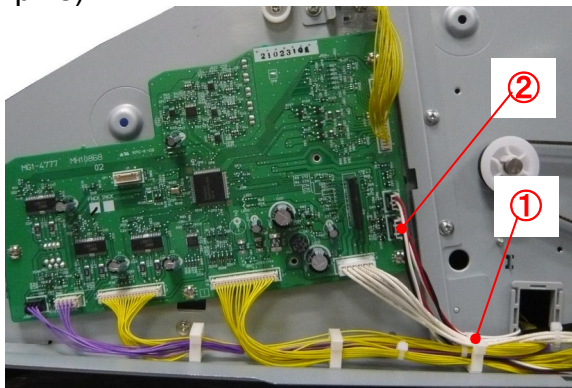
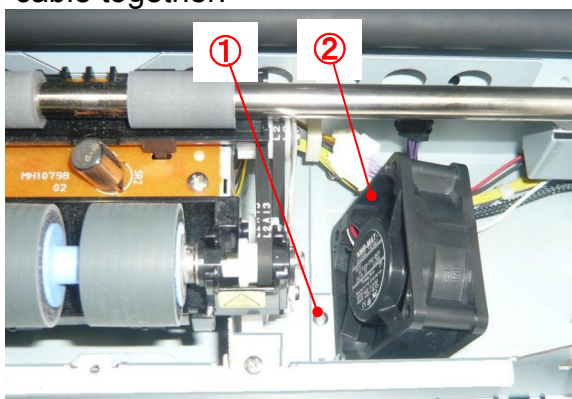

Fig. 3-615

- 5) Remove the screw [1] (M4x30), and then remove the cooling fan [2].

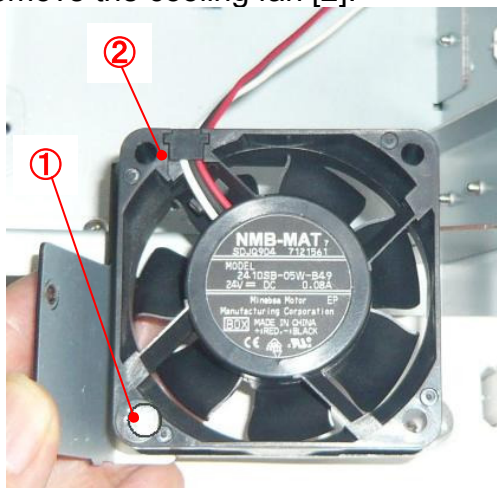

Fig. 3-616

◆Notes on assembling

Assemble the cooling fan that the label is the front side.

Chapter 4: INSTALLATION & MAINTENANCE

I. INSTALLATION

The unpacking and installation is almost the same.

Refer to the user manual for the installation for software.

The procedure related SCSI interface was deleted.

II. PARTS REPLACEMENT

1. Periodically Replaced Parts

The consumable parts for servicing were changed to the periodically replaced parts.

The pickup solenoid and the separation motor were deleted, and some items include parts numbers were changed.

No.	Parts name	Parts number	Q'ty	Expected life	Remarks	
1	Registration roller lower Bearing	MF1-4795 MS2-9004	1 2	6,000,000 sheets	<p>Because of the worn rollers, it is necessary to replace them when the document jams or the feed failures occur after the roller cleaning.</p> <p>Note:</p> <p>1) These parts names marked *1 are used in the parts catalog.</p> <p>2) Because of expected life of electrical conductivity, replace the bearing at the same time. The parts numbers are different, but specifications are the same as DR-9050C.</p> <p>3) The registration roller upper-front and reading roller upper are the same shape, but its color of gear is different. Registration roller one is black, and reading roller one is white.</p>	
2	Platen roller Bearing	MA2-8591 MS2-9003	2 4	6,000,000 sheets		
3	Reading roller lower Bearing	MF1-4597 MS2-9004	1 2	6,000,000 sheets		
4	Front U-turn roller (drive) (ROLLER, U-TURN PRE, LOWER *1) Bearing	MA2-8646 MS2-9004	1 2	6,000,000 sheets		
5	Rear U-turn roller (drive) (ROLLER, U-TURN, LOWER *1) Bearing	MA2-8647 MS2-9004	2 4	6,000,000 sheets		
6	Eject roller (drive) Bearing	MA2-8733 MS2-9004	1 2	6,000,000 sheets		
7	Registration roller upper-front Bearing	MF1-4797 MS2-9003	1 2	6,000,000 sheets		
8	Reading roller upper (ROLLER, REGISTRATION UPPER *1) Bearing	MF1-4242 MS2-9003	1 2	6,000,000 sheets		
9	Front U-turn roller (follower) (ROLLER, READING UPPER *1) Bearing	MA2-6847 MS2-9003	1 2	6,000,000 sheets		
10	Rear U-turn roller (follower) (ROLLER, U-TURN, UPPER *1) Bearing	MA2-8665 MS2-9003	2 4	6,000,000 sheets		
11	Eject roller (follower)	MG1-4801	1	6,000,000 sheets		
12	Upper reading unit (front)	MG1-8318	1	6,000,000 sheets 4,500,000 sheets		Corresponds to LED life of 1000 hours. Replace if image failure occurs. 6,000,000 sheets are calculation value for DR-G1130 and 4,500,000 sheets are one for DR-G1100.
13	Lower reading unit (Back)	MG1-8319	1	6,000,000 sheets 4,500,000 sheets		

Table 4-201

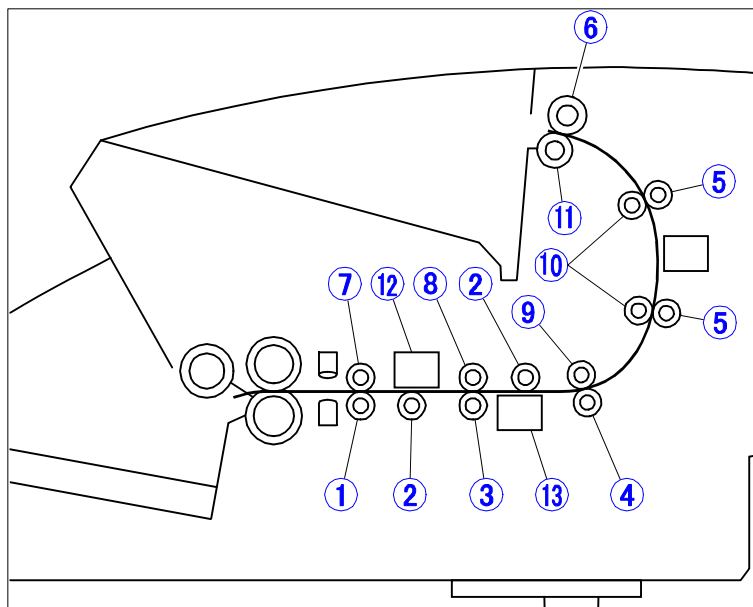

Fig. 4-201

2. Consumable Parts (Commercial Goods)

For the exchange roller kit, its item code was changed , and its expected life was changed to 450,000 sheets from 250,000 sheets.

And the separation cover was added.

No.	Item name	Item code	Expected life	Remarks
1	Exchange roller kit Pickup roller Feed roller Retard roller	8262B001	450,000 sheets	Because of the worn rollers, it is necessary to replace them when the pickup failures or the document jams occur after the roller cleaning.
2	Separation pad (Separation cover)	8262B002	6,000,000 sheets	Because of the worn pads, it is necessary to replace them when the pickup failures or the document jams occur after the roller cleaning.

Table 4-202

3. Consumable Parts (For User)

Each part of above items was set as the service part.

No.	Item name	Part number	Expected life	Remarks
1	Pickup roller	MG1-4806	450,000 sheets	Item code: 8262B001
2	Feed roller	MA3-0002		
3	Retard roller	MG1-4814		
4	Separation cover	MF1-4799	6,000,000 sheets	Item code: 8262B002

Table 4-203

III. MAINTENANCE

Refer to the “II. PARTS REPLACEMENT” above for the replacement.

While executing the service maintenance, clean the paper dust and others inside of machine.

Chapter 5: TROUBLESHOOTING

I. ERROR DISPLAY

It is shown below for the change of error display on the main body.

◆ Service calls

Code	Parts/symptom
E011	Pickup up/down motor (sensor)
E039	Cooling fan

Table 5-101

II. SERVICE MODE

It is basically the same. The function for the image adjustment was improved by adding 2 modes, the “Scale Adjustment” and the “Density Adjustment”. And also, the operation check function for the motor and sensor that were changed for this product is changed.

The service modes for the SCSI were eliminated.

B. Main Menu

- ◆ The “Scale adjustment” and “Density Adjustment” modes were added. Therefore, these items were added in the “All Adjustment”.

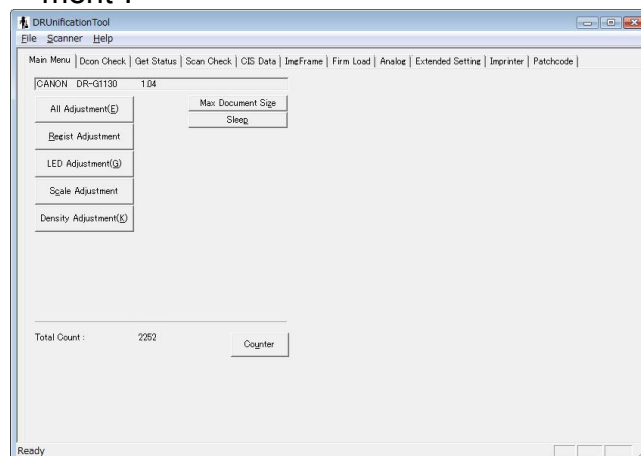

Fig. 5-201

1. All Adjustment

This mode executes 4 modes below in order.

- 1) LED Adjustment
- 2) Scale Adjustment
- 3) Regist Adjustment
- 4) Density Adjustment

When you select the “All Adjustment”, the LED Adjustment starts. And it finished, a confirmation screen for the setting of sheet for the Scale Adjustment is displayed.

Refer to each item for the “Scale Adjustment” and the “Density Adjustment”.

2. Individual Adjustments

c. Scale Adjustment

This mode adjusts the feed speeds automatically to correct the image length with feeding direction. It reads the objective length on adjustment sheet, and adjusts. It is done using the front side image.

◆ Adjustment sheet

The special adjustment sheet: TKM-0348.

◆ Operation procedure

- 1) After cleaning the feed path, set the adjustment sheet with portrait direction. And adjust the document guides for the adjustment sheet not to occur the skew.



Fig. 5-202

- 2) Select the "Scale Adjustment".
- 3) The confirmation screen is shown. See the adjustment sheet, and select "OK".

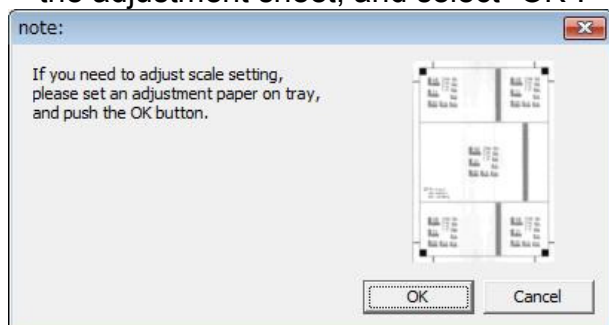

Fig. 5-203

- 4) The progress screen is shown, and the adjustment sheet is fed.

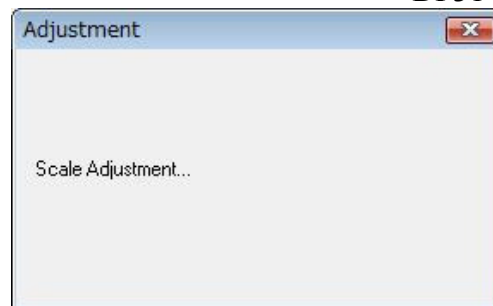

Fig. 5-204

- 5) The adjustment sheet is ejected, and it is completed when the progress screen was disappeared.

- ◆ In the field, you need to execute this adjustment when the machine had a scale failure, or the control PCB was replaced. This is the automatically adjustment, but it is able to adjust by manual also. It is using "Extended Setting" in the service mode, or "Canon Image FORMULA Utility" by users.

d. Density Adjustment

This mode adjusts the image density with both sides automatically. It reads the objective area on adjustment sheet, and calculates to get average of density, then set the adjustment value.

◆ Adjustment sheet

The special adjustment sheet: TKM-0347.

◆ Operation procedure

- 1) After cleaning the feed path, set the adjustment sheet with landscape direction. And adjust the document guides for the adjustment sheet not to occur the skew.



Fig. 5-205

- 2) Select the "Density Adjustment".
- 3) The confirmation screen is shown. See the adjustment sheet, and select "OK".

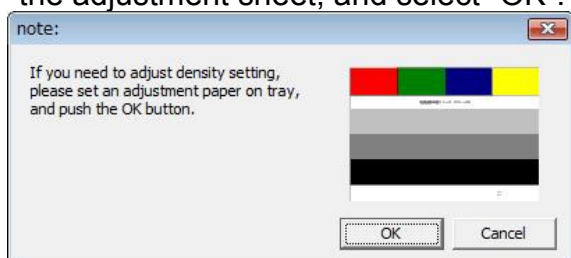

Fig. 5-206

- 4) The confirmation screen "face up" is shown. Check the print face upside and then select "OK".

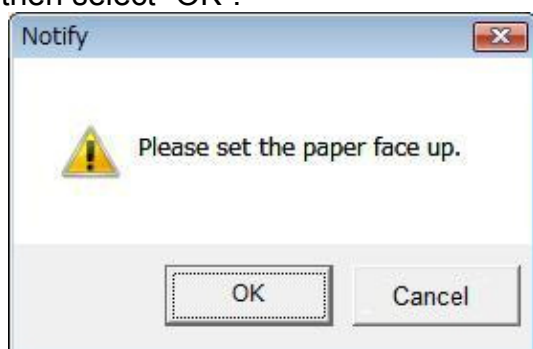

Fig. 5-207

- 5) The adjustment sheet is fed. And after ejected, the confirmation screen "face down" is shown.

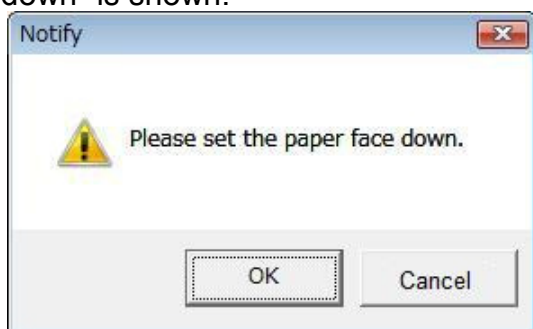

Fig. 5-208

- 6) Set the adjustment sheet upside down, and then select the "OK".



Fig. 5-209

- 7) The adjustment sheet is fed & eject again. After that, it is completed the adjustment, and the progress screen is disappeared also.

- ◆ In the field, you need to execute this adjustment when the machine had a density failure including difference between front and back sides, or the control PCB was replaced. This is the automatically adjustment, but it is able to adjust by manual also. It is using "Extended Setting" in the service mode.

C. Dcon Check

- ◆ The choices were changed because the parts were changed and the functions were added.

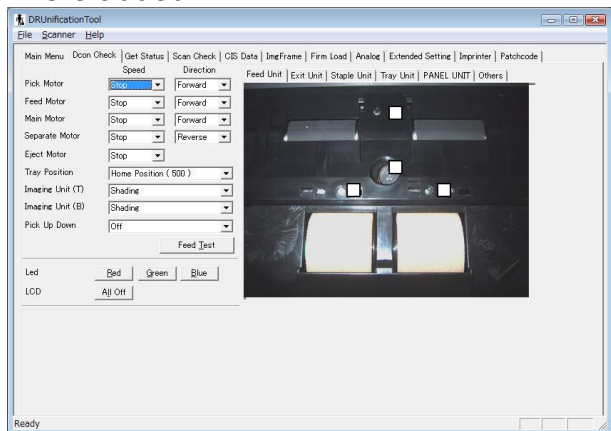

Fig. 5-210

1. Motor

- ◆ The “Lock” was added for the choice for the Separation Motor.

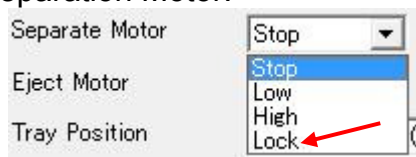

Fig. 5-211

- ◆ The choices of Pick Up Down were changed by changing to the motor from the solenoid.

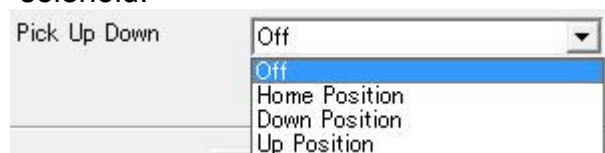

Fig. 5-212

2. Sensor

- ◆ The pickup up/down sensor was added in the screen for Tray Unit.

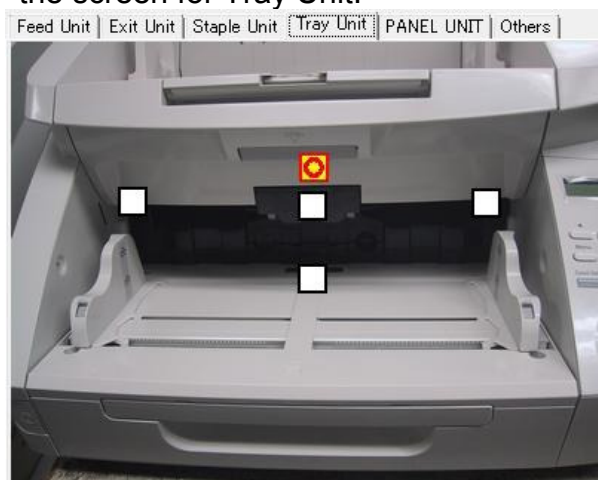

Fig. 5-213

If the “Home Position is selected in the Pick UP Down for the motor, its mark is lit. The “Down Position” or “Up Position” is selected, the mark is not lit. And the “Off” is selected, it doesn’t detect and the mark isn’t changed.

D. Get Scanner

- ◆ One item was added in the Check Device.

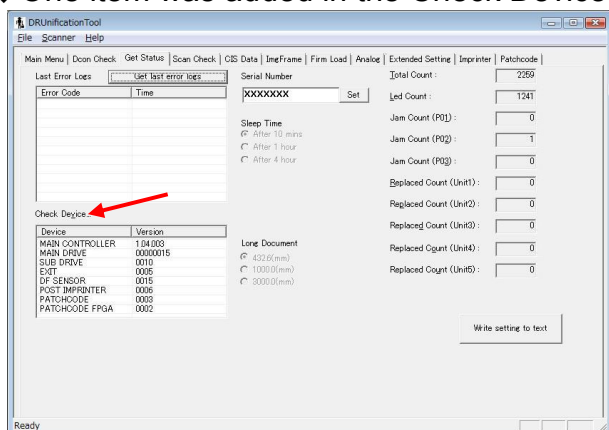

Fig. 5-214

2. Check Device

- ◆ The "PATCHCODE FPGA" was added. It shows the gate array version of patchcode PCB.

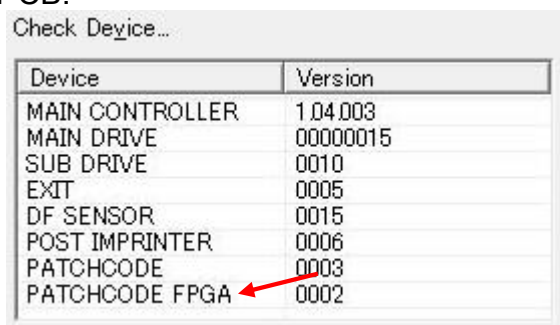

Fig. 5-215

E. Scan Check

- ◆ The zooming function was added.

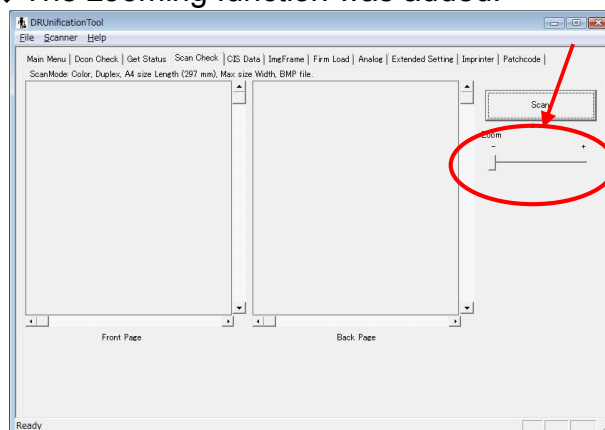

Fig. 5-216

1. Scan Check

- ◆ Before zooming

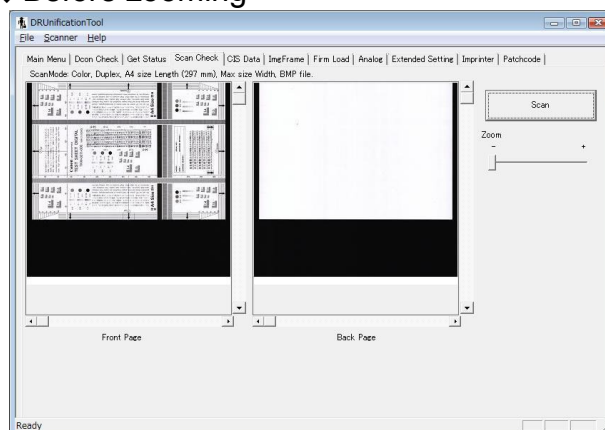

Fig. 5-217

- ◆ After zooming

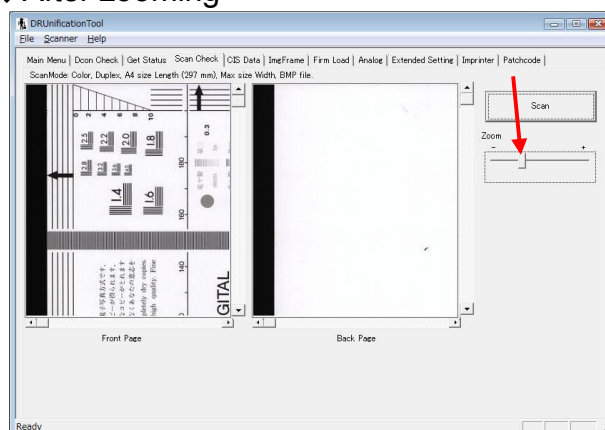

Fig. 5-218

Note: The image density of this mode is different one that user gets, so don't use this for the checking for the density adjustment.

F. Extended Setting

- ◆ The manual adjustments for the scale and density were added.

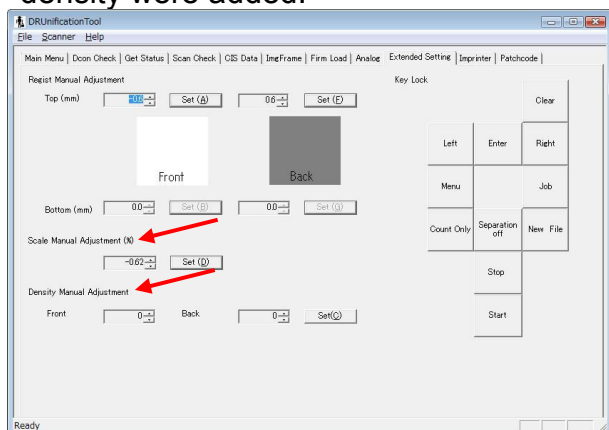

Fig. 5-219

3. Scale Manual Adjustment

This mode changes the setting value by manual after it was fixed at the factory or the “Scale Adjustment” in the main menu.

The users can be done using the “Canon ImageFORMULA Utility”.

◆ Operation procedure

- 1) Decide the adjustment value by checking the actual scanned image or the image of “Scan Check” in the service mode. The unit of the setting value is percentage at the whole length of the document. Therefore, you need to calculate its percentage. The following figure shows the scanned image of the test sheet: TKM-0271.

Note: For example, if the document is A4 size, its whole length is 297mm. So if the scanned image is 3mm short, the adjustment value is about plus 1%.

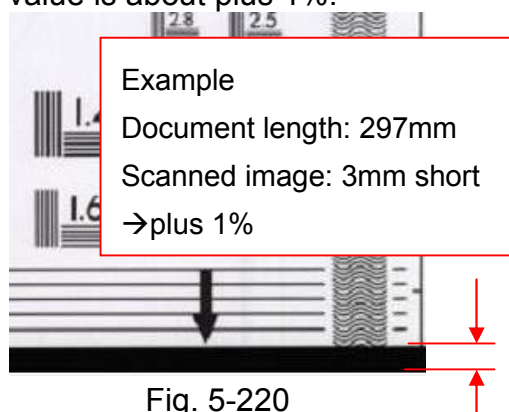

Fig. 5-220

- 2) Input the setting value in the data box using the scroll arrows. This is amount of additional adjustment value and the value previously set before.

Note: For example, if the value was already [-0.62], then adding [+1.00], you need to set [0.38].

The range of the setting value is ± 3.00 .

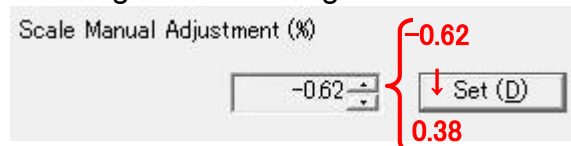

Fig. 5-221

- 3) Select the “Set”.
- 4) Check the image after adjustment. If necessary, you need to do again.

◆ Example for minus 1%

- 1) Before changing

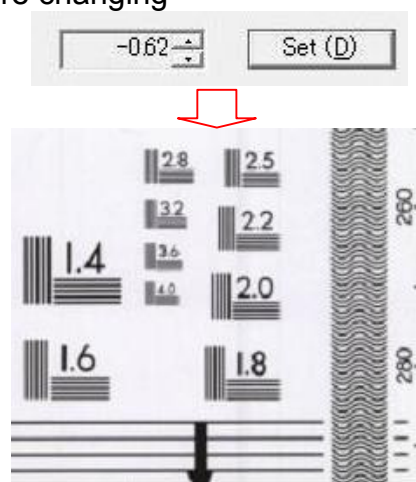

Fig. 5-222

- 2) Minus 1% [-0.62 → -1.62]

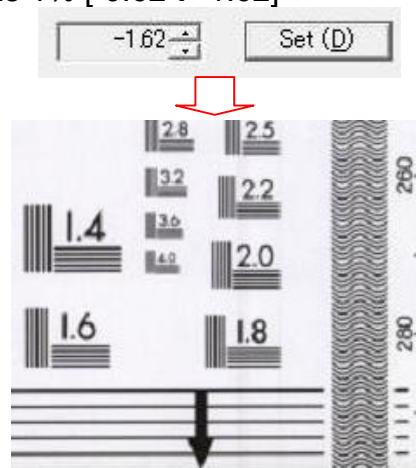

Fig. 5-223

4. Density Manual Adjustment

This mode changes the setting value by manual after it was fixed at the factory or the “Density Adjustment” in the main menu.

The automatic adjusted value is set as the middle value [128] of the brightness in the driver. By this manual adjustment, the density of the middle value [128] can be changed. And also, this mode can adjust the difference of the density between the front and back sides.

◆ Operation procedure

- 1) Decide the adjustment value by checking the actual scanned image. The adjustment value in the driver is corresponding the setting value in this mode.

Note: For example, if you want to set the density of setting value [118] to the middle value in the driver, the adjustment value in this mode is [-10] because “118-128=-10”.

- 2) Input the setting value in the data box using the scroll arrows. The values of the front and back sides are independent. The following figure shows the setting value was changed [0] to [-10] on the front side only.

The range of the setting value is ± 20 .

Note: We recommend the range ± 10 maximum. If it is over the ± 10 , the image treatment including the auto-size and other auto-detections might be wrong.

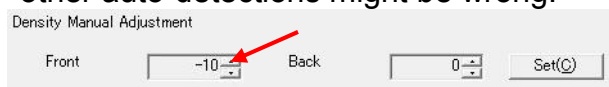

Fig. 5-224

- 3) Select the “Set”.
- 4) Check the image after adjustment. You need to do again in necessary.

Note: The density checking should be done by actual scan conditions. If it is different, the result might be different.

The image density of “Scan Check in the service mode is different one that user gets, so don’t use this for the checking for the density adjustment.

◆ Examples of result

1) Setting value [-10] → Darker

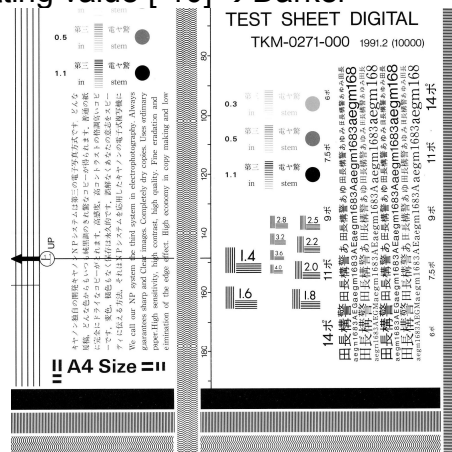

Fig. 5-225

2) Setting value [10] → Lighter

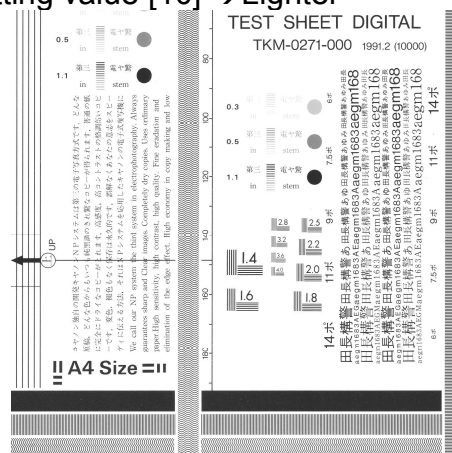

Fig. 5-226

IV. OPERATION TROUBLESHOOTING

The separation mode is provided with 3 types. Therefore, the users can be select the type depending on the document.

4. Documents are not fed property

Especially for the document to be hard to pickup and separate include soft thin paper and sticky gloss paper, the separation mode is provided with 3 types to improve the pickup/separation operation. The user selects the type depending on the document.

The "Separation Mode" in the operation panel is shown below.

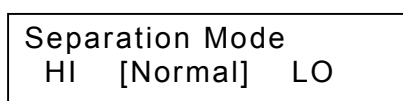

Fig. 5-227

5. Scanning speed is slow

When the [LO] in the separation mode is selected, the rotation speed of the pickup roller is slower, and the scanning speed is slower with 10 to 20% than normal. This is not failure.

V. IMAGE TROUBLESHOOTING

The deskew is provided with 2 types. Therefore, the users can select the type.

4. Image skews

The deskew is provided with 2 types, "Straightens with angle of fed documents" and "Straightens with angle & contents of fed documents". Therefore, the users can select the type in the screen of the driver in necessary.

VI. AFTER REPLACING PARTS

The position adjustment for the pickup solenoid was no need because the solenoid for pickup roller up/down is changed to the motor.

APPENDIX

I. GENERAL DIAGRAM

It was Included the changes of electrical parts.

Refer to the next page.

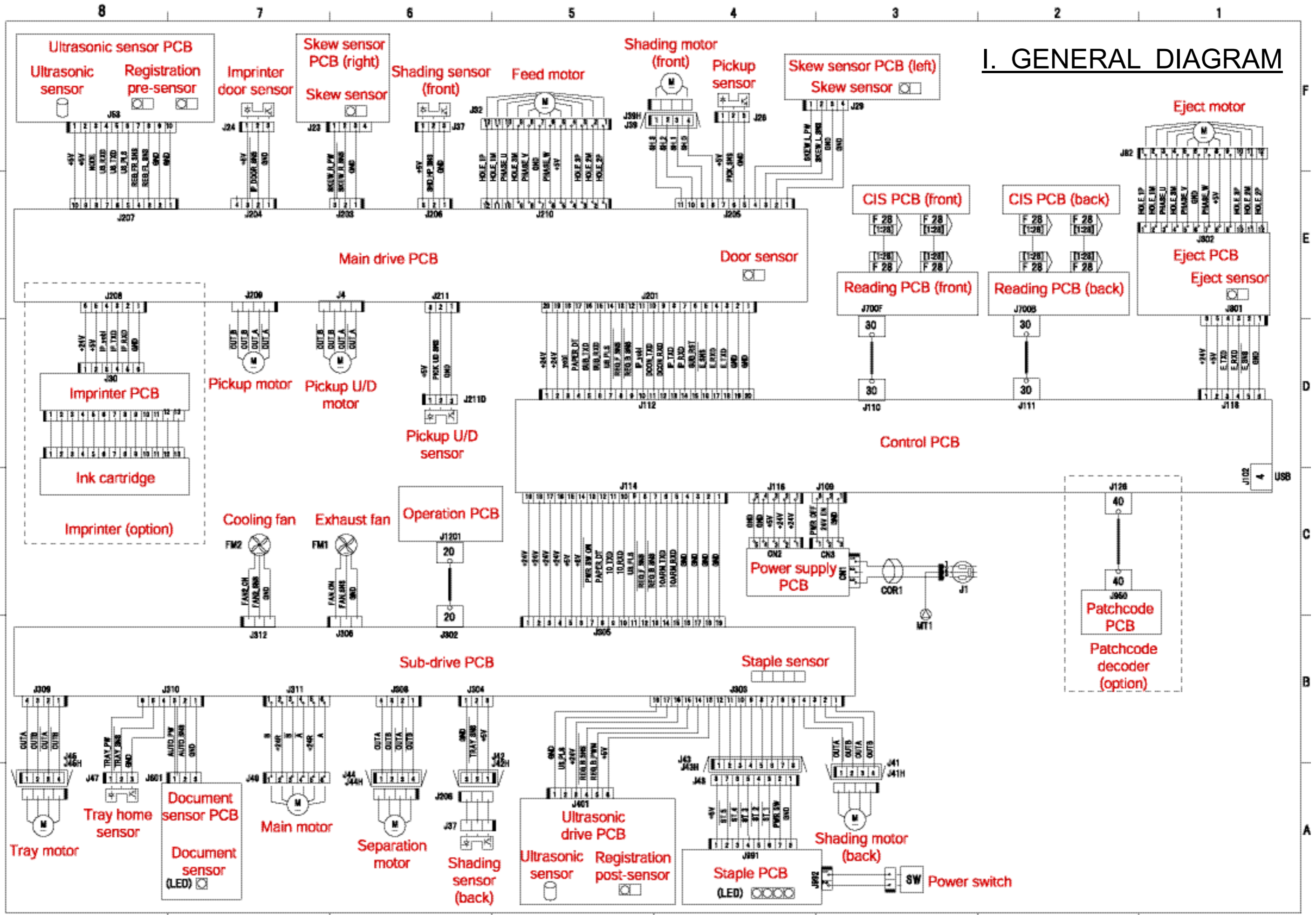

II. LIST OF SPECIAL TOOL

The adjustment sheets for the “Scale adjustment” and “Density adjustment” that were added in the service mode, and the test sheet for the image checking for the DR scanners show below.

No.	Tool name	Tool number	Rank	Usage/Remarks
1	Scale adjustment sheet	TKM-0348	B	For the scale adjustment 10 sheets/set
2	Density adjustment sheet	TKM-0347	B	For the density adjustment 10 sheets/set
3	Test sheet	TKM-0271	A	For the general image check 10 sheets/set

Table A-201

Note: Rank notation

A= Equipment that each service technician must carry.

B= Equipment that can be shared among a group of 5 service technicians.

C= Equipment that each workshop needs to have.