

imageFORMULA DR-C240

SERVICE MANUAL



Canon

March 1, 2015
Rev. 0

COPYRIGHT © CANON ELECTRONICS INC. 2015

Use of this manual should be strictly supervised to avoid disclosure of confidential information.

PREFACE

This Service Manual describes necessary basic information for field service and maintenance for maintaining the product quality and functions of this machine.

Contents

Chapter 1: General description

Product specifications, name of parts, operation method

Chapter 2: Functions and operation

Description of operation of machine system and electrical system by function

Chapter 3: Disassembly and reassembly

Disassembly method, reassembly method

Chapter 4: Installation and maintenance

Installation method, maintenance method

Chapter 5: Troubleshooting

Error display and troubleshooting

Appendix: General diagram etc.

Information in this manual is subject to change. Notification of such changes will be given in Service Information Bulletins.

Thoroughly read the information contained in this Service Manual and the Service Information Bulletins to gain a correct and deeper understanding of the machine. This is one way of fostering response for ensuring prolonged quality and function, and for investigating the cause of trouble during troubleshooting.

Quality Assurance Center
Canon Electronics Inc.

CONTENTS

CHAPTER 1 GENERAL DESCRIPTION

I.	PRODUCT OUTLINE	1-1
	1. Features	1-1
	2. Main Specifications	1-2
	3. Precautions	1-5
II.	NAME OF PARTS.....	1-6
	1. Names of Parts	1-6
III.	USER OPERATION.....	1-7
	1. Placing Documents	1-7
	2. Scanning	1-8
	3. Clearing a Paper Jam	1-9

CHAPTER 2 FUNCTIONS & OPERATION

I.	OUTLINE	2-1
	1. Main Configuration	2-1
	2. Feed Path	2-2
	3. Motor Drive	2-3
	4. Electrical Circuits	2-4
	5. Timing Chart.....	2-5
II.	READING SYSTEM.....	2-6
	1. Reading Unit	2-6
	2. Shading	2-7
III.	FEED SYSTEM	2-8
	1. Feeding Mechanism.....	2-8
	2. Registration Sensor	2-11
	3. Feed Error Detection	2-12
IV.	CONTROL SYSTEM	2-13
	1. Control Circuits	2-13
	2. Image Processing	2-15
V.	POWER SUPPLY	2-17
	1. Power Supply.....	2-17
VI.	LAYOUT OF ELECTRICAL COMPONENTS..	2-18
	1. Layout of Electrical Components	2-18
VII.	PARTS LAYOUT ON EACH PCB	2-19
	1. Control PCB	2-19

2.	Sub PCB	2-20
----	---------------	------

CHAPTER 3 DISASSEMBLY & REASSEMBLY

I.	EXTERNAL PARTS	3-1
	1. Document Feed Tray	3-1
	2. Document Eject Tray.....	3-1
	3. Upper Cover.....	3-2
	4. Lower Cover.....	3-2
II.	FRONT UNIT	3-3
	1. Sub PCB	3-3
	2. Stop Cam Drive Unit	3-5
	3. Upper Drive Unit	3-5
	4. Front Unit	3-6
	5. Upper Feed Guide Plate	3-7
	6. Registration Roller (Follower)	3-8
	7. Eject Roller (Follower).....	3-9
III.	BASE UNIT	3-10
	1. Control PCB	3-10
	2. Main Motor	3-11
	3. Eject Roller (Drive).....	3-12
	4. Registration Roller (Drive).....	3-13
	5. Dust Cover	3-14
	6. Separation Mount.....	3-14
IV.	READING UNIT	3-16
	1. Upper Reading Unit	3-16
	2. Upper Reading Guide	3-17
	3. Lower Reading Unit	3-18
	4. Lower Reading Guide	3-19

CHAPTER 4 INSTALLATION & MAINTENANCE

I.	INSTALLATION.....	4-1
	1. System Requirements.....	4-1
	2. Checking the Accessories.....	4-1
	3. Document Feed Tray and Packing Material...	4-2

4. Installing the Software	4-2
5. Connecting to a Computer	4-3
6. Power On.....	4-3
II. PARTS TO BE REPLACED	4-4
1. Periodically Replaced Parts	4-4
2. Consumable Parts.....	4-4
3. Major Parts List.....	4-5
III. MAINTENANCE	4-6
1. User Maintenance	4-6
2. Service Maintenance.....	4-9

CHAPTER 5 TROUBLESHOOTING

I. ERROR DISPLAY	5-1
1. Main Body.....	5-1
2. Computers	5-1
II. SERVICE MODE.....	5-2
1. Outline	5-2
2. How to Install	5-3
3. How to Start and Finish	5-3
4. Registration Adjustment	5-4
5. Light Adjustment.....	5-7
6. All Adjustment.....	5-8
7. Dcon Check.....	5-10
8. Check Device	5-14
9. Manual Adjust.....	5-16
10. Firm Load	5-23
11. About.....	5-24
12. Counter.....	5-25
13. Mechanical Feed Mode.....	5-26
14. Obtainment of Log Files	5-26
III. TROUBLESHOOTING LIST	5-28
1. Operation Failures.....	5-28
2. Image Failures.....	5-28
IV. OPERATION TROUBLESHOOTING	5-29
1. Power Does Not Come ON	5-29
2. No Scanner is Found.....	5-29
3. Scanning Does Not Start	5-30
4. Scanner Does Not Feed Properly	5-31
5. Scanning Speed is Slow.....	5-32

V. IMAGE TROUBLESHOOTING.....	5-33
1. All Black/All White/All Streaked	5-34
2. Too Dark/Too Light.....	5-34
3. Streaks in Image.....	5-35
4. Image Slanted	5-35
5. Wrong Image Size	5-36
6. Text Cannot be Seen	5-37
7. Moire in Image.....	5-37
VI. AFTER REPLACING PARTS	5-38

APPENDIX

I. GENERAL CIRCUIT DIAGRAM.....	A-1
II. LIST OF SPECIAL EQUIPMENT	A-2

CHAPTER 1

GENERAL DESCRIPTION

I. PRODUCT OUTLINE	1-1	III. USER OPERATION	1-7
II. NAME OF PARTS	1-6		

I. PRODUCT OUTLINE

1. Features

- 1) Scanner in the desktop work group with straight path
Upper and successor model for the DR-C130
- 2) Improvement of reliability for the feed and separation action, and strong body.
Succeeding the function of the DR-M160II
- 3) Scanning speed (A4, 200dpi)
B&W and Grayscale: 45ppm/90ipm
Color: 30ppm/60ipm
- 4) New functions
 - a) 3 registration sensors in a line
 - b) Passport scanning
- 5) Service ability
 - a) Installation by user
 - b) Roller replacement by user using the exchange roller kit
 - c) No periodically maintenance by service technician
 - d) Service tool with exclusive type
 - e) User log obtainment available

“Windows” is a trademark of Microsoft Corporation in the U.S. and other countries.

Other company names and product names mentioned in this document are registered trademarks or trademarks of the respective companies.

2. Main Specifications

No.	Item	Specifications
1	Type	Desktop type sheet-fed scanner
2	Dimensions	1) Tray closed: 291 (W) · 253 (D) · 231 (H) mm *The document feed tray is attached. 2) Tray opened: 291 (W) · 603(D) · 363 (H) mm
3	Weight	Approximately 2.8kg (Main body only)
4	Power supply	AC adapter 1) Input: 100V-240VAC, 50/60Hz 2) Output: 24VDC, 2.0A 3) Main unit power rating: 24 VDC, 1.0A
5	Power consumption	1) Operation: 19W max 2) Sleep mode: 1.4W max Power switch OFF: 0.1W max
6	External interface	USB 2.0 (Hi-speed)
7	Expected product life (In-house information only)	One of the following two items, whichever comes first. 1) 5 years 2) 1,000,000 sheets (A4 copy paper) *Replace parts if necessary.
8	Installation	By user.
9	Option	1) Flatbed scanner: FSU101, FSU201 2) Barcode module (software): 1-demention, 2-dementions 3) Carrier sheet: For passports
10	Consumable parts (Commercial goods)	1) Exchange roller kit *Feed roller and retard roller *Replaced by user. Expected life is 200,000 sheets.
11	Bundle software	1) ISIS/TWAIN driver, CapturePerfect 3.1, CaptureOnTouch 2) Others depend on Sales region
12	Sensor type, Density	1 line/3 parallel-CMOS contact image sensor, 600dpi
13	Sensor operation mode	600dpi or 300dpi
14	Effective reading width	217mm (5126 pixels)
15	Light source	3-color (RGB) LED, Single-side illumination
16	Background color	White
17	Image data memory	SDRAM 16MB *Used for the working memory together.
18	Output data to computer	1) Type: 8bit gray or 24bit color 2) Resolution: 600x600dpi, 600x400dpi, 300x300dpi, 300x240dpi, 300x200dpi, 300x150dpi, 300x100dpi

Table 1-101a

No.	Item	Specifications		
19	Mode setting in driver	1) Binary: B&W, Error diffusion, ATE, ATE-II *ATE=Advanced Text Enhancement 2) Grayscale: 8bit 3) Color: 24bit *Auto-color detection mode can be available.		
20	Resolution setting in driver	600x600dpi, 400x400dpi, 300x300dpi, 240x240dpi, 200x200dpi, 150x150dpi, 100x100dpi *Auto-resolution mode can be available.		
21	Scanning speed (A4 size)	Resolution	Grayscale (JPEG)	Color (JPEG)
		200dpi	45ppm/90ipm	30ppm/60ipm
		300dpi	45ppm/90ipm	20ppm/40ipm
		400dpi	24ppm/48ipm	7ppm/14ipm
		600dpi	16ppm/32ipm	4ppm/8ipm
		*The numbers above may differ depending on the computer, the function settings and other conditions.		
22	Document feed path	Straight path		
23	Document size	1) Width: 50.8 to 216mm 2) Length: 54 to 356mm *Some restrictions		
24	Document weight (Thickness)	1) Separation: 27 to 209g/m ² (0.04 to 0.25mm) 2) Non separation: 27 to 255g/m ² (0.04 to 0.30mm) *Some restrictions		
25	Special document	Plastic card, Business card, Post card, Folio, Long document, Passport and others are available. *The passport needs carrier sheet, and other restrictions		
26	Document storage	1) Pickup: A4 (LTR) or smaller: 60 sheets max. and 6mm height max. 2) Eject: Number of sheets above max. and 15mm height max. *Heights above are included curls.		
27	Double feed detection	1) Length detection by registration sensor 2) Double feed detection by ultrasonic sensor		
28	Operation/Indication	1) Button: Power, Start, Stop, Function, Double feed release 2) LED: 7-segments function, Power, Double feed release 3) Lever: Feed selection, Main body open		

Table 1-101b

◆ External dimensions (mm)

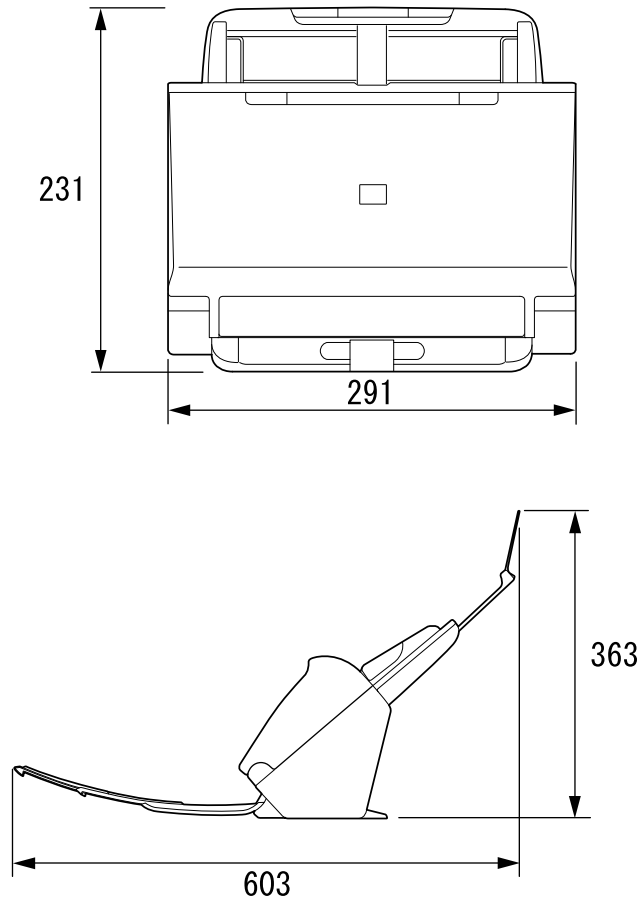

Figure 1-101

3. Precautions

This section describes items that require particular care, for example, regarding human safety.

These precautions must be observed. The user should be explained the items that relate to user safety and instructed to take appropriate actions.

1) Power OFF in emergency

If such abnormal conditions as extraordinary noise, smoke, heat and odor occur, immediately unplug the power cord.

Be careful not to get clothing (ties, long hair, etc.) caught in this machine as it may cause injury. Should this occur, immediately unplug the power cord.

Do not insert fingers in the feed section while moving the rollers.

2) Power OFF on disassembling

When disassembling and assembling are performed, unplug the power cord.

3) Prohibition of modify

This machine must not arbitrarily be modified or remade. If it is, use may be forcibly suspended.

To change the specifications or disassemble and reassemble this machine, follow the instructions described in this manual and the service information.

4) Electromagnetic wave interference

This machine complies with some standards regarding electromagnetic wave interference, such as VCCI and FCC. However, the user may have to take countermeasures if the machine causes electromagnetic wave interference.

5) "User Manual"

Read each "User Manual" thoroughly prior to use of this machine.

6) Disposal

Follow local regulations when disposing of the product and parts. This product is subject to the WEEE Directive in Europe.

II. NAME OF PARTS

1. Names of Parts

◆ Front View

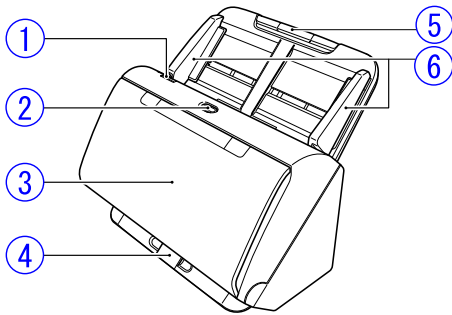

Figure 1-201

- ① OPEN lever
- ② Power button
- ③ Document eject tray
- ④ Eject tray support
- ⑤ Document feed tray
- ⑥ Document guides

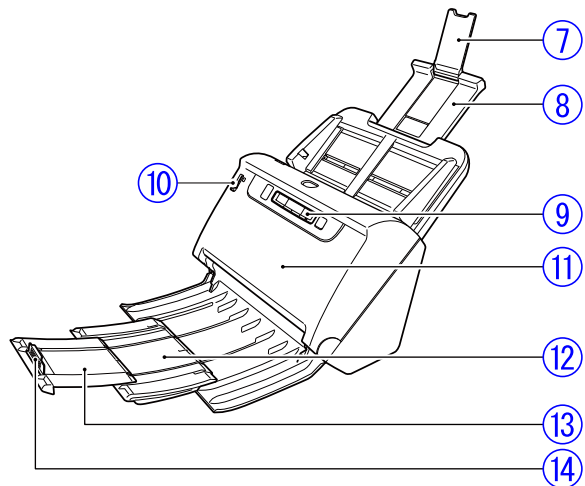

Figure 1-202

- ⑦ Feed extension support
- ⑧ Feed support
- ⑨ Operating panel
- ⑩ Feed selection lever
- ⑪ Front unit
- ⑫ Eject support
- ⑬ Document eject extension support
- ⑭ Document eject stopper

◆ Rear View

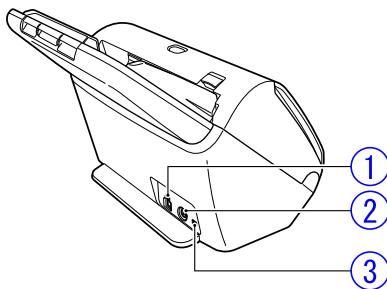

Figure 1-203

- ① USB connector
- ② Power connector
- ③ Security slot

◆ Operating panel

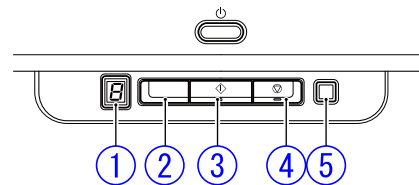

Figure 1-204

- ① Job No. indicator
- ② Job select button
- ③ Start button
- ④ Stop button
- ⑤ DFR button

III. USER OPERATION

This section shows how to scan several sheets of a regular paper document using the initial settings of CaptureOnTouch. For details on other operations, refer to the "User Manual" for this machine.

1. Placing Documents

- 1) Open the document eject tray and use the eject support and feed support, etc. to suit the document.

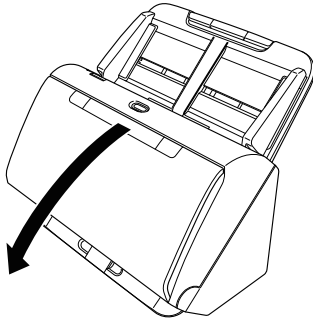

Figure 1-301

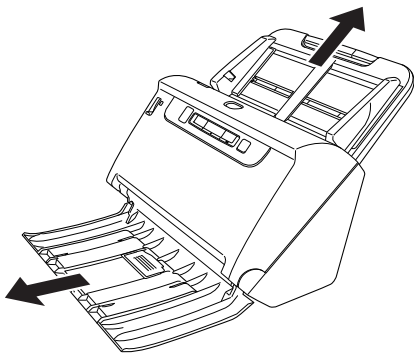

Figure 1-302

- 2) Switch the feed selection lever to normal feeding.

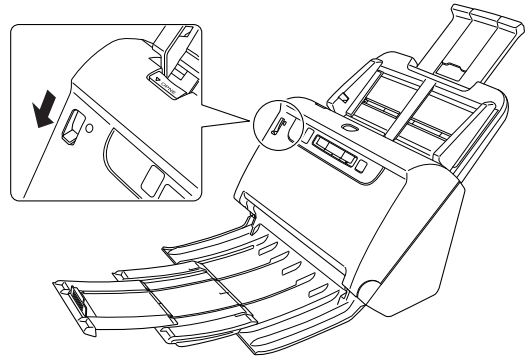

Figure 1-303

- 3) Place the document, and adjust the document guides to fit the document width.

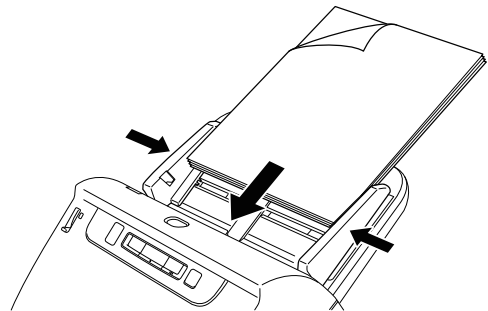

Figure 1-304

2. Scanning

This section describes how to scan using [Standard Scanning] in CaptureOnTouch.

Note: CaptureOnTouch is TWAIN compatible application.

- 1) Start CaptureOnTouch.

To start CaptureOnTouch and display the main screen, click the CaptureOnTouch icon in the task bar and click [Open CaptureOnTouch...] in the displayed menu.



Figure 1-305

- 2) From [1 Select document] in the Standard Scanning, select the appropriate scan mode panel for the document you want to scan.

In the figure below, [Full auto] is selected.



Figure 1-306

- 3) From [2 Select output], select the appropriate output panel according to how the scan image will be used.

In the figure below, [Desktop] is selected.



Figure 1-307

- 4) Click the [SCAN] button to start scanning documents.



Figure 1-308

- 5) Check the scanned image, and then click the [Finish] button.

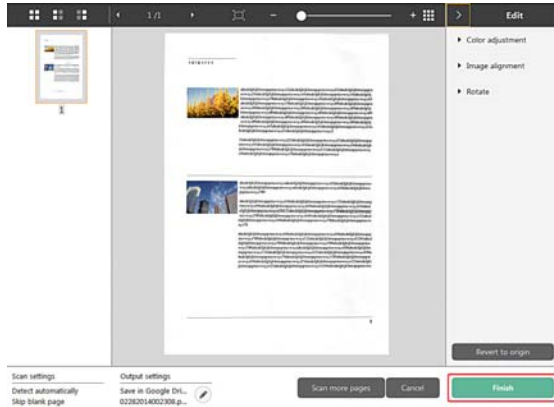

Figure 1-309

3. Clearing a Paper Jam

- 1) Remove any remaining documents from the document feed tray.

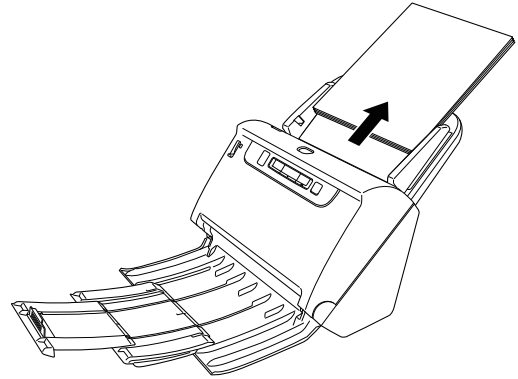

Figure 1-310

- 2) Pull the OPEN lever and open the front unit out towards you. Remove any jammed documents.

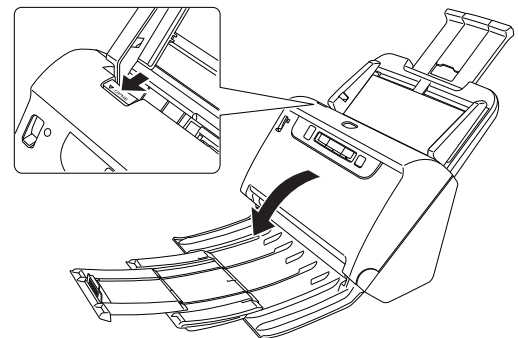

Figure 1-311

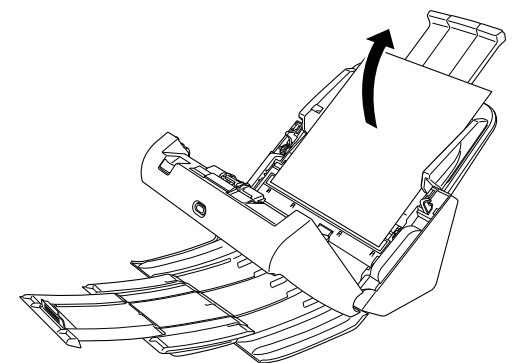

Figure 1-312

CHAPTER 2

FUNCTIONS & OPERATION

I. OUTLINE.....	2-1	V. POWER SUPPLY	2-16
II. READING SYSTEM.....	2-6	VI. LAYOUT OF ELECTRICAL COMPONENTS.....	2-17
III. FEED SYSTEM.....	2-8	VII. PARTS LAYOUT ON EACH PCB.....	2-18
IV. CONTROL SYSTEM.....	2-12		

I. OUTLINE

1. Main Configuration

Figure 2-101 shows the main configuration of this machine.

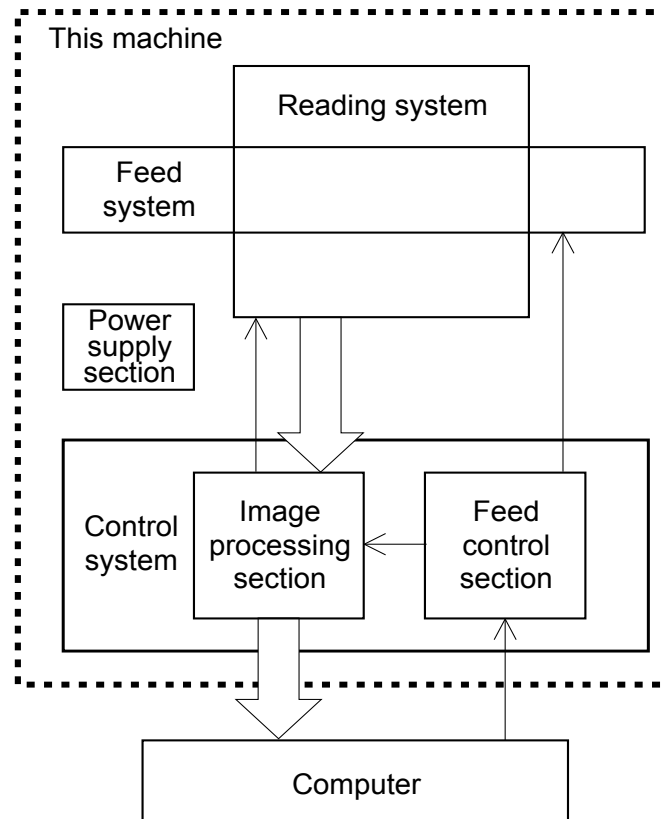

Figure 2-101

- 1) Reading system
This system reads image data from image sensors.
- 2) Feed system
This system performs from document pickup to document ejection.
- 3) Control system
This system is comprised of an image processing section and a feed control section.
The image processing section controls the reading system, and processes the read image data. The computer also processes image data.
- 4) Power supply section
This section supplies DC power, converted from AC power with the AC adapter, to the control PCB of this machine.

2. Feed Path

A sectional view of the feed path of this machine is shown below.

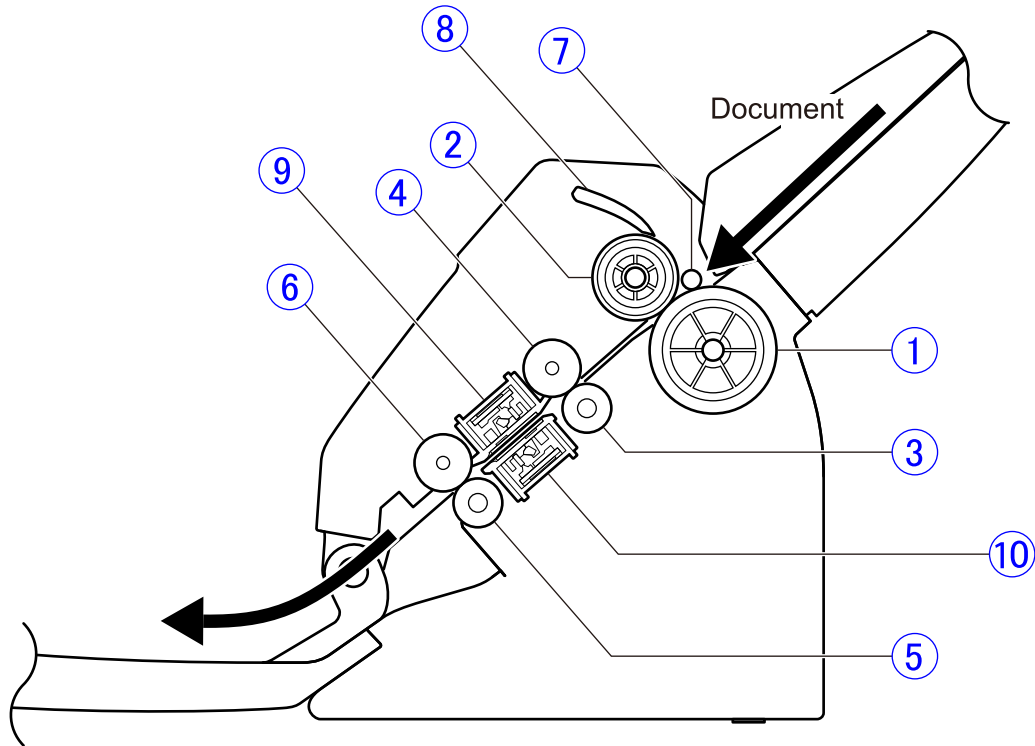

Figure 2-102

- | | |
|----------------------------------|----------------------|
| ① Feed roller | ⑦ Pressure roller |
| ② Retard roller | ⑧ Document stopper |
| ③ Registration roller (drive) | ⑨ Upper reading unit |
| ④ Registration roller (follower) | ⑩ Lower reading unit |
| ⑤ Eject roller (drive) | |
| ⑥ Eject roller (follower) | |

3. Motor Drive

This machine has a main motor.

The main motor drives the retard roller, the feed roller, the registration roller, and the eject roller.

The main motor also moves the stoppers and the pressure roller.

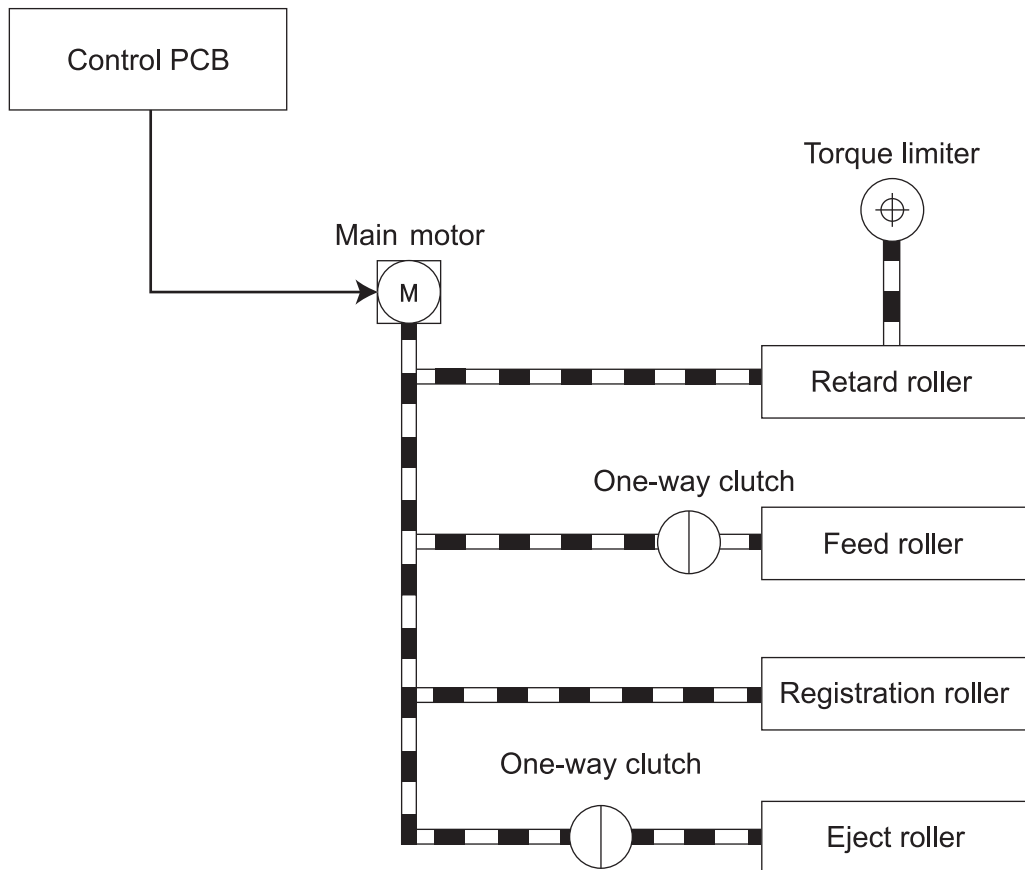

Figure 2-103

4. Electrical Circuits

An overview of the electrical circuits block diagram of this machine is shown below.

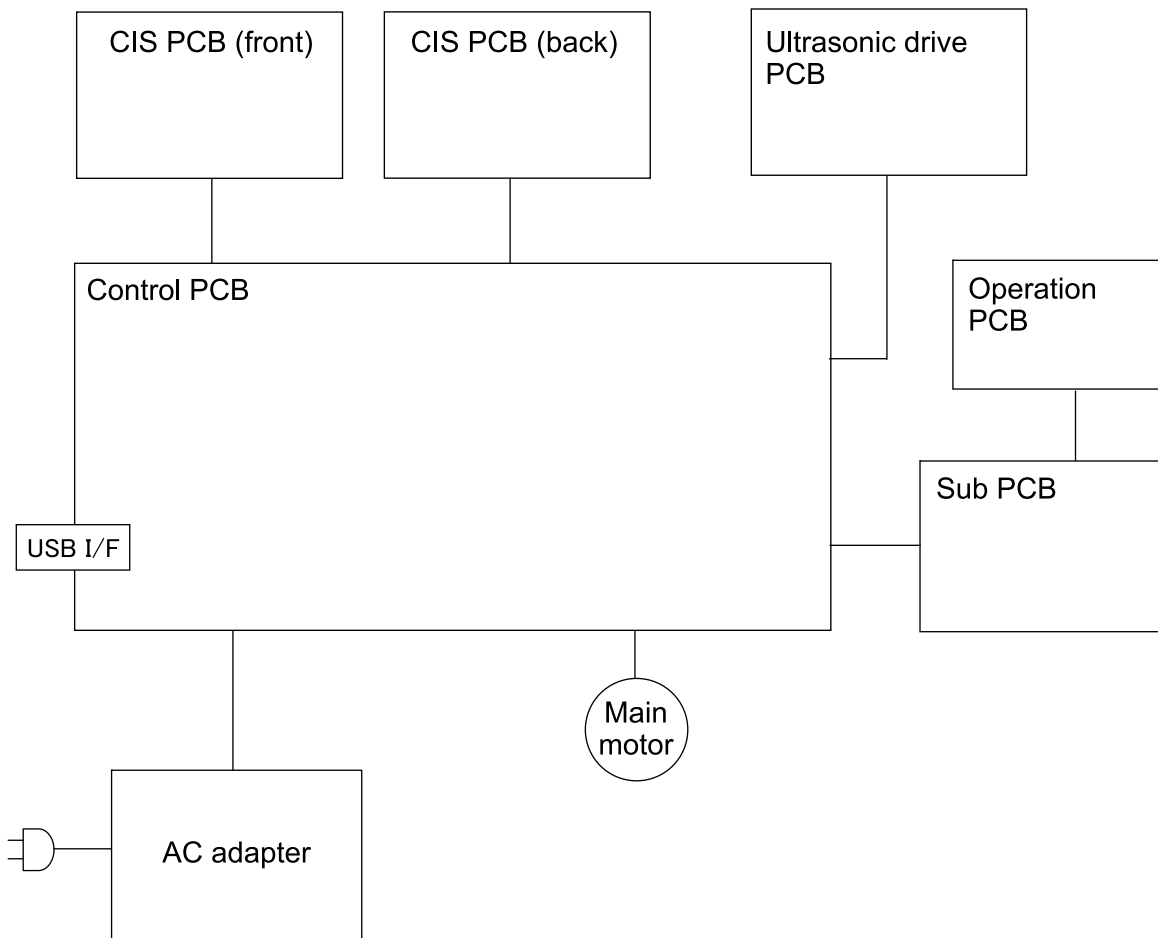

Figure 2-104

5. Timing Chart

Shown below is the timing chart for reading documents consisting of 2 sheets fed separately.

When a scan is started, the main motor starts turning, the initial operation is performed, and then the document is fed.

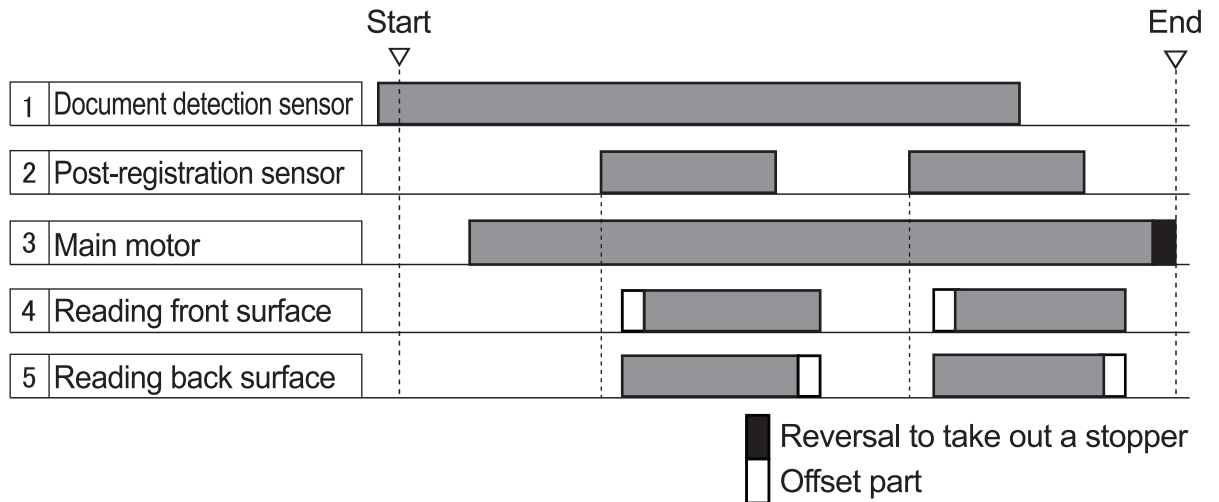

Figure 2-105

II. READING SYSTEM

1. Reading Unit

The sectional view of the reading system is shown below. The upper and lower reading units have the same configuration but the different guide shapes.

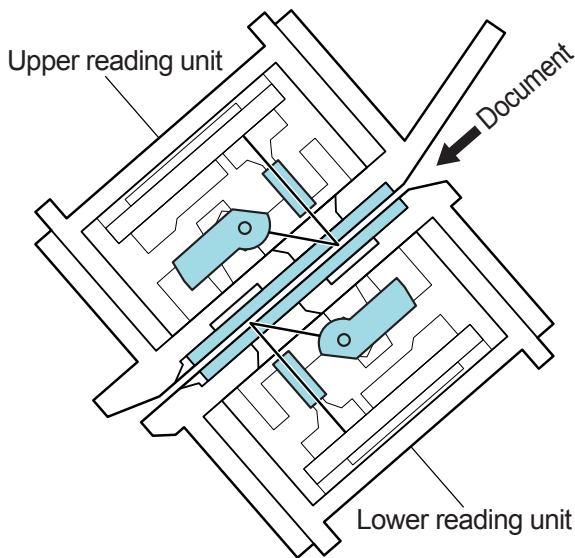

Figure 2-201

The upper reading unit reads the back side of the documents and the lower reading unit reads the front side of the documents. This configuration enables the machine to read both front and back sides of a document using a single scan.

The read image data are sent to the image processing section of the control PCB.

To prevent reading speed from decreasing, the image data is divided into three and output in parallel.

As shown in Figure 2-202, the reading unit consists of CIS unit, guide, and case.

The CIS unit consists of CIS PCB, lens array, LED (R/G/B), light guide, and case.

The reading glass and white reference sheet are mounted on the guide.

Photosensitive pixels are mounted on the CIS PCB with a density of 600 dpi in a line. The effective reading width is 217mm, and the number of effective picture elements is 5126.

A set of three basic color LEDs, red, green, and blue (RGB), is mounted only on the one side. This single-side illumination causes a shadow on a document, which may effect on the image data quality.

In the binary or grayscale modes, image data are read with composite light generated by lighting the RGB LEDs at the same time. In the color mode, the LED is successively lit, and reads image data with each color. As documents are being fed at regular speed while image data are read, the reading positions of RGB are shifted slightly.

In the color dropout mode, only the LED of a designated color lights. In the color emphasis mode, the LED of a color other than a designated color lights.

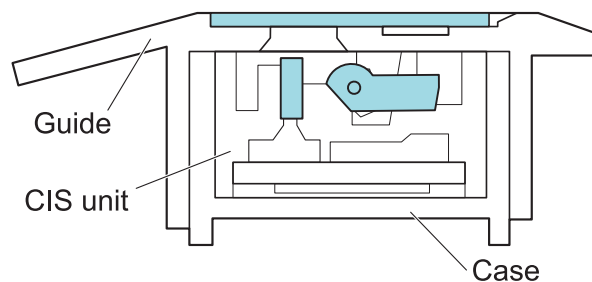

Figure 2-202

2. Shading

This section explains the reading mechanism of the white reference sheet for determination of the shading correction value.

The sectional view of the reading unit is shown below. Note that it is shown horizontally for the description.

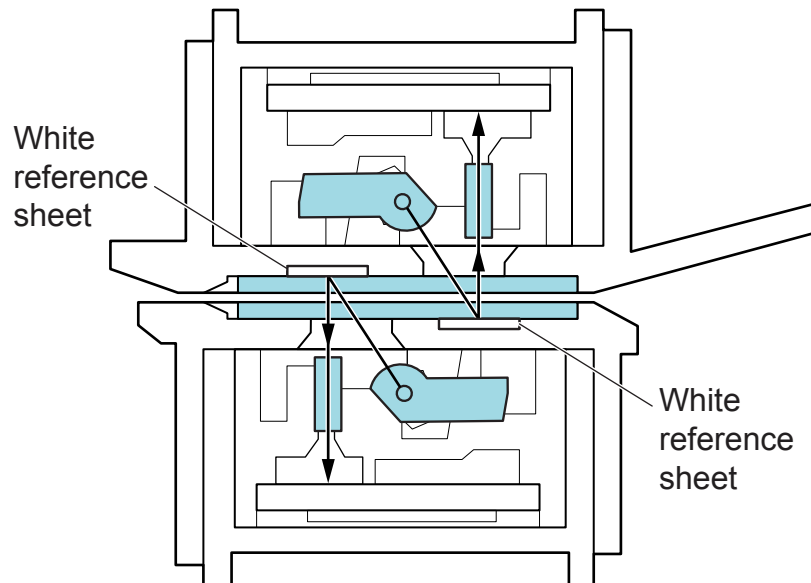

Figure 2-203

This machine can read the white reference data at the document reading position, unlike other scanners having the black background color, since its background color is white. Therefore, there is neither need to feed the shading sheet nor to move the internal white reference sheet or the reading units.

For example, when the lower reading unit reads the white reference data, the LED emitted from the lower unit is reflected from the white reference sheet on the upper unit to be input to the sensor on the CIS PCB.

Since the white reference sheet is placed under the reading glass, feeding document does not cause dirt on it. Note that executing shading while the reading

glass is dirty can cause poor images such as white lines occurring in the images.

When this machine starts scanning, it reads the white reference data to determine shading correction values.

However, the slightly different optical paths to the light receiving element are used for the actual document and the white reference sheet. Therefore this machine needs fine adjustment of the shading correction value using the service mode and the shading sheet. This fine adjustment is necessary after replacing the reading unit or after replacing the control PCB recording the shading correction value.

III. FEED SYSTEM

1. Feeding Mechanism

The sectional view of the feed system is shown below.

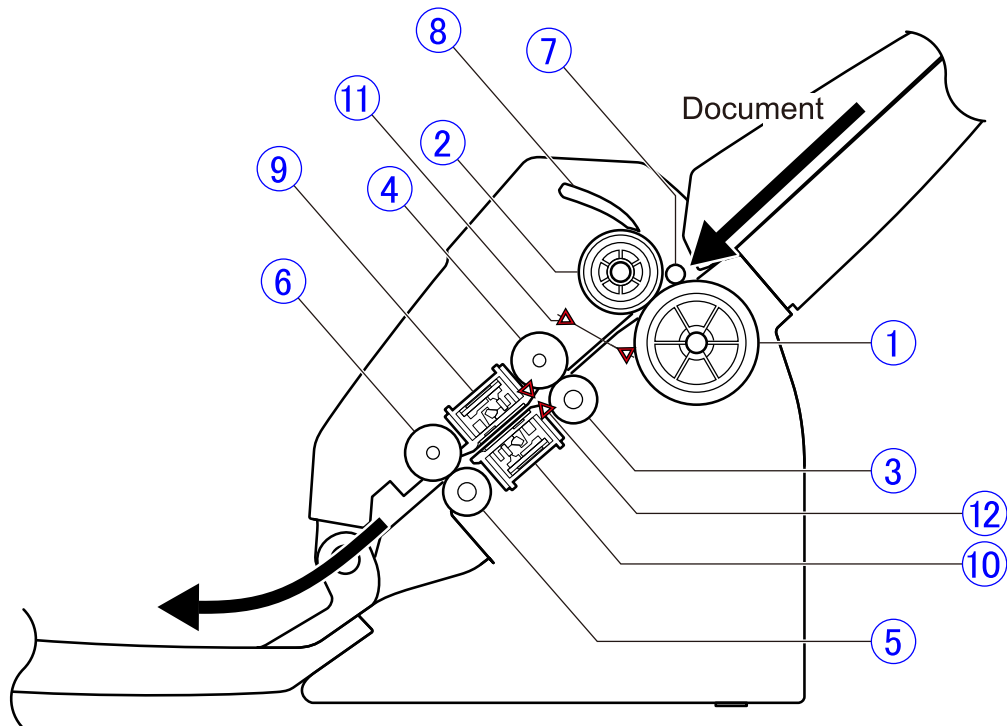

Figure 2-301

- | | |
|----------------------------------|--|
| ① Feed roller | ⑧ Document stopper |
| ② Retard roller | ⑨ Upper reading unit |
| ③ Registration roller (drive) | ⑩ Lower reading unit |
| ④ Registration roller (follower) | ⑪ Ultrasonic sensor detection point |
| ⑤ Eject roller (drive) | ⑫ Post-registration sensor detection point |
| ⑥ Eject roller (follower) | (left / center / right) |
| ⑦ Pressure roller | |

1) Feed path

The feed path of this machine is a straight path tilting at an angle of approximately 40 degrees.

For details on the arrangement of the rollers, sensors, and other components, refer to the cross sectional diagram of the feed system (Figure 2-301).

Documents placed in the inlet are ejected to the eject tray. However, the document can be output even when the eject tray is closed. When feeding cards, orient the card sideways. Also, so that the machine can feed thicker documents, such as passports, the feed path gap was widened compared to earlier models, and the retraction distances of the upper reading unit, registration roller (follower), and eject roller (follower) were increased.

2) Drive

The main motor drives the feed roller, the retard roller, the registration roller, and the eject roller. The scanning condition determines the drive speed.

In addition, for the document stopper and the pressure roller, the up or down movement is controlled by the main motor rotation direction.

3) Feed

The following shows a cross-sectional diagram of the pickup area before starting the feed. The document stopper is in the lowered position.

When a document is placed in the inlet, the edge of the document lines up at the document stopper. When a scan is started, the pressure roller moves down and then the document stopper moves up and the document begins to feed.

Documents feed from the lower side of the placed document.

Misfeeds and double feeds have been reduced by installing a document stopper and pressure roller, and increasing the diameter of the feed roller.

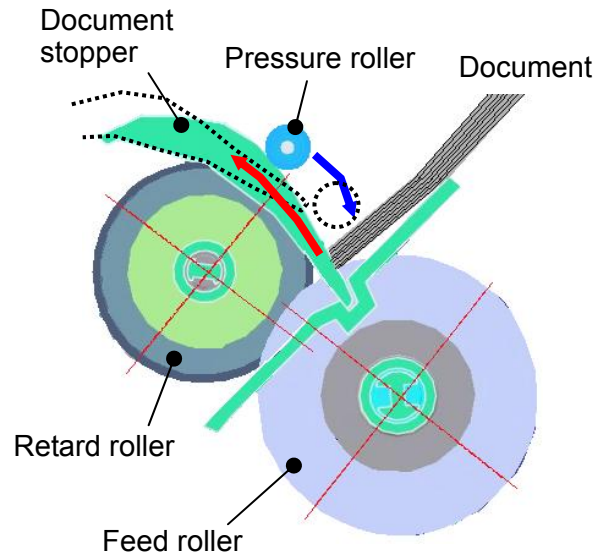

Figure 2-302

4) Separation

Separation of the documents is performed by the retard roller.

Since the torque limiter is built in the retard roller, when the outside pressure on the roller exceeds the specified value into the feed direction, the roller begins to rotate in the same direction.

As shown in Figure 2-303-a, when overlapped documents enter into the clearance between the feed roller and the retard roller, the document in contact with the feed roller is fed in the feed direction, and the retard roller rotates in the opposite direction so that the document in contact with the retard roller is not pushed in.

As shown in Figure 2-303-b, once a single document remains, the feed roller

and the document add torque on the retard roller. When this torque exceeds the retard roller torque, the retard roller rotates in the direction to feed the document due to the torque limiter.

and the registration roller, and therefore, a one-way clutch is built into the gear used in the feed roller drive system to follow the drive speed of the registration roller.

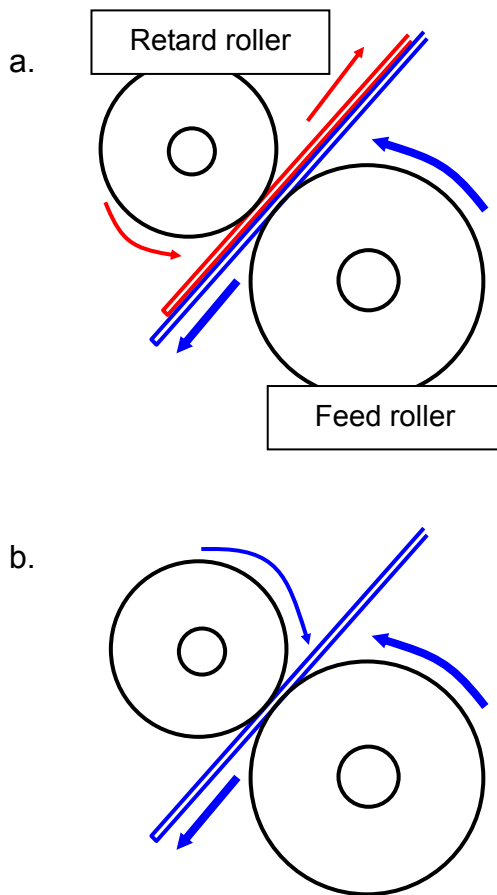

Figure 2-303

Note that if you select non-separating mode by operating the feed switch lever, the retard roller rotates freely and the separation function is disabled.

To provide space between the trailing edge of a document and the leading edge of the next document, the drive speed of the feed roller is slightly lower than the drive speed of the registration roller and eject roller. If the drive speeds are not changed, the document is braked when it touches the feed roller

2. Registration Sensor

As shown in Figure 2-304(a), this machine has the left, middle, and right registration sensors (post) between the registration roller and the reading unit on the feed path. The earlier models have the middle registration sensor only, so if the document is fed at a highly skewed angle, the sensor cannot detect the leading and trailing edge positions of the document as shown in 2-304(b). Consequently, these positions are missing in the image as shown in Figure 2-304(c). This machine has 3 registration sensors, and these sensors prevent missing in the image.

This machine does not have the pre-registration sensor.

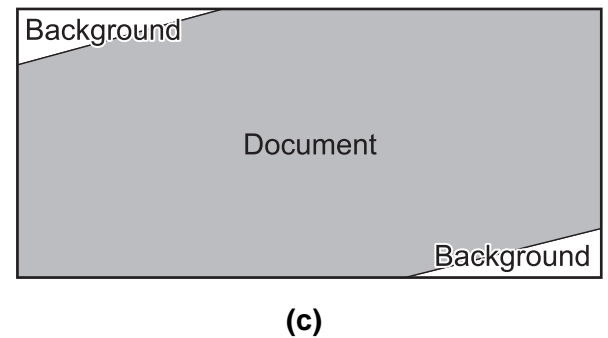
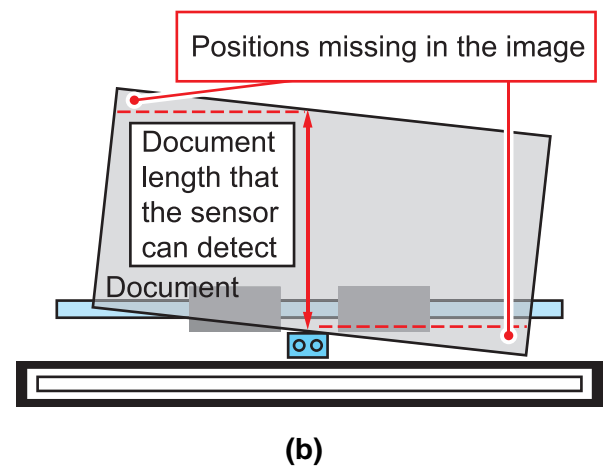
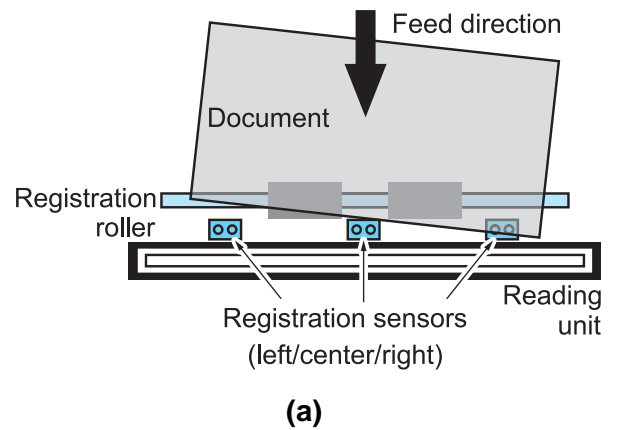

Figure 2-304

3. Feed Error Detection

1) Paper Jam Detection

Paper jams are detected by the registration sensors (post). The types of the document jams are described as follows.

a) Pickup Delay Jam (Pickup Error)

The leading edge of the document was not detected by the registration sensor within the specified time after the machine starts scanning.

b) Early Reach Jam

The leading edge of the following document was detected after the trailing edge of the document was detected by the registration sensor before the document has been fed for a specified length.

c) Residual Jam

The trailing edge of the document was not detected even though the document has been fed for the maximum specified length after the leading edge of the document was detected by the registration sensor.

d) Fast Feed Jam

The trailing edge of the document was detected after the leading edge of the document was detected by the registration sensor before the document has been fed for the minimum specified length.

e) Non-removal Jam

The machine starts scanning while the document is detected by the registration sensor and still remains inside this machine.

2) Double Feed Detection

There are 2 double feed detection methods: the document length detection

by the registration sensor and the document overlapping detection by the ultrasonic sensor.

◆ Registration sensor

The registration sensor uses the first document length of the scanned batch as a reference to detect the document length. The 35 mm or more difference from the standard is interpreted as a double feed.

◆ Ultrasonic sensor

The ultrasonic drive sensor transmits the ultrasonic and the ultrasonic receive sensor receives the ultrasonic signal to gain a specific signal level. When overlapping documents are fed, the signal level is different from when properly feeding a single document. This machine interprets this difference as a double feed. Note that since this difference in the signal occurs depending on the presence of a layer of air, a double feed will not be detected if the document is tightly adhered by static electricity or adhesive. Furthermore, double feed is judged if a double feed is detected continuously for a specific amount of time. As a result, if the overlap between sheets is less than 50 mm when a document is being fed, it might not be judged as a double feed because the detection time is short.

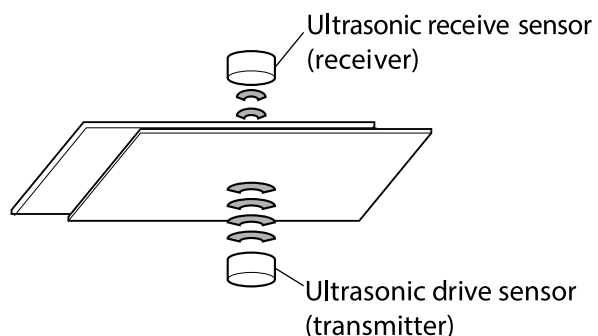

Figure 2-305

IV. CONTROL SYSTEM

1. Control Circuits

The overall system of this machine is controlled by the control PCB. The block diagram and the function list of major ICs are shown below.

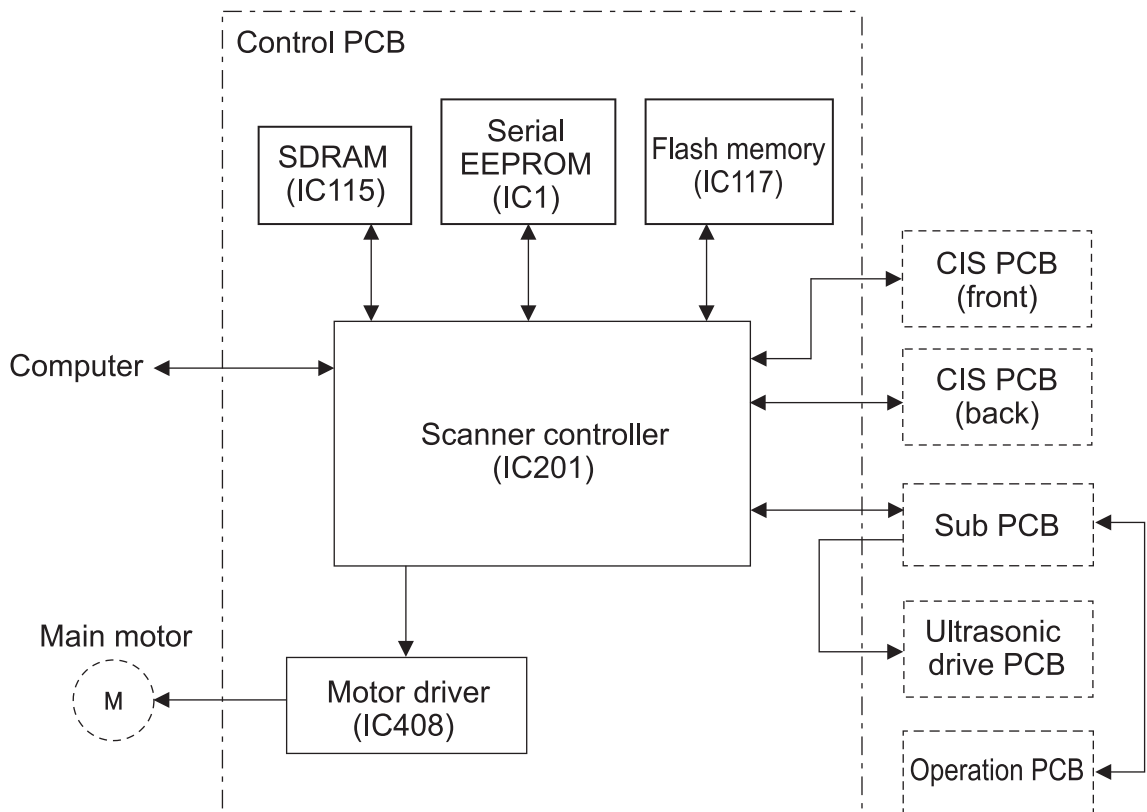

Figure 2-401

◆ Function list of major ICs

IC No.	Name	Function
IC1	Serial EEPROM (8kbit)	Saves the various setting data
IC115	SDRAM (128Mbit)	Working memory for the scanner controller and for storing image data temporarily
IC117	Flash memory (8Mbit)	Stores firmware
IC201	Scanner controller	Overall scanner control
IC408	Motor driver	For driving the main motor

Table 2-401

2. Image Processing

A block diagram of the image processing is shown below.

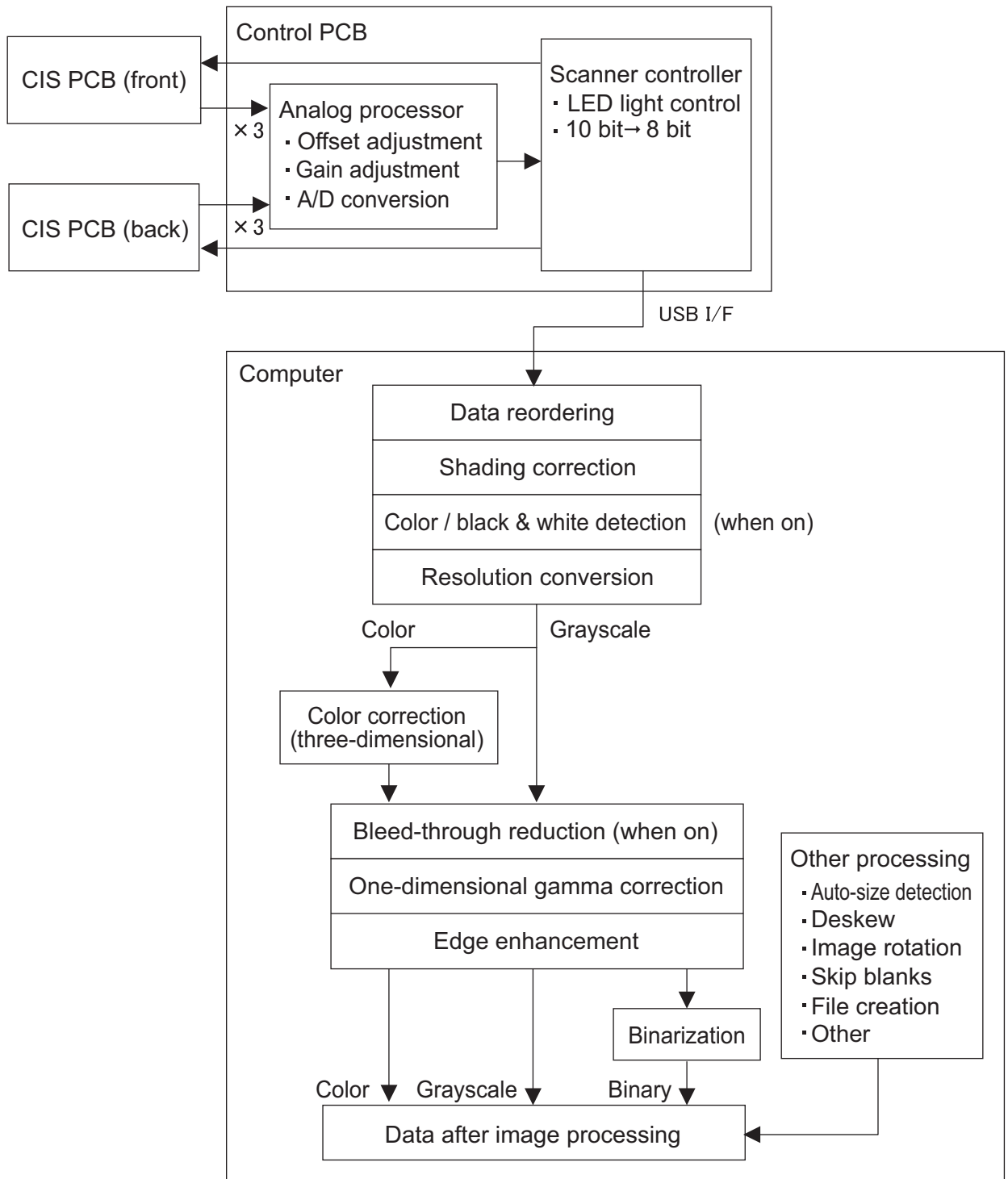

Figure 2-402

The CIS PCB outputs analog signals (3 parallel lines) proportionate to the density of each picture element to the analog processor on the scanner PCB. The CIS PCB outputs the data at 300 dpi or 600 dpi, according to the user settings.

The analog processor carries out offset adjustment, gain adjustment, and A/D conversion. The analog processor converts analog signals into 10-bit digital signals. The processor then sends the image data to the scanner controller, which converts the data from 10-bit to 8-bit.

The scanner controller then outputs the image data to the computer via the USB interface.

The computer corrects the shading and processes the image according to the user settings.

V. POWER SUPPLY

1. Power Supply

The machine uses an AC adapter for its power supply. Its rated input voltage is 100-240 VAC, 50/60 Hz and whose output is 24 VDC. Use the AC adapter bundled with this machine. The power output from the AC adapter is input to the control PCB.

In case of excess voltage or current applied to the AC adapter output, the safety system cuts the power. In this case, unplug the AC plug. After removing the cause, plug it back.

The power switch for the machine is mounted on the operation PCB. When the switch is turned on, a DC/DC converter activates to generate each of the DC voltages and supply power to each of the components.

When no documents have been fed or there has been no communication via this USB I/F for an extended period of time, the machine enters the sleep mode (Energy Star mode). When the machine is in the sleep mode, the electrical circuits enter a sleeping state. However, the CPU does not enter a sleeping state. This machine automatically returns from the sleep mode when it receives communication from the computer, when a key on the operation panel is pressed, or when the front unit is opened.

Furthermore, the power turns OFF if no operations are performed for a long period of time (4 hours).

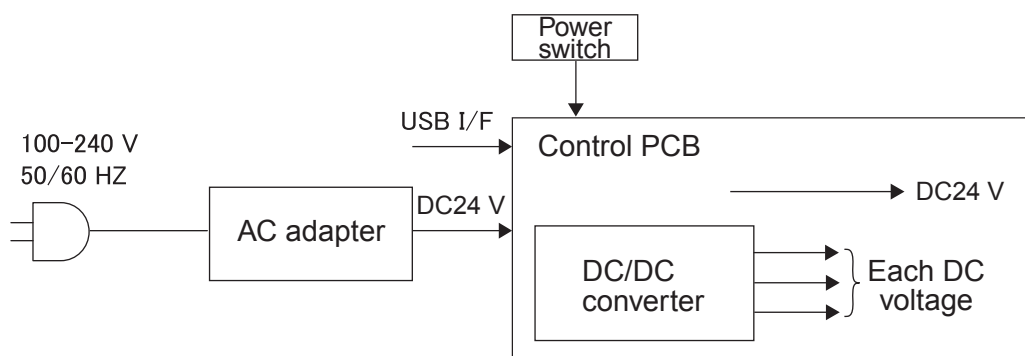

Figure 2-501

VI. LAYOUT OF ELECTRICAL COMPONENTS

1. Layout of Electrical Components

For sensors etc. on the PCBs, refer to “VII.PARTS LAYOUT ON EACH PCB”.

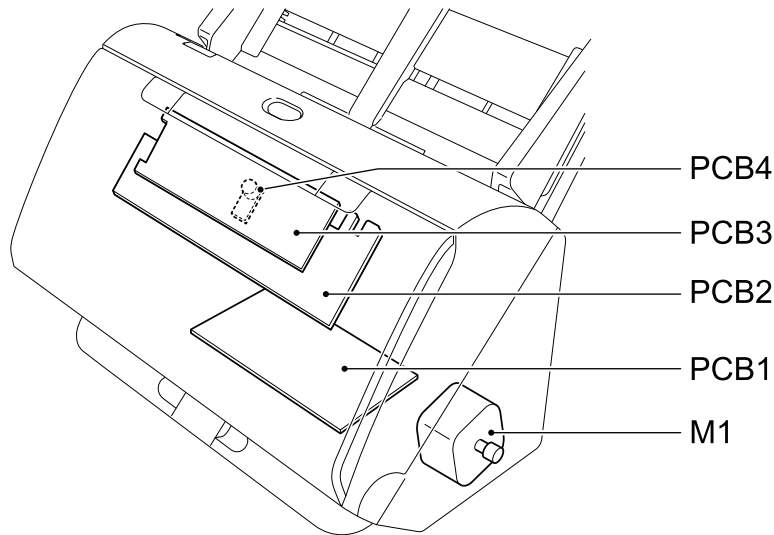

Figure 2-601

Category	Name	Location	Symbol
Motor	Main motor	Base unit (right)	M1
PCB	Control PCB	Base unit	PCB1
	Sub PCB	Front unit	PCB2
	Operation PCB	Front unit	PCB3
	Ultrasonic drive PCB	Base unit	PCB4

Table 2-601

VII. PARTS LAYOUT ON EACH PCB

1. Control PCB

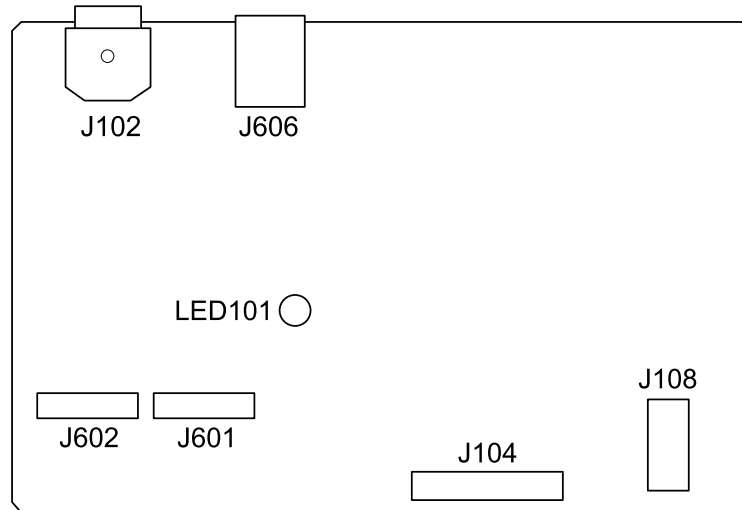

Figure 2-701

Connector		Details
J102	–	AC adapter
J104	16P	Sub PCB Ultrasonic driver PCB
J108	6P	Main motor
J601	15P	CIS PCB (front)
J602	15P	CIS PCB (back)
J606	–	USB I/F

Table 2-701

Symbol	Details
LED101	Blinking →CPU operation/DC power good

Table 2-702

2. Sub PCB

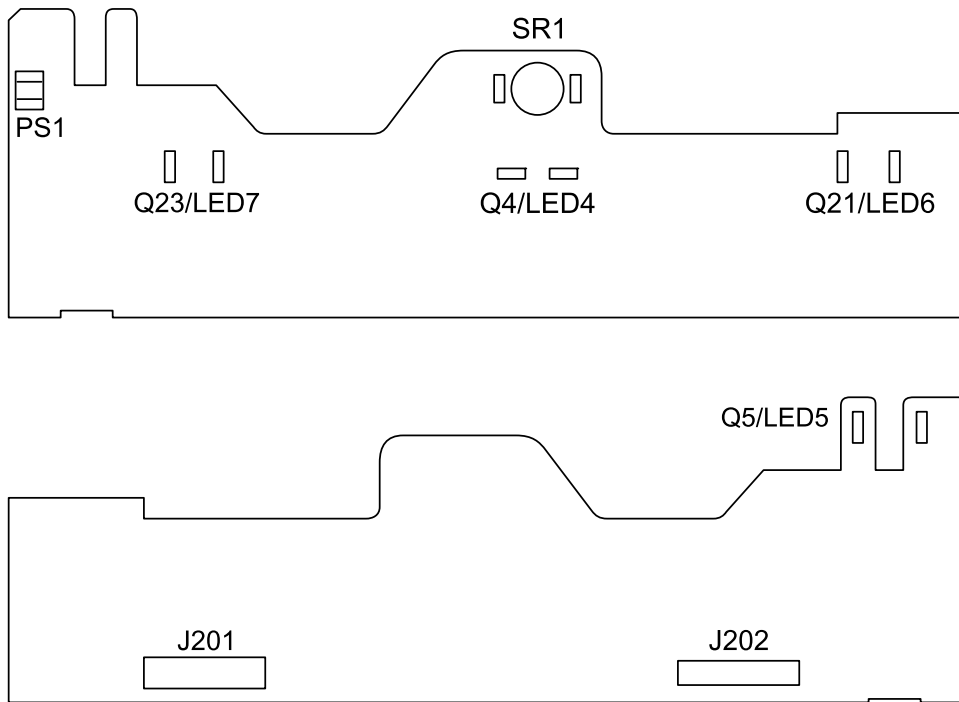

Figure 2-702

Connector		Details
J201	13P	Control PCB
J202	20P	Operation PCB

Table 2-703

Symbol	Details
Q5/LED5	Document detection sensor
Q4/LED4	Post-registration sensor (middle)
Q21/LED6	Post-registration sensor (left)
Q23/LED7	Post-registration sensor (right)
PS1	Door sensor
SR1	Ultrasonic sensor (receiver)

Table 2-704

CHAPTER 3

DISASSEMBLY & REASSEMBLY

The products shown in the figures in this chapter may be partially different from mass-production's one.

I. EXTERNAL PARTS.....	3-1	III. BASE UNIT	3-9
II. FRONT UNIT.....	3-3	IV. READING UNIT.....	3-15

I. EXTERNAL PARTS

1. Document Feed Tray

- 1) Pull up the document feed tray ① to remove it.



Figure 3-101

Note: This component may be removed before disassembling other components even if not specifically directed.

2. Document Eject Tray

- 1) Open the document eject tray ①, then unhook it by bending the fitting part ② on the left side. Next, unhook the fitting part ③ on the right side, then remove the document eject tray.



Figure 3-102

Note: This component may be removed before disassembling other components even if not specifically directed.

3. Upper Cover

- 1) Put the main unit on its side as shown in the below figure, and unhook the 4 fitting parts ①.

Note: Unhook the fitting parts by bending the hooks in the upward direction.

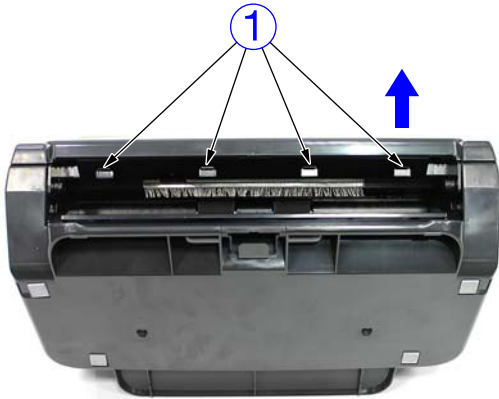

Figure 3-103

4. Lower Cover

- 1) Use a tool with thin and flat edge to unhook the 4 pairs of fitting parts ① (2 each on the left and right sides), and remove the lower cover ② while opening the gap between the lower cover and base unit.



Figure 3-105

- 2) Open the front unit, unhook the 2 fitting parts ①, and then remove the upper cover ②.

Note: When you remove the upper cover, the lock lever shaft and the coil spring on the inside, and the feed selection lever may become detached. Also, the Job No. indicator may be detached.

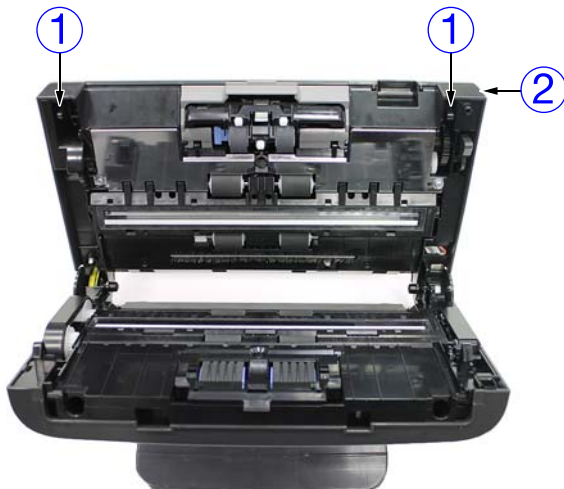

Figure 3-104

II. FRONT UNIT

1. Sub PCB

- 1) Remove the upper cover.
([Page 3-2](#))
- 2) Detach the feed selection lever ①, and then remove the lock lever shaft ② and two coil springs ③ (large and small).

Note:The document sensor lever attached to the lock lever shaft is hooked on the document stopper and should be unhooked.

Note:Do not stretch the hooks of the coil spring (small) too much.

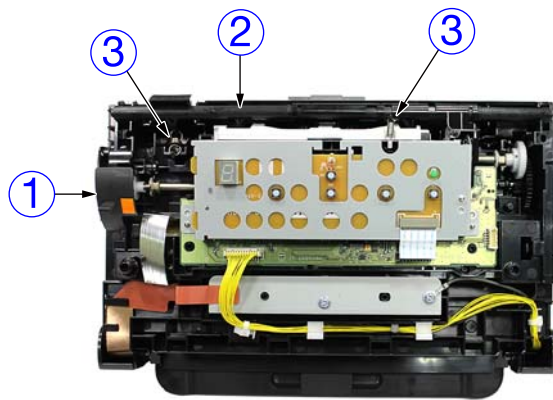

Figure 3-201

- 3) Disconnect the connector ①. Next, unhook the 4 pairs of fitting parts ② while tilting the PCB unit ③ toward you. It is easy to unhook the upper metal fitting parts first. Next, unhook the 3 pairs of fitting parts ④ while removing the PCB unit.

Note:The coil spring is mounted inside the upper part.

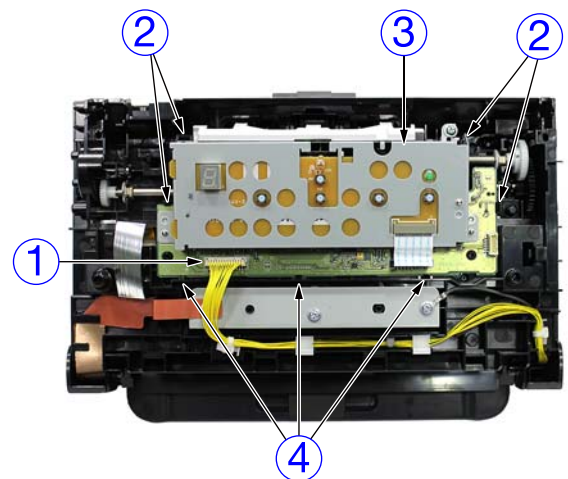

Figure 3-202

- 4) Remove the 2 screws ① (BH, M3) and remove the sub PCB ②. Remove the connector from the reverse side.

raised parts.

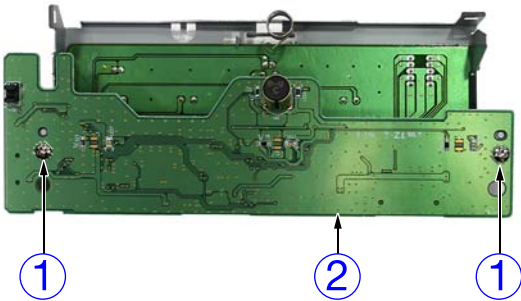

Figure 3-203

◆ **Notes on assembling**

You should attach the screws after inserting the 2 protrusions on the mounting plate into the holes for setting the position on the sub PCB.

Attach the coil spring to the PCB assembly from the straight end so that the straight end is facing the sub PCB. If the coil spring is attached in the opposite direction, the document stopper will not move up and the document will not be fed.

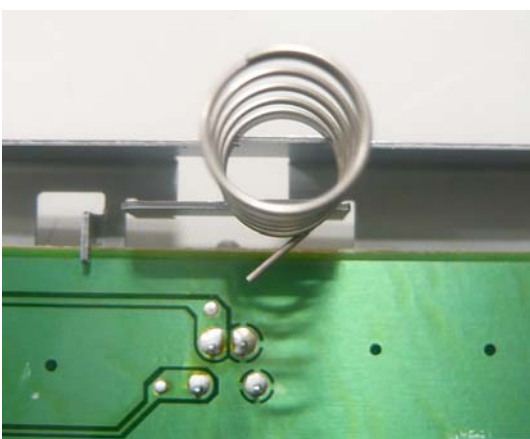

Figure 3-204

When mounting the PCB unit on the base, all of the fitting parts should be fully seated. There should not be any

2. Stop Cam Drive Unit

- 1) Remove the PCB unit.
Refer to "1. Sub PCB".
(Page 3-3)
- 2) Remove the 2 screws ① (M3, self-tapping). Next, detach the retaining ring ② and slide the bearing ③ in the direction of the arrow. Next, remove the cam on the left side of the stop cam drive unit ④ while removing it from the bottom of the pickup arm unit ⑤.

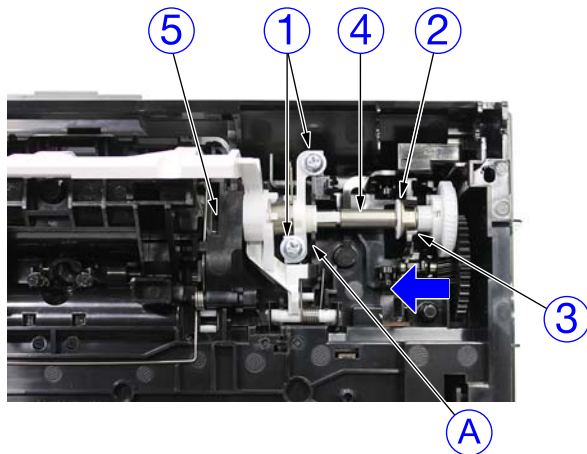

Figure 3-205

◆ Notes on assembling

The cam should be mounted between the pickup arm unit and the document stopper unit.

While tightening the screw ①, press the bearing part ④ to prevent the bearing part ④ of the stop cam drive unit moves in the rotation direction of the screw.

3. Upper Drive Unit

- 1) Remove the stop cam drive unit.
(Page 3-5)
- 2) Unhook the 4 pairs of fitting parts ①, then remove the document stopper unit ②. Next, slide the separation float unit ③ to the right while pulling it upward to remove it. Next, unhook the 2 pairs of fitting parts ④ and remove the pickup arm unit ⑤. It is easy to unhook the left fitting part first.

Note:The torsion spring that fits into the document stopper unit may become detached.

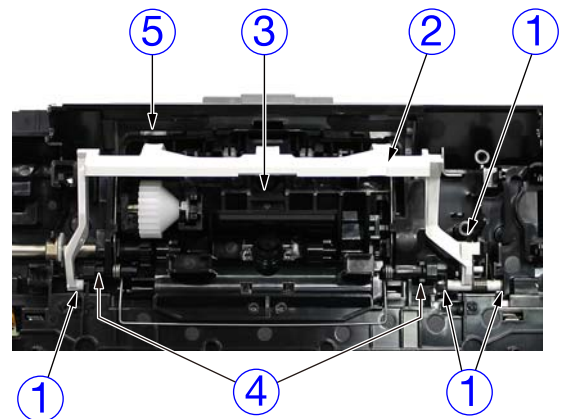

Figure 3-206

- 3) Detach the 2 retaining rings ①, slide the bearing ② in the direction of the arrow, and then detach the upper drive unit ③.

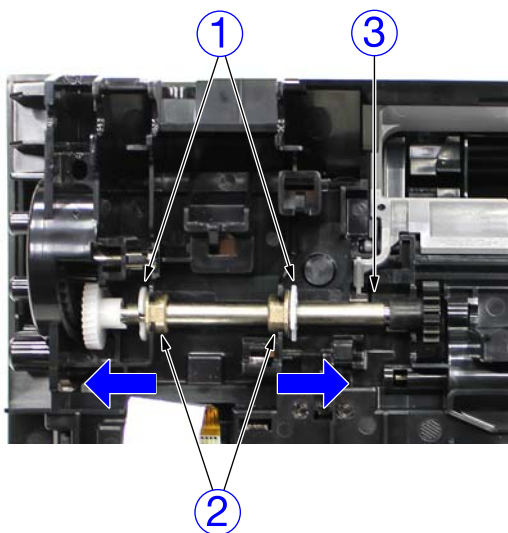

Figure 3-207

◆ **Notes on assembling**

When mounting the document stopper unit, fit the torsion spring into the shape of the upper frame as shown in the below figure.

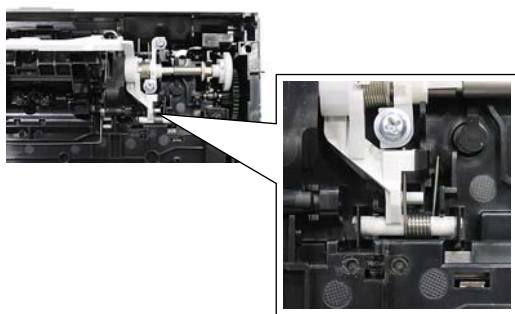

Figure 3-208

4. Front Unit

- 1) Remove the upper cover. [\(Page 3-2\)](#)
- 2) Remove the 2 screws ① (M3, self-tapping) and detach the 2 connectors ②. Next, release the 2 cable holders ③ (reusable type) and the 2 cable holders ④, and then free the cable ⑤ from the front unit ⑥.

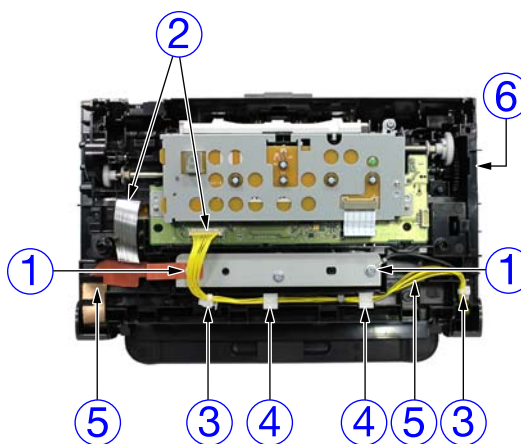

Figure 3-209

- 3) Open the front unit ① and unhook the left fitting part ② while bending it by the tool with thin and flat edge. Next, unhook the right fitting part ③, and then remove the front unit.

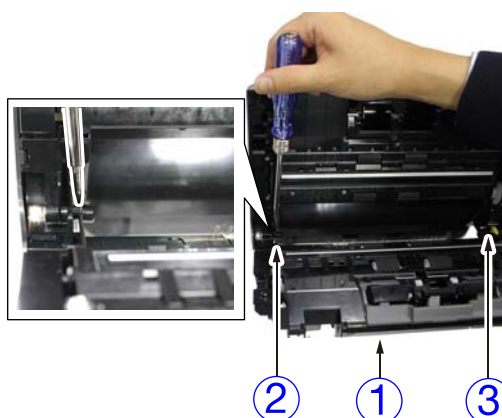

Figure 3-210

5. Upper Feed Guide Plate

- 1) Remove the upper reading unit.
(Page 3-16)
- 2) Remove the 2 screws ① (M3, self-tapping). Unhook the center fitting part ② by using the tool with the thin and flat edge, pull the lower side of the upper feed guide plate ③ toward you, release the plate from the 4 fitting parts ④, and then remove the plate.

Note: To unhook the central fitting part ②, bend the part upward by using the tool with thin and flat edge.

Do not damage the light guide by the edge of the upper feed metal plate.

All of the fitting parts should be fully seated.

There should not be any raised parts.

If the upper feed guide plate is largely deformed and cannot be return to the original shape, a malfunction may occur in the feeding process. In that case, correct the deformation of the upper feed guide plate, or replace it with a new one.

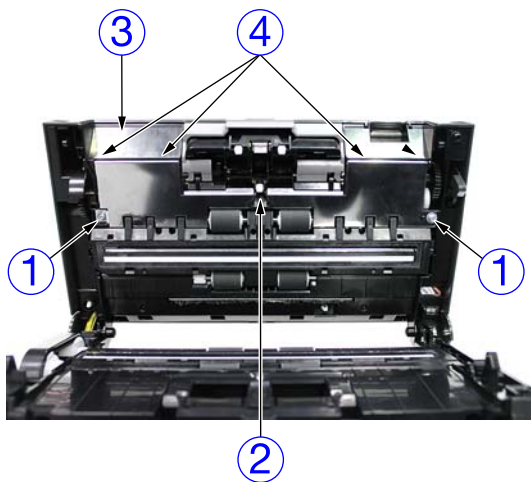

Figure 3-211

◆ Notes on assembling

You should attach the screws after inserting the upper frame protrusion ① positioned to the left of the right side screw ① into the hole for setting the position on the upper feed guide plate.

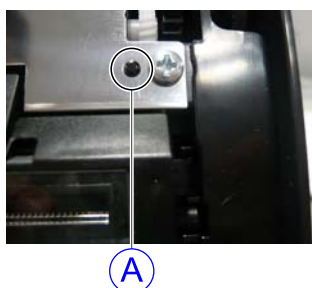

Figure 3-212

6. Registration Roller (Follower)

Note:The parts of the registration roller (follower) and the eject roller (follower) are the same (roller, shaft, shaft holder, coil spring).

- 1) Remove the upper feed guide plate.
[\(Page 3-7\)](#)
- 2) Remove the PCB unit.
[\(Page 3-3\)](#)
- 3) Unhooking the 2 fitting parts ① at the same time detaches the follower roller (2 rollers ②, shaft ③, and shaft holder ④) and the coil spring ⑤ in the rear side.

◆ Notes on assembling

Attach the coil spring so that the bending end is facing the frame.

The end of the coil spring should touch the central flat side of the axle.

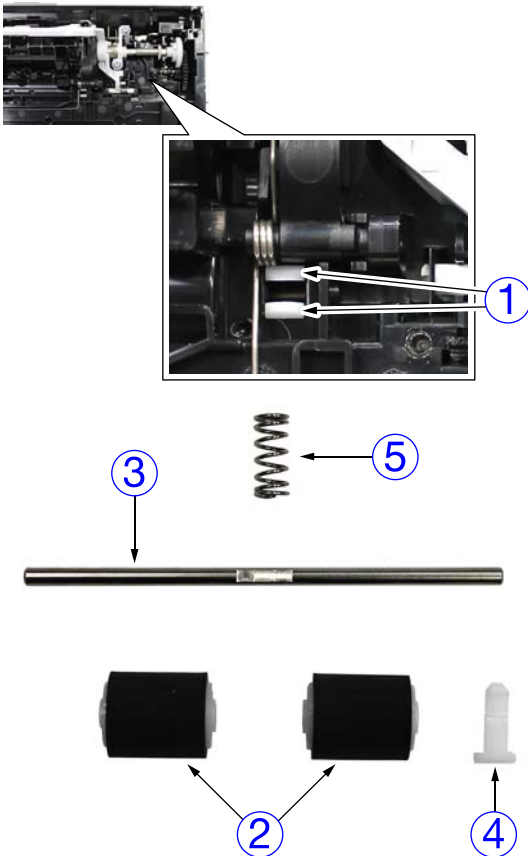

Figure 3-213

7. Eject Roller (Follower)

- 1) Remove the upper cover.
(Page 3-2)
- 2) Disconnect the connector ①, remove the 3 screws ② (M3, self-tapping), and then remove the metal plate ③ (with a static eliminator).

The end of the coil spring should touch the central flat side of the axle.

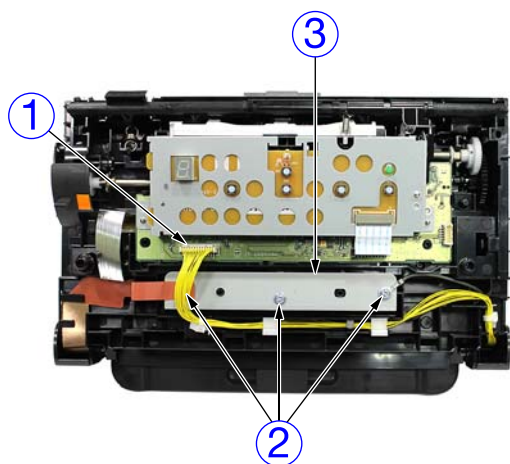

Figure 3-214

- 3) Unhooking the 2 fitting parts ① at the same time detaches the follower roller and the coil spring (Figure 3-213 ② to ⑤) in the rear side.

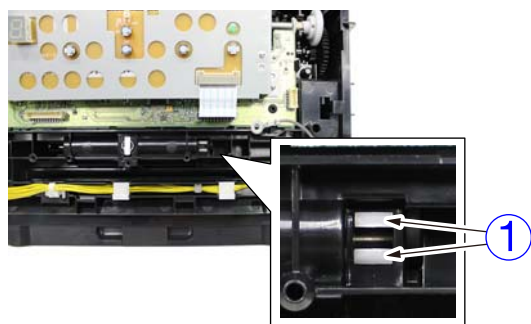

Figure 3-215

◆ Notes on assembling

The metal plate (with a static eliminator) should be attached to the coil spring before attaching the coil spring.

Attach the coil spring so that the bending end is facing the frame.

III. BASE UNIT

1. Control PCB

- 1) Remove the lower cover.
(Page 3-2)
- 2) Put the main unit on its side, remove the 4 screws ① (BH, M3), and then open the mounting plate ② (with PCB) by rotating it toward you.

Note:A cable is connected to the rear side of the mounting plate, and should not be pulled too much.

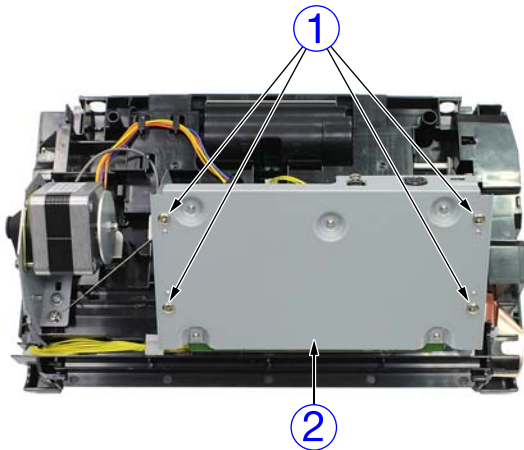

Figure 3-301

- 3) Disconnect the 4 connectors ①, and detach the mounting plate ② (with PCB).

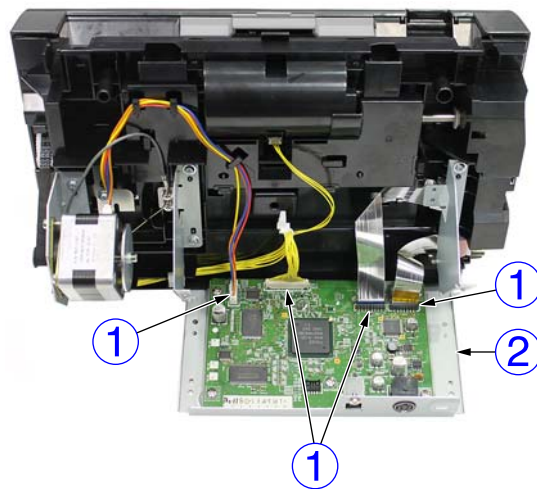

Figure 3-302

- 4) Remove the 2 screws ① (M3, with 2 washers), and then remove the main motor ② and timing belt ③.

Note:You should also remove the screw for USB on the side.

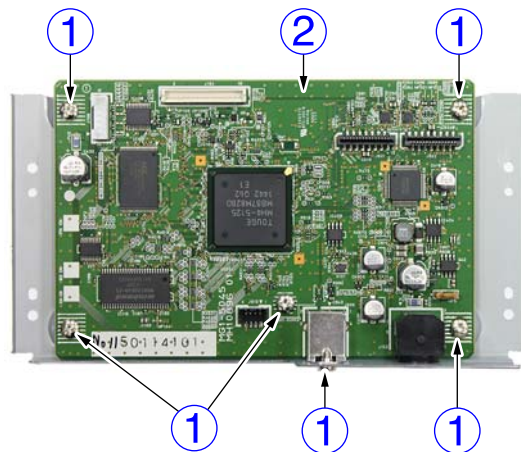

Figure 3-303

2. Main Motor

- 1) Remove the mounting plate (with PCB).
(Page 3-10)
- 2) Open the front unit, slide the pulley cover ① in the direction of the arrow to remove it from the 2 fitting parts ②. It is easy to unhook the lower fitting part first.

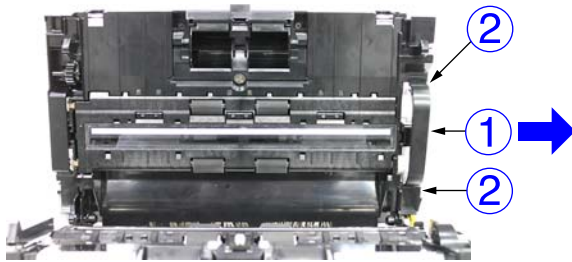

Figure 3-304

- 3) Remove the screw ① (M3, with 2 washers), and then disconnect the cable ② from the dust cover.

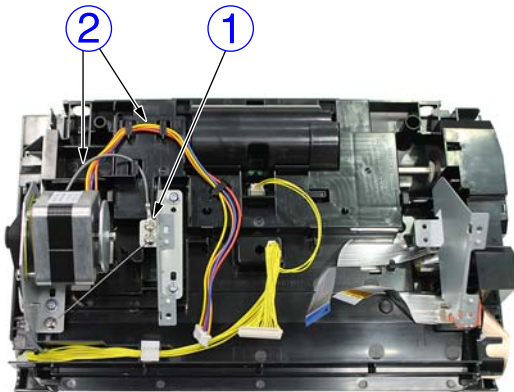

Figure 3-305

- 4) Remove the 2 screws ① (M3, with 2 washers), and then remove the main motor ② and timing belt ③.

Note:To adjust the belt tension correctly, mark the long hole ① position by using a pen before starting the work.

Note:The motor is assigned as service parts with a cable attached.

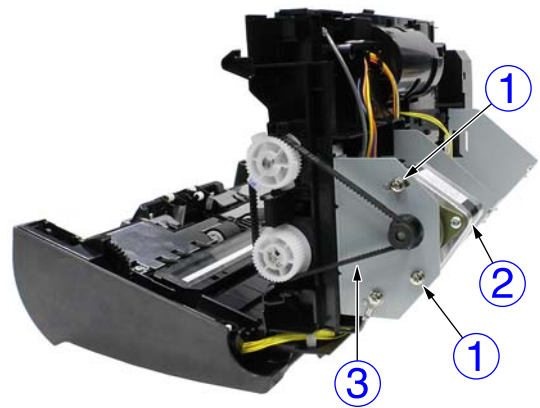

Figure 3-306

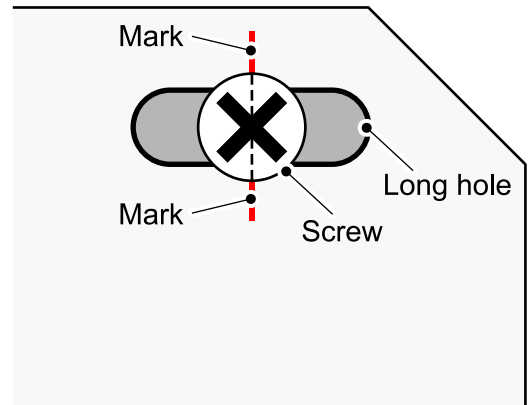

Figure 3-307

◆ Notes on assembling

If the belt tension is too weak, skipping of the gear teeth may occur, and if the belt tension is too strong, motor step-out may occur. Therefore to adjust the belt tension correctly, tighten the screw at the position that you marked during disassembly.

To adjust the tension with high precision,

mount the belt, tighten the round hole and long hole screws until the main body is no longer wobbly, and then close the front unit. Next, lay down the front unit, attach the hook of the tension gauge to the head of the long hole screw, pull the gauge in the direction of the arrow, and tighten the screws at the position where the gauge indicates 1 kgf.

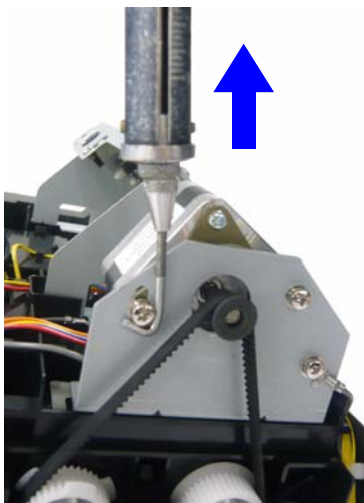

Figure 3-308

3. Eject Roller (Drive)

- 1) Remove the lower cover.
(Page 3-2)
- 2) Remove the lower reading unit.
(Page 3-18)
- 3) Slide the left and right pulley cover ① in the direction of the arrow to remove it from the 4 fitting parts ②.



Figure 3-309

- 4) Remove the timing belt ①, remove the 2 retaining rings ②, and then remove pulley ③ and washer ④. Next, slide the left and right bearings ⑤ in the direction of the arrow to detach them, and detach the eject roller (drive) ⑥.

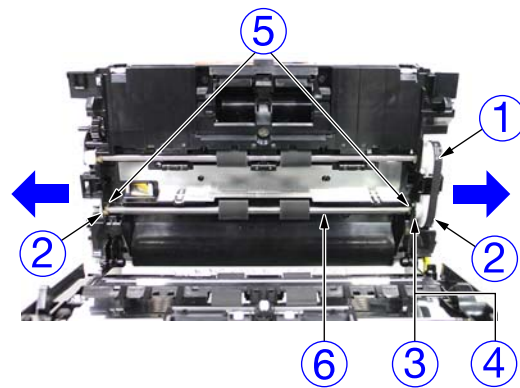

Figure 3-310

◆ Notes on assembling

The bearings should be mounted to match the shape of the frame.

4. Registration Roller (Drive)

- 1) Remove the timing belt.
Refer to "Eject Roller (Drive)".
[\(Page 3-9\)](#)
- 2) Remove the screw ① (M3, self-tapping), and then detach the fixing board ②.

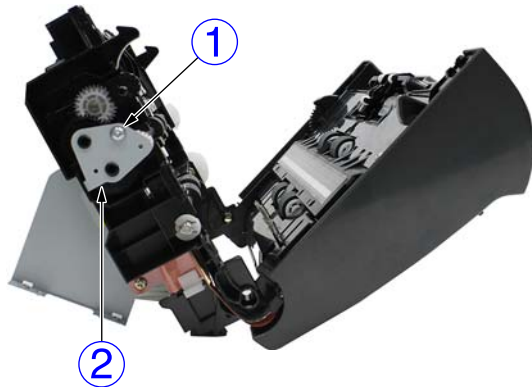

Figure 3-311

- 3) Remove the flange ①, and then remove the gear ② (small). Next, remove the 2 gears ③ (large).

Note:The gear (small) is press-fitted into the shaft

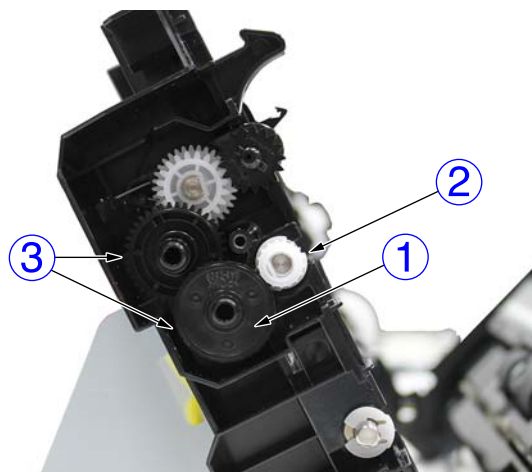

Figure 3-312

- 4) Remove the 2 retaining rings ①, and then remove the pulley ②. Next, slide the left and right bearings ③ in the direction of the arrow to detach them, and detach the registration roller (drive) ④.

Note:When detaching the registration drive roller, the central bearing may become detached. Do not lose it because it is a small part.

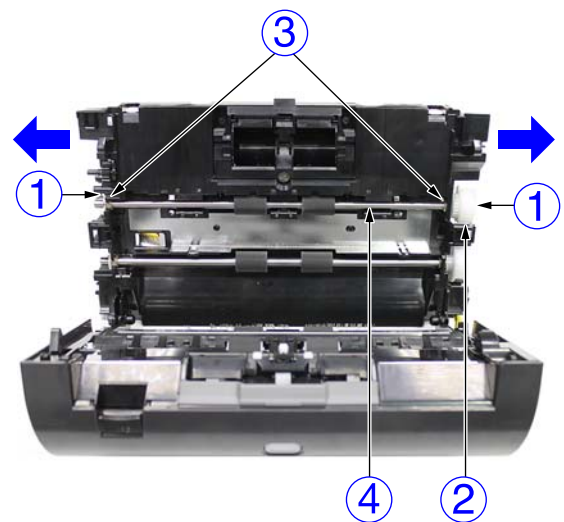

Figure 3-313

◆ Notes on assembling

The bearings should be mounted to match the shape of the frame.

5. Dust Cover

- 1) Remove the mounting plate (with PCB).
[\(Page 3-10\)](#)
- 2) Remove the connector ①, the screw (M3, with 2 washers) ②, and disconnect each of the cables from the dust cover ③.
Next, use a tool with thin and flat edge to disengage the 6 fittings ④, and then remove the dust cover.

Note: Once you remove the dust cover, you will be able to access and remove the ultrasonic drive PCB.

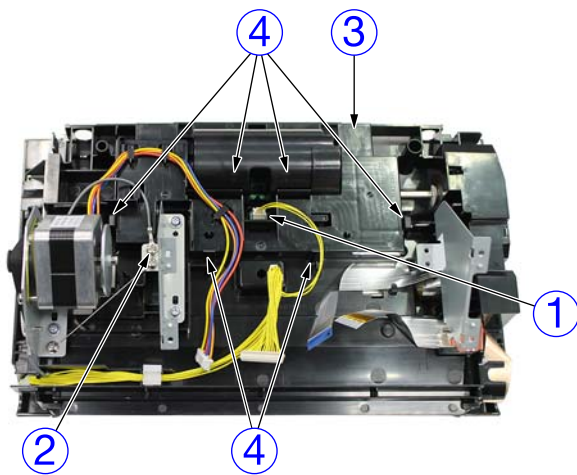

Figure 3-314

◆ Notes on assembling

Attach the ultrasonic drive PCB first. All of the fitting parts should be fully seated. There should not be any raised parts. The cable holder should be inserted in the original position and the cable should be positioned to align with the cable guide.

6. Separation Mount

- 1) Remove the dust cover.
[\(Page 3-14\)](#)
- 2) Remove the fixing board, the flange, and the gears (one small gear and two large gears).
Refer to "Registration Roller (Drive)".
[\(Page 3-13\)](#)
- 3) Remove the torsion spring ① from the fitting part ②, and then detach the gear ③ and the separation mount assembling ④.

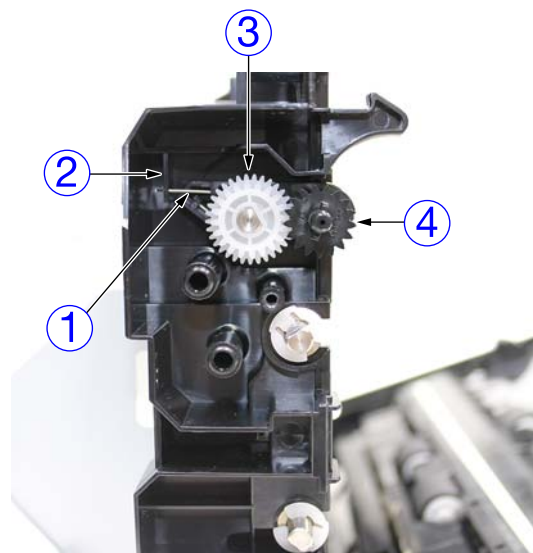

Figure 3-315

- 4) Unhooking the 2 fitting parts ① removes the torsion spring from the separation mount assembling ②.

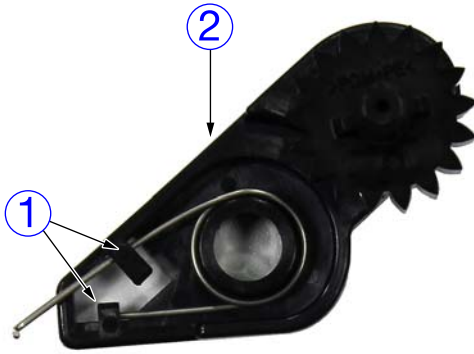

Figure 3-316

◆ **Notes on assembling**

When mounting the separation mount assembling, hook the torsion spring so that it fits into the frame.

IV. READING UNIT

1. Upper Reading Unit

Note:The shapes of the reading guides for the upper reading unit and the lower reading unit are different.

- 1) Insert a tool with thin and flat edge into the left and right holes ①, and lift up the upper reading unit ② a little bit using the tool while detaching the inside fitting parts. Next, remove the upper reading unit by pulling it straight up.

Note:A cable is connected to the rear side of the upper reading unit, and should not be pulled too much.

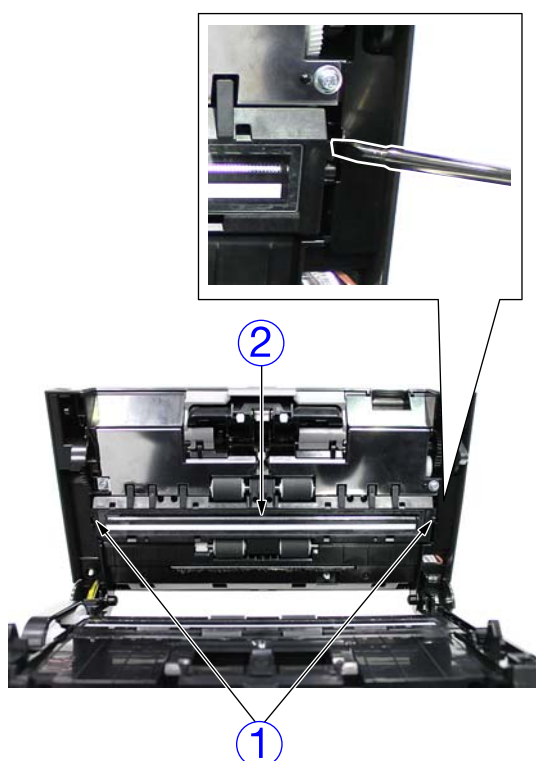

Figure 3-401

- 2) Remove the connector ①, and remove the upper reading unit ②.

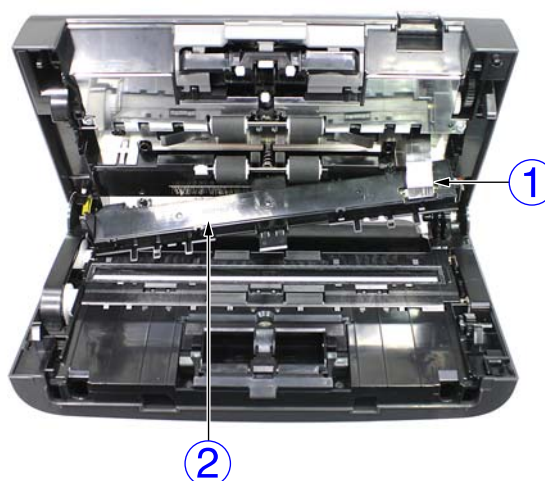

Figure 3-402

◆ Notes on assembling

After connecting the cable, and then attach the upper reading unit while pushing the cable inside of the upper frame.

Check if the upper reading unit move smoothly when the unit is attached. If it does not move smoothly, attach it again.

2. Upper Reading Guide

Note: This component has the reading glass and white reference sheet mounted on it. This component should not be disassembled unless necessary because once the component has been removed, there is a risk of dust getting inside the reading unit.

When disassembling, be careful with dusts and do not touch the inner surface of the glass or the surface of the lens array.

- 1) Remove the upper reading unit.
([Page 3-16](#))
- 2) Using a tool with thin and flat edge, detach the 8 pairs of fitting parts ①, and remove the case ②. Next, remove the CIS unit from the upper reading guide ③.

Note: Detach the fitting parts without damaging the hooks. When removing the case, do not drop the CIS unit and dustproof rubber because they are detached.

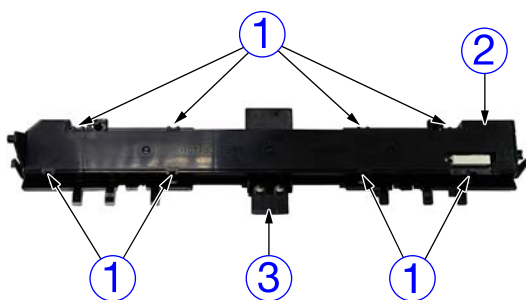

Figure 3-403

◆ Notes on assembling

The hooks of the fitting parts should not be raised or have gaps.

With the sponge side of the dustproof rubber facing down, attach the dustproof rubber by fitting it into the CIS unit connector. The figure below shows how to assemble them.

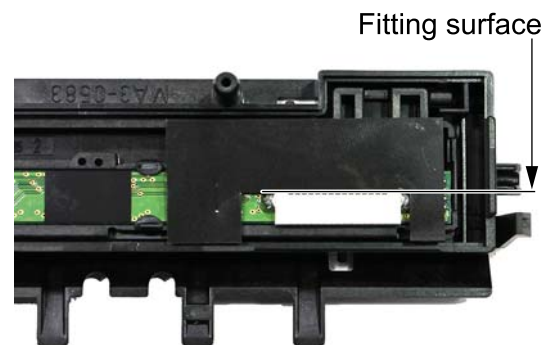

Figure 3-404

3. Lower Reading Unit

Note:The shapes of the reading guides for the upper reading unit and the lower reading unit are different.

- 1) Insert a tool with thin and flat edge into the left and right holes ①, and lift up the lower reading unit ② a little bit using the tool while detaching the inside fitting parts. Next, remove the lower reading unit by pulling it straight up.

Note:A cable is connected to the rear side of the lower reading unit, and should not be pulled too much.

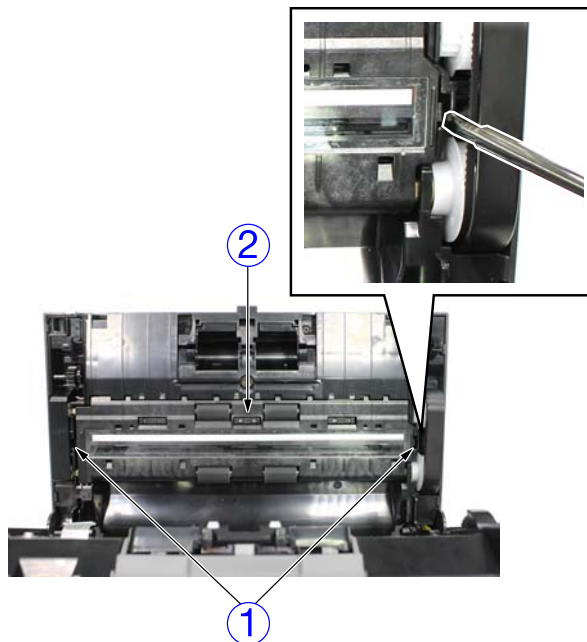

Figure 3-405

- 2) Remove the connector ①, and remove the lower reading unit ②.

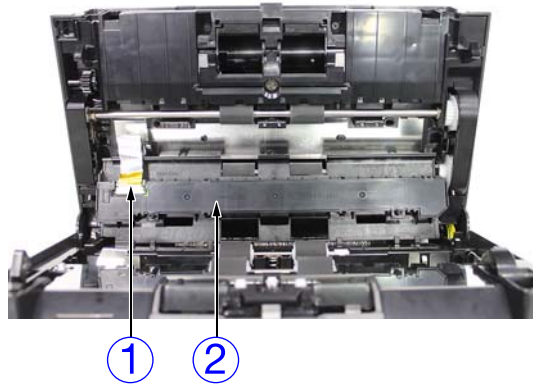

Figure 3-406

◆ Notes on assembling

After connecting the cable, and then attach the lower reading unit while pushing the cable inside of the frame.

4. Lower Reading Guide

Note: This component has the reading glass and white reference sheet mounted on it. This component should not be disassembled unless necessary because once the component has been removed, there is a risk of dust getting inside the reading unit.

When disassembling, be careful with dusts and do not touch the inner surface of the glass or the surface of the lens array.

- 1) Remove the lower reading unit.
(Page 3-18)
- 2) Using a tool with thin and flat edge, detach the 8 pairs of fitting parts ①, and remove the case ②. Next, remove the CIS unit from the lower reading guide ③.

Note: Detach the fitting parts without damaging them. When removing the case, do not drop the CIS unit and dustproof rubber because they are detached.

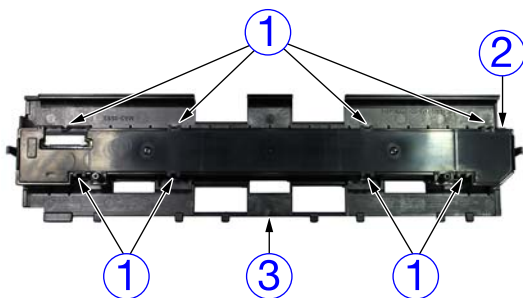

Figure 3-407

◆ Notes on assembling

The hooks of the fitting parts should not be raised or have gaps.

With the sponge side of the dustproof rubber facing down, attach the dustproof rubber by fitting it into the reading guide and the CIS unit connector. The figure below shows how to assemble them.

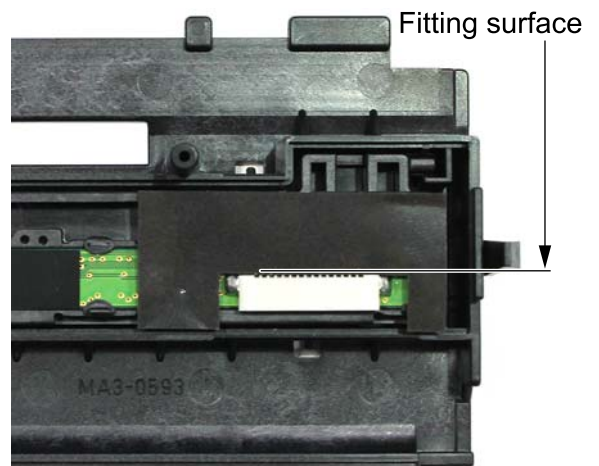

Figure 3-408

CHAPTER 4

INSTALLATION & MAINTENANCE

I. INSTALLATION	4-1	III. MAINTENANCE	4-6
II. PARTS TO BE REPLACED	4-4		

I. INSTALLATION

This machine is installed by the user. The user should be advised to install the scanner by reading the Setup Guide thoroughly. This section gives an overview of the procedure. For details, refer to the user manual.

1. System Requirements

The recommended system is as follows.

1) Computer

CPU: Intel Core 2 Duo 1.66GHz or higher

Memory: 1 GB or more

Hard disk: 3GB or more space

USB interface: Hi-speed USB 2.0

Monitor: Resolution 1024 x 768 (XGA) or higher

Optical drive: Able to read DVDs

2) OS

Microsoft Windows Vista (32/64 bit edition)

Microsoft Windows 7 (32/64 bit edition)

Microsoft Windows 8 or 8.1 (32/64 bit edition)

Microsoft Windows Server 2008 R2

Microsoft Windows Server 2012 R2

Note: For details on each version, refer to the "User Manual".

2. Checking the Accessories

Open the package, and take out the main body and its accessories.

- ① Main body
- ② Document feed tray
- ③ USB cable
- ④ AC adapter
- ⑤ Power cord
- ⑥ Setup Guide
- ⑦ Setup disk
- ⑧ Warranty, etc. (depends on the shipping region)
- ⑨ Carrier sheet

3. Document Feed Tray and Packing Material

Install the document feed tray, and remove all of the tape and protective material that is attached to the main body.

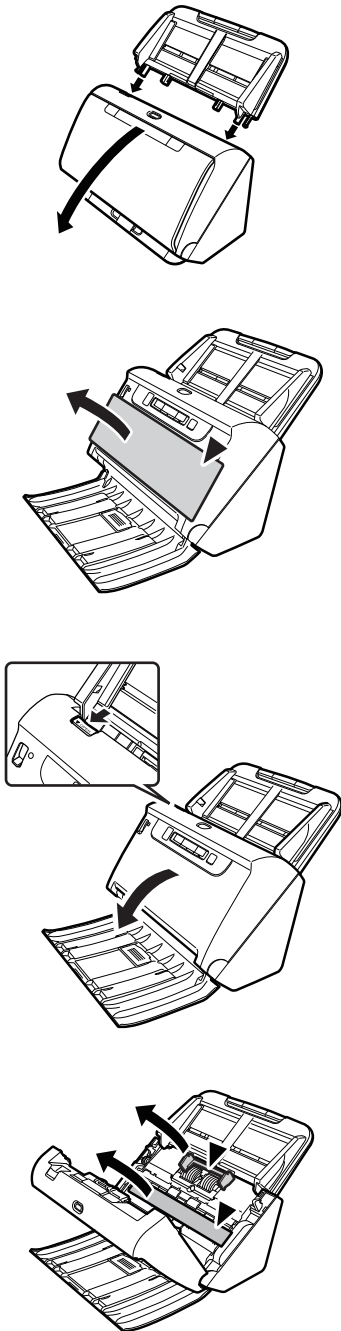

Figure 4-101

4. Installing the Software

Install the software from the included setup disk that is required in order to use the scanner.

Note: The software should be installed before connecting the machine to a computer.

The following shows an outline of the installation on Windows.

- 1) Login using an account with Administrator privileges.
- 2) Before installing the software, exit all other applications.
- 3) Load the setup disk into the DVD drive of the computer.
- 4) The setup menu starts automatically.
- 5) Click [Typical Installation].

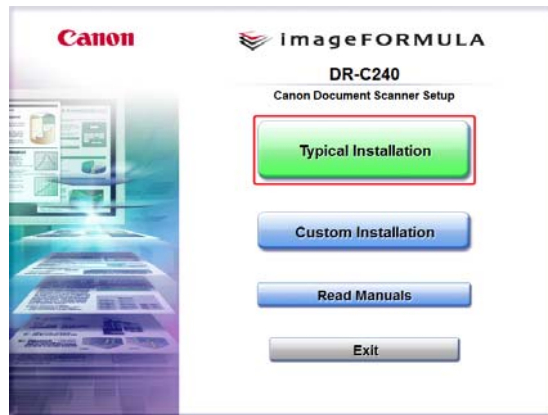

Figure 4-102

Finish the installation by following the on-screen messages.

5. Connecting to a Computer

Note: Always use the power cord and AC adapter supplied with the machine.

- 1) Connect the power cord to the AC adapter.
- 2) Insert the plug from the AC adapter into the connector on the main body, and connect the power cord to the outlet.
- 3) Check that the power switch of the machine is off. If the power is on, turn it off.
- 4) Connect the machine and the computer using the included USB cable.

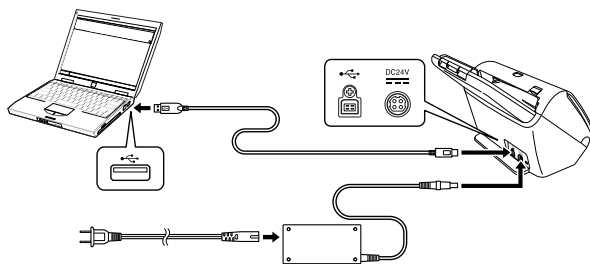

Figure 4-103

6. Power On

Press the power button. The power button lights when the power turns ON.

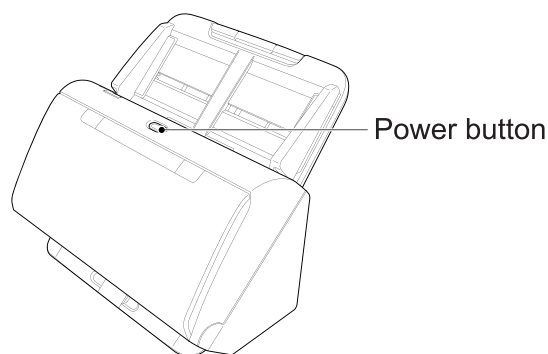

Figure 4-104

When you turn this machine connected to the computer ON, the plug-and-play function recognizes this machine, and the device driver is automatically installed.

The preparation is now complete. Check whether scanning is really performed. Refer to the "User Manual" for the details.

Note: To turn the power OFF, hold down the power button until the light goes off.

II. PARTS TO BE REPLACED

1. Periodically Replaced Parts

This machine does not have any periodically replaced parts.

2. Consumable Parts

1) Parts replaced by users

No.	Parts name	Parts number	Expected life	Remarks
1	Feed roller	MG1-5073-000	200,000 sheets	Because of the worn rollers, it is necessary to replace when the feed error are occurred after cleaning.
2	Retard roller	MG1-4620-000		

Note: The items above are assigned as service parts and an exchange roller kit is assigned as commercially available products for a set.

Table 4-201

2) Replaced by service technicians

None

3. Major Parts List

The list below shows the major service parts, except for the parts replaced by users.

Refer to the “Parts Catalog” for the details.

No.	Parts name	Parts number	Q'ty	Remarks
1	Control PCB	MG1-5045-000	1	
2	Sub PCB	MG1-5046-020	1	
3	Upper Reading Unit	MG1-8328-000	1	Includes reading guide
4	Lower Reading Unit	MG1-8329-000	1	
5	Upper Reading Guide	MF1-4876-000	1	A reading glass attached
6	Lower Reading Guide	MF1-4878-000	1	A reading glass attached
7	Main motor	MG1-5065-000	1	
8	AC adapter	MG1-4558-000	1	Other than China
9	AC adapter (China)	MG1-4892-000	1	China only

Table 4-202

III. MAINTENANCE

1. User Maintenance

Refer to the "User Manual" for the details.

1) List

[△:Clean, ●: Replace]

No.	Location/ Parts	Intervals		Details
		As necessary	200,000 sheets	
1	Main body	△		Use a cloth slightly dampened with water and well wrung out to remove any dirt, and then use a clean, dry cloth to wipe the main body.
2	Reading glass	△		Use a soft, clean, and dry cloth to wipe off any dirt.
3	Retard roller	△	●	Use a cloth slightly dampened with water and well wrung out to remove any dirt, and then use a clean, dry cloth to wipe the main body. Note: Remove the retard/feed roller from the main body before cleaning.
4	Feed roller	△	●	
5	Other rollers	△		
6	Feed path	△		Use such as air blowers to remove any dust and paper particles that have accumulated on the feed path.

Table 4-301

2) Locations to be cleaned

- Reading glass
- Roller

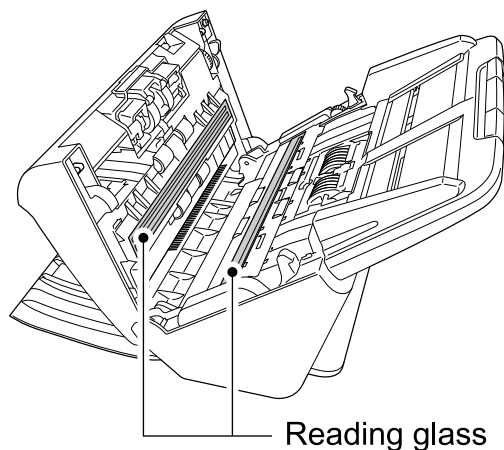

Figure 4-301

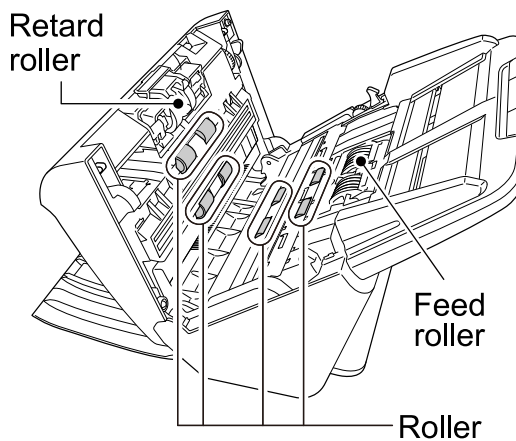

Figure 4-302

3) Replace Rollers Display

Once the number of sheets fed exceeds the guide for replacement of 200,000 sheets, a screen displaying the message [Replace Rollers] is displayed the next time the computer recognizes the machine.

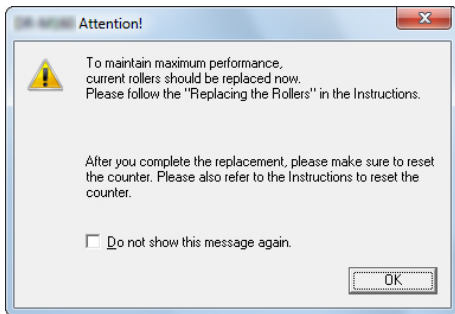

Figure 4-303

4) Method for Replacing Rollers

◆ Feed roller

Open the roller cover and remove the roller. Then assemble the new roller with the stopper on the left side facing the correct way.

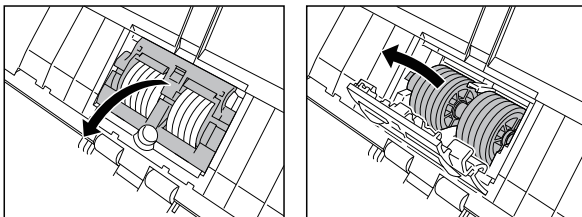

Figure 4-304

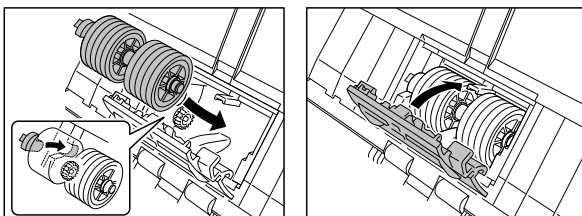

Figure 4-305

◆ Retard roller

Open the roller cover and remove the roller by pulling the lever. Then assemble the new roller by inserting the gear side to the main body first.

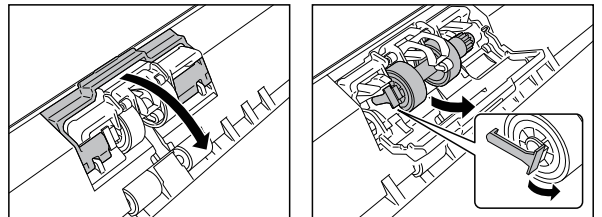

Figure 4-306

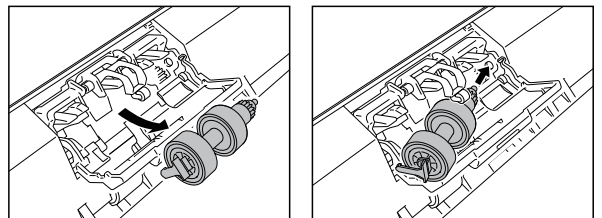

Figure 4-307

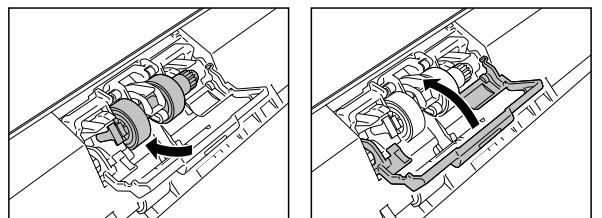

Figure 4-308

5) Resetting after replacement

The counters need to be reset after replacing the rollers. The following shows the method for doing this.

- Start Windows, and login with administrator privileges.
- Click the [Start] button on the computer, and then click [All Programs], [Canon DR-C240], and [Canon imageFORMULA Utility] in order.

Note:For Windows 8.1 and 8, the application is registered in the following location.

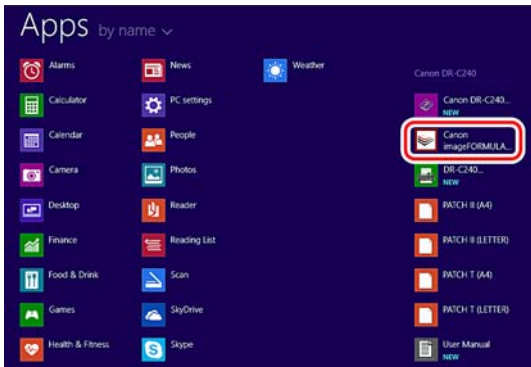

Figure 4-309

- The [Canon imageFORMULA Utility] starts, and the screen is displayed.
- Select [Canon DR-C240 USB] and then click [Properties].

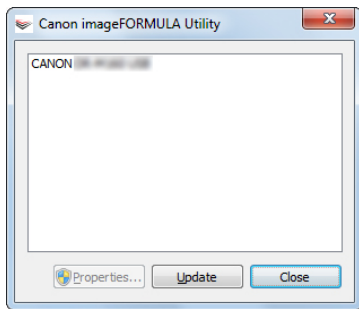

Figure 4-310

- On the next screen, click the [Maintenance] tab. Next, click [Reset].

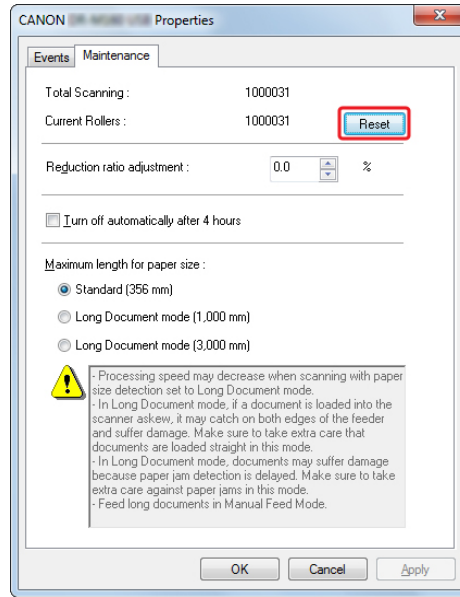

Figure 4-311

- Click [OK] and then close the property.

2. Service Maintenance

For this machine, no periodical maintenance item by the service technicians is specified.

However, when visiting a user, check whether the reading glasses and the rollers are dirty. If they are very dirty, instruct the user to follow the “user maintenance” procedures. Recommend the user to replace consumable parts if necessary. Furthermore, remove the cover, check that there is no paper dust or other foreign matter inside the main body, and then perform cleaning.

CHAPTER 5

TROUBLESHOOTING

I. ERROR DISPLAY	5-1	IV. OPERATION TROUBLESHOOTING	5-29
II. SERVICE MODE.....	5-2	V. IMAGE TROUBLESHOOTING.....	5-33
III. TROUBLESHOOTING LIST	5-28	VI. AFTER REPLACING PARTS	5-38

I. ERROR DISPLAY

1. Main Body

If an error occurs, the error is indicated by the power button and the Job No. display on the main body's control panel. The error indications are described below.

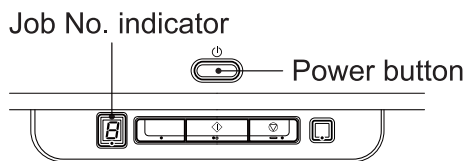

Figure 5-101

◆ Power button

Display	Details
On	Power On
Blinking (0.5 times/sec.)	Sleep mode
Blinking (2 times/sec.)	Error

Table 5-101

◆ Job No. indicator

Display	Details
[]	The front unit is open
P	A paper jam has been detected
d	A double feed was detected during scanning
E	Other errors

Table 5-102

2. Computers

Error messages are displayed on the screen of the computer connected to the machine. Each of the different pieces of software (applications, drivers, OSs) have their own unique messages which they control.

There are many user-related messages, such as when the user performs an incorrect operation. Users should resolve problems according to the error messages.

The following shows an example of an error message when using CaptureOnTouch (Windows).

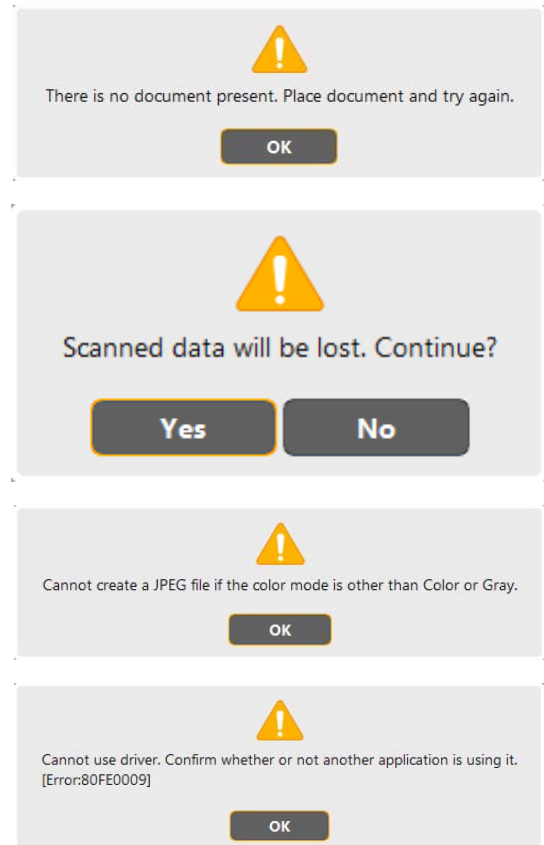

Figure 5-102

II. SERVICE MODE

1. Outline

To execute the service mode, install the software (service tool) for the service mode, which is stored in the packaged setup disc in the computer for servicing. Note that the service mode is only supported on Windows OS.

The system requirements for the computer are equivalent to those indicated in the “User Manual”. When the processing speed drops due to the CPU or memory capacity, the service mode is still available.

The service screen is shown below.

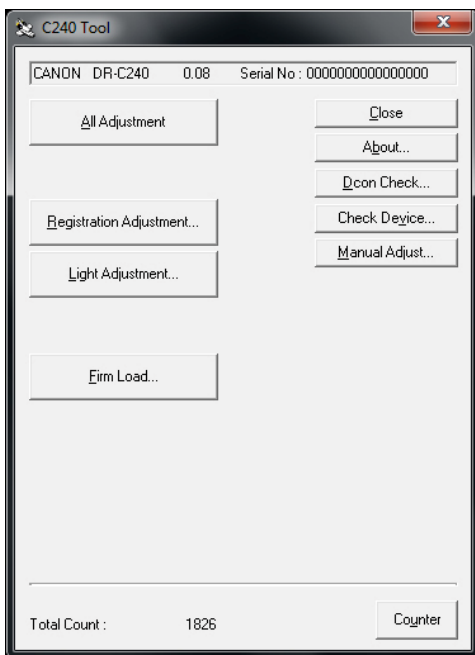

Figure 5-201

On the service screen, there are buttons to select each specified mode. Each service mode starts from this screen.

A list of the modes is shown below.

No.	Button displayed/description
1	All Adjustment Performs all adjustments of the following No.2-3, relating to image reading.
2	Registration Adjustment Performs the registration adjustment.
3	Light Adjustment Performs fine adjustments to the shading correction value.
4	Firm Load Changes the firmware.
5	About Displays the version of the service mode.
6	Dcon Check Checks operations of the hardware inside of the machine, such as an operation key, sensor, and motor.
7	Check Device Displays the versions of the internal devices. Select this button to reset the main body serial numbers or to browse the error log.
8	Manual Adjust Manually adjusts the scale and registration of images.
9	Counter Displays and updates the counters.

Table 5-201

2. How to Install

Procedure to install service tool: Never install it in the user's computer.

- 1) Turn ON the computer for servicing to start OS (Windows).
- 2) Install the setup disc packaged with this machine into the DVD drive.
- 3) An installation screen for the user is displayed, but ignore this and select the explorer of the computer.
- 4) Copy the Tools folder found in the Driver folder of the setup disk to any drive on service computer. The Tools folder contains "C240Tool.exe" and "ServiceTool.LOC".

Note: Install the driver for this machine and also install the CaptureOnTouch as necessary. Please refer to the "User Manual" on installation of them. However, when checking a specification such as the scanning speed, the system requirements for a computer described in the "User Manual" should be satisfied.

Note: Keep the name of the folder and the password confidential from the user.

3. How to Start and Finish

- ◆ How to start
 - 1) Start the computer for servicing.
 - 2) If an icon of CaptureOnTouch is displayed on the task bar, click the icon to terminate it.

Note: Refer to the "User Manual" for the details of how to operate CaptureOnTouch.

- 3) Connect the USB cable and then turn on the machine.
- 4) Run the installed file "C240Tool.exe".

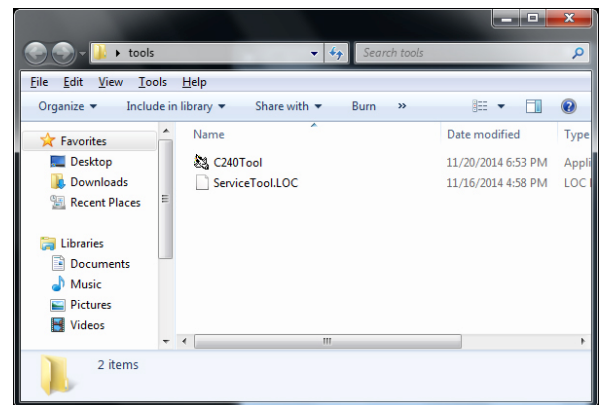

Figure 5-202

- 5) Password dialogue box appears, and enter six characters as "market" and select [OK].



Figure 5-203

- 6) Service screen appears.

Note: Do not run any other application such as CaptureOnTouch or turn off the machine while the service tool is running. If the tool becomes unresponsive, you should restart the computer.

- ◆ How to finish
Select [Close] on the service screen.

Note that if you have executed [Firm Load], you should also turn the main body power off to ensure that the firmware is overwritten reliably.

4. Registration Adjustment

This mode performs adjustments on a reading-start position and reading-end position for feed direction automatically.

If the leading- and trailing-edge positions of a scanned image are improper, perform this adjustment.

Also run this mode after replacing or reassembling the reading unit or the registration detection related part, or after replacing the control PCB recording the adjustment data. The registration sensors (post) are installed at the left, middle, and right positions of this scanner.

These 3 sensors need to be adjusted independently. To adjust the 3 registration sensors, place 3 registration adjustment sheets all at once, and feed them.

This mode and the light adjustment can be performed at the same time. For details, refer to the "All Adjustment" item.

- ◆ Adjustment sheet

You will need 3 registration adjustment sheets to execute this mode.

To create these registration adjustment sheets, use 3 sheets of the TKM-0326/0032 service tool, and draw a black line on each sheet.

Note: This adjustment is performed by calculating the offset amounts between the front leading edge registration on the registration adjustment sheets and the front trailing edge and back leading edge. The black lines are drawn so that they can be used to detect the trailing edge position of the front surface. The offset amounts of the front trailing edge and back leading edge are calculated from the front and

back trailing edge position, but if a black line shows through to the back surface, the back trailing edge position cannot be detected correctly, the front/back offset amounts cannot be calculated, and the registration roller cannot be adjusted.

The use of white copy paper and recycled paper that are generally available is therefore prohibited.

1) How to create the sheets

Blacken the trailing edge of TKM-0326/0332 with a black pen. Use the sheet after the ink has dried. Do not use a pencil.

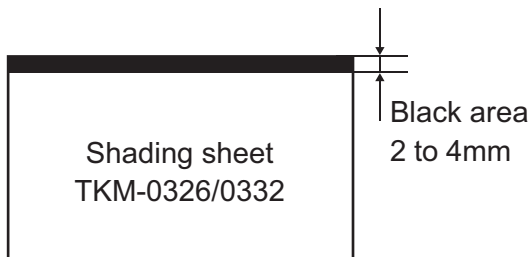

Figure 5-204

◆ Operation Procedure

- 1) Clean the feed path, roller, and reading glass.
- 2) Fully extend the document guides, and then place the 3 registration adjustment sheets.

Place each of the 3 sheets so that the black line is at the trailing edge of the front side, and align the sheets neatly.

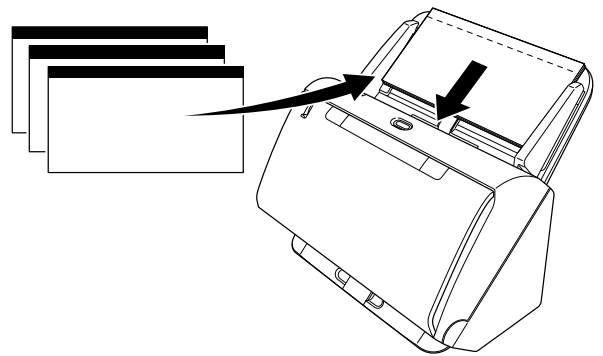

Figure 5-205

Note: Do not place extra sheets.

- 3) After placing the 3 sheets, select [Registration Adjustment] on the service screen.

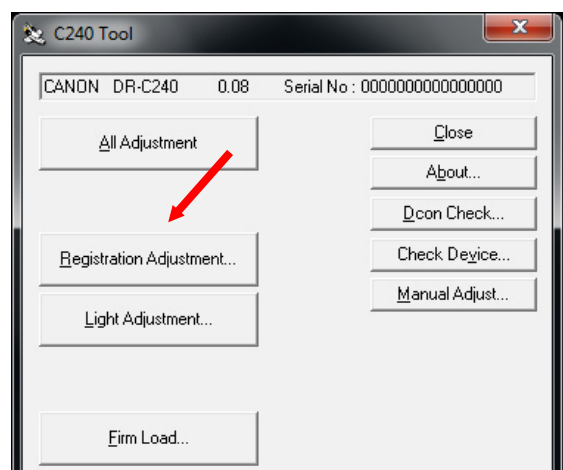

Figure 5-206

- 4) Adjustment is started automatically, and the progress screen is appeared.

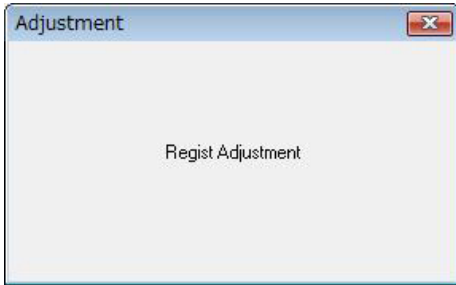

Figure 5-207

- 5) The 3 sheets you set are being fed. When finished, the progress screen is disappeared, and it returns to the service screen.
- 6) To check whether the registration has been performed, scan the test sheet provided in the TKM-0271 service tool and check the registration position. If you want to also perform fine adjustment, see 9-c Manual Registration Adjustment.
- 7) If an abnormal value is detected during the adjustment because of contamination or marks on the registration adjustment sheets, the screen shown in Figure 5-208 appears. Clean the reading glass, change the registration adjustment sheets to clean ones, and repeat adjustment.

Note: Do not follow the direction indicated with X in the market.

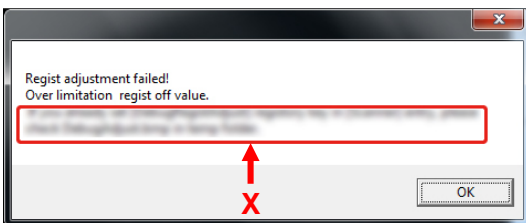

Figure 5-208

- 8) If a paper jam occurs during the adjustment because of the document setting position, the screen shown in Figure 5-209 appears. Remove the registration adjustment sheets, set the 3 registration adjustment sheets again, and repeat the adjustment.

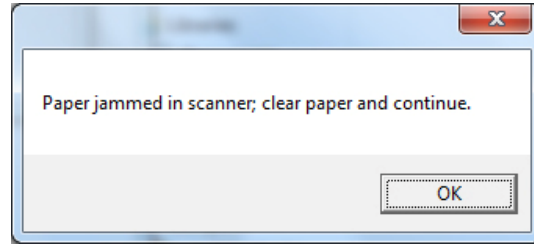

Figure 5-209

5. Light Adjustment

This mode performs fine adjustments on the shading correction values since the reading point differs between the white reference sheet inside of the reading unit and the actual document.

If the scanned image quality is degraded, perform this adjustment. Also perform this adjustment after replacing the reading unit or after replacing the control PCB recording the adjustment data.

This mode and the registration adjustment can be performed at the same time. For details, refer to the “All Adjustment” item.

◆ Adjustment sheet

The shading sheet is required to execute this mode. Use TKM-0326 or TKM-0332, which is the same shading sheet as the one used for others. Do not use a sheet with any dirt or creases.

◆ Operation Procedure

- 1) Clean feed path, roller, and reading glass.

- 2) Open the document guides fully extended, then place a shading sheet you prepared to fit the width between the document guides.

Note: Do not place extra sheets.

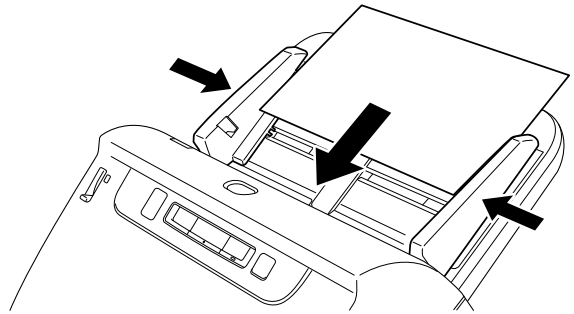

Figure 5-210

- 3) On the service screen, select [Light Adjustment].

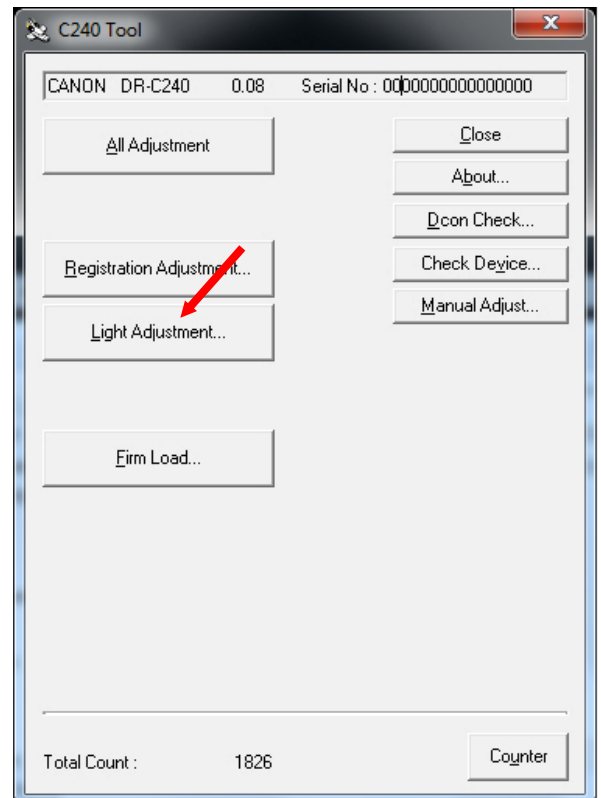

Figure 5-211

- 4) The adjustment starts automatically. The sheet is fed, and a progress screen is displayed.



Figure 5-212

- 5) Even after the sheet has been ejected, the data may be processed inside the machine. The progress screen disappears, and a warning screen is displayed. Do not turn OFF the machine or perform any operations until the warning screen disappears.

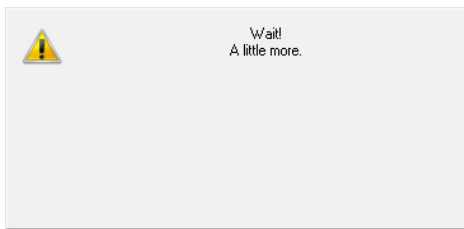

Figure 5-213

- 6) After the adjustment is complete, the warning screen disappears.

6. All Adjustment

This mode performs “Registration Adjustment” and “Light Adjustment” in sequence. For the purposes of each of these adjustments, refer to the corresponding sections.

◆ Adjustment sheet

As the shading sheet and the registration adjustment sheet, use sheets described in the previous section.

◆ Operation Procedure

- 1) Clean feed path, roller, and reading glass.
- 2) Fully extend the document guides, and then place the 3 registration adjustment sheets. Place each of the 3 sheets so that the black line is at trailing edge of the front side. Place a shading sheet on top of the adjustment sheets. Place them properly not to cause skew.

Note: Do not place extra sheets.

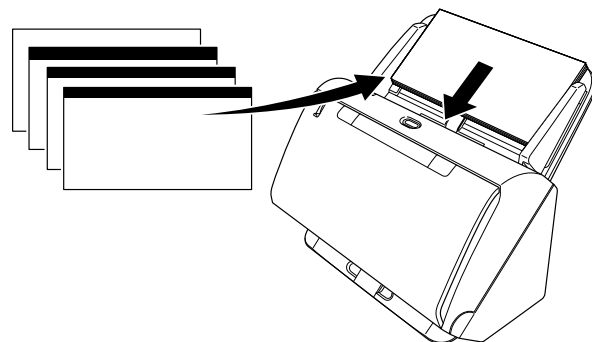

Figure 5-214

- 3) On the service screen, select [All Adjustment].

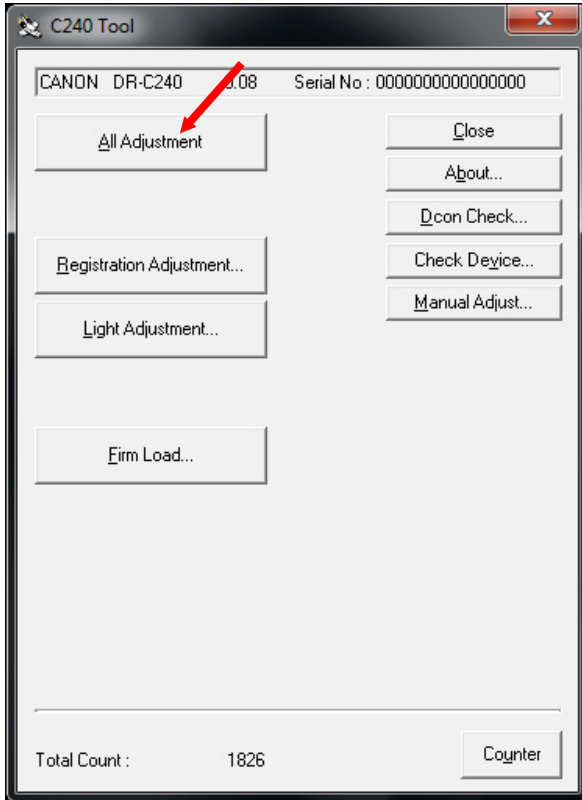

Figure 5-215

- 4) The adjustment starts automatically. The sheets are fed and the progress screen is displayed.

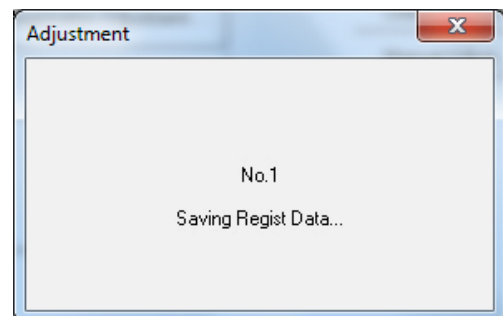
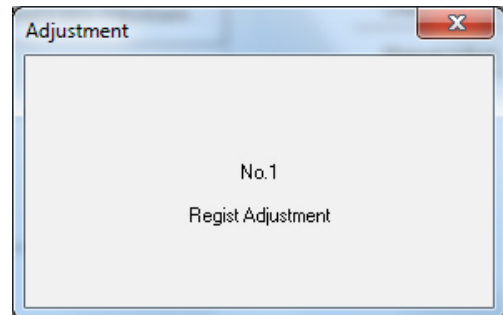
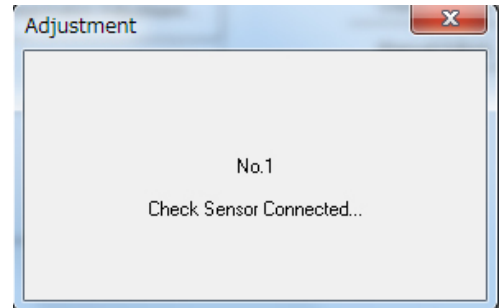

Figure 5-216

- 5) Even after the shading sheet has been ejected, the data may be processed inside the machine. The progress screen disappears, and a warning screen is displayed. Do not turn OFF the machine or perform any operations until the completion screen is displayed.

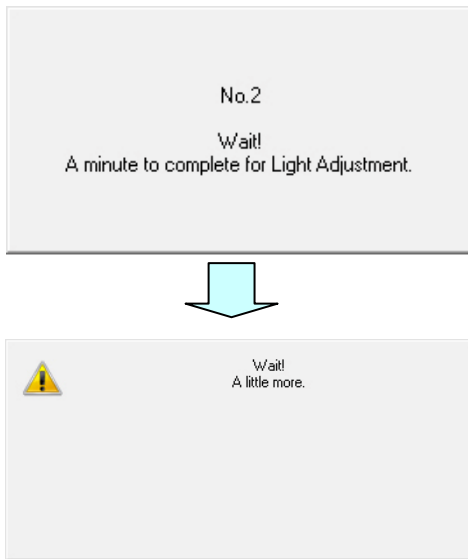

Figure 5-217

- 6) After the adjustment is complete, the completion screen is displayed. Click [OK].

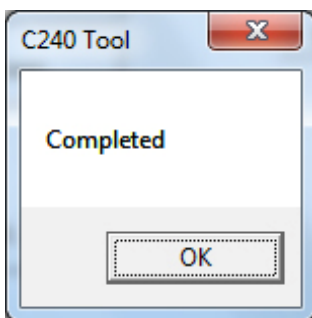

Figure 5-218

7. Dcon Check

This mode checks operations of each hardware inside of the machine.

◆ Basic screen

- 1) On the service screen, select [Dcon Check].

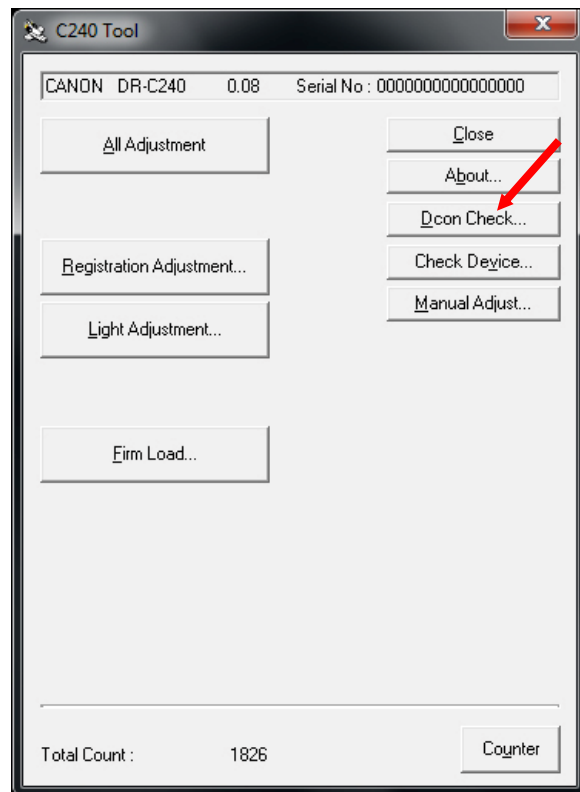

Figure 5-219

- 2) The [Dcon Check] screen is displayed.
Select a menu to execute on this screen.

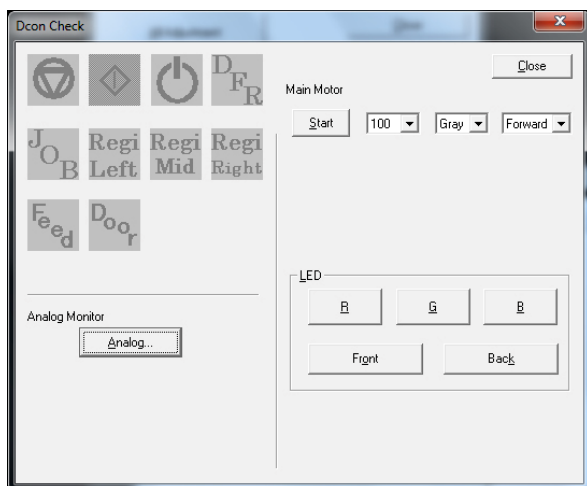

Figure 5-220

a. Sensors and switches

The operation states of sensors and switches are shown below. The following diagram indicates that the “Document sensor” is on.



Figure 5-221

Icon	Name and Description
	Stop button (stop switch) This icon lights when the Stop button is pressed.
	Start button (start switch) This icon lights when the Start button is pressed.
	Power button (power switch) This icon lights when the Start button is pressed.
	DFR button (DFR switch) This icon lights when the DFR button is pressed.
	JOB button (JOB switch) This icon lights when the JOB button is pressed.
	Left post-registration sensor This icon lights when the left post-registration sensor detects paper.
	Middle post-registration sensor This icon lights when the middle post-registration sensor detects paper.
	Right post-registration sensor This icon lights when the right post-registration sensor detects paper.
	Document sensor This icon lights when the document sensor detects paper.
	Door sensor This icon lights when the front unit is open.

Table 5-202

Note:The registration sensor icon lights even if the front unit is open.
The document sensor is indicated here by “Feed”.

b. Main motor

Checks the operation of the main motor. Select a resolution and a reading mode, then select [Start] to make the motor turn at the speed that meets the condition. Select [Stop] to stop the motor.

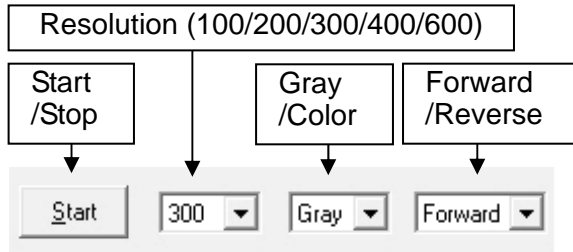

Figure 5-222

c. CIS unit LED

To turn on an LED, first select the side you want to turn on, and then select the color (RGB) you want to turn on. Select the (RGB) button again to turn off the LED.



Figure 5-223

d. Analog Monitor

The analog monitor screen allows you to check the analog values of the ultrasonic double feed detection sensor and registration sensors.

The registration sensor screen allows you to check analog values of the left, middle and right post-registration sensors.

To move from the analog monitor screen to the analog sensor confirmation screen, select the Analog button in the analog monitor.

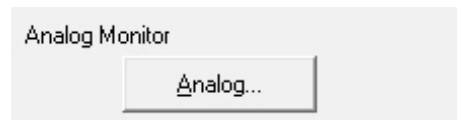

Figure 5-224

◆ Ultrasonic Double Feed Detection Sensor

When the “Ultrasonic Double Feed Detection Sensor” (USS) is selected, “Ultrasonic Double Feed Detection Sensor” (USS) screen is displayed.

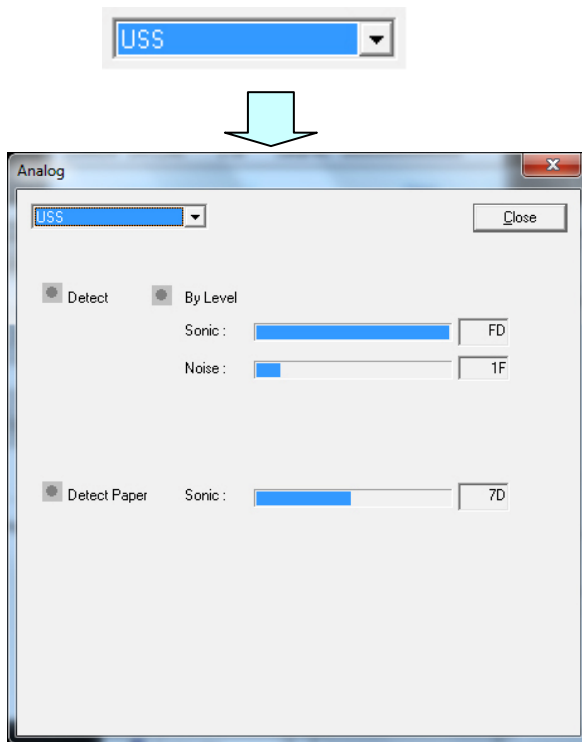

Figure 5-225

Placing a single sheet of paper on the ultrasonic sensor turns on the “Detect Paper” in red. Placing overlapping paper on the sensor turns on the two “Detect” in red. The screen when double-feeding is detected is shown below.

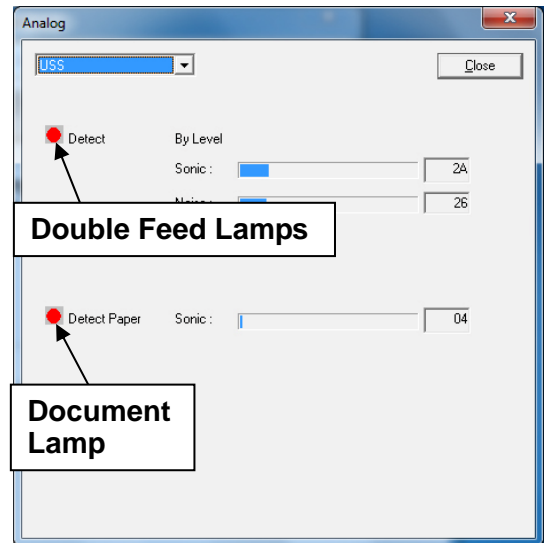

Figure 5-226

◆ Regist Sensor

Selecting [Regist Sensor] displays the regist sensor screen.

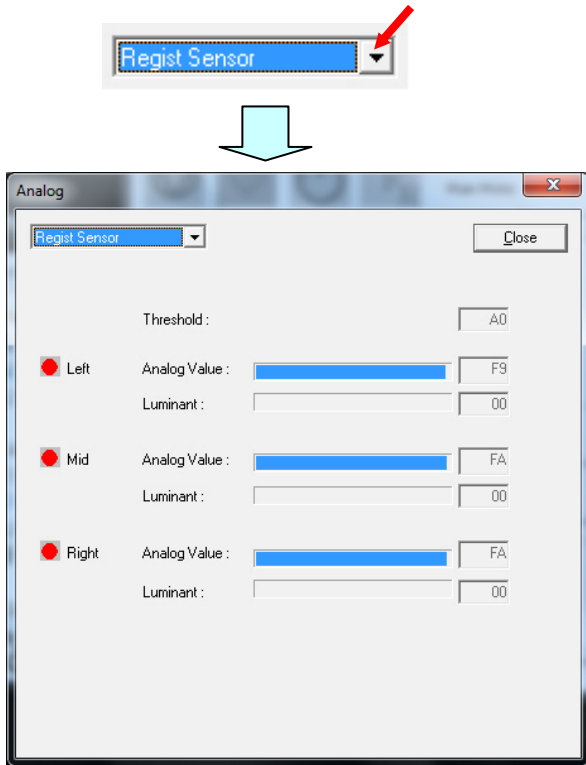

Figure 5-227

Figure 5-227 shows the left post-registration sensor on the left, the middle post-registration sensor in the middle, and the right post-registration sensor on the right.

Although the analog values of the analog sensors are not normally used in the market, you may be requested to provide this data for design studies.

8. Check Device

This mode allows you to check the version of the scanner main body firmware, and the versions, main body serial numbers, settings, and error logs of the main body internal devices.

To display the [Check Device] screen, select [Check Device] on the service screen.

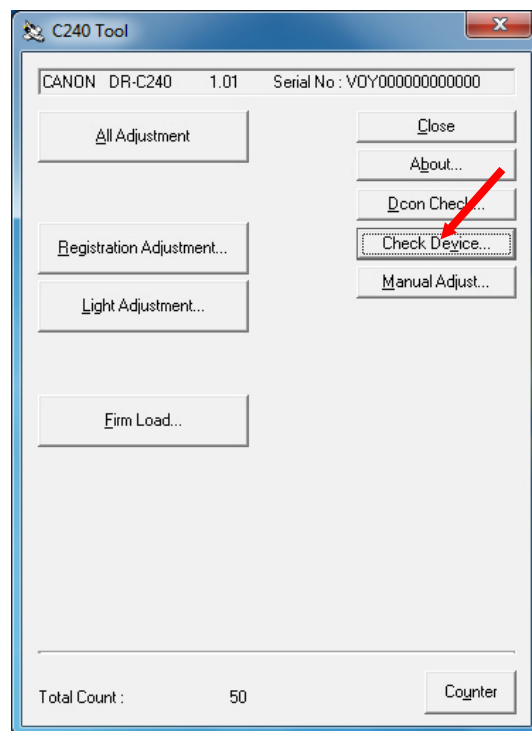

Figure 5-228

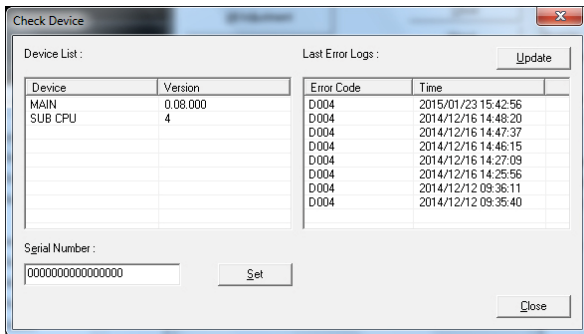

Figure 5-229

- [MAIN]
Main body firmware
- [SUB CPU]
Sub PCB firmware

Note:Version of the main body firmware can also be confirmed on the user's driver screen.

Serial number data is saved on the control PCB. If the Control PCB is replaced, enter the serial number shown on the rating label at the main body and select "Set" on the right side.

◆ Last Error Logs

Shows up to 64 latest error codes and the occurred time.

Press the update button to display the error log.

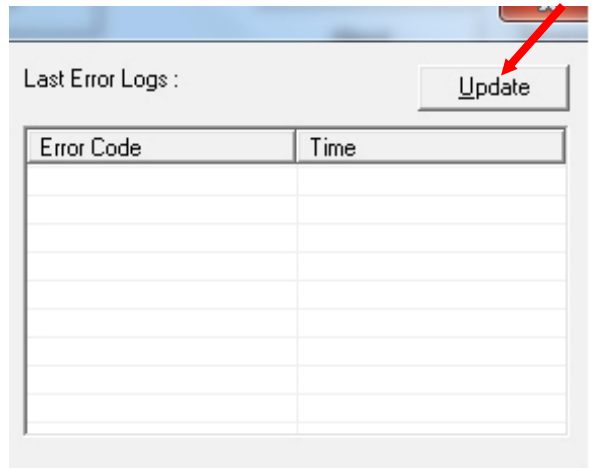

Figure 5-230

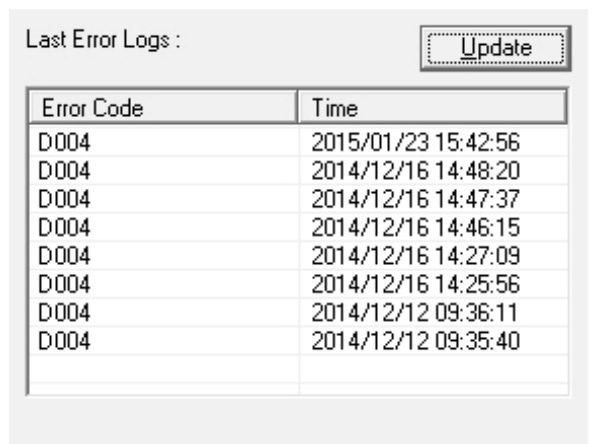

Figure 5-231

Contents of the error codes are shown below, however these are not all of the them.

Display	Details
D002	Double feed detection by length
D004	Double feed detection by ultrasonic sensor
D006	Double feed detection by length + ultrasonic sensor
E044	SUB CPU2 Communication error
E086	EEPROM Entry error
P000	Document found inside the device jam
P006	Sensor ON after registration jam
P007	Sensor OFF after registration jam (when a document is too long)
P008	Sensor OFF after registration jam (when a document is too short)

Table 5-203

9. Manual Adjust

This mode is used to manually adjust the scale parameter of images. It can also be used to manually adjust the registration position. It is used to correct changes due to the friction of the roller or to perform fine adjustment of automatic adjustment values. This mode should also be executed after replacing the control PCB that records the adjustment data.

◆ Basic screen

On the service screen, click [Manual Adjust] to display the [Scaling Control] screen.

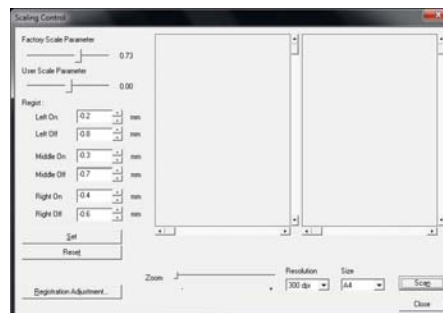
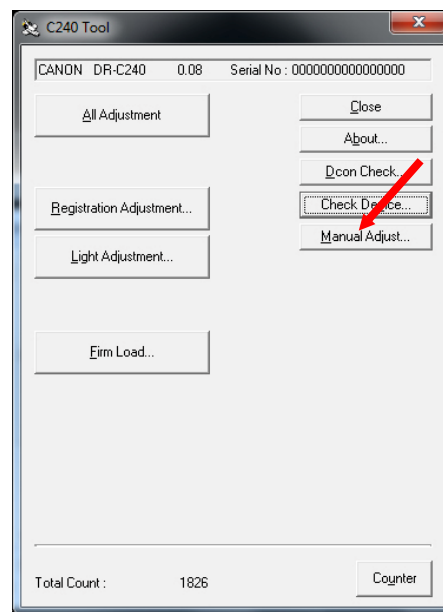

Figure 5-232

◆ Description of the Scaling Control Screen

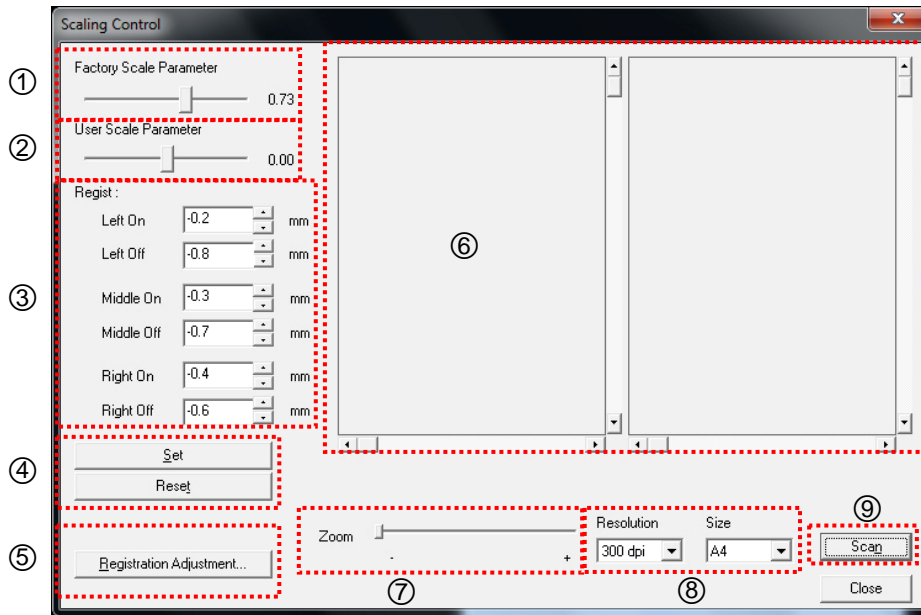

Figure 5-233

No.	Details
①	<p>Factory Scale Parameter The factory default scale parameter setting value. Can be changed using the slide bar. Units are percentage of the entire length. The setting range is ± 3.0. The [+] direction increases the length of the image.</p>
②	<p>User Scale Parameter This setting value is added to ① above. The setting range is ± 3.0. Other details are the same as ①. The setting value of ① + ② is applied.</p>
③	<p>Regist Left On: The setting value of the reading start position for the left post-registration sensor. Left Off: The setting value of the reading end position for the left post-registration sensor. Middle On: The setting value of the reading start position for the middle post-registration sensor. Middle Off: The setting value of the reading end position for the middle post-registration sensor. Right On: The setting value of the reading start position for the right post-registration sensor.</p>

No.	Details
③	<p>Right Off: The setting value of the reading end position for the right post-registration sensor. Can be changed by directly entering in the data box or by using the scroll arrows. Units are mm, and the setting range is ± 4.0. The [+] direction delays the timing. For example, if set to left edge [1.0] mm, 1mm of the leading edge of the image is cut off.</p>
④	<p>Set / Reset Set: Sets the changed values. Reset: Returns the setting values to "0".</p>
⑤	<p>Registration Adjustment Click this button to execute [Registration Adjustment].</p>
⑥	<p>Scanned Image Displays the scanned image. The left side is the front image and the right side is the back image. You can move the image using the scroll bars.</p>
⑦	<p>Zoom Enlarges the image in ⑥ above using a slide bar.</p>

Table 5-204a

No.	Details
⑧	Resolution / Size Selects the resolution and size of the scan using pull-down menus.
⑨	Scan Click this button to begin the scan.

Table 5-204b

a. Scale parameter adjustment

Performs adjustment using the front side image. The same values are applied to the reverse side image as the front side. If the image leading edge position is different, perform registration adjustment first.

◆ Adjustment sheet

Prepare a single sheet of A4 or LTR size paper printed with a pattern that makes the positions of the leading and trailing edges clear.

Service tool: You can use the TKM-0271 test sheet or a hand-made test sheet as shown below.

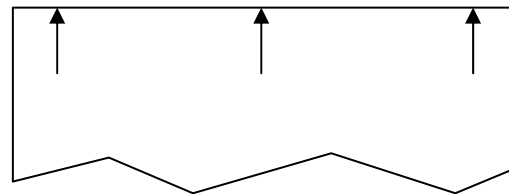

Figure 5-234

◆ Operation Procedure

- 1) The [Scaling Control] screen is displayed.
- 2) Place a single adjustment sheet, and align the document guides.
You should place the sheet with the patterned face towards you and the leading edge at the bottom (inside the machine).
- 3) Set the resolution and size, and then click the [Scan] button.

Note: Paper size is “A4” size or “Letter” size.

- 4) The scanned image is displayed.

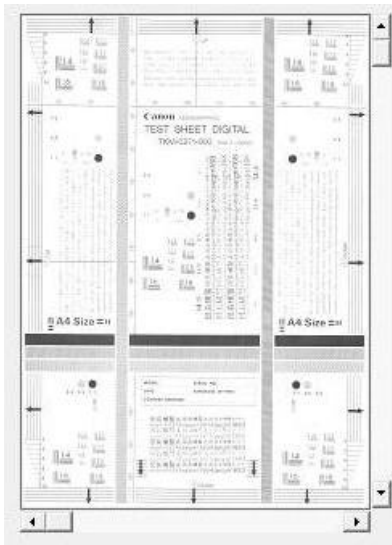

Figure 5-235

- 5) Use [Zoom] to enlarge the leading edge of the image and ensure that the position of the leading edge is correct.

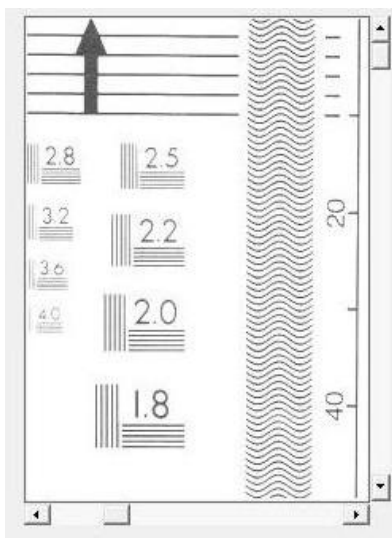

Figure 5-236

Note: If the position of the leading edge is incorrect or the image is skewed, perform the scan again.

- 6) Next, check the trailing edge image and set the adjustment values. For example if you want to extend by 2.0mm with A4 size, then since $2.0 \div 297 = 0.67\%$, set the value of [User Scale Parameter] to "0.67". After you have set the value, click the [Set] button.

Note: The [User Scale Parameter] setting value and the scale parameter adjustment value in [Utility/USB Properties/Maintenance] on the user operation screen are linked. Note that the user value is displayed to one decimal place with the value rounded.

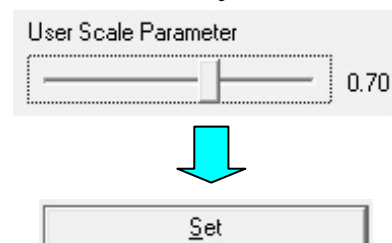
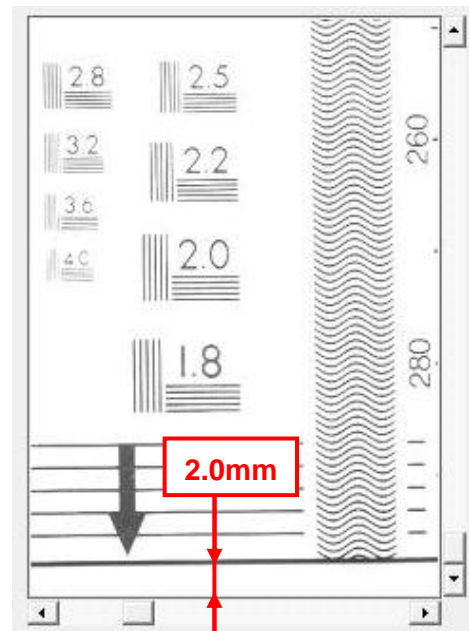

Figure 5-237

7) Place the adjustment sheet and scan again. Check the displayed image.

Note: Repeat the procedure again if the adjustments were not corrected properly.

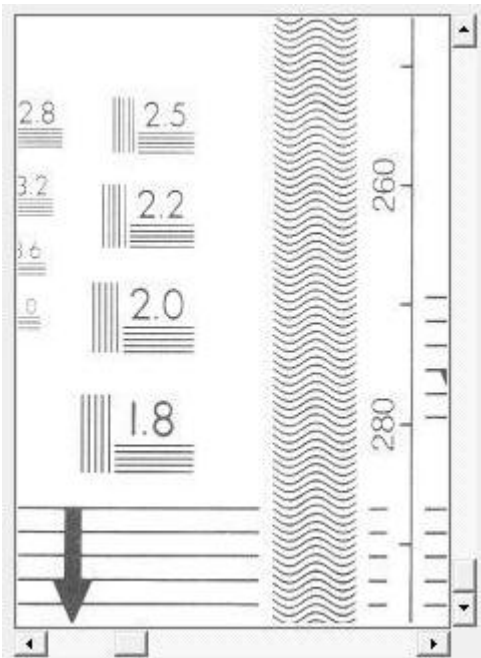

Figure 5-238

b. Automatic Registration Adjustment

The function of the [Registration Adjustment] button is the same as section "4. Registration Adjustment", and is linked to the setting value. Place the 3 registration adjustment sheets and then click this button. The set values are then displayed.

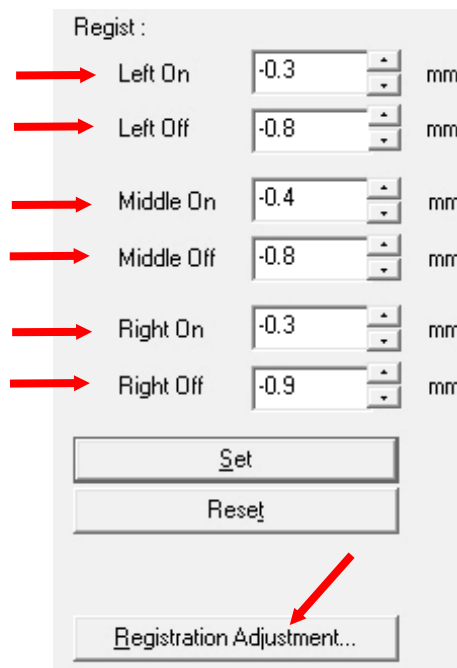

Figure 5-239

c. Manual Registration Adjustment

Registration adjustment is normally performed in automatic mode. This adjustment is a mode that performs fine adjustment of the result of the automatic registration adjustment. Note that it does not reduce variations in the registration position.

◆ Operation Procedure

- 1) Load the scale parameter adjustment sheet the same as for scale parameter adjustment and scan the image. However, set the size to "Auto Size".
- 2) Check the position of the leading edge.

- 3) Change the adjustment value by directly entering the value into the data box or by using the scroll arrows. This additional change value is added to the value previously set by the automatic adjustment. Note that when you change a value, you must concurrently change the values of the 3 registration sensors so that the same target result is obtained. For example, suppose that the values are already [0.7] for the Regist Left On, [0.6] for the Regist Middle On, and [0.7] for the Regist Right On. If you want to add 1 mm, enter [-0.3] for the Regist Left On, [-0.4] for the Regist Middle On, and [-0.3] for the Regist Right On. If you want to subtract 1 mm, enter [1.7] for the Regist Left On, [1.6] for the Regist Middle On, and [1.7] for the Regist Right On.
- 4) After entering the values, click the [Set] button.
- 5) Scan the image again and check the position.

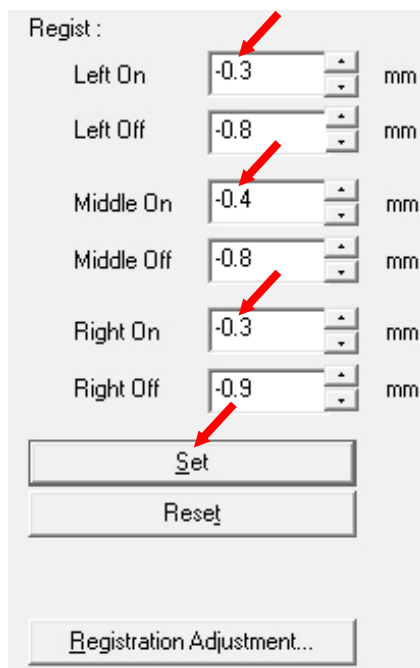

Figure 5-240

- d. Procedure after replacing the control PCB
 - This section gives the procedures for performing scale parameter adjustment and manual registration adjustment after replacing the control PCB. In particular, this gives the procedure for when you want to set the scale parameter adjustment value displayed in the user operation screen to "0.0".

◆ Without performing automatic registration adjustment

This section gives the procedure for when automatic registration adjustment has already been executed using [All Adjustment] or [Registration Adjustment], and not to execute in this mode.

- 1) Set the values of [Factory Scale Parameter] and [User Scale Parameter] to "0.00" and then click the [Set] button.

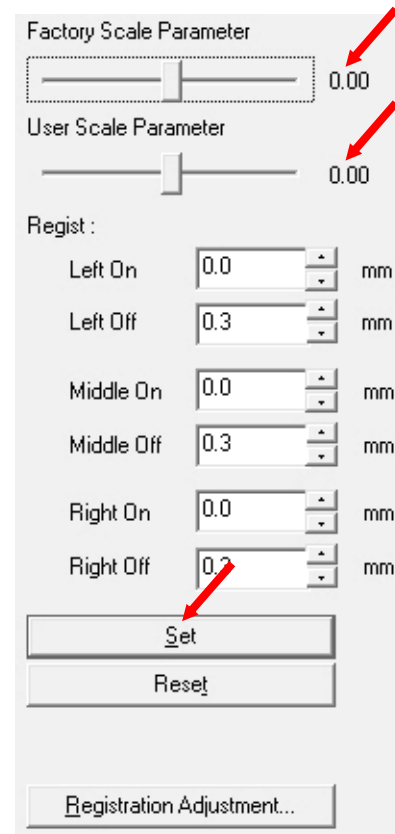

Figure 5-241

- Note:** If you cannot set the slide bar to exactly “0.00”, select the slide bar using the mouse pointer and then set the value using the arrow keys on the computer.
- 2) Place the scale parameter adjustment sheet and display the image. For details, refer to the “Scale Parameter Adjustment” section.
 - 3) Execute manual registration adjustment if required. For details, refer to the “Manual Registration Adjustment” section.
 - 4) Check the trailing edge of the image and set the scale parameter adjustment values. Note that these are the [Factory Scale Parameter] values. For more details, refer to the “Scale Parameter Adjustment” section.

Note: Note that if the roller friction is severe, the adjustment may not be possible with [Factory Scale Parameter] alone. In this case, you should also use [User Scale Parameter], or replace the roller.

- ◆ With performing automatic registration adjustment

This section gives the procedures for performing automatic registration adjustment in this mode.

- 1) Click the [Reset] button. All of the values change to zero.

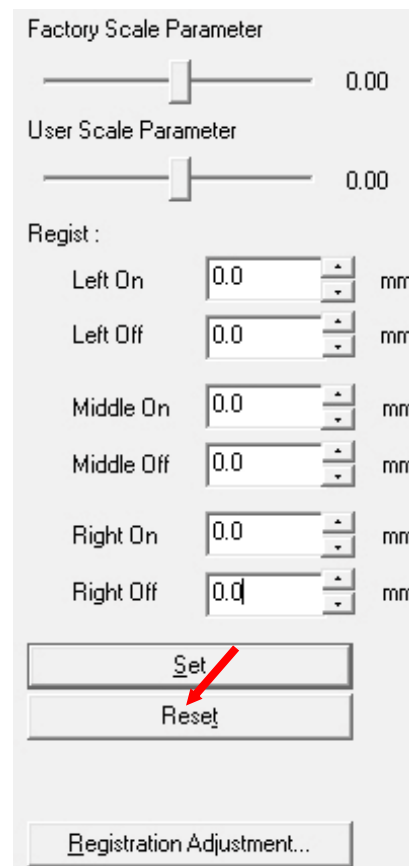

Figure 5-242

- 2) Execute automatic registration adjustment. For details, refer to the “Automatic Registration Adjustment” section.
- 3) Next, perform the procedure from Step 2 in the previous section “Without performing automatic registration adjustment “.

The following flow chart shows an overview of the scale parameter adjustment procedure when performing automatic or manual registration adjustment. Refer to the each items for details.

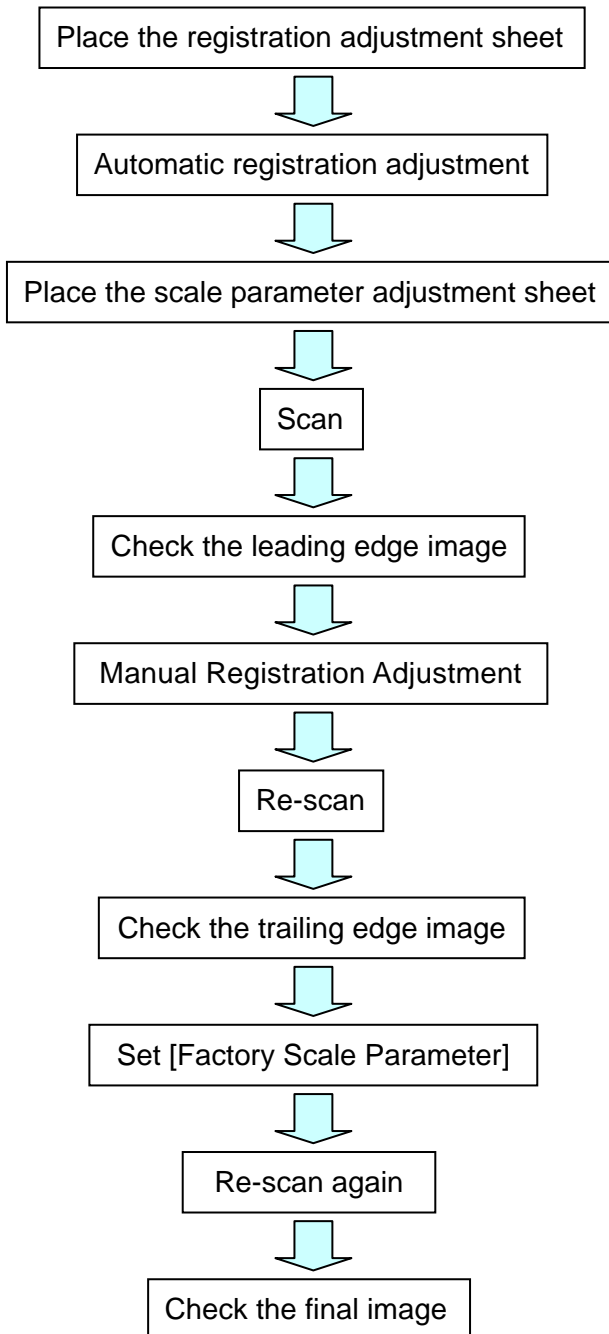

Figure 5-243

10. Firm Load

Firmware is changed in this mode. For details, refer to service information provided when firmware is changed. Do not use this mode by mistake. You can load the firmware by using either the MAIN firmware or SUBCPU firmware function.

◆ Operation Procedure

- 1) On the service screen, select [Firm Load].
- 2) The screen is displayed requiring the file in which software is stored to be selected.
- 3) Select and open the file.
- 4) It is loaded automatically and a progress screen is displayed.

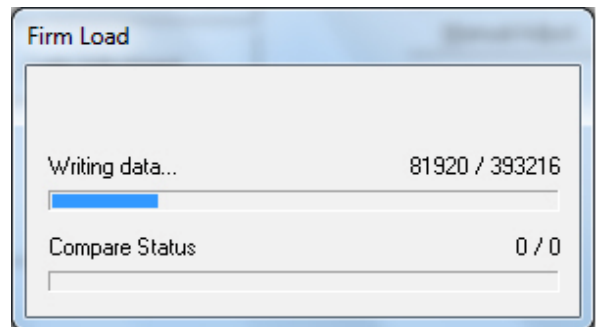

Figure 5-244

- 5) Exit the service tool.
- 6) Turn the scanner power OFF, and then ON.

- 7) Start the service tool and verify that the version and the total scanning count displayed on the service screen are correct.

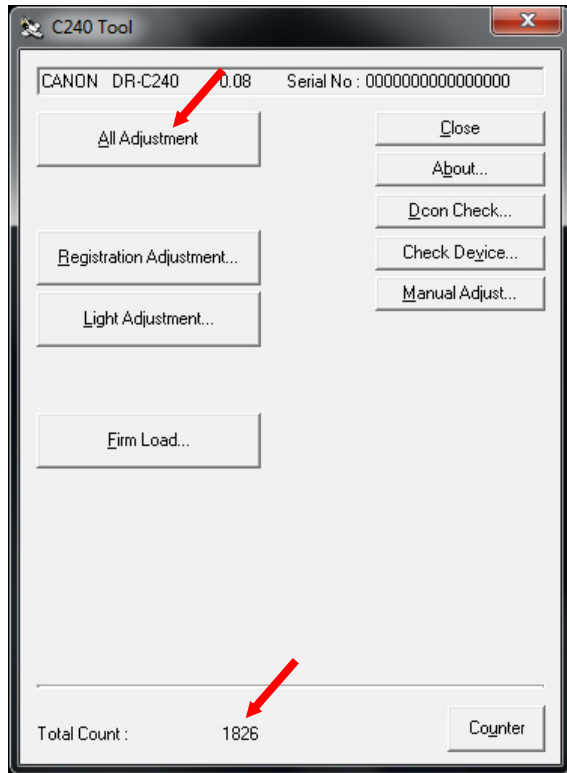

Figure 5-245

Note: Do not turn the power OFF including the USB cable is removed during loading. If the power is turned OFF, it returns to its original state when restarted, but this is not guaranteed.

11. About

This mode displays a detailed version of the service tool.

On the service screen, select [About] to display the version screen.

Press [OK] to close the version screen.

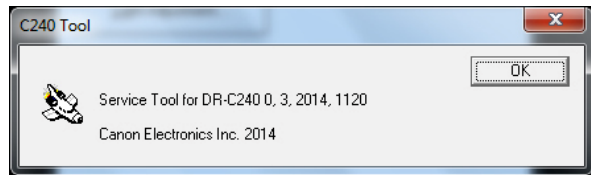

Figure 5-246

12.Counter

This mode is used to display/change the sheet fed count and the number of paper jams.

Note: Do not change the value of each item by mistake. Change it only if necessary.

a. Display

On the service screen, select [Counter] to display the [Counter] screen.

- [Total Count]
Total sheet fed count
- [P01 Jam Count]
Number of documents jams in the pickup section
- [P02 Jam Count]
Number of residual jams
- [P03 Jam Count]
Number of fast feed jams
- [Roller Count]
Sheet fed count of the roller being used (Number of feeds after reset)

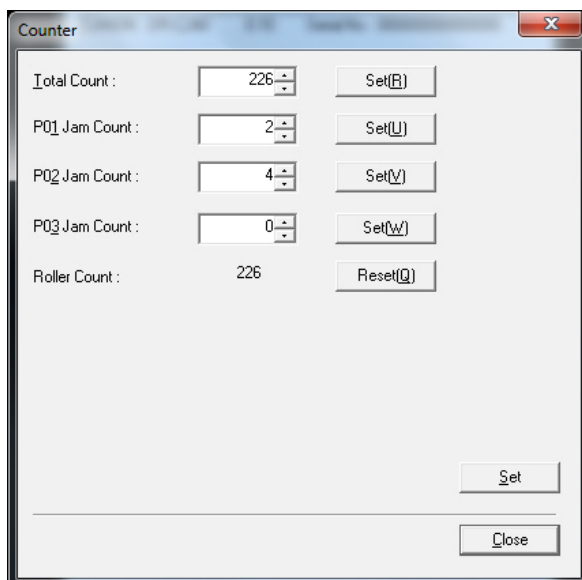

Figure 5-247

b. Change

These values are changed when the control PCB is replaced. After the replacing the control PCB, input the same values as before the replacement. If you don't know the values before the replacement, input the estimated values.

After changing the value, select the [Set] button at the right side of each item to finalize it. Pressing the [Set] button in the lower right portion of the screen finalizes values for all items. Note that [Roller Count] has a [Reset] button instead of a [Set] button. Click this [Reset] button to set the value to "0 (zero)". Do not click the [Reset] button by mistake because it is linked to the operation of the [Replace Rollers] counter for the user.

If you replace the control PCB or change the [Total Count], then the counter for [Replace Rollers] is also updated. Since the [Replace Rollers] message may be displayed the next time the user turns the power on or the counter for the [Current Roller] may take on an invalid value, you should check the counter for the [Current Roller] after exiting service mode and reset it if necessary.

13. Mechanical Feed Mode

Although it is not part of the service mode using the service tool, this machine is equipped with a mechanical feed mode for checking the state of the feed transport without using a computer. You use this mode as necessary. Note that you should not disclose this mode to users. Press the buttons on the control panel in the following sequence to enter mechanical feed mode.

◆ Entering mechanical feed mode

While holding down the Start button, press the power button until the lamp lights up, and then press the Stop button when the lamp starts blinking. Once the mode is set, the dot (·) lights up at lower-right of the Job No. display.

◆ Feeding paper

While the machine is in this mode, place paper and press the Start button to begin feeding the paper.

◆ Exiting mechanical feed mode

Hold down the power button continuously until the lamp stops lighting. This is the same as turning the power off normally.

14. Obtainment of Log Files

The Windows version of the software for this machine collects log files of user usage status information, and is equipped with a function for obtaining these log files. Since the log files are designed to be useful for resolving problems, the user may be asked to do the operation to obtain the files.

The following gives an overview of the log files and the procedure for obtaining them.

◆ Types of information

- 1) User operations
- 2) Errors
- 3) Settings
- 4) Debugging (note that this excludes default settings)
- 5) Latest information when obtaining the files

◆ Obtainment procedure (refer to the below figure)

- 1) Open the dialog screen of the scanner driver, and click the [About] button.
- 2) Click the [Log File Settings] button in the About screen.
- 3) Click the [Execute] button in the Log File Settings screen.
- 4) The Save Settings screen is displayed. Select the appropriate location to save the files.
- 5) The files are obtained with [xxx.dat] attached.

Note:[Full] Setting

On the Log File Settings screen, the type of log file can be set to [Full] or [Mini]. The default setting is [Mini].

If you need the [Full] information, set to [Full] and click the [OK] button.

If you changed the log file type, exit the application to apply the change.

Then, perform the steps to reproduce the problem and perform the obtainment operation. Note that when set to [Full], the scanning speed may be reduced.

◆ Save location of log files

The original log files of the log files to obtain are saved on the user computer. The maximum size of the log files is approx. 200 MB. Once this limit is exceeded, old data is deleted. Data is also deleted after one year has passed.

Therefore, to obtain the log file for the condition that caused the problem, obtain it from the computer that was being used at that time. If you are obtaining the log file with the mode set to [Full], try to obtain the log file immediately after the problem occurs.

For users who does not want to increase the disk usage, ask the users to delete these as necessary from the save locations shown below.

- 1) Windows XP
 C:\Documents and Settings
 \All Users\Application Data
 \Canon Electronics\Scanner Drivers\log
- 2) Windows Vista/7/8/8.1
 C:\ProgramData\Canon Electronics
 \Scanner Drivers\log

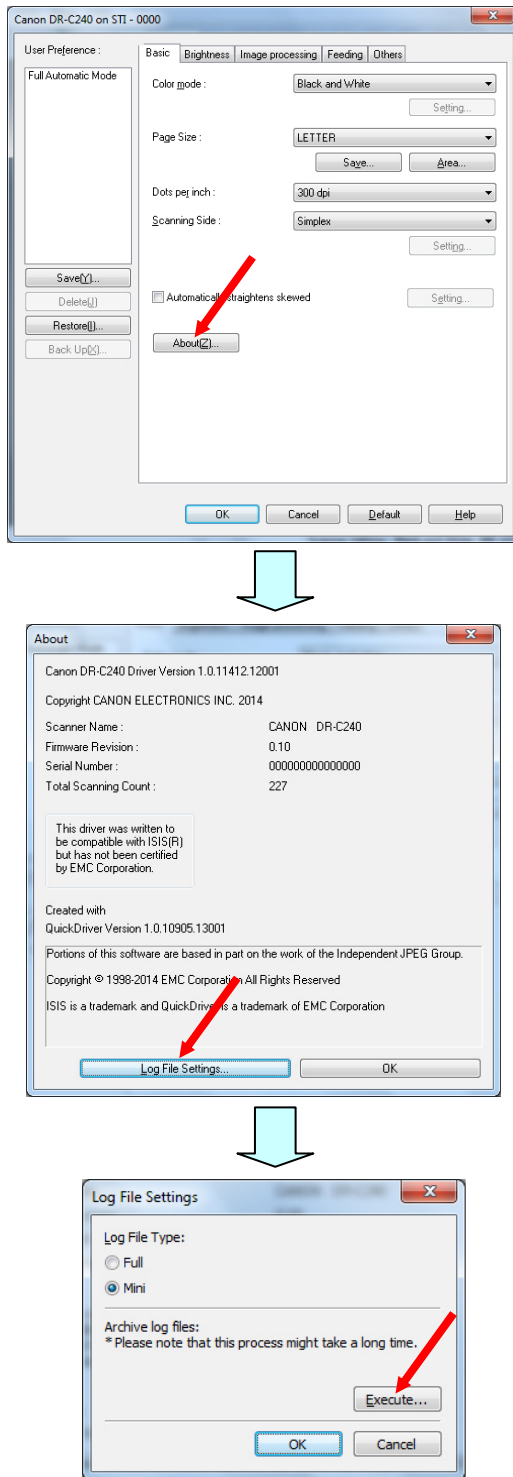

Figure 5-248

III. TROUBLESHOOTING LIST

The lists below give the major failures conditions and their causes. Refer to the next section for details of the causes and the measures to be taken.

1. Operation Failures

Note: Major causes of each failure are marked "X".

No.	Cause Failure	System/ Software	Hard- ware	Connec- tion	Dirt/ dust	Docu- ment	Settings
1	Power does not come ON.		X	X			
2	No scanner is found.	X		X			
3	Scanner does not start.	X	X	X			X
4	Scanning does not feed properly.		X		X	X	
5	Scanning speed is slow.	X					X

Table 5-301

2. Image Failures

Note: Major causes of each failure are marked "X".

No.	Cause Failure	System/ Software	Hard- ware	Connec- tion	Dirt/ dust	Docu- ment	Settings
1	All black/all white/all streaked.	X	X		X		X
2	Too dark/too light.				X		X
3	Streaks in image.		X		X		
4	Image slanted.					X	X
5	Wrong image size.					X	X
6	Text cannot be seen.					X	X
7	Moire in image.					X	X

Table 5-302

IV. OPERATION TROUBLESHOOTING

When an operation problem occurs, check the error message displayed on the display connected to a computer. Also perform an operation check on the sensors and motors using the service mode.

1. Power Does Not Come ON

The power indicator is not lit.

Note: Make sure to use the AC adapter and power cord supplied with the machine.

Cause/Faulty Locations	Step	Check Item	Result	Action
Connection of power cord	1	Is the power cord connected?	NO	Connect the connectors correctly.
AC power supply voltage	2	Is the power outlet supplying power at the rated voltage?	NO	Explain to the user that this is not a problem with the machine.
Connection of AC adapter	3	Is the AC adapter connected?	NO	Connect the connectors correctly.
Power button	4	Is the power button on?	NO	Turn the power button on.
Power cord	5	Does replacing the power cord fix the problem?	YES	Done.
AC adapter	6	Does replacing the AC adapter fix the problem?	YES	Done.
Control PCB	7	Is the LED101 on the control PCB blinking?	YES	Proceed to Step 8.
			NO	Replace the control PCB.
Sub PCB Operation PCB	8	Is the cable connected?	NO	Connect the connectors correctly.
			YES	Replace the PCB.

Table 5-401

2. No Scanner is Found

Note: You should install the driver on the computer before connecting the scanner.

Cause/Faulty Locations	Step	Check Item	Result	Action
Power Supply	1	Is power supplied to the machine?	NO	Perform "1. Power Does Not Come ON".
Connection of the USB cable	2	Is the USB cable connected?	NO	Connect the connectors correctly. Disconnect the cable and then connect it again. Connect to another USB hub.
Computer	3	Is the computer compatible?	NO	Use compatible equipment.

Table 5-402

3. Scanning Does Not Start

Note:The “cover open” and “no document” error messages may be displayed and scanning may not start due to sensor problems.

Cause/Faulty Locations	Step	Check Item	Result	Action
System	1	Was the problem solved by turning the power of the scanner OFF/ON or restarting the computer?	YES	Done.
Software	2	Was the problem solved by reinstalling the scanner driver or application?	YES	Done.
Connection of the connector (control PCB)	3	Are the motor and sensor connectors connected correctly?	NO	Connect the connectors correctly.
Drive transmission system	4	Is the transmission system of the motors normal? Are parts such as gears and belts normal?	NO	Attach the parts correctly. Replace the parts.
Motors	5	Is the operation normal when you perform an operation check with the service mode?	NO	Check the cable connections. Replace the motors.
Sensors	6	Is the operation normal when you perform an operation check with the service mode?	NO	Check the attachment of sensors and sensor levers. Check the connections of sensor cables.
Sub PCB	7	Was the problem solved by replacing the sub PCB?	YES	Done.
Control PCB	8	Was the problem solved by replacing the control PCB?	YES	Done.

Table 5-403

4. Scanner Does Not Feed Properly

Note:A “paper jam” or “double-feed” error message may be displayed due to a sensor problem.

Cause/Faulty Locations	Step	Check Item	Result	Action
Document	1	Specified document? (thickness, size, fold or curl)	NO	Use documents compliant with the specified.
Placing documents	2	Are documents stuck together?	YES	Fan the documents well.
	3	Is the position of the document guide correct?	NO	Correct the position.
	4	Do you use the extension support?	NO	Use the extension support depending on the document.
Feed selection lever	5	Is the feed selection lever switched to the appropriate position?	NO	Switch to the appropriate position.
Rollers	6	Are the rollers and the roller covers attached correctly?	NO	Attach the rollers correctly.
	7	Are they dirty or deformed?	NO	Clean or replace the rollers.
Parts in feed path	8	Parts touching documents installed properly? (no float, slant or gaps)	NO	Attach the parts correctly.
	9	Is the surface touching documents smooth? (No scratches or burrs)	NO	Replace inferior parts.
Drive transmission system	10	Does an abnormal noise occur while feeding? Are any of the gears damaged or the belts loose?	YES	Attach the parts correctly. Replace inferior parts.
Motors	11	Is the operation normal when you perform an operation check with the service mode?	NO	Check the cable connections. Replace the motors.
Sensors	12	Is the operation normal when you perform an operation check with the service mode?	NO	Check the attachment of sensors, sensor levers, and light guide. Check the connections of sensor cables.
Sub PCB Ultrasonic drive PCB	13	Was the problem solved by replacing the PCB?	YES	Done.
Control PCB	14	Was the problem solved by replacing the control PCB?	YES	Done.

Table 5-404

Note:For passports

- For details about conditions for scanning a passport and how to set the passport, refer to the user manual.
- If part of the scan image is missing, or if the scanner's correction function does not operate correctly, change the [Page Size] setting to a larger size (such as A4) in the setting screen of the scanner driver, and then scan the image again.
- If misfeeds or paper jams occur frequently, clean the feed roller and change the carrier sheet to a new one.
- If the scan image is blurred, clean the carrier sheet or change the sheet to a new one.

5. Scanning Speed is Slow

The basic speed of this machine is 45 ppm. (A4/200 dpi)

The speed is further reduced if high resolution, color settings, or special functions are selected.

If the scanning speed is still slow after taking the above into consideration, the cause may be as follows.

Cause/Faulty Locations	Step	Check Item	Result	Action
Insufficient computer memory	1	Is the memory sufficient?	NO	Increase the memory.
	2	Are other applications running?	YES	Close the other applications.
	3	Are resident applications such as a virus protection program running?	YES	Close the service-type applications.
	4	Is there insufficient hard disc space?	YES	Increase the hard disc space.
Hi-speed USB 2.0 not supported	5	Is the USB port supported?	NO	Use a computer that supports it.
	6	Is the USB cable supported?	NO	Use the included USB cable.
	7	Is the USB hub supported?	NO	Use a USB hub that supports it.
The log file setting is [Full]	8	Is the log file setting set to [Full]?	YES	Set to [Mini].
Long document mode setting	9	Is the setting for the long document mode [1000mm] or [3000mm]?	YES	Set to [Standard].

Table 5-405

V. IMAGE TROUBLESHOOTING

◆ Image Sample

Document 	Normal (B&W) 	All black 	All white 	All streaked 
Too dark 	Too light 	Streaks 1 	Streaks 2 	Streaks 3 
Slanting 	Skew correction 	Wrong size 	Auto size 	Has shadows 
Original document (B) 	Missing leading edge 	Margin at leading edge 	Stretched 	Compressed 

Table 5-501

Note:The level of reproducing the image depends on types of documents and setup conditions. Changing setup conditions sometimes works.

1. All Black/All White/All Streaked

The image is all black, all white, or all streaked.

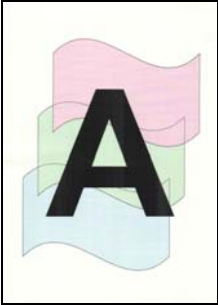
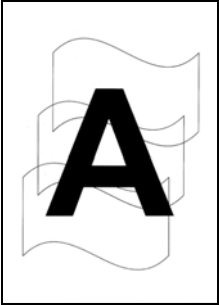
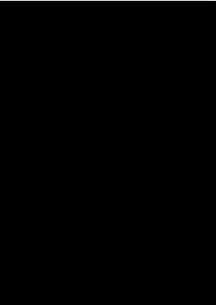
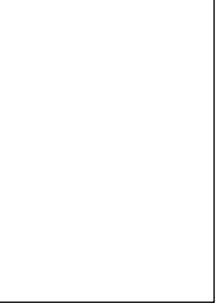
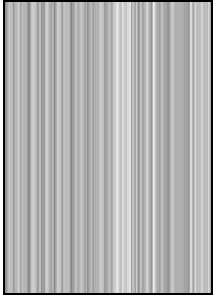
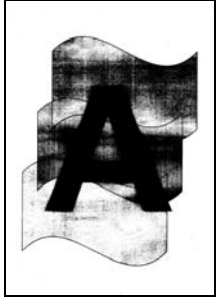
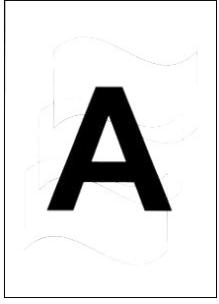
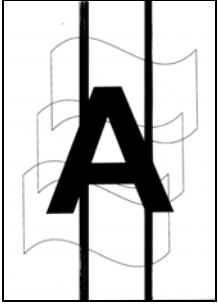
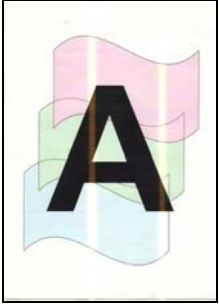
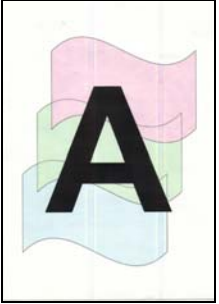
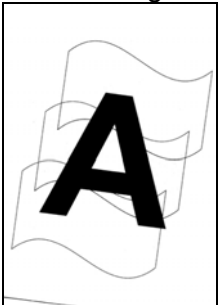
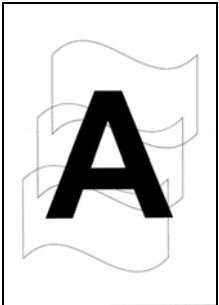
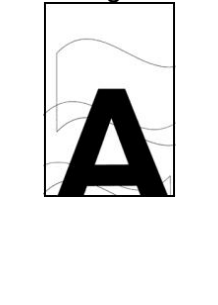
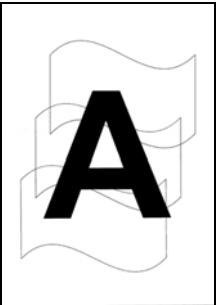
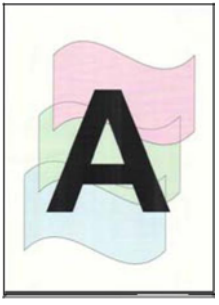
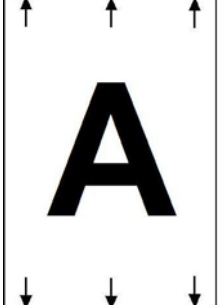
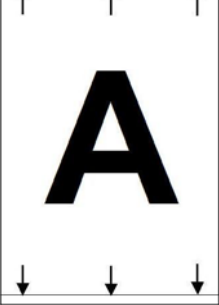
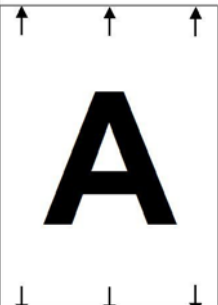
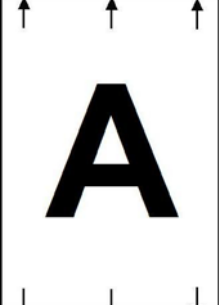
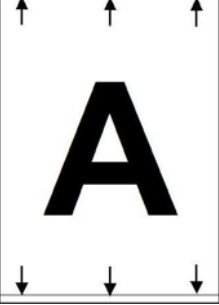
Cause/Faulty Locations	Step	Check Item	Result	Action
Placing documents	1	Is the document placed with the front/back around the right way?	NO	Place properly.
Setup of "Brightness"	2	"Brightness" setup properly?	NO	Change the setup. Change "Contrast" if necessary.
System	3	Was the problem solved by turning the power of the scanner OFF/ON or restarting the computer?	YES	Done.
Reading Unit	4	Reading-related cables connected properly?	NO	Connect properly.
	5	Was the problem solved by changing the reading-related cables?	YES	Done.
	6	Was the problem solved by replacing the reading unit?	YES	Done.
Control PCB	7	Was the problem solved by replacing the control PCB?	YES	Done.

Table 5-502

2. Too Dark/Too Light

The image cannot be seen properly because the brightness is inappropriate.

Cause/Faulty Locations	Step	Check Item	Result	Action
Setup of "Brightness"	1	"Brightness" setup properly? Normally middle value is fine, but this may need to be changed, depending on the document.	NO	Change the setup.
Setup of "Contrast"	2	"Contrast" setup properly?	NO	Change the setup.
Light Adjustment	3	Have you executed Light Adjustment?	NO	Execute the adjustment.

Table 5-503

3. Streaks in Image

Streaks in the feeding direction may appear in the image due to dirt on the reading glass. Dirt on the feeding rollers may also be transferred to the document.

When white streaks appear in the image, this is due to shading correction being performed when the reading glass is dirty.

Cause/Faulty Locations	Step	Check Item	Result	Action
Reading glass	1	Is the reading glass clean?	NO	Clean it. Replace the reading guide (reading glass) if it is damaged.
Roller	2	Is the surface clean?	NO	Clean or replace it.
Feed Unit	3	Is the feed path clean?	NO	Clean it.
CIS unit	4	Is the inside of the CIS unit clean?	NO	Clean or replace the reading unit.
Light Adjustment	5	Have you executed Light Adjustment?	NO	Execute the adjustment.

Table 5-504

4. Image Slanted

If the document is fed at an angle, the image will become slanted.

Cause/Faulty Locations	Step	Check Item	Result	Action
Placing documents	1	Is the document placed properly?	NO	Place properly.
	2	Are the document guides adjusted to fit the document width?	NO	Correct the position.
Setup of "Skew correction"	3	Was "Skew correction" set?	NO	Set it. You can correct the slant of an image using image processing.
Feeding documents	4	Are documents fed straight?	NO	Perform the checks in "IV. RESOLVING MALFUNCTIONS, 4.The Document Does Not Feed Properly".

Table 5-505

5. Wrong Image Size

There are margins around the image, or some of the image is missing.

Note: Set the paper size to “auto detection” when scanning batch of different size documents.

Cause/Faulty Locations	Step	Check Item	Result	Action
Setup of “Paper size”	1	Is the setup of “Paper size” correct?	NO	Change the setup.
Placing documents	2	Was the document placed in the correct position?	NO	Place the document in the correct position.
Setup of “Auto detection” for the paper size	3	Was “Auto detection” set?	NO	Set it.
Registration adjustment	4	Have you executed automatic registration adjustment or manual registration adjustment?	NO	Execute the adjustment.
Scale parameter adjustment	5	Have you executed scale parameter adjustment?	NO	Execute the adjustment.

Table 5-506

Note: For passports

- For details about conditions for scanning a passport and how to set the passport, refer to the user manual.
- If part of the scan image is missing, or if the scanner's correction function does not operate correctly, change the [Page Size] setting to a larger size (such as A4) in the setting screen of the scanner driver, and then scan the image again.
- If misfeeds or paper jams occur frequently, clean the feed roller, and clean the carrier sheet or change it to a new one.
- If the scan image is blurred, clean the carrier sheet or change the sheet to a new one.

6. Text Cannot be Seen

When the background includes colors or patterns, text may be hidden by the background when scanning in black and white. There are special modes such as [Advanced Text Enhancement] etc. for solving this problem.

Note: The problem may not be fixed, depending on the type of document.

Cause/Faulty Locations	Step	Check Item	Result	Action
Setup of "Mode"	1	Was the problem solved by setting to "Color" or "Grayscale"?	YES	Done.
	2	Was the problem solved by setting to a special mode such as [Advanced Text Enhancement] etc.?	YES	Done.
Setup of "Brightness"	3	Was the problem solved by changing the setup of "Brightness"?	YES	Done.
Setup of "File Type"	4	Is "Compression rate" high?	YES	Set "Compression rate" lower.

Table 5-507

7. Moire in Image

The moire effect occur when photos from magazines, catalogs, etc. are scanned at a low resolution.

Cause/Faulty Locations	Step	Check Item	Result	Action
Setup of "Moire Reduction"	1	Is "Moire Reduction" set?	NO	Set it.
			YES	Increase the resolution. Set to "High Quality Moire Reduction".

Table 5-508

VI. AFTER REPLACING PARTS

Some of the parts used in this machine require adjustments and settings after being replaced or disassembled and reassembled.

You should check the feed and images after replacing parts or reassembling and reassembling the machine.

◆ Control PCB

- 1) Execute [Regist Adjustment] and [Light Adjustment] in service mode.
- 2) Change the value in the [Counter] in service mode.
- 3) Execute the scale parameter adjustment in [Manual Adjust] screen in service mode.
- 4) Enter the serial number shown on the rating label at the main body in [Check Device] screen in service mode.

◆ Reading Unit

Execute [Regist Adjustment] and [Light Adjustment] in service mode.

◆ Registration Related Parts

If problems occur at the leading or trailing edge of images scanned after you replace or reassemble any registration related parts located in the feed path, such as a roller, a registration sensor (sub PCB), or a light guide, execute [Regist Adjustment] in service mode. Furthermore, execute the regist manual adjustment in [Manual Adjust] screen if necessary.

APPENDIX

I. GENERAL CIRCUIT DIAGRAM..... A-1	II. LIST OF SPECIAL EQUIPMENT A-2
-------------------------------------	---

I. GENERAL CIRCUIT DIAGRAM

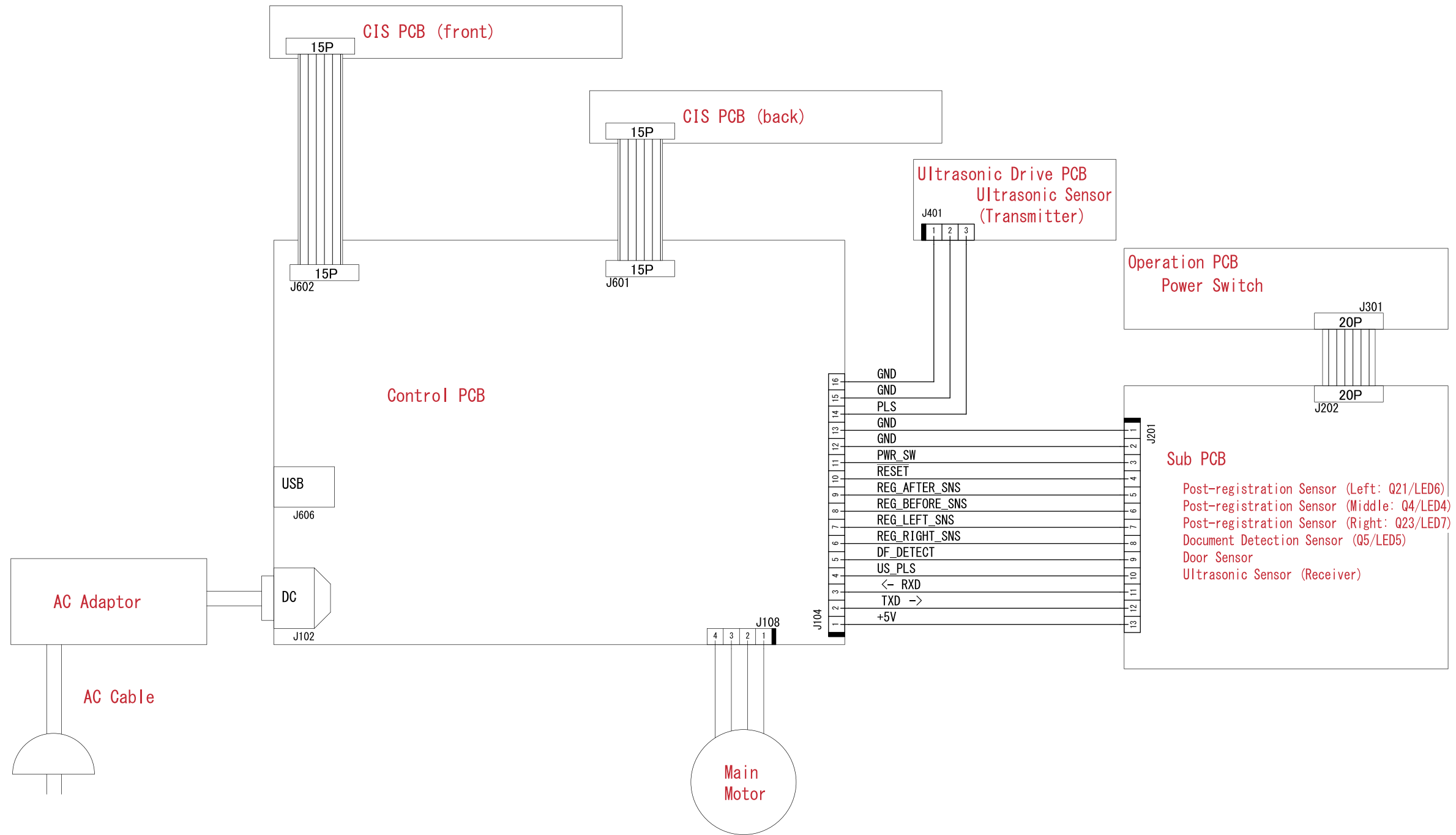

II. LIST OF SPECIAL EQUIPMENT

The list of special tools needed for service works on this machine is the following.

Note that these tools are the same as those used for other machines.

No.	Tool name	Tool number	Rank	Usage/Remarks
1	Test sheet	TKM-0271	A	For normal image display checking
2	Shading sheet	TKM-0326 or TKM-0332	B	For the light adjustment
3	Registration adjustment sheet	Self-made Draw a black line on the sheet No.2	B	For the registration adjustment
4	Scale parameter adjustment sheet	TKM-0271 or self-made	B	For the manual adjustment Can also be created from copier paper by the service technician.

Table A-201

Note: Rank notation:

A: Equipment that each service technician must carry.

B: Equipment that can be shared among a group of 5 service technicians.

C: Equipment that each workshop needs to have.

Prepared by

Quality Assurance Center
Canon Electronics Inc.

3-5-10 Shibakoen, Minato-ku
Tokyo 105-0011, Japan

FIRST EDITION: MAR. 2015

Canon