

DR-6080/9080C

SERVICE MANUAL

FIRST EDITION

Canon

OCT. 2003

MY8-13A1-000

COPYRIGHT © 2003 CANON ELECTRONICS INC.

Use of this manual should be
strictly supervised to avoid
disclosure of confidential
information

PREFACE

This Service Manual contains all the basic information required for field service and maintenance for maintaining the product quality and functions of the DR-6080/9080C.

CONTENTS

CHAPTER 1: GENERAL DESCRIPTION

Features, specifications, names of parts, and operation

CHAPTER 2: FUNCTIONS & OPERATION

Description of operation of mechanical and electrical systems by function

CHAPTER 3: DISASSEMBLY & REASSEMBLY

Description of disassembly and reassembly

CHAPTER 4: INSTALLATION & MAINTENANCE

Location and installation procedure, periodic replacement parts

CHAPTER 5: TROUBLESHOOTING

Service modes and troubleshooting procedures

APPENDIX: General circuit diagram, etc.

Information contained in this manual is subject to change without prior notice for improvement of the machine. Notification of changes will be given in the Service Information Bulletin.

Thoroughly read the information contained in this Service Manual and the Service Information Bulletins to gain a correct and deeper understanding of the machine. This is one way of fostering response for ensuring prolonged quality and function, and for investigating the cause of trouble during troubleshooting.

Quality Assurance Center
Canon Electronics Inc.

CONTENTS

CHAPTER 1: GENERAL DESCRIPTION

I. FEATURES.....	1-1	V. EXPLANATION OF OPERATION.....	1-11
II. SPECIFICATIONS.....	1-2	VI. REGULAR INSPECTION BY THE USER	
III. PRECAUTIONS.....	1-7	1-13
IV. NAMES OF PARTS.....	1-8		

CHAPTER 2: FUNCTIONS & OPERATION

I. OUTLINE.....	2-1	VII. INTERFACE.....	2-43
II. READING SYSTEM.....	2-7	VIII. OPTION.....	2-45
III. FEED SYSTEM.....	2-11	IX. LAYOUT OF ELECTRICAL	
IV. DESCRIPTION OF ELECTRICAL		COMPONENTS.....	2-49
CIRCUITS.....	2-21	X. LIST OF CONNECTORS, SWITCHES &	
V. IMAGE PROCESSING.....	2-25	LEDS FOR EACH PCB.....	2-53
VI. POWER SUPPLY.....	2-41		

CHAPTER 3: DISASSEMBLY & REASSEMBLY

I. EXTERNAL ASSEMBLY.....	3-1	IV. READING SECTION.....	3-35
II. DRIVE SYSTEM (MOTORS).....	3-12	V. ELECTRICAL PARTS.....	3-38
III. FEED SYSTEM (ROLLERS).....	3-22		

CHAPTER 4: INSTALLATION & MAINTENANCE

I. SELECTION OF LOCATION.....	4-1	VI. PERIODICALLY REPLACED PARTS....	4-16
II. UNPACKING & INSTALLATION.....	4-2	VII. CONSUMABLE PARTS AND	
III. IMPRINTER MOUNTING		CONSUMABLES.....	4-18
PROCEDURE.....	4-5	IV. PERIODIC MAINTENANCE SERVICE	
IV. ENDORSER ED600 MOUNTING		LIST.....	4-19
PROCEDURE.....	4-10		
V. MECHANICAL COUNTER			
INSTALLATION PROCEDURE.....	4-14		

CHAPTER 5: TROUBLESHOOTING

- | | |
|---------------------------------------|---|
| I. ERROR INDICATION AND SOLUTIONS 5-1 | V. IMAGE TROUBLESHOOTING.....5-22 |
| II. REMOVING DOCUMENT JAMS5-5 | VI. OPERATION TROUBLESHOOTING5-24 |
| III. SERVICE MODES5-7 | VII. FEED TROUBLESHOOTING.....5-26 |
| IV. USER MODES5-20 | VIII. AFTER REPLACING PARTS5-27 |

APPENDIX

- | | |
|--------------------------------------|-------------------------------|
| I. GENERAL CIRCUIT DIAGRAM A-1 | II. LIST OF SIGNALS A-3 |
|--------------------------------------|-------------------------------|

CHAPTER 1

GENERAL DESCRIPTION

I. FEATURES.....	1-1	IV. NAMES OF PARTS.....	1-8
II. SPECIFICATIONS.....	1-2	V. EXPLANATION OF OPERATION.....	1-11
III. PRECAUTIONS.....	1-7	VI. REGULAR INSPECTION BY THE USER	1-13

I. FEATURES

1. High Speed Scanning

Various-sized papers, from name cards or checks up to A3, can be scanned at high speed.

DR-9080C (Color, Grayscale, Binary)	DR-6080 (Grayscale, Binary)
50ppm (A4, 200 dpi, Color)	60ppm (A4, 200 dpi, Grayscale)
90ppm (A4, 200 dpi, Grayscale)	60ppm (A4, 200 dpi, Binary)
90ppm (A4, 200 dpi, Binary)	

2. High Durability

The unit is designed for a lifetime of up to 6 million sheets.

3. Easy Maintenance

Replacing the rollers, including the pick-up roller, feed roller and retard roller, can be handled by the user.

4. New Functions

New functions such as staple detection and double feed detection by ultrasonic are available.

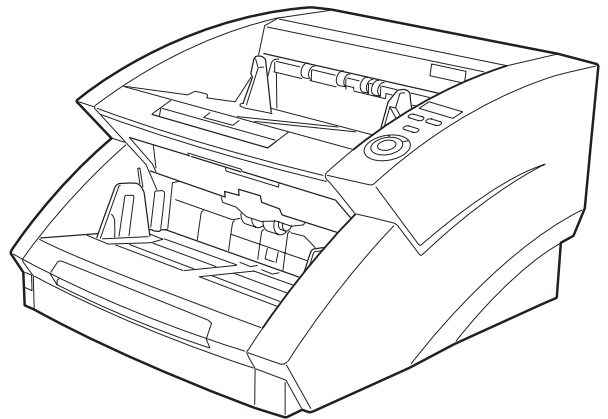

Fig. 1-101

Windows is a registered trademark of Microsoft Corporation in the U.S. and other countries.

Other company names and product names mentioned in this manual are registered trademarks or trademarks of the respective companies.

II. SPECIFICATIONS

1. Appearance / Installation

Item	Specifications	
	DR-9080C	DR-6080
1. Configuration	Desktop type	
2. Product model	1) 100 VAC, 50/60 Hz 2) 120 VAC, 60 Hz 3) 220-240 VAC, 50/60 Hz	
3. Rated power consumption or current	1) 100 VAC model: 120 W 2) 120 VAC model: 1 A 3) 220-240 VAC model: 0.5 A Note: Meets EnergyStar requirements. During sleep: 12 W or less.	
4. Performance-guaranteed ambience	15 to 27.5 °C 25 to 75%RH (Note: No condensation allowed.)	
5. Noise	1) Sound power level Standby: 40 dB or less Operation: 75 dB or less 2) Sound pressure level (By standers) Standby: 40 dB or less Operation: 60 dB or less	
6. Dimensions	Tray closed: 460 (W) x 525 (D) x 310 (H) mm	
7. Weight	Approx. 23 kg.	
8. Interface	1) SCSI-3 (ULTRA SCSI compatible) 2) USB 2.0 (High speed compatible)	
9. Bundled software	1) ISIS / TWAIN driver 2) CapturePerfect 2.0	
10. Expected product life	Whichever occurs first: 1) 5 years 2) Scans: 6,000,000 sheets (A4 size) Note: Some parts must be replaced during the product lifetime.	
11. Person in charge of installing	Service technician	
12. Options	1) Endorser: ED600 2) Imprinter 3) Hard counter (Mechanical counter) 4) Barcode module (CD-ROM)	
13. Consumable	1) Exchange roller kit 6080/9080C (pick-up/feed/retard rollers) 2) Ink cartridge (for imprinter) 3) Ink roller (for endorser) Note: These parts can be replaced by the users.	

Table 1-201

2. Document Scanning

Item	Specifications	
	DR-9080C	DR-6080
1. Sensor type	Contact Image Sensor (CIS)	
2. Sensor size	Density: 600 dpi. Effective elements: 7260 (305 mm)	
3. Output of sensor	10-bit digital output Note: Only 8 bits are available for image data.	
4. Light source	3 colors (RGB): 2 LEDs for each color	
5. Typical wave length	R: 620 nm, G: 530 nm, B: 467 nm	
6. Dropout color	Available: R/G/B	
7. Color emphasis	Available: R/G/B	
8. Scanning side	Simplex (Front/Back) / Duplex ^{*1} Note: Front/back reversing function is available.	
9. Scanning size (typical)	1) L series: LDR/LGL/LTR 2) A series: A3/A4/A5/A6 3) B series: B4/B5/B6	
10. Scanning size (atypical)	1) Main-scanning direction: Min. 64 pixels, Max. 305 mm 2) Sub-scanning direction: Min. 64 pixels, Max. 432 mm (1000 mm for long document mode)	
11. Output mode	1) Binary 2) Grayscale (8 bits: 256 gradations) 3) Color (24 bits) . ^{*1}	1) Binary 2) Grayscale (8 bits: 256 gradations)
12. Binary mode	1) Black and White (Simple binary) 2) Error diffusion 3) Advanced Text Enhancement (ATE) Note: ATE processing is done within the personal computer.	
13. Output resolution	1) 100 x 100 dpi 2) 150 x 150 dpi 3) 200 x 200 dpi 4) 240 x 240 dpi 5) 300 x 300 dpi 6) 400 x 400 dpi 7) 600 x 600 dpi . ^{*1}	

^{*1} When the document is large (A3 or LDR etc.), it is impossible to scan by duplex / color / 600 dpi due to the restriction of the memory capacity.

Table 1-202

3. Document Feeding

Item	Specifications		
	DR-9080C	DR-6080	
1. Document size	1) Width: 55 to 305 mm 2) Length: 70 to 432 mm (Up to 1000 mm for long document mode) 3) Thickness: Separation 0.06 to 0.15 mm, (48 to 120 g/m ²) Non-separation: 0.05 to 0.30 mm (40 to 240 g/m ²)		
2. Document requirements	1) Pressure-sensitive paper: Can be fed. (The orientation is restricted.) 2) Carbon-backed paper: Cannot be fed. 3) Perforated paper: Can be fed only if there are 2/3/4 holes that are $\phi 8$ mm or less in size. 4) Curled paper: Can be fed only if curl is 8 mm or less in height. (Total of the curled amount of max. pick-up storage) 5) Creased paper: Can be fed, but crease must be straightened before being fed. Note: When staple detection is used, paper curl must be 3 mm or less in height and creased paper cannot be fed.		
3. Pick-up mode	Normal/Panel/Auto/Manual Note: Manual here indicates manual feeding in non-separation mode.		
4. Pick-up storage	1) For A4 or smaller: 500 sheets (Must be 48 mm or less in height, including any curl.) 2) For larger than A4: The height must be less than 20 mm.		
5. Delivery storage	1) For A4 or smaller: 500 sheets (Must be 50 mm or less in height, including any curl.) 2) For larger than A4: The height must be less than 20 mm.		
6. Delivery direction	Face down		
7. Automatic size detection	Sensor/image processing		
8. Staple detection	1) Paper thickness: 0.06 to 0.12 mm 2) Paper size: A5 or Larger 3) Staple: Stapling must be in only one corner.		
9. Double feed detection	Overlapping (by ultrasonic)/Length		
10. Skew correction	Mechanical/image processing		
11. Feeding speed	Resolution	Binary/Grayscale	Color
	100 x 100 dpi	686 mm/sec	686 mm/sec
	150 x 150 dpi	686 mm/sec	457 mm/sec
	200 x 200 dpi	686 mm/sec	343 mm/sec
	240 x 240 dpi	686 mm/sec	286 mm/sec
	300 x 300 dpi	686 mm/sec	229 mm/sec
	400 x 400 dpi	286 mm/sec	96 mm/sec
	600 x 600 dpi	191 mm/sec	64 mm/sec

Table 1-203a (continued)

Item		Specifications				
		DR-9080C			DR-6080	
12. Scanning speed A4 size		Binary	Gray	Color	Binary	Gray
Simplex	100dpi	90 spm	90 spm	90 spm	90 spm	90 spm
	150dpi	90 spm	90 spm	69 spm	90 spm	90 spm
	200dpi	90 spm	90 spm	54 spm	63 spm	62 spm
	240dpi	90 spm	90 spm	46 spm	63 spm	62 spm
	300dpi	90 spm	87 spm	38 spm	63 spm	62 spm
	400dpi	47 spm	46 spm	16 spm	30 spm	30 spm
	600dpi	32 spm	25 spm	10 spm	20 spm	20 spm
Duplex	100dpi	90 spm	90 spm	90 spm	90 spm	90 spm
	150dpi	90 spm	90 spm	59 spm	90 spm	90 spm
	200dpi	90 spm	85 spm	46 spm	63 spm	63 spm
	240dpi	90 spm	65 spm	40 spm	63 spm	63 spm
	300dpi	90 spm	43 spm	32 spm	63 spm	42 spm
	400dpi	40 spm	26 spm	14 spm	30 spm	24 spm
	600dpi	28 spm	12 spm	6 spm	18 spm	11 spm
* spm = sheets per minute. The detailed conditions including JPEG value are omitted for grayscale and color, and may differ depending on function settings, the personal computer used, and other conditions. The color function is available only with the DR-9080C.						

Table 1-203b

4. Image Processing

Item	Specifications	
	DR-9080C	DR-6080
1. Brightness adjustment	255 levels	
2. Contrast adjustment	7 levels	
3. Gamma correction	Available (Standard/Custom)	
4. Smoothing	Available	
5. Dot erasing	Available	
6. Notch erasing	Available	
7. Border removal	Available	
8. Edge emphasis	Available (5 steps)	
9. Document orientation	Available (0° /90° /180° /270°)	
10. Reverse image	Available (only for binary mode)	
11. Text orientation recognition	Available	

Table 1-204

5. Other Functions

Item	Specifications	
	DR-9080C	DR-6080
1. Long document mode	Available	
2. Add-on	Available	
3. Scan-ahead mode	Available	
4. Count-only	Available	
5. Count verifying	Available	
6. Margin scan	Available	
7. Separate	Patch code/New file button	
8. Self-diagnostic function	Available	
9. Cumulative counter	Stored in the memory (The mechanical counter is option.)	
10. Operation panel	5 buttons; Display LED: 5 digits	

Table 1-205

These specifications are subject to change with improvements to the product.

III. PRECAUTIONS

This section describes items that require particular care regarding safety. These precautions must be observed. Explain to the user items that relate to safety, and instruct the user to take appropriate action.

1. Power OFF in Emergencies

When abnormal noise, smoke, heat or odor occur, turn the power OFF immediately and unplug the power cord.

As it may cause injury, be careful not to get clothing (ties, long hair, etc.) caught in the machine.

If this happens, turn the power OFF immediately.

Also, do not insert your fingers in the feed section while feeding documents.

2. Electromagnetic Interference Countermeasures

This machine complies with the electromagnetic interference standards (VCCI-A, FCC-A, etc.). However, the user might have to carry out separate countermeasures if the machine causes electromagnetic interference.

Do not change or modify this machine's specifications. If this has been carried out, its use may be forcibly discontinued on site. If the machine is disassembled and reassembled, follow the instructions described in this manual or in the Service Information Bulletins.

A "CAUTION LABEL" is affixed to the rear of the machine.

<p>This device complies with Part 15 of the FCC Rules. Operation is subject to the following two conditions: (1) This device may not cause harmful interference, and (2) this device must accept any interference received, including interference that may cause undesired operation.</p>	<p>This Class A digital apparatus meets all requirements of the Canadian Interference-Causing Equipment Regulations. Cet appareil numérique de la classe A respecte toutes les exigences du Règlement sur le matériel brouilleur du Canada.</p>
--	--

CAUTION LABEL (120V machines)

3. User's Manual

Read the user's manual thoroughly before using this machine.

4. Ink Cartridge

Obey the handling instruction written in the package of the ink cartridge.

5. Disposal

When disposing of the products and parts, obey local regulations.

IV. NAMES OF PARTS

1. Front View

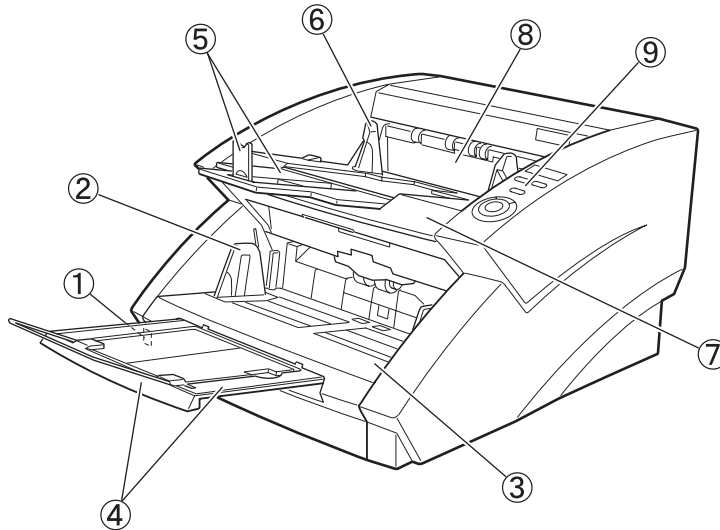

- | | |
|---|-----------------------------|
| ① Power switch | ⑥ Document eject tray guide |
| ② Document guide | ⑦ Upper unit |
| ③ Document tray | ⑧ Imprinter cover |
| ④ Document tray extension / wire | ⑨ Operation panel |
| ⑤ Document eject tray extension / stopper | |

Fig. 1-401

2. Rear View

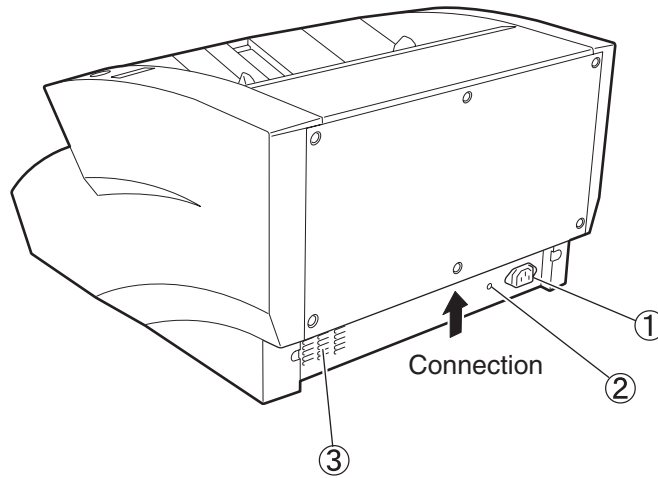

- ① Power cord connector
- ② Grounding terminal

- ③ Air vent

Fig. 1-402

Note: Do not block the air vent, otherwise the temperature will rise inside the machine and a fire might result.

3. Connection (Bottom view)

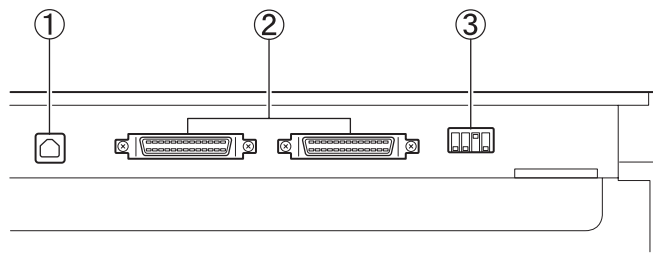

- ① USB connector
- ② SCSI connector

- ③ DIP switch

Fig. 1-403

4. Operation Panel

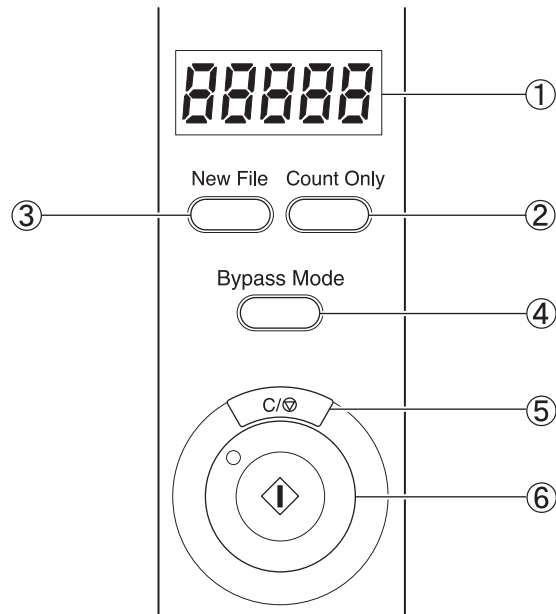

- ① Counter display
- ② Count Only key
- ③ New File key

- ④ Bypass Mode key
- ⑤ Stop key
- ⑥ Start key

Fig. 1-404

V. EXPLANATION OF OPERATION

For details, refer to the user's manual of this machine and the software used for its operation.

1. Basic Operation

The basic procedure for operating this machine is as follows:

- 1) Turn the machine ON.
- 2) Turn the personal computer ON.
- 3) Start up the software.
- 4) Set the documents.
- 5) Execute the operation.
- 6) Finish the operation.
- 7) Quit the application software.
- 8) Turn the personal computer OFF.
- 9) Turn the machine OFF.

2. Operation Window

The basic procedure for operating this machine is as follows. In the "CapturePerfect 2.0" bundled with the product, a "TWAIN" driver is used.

1) CapturePerfect 2.0

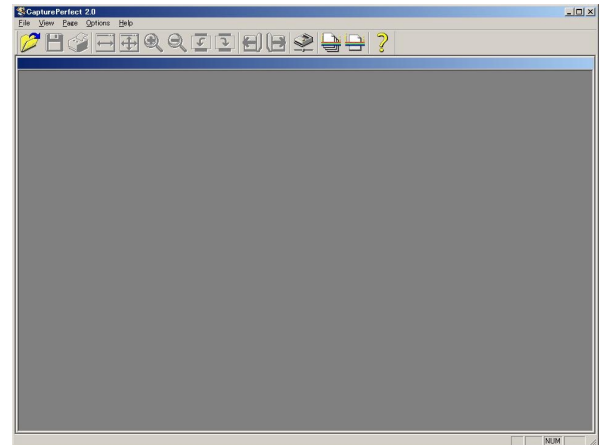

Fig. 1-501

2) Scanner Settings

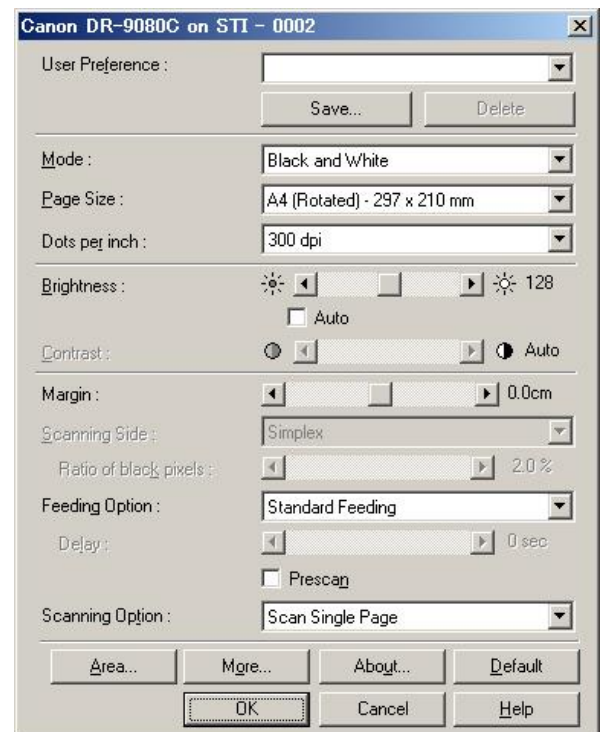

Fig. 1-502

3) Advanced Settings

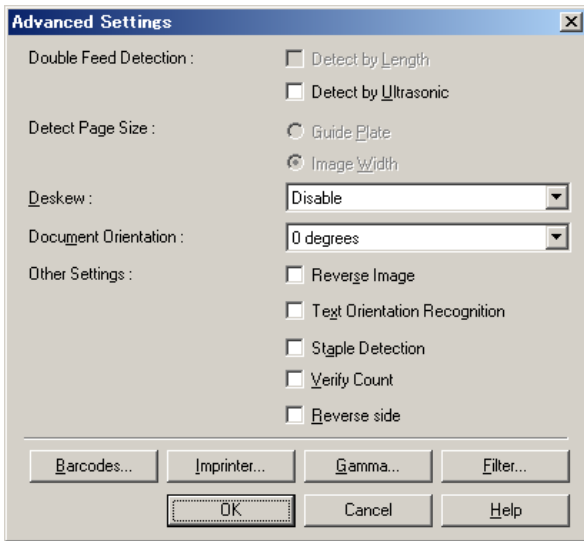

Fig. 1-503

5) Save As

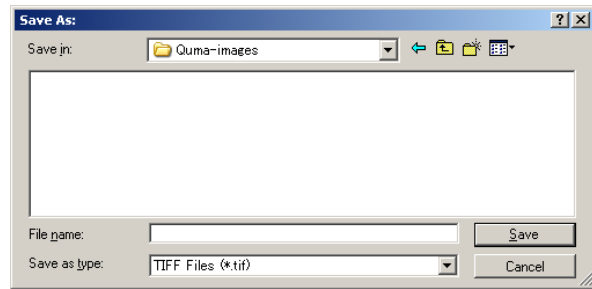

Fig. 1-505

4) Filter Settings

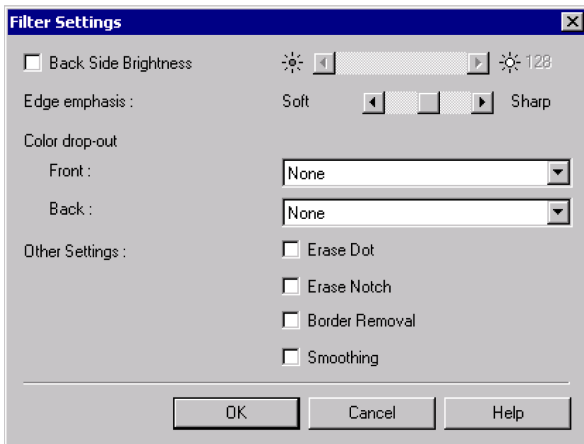

Fig. 1-504

VI. REGULAR INSPECTION BY THE USER

Instruct the user that the following locations must be cleaned about once a week.

For the details, refer to the user's manual.

1. Exterior

Wipe the covers with a cloth tightly wrung with water or neutral detergent soaked, and then wipe dry.

2. Document Sensor

Take off the dusts gathered on the document sensors with a blower or equivalent.

3. Reading glass

Wipe the reading glass (Upper, Lower) with a cloth tightly wrung with water and then wipe dry.

4. Feeder Assembly

Wipe the following rollers with a cloth tightly wrung with water and then wipe dry:

- 1) Pick-up roller
- 2) Feed roller
- 3) Retard roller
- 4) Platen roller
- 5) Feeder roller

5. Cleaning of Shading plates

Even when the reading glass and the rollers are cleaned, if the scanned image is streaked, the shading plate may be stained.

Wipe the shading plates (Upper, Lower) with a cloth tightly wrung with water and then wipe dry.

Note: Since the machine is being turned ON, be careful to proceed the work. And, take care so that the shading plates may not creased.

6. Power Cord

After the power cord is plugged in to the outlet for a long period of time, dust will collect on the connected part and could cause a fire or electric shocks. To prevent this, clean it regularly.

7. Imprinter (guide plate)

If ink adheres to the guide plate located in the inner part of the imprinter, it may contaminate the document during scanning operation. Wipe the guide plate with a cloth tightly wrung with water or neutral detergent soaked, and then wipe dry. To prevent this, clean it regularly.

8. Imprinter (ink cartridge)

Wipe softly the ink adhered to the ink nozzle of the ink cartridges with a lint-free cloth or paper (A cotton-tipped swab is also acceptable). Be careful not to wipe or touch the electrical contact part when wiping the ink.

CHAPTER 2

FUNCTIONS & OPERATION

I. OUTLINE	2-1	VII. INTERFACE	2-43
II. READING SYSTEM	2-7	VIII. OPTION	2-45
III. FEED SYSTEM	2-11	IX. LAYOUT OF ELECTRICAL COMPONENTS	2-49
IV. DESCRIPTION OF ELECTRICAL CIRCUITS.....	2-21	X. LIST OF CONNECTORS, SWITCHES & LEDS FOR EACH PCB.....	2-53
V. IMAGE PROCESSING.....	2-25		
VI. POWER SUPPLY	2-41		

I. OUTLINE

1. System Configuration

The system configuration is shown in Fig. 2-101.

For the computer specifications and operating environment, refer to the user's manual.

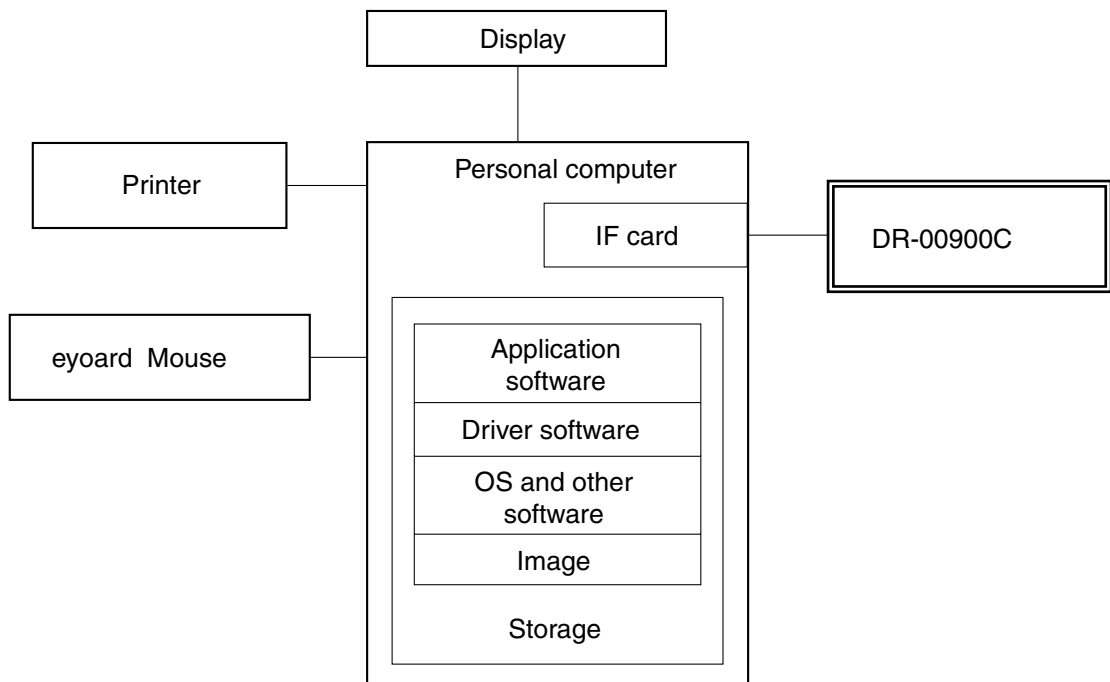

Fig. 2-101

2. Machine Internal Configuration

The machine internal configuration is shown in Fig. 2-102.

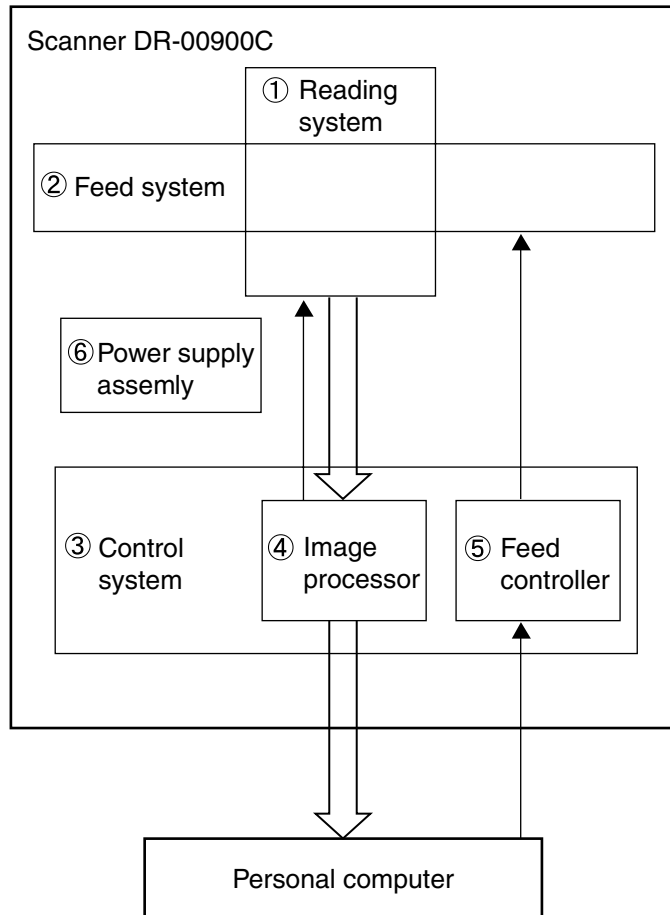

Fig. 2-102

Component	General Description
① Reading system	Scans image data from front and back sides of documents using the image sensors (CIS) of the reading units (front and back).
② Feed system	Picks up, feeds, and ejects documents placed on the document tray, using motors and rollers.
③ Control system	The control system consists of the image processor and the feed controller.
④ Image processor	Controls the reading system, processes the image data from the reading system, and outputs the data to the personal computer.
⑤ Feed controller	Controls the feed system and image processor.
⑥ Power supply assembly	Converts AC power to +24 VDC and supplies it to the various PCB assemblies.

Table 2-101

3. Motor Drive Configuration

The motor drive configuration for picking up and feeding documents is shown in Fig. 2-103.

This unit employs five motors consisting of the document tray motor (M6) for raising and

lowering documents, the pick-up motor (M2) for picking up documents, the retard motor (M5) for separating documents, the feed motor (M3) for feeding documents, and the main motor (M1) for feeding documents throughout the system.

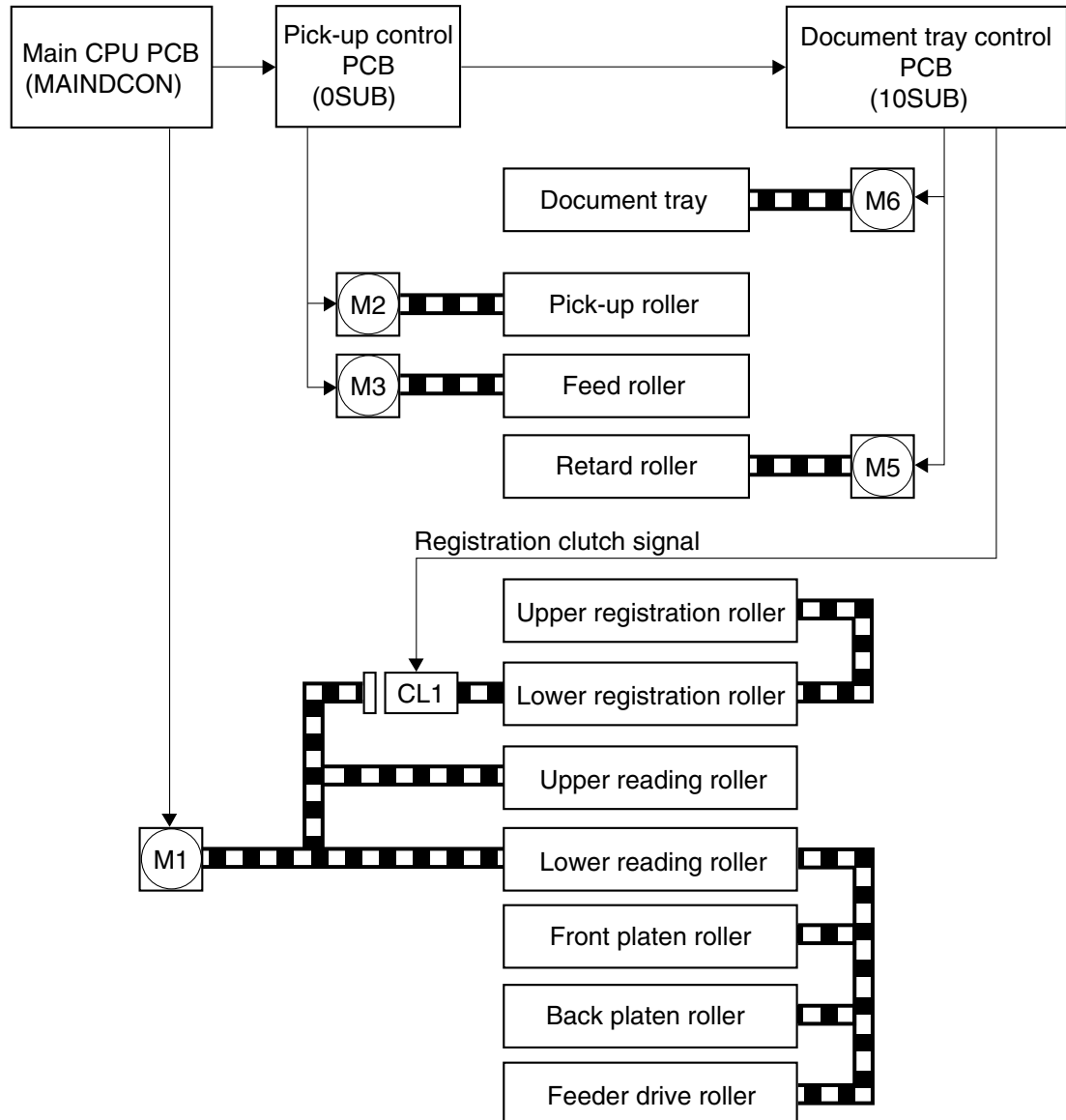

Fig. 2-103

4. Electrical Circuits

This machine uses three electrical circuits consisting of a main CPU PCB, a pick-up control PCB, and a document tray control PCB. A block diagram of these three circuits is shown in Fig. 2-104.

The pick-up control PCB controls pick-up of the document based on signals from the main CPU PCB. The document tray control PCB assembly controls the document tray based on signals from the main CPU PCB assembly and the pick-up control PCB.

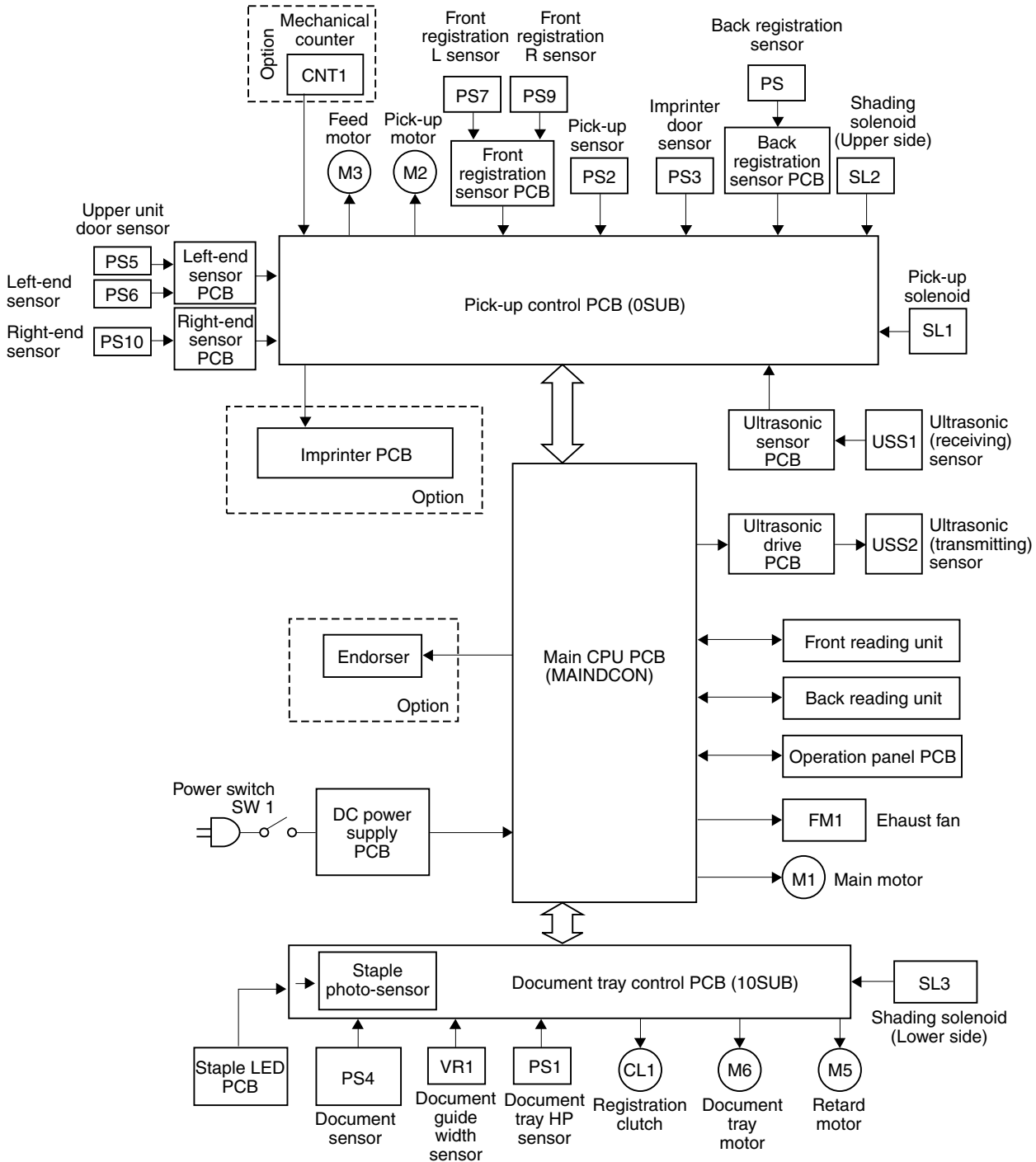
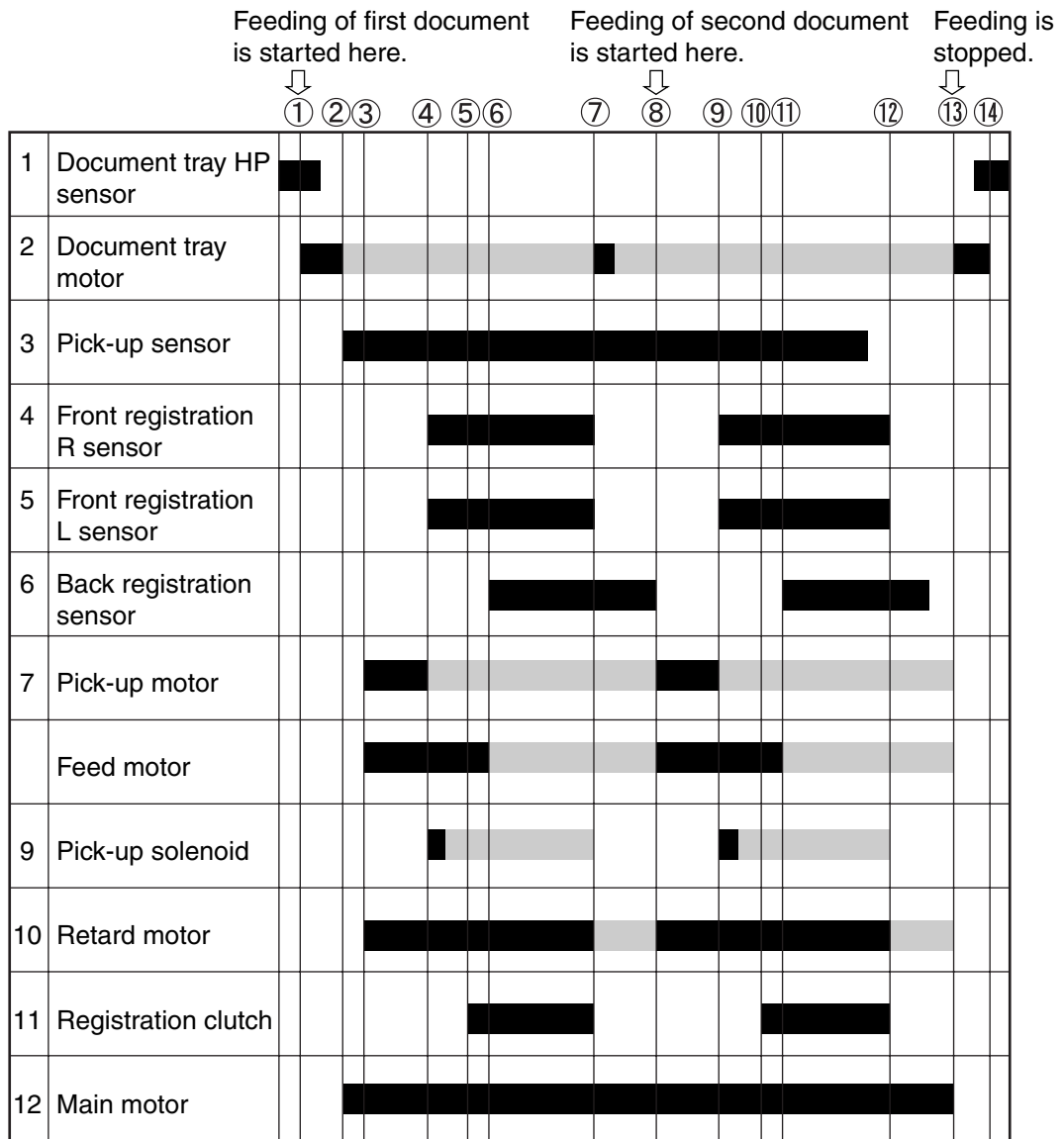

Fig. 2-104

5. Feed Timing Chart

Fig. 2-105 shows the feed timing chart. Table 2-102 explains points ① to ⑭ shown in the figure.

Feed condition: 1: Middle speed feeding, 2: Standard feeding, 3: Two documents, 4: No temporary stop



Note 1: Black area indicates the activating condition and gray area indicates the condition of staying at the present position with the torque dropped down.
 Note 2: If there is a difference in the timing marked, it indicates the occurrence of skewing.

Fig. 2-105

No.	Explanation
①	When documents are placed on the document tray and pick-up is started, the document tray motor is started. The document tray is raised by a preset amount after the document tray HP sensor is switched from ON to OFF.
②	When the document tray is raised and the pick-up sensor detects the document, the document tray motor stops and the main motor is started.
③	The pick-up motor, feed motor, and retard motor are started at the same time.
④	When the two front registration sensors (R & L) detect the document, the pick-up motor stops and the pick-up solenoid turns ON. While the pick-up solenoid is ON, the pick-up roller retracts from the document. If there is a difference in detection timing between the front registration sensors (R & L), it indicates skewing. When roller deskew (skew correction) is selected, the document is pressed against the registration roller to perform skew correction.
⑤	The registration clutch is turned ON a specified time after the front registration sensors (R & L) detect the document together.
⑥	After the back registration sensor detects a document, the feed motor stops.
⑦	After the end of the document passes the front registration sensors (R/L), the document tray is raised by one sheet when both sensors detect no document.
⑧	After the end of the document passes the back registration sensor, feeding of the second document is started when the sensor detects no document.
⑨	Same as ④.
⑩	Same as ⑤.
⑪	Same as ⑥.
⑫	After the end of the document passes the front registration sensors (R & L), the registration clutch is turned OFF when both sensors detect no document. Since the pick-up sensor is turned off, no document is detected on the document tray.
⑬	After the end of the document passes the back registration sensor, the pick-up motor, feed motor, retard motor and main motor are turned OFF a given period of time after the sensor detects no document. The document tray motor turns in reverse to lower the document tray.
⑭	A given period of time after the document tray HP sensor switches from OFF to ON, the document tray motor is turned OFF.

Note: In high speed feeding, the second document is picked up immediately after the end of the first document passes the front registration sensors (R & L) and both sensors detect no document. In slow speed feeding, the second document is picked up a given time after both sensors detect no document, after the end of the first document passes the back registration sensor. Thus, the document feeding can maintain specific intervals for high speed, medium speed, and slow speed feeding.

Table 2-102

II. READING SYSTEM

1. Outline

Fig. 2-201 shows the reading system.

The reading system consists of the image reading units and platen rollers.

The front reading unit reads the front side of the documents and the back reading unit reads the back side. This configuration enables the unit

to read both the front and back sides of a document at one time using a single pass.

These reading units illuminate the document from different directions using two LEDs to prevent shadows, and the analog image data are internally converted to 10-bit digital signals and then sent to the image processor on the main CPU PCB.

The platen rollers hold the document tightly against the reading glass to keep it in focus.

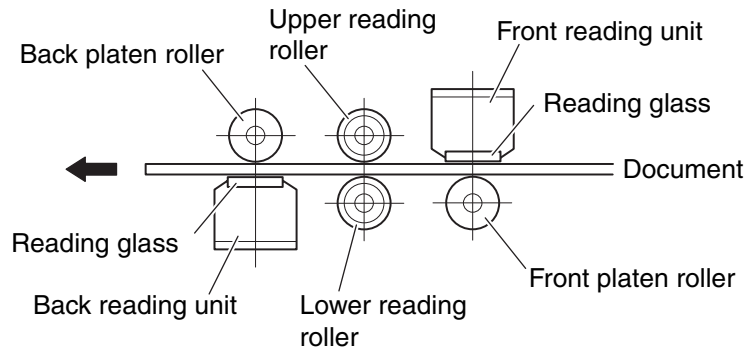

Fig. 2-201

The platen rollers hold the document against the reading glass. Two springs are attached to the back side of the reading units, to feed both thick and thin documents under the same conditions. (Refer to Fig. 2-202)

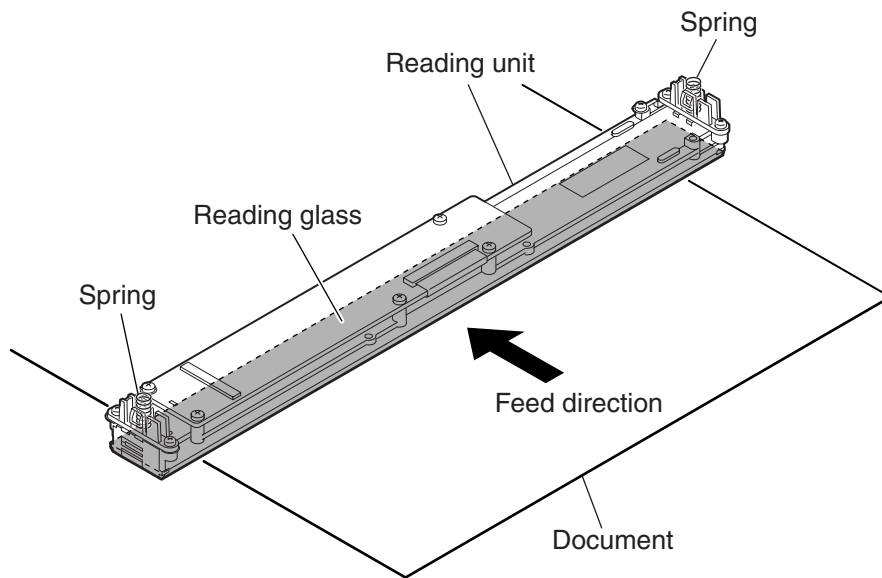

Fig. 2-202

However, if the platen rollers were to touch the reading glass when rotating, it might leave marks. Therefore, two spacers are attached to the platen rollers outside the image reading area, and the outer diameter of the spacers is a little bit larger than that of the platen rollers. This provides a small gap between the platen rollers and the reading glass when the platen rollers hold the document against the reading glass. (Refer to Fig. 2-203)

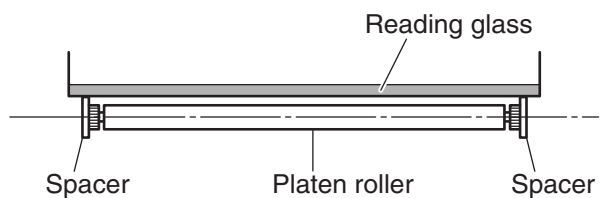

Fig. 2-203

2. Reading Unit Configuration

Fig. 2-204 is a sectional diagram of the reading unit. The reading unit consists of the sensor drive PCB, image sensor PCB, lens array, LEDs (R/G/B), light guide, and reading glass.

The contact image sensors (CIS) are mounted on the image sensor PCB in a single row, with a density of 600 dpi. The valid reading width is 305 mm, and the number of valid pixels is 7260. The optical resolution can be switched between 600 dpi and 300 dpi by an external signal.

The main feature of this reading unit is that it provides lighting for the image sensors using two LEDs, lighting the document from both the right and left sides as shown in the figure. The light guides are arranged on the right and left side, and a red (R), green (G), and blue (B) LED is arranged for each light guide on the image sensor PCB.

LEDs light illuminate the document through the light guides, and the light reflected from the document enters the image sensors through the lens array. The image sensors convert the light to an analog signal. The analog signal is sent to the sensor drive PCB, and then to the main CPU PCB as a digital signal after A/D conversion and shading correction.

In the binary or grayscale mode, the image is read with composite light generated by lighting all the RGB LEDs simultaneously. In the color mode, the RGB LEDs are sequentially lit, and the image data is read separately for each color. In the drop-out color mode, only the LEDs of the designated color are lit.

In the previous models (DR-5020/5080C), A/D conversion and shading correction were handled by the image processor on the main CPU PCB, but in this model they are processed internally by the reading unit.

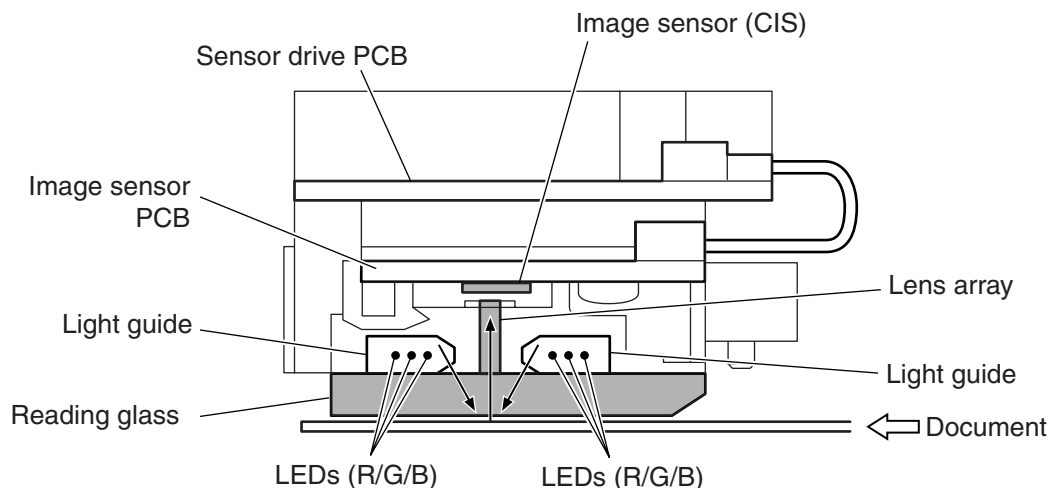

Fig. 2-204

3. Shading

In the previous models (DR-5020/5080C), a shading sheet had to be prepared separately, and the shading correction value was determined using the service mode, but this model incorporates a shading plate and a shading correction value determined by the reading unit can be used.

Two shading plates are mounted near the front and back platen rollers.

1) Shading plate mechanism

Fig. 2-205 shows the arrangement of the shading plate for the back platen roller.

The shading plate is a white sheet, 0.1 mm thick, housed near the platen roller, and is normally not visible. When shading is performed, the shading solenoid pulls in, so that the shading plate coupled to the gear pops out over the platen roller.

The lower shading plate carries out the shading for the front reading unit, and the upper shading plate does the same for the back reading unit. When the shading is completed, the shading plates move back to their original positions.

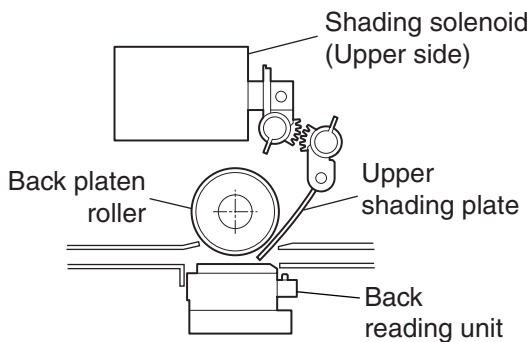

Fig. 2-205

2) Shading plate timing

The operation of the shading plates is carried out using the timing shown below.

- a. when the power is on
- b. after the upper unit is open or closed
- c. after recovering from power-saving mode
- d. at the beginning of batch processing
- e. when feeding is started, after no feeding for 10 minutes, during batch-to-batch processing

At the points a, b, and c, LED intensity is adjusted. At d and e, white level adjustment (gain adjustment) and black level adjustment (offset adjustment) are performed according to the LED intensity set at a, b, and c.

The LED intensity adjustment is carried out by changing the lighting time of the LED. When the shading plate pops out at points a, b, and c, the LED lighting time under the black-and-white (same for grayscale) and color conditions are determined by the reading unit and saved.

In this model, the white and black level adjustments are performed by the reading unit for each picture element, and the adjustment value is saved on the sensor drive PCB of the reading unit.

III. FEED SYSTEM

1. Outline

Fig. 2-301 shows a cross section of the document feed system.

The various drive rollers are rotated by motors via gears and timing belts.

For controlling the document feed, various sensors are arranged in necessary positions of the system. The arrangement of the sensors is shown in Fig. 2-301, 2-302 and 2-303.

The document feed system is equipped with the following functions.

- Document tray driving mechanism
During pick-up, this mechanism raises the document tray, and when pick-up is finished, lowers it.
- Separating mechanism
Overlapped documents can be separated by the retard roller and the feed roller, to feed the documents one by one.
- Staple detection
Detects the jumping up of documents bundled by staples when they are picked up, and stops the feeding.
- Skew correction mechanism
Detects skewed documents, enabling correction by the rollers, as well as in the scanned image. This selection is performed by the computer.
- Ultrasonic double feed detection
Overlapping documents (indicating double feeding) can be detected by the ultrasonic sensor.
- Feed error detection
Feed errors (jams) can be detected by the registration sensors (front & back).
- Special feed mode
Checks the feed condition of the machine without using the personal computer.

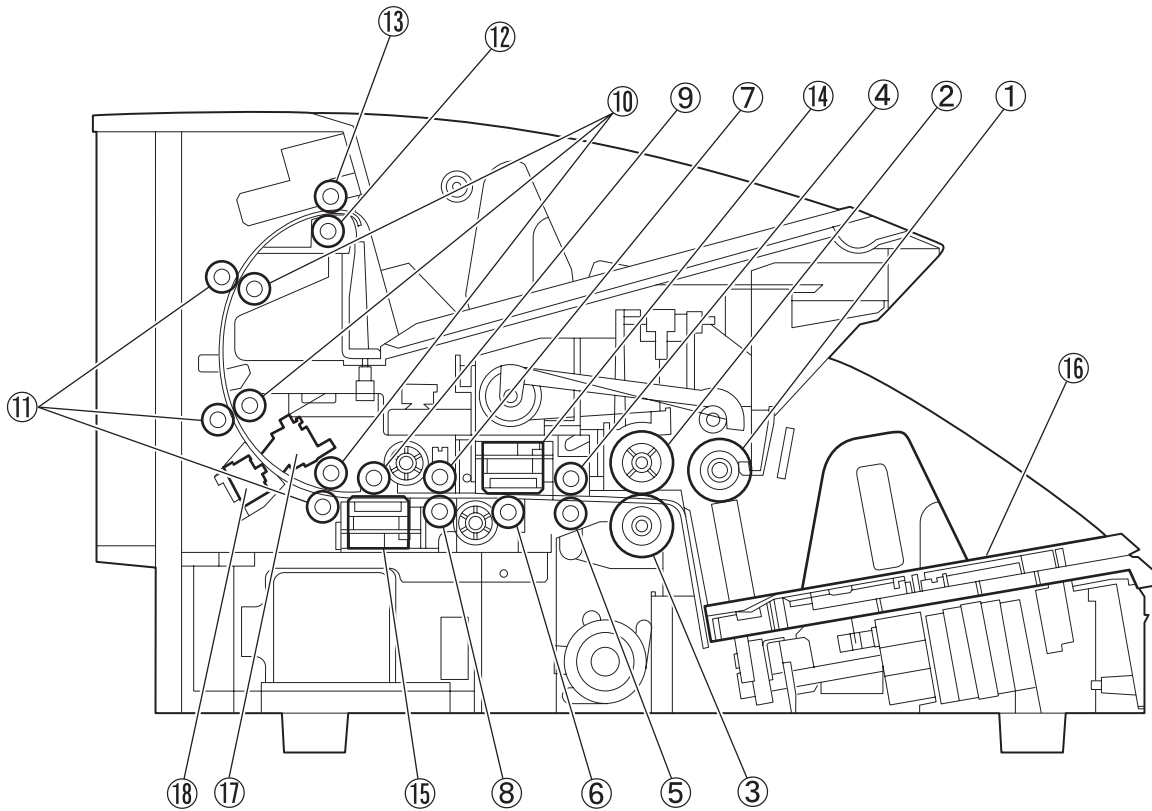

- | | |
|-----------------------------|------------------------------------|
| ① Pick-up roller | ⑩ Feeder follower roller |
| ② Feed roller | ⑪ Feeder drive roller |
| ③ Retard roller | ⑫ Delivery follower roller |
| ④ Upper registration roller | ⑬ Delivery drive roller |
| ⑤ Lower registration roller | ⑭ Front reading unit |
| ⑥ Front platen roller | ⑮ Back reading unit |
| ⑦ Upper reading roller | ⑯ Document tray |
| ⑧ Lower reading roller | ⑰ Ultrasonic (receiving) sensor |
| ⑨ Back platen roller | ⑱ Ultrasonic (transmitting) sensor |

Fig. 2-301

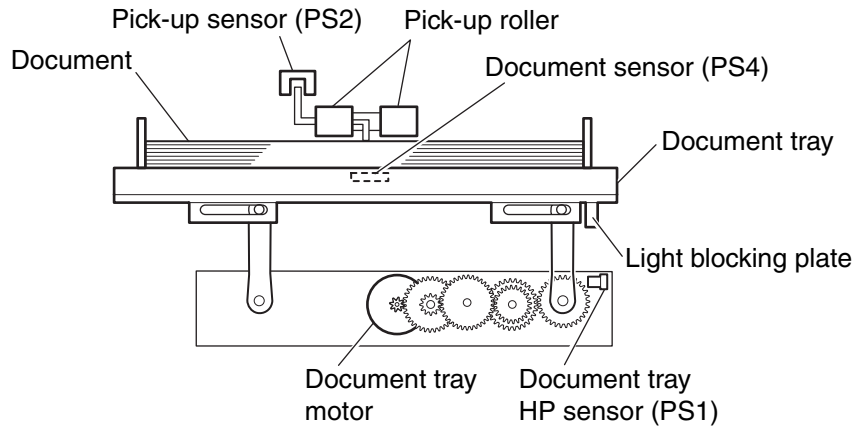

Fig. 2-302

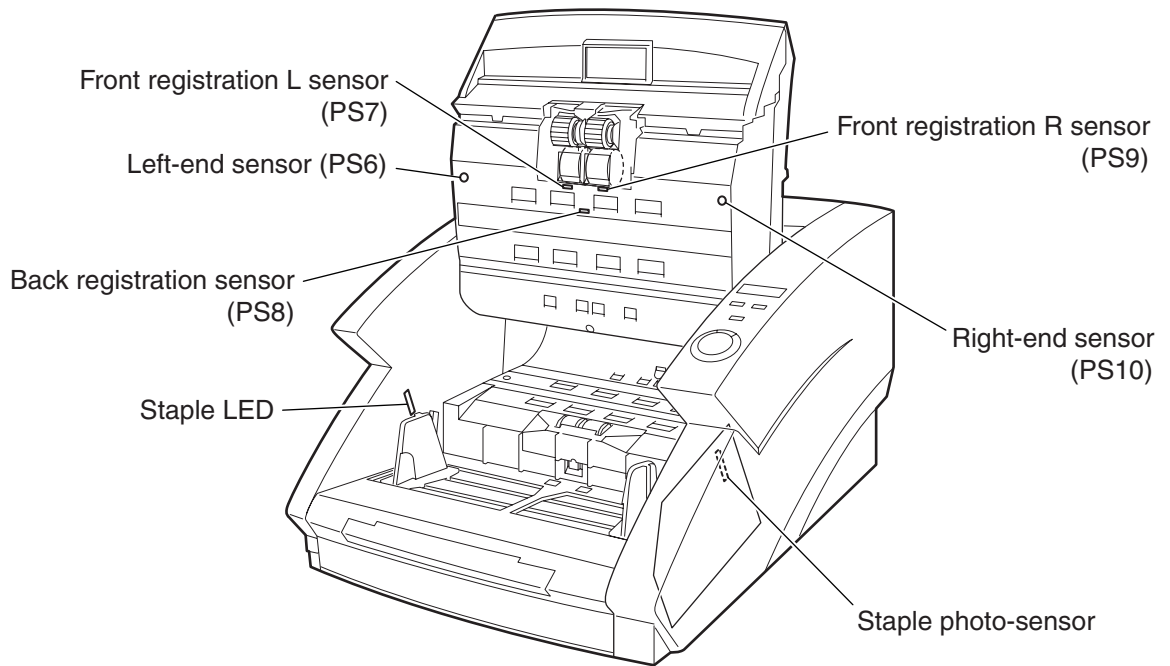

Fig. 2-303

2. Document Tray Driving Mechanism

Fig. 2-304 shows the document tray being lowered and Fig. 2-305 shows the document tray being raised.

The document tray for holding documents and a box unit designed to raise and lower the document tray work together. The arms for supporting the document tray are attached to the four corners of the box unit.

The rollers attached at the front ends of the arms are fitted to the document tray. When the arms rotate in a clockwise direction as they are laid down (Refer to Fig. 2-304), the document tray is raised up.

When the arms rotate in a counterclockwise direction as they stand vertically (Refer to Fig. 2-305), the document tray is lowered. Thus, moving the arms of the box unit enables the raising and lowering of the document tray.

Of the four arms, only the two arms fixed to the right-end gear shaft are coupled to the gear.

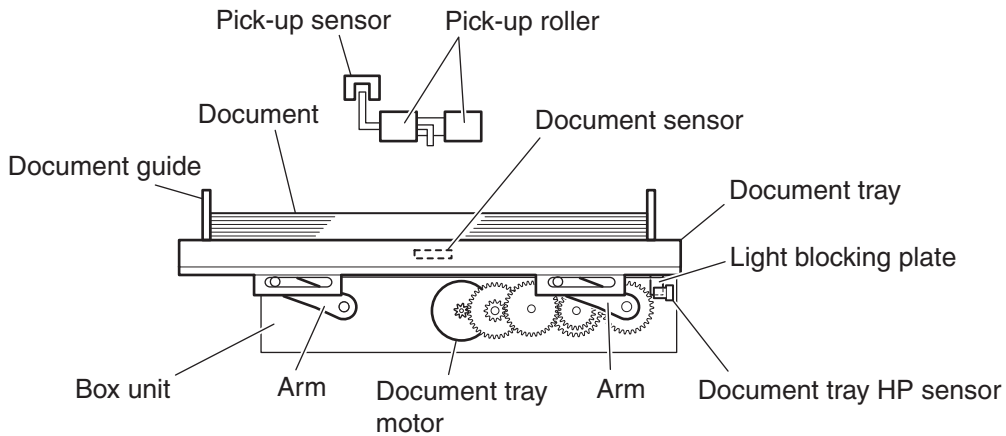

Fig. 2-304

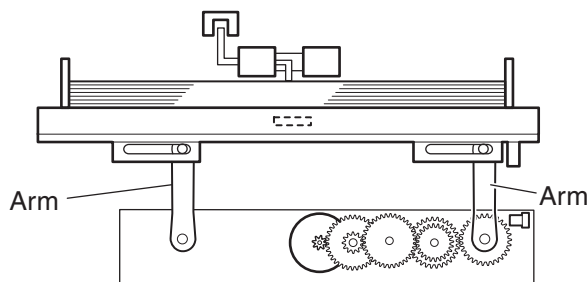

Fig. 2-305

First, the raising of the document tray will be explained.

- 1) When a document getting picked up is detected by the document sensor of the document tray, the document tray motor is started.
- 2) When the motor force is transmitted to the gear and the gear is rotating, the front and back arms fixed to the right-end gear shaft begin to rotate in a clockwise direction as they are laid down. At the same time, the document tray begins to rise.
- 3) After the document tray is slightly raised and the light blocking plate installed on the document tray switches the document tray HP sensor OFF, the document tray is raised until the motor has rotated a preset amount.
- 4) When the lever located between the pick-up rollers is pushed up by the document to turn ON the pick-up sensor, while the document tray is being raised, the document tray motor stops. At the same time, the raising of the document tray is stopped.
- 5) After that, the pick-up motor and feed motor are started simultaneously to feed the document.

Next, the lowering of the document tray will be explained.

- 1) When the documents on the document tray run out, the pick-up sensor detects no document.
- 2) After a given time, the document tray motor begins to rotate in reverse.
- 3) The front and back arms fixed to the right-end gear shaft begin to rotate in a counterclockwise direction as they stand vertically. At the same time, the document tray begins to drop down.
- 4) The light blocking plate moves, switching the document tray HP sensor from OFF to ON, and the document tray is stopped.

3. Separation Mechanism

Fig. 2-306 shows the configuration of the separation mechanism.

The retard roller is configured in elastic body and is transmitted the feed driving force in reverse to the feed roller. Since the torque limiter is mounted on the drive transmission assembly of the retard roller, when the friction of the feed roller and the document exceeds the specified value, the retard roller begins to rotate in the same feeding direction as the feed roller.

As shown in Fig. 2-306-a, when overlapped documents enter into the space between the feed roller and the retard roller, the document in contact with the feed roller is fed in the feeding direction, and the retard roller rotates in the reverse direction so that the document in contact with the retard roller is pushed backwards.

As shown in Fig. 2-306-b, once a single document remains, the retard roller rotates in conjunction with the feed roller to feed the document.

When the Bypass Mode key on the operation panel is pressed, or Manual Feed is selected on the computer, the driving of the feed roller is turned OFF and the retard roller begins to rotate in the forward direction, invalidating the separation function.

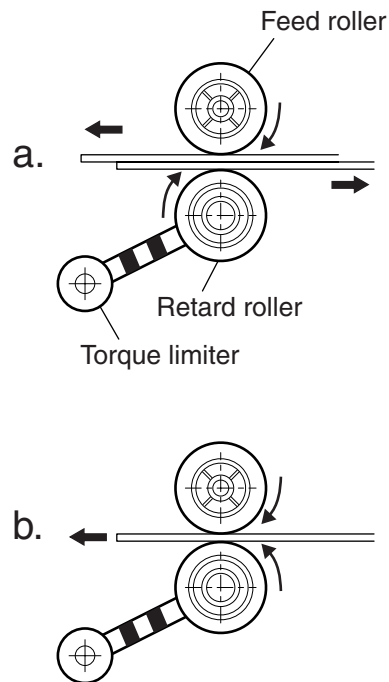

Fig. 2-306

4. Staple Detection

In this unit, a staple detection mechanism is employed which detects the jumping up of stapled documents. This mechanism is designed not to detect the staple itself, but to detect the jumping up of the stapled documents, and to stop the feeding. As such, it prevents stapled documents from being torn apart.

Fig. 2-307 shows a stapled document jumping up due to the pick-up roller.

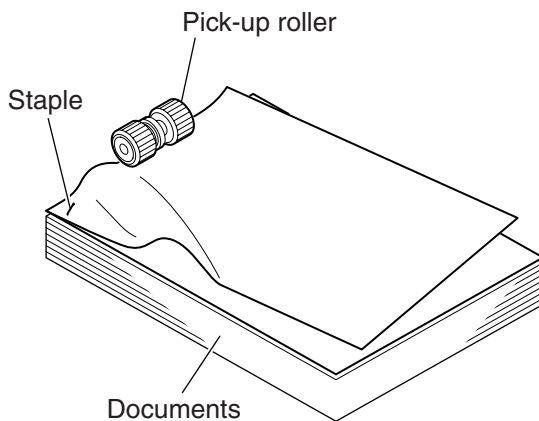

Fig. 2-307

Fig. 2-308 shows the configuration of the staple detection.

The staple detection consists of staple LEDs and a staple photo-sensor, arranged on both sides of the document pick-up opening. If there is no staple in the documents, the light emitted from the LEDs is received by the photo-sensor. If the stapled documents jump up, the light gets blocked and the documents are found to be stapled, resulting in stopping the feeding.

The five staple LEDs are mounted on the staple LED PCB. The staple photo-sensor has five sensors that correspond to the five LEDs on the staple LED PCB, and is directly mounted on the document tray control PCB (10_SUB).

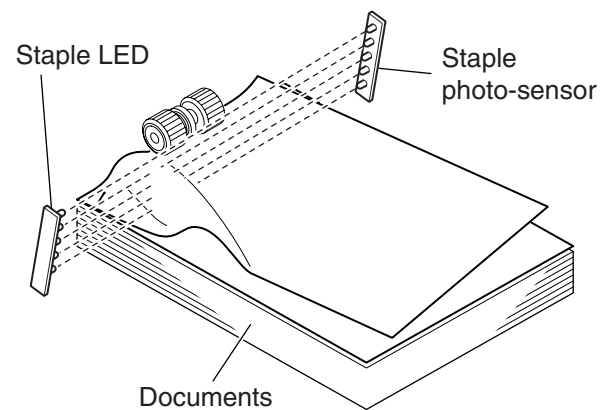

Fig. 2-308

Note: Because the documents do not jump up under the following conditions, the staple detection sensor will not work:

- When there are two or more stapled places.
- When the staple is not positioned at a corner.
- When the documents are smaller than A5.

Document curl must be 3 mm or less in height and the documents cannot be creased.

It is possible to change the level of detection accuracy with the user mode.

5 Skew Correction Mechanism

The skew correction (deskew) uses the front registration sensors and the registration rollers. Skew is detected by the front registration sensor and then is corrected by the registration rollers. Fig. 2-309 shows the arrangement of the front registration sensors and Fig. 2-310 shows the skew correction mechanism.

As shown in Fig. 2-309, the front registration sensors consist of the left sensor (L) and the right sensor (R), and are mounted in front of the registration roller. If no skewing occurs, there is no difference in the timing for both sensors detecting the document. However, if the document is skewed, one of the sensors detects the document earlier and there is a difference in the timing of detecting the document. As the skew amount is increased, the difference is also increased. The difference affects the time of the skew correction performed by the registration roller, and an increased difference will prolong the skew correction time.

The time taken from the time both sensors detect the document together until the registration roller begins to rotate is the time required for the skew correction.

As shown in Fig. 2-310, the skew correction is performed at the registration roller area. When the feed roller feeds the document in the feeding direction, either the right or left front end of the document runs into the registration roller. Since the registration roller remains stopped, the document is turned on the fore-end of the document run into the registration roller so that the skew is corrected. (Refer to Fig. 2-310-a)

When the skew correction is performed after both sensors detect the document together, the registration roller begins to rotate and the document is fed without being skewed. (Refer to 2-310-b)

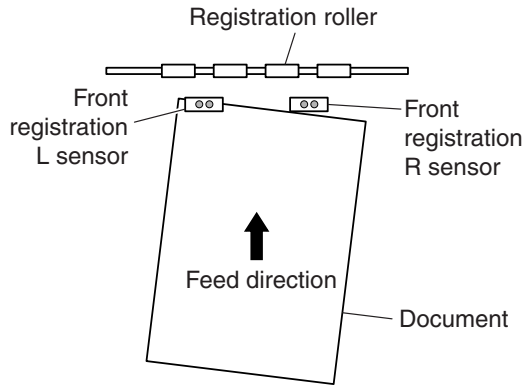

Fig. 2-309

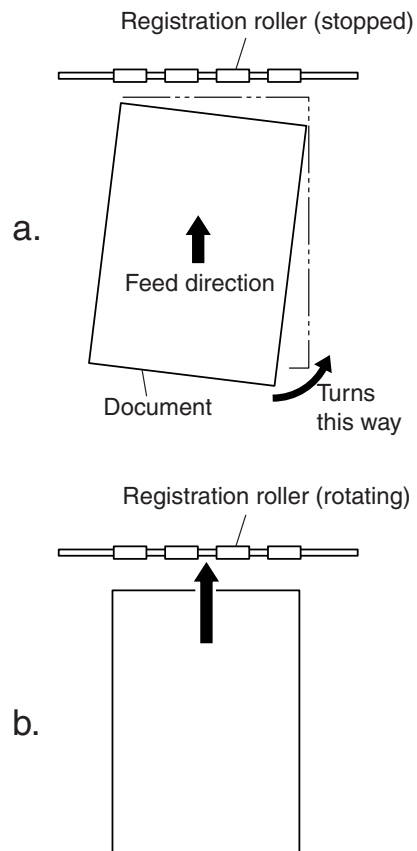

Fig. 2-310

When a larger-sized document is skewed so as to exceed the specified value, the ends of the document may be torn. Therefore, the skew detection sensors are mounted on both sides inside the machine. The left-end sensor is mounted on the left-end sensor PCB and the right-end sensor is mounted on the right-end sensor PCB. When skewing is detected by both sensors, the document feeding is stopped.

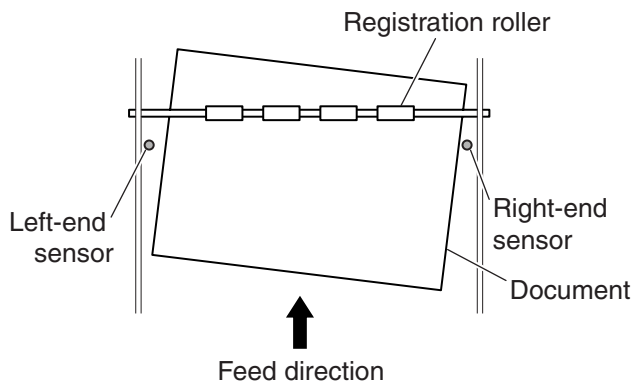

Fig. 2-311

6 Ultrasonic Double Feed Detection

Fig. 2-312 shows the double feed detection mechanism by ultrasonic.

The double feed detection by ultrasonic uses the ultrasonic (transmitting) sensor and the ultrasonic (receiving) sensor.

The ultrasonic transmitting sensor is connected to the ultrasonic drive PCB, while the ultrasonic receiving sensor is connected to the ultrasonic sensor PCB. The receiving sensor receives the ultrasonic signal transmitted by the transmitting sensor to gain a specific signal level. When overlapping documents are fed, the signal level is different from when properly feeding a single document. The unit interprets this difference as a double feed and displays an error.

Note: When the length of the overlapping portion of the documents is less than 50 mm, the double feed may not be detected.

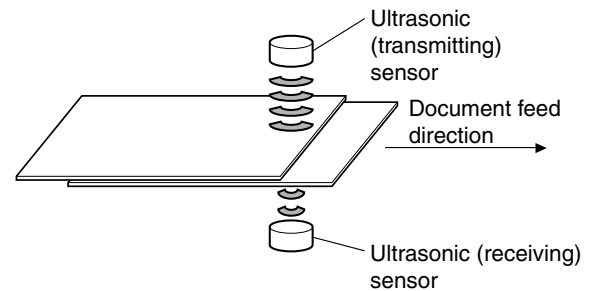

Fig. 2-312

7 Feed Error Detection

This explanation is about feed errors due to document jams. Document jams are detected by the front and the back registration sensors.

The front registration sensor and the back registration sensor are located at the front and back of the registration roller, respectively. The front registration sensors are divided into the left sensor (L) and the right sensor (R), and are mounted on the front registration sensor PCB. The back registration sensor is mounted on the back registration sensor PCB.

1) Early reach jam (P01)

The front edge of the following document was detected after the end of the proceeding document is detected before the motor finishes driving the specified length.

2) Residual jam (P02)

The end of the document is not detected even though the document has been fed for a specific length after the front edge was detected.

3) Fast feed jam (P03)

The end of the document is detected before the document has been fed for a specific length after the front edge was detected.

When the machine is powered on or the upper unit is opened/closed with a document left in the machine, a removal jam (P00) occurs.

8. Special Feed Mode

This unit also supports a mechanical feed mode to check the feed condition without using a personal computer.

This mode should not be available to the users.

The mechanical feed mode can be activated by pressing the keys on the operation panel, as follows:

- a. Turn on the power switch with the start key pressed.
- b. Continue pressing the start key for about one second.
- c. Press the stop key.

If the start key is pressed while in the mechanical feed mode, with documents in the document tray, the machine will feed the documents at a feed speed determined by the SCSI ID set on the DIP switch located at the computer connection. Images are not scanned at this time.

When specifying the feed speed is not required, it is possible to check the feeding state using the "Count Only mode".

	Feed speed	1	2	3
ID0	Black/white 200DPI	OFF	OFF	OFF
ID1	Black/white 300DPI	ON	OFF	OFF
ID2	Black/white 400DPI	OFF	ON	OFF
ID3	Black/white 600DPI	ON	ON	OFF
ID4	Color 200DPI	OFF	OFF	ON
ID5	Color 300DPI	ON	OFF	ON
ID6	Color 400DPI	OFF	ON	ON
ID7	Color 600DPI	ON	ON	ON

* The figures 1-3 above indicate the numbers of the DIP switch used to set the SCSI ID.

Table 2-301

IV. DESCRIPTION OF ELECTRICAL CIRCUITS

Fig. 2-401 shows a block diagram of the main CPU PCB for the DR-9080C and the DR-6080. The only difference between the DR-9080C and the DR-6080 is the number of 256M bit SDRAM chips. Table 2-401 lists the function of each IC shown in the block diagram.

1. Main CPU PCB (MAIN_DCON)

The main CPU PCB mainly handles image processing.

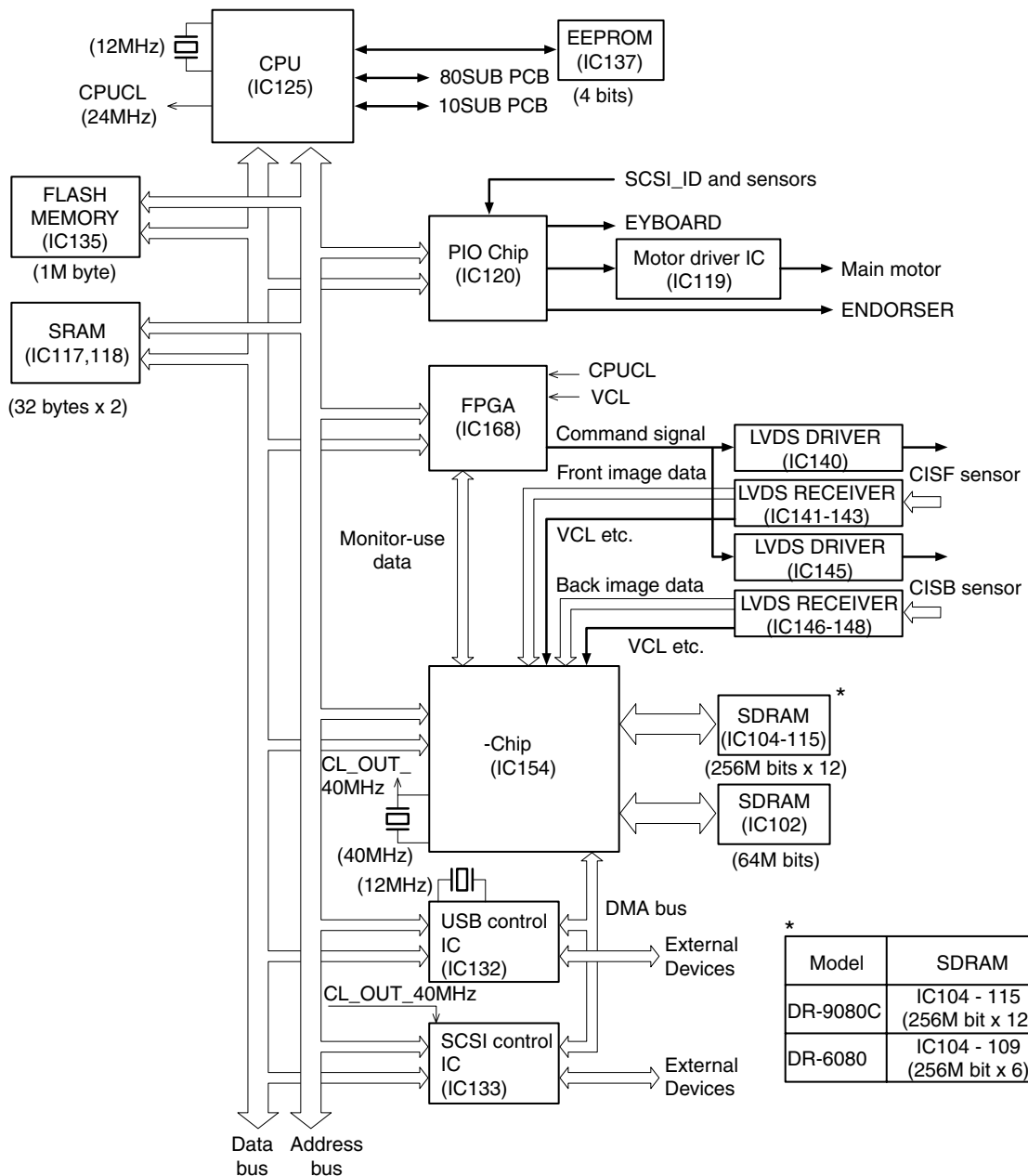

Fig. 2-401

IC No.	Name	Function
IC125	CPU	Overall control
IC137	EEPROM	Storing various settings
IC117,118	SRAM	Work memory for CPU
IC135	FLASH MEMORY	Memory for firmware and various parameters
IC120	PIO Chip	Port input and output
IC119	MOTOR DRIVER	Main motor control
IC168	FPGA	QQ-Chip correction
IC140,145	LVDS DRIVER	LVDS signal driving
IC141-143,146-148	LVDS RECEIVER	LVDS signal receiving
IC154	QQ-Chip	Total image processing
IC104-115	SDRAM	Memory for image data
IC102	SDRAM	Memory for JPEG
IC132	USB controller	USB control
IC133	SCSI controller	SCSI control
IC155	Switching regulator	18V generation
IC131	Switching regulator	3.3V generation
IC116	Switching regulator	5.0V generation
IC156	Switching regulator	12.0V generation
Q150,151	FET	Energy save mode switch

Note: The DR-9080C has 12 memory chips for image data (SDRAM) numbered from IC104 to IC115, while the DR-6080 has 6 of them numbered from IC104 to IC109.

Table 2-401

2. Pick-up Control PCB (80_SUB)

Fig. 2-402 shows a block diagram of the pick-up control PCB (80_SUB). The CPU mounted on the pick-up control PCB performs the following functions.

- 1) Obeys instruction from the main CPU PCB to pick up documents
- 2) Controls the pick-up motor, feed motor, and each solenoid

- 3) Sends instructions to the document tray control PCB
- 4) Processes signals from the sensors and mechanical counter (option)

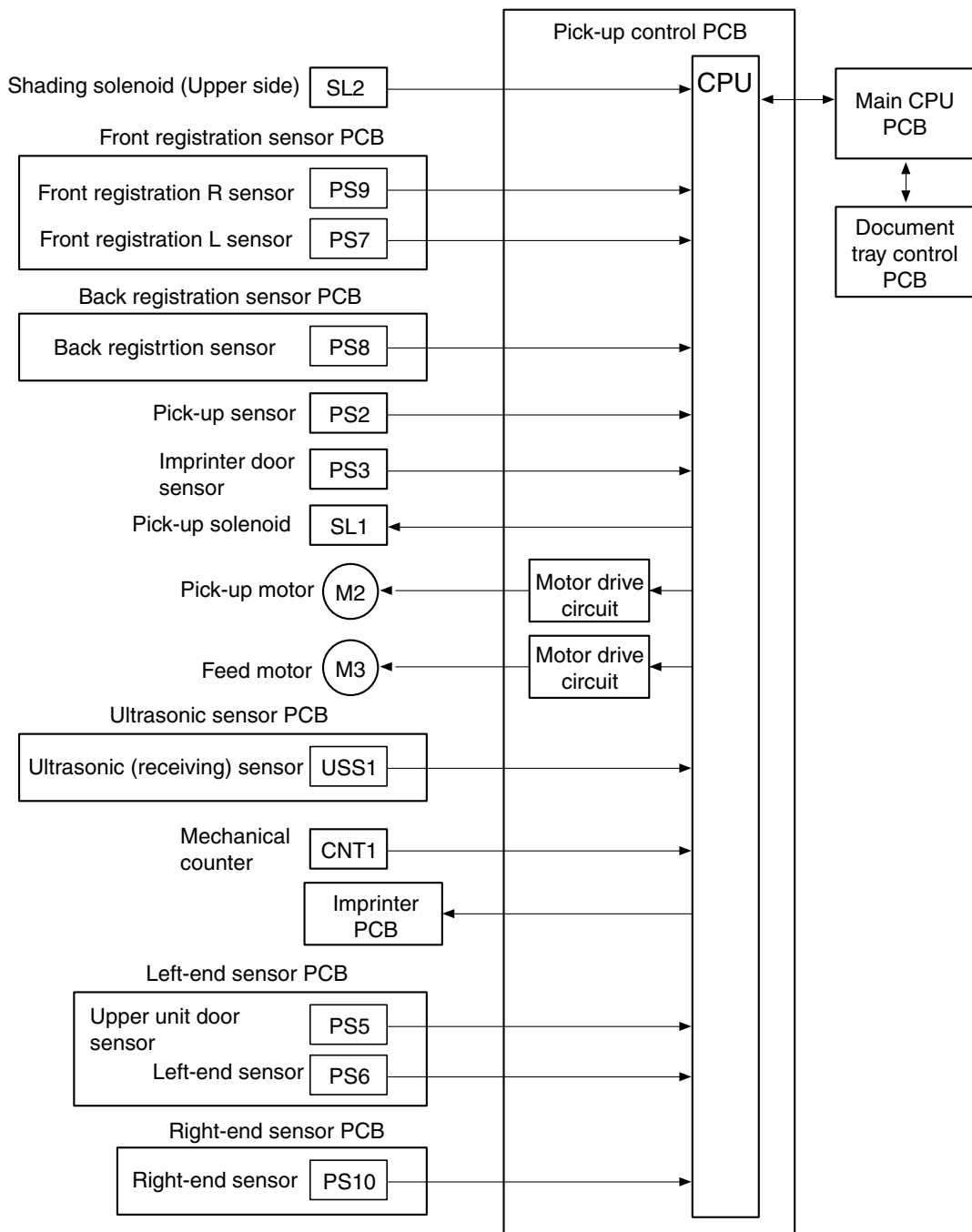

Fig. 2-402

3. Document Tray Control PCB (10_SUB)

Fig. 2-403 shows a block diagram of the document tray control PCB (10_SUB). The CPU mounted on the document tray control PCB performs the following functions.

- 1) Receives instruction from the pick-up control PCB to control the retard roller and document tray motor
- 2) Receives instructions from the main CPU PCB assembly to control the registration clutch
- 3) Processes signals from the sensors
- 4) Controls the staple LED PCB

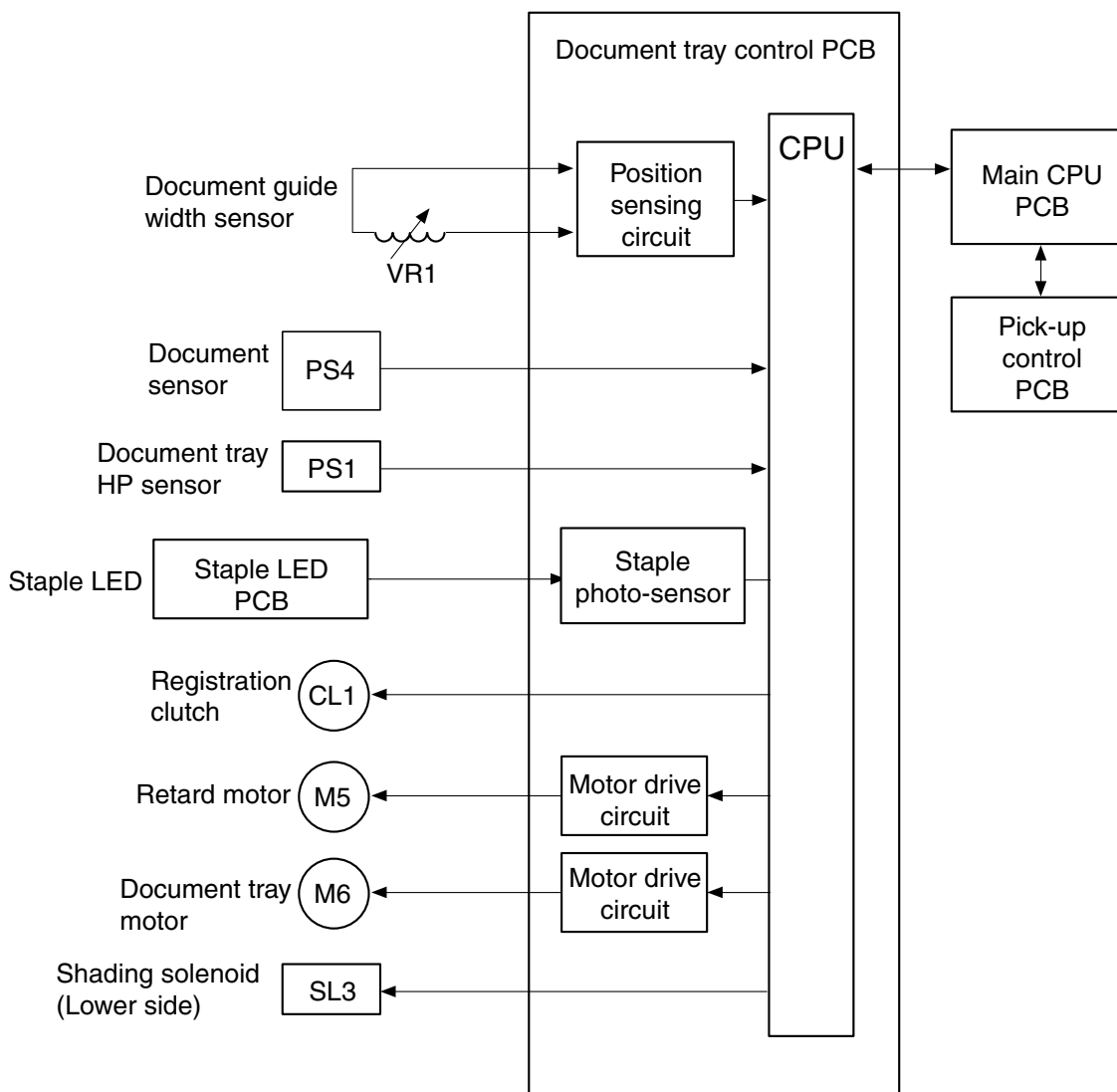

Fig. 2-403

V. IMAGE PROCESSING

1. Image Processing Within the Unit

Fig. 2-501 shows a block diagram of the image processor.

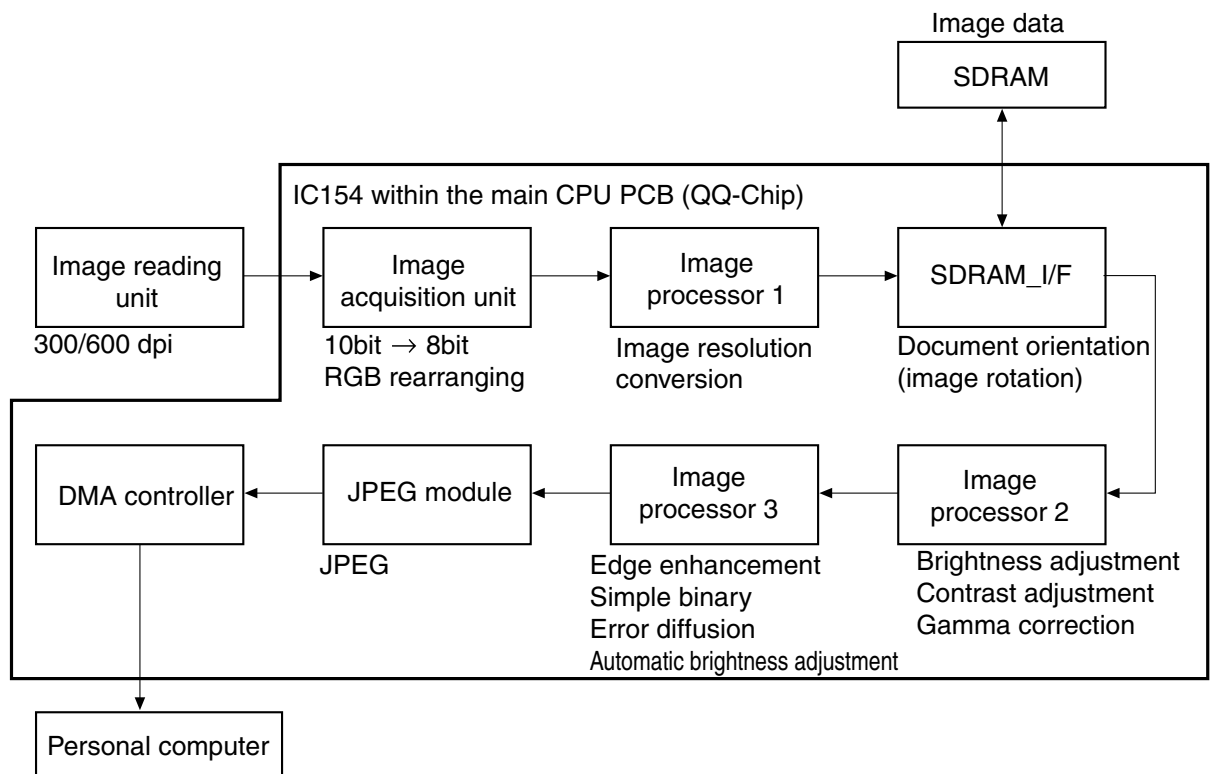

Fig. 2-501

The image processing within the machine is performed in IC154 (QQ-Chip) within the main CPU PCB.

With the reading unit, the optical resolution can be switched between 600 dpi and 300 dpi from the personal computer. For example, when the resolution set in the personal computer is 300 dpi or less (300, 240, 200, 150, 100), the optical resolution of the unit is set to 300

dpi. And, when 400 dpi or 600 dpi is set on the computer side, 600 dpi is set on the reading unit side. The image data scanned by the unit are processed (A/D conversion and shading correction) within the unit, and then are output as 10-bit digital signals to the main CPU PCB.

Since the data are processed as 8 bits within the machine, they are converted from 10 bits to 8 bits at the Image acquisition unit. And, for colored image data, RGB rearranging is executed.

- 10 bits to 8 bits
- RGB rearranging

The QQ-Chip used in this machine is designed to handle future multi-stream processing. Image processors 1 and 2 for conducting equivalent processing are provided within the QQ-Chip. However, since the software is not available for the earlier model, both processors serve to conduct the processing of image data. A multi-stream function can output different modes of data from a single scan. The description below describes the image processing in the earlier model where the multi-stream function is not available.

Image resolution conversion is carried out by image processor 1. For converting resolution, one of two methods, thinning-out and smoothing, is used according to the image mode. The smoothing process also helps to reduce moire patterns.

The image data are stored in the SDRAM, and accessed via the SDRAM_I/F (Interface).

Image processor 2 handles brightness adjustment, contrast adjustment, and gamma correction.

Image processor 3 handles edge emphasis, simple binarizing, error diffusion, and automatic brightness adjustment. The automatic brightness adjustment is valid for simple binary mode.

In the JPEG module, the grayscale and color data can be compressed. When JPEG is selected, the image data size is reduced by compression within this machine so that it can be transferred to the personal computer in less time. As a result, more documents can be scanned in a given time.

Finally, processed image data are sent from the DMA controller to the computer either through the SCSI or USB interface.

Other image processing is carried out on the personal computer.

2. RGB rearranging

An RGB rearranging diagram is shown in Fig. 2-502.

For colored images, the data is output from the reading unit in the order R, G, B for each line. (Refer to 2-502-a)

The Image acquisition unit rearranges the data in the order of RGB for each pixel.

For instance, if there were 5 pixels in a line, the data output from the reading unit would be "R1, R2, R3, R4, R5, G1, G2, G3, G4, G5, B1, B2, B3, B4, B5". After the rearrangement, the data would be "R1, G1, B1, R2, G2, B2, R3, G3, B3, R4, G4, B4, R5, G5, B5".

a. Data output

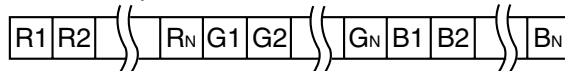

b. RGB rearrangement

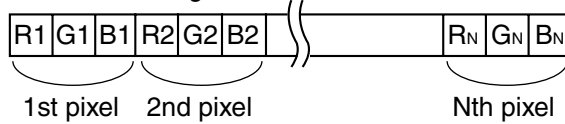

Fig. 2-502

3. Image Resolution Conversion

In this mode, the image resolution conversion differs according to the image mode. Thinning-out is available for binary mode, smoothing is available for grayscale mode, and either one is selectable for color mode.

The resolution in the main-scanning direction is the same as in the sub-scanning direction.

The optical resolution (main-scanning direction) of the reading unit can be switched between 600 and 300 dpi. Therefore, when 400 dpi is selected, the resolution is converted from 600 dpi, and when 240 dpi or less is selected, it is converted from 300 dpi.

a) Thinning-out method

For the main-scanning direction, the image resolution conversion is executed by thinning out the standard clocks for image processing. (Refer to Fig. 2-503)

When converting to 200 dpi, the standard 300 dpi clock is used, with 1 clock pulse removed from every 3 pulses. When converting to 240 dpi, 1 clock pulse is removed from every 5 pulses. And, when converting to 400 dpi, the standard 600 dpi clock is used with 1 clock removed from every 3 clock pulses.

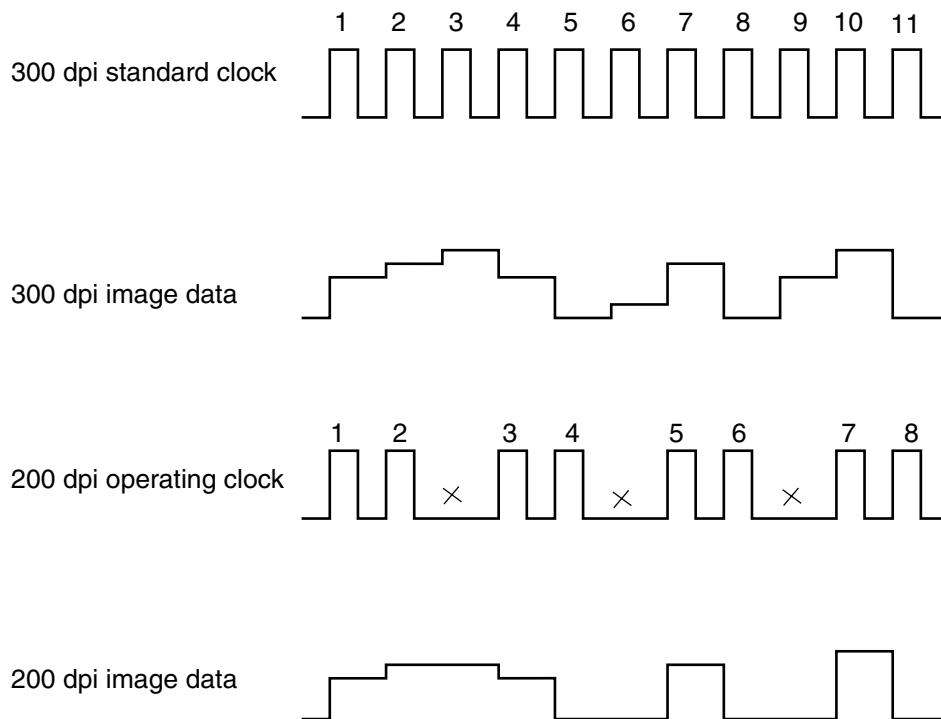

Fig. 2-503

The document is scanned in the sub-scanning direction basically by changing the feed speed.

In the case of 200 dpi, feed speed is 1.5 times that for 300 dpi. In the case of 150 dpi, it is twice the speed, and in the case of 100 dpi, three times the speed used for 300 dpi.

Since the timing for reading the data from the image sensor (CIS) is the same, the resolution in the sub-scanning direction can be converted by changing the feed speed. (Refer to Fig. 2-504a)

For low resolution binary and grayscale modes (the original data for both is grayscale), the feed speed must be raised excessively high. The feed speed can be increased by raising the motor speed. However, since the motor speed is limited, the feed speed is also limited, and therefore the thinning-out processing is executed by image processor 1. (Refer to Fig. 2-504b)

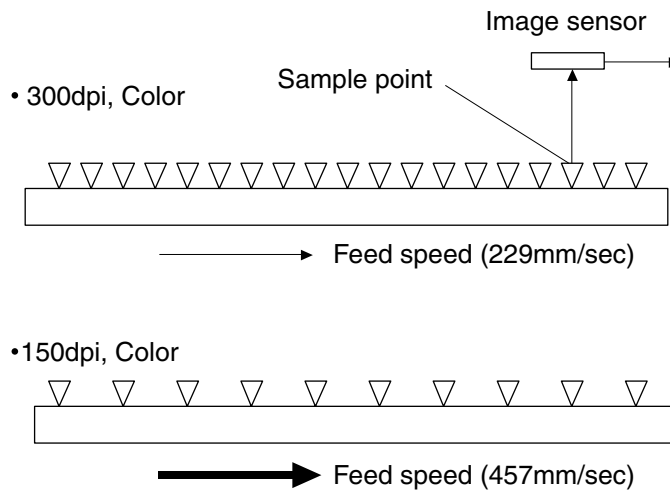

Fig. 2-504a

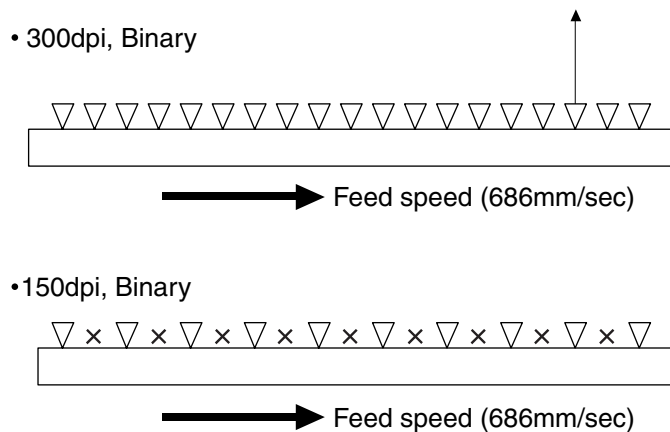

Fig. 2-504b

b. Smoothing method

The image resolution conversion by averaging is called "smoothing."

Smoothing method conversion enables the data to be smoothly transformed much better than that by thinning-out method, resulting in reducing the occurrence of Moire patterns. Smoothing is especially useful for low-resolution photographs, but the time required for the processing is longer than that for thinning-out.

Smoothing is not performed in binary mode since Moire patterns are not usually a problem.

For grayscale mode, smoothing is always performed because the number of scanned documents is not decreased even by smoothing.

For color mode, Smoothing can be selected by the user. When the optical resolution of the reading unit is 600 dpi (or 300 dpi), smoothing to 600 dpi (or 300 dpi) is not carried out.

When the resolution is set to 600 or 400 dpi on the personal computer, the reading unit reads the documents at 600 dpi. When 300 dpi or less is selected, the unit reads the documents at 300 dpi. Subsequently, the data of 600 dpi (or 300 dpi) resolution are calculated according to the selected resolution. The calculation is as follows.

- The reading unit reads the document at 600 or 300 dpi.

A	B	C	D	E	F	...
---	---	---	---	---	---	-----

- The data are calculated according to the selected resolution. An example of conversion from 300 dpi to 150 dpi is as follows:

$(A+B)/2$	$(C+D)/2$	$(E+F)/2$...
-----------	-----------	-----------	-----

The resolution of the sub-scan is converted by changing the feed speed, the same principle as the resolution conversion by thinning-out method.

Fig. 2-505 shows the aspects of 300 x 300 dpi image data and the image data smoothed to 150 x 150 dpi.

- 300 x 300 dpi

1st line	A	B	C	D	E	F	G	H	→	→
2nd line	A	B	C	D	E	F	G	H	→	→
3rd line	A	B	C	D	E	F	G	H	→	→
4th line	A	B	C	D	E	F	G	H	→	→
5th line	A	B	C	D	E	F	G	H	→	→
6th line	A	B	C	D	E	F	G	H	→	→



- 150 x 150 dpi

1st line	$(A+B)/2$	$(C+D)/2$	$(E+F)/2$	$(G+H)/2$	→
2nd line	$(A+B)/2$	$(C+D)/2$	$(E+F)/2$	$(G+H)/2$	→
3rd line	$(A+B)/2$	$(C+D)/2$	$(E+F)/2$	$(G+H)/2$	→

Fig. 2-505

4. Data Conversion

To improve the reproducibility of original documents and modify the acquired image as required by the user, it is possible to convert the original image data using conversion tables. This machine provides various conversion tables adjusted for image mode and setting value. However, there are several adjustment items not available for image mode and other conditions. For details, refer to the driver software "Help" function.

The conversion tables below are for fundamental items and may be different from actual items.

1) Brightness adjustment

This adjusts the overall brightness of the scanned image. The image brightness increases as the setting value becomes larger, and decreases as the value becomes smaller. For automatic brightness adjustment in Black & White mode, refer to the "Binarizing" section.

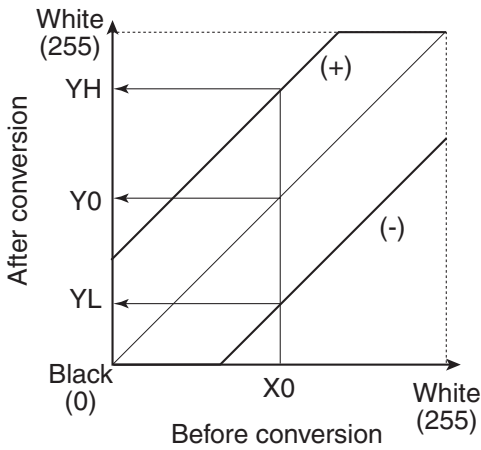

Fig. 2-506

2) Contrast adjustment

This adjusts the contrast of the scanned image. The image contrast increases as the setting value becomes larger, and decreases as the value becomes smaller.

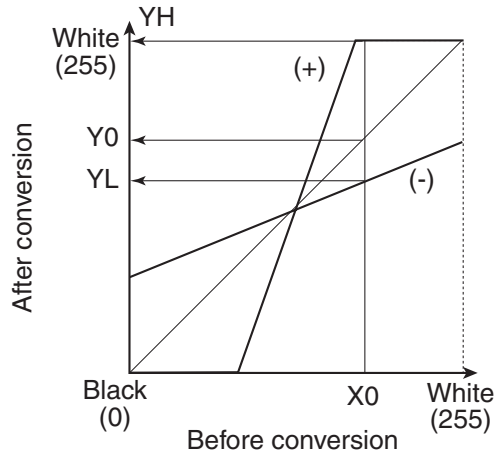

Fig. 2-507

3) Gamma correction

This is used when data conversion other than brightness and contrast adjustments is required.

It is possible for the user to use a custom conversion table for converting the gamma of the original image data. In this case, the brightness and contrast adjustments become invalid.

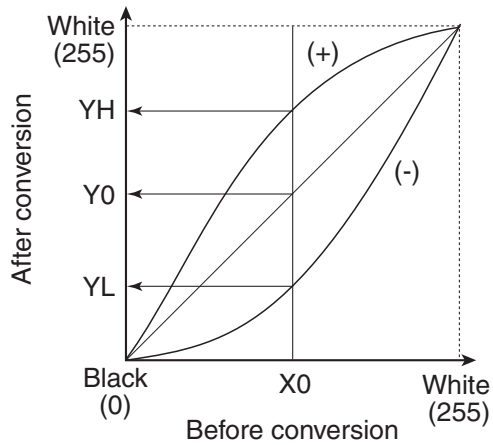

Fig. 2-508

5. Edge Emphasis

Edge emphasis is a kind of processing which emphasizes light and shade in order to make the image appear sharp. (Fig. 2-509)

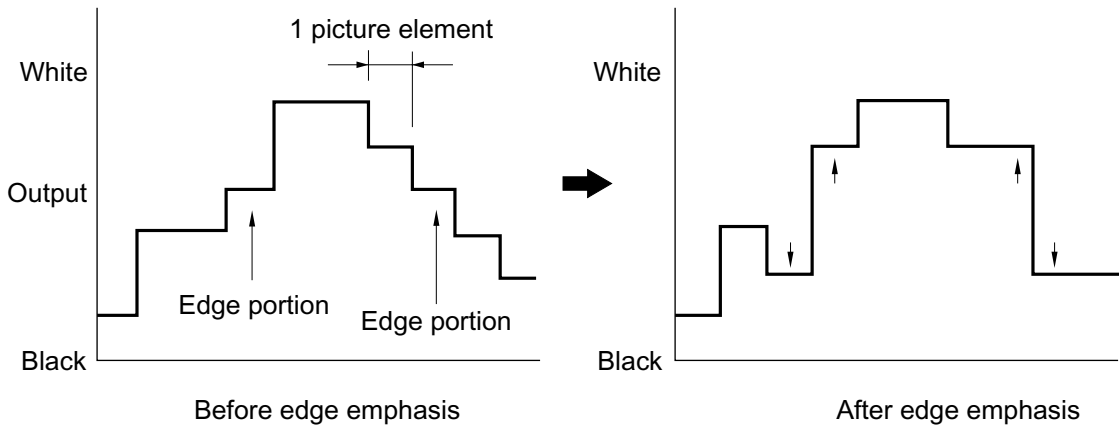

Fig. 2-509

Density processing is performed by comparing the data in the conversion table provided for performing edge emphasis, with the target picture element. (Refer to Fig. 2-510.)

The stages in edge emphasis can be changed by changing the conversion table and reproduction ratio (B) of the conversion table.

If the density of the target picture element is increased fourfold and the density of the other four points multiplied by -1, the overall density will remain unchanged.

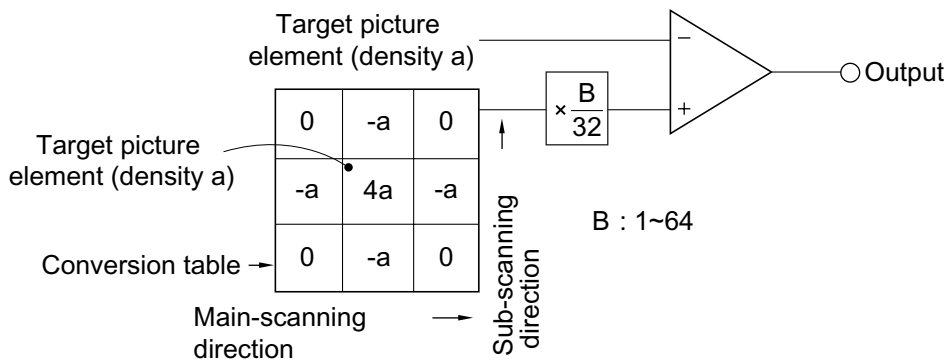

Fig. 2-510

6. Binarizing

Image binarizing is described below. For the "Advanced text enhancement," refer to the section entitled "IMAGE PROCESSING IN THE COMPUTER."

1) Simple Binarizing

Binary image data can only express picture elements as either "black" or "white."

In order to separate the picture elements into black and white, signals corresponding to the image density of the document must be cut off at a certain level, so that anything above that level is judged as "white" and anything below as "black." This is called simple binarizing. This is useful for text documents. Simple binarizing for this machine is called "Black and White" mode.

The level at which picture elements are to be divided into white or black is called the "slice level" (or threshold value).

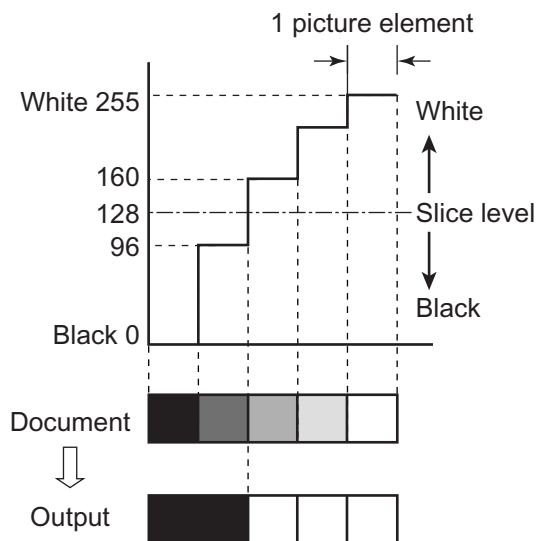

Fig. 2-511

2) Error Diffusion

Error diffusion processing is used to binarize documents containing gray levels, such as pictures and photos.

A sample case is shown below, where the output is set to 4 bits and the slice level is set to 8.

The value of 1 picture element of input image data is compared with the slice level. When it is smaller than the slice level, it is output as "0" and

when it is bigger then the slice level, it is output as "15".

The difference between the values of the input and output picture elements is then added to the next picture element to be processed.

First, when processing the first low of Line 1, since the data "12" is larger than the slice level "8", the output data becomes "15", and the resultant error becomes $-3(=12-15)$. (Refer to Fig. 2-512.)

First row of line 1

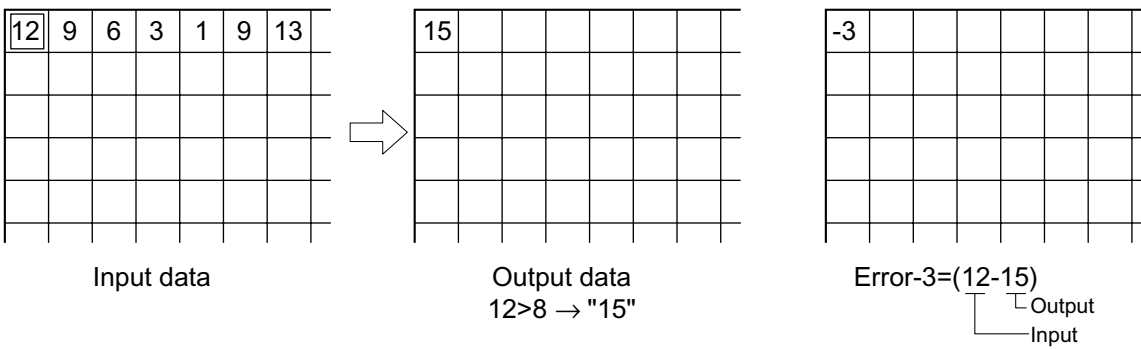

Fig. 2-512

Next, when processing the second row of Line 1, since the error is diffused to the right, the data of the picture element of the second row of Line 1 becomes "6" (=9-3).

As this value is smaller than the slice level, the output data is "0" and the error becomes "+6" [= (9-3)-0]. (Refer to Fig. 2-513.)

The third row of Line 1 and later are processed similarly.

Second row of line 1

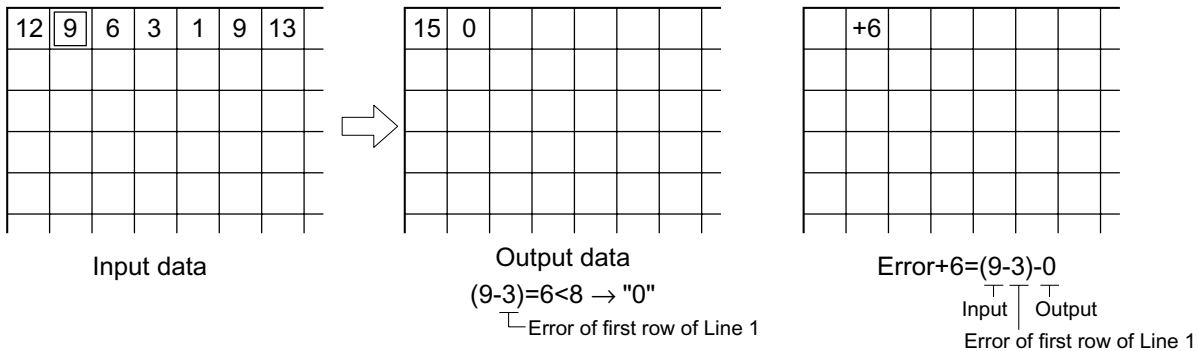

Fig. 2-513

Line 2 is processed using the first row of Line 2 as a reference. If the rest is processed similarly, the data becomes as shown in Fig. 2-514.

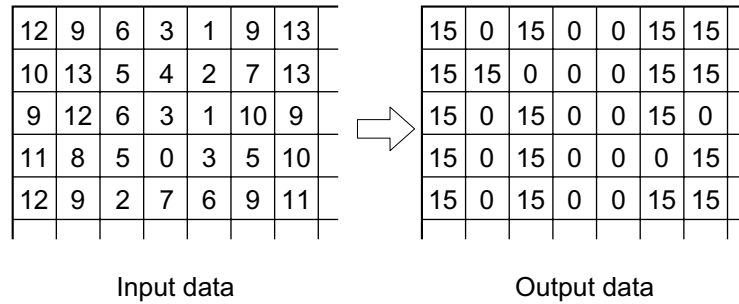

Fig. 2-514

Fig. 2-515 shows a comparison of binarizing with error diffusion processing, and binarizing without error diffusion processing (simple binarizing).

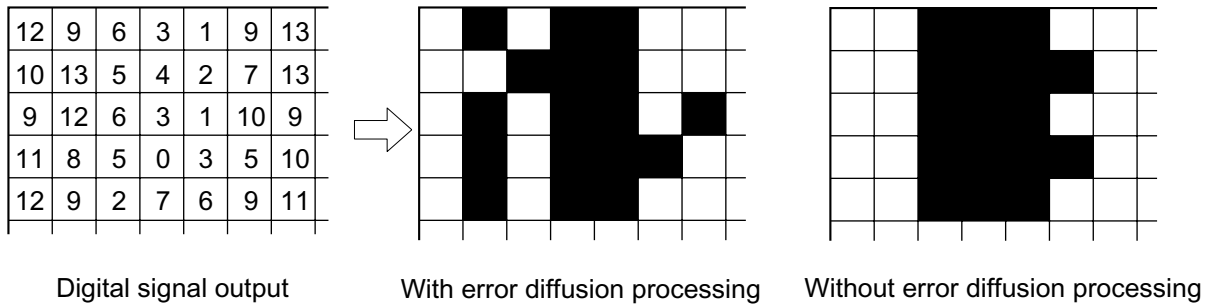

Fig. 2-515

3) Automatic Brightness Adjustment

This adjustment automatically controls the brightness of the scanned image according to the density of the document's background in the simple binary mode.

The brightness is adjusted by assessing the brightness line by line, and adjusting the level for the next line to be scanned.

This process is known as ABC (Auto Back-ground Control).

When the number of pixels of specified brightness in a line exceeds the predetermined value for the document size, the brightest output is transformed gradually, line by line.

Fig. 2-516 shows the difference in output when reading a text document with a colored background.

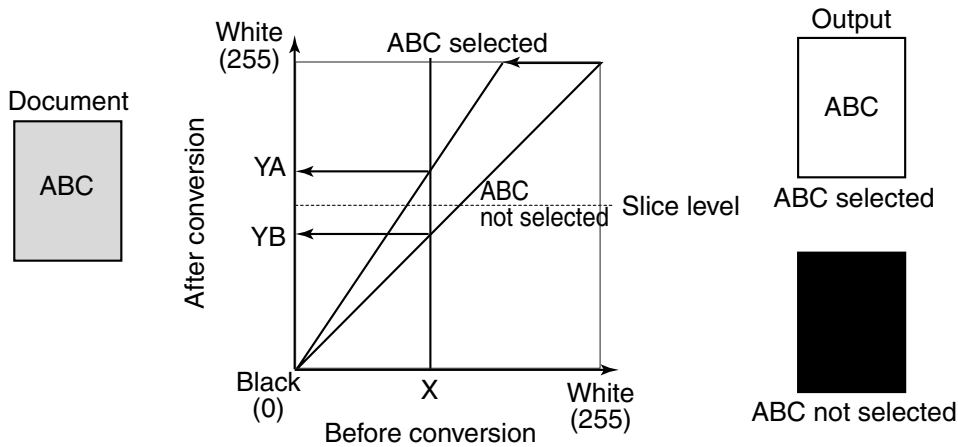

Fig. 2-516

7. Image Processing in the Computer

Various types of image processing can be executed in the personal computer, in addition to the processing executed in this machine.

- Advanced text enhancement
- Skew correction (deskew)
- Reverse image (invert image)
- Text orientation recognition
- Erase dots
- Erase notches
- Border removal
- Size detection, etc.

The main types of image processing are described below. For others, refer to the driver software "Help".

1) Advanced text enhancement

In this mode, a histogram of brightness level for each block within the scanned data is calculated, and an optimum slice level is determined to binarize the pixels.

Binarizing in this way removes the background, for example, from behind text printed on a background.

For example, as shown in the image in Fig. 2-517, a histogram for each block is calculated, and the optimum slice level is determined to binarize the pixels.

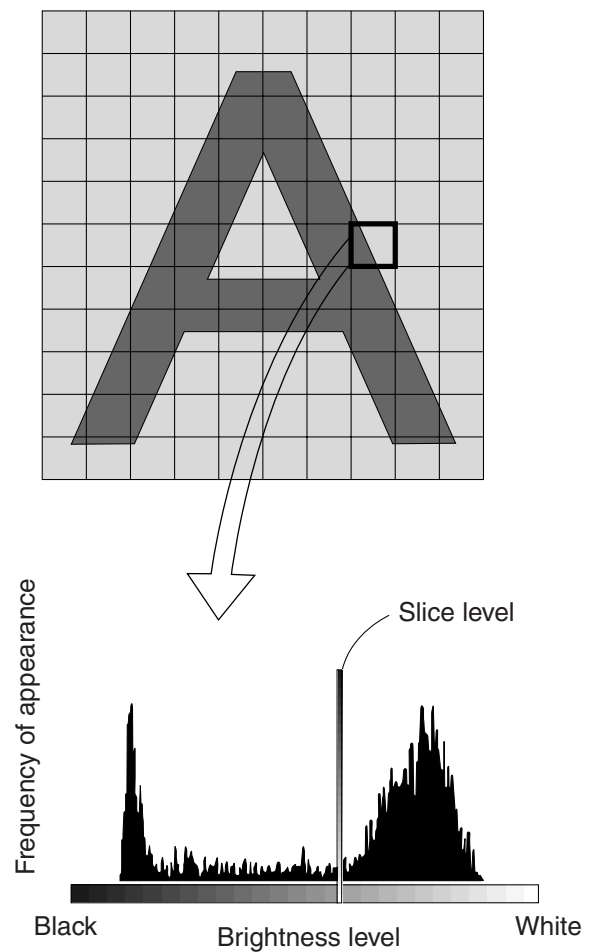

Fig. 2-517

2) Skew correction (Deskew)

When image skew correction (deskew) is enabled, the driver detects the angle of skew from the black frame that is formed. Then image data is loaded at a size slightly larger than the user-specified paper size. The skew angle is corrected for, so that the image data is restored to the set image size.

However, skew correction may not work properly if the document has dark areas on its left and right edges or if the brightness setting is incorrect.

"Skew correction (deskew)" and "margin scan" cannot be used simultaneously.

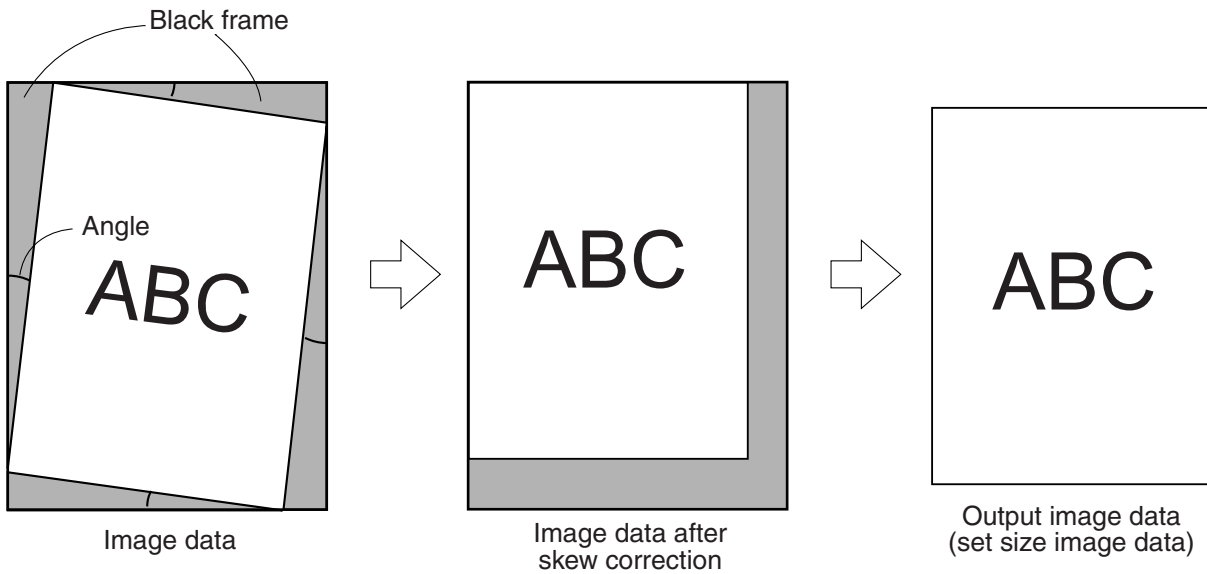

Fig. 2-518

VI. POWER SUPPLY

1. Outline

The DC power supply PCB of this machine is capable of handling power input of 100 to 240 VAC.

Fig. 2-601 shows a block diagram of the DC power supply PCB.

AC power is supplied to the DC power supply PCB by turning on the power switch.

The 100 to 240 VAC power is converted by a rectifying bridge to unsmoothed 100 to 240 VUN and sent to the booster assembly. At the booster

assembly, the power is temporarily raised to 380 VDC and then converted to DC.

A fuse is used in the DC power supply PCB to protect against over-current situations. + 24 VDC is output from the DC power supply PCB to the main CPU PCB (MAIN_DCON). The necessary voltage is generated by the switching regulator IC and FET on the main CPU PCB. (Refer to Fig. 2-602)

The DC voltages necessary for the pick-up control PCB (80_SUB) and document tray control PCB (10_SUB) are supplied from the main CPU PCB.

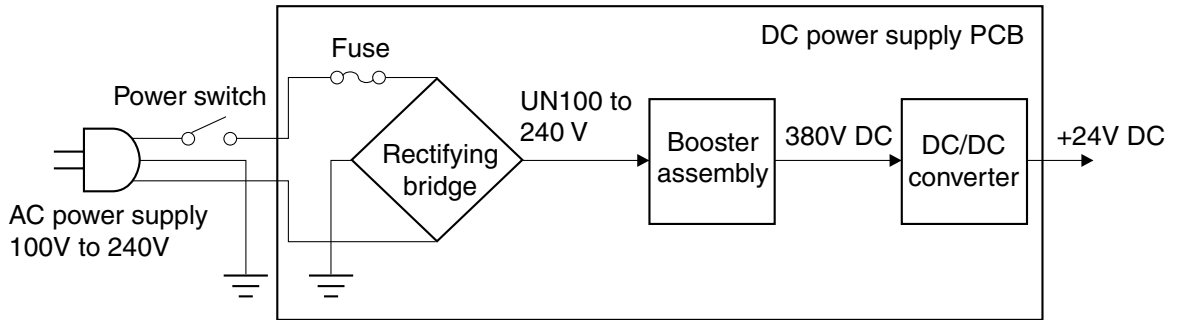

Fig. 2-601

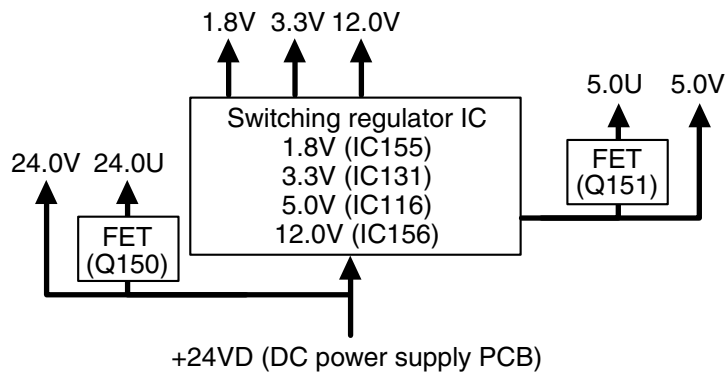

Fig. 2-602

2. Protection Function

The DC power supply PCB is a switching regulator type.

If the load is shorted and there is an over-current situation, the protection function is activated and the output is stopped.

Once the output stops, it can be automatically restored by turning the power switch off, eliminating the cause of the short circuit, discharging the capacitor (for about 10 minutes) and then turning on the power switch.

A fuse is used for protection on each PCB. If an excessive current flows into the DC/DC converter, the fuse blows and stops the power supply to the PCB.

A fuse is also used for protection of the main motor. If an excessive current flows in the + 24 VDC supplied to the main motor, the fuse blows and stops the power supply to the main motor.

3. Power Saving Mode

This machine will shift into the power saving mode if no key or pick-up operation takes place for 10 minutes or more, when the power is on. In the power saving mode, power consumption is minimized and the electrical circuits enter the "sleep" state. The CPUs, however, do not shift into power saving mode.

The machine shifts back to the standby mode when any communication is carried out on the computer side or when any key on the operation panel is pressed.

Setting the power saving mode is carried out in the user mode.

VII. INTERFACE

When sending data from this unit to a personal computer, the data is transmitted over an interface. This unit provides both SCSI-3 and USB 2.0 interfaces.

1. SCSI-3

SCSI-3 (Small Computer System Interface-3) is a Parallel Interface standard. This unit supports Ultra SCSI and the data transfer rate between the machine and the personal computer is up to 20 MB/sec.

Fig. 2-701 shows the data input/output between the machine and the computer, when connected with SCSI-3. Table 2-701 gives the signal descriptions for the SCSI connector. The connector numbers on the main CPU PCB are J105 and J121.

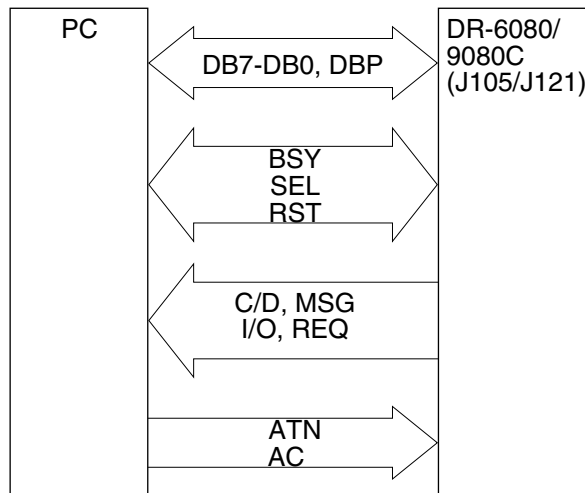

Fig. 2-701

Pin No.	Signal	Remarks
1-12	GND	(Ground)
13	OPEN	(No-connection)
14-25	GND	(Ground)
26	DB0*	(Data Bit 0)
27	DB1*	(Data Bit 1)
28	DB2*	(Data Bit 2)
29	DB3*	(Data Bit 3)
30	DB4*	(Data Bit 4)
31	DB5*	(Data Bit 5)
32	DB6*	(Data Bit 6)
33	DB7*	(Data Bit 7)
34	DBP*	(Odd Parity Data Bit)
35-37	GND	(Ground)
38	TERMPWR	(Termination Power)
39-40	GND	(Ground)
41	ATN*	(Attention)
42	GND	(Ground)
43	BSY*	(Busy)
44	ACK*	(Acknowledge)
45	RST*	(Reset)
46	MSG*	(Message)
47	SEL*	(Select)
48	C/D*	(Control/Data)
49	REQ*	(Request)
50	I/O*	(Input/Output)

The asterisk "*" at the end of the signal name denotes the signal is low-active.

Table. 2-701

The SCSI bus is made up of data signals (1 byte + parity bit = 9 signals) and control signals (9 signals) for a total of 18 lines.

2. USB 2.0

USB 2.0 (Universal Serial Bus 2.0) is a serial interface standard, and provides fast data transmission.

This machine supports High-Speed USB 2.0, and the data transfer rate between the unit and the personal computer is up to 480 Mbits/sec.

Fig. 2-702 shows the data input/output between the machine and the computer when connected with USB. Table 2-702 gives the signal descriptions for the USB connector. The connector number on the main CPU PCB is J124.

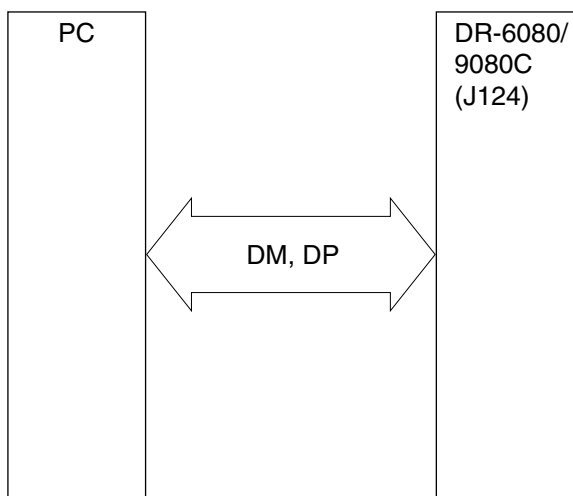

Fig. 2-702

Pin No.	Signal	Remarks
1	VBUS	Vcc (+5V)
2	DM	Differential signal(-)
3	DP	Differential signal(+)
4	GND	Ground

Table 2-702

USB is also referred to as a differential interface, and uses 2 signal lines for a single signal.

VIII.OPTION

1. IMPRINTER

An optional imprinter can be installed on the DR-6080/9080C to print specified text on the scanned documents. This imprinter is to be used with the ink cartridges made by Hewlett-Packard Company, with part numbers as follows: C6602R(Red), C6602G(Green), C6602B(Blue).

The imprinter should be installed by a service technician. For the procedure, refer to "CHAPTER 4: INSTALLATION & MAINTENANCE".

The specifications of the imprinter are shown in Table 2-801.

No	Item	Specification
1	Printing side	Front
2	Maximum number of characters	32
3	Contents to be printed	
	1) Text	ASCII code (20H•7FH)
	2) Arrows	↑/↓/←/→
	3) Date	MDY/DMY/YMD
	4) Time	hh:mm:ss
	5) Counter	Up to 9 digits, 2 levels
	6) Counter-up	New File/Per page/None
	7) Counter increment	Up to 9 digits
	8) Reset	New File/Per page/None
	9) Value after reset	Up to 9 digits
4	Font size	12 x 12 dots (Regular)/ 12 x 8 dots (small)
5	Orientation	0° / 90° / 180° / 270°
6	Power supply	Supplied from DR-6080/9080C
7	Consumables	Ink cartridge

Table. 2-801

2. Endorser

An optional endorser can be installed at the eject tray of the DR-6080/9080C to print an 8-digit number and a stamp on scanned documents, such as for checks. The ED600 for the DR-5020/5080C is used.

However, when the ED600 is used on the DR-6080/9080C, the feed and reading speeds are slowed. The maximum feed speed becomes the maximum feed speed of the ED600, 588 mm/sec. In the case of color at 400/600 dpi, the noise from the ED600 becomes high.

The endorser should be installed by a service technician. For the procedure, refer to "CHAPTER 4: INSTALLATION & MAINTENANCE". The specifications of the endorser are shown in Fig. 2-802.

No.	Item	Specification
1	Printing method	Stamping
2	Supported Document Size 1) Width 2) Length 3) Thickness	130-257mm a) 70-93mm (Check mode) b) 70-297mm (A4 mode) a) 0.08-0.15mm (Auto feed) b) 0.08-0.20mm (Manual feed) Note: A4/Letter landscape feed is not supported
3	Stamping position 1) Width direction 2) Feeding direction	Slide the print unit manually from side to side. The range is 53mm to the left and 100mm to the right based on the center of the feed path. Make sure the stamping area does not deviate from the document. Control with the adjusting dial at the document feeder. Stamping is not executed if the travel distance exceeds the length of the document. a) Stamping area for the check mode In the center, within 24mm of either side b) Stamping area for the A4 mode In the center, within 26mm of either side Note: The area size indicates the size of the date area. 

Table. 2-802-a

No.	Item	Specification
4	Stamping area size	36mm (width) x 42mm (length) Note: The stamping size is 36mm x 40mm
5	Feed speed	ifts automatically according to the signal from the DR-6080/9080C. However, the maximum speed is 588 mm/sec.
6	Storage height of documents for stamping 1) Check mode 2) A4 mode	Up to 45mm (500 sheets or less) Up to 27mm (300 sheets or less)
7	Support for functions 1) Pre-paint 2) Jam detection 3) Stamp counter 4) Function sheet	Supported Supported Supported (displayed in the operation panel) Not supported
8	Outside dimensions	360 (W) x 156 (D) x 215 (H) mm
9	Weight	4.8kg (Including the die drum and the ink roller)
10	Power supply	Supplied from the DR-6080/9080C
11	Expected lifetime of the product	5 years of use or 6 million sheets scanned, whichever comes first. Note: Guide for the time to replace the ink roller is 0.2 million sheets.

Table. 2-802-b

3. Mechanical counter

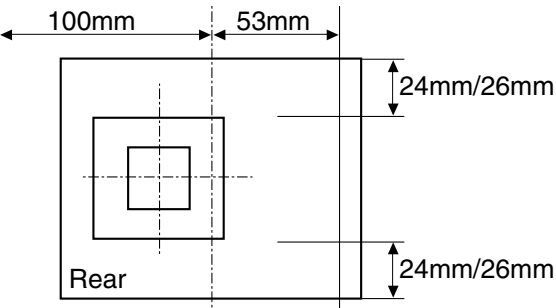
A 7-digit mechanical counter can be installed on this machine to count the total number of documents fed. If the data of the software counter is lost, the mechanical counter can show the total number of documents fed.

After the mechanical counter is installed, the installation is recognized by the DR-6080/9080C. If the counter fails or is uninstalled, an error occurs and the DR-6080/9080C cannot be operated (error code: E31). Therefore, special attention should be paid.

The mechanical counter should be installed by a service technician. For this procedure, refer to "CHAPTER 4: INSTALLATION & MAINTENANCE".

4. Barcode module

The barcode module is an add-on that adds a barcode function to the ISIS/TWAIN driver. Installing the barcode module on the personal computer enables barcode symbols to be interpreted. The barcodes supported by this module are EAN/JAN, CODABAR, CODE39, ITF, CODE128, UPC-A, and UPC-E.

The barcode module can be installed by the user.

IX. LAYOUT OF ELECTRICAL COMPONENTS

1. Switches and Sensors

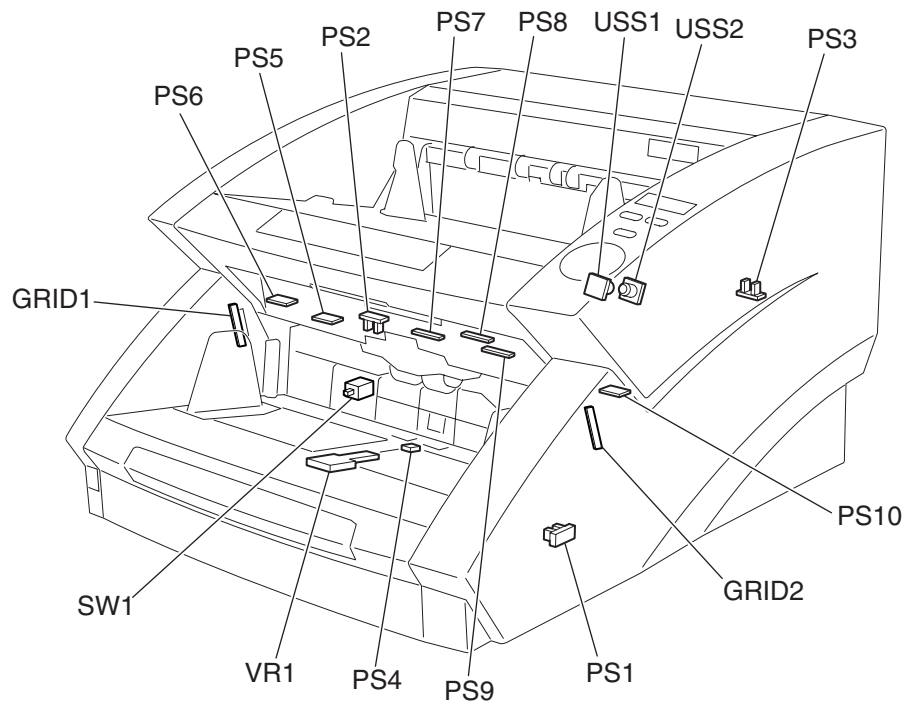

Fig. 2-901

Category	Name	Code	Function
Switch	Power switch	SW1	Turning the power ON/OFF.
Sensor	Document tray HP sensor	PS1	Detecting the HP (home position) of the document tray.
	Pick-up sensor	PS2	Detecting documents at pick-up.
	Imprinter door sensor	PS3	Detecting if the imprinter door is open or closed.
	Document sensor	PS4	Detecting if there are documents on the document tray.
	Upper unit door sensor	PS5	Detecting if the upper unit is open or closed.
	Left-end Sensor	PS6	Detecting document skew. (Left end)
	Front registration L sensor	PS7	Detecting documents at the front registration roller. (Left side)
	Back registration sensor	PS8	Detecting documents at the back registration roller.
	Front registration R sensor	PS9	Detecting documents at the front registration roller. (Right side)
	Right-end sensor	PS10	Detecting document skew. (Right end)
	Ultrasonic (receiving) sensor	USS1	Detecting double feeds.
	Ultrasonic (transmitting) sensor	USS2	
	Staple LED	GRID1	Detecting the jumping up of stapled documents.
	Staple photo-sensor	GRID2	
Document guide width sensor	VR1	Detecting the width of documents.	

Table 2-901

2. Motors, Clutches and Solenoids

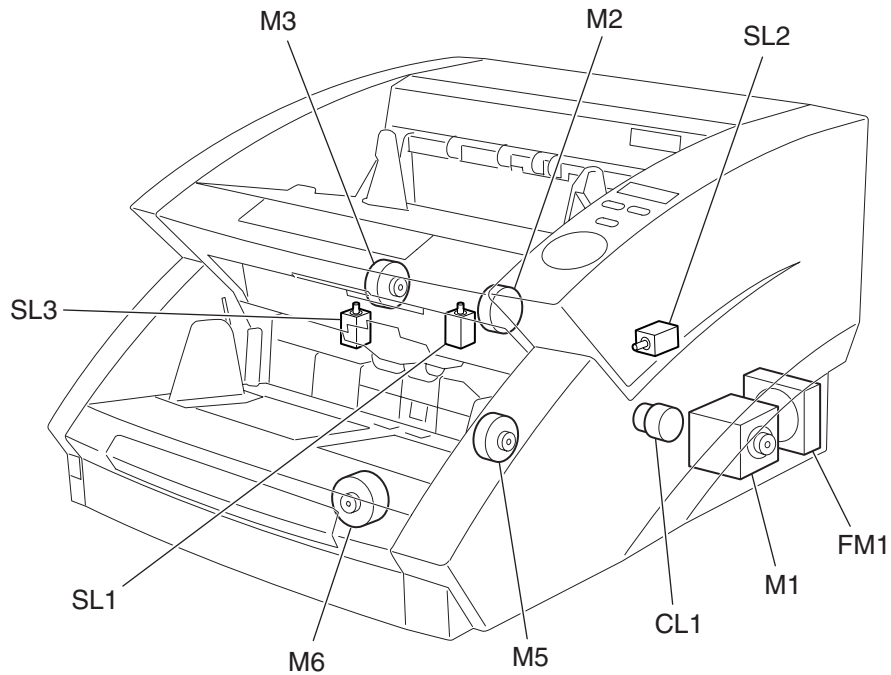

Fig. 2-902

Category	Name	Code	Function
Motor	Main motor	M1	Feeding documents.
	Pick-up motor	M2	Starting/Stopping the pick-up roller.
	Feed motor	M3	Starting/Stopping the feed roller.
	Retard motor	M5	Starting/Stopping the retard roller.
	Document tray motor	M6	Raising and lowering the document tray.
Fan	Exhaust fan	FM1	Cooling the inside of the unit.
Clutch	Registration clutch	CL1	Starting/Stopping the registration roller.
Solenoid	Pick-up solenoid	SL1	Raising the pick-up roller.
	Shading solenoid (Upper side)	SL2	Activating the shading plate of the back reading unit.
	Shading solenoid (Lower side)	SL3	Activating the shading plate of the front reading unit.

Table 2-902

3. PCB and Units

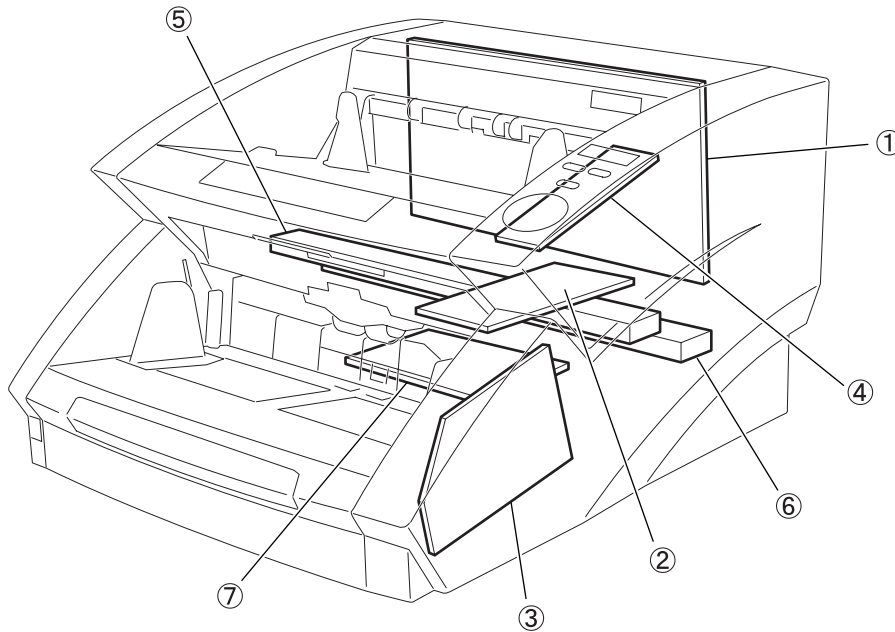

Fig. 2-903

No	Name	Function
①	Main CPU PCB (MAIN_DCON)	Processing images and overall control.
②	Pick-up control PCB (80_SUB)	Controlling document pick-up.
③	Document tray control PCB (10_SUB)	Controlling the document tray and the retard roller.
④	Operation panel PCB	Displaying the counter and errors.
⑤	Front reading unit	Reading the front side of documents.
⑥	Back reading unit	Reading the back side of documents.
⑦	DC power supply PCB	Supplying DC power.

Table 2-903

Note: For information on the PCBs related to sensors, refer to “1. Switches and Sensors”.

X. LIST OF CONNECTORS, SWITCHES & LEDS FOR EACH PCB

Shown below are the connectors, setting switches and LEDs for the main CPU PCB, pick-up control PCB, and the document tray control PCB.

The electrical parts not included in the list are set by the factory, and the adjustment or checking of these parts requires special tools and

measuring instruments as well as special skill. Therefore, take care not to touch these parts. Do not use the parts labeled "DO NOT USE."

Note: This machine does not include any potentiometers that requires adjustment in the market.

1. Main CPU PCB (MAIN_DCON)

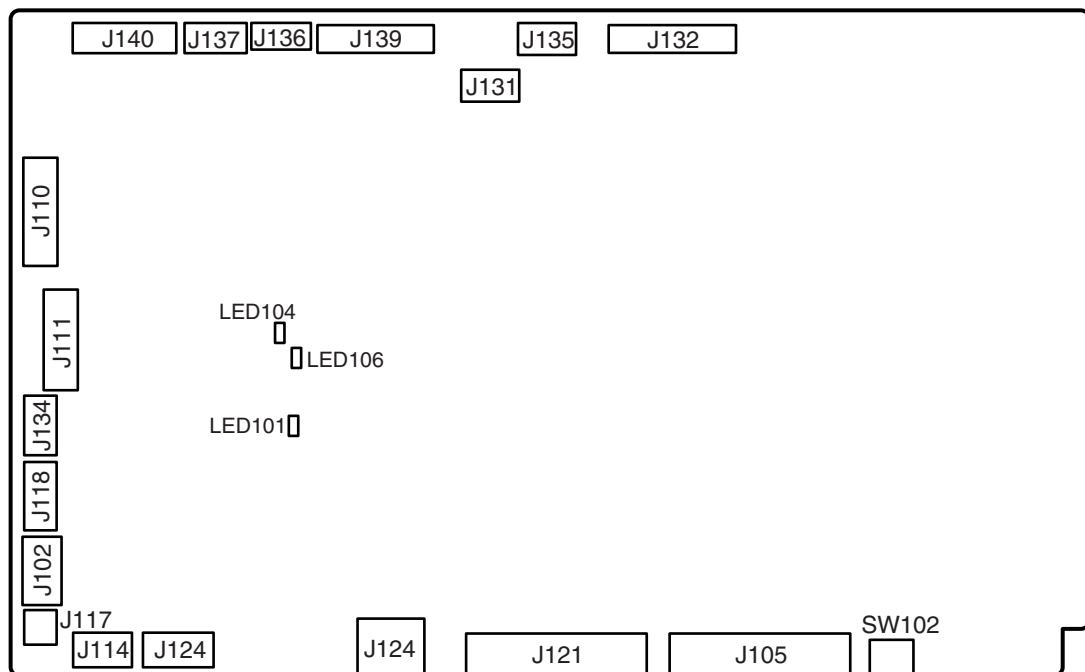
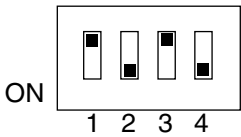

Fig. 2-1001

LED No.	Indication
LED101	Flashing when working normally (Checking the CPU operation.)
LED104	Lit when +24V is normal
LED106	Lit when +5V is normal

Table 2-1001

SW No.	Setting																																				
SW102	<p>Switches related to the SCSI interface 1 to 3: For setting the SCSI ID. 4: Turns the termination ON/OFF.</p> <p>Default setting Terminator: ON SCSI ID: 2</p>  <table border="1" style="float: right;"> <thead> <tr> <th></th> <th>1</th> <th>2</th> <th>3</th> </tr> </thead> <tbody> <tr> <td>ID 0</td> <td>OFF</td> <td>OFF</td> <td>OFF</td> </tr> <tr> <td>ID 1</td> <td>ON</td> <td>OFF</td> <td>OFF</td> </tr> <tr> <td>ID 2</td> <td>OFF</td> <td>ON</td> <td>OFF</td> </tr> <tr> <td>ID 3</td> <td>ON</td> <td>ON</td> <td>OFF</td> </tr> <tr> <td>ID 4</td> <td>OFF</td> <td>OFF</td> <td>ON</td> </tr> <tr> <td>ID 5</td> <td>ON</td> <td>OFF</td> <td>ON</td> </tr> <tr> <td>ID 6</td> <td>OFF</td> <td>ON</td> <td>ON</td> </tr> <tr> <td>ID 7</td> <td>ON</td> <td>ON</td> <td>ON</td> </tr> </tbody> </table>		1	2	3	ID 0	OFF	OFF	OFF	ID 1	ON	OFF	OFF	ID 2	OFF	ON	OFF	ID 3	ON	ON	OFF	ID 4	OFF	OFF	ON	ID 5	ON	OFF	ON	ID 6	OFF	ON	ON	ID 7	ON	ON	ON
	1	2	3																																		
ID 0	OFF	OFF	OFF																																		
ID 1	ON	OFF	OFF																																		
ID 2	OFF	ON	OFF																																		
ID 3	ON	ON	OFF																																		
ID 4	OFF	OFF	ON																																		
ID 5	ON	OFF	ON																																		
ID 6	OFF	ON	ON																																		
ID 7	ON	ON	ON																																		

Note: The switch settings should only be changed when the power is OFF.

Table 2-1002

2. Pick-up Control PCB (80_SUB)

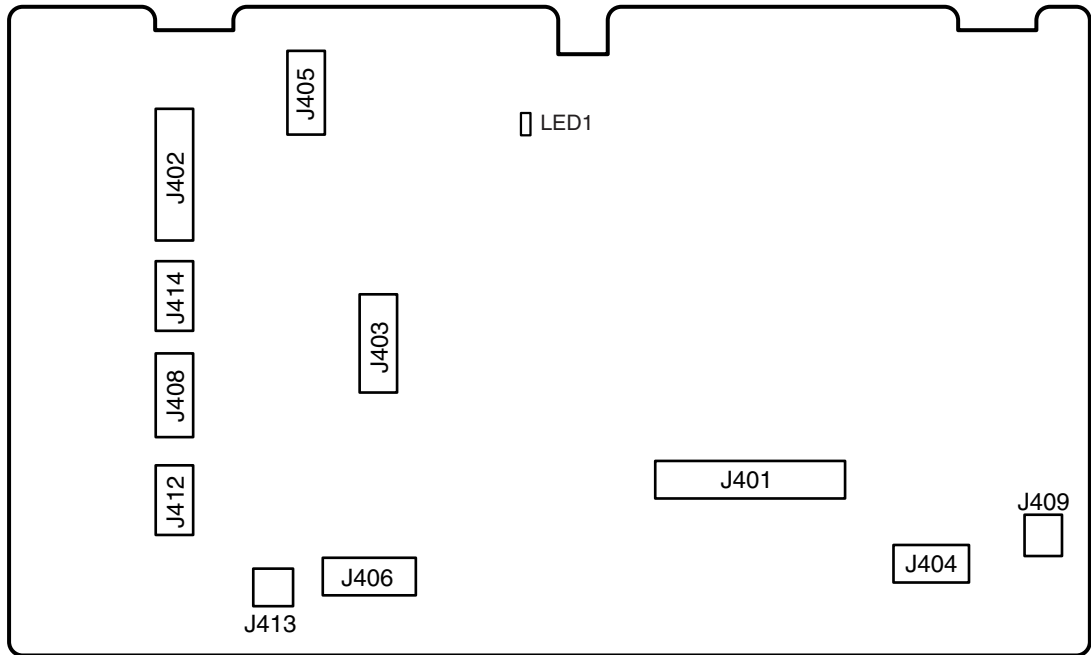

Fig. 2-1002

LED No.	Indication
LED1	Flashing when working normally

Table 2-1003

3. Document Tray PCB (10_SUB)

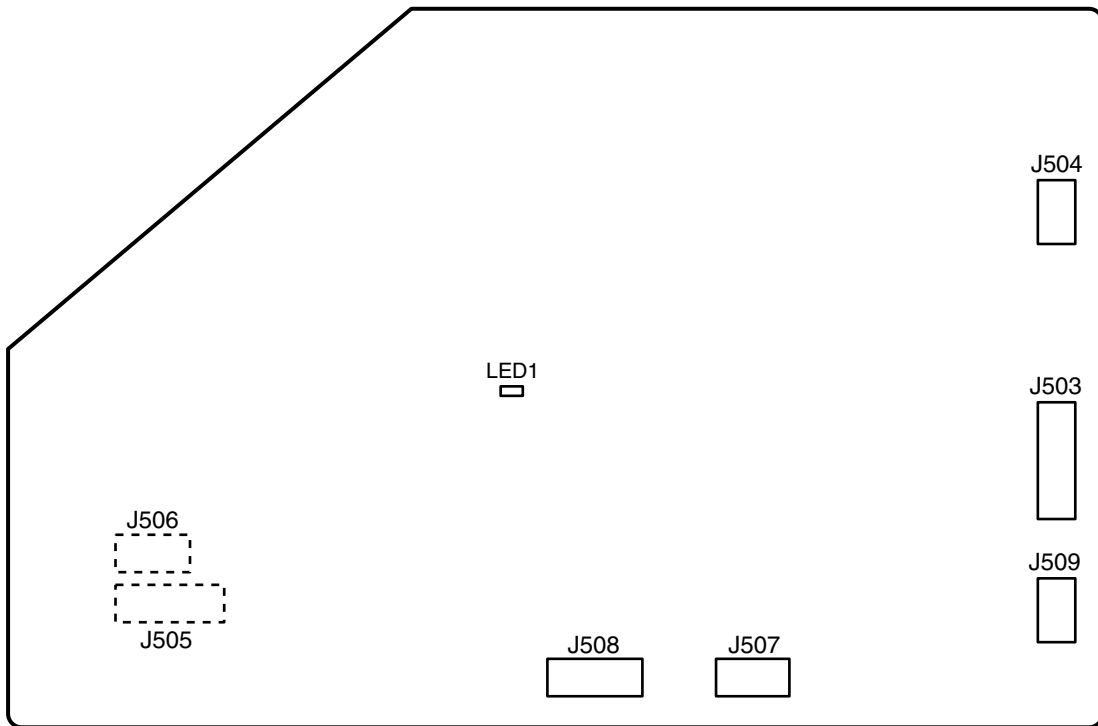

Fig. 2-1003

LED No.	Indication
LED1	Flashing when working normally

Table 2-1004

CHAPTER 3

DISASSEMBLY & REASSEMBLY

I. EXTERNAL ASSEMBLY	3-1	IV. READING SECTION.....	3-35
II. DRIVE SYSTEM (MOTORS).....	3-12	V. ELECTRICAL PARTS	3-38
III. FEED SYSTEM (ROLLERS).....	3-22		

I. EXTERNAL ASSEMBLY

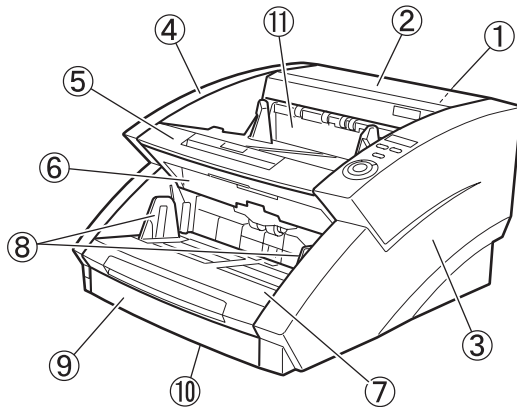

- ① Rear cover
- ② Top cover
- ③ Right cover
- ④ Left cover
- ⑤ Upper delivery cover
- ⑥ Front delivery cover
- ⑦ Document tray
- ⑧ Document guide
- ⑨ Document tray front cover
- ⑩ Lower front cover
- ⑪ Upper unit

Fig. 3-101

1. Rear cover

- 1) Remove six screws ①, then remove the rear cover ②.

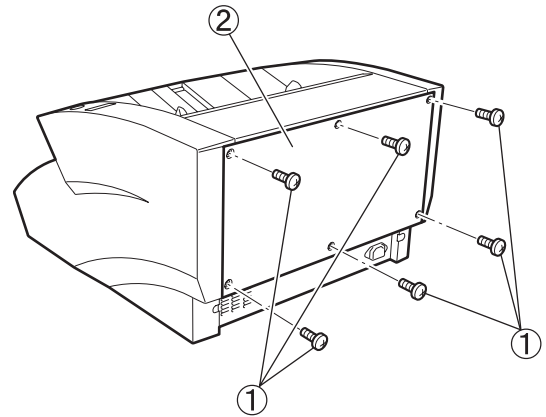

① Screw

② Rear cover

Fig. 3-102

Note: When all the screws are removed, hold the rear cover, since it can fall off.

2. Top cover

- 1) Remove the rear cover.
- 2) Remove one screw (self-tapping) ①, release two hooks ②, and take off the top cover ③.

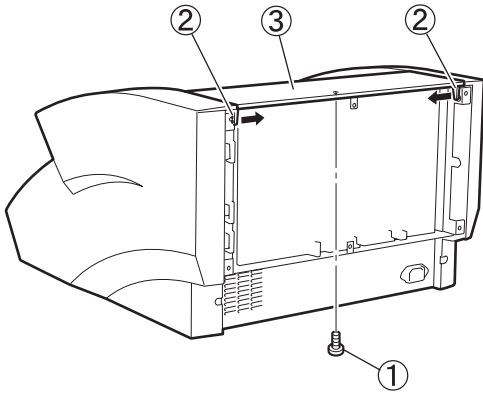

- ① Screw
- ② Hook
- ③ Top cover

Fig. 3-103

Note: Note that the blind plates A/B may fall off (see Fig. 3-104).

Precautions during assembly

- Insert the positioning boss ① of the top cover into the hole in the main body.

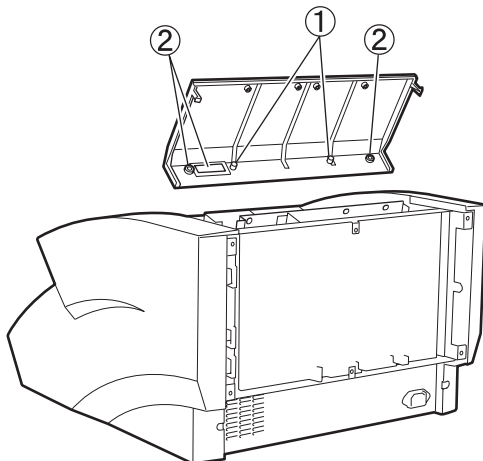

- ① Boss
- ② Blind plate A/B

Fig. 3-104

3. Right cover (assembly)

- 1) Remove the rear cover.
- 2) Unhook the connector ① and pull out the cable assembly ②.

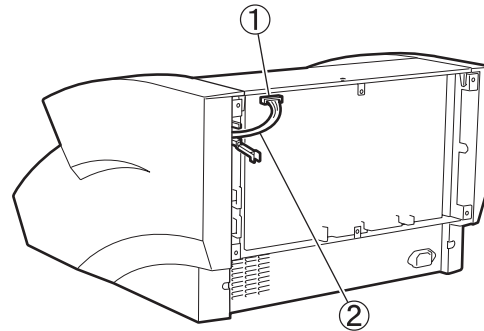

- ① Connector
- ② Cable assembly

Fig. 3-105

- 3) Open the upper unit ① to remove one screw ②.

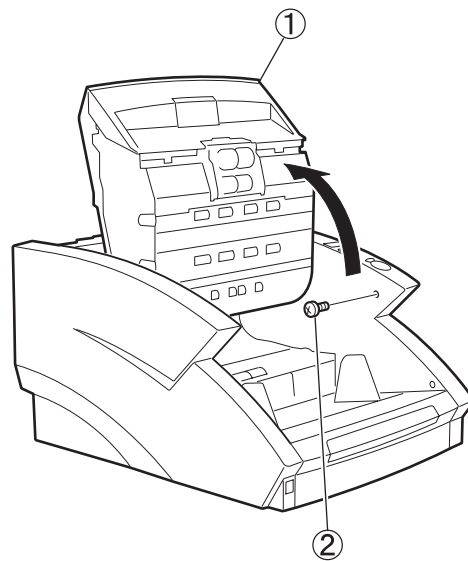

- ① Upper unit
- ② Screw

Fig. 3-106

- 4) Close the upper unit and remove two screws A (self-tapping) ① and one screw B ② on the back side. Take off the lower part on the back of the right cover assembly ④ to release two hooks ③, and then detach the front side while lifting it upward.

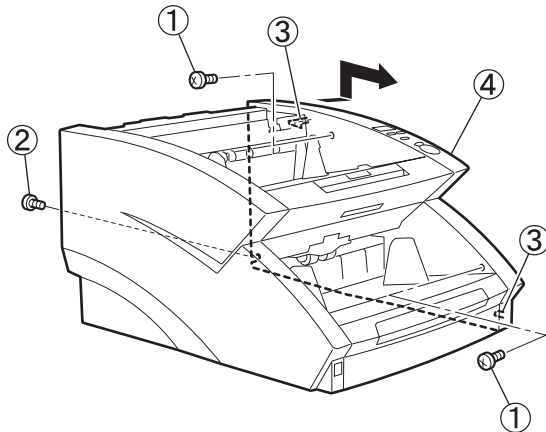

- ① Screw A ② Screw B
 ③ Hook ④ Right cover assembly

Fig. 3-107

- 5) Unhook one connector ①, remove eight screws (self-tapping) ②, and then separate the operation panel PCB (with the mounting metal bracket) ③ from the right cover ④.

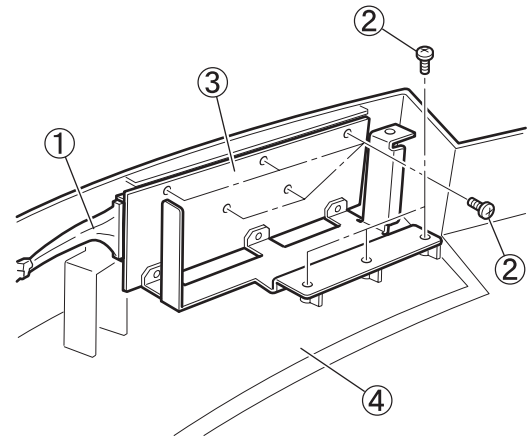

- ① Connector ② Screw
 ③ Operation panel PCB
 ④ Right cover

Fig. 3-108

4. Left cover

- 1) Take off the rear cover.
- 2) Open the upper unit ① and remove one screw (self-tapping) ②.

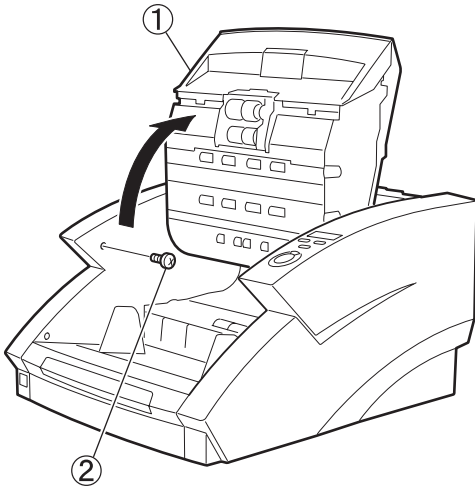

① Upper unit ② Screw

Fig. 3-109

5. Upper delivery cover (assembly)

- 1) Open the upper unit ①, remove six screws ② (three for each side), and then close the upper unit.

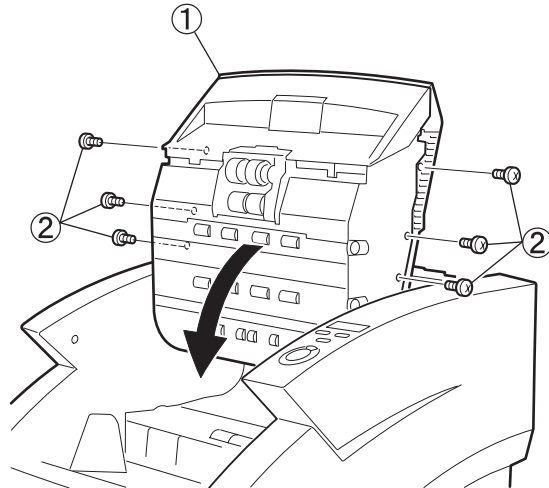

① Upper unit ② Screw

Fig. 3-111

- 3) Close the upper unit and remove two screws A (self-tapping) ① and one screw B ② on the back side. Take off the lower part on the back of the left cover ④ to release two hooks ③, and then detach the front side while lifting it upward.

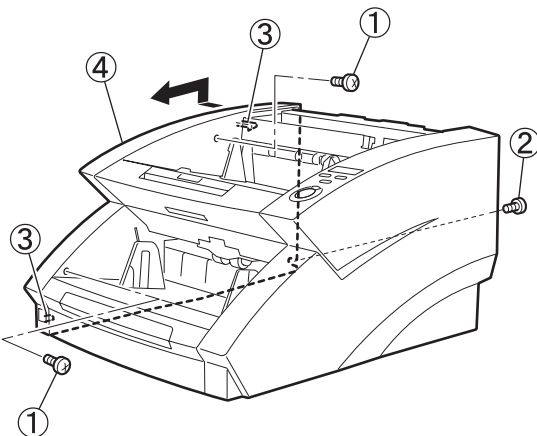

① Screw A ② Screw B
③ Hook ④ Left cover

Fig. 3-110

- 2) Push and tilt the IP cover ① toward the front, remove the screw ②, and then detach the upper delivery cover assembly ③ frontward.

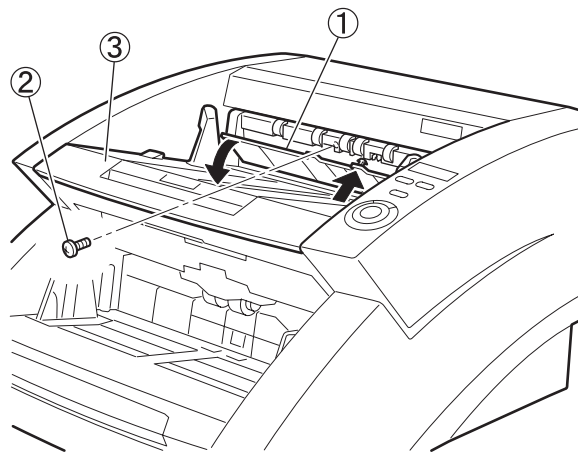

① IP cover ② Screw
③ Upper delivery cover assembly

Fig. 3-112

- 3) Rotate the delivery tray assembly ①. Remove six screws ②, unhook two claws ③, and release the front claw ④ by sliding it forward. Release two collars ⑤ and detach both the upper and lower eject tray assemblies.

Note: Be careful not to damage the claw since it is breakable.

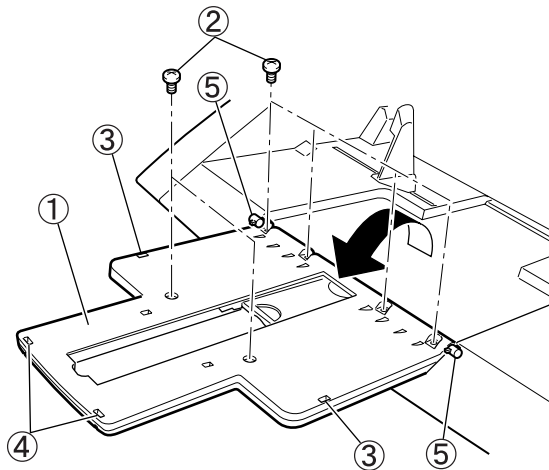

- ① Delivery tray assembly
- ② Screw
- ③ Claw
- ④ Front claw
- ⑤ Collar

Fig. 3-113

6. Front delivery cover

- 1) Detach the upper delivery cover assembly.
- 2) Remove four screws ①, pull down the roller ②, and take off the front delivery cover ③ by lifting it upward.

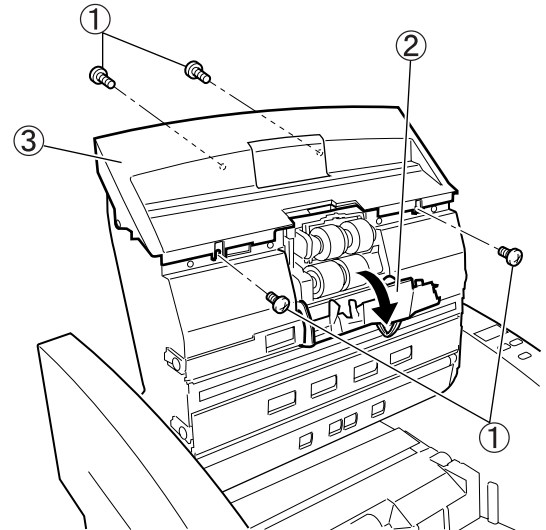

- ① Screw
- ② Roller cover
- ③ Front delivery cover

Fig. 3-115

- 4) Release the boss ② on each side by bending the IP cover ① to separate it from the upper delivery cover ③.

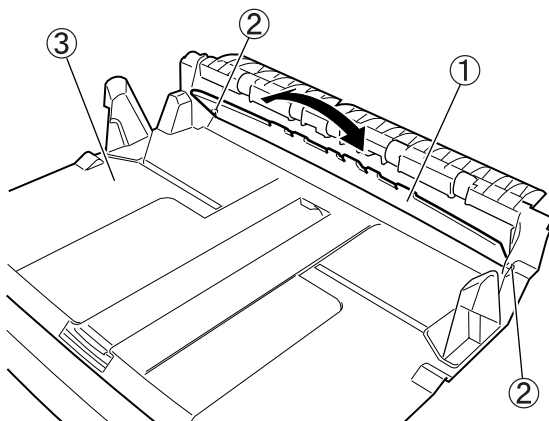

- ① IP cover
- ② Boss
- ③ Upper delivery cover

Fig. 3-114

7. Document tray assembly

- 1) Remove four screws ①.

Note: For the early produced products, a spacer is placed at the left-side two screws.

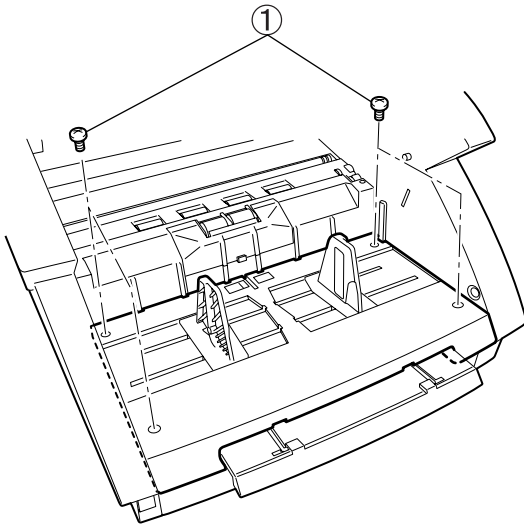

- ① Screw

Fig. 3-116

- 2) Lift the document tray assembly ①, release the connector ②, and detach the document tray assembly and document tray extension ③.

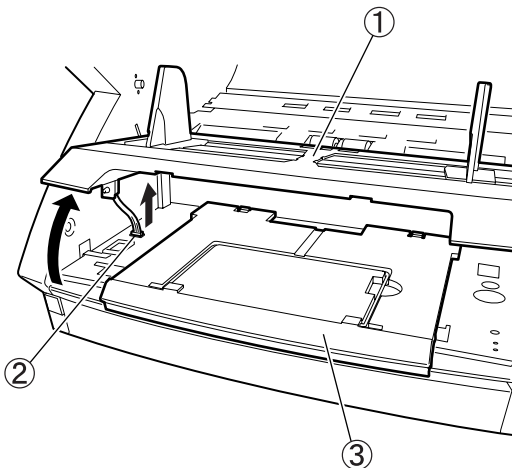

- ① Document tray assembly
- ② Connector
- ③ Document tray extension

Fig. 3-117

8. Document guide

- 1) Detach the document tray assembly.
- 2) Remove five screws (self-tapping) ①, release the leaf spring ②, and dismount the reinforcing plate ③.

Note: Be careful not to lose the leaf spring after removing the screws.

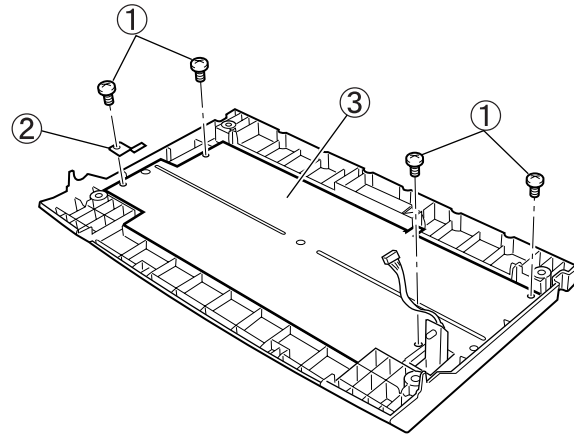

- ① Screw
- ② Leaf spring
- ③ Reinforcing plate

Fig. 3-118

- 3) Remove two screws ③ (one on each side) fixing the document guide ① and rack ② and detach the document guide.

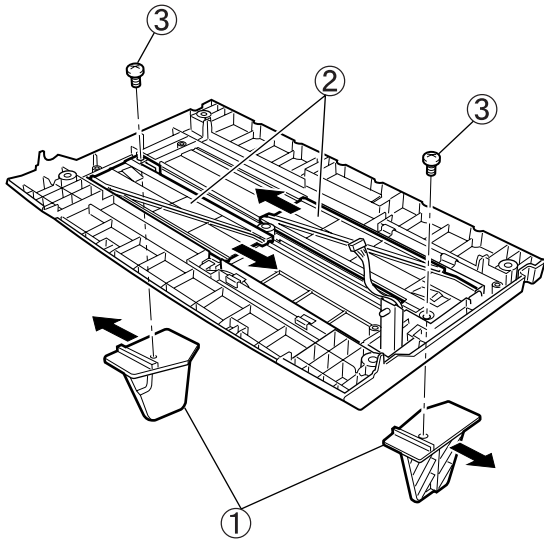

- ① Document guide
- ② Rack
- ③ Screw

Fig. 3-119

Precautions during assembly

- Position the document guide ① symmetrically during assembly.

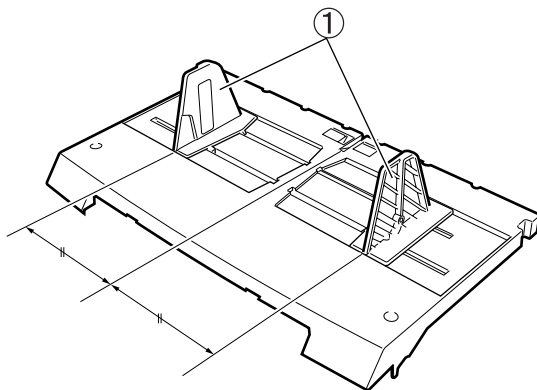

- ① Document guide

Fig. 3-120

9. Document tray front cover

- 1) Detach the document tray assembly.
- 2) Remove six screws (with round-shaped tips) ①.

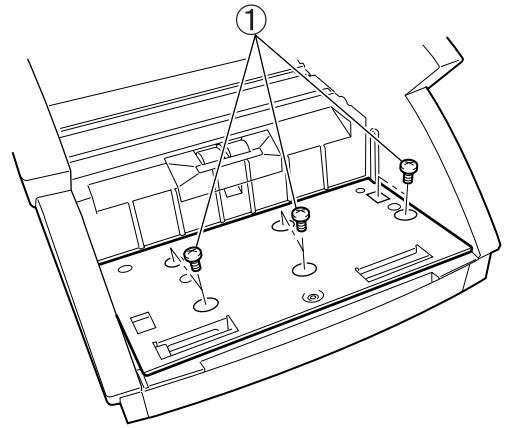

- ① Screw

Fig. 3-121

- 3) Lift the document tray driving unit ① a little, unhook two connectors ②, and then detach the document tray driving unit.

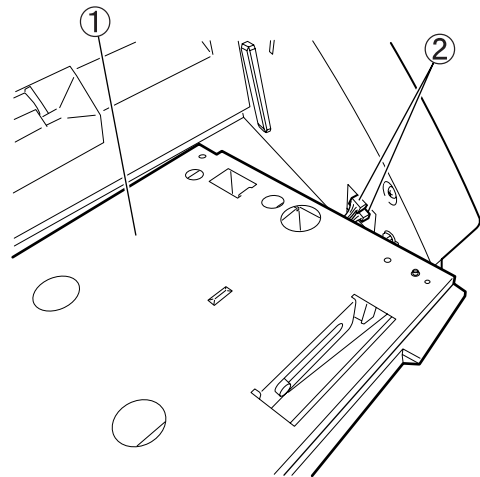

- ① Document tray driving unit
- ② Connector

Fig. 3-122

- 4) Remove three screws ② on the reverse side of the document tray driving unit ① and detach the document tray front cover ③.

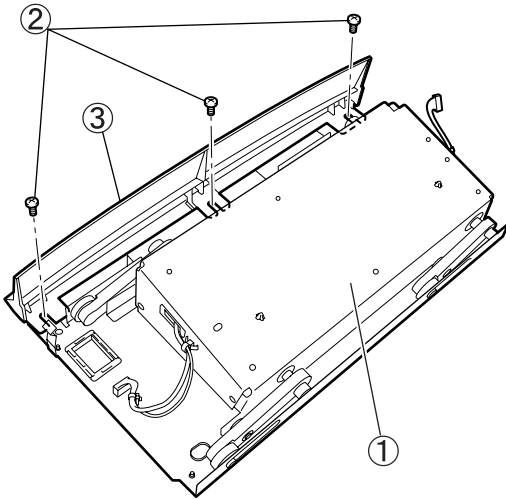

- ① Document tray driving unit
 ② Screw ③ Document tray front cover

Fig. 3-123

Precautions during assembly

- When installing the document tray driving unit, fit it to the two positioning marks ① located at the bottom. If the positioning is improper, the screw holes may be displaced, or the unit may be loose.

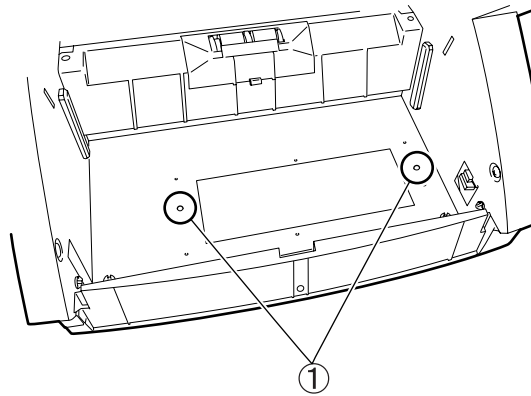

- ① Positioning mark

Fig. 3-124

- Since the tips of the screws that mount the document tray driving unit will protrude, use the screws with round-shaped tips to prevent injuries.

10. Lower front cover

- 1) Detach the right/left cover assembly.
- 2) Remove the document tray driving unit. Refer to the section entitled "Document tray front cover".
- 3) Take off the lower front cover (2) by removing three screws (1).

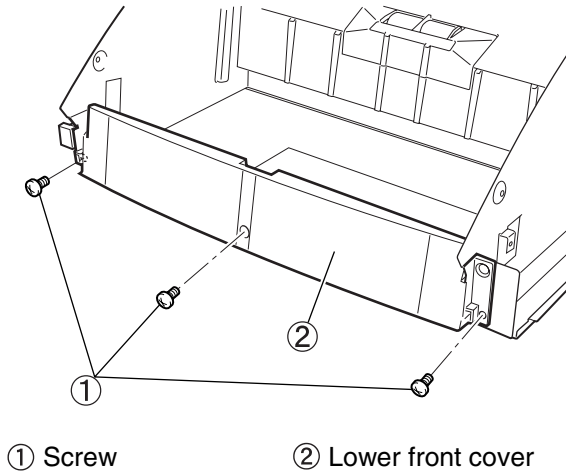
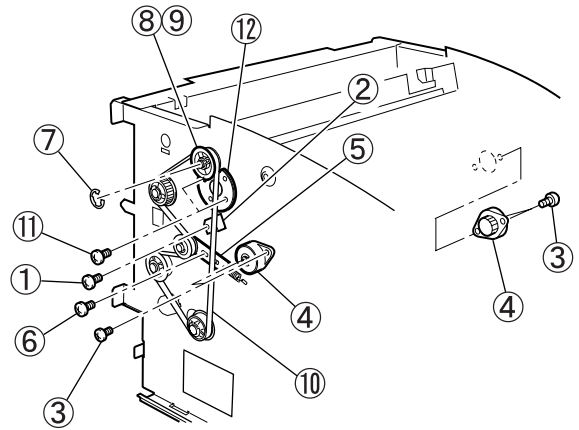

Fig. 3-125

11. Upper unit

- 1) Detach the right/left cover assembly.
The upper unit should be closed.
- 2) First, remove one screw (1) to release the leaf spring (2).
Remove two screws (with round-shaped tips) (3) and dismount the damper (white) (4).
Loosen one screw (6) of the tensioner (5) and remove the E-ring (7), pulley (8), and pin (9) and belt (10) in sequence. Remove the additional two screws (11) and detach the pivot (12).

Note: Be careful not to drop the parallel pin.



- | | |
|-------------|---------------|
| ① Screw | ② Leaf spring |
| ③ Screw | ④ Damper |
| ⑤ Tensioner | ⑥ Screw |
| ⑦ E-ring | ⑧ Pulley |
| ⑨ Pin | ⑩ Belt |
| ⑪ Screw | ⑫ Pivot |

Fig. 3-126

- 3) Unfasten the clamp ② fixing a cable ① that are pulled out from the right-side of the upper unit, and unhook four connectors ③ on the main CPU PCB.

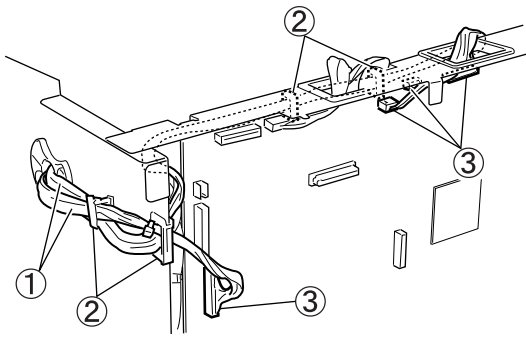

- ① Cable
② Clamp
③ Connector

Fig. 3-127

- 4) First, remove one screw ① and then the stopper ②.
Remove two screws (with round-shaped tips) ③ and dismount the damper (black) ④. Remove the additional two screws ⑤, detach the pivot ⑥, and then finally detach the upper unit ⑧ so as not to damage the cable ⑦.

Note: Detach the upper unit while holding it to prevent it from falling.

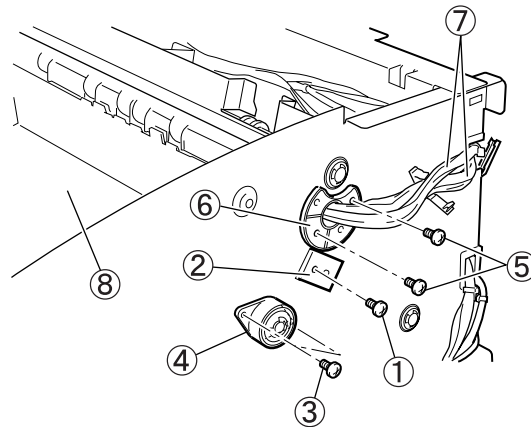

- ① Screw
② Stopper
③ Screw
④ Damper
⑤ Screw
⑥ Pivot
⑦ Cable
⑧ Upper unit

Fig. 3-128

Precautions during assembly

- Pass the cable through the hole of the cable for the right-side plate in advance.
- There are two types of dampers: the one whose outside color is white is for the left-side plate, and the one whose outside color is black is for the right-side plate.
If you make a mistake in this assembly, the upper unit will not open or close properly.
- Since the tips of the screws that mount the damper will protrude inward, use the screws with round-shaped tips to prevent injuries.
- With the upper unit closed and locked, install the damper and check that it engages the rack correctly.
- Install the leaf spring and the stopper at the end of the assembly, with the upper unit closed.

II. DRIVE SYSTEM (MOTORS)

1. Main motor

- 1) Detach the right cover assembly.
- 2) After removing four screws ①, detach the belt ② and pull out the main motor assembly ③.

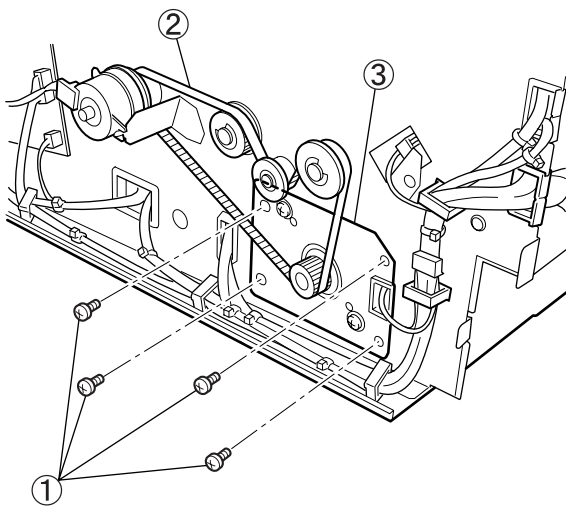

- ① Screw
- ② Belt
- ③ Main motor assembly

Fig. 3-201

- 3) Remove two screws ①, unhook the connector ②, and detach the main motor ③.

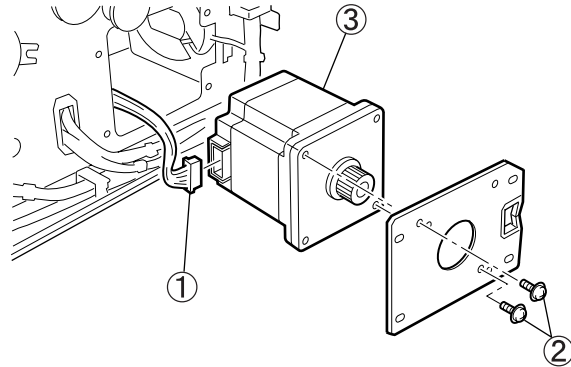

- ① Connector
- ② Screw
- ③ Main motor

Fig. 3-202

Precautions during assembly

- Fix the main motor assembly position so that the belt does not miss the sprockets. However, the fixing should not be tightened too much.

2. Document tray motor

- 1) Detach the document tray driving unit. Refer to the section entitled "Document tray front cover".
- 2) Remove four bosses ① of the document tray driving unit and dismount the reinforcing plate ③ through four slotted holes ②.

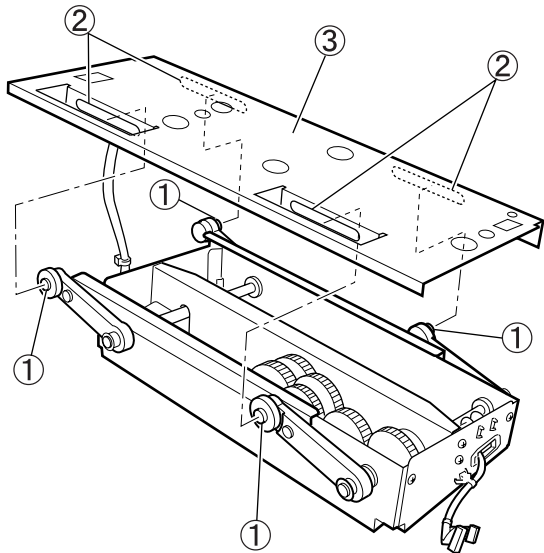

- ① Boss
- ② Slotted hole
- ③ Reinforcing plate

Fig. 3-203

- 3) After removing four screws ①, remove the additional two screws ② that fix the gear shaft, and detach the gear unit ③.

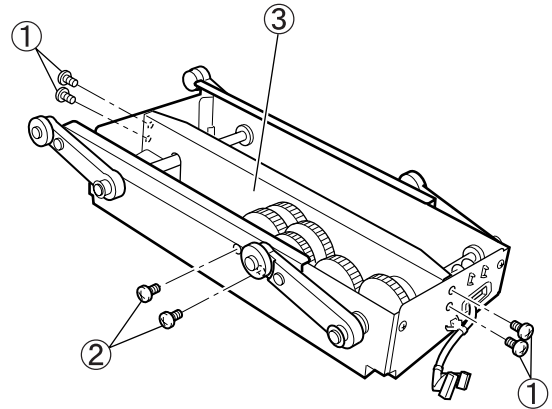

- ① Screw
- ② Screw
- ③ Gear unit

Fig. 3-204

- 4) After removing six gears ①, remove two screws ② and the connector ③, and dismount the document tray motor ④.

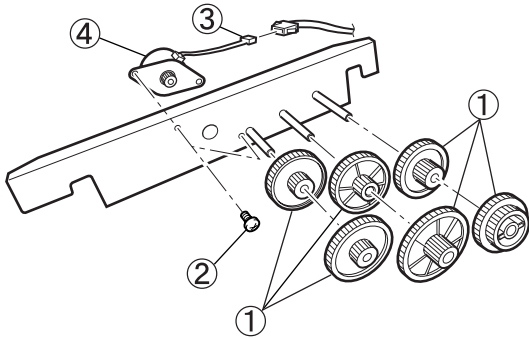

- ① Gear
② Screw
③ Connector
④ Document tray motor

Fig. 3-205

Precautions during assembly

- When installing the document tray driving unit into the main body, be careful with the positioning. Refer to the section entitled "Document tray front cover".
- Make sure that the reinforcing plate is lowered to the bottom before the installation.

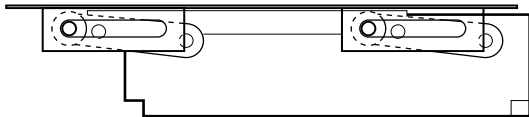
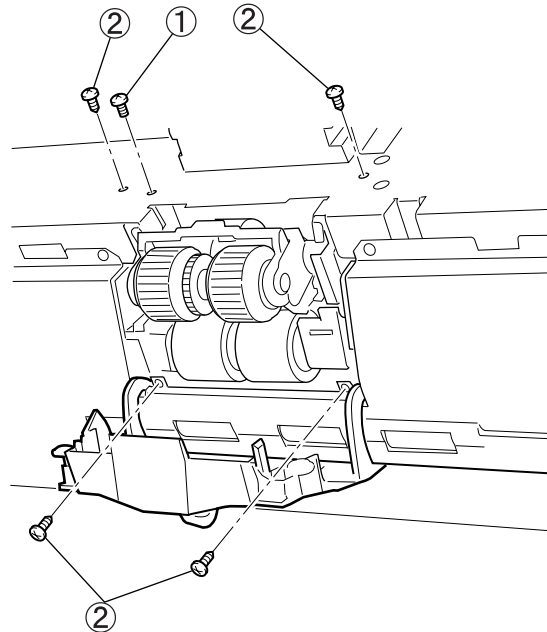

Fig. 3-206

3. Pick-up motor

- 1) Detach the front delivery cover.
- 2) Remove one screw A ① and four screws B (self-tapping) ②.



- ① Screw A
② Screw B

Fig. 3-207

- 3) Unhook four connectors ② of the pick-up control PCB ①, remove four screws ③, and then detach the pick-up assembly ④.

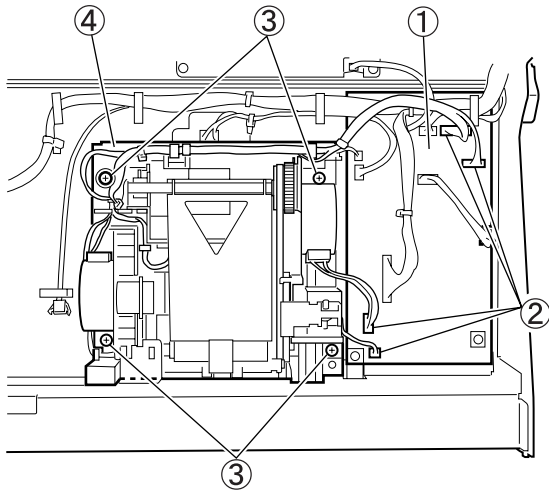

- ① Pick-up control PCB
- ② Connector
- ③ Screw
- ④ Pick-up assembly

Fig. 3-208

4. Feed motor

- 1) Detach the pick-up assembly. Refer to the section entitled "Pick-up motor".
- 2) Unhook the connector ①, remove two screws ②, and detach the feed motor assembly ③.

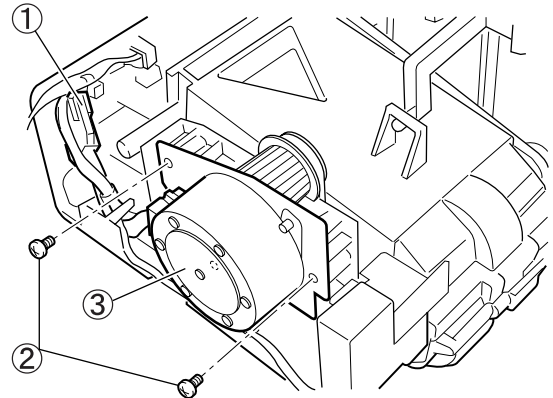

- ① Connector
- ② Screw
- ③ Feed motor assembly

Fig. 3-210

- 4) Remove two screws ① and dismount the pick-up motor ②.

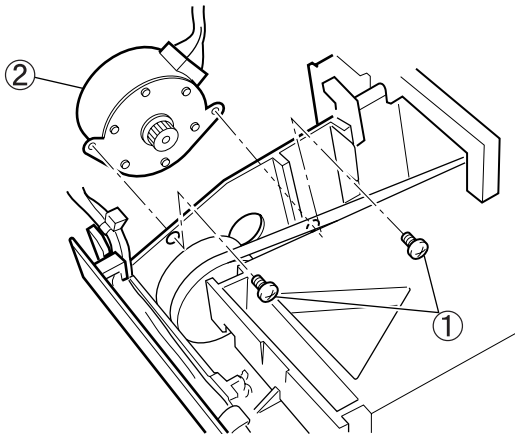

- ① Screw
- ② Pick-up motor

Fig. 3-209

- 3) Remove two screws ① and dismount the feed motor ②.

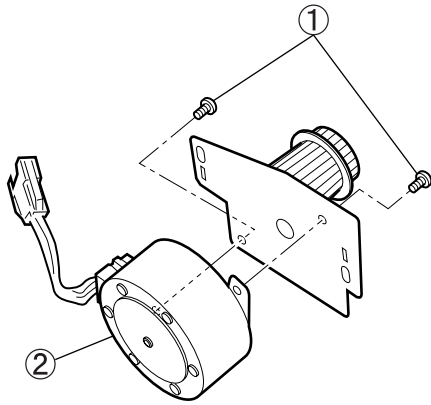

- ① Screw ② Feed motor

Fig. 3-211

Note: Be aware that documents cannot be picked up if the one-way pulley is installed backwards when replacing the feed motor belt.

5. Retard motor

- 1) Open the upper unit.
- 2) Push the lever in the direction of the arrow and take off the lower entry guide plate cover ①. Remove three screws (stepped) ② and detach the lower entry guide plate ③.

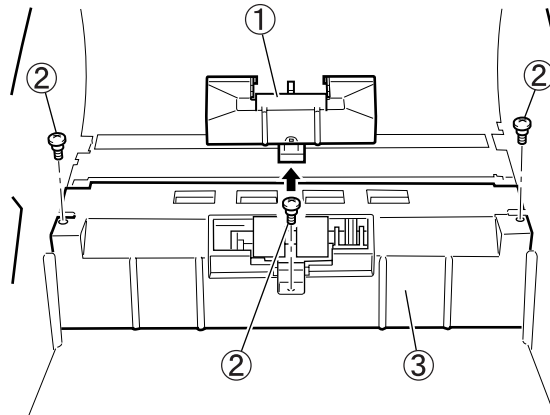

- ① Lower entry guide plate cover
 ② Screw
 ③ Lower entry guide plate

Fig. 3-212

- 3) Remove four screws (with round-shaped tips) ① and detach the retard roller unit ②. Unhook the connector ③.

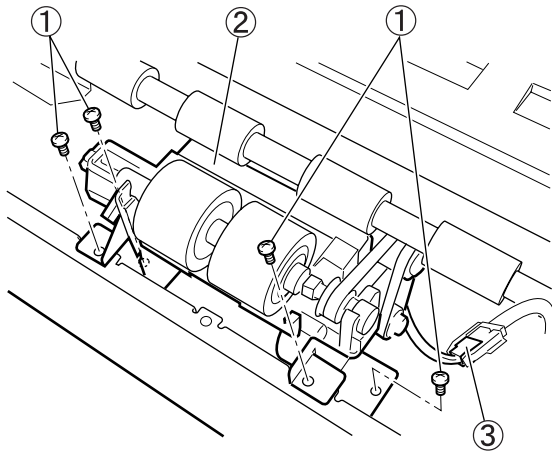

- ① Screw
② Retard roller unit
③ Connector

Fig. 3-213

- 4) Remove two screws ① and dismount the retard motor ②.

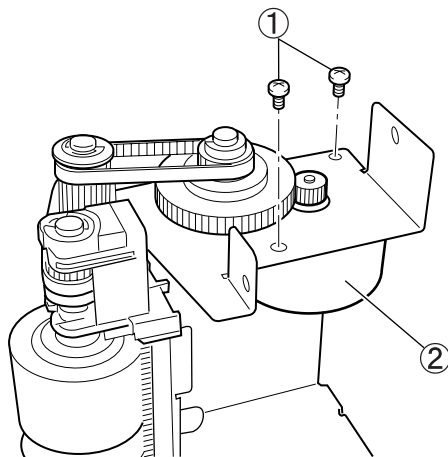

- ① Screw
② Retard motor

Fig. 3-214

Reference: Light guide

The following describes the disassembly/reassembly of the light guide, which is installed at the lower entry guide plate shown in the previous section, "Retard motor".

- Unhook the arm ① of the light guide by bending it to the direction of the arrow and detach the light guide ②. Be careful not to damage the arm. You can remove the light guide.

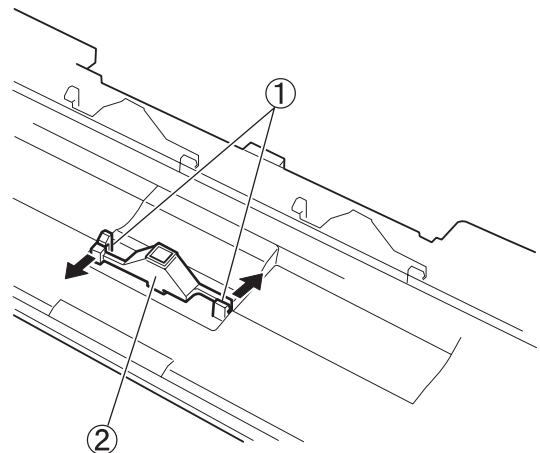

- ① Arm
② Light guide

Fig. 3-215

- There are two types of projections on the light guide: round ① and oval ②. Install the projections in the matching holes and insert the arm into the hooks until it clicks.

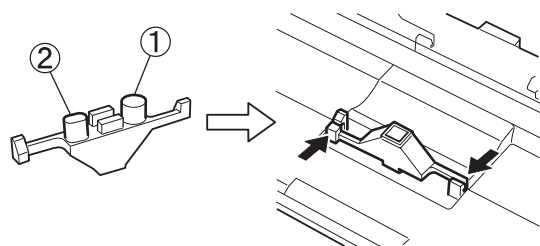

- ① Round
② Oval

Fig. 3-216

6. Pick-up solenoid

- 1) Take off the Front delivery cover.
- 2) Unhook the connector ① and remove two screws ②.

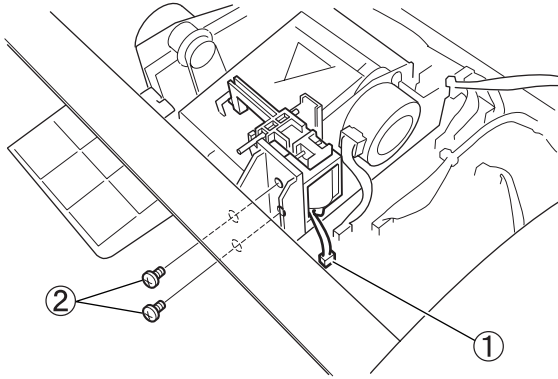

- ① Connector ② Screw

Fig. 3-217

- 3) Lift the end of the shaft ① to pull it off and detach the solenoid ②.

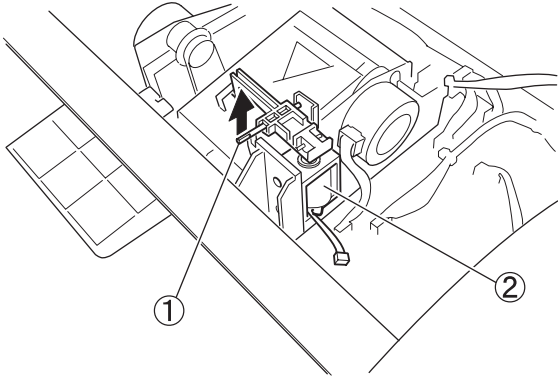

- ① Shaft ② Solenoid

Fig. 3-218

Precautions during assembly

- Push in the shaft by fitting the D-cut of the shaft into the groove.
- With the plunger of the solenoid pushed downward, fix the solenoid at the position where the pick-up roller raises upward.

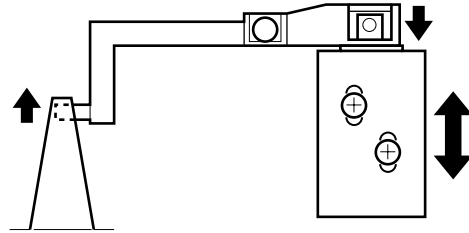
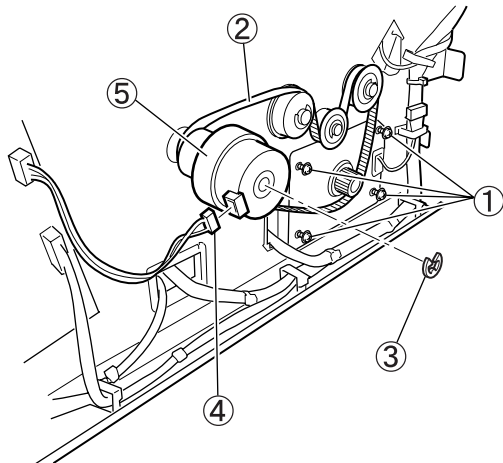

Fig. 3-219

7. Registration clutch

- 1) Detach the right cover assembly.
- 2) Loosen four screws ① of the main motor mount plate and detach the belt ②. And then, remove the E-ring ③ and unhook the connector ④ in order to pull the clutch ⑤ out of the shaft.



- ① Screw
- ② Belt
- ③ E-ring
- ④ Connector
- ⑤ Clutch

Fig. 3-220

8. Shading solenoid (lower side)

- 1) Take off the right/left cover assembly.
- 2) Detach the lower registration roller and platen unit ①. Refer to the section entitled "III. FEED SYSTEM".

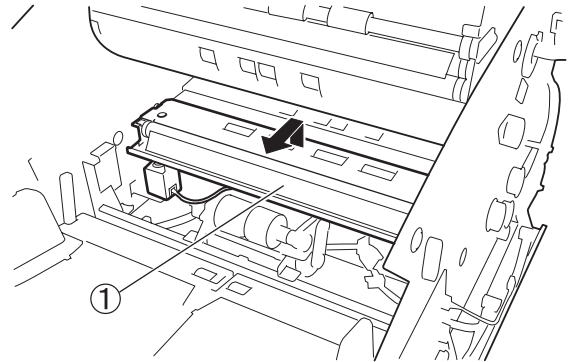

- ① Platen unit

Fig. 3-221

- 3) Turn over the platen unit, remove two screws ①, and detach the solenoid assembly ②.

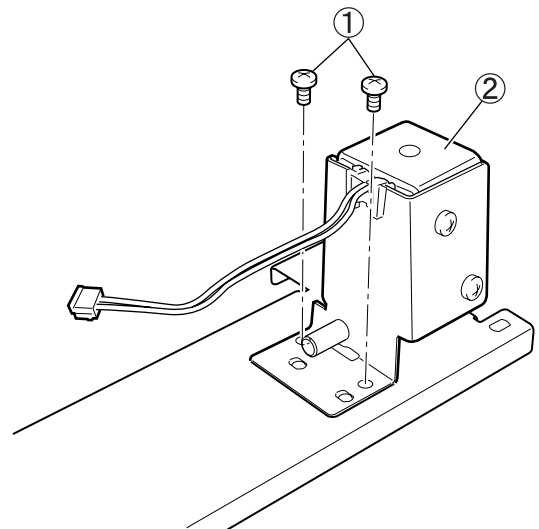

- ① Screw
- ② Solenoid assembly

Fig. 3-222

Precautions during assembly

- With the shading plate ① located all the way inside, install the gears of the solenoid side and the shading plate side so that the gear teeth (outer one) of the solenoid side ② is positioned at the top. Remember to install the spacer ③ into the plunger.

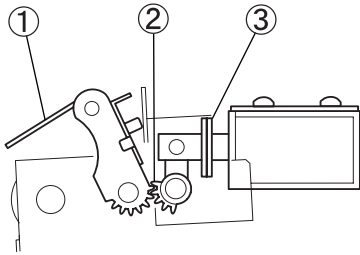

- ① Shading plate
- ② Gear teeth (outer one) of the solenoid side
- ③ Spacer

Fig. 3-223

- With the plunger of the solenoid pushed inward, fix the solenoid at the position where the shading plate is farthest outward.

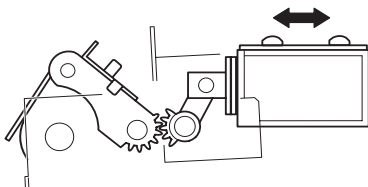
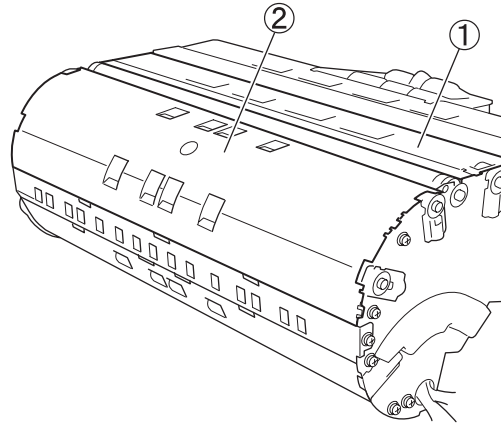

Fig. 3-224

9. Shading solenoid (upper side)

- 1) Remove the upper unit.
- 2) Dismount the reading roller guide plate ① and feed guide plate 1 ② to detach the Feeder follower roller. Refer to the section entitled "III. FEED SYSTEM".



- ① Reading roller guide plate
- ② Feed guide plate 1

Fig. 3-225

- 3) Unhook the connector ①, remove two screws A ②, and detach the solenoid body ③. Remove two screws B (with round-shaped tips) ④ and detach the plunger assembly ⑤.

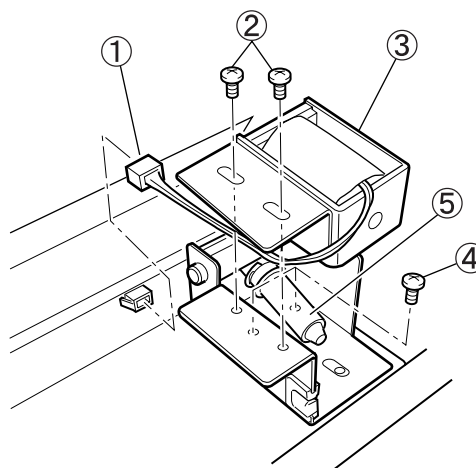

- ① Connector
- ② Screw A
- ③ Solenoid body
- ④ Screw B
- ⑤ Plunger assembly

Fig. 3-226

Precautions during assembly

- For the mount plate ① of the plunger side, with the shading plate ② fitting the platen roller ③ and positioning itself all the way outside, fix the gears so that the gear teeth ④ (outer one) of the plunger side are at the top. Remember to install the spacer ⑤ into the plunger.

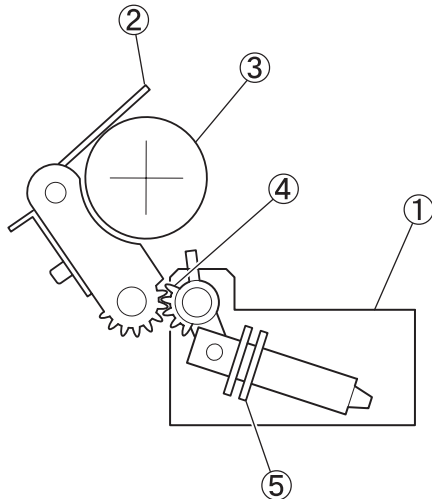

- ① Mount plate
- ② Shading plate
- ③ Platen roller
- ④ Gear teeth
- ⑤ Spacer

Fig. 3-227

- Likewise, the solenoid body should be fixed so that the gear teeth (outer one) of the plunger side are at the top, with the shading plate fitting the platen roller and positioned all the way outside.

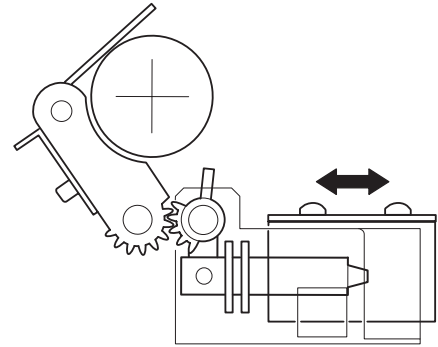

Fig. 3-228

- Before fixing the feed guide plate 1, match three fits between plate 1 and the feed guide plate 2. Refer to the section entitled "Feeder follower roller".

III. FEED SYSTEM (ROLLERS)

1. Pick-up roller

- 1) Open the upper unit.
- 2) Press the portion indicated by the arrow to open the roller cover ①.

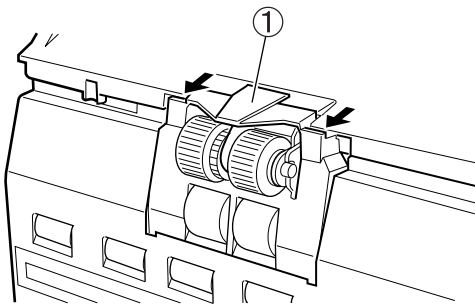

① Roller cover

Fig. 3-301

- 3) Open the roller holder ① and detach the pick-up roller ②.

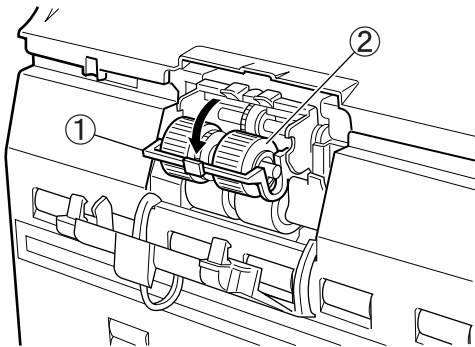

① Roller holder
② Pick-up roller

Fig. 3-302

Precautions during assembly

- Close the roller holder or the roller cover completely until it is hooked.

2. Feed roller

- 1) Open the upper unit.
- 2) Press the portion indicated by the arrow and open the roller cover ①.

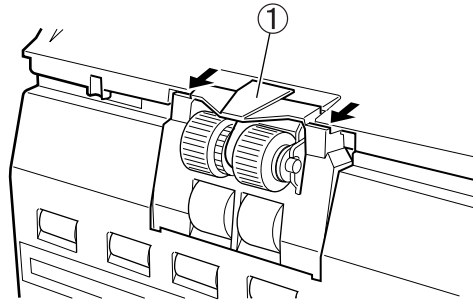

① Roller cover

Fig. 3-303

- 3) Pull the lever ② frontward so that it locks the feed roller ①.

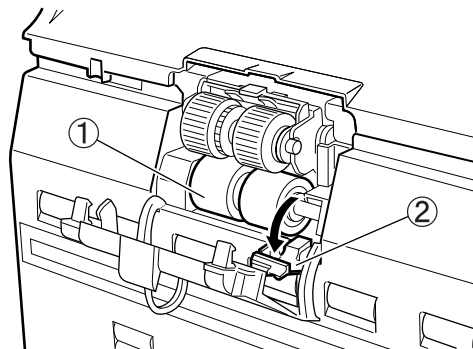

① Feed roller

② Lever

Fig. 3-304

- 4) Slide the feed roller ① to the right and raise it toward the front in order to detach it.

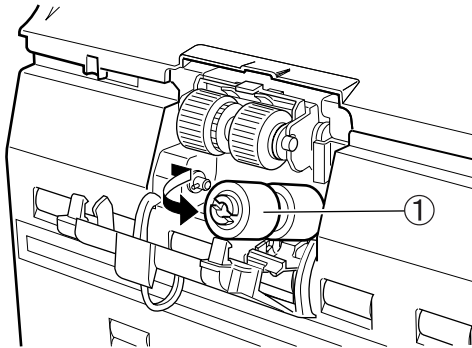

① Feed roller

Fig. 3-305

Precautions during assembly

- Fit the notch on the left side of the roller to the pin on the main body side.
- Do not push or move the right-side guide shaft to the left.

3. Retard roller

- 1) Open the upper unit.
- 2) Push the hook upward ① and take off the roller cover ②.

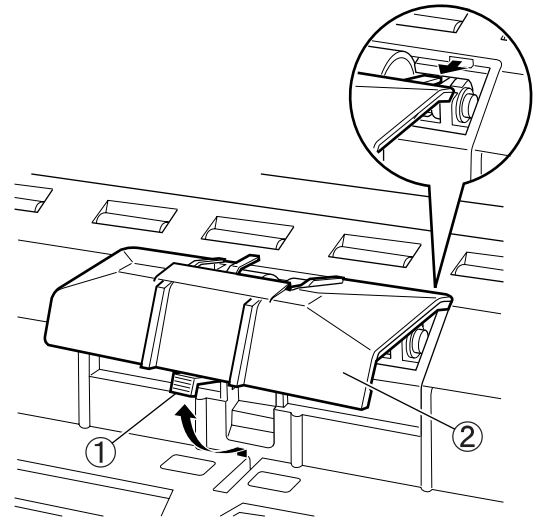

① Hook

② Roller cover

Fig. 3-306

- 3) Raise the roller fixing lever ①, slide the retard roller ② to the left, and detach the retard roller.

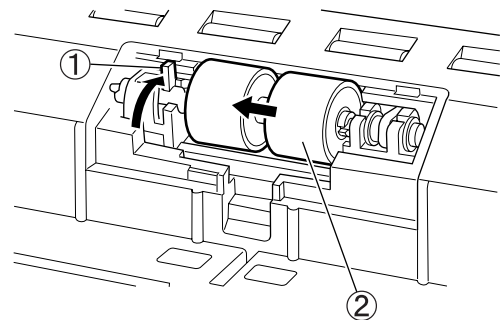

① Roller fixing lever

② Retard roller

Fig. 3-307

Precautions during assembly

- Fit the notch on the right side of the roller to the pin on the main body side.

4. Upper registration roller

- 1) Detach the right/left cover assembly.
- 2) Open the roller cover.
- 3) Remove six screws A ① and two screws B (self-tapping) ② and detach the upper registration roller guide ③.

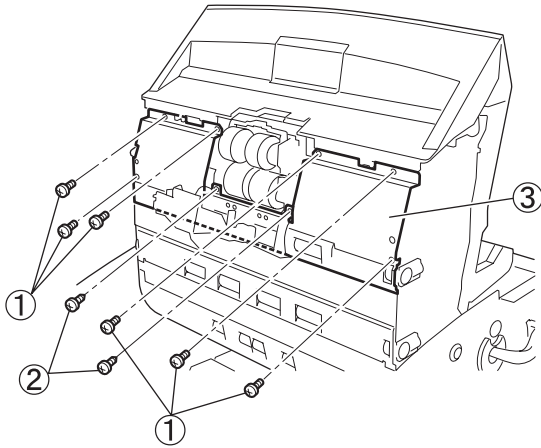

- ① Screw A
- ② Screw B
- ③ Upper registration roller guide

Fig. 3-308

- 4) Press the claw of the stopper ① from within, and detach the registration roller assembly ②.

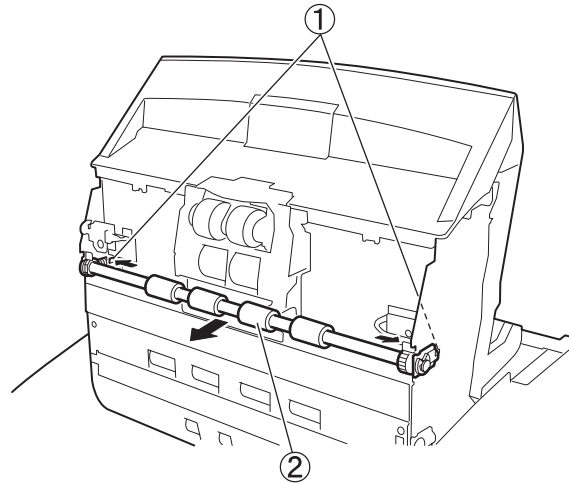

- ① Claw of the stopper
- ② Registration roller assembly

Fig. 3-309

- 5) Remove two E-rings ① (one on each side) and detach the stopper assembly ②.

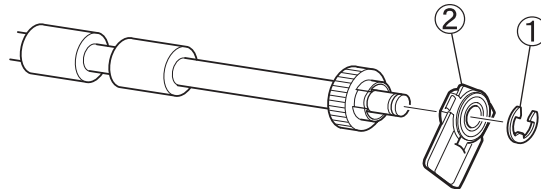

- ① E-ring
- ② Stopper assembly

Fig. 3-310

Precautions during assembly

- The stopper assemblies on both sides are the same parts. All stopper assemblies for the roller installed into the upper unit are the same. When installing the coil spring of the stopper assembly, the side where the tip of the spring is bent should contact the ball bearing ②. This dissipates static charge from the roller unit onto the side plate.

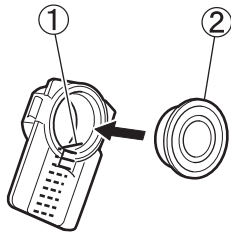

- ① Side where the tip is bent
- ② Ball bearing

Fig. 3-311

5. Upper reading roller

- 1) Detach the right/left cover assembly.
- 2) Open the upper unit.
- 3) Remove two screws ① and detach the upper reading roller guide ②.

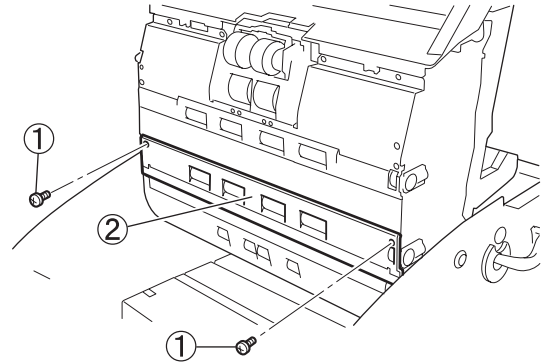

- ① Screws
- ② Upper reading roller guide

Fig. 3-312

- 4) Press the claw of the stopper ① from within and detach the upper reading roller assembly ②.

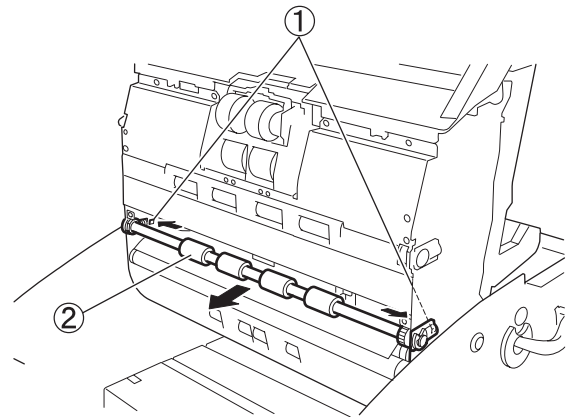

- ① Claw of the stopper
- ② Upper reading roller assembly

Fig. 3-313

- 5) Detach the stopper assembly. Refer to the section entitled "Upper registration roller".

6. Back platen roller

- 1) Dismount the upper unit.
- 2) Remove two screws A ① and detach the upper reading roller guide ②. After removing four screws B ③ (two on each side) and the back side of feed guide plate 1 ④, slide feed guide plate 1 to the right to detach it by unhooking the fit ⑤ on the front side.

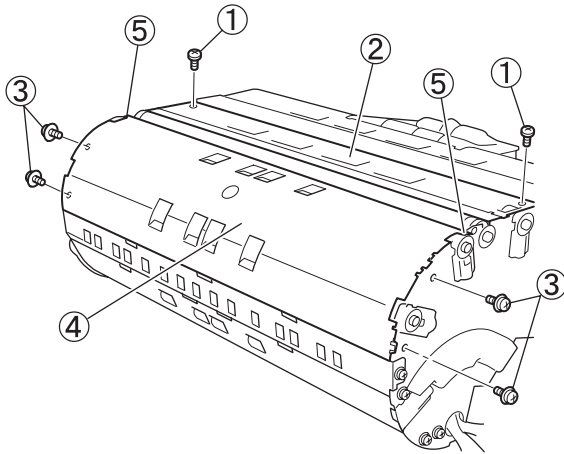

- ① Screw A
- ② Upper reading roller guide
- ③ Screw B
- ④ Feed guide plate 1
- ⑤ Fit

Fig. 3-314

- 3) Remove two E-rings ① and two bearings ② and detach the back platen roller ③. Additionally, remove two spacers ④, the pin ⑤, and the gear ⑥.

Note: The spacer comes with the bearing.

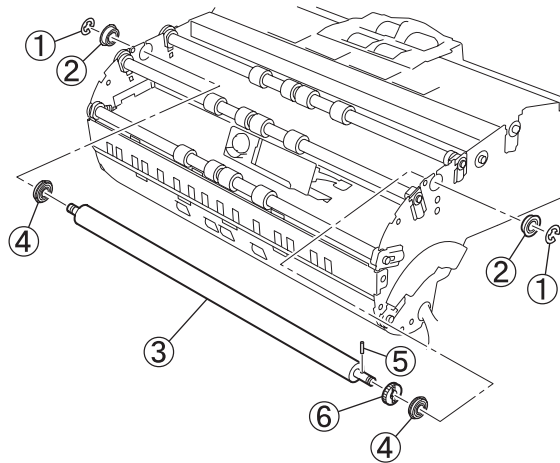

- ① E-ring
- ② Bearing
- ③ Back platen roller
- ④ Spacer
- ⑤ Pin
- ⑥ Gear

Fig. 3-315

Precautions during assembly

- Fix feed guide plate 1 by matching three fits on the back.

7. Feeder follower rollers 1, 2, and 3

- 1) Dismount the upper unit.
- 2) Remove twelve screws ① (six on each side) and detach feed guide plates 1 ②, 2 ③, and 3 ④.

Note: When detaching feed guide plate 1, remove the back side of feed guide plate 1 and slide it to the right to unhook the fit on each side of the front side.

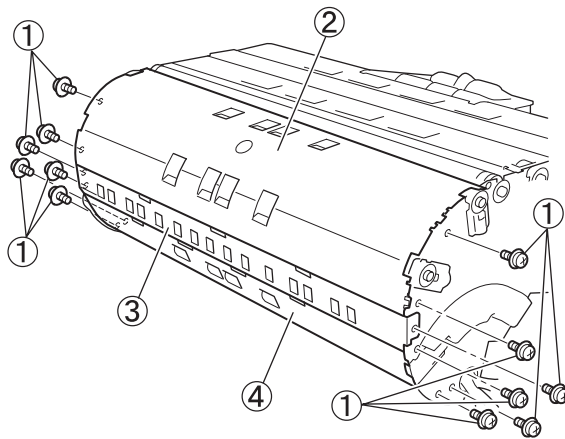

- | | |
|----------------------|----------------------|
| ① Screw | ② Feed guide plate 1 |
| ③ Feed guide plate 2 | ④ Feed guide plate 3 |

Fig. 3-316

- 3) Press the claw of the stopper ① from within and detach the feeder follower roller assemblies 1, 2, and 3 ②.

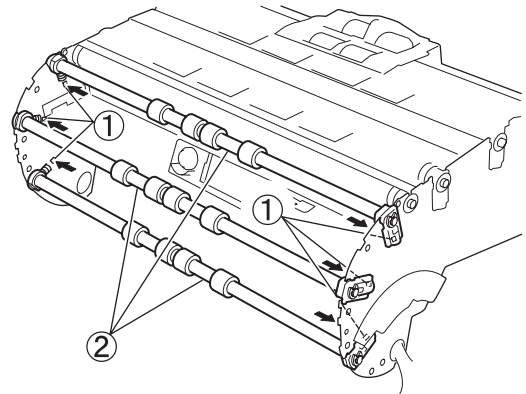

- | |
|-------------------------------------|
| ① Claw of the stopper |
| ② Feeder follower roller assemblies |

Fig. 3-317

- 4) Detach the stopper assembly. Refer to the section entitled "Upper registration roller".

Precautions during assembly

- Feeder follower rollers 1, 2 and 3 are the same parts.
- When installing the feed guide plates from the bottom side, start from plate 3, and then install 2 and 1.
- As for feed guide plate 1 ①, its upper-right projection ② is longer than the upper-left projection ③. Therefore, install it by inserting the right side first. Also, feed guide plate 2 should be fixed by its three convex parts ④ into the groove ⑤.

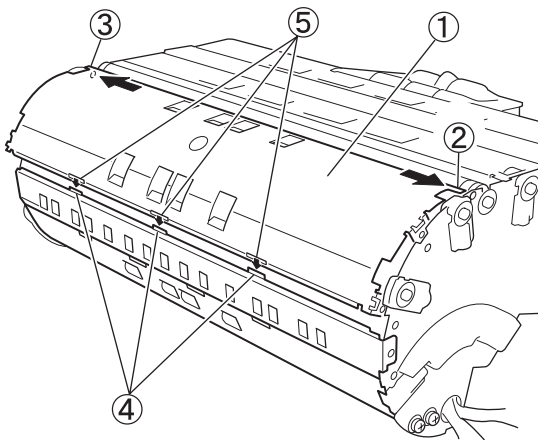

- ① Feed guide plate 1 ② Upper-right projection
- ③ Upper-left projection ④ Convex part
- ⑤ Groove

Fig. 3-318

8. Delivery follower roller

- 1) Detach the upper delivery cover assembly.
- 2) Press the delivery follower roller assembly ① in the direction of the arrow to detach it. Be aware that the shaft ②, roller ③, and coil spring ④ will come off when detaching the roller.

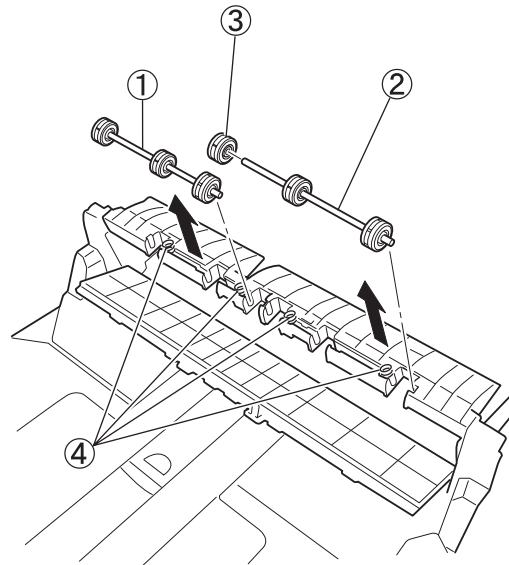

- ① Delivery follower roller assembly ③ Roller
- ② Shaft
- ④ Coil spring

Fig. 3-319

9. Lower registration roller

- 1) Detach the right/left cover assembly.
- 2) Detach the lower entry guide plate cover and the lower entry guide plate. Refer to the section entitled "Retard motor".
- 3) Detach the registration clutch.
- 4) Remove two E-rings ① (one on each side) and two bearings ② (one on each side), and lower the lever ③ to detach the lower registration roller ④.

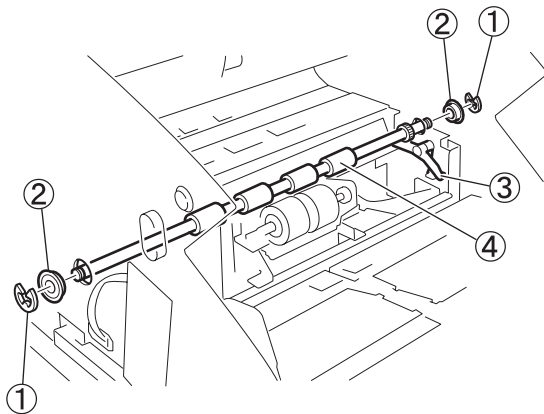

- ① E-ring ② Bearing
 ③ Lever
 ④ Lower registration roller

Fig. 3-320

Precautions during assembly

- Lower the lever ① and install the lower registration roller ② into the hole in the right-side plate so that it is positioned at the top.

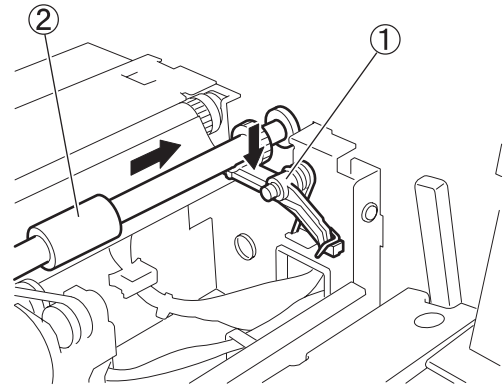

- ① Lever
 ② Lower registration roller

Fig. 3-321

10. Front platen roller

- 1) Detach the right/left cover assembly.
- 2) Detach the lower registration roller.
- 3) Open or dismount the upper unit.
- 4) Remove two screws ① located inside and detach the platen unit ② in the direction of the arrow. Unhook the connector ③.

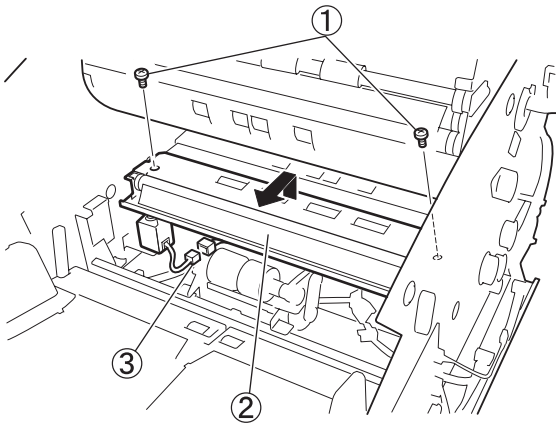

- ① Screw
- ② Platen unit
- ③ Connector

Fig. 3-322

- 5) Remove two E-rings ① (one on each side) and two bearings ② (one on each side) to detach the front platen roller. And then, remove two spacers ④ (one on each side), the pin ⑤, and the gear ⑥.

Note: The spacer comes with the bearing.

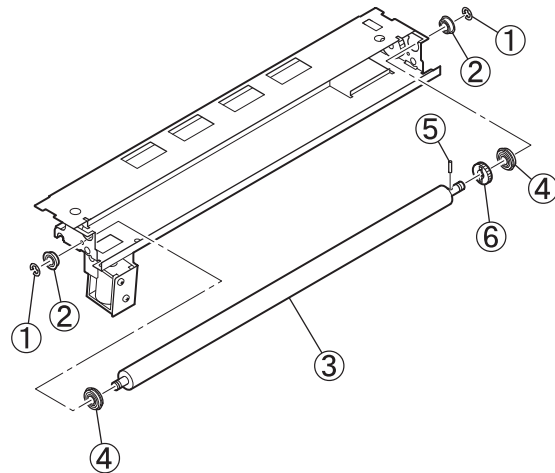

- ① E-ring
- ② Bearing
- ③ Back platen roller
- ④ Spacer
- ⑤ Pin
- ⑥ Gear

Fig. 3-323

Precautions during assembly

- Align the holes to the positioning bosses ① (one on each side) and install the platen unit ③ using two screws ②. Be careful not to drop the screws into the machine.

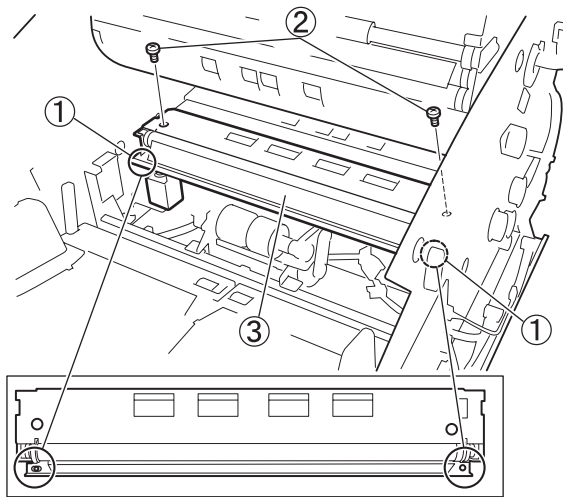

- ① Positioning boss ② Screw
③ Platen unit

Fig. 3-324**11. Lower reading roller**

- Detach the platen unit. For details, refer to the section entitled "Front platen roller".
- Unfasten two E-rings ① (one on each side), the pulley ②, pin ③, and two bearings ④ (one on each side) in sequence, and then detach the lower reading roller ⑤.

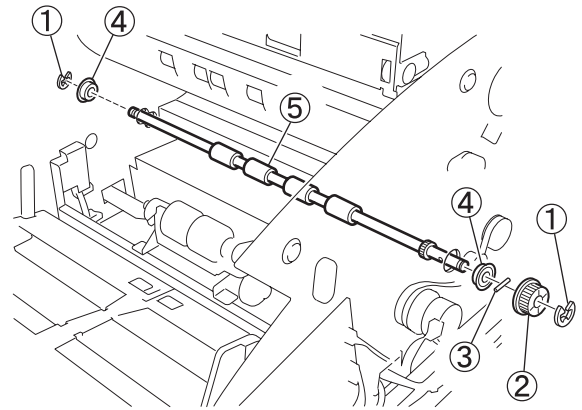

- ① E-ring ② Pulley
③ Pin ④ Bearing
⑤ Lower reading roller

Fig. 3-325**Precautions during assembly**

- Be sure to install the pulley with the flange correctly oriented. The pulley for the lower reading roller is flanged on the inside.

12. Feeder drive roller A

- 1) Detach the upper unit.
- 2) Loosen the belt on each side. Refer to the "Right belt" and "Left belt" sections.
- 3) Detach the belt ① and remove two E-rings ② (one on each side), two pulleys ③ (one on each side), and two pins ④ (one on each side) in sequence.
Additionally, remove two bearings ⑤ (one on each side) and detach feeder drive roller A ⑥.

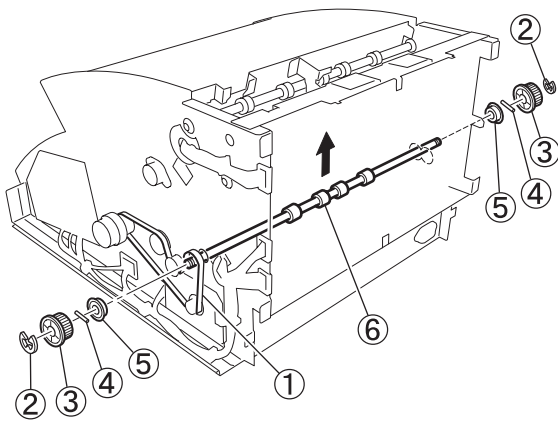

- | | |
|-----------|-------------------------|
| ① Belt | ② E-ring |
| ③ Pulley | ④ Pin |
| ⑤ Bearing | ⑥ Feeder drive roller A |

Fig. 3-326

13. Feeder drive rollers B/C

- 1) Dismount the upper unit.
- 2) Let the left belt loosen. Refer to the "Left belt" section.
- 3) Unfasten four E-rings (two on each side) ①, detach two pulleys ② and two pins ③. Additionally, remove four bearings ④ (two on each side) and feeder drive rollers (B and C) ⑤.

Note: Feeder drive rollers B and C are the same parts.

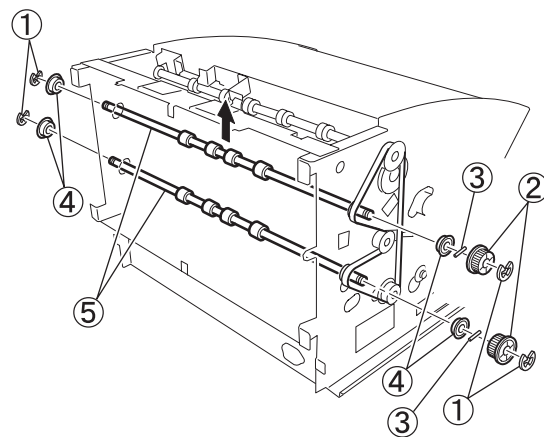

- | | |
|----------------------------|-----------|
| ① E-ring | ② Pulley |
| ③ Pin | ④ Bearing |
| ⑤ Feeder drive rollers B/C | |

Fig. 3-327

14. Delivery drive roller

- 1) Detach the right/left cover assembly and top cover.
- 2) Let the left belt loosen. Refer to the "Left belt" section.
- 3) Unfasten two E-rings (one on each side) ①, detach the pulley ② and the pin ③. Additionally, remove two bearings ④ (one on each side) and detach the delivery drive roller ⑤.

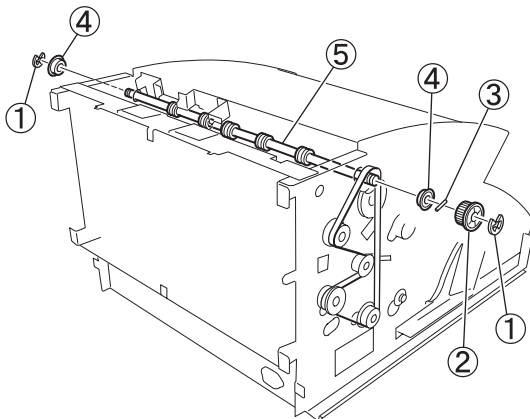

- | | |
|-------------------------|-----------|
| ① E-ring | ② Pulley |
| ③ Pin | ④ Bearing |
| ⑤ Delivery drive roller | |

Fig. 3-328

15. Right belt

- 1) Remove the right cover assembly.
- 2) Loosen four screws ② of the main motor mount plate ① and detach the belt ③.

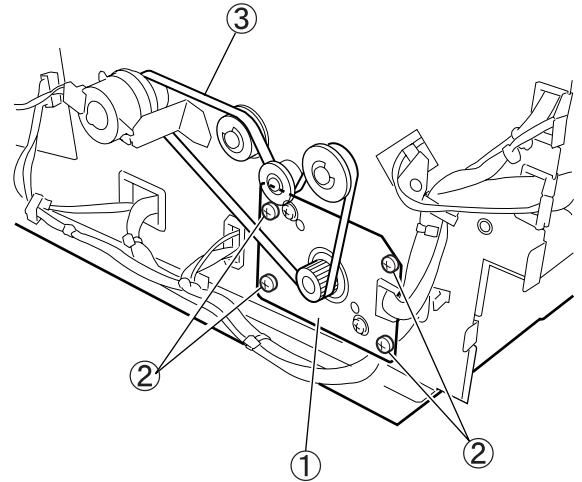

- | | |
|--------------------------|--------|
| ① Main motor mount plate | ③ Belt |
| ② Screw | |

Fig. 3-329

Precautions during assembly

- Do not allow any slack in the belt. Adjust the tension so that the belt does not miss the sprockets and the tension is not tightened too much.

16. Left belt

- 1) Remove the left cover.
- 2) Loosen one screw ② of the tension plate ① and detach the belt ③.

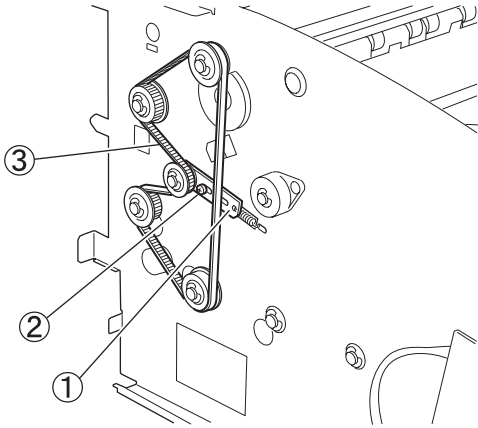

- ① Tension plate ② Screw
③ Belt

Fig. 3-330

Precautions during assembly

- Be sure to correctly orient the flange attached to the pulley (see Fig.3-330).
- After hanging the belt on the pulley, fix the screw of the tension plate. The tension of the belt can be adjusted with the coil spring attached to the tension plate.

IV. READING SECTION

1. Front reading unit

- 1) Detach the right/left cover assembly.
- 2) Open the upper unit.
- 3) Detach the upper registration roller guide ① and the upper reading roller guide ②. And then, push the stopper ③ on each side, and pull the front reading unit ④ out toward the front.

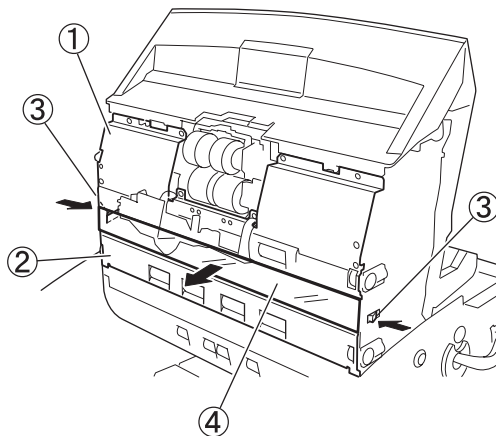

- ① Upper registration roller guide
 ② Upper reading roller guide
 ③ Stopper ④ Front reading unit

Fig. 3-401

- 4) Unhook four connectors ① and detach the front reading unit ②.

Note: Be careful not to lose the spring ③ attached to the stopper.

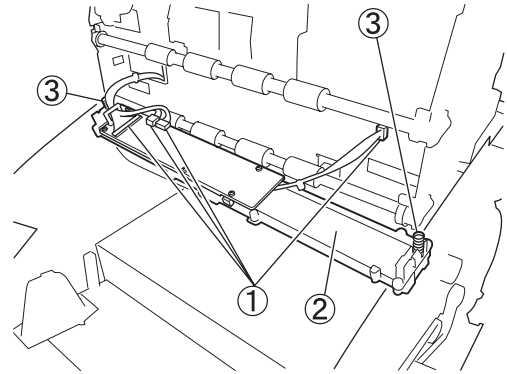

- ① Connector ② Front reading unit
 ③ Spring

Fig. 3-402

Precautions during assembly

- Be careful not to pull in the connected cable assembly.
- Remember to attach the spring on the back side.
- Clean the reading glass.
- The back registration sensor PCB is mounted in the front reading unit, Detach the PCB as necessary.

2. Back reading unit

- 1) Detach the platen unit and the lower reading roller. Refer to the "Lower reading roller" section.
- 2) Unhook the cable clamp ① and pull the back reading unit ② out toward the front.

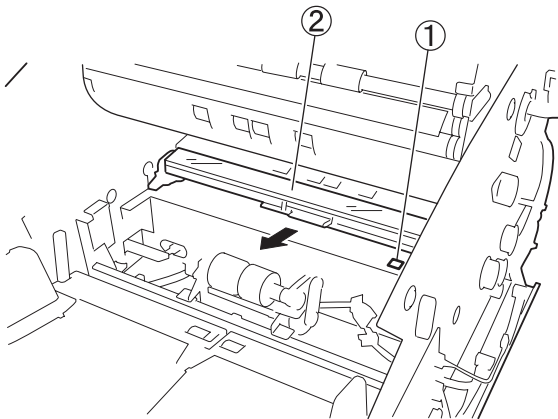

- ① Cable clamp ② Back reading unit

Fig. 3-403

- 3) Unhook three connectors ① and detach the back reading unit ②.

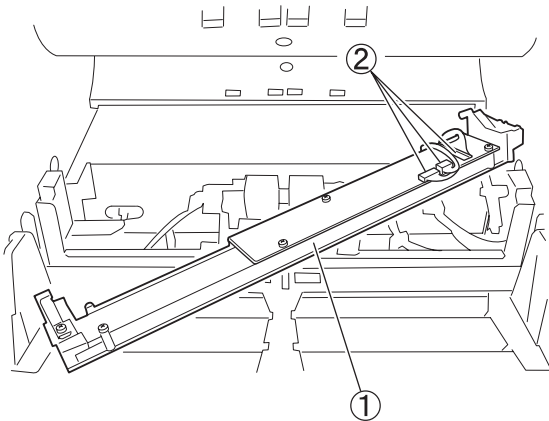

Fig. 3-404

- ① Connector ② Back reading unit

Precautions during assembly

- Be careful not to pull in the connected cable assembly.
- Since the leaf spring is attached to the rear side of the back reading unit, push it as far as it will go while pressing it against the bottom.
- Clean the reading glass.

3. Shading plate assembly (lower side)

- 1) Detach the platen unit and the front platen roller. Refer to the "Front platen roller" section.
- 2) Remove two screws ① (one on each side), two shafts ② (one on each side), and the spring ③ in sequence and detach the shading plate assembly (lower side) ④.

Note: Do not crease or scratch the shading plate.

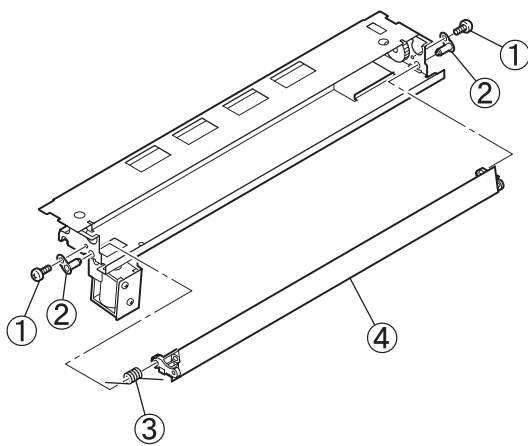

- ① Screw
- ② Shaft
- ③ Spring
- ④ Shading plate assembly (lower side)

Fig. 3-405

Precautions during assembly

- Hang either side of the left-side spring on the shading plate assembly, and fix the left-side shaft.
- After referring to the "Shading solenoid (lower side)" section, adjust the positioning of the gears on the shading plate side and the solenoid side, and also adjust the position of the solenoid.
- Clean the shading plate.

4. Shading plate assembly (upper side)

- 1) Detach the upper unit.
- 2) Detach the back platen roller. Refer to the "Back platen roller" section.
- 3) Remove two screws ① (one on each side), shaft A ②, shaft B ③, and the spring ④ in sequence, and then detach the shading plate assembly (upper side) ⑤.

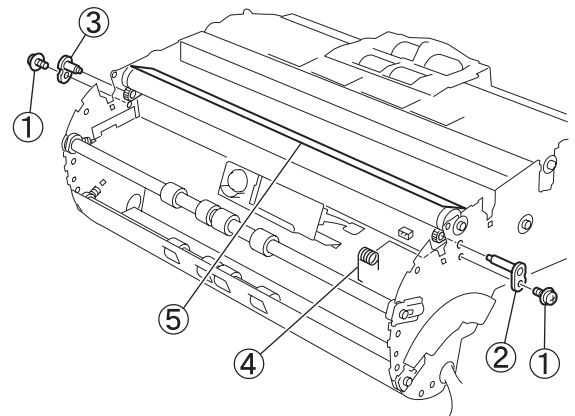

- ① Screw
- ② Shaft A
- ③ Shaft B
- ④ Spring
- ⑤ Shading plate assembly (upper side)

Fig. 3-406

Precautions during assembly

- Insert the spring onto shaft A (longer one) and hang the either side of the spring on the shading plate assembly.
- After referring to the "Shading solenoid (upper side)" section, adjust the positioning of the gears on the shading plate side and the solenoid side, and also adjust the position of the solenoid.
- Clean the shading plate.

V. ELECTRICAL PARTS

1. Main CPU PCB (MAIN-DCON)

- 1) Remove the rear cover and the top cover.
- 2) Unhook all connectors connected to the main CPU PCB ①, remove nine screws ②, and then detach the main CPU PCB.

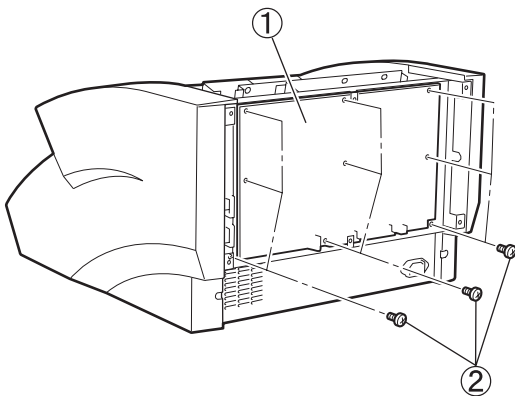

- ① Main CPU PCB
- ② Screw

Fig. 3-501

- 3) Remove seven screws ①, take off the connector cover ②, and detach the main CPU PCB ③.

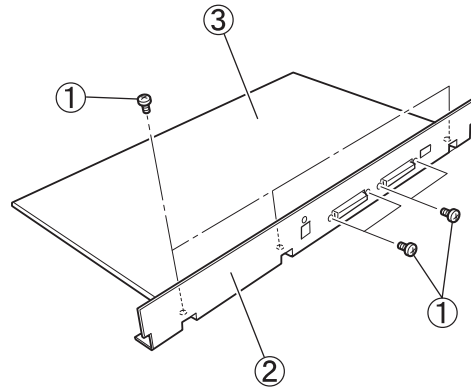

- ① Screw
- ② Connector cover
- ③ Main CPU PCB

Fig. 3-502

Precautions during assembly

- Make sure that every cable is connected and securely inserted.
- Do not pull in the cables. Fix them using cable clamps.

2. Pick-up control PCB (80-SUB)

- 1) Detach the upper delivery cover assembly.
- 2) Unhook all connectors connected to the pick-up control PCB, remove two screws ②, and then detach the pick-up control PCB while removing two stoppers ③.

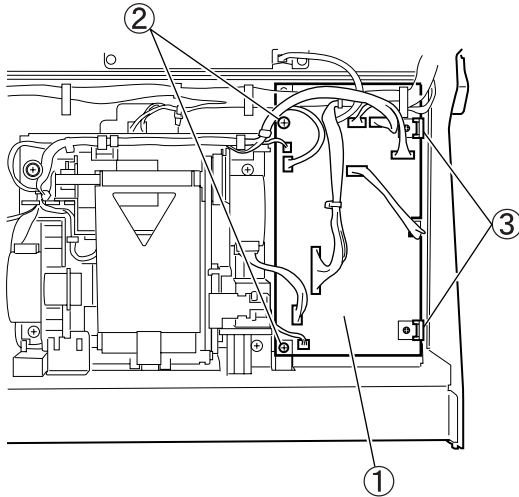

- ① Pick-up control PCB ② Screw
③ Stopper

Fig. 3-503

Precautions during assembly

- Make sure that every cable is connected and securely inserted.
- Do not pull in the cables. Fix them using cable clamps.

3. Document tray control PCB (10-SUB)

- 1) Detach the right cover assembly.
- 2) Unhook all connectors connected to the document tray control PCB ① and remove one screw A ② and two screws B (self-tapping) ③.

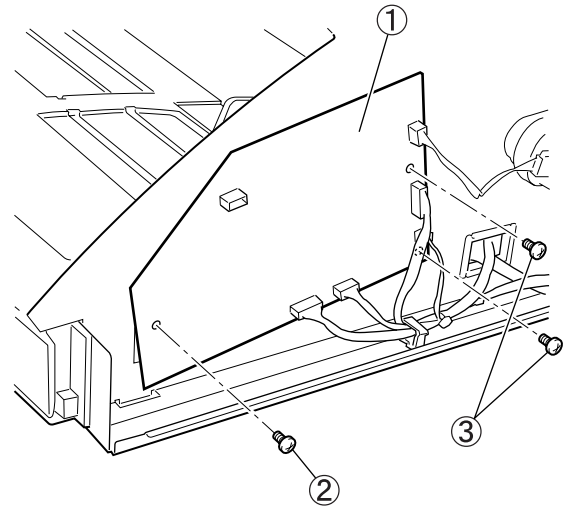

- ① Document tray control PCB
② Screw A ③ Screw B

Fig. 3-504

- 3) Disconnect two connectors ② attached to the back side of the document tray control PCB ①.

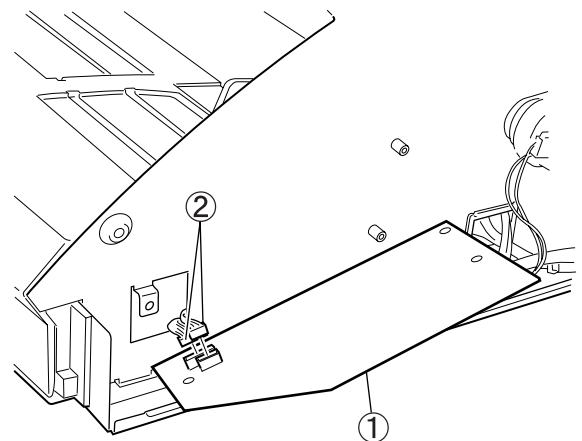

- ① Document tray control PCB
② Connector

Fig. 3-505

4. DC power supply PCB

- 1) Remove the rear cover.
- 2) Remove six screws ① and pull out the DC power supply PCB ②.

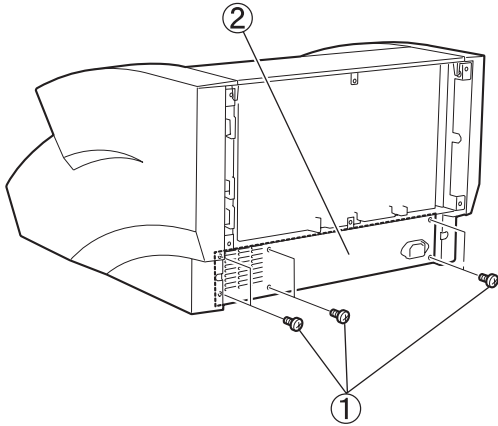

- ① Screw
- ② DC power supply PCB

Fig. 3-506

- 3) Unhook two connectors ③ and detach the DC power supply PCB ②.

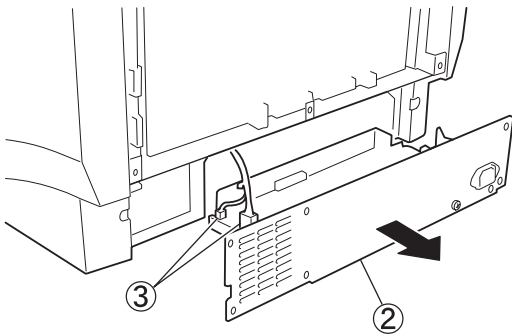

- ② DC power supply PCB
- ③ Connector

Fig. 3-507

- 4) Remove four screws (with round-shaped tips) ① and detach the panel ②

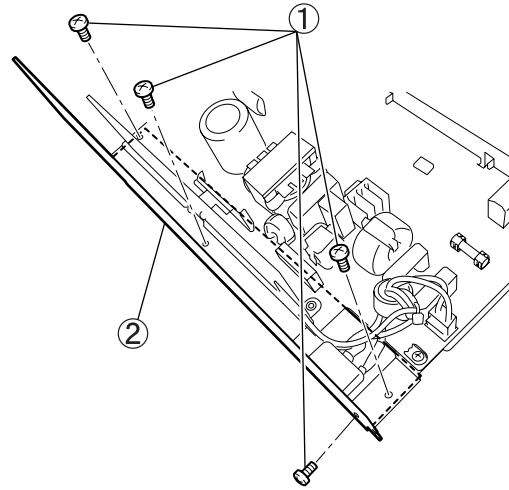

- ① Screw
- ② Panel

Fig. 3-508

Precautions during the assembly

- The power switch should be in the OFF position (in which the tip of the switch sticks out). Connect connector 4P to CN1.
- Since the tips of the three screws that fix the panel will protrude, use the screws with round-shaped tips to prevent injuries.

5. Exhaust fan

- 1) Detach the right cover assembly.
- 2) Detach the DC power supply PCB.
- 3) Unhook the connector ① of the exhaust fan on the main CPU PCB, remove two screws (M4x25) ②, and then detach the exhaust fan ③.

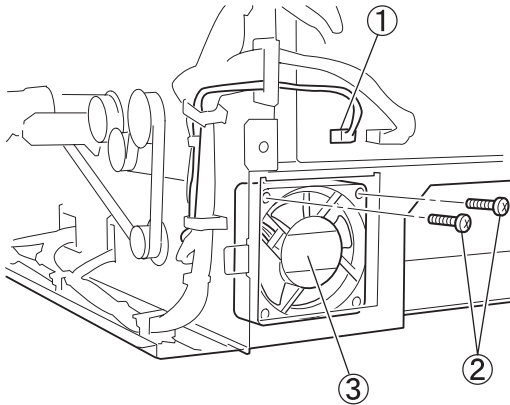

- ① Connector
② Screw
③ Exhaust fan

Fig. 3-509

6. Ultrasonic sensor PCB (upper side)

- 1) Detach the upper delivery cover assembly.
- 2) Unhook one connector ① and remove two screws ②, and detach the ultrasonic sensor PCB (with metal plates) ③.

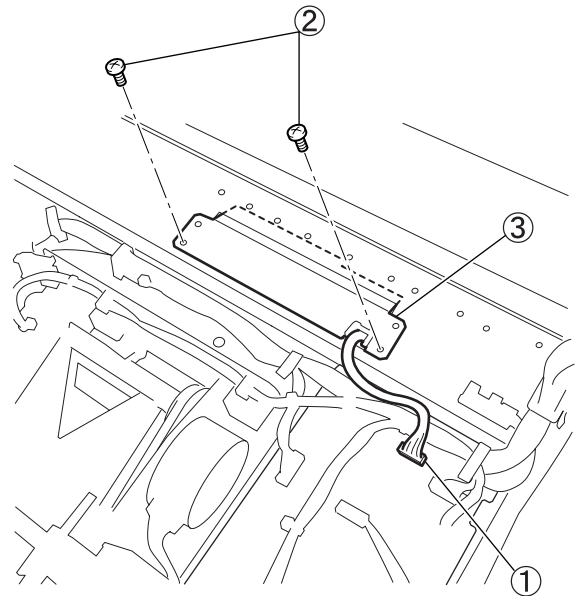

- ① Connector
② Screw
③ Ultrasonic sensor PCB (with metal plates)

Fig. 3-510

7. Ultrasonic sensor PCB (lower side)

- 1) Detach the right/left cover assembly.
- 2) Unhook the connector on the main CPU PCB, which is connected to the cable ①. Remove two screws ② (one on each side).

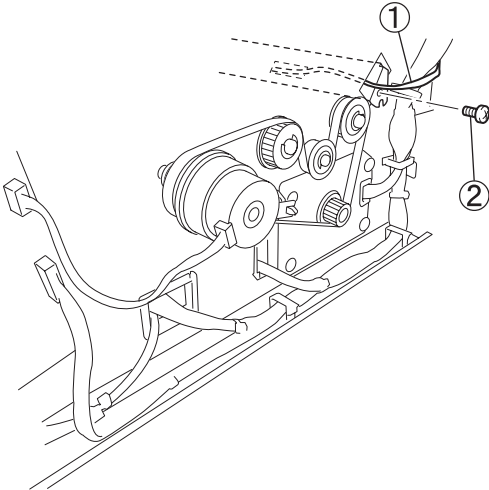

- 3) Pull off the ultrasonic sensor PCB (with metal plates) ① from the right.

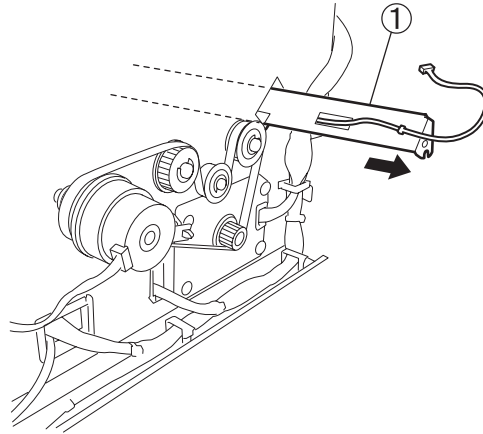

① Ultrasonic sensor PCB (with metal plates)

Fig. 3-512

Precautions during the assembly

- Match the positioning marks ① on the right side, tighten the right-side screw while holding the left side, and then tighten the screw on the left side.

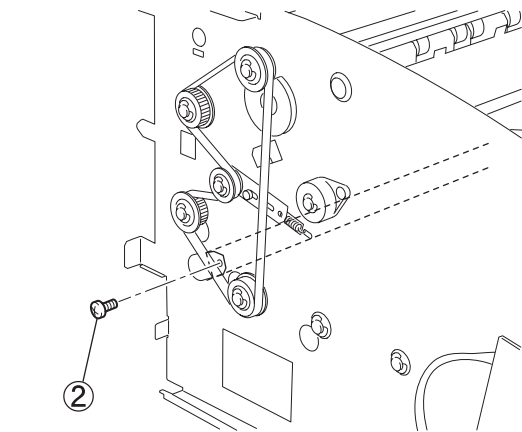

- ① Cable
- ② Screw

Fig. 3-511

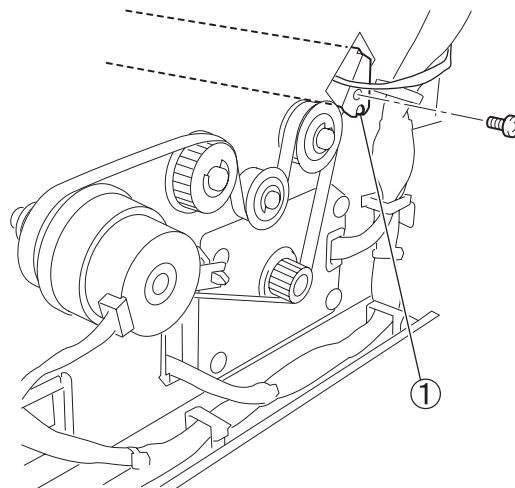

① Positioning mark

Fig. 3-513

8. Document guide width sensor

- 1) Detach the document tray assembly.
- 2) Remove five screws (self-tapping) ① and detach the leaf spring ② and reinforcing plate ③.

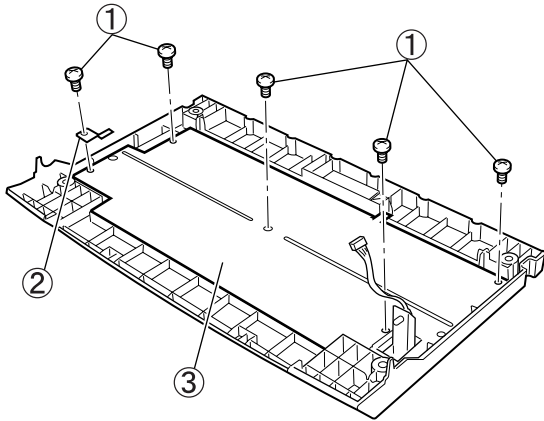

- ① Screw
- ② Leaf spring
- ③ Reinforcing plate

Fig. 3-514

- 4) Remove the spacer ①, detach the document guide width sensor ②, and unhook the connector ③.

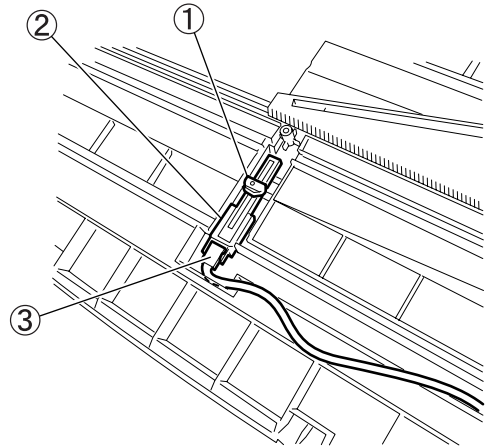

- ① Spacer
- ② Document guide width sensor
- ③ Connector

Fig. 3-516

- 3) Remove the gear ①. Additionally, remove one screw ② and detach the document guide ③ and the rack ④ by sliding them out.

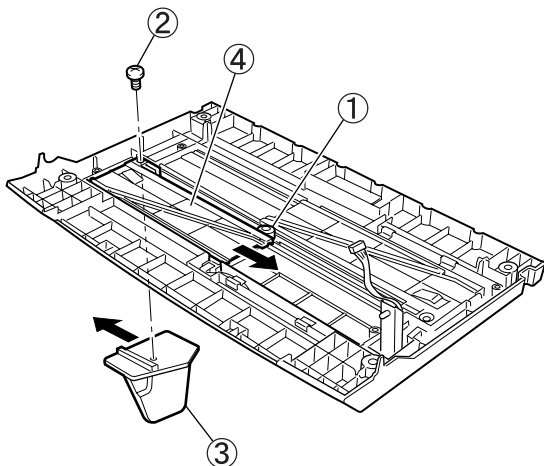

- ① Gear
- ② Screw
- ③ Document guide
- ④ Rack

Fig. 3-515

Precautions during the assembly

- Be sure to install the spacer ① in the correct direction.

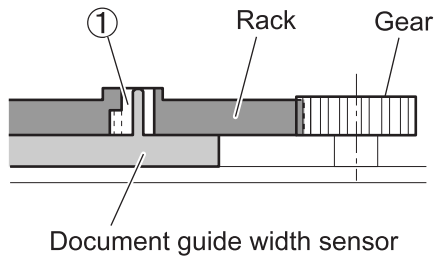

① Spacer

Fig. 3-517

- Position the document guide ① symmetrically during assembly. After reassembly, check that the document guide moves smoothly.

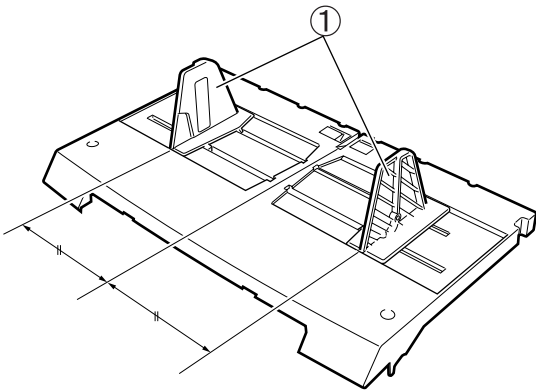

① Document guide

Fig. 3-518

CHAPTER 4

INSTALLATION & MAINTENANCE

I.	SELECTION OF LOCATION.....	4-1	VI.	PERIODICALLY REPLACED PARTS	4-16
II.	UNPACKING & INSTALLATION	4-2	VII.	CONSUMABLE PARTS AND	
III.	IMPRINTER MOUNTING PROCEDURE.....	4-5		CONSUMABLES.....	4-18
IV.	ENDORSER ED600 MOUNTING		VIII.	PERIODIC MAINTENANCE SERVICE	
	PROCEDURE	4-10		LIST	4-19
V.	MECHANICAL COUNTER INSTALLATION				
	PROCEDURE.....	4-14			

I. SELECTION OF LOCATION

It is recommended that the customer engineer personally inspect the customer's premises before installing this machine. The location should meet the following requirements:

- The power supply should be connected to an outlet capable of supplying the voltage shown on the rating plate plus or minus 10%. A grounded plug must be used.

Grounding Items

- 1) Power outlet grounding terminal
- 2) Earth lead that has been grounded for office equipment

- The machine should not be installed on unstable places such as a fragile table or inclined surface. The weight of the machine is approx. 23 Kg.
- Ambient temperature and humidity should be 10 to 32.5°C and 20 to 80% RH. However, since the performance-guaranteed ambient conditions are 15 to 27.5°C and 25 to 75% RH, it is desirable for the machine to be operated under such conditions. In particular, do not install the machine near water faucets, humidifiers, hot water heaters, and refrigerators.

- The machine should not be exposed to open flame, dust, ammonia or other corrosive gases, direct sunlight, intense vibration, or near unity that generates electromagnetic waves.
 - * Prevent cigarette smoke from coming into contact with the machine.
 - * In applications where installation in areas receiving direct sunlight is unavoidable, a heavy curtain should be installed on the windows to protect the machine.
- Maintain sufficient space around the machine during operation and maintenance, and to allow proper ventilation.
 - * The exhaust fan and power cord are located at the rear of the machine. Do not push the machine against the wall.
 - * Allow sufficient space on both sides of the machine so that you can insert your hands to lift it when the machine is to be moved.

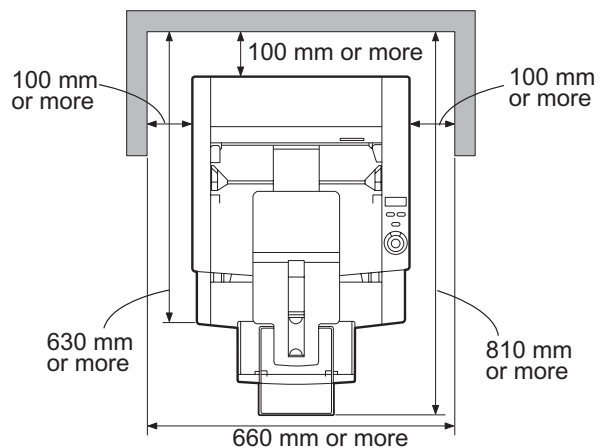

Fig. 4-101

II. UNPACKING & INSTALLATION

If the machine (in its shipping container) has been stored in a cold location, it should not be

unpacked in a warm room until it has had time to warm up. Otherwise, moisture may condense on the metal and glass parts, which can cause trouble. At least one hour should be allowed for the machine to warm up to room temperature before the shipping container is opened.

No.	Procedure	Inspection/Remarks
1	<p>Remove the exterior container and take out the parts and other materials packed inside. Check if anything is missing. The container weighs approx. 30 kg. and its external dimensions are approx. 600 (W) x 700 (D) x 450 (H) mm.</p> <ul style="list-style-type: none"> ① Main body ② Power cord ③ Grounding wire (100V model only) ④ Quick reference guide ⑤ Setup disk (CR-ROM) ⑥ User's manual ⑦ Warranty card (100V and 120V models only) 	

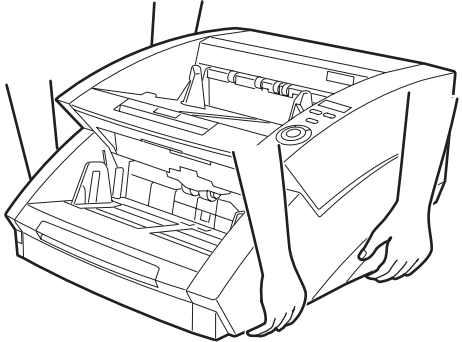
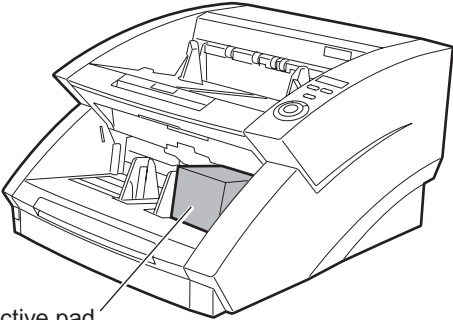
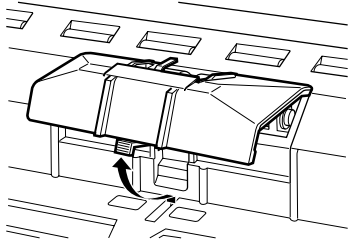
No.	Procedure	Inspection/Remarks
2	<p>Move the main body to where it is to be installed.</p> <p>Note: When moving it, two persons should hold both sides at the bottom. It is recommended to use a cart. The main body weighs approx. 23 kg.</p>	
3	<p>Peel off all the tape securing each part. The tape for the pick-up roller should be peeled off after opening the roller cover.</p>	<p>Check if the covers show any signs of damage caused during transportation.</p>
4	<p>Open the upper unit and remove the protective pad from the document guide area. Open the retard roller cover and remove the protective pad.</p>	 <p>Protective pad</p> 
5	<p>Connect the power cord. In the case of the 100V model, connect the grounding wire too.</p>	

No.	Procedure	Inspection/Remarks
6	Connect a personal computer to this machine using a SCSI or USB cable. When connecting a SCSI cable, change the SCSI ID and terminator settings if necessary. If this machine is connected at the end of the daisy chain, be sure to switch on the terminator.	
7	After turning on power to the machine, turn on power to the personal computer. Note: Before turning on power to the personal computer, make sure that "00000" appears on the counter display of the operation panel.	
8	Install the driver and application software on the personal computer. For details, refer to the user's manual.	
9	Check if the machine operates normally. For details, refer to the user's manual.	

III. IMPRINTER MOUNTING PROCEDURE

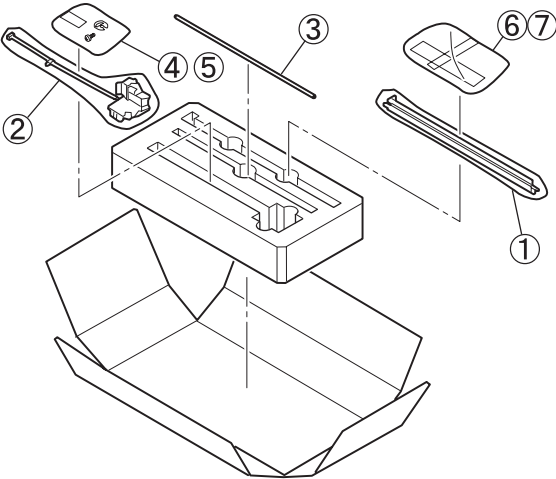
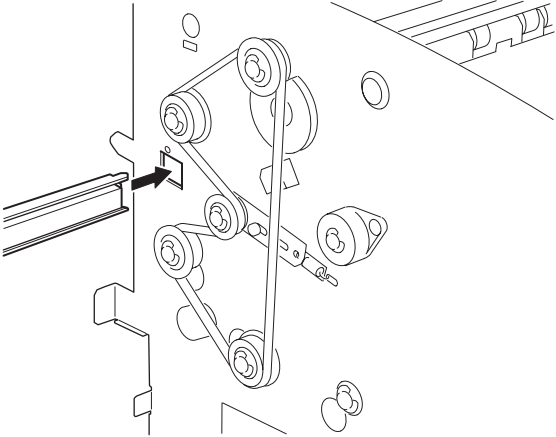
No.	Procedure	Inspection/Remarks
1	<p>Make sure that all parts are ready.</p> <ul style="list-style-type: none"> ① IP drain unit ② IP carriage ③ IP shaft ④ Resin clip (white) ⑤ Screw (BH, M3x6) ⑥ IP label ⑦ User's manual <p>Note: Since the electrical contacts of the IP carriage are exposed, handle it carefully to avoid damage due to static electricity.</p>	
2	<p>Remove the rear cover.</p> <p>Note: Refer to "CHAPTER 3: DISASSEMBLY & REASSEMBLY".</p>	
3	<p>Remove the left and right covers.</p> <p>Note: Refer to "CHAPTER 3: DISASSEMBLY & REASSEMBLY".</p>	
4	<p>Insert the IP drain unit into the hole on the left side of the machine, in the direction of the arrow, as far as it will go. Be careful to orient the unit correctly. Place the inserted tip into the hole on the right side of the machine.</p> <p>Note: Insert the unit vertically at the left side of the machine.</p>	

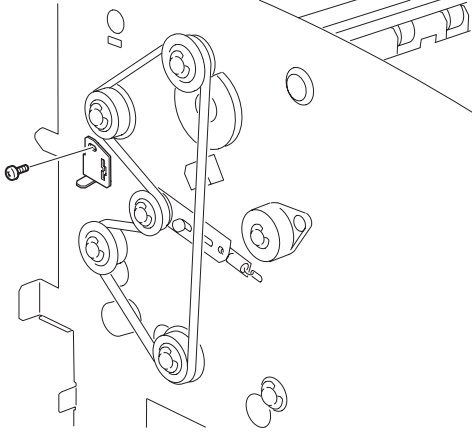
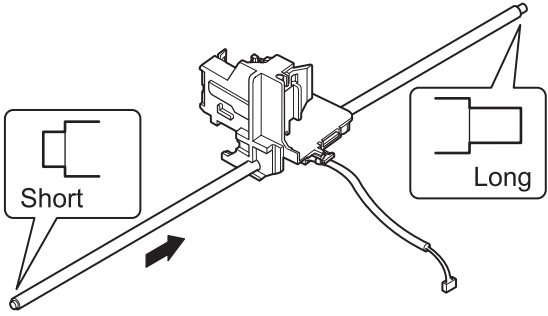
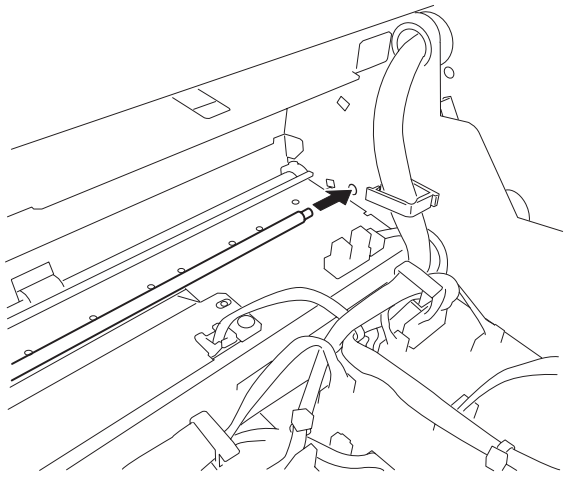
No.	Procedure	Inspection/Remarks
5	Secure the IP drain unit using screws (BH, M3x6).	 <p>A technical drawing showing the IP drain unit being secured to a metal plate. Several screws are shown being inserted into the unit. The unit has a complex shape with various ports and a central shaft area.</p>
6	Dismount the upper delivery cover assembly. Note: Refer to "CHAPTER 3: DISASSEMBLY & REASSEMBLY."	
7	Insert the IP shaft into the IP carriage. Note: Be careful to insert the IP shaft in the correct direction. As illustrated in the right figure, insert the IP shaft into the IP carriage so that the short convex tip of the shaft is to the left and the longer tip is to the right.	 <p>A diagram showing an IP shaft being inserted into an IP carriage. The shaft has two distinct sections: a shorter, convex tip on the left and a longer, straight section on the right. Callouts labeled 'Short' and 'Long' point to these respective sections. An arrow indicates the direction of insertion into the carriage.</p>
8	Insert the longer convex tip of the IP shaft into the hole inside the right side of the main body.	 <p>A detailed diagram of the main body of the device. It shows the internal structure with various components. An arrow points to a specific hole on the right side of the main body, indicating where the longer convex tip of the IP shaft should be inserted.</p>

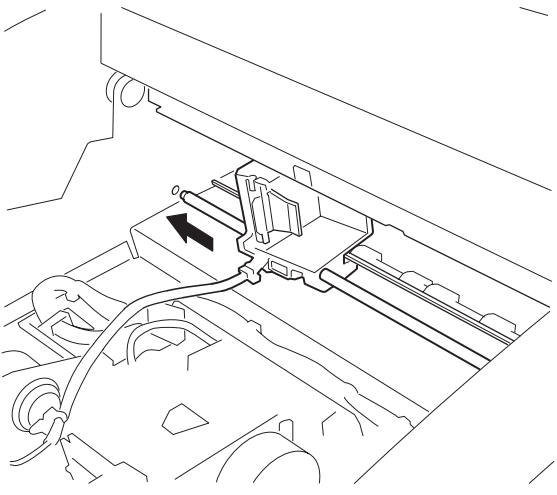
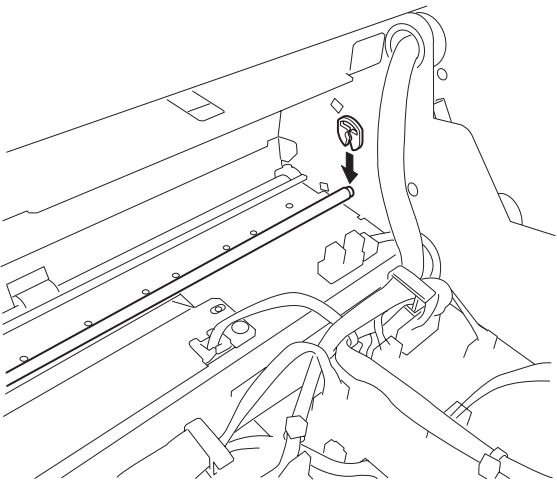
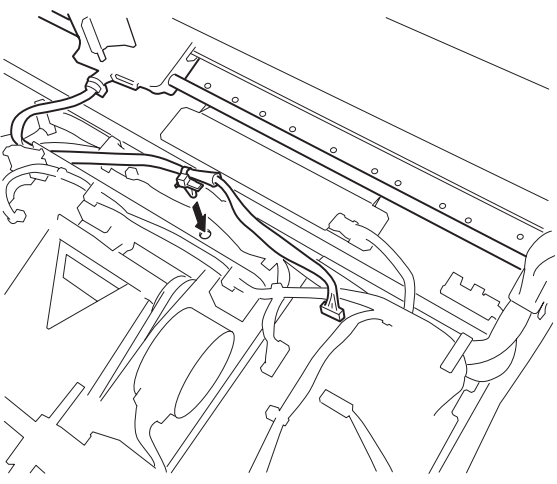
No.	Procedure	Inspection/Remarks
9	Rotate the other tip of the IP shaft in the direction of the arrow and then insert it into the hole inside the left side of the main body.	 A line drawing showing a close-up of the IP shaft assembly. A black arrow points to the left, indicating the direction to rotate the shaft tip. The shaft is being inserted into a hole on the left side of the main body.
10	Attach the resin clip to the right end of the IP shaft to secure it.	 A line drawing showing the IP shaft assembly with a resin clip being attached to its right end. A black arrow points to the clip, indicating the attachment point.
11	Insert the snap band attached to the cable assembly of the IP carriage into the hole located at the center of the main body upper frame.	 A line drawing showing the IP carriage assembly with a snap band being inserted into a hole in the center of the main body upper frame. A black arrow points to the snap band, indicating the insertion point.

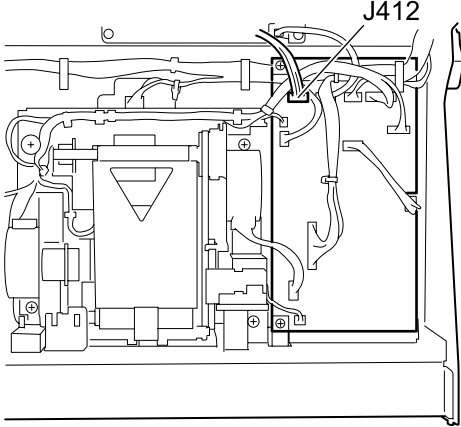
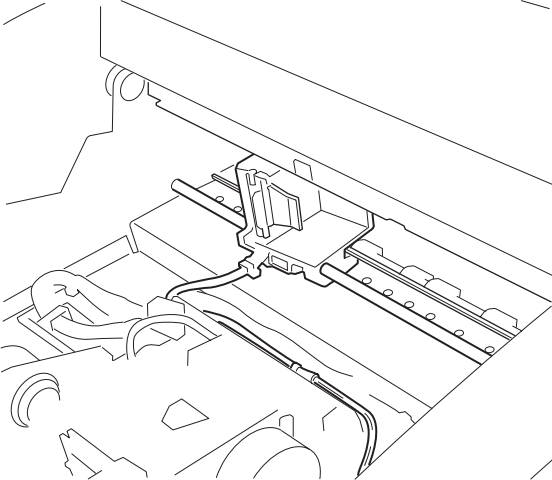
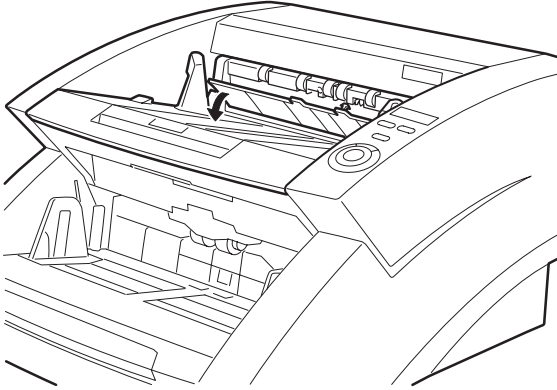
No.	Procedure	Inspection/Remarks
12	<p>Connect the connector located at the tip of the IP carriage cable assembly to J412 of the pick-up control PCB (80_SUB) on the main body.</p>	
13	<p>Check that the IP carriage can move from side to side. In the lower frame of the IP carriage there are small round grooves, and the IP carriage moves back and forth while stopping at each groove.</p> <p>Note: The IP carriage should stop at each of the grooves.</p>	
14	<p>Install the upper delivery cover assembly.</p> <p>Note: The upper delivery cover assembly should be installed with the imprinter cover opened.</p>	
15	<p>Attach the right and left covers, and the rear cover.</p>	

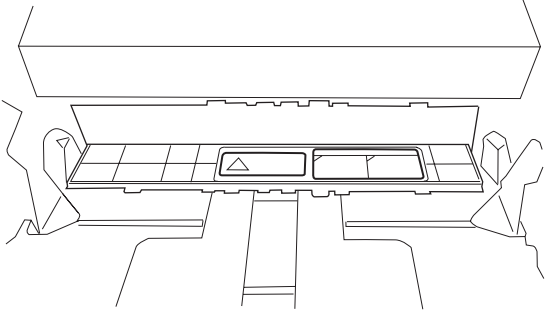
No.	Procedure	Inspection/Remarks
16	Peel off the IP label and stick it inside the IP cover. The label should be positioned correctly as viewed from the front of the main body.	
17	Install an ink cartridge.	The ink cartridges are sold separately. Use the products made by Hewlett-Packard Company, with part numbers as follows: C6602R (Red), C6602G (Green) C6602B (Blue)
18	Check that the imprinter operates normally.	

IV. ENDORSER ED600 MOUNTING PROCEDURE

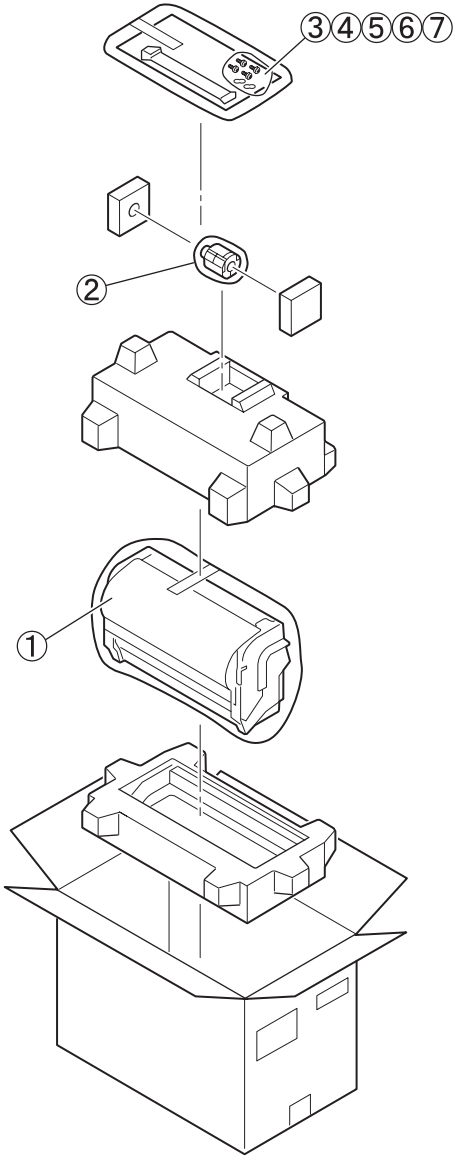
No.	Procedure	Inspection/Remarks
1	<p>Open the container and take out the endorser main body and the parts packed inside.</p> <ul style="list-style-type: none"> ① Endorser main body ② Die drum 300 (with a fixing screw) ③ Endorser cable assembly ④ Leaf springs: 2 pieces ⑤ Screws (stepped type): 2 pieces ⑥ Screw (BH, M3x4): 1 piece ⑦ User's manual <p>Note: The ink roller and stamping plate are sold separately.</p>	

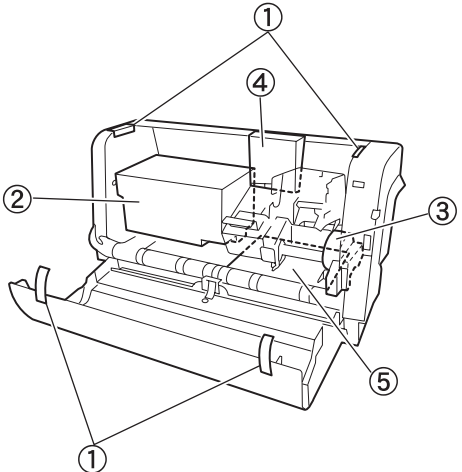
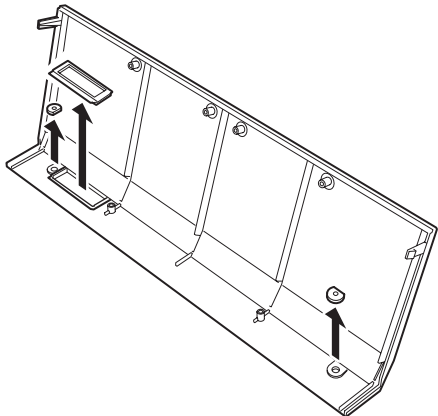
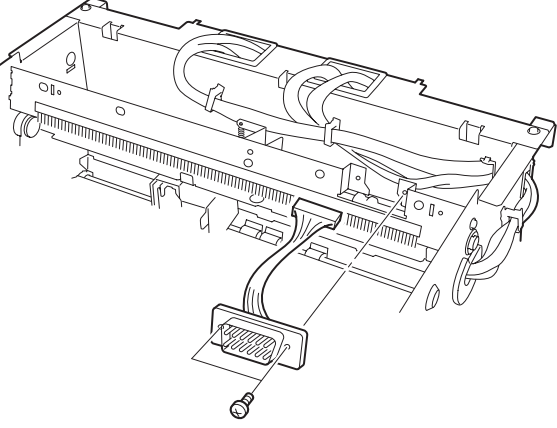
No.	Procedure	Inspection/Remarks
2	<p>Peel off all the fixing tape. Open the cover and remove the protective pads and protective sheets.</p> <ul style="list-style-type: none"> ① Fixing tape ②③④ Protective pad ⑤ Protective sheet 	
3	<p>Remove the rear cover of the DR-6080/9080C. Note: Refer to "CHAPTER 3: DISASSEMBLY & REASSEMBLY."</p>	
4	<p>Remove the top cover of the DR-6080/9080C. Note: Refer to "CHAPTER 3: DISASSEMBLY & REASSEMBLY."</p>	
5	<p>Take the blind plate (attached at three places) off of the top cover.</p>	
6	<p>Install the endorser cable assembly (with two stepped screws).</p>	

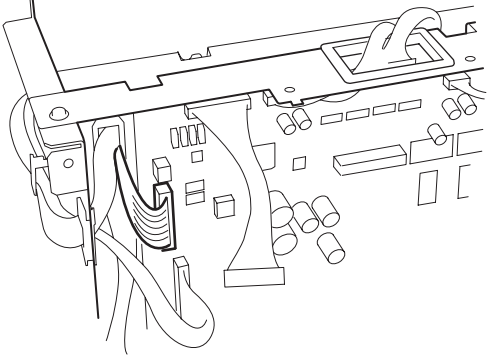
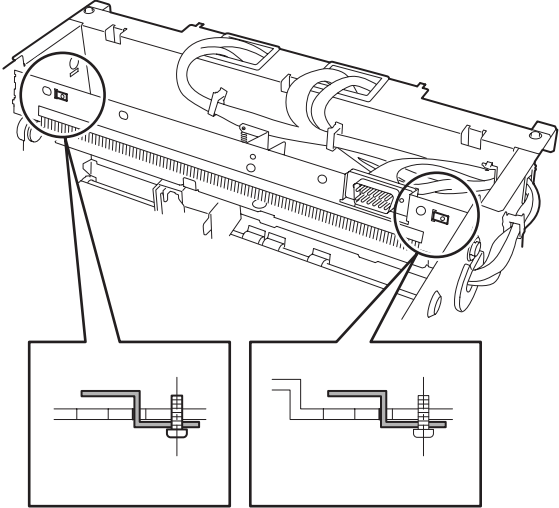
No.	Procedure	Inspection/Remarks
7	Pass the connector of the endorser cable assembly through the upper hole and connect it to J110 of the main CPU PCB (MAIN_DCON).	
8	Install a leaf spring at each side (with a screw).	
9	Attach the top and rear covers.	

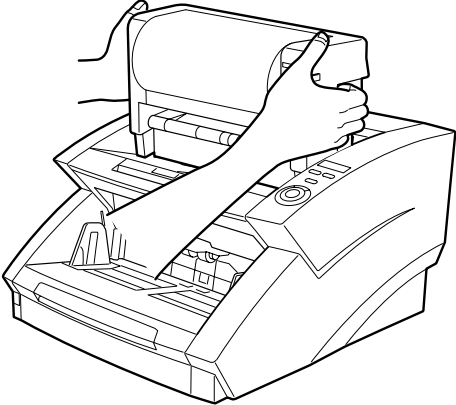
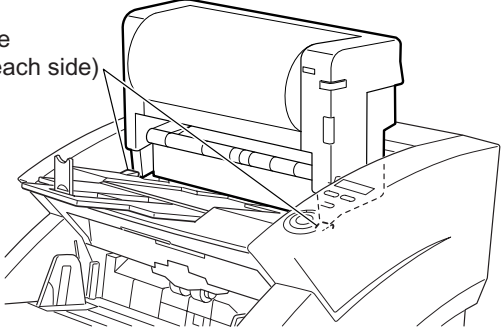
No.	Procedure	Inspection/Remarks
10	<p>Open the document eject tray guide of the DR-6080/9080C outwards. Install the endorser main unit onto the delivery area of the DR-6080/9080C. Make sure to hold the handles of the right/left cover of the endorser. Also make sure that the rear connector and the positioning pin are inserted into the DR-6080/9080C, and the lower front part of the right/left cover is fit into the upper unit guide.</p> <p>Note: Before installing the endorser, open the document eject tray extension, if needed.</p>	  <p>Guide (for each side)</p> <p>View of opened document eject tray extension</p>
11	<p>Install the die drum 300.</p> <p>Note: Attach the stamping plate properly.</p>	
12	<p>Set the ink roller.</p> <p>Note: If the height of the ink roller has to be adjusted, use the adjusting screw, which was adjusted in accordance with the standard ink roller before shipping.</p>	
13	<p>Check that the unit operates normally. For details on how to operate it, refer to the user's manuals for the DR-6080/9080C and ED600.</p>	

V. MECHANICAL COUNTER INSTALLATION PROCEDURE

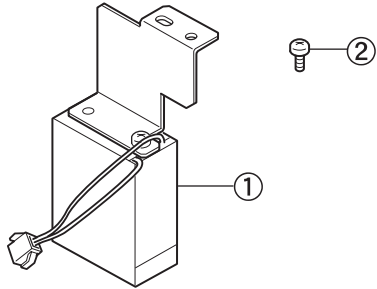
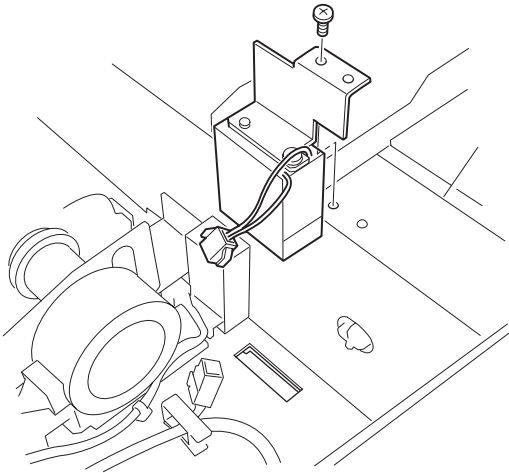
No.	Procedure	Inspection/Remarks
1	Make sure that all the mounting parts are ready. ① Mechanical counter unit ② Screw (M3x6)	
2	Remove the upper delivery assembly. Note: Refer to "CHAPTER 3: DISASSEMBLY & REASSEMBLY."	
3	Install the mechanical counter unit.	

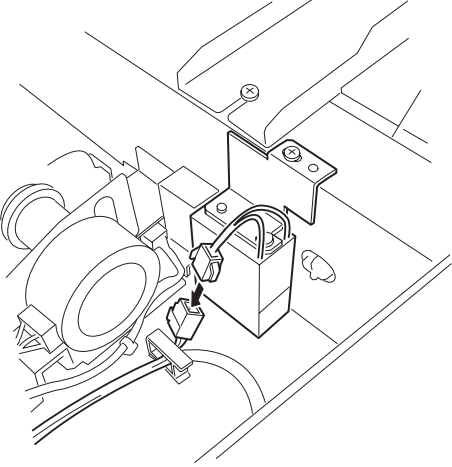
No.	Procedure	Inspection/Remarks
4	Connect the connector.	
5	Attach the upper delivery cover assembly	
6	Check that the unit operates normally. Note: Feed documents to check that the number on the counter is increased by the number of fed documents.	

VI. PERIODICALLY REPLACED PARTS

Parts must be replaced periodically to maintain the machine's functions to a constant standard. The following table shows parts that must be replaced periodically (parts that greatly influence machine operation when they are no longer functional but are not externally deformed or damaged).

Preferably these parts should be replaced when periodic servicing is carried out closest to the recommended replacement cycle. However, the rollers (3 types) can be replaced by the user and a "Replacement message" is displayed on the personal computer.

No.	Part Name	Part No.	Q'ty	Replacement Cycle (number of sheets)	Remarks
1	Pick-up roller	8927A004AA	1	250,000	The three types of rollers are sold as a set.
2	Feed roller		1		
3	Retard roller		1		
4	Pick-up solenoid	MF1-4251	1	1,500,000	

Table 4-601

Note 1: The above figures are for reference only, and may vary according to conditions of use.

Note 2: The rollers (3 types) can be replaced by the user and are sold as the "Exchange Roller Kit." For the "Replacement message", refer to the next page.

Reference: The difference between consumables, consumable parts, and periodically replaced parts

1. Consumables are parts that will be replaced when they become faulty, and are defined as products for sale. They are replaced by the user.
2. Consumable parts are the parts that will be replaced when they become faulty, and are defined as products for service. They are replaced by the user or service technician.
3. Periodically replaced parts are usually defined as products for service and replaced by the service technician.

Reference: Replacement Message

- For details on the replacement message, refer to the user’s manual.
The general outline is shown below.
- If the number of fed sheets exceeds 250,000, the following message appears when the personal computer is booted up again.



Fig 4-601

- After replacing the rollers, be sure to reset the counter. the method is shown below.

- 1) Open the “Scanners and Cameras” in control panel.



Fig 4-602

- 2) Display the “Properties” for the current scanner.
- 3) Click the “Counter” tab.
- 4) Press the “Reset” button to reset the counter to “0”.

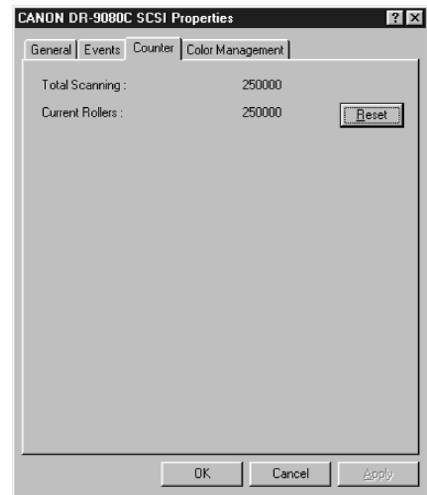

Fig 4-603

- This replacement message is not available for WindowsNT.

VII. CONSUMABLE PARTS AND CONSUMABLES

This machine has no consumable parts.

The following table shows consumables (products for sale). These items are to be replaced by the user

No.	Part Name	Application	Guide for Replacement	Remarks
1	Ink cartridge	Imprinter	1.75 million characters	Replace it when running out of the ink. The guide-for-replacement value is based on the following conditions: smaller fonts (44 dots/character), 24 characters/sheet, 100 sheets/batch, and extra ink discharging.
2	Ink roller	Endorser	200 thousand sheets	Replace it when running out of the ink.

Table 4-701

Note 1: Used consumable parts must be collected and disposed of according to local laws.

Note 2: For the ink cartridges, use the products made by Hewlett-Packard Company, with part numbers as follows: C6602R (Red), C6602G (Green) C6602B (Blue)

VIII.PERIODIC MAINTENANCE SERVICE LIST

Note: Use only the specified solvents and oils.

[△ : Cleaning ● : Replacement ☆ : Oiling □ : Adjustment ◎ : Inspection]

Unit name	Location	Maintenance cycle				Remarks
		Every 250,000 sheets	Every 500,000 sheets	Every 1.5 million Sheets	Every 3 million Sheets	
Document feed system	Pick-up roller / Feed roller / Retard roller	●				Replaceable by the user.
	Other rollers		△			Wipe with a cloth moistened with water, and then wipe dry.
	Document sensor		△			Clean with a cotton-tipped swab or air blower.
Reading system	Reading glass		△			Wipe dry.
	Shading plate		△	□		Wipe with a cloth moistened with water, and then wipe dry. Clean the inside of the machine if necessary.
Drive system	Pick-up solenoid			●		

Table 5-801

Note 1: If the parts above are very dirty, instruct the user to perform the "Daily User Inspection."

Note 2: For cleaning the shading plate, refer to the next page.

Note 3: Clean ink from inside the unit with a cotton-tipped swab, if the imprinter is being used. Refer to the user's manual packaged with the imprinter.

Note 4: Because dust on the power cord connectors may cause electrical leakage, clean them as necessary.

Reference: Cleaning the shading plate

- For details on cleaning the shading plate, refer to the user's manual.
A general outline is shown below. The internal cleaning of the machine by the service technician is also shown here.
 - Activation of the shading plate is shown below.
- 1) Fully open the upper unit. If the unit is not fully opened, the shading plate does not activate.
 - 2) When the start key is pressed, the shading plate appears.

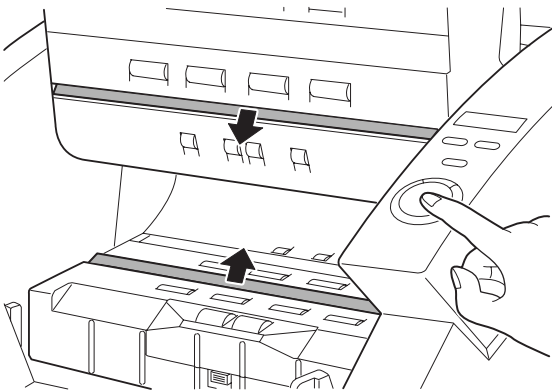
**Fig. 4-801**

- 3) When the stop key is pressed, the shading plate is retracted.
Closing the upper unit halfway enables the shading plate to be automatically retracted.
- Wipe with a cloth moistened with water, and then wipe dry. Be careful not to crease or scratch the shading plate.
 - Even after the shading plate is cleaned, paper dust from the inside of the machine may get on the plate. Clean the inside of the machine as necessary. This cleaning must be performed by a service technician, not the user.

CHAPTER 5

TROUBLESHOOTING

I. ERROR INDICATION AND SOLUTIONS ...	5-1	V. IMAGE TROUBLESHOOTING	5-22
II. REMOVING DOCUMENT JAMS	5-5	VI. OPERATION TROUBLESHOOTING	5-24
III. SERVICE MODES.....	5-7	VII. FEED TROUBLESHOOTING	5-26
IV. USER MODES	5-20	VIII. AFTER REPLACING PARTS.....	5-27

I. ERROR INDICATION AND SOLUTIONS

When various types of errors occur, this machine displays the error code on the operation panel. Error codes consist of three alphanumeric digits. Table 5-101 is a list of the error codes that can be handled by the user, and Table 5-102 is a list of the error codes requiring a service technician. If an error handled by the user is not corrected, the service technician will take care of it.

1. Error codes

1) List of error codes that can be handled by the user

Category	Code	Details	Solutions
Document jam	A01	In the event of a pick-up error, the document was fed to the front registration sensors.	Remove the document jam.
	P00	When powering on, or after opening/closing the upper unit, a document remains inside.	
	P01	Front or back registration sensor has detected a length between papers that is shorter than specified.	
	P02	Front or back registration sensor has detected a document length that is longer than specified.	
	P03	Front or back registration sensor has detected a document length that is shorter than specified.	
	P30	Document jam has occurred at the endorser.	
Door open	C01	Upper unit is open.	Close the covers completely.
	C02	Imprinter cover is open.	
	C03	Upper unit and imprinter cover are open.	
	C04	Endorser cover is open.	
	C05	Endorser cover and upper unit are open.	
	C06	Endorser cover and imprinter cover are open.	
	C07	Endorser cover, imprinter cover, and upper unit are open.	

Table 5-101a

Category	Code	Details	Solutions
Double feed	d02	Page length double feed detection.	Remove the document jam.
	d04	Ultrasonic double feed detection.	
	d06	Page length and ultrasonic double feed detection.	
Checks	H01	Ink cartridge is not installed.	Install the ink cartridge.
	J01	Staple detected (Feeding has stopped).	Remove the stapled document.
	J02	Staple detected (Pick-up has stopped).	
	J18	Skew detected.	Remove the document.
	U01	Verify error (counter<number of fed sheets) has occurred.	Check the number of documents.
	U02	Verify error (counter>number of fed sheets) has occurred.	Check if all the documents have been scanned.

Table 5-101b

2) List of error codes requiring a service technician

Category	Code	Details	Solutions
Hardware connection	E15	Voltage abnormalities in the imprinter	Check the connection and load, and replace any required parts.
	E20	Abnormalities in the main motor	
	E21	Abnormalities in the document tray motor	
	E22	Abnormalities in the retard motor	
	E24	Abnormalities in the feed motor	
	E25	Abnormalities in the pick-up motor	
	E26	Abnormalities in the pick-up solenoid	
	E27	Abnormalities in the endorser feed motor	
	E28	Abnormalities in the endorser printing motor	
	E29	Abnormalities in the registration clutch	
	E30	Abnormalities in the exhaust fan	
	E31	Abnormalities in the mechanical counter	
	E32	Wrong installation of main CPU PCB (The CPU PCB for a DR-9080C has been installed in a DR-6080 or vice versa.)	
	E33	Abnormalities in the shading solenoid (upper side) connection	
E34	Abnormalities in the shading solenoid (lower side) connection		
Communication between CPUs	E40	Can't communicate with CPU on pick-up control PCB (80_SUB).	Check the connection and replace the PCB.
	E41	Can't communicate with CPU on document tray control PCB (10_SUB).	
	E42	Can't communicate with CPU for imprinter.	
	E44	Can't communicate with CPU for ultrasonic double feed detection.	

Table 5-102

2. Error messages

In addition to error code indications, error messages will appear on the display. The error messages vary with the software.

Error messages are often due to operation mistakes or document jams, which the user can take care of in accordance with the messages.

For detailed solutions, refer to the Help menu in the software or the user's manual. If an

error is not corrected by the user, the service technician will take care of it.

Fig.5-101 and Fig. 5-102 shows an example error message. Table 5-103 shows the main error messages possible when the driver and application software CapturePerfect 2.0 bundled with this machine are used.



Fig. 5-101



Fig. 5-102

Category	Error message	Cause → Remedy
Scanner search	Can't locate SCSI device; check cable and power.	Scanner (this machine) was not recognized. → Check the power supply. → Check the SCSI cable connection. → Check the SCSI card.
Document feed	Scanner cover is open.	Upper unit is open. → Close the upper unit securely.
	No page in the scanner, add page to the scanner?	Document sensor has not detected a document. → Load a document.
	Paper jam in scanner; clear paper and continue.	Registration sensor has detected a document jam. → Check if a document remains inside. → Check the thickness and type of the document.
	No page was found in the feeder.	Registration sensor has detected no document. Document cannot be fed. → Check the thickness and type of the document. → Check the rollers for correct installation, and for dust. → Check the operation of the pick-up sensor. → Check the connection of the motors and gears.

Table 5-103

II. REMOVING DOCUMENT JAMS

1. At pick-up

- 1) Remove any documents left in the document tray or eject tray.
- 2) If the stopper or eject tray extension is open, close it.
- 3) Press the open/close button and open the upper unit until it is stopped.

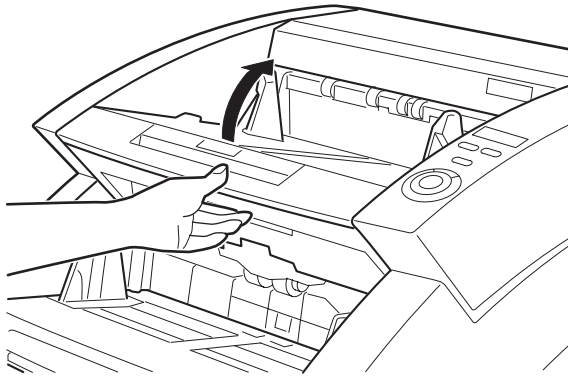

Fig. 5-201

- 4) Remove any documents remaining inside the main body.

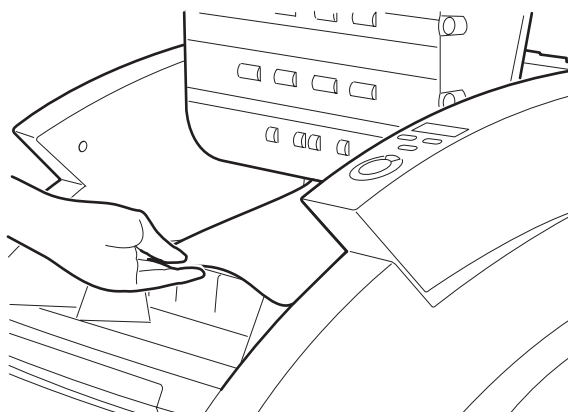

Fig. 5-202

- 5) Hold the upper unit at both sides and close it securely until it clicks.

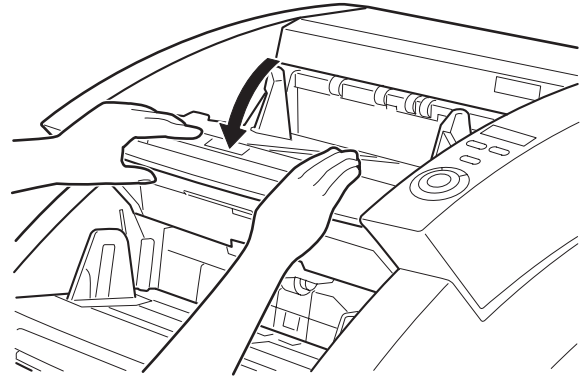

Fig. 5-203

Note: When removing the documents, be careful not to tear them.
When opening/closing the upper unit, be careful not to get your fingers caught.
Check if the last page of the ejected document was properly scanned.

2. At ejection

- 1) Remove any documents remaining in the document tray or eject tray.
- 2) If the stopper or eject tray extension is open, close it.
- 3) Press the open/close button and open the upper unit slightly.

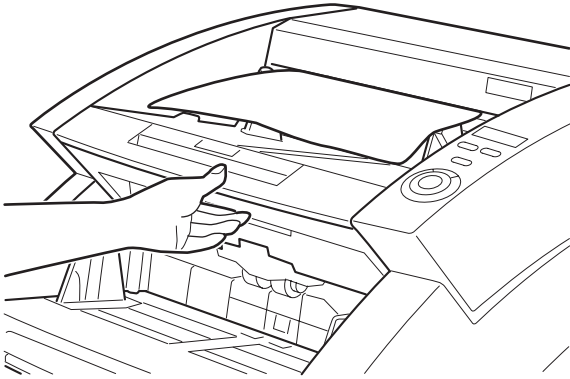

Fig. 5-204

- 4) Remove the document left in the eject tray.

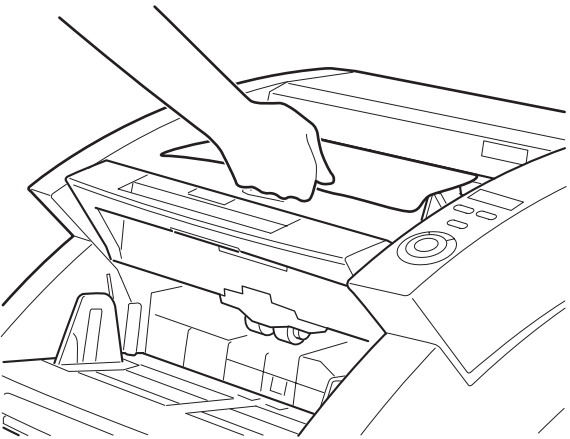

Fig. 5-205

- 5) Hold the upper unit at both sides and close it securely until it clicks.

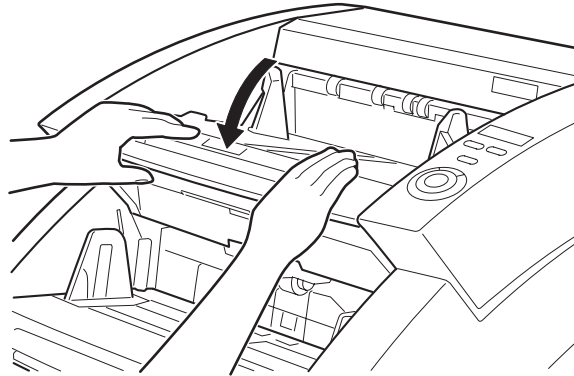

Fig. 5-206

Note: When removing the document, be careful not to tear it.
 When opening/closing the upper unit, be careful not to get your fingers caught.
 Check if the last page of the ejected document was properly scanned.

III. SERVICE MODES

1. Overview

The service modes of this machine can be enabled by installing the service mode software (found on the bundled setup disk) on a personal computer to be used for servicing.

The system requirements of the personal computer to be used should be equivalent to those described in the User's Manual. In the case of a slower CPU or less memory, the processing time may become longer, though the service modes will still be available.

Fig. 5-301 shows the Service window.

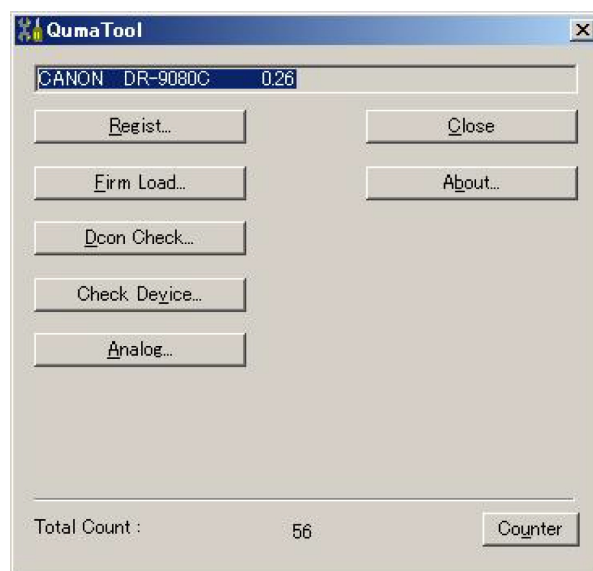

Fig.5-301

In the Service window, buttons for executing each mode are displayed. Each Service mode starts from this window. In the Service window of this machine, English is basically used, except for the OS-related displays.

- 1) **Regist**
Registration adjustment for image scanning
- 2) **Firm Load**
Firmware update.
- 3) **Dcon Check**
The operation of various kinds of hardware such as operation keys, sensors, operation panel LEDs, motors, solenoids, and shading plates is checked.
- 4) **Check Device**
Versions of devices located inside the machine are displayed and the imprinter is checked.
- 5) **Analog**
Displays analog values of sensors.
- 6) **About**
Displays the version of the service mode software.
- 7) **Counter**
The total number of fed sheets and the number of document jams can be displayed and changed.

2. Installation procedure

The following procedure is for installing the service mode software. Do not install it onto the user's personal computer.

- 1) Power on the personal computer for service and start the Windows OS.
- 2) Insert the Setup disk bundled with this machine.
- 3) Copy the folder "\Driver\Tools" in the Setup disk to any drive.

Note: To verify operation of this machine using the personal computer for service, install any necessary hardware. For details on how to install the software bundled with this machine, refer to the user's manual. When checking specifications such as the number of scanned documents, be sure the personal computer for service satisfies the personal computer system requirements described in the User's manual.

3. How to start and exit

The procedure for starting and exiting from the service mode is as follows:

- 1) Connect the personal computer for service to the machine using a SCSI or USB cable.
- 2) After powering on the machine, turn on the personal computer.
- 3) Open the installed "Tools" folder and launch the file "QumaTool.exe" inside that folder.

Note: Application software, including CapturePerfect, must be closed.

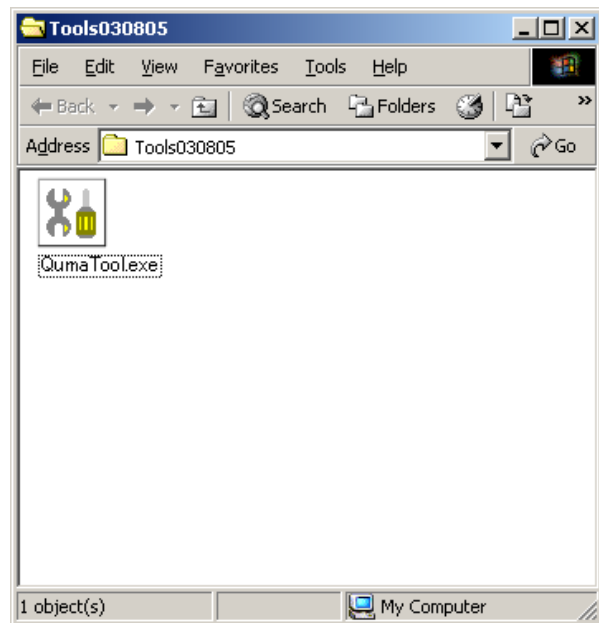

Fig. 5-302

- 4) When the Password window appears, type "quma" and click OK.



Fig. 5-303

- 5) The Service window appears.
- 6) To exit from the service mode, select "Close" in the Service window.

When turning on the personal computer for service after this machine has been connected, a window appears to ask for the installation of 'new hardware' or a 'device driver.' In this case, take the following action:

- a) When only the service mode software has been installed, click 'Cancel'.
- b) When the driver bundled with the machine has been installed, follow the user's manual.

Note: When performing service modes using the user's personal computer, make sure that the program "\Driver\Tools\QumaTool.exe" is launched from the bundled Setup disk. Do not copy the QumaTool.exe file onto the user's personal computer. When starting any service mode, pay attention not to reveal the folder name or password to the user.

4. Regist

This mode is used to adjust registration for image scanning.

- 1) Set some plain white copy paper (A4/LTR) on the document tray.

Note: Do not use dirty or creased paper. Place the sheets along the document guide so that they are not skewed.

- 2) Select "Regist" from the Service window. The state-displaying window appears (Refer to Fig.5-304).

When the registration adjustment is completed the state-displaying window disappears and the service window appears.

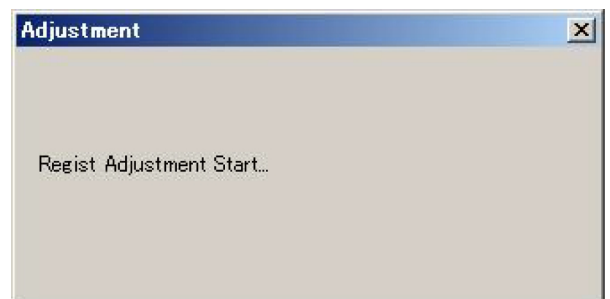

Fig. 5-304

Note: If this mode is executed with no document loaded, an error window (See Fig. 5-305) appears. Load a document and click OK to continue the registration adjustment.



Fig. 5-305

5. Firm Load

This mode is used to update the firmware in the machine. For details, refer to the service information issued with the new firmware. Avoid executing this mode by mistake.

- Brief operational procedure
 - 1) Select 'Firm Load' from the Service window.
 - 2) A window appears in which the firmware file is selected.
 - 3) Specify the file to open it.
 - 4) The firmware is loaded into the machine.

Note: When the firmware has been changed, write down the version number on the "ROM Version" label affixed on the rear side of the main body.

6. Dcon Check

This mode is used to check the operation of various kinds of hardware, such as the operation keys, sensors, operation panel LEDs, motors, solenoids, and shading plates.

- Operation window

After selecting 'Dcon Check' in the Service window, the Operation window (See Fig. 5-306) appears. To close the Operation window, press the 'Close' button.

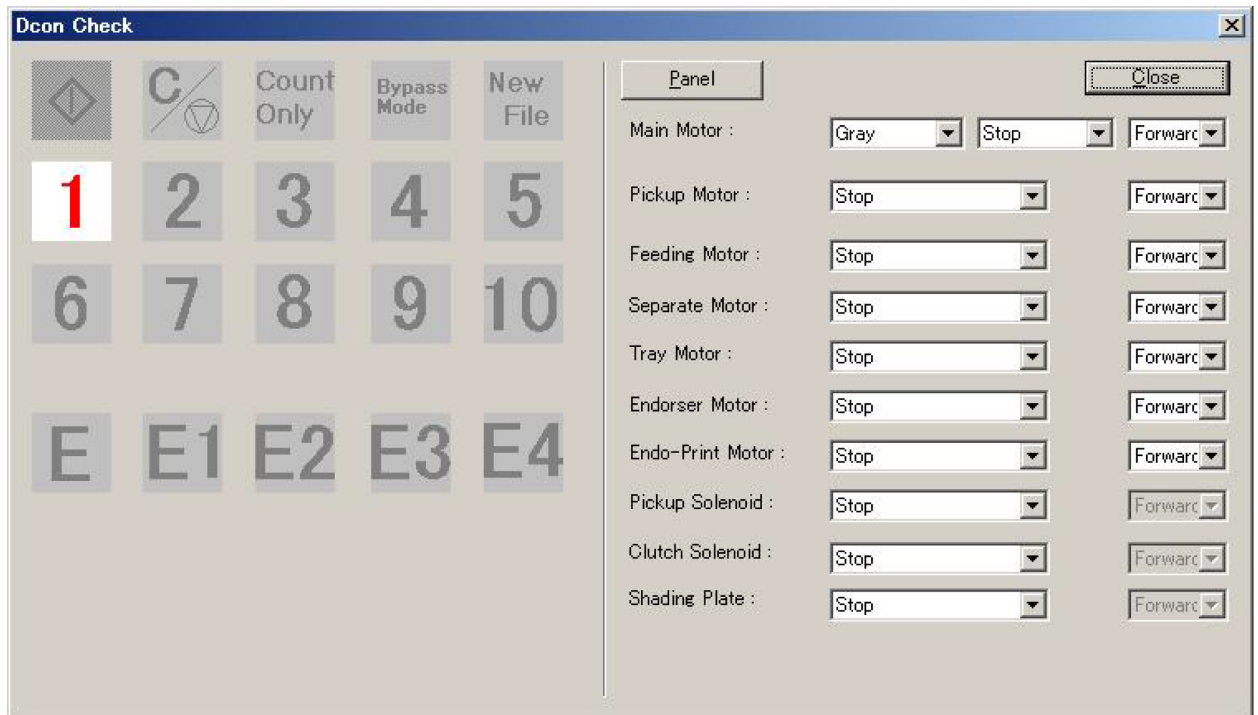

Fig. 5-306

a) Operation keys

Pressing an operation key will illuminate the corresponding mark. Fig. 5-307 shows the case in which the 'Count Only' key is pressed.

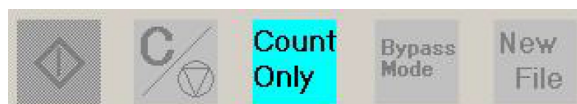

Fig. 5-307

b) Sensors of the main body

When a sensor on the main body is in a state of detection, the mark corresponding to the sensor will illuminate. Fig. 5-308 shows the case in which the document tray HP sensor and the document sensor are in a state of detection. The mark '1', which corresponds to the document tray HP sensor, will illuminate if the document tray is lowered, and will turn off when it starts to rise.



Fig. 5-308

- 1** Document tray HP sensor
- 2** Document sensor
- 3** Upper unit opening/closing sensor
- 4** Pick-up sensor (Refer to Note)
- 5** Imprinter door sensor
- 6** Left-end sensor
- 7** Front registration L sensor
- 8** Back registration sensor
- 9** Front registration R sensor
- 10** Right-end sensor

Note: When something is wrong with the operation of the pick-up sensor, the sensor position is thought to be incorrect. This problem occurs quite often, especially when disassembling or reassembling the pick-up sensor. For the adjustment, refer to the "VIII. AFTER REPLACING PARTS".

c) Endorser

As with the sensors on the main body, when the endorser button LED is pressed, or the sensor of the endorser is in a state of detection, the mark corresponding to the sensor will illuminate.

- E** Endorser button LED
- E1** Die drum HP sensor
- E2** Document sensor
- E3** Cover open sensor
- E4** Die drum open sensor

d) Operation panel LEDs

The 'Panel' button is shown in Fig. 5-309. If this button is selected, the operation panel LEDs alternate illuminating normally, illuminating all, and turning off all.



Fig. 5-309

e) Motors

Fig. 5-310 shows the part of the Operation window corresponding to various kinds of motors.

When a resolution is selected (100, 150, 200, 240, 300, 400, or 600), the main motor will rotate at the feeding speed corresponding to the resolution (See Fig. 5-311). When STOP is selected, the main motor will stop. The direction of rotation can be selected from 'Forward' or 'Reverse' (See Fig. 5-312). 'Forward' means the feeding direction, and 'Reverse' means reverse rotation. In addition, you can choose 'Gray' or 'Color' for the image mode.

The pick-up motor, feed motor ("feeding motor" on screen), retard motor ("separate motor" on screen), tray motor, endorser feed motor (Endorser Motor), and endorser stamping motor (Endo-Print Motor) will rotate at the selected torque level (Weak, Middle, or Strong; See Fig. 5-313). When STOP is selected, each motor will stop. For these motors, you can choose the direction of rotation as 'Forward' or 'Reverse', just as for the main motor.

Note: For the motor torque level, select Weak or Middle, and stop the motor as soon as you have checked its operation.

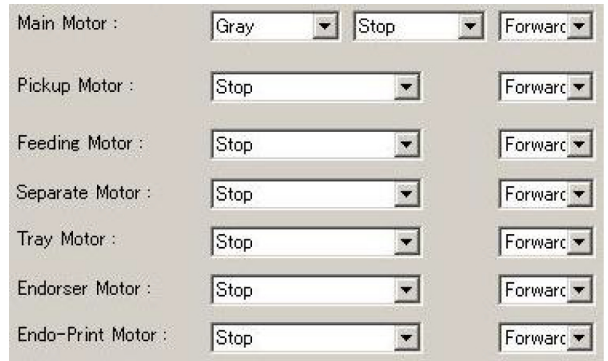

Fig. 5-310



Fig. 5-311



Fig. 5-312



Fig. 5-313

f) Solenoids

Fig. 5-314 shows the part of the Operation window corresponding to the solenoids. The Pick-up Solenoid and Clutch Solenoid (registration clutch) will pull in with the selected force (Weak, Middle, or Strong) when it is selected (See Fig. 5-315). When STOP is selected, each solenoid will stop pulling in.

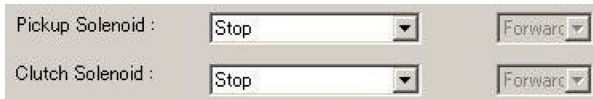

Fig. 5-314

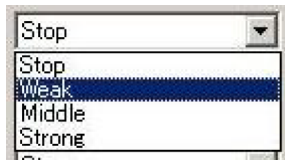

Fig. 5-315

Note: For the solenoid force level, select Weak or Middle, and stop the solenoid as soon as you have checked its operation.

g) Shading plate

Fig. 5-316 shows the part of the Operation window corresponding to the shading plates. Shading plates on the upper or lower side will pop up via a gear to overhang the platen roller, as soon as any force (Weak, Middle, and Strong) is selected (See Fig. 5-317), because the upper or lower shading solenoids are pulled in.

When STOP is selected, both shading plates will return to their original positions.



Fig. 5-316



Fig. 5-317

Note 1: When operating the shading plates, select Weak or Middle, and stop the operation as soon as you have checked it.

Note 2: Confirming the operation of the shading plates is enabled even when cleaning the shading plates.

7. Check Device

This mode is used to display the versions of the devices located inside this machine.

After selecting 'Check Device' in the Service window, a window displaying the version of each device appears (See Fig. 5-318).

Clicking the 'Imprinter Flushing' button enables the ink of the imprinter to be discharged. Setting a sheet of paper for the imprinter in the feed path and pressing this button allows you to check the ink discharge.

To close the window, press the 'Close' button.

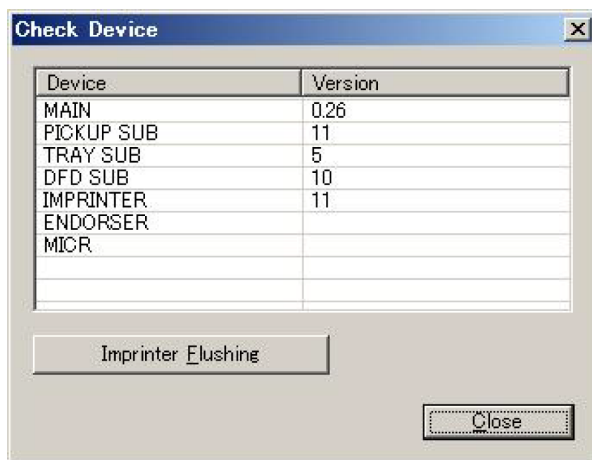

Fig. 5-318

8. Analog

This mode is used to display the analog values of sensors. It allows you to check the operation of sensors, such as the ultrasonic sensor, document guide width sensor, and staple sensor, which are not included in the main body sensors of Dcon Check operation window.

a) USS

After selecting 'Analog' in the Service window, a window displaying the analog value of each sensor appears (See Fig. 5-319). The box menu of Fig. 5-319 shows 'USS', which means the window displays the analog values related to the ultrasonic sensor.

Setting papers on the ultrasonic sensor portion in the feed path, while avoiding the registration sensors, allows you to check the operation of the ultrasonic sensor.

When one sheet is set, the "Document judgement" lamp will illuminate. When two or more sheets are set, the "Document judgement" lamp and "Amplitude judgement" lamp will illuminate, and the "Phase judgement" lamp will illuminate or flash.

To close the window, press the 'Close' button.

Opening the box menu will allow you to choose 'Feeder 1' or 'Feeder 2', in addition to 'USS' (See Fig. 5-320).

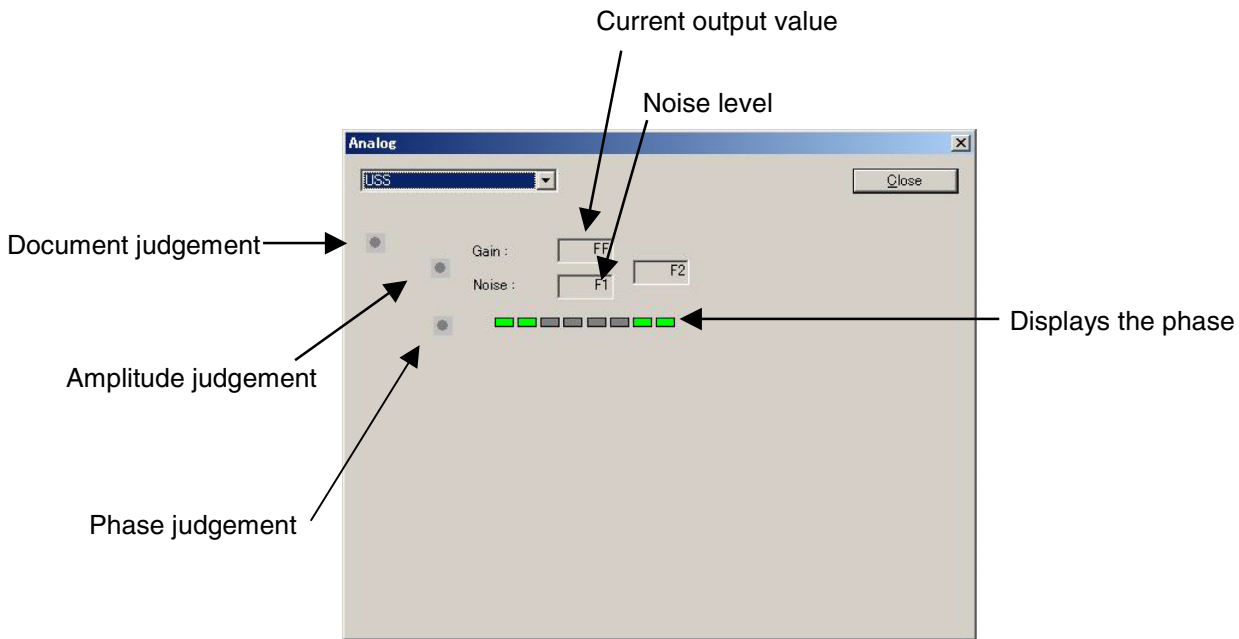

Fig. 5-319



Fig. 5-320

b) Feeder 1

Fig. 5-321 shows the window displayed after selecting 'Feeder 1' from the box menu.

In this figure, the analog values for the upper unit door sensor, left-end sensor, front registration L sensor, pick-up sensor, front registration R sensor, back registration sensor,

and right-end sensor are displayed. The mark of the sensor that has detected a document will illuminate.

The operation of these sensors must be checked using the "Dcon Check".

To close the window, press the 'Close' button.

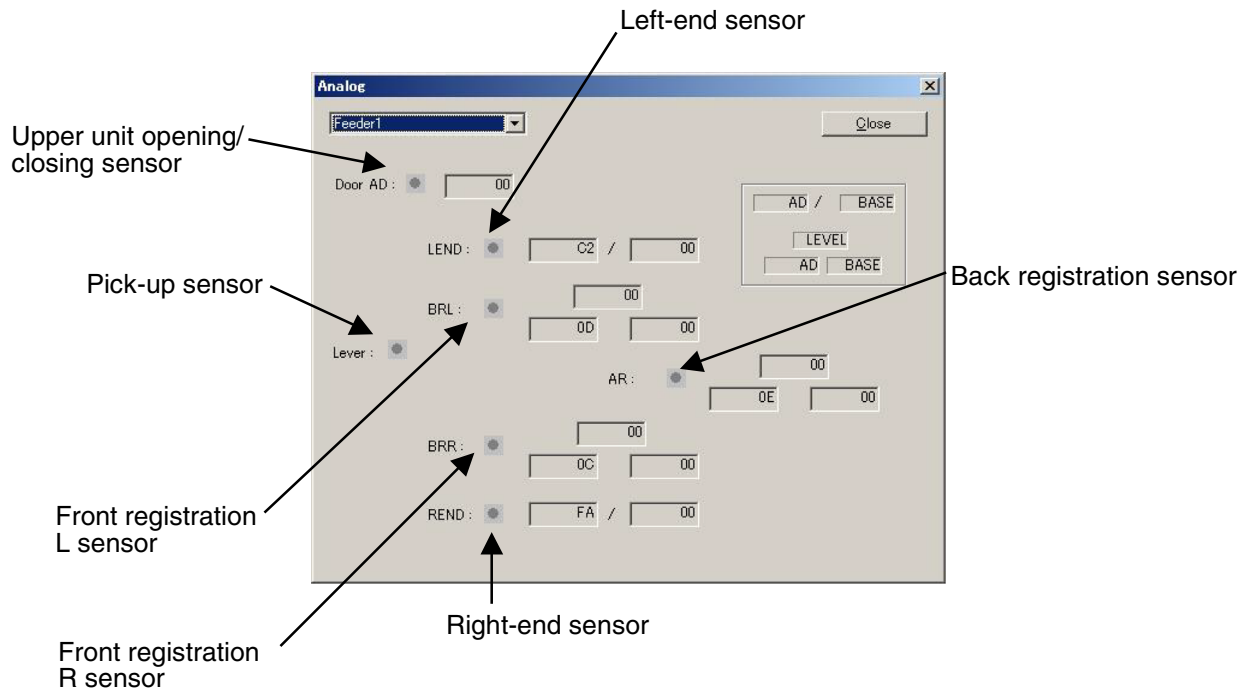

Fig. 5-321

c) Feeder 2

Fig. 5-322 shows the window displayed after selecting 'Feeder 2' from the box menu.

In this figure, the analog values for the document guide width sensor, document sensor, document tray HP sensor and staple sensor (on a one-by-one basis) are displayed. The mark for the sensor that has detected a document will illuminate.

However, the operation of the document guide width sensor and staple sensor are checked here, and the operation of the document sensor and document tray HP sensor are checked with the "Dcon Check".

- Document guide width sensor
Slide the document guide and check that the output value varies accordingly.
- Staple sensor
Block the light path of the staple sensor and check that the lamp illuminates.

To close the window, press the 'Close' button.

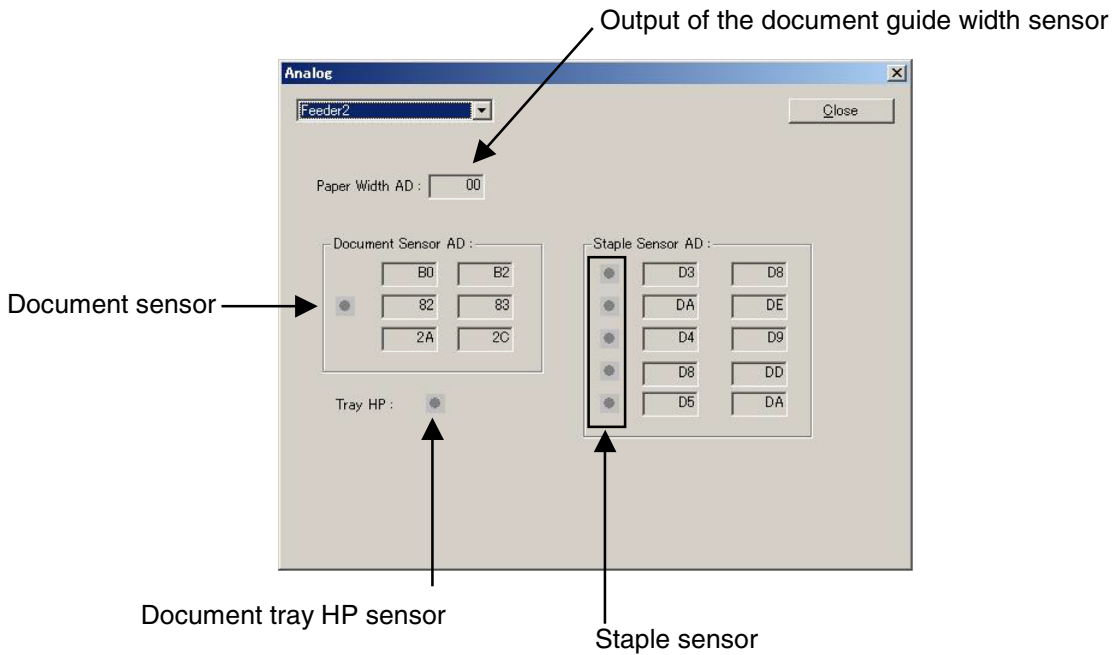

Fig. 5-322

9. About

This mode is used to display the version of the service mode software.

When 'About' is selected from the Service window, the version of the service mode software is displayed.

To close the window, press the 'Close' button.



Fig. 5-323

10. Counter

This mode is used to display or change the total number of fed sheets and the number of document jams. After 'Counter' is selected from the Service window, the Change Counter window appears (See Fig. 5-324). This window includes the following information:

- Total Count
Displays total number of fed sheets.
- P01_Jam Count
Displays the number of occurrences of error code P01.
- P02_Jam Count
Displays the number of occurrences of error code P02.
- P03_Jam Count
Displays the number of occurrences of error code P03.

After changing the numeric value and clicking the 'Set' button to the right, the new value is entered.

To close the window, press the 'Close' button.

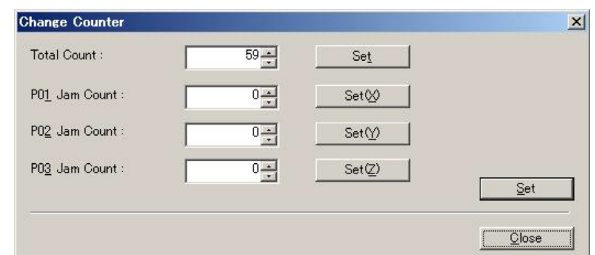

Fig. 5-324

IV. USER MODES

Table 5-401 shows a list of the user modes. To set the user modes, use the following procedure:

- 1) When the machine is in the standby state, press the NEW FILE key and Count Only key simultaneously. During the user mode, the LEDs of the NEW FILE key and Count Only key illuminate and the address (U01-U10) and data (the last digit) appear on the counter display.
- 2) When changing the address, use the NEW FILE key. Each time NEW FILE is pressed, the address changes, cycling from U01 to U10.
- 3) When changing the data, use the Count Only key. Each time Count Only is pressed, the data changes.
- 4) Pressing the Stop key exits the user mode.

Item	Address	Data	Description
Buzzer	U01	0	Does not use the buzzer.
		1	Uses the buzzer. (*)
Endorsement on Count Only	U02	0	Does not make the endorsement. (*)
		1	Makes the endorsement.
Endorser imprinting mode	U03	0	American check size (*)
		1	A4/Letter size
Double feed detection on Count Only	U04	0	Does not detect double feed. (*)
		1	Detects double feed using the ultrasonic sensor.
Staple detection on Count Only	U05	0	Does not detect staples. (*)
		1	Detects staples.
Strength for staple detection	U06	0	Staple detection strength: Weak
		1	Staple detection strength: Middle (*)
		2	Staple detection strength: Strong
Imprinter printing on Count Only	U07	0	Does not perform imprinter printing. (*)
		1	Performs imprinter printing.
Skew correction on Count Only	U08	0	Does not correct skew.
		1	Corrects skew. (*)
Power saving mode	U09	0	Does not shift to power saving mode.
		1	Shifts to power saving mode after ten minutes idle. (*)
Long document mode	U10	0	Normal mode: Document length is 432mm or less. (*)
		1	Long document mode: Document length is 1,000mm or less.

(*): Factory default settings

Table 5-401

V. IMAGE TROUBLESHOOTING

Note 1: There are times when image trouble is due to the display device or printer. In such cases, the problem cannot be corrected with the machine.

Note 2: There are times when, depending on the type of image and settings, document reproducibility becomes poor. In such case, the image may be improved by changing the settings.

1	No image is output (completely white, completely black, completely grey, mottled)
---	--

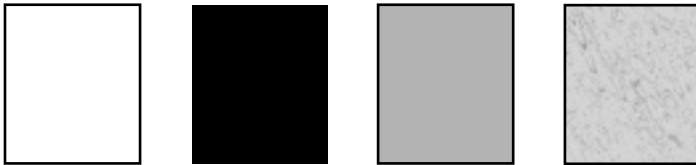

Cause	Step	Check Item	Result	Action
'Brightness' setting	1	Is the 'Brightness' setting appropriate?	NO	Change the setting. Also change 'Contrast' if necessary.
Reading glass	2	Is the reading glass clean?	NO	Clean it. Also clean the roller if necessary.
Shading plate	3	Is the shading plate clean?	NO	Clean it.
	4	Does the shading plate jumps up to the platen roller?	NO	Check the assembly of the shading plate and the operation of the shading solenoid.
Connection of reading unit	5	Are J131/J132/J135 (front side) and J136/J137/J139 (back side) of MAIN_DCON connected properly? Are J2/J3/J4 (front side) and J2B/J3B/J4B (back side) of reading unit connected properly?	NO	Check all connections.
Reading unit	6	Is the problem solved when the reading unit is replaced?	YES	End.
MAIN_DCON	7	Is the problem solved when MAIN_DCON is replaced?	YES	End.

Table 5-501

2 Uneven density, streaks (main-scanning direction)

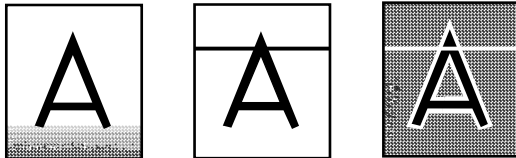

Cause	Step	Check Item	Result	Action
Rollers	1	Are the pick-up roller, feed roller and retard roller properly installed?	NO	Install them properly.
	2	Are they dirty or deformed?	NO	Clean or replace them.
Gear/belt	3	Does it turn smoothly?	NO	Adjust or replace parts.
Main motor (M1)	4	Is the problem solved when the main motor is replaced?	YES	End.
Reading unit	5	Is the problem solved when the reading unit is replaced?	YES	End.
MAIN_DCON	6	Is the problem solved when MAIN_DCON is replaced?	YES	End.

Table 5-502

3 Uneven density, streaks (sub-scanning direction)

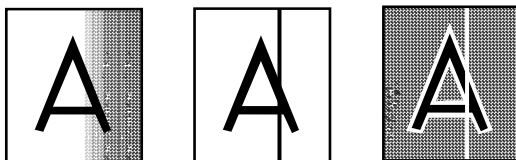

Cause	Step	Check Item	Result	Action
Reading glass	1	Is the reading glass clean?	NO	Clean it. If necessary, clean the roller too.
Shading plate	2	Is the shading plate clean?	NO	Clean it.
	3	Does the shading plate jumps up to the platen roller?	NO	Check the assembly of the shading plate and the operation of the shading solenoid.
Reading unit	4	Is the problem solved when the reading unit is replaced?	YES	End.
MAIN_DCON	5	Is the problem solved when MAIN_DCON is replaced?	YES	End.

Table 5-503

VI. OPERATION TROUBLESHOOTING

When an operation problem occurs, first check for an Error Code on the counter display. In addition, check the operation of the various sensors, motors and solenoids using the 'Service Modes'. For details on the 'Error Codes' and 'Service Modes', refer to the corresponding sections.

1	No power
----------	-----------------

Note: Immediately after the AC power supply is turned off, the capacitor on the DC power supply PCB is still charged, so wait 10 seconds or more after the AC power supply is turned off before you connect/disconnect any connectors.

Cause/Faulty location	Step	Check item	Result	Action
Connection of power cord	1	Is the power cord connected?	NO	Connect it.
AC power supply voltage	2	Is the specified voltage being supplied at the outlet?	NO	Explain to the customer that the trouble is not with the machine.
Power switch	3	Does the power switch work normally?	NO	Check the movement of the power switch shaft assembly.
Connectors related to the DC power supply	4	Are J102 and J117 of MAIN_DCON securely connected?	NO	Check that they are securely connected.
	5	Are CN1 and CN6 of DC power supply PCB securely connected?	NO	Check that they are securely connected.
Connectors related to the operation panel	6	Are J140 of MAIN_DCON and J1201 of the operation panel PCB securely connected?	NO	Connect them securely. If the LED of the operation panel does not illuminate, replace the operation panel.
DC power supply PCB	7	Does LED104 (+24V) of MAIN_DCON illuminate?	NO	Replace the DC power supply PCB.
	8	Is the problem solved when the DC power supply PCB is replaced?	YES	End.
MAIN_DCON	9	Power Does LED101 (for CPU operation check) flash, and does LED106 (+5V) illuminate?	NO	Replace the MAIN_DCON.

Table 5-601

2	PC does not recognize the machine
----------	--

This problem is caused by the SCSI or USB interface between this machine and the personal computer.

Cause/Faulty location	Step	Check item	Result	Action
Connection of SCSI/USB cable	1	Is the SCSI/USB cable properly connected?	NO	Connect it properly.
Power-on Sequence	2	Was power to the machine turned on before the personal computer was turned on?	NO	Follow the proper power-on sequence.
SCSI ID and terminator settings	3	Are the SCSI ID and terminator set properly?	NO	Set them properly.
Personal computer/SCSI PC and SCSI card settings	4	Are the personal computer and SCSI card set properly?	NO	Set them properly.

Table 5-602

3	Motors and solenoids do not operate
----------	--

Cause/Faulty location	Step	Check item	Result	Action
DC power supply	1	Is the unit receiving power?	NO	Perform the actions in section 1: 'No power.'
Counter display	2	Was the error code checked?	NO	Check the error code and identify the cause.
Connectors	3	Are the connectors for the faulty motor or sensor connected properly?	NO	Connect them properly.
Transmission system load	4	Is the transmission system driven by the motor normal? Are such parts as gears and belts normal?	NO	Remove the abnormal load. Replace needed parts.
Sensor	5	Is the operation normal when checking the sensor detection display in the service mode?	NO	Replace the sensor. Adjust the pick-up sensor position.
Motor	6	Is the operation normal when checking the operation in the service mode?	NO	Replace the motor.
Solenoid	7	Is the operation normal when checked in the service mode?	NO	Replace the solenoid.
MAIN_DCON	8	Is the problem solved when MAIN_DCON is replaced?	YES	End.

Table 5-603

VII. FEED TROUBLESHOOTING

1 Faulty document feeding (jam/double feed/wrinkles)

Note: When feeding extremely thick, thin, or pliant documents, faulty feeding can be improved by having the user change the feed condition settings.

Cause/Faulty location	Step	Check item	Result	Action
Document	1	Is the document within the specifications (thickness, dimensions, fold, curl, etc.)?	NO	Ask the customer to use documents within the specifications.
	2	Does the document have no staples?	NO	Ask the customer to remove the staples and reload the document.
	3	Do the documents slide smoothly?	NO	Ask the customer to manually feed the documents one at a time.
Improper detection of double feed	4	Is the size of batch code sheet the same as that of document?	NO	Ask the customer to use the same size sheet.
Rollers	5	Are the rollers clean?	NO	Clean them. If necessary, clean the reading glass too.
Parts in feed path	6	Are all parts that the documents contact properly installed (not loose or tilted)?	NO	Install them properly.
	7	Is the surface in contact with the document smooth (not scratched, no burrs)?	NO	Replace defective parts.
Drive transmission system	8	Is any abnormal noise emitted when feeding documents? Are any gears broken or is the belt loose?	YES	Replace defective parts. Tighten the belt properly.

Table 5-701

VIII.AFTER REPLACING PARTS

Some of the parts used in this machine require adjustments and settings after being replaced or disassembled/reassembled.

Check document feed and images after the replacement or disassembly/reassembly of the parts.

1. Main CPU PCB

- 1) When the SCSI is used, the SCSI ID and terminator must be set.
- 2) Perform the following items using the service mode.
 - Registration adjustment
 - Setting of total counter
- 3) When custom gamma data is to be used, enter the data.

2. Pick-up sensor

When the pick-up sensor is not properly installed, the document tray motion and feeding are not performed correctly.

Therefore, the adjustment of the pick-up sensor position is required not only after replacing parts, but also when a malfunction occurs after changing the position of the pick-up sensor.

The position is correct if the pick-up sensor turns ON when the document tray reaches the top with plain copy paper set on the document tray.

- Checking the operation
 - 1) Select "Dcon Check" in the service mode and keep the operating condition of the pick-up sensor visible.

If the pick-up sensor is illuminating when the document tray is not raised up, position adjustment is required.
 - 2) Press the "Count Only" key on the operation panel of the main body to activate the Count Only mode.
 - 3) Set plain copy paper on the document tray.
 - 4) Press the "Start" key to feed the document.
 - 5) If the pick-up sensor turns ON and the paper is correctly fed when the document tray reaches the top, everything is OK. Otherwise, position adjustment is required.

- How to adjust the position
 - 1) Remove the upper delivery cover and front delivery cover.
 - 2) Loosen the fixing screw ① and rotate the adjusting screw ② to move the sensor mounting plate ③ on which the pick-up sensor is mounted back and forth.

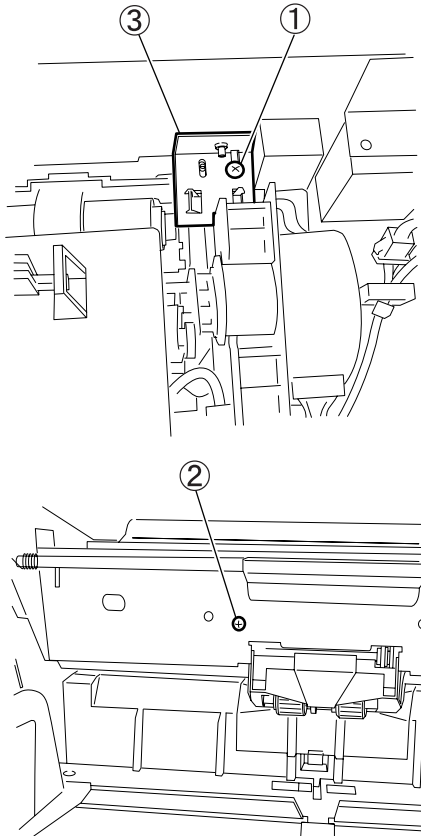

- ① Fixing screw
- ② Adjusting screw
- ③ Sensor mounting plate

Fig. 5-801

- 3) Check the sensor operation while feeding the paper. Adjust the pick-up sensor to the correct position, and then fix it with the screw.
- 4) Replace the covers and check the operation again.

APPENDIX

I. GENERAL CIRCUIT DIAGRAM.....	A-1		II. LIST OF SIGNALS.....	A-3
---------------------------------	-----	--	--------------------------	-----

I. GENERAL CIRCUIT DIAGRAM

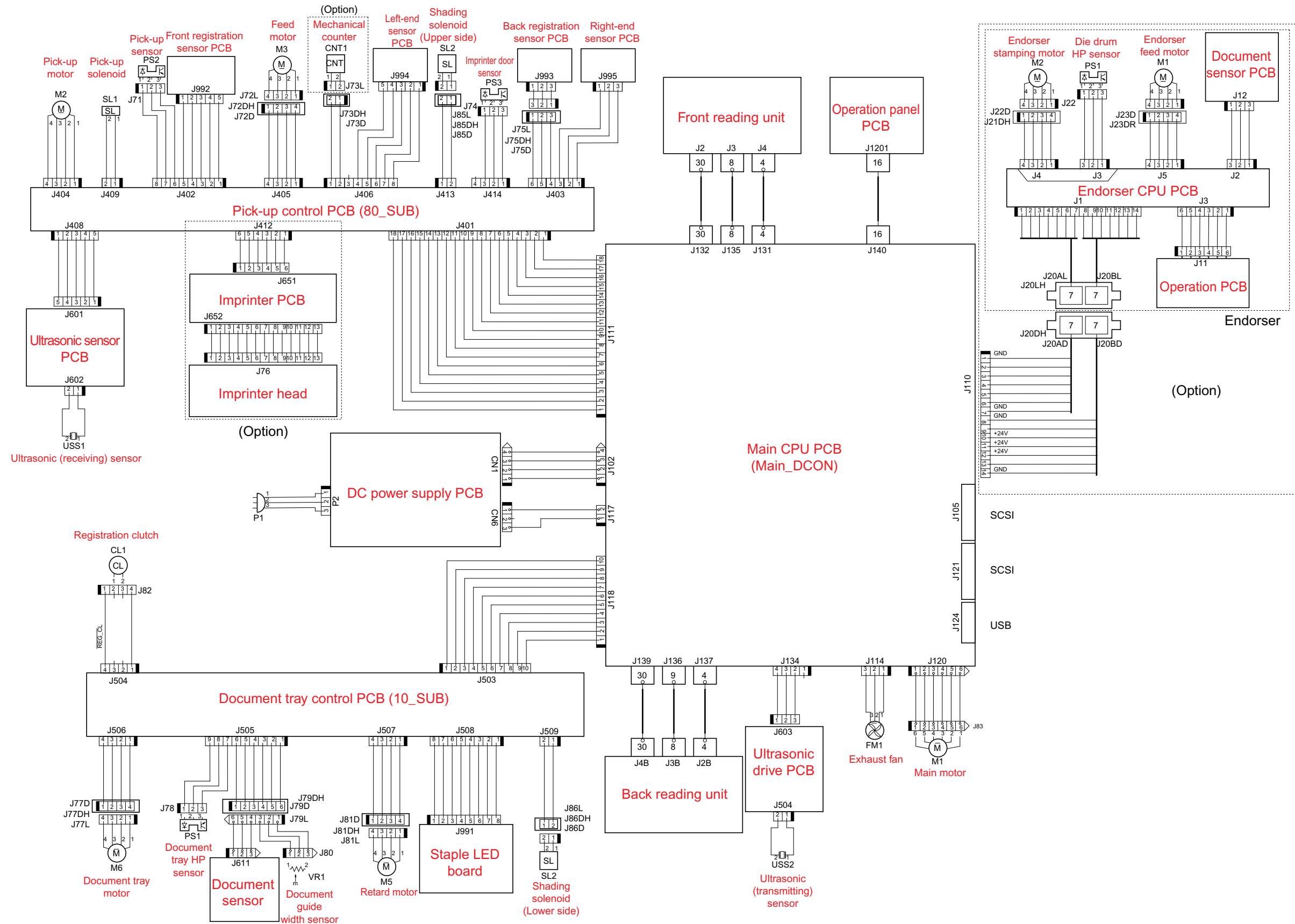

II. LIST OF SIGNALS

1. Main CPU PCB (MAIN_DCON)

The list of signals connected to the main CPU PCB is shown below.

Terminal No.	Name of Signal
J102	1 PWR_OFF
	2 24V
	3 GND
	4 GND
J105	1 SCSI
	50
J110	1 GND
	2 EN_RXD*
	3 EN_TXD*
	4 EX_PORT0
	5 EX_PORT1
	6 EX_RXD*
	7 ENDORSER*
	8 GND
	9 EX_PORT2
	10 24V
	11 24V
	12 24V
	13 EX_PORT3
	14 GND
J111	1 24V
	2 24V
	3 24V
	4 GND
	5 GND
	6 GND
	7 10_OUT
	8 10_TXD
	9 10_RXD
	10 REG_GO
	11 REG_MAE
	12 EXTRA_IN

Terminal No.	Name of Signal
J111	13 80_TXD
	14 80_RXD
	15 IP_RXD
	16 IP_TXD
	17 80IN0*
	18 DFS_PLS
J114	1 FAN_P
	2 FAN_RDY
	3 GND
J117	1 STB-
	2 STB+
J118	1 24V
	2 24V
	3 GND
	4 GND
	5 GND
	6 5V
	7 10_IN*
	8 10_TXD
	9 10_RXD
	10 10_IN_X*
J120	1 B*
	2 24V
	3 B
	4 A*
	5 24V
	6 A
J121	1 SCSI
	50

Terminal No..	Name of Signal
J124	1 VBUS
	2 DM
	3 DP
	4 GND
J131	1 FG
	2 GND
	3 5V
	4 12V
J132	1 CISF_RESET*+
	2 CISF_RESET*-
	3 CISF_SYNC•
	4 CISF_SYNC+
	5 CISF_MCLK+
	6 CISF_MCLK-
	7 CISF_INT*-
	8 CISF_INT*+
	9 CISF_DCLK+
	10 CISF_DCLK-
	11 CISF_DAT9-
	12 CISF_DAT9+
	13 CISF_DAT8+
	14 CISF_DAT8-
	15 CISF_DAT7-
	16 CISF_DAT7+
	17 CISF_DAT6+
	18 CISF_DAT6-
	19 CISF_DAT5-
	20 CISF_DAT5+
	21 CISF_DAT4+
	22 CISF_DAT4-
	23 CISF_DAT3-

Terminal No	Name of Signal	
J132	24	CISF_DAT3+
	25	CISF_DAT2+
	26	CISF_DAT2-
	27	CISF_DAT1-
	28	CISF_DAT1+
	29	CISF_DAT0+
	30	CISF_DAT0-
J135	1	GND
	2	CISF_SDD
	3	GND
	4	CISF_SDI
	5	GND
	6	CISF_SCLK
	7	GND
	8	CISF_SEN*
J136	1	(OPEN)
	2	GND
	3	CISB_SDD
	4	GND
	5	CISB_SDI
	6	GND
	7	CISB_SCLK
	8	GND
	9	CISB_SEN*
J137	1	(OPEN)
	2	FG
	3	GND
	4	5V
	5	12V
J139	1	CISB_RESET*+
	2	CISB_RESET*-
	3	CISB_SYNC-
	4	CISB_SYNC+
	5	CISB_MCLK+
	6	CISB_MCLK-
	7	CISB_INT*-
	8	CISB_INT*+
	9	CISB_DCLK+
	10	CISB_DCLK-
	11	CISB_DAT9-

Terminal No	Name of Signal		
J139	12	CISF_DAT9+	
	13	CISF_DAT8+	
	14	CISF_DAT8-	
	15	CISF_DAT7-	
	16	CISF_DAT7+	
	17	CISF_DAT6+	
	18	CISF_DAT6-	
	19	CISF_DAT5-	
	20	CISF_DAT5+	
	21	CISF_DAT4+	
	22	CISF_DAT4-	
	23	CISF_DAT3-	
	24	CISB_DAT3+	
	25	CISB_DAT2+	
	26	CISB_DAT2-	
	27	CISB_DAT1-	
	28	CISB_DAT1+	
	29	CISB_DAT0+	
	30	CISB_DAT0-	
	J140	1	KEY_IN0
		2	LED_SEL4
		3	LED_SEL3
		4	LED_SEL2
		5	LED_SEL1
		6	LED_SEL0
		7	LED_SEG8
		8	LED_SEG7
		9	LED_SEG6
		10	LED_SEG5
		11	LED_SEG4
12		LED_SEG3	
13		LED_SEG2	
14		LED_SEG1	
15		LED_SEG0	

2. Pick up Control PCB (80_SUB)

The list of signals connected to the pick-up control PCB is shown below.

Terminal No	Name of Signal	Terminal No	Name of Signal		
J401	1	DFS_PLS	J405	1	TAK_MA
	2	80IN0*		2	TAK_MA*
	3	IP_TXD		3	TAK_MB
	4	IP_RXD		4	TAK_MB*
	5	80_RXD	J406	1	24V
	6	80_TXD		2	COUNT*
	7	80_OUT		3	(OPEN)
	8	BR_F*		4	L_SEN*
	9	AR_F*		5	L_SEN_P
	10	10_RXD		6	GND
	11	10_TXD		7	DOOR_S
	12	10_OUT		8	DOOR_S_P
	13	GND	J408	1	5V
	14	GND		2	DFS_PLS
	15	GND		3	DFS_RXD*
	16	24V		4	DFS_TXD*
	17	24V		5	GND
	18	24V	J409	1	24V
		2		B_SHD_SL*	
J402	1	GND	J412	1	GND
	2	REG_FR		2	IP_TXD
	3	REG_FL		3	IP_RXD
	4	REG_FR_P		4	(OPEN)
	5	REG_FL_P		5	5V
	6	GND		6	24V
	7	PAPER_DT	J413	1	24V
	8	5V		2	PK_SL*
J403	1	GND	J414	1	GND
	2	R_SEN*		2	IP_DR_DT
	3	R_SEN_P		3	5V
	4	GND		4	(OPEN)
	5	REG_B			
	6	REG_B_P			
J404	1	PCK_MA			
	2	PCK_MA*			
	3	PCK_MB			
	4	PCK_MB*			

3. Document Tray Control PCB (10_SUB)

The list of signals connected to the document tray control PCB is shown below.

Terminal No	Name of Signal	Terminal No	Name of Signal			
J503	1	10_IN_X*	J508	1	GND	
	2	10_RXD		2	GL_0*	
	3	10_TXD		3	GL_1*	
	4	10_IN*		4	GL_2*	
	5	5V		5	GL_3*	
	6	GND		6	GL_4*	
	7	GND		7	(OPEN)	
	8	GND		8	5V	
	9	24V	J509	1	F_SHD_SL*	
	10	24V		2	24V	
J504	1	24V	J505	1	SIZE_DT	
	2	(OPEN)		2	GND	
	3	(OPEN)		3	5V	
	4	REG_CL*		4	GND	
J506	1	TYR_MA		5	AUTO_DT	
	2	TYR_MA*		6	AUTO_P	
	3	TRY_MB		7	GND	
	4	TRY_MB*		8	TRY_HP	
	J507	1		SEP_MA	9	5V
		2	SEP_MA*	J509	1	F_SHD_SL*
		3	SEP_MB		2	24V
		4	SEP_MB*			

Prepared by

**Quality Assurance Center
Canon Electronics Inc.**

**1248 Shimokagemori, Chichibu-shi
Saitama 369-1892, Japan**

FIRST EDITION (OCT. 2003)[63999a]

Canon

DR-6080/9080C

PARTS CATALOG

FIRST EDITION

DR-6080	100V	50/60Hz	M11-0481
	120V	60Hz	M11-0483
	220-240V	50/60Hz	M11-0484

DR-9080C	100V	50/60Hz	M11-0471
	120V	60Hz	M11-0473
	220-240V	50/60Hz	M11-0474

Imprinter for DR-6080/9080C

M18-0801

Canon

OCT. 2003

MY8-31A0-000

序

このパーツ・カタログは、DR-6080/9080C に対するサービス部品調達の手引として発行します。
サービス部品の要求は、キヤノン販売営業所にお問い合わせください。
製品に大きな変更がある場合は、改訂版のパーツ・カタログを発行しますが、その他の場合は随時新しい情報をお届けします。
このパーツ・カタログは当社品質保証部品質推進課が発行管理を行っています。

キヤノン電子株式会社
品質保証部 品質推進課

PREFACE

This Parts Catalog contains listings of parts used in the DR-6080/9080C.
Diagrams are provided with the listings to aid the service technician in identifying clearly, the item to be ordered.

Whenever ordering parts, consult this Parts Catalog for all of the information pertaining to each item. Be sure to include in the Parts Request, the full item description, the item part number and the quantity.

Quality Assurance Center
Canon Electronics Inc.

版權所有，無斷轉載，引用を禁ず。
Copyright © 2003 Canon Electronics Inc.

本マニュアルについては、機密保持等その取扱には十分注意して下さい。
万一取扱を誤りますと法律で処罰されることがあります。

Use of this manual should be strictly supervised to avoid disclosure of confidential information.

目 次

		イラスト	リスト
A-1	主要部品配置図-1	A-1	
A-2	主要部品配置図-2	A-2	
B	イラスト索引	B-1, B-2	
100	外装カバー部	100-1	100-2
120	排紙カバー部	120-1	120-2
140	原稿台部	140-1	140-2
141	原稿台駆動部	141-1	141-2
201	給紙ユニット部	201-1	201-2
202	上搬送ガイド部	202-1	202-2
203	上ローラ部	203-1	203-2
204	上シェーディング・ユニット部	204-1	204-2
205	上フレーム部	205-1	205-2
206	上センサ部	206-1	206-2
301	駆動ローラ部-1	301-1	301-2
302	駆動ローラ部-2	302-1	302-2
303	下シェーディング・ユニット部	303-1	303-2
304	ベース部	304-1	304-2
320	分離ローラ部	320-1	320-2
400	上下読取部	400-1	400-2
500	電装部	500-1	500-2
600	オプション	600-1	600-2
C	部品索引表	C-1, C-2, C-3	



CONTENTS

		ILLUST	LIST
A-1	ASSEMBLY LOCATION DIAGRAM-1	A-1	
A-2	ASSEMBLY LOCATION DIAGRAM-2	A-2	
B	ILLUSTRATION INDEX.....	B-1, B-2	
100	EXTERNAL COVERS.....	100-1	100-2
120	DELIVERY COVER ASSEMBLY.....	120-1	120-2
140	DOCUMENT BOARD ASSEMBLY.....	140-1	140-2
141	DOCUMENT BOARD DRIVE ASSEMBLY.....	141-1	141-2
201	FEED UNIT ASSEMBLY.....	201-1	201-2
202	UPPER FEED GUIDE ASSEMBLY.....	202-1	202-2
203	UPPER ROLLER ASSEMBLY	203-1	203-2
204	UPPER SHADING UNIT ASSEMBLY.....	204-1	204-2
205	UPPER FLAME ASSEMBLY	205-1	205-2
206	UPPER SENSOR ASSEMBLY.....	206-1	206-2
301	DRIVE ROLLER ASSEMBLY-1	301-1	301-2
302	DRIVE ROLLER ASSEMBLY-2	302-1	302-2
303	LOWER SHADING UNIT ASSEMBLY.....	303-1	303-2
304	BASE ASSEMBLY	304-1	304-2
320	SEPARATION ROLLER ASSEMBLY.....	320-1	320-2
400	IMAGE READER, UPPER/LOWER.....	400-1	400-2
500	ELECTRICAL COMPONENTS	500-1	500-2
600	OPTIONS.....	600-1	600-2
C	NUMERICAL INDEX.....	C-1, C-2, C-3	

パーツカタログの見方

主要部品配置図について

部品図番号 (Figure No.) および各アセンブリの位置を捜すとき、主要部品配置図を用います。

図中  内は部品図名称,  内は部品図番号を示しています。

また、「イラスト索引」からも検索できます。

部品番号の捜し方

どのアセンブリに使用されている部品かを、主要部品配置図またはイラスト索引で調べその部品図番号 (Figure No.) のページをめくります。

部品図の中からその部品を見つけ、そのキーNo.を部品番号リストの中から捜し出せば、部品番号・部品名称を知ることができます。

注： 電源電圧・周波数等の仕様が異なる場合は、同一のキーNo.に複数の部品番号が記されているので“REMARKS”欄を注意して見るようにしてください。

部品番号リストについて

部品番号リストの内容項目は次のとおりです。

(1) 部品図番号およびキーNo. (FIGURE & KEY No.)

部品図番号は、各部品番号リスト欄の左上に示してあり、各部品図に対応しています。

また、キーNo. は、部品図中に示してある個々の部品に対応します。

(2) 部品番号 (PART NUMBER)

リストの2番目の欄には、部品番号が示してあります。部品を発注する際は、必ずこの番号を明示してください。NPNと記載されている部品はサービスパーツに設定されていません。

注： 部品番号の末尾3桁を訂番といいます。部品改良等の目的で部品の一部が変更になった場合、訂番が変わることがあります。これらの変更については、技術情報 (Service Information) で随時連絡されますので、常にこれらの情報も注意深く読むよう心がけてください。

(3) ランク (RANK)

Nと記載されている部品はサービスパーツに設定されていますが、在庫はされていません。注文を受けてからの受注生産になります。

(4) 使用個数 (Q'TY)

4番目の使用個数欄に示してある数字は、各部品図中における各部品の使用数量を示しています。

使用個数欄には数字の他に以下のアルファベット文字も表示されています。

AR 数量を限定せず、組立時に必要に応じた数量を使用するもの、および個数の明記できないもの

(5) 部品名称 (DESCRIPTION)

個々の部品の名称が英文と和文で記されています。

部品発注の際、部品名称も必ず明示してください。

電気部品等の主な仕様・型番は、英文の末尾に記しているものもあります。

(6) 備考 (REMARKS)

電源電圧・周波数等の仕様の違いがある場合に、表示しています。

これらの表示のないものについてはすべての機械に適用できます。

部品索引表 (NUMERICAL INDEX)



部品番号の索引が巻末にあります。

部品番号がわかっている、使用場所を調べる場合に活用できます。

索引表の左の欄が部品番号 (PART No.)、中央の欄が部品図番号 (FIGURE No.) とキーNo. (KEY No.)、右の欄が使用個数 (Q'TY) を示しています。

HOW TO USE PARTS CATALOG

Assembly Location Diagrams

These diagrams show Figure Number and the locations of major assemblies of the machine. Figure names are identified in rectangular boxes , and Figure numbers are identified in elliptic boxes . Also, it is possible to be found out by "Illustration Index".

Finding a Parts Number

Refer to the Assembly Location Diagrams or Illustration Index, and find out the Figure Number. Turn to the page (s), and find its Key Number. Refer to the Parts List, and find the Key Number, Part Number and Description.

Note : While looking for a Part Number, pay particular attention to the voltage listed in the "REMARKS" column to ensure that the Part Number selected is for your type of machine.

Part List pages

The Parts List pages contain the following columns and information.

(1) Figure and Key Number.

The first column shows the Figure Number of the illustration corresponding to the Parts List, and the Key Number that identifies the part on the illustration.

(2) Part Number.

The second column shows the Part Number for the part. This Number must be used when ordering replacement parts or assemblies. Parts marked "NPN" are not service parts.

Note : The last three digits (suffix) of the Parts Number are called the Revision Number. The Revision Number is changed of the part is modified. Information regarding such changes will be provided by Service Information Bulletins. These Bulletins should be read carefully.

(3) Rank.

Parts marked "N" are service parts, but are not stock items. They are produced on a special-order basis.

(4) Quantity (Q'ty).

The quantity shown in this column is the number of parts used in the figure.

This column indicates the following alphabets as well as numeric characters.

AR This indicates that the quantity of a part is not specified, allowing the use of the number of parts needed for assembly and that the quantity cannot be mentioned clearly.

(5) Description.

The Description column lists the description in Japanese and in English. When ordering the part, such description should be use as well as the part number. Some major specifications and type numbers are described at the end of the description in English.

(6) Remarks.

When there are differences in the specifications of power supply voltage or others, the differences are described in this column.

If there are not such differences, the part is available for all machines.

Numerical Index

There is a Numerical Index at the end of this catalog. It can be used when looking for the location where the part is used, if you know the part number.

The first column shows the Part Number, the second column lists the Figure and Key Number and the third column shows the used quantities.

FIGURE A-1 ASSEMBLY LOCATION DIAGRAM-1
主要部品配置図-1

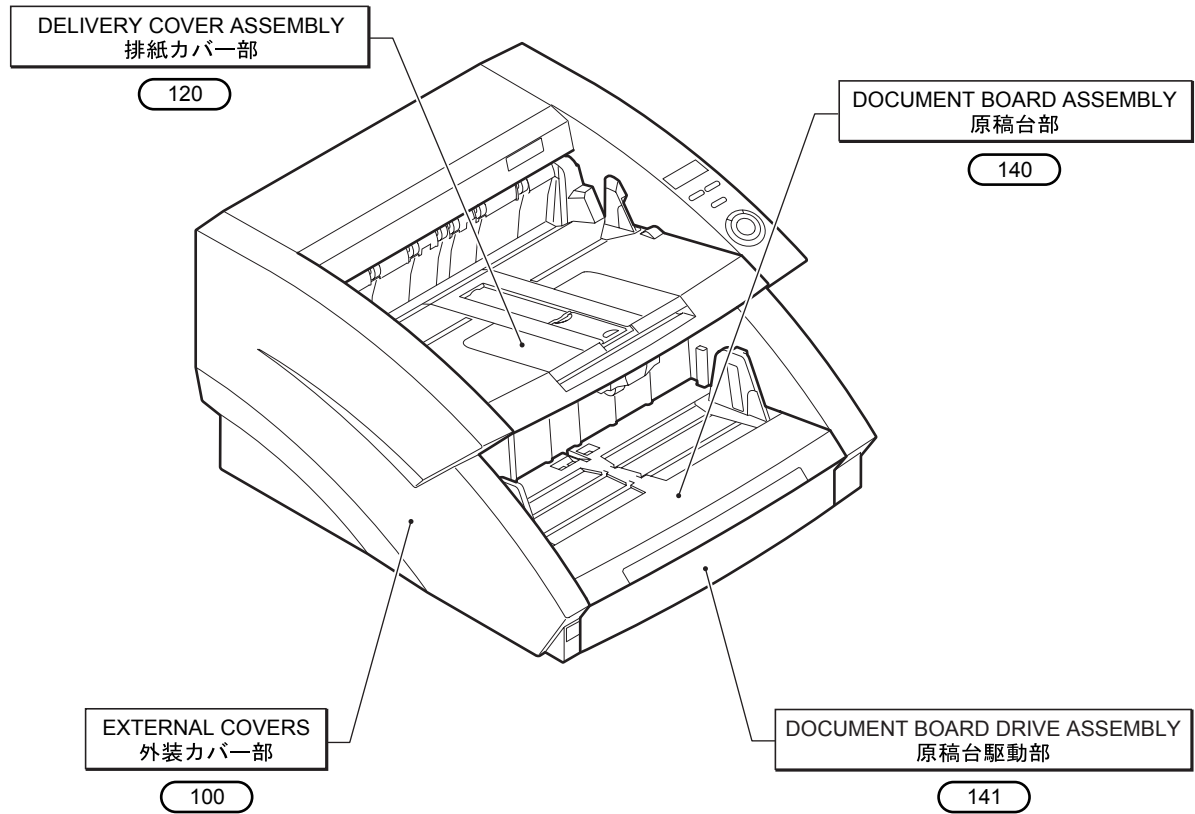

FIGURE A-2 ASSEMBLY LOCATION DIAGRAM-1 主要部品配置図-2

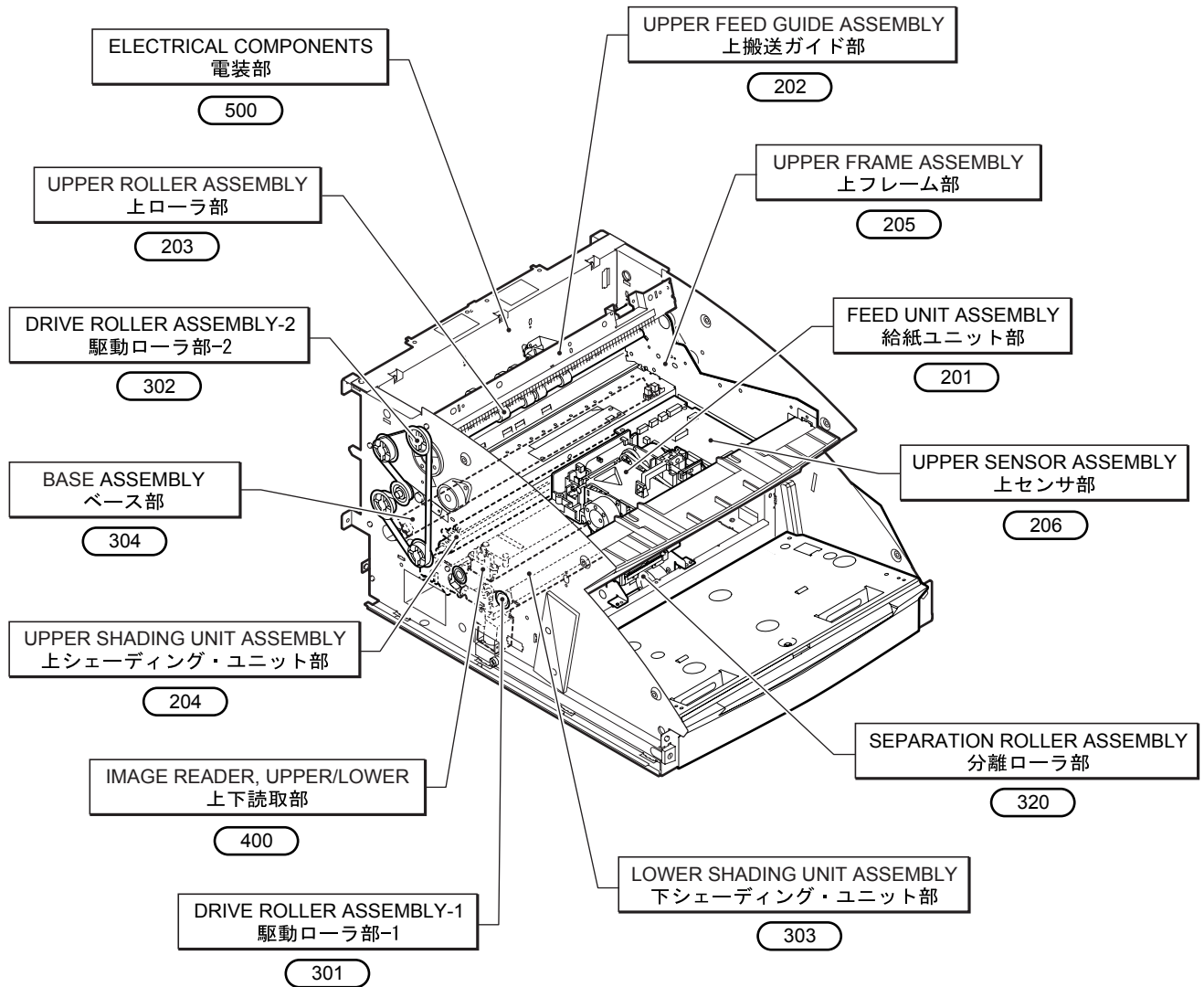

FIGURE B ILLUSTRATION INDEX

イラスト索引

<p>FIGURE 100</p> 	<p>FIGURE 120</p> 	<p>FIGURE 140</p> 
<p>FIGURE 141</p> 	<p>FIGURE 201</p> 	<p>FIGURE 202</p> 
<p>FIGURE 203</p> 	<p>FIGURE 204</p> 	<p>FIGURE 205</p> 
<p>FIGURE 206</p> 	<p>FIGURE 301</p> 	<p>FIGURE 302</p> 

FIGURE B

ILLUSTRATION INDEX

イラスト索引

FIGURE 303

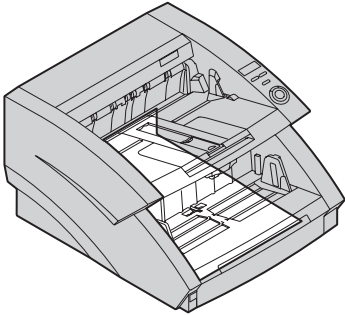
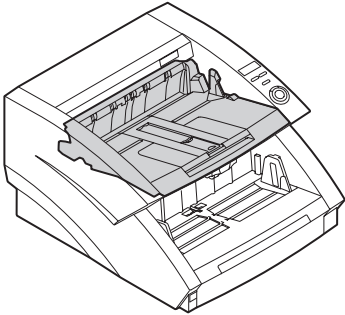
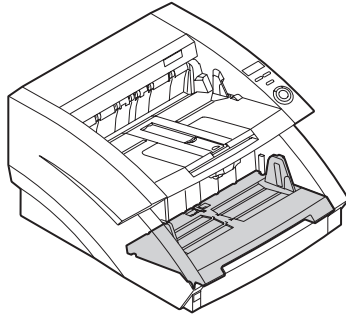
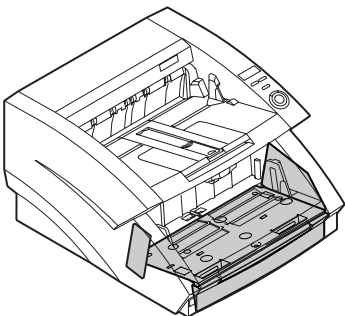
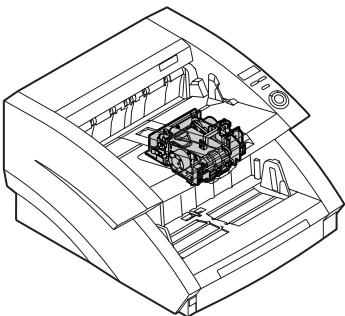
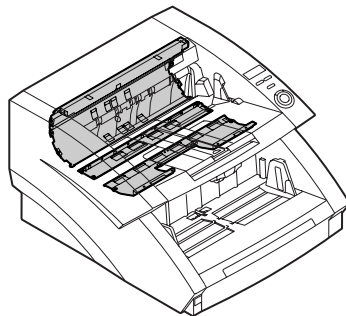
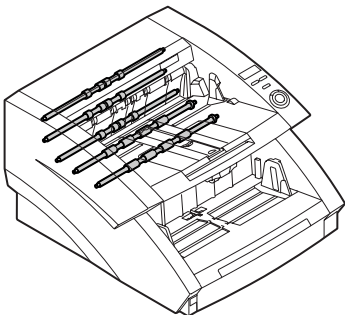
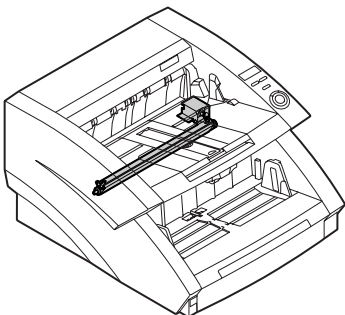
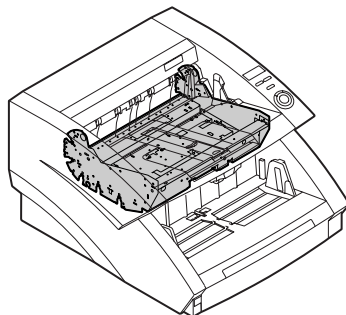
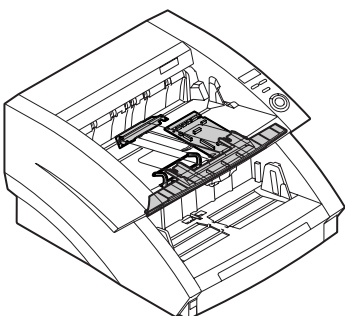
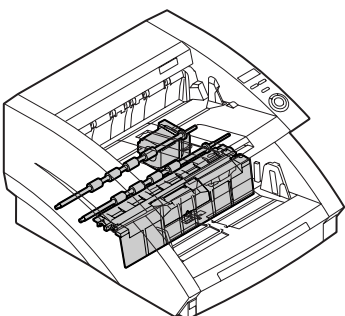
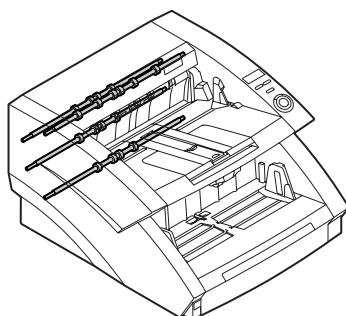
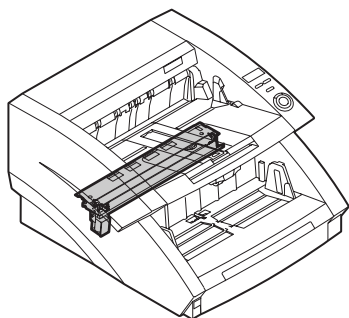

FIGURE 304

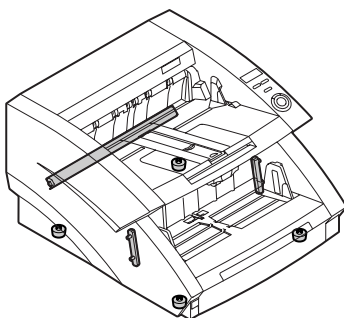

FIGURE 320

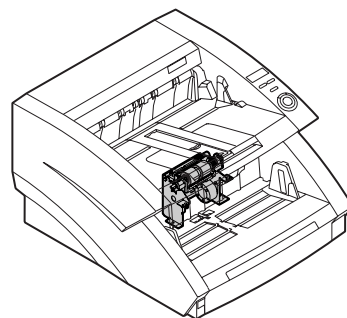

FIGURE 400

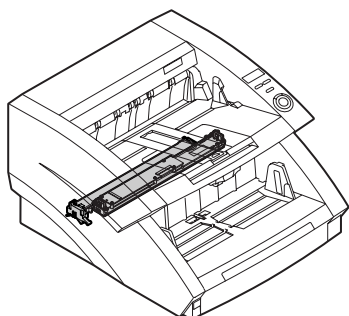

FIGURE 500

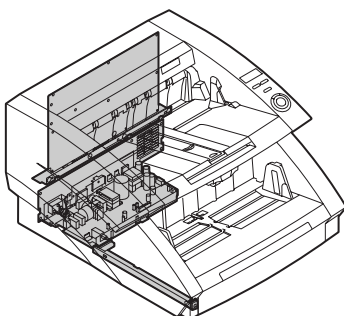

FIGURE 600

OPTION

FIGURE 100

EXTERNAL COVERS 外装カバー部

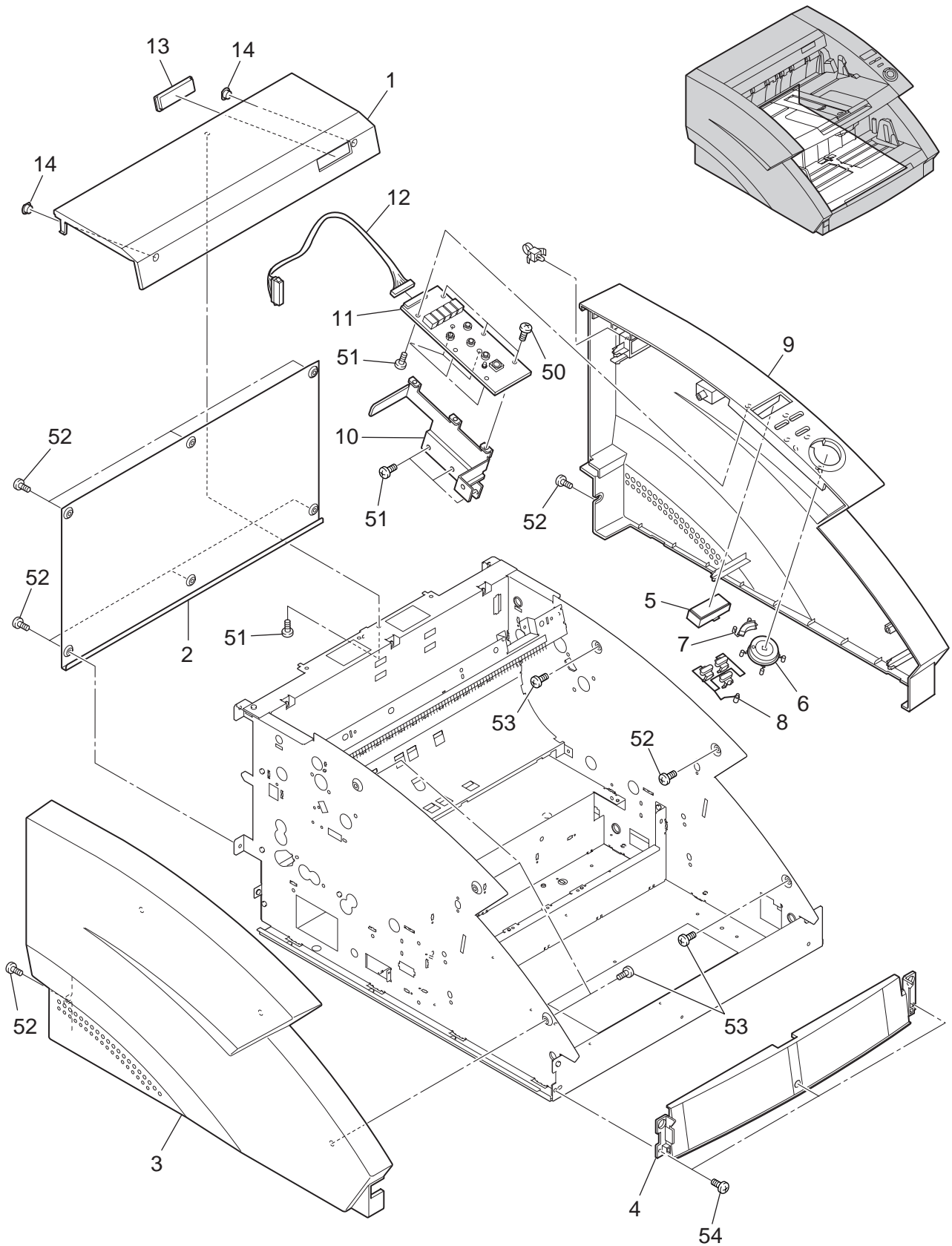

FIGURE & KEY NO.	PART NUMBER	R A N K	Q' T Y	DESCRIPTION	REMARKS
100 -	1 MA2-6726-000		1	COVER, TOP ウエ カバー	DR-6080
	MA2-6729-000		1	COVER, TOP ウエ カバー	DR-9080C
	2 MA2-6727-000		1	COVER, REAR ウシロ カバー	
	3 MA2-6728-000		1	COVER, LEFT ヒダリ カバー	
4	MA2-6731-000		1	COVER, FRONT マエ カバー	
5	MA2-6756-000	N	1	WINDOW, INDICATION ヒョウジブ カバー	
6	MA2-6757-000	N	1	KEY-TOP, STRAT スタート キー	
7	MA2-6758-000	N	1	KEY-TOP, STOP ストップ キー	
8	MA2-6759-000	N	1	KEY-TOP キー	
9	MA2-6760-000		1	COVER, RIGHT ミギ カバー	
10	MA2-6755-000	N	1	PLATE, OPERATION ソウサブ プレート	
11	MG1-3439-000		1	PCB ASS'Y, OPERATION ソウサブ PCB	
12	MG1-3440-000		1	CABLE ASS'Y, OPERATION ソウサブ ケーブル	
13	MA2-6878-000	N	1	PLATE, BLIND A メカクシバン A	
14	MA2-6879-000	N	2	PLATE, BLIND B メカクシバン B	
50	XB1-2300-605		3	SCREW, BH M3x6 バインド コネジ M3x6	
51	XB4-7300-605		9	SCREW, TAPPING, BH M3x6 B タイト バンド ビス M3x6	
52	XB1-2400-605		9	SCREW, BH M4x6 バインド コネジ M4x6	
53	XB4-7400-605		5	SCREW, TAPPING, BH M4x6 B タイト バインド ビス M4x6	
54	XB1-2400-805		3	SCREW, BH M3x8 バインド コネジ M3x8	

FIGURE 120

DELIVERY COVERS ASSEMBLY 排紙カバー部

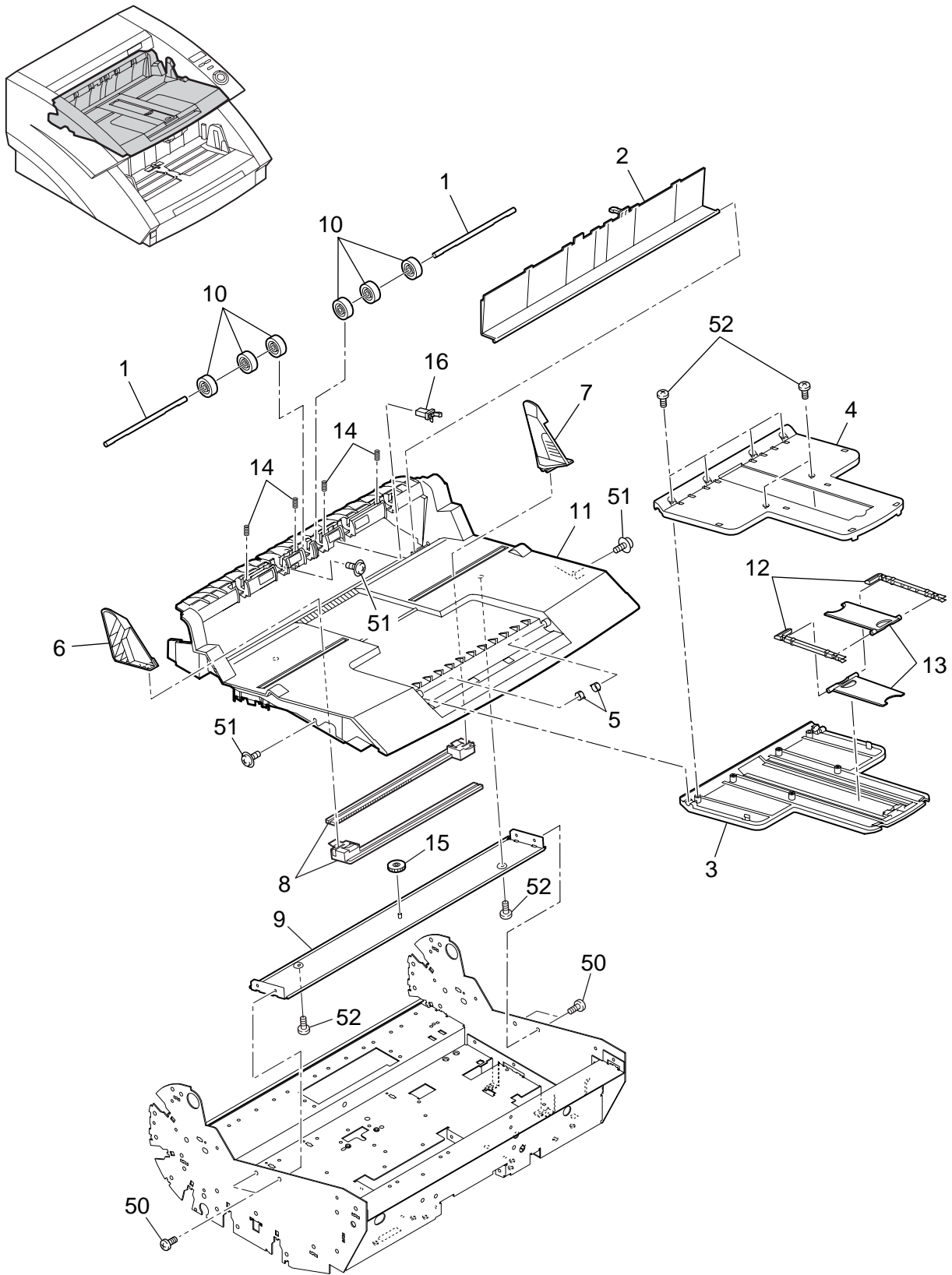

FIGURE & KEY NO.	PART NUMBER	R A N K	Q' T Y	DESCRIPTION	REMARKS
120 -	1 MA2-6817-000	N	2	SHAFT, DELIVERY ROLLER ハイシ ローラ ジク	
	2 MA2-6820-000		1	COVER, IMPRINTER IP カバー	
	3 MA2-6821-000		1	TRAY, DELIVERY 1 ハイシ カイテン トレイ 1	
	4 MA2-6822-000		1	TRAY, DELIVERY 2 ハイシ カイテン トレイ 2	
	5 MA2-6825-000	N	2	SLEEVE スリーブ	
6 MA2-6826-000	N	1	GUIDE, DELIVERY LEFT ハイシ ガイド ヒダリ		
7 MA2-6827-000	N	1	GUIDE, DELIVERY RIGHT ハイシ ガイド ミギ		
8 MA2-6828-000		2	RACK, GUIDE ガイド ラック		
9 MF1-4250-000		N	1		PLATE, MOUNT ガイド トリツケ イタ
10 MF1-4255-000		6	ROLLER, DELIVERY FOLLOWER ハイシ ジュドウ ローラー		
11 MF1-4258-000	N	1	COVER, DELIVERY ハイシ カバー		
12 MA2-6823-000		2	BLOCK, SLIDE スライド コマ		
13 MA2-6824-000	N	2	STOPPER ストッパー		
14 MS1-2473-000		4	SPRING, COMPRESSION ローラ バネ		
15 MS2-0077-000		1	GEAR, 18T ガイド ギア		
16 XZ9-0379-000		1	LATCH ウキダシ ラッチ		
50 XB1-2300-609		4	SCREW, BH M3x6 バインド コネジ M3x6		
51 XB6-7300-609		3	SCREW, TP M3x6 TP ナベ コネジ M3x6		
52 XB4-7300-605		8	SCREW, BH M2.5x4 バインド コネジ M2.5x4		

FIGURE 140

DOCUMENT BOARD ASSEMBLY 原稿台部

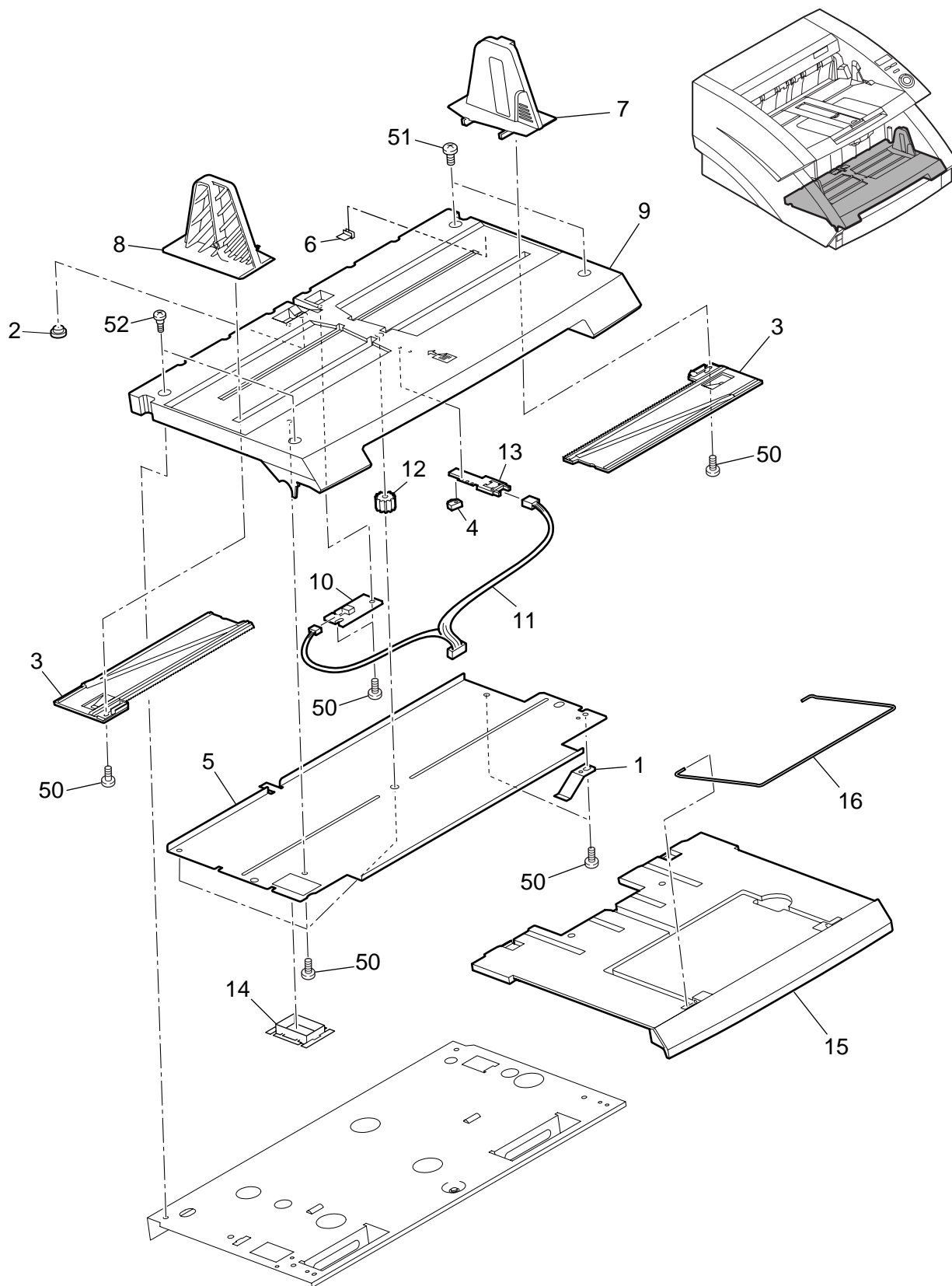

FIGURE & KEY NO.	PART NUMBER	RANK	QTY	DESCRIPTION	REMARKS	
140 -	1	MA2-5393-000	N	1	SPRING, PLATE ゲンコウダイ バネ	
	2	MA2-5403-000	N	1	PLATE, DOCUMENT SENSING ゲンコウ ケンチ マド	
	3	MA2-6733-000		2	PLATE, RACK ラック	
	4	MA2-6734-000	N	1	SPACER ガタリ	
	5	MA2-6739-000	N	1	PLATE, BLIND メカクシ プレート	
6	MA2-6761-000		7	STOPPER, CABLE タバセン ドメ		
7	MF1-4245-000	N	1	GUIDE, DOCUMENT RIGHT ゲンコウ タカサ キセイ ミギ		
8	MF1-4246-000	N	1	GUIDE, DOCUMENT LEFT ゲンコウ タカサ キセイ ヒダリ		
9	MF1-4247-000	N	1	DOCUMENT BOARD ゲンコウ ダイ		
10	MG1-3269-000		1	PCB ASS'Y, CAMERA DETECT ケンチ カイロ キバン		
11	MG1-3449-000		1	CABEL ASS'Y, TRAY-UP トレイ アップ ケーブル		
12	MS2-0081-000		1	GEAR, 14T ラック ギア		
13	VR9-5651-000		1	RESISTOR, VARIABLE カヘン テイコウ		
14	WT2-5098-000		1	BUSHING, CABLE スクウェア プッシュ		
15	MA2-6737-000		1	TRAY, PICK-UP キュウシ トレイ		
16	MA2-5404-000	N	1	EXTENSION TRAY, WIRE END エンド ワイヤ		
50	XB4-7300-605		9	SCREW, TAPPING, BH M3x8 B タイト バインド ビス M3x8		
51	XB6-7400-609		2	SCREW, TP M4x6 TP ナベ コネジ M4x6		
52	XA9-1551-000		2	SCREW, STEPPED 4, M4 ダンツキ ビス M4		

FIGURE 141

DOCUMENT BOARD DRIVE ASSEMBLY 原稿台駆動部

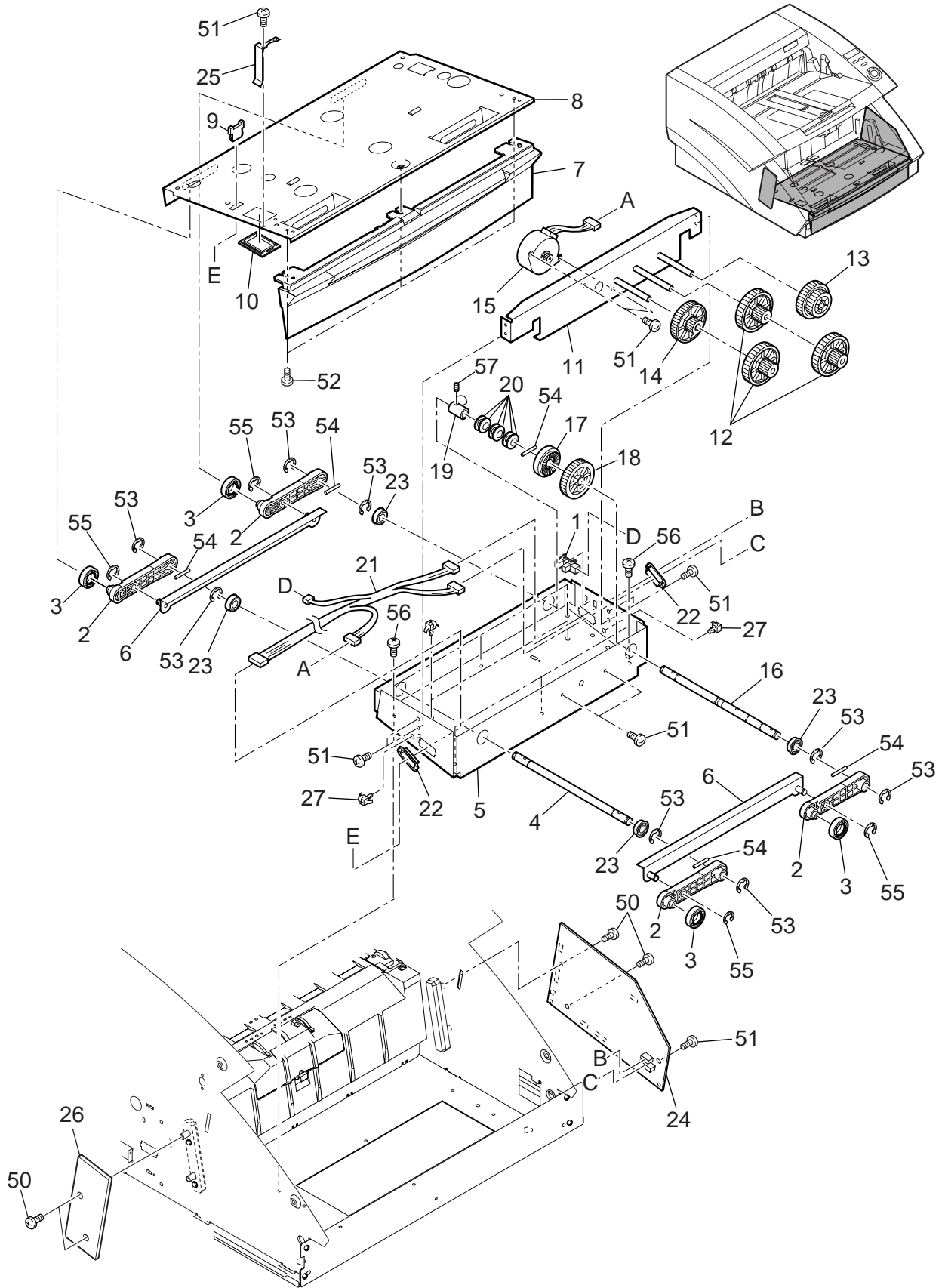

FIGURE & KEY NO.	PART NUMBER	R A N K	Q' T Y	DESCRIPTION	REMARKS
141 -	1		1	PHOTO-INTERRRUPTER フォト インタラプタ	
	2	N	4	ARM アーム	
	3	N	4	ROLLER コロ	
	4	N	1	SHAFT, ARM アーム ジク 1	
	5	N	1	BOX, DOCUMENT BOARD ゲンコウダイ ハコ プレート	
6	MF1-4244-000	N	2	PLATE, ARM アーム プレート	
7	MA2-6738-000		1	COVER, BLIND メカクシ カバー	
8	MA2-6740-000	N	1	PLATE, DOCUMENT ゲンコウ パン	
9	VS1-6492-006		1	HOLDER チュウケイ ホルダー	
10	WT2-5098-000		1	BUSHING, CABLE スクウェア ブッシュ	
11	MF1-4243-000	N	1	PLATE, MOTOR ゲンコウダイ モーター プレート	
12	MS2-0073-000		3	GEAR, STEP 43/13T ダン ギヤ	
13	MS2-0074-000		1	GEAR, STEP 37/26T ダン ギヤ	
14	MS2-0080-000		1	GEAR, STEP 70/13T ダン ギヤ	
15	RH7-1278-000		1	MOTOR, STEPPING, DC ステッピング モーター	
16	MA2-6746-000	N	1	SHAFT, ARM アーム ジク 2	
17	MA2-6748-000		1	TORQUE LIMITER トルク リミッター	
18	MA2-6749-000		1	GEAR, 39T, TORQUE LIMITER トルク リミッター ギヤ	
19	MA2-6751-000	N	1	RING, ADJUSTMENT チョウセイ リング	
20	XD9-0187-000		6	SPRING, WASHER 8.2 サラ バネ	
21	MG1-3453-000		1	CABEL ASS'Y, TRAY トレイ ケーブル	
22	WT2-5760-000		2	BUSHING, CABLE スクウェア ブッシュ	
23	XG9-0405-000		4	BALL BEARING トメワツキ ベアリング	
24	MG1-3432-000		1	PCB ASS'Y, CONTROL, 10SUB 10SUB カイロキパン	
25	MA2-6943-000	N	1	PLATE, GROUNDING ゲンコウダイ アース イタバネ	
26	MG1-3433-000		1	PCB ASS'Y, STAPLE LED ステイブル LED PCB	
27	WT2-5653-000		2	CLAMP, CABLE リユース クランプ	
50	XB4-7300-605		4	SCREW, TAPPING, BH M3x6 B タイト バインド ビス M3x6	
51	XB1-2300-605		10	SCREW, BH M3x6 バインド コネジ M3x6	
52	XB6-7300-609		3	SCREW, TP M3x6 TPナベコネジ M3x6	
53	XD2-1100-642		8	RING, E 6.4 Eリング (064)	
54	XD3-2300-222		5	PIN, SPRING 3x22 ヘイコウ ピン	
55	XD2-1100-502		4	RING, E 5 Eリング (050)	
56	XA9-1290-000		6	SCREW, ROUN-END M3x4 サキマル ビス M3x4	
57	XB6-2400-408		2	SET SCREW, M4x4 トメ ビス M4x4	

FIGURE 201

FEED UNIT ASSEMBLY 給紙ユニット部

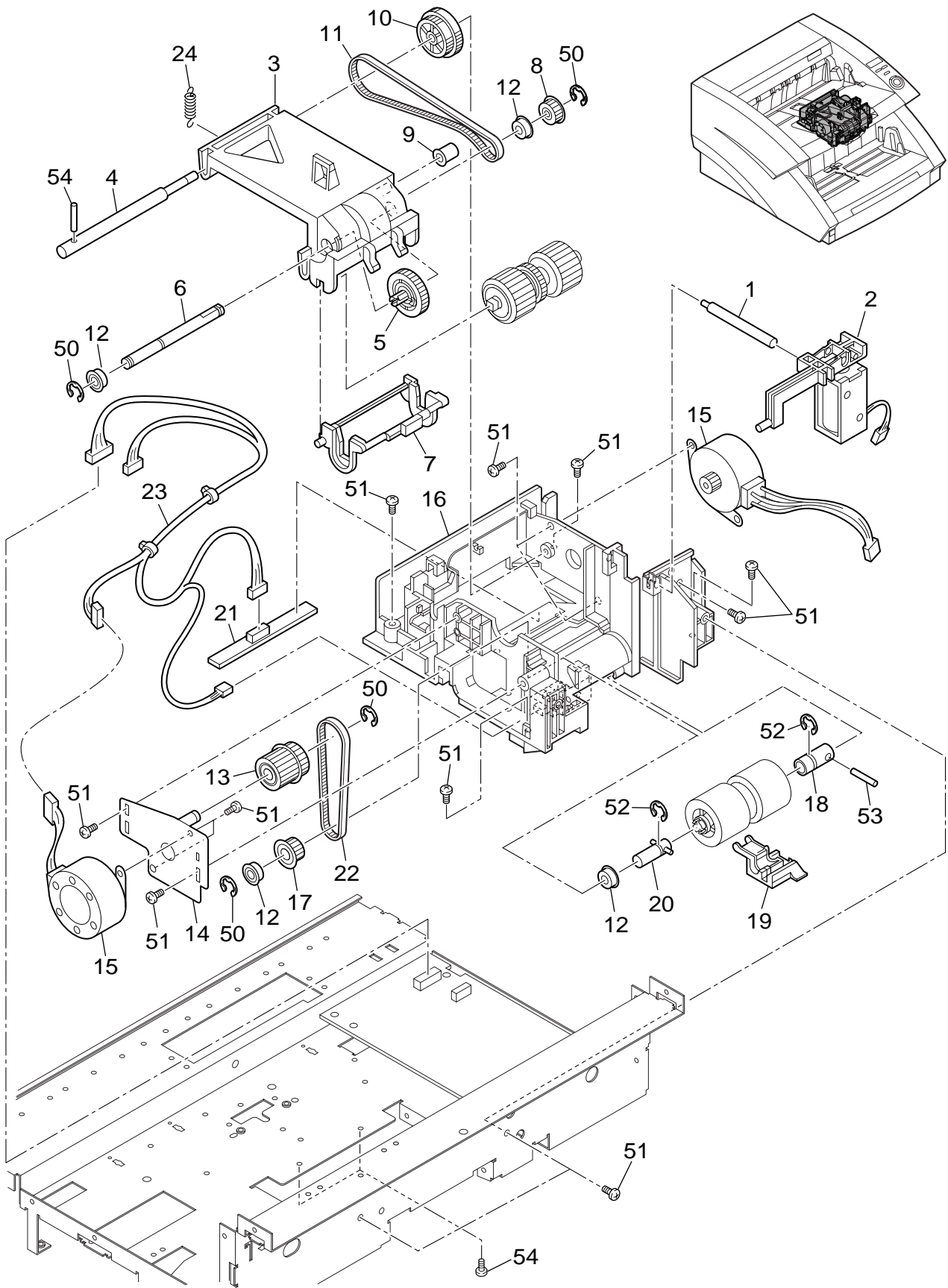

FIGURE & KEY NO.	PART NUMBER	R A N K	Q' T Y	DESCRIPTION	REMARKS
201 -	1 MA2-6764-000	N	1	SHAFT, ESCAPE キュウシ レバー タイヒ ジク	
	2 MF1-4251-000		1	SOLENOID ASSEMBLY キュウシ タイヒ レバー (ソレノイド)	
	3 MA2-6788-000	N	1	ARM, PICK-UP キュウシ アーム	
	4 MA2-6789-000	N	1	SHAFT, PICK-UP ARM キュウシ アーム ジク	
	5 MA2-6791-000		1	GEAR, ONE-WAY, 25T ワンウェイ ギヤ	
6 MA2-6792-000	N	1	SHAFT, PICK-UP キュウシ クドウ デンタツ ジク		
7 MA2-6793-000	N	1	ARM, PICK-UP ROLLER キュウシ ローラ コテイ アーム		
8 MS1-3133-000		1	PULLEY, FEEDER, 20T プーリー-20		
9 MS1-6105-000	N	1	SPACER コロ		
10 MS2-0076-000		1	PULLEY, GEAR 50/43T ギア プーリー		
11 XF2-1113-340			1	BELT, TIMING 133T タイミング ベルト	
12 XG3-6012-405			4	BALL BEARING フランジツキ ベアリング	
13 MF1-4249-000			1	PULLEY, GEAR 29T ギア プーリー	
14 MF1-4252-000	N	1	PLATE, FEED ROLLER オクリ ローラ クドウバン		
15 RH7-1278-000		2	MOTOR, STEPPING, DC ステッピング モーター		
16 MA2-6795-000	N	1	MOUNT, FEEDING ROLLER オクリ ローラ ダイ		
17 MA2-6796-000		1	PULLEY, ONE-WAY, 24T ワンウェイ プーリー		
18 MA2-6798-000	N	1	SHAFT, FEEDING ROLLER オクリ ローラー ホジジク		
19 MA2-6799-000	N	1	ARM, FEEDING ROLLER オクリ ローラー カイジョ レバー		
20 MF1-4253-000	N	1	SHAFT, FEEDING ROLLER オクリ ローラー クドウ ジク		
21 MG1-3491-000			1	PCB ASS'Y, REG-SENSOR FRONT レジ マエ センサ カイロ キバン	
22 XF2-1108-240			1	BELT, TIMING 82T タイミング ベルト	
23 MG1-3492-000			1	PCB ASS'Y, PICK-UP キュウシ ケーブル	
24 MS1-2480-000			1	SPRING, TENSION PK ローラ カアツ バネ	
50 XD2-1100-402			4	RING, E 4 Eリング (040)	
51 XB4-7300-605			16	SCREW, TAPPING, BH M3x6 Bタイト バインド ビス M3x6	
52 XD2-1100-642			2	RING, E 6.4 Eリング (064)	
53 XD3-2200-182			1	PIN, DOWEL 2x18 ヘイコウ ピン	
54 XD3-2200-202			1	PIN, DOWEL 2x20 ヘイコウ ピン	

FIGURE 202 UPPER FEED GUIDE ASSEMBLY
上搬送ガイド部

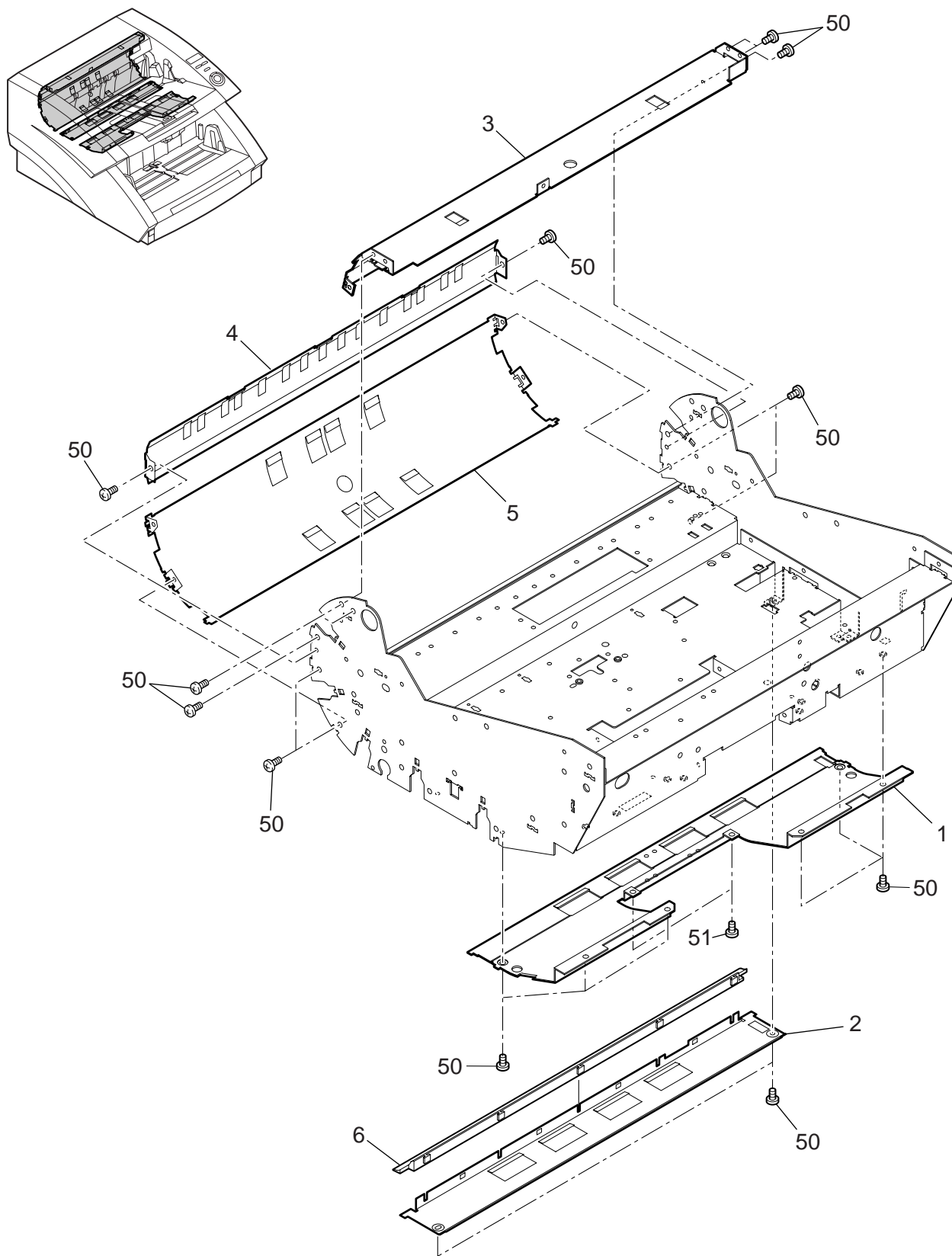

FIGURE & KEY NO.	PART NUMBER	R A N K	Q' T Y	DESCRIPTION	REMARKS
202 -	1 MA2-6800-000	N	1	GUIDE, ENTRANCE, UPPER イリグチ ウエ ガイド	
	2 MA2-6801-000	N	1	GUIDE, FEEDER UPPER ウエ ハンソウ ガイド	
	3 MA2-6811-000	N	1	GUIDE, UPPER FEED ジョウダン ハンソウ ガイド	
	4 MA2-6812-000	N	1	GUIDE, MIDDLE FEED チュウダン ハンソウ ガイド	
	5 MA2-6813-000	N	1	GUIDE, LOWER FEED ゲダン ハンソウ ガイド	
6	MA2-6906-000	N	1	GUIDE, SHADING SHEET シェーディング シート ガイド	
50	XB1-2300-605		18	SCREW, BH M3x6 バインド コネジ M3x6	
51	XB4-7300-605		2	SCREW, TAPPING, BH M3x6 B タイト バインド ビス M3x6	

FIGURE 203

UPPER ROLLER ASSEMBLY 上ローラ部

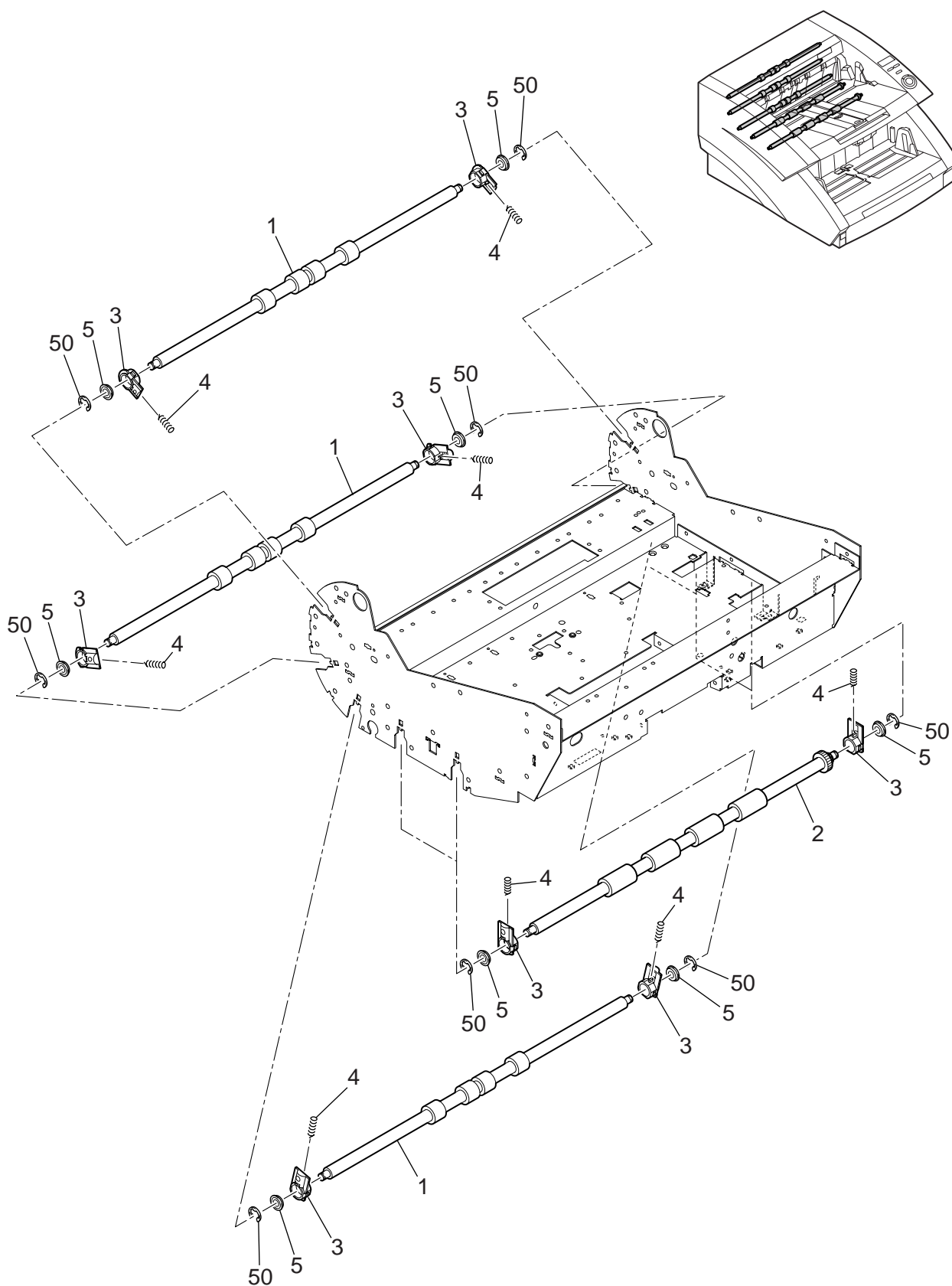

FIGURE & KEY NO.	PART NUMBER	RANK	QTY	DESCRIPTION	REMARKS
203 -	1 MA2-6848-000	N	3	ROLLER, FEEDER UPPER ハンソウ ウエ ローラー	
	2 MF1-4242-000		2	ROLLER, REGISTRATION UPPER レジスト ウエ ローラ	
	3 MA2-6860-000		10	HOLDER, BEARING ベアリング ホルダー	
	4 MS1-2475-000		10	SPRING, COMPRESSION ローラー オサエ バネ	
	5 XG3-6012-405		10	BALL BEARING フランジツキ ベアリング	
50	XD2-1100-402		10	RING, E 4 Eリング(040)	

FIGURE 204 UPPER SHADING UNIT ASSEMBLY
上シェーディング・ユニット部

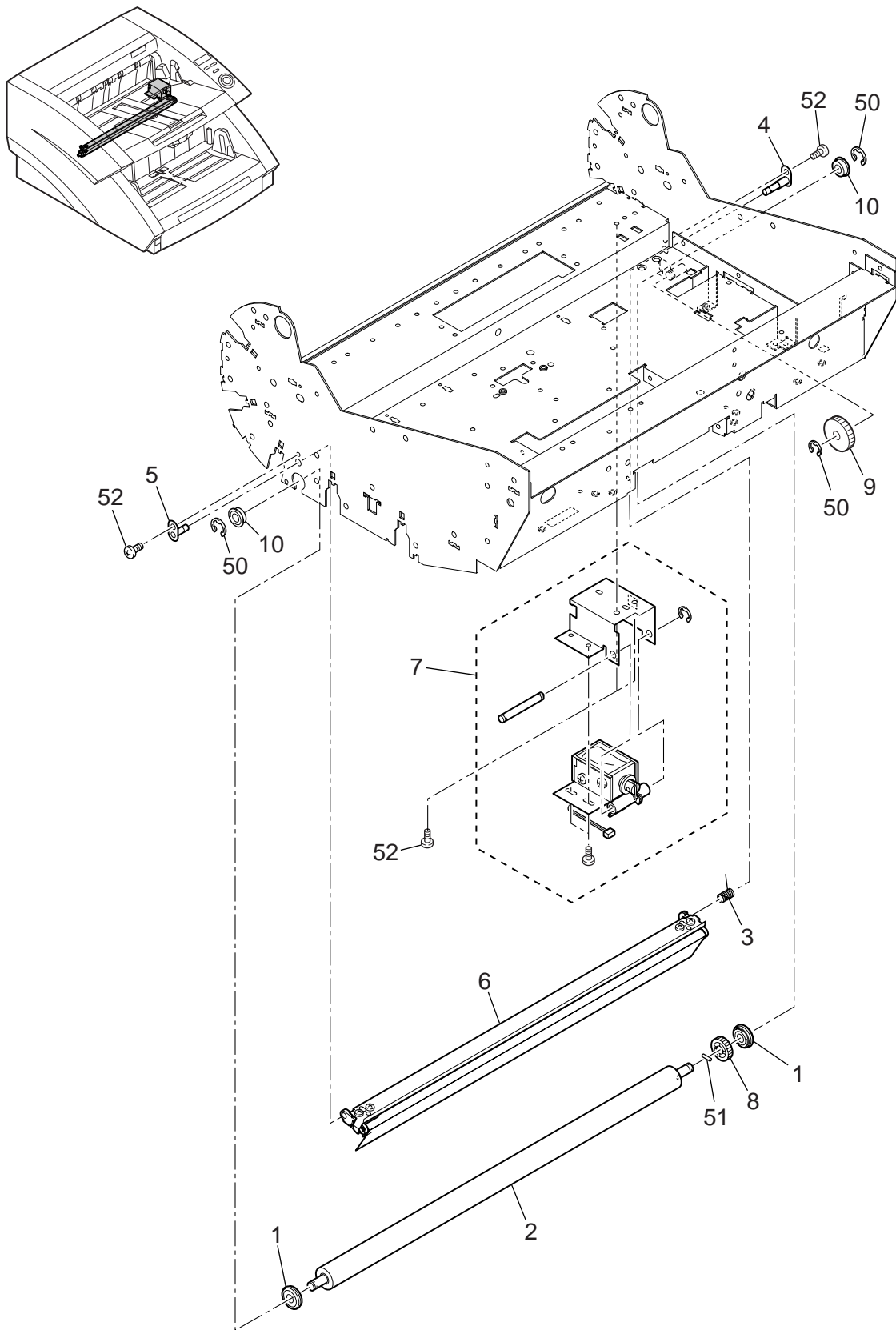

FIGURE & KEY NO.	PART NUMBER	RANK	QTY	DESCRIPTION	REMARKS
204 -	1 MF1-4263-000		2	ROLLER, SPACER スペーサ コロ	
	2 MA2-6916-000		1	ROLLER, PLATEN プラテン ローラ	
	3 MA2-6909-000		1	SPRING, TORSION トーシヨン バネ 2	
	4 MF1-4265-000	N	1	HINGE, UPPER ヒンジ ウエ	
	5 MF1-4278-000	N	1	HINGE, UPPER 2 ヒンジ ウエ 2	
6	MG1-3454-000	N	1	SHADING SHEET UNIT シェーディング シート ユニット	
7	MG1-3455-000		1	SOLENOID UNIT, UPPER ウエ ソレノイド ユニット	
8	MS2-0082-000		1	GEAR, 21T プラテン ギア	
9	MS2-0083-000		1	GEAR, 29T プラテン アイドラ ギア	
10	XG3-6012-405		2	BALL BEARING フランジツキ ベアリング	
50	XD2-1100-402		3	RING, E 4 Eリング (040)	
51	XD3-2200-102		1	PIN, DOWEL 2x10 ヘイコウ ピン	
52	XA9-1290-000		3	SCREW, ROUN-END M3x4 サキマル ビス	

FIGURE 205

UPPER FLAME ASSEMBLY 上フレーム部

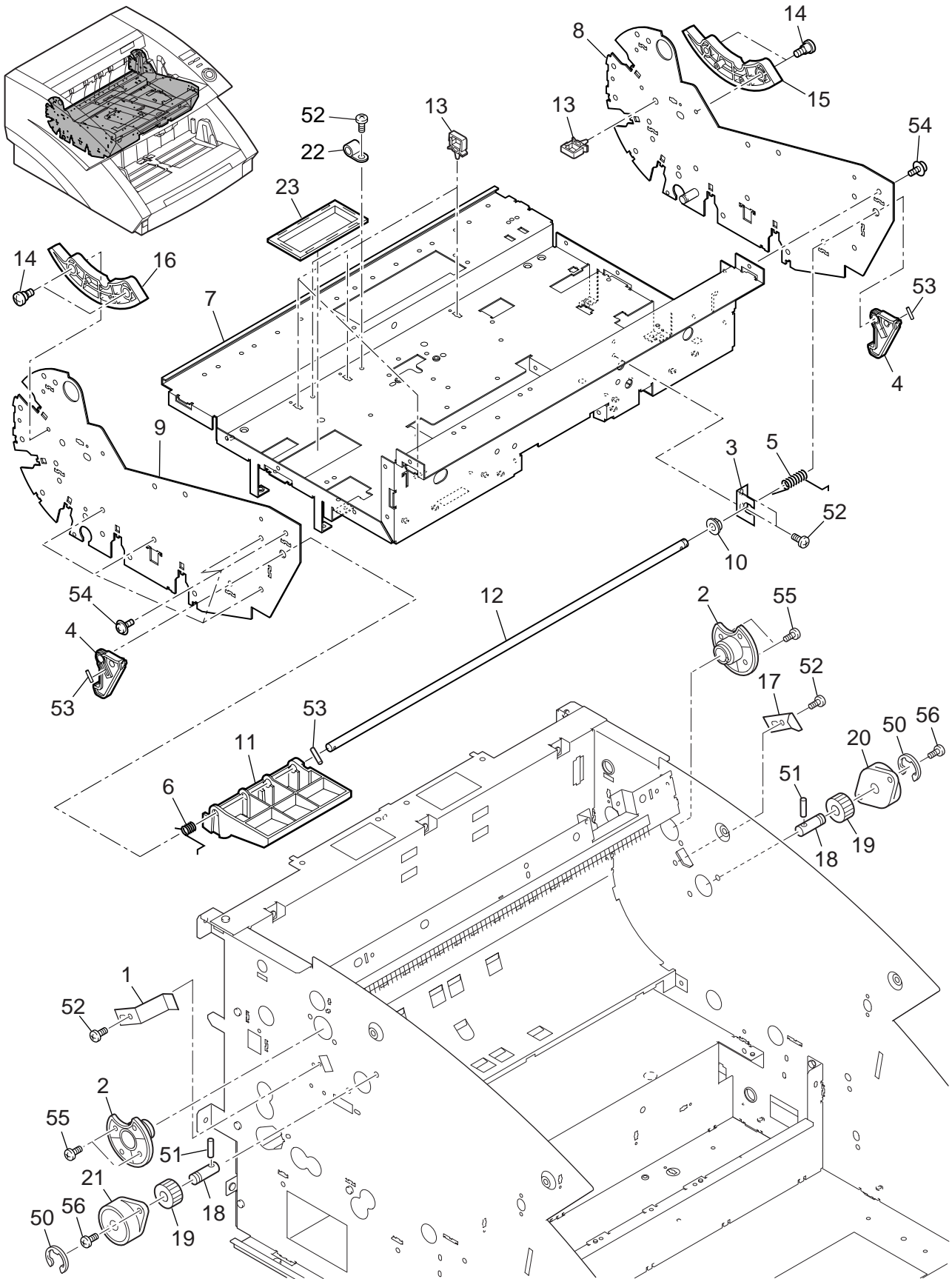

FIGURE & KEY NO.	PART NUMBER	R A N K	Q' T Y	DESCRIPTION	REMARKS
205 -	1 MA2-5393-000	N	1	SPRING, PLATE ゲンコウダイ バネ	
	2 MA2-6861-000	N	2	HINGE ヒンジ	
	3 MA2-6859-000	N	1	PLATE, LEVER SHAFT レバー ジク アシスト	
	4 MA2-6862-000	N	2	HOOK フック	
	5 MA2-6866-000		1	SPRING, TORSION フック スプリング-R	
6 MA2-6867-000		1	SPRING, TORSION フック スプリング-L		
7 MA2-6809-000	N	1	FRAME, UPPER ウエ フレーム		
8 MF1-4259-000	N	1	PALTE, UPPER RIGHT ウエ ソクバン ミギ		
9 MA2-6810-000	N	1	PALTE, UPPER LEFT ウエ ソクバン ヒダリ		
10 FS1-1205-000		1	BUSHING ジクウケ(6x6)		
11 MA2-6863-000	N	1	LEVER, HOOK フック レバー		
12 MA2-6864-000	N	1	SHAFT, HOOK フック ジク		
13 WT2-5653-000		5	CLAMP, CABLE リュース クランプ		
14 FS1-9010-000		4	SCREW, STEPPED, M3 ダンビス 2.2 M3		
15 MA2-6722-000		1	GEAR, 33T ダンピング ギヤ		
16 MA2-6883-000		1	GEAR, 33T ダンピング ギヤ 2		
17 MA2-6884-000	N	1	STOPPER ストッパー		
18 MA2-6154-000	N	2	SHAFT, DAMPER ダンパー ジク		
19 MS1-0981-000		2	GEAR, DAMPER A ダンパー レンケツ ギア A		
20 XZ9-0558-000		1	HINGE, ONE-WAY R ワンウェイ ヒンジ		
21 XZ9-0559-000		1	HINGE, ONE-WAY L ワンウェイ ヒンジ		
22 WT2-5744-000		2	CLAMP, CABLE, PLATING ハイセン コテイ ザイ		
23 WT2-5666-000		1	BUSHING スクウェア ブッシュ		
50 XD2-1100-502		2	RING, E 5 Eリング(050)		
51 XD3-2200-102		2	PIN, DOWEL 2x10 ヘイコウ ピン		
52 XB1-2300-605		6	SCREW, BH M3x6 バインド コネジ M3x6		
53 XD3-2200-202		3	PIN, DOWEL 2x20 ヘイコウ ピン		
54 XB6-7300-609		18	SCREW, TP M3x6 TP ナベ コネジ M3x6		
55 XB1-2400-605		4	SCREW, BH M4x6 バインド コネジ M4x6		
56 XA9-0894-000		4	SCREW, ROUN-END M3x6 サキマル ビス M3x6		

FIGURE 206

UPPER SENSOR ASSEMBLY 上センサ部

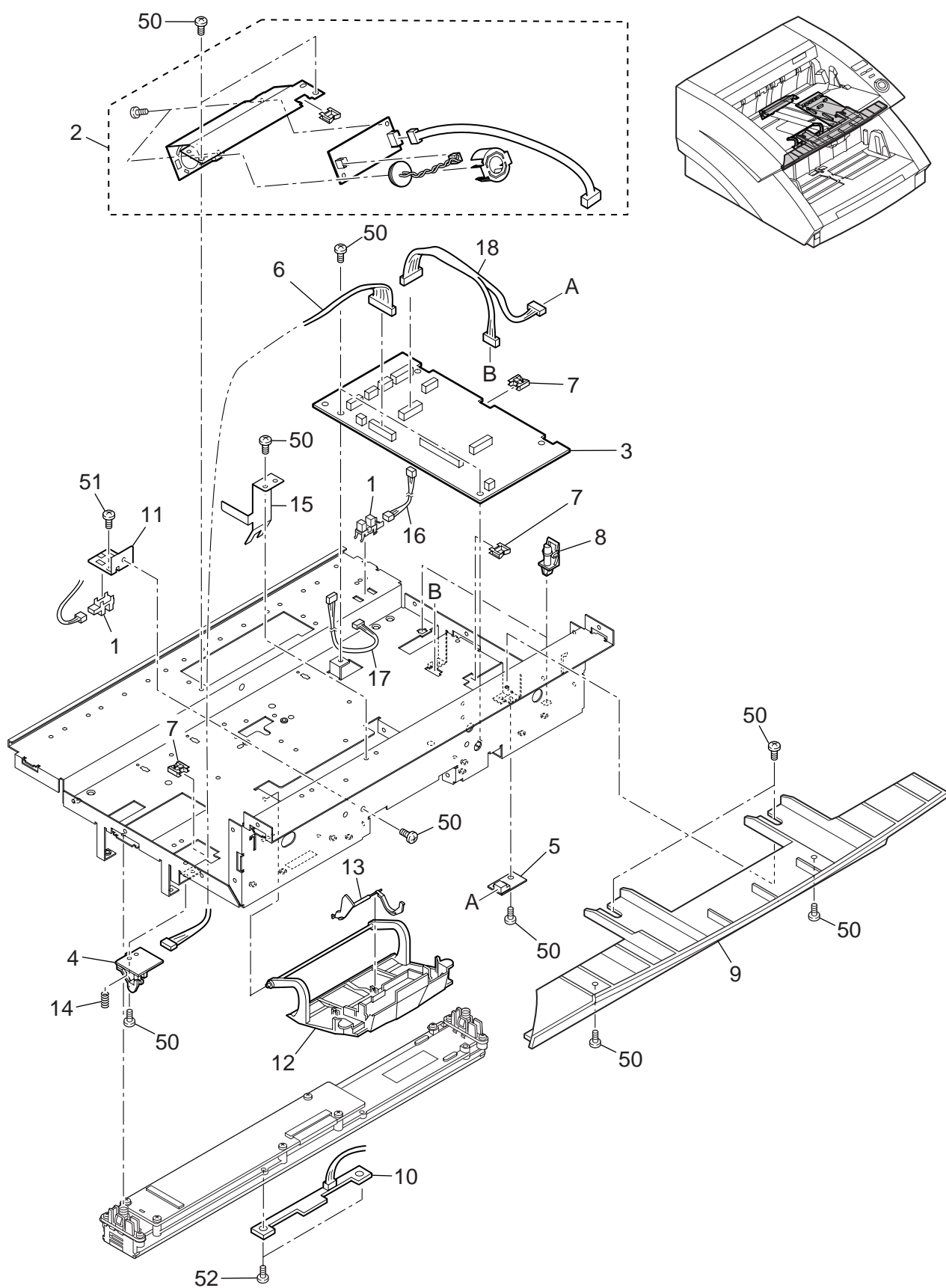

FIGURE & KEY NO.	PART NUMBER	R A N K	Q' T Y	DESCRIPTION	REMARKS
206 -	1		2	PHOTO-INTERRRUPTER フォト インタラプタ	
	2	N	1	U-SONIC SENSOR UNIT (IN) チョウオンパ センサ ユニット(ジュシン)	
	3		1	PCB ASS'Y, CONTROL, 80SUB 80SUB カイロ キバン	
	4		1	PCB ASSEMBLY, L-SENSOR L センサ キバン	
	5		1	PCB ASSEMBLY, R-SENSOR R センサ キバン	
6	MG1-3584-000		1	CABLE ASSEMBLY, L-SENSOR/CNT L センサ ケーブル	
7	WT2-5056-000		3	CLIP, CABLE エッジ サドル	
8	VT2-5019-010		2	SPACER スペーサ	
9	MA2-6730-000		1	COVER, UPPER FRONT ジョウブ マエ カバー	
10	MG1-3443-000		1	PCB ASS'Y, REG-SENSOR BACK レジゴ センサ カイロ キバン	
11	MA2-6763-000	N	1	PLATE, SENROR センサ トリツケ バン	
12	MA2-6806-000		1	COVER, PICK-UP ROLLER ローラ カバー	
13	MA2-6807-000	N	1	LEVER, DOCUMENT ゲンコウ ケンチ レバー	
14	MS1-2481-000		1	SPRING, COMPRESSION カイヘイ ケンチ バネ	
15	MA2-6790-000		1	PLATE, GROUNDING オクリ クドウ アース イタ	
16	MG1-3488-000		1	CABLE ASS'Y IMPRINTER DOOR インプリンタ ドア ケーブル	
17	MG1-3583-000		1	CABLE, ASS'Y SOLENOID ソレノイド ケーブル	
18	MG1-3503-000		1	CABLE, ASS'Y REGIST REAR レジゴ ケーブル	
50	XB1-2300-605		12	SCREW, BH M3x6 バインド コネジM3x6	
51	XB4-7300-605		1	SCREW, TAPPING, BH M3x6 B タイト バインド ビス M3x6	
52	XB4-7300-809		2	SCREW, TAPPING, BH M3x8 B タイト バインド ビス M3x8	

FIGURE 301

DRIVE ROLLER ASSEMBLY-1 駆動ローラ部-1

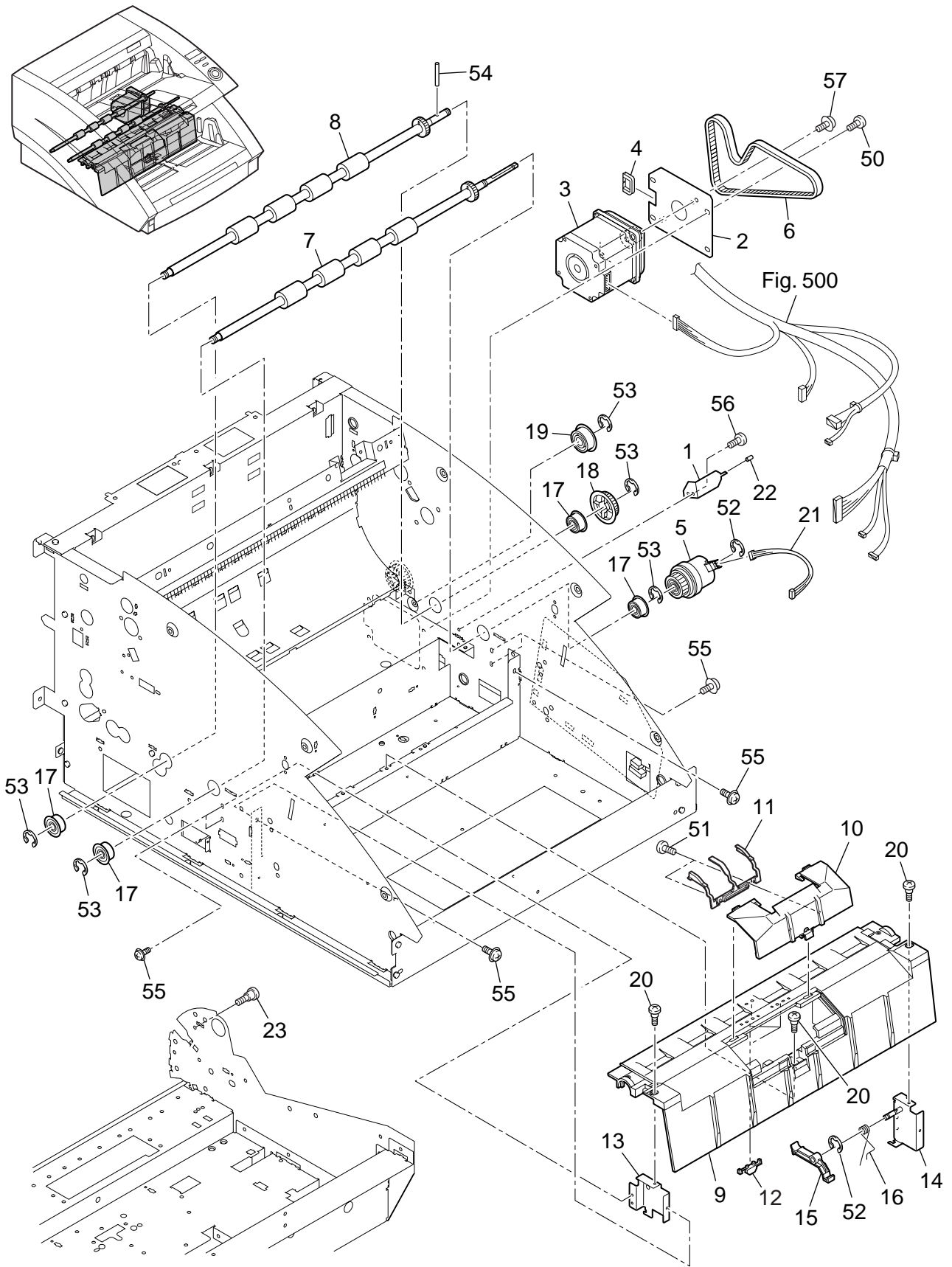

FIGURE & KEY NO.	PART NUMBER	R A N K	Q' T Y	DESCRIPTION	REMARKS	
301 -	1	MA2-6752-000	N	1	PLATE, CLUTCH クラッチ プレート	
	2	MA2-6754-000	N	1	PLATE, MAIN MOTOR メイン モーター プレート	
	3	MH7-1130-000		1	MOTOR, STEPPING, DC モーター	
	4	WT2-5011-000		1	CLIP, CABLE エッジ サドル	
	5	MH7-5052-000		1	CLUTCH, EM デンジ クラッチ	
6	XF2-1121-360		1	BELT, TIMING 213T タイミング ベルト		
7	MF1-4241-000		1	ROLLER, REGISTRATION LOWER レジスト シタ ローラー		
8	MF1-4261-000		1	ROLLER, READING LOWER ヨミトリ シタ ローラー		
9	MA2-6767-000		1	GUIDE, ENTRANCE, LOWER イリグチ シタ ガイド		
10	MA2-6768-000		1	COVER, SEPARATION ブンリ マエ カバー		
11	MA2-6804-000	N	1	GUIDE, PICK-UP キュウシ ホジヨ ガイド		
12	MA2-6802-000	N	3	GUIDE, LIGHT ライト ガイド		
13	MA2-6856-000	N	1	PLATE, STOP-END LEFT ツキアテ キジユン バン L		
14	MF1-4240-000	N	1	PLATE, STOP-END RIGHT ツキアテ キジユン バン R		
15	MA2-6769-000	N	1	ARM, BRAKE ブレーキ アーム		
16	MA2-6808-000		1	SPRING, TORSION ブレーキ カアツ バネ		
17	XG9-0405-000		4	BALL BEARING トメワツキ ベアリング		
18	MS1-3177-000		1	PULLEY, 38T プーリー38		
19	MS1-6055-000		1	IDLER アイドラー		
20	FS1-9120-000		3	SCREW, STEPPED, M3 ダンビス 1.2 M3		
21	MG1-3429-000		1	CABLE ASS'Y, CLUTCH クラッチ ケーブル		
22	MA2-4533-000	N	1	TUBE チューブ		
23	FS1-9010-000		1	SCREW, STEPPED, M3 ダンビス 2.2 M3		
50	XB1-2400-605		4	SCREW, BH M4x6 バインド コネジ M4x6		
51	XB4-7200-609		2	SCREW, TAPPING, BH M2x6 B タイト バインド ビス M2x6		
52	XD2-1100-502		2	RING, E 5 Eリング(050)		
53	XD2-1100-642		5	RING, E 6.4 Eリング(064)		
54	XD3-2200-122		1	PIN, DOWEL 2x12 ヘイコウ ピン		
55	XB6-7300-609		6	SCREW, TP M3x6 TP ナベ コネジ M4x6		
56	XB1-2300-605		1	SCREW, BH M3x6 ナベ コネジ M3x6		
57	XB6-7400-609		2	SCREW, TP M4x6 TP ナベ コネジ M4x6		

FIGURE 302

DRIVE ROLLER ASSEMBLY-2 駆動ローラ部-2

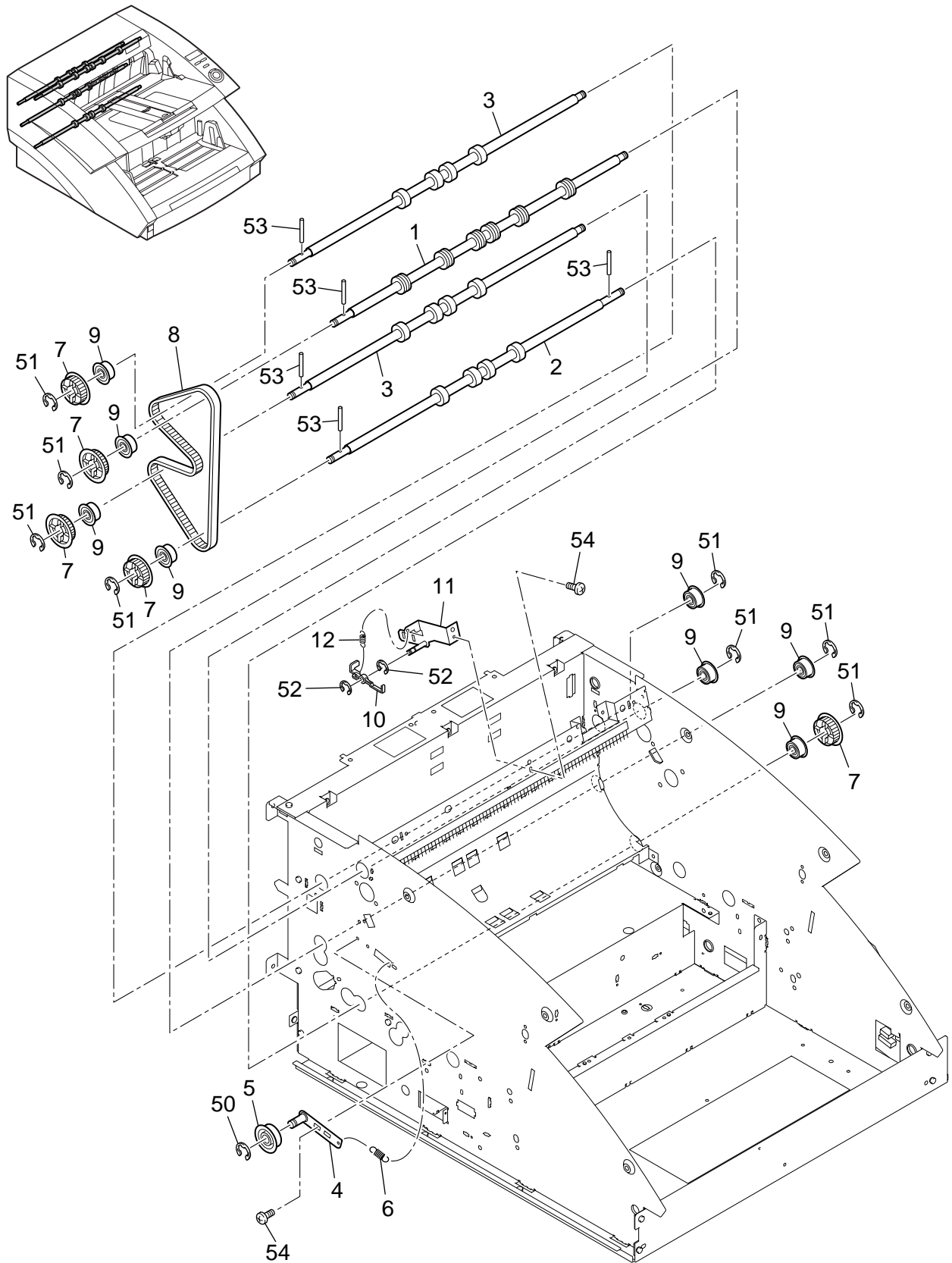

FIGURE & KEY NO.	PART NUMBER	RANK	QTY	DESCRIPTION	REMARKS
302 -	1 MA2-6814-000	N	1	ROLLER, DELIVERY ハイシ ローラー	
	2 MA2-6876-000		1	ROLLER, FEEDER 1 ハンソウ ローラー 1	
	3 MA2-6877-000		2	ROLLER, FEEDER 2 ハンソウ ローラー 2	
	4 MF1-4257-000		1	PLATE, TENSIONER テンショナー プレート	
	5 MS1-6055-000		1	IDLER アイドラー	
6 MS1-2482-000	N	1	SPRING, TENSION バネ		
7 MS1-3177-000		5	PULLEY, 38T プーリー38		
8 XF2-1125-060		1	BELT, TIMING 250T タイミング ベルト		
9 XG9-0405-000		8	BALL BEARING トメワツキ ベアリング		
10 MA2-6843-000		1	LEVER, DELIVERY ハイシ レバー		
11 MF1-4256-000	N	1	PLATE, DELIVERY LEVER ハイシ レバー ステア		
12 MS1-2479-000		1	SPRING, TENSION ハイシ レバー バネ		
50 XD2-1100-502		1	RING, E 5 Eリング (050)		
51 XD2-1100-642		8	RING, E 6.4 Eリング (064)		
52 XD2-1100-402		2	RING, E 4 Eリング (040)		
53 XD3-2200-122		5	PIN, DOWEL 2x12 ヘイコウ ピン		
54 XB1-2300-605		2	SCREW, BH M3x6 バインド コネジ M3x6		

FIGURE 303 LOWER SHADING UNIT ASSEMBLY

下シェーディング・ユニット部

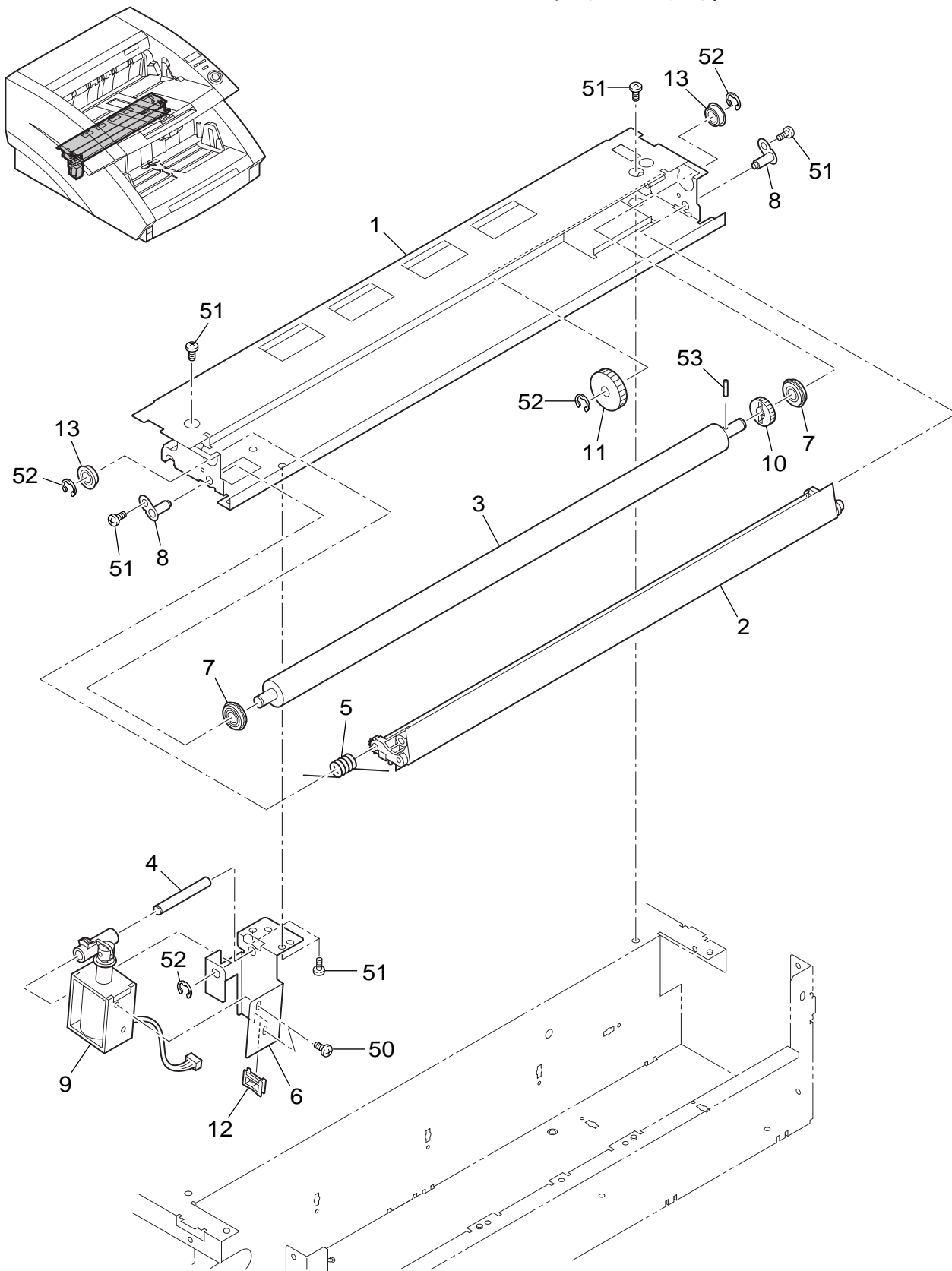

FIGURE & KEY NO.	PART NUMBER	RANK	QTY	DESCRIPTION	REMARKS	
303 -	1	MA2-6880-000	N	1	MOUNT, PLATEN ROLLER ブラテン フレーム	
	2	MG1-3454-000	N	1	SHADING SHEET UNIT シェーディング シート ユニット	
	3	MA2-6916-000		1	ROLLER, PLATEN ブラテン ローラ	
	4	MA2-6899-000	N	1	SHAFT, 3 ジク 3	
	5	MA2-6908-000		1	SPRING TORSION 1 トーション バネ1	
	6	MA2-6911-000	N	1	PLATE, SOLENOID 3 ソレノイド プレート 3	
	7	MF1-4263-000		2	ROLLER, SPACER スペーサ コロ	
	8	MF1-4266-000	N	2	HINGE, LOWER ヒンジ シタ	
	9	MF1-4267-000		1	SOLENOID, LOWER ソレノイド シタ	
	10	MS2-0082-000		1	GEAR, 21T ブラテン ギア	
	11	MS2-0083-000		1	GEAR, 29T ブラテン アイドラ ギア	
	12	WT2-5056-000		1	CLIP, CABLE エッジ サドル	
	13	XG3-6012-405		2	BALL BEARING フランジツキ ベアリング	
	50	XB1-2300-405		2	SCREW, BH M3x4 バインド コネジ M3x4	
	51	XB1-2300-605		6	SCREW, BH M3x6 バインド コネジ M3x6	
	52	XD2-1100-402		4	RING, E 4 Eリング (040)	
	53	XD3-2200-102		1	PIN, DOWEL 2x10 ヘイコウ ピン	

FIGURE 304

BASE ASSEMBLY ベース部

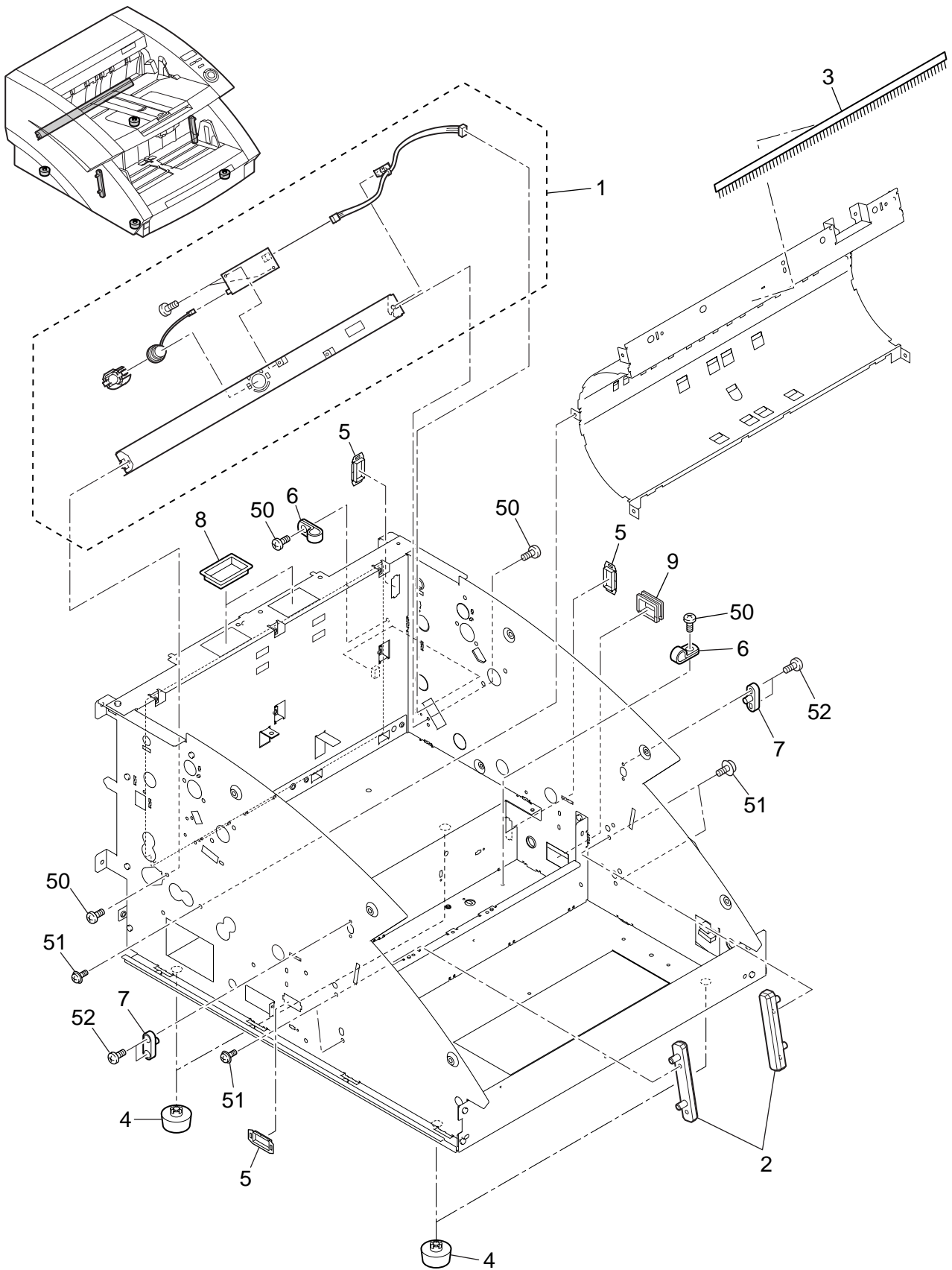

FIGURE & KEY NO.	PART NUMBER	R A N K	Q' T Y	DESCRIPTION	REMARKS	
304 -	1	MG1-3465-000	N	1	U-SONIC SENSOR UNIT (OUT) チヨウオンパ センサ ユニット(ソウシン)	
	2	MA2-6858-000	N	2	GUIDE, TRAY トレイ ガイド	
	3	MA2-6818-000	N	1	BRUSH, ELIMINATOR ジョデン ブラシ	
	4	XH9-0118-000	N	4	FOOT プラスチック フット	
	5	WT2-5760-000		3	BUSHING, CABLE スクエア プッシュ	
	6	WT2-5744-000	N	2	CLAMP, CABLE メッキツキ ケーブル トメ	
	7	MA2-6762-000		2	SHAFT, LUTCH ラッチ ジク	
	8	WT2-5061-000		2	BUSHING, CABLE スクエア プッシュ	
	9	WT2-5098-000		1	BUSHING, CABLE スクエア プッシュ	
50	XB1-2300-605	4		SCREW, BH M3x6 パインド コネジ M3x6		
	51	XB6-7300-609		10	SCREW, TP M3x6 TP ナベ コネジ M3x6	
	52	XA9-1290-000		4	SCREW, ROUN-END, M3x4 サキマル ビス	

FIGURE 320

SEPARATION ROLLER ASSEMBLY 分離ローラ部

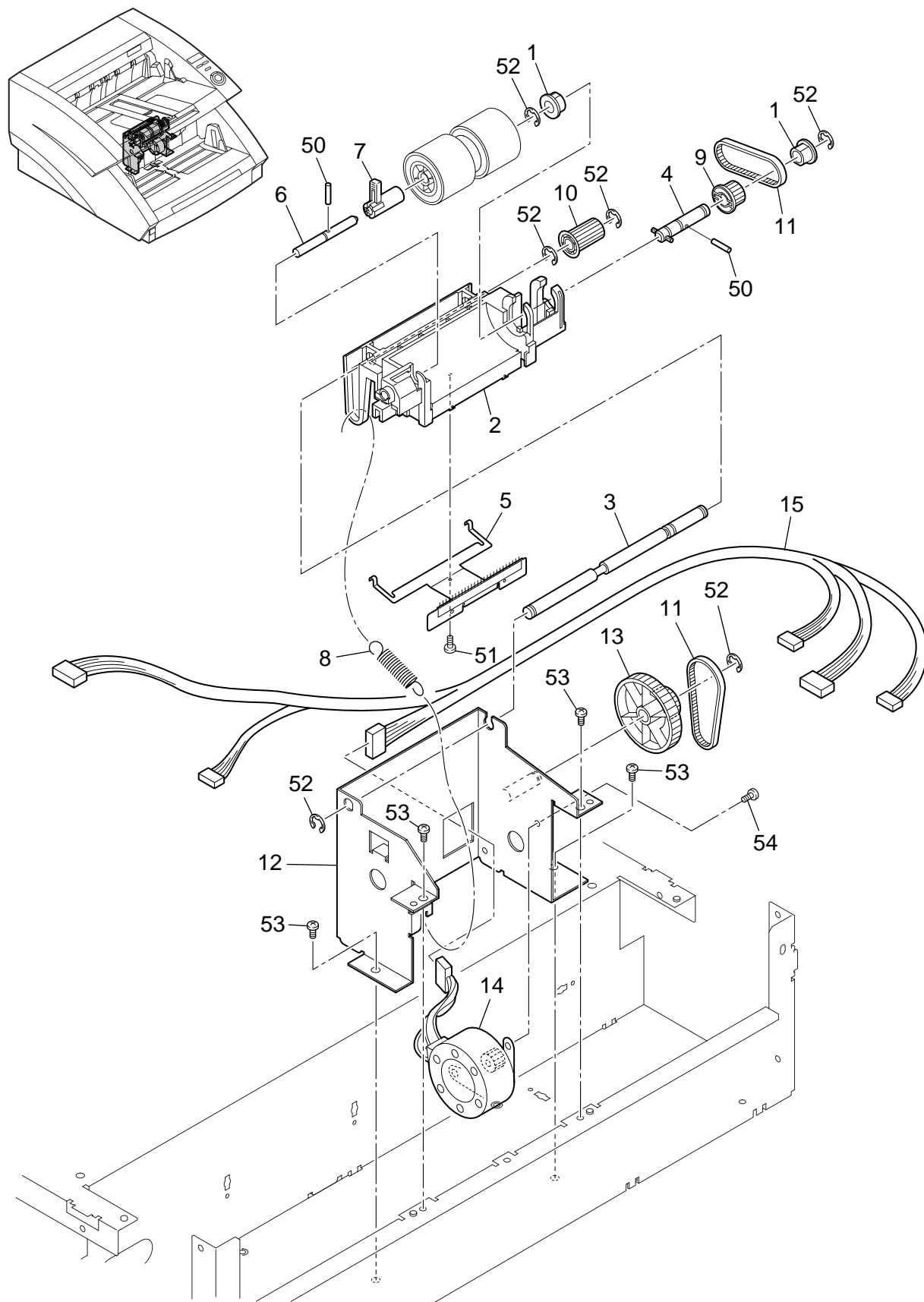

FIGURE & KEY NO.	PART NUMBER	R A N K	Q' T Y	DESCRIPTION	REMARKS
320 -	1		2	BUSHING ジクウケ (6x6)	
	2	N	1	MOUNT, SEPARATION FLOAT ブンリ フロート ダイ	
	3	N	1	SHAFT, SEPARATION FLOAT ブンリ フロート ヨウドウ ジク	
	4	N	1	SHAFT, RETARD ROLLER ブンリ ローラ クドウ ジク	
	5	N	1	BRUSH, ELIMINATOR, RETARD ブンリ ローラ ジョデン イタ	
	6	N	1	SHAFT, RETARD ROLLER ブンリ ローラー ホジ ジク	
	7	N	1	LEVER, SEPARATION RELEASE ブンリ カイジョ レバー	
	8		1	SPRING, TENSION ブンリ ローラ カネツ バネ	
	9		1	PULLEY, 20T プーリー 20	
	10		1	PULLEY, 22T プーリー 22	
	11	N	2	BELT, TIMING 58T タイミング ベルト	
	12		1	PLATE, SEPARATION DRIVE ブンリ クドウ パン	
	13		1	PULLEY, GEAR 59/22T ギア プーリー	
	14		1	MOTOR, STEPPING, DC ステッピング モーター	
	15		1	CABLE ASS'Y, SEPARATION ブンリ ケーブル	
	50		2	PIN, DOWEL 2x8 ヘイコウ ピン	
	51		1	SCREW, TAPPING, BH M3x6 B タイト バインド ビス M3x6	
	52		6	RING, E 5 Eリング (050)	
	53		4	SCREW, ROUN-END, M3x4 サキマル ビス M3x4	
	54		2	SCREW, BH M3x6 バインド コネジ M3x6	

FIGURE 400 IMAGE READER, UPPER/LOWER 上下読取部

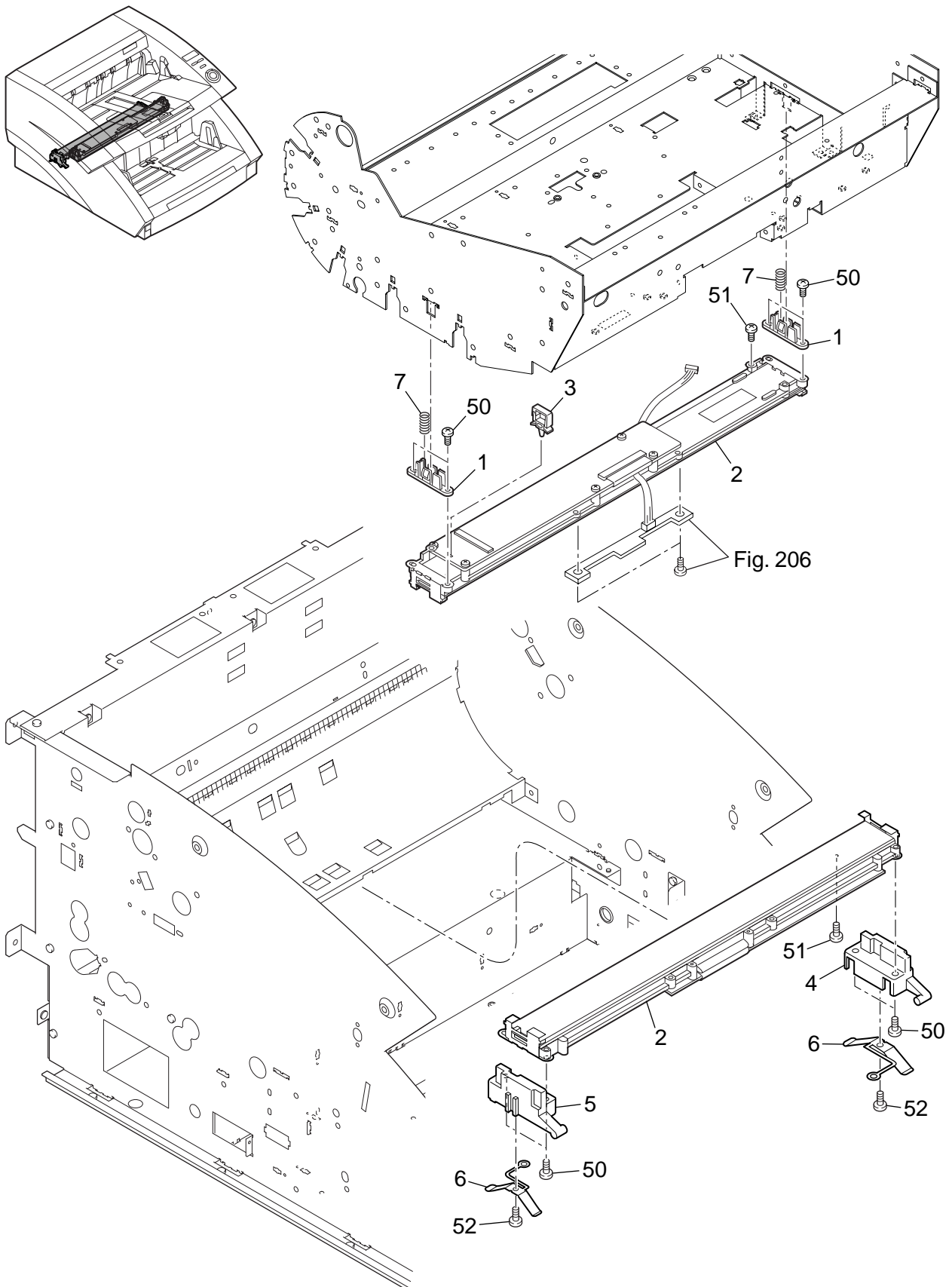

FIGURE & KEY NO.	PART NUMBER	R A N K	Q' T Y	DESCRIPTION	REMARKS	
400 -	1	MA2-6865-000	N	2	HOLDER, SENSOR ヨミトリ センサ ホルダー	
	2	MG1-3616-000		2	READING UNIT ヨミトリ ユニット	
	3	WT2-5653-000		1	CLAMP, CABLE リユース クランプ	
	4	MA2-6885-000	N	1	HOLDER, SENSOR RIGHT センサ ホルダ ミギ	
	5	MA2-6886-000	N	1	HOLDER, SENSOR LEFT センサ ホルダ ヒダリ	
6	MA2-6887-000	N	2	PLATE, HOLDING センサ オウアツ バネ		
7	MS1-2476-000		2	PLATE, HOLDING センサ オウアツ バネ		
50	XB4-7300-809		8	SCREW, TAPPING, BH M3x8 B タイト バンド ビス M3x8		
51	XB4-8261-005		2	SCREW, TAPPING, FH M2.6x10 B タイト ビス M2.6x10		
52	XB4-7300-409		2	SCREW, TAPPING, BH M3x4 B タイト バンド ビス M3x4		

FIGURE 500

ELECTRICAL COMPONENTS ASSEMBLY 電装部

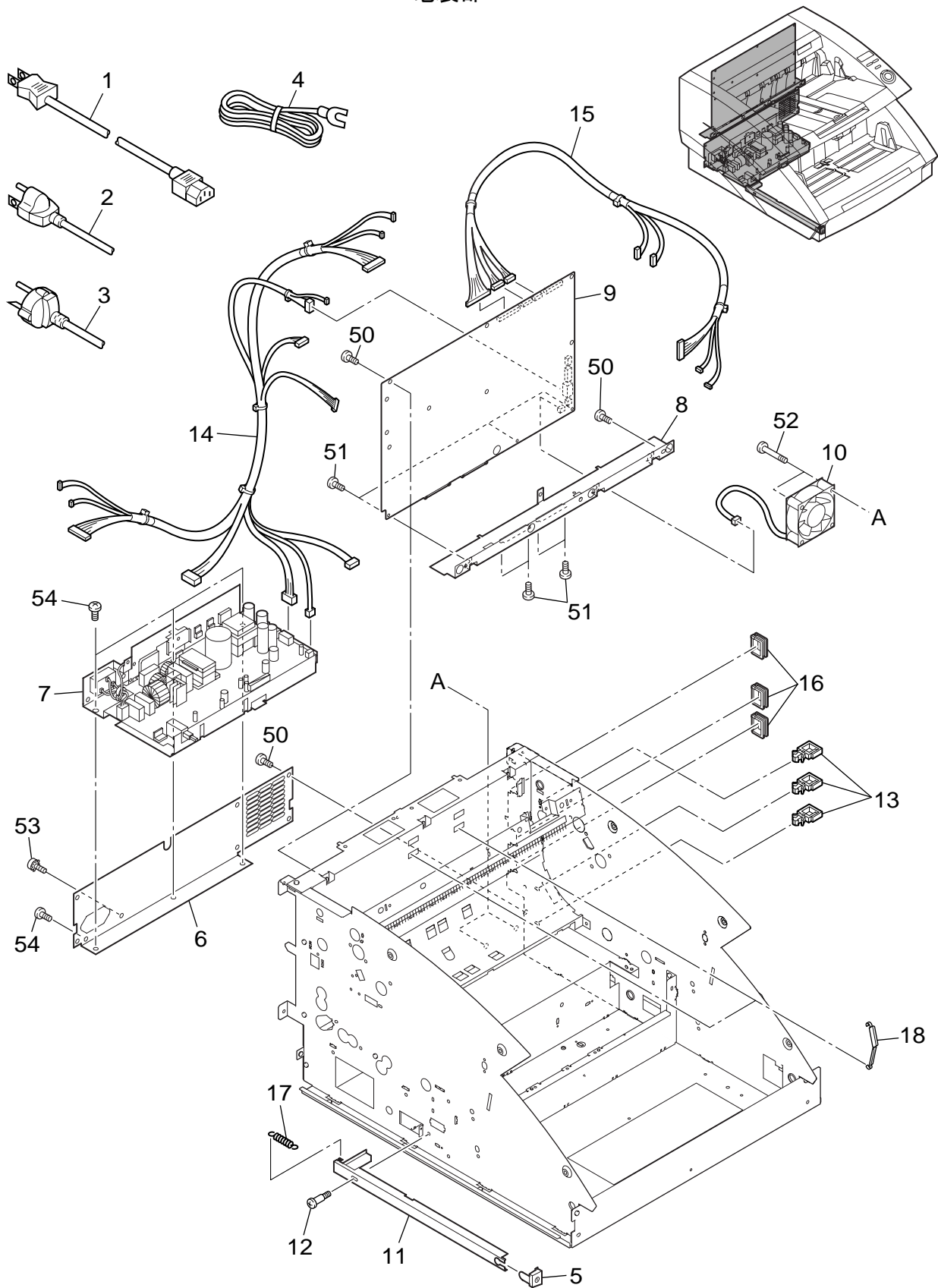

FIGURE & KEY NO.	PART NUMBER	R A N K	Q' T Y	DESCRIPTION	REMARKS
500 -	1 RH9-1015-020	N	1	POWER CORD デンゲン コード 100V	100V
	2 RH2-5145-020	N	1	POWER CORD デンゲン コード 120V	120V
	3 RH2-5116-030	N	1	POWER CORD デンゲン コード 230V	220-240V
	4 FH2-5006-030		1	CORD, GROUNDING アース コード	100V
	5 MA2-6732-000	N	1	BUTTON, POWER デンゲン スイッチ ボタン	
6 MA2-6870-000	N	1	PANEL, POWER デンゲン カバー		
7 MH3-2055-000		1	PCB ASS'Y, POWER SUPPLY スイッチング デンゲン		
8 MA2-6868-000	N	1	PLATE, CONNECTOR コネクタ プレート		
9 MG1-3507-000		1	PCB ASS'Y, CONTROL, MAIN DCON カイロ キバン (グレイ)	DR-6080	
	MG1-3506-000		1 PCB ASS'Y, CONTROL, MAIN DCON カイロ キバン (カラー)	DR-9080C	
10 MG1-3474-000		1	FAN ファン		
11 MA2-6857-000	N	1	PLATE, POWER PUSH デンゲン オシイタ		
12 FS1-9121-000		1	SCREW, STEPPED 13, M3 ダンピス 13 M3		
13 WT2-5651-000		3	CLAMP, CABLE リユース クランプ		
14 MG1-3475-000		1	CABLE ASS'Y, LOWER シタ ケーブル		
15 MG1-3502-000		1	CABLE ASS'Y, UPPER ウエ ケーブル		
16 WT2-5031-000		3	BUSHING, CABLE エッジ サドル		
17 MS1-2399-000		1	SPRING, TENSION ハイシ スプリング		
18 WT2-5580-000		2	CLAMP, CABLE ワイヤー ホルダー		
50 XB1-2400-605		16	SCREW, BH, M4x6 バインド コネジ M4x6		
51 XB1-2250-405		7	SCREW, BH M2.5x4 バインド コネジ M2.5x4		
52 XB1-2402-509		2	SCREW, BH M4x25 バインド コネジ M4x25		
53 FA9-2113-000		1	SCREW, W/TOOTH, BH M4x8 キクザツキ バインド M4x8		
54 FB3-8873-000		4	SCREW, ROUN-END, M4x4 サキマル バインド ビス M4x4		

FIGURE 600

OPTIONS オプション

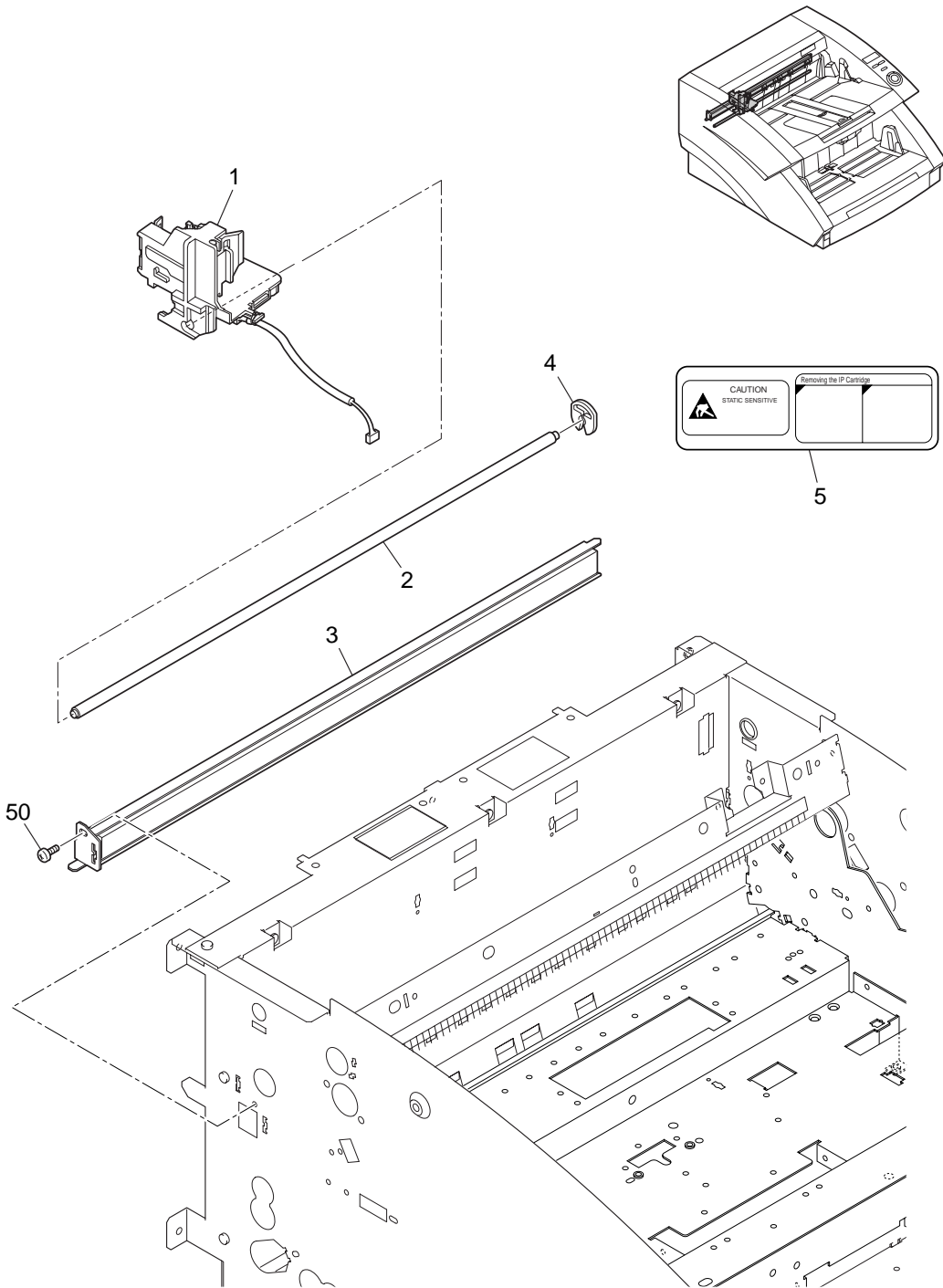

FIGURE & KEY NO.	PART NUMBER	R A N K	Q' T Y	DESCRIPTION	REMARKS
600 -	1		1	IP CARRIGE ASSEMBLY IP キャリッジ	
	2		1	SHAFT, IP IP ジグ	
	3		1	IP PAD UNIT IP キュウシュウタイ ユニット	
	4		1	RETAINING RING ジュシ キンテイ ワッシャ	
	5		1	LABEL, IP IP ソウサ ラベル	
50	XB1-2300-605		1	SCREW, BH M3x6 パインド M3x6	

FIGURE C NUMERICAL INDEX 部品索引表

PARTS NO.	FIGURE & KEY NUMBER	QTY	PARTS NO.	FIGURE & KEY NUMBER	QTY	PARTS NO.	FIGURE & KEY NUMBER	QTY
FA3-8727-000	600 - 04	1	MA2-6755-000	100 - 10	1	MA2-6818-000	304 - 03	1
FA9-2113-000	500 - 53	1	MA2-6756-000	100 - 05	1	MA2-6820-000	120 - 02	1
FB3-8873-000	500 - 54	4	MA2-6757-000	100 - 06	1	MA2-6821-000	120 - 03	1
FH2-5006-030	500 - 04	1	MA2-6758-000	100 - 07	1	MA2-6822-000	120 - 04	1
FH7-7462-000	141 - 01	1	MA2-6759-000	100 - 08	1	MA2-6823-000	120 - 12	2
↓	206 - 01	2	MA2-6760-000	100 - 09	1	MA2-6824-000	120 - 13	2
FS1-1205-000	205 - 10	1	MA2-6761-000	140 - 06	7	MA2-6825-000	120 - 05	2
↓	320 - 01	2	MA2-6762-000	304 - 07	2	MA2-6826-000	120 - 06	1
FS1-9010-000	205 - 14	4	MA2-6763-000	206 - 11	1	MA2-6827-000	120 - 07	1
↓	301 - 23	1	MA2-6764-000	201 - 01	1	MA2-6828-000	120 - 08	2
FS1-9120-000	301 - 20	3	MA2-6767-000	301 - 09	1	MA2-6834-000	600 - 02	1
FS1-9121-000	500 - 12	1	MA2-6768-000	301 - 10	1	MA2-6843-000	302 - 10	1
MA2-4533-000	301 - 22	1	MA2-6769-000	301 - 15	1	MA2-6846-000	600 - 05	1
MA2-5393-000	140 - 01	1	MA2-6774-000	320 - 12	1	MA2-6848-000	203 - 01	3
↓	205 - 01	1	MA2-6775-000	320 - 02	1	MA2-6856-000	301 - 13	1
MA2-5403-000	140 - 02	1	MA2-6776-000	320 - 03	1	MA2-6857-000	500 - 11	1
MA2-5404-000	140 - 16	1	MA2-6778-000	320 - 06	1	MA2-6858-000	304 - 02	2
MA2-6154-000	205 - 18	2	MA2-6779-000	320 - 07	1	MA2-6859-000	205 - 03	1
MA2-6722-000	205 - 15	1	MA2-6788-000	201 - 03	1	MA2-6860-000	203 - 03	10
MA2-6726-000	100 - 01	1	MA2-6789-000	201 - 04	1	MA2-6861-000	205 - 02	2
MA2-6727-000	100 - 02	1	MA2-6790-000	206 - 15	1	MA2-6862-000	205 - 04	2
MA2-6728-000	100 - 03	1	MA2-6791-000	201 - 05	1	MA2-6863-000	205 - 11	1
MA2-6729-000	100 - 01	1	MA2-6792-000	201 - 06	1	MA2-6864-000	205 - 12	1
MA2-6730-000	206 - 09	1	MA2-6793-000	201 - 07	1	MA2-6865-000	400 - 01	2
MA2-6731-000	100 - 04	1	MA2-6795-000	201 - 16	1	MA2-6866-000	205 - 05	1
MA2-6732-000	500 - 05	1	MA2-6796-000	201 - 17	1	MA2-6867-000	205 - 06	1
MA2-6733-000	140 - 03	2	MA2-6798-000	201 - 18	1	MA2-6868-000	500 - 08	1
MA2-6734-000	140 - 04	1	MA2-6799-000	201 - 19	1	MA2-6870-000	500 - 06	1
MA2-6737-000	140 - 15	1	MA2-6800-000	202 - 01	1	MA2-6876-000	302 - 02	1
MA2-6738-000	141 - 07	1	MA2-6801-000	202 - 02	1	MA2-6877-000	302 - 03	2
MA2-6739-000	140 - 05	1	MA2-6802-000	301 - 12	3	MA2-6878-000	100 - 13	1
MA2-6740-000	141 - 08	1	MA2-6804-000	301 - 11	1	MA2-6879-000	100 - 14	2
MA2-6742-000	141 - 02	4	MA2-6806-000	206 - 12	1	MA2-6880-000	303 - 01	1
MA2-6744-000	141 - 03	4	MA2-6807-000	206 - 13	1	MA2-6883-000	205 - 16	1
MA2-6746-000	141 - 16	1	MA2-6808-000	301 - 16	1	MA2-6884-000	205 - 17	1
MA2-6747-000	141 - 04	1	MA2-6809-000	205 - 07	1	MA2-6885-000	400 - 04	1
MA2-6748-000	141 - 17	1	MA2-6810-000	205 - 09	1	MA2-6886-000	400 - 05	1
MA2-6749-000	141 - 18	1	MA2-6811-000	202 - 03	1	MA2-6887-000	400 - 06	2
MA2-6750-000	141 - 05	1	MA2-6812-000	202 - 04	1	MA2-6899-000	303 - 04	1
MA2-6751-000	141 - 19	1	MA2-6813-000	202 - 05	1	MA2-6906-000	202 - 06	1
MA2-6752-000	301 - 01	1	MA2-6814-000	302 - 01	1	MA2-6908-000	303 - 05	1
MA2-6754-000	301 - 02	1	MA2-6817-000	120 - 01	2	MA2-6909-000	204 - 03	1

PARTS NO.	FIGURE & KEY NUMBER	Q'TY	PARTS NO.	FIGURE & KEY NUMBER	Q'TY	PARTS NO.	FIGURE & KEY NUMBER	Q'TY
MA2-6911-000	303 - 06	1	MG1-3454-000	303 - 02	1	MS1-6105-000	201 - 09	1
MA2-6916-000	204 - 02	1	MG1-3455-000	204 - 07	1	MS2-0073-000	141 - 12	3
↓	303 - 03	1	MG1-3465-000	304 - 01	1	MS2-0074-000	141 - 13	1
MA2-6943-000	141 - 25	1	MG1-3474-000	500 - 10	1	MS2-0075-000	320 - 13	1
MF1-4240-000	301 - 14	1	MG1-3475-000	500 - 14	1	MS2-0076-000	201 - 10	1
MF1-4241-000	301 - 07	1	MG1-3476-000	320 - 15	1	MS2-0077-000	120 - 15	1
MF1-4242-000	203 - 02	2	MG1-3477-000	600 - 01	1	MS2-0080-000	141 - 14	1
MF1-4243-000	141 - 11	1	MG1-3478-000	600 - 03	1	MS2-0081-000	140 - 12	1
MF1-4244-000	141 - 06	2	MG1-3488-000	206 - 16	1	MS2-0082-000	204 - 08	1
MF1-4245-000	140 - 07	1	MG1-3491-000	201 - 21	1	↓	303 - 10	1
MF1-4246-000	140 - 08	1	MG1-3492-000	201 - 23	1	MS2-0083-000	204 - 09	1
MF1-4247-000	140 - 09	1	MG1-3495-000	206 - 02	1	↓	303 - 11	1
MF1-4248-000	202 - 02	1	MG1-3501-000	206 - 03	1	RH2-5116-030	500 - 03	1
MF1-4249-000	201 - 13	1	MG1-3502-000	500 - 15	1	RH2-5145-020	500 - 02	1
MF1-4250-000	120 - 09	1	MG1-3503-000	206 - 18	1	RH7-1278-000	141 - 15	1
MF1-4251-000	201 - 02	1	MG1-3506-000	500 - 09	1	↓	201 - 15	2
MF1-4252-000	201 - 14	1	MG1-3507-000	500 - 09	1	↓	320 - 14	1
MF1-4253-000	201 - 20	1	MG1-3581-000	206 - 04	1	RH9-1015-020	500 - 01	1
MF1-4254-000	320 - 04	1	MG1-3582-000	206 - 05	1	VR9-5651-000	140 - 13	1
MF1-4255-000	120 - 10	6	MG1-3583-000	206 - 17	1	VS1-6492-006	141 - 09	1
MF1-4256-000	302 - 11	1	MG1-3584-000	206 - 06	1	VT2-5019-010	206 - 08	2
MF1-4257-000	302 - 04	1	MG1-3616-000	400 - 02	2	WT2-5011-000	301 - 04	1
MF1-4258-000	120 - 11	1	MH3-2055-000	500 - 07	1	WT2-5031-000	500 - 16	3
MF1-4259-000	205 - 08	1	MH7-1130-000	301 - 03	1	WT2-5056-000	206 - 07	3
MF1-4261-000	301 - 08	1	MH7-5052-000	301 - 05	1	↓	303 - 12	1
MF1-4262-000	320 - 05	1	MS1-0981-000	205 - 19	2	WT2-5061-000	304 - 08	2
MF1-4263-000	204 - 01	2	MS1-2399-000	500 - 17	1	WT2-5098-000	140 - 14	1
↓	303 - 07	2	MS1-2473-000	120 - 14	4	↓	141 - 10	1
MF1-4265-000	204 - 04	1	MS1-2475-000	203 - 04	10	↓	304 - 09	1
MF1-4266-000	303 - 08	2	MS1-2476-000	400 - 07	2	WT2-5651-000	500 - 13	3
MF1-4267-000	303 - 09	1	MS1-2478-000	320 - 08	1	WT2-5653-000	141 - 27	2
MF1-4278-000	204 - 05	1	MS1-2479-000	302 - 12	1	↓	205 - 13	5
MG1-3269-000	140 - 10	1	MS1-2480-000	201 - 24	1	↓	400 - 03	1
MG1-3429-000	301 - 21	1	MS1-2481-000	206 - 14	1	WT2-5666-000	205 - 23	1
MG1-3432-000	141 - 24	1	MS1-2482-000	302 - 06	1	WT2-5744-000	205 - 22	2
MG1-3433-000	141 - 26	1	MS1-3133-000	201 - 08	1	↓	304 - 06	2
MG1-3439-000	100 - 11	1	MS1-3177-000	301 - 18	1	WT2-5760-000	141 - 22	2
MG1-3440-000	100 - 12	1	↓	302 - 07	5	↓	304 - 05	3
MG1-3443-000	206 - 10	1	MS1-3178-000	320 - 09	1	WT2-5880-000	500 - 18	2
MG1-3449-000	140 - 11	1	MS1-3180-000	320 - 10	1	XA9-0894-000	205 - 56	4
MG1-3453-000	141 - 21	1	MS1-6055-000	301 - 19	1	XA9-1290-000	141 - 56	6
MG1-3454-000	204 - 06	1	↓	302 - 05	1	↓	204 - 52	3

PARTS NO.	FIGURE & KEY NUMBER	QTY	PARTS NO.	FIGURE & KEY NUMBER	QTY	PARTS NO.	FIGURE & KEY NUMBER	QTY
XA9-1290-000	304 - 52	4	XB6-7300-609	304 - 51	10	XZ9-0558-000	205 - 20	1
↓	320 - 53	4	XB6-7400-609	140 - 51	2	XZ9-0559-000	205 - 21	1
XA9-1551-000	140 - 52	2	↓	301 - 57	2			
XB1-2250-405	500 - 51	7	XD2-1100-402	201 - 50	4			
XB1-2300-405	303 - 50	2	↓	203 - 50	10			
XB1-2300-605	100 - 50	3	↓	204 - 50	3			
↓	141 - 51	10	↓	302 - 52	2			
↓	202 - 50	18	↓	303 - 52	4			
↓	205 - 52	6	XD2-1100-502	140 - 55	4			
↓	206 - 50	12	↓	205 - 50	2			
↓	301 - 56	1	↓	301 - 52	2			
↓	302 - 54	2	↓	302 - 50	1			
↓	303 - 51	6	↓	320 - 52	6			
↓	304 - 50	4	XD2-1100-642	141 - 53	8			
↓	320 - 54	2	↓	201 - 52	2			
↓	600 - 50	1	↓	301 - 53	5			
XB1-2300-609	120 - 50	4	↓	302 - 51	8			
XB1-2400-605	100 - 52	9	XD3-2200-082	320 - 50	2			
↓	205 - 55	4	XD3-2200-102	204 - 51	1			
↓	301 - 50	4	↓	205 - 51	2			
↓	500 - 50	16	↓	303 - 53	1			
XB1-2400-805	100 - 54	3	XD3-2200-122	301 - 54	1			
XB1-2402-509	500 - 52	2	↓	302 - 53	5			
XB4-7200-609	301 - 51	2	XD3-2200-182	201 - 53	1			
XB4-7300-409	400 - 52	2	XD3-2200-202	201 - 54	1			
XB4-7300-605	100 - 51	9	↓	205 - 53	3			
↓	120 - 52	8	XD3-2300-222	141 - 54	5			
↓	140 - 50	9	XD9-0187-000	141 - 20	6			
↓	141 - 50	4	XF2-1105-840	320 - 11	2			
↓	201 - 51	16	XF2-1108-240	201 - 22	1			
↓	202 - 51	2	XF2-1113-340	201 - 11	1			
↓	206 - 51	1	XF2-1121-360	301 - 06	1			
XB4-7300-609	320 - 51	1	XF2-1125-060	302 - 08	1			
XB4-7300-809	206 - 52	2	XG3-6012-405	201 - 12	4			
↓	400 - 50	8	↓	203 - 05	10			
XB4-7400-605	100 - 53	5	↓	204 - 10	2			
XB4-8261-005	400 - 51	2	↓	303 - 13	2			
XB6-2400-408	141 - 57	2	XG9-0405-000	141 - 23	4			
XB6-7300-609	120 - 51	3	↓	301 - 17	4			
↓	141 - 52	3	↓	302 - 09	8			
↓	205 - 54	18	XH9-0118-000	304 - 04	4			
↓	301 - 55	6	XZ9-0379-000	120 - 16	1			

〒369-1892

埼玉県秩父市下影森1248番地

キヤノン電子株式会社

品質保証部 品質推進課

2003年 10月 初版発行

Prepared by
QUALITY ASSURANCE CENTER
CANON ELECTRONICS INC.
1248 Shimokagemori, Chichibu-shi, Saitama 369-1892, Japan

FIRST EDITION (OCT. 2003)

Canon

CANON DOCUMENT SCANNER DR-6080/9080C

INSTRUCTIONS

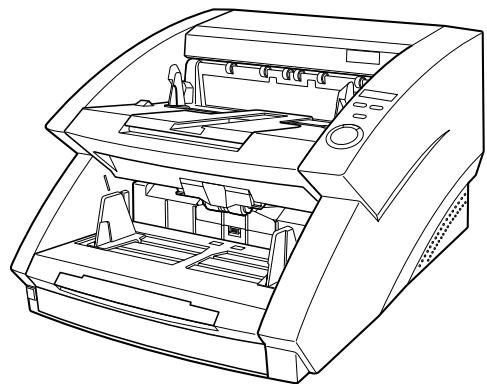

Please read this manual before operating this unit. After you finish reading this manual, store it in a safe place for future reference.

FCC REGULATIONS (For 120V models)

This equipment has been tested and found to comply with the limits for a Class B digital device, pursuant to Part 15 of the FCC Rules. These limits are designed to provide reasonable protection against harmful interference in a residential installation. This equipment generates, uses, and can radiate radio frequency energy and, if not installed and used in accordance with the instructions, may cause harmful interference to radio communications. However, there is no guarantee that interference will not occur in a particular installation. If this equipment does cause harmful interference to radio or television reception, which can be determined by turning the equipment off and on, the user is encouraged to try to correct the interference by one or more of the following measures:

- Reorient or relocate the receiving antenna.
- Increase the separation between the equipment and receiver.
- Connect the equipment into an outlet on a circuit different from that to which the receiver is connected.
- Consult the dealer or an experienced radio/TV technician for help.

Do not make any changes or modifications to the equipment unless otherwise specified in the manual. If such changes or modifications should be made, you could be required to stop operation of the equipment.

RADIO INTERFERENCE REGULATIONS (For 120V models)

This digital apparatus does not exceed the Class B limits for radio noise emissions from digital apparatus as set out in the Interference-causing equipment standard entitled "Digital Apparatus", ICES-003 of the Industry Canada.

RÈGLEMENT SUR LE BROUILLAGE RADIOÉLECTRIQUE (For 120V models)

Cet appareil numérique respecte les limites de bruits radioélectriques applicables aux appareils numériques de Classe B prescrites dans la norme sur le matériel brouilleur: "Appareils Numériques", NMB-003 édictée par l'Industrie Canada.

Für EMVG

Dieses Produkt ist zum Gebrauch im Wohnbereich, Geschäfts-und Gewerbebereich sowie in Kleinbetrieben vorgesehen.

MODEL NAMES

Model DR-6080/9080C is identical to model M11048/M11047.

Model DR-6080/9080C is the sales name of model M11048/M11047.

READ CAREFULLY BEFORE OPENING THE SEALED DISK PACKAGE

CANON SOFTWARE LICENSE AGREEMENT

IMPORTANT-READ THIS AGREEMENT BEFORE OPENING THE SEALED DISK PACKAGE! BY OPENING THE SEALED DISK PACKAGE, YOU ARE DEEMED TO AGREE TO BE BOUND BY THIS AGREEMENT.

This legal document is a license agreement between you and Canon Electronics Inc. ("Canon"). BY OPENING THE SEALED DISK PACKAGE, YOU ARE DEEMED TO AGREE TO BE BOUND BY THE TERMS OF THIS AGREEMENT. IF YOU DO NOT AGREE TO THE TERMS OF THIS AGREEMENT, DO NOT OPEN THE SEALED DISK PACKAGE AND PROMPTLY RETURN THE CANON SCANNER, THE DISK PACKAGE CONTAINING SCANNER DRIVER SOFTWARE PROGRAMS AND/OR SCANNER UTILITY SOFTWARE PROGRAM PROPRIETARY TO CANON OR ITS LICENSOR (THE "SOFTWARE") AND THE ACCOMPANYING DOCUMENTATION AND OTHER ITEMS TO THE PLACE WHERE YOU OBTAINED THEM FOR A REFUND BEFORE THEY ARE USED OR OPENED OR UNPACKED.

In consideration of the right to use the SOFTWARE, you agree to abide by the terms and conditions of this Agreement.

1. GRANT OF LICENSE: Canon grants you the personal, non-exclusive right to use the SOFTWARE only on a single computer. You may physically transfer the SOFTWARE from one computer to another provided that the SOFTWARE is used on only one computer at any time.

You shall not assign, sublicense, sell, rent, lease, loan, convey or transfer to any third party, or send or bring the SOFTWARE out of the country where you originally obtain it to other countries without required authorization of applicable governments, or copy, duplicate, translate or convert to another programming language the SOFTWARE or accompanying documentation, except as expressly provided herein.

Except as expressly permitted under the applicable law, you shall not alter, modify, disassemble, decompile or otherwise reverse engineer the SOFTWARE or accompanying documentation and you also shall not have any third party to do so.

2. BACK-UP COPY: You may make one copy of the SOFTWARE solely for a back-up purpose or copy the SOFTWARE onto the permanent storage device (e.g. a hard disk) of your computer and retain the original for a back-up purpose. Except as expressly permitted under the applicable law, any other copying of the SOFTWARE is a violation of this Agreement. You must reproduce and include the copyright notice on the back-up copy.

3. SUPPORT AND UPDATE: Canon, Canon's affiliate, their distributor or dealer is not responsible for maintaining or helping you to use the SOFTWARE. No updates, fixes or support will be made available for the SOFTWARE.

4. LIMITED WARRANTY AND DISCLAIMER OF INDEMNITY: Canon, Canon's affiliate, their distributor or dealer will not guarantee uninterrupted service, or absence or correction of errors. Therefore, the SOFTWARE is licensed on an "AS IS" basis without warranty of any kind. The diskette on which the SOFTWARE is recorded is warranted against defective material or workmanship under normal use for a period of ninety (90) days from the date you purchased the same as evidenced by a receipt or otherwise. The limited warranty does not apply if the failure of the diskette resulted from accident, abuse or misapplication of the SOFTWARE and shall not extend to anyone other than the original user of the SOFTWARE.

CANON, CANON'S AFFILIATE, THEIR DISTRIBUTOR OR DEALER DISCLAIMS ALL IMPLIED WARRANTIES, INCLUDING ANY WARRANTY OF MERCHANTABILITY OR FITNESS FOR A PARTICULAR PURPOSE, WITH RESPECT TO THE SOFTWARE OR ACCOMPANYING DOCUMENTATION.

NEITHER CANON, CANON'S AFFILIATE, THEIR DISTRIBUTOR NOR DEALER IS LIABLE FOR ANY LOSS OR DAMAGE INCLUDING CONSEQUENTIAL OR INCIDENTAL LOSS OR DAMAGE SUCH AS LOSS OF PROFITS, EXPENSE OR INCONVENIENCE, WHATSOEVER CAUSED BY OR ARISING OUT OF THE SOFTWARE, ACCOMPANYING DOCUMENTATION OR THE USE THEREOF.

CANON, CANON'S AFFILIATE, THEIR DISTRIBUTOR OR DEALER SHALL HAVE NO OBLIGATION TO INDEMNIFY YOU AGAINST ANY CLAIM OR SUIT BROUGHT BY A THIRD PARTY ALLEGING THAT THE SOFTWARE, ACCOMPANYING DOCUMENTATION OR THE USE THEREOF INFRINGES ANY INTELLECTUAL PROPERTY OF SUCH THIRD PARTY.

THE ABOVE IS CANON'S ENTIRE LIABILITY AND YOUR EXCLUSIVE REMEDY IN CONNECTION WITH THE SOFTWARE AND ACCOMPANYING DOCUMENTATION.

5. TERM: This Agreement is effective upon opening the sealed disk package and remains in effect until terminated. You may terminate this Agreement by destroying the SOFTWARE and any copy thereof. This Agreement will also terminate if you fail to comply with any of the terms of this Agreement. In addition to Canon enforcing its respective legal rights, you must then promptly destroy the SOFTWARE and any copy thereof.

6. U.S. GOVERNMENT RESTRICTED RIGHTS NOTICE: The SOFTWARE is provided with RESTRICTED RIGHTS. Use, duplication or disclosure is subject to restrictions as set forth in either subparagraph (c) (1) (ii) of the Rights in Technical Data and Computer Software clause at DFARS 252.227-7013 or subparagraph (c) (1) and (2) of the Commercial Computer Software Restricted Rights Clause at FAR 52.227-19, as applicable.

7. SEVERABILITY: In the event that provision of this Agreement is declared or found to be illegal by any court or tribunal of competent jurisdiction, such provision shall be null and void with respect to the jurisdiction of that court or tribunal and all the remaining provisions of this Agreement shall remain in full force and effect.

8. ACKNOWLEDGEMENT: BY OPENING THE SEALED DISK PACKAGE, YOU ACKNOWLEDGE THAT YOU HAVE READ THIS AGREEMENT, UNDERSTOOD IT, AND AGREE TO BE BOUND BY ITS TERMS AND CONDITIONS. YOU ALSO AGREE THAT THIS AGREEMENT IS THE COMPLETE AND EXCLUSIVE STATEMENT OF AGREEMENT BETWEEN YOU AND CANON CONCERNING THE SUBJECT MATTER HEREOF AND SUPERSEDES ALL PROPOSALS OR PRIOR AGREEMENTS, VERBAL OR WRITTEN, AND ANY OTHER COMMUNICATIONS BETWEEN YOU AND CANON RELATING TO THE SUBJECT MATTER HEREOF. NO AMENDMENT TO THIS AGREEMENT SHALL BE EFFECTIVE UNLESS SIGNED BY A DULY AUTHORIZED REPRESENTATIVE OF CANON.

Should you have any questions concerning this Agreement, or if you desire to contact Canon for any reason, please write to Canon's local affiliate.

International ENERGY STAR® Office Equipment Program



As an ENERGY STAR partner, Canon Electronics Inc. has determined that this product meets the ENERGY STAR guidelines for energy efficiency.

The International ENERGY STAR Office Equipment Program is an international program that promotes energy saving through the use of computers and other office equipment. The program backs the development and dissemination of products with functions that effectively reduce energy consumption. It is an open system in which business proprietors can participate voluntarily. The targeted products are office equipment such as computers, monitors, printers, fax machines, copiers and scanners. Their standards and logos are uniform among the participating nations.

NOTICE

- ① Copyright© 2003 by CANON ELECTRONICS INC. All rights reserved. No part of this publication may be reproduced, transmitted, transcribed, stored in a retrieval system, or translated into any language or computer language in any form or by any means, electronic, mechanical, magnetic, optical, chemical, manual, or otherwise, without the prior permission of CANON ELECTRONICS INC.
- ② The contents of this manual are subject to change without notice.
- ③ Every effort has been made to ensure the accuracy of information presented in this manual. However, Canon Electronics Inc. and the subsidiaries on the back cover assume no responsibility for any errors or their consequences.
- ④ We do not assume any responsibility for damage resulting from operations regardless of item ③.

Trademarks and Registered Trademarks

- ENERGY STAR is a United States registered mark.
- Microsoft Windows® and Microsoft Windows NT® are registered trademark of Microsoft Corporation in the United States and in other countries.
- Product names mentioned herein are for identification purposes only and may be trademarks and/or registered trademarks of their respective companies.

INTRODUCTION

Thank you for purchasing the Canon Document Scanner DR-6080/9080C. Please read this manual thoroughly before operating the machine in order to familiarize yourself with its capabilities, and to make the most of its many functions. After reading this manual, store it in a safe place for future reference.

Conventions

This manual uses the following symbols and indications. Before you start reading this manual, read the following and familiarize yourself with their meanings.



Warnings are provided for your safety and contain extremely important information. Failure to observe the instructions provided in a warning could result in death or serious injury to yourself or your coworkers.



Caution notices are also provided for your safety and contain important information. Failure to observe the instructions provided in a caution notice could result in serious injury to yourself or your coworkers or damage to the equipment.



These important notes contain important information on procedures that must be followed or actions that must be avoided. Failure to observe a request could result in damage to the equipment or a malfunction.



Notes provide additional tips or advice that can save you time and effort in using the scanner.

CONTENTS

INTRODUCTION	1
Conventions	1
Safety Precautions	5
Daily Maintenance	5
Installation Location	7
Power Supply	8
Carrying	8

Chapter 1 DR-6080/9080C

1.1 Features of the DR-6080/9080C	10
1.2 Packaging: What Is in the Box?	12
1.3 Part Names	13
◆ Front View	13
◆ Rear View	14
◆ Connectors (Bottom View)	14
◆ Operation Panel	15
1.4 Optional Products	16

Chapter 2 Preparation Before Use

2.1 Checking Your Operating Environment	18
2.2 Connecting to a Computer	19
SCSI Connections	19
◆ SCSI Cards	19
◆ Connecting the SCSI Cable	20
◆ Setting the SCSI ID and Terminator	20
USB Connections	22
◆ USB 2.0 Interface Cards	22
◆ Connecting a USB Interface Cable	23
Connecting the Power Cord	23
2.3 Preparing for Paper Feed and Eject	24
Preparing the Document Tray Extension	24
Preparing the Document Eject Tray Extension	25
◆ Long Documents	25
◆ Short Documents	26

2.4	Turning ON/OFF the Power	27
	Turning ON the Power	27
	Recognizing the Scanner	28
	Turning OFF the Power	30

Chapter 3 Software

3.1	About the Software	32
3.2	Installing the Software	33
	Installing the ISIS/TWAIN Driver	33
	Installing CapturePerfect	34
3.3	How to Use the Software	36
	How to Use the ISIS/TWAIN Driver	36
	How to Use CapturePerfect	37
	◆ Starting CapturePerfect	37
	◆ Closing CapturePerfect	38
3.4	Uninstalling the Software	39

Chapter 4 Document Feeding and Scanning

4.1	Documents	42
	Types of Documents	42
	How to Place Documents	43
4.2	Document Feeding and Scanning	44
	Scan Procedure	44
	◆ Standard Feeding	45
	◆ Panel-Feeding	46
	◆ Automatic Feeding	48
	◆ Manual Feeding (Bypass Mode)	50
	Count Only Mode	52
	Using Patch Code Sheets	53
	◆ Patch Code Sheets	53
	◆ Types of Patch Code Patterns	54
	◆ How to Use Patch Code Sheets	55

Chapter 5 Other Functions

5.1	Document Detection Function	58
	Double Feed Detection Function	58
	Skew Detection Function	58
	Staple Detection	59

5.2 Setting in the User Mode	60
How to Set the User Mode	61

Chapter 6 Troubleshooting

6.1 When the Scanner Is Not Recognized	64
SCSI Connections	64
USB Connections	66
6.2 Clearing Paper Jams	67
Paper Jam in the Paper Feed Unit	67
Paper Jam in the Paper Exit Section	70
6.3 Paper Feed Trouble	72
6.4 When the Scanned Image Is Not Normal	74
6.5 When an Error Code Is Displayed	75

Chapter 7 Daily Cleaning

7.1 Daily Cleaning	80
Cleaning the Main Unit	80
Cleaning the Document Detection Sensor	81
Cleaning the Scanning Glasses and Rollers	81
Cleaning the Shading Plates	85
Cleaning the Guide Plate (When Using the Imprinter)	87
Cleaning the Ink Jet Nozzles (When Using the Imprinter)	87
Power Outlet	87
7.2 Replacing the Rollers	88
When to Replace Rollers	88
Resetting the Counter	89
Installing and Removing the Rollers	91
◆ Installing and Removing Pickup Rollers	92
◆ Installing and Removing Feed Rollers	94
◆ Installing and Removing Retard Rollers	97
Specifications	100
Specifications for the Scanner	100
Options	101
Consumables	101
Exterior Dimensions	102
Index	103

Safety Precautions

Daily Maintenance

When you are working around the scanner, follow these precautions to avoid the hazards of fire and electrical shock:



- Never install and operate the scanner near flammable substances such as alcohol, paint thinner, benzene, or any other type of volatile solution.
- Never damage or modify the power cord, and never place heavy objects on the power cord.
- Always make sure that your hands are dry when you are handling the power cord or plug. Never grasp the plug when your hands are wet.
- Never plug the scanner into a multiplug power strip.
- Never bundle, wrap, or tie the power cord around itself or another object. Connect the plug securely to the power source.
- Use only the power cord and plug provided with the scanner.
- Never attempt to disassemble or modify the scanner.
- Never use flammable aerosol products near the scanner.
- Before you clean the scanner, turn OFF the power and disconnect the power cord from the power outlet.
- To clean the scanner exterior, use a firmly wrung cloth moistened slightly with water or mild detergent. Never use any type of volatile solution such as alcohol, benzene or paint thinner.
- If you hear a strange sound, detect smoke or abnormal heat, sense vibration, or smell odd odors around the scanner, turn OFF the power immediately and disconnect the power cord from the power outlet. Call for service immediately.
- Handle the scanner with care. Avoid shocks and vibrations to the scanner caused by reckless handling. If you suspect the scanner has been accidentally damaged, turn OFF the power immediately and disconnect the power cord from the power outlet. Call for service immediately.
- Before you move the scanner, always turn OFF the power and disconnect the power cord from the power outlet.
- The scanner weighs 55.1 lb (25 kg). Two people must carry the scanner. You may drop the scanner, or pinch your fingers if you attempt to carry it by yourself.



CAUTION

- To avoid damage to the scanner, never place the scanner on an unstable or vibrating surface. The scanner may tip or fall over, and cause an injury.
- To avoid overheating and causing a fire, never block the air vents on the rear of the scanner.
- Keep all liquids, beverages, or any type of liquid, and clips, staples, necklaces, or other metal objects away from the scanner. If you accidentally spill liquid or drop a metal object into the scanner, turn OFF the power immediately and disconnect the power cord from the power outlet. Call for service immediately.
- Never install the scanner in humid or dusty locations. Doing so might cause a fire or electrical shock.
- Never place heavy objects on top of the scanner. Such objects may tip or fall over, and cause an injury.
- When you remove the power cord, grip it by the plug head. Never attempt to disconnect the cord from the outlet by pulling on the cord. Doing so might expose or break the core leads, damage the power cord, and cause a fire or electrical shock.
- Keep the area around the power outlet clear of all obstacles so you can disconnect the power cord easily at all times.
- Never spill water or type of volatile solution (alcohol, benzene, paint thinner) into the scanner. Doing so might cause a fire or electrical shock.
- When the scanner is not being used for a long time, disconnect the power cord from the power outlet.
- Avoid wearing loose fitting clothing, dangling jewelry, long ties, or even long hair that could become entangled with moving parts, especially the rollers that feed the scanner. If such objects become entangled, immediately disconnect the power plug from the power outlet to stop the scanner.
- Be very careful when you are loading a document or removing a paper jam. You may be injured unexpectedly. For example, the paper edges may cut your fingers.
- Do not open the imprinter cover or upper scanner while the scanner is operating. Doing so might result in a malfunction or injury.
- Do not directly touch the pins and contacts on the scanner connector with your hands. Doing so might result in a malfunction.

Installation Location

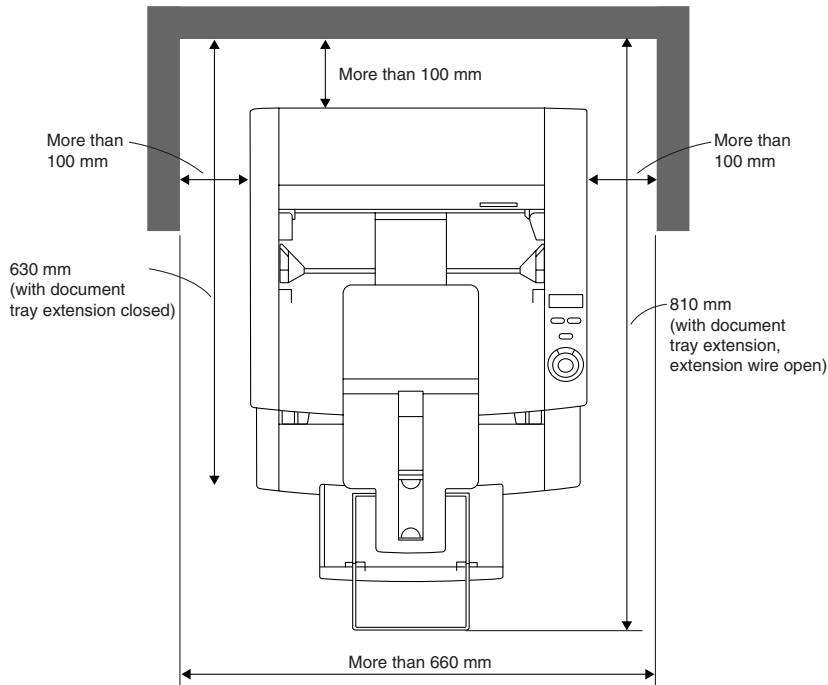

For operation, maintenance and ventilation, make sure that there is enough space around the scanner, as shown in the illustration above.

Avoid placing the scanner in the following places. Doing so may cause a malfunction and adversely affect the scanner or your computer.

- Places exposed to direct sunlight
If installation in such places is unavoidable, provide a curtain or similar object to shade the scanner.
- Places subject to dust and fumes
Dust and cigarette fumes adversely affect the components inside the scanner.
- Near running water, a heat source, water vapor, or in an area such as a laboratory exposed to ammonia gas, paint thinner, or other volatile chemicals.
- Places subject to vibration and strong shock
- Places subject to rapid changes in temperature or humidity
Condensation occurring inside the scanner may impair scan image quality. Place the scanner in a room that is well within the following range:
Room temperature 10°C to 32.5°C (50°F to 90.5°F)
Relative humidity 20% to 80% RH
Use the recommended operating environment for the ink cartridge when using the imprinter.
- Near electronic equipment or heavy equipment that generates a strong magnetic field, such as a speaker, TV, and radio.

Power Supply

- Be sure to connect to an AC 220-240V (50/60 Hz) or AC 120V (60 Hz) power supply, according to your region's requirement.
- Ensure that the scanner is connected to an independent power outlet. Do not plug the scanner into an outlet shared with another device. If you use an extension cable, pay attention to the total amperage of the cable.
- If you are unsure of anything relating to the power supply, contact your service representative.
- Never place an object on top of the power cord or step on the power cord.
- Never bundle the power cord or wrap the cord around an object, such as a table leg.
- Do not tug the power cord. When you remove the power cord, grip it by the plug head.
- Keep the area around the power outlet free of obstacles.

Carrying

Take care when moving the scanner. Two people should hold the scanner firmly on opposite sides when lifting it.

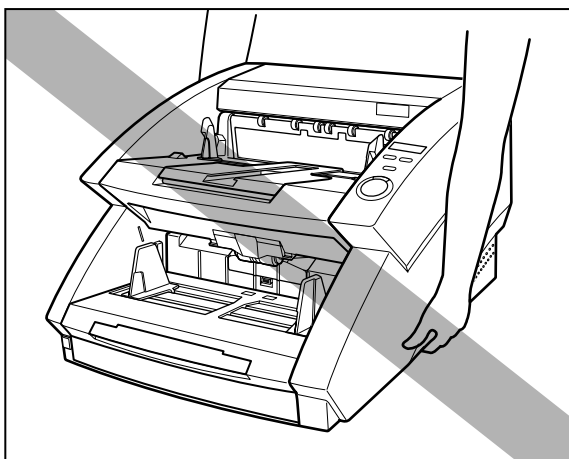

- The scanner weighs 25 kg. Two people must carry the scanner. You may drop the scanner, or pinch your fingers if you attempt to carry it by yourself.
- When moving the scanner, be sure to turn OFF the power and remove any cables. If the cables are not removed before moving the scanner, you may damage the plugs or connectors by forcibly pulling them out.

Chapter 1

DR-6080/9080C

This chapter describes the features of the scanner, what's in the box, and the names and functions of parts on the scanner.

1.1 Features of the DR-6080/9080C	10
1.2 Packaging: What Is in the Box?	12
1.3 Part Names	13
Front View	13
Rear View	14
Connectors (Bottom View)	14
Operation Panel	15
1.4 Optional Products	16



Features of the DR-6080/9080C

The DR-6080/9080C is a compact scanner that can handle large volumes of documents. Here is a summary of the outstanding features of the DR-6080/9080C.

- **Supports black-and-white (binary), and grayscale output (DR-6080)**
Supports black-and-white (binary), and grayscale.
- **Supports black-and-white (binary), grayscale and 24-bit color output (DR-9080C)**
Supports black-and-white (binary), grayscale and 24-bit color output.
- **High speed scanning**
Small documents, such as checks and business cards, all the way up to 11" x 17"/A3 size documents can be scanned. LTR/A4 size (portrait) documents can be scanned at high speed of up to 90 sheet per minute (DR-9080C).
- **Large capacity, reliable paper feeding**
 - Up to 500 sheets of A4/LTR-size documents can be placed at once.
 - A wide range of size and thickness of documents can be scanned. Paper feeding is highly reliable. Document skew is automatically aligned as it passes through the scanner. The scanner accurately handles documents of various sizes and thicknesses.
- **Double feed detection (See p.58.)**
The scanner detects double fed documents.
- **Staple detection (See p.59.)**
The scanner detects stapled documents.
- **Skew correction (See p.58.)**
This function automatically detects if the document is fed in at an angle, and straightens out skewed documents.
- **High durability**
The scanner has high durability of six million scans.
- **Compact size**
312 mm (H) x 460 mm (W) x 525 mm (D)
- **Drop out color**
This function enables drop out scanning of (that is, "drops out") a specific color in the document.

- **Various options**

The wide range of options includes the imprinter for printing characters on the document being scanned, the bar code module that reads bar codes on documents that are being scanned, and the endorser for printing numbers on the documents after scanning.

1.2

Packaging: What Is in the Box?

Make sure that you have everything. Check every item you have removed from the box. If any items are missing, contact your sales representative.

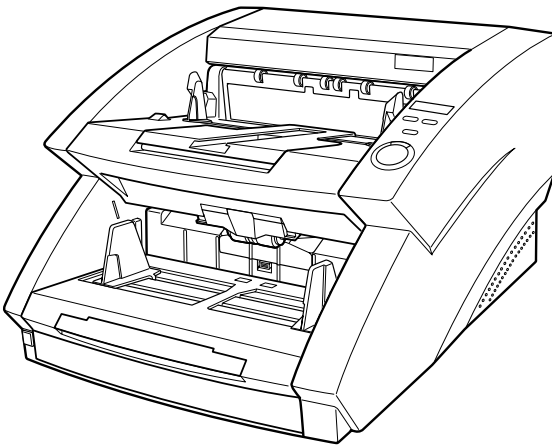

DR-6080/9080C

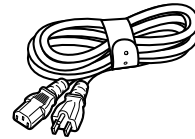

Power Cord*1

*1 The power cord varies according to country of purchase.

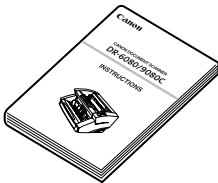

Instructions (this manual)

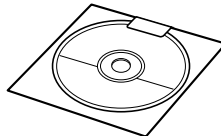

Setup Disc

1.3 Part Names

This section describes the names and functions of each part. Before you connect the DR-6080/9080C, take a few minutes to familiarize yourself with the main parts.

◆ Front View

Document Eject Tray Guide

Set this guide to the width of the document being ejected. (See p.26.)

Document Eject Tray Extension/Stopper

Use this if documents look like they are going to fall off of the eject tray. (See p.25.)

Document Guide

Set the paper guide for the width of the document you are going to scan.

Power Switch

(See p.27.)

Document Tray Extension/ Extension Wire

Pull this out and use it if documents extend beyond the edge of the document tray. (See p.24.)

Imprinter Cover

Open out this cover when you are adjusting the print position of the optional imprinter.

Operation Panel

(See p.15.)

Upper Scanner

Open the upper scanner to clean the rollers or if paper becomes jammed. (See p.70.)

Document Tray

Place the document in this tray.



CAUTION

Do not open the imprinter cover when the optional imprinter is not installed.

◆ Rear View

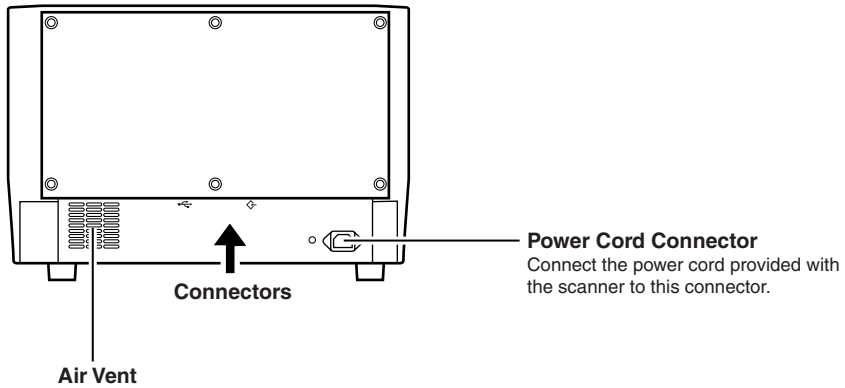

To avoid overheating and causing a fire, never block the air vents on the rear of the scanner.

◆ Connectors (Bottom View)

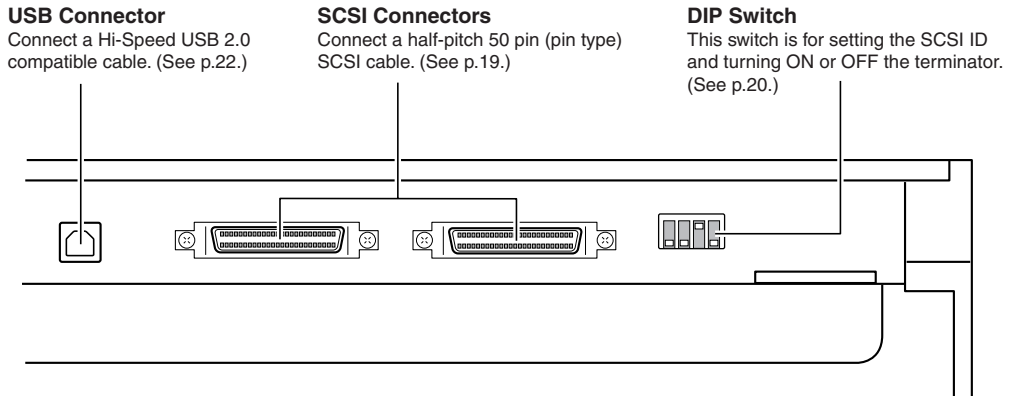

◆ Operation Panel

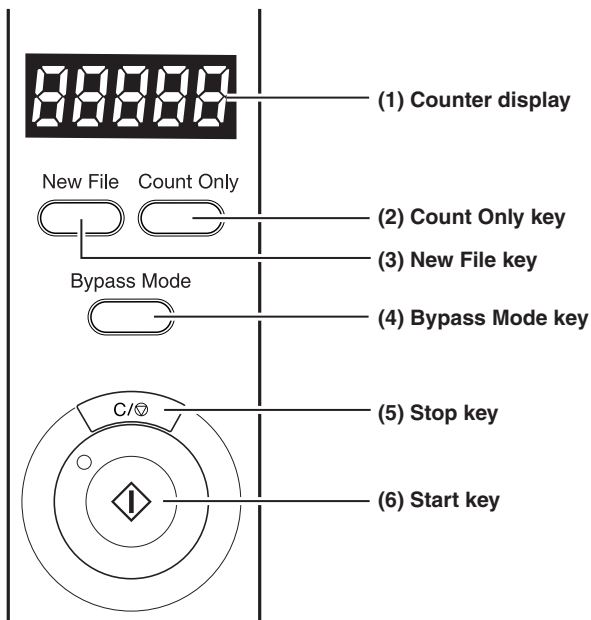

(1) Counter display

Displays an error code or the number of pages scanned.

(2) Count Only key

Sets the scanner to the Count Only mode for just counting the number of pages fed. (See p.52.)

When you press this key, it will light. If you place the document and press the Start key in this state, the document will be fed and the scanner will count the number of pages. (The document will not be scanned.)

(3) New File key

Enabled when the application supports the “Batch Separator” function. This key lights when it is pressed, or when the batch separator has been set in the application. When this function is in use, scanned images will be saved to a separate file or folder from that of the preceding images.

(4) Bypass Mode key

Press this key to set the scanner to the Bypass (manual) mode. Use this function to scan documents that might double feed or that are bound at the edge and to be fed without page separation.

(5) Stop key

Press this key to stop scanning.

Also use this key to cancel the currently set mode, or to cancel an error displayed on the counter display.

(6) Start key

LED will light when the Count Only mode is selected or the application has activated the scanner. Press the [Start] key when the LED is lit to start scanning.

1.4 Optional Products

The following options can be purchased and used on the DR-6080/9080C, if they are necessary. Contact your sales representative.

◆ **Imprinter Unit**

The imprinter unit is installed inside the scanner, and prints a text message on the front of the document being scanned. You can set the text message that is imprinted in the application.



Note

Ink cartridges used are Hewlett-Packard ink cartridges, and the model numbers are: C6602B (blue), C6602G (green), and C6602R (red).

◆ **Endorser ED-600**

The Endorser ED-600 unit is installed on top of the scanner, and prints a six digit number on the back of the document being scanned.



Note

When using the endorser, the scanning speed lowers to match the printing speed of the endorser.

◆ **Hard Counter**

The hard counter is a seven digit counter that is installed inside the upper scanner. It keeps a tally of the pages that are fed through the scanner.

◆ **Bar Code Module**

The bar code module is add-on software that allows the ISIS/TWAIN driver to recognize bar codes. The application you are using must support bar code recognition in order to use the bar code module. See the “ISIS/TWAIN Driver HELP” for more information.

Chapter 2

Preparation Before Use

This chapter describes the procedure from scanner connection through to turning ON the power.

2.1 Checking Your Operating Environment	18
2.2 Connecting to a Computer	19
SCSI Connections	19
USB Connections	22
Connecting the Power Cord	23
2.3 Preparing for Paper Feed and Eject	24
Preparing the Document Tray Extension	24
Preparing the Document Eject Tray Extension	25
2.4 Turning ON/OFF the Power	27
Turning ON the Power	27
Recognizing the Scanner	28
Turning OFF the Power	30

2.1

Checking Your Operating Environment

Your computer system must meet the following conditions to use the DR-6080/9080C.

- **IBM PC/AT or compatible machines that meet the following specifications:**
 - Intel Celeron 733 MHz or faster
 - 256 MB main memory or more (recommended)
 - 100 MB or more of free space on the hard disk
- **SCSI card that is compatible with this scanner or Hi-Speed USB 2.0 interface card (See “Connecting to a Computer,” on p.19.)**
- **Monitor that can display at a resolution of 1024 x 768 (XGA) or greater is recommended.**
- **One of the following operating systems:**
 - For SCSI**
 - Microsoft Windows 98SE
 - Microsoft Windows Me
 - Microsoft Windows NT 4.0 Workstation SP6
 - Microsoft Windows 2000 Professional SP4
 - Microsoft Windows XP SP1
 - For USB**
 - Microsoft Windows 98SE
 - Microsoft Windows Me
 - Microsoft Windows 2000 Professional SP4
 - Microsoft Windows XP SP1
- **Either an ISIS (compatible) or a TWAIN (compatible) application that operates on one of the operating systems noted above.**



- Use the latest USB 2.0 driver when using USB connections. Contact your sales representative.
- If the CPU, memory, SCSI card, or USB interface card does not meet the recommended specifications, the scanning speed may slow down or the time required to transfer data may increase.

2.2 Connecting to a Computer

There are two ways to connect the scanner to your computer, SCSI or USB. Use the method that is compatible with your computer system.



CAUTION

- Do not turn OFF the scanner or remove any interface cables when an application is running.
- Do not connect both SCSI and USB interface cables at the same time.
- Turn OFF the computer and the scanner before changing the cable format.

ENGLISH

SCSI Connections

Connect the scanner to the computer.



Note

To connect the scanner with a SCSI cable, you will need the following items that are not included in the package:

- SCSI card
 - Check that the SCSI card is installed on your computer.
 - Use one of the recommended SCSI cards.
- SCSI cable
 - The scanner's SCSI connector is a half-pitch 50-pin (pin type) connector. Check the shape of the connector on your computer's SCSI card or on the SCSI device connected to your computer, and prepare a SCSI cable that is compatible with the connector that can be connected to the scanner.

◆ SCSI Cards

Be sure to use one of the recommended SCSI cards when connecting the scanner with a SCSI cable. The recommended SCSI cards are listed below.

Recommended SCSI cards

Manufacturer: Adaptec

Product names: AHA-2930U, AHA-2940AU, AHA-2930LP, ASC-19160,
ASC-29160, APA-1480



Important

- Be sure to follow the installation procedure in your computer's operation manual when installing the SCSI card to your computer.
- Scan speed is slightly reduced with AHA-2930LP because synchronous transfer is not available in Windows 2000/XP.

◆ Connecting the SCSI Cable



CAUTION

- Before you connect the SCSI cable, make sure that the scanner and the computer are turned OFF.
- Do not connect both SCSI and USB interface cables at the same time.

Connect your computer to the scanner using the SCSI cable. Two SCSI connectors are located on the rear of the scanner. Insert the SCSI cable from the computer into one of the connectors on the bottom of the scanner. To connect another SCSI device to the computer, insert the other SCSI cable into the vacant SCSI connector on the rear of the scanner, and connect the other end of the SCSI cable into the SCSI device in a daisy chain.

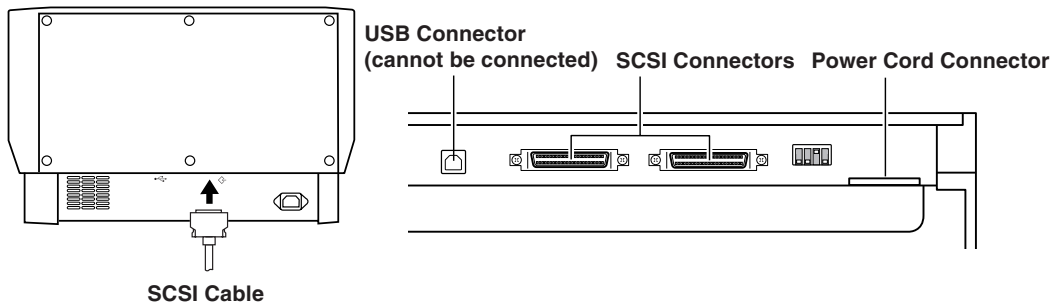

◆ Setting the SCSI ID and Terminator

Set the SCSI ID and the terminator on the DIP switches located between the SCSI connectors and the power cord connector. Move the DIP switch towards you to turn it OFF and move it towards the scanner to turn it ON.

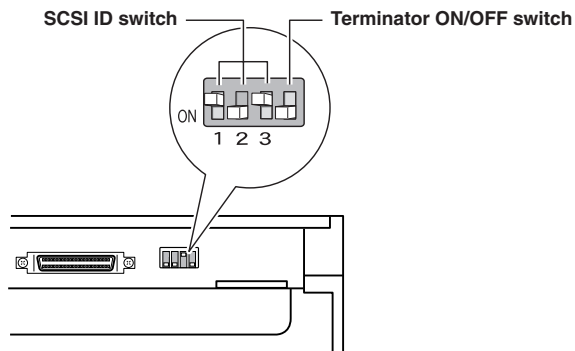

SCSI ID	SW1	SW2	SW3
0	OFF	OFF	OFF
1	ON	OFF	OFF
2	OFF	ON	OFF
3	ON	ON	OFF
4	OFF	OFF	ON
5	ON	OFF	ON
6	OFF	ON	ON
7	ON	ON	ON

Set the SCSI ID referring to the table above. Set unique SCSI IDs to any other built-in SCSI devices or SCSI devices connected to the computer.



Important

- The SCSI ID default is set to 2.
- Assign SCSI ID numbers ranging from 0 to 7 for each SCSI device. Do not select 7 as this is normally assigned to the SCSI controller. If a SCSI hard disk is mounted, do not use 0 and 1. Normally 0 and 1 are assigned for hard disks.

Set the terminator on the last SCSI device on a daisy chain to ON.

<When only the scanner is connected to your computer, or when another SCSI device is connected on a daisy chain and the scanner is the last SCSI device on the end of the daisy chain>

Set the terminator switch to ON.

In such a connection, be sure to set the terminator on all other SCSI devices to OFF.

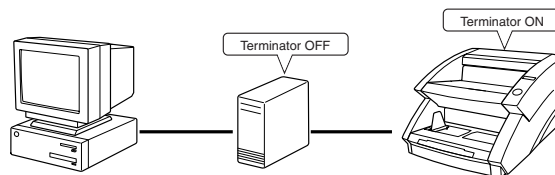

<When another SCSI device is connected as the last device of the daisy chain>

Set the terminator switch on the scanner to OFF.

In such a connection, set the terminator on the SCSI device connected as the end device to ON.

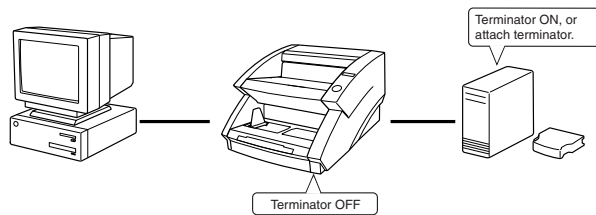

CAUTION

Be sure to set the DIP switch or use a terminator plug if this scanner is installed as the last piece of equipment in a daisy chain. Note that if you use a terminator plug and the DIP switch is set to ON, the scanner may malfunction.

USB Connections

Connect the scanner to the computer.



To connect the scanner with a USB interface cable, you will need the following items that are not included in the package.

- USB interface cable
Use an interface cable that supports Hi-Speed USB 2.0.
- USB interface card
Use an extended USB interface card that is compatible with Hi-Speed USB 2.0 and operationally tested by Canon.

◆ USB 2.0 Interface Cards

Be sure to use one of the recommended USB 2.0 interface cards when connecting the scanner with a USB interface cable. The recommended USB 2.0 interface cards are listed below.

Recommended USB 2.0 interface cards

Manufacturer: Adaptec
Product: USB 2 Connect 2000LP (AUA-2000)
USB 2 Connect 3100 (AUA-3100LP)
USB 2 Connect 5100 (AUA-5100)
USB 2 Connect for Notebooks (AUA-1420)



- Be sure to follow the installation procedure in your computer's operation manual when installing the USB 2.0 interface card to your computer.
- Use the most recent USB 2.0 driver provided by Adaptec or Microsoft.
- Windows NT operating systems do not support USB. Use a SCSI cable to connect the scanner to computers with Windows NT operating systems.
- Use a USB hub that supports USB 2.0 if you need to use a USB hub.
- This scanner has passed the Hi-Speed USB 2.0 verification test. However, it may not function properly even when Hi-Speed USB 2.0 is built-in a computer as standard.
- Scan speed may slow down when Hi-Speed USB 2.0 is not supported.

◆ Connecting a USB Interface Cable



Do not connect both a SCSI cable and USB interface cable at the same time.

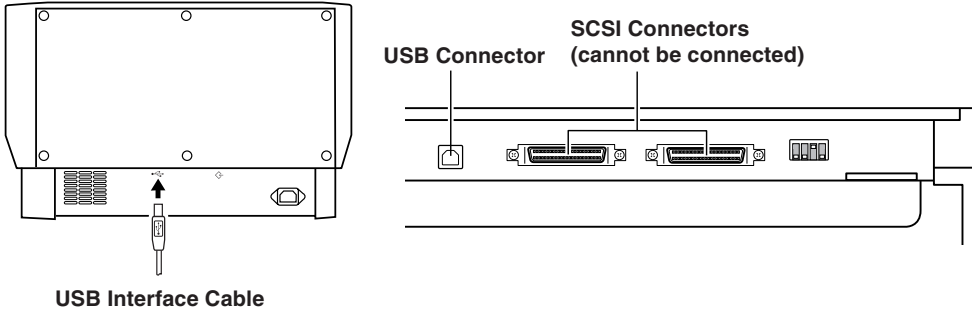

ENGLISH

Connecting the Power Cord

Connect the power cord.

Be sure to use only the power cord provided with the scanner.

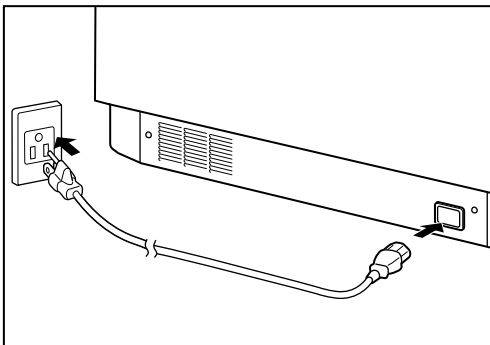

When connecting the power cord, follow these precautions. Failure to do so might cause a fire or electrical shock.

- Never grasp the plug when your hands are wet.
- Never plug the scanner into a multiplug power strip.
- Never bundle or tie the power cord around itself or another object. Connect the plug securely to the power source.
- Use only the power cord and plug provided with the scanner.
- Before you connect the power cord, be sure to turn OFF the power.
- Be sure to connect to an AC 220-240V (50/60 Hz) or AC 120V (60 Hz) power supply, according to your region's requirement.
- Do not plug the scanner into an outlet shared with another device. If you use an extension cable, pay attention to the total amperage of the cable.

2.3

Preparing for Paper Feed and Eject

Pull out the document tray extension and the document eject tray extension to match the size of the document being scanned.

Preparing the Document Tray Extension

Pull out the document tray extension to accommodate the size of the document to be scanned.

- 1 Pull out the document tray extension from the document tray.

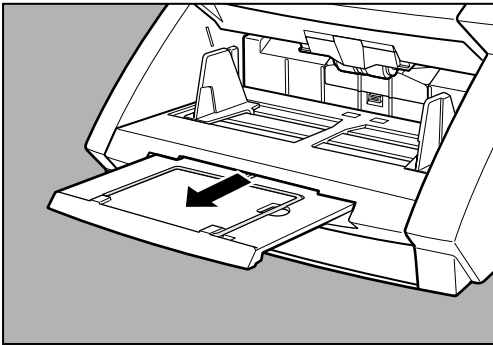

- 2 Gently open the extension wire.

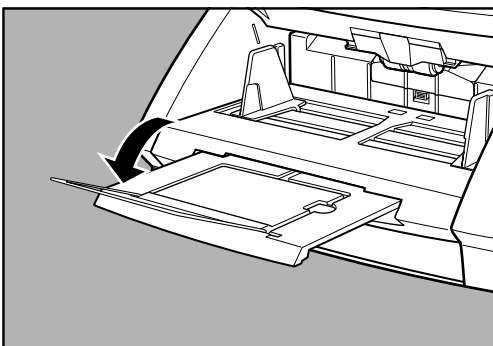

Note

Use the extension wire if the document extends beyond the edge of the document tray.

Preparing the Document Eject Tray Extension

Use the document eject tray extension and stopper to prevent scanned documents from falling off the eject tray.

◆ Long Documents

If the document you are scanning is long, open the document eject tray extension and adjust the position of the stopper as needed.

ENGLISH

- 1 Open the document eject tray extension.

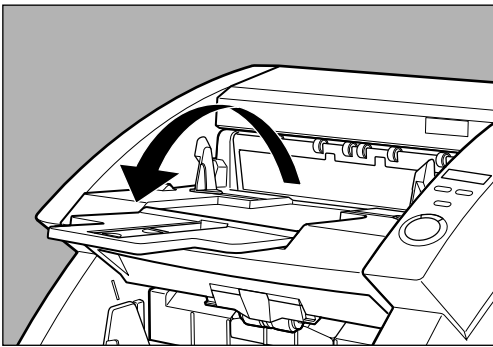

- 2 Lift up the stopper.

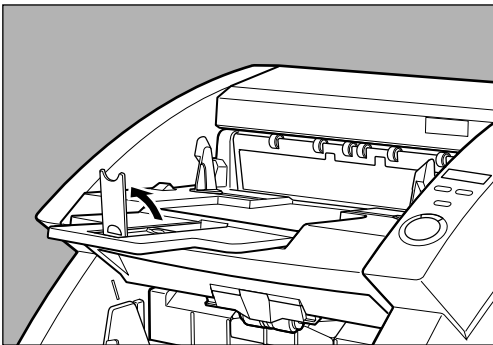

- 3 Adjust the position of the stopper to match the length of the document.



Note

You can use the stopper without opening the document eject tray extension.
(See p.26.)

◆ Short Documents

If the document you are scanning is short, use the stopper without opening the document eject tray extension.

1 Lift up the stopper.

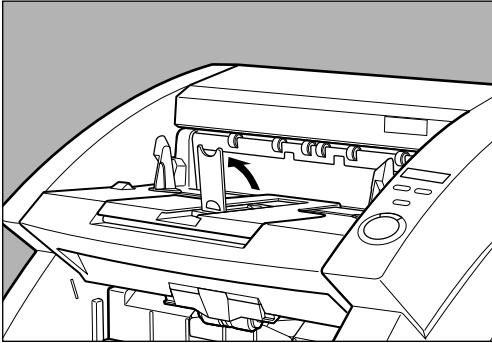

2 Adjust the position of the stopper to match the length of the document.

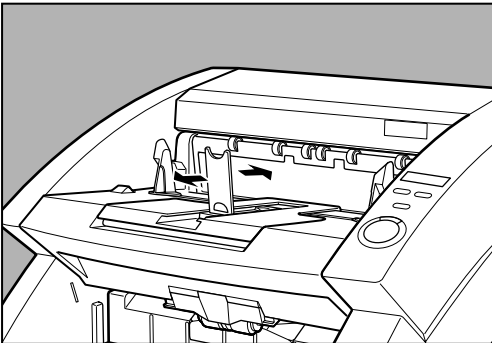

Note

Adjust the position of the document eject guides if the document being ejected drifts to the left or right.

2.4 Turning ON/OFF the Power

Follow the procedures below to turn ON or OFF the scanner power.

Turning ON the Power



Important

Be sure to turn ON the power of all connected SCSI devices before you turn ON the computer.

1 To turn ON the scanner, press the power switch.

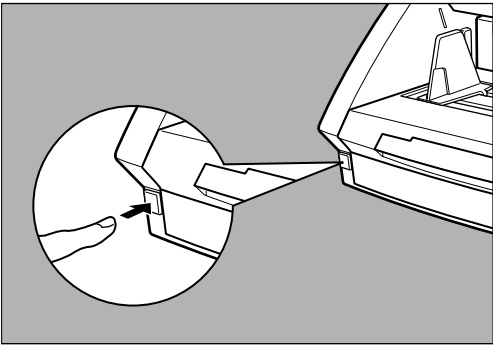

➔ “00000” is displayed on the counter display of the operation panel.



WARNING

If you hear a strange sound, detect smoke or abnormal heat, sense vibration, or smell odd odors around the scanner, turn OFF the power immediately and disconnect the power cord from the power outlet. Contact your service representative immediately. Failure to do so might cause a fire.

2 Turn ON the computer.



Note

When you connect the scanner to the computer, you need to make Windows recognize the scanner when you first start up Windows. (See “Recognizing the Scanner”, on p.28.)

Recognizing the Scanner

If you are using Windows 98/Me or Windows 2000/XP, then the first time that you turn ON your computer after connecting this scanner to your computer, Windows Plug and Play function automatically displays a screen prompting you to install the scanner driver. Follow the instructions on the screen to proceed with the installation. (The name of the installation dialog varies depending on the Windows operating system.)

- **If you are using Windows 98SE, the “Add New Hardware Wizard” dialog box appears.**

1. Click the [Next] button.
2. Select [Search for the best driver for your device. (Recommended).], and then click the [Next] button.
3. Insert the setup disc into the computer’s CD-ROM drive.
4. Select [Specify a location], enter “D:\INF” (assuming that “D” is assigned to your CD-ROM drive), and then click the [Next] button.
5. Click the [Next] button.
6. Click the [Finish] button.

- **If you are using Windows Me, the “Add New Hardware Wizard” dialog box appears.**

1. Select [Specify the location of the driver (Advanced)] and then click the [Next] button.
2. Insert the setup disc into the computer’s CD-ROM drive.
3. Select [Search for the best driver for your device. (Recommended).], and then select [Specify a location]. Enter “D:\INF” (assuming that “D” is assigned to your CD-ROM drive), and then click the [Next] button.
4. Click the [Next] button.
5. Click the [Finish] button.

- **If you are using Windows 2000 Professional, the “Found New Hardware Wizard” dialog box appears.**

1. Click the [Next] button to proceed to the “Install Hardware Device Drivers” screen.
2. Select [Search for a suitable driver for my device (recommended)], and then click the [Next] button to proceed to the “Locate Driver Files” screen.
3. Select [Specify a location], and then click the [Next] button.
4. Insert the setup disc into the computer’s CD-ROM drive.
5. Enter “D:\INF” (assuming that “D” is assigned to your CD-ROM drive), and then click the [OK] button.
6. In the “Driver Files Search Results” screen, click the [Next] button.
7. If the message “Digital Signature Not Found” appears, click [Yes] to continue installation.
8. On the “Completing the Found New Hardware Wizard” screen, click the [Finish] button.

● **If you are using Windows XP, the “Found New Hardware Wizard” dialog box appears.**

1. Insert the setup disc into the computer’s CD-ROM drive.
2. In the “Welcome to the Found New Hardware Wizard” screen, select [Install from a list or specific location (Advanced)], and then click the [Next] button.
3. Select [Search for the best driver in these locations], and then clear the [Search removable media (floppy, CD-ROM...)] check box. Select [Include this location in the search], enter “D:\INF” (assuming that “D” is assigned to your CD-ROM drive), and then click the [Next] button.
4. Click the [Continue Anyway] button in the “Hardware Installation” dialog box. Although a message appears indicating that the driver “has not passed Windows logo testing”, simply continue operation.
5. Click the [Finish] button in the “Completing the Found New Hardware Wizard” screen.



Note

- The DR-6080 will be registered as “CANON DR-6080 SCSI” or “CANON DR-6080 USB” in the “Imaging Device” directory.
- The DR-9080C will be registered as “CANON DR-9080C SCSI” or “CANON DR-9080C USB” in the “Imaging Device” directory.
- The displayed device name of the DR-6080 or DR-9080C differs depending on the connection, via SCSI or via USB. Turn OFF the power to the scanner and the computer before changing the connections, and then turn ON the power and let the computer recognize the scanner again.



Important

If you cancel the scanner recognition operation before it finishes, the driver installer screen will be displayed again when you restart your computer. Complete the driver installation.

Turning OFF the Power

1 Turn OFF the computer.

2 To turn OFF the scanner, press the power switch.

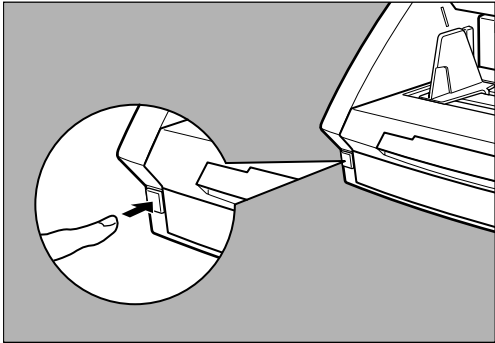

- Wait at least 10 seconds before turning ON the scanner again.
- For your safety, disconnect the power plug from the power outlet if you are not using the scanner for a long time.

Chapter 3

Software

This chapter describes how to install and use the ISIS/TWAIN driver and CapturePerfect so that you can use this scanner.

3.1 About the Software	32
3.2 Installing the Software	33
Installing the ISIS/TWAIN Driver	33
Installing CapturePerfect	34
3.3 How to Use the Software	36
How to Use the ISIS/TWAIN Driver	36
How to Use CapturePerfect	37
3.4 Uninstalling the Software	39

3.1

About the Software

The following software applications are provided on the setup disc that is packaged with the scanner. Be sure to open and read the Readme.txt file on the setup disc before installing the software.

- **ISIS/TWAIN driver**

- **CapturePerfect**

This is a TWAIN compatible application for scanning images. Install it if necessary.



- The ISIS/TWAIN driver provided with the scanner does not necessarily operate all ISIS compatible applications or all TWAIN compatible applications. Contact your sales representative for further information.
- Some functions mentioned in this manual may not be operated in some applications.

3.2

Installing the Software

This section describes how to install the ISIS/TWAIN driver and CapturePerfect so that you can use the scanner.

Installing the ISIS/TWAIN Driver

Connect the scanner to the computer.



Important

- If another ISIS compatible driver is already installed on the computer, be sure to make a backup of the following file. The content of this file may be overwritten when the ISIS/TWAIN driver is installed.
C:\Windows\PixTran*. *
C:\Windows\System\pix*.dll
- The names of the “Windows” and “Windows\System” folders are different, depending on which Windows operating system you are using. The names of the above folders are representative and should be replaced by the name of the folder used in your operating system.

1 Turn ON your computer and start Windows.



Important

Be sure to log on as an administrator if your system is Windows NT 4.0 Workstation, Windows 2000 Professional, or Windows XP.

2 Insert the setup disc into the CD-ROM drive.

This manual assumes that “D” is assigned to your CD-ROM drive.

3 Click the [Start] button, and then select [Run].

The screen depends on which Windows operating system you are using.



- 4** Enter “D:\Driver\setup.exe” in the [Open] field, and then click [OK].

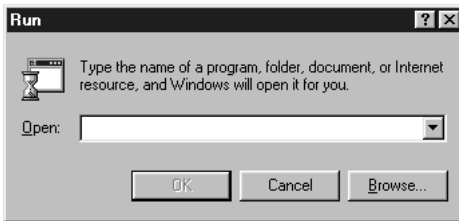

The installation starts.

- 5** Follow the instructions on the screen to complete the installation.

Installing CapturePerfect

Connect the scanner to the computer.

- 1** Turn ON your computer and start Windows.



Important

Be sure to log on as an administrator if your system is Windows NT 4.0 Workstation, Windows 2000 Professional, or Windows XP.

- 2** Insert the setup disc into the CD-ROM drive.

This manual assumes that “D” is assigned to your CD-ROM drive.

- 3** Click the [Start] button, and then select [Run].

The screen depends on which Windows operating system you are using.



- 4 Enter “D:\CapturePerfect\setup.exe” in the [Open] field, and then click [OK].

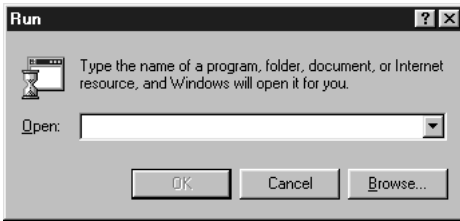

The installation starts.

- 5 Follow the instructions on the screen to complete the installation.

3.3

How to Use the Software

This section describes how to use CapturePerfect so that you can use the scanner.

Read the “ISIS/TWAIN Driver HELP” for information on using the ISIS/TWAIN driver.

How to Use the ISIS/TWAIN Driver

The explanation on how to use the ISIS/TWAIN driver is in the ISIS/TWAIN driver help file. To view the help file, click the [Start] button, then click [Programs] - [Canon DR-6080 & 9080C] - [Canon DR-6080 & 9080C Help].

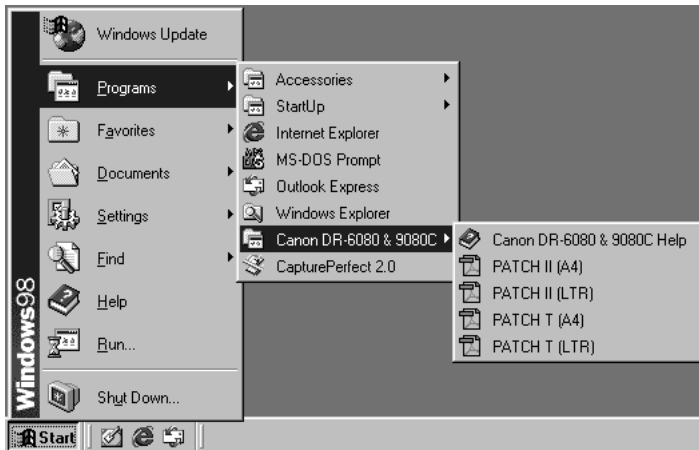

How to Use CapturePerfect

This section describes the procedure to start and end CapturePerfect. See [Help] in CapturePerfect for information on how to use CapturePerfect.

◆ Starting CapturePerfect

1 Click the [Start] button, and then click [Programs] - [CapturePerfect 2.0].

Click [All Programs] - [CapturePerfect 2.0] if your OS is Windows XP.

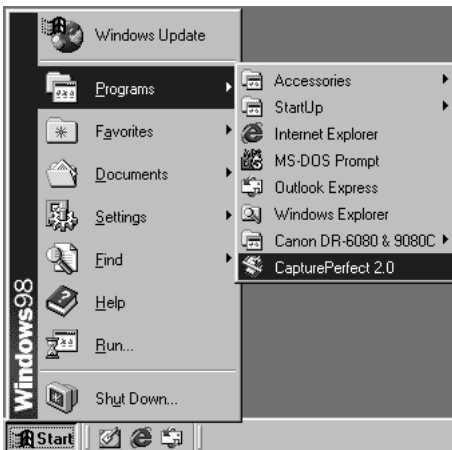

2 Start CapturePerfect.

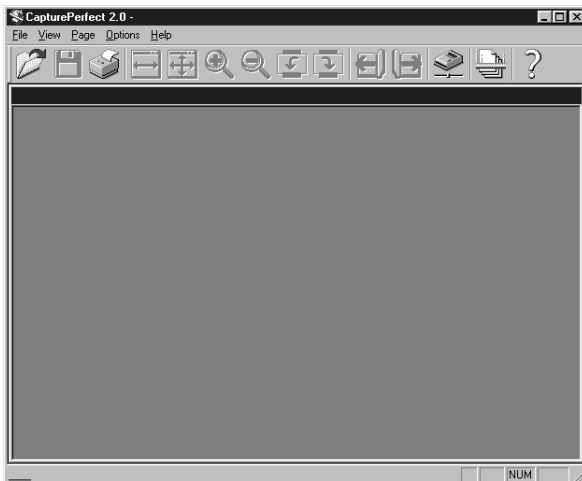

Note

The basic operation of CapturePerfect is noted in the CapturePerfect help file. Refer by selecting [Help] from the [Help] menu on the menu bar in CapturePerfect to view the explanation.

◆ Closing CapturePerfect

1 Select [Exit] from the [File] menu.

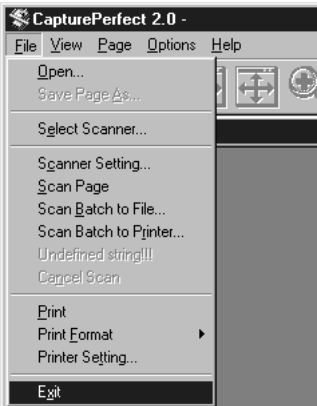

3.4

Uninstalling the Software

This section describes how to uninstall the ISIS/TWAIN driver and CapturePerfect.



- Be sure to log on as an administrator if your system is Windows NT 4.0 Workstation, Windows 2000 Professional, or Windows XP.
- The dialogs and button names in Windows XP are different from those used in the explanations in this manual. Refer to the Windows XP "Help and Support Center" to uninstall the software.

ENGLISH

1 Click the [Start] button, and then click [Settings]-[Control Panel].

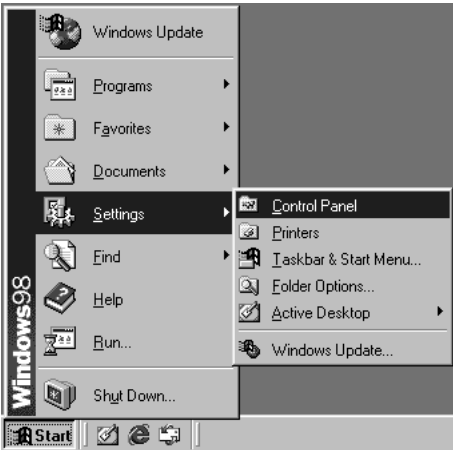

2 Double click on the [Add/Remove Programs] icon.



The [Add/Remove Programs Properties] dialog box appears.

- 3 Select “Canon DR-6080/9080C Driver” or “CapturePerfect 2.0” from the list in the dialog box, and then click the [Add/Remove] button.

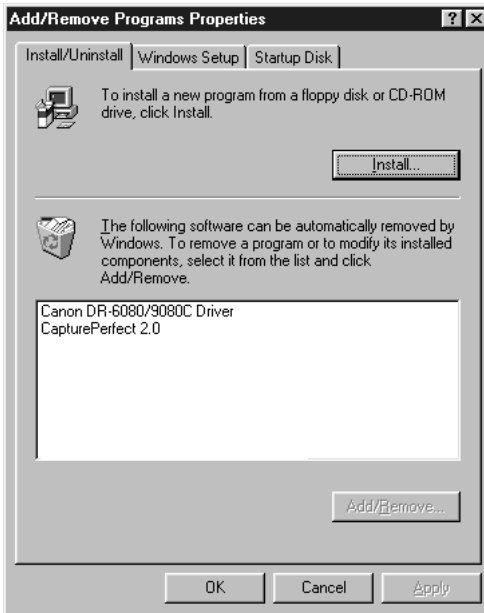

- 4 The [Confirm File Deletion] dialog box appears.

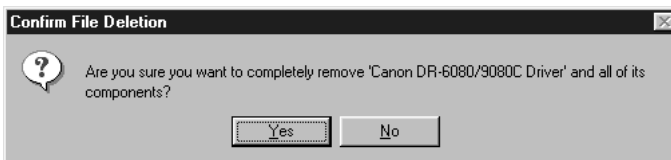

If you selected “Canon DR-6080/9080C Driver,” the above dialog box appears.

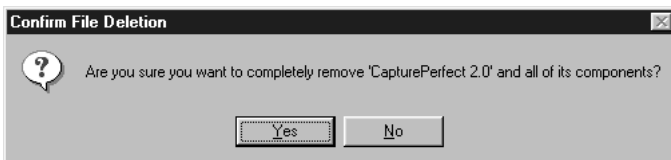

If you selected “CapturePerfect 2.0,” the above dialog box appears.

- 5 Click the [Yes] button, and the uninstaller starts.

Follow the instructions on the screen to finish uninstalling the software.

Chapter 4

Document Feeding and Scanning

This chapter describes precautions regarding documents that can be handled on this scanner and scanning operations.

4.1 Documents	42
Types of Documents.	42
How to Place Documents	43
4.2 Document Feeding and Scanning	44
Scan Procedure	44
Count Only Mode	52
Using Patch Code Sheets	53

4.1 Documents

This section describes about the types of documents and how to set them.



CAUTION

Treat the documents carefully. The paper edges may cut your fingers.

Types of Documents

The DR-6080/9080C can feed a wide variety of document sizes. The ranges of width and length for a document are:

- Width : 55 to 305 mm
- Length : 70 to 432 mm (Documents up to 1000 mm can be scanned in the long document mode.)
- Thickness : 0.06 to 0.15 mm (Auto feeding)
0.05 to 0.3 mm (Manual feeding)
- Weight : 48 to 120 g/m² (Auto feeding)
40 to 240 g/m² (Manual feeding)

Follow these guidelines when you prepare a document for scanning:

- Duplex scanning, color scanning, and high density (600 dpi) scanning cannot be done with large documents, such as 11" x 17" size paper and A3 size paper. Change the scanning mode to scan these sizes.
- Set the scan mode to "black and white" to scan long documents.
- Before scanning documents that contain pasted artwork, make sure that the ink or paste on the pages is thoroughly dry. If the documents are scanned with the ink or paste still wet, the scanner may cause problems.
- If you scan a document written in pencil, the letters may not scan properly or the pencil may rub off onto the rollers and stain subsequent documents. Before you scan this kind of document, make a copy and then scan the copy. After scanning a document written in pencil or some other soft writing material, be sure to clean the scanning rollers. (See p.81.)
- If you scan thin paper in the Duplex mode, the ink printed on the back side may be scanned. If this happens, adjust the scanning density.
- If you scan documents with a rough surface, friction between the documents may cause a feeding error. If this happens, select [Manual feed] and scan the document one by one.
- When you scan a batch of NCR documents, make sure that they are not stuck together.
- To avoid paper jams, damage to documents, and a scanner malfunction, do not feed the following types of paper. If you want to scan these types of paper, first make a copy and then scan the copy.



Wrinkled or creased paper



Carbon-backed paper



Curled paper



Coated paper or fax recording paper



Torn paper



Extremely thin paper



Paper with clips or staples



Paper with binding holes



Note

- Note that mixing documents of different thickness and size may cause a malfunction during feeding.
- Heavily curled wrinkled, or creased documents may cause them to double feed.
- Documents containing text or pictures within 5 mm of its edges or documents with a color background may cause erroneous skew detection or automatic size detection.

How to Place Documents

Note the following points when placing documents on the scanner.

- **Place the documents face up in the document tray.**
- **Do not exceed the load limitation mark when placing documents in the document tray. It may cause paper jams.**

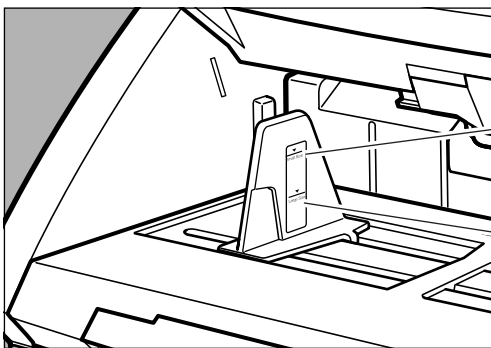

Small Size Limitation Mark:
When placing documents that are smaller than LTR/A4 size.

Large Size Limitation Mark:
When placing documents that are larger than LTR/A4 size.

- It is possible to place approximately 500 documents of regular LTR/A4 size (80g/m²), or approximately 200 documents of larger than LTR size.
- If the document tray does not rise and makes a “clacking” noise, then the amount of paper placed on the document tray may weigh too much even if the documents do not exceed the limitation mark. Reduce the amount of pages and scan the documents again.
- In the Long Document mode, if you place a long document askew in the document tray, it will rub against both sides of the feeding path and may damage the document. Be sure to align the document straight when placing it in the document tray. (See p.61.)

4.2

Document Feeding and Scanning

This section describes how to place the document in the document tray, the procedure until scanning begins, the count only mode for counting the number of sheets, and the patch code sheet for automatically separating batches of documents.



CAUTION

- Avoid wearing loose fitting clothing, dangling jewelry, long ties, or even long hair that could become entangled with moving parts, especially the rollers that feed the paper. If such objects become entangled, immediately disconnect the power plug from the power outlet to stop the scanner.
- Check the stack and remove all clips, staples, pins, or any other type of metal or plastic fastener. They may damage the document, cause a paper jam, or scanner malfunction.

Scan Procedure

The procedure for scanning a document varies depending on how the document is fed.

There are four ways to feed documents as shown below. Select [Feeding Option] on the ISIS/TWAIN driver's settings screen.

- **Standard Feeding (See p.45.)**

This feeding mode is selected from the application to start or stop scanning. Instruct the scanner to start scanning from the computer after the document is placed in the scanner.

- **Panel-Feeding (See p.46.)**

This feeding mode is useful when you want to continuously scan batches of documents that are different sizes. Place the document and adjust the document guides, then press the Start key on the scanner.

When scanning is finished, place the next document on the scanner and press the Start key to continue scanning.

- **Automatic Feeding (See p.48.)**

This feeding mode is useful when scanning documents that are all the same size. Scanning starts automatically when the scanner detects a document in the document tray.

Scanning stops when the document in the document tray is gone. Place the next document in the document tray to continue scanning.

- **Manual Feeding (See p.50.)**

Select this feeding mode if the document is prone to double feeding or if the document does not feed continuously very well. Place one page of the document in the document tray at a time and scan it.

◆ Standard Feeding

To use the standard feeding mode, instruct the scanner to start from the application.

- 1 Select [Standard Feeding] in [Feeding Option] on the ISIS/TWAIN driver's settings screen.
- 2 Align a batch of documents to be scanned until the edges are even.
- 3 Place the document face up in the document tray, aligning the document's top edge against the back of the document tray.

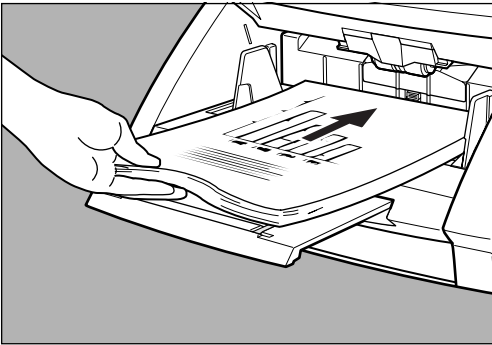

- 4 Adjust the document guides to the width of the document.

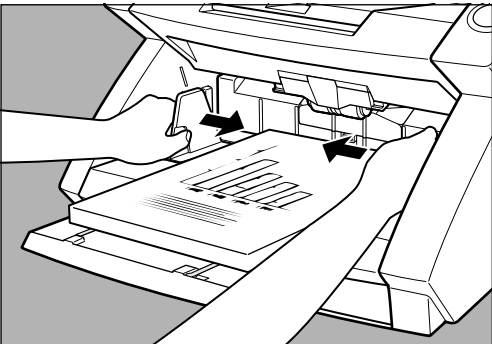

- 5 Instruct scanning to start from the application.

- 6 The document tray rises, and scanning begins. When scanning ends, the document tray is lowered.**



Note

If paper feed stops during scanning due to a system error or paper jam, make sure that the last page of the document was recorded properly before continuing to scan.

◆ Panel-Feeding

To use the panel-feeding mode, instruct the scanner to start from the application and it will go into standby mode. Start scanning by pressing the Start/Stop key on the scanner.

- 1 Select [Panel-Feeding] in [Feeding Option] on the ISIS/TWAIN driver's settings screen.**
- 2 Align a batch of documents to be scanned until the edges are even.**
- 3 Place the document face up in the document tray, aligning the document's top edge against the back of the document tray.**

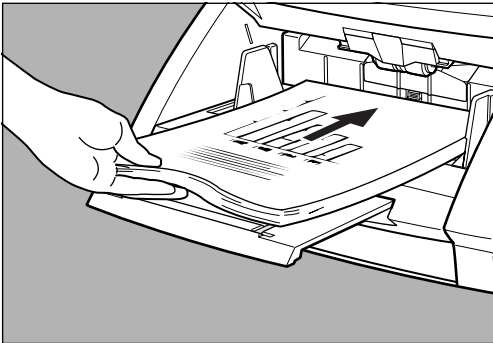

4 Adjust the document guides to the width of the document.

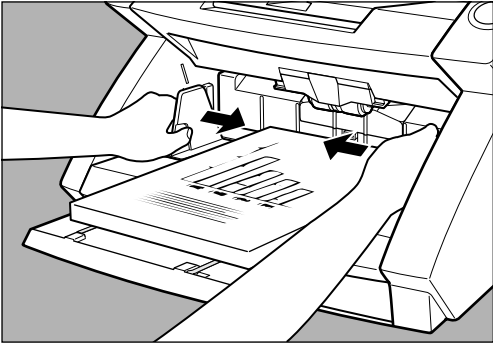

5 Instruct scanning to start from the application.

⇒ The Start key changes color from red to green.

6 Press the [Start] key.

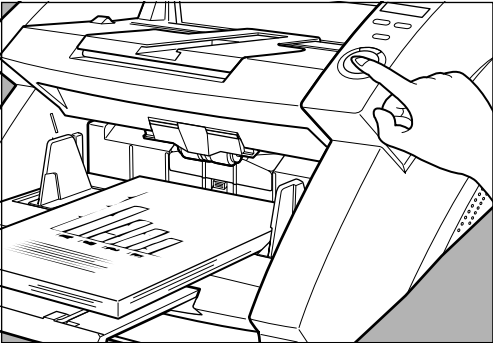

7 The document tray rises, and scanning begins. When scanning ends, the document tray is lowered.



Note

If paper feed stops during scanning due to a system error or paper jam, make sure that the last page of the document was recorded properly before continuing to scan.

8 If there are more documents to scan, place the document and press the [Start] key. To end scanning, press the [Stop] key.

◆ Automatic Feeding

To use the automatic feeding mode, after you instruct the scanner to start scanning from the application, the scanner will start scanning as soon as it detects a document in the document tray.

1 Select **[Automatic Feeding]** in **[Feeding Option]** on the **ISIS/TWAIN driver's settings screen**.

2 Place the first page of the document face up in the document tray, aligning the document's top edge against the back of the document tray. Adjust the document guides to the width of the document.

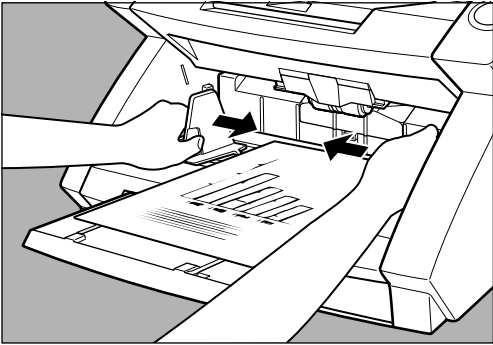

3 Instruct scanning to start from the application.



Note

Automatic scanning does not start when the document is placed before you instruct scanning to start from the application. Either press the [Start] key, or remove and place the document again.

4 Align a batch of documents to be scanned until the edges are even.

- 5** Place the remainder of the document face up in the document tray, aligning the document's top edge against the back of the document tray.

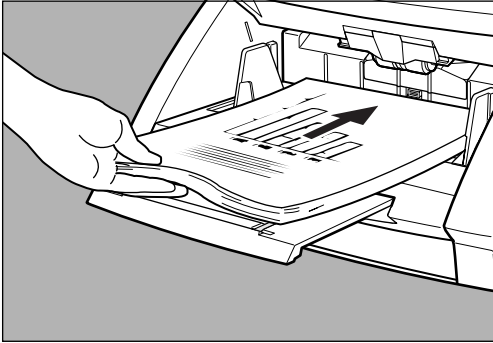

- 6** The document tray rises, and scanning begins. When scanning ends, the document tray is lowered.



- If the scanning mode is set to "Automatic Feeding," then scanning will start automatically when the sensor on the document tray shown below detects the document.
- After instructing the scanner to start, if something is placed over the sensor, it will mistakenly recognize it as a document and start scanning. Do not place anything other than documents over the sensor.

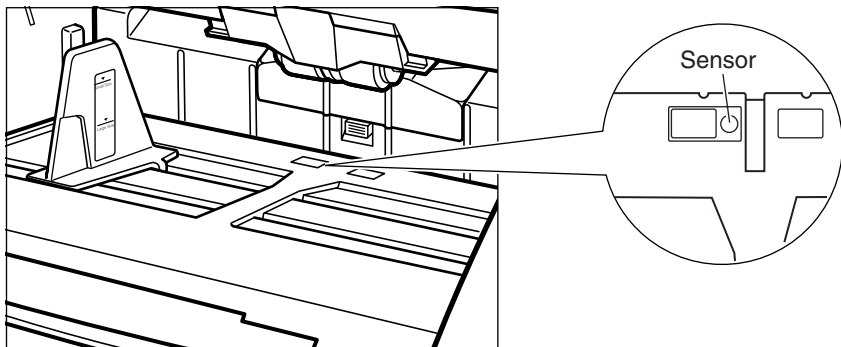

- Dust on the sensor will cause false recognition. Clean the sensor periodically. (See "Cleaning the Document Detection Sensor," on p.81.)

- 7** If there are more documents to scan, place the document, and scanning begins automatically. To end scanning, press the [Stop] key.

◆ Manual Feeding (Bypass Mode)

Use the Manual Feeding mode if the paper is thin, does not slide well, or the documents are stuck together.

- 1 Place the first page of the document face up in the document tray, aligning the document's top edge against the back of the document tray. Adjust the document guides to the width of the document.**

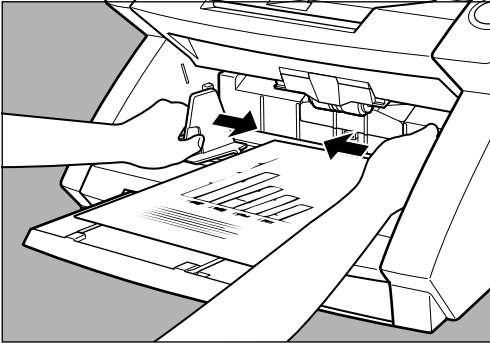

- 2 Select [Manual Feeding] in [Feeding Option] on the ISIS/TWAIN driver's settings screen. Alternatively, press the [Bypass Mode] key on the operation panel.**

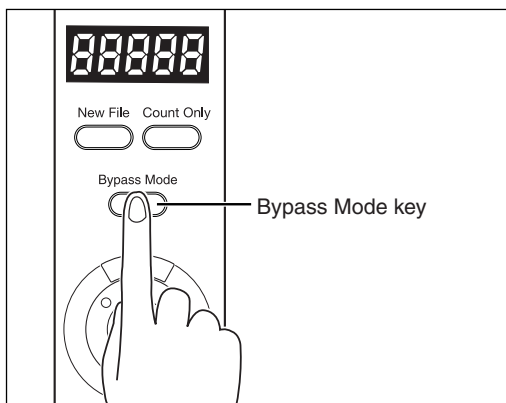

➡ The document tray rises.

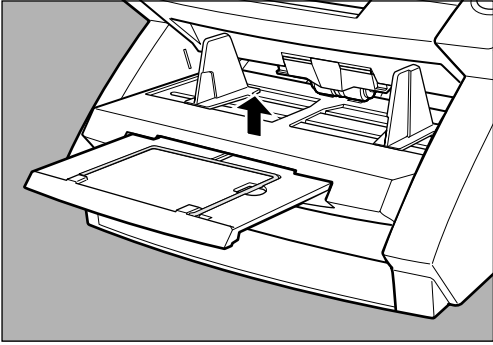

CAUTION

Be careful not to pinch your fingers in the document tray.

3 Instruct scanning to start from in the application.

4 Place the next page of the document face up in the document tray, aligning the document's top edge against the back of the document tray.

➡ The document is scanned.

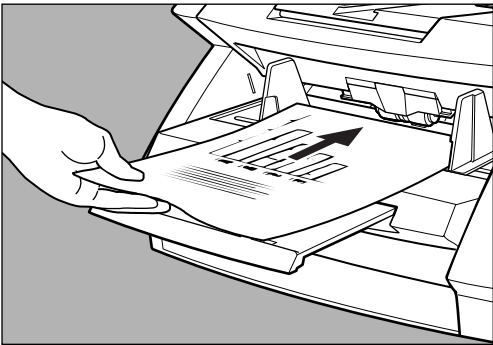

5 Continue to place the document one page at a time.

6 To end scanning, press the [Stop] key.



Note

The document tray will stay up as long as the Bypass Mode key is lit. After scanning is complete, press the [Bypass Mode key] on the operation panel to lower the document tray.

Count Only Mode

In the count only mode, the documents are fed through the scanner and the number of the documents is only counted, they are not scanned.

- 1 Press the [Count Only] key on the operation panel of the scanner.

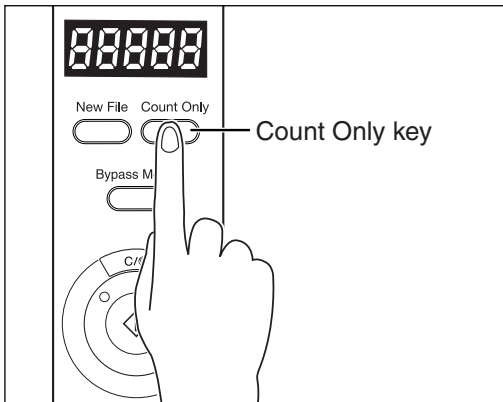

⇒ The Count Only key lights to indicate the Count Only mode.

- 2 Place the document in the document tray, aligning the document's top edge against the back of the document tray. Press the [Start] key.

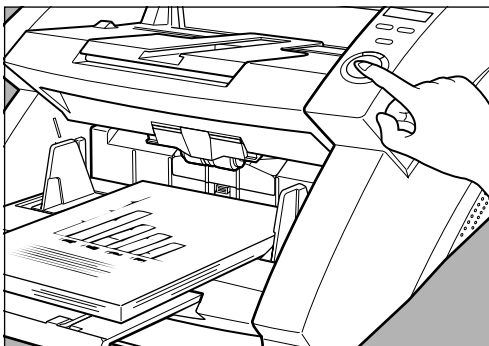

⇒ The document is fed and the number of documents appears on the counter display.

3 When counting ends, press the [Count Only] key to cancel the count only mode.

To clear the number on the counter display, press the [Stop] key down for at least two seconds.



Note

You can use the count only mode to count the number of documents and do “Verify scan” (checking the number of documents scanned against the number of documents counted). For details on verify scan, refer to “ISIS/TWAIN Driver HELP.”

ENGLISH

Using Patch Code Sheets

Patch code sheets are sheets of paper on which a special pattern is printed so that files can be separated without stopping the scanning operation. The scanner can recognize the pattern on these sheets, which allows files to be separated.



Note

- Refer to “ISIS/TWAIN Driver HELP” when using patch code sheets.
- Patch code sheets are enabled only when the application being used for scanning supports file separation.

◆ Patch Code Sheets

Patch code sheets are PDF (portable document format) data of which there are four types, [PATCH II (A4)], [PATCH II (LTR)], [PATCH T (A4)], and [PATCH T (LTR)]. Click on the [Start] button in Windows, and then click [Programs] – [Canon DR-6080 & 9080C] – [PATCH X(XX)], and use the document that is printed.

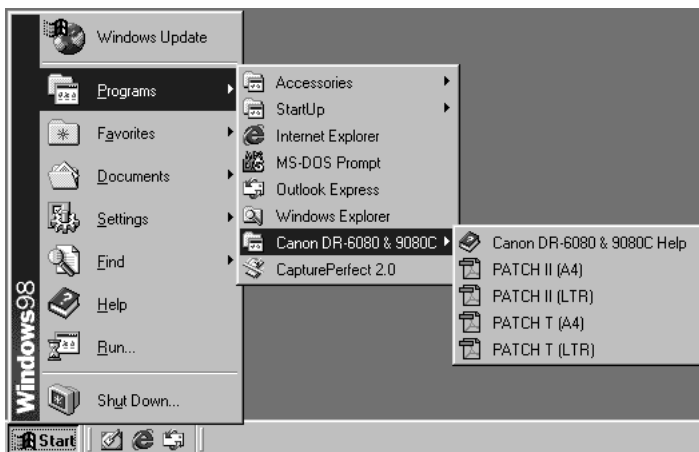

Note

You need CapturePerfect or an application that can open PDF (portable document format) files.

◆ Types of Patch Code Patterns

There are two patch code patterns as shown below. The result varies depending on the pattern.

● PATCH T (FILE A)

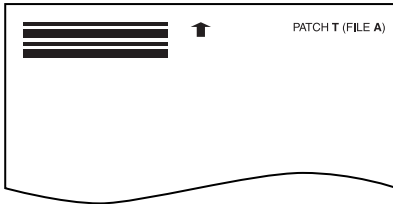

When this sheet is recognized, the document following the sheet is saved to a separate file.

● PATCH II (FILE B)

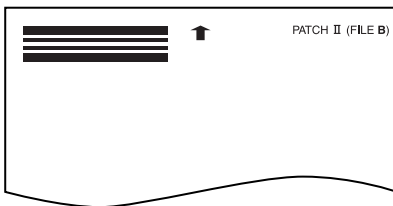

When this sheet is recognized, the file is separated after this sheet and this sheet is saved as an image, even if the patch code recognition setting is set not to save this sheet as an image.

◆ How to Use Patch Code Sheets

1 Print the patch code sheet on the printer. Print the patch code sheet data on the following size paper:

- Print [PATCH II (A4)] and [PATCH T (A4)] on A4 size paper.
- Print [PATCH II (LTR)] and [PATCH T (LTR)] on letter size paper.



Note

- Patch code patterns are detected within the enabled range shown below. When you make a copy of the patch code sheet, adjust the position of the image so that it appears in the range in which detection is enabled.

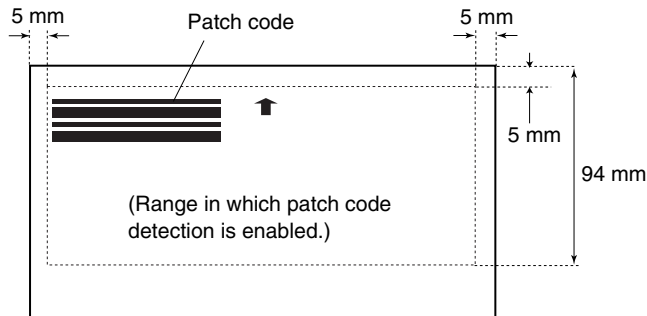

Units: millimeters

- When copying the patch code sheets, use the same size paper and the same density as the original patch code sheet. If the copied sheet is not dense enough, or if it is too dense, the scanner may not be able to recognize it correctly.
- Be careful not to let the patch code sheet get dirty, particularly for the range in which patch code detection is enabled. Do not bend or wrinkle the patch code sheet. This could prevent the scanner from recognizing the sheet.
- When the patch code sheet is being scanned, if it is not dense enough, or if it is too dense, the scanner may not be able to recognize it correctly.

- 2 Place the patch code sheet on top of the documents that are to be saved to a separate file, and then scan the documents.**

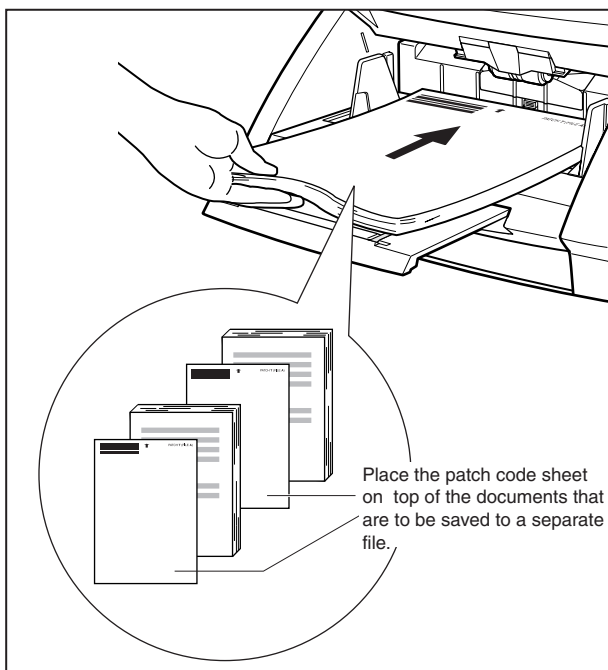

- 3 Set the scanning conditions and then start scanning.**

Chapter 5

Other Functions

This chapter describes the scanner's other functions.

5.1 Document Detection Function	58
Double Feed Detection Function	58
Skew Detection Function	58
Staple Detection	59
5.2 Setting in the User Mode	60
How to Set the User Mode	61

5.1

Document Detection Function

The scanner is equipped with a document detection function which stops a document from feeding if it detects that the document is not being fed correctly.

Double Feed Detection Function

The scanner automatically detects two pages that have been fed at the same time (double feed) and displays an error code that means “Double feed detection” when scanning documents continuously.

The following shows the double feed detection methods. Select the detection method on the ISIS/TWAIN driver’s settings screen.

- **Detect by Length**

The scanner uses the length of the first page of the document as the standard, and any pages that exceed this length by 50 mm or more are considered to be a double feed.

- **Detect by Ultrasonic**

The scanner detects the gap between the two pages that have been fed together and considers it to be a double feed.



Note

- The ultrasonic double feed detection works when a document overlaps by more than 50 mm.
- You can combine the detection methods noted above.
- The error code, which is displayed when a double feed is detected, varies depending on the combination of detection methods. For more information, see “When an Error Code Is Displayed,” on page 75.
- Double feed detection in the count only mode is set in user mode settings. For more information, see “Setting in the User Mode,” on page 60.

Skew Detection Function

If a long document is skewed, it may rip when it rubs against the feeding path or the sides of the feeding path. The scanner is equipped with a “skew detection function” that can detect skewed documents when they touch the edges of the feeding path. When a skewed document is detected, an error code is displayed and the scanner stops scanning.

Staple Detection

The scanner has sensors on both sides of the feeding slot to detect feed errors when the documents with staple is lifted up.

You can enable or disable staple detection on the ISIS/TWAIN driver's setting screen.

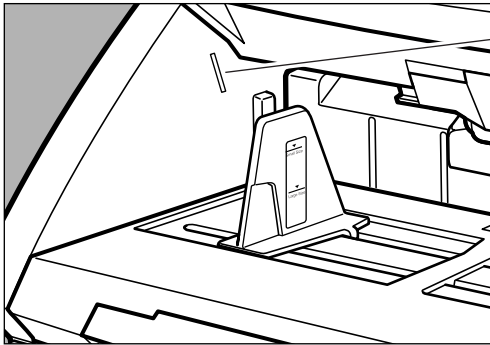

Staple Detection Sensor



Note

- The staple detector detects documents stapled in one of their four corners because the document is lifted up. It cannot accurately detect stapled documents in two corners or A5 (148 x 210 mm) or smaller because the document does not lift up high enough to be detected.

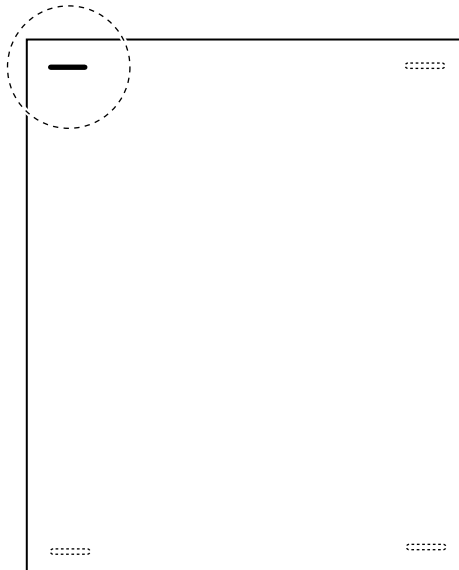

- You can set the detection accuracy for staple detection in the user mode settings. For information on the user mode, see “Setting in the User Mode,” on page 60.



Setting in the User Mode

You can select the mode of operation (user mode) for the scanner from those listed below.

- **Operation panel buzzer setting**

- U01-0 Do not sound buzzer during key operation.
- U01-1 Sound buzzer during key operation (default).

- **Count Only mode setting**

- U02-0 Do not use the endorser in the Count Only mode (default).
- U02-1 Use the endorser in the Count Only mode.

- **Endorser Stamp mode setting**

- U03-0 Use the endorser in the check mode (default).
- U03-1 Use the endorser in the A4 mode.

- **Double feed detection control settings in the Count Only mode**

- U04-0 Do not detect double feed in the Count Only mode (default).
- U04-1 Detect double feed in the Count Only mode.

- **Staple detection settings in the Count Only mode**

- U05-0 Do not detect staples in the Count Only mode (default).
- U05-1 Detect staples in the Count Only mode.

- **Staple detection accuracy settings**

- U06-0 Low level accuracy staple detection.
- U06-1 Medium level accuracy staple detection (default).
- U06-2 High level accuracy staple detection.

- **Imprinter control settings in the Count Only mode**

- U07-0 Do not use the imprinter in the Count Only mode (default).
- U07-1 Use the imprinter in the Count Only mode.

- **Skew detection control settings in the Count Only mode**

- U08-0 Do not use skew detection in the Count Only mode.
- U08-1 Use skew detection in the Count Only mode (default).

- **Energy-saving mode setting**

- U09-0 Do not go into energy-saving mode.
- U09-1 Go into energy-saving mode after 10 minutes of no operation (default).

● Length of scanned document settings

U10-0	Normal mode	Length of document is 432 mm or less (default).
U10-1	Long Document mode	Length of document is 1,000 mm or less.



Note

When using the Long Document mode, if you place a long document askew in the document tray, it will rub against both sides of the feeding path and may damage the document. Be sure to align the document straight when placing it in the document tray.

ENGLISH

How to Set the User Mode

Use the following procedure to set user modes.

- 1 Press both the [New File] key and the [Count Only] key at the same time.

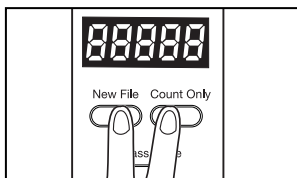

⇒ The New File key and the Count Only key flash, and the counter display shows the user mode.

- 2 Press the [New File] key, and then select a user mode (U01 to U11).

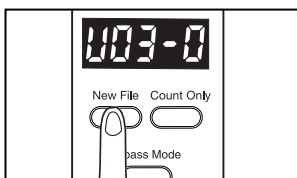

- 3 Press the [Count Only] key to select the mode (last digits only).

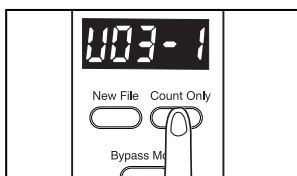

- 4 Press the [Stop] key when the settings are complete.

⇒ The mode you selected is set, and the counter returns to the page count display.

Chapter 6

Troubleshooting

This chapter describes the trouble that may occur on the DR-6080/9080C and how to correct it.

6.1 When the Scanner Is Not Recognized	64
SCSI Connections	64
USB Connections	66
6.2 Clearing Paper jams	67
Paper Jam in the Paper Feed Unit	67
Paper Jam in the Paper Exit Section	70
6.3 Paper Feed Trouble	72
6.4 When the Scanned Image Is Not Normal	74
6.5 When an Error Code Is Displayed	75



When the Scanner Is Not Recognized

The following describes possible causes of your computer not recognizing the scanner. Remedy the problem by following the procedure for the respective cause.

SCSI Connections

Cause **The scanner is not correctly connected.**

Remedy Connect the SCSI cables to the scanner in the correct way.

Cause **The SCSI card is not correctly recognized.**

Remedy Correctly connect the SCSI card referring to the SCSI card manual. Also, check the following according to the OS that your computer is running on.

<Windows 98 and Windows Me>

Click [Start]-[Settings]-[Control Panel]-[System], and then open the [Device Manager] and check if “SCSI Controller” has an “x” or “!” on it. If you can see one of these, then refer to the SCSI card’s operator’s manual to reset the SCSI card.

<Windows NT 4.0 Workstation>

Click [Start]-[Settings]-[Control Panel], and then open the [SCSI adapter] and check if the “SCSI card” is being recognized correctly. If it is not correctly recognized, then refer to the SCSI card’s operator’s manual to reset the SCSI card.

<Windows 2000 Professional>

Click [Start]-[Settings]-[Control Panel]-[System]-[Hardware], and then open the [Device Manager] and check if “SCSI controller” has an “x” or “!” on it. If you can see one of these, then refer to the SCSI card’s operator’s manual to reset the SCSI card.

<Windows XP>

Click [Start]-[Control Panel]-[Performance and Maintenance]-[System]-[Hardware], and then open the [Device Manager] and check if “SCSI controller” has an “x” or “!” on it. If you can see one of these, then refer to the SCSI card’s operator’s manual to reset the SCSI card.

Cause	Same SCSI ID is used for other SCSI devices.
Remedy	Check the SCSI ID of all connected SCSI devices, and make sure that the same SCSI ID is not set to two or more devices. Reset the SCSI IDs if the same SCSI ID is set.
Cause	The terminator is not correctly connected.
Remedy	Connect the terminator to the last SCSI device on the end of the daisy chain. Enable the terminator function if the SCSI device has a built-in terminator function.
Cause	The scanner was turned ON after the computer.
Remedy	Turn OFF the computer and scanner. Then, turn ON the scanner and turn ON the computer.
Cause	The scanner is OFF.
Remedy	Turn OFF the computer. Then, turn ON the scanner and turn ON the computer.
Cause	The scanner's power cord is disconnected from the scanner or the AC power outlet.
Remedy	Turn OFF the computer, and correctly connect the scanner's power cord. Then, turn ON the scanner and turn ON the computer.
Cause	The scanner does not support this SCSI card.
Remedy	Replace with a SCSI card compatible with the driver application. (See p.19.)

USB Connections

Cause **Scanner is not correctly connected.**

Remedy Connect the scanner correctly with a cable that supports USB 2.0.

Cause **The USB 2.0 interface card is not correctly installed to the computer.**

Remedy Refer to the USB 2.0 interface card operation manual and install it correctly. Also, check if the USB 2.0 interface card is being recognized by Windows in the operating system you are using.

Cause **The scanner is OFF.**

Remedy Check the connections with the computer, and then turn ON the scanner.

Cause **The USB 2.0 interface card dose not support the scanner.**

Remedy Use one of the recommended USB 2.0 interface cards. (See p.22.)

6.2 Clearing Paper Jams

Paper may have jammed if scanning stops midway or “PXX” appears on the counter display. Follow the procedure below to remove jammed paper from inside the DR-6080/9080C.



CAUTION

- Be careful when you clear a paper jam. You may be injured unexpectedly. For example, the paper edges may cut your fingers, or the document may be damaged.
- Remove all jammed sheets of paper. Paper scraps left inside the scanner may be drawn into the scanner again, causing another paper jam or malfunction.
- When opening or closing the upper scanner, take care not to get your fingers caught.

ENGLISH

Paper Jam in the Paper Feed Unit

- 1 Remove the documents from the document tray and the eject tray.
- 2 Close the document eject tray extension if it is open.

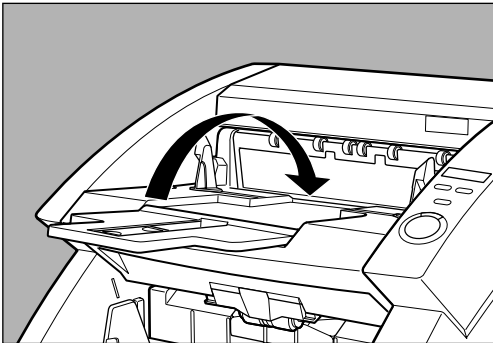

3 Open the upper scanner.

Press the open/close button, and lift up the upper scanner gently until it stops and locks in the open position.

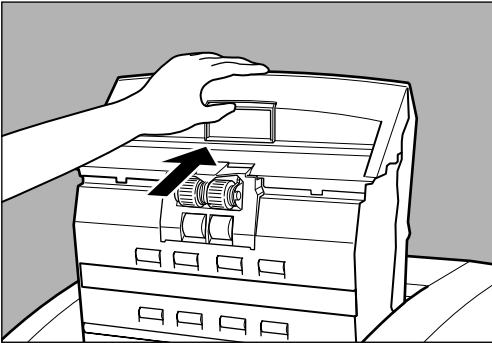
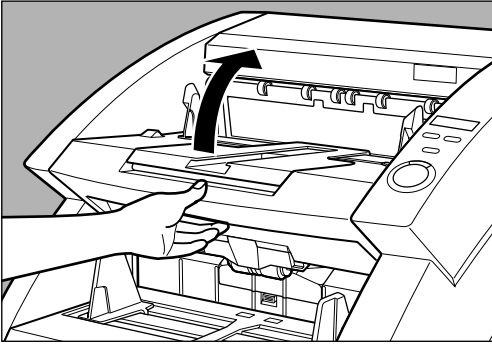

4 Remove the jammed paper from inside the scanner.

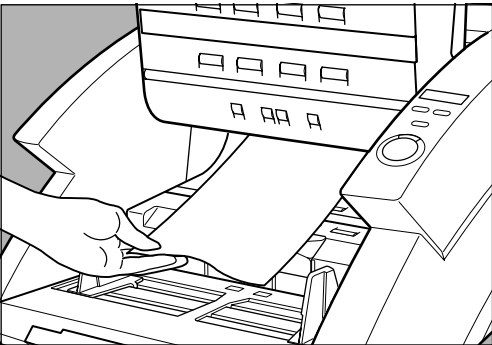

5 Carefully close the upper scanner.

Do not force the upper scanner down. Doing so might damage the scanner.

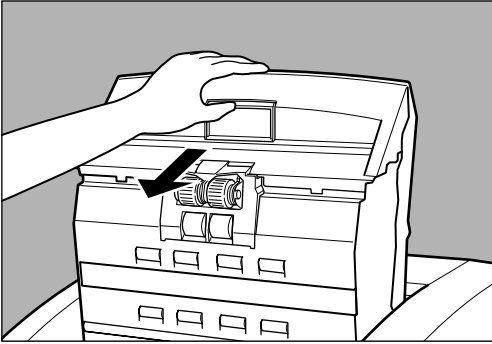

6 Press the upper scanner down firmly on both sides to close it.

If you press the upper scanner down only on one side, the opposite side will not be fully closed. Make sure that you hear it click into place.

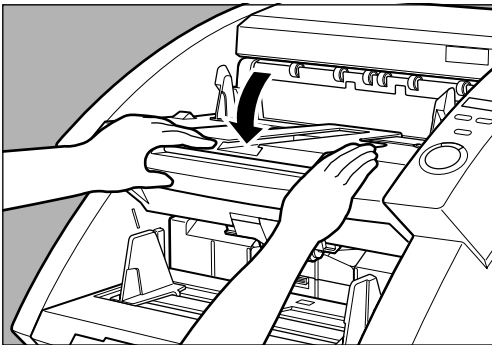

Paper Jam in the Paper Exit Section

- 1** Remove the jammed paper from the document tray or the document eject tray.
- 2** Close the document eject tray extension if it is open.

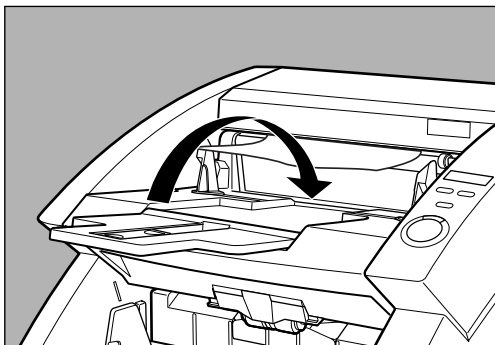

- 3** Lift up the upper scanner slightly.

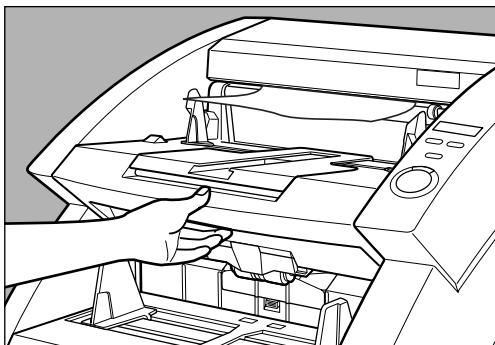

4 Remove any jammed paper from the exit section.

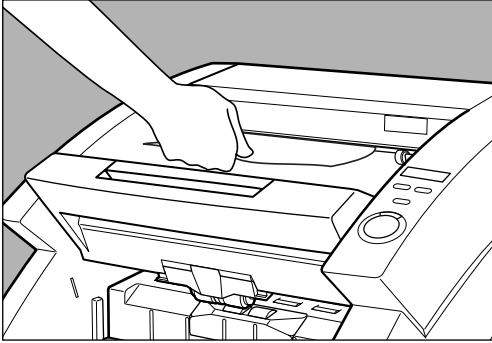

5 Press the upper scanner down firmly on both sides to close it.

If you press the upper scanner down only on one side, the opposite side will not be fully closed. Make sure that you hear it click into place.

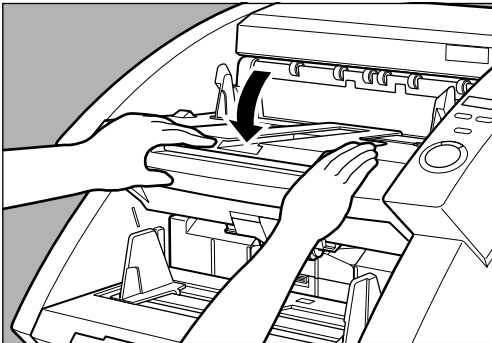

6.3 Paper Feed Trouble

If the document is not fed properly or the detection functions do not work smoothly, remedy the problem by following the procedures described below.

<p>Condition</p> <p>Cause and remedy</p>	<p>Paper jam has occurred.</p> <ul style="list-style-type: none"> • Check the document to see if the size and thickness of the document are within the ranges supported by the scanner, and to see if the quality of the document paper is appropriate. <p>For cautions on handling documents, see “Documents,” on p.42.</p> <ul style="list-style-type: none"> • Document slipping may be causing a paper feed error to occur. <p>Scan paper one sheet at a time in the Bypass (manual) mode. (See p.50.)</p> <ul style="list-style-type: none"> • Dirty or worn rollers inside the scanner cause paper jams. <p>Clean rollers if dirty. (See p.81.) Worn rollers must be replaced. Contact your service representative.</p>
<p>Condition</p> <p>Cause and remedy</p>	<p>The document tray does not rise and makes a “clacking” sound instead.</p> <p>The weight of the placed document sometimes increases due to the environment (e.g., very humid locations) in which the document is stored. If this happens, the weight of the paper will exceed the maximum allowed stacked weight even if the number of stacked sheets is below the maximum. This sometimes prevents the document tray from rising. Reduce the number of document sheets placed in the document tray, and scan the document again.</p>
<p>Condition</p> <p>Cause and remedy</p>	<p>Double feed error occurs even though the documents are not being double-fed (erroneous detection of double feed).</p> <p>If the size of the paper on which the patch code sheet is copied differs from that of the document to be scanned when the patch code sheet is used, the scanner erroneously judges this to be a double feed, and this error occurs. If this happens, turn OFF double feed detection, and scan the document again. Or, copy the patch code sheet on paper of same size as the document, and use that copy.</p>

Condition	When the document becomes dirty (with the optional imprinter installed).
Cause and remedy	This is because ink is sticking to the holes on the guide plate inside of the imprinter. Clean these holes with a cotton wool swab.

6.4

When the Scanned Image Is Not Normal

If there is a problem on the scanned image (image is not sharp or stripes appear on the image), one of the following may be a probable cause. Check the following and take the appropriate action.

- **The scanning glasses or rollers in the scanner are dirty.**

If the scanning glasses or rollers in the scanner are dirty, that dirt will appear on the scanned image.

→ Clean the scanning glasses and rollers. For details, see “Daily Cleaning,” on p.80.

- **The scan conditions are inappropriate.**

When the scan condition setup is inappropriate, the scanned image will not be sharp or will appear darkish.

→ Check the brightness and other scanner settings.

If the scanned image is foggy or the document is not scanned at all, a probable cause is that brightness is set too high.

If the scanned image appears darkish, a probable cause is that the brightness is set too low.

Also, check the settings on the driver and the application.

- **The driver or application does not run correctly.**

If the document cannot be scanned correctly even if the scan conditions are adjusted, a probable cause is that the driver or the application is not functioning correctly.

→ Reinstall the driver or application.

For details on how to install the driver, see Chapter 3, “Software.”

For details on how to install the application, see the instruction manual for the application in use.

- **Other Causes**

Even if the computer is correctly recognizing the scanner and the driver and the application is installed correctly, scanning may not be performed correctly.

A probable cause is that the interface card is not compatible. Use the recommended interface card.

If the above remedies do not rectify the problem, contact your service representative.

6.5

When an Error Code Is Displayed

When the scanner unit malfunctions or when trouble such as a paper feed or eject error occurs, an error code appears on the counter display of the operation panel. The following describes error codes that appear on the counter display and how to remedy the error.

ENGLISH

Error code	A01
Cause	The document does not feed correctly.
Remedy	Press the [Stop] key to reset the counter. Place the document back on the document tray and scan the document again.
Error code	C01
Cause	The upper scanner is open.
Remedy	Close the upper scanner.
Error code	C02
Cause	The imprinter cover is open (with the optional imprinter installed).
Remedy	Close the imprinter cover.
Error code	C03
Cause	The upper scanner and imprinter cover are open (with the optional imprinter installed).
Remedy	Close the upper scanner and imprinter cover.
Error code	C04
Cause	The endorser ED600 cover is open (with the optional endorser ED600 installed).
Remedy	Close the endorser ED600 cover.
Error code	C05
Cause	The upper scanner and endorser ED600 cover are open (with the optional endorser ED600 installed).
Remedy	Close the upper scanner and endorser ED600 cover.

Error code	C06
Cause	The imprinter cover and endorser ED600 cover are open (with the optional imprinter and endorser ED600 installed).
Remedy	Close the imprinter cover and endorser ED600 cover.

Error code	C07
Cause	The upper scanner, imprinter cover, and endorser ED600 cover are open (with the optional imprinter and endorser ED600 installed).
Remedy	Close all covers.

Error code	d02
Cause	Double feed detected by the document length.
Remedy	Check the document against the scanned image, and scan the document again.

Error code	d04
Cause	Double feed detected by the ultrasonic.
Remedy	Check the document against the scanned image, and scan the document again.

Error code	d06
Cause	Double feed detected by the document length and the ultrasonic.
Remedy	Check the document against the scanned image, and scan the document again.

Error codes	Exx (Service call error)
Cause	Scanner internal error
Remedy	The scanner must be repaired by a service engineer. Turn OFF the power, contact your service representative, and notify them of the error code.

Error code	H01
Cause	The optional imprinter's ink cartridge is not correctly installed.
Remedy	Install the imprinter cartridge properly.

Error code J01
Cause Staple detected, document transfer stopped.
Remedy Open the upper scanner and remove the document. Check to see if the document was scanned correctly, and scan the document again.

Error code J02
Cause Staple detected, document feed stopped.
Remedy Open the upper scanner and remove the document. Check to see if the document was scanned correctly, and scan the document again.

Error code J18
Cause Detected a skewed document, document feed stopped.
Remedy Open the upper scanner and remove the document. Check to see if the document was scanned correctly, and scan the document again.

Error code P00
Cause Document detected in the scanner when the power was turned ON or the upper scanner was open.
Remedy Remove the document that was left in the scanner. (See p.67.)

Error code P02
Cause Detected a document that is longer than the document that is set.
Remedy Open the upper scanner and remove the document. Check to see if the document was scanned correctly, and scan the document again.

Error code P03
Cause Detected a document that is shorter than the document that is set.
Remedy Open the upper scanner and remove the document. Check to see if the document was scanned correctly, and scan the document again.

Error code	P30
Cause	Endorser ED600 paper jam
Remedy	Clear the paper jammed from inside the optical endorser ED600, according to the instructions in the Endorser ED600 Instructions.

Error code	U01
Cause	Number of document sheets to be scanned exceeds set number of sheets in the verify scan.
Remedy	Two or more sheets may have been fed when the number of sheets is counted. Press the [Stop] key to reset the counter to "0." Check the number of sheets to see if all document sheets have been counted, and scan the document again.

Error code	U02
Cause	Number of scanned document sheets is less than the set number of sheets in the verify scan.
Remedy	Two or more sheets may have been fed when the document is scanned. Press the [Stop] key to reset the counter to "0." Check the number of scanned images with the number of document sheets to see if all document sheets have been correctly scanned, and scan the document again.

Chapter 7

Daily Cleaning

This chapter describes daily cleaning of the scanner.

7.1 Daily Cleaning	80
Cleaning the Main Unit	80
Cleaning the Document Detection Sensor	81
Cleaning the Scanning Glasses and Rollers	81
Cleaning the Shading Plates	85
Cleaning the Guide Plate (When Using the Imprinter)	87
Cleaning the Ink Jet Nozzles (When Using the Imprinter)	87
Power Outlet	87
7.2 Replacing the Rollers	88
When to Replace the Rollers	88
Resetting the Counter	89
Installing and Removing the Rollers	91

7.1

Daily Cleaning

To ensure high-quality image scanning, regularly clean your DR-6080/9080C as described below.



- Before you clean the scanner, turn OFF the scanner and computer and disconnect the power cord from the power outlet. Otherwise, it might cause an electrical shock.
- Never clean the scanner with any kind of organic solvent, such as alcohol, benzene, or paint thinner. It might cause a fire and electrical shock, or cause the exterior of the scanner to disfigure or discolor.
- Never spray mild detergent or water directly on the scanning glasses. The spray could penetrate below the glass and contaminate the internal light source and lenses.

Cleaning the Main Unit

Wipe the scanner with a firmly wrung cloth moistened slightly with water or mild detergent. Then wipe off with a clean, dry cloth.

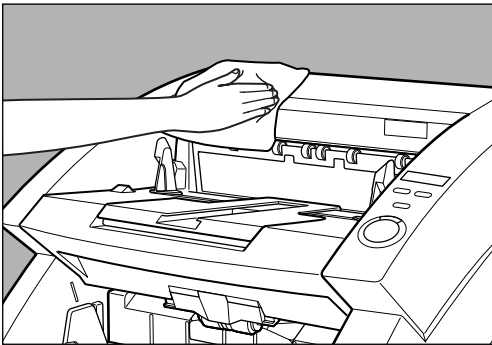

Cleaning the Document Detection Sensor

Dust and debris that collects on the sensor will cause false recognition. Clean the sensor periodically so that dust and debris do not collect on it.

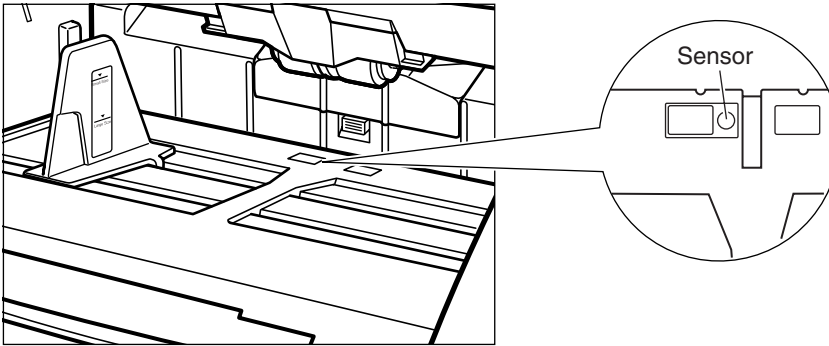

ENGLISH

Cleaning the Scanning Glasses and Rollers

A probable cause of stripes appearing on scanned images or dirt appearing on scanned documents is dirt on the scanning glasses or rollers. Clean the scanning glasses and rollers regularly.

1 Press the power switch to turn **OFF** the scanner, and unplug the power cord from the power outlet.

2 Close the document eject tray extension if it is open.

3 Open the upper scanner.

Press the open/close button, and lift up the upper scanner gently until it stop and locks in the open position.

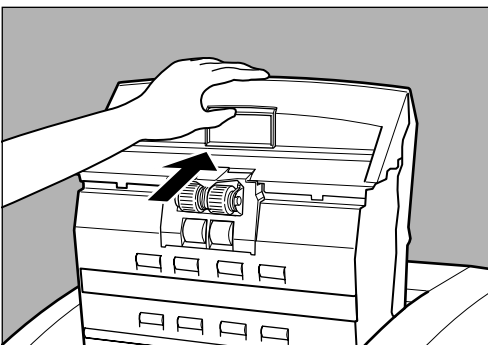

4 Use a clean, soft cloth to wipe the scanning glasses.

Be sure to clean both scanning glasses, the one below and one above.



Never spray mild detergent or water directly on the scanning glasses. The spray could penetrate below the glass and contaminate the internal light source and lenses.

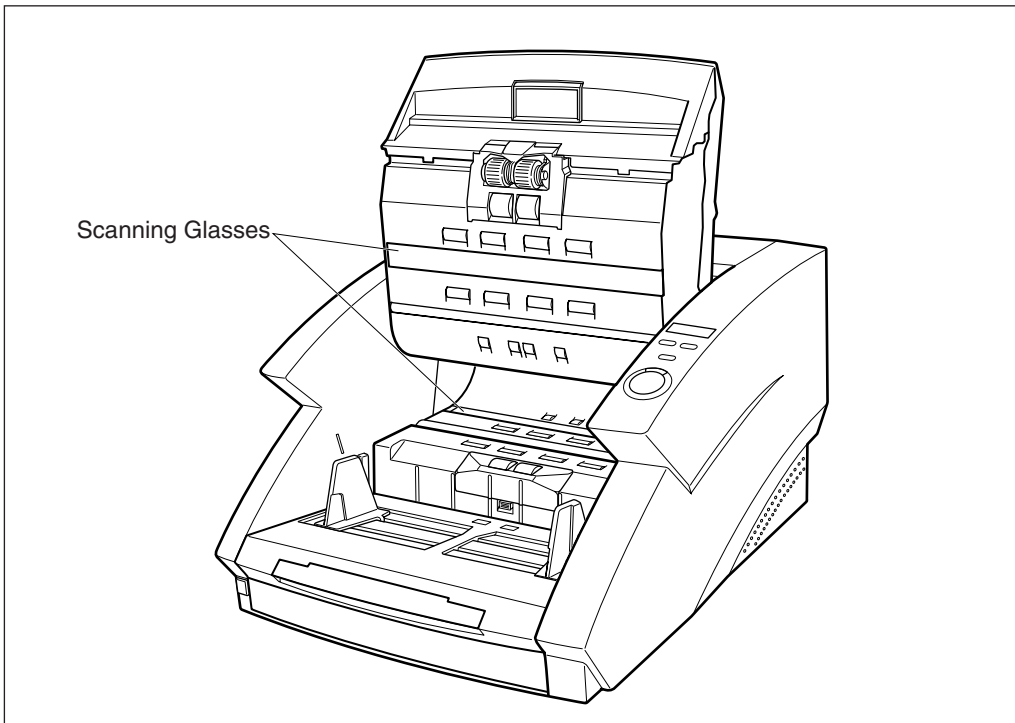

5 Wipe the rollers with a firmly wrung cloth moistened with water or mild detergent.

Rollers are located at the positions indicated in the figure below.

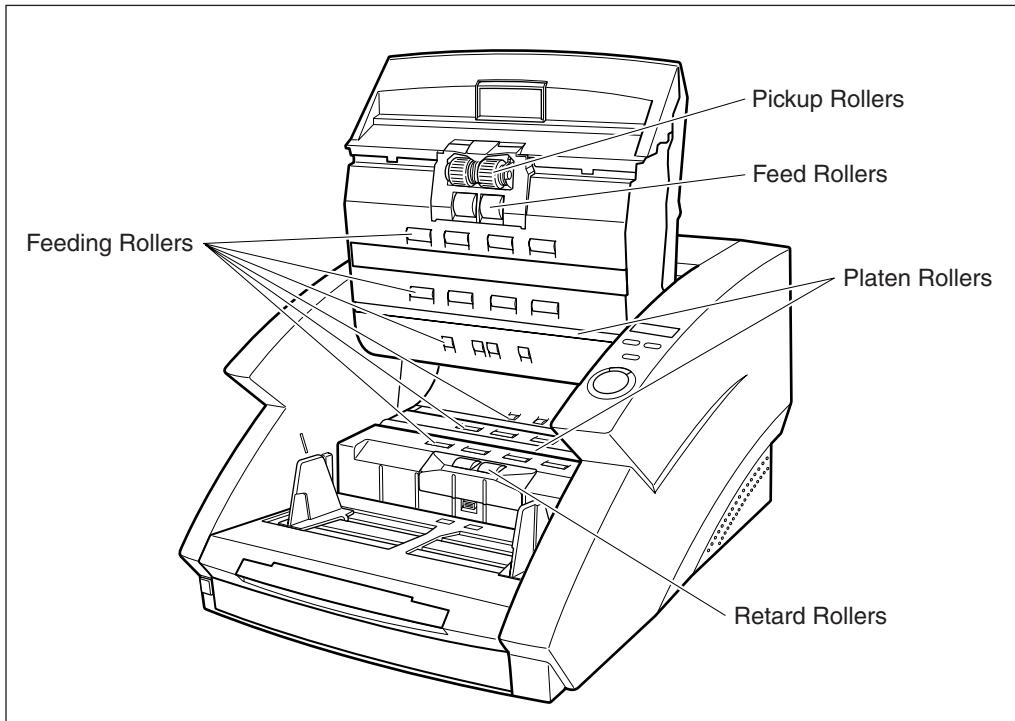

ENGLISH

6 Remove the pickup roller, retard roller, and feed roller. (See “Installing and Removing the Rollers,” on p.91.)

7 Use cloth from which all the water has been wrung out to wipe off the rollers.

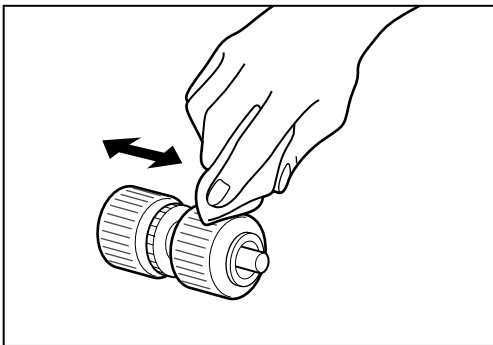

8 Replace the rollers that you removed. (See “Installing and Removing the Rollers,” on p.91.)

9 Carefully close the upper scanner.

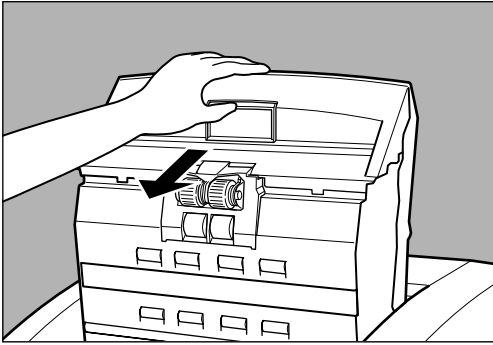

10 Press the upper scanner down firmly on both sides to close it.

If you press the upper scanner down only on one side, the opposite side will not be fully closed. Make sure that you hear it click into place.

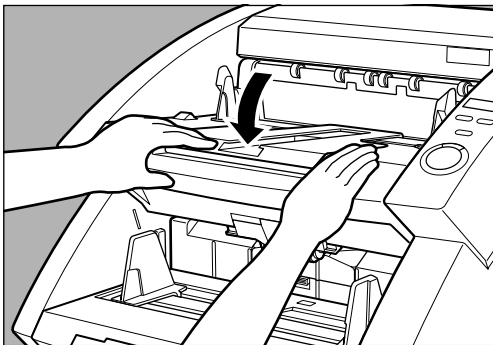

If paper jams or double-feed (feeding of two or more document pages) occurs frequently in spite of your having cleaned the rollers, a probable cause is roller friction. If this happens, replace the rollers. Contact your service representative.

Cleaning the Shading Plates

If scanned images appear scratchy even after you have cleaned the rollers, the shading plates inside the scanner may be dirty. If this happens, clean the shading plates.



The power to the scanner is ON when you are cleaning the shading plates so be very careful.

ENGLISH

1 Open the upper scanner.

Press the open/close button, and lift up the upper scanner gently until it stops and locks in the open position.

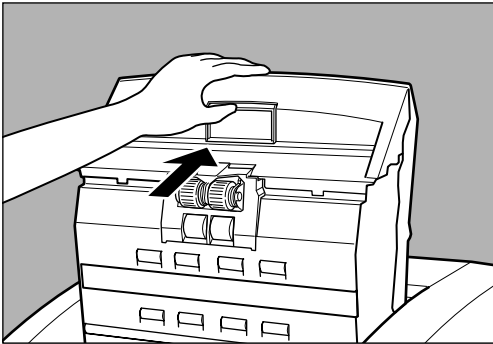

2 Press the [Start] key.

The shading plates come out from above the platen rollers.

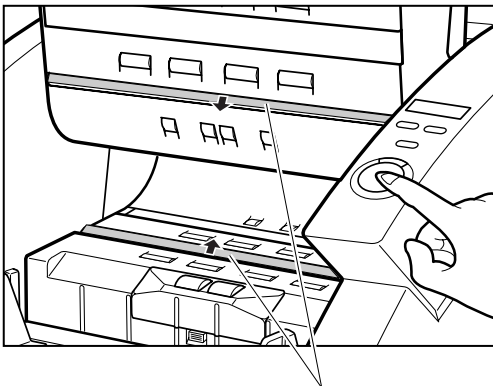

Shading Plates

3 Wipe the shading plates with a firmly wrung cloth moistened with water or mild detergent.

- 4 Press the [Stop] key.**
The shading plates retract.

- 5 Carefully close the upper scanner.**

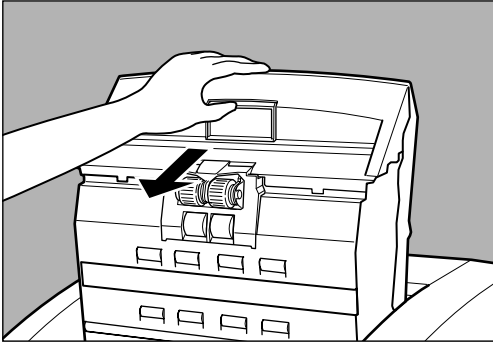

- 6 Press the upper scanner down firmly on both sides to close it.**
If you press the upper scanner down only on one side, the opposite side will not be fully closed. Make sure that you hear it click into place.

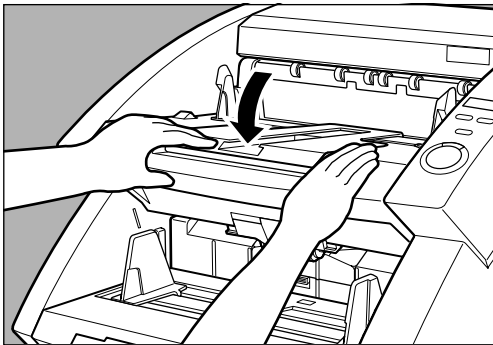

If there is no change in the appearance of the image after you have cleaned the shading plates, contact your service representative.

Cleaning the Guide Plate (When Using the Imprinter)

Ink that collects on the guide plate inside the optional imprinter may stain the documents when they are scanned. Clean off the ink with water and a mild detergent on a soft cloth that has been firmly wrung, and then thoroughly dry it with a dry cloth.

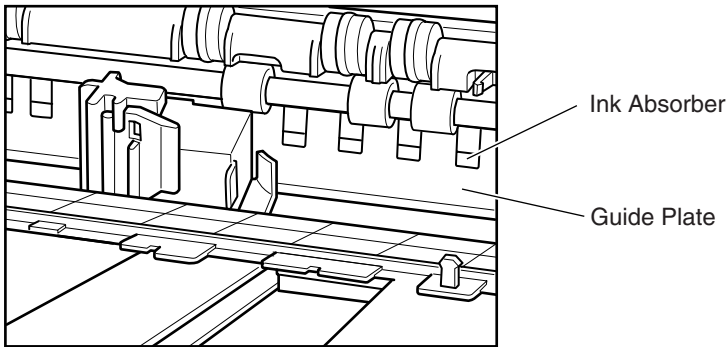

ENGLISH

Cleaning the Ink Jet Nozzles (When Using the Imprinter)

Ink that collects around the ink jet nozzle may stain your documents or cause the text to appear scratchy. Remove the ink jets and clean them periodically with cotton swabs.

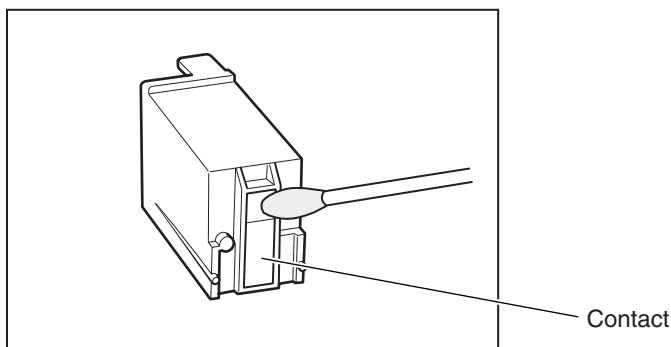

Important

Do not touch the contact while you are cleaning the ink jet nozzles. Doing so may cause incorrect printing.

Power Outlet

If you leave the power plug connected to the power outlet for a long period of time, dust may accumulate at the power outlet, and cause a fire or electrical shock. Clean it periodically.

7.2

Replacing the Rollers

The feed rollers (pickup rollers, feed rollers, and retard rollers) are consumables. The feed rollers need to be changed periodically to maintain scanning quality.

When to Replace the Rollers

If the total number of scanned documents exceeds 250,000, a message for roller replacement appears when you restart the computer. In this case, buy the exchange roller kit and replace the feed rollers (pickup rollers, feed rollers, and retard rollers).



Be sure to reset the counter after changing the counter.



Important

- Windows NT do not support a function to display a message for roller replacement. To confirm the total scan, check “Total Scanning Count” in the “About” dialog box of the ISIS/TWAIN driver and replace the feed rollers if the count shows around 250,000 scans.

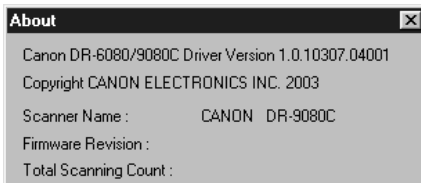

- Contact your sales representative for information about exchange roller kit (pickup rollers, feed rollers, and retard rollers).

Resetting the Counter

Do the following procedure to reset the counter after replacing the feed rollers.

- 1 Click the [Start] button, and then click [Settings]-[Control Panel].

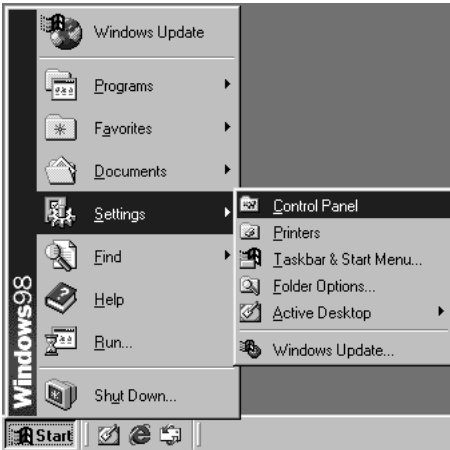

- 2 Double click on the [Scanners and Cameras] icon



Note

- Windows NT do not display the “Scanners and Cameras” icon.
- The displayed dialog box differs depending on which Windows operating system you are using.

3 Select the scanner that you are using, and click on the [Properties] button.

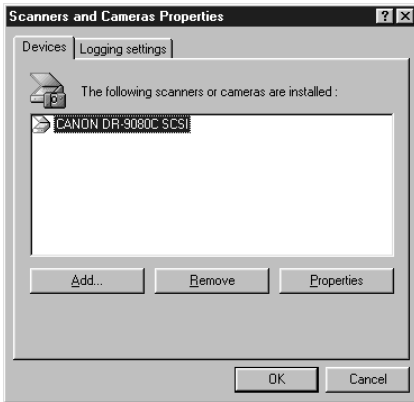

4 Click the [Counter] tab.

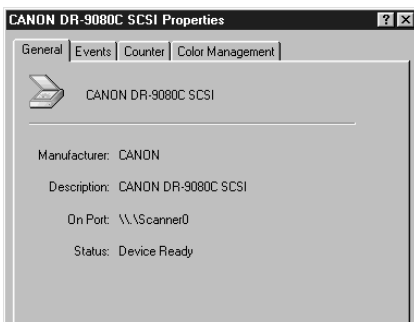

5 Click the [Reset] button and confirm whether the [Current Rollers] is reset to 0.

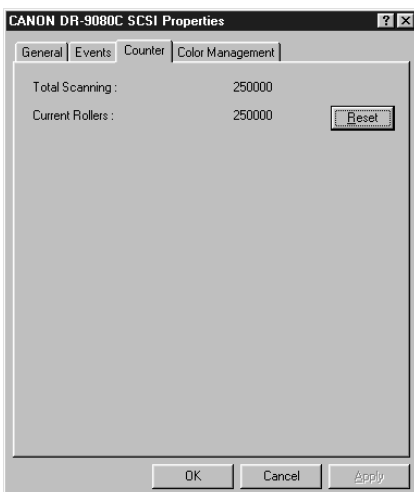

Installing and Removing the Rollers

Follow the procedure shown below to remove and install the rollers when you need to clean or replace the pickup, feed, or retard rollers.



CAUTION

- Turn OFF the power to the scanner and unplug the power cord from the power outlet when you remove or install the rollers. Leaving the power turned ON may result in an electrical shock.
- When removing or replacing the rollers be careful to not use too much force. Forcing the rollers into position may damage them.

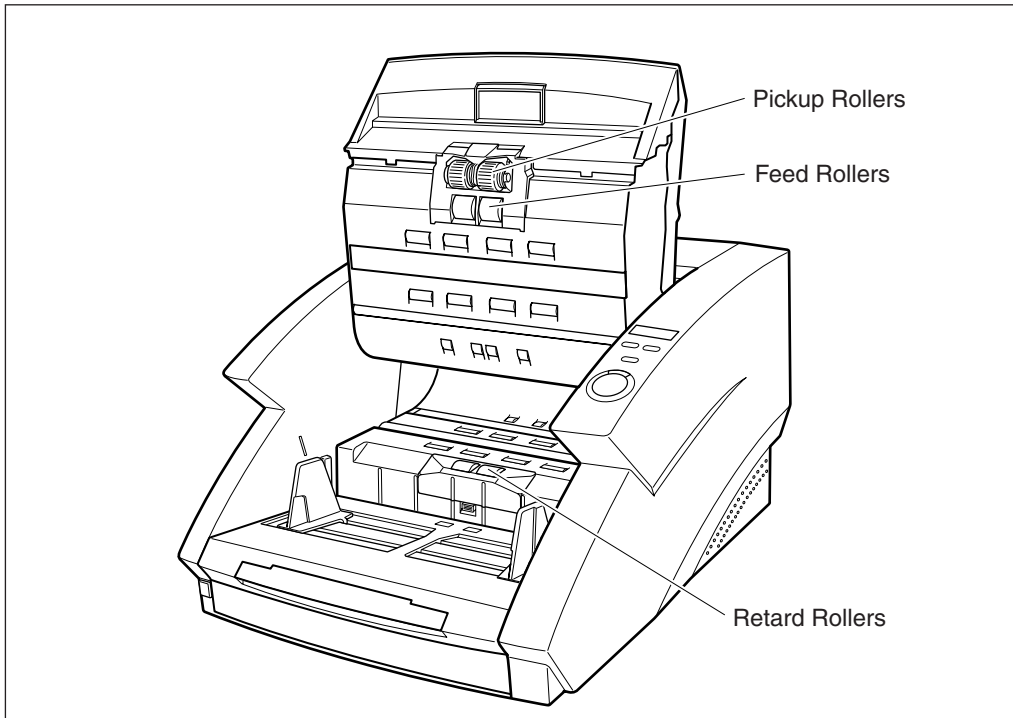

◆ Installing and Removing Pickup Rollers

1 Open the upper scanner.

2 Open the roller cover.

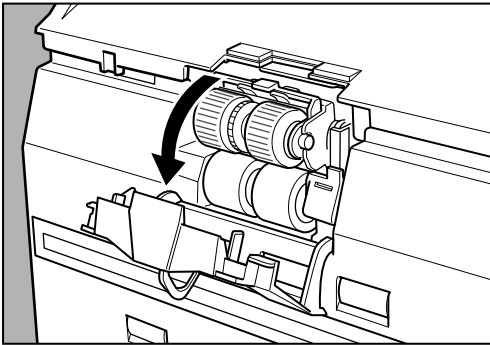

3 Open the roller holder and remove the pickup rollers.

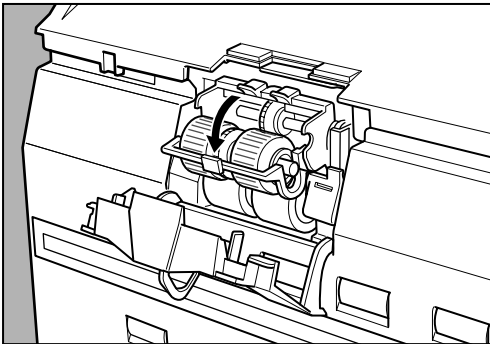

4 Position the square axle of the pickup roller on the left and insert the new pickup rollers.

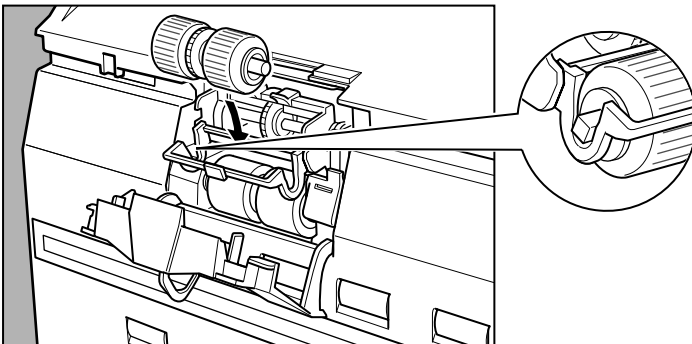

5 Firmly close the roller holder until you hear it click.

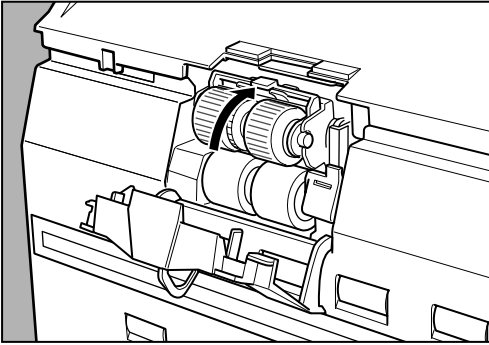

6 Firmly close the roller cover until you hear it click.

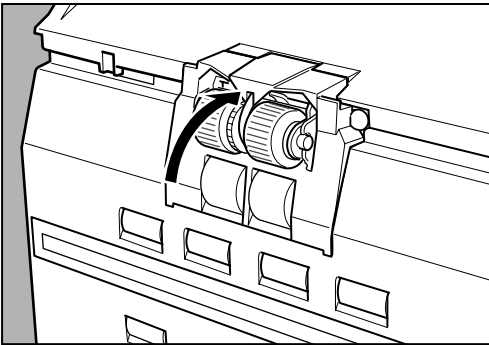

7 Carefully close the upper scanner.



Important

If the roller holder and roller cover are not firmly closed it will cause a feed error.
Always be sure to check that the roller holder and roller cover are closed.

◆ Installing and Removing Feed Rollers

1 Open the upper scanner.

2 Open the roller cover.

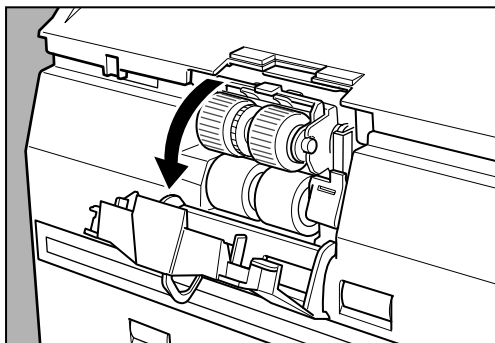

3 Pull the lever that locks the feed rollers in place towards you.

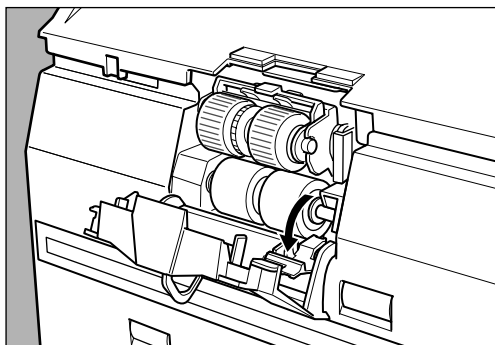

4 Slide the feed rollers to the right, and then pull them towards you.

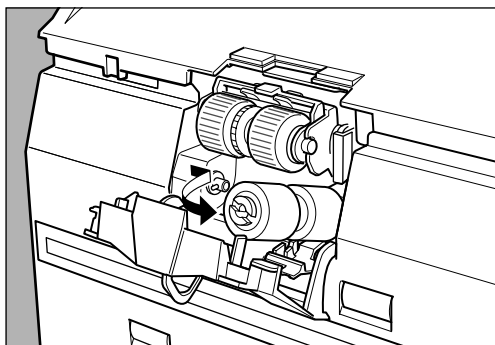

5 Remove the feed rollers.

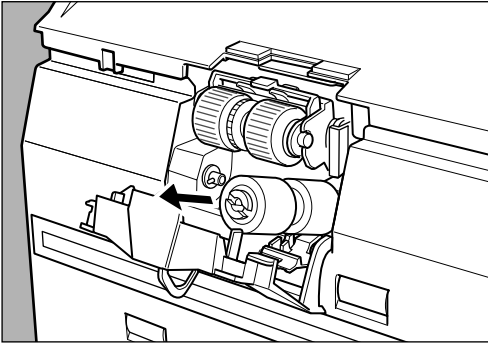

6 Place the new feed rollers on the pin.

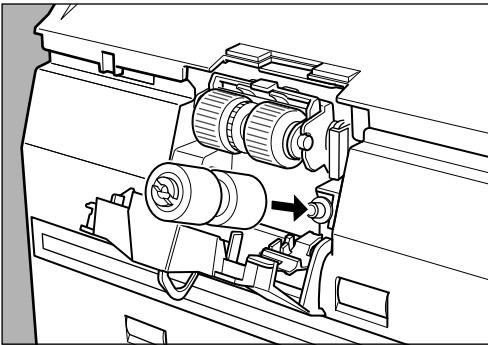

7 Set the feed rollers in place (①), and align the notch in the roller's axle with the shaft on the scanner (②).

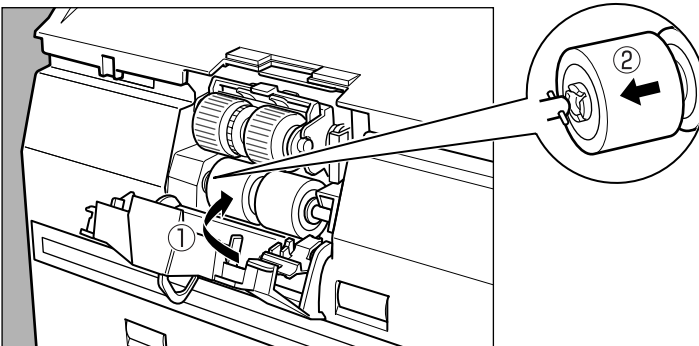

8 Lock the lever.

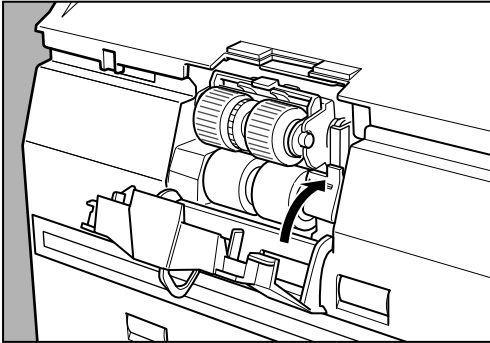

9 Firmly close the roller cover until you hear it click.

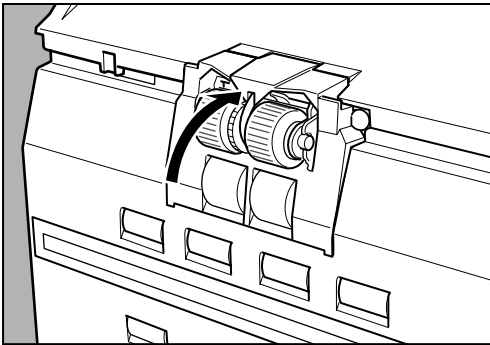

10 Carefully close the upper scanner.



If the roller cover is not firmly closed it will cause a feed error. Always be sure to check that the roller cover is closed.

◆ Installing and Removing Retard Rollers

1 Open the upper scanner.

2 Press the hook upwards and remove the roller cover.

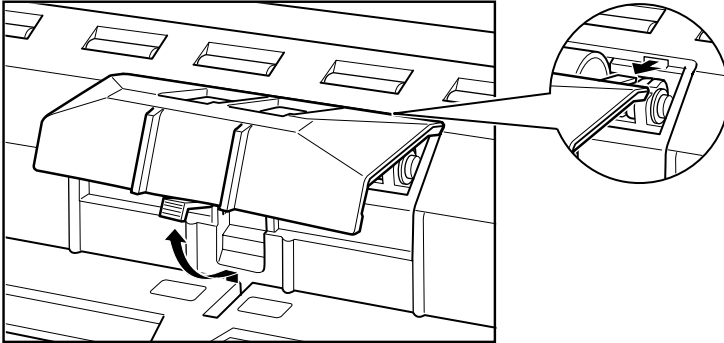

3 Lift the roller clamp lever (①) and slide it to the left (②).

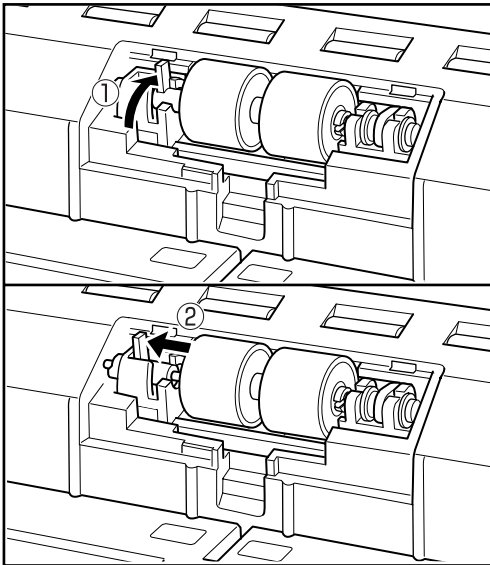

4 Move the retard rollers to the left and remove them.

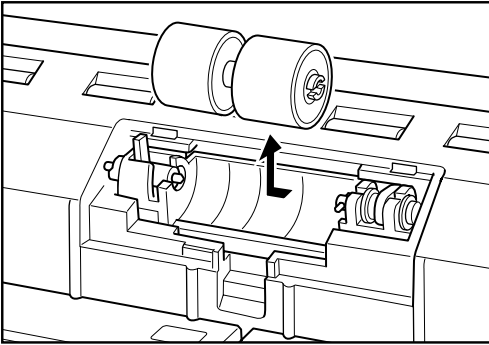

5 Set the new retard rollers in place, and align the notch in the roller's axle with the shaft on the scanner.

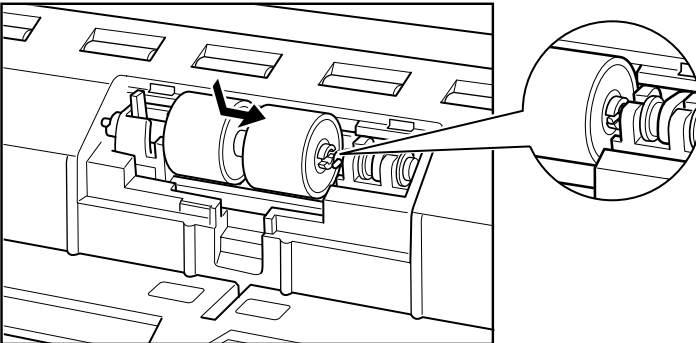

6 Slide the roller clamp lever to the right, and push it into the hole in the retard rollers.

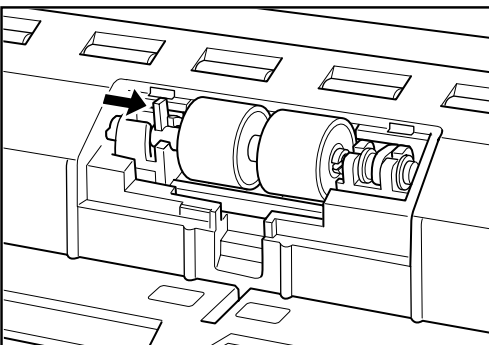

7 Pull the lever towards you to clamp the retard rollers in place.

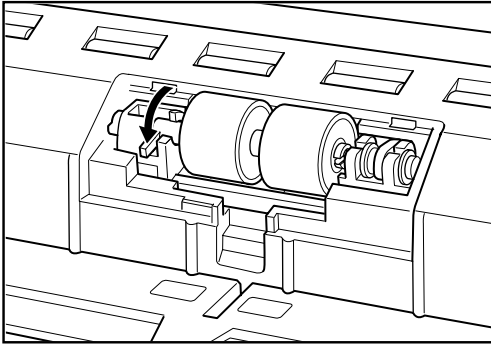

8 Put back the roller cover.

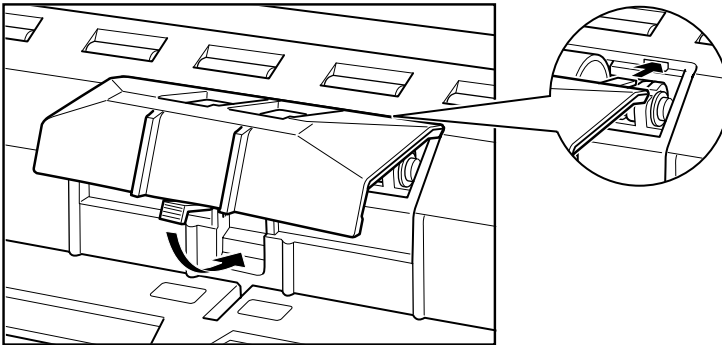

9 Carefully close the upper scanner.



CAUTION

- Be sure that the hook is completely latched and the roller cover is not loose. If the roller cover is loose, the document tray will catch on it causing the scanner to not operate correctly.
- Never clean the scanner with any kind of organic solvent, such as alcohol, benzene, or paint thinner. Doing so might cause a fire and electrical shock, or cause the exterior of the scanner to disfigure or discolor.

Specifications

Specifications for the Scanner

Type	Desktop sheet fed type			
Document size	Width:	55 to 305 mm		
	Length:	70 to 432 mm		
	Thickness:	70 to 1,000 mm (Long Document mode)		
		0.06 to 0.15 mm (Auto feeding)		
		0.05 to 0.3 mm (Manual feeding)		
	Weight:	48 to 120 g/m ² (Auto feeding)		
		40 to 240 g/m ² (Manual feeding)		
Document feeding	Semiautomatic/automatic/manual (Bypass mode)			
Scanning method	Contact image sensor (CMOS)			
Light source	Three color (RGB) single-line LED			
Scanning side	Simplex/duplex			
Scanning mode	DR-6080	Black and white, advanced text enhanced, error diffusion, 256-level grayscale		
	DR-9080C	Black and white, advanced text enhanced, error diffusion, 256-level grayscale, 24-bit color, 24 bit smoothing color		
Scanning resolution (primary scan lines x secondary scan lines)	600 x 600dpi/400 x 400dpi/300 x 300dpi/ 240 x 240dpi/200 x 200dpi/150 x 150dpi/ 100 x 100dpi			
Scanning speed (max.)			DR-9080C	DR-6080
Black and White	Simplex	300 x 300 dpi	90 ppm	63 ppm
	Duplex	300 x 300 dpi	180 ipm	126 ipm
256-level grayscale	Simplex	200 x 200 dpi	90 ppm	63 ppm
		300 x 300 dpi	87 ppm	63 ppm
	Duplex	200 x 200 dpi	170 ipm	126 ipm
		300 x 300 dpi	86 ipm	84 ipm
24-bit color	Simplex	100 x 100 dpi	90 ppm	
		200 x 200 dpi	54 ppm	
	Duplex	100 x 100 dpi	180 ipm	
		200 x 200 dpi	92 ipm	
Automatic feed capacity	A4 (LTR) or smaller: Max. 500 sheets (80g/m ²) Larger than A4 (LTR): Max. 200 sheets (80g/m ²)			
Interface	SCSI III/Hi-Speed USB 2.0			
Other functions	Automatic paper size detection, Paper thickness and double feed detection, Staple detection, Skew detection, Dropout color, Count only mode			
Dimensions	312 mm (H) x 460 mm (W) x 525 mm (D)			
Weight	Approximately 25 kg			

Power requirement	AC 220-240V (50/60 Hz) AC 120V (60 Hz)
Power consumption	
220-240V model	Operating: 0.5 A maximum Standby: Under 0.23 A
120V model	Operating: 1 A maximum Standby: Under 0.23 A
Noise	Less than 70 dB
Operating environment	Temperature: 10°C to 32.5°C (50°F to 90.5°F) Humidity: 20% to 80% RH

- You can use the functions noted above if the software supports them.
- They may not work depending on your computer's capabilities and the software you are using.
- If the scanning conditions are set to duplex scanning, color scanning, or high density (600 dpi) scanning, then large documents such as 11" x 17" size paper and A3 size paper cannot be scanned. Change the scan conditions to scan these sizes.

Specifications are subject to change without notice.

Options

Imprinter	Prints a variety of text messages on the front of the scanned document.
Endorser	Endorses a variety of text messages and a six digit number on the back of the scanned document.
Hard Counter	Counts the number of pages fed through the scanner.
Bar Code Module	Add on software that allows bar codes to be recognized by the ISIS/TWAIN driver.

- When using the endorser, the scanning speed lowers to match the printing speed of the endorser.
- Ink cartridge for the imprinter is not included. Please purchase the Hewlett-Packard ink cartridge.
- Contact your sales representative for information about optional products.

Consumables

Exchange Roller Kit	This kit is for replacing the feed rollers. If a roller replacement message appears, contact your service representative to buy an Exchange Roller Kit. (See "Replacing the Rollers," on p.88.)
----------------------------	---

Exterior Dimensions

Units: millimeters

◆ Top view

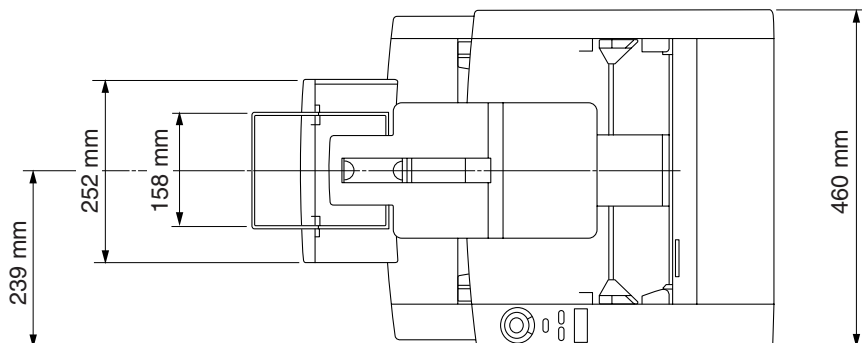

◆ Side view

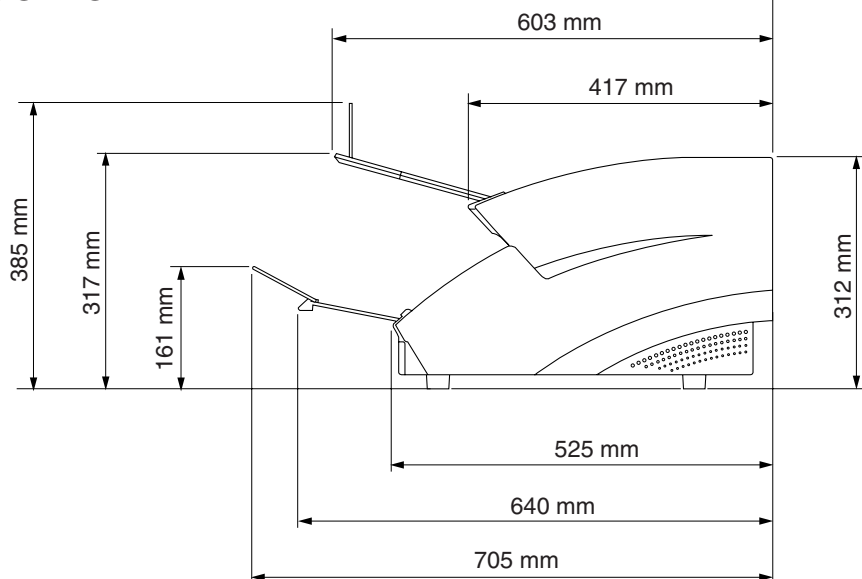

Index

- A -**
- About documents 42
 - How to place documents 43
 - Type of documents 42
- About the power supply 8
- Air vent 14
- Automatic feeding 48

- B -**
- Bypass mode 15, 50

- C -**
- CapturePerfect 32
 - How to use CapturePerfect 37
 - Install 34
- Carrying 8
- Cleaning
 - Document detection sensor 81
 - Main unit 80
 - Power outlet 87
 - Rollers 81
 - Scanning glasses 81
- Connecting to a computer 19
- Connectors 14
- Consumables 101
- Count only key 15, 52
- Count only mode 52
- Counter 89
- Counter display 15

- D -**
- Daily cleaning 80
- Daily maintenance 5
- DIP switch 14
- Document detection function 58
- Document detection sensor 49
- Document eject tray extension . 13, 25
- Document eject tray guide 13
- Document guide 13
- Document tray 13

- Document tray extension 13, 24
- Double feed detection function 58

- E -**
- Error code 75
- Extension wire 13, 24
- Exterior dimensions 102

- F -**
- Features of DR-6080/9080C 10
- Feed rollers 88
 - Installing and removing the rollers 91
 - Replacing the feed rollers 88
- File separation 53

- G -**
- Guide plate 87

- I -**
- Imprinter cover 13
- Ink absorber 87
- Installation location 7
- ISIS/TWAIN driver 32
 - How to use the ISIS/TWAIN driver 36
 - Install 33

- M -**
- Manual feeding 50

- N -**
- New file key 15

- O -**
- Operating environment 18
- Operation panel 13, 15
- Options 16, 101

- P -

Panel- feeding	46
Paper feed methods	44
- Automatic feeding	44
- Manual feeding	44
- Panel- feeding	44
- Standard feeding	44
Paper feed trouble	72
Paper jams	67
Part names	13
Patch code patterns	54
Patch code sheets	53
- How to use patch code sheets ...	53
PATCH II	54
PATCH T	54
Power cord	23
Power cord connector	14
Power switch	13, 27

- R -

Recognizing the scanner	28
Retard roller	97

- S -

SCSI connections	
- Connecting to a computer	19
- Operating environment	18
SCSI connector	14
Setup disc	12
Skew detection function	58
Software	32
- How to use the software	36
- Install	33
- Uninstall	39
Specifications	100
Standard feeding	45
Staple detection	59
Start key	15
Stop key	15
Stopper	13, 25

- T -

Troubleshooting	63
Turning OFF the power	30
Turning ON the power	27

- U -

Unpacking the scanner	12
Upper scanner	13
USB connections	
- Connecting to a computer	22
- Operating environment	18
USB connector	14
User mode	60
- How to set the user mode	61

Canon

CANON ELECTRONICS INC.

1248, SHIMOKAGEMORI, CHICHIBU-SHI, SAITAMA 369-1892, JAPAN

CANON U.S.A. INC.

ONE CANON PLAZA, LAKE SUCCESS, N.Y.11042, U.S.A.

CANON CANADA INC.

6390 DIXIE ROAD, MISSISSAUGA, ONTARIO L5T 1P7, CANADA

CANON EUROPA N.V.

BOVENKERKERWEG 59-61, P.O.BOX 2262 AMSTELVEEN, THE NETHERLANDS

CANON LATIN AMERICA, INC.

703 WATERFORD WAY SUITE 400 MIAMI, FLORIDA 33126 U.S.A.

CANON AUSTRALIA PTY. LTD.

1 THOMAS HOLT DRIVE, NORTH RYDE, SYDNEY. N.S.W, 2113. AUSTRALIA

CANON SINGAPORE PTE. LTD.

79 ANSON ROAD #09-01/06, SINGAPORE 079906

CANON HONGKONG COMPANY LTD.

9/F., THE HONG KONGCLUB BUILDING, 3A CHARTER ROAD, CENTRAL, HONG KONG.



CE-IM-423

Imprinter for DR-6080/9080C Installation Procedure

IMS Product Planning Dept.

1. Confirm the following component parts.

IP drain pad unit

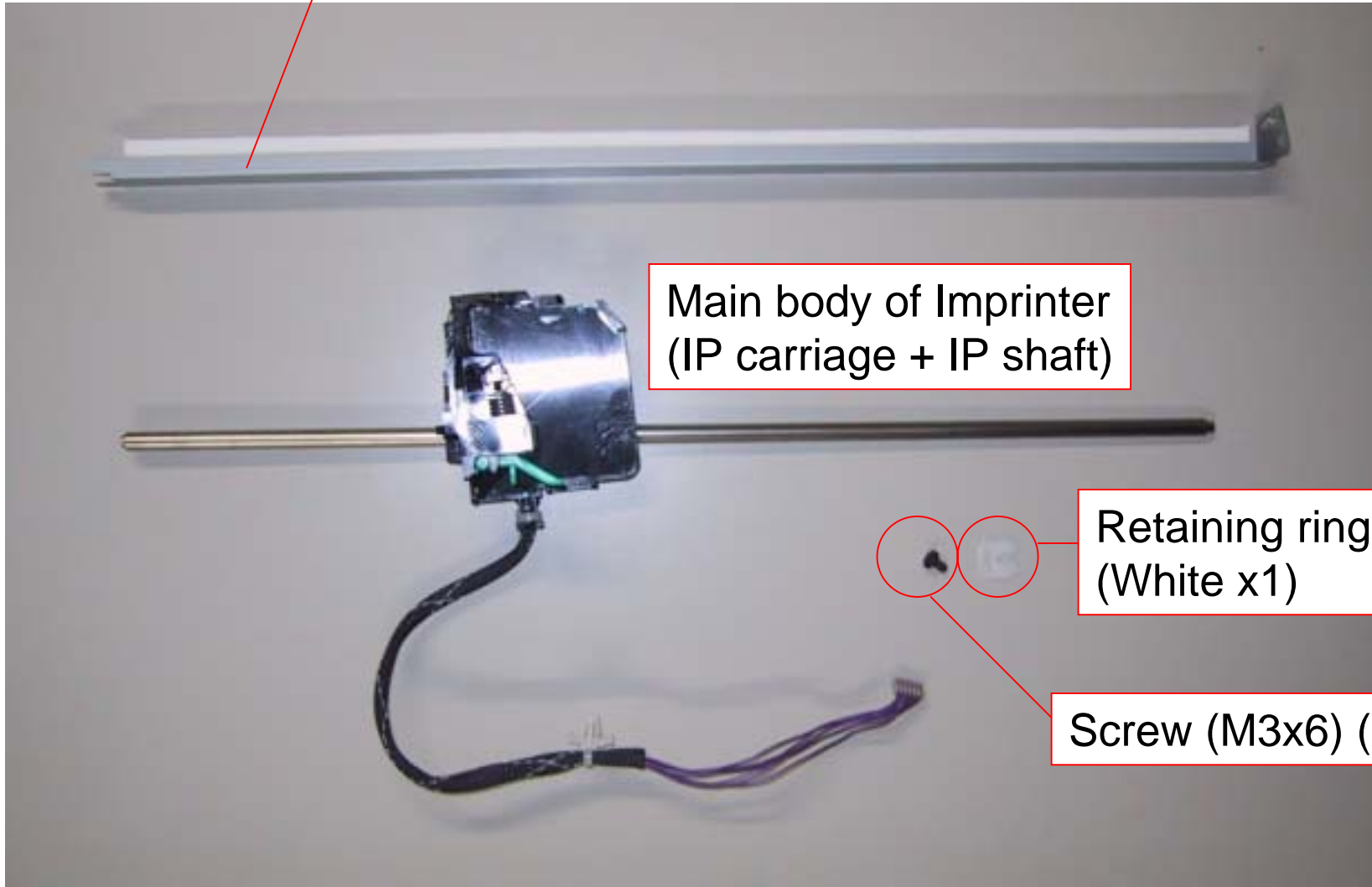

Main body of Imprinter
(IP carriage + IP shaft)

Retaining ring
(White x1)

Screw (M3x6) (x1)

2. Remove the rear cover. (6 screws)

Note) The rear cover of mass production model will be painted.

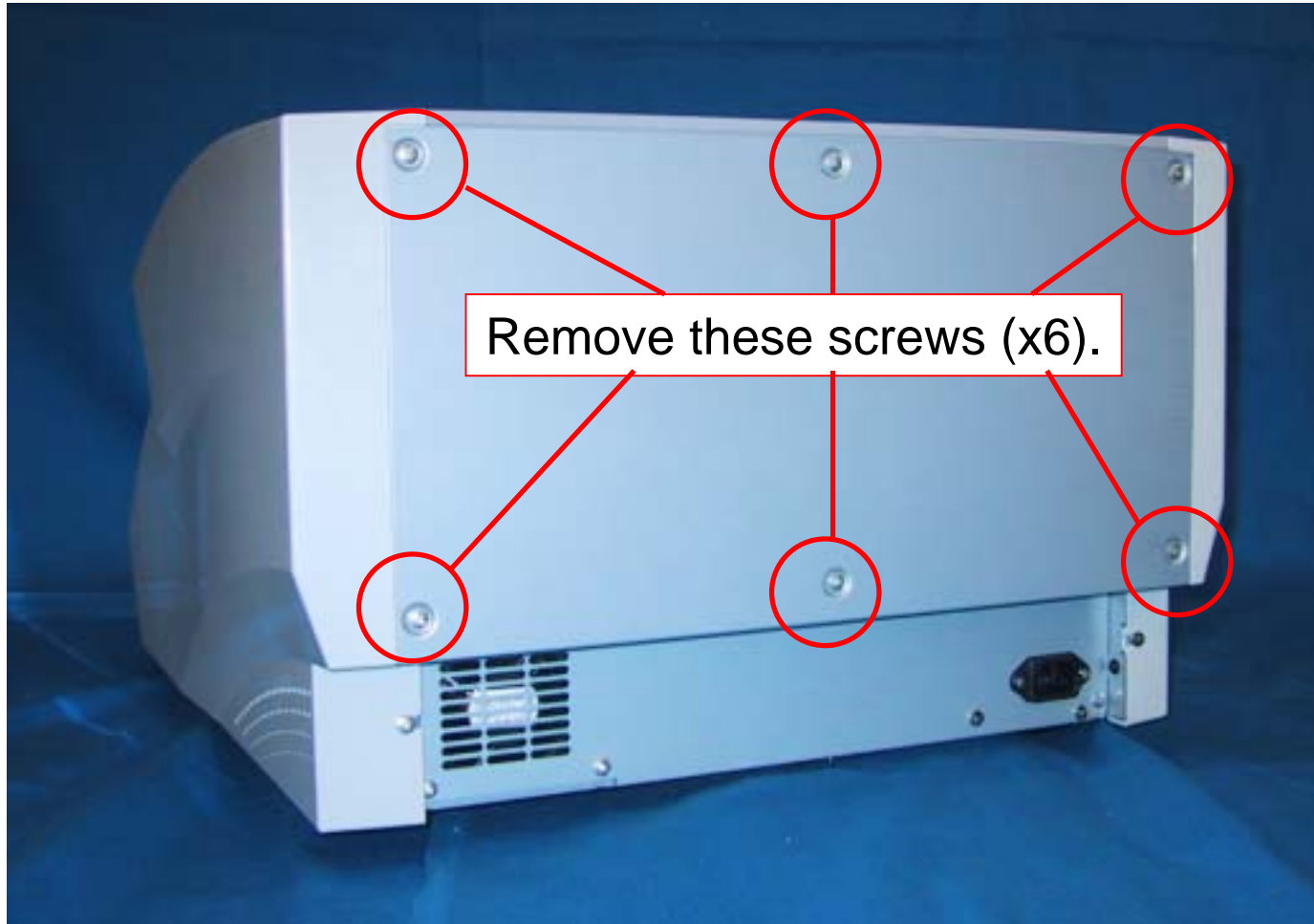

3. Remove the left cover. (4 screws)

Remove these screws. (x4)

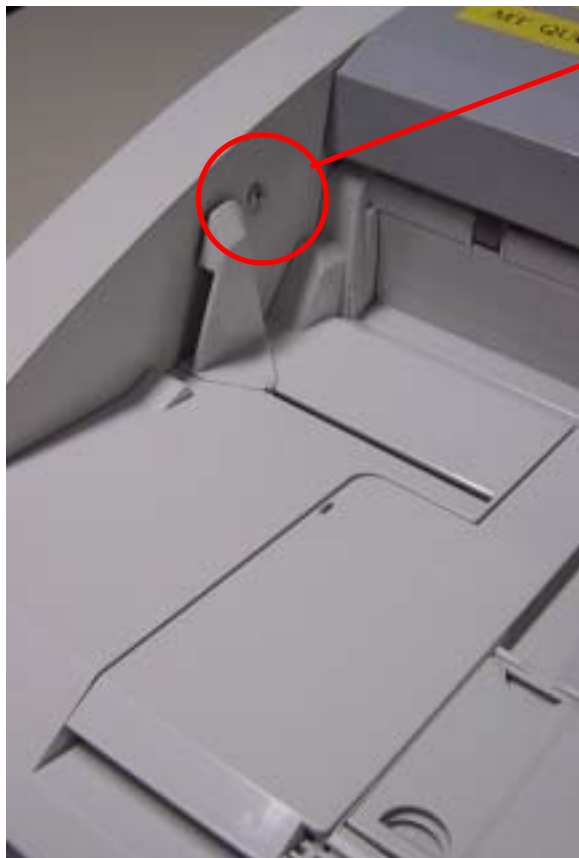

4. Open the imprinter cover of the upper unit, and remove the center screw (x1).

Press here for open the imprinter cover.



Remove this screw.

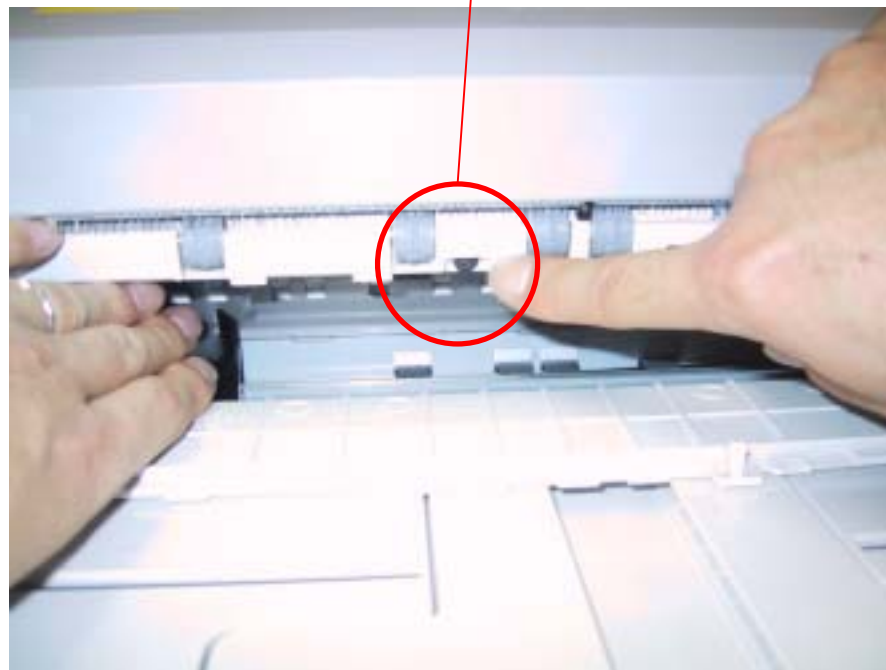

5. Open the upper unit, and remove the screws (x6) of right and left sides.

Remove these screws (x6).

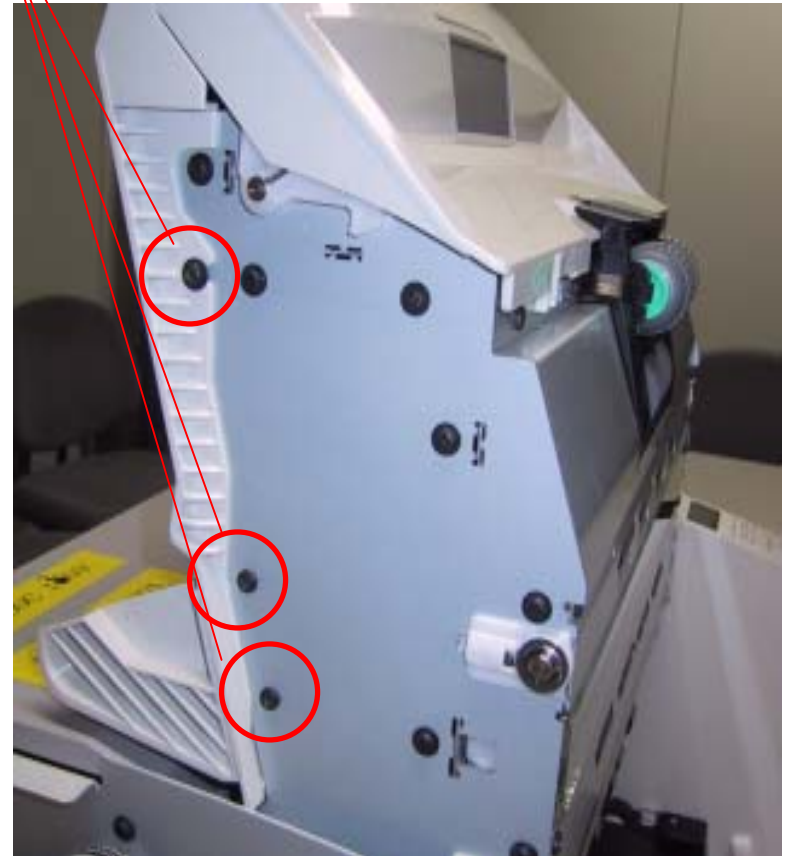
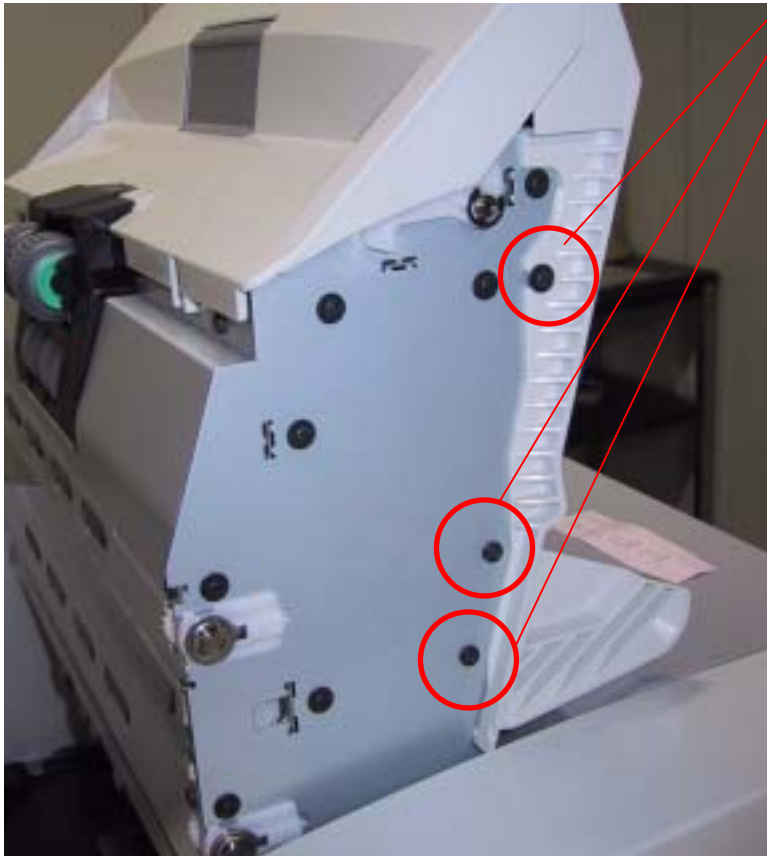

6. Insert the IP drain pad unit to the hole of left side of the main body in the proper direction.

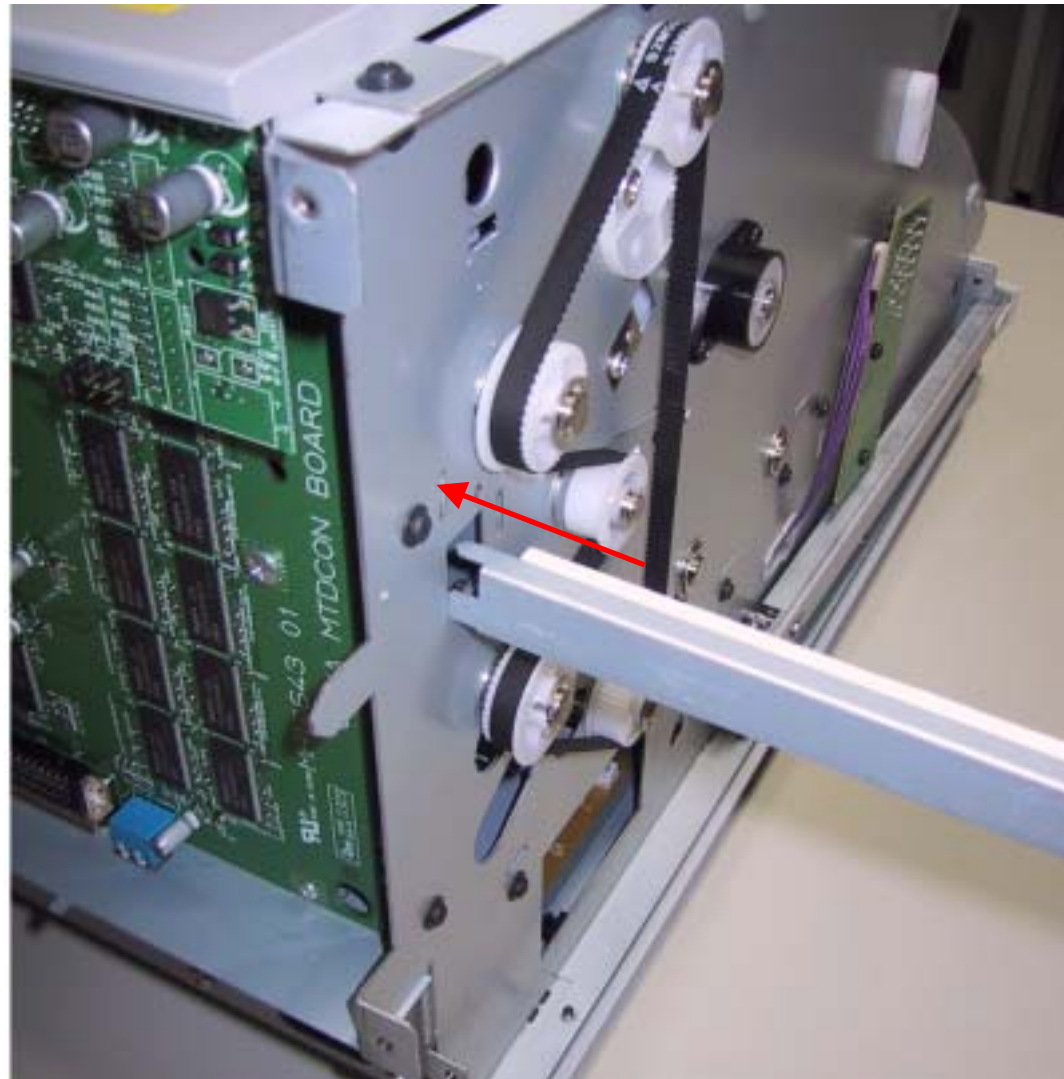

7. Insert it firmly to the back, and fix it with 1 screw (M3x6).

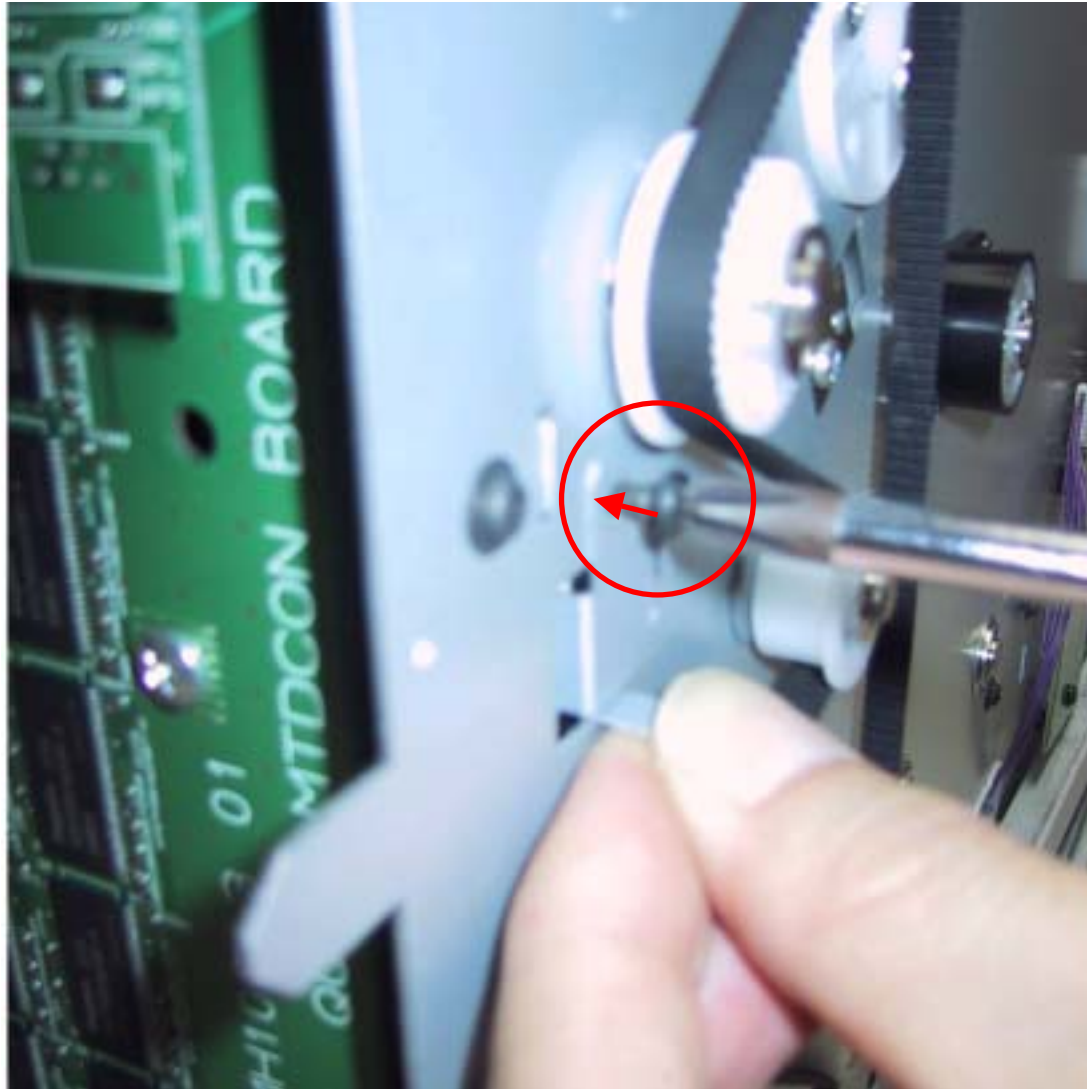

8. Remove the cable from the cable clamp of right side of main body's interior to avoid becoming an obstacle later.

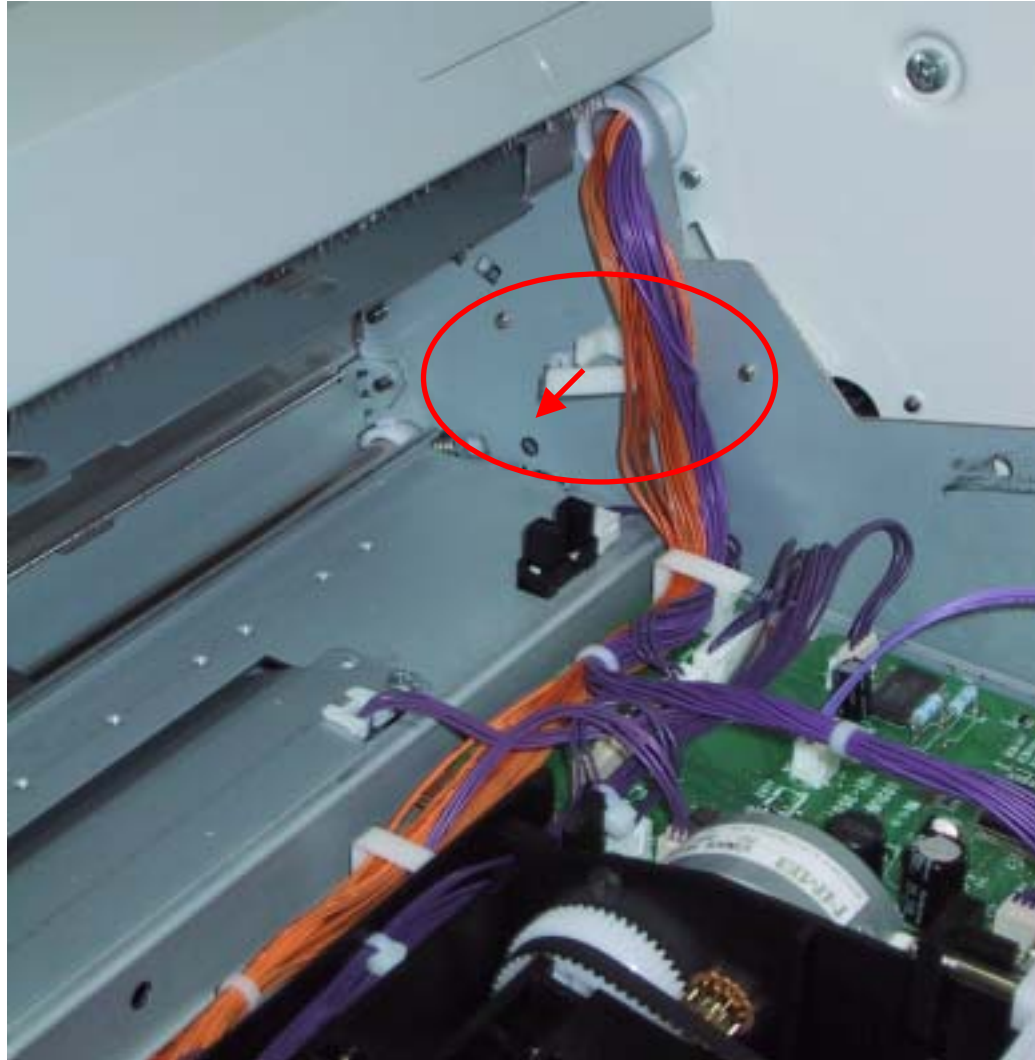

9. Insert the IP shaft to the hole of left side of main body's interior. (Insert the one that a tip is long.)

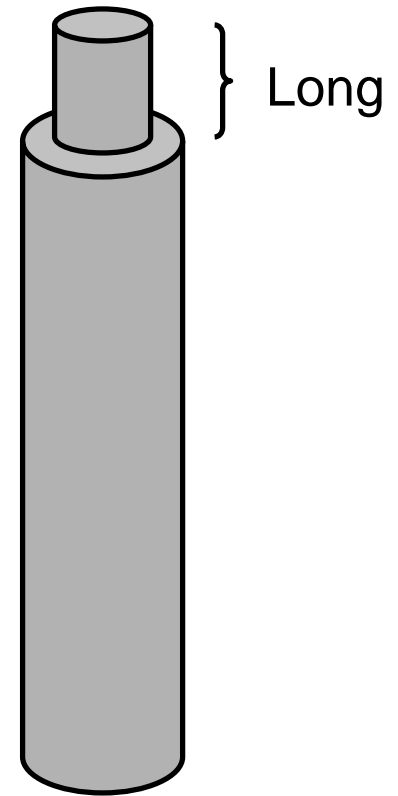

10. Insert the tip of rest one of the IP shaft to the hole of right side of main body's interior.

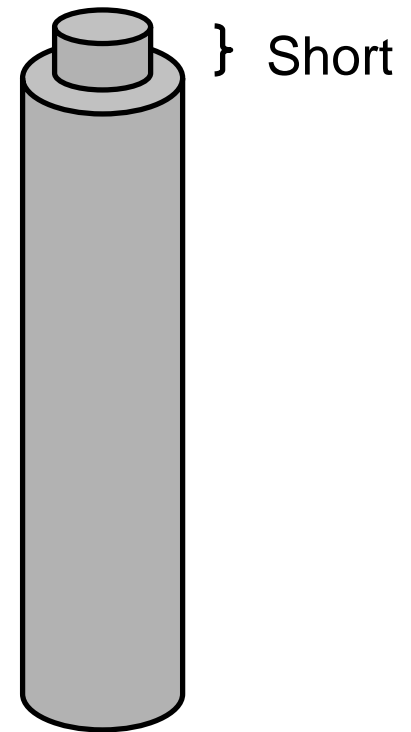
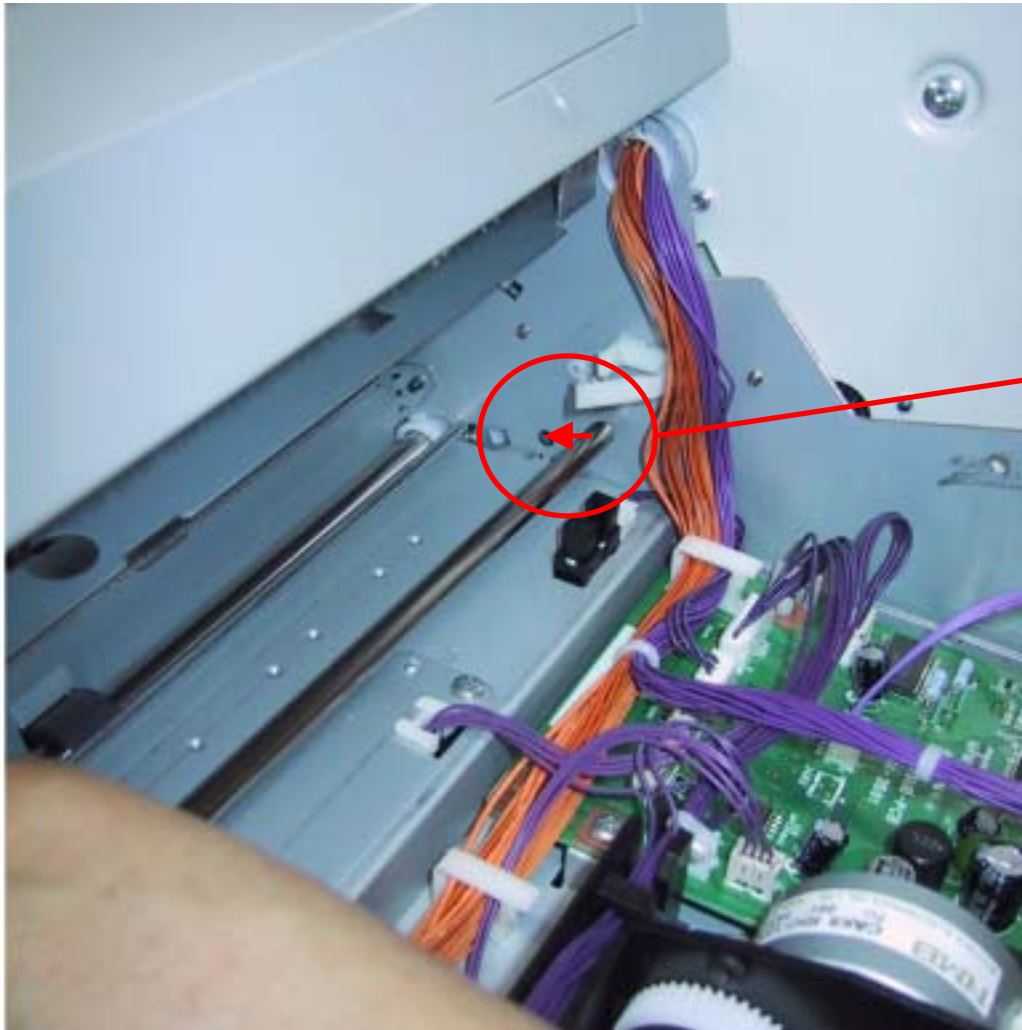

11. Fit the retaining ring to left side of the IP shaft, and fix it not to move.

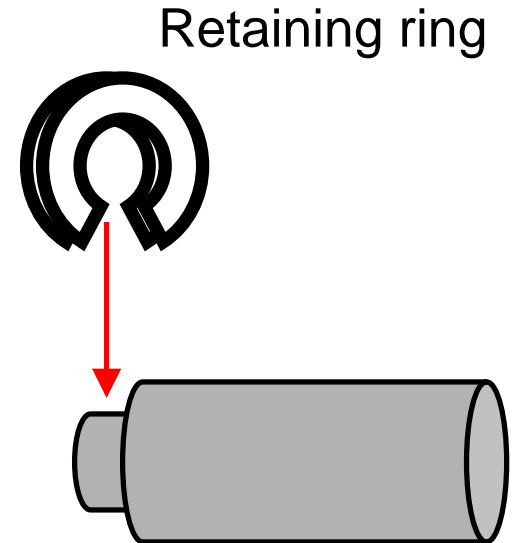
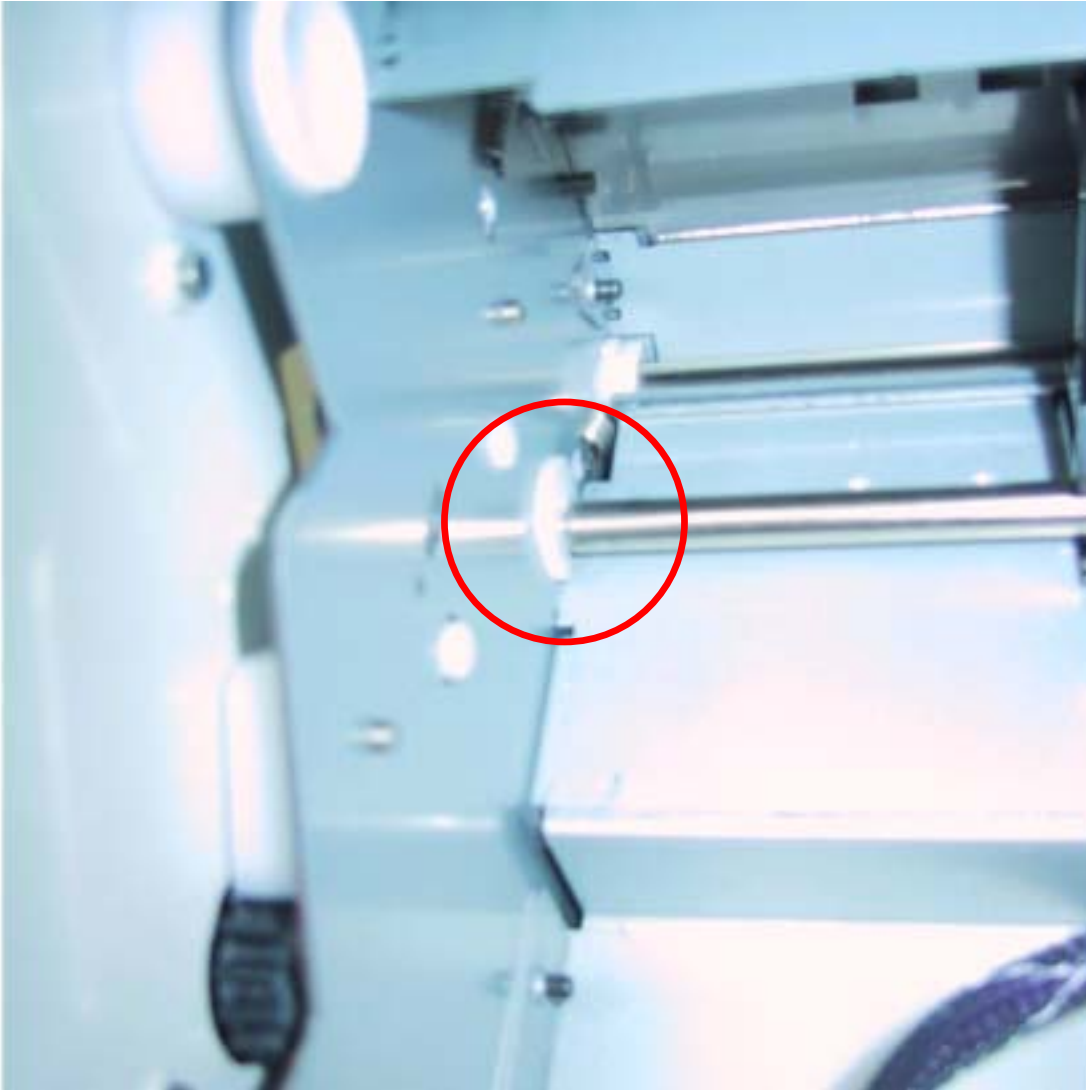

12. Insert the snap band (fastener) of the imprinter carriage's cable to the hole in center position of frame of the main body's interior.

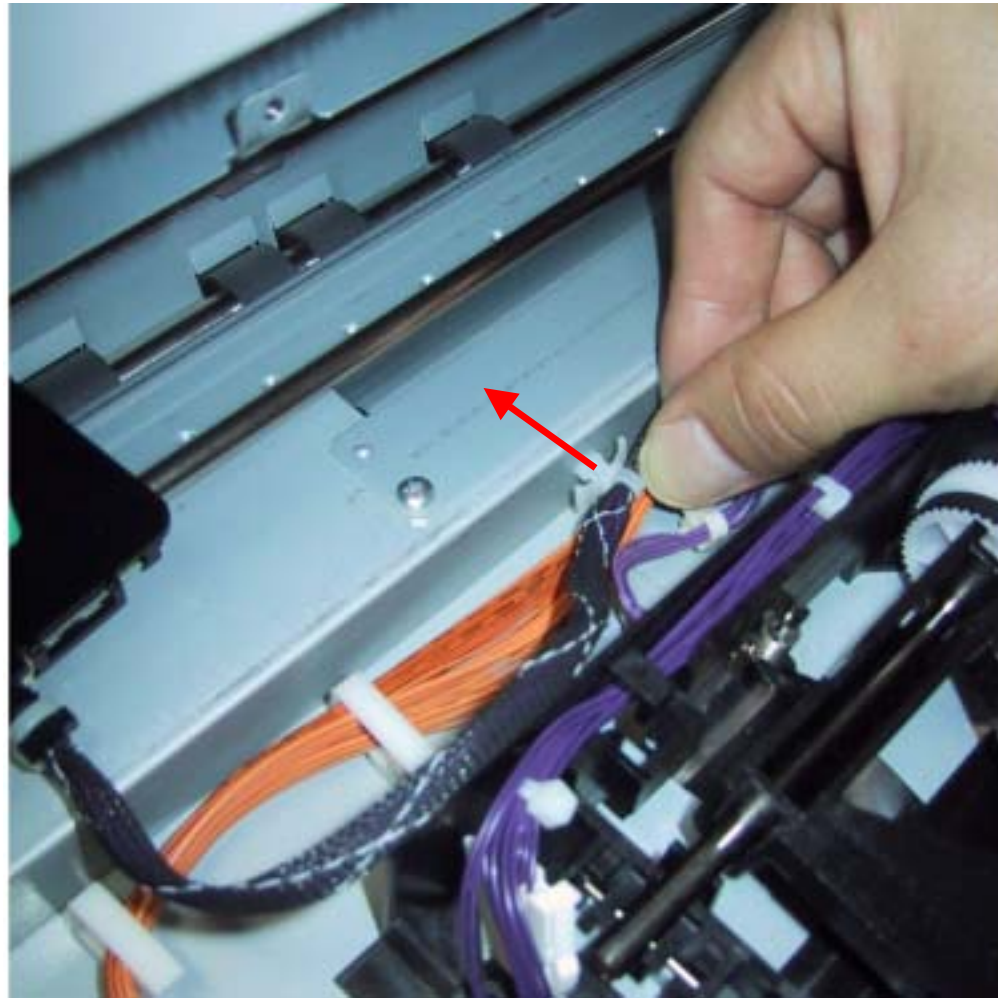

13. Insert the connector of the imprinter carriage to the following position of 80-sub PCB of main body.

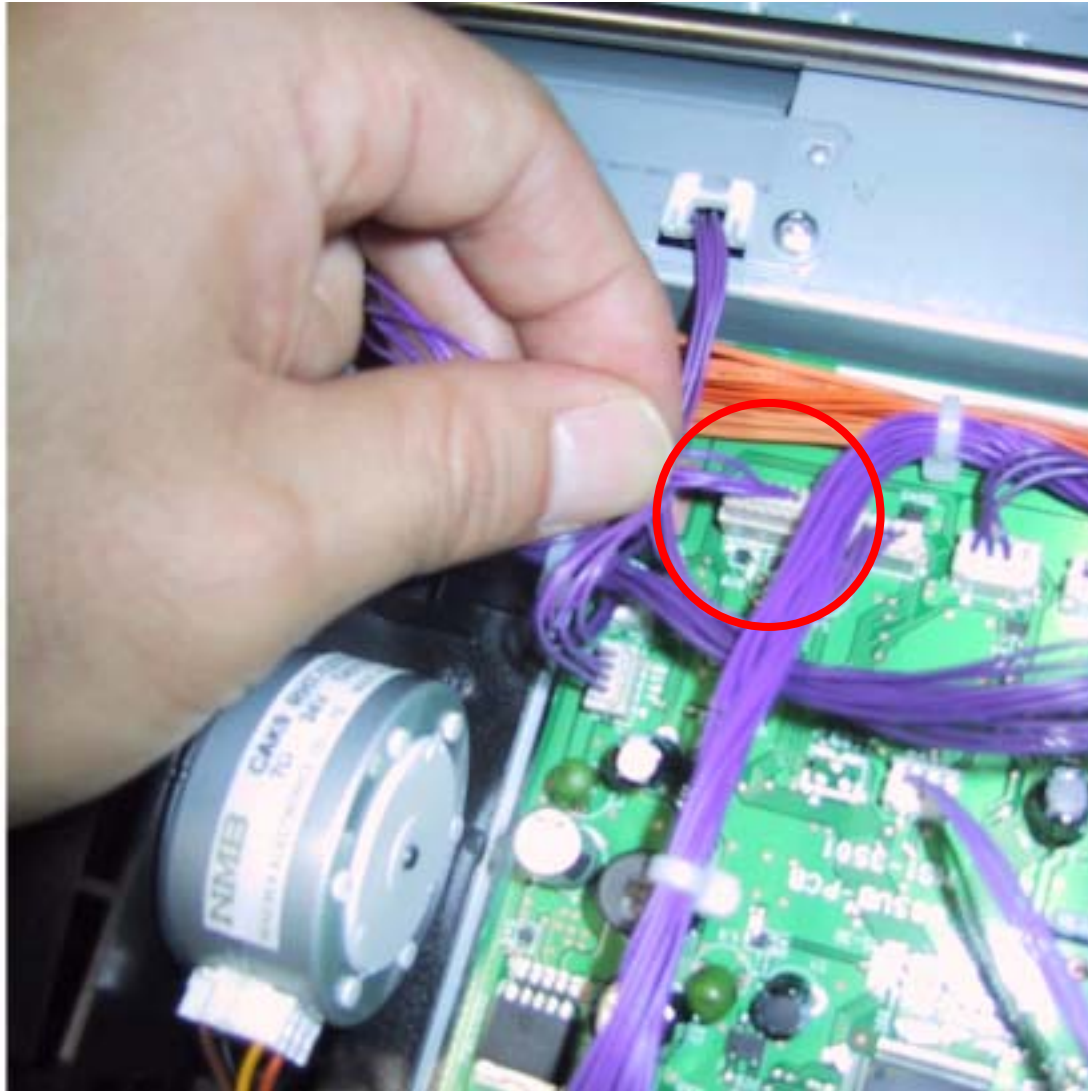

14. Replace the cable to cable clamp, and the document eject cover to the original position.

