

DR-6050C/7550C/9050C

SERVICE MANUAL



Canon

FEBRUARY 2009
REV. 0

COPYRIGHT © CANON ELECTRONICS INC. 2009

Use of this manual should be strictly supervised to avoid disclosure of confidential information.

This Service Manual describes necessary basic information for field service and maintenance for maintaining the product quality and functions of this machine.

Contents

Chapter 1: General description

Product specifications, name of parts, operation method

Chapter 2: Functions and operation

Description of operation of machine system and electrical system by function

Chapter 3: Disassembly and reassembly

Disassembly method, reassembly method

Chapter 4: Installation and maintenance

Installation method, maintenance method

Chapter 5: Troubleshooting

Error display and troubleshooting

Appendix: General diagram etc.

Information in this manual is subject to change. Notification of such changes will be given in Service Information Bulletins.

Thoroughly read the information contained in this Service Manual and the Service Information Bulletins to gain a correct and deeper understanding of the machine. This is one way of fostering response for ensuring prolonged quality and function, and for investigating the cause of trouble during troubleshooting.

Quality Assurance Center
Canon Electronics Inc.

CONTENTS

CHAPTER 1 GENERAL DESCRIPTION

I.	PRODUCT SPECIFICATIONS	1-1
1.	Features	1-1
2.	Specifications	1-2
3.	Precautions	1-8
II.	NAME OF PARTS.....	1-9
1.	Front Side	1-9
2.	Rear Side	1-10
3.	Control Panel	1-10
III.	USER OPERATION.....	1-11
1.	Preparation of Trays.....	1-11
2.	Job Function	1-12
3.	CapturePerfect 3.0.....	1-13
4.	Paper Jam Handling	1-15
5.	User Mode	1-16

CHAPTER 2 FUNCTIONS & OPERATION

I.	OUTLINE	2-1
1.	Basic Configuration.....	2-1
2.	Roller Arrangement.....	2-2
3.	Motor Drive	2-3
4.	List of Sensors	2-4
5.	Electrical Circuits	2-5
6.	Timing Chart.....	2-6
II.	READING SYSTEM.....	2-7
1.	Outline.....	2-7
2.	Image Reading.....	2-8
3.	Shading.....	2-9
III.	FEED SYSTEM	2-10
1.	Outline.....	2-10
2.	Pickup Tray Elevation	2-11
3.	Separation Mechanism	2-12
4.	Feed Error Detection	2-13
5.	Staple Detection.....	2-14
IV.	CONTROL SYSTEM	2-15
1.	Control PCB.....	2-15

2.	Drive System Block Diagram	2-17
3.	Image Processing Control.....	2-18
V.	POWER SUPPLY	2-20
1.	Power Supply	2-20
VI.	OPTION	2-22
1.	Imprinter	2-22
2.	Patchcode Decoder	2-23
3.	Barcode Module	2-23
VII.	ELECTRICAL PARTS LAYOUT	2-24
1.	Motor, Fan, Solenoid.....	2-24
2.	PCB, Sensor, Unit.....	2-26
VIII.	PARTS LAYOUT ON EACH PCB	2-28
1.	Control PCB	2-28
2.	Main Drive PCB	2-29
3.	Sub-Drive PCB.....	2-30
4.	Power Supply PCB	2-31
5.	Eject PCB.....	2-32

CHAPTER 3 DISASSEMBLY & REASSEMBLY

I.	REPLACED BY USERS	3-1
1.	Pickup Roller.....	3-1
2.	Feed Roller.....	3-1
3.	Retard Roller	3-2
II.	EXTERNAL COVERS.....	3-3
1.	Control PCB Cover	3-3
2.	Right Cover	3-3
3.	Operation Panel	3-4
4.	Left Cover.....	3-5
5.	Top Cover.....	3-6
6.	Pickup Tray Unit.....	3-6
7.	Eject Tray Unit.....	3-7
8.	Upper Front Cover	3-7
9.	Rear Cover.....	3-8
III.	UPPER UNIT-1 (ELECTRICAL SYSTEM)	3-9
1.	Main Drive PCB	3-9

2. Ultrasonic Sensor PCB.....	3-9	4. Lower Front Cover.....	3-36
3. Feed Motor	3-10	5. Lower Entrance Guide.....	3-37
4. Pickup Motor.....	3-10	6. Belt (Right).....	3-37
5. Pickup Solenoid.....	3-11	7. Belt (Left)	3-38
IV. UPPER UNIT-2 (MECHANICAL SYSTEM)		8. Registration Roller Lower	3-38
.....	3-13	9. Platen Roller Lower	3-39
1. Pickup Unit	3-13	10. Reading Roller Lower.....	3-40
2. Pickup Roller Cover.....	3-14	11. Drive U-turn Roller (Front).....	3-40
3. Upper Entrance Guide.....	3-14	12. Drive U-turn Roller (Middle)	3-41
4. Registration Roller Upper	3-15	13. Drive U-turn Roller (Rear)	3-41
5. Reading Roller Upper.....	3-16	14. Eject Drive Unit	3-42
6. Platen Roller Upper	3-16	15. Eject Roller (Drive)	3-42
7. Eject Roller (Follower)	3-17	VIII. BASE UNIT-3 (READING SYSETM).....	3-43
8. U-Turn Roller (Follower)	3-17	1. Lower Reading Unit.....	3-43
9. Eject Tray Extension.....	3-18	2. Shading Motor	3-43
10. Imprinter Cover	3-19	3. Lower Reading Glass Assembly.....	3-44
11. Eject Document Guide	3-20		
12. Entire Upper Unit.....	3-20		
V. UPPER UNIT-3 (READING SYSTEM)..	3-23		
1. Upper Reading Unit.....	3-23		
2. Shading Motor	3-24		
3. Upper Reading Glass Assembly.....	3-25		
VI. BASE UNIT-1 (ELECTRICAL SYSTEM)			
.....	3-26		
1. Control PCB.....	3-26		
2. Sub-Drive PCB	3-27		
3. Power Supply PCB.....	3-27		
4. Ultrasonic Drive PCB.....	3-28		
5. Eject PCB	3-29		
6. Document Sensor PCB	3-29		
7. Main Motor.....	3-30		
8. Tray Motor	3-31		
9. Separation Motor	3-32		
10. Eject Motor	3-32		
11. Exhaust Fan.....	3-33		
VII. BASE UNIT-2 (MECHANICAL SYSTEM)			
.....	3-34		
1. Pickup Document Guide.....	3-34		
2. Tray Drive Box.....	3-35		
3. Blind Cover.....	3-36		

CHAPTER 4 INSTALLATION & MAINTENANCE

I. INSTALLATION	4-1
1. Choosing Location.....	4-1
2. Unpacking And Installation	4-2
3. Imprinter Installation Procedure	4-8
4. Patchcode Decoder Installation Procedure.....	4-12
II. PARTS REPLACEMENT.....	4-13
1. Periodically Replaced Parts	4-13
2. Consumable Parts (Commercial Goods)	4-13
3. Consumable Parts (For User)	4-13
4. Consumable Parts (For servicing)....	4-14
III. MAINTENANCE	4-16
1. User Maintenance	4-16
2. Service Maintenance.....	4-17

CHAPTER 5 TROUBLESHOOTING

I. ERROR DISPLAY	5-1
1. Main Body	5-1
2. Computer	5-3
II. SERVICE MODE	5-4
A. Outline	5-4
1. Outline.....	5-4
2. Installation Procedure	5-9
3. Starting Up and Exiting Service Mode	5-9
B. Main Menu	5-11
1. All Adjustment	5-11
2. Individual Adjustments	5-12
3. Max Document Size.....	5-13
4. Sleep.....	5-14
5. SCSI Transfer	5-14
6. Counter	5-15
C. Dcon Check	5-17
1. Motor.....	5-17
2. Feed Test	5-18
3. Sensors.....	5-18
4. LED/LCD.....	5-21
D. Get Status	5-22
1. Last Error Logs	5-22
2. Check Device.....	5-22
3. Serial Number.....	5-23
4. Write Setting to Text.....	5-23
E. Scan.....	5-24
1. Scan Check.....	5-24
2. CIS Data	5-25
3. ImgFrame.....	5-26
F. Extended Setting	5-28
1. Regist Manual Adjustment	5-28
2. Key Lock	5-29
G. Firmware Change	5-30
1. Firmware registration	5-30
2. Controller Firmware Loading	5-32
3. Drive Firmware Loading.....	5-34
H. Others	5-35
1. Imprinter.....	5-35
2. Patchcode	5-36
3. Analog Sensor	5-36
4. Application Information	5-37
5. Simulation Mode	5-37
III. LIST OF FAILURES	5-38
1. Operation Failures	5-38
2. Images Failures	5-38
IV. OPERATION TROUBLESHOOTING.....	5-39
1. No Power Is Supplied	5-39
2. Scanner Is Not Recognized	5-40
3. Scanning Does Not Start.....	5-40
4. Documents Are Not Fed Properly	5-41
5. Scanning Speed Is Slow	5-42
V. IMAGE TROUBLESHOOTING	5-43
1. Completely Black, Completely White, All Streaks.....	5-44
2. Too Dark, Too Light	5-44
3. Black Borders Around Image	5-45
4. Image Skews	5-45
5. Streaks on Image	5-46
6. Moire on Image	5-46
7. Outer Areas of Image Disappear	5-46
8. Text Invisible	5-47
VI. AFTER REPLACING PARTS	5-48

APPENDIX

I. GENERAL DIAGRAM.....	A-1
-------------------------	-----

CHAPTER 1

GENERAL DESCRIPTION

I. PRODUCT SPECIFICATIONS.....	1-1	III. USER OPERATION	1-11
II. NAME OF PARTS	1-9		

I. PRODUCT SPECIFICATIONS

1. Features

1) 3 models suitable for each usage

DR-9050C: Color, 90 ppm/180 ipm, Tray capacity 500 sheets

DR-7550C: Color, 75 ppm/150 ipm, Tray capacity 500 sheets

DR-6050C: Color, 60 ppm/120 ipm, Tray capacity 300 sheets

2) High-speed reading

- ◆ No speed down in color mode (using 3-line sensor)

A4/200 dpi	DR-9050C	DR-7550C	DR-6050C	DR-9080C (reference)
B & W	90 ppm/180 ipm	75 ppm/150 ipm	60 ppm/120 ipm	90 ppm/180 ipm
Grayscale	90 ppm/180 ipm	75 ppm/150 ipm	60 ppm/120 ipm	90 ppm/180 ipm
Color	90 ppm/180 ipm	75 ppm/150 ipm	60 ppm/120 ipm	54 ppm/92 ipm

- ◆ No speed down with auto-size detection and deskew (using built-in IC)

3) High-durability

Expected life 14.4 millions sheets (A4 copy paper)

Reference: Outline view

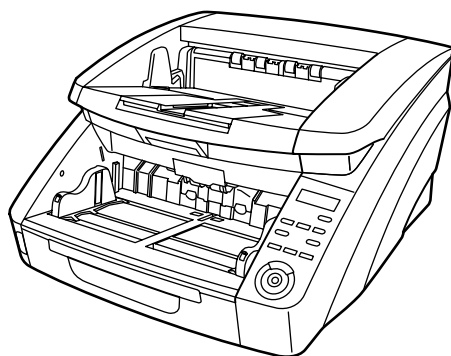

DR-9050C/DR-7550C

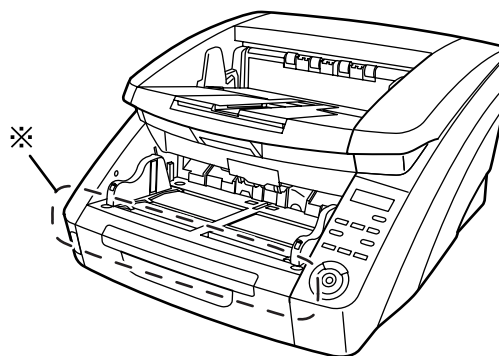

DR-6050C

The shape of only the part marked with ⊗ is different.

Figure 1-101

“Windows” is a trademark of Microsoft Corporation in the U.S. and other countries. Other company names and product names mentioned in this document are registered trademarks or trademarks of the respective companies.

2. Specifications

1) Appearance/Installation

No.	Item	Specifications
1	Type	Desktop type sheet-fed scanner
2	Power supply rating	1) 100 V model: 100 VAC, 50/60 Hz, 90 W 2) 120 V model: 120 VAC, 60 Hz, 1.4 A 3) 200 V model: 220-240 VAC, 50/60 Hz, 0.8 A
3	Power consumption	1) Operating: 86 W (100 V), 83 W (120 V), 84 W (200 V) 2) Sleep mode: 3.3 W (100 V), 3.2 W (120 V), 3.9 W (200 V) 3) Power switch OFF: 0 W *Conforms to International Energy Star Program.
4	Operating environment	10 to 32.5°C (50 to 90.5°F), 20 to 80%RH *No condensation allowed.
5	Noise	1) Standby: 40 dB max. 2) Operating: 72 dB max. *Sound power level, A4 copy paper (t=0.08 mm)
6	Dimensions *Details are described later.	Tray closed: 480 (W) × 531 (D) × 311 (H) mm Tray opened: 480 (W) × 718 (D) × 390 (H) mm
7	Weight	22.5 kg (Main body only)
8	Output interface	1) USB 2.0 (Hi-speed) 2) SCSI-3 (Ultra)
9	Expected product life (In-house information)	One of the following two items, whichever comes first. 1) 5 years 2) Sheets fed: 14.4 millions sheets (A4 copy paper) *There are parts needed to replace.
10	Installation	By service technicians
11	Bundle software	ISIS/TWAIN driver, CapturePerfect 3.0, Job Tool
12	Consumable parts (commercial goods)	1) Exchange roller kit (Pickup/Feed/Retard rollers) *Expected life 250,000 sheets 2) Ink cartridge *Ink cartridge is consumable parts for Imprinter (option).
13	Option	1) Imprinter (post) 2) Patchcode decoder 3) Barcode module (driver's option)

Table 1-101

◆ External dimensions (unit: mm)

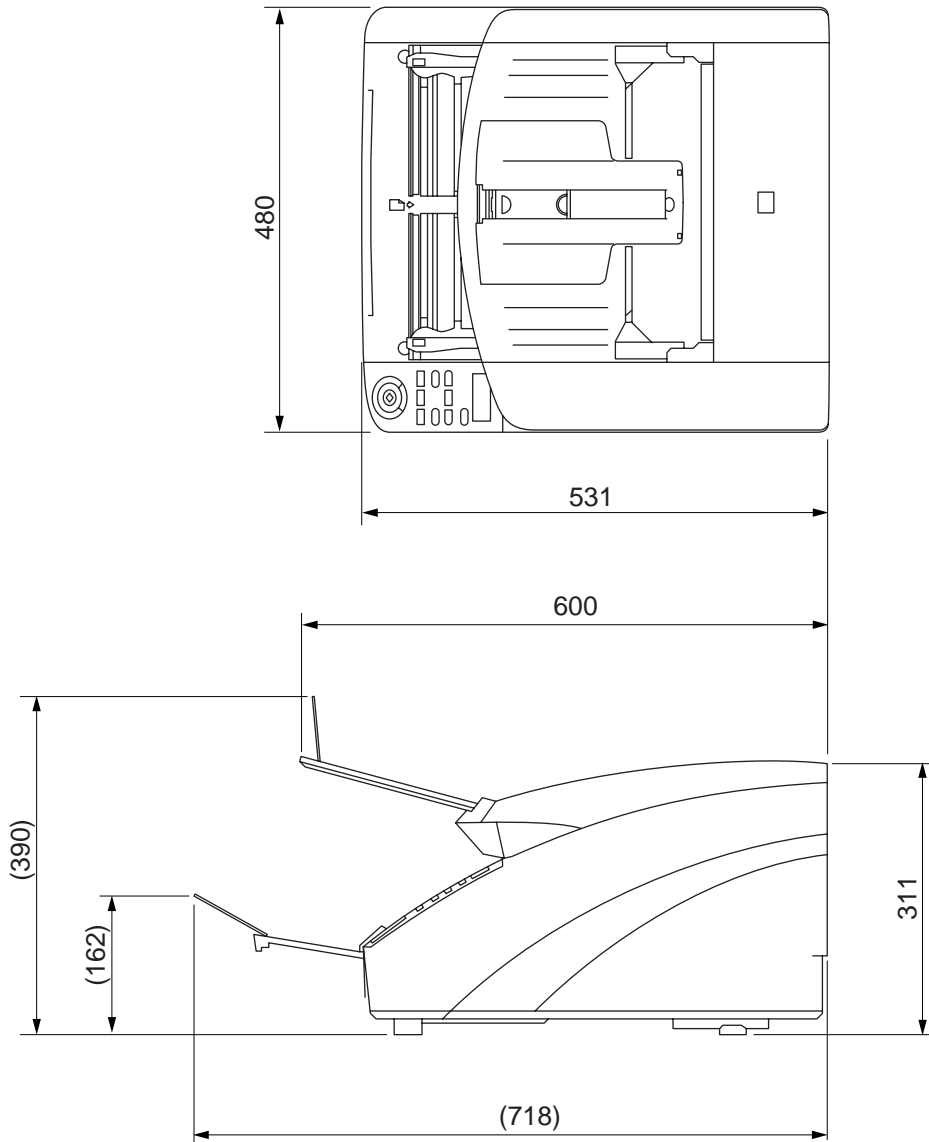

Figure 1-102

2) Document feed

No.	Item	Specifications		
1	Document feed path	U-turn path		
2	Document size	1) Width	50.8 to 305 mm	
		2) Length	70 to 432 mm *Excluded long document mode.	
		3) Weight (thickness)	1) Separation pickup 52 to 209 g/m ² (0.06 to 0.25 mm) 2) Non-separation pickup 42 to 255 g/m ² (0.05 to 0.30 mm)	
3	Document limitation	1) Pressure-sensitive paper: Can be fed with limitation of direction. 2) Carbon-backed paper: Cannot be fed. 3) Perforated paper for binder: Can be fed with limitation of holes. 4) Curled paper: Can be fed only if curl is 8 mm or less. 5) Creased paper: Can be fed, but crease must be straightened before being fed. *For the staple detection, curl is 3 mm or less, and no crease.		
4	Long document mode	Length: 1,000 mm or 3,000 mm max. *Selected by user mode *Thickness is 0.2 mm or less. *Image data size is 378 MB or less. *Feeding function is not guaranteed. *If using the Folio together, A1-size scanning is available.		
5	Document storage	Document size		DR-9050C/7550C
		A4 or less	Pickup	500 sheets max. 48 mm height max.
			Eject	300 sheets max. 28 mm height max.
		A4 over	Pickup	500 sheets max. or 48 mm height max.
Eject	20 mm height max. 12 mm height max.			
6	Feeding speed	Resolution		Binary, Grayscale, Color
		100/150/200/240/300 dpi		661.7 mm/sec
		400/600 dpi (speed priority)		
		100 to 300 dpi (high-quality Moire reduction)		165.4 mm/sec
400/600 dpi (image priority)				
7	Double feed detection	1) Length detection (by registration sensor) 2) Ultrasonic double feed detection (1 position)		
8	Other functions	1) Pickup tray position adjustment 2) Automatic eject speed control 3) Staple detection 4) Multiple document guides positioning		

Table 1-102

3) Document reading *using bundle software CapturePerfect 3.0

No.	Item	Specifications			
1	Type of sensor	3-line CMOS Contact Image Sensor (CIS)			
2	Sensor pixels	600 dpi, Effective pixels 7396 × 3 lines (313 mm) *Operation mode: 300/600 dpi exchangeable			
3	Light source	3-color (RGB) LED, Double-side illumination			
4	Background color	Black			
5	Image data memory size	384 MB (including memory size for rotation)			
6	Reading side	Simplex (front)/Duplex (both)/Blank skip/Folio			
7	Reading size	1) Typical: A3/A4/A4-R/A5/A5-R/A6/A6-R, B4/B5/B5-R/B6/B6-R, LDR/LGL/LTR/LTR-R 2) Auto-size detection 3) Maximum size (305 × 432 mm) 4) User setting 5) Margin (±10 mm)			
8	Output mode	1) Binary (Black & White/Error diffusion/ATE/ATE-II) *ATE=Advanced Text Enhancement *ATE-II is not available at 400/600 dpi. 2) Grayscale (8 bits) 3) Color (24 bits) 4) Auto image type detection			
9	Output resolution	100 × 100 dpi, 150 × 150 dpi, 200 × 200 dpi, 240 × 240 dpi, 300 × 300 dpi, 400 × 400 dpi (speed priority), 600 × 600 dpi (speed priority), 400 × 400 dpi (image priority), 600 × 600 dpi (image priority)			
10	Reading speed	A4 portrait, JPEG transportation for grayscale and color modes. Auto-size detection and deskew are set ON. The numbers may differ depending on the computer, the function settings and other conditions.			
	Model	Mode (file format)	Resolution	Simplex (ppm)	Duplex (ipm)
	DR-9050C	Black & White (TIFF)	200 dpi	90	180
			300 dpi	90	180
			600 dpi (speed priority)	83	83
			600 dpi (image priority)	22	44
		Grayscale (JPEG)	200 dpi	90	180
			300 dpi	90	180
			600 dpi (speed priority)	80	80
			600 dpi (image priority)	22	44
		Color (JPEG)	200 dpi	90	180
			300 dpi	90	170
			600 dpi (speed priority)	45	45
			600 dpi (image priority)	18	15

Table 1-103a

No.	Item	Specifications				
10	Reading speed (cont.)	Model	Mode (file format)	Resolution	Simplex (ppm)	Duplex (ipm)
		DR-7550C	Black & White (TIFF)	200 dpi	75	150
				300 dpi	75	150
				600 dpi (speed priority)	75	83
				600 dpi (image priority)	18	36
			Grayscale (JPEG)	200 dpi	75	150
				300 dpi	75	150
				600 dpi (speed priority)	75	85
				600 dpi (image priority)	18	36
			Color (JPEG)	200 dpi	75	150
				300 dpi	75	150
				600 dpi (speed priority)	45	45
				600 dpi (image priority)	17	15
		DR-6050C	Black & White (TIFF)	200 dpi	60	120
				300 dpi	60	120
				600 dpi (speed priority)	60	83
				600 dpi (image priority)	15	30
			Grayscale (JPEG)	200 dpi	60	120
				300 dpi	60	120
				600 dpi (speed priority)	60	80
				600 dpi (image priority)	15	30
			Color (JPEG)	200 dpi	60	120
				300 dpi	60	120
				600 dpi (speed priority)	45	45
				600 dpi (image priority)	15	15

Table 1-103b

4) Image processing/Other functions *using bundle software CapturePerfect 3.0

No.	Item	Specifications
1	Brightness adjustment	255 steps, back side individual setting, Auto for black and white mode (ABC processing) *Not available for ATE/ATE-II
2	Contrast adjustment	7 steps, back side individual setting
3	Gamma correction	Front/back side each, R/G/B/grayscale
4	Edge emphasize	5 steps
5	Color dropout	Dropout/emphasize, R/G/B/custom, front/back side each
6	Moire reduction	None/Hi-speed/Hi-quality *Depend on the resolution, selectable items are different.
7	Other image processing	Shading correction, Deskew, Dots erasing, Prevent bleed-through/Remove background, Text orientation recognition, Black border removal, Punch hole removal, Add-on, Resampling (included MultiStream), Pre-scan, 3-D gamma (color correction), JPEG transportation, Image rotation
8	Other functions	Skew detection, Rapid recovery scan, Continuous manual feed, Buzzer, Count only, Verify count, Batch separation
9	Operation section	Keys (Start/Stop/Functions), Display LCD (16 characters × 2 lines) *Function of keys can be invalidated by service mode.
10	User modes	Setting by operation section of the main body.
11	Job function	Save as file
12	Counter	Sheets count for total scanning and replacing parts (memorized in EEPROM on the scanner main body)

Table 1-104

The specifications above are subject to change for improvement of the product.

3. Precautions

This section describes items that require particular care, for example, regarding human safety.

These precautions must be observed. The user should be explained the items that relate to user safety and instructed to take appropriate actions.

1) Power OFF in emergency

If such abnormal conditions as extraordinary noise, smoke, heat and odor occur, immediately unplug the power cord.

Be careful not to get clothing (ties, long hair, etc.) caught in this machine as it may cause injury. Should this occur, immediately unplug the power cord. Do not insert fingers in the feed section while moving the rollers.

2) Power OFF on disassembling

When disassembling and assembling are performed, unplug the power cord.

3) Prohibition of modify

This machine must not arbitrarily be modified or remade. If it is, use of this machine may be forcibly suspended.

To change the specifications or disassemble and reassemble this machine, follow the instructions described in this manual and the service information.

4) Electromagnetic wave interference

This machine complies with some standards regarding electromagnetic wave interference, such as VCCI and FCC. However, the user may have to take countermeasures if the machine causes electromagnetic wave interference.

5) User Manual

Read each "User Manual" thoroughly prior to use of this machine.

6) Disposal

Follow local regulations when disposing of the product and parts. This product is subject to the WEEE Directive in Europe.

7) Movement

This machine weighs 22.5 kg. When lifting or moving this machine, 2 persons must hold it from both sides. Never lift it by one person.

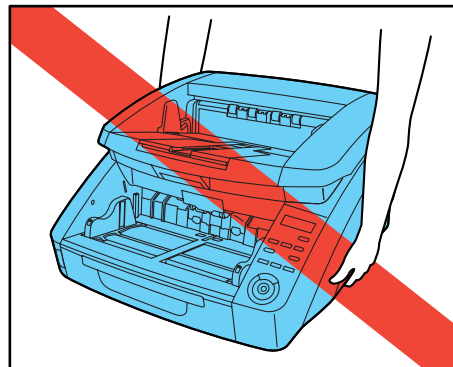

Figure 1-103

II. NAME OF PARTS

1. Front Side

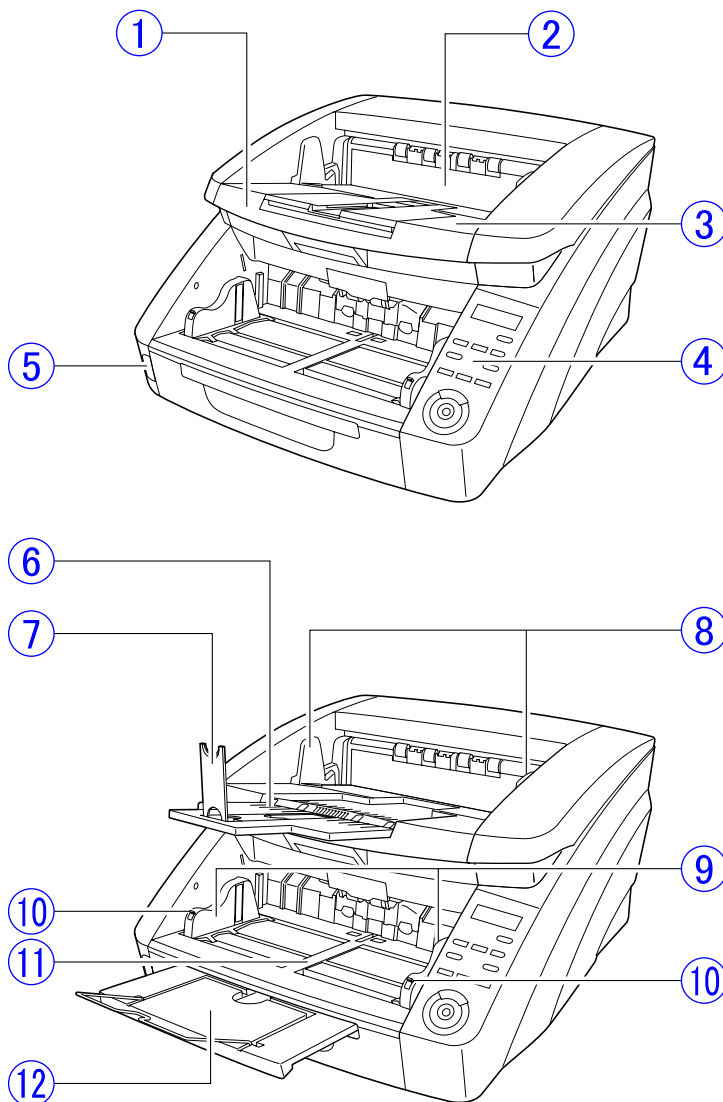

Figure 1-201

- | | |
|-------------------------------------|---|
| ① Upper unit | ⑧ Eject document guides |
| ② Imprinter cover | ⑨ Pickup document guides |
| ③ Document eject tray | ⑩ Document guide lock lever |
| ④ Control panel (Operation panel *) | ⑪ Document feed tray (Pickup tray *) |
| ⑤ Power switch | ⑫ Document feeder tray extension/extension wire |
| ⑥ Document eject tray extension | |
| ⑦ Eject paper stoppers | |

Note: In this manual, the “Control panel” may also be mentioned as the “Operation panel,” and the “Document feed tray” may also be mentioned as the “Pickup tray.”

2. Rear Side

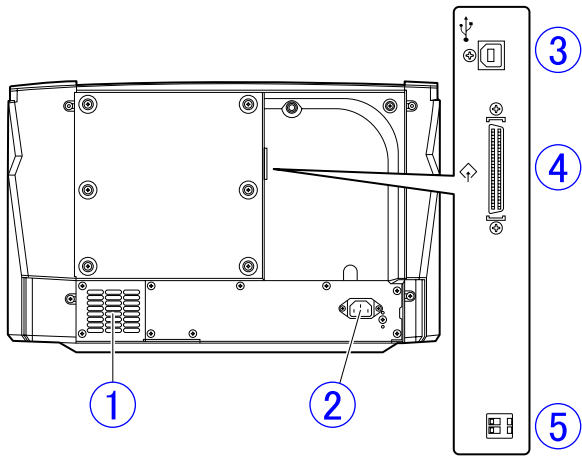

Figure 1-202

- ① Ventilation holes (exhaust fan)
- ② Power connector
- ③ USB connector (Type B)
- ④ SCSI connector (Half pitch D-sub 50 pin)
- ⑤ DIP switches (SCSI ID)

3. Control Panel

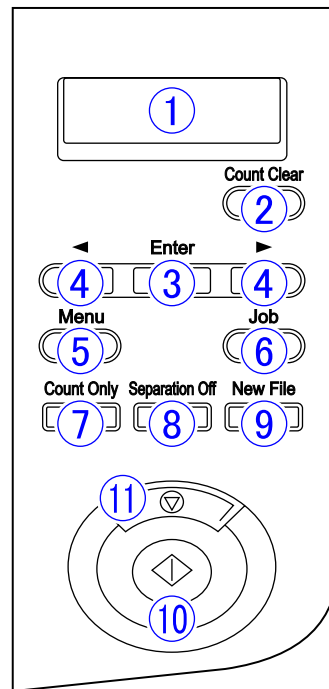

Figure 1-203

- ① Display panel
- ② Count Clear key
- ③ Enter key
- ④ ◀▶ keys (left/right keys)
- ⑤ Menu key
- ⑥ Job key
- ⑦ Count Only key
- ⑧ Separation Off key
- ⑨ New File key
- ⑩ Start key
- ⑪ Stop key

Note:In this manual, the “Control panel” may also be mentioned as the “Operation panel.”

III. USER OPERATION

This section presents an outline of the user operations. Refer to the "User Manual" of this machine for details.

1. Preparation of Trays

Before scanning documents, prepare for the document feed tray and document eject tray according to the documents.

1) Document feed tray

The height of the document feed tray can be adjusted according to the number of documents to be set and is set to the lowest position as the initial value. It is changed in user mode.

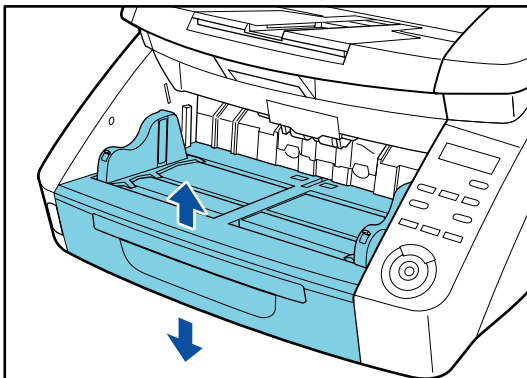

Figure 1-301

Push the document guides from both sides (①) and adjust their positions according to the document width (②).

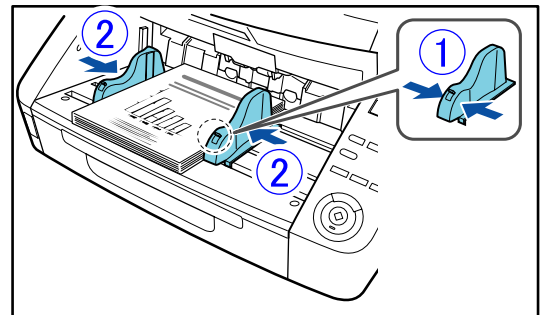

Figure 1-302

Note: The right and left positions can be changed by locking the document guides. Refer to the "User Manual" for details.

Pull out the tray extension according to the document length. Open the extension wire as required.

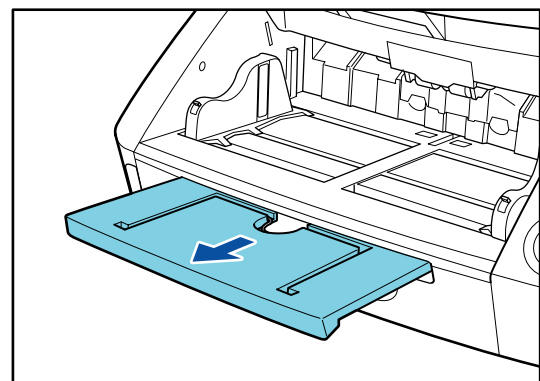

Figure 1-303

2) Document eject tray

Hold both document guides and adjust the positions according to the width of the document to be set.

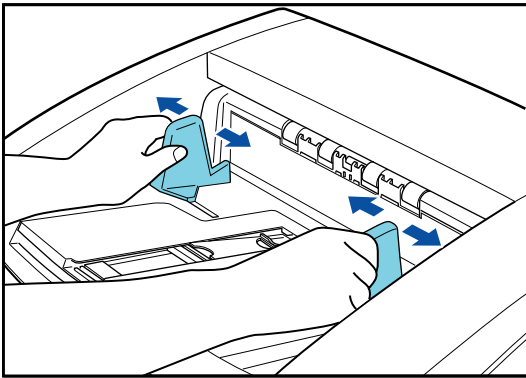

Figure 1-304

Note: The positions of the right and left document guides of the document eject tray can be changed independently of each other.

Open the document eject tray extension according to the document length. Raise the eject paper stoppers as necessary.

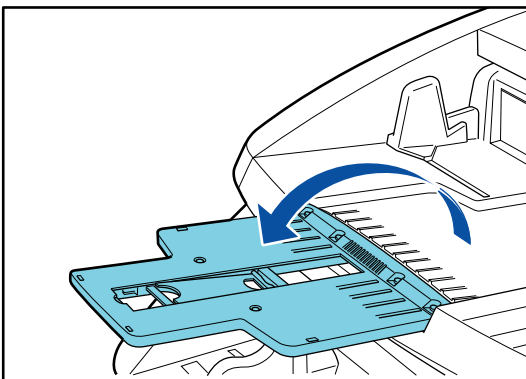

Figure 1-305

2. Job Function

The job registered with the job registration tool is performed with the following procedure.

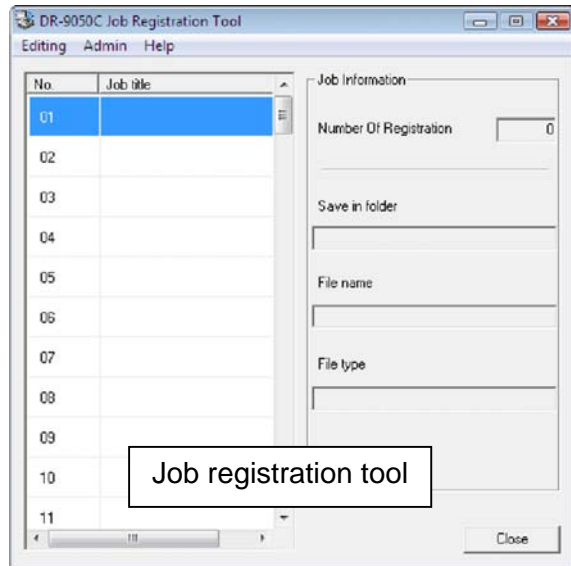

Figure 1-306

1) Press the [Job] key on the control panel.

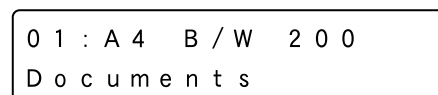
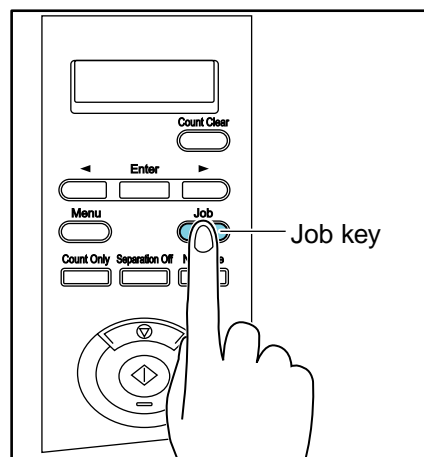

Figure 1-307

2) Select the job with the left/right keys.

- 3) Perform the job with the [Start] key.

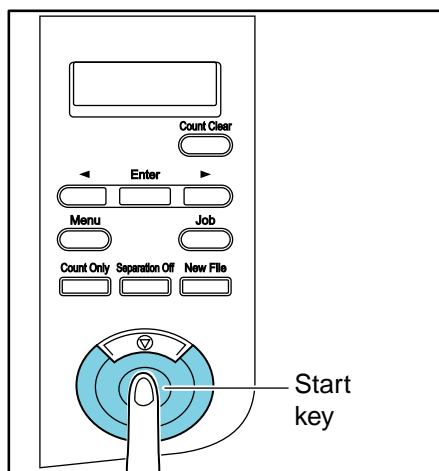

Figure 1-308

- 4) Open the specified folder and check the image file.

3. CapturePerfect 3.0

This section describes the scan procedure with [Scan Batch to File] from the activation of CapturePerfect 3.0.

- 1) Start CapturePerfect 3.0.

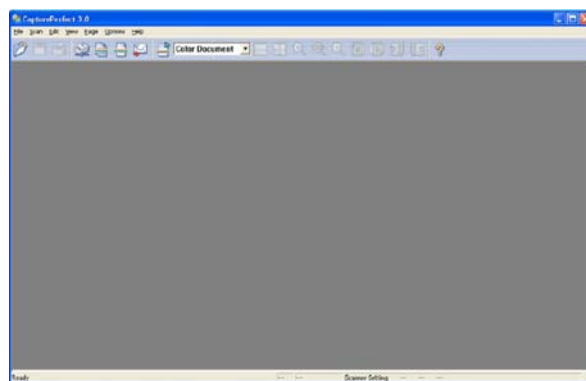

Figure 1-309

- 2) Select a scanner to be used from the [Select Scanner] screen.
 3) Select [Scanner Settings] and open the ISIS driver setting dialog box.
 First the [Basic] tab is selected.

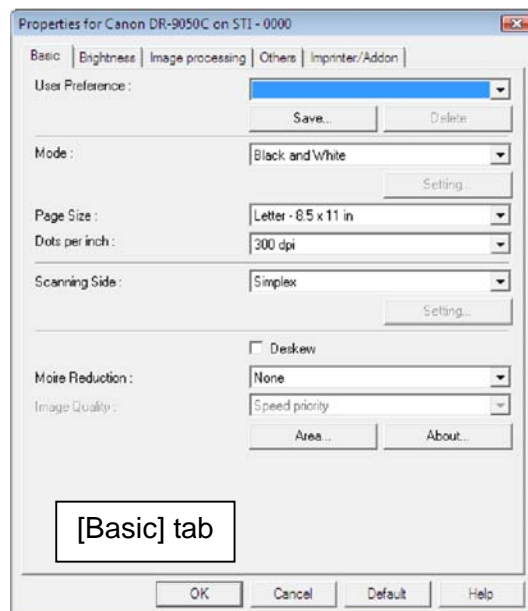

Figure 1-310

4) Set the reading conditions.

The dialog boxes other than the [Basic] tab are shown below.

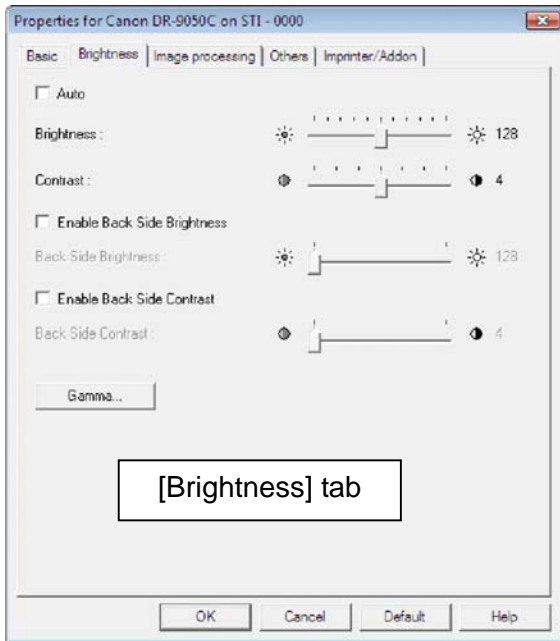

Figure 1-311

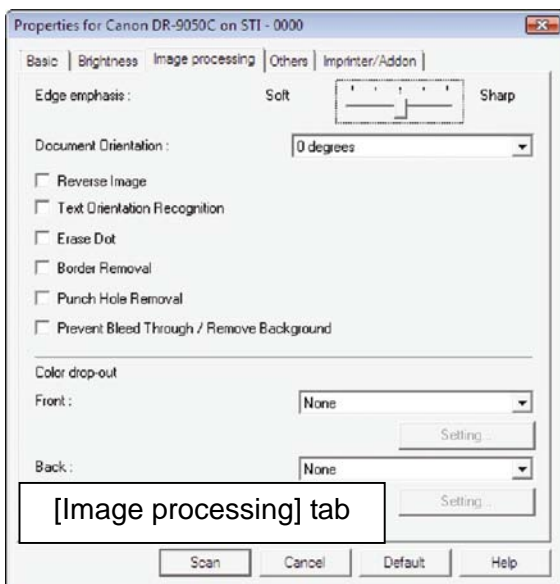

Figure 1-312

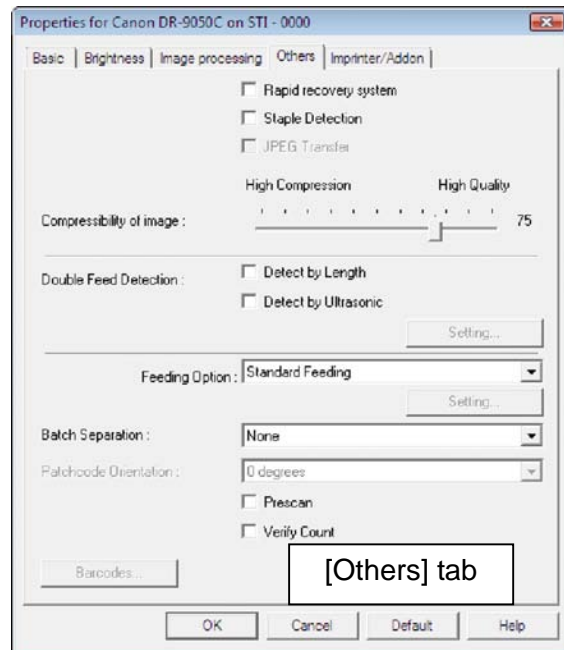

Figure 1-313

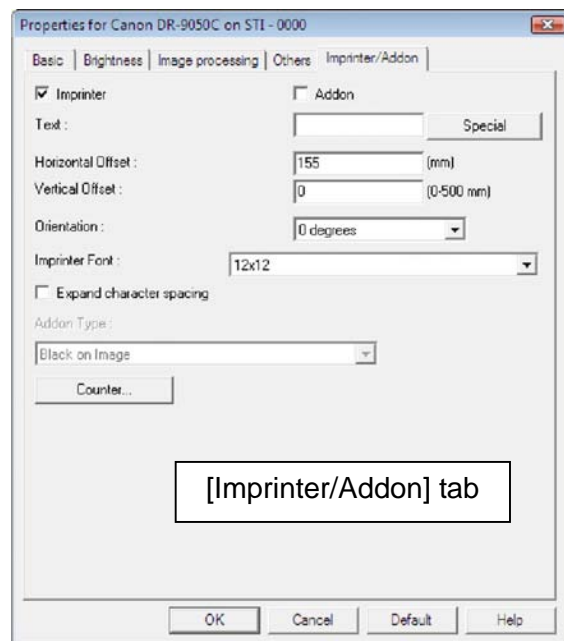

Figure 1-314

5) Select a scanning method.

Selecting “Scan Batch to File” opens the setting dialog.

6) Specify the location, file name and format for saving and then click “Save” to start scanning.

4. Paper Jam Handling

If a paper jam occurs during scanning, the following message is displayed on the display panel and feeding stops.



Figure 1-315

Note: The error code (Pxxx) changes according to the location of the jammed paper.

- 1) Remove the document remaining on the document eject tray.
- 2) While pressing the Open/Close button, open the upper unit carefully until it stops.

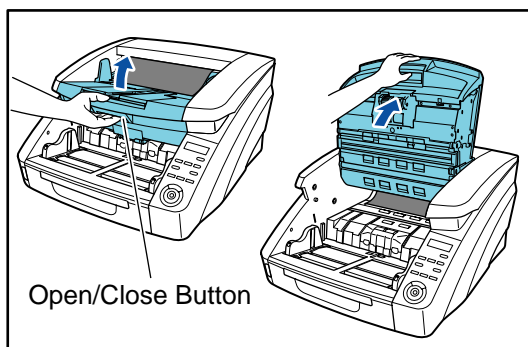

Figure 1-316

- 3) Remove a jammed paper.
If paper has stopped in the midst of ejecting to the document eject tray, open the upper unit slightly to remove it.
If paper has stopped inside the main body, open the upper unit until it stops to remove it.

- 4) Carefully close the upper unit (①). Make sure the upper unit is closed securely by pushing on both edges of the upper unit. (②)

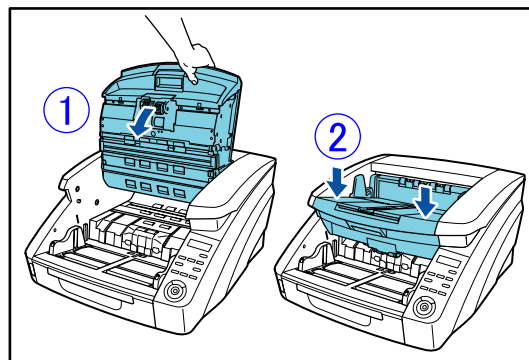

Figure 1-317

- 5) Check the last image that is saved and perform the scan again.

Note: If [Continuous Mode] is set, a message appears on the display panel after clearing paper jams.

Press Start Key

Figure 1-318

5. User Mode

This section describes the basic operation and the items in the user mode.

- 1) When the [Menu] key on the control panel is pressed, the user mode is entered. The items in the user mode are displayed.

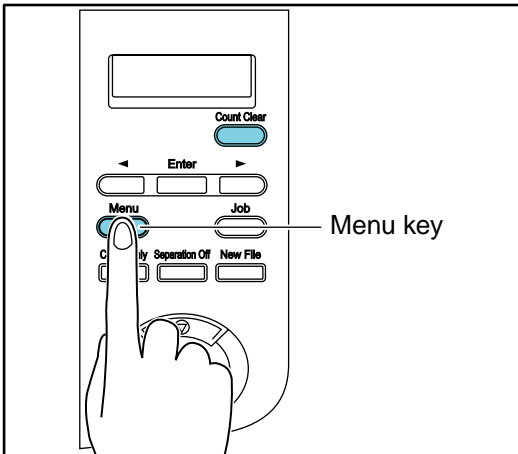

```
Buzzer Control
[ON2] ON1 OFF
```

Figure 1-319

- 2) Press the left/right keys and select the user mode.

Note:For the details on “Items and display order” of the user mode, refer to the next page.

- 3) When the [Enter] key is pressed, the setting mode of the selected user mode is entered.

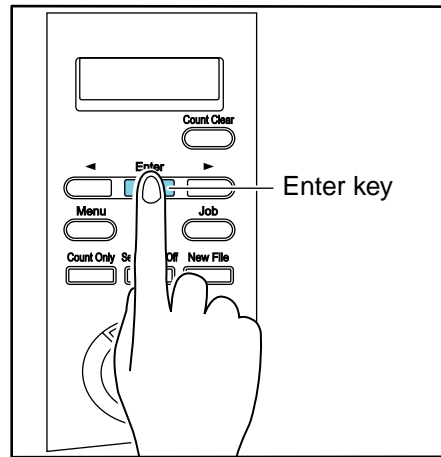

```
Long Document
ON2 ON1 [OFF]
```

Figure 1-320

- 4) Select the mode with the right/left keys and press the [Enter] key to determine it.

```
Long Document
ON2 [ON1] OFF
```

Figure 1-321

◆ Items and display order

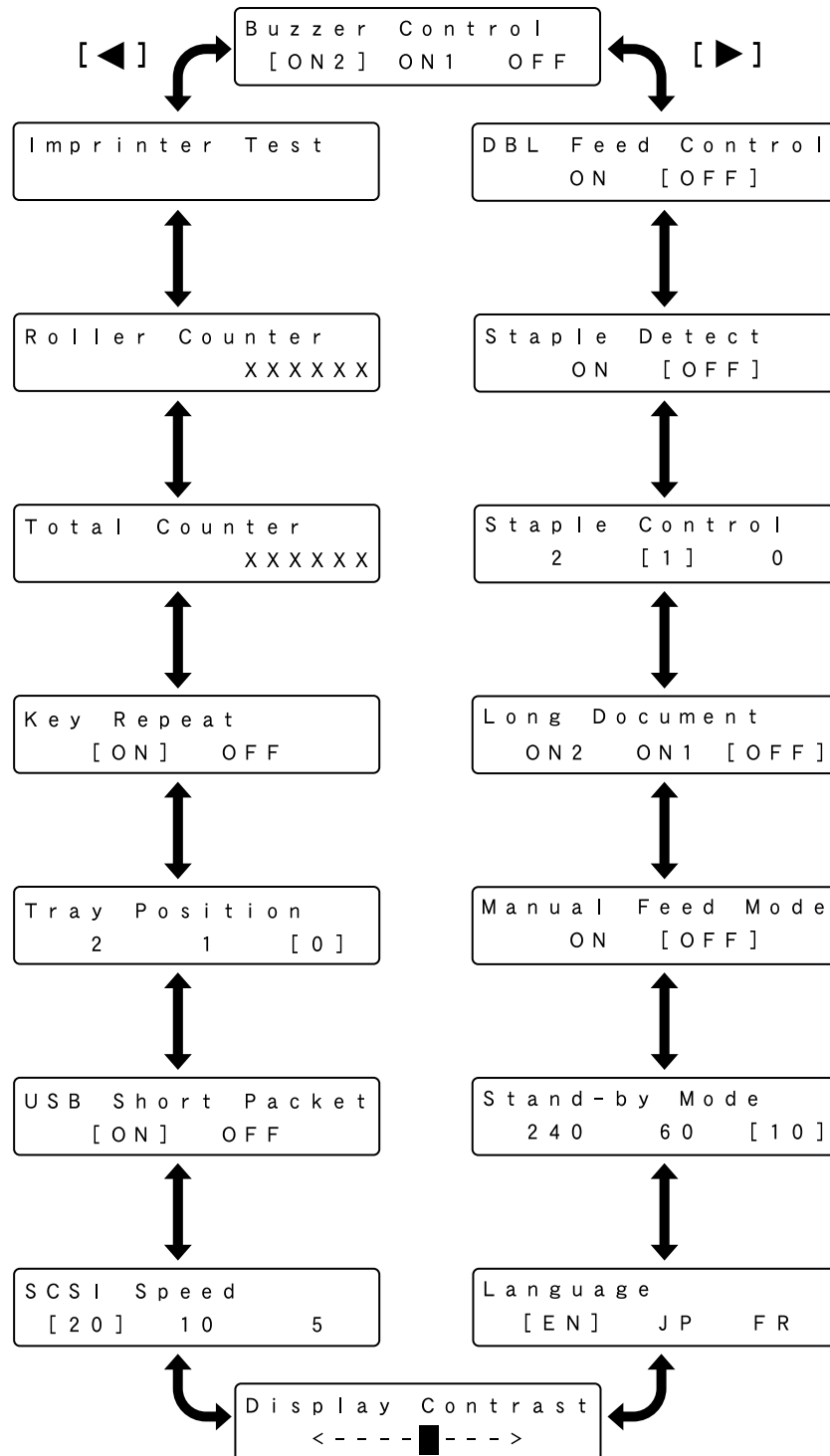

Figure 1-322

CHAPTER 2

FUNCTIONS & OPERATION

I. OUTLINE.....	2-1	V. POWER SUPPLY.....	2-20
II. READING SYSTEM.....	2-7	VI. OPTION.....	2-22
III. FEED SYSTEM.....	2-10	VII. ELECTRICAL PARTS LAYOUT	2-24
IV. CONTROL SYSTEM.....	2-15	VIII. PARTS LAYOUT ON EACH PCB.....	2-28

I. OUTLINE

1. Basic Configuration

The configuration of this machine is shown below.

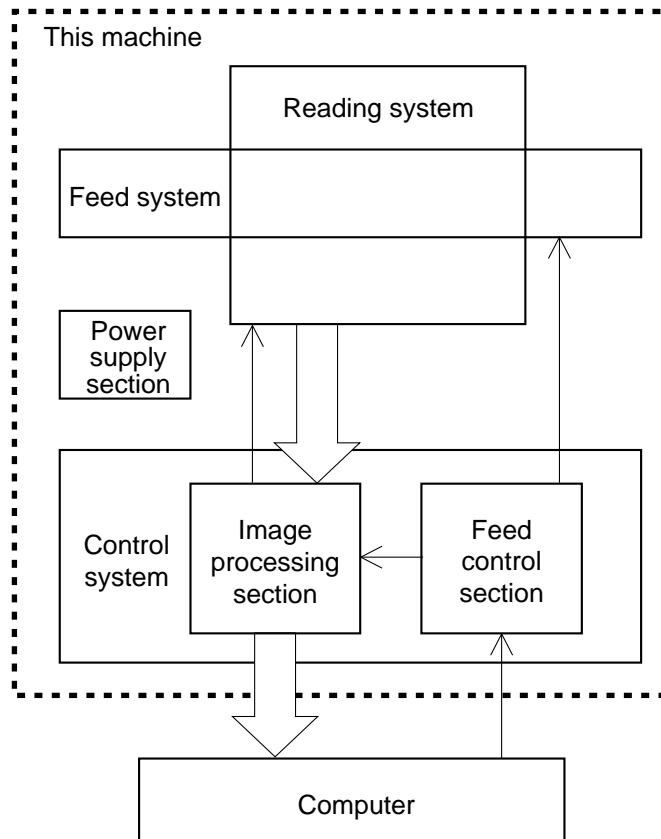

Figure 2-101

- | | |
|--|--|
| <p>1) Reading system
This system reads document frame and image data from image sensors.</p> | <p>The image processing section controls the reading system and processes the read image data.
However, image data processing is also performed by the computer.</p> |
| <p>2) Feed system
This system performs from document pickup to document ejection.</p> | <p>The feed control section controls the feed system.</p> |
| <p>3) Control system
This system is comprised of an image processing section, a feed control section and a system control section.</p> | <p>4) Power supply section
This section converts the AC power supplied from external into the DC power and supplies it to the internal PCB.</p> |

2. Roller Arrangement

A sectional view of the feed section is shown below.

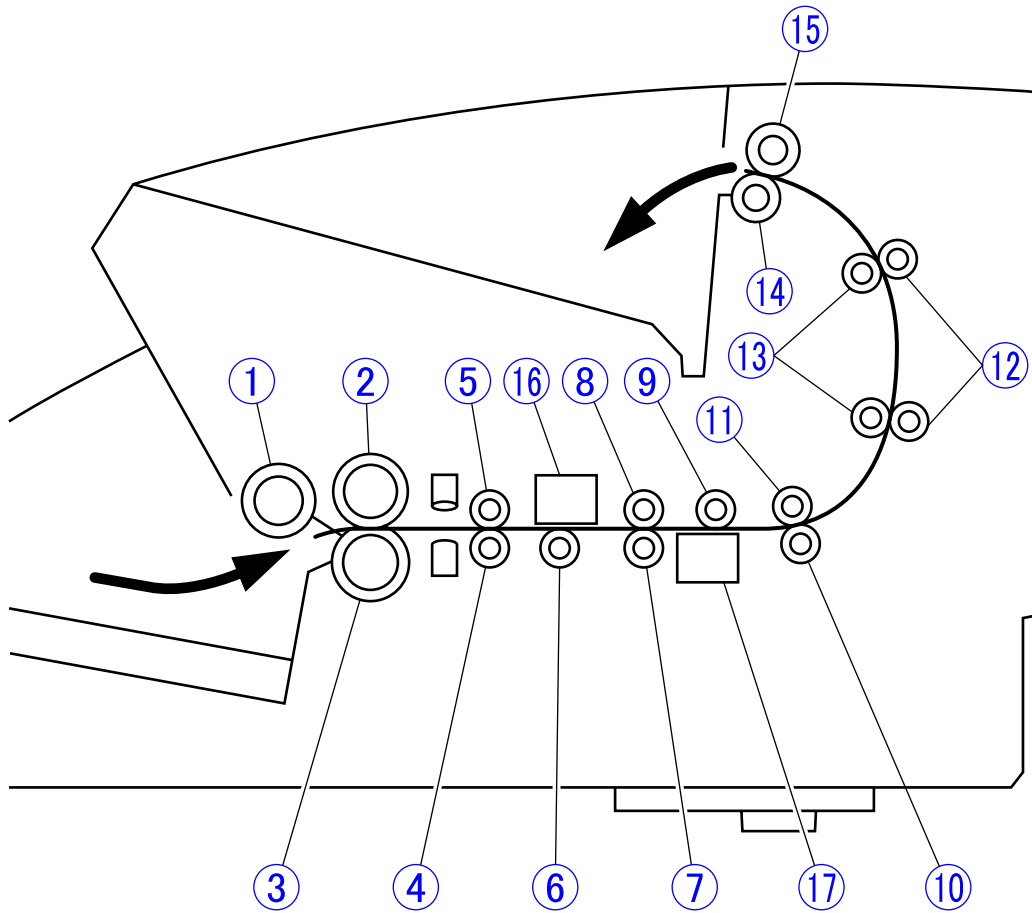

Figure 2-102

- | | |
|-----------------------------|------------------------------------|
| ① Pickup roller | ⑩ Front U-turn roller (drive) |
| ② Feed roller | ⑪ Front U-turn roller (follower) |
| ③ Retard roller | ⑫ Rear U-turn roller (drive): 2 |
| ④ Registration roller lower | ⑬ Rear U-turn roller (follower): 2 |
| ⑤ Registration roller upper | ⑭ Eject roller (follower) |
| ⑥ Platen roller lower | ⑮ Eject roller (drive) |
| ⑦ Reading roller lower | ⑯ Upper reading unit (front) |
| ⑧ Reading roller upper | ⑰ Lower reading unit (back) |
| ⑨ Platen roller upper | |

3. Motor Drive

This machine has the following 8 motors. Additionally, it also has a solenoid for operating the pickup roller vertically and an exhaust fan.

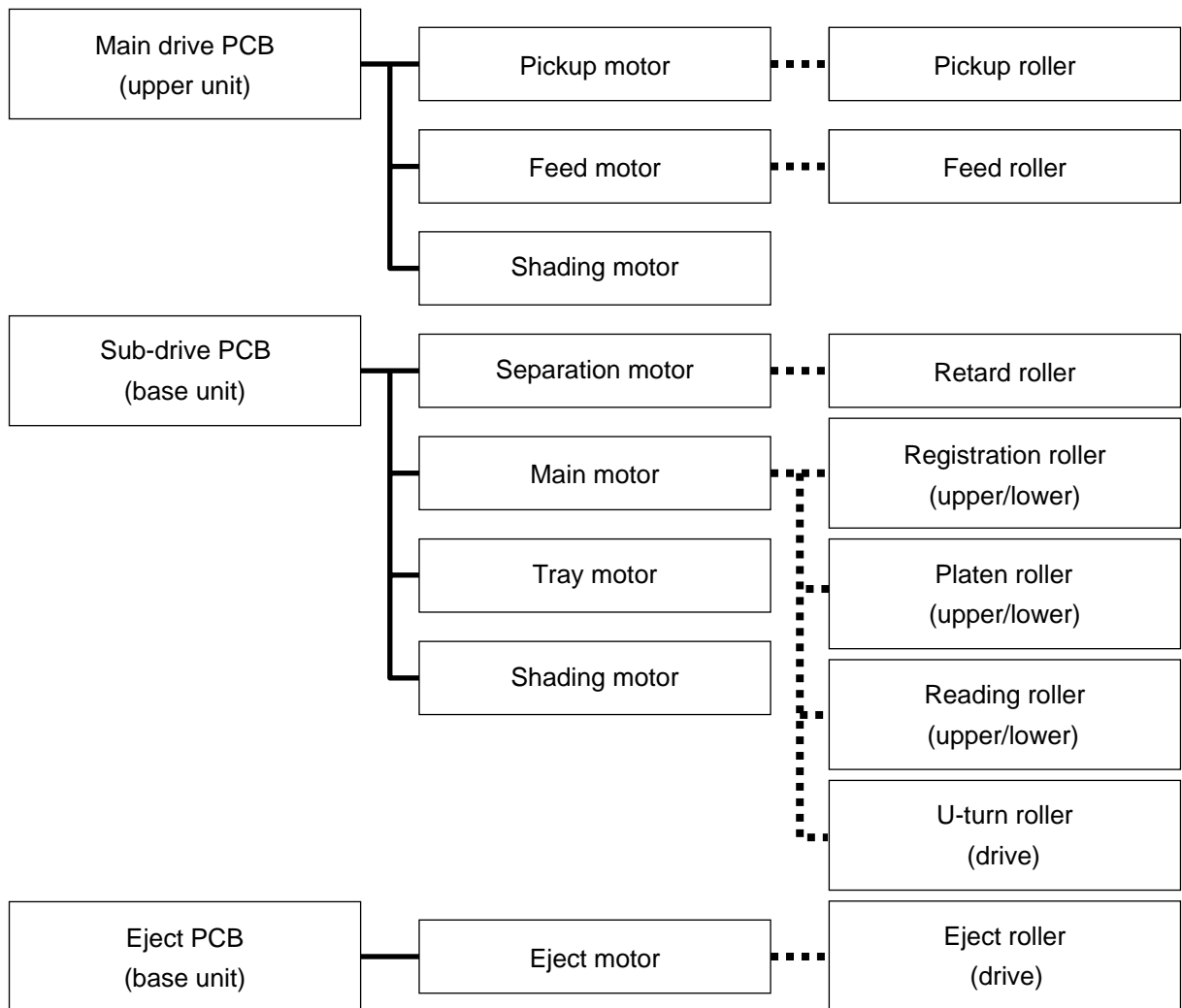

Figure 2-103

4. List of Sensors

This machine has the following sensors.

No.	Name	Functions and features
1	Document sensor	Detects whether there is a document on the pickup tray. However, a signal is received by the light-receiving elements of the staple sensor.
2	Pickup sensor	Detects whether a document is in the pickup position.
3	Registration pre-sensor (left/right)	Detects whether there is a document in front of the registration roller and double feed sensor.
4	Registration post-sensor	Detects whether there is a document behind the registration roller.
5	Eject sensor	Detects whether there is a document in front of the eject roller.
6	Skew sensor (left/right)	Detects whether the document extends beyond edges horizontally.
7	Double feed sensor (transmission/reception)	Detects double feed of a document. A pair of ultrasonic sensors is mounted.
8	Door sensor	Detects whether the upper unit is open.
9	Imprinter door sensor	Detects whether the imprinter cover is open.
10	Shading sensor (front/back)	Detects the position of the CIS unit. In the detection state, the CIS unit is in the shading data reading position.
11	Tray home sensor	Detects the home position of the pickup tray.
12	Staple sensor	Detects buildup of documents bundled with staples. Consists of 5 light-receiving elements. The 5 LEDs on the opposite side light and the light from them is detected by the light-receiving elements.

Table 2-101

5. Electrical Circuits

An overview of the electrical circuits block diagram of this machine is shown below.

The control PCB, which is mounted on the rear side of the main body, controls the entire

electrical circuits. The main drive PCB is mounted in the upper unit and the sub-drive PCB is mounted at the right side of the main body.

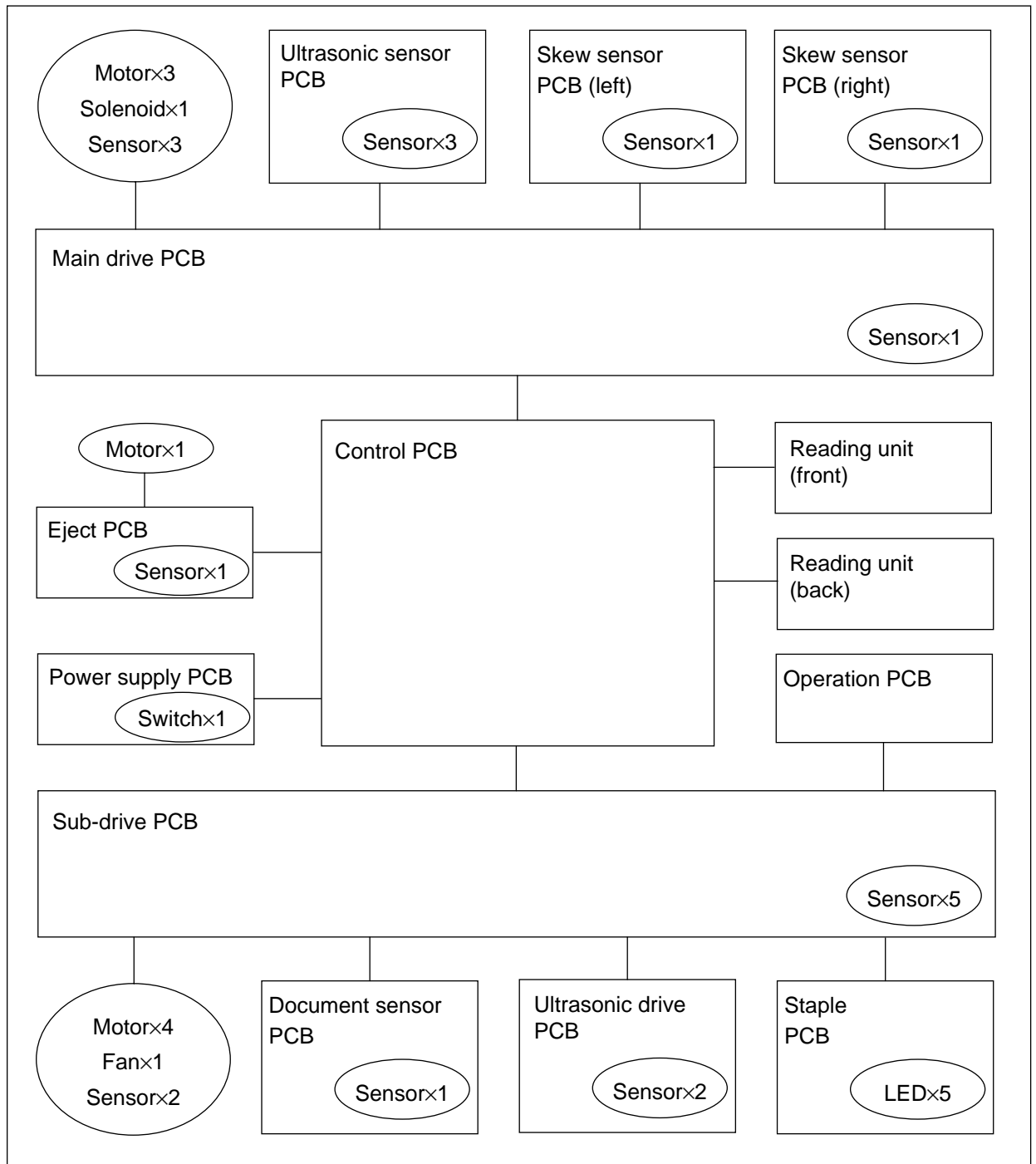
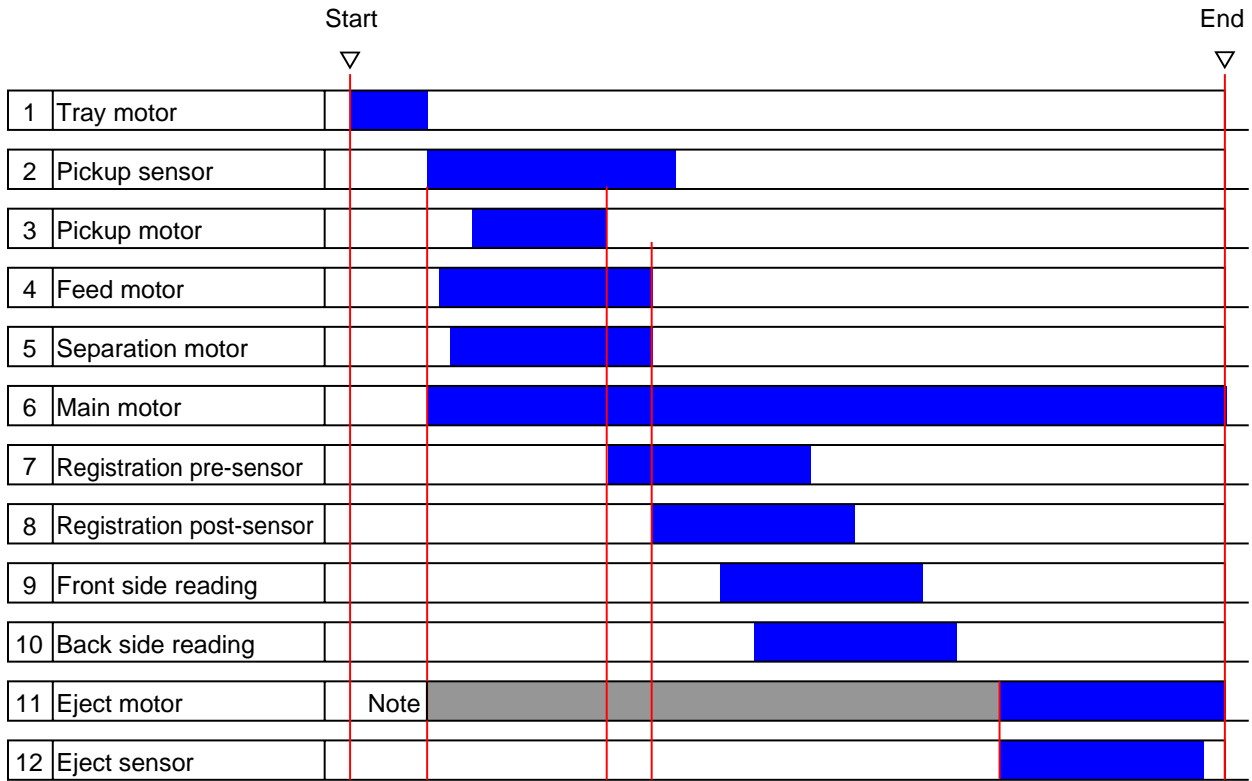

Figure 2-104

6. Timing Chart

The timing chart when 1 sheet of document is separately pickup is shown below. Once the machine starts scanning, the pickup tray lifts. Thereafter each motor starts rotating to feed the document.



Note: The gray part of the eject motor is ON for high-speed feeding and OFF for low-speed feeding.

Figure 2-105

II. READING SYSTEM

1. Outline

A sectional view of the image reading section is shown below.

The reading unit (upper) reads the front side of the documents and the reading unit (lower) reads the back side of the documents. This configuration enables the unit to read

both the front and back sides of a document using a single scan.

The platen rollers are assembled as opposed by the reading units.

The image data read are sent to the image processing section of the control PCB.

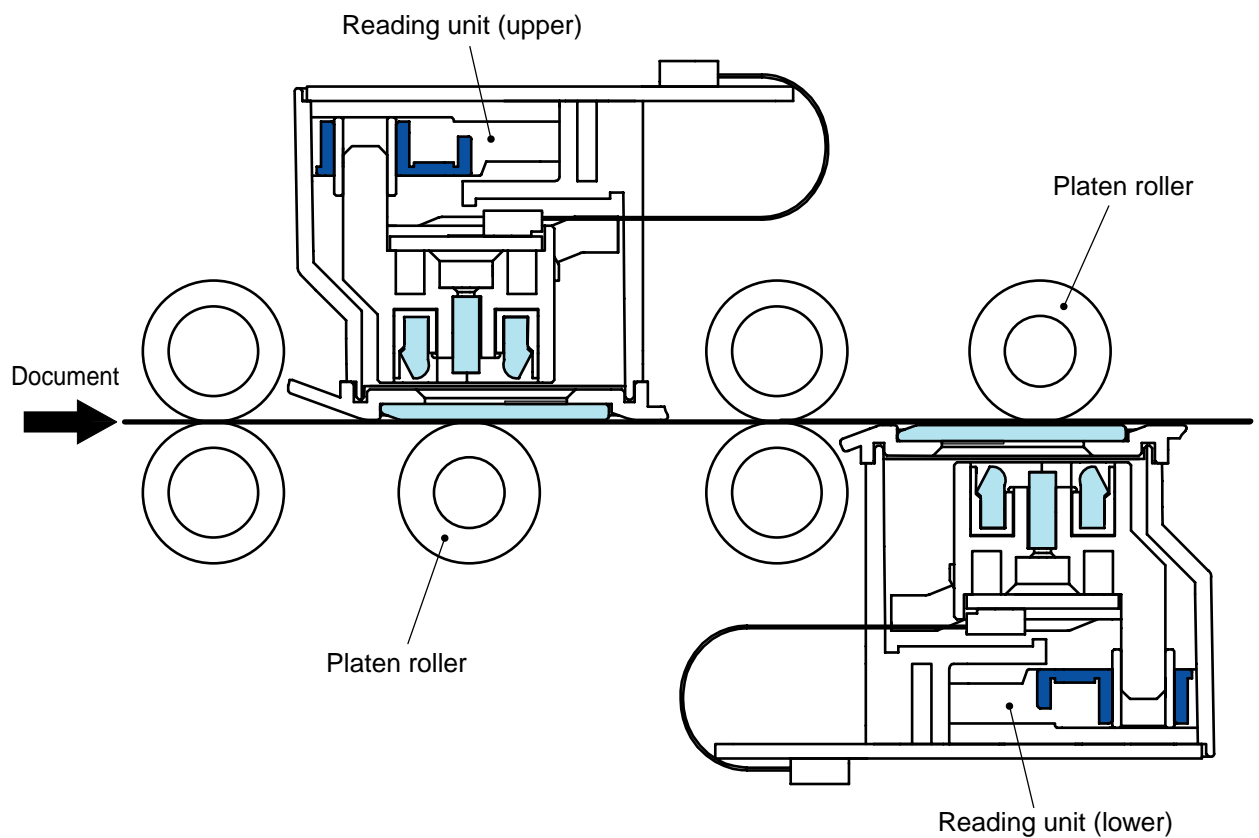

Figure 2-201

2. Image Reading

A sectional view of the image reading unit (lower) and the platen roller is shown below.

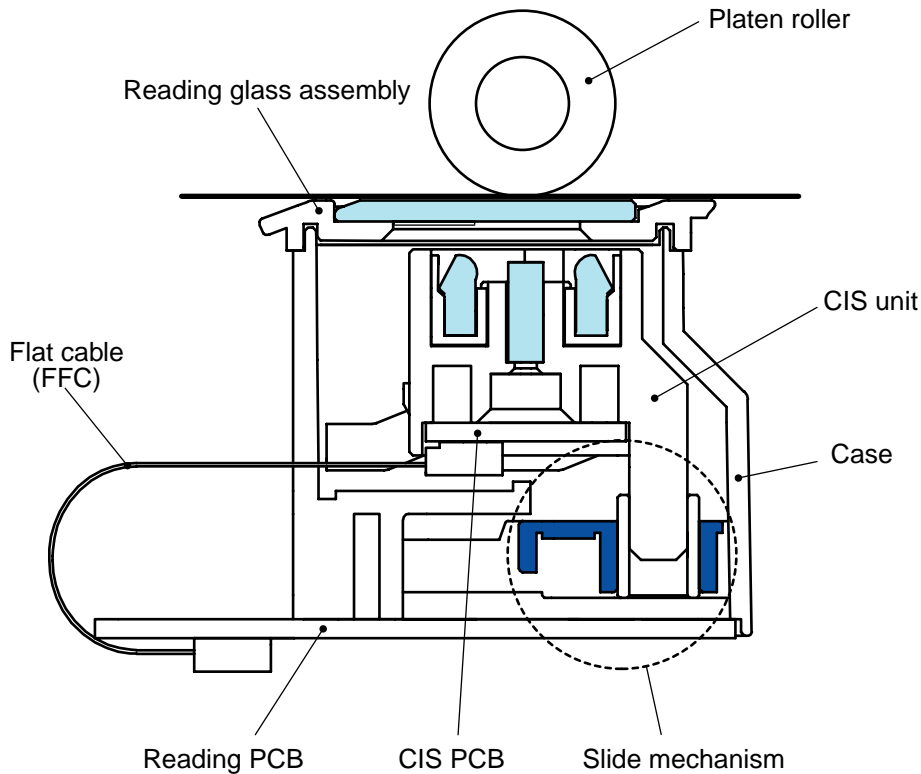

Figure 2-202

The reading unit consists of a CIS unit, a reading PCB, a reading glass assembly, flat cables (FFC), a case and a slide mechanism.

The CIS PCB in the CIS (Contact Image Sensor) unit has a light-receiving element having an optical resolution of 600 dpi. This light-receiving element is a 3-line CMOS image sensor with color filters for R, G and B. The number of effective pixels of each line is 7396 and its reading width is 313 mm.

As a 3-line type light-receiving element, it can light on the LEDs of the 3 colors at the same time for image reading, thus reducing color shift. In addition, it can prevent slow-down in reading in the color mode.

The lights from the LEDs illuminate the document through the light guides and the reading glass. The lights reflected from the document enter the image sensors through the lens arrays. The image sensors convert the lights to analog signals.

The analog signals are sent to the reading PCB, processed and transformed into digital signals. And then, they are sent to the control PCB.

As the platen roller is black, the background color becomes black.

3. Shading

The CIS unit and its slide mechanism are assembled inside the reading unit. The CIS unit is positioned in the document reading position when the documents are read. Since the scanner needs to read the white reference data when determining the shading correction value, it slides the CIS unit. The position of the CIS unit when reading an image and white reference is shown below.

This slide plate is driven by the shading

motor. Since the white reference is attached to the bottom of the reading glass, the CIS unit is slid horizontally and the CIS unit is moved downwards by the thickness of the reading glass. Thus, the reflection distances during image reading and white reference reading can be made equal.

When the power is switched ON and when scanning starts, this machine slides the CIS unit and reads the white reference data to decide the shading correction value.

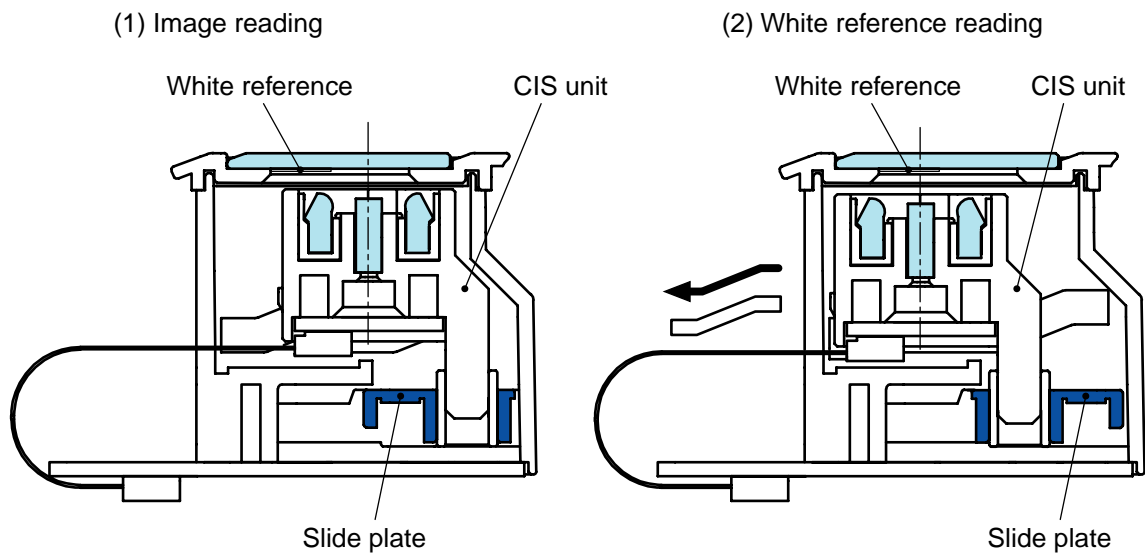

Figure 2-203

III. FEED SYSTEM

1. Outline

The drive rollers are driven by a motor and rotated by transmission of gears and belts. In addition to a roller drive motor, a pickup tray elevation motor is assembled. Sensors for feed control are also mounted.

The main characteristics of the feed system of this machine are shown below.

- 1) Pickup tray elevation
The elevation and the stop position of the pickup tray can be controlled. Thus, a large number of documents can be set and the standby position of the pickup tray can be selected.
- 2) Independent mechanism operation of the right and left document guides
The document guides of the pickup tray can be slid together and independently of each other and the document guides of the eject tray can be slid independently. Thus, the reference position at which a document is loaded can be set arbitrarily.
- 3) Document separation
Overlapped documents can be separated and fed one by one with the retard roller and feed roller.
- 4) Double feed detection
This machine contains a pair of ultrasonic sensors. Therefore, the following two double feed detections are available: the document length detection by the registration sensor and the document overlapping detection by the ultrasonic sensor.
- 5) Eject speed control
If documents are fed at a high speed and ejected at the same speed, alignment of the documents deteriorates. The speed when the trailing edge of the document is ejected is reduced and deterioration of alignment is prevented by controlling the number of revolutions of the eject motor.
- 6) Staple detection
Feeding of stapled documents can be stopped by installing a dedicated sensor at the pickup inlet.

2. Pickup Tray Elevation

The maximum loading capacity of the DR-9050C and DR-7550C is 500 sheets of ordinary copy paper and that for the DR-6050C is 300 sheets. To handle a large number of documents, the pickup tray of this machine can be elevated. A structural drawing is shown below.

There is a box unit with an elevating function below the pickup tray. The unit has 4 arms that support the pickup tray. When the arms turn sideways, the pickup tray is at the bottom position. When the arms are rotated clockwise by the drive of the tray motor, the pickup tray lifts. When they are rotated counterclockwise with erect arms, the pickup tray goes down.

A tray home sensor is mounted next to the

box unit. When part of the tray pad blocks light from this sensor, the fact that the pickup tray reaches the bottom (home position) can be detected. The fact that the pickup tray reaches the top (pickup position) can be detected with a pickup sensor mounted near the pickup roller.

If the pickup tray is at the bottom position suitable for the maximum loading capacity, waiting time until the pickup tray lifts to the pickup position increases when a few documents are scanned. Thus, it has a function that can set the standby position of the pickup tray at 3 levels: top, middle, and bottom. However, the DR-6050C has 2 levels: top and bottom. The top or middle position is controlled with the number of input pulses from the home position to the tray motor.

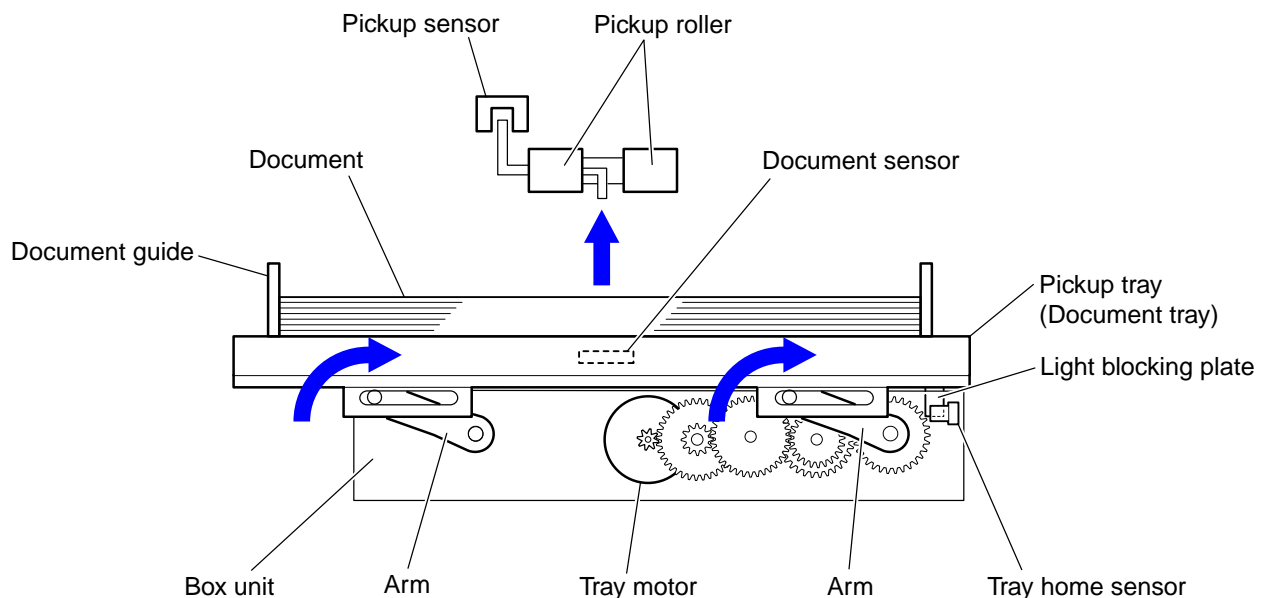

Figure 2-301

3. Separation Mechanism

The configuration of the separation mechanism is shown below.

The retard roller is configured in elastic body and is transmitted the feed driving force in reverse to the feed roller. Since the torque limiter is mounted on the drive transmission assembly of the retard roller, when the friction of the feed roller and the document exceeds the specified value, the retard roller begins to rotate in the same feeding direction as the feed roller.

As shown in Figure 2-302-a, when overlapped documents enter into the space between the feed roller and the retard roller, the document in contact with the feed roller is fed inside, and the retard roller rotates in the reverse direction so that the document in contact with the retard roller is pushed backwards to the pickup tray on the opposite side.

As shown in Figure 2-302-b, once a single document remains, the retard roller rotates in conjunction with the feed roller to feed the document.

When the Separation Off key on the operation panel is pressed, or Manual Feed is selected on the computer, the driving of the feed roller is turned OFF and the retard roller begins to rotate in the forward direction, invalidating the separation function.

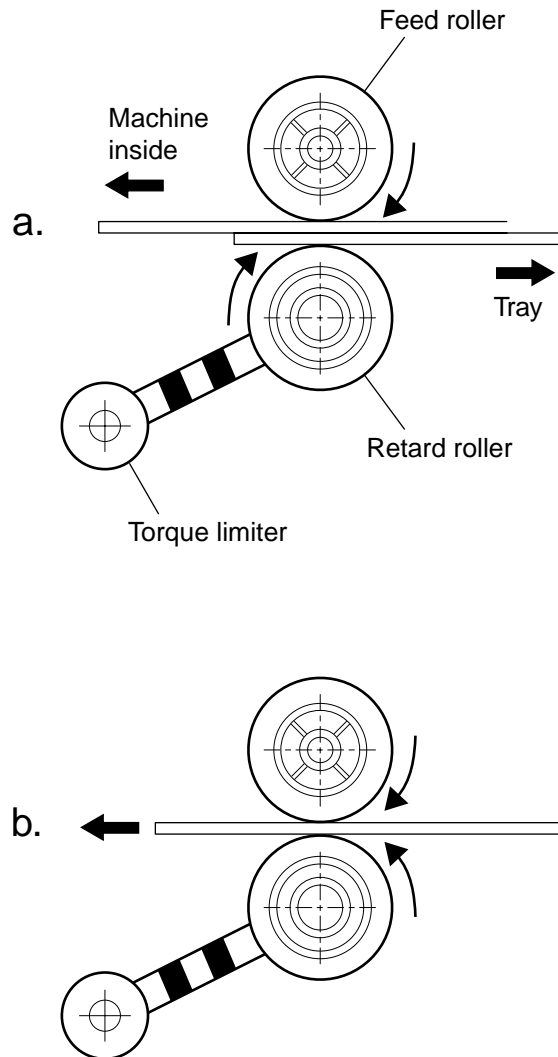

Figure 2-302

4. Feed Error Detection

◆ Jam Detection

Document jams are detected by the registration sensor. The types of the document jams are described as follows.

1) Pickup Delay Jam (Pickup Error)

The leading edge of the document was not detected by the registration sensor within the specified time after the machine starts scanning.

2) Early Reach Jam

The leading edge of the following document was detected after the trailing edge of the document was detected by the registration sensor before the document has been fed for a specified length.

3) Residual Jam

The trailing edge of the document was not detected even though the document has been fed for the maximum specified length after the leading edge of the document was detected by the registration sensor.

4) Fast Feed Jam

The trailing edge of the document was detected after the leading edge of the document was detected by the registration sensor before the document has been fed for the minimum specified length.

5) Non-removal Jam

The machine starts scanning while the document is detected by the registration sensor and still remains inside this machine.

◆ Double Feed Detection

There are 2 double feed detection methods: the document length detection by the registration sensor and the document overlapping detection by the ultrasonic sensor.

The registration sensor uses the first document length of the scanned batch as a reference to detect the document length. The 35 mm or more difference from the standard is interpreted as a double feed.

The ultrasonic drive sensor transmits the ultrasonic and the ultrasonic receive sensor receives the ultrasonic signal to gain a specific signal level. When overlapping documents are fed, the signal level is different from when properly feeding a single document. This machine interprets this difference as a double feed.

Note: The double feed detection by ultrasonic may not work if the document overlapping width is 50 mm or less. Further, the machine does not execute the double feed detection for the area of 15 mm from the leading and trailing edges of the document.

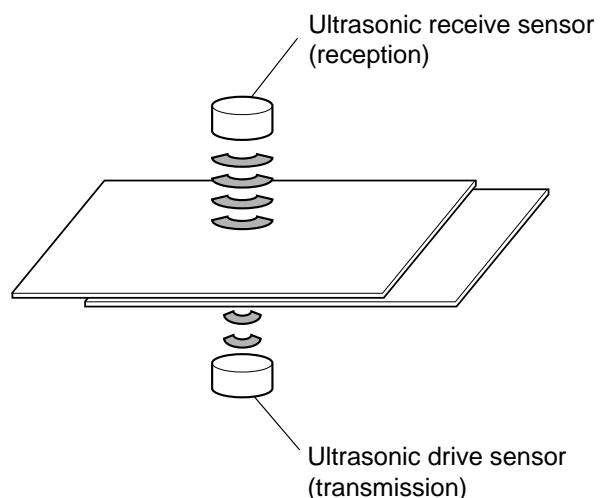

Figure 2-303

5. Staple Detection

In this unit, a staple detection mechanism is used which detects the jumping up of stapled documents.

This mechanism is designed not to detect the staple itself, but to detect the jumping up of the stapled documents when the stapled documents are picked up, and to stop the feeding. As such, it prevents stapled documents from being torn apart.

A stapled document jumping up due to the pickup roller is shown below.

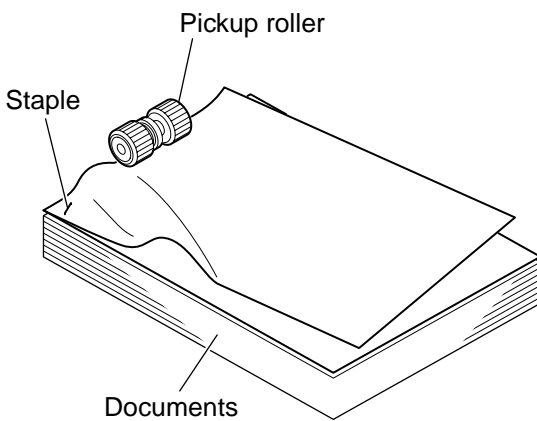

Figure 2-304

The configuration of the staple detection is shown below.

The staple detection mechanism consists of staple LEDs and a staple photo-sensor, arranged on both sides of the document pickup inlet. If there is no staple in the documents, the light emitted from the staple LEDs is directly received by the photo-sensor. If the stapled documents jump up, the light gets blocked and the documents are found to be stapled, resulting in stopping the feeding.

The five staple LEDs are mounted on the staple LED PCB. The staple photo-sensor has five sensors that correspond to the five LEDs on the staple LED, and is directly mounted on the sub-drive PCB.

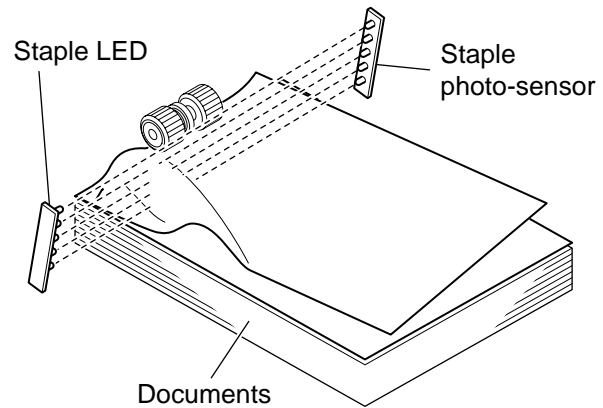

Figure 2-305

Note: Because the documents do not jump up under the following conditions, the staple detection sensor will not work:

- When there are two or more stapled places.
- When the staple is not positioned at a corner.
- When the documents are smaller than A5.

Document curl must be 3 mm or less in height and the documents cannot be creased.

It is possible to change the level of detection accuracy with the user mode.

IV. CONTROL SYSTEM

1. Control PCB

Control of this machine is performed by the control PCB. The block diagram associated with image is shown below, and Table 2-401 lists the main IC functions.

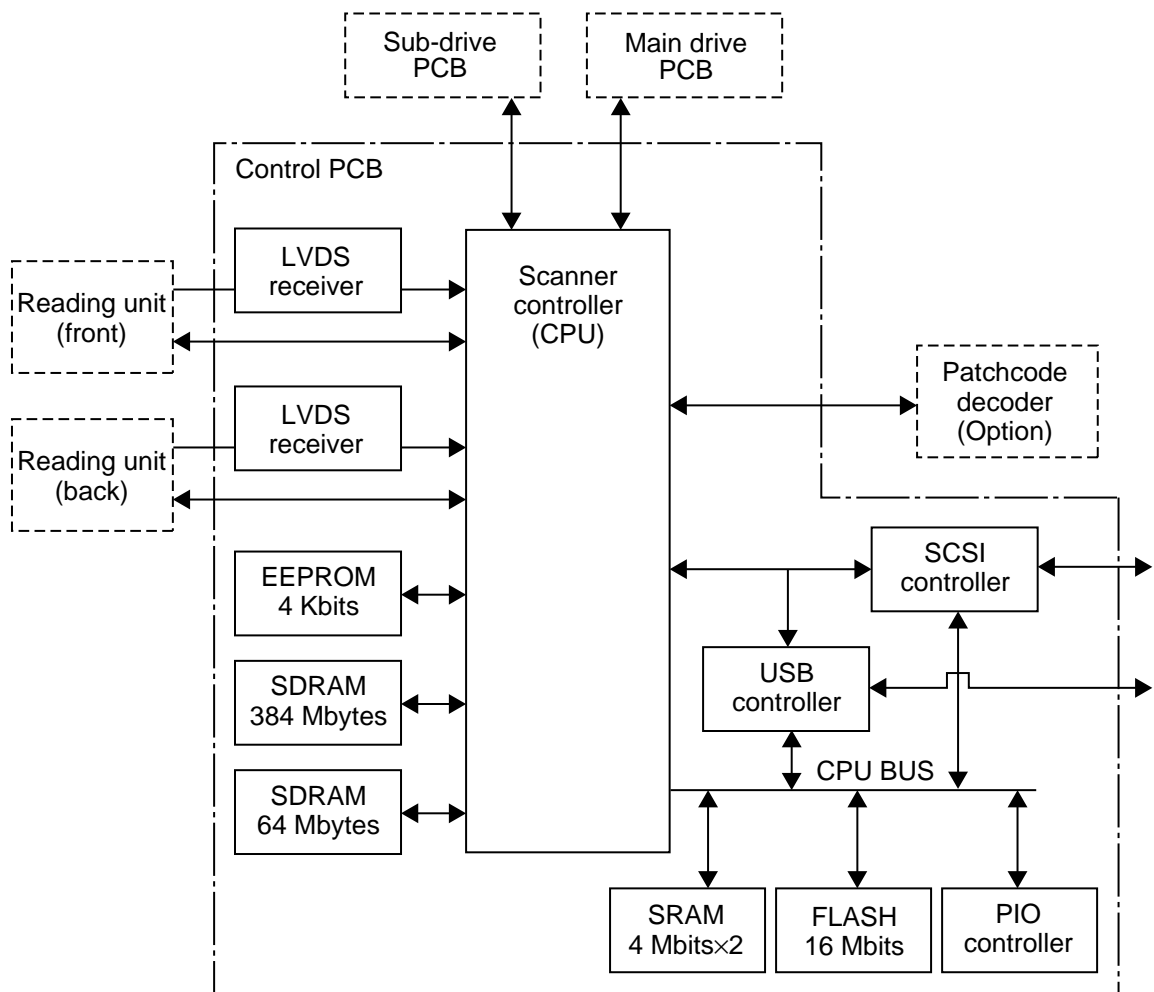

Figure 2-401

◆ Main IC functions

IC No.	Name	Function
IC108	Scanner controller	General scanner control (CPU)
IC109	EEPROM 4 Kbits	Storage of various setting data
IC110-111	SRAM 4 Mbits×2	For scanner controller work
IC144	FLASH 16 Mbits	Firmware storage
IC113-118	SDRAM 384 Mbytes	Temporary storage of image data, memory for image data processing
IC119	SDRAM 64 Mbytes	Memory for JPEG processing

Table 2-401

2. Drive System Block Diagram

The block diagram associated with motor control is shown below. It includes a solenoid and fan.

A control CPU is mounted on each PCB.

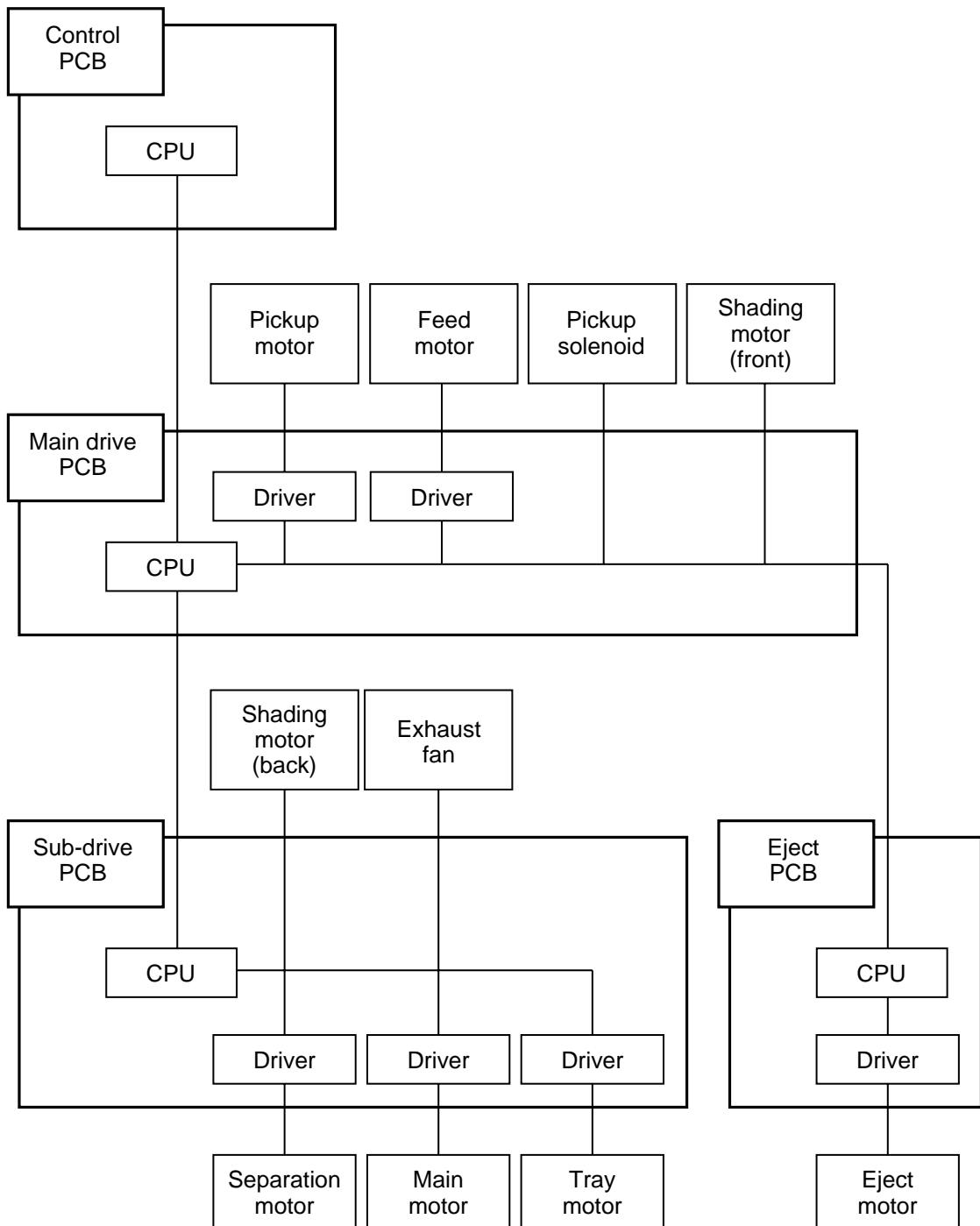

Figure 2-402

3. Image Processing Control

This machine performs main image processing using the hardware in the main body to speed up image processing.

The block diagram of the image processing in the main body is shown below.

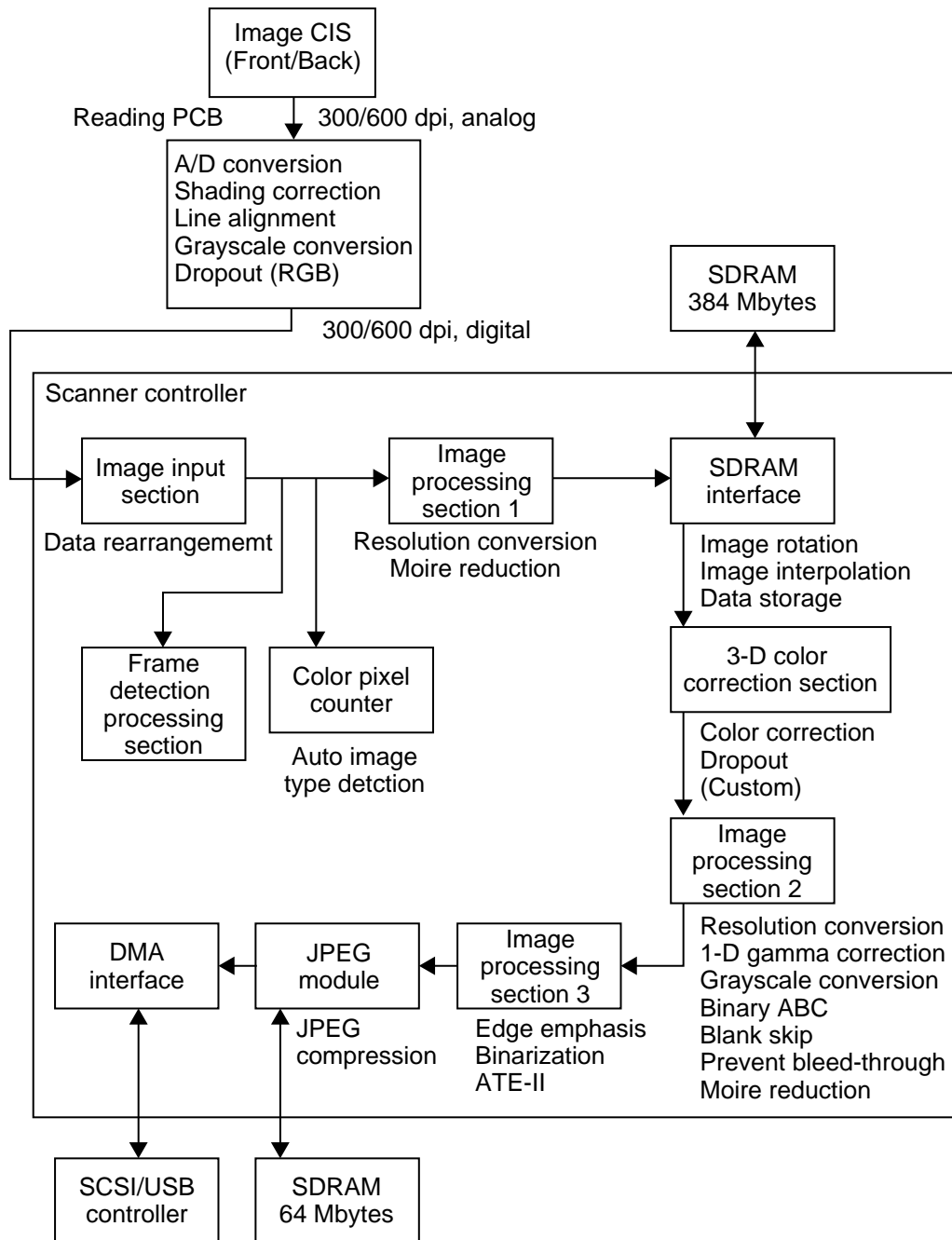

Figure 2-403

The analog signals output from the CIS unit are input to the reading PCB.

After those signals are converted into the digital signals in the reading PCB, the dedicated image processing IC performs the shading correction and rearranges the order of the data to align 3 lines.

According to the scanner settings, an optical resolution between 600 dpi and 300 dpi can be selected. In case that the resolution is set at 300 dpi or less, 300dpi data are output. The user selects either "Speed priority" or "Quality priority" for 400/600 dpi. The machine processes the image by using the 300dpi data for "Speed priority" and the 600dpi data for "Quality priority."

The image data output from the reading PCB is input to the control PCB and processed by the dedicated scanner controller (CPU).

First, the image data is rearranged in the image input section.

Image processing section 1 changes the resolution of the main-scanning direction in accordance with the scanner settings in order to convert the data into basic image data.

The basic image data are stored in the SDRAM through the SDRAM interface. SDRAM is 384 Megabytes in capacity.

And then, the 3-D color space processing section performs the 3-D gamma correction to improve the quality of colors.

Image processing section 2 changes the resolution, performs the 1-D gamma correction (adjustment of brightness and contrast, and custom gamma correction), the binary auto-brightness adjustment (ABC), and the grayscale conversion.

Image processing section 3 handles the edge emphasis, binarizing (simple binarizing, error diffusion, and ATE-II).

In the JPEG module, the grayscale and color data can be compressed in JPEG format. When JPEG is selected, the image data size is reduced by compression within this machine so that it can be transferred to the computer in less time. As a result, more documents can be read in a given time.

Finally, processed image data are sent from the DMA interface to the computer either through the SCSI or USB interface.

Auto-size detection and skew correction are processed according to the results of the frame sensor processing section. Auto image type detection is processed according to the results of the color pixel counter.

In case that the MultiStream is selected, the image data stored in the SDRAM are processed again in accordance with the secondary settings.

The following image processing is carried out inside the computer.

- ATE
- Folio processing
- Punch hole removal
- Border removal
- Text orientation recognition

V. POWER SUPPLY

1. Power Supply

The power supply PCB of this machine is divided into a 100 V system (for 100 V/120 V) and a 200 V system (for 220-240 V).

When the power switch (button) at the front of the main body is pressed, the power switch mounted on the power supply PCB is turned ON.

The supplied AC power is converted by a rectifying bridge to unsmoothed power and converted to 24 VDC power.

This DC power is supplied to the control PCB and is converted to a necessary DC voltage.

The block diagram of the power supply PCB and control PCB related blocks are shown below.

Note:The power supply with a voltage designation ending with "U*" is turned OFF at the sleep mode.

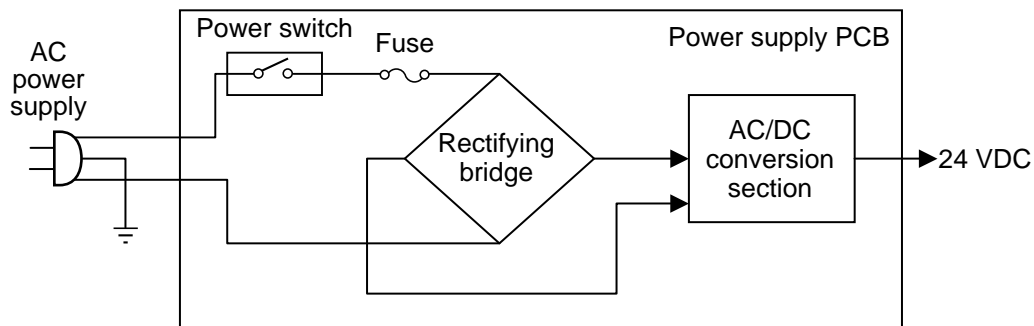

Figure 2-501

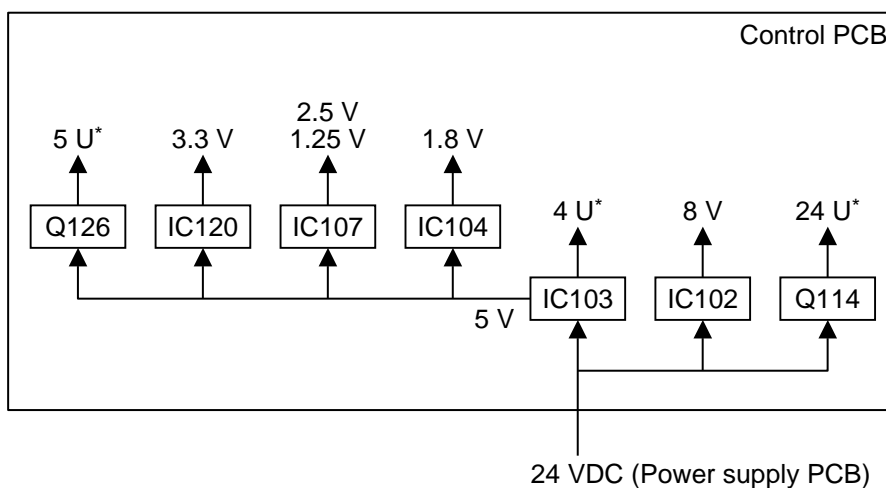

Figure 2-502

The power supply PCB contains a fuse, and if an excessive current flows, the fuse blows and the power supply stops. The motor driver has a protection function and if an excessive current flows, the power supply to the motor stops.

This machine will shift into the sleep mode (Energy Star mode) if no key or no scan operation takes place for an extended period of time after the power is turned ON. Select shifting time from 240/60/10 minutes according to the "Stand-by Mode Setting" in the user mode. It is set to "10 minutes" at the factory.

If communication is performed from a computer or a key on the operation panel is pressed, the machine resumes from the sleep mode.

This machine conforms to the standards defined by the International Energy Star Program.

VI. OPTION

1. Imprinter

Characters can be printed on the front side of the document by installing the imprinter in the scanner. This is a post-imprinter that prints after reading the document.

Ink cartridges made by Hewlett Packard are used.

Note: This imprinter is similar to the one for DR-9080C, but internal PCB is different.

The imprinters are installed by the service technician. Refer to “CHAPTER 4, INSTALLATION & MAINTENANCE” for details.

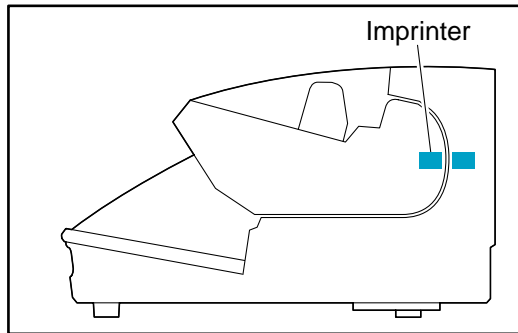

Figure 2-601

No.	Item	Description
1	Type	Post-imprinter
2	Form	Built in the main body
3	Printing surface	Front
4	Head movement method	Manual
5	Printing density	12 nozzles/line, 96 dpi
6	Maximum number of characters	32 characters
7	Character font	Original (12 × 12 dots, 12 × 8 dots)
8	Character string	1) ASCII codes: 20H to 7FH (Alphanumeric characters, symbols) 2) Special: counter, time, date, arrow
9	Printing position	1) Horizontal: An example is shown below. 2) Vertical: 0 to 500 mm from the leading edge of the document
10	Printing orientation	0/90/180/270°
11	Consumable part	Ink cartridge

Table 2-601

◆Printing position : Distributes from the center (15 places in total)

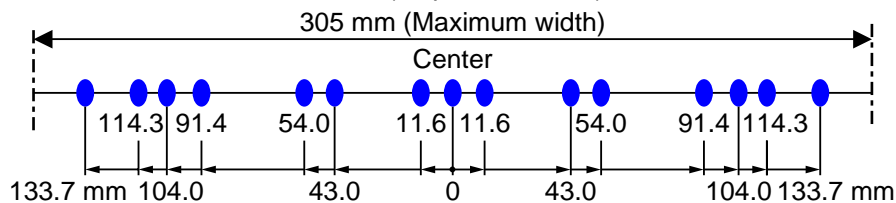

Figure 2-602

2. Patchcode Decoder

When the patchcode decoder is installed in the scanner, the scanner can recognize the patchcode printed on a patchcode sheet inserted within the documents and can perform batch separation.

The scanner can recognize two types of patchcodes: "PATCH T" and "PATCH II".

The patchcode decoder is installed by the service technician. Refer to "CHAPTER 4, INSTALLATION & MAINTENANCE" for details.

◆ PATCH T (FILE A)



Figure 2-603

The scanner creates a separate file for the document that comes after the patchcode sheet. The image of this sheet can be saved or not, depending on the application's settings.

◆ PATCH II (FILE B)



Figure 2-604

The scanner creates a separate file starting from the patchcode sheet. The image of this sheet is saved, regardless of the application's settings.

3. Barcode Module

The barcode module is an add-on module that adds the barcode detection function to the ISIS/TWAIN driver. Barcodes can be read by installing the barcode module in the computer.

The barcode module is installed by the user.

The following table lists the barcode types that can be read.

Code	No. of digits	Checksum
EAN/JAN	8 or 13	Modulus 10, Weight 3
CODABAR	3 to 32 (including Start/Stop characters)	Modulus 16, 7 DR
CODE 39	3 to 32 (including Start/Stop characters) (Standard ASCII or Full ASCII)	Modulus 43
ITF	2 to 32 (Even number of digits only)	Modulus 10, Weight 3
CODE 128	1 to 32 (Valid data only)	Modulus 103
UPC-A	13	Modulus 10, Weight 3
UPC-E	8	Modulus 10, Weight 3

Table 2-602

VII. ELECTRICAL PARTS LAYOUT

1. Motor, Fan, Solenoid

1) Upper unit

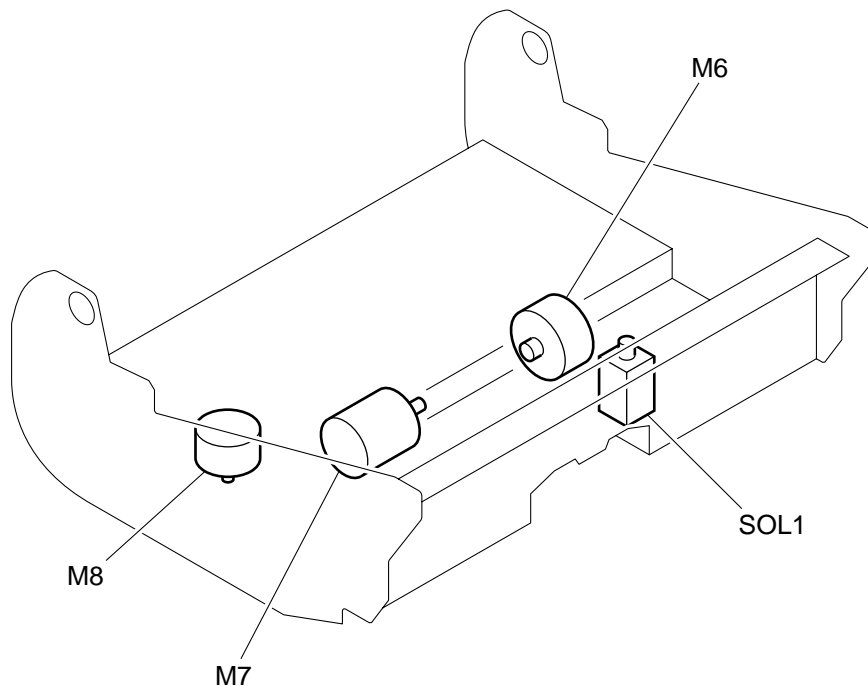

Figure 2-701

Name	Symbol	Description
Pickup motor	M6	
Feed motor	M7	
Shading motor (front)	M8	
Pickup solenoid	SOL1	

Table 2-701

2) Base unit

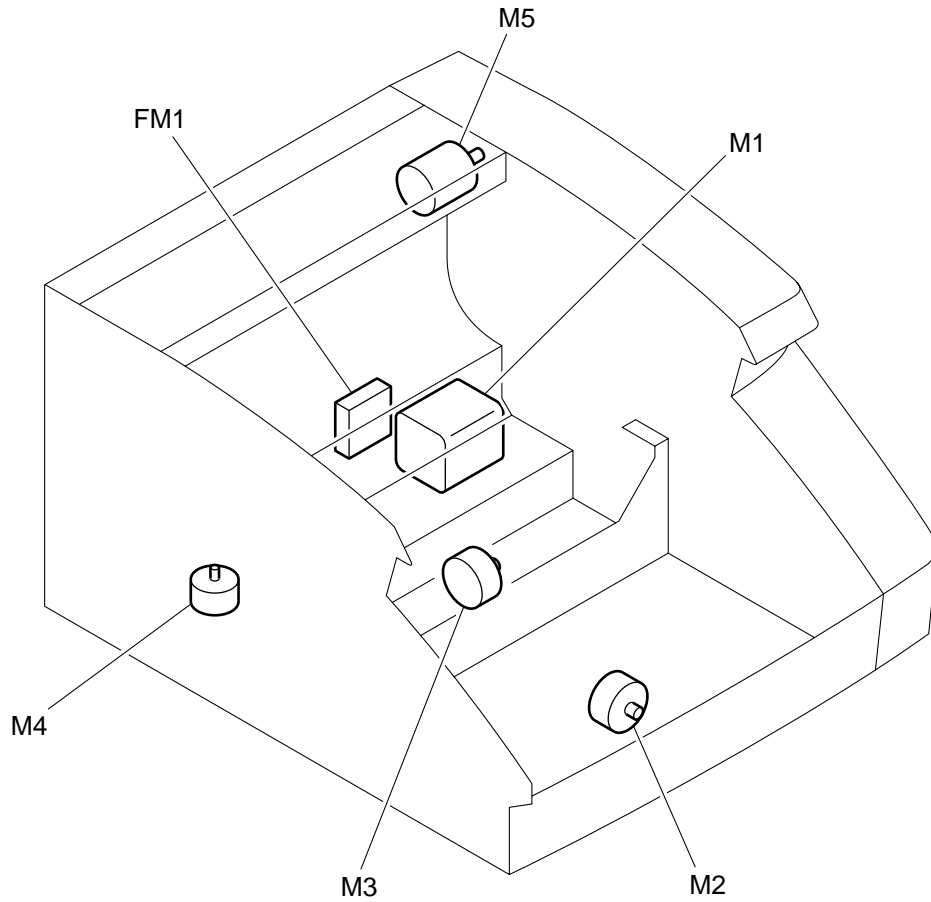

Figure 2-702

Name	Symbol	Description
Main motor	M1	
Tray motor	M2	
Separation motor	M3	
Shading motor (back)	M4	
Eject motor	M5	
Exhaust fan	FM1	

Table 2-702

2. PCB, Sensor, Unit

1) Upper unit

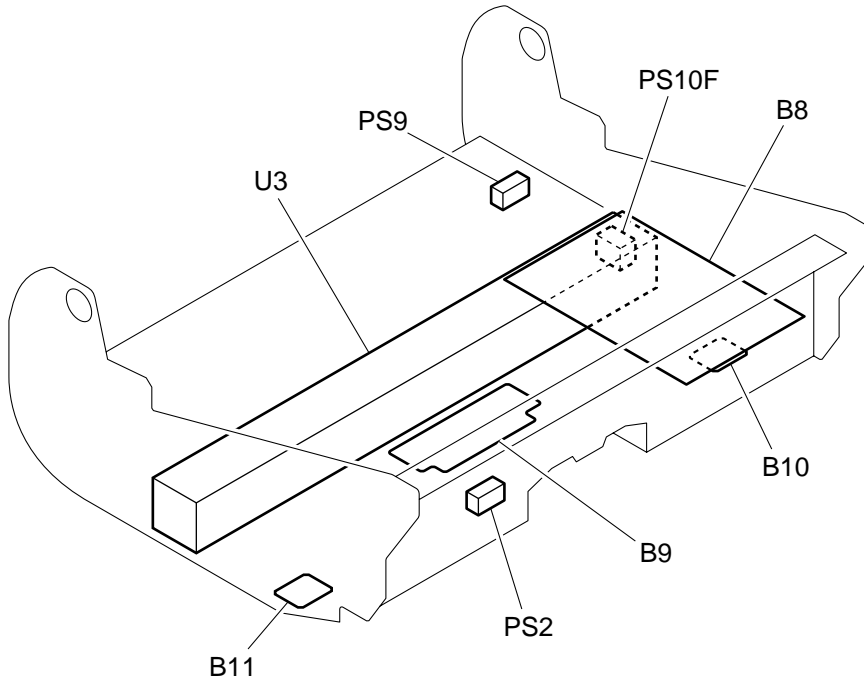

Figure 2-703

Name	Symbol	Description
Main drive PCB	B8	Door sensor PS8
Ultrasonic sensor PCB	B9	Ultrasonic sensor PS7, registration pre-sensor PS3
Skew sensor PCB (right)	B10	Skew sensor (right) PS6R
Skew sensor PCB (left)	B11	Skew sensor (left) PS6L
Pickup sensor	PS2	
Imprinter door sensor	PS9	
Shading sensor (front)	PS10F	
Reading unit (front)	U3	

Table 2-703

2) Base unit

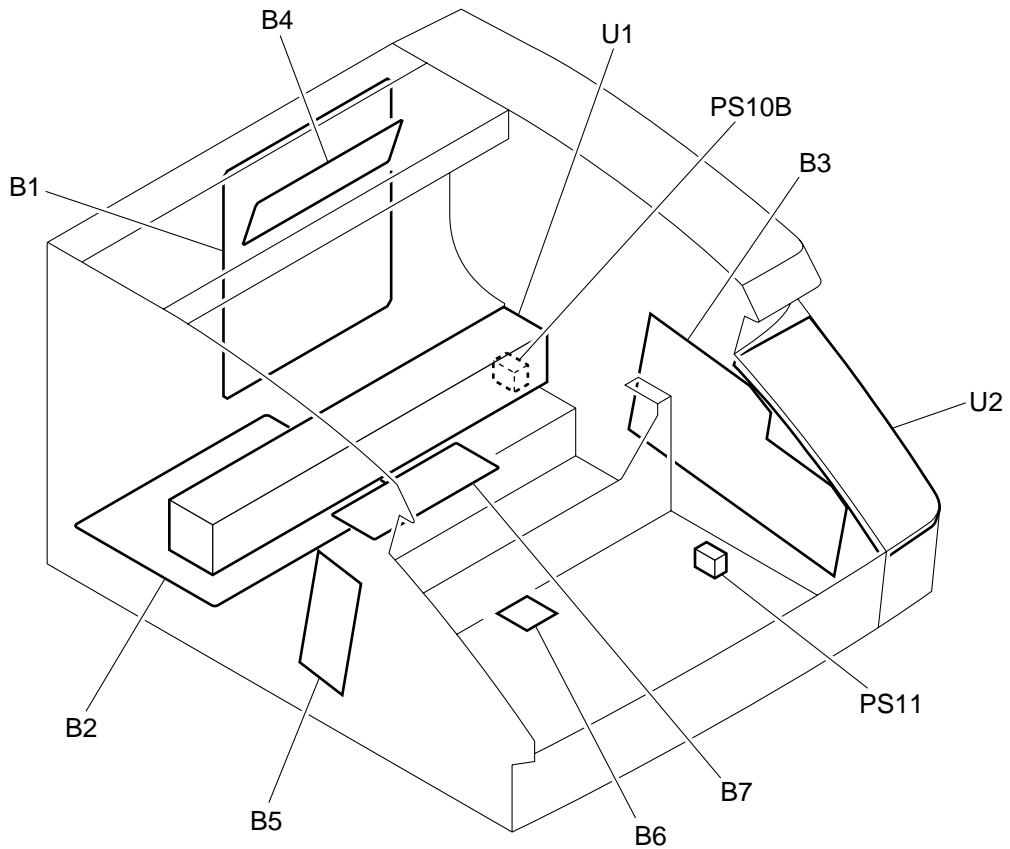

Figure 2-704

Name	Symbol	Description
Control PCB	B1	
Power PCB	B2	Power switch
Sub-drive PCB	B3	Staple sensor PS12
Eject PCB	B4	Eject sensor PS5
Staple PCB	B5	Staple sensor (LED) PS12
Document sensor PCB	B6	Document sensor (LED) PS1
Ultrasonic drive PCB	B7	Ultrasonic sensor PS7, registration post-sensor PS4
Tray home sensor	PS11	
Shading sensor (back)	PS10B	
Reading unit (back)	U1	
Operation panel unit	U2	

Table 2-704

VIII. PARTS LAYOUT ON EACH PCB

1. Control PCB

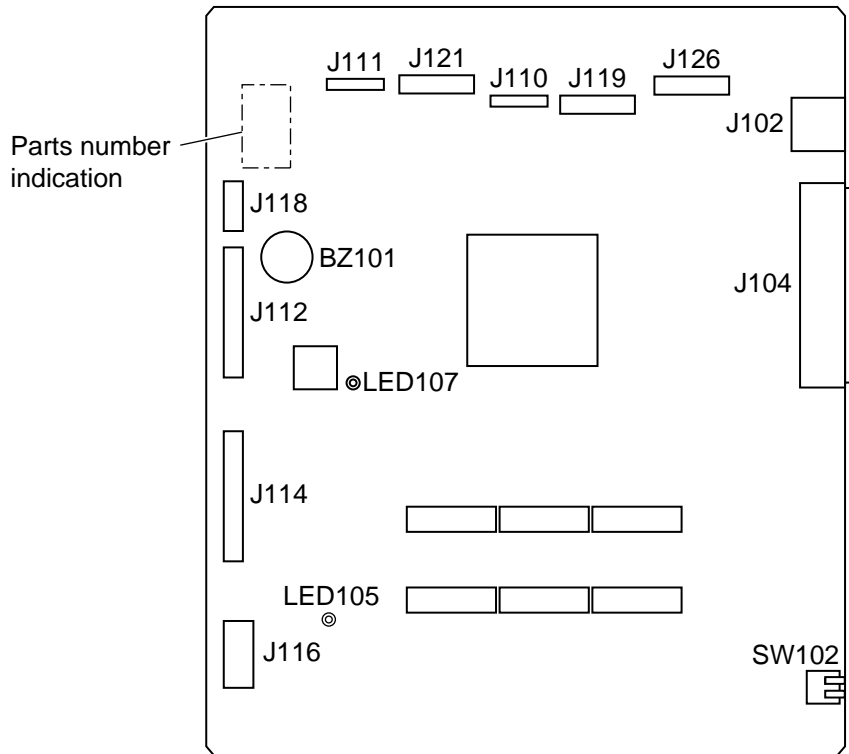

Figure 2-801

Symbol	Description															
SW102	SCSI ID settings															
	<table border="1"> <thead> <tr> <th></th> <th>SW2</th> <th>SW1</th> </tr> </thead> <tbody> <tr> <td>ID2</td> <td>OFF</td> <td>OFF</td> </tr> <tr> <td>ID3</td> <td>OFF</td> <td>ON</td> </tr> <tr> <td>ID4</td> <td>ON</td> <td>OFF</td> </tr> <tr> <td>ID5</td> <td>ON</td> <td>ON</td> </tr> </tbody> </table>		SW2	SW1	ID2	OFF	OFF	ID3	OFF	ON	ID4	ON	OFF	ID5	ON	ON
		SW2	SW1													
	ID2	OFF	OFF													
	ID3	OFF	ON													
ID4	ON	OFF														
ID5	ON	ON														
Setting at shipping: ID2																
LED105	Lit: 24 V good condition															
LED107	Flashing: CPU good condition															

Table 2-801

Note:The part number of this PCB is different for each product (DR-9050C, 7550C, 6050C).

2. Main Drive PCB

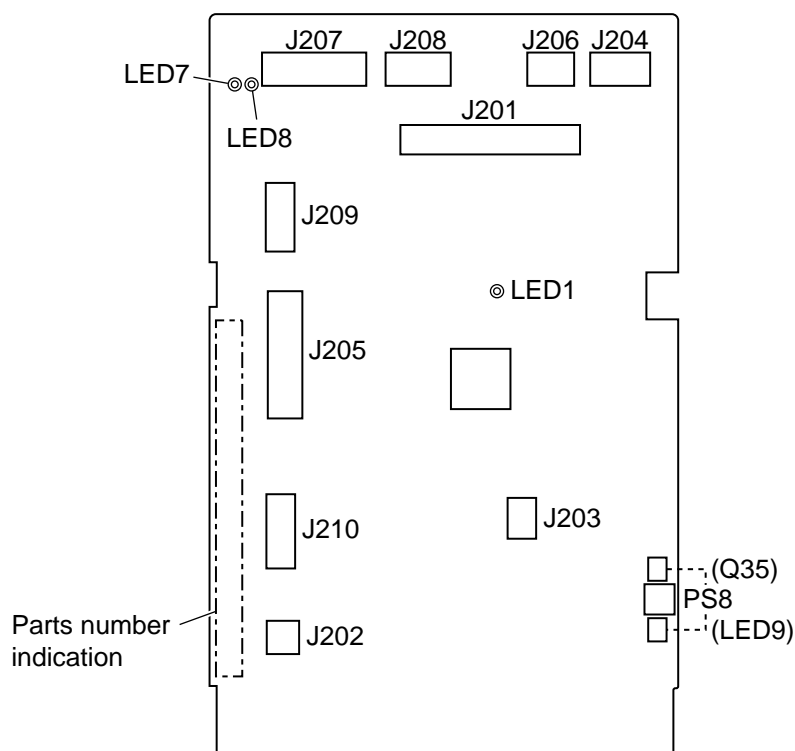

Figure 2-802

Symbol	Description
LED1	Flashing: CPU good condition
LED7	Lit: 5 V good condition
LED8	Lit: 24 V good condition
PS8	Door sensor

Note: At the sleep mode, LEDs will be put out lights

Table 2-802

Note: The part number of this PCB is different for each product (DR-9050C, 7550C, 6050C).

3. Sub-Drive PCB

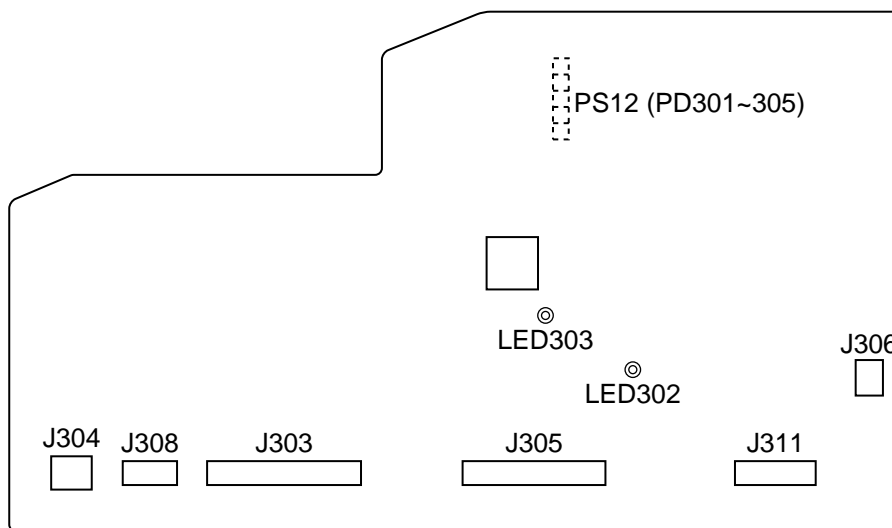

Figure 2-803

Symbol	Description
LED302	Lit: 24 V good condition
LED303	Flashing: CPU good condition
PS12	Staple sensor (reception)

Note: At the sleep mode, LED302 will be put out lights

Table 2-803

4. Power Supply PCB

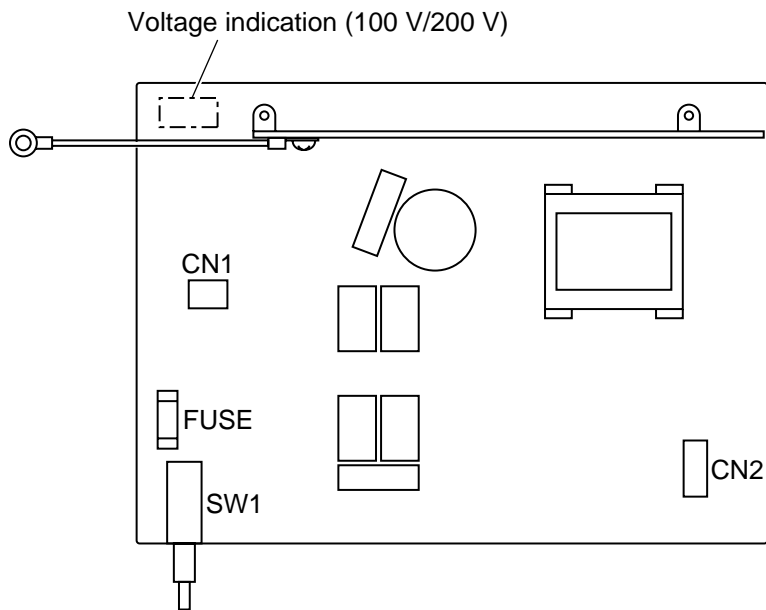

Figure 2-804

Symbol	Description
SW1	Power switch
CN1 (2P)	AC input
CN2 (4P)	24 VDC output

Table 2-804

5. Eject PCB

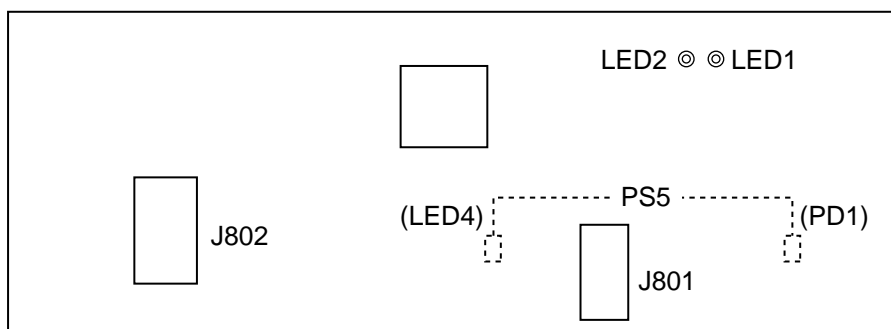

Figure 2-805

Symbol	Description
LED1	Flashing: Eject CPU good condition CPU 5 V good condition
LED2	High-speed flashing = Looks like a lit: Good communication with main CPU
PS5	Eject sensor

Note: At the sleep mode, LEDs will be put out lights

Table 2-805

CHAPTER 3

DISASSEMBLY & REASSEMBLY

I. REPLACED BY USERS.....	3-1	V. UPPER UNIT-3 (READING SYSTEM)...	3-23
II. EXTERNAL COVERS	3-3	VI. BASE UNIT-1 (ELECTRICAL SYSTEM)	
III. UPPER UNIT-1 (ELECTRICAL SYSTEM)		3-26
.....	3-9	VII. BASE UNIT-2 (MECHANICAL SYSTEM)	
IV. UPPER UNIT-2 (MECHANICAL SYSTEM)		3-34
.....	3-13	VIII. BASE UNIT-3 (READING SYSETM).....	3-43

I. REPLACED BY USERS

1. Pickup Roller

- 1) Hold the roller cover as shown in the figure below and open it to the front.

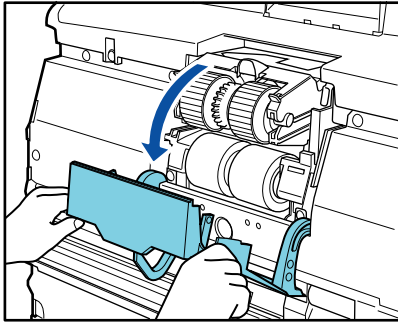

Figure 3-101

- 2) While opening the roller holder, remove the pickup roller.

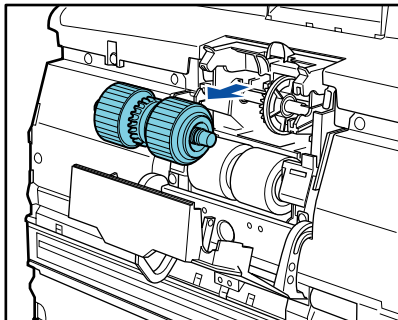
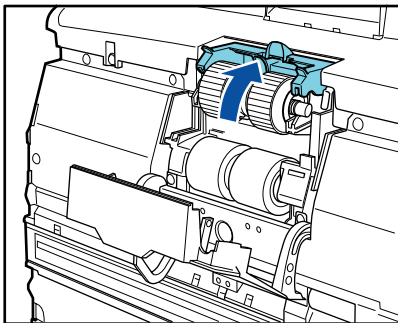

Figure 3-102

2. Feed Roller

- 1) Open the roller cover.
- 2) Open the roller lock lever to the front.

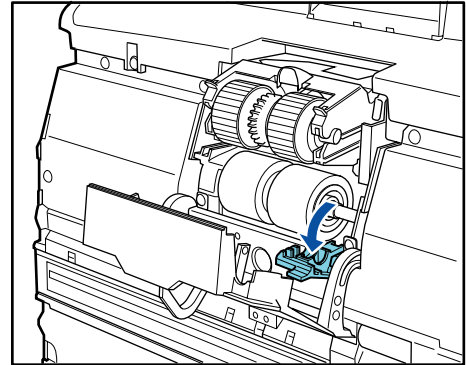

Figure 3-103

- 3) Slide the feed roller to the right and turn it to the front. Then, remove the feed roller.

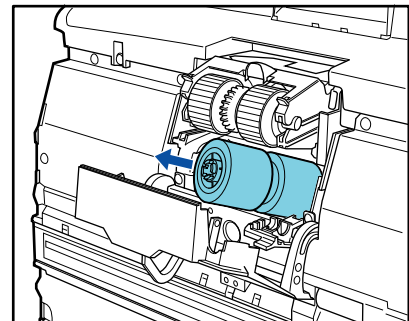

Figure 3-104

3. Retard Roller

- 1) Hold the roller cover with fingers and remove it.

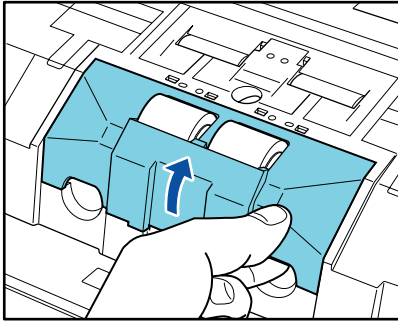

Figure 3-105

- 2) Remove the roller lock lever from the retard roller. (①→②)

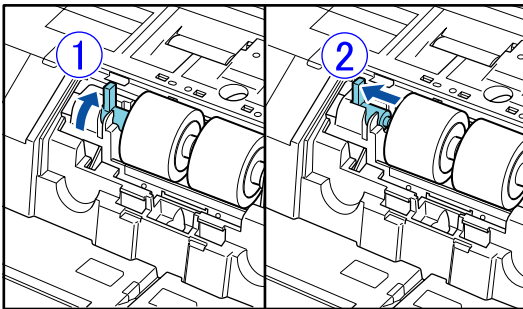

Figure 3-106

- 3) Remove the retard roller.

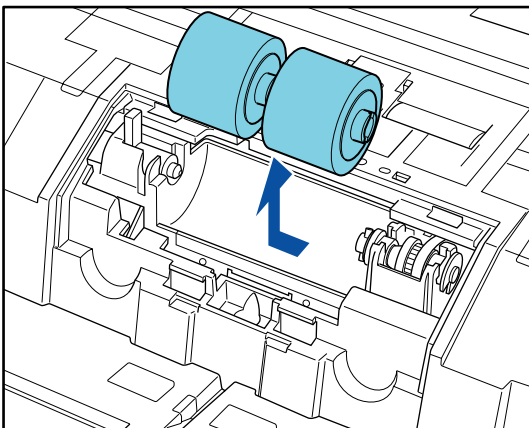

Figure 3-107

II. EXTERNAL COVERS

1. Control PCB Cover

- 1) Remove 6 screws ① (M4-bind head, round tip) and remove the control PCB cover ②.

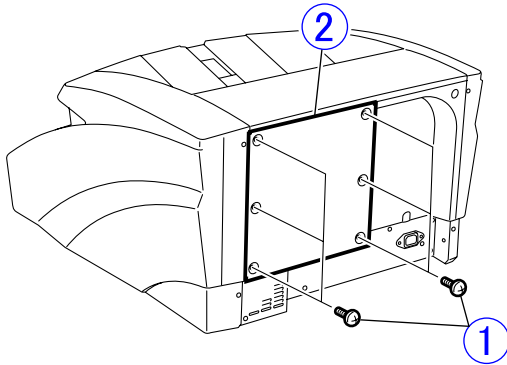

Figure 3-201

2. Right Cover

- 1) Remove 2 screws ① (M4-bind head, round tip).

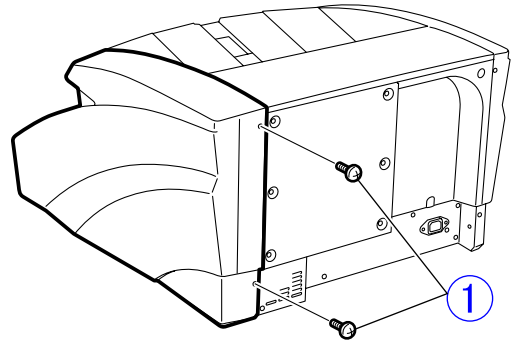

Figure 3-202

- 2) Remove 4 screws ① (M4, self-tapping).
Note: With the upper unit open, remove 2 screws.

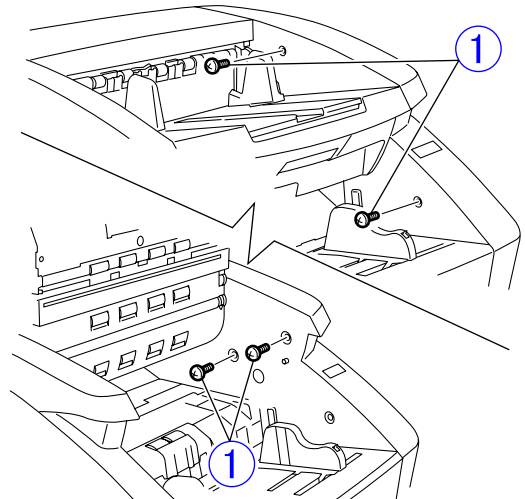

Figure 3-203

- 3) Since there are bottom and front fitting parts, remove the rear fitting part, slide the right cover ① to the bottom and front and remove it from the main body.

Note: Do not pull it excessively because a cable is connected to the back side.

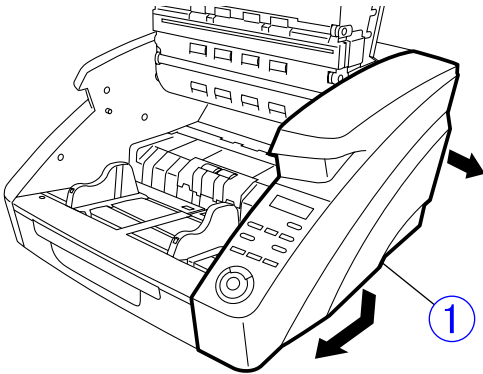

Figure 3-204

- 4) Remove the cable ① and remove the right cover ②.

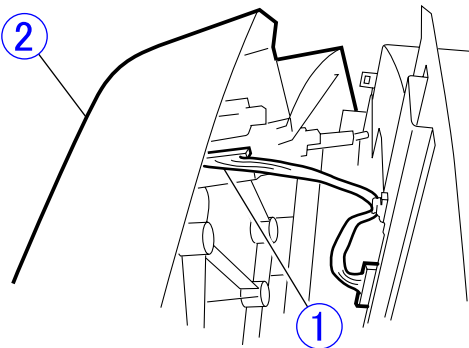

Figure 3-205

Note: Remove the operation panel if necessary.

[\(Page 3-4\)](#)

3. Operation Panel

- 1) Remove the right cover.
[\(Page 3-3\)](#)
- 2) Remove 2 screws ① (M3x8, self-tapping) and remove the operation panel ②.

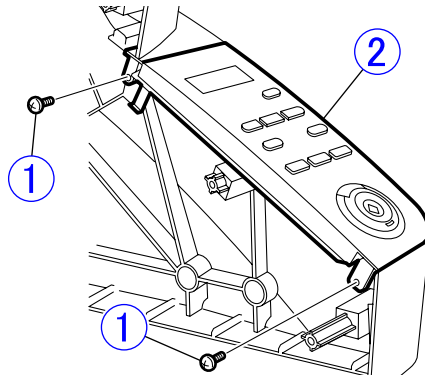

Figure 3-206

Note: Since the operation panel assembly is set as a single part, do not disassemble it.

4. Left Cover

- 1) Remove 2 screws ① (M4-bind head, round tip).

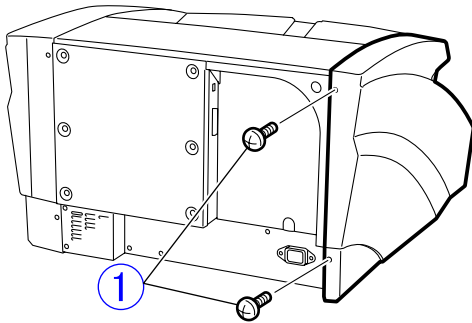

Figure 3-207

- 2) Remove 4 screws ① (M4, self-tapping).

Note: With the upper unit open, remove 2 screws.

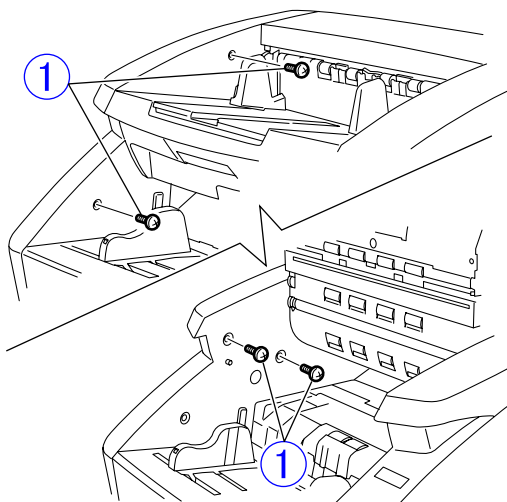

Figure 3-208

- 3) Since there are bottom and front fitting parts, remove the rear fitting part, slide the left cover ① to the bottom and front and remove it from the main body.

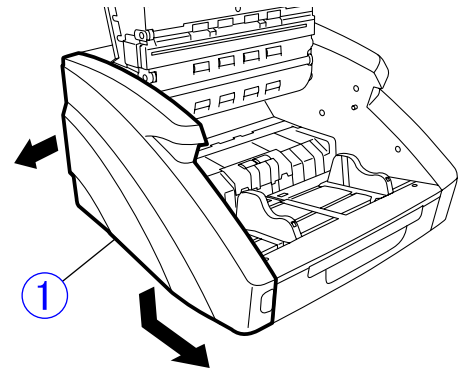

Figure 3-209

5. Top Cover

- 1) Remove the control PCB cover.
(Page 3-3)
- 2) Remove the right and left covers.
(Page 3-3), (Page 3-5)
- 3) Remove the screw ① (M3-TP head, round tip), and while unhooking 2 pairs of the right and left fitting parts ②, remove the top cover ③.

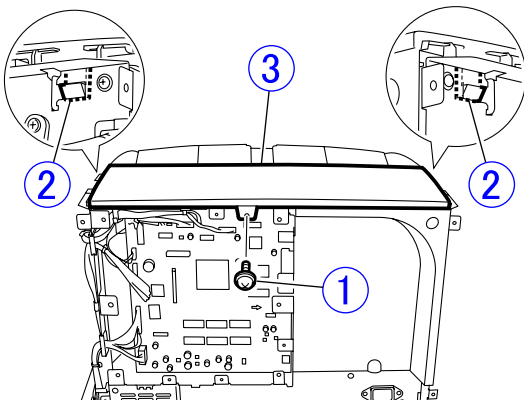

Figure 3-210

◆ Notes on assembling

Since there is a front fitting part, first assemble the front and then the back.

6. Pickup Tray Unit

Note:The shapes of the DR-6050C pickup tray unit and the extension tray are slightly different from those shown below, but the procedure is the same.

- 1) Remove 4 screws ① (M4, stepped) and remove the pickup tray unit ②.

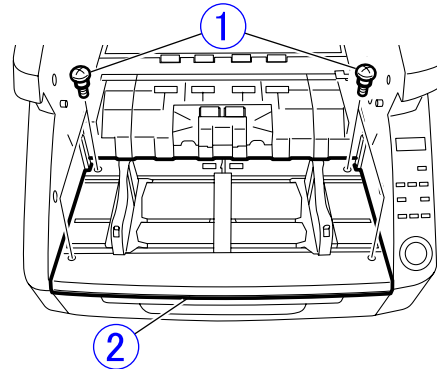

Figure 3-211

- 2) Remove the extension tray ①.

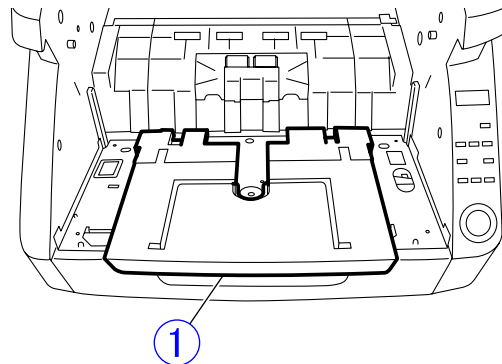

Figure 3-212

7. Eject Tray Unit

- 1) Unlock the imprinter cover. Refer to "Notes on assembling".
- 2) Remove 6 screws ① (3 on both sides, M3-TP head, round tip). Then, close the upper unit and remove the eject tray unit ② to the front.

Note: Since there are other screws with the same shape, remove the screw shown below. The screws are at symmetrical positions.

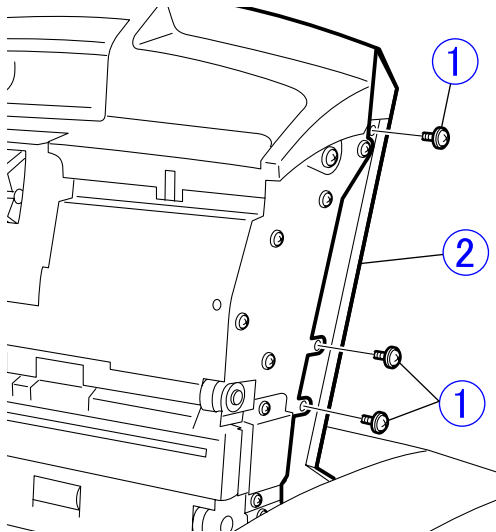

Figure 3-213

◆ Notes on assembling

Verify that the imprinter cover is unlocked before assembling.

Unlock the imprinter cover so that the projection for the imprinter door sensor is not caught by a cable and the imprinter cover does not hit the carriage of the imprinter (option).

Reference: Eject sensor light guide

The eject tray unit incorporates the imprinter door sensor lever and eject sensor light guide.

8. Upper Front Cover

- 1) Remove the eject tray unit.
(Page 3-7)
- 2) Remove 4 screws ① (M3-TP head, round tip) and remove the upper front cover ②.

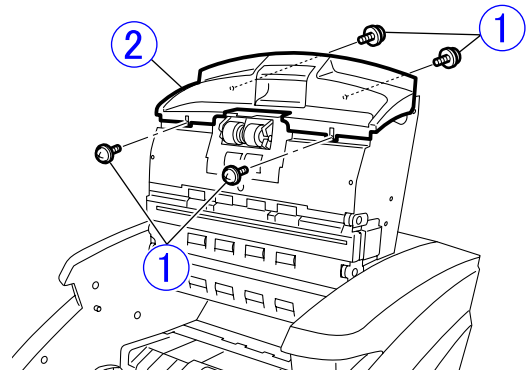

Figure 3-214

9. Rear Cover

- 1) Remove the control PCB (including the mounting plate).

[\(Page 3-26\)](#)

- 2) Remove 2 screws ① (M3-TP head, round tip). Rotate the upper part of the rear cover ② to the front and while unhooking 2 pairs of the lower fitting parts ③, remove the rear cover.

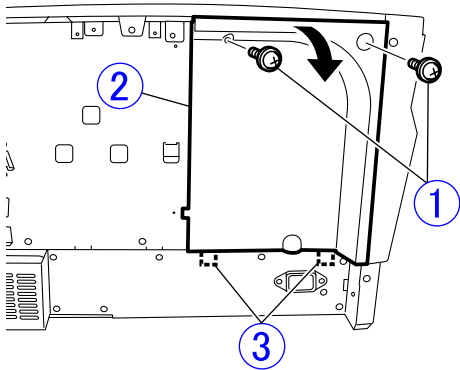

Figure 3-215

◆ Notes on assembling

Be sure not to break the lower hooks.

III. UPPER UNIT-1 (ELECTRICAL SYSTEM)

1. Main Drive PCB

- 1) Remove the eject tray unit.
([Page 3-7](#))
- 2) Remove all the cables connected to the main drive PCB ①. (A total of 9 except the imprinter)

Remove 2 screws ② (M3-bind head, round tip), and while removing 2 pairs of fitting parts ③ and the cable in the cable guide ④, remove the main drive PCB.

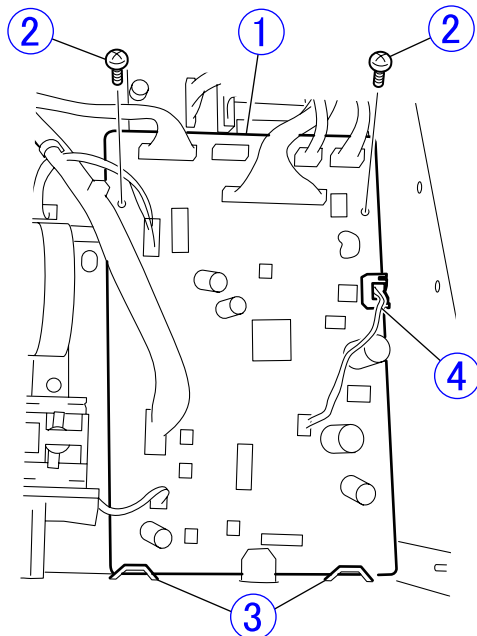

Figure 3-301

◆ Notes on assembling

Do not forget to assemble the cable (for a skew sensor) that passes through the cable guide from the bottom.

2. Ultrasonic Sensor PCB

- 1) Remove the eject tray unit.
([Page 3-7](#))
- 2) Remove the cable ① (for the ultrasonic sensor PCB) from the cable holder ② to provide clearance.

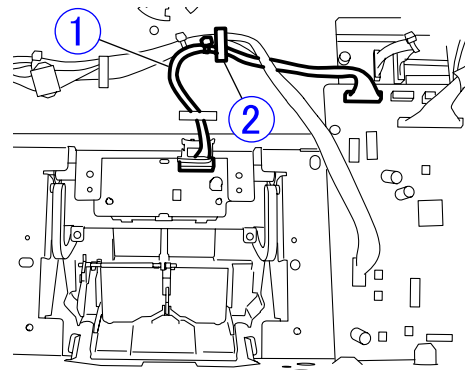

Figure 3-302

- 3) Remove the registration roller upper.
([Page 3-15](#))
- 4) Remove 2 screws ① (M3-bind head, round tip), pull out the ultrasonic sensor PCB ② (with a plastic guide plate) and remove the cable connected to the back side.

Note: Do not pull it excessively because the cable is connected to it.

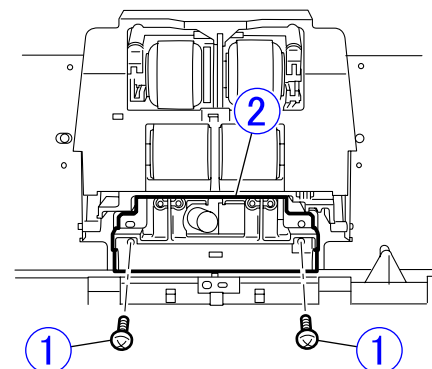

Figure 3-303

3. Feed Motor

- 1) Remove the pickup unit.
[\(Page 3-13\)](#)
- 2) Remove 3 screws ① (M3x6, self-tapping) and while removing the timing belt, remove the motor unit ② (including the mounting plate).

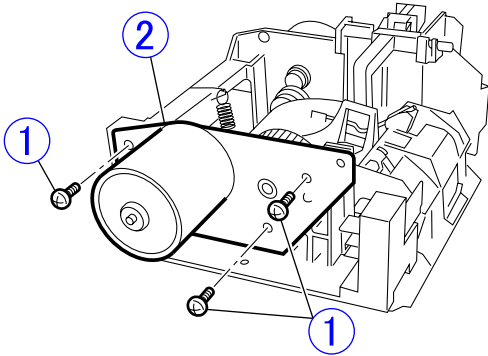

Figure 3-304

- 3) Remove 2 screws ① (M3x4, black) and remove the feed motor ②.

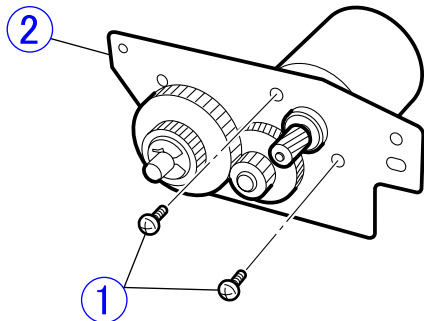

Figure 3-305

4. Pickup Motor

- 1) Remove the pickup solenoid.
[\(Page 3-11\)](#)
- 2) Remove the feed motor unit.
[\(Page 3-10\)](#)
- 3) Remove 2 screws ① (M3-bind head, round tip) and remove the pickup motor ②.

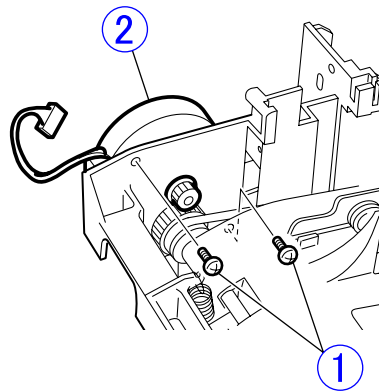

Figure 3-306

5. Pickup Solenoid

- 1) Remove the upper front cover.

(Page 3-7)

Note: The pickup unit may be removed.

- 2) Remove the cable of the pickup solenoid
① and 2 screws ② (M3-bind head, round tip).

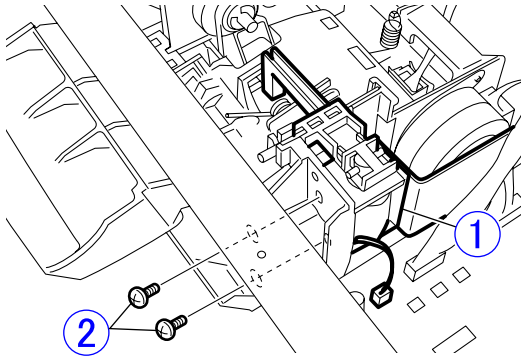

Figure 3-307

- 3) Lift the D cut side ① of the shaft, pull the shaft out and remove the pickup solenoid ② (with a radiator plate).

Note: A spacer (plastic ring) has been built in the iron core of the solenoid. Do not lose it.

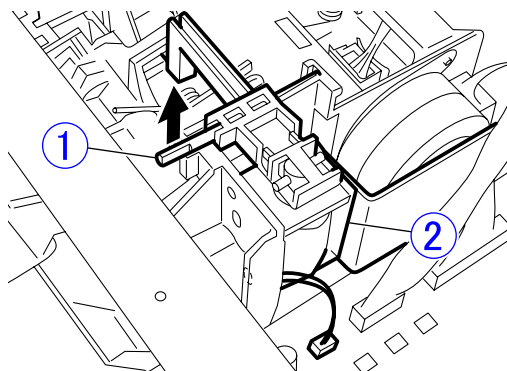

Figure 3-308

- 4) Remove 2 screws (M3-bind head, round tip) and remove the radiator plate.

◆ Notes on assembling

The position of the solenoid must be adjusted. The procedure is as follows.

If the position of the solenoid is wrong, the pickup roller cannot be lifted and double feed of thin documents may occur or the center of the leading edge of a document may be folded.

- 1) Assemble it as shown in the figure below. Verify that the spacer has been built in the iron core.

Insert the end of the solenoid arm into the hole at the top of the pickup unit.

Push the shaft by aligning the D cut shape with the groove.

Install 2 screws temporarily so that the solenoid main body can be slid.

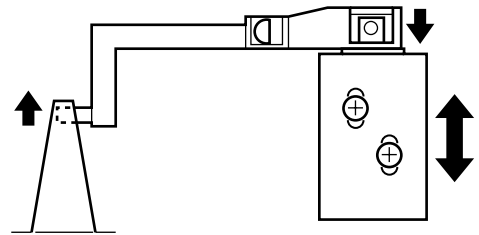

Figure 3-309

- 2) Insert the shaft ① with external shape of 4 mm in diameter (a screwdriver with a thin shaft, etc.) into the hole. When the solenoid main body is slid so that the clearance between the spacer and contact surface is approx. 2 mm, tighten screws and secure the solenoid main body.

Note: If there is no appropriate shaft, secure the solenoid at a position where there is a clearance of approx. 2 mm when the pickup roller lowers with no shaft inserted.

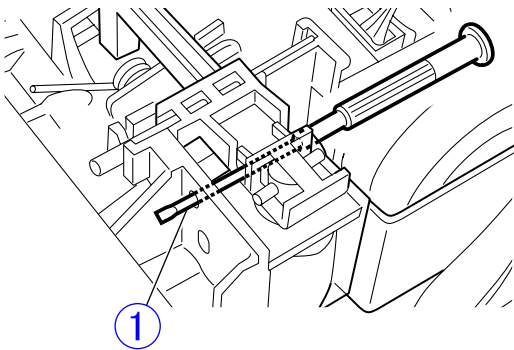

Figure 3-310

- 3) Feed a document actually in the count only mode and verify that it is operated normally. If it does not operate normally, adjust the solenoid position again.

Note: If the machine operates in the count only mode, install the eject tray unit and set the eject sensor in the detection state. When the solenoid position is adjusted, the eject tray unit does not need to be fastened with screws. It can operate in the service mode. Refer to the service mode section for details.

IV. UPPER UNIT-2 (MECHANICAL SYSTEM)

1. Pickup Unit

- 1) Remove the eject tray unit.
(Page 3-7)
- 2) Remove the upper front cover.
(Page 3-7)
- 3) Open the pickup roller cover, and remove 4 screws ① (M3x6, self-tapping) and the screw ② (M3-bind head, round tip).

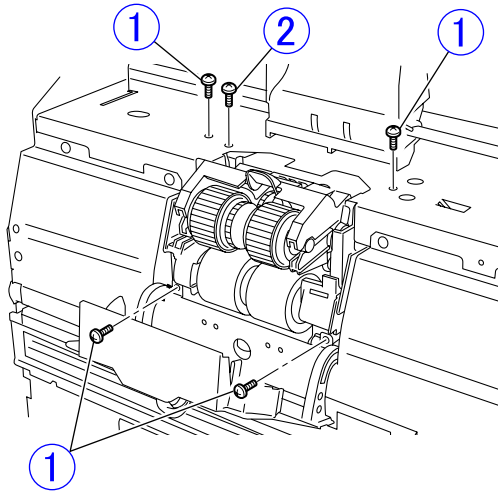

Figure 3-401

- 4) Remove the screw ① (M3-bind head, round tip) and remove the ground plate ②. Then, remove 4 cables connected to the pickup unit ③ and 2 screws ④ (M3-TP head, round tip) and remove the pickup unit.

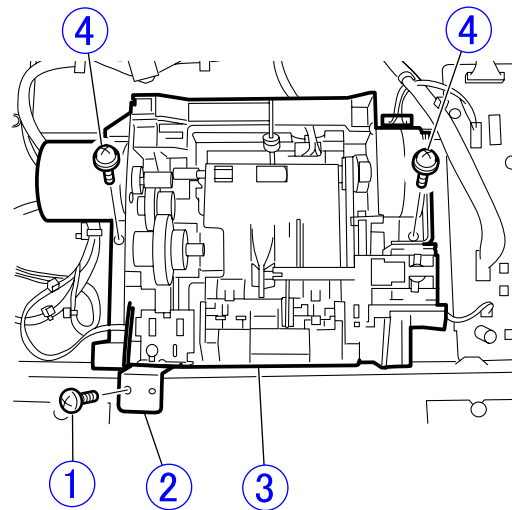

Figure 3-402

◆ Notes on assembling

Finally, install the ground plate at the original position, and tighten the screw ② (M3-bind head, round tip) for pickup sensor position adjustment, which was removed in step 3, to the extent that they do not become loose. If they are tightened excessively, the position of the pickup sensor changes or the pickup sensor mounting plate deforms.

◆ Adjustment after assembly

If the pickup sensor malfunctions after assembly, adjust the position of the pickup sensor. Refer to "CHAPTER 5 TROUBLESHOOTING, VI. AFTER REPLACING PARTS" for details.

2. Pickup Roller Cover

- 1) Remove the pickup unit.
([Page 3-13](#))
- 2) Unhook 2 pairs of the fitting parts ① and remove the pickup roller cover ②.

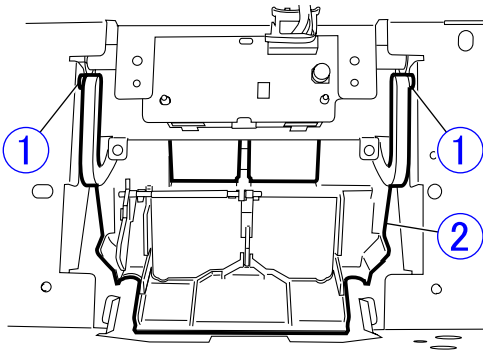

Figure 3-403

3. Upper Entrance Guide

- 1) Open the pickup roller cover.
- 2) Remove 2 screws ① (M3x6, self-tapping) and 6 screws ② (M3-bind head, round tip) and remove the upper entrance guide ③.

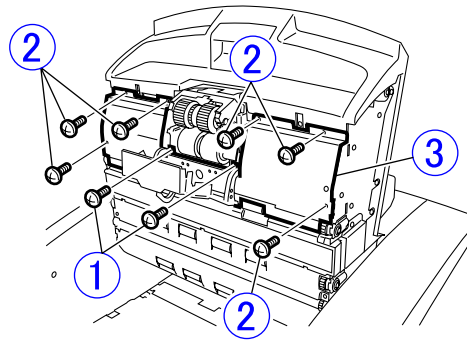

Figure 3-404

4. Registration Roller Upper

- 1) Remove the upper entrance guide.
(Page 3-14)
- 2) Open the ends (marked with *) of both bearing holders ① and while unhooking the fitting parts, remove the registration roller unit ②.

Note: Since the coil spring in the registration roller unit may be detached, do not lose it.

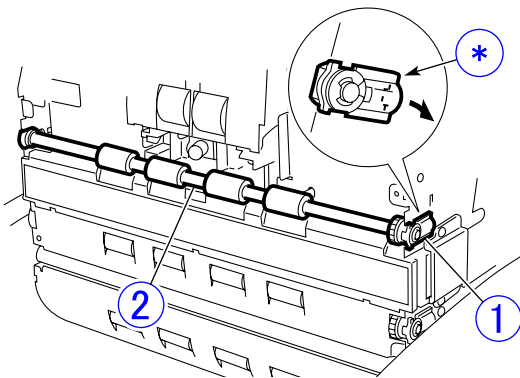

Figure 3-405

- 3) Remove 2 E-rings ① (1 on both sides) and remove the bearing holder ② from the registration roller upper ③.

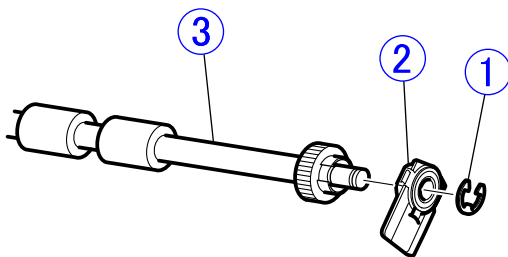

Figure 3-406

◆ Notes on assembling

When mounting the coil spring in the bearing holder, set the position of the spring bending section ① as follows. Insert the end of the bending section between the ball bearing flange ② and the bearing holder.

Since the end of the bending section touches the outer area of the ball bearing, static electricity on the roller is discharged to the side plate.

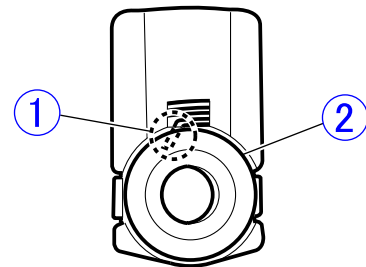

Figure 3-407

Push the right and left bearing holders into the side plate at the same time. Insert the fitting part of the bearing holder into the hole of the side plate.

Note: This part is the same part as the “reading roller upper”.

5. Reading Roller Upper

- 1) While holding the upper middle transfer guide ①, remove 2 screws ② (M3-bind head, round tip) and remove the upper middle transfer guide.

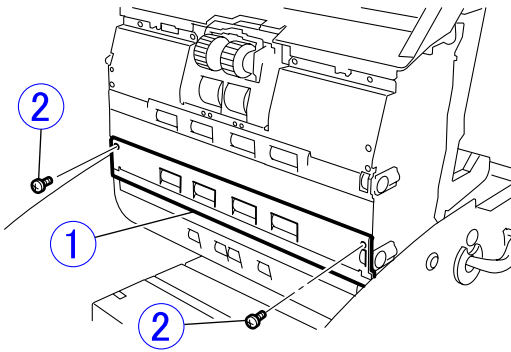

Figure 3-408

- 2) Open the ends (marked with *) of both bearing holders ①, and while unhooking the fitting parts, remove the reading roller unit ②.

Note: Since the coil spring in the reading roller unit may be detached, do not lose it.

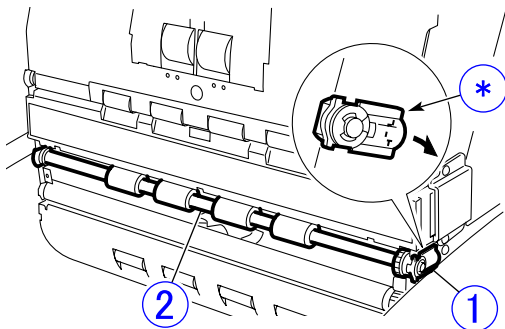

Figure 3-409

Note: This part is the same part as the “registration roller upper”. Therefore, refer to “Registration Roller Upper” for details of the subsequent procedure and precautions.

6. Platen Roller Upper

- 1) Remove the reading roller upper. ([Page 3-16](#))
- 2) While holding the platen roller upper ①, push the claw ② of the right and left bearing holders from the inside with a tool with a thin tip, and remove the platen roller upper.

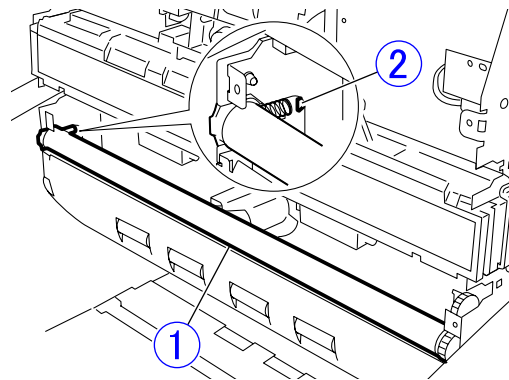

Figure 3-410

Note: Refer to “Registration Roller Upper” for details of the subsequent procedure and precautions.

([Page 3-15](#))

7. Eject Roller (Follower)

- 1) Remove the eject tray unit.
(Page 3-7)
- 2) While unhooking 2 pairs of the fitting parts
① one at a time, pull out the eject roller
(follower) ② upward.

Note: Since the fitting parts are secure, pull the roller out carefully to prevent damage to it.
4 rollers are built in the shaft. They are set as service parts in this condition.

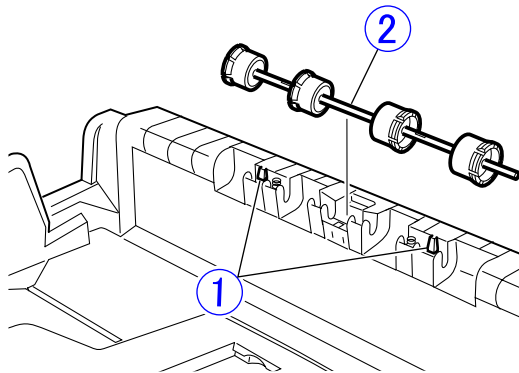

Figure 3-411

8. U-Turn Roller (Follower)

The "front U-turn roller" and "rear U-turn roller" built in the U-turn section are shown below.

- 1) Remove the entire upper unit.
(Page 3-20)
- 2) Remove 6 screws ① (3 on both sides, M3-TP head, round tip) and remove the U-turn guide ②.

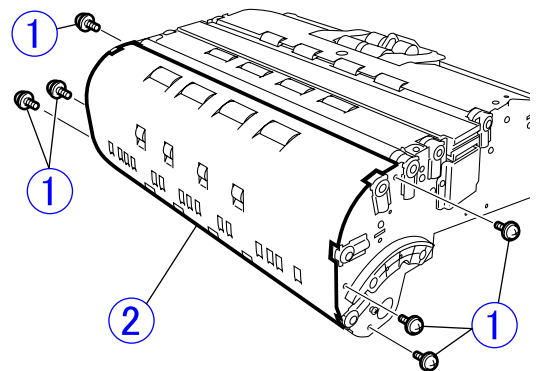

Figure 3-412

- 3) Open the end (marked with *) of both bearing holders ①, and while unhooking the fitting parts, remove the front U-turn roller ② and rear U-turn rollers ③.

Note: The roller with a wider roller rubber is a front U-turn roller.

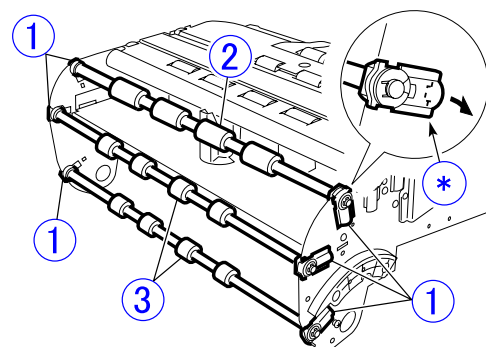

Figure 3-413

Note: Refer to “Registration Roller Upper” for details of the subsequent procedure and precautions.

[\(Page 3-15\)](#)

9. Eject Tray Extension

- 1) Remove 6 screws ① (M3x6, self-tapping). While unhooking 2 claws ②, slide the upper tray extension ③ to the front, unhook 2 claws ④ at the front, and remove the upper tray extension.

Note: Take care not to break the claws.

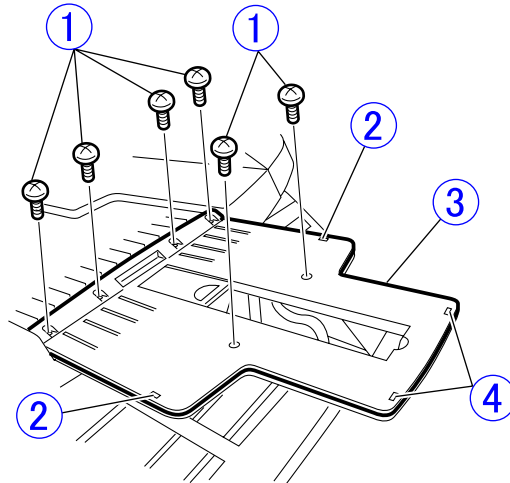

Figure 3-414

- 2) Remove the lower tray extension ① and eject stopper ②.

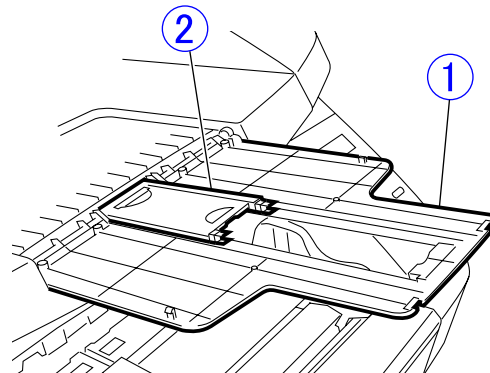

Figure 3-415

◆ Notes on assembling

If the direction of the eject stopper is mistaken when the eject tray extension is installed, the recess that is held by a finger when opening the eject tray extension is not available. Install the stopper in the <OK> direction shown below.

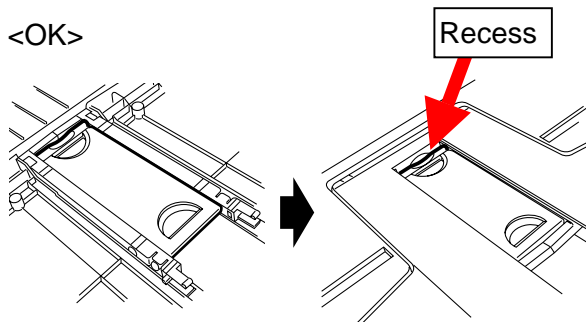

Figure 3-416

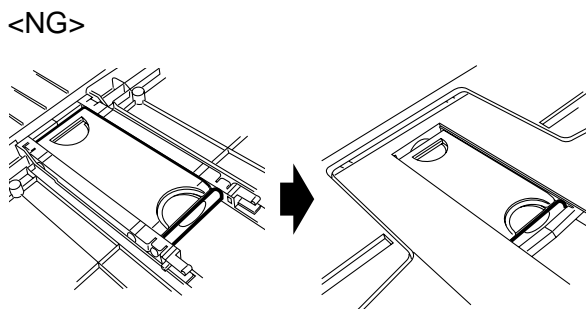

Figure 3-417

10. Imprinter Cover

- 1) Remove the eject tray unit.
(Page 3-7)
- 2) Release a lock, deflect the imprinter cover ①, unhook both bosses ② and remove the imprinter cover.

Note: Since the right boss is shorter, unhook the right one first.

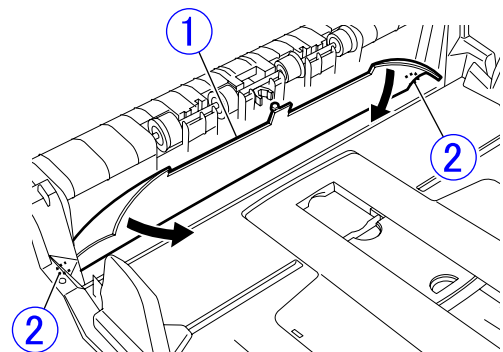

Figure 3-418

11. Eject Document Guide

- 1) Remove the eject tray unit.
([Page 3-7](#))
- 2) Remove 2 screws ① (M3x6, self-tapping) and remove the cover ②.

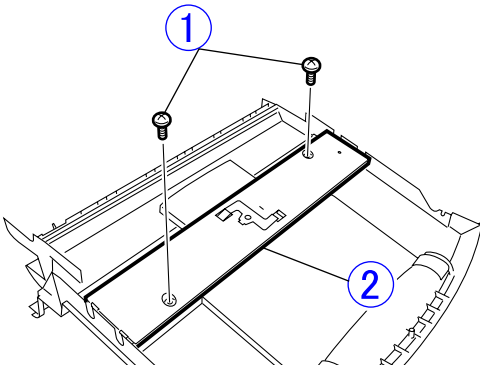

Figure 3-419

- 3) Remove 4 screws ① (2 on both sides, M3x6, self-tapping) and while holding the eject document guide on the back side, remove the guide plate ②.

Note: The right eject document guide is different from the left one in shape, but the guide plates are the same parts.

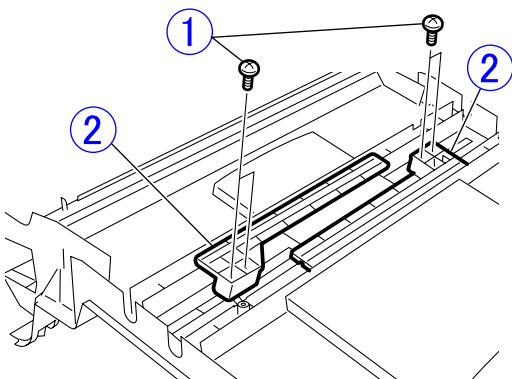

Figure 3-420

◆ Notes on assembling

Pay attention to the direction of the cover. If the direction of the cover is reversed, the screw positions are not aligned.

12. Entire Upper Unit

- 1) Remove the right and left covers.
([Page 3-3](#)), ([Page 3-5](#))
- 2) Remove the eject tray unit.
([Page 3-7](#))
- 3) Remove 3 cables ① connected to the outside of the upper unit and bring them out through the hole ②.

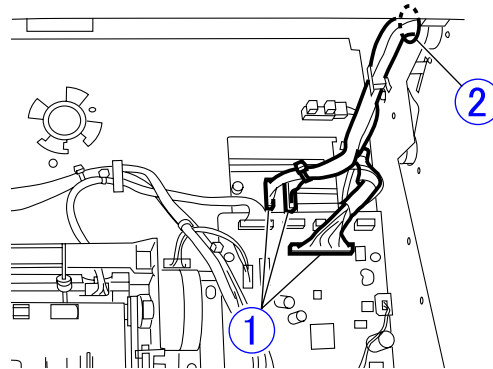

Figure 3-421

- 4) To prevent damage to the feed surface, put paper or a sheet on the feed surface of the base section, and close the upper unit.

Note: If the dampers are removed using the following procedure, the upper unit cannot be kept open, so be sure to close it.

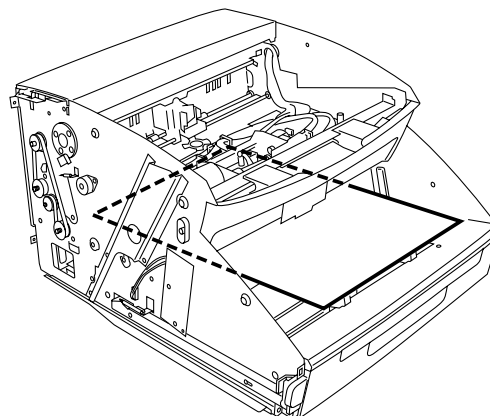

Figure 3-422

- 5) Remove the hinge ② by removing 8 screws ① (4 on both sides, M4-TP head, round tip), remove the damper ④ by removing 4 screws ③ (2 on both sides, M3-TP head, round tip), remove the check plate ⑥ by removing the right screw ⑤ (M3-bind head, round tip), and remove the ground plate ⑧ by removing the left screw ⑦ (M3-bind head, round tip).

Note: The right and left hinges are the same parts but the dampers are different parts.

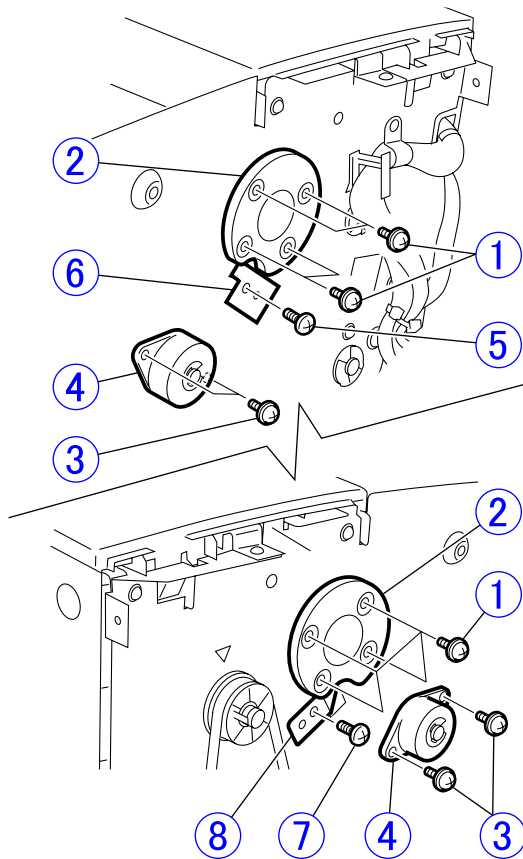

Figure 3-423

- 6) Secure a place for placing the removed upper unit first. Press the open/close button, lift the front of the upper unit slightly, and hold it by putting your hand under the bottom. Then, lift and rotate the front of the upper unit and pull it out to the front. Take care not to strike it to the side of the base unit and the feed surface.

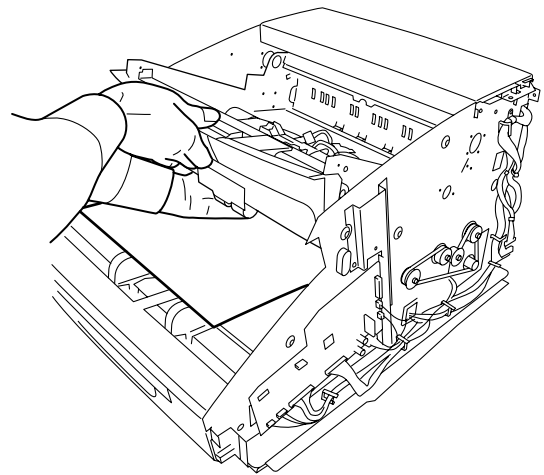
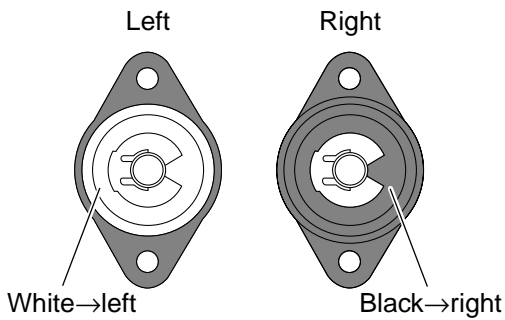

Figure 3-424

◆ Notes on assembling

- 1) After assembling the upper unit in the base unit, install the right and left hinges first. Then, install the right and left dampers, check plate and ground plate.
- 2) The right and left dampers are different in the color of the end surfaces. The left side is white and the right side is black.

**Figure 3-425**

- 3) If grease is attached to your fingers or the outside surface, wipe it off.
- 4) After assembly, ensure that the upper unit is opened and closed correctly.

V. UPPER UNIT-3 (READING SYSTEM)

1. Upper Reading Unit

- 1) Remove the eject tray unit.
([Page 3-7](#))
- 2) Remove 4 connectors ① connected to the reading unit.

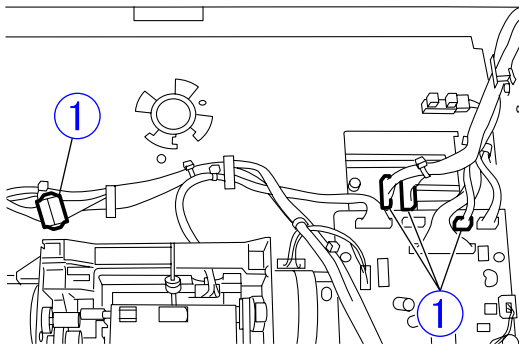

Figure 3-501

- 3) Remove the registration roller upper.
([Page 3-15](#))
- 4) Remove the reading roller upper.
([Page 3-16](#))

- 5) While holding the reading unit ①, remove 4 screws ② (2 on both sides, M3-TP head, round tip) and remove the right guide ③ and left guide ④. Then, remove the reading unit.

Note: The right guide is different from the left one in shape. They cannot be assembled reversely.

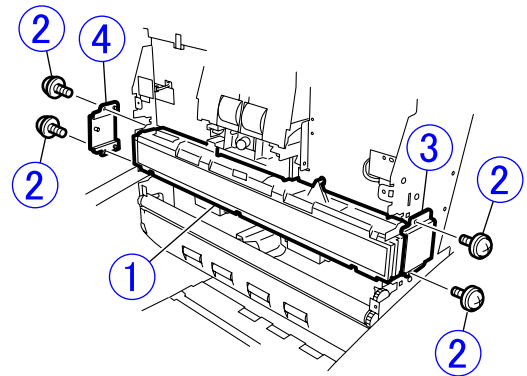

Figure 3-502

◆ Notes on assembling

Pass the motor and sensor cables connected to the reading unit through a hole and then assemble them. Be careful not to allow these cables to be caught.

2. Shading Motor

- 1) Remove the upper reading unit.
(Page 3-23)
- 2) Remove 2 screws ① (M2.6-TP head, self-tapping, black) and remove the motor assembly ② (including the mounting plate).

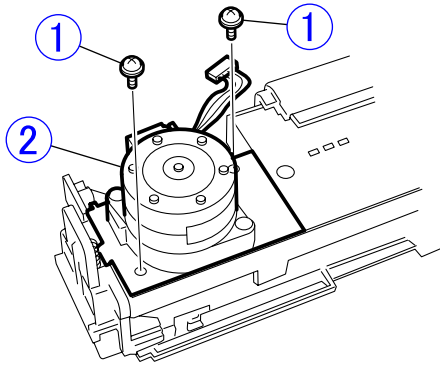

Figure 3-503

- 3) Align the direction of the arm press-fitted into the motor shaft on the back side with the direction of the hole in the mounting plate, remove 2 screws ① (M3-bind head, self-tapping) and remove the shading motor ②.

Note: It is the same part as the shading motor assembled in the lower reading unit.

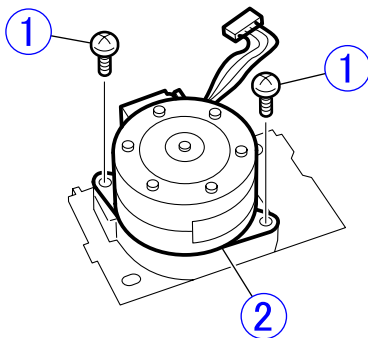

Figure 3-504

◆ Notes on assembling

To insert the end of the motor arm into the groove in the slide plate, assemble the shading motor using the following procedure:

- 1) Align the motor arm ① with the position of the hole ② of the mounting plate.

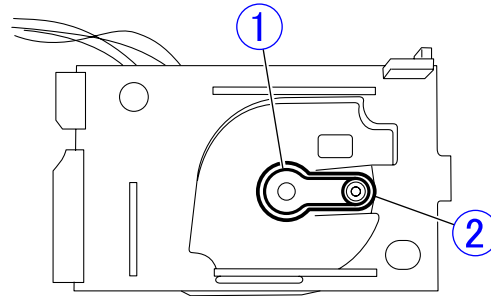

Figure 505

- 2) Move the slide plate ① of the reading unit to the contact surface.

Note: The spacer ② drops if the reading unit is turned over.

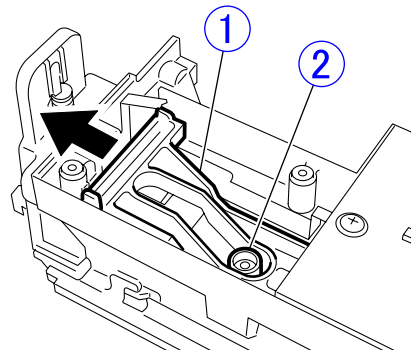

Figure 3-506

- 3) Tilt the mounting plate, place the insert part below the PCB, make it horizontal slowly and put the arm into the groove. Then, secure the mounting plate with screws.

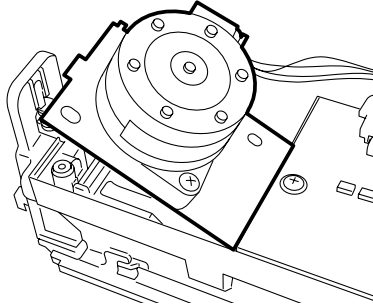

Figure 3-507

3. Upper Reading Glass Assembly

- 1) Clean the glass surface and the feed path to prevent dust from entering the reading unit.
- 2) While pushing the stopper ① with a tool with a thin tip and unhooking the fitting parts, slide the upper reading glass assembly ② until it stops and remove it.

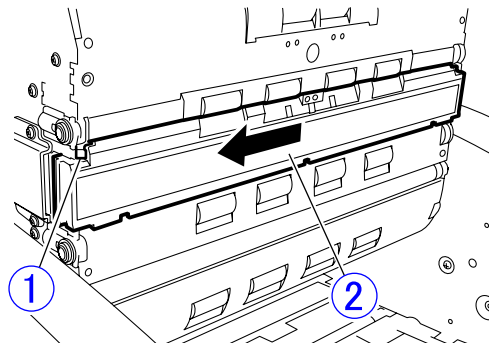

Figure 3-508

◆ Notes on assembling

Do not touch the glass rear surface and the surface of the lens array of the reading unit with fingers. If they are dirty, clean them with a clean dry cloth.

VI. BASE UNIT-1 (ELECTRICAL SYSTEM)

1. Control PCB

- 1) Remove the control PCB cover.
(Page 3-3)
- 2) Remove all 8 connectors connected to the control PCB ① and remove 7 screws ② (M3-bind head, round tip). While unhooking the hook ③ located at the upper right part by pulling the bottom of the control PCB unit, remove the PCB unit (including the mounting plate).

Note: The DC power supply connector has a lock.

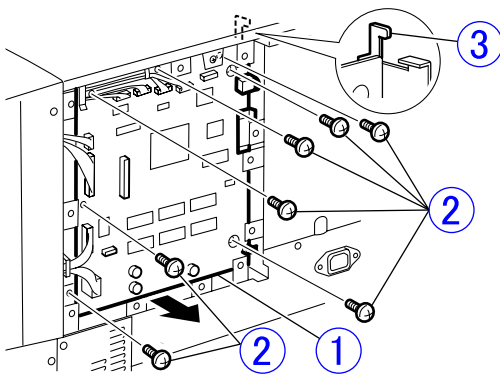

Figure 3-601

- 3) Remove 2 screws ① (M2.5x4) for the SCSI connector and 4 screws ② (M3-bind head, round tip), remove the mounting plate ③ and remove the control PCB ④.

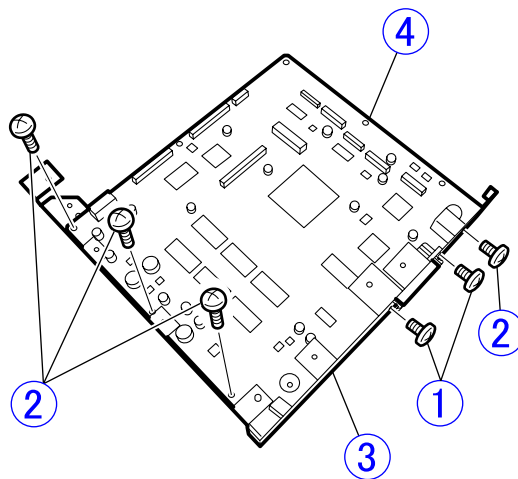

Figure 3-602

◆ Notes on assembling

Insert the hook at the upper right part of the mounting plate into the hole in the main body, then assemble the control PCB (including mounting plate).

2. Sub-Drive PCB

- 1) Remove the right cover.
(Page 3-3)
- 2) Remove all connectors connected to the sub-drive PCB ① and remove 4 screws ② (M3-bind head, round tip).

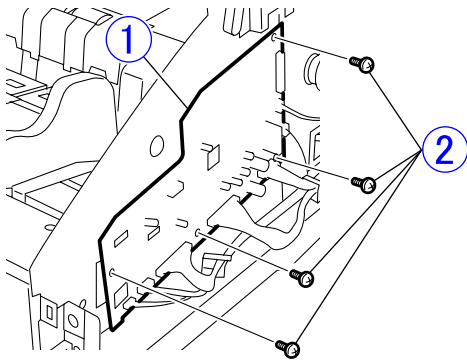

Figure 3-603

- 3) Remove 2 connectors ② attached to the back side of the sub-drive PCB ①.

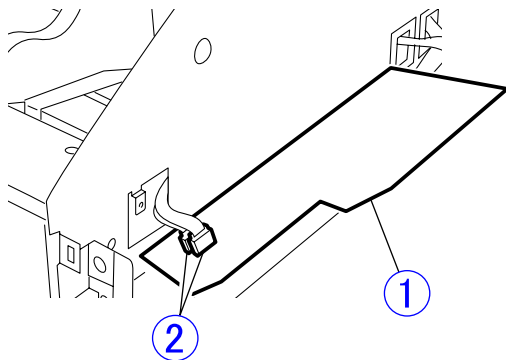

Figure 3-604

3. Power Supply PCB

- 1) Remove 9 screws ① (M4-bind head, round tip) and pull out the power supply PCB ② (including the mounting plate).

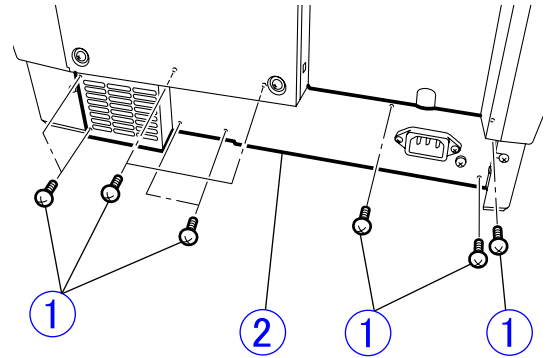

Figure 3-605

- 2) Remove the connector ① (with a lock) and remove the power supply PCB ② (including the mounting plate).

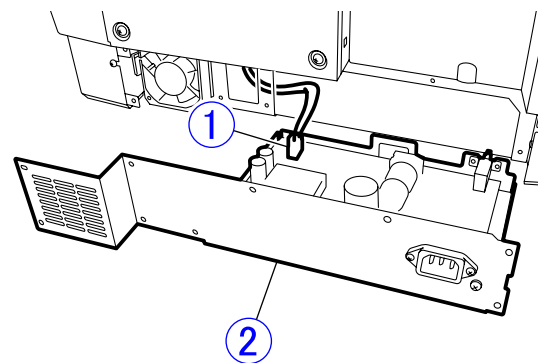

Figure 3-606

- 3) Remove 7 screws ① (M3-bind head, round tip), a screw ② (M4, with washer) and the connector ③ (with a lock) and remove the power supply PCB ④.

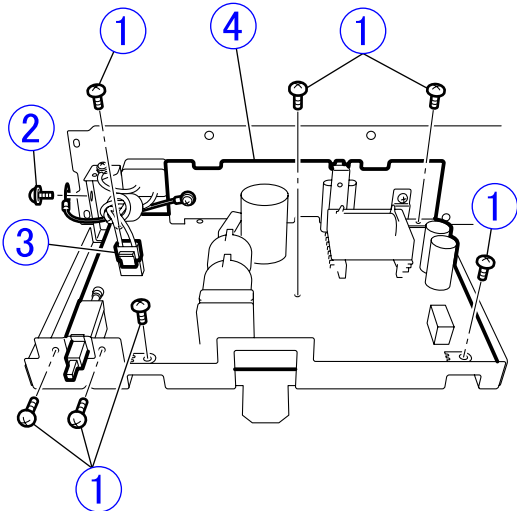

Figure 3-607

◆ **Notes on assembling**

Turn the power switch OFF (the tip is extended long).

4. Ultrasonic Drive PCB

- 1) Remove the registration roller lower. [\(Page 3-38\)](#)
- 2) Remove 2 screws ① (M3-bind head, round tip) and remove the ultrasonic drive PCB ②. Then, remove the connector on the back side.

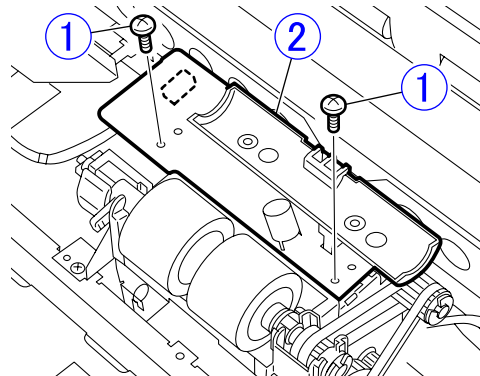

Figure 3-608

5. Eject PCB

- 1) Remove the eject drive unit.
(Page 3-42)
- 2) Remove 2 screws ① (M3-bind head, round tip), and while unhooking 2 position setters ②, remove the eject PCB ③. Then remove 2 connectors on the back side.

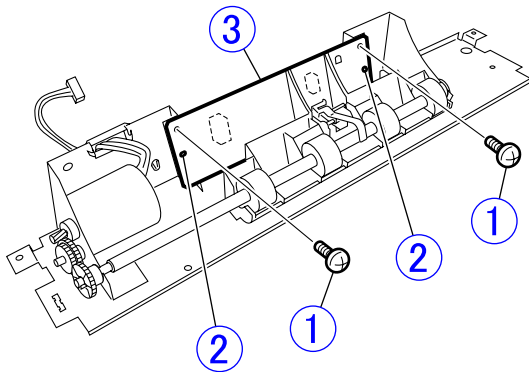

Figure 3-609

6. Document Sensor PCB

- 1) Remove the blind cover.
(Page 3-36)
- 2) Turn the gear ① by hand and lift the connecting plate ②. Then, unhook 2 pairs of the fitting parts ③ and remove the sensor cover ④ (including the PCB).

Note: Grease is applied to the gears. Wipe grease off your fingers.

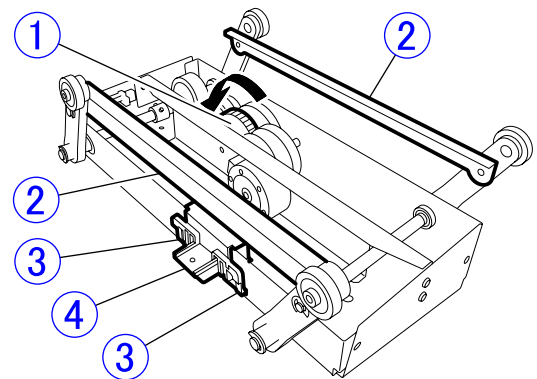

Figure 3-610

- 3) Turn the sensor cover over, unhook 2 pairs of the fitting parts ①, remove the connector ②, and remove the document sensor PCB ③.

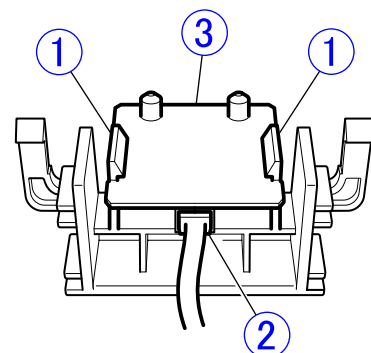

Figure 3-611

7. Main Motor

- 1) Remove the right cover.
([Page 3-3](#))
- 2) Remove the screw ① (M3-TP head, round tip) and remove the cable holder. Remove the cable from the nearby cable holder so that it can be moved. Remove 4 screws ② (M4-bind head, round tip), remove the belt ③, and while escaping the cable, pull out the main motor assembly ④.

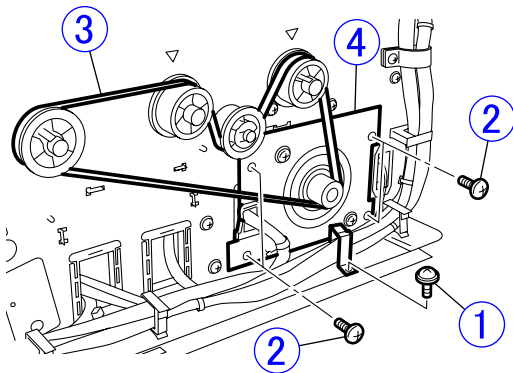

Figure 3-612

- 3) Remove the connector ①, remove 2 screws ② (M4-TP head, round tip) and remove the main motor ③.

Note: Handle the main motor carefully because it is heavy.

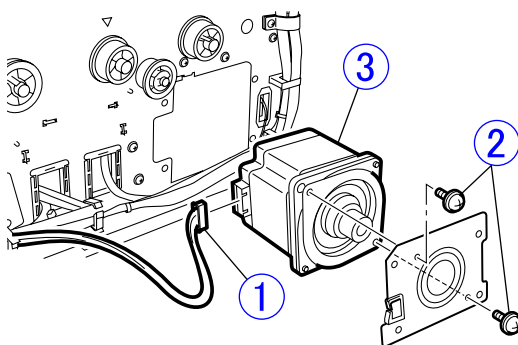

Figure 3-613

◆ Notes on assembling

Secure the main motor assembly so that the belt does not skip teeth. However, do not tighten it excessively.

8. Tray Motor

- 1) Remove the tray drive box.
(Page 3-35)
- 2) Remove the blind cover.
(Page 3-36)
- 3) Remove 2 screws ① (M4, self-tapping) and remove the flanges and washers. Then, unhook 4 bosses ② and remove the tray drive unit ③.

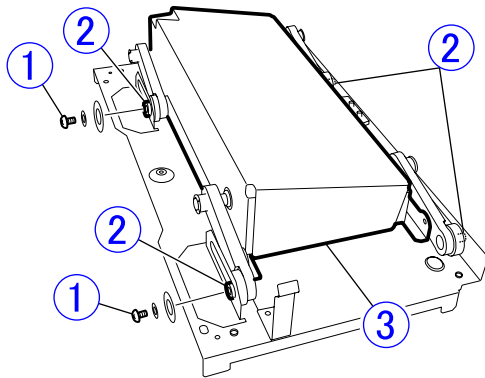

Figure 3-614

- 4) Remove 6 screws ① (M3-bind head, round tip) and remove the gear unit ②.

Note: Do not pull it excessively because the motor cables are connected to it.

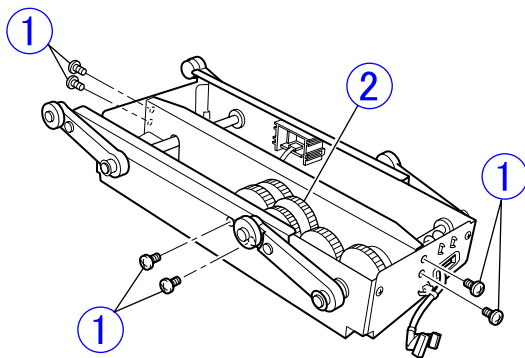

Figure 3-615

- 5) Remove 5 gears ①, then remove 2 screws ② (M3-bind head, round tip) and the connector ③ and remove the tray motor ④.

Note: The gear marked with * is black.

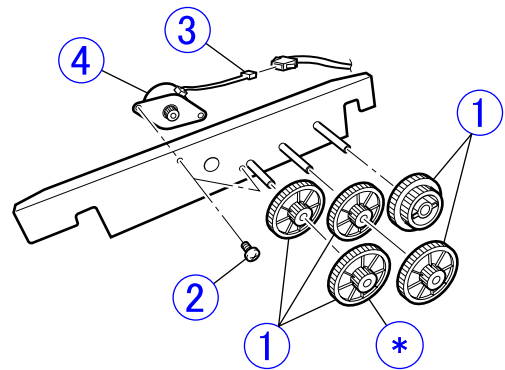

Figure 3-616

Note: Grease is applied to the gears. Wipe grease off your fingers and adjacent areas.

9. Separation Motor

- 1) Remove the registration roller lower.
(Page 3-38)
- 2) Remove 4 screws ① (M3-bind head, round tip) and 2 connectors ② and pull out the retard roller assembly ③.

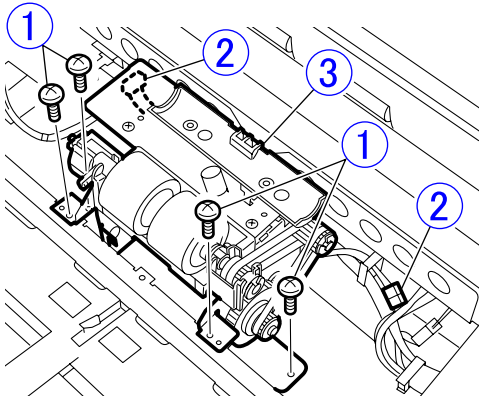

Figure 3-617

- 3) Remove 2 screws ① (M3-bind head, round tip) and remove the separation motor ②.

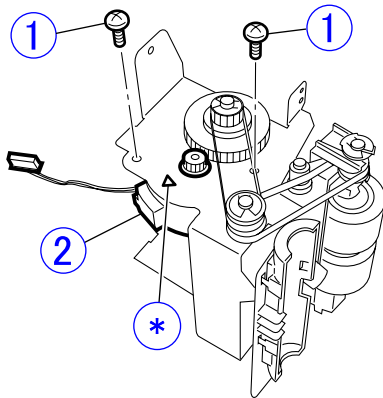

Figure 3-618

Note: "▽" indicated by mark * in the above figure shows the motor cable position.

10. Eject Motor

- 1) Remove the eject drive unit.
(Page 3-42)
- 2) Remove 2 screws ① (M3x4, black) and the connector ② and remove the eject motor ③.

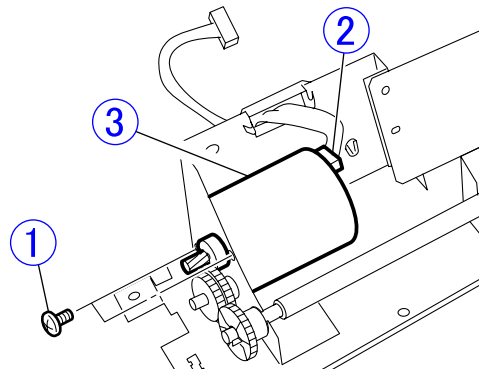

Figure 3-619

11. Exhaust Fan

- 1) Remove the right cover.
[\(Page 3-3\)](#)
- 2) Remove the power supply PCB (including a mounting plate).
[\(Page 3-27\)](#)
- 3) Remove the connector of the exhaust fan on the main drive PCB, remove the screw ① (M4x25) and remove the exhaust fan ②.

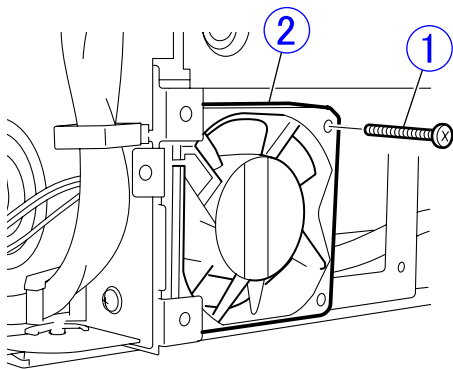

Figure 3-620

◆ Notes on assembling

Insert the projection of the main body into the upper left hole, and secure it with a screw.

VII. BASE UNIT-2 (MECHANICAL SYSTEM)

1. Pickup Document Guide

- 1) Remove the pickup tray unit.
(Page 3-6)
- 2) Remove 5 screws ① (M3x6, self-tapping) and remove the leaf spring ② and cover ③.

Note: Do not lose the leaf spring.

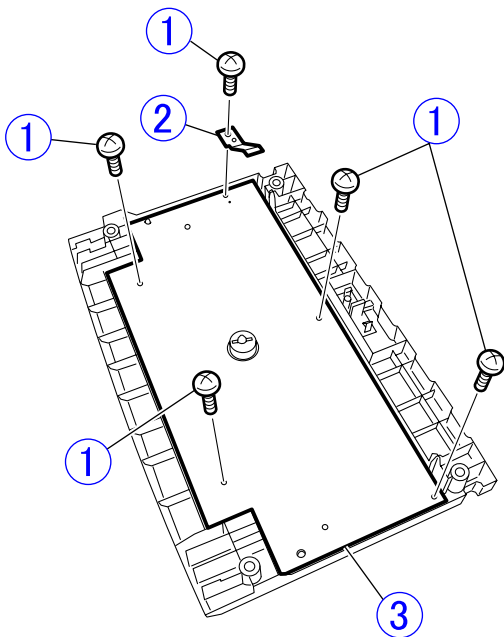

Figure 3-701

- 3) Remove 4 screws ① (2 on both sides, M3x6, self-tapping) and remove the pickup document guides ②, racks ③ and gear assembly ④.

Note: A lock lever ⑤ is built in the pickup document guide. The right pickup document guide, lock lever and rack are different from the left ones.

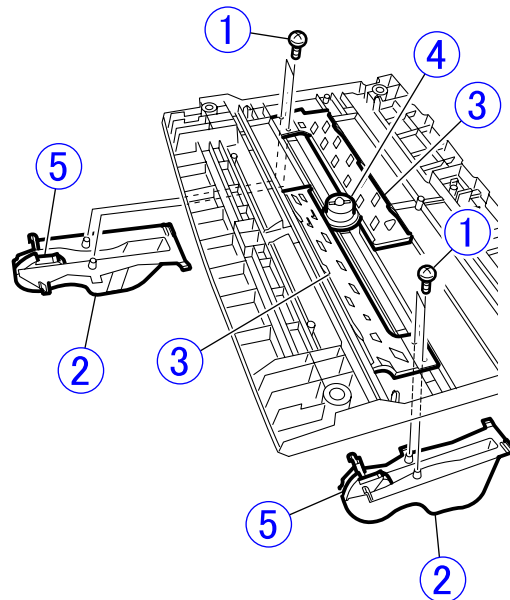

Figure 3-702

◆ Notes on assembling

Do not confuse the order of assembling the right and left racks and the gear assembly.

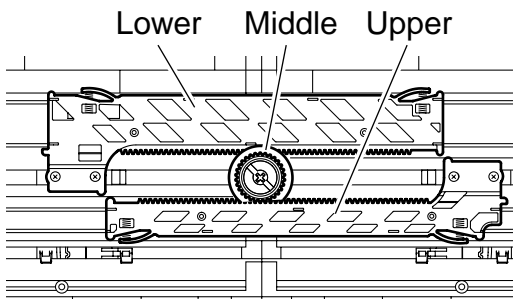

Figure 3-703

Verify that the pickup document guides work correctly after assembly.

Center the pickup document guides so that they are symmetrical.

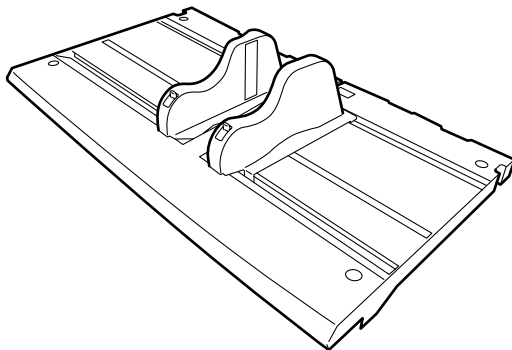

Figure 3-704

2. Tray Drive Box

- 1) Remove the pickup tray unit.
(Page 3-6)
- 2) Remove 6 screws ① (M3-bind head, round tip).

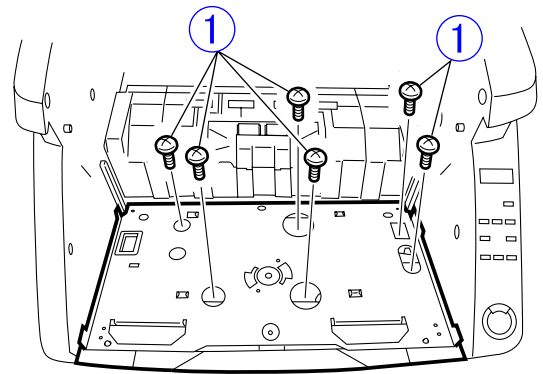

Figure 3-705

- 3) Lift the tray drive box ①, remove 2 connectors ② on the right side and remove the tray drive box.

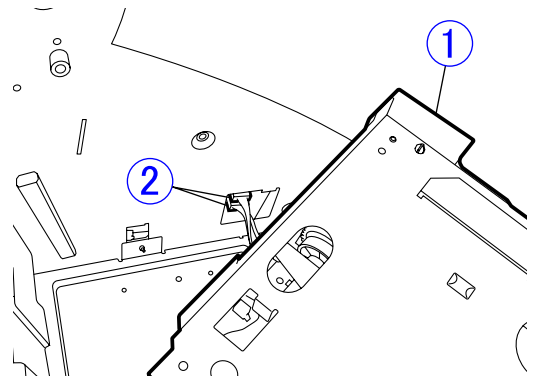

Figure 3-706

◆ Notes on assembling

There are 2 bosses for positioning at the bottom of the base unit. Insert the bosses into the holes at the bottom of the tray drive box. If the position is shifted, the screw hole position is shifted or lift occurs.

3. Blind Cover

- 1) Remove the tray drive box.
[\(Page 3-35\)](#)
- 2) Turn the tray drive box over, remove 3 screws ① (M3-TP head, round tip) and remove the blind cover ②.

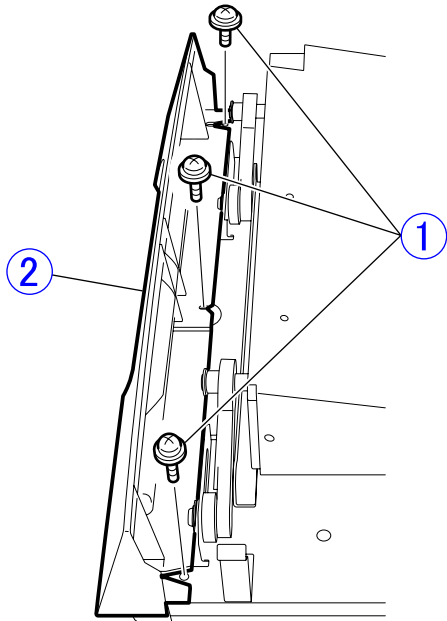

Figure 3-707

4. Lower Front Cover

- 1) Remove the right and left covers.
[\(Page 3-3\)](#), [\(Page 3-5\)](#)
- 2) Remove the tray drive box.
[\(Page 3-35\)](#)
- 3) Remove 2 screws ① (M3-bind head, round tip) and a screw ② (M3x25) and remove the lower front cover ③.

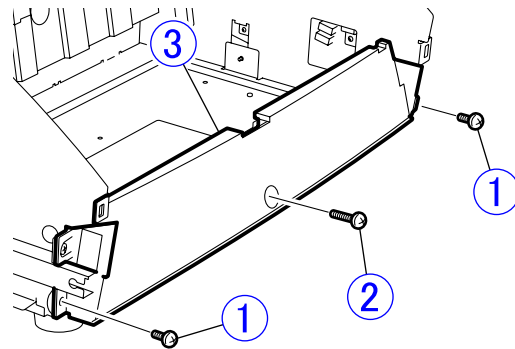

Figure 3-708

5. Lower Entrance Guide

- 1) Remove the roller cover ①. Remove 3 screws ② (M3, stepped 3.2) and remove the lower entrance guide ③.

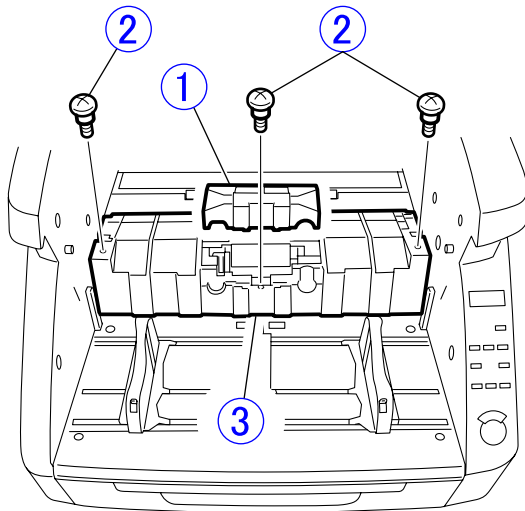

Figure 3-709

Note: Remove the light guides (total 3) if necessary. Do not damage fitting parts when removing them.

6. Belt (Right)

- 1) Remove the right cover. [\(Page 3-3\)](#)
- 2) Loosen 4 screws ② of the main motor mounting plate ① and remove the belt ③ if necessary.

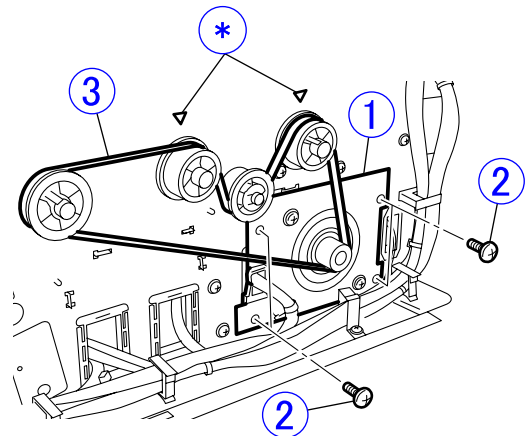

Figure 3-710

◆ Notes on assembling

Verify the orientation of the flange attached to the pulley. "▽" indicated by mark * in the above figure shows the position of the black pulley (the flange is inside). The belt must not be loose. The belt should not skip teeth and should not be tightened excessively.

7. Belt (Left)

- 1) Remove the left cover.
([Page 3-5](#))
- 2) Loosen the screw ② (M3-bind head, round tip) of the tension plate ① and remove the belt ③.

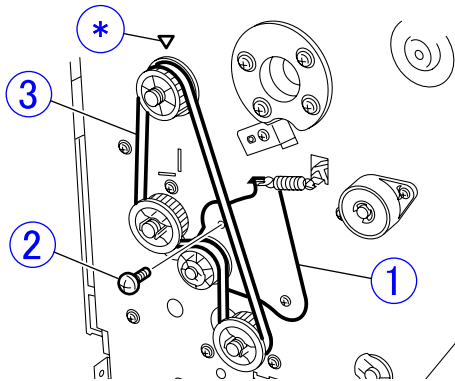

Figure 3-711

◆ Notes on assembling

Verify the orientation of the flange attached to the pulley. "▽" indicated by mark * in the above figure shows the position of the black pulley (the flange is inside).

Hang the belt on the pulley and secure the screw of the tension plate. The belt tension is adjusted by the coil spring attached to the tension plate.

8. Registration Roller Lower

- 1) Remove the right and left covers.
([Page 3-3](#)), ([Page 3-5](#))
- 2) Remove the lower entrance guide.
([Page 3-37](#))
- 3) Remove the right belt, and while unhooking the fitting part of the right pulley ①, remove the pulley and pin ②. Remove the left stopper ③. Then, remove both bearings ④ and remove the registration roller lower ⑤.

Note: Do not lose the pin.

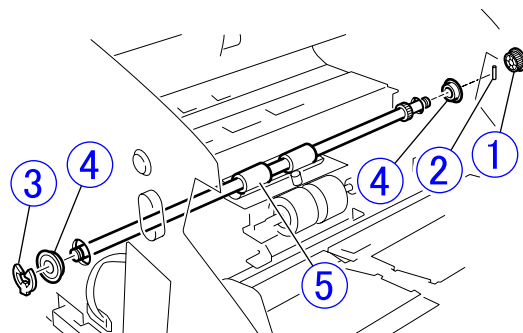

Figure 3-712

9. Platen Roller Lower

- 1) Remove the registration roller lower.
([Page 3-38](#))
- 2) Remove 2 screws ① (M3-bind head, round tip) and remove the platen unit ② in the direction of the arrow.

Note:The screwdriver may strike the upper unit and may not touch the screw vertically. Install and remove screws carefully. It is better to use a short screwdriver.

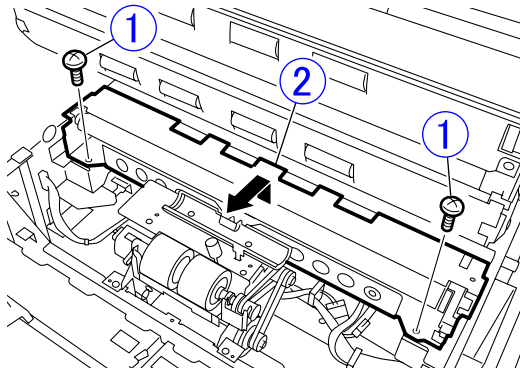

Figure 3-713

- 3) Remove 2 E-rings ① (1 on both sides) and remove 2 bearings ② and 2 bearing holders ③. Then, remove the platen roller lower ④, lever assembly ⑤ and gear ⑥.

Note:The lever assembly incorporates a torsion spring.

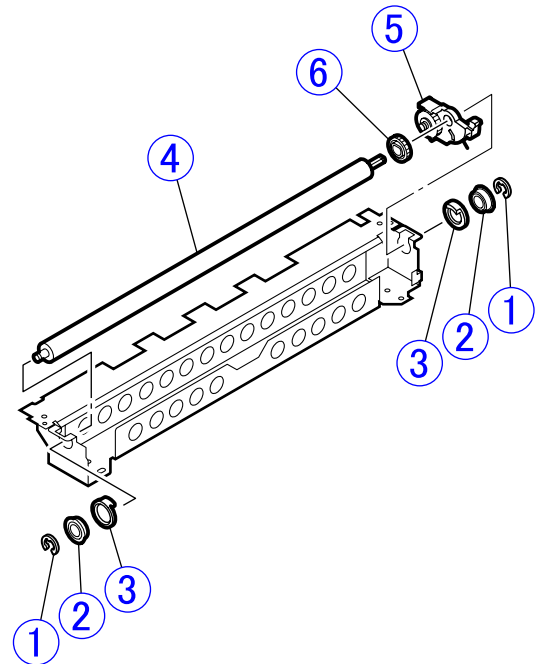

Figure 3-714

10. Reading Roller Lower

- 1) Remove the platen unit.
(Page 3-39)
- 2) While unhooking the fitting part of the right pulley ①, remove the pulley and pin ②. Remove the left stopper ③. Then, remove both bearings ④ and remove the reading roller lower ⑤.

Note: Do not lose the pin.

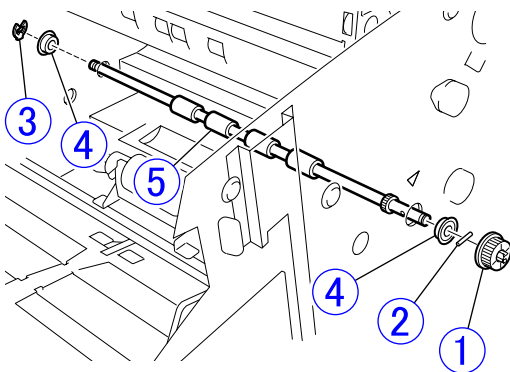

Figure 3-715

◆ **Notes on assembling**

Install the pulleys in the correct flange orientation. The flange of the pulley for the reading roller lower is inside.

11. Drive U-turn Roller (Front)

- 1) Remove the right and left belts.
(Page 3-37), (Page 3-38)
- 2) While unhooking the fitting parts of both pulleys ①, remove the pulleys and pins ②. Then, remove both bearings ③, and remove the drive U-turn roller (front) ④ from the hole marked with * being careful not to damage the rubber roller section.

Note: Do not lose the pins.

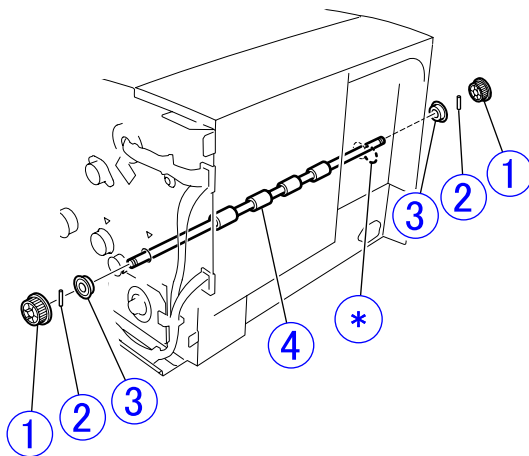

Figure 3-716

◆ **Notes on assembling**

Pay attention to the orientation of the pulley flange. The roller has a symmetrical shape.

Insert the rubber roller section into the hole in the U-turn guide.

12. Drive U-turn Roller (Middle)

- 1) Remove the left belt.
(Page 3-38)
- 2) While unhooking the fitting part of the pulley ①, remove the pulley and pin ②. Then, remove the stopper ③ and both bearings ④, and remove the drive U-turn roller (middle) ⑤ from the hole marked with * being careful not to damage the rubber roller section.

Note: Do not lose the pin.

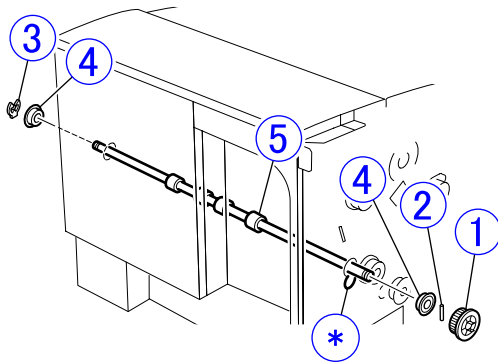

Figure 3-717

◆ Notes on assembling

Insert the rubber roller section into the hole in the U-turn guide.

Note: This part is the same part as the drive U-turn roller (rear).

13. Drive U-turn Roller (Rear)

- 1) Remove the eject drive unit.
(Page 3-42)
- 2) While unhooking the fitting part of the pulley ①, remove the pulley and pin ②. Then, remove the stopper ③ and both bearings ④, and remove the drive U-turn roller (rear) ⑤ upward being careful not to damage the rubber roller section.

Note: Do not lose the pin.

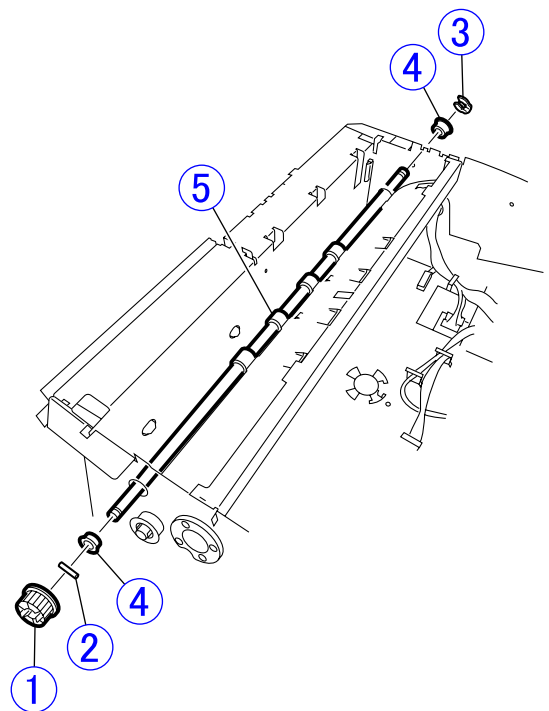

Figure 3-718

◆ Notes on assembling

Insert the rubber roller section into the hole in the U-turn guide.

Note: This part is the same part as the drive U-turn roller (middle).

14. Eject Drive Unit

- 1) Remove the control PCB cover.
([Page 3-3](#))
- 2) Remove the top cover.
([Page 3-6](#))
- 3) Remove the connector ① connected to the control PCB and 4 screws ② (M3-bind head, round tip), and remove the eject drive unit ③.

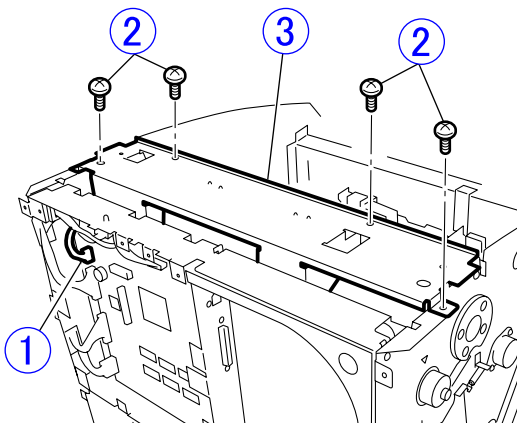

Figure 3-719

15. Eject Roller (Drive)

- 1) Remove the eject drive unit.
([Page 3-42](#))
- 2) Unhook the fitting part of the pulley ① and remove the pulley and pin ②. Remove the stopper ③ and both bearings ④, and while escaping the lever ⑤, remove the eject roller (drive) ⑥.

Note: Do not lose the pin.

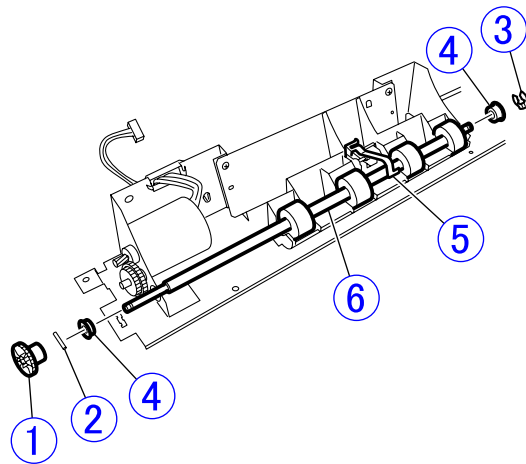

Figure 3-720

VIII. BASE UNIT-3 (READING SYSTEM)

1. Lower Reading Unit

Note: A short screwdriver is required to remove screws. If it is not available, remove the entire upper unit.

- 1) Remove the reading roller lower.
([Page 3-40](#))
- 2) Remove 2 screws ① (M3, stepped 3.2) and 2 connectors ②, lift the lower reading unit ③ slightly, and pull it out to the front.

Note: Do not pull it excessively because a cable is connected to the back side.

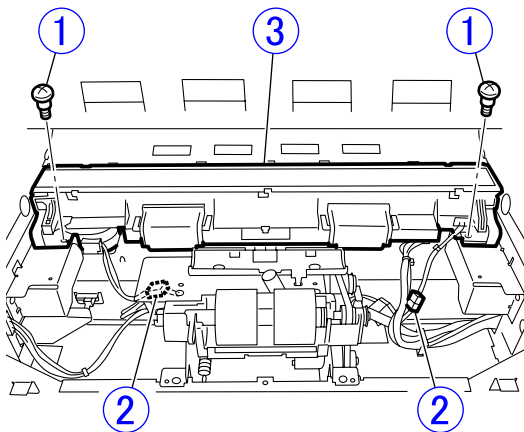

Figure 3-801

- 3) Remove 2 connectors ① and remove the lower reading unit ②.

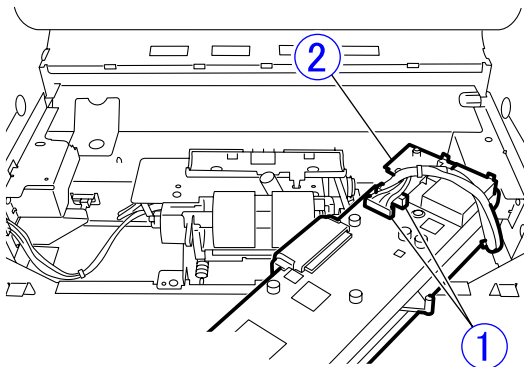

Figure 3-802

2. Shading Motor

- 1) Remove the lower reading unit.
([Page 3-43](#))

Note: Since the subsequent procedure is the same as that for the shading motor on the upper reading unit, refer to it.
([Page 3-24](#))

3. Lower Reading Glass Assembly

- 1) Clean the glass surface and the feed path to prevent dust from entering the reading unit.
- 2) While pushing the stopper ① with a tool with a thin tip, slide the lower reading glass assembly ② until it stops and remove it.

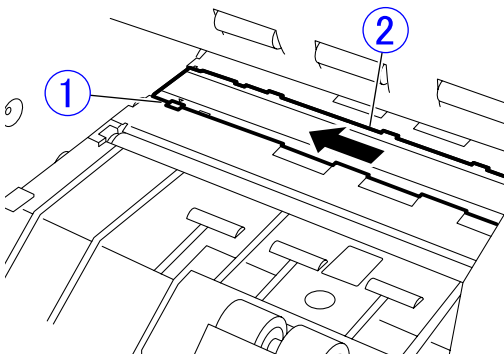

Figure 3-803

◆ Notes on assembling

Do not touch the glass rear surface and the surface of the lens array of the reading unit with fingers. If they are dirty, clean them with a clean dry cloth.

CHAPTER 4

INSTALLATION & MAINTENANCE

I. INSTALLATION	4-1	III. MAINTENANCE	4-16
II. PARTS REPLACEMENT.....	4-13		

I. INSTALLATION

1. Choosing Location

The following requirements should be met when installing this machine. The service technician should inspect the planned location before delivery.

- The power supply must be able to be connected separately from a reference voltage receptacle
- * If a ground wire must be connected, connect it to the correct location shown below.
 - 1) Ground terminal of the receptacle
 - 2) Ground wire for which grounding work for office equipment is performed
- Do not install this machine on a weak table or an inclined or unstable location. The weight of the main body is approx. 22.5 kg.
- The temperature should be between 10°C and 32.5°C and the relative humidity should be between 20% and 80%. However, since the performance is guaranteed at a temperature between 15°C and 27.5°C and a relative humidity between 25% and 75%, this machine should be installed in this range. This machine should not be installed near water faucets, boilers, humidifiers, refrigerators, etc. and should not be put in a location where the temperature or humidity changes abruptly.

- This machine should not be exposed to open flames, dust, ammonia fumes, direct sunlight, vibration, or electromagnetic wave.
- * If it has to be placed in a sunny place, the windows should be curtained to avoid direct sunlight.
- There should be an enough space around this machine for operation, maintenance and ventilation.
- * Since there are a ventilation hole and a power cord on the rear side, do not push this machine against the wall.

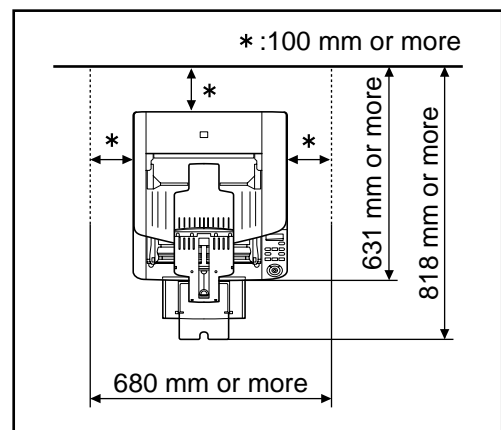

Figure 4-101

- Ensure to provide a carry-in route and a means of transporting this machine in the packing condition. The packing weight is approx. 27 kg, and the dimensions are approx. 680 (W) × 590 (D) × 430 (H) mm.

2. Unpacking And Installation

When metallic objects are brought from a cold room into a warm room, small drops of water may be formed on the surfaces. This phenomenon is called condensation and if the machine with condensation is

used, various problems may take place. Therefore, allow this machine at least one hour to adjust to room temperature before moving the machine from a cold room into a warm room and installing it.

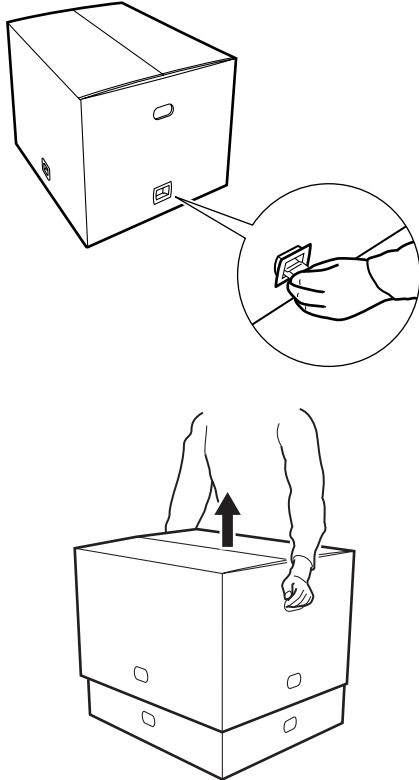
No.	Step	Details/Remarks
1	<p>Remove the box joints (4) and lift and remove the cardboard box. The packing weight is approx. 27 kg and the dimensions are approx. 680 (L) × 590 (W) × 430 (H) mm.</p> <p>Note:</p> <ol style="list-style-type: none"> 1) Do not open the top of the cardboard box, but remove the entire cardboard box. 2) The cardboard box may not be able to be removed if it contains accessories. Check the inside. 	 <p>The diagram illustrates the process of unpacking the machine. The top part shows a perspective view of a cardboard box with four small square joints on its front face. A circular callout shows a hand using a utility knife to cut one of these joints. The bottom part shows a pair of hands lifting the top of the box upwards, as indicated by a black arrow, to separate it from the machine below.</p>

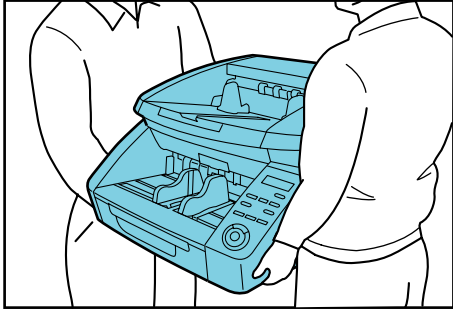
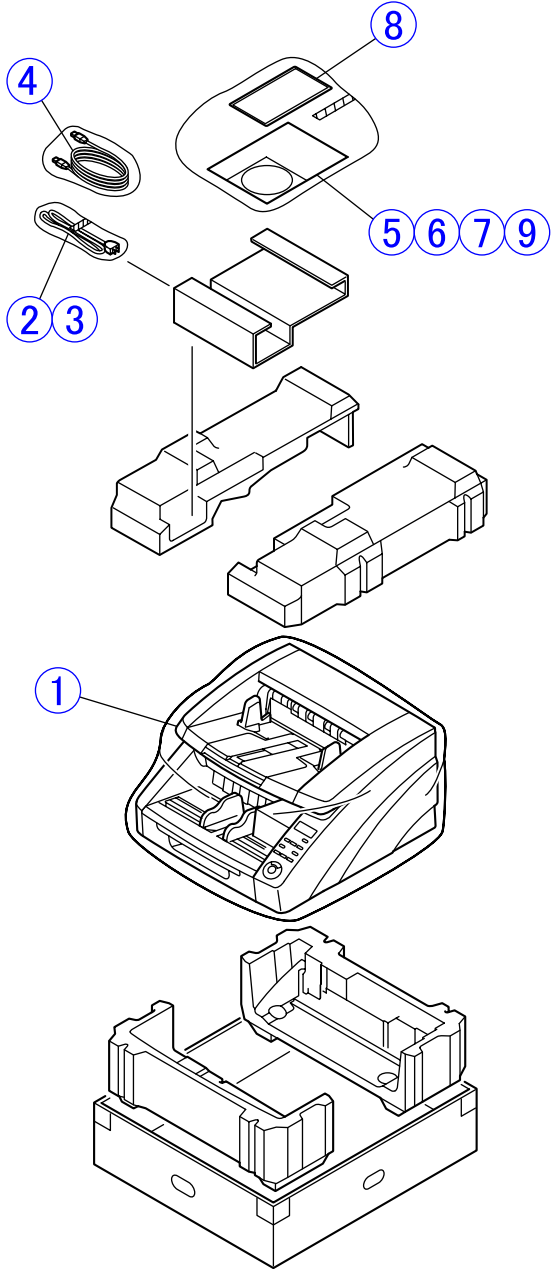
No.	Step	Details/Remarks
2	<p>Take out the main body and accessories and move the main body to the installation location. Check that the accessories are present.</p> <ul style="list-style-type: none"> ① Main body ② Power cord ③ Ground cord (100V model only) ④ USB cable ⑤ Easy Start Guide ⑥ Reference Guide ⑦ Setup Disc ⑧ Cleaning cloth ⑨ Warranty card (depending on models) <p>Note: 1) The weight of the main body is approx. 22.5 kg. When taking the main body out or moving it, 2 persons must hold it from both sides. Use a cart, etc. when moving it.</p>  <p>When taking out the main body, lift the center with no pad with one hand, then support the rear side with the other hand because the center of gravity of the main body is at the rear side.</p>	
3	<p>Place the main body at the installation location.</p> <p>Note:</p> <ul style="list-style-type: none"> 1) Since it is heavy, place it on a flat, sturdy surface. 2) Check if the covers show any signs of damage caused during transportation. 	

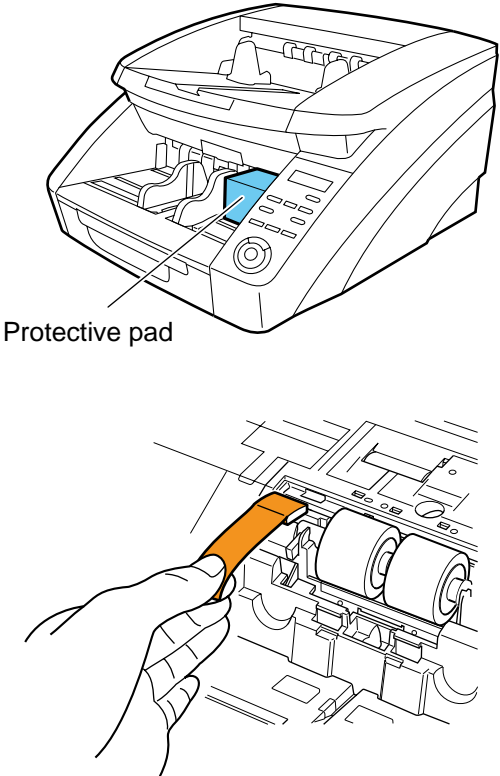
No.	Step	Details/Remarks
4	<p>Peel off all the tape securing each part.</p> <p>Open the upper unit and remove the protective pad from the document guide section.</p> <p>Open the retard roller cover, pull tape and remove the protective pad.</p>	 <p>The diagram consists of two parts. The upper part shows a perspective view of a printer with its top cover open. A blue rectangular protective pad is located in the document guide section. A line points from the text 'Protective pad' to this pad. The lower part is a detailed view of the roller assembly. A hand is shown peeling an orange tape from a roller cover. The rollers are labeled 'E2' and 'E3'.</p>

No.	Step	Details/Remarks
5	<p>Install software in the computer used for operation check as required.</p> <ul style="list-style-type: none"> ◆ If it has already been installed in the computer for servicing, it does not need to be installed during installation. ◆ If the service technician installs it in the user's computer, obtain the user's approval beforehand. ◆ If the user installs it, ask the user to install it according to the "Easy Start Guide". <p>Note:</p> <ol style="list-style-type: none"> 1) Ensure that the type of the operating system of the computer is correct. 2) Do not connect the scanner to the computer before installing software. 3) Be sure to log on with administrator privileges. 	<ol style="list-style-type: none"> 1) Insert the Setup Disc into the CD drive. <div data-bbox="954 405 1385 707" data-label="Image"> </div> 2) The setup menu starts. Click [Typical Installation] or [Custom Installation]. <div data-bbox="901 846 1433 1234" data-label="Image"> </div> 3) Later on, perform operation according to the screen instructions. 4) When all installation is completed, the installation completion screen is displayed. Click [Exit]. <div data-bbox="901 1444 1433 1832" data-label="Image"> </div>

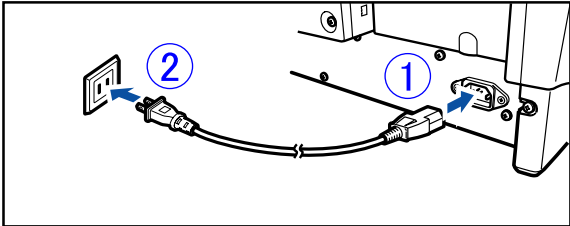
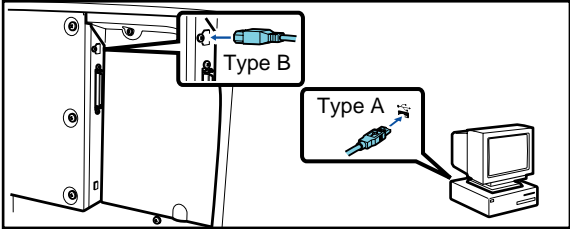
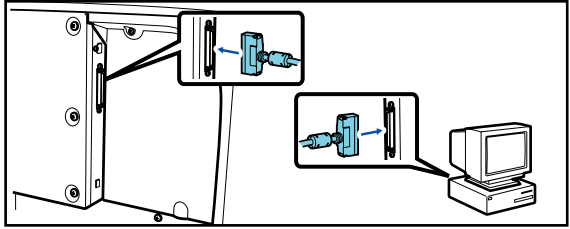
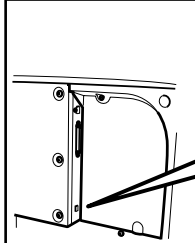
No.	Step	Details/Remarks															
6	<p>Connect the power cord and interface cable.</p> <p>Note:</p> <ol style="list-style-type: none"> Do not connect a USB cable and a SCSI cable at the same time. This machine does not include a SCSI cable. Provide a SCSI cable that matches the connector type of this machine and SCSI card beforehand. The connector type of the scanner is "D-sub, half pitch, 50 pins". If the SCSI cable is connected, turn the computer OFF. 	<p>◆Power cord</p> <ol style="list-style-type: none"> Connect the supplied power cord to the power connector on the rear side of the main body. Insert the power plug in the receptacle.  <p>◆USB cable</p> <ol style="list-style-type: none"> Connect the supplied USB cable.  <p>◆SCSI cable</p> <ol style="list-style-type: none"> Connect the provided SCSI cable.  <ol style="list-style-type: none"> Change SCSI ID if necessary.  <p>DIP Switches</p> <table border="1" data-bbox="957 1507 1321 1749"> <thead> <tr> <th>SCSI ID</th> <th>SW2</th> <th>SW1</th> </tr> </thead> <tbody> <tr> <td>2</td> <td>OFF</td> <td>OFF</td> </tr> <tr> <td>3</td> <td>OFF</td> <td>ON</td> </tr> <tr> <td>4</td> <td>ON</td> <td>OFF</td> </tr> <tr> <td>5</td> <td>ON</td> <td>ON</td> </tr> </tbody> </table> <p>Default Position (SCSI ID=2)</p>	SCSI ID	SW2	SW1	2	OFF	OFF	3	OFF	ON	4	ON	OFF	5	ON	ON
SCSI ID	SW2	SW1															
2	OFF	OFF															
3	OFF	ON															
4	ON	OFF															
5	ON	ON															

No.	Step	Details/Remarks
7	Turn the power ON and make the computer recognize the scanner.	1) Press the power switch to turn this machine ON. 2) Turn the computer power ON. 3) Windows recognizes this machine as a new hardware and installs it automatically.
8	Ensure that it operates correctly by using the supplied "CapturePerfect 3.0" or "Job Function". Refer to the "User Manual" for details. "CHAPTER 1, GENERAL DESCRIPTION, III. User Operation" of this manual provides its overview.	

3. Imprinter Installation Procedure

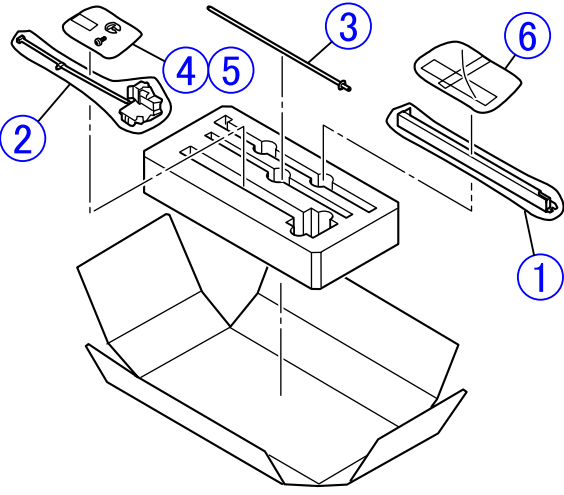
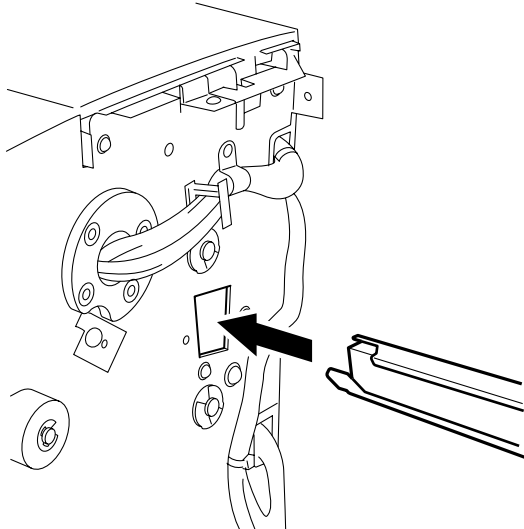
No.	Step	Details/Remarks
1	<p>Make sure that all parts are ready.</p> <ul style="list-style-type: none"> ① IP drain unit ② IP carriage ③ IP shaft ④ Plastic retaining ring ⑤ Screw (BH, M3x6) ⑥ IP label <p>Note:</p> <p>1) Since the electrical contacts of the IP carriage are exposed, handle it carefully to avoid damage due to static electricity.</p> <p>2) Provide an ink cartridge for operation check. The ink cartridge is separately sold.</p>	
2	<p>Remove the right and left covers and the eject tray unit.</p> <p>Note:</p> <p>1) Refer to "CHAPTER 3, DISASSEMBLY & REASSEMBLY" for details.</p>	
3	<p>Insert the IP drain unit into the hole on the right side of this machine, in the direction of the arrow, as far as it will go. Be careful to orient the unit correctly. Place the inserted tip into the hole on the left side of this machine.</p>	

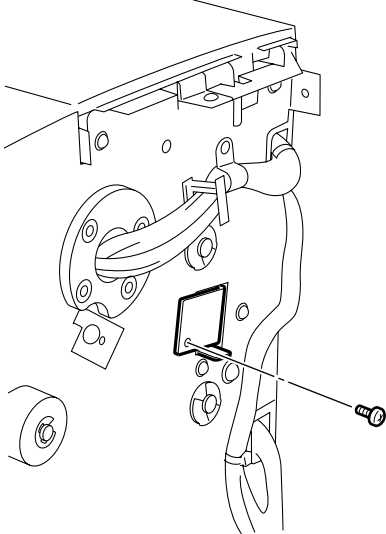
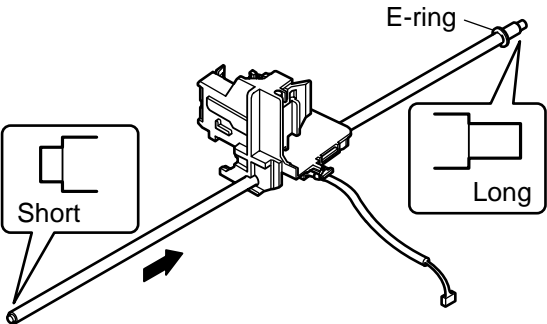
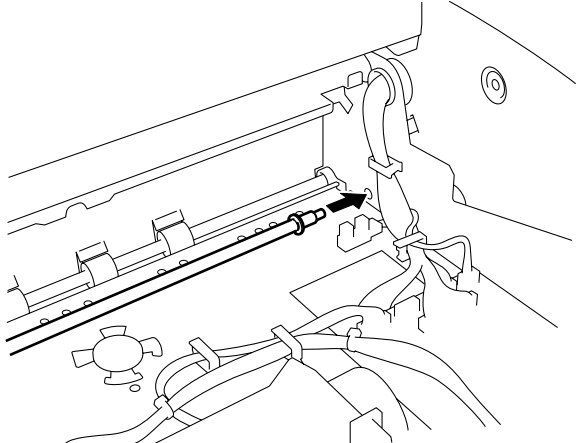
No.	Step	Details/Remarks
4	Secure the IP drain unit using the screws (BH, M3x6).	
5	Insert the IP shaft into the IP carriage. Note: 1) Be careful to insert the IP shaft in the correct direction. As illustrated in the right figure, insert the IP shaft into the IP carriage so that the shorter convex tip of the shaft is to the left and the longer tip is to the right. 2) The E-ring must be press-fitted into the IP shaft.	
6	Insert the longer convex tip of the IP shaft into the hole at the right side inside the main body.	

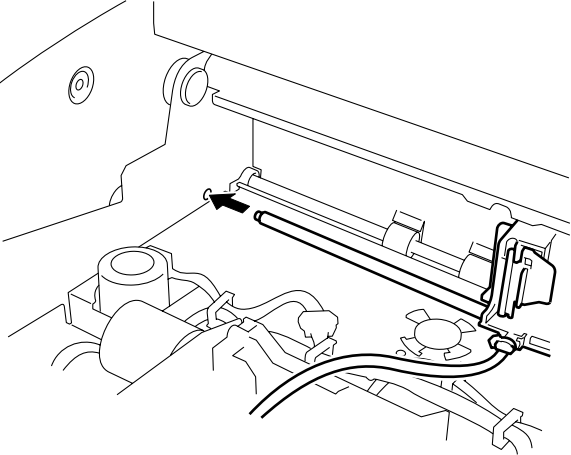
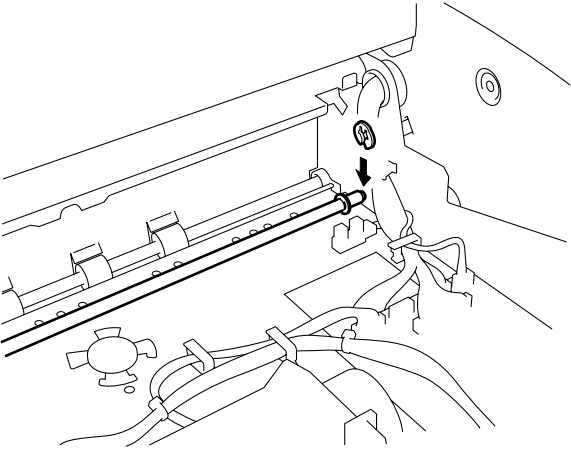
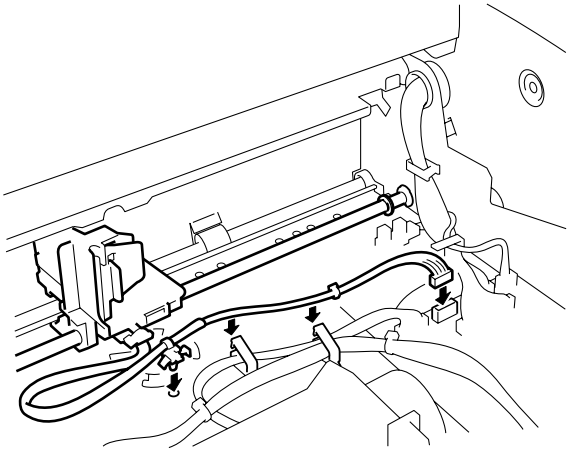
No.	Step	Details/Remarks
7	Insert the other tip of the IP shaft into the hole at the left side inside the main body.	 <p>The diagram shows a perspective view of the internal mechanism. A long, thin shaft is being inserted from the right towards a hole on the left side of the main body. An arrow points to the tip of the shaft as it enters the hole. Various other components like gears and cables are visible in the background.</p>
8	Attach the plastic retaining ring to the right end of the IP shaft to secure it.	 <p>The diagram shows the right end of the IP shaft. A small plastic retaining ring is being pushed onto the shaft. An arrow points to the ring as it is being attached. The surrounding mechanical parts are shown in a simplified line-drawing style.</p>
9	Insert the cable holder attached to the cable assembly of the IP carriage into the hole located at the center of the main body upper frame and pass the cable through the cable holders. Then insert the connector into J208 on the main drive PCB.	 <p>The diagram shows the main body upper frame with a hole in the center. A cable holder, which is part of the IP carriage assembly, is being inserted into this hole. An arrow points to the holder as it is being inserted. The cable is shown passing through the holder. Other components like the main drive PCB and various connectors are also visible.</p>

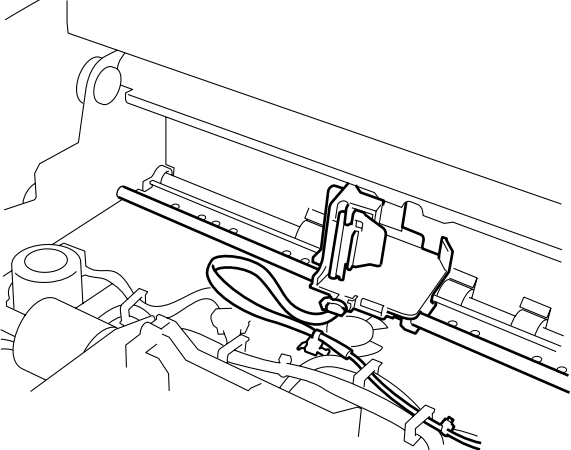
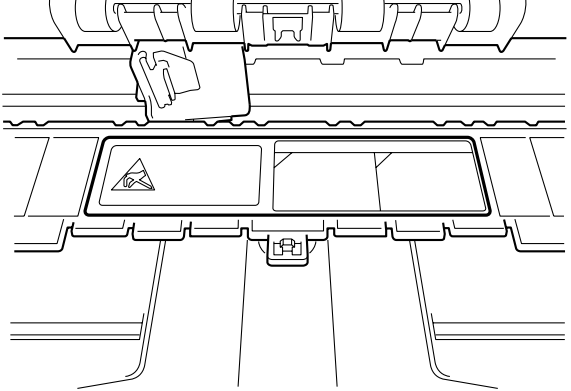
No.	Step	Details/Remarks
10	<p>Check that the IP carriage can move from side to side. In the lower frame of the IP carriage there are small round grooves, and the IP carriage moves back and forth while stopping at each groove.</p> <p>Note: 1) The IP carriage should stop at each of the grooves.</p>	
11	<p>Install the eject try unit and right and left covers.</p> <p>Note: 1) The eject try unit should be installed with the imprinter cover opened.</p>	
12	<p>Peel off the IP label and stick it inside the IP cover. The label should be positioned correctly as viewed from the front of the main body.</p> <p>Note: 1) Check the movement of the IP carriage again. The cable must not be caught by the IP carriage. In addition, there must be a click at the stop position.</p>	
13	<p>Install an ink cartridge.</p>	<p>The ink cartridges are sold separately. Use the products made by Hewlett-Packard Company, with part numbers as follows: C6602R (Red), C6602G (Green) and C6602B (Blue)</p>
14	<p>Close the imprinter cover and verify that it operates correctly. It can be verified without using a computer by using "Imprinter Test" in the user mode.</p> <p>Note: 1) If the stop position of the IP carriage is wrong, the imprinter cover cannot be closed.</p>	

4. Patchcode Decoder Installation Procedure

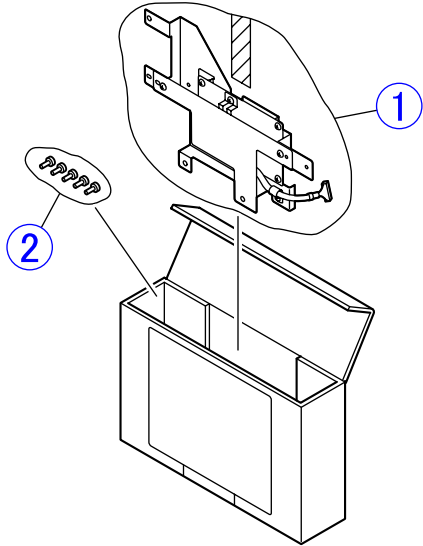
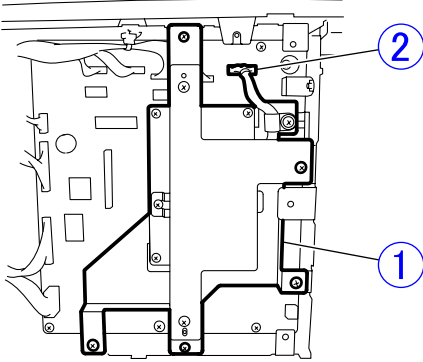
No.	Step	Details/Remarks
1	Take out the parts from the box and check that the accessories are present. ◆ Bundled items ① Main body ② 5 screws (M3) Note: 1) Provide a patchcode sheet for operation check. Its PDF data is saved in the computer when the driver is installed.	
2	Remove the control PCB cover. Refer to "CHAPTER 3, DISASSEMBLY & REASSEMBLY" for details.	
3	Secure the patchcode decoder main body ① to the mounting plate of the control PCB with 5 screws (accessories, M3). Then connect the cable ② to the connector (J126).	
4	Reinstall the removed parts.	
5	Set the provided patchcode sheet and verify that it operates correctly. Use the "Patchcode" in the service mode. Refer to the service mode section for details.	

II. PARTS REPLACEMENT

1. Periodically Replaced Parts

This machine does not have any periodically replaced parts.

2. Consumable Parts (Commercial Goods)

The list below shows the consumable parts specified as commercial goods. The user replaces them.

No.	Item name	Item code	Expected life	Remarks
1	Exchange roller kit Pickup roller Feed roller Retard roller	4009B001	250,000 sheets	Because of the worn rollers, it is necessary to replace them when the pickup failures or the document jams occur after the roller cleaning.
2	Ink cartridge: blue	3693A002	1,750,000 characters	For imprinter. Replace if ink runs out. The condition of expected life is 8×12 font, 32 characters/sheet, 100 sheets/batch, including preliminary application.
3	Ink cartridge: red	3693A003		
4	Ink cartridge: green	3693A004		

Note: The ink cartridges are Hewlett Packard part number C6602B/R/G.

Table 4-201

3. Consumable Parts (For User)

The list below shows the consumable parts that are specified as service parts and can be replaced by the user.

No.	Parts name	Parts number	Expected life	Remarks
1	Pickup roller	MG1-4268	250,000 sheets	Because of the worn rollers, it is necessary to replace them when the pickup failures or the document jams occur after the roller cleaning.
2	Feed roller	MA2-6772		
3	Retard roller	MG1-4269		

Note: The parts above are assigned as service parts and an exchange roller kit is assigned as commercially available products for a set.

Table 4-202

4. Consumable Parts (For servicing)

The list below shows the consumable parts that are specified as service parts and must be replaced by the service technician.

No.	Parts name	Parts number	Q'ty	Expected life	Remarks
1	Registration roller lower Bearing	MF1-4596 XG9-0714	1 2	6,000,000 sheets	<p>Because of the worn rollers, it is necessary to replace them when the document jams or the feed failures occur after the roller cleaning.</p> <p>Note: 1) Because of expected life of electrical conductivity, replace the bearing at the same time. 2) The reading roller upper is the same parts as the registration roller upper.</p>
2	Platen roller Bearing	MA2-8591 XG9-0678	2 4	6,000,000 sheets	
3	Reading roller lower Bearing	MF1-4597 XG9-0714	1 2	6,000,000 sheets	
4	Drive U-turn roller (front) Bearing	MA2-8646 XG9-0714	1 2	6,000,000 sheets	
5	Drive U-turn roller (rear) Bearing	MA2-8647 XG9-0714	2 4	6,000,000 sheets	
6	Eject roller (drive) Bearing	MA2-8733 XG9-0616	1 2	6,000,000 sheets	
7	Registration roller upper Bearing	MF1-4242 XG9-0678	2 4	6,000,000 sheets	
8	Follower U-turn roller (front) Bearing	MA2-6847 XG9-0678	1 2	6,000,000 sheets	
9	Follower U-turn roller (rear) Bearing	MA2-8665 XG9-0678	2 4	6,000,000 sheets	
10	Eject roller follower	MG1-4287	1	6,000,000 sheets	
11	Upper reading unit	MG1-8298	1	5,400,000 sheets 3,600,000 sheets	<p>Corresponds to LED life of 1000 hours. Replace if image failure occurs. 3,600,000 sheets are calculation value for DR-6050C and 5,400,000 sheets are one for DR-9050C.</p>
12	Lower reading unit	MG1-8299	1	5,400,000 sheets 3,600,000 sheets	
13	Pickup solenoid	MF1-4251	1	1,500,000 sheets	Replace if pickup failure occurs due to operation failure.
14	Separation motor	MH7-1165	1	7,200,000 sheets	Corresponds to motor life of 1000 hours. Replace if pickup failure occurs due to operation failure.
15	Ink drain pad unit	MG1-4311	1	6,000,000 sheets	When using an imprinter. Replace if ink is not absorbed and the document gets dirty.

Table 4-203

The figure below shows the mounting positions of the consumable parts replaced by the service technician. The numbers in the figure are the numbers shown in the above table.

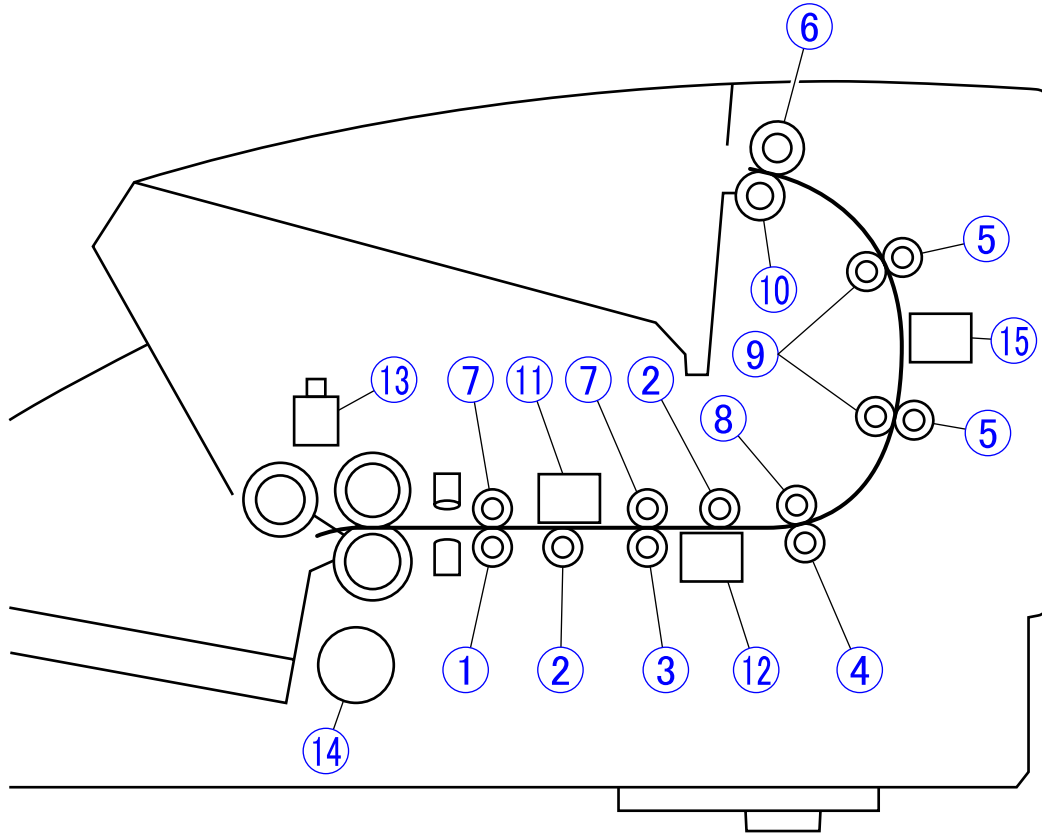

Figure 4-201

III. MAINTENANCE

1. User Maintenance

A list is shown below. Refer to the "User Manual" for details.

[△: Cleaning, ●: Replace]

No.	Location/parts	Intervals		Details
		As required	250,000 sheets	
1	Main body	△		Wipe the main body with a cloth dipped into water and wrung tightly, then wipe dry.
2	Pickup inlet/feed path	△		Using a blower, etc., remove remained dust and paper powder.
3	Pickup roller Feed roller Retard roller	△	●	Wipe the rollers with a cloth dipped into water and wrung tightly, then wipe dry. The expected life is 250,000 sheets. Refer to Note 2.
4	Power plug	△		Remove dust on the connecting portion with the receptacle.
5	Reading glass	△		Wipe the reading glass with a cloth dipped into water and wrung tightly, then wipe dry.
6	Ink cartridge	△ ●		Clean the discharge outlet of the ink head with soft cloth or paper or a cotton swab. Refer to Note 3 for replacement time.
7	Parts to which ink is attached	△		Wipe these parts with a cloth dipped into water and wrung tightly, then wipe dry.

Table 4-301

Note 1: The supplied cleaning cloth is used to clean the reading glass and rollers.

Note 2: If the number of sheets fed with the roller exceeds 250,000 sheets, a replacement message is displayed on the operation panel LCD and computer screen.

Note 3: The expected life of the ink cartridges is not shown on the "User Manual".

2. Service Maintenance

A list is shown below. For details of replacement parts, refer to the above section, "II. PARTS REPLACEMENT".

[△: Cleaning, □: Adjust, ●: Replace]

No.	Location/parts	Intervals			Remarks
		At visiting	6,000,000 sheets	Others	
1	User maintenance items	△			Perform cleaning inside this machine as well.
2	Rollers Bearing		●		
3	Pickup solenoid			●	Expected life: 1,500,000 sheets
4	Separation motor			●	Expected life: 7,200,000 sheets
5	Reading unit			●	Expected life: 5,400,000 sheets/3,600,000 sheets
6	Ink drain pad		●		If much paper powder occurs, the intervals shorten.

Table 4-302

Note 1: If rollers or feed paths are very dirty, the user should be advised to perform "user maintenance".

Note 2: If necessary, make a request to replace the roller of the exchange roller kit.

CHAPTER 5

TROUBLESHOOTING

I. ERROR DISPLAY	5-1	IV. OPERATION TROUBLESHOOTING	5-39
II. SERVICE MODE	5-4	V. IMAGE TROUBLESHOOTING.....	5-43
III. LIST OF FAILURES	5-38	VI. AFTER REPLACING PARTS	5-48

I. ERROR DISPLAY

1. Main Body

“Message” and “Code” appear on the display panel of the main body. The service call message is displayed as “Call for Service.”

◆ Display example



Figure 5-101

◆ Errors associated with user operations

No.	Message	Code	Failure
1	Cover Open	C001	The upper unit is open.
2		C009	The imprinter cover is open.
3		C010	The pickup roller cover is open.
4	DBL Feed	D002	A double feed was detected by the document length.
5		D004	A double feed was detected ultrasonically.
6	Check Imprinter	H001	An ink cartridge is not installed in the imprinter.
7	Staple Detected	J001	A stapled document has been detected.
8	Skew Detected	J018	A skewed document was detected.
9	Dust Detected	J050	Dust detected on the reading glass could not be avoided.
10	Jam	P001	A document has jammed before entering the registration pre-sensor.
11		P002	A document has jammed before exiting from the registration pre-sensor.
12		P004	A document has jammed at the eject sensor.
13		P006	A document has jammed before entering the registration post-sensor.
14		P007	A document has jammed before exiting from the registration post-sensor.
15		P050	Feeding stopped due to other document jams.
16	Count Mismatch	U001	The specified number of sheets was exceeded before the scan ended.
17		U002	The scan ended with a number of sheets less than the setting.
18	Tray Error	E021	Pickup tray operation error. The user moves the pickup tray position manually. *Refer to the service call.
19	Error occurred. See PC.	(None)	This message may appear depending on applications being used. Since no message corresponding to this error is provided by the main body, its description is displayed on the computer.

Table 5-101

◆ Service calls

If a communication error occurs between the motor or sensor and PCB, an error message appears. If it appears, reset the main body and computer power. If the same error message/code still appears, check the connection of the related part, and if it is faulty,

correct it. If there is no problem with connections, replace the related part. For motors, check the connected drive transmission parts and operation check sensor as well.

Note:The message of code “E021” is “Tray Error.”

Code	Parts/symptom
E011	Pickup solenoid
E012	Feed motor
E015	Imprinter PCB
E020	Main motor
E021	Tray motor * Refer to the section associated with user operations.
E022	Separation motor
E024	Eject motor
E025	Pickup motor
E030	Exhaust fan
E032	Control PCB model error (For example, the DR-9050C PCB is installed on the DR-6050C.)
E033	Shading motor (front)
E034	Shading motor (back)
E040	Sub-drive PCB (Man drive CPU judgment)
E041	Main drive PCB (Man drive CPU judgment)
E042	Imprinter PCB (Controller CPU judgment)
E044	Ultrasonic drive PCB (Man drive CPU judgment)

Code	Parts/symptom
E046	Main drive PCB (Controller CPU judgment)
E047	Patchcode PCB (Controller CPU judgment)
E048	Eject PCB (Man drive CPU judgment)
E049	Sub-drive PCB (Controller CPU judgment)
E050	Patchcode decode error
E054	Reading PCB (front)
E055	Reading PCB (back)
E086	Control EEPROM write error
E090	Man drive Flash checksum error
E091	Man drive Flash delete error
E092	Man drive Flash write error
E093	Sub-drive Flash checksum error
E094	Sub-drive Flash delete error
E095	Sub-drive Flash write error
E100	Scanner busy timeout error
E101	Pickup tray timeout error
E102	Pickup sensor timeout error
E103	Document sensor timeout error
E104	Shading timeout error

Table 5-102

2. Computer

The display connected to the computer shows error messages. Their contents differ depending on the software being used.

Most errors are associated with users, such as user operation mistakes and document jams. The user must take appropriate actions according to error messages.

The figure below shows several examples of error messages when using "CapturePerfect 3.0".

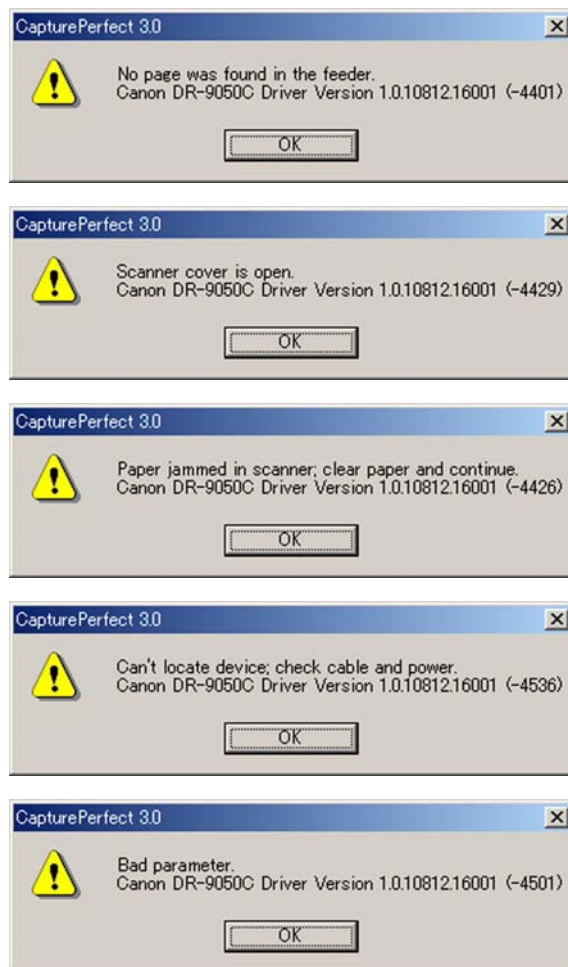

Figure 5-102

II. SERVICE MODE

A. Outline

1. Outline

The service mode of this machine can be executed by installing the service mode software (service tool) located in the setup disc bundled with this machine or supplied for servicing on the computer for servicing. This service tool is an integrated tool that consists of a common EXE file and DLL files for each product.

The system requirements for the computer to be used are the same as those described in the "User Manual." The lower the CPU performance or memory capacity, the longer the processing time.

The initial screen is shown below.



Figure 5-201

When a work button is selected on the initial screen, the corresponding screen is displayed and each service mode can be executed.

A list of items is shown below.

No.	Configuration/display name	Function
1	Select Scanner	Select a scanner to be connected.
2	Main Menu	Perform adjustment associated with image reading, display the counter and make other settings.
3	All Adjustment	All adjustments related to image reading (LED adjustment and registration adjustment)
4	Regist Adjustment	Automatic adjustment of the reading start position
5	LED Adjustment	Adjustment of the intensity for the reading LED
6	Max Document Size	Select long document mode.
7	Sleep	Select time to enter sleep mode.
8	SCSI Transfer	Select the SCSI transfer speed.
9	Counter	Display and change the total scanning count, replacement parts counter, etc.
10	Dcon Check	Check the operation of motors, sensors, and others.
11	Pick Motor	Operation check of the pickup motor
12	Feed Motor	Operation check of the feed motor
13	Main Motor	Operation check of the main motor
14	Separate Motor	Operation check of the separation motor
15	Eject Motor	Operation check of the eject motor
16	Tray Position	Operation check of the tray motor
17	Imaging Unit (T)	Operation check of the shading motor (front)
18	Imaging Unit (B)	Operation check of the shading motor (rear)
19	Pick Up Down	Operation check of the pickup solenoid
20	Feed Test	Overall operation check of document transfer
21	Led	Check lighting of the LED on the reading unit.
22	LCD	Check lighting of the LCD on operation panel.
23	Feed Unit	Confirmation of detection of sensors in the feed unit (Registration/double feed sensor)
24	Exit Unit	Confirmation of detection of sensor in the eject unit (Eject sensor)
25	Staple Unit	Confirmation of detection of staple sensor
26	Tray Unit	Confirmation of detection of sensor in the document entrance section (Document/pickup/skew sensor)
27	PANEL UNIT	Confirmation of ON/OFF of operation panel keys
28	Others	Operation check of other sensors (Door/shading sensor, etc.)
29	Get Status	Display errors, version, counter, and other settings.
30	Last Error Logs	Display up to 10 recent error codes that occurred.
31	Check Device	Display the version of internal firmware.
32	Serial Number	Display the serial number of the main body.
33	Sleep Time	Display sleep time setting.
34	SCSI Transfer Rate	Display the SCSI transfer speed setting.
35	Long Document	Display long document mode (maximum length) setting.
36	Counter	Display the counter.
37	Write setting to text	Save above information on the computer.

Table 5-201a

No.	Configuration/display name	Function
38	Scan Check	Scan documents in color at 300 dpi and save data.
39	CIS Data	Display output waveform from the reading unit.
40	Mode	Mode setting (Grayscale/color)
41	Resolution	Resolution setting (300/600 dpi)
42	Side	Reading side setting (Front/back)
43	Position	Reading position setting (Shading/Read)
44	ImgFrame	Display the outside frame of a fed document.
45	Speed	Transfer speed setting (High/low speed)
46	Save Log	Save outside frame data on the computer.
47	Firm Load	Change firmware.
48	Firm Load	Execute selected and registered control firmware.
49	Use Disk	Select and execute unregistered control firmware.
50	Main Drive CPU Firm	Select and execute main drive firmware.
51	Sub Drive CPU Firm	Select and execute sub-drive firmware.
52	Analog	Display sensor analog output. However, the operation is checked in the field using "Dcon Check".
53	Extended Setting	Make other settings.
54	Regist Manual Adjust-ment	Adjust determined registration adjustment values manually.
55	Key Lock	Disable operation panel keys.
56	Imprinter	Check the operation of the imprinter (option).
57	Patchcode	Check the operation of the patchcode decoder (option).
58	Firm Registration	Register and delete control firmware.
59	Register	Register control firmware.
60	Delete	Delete registered control firmware.
61	Add Note	Add notes to registered firmware.
62	Application information	Display the version of the service tool (EXE file).
63	Close Application	Terminate the service tool. However, it can be terminated from each operation screen.
64	Simulation mode	A trial operation can be performed without connecting the scanner.

Table 5-201b

Main screens are as follows.

● Initial screen

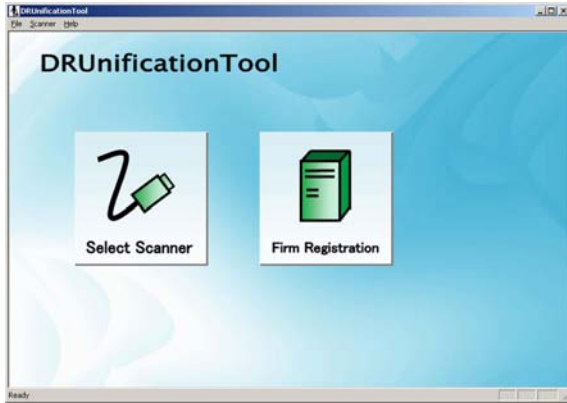

● Get Status

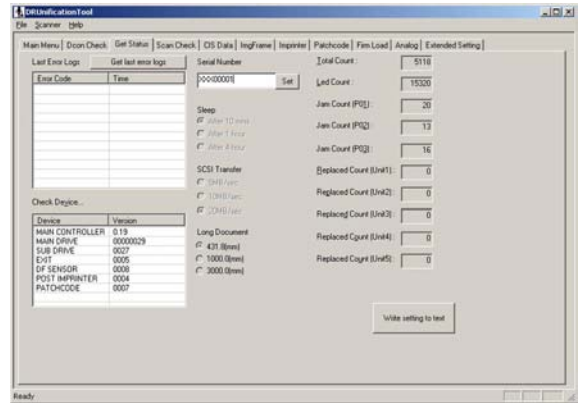

● Main Menu

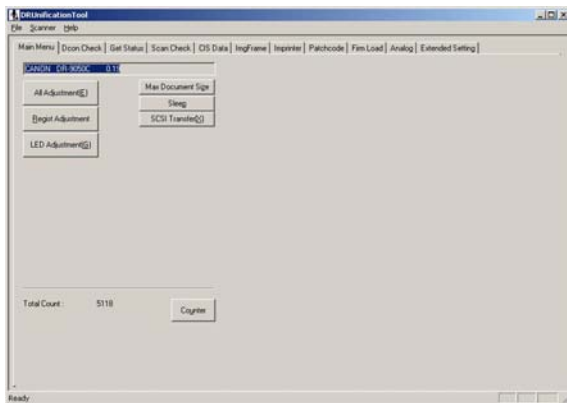

● Scan Check

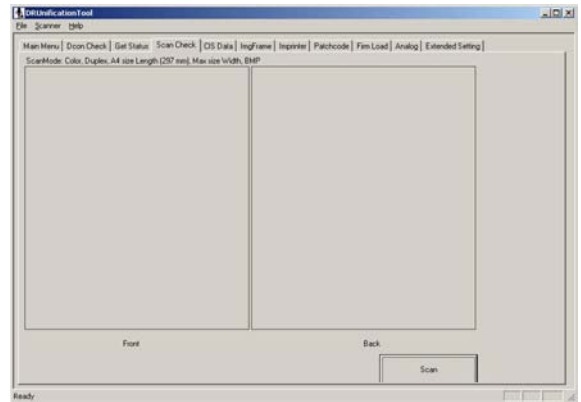

● Dcon Check

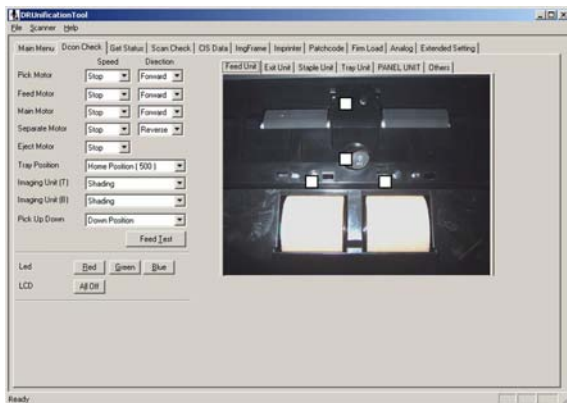

● CIS Data

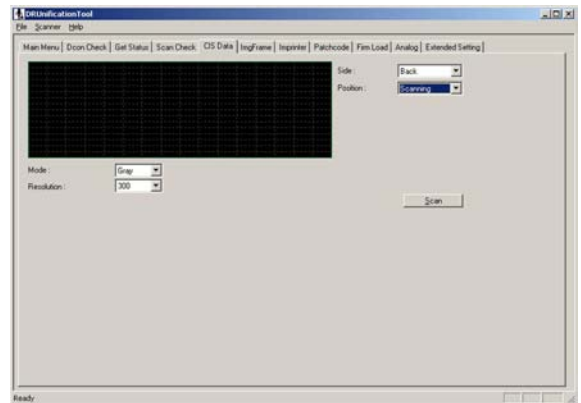
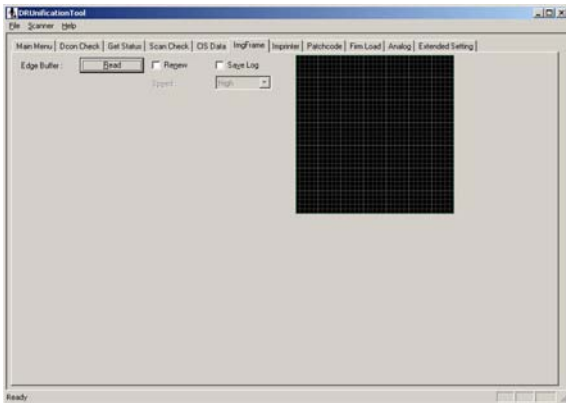
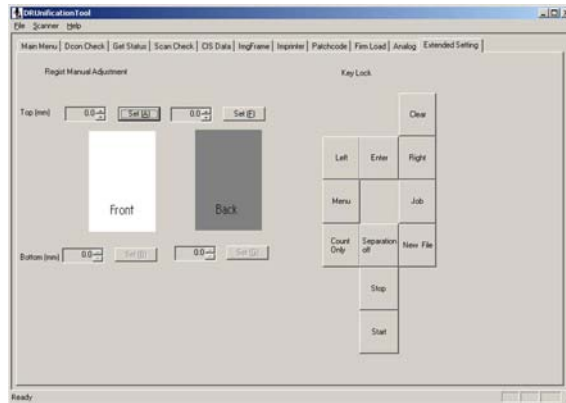

Figure 5-202

● **ImgFrame**



● **Extended Setting**



● **Firm Load**

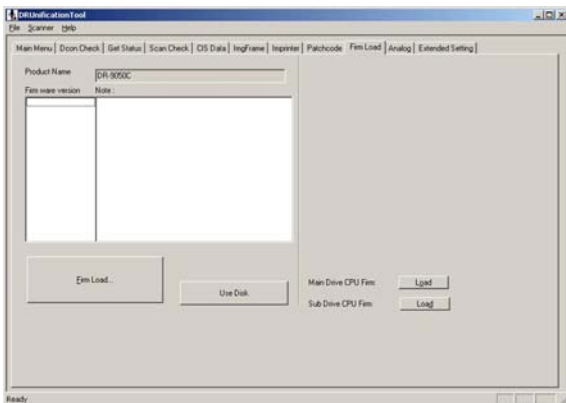

● **Firm Registration**

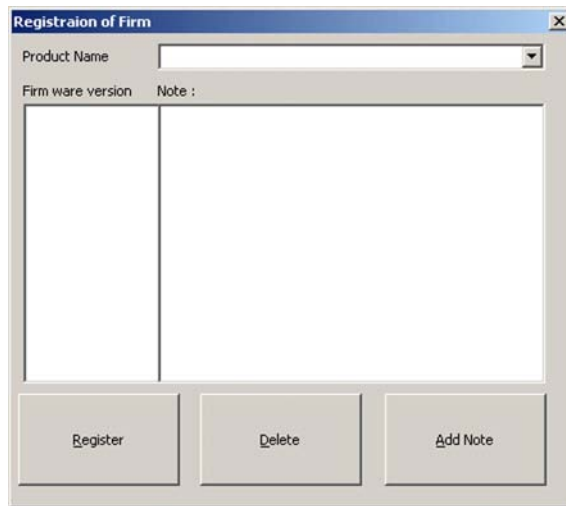

● **Analog**

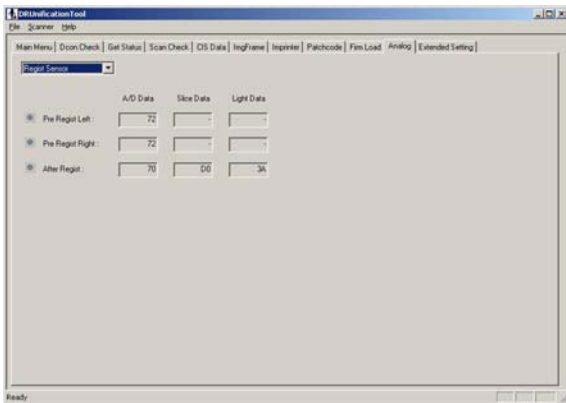

● **Balloon help**

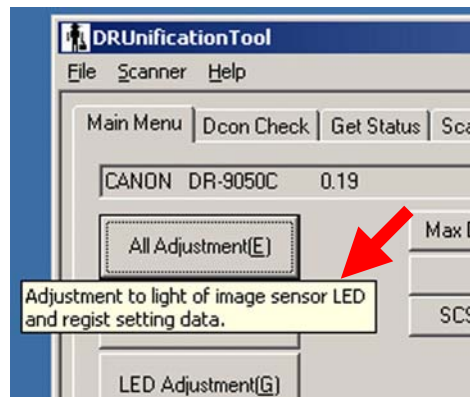

Figure 5-203

Reference: Balloon help

It displays explanation of functions and operations. The service tool has this function. When a cursor is placed over the main

execution button, a dialog box with an explanation is displayed. However, some execution buttons do not display explanation.

2. Installation Procedure

The procedure for installing the service tool from the setup disc is shown below. Do not install it on the user's computer.

- 1) Power ON the computer for servicing and start up the OS (Windows).
- 2) Set the setup disc that is bundled with this machine.
- 3) An installation screen for the user appears but ignore it. Right click on the [Start] button on the computer and select [Explorer].
- 4) Copy the “¥Driver¥Tools” folder in the setup disc to a desired drive of the computer for servicing.

Note: Make sure to also install the driver for this machine in the computer for servicing. This is required as the service tool does not have a function for detecting with the scanner.

For how to install a software for the user bundled with this machine, refer to the “User Manual.”

However, for the specifications, such as the reading speed, refer to the computer system requirements described in the “User Manual.”

Note: Do not let the user know the folder name and password to be used.

3. Starting Up and Exiting Service Mode

The procedure for starting up the service mode is described below.

- 1) Connect the computer for servicing with this machine using a USB or SCSI interface cable.
- 2) Power ON this machine.
- 3) Open the installed folder and start up the “DRUnificationTool.exe” file.

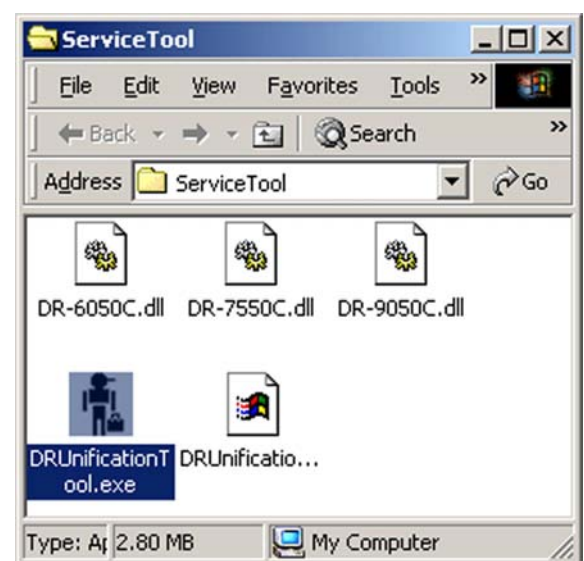

Figure 5-204

- 4) The password screen is displayed, so after inputting the 6 characters “market,” select [OK].



Figure 5-205

5) The initial screen is displayed.



Figure 5-206

- 6) If each service mode is executed, select [Select Scanner] and if the firmware is registered, select [Firm Registration].
- 7) When [Select Scanner] is selected, the scanner selection screen is displayed. Select the connected scanner.

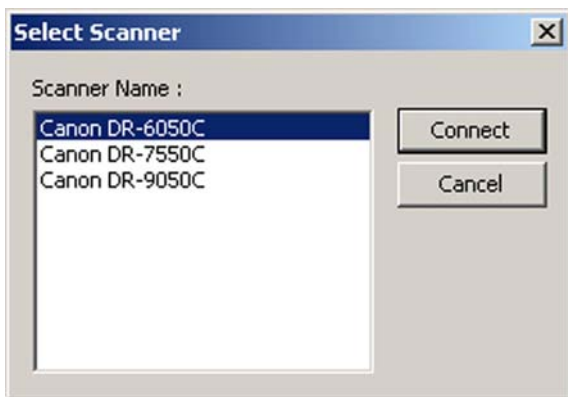

Figure 5-207

8) The Main Menu screen is displayed.

To terminate the service mode, select [ⓧ:Close] on each operation screen or select [End Application] from [File] on the toolbar.

Reference: Folder and files

Save files required for the integrated tool in the same folder. The folder name can be changed freely, but the file name must not be changed. The files necessary for this machine are the following three types:

- DRUnificationTool.exe
Execution file (EXE file)
Used in common for all products.
- DR-6050C.dll, DR-7550C.dll, DR-9050C.dll
File for each product (DLL file)
- DRUnificationTool.LOC
Language translation file (Japanese/English)

Another product for the integrated tool that will be created later can be used by saving a DLL file in this folder.

When “Firmware Registration” is executed, necessary folders and files are created in this folder. Refer to the “Firmware Registration” section for details.

B. Main Menu

1. All Adjustment

This mode is used to adjust all image reading adjustments at the same time. Be sure to execute this mode after the control PCB or the reading unit has been replaced.

This mode consists of 2 individual adjustment items: "LED Adjustment," "Regist Adjustment."

◆ Operation procedure

- 1) Clean the feed path, rollers, and reading glasses.
- 2) Set the document guide at the central position.
- 3) Set 1 to 10 sheets of regular white copy paper (A4 or LTR) in portrait mode. Set the document guide position to the paper. This paper is used for adjusting Regist Adjustment.
- 4) Select [All Adjustment] on the Main Menu screen.

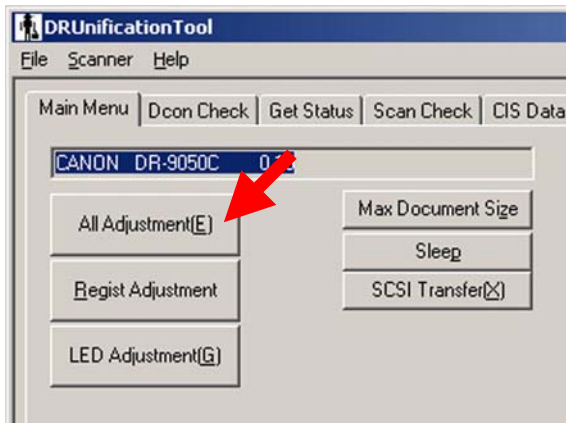

Figure 5-208

- 5) A confirmation screen related to paper setting is displayed. Check whether the paper is set correctly, then select [OK].

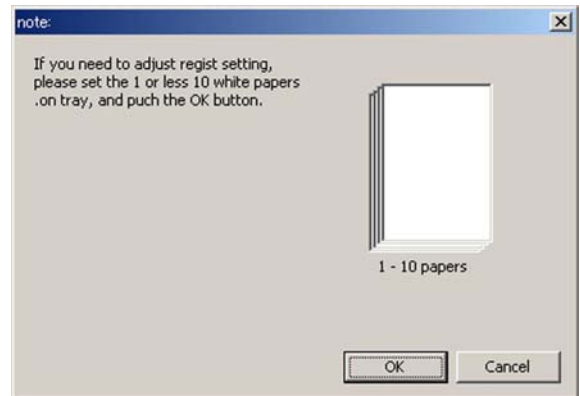

Figure 5-209

- 6) The adjustment starts automatically. The progress screen appears on the display. After "LED Adjustment" is performed, the paper is fed and "Regist Adjustment" is performed.

The display examples are shown below.

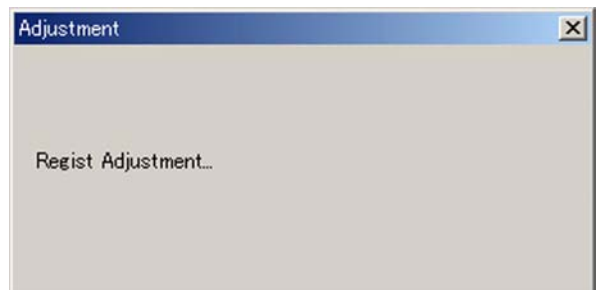
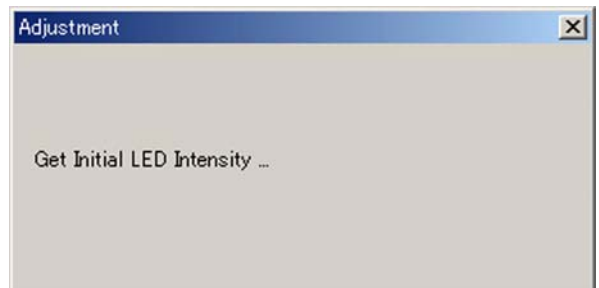

Figure 5-210

- 7) When the adjustment is finished, the progress screen disappears.
It takes approx. 2 minute to finish.

Reference: Number of sheets of paper

The adjustment value of the Regist Adjustment is an average of the number of sheets fed. The error can be reduced as the number of sheets increases.

◆ Errors

If an anomaly occurs in the adjustment value while executing this mode, an error screen is displayed, and adjustment is interrupted. If an error screen is displayed, select [OK] on the screen to stop adjustment. Then after checking the operation procedure, perform adjustment again. If adjustment is interrupted, the adjustment value remains the value prior to adjustment.

Sample error screens are shown below.



Figure 5-211

If the computer gets uncontrollable during use of the service mode including this mode, reset both the scanner and the computer.

2. Individual Adjustments

This section describes the following individual adjustment items. If all the 2 adjustments are performed, use [All Adjustment] described in the previous section.

- [LED Adjustment]
- [Regist Adjustment]

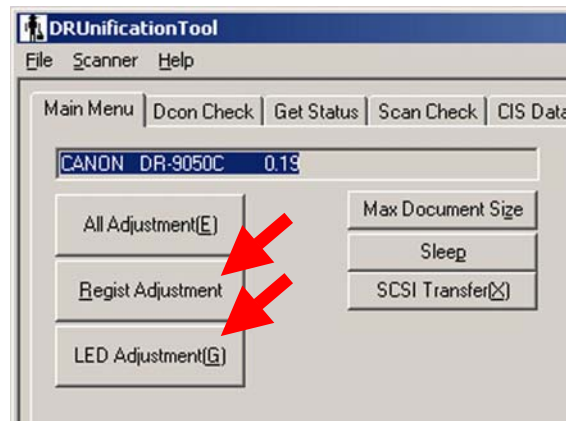

Figure 5-212

a. LED Adjustment

In this mode, 3-color LED intensity adjustment and 3-line sensor data output correction of the CIS unit are performed. Execute this mode when the quality of the read image is faulty.

◆ Operation procedure

- 1) Clean the feed path, rollers, and reading glasses.
- 2) Select [LED Adjustment] on the Main Menu screen.
- 3) The adjustment starts automatically. The progress screen appears on the display.
- 4) When the adjustment is finished, the progress screen disappears.

b. Regist Adjustment

The reading position is adjusted in this mode. Execute this mode if the leading edge of a read image is faulty.

◆ Operation procedure

- 1) Set the document guide at the central position.
- 2) Set 1 to 10 sheets of regular white copy paper (A4 or LTR) in portrait mode. Set the document guide position to the paper.
- 3) Select [Regist Adjustment] on the Main Menu screen.
- 4) A confirmation screen is displayed. Select [OK].
- 5) The adjustment starts automatically. The paper is fed and the progress screen appears on the display.
- 6) When the adjustment is finished, the progress screen disappears.

3. Max Document Size

This mode is used to set the long document mode. It is set to the standard mode at the factory setting. Changes can also be performed in the user mode.

When the long document mode is set, the document length is 1000 mm or 3000 mm at the maximum, but there are restrictions shown below:

- Document size: "Auto-detection" only
- Document thickness: 0.2 mm or less
- Image size: Approx. 378 MB or less
- Feed: Feed a sheet of paper. Performance of paper pickup/eject is not guaranteed.

When [Max Document Size] is selected on the Main Menu screen, the setting screen is displayed. To set the long document mode, change the setting to [1000.0(mm)] or [3000.0(mm)] and press the [OK] button.

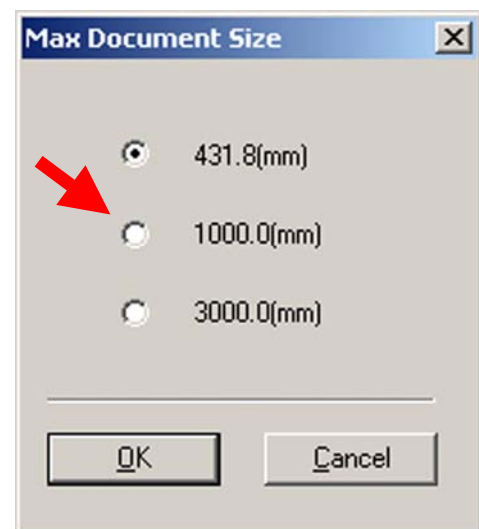

Figure 5-213

4. Sleep

This mode is used to change the time until the machine enters the sleep mode. It is set to [After 10 mins.] at the factory setting. It can also be changed in the user mode.

When [Sleep] is selected on the Main Menu screen, a setting screen is displayed. Change the setting as required and press the [OK] button.

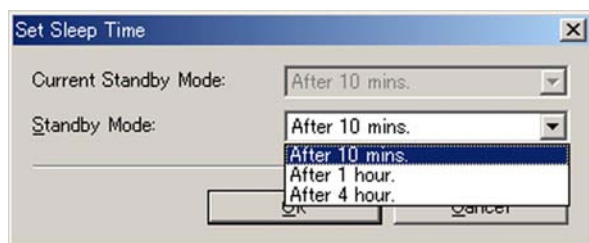

Figure 5-214

5. SCSI Transfer

This mode is used to change the maximum value of the synchronizing transfer speed of the SCSI interface.

However, there is normally no problem with the factory setting [20MB/sec], so the setting should be changed only if the machine does not work properly. It can also be changed in the user mode.

When [SCSI Transfer] is selected on the Main Menu screen, a setting screen is displayed. Change the setting as required and press the [OK] button.

Then, a confirmation screen is displayed, so select the [OK] button again.

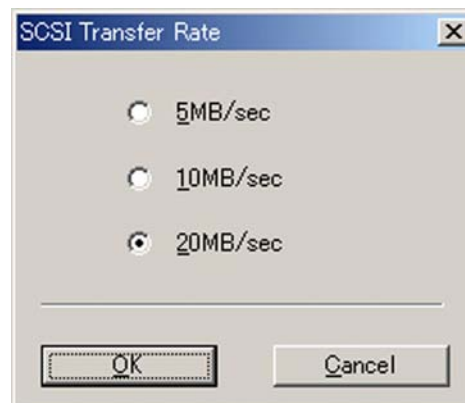

Figure 5-215

6. Counter

This mode is used to confirm the number of sheets fed and document jams and record the number of sheets fed when replacing consumable parts. These values can be changed.

When the [Counter] button is selected on the Main Menu screen, the Change Counter screen is displayed. The figure below shows the screen and list of items.

The [Total Count] value is displayed at the lower part of the Main Menu screen.

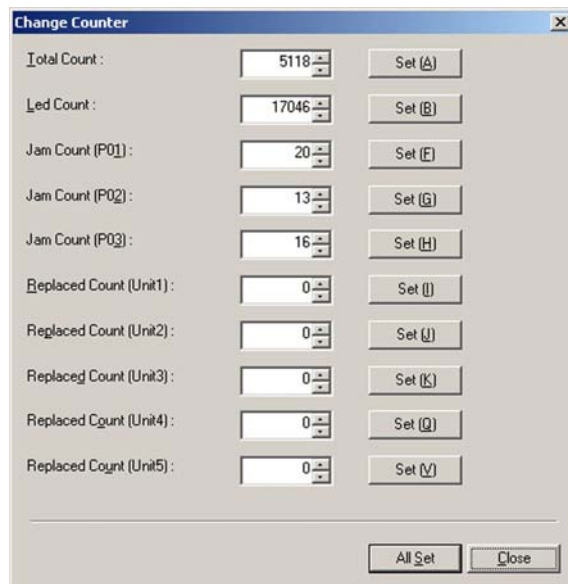

Figure 5-216

Display	Details
Total Count	Total scanning count
Led Count	Total lighting time of the LEDs used on the reading unit (upper/lower) and frame detection unit. However, the unit is "second". 1000 hours = 3,600,000 seconds
Jam Count (P01)	Number of documents jams in the pickup section. Error code P001
Jam Count (P02)	Number of documents jams in the registration section. Error code P002/006/007
Jam Count (P03)	Number of documents jams in the eject section. Error code P004
Replaced Count (Unit1)	Number of sheets fed when replacing parts replaced by users (expected life 500,000 sheets). Total scanning count when it is reset in the user mode is displayed.
Replaced Count (Unit2)	When the pickup solenoid (expected life 1,500,000 sheets) is replaced, enter the total scanning count.
Replaced Count (Unit3)	When the roller (expected life 6,000,000 sheets) is replaced, enter the total scanning count.
Replaced Count (Unit4)	When the separation motor (expected life 7,200,000 sheets) is replaced, enter the total scanning count.
Replaced Count (Unit5)	When the reading unit is replaced, enter the total scanning count.

Note: For Replaced Count (Unit2) to (Unit5), enter total scanning count manually when the service technician replaces parts as a guide for the next replacement time. The related part may be changed if necessary.

Table 5-202

When the [Set] on the right or the [All Set] on the lower right of the screen is selected after the value is changed, the changed value is determined.

To close the screen, select the [Close].

These values might be changed if the control PCB is replaced. Therefore, inputting the values again is required after the replacement. If the values before the replacement are not clear, it is better to input the recommended values.

The count of [Roller Counter] in the user mode is also changed when the control PCB is replaced or the [Total Count] is changed. When the user switches the machine power ON for the next time, the "Roller Replacement" message may appear or the count of [Roller Counter] may indicate an abnormal

count. After exiting from the service mode, therefore, be sure to check the count of [Roller Counter] and reset it if the values are abnormal.

Note: The count of [Roller Counter] is calculated by subtracting the total scanning count on the previous reset from the total scanning count at that time.

Note: Since the number of writes of [Total Count] and [Led Count] values into memory is limited, new values are not written into memory if the number of sheets fed is 10 sheets or less. Therefore, if the power is turned OFF when the number of sheets fed is 10 or less, the original value remains. However, if an abnormality, such as a document jam, occurs, they are written into memory regardless of the number of sheets fed.

C. Dcon Check

1. Motor

Check the operation of the motor and solenoid. The corresponding screen and a list of items are shown below.

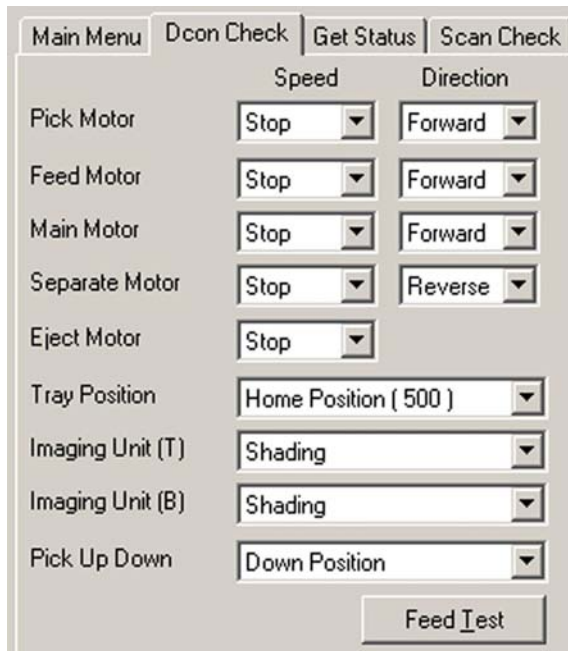

Figure 5-217

Display	Target name
Pick Motor	Pickup motor
Feed Motor	Feed motor
Main Motor	Main motor
Separate Motor	Separation motor
Eject Motor	Eject motor
Tray Position	Tray motor ^{Note 1}
Imaging Unit (T)	Shading motor (front)
Imaging Unit (B)	Shading motor (back)
Pick Up Down	Pickup solenoid ^{Note 2}

Table 5-203

◆ Operation methods

When conditions are selected from the pulldown box, the motor or solenoid is driven accordingly.

Note 1: The tray motor does not run when the eject tray unit is removed. Set the imprinter door sensor in detection state with a sheet of paper or install the eject tray unit.

Note 2: When the pickup solenoid is operated, it may not be moved from the [Down Position] to the [Up Position] due to variations of the operation force. At this time, set the document board to the [Uppermost Position] or support it by hand. The solenoid normally operates, but this may occur if the solenoid coil temperature is kept increased.

2. Feed Test

Paper can be actually fed in this mode at the Dcon Check screen. The operation of sensors during feeding can be checked. If you need to check a feed operation only, it can be used "Count only mode" instead of the Feed Test.

◆ Operation procedure

- 1) Set the paper on the pickup tray.
- 2) Select the [Feed Test].
- 3) The pickup tray lifts and each roller rotates.
- 4) The paper is fed at low speed and ejected onto the eject tray.
- 5) When the [Feed Test] is selected again, the test stops.

The operation of the sensor during feeding can be checked on the sensor confirmation screen. Refer to the "Sensors" section for details.

3. Sensors

Perform the sensor operation check.

When each sensor enters the detection state, the corresponding mark lights. Since there are many sensors, they are divided into groups. When the cursor is placed over the mark, balloon help is displayed. Lighting of the mark on the "Feed Unit" and an example of balloon help are shown below.

The operation of operation panel keys can also be checked here.

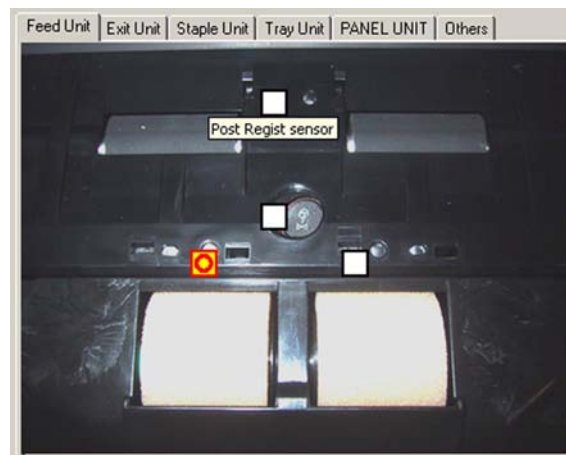

Figure 5-218

1) Feed Unit

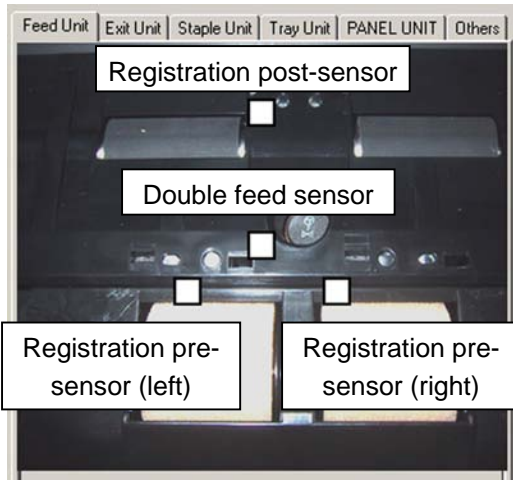
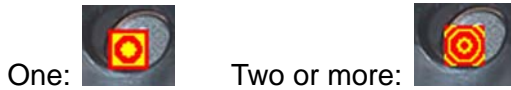

Figure 5-219

For the double feed sensor, the mark that lights when a sheet of paper is fed is different from the mark that lights when two or more sheets of paper are fed.



2) Exit Unit

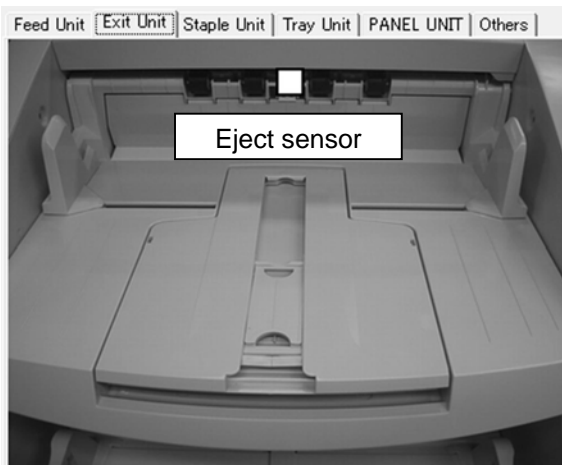

Figure 5-220

3) Staple Unit

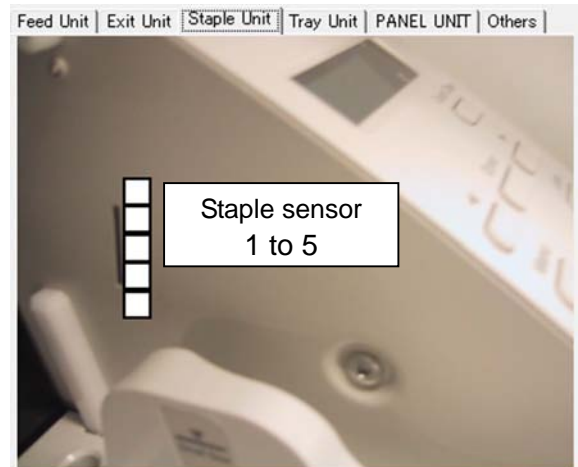

Figure 5-221

4) Tray Unit

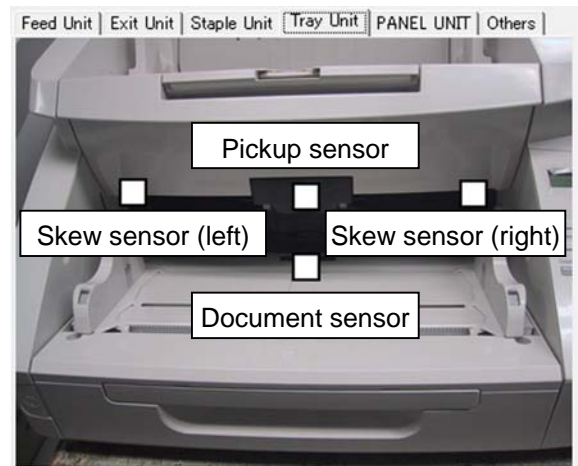

Figure 5-222

5) PANEL UNIT

The operation of keys on the operation panel is checked here. The mark lights in the same way as for the sensors in the previous section and the figure below shows that the [Menu] key is ON.

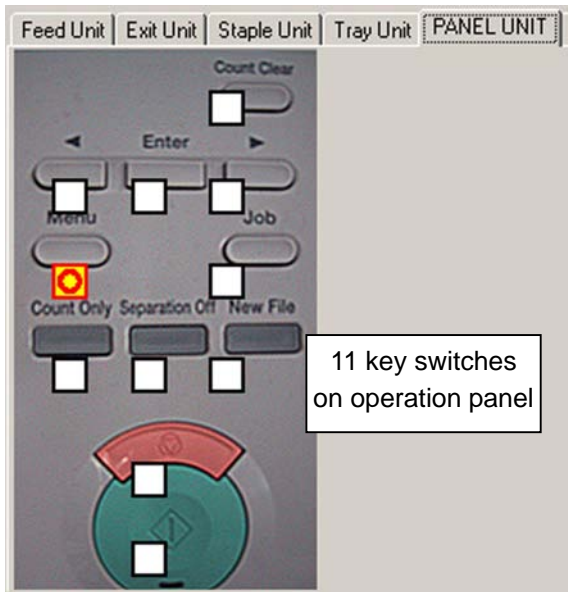

Figure 5-223

6) Others

The detection state of other sensors is displayed. When a sensor enters detection state, the display section lights. The figure below shows that [Tray Not HP BTM] is detected.

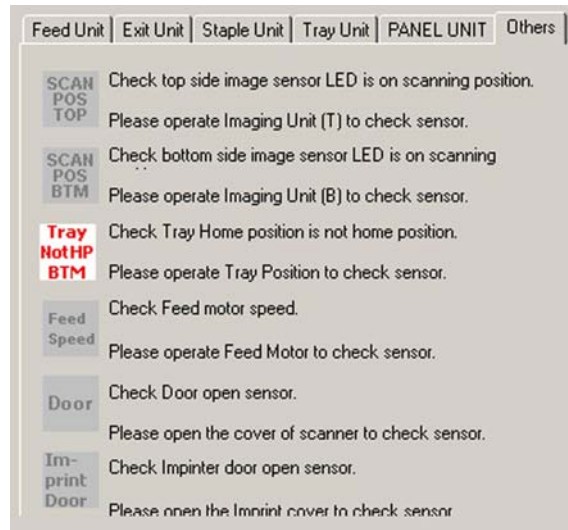

Figure 5-224

4. LED/LCD

◆ Led

Verify that LEDs of the reading unit light. When opening the upper unit and selecting the corresponding button, the LED lights. When the button is pressed again, the LED turns OFF.

Note: If an operation mistake occurs in “Dcon Check”, the LED may not light correctly. In this case, end the service mode and reset the scanner.

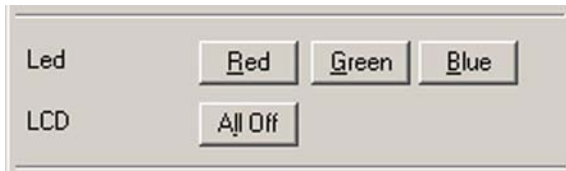

Figure 5-225

◆ LCD

Check the lighting of the display panel (LCD) in the operation panel. When closing the upper unit and selecting [All Off], all display dots of 16 characters × 2 lines turn OFF. When the button is selected again, all the dots light.

If the upper unit is open, a “Cover Open” error is displayed.

Note: If this mode operates, all LEDs remain OFF or ON after the service mode ends. Reset the scanner.

D. Get Status

1. Last Error Logs

When [Get last error logs] is selected, up to 10 recent error codes are displayed.

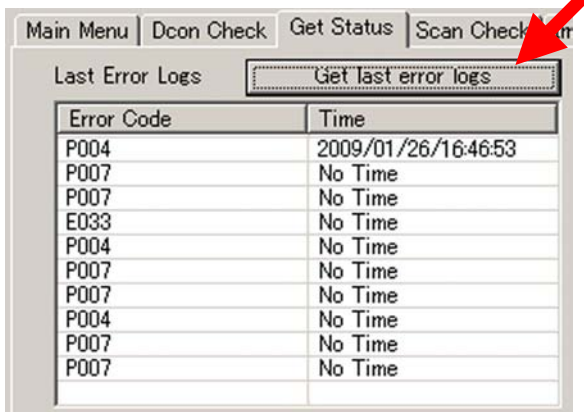

Figure 5-226

Refer to the “I. ERROR DISPLAY” section described before for details of error codes.

The date and time are displayed in the [Time] column only if the scanner obtains time from the computer, for example, if an optional imprinter is used with time print setting and an error occurs. Otherwise, “No Time” is displayed.

2. Check Device

This mode is used to check the versions of the main body firmware and the internal devices of this machine.

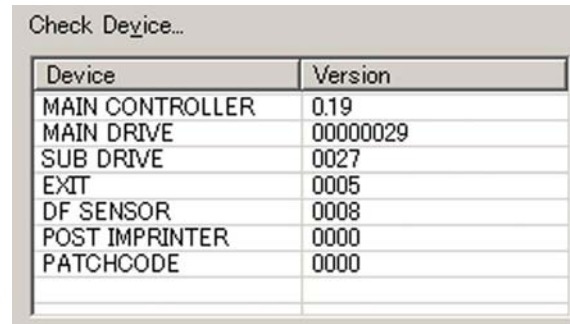

Figure 5-227

If no option is connected to this machine, “0000” is displayed.

3. Serial Number

The serial number and other information are displayed.

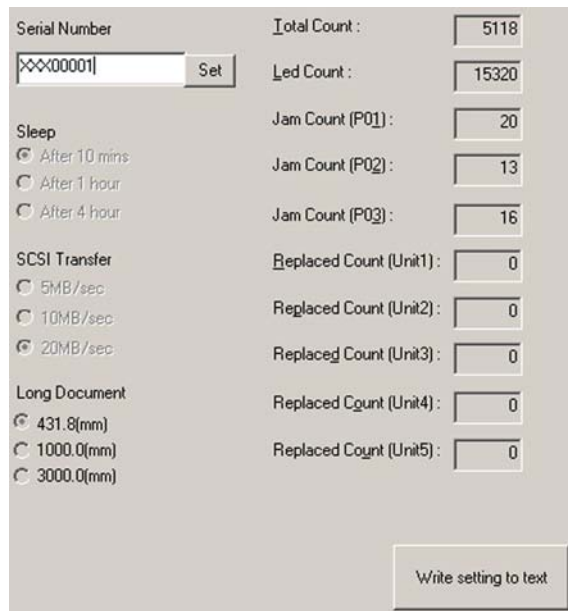

Figure 5-228

Serial number data is saved on the control PCB. If this PCB is replaced, enter a number and select [Set] on the right side.

4. Write Setting to Text

When [Write setting to text] on the lower right side is selected, displayed information can be saved in a text file.

◆ Operation procedure

- 1) Select [Get last error logs] if necessary.
- 2) Select [Write setting to text].
- 3) The save screen is displayed. Set a save location.
- 4) The data is saved.

Part of the contents of a saved file is shown below.

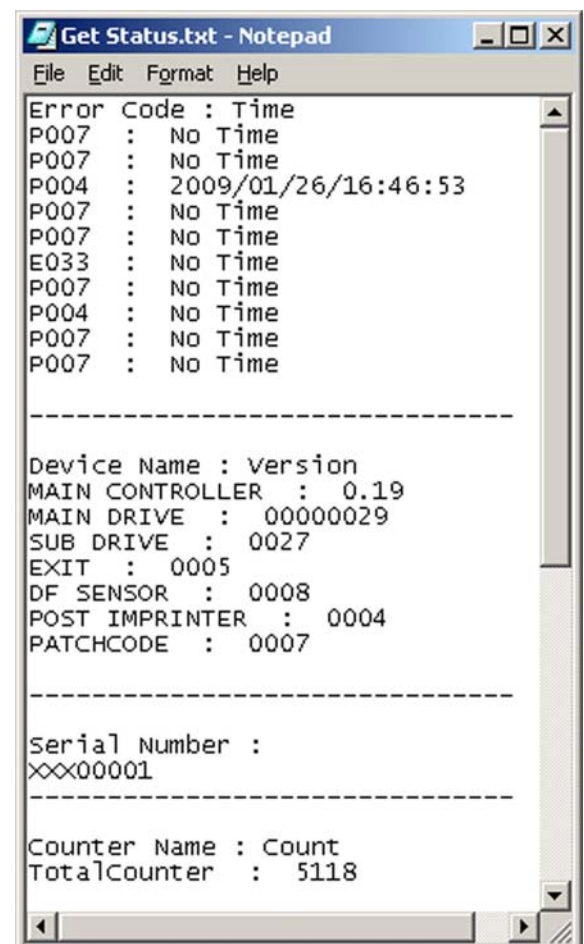

Figure 5-229

E. Scan

1. Scan Check

Actual scans can be performed in the service mode. Scanned images are displayed and saved. However, scan conditions are limited.

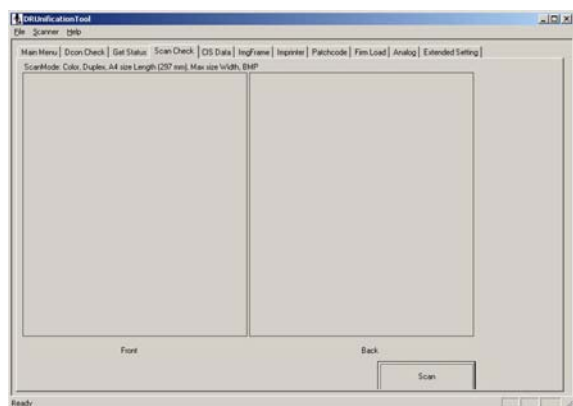

Figure 5-230

◆ Scan condition

Mode: Color, 300 dpi, duplex, one sheet
 Area: Width maximum, length A4 portrait
 Save type: BMP

◆ Operation procedure

- 1) Set a sheet of document.
- 2) Select [Scan].
- 3) The save screen is displayed. Set a save location.
- 4) The document is scanned.
- 5) An image is displayed and saved.

The display screen and an example of saved files are shown below.

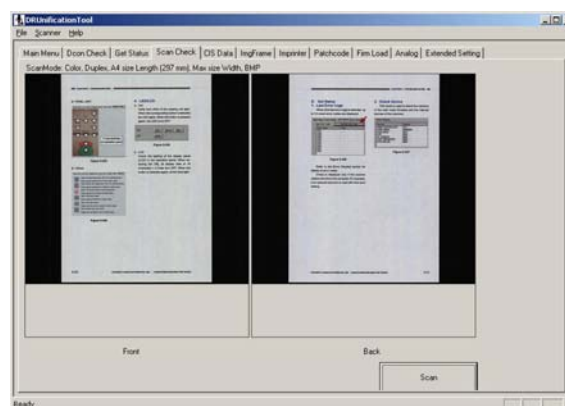

Figure 5-231

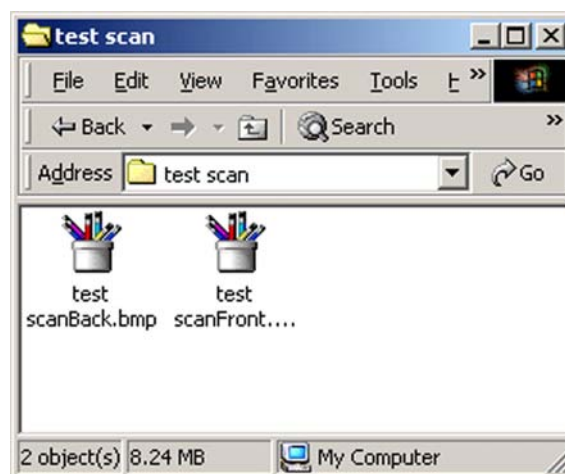

Figure 5-232

2. CIS Data

Enter line data of the reading unit at the document reading position and display its waveform. Failures of the reading unit can be confirmed. Data after shading correction is shown.



Figure 5-233

◆ Scan condition selection

Mode: Grayscale/Color
Resolution: 300/600 dpi

◆ Display condition selection

Side: Front/Back
Position: Shading/Read

◆ Operation procedure

- 1) Select scan conditions.
- 2) Select [Scan].
- 3) Select display conditions and verify waveforms.

◆ Waveform 1

This is a general waveform when [Read] is selected.

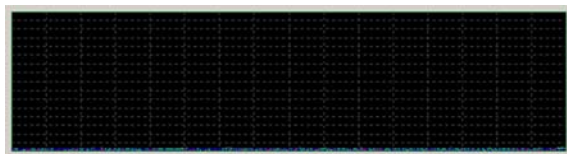

Figure 5-234

Since the background color for this machine during document reading is black, the waveform is displayed at the lower part of the display section. If it is displayed at a higher position, it is incorrect.

◆ Waveform 2

A procedure of scanning with a sheet of white paper placed on the reading glass and checking problems, such as dirt on the glass surface is shown below.

- 1) Cut a sheet of regular white copy paper according to the reading glass size.
- 2) Place the white paper on the reading glass of the target reading unit.

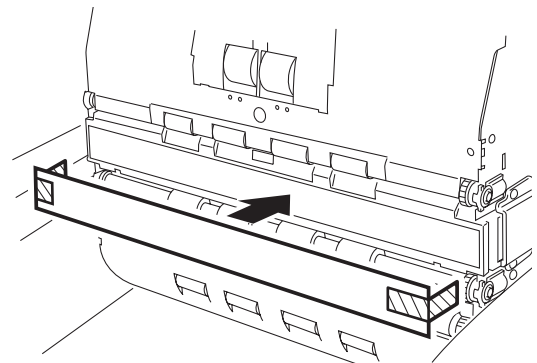

Figure 5-235

Note: The reading side must not be contaminated and the part where the paper is placed must be able to be cleaned later. If the white paper is located in a place whether it is caught by the roller section or detected by a registration sensor, data cannot be obtained.

- 3) Close the upper unit, select scan conditions, and then select [Scan].

4) Select [Read] and verify the waveform.

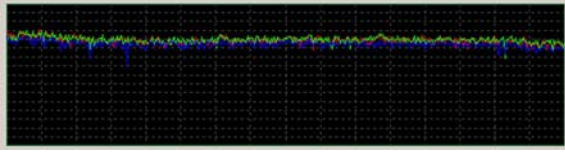

Figure 5-236

Since the white paper is scanned, a waveform is displayed at the upper part of the display section. If it is displayed lower than that, it is incorrect.

Waveforms in grayscale and color modes when there is a dark stain on the reading glass are shown below.

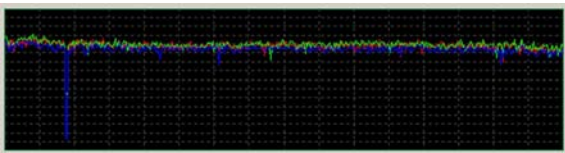
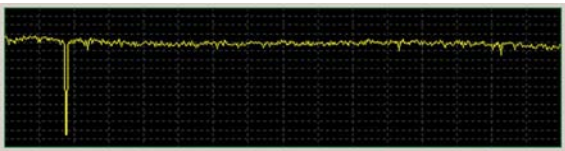

Figure 5-237

◆ Waveform 3

This is a general waveform when [Shading] is selected.



Figure 5-238

Since the white reference is scanned, a waveform is displayed at the upper part of the display section. If it is displayed at a lower position, it is incorrect.

3. ImgFrame

The outside frame of a fed document is detected, displayed and saved in this mode. How document frame detection, which is a basic function for auto-size detection and des skew, is performed can be verified.

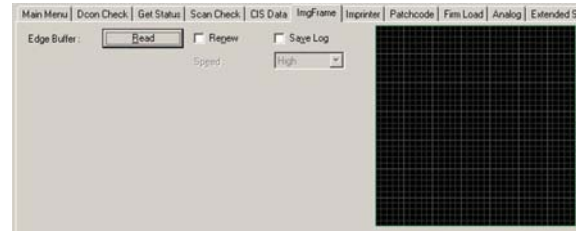

Figure 5-239

◆ Operation procedure

- 1) When [Renew] is selected, [Speed] becomes effective, so select [High] or [Low].

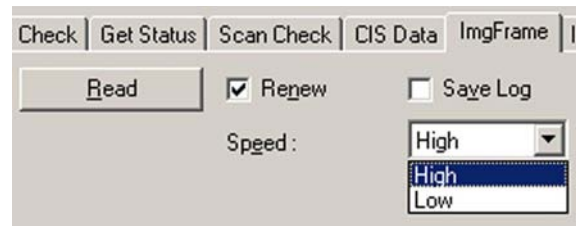

Figure 5-240

- 2) Set a sheet of paper on the pickup tray and select the [Read].
- 3) The paper is automatically fed and ejected onto the eject tray.

- 4) Data of the outside frame of the paper is saved in memory in the main body and is displayed in the display section. The area enclosed by a red line and a blue line shows the outside frame of the paper. One scale is 10 mm.

The display at the time of skewing is shown below.

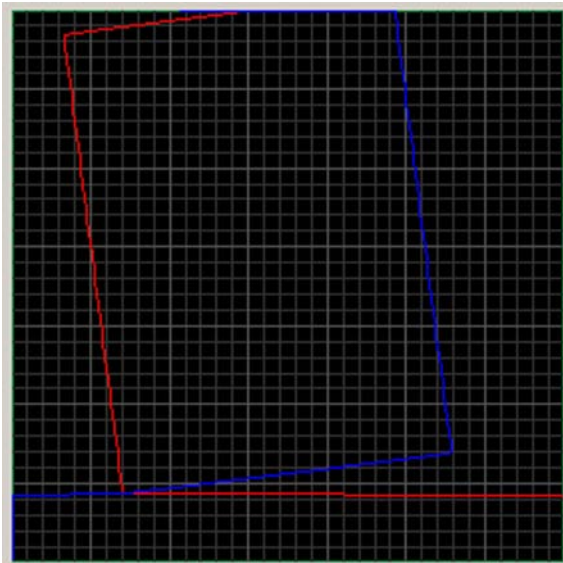

Figure 5-241

Note:When [Renew] is not selected, but the [Read] button is selected, the outside frame that was previously saved in memory in the main body is displayed.

Note:When [Save Log] is selected, outside frame data can be saved in a computer. However, saved data cannot be used in the field. This function is used only if an instruction for analysis is given.

F. Extended Setting

1. Regist Manual Adjustment

The registration initial value that has already been determined is fine-adjusted in this mode.

It is used to change the position of an image that is scanned with the initial value. However, it does not reduce variations in the leading edge position.

Note:This mode changes the timing of the reading start position. If auto-size detection or deskew is selected, the leading edge cannot be adjusted in this mode to take a document size from an image read with a margin.

◆ Operation procedure

- 1) Verify the scan image with the initial value and determine adjustment direction and its amount.

Here perform the following operation: move the front image with the initial value upward by 2 mm, i.e., delay the reading start time by the time for 2 mm.

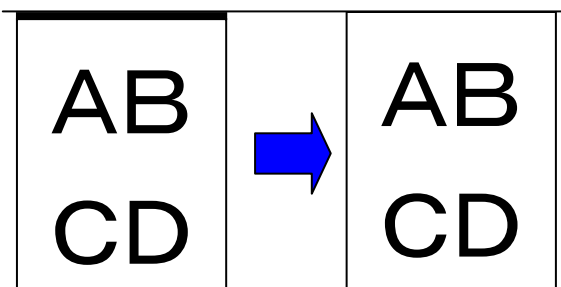

Figure 5-242

- 2) Change the value in the input box on the reading surface side to be adjusted with arrow keys. Be sure to select [Set] after change.

The value on the front side is set to “2.0” here.

Note:The input range is ± 5.0 and the unit is mm. The initial value is “0.0 mm”. If it is changed to a plus side, the image moves up and if it is changed to a minus side, it moves down.

Since the trailing edge (displayed as [Bottom] on the screen) is interlocked with the leading edge, only one of them cannot be changed independently.

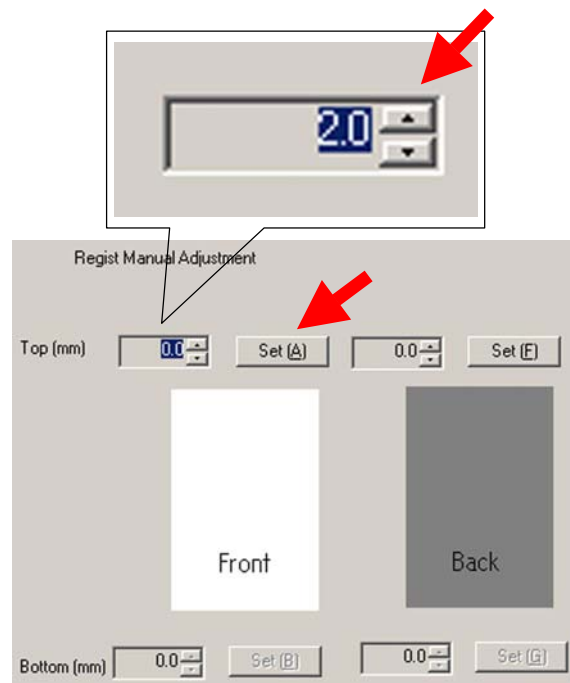

Figure 5-243

- 3) Scan the document actually and verify that the position is changed. It can be verified by using “Scan” in the service mode.

2. Key Lock

This mode disables the operation of keys on the operation panel. Do this only if the user requests to prevent operator mistakes.

Select keys to be disabled. When a key is selected, it is recessed and its color becomes a little brighter. The [Menu] key is selected in the figure below.

If the key is selected again, it is cancelled.

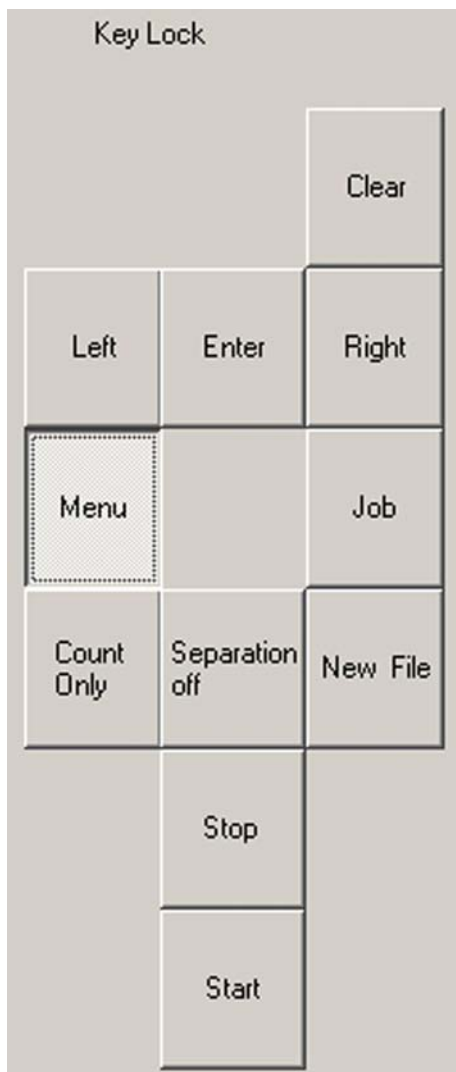

Figure 5-244

G. Firmware Change

Note:For the change of the firmware, also refer to the service information that is issued individually.

1. Firmware registration

In this mode the scanner firmware is saved in a service computer so that the firmware can be changed correctly. However, only the controller firmware can be changed, and the main drive and sub-drive firmware necessary for this machine cannot be changed.

◆ Operation procedure

- 1) Select [Firm Registration] on the initial screen.



Figure 5-245

- 2) Only if it is not registered, the following screen is displayed. Select [OK].



Figure 5-246

- 3) The firmware registration screen is displayed. Select [Register].



Figure 5-247

- 4) The file selection screen is displayed.
Select a file.

Note:The file format is “mot” as before, but only the one that suits the integrated tool can be used. The file name can be changed freely.



Figure 5-248

- 5) The firmware is registered automatically.
The “Product Name” and “Firmware version” are displayed on the firmware registration screen.

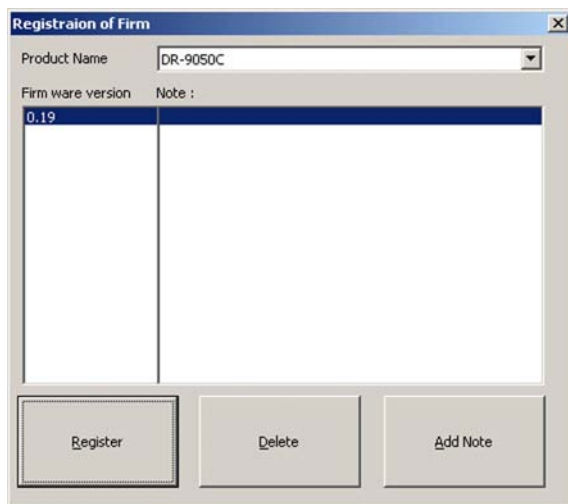

Figure 5-249

Note:For this machine, three types of firmware (DR-9050C/7550C/6050C) are registered when one mot file is registered.

Note:The registered firmware is saved together in a service tools folder. Since

information, such as product name and version number, is written in the mot file, a folder name is determined accordingly. The ini file in which setting conditions are stored is also saved at the same time. A folder and its tree are shown below.

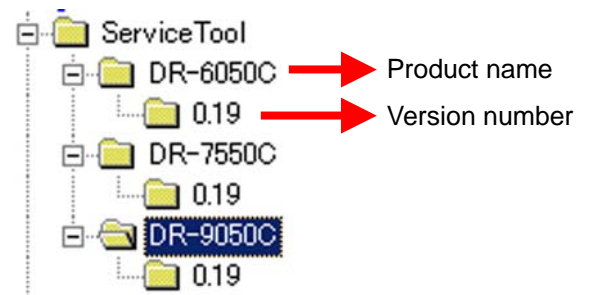
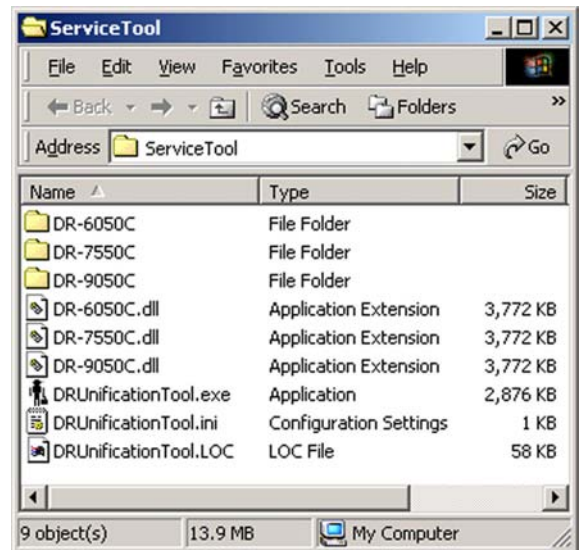

Figure 5-250

6) If necessary, select [Add Note] and enter appropriate information.

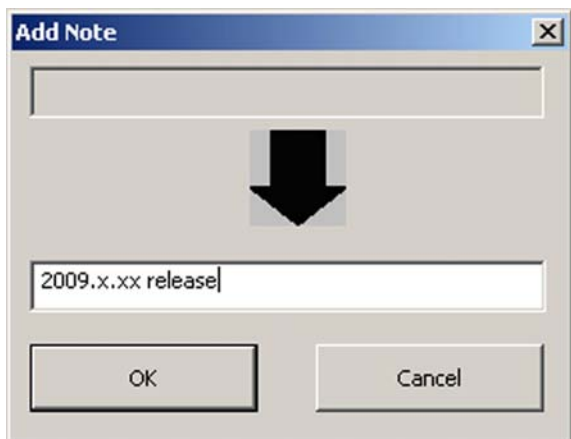

Figure 5-251

Note: To delete a version from the registration screen, select a desired version and select [Delete]. However, it is not deleted from the folder.

2. Controller Firmware Loading

The method of writing controller firmware is different whether the firmware has been registered or not. The operation procedure is shown below.

◆ Registered firmware

1) Select a version to be written and select [Firm Load].

Note: Only the firmware for the connected scanner is displayed.

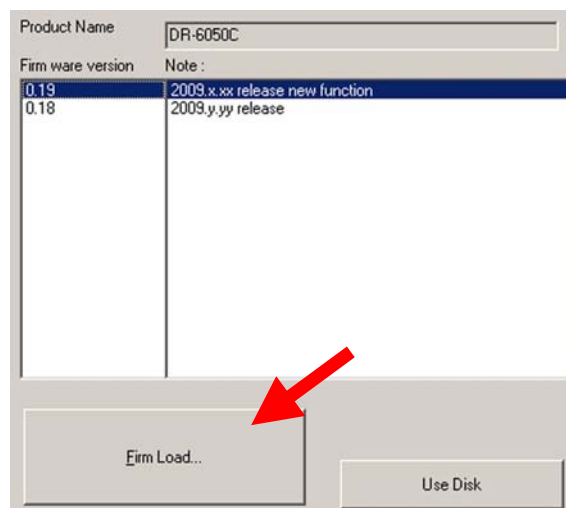

Figure 5-252

2) A caution screen is displayed. Select [OK].



Figure 5-253

- 3) Writing begins automatically and a progress screen is displayed.

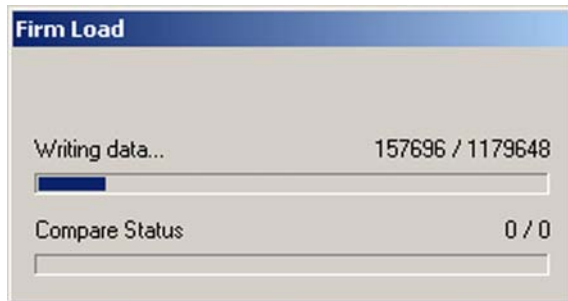

Figure 5-254

- 4) When it is finished, the progress screen disappears.
- 5) End the service mode and reset the scanner power supply.
- 6) Start the service mode again and check the version number on "Get Status".

◆ Unregistered firmware

- 1) Select [Use Disc].

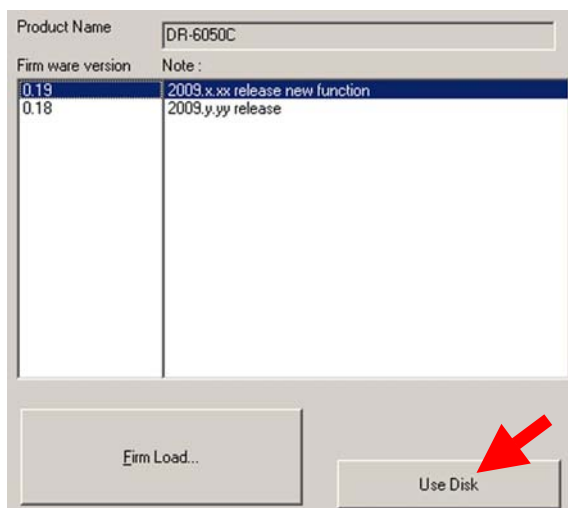

Figure 5-255

- 2) The file selection screen is displayed. Select a file.

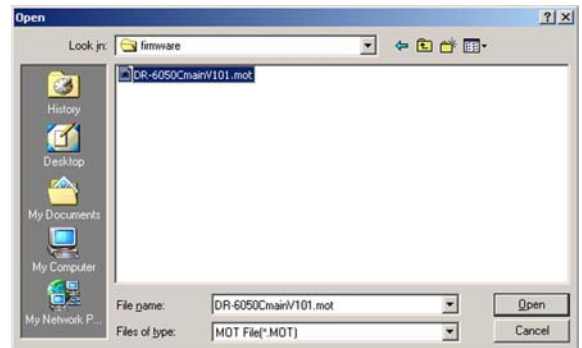

Figure 5-256

- 3) Writing begins automatically and a progress screen is displayed.

Note: Whether the file is the one for the connected scanner is detected automatically, and if it is correct, writing is performed.

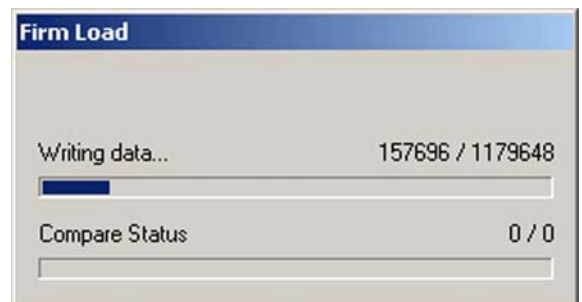

Figure 5-257

- 4) When it is finished, the progress screen disappears. The subsequent procedure is the same as the procedure for "Registered firmware".

3. Drive Firmware Loading

Since there is no drive firmware registration function, save the firmware to be written in a computer.

The operation procedure for the main drive is the same as that for the sub-drive, but buttons to be selected are different.

◆ Operation procedure

- 1) Select [Load] corresponding to the main drive or sub-drive.

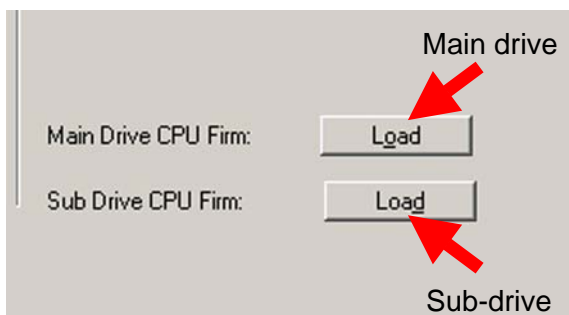

Figure 5-258

- 2) The file selection screen is displayed. Select a file.

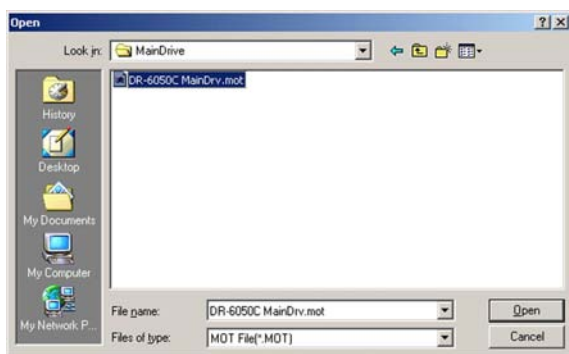

Figure 5-259

- 3) Writing begins automatically and the progress screen is displayed.

Note: Whether the file is the one for the connected scanner is detected automatically, and only if it is correct, writing is performed.

- 4) When it is finished, the progress screen disappears. The subsequent procedure is the same as the procedure for “Controller firmware”.

H. Others

1. Imprinter

The operation check of the imprinter is performed in this mode. If the imprinter is not connected, the screen is not displayed.

If normal operation is verified, however, it is easier to do so by using "Imprinter Test" in the user mode.



Figure 5-260

Since this machine is a post-type imprinter, the display on the pre-type side is grayed out.

◆ Flush (Ink ejection verification)

The ink is ejected in this mode. When [Start] is selected, ink is ejected. Set a sheet of paper and then eject ink.

Note: The position where a sheet of paper is set must cover an ink ejection part and a registration sensor part to generate a paper jam error. If a paper jam error is not generated, the paper is ejected when the upper unit is closed.

◆ Status

Check the state of the imprinter. The mark of each item lights according to its state. "Head" lights in the table below.

Mark	Sensor name/lighting state
Busy	Busy Lights during normal operation. It can be verified when the machine operates in the user mode.
Head	Head Lights when the ink cartridge is installed.
Vol Err	Voltage error Lights when the applied voltage is abnormal.
Com. Error	Communication error Lights when a data communication error occurs or the PCB is defective.

Table 5-204

2. Patchcode

The operation check of the patchcode decoder is performed in this mode.



Figure 5-261

◆ Operation procedure

- 1) Set a sheet of paper on which a patchcode is printed on the pickup tray. The patchcode should be on the top surface.
- 2) Select setting items of [Speed] and [Orientation] from the pulldown boxes.
Speed: High/Low
Orientation: 0/90/180/270 Deg.
- 3) Select the [START]. The pickup tray lifts and the paper is fed and ejected onto the eject tray.
- 4) The result is displayed.



Figure 5-262

Note: Print a patchcode in the effective range (within 100 mm from the leading edge). Refer to the “User Manual” for details.

3. Analog Sensor

This mode is used to check analog data for sensors. However, the operation check of normal sensors is performed in the [Dcon Check].

Selection of sensors is performed from the pull-down box. When a sensor enters detection state, a “red circle” on the left side lights.



Figure 5-263

4. Application Information

This mode is used to check the detailed version of the software (EXE file) for this service mode.

After selecting [Help] on the tool bar on the top of screen, select [Application Information].



Figure 5-264

5. Simulation Mode

This mode is used if the service engineer learns about the service mode when the scanner is not connected.

◆ Operation procedure

- 1) Enter 8 characters “training” as a password.
- 2) The screen is the same as the actual one and buttons other than the ones that are grayed out can be operated as usual.

Note: However, operations that need communication with the scanner are not carried out.

III. LIST OF FAILURES

The lists below give the major failures conditions and their causes. Refer to the next section for details of the causes and the measures to be taken.

1. Operation Failures

Note: Major causes of each failure are marked "X."

No.	Cause Failure	System/ Software	Hard- ware	Connec- tion	Dirt	Docu- ment	Setting
1	No power is supplied		X	X			
2	Scanner is not recognized	X		X			
3	Scanning does not start	X	X	X			X
4	Documents are not fed properly		X		X	X	
5	Scanning speed is low	X					X

Table 5-301

2. Images Failures

Note: Major causes of each failure are marked "X."

No.	Cause Failure	System/ Software	Hard- ware	Connec- tion	Dirt	Docu- ment	Setting
1	Completely black, completely white, all streaks		X	X	X		X
2	Too dark, too light				X		X
3	Black borders around image					X	X
4	Image skews					X	X
5	Streaks on image		X		X		
6	Moire on image					X	X
7	Outer areas of image disappear					X	X
8	Text invisible					X	X

Table 5-302

IV. OPERATION TROUBLESHOOTING

When an operation failure occurs, first check for an “Error Message” displayed on this machine and computer. In addition, check the operation of the various sensors, motors using the “Service Mode.”

1. No Power Is Supplied

This machine display panel does not light.

Cause/faulty location	Step	Check item	Result	Action
AC power supply voltage	1	Is the specified voltage being supplied at the outlet?	NO	Explain to the user that the trouble is not with this machine.
Connection of power cord	2	Is the power cord connected?	NO	Connect it properly.
Power cord	3	Is the problem solved when the power cord is replaced?	YES	End.
DC power supply	4	Does the LED on the control PCB light when the power switch is turned ON?	YES	The power is supplied. Check the step 5.
			NO	Check the step 6 or later.
Operation PCB	5	Is the cable connected to the PCB?	YES	Replace the operation panel.
			NO	Connect it properly.
Power switch mechanical section	6	Does the power switch of the power supply PCB operate when the power switch button is pressed on the front?	NO	Attach the parts properly.
Power supply PCB Control PCB	7	Are the cables properly connected to the PCB?	NO	Connect it properly.
	8	Is the problem solved when these PCBs are replaced?	YES	End.

Table 5-401

2. Scanner Is Not Recognized

Note: Install the driver in the computer before connecting the scanner.

Cause/faulty location	Step	Check item	Result	Action
Power supply	1	Is the power supplied to this machine?	NO	Perform the section 1: "No Power Is Supplied".
Connection of interface cable	2	Is the interface cable properly connected?	NO	Connect it properly.
Power-on sequence (SCSI connection)	3	Was the power to this machine turned ON before the computer was turned ON?	NO	Follow the proper power-on sequence.
SCSI ID settings	4	Is the SCSI ID set properly?	NO	Set them properly.
Computer, interface card	5	Are the computer and interface card set properly?	NO	Use them properly.

Table 5-402

3. Scanning Does Not Start

Note: Scanning may not start when a "cover open" or "no document" error message is displayed due to a sensor problem.

Cause/faulty location	Step	Check item	Result	Action
System	1	Is the problem solved when the scanner and computer are reset?	YES	End.
Software	2	Is the problem solved when the scanner driver and the application are reinstalled?	YES	End.
Connector connection	3	Are the motor and sensor connectors connected properly?	NO	Connect them properly.
Drive transmission system	4	Is the transmission system driven by the motor normal? Are such parts as gears and belts normal?	NO	Attach the parts properly. Replace needed parts.
Motor, solenoid	5	Is the operation normal when checking the operation in the service mode?	NO	Check the cable connections. Replace needed parts.
Sensor	6	Is the operation normal when checking the operation in the service mode?	NO	Check the attachment of the sensor, light guide and lever. Check the cable connections for the sensor.
Main drive PCB Sub-drive PCB Control PCB	7	Is the problem solved when these PCBs are replaced?	YES	End.

Table 5-403

4. Documents Are Not Fed Properly

Note: If a sensor failure occurs an error message such as “paper jam” or “double feed” may be shown.

Cause/faulty location	Step	Check item	Result	Action
Document	1	Is the document within the specifications (thickness, dimensions, fold, curl, etc.)?	NO	Ask the user to use documents within the specifications.
Document setting	2	Are the documents stuck together?	YES	Fan the stack of documents well.
	3	Are the document guides adjusted properly?	NO	Adjust them in a correct position.
Roller	4	Is the roller properly mounted?	NO	Mount it properly.
	5	Is it dirty or deformed?	NO	Clean or replace it.
Parts in feed path	6	Are all parts that the documents contact properly mounted (not loose or tilted)?	NO	Mount them properly.
	7	Is the surface in contact with the document smooth (not scratched, no burrs)?	NO	Replace faulty parts.
Drive transmission system	8	Is any abnormal noise emitted when feeding documents? Are any gears broken or is the belt loose?	YES	Mount the parts properly. Replace faulty parts.
Motor, solenoid	9	Is the operation normal when checking the operation in the service mode?	NO	Check the cable connections. Replace needed parts.
Sensor	10	Is the operation normal when checking the operation in the service mode?	NO	Check the attachment of the sensor, light guide and lever. Check the cable connections for the sensor. Replace needed parts.
Main drive PCB Sub-drive PCB Eject PCB Control PCB	11	Is the problem solved when these PCBs are replaced?	YES	End.

Table 5-404

5. Scanning Speed Is Slow

Selecting higher resolutions, color setting and/or special functions may make the scanning speed slower. Should the scanning speed be too slow after taking all of these considerations, the possible causes are as listed below.

Cause/Faulty location	Step	Check item	Result	Action
Insufficient memory capacity in computer	1	Is memory capacity sufficient?	NO	Add the memory capacity.
	2	Is any other application started up?	YES	Close other applications.
	3	Is any resident application started up such as a virus protection application?	YES	Close resident applications.
	4	Is the hard disk short of empty capacity?	YES	Increase empty capacity of the hard disk.
Hi-Speed USB2.0 is not supported (when USB is used)	5	Is the USB port supported?	NO	Use a supported computer.
	6	Is the USB cable supported?	NO	Use a included USB cable.
	7	Is the USB hub supported?	NO	Use a supported USB hub.
SCSI-3 is not supported (when SCSI is used)	8	Is the SCSI card supported?	NO	Use a supported SCSI card.
	9	Is the SCSI cable supported?	NO	Use a supported SCSI cable.

Table 5-405

V. IMAGE TROUBLESHOOTING

◆ Image Samples

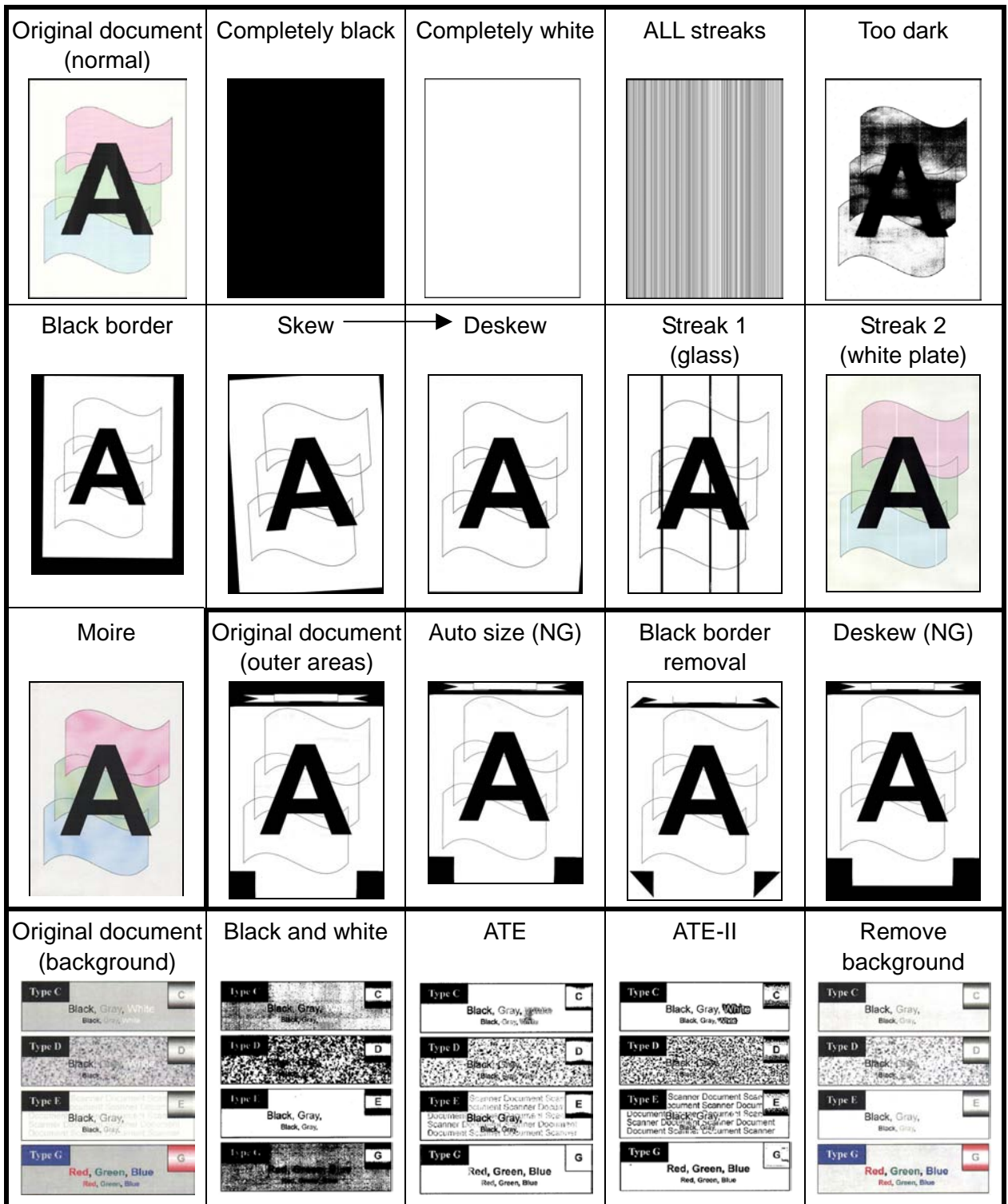

Figure 5-501

Note: There are times when, depending on the type of image and settings, document reproducibility becomes poor. In such case, the image may be improved by changing the settings.

1. Completely Black, Completely White, All Streaks

Completely Black, Completely White, or All Streaks are output.

Cause/faulty location	Step	Check item	Result	Action
"Brightness" setting	1	Is the "Brightness" setting appropriate?	NO	Change the setting. Also change "Contrast" if necessary.
System	2	Is the problem solved when the scanner power is reset and the computer is re-started?	YES	End.
Reading unit	3	Are the reading related cables connected properly?	NO	Connect them properly.
	4	Is the problem solved when the reading unit is replaced?	YES	End.
Control PCB	5	Is the problem solved when the control PCB is replaced?	YES	End.

Table 5-502

2. Too Dark, Too Light

Image does not look appropriate due to improper brightness.

Cause/faulty location	Step	Check item	Result	Action
"Brightness" setting	1	Is the "Brightness" properly set? The brightness should be set to "128" in normal case but may be required to change according to the type of document.	NO	Change the setting.
"Contrast" setting	2	Is the "Contrast" properly set? The default setting is "4".	NO	Change the setting.

Table 5-503

3. Black Borders Around Image

Black borders appear around the images.

Note, however, that borders having a thickness of about 1 mm are within the specifications, so they are not a failure.

Cause/faulty location	Step	Check item	Result	Action
"Page Size" setting	1	Is the "Page Size" properly set?	NO	Change the setting.
Document setting	2	Is the document set at the correct position?	NO	Set the document at the correct position.
Setting of "Auto-detection" for page size or "Border Removal"	3	Is "Auto-detection" or "Border Removal" set?	NO	Set the function. Black border can be removed by image processing.

Table 5-504

4. Image Skews

If the document skews when fed, the scanned image also skews.

Cause/faulty location	Step	Check item	Result	Action
Document setting	1	Is the document properly set?	NO	Properly set the document.
Document feeding	2	Is the document fed straight?	NO	Carry out check items listed in "IV. OPERATION TROUBLESHOOTING, 4. Documents Are Not Fed Properly."
"Deskew" setting	3	Is the "Deskew" set?	NO	Set the function. Slant can be corrected by image processing.

Table 5-505

5. Streaks on Image

If the reading glass surface is dirty, streaks appear on the scanned images in the feed direction. Dirt on the rollers may also be transferred to the documents.

On the other hand, white streaks appearing on the scanned images are caused by the execution of the shading correction while the reading unit is dirty.

Cause/faulty location	Step	Check item	Result	Action
Reading glasses	1	Are the reading glasses clean?	NO	Clean the reading glasses. Replace the reading glass if scratches are found.
Roller	2	Are the surfaces clean?	NO	Clean or replace the roller.
Feed path	3	Is the feed path clean?	NO	Clean the feed path.
Reading unit inside	4	Is the reading unit inside clean?	NO	Clean or replace the reading unit.

Table 5-506

6. Moire on Image

Moire is likely to appear when a photograph is color scanned with a low resolution from a magazine or a catalog.

Cause/faulty location	Step	Check item	Result	Action
"Moire Reduction" setting	1	Is the "Moire Reduction" set?	NO	Set the function.
			YES	Heighten the resolution.

Table 5-507

7. Outer Areas of Image Disappear

When scanning a document with black or deep color outer areas, selecting the "Auto-detection," the "Deskew" or the "Border Removal" may cause the outer areas to disappear from the scanned image.

Cause/faulty location	Step	Check item	Result	Action
Document	1	Is there any black or deep color on the document outer areas?	YES	Disable the functions such as the "Auto-detection".

Table 5-508

8. Text Invisible

When the background includes colors or patterns, text may be hidden by the background when scanning in black and white mode. A special mode called “ATE: Advanced Text Enhancement” exists to solve this problem.

Note: The problem may not be fixed, depending on the type of document.

Cause/faulty location	Step	Check item	Result	Action
“Mode” setting	1	Is the problem solved when the “Color” or “Grayscale” is set?	YES	End.
	2	Is the problem solved when a special mode such as the “Advanced Text Enhancement” is set?	YES	End.
“Brightness” setting	3	Is the problem solved when the “Brightness” setting is changed?	YES	End.

Table 5-509

VI. AFTER REPLACING PARTS

Some of the parts used in this machine require adjustments and settings after being replaced or disassembled/reassembled. The related parts are shown below.

Check document feed and images after the replacement or disassembly/reassembly of the parts.

1) Control PCB

Perform "All Adjustment" in the service mode. Change the value for "Counter" and enter a serial number for "Get Status".

2) Reading unit

Perform "All Adjustment" in the service mode.

3) Registration-related parts

When replacing or reassembling the ultrasonic sensor PCB and ultrasonic drive PCB on which a registration sensor is built, perform "Regist Adjustment" in the service mode.

4) Consumable parts (servicing)

When consumable parts, such as registration rollers and platen rollers, which are replaced by the service technician, are replaced, set the number of sheets fed during replacement by the "Counter" in the service mode.

5) Pickup solenoid

The position adjustment is necessary.

Refer to "CHAPTER 3 DISASSEMBLY & REASSEMBLY, III-5. Pickup Solenoid,

◆Notes on assembling".

6) Pickup sensor

When the pickup sensor is not properly installed, the pickup motion and feeding are not performed correctly.

Therefore, the adjustment of the pickup sensor position is required not only after replacing parts, but also when a malfunction occurs after changing the position of the pickup sensor.

◆ Operation check

Select "Dcon Check" in the service mode and keep the operating condition of the pickup sensor visible. If the pickup sensor lights when the pickup tray is not lifted or if the sensor does not light when the pickup tray is at the top position, position adjustment is necessary.

◆ Assembly verification

Verify that the pickup sensor and sensor mounting plate have been assembled correctly before position adjustment. Verify that the sensor cable is connected and that a positioning boss is inserted in the hole in the mounting plate.

◆ Adjustment procedure

- i) Remove the eject tray unit and upper front cover.
- ii) Loosen the fixing screw ①, rotate the adjusting screw ② and after moving the sensor mounting plate ③ on which the pickup sensor is mounted a little back and forth, fix the plate.

Note: The positioning boss ④ must be inserted into the hole in the sensor mounting plate.

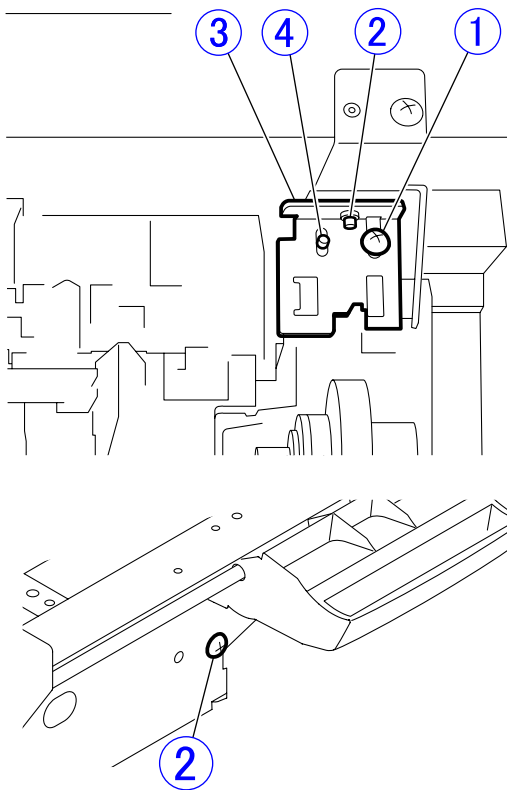

Figure 5-601

- iii) While feeding a sheet of paper, check the sensor and the feeding operation. If it is not corrected, retry the previous procedure.
- iv) If it is corrected, replace covers and check the operation again.

APPENDIX

I.	GENERAL DIAGRAM	A-1
----	-----------------------	-----

Prepared by

**Quality Assurance Center
Canon Electronics Inc.**

**3-17-7 Shibaura, Minato-ku
Tokyo 108-0023, Japan**

FIRST EDITION: FEB. 2009 (63999)

Canon

0209TG

WWW.SERVICE-MANUAL.NET