

Color imageCLASS MF820Cdn MF810Cdn

PARTS CATALOG



Canon

**November 19, 2014
Rev. 0**

PREFACE

This Parts Catalog contains listings of parts used

Diagrams are provided with the listings to aid the service technician in identifying clearly, the item to be ordered.

Whenever ordering parts, consult this Parts Catalog for all of the information pertaining to each item. Be sure to include, in the Parts Request, the full item description, the item part number, and the quantity.

COPYRIGHT (C) 1999 CANON INC.

Use of this manual should be strictly supervised to avoid disclosure of confidential information.

Contents

NUMERICAL INDEX

imageRUNNER C1225iF/C1225/imageCLASS MF820Cdn/ MF810Cdn(Numerical Index).....	1-1
--	-----

imageRUNNER C1225iF/C1225/imageCLASS MF820Cdn/ MF810Cdn(Parts Catalog)

A1	ASSEMBLY LOCATION DIAGRAM	2-1
A2	OPTION PARTS CATALOG LIST	2-6
001	ACCESSORIES	2-7
100	EXTERNAL COVERS, PANELS, ETC.	2-9
101	DOOR ASSEMBLY, FRONT	2-11
102	DOOR ASSEMBLY, RIGHT	2-13
103	INTERNAL COMPONENTS 1	2-18
104	INTERNAL COMPONENTS 2	2-20
105	INTERNAL COMPONENTS 3	2-22
106	INTERNAL COMPONENTS 4	2-24
107	INTERNAL COMPONENTS 5	2-26
108	MACHINE REAR PLATE 1	2-28
109	MACHINE REAR PLATE 2	2-30
130	CONTROL PANEL ASSEMBLY	2-32
190	CARTRIDGE AIR INTAKE FAN ASS'Y	2-34
191	DELIVERY COOLING FAN ASSEMBLY	2-35
192	DRIVE COOLING FAN ASS'Y	2-36
250	MAIN DRIVE ASSEMBLY	2-37
260	PAPER PICK-UP DRIVE ASSEMBLY	2-38
270	BOTTLE DRIVE ASSEMBLY	2-39
280	FIXING DRIVE ASSEMBLY	2-40
290	PICK-UP LIFTER DRIVE ASS'Y	2-41
300	CASSETTE	2-42
310	REGIST./PAPER PICK-UP ASS'Y	2-45
330	MULTI FEED TRAY ASSEMBLY	2-48
331	MULTI FEED PAPER PICK-UP ASS'Y	2-50
332	DUPLEXING GUIDE ASSEMBLY	2-52
350	PAPER DELIVERY/REVERSE ASS'Y	2-53
460	LASER SCANNER ASSEMBLY	2-56
530	INTER. TRANSFER BELT ASS'Y	2-57
621	BOTTLE MOUNT ASSEMBLY	2-58
622	HOPPER ASSEMBLY	2-59
771	INTERNAL COVER ASSEMBLY	2-60

Contents

810	FIXING ASSEMBLY, FX-201	2-61
900	CONTROLLER BOX ASSEMBLY	2-63
910	POWER SUPPLY ASSEMBLY	2-65
930	DC CONTROLLER PCB ASSEMBLY	2-66
B01	ADF MAINTENANCE KIT	2-67
B10	READER/ADF ASSEMBLY	2-68
B11	AUTO DOCUMENT FEEDER ASSEMBLY	2-70
B12	FEEDER COVER ASSEMBLY	2-75
B13	PAPER FEED DRIVE ASSEMBLY	2-77
D10	READER ASSEMBLY	2-79
T20	FAX ASSEMBLY (FAX model)	2-82
T21	SPEAKER (FAX model)	2-84
ZZA	MECHANICAL STANDARD PARTS (HOW TO USE)	2-85
ZZB	MECHANICAL STANDARD PARTS (SCREWS)	2-86
ZZC	MECHANICAL STANDARD PARTS (BOLTS)	2-93
ZZD	MECHANICAL STANDARD PARTS (NUTS)	2-94
ZZE	MECHANICAL STANDARD PARTS (RETAINING RINGS)	2-95

NUMERICAL INDEX

PARTS NUMBER	FIGURE & KEY NO.	PARTS NUMBER	FIGURE & KEY NO.	PARTS NUMBER	FIGURE & KEY NO.
FC0-5544-000	B10 - 2	FC0-6968-000	310 - 3	FE3-1617-000	310 - 14
FC0-5550-000	D10 - 8	FC0-6979-000	310 - 4	FE3-1618-000	310 - 15
FC0-5552-000	D10 - 17	FC0-7048-000	106 - 1	FE3-1641-010	102 - 14
FC0-5553-000	D10 - 9	FC0-7068-000	105 - 9	FE3-1642-000	331 - 4
FC0-5554-000	D10 - 10	FC0-7121-000	100 - 21	FE3-1745-000	130 - 10
FC0-5555-000	D10 - 11	FC0-7172-000	103 - 2	FE3-1746-000	130 - 11
FC0-5574-000	B11 - 57	FC0-7174-000	310 - 5	FE3-1748-000	130 - 13
FC0-5587-000	B11 - 1	FC0-7188-000	105 - 1	FE3-1760-000	102 - 15
FC0-5588-000	B11 - 2	FC0-7204-000	310 - 6	FE3-2409-000	102 - 16
FC0-5589-000	B11 - 3	FC0-7205-000	310 - 7	FE3-3585-000	102 - 17
FC0-5591-000	B11 - 4	FC0-7211-000	310 - 8	FE3-3589-010	331 - 5
FC0-5622-000	B13 - 1	FC0-7218-000	310 - 9	FE3-3594-000	102 - 18
FC0-5623-000	B13 - 2	FC0-7446-000	102 - 9	FE3-3744-000	350 - 9
FC0-5629-000	B11 - 6	FC0-7447-000	331 - 2	FE3-3745-000	350 - 10
FC0-5634-000	B11 - 7	FC0-7535-000	102 - 10	FE3-3935-000	310 - 50
FC0-5650-000	D10 - 14	FC0-7536-000	102 - 11	FE3-3950-000	300 - 6
FC0-5801-000	103 - 12	FC0-7572-000	101 - 2	FE3-4041-000	290 - 1
FC0-5846-010	101 - 7	FC0-7589-000	771 - 2	FE3-4476-000	300 - 7
FC0-5848-000	102 - 40	FC0-7660-000	300 - 27	FE3-4477-000	107 - 6
FC0-5861-000	102 - 41	FC0-7661-000	300 - 1	FE3-4759-000	102 - 19
FC0-5862-000	102 - 42	FC0-7662-000	300 - 2	FE3-4760-000	102 - 20
FC0-5875-000	102 - 1	FC0-7670-000	310 - 10	FE3-4761-000	102 - 21
FC0-5876-000	102 - 2	FC0-7698-000	350 - 7	FE3-4762-000	102 - 22
FC0-5876-000	310 - 1	FC0-7699-000	350 - 8	FE3-4764-000	102 - 23
FC0-5876-000	332 - 1	FC0-7728-000	105 - 3	FE3-4765-000	102 - 24
FC0-5876-000	350 - 1	FC0-7734-000	101 - 3	FE3-4860-000	310 - 17
FC0-5880-000	350 - 2	FC0-7807-000	101 - 12	FE3-4860-000	331 - 10
FC0-5886-000	332 - 2	FC0-7827-000	350 - 32	FE3-4861-000	310 - 18
FC0-5888-000	102 - 3	FC0-7828-000	350 - 31	FE3-5614-000	310 - 19
FC0-5888-000	310 - 2	FC0-7830-000	300 - 16	FE3-5650-000	330 - 4
FC0-5888-000	332 - 2	FC0-7832-000	300 - 15	FE3-5651-000	330 - 5
FC0-5891-000	350 - 3	FC6-1353-000	310 - 11	FE3-5654-000	102 - 32
FC0-5892-000	350 - 4	FC6-3002-000	310 - 51	FE3-5739-000	350 - 11
FC0-5912-000	106 - 4	FC6-4513-000	100 - 8	FE3-5740-000	350 - 12
FC0-5918-000	106 - 8	FC7-6052-010	B11 - 9	FE3-6111-000	350 - 13
FC0-5929-000	106 - 6	FC7-6108-000	350 - 34	FE3-6112-000	310 - 20
FC0-5935-000	102 - 4	FC7-6189-000	B12 - 2	FE3-6113-000	310 - 21
FC0-5942-000	106 - 2	FC7-6303-000	B11 - 11	FE3-6114-000	310 - 22
FC0-5943-000	102 - 7	FC8-4990-000	300 - 3	FE3-6116-000	102 - 26
FC0-5972-000	771 - 1	FC9-8607-000	105 - 7	FE3-6117-000	102 - 27
FC0-6079-000	810 - 2	FE2-1544-000	130 - 3	FE3-6119-000	310 - 23
FC0-6086-000	810 - 3	FE2-1584-000	130 - 5	FE3-6143-000	300 - 8
FC0-6088-000	810 - 4	FE2-2086-000	103 - 5	FE3-6357-000	300 - 21
FC0-6089-000	810 - 11	FE3-0387-000	331 - 3	FE3-6504-000	B11 - 12
FC0-6092-000	810 - 5	FE3-0389-000	102 - 71	FE3-6570-000	D10 - 10
FC0-6102-000	350 - 6	FE3-0481-000	300 - 28	FE3-6571-000	D10 - 10
FC0-6131-000	810 - 6	FE3-1527-000	300 - 4	FE3-7412-000	300 - 34
FC0-6156-000	810 - 7	FE3-1528-000	300 - 5	FE3-7698-000	B11 - 58
FC0-6157-000	810 - 8	FE3-1547-000	102 - 12	FE3-7699-000	B11 - 59
FC0-6502-000	105 - 10	FE3-1585-000	310 - 12	FE3-7699-000	B12 - 6
FC0-6614-000	102 - 70	FE3-1602-000	310 - 13	FE3-8153-000	300 - 35
FC0-6637-000	331 - 1	FE3-1617-000	102 - 13	FE3-8290-000	B11 - 25

NUMERICAL INDEX

PARTS NUMBER	FIGURE & KEY NO.	PARTS NUMBER	FIGURE & KEY NO.	PARTS NUMBER	FIGURE & KEY NO
FE3-8294-000	100 - 14	FE3-9500-000	130 - 1	FK2-9571-000	001 - 12
FE3-8295-000	100 - 20	FE3-9501-000	300 - 23	FK2-9904-000	001 - 11
FE3-8296-000	100 - 20	FE3-9527-000	130 - 9	FK3-1800-000	900 - IC
FE3-8297-000	B12 - 10	FE3-9549-000	130 - 12	FK3-2024-000	B13 - 4
FE3-8298-000	B11 - 60	FE3-9550-000	130 - 9	FK3-3034-000	900 - IC
FE3-8298-000	B12 - 7	FE3-9591-000	300 - 24	FK3-3035-000	D10 - 18
FE3-8380-000	B11 - 34	FE3-9592-000	310 - 16	FK3-3038-000	D10 - 20
FE3-8381-000	B11 - 10	FE3-9593-000	310 - 46	FK4-0638-000	280 - 1
FE3-8383-000	B12 - 11	FE3-9943-000	103 - 19	FK4-0640-000	260 - 1
FE3-8409-000	106 - 9	FE4-0007-000	B11 - 36	FK4-0641-000	280 - 2
FE3-8410-000	350 - 30	FE4-0226-000	B11 - 56	FK4-0648-000	107 - 2
FE3-8411-000	350 - 33	FE4-0227-000	B11 - 55	FK4-0725-000	102 - 29
FE3-8427-000	100 - 9	FE4-0306-000	300 - 26	FK4-1636-000	103 - 24
FE3-8434-000	100 - 7	FE4-0678-000	130 - 18	FK4-1637-000	103 - 25
FE3-9076-000	106 - 5	FE4-1123-000	103 - 23	FK4-1736-000	930 - 2
FE3-9079-000	100 - 5	FE4-1402-000	B11 - 8	FK4-1821-000	001 - 2
FE3-9081-000	100 - 15	FE4-1425-000	300 - 29	FK4-1822-000	001 - 3
FE3-9082-000	100 - 16	FE4-1426-000	300 - 30	FK4-2811-000	001 - 1
FE3-9086-000	101 - 4	FE4-1427-000	300 - 31	FK4-2812-000	001 - 1
FE3-9087-000	100 - 6	FE4-1428-000	300 - 32	FK4-2814-000	001 - 1
FE3-9088-000	100 - 17	FE4-1500-000	300 - 33	FL0-0237-000	101 - 5
FE3-9089-000	100 - 22	FE4-1819-000	300 - 19	FL0-1007-000	100 - 25
FE3-9091-000	100 - 10	FE4-1822-000	103 - 17	FL0-1009-000	350 - 14
FE3-9093-000	102 - 5	FE4-1823-000	330 - 11	FL0-1010-000	102 - 25
FE3-9094-000	102 - 6	FE4-1824-000	330 - 10	FL0-1010-000	350 - 15
FE3-9097-000	102 - 8	FE4-1825-000	330 - 10	FL0-1011-000	102 - 30
FE3-9099-000	330 - 1	FE4-1826-000	330 - 10	FL0-1011-000	310 - 25
FE3-9100-000	330 - 3	FE4-1827-000	100 - 23	FL0-1104-000	B11 - 13
FE3-9101-000	330 - 2	FE4-1828-000	100 - 24	FL0-1105-000	B11 - 14
FE3-9132-000	100 - 19	FE4-3656-000	101 - 11	FL0-1361-000	102 - 31
FE3-9145-000	B12 - 8	FE4-3656-000	103 - 6	FL0-1515-000	310 - 48
FE3-9178-000	D10 - 4	FE4-5352-000	330 - 6	FL0-1543-000	250 - 1
FE3-9179-000	D10 - 5	FE4-5971-000	101 - 11	FL0-1544-000	250 - 2
FE3-9180-000	D10 - 6	FE4-5971-000	103 - 6	FL0-1570-000	310 - 26
FE3-9181-000	D10 - 7	FE4-5972-000	101 - 11	FL0-1674-000	310 - 47
FE3-9184-000	B10 - 1	FE4-5972-000	103 - 6	FL0-1674-000	331 - 11
FE3-9189-000	B12 - 1	FE4-5973-000	101 - 11	FL0-1833-000	350 - 16
FE3-9190-000	B11 - 5	FE4-5973-000	103 - 6	FL0-1834-000	310 - 24
FE3-9200-000	D10 - 3	FE4-5975-000	300 - 19	FL0-2013-000	B11 - 15
FE3-9201-000	D10 - 3	FE4-5976-000	300 - 34	FL0-2019-000	D10 - 24
FE3-9202-000	D10 - 3	FE4-5989-000	D10 - 2	FL0-2020-000	B11 - 16
FE3-9203-000	D10 - 3	FE4-5990-000	D10 - 3	FL0-2021-000	B11 - 17
FE3-9204-000	D10 - 3	FE4-8394-000	130 - 22	FL0-2564-000	B12 - 5
FE3-9205-000	D10 - 3	FK2-0360-000	910 - 1	FL0-2565-000	B12 - 9
FE3-9206-000	D10 - 3	FK2-0408-010	B13 - 3	FL0-2588-000	310 - 27
FE3-9207-000	D10 - 3	FK2-0472-010	102 - 28	FL0-2604-000	100 - 11
FE3-9436-000	300 - 22	FK2-2064-000	910 - 1	FL0-2605-000	100 - 13
FE3-9437-000	300 - 20	FK2-3679-000	190 - 1	FL0-2606-000	100 - 12
FE3-9461-000	350 - 5	FK2-3679-000	191 - 1	FL0-2905-000	130 - 6
FE3-9492-000	130 - 18	FK2-3679-000	192 - 1	FL0-3261-000	103 - 22
FE3-9494-000	130 - 4	FK2-5275-000	001 - 4	FL0-3422-000	130 - 8
FE3-9495-000	130 - 2	FK2-7852-000	900 - IC	FL0-3423-000	130 - 15

NUMERICAL INDEX

PARTS NUMBER	FIGURE & KEY NO.	PARTS NUMBER	FIGURE & KEY NO.	PARTS NUMBER	FIGURE & KEY NO
FL0-3424-000	130 - 16	FM0-0072-000	810 -	FM1-C985-000	B11 - 26
FL0-3763-000	104 - 7	FM0-0073-000	810 -	FM1-C986-000	B11 - 27
FL0-3766-000	102 - 72	FM0-0074-000	104 - 3	FM1-C987-000	D10 - 23
FL0-4342-000	D10 - 13	FM0-0075-000	103 - 16	FM1-D694-000	300 -
FL0-4391-000	101 - 1	FM0-0076-000	130 - 19	FM1-D695-000	102 -
FL0-5214-000	310 - 52	FM0-0077-000	130 - 20	FM1-D696-000	100 - 1
FL0-5332-000	100 - 18	FM0-0079-000	108 - 7	FM1-D697-000	100 - 2
FL0-6873-000	810 - 25	FM0-0080-000	810 - 9	FM1-D698-000	100 - 3
FL2-6637-000	B12 - 3	FM0-0144-000	460 - 4	FM1-D699-000	100 - 4
FL3-1430-000	B11 - 18	FM1-A153-010	530 -	FM1-D700-000	101 -
FL3-6308-000	B11 - 19	FM1-A225-000	103 - 8	FM1-D705-000	300 - 13
FL3-6309-000	B11 - 20	FM1-A226-000	260 -	FM1-D706-000	330 -
FL3-6311-000	B11 - 21	FM1-A802-000	810 - 10	FM1-D707-000	102 - 34
FL3-6313-000	B11 - 22	FM1-A811-000	107 - 4	FM1-D730-000	B11 -
FL3-6314-000	B11 - 23	FM1-A812-000	107 - 4	FM1-E004-000	130 -
FL3-6315-000	B11 - 61	FM1-A819-000	192 - 2	FM1-E005-000	130 -
FL3-6317-000	D10 - 25	FM1-A820-000	109 - 15	FM1-E363-000	910 -
FL3-6320-000	B11 - 24	FM1-A823-000	460 - 2	FM1-E364-000	910 -
FL3-6443-000	102 - 33	FM1-A825-000	102 - 68	FM1-F007-000	B11 - 28
FL3-6443-000	332 - 4	FM1-A827-000	102 - 69	FM1-F008-000	B12 -
FL3-6526-000	103 - 18	FM1-A832-000	109 - 5	FM1-F009-000	B11 - 31
FL3-6526-000	300 - 9	FM1-A836-000	107 - 3	FM1-F010-000	B11 - 29
FL3-6526-000	330 - 7	FM1-A839-000	109 - 6	FM1-F727-000	104 - 5
FL3-6534-000	101 - 9	FM1-A843-000	108 - 12	FM1-G906-000	109 - 13
FL3-6538-000	130 - 17	FM1-A853-000	109 - 12	FM1-G907-000	910 - 2
FL3-6545-000	101 - 10	FM1-A854-000	109 - 11	FM1-G973-000	130 - 21
FM0-0002-000	621 -	FM1-A855-000	109 - 9	FM1-G974-000	T20 - 2
FM0-0006-000	622 -	FM1-B297-000	310 - 29	FM1-G975-000	T20 - 2
FM0-0007-000	270 -	FM1-B298-000	107 - 8	FM1-G977-000	103 - 14
FM0-0017-000	108 - 9	FM1-B308-000	331 -	FM1-G979-000	T20 - 3
FM0-0018-000	290 -	FM1-B545-000	300 - 10	FM1-G981-000	900 - 2
FM0-0021-000	350 -	FM1-B547-000	300 - 11	FM1-G982-000	T20 - 4
FM0-0029-000	310 -	FM1-B548-000	300 - 12	FM1-H163-000	D10 - 19
FM0-0030-000	310 - 28	FM1-B551-000	332 - 5	FM1-H164-000	D10 - 19
FM0-0031-000	460 - 1	FM1-B552-000	102 - 35	FM1-H417-000	D10 - 1
FM0-0032-000	105 - 6	FM1-B553-000	102 - 36	FM1-H687-000	130 -
FM0-0034-000	280 -	FM1-B554-000	102 - 37	FM1-J352-000	130 - 7
FM0-0035-000	104 - 1	FM1-B555-000	102 - 38	FM1-J353-000	130 - 14
FM0-0036-010	104 - 2	FM1-B557-000	310 - 30	FM1-J357-000	130 - 14
FM0-0037-000	103 - 11	FM1-B572-000	104 - 4	FM1-J358-000	130 - 14
FM0-0038-000	108 - 4	FM1-B574-000	107 - 7	FM1-J784-000	900 - 1
FM0-0039-010	108 - 5	FM1-C093-000	910 -	FM1-J785-000	900 - 1
FM0-0040-000	250 -	FM1-C096-000	103 - 13	FM1-J786-000	900 - 1
FM0-0042-000	108 - 6	FM1-C318-000	102 - 43	FM1-K198-000	810 - 1
FM0-0043-000	108 - 1	FM1-C323-000	107 - 9	FM1-M802-000	930 - 1
FM0-0044-000	109 - 1	FM1-C324-000	104 - 11	FM1-M804-000	T20 - 2
FM0-0046-000	109 - 2	FM1-C340-000	810 - 9	FM4-8168-000	T20 - 1
FM0-0048-000	108 - 8	FM1-C347-000	104 - 10	FM4-9857-000	B11 - 30
FM0-0049-000	103 - 1	FM1-C348-000	106 - 3	FM4-9859-000	B12 - 4
FM0-0050-000	107 - 1	FM1-C857-000	109 - 3	FM4-9862-000	B13 -
FM0-0059-000	T21 -	FM1-C981-000	103 - 9	FM4-9866-000	B01 - 1
FM0-0065-000	103 - 15	FM1-C984-000	D10 - 22	FM4-9905-000	105 - 5

NUMERICAL INDEX

PARTS NUMBER	FIGURE & KEY NO.	PARTS NUMBER	FIGURE & KEY NO.	PARTS NUMBER	FIGURE & KEY NO.
FM4-9906-000	105 - 2	FU9-0596-000	B13 - 7	FU9-2224-000	102 - 63
FM4-9907-000	105 - 4	FU9-0597-000	B13 - 8	NPN	001 -
FM4-9908-010	108 - 3	FU9-0598-000	B13 - 9	NPN	100 -
FM4-9910-000	104 - 9	FU9-0610-000	810 - 13	NPN	103 -
FM4-9911-000	104 - 8	FU9-0611-000	810 - 14	NPN	104 -
FM4-9961-000	108 - 2	FU9-0612-000	810 - 15	NPN	105 -
FS1-1205-000	310 - 31	FU9-0613-000	350 - 23	NPN	106 -
FU2-0192-000	102 - 45	FU9-0662-000	102 - 51	NPN	107 -
FU2-0197-000	102 - 46	FU9-0663-000	102 - 52	NPN	108 -
FU2-0198-000	102 - 47	FU9-0663-000	332 - 6	NPN	109 -
FU2-0230-000	810 - 12	FU9-0665-000	102 - 53	NPN	190 -
FU2-0234-000	310 - 32	FU9-0666-000	102 - 54	NPN	191 -
FU2-0236-000	310 - 49	FU9-0666-000	332 - 7	NPN	192 -
FU2-0247-000	310 - 33	FU9-0667-000	102 - 55	NPN	332 -
FU2-0248-000	310 - 34	FU9-0668-000	102 - 56	NPN	460 -
FU2-0257-000	102 - 48	FU9-0670-000	102 - 57	NPN	771 -
FU2-0259-000	102 - 49	FU9-0672-000	332 - 8	NPN	900 -
FU2-0284-000	310 - 35	FU9-0675-000	310 - 43	NPN	930 -
FU2-0287-000	310 - 36	FU9-0675-000	350 - 24	NPN	B01 -
FU2-0294-000	310 - 37	FU9-0676-000	350 - 25	NPN	B10 -
FU2-0295-000	310 - 38	FU9-0677-000	350 - 26	NPN	D10 -
FU2-0297-000	310 - 39	FU9-0680-000	350 - 27	NPN	T20 -
FU2-0298-000	310 - 40	FU9-0692-000	330 - 9	QK1-6441-000	001 - 6
FU2-0358-000	102 - 50	FU9-0720-000	332 - 9	QK1-6443-000	001 - 7
FU2-0574-000	771 - 3	FU9-2005-000	B11 - 43	QK1-6446-000	001 - 8
FU2-0577-000	103 - 10	FU9-2007-000	101 - 6	QK1-6449-000	001 - 9
FU2-0578-000	310 - 41	FU9-2008-000	B11 - 45	QK1-6450-000	001 - 10
FU2-0582-000	330 - 8	FU9-2009-000	B11 - 46	QK1-6455-000	001 - 5
FU2-0718-000	350 - 17	FU9-2010-000	B11 - 47	RC1-9396-000	300 - 14
FU2-0719-000	350 - 18	FU9-2011-000	B11 - 48	VS1-7177-002	102 - 64
FU2-0720-000	350 - 19	FU9-2015-000	B11 - 49	VS1-7177-002	108 - 14
FU2-0810-000	350 - 20	FU9-2016-000	B11 - 50	VS1-7177-002	109 - 7
FU2-0811-000	350 - 21	FU9-2017-000	B11 - 51	VS1-7177-002	810 - 23
FU2-0812-000	350 - 22	FU9-2019-000	B11 - 52	VS1-7177-002	B11 - 62
FU2-1543-000	B11 - 44	FU9-2020-000	B11 - 53	VS1-7177-003	102 - 67
FU5-1748-000	B11 - 33	FU9-2023-000	D10 - 29	VS1-7177-003	103 - 21
FU6-1304-000	331 - 6	FU9-2027-000	771 - 4	VS1-7177-003	108 - 15
FU6-2873-000	D10 - 27	FU9-2068-000	102 - 58	VS1-7177-003	109 - 8
FU6-2999-000	B11 - 32	FU9-2069-000	102 - 59	VS1-7177-003	192 - 3
FU6-8646-000	101 - 8	FU9-2070-000	102 - 60	VS1-7177-003	910 - 3
FU7-2778-000	103 - 4	FU9-2071-000	102 - 61	VS1-7177-004	108 - 16
FU8-0085-000	310 - 42	FU9-2088-000	331 - 7	VS1-7177-004	D10 - 12
FU8-0128-000	B11 - 35	FU9-2091-000	331 - 8	VS1-7177-006	810 - 24
FU9-0237-000	B11 - 37	FU9-2094-000	310 - 44	VS1-7207-003	102 - 65
FU9-0581-000	D10 - 28	FU9-2104-000	810 - 16	VS1-7207-003	109 - 10
FU9-0588-000	B13 - 5	FU9-2105-000	810 - 17	VS1-7207-003	D10 - 26
FU9-0589-000	B11 - 38	FU9-2106-000	810 - 18	VS1-7207-004	B11 - 64
FU9-0590-000	B11 - 39	FU9-2108-000	350 - 28	VS1-7207-006	102 - 66
FU9-0591-000	B11 - 40	FU9-2111-000	810 - 19	VS1-7207-006	B11 - 63
FU9-0592-000	B11 - 41	FU9-2112-000	102 - 62	VS1-7440-002	103 - 20
FU9-0594-000	B11 - 42	FU9-2181-000	460 - 3	VS1-7440-002	108 - 13
FU9-0595-000	B13 - 6	FU9-2191-000	350 - 29	VS1-7440-003	191 - 2

NUMERICAL INDEX

PARTS NUMBER	FIGURE & KEY NO.	PARTS NUMBER	FIGURE & KEY NO.	PARTS NUMBER	FIGURE & KEY NO
WC2-5803-000	103 - 3				
WG8-5783-000	810 - 21				
WG8-5935-000	102 - 39				
WG8-5935-000	109 - 4				
WG8-5935-000	290 - 2				
WG8-5935-000	310 - 45				
WG8-5935-000	331 - 9				
WG8-5935-000	621 - 1				
WG8-5935-000	810 - 20				
WG8-5935-000	B11 - 54				
WG8-5935-000	D10 - 15				
WP2-5410-000	108 - 10				
WT8-5076-000	T20 - 5				
XA9-1386-000	103 - 7				
XA9-1386-000	104 - 6				
XA9-1386-000	105 - 8				
XA9-1386-000	106 - 7				
XA9-1386-000	107 - 5				
XA9-1386-000	108 - 11				
XA9-1386-000	109 - 14				
XA9-1386-000	D10 - 16				
XA9-1449-000	D10 - 21				
XA9-1523-000	300 - 17				
XD9-0290-000	300 - 18				
XD9-0359-000	300 - 25				
XF2-1611-830	B13 - 10				
XG9-0783-000	102 - 44				
XG9-0831-000	810 - 22				

imageRUNNER imageCLASS MF810Cdn(Parts Catalog)

C1225iF/C1225/ MF820Cdn/

imageRUNNER C1225iF

230V EUR	F16-5992-000	TYF	FAX model
-----------------	---------------------	------------	------------------

imageRUNNER C1225

230V EUR	F16-5994-000	TYG	
-----------------	---------------------	------------	--

imageCLASS MF820Cdn

120V US	F16-5934-000	SYV	FAX model
----------------	---------------------	------------	------------------

imageCLASS MF810Cdn

120V US,CA	F16-5932-000	SYQ	FAX model
-------------------	---------------------	------------	------------------

230V SG,IN	F16-5942-000	SYS	FAX model
-------------------	---------------------	------------	------------------

230V AU	F16-5982-000	SYT	FAX model
----------------	---------------------	------------	------------------

Contents

A1	ASSEMBLY LOCATION DIAGRAM	2-1
A2	OPTION PARTS CATALOG LIST	2-6
001	ACCESSORIES	2-7
100	EXTERNAL COVERS, PANELS, ETC.	2-9
101	DOOR ASSEMBLY, FRONT	2-11
102	DOOR ASSEMBLY, RIGHT	2-13
103	INTERNAL COMPONENTS 1	2-18
104	INTERNAL COMPONENTS 2	2-20
105	INTERNAL COMPONENTS 3	2-22
106	INTERNAL COMPONENTS 4	2-24
107	INTERNAL COMPONENTS 5	2-26
108	MACHINE REAR PLATE 1	2-28
109	MACHINE REAR PLATE 2	2-30
130	CONTROL PANEL ASSEMBLY	2-32
190	CARTRIDGE AIR INTAKE FAN ASS'Y	2-34
191	DELIVERY COOLING FAN ASSEMBLY	2-35
192	DRIVE COOLING FAN ASS'Y	2-36
250	MAIN DRIVE ASSEMBLY	2-37
260	PAPER PICK-UP DRIVE ASSEMBLY	2-38
270	BOTTLE DRIVE ASSEMBLY	2-39
280	FIXING DRIVE ASSEMBLY	2-40
290	PICK-UP LIFTER DRIVE ASS'Y	2-41
300	CASSETTE	2-42
310	REGIST./PAPER PICK-UP ASS'Y	2-45
330	MULTI FEED TRAY ASSEMBLY	2-48
331	MULTI FEED PAPER PICK-UP ASS'Y	2-50
332	DUPLEXING GUIDE ASSEMBLY	2-52
350	PAPER DELIVERY/REVERSE ASS'Y	2-53
460	LASER SCANNER ASSEMBLY	2-56
530	INTER. TRANSFER BELT ASS'Y	2-57
621	BOTTLE MOUNT ASSEMBLY	2-58
622	HOPPER ASSEMBLY	2-59
771	INTERNAL COVER ASSEMBLY	2-60
810	FIXING ASSEMBLY, FX-201	2-61
900	CONTROLLER BOX ASSEMBLY	2-63
910	POWER SUPPLY ASSEMBLY	2-65
930	DC CONTROLLER PCB ASSEMBLY	2-66
B01	ADF MAINTENANCE KIT	2-67
B10	READER/ADF ASSEMBLY	2-68
B11	AUTO DOCUMENT FEEDER ASSEMBLY	2-70
B12	FEEDER COVER ASSEMBLY	2-75
B13	PAPER FEED DRIVE ASSEMBLY	2-77
D10	READER ASSEMBLY	2-79
T20	FAX ASSEMBLY (FAX model)	2-82
T21	SPEAKER (FAX model)	2-84

ZZA	MECHANICAL STANDARD PARTS (HOW TO USE)	2-85
ZZB	MECHANICAL STANDARD PARTS (SCREWS).....	2-86
ZZC	MECHANICAL STANDARD PARTS (BOLTS).....	2-93
ZZD	MECHANICAL STANDARD PARTS (NUTS).....	2-94
ZZE	MECHANICAL STANDARD PARTS (RETAINING RINGS)	2-95

FIGURE A1 ASSEMBLY LOCATION DIAGRAM

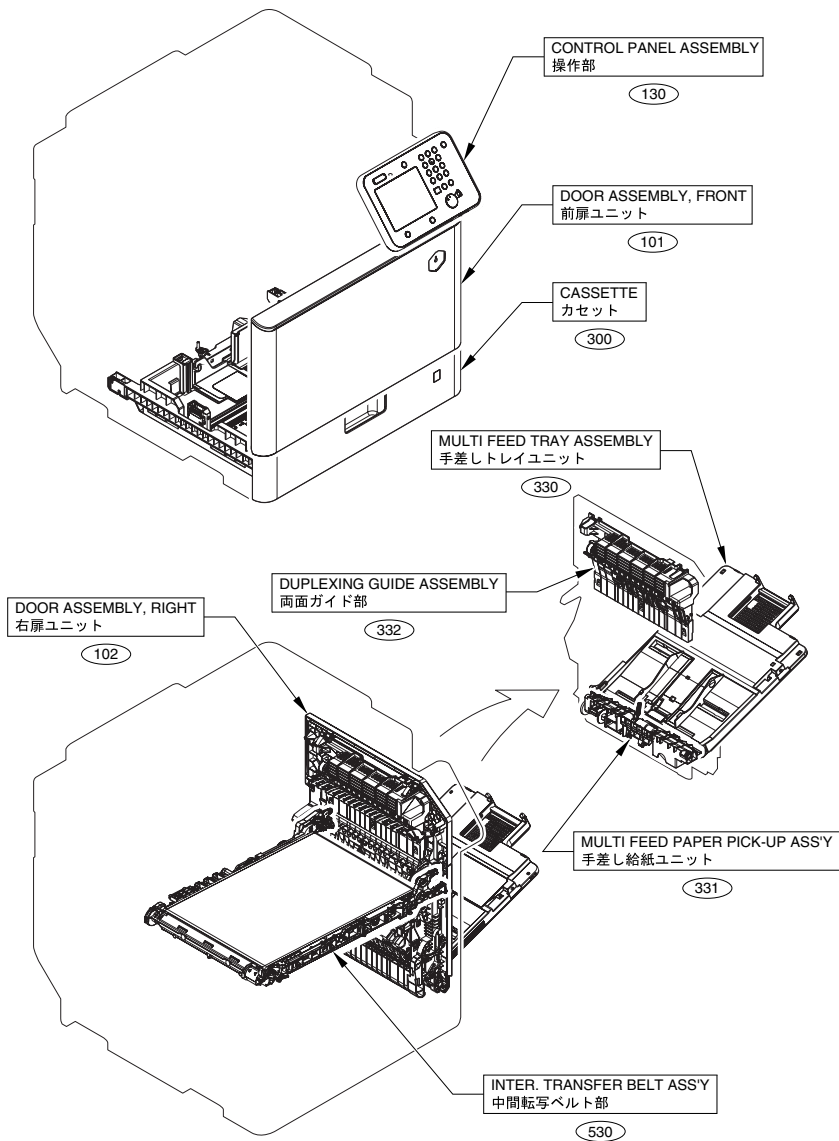

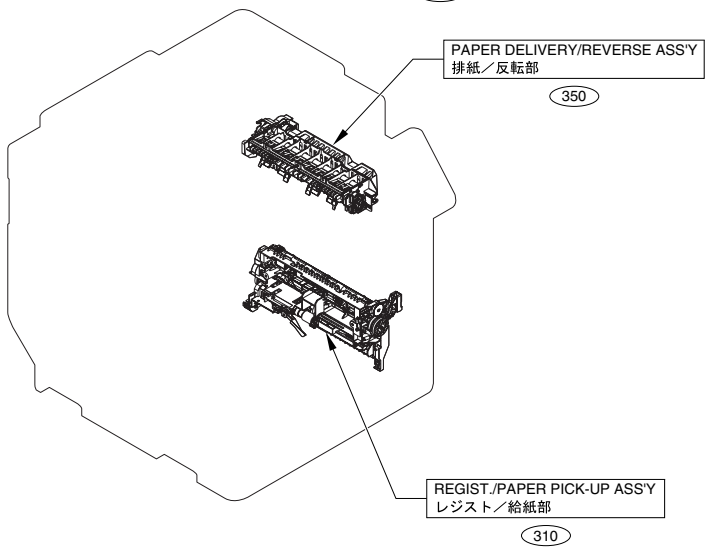
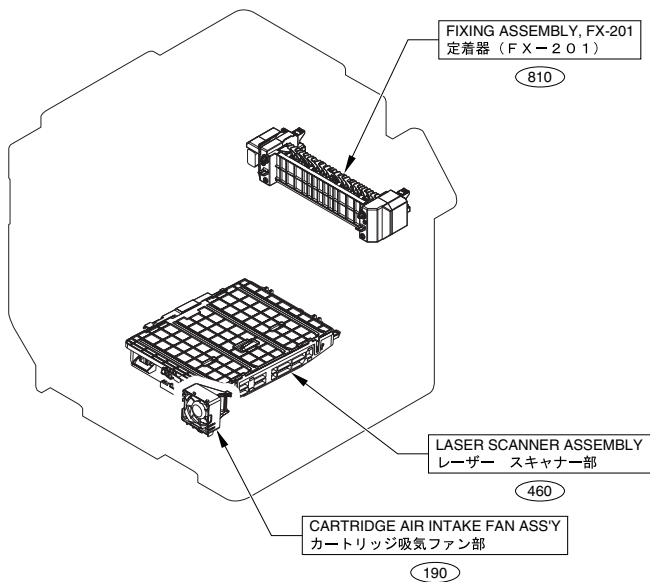

BOTTLE MOUNT ASSEMBLY
ボトル台部

621

DELIVERY COOLING FAN ASSEMBLY
排紙冷却ファン部

191

INTERNAL COVER ASSEMBLY
内部カバー部

771

PAPER FEED DRIVE ASSEMBLY
搬送ドライブ部

B13

AUTO DOCUMENT FEEDER ASSEMBLY
ADFユニット

B11

FEEDER COVER ASSEMBLY
フィーダーカバー部

B12

READER ASSEMBLY
リーダー部

D10

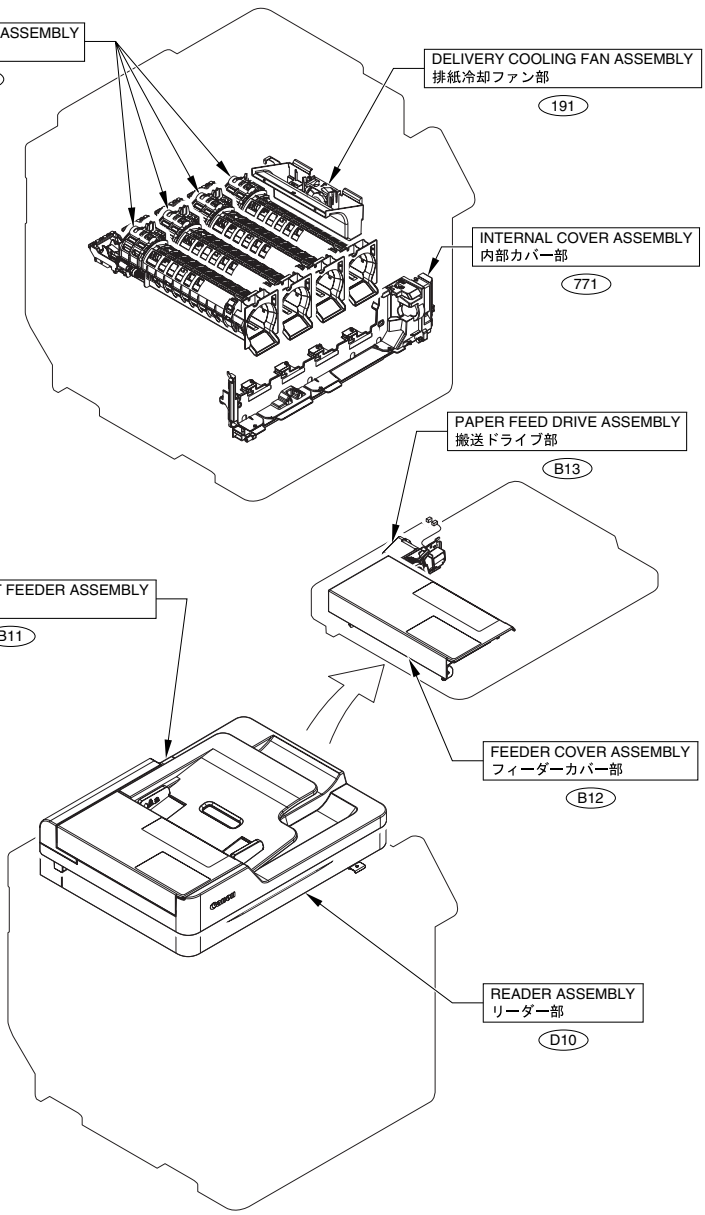

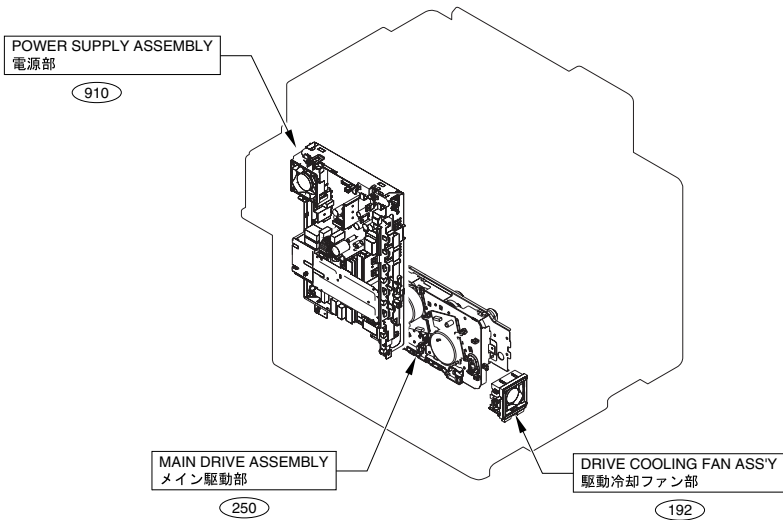
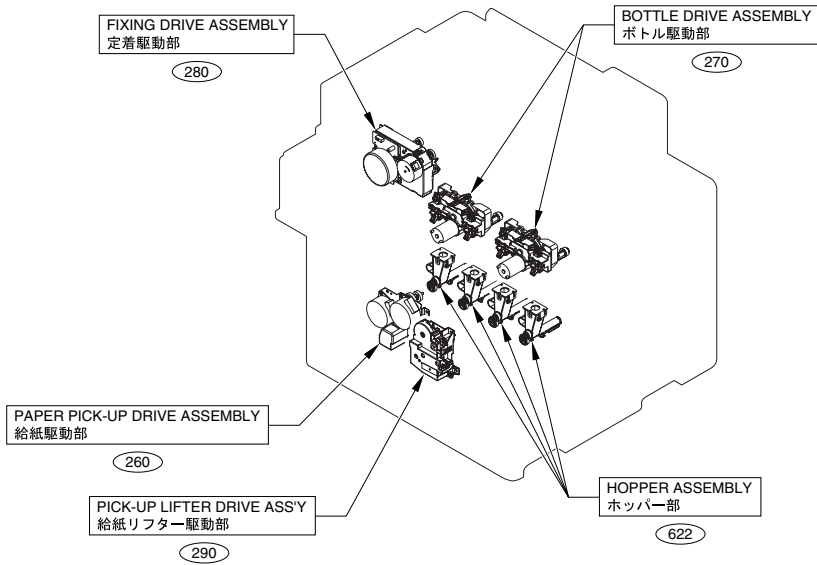

CONTROLLER BOX ASSEMBLY
コントローラー ボックス部

900

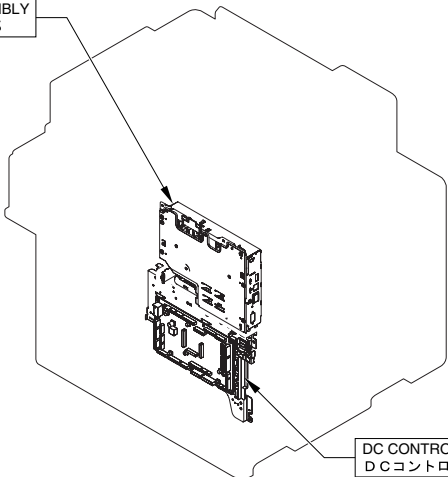

DC CONTROLLER PCB ASSEMBLY
DCコントローラー回路基板

930

FAX model

FAX ASSEMBLY
FAX部

T20

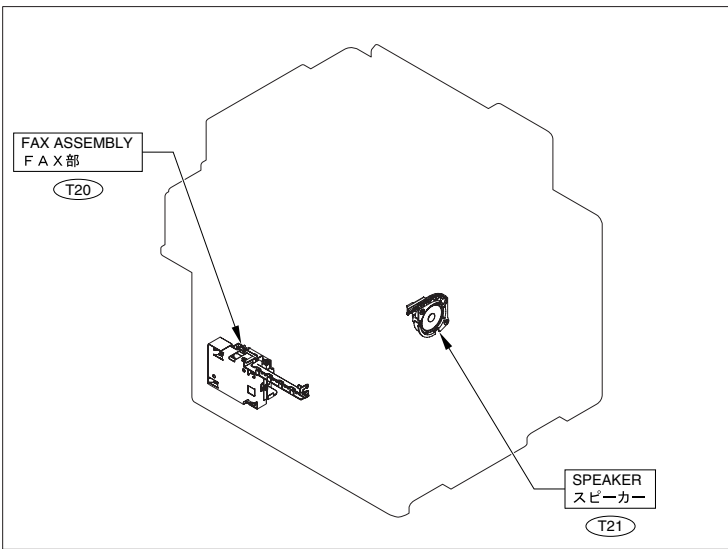

SPEAKER
スピーカー

T21

FIGURE A2 OPTION PARTS CATALOG LIST

This is the table of the machine's options whose parts catalog is issued.
本機のオプションで、パーツカタログが発行されている機種の一覧である。

No.	Model Name(English)	Model Name(Japanese)
1	Cassette Feeding Unit-AJ1/AK1	(日本仕向けなし)
2	HANDSET-J1	(日本仕向けなし)

FIGURE 001 ACCESSORIES

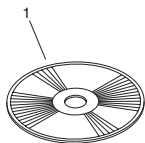

SG,IN

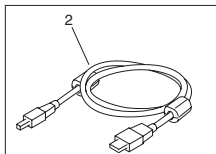

MF810Cdn 230V

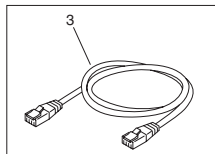

FAX model

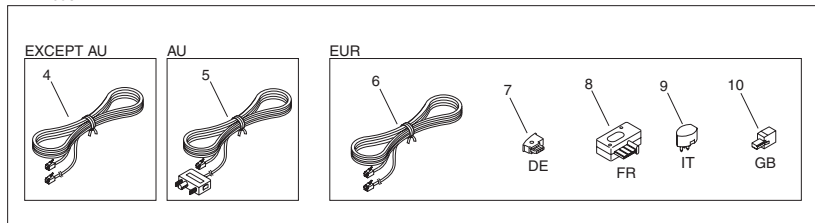

120V

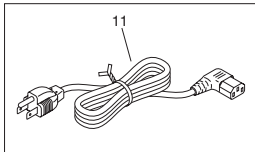

230V

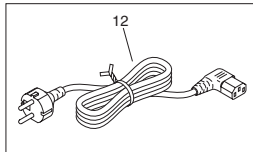

FIGURE & KEY NO.	PARTS NUMBER	RANK	Q'TY	DESCRIPTION	SERIAL NUMBER/REMARKS	SVC
Fig.001	NPN		RF	ACCESSORIES		
1	FK4-2811-000		1	DVD-ROM, USER SOFTWARE	US English,French,Spanish	
1	FK4-2814-000		1	DVD-ROM, USER SOFTWARE	UK English	
1	FK4-2812-000		1	DVD-ROM, USER SOFTWARE	UK English,French,Italian,German,Spanish,Russian,Dutch,Polish,Arabic	
2	FK4-1821-000		1	CABLE, USB	SG,IN	
3	FK4-1822-000		1	CABLE, LAN	MF810Cdn 230V	
4	FK2-5275-000		1	CORD, MODULAR	FAX model EXCEPT AU	
5	QK1-6455-000		1	CORD, MODULAR	AU	
6	QK1-6441-000		1	CORD, MODULER	EUR	
7	QK1-6443-000		1	PLUG	DE	
8	QK1-6446-000		1	PLUG	FR	
9	QK1-6449-000		1	PLUG	IT	
10	QK1-6450-000		1	PLUG	GB	
11	FK2-9904-000		1	CORD, POWER SUPPLY	120V	
12	FK2-9571-000		1	CORD, POWER SUPPLY	230V	

FIGURE 100 EXTERNAL COVERS, PANELS, ETC.

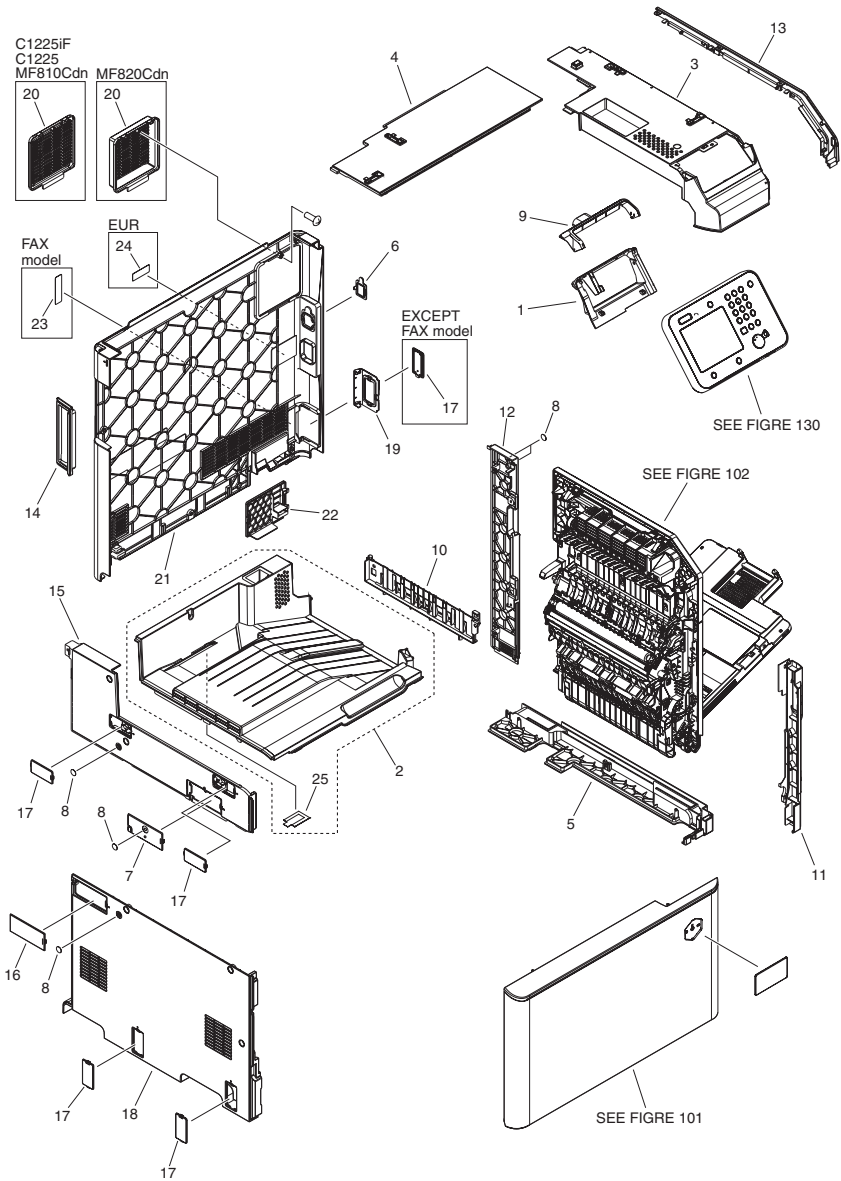
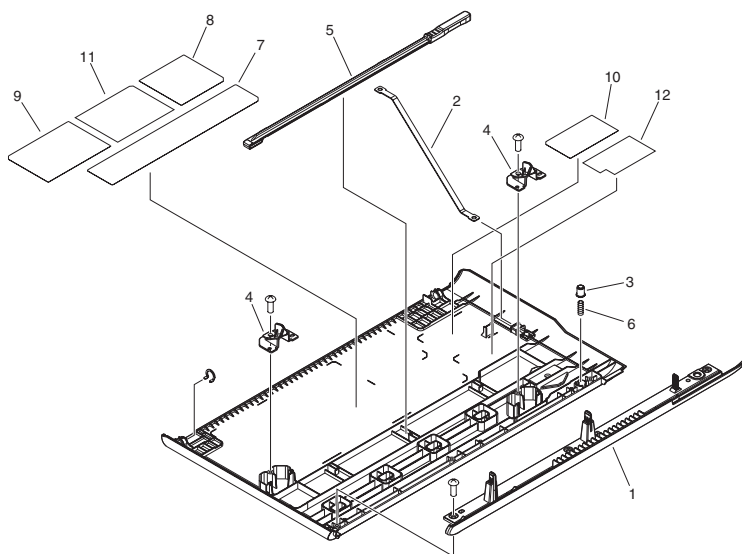

FIGURE & KEY NO.	PARTS NUMBER	RANK	Q'TY	DESCRIPTION	SERIAL NUMBER/REMARKS	SVC
Fig.100	NPN		RF	EXTERNAL COVERS, PANELS, ETC.		
1	FM1-D696-000		1	COVER, CONTROL PANEL ASSEMBLY		
2	FM1-D697-000		1	TRAY, PAPER DELIVERY		
3	FM1-D698-000		1	COVER, UPPER		
4	FM1-D699-000		1	COVER, REAR UPPER		
5	FE3-9079-000		1	COVER, RIGHT LOWER		
6	FE3-9087-000		1	COVER, ENV. HEATER SWITCH		
7	FE3-8434-000		1	COVER, DEVICE PORT		
8	FC6-4513-000		5	SEAL		
9	FE3-8427-000		1	COVER, CONTROL HINGE, REAR		
10	FE3-9091-000		1	COVER, PAPER DELIVERY		
11	FL0-2604-000		1	COVER, RIGHT FRONT		
12	FL0-2606-000		1	COVER, RIGHT REAR		
13	FL0-2605-000		1	COVER, RIGHT UPPER		
14	FE3-8294-000		1	COVER, SUB, REAR		
15	FE3-9081-000		1	COVER, UPPER, LEFT		
16	FE3-9082-000		1	COVER, DEVICE PORT		
17	FE3-9088-000		5	COVER, FAX CONNECTOR		
18	FL0-5332-000		1	COVER, LEFT LOWER		
19	FE3-9132-000		1	COVER, FAX		
20	FE3-8296-000		1	COVER, FAN	C1225IF,C1225,MF810Cdn	
20	FE3-8295-000		1	COVER, FAN	MF820Cdn	
21	FC0-7121-000		1	COVER, REAR		
22	FE3-9089-000		1	COVER, HEATER, ENVIRONMENT		
23	FE4-1827-000		1	LABEL, MODULAR	FAX model	
24	FE4-1828-000		1	LABEL, GROUNDING CAUTION	EUR	
25	FL0-1007-000		1	SHEET, PAPER DELIVERY TRAY		

FIGURE 101 DOOR ASSEMBLY, FRONT



NOTE 1 : This assembly does not include the parts shown with key No. 2, 5, 9, 10, 11 and 12.

NOTE 2 : Several kinds of labels are attached on the board for the parts of Key No. 11. The same parts as Fig-Key No. 103-6.

注 1 : このユニットにKey No. 2, 5, 9, 10, 11, 12の部品は含まれません。

注 2 : Key No. 11の部品は台紙に数種類のラベルが付いています。Fig-Key No. 103-6と同一部品です。

FIGURE & KEY NO.	PARTS NUMBER	R A N K	Q'TY	DESCRIPTION	SERIAL NUMBER/ REMARKS	S V C
Fig.101	FM1-D700-000		1	DOOR ASSEMBLY, FRONT		
1	FL0-4391-000		1	COVER, FRONT, UPPER		
2	FC0-7572-000		1	BAND, FRONT COVER, RIGHT	SEE NOTE 1	
3	FC0-7734-000		1	PIN, FRONT		
4	FE3-9086-000		2	HOOK, COVER, FRONT		
5	FL0-0237-000		1	ROD, GLASS CLEANING	SEE NOTE 1	
6	FU9-2007-000		1	SPRING, COMPRESSION		
7	FC0-5846-010		1	LABEL, CLN ROD OPERATION		
8	FU6-8646-000		1	LABEL, LASER CAUTION		
9	FL3-6534-000		1	LABEL, SERVICE	SEE NOTE 1	
10	FL3-6545-000		1	LABEL, SERVICE	SEE NOTE 1	
11	FE4-3656-000		1	LABEL, TONER TYPE	SG,IN,AU SEE NOTE 1,SEE NOTE 2	
11	FE4-5972-000		1	LABEL, TONER TYPE	US,CA SEE NOTE 1,SEE NOTE 2	
11	FE4-5971-000		1	LABEL, TONER TYPE	C1225IF EUR SEE NOTE 1,SEE NOTE 2	
11	FE4-5973-000		1	LABEL, TONER TYPE	C1225 EUR SEE NOTE 1,SEE NOTE 2	
12	FC0-7807-000		1	LABEL,EXCHANGE OPERATOR,BOTTLE	SEE NOTE 1	

FIGURE 102 DOOR ASSEMBLY, RIGHT

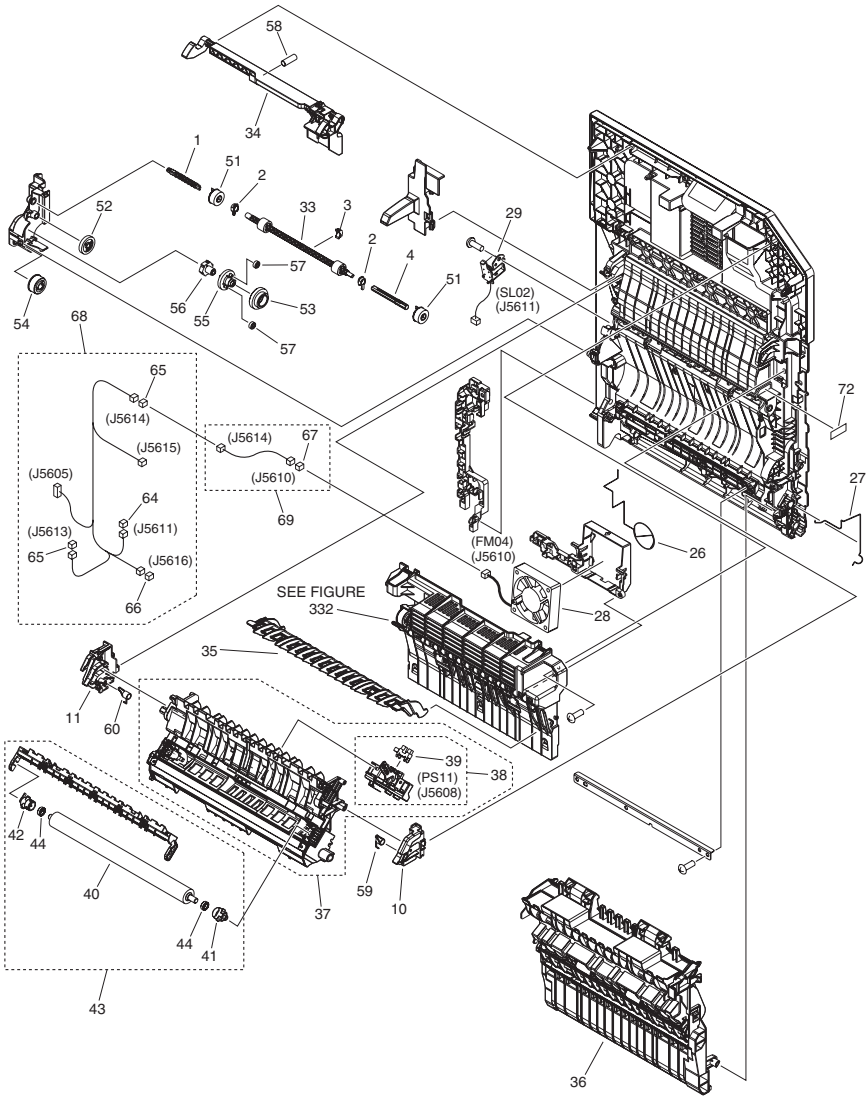

NOTE : This assembly includes the assemblies shown in Figure 330 and 331.
 注 : このユニットはFigure 330, 331のユニットを含みます。

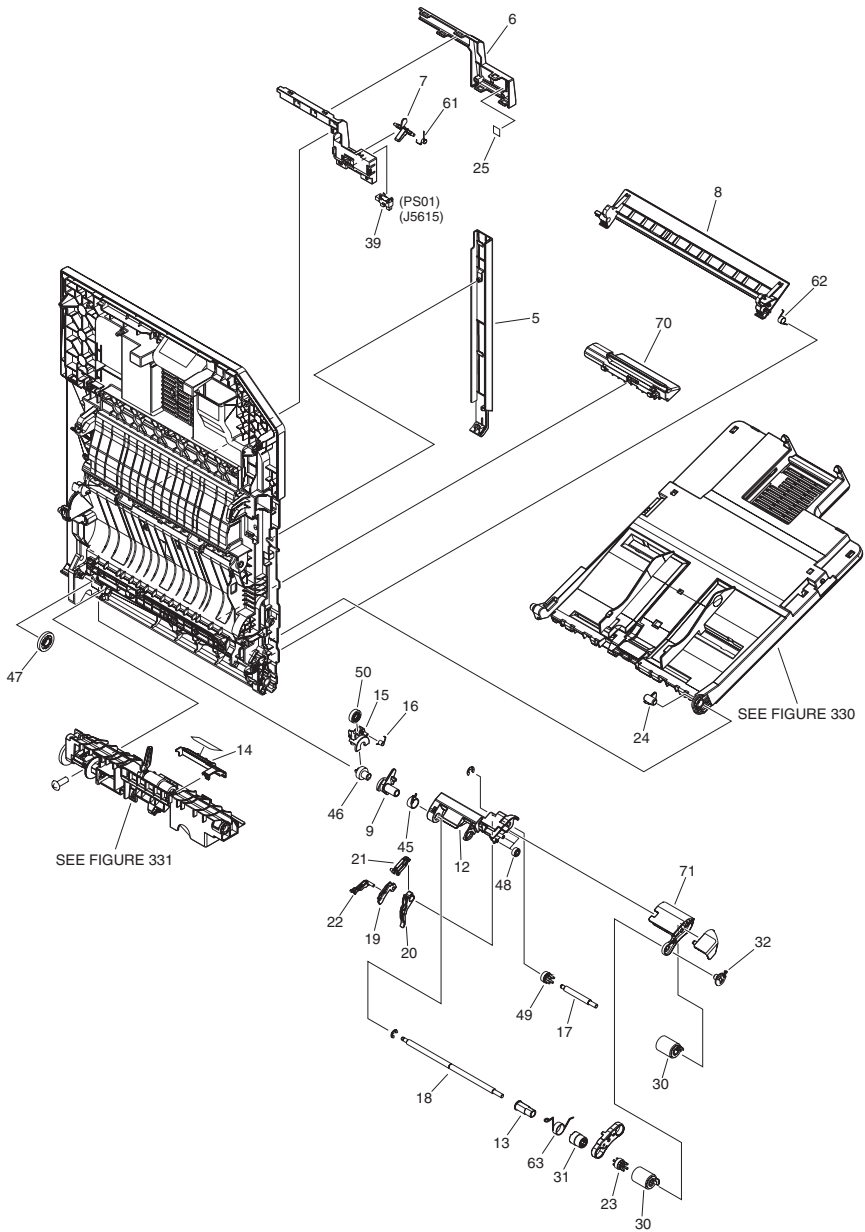
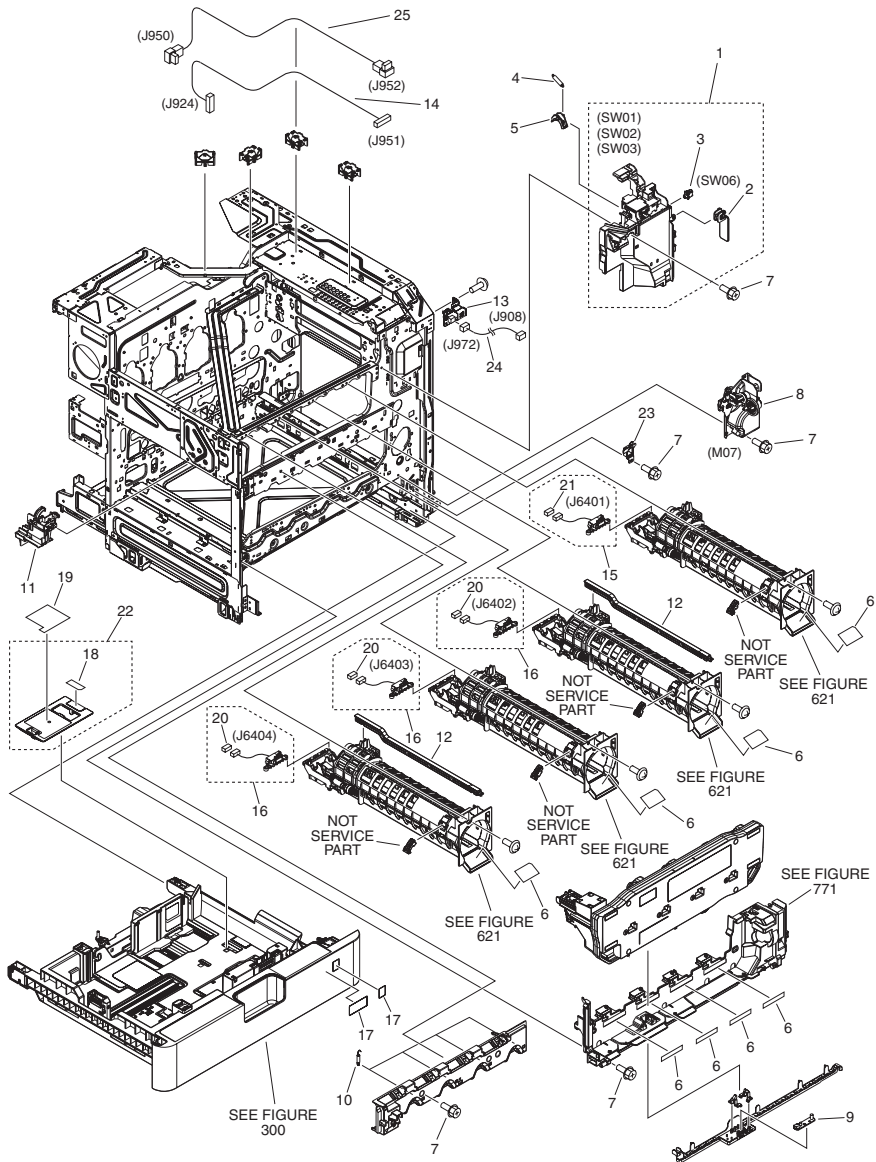

FIGURE & KEY NO.	PARTS NUMBER	R A N K	Q'TY	DESCRIPTION	SERIAL NUMBER/ REMARKS	S V C
Fig.102	FM1-D695-000		1	DOOR ASSEMBLY, RIGHT	SEE NOTE	
1	FC0-5875-000		1	SHAFT		
2	FC0-5876-000		2	BUSHING		
3	FC0-5888-000		1	BUSHING		
4	FC0-5935-000		1	SHAFT		
5	FE3-9093-000		1	PANEL, RIGHT DOOR, FRONT		
6	FE3-9094-000		1	PANEL, CABLE		
7	FC0-5943-000		1	FLAG, DUPLEXING SENSOR		
8	FE3-9097-000		1	COVER, BLANKING		
9	FC0-7446-000		1	LINK, RELEASE		
10	FC0-7535-000		1	GUIDE, LOCK, FRONT		
11	FC0-7536-000		1	GUIDE, LOCK, REAR		
12	FE3-1547-000		1	SUPPORT, ROLLER		
13	FE3-1617-000		1	BUSHING		
14	FE3-1641-010		1	COVER, PAPER FEED ROLLER		
15	FE3-1760-000		1	HOLDER, MULTI FEED SWING		
16	FE3-2409-000		1	SPRING, TORSION		
17	FE3-3585-000		1	SHAFT		
18	FE3-3594-000		1	SHAFT		
19	FE3-4759-000		1	GUIDE, SHUTTER LINK		
20	FE3-4760-000		1	SHUTTER, PAPER PICK-UP		
21	FE3-4761-000		1	LOCK, SHUTTER		
22	FE3-4762-000		1	LEVER, SHUTTER LINK		
23	FE3-4764-000		1	GEAR, 18T		
24	FE3-4765-000		1	BOSS, TRAY		
25	FL0-1010-000		1	SHEET, FLAG SILENCER		
26	FE3-6116-000		1	CABLE, FAN GROUNDING, RIGHT		
27	FE3-6117-000		1	CABLE, GROUNDING, RIGHT		
28	FK2-0472-010		1	FAN	FM04	
29	FK4-0725-000		1	SOLENOID	SL02	
30	FL0-1011-000		2	ROLLER, PAPER PICK-UP&FEED		
31	FL0-1361-000		1	CLUTCH, ONE-WAY		

FIGURE & KEY NO.	PARTS NUMBER	R A N K	Q'TY	DESCRIPTION	SERIAL NUMBER/ REMARKS	S V C
32	FE3-5654-000		1	BUSHING	PS01,PS11	
33	FL3-6443-000		1	ROLLER, DUPLEXING FEED		
34	FM1-D707-000		1	DOOR HOOK ASSEMBLY, RIGHT		
35	FM1-B552-000		1	DUPLEXING INNER GUIDE ASSEMBLY		
36	FM1-B553-000		1	RIGHT INNER DOOR ASSEMBLY		
37	FM1-B554-000		1	2ND TRNSFR. OUTER GUIDE ASSY		
38	FM1-B555-000		1	SENSOR UNIT, LOOP		
39	WG8-5935-000		2	IC, PHOTO INTERRUPTER		
40	FC0-5848-000		1	ROLLER, 2ND TRNSFR. OUTER		
41	FC0-5861-000		1	HOLDER, BUSHING, FRONT		
42	FC0-5862-000		1	HOLDER, BUSHING, REAR		
43	FM1-C318-000		1	2ND TRNSFR. OUTER ROLLER ASSY		
44	XG9-0783-000		2	BEARING, BALL, L-1060ZZ		
45	FU2-0192-000		1	SPRING, TORSION		
46	FU2-0197-000		1	GEAR, 16T		
47	FU2-0198-000		1	GEAR, 27T		
48	FU2-0257-000		3	GEAR, 14T		
49	FU2-0259-000		1	GEAR, 18T		
50	FU2-0358-000		1	GEAR, 17T		
51	FU9-0662-000		2	GEAR, 19T		
52	FU9-0663-000		1	GEAR, 25T		
53	FU9-0665-000		1	GEAR, 42T/21T		
54	FU9-0666-000		1	GEAR, 23T		
55	FU9-0667-000		1	GEAR, 28T		
56	FU9-0668-000		1	GEAR, 14T		
57	FU9-0670-000		2	GEAR, 14T		
58	FU9-2068-000		1	SPRING, COMPRESSION		
59	FU9-2069-000		1	SPRING, TORSION		
60	FU9-2070-000		1	SPRING, TORSION		
61	FU9-2071-000		1	SPRING, TORSION		
62	FU9-2112-000		1	SPRING, TORSION		
63	FU9-2224-000		1	SPRING, TORSION		

FIGURE & KEY NO.	PARTS NUMBER	RANK	Q'TY	DESCRIPTION	SERIAL NUMBER/REMARKS	SVC
64	VS1-7177-002		1	CONNECTOR, SNAP TIGHT, BK		
65	VS1-7207-003		2	CONNECTOR, SNAP TIGHT, BK		
66	VS1-7207-006		1	CONNECTOR, SNAP TIGHT		
67	VS1-7177-003		1	CONNECTOR, SNAP TIGHT, BK		
68	FM1-A825-000		1	CABLE, DOOR, RIGHT		
69	FM1-A827-000		1	CABLE, DOOR FAN, RIGHT		
70	FC0-6614-000		1	COVER, ROLLER		
71	FE3-0389-000		1	COVER, ROLLER		
72	FL0-3766-000		1	SHEET, GUIDE		

FIGURE 103 INTERNAL COMPONENTS 1



NOTE 1 : Several kinds of labels are attached on the board for the parts of Key No. 6. The same parts as Fig-Key No. 101-11.

NOTE 2 : Several kinds of labels are attached on the board for the parts of Key No. 17.

注 1 : Key No. 6の部品は台紙に数種類のラベルが付いています。Fig-Key No. 101-11と同一部品です。

注 2 : Key No. 17の部品は台紙に数種類のラベルが付いています。

FIGURE & KEY NO.	PARTS NUMBER	R A N K	Q'TY	DESCRIPTION	SERIAL NUMBER/ REMARKS	S V C
Fig.103	NPN		RF	INTERNAL COMPONENTS 1		
1	FM0-0049-000		1	COVER, INNER, FRONT, RIGHT	SW01,SW02,SW03,SW06	
2	FC0-7172-000		1	COVER, MAIN SWITCH		
3	WC2-5803-000		1	SWITCH	SW06	
4	FU7-2778-000		1	SPRING, TENSION		
5	FE2-2086-000		1	LEVER, TOGGLE		
6	FE4-3656-000		1	LABEL, TONER TYPE	SG,IN,AU SEE NOTE 1	
6	FE4-5972-000		1	LABEL, TONER TYPE	US,CA SEE NOTE 1	
6	FE4-5971-000		1	LABEL, TONER TYPE	C1225IF EUR SEE NOTE 1	
6	FE4-5973-000		1	LABEL, TONER TYPE	C1225 EUR SEE NOTE 1	
7	XA9-1386-000		AR	SCREW,RS,M3X8		
8	FM1-A225-000		1	REGISTRATION DRIVE ASS'Y	M07	
9	FM1-C981-000		1	WASTE TONER SENSOR PCB ASS'Y		
10	FU2-0577-000		4	SPRING, GROUNDING		
11	FM0-0037-000		1	TONER INTER. EJECT ASS'Y		
12	FC0-5801-000		2	ARM, BOTTLE LOCK		
13	FM1-C096-000		1	CONTROL PANEL USB PCB ASS'Y		
14	FM1-G977-000		1	CABLE, PANEL		
15	FM0-0065-000		1	CONNECTOR, NEW BOTTLE DET., BK		
16	FM0-0075-000		3	CONNECTOR, NEW BOTTLE DET., CL		
17	FE4-1822-000		1	LABEL, PAPER SIZE	SEE NOTE 2	
18	FL3-6526-000		1	SHEET, SEPARATION		
19	FE3-9943-000		1	LABEL, MOUNTING INSTRUCTION		
20	VS1-7440-002		3	CONNECTOR, SNAP TIGHT		
21	VS1-7177-003		1	CONNECTOR, SNAP TIGHT, BK		
22	FL0-3261-000		1	PLATE, LIFTING		
23	FE4-1123-000		1	BUSHING		
24	FK4-1636-000		1	CABLE, USB		
25	FK4-1637-000		1	CABLE, SATA		

FIGURE 104 INTERNAL COMPONENTS 2

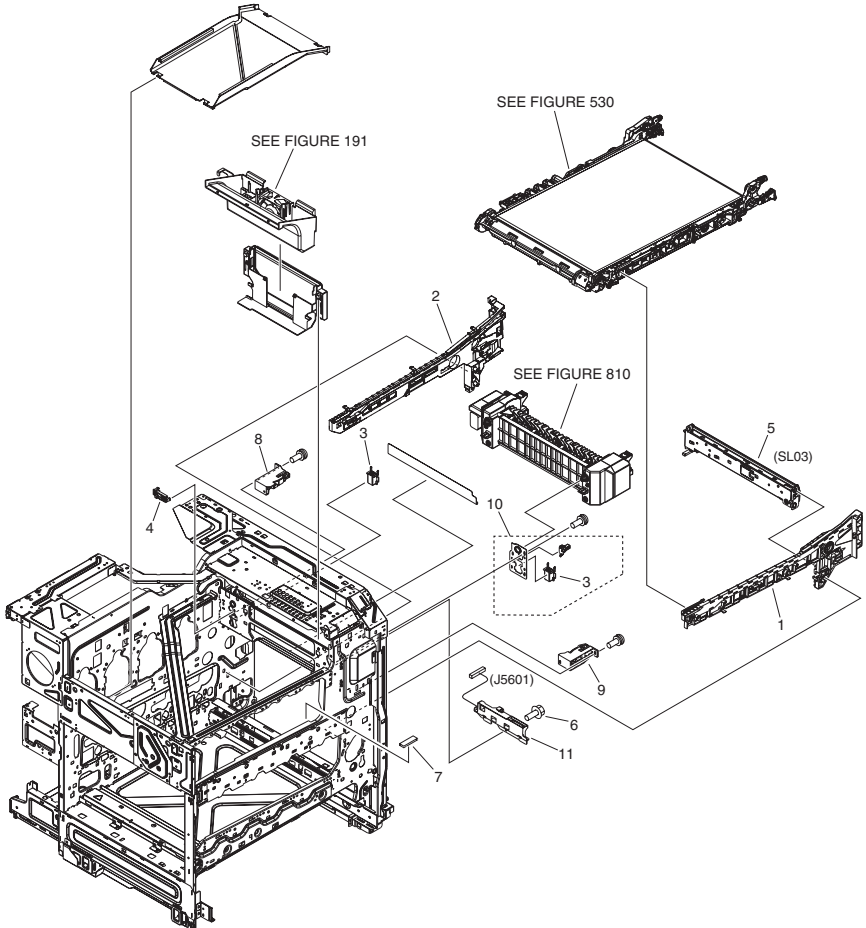

FIGURE & KEY NO.	PARTS NUMBER	RANK	Q'TY	DESCRIPTION	SERIAL NUMBER/REMARKS	SVC
Fig.104	NPN		RF	INTERNAL COMPONENTS 2		
1	FM0-0035-000		1	RAIL, I.T.B., FRONT		
2	FM0-0036-010		1	RAIL, I.T.B., REAR		
3	FM0-0074-000		2	HOLDER, FIXING LOCK		
4	FM1-B572-000		1	FIXING GROUNDING ASSEMBLY		
5	FM1-F727-000		1	REGISTRATION SENSOR ASSEMBLY	SL03	
6	XA9-1386-000		AR	SCREW,RS,M3X8		
7	FL0-3763-000		1	SHEET, PROTECTION		
8	FM4-9911-000		1	HOLDER, FIXING, REAR		
9	FM4-9910-000		1	HOLDER, FIXING, FRONT		
10	FM1-C347-000		1	PLATE ASSEMBLY		
11	FM1-C324-000		1	CONNECTING CABLE ASSEMBLY		

FIGURE 105 INTERNAL COMPONENTS 3

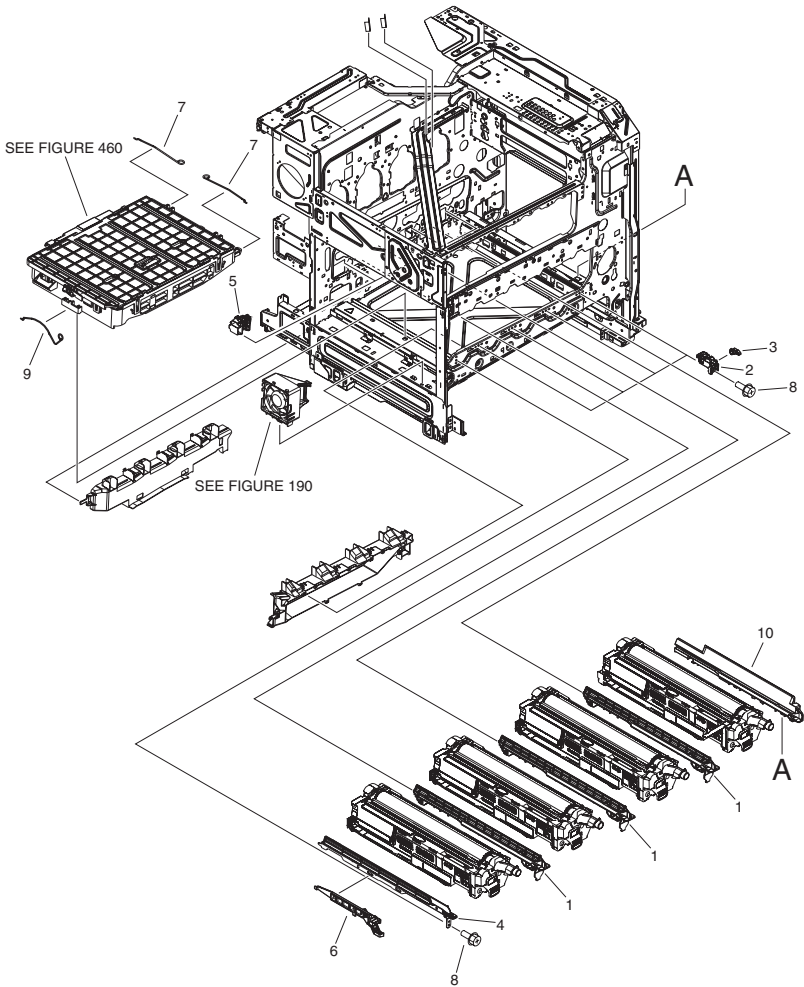

FIGURE & KEY NO.	PARTS NUMBER	RANK	Q'TY	DESCRIPTION	SERIAL NUMBER/REMARKS	SVC
Fig.105	NPN		RF	INTERNAL COMPONENTS 3		
1	FC0-7188-000		3	RAIL, PAPER PICK-UP, MIDDLE		
2	FM4-9906-000		4	BLOCK, PROCESS PRESSURE, FRONT		
3	FC0-7728-000		4	STOPPER, PROCESS UNIT, FRONT		
4	FM4-9907-000		1	RAIL ASSEMBLY, LEFT		
5	FM4-9905-000		4	LEVER, PROCESS KIT, REAR		
6	FM0-0032-000		1	SHUTTER LINK ASSEMBLY		
7	FC9-8607-000		2	SPRING		
8	XA9-1386-000		AR	SCREW,RS,M3X8		
9	FC0-7068-000		1	SPRING		
10	FC0-6502-000		1	RAIL, PROCESS CARTRIDGE, RIGHT		

FIGURE 106 INTERNAL COMPONENTS 4

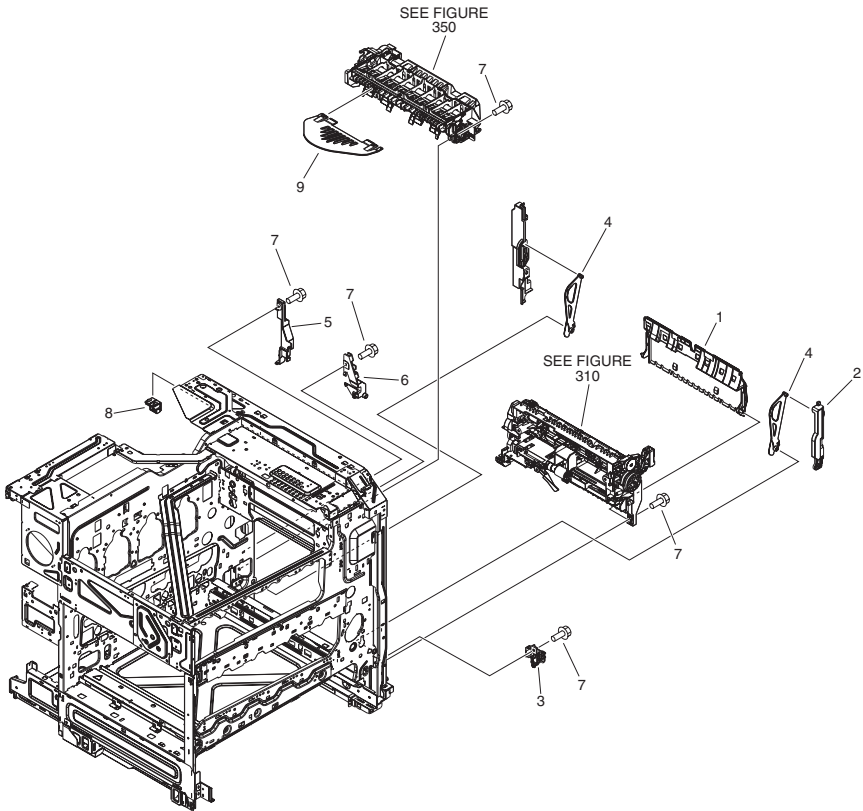

FIGURE & KEY NO.	PARTS NUMBER	RANK	Q'TY	DESCRIPTION	SERIAL NUMBER/REMARKS	SVC
Fig.106	NPN		RF	INTERNAL COMPONENTS 4		
1	FC0-7048-000		1	GUIDE, SWING		
2	FC0-5942-000		1	GUIDE, STOPPER, RIGHT DOOR		
3	FM1-C348-000		1	HINGE, EXTERNAL, FRONT		
4	FC0-5912-000		2	LEVER, STOPPER, RIGHT		
5	FE3-9076-000		1	COVER, DOOR CONNECTOR, RIGHT		
6	FC0-5929-000		1	HINGE, OUTER COVER, REAR		
7	XA9-1386-000		AR	SCREW,RS,M3X8		
8	FC0-5918-000		2	BASE, HOOK, RIGHT		
9	FE3-8409-000		1	TRAY, REVERSE		

FIGURE 107 INTERNAL COMPONENTS 5

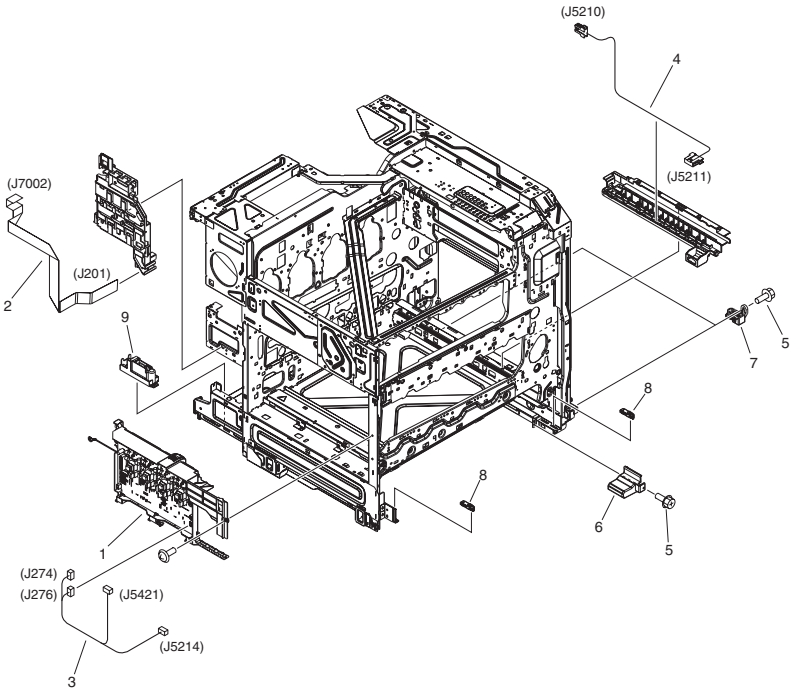

FIGURE & KEY NO.	PARTS NUMBER	RANK	Q'TY	DESCRIPTION	SERIAL NUMBER/REMARKS	SVC
Fig.107	NPN		RF	INTERNAL COMPONENTS 5		
1	FM0-0050-000		1	1ST TRANSFER H.V. PCB ASSEMBLY		
2	FK4-0648-000		1	CABLE, FLAT		
3	FM1-A836-000		1	CABLE, REG. MOTOR WASTE TONER		
4	FM1-A811-000		1	CABLE, CASSETTE HEATER	120V	
4	FM1-A812-000		1	CABLE, CASSETTE HEATER	230V	
5	XA9-1386-000		AR	SCREW,RS,M3X8		
6	FE3-4477-000		1	CAP, CONNECTOR		
7	FM1-B574-000		2	FOOT, RUBBER		
8	FM1-B298-000		2	CASSETTE STOPPER ASSEMBLY		
9	FM1-C323-000		1	OPTION CST. DRAWER ASSEMBLY		

FIGURE 108 MACHINE REAR PLATE 1

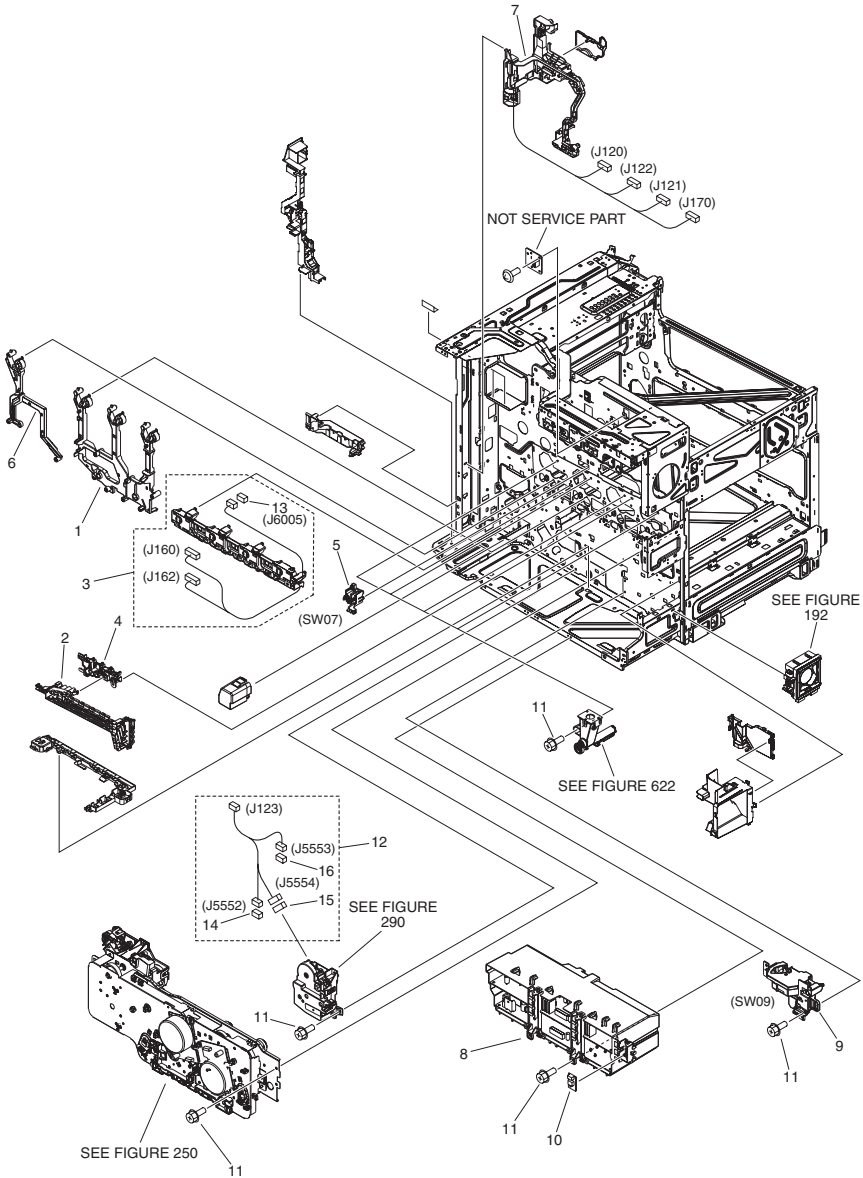

FIGURE & KEY NO.	PARTS NUMBER	RANK	Q'TY	DESCRIPTION	SERIAL NUMBER/REMARKS	SVC
Fig.108	NPN		RF	MACHINE REAR PLATE 1		
1	FM0-0043-000		1	H.V. CONTACT ASSEMBLY, COLOR		
2	FM4-9961-000		1	1ST TRANS. H.V. CONTACT ASS'Y		
3	FM4-9908-010		1	PROCESS CONTROL PCB ASS'Y		
4	FM0-0038-000		1	CONTACT, 1ST TRANSFER H.V., 1		
5	FM0-0039-010		1	I.T.B. RELEASE SWITCH ASSEMBLY	SW07	
6	FM0-0042-000		1	H.V. CONTACT ASSEMBLY, BLACK		
7	FM0-0079-000		1	2ND TRANS. H.V. CONTACT ASS'Y		
8	FM0-0048-000		1	2ND TRANSFER H.V. PCB ASSEMBLY		
9	FM0-0017-000		1	CASSETTE AUTO CLOSE ASSEMBLY	SW09	
10	WP2-5410-000		1	SENSOR, HUMIDITY		
11	XA9-1386-000		AR	SCREW,RS,M3X8		
12	FM1-A843-000		1	CABLE, CASSETTE ASS'Y		
13	VS1-7440-002		1	CONNECTOR, SNAP TIGHT		
14	VS1-7177-002		1	CONNECTOR, SNAP TIGHT, BK		
15	VS1-7177-003		1	CONNECTOR, SNAP TIGHT, BK		
16	VS1-7177-004		1	CONNECTOR, SNAP TIGHT, BK		

FIGURE 109 MACHINE REAR PLATE 2

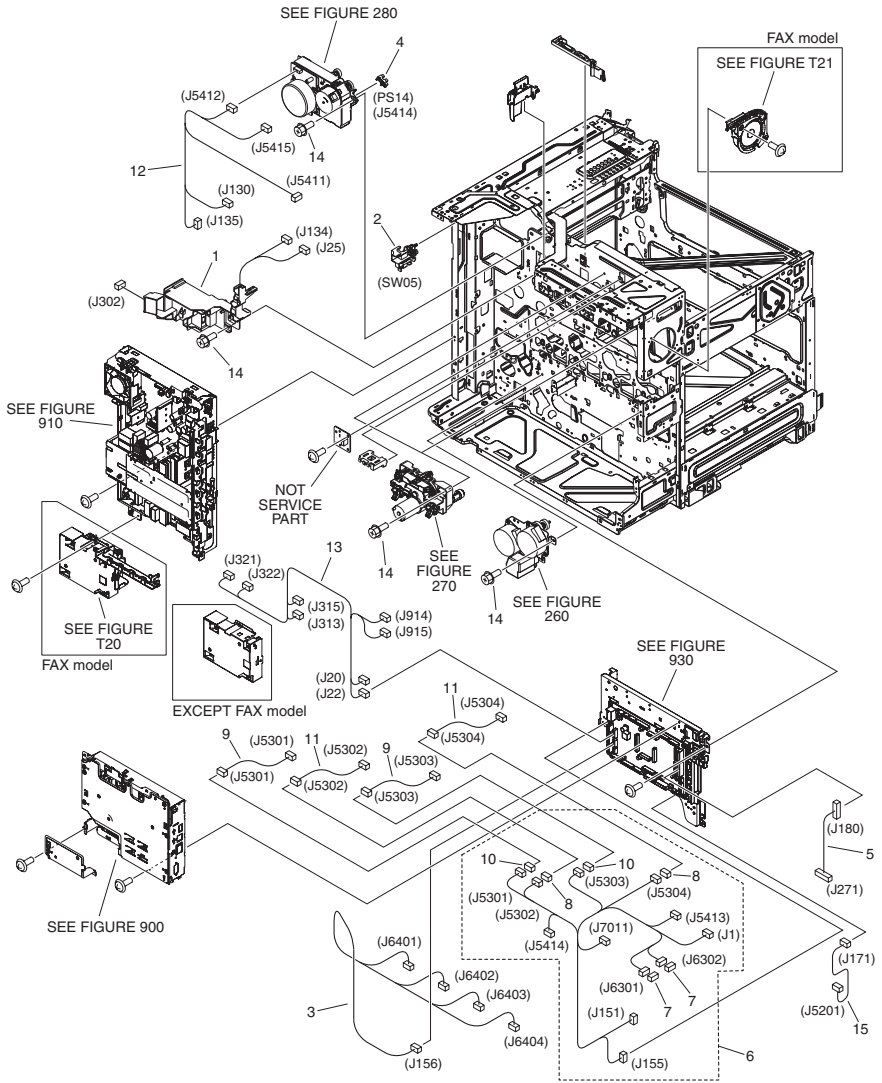
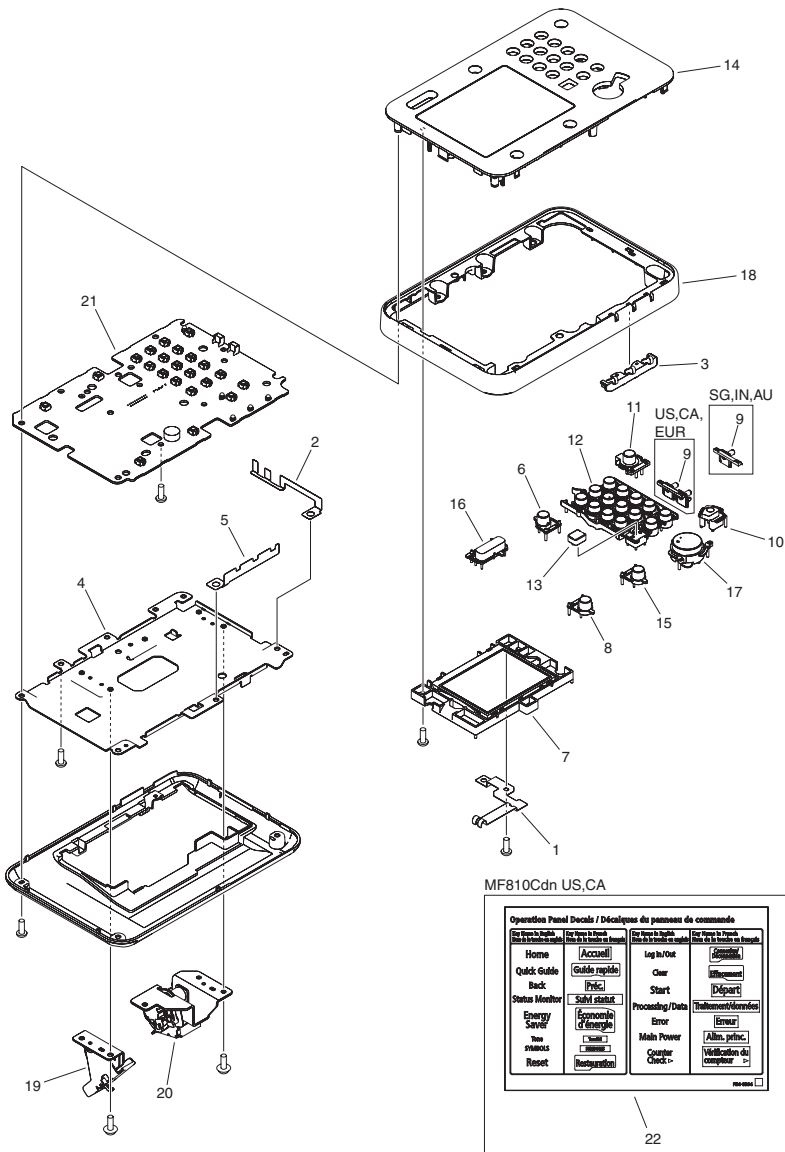

FIGURE & KEY NO.	PARTS NUMBER	R A N K	Q'TY	DESCRIPTION	SERIAL NUMBER/ REMARKS	S V C
Fig.109	NPN		RF	MACHINE REAR PLATE 2		
1	FM0-0044-000		1	INTERLOCK ASSEMBLY		
2	FM0-0046-000		1	SWITCH ASSEMBLY, RIGHT	SW05	
3	FM1-C857-000		1	CABLE, BOTTLE		
4	WG8-5935-000		1	IC, PHOTO INTERRUPTER	PS14	
5	FM1-A832-000		1	CABLE, PRIMARY TRANSFER H.V.		
6	FM1-A839-000		1	CABLE, MAIN		
7	VS1-7177-002		2	CONNECTOR, SNAP TIGHT, BK		
8	VS1-7177-003		2	CONNECTOR, SNAP TIGHT, BK		
9	FM1-A855-000		2	CABLE, BOTTLE SENSOR, Y/C		
10	VS1-7207-003		2	CONNECTOR, SNAP TIGHT, BK		
11	FM1-A854-000		2	CABLE, BOTTLE SENSOR, M/K		
12	FM1-A853-000		1	CABLE, FIXING DRIVE		
13	FM1-G906-000		1	CABLE, POWER SUPPLY		
14	XA9-1386-000		AR	SCREW,RS,M3X8		
15	FM1-A820-000		1	CABLE, ENVIRONMENT SENSOR		

FIGURE 130 CONTROL PANEL ASSEMBLY



NOTE : This assembly does not include the part shown with key No. 22.
注 : このユニットにKey No. 22の部品は含まれません。

FIGURE & KEY NO.	PARTS NUMBER	R A N K	Q'TY	DESCRIPTION	SERIAL NUMBER/ REMARKS	S V C
Fig.130	FM1-H687-000		1	CONTROL PANEL ASSEMBLY	US,CA	
Fig.130	FM1-E004-000		1	CONTROL PANEL ASSEMBLY	SG,IN,AU	
Fig.130	FM1-E005-000		1	CONTROL PANEL ASSEMBLY	EUR	
1	FE3-9500-000		1	PLATE, GROUNDING		
2	FE3-9495-000		1	PLATE, GROUNDING		
3	FE2-1544-000		1	COVER, LAMP		
4	FE3-9494-000		1	CROSSMEMBER, CONTROL PANEL		
5	FE2-1584-000		1	PLATE, DIAL, 2		
6	FL0-2905-000		1	KEY TOP, GUIDE		
7	FM1-J352-000		1	LCD HOLDER UNIT		
8	FL0-3422-000		1	KEY TOP, BACK		
9	FE3-9527-000		1	KEY TOP, VOLUME	US,CA,EUR	
9	FE3-9550-000		1	KEY TOP, VOLUME	SG,IN,AU	
10	FE3-1745-000		1	KEY TOP, STOP		
11	FE3-1746-000		1	KEY TOP, ENERGY SAVER		
12	FE3-9549-000		1	KEY TOP, TEN		
13	FE3-1748-000		1	KEY TOP, RESET		
14	FM1-J353-000		1	CONTROL PANEL UNIT	US,CA	
14	FM1-J357-000		1	CONTROL PANEL UNIT	SG,IN,AU	
14	FM1-J358-000		1	CONTROL PANEL UNIT	EUR	
15	FL0-3423-000		1	KEY TOP, STATUS MONITOR		
16	FL0-3424-000		1	KEY TOP, HOME		
17	FL3-6538-000		1	KEY, START		
18	FE3-9492-000		1	COVER, FRONT	US,CA,EUR	
18	FE4-0678-000		1	COVER, FRONT	SG,IN,AU	
19	FM0-0076-000		1	HINGE, CONTROL ASSEMBLY, LEFT		
20	FM0-0077-000		1	HINGE, CONTROL ASSEMBLY, RIGHT		
21	FM1-G973-000		1	TOUCH PANEL PCB ASSEMBLY		
22	FE4-8394-000		1	LABEL, CONTROL PANEL	MF810Cdn US,CA French SEE NOTE	

FIGURE 190 CARTRIDGE AIR INTAKE FAN ASS'Y

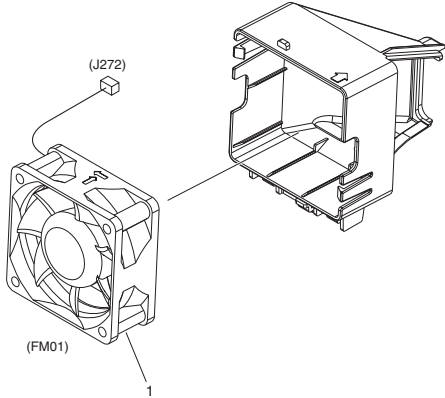

FIGURE & KEY NO.	PARTS NUMBER	RANK	Q'TY	DESCRIPTION	SERIAL NUMBER/REMARKS	SVC
Fig.190	NPN		RF	CARTRIDGE AIR INTAKE FAN ASS'Y		
1	FK2-3679-000		1	FAN	FM01	

FIGURE 191 DELIVERY COOLING FAN ASSEMBLY

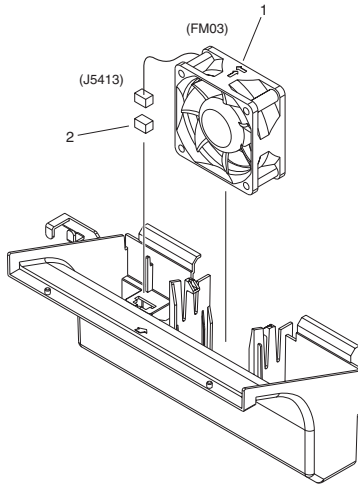

FIGURE & KEY NO.	PARTS NUMBER	RANK	Q'TY	DESCRIPTION	SERIAL NUMBER/REMARKS	SVC
Fig.191	NPN		RF	DELIVERY COOLING FAN ASSEMBLY		
1	FK2-3679-000		1	FAN	FM03	
2	VS1-7440-003		1	CONNECTOR, SNAP TIGHT		

FIGURE 192 DRIVE COOLING FAN ASS'Y

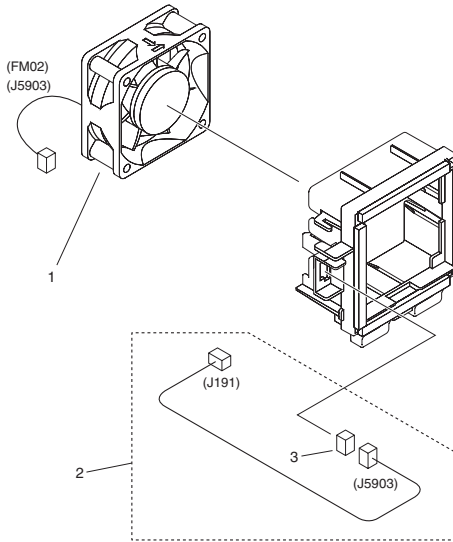

FIGURE & KEY NO.	PARTS NUMBER	RANK	QTY	DESCRIPTION	SERIAL NUMBER/REMARKS	SVC
Fig.192	NPN		RF	DRIVE COOLING FAN ASS'Y		
1	FK2-3679-000		1	FAN	FM02	
2	FM1-A819-000		1	CABLE, FAN		
3	VS1-7177-003		1	CONNECTOR, SNAP TIGHT, BK		

FIGURE 250 MAIN DRIVE ASSEMBLY

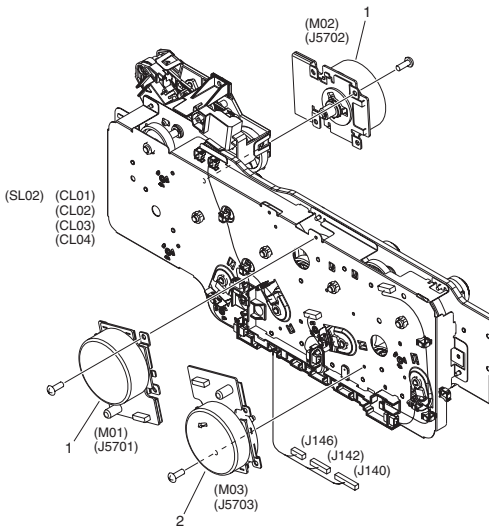

FIGURE & KEY NO.	PARTS NUMBER	RANK	Q'TY	DESCRIPTION	SERIAL NUMBER/REMARKS	SVC
Fig.250	FM0-0040-000		1	MAIN DRIVE ASSEMBLY	CL01,CL02,CL03,CL04,SL02	
1	FL0-1543-000		2	MOTOR, DC	M01,M02	
2	FL0-1544-000		1	MOTOR, DC	M03	

FIGURE 260 PAPER PICK-UP DRIVE ASSEMBLY

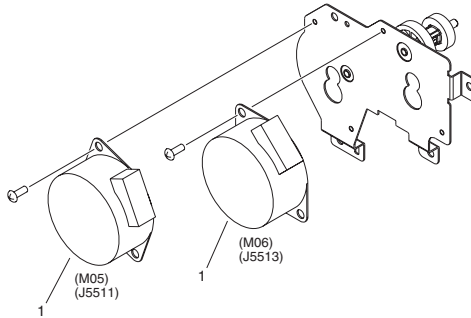

FIGURE & KEY NO.	PARTS NUMBER	RANK	QTY	DESCRIPTION	SERIAL NUMBER/REMARKS	SVC
Fig.260	FM1-A226-000		1	PAPER PICK-UP DRIVE ASSEMBLY		
1	FK4-0640-000		2	MOTOR, STEPPING	M05,M06	

FIGURE 270 BOTTLE DRIVE ASSEMBLY

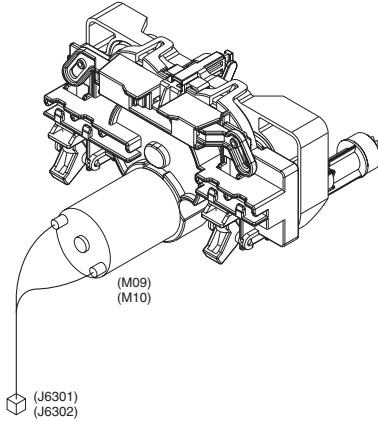

FIGURE & KEY NO.	PARTS NUMBER	RANK	Q'TY	DESCRIPTION	SERIAL NUMBER/REMARKS	SVC
Fig.270	FM0-0007-000		2	BOTTLE DRIVE ASSEMBLY	M09,M10	

FIGURE 280 FIXING DRIVE ASSEMBLY

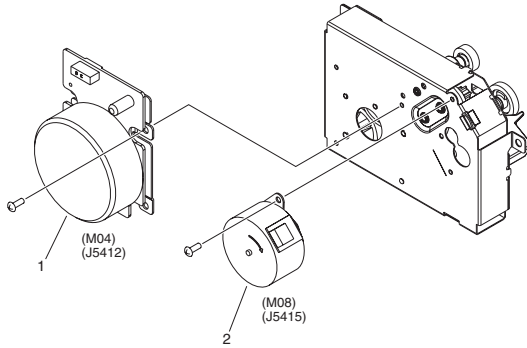

FIGURE & KEY NO.	PARTS NUMBER	RANK	QTY	DESCRIPTION	SERIAL NUMBER/REMARKS	SVC
Fig.280	FM0-0034-000		1	FIXING DRIVE ASSEMBLY		
1	FK4-0638-000		1	MOTOR, DC	M04	
2	FK4-0641-000		1	MOTOR, STEPPING	M08	

FIGURE 290 PICK-UP LIFTER DRIVE ASS'Y

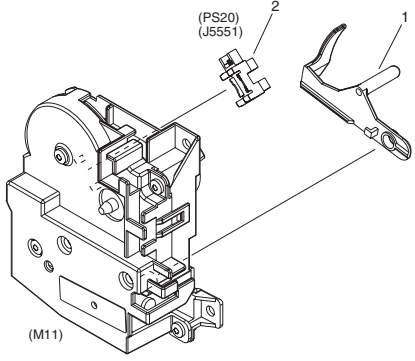
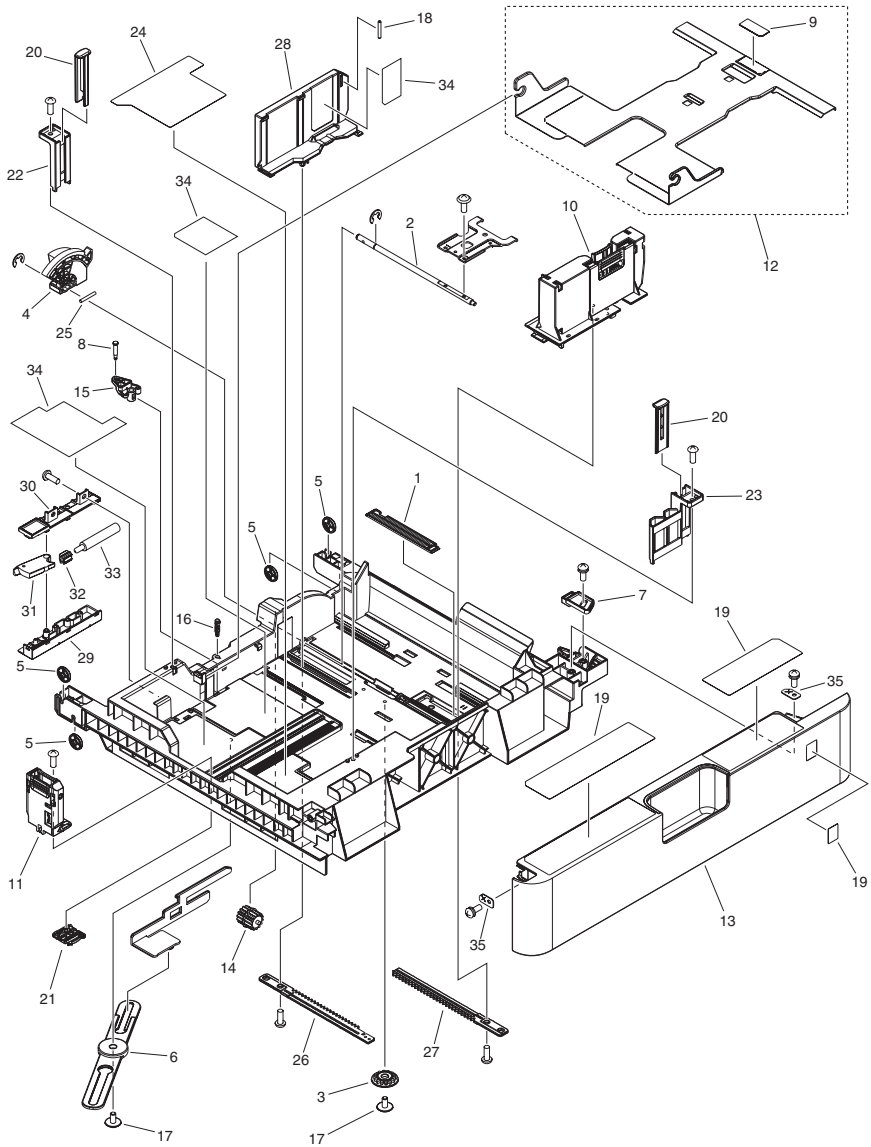

FIGURE & KEY NO.	PARTS NUMBER	RANK	Q'TY	DESCRIPTION	SERIAL NUMBER/REMARKS	SVC
Fig.290	FM0-0018-000		1	PICK-UP LIFTER DRIVE ASS'Y	M11	
1	FE3-4041-000		1	LEVER, REMNANT DETECT		
2	WG8-5935-000		1	IC, PHOTO INTERRUPTER	PS20	

FIGURE 300 CASSETTE



NOTE 1 : This assembly does not include the parts shown with key No. 19 and 34.

NOTE 2 : Several kinds of labels are attached on the board for the parts of Key No. 19 and 34.

注 1 : このユニットにKey No.19, 34の部品は含まれません。

注 2 : Key No. 19, 34の部品は台紙に数種類のラベルが付いています。

FIGURE & KEY NO.	PARTS NUMBER	R A N K	Q'TY	DESCRIPTION	SERIAL NUMBER/ REMARKS	S V C
Fig.300	FM1-D694-000		1	CASSETTE		
1	FC0-7661-000		1	STOPPER, FREE		
2	FC0-7662-000		1	SHAFT, LIFTER		
3	FC8-4990-000		1	GEAR, 14T		
4	FE3-1527-000		1	GEAR, 68T/37T		
5	FE3-1528-000		4	ROLLER, CASSETTE		
6	FE3-3950-000		1	ARM, SIZE SENSOR LINK		
7	FE3-4476-000		1	SPACER		
8	FE3-6143-000		1	PIN, GUIDE		
9	FL3-6526-000		1	SHEET, SEPARATION		
10	FM1-B545-000		1	PLATE, PAPER SIDE END, FRONT		
11	FM1-B547-000		1	PLATE, BACK END LIMIT		
12	FM1-B548-000		1	PLATE, MIDDLE		
13	FM1-D705-000		1	CASSETTE COVER ASSEMBLY, FRONT		
14	RC1-9396-000		1	GEAR, 14T		
15	FC0-7832-000		1	ARM, GUIDE		
16	FC0-7830-000		1	PIN, ARM		
17	XA9-1523-000		2	SCREW, B, M4X8		
18	XD9-0290-000		1	PIN, PARALLEL		
19	FE4-1819-000		1	LABEL, CASSETTE	EXCEPT C1225 SEE NOTE 1,SEE NOTE 2	
19	FE4-5975-000		1	LABEL, CASSETTE	C1225 SEE NOTE 1,SEE NOTE 2	
20	FE3-9437-000		2	BLOCK, PAPER SIDE END		
21	FE3-6357-000		1	PLATE, LINK		
22	FE3-9436-000		1	BLOCK, PAPER SIDE END, REAR		
23	FE3-9501-000		1	BLOCK, PAPER SIDE END, FRONT		
24	FE3-9591-000		1	LABEL, SIZE BACK END OPERATION		
25	XD9-0359-000		1	PIN, PARALLEL		
26	FE4-0306-000		1	RACK, PAPER SIDE END		
27	FC0-7660-000		1	RACK, SIDE		
28	FE3-0481-000		1	PLATE, PAPER SIDE END, REAR		
29	FE4-1425-000		1	HOLDER, DAMPER		

FIGURE & KEY NO.	PARTS NUMBER	R A N K	Q'TY	DESCRIPTION	SERIAL NUMBER/ REMARKS	S V C
30	FE4-1426-000		1	COVER, DAMPER HOLDER		
31	FE4-1427-000		1	LINK, DAMPER		
32	FE4-1428-000		1	LINK, DAMPER		
33	FE4-1500-000		1	DAMPER, OIL		
34	FE3-7412-000		1	LABEL, ENVELOPE OPERATION	EXCEPT C1225 SEE NOTE 1,SEE NOTE 2	
34	FE4-5976-000		1	LABEL, ENVELOPE OPERATION	C1225 SEE NOTE 1,SEE NOTE 2	
35	FE3-8153-000		2	WASHER		

FIGURE 310 REGIST./PAPER PICK-UP ASS'Y

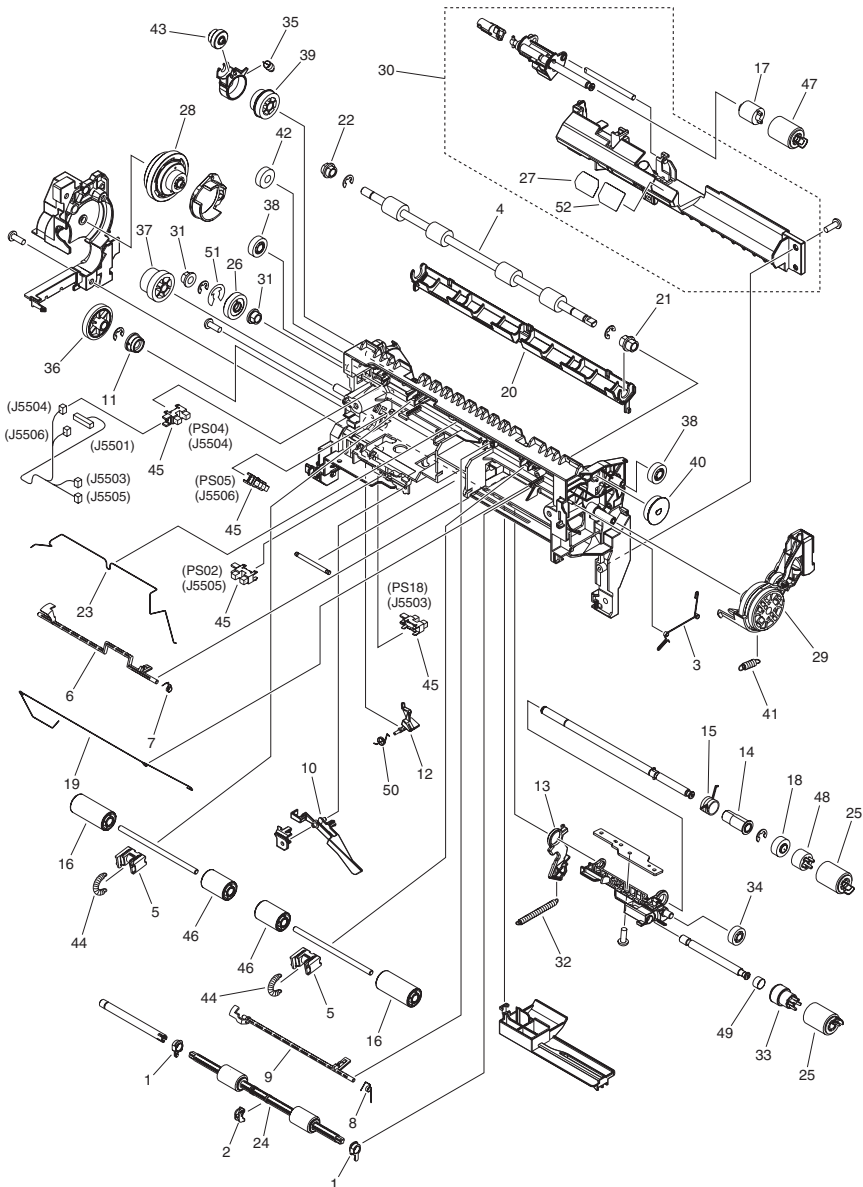

NOTE : This assembly does not include the part shown with key No. 20.
 注 : このユニットにKey No. 20の部品は含まれません。

FIGURE & KEY NO.	PARTS NUMBER	RANK	Q'TY	DESCRIPTION	SERIAL NUMBER/REMARKS	SVC
Fig.310	FM0-0029-000		1	REGIST./PAPER PICK-UP ASS'Y		
1	FC0-5876-000		2	BUSHING		
2	FC0-5888-000		1	BUSHING		
3	FC0-6968-000		1	CABLE, REG. GROUNDING		
4	FC0-6979-000		1	ROLLER, REGISTRATION		
5	FC0-7174-000		2	BLOCK, REGIST. PRESSURE		
6	FC0-7204-000		1	LEVER, PAPER PICK-UP SENSOR		
7	FC0-7205-000		1	SPRING, TORSION		
8	FC0-7211-000		1	SPRING, TORSION		
9	FC0-7218-000		1	FLAG, REGISTRATION SENSOR		
10	FC0-7670-000		1	LEVER, PAPER DETECT		
11	FC6-1353-000		1	BUSHING		
12	FE3-1585-000		1	LEVER, PAPER PICK-UP LATCH		
13	FE3-1602-000		1	ARM, PAPER PICK-UP		
14	FE3-1617-000		1	BUSHING		
15	FE3-1618-000		1	SPRING, TORSION		
16	FE3-9592-000		2	ROLLER, REGISTRATION DRIVEN		
17	FE3-4860-000		1	LIMITER, TORQUE		
18	FE3-4861-000		1	GEAR, 23T		
19	FE3-5614-000		1	SPRING, GROUNDING		
20	FE3-6112-000		1	GUIDE, PRE-REGISTRATION	SEE NOTE	
21	FE3-6113-000		1	BUSHING		
22	FE3-6114-000		1	BUSHING		
23	FE3-6119-000		1	SPRING, GROUNDING		
24	FL0-1834-000		1	ROLLER, EXTRACTION		
25	FL0-1011-000		2	ROLLER, PAPER PICK-UP&FEED		
26	FL0-1570-000		1	ONE-WAY GEAR ASSEMBLY		
27	FL0-2588-000		1	SHEET, SEPARATION ROLLER GUIDE		
28	FM0-0030-000		1	ONE-WAY GEAR ASSEMBLY		
29	FM1-B297-000		1	REG. SWING HOLDER ASSEMBLY		
30	FM1-B557-000		1	SEPARATION FRAME ASSEMBLY		
31	FS1-1205-000		2	BUSHING		

FIGURE & KEY NO.	PARTS NUMBER	R A N K	Q'TY	DESCRIPTION	SERIAL NUMBER/ REMARKS	S V C
32	FU2-0234-000		1	SPRING, TENSION	PS02,PS04,PS05,PS18	
33	FU2-0247-000		1	GEAR, 23T		
34	FU2-0248-000		1	GEAR, 22T		
35	FU2-0284-000		1	SPRING, TENSION		
36	FU2-0287-000		1	GEAR, 32T		
37	FU2-0294-000		1	GEAR, 27T/21T		
38	FU2-0295-000		2	GEAR, 17T		
39	FU2-0297-000		1	GEAR, 24T/20T		
40	FU2-0298-000		1	GEAR, 23T		
41	FU2-0578-000		1	SPRING,TENSION		
42	FU8-0085-000		1	GEAR, 18T		
43	FU9-0675-000		1	GEAR, 17T		
44	FU9-2094-000		2	SPRING, TENSION		
45	WG8-5935-000		4	IC, PHOTO INTERRUPTER		
46	FE3-9593-000		2	ROLLER, REGISTRATION DRIVEN		
47	FL0-1674-000		1	ROLLER, SEPARATION		
48	FL0-1515-000		1	ONE-WAY CLUTCH ASSEMBLY		
49	FU2-0236-000		1	SPRING, COMPRESSION		
50	FE3-3935-000		1	SPRING, TORSION		
51	FC6-3002-000		1	RING, RESIN, RETAINING		
52	FL0-5214-000		1	SHEET, GAP		

FIGURE 330 MULTI FEED TRAY ASSEMBLY

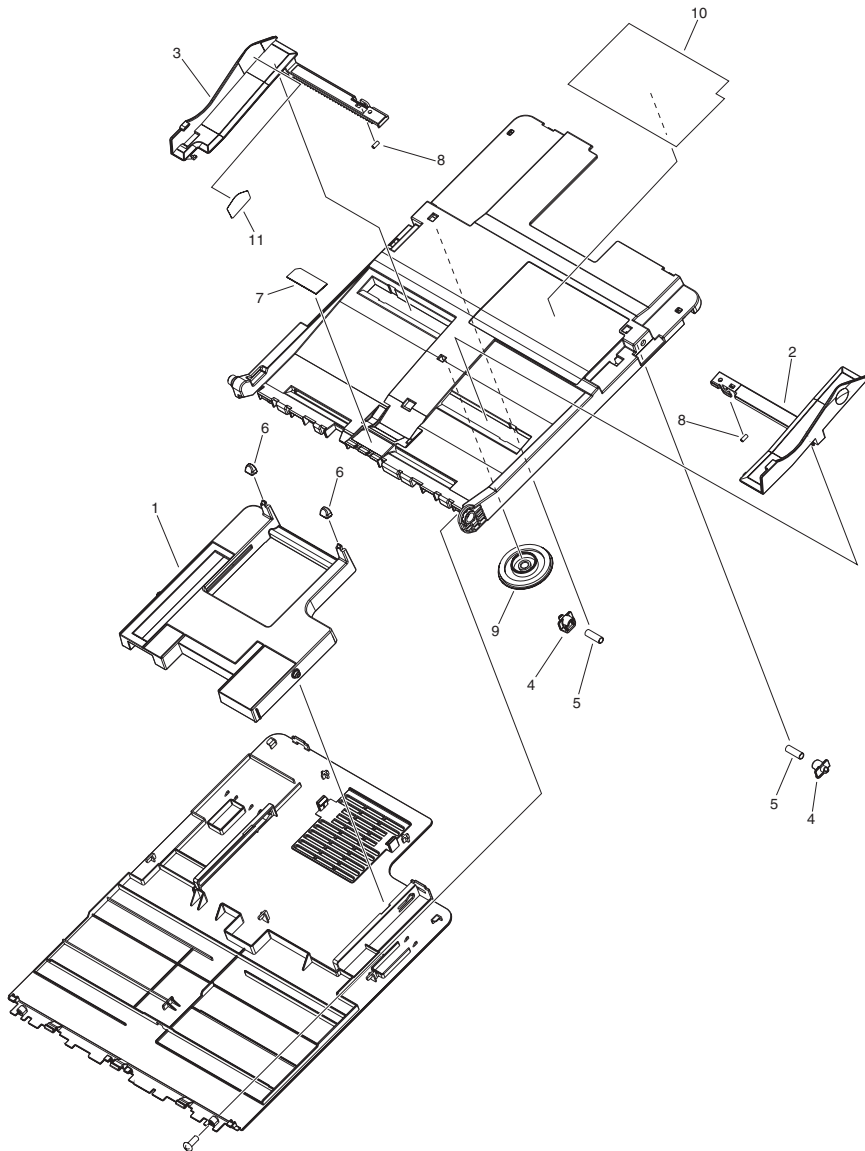

NOTE 1 : This assembly is included in the assembly shown in Figure 102.
 NOTE 2 : This assembly does not include the part shown with key No. 10.
 注 1 : このユニットはFigure 102のユニットに含まれます。
 注 2 : このユニットにKey No. 10の部品は含まれません。

FIGURE & KEY NO.	PARTS NUMBER	R A N K	Q'TY	DESCRIPTION	SERIAL NUMBER/ REMARKS	S V C
Fig.330	FM1-D706-000		1	MULTI FEED TRAY ASSEMBLY	SEE NOTE 1	
1	FE3-9099-000		1	TRAY, MULTI FEED EXTENSION		
2	FE3-9101-000		1	PLATE, PAPER SIDE END, FRONT		
3	FE3-9100-000		1	PLATE, PAPER SIDE END, REAR		
4	FE3-5650-000		2	HOOK, MULTI FEED TRAY		
5	FE3-5651-000		2	SPRING, COMPRESSION		
6	FE4-5352-000		2	CAP. MULTI FEED EXTENSION TRAY		
7	FL3-6526-000		1	SHEET, SEPARATION		
8	FU2-0582-000		2	SPRING, COMPRESSION		
9	FU9-0692-000		1	PINION, SIDE END		
10	FE4-1826-000		1	LABEL, MULTI FEED SIZE	A/INCH SIZE SEE NOTE 2	
10	FE4-1824-000		1	LABEL, MULTI FEED SIZE	INCH/A/B/K SIZE SEE NOTE 2	
10	FE4-1825-000		1	LABEL, MULTI FEED SIZE	A SIZE SEE NOTE 2	
11	FE4-1823-000		1	LABEL, MULTI PICK-UP FULL		

FIGURE 331 MULTI FEED PAPER PICK-UP ASS'Y

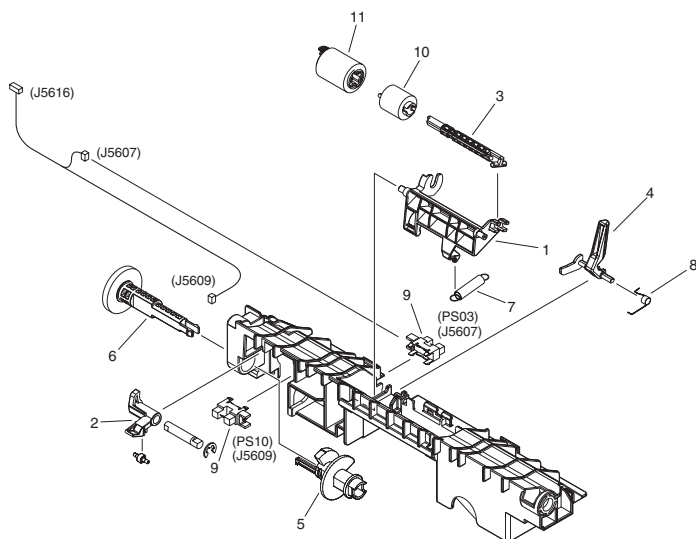

NOTE 1 : This assembly is included in the assembly shown in Figure 102.

NOTE 2 : This assembly does not include the parts shown with key No. 10 and 11.

注 1 : このユニットはFigure 102のユニットに含まれます。

注 2 : このユニットにKey No. 10, 11の部品は含まれません。

FIGURE & KEY NO.	PARTS NUMBER	R A N K	Q'TY	DESCRIPTION	SERIAL NUMBER/ REMARKS	S V C
Fig.331	FM1-B308-000		1	MULTI FEED PAPER PICK-UP ASS'Y	SEE NOTE 1	
1	FC0-6637-000		1	HOLDER, PAPER FEED ROLLER		
2	FC0-7447-000		1	LINK, RELEASE		
3	FE3-0387-000		1	SHAFT, ROLLER		
4	FE3-1642-000		1	LEVER, PAPER YES/NO SENSING		
5	FE3-3589-010		1	CAM, ROLLER ESTRANGEMENT		
6	FU6-1304-000		1	GEAR, 33T		
7	FU9-2088-000		1	SPRING, TENSION		
8	FU9-2091-000		1	SPRING, TORSION		
9	WG8-5935-000		2	IC, PHOTO INTERRUPTER	PS03,PS10	
10	FE3-4860-000		1	LIMITER, TORQUE	SEE NOTE 2	
11	FL0-1674-000		1	ROLLER, SEPARATION	SEE NOTE 2	

FIGURE 332 DUPLEXING GUIDE ASSEMBLY

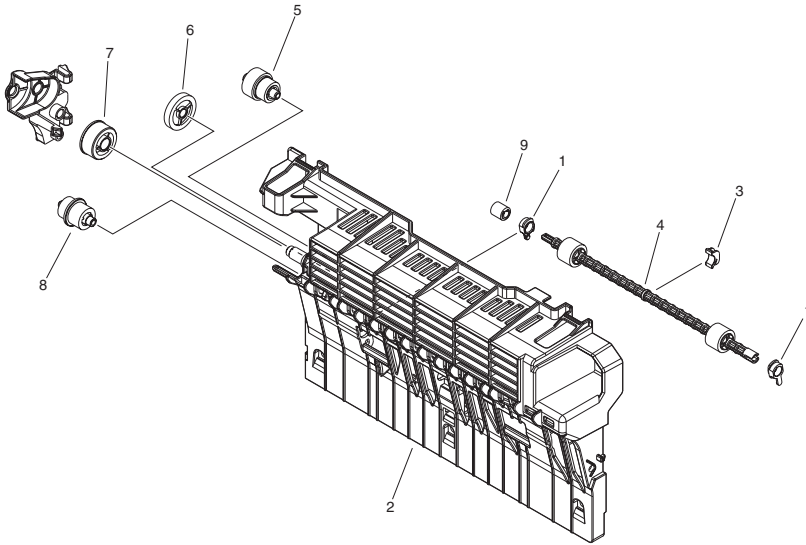

FIGURE & KEY NO.	PARTS NUMBER	RANK	Q'TY	DESCRIPTION	SERIAL NUMBER/REMARKS	SVC
Fig.332	NPN		RF	DUPLEXING GUIDE ASSEMBLY		
1	FC0-5876-000		2	BUSHING		
2	FC0-5886-000		1	GUIDE, DUPLEXING		
3	FC0-5888-000		1	BUSHING		
4	FL3-6443-000		1	ROLLER, DUPLEXING FEED		
5	FM1-B551-000		1	PLANETARY ONE-WAY GEAR ASS'Y		
6	FU9-0663-000		1	GEAR, 25T		
7	FU9-0666-000		1	GEAR, 23T		
8	FU9-0672-000		1	GEAR, 25T/14T		
9	FU9-0720-000		1	GEAR, 16T		

FIGURE 350 PAPER DELIVERY/REVERSE ASS'Y

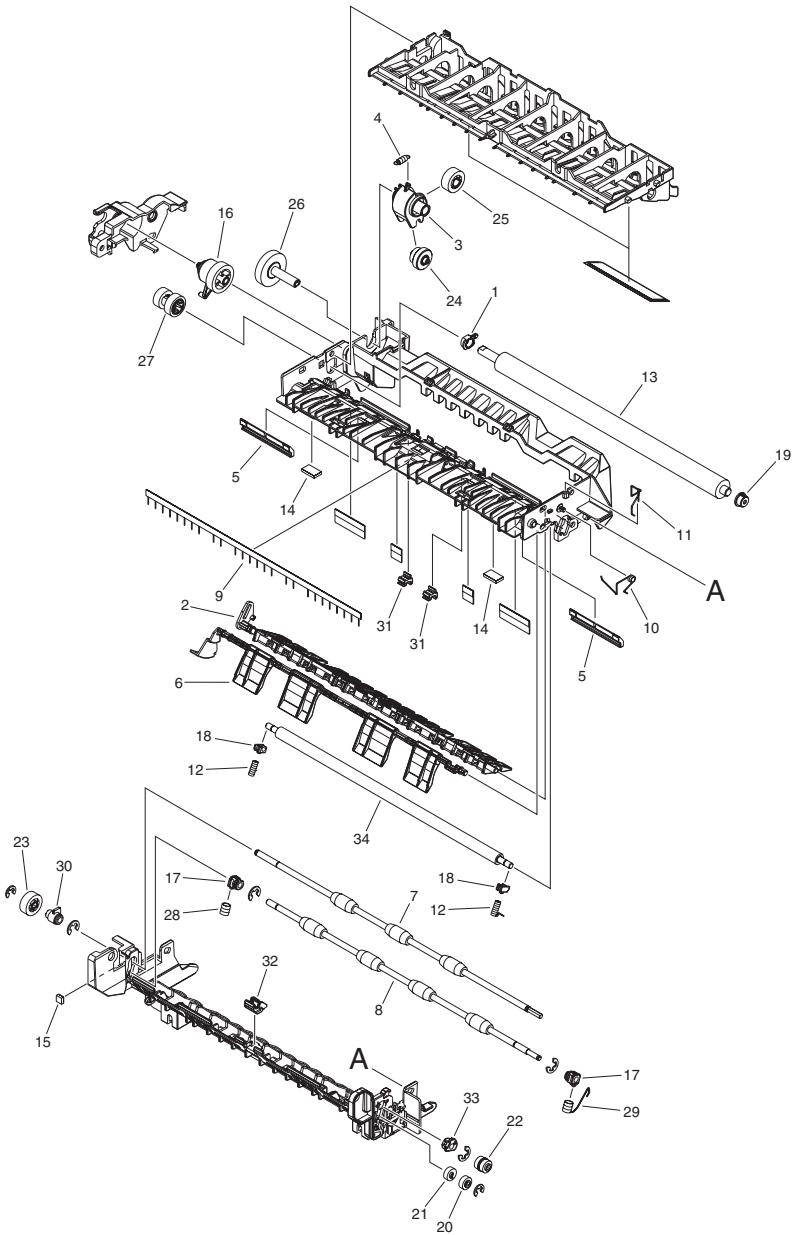

FIGURE & KEY NO.	PARTS NUMBER	R A N K	Q'TY	DESCRIPTION	SERIAL NUMBER/ REMARKS	S V C
Fig.350	FM0-0021-000		1	PAPER DELIVERY/REVERSE ASS'Y		
1	FC0-5876-000		1	BUSHING		
2	FC0-5880-000		1	FLAPPER, REVERSE		
3	FC0-5891-000		1	HOLDER, DUPLEXING SWING GEAR		
4	FC0-5892-000		1	SPRING, TENSION		
5	FE3-9461-000		2	GUIDE, ENTRANCE		
6	FC0-6102-000		1	FLAG, FULL DETECT		
7	FC0-7698-000		1	ROLLER, PAPER DELIVERY, UPPER		
8	FC0-7699-000		1	ROLLER, PAPER DELIVERY, LOWER		
9	FE3-3744-000		1	ELIMINATOR, STATIC CHARGE		
10	FE3-3745-000		1	SPRING, GROUNDING		
11	FE3-5739-000		1	SPRING, GROUNDING		
12	FE3-5740-000		2	SPRING, COMPRESSION		
13	FE3-6111-000		1	ROLLER, FIXING PAPER DELIVERY		
14	FL0-1009-000		2	SHEET, FLAG, SILENCER		
15	FL0-1010-000		1	SHEET, FLAG SILENCER		
16	FL0-1833-000		1	GEAR, 24T		
17	FU2-0718-000		2	BUSHING		
18	FU2-0719-000		2	BUSHING		
19	FU2-0720-000		1	BUSHING		
20	FU2-0810-000		1	GEAR, 9T		
21	FU2-0811-000		1	GEAR, 9T		
22	FU2-0812-000		1	GEAR, 9T/9T		
23	FU9-0613-000		1	GEAR, 18T		
24	FU9-0675-000		1	GEAR, 17T		
25	FU9-0676-000		1	GEAR, 18T		
26	FU9-0677-000		1	GEAR, 29T		
27	FU9-0680-000		1	GEAR, 17T/15T		
28	FU9-2108-000		1	SPRING, COMPRESSION		
29	FU9-2191-000		1	SPRING, TORSION		
30	FE3-8410-000		1	BUSHING		
31	FC0-7828-000		2	CLIP, SHAFT, UPPER		

FIGURE & KEY NO.	PARTS NUMBER	R A N K	Q'TY	DESCRIPTION	SERIAL NUMBER/ REMARKS	S V C
32	FC0-7827-000		1	CLIP, SHAFT, LOWER		
33	FE3-8411-000		1	BUSHING		
34	FC7-6108-000		1	ROLLER, H DRIVEN		

FIGURE 460 LASER SCANNER ASSEMBLY

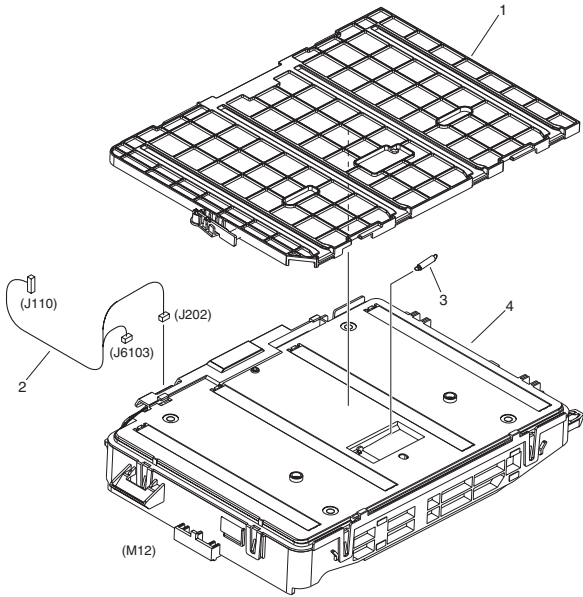

FIGURE & KEY NO.	PARTS NUMBER	RANK	Q'TY	DESCRIPTION	SERIAL NUMBER/REMARKS	SVC
Fig.460	NPN		RF	LASER SCANNER ASSEMBLY		
1	FM0-0031-000		1	DUST-PROOF SHUTTER ASSEMBLY		
2	FM1-A823-000		1	CABLE, LASER SCANNER		
3	FU9-2181-000		1	SPRING, TENSION		
4	FM0-0144-000		1	LASER SCANNER ASSEMBLY	M12	

FIGURE 530
 INTER. TRANSFER BELT ASS'Y

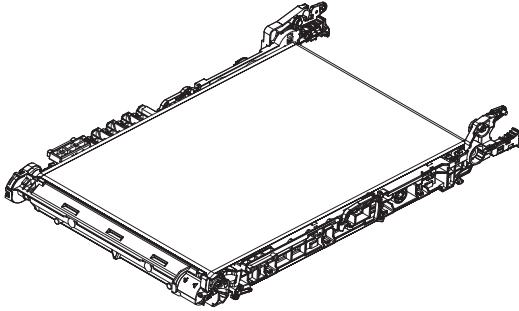

FIGURE & KEY NO.	PARTS NUMBER	R A N K	Q'TY	DESCRIPTION	SERIAL NUMBER/ REMARKS	S V C
Fig.530	FM1-A153-010		1	INTER. TRANSFER BELT ASS'Y		

FIGURE 621 BOTTLE MOUNT ASSEMBLY

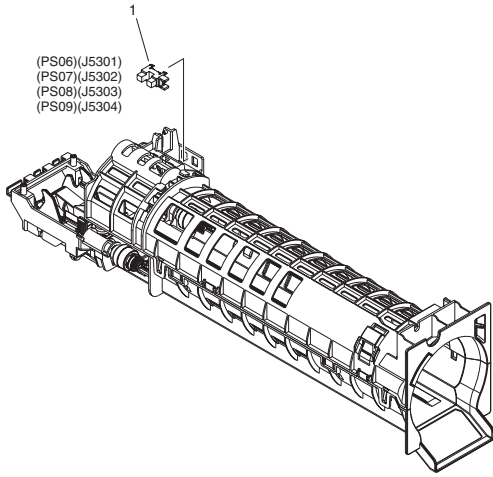

FIGURE & KEY NO.	PARTS NUMBER	RANK	QTY	DESCRIPTION	SERIAL NUMBER/REMARKS	SVC
Fig.621	FM0-0002-000		4	BOTTLE MOUNT ASSEMBLY		
1	WG8-5935-000		1	IC. PHOTO INTERRUPTER	PS06,PS07,PS08,PS09	

FIGURE 622 HOPPER ASSEMBLY

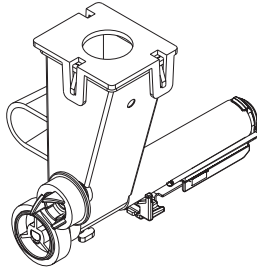

FIGURE & KEY NO.	PARTS NUMBER	RANK	Q'TY	DESCRIPTION	SERIAL NUMBER/REMARKS	SVC
Fig.622	FM0-0006-000		4	HOPPER ASSEMBLY		

FIGURE 771 INTERNAL COVER ASSEMBLY

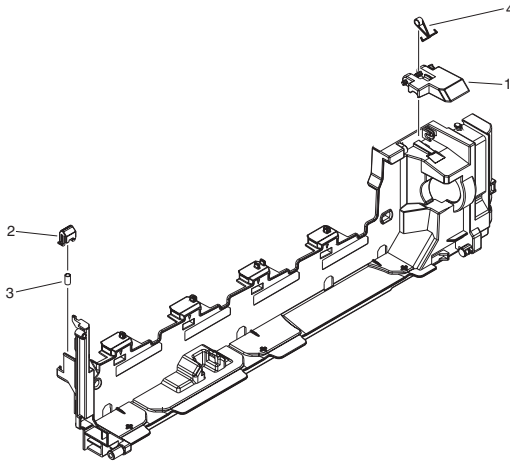

FIGURE & KEY NO.	PARTS NUMBER	RANK	QTY	DESCRIPTION	SERIAL NUMBER/REMARKS	S V C
Fig.771	NPN		RF	INTERNAL COVER ASSEMBLY		
1	FC0-5972-000		1	ARM, SENSOR		
2	FC0-7589-000		1	BLOCK, WASTE TONER		
3	FU2-0574-000		1	SPRING, COMPRESSION		
4	FU9-2027-000		1	SPRING, TORSION		

FIGURE 810
FIXING ASSEMBLY, FX-201

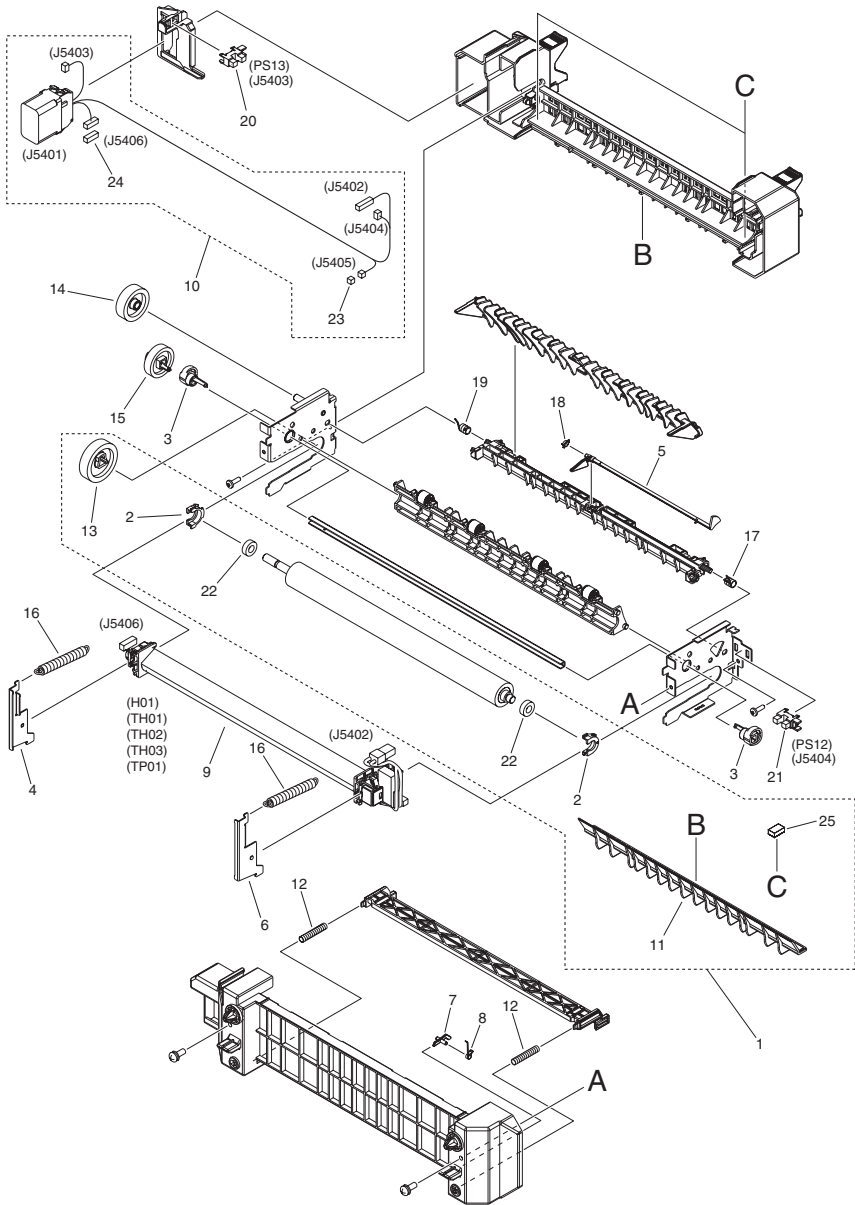

FIGURE & KEY NO.	PARTS NUMBER	RANK	Q'TY	DESCRIPTION	SERIAL NUMBER/REMARKS	SVC
Fig.810	FM0-0072-000		1	FIXING ASSEMBLY, FX-201	120V	
Fig.810	FM0-0073-000		1	FIXING ASSEMBLY, FX-201	230V	
1	FM1-K198-000		1	PRESSURE ROLLER KIT		
2	FC0-6079-000		2	HOLDER, BEARING		
3	FC0-6086-000		2	CAM, PRESSURE RELEASE		
4	FC0-6088-000		1	PLATE, PRESSURE, REAR		
5	FC0-6092-000		1	FLAG, PAPER DELIVERY SENSOR		
6	FC0-6131-000		1	PLATE, PRESSURE, LEFT		
7	FC0-6156-000		1	LOCK, SHUTTER, FRONT		
8	FC0-6157-000		1	SPRING, TORSION		
9	FM0-0080-000		1	FIXING FILM ASSEMBLY	120V H01,TH01,TH02,TH03,TP01	
9	FM1-C340-000		1	FIXING FILM ASSEMBLY	230V H01,TH01,TH02,TH03,TP01	
10	FM1-A802-000		1	CABLE, FIXING ASSEMBLY		
11	FC0-6089-000		1	FUSER, INLET, GUIDE		
12	FU2-0230-000		2	SPRING, COMPRESSION		
13	FU9-0610-000		1	GEAR, 29T		
14	FU9-0611-000		1	GEAR, 24T		
15	FU9-0612-000		1	GEAR, 30T		
16	FU9-2104-000		2	SPRING, TENSION		
17	FU9-2105-000		1	SPRING, TORSION		
18	FU9-2106-000		1	SPRING, TORSION		
19	FU9-2111-000		1	SPRING, TORSION		
20	WG8-5935-000		1	IC, PHOTO INTERRUPTER	PS13	
21	WG8-5783-000		1	IC,PHOTO-INTERRUPTER,LG248NL1A	PS12	
22	XG9-0831-000		2	BEARING, BALL, L-1260ZZR		
23	VS1-7177-002		1	CONNECTOR, SNAP TIGHT, BK		
24	VS1-7177-006		1	CONNECTOR, SNAP TIGHT, BK		
25	FL0-6873-000		2	DAMPER		

FIGURE 900 CONTROLLER BOX ASSEMBLY

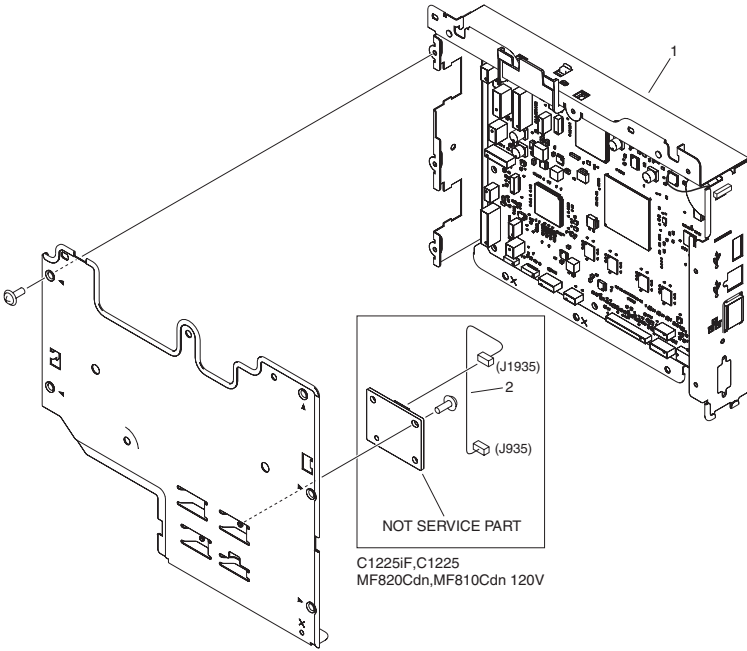

FIGURE & KEY NO.	PARTS NUMBER	RANK	Q'TY	DESCRIPTION	SERIAL NUMBER/REMARKS	SVC
Fig.900	NPN		RF	CONTROLLER BOX ASSEMBLY		
1	FM1-J784-000		1	MAIN CONTROLLER PCB ASSEMBLY	MF810Cdn 230V	
1	FM1-J785-000		1	MAIN CONTROLLER PCB ASSEMBLY	MF820Cdn	
1	FM1-J786-000		1	MAIN CONTROLLER PCB ASSEMBLY	C1225iF,C1225,MF810Cdn 120V	
2	FM1-G981-000		1	CABLE, FRAM	C1225iF,C1225,MF820Cdn,M F 810 Cdn 120V	
IC	FK2-7852-000		2	IC, T6TH5EFG-0002(0), STANDARD	IC60,IC61	
IC	FK3-1800-000		1	IC, ASIC, MB8AA4241EPBH-GE1	IC14	
IC	FK3-3034-000		1	IC, FZC0ZA012AA STANDARD CELL	IC43	

FIGURE 910 POWER SUPPLY ASSEMBLY

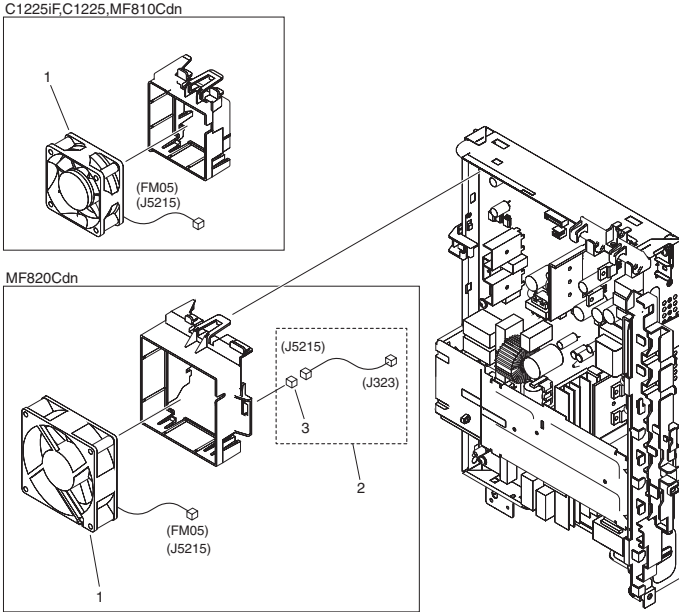

FIGURE & KEY NO.	PARTS NUMBER	R A N K	Q'TY	DESCRIPTION	SERIAL NUMBER/REMARKS	S V C
Fig.910	FM1-E364-000		1	POWER SUPPLY ASSEMBLY	MF810Cdn 120V	
Fig.910	FM1-E363-000		1	POWER SUPPLY ASSEMBLY	MF820Cdn 120V	
Fig.910	FM1-C093-000		1	POWER SUPPLY ASSEMBLY	C1225iF,C1225,MF810 230V	
1	FK2-2064-000		1	FAN	C1225iF,C1225,MF810Cdn FM05	
1	FK2-0360-000		1	FAN	MF820Cdn FM05	
2	FM1-G907-000		1	CABLE, FAN CONNECTING	MF820Cdn	
3	VS1-7177-003		1	CONNECTOR, SNAP TIGHT, BK	MF820Cdn	

FIGURE 930 DC CONTROLLER PCB ASSEMBLY

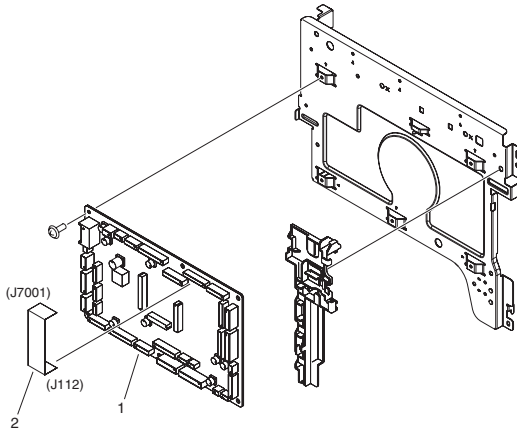

FIGURE & KEY NO.	PARTS NUMBER	RANK	QTY	DESCRIPTION	SERIAL NUMBER/REMARKS	SVC
Fig.930	NPN		RF	DC CONTROLLER PCB ASSEMBLY		
1	FM1-M802-000		1	DC CONTROLLER PCB ASSEMBLY		
2	FK4-1736-000		1	CABLE, FLAT		

FIGURE B01 ADF MAINTENANCE KIT

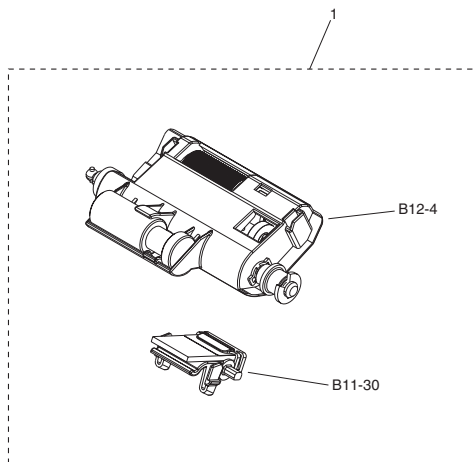

FIGURE & KEY NO.	PARTS NUMBER	RANK	Q'TY	DESCRIPTION	SERIAL NUMBER/REMARKS	SVC
Fig.B01	NPN		RF	ADF MAINTENANCE KIT		
1	FM4-9866-000		1	ADF MAINTENANCE KIT, DR-201		

FIGURE B10 READER/ADF ASSEMBLY

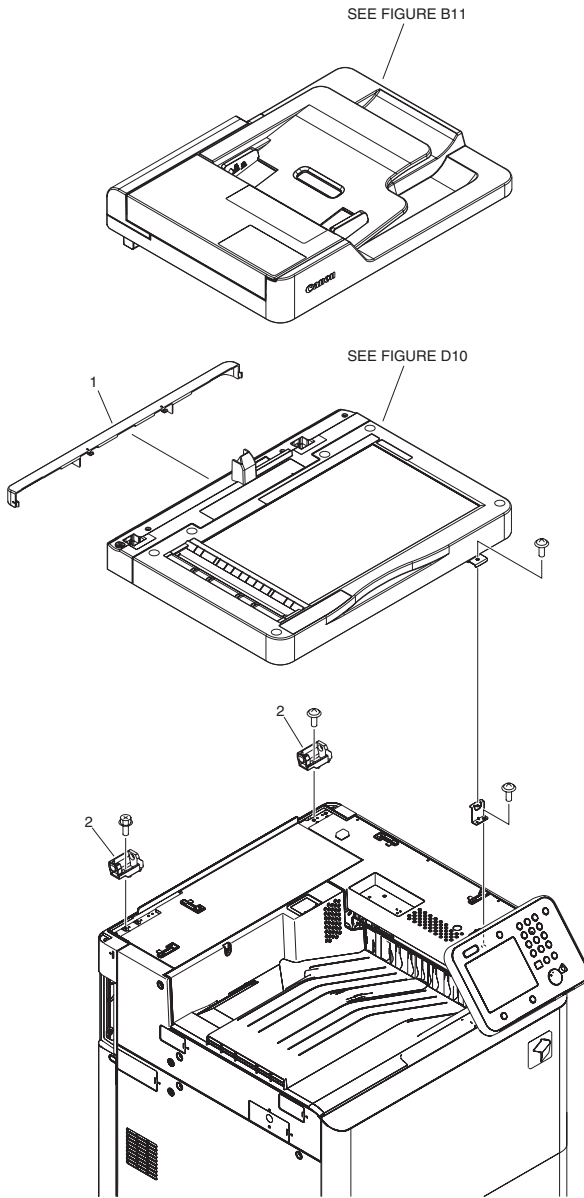
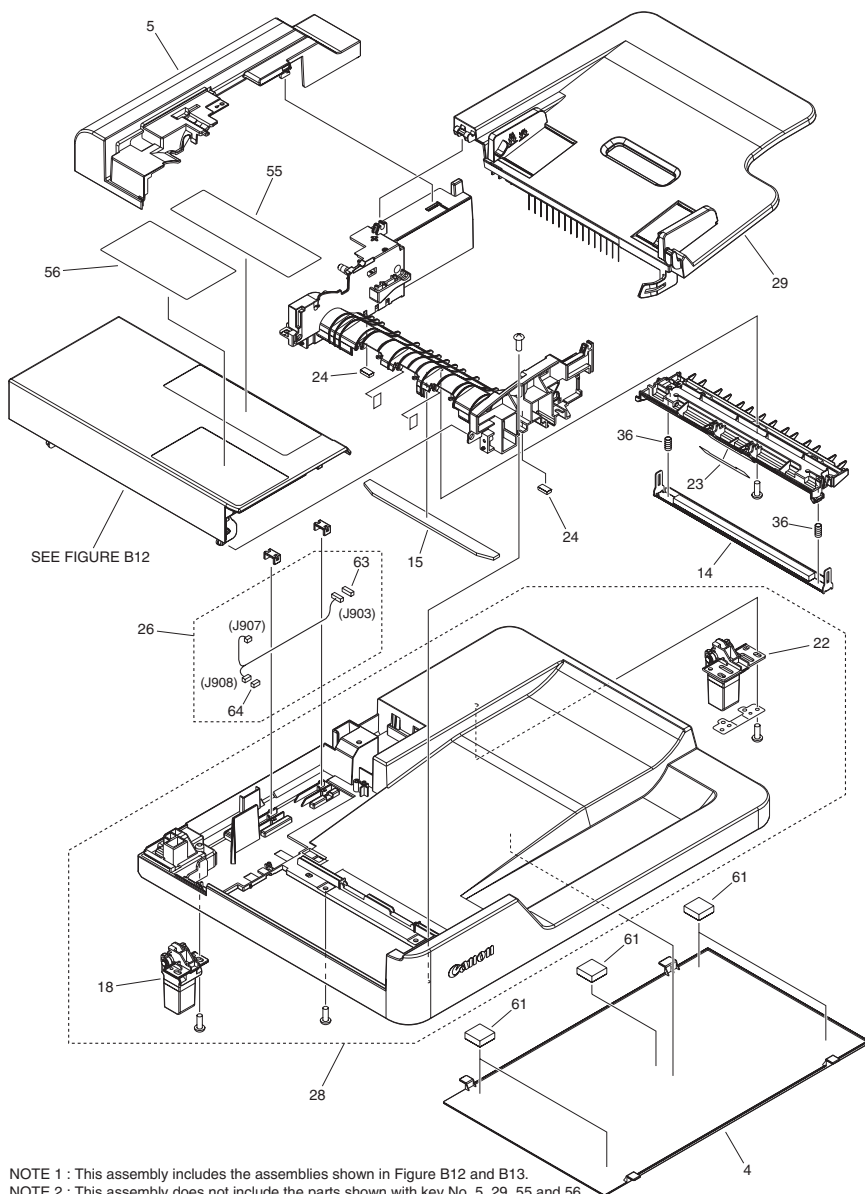

FIGURE & KEY NO.	PARTS NUMBER	RANK	Q'TY	DESCRIPTION	SERIAL NUMBER/REMARKS	SVC
Fig.B10	NPN		RF	READER/ADF ASSEMBLY		
1	FE3-9184-000		1	COVER, READER, REAR, 2		
2	FC0-5544-000		2	HINGE, READER		

FIGURE B11 AUTO DOCUMENT FEEDER ASSEMBLY



NOTE 1 : This assembly includes the assemblies shown in Figure B12 and B13.

NOTE 2 : This assembly does not include the parts shown with key No. 5, 29, 55 and 56.

注 1 : このユニットはFigure B12, B13のユニットを含みます。

注 2 : このユニットにKey No. 5, 29, 55, 56の部品は含まれません。

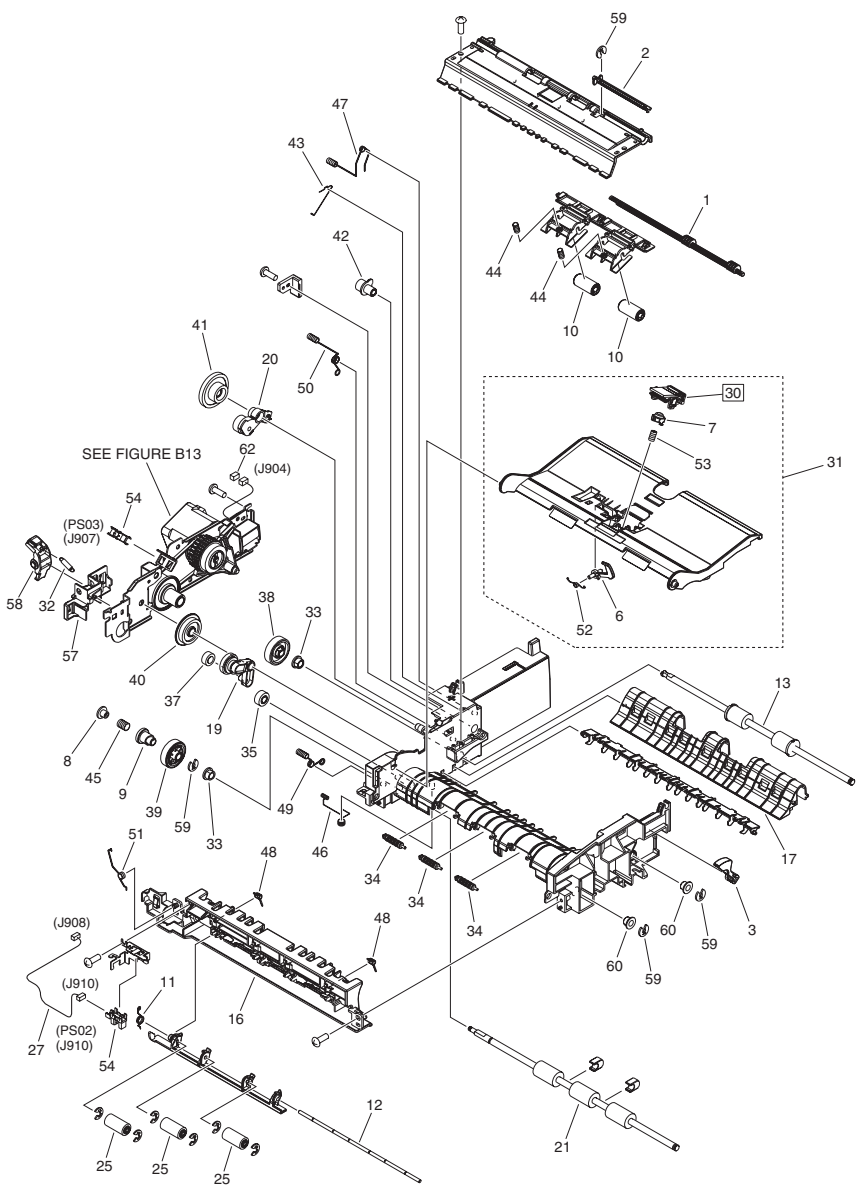
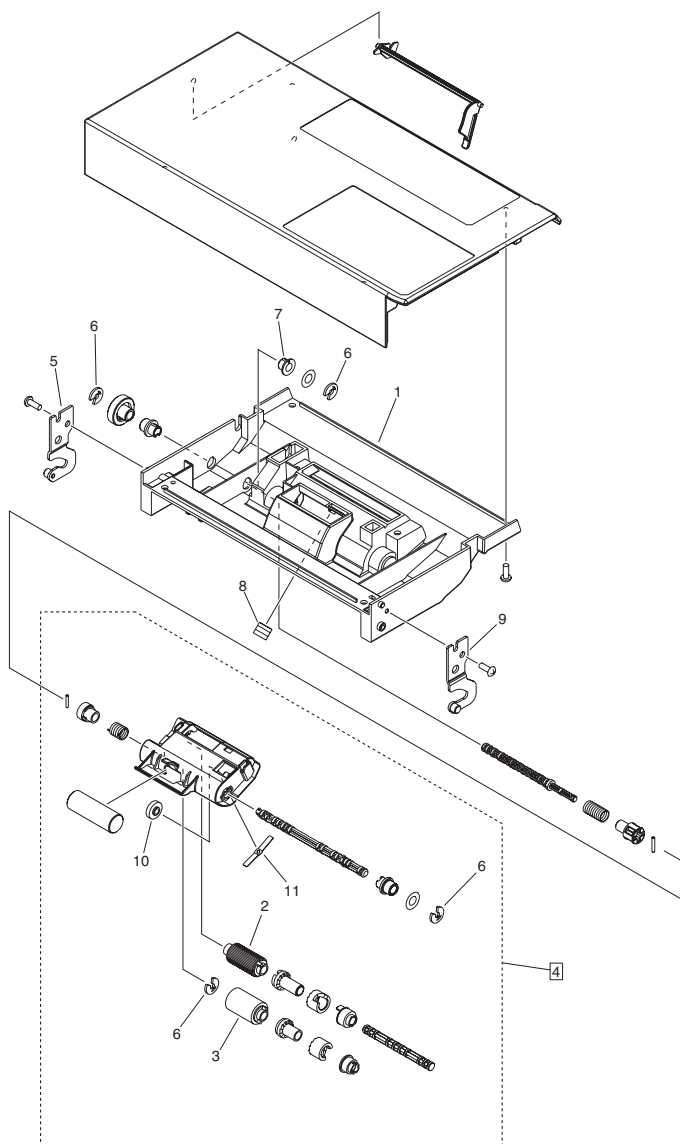

FIGURE & KEY NO.	PARTS NUMBER	R A N K	Q'TY	DESCRIPTION	SERIAL NUMBER/ REMARKS	S V C
Fig.B11	FM1-D730-000		1	AUTO DOCUMENT FEEDER ASSEMBLY	SEE NOTE 1	
1	FC0-5587-000		1	SHAFT, CAM		
2	FC0-5588-000		1	CAM, HAND		
3	FC0-5589-000		1	LEVER, ROLLER ESTRANGEMENT		
4	FC0-5591-000		1	COVER, COPYBOARD		
5	FE3-9190-000		1	COVER, ADF, REAR	SEE NOTE 2	
6	FC0-5629-000		1	STOPPER, DOCUMENT		
7	FC0-5634-000		1	COVER, SEPARATION SPRING		
8	FE4-1402-000		1	STOPPER, RATCHET SPRING		
9	FC7-6052-010		1	RATCHET, PAPER FEED ROLLER		
10	FE3-8381-000		2	ROLLER, PAPER DELIVERY		
11	FC7-6303-000		1	SPRING, TORSION		
12	FE3-6504-000		1	SHAFT		
13	FL0-1104-000		1	ROLLER, PAPER DELIVERY		
14	FL0-1105-000		1	PANEL, COPYBOARD		
15	FL0-2013-000		1	DAMPER, MAIN FRAME		
16	FL0-2020-000		1	GUIDE, FEED		
17	FL0-2021-000		1	GUIDE, PAPER DELIVERY		
18	FL3-1430-000		1	HINGE, ADF		
19	FL3-6308-000		1	ARM, PAPER FEED SWING		
20	FL3-6309-000		1	ARM, SEPARATION SWING		
21	FL3-6311-000		1	ROLLER, DF FEED		
22	FL3-6313-000		1	HINGE, ADF, RIGHT		
23	FL3-6314-000		1	SHEET, GUIDE, LOWER		
24	FL3-6320-000		2	PAD, DAMPER		
25	FE3-8290-000		3	ROLLER, PAPER FEED		
26	FM1-C985-000		1	CABLE, ADF DETECT		
27	FM1-C986-000		1	CABLE, ADF - DES		
28	FM1-F007-000		1	ADF BASE ASSEMBLY		
29	FM1-F010-000		1	DOCUMENT TRAY ASSEMBLY	SEE NOTE 2	
30	FM4-9857-000		1	SEPARATION PAD ASSEMBLY	[DP]	
31	FM1-F009-000		1	GUIDE, UPPER		

FIGURE & KEY NO.	PARTS NUMBER	R A N K	Q'TY	DESCRIPTION	SERIAL NUMBER/ REMARKS	S V C
32	FU6-2999-000		1	SPRING, TENSION		
33	FU5-1748-000		2	BUSHING		
34	FE3-8380-000		3	ROLLER, AUXILIARY		
35	FU8-0128-000		1	GEAR, 21T		
36	FE4-0007-000		2	SPRING, COMPRESSION		
37	FU9-0237-000		1	GEAR, 18T		
38	FU9-0589-000		1	GEAR, 43T		
39	FU9-0590-000		1	GEAR, 43T		
40	FU9-0591-000		1	GEAR, 41T		
41	FU9-0592-000		1	GEAR, 57T/21T		
42	FU9-0594-000		1	GEAR, 20T		
43	FU9-2005-000		1	SPRING, TORSION		
44	FU2-1543-000		2	SPRING, COMPRESSION		
45	FU9-2008-000		1	SPRING, COMPRESSION		
46	FU9-2009-000		1	SPRING, COMPRESSION		
47	FU9-2010-000		1	SPRING, TORSION		
48	FU9-2011-000		2	SPRING, TORSION		
49	FU9-2015-000		1	SPRING, TORSION		
50	FU9-2016-000		1	SPRING, TORSION		
51	FU9-2017-000		1	SPRING, TORSION		
52	FU9-2019-000		1	SPRING, TORSION		
53	FU9-2020-000		1	SPRING, COMPRESSION		
54	WG8-5935-000		2	IC, PHOTO INTERRUPTER	PS02,PS03	
55	FE4-0227-000		1	LABEL, PROHIBITION DOCUMENT	SEE NOTE 2	
56	FE4-0226-000		1	LABEL, CLEANING INSTRUCTION	SEE NOTE 2	
57	FC0-5574-000		1	HOLDER, LEVER		
58	FE3-7698-000		1	LEVER, DRIVE RELEASE		
59	FE3-7699-000		4	RING, C,EXTERNAL		
60	FE3-8298-000		2	BUSHING		
61	FL3-6315-000		5	CUSHION, WHITE SHEET		
62	VS1-7177-002		1	CONNECTOR, SNAP TIGHT, BK		
63	VS1-7207-006		1	CONNECTOR, SNAP TIGHT		

FIGURE & KEY NO.	PARTS NUMBER	R A N K	Q'TY	DESCRIPTION	SERIAL NUMBER/ REMARKS	S V C
64	VS1-7207-004		1	CONNECTOR, SNAP TIGHT, BK		

FIGURE B12 FEEDER COVER ASSEMBLY



NOTE 1 : This assembly is included in the assembly shown in Figure B11.

NOTE 2 : This assembly does not include the parts shown with key No. 5.

注 1 : このユニットはFigure B11のユニットに含まれます。

注 2 : このユニットにKey No. 5の部品は含まれません。

FIGURE & KEY NO.	PARTS NUMBER	R A N K	Q'TY	DESCRIPTION	SERIAL NUMBER/ REMARKS	S V C
Fig.B12	FM1-F008-000		1	FEEDER COVER ASSEMBLY	SEE NOTE 1	
1	FE3-9189-000		1	COVER, ADF INNER		
2	FC7-6189-000		1	ROLLER, PICK-UP		
3	FL2-6637-000		1	ROLLER, SEPARATION		
4	FM4-9859-000		1	ADF PAPER PICK-UP ASSEMBLY	[DP]	
5	FL0-2564-000		1	COVER, DF, REAR	SEE NOTE 2	
6	FE3-7699-000		4	RING, C,EXTERNAL		
7	FE3-8298-000		1	BUSHING		
8	FE3-9145-000		1	SPRING, COMPRESSION		
9	FL0-2565-000		1	COVER, DF, FRONT		
10	FE3-8297-000		1	GEAR, 23T		
11	FE3-8383-000		1	SPRING, LEAF		

FIGURE B13 PAPER FEED DRIVE ASSEMBLY

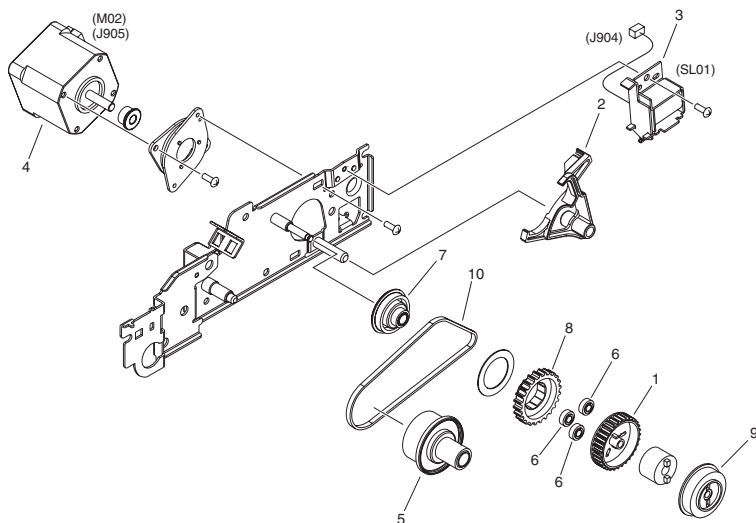

NOTE : This assembly is included in the assembly shown in Figure B11.
注 : このユニットはFigure B11のユニットに含まれます。

FIGURE & KEY NO.	PARTS NUMBER	R A N K	Q'TY	DESCRIPTION	SERIAL NUMBER/ REMARKS	S V C
Fig.B13	FM4-9862-000		1	PAPER FEED DRIVE ASSEMBLY	SEE NOTE	
1	FC0-5622-000		1	GEAR, 29T		
2	FC0-5623-000		1	STOPPER, CAM		
3	FK2-0408-010		1	SOLENOID	SL01	
4	FK3-2024-000		1	MOTOR, STEPPING	M02	
5	FU9-0588-000		1	GEAR, 47T/20T		
6	FU9-0595-000		3	GEAR, 16T		
7	FU9-0596-000		1	PULLEY		
8	FU9-0597-000		1	GEAR, 52T		
9	FU9-0598-000		1	GEAR, 55T		
10	XF2-1611-830		1	BELT, TIMING, COGGED		

FIGURE D10 READER ASSEMBLY

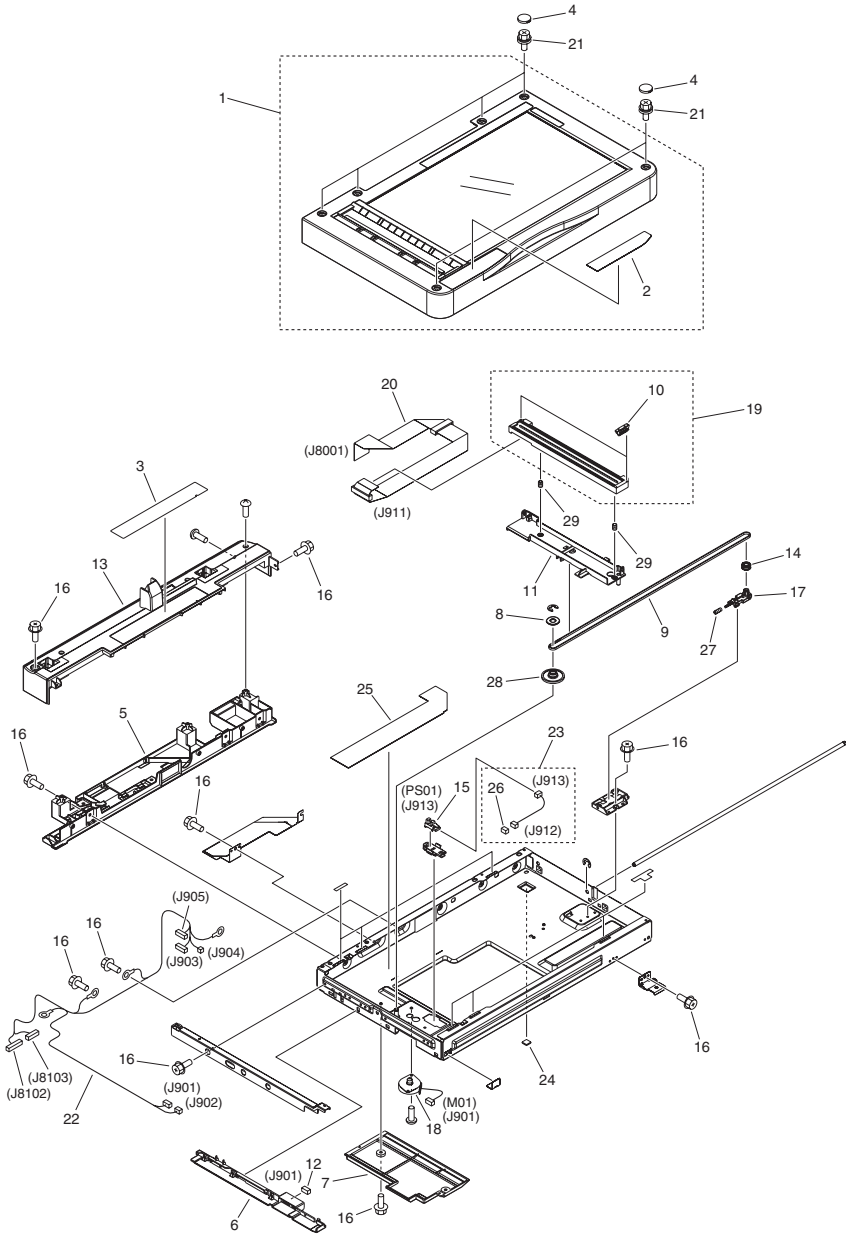

FIGURE & KEY NO.	PARTS NUMBER	RANK	Q'TY	DESCRIPTION	SERIAL NUMBER/REMARKS	SVC
Fig.D10	NPN		RF	READER ASSEMBLY		
1	FM1-H417-000		1	COVER, READER, FRON		
2	FE4-5989-000		1	LABEL, BLACK LINE, CLEANING		
3	FE3-9200-000		1	LABEL, COPY INHIBITED	Portuguese	
3	FE3-9201-000		1	LABEL, COPY INHIBITED	Canadian French	
3	FE3-9202-000		1	LABEL, COPY INHIBITED	Spanish	
3	FE3-9204-000		1	LABEL, COPY INHIBITED	UK English	
3	FE3-9205-000		1	LABEL, COPY INHIBITED	French	
3	FE3-9206-000		1	LABEL, COPY INHIBITED	German	
3	FE3-9207-000		1	LABEL, COPY INHIBITED	Italian	
3	FE4-5990-000		1	LABEL, COPY INHIBITED	Russian,Dutch,Polish,Arabic	
3	FE3-9203-000		1	LABEL, COPY INHIBITED	US English	
4	FE3-9178-000		6	CAP		
5	FE3-9179-000		1	COVER, LOWER		
6	FE3-9180-000		1	GUIDE, CABLE		
7	FE3-9181-000		1	COVER, MOTOR		
8	FC0-5550-000		1	STOPPER, BELT		
9	FC0-5553-000		1	BELT, TIMING, COGGED		
10	FC0-5554-000		2	SPACER, CONTACT IMAGE SENSOR	RANK B	
10	FE3-6570-000		2	SPACER, CONTACT IMAGE SENSOR	RANK C	
10	FE3-6571-000		2	SPACER, CONTACT IMAGE SENSOR	RANK A	
11	FC0-5555-000		1	HOLDER, CONTACT IMAGE SENSOR		
12	VS1-7177-004		1	CONNECTOR, SNAP TIGHT, BK		
13	FL0-4342-000		1	COVER, READER, REAR, 1		
14	FC0-5650-000		1	PULLEY, IDLER		
15	WG8-5935-000		1	IC, PHOTO INTERRUPTER	PS01	
16	XA9-1386-000		AR	SCREW,RS,M3X8		
17	FC0-5552-000		1	HOLDER, PULLEY, IDLER		
18	FK3-3035-000		1	MOTOR, STEPPING	M01	
19	FM1-H164-000		1	CONTACT IMAGE SENSOR ASSEMBLY	MF820Cdn	
19	FM1-H163-000		1	CONTACT IMAGE SENSOR ASSEMBLY	C1225iF,C1225,MF810Cdn	

FIGURE & KEY NO.	PARTS NUMBER	R A N K	Q'TY	DESCRIPTION	SERIAL NUMBER/ REMARKS	S V C
20	FK3-3038-000		1	CABLE, FLAT		
21	XA9-1449-000		6	SCREW, RS, M3X8		
22	FM1-C984-000		1	CABLE, READER MAIN		
23	FM1-C987-000		1	CABLE, HOME POSITION SENSOR		
24	FL0-2019-000		1	FOOT, READER		
25	FL3-6317-000		1	SHEET, INSULATING		
26	VS1-7207-003		1	CONNECTOR, SNAP TIGHT, BK		
27	FU6-2873-000		1	SPRING, COMPRESSION		
28	FU9-0581-000		1	GEAR, 85T/20T		
29	FU9-2023-000		2	SPRING, COMPRESSION		

FIGURE T20 FAX ASSEMBLY (FAX model)

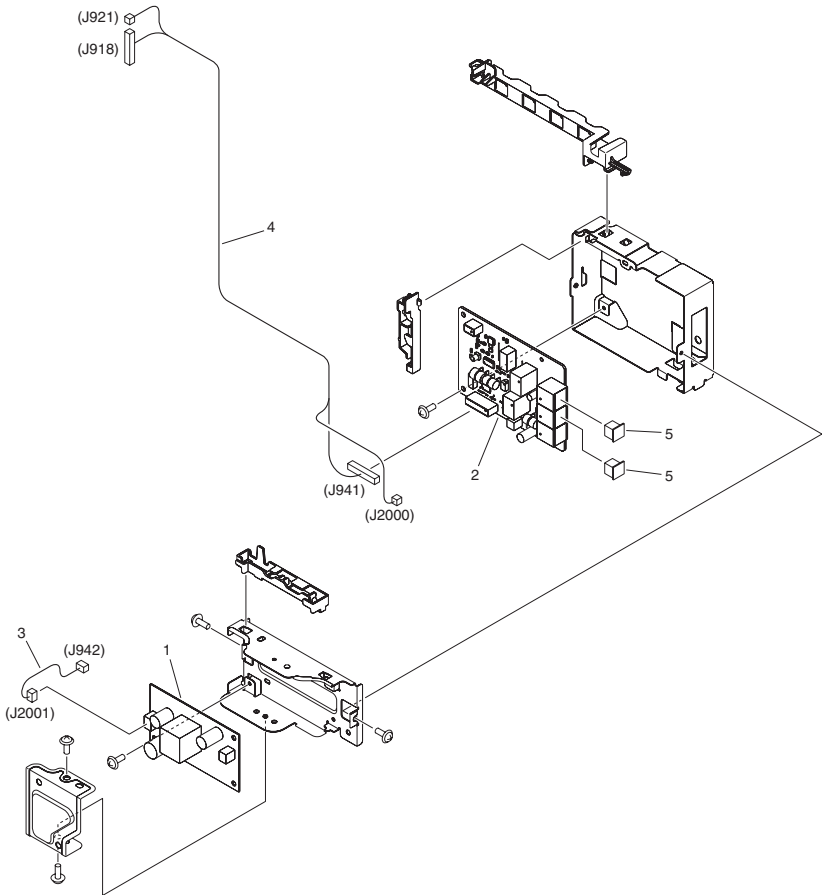

FIGURE & KEY NO.	PARTS NUMBER	RANK	Q'TY	DESCRIPTION	SERIAL NUMBER/REMARKS	SVC
Fig.T20	NPN		RF	FAX ASSEMBLY	FAX model	
1	FM4-8168-000		1	OFF-HOOK DETECT PCB ASSEMBLY		
2	FM1-G974-000		1	FAX PCB ASSEMBLY	US,CA,SG,IN	
2	FM1-M804-000		1	FAX PCB ASSEMBLY	AU	
2	FM1-G975-000		1	FAX PCB ASSEMBLY	EUR	
3	FM1-G979-000		1	CABLE, OFF-HOOK MODEM		
4	FM1-G982-000		1	CABLE, MODEM		
5	WT8-5076-000		2	SPACER,MODULAR		

FIGURE T21 SPEAKER (FAX model)

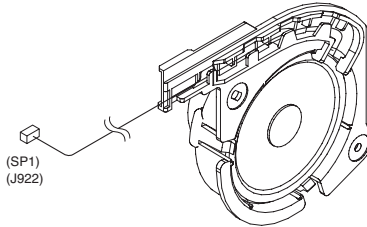

FIGURE & KEY NO.	PARTS NUMBER	RANK	QTY	DESCRIPTION	SERIAL NUMBER/REMARKS	SVC
Fig.T21	FM0-0059-000		1	SPEAKER		

FIGURE ZZA

MECHANICAL STANDARD PARTS (HOW TO USE)

Mechanical standard parts

機械標準部品

About a mechanical standard parts

A Mechanical standard parts is a mechanical part which not parts peculiar to a product. They are parts which are common to a Canon product and are used, such as a screw and a washer. The Fig No. and parts number of the mechanical standard parts are not listed in the product parts catalog. Refer to the parts catalog of mechanical standard parts when checking the parts number for screw or washer etc. and identify them by part shape or size.

機械標準部品とは

機械標準部品とは、製品特有の部品ではなく、ねじやワッシャなどキヤノン製品共通で使用されている機械部品（メカ部品）のことです。
製品のパーツカタログには、機械標準部品のFig No.や部品番号は記載していません。
ねじや、ワッシャ等の部品番号を調べるときは、機械標準部品のパーツカタログを参照し、部品の形状や大きさから判断し、使用している部品を調べてください。

Material and surface treatment of a mechanical standard parts

Material and surface treatment of mechanical standard parts are assigned commonly for each part. Refer to the Table 1 for the parts which material and surface treatment are assigned as numbers.

機械標準部品の材料および表面処理

機械標準部品の材料および表面処理については、各種部品共通で決められています。
材料および表面処理が番号で決められている部品については、表1を参照してください。

Table 1 Material and Surface treatment
表1 材料および表面処理

No. 番号	Material 材料	Surface treatment 表面処理	Color 色
1	Stainless steel ステンレス	Stainless steel black coloring (BC4) ステンレス黒着色(BC4)	Black 黒
2		not to be given なし	White 白
3	Brass 黄銅	Regular nickel plating (NL) 普通ニッケルメッキ(NL)	White 白
4		Black nickel plating (BN) 黒色ニッケルメッキ(BN)	Black 黒
5	Steel 鋼	White zinc trivalent chromate treating (ZC3) 白色亜鉛3価クロメート(ZC3)	White 白
6		Regular nickel chromium plating (NC) 普通ニッケルクロムメッキ(NC)	White 白
7		Regular nickel plating (NL) 普通ニッケルメッキ(NL)	White 白
8		Iron and steel phosphating (P1) 鉄鋼磷酸塩処理(P1)	Black 黒
9		Black zinc trivalent chromate treating (BZ3) 黒色亜鉛3価クロメート(BZ3)	Black 黒

FIGURE ZZB MECHANICAL STANDARD PARTS (SCREWS)

1. Screws ねじ

How to read Parts Numbers
部品番号の見方

Screws
ねじ

XB1-2400-609

Type No.
類別番号
Normal designation (d)
ねじの呼び(d)
Length (L)
ねじの長さ(L)
Material and Surface treatment
材料および表面処理

XB1-2 expresses Binding head machine screw.
XB1-2は、バインドねじを表す
40 expresses M4.0.
40は、M4.0を表す
0-60 expresses a length of 6.0mm.
0-60は、6.0mmの長さを表す
9 expresses Steel (Black zinc trivalent chromate
treating) from Table 1.
9は、表1より鋼(黒色亜鉛3価クロメート)を表す

1-1. Cross Recessed Head Screws for Precision Equipments 精密機器用十字穴付き小ねじ

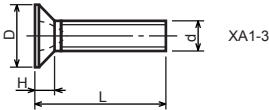
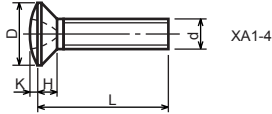
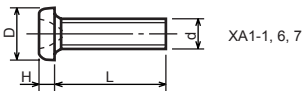

Type No. 類別番号	Type 類別	Head size (mm) 頭部寸法 (mm)							
		M1.4	M1.6	M1.7	M2	M2.5	M2.6		
XA1-1	Pan head Class 1 なべ1種	D	XA1-1	2	2.4	2.5	3	3.8	4
		H	XA1-1	0.5	0.55	0.5	0.6	0.9	0.8
XA1-3	Countersunk head Class 1 さら1種	D	XA1-3	2	2.4	2.5	3	3.8	4
		H	XA1-3	0.48	0.55	0.58	0.73	0.85	0.93
XA1-4	Oval countersunk head Class 1 丸さら1種	D	XA1-4	2	2.4	2.5	3	3.8	4
		H + K	XA1-4	0.68	0.8	0.88	1	1.25	1.3
XA1-6	Pan head Class 3 なべ3種	D	XA1-6	2.5	2.8	3	3.5	4.3	4.5
		H	XA1-6	0.8	0.85	0.9	1	1.3	1.2
XA1-7	Pan head Class 2 なべ2種	D	XA1-7	2.5	2.8	3	3.5	4.3	4.5
		H	XA1-7	0.5	0.55	0.5	0.6	0.9	0.8

1-2. Precision Tapping Screws
精密用タッピンねじ

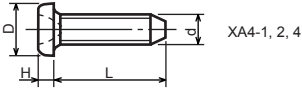

XA4-1, 2, 4

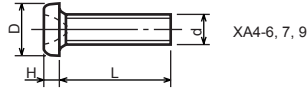

XA4-6, 7, 9

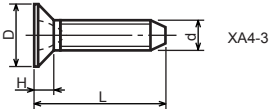

XA4-3

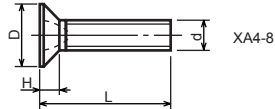

XA4-8

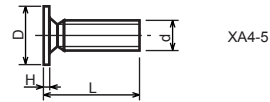

XA4-5

Type No. 類別番号	Type 類別	Head size (mm) 頭部寸法 (mm)						
		M1.4	M1.6	M1.7	M2	M2.5	M2.6	
XA4-1	With tapered end pan head Class 1 絞りなべ1種	D XA4-1	2	2.4	2.5	3	3.8	4
		H XA4-1	0.5	0.55	0.5	0.6	0.9	0.8
XA4-2	With tapered end pan head Class 3 絞りなべ3種	D XA4-2	2.5	2.8	3	3.5	4.3	4.5
		H XA4-2	0.8	0.85	0.9	1	1.3	1.2
XA4-3	With tapered end countersunk head 絞り-さら	D XA4-3	2	2.4	2.5	3	3.8	4
		H XA4-3	0.48	0.55	0.58	0.73	0.85	0.93
XA4-4	With tapered end pan head Class 2 絞りなべ2種	D XA4-4	2.5	2.8	3	3.5	4.3	4.5
		H XA4-4	0.5	0.55	0.5	0.6	0.9	0.8
XA4-5	With parallel end ultra thin head ストレート-超薄頭	D XA4-5	2.5	2.8	3	-	-	-
		H XA4-5	0.2	0.2	0.2	-	-	-
XA4-6	With parallel end pan head Class 1 ストレートなべ1種	D XA4-6	2	2.4	2.5	3	3.8	4
		H XA4-6	0.5	0.55	0.5	0.6	0.9	0.8
XA4-7	With parallel end pan head Class 3 ストレートなべ3種	D XA4-7	2.5	2.8	3	3.5	4.3	4.5
		H XA4-7	0.8	0.85	0.9	1	1.3	1.2
XA4-8	With parallel end countersunk head ストレート-さら	D XA4-8	2	2.4	2.5	3	3.8	4
		H XA4-8	0.48	0.55	0.58	0.73	0.85	0.93
XA4-9	With parallel end pan head Class 2 ストレートなべ2種	D XA4-9	2.5	2.8	3	3.5	4.3	4.5
		H XA4-9	0.5	0.55	0.5	0.6	0.9	0.8

1-3. Cross Recessed Head Screws
 一般用十字穴付き小ねじ



XB1-1

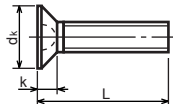

XB1-3

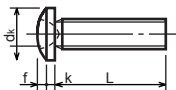

XB1-2

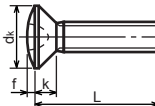

XB1-4

Type No. 類別番号	Type 類別
XB1-1	Pan head なべ
XB1-2	Binding head バインド
XB1-3	Countersunk head さら
XB1-4	Oval countersunk head 丸さら

		Head size (mm) 頭部寸法 (mm)					
		M2	M2.5	M2.6	M3	M4	M5
dk	XB1-1	3.5	4.5	4.5	5.5	7	9
k	XB1-1	1.3	1.7	1.7	2	2.6	3.3
dk	XB1-2	4.3	5.3	5.5	6.3	8.3	10.3
k+f	XB1-2	1.2	1.5	1.6	1.9	2.5	3.1
dk	XB1-3	4	5	-	6	8	10
k	XB1-3	1.2	1.45	-	1.75	2.3	2.8
dk	XB1-4	4	5	-	6	8	10
k+f	XB1-4	1.6	2	-	2.45	3.2	4
Screw part length ねじ部長さ b		8	12	12	12	16	20

1-4. Cross Recessed Head Screws with Captive Washer
 座金組み込み十字穴付き小ねじ

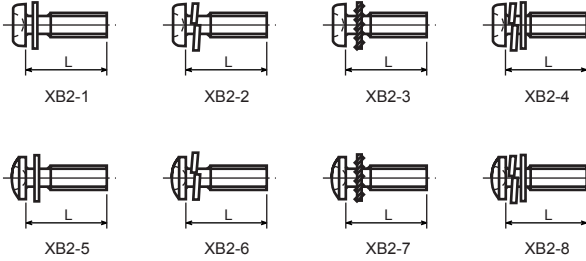

Type No. 類別番号	Type 類別
XB2-1	Pan head + Plain washer (circular bright) なべねじ+平座金
XB2-2	Pan head + Spring washer なべねじ+ばね座金
XB2-3	Pan head + Toothed lock washer なべねじ+歯付座金
XB2-4	Pan head + Spring washer and plain washer (circular bright) なべねじ+(ばね+平)座金
XB2-5	Binding head + Plain washer (circular bright) バインドねじ+平座金
XB2-6	Binding head + Spring washer バインドねじ+ばね座金
XB2-7	Binding head + Toothed lock washer バインドねじ+歯付座金
XB2-8	Binding head + Spring washer and plain washer (circular bright) バインドねじ+(ばね+平)座金

1-5. Hexagon Head Tapping Screws for Metallic Materials
 金属用六角タッピンねじ

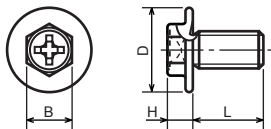

Type No. 類別番号	Type 類別	Head size (mm) 頭部寸法 (mm)	
		M3	M4
XB3-6	For metallic materials 金属用タッピン	D	8 10
		B	5.5 5.5
XB3-7	For metallic materials with clawed 金属用タッピン-つめ付き	H XB3-6	3.1 3.1
		H XB3-7	3.2 3.2

1-6. Special Tapping Screws
 特殊タッピンねじ

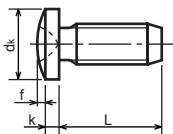

Type No. 類別番号	Type 類別	Head size (mm) 頭部寸法 (mm)	
		M3	M4
XB4-5	Binding head バインド	d _k	6.3 8.3
		k	1.3 1.7
		k+f	1.9 2.5

1-7. General Head Tapping Screws
一般用タッピンねじ

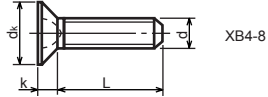
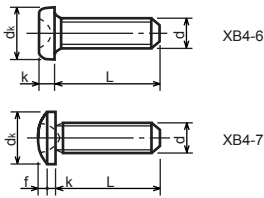

Type No. 類別番号	Type 類別	Head size (mm) 頭部寸法 (mm)						
		M2	M2.5	M2.6	M3	M4	M5	
XB4-6	Pan head なべ	d_k XB4-6	3.5	4.5	4.5	5.5	7	9
		k XB4-6	1.3	1.7	1.7	2	2.6	3.3
XB4-7	Binding head バインド	d_k XB4-7	4.3	5.3	5.5	6.3	8.3	10.3
		$k+f$ XB4-7	1.2	1.5	1.6	1.9	2.5	3.1
XB4-8	Countersunk head さら	d_k XB4-8	4	5	5.2	6	8	10
		k XB4-8	1.2	1.45	1.5	1.75	2.3	2.8

1-8. Tapping Screws for Metallic Materials
金属用タッピンねじ

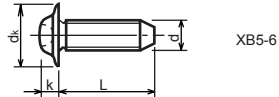
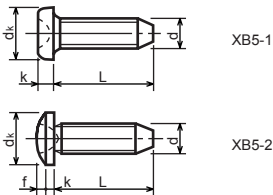

Type No. 類別番号	Type 類別	Head size (mm) 頭部寸法 (mm)					
		M2.5	M2.6	M3	M4	M5	
XB5-1	Pan head なべ	d_k XB5-1	4.5	4.5	5.5	7	9
		k XB5-1	1.7	1.7	2	2.6	3.3
XB5-2	Binding head バインド	d_k XB5-2	5.5	5.5	6.3	8.3	10.3
		$k+f$ XB5-2	1.6	1.6	1.9	2.5	3.1
XB5-6	Flanged pan head つば付きなべ	d_k XB5-6	6.5	6.5	8	10	12
		k XB5-6	2.1	2.1	1.75	3.2	4

1-9. Hexagon Socket Set Screws

六角穴付止めねじ

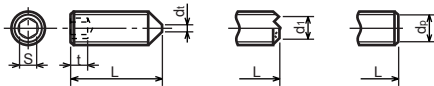

XB6-1

XB6-2

XB6-3

Type No. 類別番号	Type 類別
XB6-1	Cone point とがり先
XB6-2	Double point ダブルポイント
XB6-3	Flat point 平先

	Head size (mm) 頭部寸法 (mm)						
	M1.6 M1.7	M2	M2.5 M2.6	M3	M5	M5	M6
S	0.7	0.9	1.3	1.5	2	2.5	3
t	1.5	1.7	2	2	2.5	3	3.5
d _{t max} XB6-1	0.4	0.5	0.65	0.75	1	1.25	1.5
d _{1 max} XB6-2	-	1.2	1.5	1.7	2.2	2.8	3.3
d _{1 min} XB6-2	-	1	1.2	1.4	1.9	2.4	2.9
d _{p max} XB6-3	0.8	1	1.5	2	2.5	3.5	4
d _{p min} XB6-3	0.55	0.75	1.25	1.75	2.25	3.2	3.7

1-10. Flanged Pan Head Machine Screws

つば付きなべ小ねじ

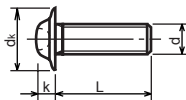

Type No. 類別番号	Type 類別
XB6-7	Flanged pan head つば付きなべ

	Head size (mm) 頭部寸法 (mm)				
	M2	M2.5 M2.6	M3	M5	M5
d _k	5	6.5	8	10	12
k	1.7	2.1	2.5	3.2	4

FIGURE ZZC MECHANICAL STANDARD PARTS (BOLTS)

2. Bolts (Socket head cap screw) ボルト

How to read Parts Numbers
部品番号の見方

Bolt (Socket head cap screw)
ボルト

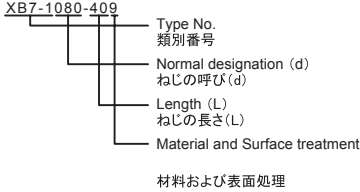

XB7-1 expresses Hexagon socket head cap screws.
XB7-1は、六角穴付きボルトを表す

080 expresses M8.0.
080は、M8.0を表す

40 expresses a length of 40mm.
40は、40mmの長さを表す

9 expresses Steel (Black zinc trivalent chromate
treating) from Table 1.

9は、表1より鋼(黒色亜鉛3価クロメート)を表す

2-1. Hexagon socket head cap screws 六角穴付きボルト

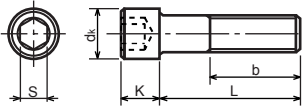

Type No. 類別番号	Type 類別
XB7-1	Hexagon socket head cap screws 六角穴付きボルト

	Head size (mm) 頭部寸法 (mm)						
	M3	M4	M5	M6	M8	M10	M12
S	2.5	3	4	5	6	8	10
d_k	5.5	7	8.5	10	13	16	18
K	3	4	5	6	8	10	12
Screw part length b_{max} ねじ部長さ b_{max}	18	20	22	24	28	32	36

FIGURE ZZD MECHANICAL STANDARD PARTS (NUTS)

3. Nuts ナット

How to read Parts Numbers
部品番号の見方

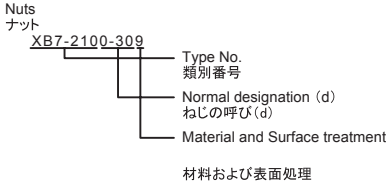

XB7-210 expresses Hexagon nut class 1.
XB7-210は、六角ナット1種を表す

0-30 expresses M3.0.
0-30は、M3.0を表す

9 expresses Steel (Black zinc trivalent chromate
treating) from Table 1.
9は、表1より鋼(黒色亜鉛3価クロメート)を表す

3-1. Hexagon Nuts and Hexagon Thin Nuts 六角ナット

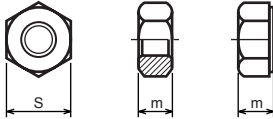

Type No. 類別番号	Type 類別
XB7-210	Hexagon nut Class 1 六角ナット-1種
XB7-220	Hexagon nut Class 3 六角ナット-3種
XB7-230	Hexagon nut Style 1 double chamfered 六角ナット-スタイル1-両面とり
XB7-231	Hexagon nut Style 1 washer faced 六角ナット-スタイル1-座付き
XB7-240	Hexagon nut Style 2 double chamfered 六角ナット-スタイル2-両面とり
XB7-241	Hexagon nut Style 2 washer faced 六角ナット-スタイル2-座付き
XB7-250	Hexagon nut 六角ナット
XB7-260	Hexagon thin nut double chamfered 六角低ナット-両面とり
XB7-270	Hexagon thin nut not chamfered 六角低ナット-面とり無し

	Head size (mm) 頭部寸法 (mm)						
	M2	M2.5	M3	M4	M5	M6	M8
S	4	5	5.5	7	8	10	13
m XB7-210	1.6	2	2.4	3.2	4	5	6.5
m XB7-220	1.2	1.6	1.8	2.4	3.2	3.6	5
m XB7-230, 231	1.6	2	2.4	3.2	4.7	5.2	6.8
m XB7-240, 241	-	-	-	-	5.1	5.7	7.5
m XB7-250	-	-	-	-	5.6	6.1	7.9
m XB7-260	1.2	1.6	1.8	2.2	2.7	3.2	4
m XB7-270	1.2	1.6	1.8	2.2	2.7	3.2	4

FIGURE ZZE MECHANICAL STANDARD PARTS (RETAINING RINGS)

5. Retaining Rings

止め輪

How to read Parts Numbers
部品番号の見方

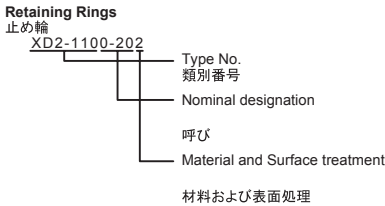

XD2-110 expresses retaining ring-E type (Type1).
XD2-110は、E形止め輪(1種)を表す

0-20 expresses a 020 of nominal designation.
(See Table 5)

0-20は、呼び020を表す(表5参照)

2 expresses Stainless steel (Surface treatment is not to be given) from Table 1.
2は、表1よりステンレス(表面処理なし)を表す

5-1. Retaining Rings - E type

E形止め輪

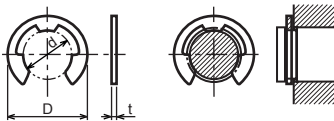

Type No. 類別番号	Type 類別
XD2-110	Retaining ring - E type (Type 1) E形止め輪(1種)
XD2-120	Retaining ring - E type (Type 2) E形止め輪(2種)

Table 5 表5

Type 種類	Nominal designation 呼び	d (mm)	D (mm)	t (mm)
Type 1 1種	007	0.65	2	0.2
	010	0.95	2.8	0.2
	013	1.25	3.3	0.3
	017	1.65	4.2	0.4
	020	1.95	4.6	0.5
	024	2.35	6	0.6
	028	2.74	6.5	0.6
	032	3.14	7.2	0.6
	037	3.64	8	0.7
	040	3.93	10	0.7
	042	4.13	10	0.7
	050	4.93	11	0.7
	058	5.73	12	0.7
	060	5.93	12.7	0.9
	064	6.32	13.5	0.9
	074	7.31	15	0.9
080	7.91	16.5	1	
Type 2 2種	008	0.8	2	0.2
	012	1.2	3	0.3
	015	1.5	4	0.4
	020	2	5	0.4
	025	2.5	6	0.4
	030	3	7	0.6
	040	4	9	0.6
	050	5	11	0.6
	060	6	12	0.8
	070	7	14	0.8
	080	8	16	0.8
	090	9	18	0.8
	100	10	20	1

5-2. Grip Rings
グリップ止め輪

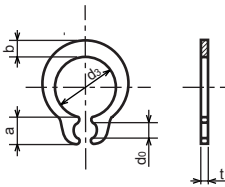

Type No. 類別番号	Type 類別
XD2-210	Grip ring グリップ止め輪

Table 5 表5

Nominal designation 呼び	d_3 (mm)	t (mm)	b (mm)	a (mm)	d_0 (mm)
020	1.9	0.5	1	1.8	0.8
025	2.35	0.5	1.2	1.9	0.9
030	2.85	0.6	1.4	1.9	0.9
035	3.3	0.6	1.6	2	0.9
040	3.8	0.8	1.8	2.8	1.2
045	4.25	0.8	2	2.9	1.3
050	4.75	0.8	2.2	2.9	1.3
060	5.7	1	2.4	3.1	1.4
070	6.7	1	2.7	3.3	1.4
080	7.7	1	3	3.5	1.4
090	8.65	1.2	3.3	4.7	1.5
100	9.65	1.2	3.5	4.7	2

5-3. Toothed Retaining Rings
歯付き形止め輪

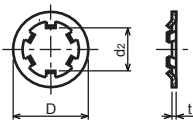

Type No. 類別番号	Type 類別
XD2-230	Toothed retaining ring 歯付き形止め輪

Table 5 表5

Nominal designation 呼び	d_z (mm)	D (mm)	t (mm)	No of teeth 歯数
015	1.4	5.2	0.25	3
020	1.9	6	0.25	3
024	2.3	6.4	0.25	3
030	2.8	8	0.25	4
040	3.8	9	0.25	4
050	4.8	10	0.25	5
060	5.8	11	0.25	5
080	7.8	13	0.25	5
100	9.8	15.4	0.25	6

5-4. Retaining Rings - C Type

C形止め輪

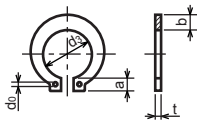

Type No. 類別番号	Type 類別
XD2-310	Retaining ring - C type for shaft C形止め輪 軸用

Table 5 表5

Nominal designation 呼び	d ₃ (mm)	t (mm)	b (mm)	a (mm)	d ₀ (mm)
010	9.3	1	1.6	3	1.2
012	11.1	1	1.8	3.2	1.5
014	12.9	1	2	3.4	1.7
015	13.8	1	2.1	3.5	1.7
016	14.7	1	2.2	3.6	1.7
017	15.7	1	2.2	3.7	1.7
018	16.5	1.2	2.6	3.8	1.7
020	18.5	1.2	2.7	3.9	2
022	20.5	1.2	2.7	4.1	2
025	23.2	1.2	3.1	4.3	2
028	25.9	1.5	3.1	4.6	2
030	27.9	1.5	3.5	4.8	2
032	29.6	1.5	3.5	5	2.5
035	32.2	1.5	4	5.4	2.5

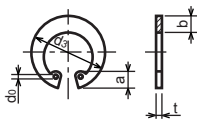

Type No. 類別番号	Type 類別
XD2-320	Retaining ring - C type for hole C形止め輪 穴用

Table 5 表5

Nominal designation 呼び	d ₃ (mm)	t (mm)	b (mm)	a (mm)	d ₀ (mm)
010	10.7	1	1.8	3.1	1.2
011	11.8	1	1.8	3.2	1.2
012	13	1	1.8	3.3	1.5
014	15.1	1	2	3.6	1.7
016	17.3	1	2	3.7	1.7
018	19.5	1	2.5	4	1.7
019	20.5	1	2.5	4	2
020	21.5	1	2.5	4	2
022	23.5	1	2.5	4.1	2
025	26.9	1.2	3	4.4	2
028	30.1	1.2	3	4.6	2
030	32.1	1.2	3	4.7	2
032	34.4	1.2	3.5	5.2	2.5
035	37.8	1.5	3.5	5.2	2.5
037	39.8	1.5	3.5	5.2	2.5
040	43.5	1.8	4	5.7	2.5
042	45.5	1.8	4	5.8	2.5
045	48.5	1.8	4.5	5.9	2.5
047	50.5	1.8	4.5	6.1	2.5
050	54.2	2	4.5	6.5	2.5
052	56.2	2	5.1	6.5	2.5
055	59.2	2	5.1	6.5	2.5
060	64.2	2	5.1	6.8	2.5
062	66.2	2	5.5	6.9	2.5
068	72.5	2.5	6	7.4	2.5
072	76.5	2.5	6.6	7.4	2.5
075	79.5	2.5	6.6	7.8	2.5
080	85.5	2.5	7	8	2.5
085	90.5	3	7	8	3
090	95.5	3	7.6	8.3	3
095	100.5	3	8	8.5	3

Prepared by
OIP Business Support Group
CANON INC.

Canon