

SERVICE MANUAL

Color imageCLASS MF743Cdw MF741Cdw



Canon

December 27, 2018
Rev. 1

Important Notices

Application

This manual has been issued by Canon Inc. for qualified persons to learn technical theory, installation, maintenance, and repair of products.

This manual covers all localities where the products are sold. For this reason, there may be information in this manual that does not apply to your locality.

Corrections

This manual may contain technical inaccuracies or typographical errors due to improvements or changes in products. When changes occur in applicable products or in the contents of this manual, Canon will release technical information as the need arises. In the event of major changes in the contents of this manual over a long or short period, Canon will issue a new edition of this manual.

The following paragraph does not apply to any countries where such provisions are inconsistent with local law.

Trademarks

The product names and company names used in this manual are the registered trademarks of the individual companies.

Copyright

The copyright of this document belongs to Canon Inc. This document may not be copied, reproduced or translated into another language, in whole or in part, without the prior consent of Canon Inc.



Copyright CANON INC. 2018









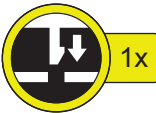







Caution

Use of this manual should be strictly supervised to avoid disclosure of confidential information.



Explanation of Symbols

The following symbols are used throughout this Service Manual.

Symbols	Explanation	Symbols	Explanation
	Check.		Remove the claw.
	Check visually.		Insert the claw.

Symbols	Explanation	Symbols	Explanation
	Check a sound.		Push the part.
	Disconnect the connector.		Connect the power cable.
	Connect the connector.		Disconnect the power cable.
	Remove the cable/wire from the cable guide or wire saddle.		Turn on the power.
	Install the cable/wire to the cable guide or wire saddle.		Turn off the power.
	Remove the screw.		Loosen the screw.
	Install the screw.		Tighten the screw.
	Cleaning is needed.		Measurement is needed.

The following rules apply throughout this Service Manual:

- Each chapter contains sections explaining the purpose of specific functions and the relationship between electrical and mechanical systems with reference to the timing of operation.
 In the diagrams,  represents the path of mechanical drive; where a signal name accompanies the symbol, the arrow  indicates the direction of the electric signal.
 The expression "turn on the power" means flipping on the power switch, closing the front door, and closing the delivery unit door, which results in supplying the machine with power.
- In the digital circuits, '1' is used to indicate that the voltage level of a given signal is "High", while '0' is used to indicate "Low". (The voltage value, however, differs from circuit to circuit.) In addition, the asterisk (*) as in "DRMD*" indicates that the DRMD signal goes on when '0'.
 In practically all cases, the internal mechanisms of a microprocessor cannot be checked in the field. Therefore, the operations of the microprocessors used in the machines are not discussed: they are explained in terms of from sensors to the input of the DC controller PCB and from the output of the DC controller PCB to the loads.

The descriptions in this Service Manual are subject to change without notice for product improvement or other purposes, and major changes will be communicated in the form of Service Information bulletins.

All service persons are expected to have a good understanding of the contents of this Service Manual and all relevant Service Information bulletins and be able to identify and isolate faults in the machine.

Contents

- Safety Precautions..... 1**
 - Laser..... 2
 - Laser Safety..... 2
 - How to Handle the Laser Scanner Unit..... 2
 - Power Supply / Lithium Battery..... 2
 - Power Supply..... 2
 - Notes When Handling a Lithium Battery..... 3
 - Toner Safety..... 3
 - About Toner..... 3
 - Handling Adhered Toner..... 3
 - Notes on works..... 3
 - Points to Note Before Servicing..... 3
 - Points to Note at Cleaning..... 4
 - Notes on Assembly/Disassembly..... 4
- 1. Product Overview..... 5**
 - Product Lineup..... 6
 - Host Machine..... 6
 - Option..... 7
 - Features..... 8
 - Specifications..... 9
 - Specifications of Host Machine..... 9
 - Reader Specifications..... 10
 - ADF Specifications..... 11
 - FAX Specifications (FAX model only)..... 11
 - Paper Type..... 12
 - Paper Size..... 12
 - Parts Name..... 14
 - External view..... 14
 - Cross Section View..... 16
 - Control Panel..... 18
- 2. Technical Explanation (Device)..... 20**
 - Basic Configuration..... 21
 - Functional Configuration..... 21
 - Original Exposure/Feed System..... 22
 - Original Exposure System..... 22
 - Original Feed System..... 24
 - Laser Exposure System..... 26
 - Functional Configuration..... 26
 - Failure Detection..... 26
 - Controller System..... 28
 - Configuration/Function..... 28
 - Main Controller PCB..... 29

Engine Controller PCB.....	30
Motor Control.....	30
Door Open Detection.....	31
Fan Control.....	32
Low-voltage Power Supply Control.....	33
Protection Function.....	34
Power-saving Mode.....	34
Image Formation System.....	36
Major Components.....	36
Image Formation Process.....	36
ITB Unit.....	36
High Voltage Power Supply Control.....	38
Image Stabilization Control.....	38
Cartridge.....	40
Pickup Feed System.....	43
Overview.....	43
Parts Configuration.....	44
Drive Configuration.....	45
Layout of Sensors.....	46
Lifter Control.....	46
Cassette Detection.....	47
Cassette Pickup Control.....	48
Multi-purpose Tray Pickup Control.....	48
Skew Correction.....	49
Arch Control.....	50
Delivery Tray Full Detection.....	51
Jam Detection.....	51
Fixing System.....	54
Functional Configuration.....	54
Fixing Temperature Control.....	54
Fixing pressure/pressure release control.....	55
Protection Function.....	55
Fixing Assembly Failure Detection.....	56

3. Technical Explanation (System)..... 57

Overview of System Management.....	58
Version Upgrade.....	59
Function Overview	59
Version Upgrade Using UST.....	60
Version Upgrade via Internet.....	60
Version Upgrade Using a USB Flash Drive (Released Only in Special Cases)	62
Setting Information Export/Import Function (DCM).....	64
Overview.....	64
Import/Export Procedure from [Settings/Registration] of Remote UI.....	66
Procedure for Exporting/Importing Service Mode Setting Information.....	70
Monitoring Function (e-Maintenance/imageWARE Remote).....	74
Overview of System.....	74
Servicing Notes.....	75
Setting Procedure.....	75
Maintenance.....	76

Security Functions.....	78
Security Policy Function.....	78
4. Periodical Service.....	82
Periodically Replaced Parts.....	83
Consumable Parts.....	84
Periodical Services.....	85
5. Parts Replacement and Cleaning.....	86
List of Parts.....	87
Major Units.....	87
Layout Drawing of Electrical Components.....	89
External Cover System.....	95
Removing the Toner Cartridge.....	95
Removing the Left Cover.....	96
Removing the Right Cover.....	98
Removing the Rear Cover Unit.....	100
Removing the Cartridge Cover	101
Removing the Cartridge Tray.....	103
Removing the Upper Front Cover.....	104
Removing the Upper Left Front Cover.....	105
Removing the Upper Right Front Cover.....	105
Removing the Upper Cover Unit	106
Original Exposure/Feed System.....	107
Removing the ADF Unit + Reader Unit.....	107
Separating the ADF Unit + Reader Unit.....	108
Removing the ADF Roller Unit.....	110
Removing the ADF Pickup Roller.....	112
Removing the ADF Separation Roller.....	113
Removing the ADF Separation Pad Unit.....	115
Removing the ADF Upper Cover Unit.....	116
Removing the ADF Feed Unit.....	118
Removing the ADF CIS (For the duplex scanning model).....	120
Removing the ADF Drive Unit.....	123
Removing the Reader Upper Cover Unit.....	125
Removing the Reader CIS.....	126
Removing the Reader CIS Timing Belt.....	129
Removing the Reader Scanner Motor.....	129
Controller System.....	131
Removing the Controller Cover	131
Removing the Wireless LAN PCB (Wi-Fi model only).....	132
Removing the Wireless LAN Support Plate (Wi-Fi model only).....	132
Removing the Main Controller PCB.....	133
Removing the Main Controller Support Plate.....	133
Removing the Engine Controller PCB.....	134
Removing the Low Voltage Power Supply Unit.....	135
Removing the Control Panel Unit.....	137
Removing the OFF Hook PCB (Fax model only).....	139
Removing the NCU PCB (Fax model only).....	140

Removing the Speaker (Fax model only).....	140
Removing the USB PCB.....	141
Removing the Cartridge Fan.....	142
Removing the Power Supply Fan.....	143
Removing the Driver PCB.....	144
Removing the Power Switch Unit.....	145
Removing the Environment Sensor.....	145
Removing the Memory Relay PCB.....	146
Laser Exposure System.....	148
Removing the Laser Scanner Unit.....	148
Image Formation System.....	154
Removing the Main Drive Assembly.....	154
Removing the Secondary Transfer Roller.....	154
Removing the Secondary Transfer Feed Unit.....	155
Removing the ITB Unit.....	157
Removing the Color Displacement Density Sensor Unit.....	159
Removing the Developing Motor.....	160
Removing the Drum Motor.....	162
Fixing System.....	164
Removing the Fixing Assembly.....	164
Removing the Fixing Power Supply Unit.....	166
Removing the Fixing Motor.....	167
Pickup Feed Delivery System.....	168
Removing the Cassette Pickup Roller/Feed Roller Unit	168
Removing the Cassette Separation Roller Unit	169
Removing the Duplex Reverse Drive Unit.....	171
Removing the Pickup Motor.....	172
Removing the Re-Pickup Unit.....	173
Removing the Lifter Drive Unit.....	175
Removing the Cassette Pickup Unit.....	177
Removing the Multi-purpose Tray Pickup Roller.....	179
Removing the Multi-purpose Tray Separation Pad.....	180
Removing the Registration Unit.....	181
6. Adjustment.....	185
Location where the service label is affixed	186
Adjustment at Parts Replacement.....	187
After Replacing the Control Panel.....	187
After Replacing the ITB Unit.....	187
After Replacing the Color Displacement Density Sensor Unit.....	187
Engine Controller PCB.....	187
Main Controller PCB.....	187
After Replacing the ADF Unit.....	196
After Replacing the Reader CIS Unit.....	198
After Replacing the Reader Upper Cover Unit.....	201
After Replacing the Reader Unit.....	205
After Replacing the ADF CIS Unit.....	212
7. Troubleshooting.....	215
Test Print.....	216

Engine Test Print.....	216
Controller test print.....	217
Cartridge Log Report.....	228
Troubleshooting Items.....	231
Remedy for Image Failure.....	231
Recurring faulty image.....	231
Confirming nip width.....	231
Action When Hue Differs between the Front and Back Sides of the Output Image at Duplex Copy (For the duplex scanning ADF model).....	232
Multi-purpose Tray Pickup Roller Not Rotating.....	234
Multi-purpose Tray Pickup Failure (Delay Jam:090x).....	234
Debug Log.....	235
Function Overview.....	235
Conditions for collecting logs.....	235
Collection procedure.....	235
8. Error/Jam/Alarm.....	237
Overview.....	238
Outline.....	238
Error Code.....	241
Error Code Details.....	241
Jam Code.....	251
Jam code.....	251
Alarm Code.....	255
Alarm Code Details.....	255
9. Service Mode.....	256
Overview.....	257
Entering Service Mode.....	257
Backing up Service Mode.....	257
Service Label.....	257
Remote UI Service Mode.....	258
Service Mode Explanation.....	259
COPIER (Service mode for printer).....	260
DISPLAY (State display mode).....	260
I/O (I/O display mode).....	262
ADJUST (Adjustment mode).....	263
FUNCTION (Operation / inspection mode).....	306
OPTION (Specification setting mode).....	323
COUNTER (Counter mode).....	334
FEEDER (ADF service mode).....	339
ADJUST (Adjustment mode).....	339
FUNCTION (Operation / inspection mode).....	340
TESTMODE (Service mode for test print, operation check, etc.).....	341
PRINT (Print test mode).....	341
FAX (FAX test mode).....	345
FAX (FAX service mode).....	349
SSSW (Bit switch registration mode).....	349
MENU (Menu switch registration mode).....	350

NUM (Numeric parameter setting mode) 351
 NCU (NCU parameter setting mode)..... 352

APPENDICES..... 356

Service Tools.....357
 Special Tools..... 357
 Solvents and Oil List.....357
 General Circuit Diagram.....358
 General Circuit Diagram (1)..... 358
 General Circuit Diagram (2)..... 359
 General Circuit Diagram (3)..... 360
 List of Items Which Can Be Imported.....361
 Service Mode.....361
 Backup Data List.....378
 Soft counter specifications..... 380

Safety Precautions

Laser.....	2
Power Supply / Lithium Battery.....	2
Toner Safety.....	3
Notes on works.....	3

Laser

Laser Safety

Since radiation emitted inside this machine is completely confined with protective housings and external covers, the laser beam cannot escape from the machine during any phase of normal use by users.

Therefore, this machine is classified as a Class 1 laser product under the international standard IEC60825-1 that is regarded as safe during normal use.

How to Handle the Laser Scanner Unit

This machine is classified as a Class 1 laser product.

However, the laser scanner unit contains source of Class 3B laser beam and exposure to the beam may cause eye injuries. Therefore, be sure not to disassemble the laser scanner unit. No adjustment can be made to the laser scanner unit in the machine in the field.

The mark or the warning label shown in the following figure is affixed on the laser scanner unit.

Dieses Gerät ist der Klasse 1 der Laserprodukte zugeordnet.

Allerdings enthält die Laserscannereinheit eine Laserstrahlquelle der Klasse 3B, die Augenschäden verursachen kann, wenn man in diesen Strahl blickt.

Deshalb darf die Laserscannereinheit nicht zerlegt werden. An der Laserscannereinheit kann keine Justage vor Ort vorgenommen werden.

Das in dem folgenden Bild dargestellte Kennzeichen bzw. der Warnaufkleber ist auf der Laserscannereinheit angebracht.

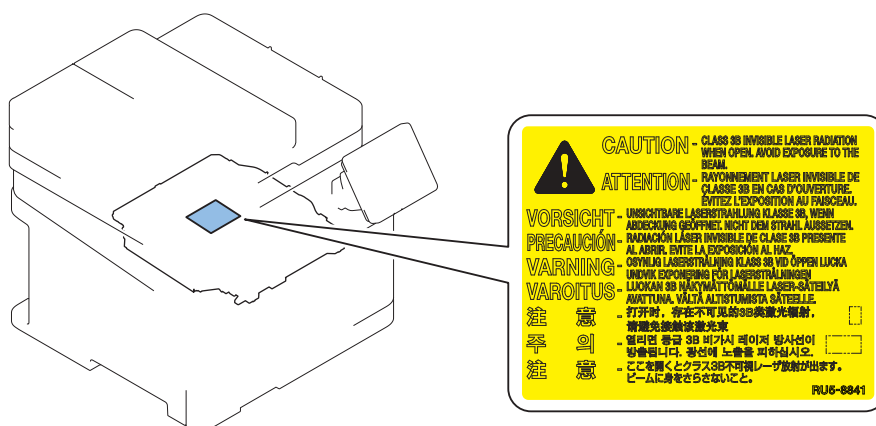

Power Supply / Lithium Battery

Power Supply

- As a general rule, do not use extension cords.

If an extension cord must be used, however, use one for local rated voltage and over, untie the cord binding, and insert the power plug completely into the extension cord outlet to ensure a firm connection between the power cord and the extension cord.

CAUTION:

Do not plug multiple cords together to an extension cord. It may cause a fire or electrical shock.

- The socket-outlet shall be installed near the equipment and shall be easily accessible.

Notes When Handling a Lithium Battery

Dispose of used batteries according to the instructions.

⚠ CAUTION:

Risk of explosion if battery is replaced by an incorrect type.

The following warnings are given to comply with Safety Principles (EN60950-1).

⚠ CAUTION:

Wenn mit dem falschen Typ ausgewechselt, besteht Explosionsgefahr.
Gebrauchte Batterien gemäß der Anleitung beseitigen.

警告
如果更換不正確之電池型式會有爆炸的風險
請依製造商說明書處理用過之電池

Toner Safety

About Toner

Toner is a nontoxic matter composed of plastic, iron and a trace of pigments.

⚠ CAUTION:

Never throw toner in flames to avoid explosion.

Handling Adhered Toner

- Use dry tissue paper to wipe off toner adhered to skin or clothes and wash in water.
- Never use warm water for cleaning up toner to prevent toner particles from being gelated to soak into fibers permanently.
- Toner particles are reactive with vinyl polymers. Avoid contacting these materials.

Notes on works

Points to Note Before Servicing

- At servicing, be sure to turn OFF the power source according to the specified steps and disconnect the power plug.
- Be sure to disconnect the power plug on a regular basis and remove dust and dirt accumulated around the outlet with dry cloth.

⚠ CAUTION:

Leaving the power plug connected for a long time in an environment having a lot of dust, moisture, or oily smoke will cause a fire. (Because dust accumulated in the surrounding area will absorb moisture and cause an insulation failure)

- Be careful not to be injured by burrs of edges, sharp corners or protrusions.

⚠ CAUTION:

Hazardous area such as corners, edges, springs and other sharp sections may be remaining on products. Always be aware of the presence of hazardous area to avoid injury caused by contacting and/or striking those area, by not over-concentrating on service work.

Points to Note at Cleaning

When performing cleaning using organic solvent such as alcohol, be sure to check that the component of solvent is vaporized completely before assembling.

Notes on Assembly/Disassembly

Follow the items below to assemble/disassemble the device.

1. Disconnect the power plug to avoid any potential dangers during assembling/disassembling works.
2. If not specially instructed, reverse the order of disassembly to reinstall.
3. Ensure to use the right screw type (length, diameter, etc.) at the right position when assembling.
4. To keep electric conduction, binding screws with washers are used to attach the grounding wire and the varistor. Ensure to use the right screw type when assembling.
5. Unless it is specially needed, do not operate the device with some parts removed.
6. Never remove the paint-locked screws when disassembling.

⚠ CAUTION:**English****CAUTION**

The fuse may be in the neutral, and that the mains shall be disconnected to de-energize the phase conductors.

German**VORSICHT**

Die Sicherung kann sich im Nulleiter befinden und das Hauptnetz muss abgetrennt werden, um die Phasenleiter stromlos zu machen.



Product Overview

Product Lineup.....	6
Features.....	8
Specifications.....	9
Parts Name.....	14

Product Lineup

Host Machine

MF744Cdw / 743Cdw



MF742Cdw / 741Cdw



Function	MF744Cdw	MF743Cdw	MF742Cdw	MF741Cdw
Copy	Yes	Yes	Yes	Yes
Print	Yes	Yes	Yes	Yes
FAX	Yes	Yes	-	-
Remote UI	Yes	Yes	Yes	Yes
ADF	2-sided scanning	2-sided scanning	1-sided scanning	1-sided scanning
2-sided printing	Yes	Yes	Yes	Yes
Control Panel	5 inch Color Touch Panel	5 inch Color Touch Panel	5 inch Color Touch Panel	5 inch Color Touch Panel
NFC	Yes	Yes	-	-
Backup of counter	-	-	-	-
MEAP	-	-	-	-
Network	Yes	Yes	Yes	Yes
Wireless LAN	Yes	Yes	Yes	Yes

PDL

	MF744Cdw	MF743Cdw	MF742Cdw	MF741Cdw
PS	Yes	-	-	-
PCL	Yes	-	Yes	-
UFR II	Yes	Yes	Yes	Yes



Name	Description
Cassette Feeding Module-AF1	550 sheets (80 g/m2) of paper can be placed. Up to 1 deck can be installed.
TELEPHONE 6 KIT Long cord Cool White	MF744Cdw only

Features

This machine is a color laser MFP that realizes a print speed of 27ppm(A4)/28ppm(LTR) in 1-sided printing.

- Improved Control Panel operability
Improved operability by adopting the Large 5 inch Color Touch Panel.
- 1-path simultaneous duplex reading
Increased productivity in 2-sided original reading by adopting the 1-path ADF (Scan, Send, Copy). (MF744Cdw/743Cdw only)
- Support for mobile print
Printing from smartphones, tablets and PCs via an application such as Apple AirPrint, Google Cloud Print and Mopria Print becomes available.
- Support for wireless LAN
Communication via mobile device and wireless LAN becomes available by connecting a wireless LAN router to the network to which this machine is connected.
- NFC (Near Field Communication)
Printing can be performed by touching a mobile device where Canon PRINT Business is installed. (MF744Cdw/743Cdw only)

Specifications

Specifications of Host Machine

Item	Specification / Function	
Copyboard	Fixed	
Device Installation	Desktop	
Light source	LED (RGB)	
Photoreceptor	OPC drum (φ20)	
Image scanning	CIS (color)	
Light exposure method	Laser beam exposure	
Charging method	Roller charging	
Developing method	Contact development	
Transfer method	Primary transfer: Sequential 4 colors transfer to Intermediate Transfer Belt Secondary transfer: 4-color batch transfer onto the transfer material by the Transfer Roller	
Separation method	Curvature separation	
Cassette paper feed	Retard separation method	
Drum cleaning method	Cleaning blade	
Transfer cleaning method	Cleaning brush and roller	
Fixing method	On-demand fixing	
Paper delivery method	Face-down	
Toner level sensor	Mounted	
Toner type	One-component toner	
Toner supply method	All-in-one cartridge (drum + toner)	
Toner save mode	N/A	
Document types	Sheet / book	
Maximum document size	Copyboard Glass: 216 mm × 297 mm Feeder: 216 mm × 356 mm	
Document size sensor	N/A	
Image size magnification	Zoom: 25 to 400% (1% increment)	
Warm-up Time*1	13 seconds or less	
Recovery Time *2	6.1 seconds or less	
Reading resolution	600 x 600 dpi (Maximum)	
Reading Speed	Copyboard: <ul style="list-style-type: none"> • N/A ADF (Send/300dpi): <ul style="list-style-type: none"> • Color: 26.1 images / minute(A4), 27.4 images / minute(LTR) (MF744Cdw/743Cdw) • B&W: 51.2 images / minute (MF744Cdw/743Cdw) • Color: 13.3 images / minute(A4), 14.0 images / minute(LTR) (MF742Cdw/741Cdw) • B&W: 26.1 images / minute (MF742Cdw/741Cdw) ADF (Copy/600dpi): <ul style="list-style-type: none"> • Color: 27 images / minute(A4), 28 images / minute(LTR) (MF744Cdw/743Cdw) • B&W: 47 images / minute(A4), 48 images / minute(LTR) (MF744Cdw/743Cdw) • Color: 13.5 images / minute(A4), 14 images / minute(LTR) (MF742Cdw/741Cdw) • B&W: 27 images / minute(A4), 28 images / minute(LTR) (MF742Cdw/741Cdw) 	
Print resolution	600 x 600 dpi	
First copy time	Copyboard	Color: Approx. 11.3 seconds(A4), Approx. 11.1 seconds(LTR) B&W: Approx. 9.8 seconds(A4), Approx. 9.5 seconds(LTR)
	ADF	Color: Approx. 12.0 seconds(A4), Approx. 11.8 seconds(LTR) B&W: Approx. 10.2 seconds(A4), Approx. 11.8 seconds(LTR)
First print time	Color: Approx. 8.6 seconds(A4), Approx. 8.5 seconds(LTR) B&W: Approx. 7.7 seconds(A4), Approx. 7.5 seconds(LTR)	
Print Speed *3	At 1-sided printing: <ul style="list-style-type: none"> • Color/B&W: Approx. 27 sheets/min.(A4), Approx. 28 sheets/min.(LTR) At 2-sided printing: <ul style="list-style-type: none"> • Color/B&W: Approx. 21.9 sheets/min.(A4), Approx. 23.1 sheets/min.(LTR) 	

Item	Specification / Function
Available paper type for cassette	Refer to "Paper Type" on page 12
Available paper type for Multi-purpose Tray	Refer to "Paper Type" on page 12
Available paper size in cassette	Refer to "Paper Size" on page 12
Multi-purpose tray paper size	Refer to "Paper Size" on page 12
Cassette capacity	Cassette: 250 sheets (60 to 90 g/m ²) Option: 550 sheets (60 to 90 g/m ²)
Multi-purpose Tray capacity	50 sheets (60 to 90 g/m ²)
Delivery tray stacking capacity *4	125 sheets (60 to 74 g/m ²)
Continuous copying	1 to 99 sheets
Automatic 2-sided printing	Available (A4, B5, LGL, LTR, EXEC, FLS)
Memory capacity	1 GB
Sleep mode	Available
Allowable environmental temperature	10 to 30 deg C
Allowable humidity	20 to 80% in relative humidity (no condensation)
Power rating	Rated input voltage: 120 V system: 120 to 127 V (60Hz) 200 V system: 220 to 240 V (50/60Hz)
Maximum power consumption	120V : 1,470 W or less 230V : 1,370 W or less
Average power at operation	120 V : Approx. 530 W 230 V : Approx. 530 W
Average power at standby	Approx. 21.8 W
Average power at sleep mode	Approx. 0.7 W
Power consumption at Main Power Switch OFF	0.3 W or less
Dimensions (W x D x H)	471 × 469 × 460 mm (MF744Cdw/743Cdw) 451 × 469 × 460 mm (MF742Cdw/741Cdw)
Weight (Without toner cartridges)	Approx. 24.5 kg

*1 : Warm-up time is an interval between when the machine is turned ON and when the main screen appears on the display. Warm-up time may vary depending on the use conditions and environment of the machine.

*2 : Time for recovery from sleep to standby.

*3 : The print speed may become lower depending on the settings such as output resolution, paper size, type, orientation, and number of sheets printed. In the case of 2-sided printing, 1 page on the front side and 1 page on the back side are output as 1 sheet.

*4 : The actual stack capacity varies depending on the site environment and the type of paper used.

Reader Specifications

Item	Specification/Function
Photo conductor	LED
Reading resolution	600 dpi x 600 dpi
Number of gradations	256 gradations
Magnification ratio	25 % to 400 % (in 1% increment)
Reading Sensor	1 line

Item	Specification/Function
Original size detection	None

ADF Specifications

Item	Specification
Original separation method	Upper separation
Document scanning method	Stream reading
Original basis weight	50 to 105 g/m ²
Original size	A4, B5, A5, LGL, LTR, STMT Feed direction: 128 to 355.6 mm, Width direction: 105.0 to 215.9 mm
Original Tray stacking capacity	A4/LTR: 50sheets (80 g/m ²) LGL: 30sheets (80 g/m ²)
Original size detection function	No
Mixed paper functions	Mix of the same configuration: Yes Mix of different configurations: No
Finished stamp function	No
Maximum document size	215.9 mm x 355.6 mm
Document processing speed	Stream reading <ul style="list-style-type: none"> • Copy (600 dpi) <ul style="list-style-type: none"> • 1-sided <ul style="list-style-type: none"> A4/LTR : 27 ipm /28 ipm (B&W) A4/LTR : 13.5 ipm /14 ipm (Color) • 2-sided <ul style="list-style-type: none"> A4/LTR : 47 ipm /48 ipm (B&W) A4/LTR : 27 ipm /28 ipm (Color) • Scan (300dpi) <ul style="list-style-type: none"> • 1-sided <ul style="list-style-type: none"> A4 : 26.1 ipm (B&W) A4/LTR : 13.3 ipm /14 ipm (Color) • 2-sided <ul style="list-style-type: none"> A4 : 51.2 ipm (B&W) A4/LTR : 26.1 ipm /27.4 ipm (Color)

FAX Specifications (FAX model only)

Item	Specifications
Telephone Line Used*1	Public Switched Telephone Network (PSTN)
Scan Line Density	<ul style="list-style-type: none"> • Normal: 8 pels²/mm x 3.85 line/mm • Fine: 8 pels²/mm x 7.7 line/mm • Photo: 8 pels²/mm x 7.7 line/mm • Superfine: 8 pels²/mm x 15.4 line/mm • Ultrafine: 16 pels²/mm x 15.4 line/mm
Transmission Speed*3	Super G3: 33.6 Kbps G3: 14.4 Kbps
Compression Method	MH, MR, MMR, JBIG
Transmission Type	Super G3, G3
Max. Sending Original Sizes	LGL
Receiving Paper Sizes	LGL to A5
Transmission Times	Approx. 3 seconds/page*4

*1: Depending on your locale or your telephone connection, you may be unable to perform data communication.

*2: Pels stands for picture elements (pixels).

*3: With the Automatic Fallback function.

*4: Value obtained with ITU-T standard test sheet No.1, standard JBIG transmission.

Paper Type

(Yes: Pickup possible, -: Pickup not possible)

Type of paper		Paper settings in this machine	Pickup Cassette Cassette Feeding Module-AF1 (option)	Multi-purpose Tray	Auto 2-sided printing
Plain	61 to 74 g/m ²	Plain 1	Yes	Yes	Yes
	75 to 82 g/m ²	Plain 2	Yes	Yes	Yes
	83 to 90 g/m ²	Plain 3	Yes	Yes	Yes
	91 to 105 g/m ²	Plain 4	Yes	Yes	Yes
Heavy paper	106 to 119 g/m ²	Heavy 1	Yes	Yes	Yes
	120 to 128 g/m ²	Heavy 2	Yes	Yes	Yes
	129 to 163 g/m ²	Heavy 3	Yes	Yes	Yes
Thin paper	60 g/m ²	Thin 1	Yes	Yes	Yes
Recycled	61 to 74 g/m ²	Recycled 1	Yes	Yes	Yes
	75 to 82 g/m ²	Recycled 2	Yes	Yes	Yes
Color	61 to 74 g/m ²	Color	Yes	Yes	Yes
Coated	100 to 120 g/m ²	Coated 1	Yes	Yes	Yes
	121 to 150 g/m ²	Coated 2	Yes	Yes	Yes
	151 to 200 g/m ²	Coated 3	Yes	Yes	Yes
Label paper		Label paper	Yes	Yes	-
Envelope		Envelope	Yes	Yes	-

Paper Size

(Yes: Pickup possible, -: Pickup not possible)

Paper size		Pickup Cassette Cassette Feeding Module-AF1 (option)	Multi-purpose Tray	Auto 2-sided printing
A4	210.0 mm x 297.0 mm	Yes	Yes	Yes
B5	182.0 mm x 257.0 mm	Yes	Yes	Yes
A5	148.0 mm x 210.0 mm	Yes	Yes	-
LGL	215.9 mm x 355.6 mm	Yes	Yes	Yes
LTR	215.9 mm x 279.4 mm	Yes	Yes	Yes
STMT	139.7 mm x 215.9 mm	Yes	Yes	-
EXEC	184.2 mm x 266.7 mm	Yes	Yes	Yes
OFICIO	215.9 mm x 317.5 mm	Yes	Yes	Yes
B-OFICIO	216 mm x 355 mm	Yes	Yes	Yes
M-OFICIO	216 mm x 341 mm	Yes	Yes	Yes
G-LTR	203.2 mm x 266.7 mm	Yes	Yes	Yes
G-LGL	203.2 mm x 330.2 mm	Yes	Yes	Yes
FLSC	215.9 mm x 330.2 mm	Yes	Yes	Yes
AFLS	206 mm x 338 mm	Yes	Yes	Yes
Indian LGL	215.0 mm x 345.0 mm	Yes	Yes	Yes
16K	195.0 mm x 270.0 mm	Yes	Yes	Yes
F4A	216.0 mm x 343.0 mm	Yes	Yes	Yes
Index Card	76.2 mm x 127.0 mm	-	Yes	-
Envelope No.10 (COM10)	104.7 mm x 241.3 mm	Yes	Yes	-
Envelope Monarch	98.4 mm x 190.5 mm	Yes	Yes	-
Envelope C5	162.0 mm x 229.0 mm	Yes	Yes	-
Envelope DL	110.0 mm x 220.0 mm	Yes	Yes	-

Paper size		Pickup Cassette Cassette Feeding Mod- ule-AF1 (option)	Multi-purpose Tray	Auto 2-sided printing
Custom paper	-	Yes *1	Yes *2	Yes *3

*1: 98 x 148 mm to 216 x 355.6 mm

*2: 76.2 x 127 mm to 216 x 355.6 mm

*3: 176 x 250 mm to 216 x 355.6 mm

Parts Name

External view

Front side of the machine

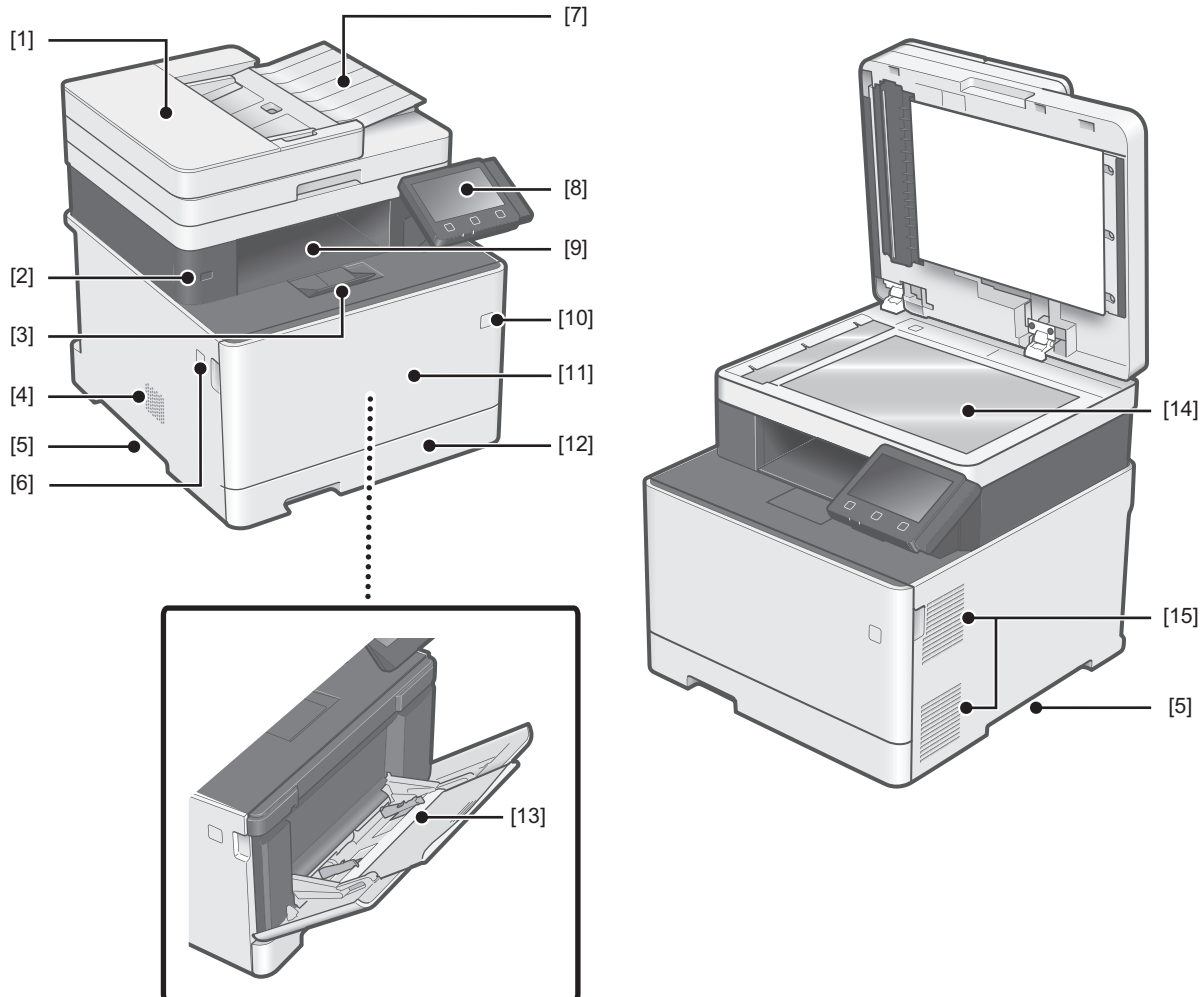

No.	Name	No.	Name
[1]	ADF Upper Cover	[9]	Delivery Tray
[2]	USB port (for USB device)	[10]	Power Switch
[3]	Delivery Stopper	[11]	Front Cover
[4]	Speaker	[12]	Pickup Cassette
[5]	Handle for carrying	[13]	Multi-purpose Tray
[6]	Front Cover Open Button	[14]	Copyboard Glass
[7]	Original pickup tray	[15]	Ventilation hole
[8]	Control Panel		

■ Rear side of the machine

MF744Cdw/743Cdw

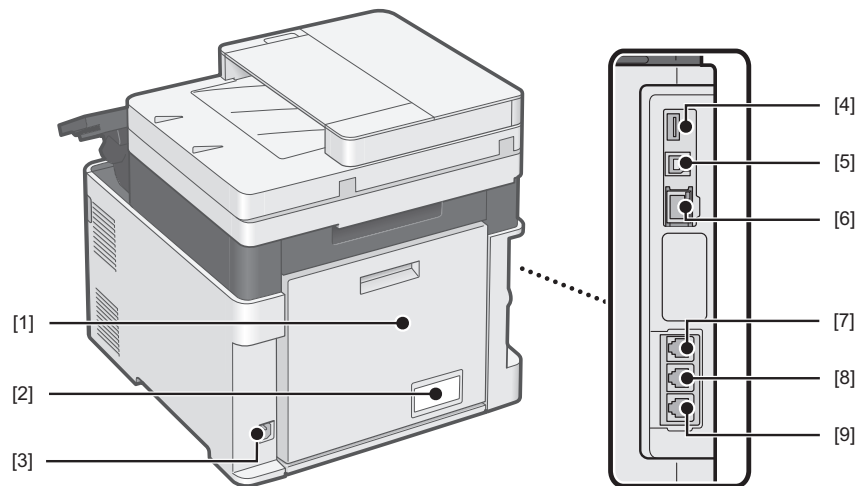

MF742Cdw/741Cdw

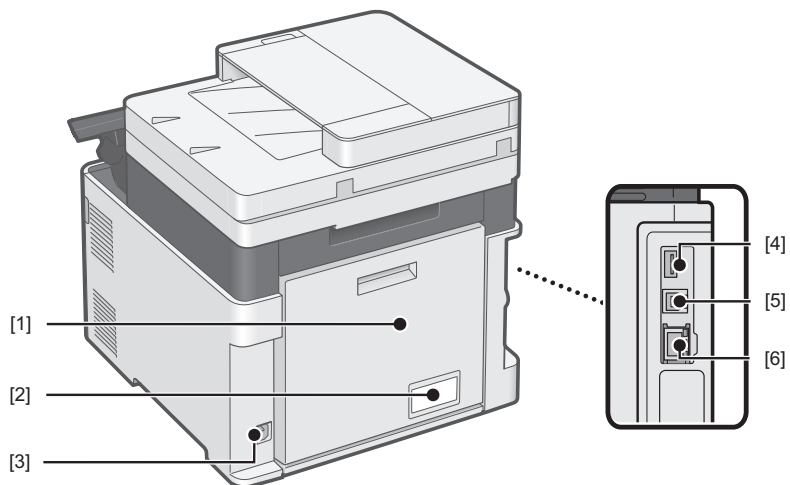

No.	Name	No.	Name
[1]	Rear Cover	[6]	LAN Port
[2]	Rating name plate label	[7]*	Terminal for Handset
[3]	Power Socket	[8]*	Terminal for external telephone
[4]	USB port (for USB device)	[9]*	Terminal for telephone line
[5]	USB port (for PC)		

*: MF744Cdw/743Cdw only

■ Inside of the host machine

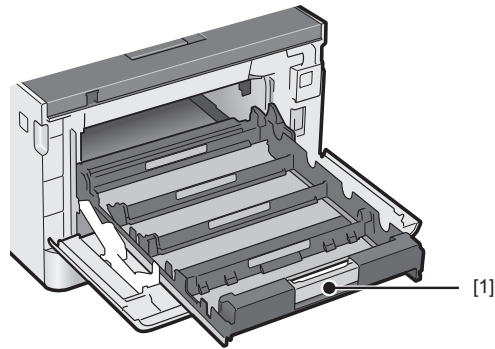

No.	Name
[1]	Toner Cartridge Tray

● Cross Section View

■ Host machine

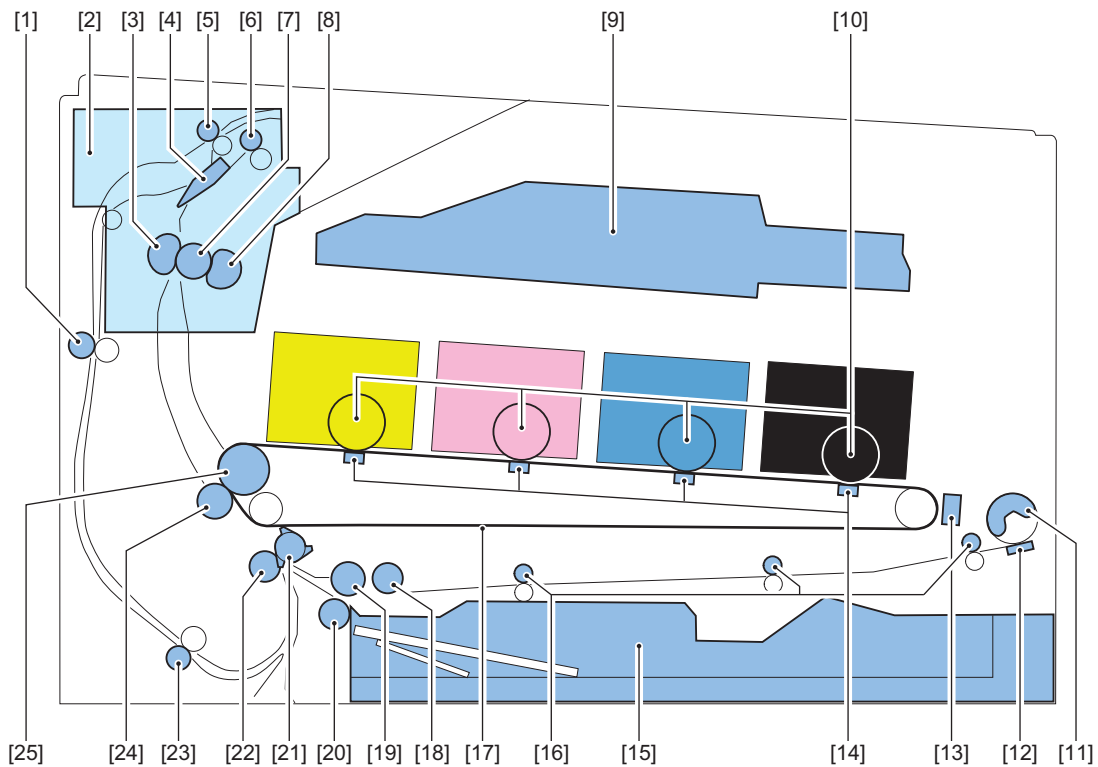

No.	Name	No.	Name
[1]	Duplex Feed Roller	[14]	Primary Transfer Brush
[2]	Fixing Assembly	[15]	Cassette
[3]	Pressure Film	[16]	Multi-purpose Tray Feed Roller
[4]	Duplex Flapper	[17]	ITB
[5]	Duplex Reverse Roller	[18]	Cassette Pickup Roller
[6]	Delivery Roller	[19]	Cassette Feed Roller
[7]	Fixing Roller	[20]	Cassette Separation Roller
[8]	Fixing Film	[21]	Registration Shutter
[9]	Laser Scanner Unit	[22]	Registration Roller
[10]	Photosensitive Drum	[23]	Duplex Re-pickup Roller
[11]	Multi-purpose Tray Pickup Roller	[24]	Secondary Transfer Roller

No.	Name	No.	Name
[12]	Multi-purpose Tray Separation Pad	[25]	ITB Drive Roller
[13]	Color Displacement/Density Sensor		

■ ADF/Reader Unit

MF744Cdw/743Cdw

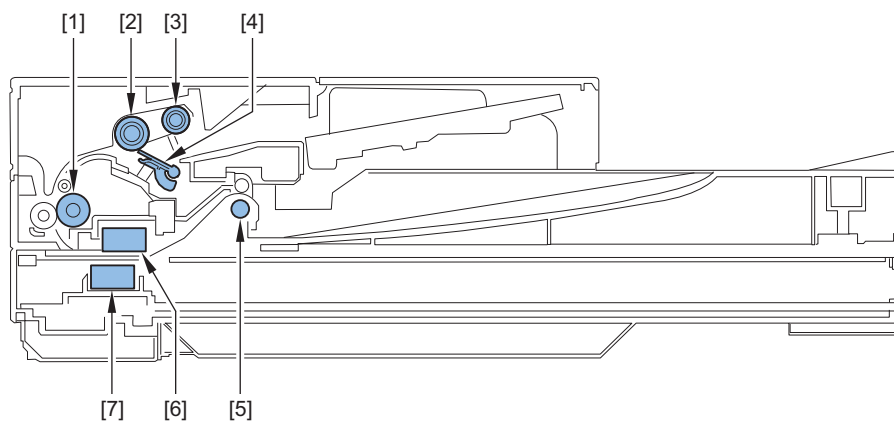

No.	Name
[1]	Feed Roller
[2]	Separation Roller
[3]	Pickup Roller
[4]	Separation Pad
[5]	Delivery Roller
[6]	Contact Image Sensor (ADF side)
[7]	Contact Image Sensor (Reader side)

MF742Cdw/741Cdw

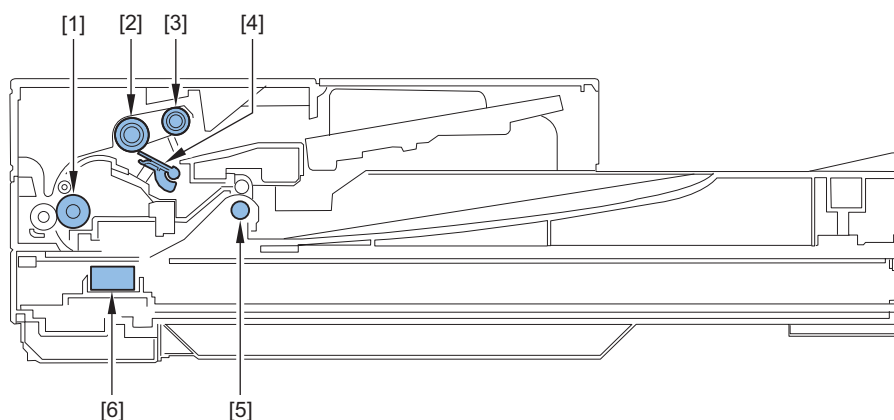

No.	Name
[1]	Feed Roller
[2]	Separation Roller
[3]	Pickup Roller
[4]	Separation Pad
[5]	Delivery Roller
[6]	Contact Image Sensor

Control Panel

MF744Cdw/743Cdw

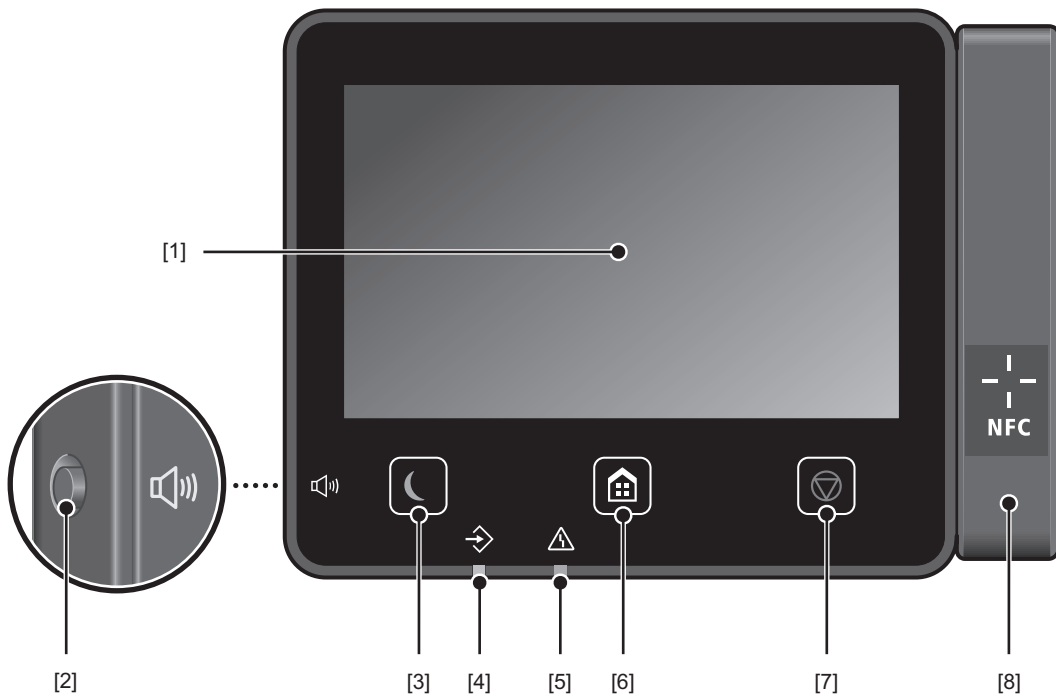

MF742Cdw/741Cdw

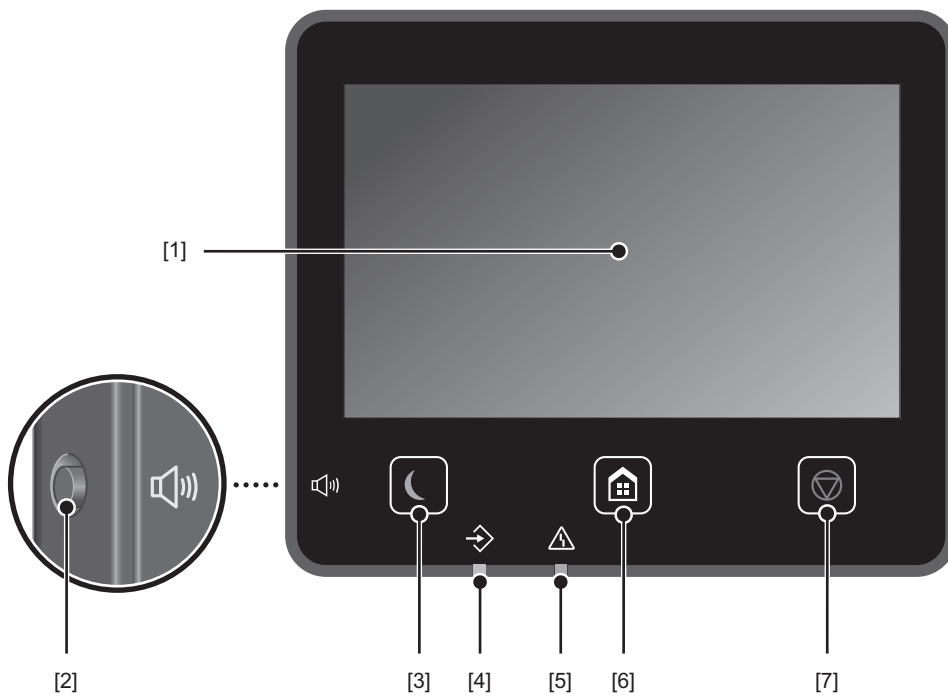

No.	Name	No.	Name
[1]	Display	[5]	Error Lamp
[2]	Volume key	[6]	Home key
[3]	Energy Saver key	[7]	Stop key
[4]	Data Lamp	[8]*	NFC(Near Field Communication)

*: MF744Cdw/743Cdw only



Technical Explanation (Device)

Basic Configuration.....	21
Original Exposure/Feed System.....	22
Laser Exposure System.....	26
Controller System.....	28
Image Formation System.....	36
Pickup Feed System.....	43
Fixing System.....	54

Basic Configuration

Functional Configuration

Description

This machine is roughly composed of the following six blocks.

- Original Exposure/Feed System
- Laser Exposure System
- Controller System
- Image Formation System
- Pickup Feed System
- Fixing System

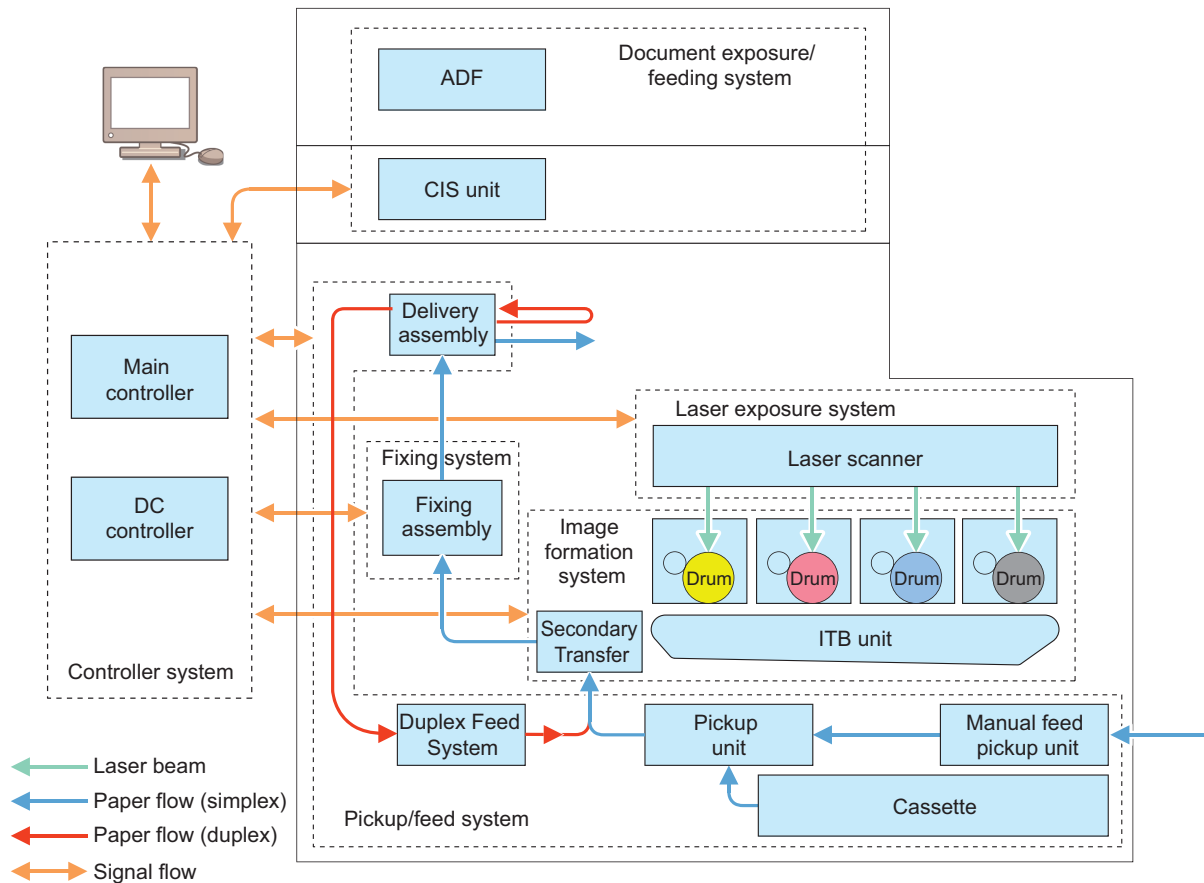

Original Exposure/Feed System

Original Exposure System

Functional Configuration

The original on the Copyboard Glass is read by moving the Contact Image Sensor (CIS) by rotating the Reader Motor based on the drive signal from the Main Controller PCB.

When using the ADF, the original is read by feeding it using the ADF, without moving the Contact Image Sensor.

Simultaneous duplex scanning models have 2 Contact Image Sensors, and the front and back sides of paper are scanned at the same time with one feed of the paper.

Major Components

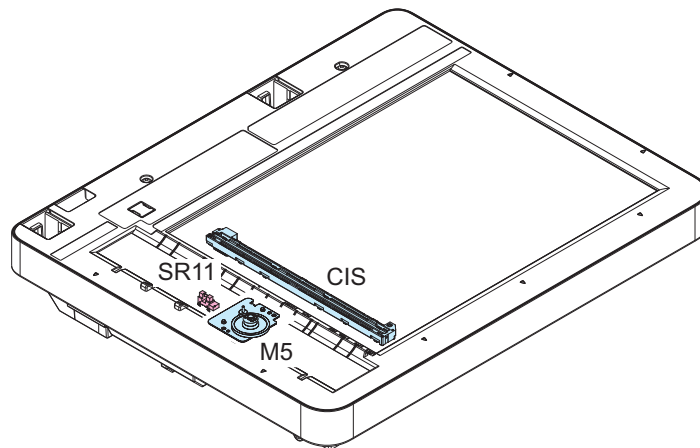

Symbol	Name
M5	Reader Motor
CIS	Contact Image Sensor
SR11	CIS HP Sensor

Dust Detection Control

Overview

Presence/absence of dust on the Stream Reading Glass is detected when an original is read. In accordance with the detection result, the original reading position is changed or image correction is performed to prevent the dust from being printed on the image.

Control of dust detection consists of the following two items:

- Dust detection correction
- Dust detection evasion

Execution Condition/Timing

Dust detection correction

During the period of time from the moment when the original of a stream reading job arrives just before the reading position to the moment when reading of the original is completed (for each page)

Dust detection evasion

When a job starts

Description

Dust detection correction

If dust on the Stream Reading Glass is detected, the image is corrected to prevent the dust from being printed.

1. Before the original arrives, the White Plate is read through the Stream Reading Glass, and points where dust may exist are detected.

2. The leading edge of the original is detected.
3. The detection results before and after the leading edge of the original appears on the Stream Reading Glass are compared. If dust does not exist at the dust point detected in step 1, it is judged to be dust on the White Plate and dust correction is not performed. If dust exists at the point detected in step 1, it is judged to be dust on the Stream Reading Glass and dust correction is performed.

Dust detection evasion

If dust is detected when the last job paper is read, the reading position of the next stream reading job is changed in order to avoid the dust.

The amount of adjustment for dust evasion is -0.5 mm (B), 0 mm (A), and +0.5 mm (C).

Each time dust is detected when reading the last paper of a stream reading job, the CIS moves to the three positions in the order shown below.

A -> B -> C -> A ->

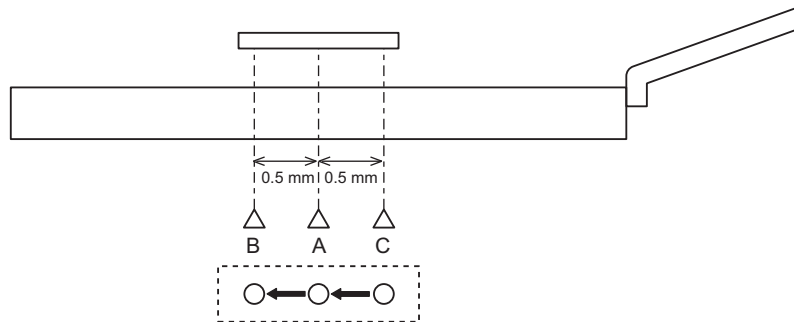

NOTE:

In the case of simultaneous duplex scanning models, this control is applied only to reading of the front side where the CIS can be moved.

If any of the following conditions is detected 6 times in a row, it is judged that the Stream Reading Glass is soiled, and a message prompting the user to clean the Stream Reading Glass is displayed on the Control Panel.

- Dust of 1 pixel or larger and smaller than 5 pixels is detected at 11 points or more.
- Dust of 5 pixels or larger is detected at 1 point or more.

Service Mode

- Adjustment of the image correction level at stream reading [front]
COPIER > OPTION > BODY > DFDST-L1
- Adjustment of the image correction level at stream reading [back]
COPIER > OPTION > BODY > DF2DSTL1

Additional Functions Mode/Menu

- ON/OFF of automatic correction at the time of dust detection
Menu > Adjustment/Maintenance > Adjust Image Quality > Remove Streaks from Orig. Scanning Area
- ON/OFF of notification to clean the Stream Reading Glass
Menu > Preferences > Display Settings > Notify to Clean Original Scanning Area

Original Feed System

Major Components

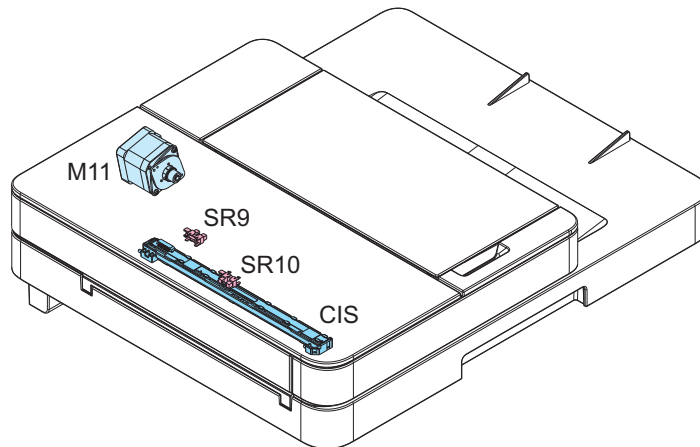

Symbol	Name	Remarks
M11	ADF Motor	
CIS	Contact Image Sensor	2-sided scanning model only
SR9	Document Sensor	
SR10	Document End Sensor	

Drive Configuration

Description

When copy, fax, or scan is started, the ADF Motor (M11) is driven by a drive command from the Main Controller PCB. The document which is placed face-up on the Original Tray is picked up and fed one sheet at a time in order from the top. When the fed original passes over the Platen Glass, the image is read by the Contact Image Sensor (CIS), and then the original is delivered face-down to the Document Delivery Assembly.

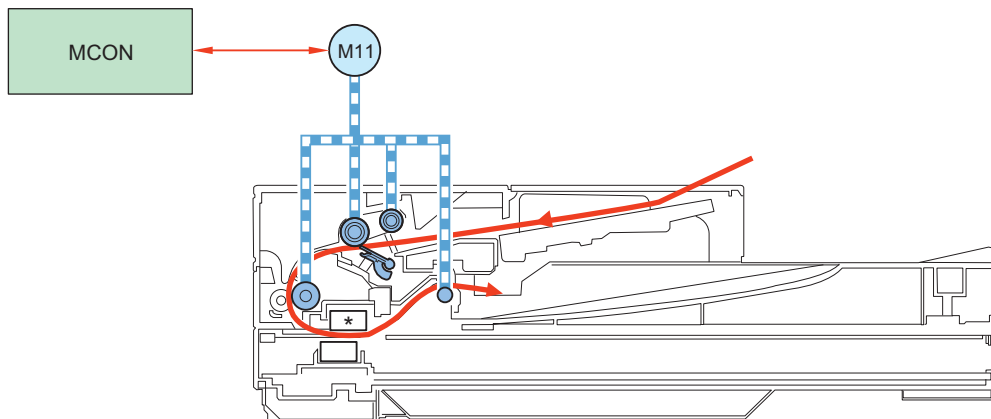

Symbol	Name
M11	ADF Motor
MCON	Main Controller PCB

*: 2-sided scanning model only.

Original Detection

Overview

This machine has the following two types of original detection functions.

- Original Detection
- Original Edge Detection

NOTE:

This machine does not have a document size (original width) detection function.

Description**Original Detection**

As the actuator is pushed up by placing an original on the Original Tray, the Document Sensor (SR9) is turned ON (light is transmitted -> light is blocked) so that the presence of an original is detected.

Original Edge Detection

As the actuator is pushed up by the leading edge of the fed original, the Document End Sensor (SR10) is turned ON (light is blocked -> light is transmitted) so that the leading edge of the original is detected.

In addition, when the trailing edge of the original passes the position of the actuator, the actuator returns to the original position, which causes the Document End Sensor (SR10) to turn OFF (light is transmitted -> light is blocked) to detect the trailing edge of the original.

Note that the original length that can be read by this machine is 400 mm and less; if an original longer than that is fed, it is stopped due to jam. The original length is determined by the time required from when the Document End Sensor (SR10) detects the original's leading edge to when it detects its trailing edge.

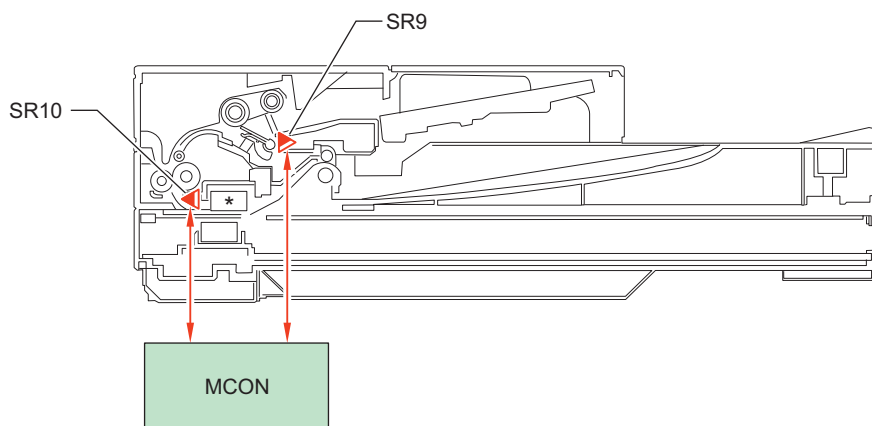

Symbol	Name
SR9	Document Sensor
SR10	Document End Sensor

*: 2-sided scanning model only.

■ Jam Detection**Execution Condition/Timing**

When the power is turned ON or when the original is being read

Description

In the following cases, it is judged that an ADF jam has occurred.

- When the original is late in arriving the Document End Sensor or remains in the ADF while the original is being read
- When the Document End Sensor detects presence of paper when the power is turned ON (residual paper jam)
- When a document of 400 mm or more is detected

When a jam is detected, the reading operation stops and "Paper is jammed." is displayed on the screen of the Control Panel. In the case of models equipped with the fax function (built-in speaker), a warning tone (beep sound) sounds when a jam is detected.

The jam can be cleared by removing the jammed paper, opening and then closing the ADF Upper Cover, and placing the original again.

Laser Exposure System

Functional Configuration

Overview

The Laser Exposure system irradiates the Photosensitive Drum with a laser to form a latent image on it according to the video signal sent from the Main Controller.

Description

The Laser Scanner Unit consists of the Laser Unit and the Scanner Motor Unit, and is controlled by the signal input from the DC Controller.

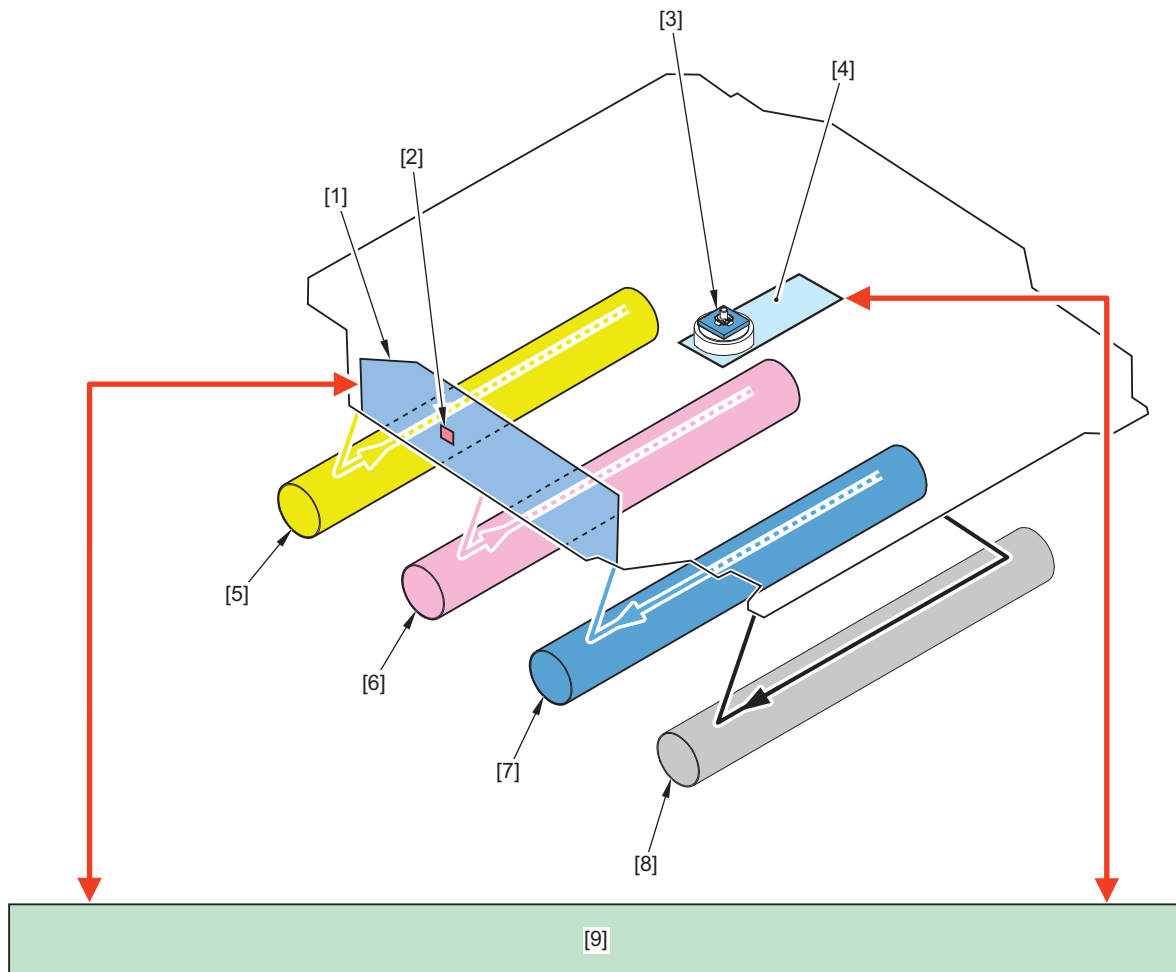

No.	Name	No.	Name
[1]	Laser Unit	[6]	Photosensitive Drum (M)
[2]	BD Sensor	[7]	Photosensitive Drum (C)
[3]	Scanner Mirror	[8]	Photosensitive Drum (Bk)
[4]	Scanner Motor Unit	[9]	DC Controller
[5]	Photosensitive Drum (Y)	-	-

Failure Detection

Overview

The DC Controller detects the following failures in the Laser Scanner Unit.

- Scanner area failure
- Scanner Motor startup failure

Description

Scanner area failure detection

If an error in any of the Scanner Motor, Laser Driver, or BD detection in the scanner area is detected, an error code is notified.

Scanner Motor startup failure detection

If the scanner does not start although a specified period of time has elapsed after the Scanner Motor is driven, an error code is notified.

Error Code

- E100-0000 : Yellow scanner area failure
- E100-0001 : Magenta scanner area failure
- E100-0002 : Cyan scanner area failure
- E100-0003 : Black scanner area failure
- E110-0000 : Primary Pseudo BD correction failure

Controller System

Configuration/Function

Description

This product is mainly controlled by the main and DC controllers.

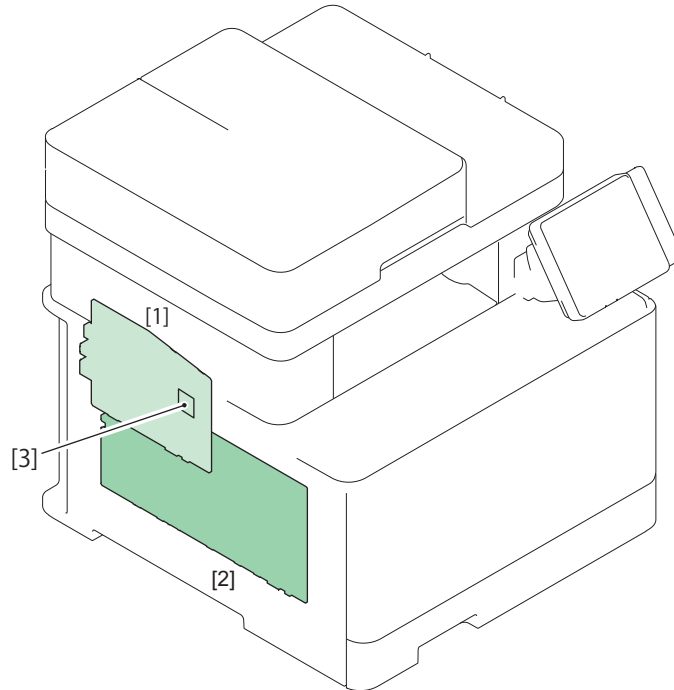

No.	Parts name	Function
[1]	Main Controller PCB	Provides controls on the system, image processing, reader / ADF, FAX and network and maintain various setting values.
[2]	Engine Controller PCB *1	Provides controls on printer, laser, high-voltage PCBs, I/O, etc. and maintain setting values.
[3]	eMMC	Storing System Software

*1: The engine controller PCB consists of it by a high voltage power supply circuit and a DC controller circuit.

Main Controller PCB

Description

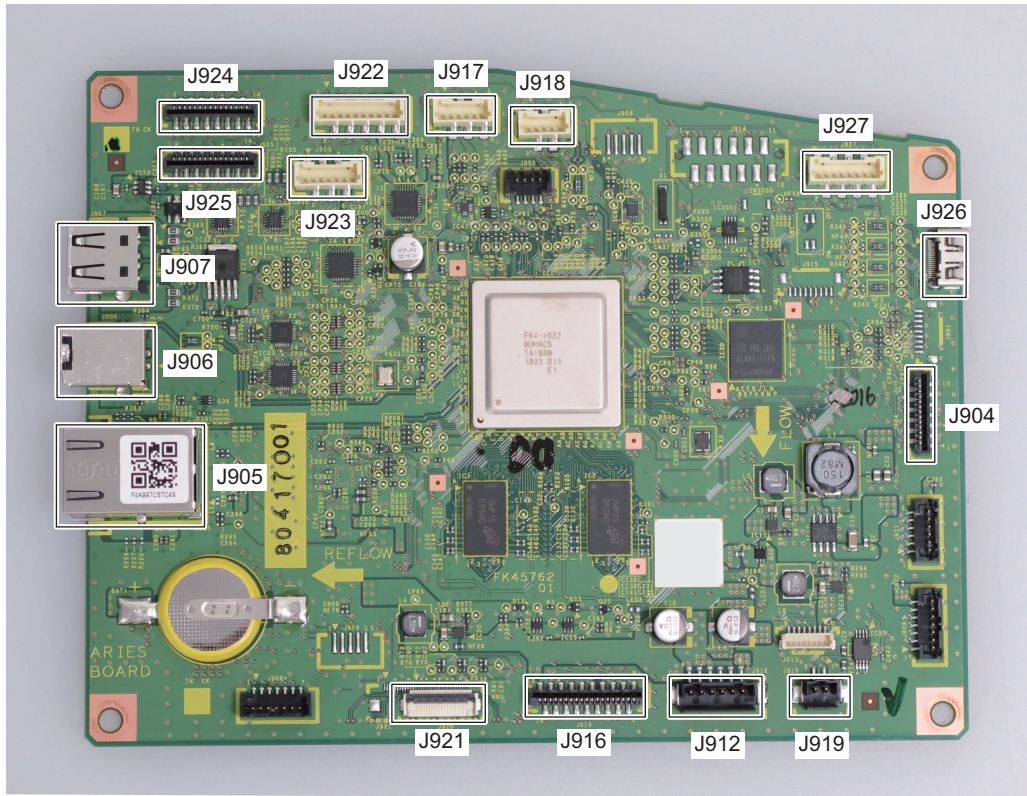

No.	Roles and Specifications	No.	Roles and Specifications
J904	Wireless LAN PCB I/F	J919*	Speaker
J905	LAN I/F	J921	Engine Controller PCB I/F
J906	USB TypeB	J922	ADF Motor I/F
J907	USB TypeA	J923	Reader Motor I/F
J912	Power supply control I/F	J924	Contact Image Sensor I/F (Reader side)
J916*	NCU PCB I/F	J925	Contact Image Sensor I/F (ADF side)
J917*	Off Hook PCB I/F	J926	Panel PCB I/F
J918	USB Relay PCB I/F	J927	Panel PCB I/F

*: MF744Cdw/743Cdw only

Engine Controller PCB

Description

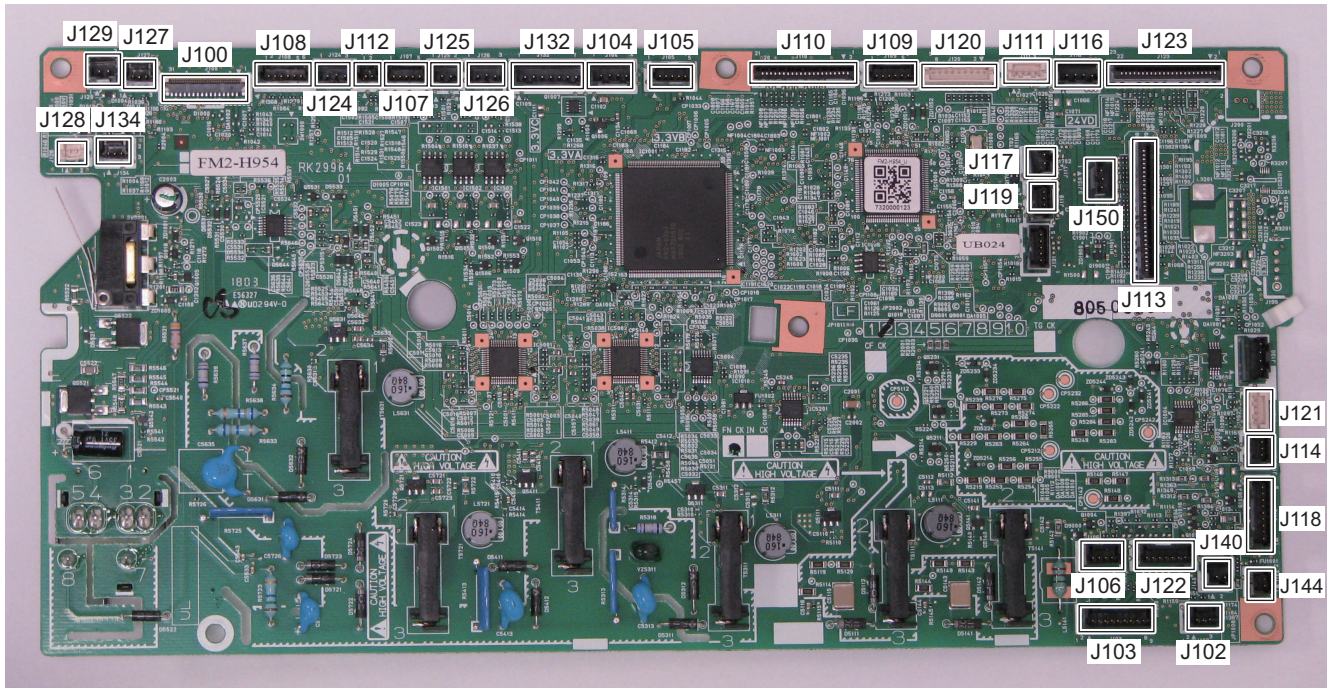

No.	Roles and Specifications	No.	Roles and Specifications
J100	Main Controller PCB I/F	J119	Power Switch PCB I/F
J102	Registration Sensor I/F	J120	Memory Relay PCB I/F
J103	Cassette Paper Sensor, Lifter Sensor and Cassette Paper Surface Sensor I/F	J121	Environment Sensor PCB I/F
J104	Low Voltage Power Supply PCB I/F	J122	Option Feeder I/F
J105	Low Voltage Power Supply PCB I/F	J123	Laser Scanner Unit I/F
J106	Primary Transfer Disengagement Solenoid and Primary Transfer Disengagement Switch I/F	J124	Main Thermistor I/F
J107	Delivery Tray Sensor I/F	J125	Sub Thermistor 1 I/F
J108	Fixing Delivery Sensor, Arch Sensor I/F	J126	Sub Thermistor 2 I/F
J109	Fixing Power Supply PCB I/F	J127	Duplex Reverse Sensor I/F
J110	Laser Scanner Unit I/F	J128	Duplex Re-pickup Clutch I/F
J111	Scanner Motor I/F	J129	Duplex Reverse Solenoid I/F
J112	Fixing Pressure Release Switch I/F	J132	Main Controller PCB I/F
J113	Driver PCB I/F	J134	Duplex Re-pickup Sensor I/F
J114	Multi-purpose Tray Paper Sensor I/F	J140	Lifter Solenoid I/F
J116	Low Voltage Power Supply PCB I/F	J144	Cassette Switch I/F
J117	Front Cover Switch I/F	J150	24V Interlock Switch I/F
J118	Color Displacement/Density Sensor PCB and Color Displacement Sensor PCB I/F		

Motor Control

Overview

This machine uses motors for paper feed and image formation.

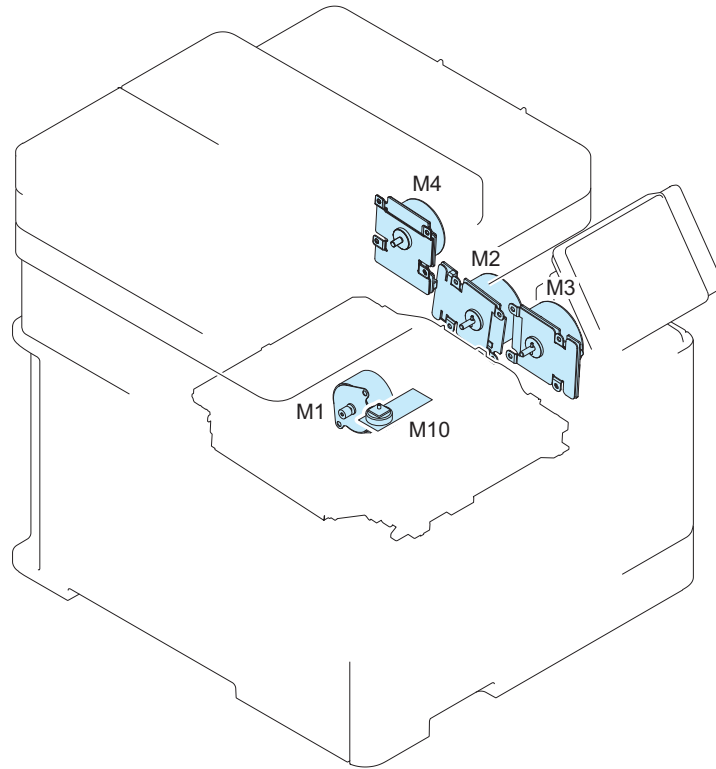

Description

Name	Symbol	Drive parts	Failure Detection
Pickup Motor	M1	Multi-purpose Tray Pickup Roller, Multi-purpose Tray Feed Roller, Cassette Pickup Roller, Cassette Feed Roller, Registration Roller, Duplex Feed Roller, Duplex Repickup Roller, and lifting up the cassette	None
Drum Motor	M2	Photosensitive Drum and ITB	Yes
Developing Motor	M3	Developing Roller and engagement/disengagement of the Developing Roller	Yes
Fixing Motor	M4	Fixing Roller, Delivery Roller, Duplex Reverse Roller, and engagement/disengagement of the Pressure Film/Fixing Roller/Fixing Film Pressure	Yes
Scanner Motor	M10	Scanner Mirror	None

Door Open Detection

Overview

This machine uses the Switch to detect whether the door is opened or closed.

Description

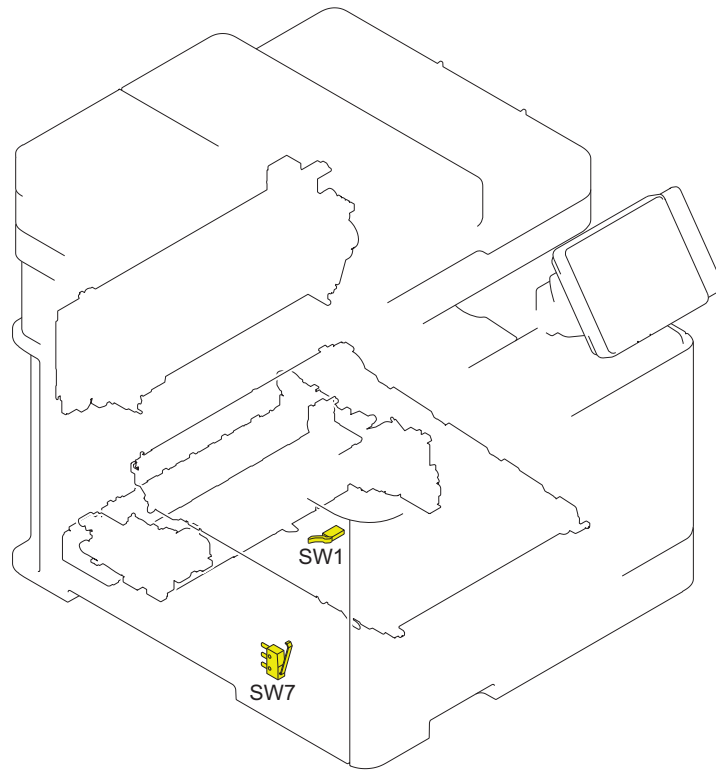

Name	Symbol	Role
Front Cover Switch	SW1	To detect whether the Front Cover is opened or closed.
Rear Cover Switch	(Inside the Engine Controller PCB)	To detect whether the Rear Cover is opened or closed.
24V Interlock Switch	SW7	When opening the Front Cover, this machine shuts down the DC24V output of the Low Voltage Power Supply PCB.

When door open is detected by this sensor, the DC Controller stops drive of the motors and the solenoids.

Fan Control

Overview

This machine uses a fan for preventing temperature rising inside the machine and for cooling the delivered paper.

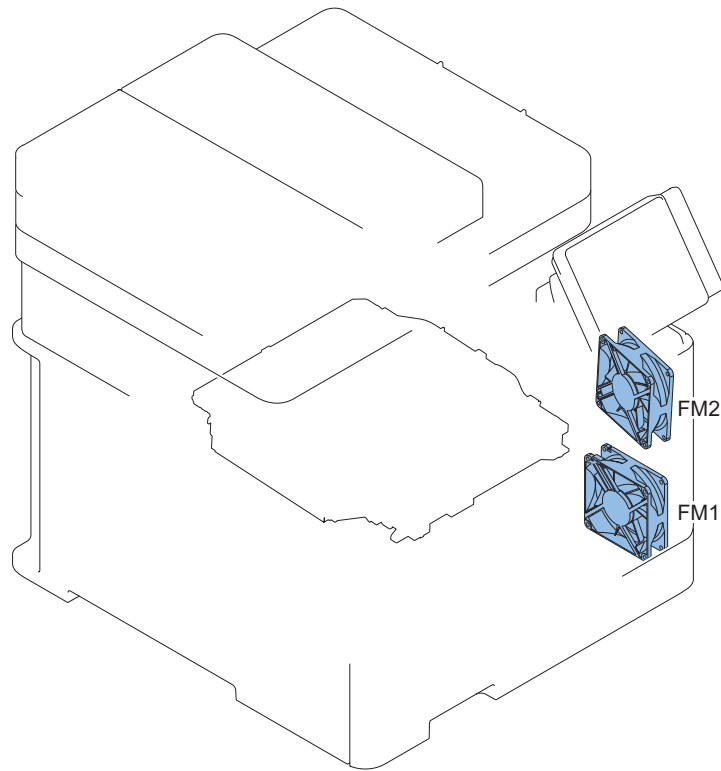

Description

Name	Sym- bol	Cooling area	Type	Speed
Power Supply Fan	FM1	Area around Low Voltage Power Supply	Suction	Variable (full speed/middle speed/low speed/ very low speed)
Cartridge Fan	FM2	Around the cartridge and Fixing Assembly	Suction	Variable (full speed/half speed)

Low-voltage Power Supply Control

Overview

This circuit converts the AC voltage to DC power supply and provides it to each load.

Description

The following shows a block diagram of the low voltage power supply and fixing power supply .

- Low voltage power supply: Generates the DC power supply needed inside the printer.
- Fixing power supply: Provides AC power supply to the low voltage power supply and controls the fixing heater temperature of the Fixing Assembly.

The low voltage power supply starts to operate when the AC power supply is connected to the inlet. The AC power supply is converted to +24 V, which is the DC power supply required by the printer, and +3.3 V.

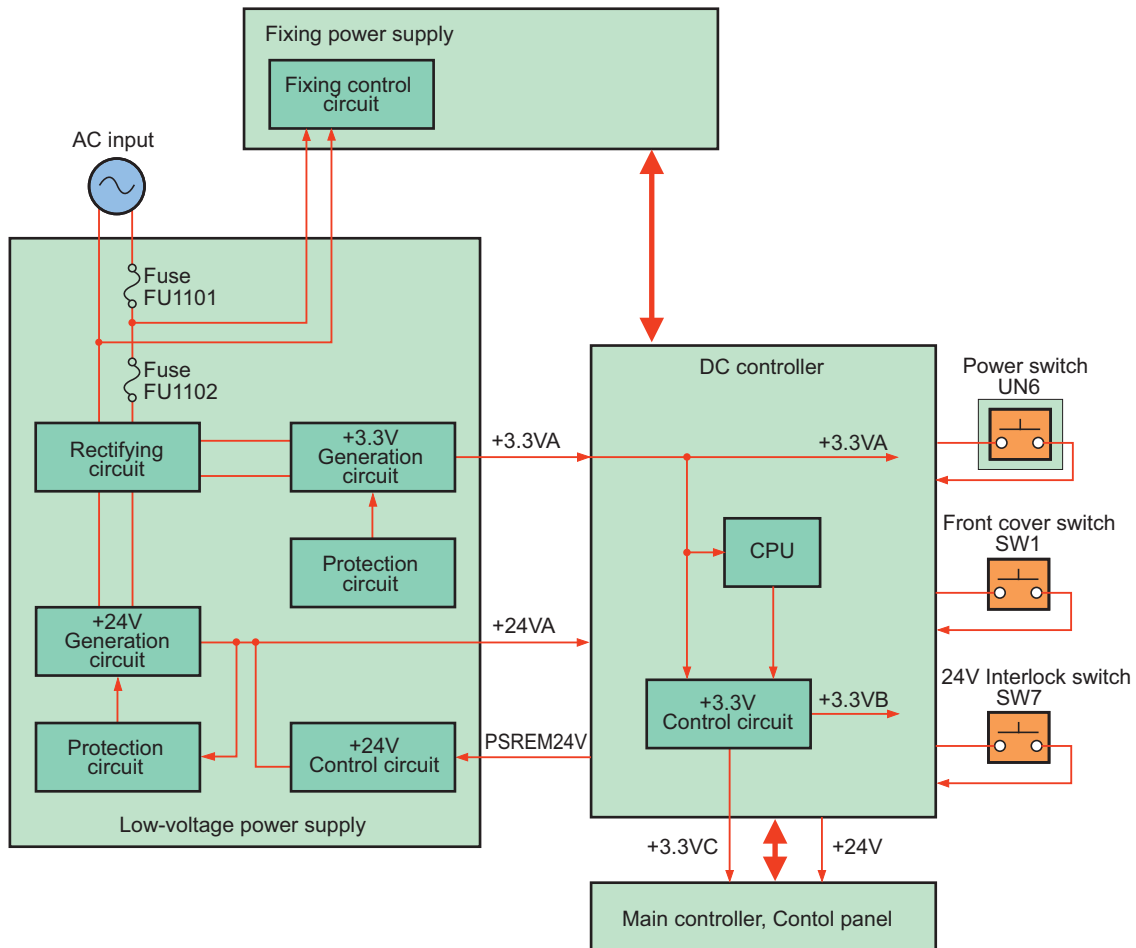

Protection Function

Overview

This machine has a protection function against overcurrent and overvoltage.

Description

If overcurrent or abnormal voltage occurs due to a trouble, the DC voltage is automatically cut off to prevent damage to the Power Supply PCBs.

When no DC voltage is output from the Low Voltage Power Supply Assembly, it is possible that the protection function has been activated. Therefore, turn OFF the Power Switch, disconnect the AC Power Supply Cord from the inlet, and then fix the trouble before turning ON the Power Switch again.

NOTE:

Leave the machine as it is for approx. 5 minutes after disconnecting the cord from the inlet. There are cases where electric charge remains in the electrolytic capacitor on the primary side of the Power Supply PCB, and time for releasing the electric charge is needed.

Power-saving Mode

Overview

Power-saving mode is a function that reduces the printer power consumption.

Description

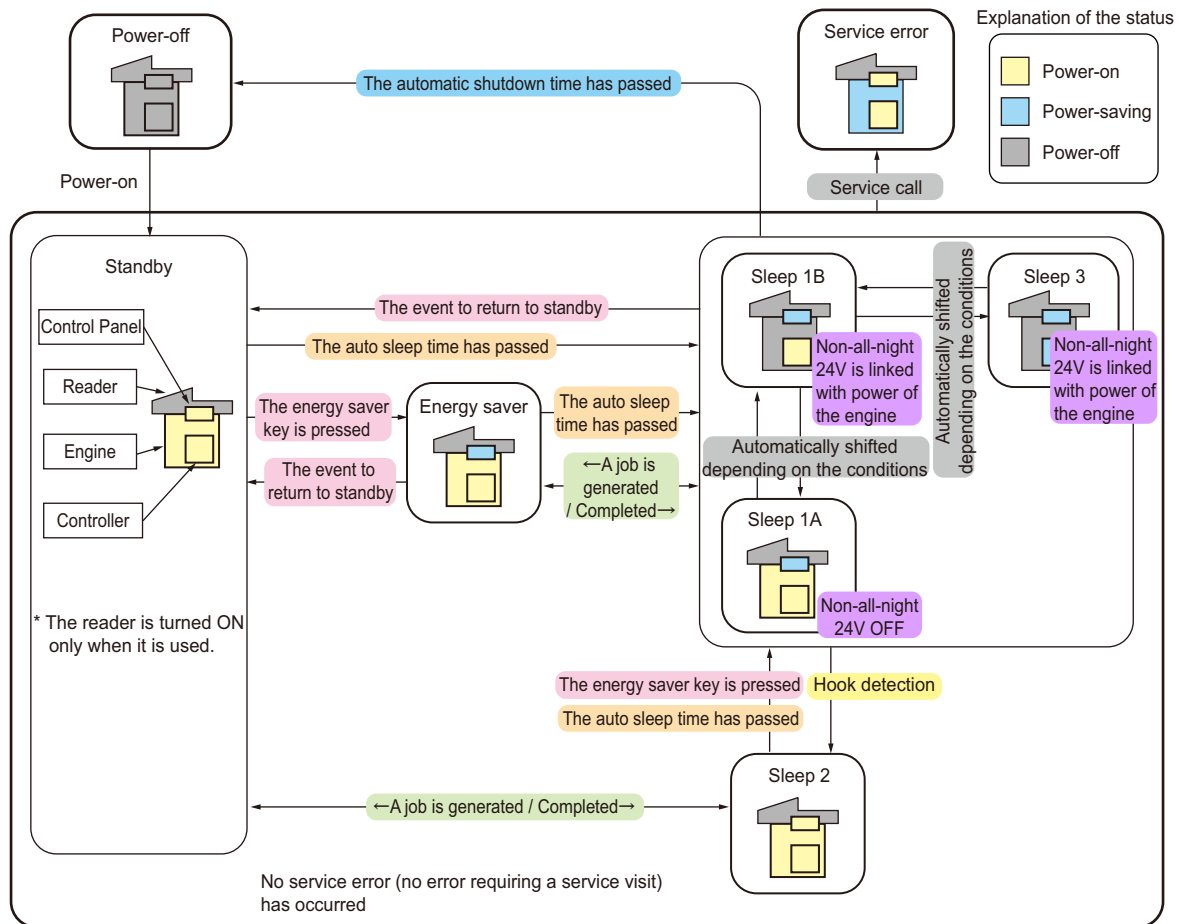

	State	Description
Standby	The machine moves to a standby state by turning ON the main switch.	When introduction of jobs become possible, timer of the auto sleep time start counting.
Energy saver	In a standby state, the machine moves to an energy saver state by pressing the Energy Saver key.	The Control Panel LCD is turned OFF. Moreover, the LED of energy saver is turned ON.
Sleep 1A	The machine is in a state where the 24V non-all-night power is ON.	When the auto sleep time has elapsed, transition to sleep 1A occurs.
Sleep 1B	The machine is in a state where the 24V non-all-night power is OFF. (Linked with power of the engine)	Sleep 1B is a state where CPU moves to an operation state from sleep 3 by a hardware interruption.
Sleep 2	When change in on-hook/off-hook state is detected while the machine is in sleep 1A, sleep 1B, or sleep 3, it moves to sleep 2.	The Control Panel LCD display is turned ON, and the machine accepts key operations. When the auto sleep time has elapsed, the machine moves back to sleep 1.
Sleep 3	The controller itself gets into a power-saving mode.	In this mode, CPU of the controller has stopped. (The most effective power saving state)
Service error	When an error requiring a service visit occurs, the machine moves to this state.	Power state of the printer remains in power-saving mode so that the machine can respond to request from service mode.

Image Formation System

Major Components

Description

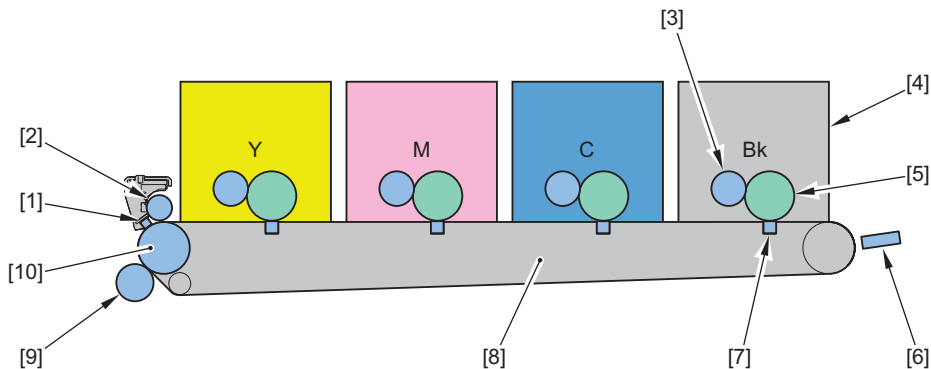

No.	Name	No.	Name
[1]	ITB Cleaning Brush	[6]	Color Displacement/Density Sensor
[2]	ITB Cleaning Roller	[7]	Primary Transfer Brush
[3]	Developing Cylinder	[8]	ITB Unit
[4]	Toner Cartridge	[9]	Secondary Transfer Roller
[5]	Photosensitive Drum	[10]	ITB Drive Roller

Image Formation Process

Description

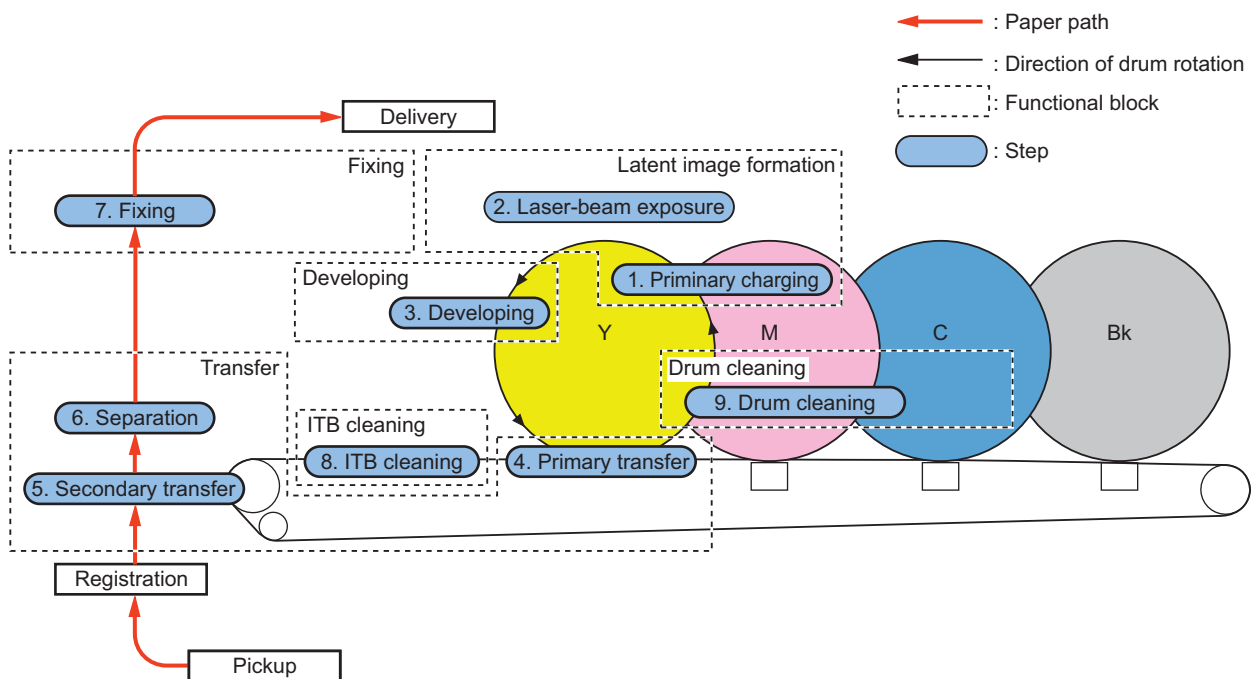

ITB Unit

Functional Configuration

The ITB Unit performs primary transfer of a toner image on the Photosensitive Drum onto the ITB.

The internal structure of the ITB Unit is as follows.

- ITB
- ITB Drive Roller
- Primary Transfer Brush

The ITB Drive Roller is driven by the Drum Motor (M2) and rotates the ITB.

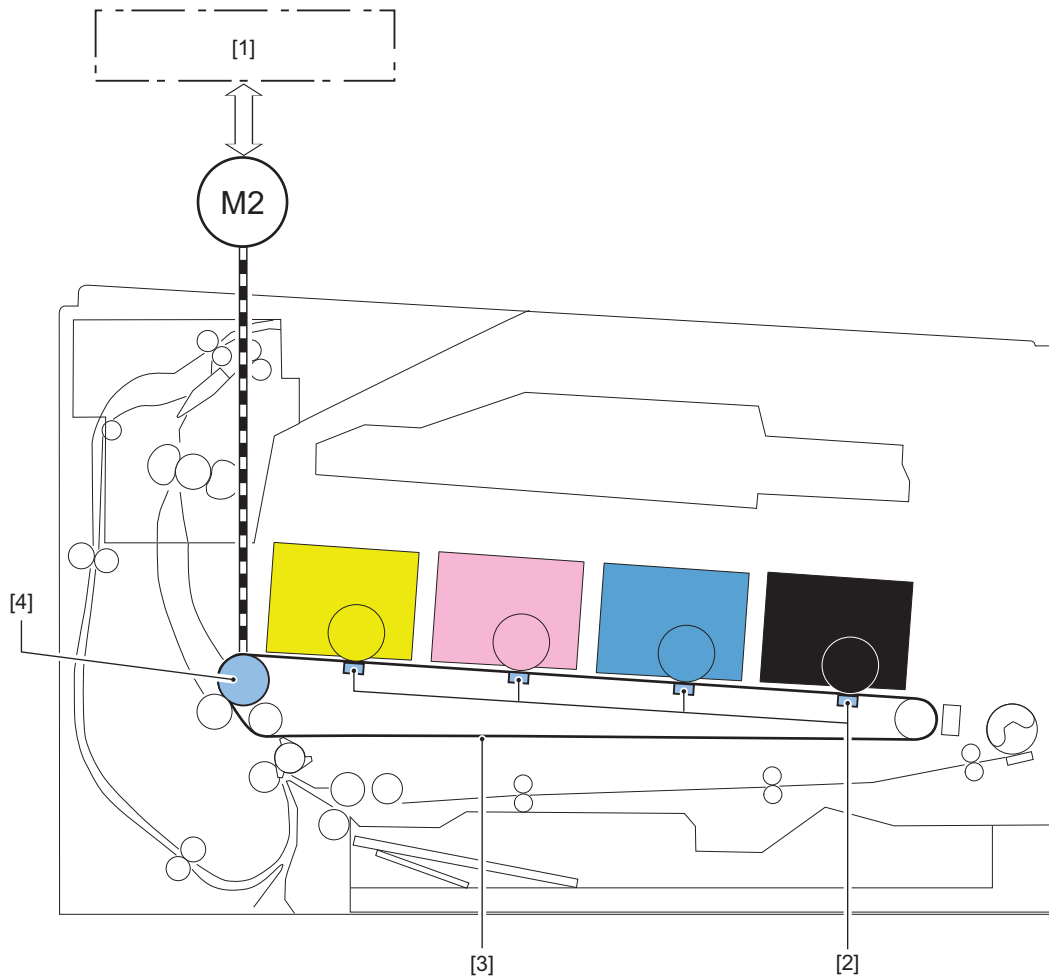

No.	Name
[1]	Engine Controller PCB
[2]	Primary Transfer Brush
[3]	ITB
[4]	ITB Drive Roller

■ Primary Transfer Brush Engagement/Disengagement Control

The ITB is engaged with the Photosensitive Drum as needed for the print operation by the Primary Transfer Brush engagement/disengagement control. There are 3 states that are switched depending on the print operation.

"All colors disengaged" state

When the power supply is turned OFF or when in the standby state, the ITB is disengaged from the Photosensitive Drum for all colors.

This state is the home position of the Primary Transfer Brush.

"All colors engaged" state

This is the state during full color print (including jobs including both B&W and color), and the ITB is engaged with the Photosensitive Drum for all colors.

Only black engaged

This is the state during B&W print, and the ITB is engaged only with the black Photosensitive Drum.

The following explains the engagement/disengagement operation of the Primary Transfer Brush.

The Drum Motor (M2) drive is transmitted by the Primary Transfer Disengagement Solenoid (SL30) to the Primary Transfer Brush Disengagement Cam and rotates the cam. The YMC or Bk Primary Transfer Brush Slide Plate slides to the left or right by the operation of the cam, and the Primary Transfer Brush raises or lowers. The ITB is engaged with or disengaged from the Photosensitive Drum by the Primary Transfer Brush moving up or down.

The DC Controller moves the Primary Transfer Brush to the home position (all colors disengaged) by rotating the Fixing Motor and turning ON the Primary Transfer Disengagement Solenoid when the power is turned ON. The Primary Transfer Brush is raised or lowered and the ITB is engaged with or disengaged from the Photosensitive Drum by turning ON the Primary Transfer Brush Disengagement Solenoid the specified number of times from this state.

High Voltage Power Supply Control

Description

The High Voltage Power Supply applies high voltage biases to the following:

- Static Eliminator
- Primary Charging Roller (inside the cartridge)
- Developing Cylinder (inside the cartridge)
- Primary Transfer Brush
- Secondary Transfer Roller
- ITB Cleaning Assembly

The high voltage biases are generated by the DC Controller controlling the High Voltage Power Supply.

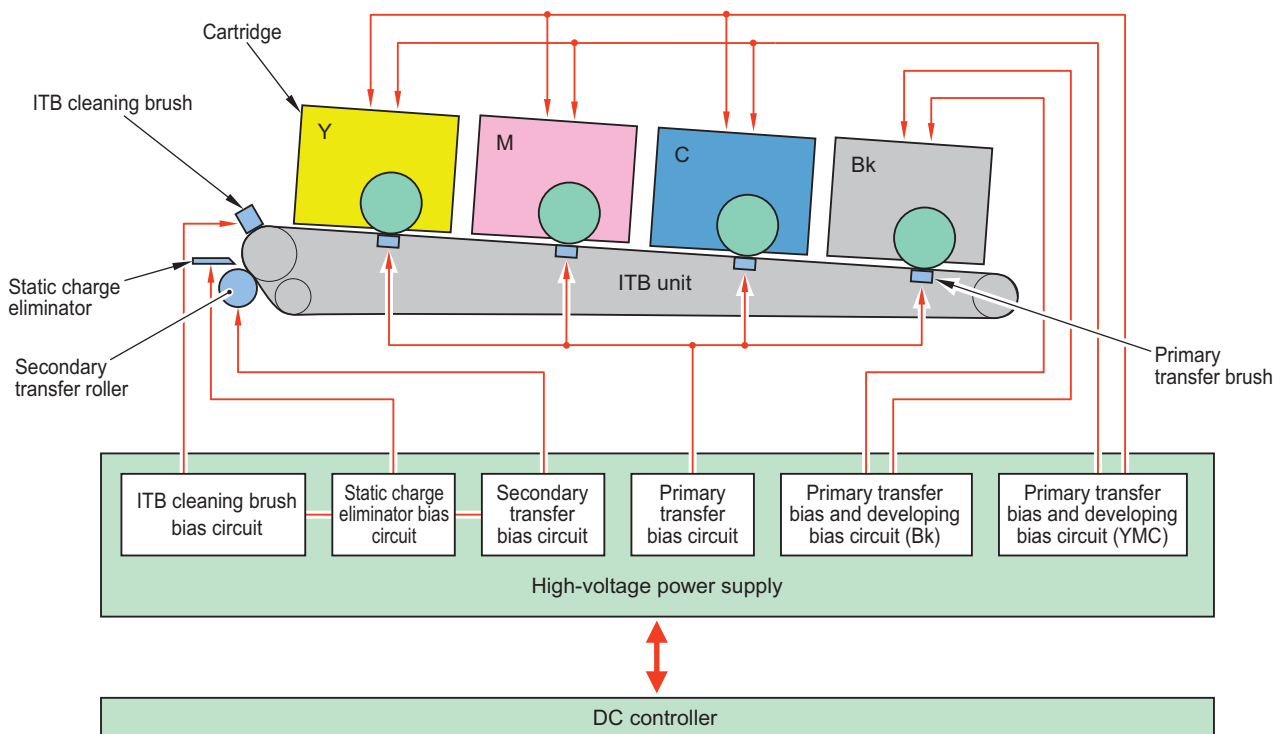
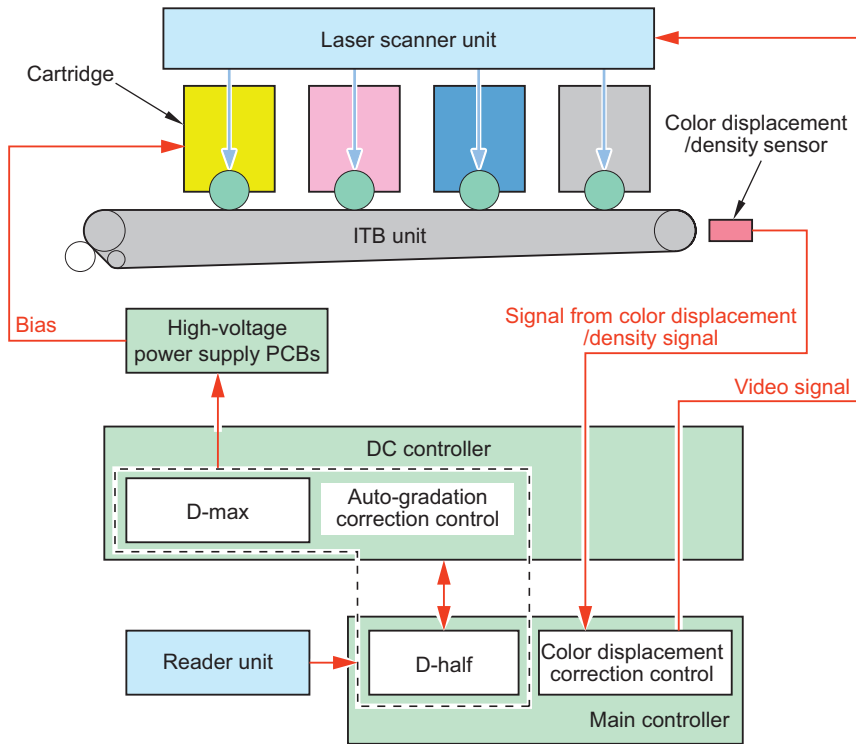

Image Stabilization Control

Overview

Image stabilization control is performed in order to prevent image failure due to change of the environment, deterioration of the Photosensitive Drum, deterioration of the toner, etc. and to ensure stable printing.

- Image Density Correction Control (D-max control)
- Image Gradation Correction Control (D-half control)
- Color Displacement Correction Control
- Auto Gradation Adjustment Control



Execution Condition/Timing

Correction controls are performed under the following conditions:

Execution timing	D-max	D-half	Color displacement correction
At power-on	Yes	Yes	Yes
When the Toner Cartridge is replaced	Yes	Yes	Yes
When the environment (temperature) changes	Yes	Yes	Yes
After printing the specified number of pages	Yes	Yes	Yes
After the specific period of time has passed	Yes	Yes	Yes
When recovering from sleep mode (8 hours or more)	Yes	Yes	-
When [Full Adjust] is executed	Yes	Yes	-
When [Quick Adjust] is executed	Yes	Yes	-
When [Adjust Copy Image] is executed	Yes	Yes	-
When [Correct Print Color Mismatch] is executed	-	-	Yes

Description

Image Density Correction Control (D-max control)

It is performed to stabilize the image density of the printer.
The DC Controller corrects the primary charging bias and developing bias values.

Image Gradation Correction Control (D-half control)

It is performed to stabilize the image gradation of the printer.
The Main Controller performs gradation adjustment based on the measurement results of the halftone density performed by the DC Controller.

Color Displacement Correction Control

Color displacement that occurs due to the individual differences of the Laser Scanner Unit and Toner Cartridge is corrected. The Main Controller performs the following color displacement corrections by controlling the video signal based on the color displacement information measured by the DC Controller.

- Write-start position in the horizontal scanning direction
- Horizontal scanning magnification ratio
- Write-start position in the vertical scanning direction

Auto Gradation Adjustment Control

It is performed to stabilize the gradation density characteristics of the image.

Item	Description	Test pattern	
		Number of output sheets	Type
Full adjustment	Gradation adjustment is performed by outputting a test pattern and reading the gradation density using the reader.	2 sheets	First sheet: For error diffusion Second sheet: For multi-value gradation
Quick Adjust	Gradation adjustment is performed by D-half Control without outputting a test pattern.	-	-
Adjust Copy Image	Gradation adjustment mainly of copied images is performed by outputting a test pattern and reading its gradation density using the reader.	1 sheet	For error diffusion

Additional Functions Mode/Menu

- Menu > Adjustment/Maintenance > Adjust Image Quality > Auto Adjust Gradation > Quick Adjust
- Menu > Adjustment/Maintenance > Adjust Image Quality > Auto Adjust Gradation > Full Adjust
- Menu > Adjustment/Maintenance > Adjust Image Quality > Auto Adjust Gradation > Adjust Copy Image
- Menu > Adjustment/Maintenance > Adjust Image Quality > Correct Print Color Mismatch

Cartridge

Description

The cartridge of this machine has the function to form a visible image on the Photosensitive Drum with toner.

There are 4 types: yellow, magenta, cyan, and black, and all of them have the same structure.

The cartridge of this machine consists of the Photosensitive Drum, Developing Unit, Primary Charging Roller, Memory, etc.

The DC Controller rotates the Drum Motor, and drives the Primary Charging Roller. It also rotates the Developing Motor, and drives the Developing Roller.

The DC Controller detects the toner level by monitoring the toner level detection signal.

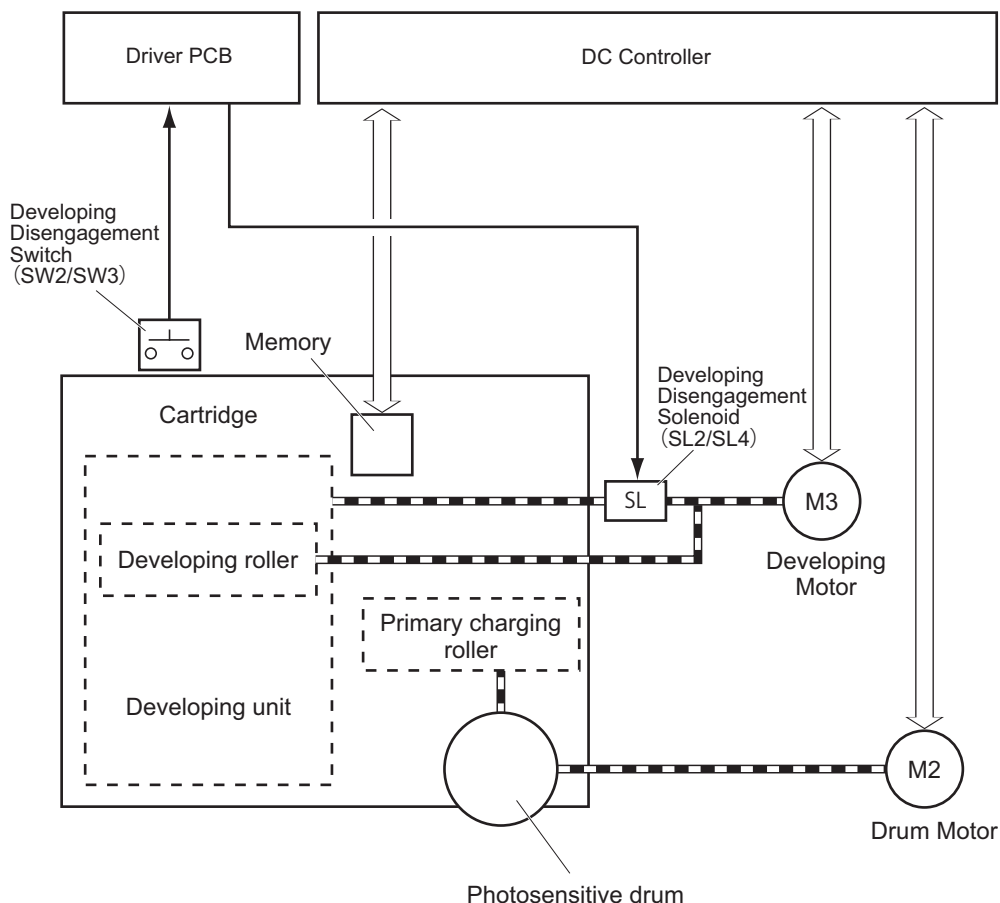

■ Memory

Description

This machine detects/records the cartridge usage status, etc. by reading/writing data stored in the memory by the DC Controller. If the memory cannot be detected, "Cartridge Communication Error. A counterfeit or non-Canon cartridge may be in use." is displayed.

■ Cartridge Detection

Execution Condition/Timing

- At power-on
- When the Front Cover is closed

Description

The DC Controller detects whether a cartridge is installed according to the change in primary charging current. The DC Controller notifies the Main Controller of the absence of a cartridge if it judges there is no cartridge.

Display on the Control Panel:
Toner Cartridge Not Inserted

■ Cartridge Life Detection

Description

The DC Controller notifies the Main Controller when cartridge consumption reaches the specified value.

Upon reception of the notification the Main Controller displays a warning or a message that the cartridge has reached the end of its life.

	Warning display*2	End of life display*4, *5
Toner level*1	Differs depending on the setting*3	0%
Detected to (location)	Memory	Memory
Message (machine operation)	Prepare cartridge.	End of Cartridge Lifetime

*1: Select the following to check the remaining toner level.

- Status Monitor > Device Information > Cartridge Information

*2: Whether to display or hide warnings can be specified in the menu.

*3: The threshold value to display a warning can be specified in the menu.

*4: The operation when the cartridge has reached the end of life can be specified in service mode.

*5: The reference value of cartridge life (Photosensitive Drum, Developing Unit, and Waste Toner) can be specified in service mode.

Service Mode

- Setting of the behavior when the cartridge reaches the end of its estimated life
COPIER > OPTION > FNC-SW > CRG-PROC
- Setting of the reference values for replacement of the Photosensitive Drum, Developing Assembly, and Waste Toner (Bk)
COPIER > OPTION > FNC-SW > CRGLF-K
- Setting of the reference values for replacement of the Photosensitive Drum, Developing Assembly, and Waste Toner (Y/M/C)
COPIER > OPTION > FNC-SW > CRGLF-CL
- ON/OFF of display of the screen for setting the threshold value for preparation of the cartridge
COPIER > OPTION > DSPLY-SW > CRGLW-LV

Additional Functions Mode/Menu

- Setting of whether to display or hide warnings
Menu > Preferences > Display Settings > Display Timing for Cartridge Prep. Notif.
- Setting of the threshold value to display a warning
Menu > Preferences > Display Settings > Display Timing for Cartridge Prep. Notif. > Custom

■ Developing Cylinder Engagement/Disengagement Control

Overview

The DC Controller engages/disengages the Developing Cylinder in the Toner Cartridge with/from the Photosensitive Drum.

Execution Condition/Timing

The Developing Cylinder is engaged or disengaged depending on the state of this machine.

State of this machine	Y/M/C	Bk
Power Supply Off/Standby	Disengagement	
B&W Print	Disengagement	Engagement
Full Color Print	Engagement	

Description

In accordance with the specified print mode (full color or B&W), only the Developing Cylinder(s) necessary for the mode is engaged with the Photosensitive Drum.

The Developing Cylinders are engaged only when needed, and this prevents deterioration of the Photosensitive Drum and ensures the maximum life.

For engagement/disengagement of the Developing Cylinders, the DC Controller drives the Developing Disengagement Solenoid (K) (SL2)/ Developing Disengagement Solenoid (YMC) (SL4) while the Developing Motor (M3) is driving to change the orientation of the Engagement/Disengagement Cam.

The DC Controller detects the current state using the Developing Disengagement Switch (K) (SW3)/Developing Disengagement Switch (YMC) (SW2), and determines the state (engaged or disengaged) of the Developing Cylinders on the basis of the amount of rotation of the Developing Motor after the Developing Disengagement Solenoid starts to be driven.

Error Code

- E015-0000 : Developing Motor Error

Pickup Feed System

Overview

Overview

The pickup, feed, and delivery systems are controlled by the DC Controller.

The DC Controller controls the blocks in the pickup, feed, and delivery systems to pickup, feed, and deliver paper inside the machine.

Description

The pickup, feed, and delivery systems consist of the following three blocks.

- Pickup/Feed: From each pickup slot to the inlet of the Fixing Assembly
- Fixing/Delivery: From the Fixing Assembly to the delivery outlet
- Duplex: From the Duplex Reverse Assembly to the Duplex Re-pickup Assembly

- ▶ Simplex paper path
- ⋯▶ Duplex paper path

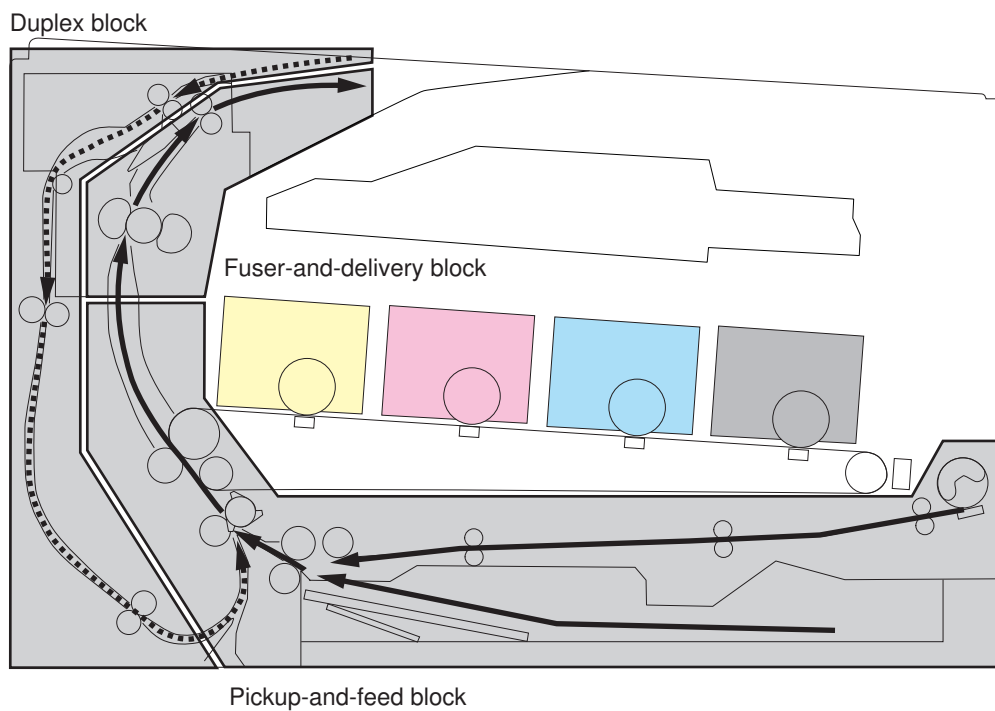

Parts Configuration

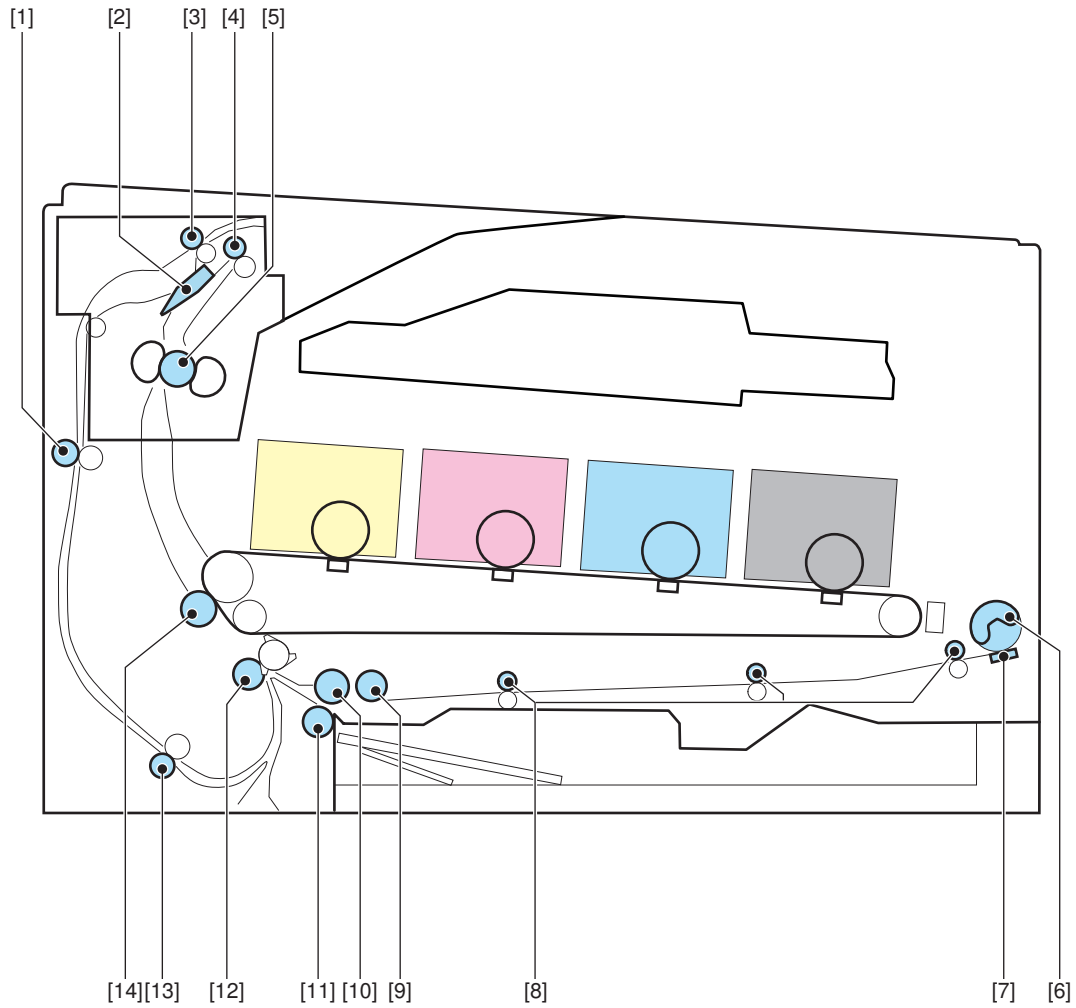

No.	Name	No.	Name
[1]	Duplex Feed Roller	[8]	Multi-purpose Tray Feed Roller
[2]	Duplex Flapper	[9]	Pickup Roller
[3]	Duplex Reverse Roller	[10]	Feed Roller
[4]	Delivery Roller	[11]	Separation Roller
[5]	Fixing Roller	[12]	Registration Roller
[6]	Multi-purpose Tray Pickup Roller	[13]	Duplex Re-pickup Roller
[7]	Multi-purpose Tray Separation Pad	[14]	Secondary Transfer Roller

Drive Configuration

Description

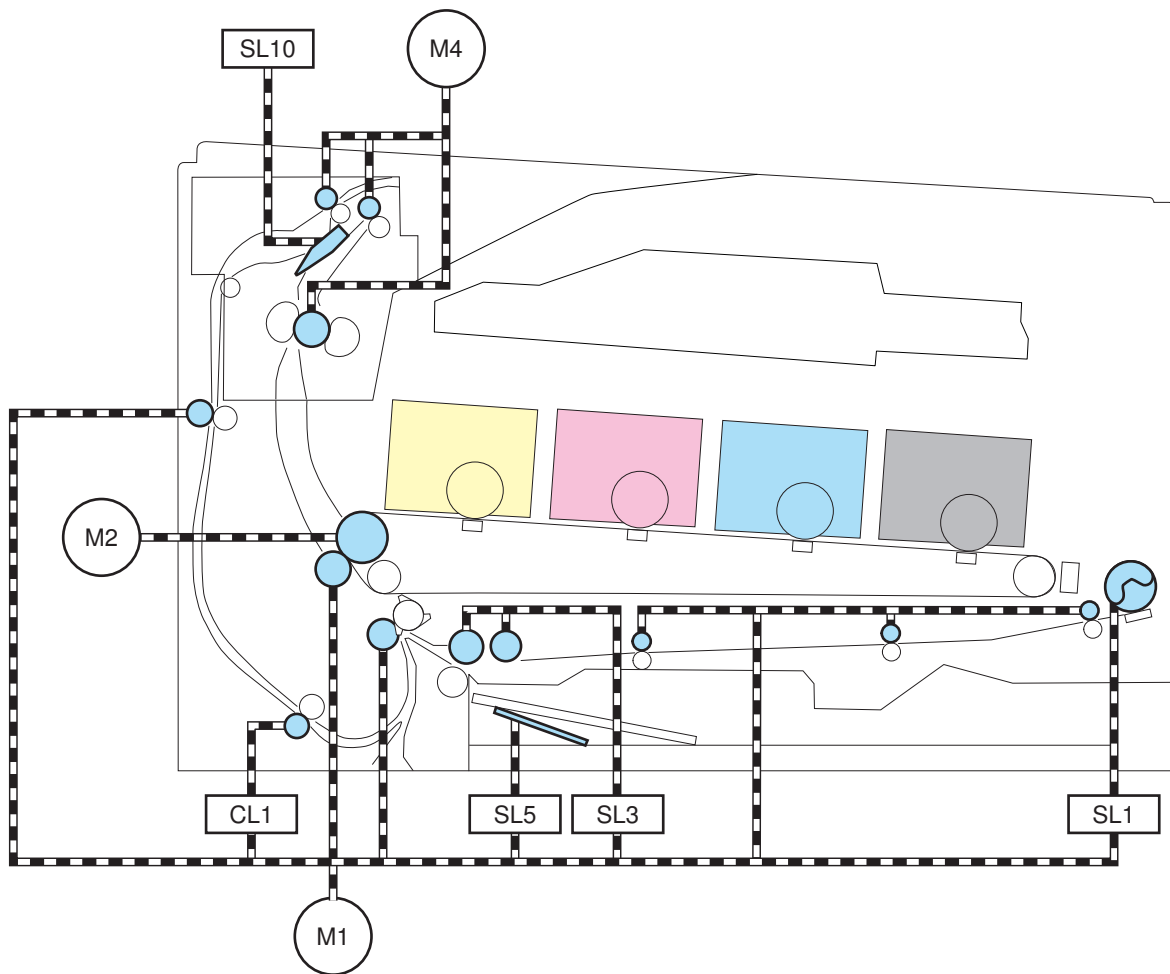

Sym- bol	Name	Sym- bol	Name
M1	Pickup Motor	SL1	Multi-purpose Tray Pickup Solenoid
M2	Drum Motor	SL3	Cassette Pickup Solenoid
M4	Fixing Motor	SL5	Lifter Solenoid
CL1	Duplex Re-pickup Clutch	SL10	Duplex Reverse Solenoid

Layout of Sensors

Description

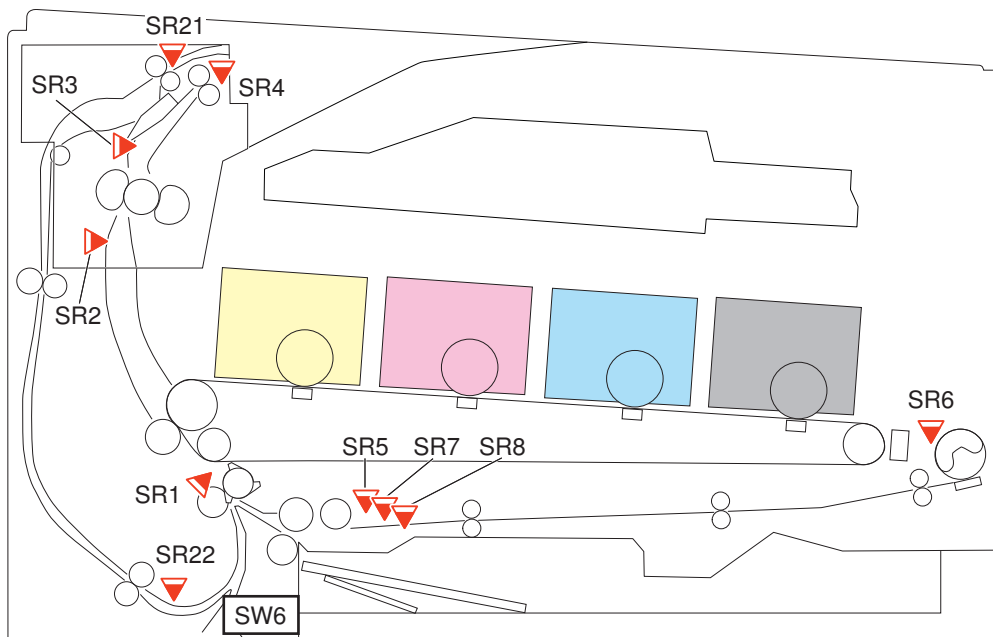

Sym- bol	Name	Symbol	Name
SW6	Cassette Switch	SR6	Multi-purpose Tray Paper Sensor
SR1	Registration Sensor	SR7	Cassette Paper Surface Sensor
SR2	Arch Sensor	SR8	Lifter Sensor
SR3	Fixing Delivery Sensor	SR21	Duplex Reverse Sensor
SR4	Delivery Sensor	SR22	Duplex Re-pickup Sensor
SR5	Cassette Paper Sensor		

Lifter Control

Description

Paper inside a cassette is lifted up by the Lifting Plate.

The Lifting Plate is lifted by driving the Pickup Motor (M1) and Lifter Solenoid (SL5).

When the paper surface reaches the position of the Pickup Roller, the Cassette Paper Surface Sensor (SR7) is turned ON to detect that the paper has reached the pickup position and stop the ascending of the Lifter Plate. The ascending of the Lifter Plate is also stopped when the Lifter Sensor (SR8) detects the Lifter Plate.

When the Lifting Plate is rising, the Pickup Motor (M1) and Lifter Solenoid (SL5) are controlled to keep the paper surface steady so that pickup can be performed stably.

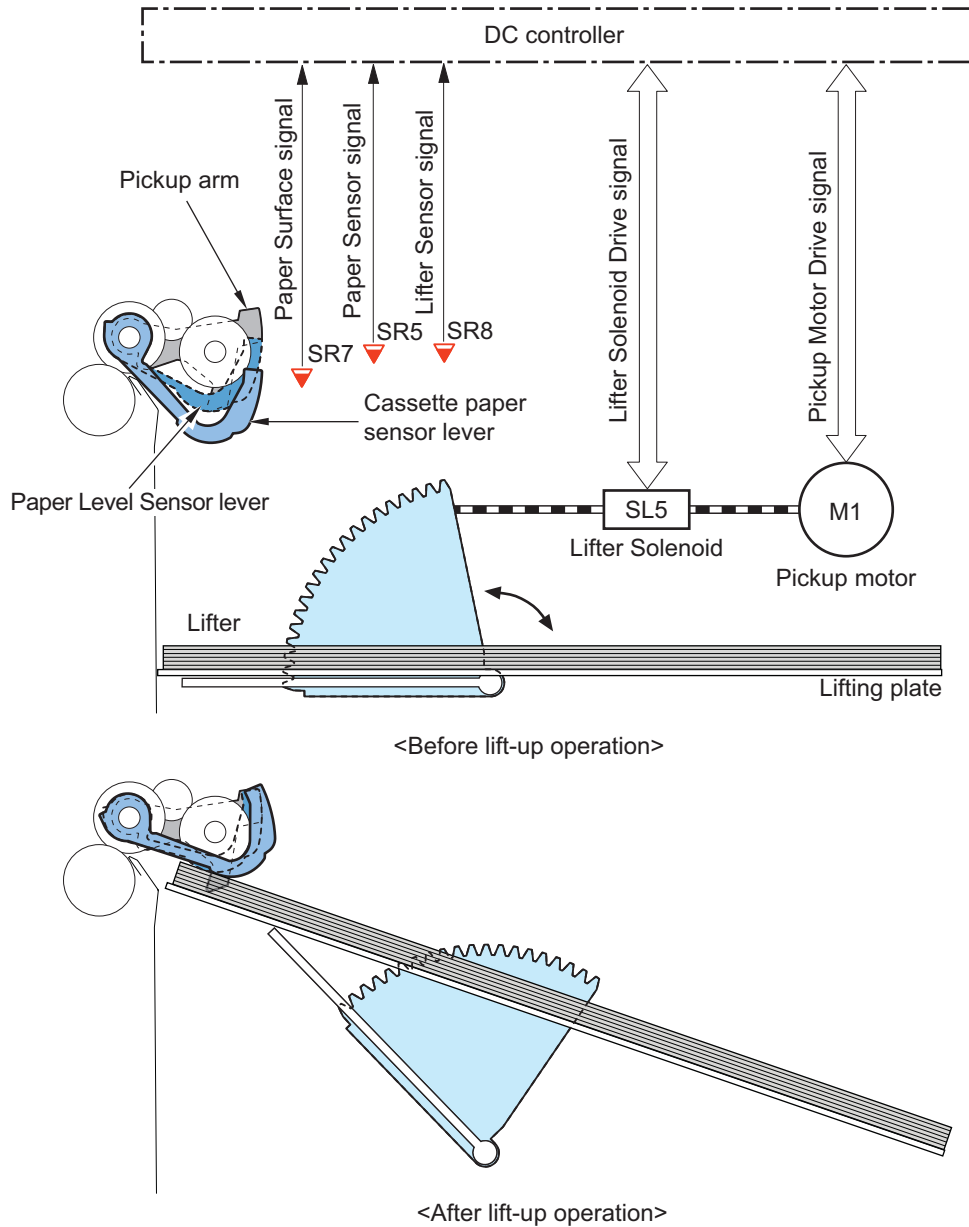

There are 2 types of lift-up operation: initial lift-up operation and lift-up operation during printing.

1. Initial lift-up operation

When the power is turned ON or a cassette is inserted, the Pickup Motor (M1) and Lifter Solenoid (SL5) are driven to lift up the Lifting Plate to the position where the Lifter Sensor (SR8) detects the Lifting Plate if the Cassette Paper Surface Sensor (SR7) does not detect the paper surface.

2. Lift-up operation during printing

This operation is performed if the paper surface is lowered a certain amount by the pickup operation.

If the Cassette Paper Surface Sensor (SR7) detects that there is no paper during printing, the Pickup Motor (M1) and Lifter Solenoid (SL5) are driven to lift up the Lifting Plate to the pickup position.

Error Code

- E015-0001 : Cassette 1 Lift up Error
- E015-0002 : Cassette 2 Lift up Error

Cassette Detection

Description

Presence of the cassette is detected using the Cassette Switch (SW6).

The cassette detection flag of the cassette is detected by the Cassette Detection Switch in the host machine.

Cassette Pickup Control

Description

The DC Controller rotates the Pickup Roller by rotating the Pickup Motor (M1).

The Pickup Arm is lifted and lowered to feed the paper by rotating the Pickup Cam with the Cassette Pickup Solenoid (SL3).

Double Feed Prevention Mechanism

This machine employs the Retard separation method for the cassette pickup double feed prevention mechanism.

The Retard separation method of this machine is a method that prevents paper double feeds by using the Separation Rollers without drive.

The Separation Rollers are driven and rotated by the Feed Roller.

- At Normal Time

The Separation Roller is driven by the Feed Roller drive via paper. This causes the Separation Rollers to rotate in the feed direction.

- During Double Feed

Since the friction force between sheets of paper becomes weaker when there are multiple sheets of paper, the Feed Roller drive force transmitted to the Separation Roller becomes extremely weak.

Since force suppressing rotation is applied to the Separation Rollers of this machine, this mechanism does not allow rotation by the weak drive force transmitted from the Feed Roller during double feed. The Separation Rollers therefore do not rotate and do not pickup double feed paper.

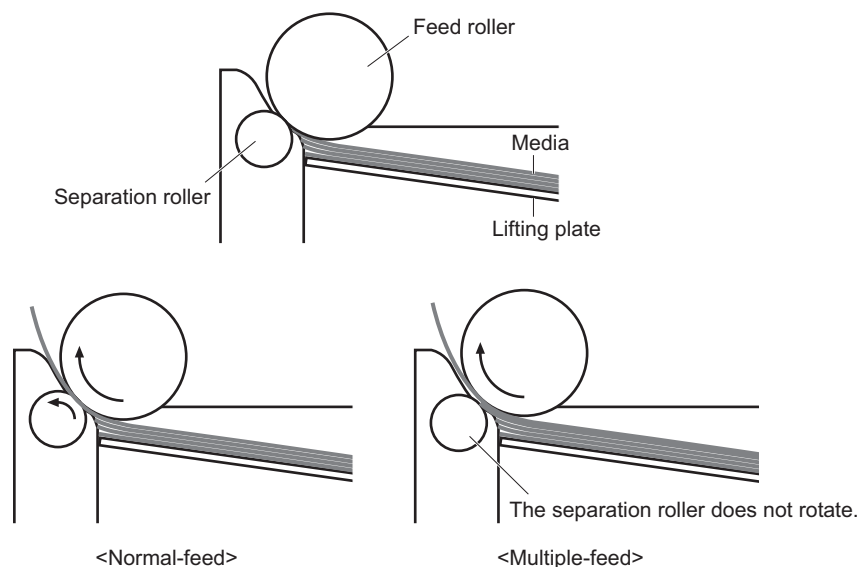

Multi-purpose Tray Pickup Control

Description

The Multi-purpose Tray pickup feeds paper from the Multi-purpose Tray one sheet at a time into the machine.

The following describes the operation of the Multi-purpose Tray pickup.

1. When a print command is input from the Main Controller, the DC Controller rotates the Pickup Motor (M1).
2. When the DC Controller turns ON the Multi-purpose Tray Pickup Solenoid (SL1), the Multi-purpose Tray Pickup Roller rotates and paper is picked up.
3. After double feed paper is removed by the Multi-purpose Tray Separation Pad, paper is fed into the machine. Note that the presence of paper on the Multi-purpose Tray is detected by the Multi-purpose Tray Paper Sensor (SR6), and printing is not performed if there is no paper.

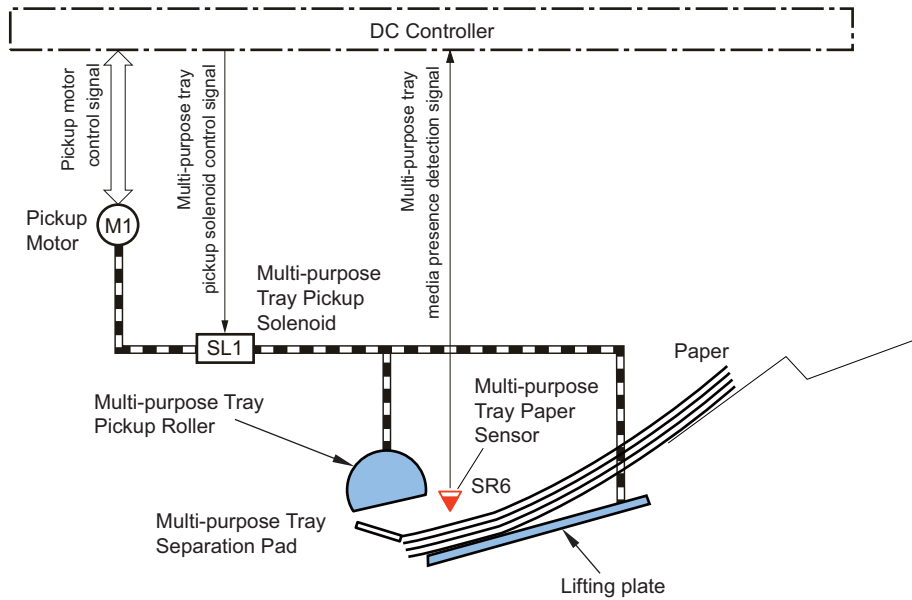

Skew Correction

Description

This machine can correct paper skew without lowering throughput.

Skew is corrected as follows.

1. The paper leading edge pushes against the Registration Shutter to align the leading edge of the paper.
2. The trailing edge of the paper is fed and slack is generated at the leading edge of the paper.
3. When the trailing edge is fed even further, the paper leading edge for which slack was generated pushes up the Registration Shutter and then the paper is fed to the Registration Roller while the paper leading edge is aligned.

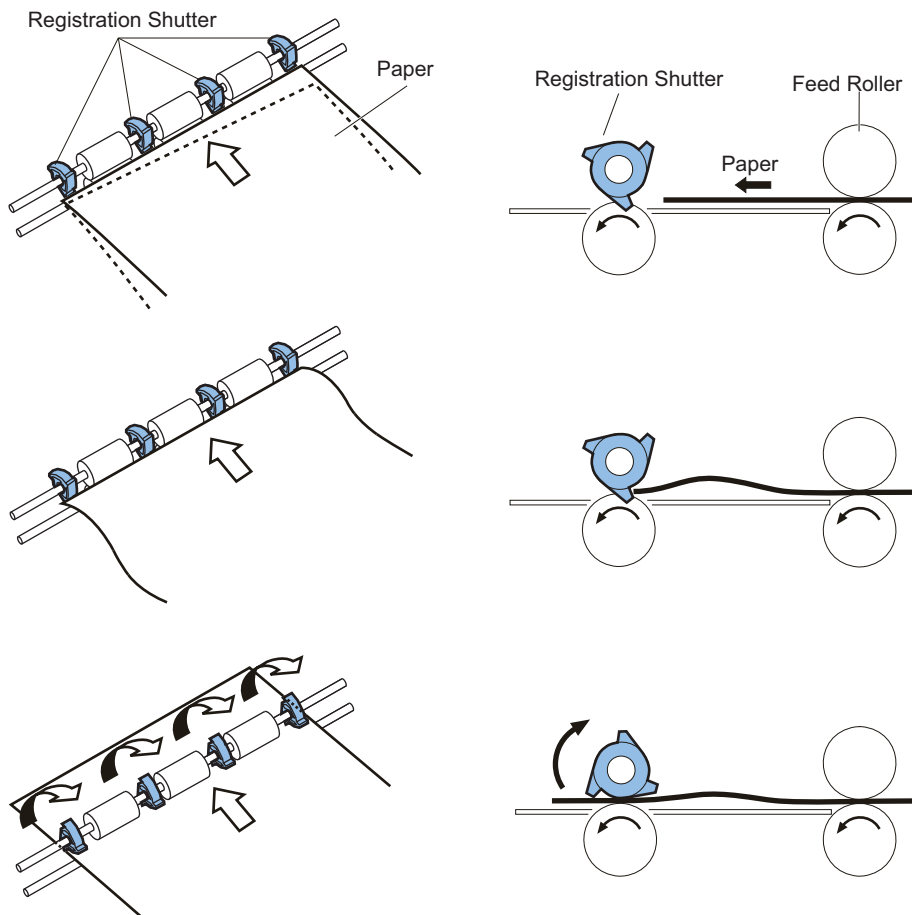

Arch Control

Arch control keeps the appropriate slack on paper to prevent image failure and feed failure.

- If the rotation speed of the Fixing Motor is slower than the rotation speed of the Drum Motor, the slack on the paper becomes larger.
- If the rotation speed of the Fixing Motor is faster than the rotation speed of the Drum Motor, the slack on the paper becomes smaller.

The DC Controller detects the slack on paper by the Arch Sensor (SR2), and controls the rotation speed of the Fixing Motor.

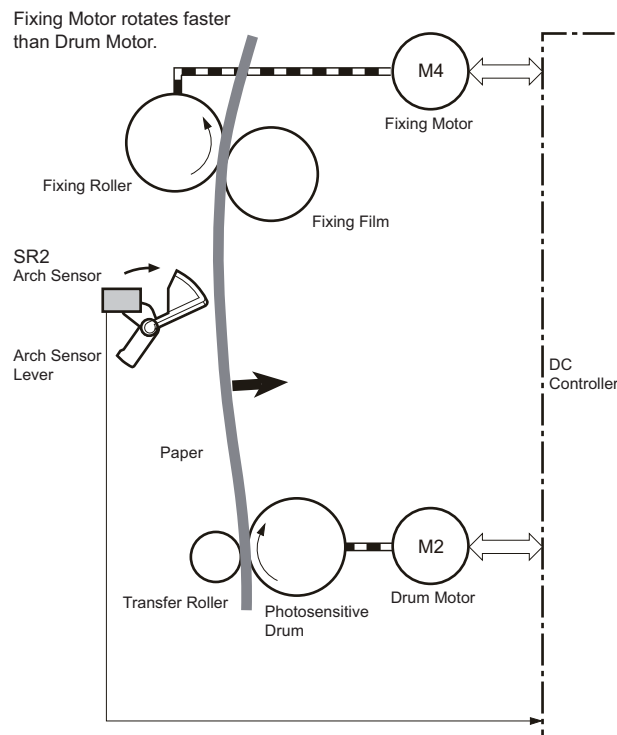
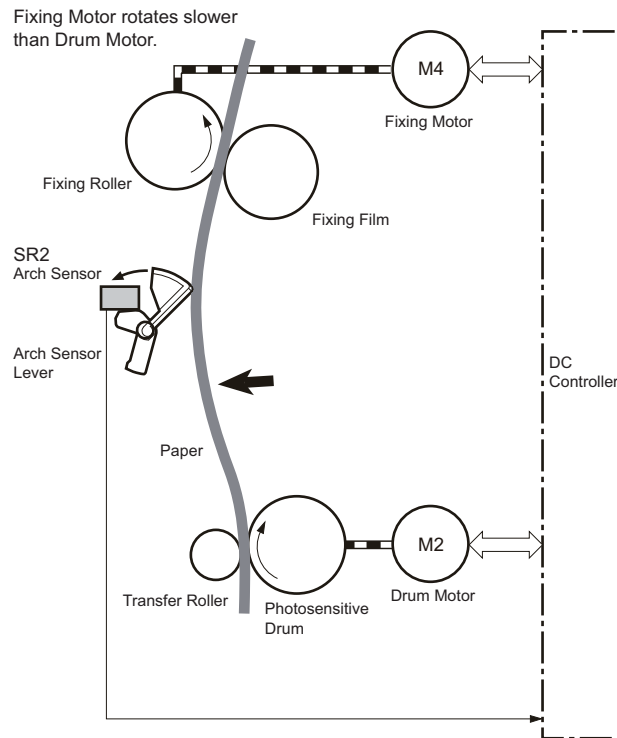

Delivery Tray Full Detection

Description

The DC Controller detects paper full in the Delivery Tray using the Delivery Sensor (SR4).

The DC Controller judges that the Delivery Tray is full and notifies the Main Controller when the Delivery Sensor detects paper for a specified period of time during printing.

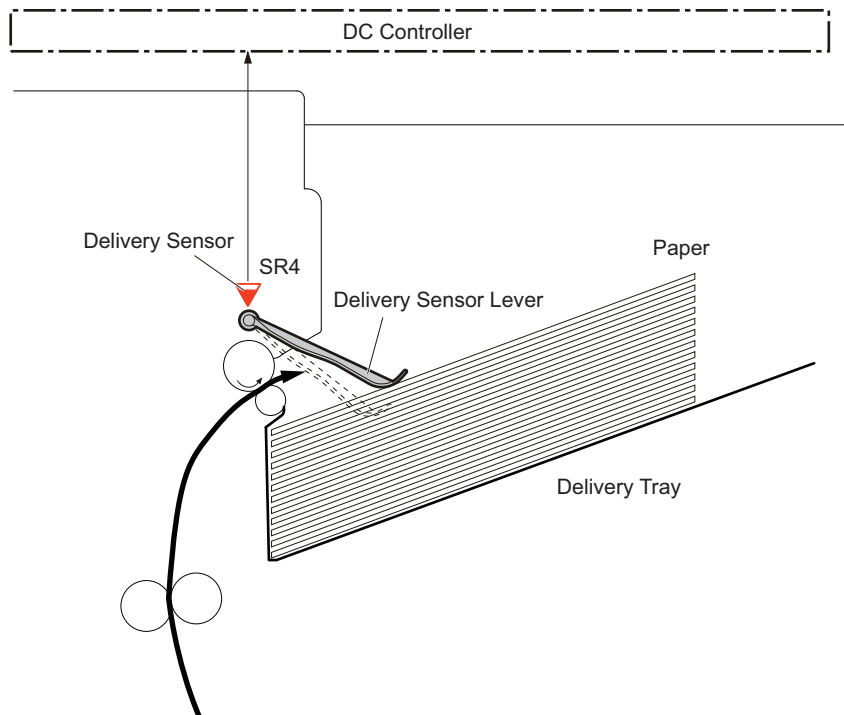

Jam Detection

Description

The sensors are provided at the locations shown below to detect the presence of print paper and whether the print paper is being fed correctly.

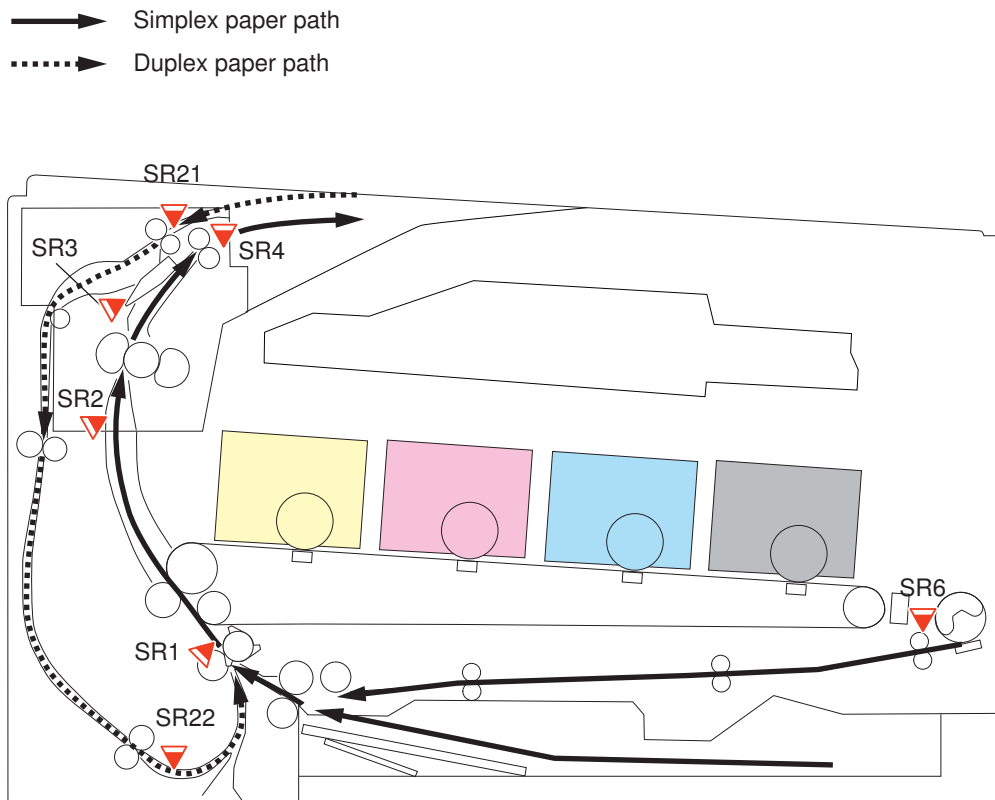

Occurrence of a jam is judged by whether paper is in the sensor area at the timings stored in the DC Controller. When the DC Controller judges that a jam has occurred, the printing operation is stopped and the jam is notified to the Main Controller at the same time.

The following shows the jams that are detected.

Jam name	Details
Pickup delay jam	At paper pickup from the Pickup Cassette of the Host Machine or Multi-purpose Tray, the Registration Sensor (SR1) does not detect the paper leading edge within the specified period of time. Otherwise, at paper pickup from the Cassette Feeding Unit, the Cassette Feed Sensor (SR31) does not detect the paper leading edge within the specified period of time.
Pickup Stationary Jam	The Registration Sensor (SR1) does not detect the paper trailing edge although a specified period of time has passed after the detection of the paper leading edge.
Fixing delivery delay jam	The Fixing Delivery Sensor (SR3) does not detect the leading edge although a specified period of time has passed after the Registration Sensor (SR1) detected the leading edge.
Fixing delivery stationary jam	The Fixing Delivery Sensor (SR3) does not detect the paper trailing edge although a specified period of time has passed after the detection of the paper leading edge.
Delivery Delay Jam	The Delivery Sensor (SR4) does not detect the paper leading edge although a specified period of time has passed after the Fixing Delivery Sensor (SR3) detected the leading edge.
Delivery Stationary Jam	The Delivery Sensor (SR4) does not detect the paper trailing edge although a specified period of time has passed after the detection of the paper leading edge.
Reverse delay Jam	The Duplex Reverse Sensor (SR21) does not detect the paper leading edge although a specified period of time has passed after the Fixing Delivery Sensor (SR3) detected the leading edge.
Reverse stationary jam	The Duplex Reverse Sensor (SR21) does not detect the paper trailing edge although a specified period of time has passed after the detection of the paper leading edge.
Duplex feed delay jam	The Duplex Re-pickup Sensor (SR22) does not detect the paper leading edge although a specified period of time has passed after the Duplex Reverse Sensor (SR21) detected the leading edge.
Duplex re-pickup delay jam	At 2nd sheet pickup, the Registration Sensor (SR1) does not detect the paper leading edge although a specified period of time has passed.
Wrapping jam	The Fixing Delivery Sensor (SR3) detected the paper trailing edge earlier than the specified period of time after the Fixing Delivery Sensor (SR3) detected the leading edge.

Jam name	Details
Internal residual jam	One of the following sensors detected presence of paper at power-on, door close, or before/after print operation. <ul style="list-style-type: none">• Registration Sensor (SR1)• Arch Sensor (SR2)• Fixing Delivery Sensor (SR3)• Duplex Reverse Sensor (SR21)• Duplex Re-pickup Sensor (SR22)• Cassette Feed Sensor (SR31)
Door Open Jam	The door open was detected during printing and feeding paper.

Fixing System

Functional Configuration

Overview

The fixing system forms a permanent image by melting the toner on the paper using pressure and heat.

Description

The fixing control circuit controls the temperature of the Fixing Assembly.
The Fixing Assembly of this machine uses the on-demand fixing method.

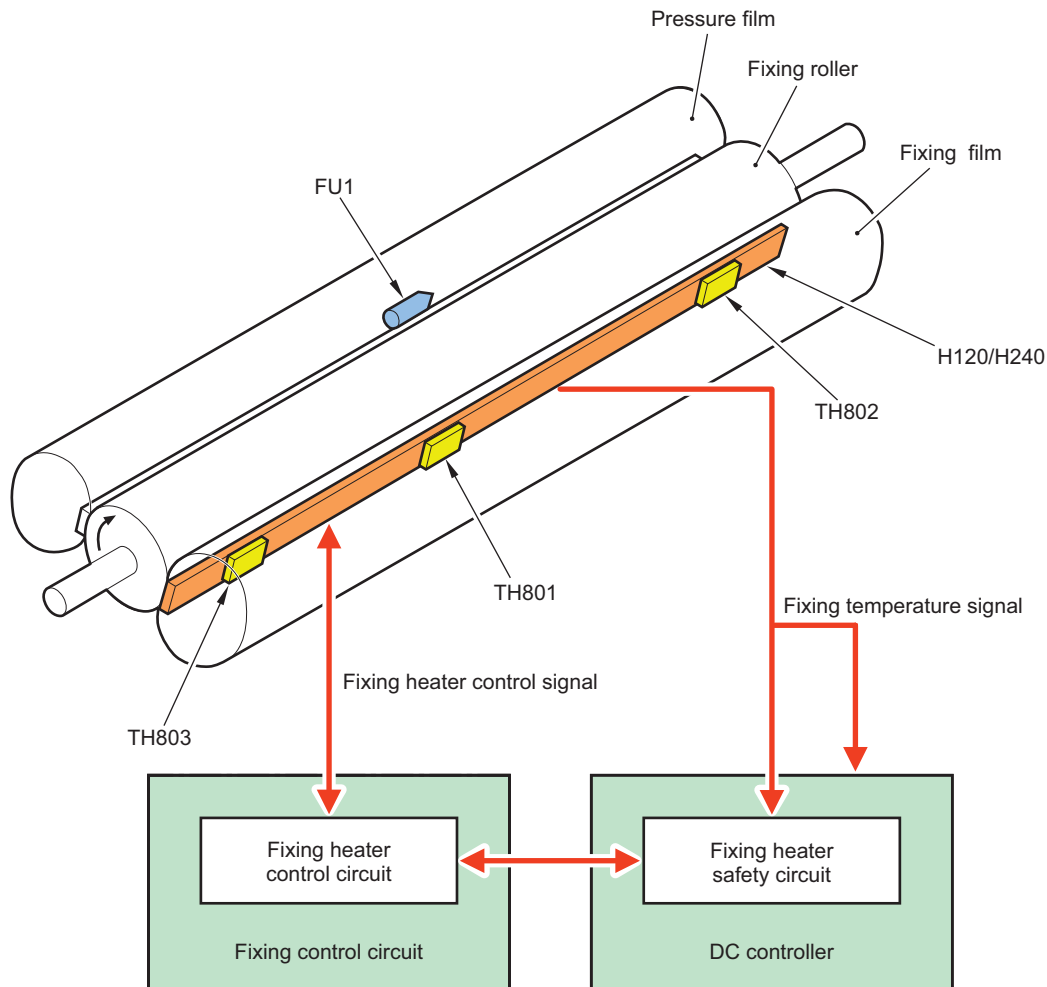

Symbol	Parts name
H120	Fixing Heater (120 V)
H240	Fixing Heater (200 V)
TH801	Main Thermistor
TH802	Sub Thermistor 1
TH803	Sub Thermistor 2
FU1	Temperature Fuse

Temperature control of the Fixing Assembly which consists of these parts is performed by the Fixing Heater control circuit and Fixing Heater safety circuit according to the command of the DC Controller.

Fixing Temperature Control

Overview

This control circuit controls the temperature such that the Fixing Heater reaches the target temperature.

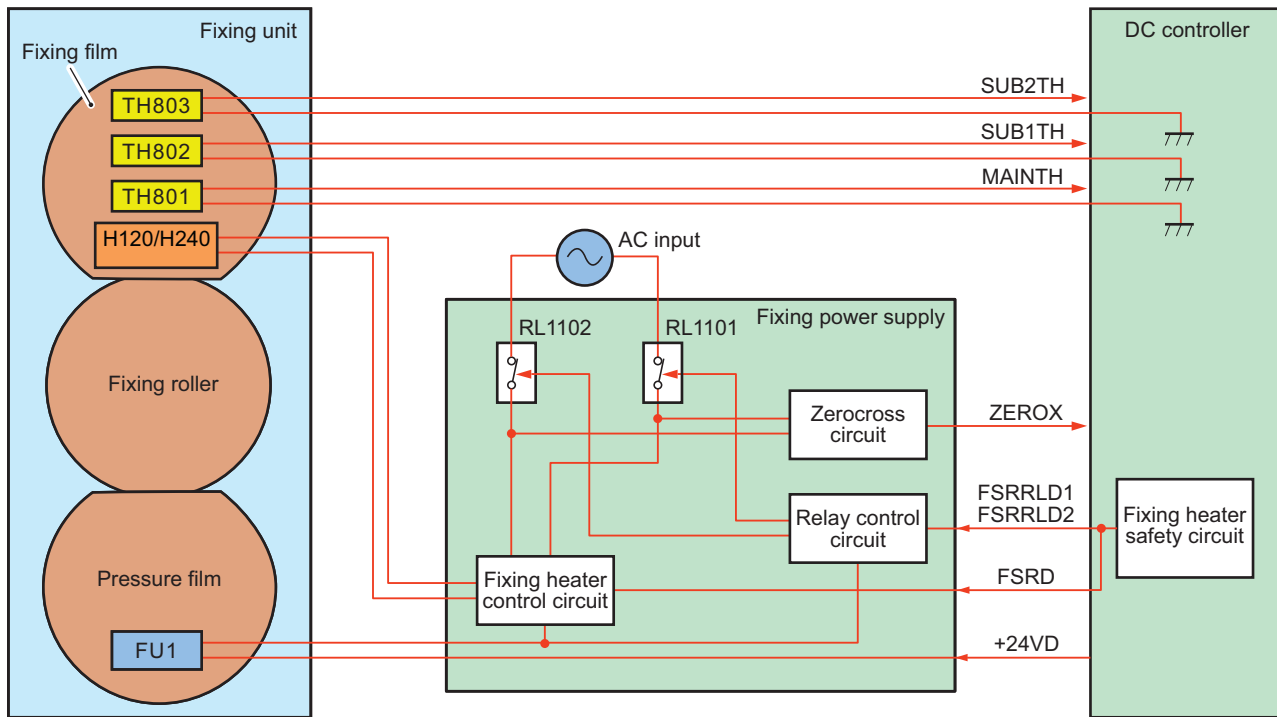

Description

The DC Controller monitors the fixing temperature detection signal and outputs a fixing control signal according to the detected temperature. The fixing control circuit controls the Fixing Heater on the basis of this signal, and controls the temperature of the Fixing Heater to the target value.

Fixing pressure/pressure release control

Description

Release/application of pressure for fixing is performed automatically by rotating the Fixing Motor (M4) clockwise or counterclockwise.

When a jam occurs, fixing pressure is released by this control so that jammed paper can be removed easily.

The release/application status of pressure for fixing is detected by the Fixing Pressure Release Switch (SW5). If disengagement operation is not detected although a specified period of time has passed, an error code is displayed.

Error Code

E840-0000 : Pressure release mechanism error

Protection Function

Overview

This machine has a function to detect abnormal temperature rising in the Fixing Assembly and cut off the power supply to the Fixing Heater.

Description

This machine has the following four protection functions to prevent abnormal temperature rising in the Fixing Heater.

- DC Controller
- Fixing Heater safety circuit
- Temperature Fuse
- Down Sequence Control

The following describes the details.

DC Controller

The DC Controller monitors the thermistor temperature of the Fixing Heater (Center). When it exceeds the specified temperature, it is judged that the temperature of the Fixing Assembly is abnormally high, and the fixing control signal (FSRD) output is stopped, the relay is turned OFF, and the power supply to the heater is turned OFF.

Fixing Heater safety circuit

The Fixing Heater safety circuit monitors the thermistor temperature of the Fixing Heater (Center). When it exceeds the specified temperature, it is judged that the temperature of the Fixing Assembly is abnormally high, and the relay is turned OFF and the power supply to the heater is turned OFF.

Temperature Fuse

If the temperature of the Fixing Heater rises abnormally and the temperature of the Fixing Fuse exceeds the specified temperature, the Temperature Fuse opens and the power supply to the heater turns OFF.

Down Sequence Control

The DC Controller monitors the thermistor temperature of the Fixing Heater (Edge) and may significantly decrease the productivity (B5/A5/EXEC: approximately 3 pages/minute , Envelope C5: approximately 2 pages/minute) to inhibit the temperature rise when the temperature has increased to a specified temperature due to such causes as continuous printing of small-size paper.

Fixing Assembly Failure Detection

Overview

When the machine is under the following conditions, the DC Controller shuts down the power supply to the Fixing Assembly and notifies an error.

- Startup failure
- Abnormal high temperature failure
- Abnormal low temperature failure
- Fixing power supply drive circuit failure

Description**Fixing Assembly startup failure**

An error code is notified if the Fixing Assembly does not reach a certain temperature within a specified period of time.

Abnormal high temperature failure

An error code is notified if an abnormally high temperature is detected in the Fixing Assembly.

Abnormal low temperature failure

An error code is notified if an abnormally low temperature is detected in the Fixing Assembly.

Fixing power supply drive circuit failure

An error code is notified if a zero cross signal is not detected for the specified period of time or more.

Error Code

- E000-0000 : Fixing Assembly startup failure
- E001-0000 : Abnormal high temperature of Fixing Assembly
- E001-0001 : Abnormal high temperature of Fixing Assembly
- E003-0000 : Abnormal low temperature of Fixing Assembly
- E003-0001 : Abnormal low temperature of Fixing Assembly
- E004-0000 : Error in fixing power supply drive circuit



Technical Explanation (System)

Overview of System Management.....	58
Version Upgrade.....	59
Setting Information Export/Import Function (DCM).....	64
Monitoring Function (e-Maintenance/ imageWARE Remote).....	74
Security Functions.....	78

Overview of System Management

This chapter describes information for service technicians on the system of this machine. Although this chapter contains some information described in the User's Guide, for details on the functions for users, refer to the e-Manual.

Version Upgrade

Function Overview

The following firmware upgrade methods are available with this device.

Version upgrade using User Support Tool (UST).

Upgrade the firmware of the device using UST

Open the file for UST version upgrade on a PC connected with the device and upgrade the firmware.

Since the host machine and the PC are connected using a USB cable, version upgrades can be performed in an environment where a network is not available.

Version upgrade via Internet

Access the dedicated server, and download and upgrade the firmware.

Provided that Internet connection is available, the system automatically configures the connection destination setting and executes processing such as download and version upgrade.

Version upgrade using a USB flash drive (released only in special cases)

Upgrade the firmware of this machine using a USB flash drive.

Connect a USB flash drive where the firmware is stored to the device, and update the firmware in service mode.

Version upgrades can be performed in an environment where a PC or network is not available.

NOTE:

Firmware that can be used for version upgrade using a USB flash drive is released only in special cases such as a tender business, and is not normally released. As for the detailed version upgrade procedure, follow the instructions given at the time of release of the customized firmware for version upgrade using a USB flash drive.

Version upgrade by replacing the PCB

Version upgrade by replacing the existing PCB with a PCB where the latest firmware is installed

CAUTION:

A message appears when an attempt is made to upgrade a host machine to which specified firmware has been applied.

This is a precaution not to use wrong firmware to upgrade a host machine to which specified firmware has been applied.

See the following regarding the combination of whether the message will be displayed:

Type of firmware applied to the host machine	Firmware to upgrade	
	General firmware	Specified firmware
General firmware	No message	No message
Specified firmware	Message displayed	Message displayed

Version Upgrade Using UST

UST is included in the firmware for the machine that can be downloaded from the website of CINC. Firmware is downloaded as a zip file and a folder containing UST is extracted by decompressing the file.

When executing UST on the PC connected to the machine with a USB Cable, the firmware can be upgraded by downloading it from the PC to the machine. For the detailed procedure, refer to "User Support Tool Operation Guide" stored in the decompressed folder. "User Support Tool Operation Guide" is also available on the website of CINC.

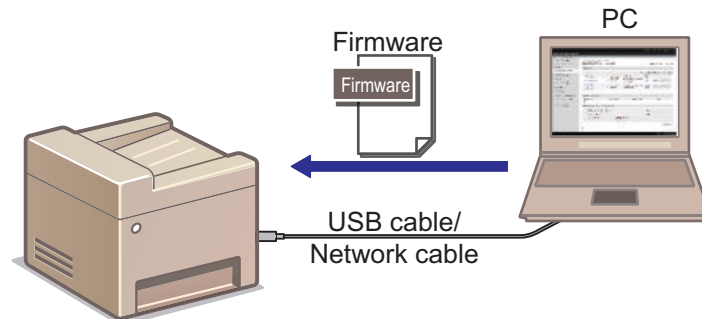

Version Upgrade via Internet

Connect to the Internet using the network function of the device, and download and upgrade the latest firmware from the server. If the device is in an environment where Internet connection is available, firmware versions can be upgraded only by operation from the menu without using PC.

Prerequisite

In order to perform version upgrade of the device via Internet, the following conditions must be met.

There should be no other jobs being executed.

Firmware cannot be upgraded while there is a job being executed. If there is a job being executed, wait for completion of the job and then perform the work.

The device should be able to be connected to the external network.

If connection is not available because, for example, there is a proxy server, follow the e-Manual to configure the proxy server settings and enable connection to the external network.

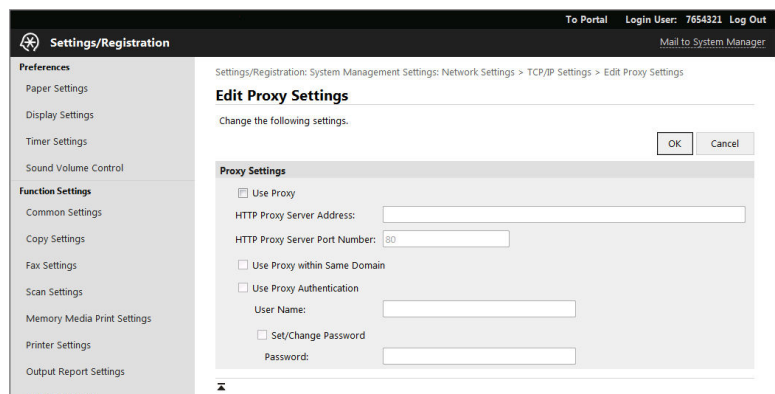

The serial number of the host machine should be shown on the Main Controller PCB.

Whether or not the serial number of the host machine is shown on the Main Controller PCB can be checked from the Control Panel or SPEC REPORT.

The procedure for checking the serial number using SPEC REPORT is shown below as reference information.

Procedure to check from SPEC REPORT

- Execute the following service mode to print SPEC REPORT.
 - COPIER > FUNCTION > MISC-P > SPEC

2. Check if the serial number (3 alphabetical characters + 5-digit number or 1-digit number + 2 alphabetical characters + 5-digit number) is shown in [MACHINE SERIAL NUMBER] of the printed SPEC REPORT.

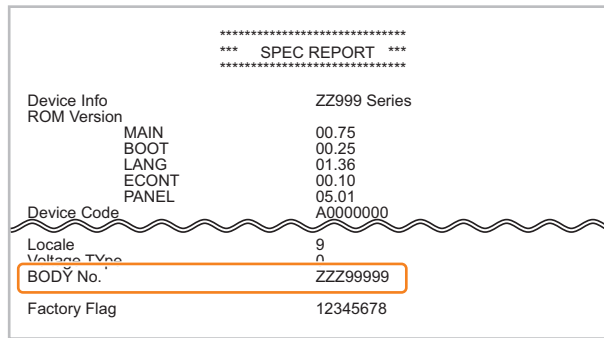

■ Procedure for Upgrading the Firmware via Internet

1. Select the following menu to upgrade the firmware via Internet:

- [Menu] > [Management Settings] > [ense Other] > [Update Firmware] > [Via Internet]

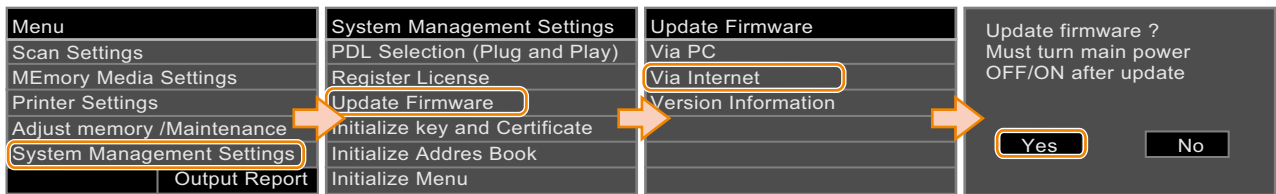

When the upgrading of firmware is completed, the machine automatically restarts.

2. Select the following menu, and check that the firmware has been correctly upgraded:

- [Menu] > [Management Settings] > [ense Other] > [Update Firmware] > [Version Information]

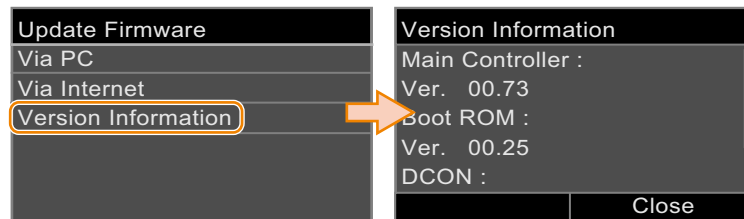

CAUTION:

This function does not support the operations from remote UI. ([Update Firmware] does not exist in the [System Management Settings] menu of the remote UI.)

■ Messages

The message displayed on the device operation panel is as follows.

No	Error message	The timing of occurrence	Remedy
1	Job in progress... Wait a moment, then try again.	If there is a job being executed:	1. Wait until the job is completed. 2. Cancel the job.
2	Cannot check the firmware version. (Server communication error.)	Network error	1. Check whether the device can be connected to the external network. 2. Check whether the proxy setting has been made (in case of access via a proxy server).
3	Cannot download the firmware. (Error during download.)		1. Check whether the device can be connected to the external network. 2. Check whether the proxy setting has been made (in case of access via a proxy server). 3. Check that the serial number of the host machine is shown on the Main Controller PCB.
4	***DOWNLOAD MODE*** NETWORK AVAILABLE IP ADDRESS IP address of the machine PRESS STOP KEY TO EXIT	If update (writing) of the firmware has ended in failure:	1. Update the firmware again using UST.
5	***DOWNLOAD MODE*** FAILED TO UPDATE		
6	***DOWNLOAD MODE*** UPDATE IS COMPLETE	If the update of the firmware is successful	-

Version Upgrade Using a USB Flash Drive (Released Only in Special Cases)

Connect a USB flash drive where the firmware is stored to this machine, and update the firmware in service mode.

NOTE:

Firmware that can be used for version upgrade using a USB flash drive is released only in special cases such as a tender business, and is not normally released. As for the detailed version upgrade procedure, follow the instructions given at the time of release of the customized firmware for version upgrade using a USB flash drive.

■ Prerequisite

In order to perform version upgrade of the machine using a USB flash drive, the following conditions must be met.

There should be no other jobs being executed.

Firmware cannot be upgraded while there is a job being executed. If there is a job being executed, wait for completion of the job and then perform the work.

■ Procedure for Upgrading the Firmware Using a USB Flash Drive

1. Connect a USB flash drive where the firmware is stored to this machine.
2. Execute one of the following service modes.
 - COPIER > FUNCTION > SYSTEM > DOWNLOAD
 - COPIER > FUNCTION > SYSTEM > DOWNLOAD_FORCE

NOTE:

If you want to apply only firmware that is newer than the firmware currently applied in the machine, execute DOWNLOAD. If you want to apply all the firmware contained in the USB flash drive regardless of whether it is newer or older, execute DOWNLOAD_FORCE.

3. The signature data of the downloaded file is verified, and download instruction information is written to the designated area of the flash memory only if the verification result is correct.

4. The machine is automatically restarted.

5. When the upgrading of firmware is completed, the machine automatically restarts.

Setting Information Export/Import Function (DCM)

Overview

Various data is stored in the storage inside the device.

Depending on the works to be done such as replacing parts, this data needs to be backed up and restored.

There are some ways to back up and restore data, and the appropriate one should be used depending on the purpose and storage destination.

This section describes the procedure for backing up and restoring service mode setting values.

For the procedure for backing up and restoring other information, refer to the e-Manual.

Function Overview

This machine has a setting information export/import function (hereinafter referred to as DCM (Device Configuration Management) function) which exports/imports the machine's setting value information as a file. The file exported/imported using the DCM function is called a DCM file, and the target setting information is as follows:

- Setting information of [Menu] ([Setting/ Registration] menu)
- Service mode setting information
- Address Book

The DCM file is exported to a USB flash drive or PC local disk from the Control Panel or remote UI.

The exported DCM file can be returned to the original device or imported to a different device.

When the file is returned to the original device, this can be used as a function to back up the settings, and when the file is imported to a different device, this can be used as a function to copy setting information.

Data can also be imported to or exported from an iR-ADV machine by using iW EMC/MC DCM Plug-in.

In the case of the setting value backup function before implementation of the DCM function, an exported file could be imported only to the same device, but the DCM function enables import of an exported file to a different device.

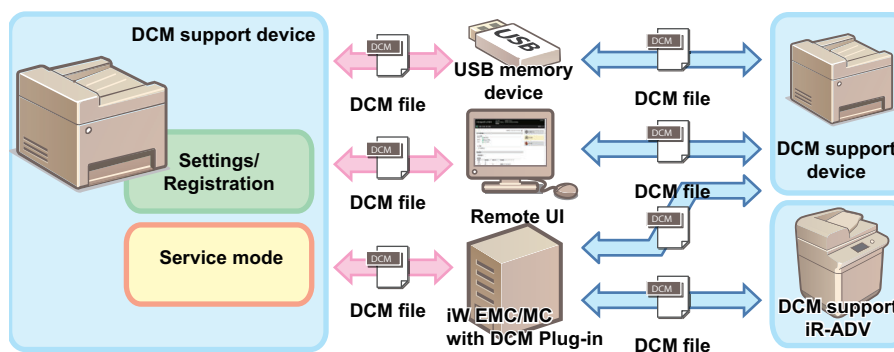

Conceptual diagram

NOTE:

In order to export or import setting information using DCM, it is necessary that the device supports DCM.

Backup/Restoration for Service Technicians

Backup and restoration from [Menu] ([Setting/ Registration] menu)

Setting information can be backed up and restored from the Control Panel of the device or from [Menu] ([Setting/ Registration] menu) of remote UI.

Although [Menu] ([Setting/ Registration] menu) is for users, the service mode settings information can be backed up and restored from the Import/Export function by changing the service mode setting.

The service mode settings information can be backed up and restored only by accessing from the remote UI [Settings/Registration] menu.

Backup/Restoration Using Service Mode

Some of the functions in service mode can be used to backup and restore data.

DC-CON/R-CON setting value information and service counter (DC-CON) values can be backed up and restored.

■ Combination of Information Exported/Imported by DCM, Means, and Storage Locations

A DCM file is exported and imported using the Control Panel, remote UI, or the iW EMC server, depending on the situation of the site.

The information exported/imported differs depending on the means.

Combinations of them are shown in the following table.

Menu used	Operation	Information exported			Save destination
		Setting values of menu options	Address book ^{**1}	Service mode setting values	
[Settings/Registration] menu	Control panel	Yes (fixed) ^{*2}	Yes (fixed) ^{*2}	No	USB flash drive
	Remote UI	Yes	Yes	With conditions ^{*3}	PC local disk
Service mode	Control panel	No	No	Yes	USB flash drive / Storage in the host machine
	Remote UI	No	No	Yes	Storage in the host machine

■ Compatibility of Data

The following table shows compatibility of data in the case where the device from which the data is exported and the device to which the data is imported differ in model and/or serial number.

For items that are imported in Cases A, B, and C, refer to “List of Items Which Can Be Imported” on page 361.

Model	Serial number	Import process
Same	Same	Items corresponding to Case A are imported. ^{*4}
Same	Different ^{*5}	Items corresponding to Case B are imported. ^{*4}
Different	Different ^{*5}	Items corresponding to Case C are imported. ^{*6}
Different	Same	The file is judged to be invalid, and the process ends with an error.

■ Replacement Mode

When this function is used for migrating the setting data upon replacement of a device, some of the data cannot be migrated if the model to which the data is migrated is different.

When this function is used in normal mode, data that is applicable to either Case B (of different serial number) or Case C (of different model) cannot be imported.

When replacement mode is enabled on the device on the importing side, data can be forcibly migrated even to a device of a different serial number or even between different models.

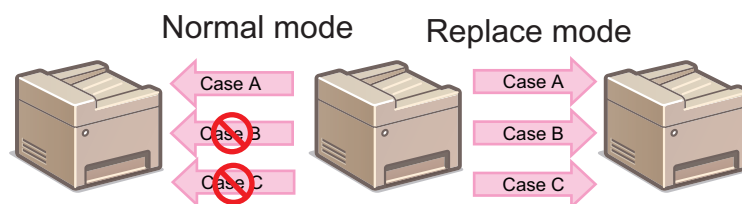

^{*1} Models without address books are excluded. In the case of a fax option model without SEND function, address books are exported only if a fax option is connected with the device.

^{*2} When the [Settings/Registration] menu is used from the Control Panel, both the setting menu information and the address book are imported/exported. It is not possible to export/import only either of them. Information which is not included in the data to be imported is not imported.

^{*3} Service mode is added to the data to be exported only when service mode COPIER > OPTION > USER > SMD-EXPT is set. For information on items that are imported, refer to "List of Items Which Can Be Imported".

^{*4} If the firmware version at the time of import differs from that at the time of export, predetermined corrective processing may be performed.

^{*5} If a serial number is missing, the serial numbers are judged to be mismatched.

^{*6} Predetermined corrective processing may be performed.

The following shows the procedure to turn ON/OFF replacement mode of the device to which the migrating data is imported.

1. Set the following service mode setting value to "1(ON)" or "0(OFF)".

- COPIER > OPTION > USER > RPL-IMP

CAUTION:

Since replacement mode is not lifted automatically, the setting value of the foregoing service mode needs to be changed back to "0" to return to normal mode.

The targeted items of replacement mode are as follows.

List of Replacement Mode Targeted Items

User mode setting items	Settings (* indicates default values)	Remarks
System settings		
Device information settings		
Device name	32 characters	Model name is displayed as a default value.
Installation site	32 characters	
Network settings		
TCP/IP settings		
IPv4 settings		
IP address	0.0.0.0 *	
IPv6 settings		
Manual address settings		
Use manual address	OFF*/ON	
Manual address	IP address input screen	
Prefix length	(0 to *64 to 128)	
Default router address	Router address input screen	
DNS settings		
Use the same host/domain name as those of IPv4	OFF/ON*	
Host name	Enter the host name	
Domain name	Enter the domain name	
mDNS Settings		
mDNS Settings	OFF/ON*	
Use the same mDNS name as that of IPv4	OFF/ON*	
mDNS name	Enter the mDNS name	
SMB settings		
NetBIOS name	NetBIOS name for own machine (15 byte)	
Workgroup name	Belonging workgroup name (15 byte)	
AirPrint settings		
Installation site	32 characters	Setting values to be referred are the same as [Installation Site] in the [System Settings]

Import/Export Procedure from [Settings/Registration] of Remote UI

This section describes the procedure for backing up and restoring service mode setting information by using the [Import/Export] function in the [Settings/Registration] menu of Remote UI.

CAUTION:

- The service mode setting information can be backed up and restored only from the [Settings/Registration] menu on Remote UI, and the operation cannot be performed from the [Settings/Registration] menu on the Control Panel.
- In the case of backing up and restoring only the setting information of the [Settings/Registration] menu or the address book, refer to the procedure described in the e-Manual.

■ Limitations

The following limitations exist when backing up and restoring the service mode settings information from the [Settings/Registrations] menu of remote UI.

A job must not be accepted during an import/export processing.

Except for the calibration requested by the engine, a job is not allowed to be accepted during a processing. In addition, import/export must not be performed during execution of a job.

Firmware must not be updated during an import/export processing.

Fax cannot be received while firmware is updated during a processing. In addition, import/export must not be performed also during firmware update.

Power must not be turned off during an import/export processing.

If power discontinuity occurs during an import processing, a rollback processing is not performed, therefore the settings imported up to that point are reflected while the rest of the settings remain as-is.

When power discontinuity occurs during an export processing, export is not executed.

■ Procedure for Export from Remote UI ([System Management Settings] Menu)

Service mode setting information can be exported from the [Management Settings] menu by setting the following service mode setting value to "1".

1. Enter service mode, and set the following item to "1".

- COPIER > OPTION > USER > SMD-EXPT

TNRB-SW	: 0
SCALL-SW	: 0
SCALLCMP	: 0
PS-MODE	: 0
SMD-EXPT	: 1
ALL-SLP	: 1
RPL-IMP	: 0

SERVICE MODE	
COPIER > OPTION > USER	
COPIER	
FEEDER	
FAX	
TESTMODE	
SERVICE REPORT	
USER	
COUNTER1	113
COUNTER2	501
COUNTER3	301
COUNTER4	0
COUNTER5	0
COUNTER6	0
CNT-SW	0
SMD-EXPT	1
ACC-SLP	1
DRMRP-SW	0

NOTE:

The [SMD-EXPT] setting can be configured either from the Control Panel or from the remote UI.

2. Exit service mode, start remote UI, log in as a system administrator, and then select the following item:

- [Setting/ Registration] > [Management Settings] > [Data Management] > [Import/Export] > [Export]

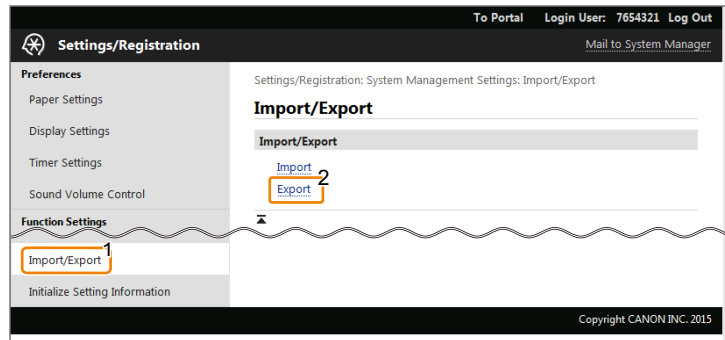

3. After confirming that [Service Mode] is displayed/selected in [Select Item to Export], enter the password and click [Start Exporting].

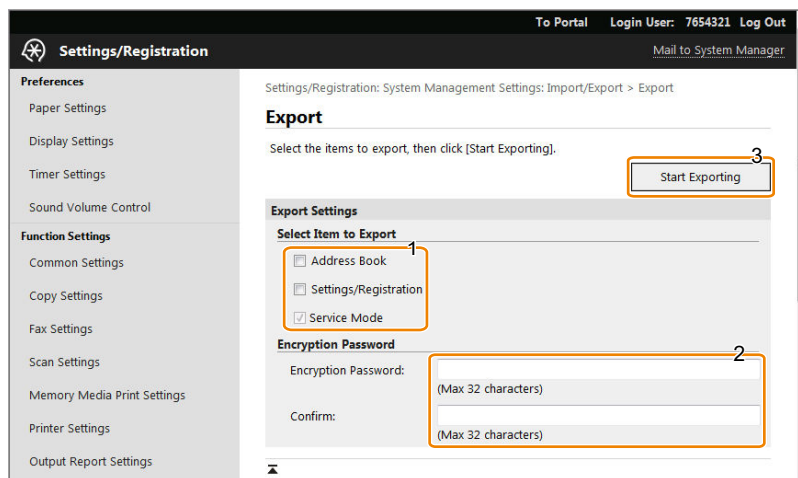

Address Book

Select the check box to export the address book data.

Settings/Registration

Select this check box to import the menu option data.

Encryption password

Enter 32 or less numeric characters set when the file was exported.

4. The [File Download] dialog box will appear. Save the file to any location.

5. Enter service mode, and set the following item to "0".

- COPIER > OPTION > USER > SMD-EXPT

CAUTION:

Since the screen of export function can also be accessed by the user, be sure to disable the [SMD-EXPT] setting (setting value: 0).

■ Procedure for Import from Remote UI ([System Management Settings] Menu)

Import the service mode setting information file that was exported in the previous procedure.

1. Enter service mode, and set the following item to "1".

- COPIER > OPTION > USER > SMD-EXPT

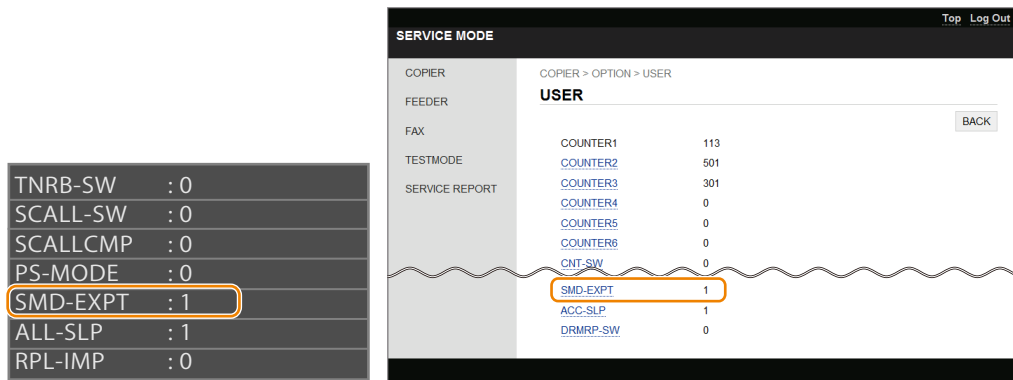

NOTE:

The [SMD-EXPT] setting can be configured either from the Control Panel or from the remote UI.

2. Exit service mode, start remote UI, log in as a system administrator, and then select the following item:

- [Setting/ Registration] > [Management Settings] > [Data Management] > [Import/Export] > [Import]

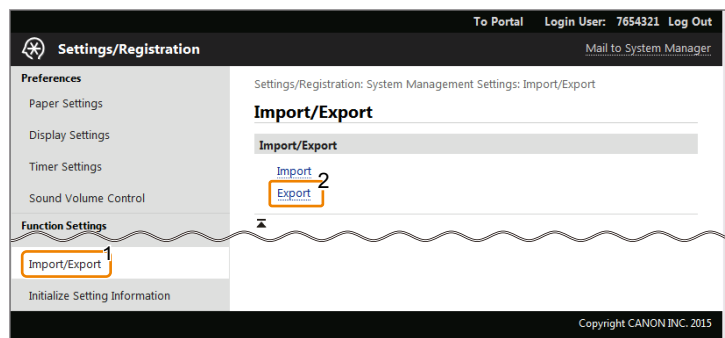

3. Configure the import setting, and click [Start Importing].

Entering the encryption password and clicking [Start Importing] imports the menu option data.

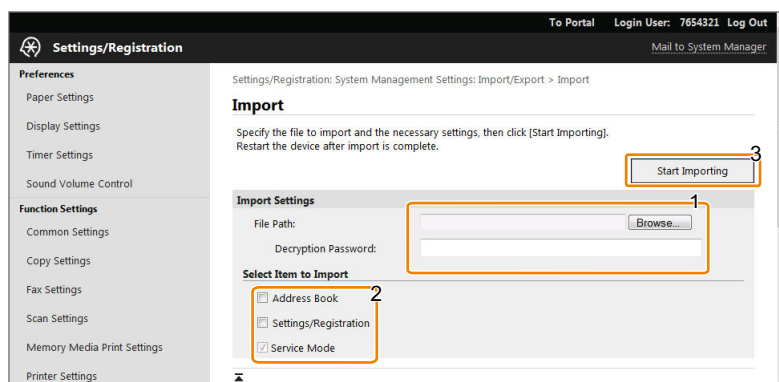

[Browse...] button

Click to select the file to import.

Decryption password

Enter 32 or less numeric characters set when the file was exported.

Address Book

Select the check box to import the address book data.

Settings/Registration

Select this check box to import the menu option data.

4. A dialog box asking whether the user wants to execute import will appear. Click [OK].

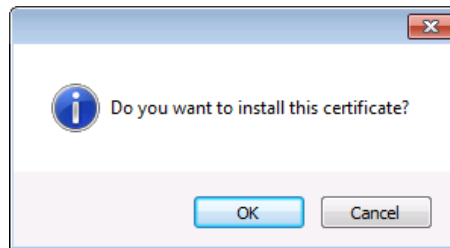

5. A message will appear to indicate that the process has been completed. Click the [OK] button.

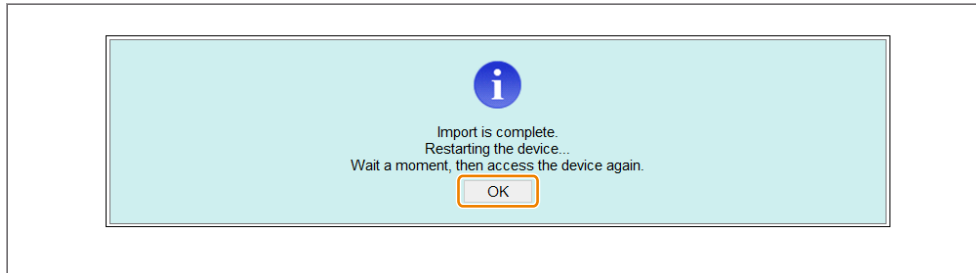

6. Restart this machine, enter service mode, and confirm that the setting information is reflected. This completes the procedure for importing a setting information file.

7. Enter service mode, and set the following item to "0".

- COPIER > OPTION > USER > SMD-EXPT

CAUTION:

Since the screen of export function can also be accessed by the user, be sure to disable the [SMD-EXPT] setting (setting value: 0).

Procedure for Exporting/Importing Service Mode Setting Information

Service mode setting information can be backed up and restored by using service mode functions. The backup file can be saved to a USB flash drive or a storage in the machine.

Backup/restoration to a USB flash drive

```
COPIER > FUNCTION > SYSTEM > EXPORT
COPIER > FUNCTION > SYSTEM > IMPORT
```

Backup/restoration to a storage in the machine

```
COPIER > FUNCTION > SYSTEM > SAVE-SM
COPIER > FUNCTION > SYSTEM > RSTR-SM
```

	Backup/restoration to a USB flash drive	Backup/restoration to a storage in the machine
Storage destination	USB flash drive	Storage in the machine
Number of files saved	Depends on the capacity of the USB flash drive	One
Duplication of the setting values for other machines	Possible	Not possible

■ Procedure for Exporting to a USB Flash Drive

Use the service mode function to save the service mode setting information to a USB flash drive.

This operation can be performed both from the Control Panel and remote UI.

The following USB flash drives can be used for export/import.

- USB flash drive in FAT 16 format (storage capacity: 2 GB)
- USB flash drive in FAT 32 format (storage capacity: 32 GB)

Note that the descriptions in parenthesis in the procedure are the descriptions in the case of remote UI.

1. Connect the USB flash drive to the USB Memory Port.



2. Enter service mode, and execute the following service mode.

- COPIER > FUNCTION > SYSTEM > EXPORT

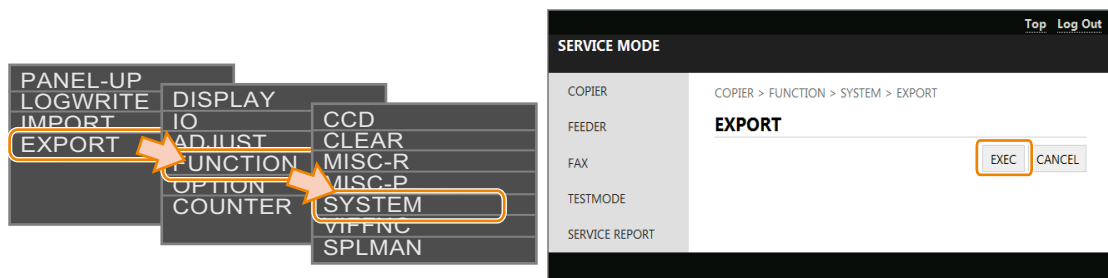

CAUTION:

Even if the service mode is executed without connecting a USB flash drive, an error is not displayed. It looks as if the process has been completed successfully, but the file has not been exported to anywhere. For the reason shown above, be sure to check before execution that a USB flash drive is connected.

3. The message shown below which is displayed during the process will disappear. When the display has returned to the original state, remove the USB flash drive.

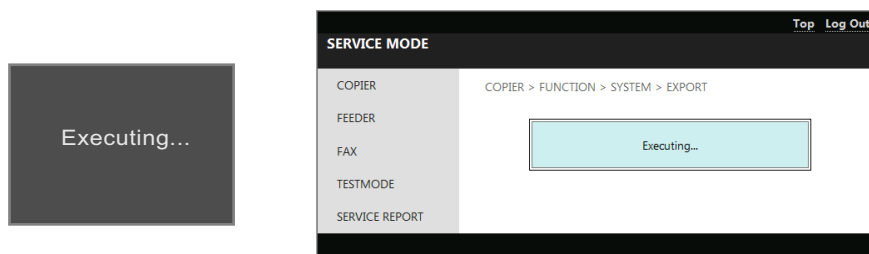

4. Check that a setting information file (service.dcm) exists in the directory directly under the root of the USB flash drive.

This completes the procedure for exporting a setting information file.

■ Procedure for Import from USB Flash Drive

1. Save the setting information file (service.dcm) to be imported to directly under the root of the USB flash drive.

2. Connect the USB flash drive to the USB Memory Port.



3. Enter service mode, and execute the following service mode.

- COPIER > FUNCTION > SYSTEM > IMPORT

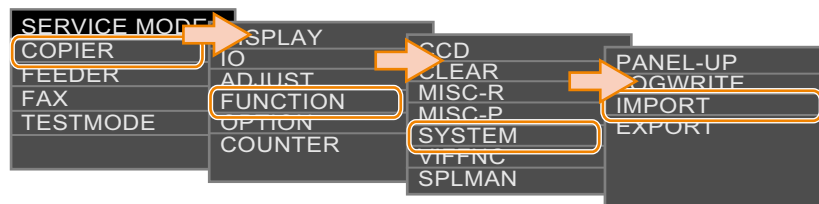

4. The message shown below which is displayed during the process will disappear. When the display has returned to the original state, remove the USB flash drive.

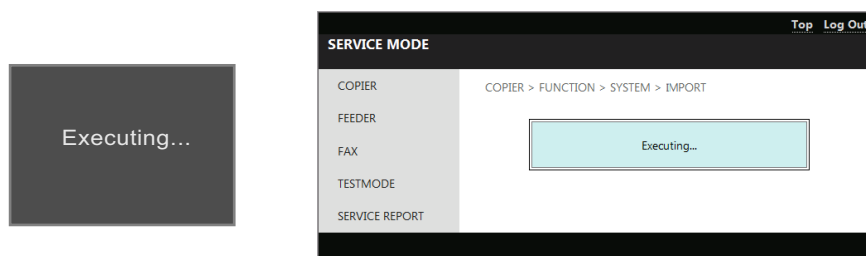

5. Restart the host machine, enter service mode, and confirm that the setting information is reflected.

This completes the procedure for importing a setting information file.

■ Backup Procedure to the Storage in the Machine

Use the service mode function to back up the service mode setting information to the storage in the machine.

This operation can be performed both from the Control Panel and remote UI.

The setting information that can be saved in the machine's storage is only one.

1. Enter service mode, and execute the following service mode.

Access service mode, select COPIER > FUNCTION > SYSTEM > SAVE-SM, and click [OK (EXEC)].

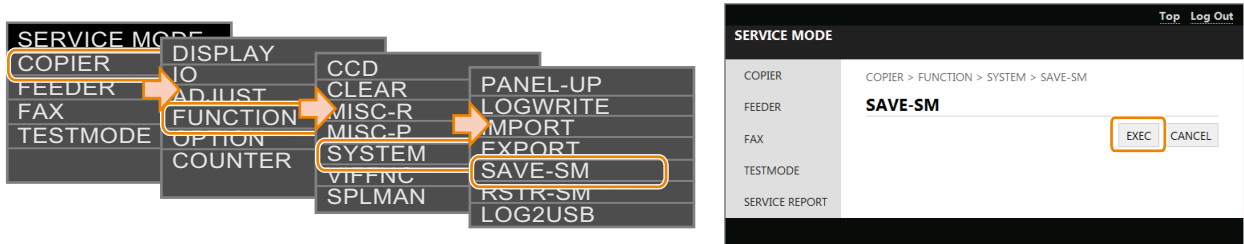

2. The following screen is displayed during the processing:

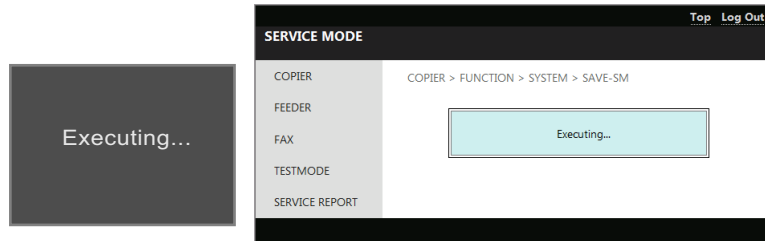

3. Finish the operation after checking that the screen returns to the previous display.

■ Procedure for Restoration from Internal Storage

Restore the service mode setting information that has been backed up to the storage in the machine in the previous procedure.

1. Enter service mode, and execute the following service mode.

- COPIER > FUNCTION > SYSTEM > RSTR-SM

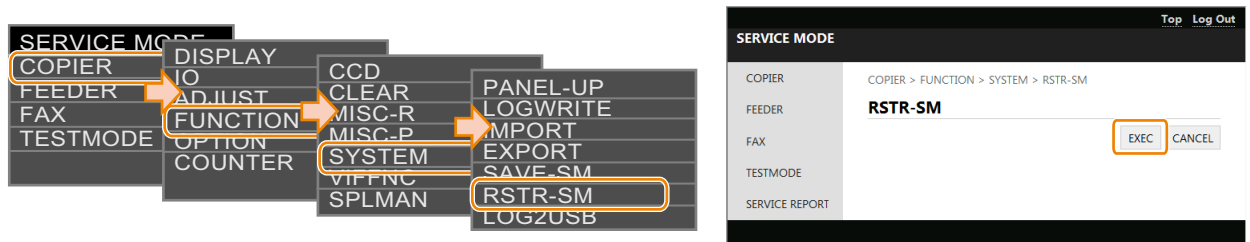

2. The following screen is displayed during the processing:

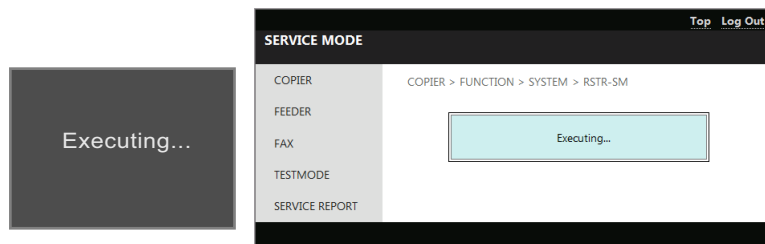

3. Finish the operation after checking that the screen returns to the previous display.

Monitoring Function (e-Maintenance/imageWARE Remote)

Overview of System

Function Overview

E-RDS (Embedded RDS) is a monitoring program that runs on the host machine. When the monitoring option is enabled by making the setting on this machine, information such as the status change of the machine, counter information, and failure information are collected. The collected device information is sent to a remote maintenance server called UGW (Universal Gateway Server) via Internet.

The information to be monitored is:

- Billing counter
- Parts counter
- ROM version
- Service call error log
- Jam log
- Alarm log
- Change of status (such as status of consumables)

Since the information shown above is customer information, HTTPS/ SOAP protocol is used for communication between the UGW server and the host machine to improve security.

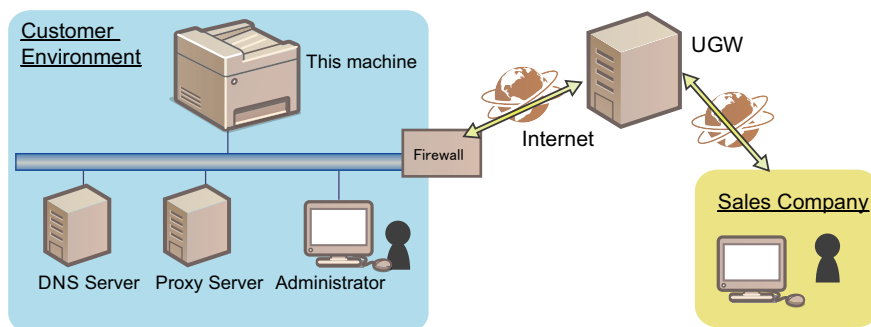

Features

E-RDS is embedded in the network module of the device, and the front-end module of the e-Maintenance/ imageWARE Remote system is realized without requiring hardware besides the device.

Main Functions

Functional category	Sub category	Description
Communication Test	Test	By executing the following service mode, E-RDS communicates with UGW, retrieves schedule information, and establish communication. COPIER > FUNCTION > INSTALL > COM-TEST
Transmission of counters	Billing/all resources/parts/mode-by-mode counters	E-RDS Periodically send billing/all resources/parts/mode-by-mode counters to the server.
Transmission of event logs	Service call/alarm/jam log	Each time a service call, alarm, or jam log occurs, the error log is sent to the server. Having alarm log or not is different by a model.
Data transmission	ROM version / Device configuration	E-RDS periodically sends the firmware information of the device to UGW. E-RDS sends the device configuration information only when there is any change in the configuration.
	E-RDS Debug log	Debug logs of E-RDS are stored in E-RDS, and they are sent to UGW only when they exceed a specific size.
	Repair request	E-RDS sends error information (image failure, jams or others) according to the instruction of the user.
	Sublog transmission	When E-RDS catches the sublog transmission of a message designation than UGW, send data such as device Sublogs and DCON logs to the server.

Functional category	Sub category	Description
Operation instruction	Operation check	E-RDS contacts UGW to check if there is processing to be executed next, and receives the following instructions if any. <ul style="list-style-type: none"> Linkage with CDS Sublog transmission

● Servicing Notes

- After clearing the Main Controller PCB, initialization of the E-RDS setting (ERDS-DAT) and a communication test (COM-TEST) need to be performed. If this work is omitted, an error may occur when counters are sent to UGW. After replacing the Main Controller PCB, all the settings need to be reconfigured.
- Do not change the values of the following service modes unless otherwise instructed. If they are changed, it will ends with a communication error with UGW.
 - Port number of UGW
COPIER > FUNCTION > INSTALL > RGW-PORT
Default: 443
- If the e-Maintenance/imageWARE Remote contract of the device becomes invalid, be sure to turn OFF the E-RDS setting (E-RDS: 0).
- When the E-RDS function is enabled, a communication test can be performed from [Check Counter] of the Control Panel of the host machine. *1

When conducting a communication test from [Check Counter], pay attention to the following points:

- During a communication test, do not take any actions such as pressing a key. Actions are not accepted until the communication test is completed (actions are ignored).
- When a communication test is being conducted from service mode or from [Check Counter], do not conduct a communication test from the other. This operation is not guaranteed.

● Setting Procedure

■ Preparation

Since this function communicates with the UGW server, it is necessary to connect to the external network. Check the following items, and make the settings if not yet set.

- IP address settings
- DNS server settings
- Proxy server settings *2
- Installation of CA certificate (arbitrary *3)

CAUTION:

- Obtain the information on the network environment from the system administrator of the user.
- When having changed the network settings, turn OF and then ON the main power of the machine.

*1. The user can perform a communication test or browse the result of communication test.

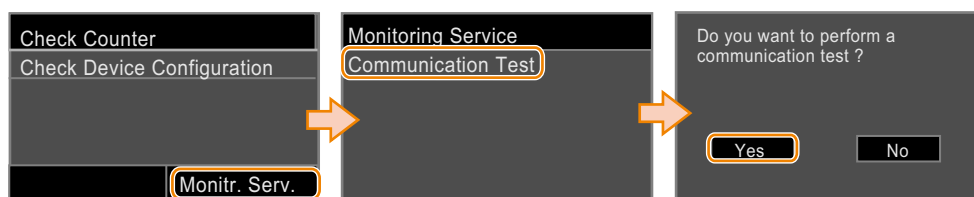

If the communication results in failure, an error code (hexadecimal number, 8 digit) is displayed on the Control Panel.

*2. If authentication is necessary, make the settings of the authentication information as well.

*3. When using a certificate other than those pre-installed in the device

■ Procedure for Setting E-RDS

1. In the following service mode, select the following service mode to initialize the E-RDS setting values:

- COPIER > FUNCTION > CLEAR > ERDS-DAT

NOTE:

This operation initializes the E-RDS settings to factory setting values.

For the setting values to be initialized, see the section of "Setting values and data to be initialized" on page 76 .

2. Enable the E-RDS function in the following service mode, and perform a communication test.

1. Select the following item:
 - COPIER > FUNCTION > INSTALL > ERDS
2. Enter [1] from the keyboard, and press [Apply].

CAUTION:

The following settings i.e. RGW-PORT in Service mode must not be change unless there are specific instructions to do so. Changing these values will cause error in communication with UGW.

When the E-RDS function is enabled, the function to communicate with UGW is enabled.

3. Select [COM-TEST] and then touch [Yes].

If the communication is successful, "OK" is displayed. If "NG" is displayed, check the network settings and USW server address (URL).

CAUTION:

The communication results with UGW can be distinguished by referring to the COM-LOG. By performing the communication test with UGW, E-RDS acquires schedule information and starts monitoring and meter reads operation.

Maintenance

■ Initializing E-RDS settings

It is possible to clear the FLASH data of E-RDS and change the E-RDS setting back to the default value.

● Initialization procedure

Follow the procedure shown below to initialize E-RDS.

1. Enter service mode as a system administrator user.
2. Select the following service mode, and press [OK] to execute.
 - COPIER > Function > CLEAR > ERDS-DAT

● Setting values and data to be initialized

The following E-RDS settings, internal data, and Alarm filtering information are initialized.

- COPIER > FUNCTION > INSTALL > ERDS
- COPIER > FUNCTION > INSTALL > RGW-PORT
- COPIER > FUNCTION > INSTALL > COM-LOG

CAUTION:

If a certificate other than the CA certificate at the time of shipment has been installed, initializing the E-RDS setting will not change the settings back to those at the time of shipment. To change the certificate back to the CA certificate at the time of shipment, delete the certificate (install the CA certificate at the time of shipment) after initializing the E-RDS settings.

■ Report Output of Communication Error Log (COM-LOG)

A report of communication error log information on five affairs can be output.

● Report output procedure

1. Select the following service mode, and press [Yes].

- COPIER > FUNCTION > MISC-P > ERDS-LOG

```
12/09 2015 10:14AM
*****
*** E-RDS-COM-LOG***
*****

No.01  DATE    12/09 2015      TIME 03:21 AM   CODE 05000003
Information  SUSPEND: Communication test is not performed.

No.02  DATE    12/09 2015      TIME 03:21 AM   CODE 00000000
Information  SUSPEND: mode changed.

No.03  DATE    12/09 2015      TIME 03:18 AM   CODE 05000003
Information  SUSPEND: Communication test is not performed.

No.04  DATE    12/09 2015      TIME 03:18 AM   CODE 00000000
Information  SUSPEND: mode changed.

No.05  DATE    12/09 2015      TIME 01:56 AM   CODE 05000003
Information  SUSPEND: Communication test is not performed.
```

Output sample

Security Functions

A technical description on the security-related functions implemented in this equipment and the works to be performed for servicing are shown below.

Security Policy Function

What is security policy function?

The security policy function is a function for collectively configuring the security-related settings on devices located at various places.

If the user has security policies such as information security basic policies and security standards, the settings can be collectively configured/managed in accordance with the security policies.

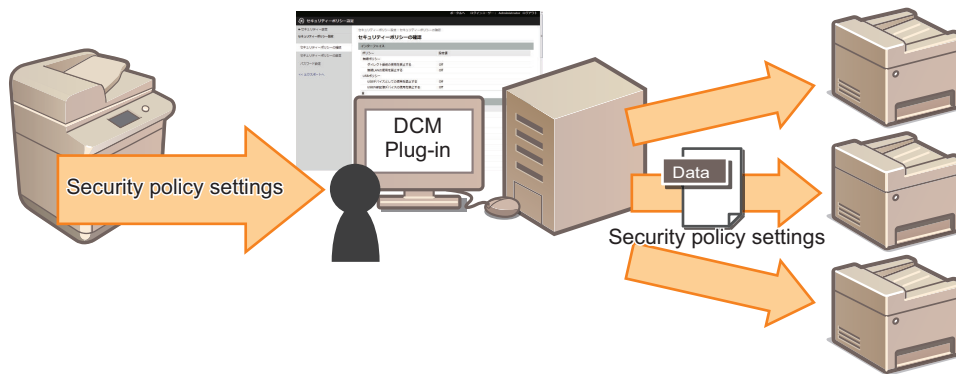

Perform either of the following works to configure the security policies on this equipment.

- Using iW EMC DCM Plug-in, distribute the security policy settings created by an iR ADVANCE third generation device.
- Import the DCM file exported from a device of the same series where the security policy settings have already been enabled.

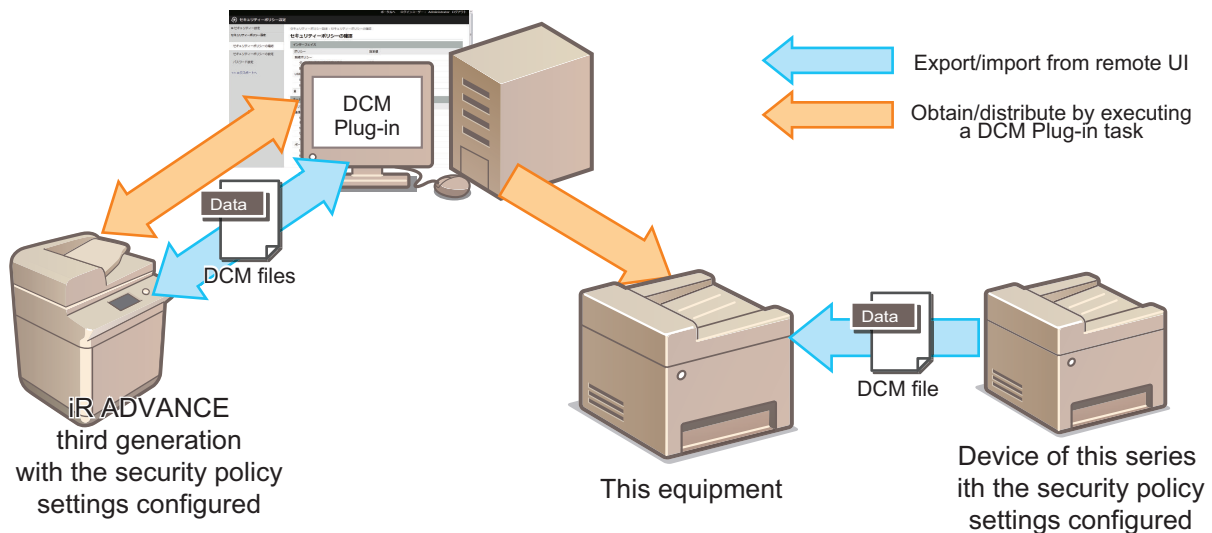

NOTE:

Security policy settings can be configured on devices of this series only by distributing the settings using iW EMC DCM Plug-in. A DCM file imported from a device of this series where the security policy settings have been configured can be used to configure the settings, but the original device where the settings have been configured can be created only by using iW EMC DCM Plug-in. In iR ADVANCE series, the security policy function is implemented only in the third generation devices.

Security Administrator

Differences between Security Administrator and System Manager

In the security policy setting function, there is an administrator called a "security administrator" in addition to the conventional "system manager".

The system manager can operate/set all the items in the [Settings/Registration] menu of the device.

However, if the security policy has been set by the security administrator described later, even the system manager cannot perform operation or change the settings against the security policy.

The security administrator is an administrator who creates, applies, edits, backs up, and restores the security policy.

The security administrator is a system manager and is a user who knows the password for the security policy settings.

	Account	[Settings/Registration] menu				Policy-related			
	Add/delete	Settings (Administrator settings)	Settings (Other than the administrator settings)	Initialize (User mode)	Initialize (Service mode)	Introduce/change	Browse	Back up/restore	Disable the restrictions
Security administrator	✓	✓*1	✓*1	✓	-	✓	✓	✓	✓
System manager	✓	✓*1	✓*1	-	-	-	✓	✓	-
End user	-	-	✓*1	-	-	-	-	-	-
Service technician	✓	-	-	-	✓	-	-	-	✓

• Security Administrator Password

The security administrator password is a password that is set to protect the configured security policy. The password setting is not mandatory.

Behavior when the security administrator password has been set

If the security administrator password has been set on this equipment, the security administrator password is required when [Initialize All Data/Settings] is executed. This is intended to prevent the device from being initialized without discretion and the configured security policy from being disabled.

NOTE:

Even if the security administrator password has not been set, as long as the security policy has been configured, [Management Settings] > [Data Management] > [Initialize Menu] is grayed out and cannot be used.

Importing the security administrator password

If a security policy setting file of iR ADVANCE series where the security administrator password has been set is imported via iW EMC DCM Plug-in, the security administrator password is not reflected.

In the case of importing the file via iW EMC DCM Plug-in, it is necessary to execute [Create Task to Change Security Policy Password] and distribute the security administrator password to set the security administrator password.

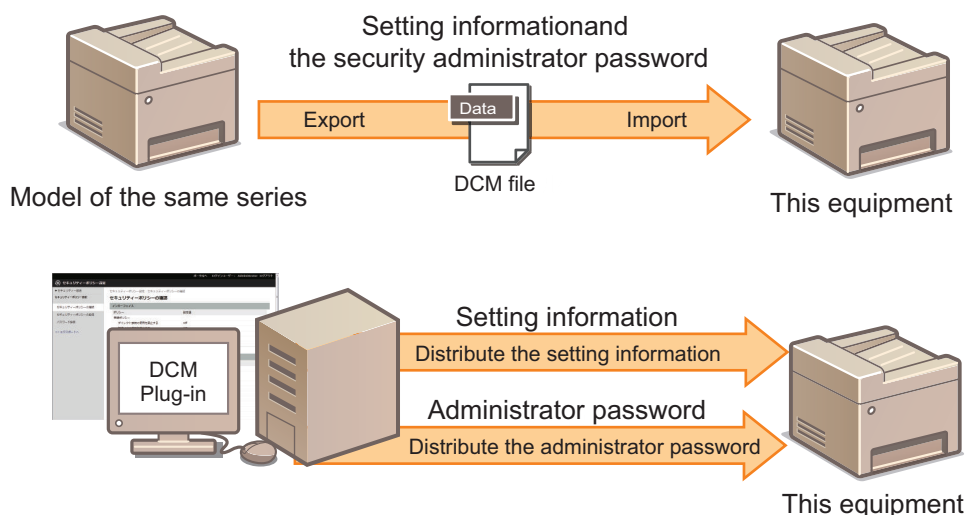

Initializing the security administrator password

In case the user has forgotten the security administrator password, there is a service mode setting for initializing the password. Execute the service mode shown below to initialize the security administrator password set on this equipment.

Service mode > COPIER > Function > CLEAR > PLPW-CLR

*1. Restrained by the policy

■ Screen Displayed When Security Policy Is Applied

If the security policy is applied, the message shown below appears when you access the [Settings/Registration] screen.

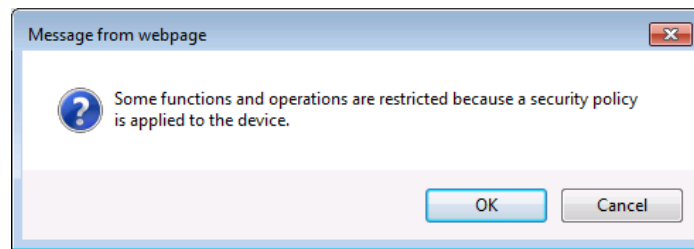

Example of the remote UI screen

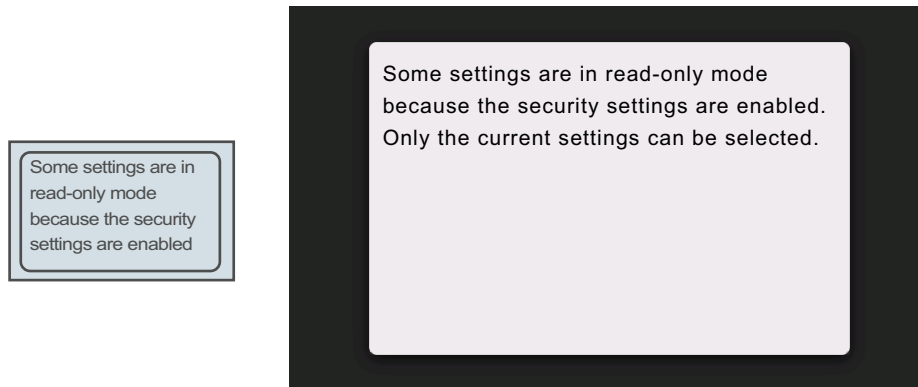

Example of the Control Panel (Touch Panel) screen

If the security administrator password has been set, the security administrator password is required when [Initialize All Data/Settings] is executed.

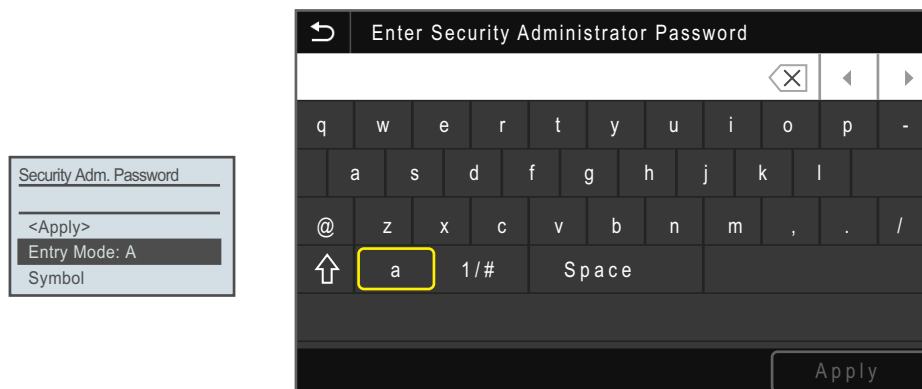

Security administrator password entry screen

■ Checking the Configured Settings

The policy settings that have been configured can be checked on the remote UI screen shown below.

1. Start remote UI as a user having the administrator privileges.

2. Display the screen shown below.

- [Settings/Registration] > [Management Settings] > [Security Settings] > [Confirm Security Policy]

Settings/Registration: Management Settings: Security Settings > Confirm Security Policy

Confirm Security Policy

Interface

Wireless Connection Policy

Prohibit Use of Direct Connection	On
Prohibit Use of Wireless LAN	On

USB Policy

Prohibit Use as USB Device	Off
Prohibit Use as USB Storage Device	Off

Network

Communication Operational Policy

Always Verify Signatures for SMS/WebDAV Server Functions	Off
Always Verify Server Certificate When Using TLS	Off
Prohibit Cleartext Authentication for Server Functions	Off
Prohibit Use of SNMPv1	Off

Port Usage Policy

*Some port numbers may have changed.

Restrict LPD Port (Port Number: 515)	Off
Restrict RAW Port (Port Number: 9100)	Off
Restrict FTP Port (Port Number: 21)	Off
Restrict WSD Port (Port Number: 3702, 60000)	Off
Restrict BMLinkS Port (Port Number: 1900)	On
Restrict IPP Port (Port Number: 631)	Off
Restrict RAW Port (Port Number: 137, 138, 139, 445)	Off
Restrict SMTP Port (Port Number: 25)	Off
Restrict Dedicated Port (Port Number: 9002, 9006, 9007, 9011-9015, 9017-9019, 9022, 9023, 9025, 20317, 47545-47547)	Off
Restrict Remote Operator's Software Port (Port Number: 5900)	Off
Restrict SP (IP Fax) Port (Port Number: 5004, 5005, 5060, 5061, 49152)	Off
Restrict mDNS Port (Port Number: 5353)	On
Restrict SLP Port (Port Number: 427)	Off
Restrict SNMP Port (Port Number: 161)	Off

Authentication

Authentication Operational Policy

Screen example

NOTE:

On the [Confirm Security Policy] screen, all the settings related to security policies are displayed regardless of the model. Therefore, policy settings related to functions that are not implemented in the model are also displayed. For example, the models of this series do not have the SMB server function, but [Restrict SMB Port] is displayed.

■ Export/Import of Setting Information

For the procedure for exporting/importing setting information, refer to the User's Guide of this equipment or the User's Guide of iW EMC DCM Plug-in.



Periodical Service

Periodically Replaced Parts.....	83
Consumable Parts.....	84
Periodical Services.....	85

Periodically Replaced Parts

This machine does not have any periodically replaced parts.

Consumable Parts

This machine does not have any consumable parts.

Periodical Services

This machine does not require any periodical service.



5

Parts Replacement and Cleaning

List of Parts.....	87
External Cover System.....	95
Original Exposure/Feed System.....	107
Controller System.....	131
Laser Exposure System.....	148
Image Formation System.....	154
Fixing System.....	164
Pickup Feed Delivery System.....	168

List of Parts

Major Units

■ ADF/Reader

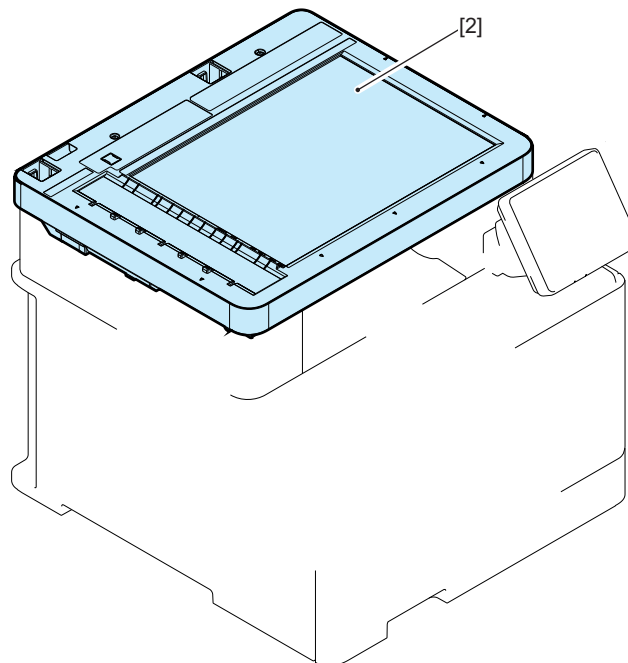
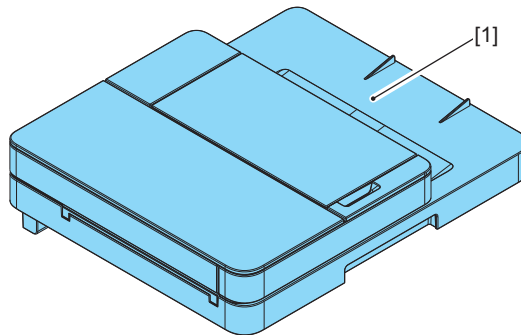

No.	Name
1	ADF Unit
2	Reader Unit

■ Host Machine

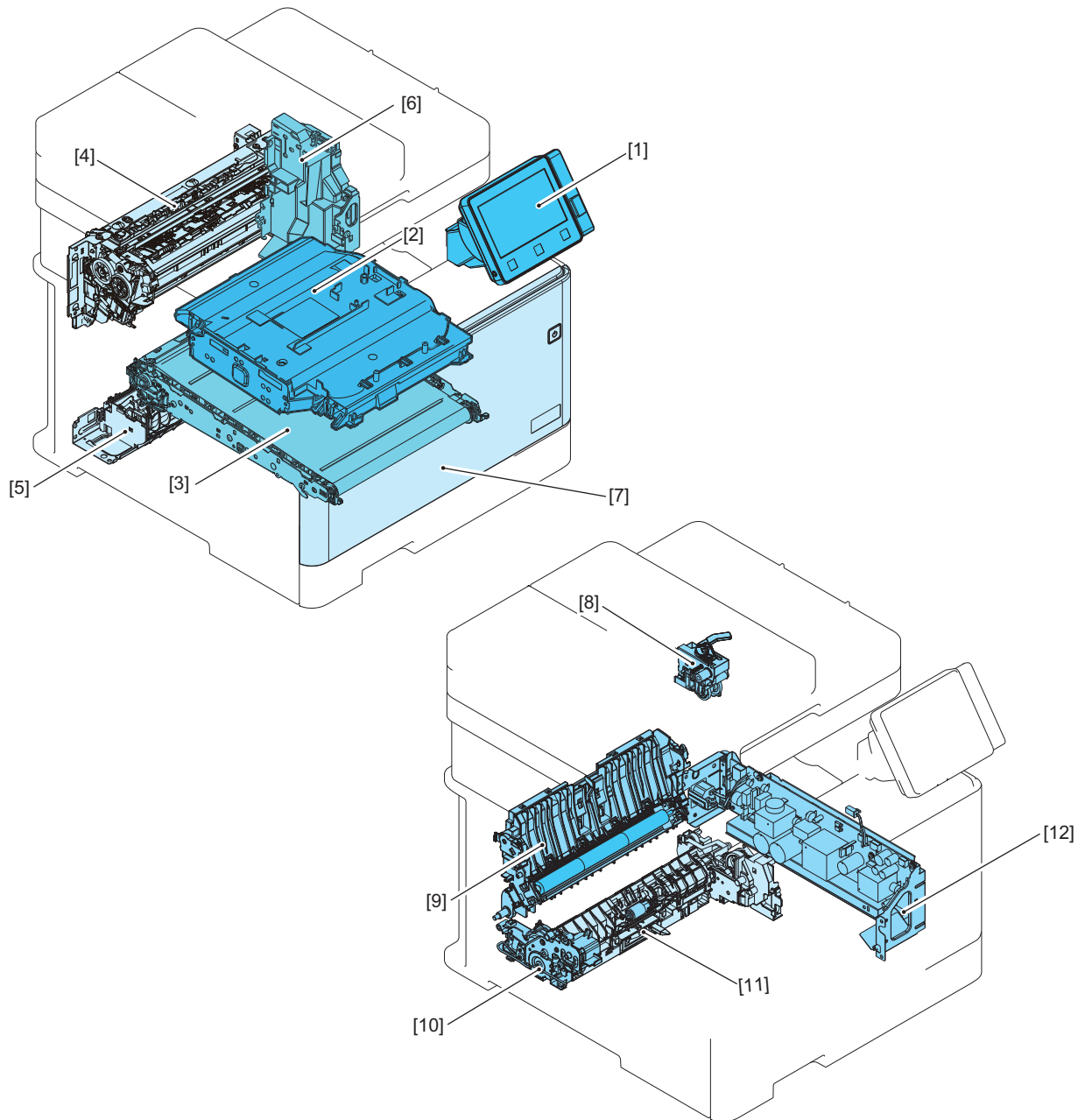

No.	Name
[1]	Control Panel Unit
[2]	Laser Scanner Unit
[3]	ITB Unit
[4]	Fixing Assembly
[5]	Re-Pickup Unit
[6]	Fixing Power Supply Unit
[7]	Cartridge Cover
[8]	Duplex Reverse Drive Unit
[9]	Secondary Transfer Feed Unit
[10]	Lifter Drive Unit
[11]	Cassette Pickup Unit
[12]	Low Voltage Power Supply Unit

CAUTION:

Do not disassemble the Main Drive Assembly.

Layout Drawing of Electrical Components

■ ADF/Reader

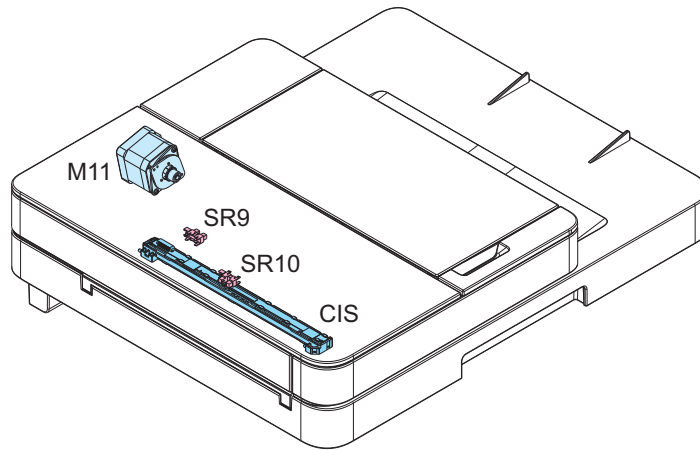

(MF742 Series)

(MF741 Series)

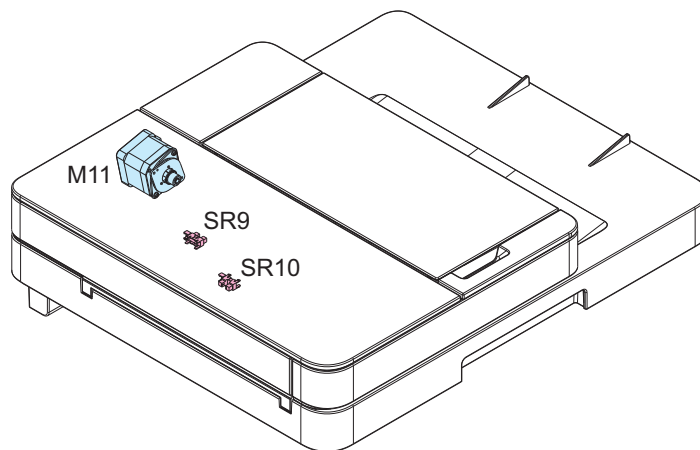

Electric code	Name
M11	ADF Motor
CIS	Contact Image Sensor (ADF CIS)
SR9	Document Sensor
SR10	Document End Sensor

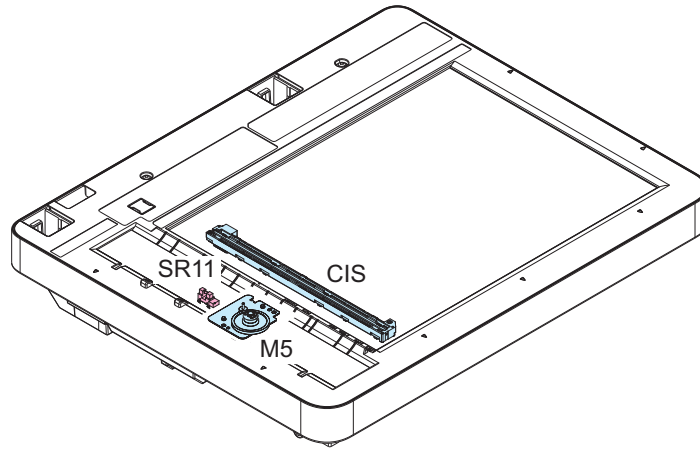

Electric code	Name
M5	Reader Motor
CIS	Contact Image Sensor (Reader CIS)
SR11	CIS HP Sensor

■ Motor/Fan

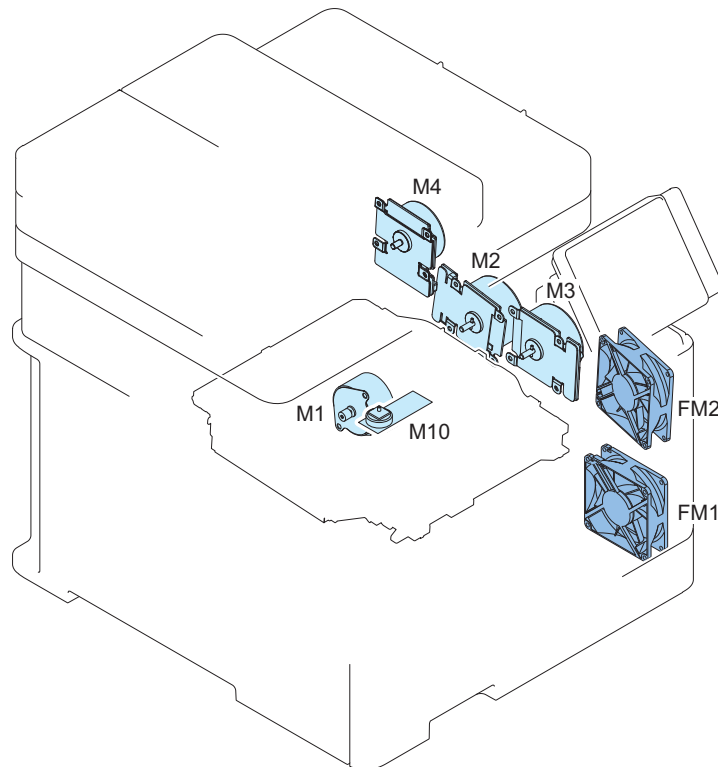

Electric code	Name
M1	Pickup Motor
M2	Drum Motor
M3	Developing Motor
M4	Fixing Motor
M10	Scanner Motor
FM1	Power Supply Fan
FM2	Cartridge Fan

■ Heater

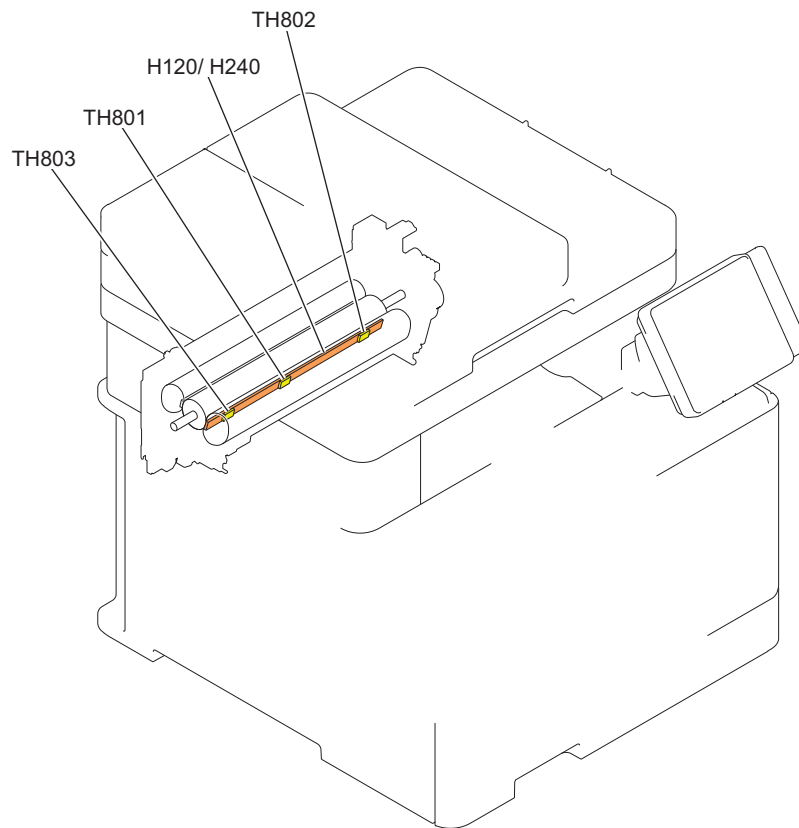

Electric code	Name
H120	Fixing Heater (120V)
H240	Fixing Heater (240V)
TH801	Main Thermistor
TH802	Sub Thermistor 1
TH803	Sub Thermistor 2

■ Switch/Solenoid/Clutch

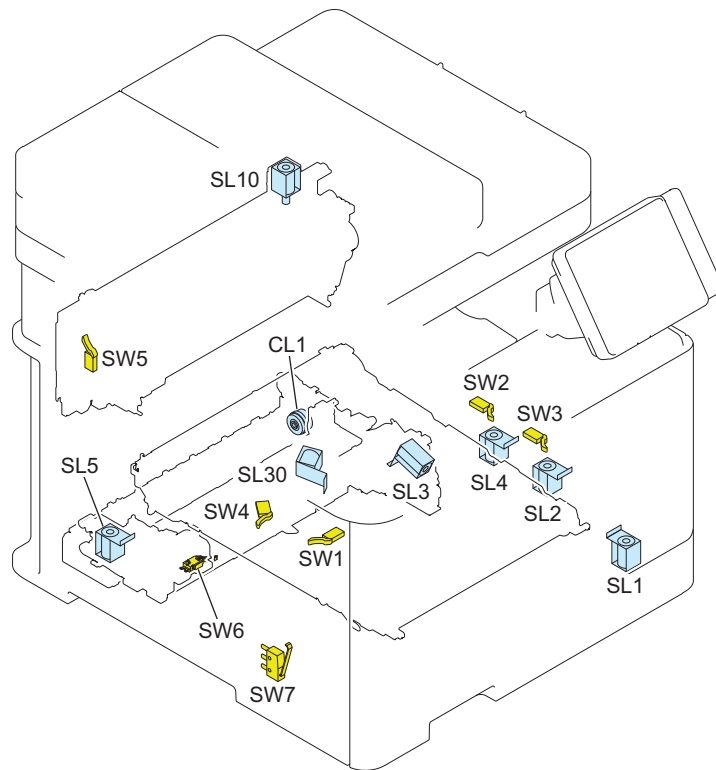

Electric code	Name
CL1	Duplex Re-pickup Clutch
SL1	MP Tray Pickup Solenoid
SL2	Developing Disengagement Solenoid (K)
SL3	Cassette Pickup Solenoid
SL4	Developing Disengagement Solenoid (YMC)
SL5	Lifter Solenoid
SL10	Duplex Reverse Solenoid
SL30	Primary Transfer Disengagement Solenoid
SW1	Front Cover Switch
SW2	Developing Disengagement Switch (YMC)
SW3	Developing Disengagement Switch (K)
SW4	Primary Transfer Disengagement Switch
SW5	Fixing Pressure Release Switch
SW6	Cassette Switch
SW7	24V Interlock Switch

■ Sensor

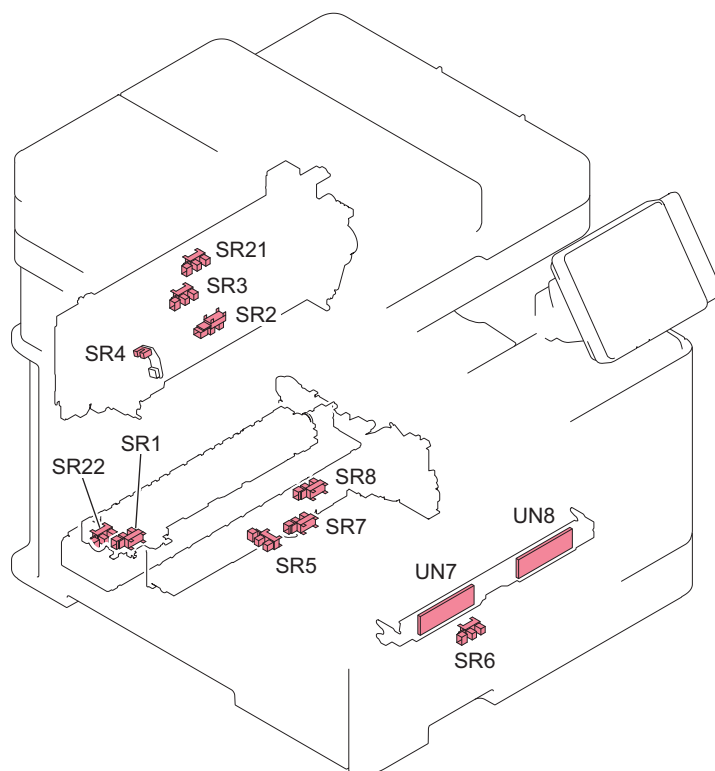

Electric code	Name
SR1	Registration Sensor
SR2	Arch Sensor
SR3	Fixing Delivery Sensor
SR4	Delivery Sensor
SR5	Cassette Paper Sensor
SR6	MP Tray Paper Sensor
SR7	Cassette Paper Surface Sensor
SR8	Lifter Sensor
SR21	Duplex Reverse Sensor
SR22	Duplex Re-pickup Sensor
UN7	Color Displacement/Density Sensor PCB
UN8	Color Displacement Sensor PCB

■ PCB

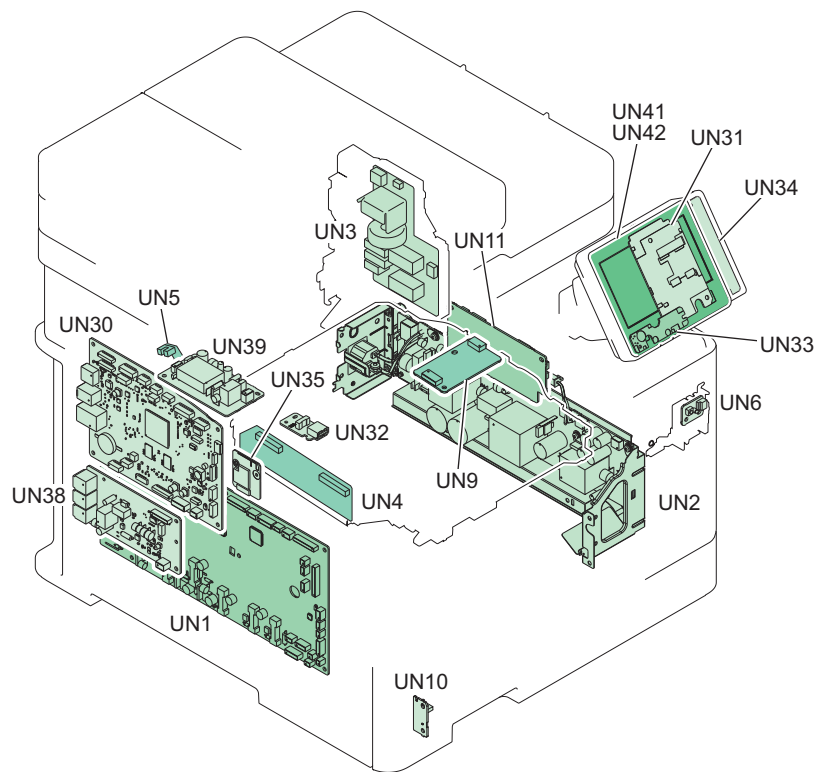

Electric code	Name
UN1	Engine Controller PCB
UN2	Low Voltage Power Supply Unit
UN3	Fixing Power Supply PCB
UN4	Laser Driver PCB
UN5	Delivery Tray Full Sensor PCB
UN6	Laser Driver PCB
UN9	Memory Relay PCB
UN10	Environment Sensor PCB
UN11	Driver PCB
UN30	Main Controller PCB
UN31	Touch Panel Main PCB
UN32	USB PCB
UN33	Panel LED PCB
UN34	Panel NFC PCB
UN35	Wireless LAN PCB
UN38	NCU PCB (Only for FAX Model)
UN39	Off-hook PCB (Only for FAX Model)
UN41	LCD
UN42	Touch Panel

External Cover System

● Removing the Toner Cartridge

■ Procedure

CAUTION:

- Be careful not to damage the Photosensitive Drum.

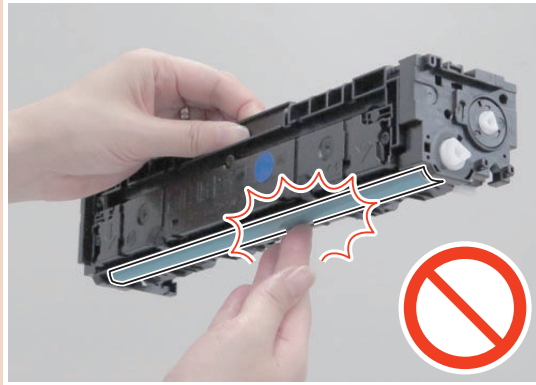

- Be sure to cover the drums with paper to block light.

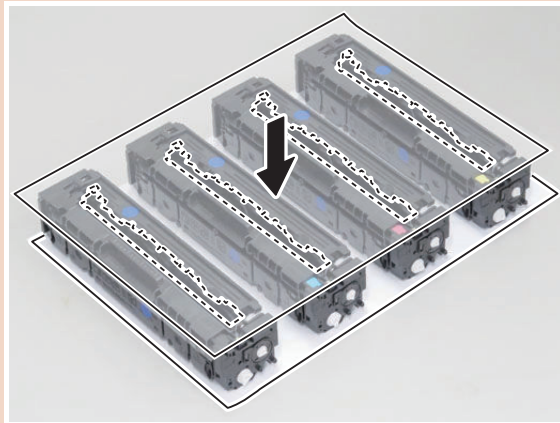

1. Pull out the Cartridge Tray, and remove the Toner Cartridges (Y, M, C, and Bk).

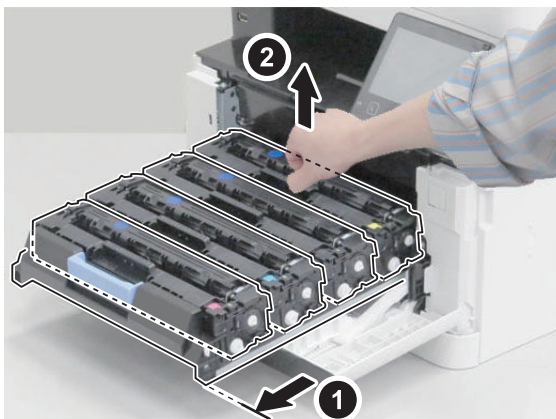

● Removing the Left Cover

■ Preparation

1. “Removing the Toner Cartridge” on page 95

■ Procedure

1. Shift the host machine by approximately 80 mm from the working table to release the claws on the bottom of the Left Cover.

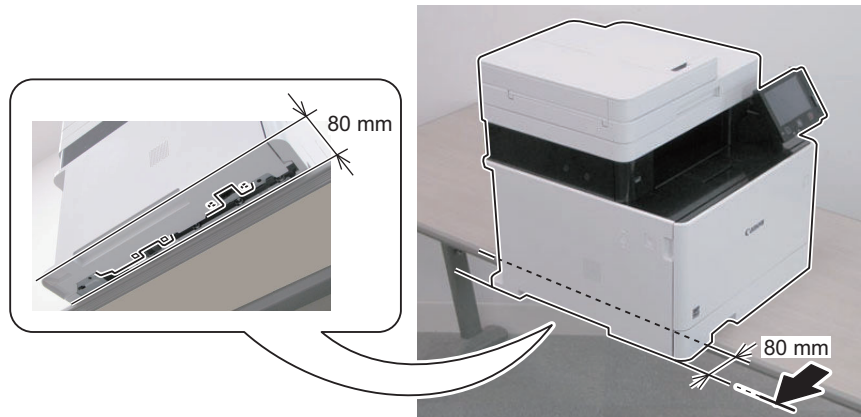

2. Pull out the cassette by approximately 80 mm.

⚠ CAUTION:

Do not completely pull out the cassette, as doing so will disturb the balance of the product and may cause it to fall down.

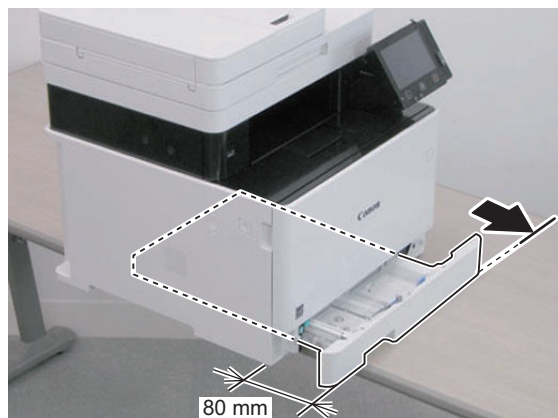

3. Open the Cartridge Cover and the Rear Cover Unit, and remove the screws.

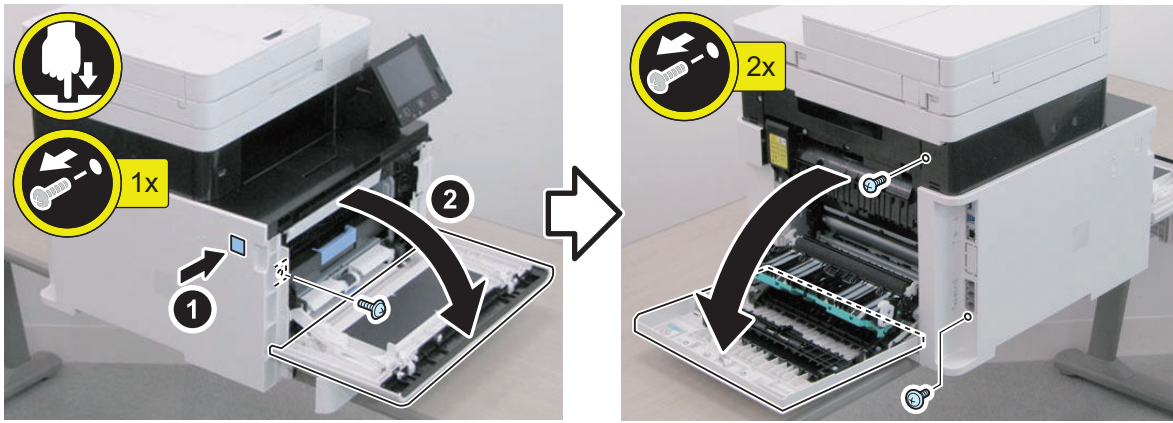

4. Free the bosses and the claw on the front side.

NOTE:

- Be sure to remove it while holding the joint because the Cartridge Cover Retainer comes off easily.
- The boss can be freed easily by pulling the Left Cover in the [A] direction and pulling the Cartridge Cover Retainer in the [B] direction.

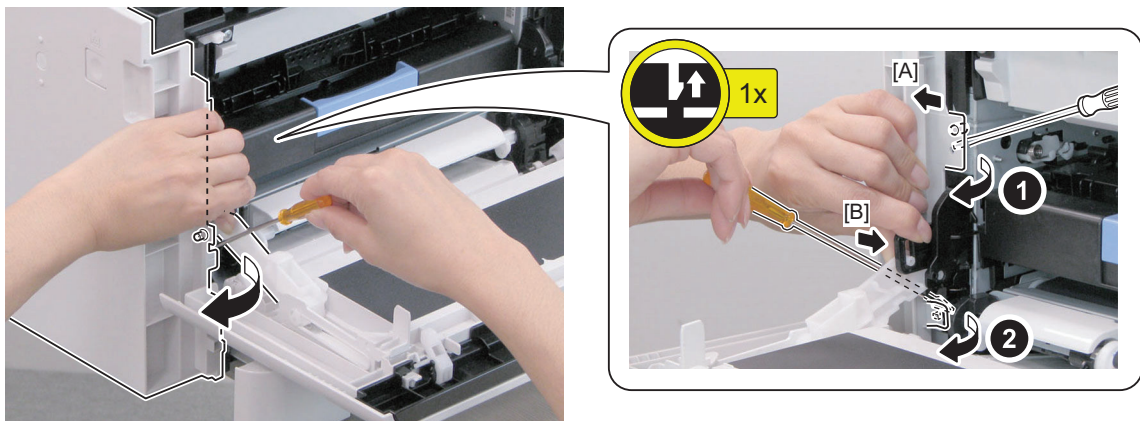

5. Release the claws while opening the Left Cover in the direction of the arrow.

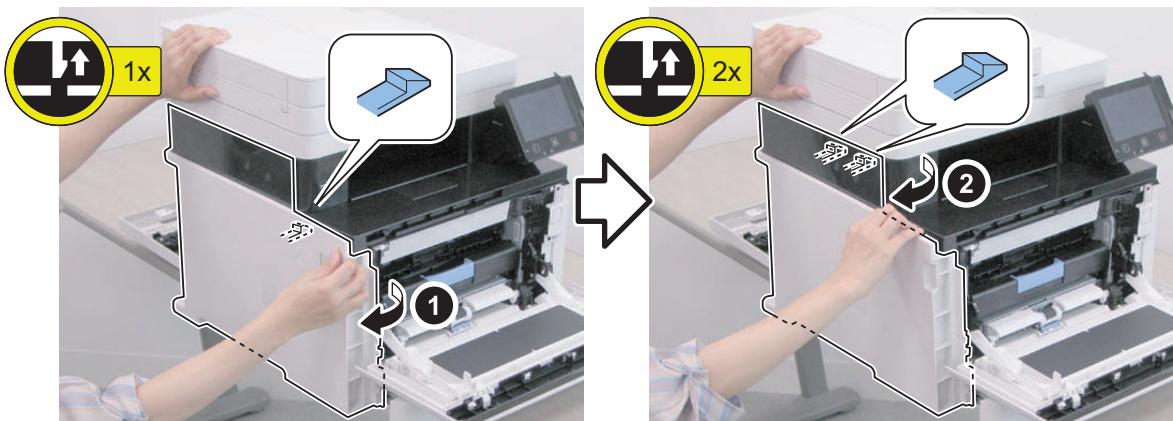

6. Release the claws while opening the Left Cover in the direction of the arrow.

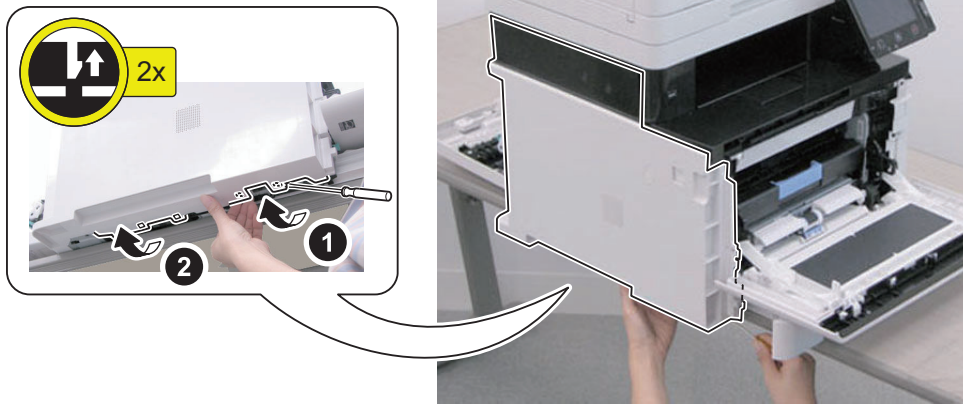

7. Free the bosses and claws, and remove the Left Cover.

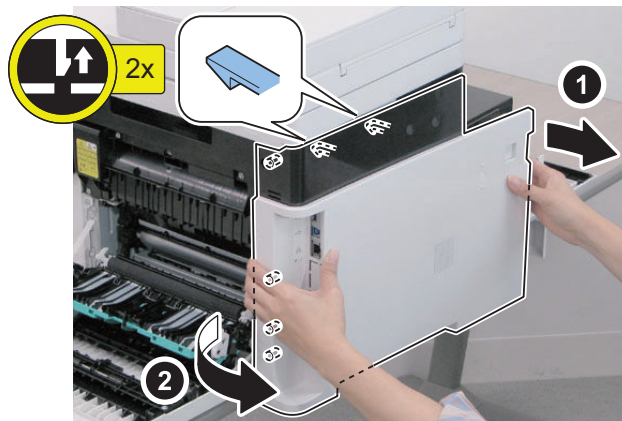

8. Shift the host machine back to the center of the working table to prevent it from falling down.

● Removing the Right Cover

■ Preparation

1. “Removing the Toner Cartridge” on page 95

■ Procedure

1. Shift the host machine by approximately 100 mm from the working table to release the claws on the bottom of the Right Cover.

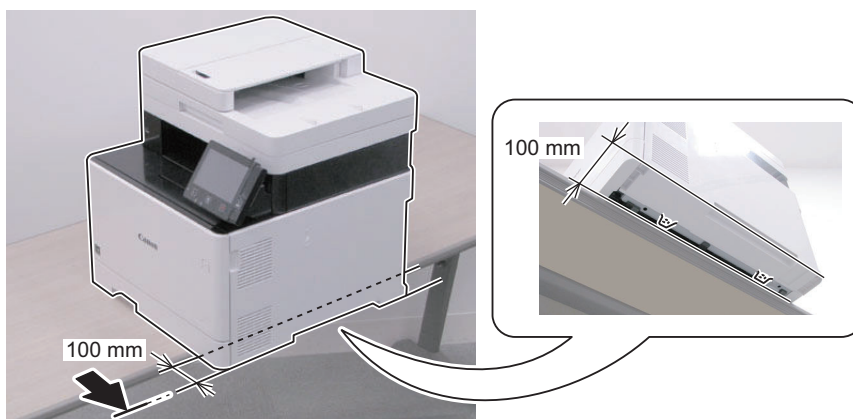

2. Pull out the cassette by approximately 80 mm.

⚠ CAUTION:

Do not completely pull out the cassette, as doing so will disturb the balance of the product and may cause it to fall down.

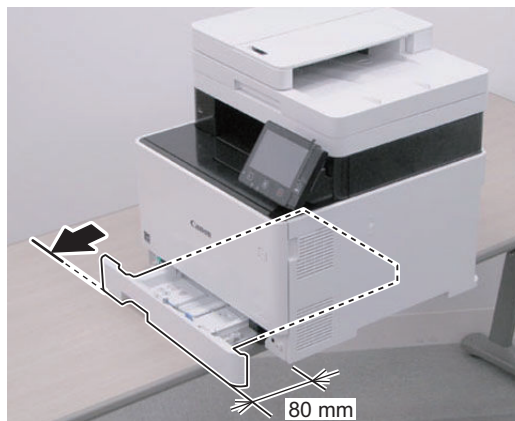
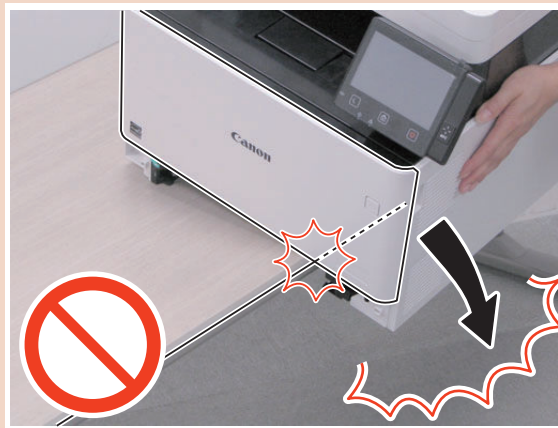

3. Open the Cartridge Cover and the Rear Cover Unit, and remove the screws.

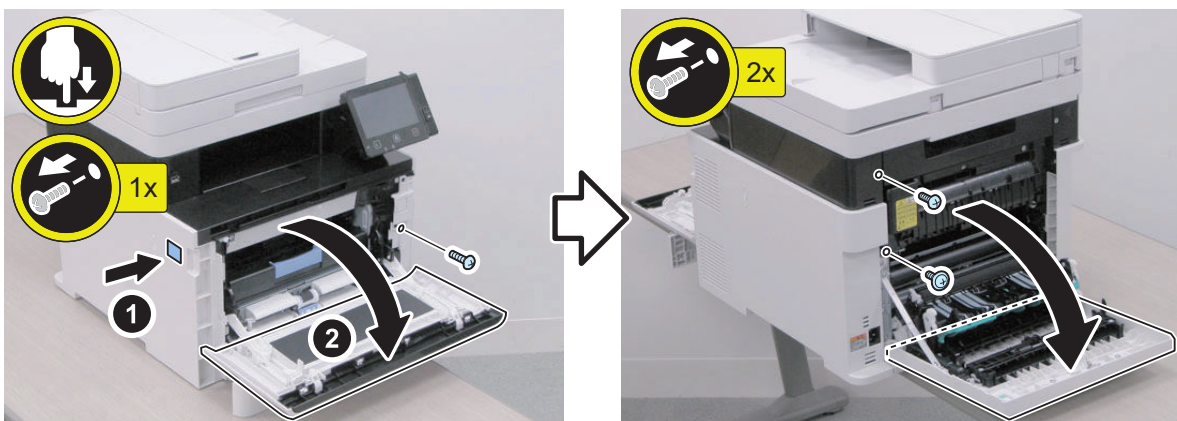

4. Release the claws while opening the Right Cover in the direction of the arrow.

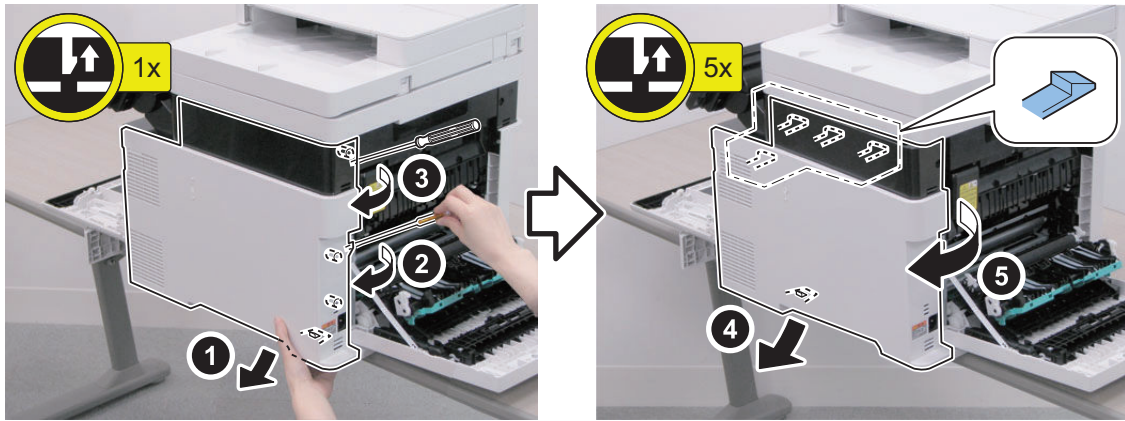

5. Free the bosses and claw, and remove the Right Cover.

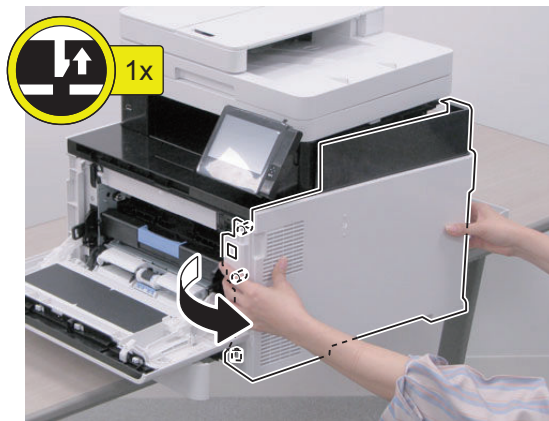

6. Shift the host machine back to the center of the working table to prevent it from falling down.

● Removing the Rear Cover Unit

■ Preparation

1. "Removing the Toner Cartridge" on page 95
2. "Removing the Left Cover" on page 96
3. "Removing the Right Cover" on page 98

■ Procedure

1. Open the Rear Cover Unit, and close the Secondary Transfer Unit.

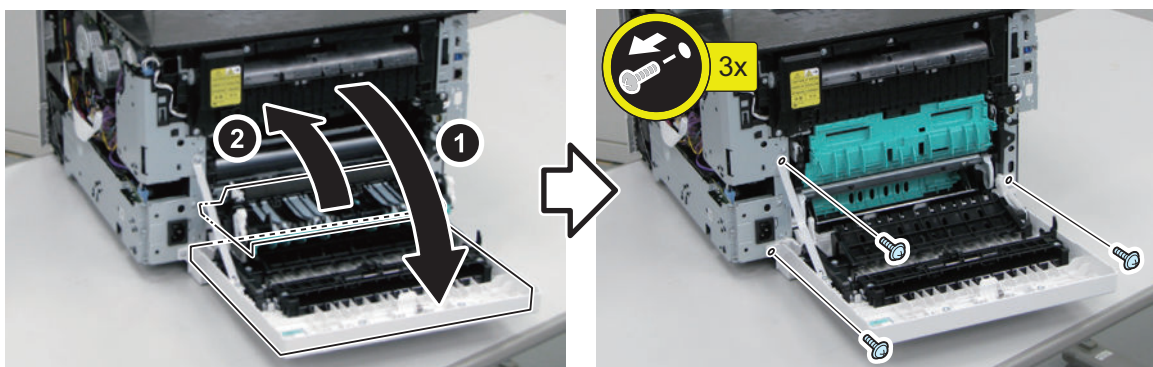

2. Remove the Rear Cover Unit.

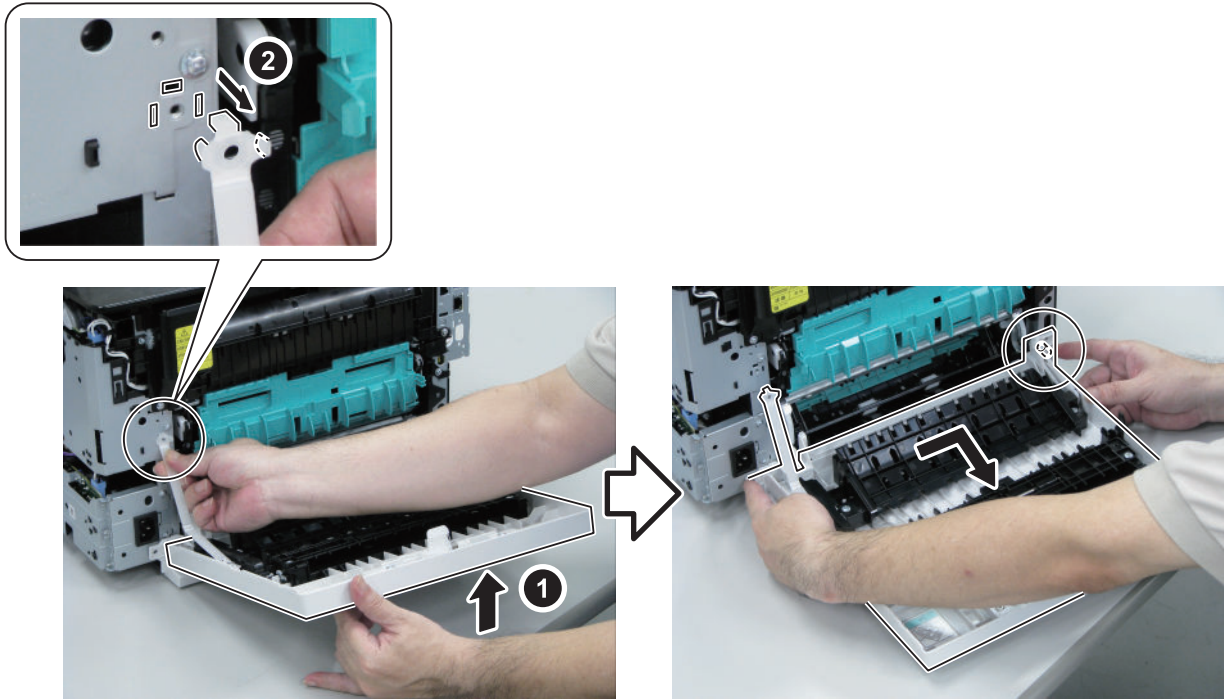

● Removing the Cartridge Cover

■ Preparation

1. "Removing the Toner Cartridge" on page 95
2. "Removing the Right Cover" on page 98

■ Procedure

1. Open the Cartridge Cover.
2. Remove the screw.

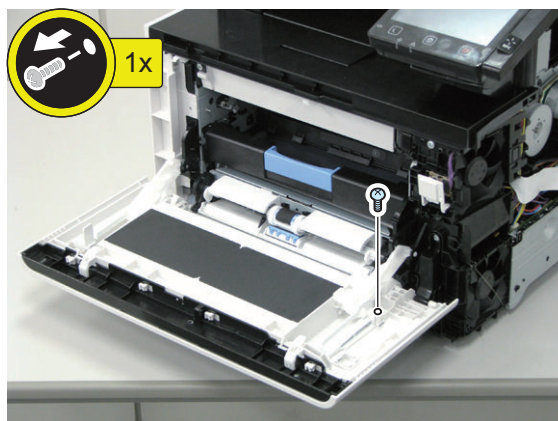

3. Release the Cartridge Cover Retainer on the right side.

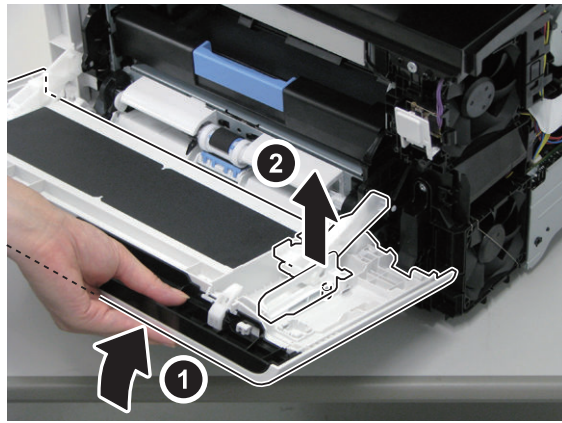

4. Release the Cartridge Cover Retainer on the left side.

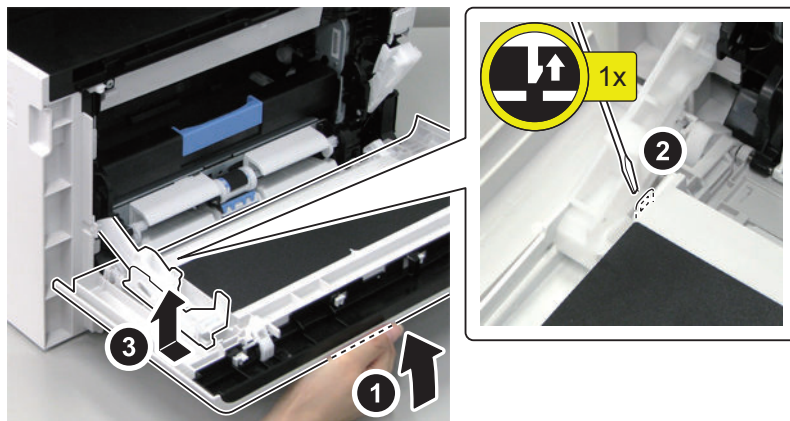

5. Remove the Cartridge Cover.

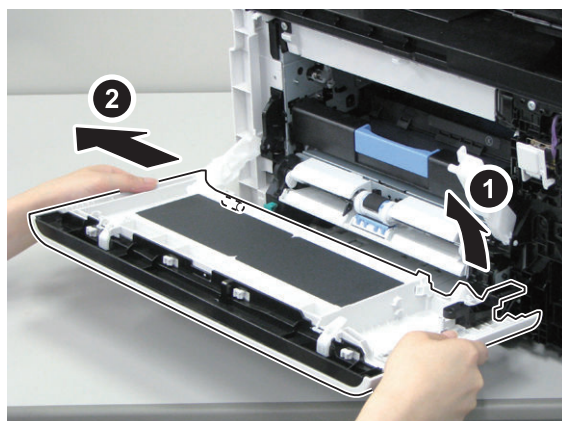
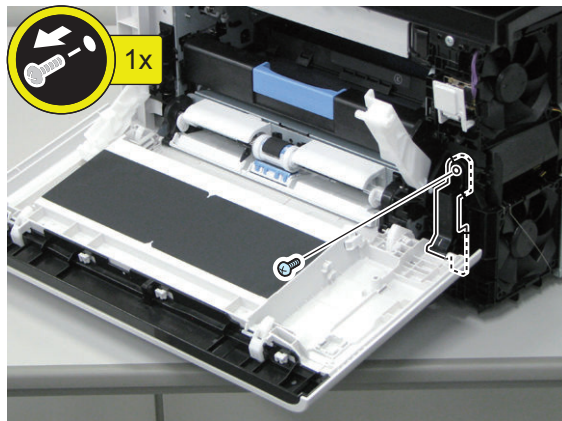

● Removing the Cartridge Tray

■ Preparation

1. “Removing the Toner Cartridge” on page 95
2. “Removing the Right Cover” on page 98
3. “Removing the Cartridge Cover ” on page 101
4. “Removing the Left Cover” on page 96

■ Procedure

1. Remove the white Front Door Arm on the left side, and remove the Arm Support Block on the left side.

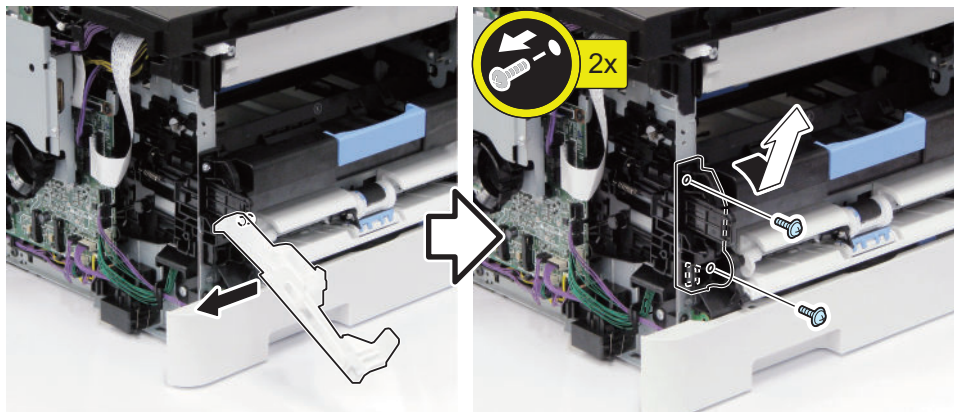

2. Pull out the Cartridge Tray.



3. Remove the guide from the pin while lifting up the left side of the tray. Also remove the guide from the pin on the right side. Since the Cartridge Tray is still in the groove of the white guide on the right side, turn the tray counterclockwise to remove it from the white guide.

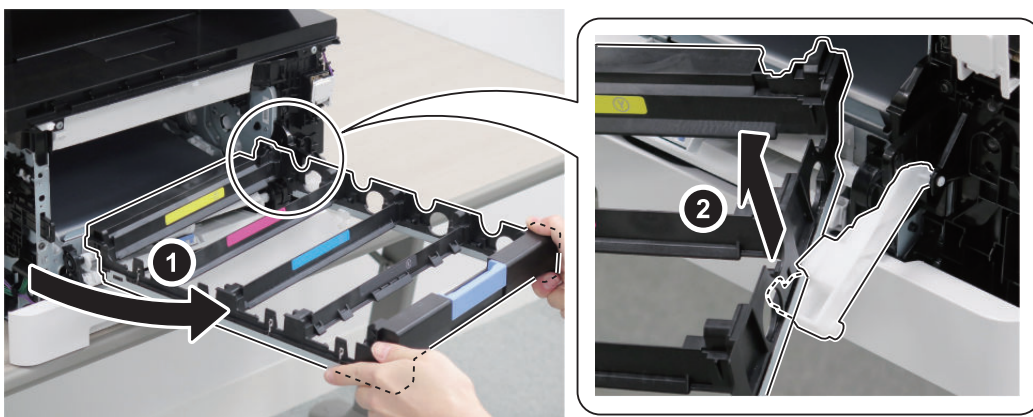

NOTE:

When installing the Cartridge Tray, first make the pin on the right side enter the groove on the tray. Next, insert the tray under the black pin on the left side, and insert it in all the way along the tray guide on the bottom.

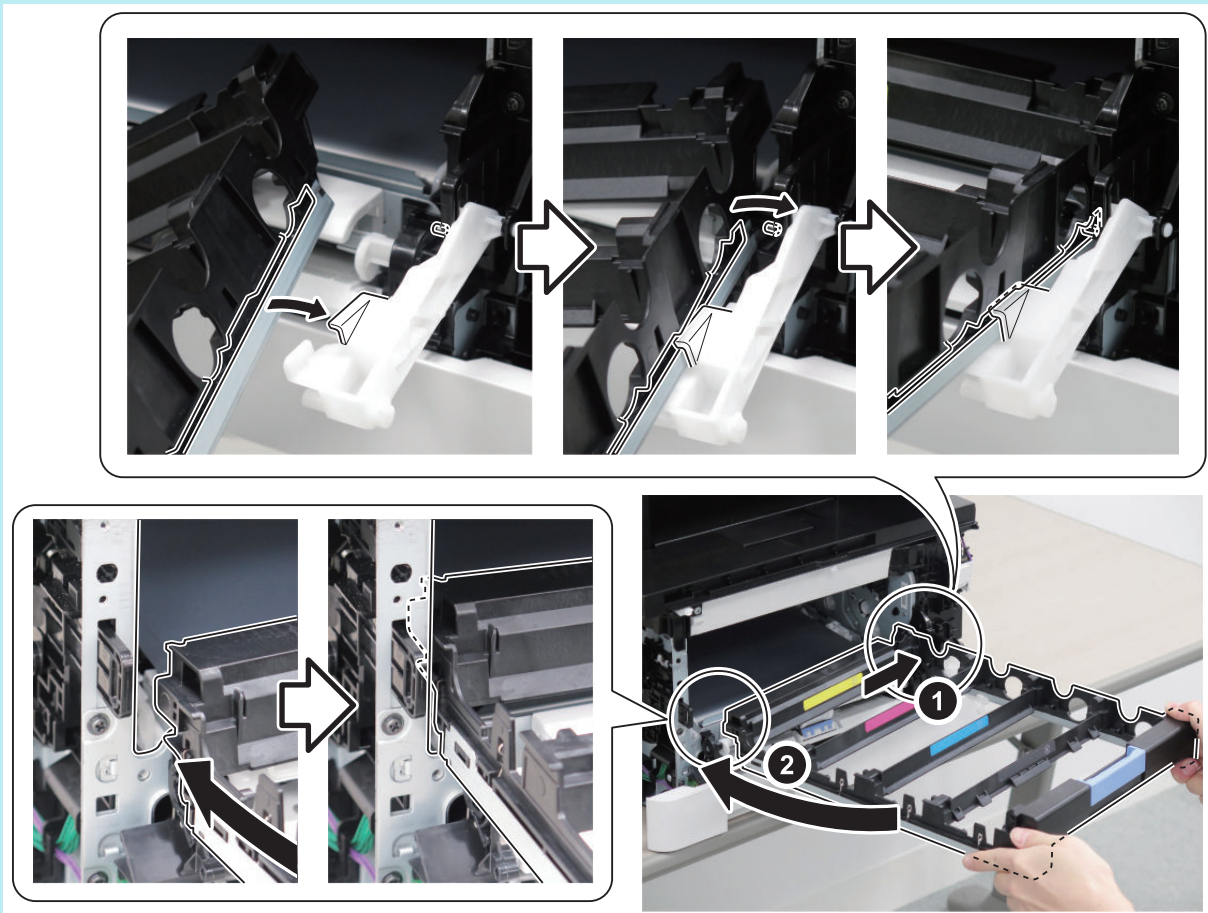

● Removing the Upper Front Cover

■ Preparation

1. “Removing the Toner Cartridge” on page 95
2. “Removing the Left Cover” on page 96
3. “Removing the Right Cover” on page 98
4. “Removing the ADF Unit + Reader Unit” on page 107

■ Procedure

1. Remove the Upper Front Cover.

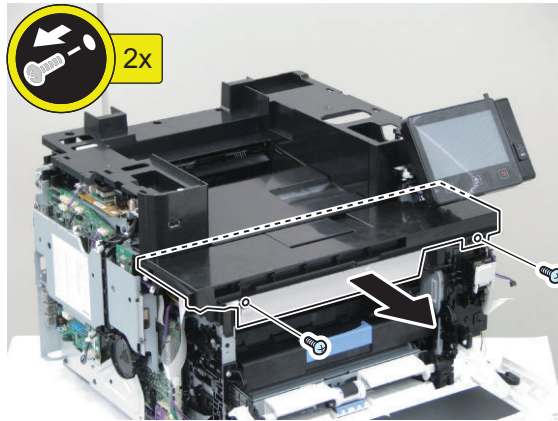

● Removing the Upper Left Front Cover

■ Preparation

1. “Removing the Toner Cartridge” on page 95
2. “Removing the Left Cover” on page 96
3. “Removing the Right Cover” on page 98
4. “Removing the ADF Unit + Reader Unit” on page 107
5. “Removing the Upper Front Cover” on page 104

■ Procedure

1. Remove the Upper Left Front Cover.

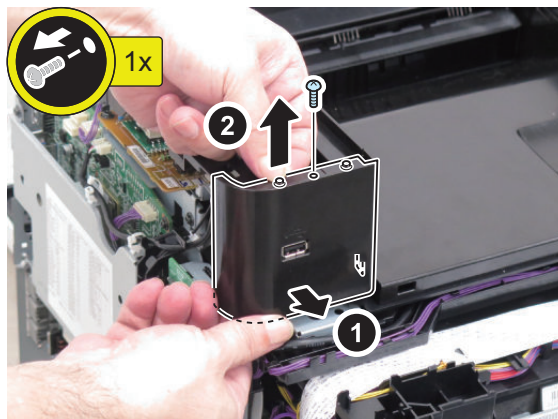

● Removing the Upper Right Front Cover

■ Preparation

1. “Removing the Toner Cartridge” on page 95
2. “Removing the Left Cover” on page 96
3. “Removing the Right Cover” on page 98
4. “Removing the ADF Unit + Reader Unit” on page 107
5. “Removing the Upper Front Cover” on page 104

■ Procedure

1. Remove the Upper Right Front Cover.

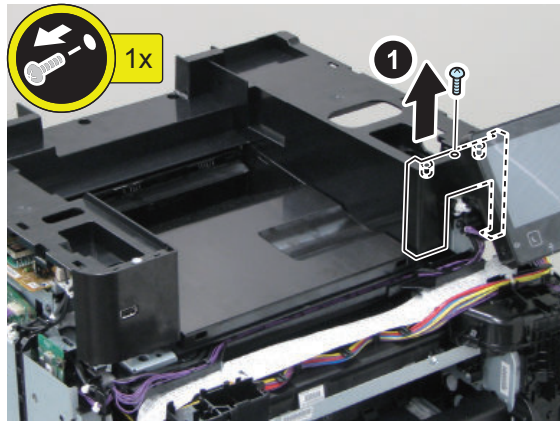

● Removing the Upper Cover Unit

■ Preparation

1. "Removing the Toner Cartridge" on page 95
2. "Removing the Left Cover" on page 96
3. "Removing the Right Cover" on page 98
4. "Removing the ADF Unit + Reader Unit" on page 107
5. "Removing the Upper Front Cover" on page 104
6. "Removing the Upper Left Front Cover" on page 105
7. "Removing the Upper Right Front Cover" on page 105
8. "Removing the Control Panel Unit" on page 137

■ Procedure

1. Remove the Upper Cover Unit.

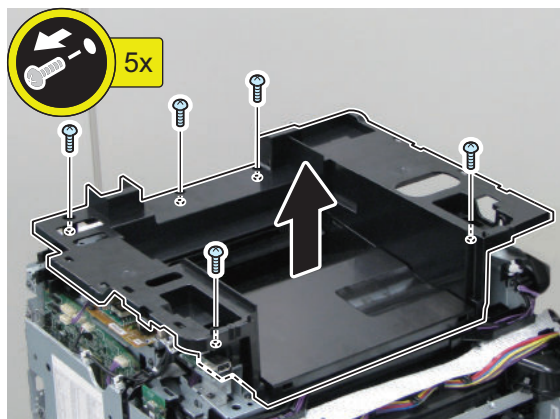

Original Exposure/Feed System

● Removing the ADF Unit + Reader Unit

■ Preparation

1. "Removing the Toner Cartridge" on page 95
2. "Removing the Left Cover" on page 96
3. "Removing the Right Cover" on page 98

■ Procedure

1. Remove the Rear Upper Cover.

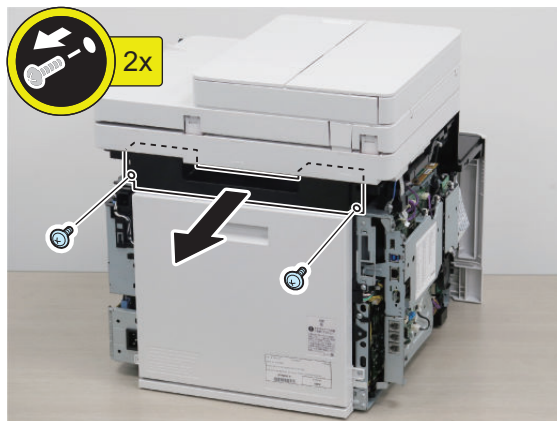

2. Remove the screws.

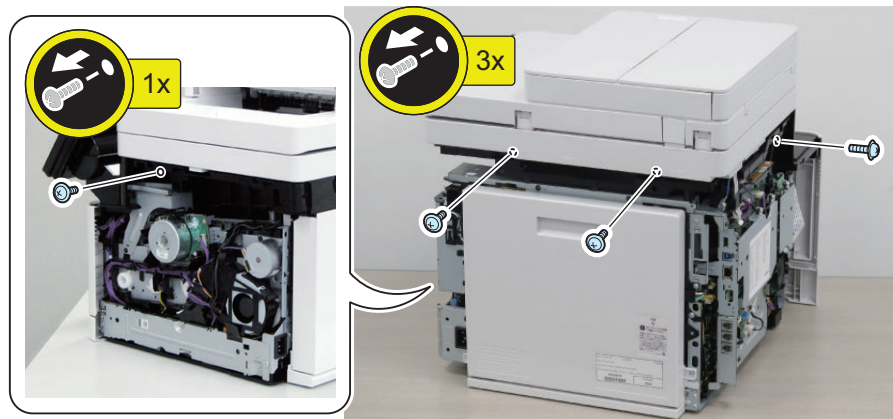

3. Disconnect the cables.

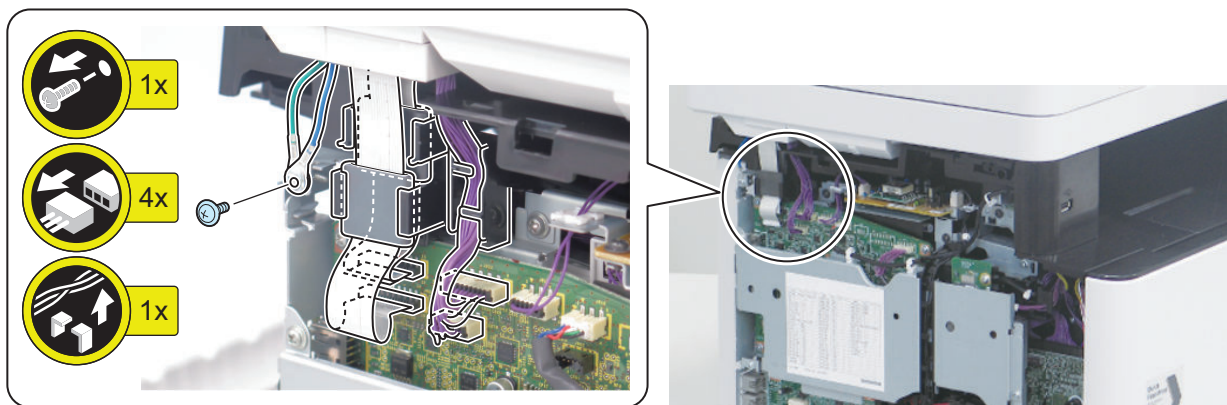

NOTE:

The Simplex ADF has one Flat Cable.

(MF741 Series)

(MF742 Series)

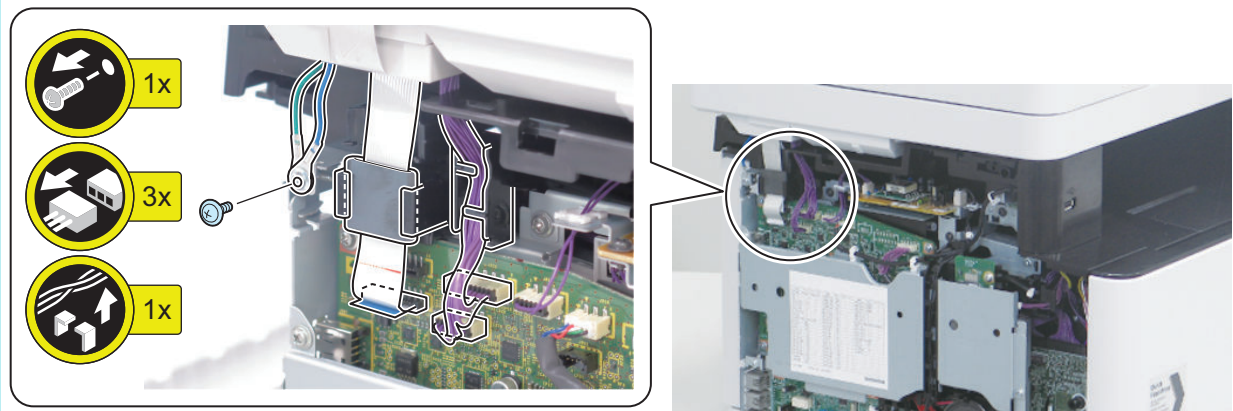

4. Remove the ADF Unit + Reader Unit.



● Separating the ADF Unit + Reader Unit

■ Preparation

1. "Removing the Toner Cartridge" on page 95
2. "Removing the Left Cover" on page 96
3. "Removing the Right Cover" on page 98
4. "Removing the ADF Unit + Reader Unit" on page 107

■ Procedure

1.

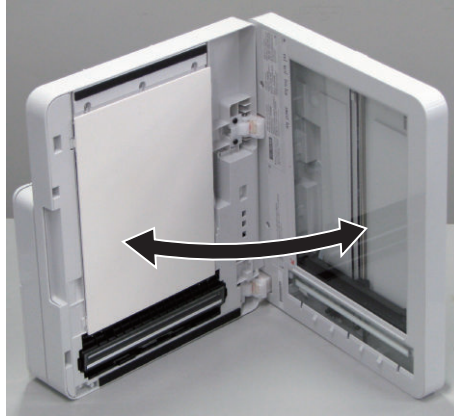

2.

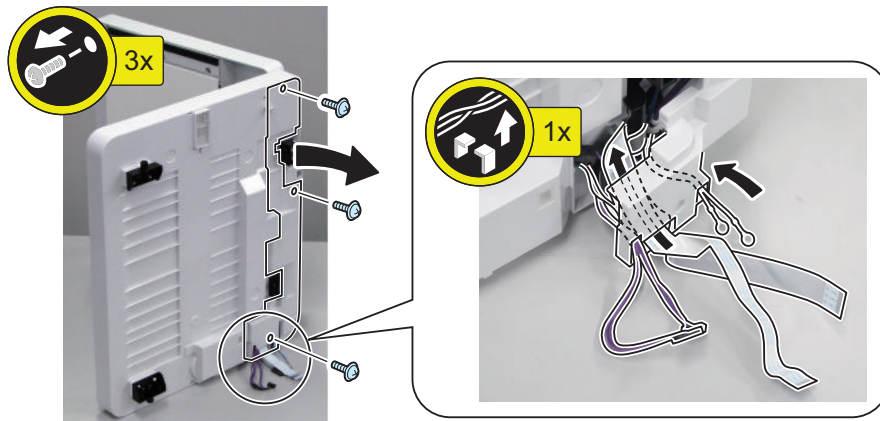

3.

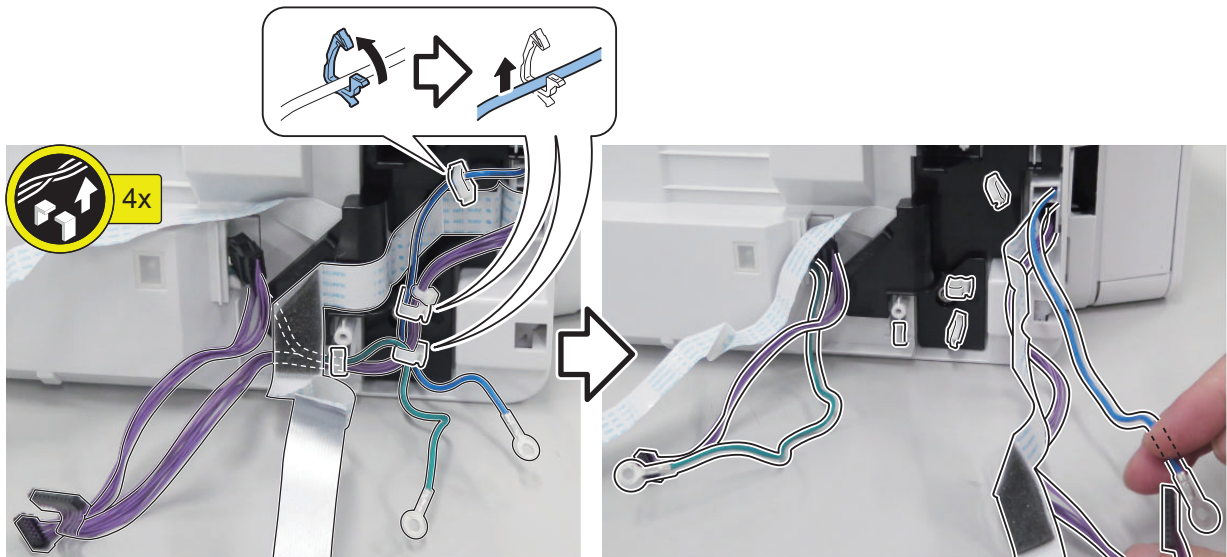

4.

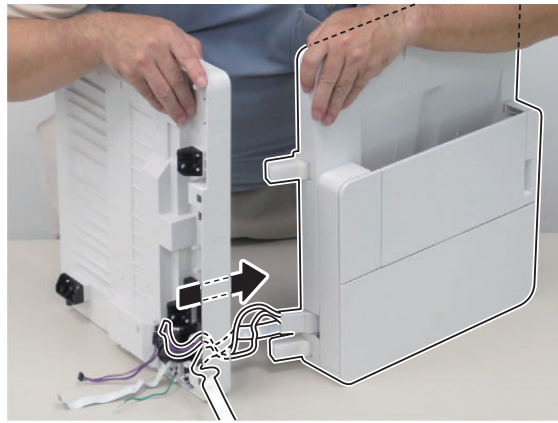

5. Actions after replacement: “After Replacing the ADF Unit” on page 196 “After Replacing the Reader Unit” on page 205

● Removing the ADF Roller Unit

■ Procedure

CAUTION:

Do not touch the surface of the roller.

1. Open the ADF Upper Cover.

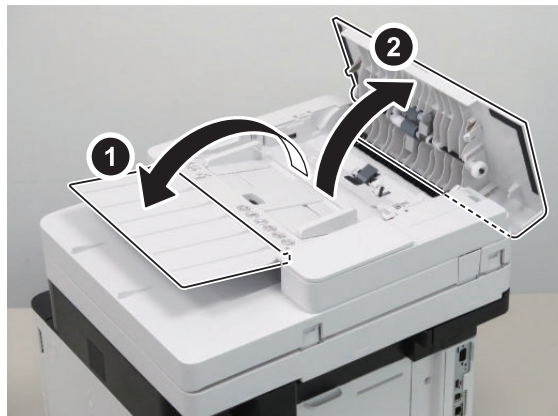

2. Remove the gear and the bushing.

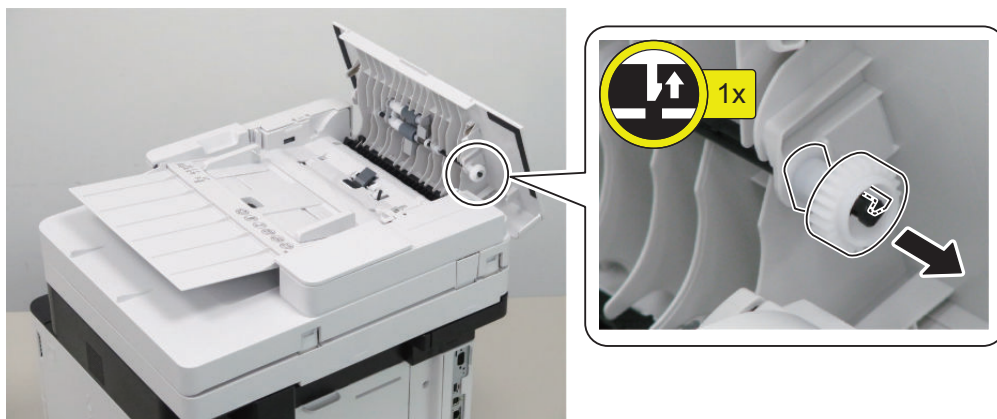

3. Remove the E-ring, and move the bushing.

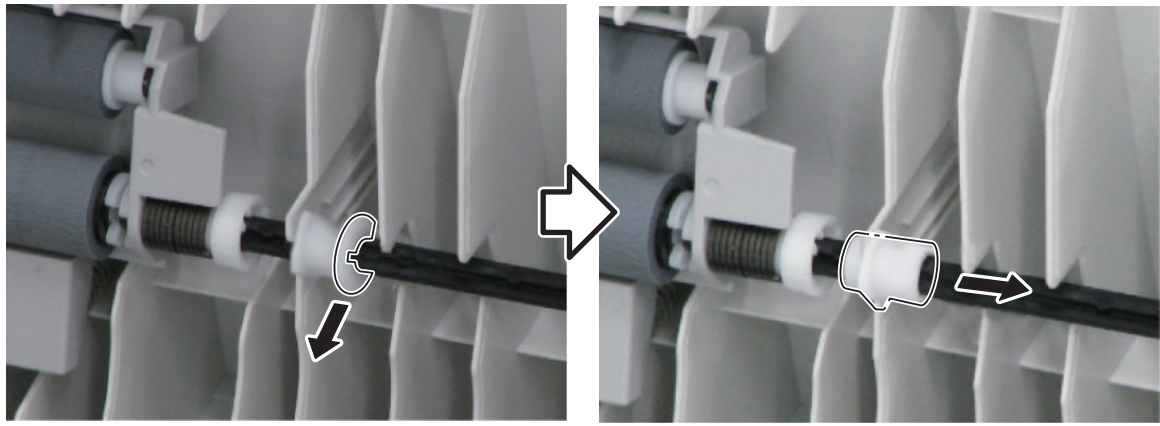

4. Remove the E-ring and the bushing, and remove the ADF Roller Unit.

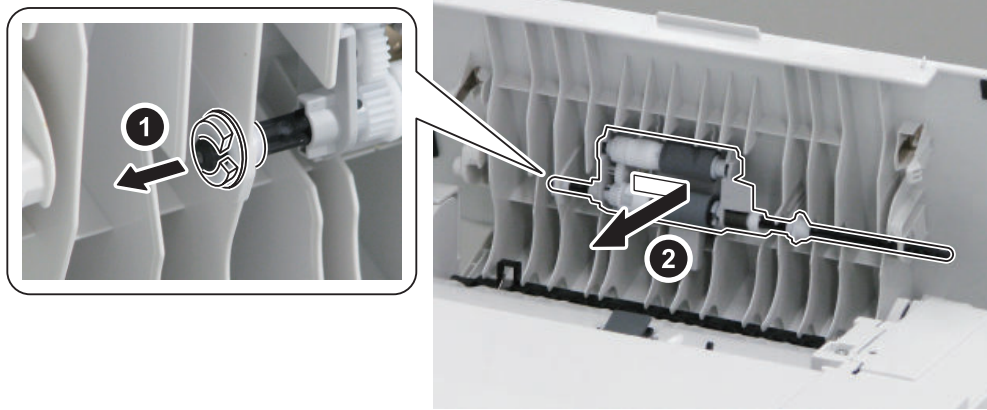
**CAUTION:**

Be careful not to lose the spring attached to the ADF Roller Unit.

**NOTE:**

When installing, match the spring of the ADF Roller Unit to the boss.

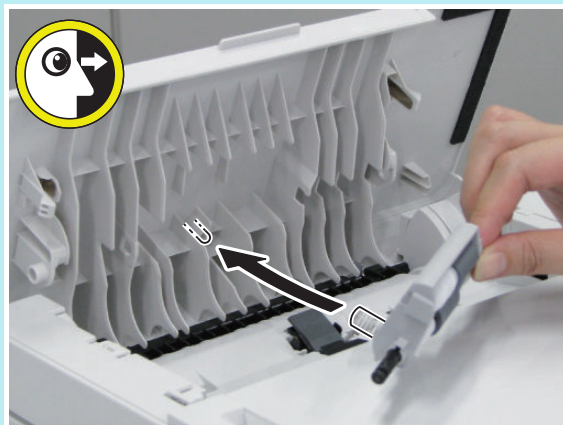

Removing the ADF Pickup Roller

■ Preparation

1. "Removing the Toner Cartridge" on page 95
2. "Removing the ADF Roller Unit" on page 110

■ Procedure

CAUTION:

Do not touch the surface of the roller.

1. Remove the ADF Pickup Roller Unit.

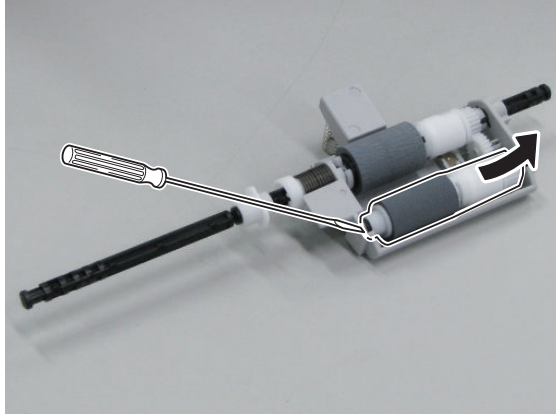

2. Remove the ADF Pickup Roller.

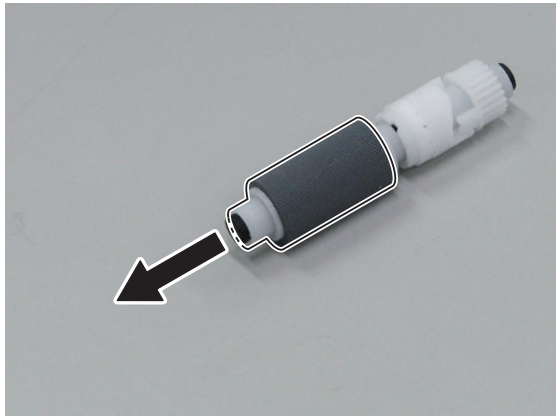

● Removing the ADF Separation Roller

■ Preparation

1. “Removing the Toner Cartridge” on page 95
2. “Removing the ADF Roller Unit” on page 110

■ Procedure

CAUTION:

Do not touch the surface of the roller.

1. Remove the bushing and 2 E-rings.

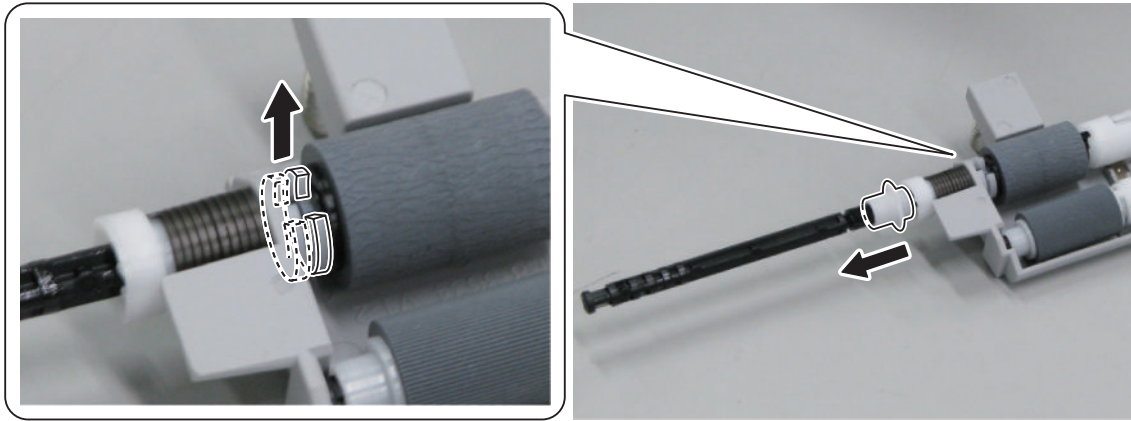

2. Move the Roller Shaft, and remove the Parallel Pin.

CAUTION:

Be careful not to lose the Parallel Pin during installation/removal.

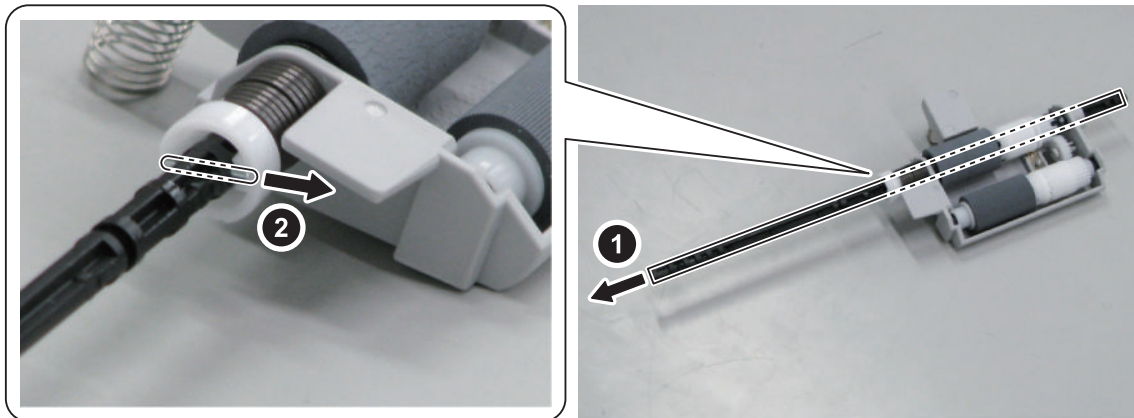

3. Turn the Roller Shaft in the direction of the arrow, and remove it after aligning the protrusion with the hole on the Roller Holder.

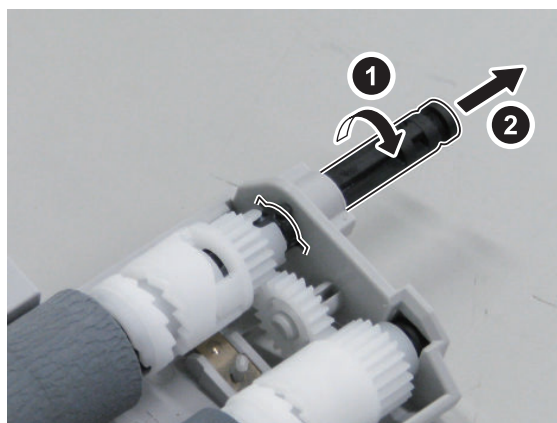

4. Remove the ADF Separation Roller.

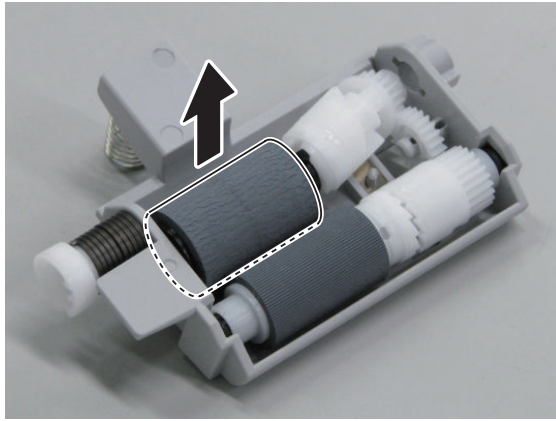

● Removing the ADF Separation Pad Unit

■ Procedure

CAUTION:

Be sure not to touch the surface of the roller/pad.

1. Open the ADF Upper Cover.

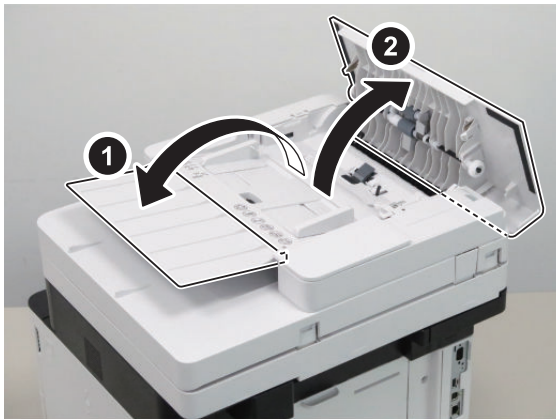

2. Remove the ADF Separation Pad Unit.

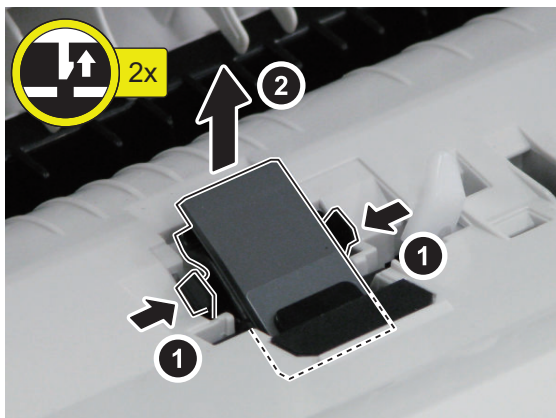

● Removing the ADF Upper Cover Unit

■ Procedure

1. Open the ADF Upper Cover.

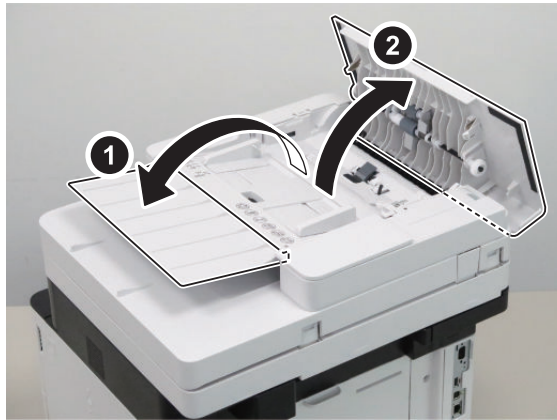

2. Lift the ADF Tray until it stops and release the shaft and hook, and then make the tray stand upright and remove it upward.



3. Release the hooks, and remove the ADF Front Cover in the direction of the arrow.

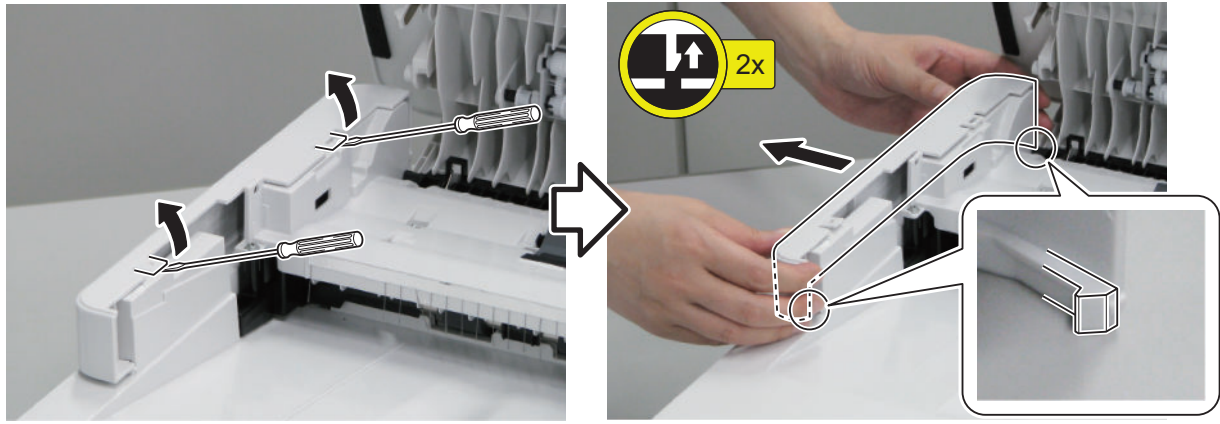

4. Release the boss, and remove the ADF Rear Cover in the direction of the arrow.

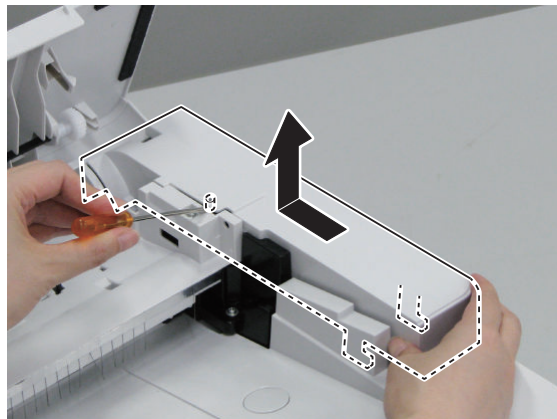

5. Remove the screws, and remove the ADF Pickup Feed Unit.

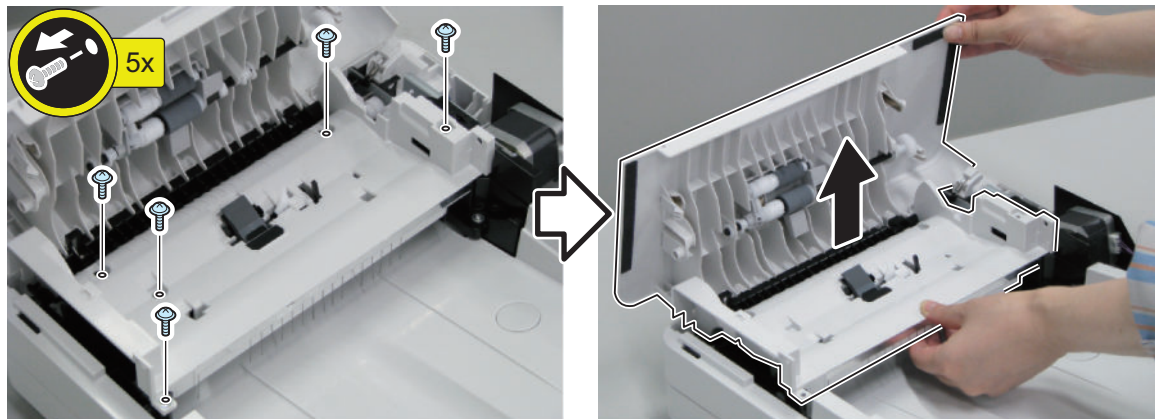

6. Remove the ADF Upper Cover Unit.

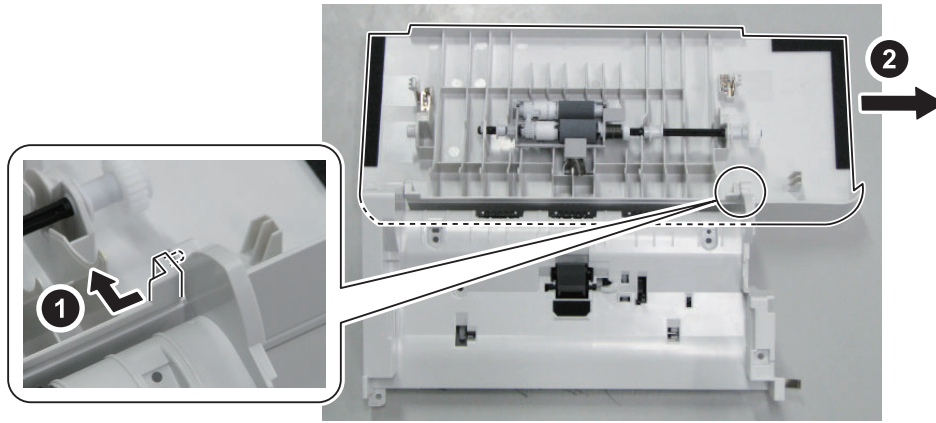

● Removing the ADF Feed Unit

■ Preparation

1. "Removing the ADF Upper Cover Unit" on page 116

■ Procedure

- 1.



- 2.

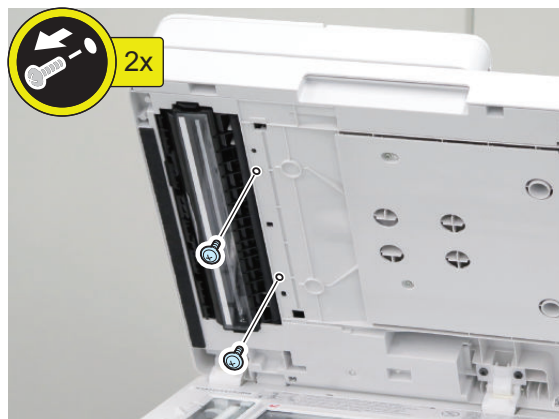

3.

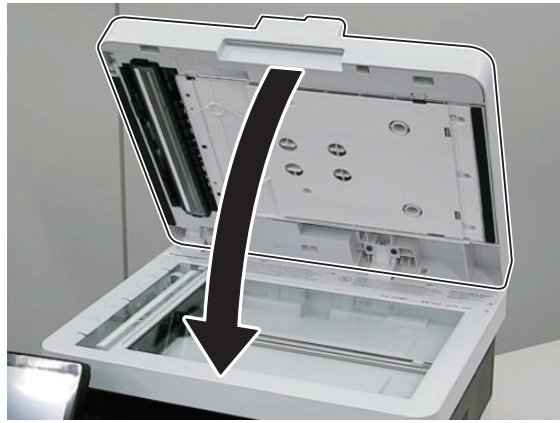

4.

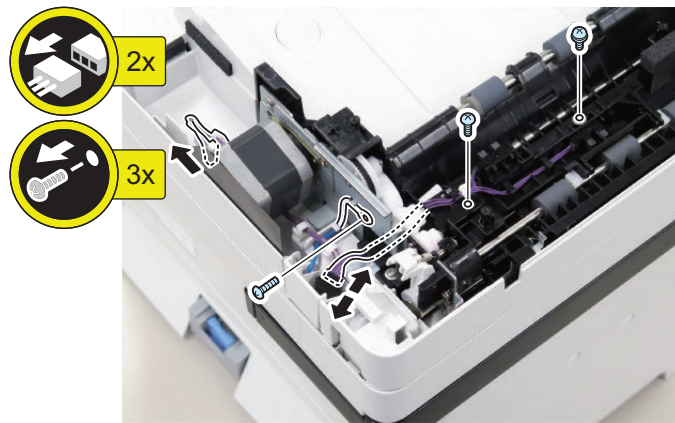

5.

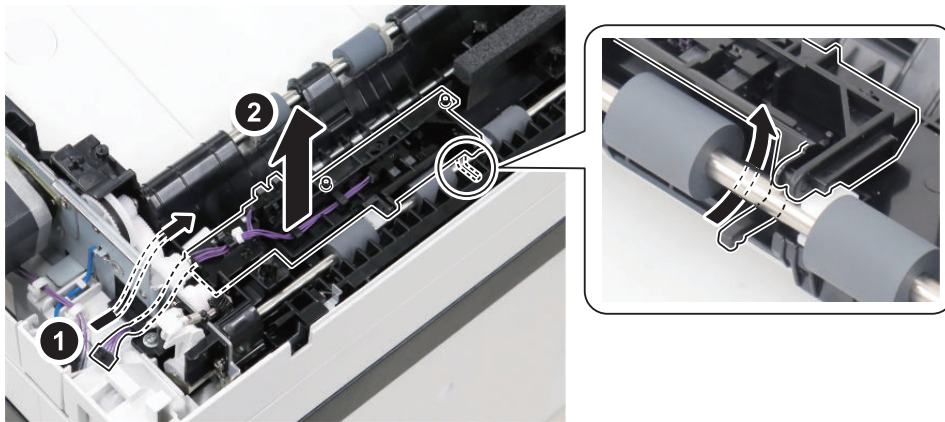

6.

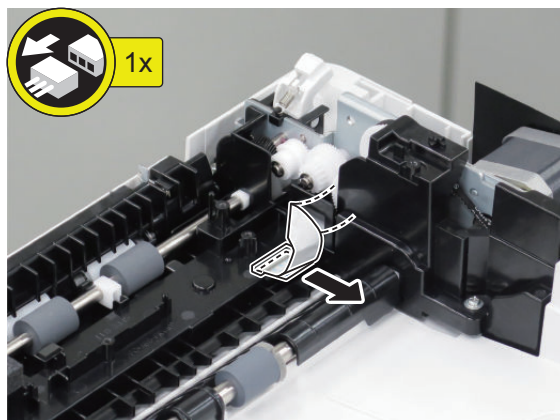

7.

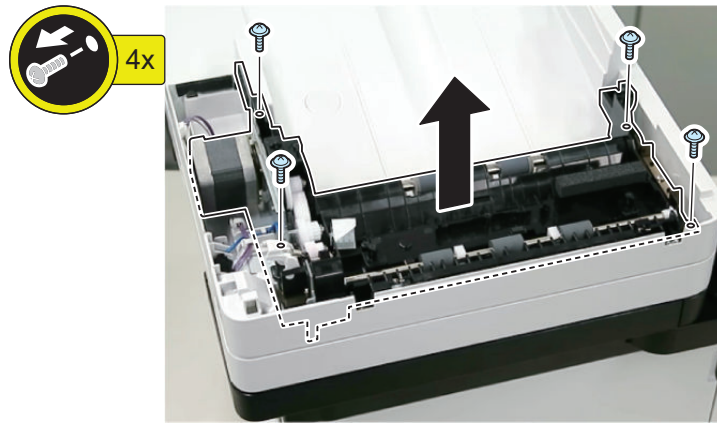

● Removing the ADF CIS (For the duplex scanning model)

■ Preparation

1. "Removing the ADF Upper Cover Unit" on page 116

■ Procedure

1.

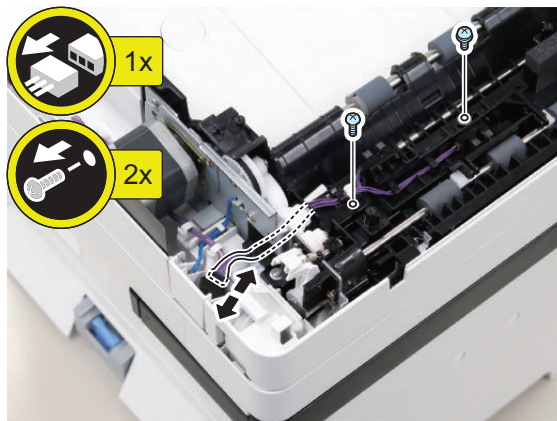

2.

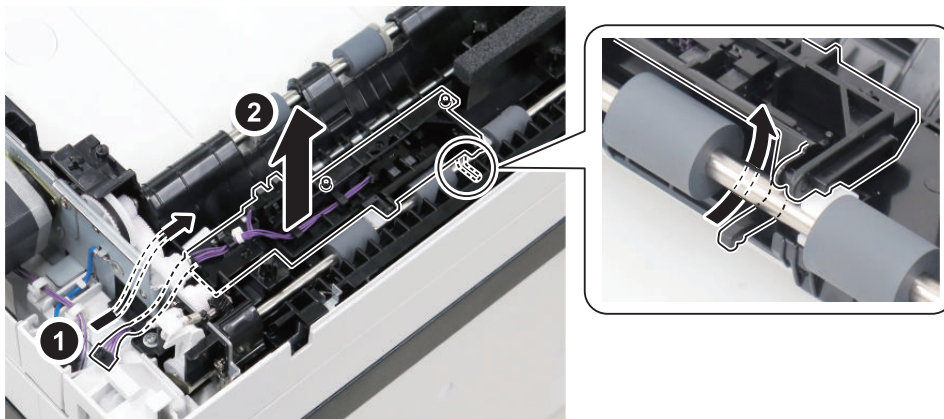

3.

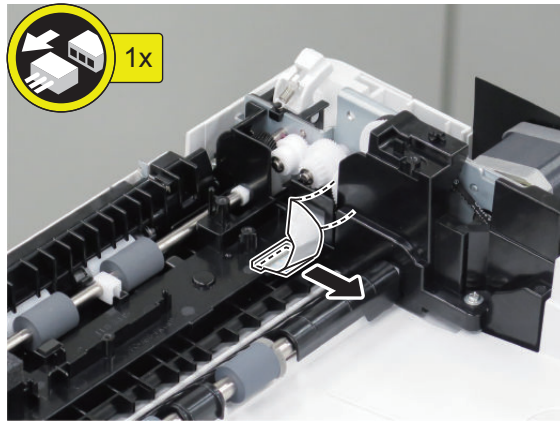

4.

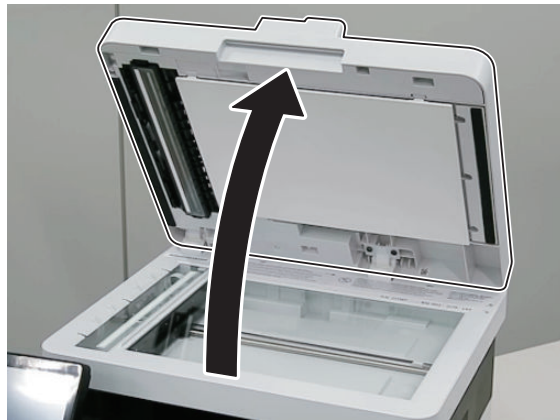

5.

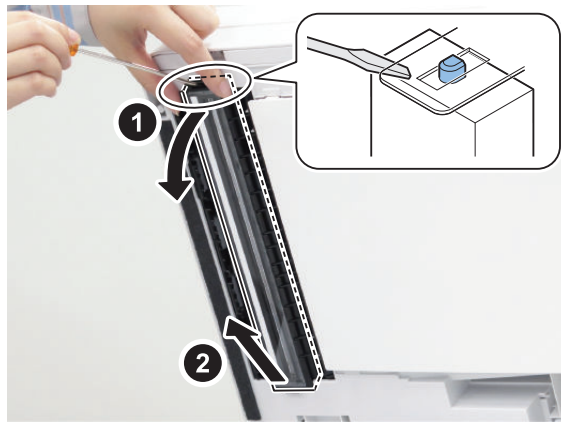

CAUTION:

Be careful not to lose the springs.

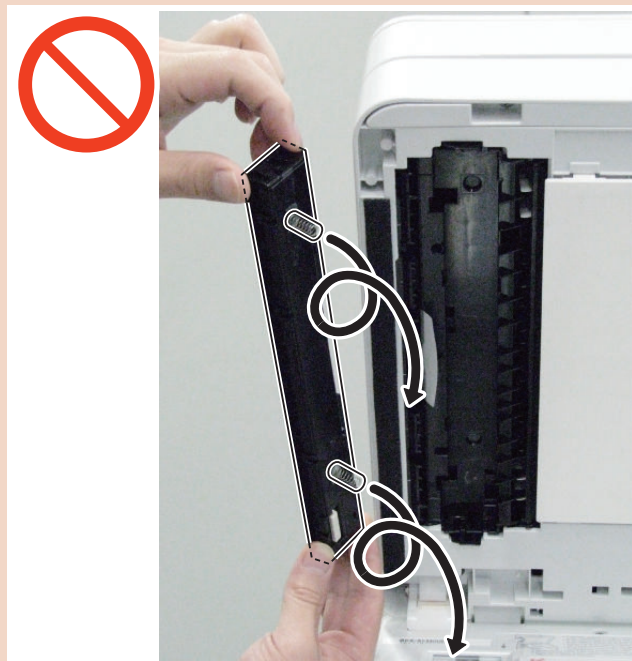

CAUTION:

When installing the ADF CIS Unit, be careful that the Guide Sheet does not get caught in the interior.



6. Place the ADF CIS Unit on clean paper with the glass surface side down.

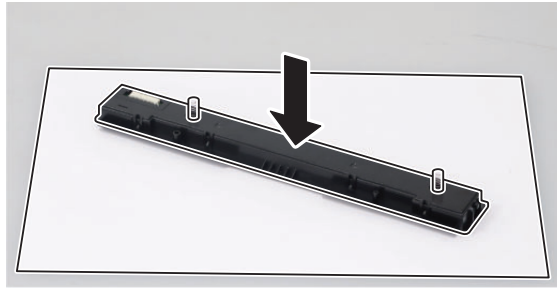

7. Remove the ADF CIS Unit Holder.

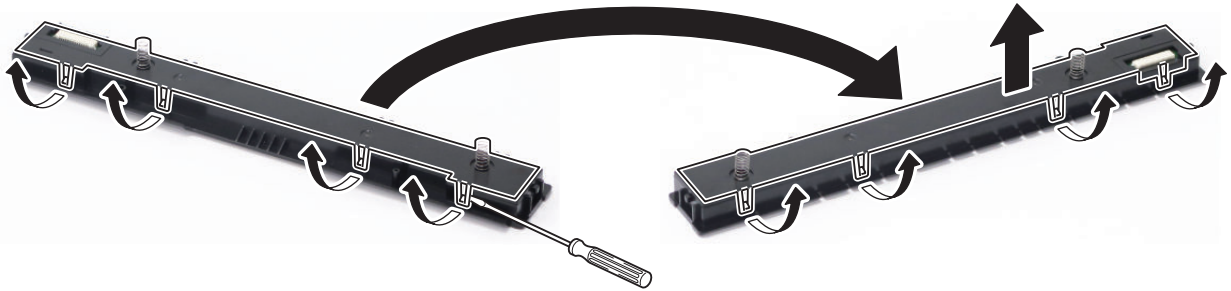

8. Remove the ADF CIS.

CAUTION:

Be sure not to touch the sensor of the ADF CIS.

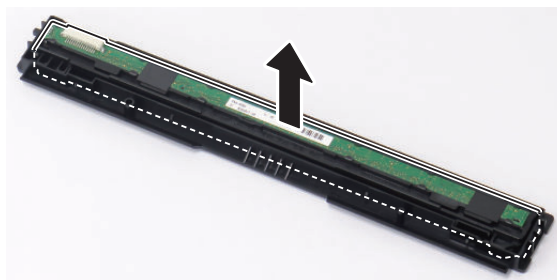

9. Actions after replacement: [“After Replacing the ADF CIS Unit” on page 212](#)

● Removing the ADF Drive Unit

■ Preparation

1. [“Removing the ADF Upper Cover Unit” on page 116](#)
2. [“Removing the ADF Feed Unit” on page 118](#)

■ Procedure

1. Remove the Leaf Spring.

NOTE:

Be sure to avoid touching grease as grease is applied to the A part.

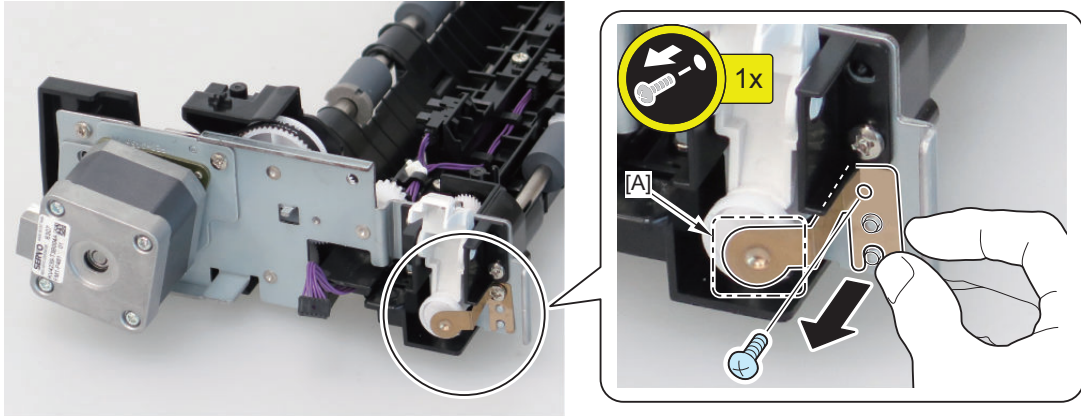

2. Remove the Pressure Release Lever.

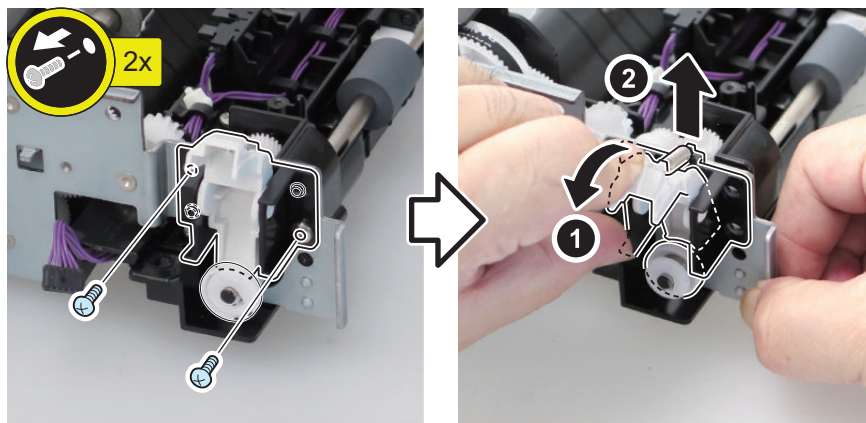

3. Remove the ADF Drive Unit.

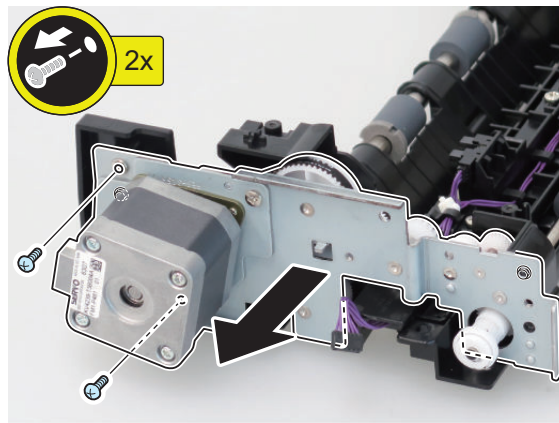

NOTE:

When installing the ADF Drive Unit, mount the lever on the bush.

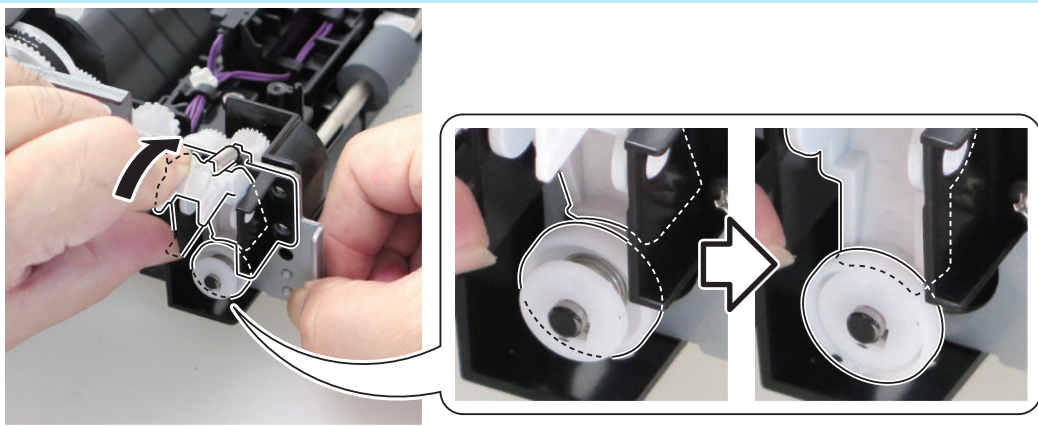

● Removing the Reader Upper Cover Unit

■ Preparation

1. "Removing the Toner Cartridge" on page 95
2. "Removing the Left Cover" on page 96
3. "Removing the Right Cover" on page 98
4. "Removing the ADF Unit + Reader Unit" on page 107
5. "Separating the ADF Unit + Reader Unit" on page 108

■ Procedure

CAUTION:

- Since the Copyboard Glass is included in the Reader Upper Cover Unit, replace the entire Reader Upper Cover Unit when replacing the Copyboard Glass.

1. Remove the Reader Upper Cover Unit.

CAUTION:

Do not touch the Copyboard Glass with your hands, as doing so will attach skin oil on it and cause image failure from soiling. If soiling is attached, wipe it with lint-free paper moistened.

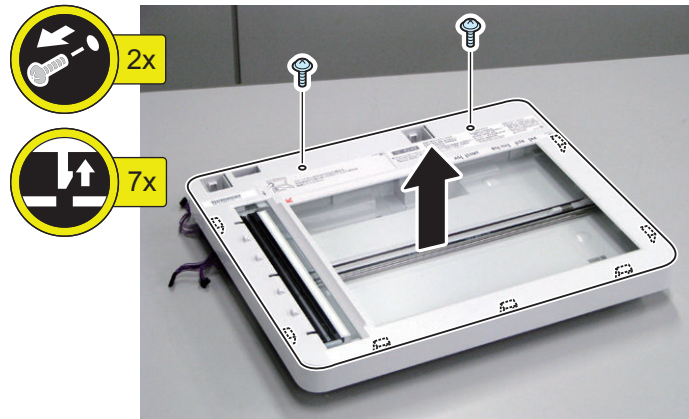

2. Actions after replacement: [“After Replacing the Reader Upper Cover Unit” on page 201](#)

● Removing the Reader CIS

■ Preparation

1. [“Removing the Toner Cartridge” on page 95](#)
2. [“Removing the Left Cover” on page 96](#)
3. [“Removing the Right Cover” on page 98](#)
4. [“Removing the ADF Unit + Reader Unit” on page 107](#)
5. [“Separating the ADF Unit + Reader Unit” on page 108](#)
6. [“Removing the Reader Upper Cover Unit” on page 125](#)

■ Procedure

1. Remove the Reader CIS Spacer.

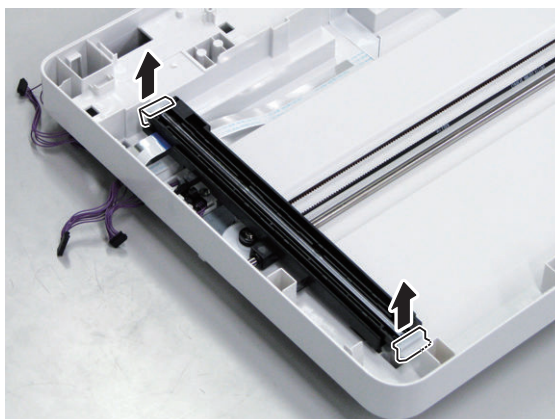

2. Remove the Flat Cable, and remove the Reader CIS Mounting Base from the Timing Belt.

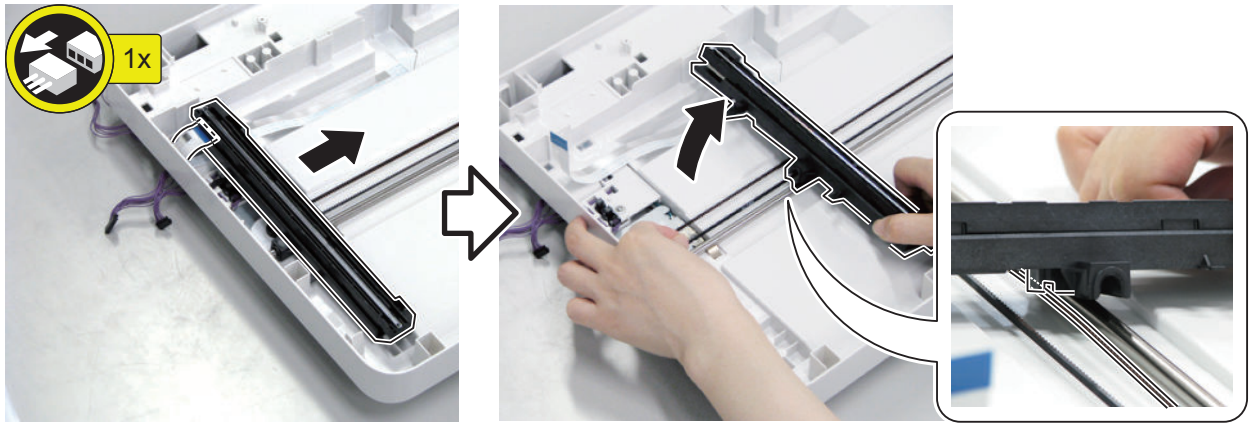

3. Lift up the Reader CIS, and remove it in the direction of the arrow. Be careful not to lose the springs.

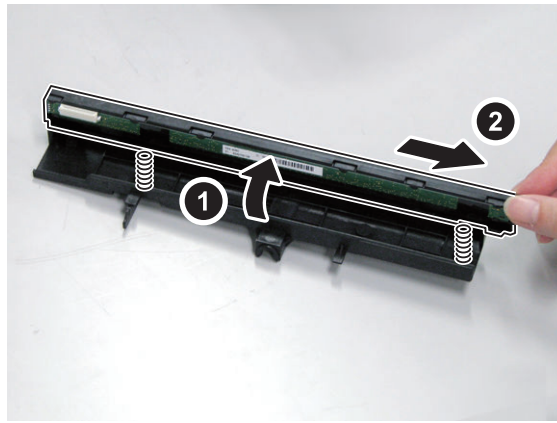

CAUTION:

Be sure not to touch the sensor of the Reader CIS.

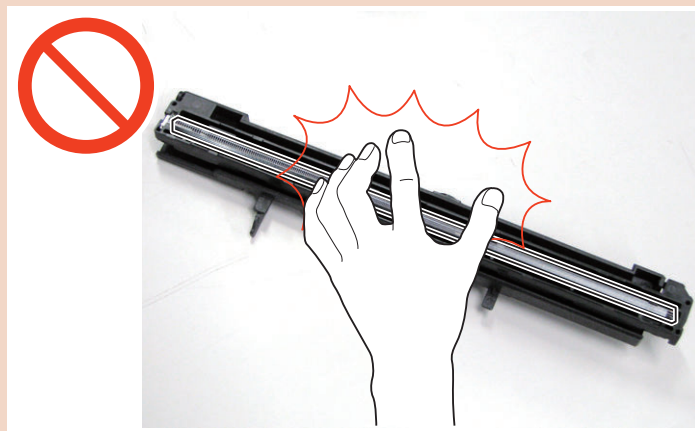

CAUTION:

When installing the Reader CIS, align the 2 shafts on the right and left, and confirm that the protrusions and grooves are properly fitted.

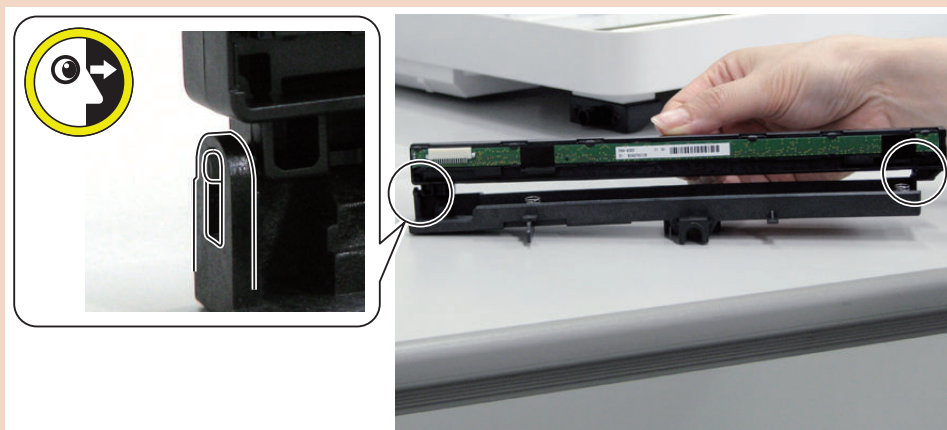

4. Actions after replacement: [“After Replacing the Reader CIS Unit” on page 198](#)

Removing the Reader CIS Timing Belt

■ Preparation

1. “Removing the Toner Cartridge” on page 95
2. “Removing the Left Cover” on page 96
3. “Removing the Right Cover” on page 98
4. “Removing the ADF Unit + Reader Unit” on page 107
5. “Separating the ADF Unit + Reader Unit” on page 108
6. “Removing the Reader Upper Cover Unit” on page 125
7. “Removing the Reader CIS” on page 126

■ Procedure

1. Remove the [A] part of the belt from the gear.



Removing the Reader Scanner Motor

■ Preparation

1. “Removing the Toner Cartridge” on page 95
2. “Removing the Left Cover” on page 96
3. “Removing the Right Cover” on page 98
4. “Removing the ADF Unit + Reader Unit” on page 107
5. “Separating the ADF Unit + Reader Unit” on page 108
6. “Removing the Reader Upper Cover Unit” on page 125
7. “Removing the Reader CIS” on page 126
8. “Removing the Reader CIS Timing Belt” on page 129

■ Procedure

1. Disconnect the connector and free the harness from the Harness Guide on the back side of the Reader Unit.

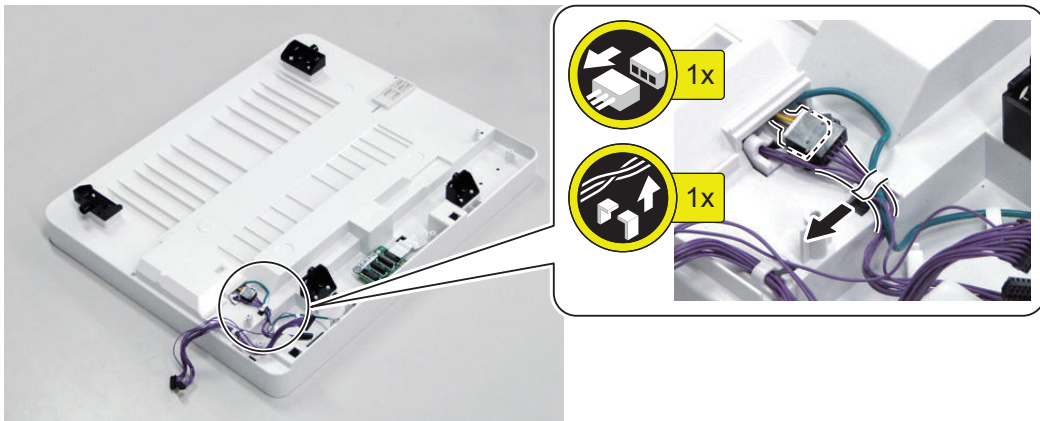

2. Turn it over so that the front side is facing up, and remove the Sensor Mounting Base.

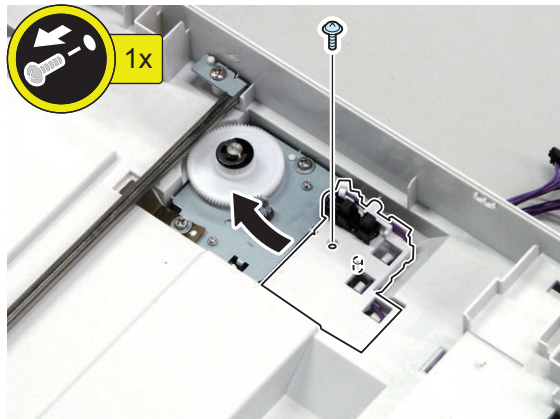

3. Remove the Motor Unit.

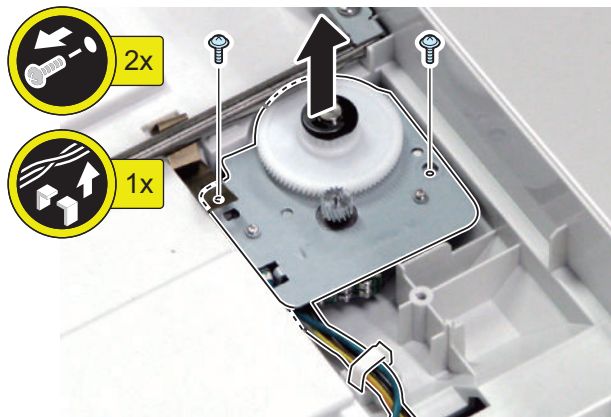

Controller System

● Removing the Controller Cover

■ Preparation

1. "Removing the Toner Cartridge" on page 95
2. "Removing the Left Cover" on page 96

■ Procedure

1. Remove the Controller Cover.

<If the Fax is installed>

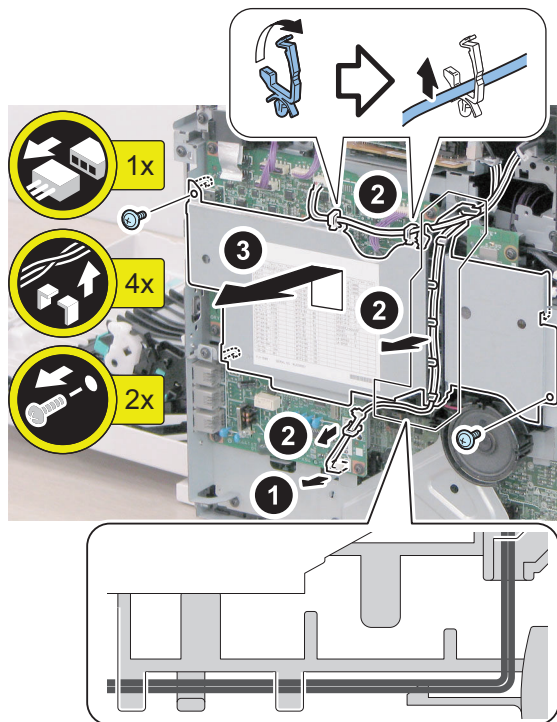

<If the Fax is not installed>

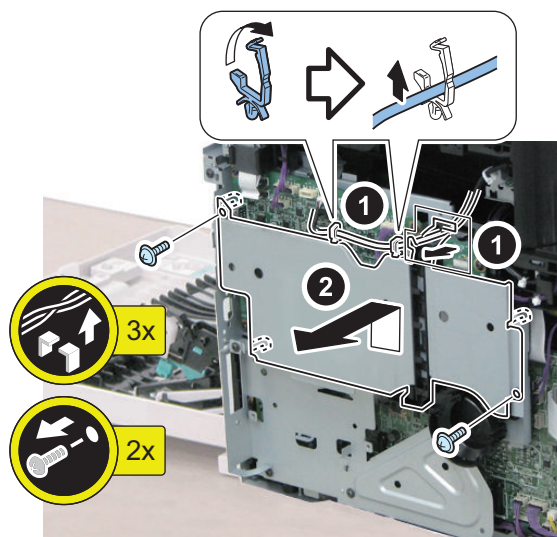

● Removing the Wireless LAN PCB (Wi-Fi model only)

■ Preparation

1. “Removing the Toner Cartridge” on page 95
2. “Removing the Left Cover” on page 96
3. “Removing the Controller Cover ” on page 131

■ Procedure

1. Remove the Wireless LAN PCB.

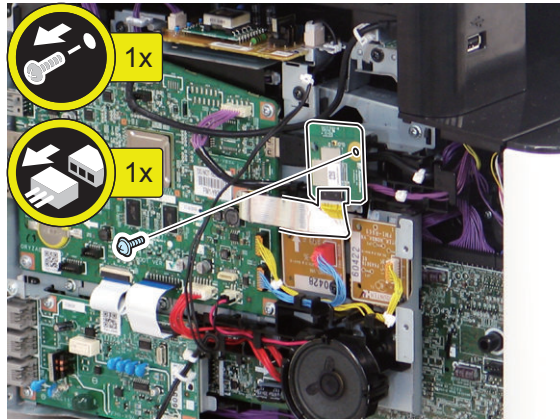

● Removing the Wireless LAN Support Plate (Wi-Fi model only)

■ Preparation

1. “Removing the Toner Cartridge” on page 95
2. “Removing the Left Cover” on page 96
3. “Removing the Controller Cover ” on page 131
4. “Removing the Wireless LAN PCB (Wi-Fi model only)” on page 132

■ Procedure

1. Remove the Wireless LAN Support Plate.

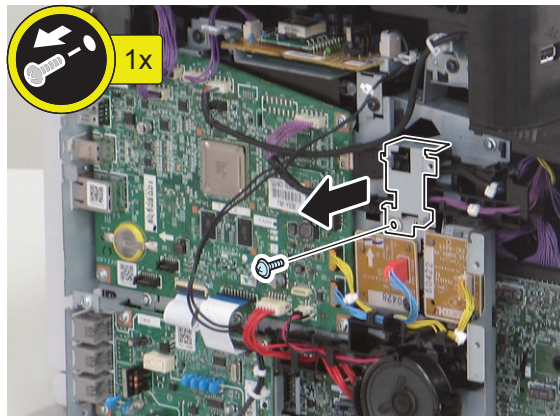

Removing the Main Controller PCB

Preparation

CAUTION:

Make sure to perform “Before Replacing the Main Controller PCB” on page 187 before replacing the Main Controller PCB.

1. “Removing the Toner Cartridge” on page 95
2. “Removing the Left Cover” on page 96
3. “Removing the Controller Cover ” on page 131

Procedure

1. Disconnect all connectors from the Main Controller PCB and then remove the PCB.

<MF744Cdw>

<MF743Cdw>

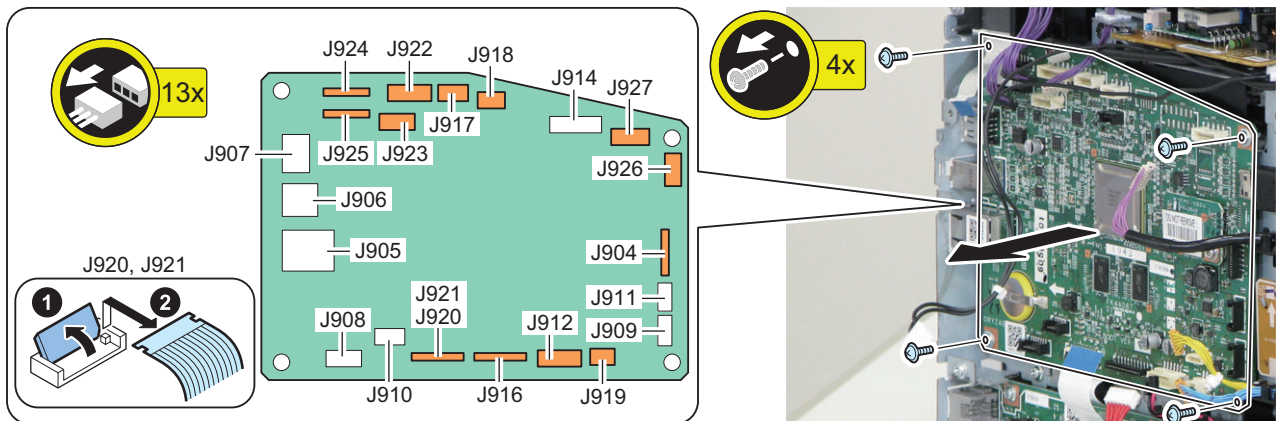

<MF742Cdw>

<MF741Cdw>

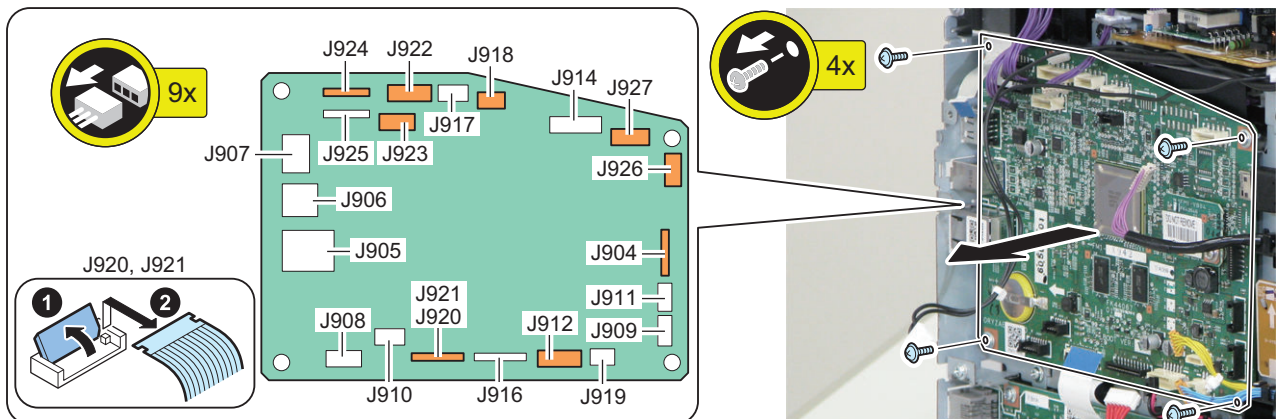

2. Actions after replacement: “After Replacing the Main Controller PCB” on page 188

Removing the Main Controller Support Plate

Preparation

1. “Removing the Toner Cartridge” on page 95
2. “Removing the Left Cover” on page 96
3. “Removing the Controller Cover ” on page 131
4. “Removing the Main Controller PCB” on page 133

5. “Removing the Wireless LAN Support Plate (Wi-Fi model only)” on page 132

■ Procedure

1. Remove the Main Controller Support Plate.

In the case of simplex ADF model, there is one Flat Cable.

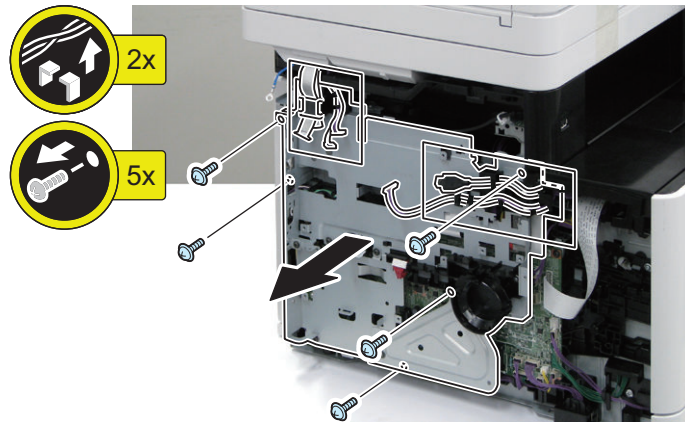

● Removing the Engine Controller PCB

■ Preparation

CAUTION:

Make sure to perform “Before Replacing the Engine Controller PCB” on page 187 before replacing the Engine Controller PCB.

1. “Removing the Toner Cartridge” on page 95
2. “Removing the Left Cover” on page 96
3. “Removing the Controller Cover ” on page 131
4. “Removing the Main Controller PCB” on page 133
5. “Removing the Wireless LAN Support Plate (Wi-Fi model only)” on page 132
6. “Removing the Main Controller Support Plate” on page 133

■ Procedure

1. Remove the Engine Controller PCB.

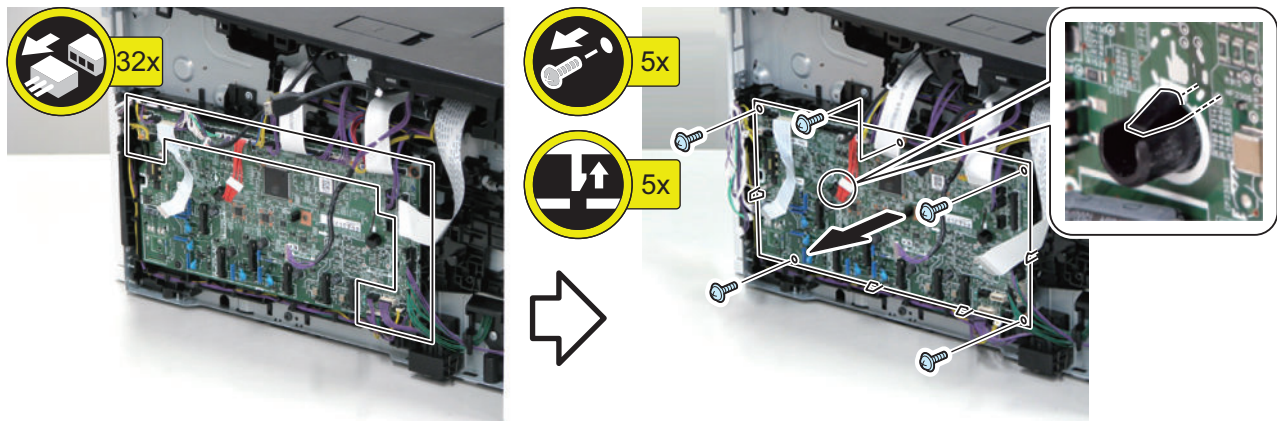

CAUTION:

When installing it, be sure that the flag of the microswitch is in the correct position.

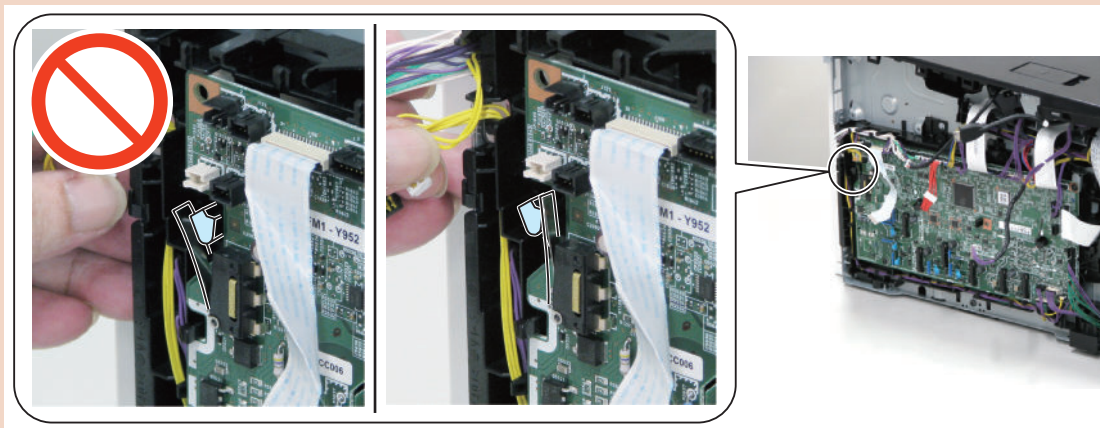

2. Actions after replacement: [“After Replacing the Engine Controller PCB” on page 187](#)

● Removing the Low Voltage Power Supply Unit

■ Preparation

1. [“Removing the Toner Cartridge” on page 95](#)
2. [“Removing the Right Cover” on page 98](#)

■ Procedure

1. Remove the Power Supply Fan Unit.

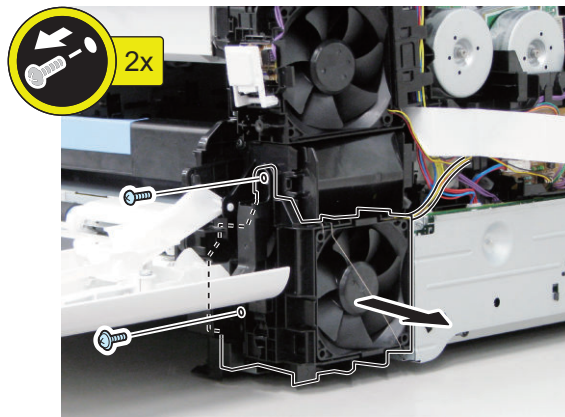

2. Remove the Low Voltage Power Supply Unit.

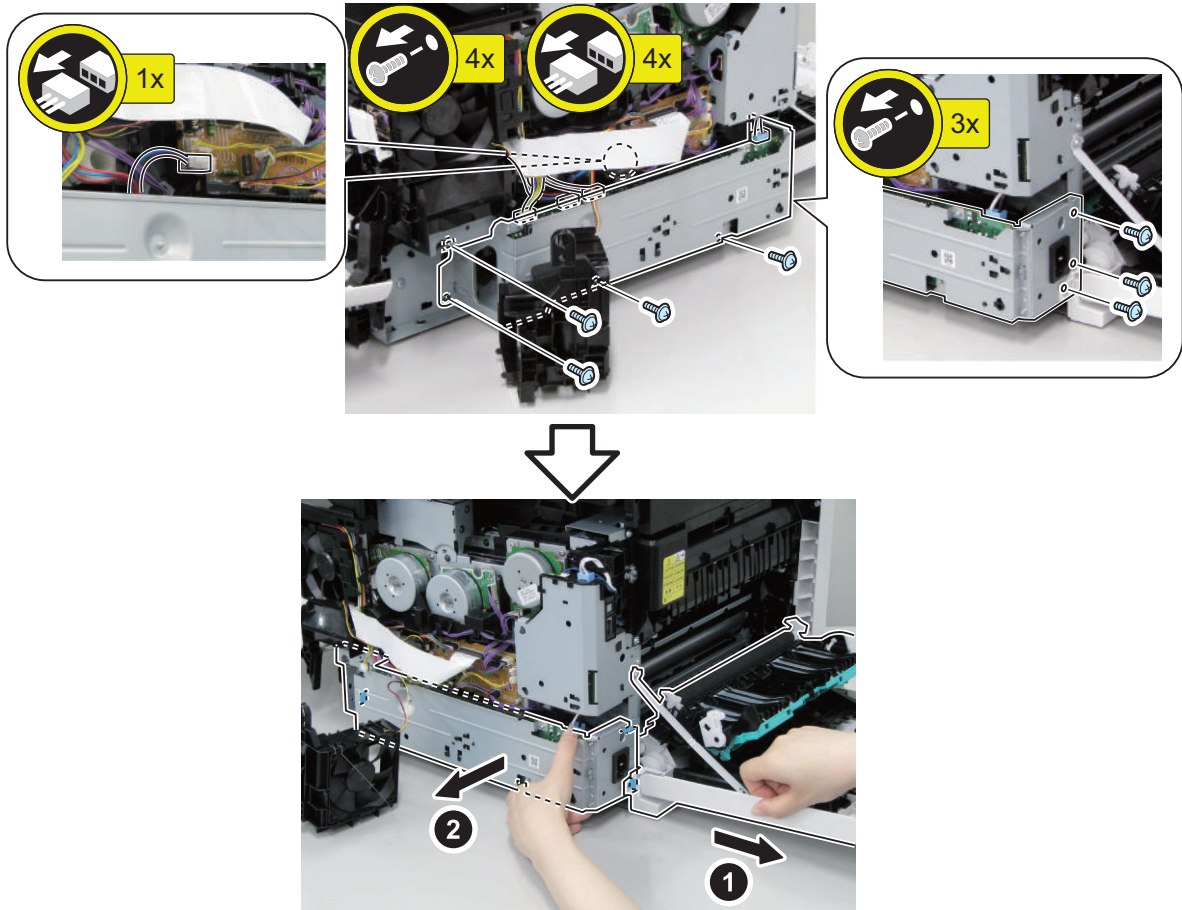

● Removing the Control Panel Unit

■ Procedure

1. Remove the Panel Arm Cover (Middle).



2. Remove the Panel Arm Right Cover and Panel Arm Left Cover.



3. Remove the Panel Rear Upper Cover.

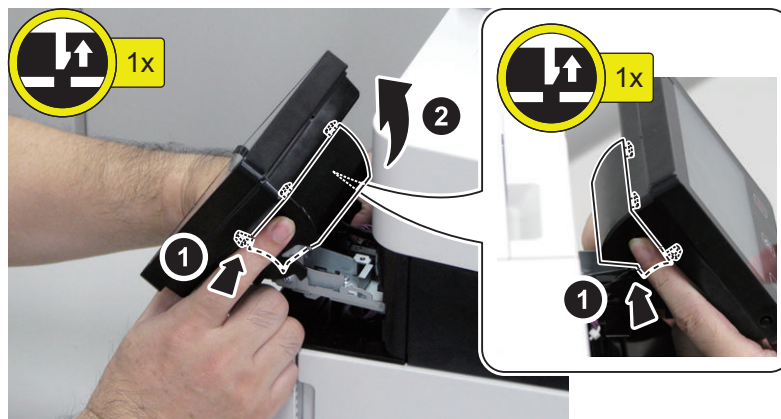

4. Remove the Panel Front Lower Cover.

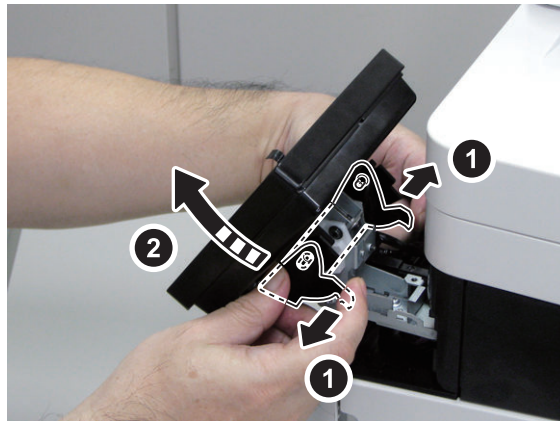

5. Remove the Control Panel.

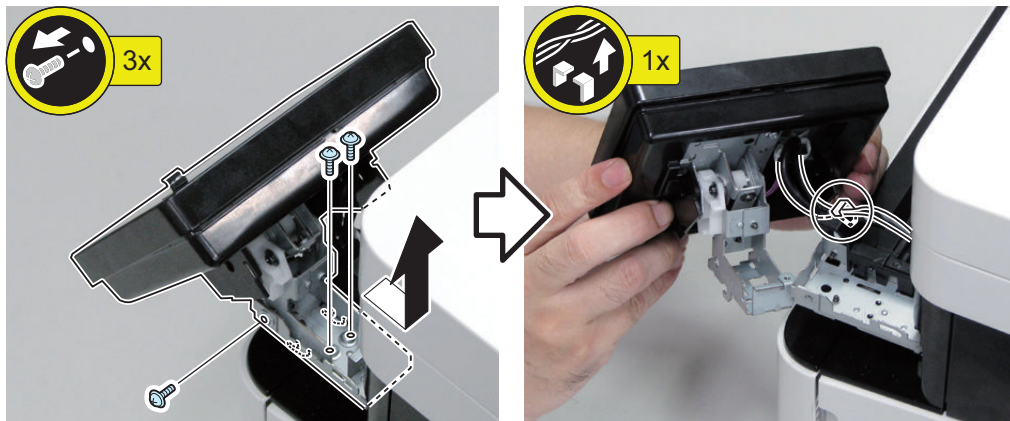

6. Remove the Panel Rear Lower Cover. Disconnect the connector and HDMI Cable, and free the harness from the Wire Saddle.

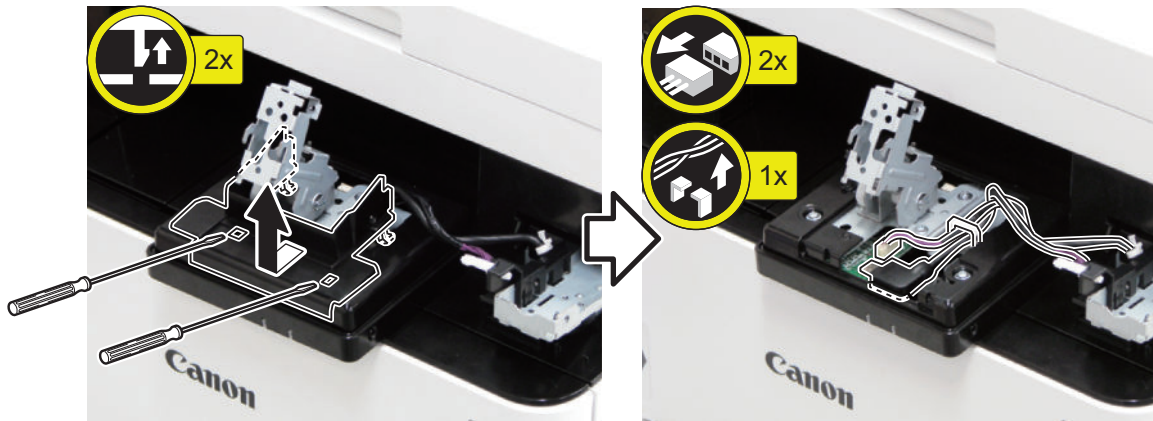

7. Remove the Panel Rear Cover.

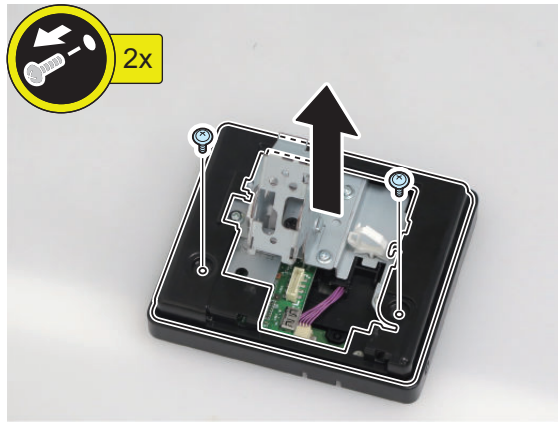

8. Remove the Hinge Unit.

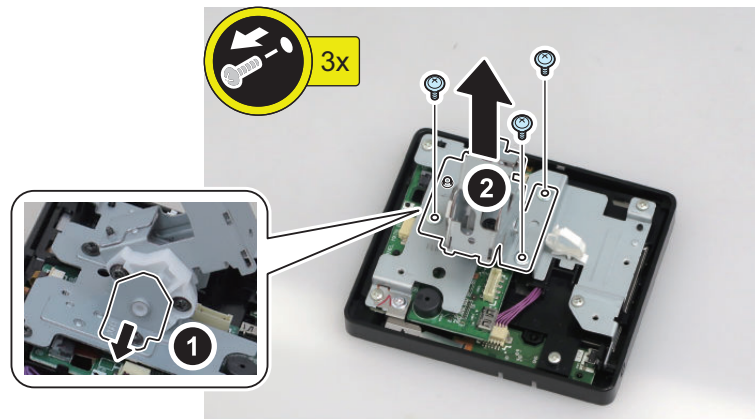

9. Actions after replacement: [“After Replacing the Control Panel”](#) on page 187

● Removing the OFF Hook PCB (Fax model only)

■ Preparation

1. [“Removing the Toner Cartridge”](#) on page 95
2. [“Removing the Left Cover”](#) on page 96

■ Procedure

1. Remove the OFF Hook PCB Unit.

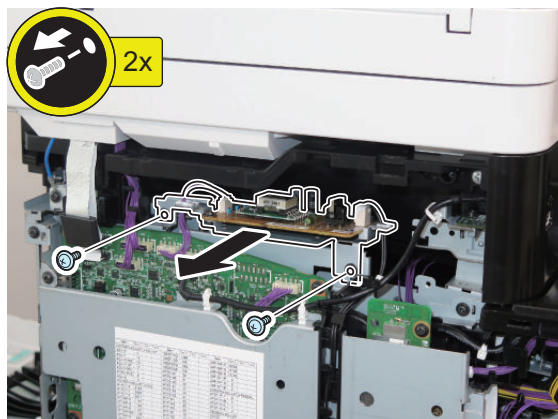

2. Remove the Connectors and the Edge Saddles.

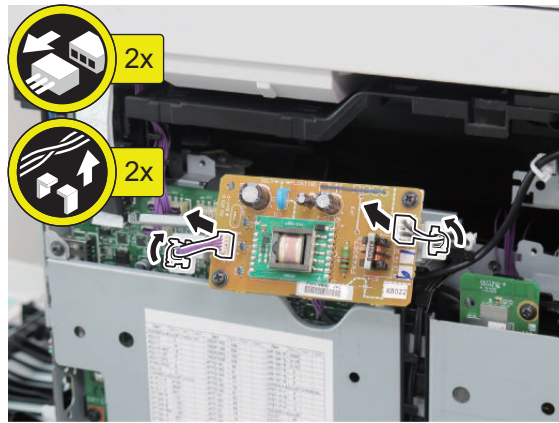

3. Remove the OFF Hook PCB.

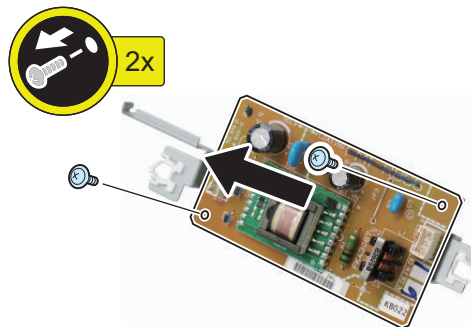

● Removing the NCU PCB (Fax model only)

■ Preparation

1. "Removing the Toner Cartridge" on page 95
2. "Removing the Left Cover" on page 96

■ Procedure

1. Remove the NCU PCB.

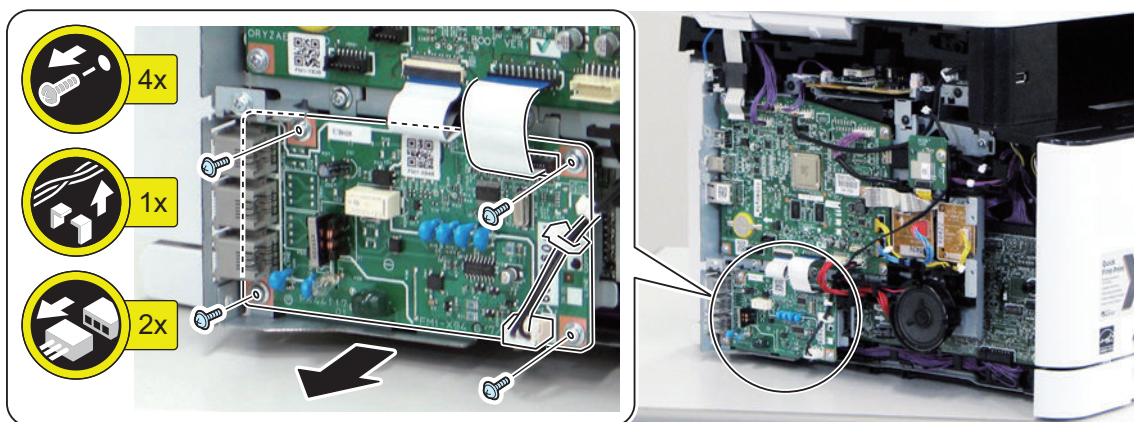

● Removing the Speaker (Fax model only)

■ Preparation

1. "Removing the Toner Cartridge" on page 95

2. “Removing the Left Cover” on page 96
3. “Removing the Controller Cover ” on page 131

■ Procedure

1. Remove the Speaker.

CAUTION:

- Do not directly touch the speaker of the Fax Unit.
- Be sure not to damage the speaker.

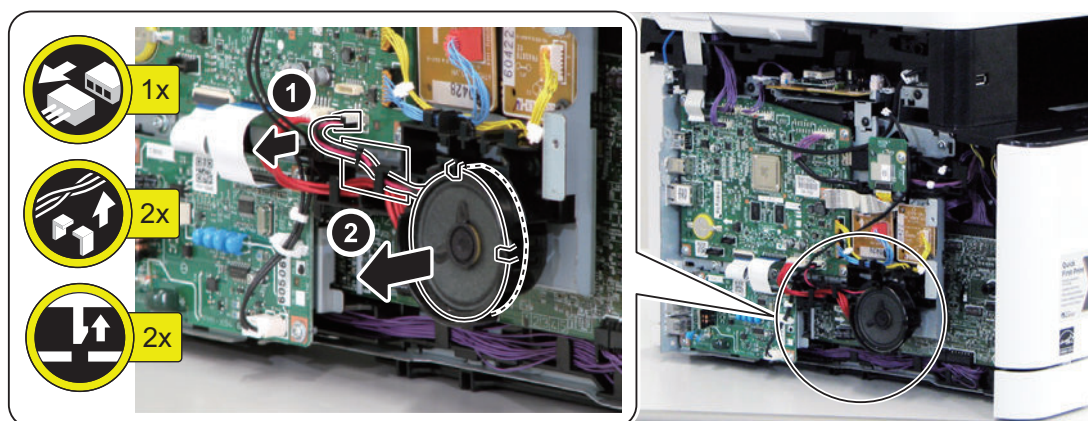
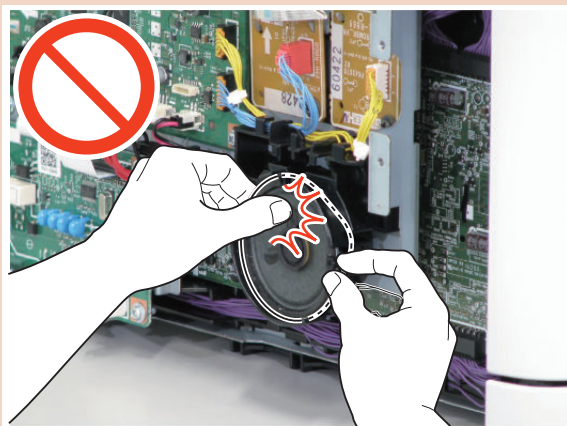

● Removing the USB PCB

■ Preparation

1. “Removing the Toner Cartridge” on page 95
2. “Removing the Left Cover” on page 96
3. “Removing the Right Cover” on page 98
4. “Removing the ADF Unit + Reader Unit” on page 107
5. “Removing the Upper Front Cover” on page 104
6. “Removing the Upper Left Front Cover” on page 105
7. “Removing the Upper Right Front Cover” on page 105
8. “Removing the Control Panel Unit” on page 137
9. “Removing the Upper Cover Unit ” on page 106

■ Procedure

1. Remove the USB PCB Unit.

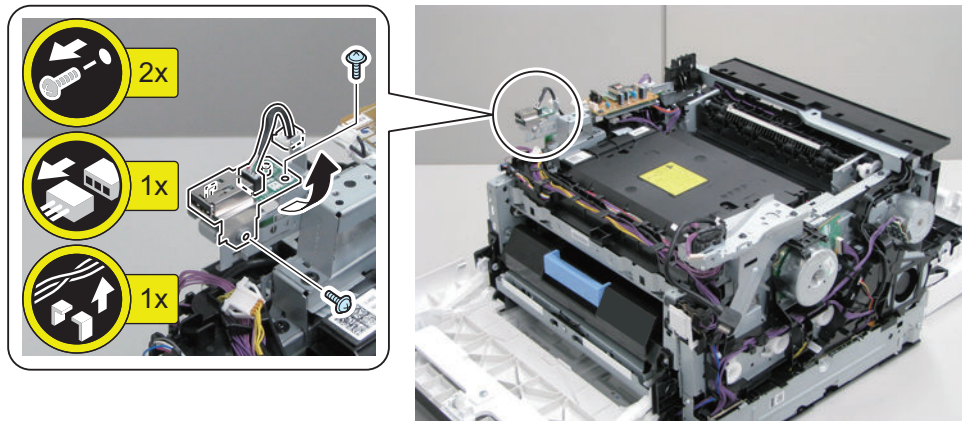

2. Remove the USB Connector Cover.

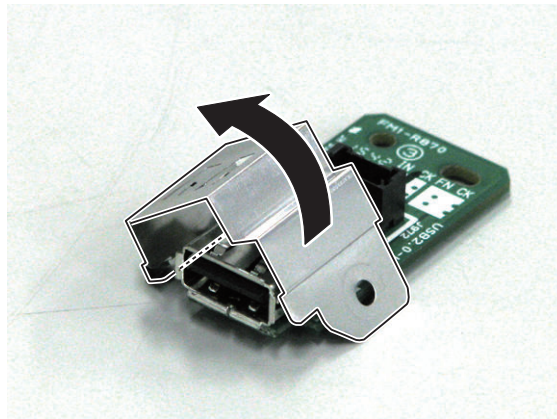

● Removing the Cartridge Fan

■ Preparation

1. "Removing the Toner Cartridge" on page 95
2. "Removing the Right Cover" on page 98

■ Procedure

1. Remove the Cartridge Fan.

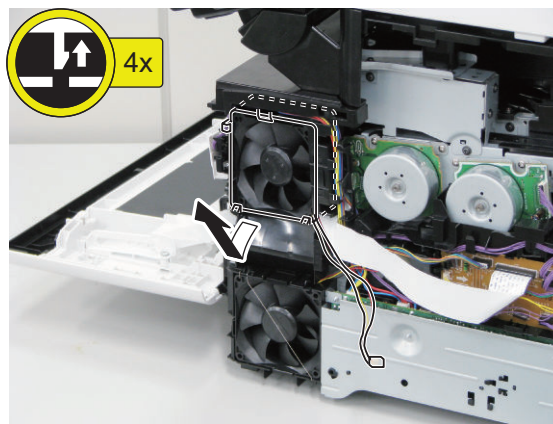
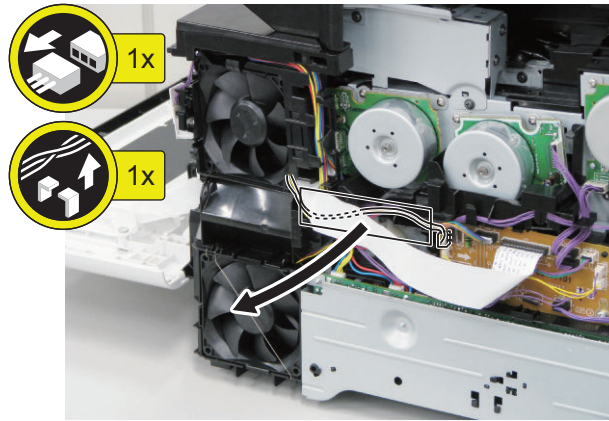

● Removing the Power Supply Fan

■ Preparation

1. "Removing the Toner Cartridge" on page 95
2. "Removing the Right Cover" on page 98

■ Procedure

1. Remove the Power Supply Fan.

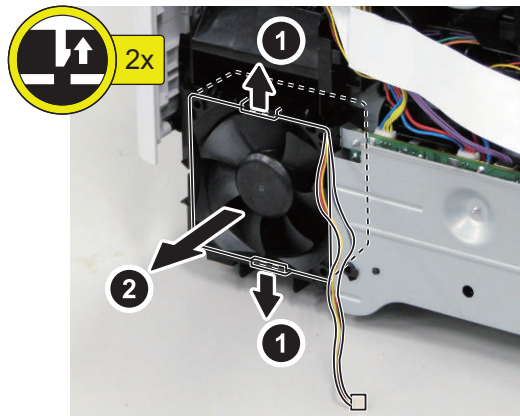
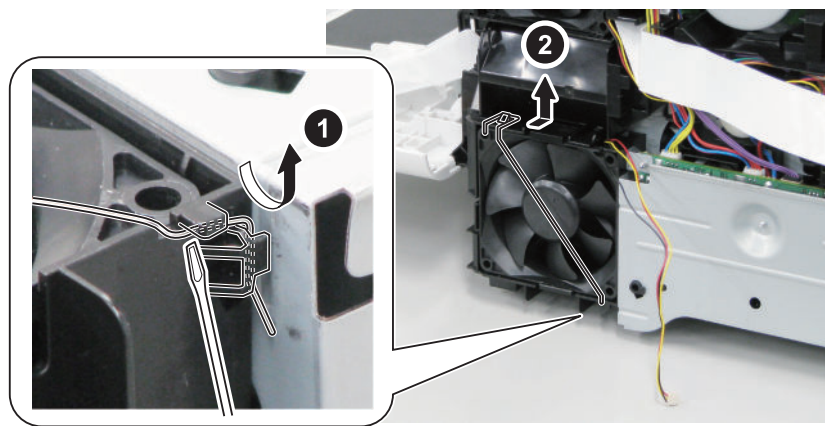
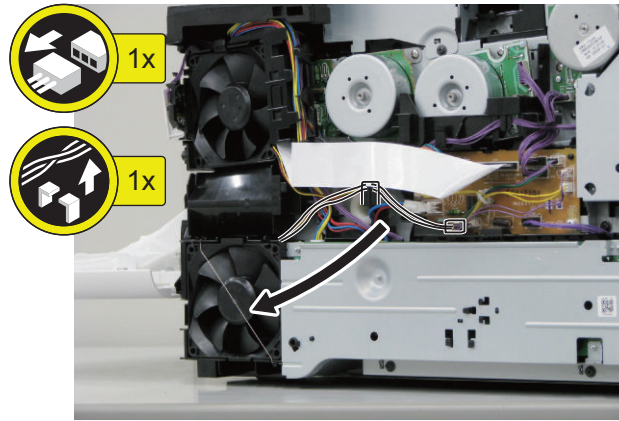

● Removing the Driver PCB

■ Preparation

1. "Removing the Toner Cartridge" on page 95
2. "Removing the Right Cover" on page 98

■ Procedure

1. Remove the Driver PCB.

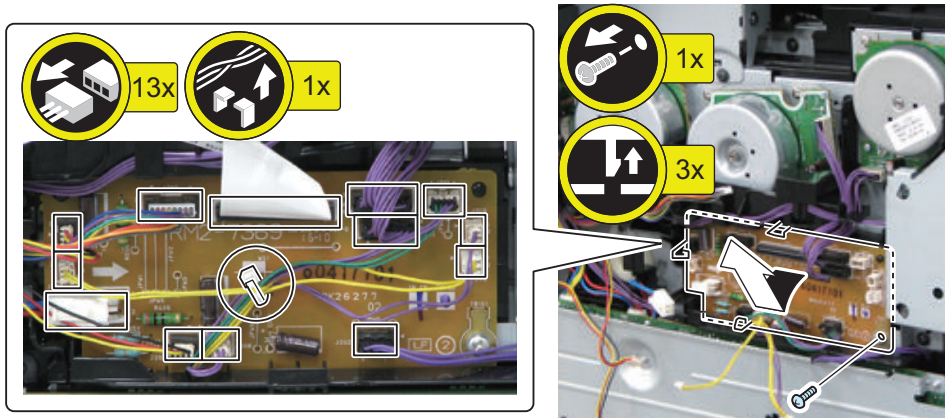

● Removing the Power Switch Unit

■ Preparation

1. “Removing the Toner Cartridge” on page 95
2. “Removing the Right Cover” on page 98

■ Procedure

1. Remove the Power Switch Unit.

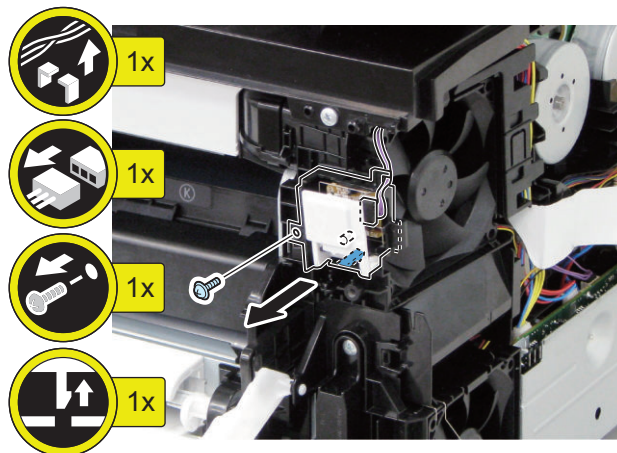

● Removing the Environment Sensor

■ Preparation

1. “Removing the Toner Cartridge” on page 95
2. “Removing the Left Cover” on page 96

■ Procedure

1. Remove the Environment Sensor.

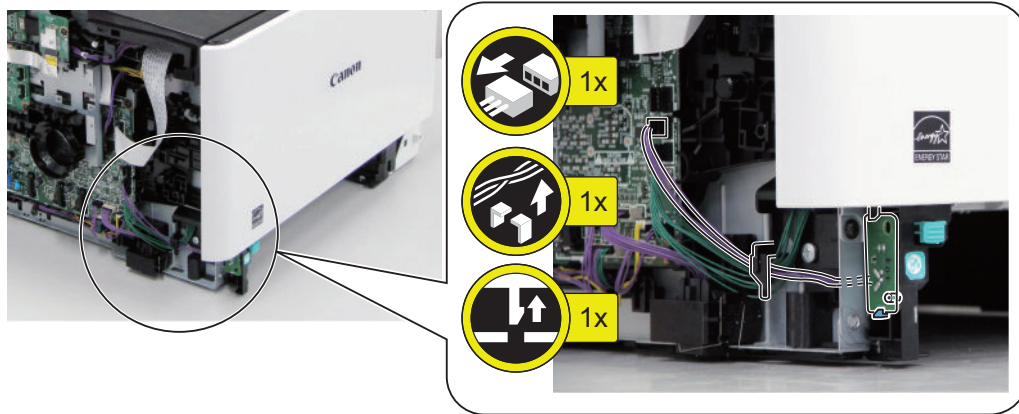

2. Remove the Harness.

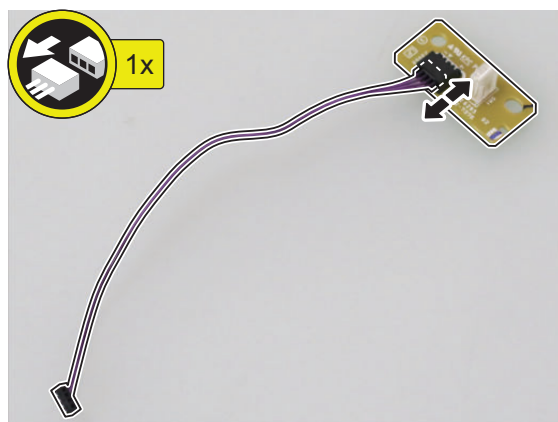

● Removing the Memory Relay PCB

■ Preparation

1. "Removing the Toner Cartridge" on page 95
2. "Removing the Right Cover" on page 98
3. "Removing the Left Cover" on page 96
4. "Removing the ADF Unit + Reader Unit" on page 107
5. "Removing the Upper Front Cover" on page 104
6. "Removing the Upper Left Front Cover" on page 105
7. "Removing the Upper Right Front Cover" on page 105
8. "Removing the Control Panel Unit" on page 137
9. "Removing the Upper Cover Unit" on page 106

■ Procedure

1. Remove the Memory Relay PCB.

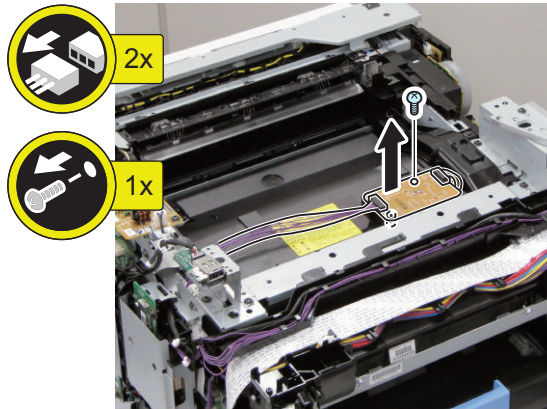

Laser Exposure System

● Removing the Laser Scanner Unit

■ Preparation

1. “Removing the Toner Cartridge” on page 95
2. “Removing the Left Cover” on page 96
3. “Removing the Right Cover” on page 98
4. “Removing the ADF Unit + Reader Unit” on page 107
5. “Removing the Upper Front Cover” on page 104
6. “Removing the Upper Left Front Cover” on page 105
7. “Removing the Upper Right Front Cover” on page 105
8. “Removing the Control Panel Unit” on page 137
9. “Removing the Upper Cover Unit ” on page 106
10. “Removing the Controller Cover ” on page 131
11. “Removing the Main Controller PCB” on page 133
12. “Removing the Wireless LAN Support Plate (Wi-Fi model only)” on page 132
13. “Removing the Main Controller Support Plate” on page 133
14. “Removing the USB PCB” on page 141

■ Procedure

1. Remove the USB Mounting Base.

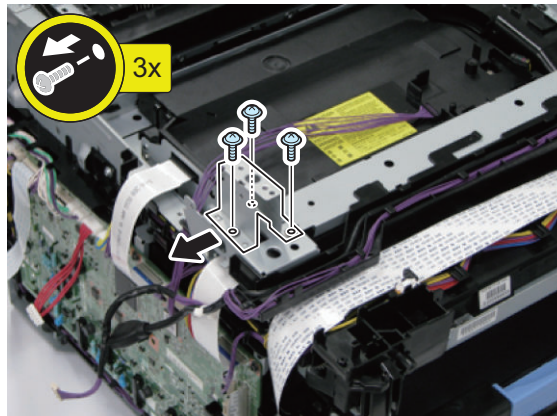

2. Remove the Laser Unit Upper Plate and Touch Panel Support Base.

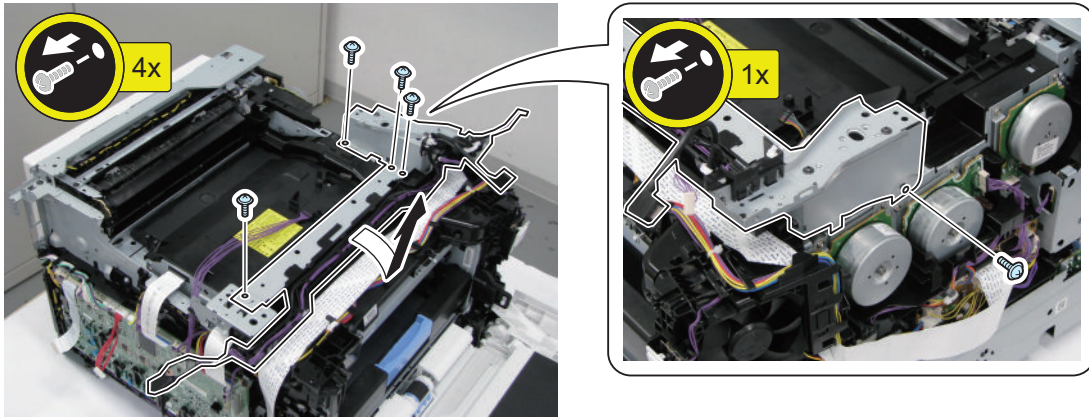

3. Remove the USB Mounting Plate.

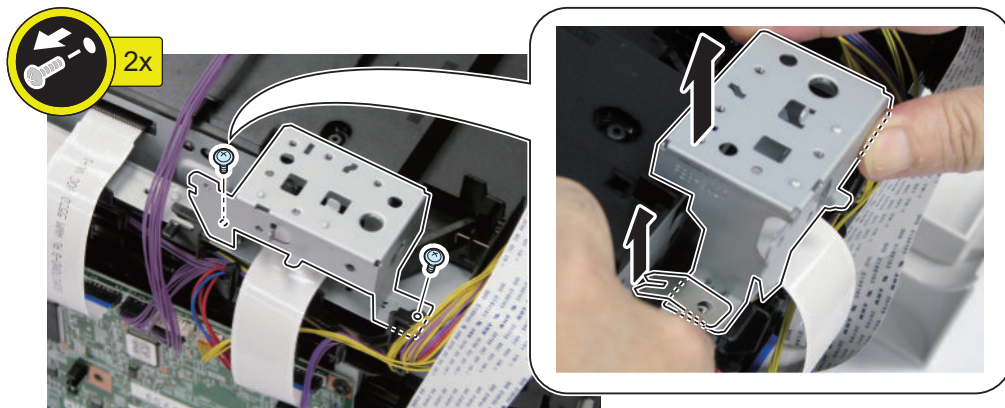

4. Disconnect the connector.

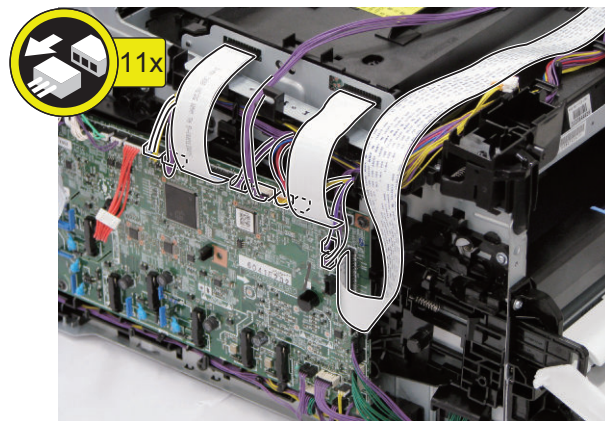

5. Remove the Memory Relay PCB.

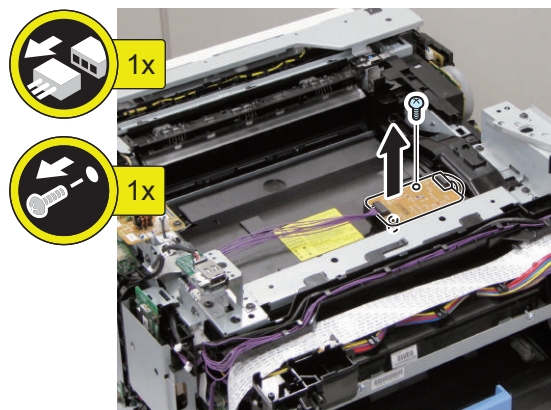

6. Free the harness.

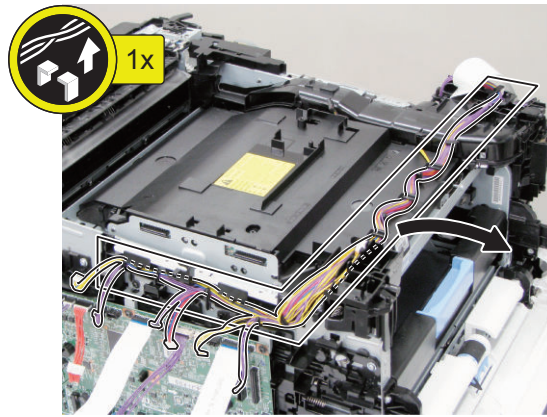

7. Remove the Laser Shutter Open/Close Detection Unit.

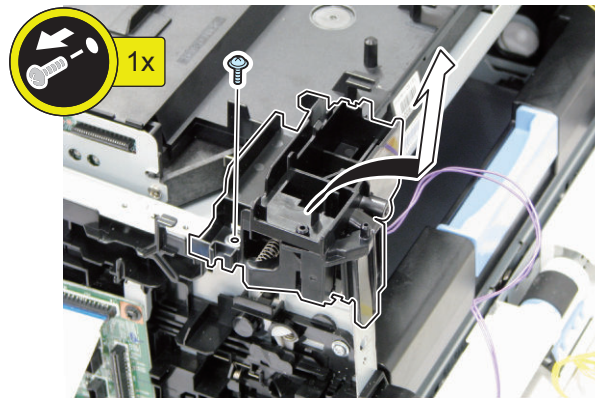

NOTE:

When installing it, be sure that the L-shaped wire is placed on the Shutter Lever of the Laser Unit.

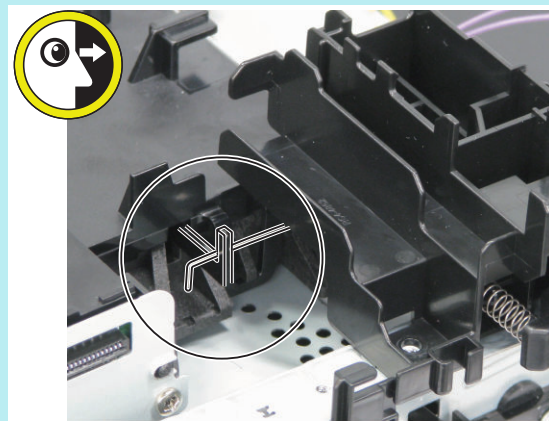

8. Remove the Gear Cover and then remove the Cover under the Gear Cover.

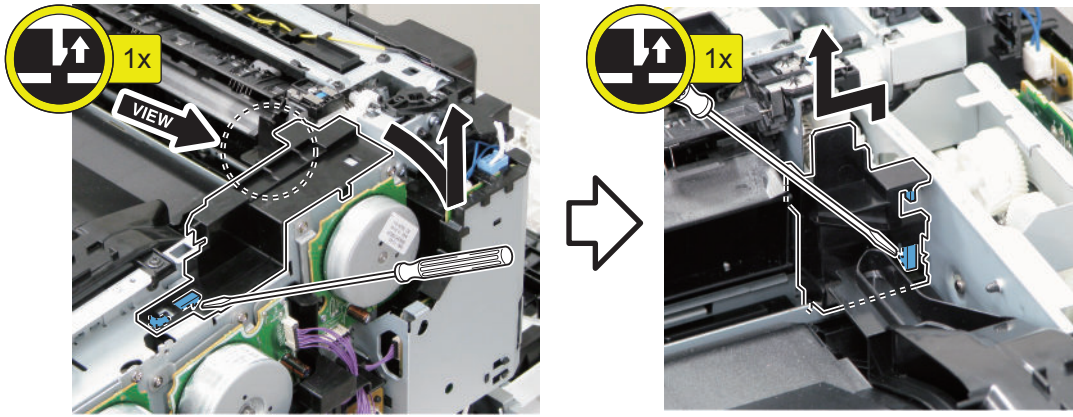

9. Remove the Duct Cover.

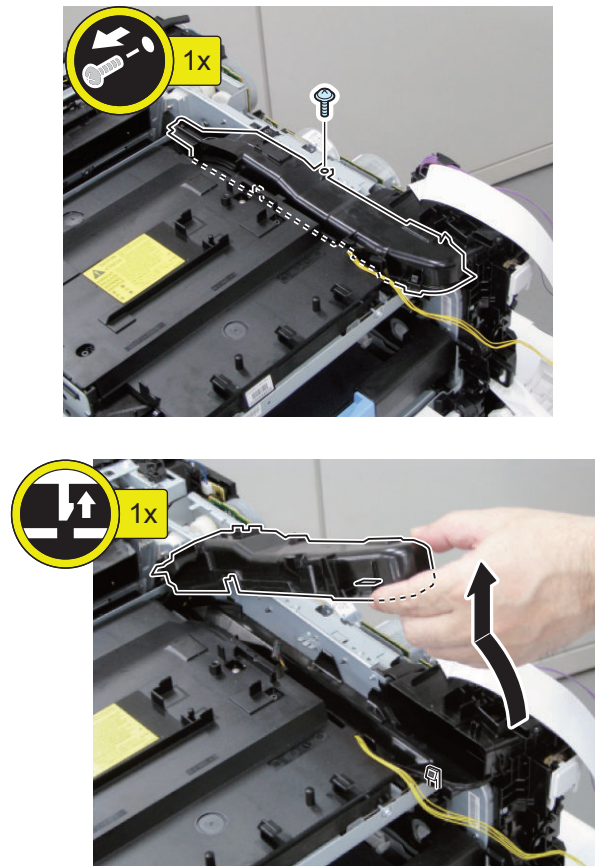

10. Loosen the screws, and remove the Laser Scanner Unit Fixation Pins.

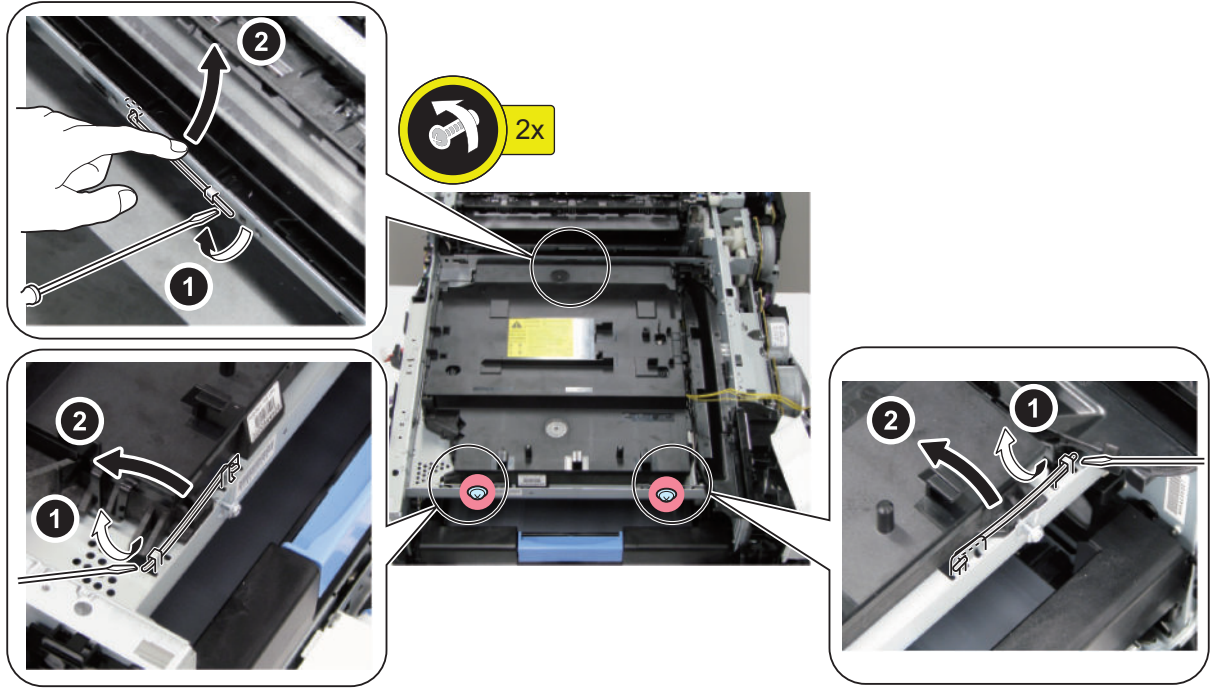

11. Remove the Laser Scanner Unit.

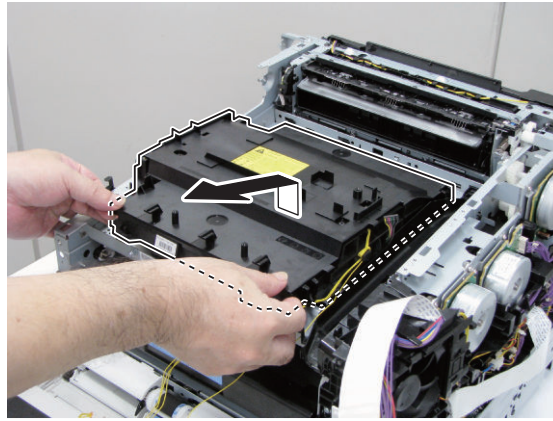

CAUTION:

Points to Note at Installation

- Insert the bosses into the positioning holes, and check that the Laser Unit is correctly positioned.
- Be sure that the Laser Unit is properly pushed down and secured with the 3 Fixation Pins. Also be sure that the Fixation Pins are securely fitted and will not come off.

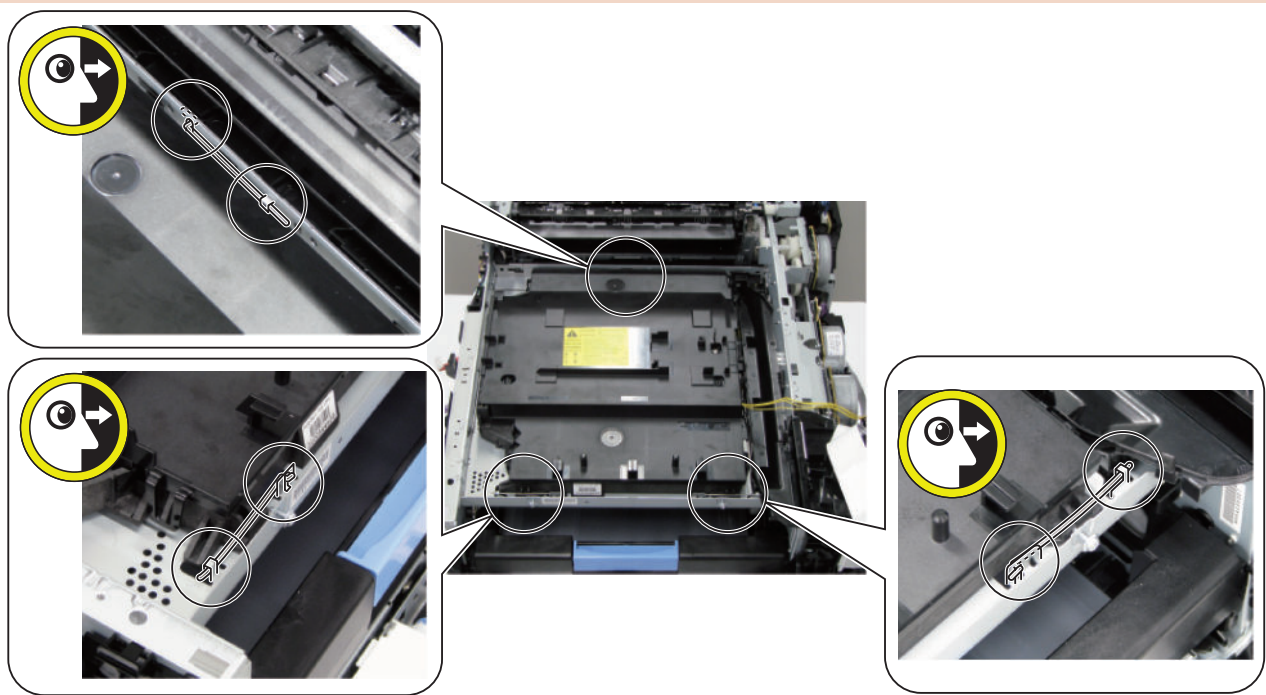
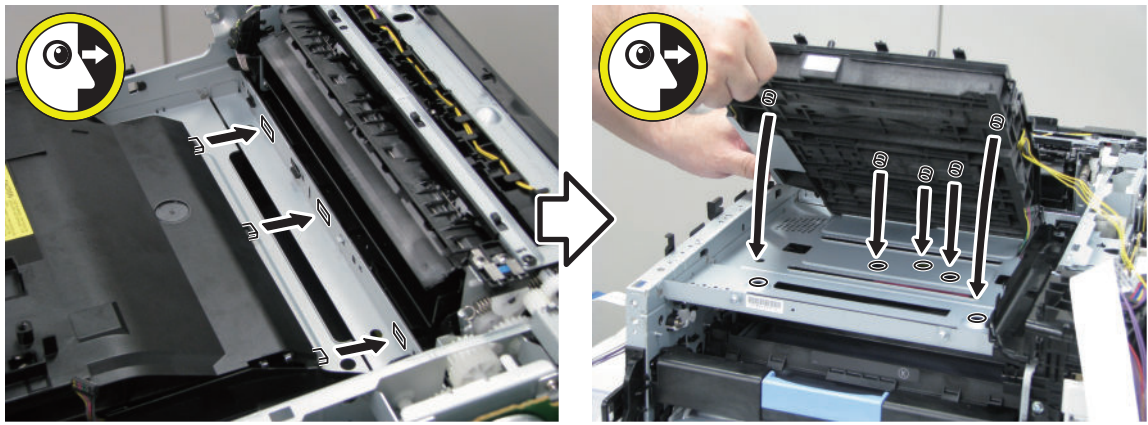

Image Formation System

● Removing the Main Drive Assembly

■ How to handle the Main Drive Assembly

CAUTION:

Do not disassemble the Main Drive Assembly as it cannot be rebuilt after the disassembly.

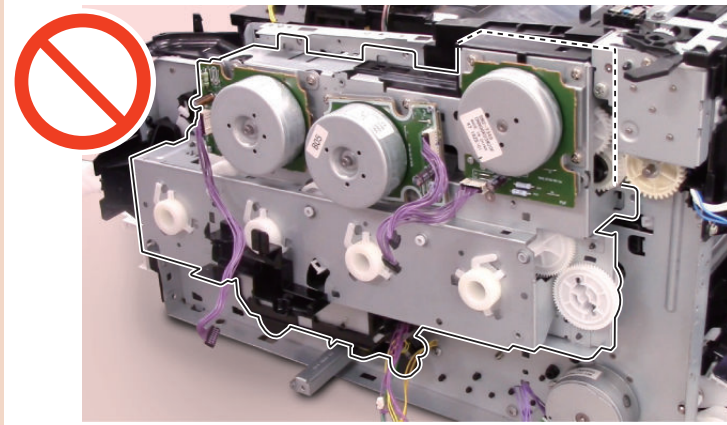

● Removing the Secondary Transfer Roller

■ Preparation

1. "Removing the Toner Cartridge" on page 95

■ Procedure

CAUTION:

Do not touch the surface of the Secondary Transf

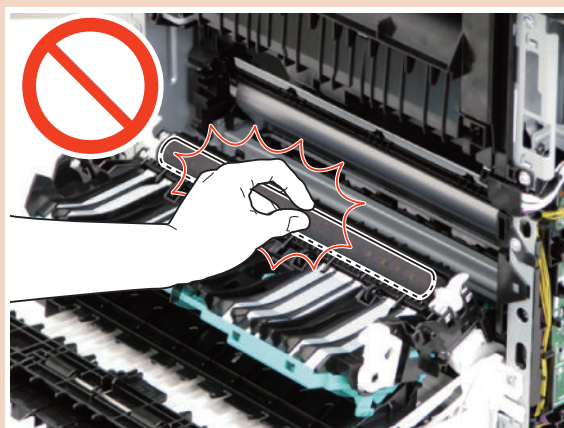

1. Open the Rear Cover Unit and the Secondary Transfer Feed Unit.

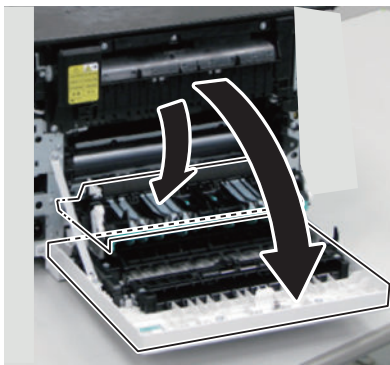

2. Remove the Secondary Transfer Roller.

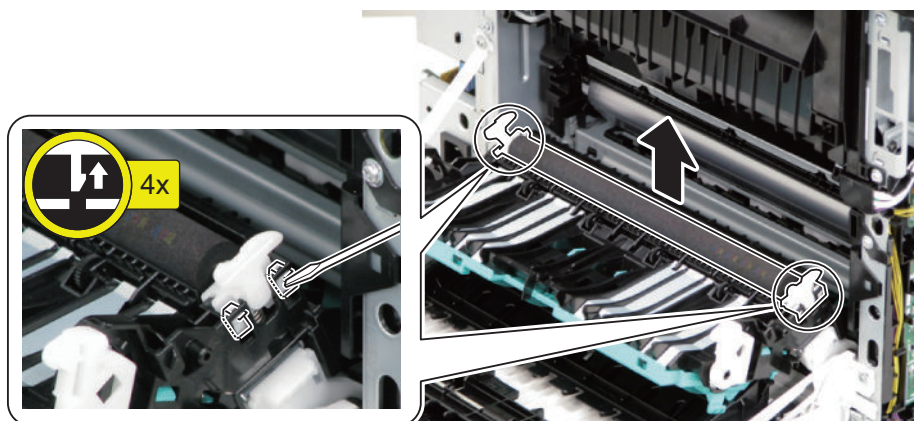

● Removing the Secondary Transfer Feed Unit

■ Preparation

1. "Removing the Toner Cartridge" on page 95
2. "Removing the Left Cover" on page 96
3. "Removing the Right Cover" on page 98
4. "Removing the Rear Cover Unit" on page 100

■ Procedure

1. Remove the Shaft Spacer on the rear left side.

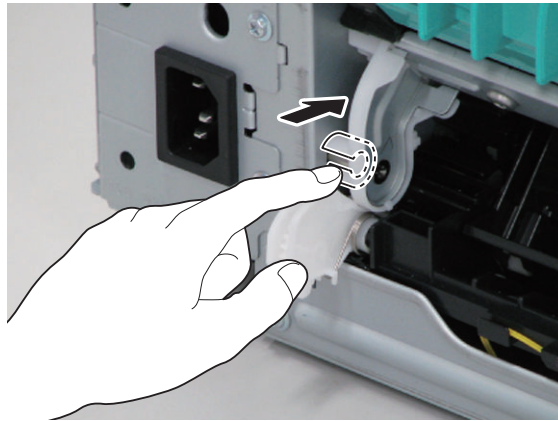

NOTE:

When installing the Shaft Spacer, install it with the Secondary Transfer Feed Unit opened. Be sure to check the installation position of the stopper.

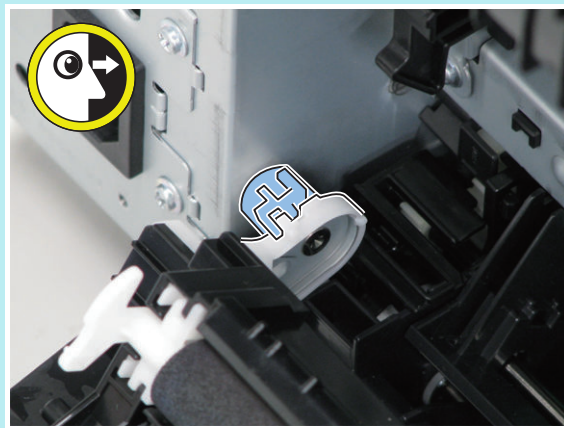

2. Open the Secondary Transfer Feed Unit, and then remove the Secondary Transfer Feed Unit.

NOTE:

Remove the Secondary Transfer Feed Unit by lifting the whole unit and moving it to the left while pushing down the gear on the left with a finger so that the gear does not interfere with the unit.

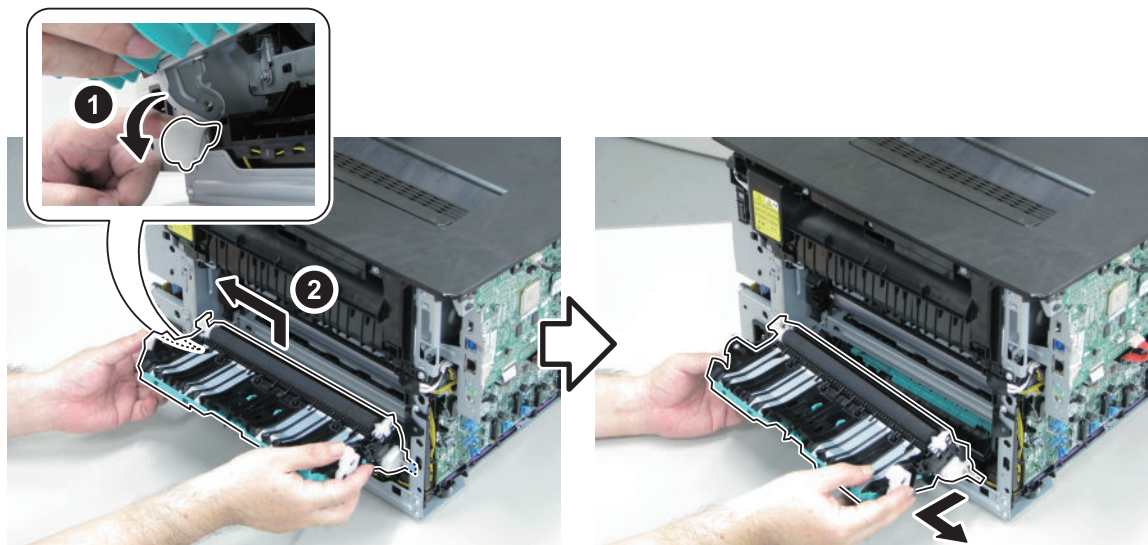

● Removing the ITB Unit

■ Preparation

1. "Removing the Toner Cartridge" on page 95
2. "Removing the Left Cover" on page 96
3. "Removing the Right Cover" on page 98
4. "Removing the Rear Cover Unit" on page 100
5. "Removing the Secondary Transfer Feed Unit" on page 155

■ Procedure

CAUTION:

- Place the ITB Unit on a sheet of paper.
- Be sure not to damage or touch the ITB Unit.

1. Remove the Connector Cover on the rear right side of the host machine, and disconnect the connectors.

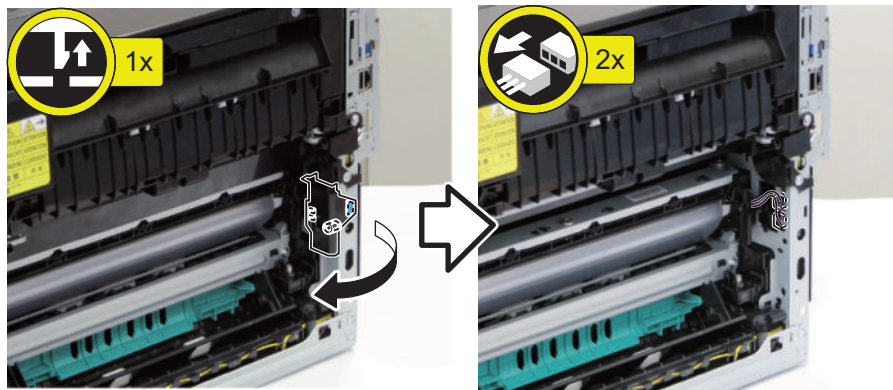

2. Remove the Rear Door Open/Close Detection Flag.

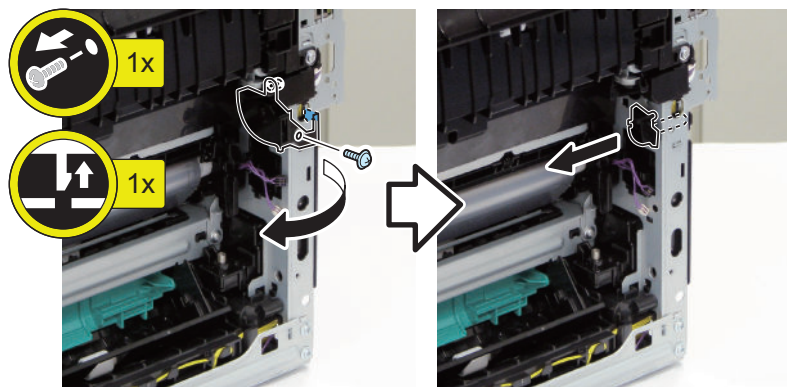

CAUTION:

When installing the Rear Door Open/Close Detection Flag, install it to the position where it pushes the lever of the microswitch.

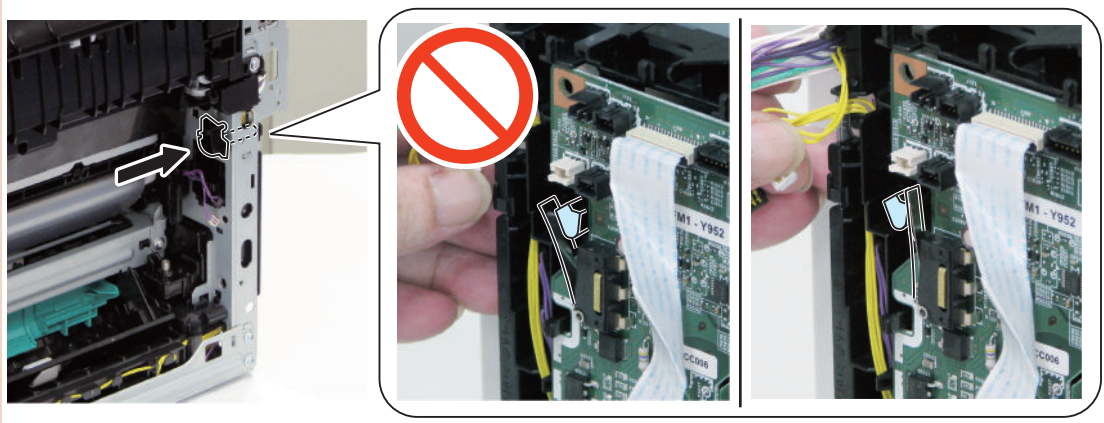

3. Remove the ITB Unit Upper Cover from the rear of the host machine.

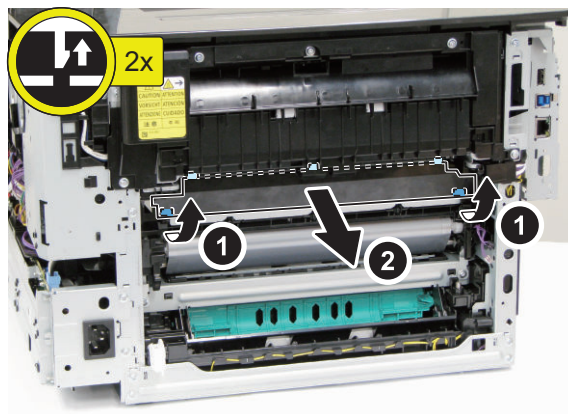

4. While releasing the lock of the 2 white levers by pushing them respectively to the direction of the arrow 1, move them to the mark 2. Then pull out the levers toward the front until they stop.

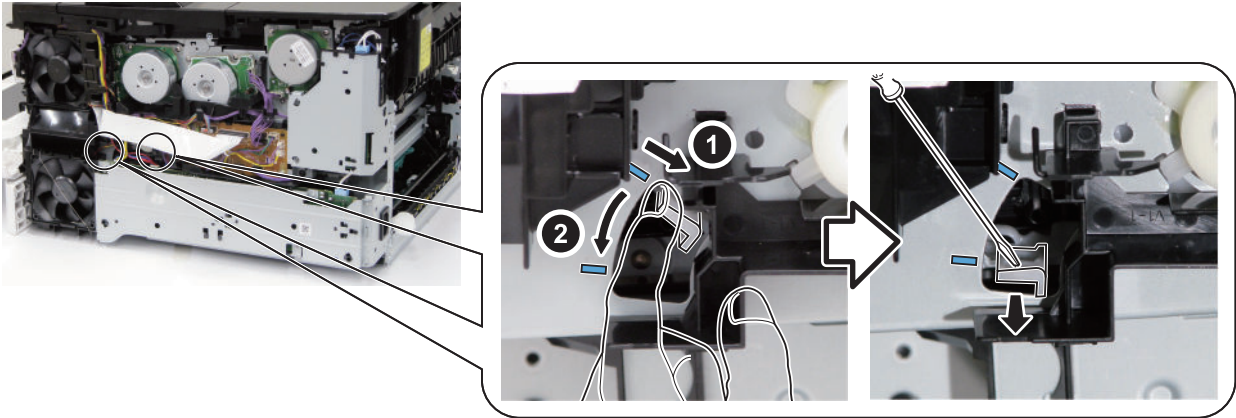

NOTE:

For installation, while pushing the two levers respectively toward the rear and then to the direction of the arrow 2, move them to the position of the upper mark.

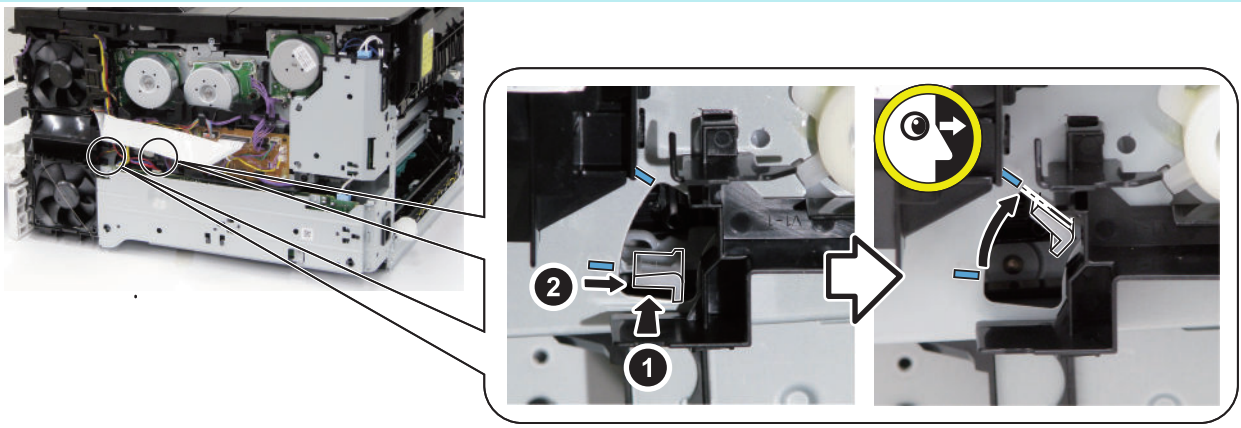

5. Remove the screws, and pull out the ITB Unit while holding the 2 levers on the left and right sides.

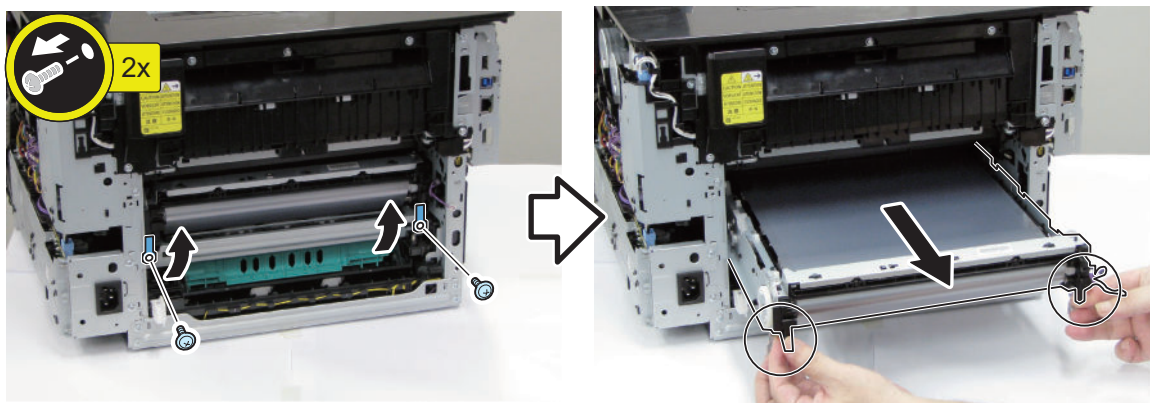

6. Actions after replacement: [“After Replacing the ITB Unit” on page 187](#)

● Removing the Color Displacement Density Sensor Unit

■ Preparation

1. [“Removing the Toner Cartridge” on page 95](#)
2. [“Removing the Left Cover” on page 96](#)

3. "Removing the Right Cover" on page 98
4. "Removing the Rear Cover Unit" on page 100
5. "Removing the Secondary Transfer Feed Unit" on page 155
6. "Removing the ITB Unit" on page 157
7. "Removing the Cartridge Cover" on page 101
8. "Removing the Cartridge Tray" on page 103

■ Procedure

1. Remove the Color Displacement Density Sensor Unit.

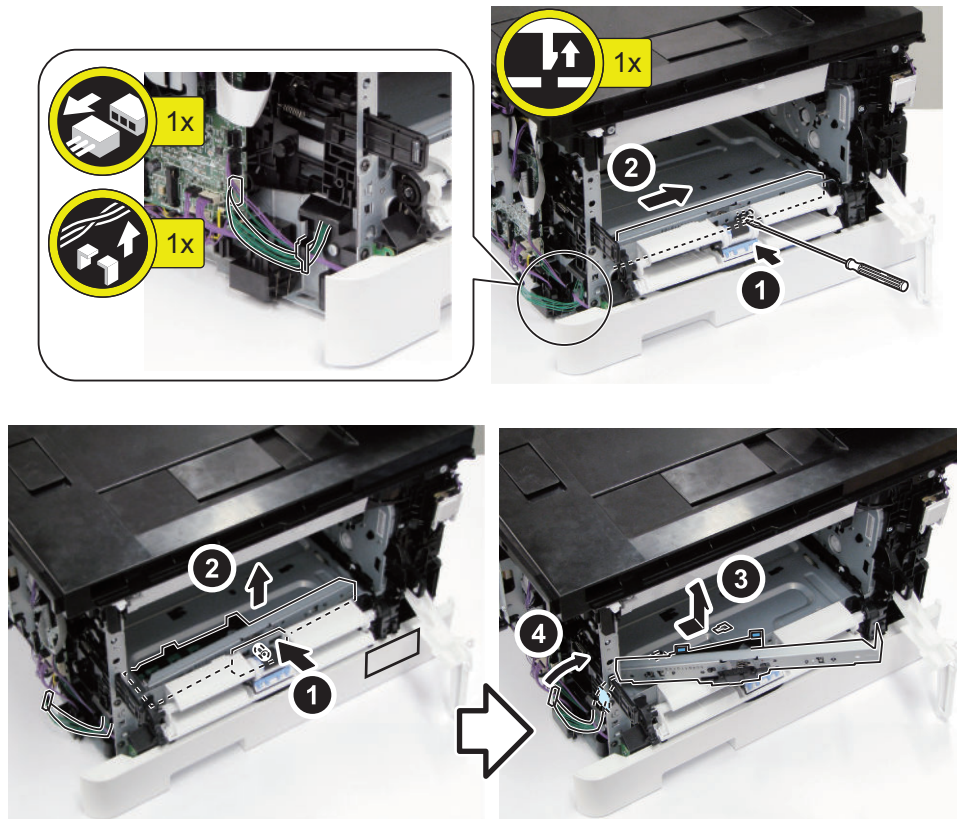

2. Actions after replacement: "After Replacing the Color Displacement Density Sensor Unit" on page 187

● Removing the Developing Motor

■ Preparation

1. "Removing the Toner Cartridge" on page 95
2. "Removing the Right Cover" on page 98
3. "Removing the Low Voltage Power Supply Unit" on page 135
4. "Removing the Driver PCB" on page 144

■ Procedure

1. Free the harness.

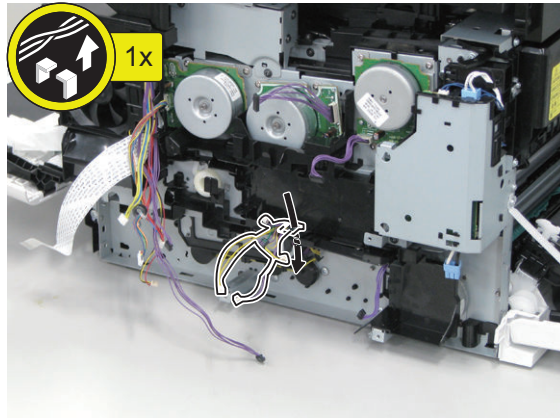

2. Remove the PCB Guide.

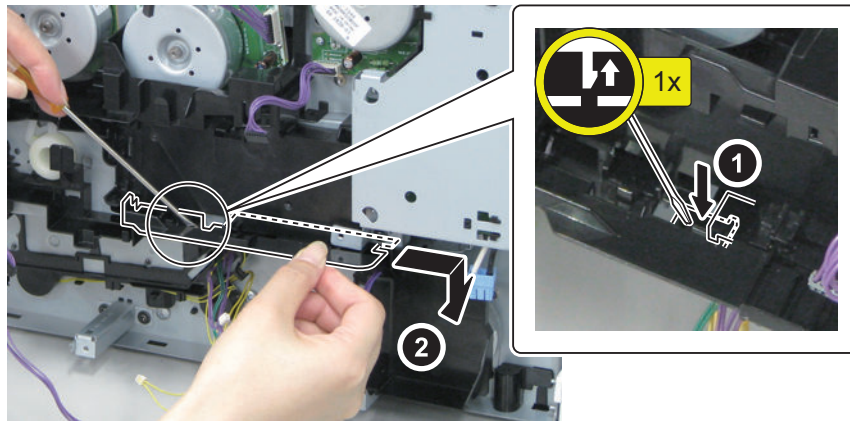

3. Remove the PCB Holder.

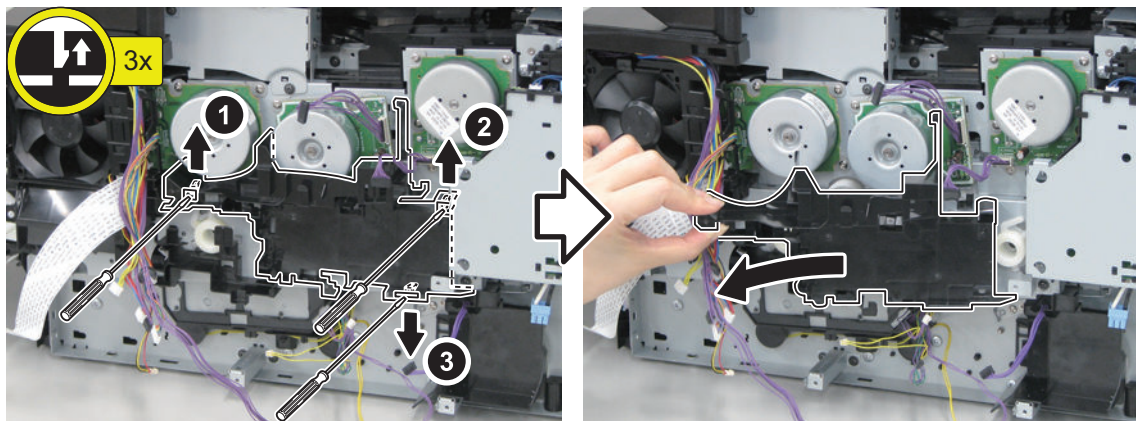

4. Remove the Developing Motor.

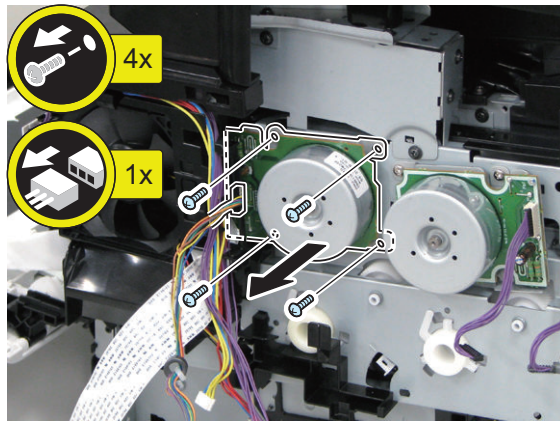

● Removing the Drum Motor

■ Preparation

1. "Removing the Toner Cartridge" on page 95
2. "Removing the Right Cover" on page 98
3. "Removing the Low Voltage Power Supply Unit" on page 135
4. "Removing the Driver PCB" on page 144

■ Procedure

1. Free the harness.

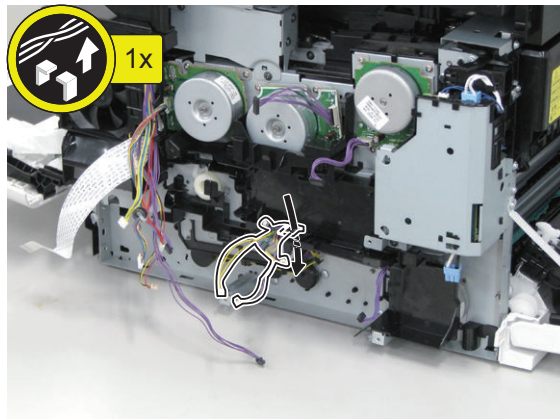

2. Remove the PCB Guide.

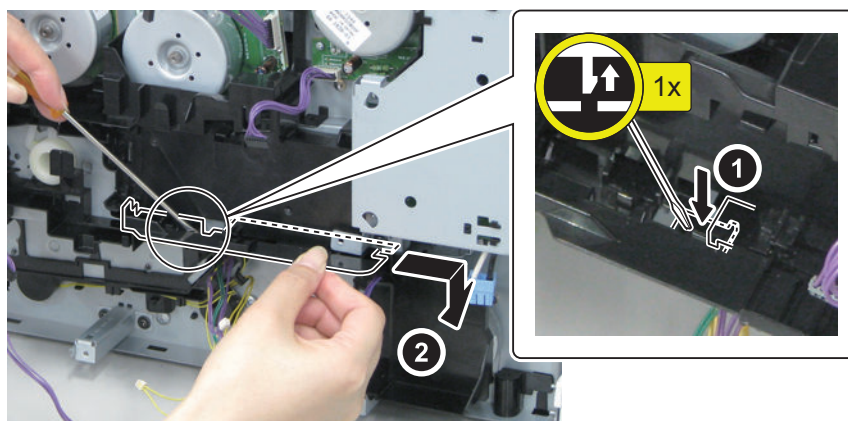

3. Remove the PCB Holder.

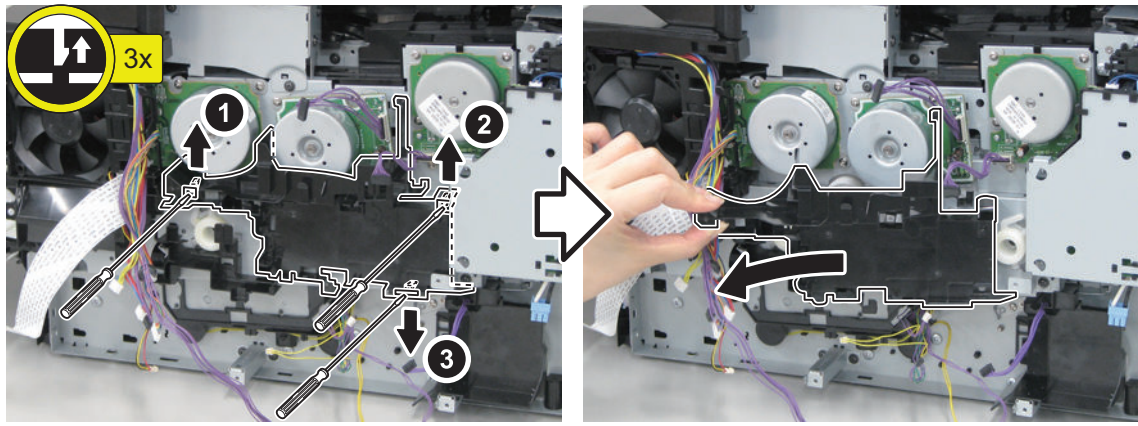

4. Remove the Drum Motor.

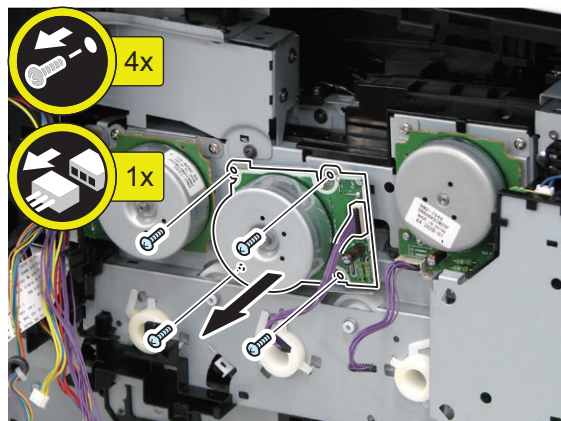

Fixing System

● Removing the Fixing Assembly

■ Preparation

1. "Removing the Toner Cartridge" on page 95
2. "Removing the Left Cover" on page 96
3. "Removing the Right Cover" on page 98
4. "Removing the ADF Unit + Reader Unit" on page 107
5. "Removing the Upper Front Cover" on page 104
6. "Removing the Upper Left Front Cover" on page 105
7. "Removing the Upper Right Front Cover" on page 105
8. "Removing the Control Panel Unit" on page 137
9. "Removing the Upper Cover Unit " on page 106
10. "Removing the Controller Cover " on page 131
11. "Removing the Main Controller PCB" on page 133
12. "Removing the Wireless LAN Support Plate (Wi-Fi model only)" on page 132
13. "Removing the Main Controller Support Plate" on page 133

■ Procedure

CAUTION:

Since the Fixing Assembly is hot immediately after the power is turned OFF, give it time to cool down before removing it.

1. Remove the Rear Upper Unit Plate.

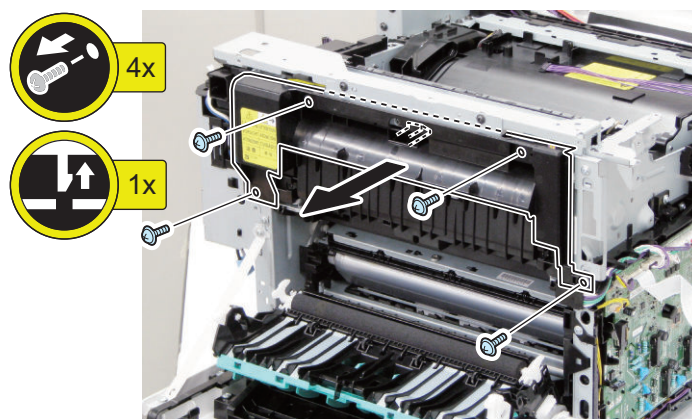

2. Free the harness.

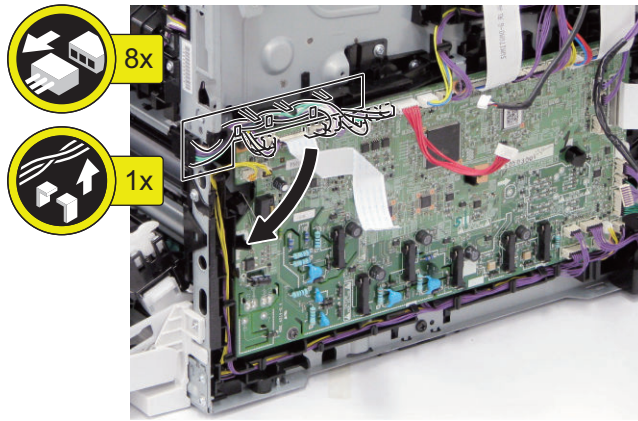

3. Disconnect the connectors and free the harness.

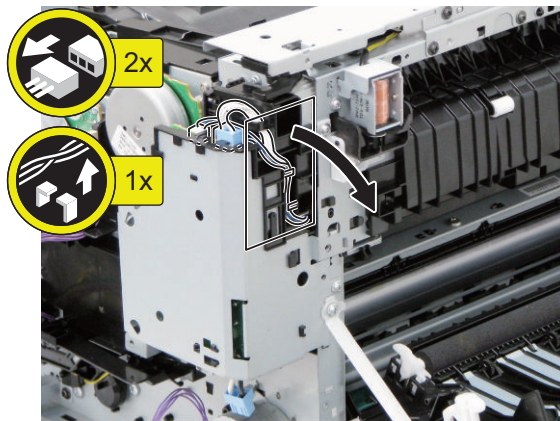

4. Remove the Rear Upper Plate.

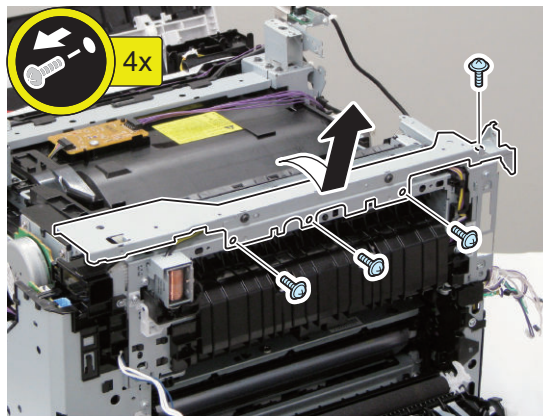

5. Remove the Fixing Assembly.

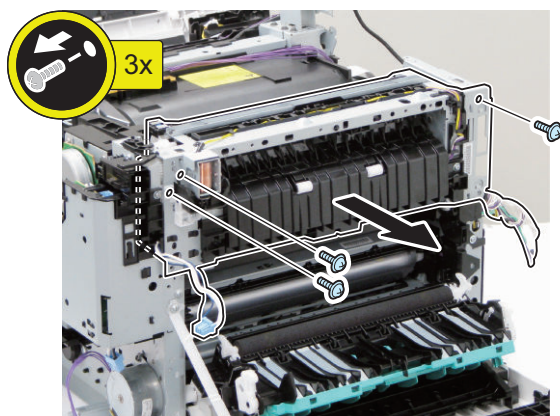
**CAUTION:**

When installing it, be careful not to let the Reverse Lever come in contact with the frame of the printer. Also be careful not to let it slip under the Reverse Stopper of the Reverse Drive Assembly.

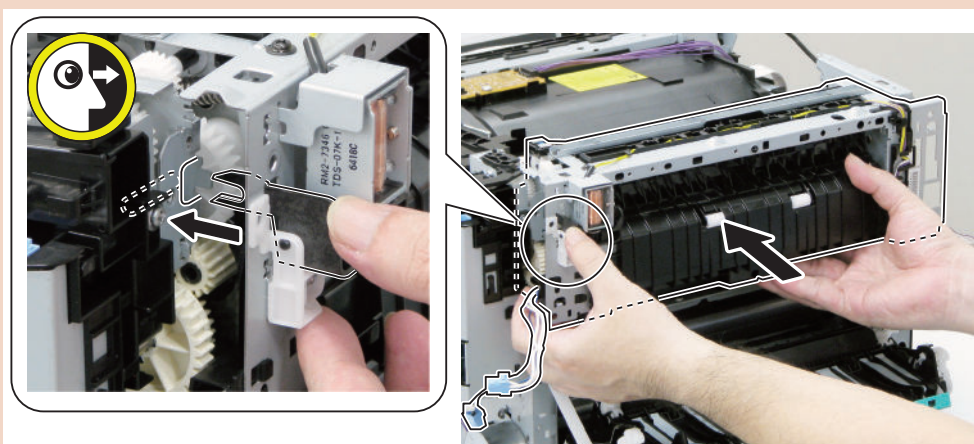

● Removing the Fixing Power Supply Unit

■ Preparation

1. "Removing the Toner Cartridge" on page 95
2. "Removing the Right Cover" on page 98

■ Procedure

1. Remove the Fixing Power Supply Unit.

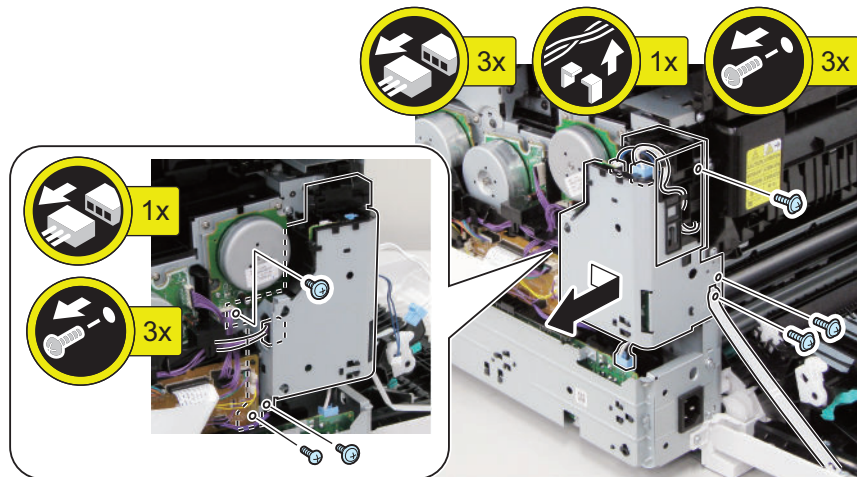

● Removing the Fixing Motor

■ Preparation

1. “Removing the Toner Cartridge” on page 95
2. “Removing the Right Cover” on page 98
3. “Removing the Fixing Power Supply Unit” on page 166

■ Procedure

1. Remove the Fixing Motor.

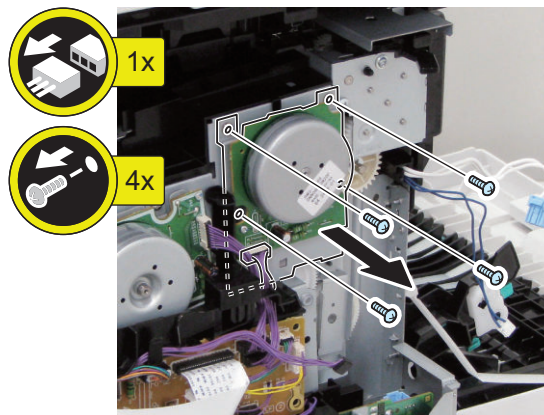

Pickup Feed Delivery System

● Removing the Cassette Pickup Roller/Feed Roller Unit

■ Preparation

1. “Removing the Toner Cartridge” on page 95

■ Procedure

CAUTION:

Be sure not to touch the surface of the Cassette Pickup Roller and the surface of the Feed Roller.

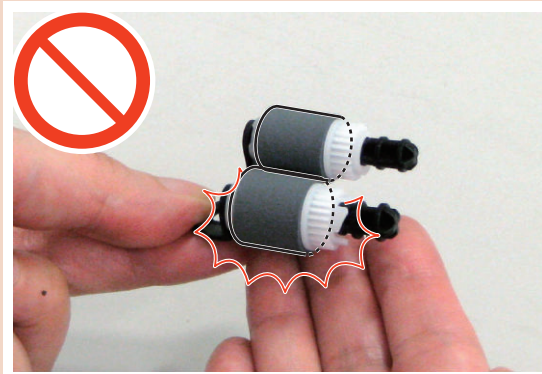
**CAUTION:**

When laying down the main body, be sure to secure the ADF Unit with tape to prevent from opening.

1. Pull out the cassette, and stand the host machine with its left side down.

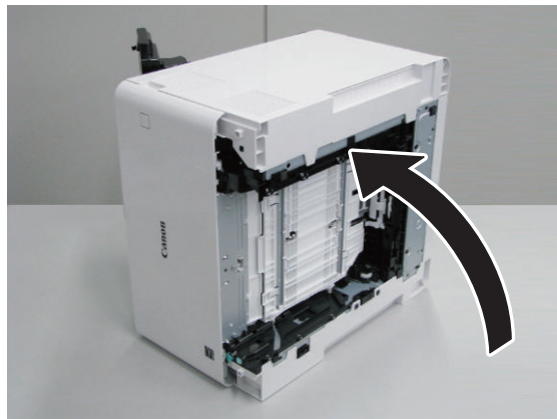

2. Move the Multi-purpose Tray Feed Guide in the direction of the arrow (2).

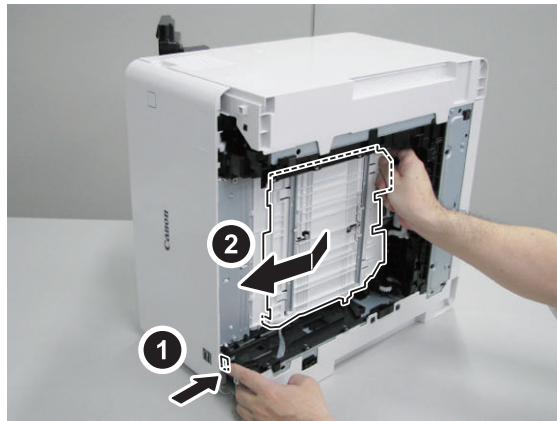

3. Press the lever, then move the Roller Retainer in the direction of an arrow to remove the Pick-up Roller and Feed Roller.

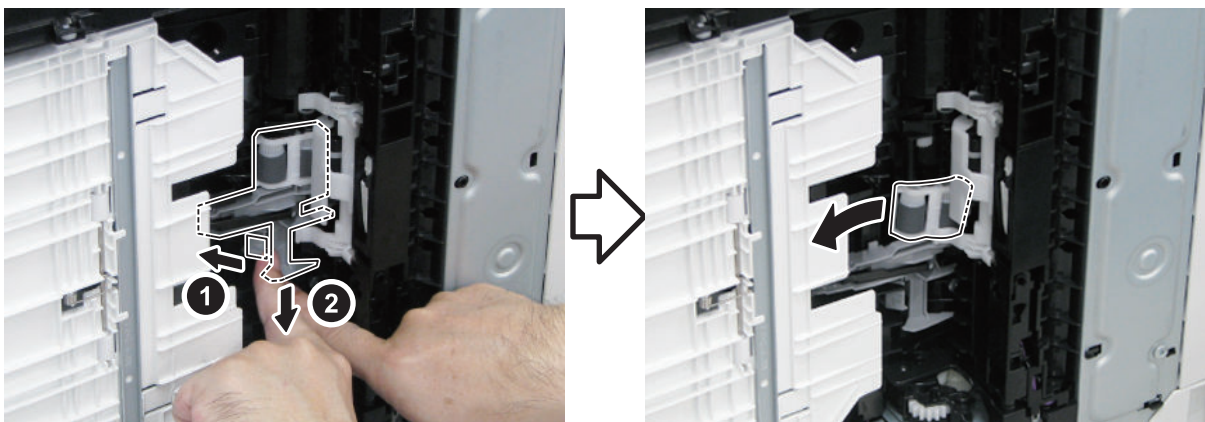

● Removing the Cassette Separation Roller Unit

■ Preparation

1. "Removing the Toner Cartridge" on page 95

■ Procedure

CAUTION:

Be sure not to touch the surface of the Separation Roller.



CAUTION:

When laying down the main body, be sure to secure the ADF Unit with tape to prevent from opening.

1. Pull out the cassette, and stand the host machine with its left side down.

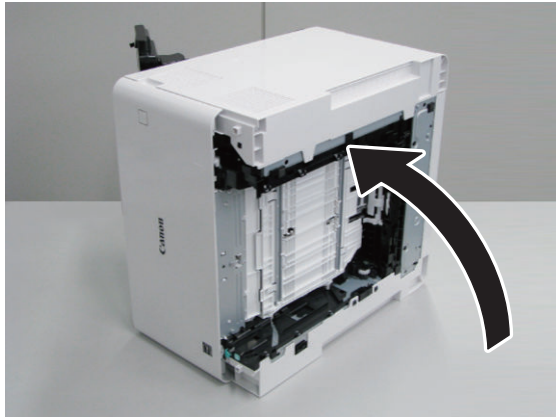

2. Remove the Separation Roller Guide.

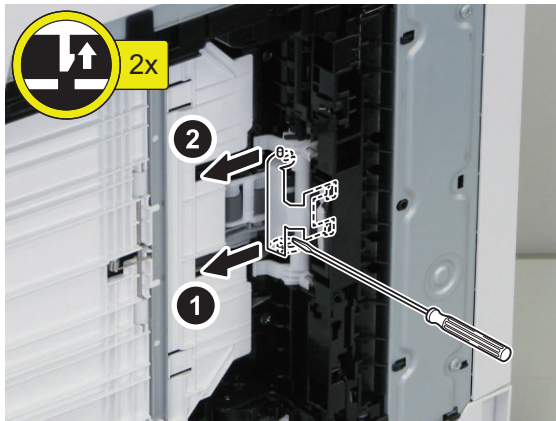

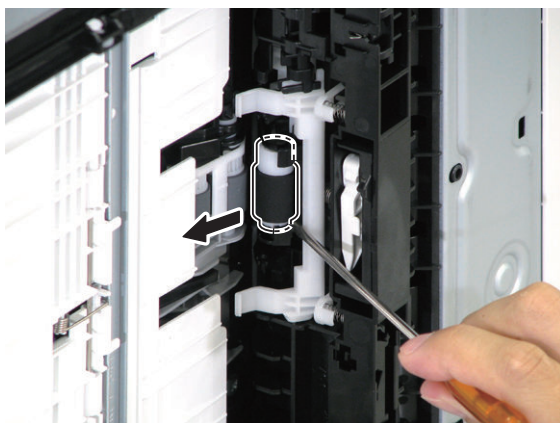
3. Remove the Separation Roller.**NOTE:**

When installing the Separation Roller, be sure to properly fit the D-cut.



● Removing the Duplex Reverse Drive Unit

■ Preparation

1. "Removing the Toner Cartridge" on page 95
2. "Removing the Left Cover" on page 96
3. "Removing the Right Cover" on page 98
4. "Removing the ADF Unit + Reader Unit" on page 107
5. "Removing the Upper Front Cover" on page 104
6. "Removing the Upper Left Front Cover" on page 105
7. "Removing the Upper Right Front Cover" on page 105
8. "Removing the Control Panel Unit" on page 137
9. "Removing the Upper Cover Unit" on page 106
10. "Removing the Controller Cover" on page 131
11. "Removing the Main Controller PCB" on page 133
12. "Removing the Wireless LAN Support Plate (Wi-Fi model only)" on page 132
13. "Removing the Main Controller Support Plate" on page 133
14. "Removing the Fixing Assembly" on page 164

15. "Removing the Fixing Power Supply Unit" on page 166

■ Procedure

1. Remove the Duplex Reverse Drive Unit.

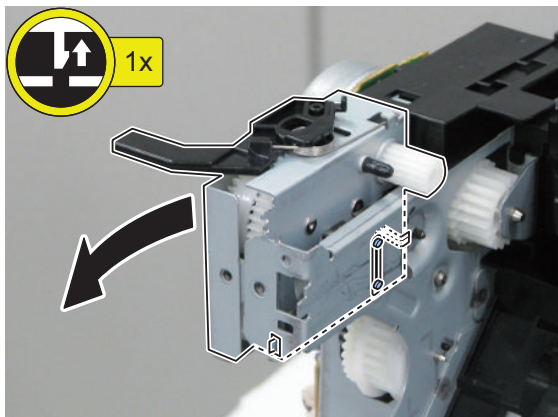

● Removing the Pickup Motor

■ Preparation

1. "Removing the Left Cover" on page 96
2. "Removing the Right Cover" on page 98
3. "Removing the Low Voltage Power Supply Unit" on page 135

■ Procedure

1. Remove the cover.

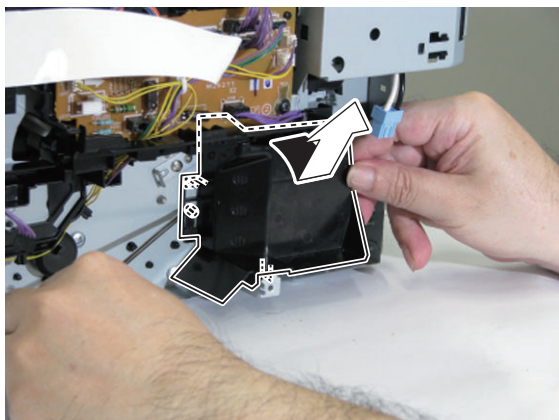

2. Remove the Pickup Motor.

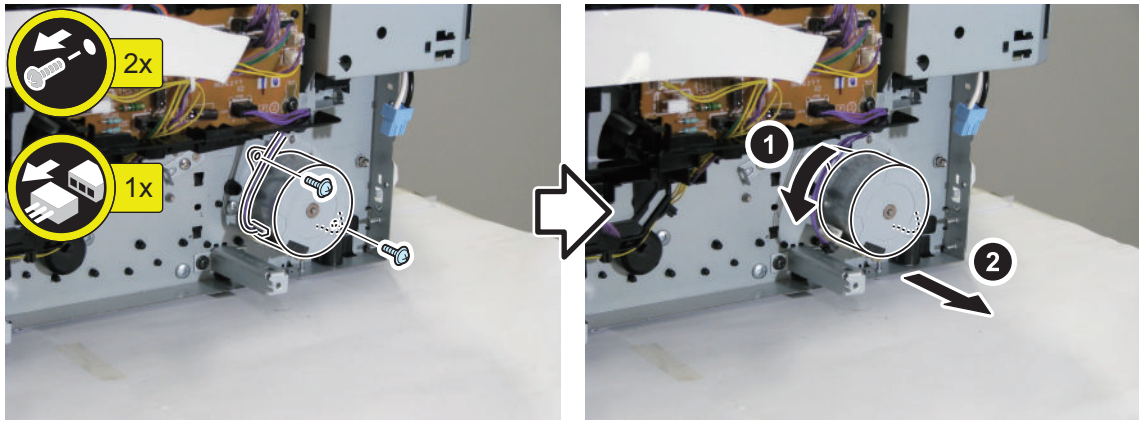

● Removing the Re-Pickup Unit

■ Preparation

1. "Removing the Toner Cartridge" on page 95
2. "Removing the Left Cover" on page 96
3. "Removing the Right Cover" on page 98
4. "Removing the ADF Unit + Reader Unit" on page 107
5. "Removing the Upper Front Cover" on page 104
6. "Removing the Upper Left Front Cover" on page 105
7. "Removing the Upper Right Front Cover" on page 105
8. "Removing the Control Panel Unit" on page 137
9. "Removing the Upper Cover Unit" on page 106
10. "Removing the Rear Cover Unit" on page 100
11. "Removing the Controller Cover" on page 131
12. "Removing the Main Controller PCB" on page 133
13. "Removing the Wireless LAN Support Plate (Wi-Fi model only)" on page 132
14. "Removing the Main Controller Support Plate" on page 133

■ Procedure

1. Stand the host machine with its right side down.

CAUTION:

Be careful not to damage the Control Panel and parts.

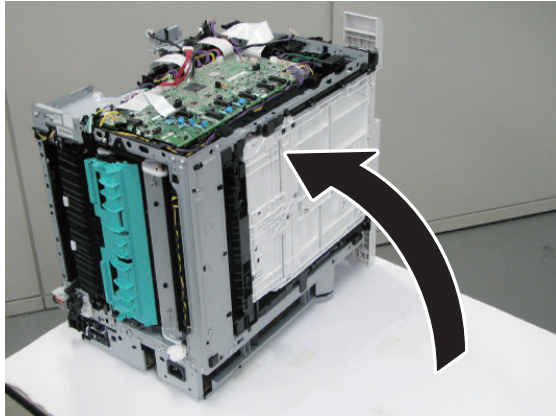

2. Disconnect the connectors and remove the screws. Be sure to remove the screws in the order from 1 to 6.

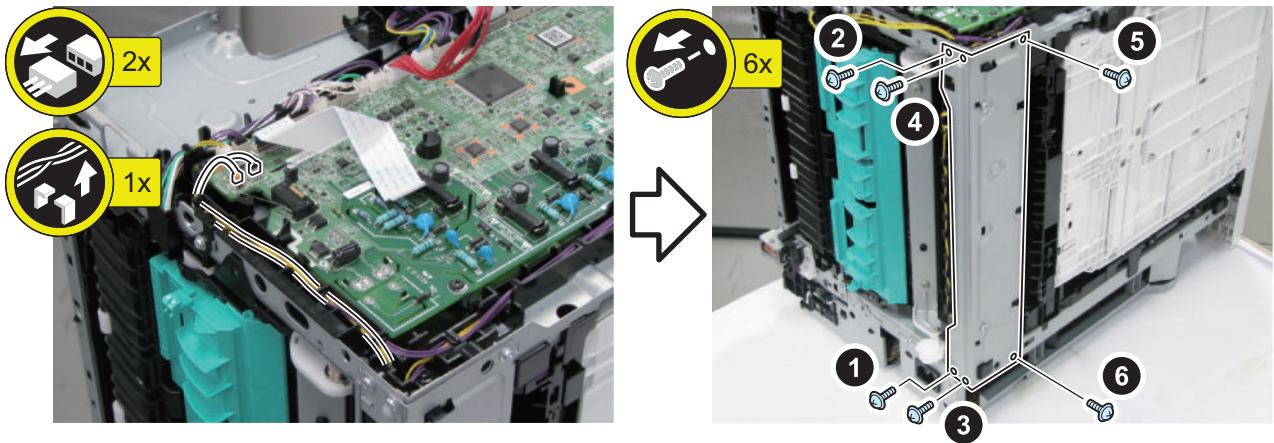

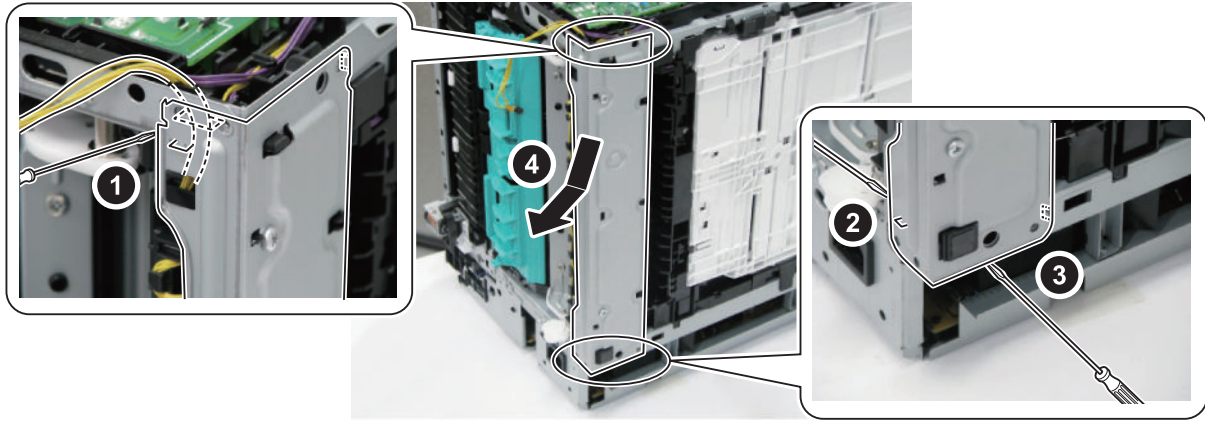
3. Remove the Re-Pickup Unit.**NOTE:**

At installation,

- By removing the block with rubber from the bottom of the host machine, the Re-Pickup Unit can be installed easily.
- Tighten the screws in the order they were removed.

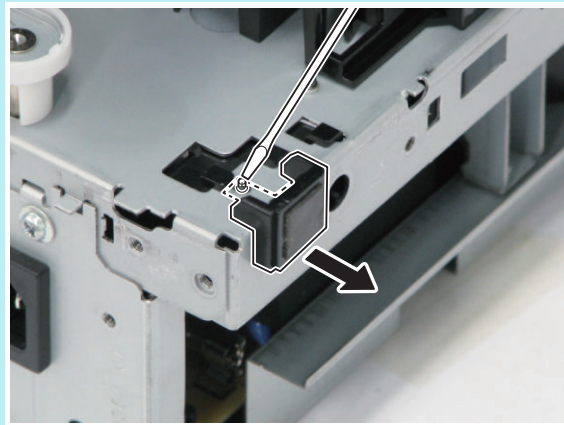

● Removing the Lifter Drive Unit

■ Preparation

1. "Removing the Toner Cartridge" on page 95
2. "Removing the Left Cover" on page 96
3. "Removing the Right Cover" on page 98
4. "Removing the ADF Unit + Reader Unit" on page 107
5. "Removing the Upper Front Cover" on page 104
6. "Removing the Upper Left Front Cover" on page 105
7. "Removing the Upper Right Front Cover" on page 105
8. "Removing the Control Panel Unit" on page 137
9. "Removing the Upper Cover Unit" on page 106
10. "Removing the Rear Cover Unit" on page 100
11. "Removing the Controller Cover" on page 131
12. "Removing the Main Controller PCB" on page 133
13. "Removing the Wireless LAN Support Plate (Wi-Fi model only)" on page 132

14. "Removing the Main Controller Support Plate" on page 133
15. "Removing the Engine Controller PCB" on page 134
16. Pull out the cassette.
17. "Removing the Re-Pickup Unit" on page 173

■ Procedure

1. Free the harness, and remove the screws, Shaft Cover, and shaft.

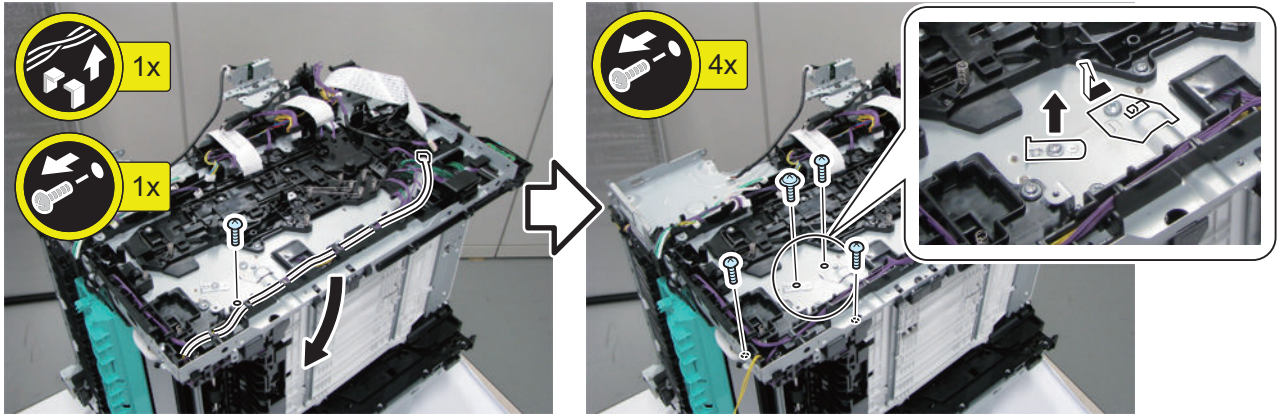

2. Remove the block with rubber.

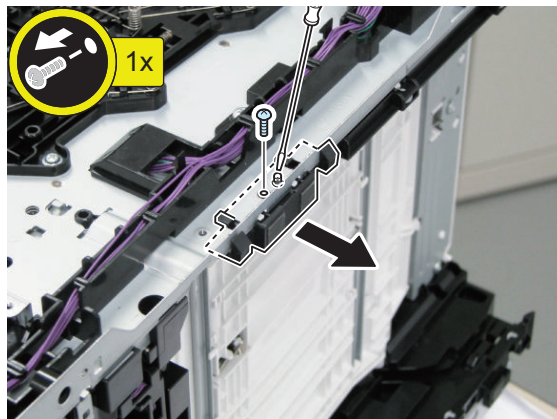

3. Remove the Cassette Detection Switch.

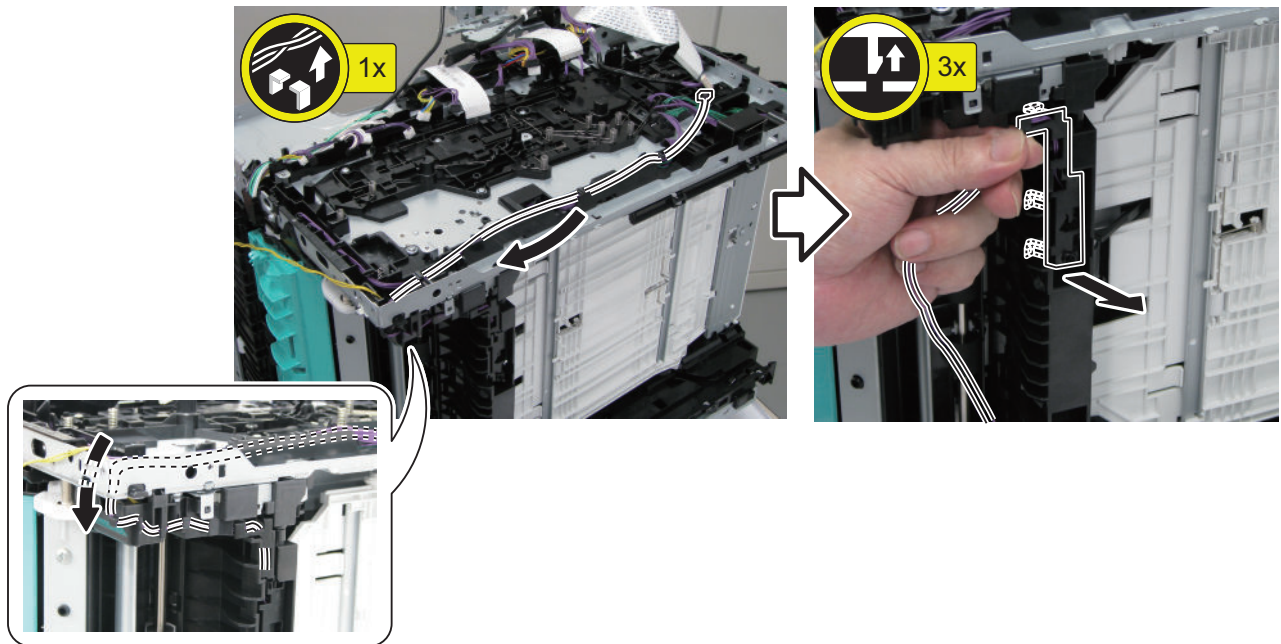

4. Remove the Lifter Drive Unit.

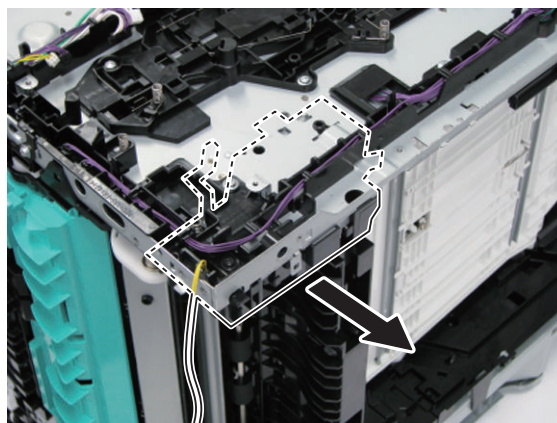

● Removing the Cassette Pickup Unit

■ Preparation

1. "Removing the Toner Cartridge" on page 95
2. "Removing the Left Cover" on page 96
3. "Removing the Right Cover" on page 98
4. "Removing the ADF Unit + Reader Unit" on page 107
5. "Removing the Upper Front Cover" on page 104
6. "Removing the Upper Left Front Cover" on page 105
7. "Removing the Upper Right Front Cover" on page 105
8. "Removing the Control Panel Unit" on page 137
9. "Removing the Upper Cover Unit" on page 106
10. "Removing the Rear Cover Unit" on page 100
11. "Removing the Controller Cover" on page 131

12. "Removing the Main Controller PCB" on page 133
13. "Removing the Wireless LAN Support Plate (Wi-Fi model only)" on page 132
14. "Removing the Main Controller Support Plate" on page 133
15. "Removing the Engine Controller PCB" on page 134
16. Pull out the cassette.
17. "Removing the Low Voltage Power Supply Unit" on page 135
18. "Removing the Re-Pickup Unit" on page 173
19. "Removing the Lifter Drive Unit" on page 175
20. "Removing the Pickup Motor" on page 172

■ Procedure

1. Remove the harness guide.

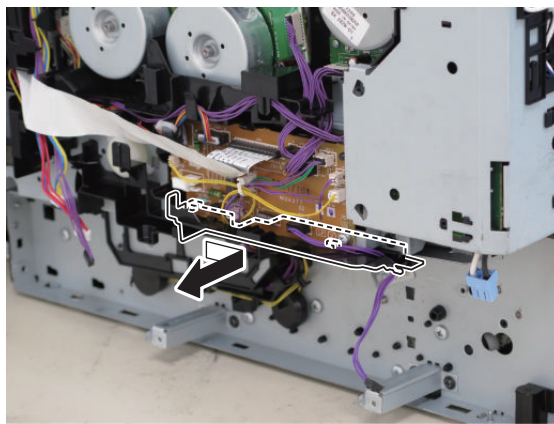

2. Remove the connector and harness.

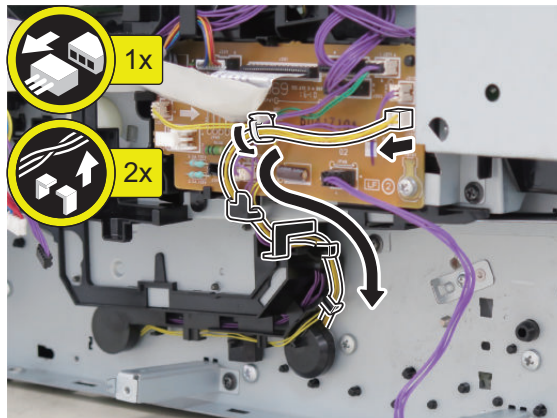

3. Remove the screws.

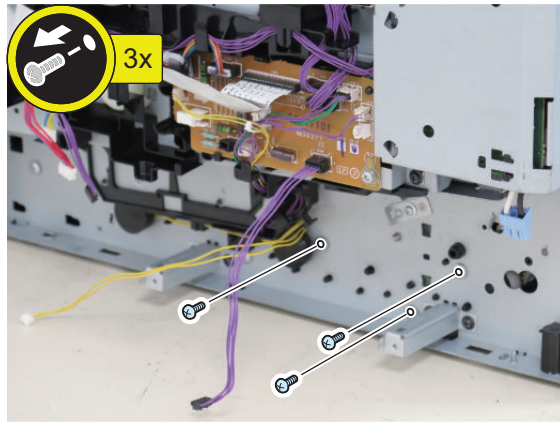

4. Stand the host machine with its right side down, and remove the Cassette Pickup Unit.

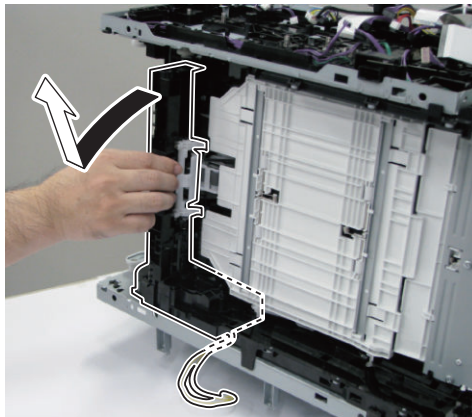

● Removing the Multi-purpose Tray Pickup Roller

■ Procedure

CAUTION:

Be sure not to touch the surface of the Multi-purpose Tray Pickup Roller.

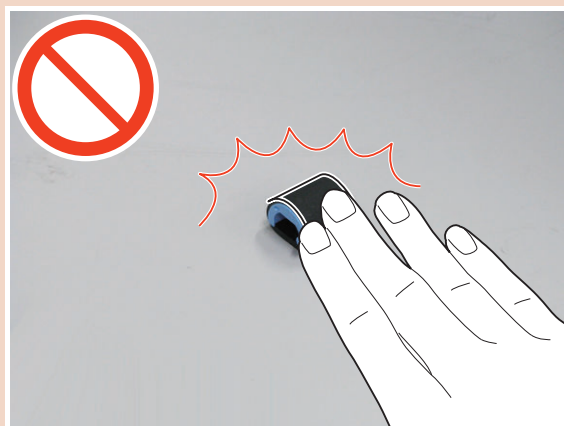

1. Open the Cartridge Cover.

2. Remove the Multi-purpose Tray Pickup Roller.

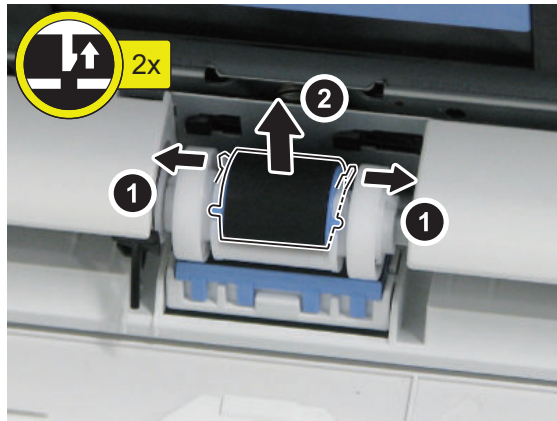

● Removing the Multi-purpose Tray Separation Pad

■ Procedure

CAUTION:

Be sure not to touch the surface of the Multi-purpose Tray Separation Pad.

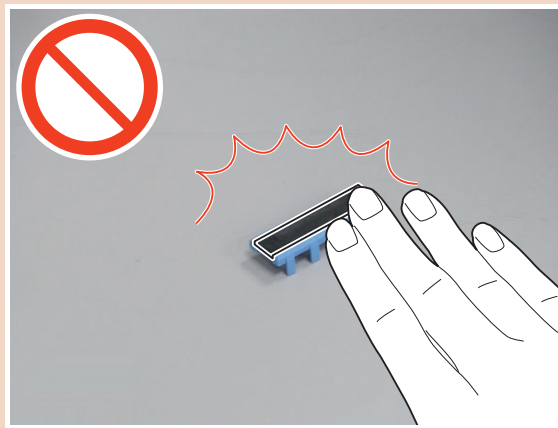

1. Open the Cartridge Cover.
2. Lower the Multi-purpose Tray Separation Pad.

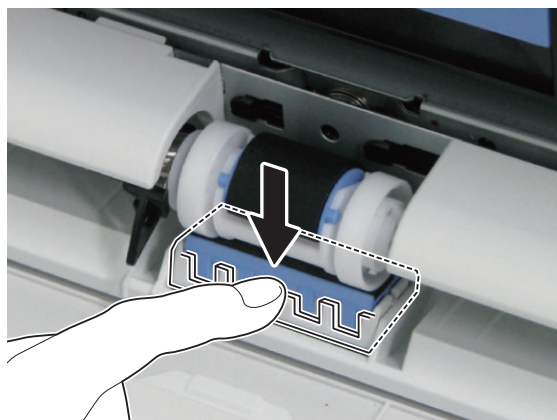

3. Remove the Multi-purpose Tray Separation Pad.

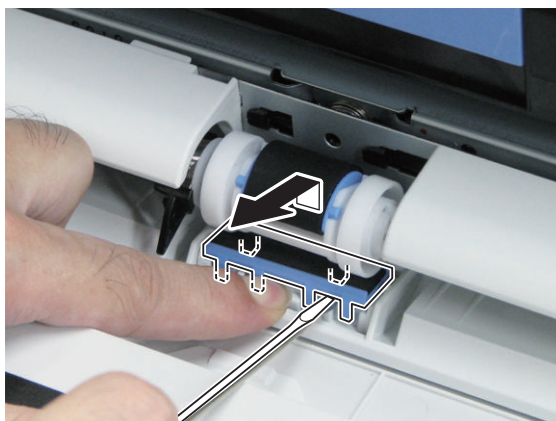

● Removing the Registration Unit

■ Preparation

1. "Removing the Toner Cartridge" on page 95
2. "Removing the Left Cover" on page 96
3. "Removing the Right Cover" on page 98
4. "Removing the ADF Unit + Reader Unit" on page 107
5. "Removing the Upper Front Cover" on page 104
6. "Removing the Upper Left Front Cover" on page 105
7. "Removing the Upper Right Front Cover" on page 105
8. "Removing the Control Panel Unit" on page 137
9. "Removing the Upper Cover Unit " on page 106
10. "Removing the Rear Cover Unit" on page 100
11. "Removing the Controller Cover " on page 131
12. "Removing the Main Controller PCB" on page 133
13. "Removing the Wireless LAN Support Plate (Wi-Fi model only)" on page 132
14. "Removing the Main Controller Support Plate" on page 133
15. "Removing the Engine Controller PCB" on page 134
16. "Removing the Low Voltage Power Supply Unit" on page 135
17. "Removing the Re-Pickup Unit" on page 173
18. "Removing the Lifter Drive Unit" on page 175
19. "Removing the Pickup Motor" on page 172
20. "Removing the Cassette Pickup Unit" on page 177

■ Procedure

1. Free the harness.

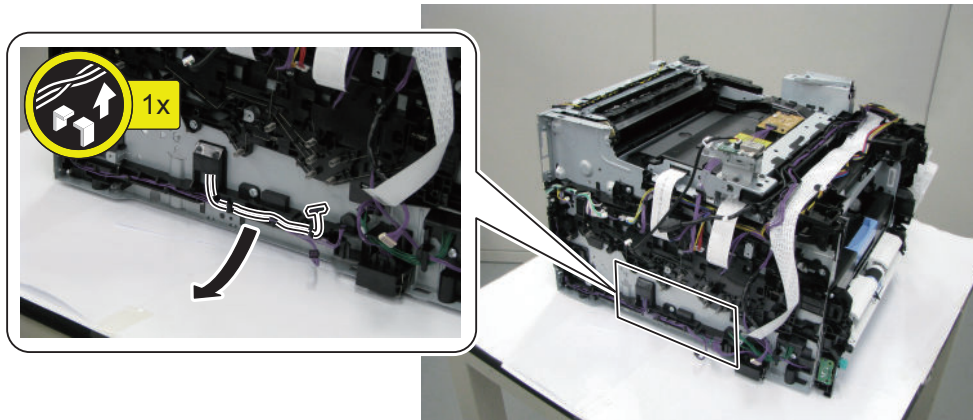

2. Remove the shaft.

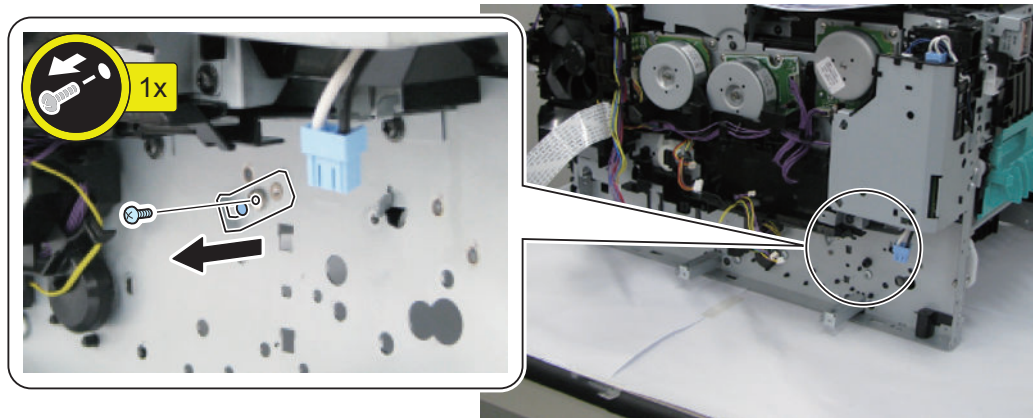

3. Stand the host machine with its right side down.

4. Move the Multi-purpose Tray Feed Guide in the direction of the arrow (2).

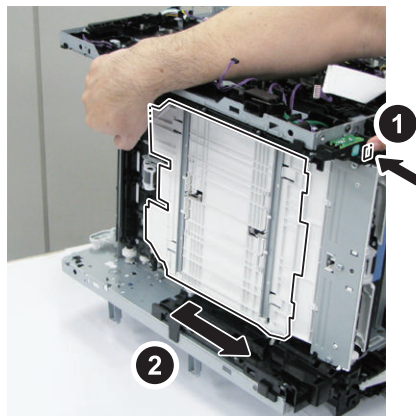

5. Remove the screws in the order of numbers in the illustration.

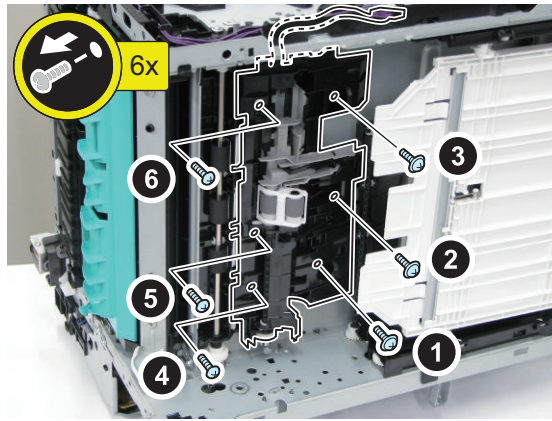

NOTE:

When installing it, tighten the screws in the order of numbers in the illustration.

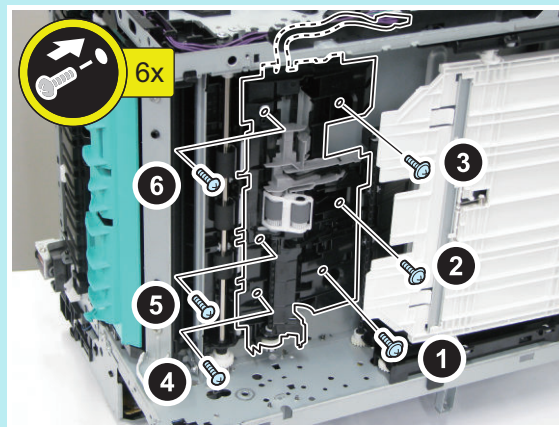

6. Remove the Feed Front Guide and the Feed Rear Guide together.

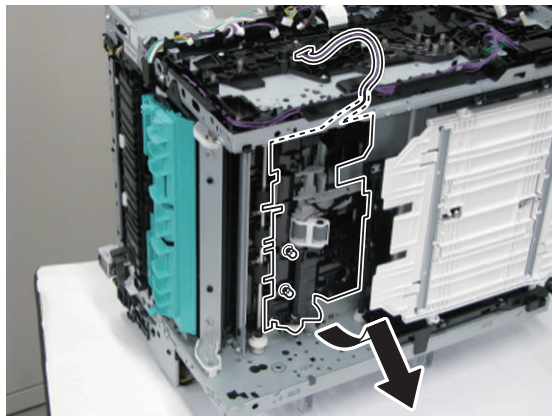

7. Remove the Registration Unit.

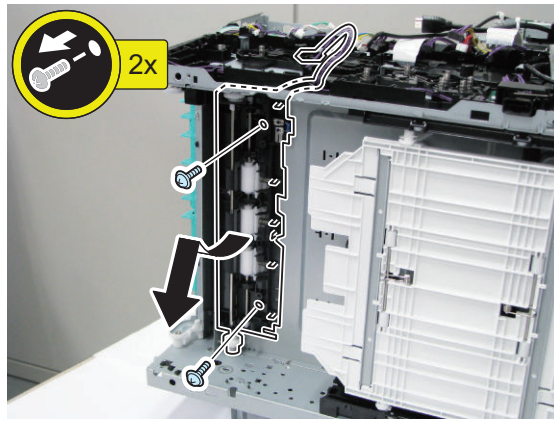



Adjustment

Location where the service label is affixed	186
Adjustment at Parts Replacement....	187

Location where the service label is affixed

NOTE:

The service label is affixed on the Main Controller Cover on the left side of the host machine.

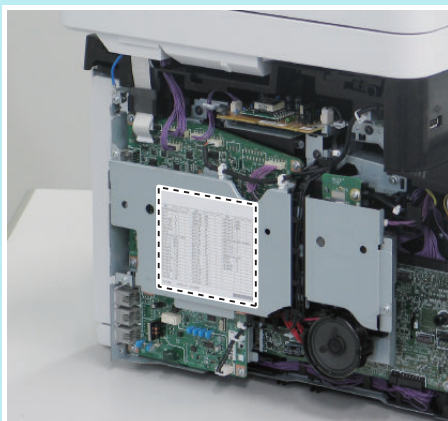

Adjustment at Parts Replacement

After Replacing the Control Panel

1. Execute the following service mode to adjust the coordinate position on the touch panel.
 - COPIER > ADJUST > PANEL > TOUCHCHK
2. Check that the service mode setting value is "1" in the following service mode.
 - COPIER > ADJUST > PANEL > TOUCH-R

CAUTION:

When the value is not "1" in the above service mode, re-adjust the coordinate position on the touch panel.

After Replacing the ITB Unit

1. Perform the following
 - Adjustment / Maintenance > > Adjust Image Quality > Full Adjust

After Replacing the Color Displacement Density Sensor Unit

1. Perform the following
 - Adjustment / Maintenance > > Adjust Image Quality > Full Adjust

Engine Controller PCB

Before Replacing the Engine Controller PCB

The setting values stored in the Engine Controller PCB NVRAM are stored as a backup in the Main Controller PCB NVRAM. Before replacing the Engine Controller PCB, be sure to perform the steps shown below to back up the setting values.

- SERVICE MODE > COPIER > FUNCTION > VIFFNC > STOR-DCN

Turn OFF and then ON the power.

CAUTION:

Perform backup immediately before replacing the Engine Controller PCB.

After Replacing the Engine Controller PCB

The setting values stored in the Engine Controller PCB NVRAM are stored as a backup in the Main Controller PCB NVRAM. After replacing the Engine Controller PCB, be sure to perform the steps shown below to restore the setting values.

- SERVICE MODE > COPIER > FUNCTION > VIFFNC > RSTR-DCN

Turn OFF and then ON the power.

Main Controller PCB

Before Replacing the Main Controller PCB

The following setting values are recorded in the Main Controller PCB. When the Main Controller PCB is replaced, these setting values are all returned to the default unless they are restored.

- User mode setting values
- Service mode setting values

These setting values can be restored by performing backup by any of the following methods:

Refer to the Backup List for the details of items that are backed up.

["Backup Data List" on page 378](#)

1. Enter service mode, and set the following item to [1].

- COPIER > OPTION > USER > SMD-EXPT

NOTE:

The setting [SMD-EXPT] can be configured either from the Control Panel or remote UI.

2. These setting values can be restored by performing backup by any of the following methods:

- SERVICE MODE > COPIER > FUNCTION > SYSTEM > EXPORT
- Menu > Management Settings > Data Management > Import/Export > Export
- RUI > Settings/Registration > Management Settings > Data Management > Import/Export > Export

CAUTION:

- Perform backup immediately before replacing the Main Controller PCB.
- When the Main Controller PCB is replaced, the user data, service data, and logs are initialized and the system manager ID and password are changed back to the default values (ID: 7654321 / PWD: 7654321).

CAUTION:

Perform backup immediately before replacing the Main Controller.

3. Be sure to output the Serial No./BODY No. and the data entered in [Location] and use them when configuring the settings after replacing the PCB.**NOTE:**

As for "Serial No./BODY No.", this number is referred to as "Serial No." in the user data list and the system manager data list, and is referred to as "BODY No." in the spec report.

- Menu > Output Report > Print List > User Data List
- Menu > Output Report > Print List > System Manager Data List
- COPIER > FUNCTION > MISC-P > SPEC

NOTE:

The output data of [Location] can be found in the system manager data list and the LUI shown below.

- Menu > Output Report > Print List > System Manager Data List
- Menu > Management Settings > Device Management > Device Information Settings > Location

■ After Replacing the Main Controller PCB**CAUTION:**

The language displayed changes to English immediately after the replacement of the Main Controller PCB. Be sure to perform the following steps 1 to 5 in order to reflect the language of the country and the country-specific settings that had been configured before the replacement of the Main Controller PCB.

1. Turn ON the power of the host machine.**2. Enter service mode.**

Setup Guide will start. Forcibly open the service mode screen.

3. Location information setting

[Setting value]

- 1: Japan, 2: North America, 3: Korea, 4: China, 5: Taiwan, 6: Europe, 7: Asia, 8: Oceania, 9: Brazil, 10: Latin America
- COPIER > OPTION > BODY > LOCALE

4. Paper size configuration setting

[Setting value]

1: AB configuration, 2: Inch configuration, 3: A configuration, 4: AB/Inch configuration

- COPIER > OPTION > BODY > SIZE-LC

5. Clear the setting information

- COPIER > FUNCTION > CLEAR > ALL

6. Clear the RCON backup

Execute the following service mode to clear the backup data of RCON.

- COPIER > FUNCTION > CLEAR > RCON

7. Enter the XYZ values

Enter the values shown on the service label in service mode.

<W-PLT-X>

- COPIER > ADJUST > CCD > W-PLT-X

<W-PLT-Y>

- COPIER > ADJUST > CCD > W-PLT-Y

<W-PLT-Z>

- COPIER > ADJUST > CCD > W-PLT-Z

8. Calculate the target value of B&W shading

Turn OFF and then ON the power of the host machine, and then execute the following service mode.

- COPIER > FUNCTION > CCD > BW-TGT

9. Enter the value of the stream reading position

Enter the values shown on the service label in service mode.

<STRD-POS>

- COPIER > ADJUST > ADJ-XY > STRD-POS

10. AGC adjustment (paper front)

1. Enter a provisional value

Change the values of the following service mode settings to 1,000.

- COPIER > ADJUST > CCD > LED-BW-R
- COPIER > ADJUST > CCD > LED-BW-G
- COPIER > ADJUST > CCD > LED-BW-B

Change the values of the following service mode settings to 1,100.

- COPIER > ADJUST > CCD > LED-CL-R
- COPIER > ADJUST > CCD > LED-CL-G
- COPIER > ADJUST > CCD > LED-CL-B

2. Execute the following service modes to perform the AGC adjustment (paper front).

- COPIER > FUNCTION > CCD > BW-AGC
- COPIER > FUNCTION > CCD > CL-AGC

CAUTION:

Be sure to close the ADF before executing the foregoing service mode. Also be sure not to open the ADF while the service mode is being executed.

3. If the operation was "successful", this procedure is completed. (There is no need to write down the values on the service label.)

4. How to judge whether the operation was successful or failed

Whether the operation was successful or failed is not shown on the UI, so perform the following procedure to judge if the operation was successful or failed.

B&W mode

Check the following values. If all of them remain at "1,000", the operation result is judged to be "failed".

- COPIER > ADJUST > CCD > LED-BW-R
- COPIER > ADJUST > CCD > LED-BW-G
- COPIER > ADJUST > CCD > LED-BW-B

In the case of a failure, turn OFF and then ON the power, and execute the following service mode again.

- COPIER > FUNCTION > CCD > BW-AGC

Color mode

Check the following values. If all of them remain at "1,100", the operation result is judged to be "failed".

- COPIER > ADJUST > CCD > LED-CL-R
- COPIER > ADJUST > CCD > LED-CL-G
- COPIER > ADJUST > CCD > LED-CL-B

In the case of a failure, turn OFF and then ON the power, and execute the following service mode again.

- COPIER > FUNCTION > CCD > CL-AGC

5. If the operation was "successful", this procedure is completed. (There is no need to write down the values on the service label.)

11. AGC adjustment (back side) (simultaneous duplex scanning models only)

1. Enter a provisional value.

B&W mode

Change the values of the following service mode settings to 1,000.

- COPIER > ADJUST > CCD > LE-BWRBK
- COPIER > ADJUST > CCD > LE-BWGBK
- COPIER > ADJUST > CCD > LE-BWBBK

Color mode

Change the values of the following service mode settings to 1,100.

- COPIER > ADJUST > CCD > LE-CLRBK
- COPIER > ADJUST > CCD > LE-CLGBK
- COPIER > ADJUST > CCD > LE-CLBBK

2. Execute the following service mode.

CAUTION:

Be sure to close the ADF before executing the following service mode. Also be sure not to open the ADF while the service mode is being executed.

- COPIER > FUNCTION > CCD > BW-AGC2
- COPIER > FUNCTION > CCD > CL-AGC2

3. How to judge whether the operation was successful or failed

Whether the operation was successful or failed is not shown on the UI, so perform the following procedure to judge if the operation was successful or failed.

B&W mode

Check the following values. If all of them remain at "1,000", the operation result is judged to be "failed".

- COPIER > ADJUST > CCD > LE-BWRBK
- COPIER > ADJUST > CCD > LE-BWGBK
- COPIER > ADJUST > CCD > LE-BWBBK

In the case of a failure, turn OFF and then ON the power, and execute the following service mode again.

- COPIER > FUNCTION > CCD > BW-AGC2

Color mode

Check the following values. If all of them remain at "1,100", the operation result is judged to be "failed".

- COPIER > ADJUST > CCD > LE-CLRBK
- COPIER > ADJUST > CCD > LE-CLGBK
- COPIER > ADJUST > CCD > LE-CLBBK

In the case of a failure, turn OFF and then ON the power, and execute the following service mode again.

- COPIER > FUNCTION > CCD > CL-AGC2

4. If the operation was "successful", this procedure is completed. (There is no need to write down the values on the service label.)

12. Paper back shading initial measurement (simultaneous duplex scanning models only)

- Execute the following service mode without placing anything on the Stream Reading Glass.
 - COPIER > FUNCTION > CCD > BK-SHD1
- Place the Paper Back Shading Adjustment Member (FL1-4365) on the Stream Reading Glass, and execute the following service mode.

CAUTION:

Be sure to close the ADF before executing the foregoing service mode. Also be sure not to open the ADF while the service mode is being executed.

- COPIER > FUNCTION > CCD > BK-SHD2



- Check the following service mode to determine if it was [1] successful or [0] failed.
 - COPIER > FUNCTION > CCD > BK-SHDST
- If it failed, clean the Stream Reading Glass and the Paper Back Shading Adjustment Member (FL1-4365), and perform the procedure from step 1 again.

13. Enter the offset values

Enter the values shown on the service label in service mode.

<DFTAR-R>

- COPIER > ADJUST > CCD > DFTAR-R

<DFTAR-G>

- COPIER > ADJUST > CCD > DFTAR-G

<DFTAR-B>

- COPIER > ADJUST > CCD > DFTAR-B

<DFTAR-BW>

- COPIER > ADJUST > CCD > DFTAR-BW

<DFTBK-R>

- COPIER > ADJUST > CCD > DFTBK-R

<DFTBK-G>

- COPIER > ADJUST > CCD > DFTBK-G

<DFTBK-B>

- COPIER > ADJUST > CCD > DFTBK-B

<DFTBK-BW>

- COPIER > ADJUST > CCD > DFTBK-BW

<ADJ-X>

- COPIER > ADJUST > ADJ-XY > ADJ-X

- <ADJ-Y>
 - COPIER > ADJUST > ADJ-XY > ADJ-Y
- <ADJ-X-MG>
 - COPIER > ADJUST > ADJ-XY > ADJ-X-MG
- <ADJ-Y-DF>
 - COPIER > ADJUST > ADJ-XY > ADJ-Y-DF
- <ADJY-DF2>
 - COPIER > ADJUST > ADJ-XY > ADJY-DF2
- <DOCST>
 - FEEDER > ADJUST > DOCST
- <DOCST2>
 - FEEDER > ADJUST > DOCST2
- <LA-SPEED>
 - FEEDER > ADJUST > LA-SPEED
- <LA-SPD2>
 - FEEDER > ADJUST > LA-SPD2
- <100-RG>
 - COPIER > ADJUST > CCD > 50-RG
 - COPIER > ADJUST > CCD > 100-RG
- <100-GB>
 - COPIER > ADJUST > CCD > 50-GB
 - COPIER > ADJUST > CCD > 100-GB
- <100DF-RG>
 - COPIER > ADJUST > CCD > 50DF-RG
 - COPIER > ADJUST > CCD > 100DF-RG
- <100DF-GB>
 - COPIER > ADJUST > CCD > 50DF-GB
 - COPIER > ADJUST > CCD > 100DF-GB
- <100DF2RG>
 - COPIER > ADJUST > CCD > 50DF2RG
 - COPIER > ADJUST > CCD > 100DF2RG
- <100DF2GB>
 - COPIER > ADJUST > CCD > 50DF2GB
 - COPIER > ADJUST > CCD > 100DF2GB
- <OFST-P-Y>
 - COPIER > ADJUST > PASCAL > OFST-P-Y
- <OFST-P-M>
 - COPIER > ADJUST > PASCAL > OFST-P-M
- <OFST-P-C>
 - COPIER > ADJUST > PASCAL > OFST-P-C
- <OFST-P-K>
 - COPIER > ADJUST > PASCAL > OFST-P-K

14. Enter the MTF values

NOTE:

To reduce the number of label items, the setting values are the same.

- The values of MTF-M1, MTF-M4, and MTF-M7 are the same.
- The values of MTF-M2, MTF-M5, and MTF-M8 are the same.
- The values of MTF-M3, MTF-M6, and MTF-M9 are the same.

<MTF-M1>

- COPIER > ADJUST > CCD > MTF-M1
- COPIER > ADJUST > CCD > MTF-M4
- COPIER > ADJUST > CCD > MTF-M7

<MTF-M2>

- COPIER > ADJUST > CCD > MTF-M2
- COPIER > ADJUST > CCD > MTF-M5
- COPIER > ADJUST > CCD > MTF-M8

<MTF-M3>

- COPIER > ADJUST > CCD > MTF-M3
- COPIER > ADJUST > CCD > MTF-M6
- COPIER > ADJUST > CCD > MTF-M9

NOTE:

To reduce the number of label items, the setting values are the same.

- The values of MTF2-M1, MTF2-M4, and MTF2-M7 are the same.
- The values of MTF2-M2, MTF2-M5, and MTF2-M8 are the same.
- The values of MTF2-M3, MTF2-M6, and MTF2-M9 are the same.

<MTF2-M1>

- COPIER > ADJUST > CCD > MTF2-M1
- COPIER > ADJUST > CCD > MTF2-M4
- COPIER > ADJUST > CCD > MTF2-M7

<MTF2-M2>

- COPIER > ADJUST > CCD > MTF2-M2
- COPIER > ADJUST > CCD > MTF2-M5
- COPIER > ADJUST > CCD > MTF2-M8

<MTF2-M3>

- COPIER > ADJUST > CCD > MTF2-M3
- COPIER > ADJUST > CCD > MTF2-M6
- COPIER > ADJUST > CCD > MTF2-M9

NOTE:

To reduce the number of label items, the setting values are the same.

- The values of MTF3-M1, MTF3-M4, and MTF3-M7 are the same.
- The values of MTF3-M2, MTF3-M5, and MTF3-M8 are the same.
- The values of MTF3-M3, MTF3-M6, and MTF3-M9 are the same.

<MTF3-M1>

- COPIER > ADJUST > CCD > MTF3-M1
- COPIER > ADJUST > CCD > MTF3-M4
- COPIER > ADJUST > CCD > MTF3-M7

<MTF3-M2>

- COPIER > ADJUST > CCD > MTF3-M2
- COPIER > ADJUST > CCD > MTF3-M5
- COPIER > ADJUST > CCD > MTF3-M8

<MTF3-M3>

- COPIER > ADJUST > CCD > MTF3-M3
- COPIER > ADJUST > CCD > MTF3-M6
- COPIER > ADJUST > CCD > MTF3-M9

NOTE:

To reduce the number of label items, the setting values are the same.

- The values of MTF-S1, MTF-S4, and MTF-S7 are the same.
- The values of MTF-S2, MTF-S5, and MTF-S8 are the same.
- The values of MTF-S3, MTF-S6, and MTF-S9 are the same.

<MTF-S1>

- COPIER > ADJUST > CCD > MTF-S1
- COPIER > ADJUST > CCD > MTF-S4
- COPIER > ADJUST > CCD > MTF-S7

<MTF-S2>

- COPIER > ADJUST > CCD > MTF-S2
- COPIER > ADJUST > CCD > MTF-S5
- COPIER > ADJUST > CCD > MTF-S8

<MTF-S3>

- COPIER > ADJUST > CCD > MTF-S3
- COPIER > ADJUST > CCD > MTF-S6
- COPIER > ADJUST > CCD > MTF-S9

NOTE:

To reduce the number of label items, the setting values are the same.

- The values of MTF2-S1, MTF2-S4, and MTF2-S7 are the same.
- The values of MTF2-S2, MTF2-S5, and MTF2-S8 are the same.
- The values of MTF2-S3, MTF2-S6, and MTF2-S9 are the same.

<MTF2-S1>

- COPIER > ADJUST > CCD > MTF2-S1
- COPIER > ADJUST > CCD > MTF2-S4
- COPIER > ADJUST > CCD > MTF2-S7

<MTF2-S2>

- COPIER > ADJUST > CCD > MTF2-S2
- COPIER > ADJUST > CCD > MTF2-S5
- COPIER > ADJUST > CCD > MTF2-S8

<MTF2-S3>

- COPIER > ADJUST > CCD > MTF2-S3
- COPIER > ADJUST > CCD > MTF2-S6
- COPIER > ADJUST > CCD > MTF2-S9

NOTE:

To reduce the number of label items, the setting values are the same.

- The values of MTF3-S1, MTF3-S4, and MTF3-S7 are the same.
- The values of MTF3-S2, MTF3-S5, and MTF3-S8 are the same.
- The values of MTF3-S3, MTF3-S6, and MTF3-S9 are the same.

<MTF3-S1>

- COPIER > ADJUST > CCD > MTF3-S1
- COPIER > ADJUST > CCD > MTF3-S4
- COPIER > ADJUST > CCD > MTF3-S7

<MTF3-S2>

- COPIER > ADJUST > CCD > MTF3-S2
- COPIER > ADJUST > CCD > MTF3-S5
- COPIER > ADJUST > CCD > MTF3-S8

<MTF3-S3>

- COPIER > ADJUST > CCD > MTF3-S3
- COPIER > ADJUST > CCD > MTF3-S6
- COPIER > ADJUST > CCD > MTF3-S9

15. Enter the linearity correction values

Enter the following values shown on the service label in service mode.

- COPIER > ADJUST > CCD > LNR-GA-R
- COPIER > ADJUST > CCD > LNR-GA-G
- COPIER > ADJUST > CCD > LNR-GA-B
- COPIER > ADJUST > CCD > LNR-OF-R
- COPIER > ADJUST > CCD > LNR-OF-G
- COPIER > ADJUST > CCD > LNR-OF-B

16. Execute initial adjustment

1. Execute the following service mode to back up the Engine Controller setting values.
 - COPIER > FUNCTION > VIFFNC > STOR-DCN
2. Configure the wireless LAN function settings. (In the case of the host machine having the wireless LAN function)
 - COPIER > OPTION > ACC > WLAN
3. Turn OFF and then ON the power of the host machine.
Setup Guide will start. Follow the instructions on the screen to configure the settings.
4. In the following service mode, adjust the Touch Panel.
 - COPIER > ADJUST > PANEL > TOUCHCHK

17. Migrate the serial number

1. In the following LUI, enter the serial number (8-digit alphanumeric number).
 - Menu > Management Settings > Device Management > Device Information Settings > Location
2. Execute the following service mode, and write down the serial number on the Main Controller PCB.
 - COPIER > OPTION > SERIAL > SN-MAIN
3. Execute the following service mode to output the spec report, and check it.
 - COPIER > FUNCTION > MISC-P > SPEC

18. Migrate the user data and service mode setting information

1. Enter service mode, and set the following item to [1].
 - COPIER > OPTION > USER > SMD-EXPT

NOTE:

The [SMD-EXPT] setting can be configured either from the Control Panel or from the remote UI.

2. Restore the data in the same way as that of backup.
Refer to the Backup List for the details of items that are restored.
["Backup Data List" on page 378](#)
 - COPIER > FUNCTION > SYSTEM > IMPORT
 - Menu > Management Settings > Data Management > Import/Export > Import
 - RUI > Settings/Registration > Management Settings > Data Management > Import/Export > Import

CAUTION:

Be sure to restore the data after replacing the Main Controller PCB.

3. Enter service mode, and set the following item to [0].
 - COPIER > OPTION > USER > SMD-EXPT

NOTE:

The [SMD-EXPT] setting can be configured either from the Control Panel or from the remote UI.

19. Reinstall the drivers

1. Uninstall the following drivers on the user's PC.
 - Printer driver
 - Fax driver
 - Scanner driver
 - MF Scan Utility

2. Refer to the following items in Getting Started and install the drivers which were uninstalled.
 - In case of network connection: "To connect via wired LAN"
 - In case of USB connection: "To connect via USB"

NOTE:

MAC address information is changed after replacement of the Main Controller PCB. Therefore, when the PC and the machine are connected by the network, the PC will not be able to recognize the machine on the network. When the PC and the machine are connected by USB, the PC will not be able to recognize the machine if the USB ID is changed. That is why the drivers need to be reinstalled.

After Replacing the ADF Unit

1. Automatic adjustment of the stream reading position

1. Entering a provisional value
 - COPIER > ADJUST > ADJ-XY > STRD-POS, set the value to "-20".
2. Executing the service mode
Execute the following service mode.
 - COPIER > FUNCTION > INSTALL > STRD-POS

CAUTION:

Be sure to close the ADF before executing the foregoing service mode. Also be sure not to open the ADF while the service mode is being executed.

3. If OK or NG is displayed on the UI, whether the operation was successful or failed can be judged based on it. If OK or NG is not displayed, check the following value.
 - COPIER > ADJUST > ADJ-XY > STRD-POS
 If the value above is -20 and remains unchanged, it is judged that the operation failed.
4. In the case of a failure, turn OFF and then ON the power of the host machine, and execute the following service mode again.
 - COPIER > FUNCTION > INSTALL > STRD-POS
5. If the operation is successful
Write the following value on the service label.
 - COPIER > ADJUST > ADJ-XY > STRD-POS

2. AGC adjustment (back side) (duplex scanning ADF model only)

1. Entering a provisional value
Change the values of the following service mode settings to 1,000
 - COPIER > ADJUST > CCD > LE-BWRBK
 - COPIER > ADJUST > CCD > LE-BWGBK
 - COPIER > ADJUST > CCD > LE-BWBBK
 Change the values of the following service mode settings to 1,100.
 - COPIER > ADJUST > CCD > LE-CLRBK
 - COPIER > ADJUST > CCD > LE-CLGBK
 - COPIER > ADJUST > CCD > LE-CLBBK
2. Execute the following service modes to perform the AGC adjustment (surface).
 - COPIER > FUNCTION > CCD > BW-AGC2
 - COPIER > FUNCTION > CCD > CL-AGC2

CAUTION:

Be sure to close the ADF before executing the foregoing service mode. Also be sure not to open the ADF while the service mode is being executed.

3. If the operation was "successful", this procedure is completed. (There is no need to write the value on the service label.)

4. How to judge whether the operation was successful or failed.

Whether the operation was successful or failed is not shown on the UI, so perform the following procedure to judge if the operation was successful or failed.

B&W mode

Check the following values. If all values remain unchanged at "1,000", the operation result is judged to be "failed".

- COPIER > ADJUST > CCD > LE-BWRBK
- COPIER > ADJUST > CCD > LE-BWGBK
- COPIER > ADJUST > CCD > LE-BWBBK

If the operation result is judged to be "failed", turn OFF and then ON the power, and execute COPIER > FUNCTION > CCD > BW-AGC2 again.

Color mode

Check the following values. If all values remain unchanged at "1,100", the operation result is judged to be "failed".

- COPIER > ADJUST > CCD > LE-CLRBK
- COPIER > ADJUST > CCD > LE-CLGBK
- COPIER > ADJUST > CCD > LE-CLBBK

If the operation result is judged to be "failed", turn OFF and then ON the power, and execute COPIER > FUNCTION > CCD > CL-AGC2 again.

3. Paper back shading initial measurement (duplex scanning ADF model only)

1. Execute the following service mode without placing anything on the Stream Reading Glass.
 - COPIER > FUNCTION > CCD > BK-SHD1
2. Place the Paper Back Shading Adjustment Jig (FL1-4365) on the Stream Reading Glass and execute the following service mode.
 - COPIER > FUNCTION > CCD > BK-SHD2

CAUTION:

Be sure to close the ADF before executing the foregoing service mode. Also be sure not to open the ADF while the service mode is being executed.



3. Check COPIER > DISPLAY > CCD > BK-SHDST to determine if it was [1] successful or [0] failed.
4. If it failed, clean the Stream Reading Glass and the Paper Back Shading Adjustment Jig (FL1-4365) and execute the initial measurement of the paper back shading again.

4. DF white level (DF shading target) adjustment

- Enter the values in the following service mode items respectively, and then adjust the white level.
 - Set the value of COPIER > ADJUST > CCD > DFTAR-R to 299.
 - Set the value of COPIER > ADJUST > CCD > DFTAR-G to 309.
 - Set the value of COPIER > ADJUST > CCD > DFTAR-B to 307.
 - Set the value of COPIER > ADJUST > CCD > DFTAR-BW to 315.

In the case of the duplex scanning ADF model also change the following settings.

 - Set the value of COPIER > ADJUST > CCD > DFTBK-R to 299.
 - Set the value of COPIER > ADJUST > CCD > DFTBK-G to 309.
 - Set the value of COPIER > ADJUST > CCD > DFTBK-B to 307.
 - Set the value of COPIER > ADJUST > CCD > DFTBK-BW to 315.
- Place a sheet of A4 or LTR blank paper (paper recommended by Canon) on the Copyboard Glass of the reader and execute the following service mode.
 - COPIER > FUNCTION > CCD > DF-WLVL1
- Place the same blank paper on the ADF and execute the following service mode.
 - COPIER > FUNCTION > CCD > DF-WLVL2
- If the operation was successful, write the setting value on the service label.
- How to judge whether the operation was successful or failed.

Whether the operation was successful or failed is not shown on the UI, so perform the following procedure to judge if the operation was successful or failed.

 - COPIER > ADJUST > CCD > DFTAR-R
 - COPIER > ADJUST > CCD > DFTAR-G
 - COPIER > ADJUST > CCD > DFTAR-B
 - COPIER > ADJUST > CCD > DFTAR-BW

Check the foregoing values, and if all the values remain the same as those you entered, the operation result is judged to be "failed".
- In the case of a failure, turn OFF and then ON the power, and execute the following service mode items in sequence. Place a sheet of A4 or LTR blank paper (paper recommended by Canon) on the Copyboard Glass of the reader and execute the service mode.
 - COPIER > FUNCTION > CCD > DF-WLVL1

Place the same blank paper on the ADF and execute the service mode.

 - COPIER > FUNCTION > CCD > DF-WLVL2
- In the case of the duplex scanning ADF model, check the following:
 - COPIER > ADJUST > CCD > DFTBK-R
 - COPIER > ADJUST > CCD > DFTBK-G
 - COPIER > ADJUST > CCD > DFTBK-B
 - COPIER > ADJUST > CCD > DFTBK-BW

If all the values remain the same as those you entered, the operation result is judged to be "failed".

In the case of the 1-PASS ADF 1-sided model, the operation result is judged to be OK even if this value does not change.
- In the case of a failure, turn OFF and then ON the power, and execute the following service mode items again.
 - COPIER > FUNCTION > CCD > DF-WLVL1
 - COPIER > FUNCTION > CCD > DF-WLVL2

5. ADF (front/back) geometric adjustment

- On an image copied using the ADF, check the non-image width in the X and Y directions and the expansion/contraction in the X direction. If adjustment is needed, enter the following adjustment values.
 - COPIER > ADJUST > ADJ-XY > ADJ-Y-DF
 - COPIER > ADJUST > ADJ-XY > ADJY-DF2
 - FEEDER > ADJUST > DOCST
 - FEEDER > ADJUST > DOCST2
 - FEEDER > ADJUST > LA-SPEED
 - FEEDER > ADJUST > LA-SPD2
- If you enter adjustment values, write the final values on the service label.

After Replacing the Reader CIS Unit

1. Automatic adjustment of the stream reading position

- Entering a provisional value
 - In COPIER > ADJUST > ADJ-XY > STRD-POS , set the value to "-20".

2. Executing the service mode
Execute the following service mode.
 - COPIER > FUNCTION > INSTALL > STRD-POS

CAUTION:

Be sure to close the ADF before executing the foregoing service mode. Also be sure not to open the ADF while the service mode is being executed.

3. If OK or NG is displayed on the UI, whether the operation was successful or failed can be judged based on it. If OK or NG is not displayed, check the following value.
 - COPIER > ADJUST > ADJ-XY > STRD-POS
 If the value above is -20 and remains unchanged, it is judged that the operation failed.
4. In the case of a failure, turn OFF and then ON the power of the host machine, and execute the following service mode again.
 - COPIER > FUNCTION > INSTALL > STRD-POS
5. If the operation is successful
Write the following value on the service label.
 - COPIER > ADJUST > ADJ-XY > STRD-POS

2. AGC adjustment (paper front)

1. Entering a provisional value
Change the values of the following service mode settings to 1,000.
 - COPIER > ADJUST > CCD > LED-BW-R
 - COPIER > ADJUST > CCD > LED-BW-G
 - COPIER > ADJUST > CCD > LED-BW-B
 Change the values of the following service mode settings to 1,100.
 - COPIER > ADJUST > CCD > LED-CL-R
 - COPIER > ADJUST > CCD > LED-CL-G
 - COPIER > ADJUST > CCD > LED-CL-B
2. Execute the following service modes to perform the AGC adjustment (surface).
 - COPIER > FUNCTION > CCD > BW-AGC
 - COPIER > FUNCTION > CCD > CL-AGC

CAUTION:

Be sure to close the ADF before executing the foregoing service mode. Also be sure not to open the ADF while the service mode is being executed.

3. If the operation was "successful", this procedure is completed. (There is no need to write the value on the service label.)
4. How to judge whether the operation was successful or failed.
Whether the operation was successful or failed is not shown on the UI, so perform the following procedure to judge if the operation was successful or failed.
B&W mode
Check the following values. If all of them remain at "1,000", the operation result is judged to be "failed"
 - COPIER > ADJUST > CCD > LED-BW-R
 - COPIER > ADJUST > CCD > LED-BW-G
 - COPIER > ADJUST > CCD > LED-BW-B
 If the operation result is judged to be "failed", turn OFF and then ON the power, and execute COPIER > FUNCTION > CCD > BW-AGC again.
- Color mode
Check the following values. If all of them remain at "1,100", the operation result is judged to be "failed".
 - COPIER > ADJUST > CCD > LED-CL-R
 - COPIER > ADJUST > CCD > LED-CL-G
 - COPIER > ADJUST > CCD > LED-CL-B
 If the operation result is judged to be "failed", turn OFF and then ON the power, and execute COPIER > FUNCTION > CCD > CL-AGC again.

3. Paper back shading initial measurement (duplex scanning ADF model only)

1. Execute the following service mode without placing anything on the Stream Reading Glass.
 - COPIER > FUNCTION > CCD > BK-SHD1

2. Place the Paper Back Shading Adjustment Jig (FL1-4365) on the Stream Reading Glass and execute the following service mode.
 - COPIER > FUNCTION > CCD > BK-SHD2

CAUTION:

Be sure to close the ADF before executing the foregoing service mode. Also be sure not to open the ADF while the service mode is being executed.



3. Check COPIER > DISPLAY > CCD > BK-SHDST to determine if it was [1] successful or [0] failed.
4. If it failed, clean the Stream Reading Glass and the Paper Back Shading Adjustment Jig (FL1-4365) and execute the initial measurement of the paper back shading again.

4. DF white level (DF shading target) adjustment.

1. Enter the values in the following service mode items respectively, and then adjust the white level
 - Set the value of COPIER > ADJUST > CCD > DFTAR-R to 299.
 - Set the value of COPIER > ADJUST > CCD > DFTAR-G to 309.
 - Set the value of COPIER > ADJUST > CCD > DFTAR-B to 307.
 - Set the value of COPIER > ADJUST > CCD > DFTAR-BW to 315.
 In the case of the duplex scanning ADF model, also change the following settings.
 - Set the value of COPIER > ADJUST > CCD > DFTBK-R to 299.
 - Set the value of COPIER > ADJUST > CCD > DFTBK-G to 309.
 - Set the value of COPIER > ADJUST > CCD > DFTBK-B to 307.
 - Set the value of COPIER > ADJUST > CCD > DFTBK-BW to 315.
2. Place a sheet of A4 or LTR blank paper (paper recommended by Canon) on the Copyboard Glass of the reader and execute the following service mode.
 - COPIER > FUNCTION > CCD > DF-WLVL1
3. Place the same blank paper on the ADF and execute the following service mode.
 - COPIER > FUNCTION > CCD > DF-WLVL2
4. If the operation was successful, write the setting value on the service label.

5. How to judge whether the operation was successful or failed.

Whether the operation was successful or failed is not shown on the UI, so perform the following procedure to judge if the operation was successful or failed.

- COPIER > ADJUST > CCD > DFTAR-R
- COPIER > ADJUST > CCD > DFTAR-G
- COPIER > ADJUST > CCD > DFTAR-B
- COPIER > ADJUST > CCD > DFTAR-BW

Check the foregoing values, and if all the values remain the same as those you entered, the operation result is judged to be "failed".

6. In the case of a failure, turn OFF and then ON the power, and execute the following service mode items in sequence. Place a sheet of A4 or LTR blank paper (paper recommended by Canon) on the Copyboard Glass of the reader and execute the service mode.

- COPIER > FUNCTION > CCD > DF-WLVL1

Place the same blank paper on the ADF and execute the service mode.

- COPIER > FUNCTION > CCD > DF-WLVL2

7. In the case of the duplex scanning ADF model, check the following:

- COPIER > ADJUST > CCD > DFTBK-R
- COPIER > ADJUST > CCD > DFTBK-G
- COPIER > ADJUST > CCD > DFTBK-B
- COPIER > ADJUST > CCD > DFTBK-BW

If all the values remain the same as those you entered, the operation result is judged to be "failed".

In the case of the single sided scanning ADF model, the operation result is judged to be OK even if this value does not change.

8. In the case of a failure, turn OFF and then ON the power, and execute the following service mode items again.

- COPIER > FUNCTION > CCD > DF-WLVL1
- COPIER > FUNCTION > CCD > DF-WLVL2

5. Copyboard geometric adjustment

Enter the values shown on the label that comes with the part in the following service mode items.

Enter the values of ADJ-X, ADJ-Y, and ADJ-X-MG shown on the replacement label in the following service modes.

- COPIER > ADJUST > ADJ-XY > ADJ-X
- COPIER > ADJUST > ADJ-XY > ADJ-Y
- COPIER > ADJUST > ADJ-XY > ADJ-X-MG

Write the entered values on the service label.

6. ADF (front/back) geometric adjustment

1. On an image copied using the ADF, check the non-image width in the X and Y directions and the expansion/contraction in the X direction. If adjustment is needed, enter the following adjustment values.

- COPIER > ADJUST > ADJ-XY > ADJ-Y-DF
- COPIER > ADJUST > ADJ-XY > ADJY-DF2
- FEEDER > ADJUST > DOCST
- FEEDER > ADJUST > DOCST2
- FEEDER > ADJUST > LA-SPEED
- FEEDER > ADJUST > LA-SPD2

2. If you enter adjustment values, write the final values on the service label.

After Replacing the Reader Upper Cover Unit

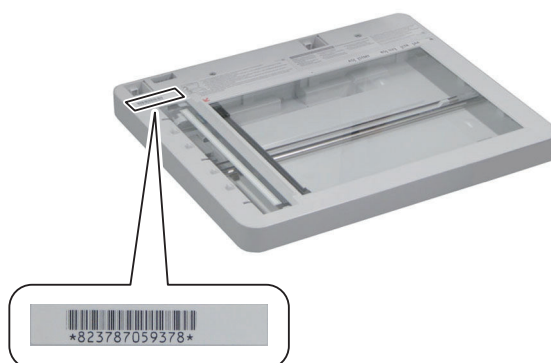
1. Check the setting value of the Standard White Plate.

2. After entering the X, Y, and Z values shown on the barcode on the Copyboard Glass in the following service mode items, and then write the entered values (the X, Y, and Z values shown on the barcode on the Copyboard Glass) on the service label.

- COPIER > ADJUST > CCD > W-PLT-X
- COPIER > ADJUST > CCD > W-PLT-Y
- COPIER > ADJUST > CCD > W-PLT-Z

NOTE:

The value of W-PLT-X: The first four digits of the value on the label

The value of W-PLT-Y: The four digits in the middle of the value on the label

The value of W-PLT-Z: The last four digits of the value on the label

3. Calculate the target value of B&W shading

Turn OFF and then ON the power of the host machine, and then execute the following service mode.

- COPIER > FUNCTION > CCD > BW-TGT

4. Automatic adjustment of the stream reading position

1. Entering a provisional value
 - In COPIER > ADJUST > ADJ-XY > STRD-POS, set the value to "-20".
2. Executing the service mode

Execute the following service mode.

 - COPIER > FUNCTION > INSTALL > STRD-POS

CAUTION:

Be sure to close the ADF before executing the foregoing service mode. Also be sure not to open the ADF while the service mode is being executed.

3. If OK or NG is displayed on the UI, whether the operation was successful or failed can be judged based on it. If OK or NG is not displayed, check the following value.
 - COPIER > ADJUST > ADJ-XY > STRD-POS

If the value above is -20 and remains unchanged, it is judged that the operation failed.
4. In the case of a failure, turn OFF and then ON the power of the host machine, and execute the following service mode again.
 - COPIER > FUNCTION > INSTALL > STRD-POS
5. If the operation is successful

Write the following value on the service label.

 - COPIER > ADJUST > ADJ-XY > STRD-POS

5. AGC adjustment (paper front)

1. Entering a provisional value

Change the values of the following service mode settings to 1,000.

 - COPIER > ADJUST > CCD > LED-BW-R
 - COPIER > ADJUST > CCD > LED-BW-G
 - COPIER > ADJUST > CCD > LED-BW-B

Change the values of the following service mode settings to 1,100.

 - COPIER > ADJUST > CCD > LED-CL-R
 - COPIER > ADJUST > CCD > LED-CL-G
 - COPIER > ADJUST > CCD > LED-CL-B
2. Execute the following service modes to perform the AGC adjustment (surface).
 - COPIER > FUNCTION > CCD > BW-AGC
 - COPIER > FUNCTION > CCD > CL-AGC

CAUTION:

Be sure to close the ADF before executing the foregoing service mode. Also be sure not to open the ADF while the service mode is being executed.

3. If the operation was "successful", this procedure is completed. (There is no need to write the value on the service label.)

4. How to judge whether the operation was successful or failed

Whether the operation was successful or failed is not shown on the UI, so perform the following procedure to judge if the operation was successful or failed.

B&W mode

Check the following values. If all of them remain at "1,000", the operation result is judged to be "failed"

- COPIER > ADJUST > CCD > LED-BW-R
- COPIER > ADJUST > CCD > LED-BW-G
- COPIER > ADJUST > CCD > LED-BW-B

If the operation result is judged to be "failed", turn OFF and then ON the power, and execute COPIER > FUNCTION > CCD > BW-AGC again.

Color mode

Check the following values. If all of them remain at "1,100", the operation result is judged to be "failed".

- COPIER > ADJUST > CCD > LED-CL-R
- COPIER > ADJUST > CCD > LED-CL-G
- COPIER > ADJUST > CCD > LED-CL-B

If the operation result is judged to be "failed", turn OFF and then ON the power, and execute COPIER > FUNCTION > CCD > BW-AGC again.

6. AGC adjustment (back side) (duplex scanning ADF model only)

1. Entering a provisional value

Change the values of the following service mode settings to 1,000

- COPIER > ADJUST > CCD > LE-BWRBK
- COPIER > ADJUST > CCD > LE-BWGBK
- COPIER > ADJUST > CCD > LE-BWBBK

Change the values of the following service mode settings to 1,100.

- COPIER > ADJUST > CCD > LE-CLRBK
- COPIER > ADJUST > CCD > LE-CLGBK
- COPIER > ADJUST > CCD > LE-CLBBK

2. Execute the following service modes to perform the AGC adjustment (surface).

- COPIER > FUNCTION > CCD > BW-AGC2
- COPIER > FUNCTION > CCD > CL-AGC2

CAUTION:

Be sure to close the ADF before executing the foregoing service mode. Also be sure not to open the ADF while the service mode is being executed.

3. If the operation was "successful", this procedure is completed. (There is no need to write the value on the service label.)

4. How to judge whether the operation was successful or failed

Whether the operation was successful or failed is not shown on the UI, so perform the following procedure to judge if the operation was successful or failed.

B&W mode

- COPIER > ADJUST > CCD > LE-BWRBK
- COPIER > ADJUST > CCD > LE-BWGBK
- COPIER > ADJUST > CCD > LE-BWBBK

If the operation result is judged to be "failed", turn OFF and then ON the power, and execute COPIER > FUNCTION > CCD > BW-AGC2 again.

Color mode

Check the following values. If all values remain unchanged at "1,100", the operation result is judged to be "failed".

- COPIER > ADJUST > CCD > LE-CLRBK
- COPIER > ADJUST > CCD > LE-CLGBK
- COPIER > ADJUST > CCD > LE-CLBBK

If the operation result is judged to be "failed", turn OFF and then ON the power, and execute COPIER > FUNCTION > CCD > CL-AGC2 again.

7. Paper back shading initial measurement (duplex scanning ADF model only)

1. Execute the following service mode without placing anything on the Stream Reading Glass.

- COPIER > FUNCTION > CCD > BK-SHD1

2. Place the Paper Back Shading Adjustment Jig (FL1-4365) on the Stream Reading Glass and execute the following service mode.
 - COPIER > FUNCTION > CCD > BK-SHD2

CAUTION:

Be sure to close the ADF before executing the foregoing service mode. Also be sure not to open the ADF while the service mode is being executed.

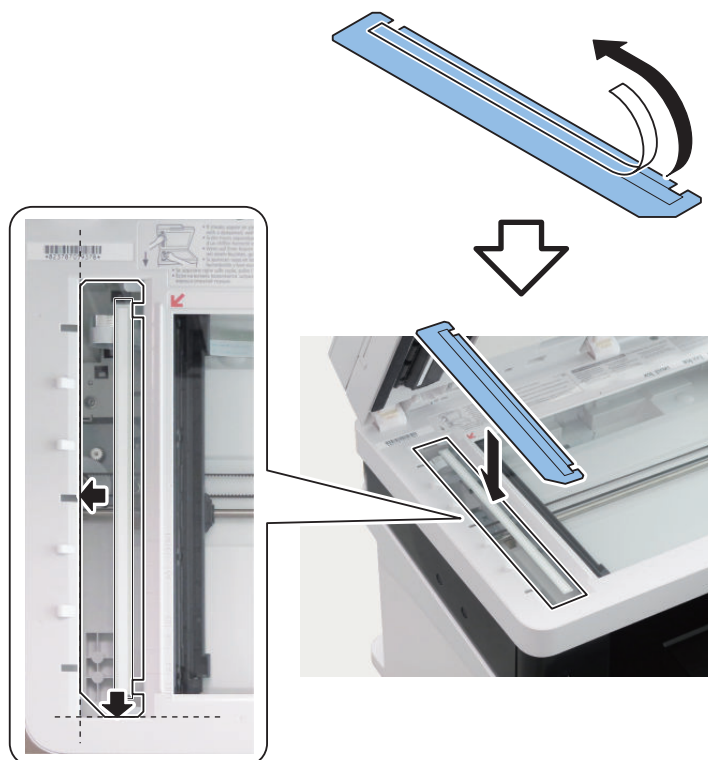

3. Check COPIER > DISPLAY > CCD > BK-SHDST to determine if it was [1] successful or [0] failed.
4. If it failed, clean the Stream Reading Glass and the Paper Back Shading Adjustment Jig (FL1-4365) and execute the initial measurement of the paper back shading again.

8. DF white level (DF shading target) adjustment

1. Enter the values in the following service mode items respectively, and then adjust the white level
 - Set the value of COPIER > ADJUST > CCD > DFTAR-R to 299.
 - Set the value of COPIER > ADJUST > CCD > DFTAR-G to 309.
 - Set the value of COPIER > ADJUST > CCD > DFTAR-B to 307.
 - Set the value of COPIER > ADJUST > CCD > DFTAR-BW to 315.

In the case of the duplex scanning ADF model, also change the following settings.

 - Set the value of COPIER > ADJUST > CCD > DFTBK-R to 299.
 - Set the value of COPIER > ADJUST > CCD > DFTBK-G to 309.
 - Set the value of COPIER > ADJUST > CCD > DFTBK-B to 307.
 - Set the value of COPIER > ADJUST > CCD > DFTBK-BW to 315.
2. Place a sheet of A4 or LTR blank paper (paper recommended by Canon) on the Copyboard Glass of the reader and execute the following service mode.
 - COPIER > FUNCTION > CCD > DF-WLVL1
3. Place the same blank paper on the ADF and execute the following service mode.
 - COPIER > FUNCTION > CCD > DF-WLVL2
4. If the operation was successful, write the setting value on the service label.

5. How to judge whether the operation was successful or failed

Whether the operation was successful or failed is not shown on the UI, so perform the following procedure to judge if the operation was successful or failed.

- COPIER > ADJUST > CCD > DFTAR-R
- COPIER > ADJUST > CCD > DFTAR-G
- COPIER > ADJUST > CCD > DFTAR-B
- COPIER > ADJUST > CCD > DFTAR-BW

Check the foregoing values, and if all the values remain the same as those you entered, the operation result is judged to be "failed".

6. In the case of a failure, turn OFF and then ON the power, and execute the following service mode items in sequence. Place a sheet of A4 or LTR blank paper (paper recommended by Canon) on the Copyboard Glass of the reader and execute the service mode.

- COPIER > FUNCTION > CCD > DF-WLVL1

Place the same blank paper on the ADF and execute the service mode.

- COPIER > FUNCTION > CCD > DF-WLVL2

7. In the case of the duplex scanning ADF model, check the following:

- COPIER > ADJUST > CCD > DFTBK-R
- COPIER > ADJUST > CCD > DFTBK-G
- COPIER > ADJUST > CCD > DFTBK-B
- COPIER > ADJUST > CCD > DFTBK-BW

If all the values remain the same as those you entered, the operation result is judged to be "failed".

In the case of the single sided scanning ADF model, the operation result is judged to be OK even if this value does not change.

8. In the case of a failure, turn OFF and then ON the power, and execute the following service mode items again.

- COPIER > FUNCTION > CCD > DF-WLVL1
- COPIER > FUNCTION > CCD > DF-WLVL2

9. Copyboard geometric adjustment

Enter the values shown on the label that comes with the part in the following service mode items.

Enter the values of ADJ-X, ADJ-Y, and ADJ-X-MG shown on the replacement label in the following service modes.

- COPIER > ADJUST > ADJ-XY > ADJ-X
- COPIER > ADJUST > ADJ-XY > ADJ-Y
- COPIER > ADJUST > ADJ-XY > ADJ-X-MG

Write the entered values on the service label.

10. ADF (front/back) geometric adjustment

1. On an image copied using the ADF, check the non-image width in the X and Y directions and the expansion/contraction in the X direction. If adjustment is needed, enter the following adjustment values.

- COPIER > ADJUST > ADJ-XY > ADJ-Y-DF
- COPIER > ADJUST > ADJ-XY > ADJY-DF2
- FEEDER > ADJUST > DOCST
- FEEDER > ADJUST > DOCST2
- FEEDER > ADJUST > LA-SPEED
- FEEDER > ADJUST > LA-SPD2

2. If you enter adjustment values, write the final values on the service label.

After Replacing the Reader Unit

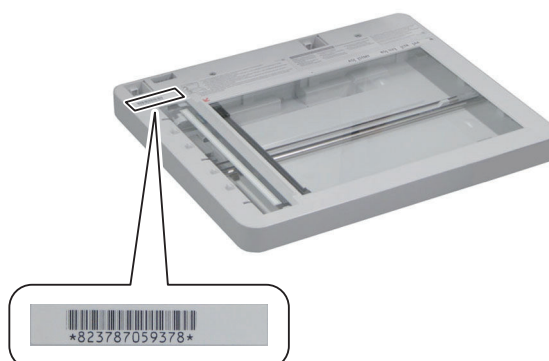
1. Check the setting value of the Standard White Plate.

2. After entering the X, Y, and Z values shown on the barcode on the Copyboard Glass in the following service mode items, and then write the entered values (the X, Y, and Z values shown on the barcode on the Copyboard Glass) on the service label.

- COPIER > ADJUST > CCD > W-PLT-X
- COPIER > ADJUST > CCD > W-PLT-Y
- COPIER > ADJUST > CCD > W-PLT-Z

NOTE:

The value of W-PLT-X: The first four digits of the value on the label

The value of W-PLT-Y: The four digits in the middle of the value on the label

The value of W-PLT-Z: The last four digits of the value on the label

3. Calculate the target value of B&W shading

Turn OFF and then ON the power of the host machine, and then execute the following service mode.

- COPIER > FUNCTION > CCD > BW-TGT

4. Automatic adjustment of the stream reading position

1. Entering a provisional value
 - COPIER > ADJUST > ADJ-XY > STRD-POS, set the value to "-20".
2. Executing the service mode
Execute the following service mode.
 - COPIER > FUNCTION > INSTALL > STRD-POS

CAUTION:

Be sure to close the ADF before executing the foregoing service mode. Also be sure not to open the ADF while the service mode is being executed.

3. If OK or NG is displayed on the UI, whether the operation was successful or failed can be judged based on it. If OK or NG is not displayed, check the following value.
 - COPIER > ADJUST > ADJ-XY > STRD-POS
 If the value above is -20 and remains unchanged, it is judged that the operation failed.
4. In the case of a failure, turn OFF and then ON the power of the host machine, and execute the following service mode again.
 - COPIER > FUNCTION > INSTALL > STRD-POS
5. If the operation is successful
Write the following value on the service label.
 - COPIER > ADJUST > ADJ-XY > STRD-POS

5. AGC adjustment (paper front)

1. Entering a provisional value
Change the values of the following service mode settings to 1,000.
 - COPIER > ADJUST > CCD > LED-BW-R
 - COPIER > ADJUST > CCD > LED-BW-G
 - COPIER > ADJUST > CCD > LED-BW-B
 Change the values of the following service mode settings to 1,100.
 - COPIER > ADJUST > CCD > LED-CL-R
 - COPIER > ADJUST > CCD > LED-CL-G
 - COPIER > ADJUST > CCD > LED-CL-B
2. Execute the following service modes to perform the AGC adjustment (surface).
 - COPIER > FUNCTION > CCD > BW-AGC
 - COPIER > FUNCTION > CCD > CL-AGC

CAUTION:

Be sure to close the ADF before executing the foregoing service mode. Also be sure not to open the ADF while the service mode is being executed.

3. If the operation was "successful", this procedure is completed. (There is no need to write the value on the service label.)

4. How to judge whether the operation was successful or failed

Whether the operation was successful or failed is not shown on the UI, so perform the following procedure to judge if the operation was successful or failed.

B&W mode

Check the following values. If all of them remain at "1,000", the operation result is judged to be "failed"

- COPIER > ADJUST > CCD > LED-BW-R
- COPIER > ADJUST > CCD > LED-BW-G
- COPIER > ADJUST > CCD > LED-BW-B

If the operation result is judged to be "failed", turn OFF and then ON the power, and execute COPIER > FUNCTION > CCD > BW-AGC again.

Color mode

Check the following values. If all of them remain at "1,100", the operation result is judged to be "failed".

- COPIER > ADJUST > CCD > LED-CL-R
- COPIER > ADJUST > CCD > LED-CL-G
- COPIER > ADJUST > CCD > LED-CL-B

If the operation result is judged to be "failed", turn OFF and then ON the power, and execute COPIER > FUNCTION > CCD > CL-AGC again.

6. AGC adjustment (back side) (For the duplex scanning ADF model only)

1. Entering a provisional value

Change the values of the following service mode settings to 1,000

- COPIER > ADJUST > CCD > LE-BWRBK
- COPIER > ADJUST > CCD > LE-BWGBK
- COPIER > ADJUST > CCD > LE-BWBBK

Change the values of the following service mode settings to 1,100.

- COPIER > ADJUST > CCD > LE-CLRBK
- COPIER > ADJUST > CCD > LE-CLGBK
- COPIER > ADJUST > CCD > LE-CLBBK

2. Execute the following service modes to perform the AGC adjustment (surface).

- COPIER > FUNCTION > CCD > BW-AGC2
- COPIER > FUNCTION > CCD > CL-AGC2

CAUTION:

Be sure to close the ADF before executing the foregoing service mode. Also be sure not to open the ADF while the service mode is being executed.

3. If the operation was "successful", this procedure is completed. (There is no need to write the value on the service label.)

4. How to judge whether the operation was successful or failed

Whether the operation was successful or failed is not shown on the UI, so perform the following procedure to judge if the operation was successful or failed.

B&W mode

Check the following values. If all values remain unchanged at "1,000", the operation result is judged to be "failed".

- COPIER > ADJUST > CCD > LE-BWRBK
- COPIER > ADJUST > CCD > LE-BWGBK
- COPIER > ADJUST > CCD > LE-BWBBK

If the operation result is judged to be "failed", turn OFF and then ON the power, and execute COPIER > FUNCTION > CCD > BW-AGC2 again.

Color mode

Check the following values. If all values remain unchanged at "1,100", the operation result is judged to be "failed".

- COPIER > ADJUST > CCD > LE-CLRBK
- COPIER > ADJUST > CCD > LE-CLGBK
- COPIER > ADJUST > CCD > LE-CLBBK

If the operation result is judged to be "failed", turn OFF and then ON the power, and execute COPIER > FUNCTION > CCD > CL-AGC2 again.

7. Paper back shading initial measurement (duplex scanning ADF model only)

1. Execute the following service mode without placing anything on the Stream Reading Glass.

- COPIER > FUNCTION > CCD > BK-SHD1

2. Place the Paper Back Shading Adjustment Jig (FL1-4365) on the Stream Reading Glass and execute the following service mode.
 - COPIER > FUNCTION > CCD > BK-SHD2

CAUTION:

Be sure to close the ADF before executing the foregoing service mode. Also be sure not to open the ADF while the service mode is being executed.



3. Check COPIER > DISPLAY > CCD > BK-SHDST to determine if it was [1] successful or [0] failed.
4. If it failed, clean the Stream Reading Glass and the Paper Back Shading Adjustment Jig (FL1-4365) and execute the initial measurement of the paper back shading again.

8. DF white level (DF shading target) adjustment

1. Enter the values in the following service mode items respectively, and then adjust the white level
 - Set the value of COPIER > ADJUST > CCD > DFTAR-R to 299.
 - Set the value of COPIER > ADJUST > CCD > DFTAR-G to 309.
 - Set the value of COPIER > ADJUST > CCD > DFTAR-B to 307.
 - Set the value of COPIER > ADJUST > CCD > DFTAR-BW to 315.
 In the case of the duplex scanning ADF model, also change the following settings.
 - Set the value of COPIER > ADJUST > CCD > DFTBK-R to 299.
 - Set the value of COPIER > ADJUST > CCD > DFTBK-G to 309.
 - Set the value of COPIER > ADJUST > CCD > DFTBK-B to 307.
 - Set the value of COPIER > ADJUST > CCD > DFTBK-BW to 315.
2. Place a sheet of A4 or LTR blank paper (paper recommended by Canon) on the Copyboard Glass of the reader and execute the following service mode.
 - COPIER > FUNCTION > CCD > DF-WLVL1
3. Place the same blank paper on the ADF and execute the following service mode.
 - COPIER > FUNCTION > CCD > DF-WLVL2
4. If the operation was successful, write the setting value on the service label.

5. How to judge whether the operation was successful or failed

Whether the operation was successful or failed is not shown on the UI, so perform the following procedure to judge if the operation was successful or failed.

- COPIER > ADJUST > CCD > DFTAR-R
- COPIER > ADJUST > CCD > DFTAR-G
- COPIER > ADJUST > CCD > DFTAR-B
- COPIER > ADJUST > CCD > DFTAR-BW

Check the foregoing values, and if all the values remain the same as those you entered, the operation result is judged to be "failed".

6. In the case of a failure, turn OFF and then ON the power, and execute the following service mode items in sequence. Place a sheet of A4 or LTR blank paper (paper recommended by Canon) on the Copyboard Glass of the reader and execute the service mode.

- COPIER > FUNCTION > CCD > DF-WLVL1

Place the same blank paper on the ADF and execute the service mode.

- COPIER > FUNCTION > CCD > DF-WLVL2

7. In the case of the duplex scanning ADF model, check the following:

- COPIER > ADJUST > CCD > DFTBK-R
- COPIER > ADJUST > CCD > DFTBK-G
- COPIER > ADJUST > CCD > DFTBK-B
- COPIER > ADJUST > CCD > DFTBK-BW

If all the values remain the same as those you entered, the operation result is judged to be "failed".

In the case of the single sided scanning model, the operation result is judged to be OK even if this value does not change.

8. In the case of a failure, turn OFF and then ON the power, and execute the following service mode items again.

- COPIER > FUNCTION > CCD > DF-WLVL1
- COPIER > FUNCTION > CCD > DF-WLVL2

9. Copyboard geometric adjustment

Enter the values shown on the label that comes with the part in the following service mode items.

100-RG

- COPIER > ADJUST > CCD > 50-RG
- COPIER > ADJUST > CCD > 100-RG

100-GB

- COPIER > ADJUST > CCD > 50-GB
- COPIER > ADJUST > CCD > 100-GB

Write the entered values on the service label.

To reduce the number of label items, the values of 100-xx and 50-xx are the same.

10. DF white level (DF shading target) adjustment

1. Enter the values in the following service mode items respectively, and then adjust the white level

- Set the value of COPIER > ADJUST > CCD > DFTAR-R to 299.
- Set the value of COPIER > ADJUST > CCD > DFTAR-G to 309.
- Set the value of COPIER > ADJUST > CCD > DFTAR-B to 307.
- Set the value of COPIER > ADJUST > CCD > DFTAR-BW to 315.

In the case of the duplex scanning ADF model, also change the following settings.

- Set the value of COPIER > ADJUST > CCD > DFTBK-R to 299.
- Set the value of COPIER > ADJUST > CCD > DFTBK-G to 309.
- Set the value of COPIER > ADJUST > CCD > DFTBK-B to 307.
- Set the value of COPIER > ADJUST > CCD > DFTBK-BW to 315.

2. Place a sheet of A4 or LTR blank paper (paper recommended by Canon) on the Copyboard Glass of the reader and execute the following service mode.

- COPIER > FUNCTION > CCD > DF-WLVL1

3. Place the same blank paper on the ADF and execute the following service mode.

- COPIER > FUNCTION > CCD > DF-WLVL2

4. If the operation was successful, write the setting value on the service label.

5. How to judge whether the operation was successful or failed

Whether the operation was successful or failed is not shown on the UI, so perform the following procedure to judge if the operation was successful or failed.

- COPIER > ADJUST > CCD > DFTAR-R
- COPIER > ADJUST > CCD > DFTAR-G
- COPIER > ADJUST > CCD > DFTAR-B
- COPIER > ADJUST > CCD > DFTAR-BW

Check the foregoing values, and if all the values remain the same as those you entered, the operation result is judged to be "failed".

6. In the case of a failure, turn OFF and then ON the power, and execute the following service mode items in sequence. Place a sheet of A4 or LTR blank paper (paper recommended by Canon) on the Copyboard Glass of the reader and execute the service mode.

- COPIER > FUNCTION > CCD > DF-WLVL1

Place the same blank paper on the ADF and execute the service mode.

- COPIER > FUNCTION > CCD > DF-WLVL2

7. In the case of the duplex scanning ADF model, check the following:

- COPIER > ADJUST > CCD > DFTBK-R
- COPIER > ADJUST > CCD > DFTBK-G
- COPIER > ADJUST > CCD > DFTBK-B
- COPIER > ADJUST > CCD > DFTBK-BW

If all the values remain the same as those you entered, the operation result is judged to be "failed".

In the case of the 1-PASS ADF 1-sided model, the operation result is judged to be OK even if this value does not change.

8. In the case of a failure, turn OFF and then ON the power, and execute the following service mode items again.

- COPIER > FUNCTION > CCD > DF-WLVL1
- COPIER > FUNCTION > CCD > DF-WLVL2

11. Copyboard geometric adjustment

Enter the values shown on the label that comes with the part in the following service mode items.

Enter the values of ADJ-X, ADJ-Y, and ADJ-X-MG shown on the replacement label in the following service modes.

- COPIER > ADJUST > ADJ-XY > ADJ-X
- COPIER > ADJUST > ADJ-XY > ADJ-Y
- COPIER > ADJUST > ADJ-XY > ADJ-X-MG

Write the entered values on the service label.

12. ADF (front/back) geometric adjustment

1. On an image copied using the ADF, check the non-image width in the X and Y directions and the expansion/contraction in the X direction. If adjustment is needed, enter the following adjustment values.

- COPIER > ADJUST > ADJ-XY > ADJ-Y-DF
- COPIER > ADJUST > ADJ-XY > ADJY-DF2
- FEEDER > ADJUST > DOCST
- FEEDER > ADJUST > DOCST2
- FEEDER > ADJUST > LA-SPEED
- FEEDER > ADJUST > LA-SPD2

2. If you enter adjustment values, write the final values on the service label.

13. Copyboard color displacement offset adjustment

Enter the values shown on the label that comes with the part in the following service mode items.

100-RG

- COPIER > ADJUST > CCD > 50-RG
- COPIER > ADJUST > CCD > 100-RG

100-GB

- COPIER > ADJUST > CCD > 50-GB
- COPIER > ADJUST > CCD > 100-GB

Write the entered values on the service label.

To reduce the number of label items, the values of 100-xx and 50-xx are the same.

14. ADF (front/back) color displacement offset adjustment

Enter the values shown on the label that comes with the part in the following service mode items.

Enter the value of 100DF-RG shown on the replacement label in the following service modes.

- COPIER > ADJUST > CCD > 50DF-RG
- COPIER > ADJUST > CCD > 100DF-RG

Enter the value of 100DF-GB shown on the replacement label in the following service modes.

- COPIER > ADJUST > CCD > 50DF-GB
- COPIER > ADJUST > CCD > 100DF-GB

In the case of the duplex scanning ADF model

Enter the values shown on the label that comes with the part in the following service mode items.

Enter the value of 100DF2RG shown on the replacement label in the following service modes.

- COPIER > ADJUST > CCD > 50DF2RG
- COPIER > ADJUST > CCD > 100DF2RG

Enter the value of 100DF2GB shown on the replacement label in the following service modes.

- COPIER > ADJUST > CCD > 50DF2GB
- COPIER > ADJUST > CCD > 100DF2GB

15. PASCAL adjustment

Enter the values shown on the label that comes with the part in the following service mode items.

Enter the values of OFST-P-Y, OFST-P-M, OFST-P-C, and OFST-P-K shown on the replacement label in the following service modes.

- COPIER > ADJUST > PASCAL > OFST-P-Y
- COPIER > ADJUST > PASCAL > OFST-P-M
- COPIER > ADJUST > PASCAL > OFST-P-C
- COPIER > ADJUST > PASCAL > OFST-P-K

Write the entered values on the service label.

16. Enter the MTF values

Enter the following values shown on the replacement label that comes with the part in the following service mode items

<MTF-M1>

- COPIER > ADJUST > CCD > MTF-M1
- COPIER > ADJUST > CCD > MTF-M4
- COPIER > ADJUST > CCD > MTF-M7

<MTF-M2>

- COPIER > ADJUST > CCD > MTF-M2
- COPIER > ADJUST > CCD > MTF-M5
- COPIER > ADJUST > CCD > MTF-M8

<MTF-M3>

- COPIER > ADJUST > CCD > MTF-M3
- COPIER > ADJUST > CCD > MTF-M6
- COPIER > ADJUST > CCD > MTF-M9

<MTF-S1>

- COPIER > ADJUST > CCD > MTF-S1
- COPIER > ADJUST > CCD > MTF-S4
- COPIER > ADJUST > CCD > MTF-S7

<MTF-S2>

- COPIER > ADJUST > CCD > MTF-S2
- COPIER > ADJUST > CCD > MTF-S5
- COPIER > ADJUST > CCD > MTF-S8

<MTF-S3>

- COPIER > ADJUST > CCD > MTF-S3
- COPIER > ADJUST > CCD > MTF-S6
- COPIER > ADJUST > CCD > MTF-S9

Write the entered values on the service label.

17. Enter the linearity correction values

Enter the following values shown on the service label in service mode

- COPIER > ADJUST > CCD > LNR-GA-R
- COPIER > ADJUST > CCD > LNR-GA-G
- COPIER > ADJUST > CCD > LNR-GA-B
- COPIER > ADJUST > CCD > LNR-OF-R
- COPIER > ADJUST > CCD > LNR-OF-G
- COPIER > ADJUST > CCD > LNR-OF-B

After Replacing the ADF CIS Unit

1. Automatic adjustment of the stream reading position

1. Entering a provisional value
 - In COPIER > ADJUST > ADJ-XY > STRD-POS , set the value to "-20".
2. Executing the service mode

Execute the following service mode.

 - COPIER > FUNCTION > INSTALL > STRD-POS

CAUTION:

Be sure to close the ADF before executing the foregoing service mode. Also be sure not to open the ADF while the service mode is being executed.

3. If OK or NG is displayed on the UI, whether the operation was successful or failed can be judged based on it. If OK or NG is not displayed, check the following value.
 - COPIER > ADJUST > ADJ-XY > STRD-POS

If the value above is -20 and remains unchanged, it is judged that the operation failed.
4. In the case of a failure, turn OFF and then ON the power of the host machine, and execute the following service mode again.
 - COPIER > FUNCTION > INSTALL > STRD-POS
5. If the operation is successful

Write the following value on the service label.

 - COPIER > ADJUST > ADJ-XY > STRD-POS

2. AGC adjustment (back side) (duplex scanning ADF model only)

1. Entering a provisional value

Change the values of the following service mode settings to 1,000.

 - COPIER > ADJUST > CCD > LE-BWRBK
 - COPIER > ADJUST > CCD > LE-BWGBK
 - COPIER > ADJUST > CCD > LE-BWBBK

Change the values of the following service mode settings to 1,100.

 - COPIER > ADJUST > CCD > LE-CLRBK
 - COPIER > ADJUST > CCD > LE-CLGBK
 - COPIER > ADJUST > CCD > LE-CLBBK
2. Execute the following service modes to perform the AGC adjustment (surface).
 - COPIER > FUNCTION > CCD > BW-AGC2
 - COPIER > FUNCTION > CCD > CL-AGC2

CAUTION:

Be sure to close the ADF before executing the foregoing service mode. Also be sure not to open the ADF while the service mode is being executed.

3. If the operation was "successful", this procedure is completed. (There is no need to write the value on the service label.)
4. How to judge whether the operation was successful or failed

Whether the operation was successful or failed is not shown on the UI, so perform the following procedure to judge if the operation was successful or failed.

B&W mode

Check the following values. If all of them remain at "1,000", the operation result is judged to be "failed"

 - COPIER > ADJUST > CCD > LE-BWRBK
 - COPIER > ADJUST > CCD > LE-BWGBK
 - COPIER > ADJUST > CCD > LE-BWBBK

If the operation result is judged to be "failed", turn OFF and then ON the power, and execute COPIER > FUNCTION > CCD > BW-AGC again.

Color mode

Check the following values. If all of them remain at "1,100", the operation result is judged to be "failed".

 - COPIER > ADJUST > CCD > LE-CLRBK
 - COPIER > ADJUST > CCD > LE-CLGBK
 - COPIER > ADJUST > CCD > LE-CLBBK

If the operation result is judged to be "failed", turn OFF and then ON the power, and execute COPIER > FUNCTION > CCD > CL-AGC again.

3. Paper back shading initial measurement (duplex scanning ADF model only)

- Execute the following service mode without placing anything on the Stream Reading Glass.
 - COPIER > FUNCTION > CCD > BK-SHD1
- Place the Paper Back Shading Adjustment Jig (FL1-4365) on the Stream Reading Glass and execute the following service mode.
 - COPIER > FUNCTION > CCD > BK-SHD2

CAUTION:

Be sure to close the ADF before executing the foregoing service mode. Also be sure not to open the ADF while the service mode is being executed.



- Check COPIER > DISPLAY > CCD > BK-SHDST to determine if it was [1] successful or [0] failed.
- If it failed, clean the Stream Reading Glass and the Paper Back Shading Adjustment Jig (FL1-4365) and execute the initial measurement of the paper back shading again.

4. DF white level (DF shading target) adjustment

- Enter the values in the following service mode items respectively, and then adjust the white level
 - Set the value of COPIER > ADJUST > CCD > DFTAR-R to 299.
 - Set the value of COPIER > ADJUST > CCD > DFTAR-G to 309.
 - Set the value of COPIER > ADJUST > CCD > DFTAR-B to 307.
 - Set the value of COPIER > ADJUST > CCD > DFTAR-BW to 315.

In the case of the duplex scanning ADF model, also change the following settings.

 - Set the value of COPIER > ADJUST > CCD > DFTBK-R to 299.
 - Set the value of COPIER > ADJUST > CCD > DFTBK-G to 309.
 - Set the value of COPIER > ADJUST > CCD > DFTBK-B to 307.
 - Set the value of COPIER > ADJUST > CCD > DFTBK-BW to 315.
- Place a sheet of A4 or LTR blank paper (paper recommended by Canon) on the Copyboard Glass of the reader and execute the following service mode.
 - COPIER > FUNCTION > CCD > DF-WLVL1
- Place the same blank paper on the ADF and execute the following service mode.
 - COPIER > FUNCTION > CCD > DF-WLVL2
- If the operation was successful, write the setting value on the service label.

5. How to judge whether the operation was successful or failed

Whether the operation was successful or failed is not shown on the UI, so perform the following procedure to judge if the operation was successful or failed.

- COPIER > ADJUST > CCD > DFTAR-R
- COPIER > ADJUST > CCD > DFTAR-G
- COPIER > ADJUST > CCD > DFTAR-B
- COPIER > ADJUST > CCD > DFTAR-BW

Check the foregoing values, and if all the values remain the same as those you entered, the operation result is judged to be "failed".

6. In the case of a failure, turn OFF and then ON the power, and execute the following service mode items in sequence. Place a sheet of A4 or LTR blank paper (paper recommended by Canon) on the Copyboard Glass of the reader and execute the service mode.

- COPIER > FUNCTION > CCD > DF-WLVL1

Place the same blank paper on the ADF and execute the service mode.

- COPIER > FUNCTION > CCD > DF-WLVL2

7. In the case of the single sided scanning ADF model, check the following:

- COPIER > ADJUST > CCD > DFTBK-R
- COPIER > ADJUST > CCD > DFTBK-G
- COPIER > ADJUST > CCD > DFTBK-B
- COPIER > ADJUST > CCD > DFTBK-BW

If all the values remain the same as those you entered, the operation result is judged to be "failed".

In the case of the single sided scanning ADF model, the operation result is judged to be OK even if this value does not change.

8. In the case of a failure, turn OFF and then ON the power, and execute the following service mode items again.

- COPIER > FUNCTION > CCD > DF-WLVL1
- COPIER > FUNCTION > CCD > DF-WLVL2

5. ADF (front/back) geometric adjustment

1. On an image copied using the ADF, check the non-image width in the X and Y directions and the expansion/contraction in the X direction. If adjustment is needed, enter the following adjustment values.

- COPIER > ADJUST > ADJ-XY > ADJ-Y-DF
- COPIER > ADJUST > ADJ-XY > ADJY-DF2
- FEEDER > ADJUST > DOCST
- FEEDER > ADJUST > DOCST2
- FEEDER > ADJUST > LA-SPEED
- FEEDER > ADJUST > LA-SPD2

2. If you enter adjustment values, write the final values on the service label.



Troubleshooting

Test Print.....	216
Cartridge Log Report.....	228
Troubleshooting Items.....	231
Debug Log.....	235

Test Print

Engine Test Print

This machine has an engine test print function to check whether the printer engine is operating normally.

NOTE:

In the case of engine test print, a test print can be performed by using only the Engine Controller.

There are two types of engine test print: 1-sided print and 2-sided print.

1. Load A4/LTR paper in the Pickup Cassette.
2. While the machine is in the standby mode, open and close the Front Cover [1] for the predetermined number of times in a row.

CAUTION:

Be sure to perform the next cycle of open/close within 1.5 seconds after the last cycle of open/close.

- In case of 1-sided print
4 times
- In case of 2-sided print
5 times or more

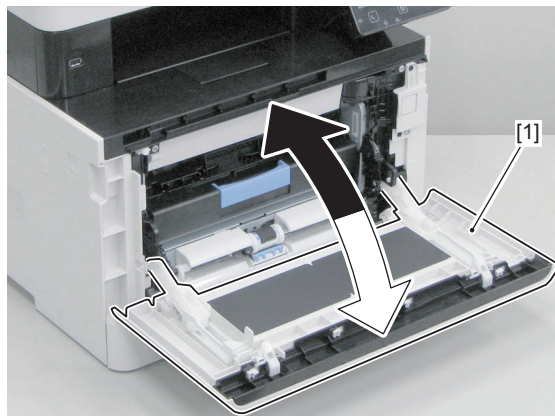

3. An engine test print is executed, and the test pattern as shown below is printed on one side or both sides of a sheet of paper.

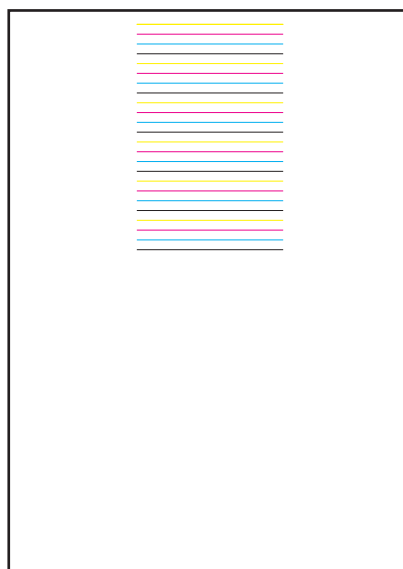

Controller test print

The following test print types are available with this machine, and you can check for failure of an image with a circle 'Yes' described in the image check items in the table below. When no failure is found in the test print in normal output mode, it can be caused in PDL input or Reader.

The image of the test print is generated by the Main Controller PCB.

PG TYPE	TYPE Pattern	Image check items														
		Grada- tion	Fog- ging	Trans- fer Fault	Black line (Color line)	White line	Un- even Den- sity	Un- even Den- sity at the Front/ Rear	Right Angle	Straig- ht Lines	Color dis- place- ment	Color	Ghost	Den- sity	White spots	
0-1	For R&D use															
2	Color chart											Yes				
3	For R&D use															
4	Rainbow chart (vertical scanning direction, A4)										Yes					
5	Rainbow chart (horizontal scan- ning direction, A4)										Yes					
6	Color grid (A4)								Yes	Yes	Yes					
7	Rainbow chart (vertical scanning direction, LTR/ LGL)										Yes					
8	Rainbow chart (horizontal scan- ning direction, LTR/LGL)										Yes					
9	Color grid (LTR/ LGL)								Yes	Yes	Yes					
10	16 gradations	Yes	Yes			Yes		Yes								
11	17 gradations of Y/M/C/Bk/R/G/B	Yes														
12	Halftone			Yes	Yes	Yes	Yes	Yes								
13	For checking ghost due to transfer failure												Yes			
14	For checking the density patch							Yes						Yes		
15	For checking transfer				Yes	Yes		Yes								
20	For R&D use															
21	For checking de- veloping perform- ance (white spots)	Yes														Yes
22	For checking res- olution				Yes	Yes	Yes									
23	For checking banding image				Yes	Yes	Yes									
24	4 colors (land- scape)			Yes	Yes	Yes		Yes								
25	4 colors (portrait)			Yes	Yes	Yes	Yes									

PG TYPE	TYPE Pattern	Image check items														
		Gra- dation	Fog- ging	Trans- fer Fault	Black line (Color line)	White line	Un- even Den- sity	Un- even Den- sity at the Front/ Rear	Right Angle	Straig- ht Lines	Color dis- place- ment	Color	Ghost	Den- sity	White spots	
26	For calibrating color difference between the front and back sides with DADF (2-sided scanning model)															

Follow the procedure shown below to output the test print.

1. Select the TYPE number of the test print by the following service mode.

TESTMODE > PRINT > PG-TYPE

NOTE:

If necessary, change the settings for test print in the following service mode.

If the settings are not changed, a test print will be executed with the initial values of service mode settings.

- Setting of the number of output sheets:
TESTMODE > PRINT > COUNT
- Setting of 1-sided/2-sided printing:
TESTMODE > PRINT > PHASE
- Setting of the image formation method:
TESTMODE > PRINT > MODE
- Setting of the image correction table:
TESTMODE > PRINT > THRU
- Setting of ON/OFF of the laser scanning interpolation process:
TESTMODE > PRINT > NRKE
- Setting of ON/OFF of the test print interpolation process:
TESTMODE > PRINT > BLND
- Setting of the paper source used when outputting a test print:
TESTMODE > PRINT > FEED

2. Execute the following service mode to output a test print.

TESTMODE > PRINT > START

■ How to use the test print

● Color chart (TYPE=2)



Check item	Checking method	Assumed cause
Color	Check the color.	Cartridge error Soiling on the Color Displacement/Density Sensor ITB Unit error Reader error

● Rainbow chart (vertical scanning direction) (TYPE=4, TYPE=7)

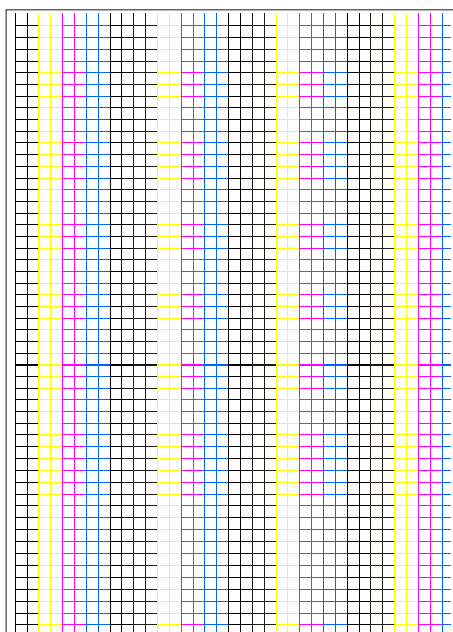

Check item	Checking method	Assumed cause
Color displacement	Output the PG after performing color displacement correction, and check the displacement for each color in the feed direction.	Soiling on the Color Displacement/Density Sensor Cartridge error ITB Unit error Main Drive Unit error

• **Rainbow chart (horizontal scanning direction) (TYPE=5, TYPE=8)**

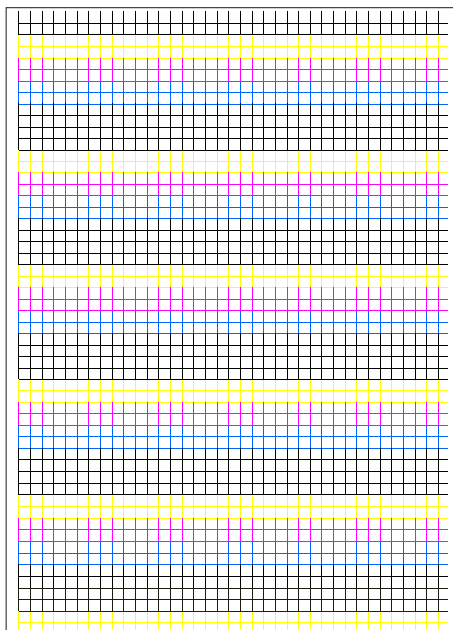

Check item	Checking method	Assumed cause
Color displacement	Output the PG after performing color displacement correction, and check the displacement for each color in the shaft direction.	Soiling on the Color Displacement/Density Sensor Cartridge error ITB Unit error Laser Scanner Unit error Main Controller PCB error

• **Color grid (TYPE=6, TYPE=9)**

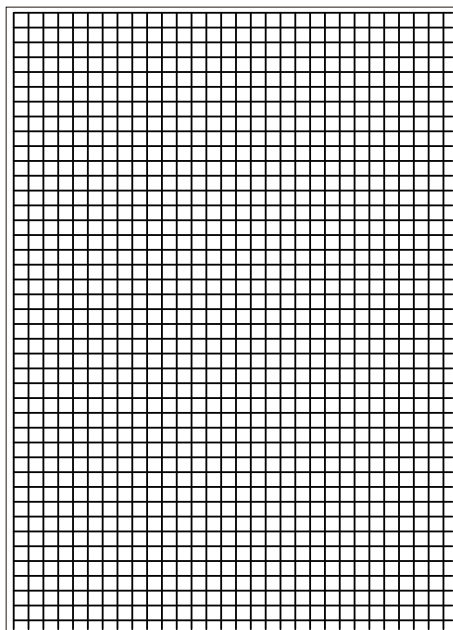

Check item	Checking method	Assumed cause
Color displacement	Check that there is no displacement between the lines of the respective colors.	Laser Scanner Unit error ITB Unit error Soiling on the Registration Sensor Secondary Transfer Roller error Main Drive Unit (drum rotation) error
Right angle accuracy and linearity	Check that there is nothing wrong with the right angle accuracy and linearity between the lines of the respective colors.	Laser Scanner Unit error Registration Roller error Secondary Transfer Roller error

• 16 gradations (TYPE=10)

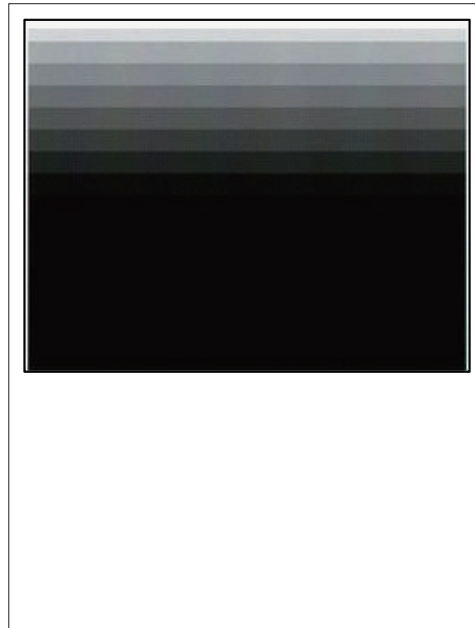

Check item	Checking method	Assumed cause
Gradation	Check that the 16 density gradations are recognizable.	Photosensitive Drum error Laser Scanner Unit error
Fogging	Check whether fogging appears only in the blank area.	Photosensitive Drum error Laser Scanner Unit error
White line	Check the entire image for any white line.	Photosensitive Drum error Laser Scanner Unit error
Uneven density between the front and rear	Check for any uneven density between the rear and front sides.	Photosensitive Drum error Laser Scanner Unit error Soiling on the laser light path

• 17 gradations of Y/M/C/Bk/R/G/B (TYPE=11)

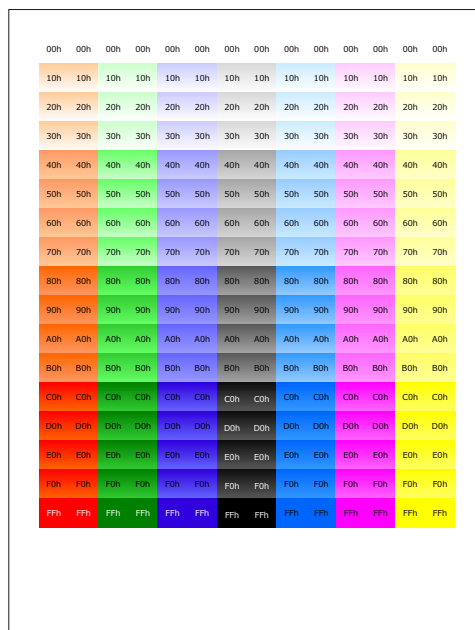

Check item	Checking method	Assumed cause
Gradation	Check that the 16 density gradations are recognizable.	Photosensitive Drum error Laser Scanner Unit error

- Halftone (TYPE=12)

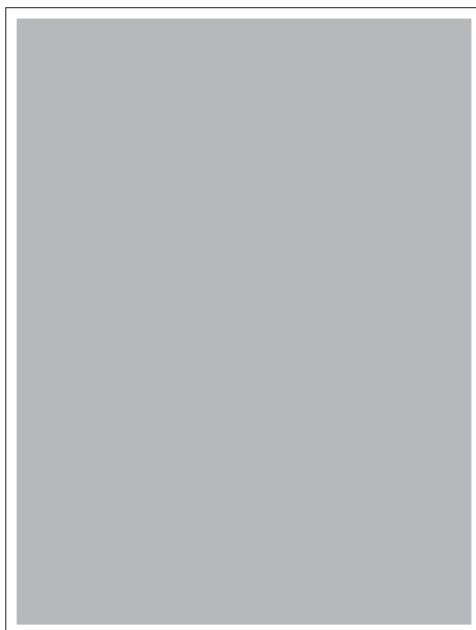
**NOTE:**

Various settings can be configured in the following service mode.

- Output of each developing color:
 - TESTMODE > PRINT > SW-Y
 - TESTMODE > PRINT > SW-M
 - TESTMODE > PRINT > SW-C
 - TESTMODE > PRINT > SW-K
- Print density setting:
 - TESTMODE > PRINT > DENS-Y
 - TESTMODE > PRINT > DENS-M
 - TESTMODE > PRINT > DENS-C
 - TESTMODE > PRINT > DENS-K

Check item	Checking method	Assumed cause
Transfer failure	Check the entire image for any transfer failure.	ITB error (scratches or soiling) Primary Transfer Pad error (scratches or soiling) Secondary Transfer Roller error (scratches or soiling)
Black line (colored line)	Check the entire image for any black line.	Scratches on the Photosensitive Drum
White line	Check the entire image for any white line.	ITB Unit error Secondary Transfer Roller error Soiling on the laser light path
Uneven density at regular intervals	Check the entire image for any uneven density at regular intervals.	Photosensitive Drum error
Uneven density	Check the entire image for any uneven density.	Soiling on the Dustproof Glas Deterioration of the ITB

- For checking ghost due to transfer failure (TYPE=13)

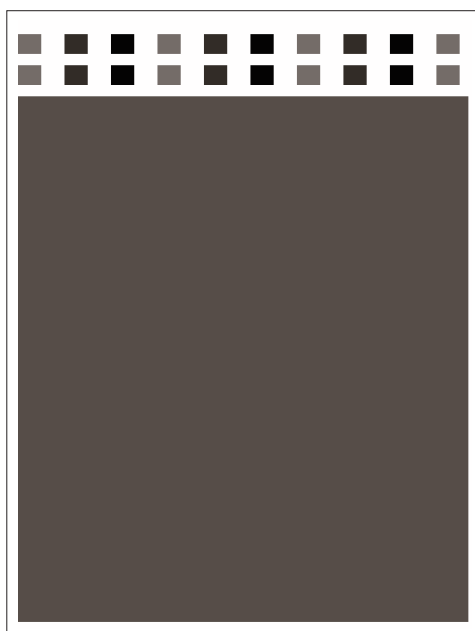

Check item	Checking method	Assumed cause
Ghost	Check the degree of ghosting (area where the density is too high or low) in halftone areas.	Cartridge error ITB Unit error

- For checking the density patch (TYPE=14)

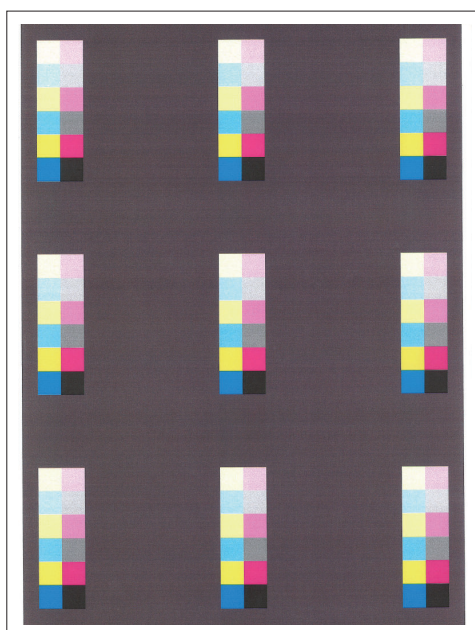

Check item	Checking method	Assumed cause
Density	Check the density of each patch after calibration.	Cartridge error ITB Unit error Secondary Transfer Roller error Soiling on the Color Displacement/Density Sensor Reader error
Uneven density	Check the difference in density among patches.	Cartridge error ITB Unit error

- For checking transfer (TYPE=15)

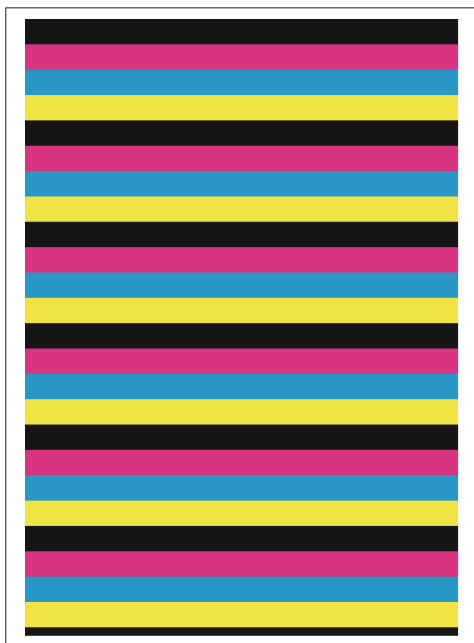

Check item	Checking method	Assumed cause
Uneven density	Check that there is no uneven density in the solid area of each color.	Laser Scanner Unit error Cartridge error Primary Transfer Pad error
Black line (colored line)	Check that there is no black line (colored line) in the solid area of each color.	Scratches on the Photosensitive Drum Soiling on the Primary Charging Roller
White line	Check that there is no white line in the solid area of each color.	ITB Unit error Secondary Transfer Roller error Soiling on the laser light path

- For checking developing performance (white spots) (TYPE=21)

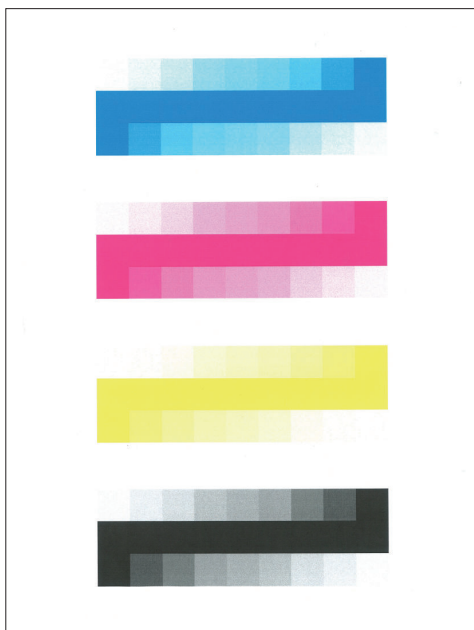

Check item	Checking method	Assumed cause
Gradation	Check the gradation performance.	Cartridge error Soiling on the Color Displacement/Density Sensor ITB Unit error Reader error

Check item	Checking method	Assumed cause
White spots	White spots near the solid patches in halftone patches just before and after the solid patches	Cartridge error

• For checking resolution (TYPE=22)

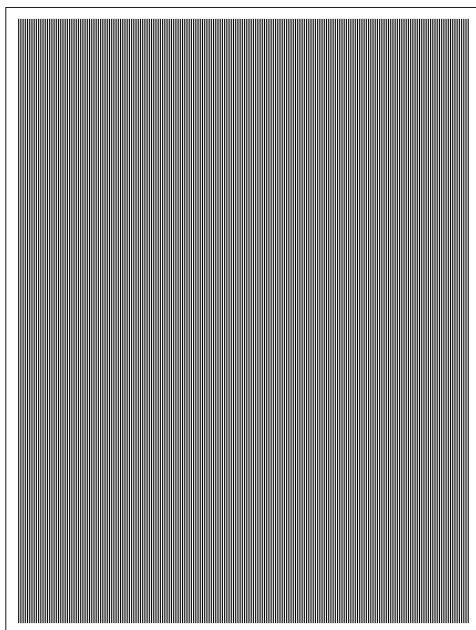

Check item	Checking method	Assumed cause
Line	Check the position and interval.	Laser Scanner Unit error Main Controller PCB error

• For checking banding image (TYPE=23)

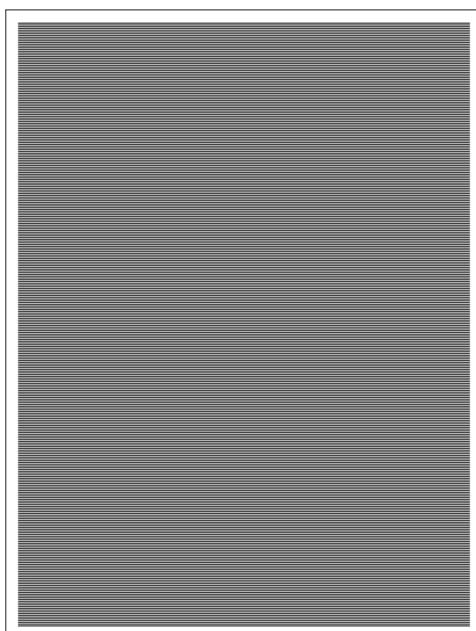

Check item	Checking method	Assumed cause
Line	Check the position and interval.	Cartridge error Main Drive Unit error ITB Unit error Fixing Assembly error Error in the feed path Paper slip at paper pickup

- 4 colors (landscape) (TYPE=24)

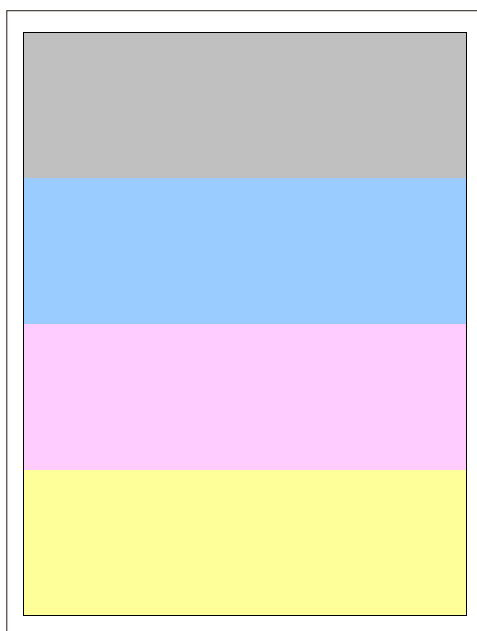

Check item	Checking method	Assumed cause
Line	Check the position of the line, and check whether the line occurs in all colors.	<p>If it occurs during copying but not with this PG:</p> <ul style="list-style-type: none"> Reader error <p>If it occurs only in a single color:</p> <ul style="list-style-type: none"> Cartridge error Laser Scanner Unit error ITB Unit error <p>If it occurs in all colors:</p> <ul style="list-style-type: none"> ITB Unit error Secondary Transfer Roller error Fixing Assembly error

- 4 colors (portrait) (TYPE=25)

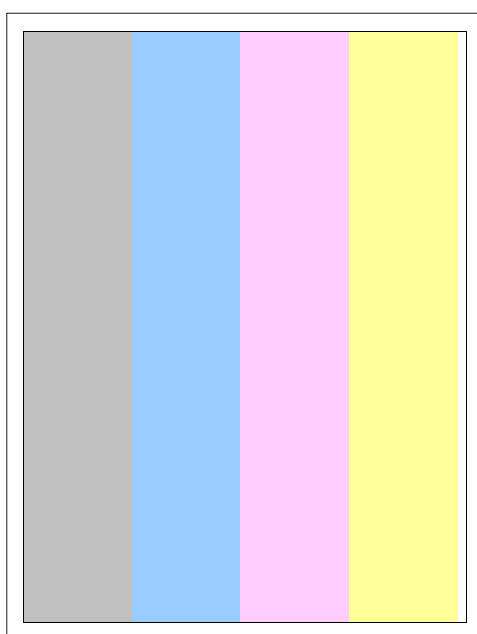

Check item	Checking method	Assumed cause
Line	Check the position of the line, and check whether the line occurs in all colors.	<p>If it occurs during copying but not with this PG:</p> <ul style="list-style-type: none"> Reader error <p>If it occurs only in a single color:</p> <ul style="list-style-type: none"> Cartridge error Laser Scanner Unit error ITB Unit error <p>If it occurs in all colors:</p> <ul style="list-style-type: none"> ITB Unit error Secondary Transfer Roller error Fixing Assembly error

Cartridge Log Report

Logs such as history of cartridge replacement are output as a report.

There are two types of cartridge log reports; one for users and one for service technicians.

CAUTION:

Do not provide users with the cartridge log report for service technicians because it contains detailed information that is not disclosed to end users.

31/10 2018 1:51PM 0001

```

*****
***  CARTRIDGE LOG REPORT  ***
*****
Serial Number
Cyan
(1)      (/2) (/3)      (4/6)      (S1/S5)  (5/7)  (S2/S6) (S3/S7) (S4/S8)
Serial No. Type Cpcty. First/Last Used Pg. Count Left Toner Drum Parts
-----
          C1 Std.    24/10 2018 10:43 PM 00000091 82% 82% 86% 83%
          C1 Std.    25/10 2018 09:09 PM 00000092 82% 82% 85% 82%

Magenta
(1)      (/2) (/3)      (4/6)      (S1/S5)  (5/7)  (S2/S6) (S3/S7) (S4/S8)
Serial No. Type Cpcty. First/Last Used Pg. Count Left Toner Drum Parts
-----
          C1 Std.    24/10 2018 10:43 PM 00000107 80% 80% 84% 80%
          C1 Std.    25/10 2018 09:09 PM 00000108 80% 80% 83% 80%

Yellow
(1)      (/2) (/3)      (4/6)      (S1/S5)  (5/7)  (S2/S6) (S3/S7) (S4/S8)
Serial No. Type Cpcty. First/Last Used Pg. Count Left Toner Drum Parts
-----
          C1 Std.    24/10 2018 10:43 PM 00000106 78% 78% 84% 80%
          C1 Std.    25/10 2018 09:09 PM 00000107 78% 78% 83% 80%

Black
(1)      (/2) (/3)      (4/6)      (S1/S5)  (5/7)  (S2/S6) (S3/S7) (S4/S8)
Serial No. Type Cpcty. First/Last Used Pg. Count Left Toner Drum Parts
-----
          C1 Std.    24/10 2018 10:43 PM 00000084 79% 79% 87% 79%
          C1 Std.    25/10 2018 09:09 PM 00000085 78% 78% 87% 78%

C4: 00000 0000000000
C5: 00000 0000000000
C6: 00000 0000000000
C7: 00000 0000000000
C8: 00000 0000000000
C9: 00000 0000000000

```

[1] points to the title 'CARTRIDGE LOG REPORT'.

[2] points to the 'C4:' label.

[3] points to the '00000' value for C4.

[4] points to the '0000000000' value for C4.

Cartridge Log Report (For service technicians)

No.	Description
[1]	Replacement logs
[2]	Cartridge type
[3]	The number of times a non-genuine cartridge has been detected
[4]	Non-genuine cartridge page count

NOTE:

In addition to output as a report, cartridge logs can also be displayed on the remote UI service mode screen (for service technicians) or remote UI screen (for users).

- To display cartridge logs (for service technicians):
SERVICE REPORT > CRG-LOG
- To display cartridge logs (for users)*:
Status Monitor/Cancel > Cartridge Log

* : When not displaying the cartridge log to users, set the following service mode to "0" (OFF).

- ON/OFF of [Cartridge Log] display:
COPIER > OPTION > DSPLY-SW > CRG-LOG

Output method

Execute the following service mode to output a cartridge log report for service technicians.

- To output a report on cartridge replacement history:
COPIER > FUNCTION > MISC-P > CRG-LOG

NOTE:

- To output a cartridge log report (for users)*:
Menu > Output Reports > Print List > Cartridge Log Report

* : When not allowing users to output the cartridge log report, set the following service mode to "0" (OFF).

- ON/OFF of [Cartridge Log Report] display:
COPIER > OPTION > DSPLY-SW > CRG-LOG

Replacement logs

The record of replacement and usage of cartridges will be printed.

CAUTION:

Just after the cartridge has been replaced with a genuine cartridge or when a non-genuine cartridge is used, accurate information cannot be obtained and a random or approximate value may be printed.

Item	Description	Remarks
(1) Serial No.	Serial number of the cartridge	
(2) Type	Cartridge type	<ul style="list-style-type: none"> C1 : Genuine C2 to C8 : Non-genuine C0 : Unknown
(3) Cpcty.	Cartridge capacity	Displayed in accordance with the toner fillup amount
(4/6) First/Last Used	The date and time it was installed/last used	
(S1/S5) Pg. Count *	Cartridge page count (when it was installed/last used)	00000000 to 99999999
(5/7) Left	The amount remaining in the cartridge (when it was installed/last used)	0 to 100% New: 100%, Non-genuine: -)
(S2/S6) Toner *	The remaining life of the toner (when it was installed/last used)	-128 to 100% (New: 100%, Indefinite: -%)
(S3/S7) Drum *	The remaining life of the drum (when it was installed/last used)	-128 to 100% (New: 100%, Indefinite: -%)
(S4/S8) Parts *	The remaining life of the Developing Assembly (when it was installed/last used)	-128 to 100% (New: 100%, Indefinite: -%)

* : S1 to S8 are printed only on reports for service technicians.

Number of detections of non-genuine cartridge / Page count of non-genuine cartridge

When a non-genuine cartridge is installed, it is classified as a cartridge type C2 to C9 according to the reason for judging it nongenuine, and the number of detections of each type and the number of pages printed with the cartridge installed are recorded.

Reason for judging it non-genuine	Cartridge type		Description
	Report for users*	Report for service	
OEM	C3	C5	The number of detections of an OEM cartridge, and the number of pages printed

Reason for judging it non-genuine	Cartridge type		Description
	Report for users*	Report for service	
Communication error	C2	C4	The number of detections of a cartridge without memory and the number of pages printed
Refill	C3	C6	The number of detections of a cartridge prepared by refilling toner into a genuine cartridge, and the number of pages printed
Copied memory	C3	C7	The number of detections of a cartridge prepared by refilling toner into a genuine cartridge and copying the contents of a normal memory, and the number of pages printed
Authentication failed	C2	C8	The number of detections of a cartridge that cannot be authenticated, and the number of pages printed
Incompatible	C9	C9	The number of detections of an incompatible cartridge that can be installed physically, and the number of pages printed.

* : Only C2, C3 and C9 are displayed. The total count of the values of the reasons for judging the cartridge non-genuine is displayed.

NOTE:

The number of detections of non-genuine cartridge and the page count of non-genuine cartridge can be reset.

- To clear the cartridge replacement log:
COPIER > FUNCTION > CLEAR > CRGL-CNT

Troubleshooting Items

Remedy for Image Failure

When an image failure occurs, perform the remedy by referring to the User's Guide.

- User's Guide > Top page > Troubleshooting > When You Cannot Print Properly

NOTE:

URL of User's Guide:

<http://canon.com/oip-manual>

Recurring faulty image

Overview

Foreign matters or lines on rollers along the paper feed path may cause faulty images in the vertical scanning direction.

Field Remedy

See the roller pitches listed in the tables below to clean and/or replace the corresponding parts.

CAUTION:

Since the Primary Charging Roller, Photosensitive Drum, and Developing Roller are located inside the cartridge and cannot be cleaned, replace the cartridge.

Roller pitch	Parts
Approx. 44 mm	Registration Roller
Approx. 51 mm	Secondary Transfer Roller
Approx. 19 mm	Primary Charging Roller
Approx. 63 mm	Photosensitive Drum
Approx. 31 mm	Developing Roller
Approx. 57 mm	Fixing Roller
Approx. 57 mm	Pressure Firm

Confirming nip width

Overview

Although the nip width of the Fixing Assembly cannot be adjusted with this machine, it can be checked.

By checking the nip width when fixing failure occurs, it is possible to judge whether there is a problem with the Fixing Assembly.

Field Remedy

Check the nip width of the Fixing Assembly by the following procedure.

1. Print a solid black image on an A4/LTR size paper using the cartridge of this machine and bring it to the customer site.
2. Load the solid black printed paper with its printing side facing down in a cassette of the machine.
3. Use an external device to print a solid white image.
4. Open the Front Cover after approx. 25 seconds, leave it for 10 seconds or more, and then take out the printed paper.

5. Measure the widths of the glossy part of the toner on the printed paper, and check that they are within the range as follows.

- Center (a): 6.0 to 7.0 mm
- Edge (b) and (c): 6.0 to 7.0 mm each
- Difference between left and right ($|b - c|$): 1.0 mm or less

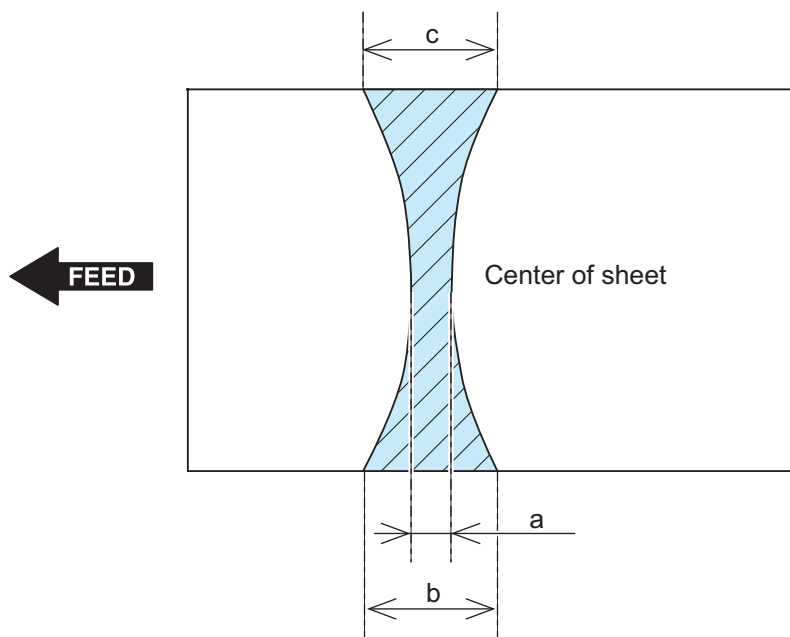

Action When Hue Differs between the Front and Back Sides of the Output Image at Duplex Copy (For the duplex scanning ADF model)

Overview

If hue differs between the front and back sides of the output image when making a copy of 2-sided original, perform color difference correction on both front and back sides.

Field Remedy

Follow the procedure shown below to perform color difference correction.

- 1. Execute full adjustment of auto gradation adjustment. (Adjustment of density of the printed output)**
Adjustment/Maintenance > Adjust Image Quality > Auto Adjust Gradation > Full Adjust
- 2. Output PG-TYPE 26 from test mode in service mode.**
 - TESTMODE > PRINT > PG-TYPE

3. Read the chart using the duplex scanning model (front side).

Place the chart PG-TYPE 26 output in test mode on the ADF with the printed side facing up and execute the following service mode.

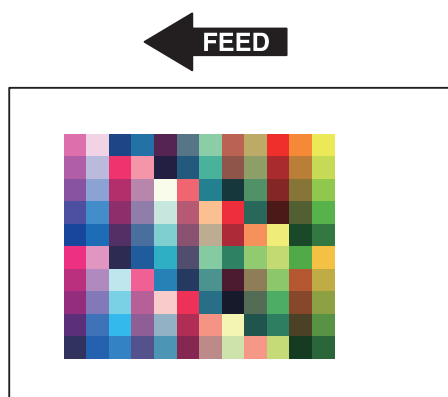

- COPIER > FUNCTION > MISC-R > 1PSCLB-A

4. Read the chart using the duplex scanning model (back side).

Place the chart PG-TYPE 26 output in test mode on the ADF with the printed side facing down and execute the following service mode.

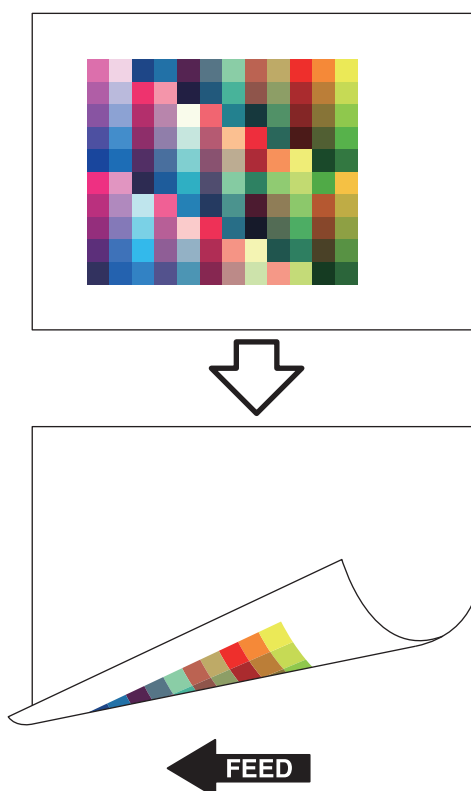

- COPIER > FUNCTION > MISC-R > 1PSCLB-B

5. Judgment

Check that the following service mode values are 1 (reading succeeded).

- COPIER > DISPLAY > CCD > 1P-ERR-A
- COPIER > DISPLAY > CCD > 1P-ERR-B

If any value other than 1 (reading succeeded) is displayed, turn OFF and then ON the power of the host machine and read the chart again.

Multi-purpose Tray Pickup Roller Not Rotating

Overview

If there is a failure in parts of the Multi-purpose Tray Pickup system, the Multi-purpose Tray Pickup Roller may fail to rotate.

Field Remedy

Perform the following remedies.

<If papers are picked up only from the Cassettes>

1. Disconnect and then connect the Connector (J207) of the Multi-purpose Tray Pickup Solenoid (SL1).
2. Replace the Driver PCB (UN11) or Engine Controller PCB (UN1).
3. Check for any missing teeth of the gear of Multi-purpose Tray Pickup Unit.
4. If there is a missing teeth, replace the Multi-purpose Tray Pickup Unit.

<If papers are also not picked up from the Cassettes>

1. Check that the Pickup Motor (M1) is operating. -> Proceed to step 4 if the Motor is in operation.
2. Disconnect and then connect the Connector (J202) of the Pickup Motor. -> Proceed to step 4 if the Motor is in operation.
3. Replace the Driver PCB (UN11) or Engine Controller PCB (UN1).
4. If the Pickup Motor is operating, check the gear of Multi-purpose Tray Pickup Unit.
5. If there is a missing teeth, replace the Multi-purpose Tray Pickup Unit.

Multi-purpose Tray Pickup Failure (Delay Jam:090x)

Overview

If the user operated the device inappropriately or there is a failure in parts of the Multi-purpose Tray Pickup system, the delay jam (jam code: 090x) due to the Multi-purpose Tray pickup failure may occur.

Field Remedy

Perform the following remedies.

1. Check if there are residuals like paper lint around the area from Multi-purpose Tray pickup to the registration. Remove paper lint if present.
2. Check how the device is used by the user (whether the paper guide is fit alongside the paper and paper type/paper size settings are correct).
3. Lower the Multi-purpose Tray Pickup Roller, Separation Pad and Multi-purpose Tray Feed Guide to clean the Multi-purpose Tray Pickup Roller (2 rollers).
4. Replace the Multi-purpose Tray Pickup Roller and Separation Pad.
5. If paper jam is occurring near the Registration Sensor (SR1), disconnect and then connect the Registration Sensor Connector (J102).
6. Replace the Registration Assembly or Engine Controller PCB (UN1).

Debug Log

Function Overview

The debug log is a log that analyzes the program behavior of the machine to enable developers to identify problems. This machine is embedded with a function that compiles the log of the behavior of each software module as debug log and outputs it as integrated log for analyzing problems.

Be sure to collect the debug log when the Support Dept. of sales company so instructs.

Note that there is no need for service technicians to check the content of collected debug log.

Cases in which collection of debug log is effective

Collection of debug log is effective in the following cases:

- Neither the Support Dept. of sales company nor CINC can reproduce the trouble that occurred at the customer site
- When the error frequency is low
- When the failure is suspected to be due to firmware rather than a mechanical/electrical failure.

CAUTION:

If the procedure for reproducing the failure is clear and the Support Dept. of sales company and CINC can reproduce it, collection of debug log is not necessary.

Conditions for collecting logs

Conditions for not being able to collect logs

In the following cases, the procedure for obtaining logs is not required because logs cannot be obtained.

- Service mode screen cannot be accessed
- The machine cannot recognize a USB flash drive
- No USB port is installed in the machine (when the model has only a copy function)

What is necessary to collect logs

A USB flash drive that satisfies the following conditions is required to obtain the debug logs of the machine:

- Formatted in FAT 16/FAT32
- There is a free space of approx. 100MB.
- Can be recognized by the machine

Collection procedure

The following shows the procedure for collecting the debug log from the Control Panel.

1. **Connect a USB flash drive to the machine. In the case of a model having a USB connector on a side of the Control Panel, be sure to connect the USB flash drive to the Control Panel. In the case of a model having a USB connector only on the rear side, connect the USB flash drive to the USB connector on the rear side.**

CAUTION:

In the case of a model having a USB connector on the Control Panel, if the USB flash drive is connected to the USB connector on the rear side, debug logs are not transferred to the USB flash drive.

2. **Execute the following service mode from the Control Panel or Remote UI.**

- COPIER > FUNCTION > SYSTEM > LOGWRITE

"Executing..." is displayed while log collection is executed. When it is completed, the screen shows the service mode screen again.

3. **Execute the following service mode from the Control Panel or Remote UI.**

- COPIER > FUNCTION > SYSTEM > LOG2USB

"Executing..." is displayed while log collection is executed. When it is completed, the screen shows the service mode screen again.

4. Remove the USB flash drive by the correct procedure.

Connect the USB flash drive to the PC, and check that the log file shown below has been saved.

- Output by LOGWRITE: SUBLOG.TXT
- Output by LOG2USB: SUBLOG_YYYYMMDD.HHMMSS_XXX.gz (the file may be divided into multiple files)



Error/Jam/Alarm

Overview.....	238
Error Code.....	241
Jam Code.....	251
Alarm Code.....	255

Overview

Outline

This chapter describes various codes which are displayed when a failure occurs on the product. These are classified into 3 codes as follows.

Code type	Explanation
Error code	This code is displayed when an error occurs on the machine.
Jam code	This code is displayed when a jam occurs inside the machine.
Alarm code	This code is displayed when a function of the machine is malfunctioned.

■ Error/Jam Log indication

Error log

SERVICE MODE > COPIER > DISPLAY > ERR

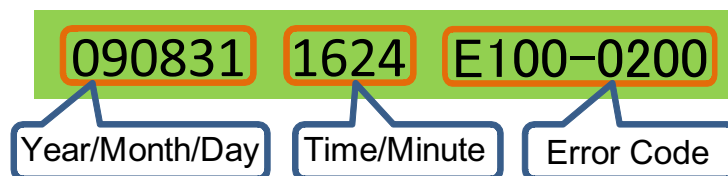

Indication example

```

↳ ERR
090831 1624 E100-0200
-----
-----
-----
-----
-----

```

Jam log

SERVICE MODE > COPIER > DISPLAY > JAM

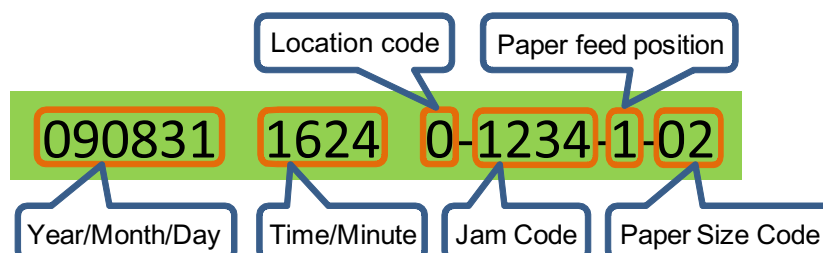

Indication example

```

↳ JAM
090831 1624 0-1234-1-02
-----
-----
-----
-----
-----

```

■ JAM/ERR LOG REPORT

Output procedure of the JAM/ERR LOG REPORT

Service Mode > COPIER > FUNCTION > MISC-P > ERR-LOG

```

*****
***   JAM/ERR LOG REPORT   ***
*****

JAM
001  07/19 16:02 16:02 3 0 7907 000033 1 00002
002  07/19 16:10 16:10 4 1 0002 000034 0 00000

ERROR
001  03/19 07:20 3 733 0000 000010
002  03/19 10:20 3 004 0002 000018

ALARM2
001  03/19 06:20 3 100100 000072 000033
002  03/19 06:20 3 100100 000073 000033
003  03/19 06:20 3 100100 000074 000033
004  03/19 06:20 3 100100 000071 000033

ALARM3

```

No.	Item
1	Month/Day Time/Minute
2	Position summary code
3	Location code
4	Jam code
5	Total counter
6	Pickup position code
7	Paper size
8	Position summary code
9	Error code
10	Error details code
11	Total counter
12	Alarm level (For R&D)
13	Alarm code
14	Alarm details code (For R&D)
15	Total counter

■ Position Summary Code

The position summary information is displayed in a single digit and has the meaning shown below.

Device	Position summary code
Host machine	3
ADF *1	4

*1 : Printed only on Jam history.

■ Location Code

The jam codes of this machine contain information on the location.

The location information is displayed in a single digit and has the meaning shown below:

Device	Location code
Host machine	0
ADF	1

■ Pickup Position Code

When a jam occurs, the pickup location is indicated with the following pickup position code.

Pickup position	Pickup position code
Multi-purpose Tray	0
Paper drawer	1
Option cassette	2
At duplex printing	7

■ Paper Size Code

Paper size is coded and indicated with the size codes as shown below when a paper jam occurs. Note that the paper size may not be supported by this machine.

Paper size	Paper size code	
	Control Panel (UI)	Jam/Err Log Report *1
A4	02	00002
B5	07	00007
A5	03	00003
A6	04	00004
16K	D4	00212
LGL	0C	00012
LTR	0D	00013
STMT	3C	00060
EXEC	0A	00010
Oficio	3E	00062
Oficio (Brazil)	CC	00204
Oficio (Mexico)	D2	00210
F4A	D6	00214
LTR (Government)	D0	00208
LGL (Government)	D1	00209
Foolscap/Folio	3D	00061
Foolscap (Australia)	CA	00202
LGL (India)	D7	00215
3 x 5 inch	40	00064
Envelope No.10 (COM10)	16	00022
Envelope Monarch	17	00023
Envelope C5	15	00021
Envelope DL	18	00024

*1: Size code on the JAM/ERR LOG REPORT.

Error Code

Error Code Details

E000-0000--	Error in temperature rising of Fixing Assembly
Detection Description	The temperature of the Fixing Assembly did not reach a certain temperature within the specified time after starting temperature control.
Remedy	<ol style="list-style-type: none"> 1. Check the harness/connector between the Fixing Assembly and the Engine Controller PCB (UN1). 2. Check the harness/connector between the Fixing Assembly and the Fixing Power Supply PCB (UN3). 3. Check the harness/connector between the Fixing Power Supply PCB (UN3) and the Engine Controller PCB (UN1). 4. Replace the Fixing Assembly. 5. Replace the Fixing Power Supply PCB (UN3). 6. Replace the Low Voltage Power Supply PCB (UN2). 7. Replace the Engine Controller PCB (UN1).
E001-0000--	Abnormal high temperature of the Fixing Assembly
Detection Description	It was detected that the temperature of the Fixing Assembly (Main Thermistor) (TH801) was abnormally high.
Remedy	<ol style="list-style-type: none"> 1. Check the harness/connector between the Fixing Assembly and the Engine Controller PCB (UN1). 2. Check the harness/connector between the Fixing Assembly and the Fixing Power Supply PCB (UN3). 3. Check the harness/connector between the Fixing Power Supply PCB (UN3) and the Engine Controller PCB (UN1). 4. Replace the Fixing Assembly. 5. Replace the Fixing Power Supply PCB (UN3). 6. Replace the Low Voltage Power Supply PCB (UN2). 7. Replace the Engine Controller PCB (UN1).
E001-0001--	Abnormal high temperature of the Fixing Assembly
Detection Description	It was detected that the temperature of the Fixing Assembly (Sub Thermistor) (TH802/TH803) was abnormally high.
Remedy	<ol style="list-style-type: none"> 1. Check the harness/connector between the Fixing Assembly and the Engine Controller PCB (UN1). 2. Check the harness/connector between the Fixing Assembly and the Fixing Power Supply PCB (UN3). 3. Check the harness/connector between the Fixing Power Supply PCB (UN3) and the Engine Controller PCB (UN1). 4. Replace the Fixing Assembly. 5. Replace the Fixing Power Supply PCB (UN3). 6. Replace the Low Voltage Power Supply PCB (UN2). 7. Replace the Engine Controller PCB (UN1).
E003-0000--	Abnormal low temperature of the Fixing Assembly
Detection Description	It was detected that the temperature of the Fixing Assembly (main Thermistor) (TH801) was abnormally low.
Remedy	<ol style="list-style-type: none"> 1. Check the harness/connector between the Fixing Assembly and the Engine Controller PCB (UN1). 2. Check the harness/connector between the Fixing Assembly and the Fixing Power Supply PCB (UN3). 3. Check the harness/connector between the Fixing Power Supply PCB (UN3) and the Engine Controller PCB (UN1). 4. Replace the Fixing Assembly. 5. Replace the Fixing Power Supply PCB (UN3). 6. Replace the Low Voltage Power Supply PCB (UN2). 7. Replace the Engine Controller PCB (UN1).

E003-0001--	Abnormal low temperature of the Fixing Assembly
Detection Description	It was detected that the temperature of the Fixing Assembly (Sub Thermistor) (TH802/TH803) was abnormally low.
Remedy	<ol style="list-style-type: none"> 1. Check the harness/connector between the Fixing Assembly and the Engine Controller PCB (UN1). 2. Check the harness/connector between the Fixing Assembly and the Fixing Power Supply PCB (UN3). 3. Check the harness/connector between the Fixing Power Supply PCB (UN3) and the Engine Controller PCB (UN1). 4. Replace the Fixing Assembly. 5. Replace the Fixing Power Supply PCB (UN3). 6. Replace the Low Voltage Power Supply PCB (UN2). 7. Replace the Engine Controller PCB (UN1).
E004-0000--	Error in fixing power supply drive circuit
Detection Description	The zero cross signal was not detected for the specified period of time or longer.
Remedy	<ol style="list-style-type: none"> 1. Check the harness/connector between the Engine Controller PCB (UN1) and the Thermistor (TH801/TH802/TH803). 2. Check the harness/connectors between the Fixing Assembly and the Fixing Power Supply PCB (UN3). 3. Check the harness/connector between the Fixing Power Supply PCB (UN3) and the Engine Controller PCB (UN1). 4. Replace the Fixing Assembly. 5. Replace the Fixing Power Supply PCB (UN3). 6. Replace the Low Voltage Power Supply PCB (UN2). 7. Replace the Engine Controller PCB (UN1).
E012-0000--	Drum Motor startup error
Detection Description	Revolution of the Drum Motor (M2) did not reach the specified value
Remedy	<ol style="list-style-type: none"> 1. Check the harness/connector between the Drum Motor (M2) and the Driver PCB (UN11). 2. Check the harness/connectors between the Driver PCB (UN11) and the Engine Controller PCB (UN1). 3. Replace the Drum Motor (M2). 4. Replace the Driver PCB (UN11). 5. Replace the Engine Controller PCB (UN1).
E012-0001--	Drum Motor rotation error
Detection Description	Revolution of the Drum Motor (M2) was out of the specified range.
Remedy	<ol style="list-style-type: none"> 1. Check the harness/connector between the Drum Motor (M2) and the Driver PCB (UN11). 2. Check the harness/connectors between the Driver PCB (UN11) and the Engine Controller PCB (UN1). 3. Replace the Drum Motor (M2). 4. Replace the Driver PCB (UN11). 5. Replace the Engine Controller PCB (UN1).
E014-0000--	Error in startup of the Fixing motors
Detection Description	Revolution of the Fixing Motor (M4) did not reach the specified value.
Remedy	<ol style="list-style-type: none"> 1. Check the harness/connector between the Fixing Motor (M4) and the Driver PCB (UN11). 2. Check the harness/connector between the Driver PCB (UN11) and the Engine Controller PCB (UN1). 3. Replace the Fixing Motor (M4). 4. Replace the Driver PCB (UN11). 5. Replace the Engine Controller PCB (UN1).

E014-0001--	Fixing Motor rotation error
Detection Description	Revolution of the Fixing Motor (M4) did not reach the specified value.
Remedy	<ol style="list-style-type: none"> 1. Check the harness/connector between the Fixing Motor (M4) and the Driver PCB (UN11). 2. Check the harness/connector between the Driver PCB (UN11) and the Engine Controller PCB (UN1). 3. Replace the Fixing Motor (M4). 4. Replace the Driver PCB (UN11). 5. Replace the Engine Controller PCB (UN1).
E015-0000--	Development engagement/disengagement error
Detection Description	The error was detected after the development disengagement operation.
Remedy	<p>The error is likely caused by failure of the Developing Disengagement Solenoid (K) (SL2) / Developing Disengagement Solenoid (YMC) (SL4) or the Developing Disengagement Switch (K) (SW3) / Developing Disengagement Switch (YMC) (SW2).</p> <ol style="list-style-type: none"> 1. Check the harness/connector between the Developing Disengagement Solenoid (K) (SL2) / Developing Disengagement Solenoid (YMC) (SL4) and the Driver PCB (UN11), and the harness/connector between the Developing Disengagement Switch (K) (SW3) / Developing Disengagement Switch (YMC) (SW2) and the Driver PCB (UN11). 2. Check the harness/connector between the Driver PCB (UN11) and the Engine Controller PCB (UN1). 3. Replace the Developing Disengagement Switch (K) (SW3) or the Developing Disengagement Switch (YMC) (SW2). 4. Replace the Developing Disengagement Solenoid (K) (SL2) or the Developing Disengagement Solenoid (YMC) (SL4). 5. Replace the Driver PCB (UN11). 6. Replace the Engine Controller PCB (UN1).
E015-0001--	Pickup cassette (host machine) lift-up error
Detection Description	After lift-up of the Lifting Plate of the cassette of the host machine started, ON status of the Paper Surface Sensor of the cassette of the host machine was not detected within the specified period of time.
Remedy	<ol style="list-style-type: none"> 1. While the cassette of the host machine is removed, turn ON the power and insert the cassette, then check the operation sound of the Lifter Motor. When there is operation sound of the Lifter Motor, check if the Lifting Plate has been lifted up. <When the Lifting Plate has been lifted up>1. Check the harness/connector between the Cassette Feeder Driver PCB (UN20) and the Cassette Paper Surface Sensor (SR32) of the host machine. 2. Replace the Cassette Paper Surface Sensor (SR32). 3. Replace the Cassette Feeder Driver PCB (UN20). 4. Replace the Engine Controller PCB (UN1). <When the Lifting Plate has not been lifted up>1. Check the condition of the gear at the host machine side (missing teeth, swing). 2. Check the harness/connector between the Lifter Solenoid (SL5) and the Engine Controller PCB (UN1). 3. Check the harness/connector between the Pickup Motor (M1) and the Driver PCB (UN11). 4. Check the harness/connector between the Driver PCB (UN11) and the Engine Controller PCB (UN1). 5. Replace the Lifter Solenoid (SL5) 6. Replace the Pickup Motor (M1). 7. Replace the Driver PCB (UN11). 8. Replace the Engine Controller PCB (UN1). <When there is no operation sound of the motor>1. Check the harness/connector between the Pickup Motor (M1) and the Driver PCB (UN11). 2. Check the harness/connector between the Driver PCB (UN11) and the Engine Controller PCB (UN1). 3. Replace the Pickup Motor (M1). 4. Replace the Driver PCB (UN11). 5. Replace the Engine Controller PCB (UN1).

E015-0002--	Pickup Cassette (Option) lift-up error
Detection Description	After lift-up of the Lifting Plate of the 1st Paper Feeder started, ON status of the Paper Surface Sensor of the 1st Paper Feeder was not detected within the specified period of time.
Remedy	<ol style="list-style-type: none"> 1. While the cassette of the Paper Feeder is removed, turn ON the power and insert the cassette, then check the operation sound of the Lifter Motor. When there is operation sound of the Lifter Motor, check if the Lifting Plate has been lifted up. <When the Lifting Plate has been lifted up>1. Check the harness/connector between the Cassette Feeder Driver PCB (UN20) and the Cassette Paper Surface Sensor (SR32).2. Replace the Cassette Paper Surface Sensor (SR32).3. Replace the Cassette Feeder Driver PCB (UN20).<When the Lifting Plate has not been lifted up>1. Check the condition of the gear of the Paper Feeder (missing teeth, swing). 2. Check the harness/connector between the Lifter Solenoid (SL21) and the Cassette Feeder Driver PCB (UN20). 2. Check the harness/connector between the Cassette Feeder Driver PCB (UN20) and the Pickup Motor (M9).3. Replace the Pickup Motor (M9). 4. Replace the Lifter Solenoid (SL21). 5. Replace the Cassette Feeder Driver PCB (UN20).<When there is no operation sound of the motor>,1. Check the harness/connector between the Cassette Feeder Driver PCB (UN20) and the Pickup Motor (M9)2. Replace the Pickup Motor (M9).3. Replace the Cassette Feeder Driver PCB (UN20).
E020-0000--	Color Displacement/Density Sensor error
Detection Description	An error in the Color Displacement/Density Sensor was detected.
Remedy	<ol style="list-style-type: none"> 1. Check the harness/connector between the RD Sensor (UN7) and the Engine Controller PCB (UN1). 2. Replace the RD Sensor (UN7). 3. Replace the Engine Controller PCB (UN1).
E021-1000--	Yellow Developing Motor rotation error
Detection Description	It was judged that the Developing Motor did not rotate.
Remedy	<ol style="list-style-type: none"> 1. Check the harness/connector between the Developing Motor (M3) and the Driver PCB (UN11). 2. Check the harness/connector between the Driver PCB (UN11) and the Engine Controller PCB (UN1). 3. Replace the Developing Motor (M3). 4. Replace the Driver PCB (UN11). 5. Replace the Engine Controller PCB (UN1)
E021-1001--	Magenta Developing Motor rotation error
Detection Description	It was judged that the Developing Motor did not rotate.
Remedy	<ol style="list-style-type: none"> 1. Check the harness/connector between the Developing Motor (M3) and the Driver PCB (UN11). 2. Check the harness/connector between the Driver PCB (UN11) and the Engine Controller PCB (UN1). 3. Replace the Developing Motor (M3). 4. Replace the Driver PCB (UN11). 5. Replace the Engine Controller PCB (UN1).
E021-1002--	Cyan Developing Motor rotation error
Detection Description	It was judged that the Developing Motor did not rotate.
Remedy	<ol style="list-style-type: none"> 1. Check the harness/connector between the Developing Motor (M3) and the Driver PCB (UN11). 2. Check the harness/connector between the Driver PCB (UN11) and the Engine Controller PCB (UN1). 3. Replace the Developing Motor (M3). 4. Replace the Driver PCB (UN11). 5. Replace the Engine Controller PCB (UN1).

E021-1003--	Black Developing Motor rotation error
Detection Description	It was judged that the Developing Motor did not rotate.
Remedy	<ol style="list-style-type: none"> 1. Check the harness/connector between the Developing Motor (M3) and the Driver PCB (UN11). 2. Check the harness/connector between the Driver PCB (UN11) and the Engine Controller PCB (UN1). 3. Replace the Developing Motor (M3). 4. Replace the Driver PCB (UN11). 5. Replace the Engine Controller PCB (UN1).
E021-2000--	Error in startup of the Yellow Developing Motor
Detection Description	Revolution of the Developing Motor did not reach the specified value.
Remedy	<ol style="list-style-type: none"> 1. Check the harness/connector between the Developing Motor (M3) and the Driver PCB (UN11). 2. Check the harness/connector between the Driver PCB (UN11) and the Engine Controller PCB (UN1). 3. Replace the Developing Motor (M3). 4. Replace the Driver PCB (UN11). 5. Replace the Engine Controller PCB (UN1).
E021-2001--	Error in startup of the Magenta Developing Motor
Detection Description	Revolution of the Developing Motor did not reach the specified value.
Remedy	<ol style="list-style-type: none"> 1. Check the harness/connector between the Developing Motor (M3) and the Driver PCB (UN11). 2. Check the harness/connector between the Driver PCB (UN11) and the Engine Controller PCB (UN1). 3. Replace the Developing Motor (M3). 4. Replace the Driver PCB (UN11). 5. Replace the Engine Controller PCB (UN1).
E021-2002--	Error in startup of the Cyan Developing Motor
Detection Description	Revolution of the Developing Motor did not reach the specified value.
Remedy	<ol style="list-style-type: none"> 1. Check the harness/connector between the Developing Motor (M3) and the Driver PCB (UN11). 2. Check the harness/connector between the Driver PCB (UN11) and the Engine Controller PCB (UN1). 3. Replace the Developing Motor (M3). 4. Replace the Driver PCB (UN11). 5. Replace the Engine Controller PCB (UN1).
E021-2003--	Error in startup of the Black Developing Motor
Detection Description	Revolution of the Developing Motor did not reach the specified value.
Remedy	<ol style="list-style-type: none"> 1. Check the harness/connector between the Developing Motor (M3) and the Driver PCB (UN11). 2. Check the harness/connector between the Driver PCB (UN11) and the Engine Controller PCB (UN1). 3. Replace the Developing Motor (M3). 4. Replace the Driver PCB (UN11). 5. Replace the Engine Controller PCB (UN1).
E052-0000--	Duplex Feed Unit absent error
Detection Description	Connection of the Duplex Feed Unit was not correct.
Remedy	<ol style="list-style-type: none"> 1. Replace the Engine Controller PCB (UN1).
E066-0000--	Environment Sensor error
Detection Description	An error in the Environment Sensor was detected.
Remedy	<ol style="list-style-type: none"> 1. Check the harness/connection between the Engine Controller PCB (UN1) and the Environment Sensor PCB (UN10). 2. Replace the Environment Sensor PCB (UN10). 3. Replace the Engine Controller PCB (UN1).

E078-0000--	Primary transfer disengagement mechanism error
Detection Description	Primary transfer disengagement mechanism did not work properly.
Remedy	<ol style="list-style-type: none"> 1. Check the harness/connector between the Primary Transfer Disengagement Switch (SW4) and the Engine Controller PCB (UN1). 2. Check the harness/connector between the Primary Transfer Disengagement Solenoid (SL30) and the Engine Controller PCB (UN1). 3. Replace the ITB Unit (including the Primary Transfer Disengagement Switch / Primary Transfer Disengagement Solenoid). 4. Replace the Engine Controller PCB (UN1).
E100-0000--	Yellow Scanner area failure
Detection Description	Error in the Scanner Motor, Laser Scanner Unit, or BD detection in the yellow scanner area was detected.
Remedy	<ol style="list-style-type: none"> 1. Check the harness/connector between the Laser Scanner Unit and the Engine Controller PCB (UN1). 2. Replace the Laser Scanner Unit. 3. Replace the Engine Controller PCB (UN1).
E100-0001--	Magenta Scanner area failure
Detection Description	Error in the Scanner Motor, Laser Scanner Unit, or BD detection in the magenta scanner area was detected.
Remedy	<ol style="list-style-type: none"> 1. Check the harness/connector between the Laser Scanner Unit and the Engine Controller PCB (UN1). 2. Replace the Laser Scanner Unit. 3. Replace the Engine Controller PCB (UN1).
E100-0002--	Cyan Scanner area failure
Detection Description	Error in the Scanner Motor, Laser Unit, or BD detection in the cyan scanner area was detected.
Remedy	<ol style="list-style-type: none"> 1. Check the harness/connector between the Laser Scanner Unit and the Engine Controller PCB (UN1). 2. Replace the Laser Scanner Unit. 3. Replace the Engine Controller PCB (UN1).
E100-0003--	Black scanner area failure
Detection Description	Error in the Scanner Motor, Laser Scanner Unit, or BD detection in the black scanner area was detected.
Remedy	<ol style="list-style-type: none"> 1. Check the harness/connector between the Laser Scanner Unit and the Engine Controller PCB (UN1). 2. Replace the Laser Scanner Unit. 3. Replace the Engine Controller PCB (UN1).
E110-0000--	Pseudo BD detection error
Detection Description	The error is detected when the completion of pseudo BD measurement is not notified within the specified period of time after the pseudo BD generation.
Remedy	<ol style="list-style-type: none"> 1. Check the harness/connector between the Laser Scanner Unit and the Engine Controller PCB (UN1). 2. Replace the Laser Scanner Unit. 3. Replace the Engine Controller PCB (UN1).
E194-0000--	Color Displacement/Density Sensor, Color Displacement Sensor error
Detection Description	An error in the Color Displacement/Density Sensor, Color Displacement Sensor were detected.
Remedy	<ol style="list-style-type: none"> 1. Replace the Toner Cartridge. 2. Check the harness/connector between the Color Displacement/Density Sensor and the Engine Controller PCB (UN1). 3. Replace the Color Displacement/Density Sensor. 4. Replace the Engine Controller PCB (UN1) 5. Replace the ITB Unit.

E196-0000--	DC Controller error
Detection Description	Update of the DC Controller failed.
Remedy	<ol style="list-style-type: none"> 1. Install the set of controller firmware. 2. Replace the Engine Controller PCB (UN1).
E196-1000--	ROM writing/reading error (Main ROM)
Detection Description	Error in the writing/reading of the main program in the Main Controller PCB (Main ROM)
Remedy	<ol style="list-style-type: none"> 1. Update the firmware. 2. Replace the Main Controller PCB (UN30).
E196-2000--	ROM writing/reading error (Setting values storage ROM)
Detection Description	Error in the writing/reading the setting values storage area in the Main Controller PCB (Setting values storage ROM)
Remedy	<ol style="list-style-type: none"> 1. Update the firmware. 2. Replace the Main Controller PCB (UN30).
E196-3000--	ROM writing/reading error (eMMC)
Detection Description	Unable to read/write data from the eMMC. The eMMC failure occurred.
Remedy	<ol style="list-style-type: none"> 1. Update the firmware. 2. Replace the Main Controller PCB (UN30).
E196-3001--	ROM-ID mismatch (eMMC)
Detection Description	The eMMC was replaced incorrectly. The eMMC failure occurred.
Remedy	<ol style="list-style-type: none"> 1. Update the firmware. 2. Replace the Main Controller PCB (UN30).
E198-0000--	Engine Controller memory failure
Detection Description	Error in the nonvolatile memory on the Engine Controller PCB
Remedy	<ol style="list-style-type: none"> 1. Turn OFF and then ON the power and check if the symptom occurs again. 2. Replace the Engine Controller PCB (UN1).
E202-0001--	CIS Unit HP error (outward)
Detection Description	The Scanner (CIS) could not detect the home position when starting scanning operation.
Remedy	<ol style="list-style-type: none"> 1. Check the harnesses/connectors connecting from the Main Controller PCB (UN30) to the CIS Unit HP Sensor (SR11) and the Reader Motor (M5) 2. Replace the CIS HP Sensor (SR11). 3. Replace the Reader Motor (M5). 4. Replace the CIS Unit. 5. Replace the Reader Unit. 6. Replace the Main Controller PCB (UN30).
E202-0002--	CIS Unit HP error (homeward)
Detection Description	The Scanner (CIS) could not detect the home position when completing scanning operation.
Remedy	<ol style="list-style-type: none"> 1. Check the harnesses/connectors connecting from the Main Controller PCB (UN30) to the CIS Unit HP Sensor (SR11) and the Reader Motor (M5) 2. Replace the CIS HP Sensor (SR11). 3. Replace the Reader Motor (M5). 4. Replace the CIS Unit. 5. Replace the Reader Unit. 6. Replace the Main Controller PCB (UN30).
E225-0001--	Light intensity of the CIS Unit at the reference level or below
Detection Description	When the light intensity is at the reference level or below at shading.
Remedy	<ol style="list-style-type: none"> 1. Disconnect and then connect the Flexible Cable. 2. Replace the Flexible Cable. 3. Replace the CIS Unit. 4. Replace the Main Controller PCB (UN30).

E246-0000--	System error
Detection Description	System error.
Remedy	Contact the sales company.
E247-0000--	System error
Detection Description	System error.
Remedy	Contact the sales company.
E248-0001--	Error in access to backup data for the Reader (reading error at power-on)
Detection Description	The Reader-related adjustment values could not be read.
Remedy	1. Install the set of the controller firmware. 2. Replace the Main Controller PCB (UN30).
E350-0000--	System error
Detection Description	System error.
Remedy	Contact the sales company.
E351-0000--	Main Controller PCB error (Scanner system)
Detection Description	System error.
Remedy	1. Update the firmware. 2. Replace the Main Controller PCB (UN30).
E354-0000--	System error
Detection Description	System error.
Remedy	Contact the sales company.
E355-0000--	System error
Detection Description	System error.
Remedy	Contact the sales company.
E355-0004--	System error
Detection Description	System error.
Remedy	Contact the sales company.
E355-0005--	System error
Detection Description	System error.
Remedy	Contact the sales company.
E719-0000--	Error in communication with the New Card Reader (serial communication)
Detection Description	Unable to communicate with the new Card Reader.
Remedy	1. Check the connection of the New Card Reader.
E732-0000--	Scanner communication error.
Detection Description	Scanner communication error
Remedy	1. Install the set of the controller firmware. 2. Replace the Main Controller PCB (UN30).
E733-0000--	Printer communication error
Detection Description	Communication error between the Engine Controller PCB and the Main Controller PCB occurred.
Remedy	1. Check the harness/connector connection between the Engine Controller PCB (UN1) and the Main Controller PCB (UN30). 2. Install the set of the controller firmware. 3. Replace the Main Controller PCB (UN30). 4. Replace the Engine Controller PCB (UN1).

E736-0000--	Fax communication error
Detection Description	Communication error with CCU/modem.
Remedy	<ol style="list-style-type: none"> 1. Check the connection of the NCU PCB (UN38). 2. Replace the NCU PCB (UN38). 3. Replace the Main Controller PCB (UN30).
E736-0001--	Error in ROM for backing up fax data
Detection Description	An error occurred in ROM for backing up fax data.
Remedy	<ol style="list-style-type: none"> 1. Check the connection of the NCU PCB (UN38). 2. Replace the NCU PCB (UN38). 3. Replace the Main Controller PCB (UN30).
E743-0000--	DDI communication error
Detection Description	Software sequence error
Remedy	1. Turn OFF and then ON the power.
E744-0001--	Incorrect combination of language file versions
Detection Description	Language file version did not match that of the main program.
Remedy	1. Update the firmware
E744-0002--	Language file error
Detection Description	The size of the language file exceeded the allowed size.
Remedy	1. Update the firmware.
E744-1001--	Version mismatch between BOOTABLE and BOOTROM
Detection Description	Version of the main program and that of the start-up program did not mach.
Remedy	1. Update the firmware.
E744-4000--	Invalid engine connection error
Detection Description	Invalid engine connection was detected.
Remedy	<ol style="list-style-type: none"> 1. Check if the valid Engine Controller PCB (UN1) is installed. 2. Update the firmware. 3. Replace the Engine Controller PCB (UN1).
E744-5000--	Communication error between the Controller PCB and the Main Controller PCB
Detection Description	Communication with the Control Panel PCB could not be established.
Remedy	<ol style="list-style-type: none"> 1. Check the harness/connector between the Panel PCB (UN31) and the Main Controller PCB (UN30). 2. Replace the Control Panel (including the Panel PCB(UN31)). 3. Replace the Main Controller PCB (UN30).
E744-6000--	Communication error with Wireless LAN PCB
Detection Description	Communication with the Wireless LAN PCB could not be established.
Remedy	<ol style="list-style-type: none"> 1. Turn OFF and then ON the main power. 2. Check the harness/connector connection between the Wireless LAN PCB (UN35) and the Main Controller PCB (UN30) 3. Install the set of the controller firmware. 4. Replace the Wireless LAN PCB (UN35). 5. Replace the Main Controller PCB (UN30).
E744-7000--	Backup microcomputer error
Detection Description	An error in the microcomputer which retains fax job information of the Main Controller PCB.
Remedy	<ol style="list-style-type: none"> 1. Update the firmware. 2. Replace the Main Controller PCB (UN30).

E746-0000--	Main Controller PCB error (others)
Detection Description	A communication error of the Main Controller PCB occurred (other than scan-related communication error).
Remedy	<ol style="list-style-type: none"> 1. Update the firmware. 2. Replace the Main Controller PCB (UN30).
E766-8000--	Firmware error
Detection Description	Information on digital registration could not be obtained.
Remedy	<ol style="list-style-type: none"> 1. Install the Engine Controller firmware. 2. Install the set of Controller firmware. 3. Replace the Engine Controller (UN1).
E766-9000--	Scanner power state error
Detection Description	Error in power state of the Laser Scanner Unit (firmware-dependent).
Remedy	<ol style="list-style-type: none"> 1. Update the firmware. 2. Replace the Laser Scanner Unit.
E805-0005--	Cartridge Fan error
Detection Description	The Cartridge Fan failed to rotate at the specified revolution.
Remedy	<ol style="list-style-type: none"> 1. Check the connection of the Cartridge Fan (FM2). 2. Replace the Cartridge Fan (FM2).
E806-0000--	Power Supply Fan error
Detection Description	The Power Supply Fan (power supply) failed to rotate at the specified revolution.
Remedy	<ol style="list-style-type: none"> 1. Check the connection of the Power Supply Fan. 2. Replace the Power Supply Fan (FM1).
E808-0000--	Low voltage power supply failure
Detection Description	When the printer has detected a low voltage power supply failure.
Remedy	<ol style="list-style-type: none"> 1. Check the harness/connector between the Engine Controller PCB (UN1) and the Low Voltage Power Supply PCB (UN2). 2. Replace the Low Voltage Power Supply PCB (UN2). 3. Replace the Engine Controller PCB (UN1).
E840-0000--	Pressure release mechanism error
Detection Description	An error in pressure release mechanism of the Fixing Assembly was detected.
Remedy	<ol style="list-style-type: none"> 1. Check the harness/connector between the Fixing Pressure Release Switch (SW5) and the Engine Controller PCB (UN1). 2. Check the harness/connector between the Fixing Motor (M4) and the Driver PCB (UN11). 3. Check the harness/connector between the Driver PCB (UN11) and the Engine Controller PCB (UN1). 4. Replace the Fixing Pressure Release Switch (SW5). 5. Replace the Fixing Motor (M4). 6. Replace the Fixing Assembly. 7. Replace the Driver PCB (UN11). 8. Replace the Engine Controller PCB (UN1).

Jam Code

Jam code

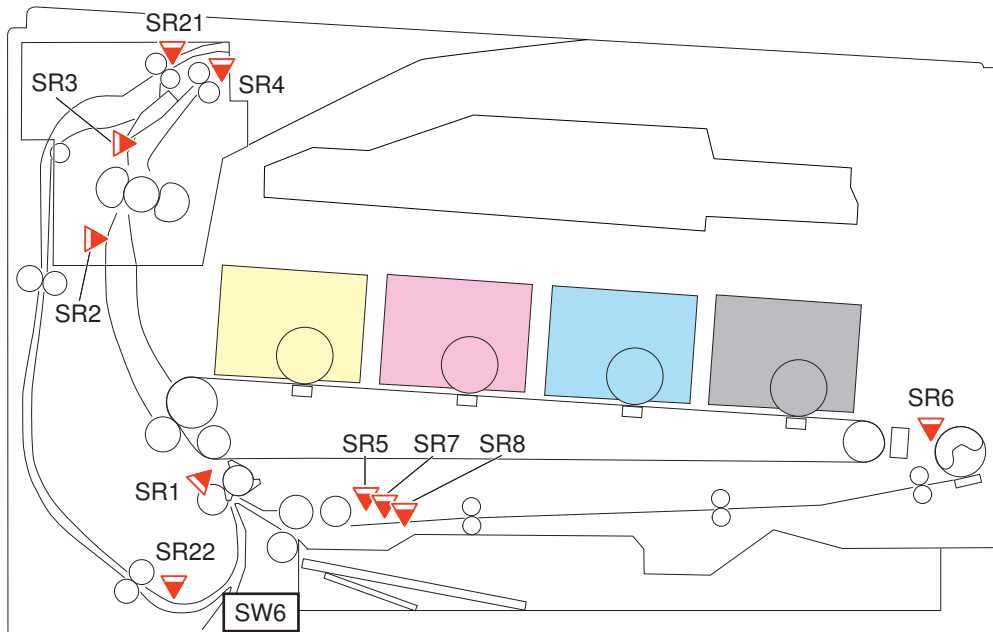

Location Code	Jam code	Jam Type	Sensor Name	Sensor No.	Residual Paper Area		
1	0001	Delay jam	Document End Sensor	SR10	ADF Pickup Feed Area		
1	0002	Stationary Jam					
1	0021	Other					
1	0094	Initial Residual Jam					
1	0071	Sequence Jam (Timing Error)	-	-	-		
1	0096	Other	-	-	-		
0	0901	Pickup Delay Jam	Registration Sensor	SR1	Pickup Cassette of the host machine		
0	0902				Multi-purpose Tray		
0	0903				Cassette Feeding Module		
0	0907				Registration to Drum Area		
0	0908				Drum to Fixing Area		
0	0909				Fixing to Delivery Area		
0	090C				Duplex Reverse Area		
0	090D				Duplex Feed Area		
0	0A01				Cassette Feed Sensor	SR31	Pickup Cassette of the host machine
0	0A03						Cassette Feeding Module
0	0A07						Registration to Drum Area
0	0A08						Drum to Fixing Area
0	0A09						Fixing to Delivery Area
0	0A0C						Duplex Reverse Area
0	0A0D	Duplex Feed Area					

Location Code	Jam code	Jam Type	Sensor Name	Sensor No.	Residual Paper Area
0	1101	Pickup Stationary Jam	Registration Sensor	SR1	Pickup Cassette of the host machine
0	1103				Cassette Feeding Module
0	1107				Registration to Drum Area
0	1108				Drum to Fixing Area
0	1109				Fixing to Delivery Area
0	110C				Duplex Reverse Area
0	110D				Duplex Feed Area
0	1901				Fixing Delivery Delay Jam
0	1903	Cassette Feeding Module			
0	1907	Registration to Drum Area			
0	1908	Drum to Fixing Area			
0	1909	Fixing to Delivery Area			
0	190C	Duplex Reverse Area			
0	190D	Duplex Feed Area			
0	2101	Fixing Delivery Stationary Jam	Registration Sensor	SR1	
0	2103				Cassette Feeding Module
0	2107				Registration to Drum Area
0	2108				Drum to Fixing Area
0	2109				Fixing to Delivery Area
0	210C				Duplex Reverse Area
0	210D				Duplex Feed Area
0	2901				Delivery Delay Jam
0	2903	Cassette Feeding Module			
0	2907	Registration to Drum Area			
0	2908	Drum to Fixing Area			
0	2909	Fixing to Delivery Area			
0	290C	Duplex Reverse Area			
0	290D	Duplex Feed Area			
0	3101	Delivery Stationary Jam	Delivery Sensor	SR4	
0	3103				Cassette Feeding Module
0	3107				Registration to Drum Area
0	3108				Drum to Fixing Area
0	3109				Fixing to Delivery Area
0	310A				Delivery Area
0					Duplex Reverse Area
0	310D				Duplex Feed Area

Location Code	Jam code	Jam Type	Sensor Name	Sensor No.	Residual Paper Area
0	3901	Reverse Delay Jam	Duplex Reverse Sensor	SR21	Pickup Cassette of the host machine
0	3903				Cassette Feeding Module
0	3907				Registration to Drum Area
0	3908				Drum to Fixing Area
0	3909				Fixing to Delivery Area
0	390C				Duplex Reverse Area
0	390D				Duplex Feed Area
0	4101	Reverse Stationary Jam	Duplex Reverse Sensor	SR21	Pickup Cassette of the host machine
0	4103				Cassette Feeding Module
0	4107				Registration to Drum Area
0	4108				Drum to Fixing Area
0	4109				Fixing to Delivery Area
0	410C				Duplex Reverse Area
0	410D				Duplex Feed Area
0	4901	Duplex Feed Delay Jam	Duplex Re-pickup Sensor	SR22	Pickup Cassette of the host machine
0	4903				Cassette Feeding Module
0	4907				Registration to Drum Area
0	4908				Drum to Fixing Area
0	4909				Fixing to Delivery Area
0	490C				Duplex Reverse Area
0	490D				Duplex Feed Area
0	5901	Duplex Re-pickup Jam	Registration Sensor	SR1	Pickup Cassette of the host machine
0	5903				Cassette Feeding Module
0	5907				Registration to Drum Area
0	5908				Drum to Fixing Area
0	5909				Fixing to Delivery Area
0	590C				Duplex Reverse Area
0	590D				Duplex Feed Area
0	590E	Duplex Pickup Area			
0	6101	Wrapping Jam	Fixing Delivery Sensor Duplex Reverse Sensor	SR3 SR21	Pickup Cassette of the host machine
0	6103				Cassette Feeding Module
0	6107				Registration to Drum Area
0	6108				Drum to Fixing Area
0	6109				Fixing to Delivery Area
0	610C				Duplex Reverse Area
0	610D				Duplex Feed Area

Location Code	Jam code	Jam Type	Sensor Name	Sensor No.	Residual Paper Area			
0	6201	Wrapping Jam	Fixing Delivery Sensor Duplex Reverse Sensor	SR3 SR21	Pickup Cassette of the host machine			
0	6203				Cassette Feeding Module			
0	6207				Registration to Drum Area			
0	6208				Drum to Fixing Area			
0	6209				Fixing to Delivery Area			
0	620C				Duplex Reverse Area			
0	620D				Duplex Feed Area			
0	7101				Internal residual jam	Registration Sensor Fixing Delivery Sensor Arch Sensor	SR1 SR3 SR2	Pickup Cassette of the host machine
0	7102	Multi-purpose Tray						
0	7103	Cassette Feeding Module						
0	7107	Registration to Drum Area						
0	7108	Drum to Fixing Area						
0	7109	Fixing to Delivery Area						
0	710C	Duplex Reverse Area						
0	710D	Duplex Feed Area						
0	710E	Duplex Pickup Area						
0	7201	Pickup Cassette of the host machine						
0	7202	Multi-purpose Tray						
0	7203	Cassette Feeding Module						
0	7207	Registration to Drum Area						
0	7208	Drum to Fixing Area						
0	7209	Fixing to Delivery Area						
0	720C	Duplex Reverse Area						
0	720D	Duplex Feed Area						
0	720E	Duplex Pickup Area						
0	7901	Door Open Jam	Registration Sensor Multi-purpose Tray Paper Sensor Fixing Delivery Sensor Delivery Sensor Duplex Re-pickup Sensor	SR1 SR6 SR3 SR4 SR22				Pickup Cassette of the host machine
0	7902							Multi-purpose Tray
0	7903							Cassette Feeding Module
0	7907							Registration to Drum Area
0	7908							Drum to Fixing Area
0	7909							Fixing to Delivery Area
0	790C				Duplex Reverse Area			
0	790D				Duplex Feed Area			
0	790E				Duplex Pickup Area			

Alarm Code

Alarm Code Details

10-0100	Toner Cartridge replacement notification alarm (K)
A. Operation / B. Cause / C. Remedy	Detail Code: 0071 When the replacement with a genuine Toner Cartridge was detected.
10-0100	Toner Cartridge replacement notification alarm (Y)
A. Operation / B. Cause / C. Remedy	Detail Code: 0072 When the replacement with a genuine Toner Cartridge was detected.
10-0100	Toner Cartridge replacement notification alarm (M)
A. Operation / B. Cause / C. Remedy	Detail Code: 0073 When the replacement with a genuine Toner Cartridge was detected.
10-0100	Toner Cartridge replacement notification alarm (C)
A. Operation / B. Cause / C. Remedy	Detail Code: 0074 When the replacement with a genuine Toner Cartridge was detected.
10-0100	Unidentified Toner Cartridge replacement notification alarm (K)
A. Operation / B. Cause / C. Remedy	Detail Code: 0181 When the replacement with a non-genuine Toner Cartridge was detected.
10-0100	Unidentified Toner Cartridge replacement notification alarm (Y)
A. Operation / B. Cause / C. Remedy	Detail Code: 0182 When the replacement with a non-genuine Toner Cartridge was detected.
10-0100	Unidentified Toner Cartridge replacement notification alarm (M)
A. Operation / B. Cause / C. Remedy	Detail Code: 0183 When the replacement with a non-genuine Toner Cartridge was detected.
10-0100	Unidentified Toner Cartridge replacement notification alarm (C)
A. Operation / B. Cause / C. Remedy	Detail Code: 0184 When the replacement with a non-genuine Toner Cartridge was detected.
10-0401	Toner Cartridge empty alarm (Y)
A. Operation / B. Cause / C. Remedy	Alarm to be generated once the Toner Cartridge becomes empty.
10-0402	Toner Cartridge empty alarm (M)
A. Operation / B. Cause / C. Remedy	Alarm to be generated once the Toner Cartridge becomes empty.
10-0403	Toner Cartridge empty alarm (C)
A. Operation / B. Cause / C. Remedy	Alarm to be generated once the Toner Cartridge becomes empty.
10-0404	Toner Cartridge empty alarm (Bk)
A. Operation / B. Cause / C. Remedy	Alarm to be generated once the Toner Cartridge becomes empty.



Service Mode

Overview.....	257
COPIER (Service mode for printer)...	260
FEEDER (ADF service mode).....	339
TESTMODE (Service mode for test print, operation check, etc.).....	341
FAX (FAX service mode).....	349

Overview

Entering Service Mode

For information on how to enter service mode, contact the Support Dept. of the sales company.

Backing up Service Mode

Because setting values and management data of the host machine are stored in the Main Controller PCB, they need to be backed up before replacing the Main Controller PCB. (Do not remove the Main Controller PCB.) Also, restoration of the backup data is necessary after replacing the Main Controller PCB.

Backup: Connect a USB flash drive to the USB memory port.

COPIER > FUNCTION > SYSTEM > EXPORT

Restore: Restore backup data of the USB flash drive.

COPIER > FUNCTION > SYSTEM > IMPORT

NOTE:

As for the user data (the Settings/Registration data, etc.), be sure to back up the user data before replacing the Main Controller PCB and then restore it after replacement by either of the following methods:

Backup

- Menu > Management Settings > Data Management > Import/Export > Export
- Remote UI > Settings/Registration > Management Settings > Data Management > Import/Export > Export

Restore

- Menu > Management Settings > Data Management > Import/Export > Import
- Remote UI > Settings/Registration > Management Settings > Data Management > Import/Export > Import

Service Label

In factory setting, adjustments are made for each machine, and adjustment values are written in the service label.

In the case of the following, adjustment values for ADJUST or OPTION return to default. Therefore, when you made adjustments in the field.

- Changed Main Controller PCB
- Changed Engine Controller PCB
- After RAM clear execution

Therefore, when you made adjustments and changed values of the Service Mode in the field, be sure to write down the changed values in the service label. When there is no relevant field in the service label, write down the values in a blank field.

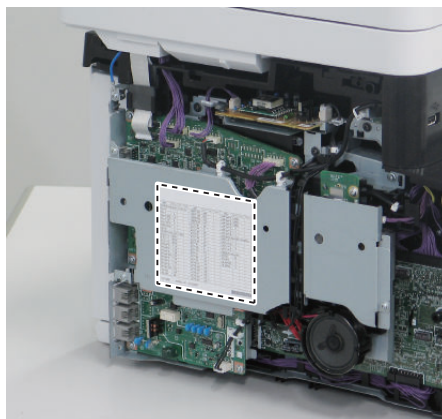

Remote UI Service Mode

Function Overview

It is possible to display, configure, and execute various service mode modes as well as restart the host machine by using remote UI.

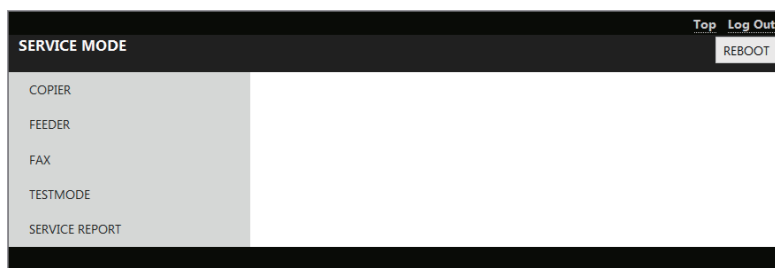

Operating conditions

In order to operate service mode using Remote UI, the following conditions must be met.

- Service mode is not used on the Control Panel.
If service mode is accessed from the Control Panel of the host machine, "Log-in user exists already." is displayed when service mode is accessed from Remote UI.

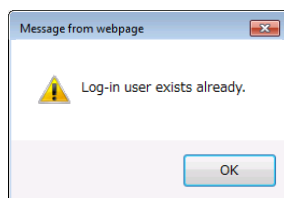

- When Remote UI service mode (this function) is not being logged in by other users
When service mode is being accessed from Remote UI, "Remote service mode" is displayed on the UI of the host machine.

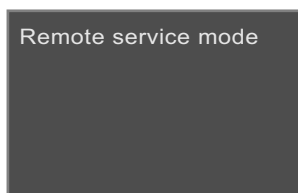

- When Remote UI is enabled in the setting on the Control Panel
[Settings/Registration] > [System Settings] > [Remote UI Settings] > [Use Remote UI] > [ON]
- When the following setting (Remote UI service mode function) is enabled (setting value: 1) in service mode
COPIER > OPTION > BODY > RMT-SW
0:OFF(default), 1:ON

How to Use



1. Activate the Web browser, and access the following URL:

<http://<Host machine's IP address or host name>/servicemode.html>

2. Enter the password, and click [LOGIN].

Password required for authentication differs depending on the following service mode setting: COPIER > OPTION > BODY > PSWD-SW

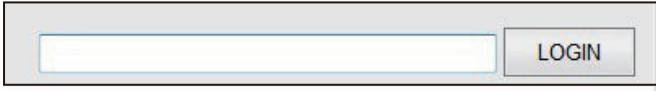
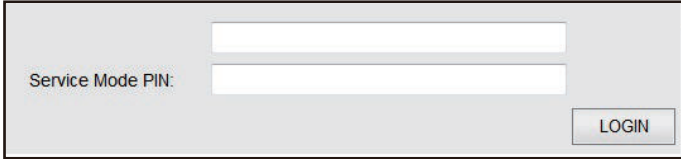
Combinations of service mode settings and required passwords

PSWD-SW setting value	Password required for authentication	Authentication screen
0	<ul style="list-style-type: none"> Password of remote UI service mode 	
1	<ul style="list-style-type: none"> Password of remote UI service mode Service mode password 	
2	<ul style="list-style-type: none"> Password of RUI service mode User's system administrator ID Password of system administrator Service mode password 	

NOTE:

- If you do not know the password of remote UI service mode, contact the Support Dept. of the sales company.
- Password of service mode can be changed in COPIER > OPTION > BODY > PSWD-SW.

3. If you do not know the password of remote UI service mode, contact the Support Dept. of the sales company. When finishing the operation, click [REBOOT] or [Log Out].

NOTE:

If the user logged in and then closed the browser without logging out, connection status remains as "LOGIN". If the user attempts to log in to service mode under "LOGIN" status, exclusive control is executed so that the user cannot access service mode. In that case, wait for a fixed time (3 minutes) from the last access to let the user be automatically logged out, or turn OFF/ON the power of the machine to be forcibly logged out.

Service Mode Explanation

The detailed explanation of service mode is indicating the key operation (press the Apply key) for the 5-inch Touch Panel. Note that the key operation is (Press the OK key) for the 5-line LCD model that does not have the Apply key.

COPIER (Service mode for printer)

DISPLAY (State display mode)

VERSION

COPIER (Service mode for printer) > DISPLAY (State display mode) > VERSION

MAIN	Display of Bootable version
Detail	To display the firmware version of Main Controller PCB.
Use Case	When upgrading the firmware
Adj/Set/Operate Method	N/A (Display only)
Display/Adj/Set Range	00.00 to 99.99
BOOT	Display of BootROM version
Detail	To display the version of Boot ROM (BOOT program).
Use Case	When upgrading the firmware
Adj/Set/Operate Method	N/A (Display only)
Display/Adj/Set Range	00.00 to 99.99
LANG	Display of language pack version
Detail	To display the version of language pack.
Use Case	When upgrading the firmware
Adj/Set/Operate Method	N/A (Display only)
Display/Adj/Set Range	00.00 to 99.99
DEMODATA	Display of demo print data version
Detail	To display the version of demo print data. For the models not having demo print function, "FF.FF" is displayed.
Use Case	When upgrading the firmware
Adj/Set/Operate Method	N/A (Display only)
Display/Adj/Set Range	00.00 to 99.99
ECONT	Display of Engine Controller version
Detail	To display the version of Engine Controller PCB.
Use Case	When upgrading the firmware
Adj/Set/Operate Method	N/A (Display only)
Display/Adj/Set Range	00.00 to 99.99
PANEL	Display of firmware version of panel
Detail	To display the firmware version of Control Panel CPU PCB.
Use Case	When upgrading the firmware
Adj/Set/Operate Method	N/A (Display only)
Display/Adj/Set Range	00.00 to 99.99
Related Service Mode	COPIER > FUNCTION > SYSTEM > PANEL-UP

■ CCD

COPIER (Service mode for printer) > DISPLAY (State display mode) > CCD

TARGET-B	Display of shading target value (B)
Detail	To display the shading target value of Blue. Continuous display of 0 (minimum) or 2048 (maximum) is considered as a failure of the Scanner Unit.
Use Case	At scanned image failure
Adj/Set/Operate Method	N/A (Display only)
Display/Adj/Set Range	0 to 2048
Default Value	1202
Related Service Mode	COPIER > ADJUST > CCD > DFTAR-B
TARGET-G	Display of shading target value (G)
Detail	To display the shading target value of Green. Continuous display of 0 (minimum) or 2048 (maximum) is considered as a failure of the Scanner Unit.
Use Case	At scanned image failure
Adj/Set/Operate Method	N/A (Display only)
Display/Adj/Set Range	0 to 2048
Default Value	1163
Related Service Mode	COPIER > ADJUST > CCD > DFTAR-G
TARGET-R	Display of shading target value (R)
Detail	To display the shading target value of Red. Continuous display of 0 (minimum) or 2048 (maximum) is considered as a failure of the Scanner Unit.
Use Case	At scanned image failure
Adj/Set/Operate Method	N/A (Display only)
Display/Adj/Set Range	0 to 2048
Default Value	1135
Related Service Mode	COPIER > ADJUST > CCD > DFTAR-R
TARGETBW	Display of shading target value (B&W)
Detail	To display the shading target value at B&W jobs. Continuous display of 0 (minimum) or 2048 (maximum) is considered a failure of the Main Controller PCB.
Use Case	At scanned image failure
Adj/Set/Operate Method	N/A (Display only)
Display/Adj/Set Range	0 to 2048
Default Value	1072
Related Service Mode	COPIER > ADJUST > CCD > DFTAR-BW
BK-SHDST	Display paper back shading correct result
Detail	To display the paper back shading correction result. Whether the results of BK-SHD1 and BK-SHD2 are correct is displayed.
Use Case	When replacing the Scanner Unit (for back side)
Adj/Set/Operate Method	N/A (Display only)
Display/Adj/Set Range	0 to 1 0: NG 1: OK
Related Service Mode	COPIER > FUNCTION > CCD > BK-SHD1/2

COPIER (Service mode for printer) > DISPLAY (State display mode) > CCD

1P-ERR-A		Frt/bck clr dif calibr PG read rslt: frt	
Detail	To display the result of reading of PG for calibrating color difference between the front and back sides with the Scanner Unit (for front side). If 1 is displayed in both this item and 1P-ERR-B, it means that calibration for color difference on front and back sides has succeeded.		
Adj/Set/Operate Method	N/A (Display only)		
Display/Adj/Set Range	0 to 8 0: Reading is not executed 1: Reading is executed 2: Reading failed (e.g.: no originals placed, jam) 3: Detection of patch edge failed (e.g.: 1st/2nd side of original reversed) 4: Failed because the degree of skew of original was too large 5: Invalid patch reading value (e.g.: original was upside down) 6: Failed due to other causes 7 to 8: Not used		
Default Value	0		
Related Service Mode	COPIER > FUNCTION > MISC-R > 1PSCLB-A COPIER > DISPLAY > CCD > 1P-ERR-B		
1P-ERR-B		Frt/bck clr dif calibr PG read rslt: bck	
Detail	To display the result of reading of PG for calibrating color difference between the front and back sides with the Scanner Unit (for back side). If 1 is displayed in both this item and 1P-ERR-A, it means that calibration for color difference on front and back sides has succeeded.		
Adj/Set/Operate Method	N/A (Display only)		
Display/Adj/Set Range	0 to 8 0: Reading is not executed 1: Reading is executed 2: Reading failed (e.g.: no originals placed, jam) 3: Detection of patch edge failed (e.g.: 1st/2nd side of original reversed) 4: Failed because the degree of skew of original was too large 5: Invalid patch reading value (e.g.: original was upside down) 6: Failed due to other causes 7 to 8: Not used		
Default Value	0		
Related Service Mode	COPIER > FUNCTION > MISC-R > 1PSCLB-B COPIER > DISPLAY > CCD > 1P-ERR-A		

I/O (I/O display mode)

■ Reader (R-CON > P001)

Address	bit	Name	Symbol	Remarks
P001	7	-	-	-
	6	-	-	-
	5	-	-	-
	4	-	-	-
	3	-	-	-
	2	CIS HP Sensor	SR11	H: HP
	1	Document Sensor	SR9	H: Paper
	0	Document End Sensor	SR10	H: Paper

ADJUST (Adjustment mode)

■ ADJ-XY

COPIER (Service mode for printer) > ADJUST (Adjustment mode) > ADJ-XY

ADJ-X		Adj start pstn in book mode: vert scan
Detail		To adjust the image reading start position (image leading edge position) in the vertical scanning direction at copyboard reading. When replacing the Main Controller PCB, enter the value of service label. Decrease the value when the non-image width is larger than the standard value. Increase the value when out of original area is copied. As the value is incremented by 1, the image position is moved to the trailing edge side by 0.1 mm.
Use Case		- When replacing the Reader Unit - When replacing the Scanner Unit - When replacing the Main Controller PCB
Adj/Set/Operate Method		Enter the setting value (switch negative/positive by +/- key), and then press Apply key.
Caution		After the setting value is changed, write the changed value in the service label.
Display/Adj/Set Range		-30 to 30
Unit		0.1 mm
Default Value		0
ADJ-Y		Adj start pstn in book mode: horz scan
Detail		To adjust the image reading start position in the horizontal scanning direction at copyboard reading. When replacing the Main Controller PCB, enter the value of service label. Decrease the value when the non-image width is larger than the standard value. Increase the value when out of original area is copied. As the value is incremented by 1, the image position is moved to the rear side by 0.1 mm.
Use Case		- When replacing the Reader Unit - When replacing the Scanner Unit - When replacing the Main Controller PCB
Adj/Set/Operate Method		Enter the setting value (switch negative/positive by +/- key), and then press Apply key.
Caution		After the setting value is changed, write the changed value in the service label.
Display/Adj/Set Range		-15 to 15
Unit		0.1 mm
Default Value		0
ADJ-Y-DF		Adj start pstn: stream, horz scan, front
Detail		To adjust the front side image reading start position in horizontal scanning direction at stream reading. When replacing the Main Controller PCB, enter the value of service label. As the value is incremented by 1, the image position is moved to the front side by 0.1 mm.
Use Case		- When replacing the DADF - When replacing the Scanner Unit - When replacing the Main Controller PCB
Adj/Set/Operate Method		Enter the setting value (switch negative/positive by +/- key), and then press Apply key.
Caution		After the setting value is changed, write the changed value in the service label.
Display/Adj/Set Range		-15 to 15
Unit		0.1 mm
Default Value		0

COPIER (Service mode for printer) > ADJUST (Adjustment mode) > ADJ-XY

ADJY-DF2		Adj start pstn: stream, horz scan, back
Detail	To adjust the back side image reading start position in horizontal scanning direction at stream reading. When replacing the Main Controller PCB, enter the value of service label. As the value is incremented by 1, the image position is moved to the rear side by 0.1 mm.	
Use Case	- When replacing the DADF - When replacing the Scanner Unit - When replacing the Main Controller PCB	
Adj/Set/Operate Method	Enter the setting value (switch negative/positive by +/- key), and then press Apply key.	
Caution	After the setting value is changed, write the changed value in the service label.	
Display/Adj/Set Range	-15 to 15	
Unit	0.1 mm	
Default Value	0	
ADJ-X-MG		Fine adj img ratio: book mode, vert scan
Detail	To make a fine adjustment of image magnification ratio in vertical scanning direction at copyboard reading. When replacing the Main Controller PCB/clearing RAM data, enter the value of service label. As the value is changed by 1, the image magnification ratio is changed by 0.01 %. +: Enlarge -: Reduce	
Use Case	- When replacing the DADF - When replacing the Scanner Unit - When replacing the Main Controller PCB	
Adj/Set/Operate Method	Enter the setting value (switch negative/positive by +/- key), and then press Apply key.	
Caution	After the setting value is changed, write the changed value in the service label.	
Display/Adj/Set Range	-200 to 200	
Unit	0.01%	
Default Value	0	
STRD-POS		Adj Scan Unit pstn: stream, fd way, frt
Detail	To adjust the position of the Scanner Unit on the Reader side in feed direction at stream reading. When replacing the Main Controller PCB, enter the value of service label. The setting is applied to only the image on the front side.	
Use Case	- When replacing the DADF - When replacing the Scanner Unit - When replacing the Main Controller PCB	
Adj/Set/Operate Method	Enter the setting value (switch negative/positive by +/- key), and then press Apply key.	
Caution	After the setting value is changed, write the changed value in the service label.	
Display/Adj/Set Range	-30 to 20	
Unit	0.1 mm	
Default Value	0	
Related Service Mode	COPIER > FUNCTION > INSTALL > STRD-POS	

COPIER (Service mode for printer) > ADJUST (Adjustment mode) > ADJ-XY

ADJ-S Adjustment of Reader shading position	
Detail	To adjust the position of the Scanner Unit on the Reader side in feed direction when reading the White Plate on the left edge of the Copyboard Glass. When replacing the Scanner Unit, execute RDSHDPOS and write the value of this item in the service label. When clearing the Reader-related RAM data, enter the value of service label. As the value is incremented by 1, the reading position moves to the trailing edge side by 0.1 mm.
Use Case	- When black lines/white lines appear - When replacing the Scanner Unit - When clearing the Reader-related RAM data
Adj/Set/Operate Method	Enter the setting value (switch negative/positive by +/- key), and then press Apply key.
Caution	After the setting value is changed, write the changed value in the service label.
Display/Adj/Set Range	-20 to 20
Unit	0.1 mm
Default Value	0
Related Service Mode	COPIER > FUNCTION > INSTALL > RDSHDPOS
Supplement/Memo	The shading position can be adjusted automatically by RDSHDPOS.

■ CCD

COPIER (Service mode for printer) > ADJUST (Adjustment mode) > CCD

W-PLT-X Stdrd White Plt white lvl data (X) entry	
Detail	To enter the white level data (X) for the Standard White Plate. When replacing the DADF/Reader Unit, Reader Upper Cover Unit or Main Controller PCB, enter "XXXX" of the value (XXXXYYYYZZZZ) shown on the barcode label affixed at the upper left of the Copyboard Glass.
Use Case	- When replacing the DADF/Reader Unit - When replacing the Reader Upper Cover Unit - When replacing the Main Controller PCB
Adj/Set/Operate Method	Enter the setting value, and then press Apply key.
Caution	After the setting value is changed, write the changed value in the service label.
Display/Adj/Set Range	7000 to 9999
Default Value	8273
Related Service Mode	COPIER > ADJUST > CCD > W-PLT-Y/Z
W-PLT-Y Stdrd White Plt white lvl data (Y) entry	
Detail	To enter the white level data (Y) for the Standard White Plate. When replacing the DADF/Reader Unit, Reader Upper Cover Unit or Main Controller PCB, enter "YYYY" of the value (XXXXYYYYZZZZ) shown on the barcode label affixed at the upper left of the Copyboard Glass.
Use Case	- When replacing the DADF/Reader Unit - When replacing the Reader Upper Cover Unit - When replacing the Main Controller PCB
Adj/Set/Operate Method	Enter the setting value, and then press Apply key.
Caution	After the setting value is changed, write the changed value in the service label.
Display/Adj/Set Range	7000 to 9999
Default Value	8737
Related Service Mode	COPIER > ADJUST > CCD > W-PLT-X/Z

COPIER (Service mode for printer) > ADJUST (Adjustment mode) > CCD

W-PLT-Z		Stdrd White Plt white lvl data (Z) entry
Detail	To enter the white level data (Z) for the Standard White Plate. When replacing the DADF/Reader Unit, Reader Upper Cover Unit or Main Controller PCB, enter "ZZZZ" of the value (XXXXYYYYZZZZ) shown on the barcode label affixed at the upper left of the Copyboard Glass.	
Use Case	<ul style="list-style-type: none"> - When replacing the DADF/Reader Unit - When replacing the Reader Upper Cover Unit - When replacing the Main Controller PCB 	
Adj/Set/Operate Method	Enter the setting value, and then press Apply key.	
Caution	After the setting value is changed, write the changed value in the service label.	
Display/Adj/Set Range	7000 to 9999	
Default Value	9427	
Related Service Mode	COPIER > ADJUST > CCD > W-PLT-X/Y	
DFTAR-R		Shading target VL (R) entry: front side
Detail	To enter the shading target value of Red of the Scanner Unit (for front side) at stream reading. When replacing the Main Controller PCB/clearing RAM data, enter the value of service label. When replacing the DADF/Reader Unit, Scanner Unit, or Reader Upper Cover Unit, execute DF-WLVL1 and DF-WLVL2 and write the value which is automatically set in the service label. The setting is applied to only the image on the front side.	
Use Case	<ul style="list-style-type: none"> - When replacing the Main Controller PCB/clearing RAM data - When replacing the DADF/Reader Unit - When replacing the Scanner Unit - When replacing the Reader Upper Cover Unit 	
Adj/Set/Operate Method	Enter the setting value, and then press Apply key.	
Display/Adj/Set Range	0 to 2048	
Default Value	1105	
Related Service Mode	COPIER > DISPLAY > CCD > TARGET-R COPIER > FUNCTION > CCD > DF-WLVL1/2	
DFTAR-G		Shading target VL (G) entry: front side
Detail	To enter the shading target value of Green of the Scanner Unit (for front side) at stream reading. When replacing the Main Controller PCB/clearing RAM data, enter the value of service label. When replacing the DADF/Reader Unit, Scanner Unit, or Reader Upper Cover Unit, execute DF-WLVL1 and DF-WLVL2 and write the value which is automatically set in the service label. The setting is applied to only the image on the front side.	
Use Case	<ul style="list-style-type: none"> - When replacing the Main Controller PCB/clearing RAM data - When replacing the DADF/Reader Unit - When replacing the Scanner Unit - When replacing the Reader Upper Cover Unit 	
Adj/Set/Operate Method	Enter the setting value, and then press Apply key.	
Display/Adj/Set Range	0 to 2048	
Default Value	1129	
Related Service Mode	COPIER > DISPLAY > CCD > TARGET-G COPIER > FUNCTION > CCD > DF-WLVL1/2	

COPIER (Service mode for printer) > ADJUST (Adjustment mode) > CCD

DFTAR-B		Shading target VL (B) entry: front side
Detail		To enter the shading target value of Blue of the Scanner Unit (for front side) at stream reading. When replacing the Main Controller PCB/clearing RAM data, enter the value of service label. When replacing the DADF/Reader Unit, Scanner Unit, or Reader Upper Cover Unit, execute DF-WLVL1 and DF-WLVL2 and write the value which is automatically set in the service label. The setting is applied to only the image on the front side.
Use Case		- When replacing the Main Controller PCB/clearing RAM data - When replacing the DADF/Reader Unit - When replacing the Scanner Unit - When replacing the Reader Upper Cover Unit
Adj/Set/Operate Method		Enter the setting value, and then press Apply key.
Display/Adj/Set Range		0 to 2048
Default Value		1151
Related Service Mode		COPIER > DISPLAY > CCD > TARGET-B COPIER > FUNCTION > CCD > DF-WLVL1/2
DFTAR-BW		Shading target VL (B&W) entry: front
Detail		To enter the B&W shading target value of the Scanner Unit (for front side) at stream reading. When replacing the Main Controller PCB/clearing RAM data, enter the value of service label. When replacing the DADF/Reader Unit, Scanner Unit, or Reader Upper Cover Unit, execute DF-WLVL1 and DF-WLVL2 and write the value which is automatically set in the service label. The setting is applied to only the image on the front side.
Use Case		- When replacing the Main Controller PCB/clearing RAM data - When replacing the DADF/Reader Unit - When replacing the Scanner Unit - When replacing the Reader Upper Cover Unit
Adj/Set/Operate Method		Enter the setting value, and then press Apply key.
Display/Adj/Set Range		0 to 2048
Default Value		1072
Related Service Mode		COPIER > DISPLAY > CCD > TARGETBW COPIER > FUNCTION > CCD > DF-WLVL1/2
DFTBK-R		Shading target VL (R) entry: back side
Detail		To enter the shading target value of Red of the Scanner Unit (for back side) at stream reading. When replacing the Main Controller PCB/clearing RAM data, enter the value of service label. When replacing the DADF/Reader Unit, Scanner Unit, or Reader Upper Cover Unit, execute DF-WLVL1 and DF-WLVL2 and write the value which is automatically set in the service label. The setting is applied to only the image on the back side.
Use Case		- When replacing the Main Controller PCB/clearing RAM data - When replacing the DADF/Reader Unit - When replacing the Scanner Unit - When replacing the Reader Upper Cover Unit
Adj/Set/Operate Method		Enter the setting value, and then press Apply key.
Display/Adj/Set Range		0 to 2048
Default Value		1105
Related Service Mode		COPIER > DISPLAY > CCD > TARGET-R COPIER > FUNCTION > CCD > DF-WLVL1/2

COPIER (Service mode for printer) > ADJUST (Adjustment mode) > CCD

DFTBK-G	Shading target VL (G) entry: back side
Detail	To enter the shading target value of Green of the Scanner Unit (for back side) at stream reading. When replacing the Main Controller PCB/clearing RAM data, enter the value of service label. When replacing the DADF/Reader Unit, Scanner Unit, or Reader Upper Cover Unit, execute DF-WLVL1 and DF-WLVL2 and write the value which is automatically set in the service label. The setting is applied to only the image on the back side.
Use Case	- When replacing the Main Controller PCB/clearing RAM data - When replacing the DADF/Reader Unit - When replacing the Scanner Unit - When replacing the Reader Upper Cover Unit
Adj/Set/Operate Method	Enter the setting value, and then press Apply key.
Display/Adj/Set Range	0 to 2048
Default Value	1129
Related Service Mode	COPIER > DISPLAY > CCD > TARGET-G COPIER > FUNCTION > CCD > DF-WLVL1/2
DFTBK-B	Shading target VL (B) entry: back side
Detail	To enter the shading target value of Blue of the Scanner Unit (for back side) at stream reading. When replacing the Main Controller PCB/clearing RAM data, enter the value of service label. When replacing the DADF/Reader Unit, Scanner Unit, or Reader Upper Cover Unit, execute DF-WLVL1 and DF-WLVL2 and write the value which is automatically set in the service label. The setting is applied to only the image on the back side.
Use Case	- When replacing the Main Controller PCB/clearing RAM data - When replacing the DADF/Reader Unit - When replacing the Scanner Unit - When replacing the Reader Upper Cover Unit
Adj/Set/Operate Method	Enter the setting value, and then press Apply key.
Display/Adj/Set Range	0 to 2048
Default Value	1151
Related Service Mode	COPIER > DISPLAY > CCD > TARGET-B COPIER > FUNCTION > CCD > DF-WLVL1/2
OF2CL1BK	Adj Img Read Sns 2 offset: bck,clr,600dpi
Detail	To adjust the offset (black level) of the Image Reading Sensor 2 (Center) of the Scanner Unit (for back side) in color mode with 600 dpi. When replacing the Main Controller PCB/clearing RAM data, enter the value of service label.
Use Case	When replacing the Main Controller PCB/clearing RAM data
Adj/Set/Operate Method	Enter the setting value, and then press Apply key.
Display/Adj/Set Range	0 to 255
Default Value	0
Related Service Mode	COPIER > FUNCTION > CCD > CL-AGC2
OF2CL2BK	Adj Img Read Sns 3 offset: bck,clr,600dpi
Detail	To adjust the offset (black level) of the Image Reading Sensor 3 (Front) of the Scanner Unit (for back side) in color mode with 600 dpi. When replacing the Main Controller PCB/clearing RAM data, enter the value of service label.
Use Case	When replacing the Main Controller PCB/clearing RAM data
Adj/Set/Operate Method	Enter the setting value, and then press Apply key.
Display/Adj/Set Range	0 to 255
Default Value	0
Related Service Mode	COPIER > FUNCTION > CCD > CL-AGC2

COPIER (Service mode for printer) > ADJUST (Adjustment mode) > CCD

GAIN-BW0	Adj Img Read Sns 1 gain: frt,B&W,300dpi
Detail	To adjust the gain of the Image Reading Sensor 1 (Rear) of the Scanner Unit (for front side) in black mode with 300 dpi. When replacing the Main Controller PCB/clearing RAM data, enter the value of service label.
Use Case	When replacing the Main Controller PCB/clearing RAM data
Adj/Set/Operate Method	Enter the setting value, and then press Apply key.
Display/Adj/Set Range	0 to 255
Default Value	0
Related Service Mode	COPIER > FUNCTION > CCD > BW-AGC
GAIN2BW0	Adj Img Read Sns 1 gain: frt,B&W,600dpi
Detail	To adjust the gain of the Image Reading Sensor 1 (Rear) of the Scanner Unit (for front side) in black mode with 600 dpi. When replacing the Main Controller PCB/clearing RAM data, enter the value of service label.
Use Case	When replacing the Main Controller PCB/clearing RAM data
Adj/Set/Operate Method	Enter the setting value, and then press Apply key.
Display/Adj/Set Range	0 to 255
Default Value	0
Related Service Mode	COPIER > FUNCTION > CCD > BW-AGC
GAIN-CL0	Adj Img Read Sns 1 gain: frt,clr,300dpi
Detail	To adjust the gain of the Image Reading Sensor 1 (Rear) of the Scanner Unit (for front side) in color mode with 300 dpi. When replacing the Main Controller PCB/clearing RAM data, enter the value of service label.
Use Case	When replacing the Main Controller PCB/clearing RAM data
Adj/Set/Operate Method	Enter the setting value, and then press Apply key.
Display/Adj/Set Range	0 to 255
Default Value	0
Related Service Mode	COPIER > FUNCTION > CCD > CL-AGC
GAIN2CL0	Adj Img Read Sns 1 gain: frt,clr,600dpi
Detail	To adjust the gain of the Image Reading Sensor 1 (Rear) of the Scanner Unit (for front side) in color mode with 600 dpi. When replacing the Main Controller PCB/clearing RAM data, enter the value of service label.
Use Case	When replacing the Main Controller PCB/clearing RAM data
Adj/Set/Operate Method	Enter the setting value, and then press Apply key.
Display/Adj/Set Range	0 to 255
Default Value	0
Related Service Mode	COPIER > FUNCTION > CCD > CL-AGC
GA-BW0BK	Adj Img Read Sns 1 gain: bck,B&W,300dpi
Detail	To adjust the gain of the Image Reading Sensor 1 (Rear) of the Scanner Unit (for back side) in black mode with 300 dpi. When replacing the Main Controller PCB/clearing RAM data, enter the value of service label.
Use Case	When replacing the Main Controller PCB/clearing RAM data
Adj/Set/Operate Method	Enter the setting value, and then press Apply key.
Display/Adj/Set Range	0 to 255
Default Value	0
Related Service Mode	COPIER > FUNCTION > CCD > BW-AGC2

COPIER (Service mode for printer) > ADJUST (Adjustment mode) > CCD

GA2BW0BK	Adj Img Read Sns 1 gain: bck,B&W,600dpi
Detail	To adjust the gain of the Image Reading Sensor 1 (Rear) of the Scanner Unit (for back side) in black mode with 600 dpi. When replacing the Main Controller PCB/clearing RAM data, enter the value of service label.
Use Case	When replacing the Main Controller PCB/clearing RAM data
Adj/Set/Operate Method	Enter the setting value, and then press Apply key.
Display/Adj/Set Range	0 to 255
Default Value	0
Related Service Mode	COPIER > FUNCTION > CCD > BW-AGC2
GA-CL0BK	Adj Img Read Sns 1 gain: bck,clr,300dpi
Detail	To adjust the gain of the Image Reading Sensor 1 (Rear) of the Scanner Unit (for back side) in color mode with 300 dpi. When replacing the Main Controller PCB/clearing RAM data, enter the value of service label.
Use Case	When replacing the Main Controller PCB/clearing RAM data
Adj/Set/Operate Method	Enter the setting value, and then press Apply key.
Display/Adj/Set Range	0 to 255
Default Value	0
Related Service Mode	COPIER > FUNCTION > CCD > CL-AGC2
GA2CL0BK	Adj Img Read Sns 1 gain: bck,clr,600dpi
Detail	To adjust the gain of the Image Reading Sensor 1 (Rear) of the Scanner Unit (for back side) in color mode with 600 dpi. When replacing the Main Controller PCB/clearing RAM data, enter the value of service label.
Use Case	When replacing the Main Controller PCB/clearing RAM data
Adj/Set/Operate Method	Enter the setting value, and then press Apply key.
Display/Adj/Set Range	0 to 255
Default Value	0
Related Service Mode	COPIER > FUNCTION > CCD > CL-AGC2
DFTBK-BW	Shading target VL (B&W) entry: back
Detail	To enter the B&W shading target value of the Scanner Unit (for back side) at stream reading. When replacing the Main Controller PCB/clearing RAM data, enter the value of service label. When replacing the DADF/Reader Unit, Scanner Unit, or Reader Upper Cover Unit, execute DF-WLVL1 and DF-WLVL2 and write the value which is automatically set in the service label. The setting is applied to only the image on the back side.
Use Case	- When replacing the Main Controller PCB/clearing RAM data - When replacing the DADF/Reader Unit - When replacing the Scanner Unit - When replacing the Reader Upper Cover Unit
Adj/Set/Operate Method	Enter the setting value, and then press Apply key.
Display/Adj/Set Range	0 to 2048
Default Value	1072
Related Service Mode	COPIER > DISPLAY > CCD > TARGETBW COPIER > FUNCTION > CCD > DF-WLVL1/2

COPIER (Service mode for printer) > ADJUST (Adjustment mode) > CCD

LED-BW-R	Scan Unit LED lgt time(R): frt,B&W,300dpi
Detail	To adjust the lighting time of the red color LED of the Scanner Unit (for front side) in black mode with 300 dpi. When replacing the Main Controller PCB/clearing RAM data, enter the value of service label.
Use Case	When replacing the Main Controller PCB/clearing RAM data
Adj/Set/Operate Method	Enter the setting value, and then press Apply key.
Display/Adj/Set Range	0 to 4096
Default Value	609
Related Service Mode	COPIER > FUNCTION > CCD > BW-AGC
LED-BW-G	Scan Unit LED lgt time(G): frt,B&W,300dpi
Detail	To adjust the lighting time of the green color LED of the Scanner Unit (for front side) in black mode with 300 dpi. When replacing the Main Controller PCB/clearing RAM data, enter the value of service label.
Use Case	When replacing the Main Controller PCB/clearing RAM data
Adj/Set/Operate Method	Enter the setting value, and then press Apply key.
Display/Adj/Set Range	0 to 4096
Default Value	609
Related Service Mode	COPIER > FUNCTION > CCD > BW-AGC
LED-BW-B	Scan Unit LED lgt time(B): frt,B&W,300dpi
Detail	To adjust the lighting time of the blue color LED of the Scanner Unit (for front side) in black mode with 300 dpi. When replacing the Main Controller PCB/clearing RAM data, enter the value of service label.
Use Case	When replacing the Main Controller PCB/clearing RAM data
Adj/Set/Operate Method	Enter the setting value, and then press Apply key.
Display/Adj/Set Range	0 to 4096
Default Value	609
Related Service Mode	COPIER > FUNCTION > CCD > BW-AGC
LED2BW-R	Scan Unit LED lgt time(R): frt,B&W,600dpi
Detail	To adjust the lighting time of the red color LED of the Scanner Unit (for front side) in black mode with 600 dpi. When replacing the Main Controller PCB/clearing RAM data, enter the value of service label.
Use Case	When replacing the Main Controller PCB/clearing RAM data
Adj/Set/Operate Method	Enter the setting value, and then press Apply key.
Display/Adj/Set Range	0 to 4096
Default Value	1121
Related Service Mode	COPIER > FUNCTION > CCD > BW-AGC
LED2BW-G	Scan Unit LED lgt time(G): frt,B&W,600dpi
Detail	To adjust the lighting time of the green color LED of the Scanner Unit (for front side) in black mode with 600 dpi. When replacing the Main Controller PCB/clearing RAM data, enter the value of service label.
Use Case	When replacing the Main Controller PCB/clearing RAM data
Adj/Set/Operate Method	Enter the setting value, and then press Apply key.
Display/Adj/Set Range	0 to 4096
Default Value	1121
Related Service Mode	COPIER > FUNCTION > CCD > BW-AGC

COPIER (Service mode for printer) > ADJUST (Adjustment mode) > CCD

LED2BW-B	Scan Unit LED lgt time(B): frt,B&W,600dpi
Detail	To adjust the lighting time of the blue color LED of the Scanner Unit (for front side) in black mode with 600 dpi. When replacing the Main Controller PCB/clearing RAM data, enter the value of service label.
Use Case	When replacing the Main Controller PCB/clearing RAM data
Adj/Set/Operate Method	Enter the setting value, and then press Apply key.
Display/Adj/Set Range	0 to 4096
Default Value	1121
Related Service Mode	COPIER > FUNCTION > CCD > BW-AGC
LED-CL-R	Scan Unit LED lgt time(R): frt,clr,300dpi
Detail	To adjust the lighting time of the red color LED of the Scanner Unit (for front side) in color mode with 300 dpi. When replacing the Main Controller PCB/clearing RAM data, enter the value of service label.
Use Case	When replacing the Main Controller PCB/clearing RAM data
Adj/Set/Operate Method	Enter the setting value, and then press Apply key.
Display/Adj/Set Range	0 to 4096
Default Value	865
Related Service Mode	COPIER > FUNCTION > CCD > CL-AGC
LED-CL-G	Scan Unit LED lgt time(G): frt,clr,300dpi
Detail	To adjust the lighting time of the green color LED of the Scanner Unit (for front side) in color mode with 300 dpi. When replacing the Main Controller PCB/clearing RAM data, enter the value of service label.
Use Case	When replacing the Main Controller PCB/clearing RAM data
Adj/Set/Operate Method	Enter the setting value, and then press Apply key.
Display/Adj/Set Range	0 to 4096
Default Value	865
Related Service Mode	COPIER > FUNCTION > CCD > CL-AGC
LED-CL-B	Scan Unit LED lgt time(B): frt,clr,300dpi
Detail	To adjust the lighting time of the blue color LED of the Scanner Unit (for front side) in color mode with 300 dpi. When replacing the Main Controller PCB/clearing RAM data, enter the value of service label.
Use Case	When replacing the Main Controller PCB/clearing RAM data
Adj/Set/Operate Method	Enter the setting value, and then press Apply key.
Display/Adj/Set Range	0 to 4096
Default Value	865
Related Service Mode	COPIER > FUNCTION > CCD > CL-AGC
LED2CL-R	Scan Unit LED lgt time(R): frt,clr,600dpi
Detail	To adjust the lighting time of the red color LED of the Scanner Unit (for front side) in color mode with 600 dpi. When replacing the Main Controller PCB/clearing RAM data, enter the value of service label.
Use Case	When replacing the Main Controller PCB/clearing RAM data
Adj/Set/Operate Method	Enter the setting value, and then press Apply key.
Display/Adj/Set Range	0 to 4096
Default Value	1377
Related Service Mode	COPIER > FUNCTION > CCD > CL-AGC

COPIER (Service mode for printer) > ADJUST (Adjustment mode) > CCD

50-RG	RG clr displace correct: 50% book mode
Detail	To correct the color displacement between R and G lines in vertical scanning direction that occurs at 50% copyboard reading. When replacing the Main Controller PCB/clearing RAM data, enter the value of service label.
Use Case	When replacing the Main Controller PCB/clearing RAM data
Adj/Set/Operate Method	Enter the setting value (switch negative/positive by +/- key), and then press Apply key.
Caution	After the setting value is changed, write the changed value in the service label.
Display/Adj/Set Range	-512 to 512
Unit	0.001 line
Default Value	-333
Supplement/Memo	50% reading: 300 dpi in horizontal scanning direction x 600 dpi in vertical scanning direction
LED2CL-G	Scan Unit LED lgt time(G): frt,clr,600dpi
Detail	To adjust the lighting time of the green color LED of the Scanner Unit (for front side) in color mode with 600 dpi. When replacing the Main Controller PCB/clearing RAM data, enter the value of service label.
Use Case	When replacing the Main Controller PCB/clearing RAM data
Adj/Set/Operate Method	Enter the setting value, and then press Apply key.
Display/Adj/Set Range	0 to 4096
Default Value	1377
Related Service Mode	COPIER > FUNCTION > CCD > CL-AGC
LED2CL-B	Scan Unit LED lgt time(B): frt,clr,600dpi
Detail	To adjust the lighting time of the blue color LED of the Scanner Unit (for front side) in color mode with 600 dpi. When replacing the Main Controller PCB/clearing RAM data, enter the value of service label.
Use Case	When replacing the Main Controller PCB/clearing RAM data
Adj/Set/Operate Method	Enter the setting value, and then press Apply key.
Display/Adj/Set Range	0 to 4096
Default Value	1377
Related Service Mode	COPIER > FUNCTION > CCD > CL-AGC
LE-BWRBK	Scan Unit LED lgt time(R): bck,B&W,300dpi
Detail	To adjust the lighting time of the red color LED of the Scanner Unit (for back side) in black mode with 300 dpi. When replacing the Main Controller PCB/clearing RAM data, enter the value of service label.
Use Case	When replacing the Main Controller PCB/clearing RAM data
Adj/Set/Operate Method	Enter the setting value, and then press Apply key.
Display/Adj/Set Range	0 to 4096
Default Value	609
Related Service Mode	COPIER > FUNCTION > CCD > BW-AGC2
LE-BWGBK	Scan Unit LED lgt time(G): bck,B&W,300dpi
Detail	To adjust the lighting time of the green color LED of the Scanner Unit (for back side) in black mode with 300 dpi. When replacing the Main Controller PCB/clearing RAM data, enter the value of service label.
Use Case	When replacing the Main Controller PCB/clearing RAM data
Adj/Set/Operate Method	Enter the setting value, and then press Apply key.
Display/Adj/Set Range	0 to 4096
Default Value	609
Related Service Mode	COPIER > FUNCTION > CCD > BW-AGC2

COPIER (Service mode for printer) > ADJUST (Adjustment mode) > CCD

LE-BWBBK	Scan Unit LED lgt time(B): bck,B&W,300dpi
Detail	To adjust the lighting time of the blue color LED of the Scanner Unit (for back side) in black mode with 300 dpi. When replacing the Main Controller PCB/clearing RAM data, enter the value of service label.
Use Case	When replacing the Main Controller PCB/clearing RAM data
Adj/Set/Operate Method	Enter the setting value, and then press Apply key.
Display/Adj/Set Range	0 to 4096
Default Value	609
Related Service Mode	COPIER > FUNCTION > CCD > BW-AGC2
LE2BWRBK	Scan Unit LED lgt time(R): bck,B&W,600dpi
Detail	To adjust the lighting time of the red color LED of the Scanner Unit (for back side) in black mode with 600 dpi. When replacing the Main Controller PCB/clearing RAM data, enter the value of service label.
Use Case	When replacing the Main Controller PCB/clearing RAM data
Adj/Set/Operate Method	Enter the setting value, and then press Apply key.
Display/Adj/Set Range	0 to 4096
Default Value	1121
Related Service Mode	COPIER > FUNCTION > CCD > BW-AGC2
LE2BWGBK	Scan Unit LED lgt time(G): bck,B&W,600dpi
Detail	To adjust the lighting time of the green color LED of the Scanner Unit (for back side) in black mode with 600 dpi. When replacing the Main Controller PCB/clearing RAM data, enter the value of service label.
Use Case	When replacing the Main Controller PCB/clearing RAM data
Adj/Set/Operate Method	Enter the setting value, and then press Apply key.
Display/Adj/Set Range	0 to 4096
Default Value	1121
Related Service Mode	COPIER > FUNCTION > CCD > BW-AGC2
LE2BWBBK	Scan Unit LED lgt time(B): bck,B&W,600dpi
Detail	To adjust the lighting time of the blue color LED of the Scanner Unit (for back side) in black mode with 600 dpi. When replacing the Main Controller PCB/clearing RAM data, enter the value of service label.
Use Case	When replacing the Main Controller PCB/clearing RAM data
Adj/Set/Operate Method	Enter the setting value, and then press Apply key.
Display/Adj/Set Range	0 to 4096
Default Value	1121
Related Service Mode	COPIER > FUNCTION > CCD > BW-AGC2
LE-CLRBK	Scan Unit LED lgt time(R): bck,clr,300dpi
Detail	To adjust the lighting time of the red color LED of the Scanner Unit (for back side) in color mode with 300 dpi. When replacing the Main Controller PCB/clearing RAM data, enter the value of service label.
Use Case	When replacing the Main Controller PCB/clearing RAM data
Adj/Set/Operate Method	Enter the setting value, and then press Apply key.
Display/Adj/Set Range	0 to 4096
Default Value	865
Related Service Mode	COPIER > FUNCTION > CCD > CL-AGC2

COPIER (Service mode for printer) > ADJUST (Adjustment mode) > CCD

LE-CLGBK		Scan Unit LED lgt time(G): bck,clr,300dpi
Detail	To adjust the lighting time of the green color LED of the Scanner Unit (for back side) in color mode with 300 dpi. When replacing the Main Controller PCB/clearing RAM data, enter the value of service label.	
Use Case	When replacing the Main Controller PCB/clearing RAM data	
Adj/Set/Operate Method	Enter the setting value, and then press Apply key.	
Display/Adj/Set Range	0 to 4096	
Default Value	865	
Related Service Mode	COPIER > FUNCTION > CCD > CL-AGC2	
50-GB		GB clr displace correct: 50% book mode
Detail	To correct the color displacement between G and B lines in vertical scanning direction that occurs at 50% copyboard reading. When replacing the Main Controller PCB/clearing RAM data, enter the value of service label.	
Use Case	When replacing the Main Controller PCB/clearing RAM data	
Adj/Set/Operate Method	Enter the setting value (switch negative/positive by +/- key), and then press Apply key.	
Caution	After the setting value is changed, write the changed value in the service label.	
Display/Adj/Set Range	-512 to 512	
Unit	0.001 line	
Default Value	333	
Supplement/Memo	50% reading: 300 dpi in horizontal scanning direction x 600 dpi in vertical scanning direction	
LE-CLBBK		Scan Unit LED lgt time(B): bck,clr,300dpi
Detail	To adjust the lighting time of the blue color LED of the Scanner Unit (for back side) in color mode with 300 dpi. When replacing the Main Controller PCB/clearing RAM data, enter the value of service label.	
Use Case	When replacing the Main Controller PCB/clearing RAM data	
Adj/Set/Operate Method	Enter the setting value, and then press Apply key.	
Display/Adj/Set Range	0 to 4096	
Default Value	865	
Related Service Mode	COPIER > FUNCTION > CCD > CL-AGC2	
LE2CLR BK		Scan Unit LED lgt time(R): bck,clr,600dpi
Detail	To adjust the lighting time of the red color LED of the Scanner Unit (for back side) in color mode with 600 dpi. When replacing the Main Controller PCB/clearing RAM data, enter the value of service label.	
Use Case	When replacing the Main Controller PCB/clearing RAM data	
Adj/Set/Operate Method	Enter the setting value, and then press Apply key.	
Display/Adj/Set Range	0 to 4096	
Default Value	1377	
Related Service Mode	COPIER > FUNCTION > CCD > CL-AGC2	
LE2CLGBK		Scan Unit LED lgt time(G): bck,clr,600dpi
Detail	To adjust the lighting time of the green color LED of the Scanner Unit (for back side) in color mode with 600 dpi. When replacing the Main Controller PCB/clearing RAM data, enter the value of service label.	
Use Case	When replacing the Main Controller PCB/clearing RAM data	
Adj/Set/Operate Method	Enter the setting value, and then press Apply key.	
Display/Adj/Set Range	0 to 4096	
Default Value	1377	
Related Service Mode	COPIER > FUNCTION > CCD > CL-AGC2	

COPIER (Service mode for printer) > ADJUST (Adjustment mode) > CCD

LE2CLBBK	Scan Unit LED lgt time(B): bck,clr,600dpi
Detail	To adjust the lighting time of the blue color LED of the Scanner Unit (for back side) in color mode with 600 dpi. When replacing the Main Controller PCB/clearing RAM data, enter the value of service label.
Use Case	When replacing the Main Controller PCB/clearing RAM data
Adj/Set/Operate Method	Enter the setting value, and then press Apply key.
Display/Adj/Set Range	0 to 4096
Default Value	1377
Related Service Mode	COPIER > FUNCTION > CCD > CL-AGC2
LNR-GA-R	Frt/bck linearity gain crrect coeffct (R)
Detail	To adjust the red color gain correction coefficient of the front/back side linearity.
Use Case	When replacing the Main Controller PCB/clearing RAM data
Adj/Set/Operate Method	Enter the setting value, and then press Apply key.
Display/Adj/Set Range	0 to 65535
Default Value	10000
LNR-GA-G	Frt/bck linearity gain crrect coeffct (G)
Detail	To adjust the green color gain correction coefficient of the front/back side linearity.
Use Case	When replacing the Main Controller PCB/clearing RAM data
Adj/Set/Operate Method	Enter the setting value, and then press Apply key.
Display/Adj/Set Range	0 to 65535
Default Value	10000
LNR-GA-B	Frt/bck linearity gain crrect coeffct (B)
Detail	To adjust the blue color gain correction coefficient of the front/back side linearity.
Use Case	When replacing the Main Controller PCB/clearing RAM data
Adj/Set/Operate Method	Enter the setting value, and then press Apply key.
Display/Adj/Set Range	0 to 65535
Default Value	10000
LNR-OF-R	Frt/bck linearity offset crrect coeff (R)
Detail	To adjust the red color offset correction coefficient of the front/back side linearity.
Use Case	When replacing the Main Controller PCB/clearing RAM data
Adj/Set/Operate Method	Enter the setting value, and then press Apply key.
Display/Adj/Set Range	-128 to 127
Default Value	0
LNR-OF-G	Frt/bck linearity offset crrect coeff (G)
Detail	To adjust the green color offset correction coefficient of the front/back side linearity.
Use Case	When replacing the Main Controller PCB/clearing RAM data
Adj/Set/Operate Method	Enter the setting value, and then press Apply key.
Display/Adj/Set Range	-128 to 127
Default Value	0
LNR-OF-B	Frt/bck linearity offset crrect coeff (B)
Detail	To adjust the blue color offset correction coefficient of the front/back side linearity.
Use Case	When replacing the Main Controller PCB/clearing RAM data
Adj/Set/Operate Method	Enter the setting value, and then press Apply key.
Display/Adj/Set Range	-128 to 127
Default Value	0

COPIER (Service mode for printer) > ADJUST (Adjustment mode) > CCD

100-RG	RG clr displace correct: 100% book mode
Detail	To correct the color displacement between R and G lines in vertical scanning direction that occurs at 100% copyboard reading. When replacing the Main Controller PCB/clearing RAM data, enter the value of service label.
Use Case	When replacing the Main Controller PCB/clearing RAM data
Adj/Set/Operate Method	Enter the setting value (switch negative/positive by +/- key), and then press Apply key.
Caution	After the setting value is changed, write the changed value in the service label.
Display/Adj/Set Range	-512 to 512
Unit	0.001 line
Default Value	-333
Supplement/Memo	100 reading: 600 dpi in horizontal scanning direction x 600 dpi in vertical scanning direction
100-GB	GB clr displace correct: 100% book mode
Detail	To correct the color displacement between G and B lines in vertical scanning direction that occurs at 100% copyboard reading. When replacing the Main Controller PCB/clearing RAM data, enter the value of service label.
Use Case	When replacing the Main Controller PCB/clearing RAM data
Adj/Set/Operate Method	Enter the setting value (switch negative/positive by +/- key), and then press Apply key.
Caution	After the setting value is changed, write the changed value in the service label.
Display/Adj/Set Range	-512 to 512
Unit	0.001 line
Default Value	333
Supplement/Memo	100 reading: 600 dpi in horizontal scanning direction x 600 dpi in vertical scanning direction
50DF-RG	RG clr displace crrect: 50% DADF, front
Detail	To correct the color displacement between R and G lines in vertical scanning direction that occurs at 50% DADF mode. When replacing the Main Controller PCB/clearing RAM data, enter the value of service label. The setting is applied to only the image on the front side.
Use Case	When replacing the Main Controller PCB/clearing RAM data
Adj/Set/Operate Method	Enter the setting value (switch negative/positive by +/- key), and then press Apply key.
Caution	After the setting value is changed, write the changed value in the service label.
Display/Adj/Set Range	-512 to 512
Unit	0.001 line
Default Value	-333
Supplement/Memo	50% reading: 300 dpi in horizontal scanning direction x 600 dpi in vertical scanning direction
50DF-GB	GB clr displace crrect: 50% DADF, front
Detail	To correct the color displacement between G and B lines in vertical scanning direction that occurs at 50% DADF mode. When replacing the Main Controller PCB/clearing RAM data, enter the value of service label. The setting is applied to only the image on the front side.
Use Case	When replacing the Main Controller PCB/clearing RAM data
Adj/Set/Operate Method	Enter the setting value (switch negative/positive by +/- key), and then press Apply key.
Caution	After the setting value is changed, write the changed value in the service label.
Display/Adj/Set Range	-512 to 512
Unit	0.001 line
Default Value	333
Supplement/Memo	50% reading: 300 dpi in horizontal scanning direction x 600 dpi in vertical scanning direction

COPIER (Service mode for printer) > ADJUST (Adjustment mode) > CCD

100DF-RG	RG clr displace crct: 100% DADF, front
Detail	To correct the color displacement between R and G lines in vertical scanning direction that occurs at 100% DADF mode. When replacing the Main Controller PCB/clearing RAM data, enter the value of service label. The setting is applied to only the image on the front side.
Use Case	When replacing the Main Controller PCB/clearing RAM data
Adj/Set/Operate Method	Enter the setting value (switch negative/positive by +/- key), and then press Apply key.
Caution	After the setting value is changed, write the changed value in the service label.
Display/Adj/Set Range	-512 to 512
Unit	0.001 line
Default Value	-333
Supplement/Memo	100 reading: 600 dpi in horizontal scanning direction x 600 dpi in vertical scanning direction
100DF-GB	GB clr displace crct: 100% DADF, front
Detail	To correct the color displacement between G and B lines in vertical scanning direction that occurs at 100% DADF mode. When replacing the Main Controller PCB/clearing RAM data, enter the value of service label. The setting is applied to only the image on the front side.
Use Case	When replacing the Main Controller PCB/clearing RAM data
Adj/Set/Operate Method	Enter the setting value (switch negative/positive by +/- key), and then press Apply key.
Caution	After the setting value is changed, write the changed value in the service label.
Display/Adj/Set Range	-512 to 512
Unit	0.001 line
Default Value	333
Supplement/Memo	100 reading: 600 dpi in horizontal scanning direction x 600 dpi in vertical scanning direction
50DF2RG	RG clr displace crct: 50% DADF, back
Detail	To correct the color displacement between R and G lines in vertical scanning direction that occurs at 50% DADF mode. When replacing the Main Controller PCB/clearing RAM data, enter the value of service label. The setting is applied to only the image on the back side.
Use Case	When replacing the Main Controller PCB/clearing RAM data
Adj/Set/Operate Method	Enter the setting value (switch negative/positive by +/- key), and then press Apply key.
Caution	After the setting value is changed, write the changed value in the service label.
Display/Adj/Set Range	-512 to 512
Unit	0.001 line
Default Value	-333
Supplement/Memo	50% reading: 300 dpi in horizontal scanning direction x 600 dpi in vertical scanning direction
50DF2GB	GB clr displace crct: 50% DADF, back
Detail	To correct the color displacement between G and B lines in vertical scanning direction that occurs at 50% DADF mode. When replacing the Main Controller PCB/clearing RAM data, enter the value of service label. The setting is applied to only the image on the back side.
Use Case	When replacing the Main Controller PCB/clearing RAM data
Adj/Set/Operate Method	Enter the setting value (switch negative/positive by +/- key), and then press Apply key.
Caution	After the setting value is changed, write the changed value in the service label.
Display/Adj/Set Range	-512 to 512
Unit	0.001 line
Default Value	333
Supplement/Memo	50% reading: 300 dpi in horizontal scanning direction x 600 dpi in vertical scanning direction

COPIER (Service mode for printer) > ADJUST (Adjustment mode) > CCD

100DF2RG	RG clr displace crct: 100% DADF, back
Detail	To correct the color displacement between R and G lines in vertical scanning direction that occurs at 100% DADF mode. When replacing the Main Controller PCB/clearing RAM data, enter the value of service label. The setting is applied to only the image on the back side.
Use Case	When replacing the Main Controller PCB/clearing RAM data
Adj/Set/Operate Method	Enter the setting value (switch negative/positive by +/- key), and then press Apply key.
Caution	After the setting value is changed, write the changed value in the service label.
Display/Adj/Set Range	-512 to 512
Unit	0.001 line
Default Value	-333
Supplement/Memo	100 reading: 600 dpi in horizontal scanning direction x 600 dpi in vertical scanning direction
100DF2GB	GB clr displace crct: 100% DADF, back
Detail	To correct the color displacement between G and B lines in vertical scanning direction that occurs at 100% DADF mode. When replacing the Main Controller PCB/clearing RAM data, enter the value of service label. The setting is applied to only the image on the back side.
Use Case	When replacing the Main Controller PCB/clearing RAM data
Adj/Set/Operate Method	Enter the setting value (switch negative/positive by +/- key), and then press Apply key.
Caution	After the setting value is changed, write the changed value in the service label.
Display/Adj/Set Range	-512 to 512
Unit	0.001 line
Default Value	333
Supplement/Memo	100 reading: 600 dpi in horizontal scanning direction x 600 dpi in vertical scanning direction
MTF2-M1	MTF value 1 entry: DADF, front, horz scan
Detail	To enter the setting value for calculating MTF filter coefficient in horizontal scanning direction on the front side at DADF stream reading. When replacing the Main Controller PCB/clearing the Reader-related RAM data, enter the value of the service label on the reader. When replacing the Scanner Unit (for front side), enter the value of service label on a new unit.
Use Case	- When replacing the Main Controller PCB/clearing the Reader-related RAM data - When replacing the Scanner Unit (for front side)
Adj/Set/Operate Method	Enter the setting value, and then press Apply key.
Display/Adj/Set Range	0 to 100
Default Value	100
MTF2-M2	MTF value 2 entry: DADF, front, horz scan
Detail	To enter the setting value for calculating MTF filter coefficient in horizontal scanning direction on the front side at DADF stream reading. When replacing the Main Controller PCB/clearing the Reader-related RAM data, enter the value of the service label on the reader. When replacing the Scanner Unit (for front side), enter the value of service label on a new unit.
Use Case	- When replacing the Main Controller PCB/clearing the Reader-related RAM data - When replacing the Scanner Unit (for front side)
Adj/Set/Operate Method	Enter the setting value, and then press Apply key.
Display/Adj/Set Range	0 to 100
Default Value	100

COPIER (Service mode for printer) > ADJUST (Adjustment mode) > CCD

MTF2-M3	MTF value 3 entry: DADF, front, horz scan
Detail	To enter the setting value for calculating MTF filter coefficient in horizontal scanning direction on the front side at DADF stream reading. When replacing the Main Controller PCB/clearing the Reader-related RAM data, enter the value of the service label on the reader. When replacing the Scanner Unit (for front side), enter the value of service label on a new unit.
Use Case	- When replacing the Main Controller PCB/clearing the Reader-related RAM data - When replacing the Scanner Unit (for front side)
Adj/Set/Operate Method	Enter the setting value, and then press Apply key.
Display/Adj/Set Range	0 to 100
Default Value	100
MTF2-M4	MTF value 4 entry: DADF, front, horz scan
Detail	To enter the setting value for calculating MTF filter coefficient in horizontal scanning direction on the front side at DADF stream reading. When replacing the Main Controller PCB/clearing the Reader-related RAM data, enter the value of the service label on the reader. When replacing the Scanner Unit (for front side), enter the value of service label on a new unit.
Use Case	- When replacing the Main Controller PCB/clearing the Reader-related RAM data - When replacing the Scanner Unit (for front side)
Adj/Set/Operate Method	Enter the setting value, and then press Apply key.
Display/Adj/Set Range	0 to 100
Default Value	100
MTF2-M5	MTF value 5 entry: DADF, front, horz scan
Detail	To enter the setting value for calculating MTF filter coefficient in horizontal scanning direction on the front side at DADF stream reading. When replacing the Main Controller PCB/clearing the Reader-related RAM data, enter the value of the service label on the reader. When replacing the Scanner Unit (for front side), enter the value of service label on a new unit.
Use Case	- When replacing the Main Controller PCB/clearing the Reader-related RAM data - When replacing the Scanner Unit (for front side)
Adj/Set/Operate Method	Enter the setting value, and then press Apply key.
Display/Adj/Set Range	0 to 100
Default Value	100
MTF2-M6	MTF value 6 entry: DADF, front, horz scan
Detail	To enter the setting value for calculating MTF filter coefficient in horizontal scanning direction on the front side at DADF stream reading. When replacing the Main Controller PCB/clearing the Reader-related RAM data, enter the value of the service label on the reader. When replacing the Scanner Unit (for front side), enter the value of service label on a new unit.
Use Case	- When replacing the Main Controller PCB/clearing the Reader-related RAM data - When replacing the Scanner Unit (for front side)
Adj/Set/Operate Method	Enter the setting value, and then press Apply key.
Display/Adj/Set Range	0 to 100
Default Value	100

COPIER (Service mode for printer) > ADJUST (Adjustment mode) > CCD

MTF2-M7	MTF value 7 entry: DADF, front, horz scan
Detail	To enter the setting value for calculating MTF filter coefficient in horizontal scanning direction on the front side at DADF stream reading. When replacing the Main Controller PCB/clearing the Reader-related RAM data, enter the value of the service label on the reader. When replacing the Scanner Unit (for front side), enter the value of service label on a new unit.
Use Case	- When replacing the Main Controller PCB/clearing the Reader-related RAM data - When replacing the Scanner Unit (for front side)
Adj/Set/Operate Method	Enter the setting value, and then press Apply key.
Display/Adj/Set Range	0 to 100
Default Value	100
MTF2-M8	MTF value 8 entry: DADF, front, horz scan
Detail	To enter the setting value for calculating MTF filter coefficient in horizontal scanning direction on the front side at DADF stream reading. When replacing the Main Controller PCB/clearing the Reader-related RAM data, enter the value of the service label on the reader. When replacing the Scanner Unit (for front side), enter the value of service label on a new unit.
Use Case	- When replacing the Main Controller PCB/clearing the Reader-related RAM data - When replacing the Scanner Unit (for front side)
Adj/Set/Operate Method	Enter the setting value, and then press Apply key.
Display/Adj/Set Range	0 to 100
Default Value	100
MTF2-M9	MTF value 9 entry: DADF, front, horz scan
Detail	To enter the setting value for calculating MTF filter coefficient in horizontal scanning direction on the front side at DADF stream reading. When replacing the Main Controller PCB/clearing the Reader-related RAM data, enter the value of the service label on the reader. When replacing the Scanner Unit (for front side), enter the value of service label on a new unit.
Use Case	- When replacing the Main Controller PCB/clearing the Reader-related RAM data - When replacing the Scanner Unit (for front side)
Adj/Set/Operate Method	Enter the setting value, and then press Apply key.
Display/Adj/Set Range	0 to 100
Default Value	100
MTF2-S1	MTF value 1 entry: DADF, front, vert scan
Detail	To enter the setting value for calculating MTF filter coefficient in vertical scanning direction on the front side at DADF stream reading. When replacing the Main Controller PCB/clearing the Reader-related RAM data, enter the value of the service label on the reader. When replacing the Scanner Unit (for front side), enter the value of service label on a new unit.
Use Case	- When replacing the Main Controller PCB/clearing the Reader-related RAM data - When replacing the Scanner Unit (for front side)
Adj/Set/Operate Method	Enter the setting value, and then press Apply key.
Display/Adj/Set Range	0 to 100
Default Value	100

COPIER (Service mode for printer) > ADJUST (Adjustment mode) > CCD

MTF2-S2	MTF value 2 entry: DADF, front, vert scan
Detail	To enter the setting value for calculating MTF filter coefficient in vertical scanning direction on the front side at DADF stream reading. When replacing the Main Controller PCB/clearing the Reader-related RAM data, enter the value of the service label on the reader. When replacing the Scanner Unit (for front side), enter the value of service label on a new unit.
Use Case	- When replacing the Main Controller PCB/clearing the Reader-related RAM data - When replacing the Scanner Unit (for front side)
Adj/Set/Operate Method	Enter the setting value, and then press Apply key.
Display/Adj/Set Range	0 to 100
Default Value	100
MTF2-S3	MTF value 3 entry: DADF, front, vert scan
Detail	To enter the setting value for calculating MTF filter coefficient in vertical scanning direction on the front side at DADF stream reading. When replacing the Main Controller PCB/clearing the Reader-related RAM data, enter the value of the service label on the reader. When replacing the Scanner Unit (for front side), enter the value of service label on a new unit.
Use Case	- When replacing the Main Controller PCB/clearing the Reader-related RAM data - When replacing the Scanner Unit (for front side)
Adj/Set/Operate Method	Enter the setting value, and then press Apply key.
Display/Adj/Set Range	0 to 100
Default Value	100
MTF2-S4	MTF value 4 entry: DADF, front, vert scan
Detail	To enter the setting value for calculating MTF filter coefficient in vertical scanning direction on the front side at DADF stream reading. When replacing the Main Controller PCB/clearing the Reader-related RAM data, enter the value of the service label on the reader. When replacing the Scanner Unit (for front side), enter the value of service label on a new unit.
Use Case	- When replacing the Main Controller PCB/clearing the Reader-related RAM data - When replacing the Scanner Unit (for front side)
Adj/Set/Operate Method	Enter the setting value, and then press Apply key.
Display/Adj/Set Range	0 to 100
Default Value	100
MTF2-S5	MTF value 5 entry: DADF, front, vert scan
Detail	To enter the setting value for calculating MTF filter coefficient in vertical scanning direction on the front side at DADF stream reading. When replacing the Main Controller PCB/clearing the Reader-related RAM data, enter the value of the service label on the reader. When replacing the Scanner Unit (for front side), enter the value of service label on a new unit.
Use Case	- When replacing the Main Controller PCB/clearing the Reader-related RAM data - When replacing the Scanner Unit (for front side)
Adj/Set/Operate Method	Enter the setting value, and then press Apply key.
Display/Adj/Set Range	0 to 100
Default Value	100

COPIER (Service mode for printer) > ADJUST (Adjustment mode) > CCD

MTF2-S6	MTF value 6 entry: DADF, front, vert scan
Detail	To enter the setting value for calculating MTF filter coefficient in vertical scanning direction on the front side at DADF stream reading. When replacing the Main Controller PCB/clearing the Reader-related RAM data, enter the value of the service label on the reader. When replacing the Scanner Unit (for front side), enter the value of service label on a new unit.
Use Case	- When replacing the Main Controller PCB/clearing the Reader-related RAM data - When replacing the Scanner Unit (for front side)
Adj/Set/Operate Method	Enter the setting value, and then press Apply key.
Display/Adj/Set Range	0 to 100
Default Value	100
MTF2-S7	MTF value 7 entry: DADF, front, vert scan
Detail	To enter the setting value for calculating MTF filter coefficient in vertical scanning direction on the front side at DADF stream reading. When replacing the Main Controller PCB/clearing the Reader-related RAM data, enter the value of the service label on the reader. When replacing the Scanner Unit (for front side), enter the value of service label on a new unit.
Use Case	- When replacing the Main Controller PCB/clearing the Reader-related RAM data - When replacing the Scanner Unit (for front side)
Adj/Set/Operate Method	Enter the setting value, and then press Apply key.
Display/Adj/Set Range	0 to 100
Default Value	100
MTF2-S8	MTF value 8 entry: DADF, front, vert scan
Detail	To enter the setting value for calculating MTF filter coefficient in vertical scanning direction on the front side at DADF stream reading. When replacing the Main Controller PCB/clearing the Reader-related RAM data, enter the value of the service label on the reader. When replacing the Scanner Unit (for front side), enter the value of service label on a new unit.
Use Case	- When replacing the Main Controller PCB/clearing the Reader-related RAM data - When replacing the Scanner Unit (for front side)
Adj/Set/Operate Method	Enter the setting value, and then press Apply key.
Display/Adj/Set Range	0 to 100
Default Value	100
MTF2-S9	MTF value 9 entry: DADF, front, vert scan
Detail	To enter the setting value for calculating MTF filter coefficient in vertical scanning direction on the front side at DADF stream reading. When replacing the Main Controller PCB/clearing the Reader-related RAM data, enter the value of the service label on the reader. When replacing the Scanner Unit (for front side), enter the value of service label on a new unit.
Use Case	- When replacing the Main Controller PCB/clearing the Reader-related RAM data - When replacing the Scanner Unit (for front side)
Adj/Set/Operate Method	Enter the setting value, and then press Apply key.
Display/Adj/Set Range	0 to 100
Default Value	100

COPIER (Service mode for printer) > ADJUST (Adjustment mode) > CCD

MTF-M1	MTF value 1 entry: Copyboard, horz scan
Detail	To enter the setting value for calculating MTF filter coefficient in horizontal scanning direction at copyboard reading. When replacing the Main Controller PCB/clearing the Reader-related RAM data, enter the value of the service label on the reader. When replacing the Scanner Unit (for front side), enter the value of service label on a new unit.
Use Case	- When replacing the Main Controller PCB/clearing the Reader-related RAM data - When replacing the Scanner Unit (for front side)
Adj/Set/Operate Method	Enter the setting value, and then press Apply key.
Display/Adj/Set Range	0 to 100
Default Value	100
MTF-M2	MTF value 2 entry: Copyboard, horz scan
Detail	To enter the setting value for calculating MTF filter coefficient in horizontal scanning direction at copyboard reading. When replacing the Main Controller PCB/clearing the Reader-related RAM data, enter the value of the service label on the reader. When replacing the Scanner Unit (for front side), enter the value of service label on a new unit.
Use Case	- When replacing the Main Controller PCB/clearing the Reader-related RAM data - When replacing the Scanner Unit (for front side)
Adj/Set/Operate Method	Enter the setting value, and then press Apply key.
Display/Adj/Set Range	0 to 100
Default Value	100
MTF-M3	MTF value 3 entry: Copyboard, horz scan
Detail	To enter the setting value for calculating MTF filter coefficient in horizontal scanning direction at copyboard reading. When replacing the Main Controller PCB/clearing the Reader-related RAM data, enter the value of the service label on the reader. When replacing the Scanner Unit (for front side), enter the value of service label on a new unit.
Use Case	- When replacing the Main Controller PCB/clearing the Reader-related RAM data - When replacing the Scanner Unit (for front side)
Adj/Set/Operate Method	Enter the setting value, and then press Apply key.
Display/Adj/Set Range	0 to 100
Default Value	100
MTF-M4	MTF value 4 entry: Copyboard, horz scan
Detail	To enter the setting value for calculating MTF filter coefficient in horizontal scanning direction at copyboard reading. When replacing the Main Controller PCB/clearing the Reader-related RAM data, enter the value of the service label on the reader. When replacing the Scanner Unit (for front side), enter the value of service label on a new unit.
Use Case	- When replacing the Main Controller PCB/clearing the Reader-related RAM data - When replacing the Scanner Unit (for front side)
Adj/Set/Operate Method	Enter the setting value, and then press Apply key.
Display/Adj/Set Range	0 to 100
Default Value	100

COPIER (Service mode for printer) > ADJUST (Adjustment mode) > CCD

MTF-M5	MTF value 5 entry: Copyboard, horz scan
Detail	To enter the setting value for calculating MTF filter coefficient in horizontal scanning direction at copyboard reading. When replacing the Main Controller PCB/clearing the Reader-related RAM data, enter the value of the service label on the reader. When replacing the Scanner Unit (for front side), enter the value of service label on a new unit.
Use Case	- When replacing the Main Controller PCB/clearing the Reader-related RAM data - When replacing the Scanner Unit (for front side)
Adj/Set/Operate Method	Enter the setting value, and then press Apply key.
Display/Adj/Set Range	0 to 100
Default Value	100
MTF-M6	MTF value 6 entry: Copyboard, horz scan
Detail	To enter the setting value for calculating MTF filter coefficient in horizontal scanning direction at copyboard reading. When replacing the Main Controller PCB/clearing the Reader-related RAM data, enter the value of the service label on the reader. When replacing the Scanner Unit (for front side), enter the value of service label on a new unit.
Use Case	- When replacing the Main Controller PCB/clearing the Reader-related RAM data - When replacing the Scanner Unit (for front side)
Adj/Set/Operate Method	Enter the setting value, and then press Apply key.
Display/Adj/Set Range	0 to 100
Default Value	100
MTF-M7	MTF value 7 entry: Copyboard, horz scan
Detail	To enter the setting value for calculating MTF filter coefficient in horizontal scanning direction at copyboard reading. When replacing the Main Controller PCB/clearing the Reader-related RAM data, enter the value of the service label on the reader. When replacing the Scanner Unit (for front side), enter the value of service label on a new unit.
Use Case	- When replacing the Main Controller PCB/clearing the Reader-related RAM data - When replacing the Scanner Unit (for front side)
Adj/Set/Operate Method	Enter the setting value, and then press Apply key.
Display/Adj/Set Range	0 to 100
Default Value	100
MTF-M8	MTF value 8 entry: Copyboard, horz scan
Detail	To enter the setting value for calculating MTF filter coefficient in horizontal scanning direction at copyboard reading. When replacing the Main Controller PCB/clearing the Reader-related RAM data, enter the value of the service label on the reader. When replacing the Scanner Unit (for front side), enter the value of service label on a new unit.
Use Case	- When replacing the Main Controller PCB/clearing the Reader-related RAM data - When replacing the Scanner Unit (for front side)
Adj/Set/Operate Method	Enter the setting value, and then press Apply key.
Display/Adj/Set Range	0 to 100
Default Value	100

COPIER (Service mode for printer) > ADJUST (Adjustment mode) > CCD

MTF-M9	MTF value 9 entry: Copyboard, horz scan
Detail	To enter the setting value for calculating MTF filter coefficient in horizontal scanning direction at copyboard reading. When replacing the Main Controller PCB/clearing the Reader-related RAM data, enter the value of the service label on the reader. When replacing the Scanner Unit (for front side), enter the value of service label on a new unit.
Use Case	- When replacing the Main Controller PCB/clearing the Reader-related RAM data - When replacing the Scanner Unit (for front side)
Adj/Set/Operate Method	Enter the setting value, and then press Apply key.
Display/Adj/Set Range	0 to 100
Default Value	100
MTF-S1	MTF value entry: Copyboard, vert scan
Detail	To enter the setting value for calculating MTF filter coefficient in vertical scanning direction at copyboard reading. When replacing the Main Controller PCB/clearing the Reader-related RAM data, enter the value of the service label on the reader. When replacing the Scanner Unit (for front side), enter the value of service label on a new unit.
Use Case	- When replacing the Main Controller PCB/clearing the Reader-related RAM data - When replacing the Scanner Unit (for front side)
Adj/Set/Operate Method	Enter the setting value, and then press Apply key.
Display/Adj/Set Range	0 to 100
Default Value	100
MTF-S2	MTF value 2 entry: Copyboard, vert scan
Detail	To enter the setting value for calculating MTF filter coefficient in vertical scanning direction at copyboard reading. When replacing the Main Controller PCB/clearing the Reader-related RAM data, enter the value of the service label on the reader. When replacing the Scanner Unit (for front side), enter the value of service label on a new unit.
Use Case	- When replacing the Main Controller PCB/clearing the Reader-related RAM data - When replacing the Scanner Unit (for front side)
Adj/Set/Operate Method	Enter the setting value, and then press Apply key.
Display/Adj/Set Range	0 to 100
Default Value	100
MTF-S3	MTF value 3 entry: Copyboard, vert scan
Detail	To enter the setting value for calculating MTF filter coefficient in vertical scanning direction at copyboard reading. When replacing the Main Controller PCB/clearing the Reader-related RAM data, enter the value of the service label on the reader. When replacing the Scanner Unit (for front side), enter the value of service label on a new unit.
Use Case	- When replacing the Main Controller PCB/clearing the Reader-related RAM data - When replacing the Scanner Unit (for front side)
Adj/Set/Operate Method	Enter the setting value, and then press Apply key.
Display/Adj/Set Range	0 to 100
Default Value	100

COPIER (Service mode for printer) > ADJUST (Adjustment mode) > CCD

MTF-S4	MTF value 4 entry: Copyboard, vert scan
Detail	To enter the setting value for calculating MTF filter coefficient in vertical scanning direction at copyboard reading. When replacing the Main Controller PCB/clearing the Reader-related RAM data, enter the value of the service label on the reader. When replacing the Scanner Unit (for front side), enter the value of service label on a new unit.
Use Case	- When replacing the Main Controller PCB/clearing the Reader-related RAM data - When replacing the Scanner Unit (for front side)
Adj/Set/Operate Method	Enter the setting value, and then press Apply key.
Display/Adj/Set Range	0 to 100
Default Value	100
MTF-S5	MTF value 5 entry: Copyboard, vert scan
Detail	To enter the setting value for calculating MTF filter coefficient in vertical scanning direction at copyboard reading. When replacing the Main Controller PCB/clearing the Reader-related RAM data, enter the value of the service label on the reader. When replacing the Scanner Unit (for front side), enter the value of service label on a new unit.
Use Case	- When replacing the Main Controller PCB/clearing the Reader-related RAM data - When replacing the Scanner Unit (for front side)
Adj/Set/Operate Method	Enter the setting value, and then press Apply key.
Display/Adj/Set Range	0 to 100
Default Value	100
MTF-S6	MTF value 6 entry: Copyboard, vert scan
Detail	To enter the setting value for calculating MTF filter coefficient in vertical scanning direction at copyboard reading. When replacing the Main Controller PCB/clearing the Reader-related RAM data, enter the value of the service label on the reader. When replacing the Scanner Unit (for front side), enter the value of service label on a new unit.
Use Case	- When replacing the Main Controller PCB/clearing the Reader-related RAM data - When replacing the Scanner Unit (for front side)
Adj/Set/Operate Method	Enter the setting value, and then press Apply key.
Display/Adj/Set Range	0 to 100
Default Value	100
MTF-S7	MTF value 7 entry: Copyboard, vert scan
Detail	To enter the setting value for calculating MTF filter coefficient in vertical scanning direction at copyboard reading. When replacing the Main Controller PCB/clearing the Reader-related RAM data, enter the value of the service label on the reader. When replacing the Scanner Unit (for front side), enter the value of service label on a new unit.
Use Case	- When replacing the Main Controller PCB/clearing the Reader-related RAM data - When replacing the Scanner Unit (for front side)
Adj/Set/Operate Method	Enter the setting value, and then press Apply key.
Display/Adj/Set Range	0 to 100
Default Value	100

COPIER (Service mode for printer) > ADJUST (Adjustment mode) > CCD

MTF-S8	MTF value 8 entry: Copyboard, vert scan
Detail	To enter the setting value for calculating MTF filter coefficient in vertical scanning direction at copyboard reading. When replacing the Main Controller PCB/clearing the Reader-related RAM data, enter the value of the service label on the reader. When replacing the Scanner Unit (for front side), enter the value of service label on a new unit.
Use Case	- When replacing the Main Controller PCB/clearing the Reader-related RAM data - When replacing the Scanner Unit (for front side)
Adj/Set/Operate Method	Enter the setting value, and then press Apply key.
Display/Adj/Set Range	0 to 100
Default Value	100
MTF-S9	MTF value 9 entry: Copyboard, vert scan
Detail	To enter the setting value for calculating MTF filter coefficient in vertical scanning direction at copyboard reading. When replacing the Main Controller PCB/clearing the Reader-related RAM data, enter the value of the service label on the reader. When replacing the Scanner Unit (for front side), enter the value of service label on a new unit.
Use Case	- When replacing the Main Controller PCB/clearing the Reader-related RAM data - When replacing the Scanner Unit (for front side)
Adj/Set/Operate Method	Enter the setting value, and then press Apply key.
Display/Adj/Set Range	0 to 100
Default Value	100
MTF3-M1	MTF value 1 entry: DADF, back, horz scan
Detail	To enter the setting value for calculating MTF filter coefficient in horizontal scanning direction on the back side at DADF stream reading. When replacing the Main Controller PCB/clearing the Reader-related RAM data, enter the value of the service label on the reader. When replacing the Scanner Unit (for back side), enter the value of service label on a new unit.
Use Case	- When replacing the Main Controller PCB/clearing the Reader-related RAM data - When replacing the Scanner Unit (for back side)
Adj/Set/Operate Method	Enter the setting value, and then press Apply key.
Display/Adj/Set Range	0 to 100
Default Value	100
MTF3-M2	MTF value 2 entry: DADF, back, horz scan
Detail	To enter the setting value for calculating MTF filter coefficient in horizontal scanning direction on the back side at DADF stream reading. When replacing the Main Controller PCB/clearing the Reader-related RAM data, enter the value of the service label on the reader. When replacing the Scanner Unit (for back side), enter the value of service label on a new unit.
Use Case	- When replacing the Main Controller PCB/clearing the Reader-related RAM data - When replacing the Scanner Unit (for back side)
Adj/Set/Operate Method	Enter the setting value, and then press Apply key.
Display/Adj/Set Range	0 to 100
Default Value	100

COPIER (Service mode for printer) > ADJUST (Adjustment mode) > CCD

MTF3-M3	MTF value 3 entry: DADF, back, horz scan
Detail	To enter the setting value for calculating MTF filter coefficient in horizontal scanning direction on the back side at DADF stream reading. When replacing the Main Controller PCB/clearing the Reader-related RAM data, enter the value of the service label on the reader. When replacing the Scanner Unit (for back side), enter the value of service label on a new unit.
Use Case	- When replacing the Main Controller PCB/clearing the Reader-related RAM data - When replacing the Scanner Unit (for back side)
Adj/Set/Operate Method	Enter the setting value, and then press Apply key.
Display/Adj/Set Range	0 to 100
Default Value	100
MTF3-M4	MTF value 4 entry: DADF, back, horz scan
Detail	To enter the setting value for calculating MTF filter coefficient in horizontal scanning direction on the back side at DADF stream reading. When replacing the Main Controller PCB/clearing the Reader-related RAM data, enter the value of the service label on the reader. When replacing the Scanner Unit (for back side), enter the value of service label on a new unit.
Use Case	- When replacing the Main Controller PCB/clearing the Reader-related RAM data - When replacing the Scanner Unit (for back side)
Adj/Set/Operate Method	Enter the setting value, and then press Apply key.
Display/Adj/Set Range	0 to 100
Default Value	100
MTF3-M5	MTF value 5 entry: DADF, back, horz scan
Detail	To enter the setting value for calculating MTF filter coefficient in horizontal scanning direction on the back side at DADF stream reading. When replacing the Main Controller PCB/clearing the Reader-related RAM data, enter the value of the service label on the reader. When replacing the Scanner Unit (for back side), enter the value of service label on a new unit.
Use Case	- When replacing the Main Controller PCB/clearing the Reader-related RAM data - When replacing the Scanner Unit (for back side)
Adj/Set/Operate Method	Enter the setting value, and then press Apply key.
Display/Adj/Set Range	0 to 100
Default Value	100
MTF3-M6	MTF value 6 entry: DADF, back, horz scan
Detail	To enter the setting value for calculating MTF filter coefficient in horizontal scanning direction on the back side at DADF stream reading. When replacing the Main Controller PCB/clearing the Reader-related RAM data, enter the value of the service label on the reader. When replacing the Scanner Unit (for back side), enter the value of service label on a new unit.
Use Case	- When replacing the Main Controller PCB/clearing the Reader-related RAM data - When replacing the Scanner Unit (for back side)
Adj/Set/Operate Method	Enter the setting value, and then press Apply key.
Display/Adj/Set Range	0 to 100
Default Value	100

COPIER (Service mode for printer) > ADJUST (Adjustment mode) > CCD

MTF3-M7	MTF value 7 entry: DADF, back, horz scan
Detail	To enter the setting value for calculating MTF filter coefficient in horizontal scanning direction on the back side at DADF stream reading. When replacing the Main Controller PCB/clearing the Reader-related RAM data, enter the value of the service label on the reader. When replacing the Scanner Unit (for back side), enter the value of service label on a new unit.
Use Case	- When replacing the Main Controller PCB/clearing the Reader-related RAM data - When replacing the Scanner Unit (for back side)
Adj/Set/Operate Method	Enter the setting value, and then press Apply key.
Display/Adj/Set Range	0 to 100
Default Value	100
MTF3-M8	MTF value 8 entry: DADF, back, horz scan
Detail	To enter the setting value for calculating MTF filter coefficient in horizontal scanning direction on the back side at DADF stream reading. When replacing the Main Controller PCB/clearing the Reader-related RAM data, enter the value of the service label on the reader. When replacing the Scanner Unit (for back side), enter the value of service label on a new unit.
Use Case	- When replacing the Main Controller PCB/clearing the Reader-related RAM data - When replacing the Scanner Unit (for back side)
Adj/Set/Operate Method	Enter the setting value, and then press Apply key.
Display/Adj/Set Range	0 to 100
Default Value	100
MTF3-M9	MTF value 9 entry: DADF, back, horz scan
Detail	To enter the setting value for calculating MTF filter coefficient in horizontal scanning direction on the back side at DADF stream reading. When replacing the Main Controller PCB/clearing the Reader-related RAM data, enter the value of the service label on the reader. When replacing the Scanner Unit (for back side), enter the value of service label on a new unit.
Use Case	- When replacing the Main Controller PCB/clearing the Reader-related RAM data - When replacing the Scanner Unit (for back side)
Adj/Set/Operate Method	Enter the setting value, and then press Apply key.
Display/Adj/Set Range	0 to 100
Default Value	100
MTF3-S1	MTF value 1 entry: DADF, back, vert scan
Detail	To enter the setting value for calculating MTF filter coefficient in vertical scanning direction on the back side at DADF stream reading. When replacing the Main Controller PCB/clearing the Reader-related RAM data, enter the value of the service label on the reader. When replacing the Scanner Unit (for back side), enter the value of service label on a new unit.
Use Case	- When replacing the Main Controller PCB/clearing the Reader-related RAM data - When replacing the Scanner Unit (for back side)
Adj/Set/Operate Method	Enter the setting value, and then press Apply key.
Display/Adj/Set Range	0 to 100
Default Value	100

COPIER (Service mode for printer) > ADJUST (Adjustment mode) > CCD

MTF3-S2	MTF value 2 entry: DADF, back, vert scan
Detail	To enter the setting value for calculating MTF filter coefficient in vertical scanning direction on the back side at DADF stream reading. When replacing the Main Controller PCB/clearing the Reader-related RAM data, enter the value of the service label on the reader. When replacing the Scanner Unit (for back side), enter the value of service label on a new unit.
Use Case	- When replacing the Main Controller PCB/clearing the Reader-related RAM data - When replacing the Scanner Unit (for back side)
Adj/Set/Operate Method	Enter the setting value, and then press Apply key.
Display/Adj/Set Range	0 to 100
Default Value	100
MTF3-S3	MTF value 3 entry: DADF, back, vert scan
Detail	To enter the setting value for calculating MTF filter coefficient in vertical scanning direction on the back side at DADF stream reading. When replacing the Main Controller PCB/clearing the Reader-related RAM data, enter the value of the service label on the reader. When replacing the Scanner Unit (for back side), enter the value of service label on a new unit.
Use Case	- When replacing the Main Controller PCB/clearing the Reader-related RAM data - When replacing the Scanner Unit (for back side)
Adj/Set/Operate Method	Enter the setting value, and then press Apply key.
Display/Adj/Set Range	0 to 100
Default Value	100
MTF3-S4	MTF value 4 entry: DADF, back, vert scan
Detail	To enter the setting value for calculating MTF filter coefficient in vertical scanning direction on the back side at DADF stream reading. When replacing the Main Controller PCB/clearing the Reader-related RAM data, enter the value of the service label on the reader. When replacing the Scanner Unit (for back side), enter the value of service label on a new unit.
Use Case	- When replacing the Main Controller PCB/clearing the Reader-related RAM data - When replacing the Scanner Unit (for back side)
Adj/Set/Operate Method	Enter the setting value, and then press Apply key.
Display/Adj/Set Range	0 to 100
Default Value	100
MTF3-S5	MTF value 5 entry: DADF, back, vert scan
Detail	To enter the setting value for calculating MTF filter coefficient in vertical scanning direction on the back side at DADF stream reading. When replacing the Main Controller PCB/clearing the Reader-related RAM data, enter the value of the service label on the reader. When replacing the Scanner Unit (for back side), enter the value of service label on a new unit.
Use Case	- When replacing the Main Controller PCB/clearing the Reader-related RAM data - When replacing the Scanner Unit (for back side)
Adj/Set/Operate Method	Enter the setting value, and then press Apply key.
Display/Adj/Set Range	0 to 100
Default Value	100

COPIER (Service mode for printer) > ADJUST (Adjustment mode) > CCD

MTF3-S6	MTF value 6 entry: DADF, back, vert scan
Detail	To enter the setting value for calculating MTF filter coefficient in vertical scanning direction on the back side at DADF stream reading. When replacing the Main Controller PCB/clearing the Reader-related RAM data, enter the value of the service label on the reader. When replacing the Scanner Unit (for back side), enter the value of service label on a new unit.
Use Case	- When replacing the Main Controller PCB/clearing the Reader-related RAM data - When replacing the Scanner Unit (for back side)
Adj/Set/Operate Method	Enter the setting value, and then press Apply key.
Display/Adj/Set Range	0 to 100
Default Value	100
MTF3-S7	MTF value 7 entry: DADF, back, vert scan
Detail	To enter the setting value for calculating MTF filter coefficient in vertical scanning direction on the back side at DADF stream reading. When replacing the Main Controller PCB/clearing the Reader-related RAM data, enter the value of the service label on the reader. When replacing the Scanner Unit (for back side), enter the value of service label on a new unit.
Use Case	- When replacing the Main Controller PCB/clearing the Reader-related RAM data - When replacing the Scanner Unit (for back side)
Adj/Set/Operate Method	Enter the setting value, and then press Apply key.
Display/Adj/Set Range	0 to 100
Default Value	100
MTF3-S8	MTF value 8 entry: DADF, back, vert scan
Detail	To enter the setting value for calculating MTF filter coefficient in vertical scanning direction on the back side at DADF stream reading. When replacing the Main Controller PCB/clearing the Reader-related RAM data, enter the value of the service label on the reader. When replacing the Scanner Unit (for back side), enter the value of service label on a new unit.
Use Case	- When replacing the Main Controller PCB/clearing the Reader-related RAM data - When replacing the Scanner Unit (for back side)
Adj/Set/Operate Method	Enter the setting value, and then press Apply key.
Display/Adj/Set Range	0 to 100
Default Value	100
MTF3-S9	MTF value 9 entry: DADF, back, vert scan
Detail	To enter the setting value for calculating MTF filter coefficient in vertical scanning direction on the back side at DADF stream reading. When replacing the Main Controller PCB/clearing the Reader-related RAM data, enter the value of the service label on the reader. When replacing the Scanner Unit (for back side), enter the value of service label on a new unit.
Use Case	- When replacing the Main Controller PCB/clearing the Reader-related RAM data - When replacing the Scanner Unit (for back side)
Adj/Set/Operate Method	Enter the setting value, and then press Apply key.
Display/Adj/Set Range	0 to 100
Default Value	100

COPIER (Service mode for printer) > ADJUST (Adjustment mode) > CCD

OFST-BW0	Adj Img Read Sns 1 offset: frt,B&W,300dpi
Detail	To adjust the offset (black level) of the Image Reading Sensor 1 (Rear) of the Scanner Unit (for front side) in black mode with 300 dpi. When replacing the Main Controller PCB/clearing RAM data, enter the value of service label.
Use Case	When replacing the Main Controller PCB/clearing RAM data
Adj/Set/Operate Method	Enter the setting value, and then press Apply key.
Display/Adj/Set Range	0 to 255
Default Value	0
Related Service Mode	COPIER > FUNCTION > CCD > BW-AGC
OFST-BW1	Adj Img Read Sns 2 offset: frt,B&W,300dpi
Detail	To adjust the offset (black level) of the Image Reading Sensor 2 (Center) of the Scanner Unit (for front side) in black mode with 300 dpi. When replacing the Main Controller PCB/clearing RAM data, enter the value of service label.
Use Case	When replacing the Main Controller PCB/clearing RAM data
Adj/Set/Operate Method	Enter the setting value, and then press Apply key.
Display/Adj/Set Range	0 to 255
Default Value	0
Related Service Mode	COPIER > FUNCTION > CCD > BW-AGC
OFST-BW2	Adj Img Read Sns 3 offset: frt,B&W,300dpi
Detail	To adjust the offset (black level) of the Image Reading Sensor 3 (Front) of the Scanner Unit (for front side) in black mode with 300 dpi. When replacing the Main Controller PCB/clearing RAM data, enter the value of service label.
Use Case	When replacing the Main Controller PCB/clearing RAM data
Adj/Set/Operate Method	Enter the setting value, and then press Apply key.
Display/Adj/Set Range	0 to 255
Default Value	0
Related Service Mode	COPIER > FUNCTION > CCD > BW-AGC
OFST2BW0	Adj Img Read Sns 1 offset: frt,B&W,600dpi
Detail	To adjust the offset (black level) of the Image Reading Sensor 1 (Rear) of the Scanner Unit (for front side) in black mode with 600 dpi. When replacing the Main Controller PCB/clearing RAM data, enter the value of service label.
Use Case	When replacing the Main Controller PCB/clearing RAM data
Adj/Set/Operate Method	Enter the setting value, and then press Apply key.
Display/Adj/Set Range	0 to 255
Default Value	0
Related Service Mode	COPIER > FUNCTION > CCD > BW-AGC
OFST2BW1	Adj Img Read Sns 2 offset: frt,B&W,600dpi
Detail	To adjust the offset (black level) of the Image Reading Sensor 2 (Center) of the Scanner Unit (for front side) in black mode with 600 dpi. When replacing the Main Controller PCB/clearing RAM data, enter the value of service label.
Use Case	When replacing the Main Controller PCB/clearing RAM data
Adj/Set/Operate Method	Enter the setting value, and then press Apply key.
Display/Adj/Set Range	0 to 255
Default Value	0
Related Service Mode	COPIER > FUNCTION > CCD > BW-AGC

COPIER (Service mode for printer) > ADJUST (Adjustment mode) > CCD

OFST2BW2	Adj Img Read Sns 3 offset: frt,B&W,600dpi
Detail	To adjust the offset (black level) of the Image Reading Sensor 3 (Front) of the Scanner Unit (for front side) in black mode with 600 dpi. When replacing the Main Controller PCB/clearing RAM data, enter the value of service label.
Use Case	When replacing the Main Controller PCB/clearing RAM data
Adj/Set/Operate Method	Enter the setting value, and then press Apply key.
Display/Adj/Set Range	0 to 255
Default Value	0
Related Service Mode	COPIER > FUNCTION > CCD > BW-AGC
OF-BW0BK	Adj Img Read Sns 1 offset: bck,B&W,300dpi
Detail	To adjust the offset (black level) of the Image Reading Sensor 1 (Rear) of the Scanner Unit (for back side) in black mode with 300 dpi. When replacing the Main Controller PCB/clearing RAM data, enter the value of service label.
Use Case	When replacing the Main Controller PCB/clearing RAM data
Adj/Set/Operate Method	Enter the setting value, and then press Apply key.
Display/Adj/Set Range	0 to 255
Default Value	0
Related Service Mode	COPIER > FUNCTION > CCD > BW-AGC2
OF-BW1BK	Adj Img Read Sns 2 offset: bck,B&W,300dpi
Detail	To adjust the offset (black level) of the Image Reading Sensor 2 (Center) of the Scanner Unit (for back side) in black mode with 300 dpi. When replacing the Main Controller PCB/clearing RAM data, enter the value of service label.
Use Case	When replacing the Main Controller PCB/clearing RAM data
Adj/Set/Operate Method	Enter the setting value, and then press Apply key.
Display/Adj/Set Range	0 to 255
Default Value	0
Related Service Mode	COPIER > FUNCTION > CCD > BW-AGC2
OF-BW2BK	Adj Img Read Sns 3 offset: bck,B&W,300dpi
Detail	To adjust the offset (black level) of the Image Reading Sensor 3 (Front) of the Scanner Unit (for back side) in black mode with 300 dpi. When replacing the Main Controller PCB/clearing RAM data, enter the value of service label.
Use Case	When replacing the Main Controller PCB/clearing RAM data
Adj/Set/Operate Method	Enter the setting value, and then press Apply key.
Display/Adj/Set Range	0 to 255
Default Value	0
Related Service Mode	COPIER > FUNCTION > CCD > BW-AGC2
OF2BW0BK	Adj Img Read Sns 1 offset: bck,B&W,600dpi
Detail	To adjust the offset (black level) of the Image Reading Sensor 1 (Rear) of the Scanner Unit (for back side) in black mode with 600 dpi. When replacing the Main Controller PCB/clearing RAM data, enter the value of service label.
Use Case	When replacing the Main Controller PCB/clearing RAM data
Adj/Set/Operate Method	Enter the setting value, and then press Apply key.
Display/Adj/Set Range	0 to 255
Default Value	0
Related Service Mode	COPIER > FUNCTION > CCD > BW-AGC2

COPIER (Service mode for printer) > ADJUST (Adjustment mode) > CCD

OF2BW1BK	Adj Img Read Sns 2 offset: bck,B&W,600dpi
Detail	To adjust the offset (black level) of the Image Reading Sensor 2 (Center) of the Scanner Unit (for back side) in black mode with 600 dpi. When replacing the Main Controller PCB/clearing RAM data, enter the value of service label.
Use Case	When replacing the Main Controller PCB/clearing RAM data
Adj/Set/Operate Method	Enter the setting value, and then press Apply key.
Display/Adj/Set Range	0 to 255
Default Value	0
Related Service Mode	COPIER > FUNCTION > CCD > BW-AGC2
OF2BW2BK	Adj Img Read Sns 3 offset: bck,B&W,600dpi
Detail	To adjust the offset (black level) of the Image Reading Sensor 3 (Front) of the Scanner Unit (for back side) in black mode with 600 dpi. When replacing the Main Controller PCB/clearing RAM data, enter the value of service label.
Use Case	When replacing the Main Controller PCB/clearing RAM data
Adj/Set/Operate Method	Enter the setting value, and then press Apply key.
Display/Adj/Set Range	0 to 255
Default Value	0
Related Service Mode	COPIER > FUNCTION > CCD > BW-AGC2
OFST-CL0	Adj Img Read Sns 1 offset: frt,clr,300dpi
Detail	To adjust the offset (black level) of the Image Reading Sensor 1 (Rear) of the Scanner Unit (for front side) in color mode with 300 dpi. When replacing the Main Controller PCB/clearing RAM data, enter the value of service label.
Use Case	When replacing the Main Controller PCB/clearing RAM data
Adj/Set/Operate Method	Enter the setting value, and then press Apply key.
Display/Adj/Set Range	0 to 255
Default Value	0
Related Service Mode	COPIER > FUNCTION > CCD > CL-AGC
OFST-CL1	Adj Img Read Sns 2 offset: frt,clr,300dpi
Detail	To adjust the offset (black level) of the Image Reading Sensor 2 (Center) of the Scanner Unit (for front side) in color mode with 300 dpi. When replacing the Main Controller PCB/clearing RAM data, enter the value of service label.
Use Case	When replacing the Main Controller PCB/clearing RAM data
Adj/Set/Operate Method	Enter the setting value, and then press Apply key.
Display/Adj/Set Range	0 to 255
Default Value	0
Related Service Mode	COPIER > FUNCTION > CCD > CL-AGC
OFST-CL2	Adj Img Read Sns 3 offset: frt,clr,300dpi
Detail	To adjust the offset (black level) of the Image Reading Sensor 3 (Front) of the Scanner Unit (for front side) in color mode with 300 dpi. When replacing the Main Controller PCB/clearing RAM data, enter the value of service label.
Use Case	When replacing the Main Controller PCB/clearing RAM data
Adj/Set/Operate Method	Enter the setting value, and then press Apply key.
Display/Adj/Set Range	0 to 255
Default Value	0
Related Service Mode	COPIER > FUNCTION > CCD > CL-AGC

COPIER (Service mode for printer) > ADJUST (Adjustment mode) > CCD

OFST2CL0	Adj Img Read Sns 1 offset: frt,clr,600dpi
Detail	To adjust the offset (black level) of the Image Reading Sensor 1 (Rear) of the Scanner Unit (for front side) in color mode with 600 dpi. When replacing the Main Controller PCB/clearing RAM data, enter the value of service label.
Use Case	When replacing the Main Controller PCB / clearing RAM data
Adj/Set/Operate Method	Enter the setting value, and then press Apply key.
Display/Adj/Set Range	0 to 255
Default Value	0
Related Service Mode	COPIER > FUNCTION > CCD > CL-AGC
Supplement/Memo	The offset value is automatically updated by executing CL-AGC.
OFST2CL1	Adj Img Read Sns 2 offset: frt,clr,600dpi
Detail	To adjust the offset (black level) of the Image Reading Sensor 2 (Center) of the Scanner Unit (for front side) in color mode with 600 dpi. When replacing the Main Controller PCB/clearing RAM data, enter the value of service label.
Use Case	When replacing the Main Controller PCB / clearing RAM data
Adj/Set/Operate Method	Enter the setting value, and then press Apply key.
Display/Adj/Set Range	0 to 255
Default Value	0
Related Service Mode	COPIER > FUNCTION > CCD > CL-AGC
Supplement/Memo	The offset value is automatically updated by executing CL-AGC.
OFST2CL2	Adj Img Read Sns 3 offset: frt,clr,600dpi
Detail	To adjust the offset (black level) of the Image Reading Sensor 3 (Front) of the Scanner Unit (for front side) in color mode with 600 dpi. When replacing the Main Controller PCB/clearing RAM data, enter the value of service label.
Use Case	When replacing the Main Controller PCB / clearing RAM data
Adj/Set/Operate Method	Enter the setting value, and then press Apply key.
Display/Adj/Set Range	0 to 255
Default Value	0
Related Service Mode	COPIER > FUNCTION > CCD > CL-AGC
Supplement/Memo	The offset value is automatically updated by executing CL-AGC.
OF-CL0BK	Adj Img Read Sns 1 offset: bck,clr,300dpi
Detail	To adjust the offset (black level) of the Image Reading Sensor 1 (Rear) of the Scanner Unit (for back side) in color mode with 300 dpi. When replacing the Main Controller PCB/clearing RAM data, enter the value of service label.
Use Case	When replacing the Main Controller PCB/clearing RAM data
Adj/Set/Operate Method	Enter the setting value, and then press Apply key.
Display/Adj/Set Range	0 to 255
Default Value	0
Related Service Mode	COPIER > FUNCTION > CCD > CL-AGC2
OF-CL1BK	Adj Img Read Sns 2 offset: bck,clr,300dpi
Detail	To adjust the offset (black level) of the Image Reading Sensor 2 (Center) of the Scanner Unit (for back side) in color mode with 300 dpi. When replacing the Main Controller PCB/clearing RAM data, enter the value of service label.
Use Case	When replacing the Main Controller PCB/clearing RAM data
Adj/Set/Operate Method	Enter the setting value, and then press Apply key.
Display/Adj/Set Range	0 to 255
Default Value	0
Related Service Mode	COPIER > FUNCTION > CCD > CL-AGC2

COPIER (Service mode for printer) > ADJUST (Adjustment mode) > CCD

OF-CL2BK		Adj Img Read Sns 3 offset: bck,clr,300dpi
Detail	To adjust the offset (black level) of the Image Reading Sensor 3 (Front) of the Scanner Unit (for back side) in color mode with 300 dpi. When replacing the Main Controller PCB/clearing RAM data, enter the value of service label.	
Use Case	When replacing the Main Controller PCB/clearing RAM data	
Adj/Set/Operate Method	Enter the setting value, and then press Apply key.	
Display/Adj/Set Range	0 to 255	
Default Value	0	
Related Service Mode	COPIER > FUNCTION > CCD > CL-AGC2	
OF2CL0BK		Adj Img Read Sns 1 offset: bck,clr,600dpi
Detail	To adjust the offset (black level) of the Image Reading Sensor 1 (Rear) of the Scanner Unit (for back side) in color mode with 600 dpi. When replacing the Main Controller PCB/clearing RAM data, enter the value of service label.	
Use Case	When replacing the Main Controller PCB/clearing RAM data	
Adj/Set/Operate Method	Enter the setting value, and then press Apply key.	
Display/Adj/Set Range	0 to 255	
Default Value	0	
Related Service Mode	COPIER > FUNCTION > CCD > CL-AGC2	

■ PASCAL

COPIER (Service mode for printer) > ADJUST (Adjustment mode) > PASCAL

OFST-P-Y		Adj Y-color density at test print read
Detail	To adjust the offset of Y-color test print reading signal at auto gradation adjustment (full adjustment). When replacing the Main Controller PCB/clearing RAM data, enter the value of service label. As the value is larger, the image after adjustment gets darker.	
Use Case	- When replacing the Reader Unit - When replacing the Main Controller PCB/clearing RAM data	
Adj/Set/Operate Method	Enter the setting value (switch negative/positive by +/- key), and then press Apply key.	
Caution	After the setting value is changed, write the changed value in the service label.	
Display/Adj/Set Range	-128 to 128	
Default Value	0	
OFST-P-M		Adj M-color density at test print read
Detail	To adjust the offset of M-color test print reading signal at auto gradation adjustment (full adjustment). When replacing the Main Controller PCB/clearing RAM data, enter the value of service label. As the value is larger, the image after adjustment gets darker.	
Use Case	- When replacing the Reader Unit - When replacing the Main Controller PCB/clearing RAM data	
Adj/Set/Operate Method	Enter the setting value (switch negative/positive by +/- key), and then press Apply key.	
Caution	After the setting value is changed, write the changed value in the service label.	
Display/Adj/Set Range	-128 to 128	
Default Value	0	

COPIER (Service mode for printer) > ADJUST (Adjustment mode) > PASCAL

OFST-P-C	Adj C-color density at test print read
Detail	To adjust the offset of C-color test print reading signal at auto gradation adjustment (full adjustment). When replacing the Main Controller PCB/clearing RAM data, enter the value of service label. As the value is larger, the image after adjustment gets darker.
Use Case	- When replacing the Reader Unit - When replacing the Main Controller PCB/clearing RAM data
Adj/Set/Operate Method	Enter the setting value (switch negative/positive by +/- key), and then press Apply key.
Caution	After the setting value is changed, write the changed value in the service label.
Display/Adj/Set Range	-128 to 128
Default Value	0

OFST-P-K	Adj Bk-color density at test print read
Detail	To adjust the offset of Bk-color test print reading signal at auto gradation adjustment (full adjustment). When replacing the Main Controller PCB/clearing RAM data, enter the value of service label. As the value is larger, the image after adjustment gets darker.
Use Case	- When replacing the Reader Unit - When replacing the Main Controller PCB/clearing RAM data
Adj/Set/Operate Method	Enter the setting value (switch negative/positive by +/- key), and then press Apply key.
Caution	After the setting value is changed, write the changed value in the service label.
Display/Adj/Set Range	-128 to 128
Default Value	0

■ FEED-ADJ

COPIER (Service mode for printer) > ADJUST (Adjustment mode) > FEED-ADJ

ADJ-MFY	Adjustment of write start position in feed direction at Multi-purpose Tray pickup (1-sided print/2nd side of 2-sided print)
Detail	To adjust the image write start position in the feed direction at the time of pickup from the Multi-purpose Tray. As the value is changed by 1, the leading edge margin is changed by 0.001 mm. +: Leading edge margin becomes larger. (An image moves to the trailing edge side.) -: Leading edge margin becomes smaller. (An image moves to the leading edge side.) When replacing the Engine Controller PCB/clearing RAM data, enter the value of service label. The setting is applied to the 1st side at 1-sided print and the 2nd side at 2-sided print.
Use Case	When replacing the Engine Controller PCB/clearing RAM data
Adj/Set/Operate Method	Enter the setting value (switch negative/positive by +/- key) and press Apply key.
Caution	This setting is linked with the setting of [Adjust Print Position] in [Settings/Registration]. The setting value is not cleared even if COPIER> FUNCTION> CLEAR> SRVC-DAT is executed.
Display/Adj/Set Range	-5080 to 5080
Unit	0.001 mm
Default Value	0
Related Service Mode	COPIER > FUNCTION > CLEAR > SRVC-DAT
Additional Functions Mode	Adjustment/Maintenance > Adjust Image Quality > Adjust Print Position

COPIER (Service mode for printer) > ADJUST (Adjustment mode) > FEED-ADJ

ADJ-MFX	Adjustment of write start position in horizontal scanning direction at Multi-purpose Tray pickup (1-sided print/2nd side of 2-sided print)
Detail	To adjust the write start position in the horizontal scanning direction for the image on the 1st side at the time of pickup from the Multi-purpose Tray. As the value is changed by 1, the left margin is changed by 0.001 mm. +: Left margin becomes larger. (An image moves to the right.) -: Left margin becomes smaller. (An image moves to the left.) When replacing the Engine Controller PCB/clearing RAM data, enter the value of service label. The setting is applied to the 1st side at 1-sided print and the 2nd side at 2-sided print.
Use Case	When replacing the Engine Controller PCB/clearing RAM data
Adj/Set/Operate Method	Enter the setting value (switch negative/positive by +/- key) and press Apply key.
Caution	This setting is linked with the setting of [Adjust Print Position] in [Settings/Registration]. The setting value is not cleared even if COPIER> FUNCTION> CLEAR> SRVC-DAT is executed.
Display/Adj/Set Range	-5080 to 5080
Unit	0.001 mm
Default Value	0
Related Service Mode	COPIER > FUNCTION > CLEAR > SRVC-DAT
Additional Functions Mode	Adjustment/Maintenance > Adjust Image Quality > Adjust Print Position
ADJ-MFYR	Adjustment of write start position in feed direction at Multi-purpose Tray pickup (1st side of 2-sided print)
Detail	To adjust the write start position in the feed direction for the image on the 2nd side at the time of pickup from the Multi-purpose Tray. As the value is changed by 1, the leading edge margin is changed by 0.001 mm. +: Leading edge margin becomes larger. (An image moves to the trailing edge side.) -: Leading edge margin becomes smaller. (An image moves to the leading edge side.) When replacing the Engine Controller PCB/clearing RAM data, enter the value of service label. The setting is applied to the 1st side at 2-sided print.
Use Case	When replacing the Engine Controller PCB/clearing RAM data
Adj/Set/Operate Method	Enter the setting value (switch negative/positive by +/- key) and press Apply key.
Caution	This setting is linked with the setting of [Adjust Print Position] in [Settings/Registration]. The setting value is not cleared even if COPIER> FUNCTION> CLEAR> SRVC-DAT is executed.
Display/Adj/Set Range	-5080 to 5080
Unit	0.001 mm
Default Value	0
Related Service Mode	COPIER > FUNCTION > CLEAR > SRVC-DAT
Additional Functions Mode	Adjustment/Maintenance > Adjust Image Quality > Adjust Print Position

COPIER (Service mode for printer) > ADJUST (Adjustment mode) > FEED-ADJ

ADJ-MFXR	Adjustment of write start position in horizontal scanning direction at Multi-purpose Tray pickup (1st side of 2-sided print)
Detail	To adjust the write start position in the horizontal scanning direction for the image on the 2nd side at the time of pickup from the Multi-purpose Tray. As the value is changed by 1, the left margin is changed by 0.001 mm. +: Left margin becomes larger. (An image moves to the right.) -: Left margin becomes smaller. (An image moves to the left.) When replacing the Engine Controller PCB/clearing RAM data, enter the value of service label. The setting is applied to the 1st side at 2-sided print.
Use Case	When replacing the Engine Controller PCB/clearing RAM data.
Adj/Set/Operate Method	Enter the setting value (switch negative/positive by +/- key) and press Apply key.
Caution	This setting is linked with the setting of [Adjust Print Position] in [Settings/Registration]. The setting value is not cleared even if COPIER> FUNCTION> CLEAR> SRVC-DAT is executed.
Display/Adj/Set Range	-5080 to 5080
Unit	0.001 mm
Default Value	0
Related Service Mode	COPIER > FUNCTION > CLEAR > SRVC-DAT
Additional Functions Mode	Adjustment/Maintenance > Adjust Image Quality > Adjust Print Position
ADJ-C1Y	Adjustment of write start position in feed direction at Cassette 1 pickup (1-sided print/2nd side of 2-sided print)
Detail	To adjust the image write start position in the feed direction at the time of pickup from the Cassette 1. As the value is changed by 1, the leading edge margin is changed by 0.001 mm. +: Leading edge margin becomes larger. (An image moves to the trailing edge side.) -: Leading edge margin becomes smaller. (An image moves to the leading edge side.) When replacing the Engine Controller PCB/clearing RAM data, enter the value of service label. The setting is applied to the 1st side at 1-sided print and the 2nd side at 2-sided print.
Use Case	When replacing the Engine Controller PCB/clearing RAM data
Adj/Set/Operate Method	Enter the setting value (switch negative/positive by +/- key) and press Apply key.
Caution	This setting is linked with the setting of [Adjust Print Position] in [Settings/Registration]. The setting value is not cleared even if COPIER> FUNCTION> CLEAR> SRVC-DAT is executed.
Display/Adj/Set Range	-5080 to 5080
Unit	0.001 mm
Default Value	0
Related Service Mode	COPIER > FUNCTION > CLEAR > SRVC-DAT
Additional Functions Mode	Adjustment/Maintenance > Adjust Image Quality > Adjust Print Position

COPIER (Service mode for printer) > ADJUST (Adjustment mode) > FEED-ADJ

ADJ-C1X	Adjustment of write start position in horizontal scanning direction at Cassette 1 pickup (1-sided print/2nd side of 2-sided print)
Detail	To adjust the write start position in the horizontal scanning direction for the image on the 1st side at the time of pickup from the Cassette 1. As the value is changed by 1, the left margin is changed by 0.001 mm. +: Left margin becomes larger. (An image moves to the right.) -: Left margin becomes smaller. (An image moves to the left.) When replacing the Engine Controller PCB/clearing RAM data, enter the value of service label. The setting is applied to the 1st side at 1-sided print and the 2nd side at 2-sided print.
Use Case	When replacing the Engine Controller PCB/clearing RAM data
Adj/Set/Operate Method	Enter the setting value (switch negative/positive by +/- key) and press Apply key.
Caution	This setting is linked with the setting of [Adjust Print Position] in [Settings/Registration]. The setting value is not cleared even if COPIER> FUNCTION> CLEAR> SRVC-DAT is executed.
Display/Adj/Set Range	-5080 to 5080
Unit	0.001 mm
Default Value	0
Related Service Mode	COPIER > FUNCTION > CLEAR > SRVC-DAT
Additional Functions Mode	Adjustment/Maintenance > Adjust Image Quality > Adjust Print Position
ADJ-C1YR	Adjustment of write start position in feed direction at Cassette 1 pickup (1st side of 2-sided print)
Detail	To adjust the write start position in the feed direction for the image on the 2nd side at the time of pickup from the Cassette 1. As the value is changed by 1, the leading edge margin is changed by 0.001 mm. +: Leading edge margin becomes larger. (An image moves to the trailing edge side.) -: Leading edge margin becomes smaller. (An image moves to the leading edge side.) When replacing the Engine Controller PCB/clearing RAM data, enter the value of service label. The setting is applied to the 1st side at 2-sided print.
Use Case	When replacing the Engine Controller PCB/clearing RAM data
Adj/Set/Operate Method	Enter the setting value (switch negative/positive by +/- key) and press Apply key.
Caution	This setting is linked with the setting of [Adjust Print Position] in [Settings/Registration]. The setting value is not cleared even if COPIER> FUNCTION> CLEAR> SRVC-DAT is executed.
Display/Adj/Set Range	-5080 to 5080
Unit	0.001 mm
Default Value	0
Related Service Mode	COPIER > FUNCTION > CLEAR > SRVC-DAT
Additional Functions Mode	Adjustment/Maintenance > Adjust Image Quality > Adjust Print Position

COPIER (Service mode for printer) > ADJUST (Adjustment mode) > FEED-ADJ

ADJ-C1XR	Adjustment of write start position in horizontal scanning direction at Cassette 1 pickup (1st side of 2-sided print)
Detail	To adjust the write start position in the horizontal scanning direction for the image on the 2nd side at the time of pickup from the Cassette 1. As the value is changed by 1, the left margin is changed by 0.001 mm. +: Left margin becomes larger. (An image moves to the right.) -: Left margin becomes smaller. (An image moves to the left.) When replacing the Engine Controller PCB/clearing RAM data, enter the value of service label. The setting is applied to the 1st side at 2-sided print.
Use Case	When replacing the Engine Controller PCB/clearing RAM data
Adj/Set/Operate Method	Enter the setting value (switch negative/positive by +/- key) and press Apply key.
Caution	This setting is linked with the setting of [Adjust Print Position] in [Settings/Registration]. The setting value is not cleared even if COPIER> FUNCTION> CLEAR> SRVC-DAT is executed.
Display/Adj/Set Range	-5080 to 5080
Unit	0.001 mm
Default Value	0
Related Service Mode	COPIER > FUNCTION > CLEAR > SRVC-DAT
Additional Functions Mode	Adjustment/Maintenance > Adjust Image Quality > Adjust Print Position
ADJ-C2Y	Adjustment of write start position in feed direction at Cassette 2 pickup (1-sided print/2nd side of 2-sided print)
Detail	To adjust the image write start position in the feed direction at the time of pickup from the Cassette 2. As the value is changed by 1, the leading edge margin is changed by 0.001 mm. +: Leading edge margin becomes larger. (An image moves to the trailing edge side.) -: Leading edge margin becomes smaller. (An image moves to the leading edge side.) When replacing the Engine Controller PCB/clearing RAM data, enter the value of service label. The setting is applied to the 1st side at 1-sided print and the 2nd side at 2-sided print.
Use Case	When replacing the Engine Controller PCB/clearing RAM data
Adj/Set/Operate Method	Enter the setting value (switch negative/positive by +/- key) and press Apply key.
Caution	This setting is linked with the setting of [Adjust Print Position] in [Settings/Registration]. The setting value is not cleared even if COPIER> FUNCTION> CLEAR> SRVC-DAT is executed.
Display/Adj/Set Range	-5080 to 5080
Unit	0.001 mm
Default Value	0
Related Service Mode	COPIER > FUNCTION > CLEAR > SRVC-DAT
Additional Functions Mode	Adjustment/Maintenance > Adjust Image Quality > Adjust Print Position

COPIER (Service mode for printer) > ADJUST (Adjustment mode) > FEED-ADJ

ADJ-C2X	Adjustment of write start position in horizontal scanning direction at Cassette 2 pickup (1-sided print/2nd side of 2-sided print)
Detail	To adjust the write start position in the horizontal scanning direction for the image on the 1st side at the time of pickup from the Cassette 2. As the value is changed by 1, the left margin is changed by 0.001 mm. +: Left margin becomes larger. (An image moves to the right.) -: Left margin becomes smaller. (An image moves to the left.) When replacing the Engine Controller PCB/clearing RAM data, enter the value of service label. The setting is applied to the 1st side at 1-sided print and the 2nd side at 2-sided print.
Use Case	When replacing the Engine Controller PCB/clearing RAM data
Adj/Set/Operate Method	Enter the setting value (switch negative/positive by +/- key) and press Apply key.
Caution	This setting is linked with the setting of [Adjust Print Position] in [Settings/Registration]. The setting value is not cleared even if COPIER> FUNCTION> CLEAR> SRVC-DAT is executed.
Display/Adj/Set Range	-5080 to 5080
Unit	0.001 mm
Default Value	0
Related Service Mode	COPIER > FUNCTION > CLEAR > SRVC-DAT
Additional Functions Mode	Adjustment/Maintenance > Adjust Image Quality > Adjust Print Position
ADJ-C2YR	Adjustment of write start position in feed direction at Cassette 2 pickup (1st side of 2-sided print)
Detail	To adjust the write start position in the feed direction for the image on the 2nd side at the time of pickup from the Cassette 2. As the value is changed by 1, the leading edge margin is changed by 0.001 mm. +: Leading edge margin becomes larger. (An image moves to the trailing edge side.) -: Leading edge margin becomes smaller. (An image moves to the leading edge side.) When replacing the Engine Controller PCB/clearing RAM data, enter the value of service label. The setting is applied to the 1st side at 2-sided print.
Use Case	When replacing the Engine Controller PCB/clearing RAM data
Adj/Set/Operate Method	Enter the setting value (switch negative/positive by +/- key) and press Apply key.
Caution	This setting is linked with the setting of [Adjust Print Position] in [Settings/Registration]. The setting value is not cleared even if COPIER> FUNCTION> CLEAR> SRVC-DAT is executed.
Display/Adj/Set Range	-5080 to 5080
Unit	0.001 mm
Default Value	0
Related Service Mode	COPIER > FUNCTION > CLEAR > SRVC-DAT
Additional Functions Mode	Adjustment/Maintenance > Adjust Image Quality > Adjust Print Position

COPIER (Service mode for printer) > ADJUST (Adjustment mode) > FEED-ADJ

ADJ-C2XR	Adjustment of write start position in horizontal scanning direction at Cassette 2 pickup (1st side of 2-sided print)
Detail	To adjust the write start position in the horizontal scanning direction for the image on the 2nd side at the time of pickup from the Cassette 2. As the value is changed by 1, the left margin is changed by 0.001 mm. +: Left margin becomes larger. (An image moves to the right.) -: Left margin becomes smaller. (An image moves to the left.) When replacing the Engine Controller PCB/clearing RAM data, enter the value of service label. The setting is applied to the 1st side at 2-sided print.
Use Case	When replacing the Engine Controller PCB/clearing RAM data
Adj/Set/Operate Method	Enter the setting value (switch negative/positive by +/- key) and press Apply key.
Caution	This setting is linked with the setting of [Adjust Print Position] in [Settings/Registration]. The setting value is not cleared even if COPIER> FUNCTION> CLEAR> SRVC-DAT is executed.
Display/Adj/Set Range	-5080 to 5080
Unit	0.001 mm
Default Value	0
Related Service Mode	COPIER > FUNCTION > CLEAR > SRVC-DAT
Additional Functions Mode	Adjustment/Maintenance > Adjust Image Quality > Adjust Print Position

■ PANEL

COPIER (Service mode for printer) > ADJUST (Adjustment mode) > PANEL

TOUCHCHK	Adj of coordinate pstn on Touch Panel
Detail	To adjust the coordinate position on the Touch Panel of the Control Panel. By making adjustment, the setting of TOUCH-R becomes 1.
Use Case	When replacing the LCD Panel
Adj/Set/Operate Method	1) Select the item, and then press Yes key. 2) Press the nine "+" keys in sequence.
Related Service Mode	COPIER > ADJUST > PANEL > TOUCH-R
TOUCH-R	Touch Panel coordinate pstn adj result
Detail	To set whether adjustment of the coordinate position on the Touch Panel of the Control Panel is completed. When adjustment with TOUCHCHK is completed, the setting of this item becomes 1.
Use Case	When replacing the LCD Panel
Adj/Set/Operate Method	Enter the setting value, and then press Apply key.
Display/Adj/Set Range	0 to 1 0: Not completed 1: Completed
Default Value	0
Related Service Mode	COPIER > ADJUST > PANEL > TOUCHCHK

■ VIFADJ

COPIER (Service mode for printer) > ADJUST (Adjustment mode) > VIFADJ

DEV-HV-Y	Adjustment of developing bias setting value (Y)
Detail	To adjust the setting value of Y-color developing bias.
Use Case	When an image failure occurs
Adj/Set/Operate Method	Enter the setting value (switch negative/positive by +/- key), and then press Apply key.
Display/Adj/Set Range	-5 to 5
Default Value	0
Related Service Mode	COPIER > ADJUST > VIFADJ > DEV-HV-M/C/K

COPIER (Service mode for printer) > ADJUST (Adjustment mode) > VIFADJ

DEV-HV-M	Adjustment of developing bias setting value (M)
Detail	To adjust the setting value of M-color developing bias.
Use Case	When an image failure occurs
Adj/Set/Operate Method	Enter the setting value (switch negative/positive by +/- key), and then press Apply key.
Display/Adj/Set Range	-5 to 5
Default Value	0
Related Service Mode	COPIER > ADJUST > VIFADJ > DEV-HV-Y/C/K
DEV-HV-C	Adjustment of developing bias setting value (C)
Detail	To adjust the setting value of C-color developing bias.
Use Case	When an image failure occurs
Adj/Set/Operate Method	Enter the setting value (switch negative/positive by +/- key), and then press Apply key.
Display/Adj/Set Range	-5 to 5
Default Value	0
Related Service Mode	COPIER > ADJUST > VIFADJ > DEV-HV-Y/M/K
DEV-HV-K	Adjustment of developing bias setting value (Bk)
Detail	To adjust the setting value of Bk-color developing bias.
Use Case	When an image failure occurs
Adj/Set/Operate Method	Enter the setting value (switch negative/positive by +/- key), and then press Apply key.
Display/Adj/Set Range	-5 to 5
Default Value	0
Related Service Mode	COPIER > ADJUST > VIFADJ > DEV-HV-Y/M/C
TR2SF-HV	Adj sec transfer bias set VL (1st side)
Detail	To adjust the setting value of secondary transfer bias applied to the 1st side.
Use Case	When an image failure occurs
Adj/Set/Operate Method	Enter the setting value (switch negative/positive by +/- key), and then press Apply key.
Display/Adj/Set Range	-5 to 5
Default Value	0
Related Service Mode	COPIER > ADJUST > VIFADJ > TR2BK-HV
TR2BK-HV	Adj sec transfer bias set VL (2nd side)
Detail	To adjust the setting value of secondary transfer bias applied to the 2nd side.
Use Case	When an image failure occurs
Adj/Set/Operate Method	Enter the setting value (switch negative/positive by +/- key), and then press Apply key.
Display/Adj/Set Range	-5 to 5
Default Value	0
Related Service Mode	COPIER > ADJUST > VIFADJ > TR2SF-HV
ICL-HV	Adj of ITB cleaning bias setting value
Detail	To adjust the setting value of the bias to be applied at the time of ITB cleaning.
Use Case	When an image failure occurs
Adj/Set/Operate Method	Enter the setting value (switch negative/positive by +/- key), and then press Apply key.
Display/Adj/Set Range	-5 to 5
Default Value	0

COPIER (Service mode for printer) > ADJUST (Adjustment mode) > VIFADJ

FU-TMP	Adj of Fixing Film surface temp set VL
Detail	To adjust the setting value of the surface temperature of the Fixing Film.
Use Case	When an image failure occurs
Adj/Set/Operate Method	Enter the setting value (switch negative/positive by +/- key), and then press Apply key.
Display/Adj/Set Range	-2 to 2
Default Value	0

FUNCTION (Operation / inspection mode)

■ INSTALL

COPIER (Service mode for printer) > FUNCTION (Operation / inspection mode) > INSTALL

STRD-POS	Auto adj of read position at stream read
Detail	To automatically adjust the Scanner Unit position in feed direction when stream reading original with DADF. The adjustment result is reflected to COPIER> ADJUST> ADJ-XY> STRD-POS.
Use Case	- At DADF installation/uninstallation - When replacing the Scanner Unit/clearing RAM data
Adj/Set/Operate Method	1) Close the DADF. 2) Select the item, and then press Yes key. The operation automatically stops after the adjustment. 3) Write the value displayed by COPIER> ADJUST> ADJ-XY> STRD-POS in the service label.
Caution	Write the adjusted value in the service label.
Required Time	10 sec
Related Service Mode	COPIER > ADJUST > ADJ-XY > STRD-POS

ERDS	ON/OFF of Embedded-RDS
Detail	To set whether to use the Embedded-RDS function.
Use Case	When using Embedded-RDS
Adj/Set/Operate Method	1) Enter the setting value, and then press Apply key. 2) Turn OFF/ON the main power switch.
Caution	Be sure to use ERDS, RGW-PORT, COM-TEST, COM-RSLT, and COM-LOG as a set.
Display/Adj/Set Range	0 to 1 0: OFF 1: ON
Related Service Mode	COPIER > FUNCTION > INSTALL > RGW-PORT, COM-TEST, COM-RSLT, COM-LOG
Supplement/Memo	Embedded-RDS: Function to send device information such as the device counter, failure, and consumables to UGW via SOAP protocol UGW (Universal Gate Way): Remote monitoring service system

RGW-PORT	Setting of UGW port number when using Embedded-RDS
Detail	To set the port number of UGW to be used for Embedded-RDS.
Use Case	When using Embedded-RDS
Adj/Set/Operate Method	1) Enter the setting value, and then press Apply key. 2) Turn OFF/ON the main power switch.
Caution	Be sure to use ERDS, RGW-PORT, COM-TEST, COM-RSLT, and COM-LOG as a set.
Display/Adj/Set Range	1 to 65535
Default Value	443
Related Service Mode	COPIER > FUNCTION > INSTALL > ERDS, COM-TEST, COM-RSLT, COM-LOG
Supplement/Memo	Embedded-RDS: Function to send device information such as the device counter, failure, and consumables to the sales company's server via SOAP protocol

COPIER (Service mode for printer) > FUNCTION (Operation / inspection mode) > INSTALL

COM-TEST		Execution of Embedded-RDS communication test
Detail	To execute Embedded-RDS communication test. If the connection fails, the information is added to the communication error log.	
Use Case	When using E-RDS	
Adj/Set/Operate Method	Select the item, and then press Yes key.	
Caution	Be sure to use ERDS, RGW-PORT, COM-TEST, COM-RSLT, and COM-LOG as a set.	
Related Service Mode	COPIER > FUNCTION > INSTALL > ERDS, RGW-PORT, COM-RSLT, COM-LOG	
Supplement/Memo	Embedded-RDS: Function to send device information such as the device counter, failure, and consumables to UGW via SOAP protocol UGW (Universal Gate Way): Remote monitoring service system	
COM-RSLT		Display of Embedded-RDS comctn test result
Detail	To display the Embedded-RDS communication test result.	
Use Case	When using E-RDS	
Adj/Set/Operate Method	N/A (Display only)	
Caution	Be sure to use ERDS, RGW-PORT, COM-TEST, COM-RSLT, and COM-LOG as a set.	
Display/Adj/Set Range	When not in execution: Unknown When connection is completed: OK When connection is failed: NG	
Default Value	Unknown	
Related Service Mode	COPIER > FUNCTION > INSTALL > ERDS, RGW-PORT, COM-TEST, COM-LOG	
Supplement/Memo	Embedded-RDS: Function to send device information such as the device counter, failure, and consumables to UGW via SOAP protocol UGW (Universal Gate Way): Remote monitoring service system	
COM-LOG		Display of Embedded-RDS comctn error log
Detail	To display the Embedded-RDS communication error log. The dates, times, and error codes of the latest 5 errors that occurred are displayed. As for the error detail information, the report can be output by executing ERDS-LOG.	
Use Case	When using Embedded-RDS	
Adj/Set/Operate Method	N/A (Display only)	
Caution	Be sure to use ERDS, RGW-PORT, COM-TEST, COM-RSLT, and COM-LOG as a set.	
Display/Adj/Set Range	Date: 6 digits Time: 4 digits Error code: 8 digits	
Related Service Mode	COPIER > FUNCTION > INSTALL > ERDS, RGW-PORT, COM-TEST, COM-RSLT COPIER > FUNCTION > MISC-P > ERDS-LOG	
Supplement/Memo	Embedded-RDS: Function to send device information such as the device counter, failure, and consumables to UGW via SOAP protocol UGW (Universal Gate Way): Remote monitoring service system	
RGW-ADSW		UGW connection destination settings for Embedded-RDS
Detail	To change the server URL that the Embedded-RDS uses.	
Adj/Set/Operate Method	Enter the setting value, and then press OK key.	
Caution	Com-TEST needs to be executed to reflect the settings.	
Display/Adj/Set Range	0 to 2 0 : SHA1 1 : SHA2 2 : D1 Environment (for testing)	
Default Value	0	
Related Service Mode	COPIER > FUNCTION > INSTALL > COM-TEST	
Supplement/Memo	Embedded-RDS: Function to send device information such as the device counter, failure, and consumables to UGW via SOAP protocol UGW (Universal Gate Way): Remote monitoring service system	

■ CCD

COPIER (Service mode for printer) > FUNCTION (Operation / inspection mode) > CCD

DF-WLVL1	White level adj in book mode: color
Detail	To adjust the white level for copyboard scanning automatically by setting the paper which is usually used by the user on the Copyboard Glass.
Use Case	- When replacing the Copyboard Glass - When replacing the Scanner Unit - When replacing the Main Controller PCB/clearing RAM data
Adj/Set/Operate Method	1) Set a paper on the Copyboard Glass. 2) Select the item, and then press Yes key.
Caution	Be sure to execute DF-WLVL2 in a row.
Related Service Mode	COPIER > FUNCTION > CCD > DF-WLVL2
Supplement/Memo	The Scanner Unit (for front side) calculates the white level correction coefficient based on the luminance at copyboard reading detected with DF-WLVL1, the luminance at stream reading detected with DF-WLVL2, and the luminance at stream reading that the Scanner Unit (for back side) detected with DF-WLVL2.
DF-WLVL2	White level adj: stream reading, color
Detail	To adjust the white level for stream reading by setting the paper which is usually used by the user on the DADF.
Use Case	- When replacing the Copyboard Glass - When replacing the Scanner Unit - When replacing the Main Controller PCB/clearing RAM data
Adj/Set/Operate Method	1) Set paper on the DADF. 2) Select the item, and then press Yes key.
Caution	Be sure to execute this item after DF-WLVL1.
Related Service Mode	COPIER > FUNCTION > CCD > DF-WLVL1
Supplement/Memo	The Scanner Unit (for front side) calculates the white level correction coefficient based on the luminance at copyboard reading detected with DF-WLVL1, the luminance at stream reading detected with DF-WLVL2, and the luminance at stream reading that the Scanner Unit (for back side) detected with DF-WLVL2.
CL-AGC	Adj Scan Unit (frt) B&W ref: stream, clr
Detail	To automatically adjust the black/white reference level of the Scanner Unit (for front side) at stream reading in color mode. To make the adjustment with both resolutions 300 dpi and 600 dpi. When this item is executed, the values of OFST-CL0/CL1/CL2, GAIN-CL0, LED-CL-R/G/B, OFST2CL0/CL1/CL2, GAIN2CL0, and LED2CL-R/G/B are automatically calculated.
Use Case	- When replacing the Reader Unit - When replacing the Scanner Unit
Adj/Set/Operate Method	1) Set paper on the DADF. 2) Select the item, and then press Yes key.
Related Service Mode	COPIER > FUNCTION > CCD > BW-AGC COPIER > ADJUST > CCD > OFST-CL0/CL1/CL2, GAIN-CL0, LED-CL-R/G/B, OFST2CL0/CL1/CL2, GAIN2CL0, LED2CL-R/G/B
Supplement/Memo	AGC: Automatic Gain Control

COPIER (Service mode for printer) > FUNCTION (Operation / inspection mode) > CCD

BW-AGC	Adj Scan Unit (frt) B&W ref: stream, B&W
Detail	To automatically adjust the black/white reference level of the Scanner Unit (for front side) at stream reading in black mode. To make the adjustment with both resolutions 300 dpi and 600 dpi. When this item is executed, the values of OFST-BW0/BW1/BW2, GAIN-BW0, LED-BW-R/G/B, OFST2BW0/BW1/BW2, GAIN2BW0, and LED2BW-R/G/B are automatically calculated.
Use Case	- When replacing the Reader Unit - When replacing the Scanner Unit
Adj/Set/Operate Method	1) Set paper on the DADF. 2) Select the item, and then press Yes key.
Related Service Mode	COPIER > FUNCTION > CCD > CL-AGC COPIER > ADJUST > CCD > OFST-BW0/BW1/BW2, GAIN-BW0, LED-BW-R/G/B, OFST2BW0/BW1/BW2, GAIN2BW0, LED2BW-R/G/B
Supplement/Memo	AGC: Automatic Gain Control
CL-AGC2	Adj Scan Unit (bck) B&W ref: stream, clr
Detail	To automatically adjust the black/white reference level of the Scanner Unit (for back side) at stream reading in color mode. To make the adjustment with both resolutions 300 dpi and 600 dpi. When this item is executed, the values of OF-CL0BK/CL1BK/CL2BK, GA-CL0BK, LE-CLRBK/GBK/BBK, OF2CL0BK/CL1BK/CL2BK, GA2CL0BK, and LE2CLRBK/GBK/BBK are automatically calculated.
Use Case	- When replacing the Reader Unit - When replacing the Scanner Unit
Adj/Set/Operate Method	1) Set paper on the DADF. 2) Select the item, and then press Yes key.
Related Service Mode	COPIER > FUNCTION > CCD > BW-AGC2 COPIER > ADJUST > CCD > OF-CL0BK/CL1BK/CL2BK, GA-CL0BK, LE-CLRBK/GBK/BBK, OF2CL0BK/CL1BK/CL2BK, GA2CL0BK, LE2CLRBK/GBK/BBK
Supplement/Memo	AGC: Automatic Gain Control
BW-AGC2	Adj Scan Unit (bck) B&W ref: stream, B&W
Detail	To automatically adjust the black/white reference level of the Scanner Unit (for back side) at stream reading in black mode. To make the adjustment with both resolutions 300 dpi and 600 dpi. When this item is executed, the values of OF-BW0BK/BW1BK/BW2BK, GA-BW0BK, LE-BWRBK/GBK/BBK, OF2BW0BK/BW1BK/BW2BK, GA2BW0BK, and LE2BWRBK/GBK/BBK are automatically calculated.
Use Case	- When replacing the Reader Unit - When replacing the Scanner Unit
Adj/Set/Operate Method	1) Set paper on the DADF. 2) Select the item, and then press Yes key.
Related Service Mode	COPIER > FUNCTION > CCD > CL-AGC2 COPIER > ADJUST > CCD > OF-BW0BK/BW1BK/BW2BK, GA-BW0BK, LE-BWRBK/GBK/BBK, OF2BW0BK/BW1BK/BW2BK, GA2BW0BK, LE2BWRBK/GBK/BBK
Supplement/Memo	AGC: Automatic Gain Control
BW-TGT	Set of B&W shading target value
Detail	After the white level data (X/Y/Z) for the Standard White Plate is set, read the Standard White Plate and set the black and white shading target value.
Use Case	When replacing the Copyboard Glass/Scanner Unit
Adj/Set/Operate Method	Select the item, and then press Apply key.
Caution	Be sure to execute this item after execution of W-PLT-X/Y/Z.
Related Service Mode	COPIER > ADJUST > CCD > W-PLT-X/Y/Z COPIER > DISPLAY > CCD > TARGETBW

COPIER (Service mode for printer) > FUNCTION (Operation / inspection mode) > CCD

BK-SHD1		Paper back shading correction 1
Detail		To generate the paper back shading correction data by scanning the Standard White Plate of the Paper Back Reading Glass with the Scanner Unit (for back side).
Use Case		- When replacing the SATA Flash PCB - When replacing the Scanner Unit (for back side)
Adj/Set/Operate Method		1) Clean the glass of the Scanner Unit (for back side) and the Reading Glass. 2) Close the DADF. 3) Select the item, and then press Apply key.
Caution		Execute BK-SHD1 and then BK-SHD2 in that order.
Related Service Mode		COPIER > FUNCTION > CCD > BK-SHD2 COPIER > DISPLAY > CCD > BK-SHDST
BK-SHD2		Paper back shading correction 2
Detail		To generate the paper back shading correction data by scanning the Standard White Plate of the Paper Back Reading Glass with the Scanner Unit (for back side).
Use Case		- When replacing the SATA Flash PCB - When replacing the Scanner Unit (for back side)
Adj/Set/Operate Method		1) Clean the glass of the Scanner Unit (for back side) and the Reading Glass. 2) Close the DADF. 3) Select the item, and then press Apply key.
Caution		Execute BK-SHD1 and then BK-SHD2 in that order.
Related Service Mode		COPIER > FUNCTION > CCD > BK-SHD1 COPIER > DISPLAY > CCD > BK-SHDST

■ CLEAR

COPIER (Service mode for printer) > FUNCTION (Operation / inspection mode) > CLEAR

R-CON		Initialization of Reader/DADF
Detail		To initialize the factory adjustment values of the Reader/DADF.
Use Case		When clearing RAM data of the Reader/DADF
Adj/Set/Operate Method		Select the item, and then press Yes key.
Caution		RAM data is cleared after the main power switch is turned OFF/ON.
SRVC-DAT		Clearing of service mode setting values
Detail		To clear the service mode setting values. The user mode setting values are not cleared. The factory adjustment values of the Reader/DADF are not initialized.
Adj/Set/Operate Method		1) Select the item, and then press Yes key. 2) Turn OFF/ON the main power switch.
COUNTER		Clearing of service counter
Detail		To clear the counter by maintenance/part. The numerator printed on a system dump list becomes 0.
Adj/Set/Operate Method		1) Select the item, and then press Yes key. 2) Turn OFF/ON the main power switch.
HIST		Clearing of logs
Detail		To clear the communication management/print/jam/alarm/error log.
Use Case		When clearing logs
Adj/Set/Operate Method		1) Select the item, and then press Yes key. 2) Turn OFF/ON the main power switch.

COPIER (Service mode for printer) > FUNCTION (Operation / inspection mode) > CLEAR

ALL		Clearing of setting information
Detail	To clear/initialize the following setting information according to the location set in LOCALE and SIZE-LC. - User mode setting values - Service mode setting values (excluding the service counter) - ID and password of the system administrator - Communication management/print/jam/alarm/error log - E719 error (counter meter-installed models only) The following items are not cleared/initialized. - Service counter - Factory adjustment values of the Reader/DADF	
Use Case	At installation	
Adj/Set/Operate Method	1) Select the item, and then press Yes key. 2) Turn OFF/ON the main power switch.	
Default Value	0	
Related Service Mode	COPIER > OPTION > BODY > LOCALE, SIZE-LC COPIER > FUNCTION > CLEAR > E719-CLR	
ERDS-DAT		Initialize of Embedded-RDS setting value
Detail	To initialize the Embedded-RDS setting values. ON/OFF of Embedded-RDS, UGW port number and communication error log set in ERDS, RGW-PORT, and COM-LOG are cleared.	
Use Case	When upgrading the Bootable in the Embedded-RDS environment	
Adj/Set/Operate Method	Select the item, and then press Yes key.	
Caution	Use of the SRAM in Embedded-RDS differs depending on the Bootable version. Therefore, unless initialization is executed at the time of version upgrade, data inconsistency occurs.	
Related Service Mode	COPIER > FUNCTION > INSTALL > ERDS, RGW-PORT, COM-LOG	
Supplement/Memo	Embedded-RDS: Function to send device information such as the device counter, failure, and consumables to UGW via SOAP protocol UGW (Universal Gate Way): Remote monitoring service system	
PLPW-CLR		Clear security policy setting password
Detail	To clear the password of the security administrator set in the security policy settings.	
Use Case	When clearing the password of the security administrator	
Adj/Set/Operate Method	Select the item, and then press Yes key.	
CRGL-CNT		Clearing of cartridge replacement log
Detail	To clear the cartridge replacement log.	
Adj/Set/Operate Method	Select the item, and then press Yes key.	
Related Service Mode	COPIER > FUNCTION > MISC-P > CRG-LOG	

■ MISC-R

COPIER (Service mode for printer) > FUNCTION (Operation / inspection mode) > MISC-R

SCANLAMP		Lighting check of CIS Unit LED: front
Detail	To light up the Scanning LED of the Scanner Unit (for front side).	
Use Case	When replacing the CIS Unit LED	
Adj/Set/Operate Method	Select the item, and then press Yes key.	
SCAN-ON		Execution of copyboard reading operation
Detail	To execute reading of the original on the Copyboard Glass.	
Adj/Set/Operate Method	1) Place paper on the Copyboard Glass. 2) Select the item, and then press Yes key.	

COPIER (Service mode for printer) > FUNCTION (Operation / inspection mode) > MISC-R

SCANLMP2	Lighting check of CIS Unit LED: back
Detail	To light up the Scanning LED of the Scanner Unit (for back side).
Use Case	When replacing the CIS Unit LED
Adj/Set/Operate Method	Select the item, and then press Yes key.
1PSCLB-A	Exe frt/bck clr differ calibration: frt
Detail	To read the PG for calibrating color difference between the front and back sides with the Scanner Unit (for front side) in order to correct the color difference between the front and back sides at duplex stream reading. A significant color difference may occur between the images on the front and back sides scanned with the DADF caused by variations in the LED and changes in durability. Such a color difference is corrected by executing 1PSCLB-B following 1PSCLB-A.
Use Case	When a significant color difference occurs between the front and back side at DADF duplex reading
Adj/Set/Operate Method	1) Place the paper on which PG is printed on the DADF. 2) Select the item, and then press OK key.
Caution	- Do not turn OFF/ON the main power switch during execution of 1PSCLB-A and then 1PSCLB-B. - Until 1 is displayed in both 1P-ERR-A and 1P-ERR-B, calibration of color difference between the front and back sides is not completed.
Related Service Mode	COPIER > FUNCTION > MISC-R > 1PSCLB-B COPIER > DISPLAY > CCD > 1P-ERR-A/B
Supplement/Memo	The execution result of this item is displayed in 1P-ERR-A.
1PSCLB-B	Exe frt/bck clr differ calibration: bck
Detail	To read the PG for calibrating color difference between the front and back sides with the Scanner Unit (for back side) in order to correct the color difference between the front and back sides at duplex stream reading. A significant color difference may occur between the images on the front and back sides scanned with the DADF caused by variations in the LED and changes in durability. Such a color difference is corrected by executing 1PSCLB-B following 1PSCLB-A.
Use Case	When a significant color difference occurs between the front and back side at DADF duplex reading
Adj/Set/Operate Method	1) Place the paper used by 1PSCLB-A on the DADF so that the front side is faced down and the cyan image is placed at the left rear side. 2) Select the item, and then press OK key.
Caution	- Do not turn OFF/ON the main power switch during execution of 1PSCLB-A and then 1PSCLB-B. - Until 1 is displayed in both 1P-ERR-A and 1P-ERR-B, calibration of color difference between the front and back sides is not completed.
Related Service Mode	COPIER > FUNCTION > MISC-R > 1PSCLB-A COPIER > DISPLAY > CCD > 1P-ERR-A/B
Supplement/Memo	The execution result of this item is displayed in 1P-ERR-B.

COPIER (Service mode for printer) > FUNCTION (Operation / inspection mode) > MISC-R

1PCLBUDR		ON/OFF frt/bck clr dif calibr l-lmt set
Detail	To set whether to set the lower limit of the target color difference for correction when correcting color difference between the front and back sides at duplex stream reading. In some cases, colors which do not need to be corrected are also corrected by performing color difference correction at duplex stream reading. When 1 is set, the correction level is adjusted to weaken the effect of correction. Unnecessary correction is not executed, but an expected effect may not be obtained for other colors. The result is reflected when color difference correction is executed again after the setting is made.	
Use Case	When color difference occurs on the colors which did not have any difference before correction	
Adj/Set/Operate Method	Enter the setting value, and then press Apply key.	
Caution	Expected correction result may not be obtained.	
Display/Adj/Set Range	0 to 1 0: OFF 1: ON	
Default Value	0	
Related Service Mode	COPIER > FUNCTION > MISC-R > 1PSCLB-A/B, 1PCLBOVR	
1PCLBOVR		ON/OFF frt/bck clr dif calibr u-lmt set
Detail	To set whether to set the upper limit of the target color difference for correction when correcting color difference between the front and back sides at duplex stream reading. Excessive correction is sometimes made when correcting color difference at duplex stream reading. When 1 or 2 is set, the correction level is adjusted to weaken the effect of correction. Excessive correction is not executed, but an expected effect may not be obtained for other colors. The result is reflected when color difference correction is executed again after the setting is made.	
Use Case	When color difference occurs on the colors which did not have any difference before correction	
Adj/Set/Operate Method	Enter the setting value, and then press Apply key.	
Caution	Expected correction result may not be obtained.	
Display/Adj/Set Range	0 to 2 0: No control 1: Weak control 2: Strong control	
Default Value	0	
Related Service Mode	COPIER > FUNCTION > MISC-R > 1PSCLB-A/B, 1PCLBUDR	
1PCLBRST		Init frt/bck clr difference calibration
Detail	To initialize the correction result of calibration of color difference between the front and back sides. Execute this item when color difference is not corrected appropriately even though 1PSCLB-A/B is executed.	
Use Case	When the calibration result is not appropriate	
Adj/Set/Operate Method	Select the item, and then press Yes key.	
Related Service Mode	COPIER > FUNCTION > MISC-R > 1PSCLB-A/B	

■ MISC-P

COPIER (Service mode for printer) > FUNCTION (Operation / inspection mode) > MISC-P

SRVC-DAT		Output system data list/system dump list
Detail	To output the system data list and the system dump list in the form of a report. System data list: The service software switches and parameters used in FAX function System dump list: The number of sends/receives, the number of pages sent/received, the number of sheets printed/read, the number of errors, etc.	
Adj/Set/Operate Method	Select the item, and then press Yes key.	
Supplement/Memo	FAX model only	

COPIER (Service mode for printer) > FUNCTION (Operation / inspection mode) > MISC-P

SYS-DAT	Output of system data list
Detail	To output the system data list in the form of a report. The service software switches and parameters used in FAX function are output.
Adj/Set/Operate Method	Select the item, and then press Yes key.
Supplement/Memo	FAX model only
SYS-DMP	Output of system dump list
Detail	To output the system dump list in the form of a report. The number of sends/receives, the number of pages sent/received, the number of sheets printed/read, the number of errors, etc. are output.
Adj/Set/Operate Method	Select the item, and then press Yes key.
Supplement/Memo	FAX model only
CNTR	Output of counter report
Detail	To output the counter values in the form of a report. The usage of functions (reading, recording, communication and copy) is output.
Adj/Set/Operate Method	Select the item, and then press Yes key.
ERR-LOG	Output of error log report
Detail	To output the error log in the form of a report.
Adj/Set/Operate Method	Select the item, and then press Yes key.
SPEC	Output of spec report
Detail	To output the specifications in the form of a report. The current device specifications such as the location, model information, and ROM version are output.
Adj/Set/Operate Method	Select the item, and then press Yes key.
ERDS-LOG	Output of Embedded-RDS log report
Detail	To output the log relating to Embedded-RDS in the form of a report. The date, time, and code (8 digits) of each error that occurred are output.
Use Case	When using Embedded-RDS
Adj/Set/Operate Method	Select the item, and then press Yes key.
Related Service Mode	COPIER > FUNCTION > INSTALL > COM-LOG
Supplement/Memo	Embedded-RDS: Function to send device information such as the device counter, failure, and consumables to UGW via SOAP protocol UGW (Universal Gate Way): Remote monitoring service system
CRG-LOG	Output cartridge replacement log report
Detail	To output the cartridge replacement log in the form of a report.
Use Case	When checking the cartridge replacement log
Adj/Set/Operate Method	Select the item, and then press Yes key.

■ SYSTEM

COPIER (Service mode for printer) > FUNCTION (Operation / inspection mode) > SYSTEM

DOWNLOAD	Upgrading of machine firmware: difference
Detail	To upgrade the machine firmware using a USB flash drive. Compare the versions of firmware in the machine and the USB flash drive, and update the differences.
Use Case	At upgrade
Adj/Set/Operate Method	1) Connect the USB flash drive. 2) Select the item, and then press Yes key. The machine restarts in download mode.
Caution	Do not turn OFF/ON the power before "Executing..." disappears.
Related Service Mode	COPIER > FUNCTION > SYSTEM > DL-FORCE

COPIER (Service mode for printer) > FUNCTION (Operation / inspection mode) > SYSTEM

PANEL-UP	Upgrading of Control Panel CPU PCB firm
Detail	To upgrade the firmware of the Control Panel CPU PCB using a USB flash drive. Upgrading is performed when PANEL exists in the root directory of the USB flash drive.
Use Case	At upgrade
Adj/Set/Operate Method	1. Connect the USB flash drive. 2. Select the item, and then press Yes. 3. Turn OFF/ON the main power.
Caution	Do not turn OFF/ON the power before "Executing..." disappears.
Related Service Mode	COPIER > DISPLAY > VERSION > PANEL
LOGWRITE	Writing sublog to USB flash drive
Detail	To write sublog that includes the following information to the USB flash drive. - Job list (job names, user names, and destinations) - Communications log (destinations and user names) - Job log (user names and job names)
Use Case	When analyzing the cause of a problem
Adj/Set/Operate Method	1. Connect the USB flash drive. 2. Select the item, and then press Yes. 3. Turn OFF/ON the main power.
Caution	Do not turn OFF/ON the power before "Executing..." disappears.
Related Service Mode	COPIER > FUNCTION > SYSTEM > LOG2USB
IMPORT	Read s-mode set VL from USB flash drive
Detail	To read the service mode setting information (excluding those related to Reader/DADF) from the USB flash drive.
Use Case	When replacing the Main Controller PCB
Adj/Set/Operate Method	1. Connect the USB flash drive. 2. Select the item, and then press Yes. 3. Turn OFF/ON the main power.
Caution	Do not turn OFF/ON the power before "Executing..." disappears.
Related Service Mode	COPIER > FUNCTION > SYSTEM > EXPORT
EXPORT	Writing of service mode setting value to USB memory
Detail	To write the service mode setting information (excluding those related to Reader/DADF) to the USB flash drive.
Use Case	When replacing the Main Controller PCB
Adj/Set/Operate Method	1) Connect the USB flash drive. 2) Select the item, and then press Yes key. "Executing..." disappears when writing is completed.
Related Service Mode	COPIER > FUNCTION > SYSTEM > IMPORT
SAVE-SM	Backup of service mode setting info
Detail	To back up the service mode setting information (excluding those related to Reader/DADF, but including those related to Finisher) as a file to the USB flash drive using DCM function. The setting information which has been backed up can be restored with RSTR-SM.
Use Case	When saving the setting information before changing the service mode settings
Adj/Set/Operate Method	Select the item, and then press Yes key.
Related Service Mode	COPIER > FUNCTION > SYSTEM > RSTR-SM
Supplement/Memo	DCM (Device Configuration Management): A function to export/import the machine's setting information as a file.

COPIER (Service mode for printer) > FUNCTION (Operation / inspection mode) > SYSTEM

RSTR-SM		Restore of service mode setting info
Detail		To restore the service mode setting information (excluding those related to Reader/DADF, but including those related to Finisher) which has been backed up with SAVE-SM from the USB flash drive using DCM function.
Use Case		When changing the service mode settings back to those before the change
Adj/Set/Operate Method		Select the item, and then press Yes key.
Caution		It is necessary to back up the setting information using SAVE-SM in order to restore the information with RSTR-SM.
Related Service Mode		COPIER > FUNCTION > SYSTEM > SAVE-SM
Supplement/Memo		DCM (Device Configuration Management): A function to export/import the machine's setting information as a file.
LOG2USB		Writing of debug log to USB flash drive
Detail		To write the debug log stored in the eMMC to the USB flash drive.
Use Case		When analyzing the cause of a problem
Adj/Set/Operate Method		1) Connect the USB flash drive. 2) Select the item, and then press Yes key.
Related Service Mode		COPIER > FUNCTION > SYSTEM > LOGWRITE
LOG-DEL		Deletion of debug log
Detail		To delete the debug log stored in the eMMC.
Use Case		When the debug log is no longer needed
Adj/Set/Operate Method		Select the item, and then press Yes key.
DL-FORCE		Install machine firmware: overwriting
Detail		To forcibly overwrite the machine firmware with the firmware stored in the USB flash drive.
Use Case		At upgrade/downgrade
Adj/Set/Operate Method		1) Connect the USB flash drive. 2) Select the item, and then press Yes key.
Caution		Do not turn OFF/ON the power before "Executing..." disappears.
Related Service Mode		COPIER > FUNCTION > SYSTEM > DOWNLOAD

■ SPLMAN

COPIER (Service mode for printer) > FUNCTION (Operation / inspection mode) > SPLMAN

SPL14159		ON/OFF of USB device ID fixing
Detail		To set whether to fix the USB device ID to "000000000000". A PC attempts to install the driver every time it is connected to a machine. However, by fixing the USB device ID, it recognizes that the same machine is connected so that it does not attempt to install the driver again.
Use Case		When saving the trouble of selecting a device used for printing from the candidate devices because the driver is installed every time a USB is connected
Adj/Set/Operate Method		1) Enter the setting value, and then press Apply key. 2) Turn OFF/ON the main power switch.
Display/Adj/Set Range		0 to 1 0: OFF, 1: ON
Default Value		0

COPIER (Service mode for printer) > FUNCTION (Operation / inspection mode) > SPLMAN

SPL37510	ON/OFF of ITB cleaning at paper size mismatch
Detail	Normally, when paper other than that of the specified size is fed, ITB cleaning is executed to remove toner. When 1 is set, ITB cleaning is not executed even if paper size is mismatched. Productivity improves, but toner soiling may occur.
Use Case	When paper size is mismatched
Adj/Set/Operate Method	Enter the setting value, and then press Apply key.
Caution	Be sure to get approval from the user by telling that toner soiling may occur to improve productivity.
Display/Adj/Set Range	0 to 1 0: OFF 1: ON
Default Value	0
SPL65677	Increase of paper leading edge margin
Detail	To increase the margin on the leading edge of paper. As the value is incremented by 1, the margin is increased by 0.1 mm. Actually, a value where the setting value of SPL68676 is subtracted from the setting value of this item is applied. The margin settings which are job-specific or based on the printable area are applied regardless of the setting of this item.
Adj/Set/Operate Method	1) Enter the setting value, and then press Apply key. 2) Turn OFF/ON the main power switch.
Display/Adj/Set Range	0 to 20
Unit	0.1 mm
Default Value	0
Related Service Mode	COPIER > FUNCTION > SPLMAN > SPL68676
SPL68676	Decrease of paper leading edge margin
Detail	To decrease the margin on the leading edge of paper. As the value is incremented by 1, the margin is decreased by 0.1 mm. Actually, a value where the setting value of this item is subtracted from the setting value of SPL65677 is applied. The margin settings which are job-specific or based on the printable area are applied regardless of the setting of this item.
Adj/Set/Operate Method	1) Enter the setting value, and then press Apply key. 2) Turn OFF/ON the main power switch.
Display/Adj/Set Range	0 to 20
Unit	0.1 mm
Default Value	0
Related Service Mode	COPIER > FUNCTION > SPLMAN > SPL65677
SPL68677	Increase of the left edge margin of paper
Detail	To increase the margins on the left edge of paper. As the value is incremented by 1, the margin is increased by 0.1 mm. Actually, a value where the setting value of SPL25607 is subtracted from the setting value of this item is applied. The margin settings which are job-specific or based on the printable area are applied regardless of the setting of this item.
Adj/Set/Operate Method	1) Enter the setting value, and then press Apply key. 2) Turn OFF/ON the main power switch.
Display/Adj/Set Range	0 to 20
Unit	0.1 mm
Default Value	0
Related Service Mode	COPIER > FUNCTION > SPLMAN > SPL25607

COPIER (Service mode for printer) > FUNCTION (Operation / inspection mode) > SPLMAN

SPL25607	Decrease of the left edge margin of paper
Detail	To decrease the margins on the left edge of paper. As the value is incremented by 1, the margin is decreased by 0.1 mm. Actually, a value where the setting value of this item is subtracted from the setting value of SPL68677 is applied. The margin settings which are job-specific or based on the printable area are applied regardless of the setting of this item.
Adj/Set/Operate Method	1) Enter the setting value, and then press Apply key. 2) Turn OFF/ON the main power switch.
Display/Adj/Set Range	0 to 20
Unit	0.1 mm
Default Value	0
Related Service Mode	COPIER > FUNCTION > SPLMAN > SPL68677
SPL93822	Setting of department ID count all clear
Detail	To set whether to disable clearing of all department ID counts.
Use Case	When prohibiting clearing of all department ID counts
Adj/Set/Operate Method	1) Enter the setting value, and then press Apply key. 2) Turn OFF/ON the main power switch.
Caution	Be sure to perform this mode after consulting with the system administrator at user's site.
Display/Adj/Set Range	0 to 1 0: Disabled 1: Enabled
Default Value	0
Related Service Mode	COPIER > FUNCTION > SPLMAN > SPL78788
SPL78788	Setting of department ID count clear
Detail	To set whether to disable clearing of department ID count.
Use Case	When prohibiting clearing of department ID count
Adj/Set/Operate Method	1) Enter the setting value, and then press Apply key. 2) Turn OFF/ON the main power switch.
Caution	Be sure to perform this mode after consulting with the system administrator at user's site.
Display/Adj/Set Range	0 to 1 0: Disabled 1: Enabled
Default Value	0
Related Service Mode	COPIER > FUNCTION > SPLMAN > SPL93822
SPL41250	Initialize color displacement correction
Detail	To initialize the color displacement correction result. If shortage of toner occurs while [Continue Printing (Quality Not Guaranteed)] is selected by the user, color displacement correction cannot be executed. If color displacement correction cannot be executed while 1 is set, printing is continued based on the setting at the time of factory shipment. When 1 is set in the case that color displacement correction fails after replacement of the cartridge, the correction may succeed.
Use Case	- When prioritizing productivity over image quality - When color displacement correction fails even though there is sufficient toner remains
Adj/Set/Operate Method	1) Select the item, and then press Yes key. 2) Turn OFF/ON the main power switch. 3) Execute print color displacement correction.
Caution	- Do not turn OFF/ON the power before "Executing..." disappears. - Be sure to perform print color displacement correction after turning OFF/ON the power.
Additional Functions Mode	Adjustment/Maintenance> Adjust Image Quality> Correct Print Color Mismatch

COPIER (Service mode for printer) > FUNCTION (Operation / inspection mode) > SPLMAN

SPL71100	Setting of the duty of Off-hook PCB
Detail	This is the mode to make handsets of particular manufacturers to ring when fax reception mode is set to "Fax / Tel (Auto Switch)".
Use Case	When making the handsets of particular manufacturers to ring at the time of switching Fax/Tel
Adj/Set/Operate Method	1) Enter the setting value, and then press Apply key. 2) Turn OFF/ON the main power switch.
Display/Adj/Set Range	1 to 99
Default Value	50
Supplement/Memo	FAX model only
SPL00171	Set auto sleep shift time maximum value
Detail	To set the maximum auto sleep shift time displayed in [Auto Sleep Time] in [Settings/Registration]. When 0 is set, the time that can be set is 60 minutes maximum.
Use Case	When changing the setting time to shift to auto sleep mode
Adj/Set/Operate Method	1) Enter the setting value, and then press Apply key. 2) Turn OFF/ON the main power switch.
Display/Adj/Set Range	0 to 1 0: 60 minutes 1: Time specified for each model
Default Value	0 (Europe)/1 (Others)
Additional Functions Mode	Timer Settings> Auto Sleep Time
SPL80100	ON/OFF image left edge mask: book mode
Detail	To set whether to mask the left edge of the image at copyboard reading. When 0 is set, mask with the width based on the specification is applied for each job. When 1 is set, mask is canceled.
Use Case	Upon user's request (to print the left edge of the image)
Adj/Set/Operate Method	1) Enter the setting value, and then press Apply key. 2) Turn OFF/ON the main power switch.
Display/Adj/Set Range	0 to 1 0: ON, 1: OFF
Default Value	0
SPL27354	PC-less update/RMDS preferences
Detail	PC-less update/RMDS preferences
Display/Adj/Set Range	0 to 5 0: Production environment/release environment 1: Product environment/staging environment 2: Maintenance environment 1/release environment 3: Maintenance environment 1/staging environment 4: Maintenance environment 2/release environment 5: Maintenance environment 2/staging environment
Default Value	0

COPIER (Service mode for printer) > FUNCTION (Operation / inspection mode) > SPLMAN

SPL84194	ON/OFF of Embedded-RDS
Detail	To set ON/OFF of Embedded-RDS function.
Use Case	When using Embedded-RDS
Adj/Set/Operate Method	1) Enter the setting value, and then press Apply key. 2) Turn OFF/ON the main power switch.
Display/Adj/Set Range	0 to 1 0: ON, 1: OFF
Default Value	It differs according to the location.
Supplement/Memo	Embedded-RDS: Function to send device information such as the device counter, failure, and consumables to UGW via SOAP protocol UGW (Universal Gate Way): Remote monitoring service system
SPL32620	ON/OFF of PC-less update function
Detail	To set whether to disable the PC-less update function.
Adj/Set/Operate Method	1) Enter the setting value, and then press Apply key. 2) Turn OFF / ON the main power switch.
Caution	When LCDSFLG is 1, the setting of this item is disabled (the PC-less update function is turned OFF).
Display/Adj/Set Range	0 to 1 0: OFF, 1: ON
Default Value	1
Related Service Mode	COPIER > OPTION > FNC-SW > LCDSFLG
Supplement/Memo	PC-less update: A function to directly download the firmware from the GDLS server and update it.
SPL60061	Dspl/hide cloud print connct dest URL chng scrn
Detail	To set whether to display or hide the connection destination URL settings for Google Cloud Print on remote UI.
Use Case	When Google has changed the connection destination URL for cloud print
Adj/Set/Operate Method	1) Enter the setting value, and then press Apply key. 2) Turn OFF / ON the main power switch.
Display/Adj/Set Range	0 to 1 0: Display 1: Hide
SPL71700	Writing sublog to USB flash drive
Detail	To write the sublog stored in the eMMC to the USB flash drive.
Use Case	When analyzing the cause of a problem
Adj/Set/Operate Method	Select the item, and then press Yes key.
SPL01734	ON/OFF of remote UI service mode
Detail	To set whether to allow using service mode on remote UI.
Use Case	When using service mode on remote UI
Adj/Set/Operate Method	1) Enter the setting value, and then press Apply key. 2) Turn OFF/ON the main power switch.
Caution	The setting value is linked with that of RMT-SW.
Display/Adj/Set Range	0 to 1 0: OFF, 1: ON
Default Value	1
Related Service Mode	COPIER > OPTION > BODY > RMT-SW
SPL39533	ON/OFF of department ID management
Detail	To set whether to disable the department ID management.
Use Case	When disabling the department ID management
Adj/Set/Operate Method	Select the item, and then press Yes key.

COPIER (Service mode for printer) > FUNCTION (Operation / inspection mode) > SPLMAN

SPL43810	Clear of system administrator settings
Detail	To completely delete the following setting information. - System Manager ID - PIN After clearing of the information, it is necessary to set the system manager ID/PIN again.
Use Case	When the system manager ID/PIN has been forgotten
Adj/Set/Operate Method	Select the item, and then press Yes key.
Caution	Do not forget to set the system manager ID/PIN after clearing of the information.
SPL08159	ON/OFF of fax image backup data clear
Detail	To set whether to clear the fax image data which has been backed up. When 1 is set, it is cleared at next startup.
Adj/Set/Operate Method	Enter the setting value, and then press Apply key.
Display/Adj/Set Range	0 to 1 0: OFF, 1: ON
Default Value	0
SPL97097	ON/OFF of user setting backup data clear
Detail	To set whether to clear all the user setting data which has been backed up. When 1 is set, it is cleared at next startup.
Adj/Set/Operate Method	Enter the setting value, and then press Apply key.
Display/Adj/Set Range	0 to 1 0: OFF, 1: ON
Default Value	1
SPL09876	ON/OFF of Aladdin app debug log console'
Detail	To set whether to enable the Aladdin application debug log console function.
SPL07041	ON/OFF of remote shutdown with fax line
Detail	To set whether to allow remote shut down when a FAX line is connected.
Display/Adj/Set Range	0/1 0: Do Not Allow 1: Allow
Default Value	1
Supplement/Memo	Supported by models with FAX only
SPL50444	Select paper source for PCL5
Detail	To select a paper source for PCL5..
Display/Adj/Set Range	0 to 3 0: HP compatible 1: Lexmark compatible 2: Zoran PCL compatible 3: Not used
Default Value	0
SPL98765	Execution of disabling function of all Aladdin application
Detail	To set whether to execute disabling function of all Aladdin applications.
Display/Adj/Set Range	0 to 99999999
Default Value	0
Supplement/Memo	Executed with entering the system administrator's password.

■ VIFFNC

COPIER (Service mode for printer) > FUNCTION (Operation / inspection mode) > VIFFNC

FEED-IMP	ON/OFF of pickup jam reduction mode
Detail	To set whether to execute the pickup jam reduction mode. When using paper with which double feed is more likely to occur, pickup operation cannot be performed at the appropriate timing because of double feed. As a result of that, pickup delay jam may occur. In such cases, the pickup interval is extended by setting 1. As a result of that, jam occurrence can be reduced, but productivity is decreased.
Use Case	When pickup jam occurs with paper with which double feed is more likely to occur
Adj/Set/Operate Method	Enter the setting value, and then press Apply key.
Caution	Be sure to get approval from the user by telling that the productivity decreases to prevent jam occurrence.
Display/Adj/Set Range	0 to 1 0: OFF, 1: ON
Default Value	0
FOG-PV	ON/OFF of image fogging prevention mode
Detail	To set whether to execute the image fogging prevention mode. Set 1 when fogging which looks like fine vertical lines appears. Execute the image fogging prevention mode.
Use Case	When fogging which looks like fine vertical lines occurs
Adj/Set/Operate Method	Enter the setting value, and then press Apply key.
Display/Adj/Set Range	0 to 1 0: OFF, 1: ON
Default Value	0
ICL-IMP	ON/OFF ITB clean failure alleviate mode
Detail	To set whether to execute ITB cleaning failure alleviation mode. An image that was on 2 sheets before may appear lightly depending on paper type and image ratio (in case of high image ratio). In such a case, set 1 to execute process to alleviate ITB cleaning failure.
Use Case	When an image failure (ghosting of an image on the 2 sheets before) occurs
Adj/Set/Operate Method	Enter the setting value, and then press Apply key.
Display/Adj/Set Range	0 to 1 0: OFF, 1: ON
Default Value	0
STOR-DCN	Backup of DC Controller PCB NVRAM
Detail	To back up the setting information in NVRAM of the DC Controller PCB to NVRAM of the Main Controller PCB.
Use Case	Before replacing the DC Controller PCB
Adj/Set/Operate Method	Select the item, and then press Yes key.
Caution	During operation, the setting information changes by manual or automatic adjustment. When backup data which has been left for a long period of time is restored, it is overwritten with the old setting information and the new information is deleted.
Related Service Mode	COPIER > FUNCTION > SYSTEM > RSTR-DCN

COPIER (Service mode for printer) > FUNCTION (Operation / inspection mode) > VIFFNC

RSTR-DCN	Restoration of DC Controller PCB NVRAM
Detail	To restore the setting information which has been backed up to NVRAM of the Main Controller PCB to the NVRAM of the DC Controller PCB.
Use Case	After replacing the DC Controller PCB
Adj/Set/Operate Method	1) Select the item, and then press Yes key. 2) Turn OFF/ON the main power switch.
Caution	During operation, the setting information changes by manual or automatic adjustment. When backup data which has been left for a long period of time is restored, it is overwritten with the old setting information and the new information is deleted.
Related Service Mode	COPIER > FUNCTION > SYSTEM > STOR-DCN

OPTION (Specification setting mode)

■ BODY

COPIER (Service mode for printer) > OPTION (Specification setting mode) > BODY

DFDST-L1	Adj image correction level: stream read
Detail	To set whether to perform image correction between originals in the Scanner Unit at stream reading based on the result of dust detection. Increase the value when black lines appear. As the value is larger, the image is more likely to be corrected because the machine is more likely to respond to small dust. Decrease the value if a fine image portion is unclear as a result of dust detection correction control. As the value is smaller, the image is less likely to be corrected because the machine is less likely to respond to dust.
Use Case	- When black line occurs due to dust - Upon user's request
Adj/Set/Operate Method	1) Enter the setting value, and then press Apply key. 2) Turn OFF/ON the main power switch.
Caution	- If the value is too large, a fine image portion may be unclear. If the value is too small, black lines may appear on the image. - When the value of DFDST-L1 is changed to any value other than 0 while the values of DFDST-L1 and DFDST-L2 are 0, the value of DFDST-L2 is returned to the previous value (a value before setting 0). - When setting 0 for DFDST-L2, the value of DFDST-L1 also become 0 automatically (image correction is not performed).
Display/Adj/Set Range	0 to 255 0: OFF
Default Value	200
Related Service Mode	COPIER > OPTION > BODY > DFDST-L2
Supplement/Memo	Black lines may appear on the image if there is dust. With dust detection correction control, the image is corrected to prevent black lines once dust is detected.

COPIER (Service mode for printer) > OPTION (Specification setting mode) > BODY

DF2DSTL1	Adj dust dtct level: stream read, back
Detail	To adjust the level of dust detection that is executed between originals in the Scanner Unit (for back side) at stream reading. Reduce the value in the case of frequent display of cleaning instruction at the time of dust detection. As the value is smaller, dust is less likely to be detected. Increase the value when black lines appear. As the value is larger, the small dust is more likely to be detected.
Use Case	Upon user's request
Adj/Set/Operate Method	1) Enter the setting value, and then press Apply key. 2) Turn OFF/ON the main power switch.
Caution	If the value is too large, the cleaning instruction screen may appear too often since even small dust that will not appear on the image can be detected. If the value is too small, black lines may appear.
Display/Adj/Set Range	1 to 255 1 to 84: Weakest 85 to 169: Weak 170 to 254: Moderate 255: Strong
Default Value	200
Supplement/Memo	Black lines may appear on the image if there is dust. With dust detection correction control, the image is corrected to prevent black lines once dust is detected.
LOCALE	Setting of location
Detail	To set the location. Set the location in this item and the paper size configuration in SIZE-LC, and then clear the setting information in ALL.
Use Case	- When replacing the Main Controller PCB - When changing the location information
Adj/Set/Operate Method	1) Enter the setting value in this item, and then press Apply key. 2) Set the paper size configuration in SIZE-LC. 3) Execute ALL. 4) Turn OFF/ON the main power switch.
Caution	The setting information such as user mode and service mode is initialized by executing ALL. The settings of this item and SIZE-LC are not initialized.
Display/Adj/Set Range	1 to 10 1: Japan 2: North America 3: Korea 4: China 5: Taiwan 6: Europe 7: Asia 8: Oceania 9: Brazil 10: Latin
Related Service Mode	COPIER > FUNCTION > CLEAR > ALL COPIER > OPTION > BODY > SIZE-LC

COPIER (Service mode for printer) > OPTION (Specification setting mode) > BODY

SIZE-LC		Setting of paper size configuration
Detail	To set the paper size configuration. When replacing the Main Controller PCB, set the location in LOCALE and the paper size configuration in this item, and then clear the setting information in ALL.	
Use Case	- When replacing the Main Controller PCB - Upon user's request	
Adj/Set/Operate Method	1) Set the location in LOCALE. 2) Enter the setting value in this item, and then press Apply key. 3) Execute ALL. 4) Turn OFF/ON the main power switch.	
Caution	The setting information such as user mode and service mode is initialized by executing ALL. The settings of this item and LOCALE are not initialized.	
Display/Adj/Set Range	1 to 4 1: AB configuration 2: Inch configuration 3: A configuration 4: AB/Inch configuration	
Related Service Mode	COPIER > FUNCTION > CLEAR > ALL COPIER > OPTION > BODY > LOCALE	
MIBCOUNT		Set of charge counter MIB scope range
Detail	To set the range of counter information that can be obtained as MIB (Management Information Base).	
Adj/Set/Operate Method	1) Enter the setting value, and then press Apply key. 2) Turn OFF/ON the main power switch.	
Display/Adj/Set Range	0 to 2 0: All charge counters are obtained 1: Only displayed counter* is obtained 2: All charge counters are not obtained * : Counter specified by COUNTER 1 to 6	
Default Value	0	
Related Service Mode	COPIER > OPTION > USER > COUNTER1 - 6	
Supplement/Memo	Counter meter-installed models only	
NS-CMD5		Limit CRAM-MD5 auth method: SMTP auth
Detail	To restrict use of CRAM-MD5 authentication method at the time of SMTP authentication.	
Use Case	Upon user's request	
Adj/Set/Operate Method	1) Enter the setting value, and then press Apply key. 2) Turn OFF/ON the main power switch.	
Display/Adj/Set Range	0 to 1 0: SMTP server-dependent 1: Not used	
Default Value	0	
Supplement/Memo	SMTP authentication: Protocol in which user authentication function is added to SMTP, which is the protocol to be used for e-mail transmission. At the time of e-mail transmission, this protocol executes authentication of the user account and the password between the SMTP server and the user to approve e-mail transmission only when it's authenticated.	

COPIER (Service mode for printer) > OPTION (Specification setting mode) > BODY

NS-PLN		Limit plaintext auth: SMTP auth, noencyr
Detail	To restrict use of PLAIN/LOGIN authentication, which is plaintext, at the time of SMTP authentication under the environment where the communication packet is not encrypted.	
Use Case	Upon user's request	
Adj/Set/Operate Method	1) Enter the setting value, and then press Apply key. 2) Turn OFF/ON the main power switch.	
Display/Adj/Set Range	0 to 1 0: SMTP server-dependent 1: Not used	
Default Value	0	
Supplement/Memo	SMTP authentication: Protocol in which user authentication function is added to SMTP, which is the protocol to be used for e-mail transmission. At the time of e-mail transmission, this protocol executes authentication of the user account and the password between the SMTP server and the user to approve e-mail transmission only when it's authenticated.	
NS-LGN		Limit LOGIN authentication: SMTP auth
Detail	To restrict use of LOGIN authentication at the time of SMTP authentication.	
Use Case	Upon user's request	
Adj/Set/Operate Method	1) Enter the setting value, and then press Apply key. 2) Turn OFF/ON the main power switch.	
Display/Adj/Set Range	0 to 1 0: SMTP server-dependent 1: Not used	
Default Value	0	
Supplement/Memo	SMTP authentication: Protocol in which user authentication function is added to SMTP, which is the protocol to be used for e-mail transmission. At the time of e-mail transmission, this protocol executes authentication of the user account and the password between the SMTP server and the user to approve e-mail transmission only when it's authenticated.	
SLPMODE		Setting of shift to sleep mode
Detail	To restrict shift to sleep mode 1/sleep mode 3. When 1 is set, the machine does not shift to sleep mode.	
Use Case	When sleep failure occurs	
Adj/Set/Operate Method	1) Enter the setting value, and then press Apply key. 2) Turn OFF/ON the main power switch.	
Display/Adj/Set Range	0 to 1 0 : Shift is available. 1 : Shift is not available.	
Default Value	0	
SDTM-DSP		ON/OFF of auto shutdown shift time dspI
Detail	To set whether to display [Auto Shutdown Time] in [Menu]. The setting is enabled only for the model with automatic shutdown function.	
Use Case	When switching to display or hide the items related to auto shutdown	
Adj/Set/Operate Method	Enter the setting value, and then press Apply key.	
Caution	For the model without automatic shutdown function, the setting is disabled even if it is configured.	
Display/Adj/Set Range	0 to 1 0: OFF 1: ON	
Additional Functions Mode	Preferences> Timer/Energy Settings> Auto Shutdown Time	

COPIER (Service mode for printer) > OPTION (Specification setting mode) > BODY

RMT-SW		ON/OFF of remote UI service mode
Detail		To set whether to allow using service mode on remote UI.
Use Case		When using service mode on remote UI
Adj/Set/Operate Method		1) Enter the setting value, and then press Apply key. 2) Turn OFF/ON the main power switch.
Display/Adj/Set Range		0 to 1 0: OFF, 1: ON
Default Value		0
PSWD-SW		Set password type to enter service mode
Detail		To set the type of password that is required to enter when getting into service mode. 2 types are available: one for "service technician" and the other for "system administrator + service technician". When selecting the type for "system administrator + service technician", enter the password for service technician after the password entry by the user's system administrator.
Use Case		Upon request from the user who concerns security
Adj/Set/Operate Method		1) Enter the setting value, and then press Apply key. 2) Turn OFF/ON the main power switch.
Display/Adj/Set Range		0 to 2 0: No password 1: Service technician 2: System administrator + service technician
Default Value		0
SM-PSWD		Password setting for service technician
Detail		To set password for service technician that is used when getting into service mode.
Use Case		When password is required to get into service mode
Adj/Set/Operate Method		1) Enter the setting value, and then press Apply key. 2) Turn OFF/ON the main power switch.
Caution		Be sure to select 1 or 2 with PSWD-SW in advance.
Display/Adj/Set Range		11111111 to 99999999
Default Value		11111111
Related Service Mode		COPIER > OPTION > BODY > PSWD-SW

■ FNC-SW

COPIER (Service mode for printer) > OPTION (Specification setting mode) > FNC-SW

IMGCNTPR		Setting of image quality mode
Detail		To set the image quality mode. When 0 is set, "image quality priority mode" is applied. When 1 is set, "counter priority mode" is applied. When 2 is set, "image quality priority (photo) mode" is applied.
Use Case		Upon user's request
Adj/Set/Operate Method		Enter the setting value, and then press Apply key.
Display/Adj/Set Range		0 to 2 0: Image quality priority mode 1: Counter priority mode 2: Image quality priority (photo) mode
Default Value		1

COPIER (Service mode for printer) > OPTION (Specification setting mode) > FNC-SW

LCDSFLG		Enabling of local CDS server
Detail		To set whether to use the local CDS server.
Use Case		When using the local CDS server
Adj/Set/Operate Method		Enter the setting value, and then press Apply key.
Display/Adj/Set Range		0 to 1 0: Disabled 1: Enabled
Default Value		0
Related Service Mode		COPIER > FUNCTION > SPLMAN > SPL32620
Supplement/Memo		When local CDS is used, iW EMC/MC device firmware update plug-in is required.
CRG-PROC		Set oprtn at cartridge estd life reach
Detail		To set the operation of the machine when the parts counter of the cartridge reaches the estimated life value.
Adj/Set/Operate Method		Enter the setting value, and then press Apply key.
Display/Adj/Set Range		0 to 2 0: Not stopped 1: Stopped once 2: Completely stopped
Default Value		0
CRGLF-K		Set replacement ref VL (Bk): drum, etc.
Detail		To set the reference values for judging replacement of the component other than toner (Photosensitive Drum, Developing Assembly, and waste toner) included in the life of Bk-color cartridge. These values are used as the basis for calculation of component other than toner when deriving the estimated life value of the cartridge.
Use Case		When toner consumption is low (when the life of the Photosensitive Drum or the Developing Assembly decreases faster than that of toner)
Adj/Set/Operate Method		Enter the setting value, and then press Apply key.
Display/Adj/Set Range		100 to 200
Unit		0.01
Default Value		100
CRGLF-CL		Set replacement ref VL(Y/M/C): drum, etc.
Detail		To set the reference values for judging replacement of the component other than toner (Photosensitive Drum, Developing Assembly, and waste toner) included in the life of Y/M/C-color cartridge. These values are used as the basis for calculation of component other than toner when deriving the estimated life value of the cartridge.
Use Case		When toner consumption is low (when the life of the Photosensitive Drum or the Developing Assembly decreases faster than that of toner)
Adj/Set/Operate Method		Enter the setting value, and then press Apply key.
Display/Adj/Set Range		100 to 200
Unit		0.01
Default Value		100

COPIER (Service mode for printer) > OPTION (Specification setting mode) > FNC-SW

RPT2SIDE		Set of report 1-sided/2-sided output
Detail		To set whether to use 1-sided or 2-sided for report output of service mode.
Use Case		When making 1-sided report output
Adj/Set/Operate Method		1) Enter the setting value, and then press Apply key. 2) Turn OFF/ON the main power switch.
Display/Adj/Set Range		0 to 1 0: 1-sided 1: 2-sided
Default Value		1
EDB-ADSW		Setting for using a test environment when constructing an automatic ordering system
Detail		To set whether to use a test environment when constructing an automatic ordering system.
Adj/Set/Operate Method		1) Enter the setting value, and then press Apply key. 2) Turn OFF/ON the main power switch.
Display/Adj/Set Range		0 to 2 0: Field (product) environment 1: Environment to test external collaboration of the version before release 2: Environment to test collaboration of the same version as product environment
Default Value		0

■ DSPLY-SW

COPIER (Service mode for printer) > OPTION (Specification setting mode) > DSPLY-SW

CRGLW-LV		ON/OFF ctrdg prep thrshld set scrn dspl
Detail		To set whether to display the screen to set the threshold value for the toner level to prompt preparation of a cartridge. When 1 is set, [Custom] is displayed in [Display Timing for Cartridge Prep. Notif.] so that the user can set the toner level (1 to 99%). When 0 is set, the item is not displayed, so the user cannot set the toner level.
Adj/Set/Operate Method		Enter the setting value, and then press Apply key.
Display/Adj/Set Range		0 to 1 0: OFF, 1: ON
Default Value		1
Additional Functions Mode		Preferences > Display Settings > Display Timing for Cartridge Prep. Notif.
CRG-LOG		Output cartridge replacement log report
Detail		To output the cartridge replacement log in the form of a report.
Adj/Set/Operate Method		Enter the setting value, and then press Apply key.
Display/Adj/Set Range		0 to 1 0: OFF 1: ON
Default Value		1
GEN-CRG		ON/OFF of Canon Genuine Mode display
Detail		To set whether to display Canon Genuine Mode.
Adj/Set/Operate Method		Enter the setting value, and then press Apply key.
Display/Adj/Set Range		0/1 0: Hide 1: Display
Default Value		1
Supplement/Memo		Enabled only for Cartridge models.

■ IMG-MCON

COPIER (Service mode for printer) > OPTION (Specification setting mode) > IMG-MCON

TMIC-BK	TMIC Bk PASCAL gamma LUT end edge crrcrct
Detail	To set whether to perform the trailing edge correction of Bk-color PASCAL gamma LUT used by TMIC. When 1 is set, the trailing edge correction is not performed so that density of the high density area becomes high. Consequently, texts and thin lines become clear; however, gradation of photos may become unnatural. When 0 is set, density of the high density area becomes low by the trailing edge correction. Consequently, gradation of photos is improved, but thin lines may be partly missing or texts may be faded.
Use Case	- When gradation of photos become unnatural - When thin lines are partly missing or characters are faded
Adj/Set/Operate Method	Enter the setting value, and then press Apply key.
Display/Adj/Set Range	0 to 1 0: OFF, 1: ON
Default Value	1
Supplement/Memo	TMIC: Error diffusion correction of photo/high image quality.

TMIC-CMY	TMIC Y/M/C PASCAL gamma LUT end correct
Detail	To set whether to perform the trailing edge correction of Y/M/C-color PASCAL gamma LUT used by TMIC. When 1 is set, the trailing edge correction is not performed so that density of the high density area becomes high. Consequently, texts and thin lines become clear; however, gradation of photos may become unnatural. When 0 is set, density of the high density area becomes low by the trailing edge correction. Consequently, gradation of photos is improved, but thin lines may be partly missing or texts may be faded.
Use Case	- When gradation of photos become unnatural - When thin lines are partly missing or characters are faded
Adj/Set/Operate Method	Enter the setting value, and then press Apply key.
Display/Adj/Set Range	0 to 1 0: OFF, 1: ON
Default Value	1
Supplement/Memo	TMIC: Error diffusion correction of photo/high image quality.

■ USER

COPIER (Service mode for printer) > OPTION (Specification setting mode) > USER

COUNTER1	Display of software counter 1
Detail	To display counter type for software counter 1 on the Counter Check screen.
Use Case	Upon user/dealer's request
Adj/Set/Operate Method	N/A (Display only)
Caution	Display only. No change is available.
Display/Adj/Set Range	0 to 999 0: No registration
Default Value	It differs according to the location.

COPIER (Service mode for printer) > OPTION (Specification setting mode) > USER

COUNTER2		Setting of software counter 2
Detail	To set counter type for software counter 2 on the Counter Check screen.	
Use Case	Upon user/dealer's request	
Adj/Set/Operate Method	1) Enter the setting value, and then press Apply key. 2) Turn OFF/ON the main power switch.	
Display/Adj/Set Range	0 to 999 0: No registration	
Default Value	It differs according to the location.	
COUNTER3		Setting of software counter 3
Detail	To set counter type for software counter 3 on the Counter Check screen.	
Use Case	Upon user/dealer's request	
Adj/Set/Operate Method	1) Enter the setting value, and then press Apply key. 2) Turn OFF/ON the main power switch.	
Display/Adj/Set Range	0 to 999 0: No registration	
Default Value	It differs according to the location.	
COUNTER4		Setting of software counter 4
Detail	To set counter type for software counter 4 on the Counter Check screen.	
Use Case	Upon user/dealer's request	
Adj/Set/Operate Method	1) Enter the setting value, and then press Apply key. 2) Turn OFF/ON the main power switch.	
Display/Adj/Set Range	0 to 999 0: No registration	
Default Value	It differs according to the location.	
COUNTER5		Setting of software counter 5
Detail	To set counter type for software counter 5 on the Counter Check screen.	
Use Case	Upon user/dealer's request	
Adj/Set/Operate Method	1) Enter the setting value, and then press Apply key. 2) Turn OFF/ON the main power switch.	
Display/Adj/Set Range	0 to 999 0: No registration	
Default Value	It differs according to the location.	
COUNTER6		Setting of software counter 6
Detail	To set counter type for software counter 6 on the Counter Check screen.	
Use Case	Upon user/dealer's request	
Adj/Set/Operate Method	1) Enter the setting value, and then press Apply key. 2) Turn OFF/ON the main power switch.	
Display/Adj/Set Range	0 to 999 0: No registration	
Default Value	It differs according to the location.	

COPIER (Service mode for printer) > OPTION (Specification setting mode) > USER

CNT-SW	Set default Display items on charge counter
Detail	To set default display items of the charge counter on the Counter Check screen. For details of each type, refer to the Service Manual.
Use Case	Upon user's request
Adj/Set/Operate Method	1) Enter the setting value, and then press Apply key. 2) Turn OFF/ON the main power switch.
Display/Adj/Set Range	0 to 3 0: Type1 1: Type2 2: Type3 3: Type4
Default Value	0
Supplement/Memo	Counter meter-installed models only
CTCHKDSP	ON/OFF of charge counter list output
Detail	To set whether to print the charge counter in the system management data list.
Use Case	Upon user's request
Adj/Set/Operate Method	1) Enter the setting value, and then press Apply key. 2) Turn OFF/ON the main power switch.
Display/Adj/Set Range	0 to 1 0: ON, 1: OFF
Default Value	1
Additional Functions Mode	Output Report > Print List > System Manager Data List
Supplement/Memo	Counter meter-installed models only
PS-MODE	Setting of compatible mode at PS usage
Detail	To set the image processing at PS print. Set 8 when line width differs depending on the drawing position although the same line width is set. Setting of a value other than the setting values means that multiple settings are combined. (Example: 12=4+8)
Use Case	Upon user's request
Adj/Set/Operate Method	1) Enter the setting value, and then press Apply key. 2) Turn OFF/ON the main power switch.
Display/Adj/Set Range	0 to 63 4: Compatible with EFI at PS 2-sided delivery 8: strokeadjustment is enabled Any value other than those mentioned above: Not used
Default Value	0
SMD-EXPT	Set of service mode set VL export target
Detail	To set whether to export "service mode data" from remote UI. When 1 is set, "service mode data" is displayed as the target data of export on remote UI. When installing more than 1 machine at the same time, the same service mode data can be registered.
Use Case	When installing more than 1 machine at the same time
Adj/Set/Operate Method	1) Enter the setting value, and then press Apply key. 2) Turn OFF/ON the main power switch.
Display/Adj/Set Range	0 to 1 0: Not targeted 1: Targeted
Default Value	0
Supplement/Memo	If selecting "service mode data" as the target data of export on remote UI after setting SMD-EXPT to 1, service mode data can be exported.

COPIER (Service mode for printer) > OPTION (Specification setting mode) > USER

ACC-SLP		Set shift to sleep3: Card Reader connect
Detail		To set whether to shift to sleep mode 3 when the Card Reader is connected.
Adj/Set/Operate Method		Enter the setting value, and then press Apply key.
Display/Adj/Set Range		0 to 1 0: Not shifted 1: Shifted
Default Value		1
RPL-IMP		ON/OFF of replacement mode
Detail		To set whether to import the setting information of a machine which has been exported to a different one of the same model using DCM function. When 0 is set, the setting information which has been exported can be imported only to the same machine. When 1 is set, the machine-specific setting information such as IPv4 address setting can be imported to a different machine.
Use Case		When migrating the setting of a machine to a different machine of the same series that has been replaced
Display/Adj/Set Range		0 to 1 0: OFF, 1: ON
Default Value		0
Supplement/Memo		DCM (Device Configuration Management): A function to export/import the machine's setting information as a file.

■ ACC

COPIER (Service mode for printer) > OPTION (Specification setting mode) > ACC

WLAN		Setting of wireless LAN function
Detail		To set whether to enable the wireless LAN function.
Use Case		Upon user's request
Adj/Set/Operate Method		1) Enter the setting value, and then press Apply key. 2) Turn OFF/ON the main power switch.
Display/Adj/Set Range		0 to 1 0: Disabled 1: Enabled
Default Value		It differs according to the model.

■ SERIAL

COPIER (Service mode for printer) > OPTION (Specification setting mode) > SERIAL

SN-MAIN	Registration of serial number
Detail	To write the serial number of this machine in the Main Controller PCB. When this item is executed, the 1-byte alphanumeric characters entered in [Location] in [Settings/Registration] are written in the Main Controller PCB. When replacing the Main Controller PCB, be sure to write the serial number in the new PCB to prepare for trouble since the serial number of the device is not succeeded.
Use Case	When replacing the Main Controller PCB
Adj/Set/Operate Method	1) Write down the current data in [Location]. 2) Turn OFF the main power switch. 3) Replace the Main Controller PCB. 4) Turn ON the main power switch. 5) Enter the serial number of the machine in [Location]. 6) Execute this item. 7) Turn OFF/ON the main power switch. After the serial number of this machine is written in the Main Controller PCB, data in [Location] is deleted. 8) Output the spec report by SPEC, and check that the entered serial number is registered. 9) Enter the data backed up in step 1 in [Location].
Caution	Since the above "Location" is only temporarily used to store data, back up the data before input and enter it again after writing is completed.
Related Service Mode	COPIER > FUNCTION > MISC-P > SPEC
Additional Functions Mode	System Settings> Device Information> Location

COUNTER (Counter mode)

■ TOTAL

COPIER (Service mode for printer) > COUNTER (Counter mode) > TOTAL

SERVICE1	Service-purposed total counter 1
Detail	To count up when the printout is delivered outside the machine. Large size: 1, Small size: 1 A blank sheet is not counted.
Adj/Set/Operate Method	N/A (Display only)
Display/Adj/Set Range	0 to 99999999
Unit	1 sheet
Default Value	0
SERVICE2	Service-purposed total counter 2
Detail	To count up when the printout is delivered outside the machine. Large size: 2, Small size: 1 A blank sheet is not counted.
Adj/Set/Operate Method	N/A (Display only)
Display/Adj/Set Range	0 to 99999999
Unit	1 sheet
Default Value	0

COPIER (Service mode for printer) > COUNTER (Counter mode) > TOTAL

TTL		Total counter
Detail	To display the total of counters of COPY, PDL-PRT, FAX-PRT, RPT-PRT, and MD-PRT.	
Adj/Set/Operate Method	N/A (Display only)	
Display/Adj/Set Range	0 to 99999999	
Unit	1 sheet	
Default Value	0	
Related Service Mode	COPIER > COUNTER > TOTAL > COPY, PDL-PRT, FAX-PRT, RPT-PRT, MD-PRT	
COPY		Total copy counter
Detail	To count up when the printout is delivered outside the machine. Large size: 1, Small size: 1 A blank sheet is not counted.	
Adj/Set/Operate Method	N/A (Display only)	
Display/Adj/Set Range	0 to 99999999	
Unit	1 sheet	
Default Value	0	
PDL-PRT		PDL print counter
Detail	To count up when the printout is delivered outside the machine/2-sided printout is stacked at PDL print. Large size: 1, Small size: 1 A blank sheet is not counted.	
Adj/Set/Operate Method	N/A (Display only)	
Display/Adj/Set Range	0 to 99999999	
Unit	1 sheet	
Default Value	0	
FAX-PRT		FAX reception print counter
Detail	To count up when the FAX reception print is delivered outside the machine/2-sided printout is stacked. Large size: 1, Small size: 1 The counter is not advanced by blank paper or delivery in service mode.	
Adj/Set/Operate Method	N/A (Display only)	
Display/Adj/Set Range	0 to 99999999	
Unit	1 sheet	
Default Value	0	
Related Service Mode	COPIER > COUNTER > TOTAL > TTL	
Supplement/Memo	FAX model only	
RPT-PRT		Report print counter
Detail	To count up when the report print is delivered outside the machine/2-sided printout is stacked. Large size: 1, Small size: 1 The counter is not advanced by blank paper or delivery in service mode.	
Adj/Set/Operate Method	N/A (Display only)	
Display/Adj/Set Range	0 to 99999999	
Unit	1 sheet	
Default Value	0	
Related Service Mode	COPIER > COUNTER > TOTAL > TTL	

COPIER (Service mode for printer) > COUNTER (Counter mode) > TOTAL

MD-PRT		Media print counter
Detail	To count up when the media print is delivered outside the machine. Large size: 1, Small size: 1 The counter is not advanced by blank paper or delivery in service mode.	
Adj/Set/Operate Method	N/A (Display only)	
Display/Adj/Set Range	0 to 99999999	
Unit	1 sheet	
Default Value	0	
Related Service Mode	COPIER > COUNTER > TOTAL > TTL	
2-SIDE		2-sided copy/print counter
Detail	To count up the number of 2-sided copies/prints when the copy/printout is delivered outside the machine/2-sided copy/printout is stacked. Large size: 1, Small size: 1 A blank sheet is not counted.	
Adj/Set/Operate Method	N/A (Display only)	
Display/Adj/Set Range	0 to 99999999	
Unit	1 time	
Default Value	0	
SCAN		Scan counter
Detail	To count the number of scan operations when the scanning operation is complete. Large size: 1, Small size: 1	
Adj/Set/Operate Method	N/A (Display only)	
Display/Adj/Set Range	0 to 99999999	
Unit	1 time	
Default Value	0	

■ PICK-UP

COPIER (Service mode for printer) > COUNTER (Counter mode) > PICK-UP

C1		Cassette 1 pickup total counter
Detail	To count up the number of sheets picked up from the Cassette 1. Large size: 1, Small size: 1 The counter is advanced by printout in service mode.	
Adj/Set/Operate Method	N/A (Display only)	
Display/Adj/Set Range	0 to 99999999	
Unit	1 sheet	
Default Value	0	
C2		Cassette 2 pickup total counter
Detail	To count up the number of sheets picked up from the Cassette 2. Large size: 1, Small size: 1 The counter is advanced by printout in service mode.	
Adj/Set/Operate Method	N/A (Display only)	
Display/Adj/Set Range	0 to 99999999	
Unit	1 sheet	
Default Value	0	

COPIER (Service mode for printer) > COUNTER (Counter mode) > PICK-UP

MF	Multi-purpose Tray pickup total counter
Detail	To count up the number of sheets picked up from the Multi-purpose Tray Pickup Unit. Large size: 1, Small size: 1 The counter is advanced by printout in service mode.
Adj/Set/Operate Method	N/A (Display only)
Display/Adj/Set Range	0 to 99999999
Unit	1 sheet
Default Value	0

2-SIDE	2-sided pickup total counter
Detail	To count up the number of sheets picked up in duplex mode. Large size: 1, Small size: 1 The counter is advanced by printout in service mode.
Adj/Set/Operate Method	N/A (Display only)
Display/Adj/Set Range	0 to 99999999
Unit	1 sheet
Default Value	0

■ FEEDER

COPIER (Service mode for printer) > COUNTER (Counter mode) > FEEDER

FEED	DADF original pickup total counter
Detail	To count up the number of originals picked up from the DADF regardless of the size.
Use Case	When checking the total counter of original pickup by DADF
Adj/Set/Operate Method	N/A (Display only)
Display/Adj/Set Range	0 to 99999999
Unit	1 sheet
Default Value	0

■ JAM

COPIER (Service mode for printer) > COUNTER (Counter mode) > JAM

TOTAL	Total jam counter
Detail	To count up the number of total jam occurrences.
Use Case	When checking the jam counter
Adj/Set/Operate Method	N/A (Display only)
Display/Adj/Set Range	0 to 99999999
Unit	1 time
Default Value	0

FEEDER	DADF jam counter
Detail	To count up the number of jam occurrences in the DADF.
Use Case	When checking the jam counter
Adj/Set/Operate Method	N/A (Display only)
Display/Adj/Set Range	0 to 99999999
Unit	1 time
Default Value	0

COPIER (Service mode for printer) > COUNTER (Counter mode) > JAM

2-SIDE	Duplex Unit jam counter
Detail	To count up the number of jam occurrences in the Duplex Unit.
Use Case	When checking the jam counter
Adj/Set/Operate Method	N/A (Display only)
Display/Adj/Set Range	0 to 99999999
Unit	1 time
Default Value	0
MF	Multi-purpose Tray jam counter
Detail	To count up the number of jam occurrences in the Multi-purpose Tray. The counter is advanced even in the case of paper size mismatch or misprint.
Use Case	When checking the jam counter
Adj/Set/Operate Method	N/A (Display only)
Display/Adj/Set Range	0 to 99999999
Unit	1 time
Default Value	0
C1	Cassette 1 jam counter
Detail	To count up the number of jam occurrences in the Cassette 1. The counter is advanced even in the case of paper size mismatch or misprint.
Use Case	When checking the jam counter
Adj/Set/Operate Method	N/A (Display only)
Display/Adj/Set Range	0 to 99999999
Unit	1 time
Default Value	0
C2	Cassette 2 jam counter
Detail	To count up the number of jam occurrences in the Cassette 2. The counter is advanced even in the case of paper size mismatch or misprint.
Use Case	When checking the jam counter
Adj/Set/Operate Method	N/A (Display only)
Display/Adj/Set Range	0 to 99999999
Unit	1 time
Default Value	0

FEEDER (ADF service mode)

ADJUST (Adjustment mode)

FEEDER (ADF service mode) > ADJUST (Adjustment mode)

DOCST	Adj img lead edge margin: stream, front
Detail	To adjust the leading edge margin of the image on the front side at stream reading. Execute this item when the output image after DADF installation is displaced. When replacing the Main Controller PCB/clearing RAM data, enter the value of service label. As the value is incremented by 1, the margin is reduced by 0.1 mm. (The image moves upward.) The setting is applied to the image on the front side.
Use Case	- When installing the DADF - When replacing the Main Controller PCB/clearing RAM data
Adj/Set/Operate Method	Enter the setting value (switch negative/positive by +/- key), and then press Apply key.
Display/Adj/Set Range	-30 to 30
Unit	0.1 mm
Default Value	0
LA-SPEED	Fine adj img ratio: stream,vert scan,frt
Detail	To make a fine adjustment of the image magnification ratio in vertical scanning direction on the front side at stream reading. When replacing the Main Controller PCB/clearing RAM data, enter the value of service label. As the value is incremented by 1, the image is reduced by 0.01% in vertical scanning direction. (The feeding speed increases, and the image is reduced.) The setting is applied to the image on the front side.
Use Case	- When installing the DADF - When replacing the Main Controller PCB/clearing RAM data
Adj/Set/Operate Method	Enter the setting value (switch negative/positive by +/- key), and then press Apply key.
Display/Adj/Set Range	-200 to 200
Unit	0.01%
Default Value	0
DOCST2	Adj img lead edge margin: stream, back
Detail	To adjust the leading edge margin of the image on the back side at stream reading. Execute this item when the output image after DADF installation is displaced. When replacing the Main Controller PCB/clearing RAM data, enter the value of service label. As the value is incremented by 1, the margin is reduced by 0.1 mm. (The image moves upward.) The setting is applied to the image on the back side.
Use Case	- When installing the DADF - When replacing the Main Controller PCB/clearing RAM data
Adj/Set/Operate Method	Enter the setting value (switch negative/positive by +/- key), and then press Apply key.
Display/Adj/Set Range	-30 to 30
Unit	0.1 mm
Default Value	0

FEEDER (ADF service mode) > ADJUST (Adjustment mode)

LA-SPD2	Fine adj img ratio: stream,vert scan,bck
Detail	To make a fine adjustment of the image magnification ratio in vertical scanning direction on the back side at stream reading. When replacing the Main Controller PCB/clearing RAM data, enter the value of service label. As the value is incremented by 1, the image is reduced by 0.01% in vertical scanning direction. (The feeding speed increases, and the image is reduced.) The setting is applied to the image on the back side.
Use Case	- When installing the DADF - When replacing the Main Controller PCB/clearing RAM data
Adj/Set/Operate Method	Enter the setting value (switch negative/positive by +/- key), and then press Apply key.
Display/Adj/Set Range	-200 to 200
Unit	0.01%
Default Value	0

FUNCTION (Operation / inspection mode)

FEEDER (ADF service mode) > FUNCTION (Operation / inspection mode)

MTR-ON	Operation check of ADF Motor
Detail	To start operation check of ADF Motor (M702).
Use Case	At operation check
Adj/Set/Operate Method	1) Select the item, and then press Yes key. It is driven for approximately 5 seconds and is automatically stopped. 2) Press Yes key. The operation check is completed.
Required Time	5 seconds
FEED-ON	Operation check of DADF individual feed
Detail	To start operation check of the feed mode specified by FEED-CHK.
Use Case	At operation check
Adj/Set/Operate Method	Select the item, and then press Yes key.
Related Service Mode	FEEDER > FUNCTION > FEED-CHK
FEED-CHK	Specify DADF individual feed operation
Detail	To specify the feed mode for DADF. Feed operation is activated by FEED-ON.
Use Case	At operation check
Adj/Set/Operate Method	Enter the setting value, and then press Apply key.
Display/Adj/Set Range	0 to 1 0: 1-sided 1: 2-sided
Default Value	0
Related Service Mode	FEEDER > FUNCTION > FEED-ON
Supplement/Memo	In the case of DADF (1-path model), operation is the same when either value is set.

TESTMODE (Service mode for test print, operation check, etc.)

PRINT (Print test mode)

TESTMODE (Service mode for test print, operation check, etc.) > PRINT (Print test mode)

PG-TYPE		Setting of PG number
	Detail	To set the PG number of the test print.
	Use Case	At trouble analysis
	Adj/Set/Operate Method	Enter the setting value, and then press Apply key.
	Display/Adj/Set Range	0 to 26 0 to 1: For R&D use 2: Color chart 3: For R&D use 4: Rainbow chart (vertical scanning direction, A4) 5: Rainbow chart (horizontal scanning direction, A4) 6: Color grid (A4) 7: Rainbow chart (vertical scanning direction, LTR/LGL) 8: Rainbow chart (horizontal scanning direction, LTR/LGL) 9: Color grid (LTR/LGL) 10: 16 gradations 11: 17 gradations of Y/M/C/Bk/R/G/B 12: Halftone 13: For checking ghost due to transfer failure 14: For checking the density patch 15: For checking transfer 20: For R&D use 21: For checking developing performance (white spots) 22: For checking resolution 23: For checking banding image 24: 4 colors (landscape) 25: 4 colors (portrait) 26: For calibrating color difference between the front and back sides with DADF (1-path model)
	Default Value	0
COUNT		Setting of PG output quantity
	Detail	To set the number of sheets for PG output.
	Use Case	At trouble analysis
	Adj/Set/Operate Method	Enter the setting value, and then press Apply key.
	Display/Adj/Set Range	1 to 99
	Unit	1 sheet
	Default Value	1
PHASE		Set 1-sided/2-sided print for PG output
	Detail	To set 1-sided/2-sided print for PG output. Even if 1 is set for a machine supporting 1-sided print, the setting is disabled.
	Use Case	At trouble analysis
	Adj/Set/Operate Method	Enter the setting value, and then press Apply key.
	Display/Adj/Set Range	0 to 1 0: 1-sided 1: 2-sided
	Default Value	0

TESTMODE (Service mode for test print, operation check, etc.) > PRINT (Print test mode)

MODE		Setting of test print image formation method
Detail	To set the image formation method for the test print. If PG-TYPE is 0 or 1, this setting is disabled because a specific image formation method is applied.	
Use Case	At trouble analysis	
Adj/Set/Operate Method	Enter the setting value, and then press Apply key.	
Display/Adj/Set Range	0 to 3 0: T-MIC 1: High screen ruling (SCA) 2: Low screen ruling (SCB) 3: TBIC	
Default Value	0	
Related Service Mode	TESTMODE > PRINT > PG-TYPE	
THRU		Setting of image correction table at test print
Detail	To set the image correction table that is used at the time of test print output. When 0 is set, normal gamma LUT is used so that the density characteristics by the density correction process can be checked. When 1 is set, linear gamma LUT is used so that the density characteristics of this machine can be checked. When 2 is set, the high density area of Bk-color is printed darker.	
Use Case	At trouble analysis	
Adj/Set/Operate Method	Enter the setting value, and then press Apply key.	
Display/Adj/Set Range	0 to 2 0: Normal gamma LUT 1: Through (linear) gamma LUT 2: With trailing edge correction of Bk-color	
Default Value	0	
Supplement/Memo	Gamma LUT: Density gradation characteristic table	
NRKE		ON/OFF of laser scanning transfer process of test print
Detail	To set whether to perform line transfer process for skew correction of laser scanning at test print.	
Use Case	At trouble analysis	
Adj/Set/Operate Method	Enter the setting value, and then press Apply key.	
Display/Adj/Set Range	0 to 1 0: OFF 1: ON	
Default Value	0	
Supplement/Memo	Transfer process: A process to correct skew of laser scanning toward vertical scanning direction	
BLND		ON/OFF of interpolation process at test print
Detail	To set whether to perform interpolation process at test print. When 1 is set, interpolation process is performed (no phase shift).	
Use Case	At trouble analysis	
Adj/Set/Operate Method	Enter the setting value, and then press Apply key.	
Display/Adj/Set Range	0 to 1 0: OFF 1: ON	
Default Value	0	
Supplement/Memo	Interpolation process: A process to predict, for pixels holding no color information, color based on the surrounding pixels, and then set up the color information.	

TESTMODE (Service mode for test print, operation check, etc.) > PRINT (Print test mode)

DENS-Y	Adj of Y-color density at test print
Detail	To adjust Y-color density when performing test print . As the value is larger, the image gets darker.
Use Case	At test print
Adj/Set/Operate Method	Enter the setting value, and then press Apply key.
Display/Adj/Set Range	0 to 255
Default Value	128
Related Service Mode	TESTMODE > PRINT > PG-TYPE
DENS-M	Adj of M-color density at test print
Detail	To adjust M-color density when performing test print . As the value is larger, the image gets darker.
Use Case	At test print
Adj/Set/Operate Method	Enter the setting value, and then press Apply key.
Display/Adj/Set Range	0 to 255
Default Value	128
Related Service Mode	TESTMODE > PRINT > PG-TYPE
DENS-C	Adj of C-color density at test print
Detail	To adjust C-color density when performing test print . As the value is larger, the image gets darker.
Use Case	At test print
Adj/Set/Operate Method	Enter the setting value, and then press Apply key.
Display/Adj/Set Range	0 to 255
Default Value	128
Related Service Mode	TESTMODE > PRINT > PG-TYPE
DENS-K	Adj of Bk-color density at test print
Detail	To adjust Bk-color density when performing test print . As the value is larger, the image gets darker.
Use Case	At test print
Adj/Set/Operate Method	Enter the setting value, and then press Apply key.
Display/Adj/Set Range	0 to 255
Default Value	128
Related Service Mode	TESTMODE > PRINT > PG-TYPE
SW-Y	ON/OFF of Y-color output at test print
Detail	To set whether to output Y-color at the time of test print .
Use Case	At test print
Adj/Set/Operate Method	Enter the setting value, and then press Apply key.
Display/Adj/Set Range	0 to 1 0: OFF, 1: ON
Default Value	1
Related Service Mode	TESTMODE > PRINT > PG-TYPE
SW-M	ON/OFF of M-color output at test print
Detail	To set whether to output M-color at the time of test print .
Use Case	At test print
Adj/Set/Operate Method	Enter the setting value, and then press Apply key.
Display/Adj/Set Range	0 to 1 0: OFF, 1: ON
Default Value	1

TESTMODE (Service mode for test print, operation check, etc.) > PRINT (Print test mode)

SW-C	ON/OFF of C-color output at test print
Detail	To set whether to output C-color at the time of test print .
Use Case	At test print
Adj/Set/Operate Method	Enter the setting value, and then press Apply key.
Display/Adj/Set Range	0 to 1 0: OFF, 1: ON
Default Value	1
SW-K	ON/OFF of Bk-color output at test print
Detail	To set whether to output Bk-color at the time of test print .
Use Case	At test print
Adj/Set/Operate Method	Enter the setting value, and then press Apply key.
Display/Adj/Set Range	0 to 1 0: OFF, 1: ON
Default Value	1
MONOMODE	ON/OFF of black mode at test print
Detail	To set whether to enable black mode at the time of test print.
Use Case	At test print
Adj/Set/Operate Method	Enter the setting value, and then press Apply key.
Display/Adj/Set Range	0 to 1 0: OFF, 1: ON
Default Value	0
IS1200DPI	Setting of PG drawing
Detail	To set whether to draw PG at 1200 dpi
Display/Adj/Set Range	0/1 0: Do not draw 1: Draw
Default Value	0
FEED	Setting of paper source at test print
Detail	To set the paper source at the time of test print output. If this mode is set when there is no Cassette 2 (option Pickup Cassette), the output is made from Cassette 1 (standard Pickup Cassette).
Use Case	At trouble analysis
Adj/Set/Operate Method	Enter the setting value, and then press Apply key.
Caution	In case of using the Multi-purpose Tray, be sure to place paper on the tray before executing this item.
Display/Adj/Set Range	0 to 4 0: Multi-purpose Tray 1: Cassette 1 2: Cassette 2 3: Cassette 3 4: Cassette 4
Default Value	1
START	Output of test print
Detail	To output a test print with the PG pattern set in PG-TYPE, MODE, etc.
Use Case	At trouble analysis
Adj/Set/Operate Method	Select the item, and then press Yes key.
Related Service Mode	TESTMODE > PRINT

FAX (FAX test mode)

■ MODEM

TESTMODE (Service mode for test print, operation check, etc.) > FAX (FAX test mode) > MODEM

RELAY-1	NCU relay test 1
Detail	To test ON/OFF of relay and port switch of NCU. This mode is disabled for an NCU with no relay and port switch.
Use Case	At problem analysis
Adj/Set/Operate Method	Enter the setting value, and then press OK key.
Caution	Be sure to set the value back to 0 after the test.
Display/Adj/Set Range	0 to 6 0: All OFF 1: CML ON/OFF 2: P ON/OFF 3: S ON/OFF 4: H ON/OFF 5: HD ON/OFF 6: R ON/OFF
Default Value	0
Related Service Mode	TESTMODE > FAX > MODEM > RELAY-2
Supplement/Memo	Available only with the machine with fax installed.
RELAY-2	NCU relay test 2
Detail	To test ON/OFF of relay and port switch of NCU. This mode is disabled for an NCU with no relay and port switch.
Use Case	At problem analysis
Adj/Set/Operate Method	Enter the setting value, and then press OK key.
Caution	Be sure to set the value back to 0 after the test.
Display/Adj/Set Range	0 to 7 0: All OFF 1: CIST2 ON/OFF 2: C1 ON/OFF 3: NORG ON/OFF 4: DCSEL ON/OFF 5: DCLIM ON/OFF 6: IPSEL1 ON/OFF 7: IPSEL2 ON/OFF
Default Value	0
Related Service Mode	TESTMODE > FAX > MODEM > RELAY-1
Supplement/Memo	Available only with the machine with fax installed.

TESTMODE (Service mode for test print, operation check, etc.) > FAX (FAX test mode) > MODEM

FREQ		Frequency test
Detail		To test whether the specified frequency is oscillated. By closing or opening the DC circuit in accordance with the setting value, the specified frequency is oscillated by the tone transmission function of the modem. Check this with the speaker.
Adj/Set/Operate Method		Enter the setting value, and then press OK key.
Caution		Be sure to set the value back to 0 after the test.
Display/Adj/Set Range		0 to 7 0: OFF 1: 462 Hz 2: 1100 Hz 3: 1300 Hz 4: 1500 Hz 5: 1650 Hz 6: 1850 Hz 7: 2100 Hz
Default Value		0
Supplement/Memo		Available only with the machine with fax installed.
G3TX		G3 signal transmission test
Detail		To test whether the specified G3 signal is transmitted. By closing or opening the DC circuit in accordance with the setting value, the specific G3 signal pattern is transmitted at the specified transmission speed by the G3 signal transmission function of the modem. Check this with the speaker.
Adj/Set/Operate Method		Enter the setting value, and then press OK key.
Caution		Be sure to set the value back to 0 after the test.
Display/Adj/Set Range		0 to 9 0: OFF 1: 300 bps 2: 2400 bps 3: 4800 bps 4: 7200 bps 5: 9600 bps 6: TC7200 bps 7: TC9600 bps 8: 12000 bps 9: 14400 bps
Default Value		0
Supplement/Memo		Available only with the machine with fax installed.

TESTMODE (Service mode for test print, operation check, etc.) > FAX (FAX test mode) > MODEM

DTMFTX		DTMF transmission test
Detail	To test whether the specified DTMF signal is transmitted. By closing or opening the DC circuit in accordance with the setting value, the specified DTMF signal is transmitted by the DTMF transmission function of the modem. Check this with the speaker.	
Adj/Set/Operate Method	Enter the setting value, and then press OK key.	
Caution	Be sure to set the value back to 0 after the test.	
Display/Adj/Set Range	0 to 12 0: OFF 1: 1 2: 2 3: 3 4: 4 5: 5 6: 6 7: 7 8: 8 9: 9 10: 0 11: * 12: #	
Default Value	0	
Supplement/Memo	DTMF (Dual Tone Multi Frequency) : Signal method combining two specific frequencies like a push-tone phone. Available only with the machine with fax installed.	
V34G3TX		V.34 G3 signal transmission test
Detail	To test whether the specified V.34 G3 signal is transmitted. By closing or opening the DC circuit in accordance with the setting value, the specific G3 signal pattern is transmitted at the specified transmission speed and modulation speed by the G3 signal transmission function (V.34) of the modem. Check this with the speaker. A setting value other than 0 is indicated as a 3-digit integer (1st digit: modulation speed, last 2 digits: transmission speed) . A value other than the specified numerical value is invalid.	
Adj/Set/Operate Method	Enter the setting value, and then press OK key.	
Caution	Be sure to set the value back to 0 after the test.	
Display/Adj/Set Range	0 to 614 0: OFF - First digit (Modulation speed/baud rate) 1: 2400 baud, 2: 2743 baud, 3: 2800 baud, 4: 3000 baud, 5: 3200 baud, 6: 3429 baud - Last 2 digits (Transmission speed) 01: 2400 bps, 02: 4800 bps, 03: 7200 bps, 04: 9600 bps, 05: 12000 bps, 06: 14400 bps, 07: 16800 bps, 08: 19200bps, 09: 21600 bps, 10: 24000 bps, 11: 26400 bps, 12: 28800 bps, 13: 31200 bps, 14: 33600 bps	
Default Value	0	
Supplement/Memo	Available only with the machine with fax installed.	

■ FACULTY

TESTMODE (Service mode for test print, operation check, etc.) > FAX (FAX test mode) > FACULTY

G34800TX	G3 4800 bps signal transmission test
Detail	To test whether the G3 signal is transmitted at 4800 bps. By closing or opening the DC circuit, the specific G3 signal pattern is transmitted at 4800 bps by the G3 signal transmission function. Check this with the speaker.
Adj/Set/Operate Method	Enter the setting value, and then press OK key.
Caution	Be sure to set the value back to 0 after the test.
Display/Adj/Set Range	0 to 1 0: OFF 1: ON
Default Value	0
Supplement/Memo	Available only with the machine with fax installed.
DETECT1	Ring detection
Detail	To check the ON/OFF state of CI, FC, and hook from the line. The detection results are displayed on the console (UART) .
Adj/Set/Operate Method	Enter the setting value, and then press OK key.
Caution	Be sure to set the value back to 0 after the test.
Display/Adj/Set Range	0/1 0: OFF 1: ON
Default Value	0
Supplement/Memo	CI (Calling Identification) : Ring signal UART (Universal Asynchronous Receiver Transmitter) : Console Available only with the machine with fax installed.
DETECT2	Calling tone detection test 1
Detail	To check calling tone signal and FED. Set the CML relay to ON and detect the calling tone. The detection results are displayed on the console (UART) .
Adj/Set/Operate Method	Enter the setting value, and then press OK key.
Caution	Be sure to set the value back to 0 after the test.
Display/Adj/Set Range	0/1 0: OFF 1: ON
Default Value	0
Supplement/Memo	CML (Connect Modem to Line) relay: Relay installed at the NCU (Network Control Unit) Board to switch between the telephone and fax. Available only with the machine with fax installed.
DETECT3	Calling tone detection test 2
Detail	To check calling tone signal and FED. Set the CML relay to OFF and detect the calling tone. The detection results are displayed on the console (UART) .
Adj/Set/Operate Method	Enter the setting value, and then press OK key.
Caution	Be sure to set the value back to 0 after the test.
Display/Adj/Set Range	0/1 0: OFF 1: ON
Default Value	0
Supplement/Memo	CML (Connect Modem to Line) relay: Relay installed at the NCU (Network Control Unit) Board to switch between the telephone and fax. Available only with the machine with fax installed.

FAX (FAX service mode)

SSSW (Bit switch registration mode)

SSSW No.	Bit No.	Function
SW 01		(Switch relating to error and copy)
	Bit 0	Output of error code for service technician
	Bit 1	Error memory dump
	Bit 2 to Bit 7	Not in use
SW 02		(Switch relating to settings for network connection condition)
	Bit 0 to Bit 6	Not in use
	Bit 7	Connect the terminal as F network type 2
SW 03		(Switch relating to echo prevention)
	Bit 0	TCF EQM check
	Bit 1 to Bit 6	Not in use
SW 04		(Switch relating to prevention of communication problems)
	Bit 0	Not in use
	Bit 1	Frequency check of CI signal
	Bit 2	Not in use
	Bit 3	Prohibit T.30 node F kept by both parties
	Bit 4	T.30 node F echo timer
	Bit 5	Frequency check of CI signal at PBX settings
	Bit 6	No CNG transmission at the time of manual transmission
Bit 7	No CED transmission at the time of manual transmission	
SW 05		(Switch relating to standard functions and DIS signal settings)
	Bit 0 to Bit 1	Not in use
	Bit 2	mm/inch conversion (text/photo mode / photo mode)
	Bit 3	Prohibition of bit transmission after DIS bit 33
	Bit 4	Declaration of cut paper
	Bit 5 to Bit 7	Not in use
SW 06		(Switch relating to settings for reading condition)
	Bit 0 to Bit 3	Not in use
	Bit 4	Scan width (0: A4, 1: LTR)
	Bit 5 to Bit 7	Not in use
SW 07	Bit 0 to Bit 7	Not in use
SW 08	Bit 0 to Bit 7	Not in use
SW 09	Bit 0 to Bit 7	Not in use
SW 10	Bit 0 to Bit 7	Not in use
SW 11	Bit 0 to Bit 7	Not in use
SW 12		(Switch relating to settings for page timer)
	Bit 0	Timeout period for 1 page (transmission)
	Bit 1	
	Bit 2	Timeout period for 1 page (Halftone transmission)
	Bit 3	
	Bit 4	Timeout period for 1 page (Reception)
	Bit 5	
	Bit 6	Not in use
Bit 7	Timeout period for 1 page	
SW 13	Bit 0 to Bit 1	Not in use
	Bit 2	Execution of mm/inch conversion when sending the received image
	Bit 3 to Bit 7	Not in use
SW 14	Bit 0 to Bit 1	Not in use

SSSW No.	Bit No.	Function
SW 14	Bit 2	Setting whether to execute inch to mm conversion in horizontal and vertical scanning directions or in vertical scanning direction only
	Bit 3	Not in use
	Bit 4	Declaration of inch-configuration resolution
	Bit 5 to Bit 7	Not in use
SW 15	Bit 0 to Bit 7	Not in use
SW 16	Bit 0 to Bit 7	Not in use
SW 17	Bit 0	Not in use
	Bit 1	Range of selection of transmission level of modem (0: 8 to 15, 1: 0 to 15)
	Bit 2 to Bit 7	Not in use
SW 18	Bit 0	Detection of carrier disconnection between DCS and TCF
	Bit 1	Time to wait for carrier disconnection between DCS and TCF
	Bit 2	Prohibition of communication control for IP network
	Bit 3	Number of command retransmission (V1.7 or earlier) (0: 3 times, 1: 6 times)
	Bit 4	Retransmission request of all frames after frame loss at JBIG reception (0: Not requested, 1: Requested)
	Bit 5 to Bit 7	Not in use
SW 19	Bit 0 to Bit 7	Not in use
SW 20	Bit 0 to Bit 7	Not in use
SW 21	Bit 0 to Bit 7	Not in use
SW 22	Bit 0 to Bit 2	Not in use
	Bit 3	Prohibition of manual polling operation
	Bit 4 to Bit 7	Not in use
SW 23	Bit 0 to Bit 7	Not in use
SW 24	Bit 0 to Bit 7	Not in use
SW 25		(Setting for report display function)
	Bit 0	Prioritize the received abbreviated name to the dialed abbreviated name
	Bit 1 to Bit 7	Not in use
SW 26	Bit 0 to Bit 7	Not in use
SW 27	Bit 0 to Bit 7	Not in use
SW 28	Bit 0	Prohibit calling party for V8 procedure
	Bit 1	Prohibit called party from V8 procedure
	Bit 2	Prohibit calling party from V8 late-start
	Bit 3	Prohibit called party from V8 late-start
	Bit 4	Prohibit V.34 called party from starting fallback
	Bit 5	Prohibit V.34 calling party from starting fallback
	Bit 6 to Bit 7	Not in use
SW 29	Bit 0 to Bit 7	Not in use
SW 30	Bit 0 to Bit 7	Not in use
SW 31	Bit 0 to Bit 7	Not in use
SW 32	Bit 0 to Bit 7	Not in use
SW 33	Bit 0 to Bit 7	Not in use
SW 34	Bit 0 to Bit 7	Not in use
SW 35	Bit 0 to Bit 7	Not in use

MENU (Menu switch registration mode)

No.	Parameter	Selection
1	Not in use	-
2	Not in use	-
3	Not in use	-
4	Not in use	-
5	Not in use	-

No.	Parameter	Selection
6	Telephone line monitor	0 to 3 0: DIAL 1: SERVICE TECHNICIAN 1 2: SERVICE TECHNICIAN 2 3: OFF
7	Transmission level (ATT)	8 to 15
8	Upper limit of V.34 modulation speed	0 to 5 0: 3,429 BAUD 1: 3,200 BAUD 2: 3,000 BAUD 3: 2,800 BAUD 4: 2,743 BAUD 5: 2,400 BAUD
9	Upper limit of V.34 data speed	0 to 13 0: 33.6 kbps 1: 31.2 kbps 2: 28.8 kbps 3: 26.4 kbps 4: 24.0 kbps 5: 21.6 kbps 6: 19.2 kbps 7: 16.8 kbps 8: 14.4 kbps 9: 12.0 kbps 10: 9.6 kbps 11: 7.2 kbps 12: 4.8 kbps 13: 2.4 kbps
10	OFF Hook signal frequency	0 to 2 0: 50 Hz 1: 25 Hz 2: 17 Hz

NUM (Numeric parameter setting mode)

No.	Parameter	Allowable setting range
001	Not in use	-
002	RTN transmission criteria X	1 to 99%
003	RTN transmission criteria n	2 to 99times
004	RTN transmission criteria m	1 to 99lines
005	NCC pause (before ID code)	1 to 60 sec
006	NCC pause (after ID code)	1 to 60 sec
007	Not in use	-
008	STORED_DIAL_MODE wait timer	0 to 65 sec
009	Not in use	-
010	T.30 T0 timer	0 to 9,999 (55 sec principally: 5,500)
011	T.30 T1 timer (for incoming transmission)	0 to 9,999 (France: 3,500, Others: 3,000)
012	Maximum incoming lines	0 to 65,535 lines (0: without limitation)
013	T.30 EOL timer	500 to 3,000 (default 13 sec: 1,300)
014	Not in use	-
015	Threshold between hokking nad on-hook	0 to 999
016	Lead time to the first response when switching between FAX and TEL	0 to 9
017	Duration to activate pseudo-RBT cadence	0 to 999
018	Duration to deactivate pseudo-RBT cadence (short)	0 to 999

No.	Parameter	Allowable setting range
019	Duration to deactivate pseudo-RBT cadence (long)	0 to 999
020	Duration to activate pseudo-ring cadence	0 to 999
021	Duration to deactivate OFF Hook cadence (short)	0 to 999
022	Duration to deactivate OFF Hook cadence (long)	0 to 999
023	Not in use	-
024	Not in use	-
025	CNG monitor duration while the answering device is activated	0 to 999
026	Not in use	-
027	Not in use	-
028	Not in use	-
029	Off-hook PCB duty settings (For NAC, setting can be made with SPL71100 in special management mode.)	1 to 99
030	Not in use	-
031	Not in use	-
032	Not in use	-
033	Not in use	-
034	Not in use	-
035	Not in use	-
036	Not in use	-
037	Not in use	-
038	Not in use	-
039	Not in use	-
040	Not in use	-
041	Not in use	-
042	Not in use	-
043	Not in use	-
044	Not in use	-
045	Not in use	-
046	Not in use	-
047	Not in use	-
048	Not in use	-
049	NSX MODEL ID	0 to 4,095
050	Not in use	-
051	Threshold to detect hook	0 to 9,999
052	Not in use	-
053	Set DTMF calling counts when receiving FAX remotely	0 to 9,999 (default: 2)
054	Not in use	-

NCU (NCU parameter setting mode)

■ TONE

Parameter No.	Function	Setting range
001	Tone signal sending time (PSTN)	10 to 9,999 msec
002	Minimum pause time (PSTN)	10 to 9,999 msec

■ PULSE

Item/Parameter No.	Function	Setting range
FORM	Pulse digit format	0: DP (N) 1: DP (N+1) 2: DP (10-N)

Item/Parameter No.	Function	Setting range
001	Not in use	-
002	Not in use	-
003	Pulse dial make ratio	10 to 90%
004	Minimum pause time	10 to 9,999 msec

■ DIAL TONE

Bit Switch

Bit No.	Function	1	0
Bit 0	-	-	-
Bit 1	Cadence pattern check	Not detected	Detected
Bit 2	Signal frequency	Changed	Not changed
Bit 3	-	-	-
Bit 4	Judgment of intermittent signal	start from valid ON signal	start from either valid ON signal or OFF signal
Bit 5	-	-	-
Bit 6	Signal form	Continuous	Intermittent
Bit 7	Signal detection	Detected	Not detected

Numeric value parameter

Parameter No.	Function	Setting range
001	T0 timer	0 to 9,999 (x 10 msec)
002	T1 timer	0 to 9,999 (x 10 msec)
003	T2 timer	0 to 9,999 (x 10 msec)
004	T3 timer	0 to 9,999 (x 10 msec)
005	T4 timer	0 to 9,999 (x 10 msec)
006	Signal detection table	0 to 16
007	Signal detection level	0 to 7
008	Number of signal frequency	0 to 9,999

■ 2ND DLTN (2nd DIAL TONE)

Not in use

■ BUSY TONE 0

Bit Switch

Bit No.	Function	1	0
Bit 0	-	-	-
Bit 1	-	-	-
Bit 2	-	-	-
Bit 3	-	-	-
Bit 4	-	-	-
Bit 5	-	-	-
Bit 6	-	-	-
Bit 7	Signal detection	Detected	Not detected

Numeric value parameter

Not in use

■ BUSY TONE 1

Bit Switch

Bit No.	Function	1	0
Bit 0	-	-	-
Bit 1	-	-	-
Bit 2	-	-	-
Bit 3	-	-	-
Bit 4	-	-	-
Bit 5	-	-	-
Bit 6	-	-	-
Bit 7	Signal detection	Detected	Not detected

Numeric value parameter

Parameter No.	Function	Setting range
001	-	-
002	T1 timer	0 to 9,999 (x 10 msec)
003	T2 timer	0 to 9,999 (x 10 msec)
004	T3 timer	0 to 9,999 (x 10 msec)
005	T4 timer	0 to 9,999 (x 10 msec)
006	Signal detection table	0 to 16
007	Signal detection level	0 to 7
008	Number of signal frequency	0 to 9,999

■ REORDER TONE

Bit Switch

Bit No.	Function	1	0
Bit 0	-	-	-
Bit 1	-	-	-
Bit 2	-	-	-
Bit 3	-	-	-
Bit 4	-	-	-
Bit 5	-	-	-
Bit 6	-	-	-
Bit 7	Signal detection	Detected	Not detected

Numeric value parameter

Parameter No.	Function	Setting range
001	-	-
002	T1 timer	0 to 9,999 (x 10 msec)
003	T2 timer	0 to 9,999 (x 10 msec)
004	T3 timer	0 to 9,999 (x 10 msec)
005	T4 timer	0 to 9,999 (x 10 msec)
006	Signal detection table	0 to 21
007	Signal detection level	0 to 7
008	Number of signal frequency	0 to 9,999

■ AUTO RX

Numeric value parameter

Parameter No.	Function	Setting range
001	CI ON time	0 to 9,999 (x 10 msec)
002	CI LONG ON time	0 to 9,999 (x 10 msec)
003	CI OFF time	0 to 9,999 (x 10 msec)
004	CI LONG OFF time	0 to 9,999 (x 10 msec)
005	CI MAX OFF time	0 to 9,999 (x 10 msec)
006	CI WAIT time	0 to 9,999 (x 10 msec)
007	CI frequency	0 to 9,999 cycle
008	CI frequency lower limit	0 to 9,999 Hz
009	CI frequency upper limit	0 to 9,999 Hz

■ CNG DETECT

Numeric value parameter

Parameter No.	Description		Setting range
001	At F/T switching	CNG MIN ON time	0 to 9,999 (x 10 msec)
002		CNG MAX ON time	0 to 9,999 (x 10 msec)
003		Not in use	-
004		Not in use	-
005		Not in use	-
006		-	-
007	At direct connecting to answering phone	CNG MIN ON time	0 to 9,999 (x 10 msec)
008		CNG MAX ON time	0 to 9,999 (x 10 msec)
009		Tolerable time of instantaneous interruption	0 to 9,999 (x 10 msec)
010		Not in use	-
011		Number of detection	0 to 9,999 times
012		Hit ratio	0 to 9,999%

■ SPECIALB

Not in use

■ SPECIALN

Not in use

■ RKEY

Numeric value parameter

Parameter No.	Function	Setting range
001	Connection time of flash	0 to 9,999 (x 10 msec)
002	Connection time of grounding wire	0 to 9,999 (x 10 msec)

■ PBXDIALT (PBX DIAL TONE)

Not in use

■ PBXBUSYT (PBX BUSY TONE)

Not in use

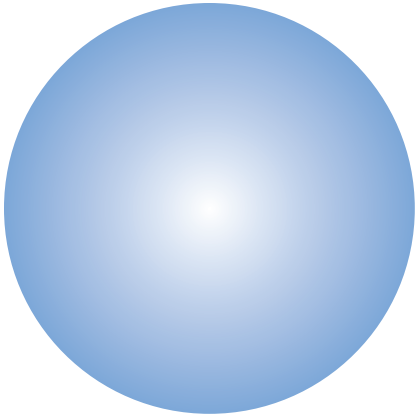

APPENDICES

Service Tools.....	357
General Circuit Diagram.....	358
List of Items Which Can Be Imported	361
Backup Data List.....	378
Soft counter specifications.....	380

Service Tools

Special Tools

- No special tools are required when servicing the machine.

Solvents and Oil List

No.	Type	Purpose	Remark
1	Ethyl alcohol	<ul style="list-style-type: none">• Cleaning: metal part, oil stains, toner stains	<ul style="list-style-type: none">• Purchase locally• Keep away from flame

General Circuit Diagram

General Circuit Diagram (1)

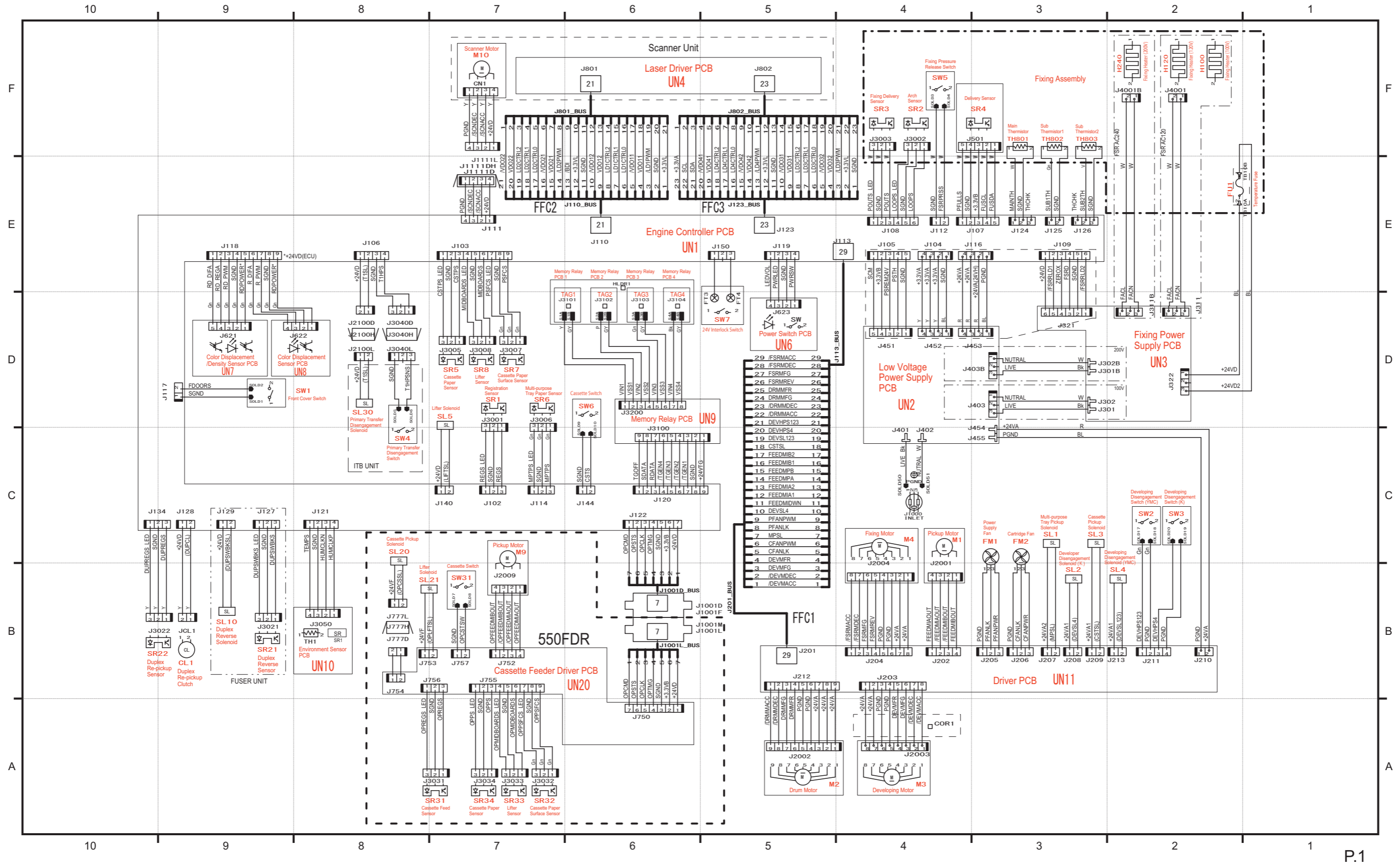

General Circuit Diagram (2)

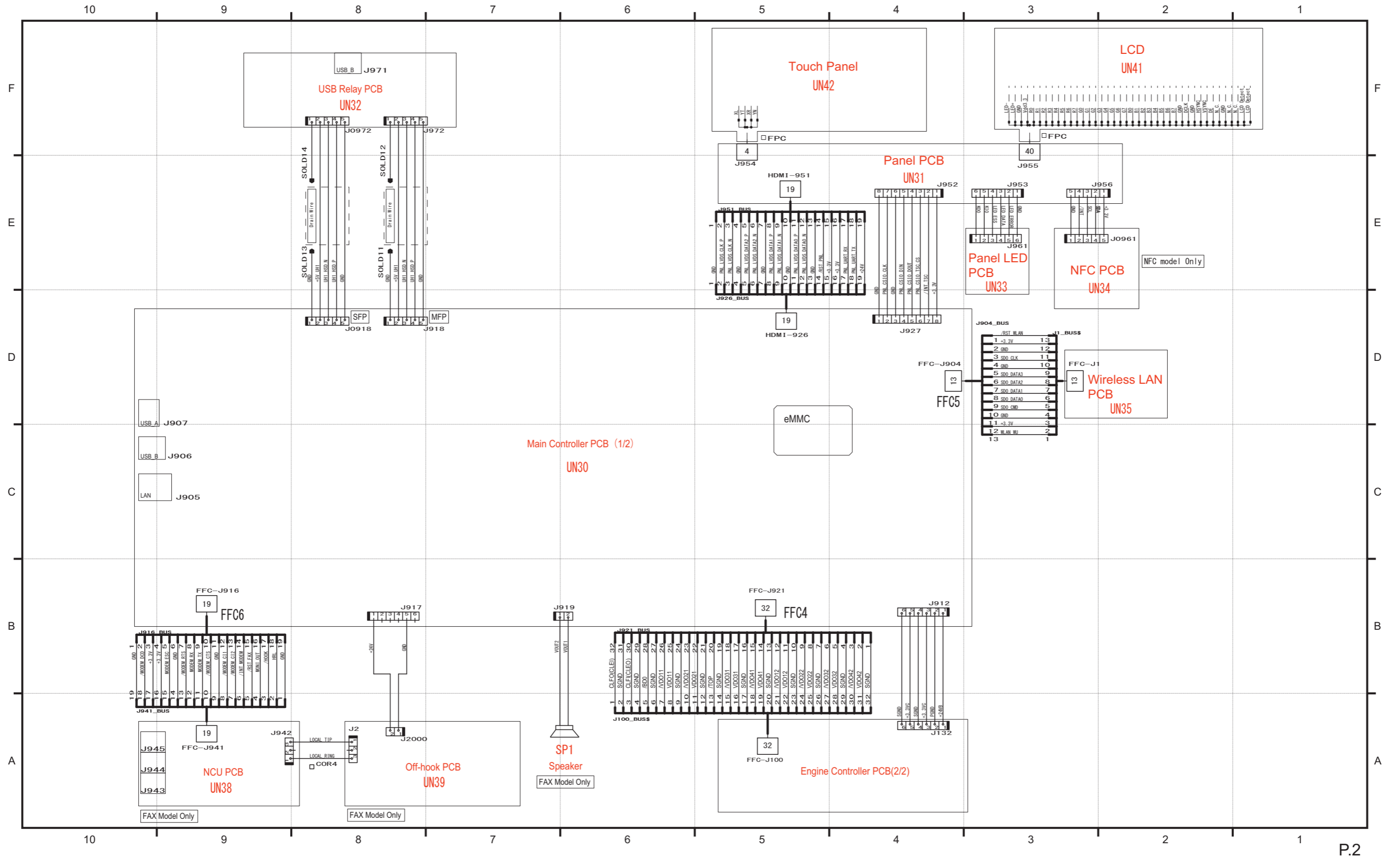

General Circuit Diagram (3)

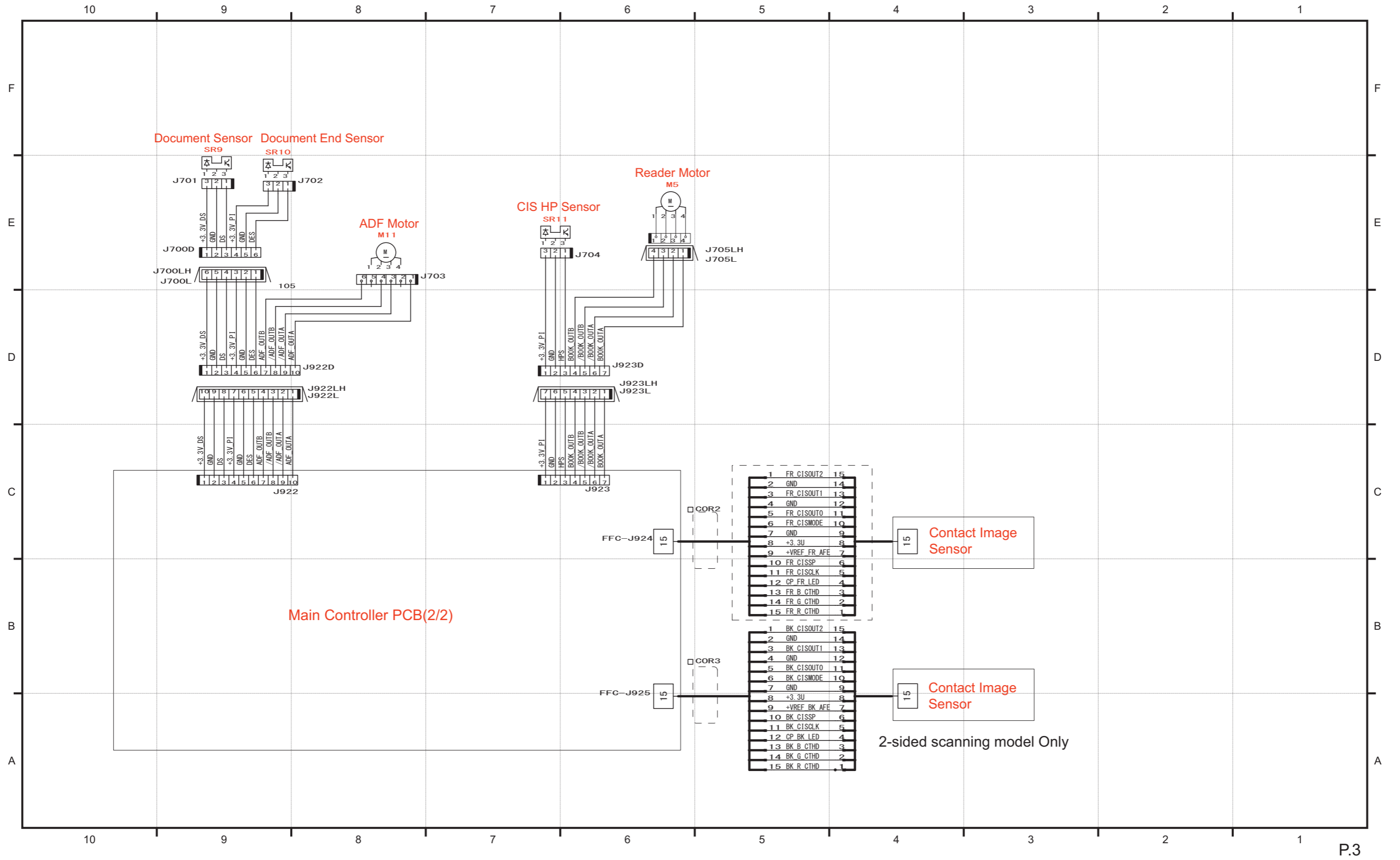

List of Items Which Can Be Imported

The following shows items to be imported for this function.

Note that the setting values are not imported in cases such as below:

- Items which are originally not included in a DCM file (e.g.: "Settings/Registration Basic Information" of a DCM file exported using service mode)
- Not included in the import coverage (Cases A to C)
- There are no options and functions related to setting values

The import coverage shown in the table below is as shown below. Those that are not described here cannot be imported.

Import coverage	Description
Case A: The same machine	Import to the same machine (for backup and restoration, etc.)
Case B: The same model	Import to a different machine of the same model (the same series)
Case C: Different model	Import to a different machine of a different model (a different series)

NOTE:

This list is the common list for this function.

Therefore, this list may contain some items that are not supported by this function.

Service Mode

No.	Initial screen	Large	Middle	Small	Case A	Case B	Case C
1	COPIER	ADJUST	IMG-REG	REG-H-Y	Yes	-	-
2	COPIER	ADJUST	IMG-REG	REG-H-C	Yes	-	-
3	COPIER	ADJUST	IMG-REG	REG-H-K	Yes	-	-
4	COPIER	ADJUST	IMG-REG	REG-HS-Y	Yes	-	-
5	COPIER	ADJUST	IMG-REG	REG-HS-C	Yes	-	-
6	COPIER	ADJUST	IMG-REG	REG-HS-K	Yes	-	-
7	COPIER	ADJUST	IMG-REG	REG-V-Y	Yes	-	-
8	COPIER	ADJUST	IMG-REG	REG-V-C	Yes	-	-
9	COPIER	ADJUST	IMG-REG	REG-V-K	Yes	-	-
10	COPIER	ADJUST	IMG-REG	REG-H-M	Yes	-	-
11	COPIER	ADJUST	IMG-REG	REG-V-M	Yes	-	-
12	COPIER	ADJUST	IMG-REG	REG-HS-M	Yes	-	-
13	COPIER	ADJUST	IMG-REG	BEND-Y	Yes	-	-
14	COPIER	ADJUST	IMG-REG	BEND-M	Yes	-	-
15	COPIER	ADJUST	IMG-REG	BEND-K	Yes	-	-
16	COPIER	ADJUST	IMG-REG	LSR-V-M1	Yes	-	-
17	COPIER	ADJUST	IMG-REG	LSR-V-M2	Yes	-	-
18	COPIER	ADJUST	IMG-REG	LSR-V-C1	Yes	-	-
19	COPIER	ADJUST	IMG-REG	LSR-V-C2	Yes	-	-
20	COPIER	ADJUST	IMG-REG	LSR-V-K1	Yes	-	-
21	COPIER	ADJUST	IMG-REG	LSR-V-K2	Yes	-	-
22	COPIER	ADJUST	IMG-REG	ITBDRBL1	Yes	-	-
23	COPIER	ADJUST	IMG-REG	BEND-C	Yes	-	-
24	COPIER	ADJUST	IMG-REG	SLOP-Y	Yes	-	-
25	COPIER	ADJUST	IMG-REG	MAGV-C1	Yes	-	-
26	COPIER	ADJUST	IMG-REG	MAGV-C2	Yes	-	-
27	COPIER	ADJUST	IMG-REG	MAGV-MF1	Yes	-	-
28	COPIER	ADJUST	IMG-REG	MAGV-MF2	Yes	-	-
29	COPIER	ADJUST	IMG-REG	MAGV-DU1	Yes	-	-
30	COPIER	ADJUST	IMG-REG	MAGV-DU2	Yes	-	-
31	COPIER	ADJUST	DENS	SGNL-Y	Yes	-	-
32	COPIER	ADJUST	DENS	SGNL-M	Yes	-	-

No.	Initial screen	Large	Middle	Small	Case A	Case B	Case C
33	COPIER	ADJUST	DENS	SGNL-C	Yes	-	-
34	COPIER	ADJUST	DENS	SGNL-K	Yes	-	-
35	COPIER	ADJUST	DENS	HLMT-PTY	Yes	-	-
36	COPIER	ADJUST	DENS	HLMT-PTM	Yes	-	-
37	COPIER	ADJUST	DENS	HLMT-PTC	Yes	-	-
38	COPIER	ADJUST	DENS	LLMT-PTY	Yes	-	-
39	COPIER	ADJUST	DENS	LLMT-PTM	Yes	-	-
40	COPIER	ADJUST	DENS	LLMT-PTC	Yes	-	-
41	COPIER	ADJUST	DENS	T-SPLY-Y	Yes	-	-
42	COPIER	ADJUST	DENS	T-SPLY-M	Yes	-	-
43	COPIER	ADJUST	DENS	T-SPLY-C	Yes	-	-
44	COPIER	ADJUST	DENS	T-SPLY-K	Yes	-	-
45	COPIER	ADJUST	DENS	DMAX-Y	Yes	-	-
46	COPIER	ADJUST	DENS	DMAX-M	Yes	-	-
47	COPIER	ADJUST	DENS	DMAX-C	Yes	-	-
48	COPIER	ADJUST	DENS	P-TG-Y	Yes	-	-
49	COPIER	ADJUST	DENS	P-TG-M	Yes	-	-
50	COPIER	ADJUST	DENS	P-TG-C	Yes	-	-
51	COPIER	ADJUST	DENS	P-TG-K	Yes	-	-
52	COPIER	ADJUST	DENS	DMAX-K	Yes	-	-
53	COPIER	ADJUST	DENS	HLMT-PTK	Yes	-	-
54	COPIER	ADJUST	DENS	LLMT-PTK	Yes	-	-
55	COPIER	ADJUST	DENS	CONT-C	Yes	-	-
56	COPIER	ADJUST	DENS	CONT-K	Yes	-	-
57	COPIER	ADJUST	DENS	CONT-M	Yes	-	-
58	COPIER	ADJUST	DENS	CONT-Y	Yes	-	-
59	COPIER	ADJUST	DENS	PALPHA-F	Yes	-	-
60	COPIER	ADJUST	DENS	PALPHA-R	Yes	-	-
61	COPIER	ADJUST	DENS	REF-C	Yes	-	-
62	COPIER	ADJUST	DENS	REF-K	Yes	-	-
63	COPIER	ADJUST	DENS	REF-M	Yes	-	-
64	COPIER	ADJUST	DENS	REF-Y	Yes	-	-
65	COPIER	ADJUST	DENS	SGNL-C	Yes	-	-
66	COPIER	ADJUST	DENS	SGNL-K	Yes	-	-
67	COPIER	ADJUST	DENS	SGNL-M	Yes	-	-
68	COPIER	ADJUST	DENS	SGNL-Y	Yes	-	-
69	COPIER	ADJUST	DENS	T-SPLY-C	Yes	-	-
70	COPIER	ADJUST	DENS	T-SPLY-K	Yes	-	-
71	COPIER	ADJUST	DENS	T-SPLY-M	Yes	-	-
72	COPIER	ADJUST	DENS	T-SPLY-Y	Yes	-	-
73	COPIER	ADJUST	DENS	POFST-F1	Yes	-	-
74	COPIER	ADJUST	DENS	POFST-R1	Yes	-	-
75	COPIER	ADJUST	DENS	SOFST-F1	Yes	-	-
76	COPIER	ADJUST	DENS	SOFST-R1	Yes	-	-
77	COPIER	ADJUST	DENS	POFST-F2	Yes	-	-
78	COPIER	ADJUST	DENS	POFST-R2	Yes	-	-
79	COPIER	ADJUST	DENS	SOFST-F2	Yes	-	-
80	COPIER	ADJUST	DENS	SOFST-R2	Yes	-	-
81	COPIER	ADJUST	EXP-LED	INTEXP-C	Yes	-	-
82	COPIER	ADJUST	EXP-LED	INTEXP-K	Yes	-	-
83	COPIER	ADJUST	EXP-LED	INTEXP-M	Yes	-	-
84	COPIER	ADJUST	EXP-LED	INTEXP-Y	Yes	-	-
85	COPIER	ADJUST	V-CONT	VCONT-Y	Yes	-	-
86	COPIER	ADJUST	V-CONT	VCONT-M	Yes	-	-

No.	Initial screen	Large	Middle	Small	Case A	Case B	Case C
87	COPIER	ADJUST	V-CONT	VCONT-C	Yes	-	-
88	COPIER	ADJUST	V-CONT	VCONT-K	Yes	-	-
89	COPIER	ADJUST	V-CONT	VBACK-Y	Yes	-	-
90	COPIER	ADJUST	V-CONT	VBACK-M	Yes	-	-
91	COPIER	ADJUST	V-CONT	VBACK-C	Yes	-	-
92	COPIER	ADJUST	V-CONT	VBACK-K	Yes	-	-
93	COPIER	ADJUST	V-CONT	VBACK2-Y	Yes	-	-
94	COPIER	ADJUST	V-CONT	VBACK2-M	Yes	-	-
95	COPIER	ADJUST	V-CONT	VBACK2-C	Yes	-	-
96	COPIER	ADJUST	V-CONT	VBACK2-K	Yes	-	-
97	COPIER	ADJUST	V-CONT	VBACK3-Y	Yes	-	-
98	COPIER	ADJUST	V-CONT	VBACK3-M	Yes	-	-
99	COPIER	ADJUST	V-CONT	VBACK3-C	Yes	-	-
100	COPIER	ADJUST	V-CONT	VBACK3-K	Yes	-	-
101	COPIER	ADJUST	HV-PRI	LSUB-YDC	Yes	-	-
102	COPIER	ADJUST	HV-PRI	OFST1-DC	Yes	-	-
103	COPIER	ADJUST	HV-PRI	OFST1-AC	Yes	-	-
104	COPIER	ADJUST	HV-TR	1TR-TGY	Yes	-	-
105	COPIER	ADJUST	HV-TR	1TR-TGM	Yes	-	-
106	COPIER	ADJUST	HV-TR	1TR-TGC	Yes	-	-
107	COPIER	ADJUST	HV-TR	1TR-TGK1	Yes	-	-
108	COPIER	ADJUST	HV-TR	1TR-TGK4	Yes	-	-
109	COPIER	ADJUST	HV-TR	2TR-OFF	Yes	-	-
110	COPIER	ADJUST	HV-TR	1TR-TGY2	Yes	-	-
111	COPIER	ADJUST	HV-TR	1TR-TGM2	Yes	-	-
112	COPIER	ADJUST	HV-TR	1TR-TGC2	Yes	-	-
113	COPIER	ADJUST	HV-TR	1TR-TK12	Yes	-	-
114	COPIER	ADJUST	HV-TR	1TR-TGY3	Yes	-	-
115	COPIER	ADJUST	HV-TR	1TR-TGM3	Yes	-	-
116	COPIER	ADJUST	HV-TR	1TR-TGC3	Yes	-	-
117	COPIER	ADJUST	HV-TR	1TR-TK13	Yes	-	-
118	COPIER	ADJUST	HV-TR	1TR-TK42	Yes	-	-
119	COPIER	ADJUST	HV-TR	1TR-TK43	Yes	-	-
120	COPIER	ADJUST	HV-TR	2TR-N1-1	Yes	-	-
121	COPIER	ADJUST	HV-TR	2TR-N1-2	Yes	-	-
122	COPIER	ADJUST	HV-TR	2TR-N2-1	Yes	-	-
123	COPIER	ADJUST	HV-TR	2TR-N2-2	Yes	-	-
124	COPIER	ADJUST	HV-TR	2TR-N3-1	Yes	-	-
125	COPIER	ADJUST	HV-TR	2TR-N3-2	Yes	-	-
126	COPIER	ADJUST	HV-TR	2TR-R1-1	Yes	-	-
127	COPIER	ADJUST	HV-TR	2TR-R1-2	Yes	-	-
128	COPIER	ADJUST	HV-TR	2TR-R2-1	Yes	-	-
129	COPIER	ADJUST	HV-TR	2TR-R2-2	Yes	-	-
130	COPIER	ADJUST	HV-TR	2TR-R3-1	Yes	-	-
131	COPIER	ADJUST	HV-TR	2TR-R3-2	Yes	-	-
132	COPIER	ADJUST	HV-TR	2TR-H1-1	Yes	-	-
133	COPIER	ADJUST	HV-TR	2TR-H1-2	Yes	-	-
134	COPIER	ADJUST	HV-TR	2TR-H2-1	Yes	-	-
135	COPIER	ADJUST	HV-TR	2TR-H2-2	Yes	-	-
136	COPIER	ADJUST	HV-TR	2TR-H3-1	Yes	-	-
137	COPIER	ADJUST	HV-TR	2TR-H3-2	Yes	-	-
138	COPIER	ADJUST	HV-TR	2TR-C1-1	Yes	-	-
139	COPIER	ADJUST	HV-TR	2TR-C1-2	Yes	-	-
140	COPIER	ADJUST	HV-TR	2TR-C2-1	Yes	-	-

No.	Initial screen	Large	Middle	Small	Case A	Case B	Case C
141	COPIER	ADJUST	HV-TR	2TR-C2-2	Yes	-	-
142	COPIER	ADJUST	HV-TR	2TR-CP-1	Yes	-	-
143	COPIER	ADJUST	HV-TR	2TR-CP-2	Yes	-	-
144	COPIER	ADJUST	HV-TR	2TR-O-1	Yes	-	-
145	COPIER	ADJUST	HV-TR	2TR-LA-1	Yes	-	-
146	COPIER	ADJUST	HV-TR	2TR-LA-2	Yes	-	-
147	COPIER	ADJUST	HV-TR	2TR-NC-1	Yes	-	-
148	COPIER	ADJUST	HV-TR	2TR-NC-2	Yes	-	-
149	COPIER	ADJUST	HV-TR	2TR-B-1	Yes	-	-
150	COPIER	ADJUST	HV-TR	2TR-B-2	Yes	-	-
151	COPIER	ADJUST	HV-TR	2TR-PA-1	Yes	-	-
152	COPIER	ADJUST	HV-TR	2TR-PA-2	Yes	-	-
153	COPIER	ADJUST	HV-TR	2TR-EN-1	Yes	-	-
154	COPIER	ADJUST	HV-TR	2TR-EN-2	Yes	-	-
155	COPIER	ADJUST	HV-TR	2TR-P-1	Yes	-	-
156	COPIER	ADJUST	HV-TR	2TR-P-2	Yes	-	-
157	COPIER	ADJUST	HV-TR	T2TR-N1	Yes	-	-
158	COPIER	ADJUST	HV-TR	T2TR-N2	Yes	-	-
159	COPIER	ADJUST	HV-TR	T2TR-N3	Yes	-	-
160	COPIER	ADJUST	HV-TR	T2TR-R1	Yes	-	-
161	COPIER	ADJUST	HV-TR	T2TR-R2	Yes	-	-
162	COPIER	ADJUST	HV-TR	T2TR-R3	Yes	-	-
163	COPIER	ADJUST	HV-TR	T2TR-H1	Yes	-	-
164	COPIER	ADJUST	HV-TR	T2TR-H2	Yes	-	-
165	COPIER	ADJUST	HV-TR	T2TR-H3	Yes	-	-
166	COPIER	ADJUST	HV-TR	T2TR-C1	Yes	-	-
167	COPIER	ADJUST	HV-TR	T2TR-C2	Yes	-	-
168	COPIER	ADJUST	HV-TR	T2TR-P	Yes	-	-
169	COPIER	ADJUST	HV-TR	T2TR-LNG	Yes	-	-
170	COPIER	ADJUST	HV-TR	2TR-TH-1	Yes	-	-
171	COPIER	ADJUST	HV-TR	2TR-TH-2	Yes	-	-
172	COPIER	ADJUST	HV-TR	T2TR-TH	Yes	-	-
173	COPIER	ADJUST	HV-TR	1ATVCTMG	Yes	-	-
174	COPIER	ADJUST	HV-TR	TR-DUP1	Yes	-	-
175	COPIER	ADJUST	HV-TR	TR-DUP10	Yes	-	-
176	COPIER	ADJUST	HV-TR	TR-DUP11	Yes	-	-
177	COPIER	ADJUST	HV-TR	TR-DUP12	Yes	-	-
178	COPIER	ADJUST	HV-TR	TR-DUP13	Yes	-	-
179	COPIER	ADJUST	HV-TR	TR-DUP14	Yes	-	-
180	COPIER	ADJUST	HV-TR	TR-DUP15	Yes	-	-
181	COPIER	ADJUST	HV-TR	TR-DUP16	Yes	-	-
182	COPIER	ADJUST	HV-TR	TR-DUP2	Yes	-	-
183	COPIER	ADJUST	HV-TR	TR-DUP3	Yes	-	-
184	COPIER	ADJUST	HV-TR	TR-DUP4	Yes	-	-
185	COPIER	ADJUST	HV-TR	TR-DUP5	Yes	-	-
186	COPIER	ADJUST	HV-TR	TR-DUP6	Yes	-	-
187	COPIER	ADJUST	HV-TR	TR-DUP7	Yes	-	-
188	COPIER	ADJUST	HV-TR	TR-DUP8	Yes	-	-
189	COPIER	ADJUST	HV-TR	TR-DUP9	Yes	-	-
190	COPIER	ADJUST	HV-TR	TR-ENV1	Yes	-	-
191	COPIER	ADJUST	HV-TR	TR-ENV10	Yes	-	-
192	COPIER	ADJUST	HV-TR	TR-ENV11	Yes	-	-
193	COPIER	ADJUST	HV-TR	TR-ENV12	Yes	-	-
194	COPIER	ADJUST	HV-TR	TR-ENV13	Yes	-	-

No.	Initial screen	Large	Middle	Small	Case A	Case B	Case C
195	COPIER	ADJUST	HV-TR	TR-ENV14	Yes	-	-
196	COPIER	ADJUST	HV-TR	TR-ENV15	Yes	-	-
197	COPIER	ADJUST	HV-TR	TR-ENV16	Yes	-	-
198	COPIER	ADJUST	HV-TR	TR-ENV2	Yes	-	-
199	COPIER	ADJUST	HV-TR	TR-ENV3	Yes	-	-
200	COPIER	ADJUST	HV-TR	TR-ENV4	Yes	-	-
201	COPIER	ADJUST	HV-TR	TR-ENV5	Yes	-	-
202	COPIER	ADJUST	HV-TR	TR-ENV6	Yes	-	-
203	COPIER	ADJUST	HV-TR	TR-ENV7	Yes	-	-
204	COPIER	ADJUST	HV-TR	TR-ENV8	Yes	-	-
205	COPIER	ADJUST	HV-TR	TR-ENV9	Yes	-	-
206	COPIER	ADJUST	HV-TR	TR-PPR1	Yes	-	-
207	COPIER	ADJUST	HV-TR	TR-PPR10	Yes	-	-
208	COPIER	ADJUST	HV-TR	TR-PPR11	Yes	-	-
209	COPIER	ADJUST	HV-TR	TR-PPR12	Yes	-	-
210	COPIER	ADJUST	HV-TR	TR-PPR13	Yes	-	-
211	COPIER	ADJUST	HV-TR	TR-PPR14	Yes	-	-
212	COPIER	ADJUST	HV-TR	TR-PPR15	Yes	-	-
213	COPIER	ADJUST	HV-TR	TR-PPR16	Yes	-	-
214	COPIER	ADJUST	HV-TR	TR-PPR2	Yes	-	-
215	COPIER	ADJUST	HV-TR	TR-PPR3	Yes	-	-
216	COPIER	ADJUST	HV-TR	TR-PPR4	Yes	-	-
217	COPIER	ADJUST	HV-TR	TR-PPR5	Yes	-	-
218	COPIER	ADJUST	HV-TR	TR-PPR6	Yes	-	-
219	COPIER	ADJUST	HV-TR	TR-PPR7	Yes	-	-
220	COPIER	ADJUST	HV-TR	TR-PPR8	Yes	-	-
221	COPIER	ADJUST	HV-TR	TR-PPR9	Yes	-	-
222	COPIER	ADJUST	FEED-ADJ	REGIST	Yes	-	-
223	COPIER	ADJUST	FEED-ADJ	ADJ-C1	Yes	-	-
224	COPIER	ADJUST	FEED-ADJ	ADJ-C1	Yes	-	-
225	COPIER	ADJUST	FEED-ADJ	ADJ-C2	Yes	-	-
226	COPIER	ADJUST	FEED-ADJ	ADJ-C2	Yes	-	-
227	COPIER	ADJUST	FEED-ADJ	ADJ-C3	Yes	-	-
228	COPIER	ADJUST	FEED-ADJ	ADJ-C4	Yes	-	-
229	COPIER	ADJUST	FEED-ADJ	ADJ-MF	Yes	-	-
230	COPIER	ADJUST	FEED-ADJ	ADJ-MF	Yes	-	-
231	COPIER	ADJUST	FEED-ADJ	ADJ-C1RE	Yes	-	-
232	COPIER	ADJUST	FEED-ADJ	ADJ-C2RE	Yes	-	-
233	COPIER	ADJUST	FEED-ADJ	ADJ-C3RE	Yes	-	-
234	COPIER	ADJUST	FEED-ADJ	ADJ-C4RE	Yes	-	-
235	COPIER	ADJUST	FEED-ADJ	ADJ-MFRE	Yes	-	-
236	COPIER	ADJUST	FEED-ADJ	ADJ-REFE	Yes	-	-
237	COPIER	ADJUST	FEED-ADJ	REG-THCK	Yes	-	-
238	COPIER	ADJUST	FEED-ADJ	REG-DUP1	Yes	-	-
239	COPIER	ADJUST	FEED-ADJ	REG-DUP2	Yes	-	-
240	COPIER	ADJUST	FEED-ADJ	LP-FEED1	Yes	-	-
241	COPIER	ADJUST	FEED-ADJ	LP-FEED2	Yes	-	-
242	COPIER	ADJUST	FEED-ADJ	REG-SPD	Yes	-	-
243	COPIER	ADJUST	FEED-ADJ	REG-LEFT	Yes	-	-
244	COPIER	ADJUST	FEED-ADJ	REG-MF	Yes	-	-
245	COPIER	ADJUST	FEED-ADJ	REG-MF	Yes	-	-
246	COPIER	ADJUST	FEED-ADJ	REG-MFH1	Yes	-	-
247	COPIER	ADJUST	FEED-ADJ	REG-MFH2	Yes	-	-
248	COPIER	ADJUST	FEED-ADJ	REG-N3	Yes	-	-

No.	Initial screen	Large	Middle	Small	Case A	Case B	Case C
249	COPIER	ADJUST	FEED-ADJ	REG-DUP3	Yes	-	-
250	COPIER	ADJUST	FEED-ADJ	LP-FEED3	Yes	-	-
251	COPIER	ADJUST	FEED-ADJ	REG-MENV	Yes	-	-
252	COPIER	ADJUST	FEED-ADJ	REG-ENV	Yes	-	-
253	COPIER	ADJUST	FEED-ADJ	REG-MFPC	Yes	-	-
254	COPIER	ADJUST	FEED-ADJ	ADJ-ENV	Yes	-	-
255	COPIER	ADJUST	FEED-ADJ	REG-CST	Yes	-	-
256	COPIER	ADJUST	FEED-ADJ	REG-CST2	Yes	-	-
257	COPIER	ADJUST	FEED-ADJ	REG-DUP	Yes	-	-
258	COPIER	ADJUST	FEED-ADJ	REG-MF2	Yes	-	-
259	COPIER	ADJUST	FEED-ADJ	REG-DUP4	Yes	-	-
260	COPIER	ADJUST	FEED-ADJ	LOOP-CST	Yes	-	-
261	COPIER	ADJUST	FEED-ADJ	LOOP-MF	Yes	-	-
262	COPIER	ADJUST	FEED-ADJ	LOOP-OP	Yes	-	-
263	COPIER	ADJUST	FEED-ADJ	LOOP-DU	Yes	-	-
264	COPIER	ADJUST	FEED-ADJ	LOOP-THK	Yes	-	-
265	COPIER	ADJUST	FEED-ADJ	EXT-SPD	Yes	-	-
266	COPIER	ADJUST	FEED-ADJ	ADJ-C1	Yes	-	-
267	COPIER	ADJUST	FEED-ADJ	ADJ-C2	Yes	-	-
268	COPIER	ADJUST	FEED-ADJ	ADJ-MF	Yes	-	-
269	COPIER	ADJUST	FEED-ADJ	ADJ-REFE	Yes	-	-
270	COPIER	ADJUST	FEED-ADJ	ADJ-MFY	Yes	-	-
271	COPIER	ADJUST	FEED-ADJ	ADJ-MFX	Yes	-	-
272	COPIER	ADJUST	FEED-ADJ	ADJ-MFYR	Yes	-	-
273	COPIER	ADJUST	FEED-ADJ	ADJ-MFXR	Yes	-	-
274	COPIER	ADJUST	FEED-ADJ	ADJ-C1Y	Yes	-	-
275	COPIER	ADJUST	FEED-ADJ	ADJ-C1X	Yes	-	-
276	COPIER	ADJUST	FEED-ADJ	ADJ-C1YR	Yes	-	-
277	COPIER	ADJUST	FEED-ADJ	ADJ-C1XR	Yes	-	-
278	COPIER	ADJUST	FEED-ADJ	ADJ-C2Y	Yes	-	-
279	COPIER	ADJUST	FEED-ADJ	ADJ-C2X	Yes	-	-
280	COPIER	ADJUST	FEED-ADJ	ADJ-C2YR	Yes	-	-
281	COPIER	ADJUST	FEED-ADJ	ADJ-C2XR	Yes	-	-
282	COPIER	ADJUST	CST-ADJ	MF-MAX	Yes	-	-
283	COPIER	ADJUST	CST-ADJ	MF-MIN	Yes	-	-
284	COPIER	ADJUST	CST-ADJ	CST-VLM1	Yes	-	-
285	COPIER	ADJUST	CST-ADJ	CST-VLM2	Yes	-	-
286	COPIER	ADJUST	CST-ADJ	CST-VLM3	Yes	-	-
287	COPIER	ADJUST	CST-ADJ	CST-VLM4	Yes	-	-
288	COPIER	ADJUST	BLANK	BLANK-T	Yes	-	-
289	COPIER	ADJUST	BLANK	BLANK-B	Yes	-	-
290	COPIER	ADJUST	BLANK	BLANK-L	Yes	-	-
291	COPIER	ADJUST	BLANK	BLANK-R	Yes	-	-
292	COPIER	ADJUST	BLANK	BLANK-B2	Yes	-	-
293	COPIER	ADJUST	MISC	ACS-ADJ	Yes	Yes	Yes
294	COPIER	ADJUST	MISC	ACS-EN	Yes	Yes	Yes
295	COPIER	ADJUST	MISC	ACS-CNT	Yes	Yes	Yes
296	COPIER	ADJUST	MISC	ACS-EN2	Yes	Yes	Yes
297	COPIER	ADJUST	MISC	ACS-CNT2	Yes	Yes	Yes
298	COPIER	ADJUST	VIFADJ	DEV-HV-Y	Yes	-	-
299	COPIER	ADJUST	VIFADJ	DEV-HV-M	Yes	-	-
300	COPIER	ADJUST	VIFADJ	DEV-HV-C	Yes	-	-
301	COPIER	ADJUST	VIFADJ	DEV-HV-K	Yes	-	-
302	COPIER	ADJUST	VIFADJ	TR1-HV-Y	Yes	-	-

No.	Initial screen	Large	Middle	Small	Case A	Case B	Case C
303	COPIER	ADJUST	VIFADJ	TR1-HV-M	Yes	-	-
304	COPIER	ADJUST	VIFADJ	TR1-HV-C	Yes	-	-
305	COPIER	ADJUST	VIFADJ	TR1-HV-K	Yes	-	-
306	COPIER	ADJUST	VIFADJ	TR2SF-HV	Yes	-	-
307	COPIER	ADJUST	VIFADJ	TR2BK-HV	Yes	-	-
308	COPIER	ADJUST	VIFADJ	ICL-HV	Yes	-	-
309	COPIER	ADJUST	VIFADJ	FU-TMP	Yes	-	-
310	COPIER	ADJUST	SCNR	SUB-S-Y0	Yes	-	-
311	COPIER	ADJUST	SCNR	SUB-S-M0	Yes	-	-
312	COPIER	ADJUST	SCNR	SUB-S-C0	Yes	-	-
313	COPIER	ADJUST	SCNR	SUB-S-K0	Yes	-	-
314	COPIER	ADJUST	SCNR	SUB-S-Y1	Yes	-	-
315	COPIER	ADJUST	SCNR	SUB-S-M1	Yes	-	-
316	COPIER	ADJUST	SCNR	SUB-S-C1	Yes	-	-
317	COPIER	ADJUST	SCNR	SUB-S-K1	Yes	-	-
318	COPIER	ADJUST	SCNR	SUB-S-Y2	Yes	-	-
319	COPIER	ADJUST	SCNR	SUB-S-M2	Yes	-	-
320	COPIER	ADJUST	SCNR	SUB-S-C2	Yes	-	-
321	COPIER	ADJUST	SCNR	SUB-S-K2	Yes	-	-
322	COPIER	ADJUST	SCNR	MAI-S-Y0	Yes	-	-
323	COPIER	ADJUST	SCNR	MAI-S-M0	Yes	-	-
324	COPIER	ADJUST	SCNR	MAI-S-C0	Yes	-	-
325	COPIER	ADJUST	SCNR	MAI-S-K0	Yes	-	-
326	COPIER	ADJUST	SCNR	MAI-S-Y1	Yes	-	-
327	COPIER	ADJUST	SCNR	MAI-S-M1	Yes	-	-
328	COPIER	ADJUST	SCNR	MAI-S-C1	Yes	-	-
329	COPIER	ADJUST	SCNR	MAI-S-K1	Yes	-	-
330	COPIER	ADJUST	SCNR	MAI-S-Y2	Yes	-	-
331	COPIER	ADJUST	SCNR	MAI-S-M2	Yes	-	-
332	COPIER	ADJUST	SCNR	MAI-S-C2	Yes	-	-
333	COPIER	ADJUST	SCNR	MAI-S-K2	Yes	-	-
334	COPIER	ADJUST	DEVELOP	DE-OFST	Yes	-	-
335	COPIER	FUNCTION	MISC-P	OPF-DSEQ	Yes	-	-
336	COPIER	FUNCTION	VIFFNC	SMEAR-PV	Yes	-	-
337	COPIER	FUNCTION	VIFFNC	FEED-IMP	Yes	-	-
338	COPIER	FUNCTION	VIFFNC	FOG-PV	Yes	-	-
339	COPIER	FUNCTION	VIFFNC	ICL-IMP	Yes	-	-
340	COPIER	FUNCTION	SPLMAN	SPL14159	Yes	Yes	Yes
341	COPIER	FUNCTION	SPLMAN	SPL27767	Yes	-	-
342	COPIER	FUNCTION	SPLMAN	SPL26535	Yes	-	-
343	COPIER	FUNCTION	SPLMAN	SPL89793	Yes	-	-
344	COPIER	FUNCTION	SPLMAN	SPL23846	Yes	-	-
345	COPIER	FUNCTION	SPLMAN	SPL26433	Yes	-	-
346	COPIER	FUNCTION	SPLMAN	SPL14682	Yes	-	-
347	COPIER	FUNCTION	SPLMAN	SPL83279	Yes	-	-
348	COPIER	FUNCTION	SPLMAN	SPL50288	Yes	-	-
349	COPIER	FUNCTION	SPLMAN	SPL41971	Yes	-	-
350	COPIER	FUNCTION	SPLMAN	SPL69399	Yes	-	-
351	COPIER	FUNCTION	SPLMAN	SPL35607	Yes	-	-
352	COPIER	FUNCTION	SPLMAN	SPL37510	Yes	-	-
353	COPIER	FUNCTION	SPLMAN	SPL65677	Yes	-	-
354	COPIER	FUNCTION	SPLMAN	SPL68676	Yes	-	-
355	COPIER	FUNCTION	SPLMAN	SPL68677	Yes	-	-
356	COPIER	FUNCTION	SPLMAN	SPL25607	Yes	-	-

No.	Initial screen	Large	Middle	Small	Case A	Case B	Case C
357	COPIER	FUNCTION	SPLMAN	SPL93822	Yes	Yes	Yes
358	COPIER	FUNCTION	SPLMAN	SPL78788	Yes	Yes	Yes
359	COPIER	FUNCTION	SPLMAN	SPL15176	Yes	-	-
360	COPIER	FUNCTION	SPLMAN	SPL58122	Yes	-	-
361	COPIER	FUNCTION	SPLMAN	SPL71100	Yes	-	-
362	COPIER	FUNCTION	SPLMAN	SPL00171	Yes	Yes	Yes
363	COPIER	FUNCTION	SPLMAN	SPL80100	Yes	Yes	Yes
364	COPIER	FUNCTION	SPLMAN	SPL84194	Yes	Yes	Yes
365	COPIER	FUNCTION	SPLMAN	SPL90001	Yes	-	-
366	COPIER	FUNCTION	SPLMAN	SPL90002	Yes	-	-
367	COPIER	FUNCTION	SPLMAN	SPL78148	Yes	-	-
368	COPIER	FUNCTION	INSTALL	ERDS	Yes	Yes	Yes
369	COPIER	FUNCTION	INSTALL	RGW-PORT	Yes	Yes	Yes
370	COPIER	OPTION	BODY	TMIC-BK	Yes	-	-
371	COPIER	OPTION	BODY	TMIC-CMY	Yes	-	-
372	COPIER	OPTION	BODY	MIBCOUNT	Yes	Yes	Yes
373	COPIER	OPTION	BODY	NS-CMD5	Yes	-	-
374	COPIER	OPTION	BODY	NS-PLN	Yes	-	-
375	COPIER	OPTION	BODY	NS-LGN	Yes	-	-
376	COPIER	OPTION	BODY	SLPMODE	Yes	Yes	Yes
377	COPIER	OPTION	BODY	SDTM-DSP	Yes	Yes	Yes
378	COPIER	OPTION	BODY	PASCL-TY	Yes	Yes	-
379	COPIER	OPTION	BODY	DEV-SP1	Yes	-	-
380	COPIER	OPTION	BODY	DEV-SP2	Yes	-	-
381	COPIER	OPTION	BODY	DEV-SP3	Yes	-	-
382	COPIER	OPTION	BODY	DEV-SP4	Yes	-	-
383	COPIER	OPTION	BODY	DEV-SP5	Yes	-	-
384	COPIER	OPTION	BODY	DEV-SP6	Yes	-	-
385	COPIER	OPTION	BODY	DEV-SP7	Yes	-	-
386	COPIER	OPTION	BODY	DEV-SP8	Yes	-	-
387	COPIER	OPTION	FNC-SW	DH-SW	Yes	-	-
388	COPIER	OPTION	FNC-SW	INTROT-1	Yes	-	-
389	COPIER	OPTION	FNC-SW	INTROT-2	Yes	-	-
390	COPIER	OPTION	FNC-SW	DMAX-SW	Yes	-	-
391	COPIER	OPTION	FNC-SW	BK-4CSW	Yes	-	-
392	COPIER	OPTION	FNC-SW	FXWRNLVL	Yes	-	-
393	COPIER	OPTION	FNC-SW	KSIZE-SW	Yes	Yes	-
394	COPIER	OPTION	FNC-SW	ORG-LDR	Yes	Yes	-
395	COPIER	OPTION	FNC-SW	ORG-B5	Yes	Yes	-
396	COPIER	OPTION	FNC-SW	ORG-B4	Yes	Yes	-
397	COPIER	OPTION	FNC-SW	ORG-LGL	Yes	Yes	-
398	COPIER	OPTION	FNC-SW	ORG-LTR	Yes	Yes	-
399	COPIER	OPTION	FNC-SW	ORG-LTRR	Yes	Yes	-
400	COPIER	OPTION	FNC-SW	PSCL-MS	Yes	-	-
401	COPIER	OPTION	FNC-SW	AUTO-OUT	Yes	-	-
402	COPIER	OPTION	FNC-SW	CPR-SW	Yes	-	-
403	COPIER	OPTION	FNC-SW	DMAX-DAY	Yes	-	-
404	COPIER	OPTION	FNC-SW	T-DLV-BK	Yes	-	-
405	COPIER	OPTION	FNC-SW	T-DLV-CL	Yes	-	-
406	COPIER	OPTION	FNC-SW	D-DLV-BK	Yes	-	-
407	COPIER	OPTION	FNC-SW	D-DLV-BK	Yes	-	-
408	COPIER	OPTION	FNC-SW	D-DLV-CL	Yes	-	-
409	COPIER	OPTION	FNC-SW	JM-ERR-D	Yes	-	-
410	COPIER	OPTION	FNC-SW	TNR-RS	Yes	-	-

No.	Initial screen	Large	Middle	Small	Case A	Case B	Case C
411	COPIER	OPTION	FNC-SW	TNNEWQCK	Yes	-	-
412	COPIER	OPTION	FNC-SW	R-DR-FAN	Yes	-	-
413	COPIER	OPTION	FNC-SW	PWR-FAN	Yes	-	-
414	COPIER	OPTION	FNC-SW	DLVY-FAN	Yes	-	-
415	COPIER	OPTION	FNC-SW	CRG-FANR	Yes	-	-
416	COPIER	OPTION	FNC-SW	CRG-FANF	Yes	-	-
417	COPIER	OPTION	FNC-SW	ECO-TMP	Yes	Yes	-
418	COPIER	OPTION	FNC-SW	STP-TMP	Yes	Yes	-
419	COPIER	OPTION	FNC-SW	WT-FL-LM	Yes	-	-
420	COPIER	OPTION	FNC-SW	DFAN-SPD	Yes	-	-
421	COPIER	OPTION	FNC-SW	T1CL-UP	Yes	-	-
422	COPIER	OPTION	FNC-SW	DLVFN-SW	Yes	-	-
423	COPIER	OPTION	FNC-SW	IMGCNTPR	Yes	Yes	Yes
424	COPIER	OPTION	FNC-SW	2TR-TBLS	Yes	Yes	-
425	COPIER	OPTION	FNC-SW	LCDSFLG	Yes	Yes	Yes
426	COPIER	OPTION	FNC-SW	CRG-PROC	Yes	Yes	-
427	COPIER	OPTION	FNC-SW	CRGLF-K	Yes	Yes	-
428	COPIER	OPTION	FNC-SW	CRGLF-CL	Yes	Yes	-
429	COPIER	OPTION	FNC-SW	T-END-BK	Yes	Yes	-
430	COPIER	OPTION	FNC-SW	RPT2SIDE	Yes	Yes	Yes
431	COPIER	OPTION	FNC-SW	2TR-TBLS	Yes	Yes	-
432	COPIER	OPTION	FNC-SW	BK-4CSW	Yes	-	-
433	COPIER	OPTION	FNC-SW	D-DLV-C	Yes	-	-
434	COPIER	OPTION	FNC-SW	D-DLV-M	Yes	-	-
435	COPIER	OPTION	FNC-SW	D-DLV-Y	Yes	-	-
436	COPIER	OPTION	FNC-SW	DMAX-SW	Yes	-	-
437	COPIER	OPTION	FNC-SW	DV-DLV-C	Yes	-	-
438	COPIER	OPTION	FNC-SW	DV-DLV-K	Yes	-	-
439	COPIER	OPTION	FNC-SW	DV-DLV-M	Yes	-	-
440	COPIER	OPTION	FNC-SW	DV-DLV-Y	Yes	-	-
441	COPIER	OPTION	FNC-SW	FIX-DLV	Yes	-	-
442	COPIER	OPTION	FNC-SW	INTROT-2	Yes	-	-
443	COPIER	OPTION	FNC-SW	PREXP-SW	Yes	-	-
444	COPIER	OPTION	CUSTOM	TEMP-TBL	Yes	-	-
445	COPIER	OPTION	CUSTOM	TEMP-TBL	Yes	Yes	-
446	COPIER	OPTION	CUSTOM	FAN-ROT	Yes	Yes	-
447	COPIER	OPTION	CUSTOM	DEV-SP1	Yes	-	-
448	COPIER	OPTION	CUSTOM	DEV-SP2	Yes	-	-
449	COPIER	OPTION	CUSTOM	DEV-SP3	Yes	-	-
450	COPIER	OPTION	CUSTOM	DEV-SP4	Yes	-	-
451	COPIER	OPTION	CUSTOM	DEV-SP5	Yes	-	-
452	COPIER	OPTION	CUSTOM	DEV-SP6	Yes	-	-
453	COPIER	OPTION	CUSTOM	DEV-SP7	Yes	-	-
454	COPIER	OPTION	CUSTOM	DEV-SP8	Yes	-	-
455	COPIER	OPTION	CUSTOM	EXT-TBOX	Yes	-	-
456	COPIER	OPTION	CUSTOM	FAN-POST	Yes	Yes	-
457	COPIER	OPTION	CUSTOM	FLK-RD	Yes	Yes	-
458	COPIER	OPTION	CUSTOM	DEV-SP1	Yes	-	-
459	COPIER	OPTION	CUSTOM	DEV-SP2	Yes	-	-
460	COPIER	OPTION	CUSTOM	DEV-SP3	Yes	-	-
461	COPIER	OPTION	CUSTOM	DEV-SP4	Yes	-	-
462	COPIER	OPTION	CUSTOM	DEV-SP5	Yes	-	-
463	COPIER	OPTION	CUSTOM	DEV-SP6	Yes	-	-
464	COPIER	OPTION	CUSTOM	DEV-SP7	Yes	-	-

No.	Initial screen	Large	Middle	Small	Case A	Case B	Case C
465	COPIER	OPTION	CUSTOM	DEV-SP8	Yes	-	-
466	COPIER	OPTION	IMG-DEV	AUTO-DH	Yes	-	-
467	COPIER	OPTION	IMG-DEV	DV-RT-LG	Yes	-	-
468	COPIER	OPTION	IMG-DEV	ADJ-VPP	Yes	-	-
469	COPIER	OPTION	IMG-DEV	ADJ-VPPN	Yes	-	-
470	COPIER	OPTION	IMG-DEV	DEVL-THY	Yes	-	-
471	COPIER	OPTION	IMG-DEV	DEVL-THM	Yes	-	-
472	COPIER	OPTION	IMG-DEV	DEVL-THC	Yes	-	-
473	COPIER	OPTION	IMG-DEV	DEVL-THK	Yes	-	-
474	COPIER	OPTION	IMG-DEV	TNNEWCNT	Yes	-	-
475	COPIER	OPTION	IMG-DEV	TNENDCNT	Yes	-	-
476	COPIER	OPTION	IMG-DEV	D-PTN	Yes	-	-
477	COPIER	OPTION	IMG-DEV	ADJ-VPP3	Yes	-	-
478	COPIER	OPTION	IMG-DEV	DV-RT-KP	Yes	-	-
479	COPIER	OPTION	IMG-DEV	ADJ-BLNK	Yes	-	-
480	COPIER	OPTION	IMG-DEV	AUTO-DH	Yes	-	-
481	COPIER	OPTION	IMG-DEV	DELV-DNS	Yes	-	-
482	COPIER	OPTION	IMG-DEV	DRM-IDL	Yes	Yes	Yes
483	COPIER	OPTION	IMG-DEV	TNENDCNT	Yes	-	-
484	COPIER	OPTION	IMG-DEV	DMX-OF-Y	Yes	-	-
485	COPIER	OPTION	IMG-DEV	DMX-OF-M	Yes	-	-
486	COPIER	OPTION	IMG-DEV	DMX-OF-C	Yes	-	-
487	COPIER	OPTION	IMG-DEV	DMX-OF-K	Yes	-	-
488	COPIER	OPTION	DSPLY-SW	T-LW-LVL	Yes	-	-
489	COPIER	OPTION	DSPLY-SW	DRM-WARN	Yes	-	-
490	COPIER	OPTION	DSPLY-SW	TNR-WARN	Yes	Yes	-
491	COPIER	OPTION	DSPLY-SW	WT-WARN	Yes	Yes	-
492	COPIER	OPTION	DSPLY-SW	PUMF-DSP	Yes	Yes	-
493	COPIER	OPTION	DSPLY-SW	PUC1-DSP	Yes	Yes	-
494	COPIER	OPTION	DSPLY-SW	PUC2-DSP	Yes	Yes	-
495	COPIER	OPTION	DSPLY-SW	PUC3-DSP	Yes	Yes	-
496	COPIER	OPTION	DSPLY-SW	PUC4-DSP	Yes	Yes	-
497	COPIER	OPTION	DSPLY-SW	CLN-SEL	Yes	Yes	-
498	COPIER	OPTION	DSPLY-SW	CLN-SEL	Yes	Yes	-
499	COPIER	OPTION	DSPLY-SW	DF-DSP	Yes	Yes	-
500	COPIER	OPTION	DSPLY-SW	2TR-DSP	Yes	Yes	-
501	COPIER	OPTION	DSPLY-SW	ITB-DSP	Yes	Yes	-
502	COPIER	OPTION	DSPLY-SW	FXU-DSP	Yes	Yes	-
503	COPIER	OPTION	DSPLY-SW	CRGLW-LV	Yes	Yes	Yes
504	COPIER	OPTION	DSPLY-SW	LOCAL-SZ	Yes	Yes	-
505	COPIER	OPTION	DSPLY-SW	T-LW-BK	Yes	-	-
506	COPIER	OPTION	DSPLY-SW	T-LW-CL	Yes	-	-
507	COPIER	OPTION	DSPLY-SW	COM10-DL	Yes	Yes	-
508	COPIER	OPTION	DSPLY-SW	DRM-CNTR	Yes	-	-
509	COPIER	OPTION	DSPLY-SW	DVLF-DSP	Yes	Yes	-
510	COPIER	OPTION	DSPLY-SW	FIX-LFC	Yes	-	-
511	COPIER	OPTION	DSPLY-SW	FIX-WARN	Yes	-	-
512	COPIER	OPTION	DSPLY-SW	FXMSG-SW	Yes	Yes	Yes
513	COPIER	OPTION	DSPLY-SW	EXTH-SW	Yes	Yes	-
514	COPIER	OPTION	DSPLY-SW	FIX-WRN1	Yes	Yes	Yes
515	COPIER	OPTION	CLEANING	OHP-PTH	Yes	-	-
516	COPIER	OPTION	CLEANING	ITBB-TMG	Yes	-	-
517	COPIER	OPTION	CLEANING	DR-CL-L	Yes	-	-
518	COPIER	OPTION	CLEANING	DR-CL-T	Yes	-	-

No.	Initial screen	Large	Middle	Small	Case A	Case B	Case C
519	COPIER	OPTION	CLEANING	ITB-CL-L	Yes	-	-
520	COPIER	OPTION	CLEANING	ITB-CL-T	Yes	-	-
521	COPIER	OPTION	CLEANING	FX-CN-SW	Yes	-	-
522	COPIER	OPTION	IMG-MCON	PSCL-TBL	Yes	-	-
523	COPIER	OPTION	IMG-MCON	SCR-SLCT	Yes	Yes	-
524	COPIER	OPTION	IMG-MCON	TNR-DWN	Yes	-	-
525	COPIER	OPTION	IMG-MCON	TMIC-BK	Yes	Yes	-
526	COPIER	OPTION	IMG-MCON	TMIC-BK	Yes	-	-
527	COPIER	OPTION	IMG-MCON	TMIC-BK	Yes	-	-
528	COPIER	OPTION	IMG-MCON	TMIC-CMY	Yes	-	-
529	COPIER	OPTION	IMG-MCON	SCR-SW	Yes	-	-
530	COPIER	OPTION	IMG-MCON	ERS-SEL2	Yes	-	-
531	COPIER	OPTION	IMG-MCON	BGE-OFS	Yes	-	-
532	COPIER	OPTION	IMG-MCON	REGM-SEL	Yes	-	-
533	COPIER	OPTION	IMG-SPD	FX-D-TMP	Yes	-	-
534	COPIER	OPTION	IMG-SPD	FIX-ROT	Yes	-	-
535	COPIER	OPTION	IMG-SPD	ARC-INT1	Yes	-	-
536	COPIER	OPTION	IMG-SPD	ARC-INT2	Yes	-	-
537	COPIER	OPTION	IMG-SPD	DWN-TMP3	Yes	Yes	-
538	COPIER	OPTION	IMG-SPD	ARC-INT1	Yes	-	-
539	COPIER	OPTION	IMG-SPD	ARC-INT2	Yes	-	-
540	COPIER	OPTION	IMG-FIX	NEGA-GST	Yes	-	-
541	COPIER	OPTION	IMG-FIX	FX-S-TMP	Yes	-	-
542	COPIER	OPTION	IMG-FIX	TMP-TBL2	Yes	-	-
543	COPIER	OPTION	IMG-FIX	TMP-TBL2	Yes	-	-
544	COPIER	OPTION	IMG-FIX	TMP-TBL3	Yes	-	-
545	COPIER	OPTION	IMG-FIX	TMP-TBL4	Yes	-	-
546	COPIER	OPTION	IMG-FIX	TMP-TBL4	Yes	-	-
547	COPIER	OPTION	IMG-FIX	TMP-TBL5	Yes	-	-
548	COPIER	OPTION	IMG-FIX	TMP-TBL6	Yes	-	-
549	COPIER	OPTION	IMG-FIX	TMP-TBL6	Yes	-	-
550	COPIER	OPTION	IMG-FIX	FXS-TMP2	Yes	-	-
551	COPIER	OPTION	IMG-FIX	FXS-TMP3	Yes	-	-
552	COPIER	OPTION	IMG-FIX	FXS-TMP4	Yes	-	-
553	COPIER	OPTION	IMG-FIX	FXS-TMP5	Yes	-	-
554	COPIER	OPTION	IMG-FIX	FXS-TMP6	Yes	-	-
555	COPIER	OPTION	IMG-FIX	FXST2-N2	Yes	-	-
556	COPIER	OPTION	IMG-FIX	FXST2-UH	Yes	-	-
557	COPIER	OPTION	IMG-FIX	FLYING	Yes	-	-
558	COPIER	OPTION	IMG-FIX	TMP-TBL7	Yes	-	-
559	COPIER	OPTION	IMG-FIX	TMP-TBL8	Yes	-	-
560	COPIER	OPTION	IMG-FIX	TMP-TBL9	Yes	-	-
561	COPIER	OPTION	IMG-FIX	TMP-TB10	Yes	-	-
562	COPIER	OPTION	IMG-FIX	FXS-TMP7	Yes	-	-
563	COPIER	OPTION	IMG-FIX	FXS-TMP8	Yes	-	-
564	COPIER	OPTION	IMG-FIX	FXS-TM10	Yes	-	-
565	COPIER	OPTION	IMG-FIX	FIXMIXBD	Yes	Yes	-
566	COPIER	OPTION	IMG-FIX	FXS-TMP9	Yes	-	-
567	COPIER	OPTION	IMG-FIX	TMP-TB12	Yes	-	-
568	COPIER	OPTION	IMG-FIX	TMP-TB13	Yes	-	-
569	COPIER	OPTION	IMG-FIX	TMP-TB11	Yes	-	-
570	COPIER	OPTION	IMG-FIX	FXS-TM11	Yes	-	-
571	COPIER	OPTION	IMG-FIX	PRE-FXRL	Yes	-	-
572	COPIER	OPTION	IMG-FIX	FXS-TM12	Yes	-	-

No.	Initial screen	Large	Middle	Small	Case A	Case B	Case C
573	COPIER	OPTION	IMG-FIX	FXS-TM13	Yes	-	-
574	COPIER	OPTION	IMG-FIX	FXS-TM14	Yes	-	-
575	COPIER	OPTION	IMG-FIX	TMP-TB17	Yes	-	-
576	COPIER	OPTION	IMG-FIX	EDG-WAIT	Yes	-	-
577	COPIER	OPTION	IMG-FIX	FIX-SMR	Yes	-	-
578	COPIER	OPTION	IMG-FIX	TMP-TBLC	Yes	-	-
579	COPIER	OPTION	IMG-FIX	TMPTBLC2	Yes	-	-
580	COPIER	OPTION	IMG-FIX	TMP-TB14	Yes	-	-
581	COPIER	OPTION	IMG-FIX	FXS-TM11	Yes	-	-
582	COPIER	OPTION	IMG-FIX	FX-WNKL	Yes	Yes	-
583	COPIER	OPTION	IMG-FIX	EXTH-LP	Yes	-	-
584	COPIER	OPTION	IMG-FIX	FIX-RTTH	Yes	-	-
585	COPIER	OPTION	IMG-FIX	TMP-TB24	Yes	-	-
586	COPIER	OPTION	FEED-SW	EVLP-SPD	Yes	-	-
587	COPIER	OPTION	FEED-SW	PINT-REG	Yes	-	-
588	COPIER	OPTION	FEED-SW	REGASST	Yes	-	-
589	COPIER	OPTION	IMG-LSR	PRI-CLN	Yes	-	-
590	COPIER	OPTION	IMG-LSR	SC-PR-SW	Yes	-	-
591	COPIER	OPTION	IMG-TR	2TR-RVON	Yes	-	-
592	COPIER	OPTION	IMG-TR	TR-BS-SW	Yes	-	-
593	COPIER	OPTION	IMG-TR	SP-BS-SW	Yes	-	-
594	COPIER	OPTION	IMG-TR	FX-SP-H	Yes	-	-
595	COPIER	OPTION	IMG-TR	HUM-SW	Yes	-	-
596	COPIER	OPTION	IMG-TR	FX-BSSW1	Yes	-	-
597	COPIER	OPTION	IMG-TR	FX-BSSW2	Yes	-	-
598	COPIER	OPTION	USER	COUNTER1	Yes	-	-
599	COPIER	OPTION	USER	COUNTER2	Yes	-	-
600	COPIER	OPTION	USER	COUNTER3	Yes	-	-
601	COPIER	OPTION	USER	COUNTER4	Yes	-	-
602	COPIER	OPTION	USER	COUNTER5	Yes	-	-
603	COPIER	OPTION	USER	COUNTER6	Yes	-	-
604	COPIER	OPTION	USER	CNT-SW	Yes	-	-
605	COPIER	OPTION	USER	CONTROL	Yes	-	-
606	COPIER	OPTION	USER	B4-L-CNT	Yes	-	-
607	COPIER	OPTION	USER	CTCHKDSP	Yes	-	-
608	COPIER	OPTION	USER	TNRB-SW	Yes	-	-
609	COPIER	OPTION	USER	SCALL-SW	Yes	Yes	Yes
610	COPIER	OPTION	USER	SMD-EXPT	Yes	-	-
611	COPIER	OPTION	USER	ACC-SLP	Yes	Yes	Yes
612	COPIER	OPTION	USER	TRY-STP	Yes	-	-
613	COPIER	OPTION	USER	P-CRG-LF	Yes	-	-
614	COPIER	OPTION	USER	DRMRP-SW	Yes	Yes	-
615	COPIER	OPTION	USER	OP-SZ-DT	Yes	Yes	-
616	COPIER	OPTION	USER	DOC-REM	Yes	Yes	-
617	COPIER	OPTION	USER	HDD-USE	Yes	Yes	-
618	COPIER	OPTION	USER	SZCHKSW	Yes	Yes	-
619	COPIER	OPTION	CST	C2-K-SW	Yes	Yes	Yes
620	COPIER	OPTION	CST	C3-K-SW	Yes	Yes	Yes
621	COPIER	OPTION	CST	C4-K-SW	Yes	Yes	Yes
622	COPIER	OPTION	CST	CST1-P1	Yes	Yes	-
623	COPIER	OPTION	CST	CST2-P1	Yes	Yes	-
624	COPIER	OPTION	CST	CST3-P1	Yes	Yes	-
625	COPIER	OPTION	CST	CST4-P1	Yes	Yes	-
626	COPIER	OPTION	CST	CST-K-SW	Yes	Yes	Yes

No.	Initial screen	Large	Middle	Small	Case A	Case B	Case C
627	COPIER	OPTION	ACC	COIN	Yes	-	-
628	COPIER	OPTION	ACC	CARD-SW	Yes	-	-
629	COPIER	OPTION	ACC	CC-SPSW	Yes	-	-
630	COPIER	OPTION	ACC	C2-EXIST	Yes	-	-
631	COPIER	OPTION	ACC	IN-TRAY	Yes	-	-
632	COPIER	OPTION	ACC	OUT-TRAY	Yes	-	-
633	COPIER	OPTION	ENV-SET	IMG-BLD1	Yes	-	-
634	COPIER	OPTION	ENV-SET	IMG-BLD2	Yes	-	-
635	COPIER	OPTION	ENV-SET	IMG-BLD3	Yes	-	-
636	COPIER	OPTION	ENV-SET	AINR-TM	Yes	-	-
637	COPIER	OPTION	ENV-SET	CLD-REV	Yes	Yes	-
638	COPIER	OPTION	ENV-SET	INTRTMPH	Yes	-	-
639	COPIER	OPTION	ENV-SET	INTRTMPL	Yes	-	-
640	COPIER	OPTION	ENV-SET	LES-CNDS	Yes	-	-
641	SORTER	ADJUST	CENT-ALG	-	Yes	-	-
642	SORTER	ADJUST	FR-ST-PS	-	Yes	Yes	-
643	SORTER	ADJUST	FR-STP-X	-	Yes	-	-
644	SORTER	ADJUST	FR-STP-Y	-	Yes	-	-
645	SORTER	ADJUST	INF-ALG1	-	Yes	-	-
646	SORTER	ADJUST	INF-ALG2	-	Yes	-	-
647	SORTER	ADJUST	INSTP-F1	-	Yes	-	-
648	SORTER	ADJUST	INSTP-R1	-	Yes	-	-
649	SORTER	ADJUST	MSTP-2P	-	Yes	-	-
650	SORTER	ADJUST	RBLT-PRS	-	Yes	-	-
651	SORTER	ADJUST	STP-2P	-	Yes	-	-
652	SORTER	ADJUST	SFT-SPD	-	Yes	-	-
653	SORTER	ADJUST	PULL-SPD	-	Yes	-	-
654	SORTER	ADJUST	SFT-AMT	-	Yes	Yes	-
655	SORTER	ADJUST	ST-ALG1	-	Yes	-	-
656	SORTER	OPTION	FR-ST-PO	-	Yes	Yes	-
657	SORTER	OPTION	FR-ST-SW	-	Yes	Yes	-
658	SORTER	OPTION	MD-SPRTN	-	Yes	-	-
659	SORTER	OPTION	MSTP-TMG	-	Yes	Yes	Yes
660	SORTER	OPTION	MSTP-WT	-	Yes	Yes	-
661	SORTER	OPTION	PADL-TM	-	Yes	Yes	-
662	SORTER	OPTION	TRY-PSTN	-	Yes	Yes	-
663	SORTER	OPTION	TRY-STP	-	Yes	Yes	-
664	SORTER	OPTION	EXEC-SFT	-	Yes	Yes	-
665	SORTER	OPTION	MD-SPRTN	-	Yes	-	-
666	FAX	SSSW	SW01	-	Yes	-	-
667	FAX	SSSW	SW02	-	Yes	-	-
668	FAX	SSSW	SW03	-	Yes	-	-
669	FAX	SSSW	SW04	-	Yes	-	-
670	FAX	SSSW	SW05	-	Yes	-	-
671	FAX	SSSW	SW06	-	Yes	-	-
672	FAX	SSSW	SW07	-	Yes	-	-
673	FAX	SSSW	SW08	-	Yes	-	-
674	FAX	SSSW	SW09	-	Yes	-	-
675	FAX	SSSW	SW10	-	Yes	-	-
676	FAX	SSSW	SW11	-	Yes	-	-
677	FAX	SSSW	SW12	-	Yes	-	-
678	FAX	SSSW	SW13	-	Yes	-	-
679	FAX	SSSW	SW14	-	Yes	-	-
680	FAX	SSSW	SW15	-	Yes	-	-

No.	Initial screen	Large	Middle	Small	Case A	Case B	Case C
681	FAX	SSSW	SW16	-	Yes	-	-
682	FAX	SSSW	SW17	-	Yes	-	-
683	FAX	SSSW	SW18	-	Yes	-	-
684	FAX	SSSW	SW19	-	Yes	-	-
685	FAX	SSSW	SW20	-	Yes	-	-
686	FAX	SSSW	SW21	-	Yes	-	-
687	FAX	SSSW	SW22	-	Yes	-	-
688	FAX	SSSW	SW23	-	Yes	-	-
689	FAX	SSSW	SW24	-	Yes	-	-
690	FAX	SSSW	SW25	-	Yes	-	-
691	FAX	SSSW	SW26	-	Yes	-	-
692	FAX	SSSW	SW27	-	Yes	-	-
693	FAX	SSSW	SW28	-	Yes	-	-
694	FAX	SSSW	SW29	-	Yes	-	-
695	FAX	SSSW	SW30	-	Yes	-	-
696	FAX	SSSW	SW31	-	Yes	-	-
697	FAX	SSSW	SW32	-	Yes	-	-
698	FAX	MENU	005	-	Yes	-	-
699	FAX	MENU	006	-	Yes	-	-
700	FAX	MENU	007	-	Yes	-	-
701	FAX	MENU	008	-	Yes	-	-
702	FAX	MENU	009	-	Yes	-	-
703	FAX	MENU	010	-	Yes	-	-
704	FAX	NUM	002	-	Yes	-	-
705	FAX	NUM	003	-	Yes	-	-
706	FAX	NUM	004	-	Yes	-	-
707	FAX	NUM	005	-	Yes	-	-
708	FAX	NUM	006	-	Yes	-	-
709	FAX	NUM	008	-	Yes	-	-
710	FAX	NUM	010	-	Yes	-	-
711	FAX	NUM	011	-	Yes	-	-
712	FAX	NUM	012	-	Yes	-	-
713	FAX	NUM	013	-	Yes	-	-
714	FAX	NUM	015	-	Yes	-	-
715	FAX	NUM	016	-	Yes	-	-
716	FAX	NUM	017	-	Yes	-	-
717	FAX	NUM	018	-	Yes	-	-
718	FAX	NUM	019	-	Yes	-	-
719	FAX	NUM	020	-	Yes	-	-
720	FAX	NUM	021	-	Yes	-	-
721	FAX	NUM	022	-	Yes	-	-
722	FAX	NUM	023	-	Yes	-	-
723	FAX	NUM	024	-	Yes	-	-
724	FAX	NUM	025	-	Yes	-	-
725	FAX	NUM	026	-	Yes	-	-
726	FAX	NUM	027	-	Yes	-	-
727	FAX	NUM	029	-	Yes	-	-
728	FAX	NUM	049	-	Yes	-	-
729	FAX	NUM	051	-	Yes	-	-
730	FAX	NUM	053	-	Yes	-	-
731	FAX	NUM	054	-	Yes	-	-
732	FAX	NCU	TONE	001	Yes	-	-
733	FAX	NCU	TONE	002	Yes	-	-
734	FAX	NCU	PULSE	FORM	Yes	-	-

No.	Initial screen	Large	Middle	Small	Case A	Case B	Case C
735	FAX	NCU	PULSE	001	Yes	-	-
736	FAX	NCU	PULSE	002	Yes	-	-
737	FAX	NCU	PULSE	003	Yes	-	-
738	FAX	NCU	PULSE	004	Yes	-	-
739	FAX	NCU	DIALTONE	BIT	Yes	-	-
740	FAX	NCU	DIALTONE	001	Yes	-	-
741	FAX	NCU	DIALTONE	002	Yes	-	-
742	FAX	NCU	DIALTONE	003	Yes	-	-
743	FAX	NCU	DIALTONE	004	Yes	-	-
744	FAX	NCU	DIALTONE	005	Yes	-	-
745	FAX	NCU	DIALTONE	006	Yes	-	-
746	FAX	NCU	DIALTONE	007	Yes	-	-
747	FAX	NCU	DIALTONE	008	Yes	-	-
748	FAX	NCU	2ND DLTN	BIT	Yes	-	-
749	FAX	NCU	2ND DLTN	001	Yes	-	-
750	FAX	NCU	2ND DLTN	002	Yes	-	-
751	FAX	NCU	2ND DLTN	003	Yes	-	-
752	FAX	NCU	2ND DLTN	004	Yes	-	-
753	FAX	NCU	2ND DLTN	005	Yes	-	-
754	FAX	NCU	2ND DLTN	006	Yes	-	-
755	FAX	NCU	2ND DLTN	007	Yes	-	-
756	FAX	NCU	2ND DLTN	008	Yes	-	-
757	FAX	NCU	BUSTONE0	BIT	Yes	-	-
758	FAX	NCU	BUSTONE0	001	Yes	-	-
759	FAX	NCU	BUSTONE0	002	Yes	-	-
760	FAX	NCU	BUSTONE0	003	Yes	-	-
761	FAX	NCU	BUSTONE0	004	Yes	-	-
762	FAX	NCU	BUSTONE0	005	Yes	-	-
763	FAX	NCU	BUSTONE0	006	Yes	-	-
764	FAX	NCU	BUSTONE0	007	Yes	-	-
765	FAX	NCU	BUSTONE0	008	Yes	-	-
766	FAX	NCU	BUSTONE1	BIT	Yes	-	-
767	FAX	NCU	BUSTONE1	001	Yes	-	-
768	FAX	NCU	BUSTONE1	002	Yes	-	-
769	FAX	NCU	BUSTONE1	003	Yes	-	-
770	FAX	NCU	BUSTONE1	004	Yes	-	-
771	FAX	NCU	BUSTONE1	005	Yes	-	-
772	FAX	NCU	BUSTONE1	006	Yes	-	-
773	FAX	NCU	BUSTONE1	007	Yes	-	-
774	FAX	NCU	BUSTONE1	008	Yes	-	-
775	FAX	NCU	REORDRTN	BIT	Yes	-	-
776	FAX	NCU	REORDRTN	001	Yes	-	-
777	FAX	NCU	REORDRTN	002	Yes	-	-
778	FAX	NCU	REORDRTN	003	Yes	-	-
779	FAX	NCU	REORDRTN	004	Yes	-	-
780	FAX	NCU	REORDRTN	005	Yes	-	-
781	FAX	NCU	REORDRTN	006	Yes	-	-
782	FAX	NCU	REORDRTN	007	Yes	-	-
783	FAX	NCU	REORDRTN	008	Yes	-	-
784	FAX	NCU	AUTO RX	001	Yes	-	-
785	FAX	NCU	AUTO RX	002	Yes	-	-
786	FAX	NCU	AUTO RX	003	Yes	-	-
787	FAX	NCU	AUTO RX	004	Yes	-	-
788	FAX	NCU	AUTO RX	005	Yes	-	-

No.	Initial screen	Large	Middle	Small	Case A	Case B	Case C
789	FAX	NCU	AUTO RX	006	Yes	-	-
790	FAX	NCU	AUTO RX	007	Yes	-	-
791	FAX	NCU	AUTO RX	008	Yes	-	-
792	FAX	NCU	AUTO RX	009	Yes	-	-
793	FAX	NCU	CNGDTCT	001	Yes	-	-
794	FAX	NCU	CNGDTCT	002	Yes	-	-
795	FAX	NCU	CNGDTCT	006	Yes	-	-
796	FAX	NCU	CNGDTCT	007	Yes	-	-
797	FAX	NCU	CNGDTCT	008	Yes	-	-
798	FAX	NCU	CNGDTCT	009	Yes	-	-
799	FAX	NCU	CNGDTCT	011	Yes	-	-
800	FAX	NCU	CNGDTCT	012	Yes	-	-
801	FAX	NCU	SPECIALB	SW01	Yes	-	-
802	FAX	NCU	SPECIALB	SW02	Yes	-	-
803	FAX	NCU	SPECIALB	SW03	Yes	-	-
804	FAX	NCU	SPECIALB	SW04	Yes	-	-
805	FAX	NCU	SPECIALB	SW05	Yes	-	-
806	FAX	NCU	SPECIALB	SW06	Yes	-	-
807	FAX	NCU	SPECIALB	SW07	Yes	-	-
808	FAX	NCU	SPECIALB	SW08	Yes	-	-
809	FAX	NCU	SPECIALB	SW09	Yes	-	-
810	FAX	NCU	SPECIALB	SW10	Yes	-	-
811	FAX	NCU	SPECIALB	SW11	Yes	-	-
812	FAX	NCU	SPECIALB	SW12	Yes	-	-
813	FAX	NCU	SPECIALB	SW13	Yes	-	-
814	FAX	NCU	SPECIALB	SW14	Yes	-	-
815	FAX	NCU	SPECIALB	SW15	Yes	-	-
816	FAX	NCU	SPECIALB	SW16	Yes	-	-
817	FAX	NCU	SPECIALB	SW17	Yes	-	-
818	FAX	NCU	SPECIALB	SW18	Yes	-	-
819	FAX	NCU	SPECIALB	SW19	Yes	-	-
820	FAX	NCU	SPECIALB	SW20	Yes	-	-
821	FAX	NCU	SPECIALB	SW21	Yes	-	-
822	FAX	NCU	SPECIALB	SW22	Yes	-	-
823	FAX	NCU	SPECIALB	SW23	Yes	-	-
824	FAX	NCU	SPECIALB	SW24	Yes	-	-
825	FAX	NCU	SPECIALB	SW25	Yes	-	-
826	FAX	NCU	SPECIALB	SW26	Yes	-	-
827	FAX	NCU	SPECIALB	SW27	Yes	-	-
828	FAX	NCU	SPECIALB	SW28	Yes	-	-
829	FAX	NCU	SPECIALB	SW29	Yes	-	-
830	FAX	NCU	SPECIALB	SW30	Yes	-	-
831	FAX	NCU	SPECIALN	004	Yes	-	-
832	FAX	NCU	SPECIALN	005	Yes	-	-
833	FAX	NCU	SPECIALN	006	Yes	-	-
834	FAX	NCU	SPECIALN	007	Yes	-	-
835	FAX	NCU	SPECIALN	008	Yes	-	-
836	FAX	NCU	SPECIALN	009	Yes	-	-
837	FAX	NCU	SPECIALN	011	Yes	-	-
838	FAX	NCU	SPECIALN	012	Yes	-	-
839	FAX	NCU	SPECIALN	013	Yes	-	-
840	FAX	NCU	SPECIALN	014	Yes	-	-
841	FAX	NCU	SPECIALN	015	Yes	-	-
842	FAX	NCU	SPECIALN	016	Yes	-	-

No.	Initial screen	Large	Middle	Small	Case A	Case B	Case C
843	FAX	NCU	SPECIALN	017	Yes	-	-
844	FAX	NCU	SPECIALN	019	Yes	-	-
845	FAX	NCU	SPECIALN	020	Yes	-	-
846	FAX	NCU	SPECIALN	024	Yes	-	-
847	FAX	NCU	SPECIALN	025	Yes	-	-
848	FAX	NCU	SPECIALN	026	Yes	-	-
849	FAX	NCU	SPECIALN	027	Yes	-	-
850	FAX	NCU	SPECIALN	030	Yes	-	-
851	FAX	NCU	SPECIALN	040	Yes	-	-
852	FAX	NCU	SPECIALN	041	Yes	-	-
853	FAX	NCU	SPECIALN	042	Yes	-	-
854	FAX	NCU	SPECIALN	044	Yes	-	-
855	FAX	NCU	SPECIALN	045	Yes	-	-
856	FAX	NCU	SPECIALN	046	Yes	-	-
857	FAX	NCU	SPECIALN	047	Yes	-	-
858	FAX	NCU	SPECIALN	048	Yes	-	-
859	FAX	NCU	SPECIALN	065	Yes	-	-
860	FAX	NCU	SPECIALN	066	Yes	-	-
861	FAX	NCU	RKEY	001	Yes	-	-
862	FAX	NCU	RKEY	002	Yes	-	-
863	FAX	NCU	PBXDIALT	BIT	Yes	-	-
864	FAX	NCU	PBXDIALT	001	Yes	-	-
865	FAX	NCU	PBXDIALT	002	Yes	-	-
866	FAX	NCU	PBXDIALT	003	Yes	-	-
867	FAX	NCU	PBXDIALT	004	Yes	-	-
868	FAX	NCU	PBXDIALT	005	Yes	-	-
869	FAX	NCU	PBXDIALT	006	Yes	-	-
870	FAX	NCU	PBXDIALT	007	Yes	-	-
871	FAX	NCU	PBXDIALT	008	Yes	-	-
872	FAX	NCU	PBXBUSYT	BIT	Yes	-	-
873	FAX	NCU	PBXBUSYT	001	Yes	-	-
874	FAX	NCU	PBXBUSYT	002	Yes	-	-
875	FAX	NCU	PBXBUSYT	003	Yes	-	-
876	FAX	NCU	PBXBUSYT	004	Yes	-	-
877	FAX	NCU	PBXBUSYT	005	Yes	-	-
878	FAX	NCU	PBXBUSYT	006	Yes	-	-
879	FAX	NCU	PBXBUSYT	007	Yes	-	-
880	FAX	NCU	PBXBUSYT	008	Yes	-	-

Backup Data List

Data	Location	Replace		Delete																	Backup by User			Backup by Service			
				Menu > System Management Settings									Service Mode > COPIER > FUNCTION >														
		Engine Control-ler PCB	Main Control-ler PCB	Initialize All Data / Settings	Initializ-ing Key and Cer-tificate	Initializ-ing Ad-dress Book	Menu Clear					CLEAR							SPLMAN	Yes/No	Method	Location to be stored	Yes/No	Method	Location to be stored		
							Preferen-ces	Function Settings	Set Desti-nation	Manage-ment Set-tings	Network Settings	Clear All	R-CON *1	"SRVC-DAT*2"	COUN-TER	HIST *3	ALL	PLPW-CLR								DC-CON	SPL4381 0
Address Book	Main Control-ler PCB	-	Clear	Clear	-	Clear	-	-	-	-	-	-	-	-	-	Clear	-	-	-	-	Yes	Remote UI *6 LUI *7	PC, USB memory	No	-	-	
Settings Menu																											
Preferen-ces	Main Control-ler PCB	-	Clear	Clear	-	-	Clear*9	-	-	-	Clear*10	Clear	-	-	-	Clear	-	-	-	-	Yes	Remote UI *6 LUI *7	PC, USB memory	No	-	-	
Function Settings	Main Control-ler PCB	-	Clear	Clear	-	-	-	Clear	-	-	-	Clear	-	-	-	Clear	-	-	-	-	Yes	Remote UI *6 LUI *7	PC, USB memory	No	-	-	
Set Desti-nation	Main Control-ler PCB	-	Clear	Clear	-	-	-	-	Clear	-	-	Clear	-	-	-	Clear	-	-	-	-	Yes	Remote UI *6 LUI *7	PC, USB memory	No	-	-	
Management Set-tings	Main Control-ler PCB	-	Clear	Clear	-	-	-	-	-	Clear	-	Clear	-	-	-	Clear	-	-	-	-	Yes	Remote UI *6 LUI *7	PC, USB memory	No	-	-	
Status Monitor/Cancel																											
Job Log	Main Control-ler PCB	-	Clear	Clear	-	-	-	-	-	-	-	-	-	-	-	Clear	Clear	-	-	-	No	-	-	No	-	-	
Counter																											
Page counter (Main Control-ler)	Main Control-ler PCB	-	Clear	-	-	-	-	-	-	-	-	-	-	-	-	-	-	-	-	-	No	-	-	No	-	-	
Part counter (Main Control-ler)	Main Control-ler PCB	-	Clear	Clear	-	-	-	-	-	-	-	-	-	Clear	-	-	-	-	-	-	No	-	-	No	-	-	
Part counter (DC Con-troller)	Engine Control-ler PCB	Clear	-	-	-	-	-	-	-	-	-	-	-	-	-	-	-	-	-	-	No	-	-	No	-	-	
Other																											
Serial number	Main Control-ler PCB	-	Clear	-	-	-	-	-	-	-	-	-	-	-	-	-	-	-	-	-	No	-	-	No	-	-	
Key and Certifi-cate Set-tings	Main Control-ler PCB	-	Clear	Clear	Clear	-	-	-	-	-	-	-	-	-	-	Clear	-	-	-	-	No	-	-	No	-	-	
Service mode																											
Service mode setting values (Reader)	Main Control-ler PCB	-	Clear	-	-	-	-	-	-	-	-	-	Clear	-	-	-	-	-	-	-	No	-	-	No	-	-	

Data	Location	Replace		Delete																	Backup by User			Backup by Service		
				Menu > System Management Settings								Service Mode > COPIER > FUNCTION >														
		Engine Controller PCB	Main Controller PCB	Initialize All Data / Settings	Initializing Key and Certificate	Initializing Address Book	Menu Clear					CLEAR						SPLMAN	Yes/No	Method	Location to be stored	Yes/No	Method	Location to be stored		
							Preferences	Function Settings	Set Destination	Management Settings	Network Settings	Clear All	R-CON *1	"SRVC-DAT*2"	COUNTER	HIST *3	ALL								PLPW-CLR	DC-CON
Service mode setting values (Main Controller)	Main Controller PCB	-	Clear	-	-	-	-	-	-	-	-	-	-	Clear	-	-	Clear	-	-	-	Yes	Remote UI *6 LUI *7	PC, USB memory	Yes	Service mode*5	USB memory
Service mode setting values (DC Controller)	Engine Controller PCB	Clear	-	-	-	-	-	-	-	-	-	-	-	-	-	-	-	-	Clear	-	Yes	Remote UI *6 LUI *7	PC, USB memory	Yes	Service mode*5 *8	USB memory / Main Controller
Password																										
System Administrator password	Main Controller PCB	-	Clear*4	Clear*4	-	-	-	-	-	Clear*4	-	Clear*4	-	-	-	-	Clear*4	-	-	Clear*11	No	-	-	No	-	-
Security Policy Administrator password	Main Controller PCB	-	Clear	Clear	-	-	-	-	-	Clear	-	Clear	-	-	-	-	Clear	Clear	-	-	No	-	-	No	-	-
Service Mode password*12	Main Controller PCB	-	Clear	Clear	-	-	-	-	-	-	-	-	-	-	-	-	-	-	-	-	No	-	-	No	-	-

*1. The factory adjustment values of the Reader and ADF are initialized.

*2. Service data (Except "COPIER > COUNTER" and "COPIER > FEED-ADJ") are cleared. The factory adjustment values of the Reader and ADF are not initialized.

*3. Service data is cleared. User data is not cleared. The factory adjustment values of the Reader and ADF are not initialized.

*4. In except counter meter-installed model: The user data and service data and each history and the settings of the system administrator are cleared. (The system manager ID and password are changed back to the default values ID: 0/PWD: 0)
The factory adjustment values of the Reader and ADF are not initialized.

*5. COPIER > FUNCTION > SYSTEM > IMPORT / COPIER > FUNCTION > SYSTEM > EXPORT

*6. Settings/Registration > Management Settings > Data Management > Import/Export

*7. Settings Menu > Management Settings > Data Management > Import/Export

*8. COPIER > FUNCTION > VIFFNC > STOR-DCN

*9. Except "Preferences > Network Settings"

*10. Clear only an item of the "Preferences > Network Settings".

*11. Because the settings of the "System Manager ID and PIN" are cleared, set "System Manager ID and PIN" again.

*12. COPIER > OPTION > BODY > SM-PSWD(Setup password by SM-PSWD)

Soft counter specifications

The numbers entered for software counters are classified as follows:

No.	Counter Details	No.	Counter Details
000 to 099	Toner Bottle	500 to 599	Scan
100 to 199	Total	600 to 699	Memory media print
200 to 299	Copy	700 to 799	Reception print
300 to 399	Print	800 to 899	Report print
400 to 499	Copy and print	900 to 999	Transmission

000 to 099

No.	Counter Name	No.	Counter Name
071	Toner Bottle (Black)	073	Toner Bottle (magenta)
072	Toner Bottle (yellow)	074	Toner Bottle (cyan)

100 to 199

No.	Counter Name	No.	Counter Name
101	Total 1	147	Total A (full color +mono color /small)
102	Total 2	148	Total A (full color +mono color 2)
104	Total (Small)	149	Total A (full color +mono color 1)
105	Total (full color1)	150	Total B1
106	Total (full color2)	151	Total B2
108	Total (Black1)	153	Total B (Small)
109	Total (Black2)	154	Total B (full color 1)
113	Total (Black / Small)	155	Total B (full color 2)
114	Total 1 (2-Sided)	156	Total B (Black1)
115	Total 2 (2-Sided)	157	Total B (Black2)
117	Small (2-Sided)	161	Total B (Black / Small)
121	Total (full color /small)	162	Total B1 (2-Sided)
123	Total (full color +mono color /small)	163	Total B2 (2-Sided)
124	Total (full color +mono color 2)	165	SmallB (2-Sided)
125	Total (full color +mono color 1)	169	Total B (full color /small)
126	Total A1	171	Total B (full color +mono color /small)
127	Total A2	172	Total B (full color +mono color 2)
129	Total A (Small)	173	Total B (full color +mono color 1)
130	Total A (full color 1)	181	Black Toner
131	Total A (full color 2)	182	Yellow Toner
132	Total A (Black1)	183	Magenta Toner
133	Total A (Black2)	184	Cyan Toner
137	Total A (Black / Small)	191	Toner replacement /Yellow
138	Total A1 (2-Sided)	192	Toner replacement /Magenta
139	Total A2 (2-Sided)	193	Toner replacement /Cyan
141	SmallA (2-Sided)	194	Toner replacement /Black
145	Total A (full color /small)		

200 to 299

No.	Counter Name	No.	Counter Name
201	Copy (Total 1)	246	CopyA (full color 2)
202	Copy (Total 2)	249	CopyA (Black1)
204	Copy (Small)	250	CopyA (Black2)
205	CopyA (Total 1)	252	CopyA (full color /small)
206	CopyA (Total 2)	256	CopyA (Black / Small)

No.	Counter Name	No.	Counter Name
208	CopyA (Small)	258	CopyA (full color +mono color /small)
209	Local Copy (Total 1)	259	CopyA (full color +mono color 2)
210	Local Copy (Total 2)	260	CopyA (full color +mono color 1)
212	Local Copy (Small)	262	CopyA (full color /small/double sided)
217	Copy (full color 1)	266	CopyA (Black / Small / 2-Sided)
218	Copy (full color 2)	273	Local (full color 1)
221	Copy (Black1)	274	Local (full color 2)
222	Copy (Black2)	277	Local Copy (Black1)
224	Copy (full color /small)	278	Local Copy (Black2)
228	Copy (Black / Small)	280	Local Copy (full color /small)
230	Copy (full color +mono color /small)	284	Local Copy (Black / Small)
231	Copy (full color +mono color 2)	286	Local Copy (full color +mono color /small)
232	Copy (full color +mono color 1)	287	Local Copy (full color +mono color 2)
234	Copy (full color /small /double sided)	288	Local Copy (full color +mono color 1)
238	Copy (Black / Small / 2-Sided)	290	Local Copy (full color /small/double sided)
245	CopyA (full color 1)	294	Local Copy (Black / Small / 2-Sided)

300 to 399

No.	Counter Name	No.	Counter Name
301	Print (Total 1)	324	Print (full color +mono color 1)
302	Print (Total 2)	326	Print (full color /small/double sided)
304	Print (Small)	330	Print (Black / Small / 2-Sided)
305	Print A (Total 1)	331	PDLPrint (Total 1)
306	Print A (Total 2)	332	PDLPrint (Total 2)
308	Print A (Small)	334	PDLPrint (Small)
309	Print (full color 1)	335	PDLPrint (full color 1)
310	Print (full color 2)	336	PDLPrint (full color 2)
313	Print (Black1)	339	PDLPrint (Black1)
314	Print (Black2)	340	PDLPrint (Black2)
316	Print (full color /small)	342	PDLPrint (full color /small)
320	Print (Black / Small)	346	PDLPrint (Black / Small)
322	Print (full color +mono color /small)	352	PDLPrint (full color /small/double sided)
323	Print (full color +mono color 2)	356	PDLPrint (Black / Small / 2-Sided)

400 to 499

No.	Counter Name	No.	Counter Name
402	Copy + Print (full color /small)	410	Copy + Print (full color +mono color 1)
404	Copy + Print (Black / Small)	412	Copy + Print (Small)
405	Copy + Print (Black2)	413	Copy + Print (2)
406	Copy + Print (Black1)	414	Copy + Print (1)
408	Copy + Print (full color +mono color /small)	418	Copy + Print (full color /small/double sided)
409	Copy + Print (full color +mono color 2)	422	Copy + Print (Black / Small / 2-Sided)

500 to 599

No.	Counter Name	No.	Counter Name
501	Scan (Total 1)	509	Color Scan (Total 1)
505	BlackScan (Total 1)	510	Color Scan (Total 2)
506	BlackScan (Total 2)	512	Color Scan (Small)
508	BlackScan (Small)		

600 to 699

No.	Counter Name	No.	Counter Name
631	Memory Media Print (Total 1)	642	Memory Media Print (full color /small)
632	Memory Media Print (Total 2)	646	Memory Media Print (Black / Small)
634	Memory Media Print (Small)	648	Memory Media Print (full color +mono color /small)
635	Memory Media Print (full color 1)	649	Memory Media Print (full color +mono color 2)
636	Memory Media Print (full color 2)	650	Memory Media Print (full color +mono color 1)
639	Memory Media Print (Black1)	652	Memory Media Print (full color /small/double sided)
640	Memory Media Print (Black2)	656	Memory Media Print (Black / Small / 2-Sided)

700 to 799

No.	Counter Name	No.	Counter Name
701	Receive Print (Total 1)	710	Receive Print (Black2)
702	Receive Print (Total 2)	712	Receive Print (full color /small)
704	Receive Print (Small)	716	Receive Print (Black / Small)
705	Receive Print (full color 1)	722	Receive Print (full color /small/double sided)
706	Receive Print (full color 2)	726	Receive Print (Black / Small / 2-Sided)
709	Receive Print (Black1)		

800 to 899

No.	Counter Name	No.	Counter Name
801	Report Print (Total 1)	810	Report Print (Black2)
802	Report Print (Total 2)	816	Report Print (Black / Small)
804	Report Print (Small)	826	Report Print (Black / Small / 2-Sided)
809	Report Print (Black1)		

900 to 999

No.	Counter Name	No.	Counter Name
921	TX ScanTotal 5 (Color)	945	TX Scan / E-Mail (Color)
922	TX ScanTotal 5 (Black)	946	TX Scan / E-Mail (Black)
939	Remote Scan (Color)	959	Memory Media Scan (Color)
940	Remote Scan (Black)	960	Memory Media Scan (Black)