

Canon

Color
imageCLASS
MF b28 Cw

Color
imageCLASS
MF b24 Cw



Service Guide

For Authorized Service Facilities

Published by
Canon U.S.A., Inc.
One Canon Park
Melville, NY 11747-3336
1-800-OK-CANON
serviceplanning@cusa.canon.com

Canon U.S.A. Homepage: <http://www.usa.canon.com>
Canon U.S.A. e-Support Center Web site: <http://www.support.cusa.canon.com>
Canon U.S.A. ISG Central Web site: <http://www.isgcentral.cusa.canon.com>
Canon Network Access (CNA) Web site: <http://www.cna.cusa.canon.com>

IMPORTANT

THIS SERVICE GUIDE INCLUDES THE INFORMATION RELATING TO THE Color imageCLASS MF628Cw and MF624Cw.

SPECIFICATIONS AND OTHER INFORMATION CONTAINED HEREIN MAY VARY SLIGHTLY FROM ACTUAL DEVICE VALUES OR THOSE FOUND IN ADVERTISING AND OTHER PRINTED MATTER.

USE OF THIS SERVICE GUIDE SHOULD BE STRICTLY SUPERVISED TO AVOID DISCLOSURE OF CONFIDENTIAL INFORMATION.

ALL PRICES LISTED ARE SUBJECT TO CHANGE WITHOUT NOTICE.

PART NUMBERS LISTED MAY BE CHANGED WITHOUT NOTICE TO REFLECT ENGINEERING REVISIONS.

REVISION HISTORY

Revision	Date	Section(s)	Details
—	September 2015	All	Release of the Color imageCLASS MF628Cw/MF624Cw Service Guide

COPYRIGHTS AND TRADEMARKS

This Service Guide is the property of Canon U.S.A., Inc.
© Canon U.S.A., Inc. 2015. All rights reserved.

Canon, imageCLASS, and Always Ask for Canon Genuine Toner, Parts & Supplies are registered trademarks of Canon Inc.

All other company names and product names may be trademarks or registered trademarks of their respective owners, and are hereby acknowledged.

LEGAL NOTICES

The information contained in this Service Guide constitutes confidential information of Canon U.S.A., Inc.

Pursuant to the authorized Service Agreement with Canon U.S.A., Inc., this Service Guide is solely for reference purposes and may be used only by an authorized Service Provider of Canon U.S.A., Inc. No part of this Service Guide may be reproduced or transmitted in any form by any means, electronic or mechanical, for any purpose without the prior written consent of Canon U.S.A., Inc., except as expressly permitted herein.

Pursuant to the authorized Service Agreement with Canon U.S.A., Inc., Service Provider agrees to indemnify Canon U.S.A., Inc. and to hold it harmless from and against any and all claims arising out of Service Provider's possession, use, or misuse of this Service Guide.

Canon U.S.A., Inc. from time to time updates this online Service Guide and may modify the information and/or specifications contained in it at any time without notice. Additionally, all prices and availability dates listed herein are subject to change without notice. The latest version is available online at the ISG Central and e-Support Web sites noted above. Please make certain that you are using the latest version. Specimens of Web pages included herein are for illustration purposes only.

DISCLAIMER

NEITHER CANON NOR ITS SUPPLIERS NOR ANY AUTHORIZED SERVICE PROVIDER SHALL BE LIABLE FOR PERSONAL INJURY OR PROPERTY DAMAGE (UNLESS CAUSED SOLELY AND DIRECTLY BY THE NEGLIGENCE OF CANON OR ANY AUTHORIZED SERVICE PROVIDER), LOSS OF REVENUE OR PROFIT, FAILURE TO REALIZE SAVINGS OR OTHER BENEFITS, EXPENDITURES FOR SUBSTITUTE EQUIPMENT OR SERVICES, LOSS OR CORRUPTION OF DATA, INCLUDING, WITHOUT LIMITATION, DATA STORED ON THE PRODUCT'S OPTIONAL HARD DISK DRIVE, STORAGE CHARGES OR OTHER SPECIAL, INCIDENTAL OR CONSEQUENTIAL DAMAGES CAUSED BY THE USE, MISUSE OR INABILITY TO USE THE PRODUCT, REGARDLESS OF THE LEGAL THEORY ON WHICH THE CLAIM IS BASED AND EVEN IF CANON OR ITS SUPPLIERS OR ANY AUTHORIZED SERVICE PROVIDER HAS BEEN ADVISED OF THE POSSIBILITY OF SUCH DAMAGES. NOR SHALL RECOVERY OF ANY KIND AGAINST CANON OR ITS SUPPLIERS OR ANY AUTHORIZED SERVICE PROVIDER BE GREATER IN AMOUNT THAN THE PURCHASE PRICE OF THE PRODUCT CAUSING THE ALLEGED DAMAGE. WITHOUT LIMITING THE FOREGOING, THE PURCHASER ASSUMES ALL RISKS AND LIABILITY FOR LOSS, DAMAGE OR INJURY TO PERSONS AND THE PROPERTY OF THE PURCHASER OR OTHERS ARISING OUT OF THE POSSESSION, USE, MISUSE, OR INABILITY TO USE THE PRODUCT NOT CAUSED SOLELY AND DIRECTLY BY THE NEGLIGENCE OF CANON OR ANY AUTHORIZED SERVICE PROVIDER.

Contents

I.	Product Overview -----	1
II.	Product Configuration and Box Contents -----	2
	A. Configuration and CarePAKs -----	2
	B. Box Contents -----	4
III.	Service Authorization -----	5
IV.	Educational Training -----	5
	A. Training Program Overview -----	5
	B. Certification -----	5
	C. Who Should Complete -----	5
	D. Prerequisites -----	6
	E. Course Format -----	6
	F. Course Equipment -----	7
V.	Servicing Notes -----	8
	A. Power and Plug Requirements -----	8
	B. Installation Space Requirements -----	9
	C. Estimated Installation Time -----	11
	D. Notes on the Wireless LAN -----	11
	E. Special Tools, Solvents, and Oils -----	12
	F. Cleaning -----	13
	G. Consumables -----	14
	H. Consumable Parts -----	15
	I. Counters -----	15
	J. Periodic Replacement Parts -----	15
	K. Firmware Upgrade -----	16
	L. Computer Requirements for Downloading Firmware -----	16
VI.	End-User Customer Service Offerings -----	17
	A. Monthly Copy/Print Volume -----	17
	B. Limited Warranty Support -----	17
	C. Technical Support for the End-User -----	18
	1. Carry-In Service-----	18
	2. Exchange Service-----	19
	3. Internet Support-----	20
	D. Post-Warranty Support -----	21
	1. CarePAK Extended Service Plans-----	21
VII.	Authorized Service Facility Program -----	24
VIII.	ASF Technical Support Offerings -----	25
	A. ASF Support -----	25
	B. Internet Support -----	25
	C. Call Escalation Procedure -----	27
IX.	Warranty Procedures -----	28
	A. Warranty Service Claim Guidelines -----	29
	B. Warranty Compensation Procedures -----	30
	1. Adding a New Technician-----	31
	2. Submit a Warranty Claim-----	33
	3. Parts Return-----	35

X.	Parts Support	37
A.	Parts and Service Material Orders	37
1.	Canon Network Access	37
2.	Parts Order Desk	38
B.	Parts Order Entry	39
1.	Regular Orders	39
2.	Rush Orders	39
C.	Parts Information/Parts Price List Download	39
D.	Parts Discontinuation Schedule Information	39
E.	Order/Invoice Inquiry	40
XI.	Appendix	41
A.	Specifications	41
B.	Warranty	47
1.	imageCLASS Series Exchange/Carry-In Limited Warranty	47
2.	Canon Toner Cartridge Limited Warranty	48
C.	List of Tables	50
D.	List of Figures	50

I. Product Overview

The Canon Color imageCLASS MF628Cw is a compact, color and B&W (Black-and-White), wireless, laser, multifunction device with copy, print, scan, and fax capabilities. The Canon Color imageCLASS MF624Cw is a compact, color and B&W, wireless, laser, multifunction device with copy, print, and scan capabilities. These models also bring the following capabilities to users:

- Print speeds (color and B&W using LTR (letter-sized) paper) up to 14 ppm¹ (pages-per-minute) and copy speeds up to 21 ppm¹ B&W and 10 ppm¹ color.
- Color scanning at an interpolated resolution of up to 9,600 x 9,600 dpi (dots per inch), and optical scanning at a resolution of up to 600 x 600 dpi.
- Standard 33.6 Kbps Super G3 fax capabilities (MF628Cw only).
- Connectivity:
 - USB 2.0 High Speed port for printing and scanning from USB memory.
 - 10/100/1000 Base-T Ethernet connectivity that supports network printing, scanning, and PC faxing (MF628Cw only).
- Includes an automatic document feeder with a capacity up to 50 sheets, a front-loading paper cassette with a capacity of up to 150 sheets, and a manual feed slot.
- Meets the ENERGY STAR guidelines for energy efficiency.
- Standard UFR II LT printing.
- One click scan-to-cloud services (Dropbox, Evernote).
- Remote User Interface allows remote printer configuration and management.
- Scan documents to, or print documents from a USB flash drive.
- Scan documents, and send them via e-mail message directly from the printer, or store them in a shared network folder.
- Total color and black-and-white print and scan counters.
- Support for mobile printing from Apple iOS and Android mobile devices.
- WiFi capabilities include Print, Scan, and PC Fax (MF628Cw only) at speeds of up to 802.11 b/g/n².

1 The copy/print speed is measured during continuous copy/print runs. Copy/print speeds may vary, depending on the paper type, size, and paper feeding direction. Copy/print speeds on smaller paper sizes may be slower. Also, the machine may experience downtime, or slow down in the middle of a continuous copy/print run to adjust the temperature inside the machine, and maintain optimal print quality.

2 Wireless performance may vary, depending on terrain and distance between the printer and wireless network clients.

II. Product Configuration and Box Contents

A. Configuration and CarePAKs

Note: All configurations shown are for reference purposes only, and are subject to change without notice. Please refer to the Price List in the CNA (Canon Network Access) Web site www.cna.cusa.canon.com for the most up-to-date item numbers.

Table 1 — Configuration

Item	Item Number ³
<p>Color imageCLASS MF628Cw</p> 	
Color imageCLASS MF628Cw	9946B007AA
Color imageCLASS MF624Cw	9946B016AA

³ Item numbers and part numbers are subject to change without notice.

Table 1 — Configuration Continued

Supplies and Consumables	Item Number ³
Cartridge 131 Black	6272B001AA
Cartridge 131 H Black (Hi-Capacity)	6273B001AA
Cartridge 131 Yellow	6269B001AA
Cartridge 131 Magenta	6270B001AA
Cartridge 131 Cyan	6271B001AA
Service Materials and Parts Catalog	
Color imageCLASS MF628Cw/MF624Cw Service Manual	Available for download on the e-Support Web site
Color imageCLASS MF628Cw/MF624Cw Parts Catalog	

³ Item numbers and part numbers are subject to change without notice.

Table 2 — eCarePAKs

eCarePAKs are available for purchase through a Canon Authorized Service Facility. For more information, see [“CarePAK Extended Service Plans.”](#) on p. 21.

Model	Tier	Extended Coverage Length and Type	Item Number ³
Color imageCLASS MF628Cw and MF624Cw	2E	1 Year On-site	5707B042AA
		2 Year On-site	5707B043AA
		3 Year On-site	5707B044AA
		4 Year On-site	5707B045AA

³ Item numbers and part numbers are subject to change without notice.

B. Box Contents

Note: The box contents shown below are for reference purposes only, and are subject to change without notice.

- Color imageCLASS MF628Cw or MF624Cw Device
- Power Cord
- Cartridge 131 Starters (CMYK)
- Telephone Cable (MF628Cw only)
- Starter Guide
- Warranty Card
- User Manual/Software DVD-ROM

III. Service Authorization

To obtain and maintain authorization to provide warranty and post-warranty service, each Authorized Service Facility must have at least one (1) technician who has successfully completed the Color imageCLASS MF700Cdw/MF600Cw Online Training Program.

IV. Educational Training

A. Training Program Overview

Technicians who successfully complete the Color imageCLASS MF700Cdw/MF600Cw Online Training Program and pass the certification exam are authorized to service and support the Color imageCLASS MF700Cdw and MF600Cw Series.

The Color imageCLASS MF700Cdw/MF600Cw Online Training Program is available via the TRAINING section of the [e-Support Center Web](#) site.

B. Certification

The successful completion of the Color imageCLASS MF700Cdw/MF600Cw Online Training Program and passing of the final assessment exam are required to sell and service this product.

Certification includes the following models:

- imageCLASS MF729Cdw
- imageCLASS MF726Cdw
- imageCLASS MF628Cw
- imageCLASS MF624Cw.

C. Who Should Complete

All service technicians who are responsible for installing, servicing, and supporting the Color imageCLASS MF600Cw Series machine must successfully complete the Color imageCLASS MF700Cdw/MF600Cw Online Training Program and pass the certification exam to receive technical support and dealer authorization to sell these products.

D. Prerequisites

Prior to taking the Color imageCLASS MF700Cdw/MF600Cw Online Training Program, technicians are required to successfully complete the Color imageCLASS MF8580Cdw/8280Cw online training.

The Color imageCLASS MF8580Cdw/MF8280Cw online course is available via the TRAINING section of the [e-Support Center](#) Web site.

It is also highly recommended the service technician have:

- Prior experience with Canon imageCLASS MF devices
- Experience with taking eLearning courses
- Familiarity with common hand tools to disassemble and service Canon devices

E. Course Format

The Color imageCLASS MF700Cdw/MF600Cw Online Training Program is a self-paced course. It covers the differences between this series and its predecessor, the MF8580/8280 series.

Learners should download the following resources to have as a reference while taking this course:

- Print Version of the Course
- Service Manual
- e-Manual

It takes approximately 1 hour to complete this course successfully. It is important that a quiet and undistracted learning area be set up by the student beforehand to effectively take this course.

F. Course Equipment

- Windows workstation with audio and access to the Training section of the [e-Support Center](#) Web site
- Flash-enabled Web browser (preferably Microsoft Internet Explorer)

It is necessary to enable file downloads in Internet Explorer to download the documents supplied within the course. Internet Explorer 8 disables the file download option by default. To enable Internet Explorer 8 to download files, perform the following steps:

1. Open Internet Explorer, select the “Tools” menu.
2. Click “Internet Options”.
3. Click “Security”.
4. Click “Custom level”.
5. Scroll down to the Downloads section, and click “Enable” under <Automatic prompting for file downloads> and under <File download>.
6. Click “OK” to close all the dialog boxes.
7. Close and reopen Internet Explorer. You should now be able to download the learning resources contained within the course.

V. Servicing Notes

A. Power and Plug Requirements

Canon USA strongly suggests dedicated and properly grounded outlets be provided for the Color imageCLASS MF628Cw and MF624Cw devices.

The Color imageCLASS MF628Cw and MF624Cw devices require a NEMA 5-15 receptacle for proper operation. Before installation, confirm that the proper dedicated NEMA receptacles are available for these devices.

Table 3 — Power and Plug Requirements

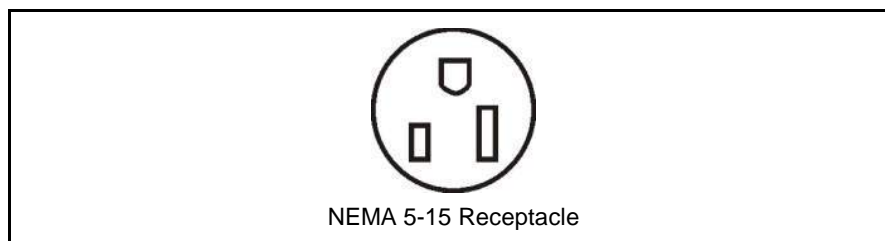

Table 4 — Power Requirements for the Main Unit

Part or Accessory	Power Supply	Power Supply Cord/Plug Specifications	Length of Power Cord
Main Unit	1-120V/15 A outlet	NEMA 5-15	8.5' (2.6 m)



IMPORTANT

- We recommend an additional standard 120V/15 A outlet for service tools, such as a laptop computer or vacuum that may be used when servicing or configuring the machine.
- Use only dedicated and properly grounded outlets for the main unit. It is also strongly suggested to use dedicated and properly grounded outlets for each optional accessory. Do not use extension cords. The ground connection serves to provide the internal electronics with a reference voltage. Faulty or poor ground sources will cause this reference voltage to fall into a range that no longer serves as a reliable reference voltage. The internal logic and programming of the Color imageCLASS MF628Cw and MF624Cw machines will not perform reliably because there is an insufficient difference between the internal operating signal voltages and the poor ground reference signal. A qualified electrician can measure and provide the ground source that the Color imageCLASS MF628Cw and MF624Cw machines or any computer controlled office equipment requires.
- Before installation, confirm that all necessary receptacles are available.

B. Installation Space Requirements

The Color imageCLASS MF628Cw and MF624Cw machine approximate installation space requirements may differ, depending on how the machine is configured and the optional accessories attached. Always ensure that there is enough space for service and operation of the device.



IMPORTANT

- Make sure to keep the back and sides of the machine approximately 4” (100 mm) away from a wall for the proper servicing of the equipment.
- Make sure that approximately 19 3/4” (500 mm) or more space is left around the front, left, and right sides of the machine for the proper servicing of the equipment.
- The surface must be level (with no bows) and flat for the stabilization and support of the machine.

Color imageCLASS Model	Width	Depth	Height
MF628Cw/MF624Cw	17” (430 mm)	19.2” (484 mm)	16.9” (429 mm)

Table 5 — Color imageCLASS MF628Cw/MF624Cw Installation Space Requirements

Width and Depth Requirements

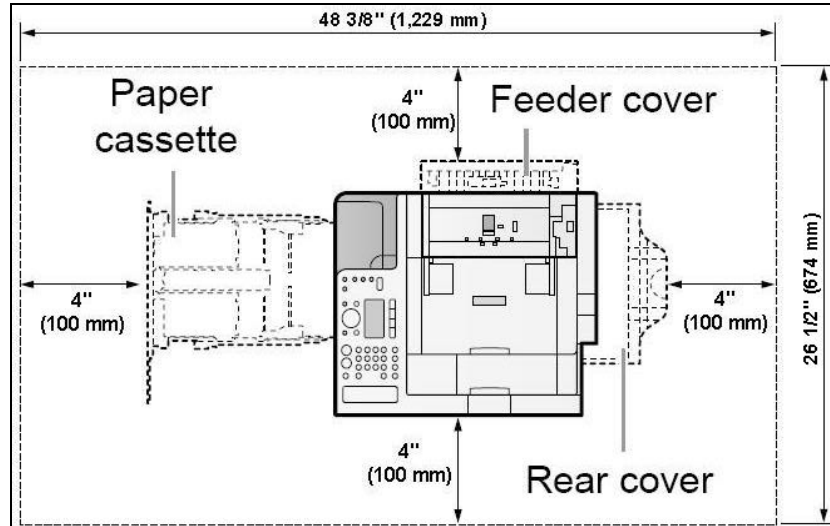

Height Requirements

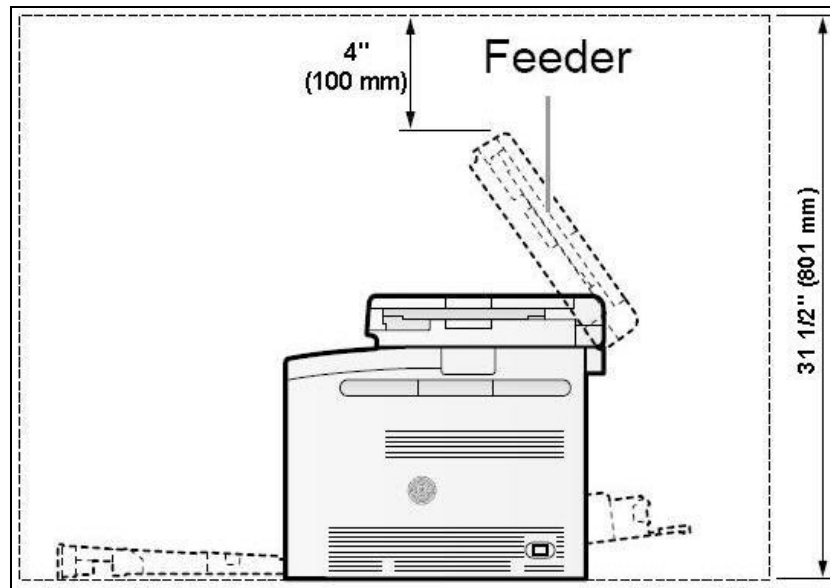

C. Estimated Installation Time

The table below indicates the estimated length of time needed to unpack and install the main unit and optional accessories. The estimated installation times are based on one (1) experienced technician.

Table 6 — Estimated Installation Times

Description	Estimated Time
Color imageCLASS MF628Cw/MF624Cw Main Unit	7 minutes

Note: Use at least two people to carry the machine.

D. Notes on the Wireless LAN

- The Color imageCLASS MF628Cw and MF624Cw is designed for indoor use, and must be kept at a close distance (approximately 16.4' (5 m)) from an access point.
- It is recommended to check if masking is found. Communications between walls and floors can deteriorate; therefore, arrange for the proper installation of the machine to reduce any deterioration in communications.
- Radio wave interference may occur if radio wave equipment, such as a microwave is near the machine, and it is in the same frequency band as the radio wave used by the wireless LAN. Keep the machine away from radio wave sources as much as possible.

E. Special Tools, Solvents, and Oils

The tools listed in the tables below are necessary for the proper servicing of the machine. For more information on the tools below, see the *Color imageCLASS MF628Cw and MF624Cw Service Manual*.

Table 7 — Service Tools

Tool Name	Part Number ³	Usage/Remarks
Tool Case	TKN-0001	—
Jumper Wire	TKN-0069	With clip.
Gap Gauge	CK-0057	0.02 mm to 0.03 mm
Spring Scale	CK-0058	Used to check the paper cassette's spring pressure.
Philips Screwdriver	CK-0101	M4, M5 length: 363 mm
	CK-0104	M3, M4 length: 155 mm
	CK-0105	M4, M5 length: 191 mm
	CK-0106	M4, M5 length: 85 mm
Flat-Blade Screwdriver	CK-0111	—
Precision Slot Head Screwdriver	CK-0114	Six-piece set
Hex-Key Wrench Set	CK-0151	Five-piece set
Smooth File	CK-0161	—
Hex Screwdriver	CK-0170	M4, length: 107 mm
Nipper	CK-0201	—
Long-Nose Pliers	CK-0202	—
Pliers	CK-0203	—
Stop-Ring Pliers	CK-0205	For shaft ring.
Crimping Tool	CK-0218	—
Tweezers	CK-0302	—
Scale	CK-0303	150 mm for measurement
Plastic Hammer	CK-0314	—
Brush	CK-0315	—
Penlight	CK-0327	—
Plastic Bottle	CK-0328	—
Lint-Free Cloth	CK-0336	500 SH/PKG
Oiler	CK-0349	30 cc
Plastic Bottle	CK-0351	30 cc
Digital Multimeter	FY9-2032	—

³ Item numbers and part numbers are subject to change without notice.

Table 8 — Special Tools List

Description	Appearance	Rank	Part Number ³	Remarks
Digital Multimeter		A	FY9-2002-000	Used for electrical checks and adjustment of laser power with the laser power checker.
Rank Description				
A: Each service person must carry one.				

³ Item numbers and part numbers are subject to change without notice.

Table 9 — Solvents and Oils

Type	Uses	Remarks
Alcohol	Cleaning plastic, rubber, metal, oil and toner stains	<ul style="list-style-type: none"> Do not put near fire. Procure locally
Lubricant	Application to gear	<ul style="list-style-type: none"> HY9-0007 (MOLYCOTE EM-50L)
Lubricant	Application to ADF scanning area	<ul style="list-style-type: none"> FY9-6020 (Oil glass cleaner)

F. Cleaning

The parts in the table below require cleaning during a service visit. Follow the procedure listed in the table to clean the corresponding part of the machine.

A diagram of the inside of the machine with the location of the parts in the table below is provided in the *MF628Cw and MF624Cw Service Manual*.

Table 10 — Parts That Require Cleaning

Part	Cleaning Procedure
Pickup Roller	Clean with a dry, lint-free cloth. For heavily soiled parts, use alcohol on the lint-free cloth to wipe off the stains.
Separation Roller	
Paper Feed Guide	
Fixing Front Guide	

G. Consumables

Consumables are all products and materials that are consumed with regular use and cannot be reused. Such consumables include but are not limited to paper and toner.

A number of factors are considered to determine the approximate yield expectancy of a consumable item, including paper size and the amount of coverage per page.

Note: All consumables shown in the table below are estimates for reference purposes only, and are subject to change without notice.

Table 11 — Main Unit Consumables List

Description	Item Number ³	Quantity	Estimated Life (prints) ⁴	Remarks
Cartridge 131 Black	6272B001AA	1	1,400	Based on the ISO/IEC 19798 Standard
Cartridge 131 H Black	6273B001AA	1	2,400	
Cartridge 131 Yellow	6269B001AA	1	1,500	
Cartridge 131 Magenta	6270B001AA	1	1,500	
Cartridge 131 Cyan	6271B001AA	1	1,500	

³ Item numbers are subject to change without notice.

⁴ The value is based on LTR paper with the factory default print density setting.

H. Consumable Parts

Consumable parts are parts that have a limited life, which will be reached during a customer’s specific machine operation, and should then be replaced as needed by a service technician.

The Color imageCLASS MF628Cw/MF624Cw does not have any consumable parts.

Counters

The Color imageCLASS MF628Cw and MF624Cw machines use soft counters to track their functional copy use.

The table below indicates the counter configuration of the Color imageCLASS MF628Cw and MF624Cw machines displayed on the Device Status Check Counter screens. For more information on the counters, see “Viewing the Counter Value” in the *Color imageCLASS MF729Cdw/MF726Cdw/MF628Cw/MF624Cw e-Manual* Maintenance section.

Table 12 — Soft Counter Configuration

Counter	Description
1	Color Total
2	Black & White Total

J. Periodic Replacement Parts

The Color imageCLASS MF628Cw/MF624Cw does not have any periodically replaced parts.

K. Firmware Upgrade

Firmware can be downloaded by the end-user or service technician via a USB cable or a wired/wireless network that is connected to a computer. Firmware is available for download on Canon U.S.A., Inc.'s (hereinafter referred to as Canon USA) public Web site (<http://www.usa.canon.com/cusa/support/consumer/>). When servicing the machine, make sure to go to Canon USA's public Web site, and download the most recent firmware.

Note:

- A computer and the most recent UST (User Support Tool) file are required to install upgraded firmware.
- Only the Main Controller PCB can be upgraded using the UST.
- The UST and firmware are included in the firmware package download from Canon USA's public Web site.

L. Computer Requirements for Downloading Firmware

The recommended desktop PC or laptop requirements⁵ to download the firmware are:

- CPU: Celeron 400 MHz or higher (32-bit processor only)
- Memory: 32 MB of RAM or more
- Free HDD Capacity: 100 MB or more of available hard disk space
- High-Speed USB 2.0 (recommended) or 1.1
- Display: 640 x 480 resolution or better, 256 colors or more
- Operating System (any of the following):
 - Microsoft Windows 2000 Server/Professional
 - Microsoft Windows XP Professional or Home Edition
 - Microsoft Windows Server 2003
 - Microsoft Windows Vista (32-bit processor version only)
 - Microsoft Windows 7, 8, or 8.1
 - Microsoft Windows Server 2008/2012
 - Mac OS X 10.3 or later
- Necessary Cables: High-Speed USB 2.0-compliant cable (as short as possible to avoid connection problems).

Note: Do not use extension cables.

⁵ Specifications are subject to change without notice.

VI. End-User Customer Service Offerings

A. Monthly Copy/Print Volume

The optimum performance range is the volume range that the equipment is intended to run on a regular basis to maintain a high-level of performance and print/copy quality.

The maximum print/copy monthly volume is the maximum number of pages the machine can produce within a one-month period (based on letter size paper). However, the device should not be used to produce the maximum number of pages, or a greater volume, on a consistent monthly basis.

Table 13 — Monthly Copy/Print Volume

Model	Optimum Performance Range	Maximum Monthly Copy/Print Volume
Color imageCLASS MF628Cw and Color imageCLASS MF624Cw	138 to 550 copies/prints	Up to 30,000 copies/prints

B. Limited Warranty Support

The Canon Color imageCLASS MF628Cw/MF624Cw Product Limited Warranty is effective for a period of one (1) year following the delivery of the machine to the original purchaser.

The Canon Toner Cartridge and Drum Limited Warranty is effective for a period of thirty (30) days from the date of the original purchase.

There is no warranty on any consumables, such as paper.

For detailed warranty information, refer to the Limited Warranty card located in the [Appendix](#).

Technical Support for the End-User

The first technical support call from the end-user is handled by CITS (Canon Information Technology Services). The CITS help desk, at 1-800-OK-CANON (1-800-652-2666), is available Monday through Friday, 8 A.M. to 8 P.M. EST (Eastern Standard Time), except for holidays. The CITS help desk provides the following support:

- Answers product related questions.
- Assists the end-user with pre- and post-sales inquiries.
- Attempts to resolve hardware, software, and operational problems.
- Assists the customer with installation and setup.
- If telephone-based troubleshooting fails to resolve a problem, CITS either provides the end-user with the contact information of the nearest ASF for Carry-In Service, or processes an Exchange Service.

Note:

- The CITS help desk times may change without notice.
- The CITS help desk only diagnoses problems with your machine.

1. Carry-In Service

Carry-In Service provides the end-user with a local ASF where they can carry in the defective product and have it repaired.

CITS will help the end-user over the telephone to diagnose any problems with the machine first. If telephone-based troubleshooting fails to resolve the problem, the CITS help desk will provide the end-user with the contact information of the nearest ASF location that can provide Carry-In Service.

The end-user needs to contact the ASF to schedule a repair.

2. Exchange Service

The Exchange Service option enables Canon USA to ship the end-user a replacement product for the defective product.

CITS will help the end-user over the telephone to diagnose any problems with the machine first. If telephone-based troubleshooting fails to resolve the problem, and Exchange Service is requested, the CITS help desk issues the end-user a Return Authorization Number.

The end-user must provide the CITS help desk with the following information:

- Product serial number
- A ship to location for the replacement product

Canon USA will ship a replacement product to the end-user by the next business day (two (2) business days Exchange Service for Alaska and Hawaii), provided the request is made prior to 4 P.M. EST, Monday through Friday, except for holidays.

The replacement product includes a prepaid shipping label for the return shipment of the defective product back to Canon USA. The end-user must ship the defective product within ten (10) days of receipt of the replacement product.

3. Internet Support

End-user support is also available via the Canon USA consumer Web site: <http://consumer.usa.canon.com>. The end-user can access print drivers, software downloads, FAQs (Frequently Asked Questions), register their product, review promotions, and research products. Information for technical support by telephone, e-mail, and third-party service provider locations is also available on the consumer Web site.

Figure 1 — Canon USA’s Consumer Web Site

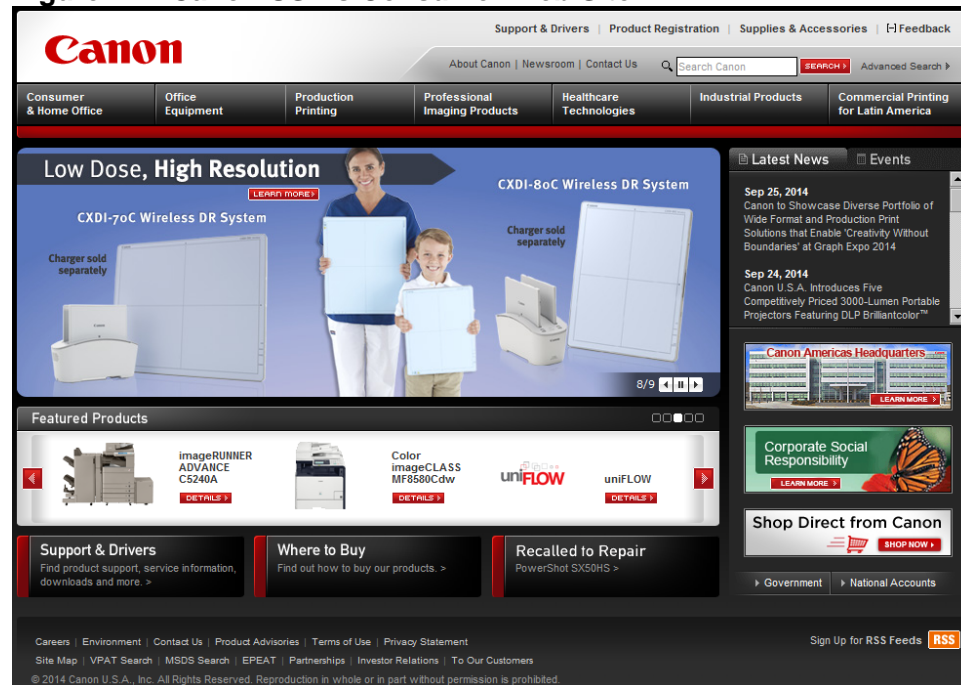

Post-Warranty Support

1. CarePAK Extended Service Plans

There are two CarePAK Extended Service Plans offered by Canon USA, and they differ only in the way one purchases the CarePAK.

Virtual eCarePAK: Purchased directly by the end-user from Canon USA's public Web site www.shop.usa.canon.com.

eCarePAK: Purchased in bulk by a distributor or dealer, who then sells the eCarePAK to their customers.

Both of the Canon CarePAK Extended Service Plans enable the customer to extend the service coverage on their Canon product beyond the one (1) year limited warranty. They provide the customer toll-free telephone support, and if needed, Exchange Service for their Canon product for the duration of the extended coverage. A customer can purchase a 1 to 4 year extended coverage plan for a total of 5 years of coverage.

Note:

- CarePAK coverage cannot be extended beyond the original term purchased.
- The CarePAK Extended Service Plan must be purchased during the product warranty period, and goes into effect on the day the original warranty expires.
- The CarePAK Extended Service Plan does not include coverage for any consumables, such as waste toner containers or paper.
- Reimbursement to the ASF during the CarePAK Extended Service Plan is through the ECP (Electronic Claims Processing) system. See [“Warranty Compensation Procedures,”](#) on p. 30.

a. Virtual eCarePAK Extended Service Plan

1. Purchasing a Virtual eCarePAK Extended Service Plan

An end-user can purchase a Virtual eCarePAK Extended Service Plan online by following the steps below:

1. Go to www.shop.usa.canon.com.
2. Click the "SHOP PRODUCTS" drop-down list.
3. Click "Service Plans".
4. Click the "eCarePAK" icon for imageCLASS products.
5. In the "Enter your product for applicable plans" text box, enter "imageCLASS Laser Printers".
6. Select your imageCLASS model.
7. Select the desired extended service plan's radio button.
8. Read and accept the "Terms & Conditions".
9. Click "ADD TO CART," and follow the instructions to complete the purchase.

Note: During the online purchase process, the end-user is prompted to enter their e-mail address. Once the end-user completes their purchase, they are sent a CarePAK registration number (also called an "Enrollment Number") via an e-mail message with a link to the registration site. (The end-user must purchase and register their Virtual eCarePAK within the manufacturer's warranty period.)

2. Registering a Virtual eCarePAK Extended Service Plan

An end-user can register their Canon CarePAK Extended Service Plan online by following the steps below:

1. Go to www.shop.usa.canon.com.
2. Click the "SHOP PRODUCTS" drop-down list.
3. Click "Service Plans".
4. Next to <Already Purchased a Service Plan for your Product?>, click "Register".
5. Enter the registration number, click "Continue," and then follow the instructions to complete the registration.

Note: After registration is complete, a Certificate of Registration is mailed to the end-user.

b. eCarePAK Extended Service Plan**1. Purchasing an eCarePAK Extended Service Plan**

A customer (end-user) can purchase an eCarePAK Extended Service Plan from the dealer or reseller who sold them the machine. Only an authorized dealer or distributor can purchase an eCarePAK from Canon.

eCarePAK orders must contain the following information:

- Reseller's e-mail address, name, and address
- Customer's e-mail address, name, and address
- The device's model number, serial number, and purchase date

2. Registering an eCarePAK Extended Service Plan

Canon USA registers each eCarePAK, and provides the customer with the terms and conditions that pertain to their purchased eCarePAK Extended Service Plan via U.S. Mail.

Note: Any questions on eCarePAKs should be asked via e-mail message to ecarepak_support@cusa.canon.com.

VII. Authorized Service Facility Program

The Canon USA Authorized Service Facility program enables ASFs to provide warranty and post-warranty service for the Color imageCLASS MF628Cw and MF624Cw.

ASF responsibilities:

For a service facility to be authorized as an ASF, the facility must meet and maintain eligibility requirements under the ASF program. This includes, but is not limited to the following:

- Service technicians must be trained on the Canon Color imageCLASS MF628Cw or MF624Cw.
- The ASF must be able to invoice for repair service through the Internet.
- ASFs must maintain accurate service records. All repairs must be properly recorded, and the records be made available to Canon USA when requested. The ASF must verify the product purchase date, product model, serial number, and log all repairs with any parts used.
- The ASF must inform Canon USA of any changes in company status, including a change of address and changes in service management.
- The ASF must have an established line of credit with Canon USA to facilitate the purchase of spare parts, training programs, and other service materials, as required, to properly support the customer base.
- ASFs are expected to maintain a spare parts inventory, sufficient to support the expected repair volume. ASFs must use **Genuine Canon USA parts** in all repairs.

VIII. ASF Technical Support Offerings

A. ASF Support

ASFs can contact CITS Monday through Friday, 8 A.M. to 8 P.M. EST, except for holidays at 1-866-702-2666. Before contacting CITS, a technician must exhaust all other resources including the service manual, and the [e-Support Center](#) Web site for technical publications and their internal service support infrastructure.

Note: The ASF support times may change without notice.

B. Internet Support

The [Authorized Service Facility Support Center](#) Web site, available from Canon USA's Engineering Services and Solutions Division, provides high-quality support via the Internet.

Canon USA's [Authorized Service Facility Support Center](#) Web site is designed to give ASFs access to the following technical support information:

- Notification of new product releases, patches, and technical publications.
- Read and download online documentation.
- Warranty Claims Processing: ECP (Electronic Claims Processing) System.
- Technical documentation (Service Manuals and Parts Catalogs) and training information.

For information on how to access the WARRANTY section of the Authorized Service Facility Support Center, or how to file a claim, see ["Warranty Compensation Procedures,"](#) on p. 30.

To access online support for ASFs, go to www.support.cusa.canon.com, locate the "Authorized Service Facility Login," and enter the universal PC Copier Servicer ID: **20000** and password: **pccopier**. This serves as your permanent access ID to the Authorized Service Facility Support Center's Web site.

Figure 2 — Authorized Service Facility Login

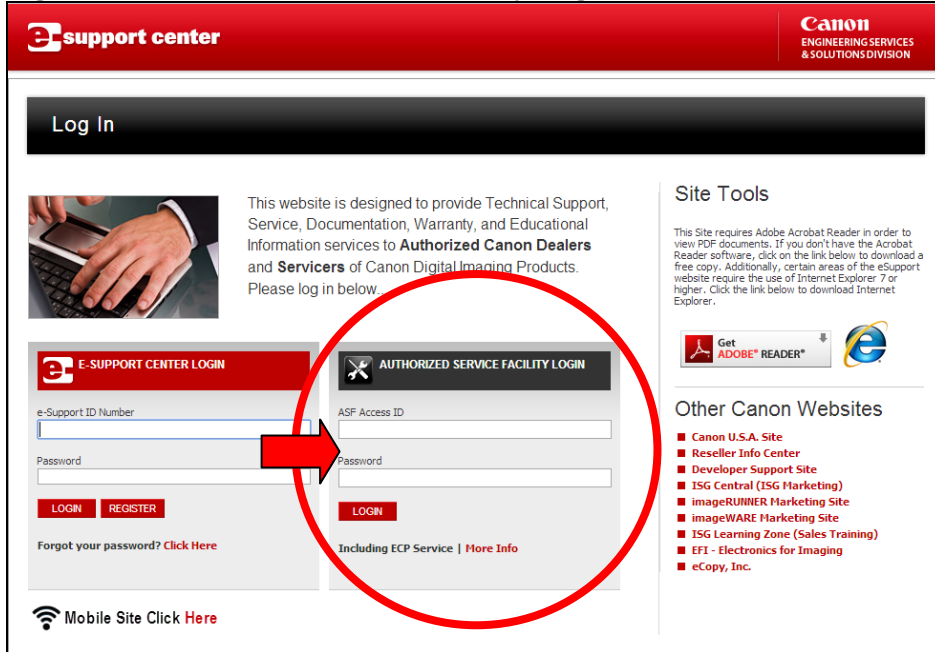
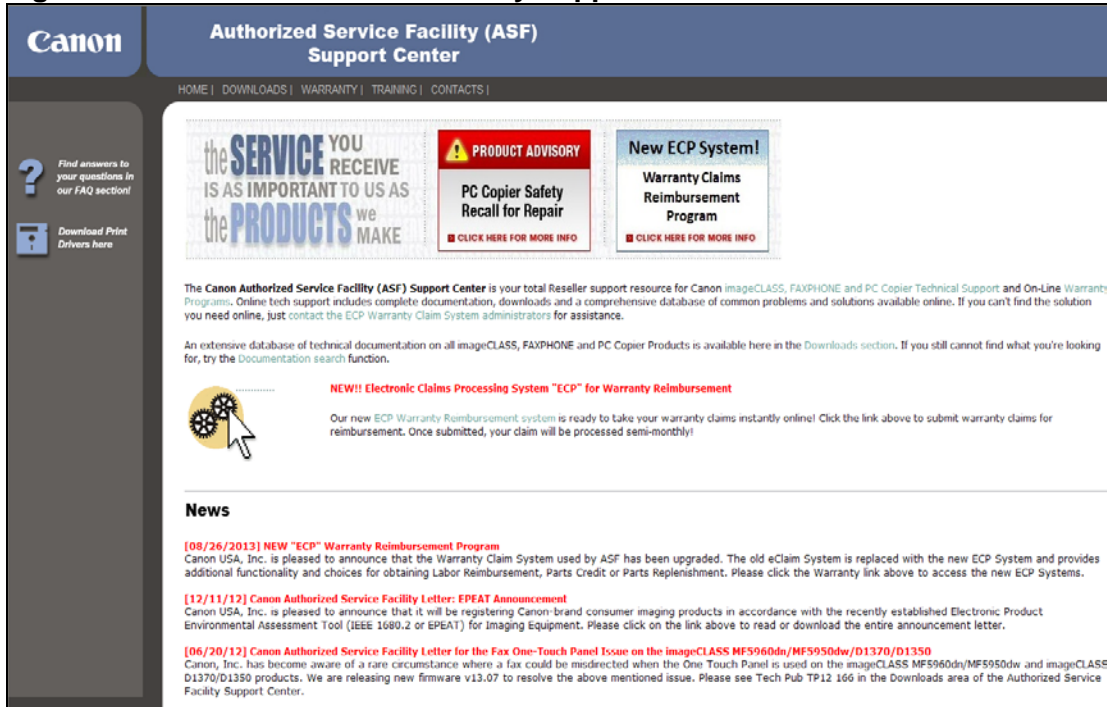

Figure 3 — Authorized Service Facility Support Center



C. Call Escalation Procedure

Canon USA provides a time-sensitive call escalation process for all Color imageCLASS MF628Cw and MF624Cw ASFs. The CITS help desk is the single point of entry for this process. Once a call is placed to the CITS help desk and information is logged into the call management system, a case number is assigned to the call. Every effort is made to resolve the problem during the call. For problems that cannot be resolved during the initial call and require escalation, follow the process below.

Figure 4 — Call Escalation Procedure Flow Chart

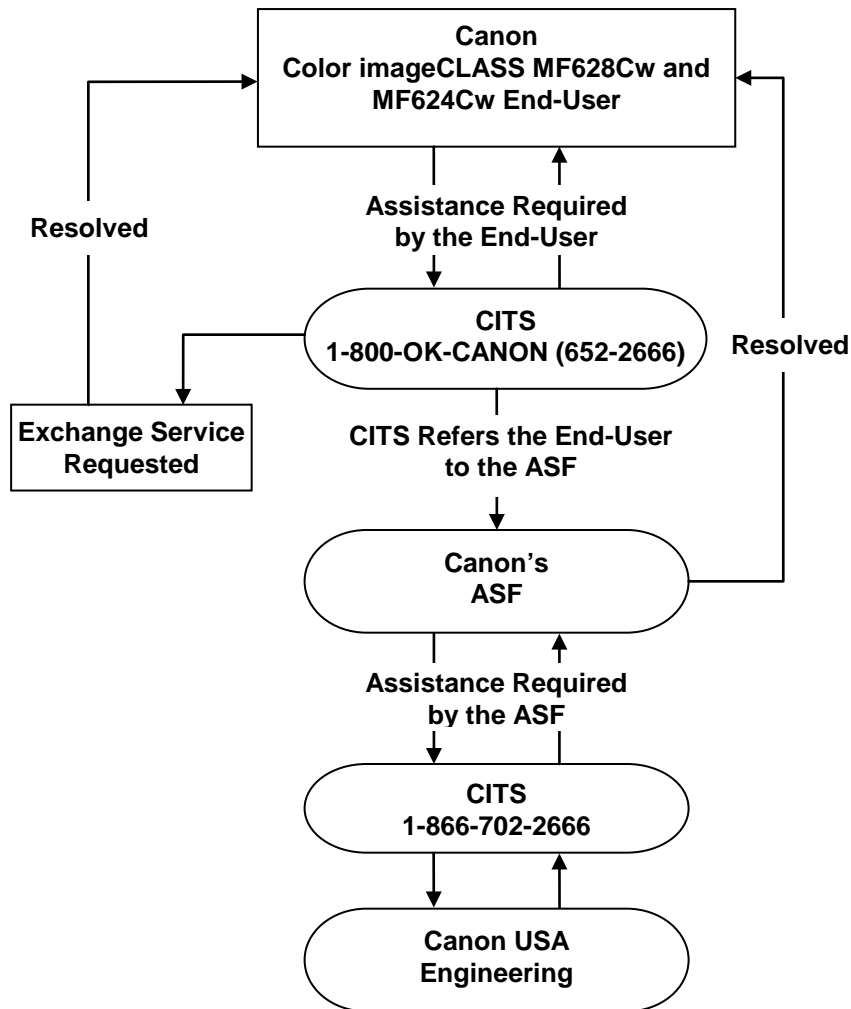

IX. Warranty Procedures

The ECP warranty system includes:

Parts Return Threshold: Defective parts with a dealer cost of \$95.00 or more must be returned to Canon Virginia, Inc. along with a print out of the ECP warranty claim form. Warranty parts claimed and submitted with a value of \$95.00 or more, are put on hold with a status of "Pending Receive" until the parts are received and validated.

Shipping Address for Defective Parts:

Canon Virginia, Inc.
SOHO ASF Warranty
933 Achievement Way
Newport News, VA 23606

Serial Number Validation: The system validates the format of the serial number based on the model submitted for each claim.

Claim Volume Threshold: The ECP system checks the count of how many claims are submitted by the ASF within a 30-day period. If the 30-day period claim count exceeds the claim volume threshold, the claim will not be validated or accepted.

A. Warranty Service Claim Guidelines

The table below describes the guidelines used to determine whether a warranty claim is valid. If a claim does not meet the guidelines for warranty compensation, the customer should be charged for the repair.

Table 14 — Warranty Service Claim Guidelines

Incident Type	Warranty
Manufacturer's defect	Yes
Manufacturer's upgrade	Yes
Service adjustments/normal wear-and-tear	Yes
Installation	No
Installation of drivers	No
Software application related	No
Configuration setup	No
Cleaning	No
Preventative maintenance	No
Customer replaceable items or consumables	No
Tampering	No
Misuse or neglect	No
User training	No
Acts of God	No
Product on which original identifying marks or serial numbers have been defaced, removed, or altered.	No
Problems caused by electrical power fluctuations	No

For questions as to the validity of a repair, contact CITS Monday through Friday, 8 A.M. to 8 P.M. EST, except for holidays at 1-866-702-2666 for authorization.

All ASF repairs must be warranted by the ASF for a period of thirty (30) days. If the same problem occurs within the thirty (30) day time period, the ASF repairs the machine free of charge to the customer. Additional parts may be claimed; however, no additional labor compensation is provided.

B. Warranty Compensation Procedures

The following procedures are designed to help ASFs receive parts and labor compensation for repairs performed under the terms and conditions of the Canon USA limited warranty. To receive warranty compensation during the warranty period, the customer's product serial number is required. Parts costing \$95.00 or more must be returned to Canon Virginia, Inc. as directed through the ECP system. ECP can be accessed through the Authorized Service Facility Support Center's Web site (www.support.cusa.canon.com) in the WARRANTY section. For access to the ECP warranty processing system, click on the WARRANTY tab. You are prompted for your User ID and Password via the CNA (Canon Network Access) screen.

Contact the ECP administrator directly at eclaimadmin@cusa.canon.com to report problems with the ECP system, or if you experience problems accessing this site.

Figure 5 — ECP Log In

There is an *Electronic Claims Processing User's Guide for Authorized Service Facilities* available online to assist with questions regarding the ECP system.

All claims must be submitted within thirty (30) days of repair.

To access the ECP Claims Processing Center, click on the “ECP BISG Division” link.

Figure 6 — ECP Access Link



1. Adding a New Technician

Before an ASF can submit a new claim, a technician must be added to the Technician List.

From the ECP Home Page, select the “ASF” tab, and then select “Technician List”.

Figure 7 — ECP Home Page – ASF Tab

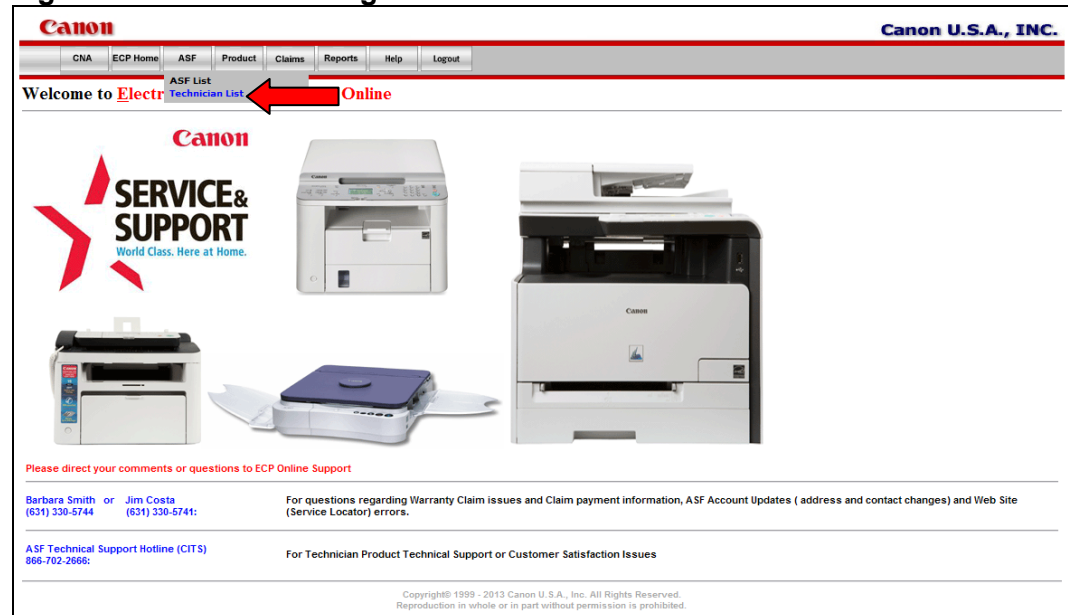

Click “Add New”, enter the technician’s information, and then click “Submit”.

Figure 8 — ECP ASF Tab – Technician List

Figure 9 — ECP ASF Tab - Add Technician Information

2. Submit a Warranty Claim

To open a new warranty claim, select “Open New Claim” from the “Claims” tab at the top of the ECP home page. Select your ASF location, and the screen self-populates with your company’s name.

You are required to select or enter the following information:

- Technician Name who performed the service
- Model Name
- Serial Number
- POP (Proof of Purchase) Date

After all the information is entered, click the “Validate” button to process the claim. If a warning is displayed about the data entered during the claim process, the system specifies which values are invalid. The system also checks whether the unit is still under warranty, and generates a unique claim number for the submitted claim. Continue filling in your claim information, including the Problem Code, Cause Code, and any parts used in the service of the unit.

Warranty labor compensation is issued via Direct Deposit on a bi-weekly basis, as claims are validated by the ECP System Administrator.

Figure 10 — ECP Home Page – Claims Tab

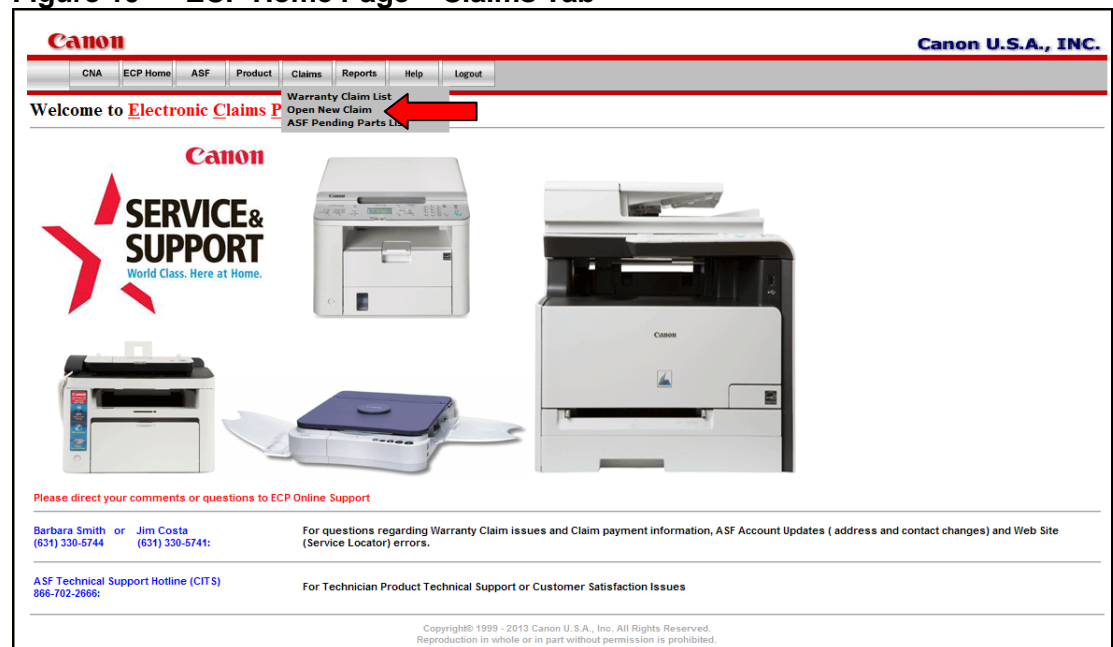

Figure 11 — ECP - Open New Claim Screen

Canon **Canon U.S.A., INC.**

CNA ECP Home ASF Product Claims Reports Help Logout

Open New Claim

Step 1 of 3 - Model Information Validation

Claim#:		Claim Status:	Not Submitted
Account Code:	H26C	Account Name:	HY TECH COPERS INC
Tech Name:	Please select a Technician	Account Phone:	562-
Model Name:	Please select a Model	Model Number:	
Serial#:		Repair Number:	
Warranty Days:		POP Date:	
Exception Code:		Submitted Date:	08/30/2013

Copyright© 1999 - 2013 Canon U.S.A., Inc. All Rights Reserved.
Reproduction in whole or in part without permission is prohibited.

3. Parts Return

Once the Parts List section on the Open New Claim screen is saved, the screen displays additional fields for Parts Compensation.

Select either “Replenish” or “Credit” for “Parts Compensation”, depending on if you want to replenish the parts used from your inventory, or receive a credit for the parts used to repair the unit.

Note: For each claim, the ASF can select to either receive a credit for the purchase price of the parts, or replenish the parts used to repair the unit. If “Credit” is selected, the ASF receives a credit to their account that can be used to purchase other parts in the future. If “Replenish” is selected, then Canon ships the parts listed free of charge to the ASF.

Figure 12 — ECP – Submit Parts Compensation

The screenshot displays the 'Open New Claim' interface for Canon U.S.A., INC. The form is divided into three steps. Step 1 (Model Information Validation) includes fields for Claimant, Account Code, Tech Name, Model Name, Serial#, Warranty Days, Exception Code, and ASF Dispatch Flag. Step 2 (Save Customer Problem/Cause & Parts Used In Claim - Information) includes fields for First Name, Last Name, Address, City, State, Zip, Phone, Company, Fax, Problem Code, and Cause Code. A Part List table is shown below Step 2. Step 3 (Submit Part Compensation/Location/Action/Repair Time) is highlighted with a red box and includes the 'Parts Compensation' section with radio buttons for 'Replenish' and 'Credit', an 'Action Code' dropdown, 'Ship Method' and 'Location Code' dropdowns, 'BMW Page Count', 'Total Repair Time', and 'Completion Date' fields, along with a 'Comments' text area and 'Submit' and 'Cancel' buttons.

Enclose a copy of the ECP warranty claim in the box with the defective parts. Parts identified for return must be received within fifteen (15) days. Defective parts that were replaced during warranty service, with a cost over \$95.00, must be returned and shipped to:

Canon Virginia, Inc.
SOHO ASF Warranty
933 Achievement Way
Newport News, VA 23606

Note: For defective parts over \$95.00 that must be returned, Canon USA will reimburse the ASF \$7.50 for the shipping costs to Canon Virginia, Inc.

X. Parts Support

A. Parts and Service Material Orders

1. Canon Network Access

If you have direct access to CNA, log on to the CNA Web site via <http://www.cna.cusa.canon.com>. However, you can also access CNA through Canon USA’s ISG Central Web site, and access the CNA section via the “Canon Network Access (CNA)” tab.

All Authorized Service Facilities are recommended to submit their parts purchase orders electronically via CNA. The Authorized Service Facility is responsible for all shipping costs related to their order.

Figure 13 — CNA Log In

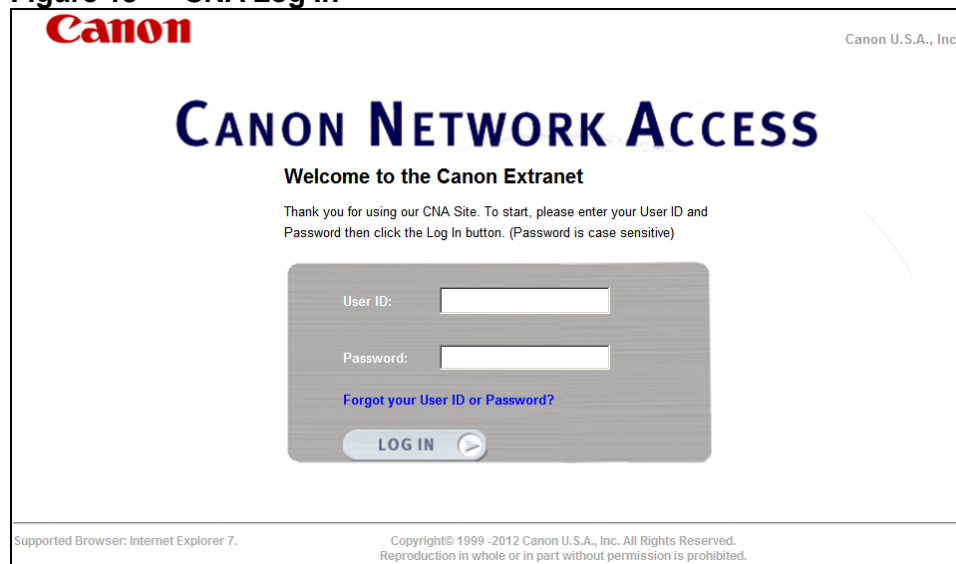

Figure 14 — ISG Central



The CNA Web site enables you to:

- Order parts
- Download parts information and the parts price list
- View the parts discontinuation schedule information
- Inquire about orders and invoices

The CNA Web site is accessible 24 hours a day, and 7 days a week.

2. Parts Order Desk

Authorized Servicer Facilities without access to the CNA Web site must contact the Canon Parts Order Desk at 1-866-481-2569. The Authorized Service Facility is responsible for all shipping costs related to their order.

B. Parts Order Entry

1. Regular Orders

All parts for regular orders are shipped via ground once the parts orders are printed by Canon USA, unless an alternate shipping method is requested by the Authorized Service Facility for rush orders.

Note: Shipments may be delayed for credit review.

2. Rush Orders

To ensure same day shipment of rush orders, submit all one (1) and two (2) day emergency purchase orders no later than 4 P.M. EST.

All purchase orders placed through CNA are confirmed via an e-mail message.

C. Parts Information/Parts Price List Download

All parts information for active parts are made available on the CNA Web site under the Parts Information link. Downloadable files by model and product are also available under the Parts Information link.

Note: Authorized Service Facilities without access to the CNA Web site must contact the Canon Parts Order Desk at 1-866-481-2569.

D. Parts Discontinuation Schedule Information

Parts discontinuation information is available on the CNA Web site under the Parts/Supply Discontinuation link. Information is available regarding active machines, machines scheduled to be discontinued within the year, and discontinued machines.

Note: Authorized Service Facilities without access to the CNA Web site must contact the Canon Parts Order Desk at 1-866-481-2569.

E. Order/Invoice Inquiry

Inquiries concerning purchase orders and invoices can be made on the CNA Web site. You can search using the purchase order, invoice number, or conduct a search for the most recent date required. For additional tracking information, purchase orders that have been shipped contain a link to the UPS (United Parcel Service) Web site. For questions concerning parts, please send an e-mail message to canonparts@cusa.canon.com.

Note: New Accounts are not available on the CNA Web site. Authorized Service Facilities without access to the CNA Web site should contact the Canon Parts Order Desk at 1-866-481-2569 for order and invoice inquiries.

Figure 15 — Canon Network Access



XI. Appendix
A. Specifications

Note: All specifications are for reference purposes only, and are subject to change without notice.

Table 15 — Machine Specifications

Item		Description
Dimensions (H x W x D)		Approximately 16.9" x 17" x 19.2" (429 mm x 430 mm x 484 mm)
Weight		Approximately 57.3 lb (26 kg)
Cartridge		Canon Cartridge 131 Black yields approximately 1,400 LTR pages with the factory default print density setting. Canon Cartridge 131 H Black yields approximately 2,400 LTR pages with the factory default print density setting. Canon Cartridges 131 Yellow, Magenta, and Cyan yield approximately 1,500 pages with the factory default print density setting.
Cartridge Type		Four cartridge system (Black, Yellow, Magenta, and Cyan)
Maximum Monthly Print Volume		Up to 30,000 prints
Power Requirements		120V AC, 60 Hz
Plug		NEMA 5-15
Power Consumption	Maximum	Approximately 900 W
	Standby Mode	Approximately 20 W
	Sleep Mode	Approximately 2 W
	Main Power Switch Turned OFF	Approximately 0.5W
Warm-Up Time		Approximately 23 seconds ⁶ (Temperature: 23°C (73.4°F), humidity: 65% RH (Relative Humidity); from when the machine is turned ON using the main power switch to when copying becomes available)
Environmental Conditions		Temperature: 50°F to 86°F (10°C to 30°C) Humidity: 20% to 80% RH (Relative Humidity) (no condensation)

⁶ Warm-up time may vary, depending on the installation environmental conditions.

Table 16 — Copy Specifications

Item	Description
Copy Speed⁷ (LTR)	Up to 14 cpm
Copy Resolution	Text/Photo/Map Color (High Speed): Up to 300 dpi x 300 dpi Text/Photo/Map B/W (High Speed): Up to 300 dpi x 600 dpi Text/Photo/Map B/W: Up to 300 dpi x 600 dpi Text/Photo/Map (Quality), Photo, Text: Up to 600 dpi x 600 dpi
First Copy Time⁸	Approximately 19 seconds
Reduction/Enlargement	25%, 50%, 64%, 78%, 100%, 129%, 200%, 400%
Zoom	25% to 400% in 1% increments
Continuous Copying Capacity	Up to 99 copies
Maximum Copy Size	Platen: Up to 8 1/2" x 11" ADF: Up to 8 1/2" x 14"
Copy Memory	512 MB (Shared)

7 The copy/print speed is measured during continuous copy/print runs. Copy/print speeds may vary, depending on the paper type, size, and paper feeding direction. Copy/print speeds on smaller paper sizes may be slower. Also, the machine may experience downtime or decrease the copy/print speed in the middle of a continuous copy/print run to adjust the temperature inside the machine or maintain the optimal print quality.

8 LTR size, after returning from the Energy Saver mode.

Table 17 — Print Specifications

Item	Description
Type	Color Laser
Print Speed ⁷ (LTR, Plain Paper)	Up to 14 ppm (pages per minute)
First Print Time ⁹	Approximately 18 seconds
Printer Language	Canon UFR II LT (Host-based)
Print Resolution	Up to 600 x 600 dpi
Gradation	256 gradations
Maximum Print Size	Up to 8 1/2" x 14" (LGL)
Output Tray Capacity	Approximately 150 sheets (21 lb bond (80 g/m ²))
Print Memory	512 MB (Shared)

⁷ The copy/print speed is measured during continuous copy/print runs. Copy/print speeds may vary, depending on the paper type, size, and paper feeding direction. Copy/print speeds on smaller paper sizes may be slower. Also, the machine may experience downtime or decrease the copy/print speed in the middle of a continuous copy/print run to adjust the temperature inside the machine or maintain the optimal print quality.

Table 18 — Scan Specifications

Item	Description
Scanner Type	CIS (Color Contact Image Sensor)
Scanning Speed (LTR at 300 x 600 dpi)	Color: Up to 10 ipm B/W: Up to 21 ipm
Scan Resolution	Optical: Feeder: Up to 300 x 300 dpi Platen Glass: Up to 600 x 600 dpi Software Interpolated: Up to 9,600 x 9,600 dpi
Maximum Document Size	Up to 8 1/2" x 14" (LGL)
Driver	TWAIN WIA (Windows Image Acquisition) 1.0 (Windows XP) WIA 2.0 (Windows Vista, 7, 8, and 8.1)

⁹ May vary, depending on the output environment.

Table 19 — Paper Handling Specifications

Item	Description
Paper Source/Capacity	Paper Cassette: 150 sheet capacity ¹⁰
Document Feeder	Up to 50 sheets (Letter, Legal, Statement) ¹⁰
Paper Output	Approximately 125 sheets (face-down)
Paper Weight	Paper Cassette: 16 lb to 58 lb bond (60 to 216 g/m ²) Manual Feed Slot: 16 lb to 58 lb bond (60 to 216 g/m ²)
Media Sizes	LGL, LTR, STMT, EXEC
Media Types	Plain Paper, Heavy Paper, Bond Paper, Labels, Index Cards, Transparencies, Recycled Paper, and Envelopes
Envelope Capacity	Paper Cassette: Ten (10) envelopes Manual Feed Slot: One envelope
Envelope Types	Com 10, Monarch, DL, C5

Table 20 — Fax Specifications (Color imageCLASS MF628Cw only)

Item	Description
Line Used	PSTN (Public Switched Telephone Network) ¹¹
Communication Mode	Super G3, G3
Modem Speed	Super G3: Up to 33.6 Kbps G3: Up to 14.4 Kbps Automatic Fallback
Compression Method	MH, MR, MMR, JBIG
Transmission Speed	Approximately 3.0 seconds per page ¹² (ECM-MMR, transmitting from memory at 33.6 Kbps)
Fax Resolution	Up to 400 x 400 dpi (Ultra Fine)
Memory Capacity (Sending and Receiving)	Up to 512 pages ¹² (Total pages of transmission/reception) Maximum number of fax jobs that can be sent from memory: 10 Maximum number of fax jobs that can be received into memory: 90
Dialing	19 One-Touch Key destinations, 281 Coded Dialing destinations, 199 Group Dialing destinations, Address Book Dialing, Regular Dialing with the numeric keys, Automatic Redialing, Manual Redialing, 310 Sequential Broadcast destinations, Fax Forwarding, Dial Access, Remote Reception, PC FAX (TX only), Distinctive Ring Pattern Detection, Error Correction Mode, and Auto Redial
Reports	Send Results, Transmission Management Report ¹³ , and RX Results Report

10 Based on 20 lb bond (80 g/m²) plain paper.

11 The Public Switched Telephone Network currently supports fax modem speeds up to 28.8 Kbps, depending on telephone line conditions. Fax machines that can send and receive documents must conform to ITU-T v.34 guidelines.

12 Based on the ITU-T (ITU Telecommunication Standardization Sector) Standard Chart No. 1, MMR standard mode.

13 Output automatically after 40 transmissions.

Table 21 — Connectivity and Software Specifications

Item	Description
Standard Interfaces	<ul style="list-style-type: none"> • USB/USB 2.0 High-Speed (A USB cable is not included.) • 10/100/1000 Base-TX Ethernet (Network) • WiFi 802.11 b/g/n
USB Functions	Print, PC Fax (MF628Cw only), and Scan
Network Functions	Print, PC Fax (MF628Cw only), and Scan
Remote UI	Yes
Bundled Software	Canon drivers, Network Scan Utility, MF Toolbox (scan application), Presto! PageManager, imageWARE Enterprise Management Console Drivers and the Toner Status app are available for download from www.usa.canon.com .
Supported Operating Systems	Windows 10, 8.1, 8, 7, Windows Server 2012 R2, 2012, 2008 R2, 2008, 2003, Windows Vista, Mac OS X 10.5.8 and up, and Linux (Print Only)

Table 22 — E-mail Sending Specifications

Item	Description
Communications Protocol	SMTP
Data Format	PDF (Compact), PDF
Resolution	Black and White: PDF: 300 dpi (MMR Compression) PDF (Compact): Text 300 dpi, Background 150 dpi Color: PDF: 200 dpi (JPEG Compression) PDF (Compact): Text 300 dpi, Background 150 dpi
System Environment	Windows XP/Vista/7/8/8.1/10/Server 2003/Server 2008/Server 2012 Solaris Version 2.6 or later (with Samba 2.2 or later) Mac OS X Red Hat Linux 7.2 or later (with Samba 2.2 or later)
Interface	100BASE-TX, 10BASE-T
Color Mode	Color, Black-and-white
Inputted Image	Text, Text/Photo, Photo
Paper Size	LTR, LGL, STMT

Table 23 — Scanning to Shared Folders Specifications

Item	Description
Communications Protocol	SMB (TCP/IP)
Data Format	PDF (Compact), PDF, JPEG, TIFF
Resolution	Black and White: JPEG: 300dpi TIFF: 300 dpi (MMR Compression) PDF: 300 dpi (MMR Compression) PDF (Compact): Text 300 dpi, Background 150 dpi Color: JPEG: 300 dpi TIFF: 300 dpi (JPEG Compression) PDF: 200 dpi (JPEG Compression) PDF (Compact): Text 300 dpi, Background 150 dpi
System Environment	Windows XP/Vista/7/8/8.1/10/Server 2003/Server 2008/Server 2012 Solaris Version 2.6 or later (with Samba 2.2 or later) Mac OS X (Mac OS X 10.7 and 10.8 not supported) Red Hat Linux 7.2 or later (with Samba 2.2 or later)
Interface	100BASE-TX, 10BASE-T
Color Mode	Color, Black-and-white
Inputted Image	Text, Text/Photo, Photo
Paper Size	LTR, LGL, STMT

B. Warranty

1. imageCLASS Series Exchange/Carry-In Limited Warranty

CANON imageCLASS SERIES EXCHANGE/CARRY-IN PRODUCT LIMITED WARRANTY

The limited warranty set forth below is given by Canon U.S.A., Inc. ("Canon USA") with respect to the Canon imageCLASS Series product and accessories packaged with this limited warranty (collectively, the "Product") when purchased and used in the United States.

Cartridges for the product are covered by a separate warranty. Accordingly, this limited warranty does not cover any cartridges for the product, whether shipped with the product or purchased thereafter.

Canon USA warrants the Product to be free from defects in workmanship and materials under normal use and service for a period of one year after delivery to the original purchaser ("Purchaser") by Canon USA or its authorized Reseller. During the relevant warranty period, and in its sole discretion, Canon USA shall, or shall cause its authorized service provider ("Service Provider"), to, without charge, repair, or replace any defective part with a new or comparable rebuilt part, or exchange the Product with a new or refurbished Product. Warranty replacement shall not extend the warranty period of the malfunctioning Product. This warranty shall not extend to consumables, such as paper, as to which there shall be no warranty or replacement.

Canon USA offers assistance for installation, operation, and support* of the Product as follows:

(a) On-line troubleshooting via a searchable Knowledgebase, answers to frequently asked questions, the latest driver and firmware downloads, and email support at www.cusa.canon.com/support. (b) Toll free telephone support at 1-800-OK-CANON (652-2666), Monday through Friday from 8:00 a.m. to 8:00 p.m. Eastern Time (excluding holidays).

If Canon USA's remote assistance above cannot fix your Product's malfunction, Canon USA shall provide the contact information of the nearest authorized Canon USA Service Provider ("Service Provider") for service, or will exchange the Product, except where the malfunction involves a user replaceable item, in which case Canon USA will send you a replacement part with installation instructions. You will be responsible for installing the user replaceable items in your Product.

If the service or exchange is performed, and (1) the Product malfunction is not covered by this limited warranty, or (2) the applicable warranty period has expired or has not been sufficiently established by appropriate documentation, then you will be charged for such service at the then current service rates of Canon USA or the Service Provider, or for such exchange, as applicable.

This warranty shall only apply if the Product is used in conjunction with compatible computers, peripheral equipment, and software. Canon USA shall have no responsibility for such items except for compatible Canon brand peripheral equipment covered by a separate warranty ("Separate Warranty"). Repairs of such Canon brand peripheral equipment shall be governed by the terms of the Separate Warranty. NON-CANON BRAND COMPUTERS, PERIPHERAL EQUIPMENT AND SOFTWARE WHICH MAY BE DISTRIBUTED WITH THE PRODUCT ARE SOLD AS IS, WITHOUT WARRANTY OF ANY KIND BY CANON USA, INCLUDING ANY IMPLIED WARRANTY OF MERCHANTABILITY OR FITNESS FOR A PARTICULAR PURPOSE. The sole warranty, if any, with respect to such non-Canon brand item is given by the manufacturer or producer thereof.

NO IMPLIED WARRANTY, INCLUDING ANY IMPLIED WARRANTY OF MERCHANTABILITY OR FITNESS FOR A PARTICULAR PURPOSE, APPLIES TO THE PRODUCT AFTER THE APPLICABLE PERIOD OF THE EXPRESS LIMITED WARRANTY STATED ABOVE. NO OTHER WARRANTY OR GUARANTEE, EXCEPT AS MENTIONED ABOVE, GIVEN BY ANY PERSON, FIRM, OR CORPORATION WITH RESPECT TO THE PRODUCT SHALL BIND CANON USA OR ANY SERVICE PROVIDER. NO WARRANTY IS GIVEN ON ANY USED PRODUCT.

This warranty shall be void and of no force and effect if the Product is damaged as a result of (a) abuse, neglect, mishandling, alteration, electric current fluctuation or accident, (b) improper use, including failure to follow operating or maintenance instructions in, or environmental conditions prescribed in, Canon USA's operator's manual or other documentation, (c) installation or repair by other than authorized service representatives qualified by Canon USA who are acting in accordance with Canon USA's service bulletins, (d) use of supplies or parts (other than those distributed by Canon USA) which damage the Product or cause abnormally frequent service calls or service problems, or (e) use of the Product with non-compatible computers, peripheral equipment or software, including the use of the Product in any system configuration not recommended in any manual distributed with the Product. Nor does this warranty extend to any Product on which the original identification marks or serial numbers have been defaced, removed, or altered.

ANY SYSTEM SOFTWARE (WHETHER FACTORY LOADED ON THE PRODUCT OR CONTAINED ON THE SOFTWARE CD-ROMS ENCLOSED WITH, OR ACCOMPANYING, THE PRODUCT), AND ANY UTILITY SOFTWARE, DISTRIBUTED WITH OR FOR THE PRODUCT, IS SOLD "AS IS" AND WITHOUT WARRANTY BY CANON USA. THE SOLE WARRANTY WITH RESPECT TO SUCH SOFTWARE IS CONTAINED IN THE SOFTWARE MANUFACTURER'S LICENSE AGREEMENT DISTRIBUTED THEREWITH, INCLUDING ANY LIMITATIONS AND DISCLAIMERS THEREON. PLEASE CONTACT CANON USA IMMEDIATELY IF YOU HAVE NOT RECEIVED A COPY OF THE SOFTWARE MANUFACTURER'S LICENSE AGREEMENT.

NEITHER CANON USA NOR ANY SERVICE PROVIDER SHALL BE LIABLE FOR PERSONAL INJURY OR PROPERTY DAMAGE (UNLESS CAUSED SOLELY AND DIRECTLY BY THE NEGLIGENCE OF CANON USA OR ANY SERVICE PROVIDER), LOSS OF REVENUE OR PROFIT, FAILURE TO REALIZE SAVINGS OR OTHER BENEFITS, EXPENDITURES FOR SUBSTITUTE EQUIPMENT OR SERVICES, LOSS OR CORRUPTION OF DATA, INCLUDING, WITHOUT LIMITATION, STORAGE CHARGES OR OTHER SPECIAL, INCIDENTAL OR CONSEQUENTIAL DAMAGES CAUSED BY THE USE, MISUSE OR INABILITY TO USE THE PRODUCT, REGARDLESS OF THE LEGAL THEORY ON WHICH THE CLAIM IS BASED AND EVEN IF CANON USA OR ANY SERVICE PROVIDER HAS BEEN ADVISED OF THE POSSIBILITY OF SUCH DAMAGES. NOR SHALL RECOVERY OF ANY KIND AGAINST CANON USA OR ANY SERVICE PROVIDER BE GREATER IN AMOUNT THAN THE PURCHASE PRICE OF THE PRODUCT CAUSING THE ALLEGED DAMAGE. WITHOUT LIMITING THE FOREGOING, THE PURCHASER ASSUMES ALL RISKS AND LIABILITY FOR LOSS, DAMAGE OR INJURY TO PERSONS AND PROPERTY OF THE PURCHASER OR OTHERS ARISING OUT OF THE POSSESSION, USE, MISUSE, OR INABILITY TO USE THE PRODUCT NOT CAUSED SOLELY AND DIRECTLY BY THE NEGLIGENCE OF CANON USA OR ANY SERVICE PROVIDER. THIS WARRANTY SHALL NOT EXTEND TO ANYONE OTHER THAN THE ORIGINAL PURCHASER OF THE PRODUCT AND STATES SUCH PURCHASER'S EXCLUSIVE REMEDY.

*Support options are subject to change without notice.

THIS WARRANTY APPLIES TO PRODUCTS SOLD AND USED IN THE U.S.A. ONLY.



Canon U.S.A., Inc. One Canon Park, Melville, New York 11747
 Canon is a registered trademark of Canon Inc.

Printed in China

FT6-1324-000

2. Canon Toner Cartridge Limited Warranty

CANON TONER CARTRIDGE LIMITED WARRANTY

Canon U.S.A., Inc. and Canon Canada Inc., (collectively "Canon") warrant to the original purchaser ("the Purchaser") of the Canon Toner Cartridge packaged with this limited warranty (the "Cartridge"), when used in a compatible* Canon-brand product (the "Product"), to be free from defects in workmanship and materials under normal use and service for a period of thirty (30) days from the date of original purchase. A defective Cartridge returned to Canon U.S.A., Inc., Canon Canada, Inc. or an authorized dealer (a "Dealer") of Canon U.S.A., Inc. or Canon Canada, Inc. within the thirty (30) day warranty period and proven to be defective upon inspection will be exchanged for a new Cartridge. The warranty period for any replacement Cartridge shall begin upon its shipment and will extend for no longer than the balance of the period remaining on the warranty for the defective Cartridge at the time of such shipment.

When returning any Cartridge under this limited warranty, you must pack the Cartridge in its original carton with a copy of the bill of sale (or invoice of purchase), together with a complete explanation of the problem and return it to the entity from whom you purchased the Cartridge (i.e. Canon USA, Inc., Canon Canada, Inc. or a Dealer). To obtain the shipping address of Canon U.S.A, Inc. or Canon Canada, Inc., please call the Canon U.S.A., Inc. Help Desk at 1-800-828-4040 or Canon Canada Technical Support at 1-800-OK-CANON. Shipping charges, if any, must be prepaid. If your Cartridge is covered by this limited warranty, a new Cartridge will be returned to you without charge by Canon U.S.A., Inc., Canon Canada, Inc. or the Dealer from whom you purchased the Cartridge.

NO IMPLIED WARRANTY OR CONDITION**, INCLUDING ANY IMPLIED WARRANTY OR CONDITION** OF MERCHANTABILITY OR FITNESS FOR A PARTICULAR PURPOSE, APPLIES TO THE CARTRIDGE AFTER THE APPLICABLE PERIOD OF THE EXPRESS LIMITED WARRANTY STATED ABOVE, AND NO OTHER EXPRESS WARRANTY, CONDITION** OR GUARANTY, EXCEPT AS MENTIONED ABOVE, GIVEN BY ANY PERSON OR ENTITY WITH RESPECT TO THE CARTRIDGE SHALL BIND CANON OR ANY SERVICE PROVIDER (SOME STATES AND PROVINCES DO NOT ALLOW LIMITATIONS ON HOW LONG AN IMPLIED WARRANTY LASTS, SO THE ABOVE LIMITATION MAY NOT APPLY TO YOU). NO WARRANTY IS GIVEN ON ANY USED CARTRIDGE.

This limited warranty does not apply to, and does not guarantee, any particular cartridge yield (i.e., number of copies per Cartridge). Cartridge yield will vary depending on average density of originals copied and other factors. See Canon U.S.A.'s or Canon Canada's operator's manual for the Product for further information.

This warranty is void and of no force and effect if the Cartridge is damaged as a result of (a) abuse, neglect, mishandling or alteration of the Cartridge, a Product Accessory or a Product in which the Cartridge is incorporated, electric current fluctuation, exposure to light, or accident; (b) improper use, including failure to follow operating or maintenance instructions in, or environmental conditions prescribed in, the applicable operator's manual or other documentation; (c) installation or repair by other than service representatives qualified by Canon who are acting in accordance with Canon's service bulletins; or, (d) use of supplies or parts (other than those distributed by Canon) which damage the Cartridge or cause abnormally frequent service calls or service problems. Nor does this warranty extend to any Cartridge on which the original lot numbers or dating have been defaced, removed, or altered.

NEITHER CANON NOR ANY SERVICE PROVIDER SHALL BE LIABLE FOR PERSONAL INJURY OR PROPERTY DAMAGE (UNLESS CAUSED SOLELY AND DIRECTLY BY THE NEGLIGENCE OF CANON OR ANY SERVICE PROVIDER), LOSS OF REVENUE OR PROFIT, FAILURE TO REALIZE SAVINGS OR OTHER BENEFITS, EXPENDITURES FOR SUBSTITUTE EQUIPMENT OR SERVICES, LOSS OR CORRUPTION OF DATA, STORAGE CHARGES OR OTHER SPECIAL, INCIDENTAL OR CONSEQUENTIAL DAMAGES CAUSED BY THE USE, MISUSE OR INABILITY TO USE THE CARTRIDGE, REGARDLESS OF THE LEGAL THEORY ON WHICH THE CLAIM IS BASED AND EVEN IF CANON OR ANY SERVICE PROVIDER HAS BEEN ADVISED OF THE POSSIBILITY OF SUCH DAMAGES. NOR SHALL RECOVERY OF ANY KIND AGAINST CANON OR ANY SERVICE PROVIDER BE GREATER IN AMOUNT THAN THE PURCHASE PRICE OF THE CARTRIDGE CAUSING THE ALLEGED DAMAGE. WITHOUT LIMITING THE FOREGOING, THE PURCHASER ASSUMES ALL RISKS AND LIABILITY FOR LOSS, DAMAGE OR INJURY TO PERSONS AND PROPERTY OF THE PURCHASER OR OTHERS ARISING OUT OF THE POSSESSION, USE, MISUSE, OR INABILITY TO USE ANY CARTRIDGE SOLD BY CANON NOT CAUSED SOLELY AND DIRECTLY BY THE NEGLIGENCE OF CANON OR ANY SERVICE PROVIDER. THIS WARRANTY SHALL NOT EXTEND TO ANYONE OTHER THAN THE ORIGINAL PURCHASER OF THE CARTRIDGE.

This limited warranty gives you specific legal rights, and you may also have other rights which vary from state to state or province to province.

THIS WARRANTY APPLIES TO CARTRIDGES SOLD AND USED IN THE U.S.A. AND CANADA ONLY.

* As specified in the Product's operator's manual.

** In Canada

CAUTION:
 Keep out of reach of children.
 Keep from contact with oxidizing materials.
 Refer to instructions for handling and storing.



Canon U.S.A., Inc. One Canon Park, Melville, New York 11747
 Canon Canada, Inc. 6390 Dixie Road Mississauga, Ontario L5T 1P7 Canada

Canon is a registered trademark of Canon Inc.

C. List of Tables

Table 1 — Configuration.....2

Table 2 — eCarePAKs3

Table 3 — Power and Plug Requirements8

Table 4 — Power Requirements for the Main Unit8

Table 5 — Color imageCLASS MF628Cw/MF624Cw Installation Space Requirements10

Table 6 — Estimated Installation Times11

Table 7 — Service Tools12

Table 8 — Special Tools List13

Table 9 — Solvents and Oils13

Table 10 — Parts That Require Cleaning13

Table 11 — Main Unit Consumables List14

Table 12 — Soft Counter Configuration.....15

Table 13 — Monthly Copy/Print Volume17

Table 14 — Warranty Service Claim Guidelines29

Table 15 — Machine Specifications41

Table 16 — Copy Specifications.....42

Table 17 — Print Specifications.....43

Table 18 — Scan Specifications.....43

Table 19 — Paper Handling Specifications44

Table 20 — Fax Specifications (Color imageCLASS MF628Cw only)44

Table 21 — Connectivity and Software Specifications45

Table 22 — E-mail Sending Specifications.....45

Table 23 — Scanning to Shared Folders Specifications46

D. List of Figures

Figure 1 — Canon USA’s Consumer Web Site20

Figure 2 — Authorized Service Facility Login26

Figure 3 — Authorized Service Facility Support Center26

Figure 4 — Call Escalation Procedure Flow Chart27

Figure 5 — ECP Log In.....30

Figure 6 — ECP Access Link31

Figure 7 — ECP Home Page – ASF Tab31

Figure 8 — ECP ASF Tab – Technician List32

Figure 9 — ECP ASF Tab - Add Technician Information32

Figure 10 — ECP Home Page – Claims Tab33

Figure 11 — ECP - Open New Claim Screen.....34

Figure 12 — ECP – Submit Parts Compensation.....35

Figure 13 — CNA Log In37

Figure 14 — ISG Central38

Figure 15 — Canon Network Access40