

imageCLASS MF420 Series

PARTS CATALOG



Canon

November 8, 2017
Rev. 0

Index

SNL	Product Code No./Serial No.
A1	ASSEMBLY LOCATION DIAGRAM
A2	OPTION PARTS CATALOG LIST
001A	ACCESSORIES (120V)
001B	ACCESSORIES (230V)
100A	EXTERNAL COVERS, PANELS, ETC. (MF429dw)
100B	EXTERNAL COVERS, PANELS, ETC. (MF429x)
100C	EXTERNAL COVERS, PANELS, ETC. (MF426dw)
100D	EXTERNAL COVERS, PANELS, ETC. (MF424dw)
101A	INTERNAL COMPONENTS 1 (120V)
101B	INTERNAL COMPONENTS 1 (230V)
102A	INTERNAL COMPONENTS 2 (120V)
102B	INTERNAL COMPONENTS 2 (230V FAX model)
103	INTERNAL COMPONENTS 3
104A	INTERNAL COMPONENTS 4 (MF429dw, MF429x)
104B	INTERNAL COMPONENTS 4 (MF426dw)
104C	INTERNAL COMPONENTS 4 (MF424dw)
130	CONTROL PANEL ASS'Y
160	READER/ADF ASSEMBLY
161	PAPER FEEDER ASSEMBLY
400A	READER ASSEMBLY (US, CA, 120V LTN)
400C	READER ASSEMBLY (AU, SG, IN, HK, 230V LTN)
ZZA	MECHANICAL STANDARD PARTS (HOW TO USE)
ZZB	MECHANICAL STANDARD PARTS (SCREWS)
ZZC	MECHANICAL STANDARD PARTS (BOLTS)
ZZD	MECHANICAL STANDARD PARTS (NUTS)
ZZE	MECHANICAL STANDARD PARTS (RETAINING RINGS)

Figure SNL Product Code No./Serial No.

	Product Code No.	Model Name	Remarks	Serial No.
1	F17-3431-000	imageCLASS MF429dw	120V US, CA, LTN	2BP
2	F17-3441-000	imageCLASS MF429x	230V LTN	2BY
3	F17-3433-000	imageCLASS MF426dw	120V US, CA, LTN	2BQ
4	F17-3443-000	imageCLASS MF426dw	230V LTN	2BZ
5	F17-3434-000	imageCLASS MF424dw	120V US, CA, LTN	2BR

	中オーダー	製品名	備考	シリアル No.
1	F17-3431-000	imageCLASS MF429dw	120V US, CA, LTN	2BP
2	F17-3441-000	imageCLASS MF429x	230V LTN	2BY
3	F17-3433-000	imageCLASS MF426dw	120V US, CA, LTN	2BQ
4	F17-3443-000	imageCLASS MF426dw	230V LTN	2BZ
5	F17-3434-000	imageCLASS MF424dw	120V US, CA, LTN	2BR

FIGURE & KEY NO.	PART NUMBER	RANK	QTY	DESCRIPTION	SERIAL NUMBER /REMARKS
SNL	NPN		RF	Product Code No./Serial No.	
1	F17-3431-000		1	imageCLASS MF429dw	2BP 120V US, CA, LTN
2	F17-3441-000		1	imageCLASS MF429x	2BY 230V LTN
3	F17-3433-000		1	imageCLASS MF426dw	2BQ 120V US, CA, LTN
4	F17-3443-000		1	imageCLASS MF426dw	2BZ 230V LTN
5	F17-3434-000		1	imageCLASS MF424dw	2BR 120V US, CA, LTN

Figure A1 ASSEMBLY LOCATION DIAGRAM

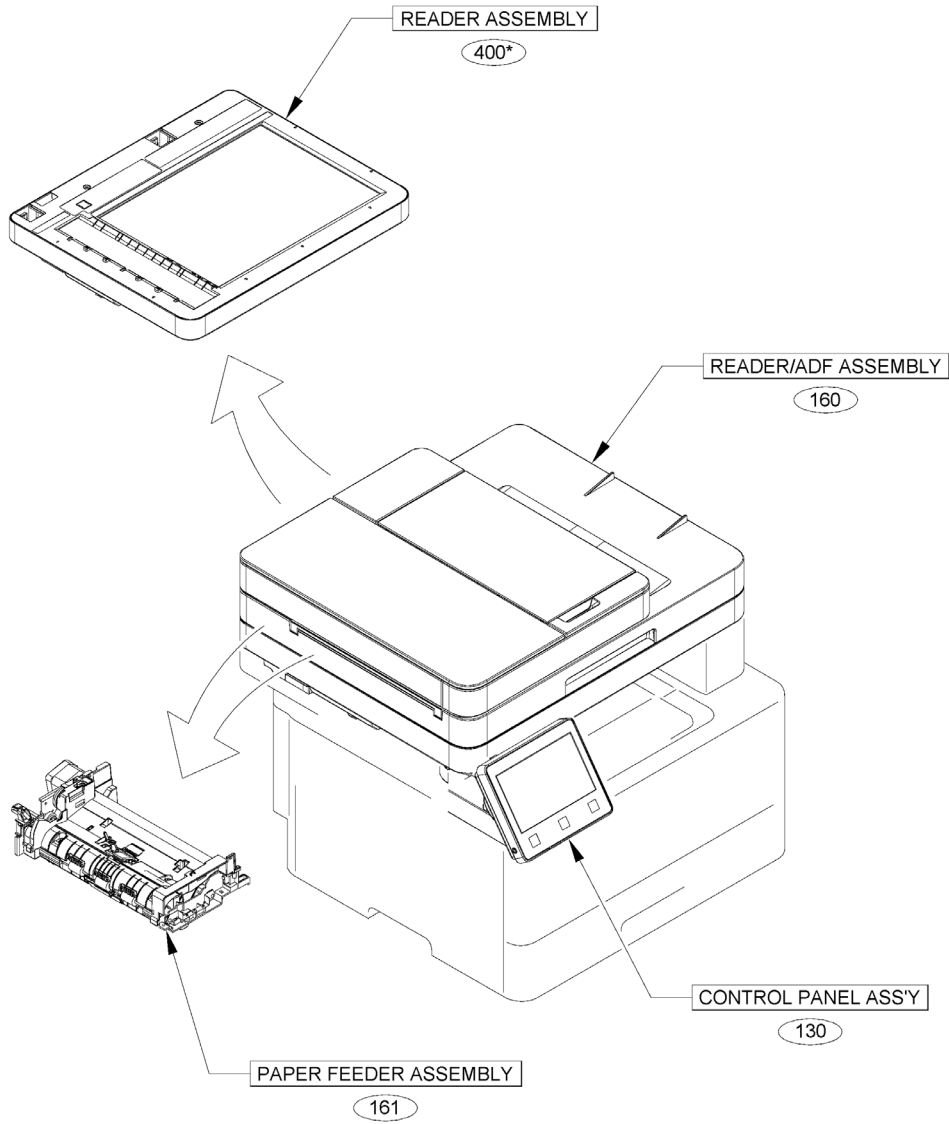

Figure A2 OPTION PARTS CATALOG LIST

This is the table of the machine's options whose parts catalog is issued.
 本機のオプションで、パーツカタログが発行されている機種の一覧である。

No.	Model Name(English)	Model Name(Japanese)
1	Cassette Feeding Module-AH1	(日本仕向けなし)
2	Copy Card Reader Attachment-J1	(日本仕向けなし)
3	HANDSET KIT 3 Long cord Cool White	(日本仕向けなし)
4	TELEPHONE 6 KIT Long cord	(日本仕向けなし)
5	Copy Control Interface Kit-C1	(日本仕向けなし)
6	Copy Card Reader-F1	(日本仕向けなし)
7	MiCARD Attachment Kit-B1	(日本仕向けなし)

Figure 001A ACCESSORIES (120V)

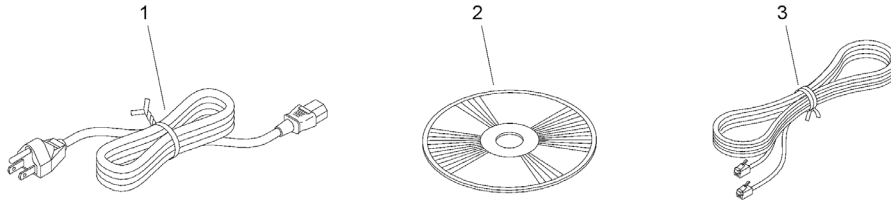

FIGURE & KEY NO.	PART NUMBER	RANK	QTY	DESCRIPTION	SERIAL NUMBER /REMARKS
001A	NPN		RF	ACCESSORIES	120V
1	FK4-3387-000		1	CORD, POWER	
2	FM2-G872-000		1	DVD-ROM, USER SOFTWARE	
3	FK2-5275-000		1	CORD, MODULAR	

Figure 001B ACCESSORIES (230V)

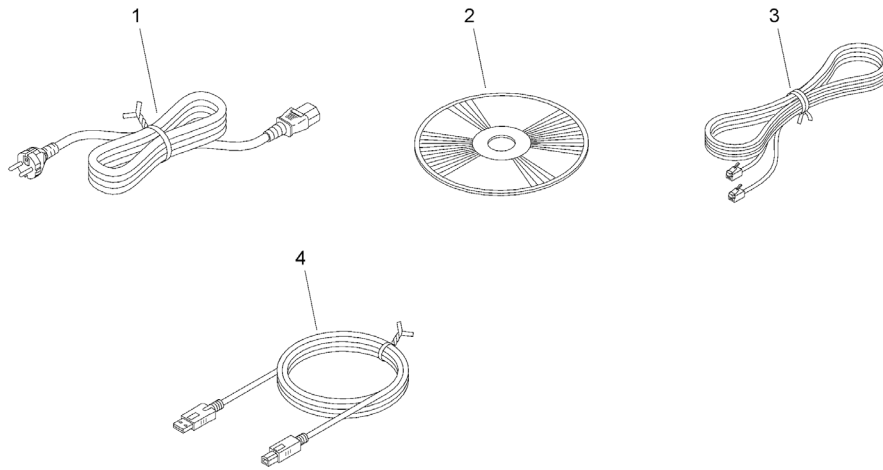

FIGURE & KEY NO.	PART NUMBER	RANK	QTY	DESCRIPTION	SERIAL NUMBER /REMARKS
001B	NPN		RF	ACCESSORIES	230V
1	FK4-3388-000		1	CORD, POWER	
2	FM2-G872-000		1	DVD-ROM, USER SOFTWARE	
3	FK2-5275-000		1	CORD, MODULAR	
4	RK2-1302-000		1	CABLE, USB HOST POWER SUPPLY	

Figure 100A EXTERNAL COVERS, PANELS, ETC. (MF429dw)

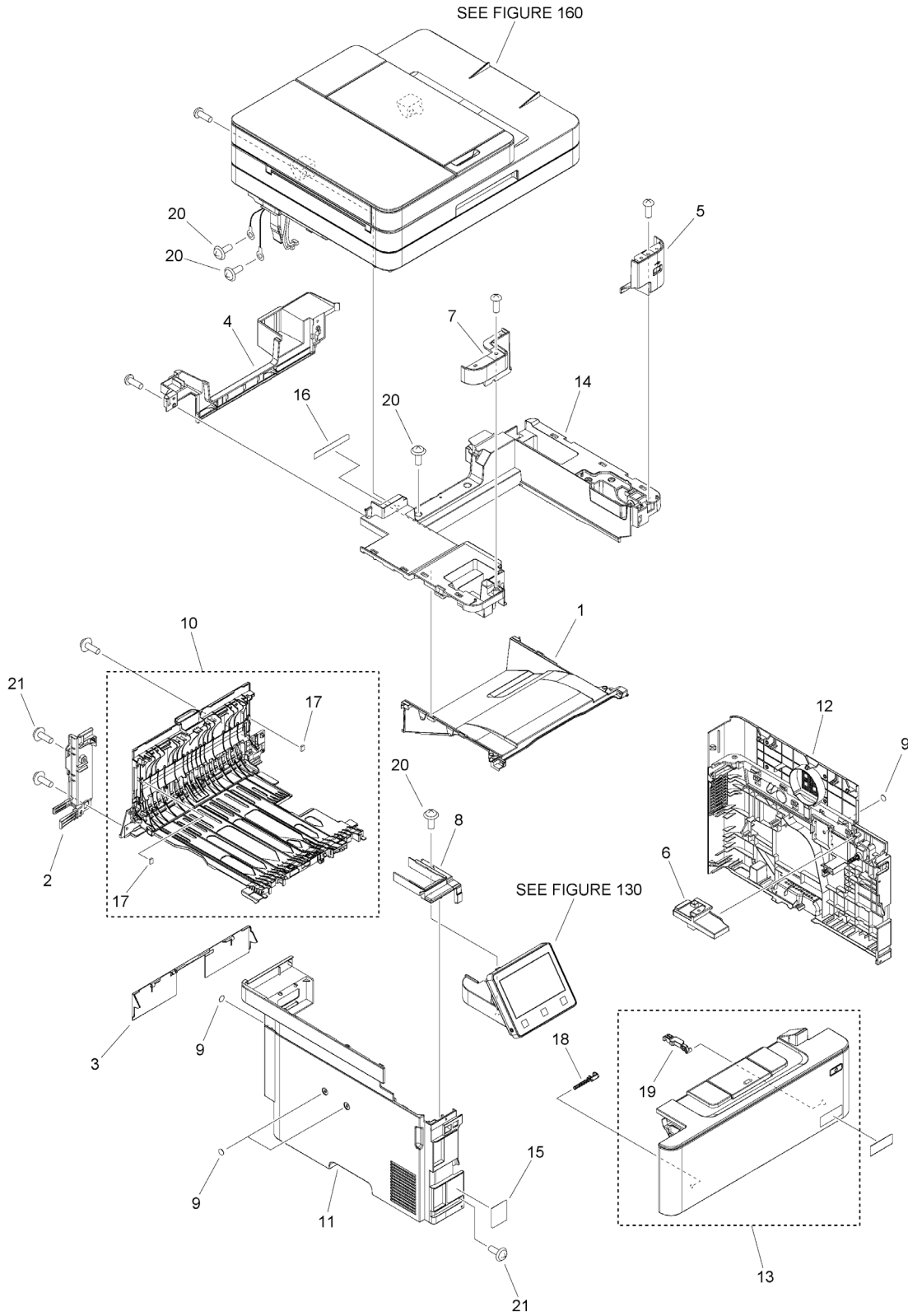

FIGURE & KEY NO.	PART NUMBER	RANK	QTY	DESCRIPTION	SERIAL NUMBER /REMARKS
100A	NPN		RF	EXTERNAL COVERS, PANELS, ETC.	MF429dw
1	FE8-6191-000		1	TRAY, PAPER DELIVERY	
2	FE8-6203-000		1	COVER, LEFT REAR	
3	FE8-6208-000		1	COVER, CASSETTE, REAR	
4	FE8-6747-000		1	COVER, TOP, REAR	
5	FE8-6749-000		1	COVER, TOP, RIGHT FRONT	
6	FE8-6750-000		1	COVER, BLE	
7	FE8-6752-000		1	COVER, TOP, LEFT FRONT	
8	FE8-6753-000		1	COVER, TOP, LEFT	
9	FL1-0525-000		4	SHEET, HANDSET	
10	FM1-R685-000		1	REAR DOOR ASS'Y	
11	FM1-T425-000		1	COVER ASSEMBLY, LEFT	
12	FM1-T443-000		1	COVER ASSEMBLY, RIGHT	
13	FM1-T444-000		1	CARTRIDGE DOOR ASS'Y	
14	FM1-T447-000		1	COVER ASSEMBLY, TOP	
15	FU2-2392-000		1	LABEL, CASSETTE OPERATOR	
16	FU2-2393-000		1	LABEL, HIGH TMP. CAUTION	
17	RC2-6075-000		2	SHEET, DAMPER	
18	RC4-3002-000		1	SHAFT, SUPPORT	
19	RC4-4479-000		1	LINK, PRESSURE RELEASE	
20	XA9-1503-000		10	SCREW, TAP, M3X6	
21	XA9-1671-000		2	SCREW, D, M3X8	

Figure 100B EXTERNAL COVERS, PANELS, ETC. (MF429x)

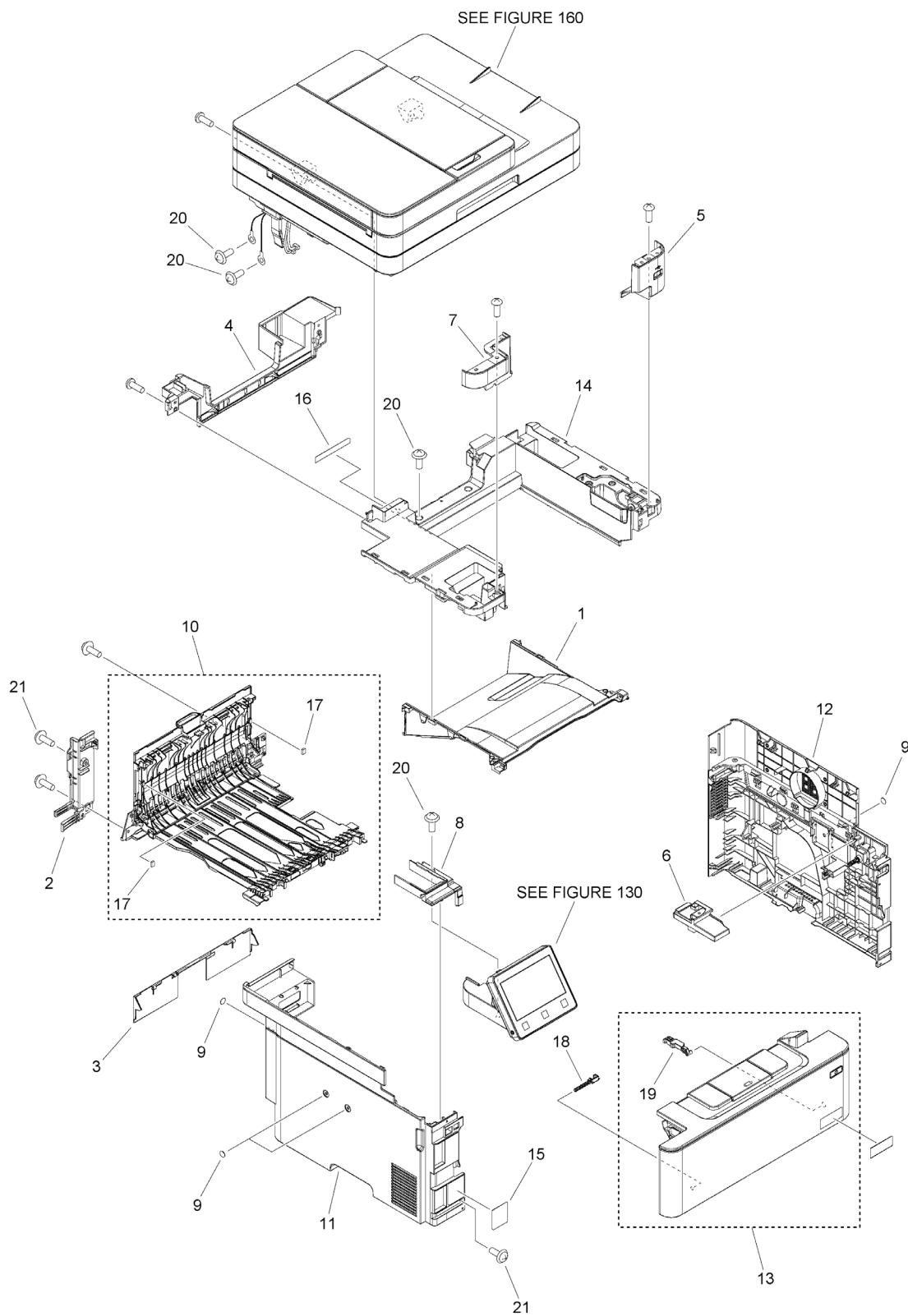

FIGURE & KEY NO.	PART NUMBER	RANK	QTY	DESCRIPTION	SERIAL NUMBER /REMARKS
100B	NPN		RF	EXTERNAL COVERS, PANELS, ETC.	MF429x
1	FE8-6191-000		1	TRAY, PAPER DELIVERY	
2	FE8-6203-000		1	COVER, LEFT REAR	
3	FE8-6208-000		1	COVER, CASSETTE, REAR	
4	FE8-6747-000		1	COVER, TOP, REAR	
5	FE8-6749-000		1	COVER, TOP, RIGHT FRONT	
6	FE8-6750-000		1	COVER, BLE	
7	FE8-6752-000		1	COVER, TOP, LEFT FRONT	
8	FE8-6753-000		1	COVER, TOP, LEFT	
9	FL1-0525-000		4	SHEET, HANDSET	
10	FM1-R685-000		1	REAR DOOR ASS'Y	
11	FM1-T425-000		1	COVER ASSEMBLY, LEFT	
12	FM1-T443-000		1	COVER ASSEMBLY, RIGHT	
13	FM1-T444-000		1	CARTRIDGE DOOR ASS'Y	
14	FM1-T447-000		1	COVER ASSEMBLY, TOP	
15	FU2-2392-000		1	LABEL, CASSETTE OPERATOR	
16	FU2-2393-000		1	LABEL, HIGH TMP. CAUTION	
17	RC2-6075-000		2	SHEET, DAMPER	
18	RC4-3002-000		1	SHAFT, SUPPORT	
19	RC4-4479-000		1	LINK, PRESSURE RELEASE	
20	XA9-1503-000		10	SCREW, TAP, M3X6	
21	XA9-1671-000		2	SCREW, D, M3X8	

Figure 100C EXTERNAL COVERS, PANELS, ETC. (MF426dw)

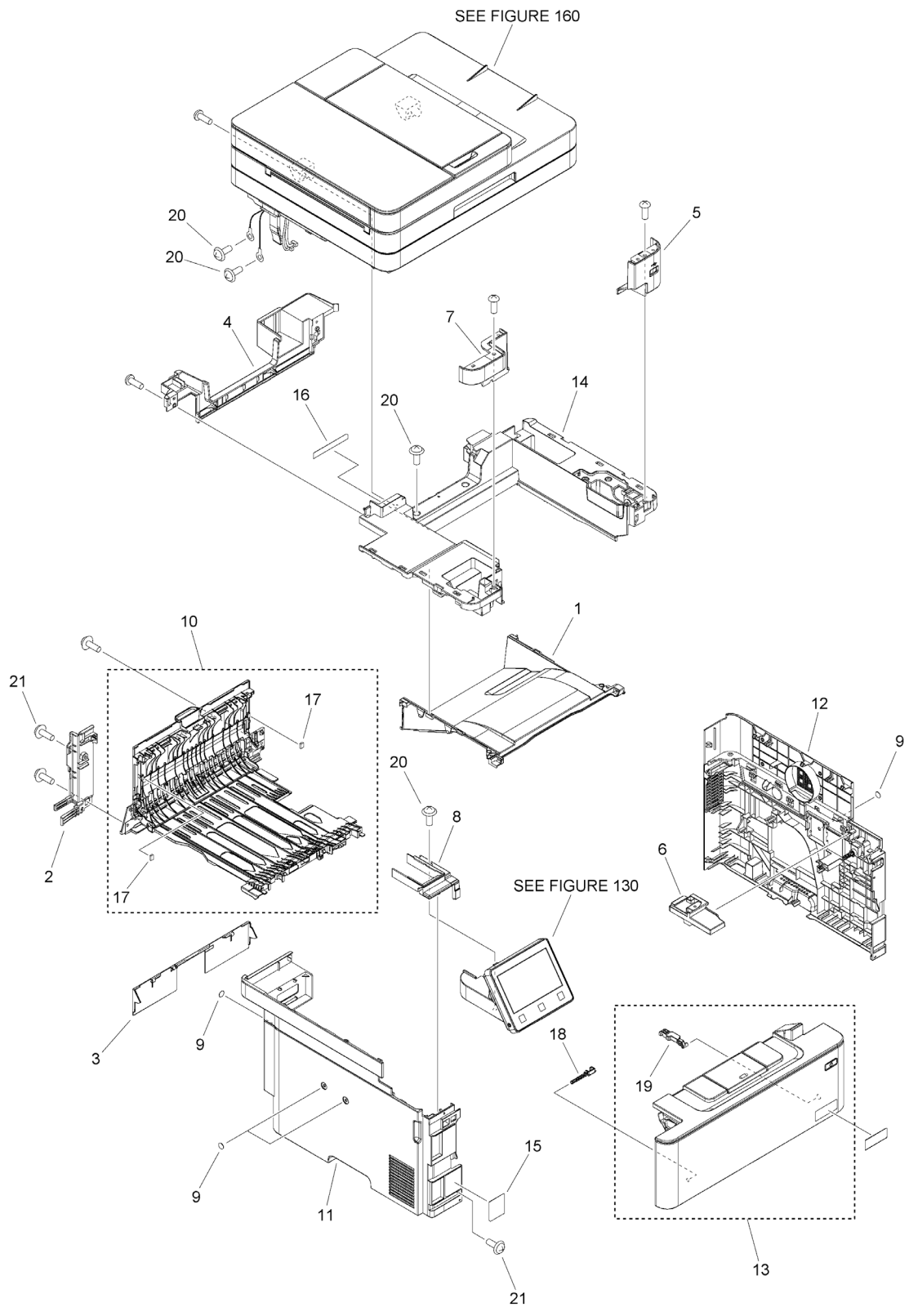

FIGURE & KEY NO.	PART NUMBER	RANK	QTY	DESCRIPTION	SERIAL NUMBER /REMARKS
100C	NPN		RF	EXTERNAL COVERS, PANELS, ETC.	MF426dw
1	FE8-6191-000		1	TRAY, PAPER DELIVERY	
2	FE8-6203-000		1	COVER, LEFT REAR	
3	FE8-6208-000		1	COVER, CASSETTE, REAR	
4	FE8-6747-000		1	COVER, TOP, REAR	
5	FE8-6749-000		1	COVER, TOP, RIGHT FRONT	
6	FE8-6750-000		1	COVER, BLE	
7	FE8-6752-000		1	COVER, TOP, LEFT FRONT	
8	FE8-6753-000		1	COVER, TOP, LEFT	
9	FL1-0525-000		4	SHEET, HANDSET	
10	FM1-R685-000		1	REAR DOOR ASS'Y	
11	FM1-T425-000		1	COVER ASSEMBLY, LEFT	
12	FM1-T443-000		1	COVER ASSEMBLY, RIGHT	
13	FM1-T444-000		1	CARTRIDGE DOOR ASS'Y	
14	FM1-T447-000		1	COVER ASSEMBLY, TOP	
15	FU2-2392-000		1	LABEL, CASSETTE OPERATOR	
16	FU2-2393-000		1	LABEL, HIGH TMP. CAUTION	
17	RC2-6075-000		2	SHEET, DAMPER	
18	RC4-3002-000		1	SHAFT, SUPPORT	
19	RC4-4479-000		1	LINK, PRESSURE RELEASE	
20	XA9-1503-000		10	SCREW, TAP, M3X6	
21	XA9-1671-000		2	SCREW, D, M3X8	

Figure 100D EXTERNAL COVERS, PANELS, ETC. (MF424dw)

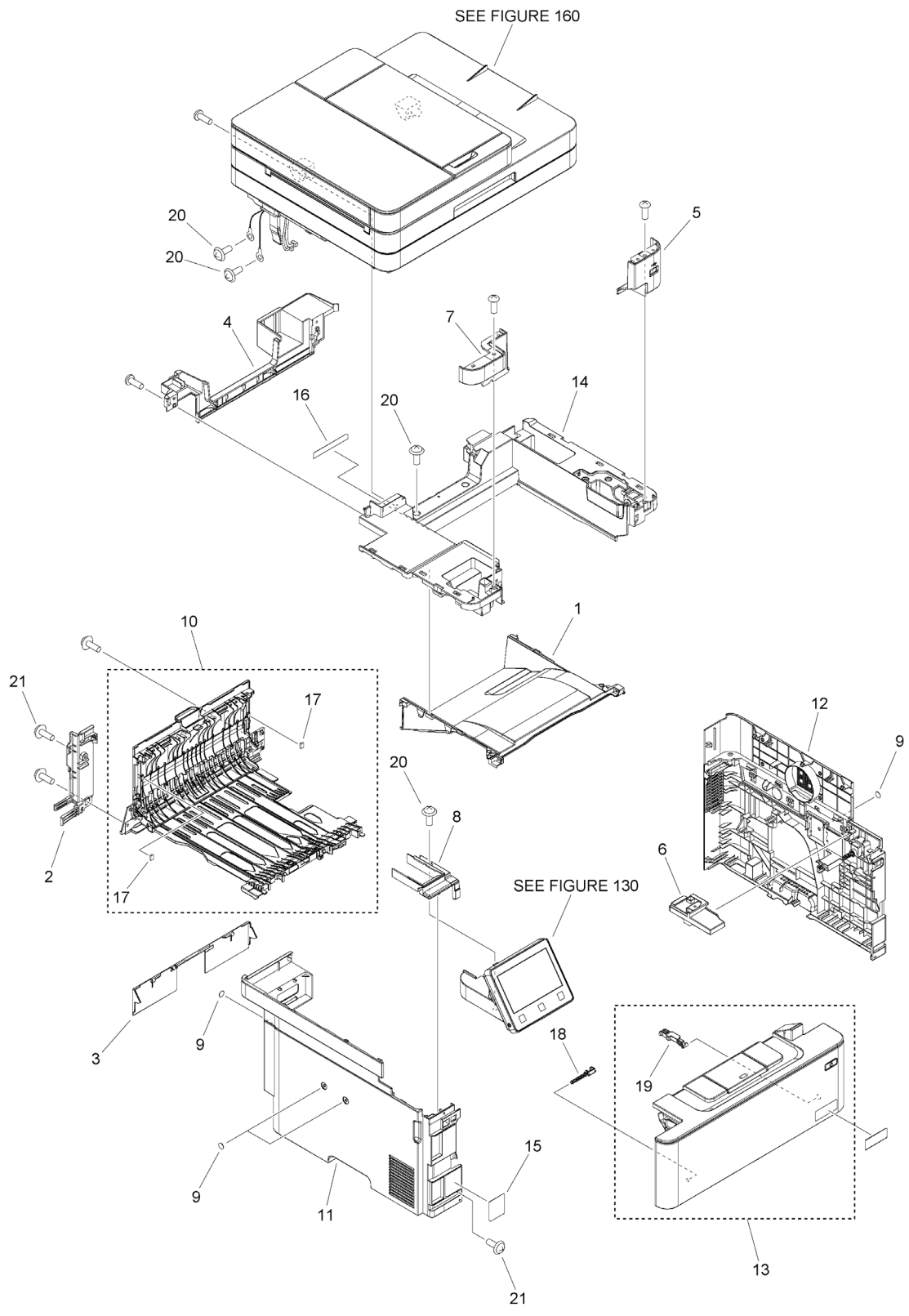

FIGURE & KEY NO.	PART NUMBER	RANK	QTY	DESCRIPTION	SERIAL NUMBER /REMARKS
100D	NPN		RF	EXTERNAL COVERS, PANELS, ETC.	MF424dw
1	FE8-6191-000		1	TRAY, PAPER DELIVERY	
2	FE8-6203-000		1	COVER, LEFT REAR	
3	FE8-6208-000		1	COVER, CASSETTE, REAR	
4	FE8-6747-000		1	COVER, TOP, REAR	
5	FE8-6749-000		1	COVER, TOP, RIGHT FRONT	
6	FE8-6750-000		1	COVER, BLE	
7	FE8-6752-000		1	COVER, TOP, LEFT FRONT	
8	FE8-6753-000		1	COVER, TOP, LEFT	
9	FL1-0525-000		4	SHEET, HANDSET	
10	FM1-R685-000		1	REAR DOOR ASS'Y	
11	FM1-T425-000		1	COVER ASSEMBLY, LEFT	
12	FM1-T443-000		1	COVER ASSEMBLY, RIGHT	
13	FM1-T444-000		1	CARTRIDGE DOOR ASS'Y	
14	FM1-T447-000		1	COVER ASSEMBLY, TOP	
15	FU2-2392-000		1	LABEL, CASSETTE OPERATOR	
16	FU2-2393-000		1	LABEL, HIGH TMP. CAUTION	
17	RC2-6075-000		2	SHEET, DAMPER	
18	RC4-3002-000		1	SHAFT, SUPPORT	
19	RC4-4479-000		1	LINK, PRESSURE RELEASE	
20	XA9-1503-000		10	SCREW, TAP, M3X6	
21	XA9-1671-000		2	SCREW, D, M3X8	

Figure 101A INTERNAL COMPONENTS 1 (120V)

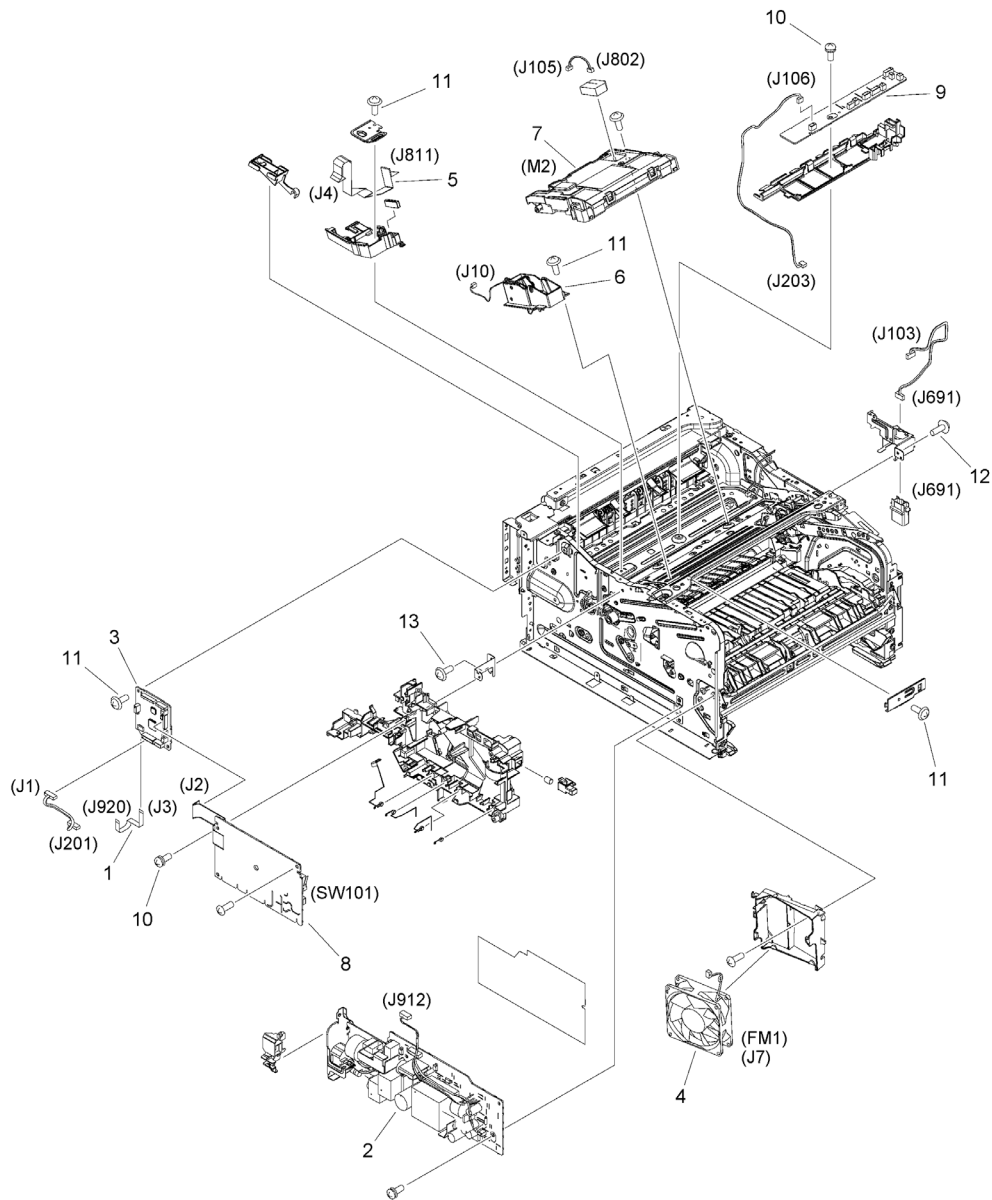

FIGURE & KEY NO.	PART NUMBER	RANK	QTY	DESCRIPTION	SERIAL NUMBER /REMARKS
101A	NPN		RF	INTERNAL COMPONENTS 1	120V
1	FK4-4929-000		1	CABLE, FLEXIBLE FLAT	
2	FM1-Z938-000		1	L.V. POWER SUPPLY PCB ASS'Y	
3	FM2-D811-000		1	DC CONTROLLER PCB ASS'Y	
4	RK2-1378-000		1	FAN	FM1
5	RK2-6919-000		1	CABLE, FLEXIBLE FLAT, LASER	
6	RM2-5426-000		1	TAG CABLE ASS'Y	
7	RM2-5528-000		1	LASER SCANNER ASS'Y	M2
8	RM2-7508-000		1	H.V. POWER SUPPLY PCB ASS'Y	SW101
9	RM2-7510-000		1	CONNECTING PCB ASS'Y	
10	XA9-1420-000		2	SCREW, W/WASHER, M3X8	
11	XA9-1503-000		8	SCREW, TAP, M3X6	
12	XA9-1670-000		1	SCREW, D, M3X6	
13	XA9-1671-000		1	SCREW, D, M3X8	

Figure 101B INTERNAL COMPONENTS 1 (230V)

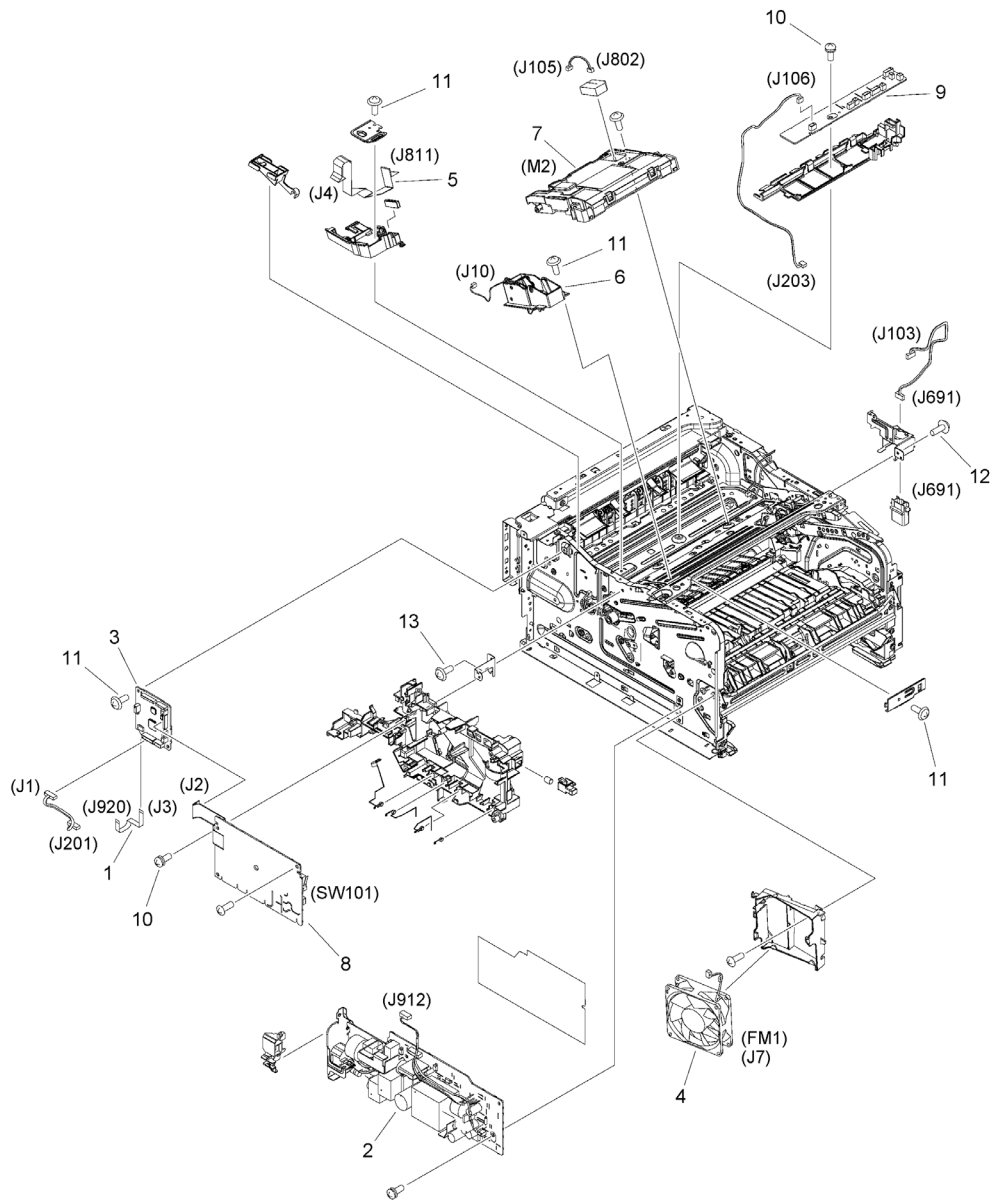

FIGURE & KEY NO.	PART NUMBER	RANK	QTY	DESCRIPTION	SERIAL NUMBER /REMARKS
101B	NPN		RF	INTERNAL COMPONENTS 1	230V
1	FK4-4929-000		1	CABLE, FLEXIBLE FLAT	
2	FM1-Z941-000		1	L.V. POWER SUPPLY PCB ASS'Y	
3	FM2-D811-000		1	DC CONTROLLER PCB ASS'Y	
4	RK2-1378-000		1	FAN	FM1
5	RK2-6919-000		1	CABLE, FLEXIBLE FLAT, LASER	
6	RM2-5426-000		1	TAG CABLE ASS'Y	
7	RM2-5528-000		1	LASER SCANNER ASS'Y	M2
8	RM2-7508-000		1	H.V. POWER SUPPLY PCB ASS'Y	SW101
9	RM2-7510-000		1	CONNECTING PCB ASS'Y	
10	XA9-1420-000		2	SCREW, W/WASHER, M3X8	
11	XA9-1503-000		8	SCREW, TAP, M3X6	
12	XA9-1670-000		1	SCREW, D, M3X6	
13	XA9-1671-000		1	SCREW, D, M3X8	

Figure 102A INTERNAL COMPONENTS 2 (120V)

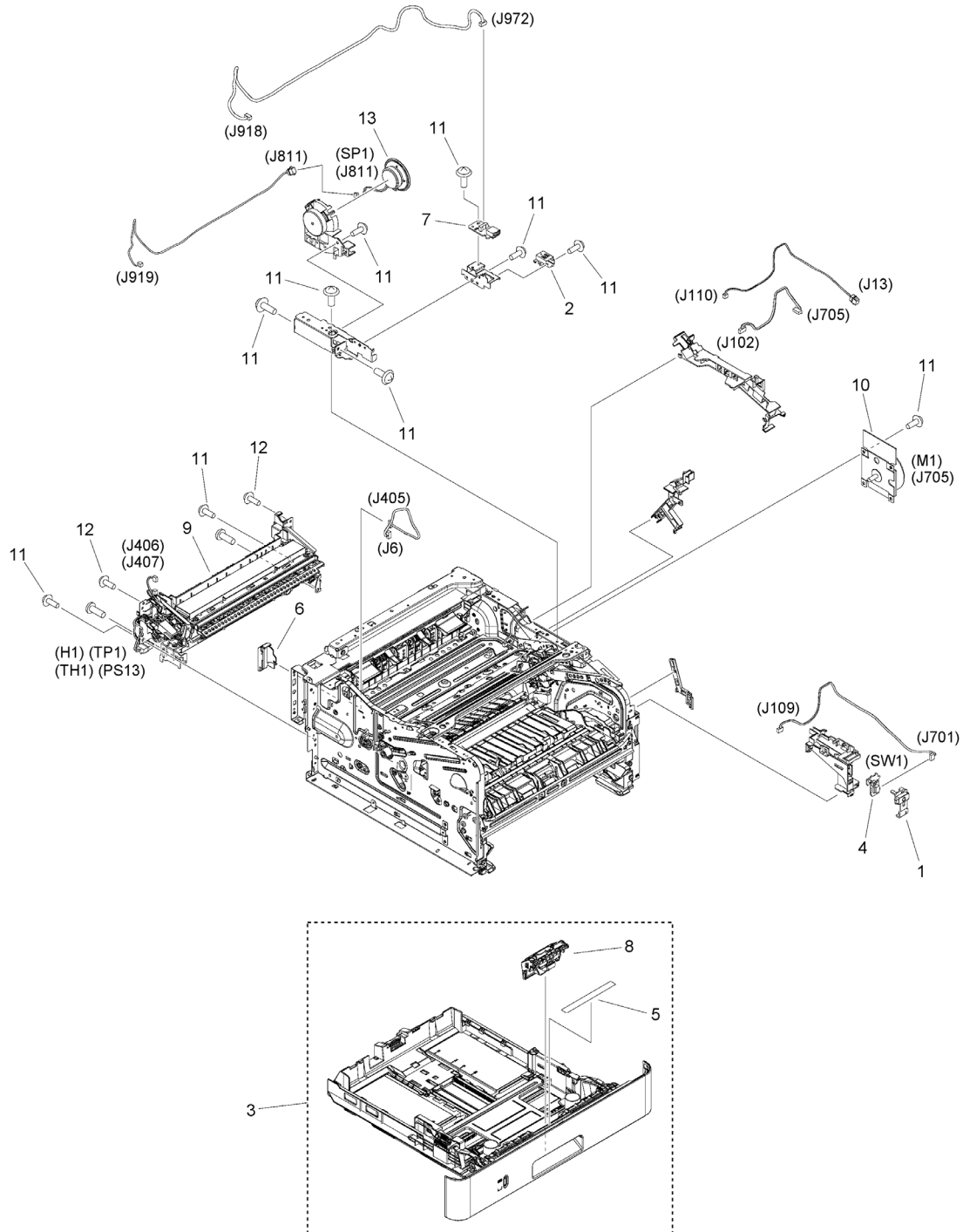

FIGURE & KEY NO.	PART NUMBER	RANK	QTY	DESCRIPTION	SERIAL NUMBER /REMARKS
102A	NPN		RF	INTERNAL COMPONENTS 2	120V
1	FE8-6227-000		1	LEVER, SWITCH	
2	FE8-7096-000		1	PLATE, GROUNDING	
3	FM1-R683-000		1	CASSETTE ASS'Y	
4	FM1-Z945-000		1	POWER SWITCH PCB ASS'Y	SW1
5	FU2-1855-000		1	LABEL, CST. PAPER SIZE	
6	RC4-3219-000		1	COVER, FULL DETECT SENSOR	
7	FM1-R870-000		1	USB RELAY PCB ASSEMBLY	
8	RM2-5397-000		1	CASSETTE SEPARATION ASS'Y	
9	FM1-V137-000		1	FIXING ASS'Y	H1, PS13, TH1, TP1
10	RM2-8684-000		1	MAIN MOTOR ASS'Y	M1
11	XA9-1503-000		14	SCREW, TAP, M3X6	
12	XA9-1522-000		2	SCREW, M3X6	
13	FK3-3944-000		1	SPEAKER	SP1

FIGURE & KEY NO.	PART NUMBER	RANK	QTY	DESCRIPTION	SERIAL NUMBER /REMARKS
102B	NPN		RF	INTERNAL COMPONENTS 2	230V FAX model
1	FE8-6227-000		1	LEVER, SWITCH	
2	FE8-7096-000		1	PLATE, GROUNDING	
3	FM1-R683-000		1	CASSETTE ASS'Y	
4	FM1-Z945-000		1	POWER SWITCH PCB ASS'Y	SW1
5	FU2-1855-000		1	LABEL, CST. PAPER SIZE	
6	RC4-3219-000		1	COVER, FULL DETECT SENSOR	
7	FM1-R870-000		1	USB RELAY PCB ASSEMBLY	
8	RM2-5397-000		1	CASSETTE SEPARATION ASS'Y	
9	FM1-V141-000		1	FIXING ASS'Y	H1, PS13, TH1, TP1
10	RM2-8684-000		1	MAIN MOTOR ASS'Y	M1
11	XA9-1503-000		14	SCREW, TAP, M3X6	
12	XA9-1522-000		2	SCREW, M3X6	
13	FK3-3944-000		1	SPEAKER	SP1

Figure 103 INTERNAL COMPONENTS 3

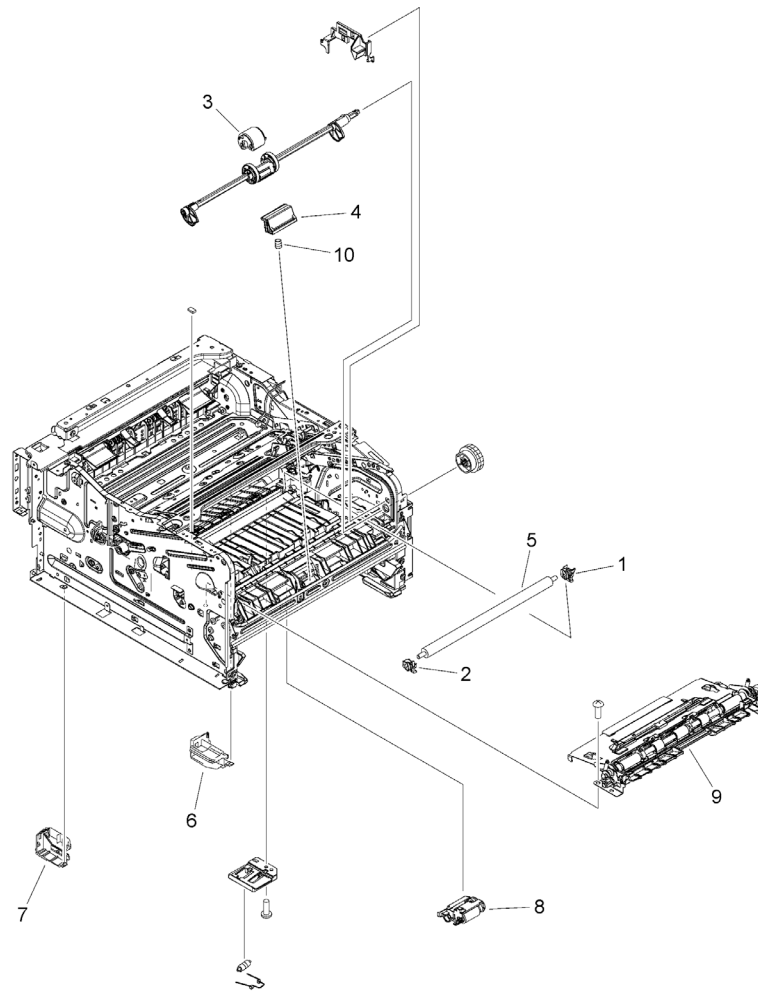

FIGURE & KEY NO.	PART NUMBER	RANK	QTY	DESCRIPTION	SERIAL NUMBER /REMARKS
103	NPN		RF	INTERNAL COMPONENTS 3	
1	RC4-3133-000		1	HOLDER, TRANSFER ROLLER, RIGHT	
2	RC4-3134-000		1	HOLDER, TRANSFER ROLLER, LEFT	
3	RL2-0656-000		1	ROLLER, MULTI-PURPOSE	
4	RL2-0657-000		1	PAD, MULTI-PURPOSE SEPARATION	
5	RM1-4023-000		1	ROLLER, TRANSFER	
6	RM2-5423-000		1	FOOT, REAR, RIGHT	
7	RM2-5429-000		1	FOOT, REAR, LEFT	
8	RM2-5452-000		1	PAPER PICK-UP ROLLER ASS'Y	
9	FM1-N761-000		1	REGISTRATION ASS'Y	
10	RU8-2935-000		2	SPRING, COMPRESSION	

Figure 104A INTERNAL COMPONENTS 4 (MF429dw, MF429x)

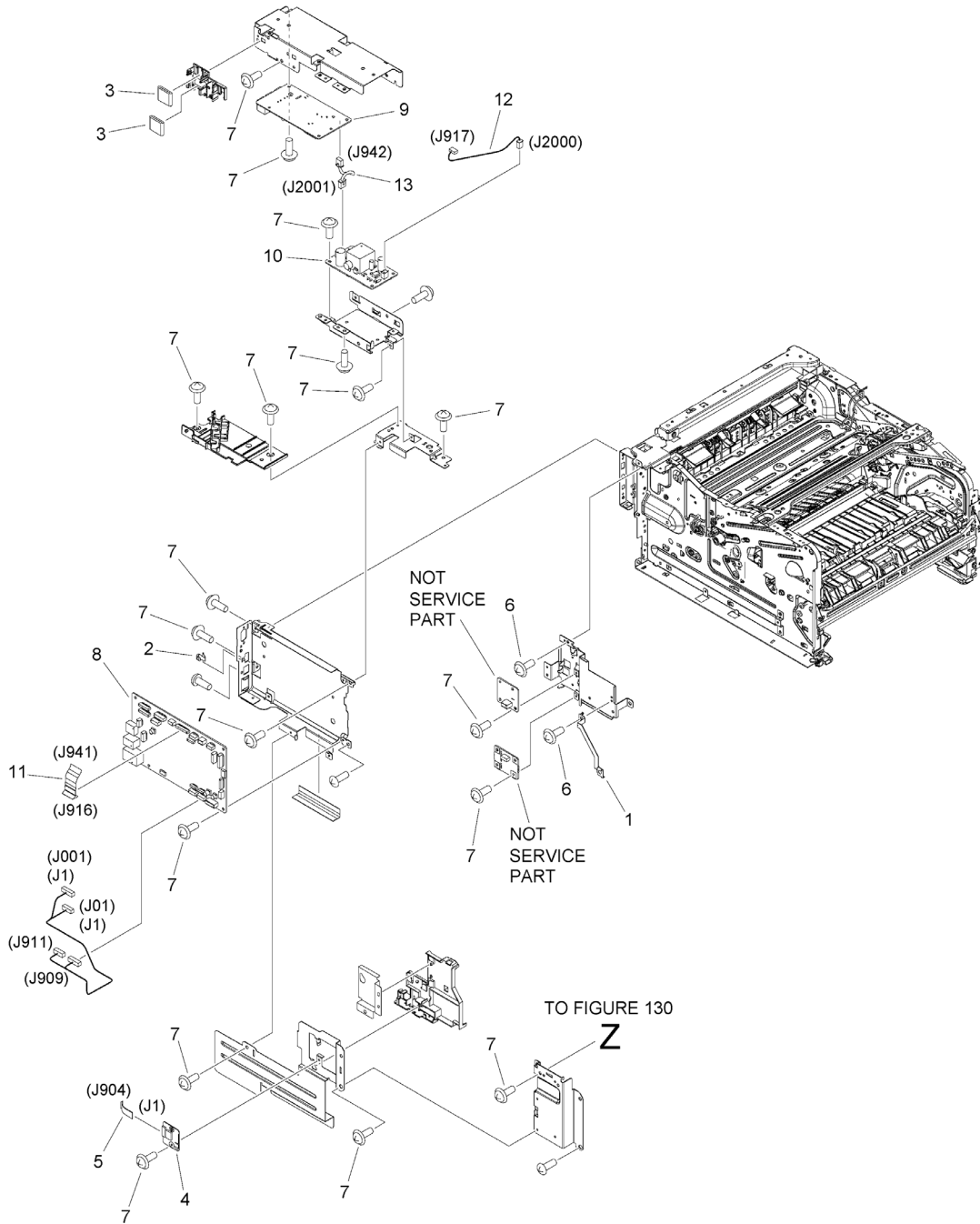

FIGURE & KEY NO.	PART NUMBER	RANK	QTY	DESCRIPTION	SERIAL NUMBER /REMARKS
104A	NPN		RF	INTERNAL COMPONENTS 4	MF429dw, MF429x
1	FE8-6628-000		1	PLATE, GROUNDING	
2	FE8-7079-000		1	PLATE, GROUNDING	
3	FK2-8767-000		2	CORE, FERRITE	
4	FK4-4651-000		1	MODULE, WLAN	
5	FK4-4931-000		1	CABLE, FLEXIBLE FLAT	
6	XA9-1670-000		4	SCREW, D, M3X6	
7	XA9-1503-000		15	SCREW, TAP, M3X6	
8	FM1-U536-000		1	MAIN CONTROLLER PCB ASS'Y SET	
9	FM1-X947-000		1	NCU PCB ASSEMBLY	
10	FM1-R867-000		1	OFFHOOK PCB ASSEMBLY	
11	FK4-5022-000		1	CABLE, FLEXIBLE FLAT	
12	FM2-C861-000		1	CABLE, CNT OFFHOOK	
13	FM2-C863-000		1	CABLE, OFFHOOK LINECOMM	

Figure 104B INTERNAL COMPONENTS 4 (MF426dw)

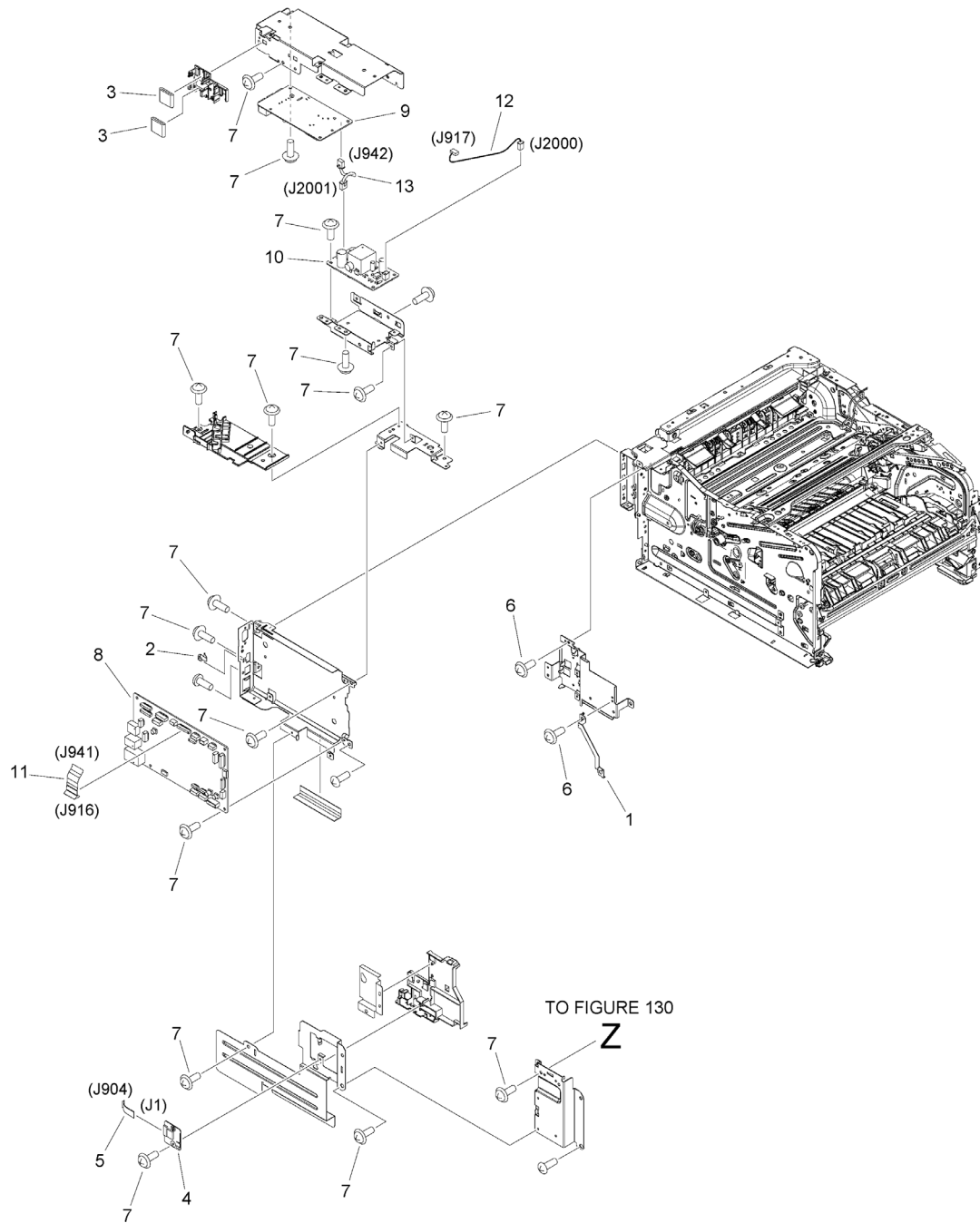

FIGURE & KEY NO.	PART NUMBER	RANK	QTY	DESCRIPTION	SERIAL NUMBER /REMARKS
104B	NPN		RF	INTERNAL COMPONENTS 4	MF426dw
1	FE8-6628-000		1	PLATE, GROUNDING	
2	FE8-7079-000		1	PLATE, GROUNDING	
3	FK2-8767-000		2	CORE, FERRITE	
4	FK4-4651-000		1	MODULE, WLAN	
5	FK4-4931-000		1	CABLE, FLEXIBLE FLAT	
6	XA9-1670-000		4	SCREW, D, M3X6	
7	XA9-1503-000		15	SCREW, TAP, M3X6	
8	FM1-U538-000		1	MAIN CONTROLLER PCB ASS'Y SET	
9	FM1-X947-000		1	NCU PCB ASSEMBLY	
10	FM1-R867-000		1	OFFHOOK PCB ASSEMBLY	
11	FK4-5022-000		1	CABLE, FLEXIBLE FLAT	
12	FM2-C861-000		1	CABLE, CNT OFFHOOK	
13	FM2-C863-000		1	CABLE, OFFHOOK LINECOMM	

Figure 104C INTERNAL COMPONENTS 4 (MF424dw)

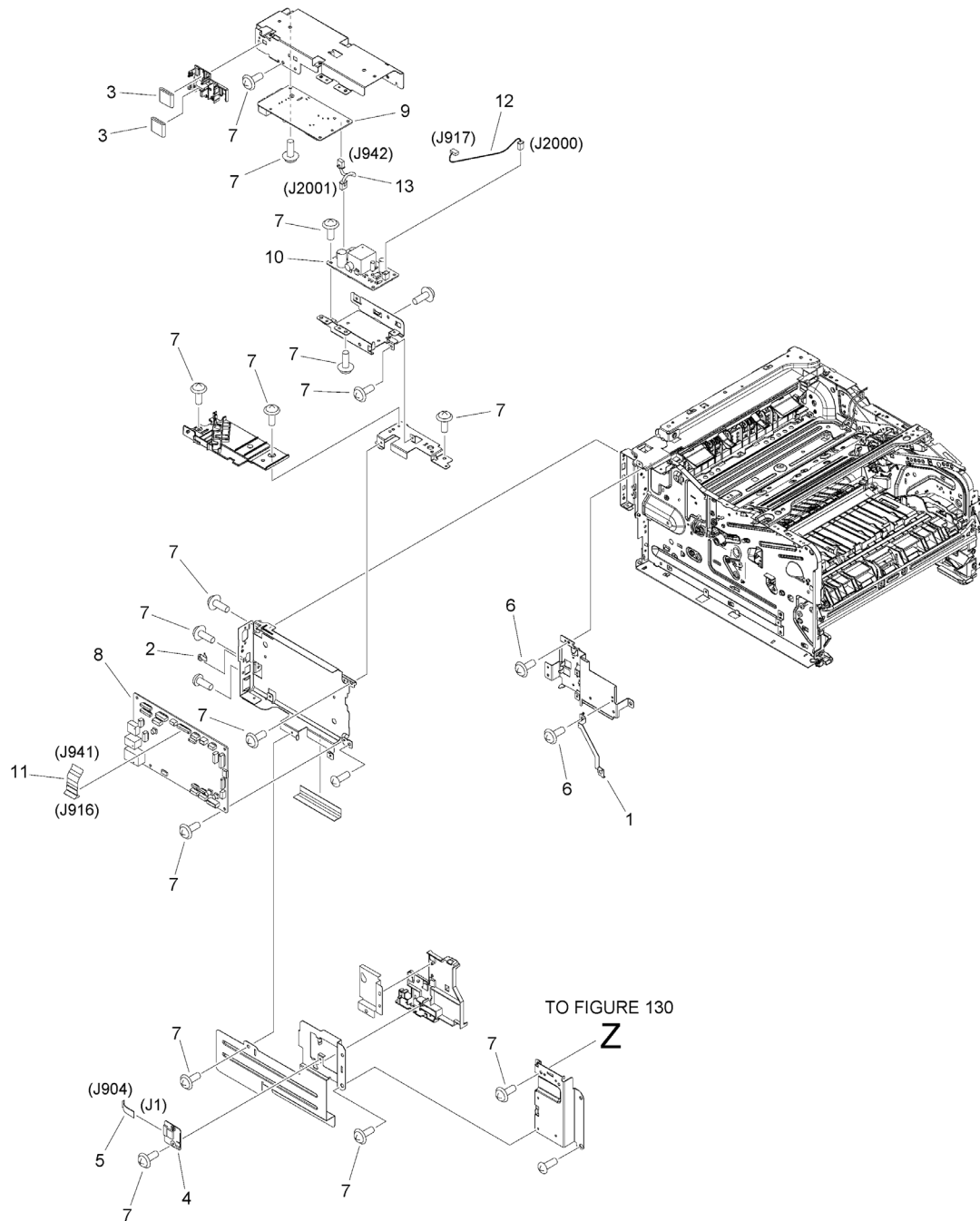

FIGURE & KEY NO.	PART NUMBER	RANK	QTY	DESCRIPTION	SERIAL NUMBER /REMARKS
104C	NPN		RF	INTERNAL COMPONENTS 4	MF424dw
1	FE8-6628-000		1	PLATE, GROUNDING	
2	FE8-7079-000		1	PLATE, GROUNDING	
3	FK2-8767-000		2	CORE, FERRITE	
4	FK4-4651-000		1	MODULE, WLAN	
5	FK4-4931-000		1	CABLE, FLEXIBLE FLAT	
6	XA9-1670-000		4	SCREW, D, M3X6	
7	XA9-1503-000		15	SCREW, TAP, M3X6	
8	FM1-U539-000		1	MAIN CONTROLLER PCB ASS'Y SET	
9	FM1-X947-000		1	NCU PCB ASSEMBLY	
10	FM1-R867-000		1	OFFHOOK PCB ASSEMBLY	
11	FK4-5022-000		1	CABLE, FLEXIBLE FLAT	
12	FM2-C861-000		1	CABLE, CNT OFFHOOK	
13	FM2-C863-000		1	CABLE, OFFHOOK LINECOMM	

FIGURE & KEY NO.	PART NUMBER	RANK	QTY	DESCRIPTION	SERIAL NUMBER /REMARKS
130	NPN		RF	CONTROL PANEL ASS'Y	
1	FE8-6209-000		1	COVER, PANEL, REAR UPPER	
2	FE8-6210-000		1	COVER, PANEL, REAR LOWER	
3	FE8-6211-000		1	COVER, PANEL, LOWER	
4	FE8-7086-000		1	COVER, PANEL, REAR	
5	FK4-5021-000		1	CABLE, SANMARINO HDMI	
6	FM1-R686-000		1	CONTROL PANEL ASS'Y	
7	FM1-T109-000		1	HINGE ASSEMBLY	
8	FE8-6772-000		1	COVER, PANEL MOUNT, LEFT	
9	FE8-6773-000		1	COVER, PANEL MOUNT, RIGHT	
10	FE8-6774-000		1	COVER, PANEL MOUNT, UPPER	
11	XA9-1503-000		9	SCREW, TAP, M3X6	
12	XA9-1671-000		2	SCREW, D, M3X8	

Figure 160 READER/ADF ASSEMBLY

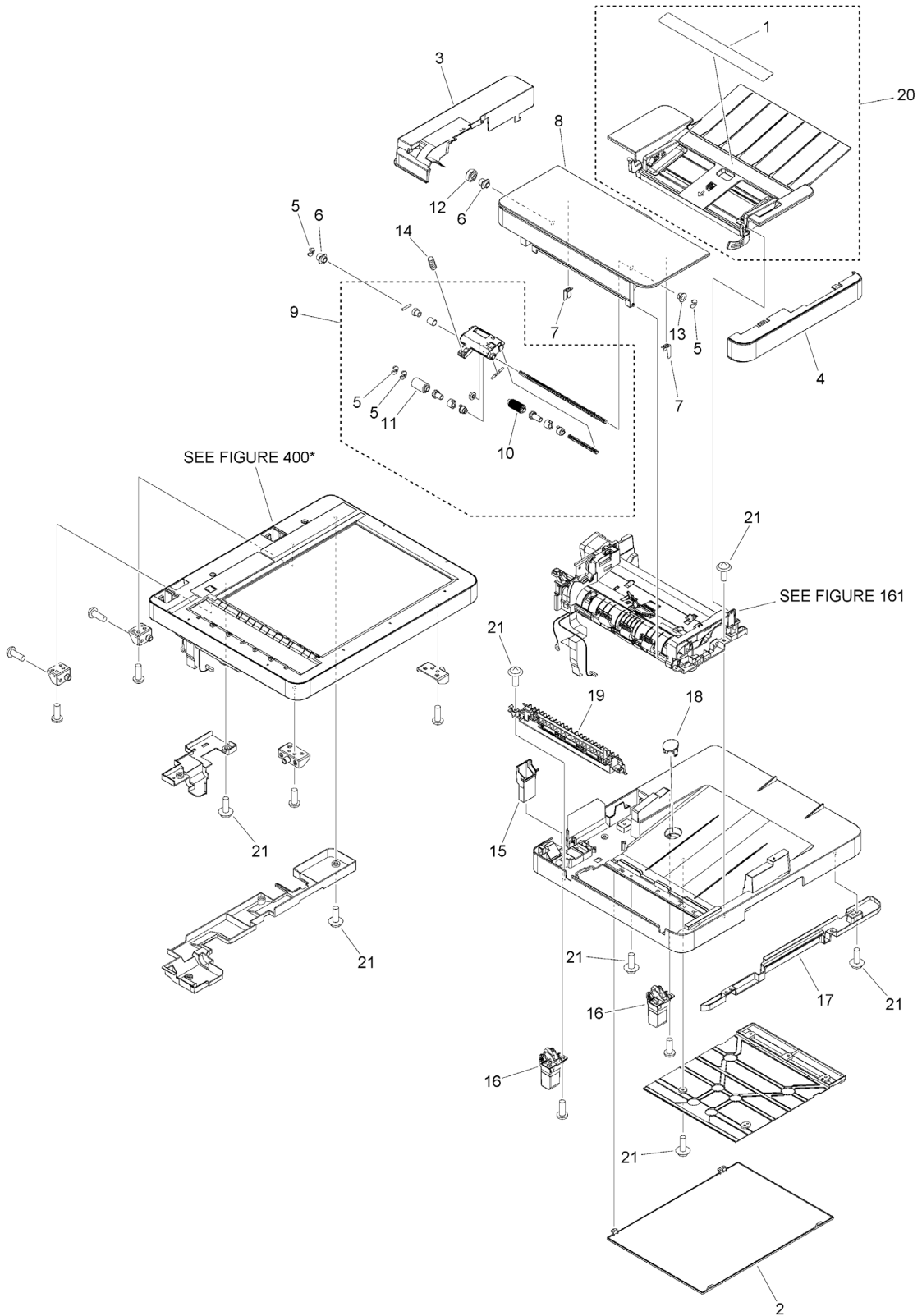

FIGURE & KEY NO.	PART NUMBER	RANK	QTY	DESCRIPTION	SERIAL NUMBER /REMARKS
160	NPN		RF	READER/ADF ASSEMBLY	
1	FE8-4191-000		1	LABEL, DOCUMENT SIZE	
2	FE8-3469-000		1	SHEET, WHITE	
3	FE8-3474-000		1	COVER, REAR	
4	FE8-3475-000		1	COVER, FRONT	
5	FE8-3636-000		4	RING, E	
6	FE8-3643-000		2	BUSHING	
7	FE8-3644-000		2	SPRING, LEAF	
8	FL1-2517-000		1	PANEL, OPEN/CLOSE	
9	FM1-N703-000		1	SEPARATION ROLLER ASSEMBLY	
10	FC8-9251-000		1	ROLLER, PICK-UP	
11	FL3-1023-000		1	ROLLER, SEPARATION	
12	FU2-1865-000		1	GEAR, 23T	
13	FU2-1902-000		1	BUSHING	
14	FU2-1903-000		1	SPRING, COMPRESSION	
15	FE8-3462-000		1	GUIDE, CABLE	
16	FM1-T687-000		2	HINGE	
17	FE8-3467-000		1	COVER, LOWER	
18	FE8-4189-000		1	CAP	
19	FM1-P584-000		1	PAPER FEED GUIDE ASSEMBLY	
20	FM1-N711-000		1	DOCUMENT TRAY ASSEMBLY	
21	XA9-0476-000		15	SCREW, TP M3X8	

Figure 161 PAPER FEEDER ASSEMBLY

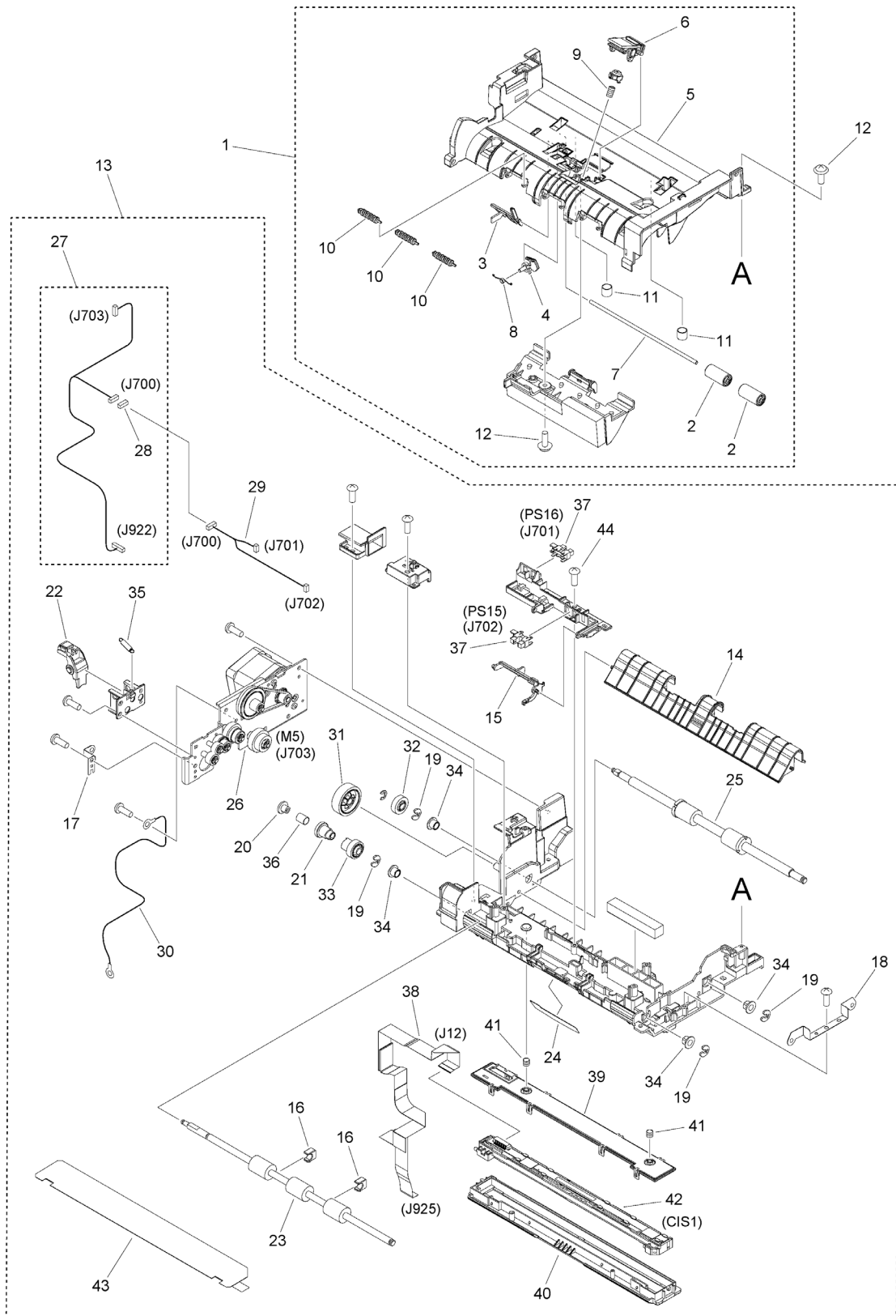

FIGURE & KEY NO.	PART NUMBER	RANK	QTY	DESCRIPTION	SERIAL NUMBER /REMARKS
161	NPN		RF	PAPER FEEDER ASSEMBLY	
1	FM1-N704-000		1	GUIDE ASSEMBLY, UPPER	
2	FE8-3440-000		2	ROLLER	
3	FE8-3444-000		1	FLAG, SENSOR	
4	FE8-3645-000		1	STOPPER, DOCUMENT	
5	FL1-2518-000		1	GUIDE, UPPER	
6	FM1-P580-000		1	SEPARATION PAD ASSEMBLY	
7	FU2-1875-000		1	SHAFT, TRANSMISSION	
8	FU2-1904-000		1	SPRING, TORSION	
9	FU2-1905-000		1	SPRING, COMPRESSION	
10	FU2-1906-000		3	ROLLER, AUXILIARY	
11	FU2-1922-000		2	SPRING, COMPRESSION	
12	XA9-0476-000		7	SCREW, TP M3X8	
13	FM1-U531-000		1	PAPER FEEDER ASSEMBLY SET	
14	FE8-3446-000		1	GUIDE, PAPER DELIVERY	
15	FE8-3448-000		1	FLAG, SENSOR	
16	FE8-3458-000		2	BUSHING	
17	FE8-3459-000		1	PLATE, GROUNDING	
18	FE8-3460-000		1	PLATE, GROUNDING	
19	FE8-3636-000		4	RING, E	
20	FE8-3655-000		1	STOPPER, RATCHET SPRING	
21	FE8-3656-000		1	RATCHET, PAPER FEED ROLLER	
22	FE8-3657-000		1	LEVER, RELEASE	
23	FL1-1367-000		1	ROLLER, PAPER FEED	
24	FL1-1369-000		1	SHEET, GUIDE	
25	FM1-N407-000		1	ROLLER, PAPER DELIVERY	
26	FM1-N709-000		1	MOTOR DRIVE ASS'Y	M5
27	FM2-C963-000		1	CABLE, SIGNAL, DF, 2	
28	VS1-7207-006		1	CONNECTOR, SNAP TIGHT	
29	FM1-X903-000		1	CABLE, SENSOR	
30	FM2-C965-000		1	CABLE, GROUNDING	
31	FU2-1867-000		1	GEAR, 67T	
32	FU2-1869-000		1	GEAR, 25T	
33	FU2-1870-000		1	GEAR, 38T	
34	FU2-1902-000		4	BUSHING	
35	FU2-1907-000		1	SPRING, TENSION	
36	FU2-1908-000		1	SPRING, COMPRESSION	
37	WG8-5935-000		2	IC, PHOTO INTERRUPTER	PS15, PS16
38	FK4-4059-000		1	CABLE, FLEXIBLE FLAT	
39	FE8-3450-000		1	HOLDER, CONTACT IMAGE SENSOR	
40	FL1-2502-000		1	GLASS HOLDER UNIT	
41	FU2-1924-000		2	SPRING, COMPRESSION	
42	FM1-T027-000		1	CONTACT IMAGE SENSOR SET	CIS1
43	FL1-4365-000		1	SHEET, WHITE	

FIGURE & KEY NO.	PART NUMBER	R A N K	QTY	DESCRIPTION	SERIAL NUMBER /REMARKS
44	XA9-2049-000		1	SCREW, W/WASHER P, M3X10	

Figure 400A READER ASSEMBLY (US, CA, 120V LTN)

NOTE : This assembly does not include the parts shown with key No. 13 and 14.

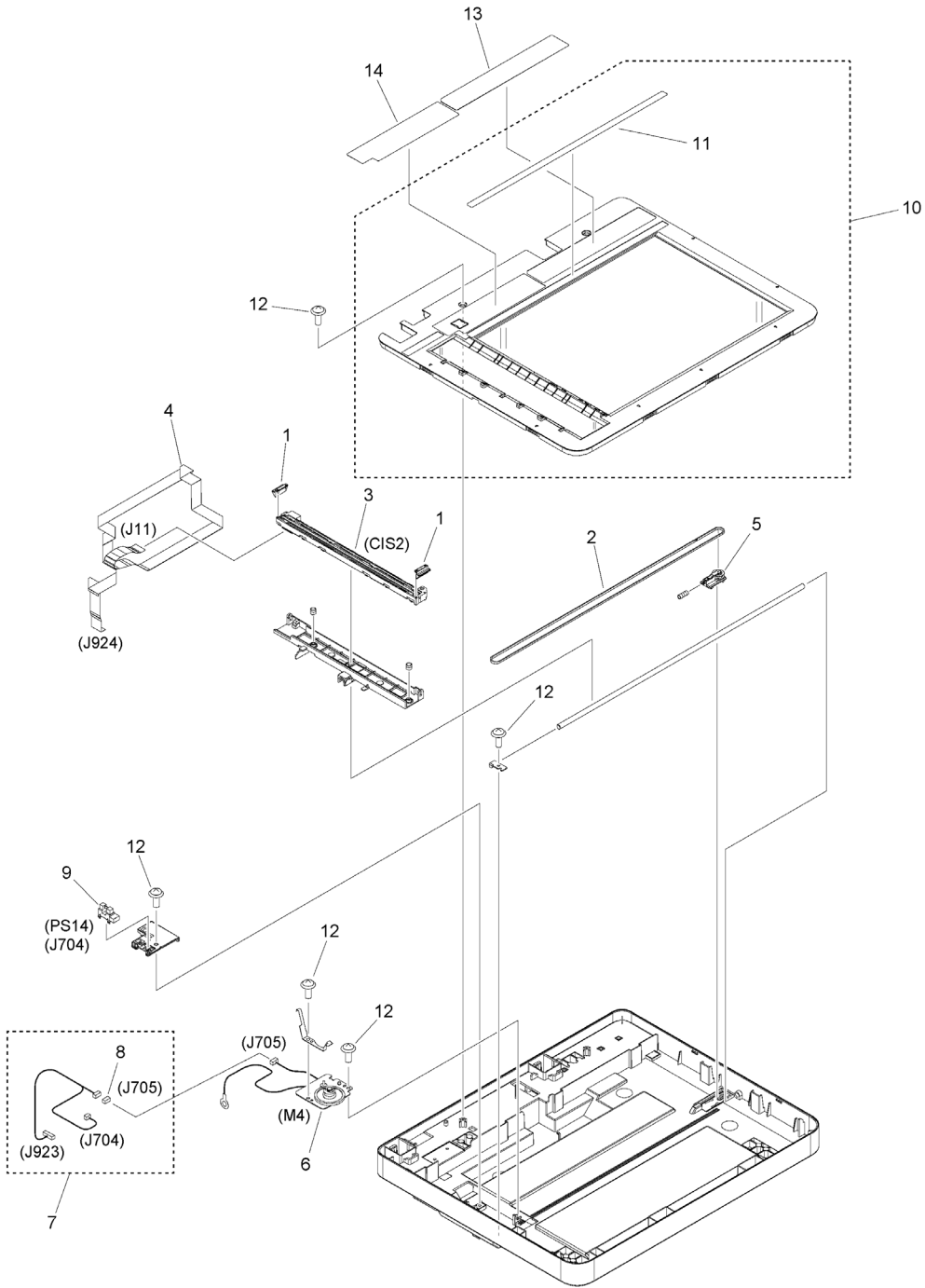

FIGURE & KEY NO.	PART NUMBER	RANK	QTY	DESCRIPTION	SERIAL NUMBER /REMARKS
400A	FM1-U533-000		1	READER ASSEMBLY	US, CA, 120V LTN
1	FE8-3479-000		2	SPACER, CIS	
2	FE8-3582-000		1	BELT, TIMING	
3	FK4-4050-000		1	CONTACT IMAGE SENSOR,FA106H-01	CIS2
4	FK4-4058-000		1	CABLE, FLEXIBLE FLAT	
5	FL1-1412-000		1	PULLEY UNIT	
6	FM1-N718-000		1	DC MOTOR ASSEMBLY	M4
7	FM2-C964-000		1	CABLE, READER SIGNAL, 2	
8	VS1-7177-004		1	CONNECTOR, SNAP TIGHT, BK	
9	WG8-5935-000		1	IC, PHOTO INTERRUPTER	PS14
10	FM1-U354-000		1	COPYBOARD GLASS UNIT	
11	FE8-4192-000		1	LABEL, WIDTH SIZE	
12	XA9-0476-000		6	SCREW,TP M3X8	
13	FE8-9143-000		1	LABEL, COPY PROHIBITION	SEE NOTE
14	FE8-4194-000		1	LABEL, GLASS CLEANING	SEE NOTE

Figure 400C READER ASSEMBLY (AU, SG, IN, HK, 230V LTN)

NOTE : This assembly does not include the parts shown with key No. 13 and 14.

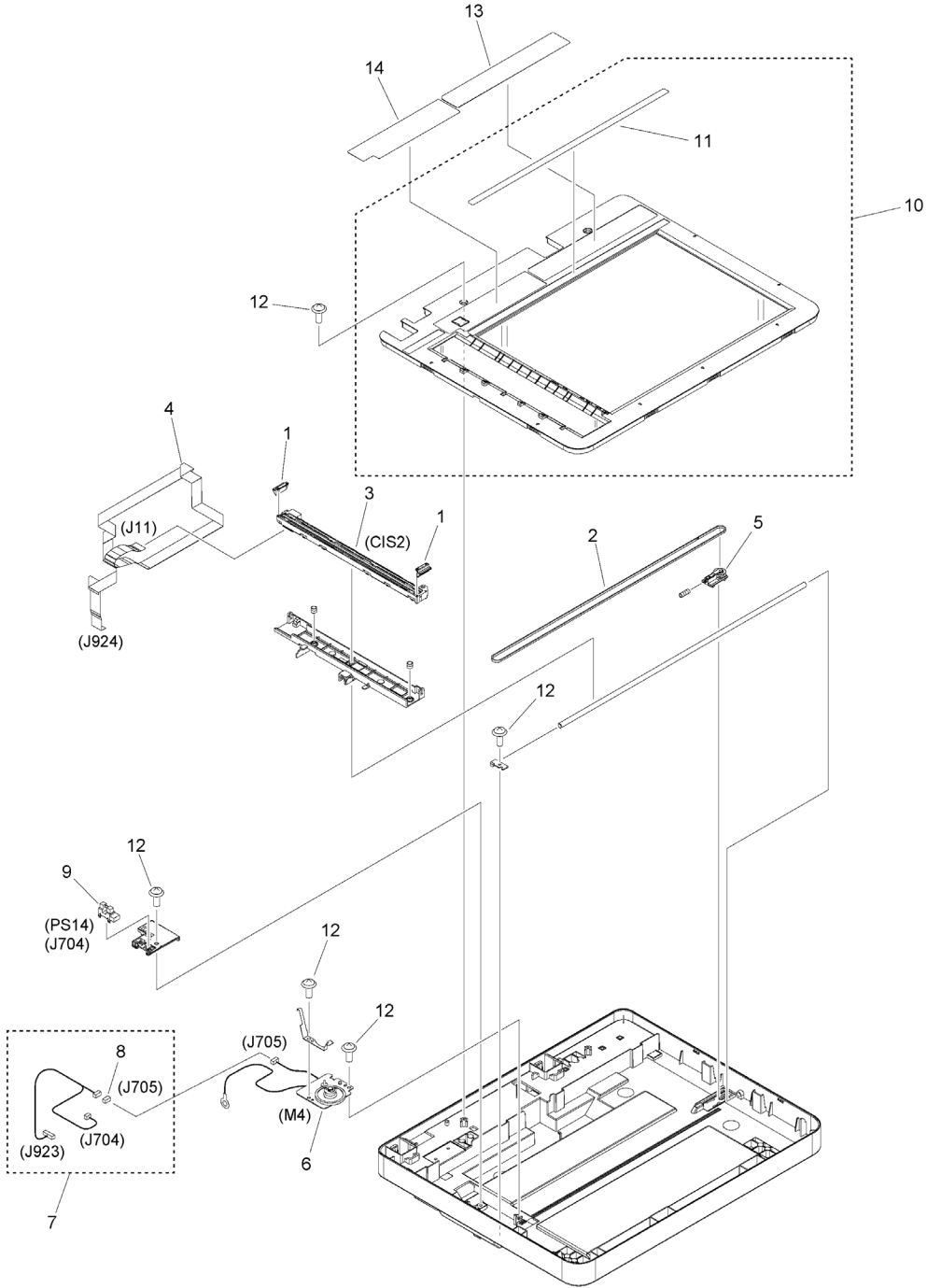

FIGURE & KEY NO.	PART NUMBER	RANK	QTY	DESCRIPTION	SERIAL NUMBER /REMARKS
400C	FM1-U533-000		1	READER ASSEMBLY	AU, SG, IN, HK, 230V LTN
1	FE8-3479-000		2	SPACER, CIS	
2	FE8-3582-000		1	BELT, TIMING	
3	FK4-4050-000		1	CONTACT IMAGE SENSOR,FA106H-01	CIS2
4	FK4-4058-000		1	CABLE, FLEXIBLE FLAT	
5	FL1-1412-000		1	PULLEY UNIT	
6	FM1-N718-000		1	DC MOTOR ASSEMBLY	M4
7	FM2-C964-000		1	CABLE, READER SIGNAL, 2	
8	VS1-7177-004		1	CONNECTOR, SNAP TIGHT, BK	
9	WG8-5935-000		1	IC, PHOTO INTERRUPTER	PS14
10	FM1-U354-000		1	COPYBOARD GLASS UNIT	
11	FE8-4192-000		1	LABEL, WIDTH SIZE	
12	XA9-0476-000		6	SCREW,TP M3X8	
13	FE8-9143-000		1	LABEL, COPY PROHIBITION	SEE NOTE
14	FE8-4196-000		1	LABEL, GLASS CLEANING	SEE NOTE

Figure ZZA MECHANICAL STANDARD PARTS (HOW TO USE)

Mechanical standard parts 機械標準部品

About a mechanical standard parts

A Mechanical standard parts is a mechanical part which not parts peculiar to a product.
They are parts which are common to a Canon product and are used, such as a screw and a washer.
The Fig No. and parts number of the mechanical standard parts are not listed in the product parts catalog.
Refer to the parts catalog of mechanical standard parts when checking the parts number for screw or washer etc. and identify them by part shape or size.

機械標準部品とは

機械標準部品とは、製品特有の部品ではなく、ねじやワッシャなどキヤノン製品共通で使用されている機械部品（メカ部品）のことです。
製品のパーツカタログには、機械標準部品のFig No.や部品番号は記載しておりません。
ねじや、ワッシャ等の部品番号を調べる時は、機械標準部品のパーツカタログを参照し、部品の形状や大きさから判断し、使用している部品を調べてください。

Material and surface treatment of a mechanical standard parts

Material and surface treatment of mechanical standard parts are assigned commonly for each part.
Refer to the Table 1 for the parts which material and surface treatment are assigned as numbers.

機械標準部品の材料および表面処理

機械標準部品の材料および表面処理については、各種部品共通で決められています。
材料および表面処理が番号で決められている部品については、表1を参照してください。

Table 1 Material and Surface treatment
表1 材料および表面処理

No. 番号	Material 材料	Surface treatment 表面処理	Color 色
1	Stainless steel ステンレス	Stainless steel black coloring (BC4) ステンレス黒着色(BC4)	Black 黒
2		not to be given なし	White 白
3	Brass 黄銅	Regular nickel plating (NL) 普通ニッケルメッキ(NL)	White 白
4		Black nickel plating (BN) 黒色ニッケルメッキ(BN)	Black 黒
5	Steel 鋼	White zinc trivalent chromate treating (ZC3) 白色亜鉛3価クロメート(ZC3)	White 白
6		Regular nickel chromium plating (NC) 普通ニッケルクロムメッキ(NC)	White 白
7		Regular nickel plating (NL) 普通ニッケルメッキ(NL)	White 白
8		Iron and steel phosphating (P1) 鉄鋼燐酸塩処理(P1)	Black 黒
9		Black zinc trivalent chromate treating (BZ3) 黒色亜鉛3価クロメート(BZ3)	Black 黒

Figure ZZB (1/7)MECHANICAL STANDARD PARTS (SCREWS)

1. Screws
ねじ

How to read Parts Numbers
部品番号の見方

Screws
ねじ

XB1-2400-609

Type No.
類別番号
Normal designation (d)
ねじの呼び (d)
Length (L)
ねじの長さ (L)
Material and Surface treatment
材料および表面処理

XB1-2 expresses Binding head machine screw.
XB1-2は、バインドねじを表す
40 expresses M4.0.
40は、M4.0を表す
0-60 expresses a length of 6.0mm.
0-60は、6.0mmの長さを表す
9 expresses Steel (Black zinc trivalent chromate
treating) from Table 1.
9は、表1より鋼 (黒色亜鉛3価クロメート) を表す

1-1. Cross Recessed Head Screws for Precision Equipments
精密機器用十字穴付き小ねじ

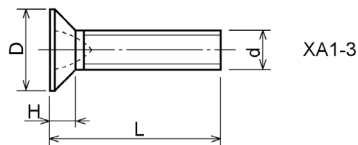
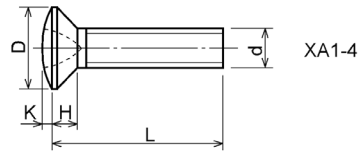
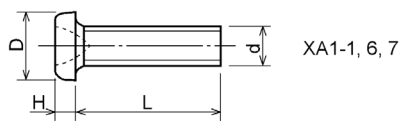

Type No. 類別番号	Type 類別	Head size (mm) 頭部寸法 (mm)						
		M1.4	M1.6	M1.7	M2	M2.5	M2.6	
XA1-1	Pan head Class 1 なべ1種	D	2	2.4	2.5	3	3.8	4
		H	0.5	0.55	0.5	0.6	0.9	0.8
XA1-3	Countersunk head Class 1 さら1種	D	2	2.4	2.5	3	3.8	4
		H	0.48	0.55	0.58	0.73	0.85	0.93
XA1-4	Oval countersunk head Class 1 丸さら1種	D	2	2.4	2.5	3	3.8	4
		H + K	0.68	0.8	0.88	1	1.25	1.3
XA1-6	Pan head Class 3 なべ3種	D	2.5	2.8	3	3.5	4.3	4.5
		H	0.8	0.85	0.9	1	1.3	1.2
XA1-7	Pan head Class 2 なべ2種	D	2.5	2.8	3	3.5	4.3	4.5
		H	0.5	0.55	0.5	0.6	0.9	0.8

Figure ZZB (2/7) MECHANICAL STANDARD PARTS (SCREWS)

1-2. Precision Tapping Screws
精密用タッピンねじ

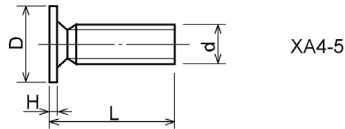
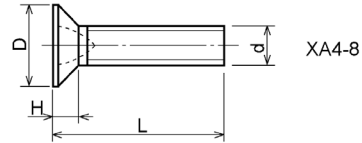
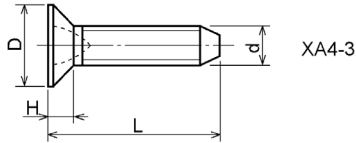
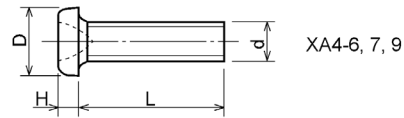
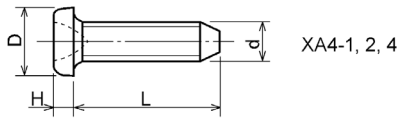

Type No. 類別番号	Type 類別	Head size (mm) 頭部寸法 (mm)						
		M1.4	M1.6	M1.7	M2	M2.5	M2.6	
XA4-1	With tapered end pan head Class 1 絞り-なべ1種	D XA4-1	2	2.4	2.5	3	3.8	4
		H XA4-1	0.5	0.55	0.5	0.6	0.9	0.8
XA4-2	With tapered end pan head Class 3 絞り-なべ3種	D XA4-2	2.5	2.8	3	3.5	4.3	4.5
		H XA4-2	0.8	0.85	0.9	1	1.3	1.2
XA4-3	With tapered end countersunk head 絞り-さら	D XA4-3	2	2.4	2.5	3	3.8	4
		H XA4-3	0.48	0.55	0.58	0.73	0.85	0.93
XA4-4	With tapered end pan head Class 2 絞り-なべ2種	D XA4-4	2.5	2.8	3	3.5	4.3	4.5
		H XA4-4	0.5	0.55	0.5	0.6	0.9	0.8
XA4-5	With parallel end ultra thin head ストレート-超薄頭	D XA4-5	2.5	2.8	3	-	-	-
		H XA4-5	0.2	0.2	0.2	-	-	-
XA4-6	With parallel end pan head Class 1 ストレート-なべ1種	D XA4-6	2	2.4	2.5	3	3.8	4
		H XA4-6	0.5	0.55	0.5	0.6	0.9	0.8
XA4-7	With parallel end pan head Class 3 ストレート-なべ3種	D XA4-7	2.5	2.8	3	3.5	4.3	4.5
		H XA4-7	0.8	0.85	0.9	1	1.3	1.2
XA4-8	With parallel end countersunk head ストレート-さら	D XA4-8	2	2.4	2.5	3	3.8	4
		H XA4-8	0.48	0.55	0.58	0.73	0.85	0.93
XA4-9	With parallel end pan head Class 2 ストレート-なべ2種	D XA4-9	2.5	2.8	3	3.5	4.3	4.5
		H XA4-9	0.5	0.55	0.5	0.6	0.9	0.8

Figure ZZB (3/7) MECHANICAL STANDARD PARTS (SCREWS)

1-3. Cross Recessed Head Screws
一般用十字穴付き小ねじ

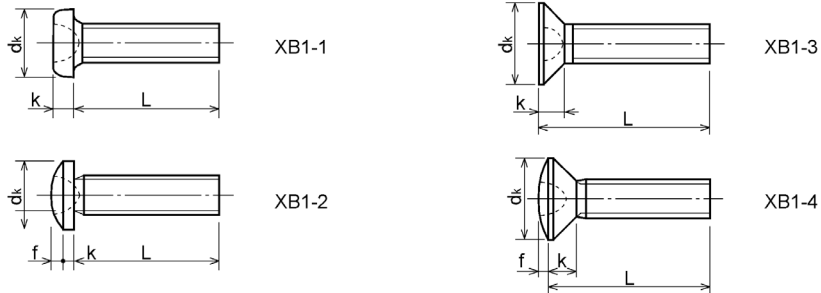

Type No. 類別番号	Type 類別
XB1-1	Pan head なべ
XB1-2	Binding head バインド
XB1-3	Countersunk head さら
XB1-4	Oval countersunk head 丸さら

		Head size (mm) 頭部寸法 (mm)					
		M2	M2.5	M2.6	M3	M4	M5
d_k	XB1-1	3.5	4.5	4.5	5.5	7	9
k	XB1-1	1.3	1.7	1.7	2	2.6	3.3
d_k	XB1-2	4.3	5.3	5.5	6.3	8.3	10.3
$k+f$	XB1-2	1.2	1.5	1.6	1.9	2.5	3.1
d_k	XB1-3	4	5	-	6	8	10
k	XB1-3	1.2	1.45	-	1.75	2.3	2.8
d_k	XB1-4	4	5	-	6	8	10
$k+f$	XB1-4	1.6	2	-	2.45	3.2	4
Screw part length ねじ部長さ b		8	12	12	12	16	20

Figure ZZB (4/7) MECHANICAL STANDARD PARTS (SCREWS)

1-4. Cross Recessed Head Screws with Captive Washer
座金組込み十字穴付き小ねじ

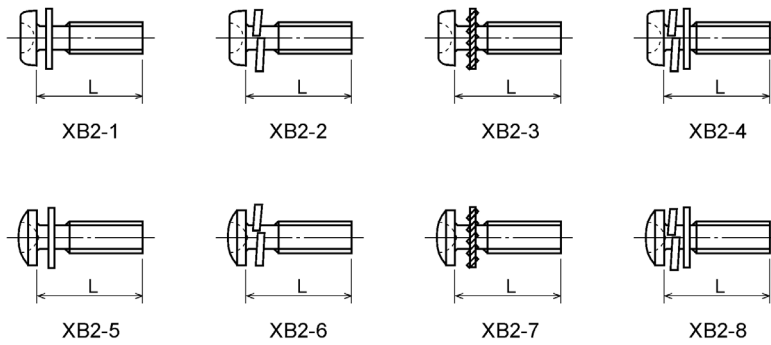

Type No. 類別番号	Type 類別
XB2-1	Pan head + Plain washer (circular bright) なべねじ+平座金
XB2-2	Pan head + Spring washer なべねじ+ばね座金
XB2-3	Pan head + Toothed lock washer なべねじ+歯付座金
XB2-4	Pan head + Spring washer and plain washer (circular bright) なべねじ+(ばね+平)座金
XB2-5	Binding head + Plain washer (circular bright) バインドねじ+平座金
XB2-6	Binding head + Spring washer バインドねじ+ばね座金
XB2-7	Binding head + Toothed lock washer バインドねじ+歯付座金
XB2-8	Binding head + Spring washer and plain washer (circular bright) バインドねじ+(ばね+平)座金

Figure ZZB (5/7) MECHANICAL STANDARD PARTS (SCREWS)

1-5. Hexagon Head Tapping Screws for Matallic Materials
 金属用六角タッピンねじ

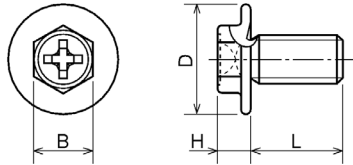

Type No. 類別番号	Type 類別	Head size (mm) 頭部寸法 (mm)		
		M3	M4	
XB3-6	For metallic materials 金属用タッピン	D	8	10
		B	5.5	5.5
XB3-7	For metallic materials with clawed 金属用タッピン-つめ付き	H XB3-6	3.1	3.1
		H XB3-7	3.2	3.2

1-6. Special Tapping Screws
 特殊タッピンねじ

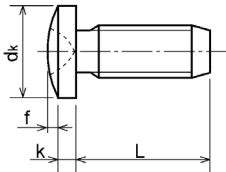

Type No. 類別番号	Type 類別	Head size (mm) 頭部寸法 (mm)		
		M3	M4	
XB4-5	Binding head バインド	dk	6.3	8.3
		k	1.3	1.7
		k+f	1.9	2.5

Figure ZZB (6/7) MECHANICAL STANDARD PARTS (SCREWS)

1-7. General Head Tapping Screws
一般用タッピンねじ

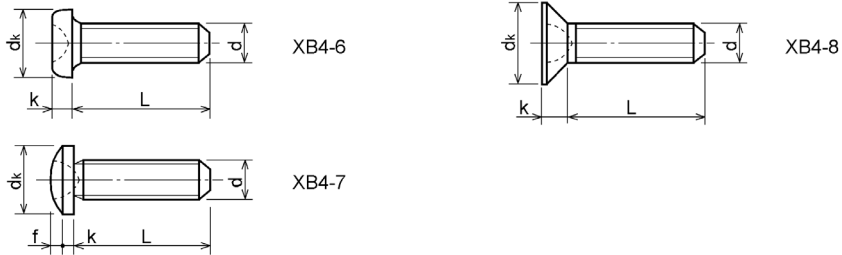

Type No. 類別番号	Type 類別	Head size (mm) 頭部寸法 (mm)						
		M2	M2.5	M2.6	M3	M4	M5	
XB4-6	Pan head なべ	dk	3.5	4.5	4.5	5.5	7	9
		k	1.3	1.7	1.7	2	2.6	3.3
XB4-7	Binding head バインド	dk	4.3	5.3	5.5	6.3	8.3	10.3
		k+f	1.2	1.5	1.6	1.9	2.5	3.1
XB4-8	Countersunk head さら	dk	4	5	5.2	6	8	10
		k	1.2	1.45	1.5	1.75	2.3	2.8

1-8. Tapping Screws for Metallic Materials
金属用タッピンねじ

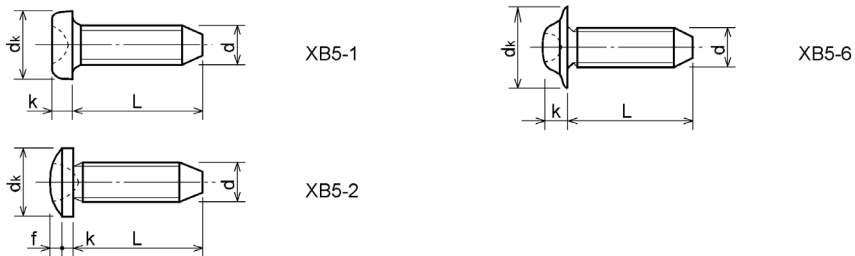

Type No. 類別番号	Type 類別	Head size (mm) 頭部寸法 (mm)					
		M2.5	M2.6	M3	M4	M5	
XB5-1	Pan head なべ	dk	4.5	4.5	5.5	7	9
		k	1.7	1.7	2	2.6	3.3
XB5-2	Binding head バインド	dk	5.5	5.5	6.3	8.3	10.3
		k+f	1.6	1.6	1.9	2.5	3.1
XB5-6	Flanged pan head つば付きなべ	dk	6.5	6.5	8	10	12
		k	2.1	2.1	1.75	3.2	4

Figure ZZB (7/7) MECHANICAL STANDARD PARTS (SCREWS)

1-9. Hexagon Socket Set Screws
六角穴付き止めねじ

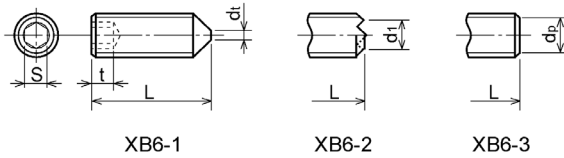

Type No. 類別番号	Type 類別	Head size (mm) 頭部寸法 (mm)						
		M1.6 M1.7	M2	M2.5 M2.6	M3	M5	M5	M6
	S	0.7	0.9	1.3	1.5	2	2.5	3
	t	1.5	1.7	2	2	2.5	3	3.5
	dt max XB6-1	0.4	0.5	0.65	0.75	1	1.25	1.5
	d1 max XB6-2	-	1.2	1.5	1.7	2.2	2.8	3.3
	d1 min XB6-2	-	1	1.2	1.4	1.9	2.4	2.9
	ds max XB6-3	0.8	1	1.5	2	2.5	3.5	4
	ds min XB6-3	0.55	0.75	1.25	1.75	2.25	3.2	3.7

1-10. Flanged Pan Head Machine Screws
つば付きなべ小ねじ

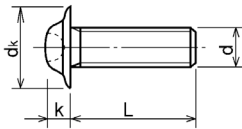

Type No. 類別番号	Type 類別	Head size (mm) 頭部寸法 (mm)				
		M2	M2.5 M2.6	M3	M5	M5
	dk	5	6.5	8	10	12
	k	1.7	2.1	2.5	3.2	4

Figure ZZC MECHANICAL STANDARD PARTS (BOLTS)

2. Bolts (Socket head cap screw)
ボルト

How to read Parts Numbers
部品番号の見方

Bolt (Socket head cap screw)
ボルト

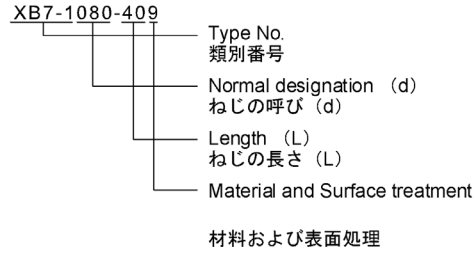

XB7-1 expresses Hexagon socket head cap screws.
XB7-1は、六角穴付きボルトを表す

080 expresses M8.0.
080は、M8.0を表す

40 expresses a length of 40mm.
40は、40mmの長さを表す

9 expresses Steel (Black zinc trivalent chromate treating) from Table 1.
9は、表1より鋼（黒色亜鉛3価クロメート）を表す

2-1. Hexagon socket head cap screws
六角穴付きボルト

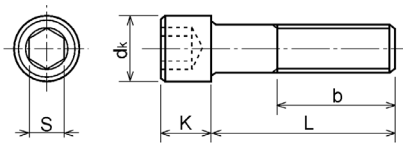

Type No. 類別番号	Type 類別	Head size (mm) 頭部寸法 (mm)						
		M3	M4	M5	M6	M8	M10	M12
S		2.5	3	4	5	6	8	10
dk		5.5	7	8.5	10	13	16	18
K		3	4	5	6	8	10	12
Screw part length ねじ部長さ b_{max}		18	20	22	24	28	32	36

Figure ZZD MECHANICAL STANDARD PARTS (NUTS)

3. Nuts
ナット

How to read Parts Numbers
部品番号の見方

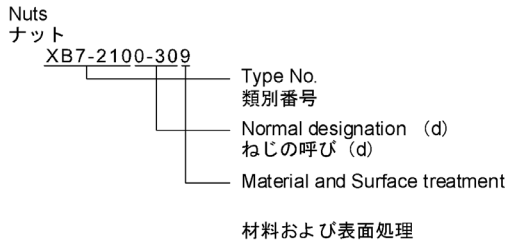

XB7-210 expresses Hexagon nut class 1.
XB7-210は、六角ナット1種を表す
0-30 expresses M3.0.
0-30は、M3.0を表す
9 expresses Steel (Black zinc trivalent chromate treating) from Table 1.
9は、表1より鋼（黒色亜鉛3価クロメート）を表す

3-1. Hexagon Nuts and Hexagon Thin Nuts
六角ナット

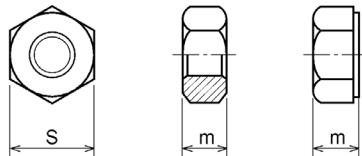

Type No. 類別番号	Type 類別
XB7-210	Hexagon nut Class 1 六角ナット-1種
XB7-220	Hexagon nut Class 3 六角ナット-3種
XB7-230	Hexagon nut Style 1 double chamfered 六角ナット-スタイル1-両面とり
XB7-231	Hexagon nut Style 1 washer faced 六角ナット-スタイル1-座付き
XB7-240	Hexagon nut Style 2 double chamfered 六角ナット-スタイル2-両面とり
XB7-241	Hexagon nut Style 2 washer faced 六角ナット-スタイル2-座付き
XB7-250	Hexagon nut 六角ナット
XB7-260	Hexagon thin nut double chamfered 六角低ナット-両面とり
XB7-270	Hexagon thin nut not chamfered 六角低ナット-面とり無し

	Head size (mm) 頭部寸法 (mm)						
	M2	M2.5	M3	M4	M5	M6	M8
S	4	5	5.5	7	8	10	13
m XB7-210	1.6	2	2.4	3.2	4	5	6.5
m XB7-220	1.2	1.6	1.8	2.4	3.2	3.6	5
m XB7-230, 231	1.6	2	2.4	3.2	4.7	5.2	6.8
m XB7-240, 241	-	-	-	-	5.1	5.7	7.5
m XB7-250	-	-	-	-	5.6	6.1	7.9
m XB7-260	1.2	1.6	1.8	2.2	2.7	3.2	4
m XB7-270	1.2	1.6	1.8	2.2	2.7	3.2	4

Figure ZZE (1/3)MECHANICAL STANDARD PARTS (RETAINING RINGS)

5. Retaining Rings
止め輪

How to read Parts Numbers
部品番号の見方

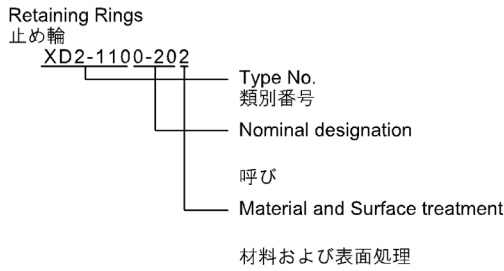

XD2-110 expresses retaining ring-E type (Type1).
XD2-110は、E形止め輪（1種）を表す

0-20 expresses a 020 of nominal designation.
(See Table 5)
0-20は、呼び020を表す（表5参照）

2 expresses Stainless steel (Surface treatment is not to be given) from Table 1.
2は、表1よりステンレス（表面処理なし）を表す

5-1. Retaining Rings - E type
E形止め輪

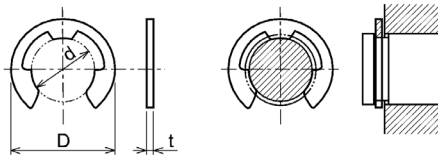

Type No. 類別番号	Type 類別
XD2-110	Retaining ring - E type (Type 1) E形止め輪（1種）
XD2-120	Retaining ring - E type (Type 2) E形止め輪（2種）

Table 5 表5

Type 種類	Nominal designation 呼び	d (mm)	D (mm)	t (mm)
Type 1 1種	007	0.65	2	0.2
	010	0.95	2.8	0.2
	013	1.25	3.3	0.3
	017	1.65	4.2	0.4
	020	1.95	4.6	0.5
	024	2.35	6	0.6
	028	2.74	6.5	0.6
	032	3.14	7.2	0.6
	037	3.64	8	0.7
	040	3.93	10	0.7
	042	4.13	10	0.7
	050	4.93	11	0.7
	058	5.73	12	0.7
	060	5.93	12.7	0.9
064	6.32	13.5	0.9	
074	7.31	15	0.9	
080	7.91	16.5	1	
Type 2 2種	008	0.8	2	0.2
	012	1.2	3	0.3
	015	1.5	4	0.4
	020	2	5	0.4
	025	2.5	6	0.4
	030	3	7	0.6
	040	4	9	0.6
	050	5	11	0.6
	060	6	12	0.8
	070	7	14	0.8
	080	8	16	0.8
	090	9	18	0.8
100	10	20	1	

Figure ZZE (2/3)MECHANICAL STANDARD PARTS (RETAINING RINGS)

5-2. Grip Rings
グリップ止め輪

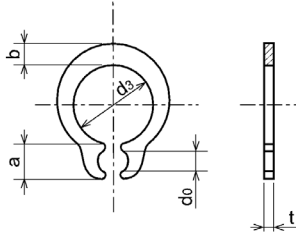

Table 5 表5

Nominal designation 呼び	d_3 (mm)	t (mm)	b (mm)	a (mm)	d_o (mm)
020	1.9	0.5	1	1.8	0.8
025	2.35	0.5	1.2	1.9	0.9
030	2.85	0.6	1.4	1.9	0.9
035	3.3	0.6	1.6	2	0.9
040	3.8	0.8	1.8	2.8	1.2
045	4.25	0.8	2	2.9	1.3
050	4.75	0.8	2.2	2.9	1.3
060	5.7	1	2.4	3.1	1.4
070	6.7	1	2.7	3.3	1.4
080	7.7	1	3	3.5	1.4
090	8.65	1.2	3.3	4.7	1.5
100	9.65	1.2	3.5	4.7	2

Type No. 類別番号	Type 類別
XD2-210	Grip ring グリップ止め輪

5-3. Toothed Retaining Rings
歯付き形止め輪

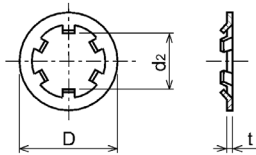

Table 5 表5

Nominal designation 呼び	d_z (mm)	D (mm)	t (mm)	No of teeth 歯数
015	1.4	5.2	0.25	3
020	1.9	6	0.25	3
024	2.3	6.4	0.25	3
030	2.8	8	0.25	4
040	3.8	9	0.25	4
050	4.8	10	0.25	5
060	5.8	11	0.25	5
080	7.8	13	0.25	5
100	9.8	15.4	0.25	6

Type No. 類別番号	Type 類別
XD2-230	Toothed retaining ring 歯付き形止め輪

Figure ZZE (3/3)MECHANICAL STANDARD PARTS (RETAINING RINGS)

5-4. Retaining Rings - C Type
C形止め輪

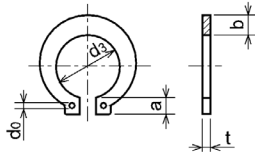

Type No. 類別番号	Type 類別
XD2-310	Retaining ring - C type for shaft C形止め輪 軸用

Table 5 表5

Nominal designation 呼び	ds (mm)	t (mm)	b (mm)	a (mm)	do (mm)
010	9.3	1	1.6	3	1.2
012	11.1	1	1.8	3.2	1.5
014	12.9	1	2	3.4	1.7
015	13.8	1	2.1	3.5	1.7
016	14.7	1	2.2	3.6	1.7
017	15.7	1	2.2	3.7	1.7
018	16.5	1.2	2.6	3.8	1.7
020	18.5	1.2	2.7	3.9	2
022	20.5	1.2	2.7	4.1	2
025	23.2	1.2	3.1	4.3	2
028	25.9	1.5	3.1	4.6	2
030	27.9	1.5	3.5	4.8	2
032	29.6	1.5	3.5	5	2.5
035	32.2	1.5	4	5.4	2.5

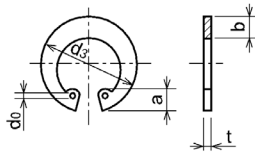

Type No. 類別番号	Type 類別
XD2-320	Retaining ring - C type for hole C形止め輪 穴用

Table 5 表5

Nominal designation 呼び	ds (mm)	t (mm)	b (mm)	a (mm)	do (mm)
010	10.7	1	1.8	3.1	1.2
011	11.8	1	1.8	3.2	1.2
012	13	1	1.8	3.3	1.5
014	15.1	1	2	3.6	1.7
016	17.3	1	2	3.7	1.7
018	19.5	1	2.5	4	1.7
019	20.5	1	2.5	4	2
020	21.5	1	2.5	4	2
022	23.5	1	2.5	4.1	2
025	26.9	1.2	3	4.4	2
028	30.1	1.2	3	4.6	2
030	32.1	1.2	3	4.7	2
032	34.4	1.2	3.5	5.2	2.5
035	37.8	1.5	3.5	5.2	2.5
037	39.8	1.5	3.5	5.2	2.5
040	43.5	1.8	4	5.7	2.5
042	45.5	1.8	4	5.8	2.5
045	48.5	1.8	4.5	5.9	2.5
047	50.5	1.8	4.5	6.1	2.5
050	54.2	2	4.5	6.5	2.5
052	56.2	2	5.1	6.5	2.5
055	59.2	2	5.1	6.5	2.5
060	64.2	2	5.1	6.8	2.5
062	66.2	2	5.5	6.9	2.5
068	72.5	2.5	6	7.4	2.5
072	76.5	2.5	6.6	7.4	2.5
075	79.5	2.5	6.6	7.8	2.5
080	85.5	2.5	7	8	2.5
085	90.5	3	7	8	3
090	95.5	3	7.6	8.3	3
095	100.5	3	8	8.5	3