

Color imageCLASS LBP712Cdn

SERVICE MANUAL



Canon

**April 7, 2016
Rev. 1**

Introduction

Important Notices

Application

This manual has been issued by Canon Inc. for qualified persons to learn technical theory, installation, maintenance, and repair of products.

This manual covers all localities where the products are sold. For this reason, there may be information in this manual that does not apply to your locality.

Corrections

This manual may contain technical inaccuracies or typographical errors due to improvements or changes in products. When changes occur in applicable products or in the contents of this manual, Canon will release technical information as the need arises. In the event of major changes in the contents of this manual over a long or short period, Canon will issue a new edition of this manual.

The following paragraph does not apply to any countries where such provisions are inconsistent with local law.

Trademarks

The product names and company names used in this manual are the registered trademarks of the individual companies.

Copyright

This manual is copyrighted with all rights reserved. Under the copyright laws, this manual may not be copied, reproduced or translated into another language, in whole or in part, without the consent of Canon Inc.







Copyright CANON INC. 2016















Caution

Use of this manual should be strictly supervised to avoid disclosure of confidential information.



Explanation of Symbols

The following symbols are used throughout this Service Manual.

Symbols	Explanation	Symbols	Explanation
	Check.		Remove the claw.
	Check visually.		Insert the claw.
	Check a sound.		Push the part.

Symbols	Explanation	Symbols	Explanation
	Disconnect the connector.		Connect the power cable.
	Connect the connector.		Disconnect the power cable.
	Remove the cable/wire from the cable guide or wire saddle.		Turn on the power.
	Install the cable/wire to the cable guide or wire saddle.		Turn off the power.
	Remove the screw.		Loosen the screw.
	Install the screw.		Tighten the screw.
	Cleaning is needed.		Measurement is needed.

The following rules apply throughout this Service Manual:

- Each chapter contains sections explaining the purpose of specific functions and the relationship between electrical and mechanical systems with reference to the timing of operation.
In the diagrams,  represents the path of mechanical drive; where a signal name accompanies the symbol, the arrow  indicates the direction of the electric signal.
The expression "turn on the power" means flipping on the power switch, closing the front door, and closing the delivery unit door, which results in supplying the machine with power.
- In the digital circuits, '1' is used to indicate that the voltage level of a given signal is "High", while '0' is used to indicate "Low". (The voltage value, however, differs from circuit to circuit.) In addition, the asterisk (*) as in "DRMD*" indicates that the DRMD signal goes on when '0'.
In practically all cases, the internal mechanisms of a microprocessor cannot be checked in the field. Therefore, the operations of the microprocessors used in the machines are not discussed: they are explained in terms of from sensors to the input of the DC controller PCB and from the output of the DC controller PCB to the loads.

The descriptions in this Service Manual are subject to change without notice for product improvement or other purposes, and major changes will be communicated in the form of Service Information bulletins.

All service persons are expected to have a good understanding of the contents of this Service Manual and all relevant Service Information bulletins and be able to identify and isolate faults in the machine.

Contents

Safety Precautions	1
Laser Safety.....	2
How to Handle the Laser Scanner Unit.....	2
Toner Safety.....	2
About Toner.....	2
Handling Adhered Toner.....	3
Notes When Handling a Lithium Battery.....	3
Notes on Assembly/Disassembly.....	3
1. Product Overview	4
Product Lineup.....	5
Host machine.....	5
Options.....	5
Product Features.....	6
Specifications.....	7
Product Specifications.....	7
Print speed.....	9
Paper type.....	9
Paper Size.....	9
Parts Name.....	11
External View.....	11
Cross Section View.....	14
Control Panel.....	15
2. Technical Explanation (Device)	16
Basic Configuration.....	17
Function Configuration.....	17
Operation Sequence.....	18
Overview.....	18
Laser Exposure System.....	19
Overview.....	19
Laser Scanner Motor Control.....	19
Image Formation System.....	21
Overview.....	21
Image Formation Process.....	23
Cartridge.....	28
ITB Unit.....	31
High Voltage Power Supply Control.....	34
Calibration.....	35
Paper interval patch control.....	36
Pickup Feed System.....	37
Overview.....	37
Controls.....	39
Jam Detection.....	44

Fixing System.....	47
Overview.....	47
Main Parts in the Fixing Assembly.....	47
Controls.....	48
Controller System.....	52
Overview.....	52
Main Controller.....	52
DC Controller.....	53
Low Voltage Power Supply.....	57
Quick Startup.....	59
Energy Saving Function.....	60
3. Technical Explanation (System).....	61
Overview of System Management.....	62
Version Upgrade.....	63
Overview.....	63
Version Upgrade Using UST.....	64
Update Using Updater.....	64
Backup/Restoration.....	81
Backup/Restoration Using the DCM Function.....	81
Backup/Restoration Using a Function Other Than the DCM Function.....	90
Monitoring Function (imageWARE Remote).....	98
Overview of System.....	98
Cautions when Using E-RDS.....	99
Setting Procedure.....	99
Maintenance.....	101
MEAP Application Management.....	105
About MEAP.....	105
About SMS.....	105
Setting Procedure.....	108
Maintenance.....	116
4. Periodical Service.....	119
Periodically Replaced Parts.....	120
Consumable parts.....	121
Periodical Service.....	122
5. Disassembly/Assembly.....	123
List of Parts.....	124
Main Unit.....	124
Electrical Components List.....	126
Removing from the connection equipment.....	129
Disengaging the Paper Feeder.....	129
External Cover System.....	130
Removing the Waste Toner Container Cover Unit.....	130
Removing the Rear Cover.....	131
Removing the Left Cover.....	132
Removing the Right Rear Cover.....	133

Removing the Right Cover Unit.....	134
Removing the Right Lower Cover.....	136
Removing the Upper Cover Unit.....	137
Removing the Output Tray Unit.....	138
Removing the Front Cover Unit.....	140
Laser Exposure System.....	142
Removing the Laser Scanner Unit.....	142
Image Formation System.....	147
Removing the Secondary Transfer Unit.....	147
Removing the Secondary Transfer Roller Unit.....	148
Removing the ITB Unit.....	150
Removing the Developing Disengagement Motor.....	152
Removing the Drum Motor (Y).....	153
Removing the Drum Motor (M).....	154
Removing the Drum Motor (C).....	154
Removing the Color Displacement Density Sensor Unit.....	155
Fixing System.....	158
Removing the Fixing Assembly.....	158
Removing the Fixing Drive Unit.....	158
Removing the Fixing Motor.....	160
Pickup Feed Delivery System.....	162
Removing the Delivery Unit.....	162
Removing the Lifter Drive Unit.....	163
Removing the Pickup Drive Unit.....	165
Removing the Registration Unit.....	166
Removing the Cassette Pickup Unit.....	170
Removing the Cassette Pickup Roller Unit.....	172
Removing the Cassette Separation Roller Unit.....	174
Removing the Multi-purpose Tray Pickup Roller.....	176
Removing the Multi-purpose Tray Separation Roller.....	177
Removing the Duplex Reverse Drive Unit.....	179
Controller System.....	182
Removing the Controller Cover.....	182
Removing the Main Controller PCB.....	182
Removing the DC Controller PCB.....	184
Removing the Fixing Power Supply Unit.....	185
Removing the Controller Box.....	187
Removing the Low Voltage Power Supply Unit.....	189
Removing the DC Controller Support Plate.....	190
Removing the Lower High Voltage Power Supply PCB.....	191
Removing the Upper High Voltage Power Supply PCB.....	192
Removing the Main Drive Unit.....	193
Removing the Control Panel Unit.....	198
Removing the Control Panel Unit Key PCB.....	199
Removing the Power Fan.....	201
Removing the Cartridge Fan.....	202
Removing the Exhaust Fan.....	203
Removing the Fixing Fan.....	205

6. Adjustment.....	210
Actions after Replacement.....	211
Before Replacing the Main Controller PCB.....	211
After Replacing the Main Controller PCB.....	211
Before Replacing the DC Controller PCB.....	211
After Replacing the DC Controller PCB.....	211
7. Troubleshooting.....	212
Test Print.....	213
Overview.....	213
Device Log List.....	218
Troubleshooting.....	220
Remedy for Image Failure.....	220
Intervals of Soiling, White Spots, Etc. That Occur on Images.....	220
Checking the Amount of Fixing Nip.....	220
Installing the Laser Scanner Dustproof Glass Cleaning Tools When They Have Come Off.....	221
Obtaining Debug Log.....	225
Function Overview.....	225
Sublog.....	225
Conditions for collecting logs.....	225
Sublog Collection Procedure.....	226
8. Error/Jam/Alarm.....	229
Overview.....	230
Error Code Details.....	231
Jam Code.....	238
Alarm Code.....	240
9. Service Mode.....	241
Overview.....	242
Entering Service Mode.....	242
Remote UI Service Mode.....	242
Service Report.....	243
Service Mode.....	246
COUNTER GR.....	246
ADJUST GR.....	246
OPTION GR.....	247
FUNCTION GR.....	248
LOG GR.....	250
PANEL GR.....	251
F/W UPDATE GR.....	251
NETWORK GR.....	251
SP.ADMIN.MODE.....	253
APPENDICES.....	254
Service Tools.....	255
Solvents and Oil List.....	255

General Circuit Diagram.....	256
General Circuit Diagram.....	256
Backup Data List.....	257
Backup Data.....	257
Soft counter specifications.....	258

Safety Precautions

Laser Safety.....	2
How to Handle the Laser Scanner Unit	2
Toner Safety.....	2
Notes When Handling a Lithium Battery.....	3
Notes on Assembly/Disassembly.....	3

Laser Safety

Since radiation emitted inside the machine is completely confined within protective housings and external covers, the laser beam cannot escape from the machine during any phase of user operation.

Therefore this machine is classified in Class 1 laser products that are regarded as safe during normal use according to International Standard IEC60825-1.

How to Handle the Laser Scanner Unit

This machine is classified in Class 1 laser products.

However, inside the scanner unit, there is source of Class 3B laser beam and the laser beam is hazardous when entered into an eye. So, be sure not to disassemble the laser scanner unit. No adjustment can be made to the laser scanner unit in this machine in the field.

The label show in the following figure is attached on the laser scanner unit.

The following warnings are given to comply with Safety Principles (EN60950-1).

Diese Maschine ist der Klasse 1 der Laserprodukte zugeordnet.

Innerhalb der Scannereinheit befindet sich jedoch die Laserstrahlquelle der Klasse 3B und es ist gefährlich, wenn dieser Strahl in die Augen gerät. Die Laserscannereinheit darf unter keinen Umständen entfernt werden. Es dürfen in diesem Umfeld der Maschine keine Justagen an der Laserscannereinheit vorgenommen werden.

Das Etikett in folgendem Bild ist auf der Laserscannereinheit angebracht.

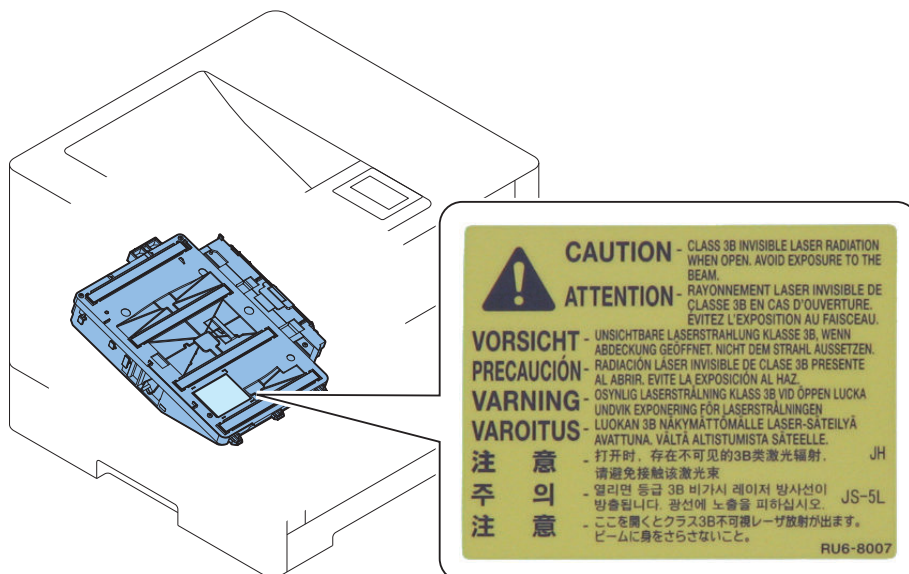

Toner Safety

About Toner

Toner is a nontoxic matter composed of plastic, iron and a trace of pigments.

CAUTION:

Never throw toner in flames to avoid explosion.

Handling Adhered Toner

- Use dry tissue paper to wipe off toner adhered to skin or clothes and wash in water.
- Never use warm water for cleaning up toner to prevent toner particles from being gelated to soak into fibers permanently.
- Toner particles are reactive with vinyl polymers. Avoid contacting these materials.

Notes When Handling a Lithium Battery

CAUTION:

RISK OF EXPLOSION IF BATTERY IS REPLACED BY AN INCORRECT TYPE.
DISPOSE OF USED BATTERIES ACCORDING TO THE INSTRUCTIONS.

The following warnings are given to comply with Safety Principles (EN60950-1).

CAUTION:

Wenn mit dem falschen Typ ausgewechselt, besteht Explosionsgefahr.
Gebrauchte Batterien gemäß der Anleitung beseitigen.

警告

如果更換不正確之電池型式會有爆炸的風險
請依製造商說明書處理用過之電池

Notes on Assembly/Disassembly

Follow the items below to assemble/disassemble the device.

1. Disconnect the power plug to avoid any potential dangers during assembling/disassembling works.
2. If not specially instructed, reverse the order of disassembly to reinstall.
3. Ensure to use the right screw type (length, diameter, etc.) at the right position when assembling.
4. To keep electric conduction, binding screws with washers are used to attach the grounding wire and the varistor. Ensure to use the right screw type when assembling.
5. Unless it is specially needed, do not operate the device with some parts removed.
6. Never remove the paint-locked screws when disassembling.



Product Overview

Product Lineup.....	5
Product Features.....	6
Specifications.....	7
Parts Name.....	11

Product Lineup

Host machine

Function	LBP712Cdn/ LBP712Cx LBP710Cx
External view	
Copy	-
Print	Yes
Fax	-
Remote UI	Yes
2-sided printing	Yes
MEAP	Yes
Network	Yes
Wireless LAN	-

Options

Name	Description
Paper Feeder PF-D1	LBP712Cdn/ LBP712Cx: A Paper Feeder with up to 3 decks can be installed. LBP710Cx: A Paper Feeder with up to 1 deck can be installed.

Product Features

High-end A4/LTR Color SFP of high speed and high capacity pickup

1. High speed

This machine is a high-speed printer that realizes the print speed shown below.

- LBP712Cdn/ LBP712Cx:
1-sided 38/40 ppm (A4/LTR)
- LBP710Cx:
1-sided 33/35 ppm (A4/LTR)

2. High capacity pickup

In addition to the Multi-purpose Tray and Standard Drawer, the Paper Feeder (550 sheets) can be installed as an option.

- LBP712Cdn/ LBP712Cx:
Up to 3 units can be installed.
This enables continuous and automatic pickup of up to 2,300 sheets (in the case of 80 g/m²).
- LBP710Cx:
Only 1 unit can be installed.
This enables continuous and automatic pickup of up to 1,200 sheets (in the case of 80 g/m²).

Adoption of large capacity color cartridges

This machine is the first to adopt large capacity cartridges for color cartridges (YMC) to realize low running cost and low initial cost.

Automatic identification of the paper type

When paper is fed, the paper type can be automatically identified by the Media Sensor.

In the case of printing using mixed paper types, this function prevents deterioration of print quality (fixing errors, jams, etc.) caused by failing to configure the paper type settings on the driver.

Specifications

Product Specifications

Item	Specification/Function
Machine installation method	Desktop page printer
Photosensitive medium	OPC Drum (24 mm dia.)
Exposure method	Laser beam
Charging method	Roller charging
Developing method	Contact development
Transfer method	Primary transfer: Intermediate Belt transfer Secondary transfer: Roller transfer
Separation method	Curvature separation
Pickup method	Cassette: Separation Roller Multi-purpose Tray: Separation Roller
Fixing method	On-demand fixing method
Delivery method	Face-down
Drum cleaning method	Cleaning Blade
Toner type	Non-magnetic 1-component fine-grained toner
Toner supplying method	By replacing the cartridge
Toner level detection function	Yes
Toner save mode	Yes
Print method	Semiconductor laser + Dry-type electrophotographic method
Print resolution	Equivalent to 9,600 dpi x 600 dpi
Print speed*1 (Plain paper (60 to 90 g/m ²), At continuous A4/LTR print)	LBP712Cdn/ LBP712Cx: 38 sheets/min (A4), 40 sheets/min (LTR) LBP710Cx: 33 sheets/min (A4), 35 sheets/min (LTR)
Warm-up time*2 (Duration from power-on to standby of the machine)	At normal startup: 31 sec. or less At quick startup: 2 sec. or less
Recovery time*3 (Time for recovery from deep sleep to standby)	6 sec. or less
First print time*3 (At 1-sided A4/LTR print)	6 sec. or less
Paper type	Cassette: Plain paper (60 to 90 g/m ²), Recycled paper (60 to 90 g/m ²), Heavy paper (91 to 163 g/m ²), Rough paper (60 to 105 g/m ²), Label paper Multi-purpose Tray: Plain paper (60 to 90 g/m ²), Recycled paper (60 to 90 g/m ²), Heavy paper (91 to 216 g/m ²), Rough paper (60 to 105 g/m ²), Postcard, Reply postcard, 4 on 1 postcard, Envelope

Item	Specification/Function
Paper size	<p>Cassette 1: A4, B5, A5, A6, LTR, EXEC, STMT, 16K, Custom paper (Portrait: Width 148.0 to 215.9 mm, Length 148.0 to 215.9 mm / Landscape: Width 101.6 to 215.9 mm, Length 148.0 to 297.0 mm)</p> <p>Cassettes 2 to 4 (option): A4, B5, A5, A6, LGL, LTR, EXEC, STMT, FLS, 16K, Custom paper (Portrait: Width 148.0 to 215.9 mm, Length 148.0 to 215.9 mm / Landscape: Width 101.6 to 215.9 mm, Length 148.0 to 355.6 mm)</p> <p>Multi-purpose Tray: A4, B5, A5, A6, LGL, LTR, EXEC, STMT, FLS, 16K, Index Card (3" x 5"), Postcard, Reply postcard, 4 on 1 postcard, Envelope (Nagagata 3, Yougatanaga 3, No.10 (COM10), Monarch, C5, DL), Index Card (3" x 5"), Custom paper (Portrait: Width 127.0 to 215.9 mm, Length 127.0 to 215.9 mm / Landscape: Width 76.2 to 215.9 mm, Length 127.0 to 355.6 mm)</p>
Maximum stacking capacity	<p>Cassette: 550 sheets (80 g/m²), 680 sheets (64 g/m²)</p> <p>Multi-purpose Tray: 100 sheets</p>
Delivery stacking capacity*4	Approx. 250 sheets
2-sided printing	A4, B5, A5, LGL, LTR, EXEC, FLS, 16K, Custom paper (Width: 148.0 to 215.9 mm, Length: 210.0 to 355.6 mm)
Host Interface	<p>USB Interface: Hi-Speed USB x 4 (1 on the front, 3 on the rear)</p> <p>Network Interface: Common to 10BASE-T, 100BASE-TX, and 1000BASE-T (RJ-45), Full/Half Duplex</p>
Memory capacity	1,024 MB
Usage environment temperature range	10 to 30 deg C
Environment humidity range	20 to 80 % RH (Relative humidity; without dew condensation)
Operating noise (Measured based on ISO7779, Declared noise emission value based on ISO9296)	<p>LBP712Cdn/ LBP712Cx:</p> <p>LwAd (declared A-weighted sound power level (1 B = 10 dB)): At standby: 5.3 B or less At printing: • B&W: 7.23 B or less • Color: 7.24 B or less</p> <p>LBP710Cx:</p> <p>LwAd (declared A-weighted sound power level (1 B = 10 dB)): At standby: 5.3 B or less At printing: • B&W: 7.09 B or less • Color: 7.06 B or less</p>
Rated power supply	AC 120 to 127 V, 60 Hz AC 220 to 240 V, 50/60 Hz
Power consumption (Reference value)	<p>Maximum: 1,200 W or less</p> <p>At operation: Approx. 600 W</p> <p>At standby: Approx. 33 W</p> <p>During sleep mode: Wired LAN connection: Approx. 1.2 W USB connection: Approx. 2.2 W</p> <p>At power OFF: • At shutdown: 0.06 W or less • In quick off mode: 0.69 W or less</p>
Dimensions (W x D x H)	458 x 464 x 388 mm

Item	Specification/Function
Weight *5	Approx. 24.8 kg

*1: The print speed may become lower depending on the settings such as output resolution, paper size, type, orientation, and number of sheets printed.

*2: This may vary depending on the usage conditions of this machine (presence/absence of installed options, installation environment, etc.).

*3: This may vary depending on the print environment.

*4: This may vary depending on the site environment and the type of paper used.

*5: Excluding the Toner Cartridge

Print speed

LBP712Cdn/ LBP712Cx

- At 1-sided printing: 38 sheets/min (A4), 40 sheets/min (LTR)
- At 2-sided printing: 38 pages/min (A4), 40 pages/min (LTR)

LBP710Cx

- At 1-sided printing: 33 sheets/min (A4), 35 sheets/min (LTR)
- At 2-sided printing: 33 pages/min (A4), 35 pages/min (LTR)

* The print speed may become lower depending on the settings such as output resolution, paper size, type, orientation, and number of sheets printed. In the case of 2-sided printing, 1 page on the front side and 1 page on the back side are output as 1 sheet.

Paper type

(YES: Pickup possible -: Pickup not possible)

Type of paper		Paper settings in this machine	Cassette	Multi-purpose Tray
Plain paper / Recycled paper	60 g/m ²	Plain L2	YES	YES
	61 to 74 g/m ²	Plain L	YES	YES
	75 to 90 g/m ²	Plain	YES	YES
Heavy	91 to 119 g/m ²	Heavy 1	YES	YES
	120 to 128 g/m ²	Heavy 2	YES	YES
	129 to 163 g/m ²	Heavy 3	YES	YES
	164 to 200 g/m ²		-	YES
	201 to 216 g/m ²	Heavy 4	-	YES
Rough	60 to 74 g/m ²	Rough 1	YES	YES
	75 to 105 g/m ²	Rough 2	YES	YES
Label paper		Labels	YES	-
Postcard, Reply Postcard, 4 on 1 Postcard*		Postcard	-	YES
Envelope		Envelope	-	YES

* Ink-jet postcards and reply postcards cannot be used.

Paper Size

(YES: Pickup possible -: Pickup not possible)

Paper size		Cassette 1	Cassettes 2 to 4 (Option)	Multi-purpose Tray
A4	210.0 mm x 297.0 mm	YES	YES	YES
B5	182.0 mm x 257.0 mm	YES	YES	YES
A5	148.0 mm x 210.0 mm	YES	YES	YES

Paper size		Cassette 1	Cassettes 2 to 4 (Option)	Multi-purpose Tray
A6	105.0 mm x 148.0 mm	YES	YES	YES
LGL	215.9 mm x 355.6 mm	-	YES	YES
LTR	215.9 mm x 279.4 mm	YES	YES	YES
STMT	139.7 mm x 215.9 mm	YES	YES	YES
EXEC	184.1 mm x 266.7 mm	YES	YES	YES
FLS	215.9 mm x 330.2 mm	-	YES	YES
16K	195.0 mm x 270.0 mm	YES	YES	YES
Index Card (3" x 5")	76.2 mm x 127.0 mm	-	-	YES
Postcard	100.0 mm x 148.0 mm	-	-	YES
Reply Postcard	148.0 mm x 200.0 mm	-	-	YES
4 on1 Postcard	200.0 mm x 296.0 mm	-	-	YES
Envelope Nagagata 3	120.0 mm x 235.0 mm	-	-	YES
Envelope Yougatanaga 3	235.0 mm x 120.0 mm	-	-	YES
Envelope No.10 (COM10)	104.7 mm x 241.3 mm	-	-	YES
Envelope Monarch	98.4 mm x 190.5 mm	-	-	YES
Envelope C5	162.0 mm x 229.0 mm	-	-	YES
Envelope DL	110.0 mm x 220.0 mm	-	-	YES
Custom paper	-	YES*1	YES*2	YES*3

*1:

When paper is set in portrait orientation (only when using the LIPS LX printer driver): Width 148.0 to 215.9 mm, Length 148.0 to 215.9 mm

When paper is set in landscape orientation: Width 101.6 to 215.9 mm, Length 148.0 to 297.0 mm

*2:

When paper is set in portrait orientation (only when using the LIPS LX printer driver): Width 148.0 to 215.9 mm, Length 148.0 to 215.9 mm

When paper is set in landscape orientation: Width 101.6 to 215.9 mm, Length 148.0 to 355.6 mm

*3:

When paper is set in portrait orientation (only when using the LIPS LX printer driver): Width 127.0 to 215.9 mm, Length 127.0 to 215.9 mm

When paper is set in landscape orientation: Width 76.2 to 215.9 mm, Length 127.0 to 355.6 mm

Parts Name

External View

Front side of the machine

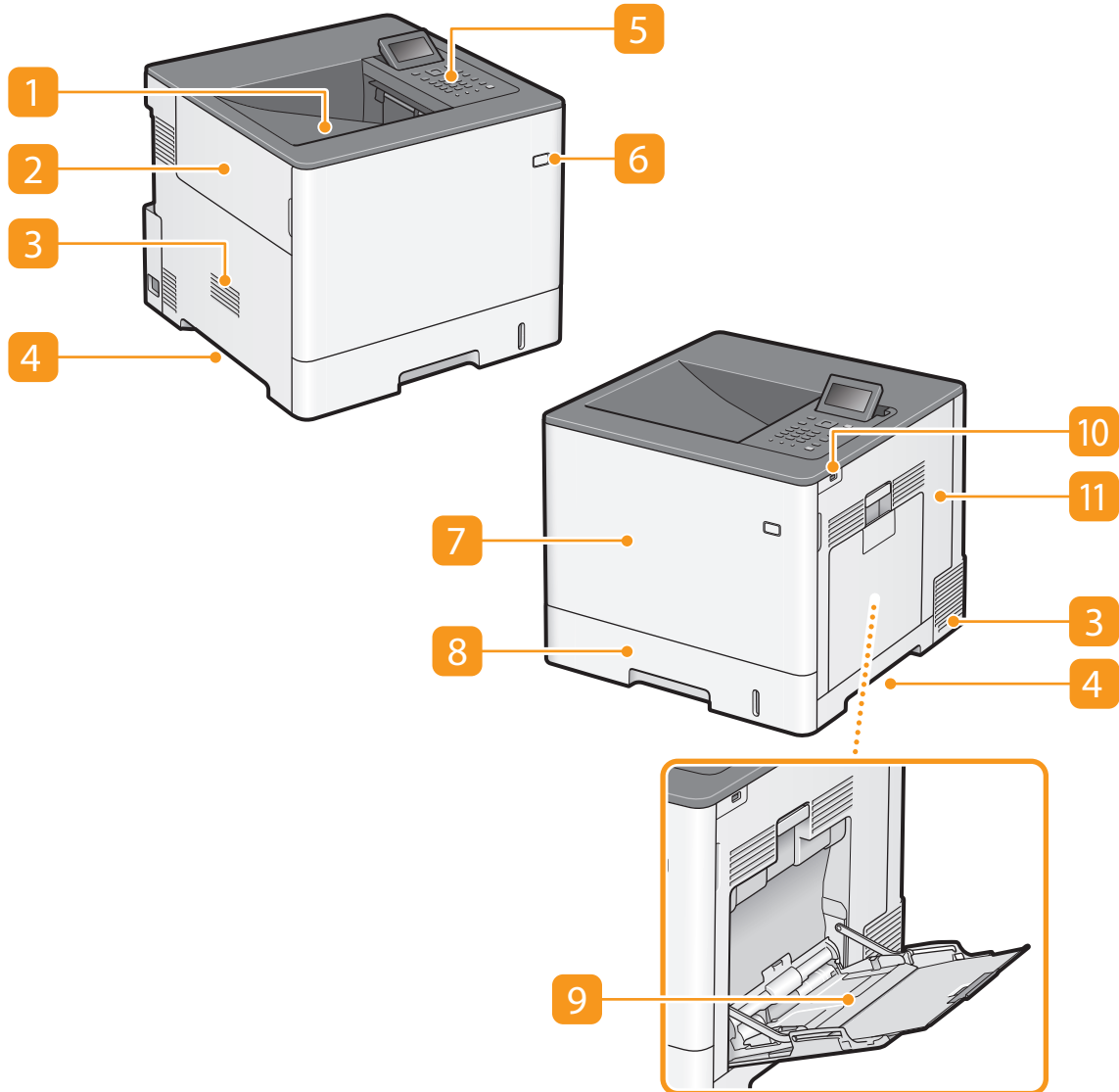

No.	Name	No.	Name
1	Delivery Tray	7	Front Cover
2	Left Cover	8	Pickup Cassette
3	Ventilation hole	9	Multi-purpose Tray
4	Handle for carrying	10	USB port (for USB flash drive)
5	Control Panel	11	Right Cover
6	Power Switch		

■ Rear side of the machine

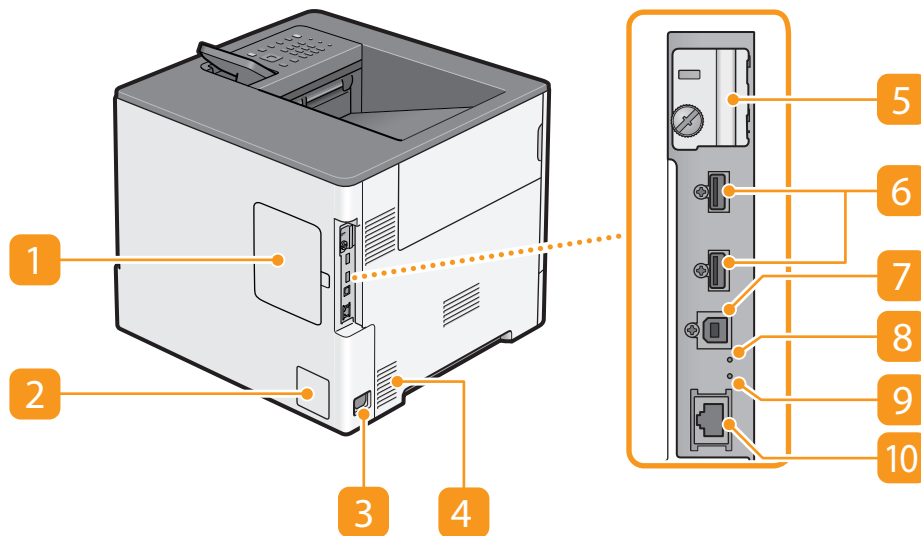

No.	Name	No.	Name
1	Rear Cover	6	USB port (for USB device)
2	Rating name plate label	7	USB port (for PC connection)
3	Power Socket	8	ACT Lamp
4	Ventilation hole	9	LNK Lamp
5	SD Card Slot Cover	10	LAN Port

■ Inside of the host machine

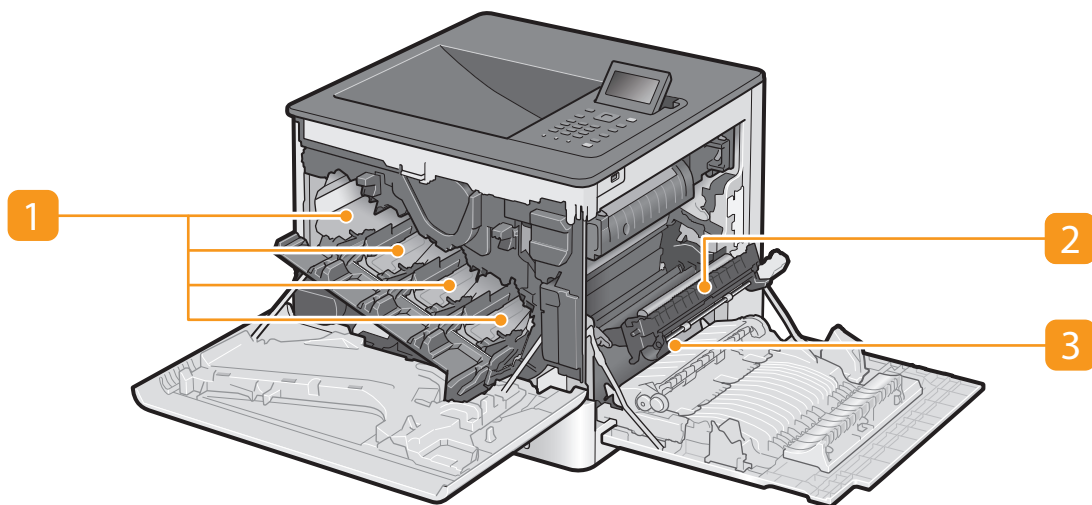

No.	Name	No.	Name
1	Toner Cartridge Slot	3	Transport Guide
2	Delivery Unit		

■ Multi-purpose Tray

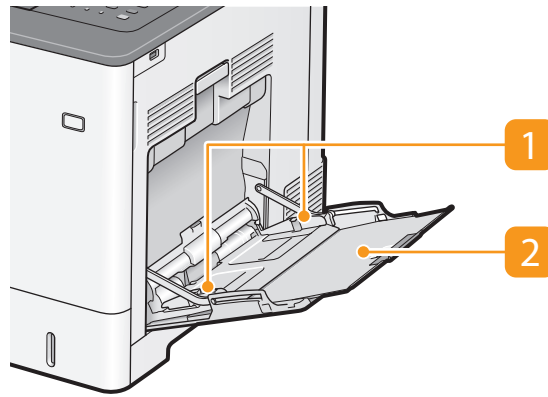

No.	Name	No.	Name
1	Paper Guide	2	Paper Tray

■ Pickup Cassette

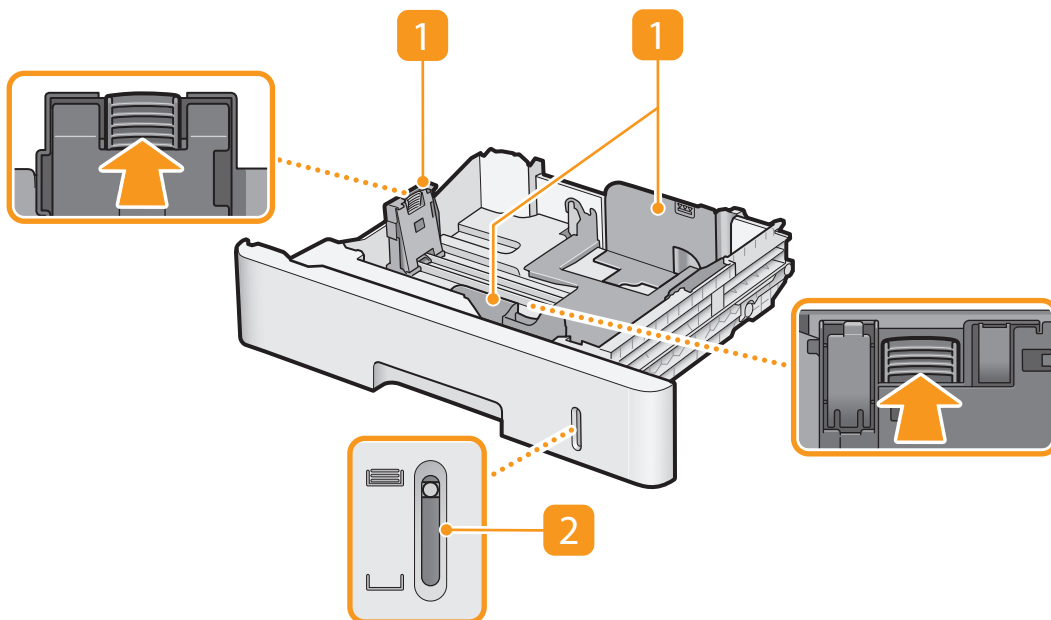

No.	Name	No.	Name
1	Paper Guide	2	Paper level display

Cross Section View

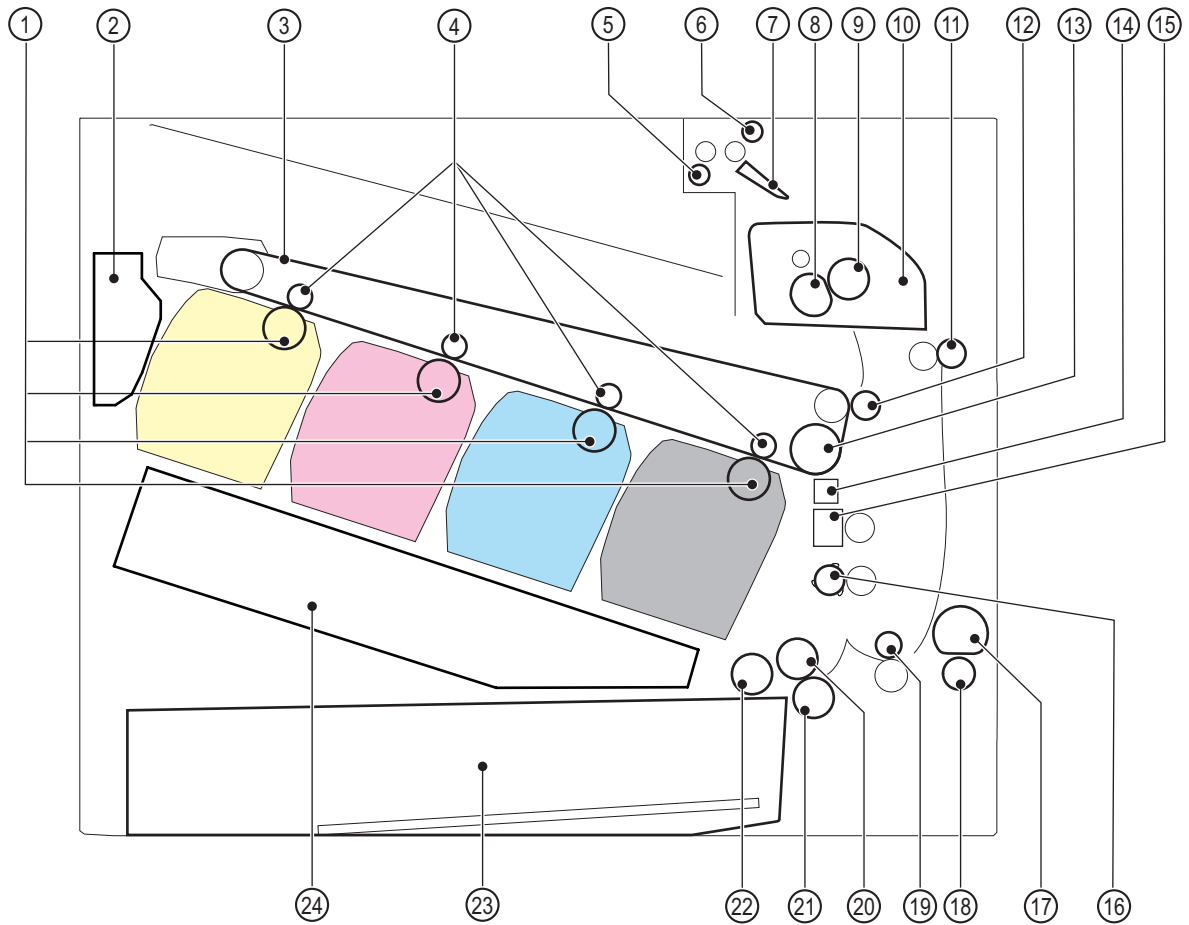

No.	Name	No.	Name
[1]	Photosensitive Drum	[13]	ITB Drive Roller
[2]	Waste Toner Container	[14]	Color Displacement/Density Sensor
[3]	ITB	[15]	Media Sensor
[4]	Primary Transfer Roller	[16]	Registration Roller
[5]	Delivery Roller	[17]	Multi-purpose Tray Pickup Roller
[6]	Duplex Reverse Roller	[18]	Multi-purpose Tray Separation Roller
[7]	Duplex Flapper	[19]	Duplex Re-pickup Roller
[8]	Fixing Film	[20]	Cassette Feed Roller
[9]	Pressure Roller	[21]	Cassette Separation Roller
[10]	Fixing Assembly	[22]	Cassette Pickup Roller
[11]	Duplex Feed Roller	[23]	Cassette
[12]	Secondary Transfer Roller	[24]	Laser Scanner Assembly

Control Panel

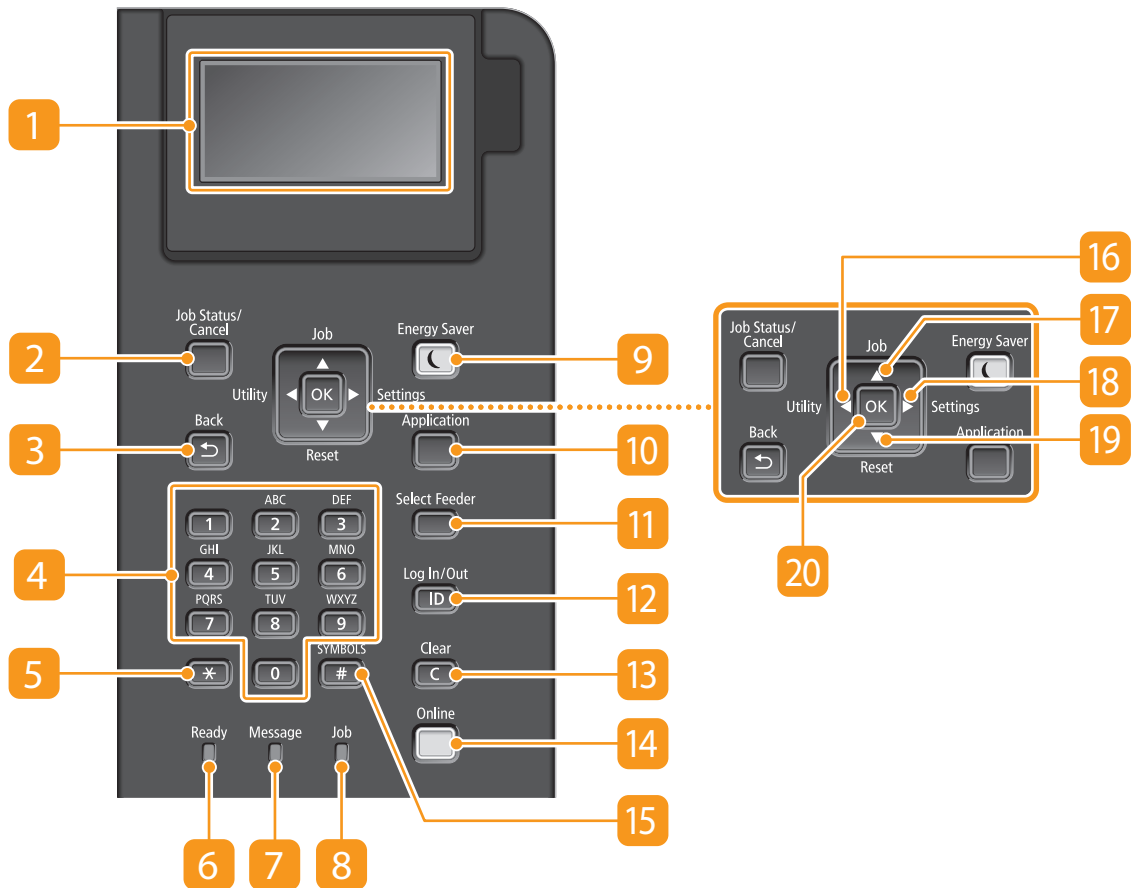

No.	Name	No.	Name
1	Display	11	[Select Feeder] key
2	[Job Status/Cancel] key	12	[Authentication] key
3	[Back] key	13	[Clear] key
4	Numeric keys ([0] to [9])	14	[Online] key
5	[Alphanumeric] key	15	[Symbol] key
6	[Print ready] lamp	16	[Utility] key / [←] key
7	[Message] lamp	17	[Job] key / [^] key
8	[Job] lamp	18	[Setup] key / [→] key
9	[Energy Saver] key	19	[Reset] key / [v] key
10	[Select Function] key	20	[OK] key



Technical Explanation (Device)

Basic Configuration.....	17
Operation Sequence.....	18
Laser Exposure System.....	19
Image Formation System.....	21
Pickup Feed System.....	37
Fixing System.....	47
Controller System.....	52

Basic Configuration

Function Configuration

The functions of this machine can be broadly divided into the following 5 blocks.

- Engine Control System
- Laser Scanner System
- Image Formation System
- Pickup Feed Delivery System
- Options

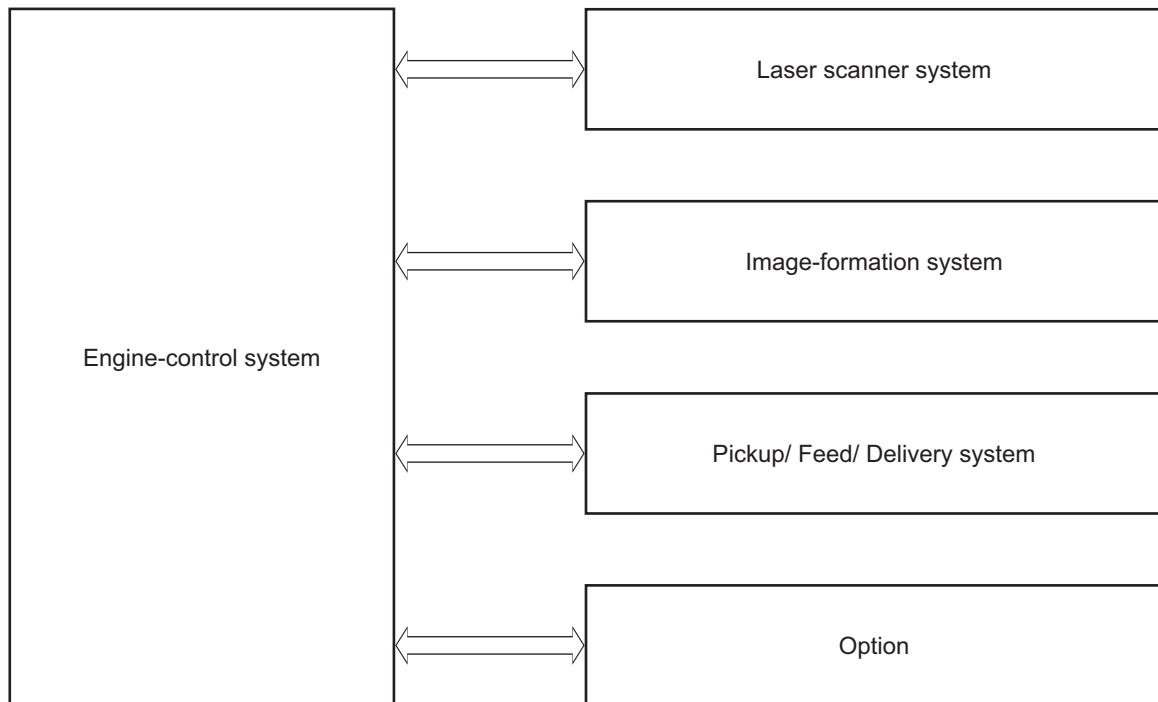

Operation Sequence

Overview

The operation sequence is controlled by the DC Controller in the engine control system. The following shows the operation of each area from when the machine is turned ON until printing is finished and the motors are stopped.

	Area	Operation
WAIT (Wait)	Period of time from the moment when the power switch is turned ON, the door is closed, or the machine recovers from sleep mode to the moment when the machine becomes ready to print.	Start up the machine until it becomes ready to print. <ul style="list-style-type: none"> Heat the Fixing Film of the Fixing Assembly Engage the Pressure Roller of the Fixing Assembly Detect presence of the cartridge Detect presence of the Fixing Assembly Detect presence of the ITB Disengage all the Developing Rollers Disengage all the Primary Transfer Rollers Stop after rotating each motor Stop after rotating each fan ITB cleaning Secondary Transfer Roller cleaning
STBY (Standby)	Period of time from the moment when "wait" is finished or the last rotation is finished to the moment when a print command from the Main Controller is received or the power switch is turned OFF.	Keep the machine ready to print. <ul style="list-style-type: none"> Shift to sleep mode in accordance with a sleep command Rotate each fan and then stop Execute calibration in accordance with a calibration command
INTR (Initial rotation)	Period of time from the moment when a print command is input from the Main Controller to the moment when the Fixing Assembly reaches the target temperature	Perform preparation for printing. <ul style="list-style-type: none"> Rotate each motor Rotate each fan Output high voltage bias Start up the Laser Scanner Unit Start up the Fixing Heater
PRINT (Print)	Period of time from the moment when initial rotation is finished to the moment when fixing of the last sheet of paper is finished.	Execute printing <ul style="list-style-type: none"> Create an image on the Photosensitive Drum Transfer toner to the paper Fix the toner on the paper
LASTR (Last rotation)	Period of time from the moment when printing is finished to the moment when the motor is stopped.	Completely eject the last sheet of paper. <ul style="list-style-type: none"> Stop each motor Stop each fan Stop high voltage bias Stop the Laser Scanner Unit Stop the Fixing Heater <p>If a print command is input from the Main Controller during this period, the machine shifts to initial rotation immediately after last rotation is finished.</p>

Laser Exposure System

Overview

The Laser Exposure system forms a latent image on the Photosensitive Drum according to the video signal sent from the Main Controller.

The Laser Scanner Unit consists of the Laser Unit and the Scanner Motor Unit, and is controlled by the signal input from the DC Controller.

The following shows an outline drawing of the Laser Scanner Unit.

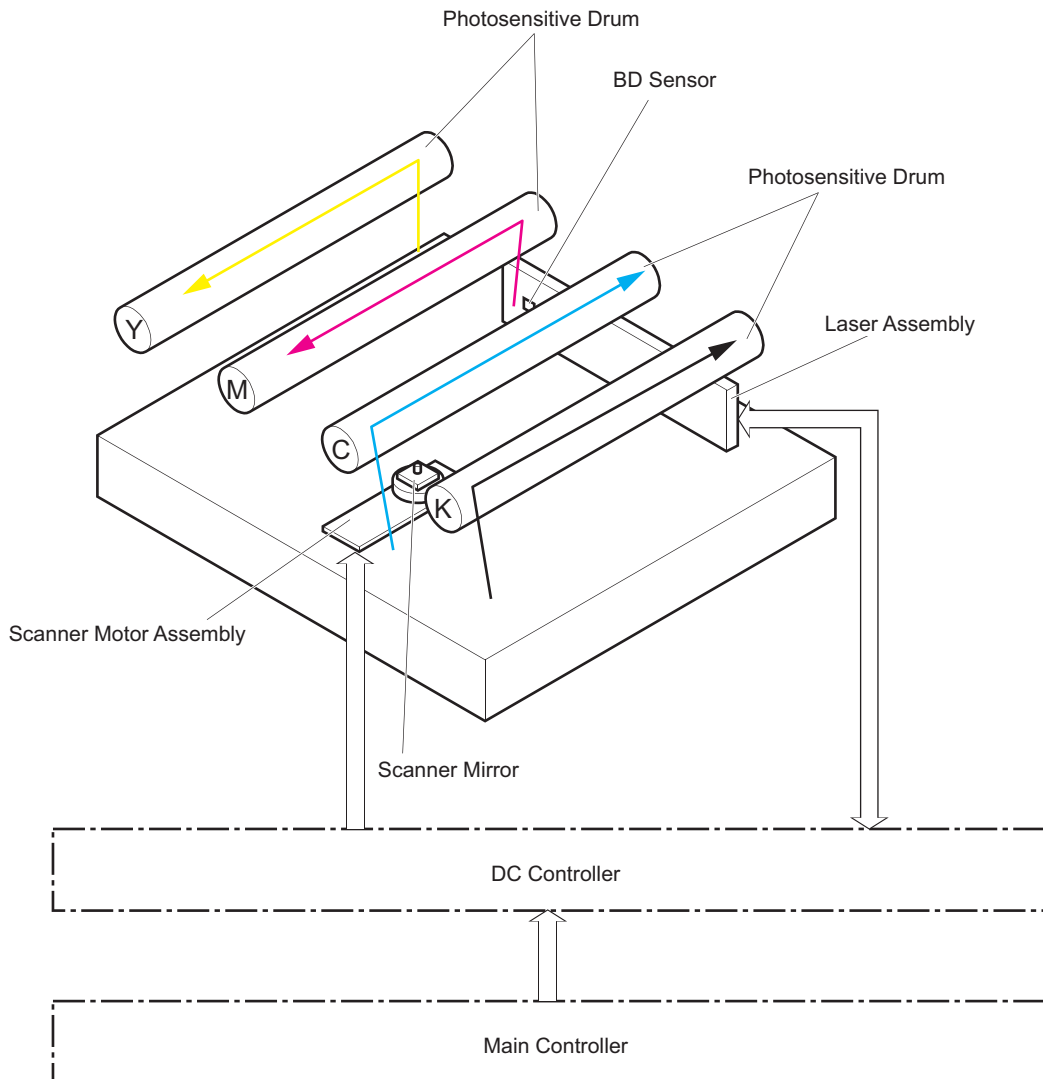

Laser Scanner Motor Control

Rotates the Polygon Mirror at a specified speed.

<Execution timing>

At startup of the Laser Scanner Motor

<Control description>

1. The DC Controller PCB forcefully rotates the Laser Scanner Motor.
2. Sends acceleration signals (ACC) and deceleration signals (DEC) to the Laser Scanner Motor to control the speed to the specified speed.

<Related error codes>

- E110-0000: Error in the initial operation of the Scanner Motor
- E110-0001: Scanner Motor rotation error

This page is intentionally blank

Image Formation System

Overview

The image formation system creates a toner image on the paper.

The image formation system consists of the followings:

- Cartridge
- Primary Transfer Roller
- Secondary Transfer Roller
- Fixing Assembly
- Laser Scanner Unit
- High Voltage Power Supply

The DC Controller controls the Laser Scanner Unit and High Voltage Power Supply to create the toner image on the Photosensitive Drum, and transfers and fixes this to the paper.

The following shows an outline drawing of the image formation system.

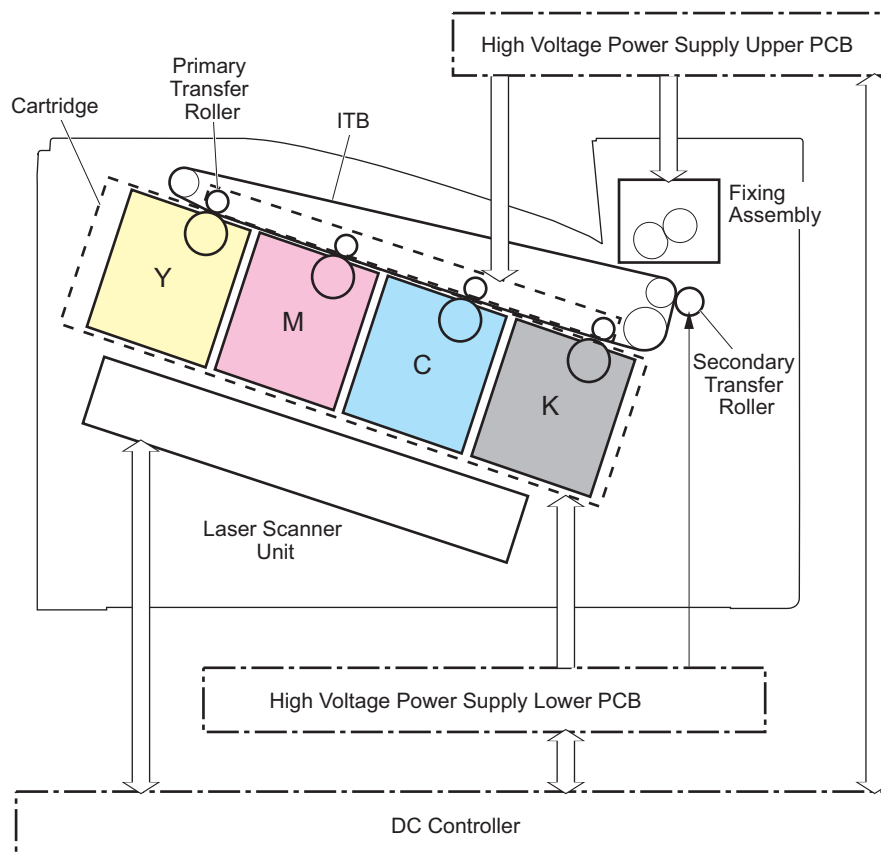

Load drives of electrical components

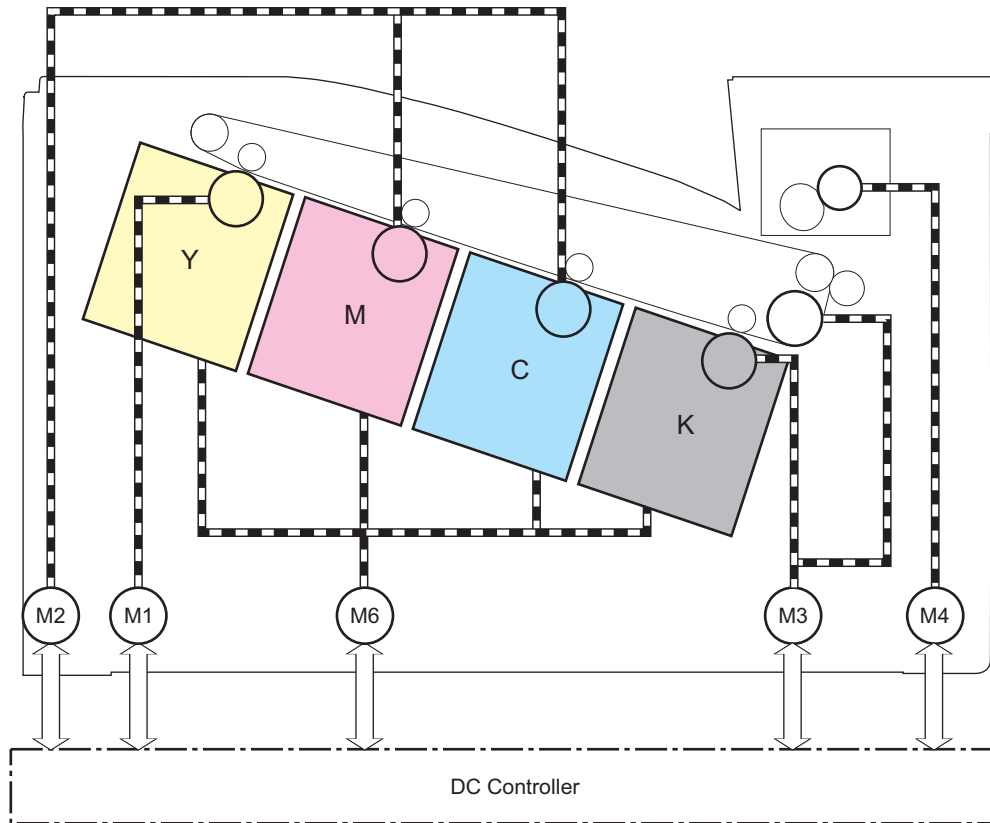

Name	Electric code
Drum Motor 1	M1
Drum Motor 2	M2
Drum Motor 3	M3
Fixing Motor	M4
Developing Disengagement Motor	M6

Outline drawing of sensors

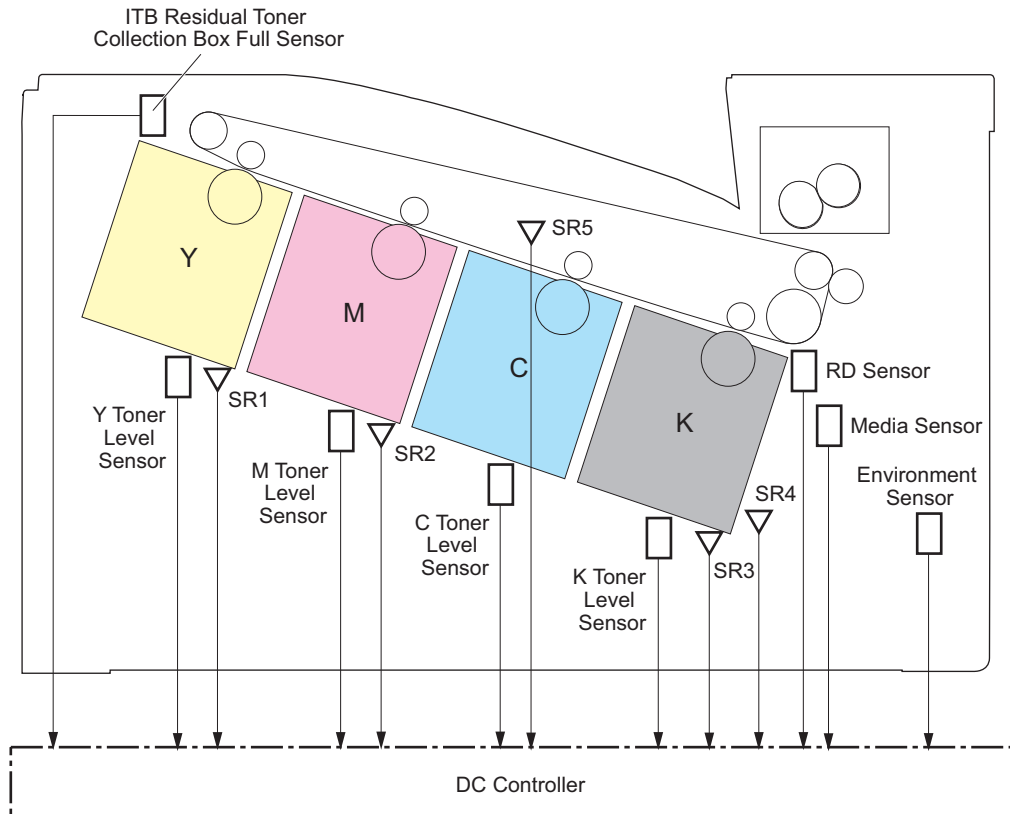

Name	Electric code
Drum Home Position Sensor 1	SR1
Drum Home Position Sensor 2	SR2
Drum Home Position Sensor 3	SR3
Developing Home Position Sensor	SR4
Primary Transfer Roller Detachment Sensor	SR5

Image Formation Process

Overview

The image formation process of this machine is roughly made up of six blocks and ten steps.

Static latent image formation block

- Step 1: Pre-exposure
- Step 2: Primary charging
- Step 3: Laser beam exposure

Developing block

- Step 4: Developing

Transfer block

- Step 5: Primary transfer
- Step 6: Secondary transfer
- Step 7: Separation

Fixing block

- Step 8: Fixing

ITB Cleaning Block

- Step 9: ITB cleaning

Drum cleaning block

- Step 10: Drum cleaning

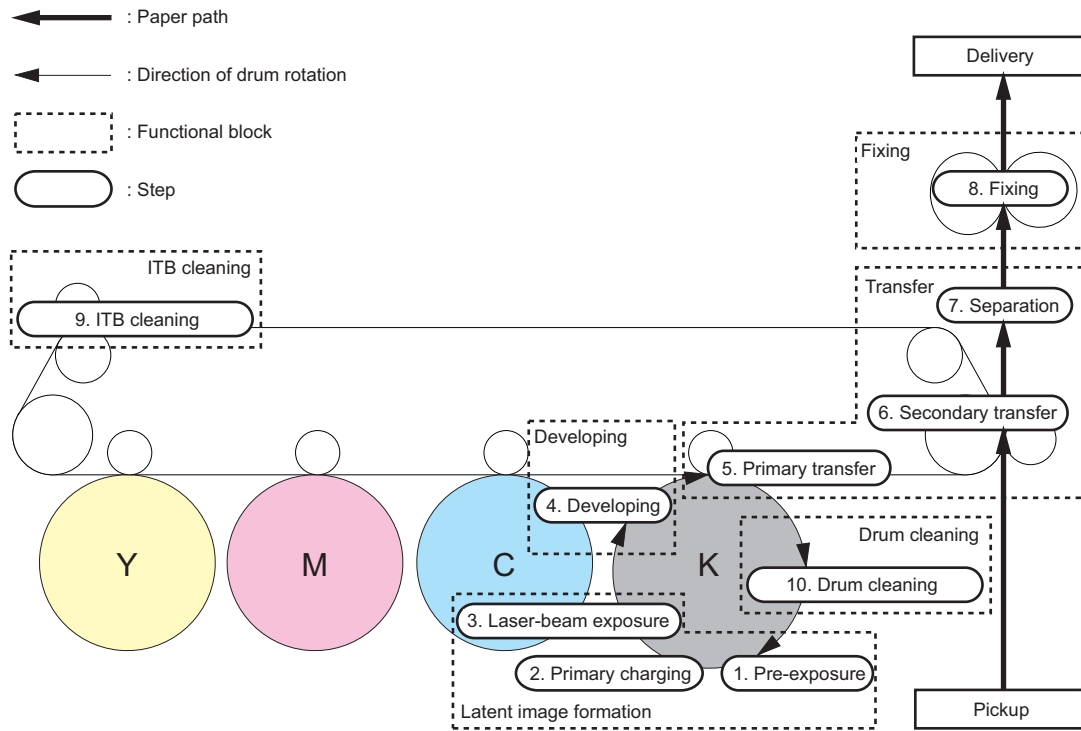

■ Static Latent Image Formation Block

This block consists of 3 steps for forming the static latent image on the Photosensitive Drum.

Step 1: Pre-exposure

In this step, residual charge on the Photosensitive Drum surface is removed as preparation for primary charging. Residual charge is removed from the Photosensitive Drum surface by the light from the LED.

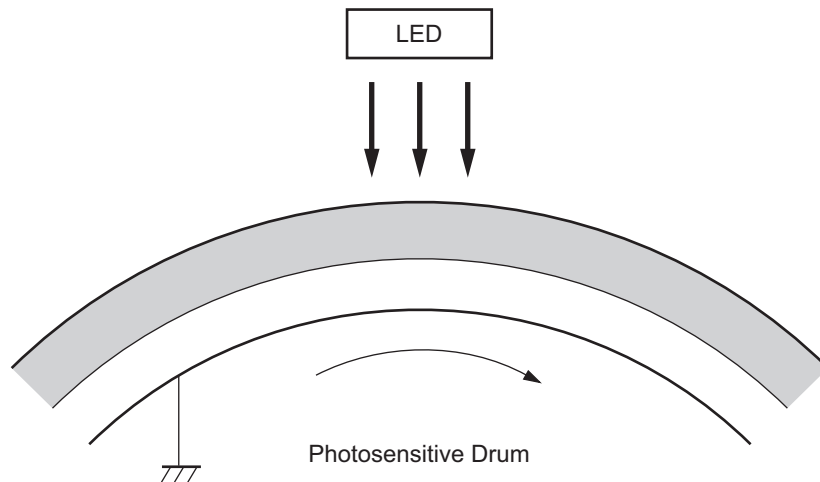

Step 2: Primary charging

In this step, as preparation for latent image formation, the surface of the Photosensitive Drum is uniformly charged with negative potential.

This method directly charges the Photosensitive Drum from the Primary Charging Roller, and the primary charging bias is applied in order to negatively charge the surface of the Photosensitive Drum.

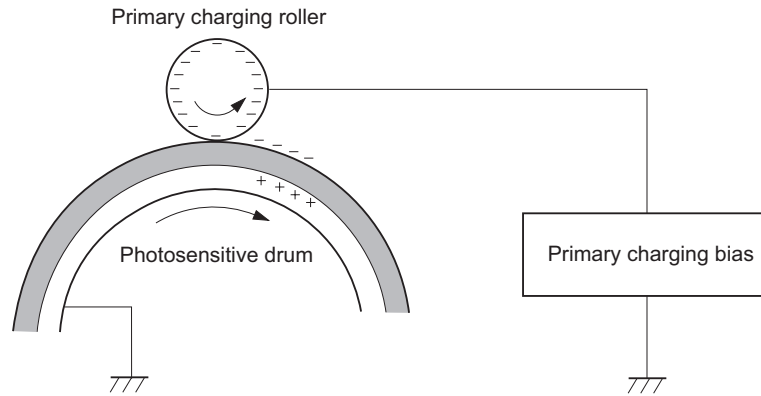

Step 3: Laser beam exposure

In this step, a static latent image is formed on the Photosensitive Drum by the laser beam. When the negatively charged Photosensitive Drum is scanned by the laser beam, the negative charge is neutralized and this area turns into a static latent image.

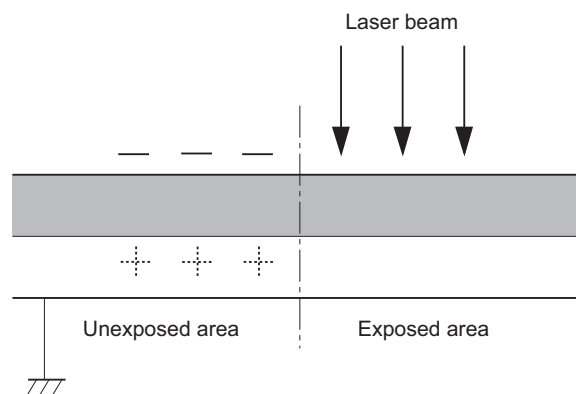

■ Developing Block

This block turns the static latent image into a visible image by applying toner to the static latent image on the surface of the Photosensitive Drum.

Step 4: Developing

In this step, the toner is attached to the static latent image on the surface of the Photosensitive Drum. The toner is negatively charged by friction between the Developing Roller and Developing Blade surface. Areas on the Photosensitive Drum exposed to the laser beam have a potential higher than the Developing Roller, and toner jumps and adheres to the drum surface to form a visible image due to the potential difference between the drum surface and the Developing Roller. Developing bias is applied to the Developing Roller.

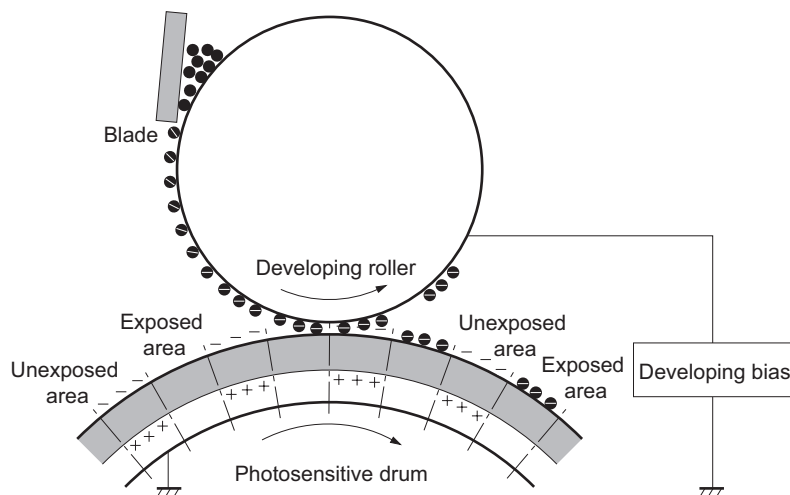

■ Transfer Block

This block consists of 3 steps, and transfers the toner image on the Photosensitive Drum surface to the paper.

Step 5: Primary transfer

In this step, toner on the Photosensitive Drum is transferred to the ITB. A transfer bias is applied to the Transfer Roller, and the paper is positively charged. Thus the negatively charged toner on the surface of the Photosensitive Drum is transferred to the ITB.

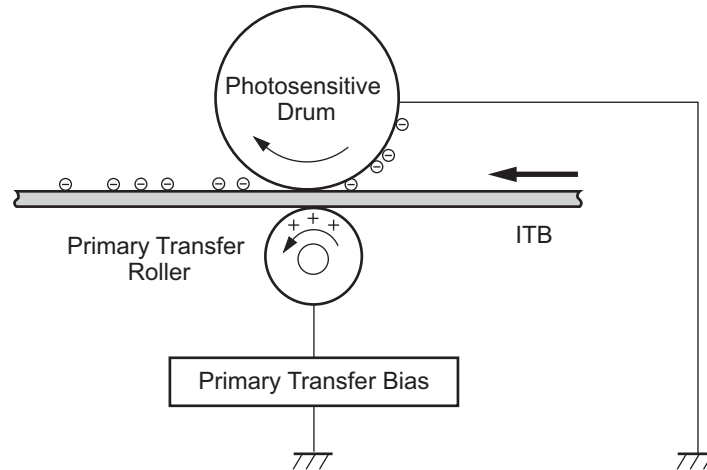

Step 6: Secondary transfer

In this step, toner on the ITB surface is transferred to the paper. A secondary transfer bias is applied to the Secondary Transfer Roller, and the paper is positively charged. Thus the negatively charged toner on the surface of the ITB is transferred to the paper.

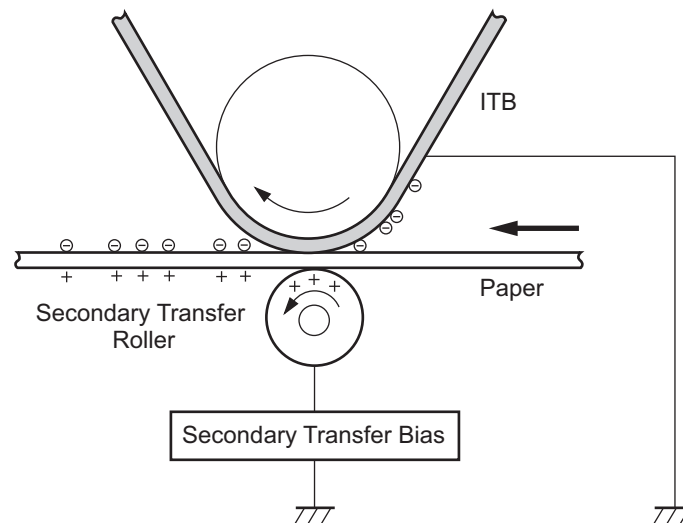

Step 7: Separation

In this step, the paper is separated from the ITB by the elasticity of the paper and the curvature of the drum. For stability of paper feed and image quality, the electric charge on the back side of the paper is reduced by the Static Eliminator.

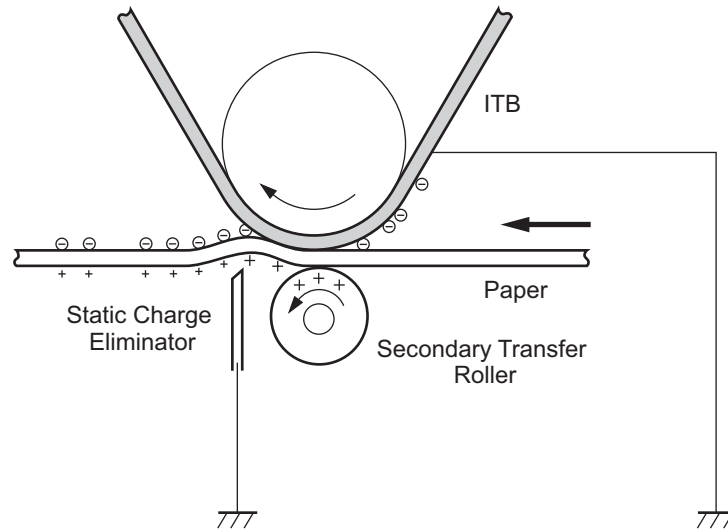

■ Fixing Block

In this block, the toner image is fixed on the paper.

Step 8: Fixing

In this step, the toner image on the paper is fixed on the paper by on-demand fixing. The toner is fused onto the paper to form a permanent image by applying pressure and heat. Fixing bias is applied to the Fixing Film in order to improve the image quality.

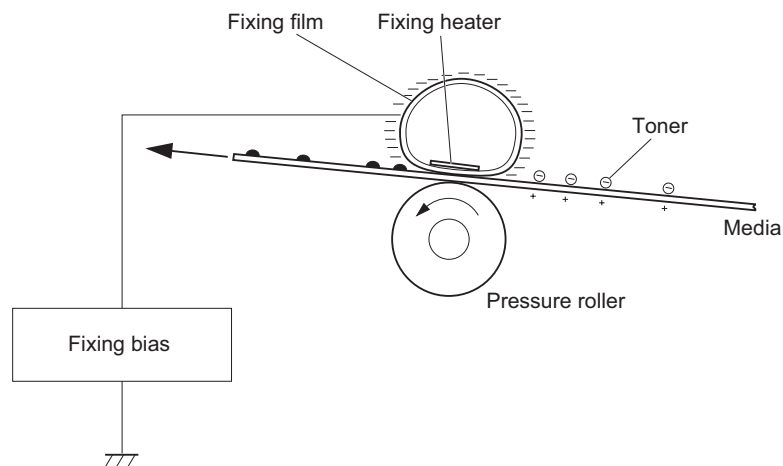

■ ITB Cleaning Block

This block cleans residual toner on the ITB.

Step 9: ITB cleaning

This step uses the Cleaning Blade to scrape off the residual toner on the surface of the ITB and collects the toner in the Waste Toner Collection Box.

- Phillips Potential Residual Toner
- Slotted Potential Residual Toner

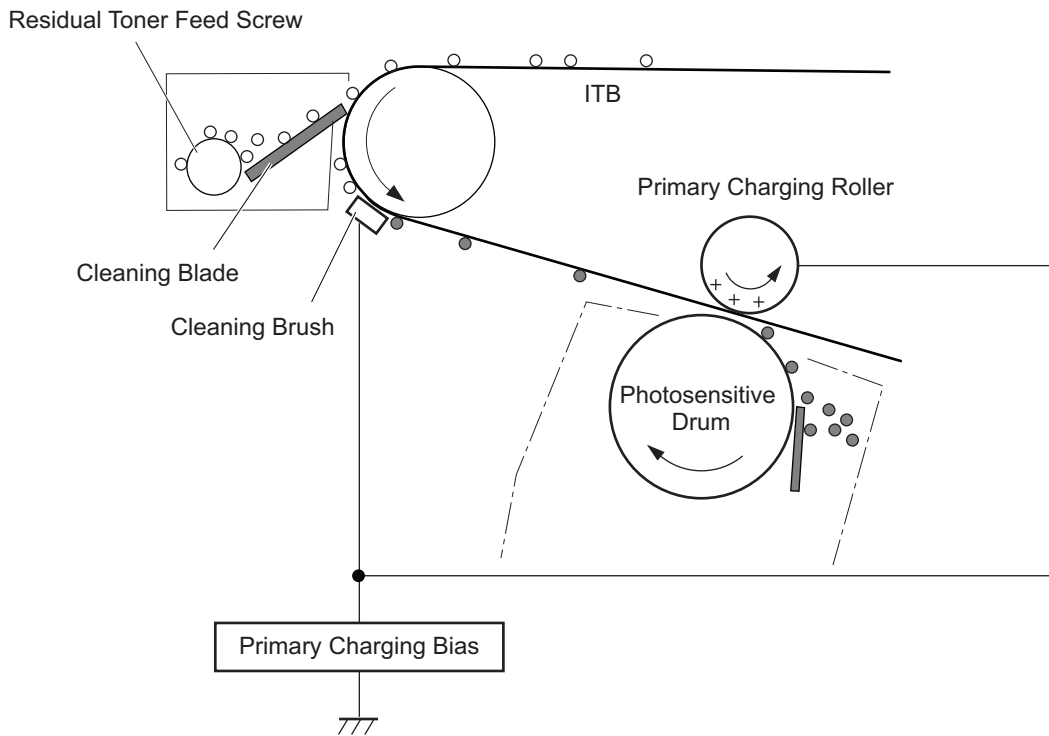

■ Drum Cleaning Block

This block cleans residual toner on the Photosensitive Drum.

Step 10: Drum cleaning

This step uses the Cleaning Blade to scrape off the residual toner on the surface of the Photosensitive Drum and collects the toner in the Waste Toner Collection Box.

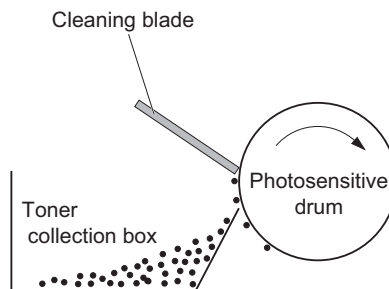

● Cartridge

■ Overview

The cartridge of this machine has the function to form a visible image on the Photosensitive Drum with toner. There are 4 types: yellow, magenta, cyan, and black, and all of them have the same structure. The following shows an outline drawing of the cartridge of this machine.

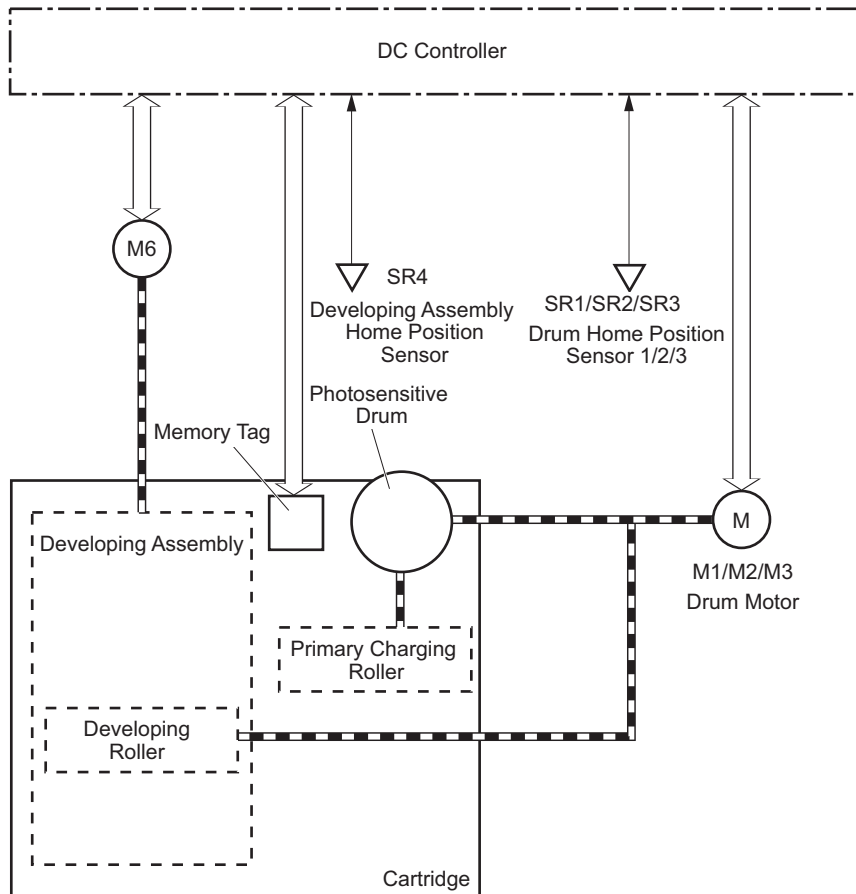

The cartridge of this machine consists of the Photosensitive Drum, Developing Assembly, Primary Charging Roller, Memory Tag, etc.

The DC Controller rotates the Drum Motor, and drives the Photosensitive Drum, Developing Assembly, and Primary Charging Roller.

The DC Controller detects the toner level by monitoring the toner level detection signal.

■ Memory Tag

This machine detects/records the cartridge usage status, etc. by reading/writing data stored in the memory tag by the DC Controller PCB.

If the memory tag cannot be detected, "Error. Non-Canon cart. not covered by warranty" is displayed.

■ Cartridge Detection

The DC Controller detects whether a cartridge is installed according to the change in primary charging current. The DC Controller notifies the Main Controller of the absence of a cartridge if it judges there is no cartridge.

Detection timing:

- At power-on
- When the Upper Cover is closed

Display on the Control Panel:

- Insert the C toner cartridge.
- Insert the M toner cartridge.
- Insert the Y toner cartridge.
- Insert the K toner cartridge.

■ Cartridge Life Detection

The DC Controller notifies the Main Controller when cartridge consumption reaches the specified value.

Upon reception of the notification the Main Controller displays a warning or a message that the cartridge has reached the end of its life.

	Warning display*2	End of life display*4, *5
Toner level*1	Differs depending on the setting*3	0%

	Warning display*2	End of life display*4, *5
Detected to (location)	Memory tag	Memory tag
Message (machine operation)	C_toner_cartridge_will soon_reach_life-time. M_toner_cartridge_will soon_reach_life-time. Y_toner_cartridge_will soon_reach_life-time. K_toner_cartridge_will soon_reach_life-time.	Change_C_toner cartridge. Change_C_toner cartridge. Change_Y_toner cartridge. Change_K_toner cartridge.

*1: Can be checked in "Utility Menu > Consumables Info. > Remaining Toner > Cyan, Magenta, Yellow, Black".

*2: "Display" or "hide" can be set in [Setup > Warning Step > Toner Cart. Warning].

*3: Value set in [Setup > User Maintenance > Toner Check Timing/Spec Tnr Chk Timing]

*4: The operation when the cartridge has reached the end of life can be set in [SERVICE MODE > OPTION GR. > CRG LIFE STEP].

*5: The cartridge life value can be changed in [SERVICE MODE > OPTION GR. > CRG LIFE STOP].

■ Developing Assembly Engagement/Disengagement Control

The Developing Assembly engagement/disengagement control is used to engage/disengage the Developing Assembly with/from the Photosensitive Drum as needed depending on the specified print mode (full color/black and white).

Through this control, the Developing Assembly is engaged with the Photosensitive Drum only when needed, which prevents deterioration of the Photosensitive Drum and ensures the maximum life.

<All developing assemblies are engaged with the photosensitive drums>

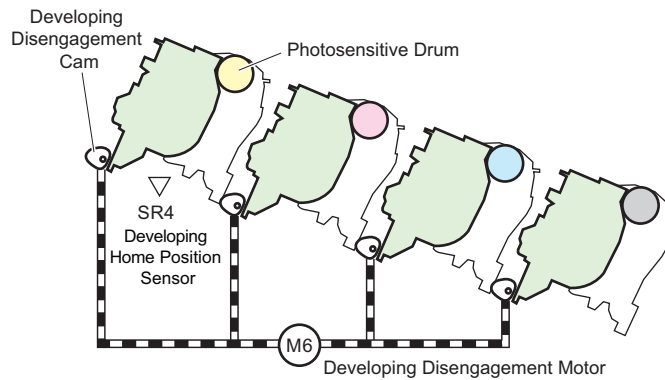

<When only the Bk developing assembly is engaged with the photosensitive drum>

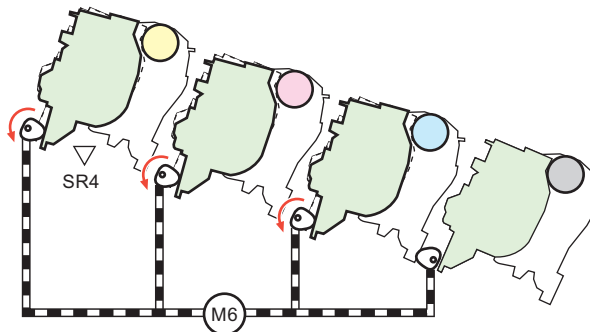

<When all developing assemblies are disengaged from the photosensitive drums>

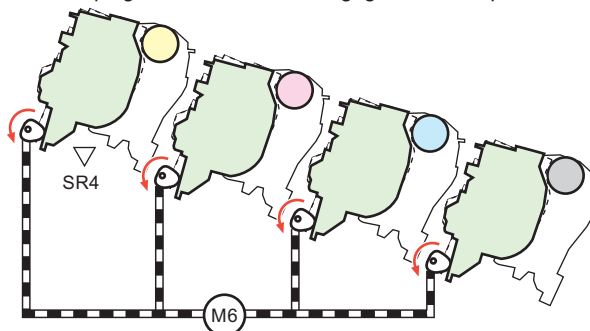

For engagement/disengagement of the Developing Assembly, the Developing Assembly is engaged with or disengaged from the Photosensitive Drum by the DC Controller rotating the Developing Disengagement Motor to change the orientation of the Engagement/Disengagement Cam.

The DC Controller controls the state of the Developing Assembly (engaged or disengaged) by the amount of rotation of the Development Disengagement Motor after detecting the output of the Developing Home Position Sensor.

When the power is turned off, when in standby, and when printing has finished, the Developing Assembly is disengaged from the Photosensitive Drum. When in full color print mode (including jobs including both B&W and color), all of the Developing Assemblies are engaged with the Photosensitive Drum, and during B&W printing, only the BK Developing Assembly is engaged with the Photosensitive Drum.

If the signal state of the specified Developing Home Position Sensor cannot be detected when the Developing Assembly is engaged or disengaged, the DC Controller judges that an error has occurred in the Developing Disengagement Motor and notifies the Main Controller.

ITB Unit

■ Overview

The ITB Unit performs primary transfer of a toner image on the Photosensitive Drum onto the ITB.

The internal structure of the ITB Unit is as follows.

- ITB
- ITB Drive Roller
- ITB Slave Roller
- Primary Transfer Roller
- ITB Cleaner

The ITB Drive Roller is driven by the Drum Motor 3 (M3) and rotates the ITB.

The Primary Transfer Roller rotates along with the ITB.

The ITB Cleaner cleans the ITB surface.

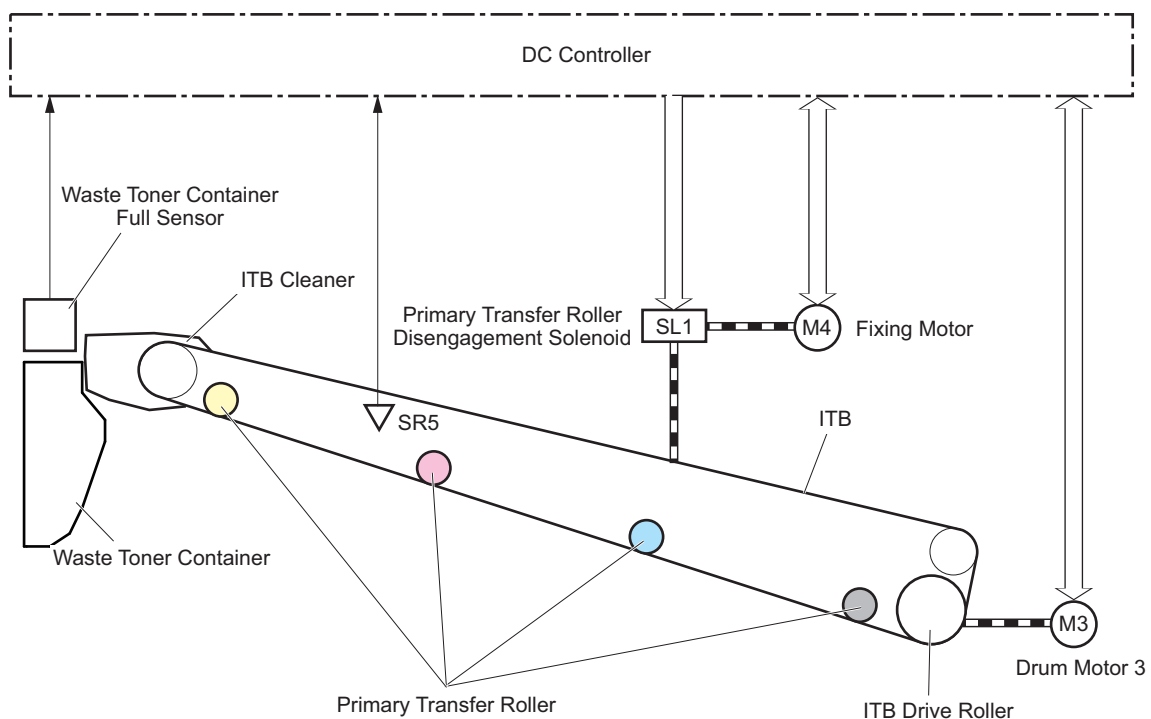

■ Primary Transfer Roller Engagement/Disengagement Control

The ITB is engaged with the Photosensitive Drum as needed for the print operation by the Primary Transfer Roller engagement/disengagement control. There are 3 states that are switched depending on the print operation.

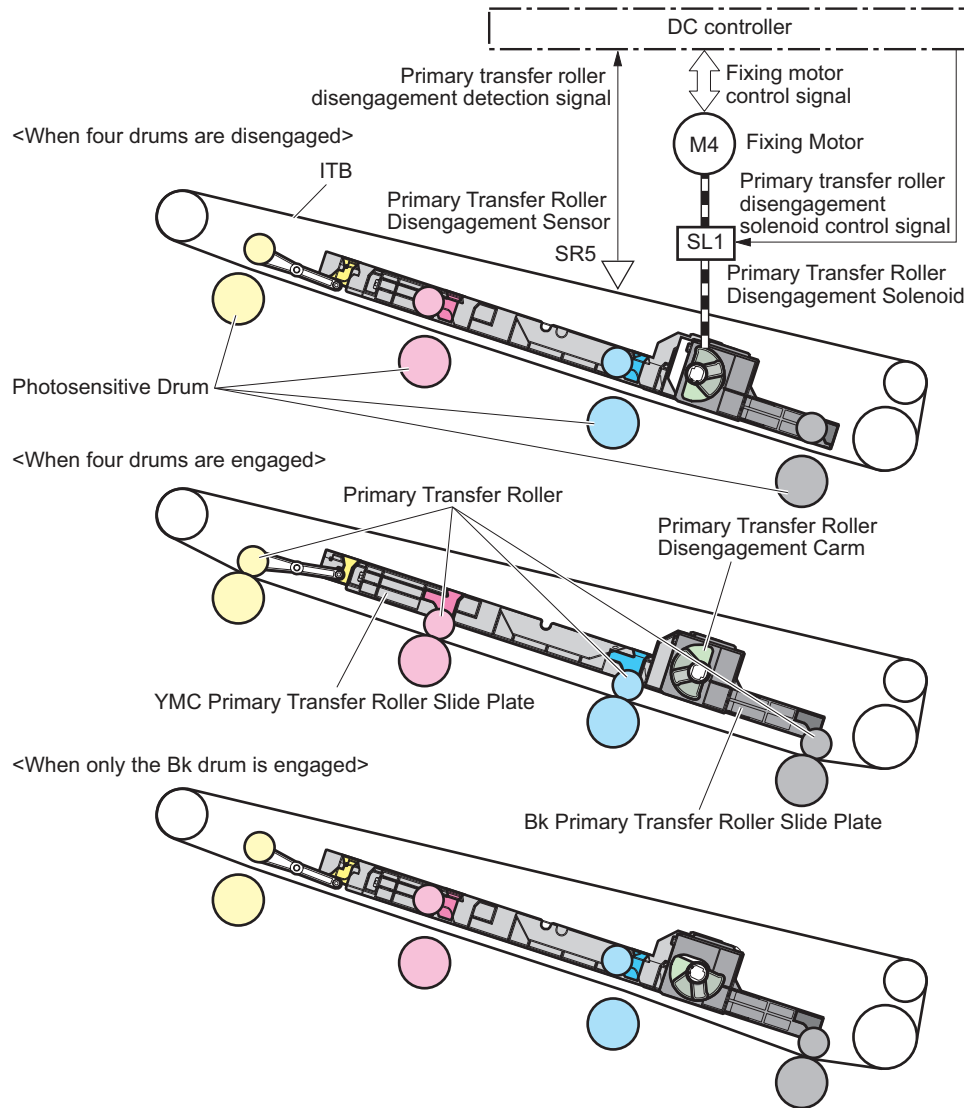

The following explains the engagement/disengagement operation of the Primary Transfer Roller.

The Fixing Motor drive is transmitted by the Primary Transfer Roller Disengagement Solenoid to the Primary Transfer Roller Disengagement Cam and rotates the cam. The YMC or Bk Primary Transfer Roller Slide Plate slides to the left or right by the operation of the cam, and the Primary Transfer Roller raises or lowers. The ITB is engaged with or disengaged from the Photosensitive Drum by the Primary Transfer Roller moving up or down.

The DC Controller moves the Primary Transfer Roller to the home position (all colors disengaged) by rotating the Fixing Motor and turning ON the Primary Transfer Roller Disengagement Solenoid when the power is turned ON. The Primary Transfer Roller is raised or lowered and the ITB is engaged with or disengaged from the Photosensitive Drum by turning ON the Primary Transfer Roller Disengagement Solenoid the specified number of times from this state.

There are 3 states that are switched depending on the print operation.

"All colors disengaged" state

When the power supply is turned OFF or when in the standby state, the ITB is disengaged from the Photosensitive Drum for all colors.

This state is the home position of the Primary Transfer Roller.

"All colors engaged" state

This is the state during full color print (including jobs including both B&W and color), and the ITB is engaged with the Photosensitive Drum for all colors.

Only black engaged

This is the state during B&W print, and the ITB is engaged only with the black Photosensitive Drum.

■ Detection of Error in the Primary Transfer Disengagement Mechanism

If the specified output is not obtained from the Primary Transfer Roller Disengagement Sensor when the Primary Transfer Roller Disengagement Solenoid has been turned on in order to perform engagement/disengagement of the Primary Transfer Roller, the DC Controller judges that an error has occurred in the primary transfer disengagement mechanism and notifies the Main Controller.

■ ITB Life Detection

The DC Controller notifies the Main Controller when the life value of the ITB reaches the specified value. Upon receipt of the notification, the Main Controller displays a warning.

	Warning display*1
Message (machine operation)	9I Preparation for replacement of the ITB Unit

*1: "Display" or "hide" can be set in [SERVICE MODE > OPTION GR. > Show Warnings > ITB Unit Warning]

■ ITB Blade Cleaning Mechanism

The ITB Cleaner cleans the ITB surface.

Waste toner that remains on the ITB surface is scraped by the Cleaning Blade in the Cleaner.

Waste toner is fed to the Waste Toner Container by the Waste Toner Feed Screw in the Cleaner.

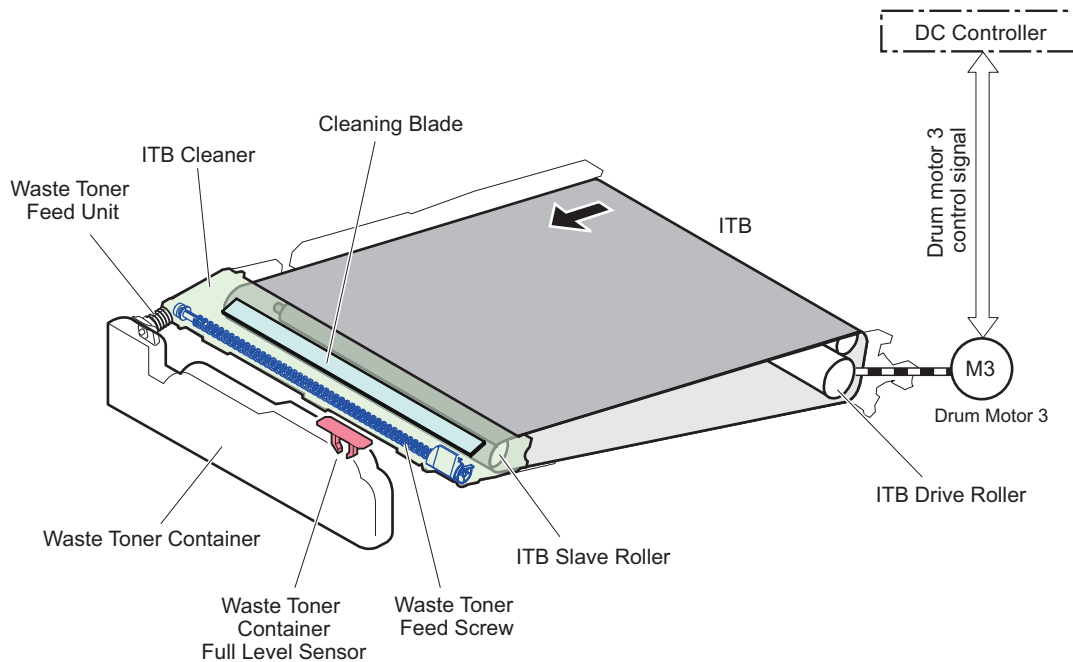

■ Waste Toner Container Full Level Detection

The DC Controller detects whether or not the toner collected into the Waste Toner Container is full from the Waste Toner Full Sensor. When the DC Controller detects toner full, a toner full error message is displayed on the Control Panel.

Upon receipt of the notification, the Main Controller displays a warning or a replacement message.

	Warning display	Display that prompts replacement
Detected to (location)	Waste Toner Full Sensor	Waste Toner Full Sensor
Message (machine operation)	E1 Preparation for replacement of the Waste Toner Container	Waste Toner Container replacement

*1: Can be checked in "Utility Menu > Check Consumables > Waste Toner Status> Message"

High Voltage Power Supply Control

■ Overview

The High Voltage Power Supply applies biases to the followings.

- Primary Charging Roller and Developing Roller: Roller inside the cartridge of each color
- Primary Transfer Roller and Secondary Transfer Outer Roller
- Pressure Roller
- ITB Cleaning Brush

These high voltage biases are generated by the DC Controller controlling the High Voltage Power Supply.

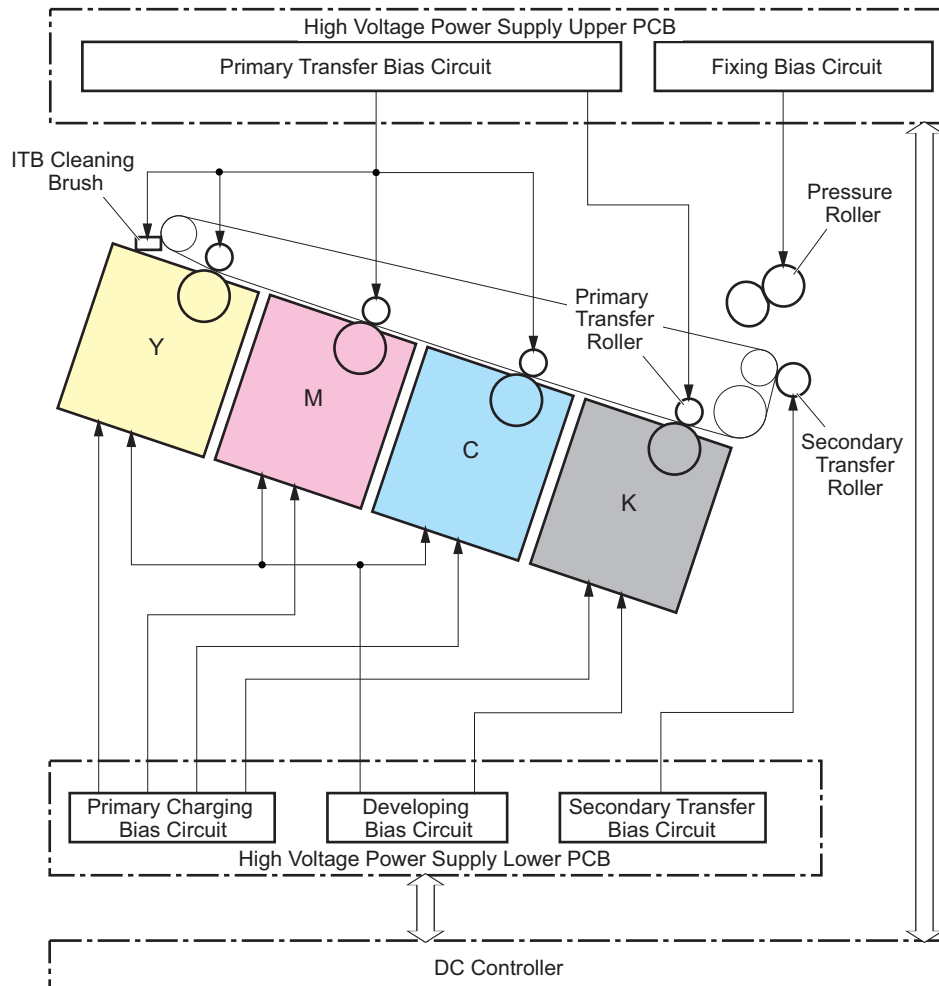

■ Generating Each Bias

Generating the primary charging bias

It is a DC negative bias which is output to uniformly charge the surface of the Photosensitive Drum with negative potential in preparation for image formation. The bias is generated for each color (Y, M, C, Bk) by the primary charging bias generation circuit of the Lower High Voltage Power Supply PCB.

Generating the developing bias

This is the DC negative bias output for attaching toner to the static latent image formed on the Photosensitive Drum. The bias is generated for each color (Y, M, C, Bk) by the developing bias generation circuit of the Lower High Voltage Power Supply PCB.

Generating the primary transfer bias

This is the DC positive bias output for transferring the toner on the Photosensitive Drum to the ITB. The bias is generated for each color (Y, M, C, Bk) by the primary transfer bias generation circuit of the Upper High Voltage Power Supply PCB.

Generating the secondary transfer bias

This is the DC bias output for transferring the toner on the ITB to the paper.

A DC positive bias (for transfer) and DC negative bias (for cleaning) are both generated by the secondary transfer bias generation circuit of the Lower High Voltage Power Supply PCB.

Generating the fixing bias

This is the DC bias output for fixing toner to the paper.

The bias is generated by the fixing bias circuit of the Upper High Voltage Power Supply PCB.

Calibration

Overview

Calibration is a control for printing appropriate images by correcting image color displacement and image density variations caused by environment changes and individual differences between host machines.

This machine has 3 types of calibrations as shown below.

- Image color displacement correction control
- Image density correction control (D-max)
- Image gradation adjustment control (D-half)

Correction controls are performed under the following conditions:

No.	Execution timing	Condition
1	Power ON	Power ON
2	Replace the cartridge.	When the door is closed
3	Replace the ITB Unit.	When [SERVICE MODE > COUNTER GR. > INT.ITB UNIT] is executed
4	Replace the Laser Scanner Unit.	When the power is turned OFF and then ON after replacement of the Laser Scanner Unit
5	Environmental change	Detection by the Environment Sensor
6	After reaching a specific number of sheets	Each 1000 pages printed after the previous execution
7	After the specific period of time has passed	When it is judged that the engine needs adjustment 8 hours after execution of the previous print
8	Execution command by the user	-

Image Color Displacement Correction Control

This control corrects for the color displacement that occurs due to the individual differences of the Laser Scanner Unit and Cartridge Unit.

This control corrects the color displacements shown below:

- Write-start position in the horizontal scanning direction
- Horizontal scanning magnification ratio
- Write-start position in the vertical scanning direction

This control is performed by the DC Controller PCB controlling the Color Displacement Density Sensor.

When the data value obtained from the Color Displacement/Density Sensor is outside the specified range at cartridge detection or start of image color displacement measurement control, the DC Controller judges that a Color Displacement/Density Sensor failure has occurred and notifies the Main Controller.

Image Density Correction Control (D-max)

This control is performed in order to stabilize variations in image density due to variations in the characteristics of the Photosensitive Drum and toner.

When the specific conditions are satisfied, the DC Controller PCB performs D-max control in the following order.

1. Measure the density detection patterns of each color drawn on the ITB.
2. Control the primary charging bias and developing bias so that the appropriate density is output from the densities of each of the measured patterns.

Image Gradation Correction Control (D-half)

This control is a control where the Main Controller PCB performs gradation adjustment based on the measurement results of the halftone density performed by the DC Controller PCB.

After D-max control is completed, the DC Controller PCB and Main Controller PCB perform D-half control in the order shown below.

1. The DC Controller PCB measures the density detection pattern of each color drawn on the ITB at the optimal primary charging bias and developing bias determined by D-max control, and sends the density data to the Main Controller PCB.
2. Based on the density data above, the Main Controller PCB executes gradation adjustment to obtain ideal halftone image.

Paper interval patch control

This control supplies toner as lubrication by forming patches between sheets (paper trailing edge side) during printing to prevent the ITB Cleaning Blade from flipping.

Paper interval patch control is performed under the following conditions.

No	Item	Condition	Remarks
1	Execute paper interval patches	Around the paper trailing edge of each page at normal print	Executed between sheets as needed

Pickup Feed System

Overview

The Pickup Feed System performs pickup, feed, and delivery of print paper, and consists of various rollers.

Print paper flow

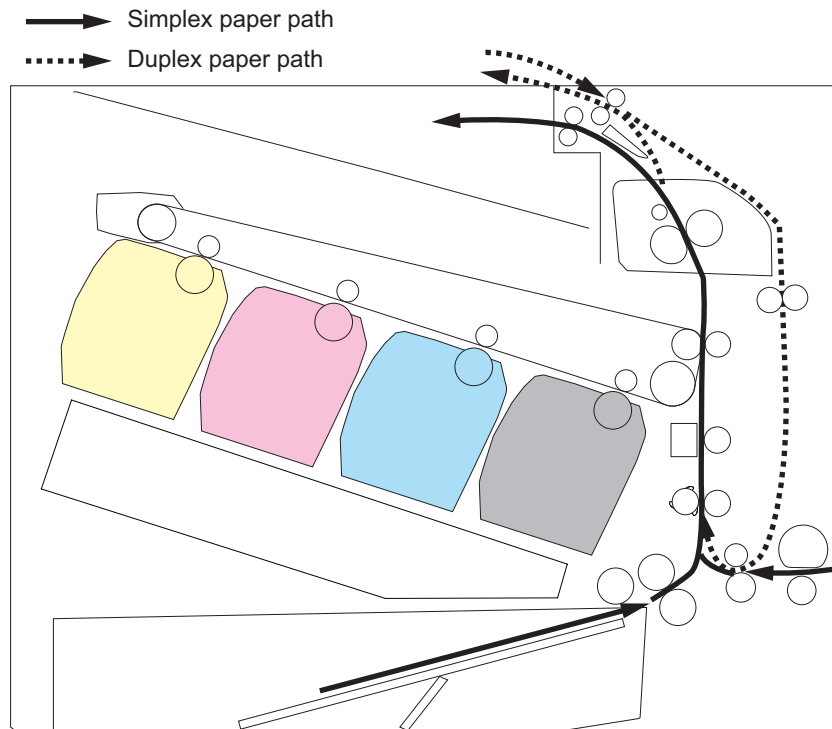

Load drives of electrical components

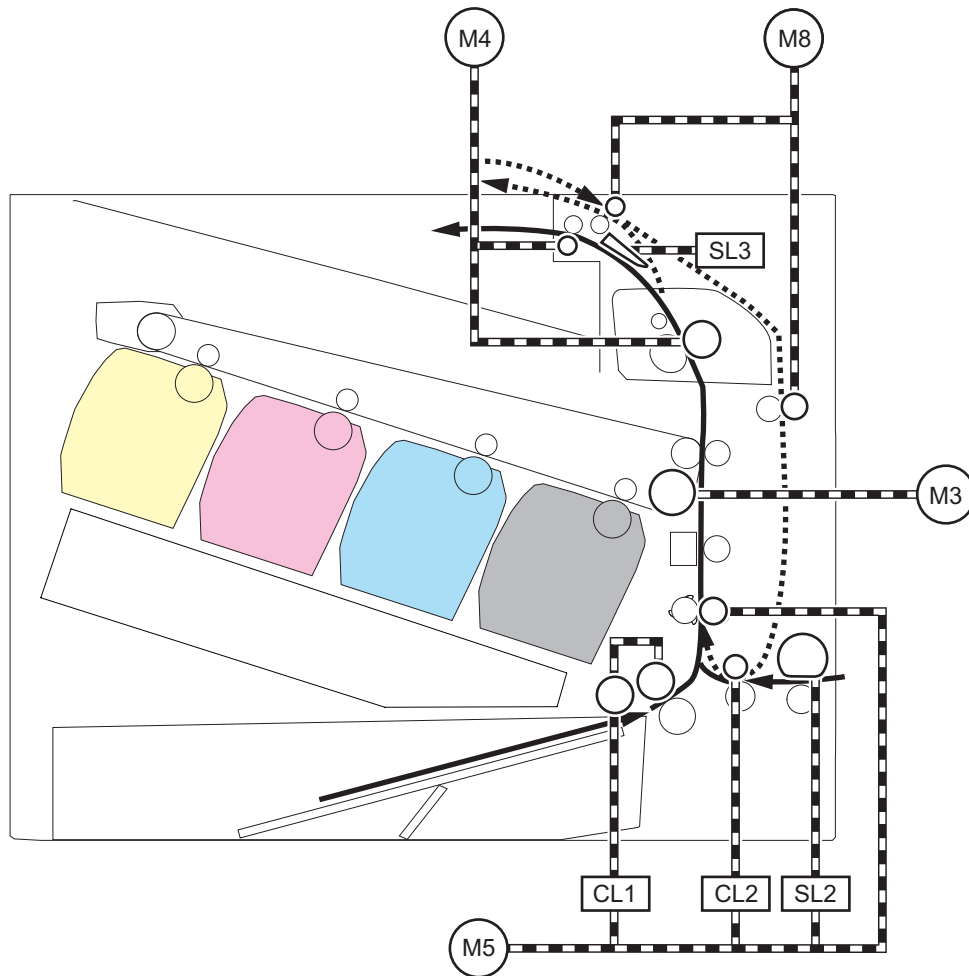

Name	Electric code
Drum Motor 3	M3
Fixing Motor	M4
Pickup Motor	M5
Duplex Reverse Motor	M8
Multi-purpose Tray Pickup Solenoid	SL2
Duplex Reverse Solenoid	SL3
Cassette Pickup Clutch	CL1
Duplex Re-pickup Clutch	CL2

Outline drawing of sensors and rollers

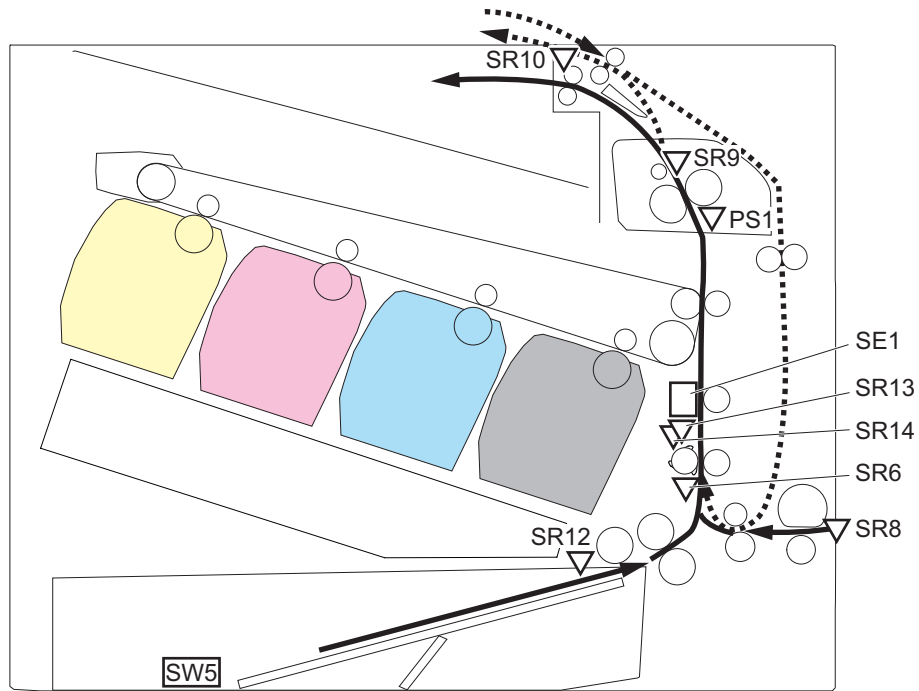

Name	Electric code
TOP Sensor	SR6
Multi-purpose Tray Media Presence Sensor	SR8
Fixing Delivery Sensor	SR9
Delivery Tray Full Level Sensor	SR10
Cassette Media Presence Sensor	SR12
Paper Width Sensor Front	SR13
Paper Width Sensor Rear	SR14
Loop Sensor	PS1
Media Sensor	SE1
Cassette Detection Switch	SW5

Controls

■ Lift-up Operation

Paper inside a cassette is lifted up by the Lifting Plate.

The Lifting Plate is lifted up by rotating the Pickup Motor (M5).

Presence of paper is detected by the Cassette Media Presence Sensor (SR12).

When the Lifting Plate is rising, the Pickup Motor (M5) is controlled to keep the paper surface steady so that pickup can be performed stably.

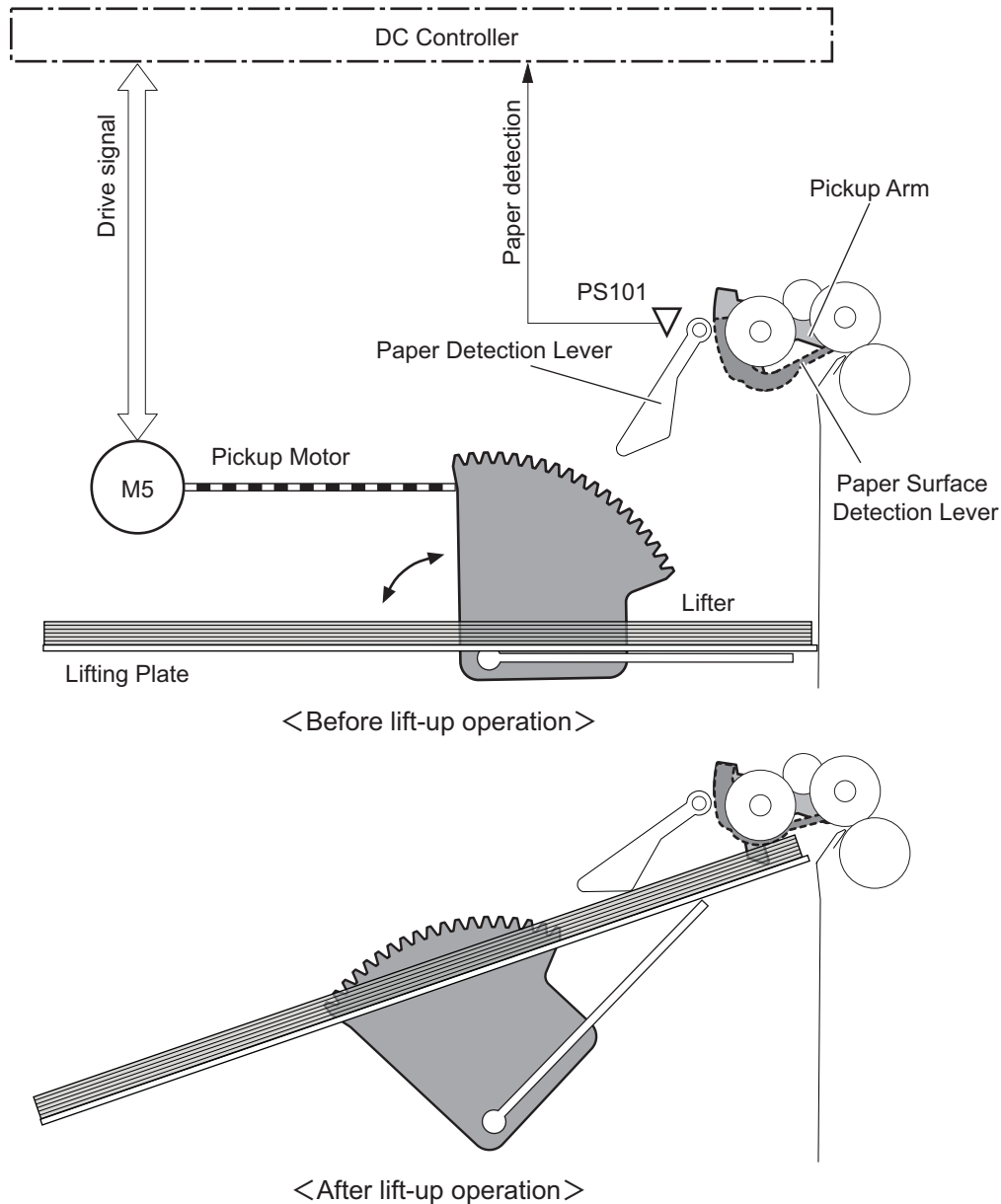

■ Cassette Detection

Presence of the cassette is detected using the Cassette Detection Switch (SW5).
The cassette detection flag of the cassette is detected by the Cassette Detection Switch in the host machine.

■ Cassette Pickup Control

The DC Controller rotates the Pickup Roller by rotating the Pickup Motor (M5).
When a cassette is loaded, paper is picked up by lowering the Pickup Arm and rotating the Pickup Roller by the Pickup Motor.

■ Cassette Double Feed Prevention Mechanism

This machine employs the Separation Roller method for the cassette pickup double feed prevention mechanism.
The Separation Roller method of this machine is a method that prevents paper double feeds by using the Cassette Separation Rollers without drive. The Cassette Separation Rollers are driven and rotated by the Cassette Pickup Roller.

● At Normal Time

The Cassette Separation Roller is driven by the Cassette Pickup Roller drive via paper. This causes the Cassette Separation Rollers to rotate in the feed direction.

● During Double Feed

Since the friction force between sheets of paper becomes weaker when there are multiple sheets of paper, the Cassette Pickup Roller drive force transmitted to the Cassette Separation Roller becomes extremely weak. Since force suppressing rotation is applied to the Cassette Separation Rollers of this machine, this mechanism does not allow rotation by the weak drive force transmitted from the Cassette Pickup Roller during double feed. The Separation Rollers therefore do not rotate and do not pickup double feed paper.

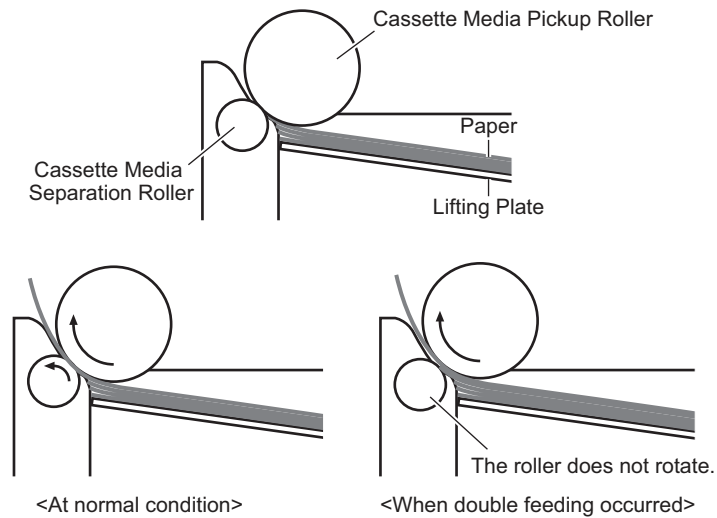

■ Multi-purpose Tray Pickup Control

The Multi-purpose Tray pickup feeds paper from the Multi-purpose Tray one sheet at a time into the machine. The following describes the operation of the Multi-purpose Tray pickup.

1. When a print command is input from the Main Controller, the DC Controller rotates the Pickup Motor (M5).
2. When the DC Controller turns the Multi-purpose Tray Pickup Solenoid (SL2) on, the Multi-purpose Tray Pickup Roller rotates and paper is picked up.
3. After double feed paper is removed by the Multi-purpose Tray Separation Pad, paper is fed into the machine. Note that the presence of paper on the Multi-purpose Tray is detected by the Multi-purpose Tray Media Presence Sensor (SR8), and printing is not performed if there is no paper.

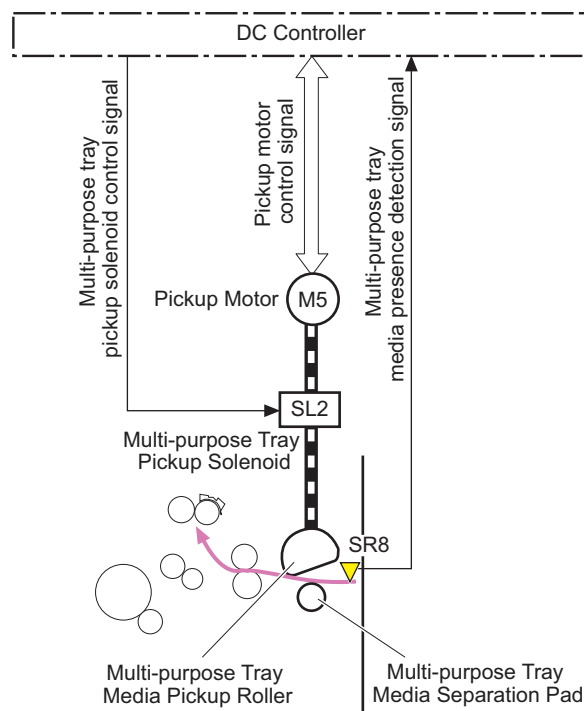

■ Skew Correction

This machine can correct paper skew without lowering throughput.

Skew is corrected as follows.

1. The paper leading edge pushes against the Registration Shutter to align the leading edge of the paper.
2. The trailing edge of the paper is fed and slack is generated at the leading edge of the paper.
3. When the trailing edge is fed even further, the paper leading edge for which slack was generated pushes up the Registration Shutter and then the paper is fed to the Registration Roller while the paper leading edge is aligned.

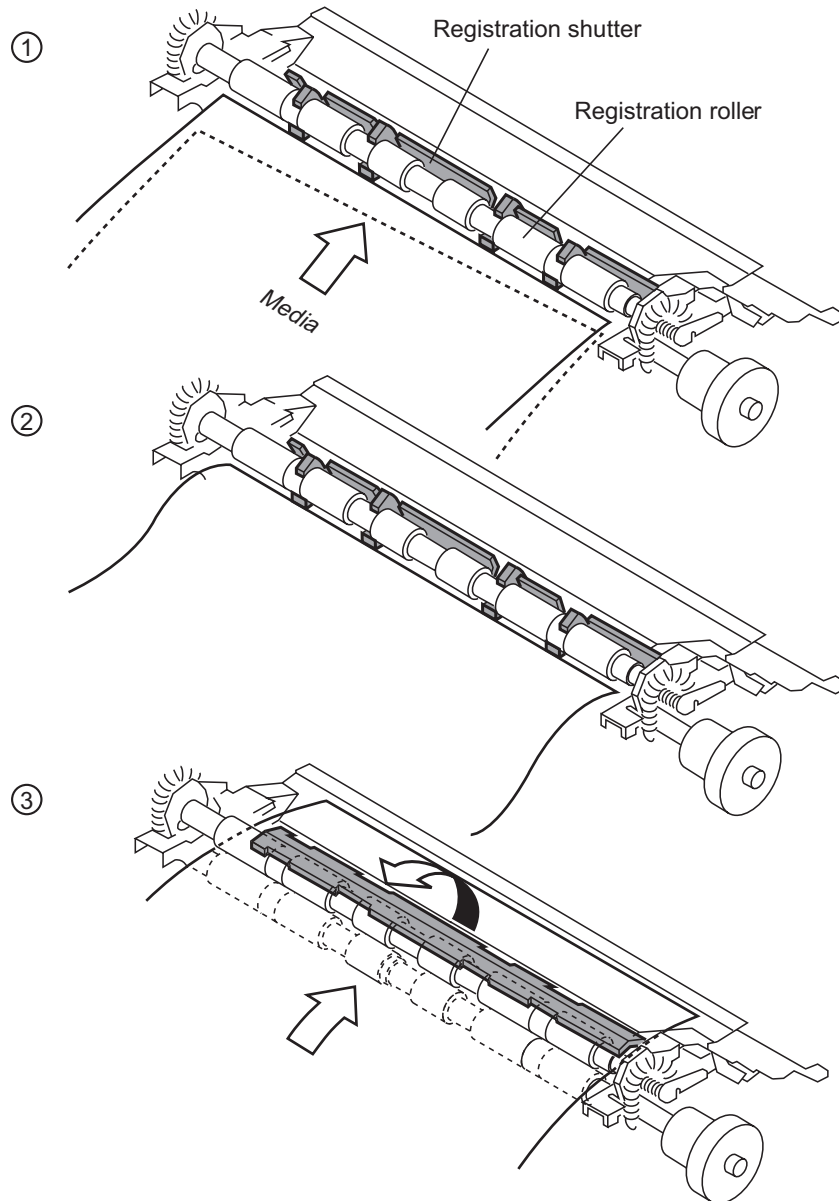

■ Paper Width Detection

Detection of paper width is performed to prevent temperature increase at the edge of the Fixing Heater. Width and position of paper being fed are detected by the Paper Width Sensor Front/Rear (SR13/SR14). If the paper width detected by the Paper Width Sensors did not match the paper size set, "Check paper size." is displayed on the Control Panel.

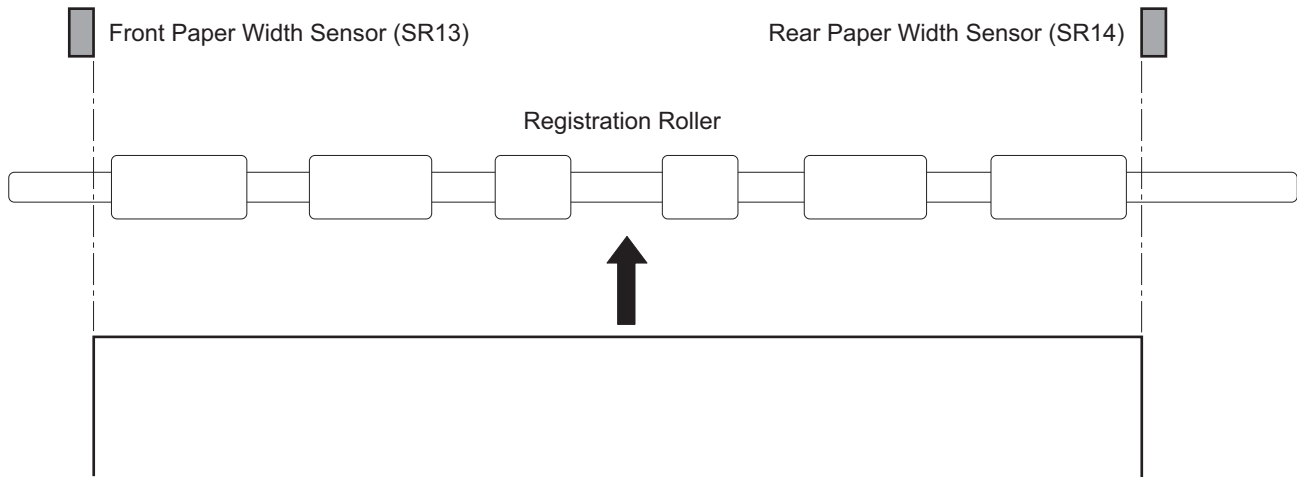

Paper Width Sensor Front (SR13)	Paper Width Sensor Rear (SR14)	Detection result	Paper size
ON	ON	Paper width: Wider than the standard	A4, B5, LTR, LGL, Executive
OFF	OFF	Paper width: Shorter than the standard	A5, A6
OFF	ON	Paper position: Right side	-
ON	OFF	Paper position: Right side	-

■ Paper Length Detection

The TOP Sensor (SR6) measures the paper length to prevent soiling of the Transfer Roller.

There is no way to detect the size in the Multi-purpose Tray.

The DC Controller detects the actual length of the paper by measuring the time when paper is fed using the TOP Sensor (SR6). If the detected paper is detected to be shorter than the specified size, image masking is performed from that point in time to prevent toner soiling of the Transfer Roller.

■ Feed Speed Control

The printer changes the feed speed for each paper type to prevent fixing failures.

The DC Controller changes the paper feed speed (1/1 speed, 1/2 speed, 1/3 speed, or 4/5 speed) for each paper type to prevent the temperature rise at the edge of the Fixing Assembly.

Paper type	Paper Settings	Pickup from Multi-Purpose Tray/Cassette	
		Full color	B&W
Plain paper	Plain L2	1/1	1/1
	Plain L	1/1	1/1
	Plain	1/1	1/1
Heavy	Heavy 1	4/5	4/5
	Heavy 2	1/2	1/2
	Heavy 3	1/3	1/3
	Heavy 4	1/3	1/3
Rough	Rough 1	4/5	4/5
	Rough 2	1/2	1/2
Postcard, Reply Postcard, 4 on 1 Postcard*	Postcard *1	1/3	1/3
Envelope	Envelope *1	1/2	1/2
Label paper	Labels *2	1/2	1/2

*1: Supported only at paper pickup from the Multi-purpose Tray

*2: For label paper, only paper pickup from the cassette is supported.

■ Media Detection

This machine automatically selects the optimal print mode for the media using the Media Sensor when the media is fed. The Media Sensor consists of a LED Sensor that detects the surface nature and an Ultrasound Sensor that detects the paper weight.
2

The DC Controller detects the type of paper and switches the print mode based on the results detected by the Media Sensor. The print modes are shown below.

Paper type	Paper weight	Paper Settings
Plain paper	60 g/m ²	Plain L2
	61 to 74 g/m ²	Plain L
	75 to 90 g/m ²	Plain paper
Heavy paper	91 to 119 g/m ²	Heavy 1
	120 to 128 g/m ²	Heavy 2
	129 to 200 g/m ²	Heavy 3
	201 to 216 g/m ²	Heavy 4

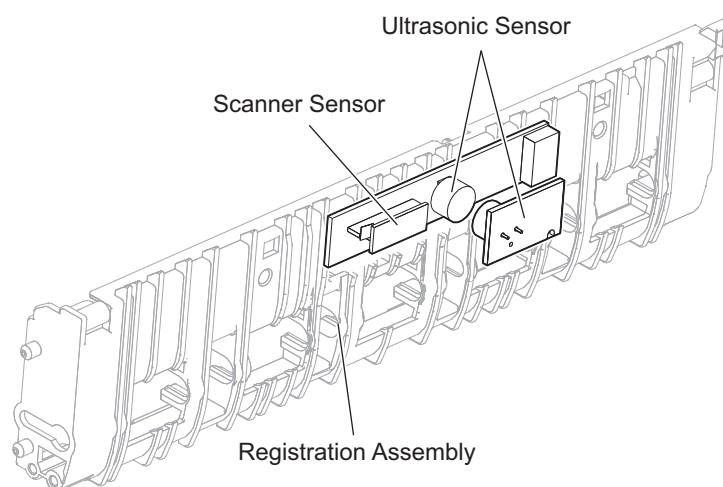

If the value detected by the Media Sensor at warm-up rotation or at printing does not meet the specified value, the DC Controller judges that a media sensor error warning should be generated and notifies the Main Controller.

● Jam Detection

■ Overview

The sensors are provided at the locations shown below to detect the presence of print paper and whether the print paper is being fed correctly.

- SR10: Delivery Tray Full Level Sensor
- SR9: Fixing Delivery Sensor
- PS1: Loop Sensor
- SE1: Media Sensor
- SR13: Paper Width Sensor Front
- SR14: Paper Width Sensor Rear
- SR6: TOP Sensor
- SR8: Multi-purpose Tray Media Presence Sensor
- SR12: Cassette Media Presence Sensor
- SR21: PF Media Path Sensor (option)

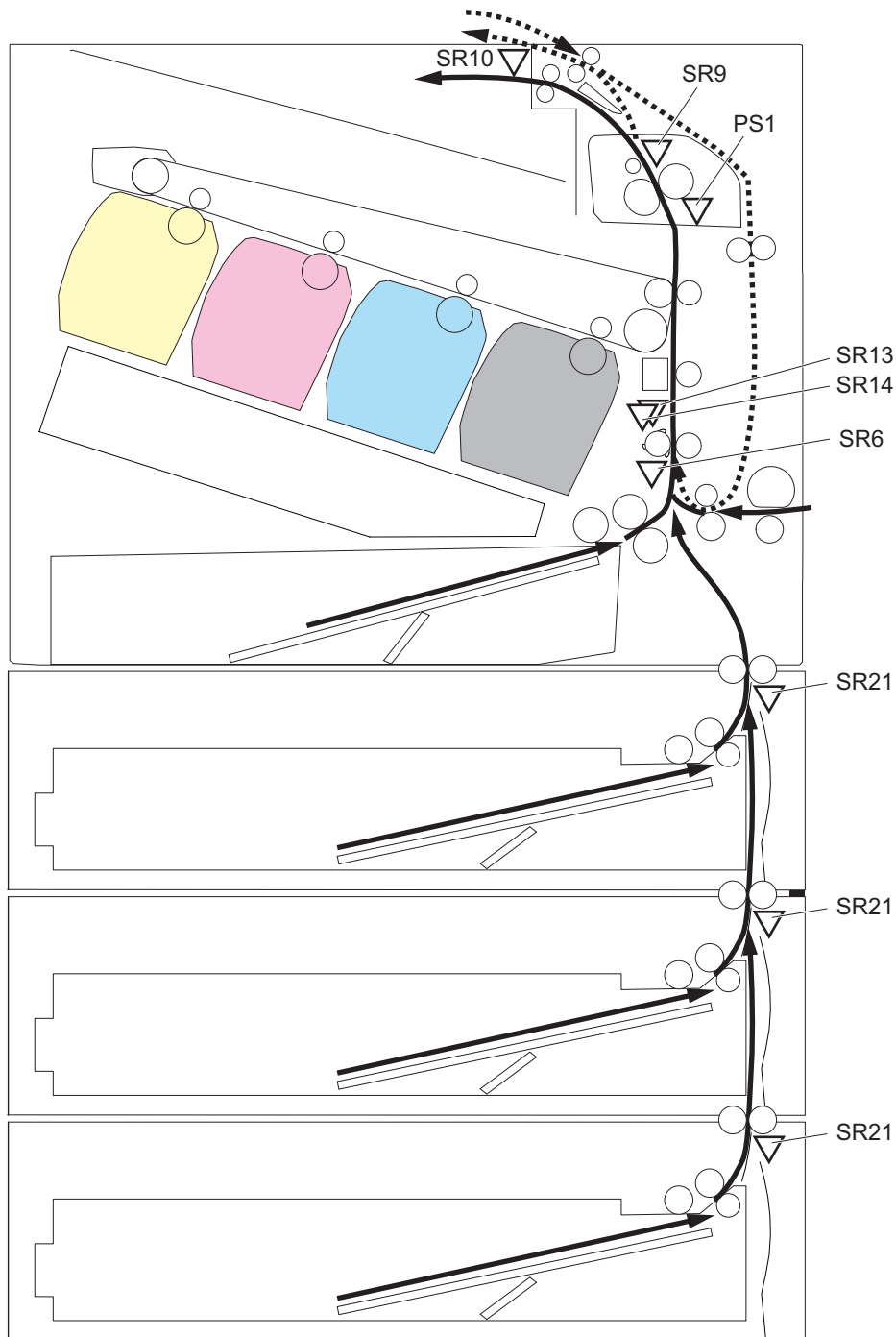

Occurrence of a jam is judged by whether paper is in the sensor area at the timings stored in the DC Controller. When the DC Controller judges that a jam has occurred, the printing operation is stopped and the jam is notified to the Main Controller at the same time. The following shows the jams that are detected.

■ Pickup Delay Jam 1

At paper pickup, the TOP Sensor (SR6) does not detect the paper leading edge although a specified period of time has passed.

■ Pickup Delay Jam 2

Paper was picked up from the first, second, or third cassette of the Paper Feeder, but the Feed Sensor (SR21) of its pickup slot failed to detect the paper leading edge.

■ Pickup Delay Jam 3

Paper was picked up from the second or third cassette of the Paper Feeder, but the Feed Sensor (SR21) of the cassette just above its pickup slot failed to detect the paper leading edge.

■ Pickup Stationary Jam 1

The TOP Sensor (SR6) does not detect the trailing edge although a specified period of time has passed after detection of the leading edge.

■ Fixing Delivery Delay Jam

The Fixing Delivery Sensor (SR9) does not detect the leading edge although a specified period of time has passed after the TOP Sensor (SR6) detects the leading edge.

■ Fixing Delivery Stationary Jam 1

The Fixing Delivery Sensor (SR9) does not detect the trailing edge although a specified period of time has passed after the TOP Sensor (SR6) detects the trailing edge.

■ Fixing delivery stationary jam 2

The Fixing Delivery Sensor (SR9) detected the paper trailing edge, but the Delivery Tray Full Level Sensor (SR10) failed to detect the paper leading edge.

■ Internal Stationary Jam 1

During warm-up rotation, residual paper was detected by a sensor.

■ Door Open Jam

The door open was detected after the pickup operation started.

■ Paper Wrapping Jam

The time from when the Fixing Delivery Sensor (SR9) detected the paper leading edge until the OFF status of the sensor was detected was shorter than the predetermined time.

■ Duplex Re-pickup Assembly Jam

At 2-sided print, the paper was reversed, but the TOP Sensor (SR6) failed to detect the paper leading edge within the specified period of time.

Fixing System

Overview

Fixing Delivery Assembly consists of the Fixing Assembly for fixing toner on the print paper and the Delivery Assembly for delivering print paper on which toner is fixed to the Delivery Outlet.

Main Parts in the Fixing Assembly

This circuit is for controlling the temperature of the Fixing Assembly.

The Fixing Assembly of this machine uses an on-demand fixing method, and consists of the following parts:

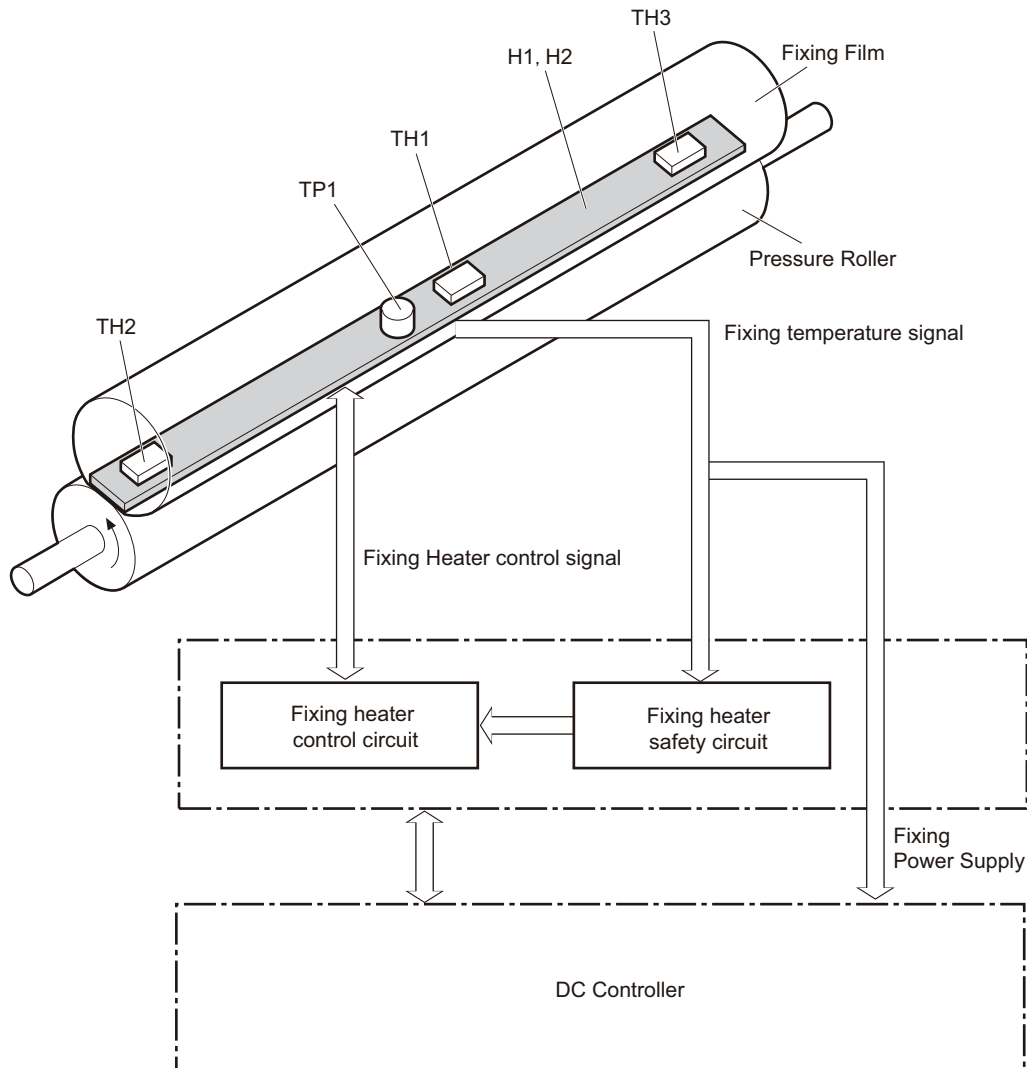

- Fixing Main Heater (H1):
Ceramic Heater for heating the center of the Fixing Film
- Fixing Sub Heater (H2):
Ceramic Heater for heating the edges of the Fixing Film

- Thermistors (TH1, TH2, and TH3):
Thermistors for detecting the fixing temperature
3 contact-type thermistors are used in this Fixing Assembly.
 - Main Thermistor (TH1):
This thermistor is in contact with the center of the Fixing Heater and detects the temperature of the Fixing Heater. (Contact type)
 - Sub Thermistor 1 (TH2):
This thermistor is in contact with the edge of the Fixing Heater and detects the temperature of the Fixing Heater. (Contact type)
 - Sub Thermistor 2 (TH3):
- Thermoswitch (TP1):
Thermoswitch for preventing the abnormal temperature rise of the Fixing Heater.
This thermoswitch is a contact-type thermoswitch, and is installed at the center of the Fixing Heater.
If the temperature of the Fixing Heater has risen abnormally, the contact point opens to stop the power supply to the Fixing Heater.

Temperature control of the Fixing Assembly which consists of these parts is performed by the fixing control circuit and Fixing Heater safety circuit according to the command of the CPU on the DC Controller.

Controls

■ Fixing Assembly Temperature Control

This control detects the surface temperature of the Fixing Heater and controls the drive signal of the Fixing Heater so that the temperature of the Fixing Heater becomes the target temperature.

The temperature is detected by the Main Thermistor, and the DC Controller controls the temperature to become the target temperature using the Fixing Heater drive (FSRD_MAIN/FSRD_SUB/FSR_TH_SUB_R).

The following shows this control circuit:

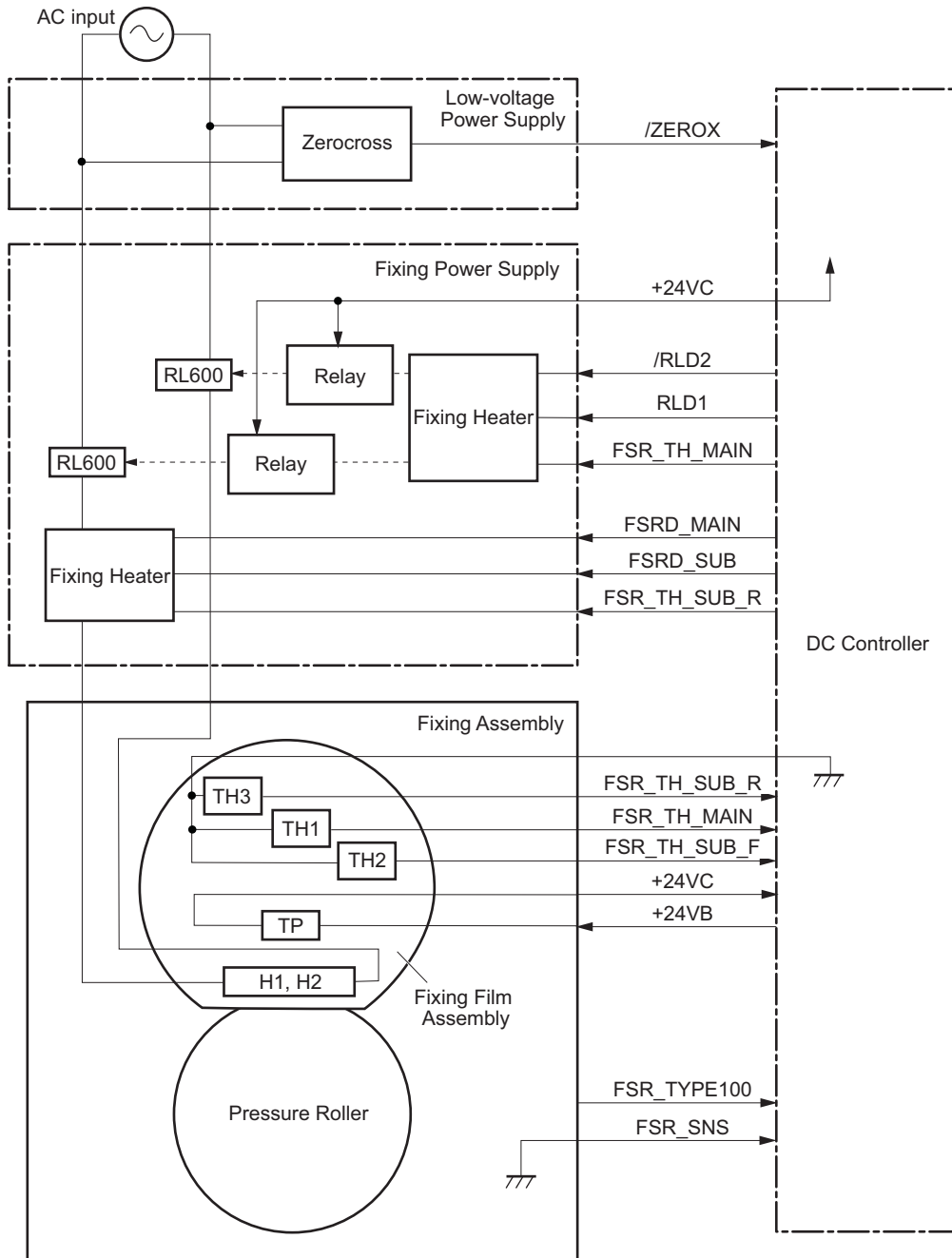

■ Fixing Pressure/Disengagement Control

The Fixing Film Unit is disengaged from the Pressure Roller under a specific condition in order to improve jam removability.

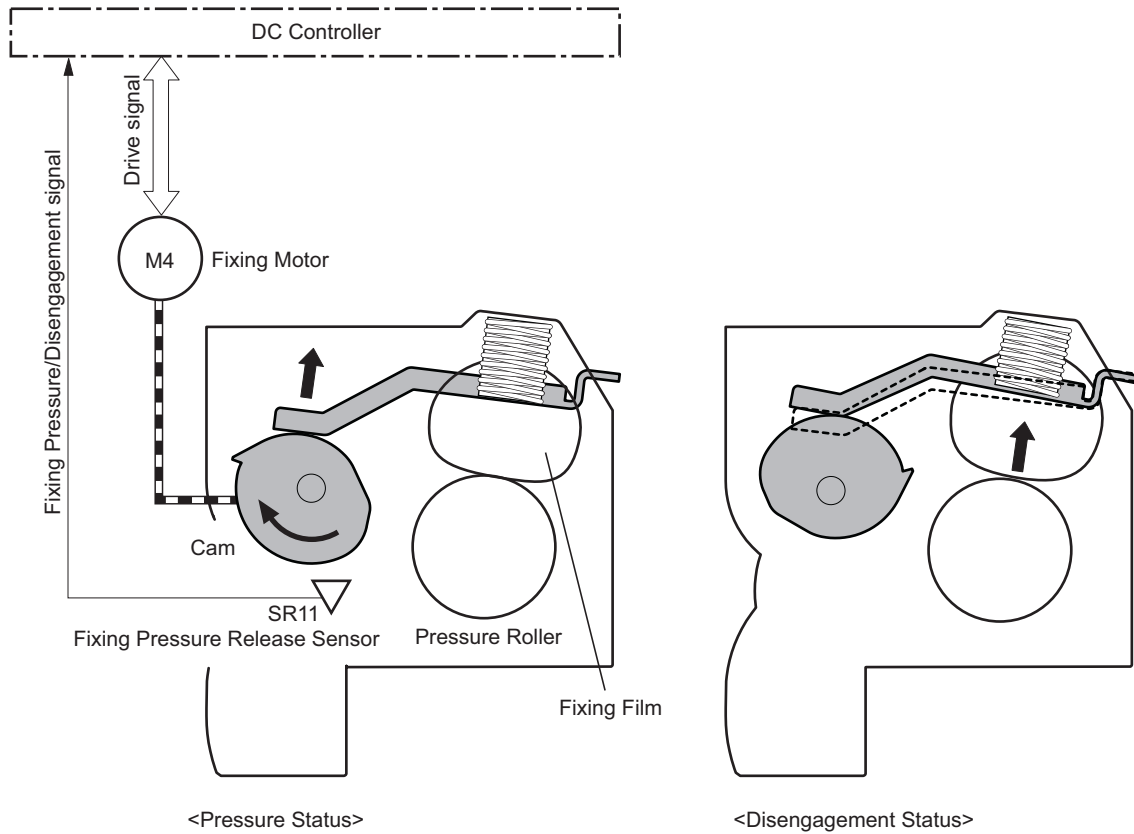

Execution condition/timing of disengagement operation:

- At occurrence of a jam
- Default status

If disengagement operation is not performed although a specified period of time has passed, an error code is notified.

<Related error codes>

E840-0000: Fixing disengagement error

■ Protection function

● Protection function

The Protection Circuit shuts down the power supply to the Fixing Heater if the Fixing Assembly detects abnormal temperature rising.

The following three methods are used to perform detection to prevent abnormal temperature rising.

- DC Controller
- Fixing Heater safety circuit
- Thermoswitch

The following explains each of the functions.

1. DC Controller

The DC Controller monitors the detected temperatures of the Main Thermistor (TH1), Sub Thermistor 1 (TH2), and Sub Thermistor 2 (TH3).

The DC Controller stops the fixing drive and shuts down the power supply when a thermistor exceeds a certain temperature.

2. Fixing Heater safety circuit

The Fixing Heater safety circuit detects the temperature of the Main Thermistor (TH1), Sub Thermistor 1 (TH2), and Sub Thermistor 2 (TH3).

When the Fixing Heater safety circuit detects a temperature above a certain temperature, it shuts down the power supply to the Fixing Assembly.

3. Thermoswitch

When the temperature of the Fixing Heater rises abnormally and the Thermoswitch (TP1) exceeds a certain temperature, the contact of the Thermoswitch is disconnected to shut down the power supply to the Fixing Assembly.

● Fixing Assembly failure detection

When the machine is under the following conditions, the DC Controller shuts down the power supply to the Fixing Assembly and notifies an error.

Fixing temperature rising error

Temperature of the thermistor does not rise although a specified period of time has passed since the heater was turned ON.

<Related error code>

- E000-0000: Temperature of the Main Thermistor did not become a certain temperature although the specified time had passed

Abnormally high fixing temperature detection

When a Thermistor reaches a certain temperature or higher, it is judged as abnormal high temperature for the thermistor.

<Related error codes>

- E001-0000: The Main Thermistor detected a temperature higher than a certain temperature.
- E001-0001: The Sub Thermistor 1 detected a temperature higher than a certain temperature.
- E001-0004: The Sub Thermistor 2 detected a temperature higher than a certain temperature.

Abnormally low fixing temperature detection

After it was detected that the temperature of the Fixing Main Thermistor was 100 deg C or higher while the Fixing Heater was ON, a temperature lower than a certain temperature was detected.

<Related error codes>

- E003-0000: Temperature of the Main Thermistor was lower than a certain temperature although a specified period of time has passed since the heater was turned ON.
- E003-0001: Temperature of the Sub Thermistor 1 was lower than a certain temperature although a specified period of time has passed since the heater was turned ON.
- E003-0004: Temperature of the Sub Thermistor 2 was lower than a certain temperature although a specified period of time has passed since the heater was turned ON.

Fixing drive circuit error

When the DC Controller cannot detect a specific frequency, a fixing drive circuit failure is judged to have occurred.

<Related error codes>

- E004-0000: Error in either the Fixing Heater or the Fixing Motor

Fixing Assembly error

It is judged that a Low Voltage Power Supply Unit error has occurred.

<Related error codes>

- E004-0001: Low Voltage Power Supply Unit error

Fixing Assembly detection

The printer detects the Fixing Assembly when the main power is turned on and when operation starts.

The DC Controller monitors the Fixing Assembly detection signal to detect the presence of the Fixing Assembly.

Consequently, when the DC Controller determines that the Fixing Assembly is not connected, it outputs a warning message.

Power supply type detection

This machine does not perform detection of the fixing type based on power supply differences.

■ Fixing Life Detection

The life of the Fixing Assembly is detected to prevent fixing errors due to the Fixing Assembly having reached the end of life.

This machine has a counter in the controller to determine the life of the Fixing Assembly.

- SERVICEMODE > COUNTER GR. > FIXER COUNTER

When the foregoing counter value reaches the setting value, a message is displayed on the Control Panel and the alarm code is recorded in the log.

Control Panel display: E5 Prepare_fixing_unit.

Alarm code: 06-0002 Fixing Assembly warning alarm

Controller System

Overview

The controller system controls all blocks according to the instructions from the Main Controller. The controller system consists of the followings.

- DC Controller
- High Voltage Power Supply (Upper/Lower)
- Low Voltage Power Supply
- Fixing control

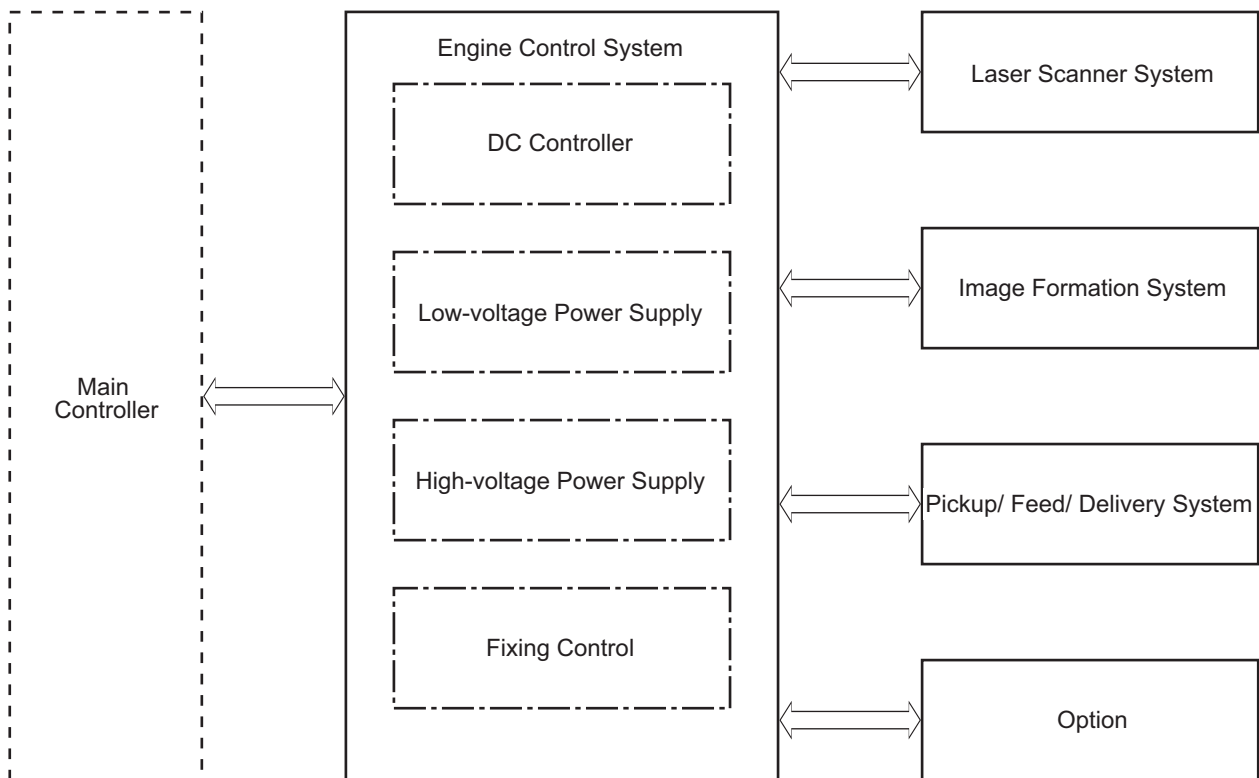

Main Controller

The Main Controller receives print information from the external equipment (host computer, etc.) via the interface cable.

This print information includes commands to exchange the status or unique information of a printer and the PDL data of the image data.

The PDL data is converted to a bitmap and then sent to the DC Controller.

The external equipment can view the printer status using a two-way interface.

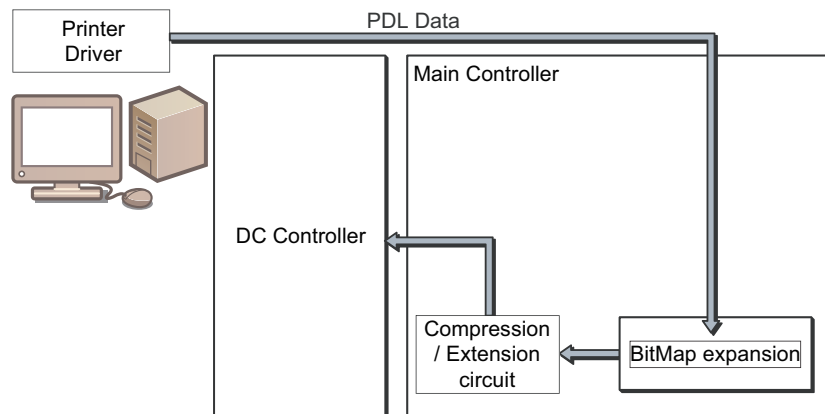

J No.	Connection destination		
	Electric code	Name	J No.
J1120	-	Control Panel PCB	J1
J1128	-	Memory PCB	J1
J1016	-	SOFT-ID PCB	J1
J1004	-	USB (Front)	-
J807	SW7	Power Switch	-
J18	-	DC Controller PCB	J109
J808			J115
J2802	-	Low Voltage Power Supply PCB	-
J1400	-	Sublog Board	-

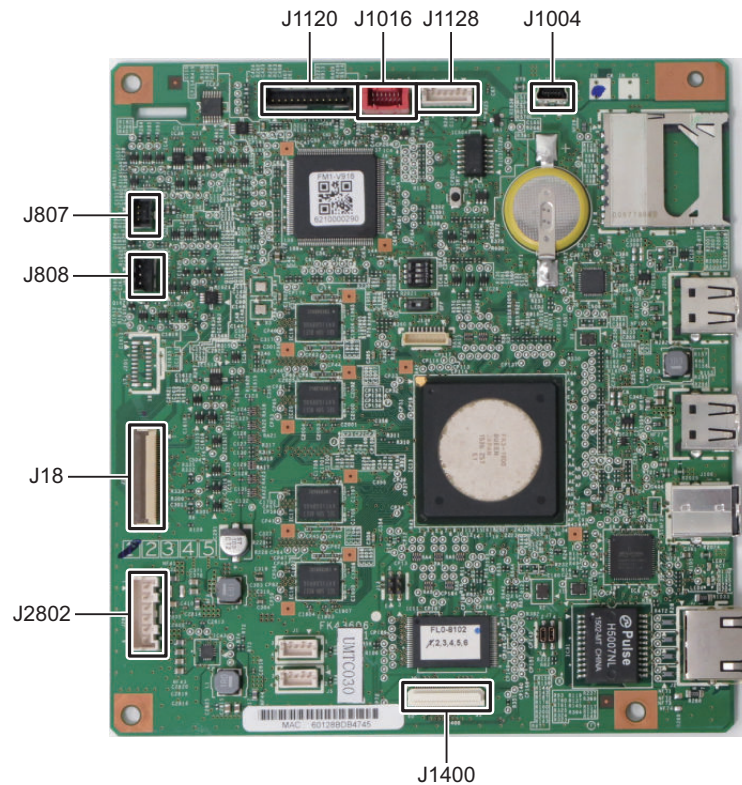

DC Controller

The DC Controller is a circuit to control the operation sequences of this machine, and controlled by the CPU in the DC Controller. The following explains the operation of the DC controller.

1. When the Power Switch of this machine is turned ON, DC power is supplied from the Power Supply PCB to the DC Controller.
2. The CPU in the DC Controller starts printer operation control.
3. When this machine enters the standby state, the CPU outputs signals to drive various loads such as laser diodes, motors, and solenoids based on the print instruction command and image data input from the Main Controller.

The following shows a block diagram of this circuit.

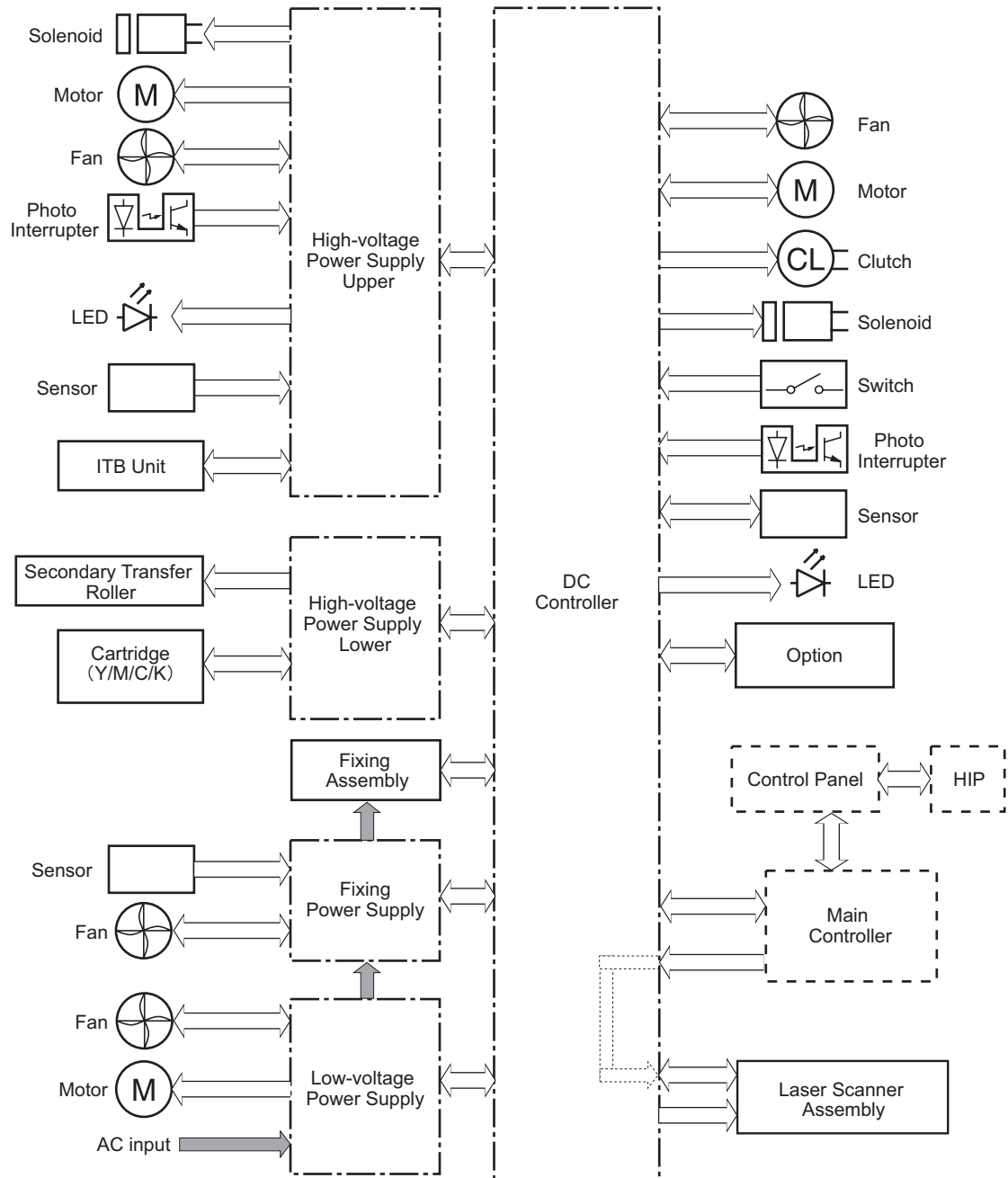

J No.	Connection destination		
	Electric code	Name	J No.
J101	SW1	24V Interlock Switch	J99
J102	-	Low Voltage Power Supply Unit	J601
J103	M7	Scanner Motor	J47
	-	Cartridge Tag Y	J91
	-	Cartridge Tag M	J92
	-	Cartridge Tag C	J93
	-	Cartridge Tag K	J94
	-	Paper Feeder (Option)	-
J105	-	Low Voltage Power Supply Unit	J602
J106	-	Main Controller PCB	J18
J109	-	Upper High Voltage Power Supply PCB	J2501
J111	M1	Drum Motor 1	J41
	M2	Drum Motor 2	J42
J114	M4	Fixing Motor	J44
	SL1	Primary Transfer Roller Disengagement Solenoid	J57

J No.	Connection destination		
	Electric code	Name	J No.
J114	SR1	Drum Home Position Sensor 1	J84
	SR2	Drum Home Position Sensor 2	J12
	SR3	Drum Home Position Sensor 3	J13
J115	SW3	Right Door Switch	J26
	SR11	Fixing Pressure Release Sensor	J79
J116	TH1	Main Thermistor	J2607
	TH3	Sub Thermistor 2	J2606
J118	CL2	Duplex Re-pickup Clutch	J67
	SR6	TOP Sensor	J16
	SR13	Paper Width Sensor (Front)	J20
	SR14	Paper Width Sensor (Rear)	J21
J120	-	Color Displacement Density Sensor Unit	-
J121	SR12	Cassette Media Presence Sensor	J22
J122	SL2	Multi-purpose Tray Pickup Solenoid	J58
	CL1	Cassette Pickup Clutch	J39
	SW5	Cassette Detection Switch	J82
	SR8	Multi-purpose Tray Media Presence Sensor	J18
J124	SE1	Media Sensor	-
J125	-	Lower High Voltage Power Supply PCB	J2401
J126	-	BD PCB 1	J201
J127	-	BD PCB 2	J202
J128	-	Fixing Power Supply Unit	J6003
J129	-	Y Toner Level Sensor	-
	-	M Toner Level Sensor	-
	-	C Toner Level Sensor	-
	-	K Toner Level Sensor	-
J130	M3	Drum Motor 3	J43
	SR4	Developing Home Position Sensor	
J131	SR10	Delivery Tray Full Level Sensor	J78
J132	M6	Developing Disengagement Motor	J46

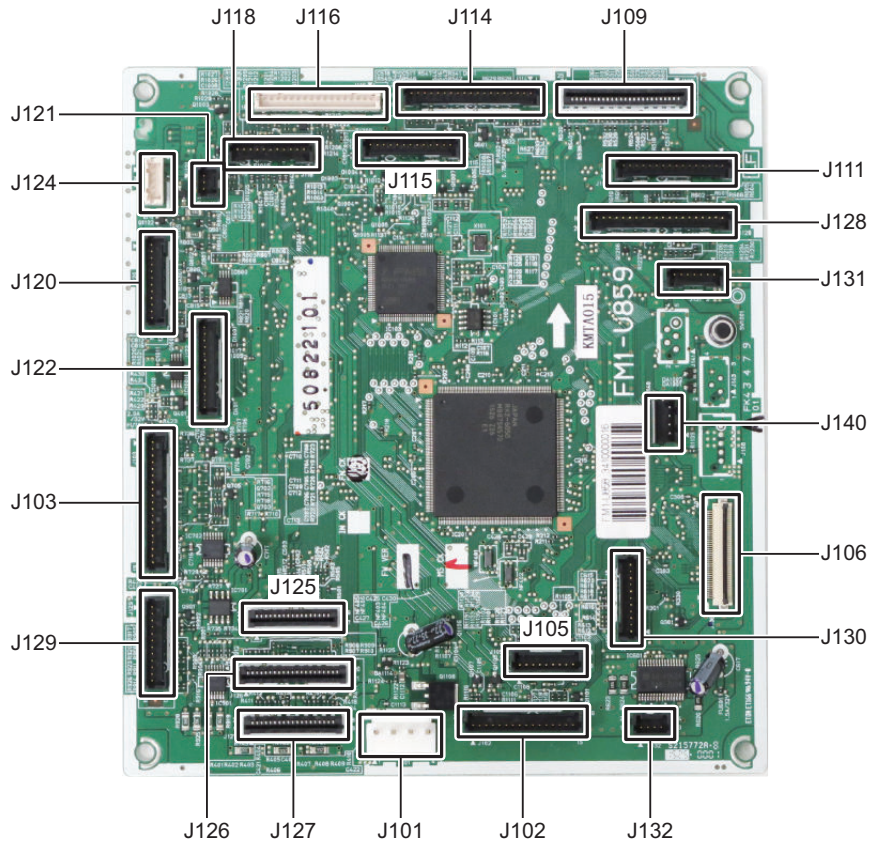

■ Motor/Fan Control

This machine uses 8 motors for paper feed and image formation. Furthermore, the machine has 4 Fan Motors for preventing overheating inside the machine.

Specifications of Each Fan

Name		Cooling area	Type	Speed
Power Supply Fan	FM1	Area around Low Voltage Power Supply	Suction	Full speed / Half speed
Cartridge Fan	FM2	Area around the cartridge	Suction	Full speed
Exhaust Fan	FM3	Area around the controller	Exhaust	Full speed / Half speed
Fixing Fan	FM4	Fixing Assembly	Exhaust	Full speed / Half speed

Specifications of Each Motor

Name		Drive parts
Drum Motor 1	M1	Photosensitive Drum (Y), Developing Assembly (Y/M)
Drum Motor 2	M2	Photosensitive Drum (M/C), Developing Assembly (C)
Drum Motor 3	M3	Photosensitive Drum (K), Developing Assembly (K), ITB
Fixing Motor	M4	Pressure Roller, Delivery Roller, Fixing Pressure, Pressure Release, Primary Transfer Roller Engagement/Disengagement, Secondary Transfer Roller Engagement/Disengagement
Pickup Motor	M5	Multi-purpose Tray, Cassette Pickup Roller, Feed Roller, Registration Roller
Developing Disengagement Motor	M6	Engagement/disengagement of the Developing Assembly
Scanner Motor	M7	Scanner Mirror
Duplex Reverse Motor	M8	Duplex Reverse Roller

■ Failure Detection

Motor Failure Detection

Fixing Motor, Drum Motor 1 to 3, Scanner Motor (Y/M, C/Bk), Developing Disengagement Motor:

When the following state occurs, the DC Controller judges a motor failure and notifies the Main Controller.

- Error in startup of the Motor
If the motor speed does not reach the specified speed after the specified period of time has passed after starting the motor.
- Motor rotation error
If the speed of each motor fails to meet the specified speed continuously for more than the specified period of time after the speed once reached the specified speed.

<Related error codes>

- E012-0000: Pickup Motor error (startup error)
- E012-0001: Pickup Motor error (rotation error)
- E012-0002: Y Drum Motor error (startup error)
- E012-0003: Y Drum Motor error (rotation error)
- E012-0004: M Drum Motor error (startup error)
- E012-0005: M Drum Motor error (rotation error)
- E012-0006: C Drum Motor error (startup error)
- E012-0007: C Drum Motor error (rotation error)
- E012-0008: B Drum Motor error (startup error)
- E012-0009: B Drum Motor error (rotation error)
- E014-0000: Error in startup of the Fixing Motor
- E014-0001: Error in rotation of the Fixing Motor
- E015-0000: Error in rotation of the Developing Disengagement Motor

Fan Failure Detection

If each of the fans is locked continuously for the specified period of time from startup, the DC Controller judges a fan failure and notifies the Main Controller.

<Related error codes>

- E805-0000: Fixing Fan failure
- E805-0018: Exhaust Fan failure
- E805-0019: Cartridge Fan failure
- E805-0020: Power Fan failure

Low Voltage Power Supply

■ Overview

The low voltage power supply converts the AC voltage input from the power supply receptacle to DC power supply and then supplies the DC power supply to each load.

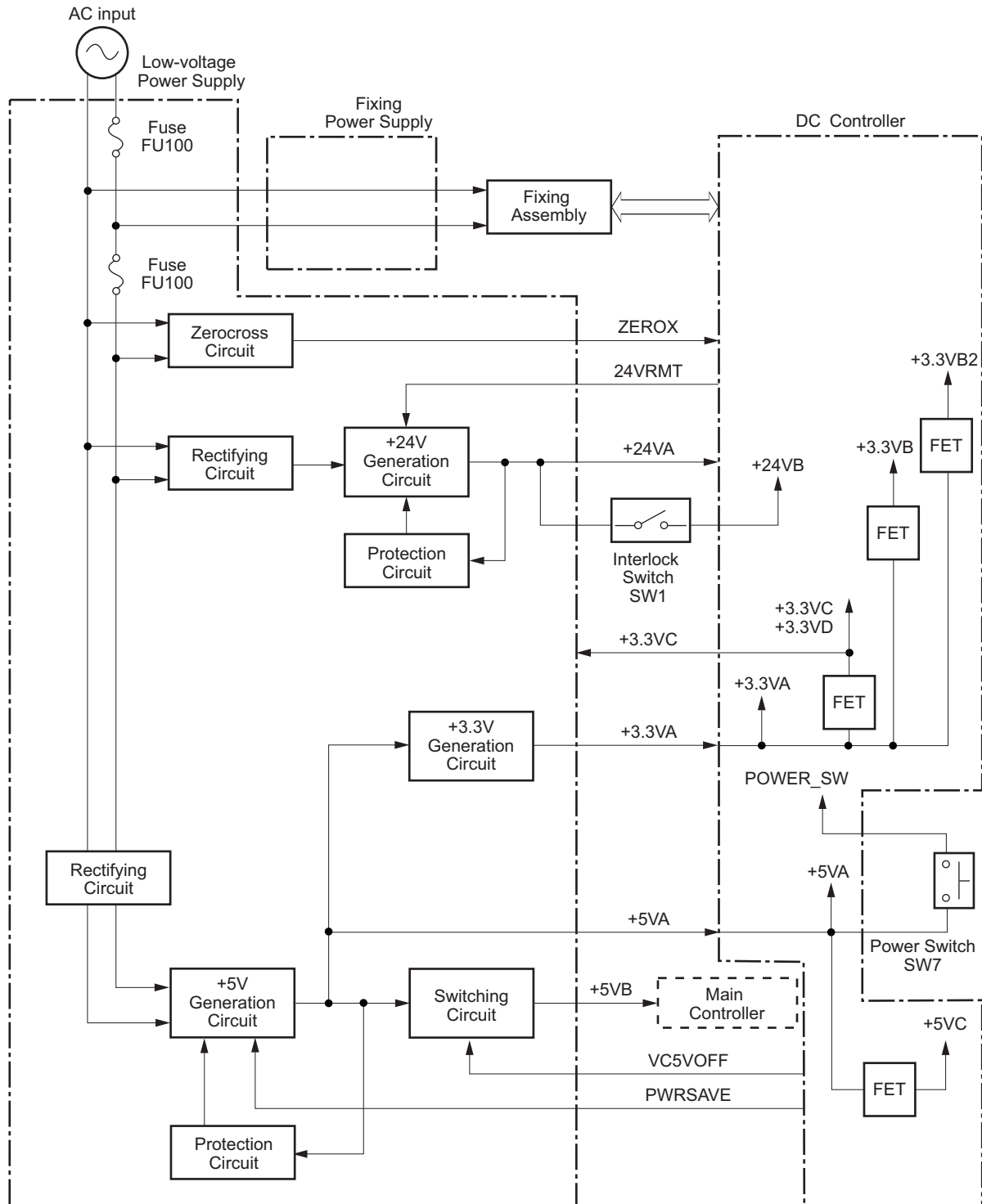

The low voltage power supply converts the supplied AC power supply to the +24 V, +5 V, and +3.3 V DC power supply required by the printer.

The +24V supply consists of +24VA which is always supplied from the low voltage power supply and the +24VB and +24VC which stop supplying power when the Right Door is opened.

The +5VC, +3.3VC, and +3.3VD stop supplying power during sleep mode.

■ Protection function

The Low Voltage Power Supply has functions to protect against overcurrent and overvoltage to prevent damage to the Power Supply PCBs by automatically cutting off output voltage if overcurrent or abnormal voltage occurs due to a trouble.

When no DC voltage is output from the Low Voltage Power Supply Assembly, the protection function is possibly activated.

Therefore, turn OFF the Power Switch, disconnect the Power Supply Cord from the Inlet, and then fix the trouble before connecting the Power Supply Cord and turning ON the Power Switch again.

The machine has power supply fuses immediately after the inlet and inside the Low Voltage Power Supply PCB as additional protection functions. If overcurrent occurs in the AC line, the power supply fuse blows and cuts off the power supply.

■ Safety

This device has a function that stops supplying the 24VB and 24VC for the safety of users and service technicians. For the 24VB and 24VC which are supplied to the Fixing Assembly, High Voltage Power Supply PCB, and each of the motors, the interlock switch turns OFF under the following conditions and stops supplying the 24VB and 24VC.

- When the Right Door is opened

■ Low-voltage Power Supply Failure

If +24V is not output from the low voltage power supply, the DC Controller judges a low voltage power supply failure and notifies the Main Controller.

<Related error codes>

E004-0001: Low Voltage Power Supply Unit error

E808-0001: Low Voltage Power Supply PCB failure

Quick Startup

Setting quick startup reduces the time from when the Power Switch is pressed until screen operation becomes possible. When the quick startup is set, pressing the Power Switch to turn off the power enables quick startup the next time the power is turned on (quick off).

NOTE:

The quick startup function can be set from the following menu.

- Setup > Control Menu > Main Pwr Quick Start
 - [ON]: Quick startup is executed.
 - [Off]: Quick startup is not executed (default).

The power supply to the PCBs depends on whether the quick startup function is ON or OFF as follows:

PCB name	Power supply status	
	Quick startup setting ON (quick off)	Quick startup setting OFF
Low Voltage Power Supply PCB	Power is supplied	Power is supplied
Main Controller PCB	Power is supplied	OFF

Note that under the following conditions (settings), the machine always starts up normally (even if quick startup is ON).

- At first startup after the power plug is connected to the outlet
- When the network-related settings are configured as follows:
 - Setup > Network > TCP/IP Settings > IPv6 Settings > On
 - Setup > Network > TCP/IP Settings > IPv4 Settings > Protocol > Use BOOTP > ON
 - Setup > Network > TCP/IP Settings > IPv4 Settings > Protocol > Use RARP > ON
 - When IPsec is set
- MEAP-related Information
 - During execution of an MEAP application which prohibits quick startup
 - When a login application is switched by SMS
- When a job is being executed (including internal jobs in progress such as calibration or cleaning)
- During import of setting values using service mode or RUI
- When the menu setting values are changed using remote UI or the Operation Panel
- Others
 - When the Main Power Switch is pressed for at least 5 seconds
 - When an error code or a jam occurs
 - When a cover is open
 - When the accumulated time during which the machine is powered ON as well as powered OFF (with quick startup turned ON) is 110 hours or more.
 - When a system option license is registered

■ Prohibited Items at Quick Off

The following operations are prohibited during quick off mode (when the power is turned off while the quick startup function is enabled).

- Disconnecting the power plug from the outlet
- Inserting and removing an SD card
- Installing and removing pickup options

Performing any of the above operations will cause an engine failure, controller PCB failure, MEAP data damage, etc.

To perform these operations during quick off mode, always perform "Shut Down" using the following procedure and disconnect the power plug before performing the work.

1. Turn ON the power. (Recover from quick off mode)
2. Select the following menu item to perform shutdown.
 - Reset > Shut Down > Yes
3. Check that the power is OFF, and disconnect the power plug from the outlet.

CAUTION:

Never operate the Main Power Switch while outputting sublogs to the USB flash drive. There is a risk that the shutdown processing will not be performed correctly, and the devices and log files being saved may become damaged.

NOTE:

A shutdown can be performed by pressing the Main Power Switch for at least 5 seconds, but this is not recommended because the power may be turned OFF before the MEAP shutdown process completes.

Energy Saving Function

This machine is equipped with a power-saving function.

The following shows energy saving status and condition of transition.

Status	Description	Condition of Transition
Panel sleep	Panel Off	Press [Power key].
Engine sleep	The panel and engine are turned OFF.	When the time to transition to these modes has elapsed (Default setting: 5 minutes) * When USB is connected, the mode remains unchanged.
Deep sleep	The panel, engine and controller are turned OFF. (Only Power LED lights up.)	

Conditions for Not Entering Deep Sleep

- When a job is in progress (including internal jobs in progress such as calibration and cleaning)
- While a door is open
- When an error code or jam occurs
- During a firmware update
- When the Toner Cartridge is not installed
- When information cannot be read from the Toner Cartridge Memory (including a failure of memory tag and a state in which memory tag is not yet connected)
- When the life warning of the Toner Cartridge is displayed



Technical Explanation (System)

Overview of System Management.....	62
Version Upgrade.....	63
Backup/Restoration.....	81
Monitoring Function (imageWARE Remote).....	98
MEAP Application Management.....	105

Overview of System Management

This chapter describes information for service technicians on the system of this machine.

Although this chapter contains some information described in the User's Guide, for details on the functions for users, refer to the e-Manual.

Version Upgrade

Overview

The following methods exist for version upgrade the system of the device.

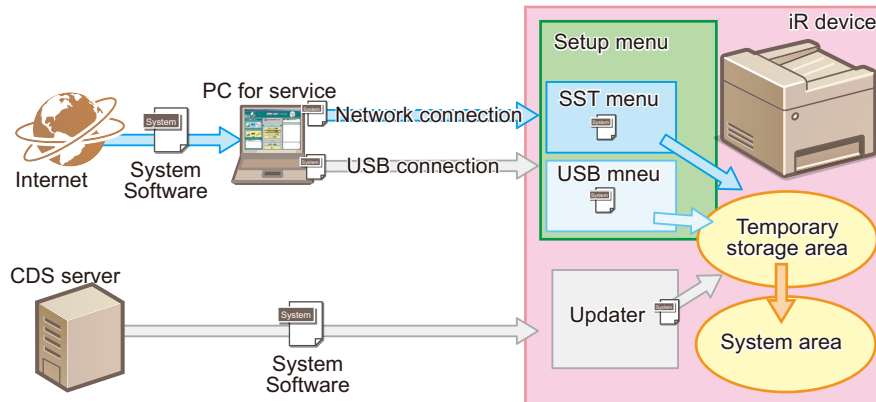

Version Upgrade Using UST (User Support Tool)

UST is a firmware update tool for general users that is included with the firmware for this machine.

Connect this machine to a PC with a USB cable or network cable, and execute UST on a PC to upgrade the firmware.

When connecting the host machine and the PC using a USB cable, version upgrades can be performed in an environment where a network is not available.

Version Upgrade Using Updater (CDS)

Send a command using service mode or the [Settings/Registration] menu of the Remote UI to download the firmware data from the CDS server to perform an upgrade.

When upgrading using the Updater, you can also link with the UGW server to automatically download the firmware.

CAUTION:

A message appears when an attempt is made to upgrade a host machine to which specified firmware has been applied. ? This is a precaution not to use wrong firmware to upgrade a host machine to which specified firmware has been applied. See the following regarding the combination of whether the message will be displayed:

Type of firmware applied to the host machine	Firmware to upgrade	
	General firmware	Specified firmware
General firmware	No message	No message
Specified firmware	Message displayed	Message displayed

Version Check

Before upgrading the version, output the status print, and check the model name of a target device and the version of the system software.

Version upgrade is not required if the system software is the latest.

1. Execute the following menu from the Control Panel and output the status print.

- [Utility] > [Status Print]

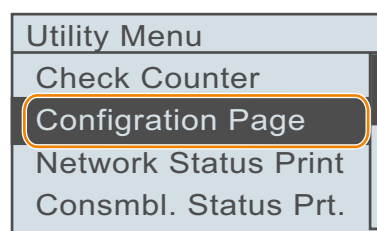

2. Check the output status print.

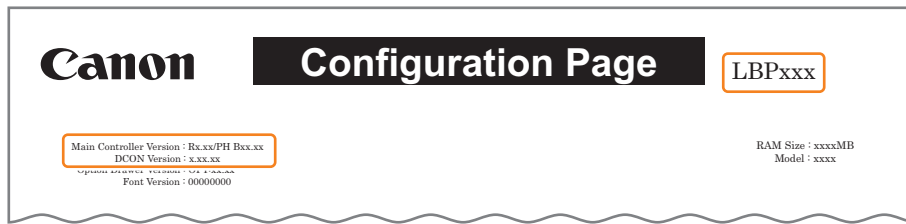

Version display

R: Main Controller BOOTABLE version

B: Main Controller BOOTROM version

Version Upgrade Using UST

UST is included in the firmware for the machine that can be downloaded from the website of CINC. Firmware is downloaded as a zip file and a folder containing UST is extracted by decompressing the file.

When executing UST on the PC connected to the machine with a USB Cable, the firmware can be upgraded by downloading it from the PC to the machine. For the detailed procedure, refer to the UST Operation Guide stored in the decompressed folder.

The UST Operation Guide is also available from the website of CINC.

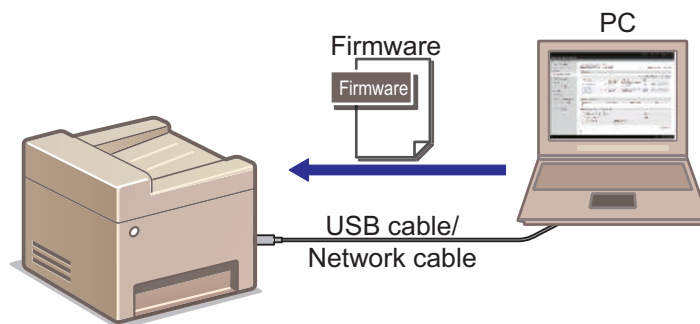

Update Using Updater

Updater provides functions that enable network communication with Content Delivery System (hereinafter CDS) to install firmware, MEAP applications and system options.

Firmware Installation

Updater function enables users to distribute firmware through CDS via Internet. Particularly on UGW enabled devices, firmware can be updated remotely, which effectively slashes costs incurred in field services.

MEAP Application

By linking devices to CDS and License Management System (providing the function to manage licenses; hereinafter LMS), applications can be installed in devices via Updater.

■ Upgrading Method

Although there are three methods to upgrade the firmware of this machine using Updater, service technicians use the following two methods.

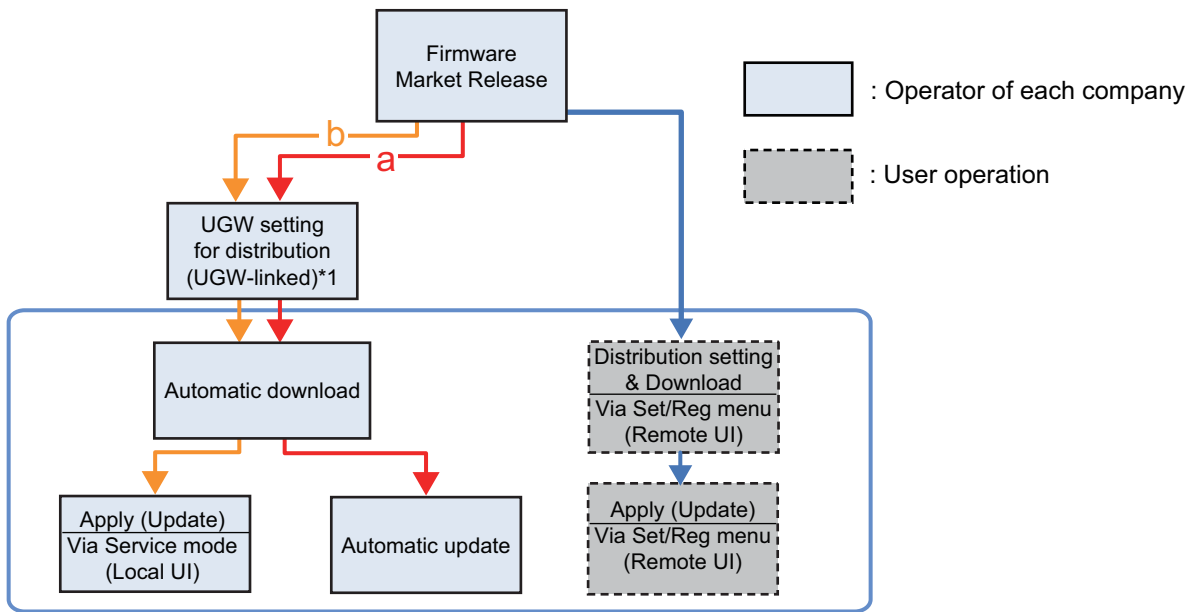

*1: When UGW is linked, schedule information is saved to CDS.

Distribution Method	Download instruction Source	Update timing	Versions which can be distributed		
			Older than the current	Same as the current	Newer than the current
a. CDS Remote Update (download and update in conjunction with UGW)	UGW		No	Yes ^{*1}	Yes ^{*2}
b. CDS Remote Download (download in conjunction with UGW)	UGW		Yes	Yes ^{*1}	Yes

a. CDS Remote Update (download and update in conjunction with UGW)

Firmware can be completely updated remotely, by registering a distribution schedule and update settings from UGW in devices using UGW in advance. Devices download firmware from CDS and then update the obtained firmware. Start of operation will be announced from the department in charge of management.

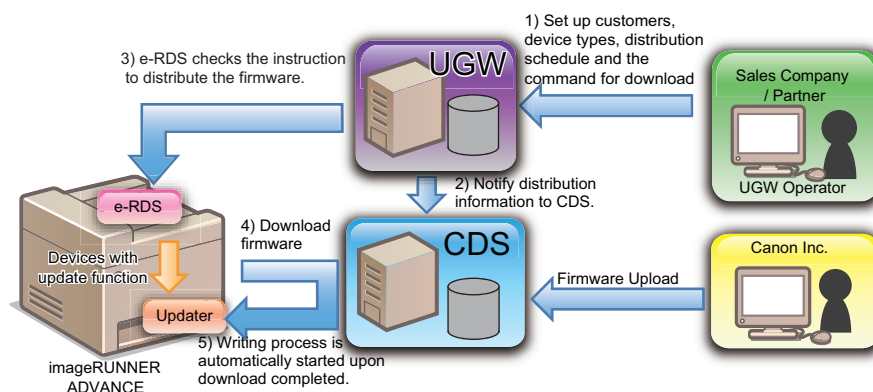

*1. Do not execute [Updated Module Only].

*2. Only versions where manual remote update is allowed can be selected.

b. CDS Remote Download (download in conjunction with UGW)

Firmware distribution can be done before service technicians visit the customer, by registering a distribution schedule from UGW in devices using UGW in advance. Service technicians visiting the customer can perform manual update after checking the device status.

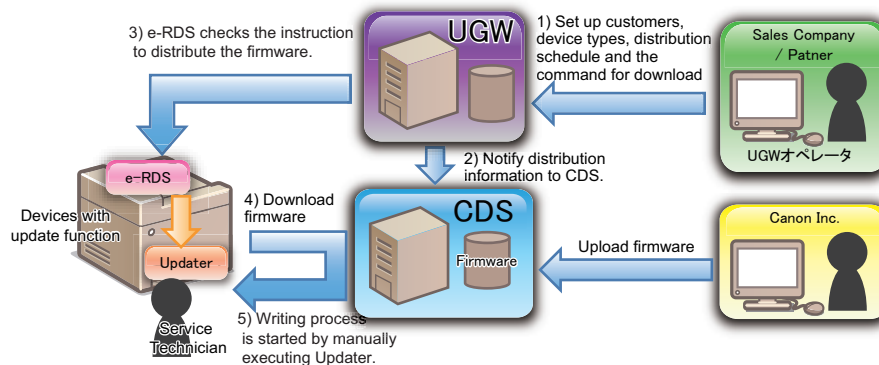

■ List of Functions

The matrix below shows the list of functions provided by Updater.

Category	Function	Remote UI	UGWlinked
Firmware	Checking firmware compatibility	—	—
	Checking special firmware	—	—
	Checking latest firmware version	Yes	—
	Registering/deleting firmware distribution schedule	Yes	—
	Confirming and downloading firmware	—	Yes
	Updating downloaded firmware	Yes	—
	Cancelling downloaded firmware	Yes	—
	Acquiring firmware distribution information registered from UGW	Yes	Yes
	Notifying firmware version information	—	Yes
MEAP application / system option	Installing MEAP application	Yes	—
	Installing system option	Yes	—
System Management	Settings	Yes	—
	Testing communications	Yes	—
	Displaying update logs	Yes	—
	Displaying system logs	Yes	—
Internal system error notification	Notifying internal system error occurrence to distribution server	Yes	Yes

■ Limitations and Cautions

● Limitations

Changing Date/Time on Device

When a user changes the date/time setting on the device (including change of the setting according to daylight saving time), the firmware distribution may not be performed as scheduled.

But there is not the problem if it is time adjustment of several minutes with NTP servers.

Change of Setting from Service mode

Any settings from Service mode will be enabled after restarting the device.

● Cautions

Concurrent use of Updater functions

Multiple users cannot use Updater functions on a device concurrently by using it together with Remote UI.

Coexistence of Remote UI and other tools

Users logged in SMS (Service Management Service) are unable to use Update functions from Remote UI.

Using Updater function from Remote UI

Upon the following operations done, Updater functions are suspended from Remote UI for certain duration.

- When a user exits Web browser without clicking [Portal] or [Log Out] button in the setting of Remote Login Service via SMS
- When a user exits Web browser without clicking [Portal] button in the setting of not to use Remote Login Service via SMS.
- When a user exits Web browser without clicking [Log out from SMS] or [To Remote UI] button.

Wait for EOJ (end of job) Function

Firmware update will be triggered only after the following jobs are completed.

This is the Updater-specific specification.

Job/Function type	Receiving	Printing	Queued print jobs
PRINT	Wait for EOJ (end of job)	Wait for EOJ	Wait for EOJ
I-FAX Receipt	Cancel processing to trigger update *	Wait for EOJ	Wait for EOJ
Report Print	-	Wait for EOJ	Wait for EOJ

*The data are guaranteed even if cut off in the middle of a job. It becomes the recovery object after the device reboot and carry out send / reception again.

Even during transfer, Pull SCAN job processing is cancelled soon after scanning is completed.

Firmware update is cancelled if the jobs are not completed within 10 minutes. If this occurs, the error code, 8x001106, will be returned (different numbers will be shown for x depending on the execution modes).

Firmware update is executed if the jobs stated above are not in the queue.

Follow the shutdown sequence to reboot the device after the firmware is updated.

■ Preparation

● Setting Sales Company's Support Department

When using devices input in the markets listed below, the default setting of the sales company's Support Department should be changed before obtaining firmware distributed from CDS. Unless the setting is changed properly, the desired firmware may not be able to be selected.

Market	Default Setting of the sales company's Support Department.	Setting of the sales company's Support Department. after Change
Canada	US	CA
Latin America	US	LA

Go to the following screen to change the setting of the sales company's Support Department.

- SERVICE MODE > FUNCTION GR. > MEAP > CDS-CTL

NOTE:

The list below shows the setting of the sales company's Support Department for CDS-CTS by market. Check and adhere to the appropriate setting for your market.

Japan : JP	China : CN	Canada : CA	Singapore : SG	Latin America : LA
USA : US	Hong Kong : HK	Korea : KR	Europe : NL	Australia : AU

● Network Settings

Connecting to External Network

The method of connecting to external network is similar to a normal network connection method. Refer to user manual of the device for details.

NOTE:

- Before using UGW link or User mode, see the sections below to prepare as required.
 - “Enabling UGW Link” on page 70
 - “[Delivered Update] Button on the [Register/Update Software] Screen” on page 71
 - “Enabling [Manual Update] Button of [Settings / Registration] Menu” on page 71
- “External Network” here means the network connecting the device to CDS via Internet.

Confirming URL Setting of Distribution Server

Confirm the URL setting of the distribution server (UGW server) set in the machine.

1. Access the following URL from the browser on a PC connected to the same network as this machine, and log in to the management screen.

- `https://<machine's IP address>:8443/svm/`

Confirm the password to the Support Dept. of the sales company.

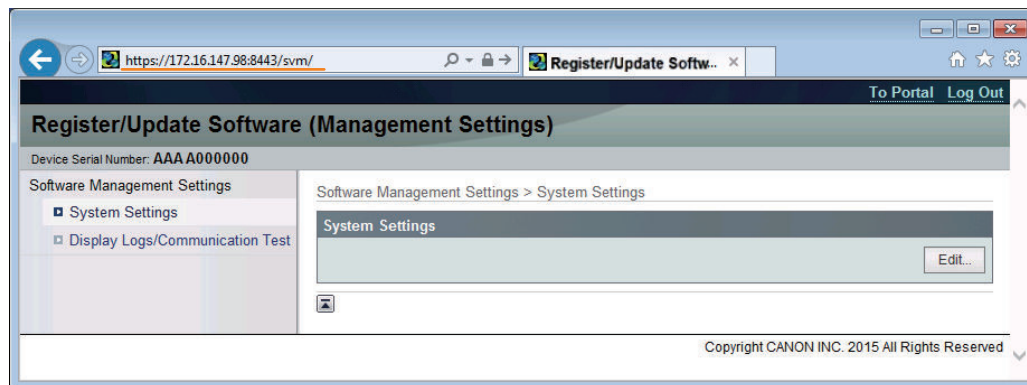
**CAUTION:**

In the case of the following, you cannot log in even if you input a right password.

- The other user is using "Register/Update Software (Management Settings)".
- The other user is using "Register/Update Software" in normal Remote UI.
- Because you have closed a browser without logging out definitely, you are still logging in it. Waiting for time-out.

2. Select [System Settings] > [Edit].

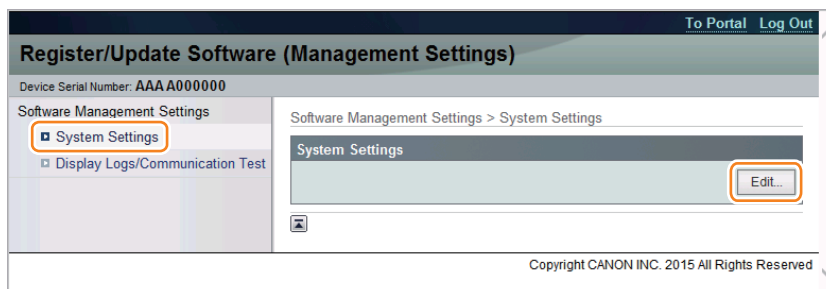

3. Confirm that the following information is set, and click [Cancel] if the settings are correct. If incorrect information is set, correct it and click [Configure].

- [Delivery Server URL] : https://device.c-cdsknn.net/cds_soap/updaterif
- [Log Level] : 1 to 4

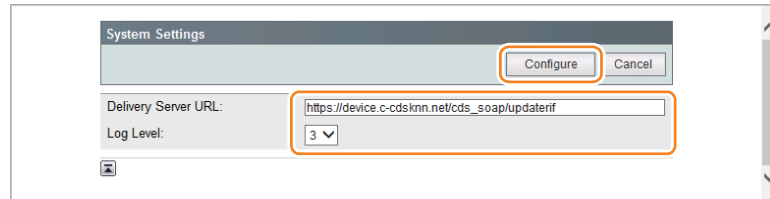

CAUTION:

The larger the value of the log level is, the more detailed the output log is (see the table below). Since changing the log level setting affects the performance, do not set a higher level than required. (Unless asked to do so by the Support Dept. of the sales company or the Canon R&D.)

Especially when the level 4 is set, the performance will be significantly lower and it will take time to collect logs.

Log Level and Leg Output Type

Log Output Type	Log Level					Description
	0	1	2	3	4	
Trace	-	-	-	-	Yes	Detailed logs for debug
Information	-	-	-	Yes	Yes	Logs related to operations done on the system
Important Message	-	-	Yes	Yes	Yes	Update logs output by firmware type Installation logs by MEAP application Logs related to enabled functions by system option
Ordinary Error	-	Yes	Yes	Yes	Yes	Logs for ordinary errors
System Error	Yes	Yes	Yes	Yes	Yes	Logs for internal system errors

4. Click [Yes] when a dialog box confirming whether you want to update the settings is displayed.

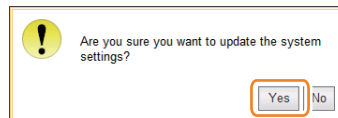

This completes the procedure for confirming the URL setting of the distribution server.

Communication Test with the Distribution Server

This section describes how to check if the communication is normally done to the distribution server and/or the file server.

NOTE:

Since the server accessed by the CDS function and the server accessed by the RDS function differ, make sure to perform a communication test for the CDS function even if the communication test for the RDS function is successful.

1. Access the following URL from the browser on a PC connected to the same network as this machine, and log in to the management screen.

- <https://<machine's IP address>:84433/svm/>

Confirm the password to the Support Dept. of the sales company.

2. Select [Display Log/Communication Test], and click [Communications Test].

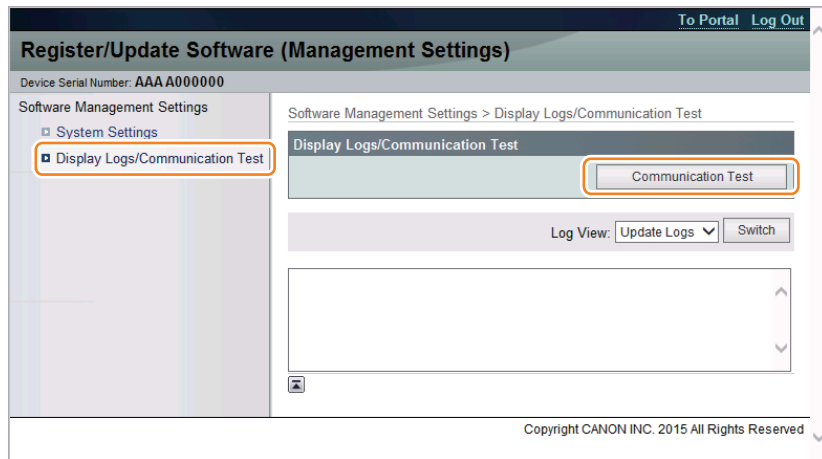

3. Click [Yes] when a dialog box confirming whether you want to execute the test is displayed.

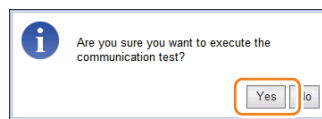

The Communication Test is carried out.

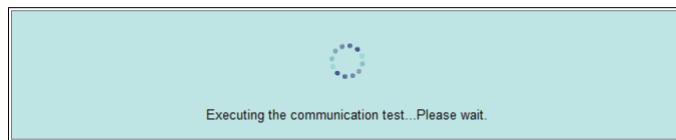

4. Upon the communication test completed, the communication test result screen is shown. Press [Back] button to exit this operation.

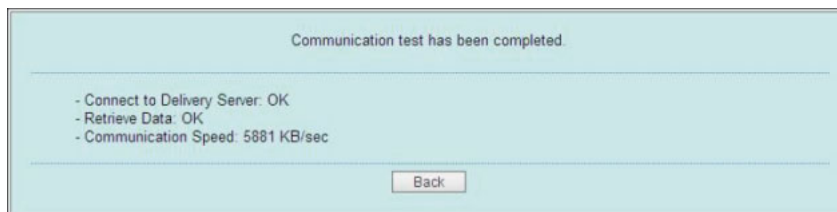

If "NG" is displayed as the result of the test, check the network settings and server URL settings.

• Enabling UGW Link

When installing the firmware in the method of "UGW-linked Download and Update" or "UGW-linked Download", the following should be set before actually using UGW link.

1. Set "On" for the following service mode:

- SERVICE MODE > FUNCTION GR. >MEAP > CDS-UGW

2. Access the [Customer Information] screen of the UGW WebPortal, and specify [Yes] for the following setting:

- Firmware Distribution

CAUTION:

- See imageWARE Remote Operator's Manual for how to operate UGW WebPortal.
- [Distribute Firmware] should be set on [Customer Management] screen for staff in charge of setting for [Enter customer information] or [Command for firmware distribution] in order to allow them to select the desired device on [Firmware Distribution Information] screen.
- If [Distribute Firmware] is not shown on [Customer Management] screen of UGW WebPortal, appropriate authorities may not be set to each account in Firmware Distribution Information. Contact the sales company's Support Department concerned for confirmation.

• Remote UI Button Settings

Activate (or deactivate) the button for upgrading the firmware using the Updater on the [Settings/Registration] > [Management Settings] > [License/Other] > [Register/Update Software] screen (hereinafter "[Register/Update Software] screen") of the Remote UI.

[Delivered Update] Button on the [Register/Update Software] Screen

Set to display [Delivered Installation] in the [Install Application/Option] menu on the [Register/Update Software] screen of the Remote UI.

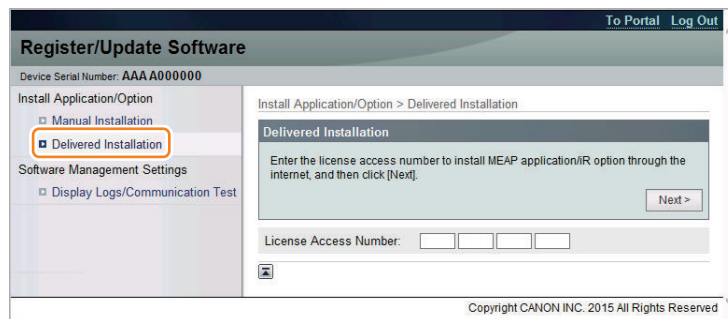

Specify this setting to allow users to install MEAP applications using the Updater function. This operation is not necessary if you do not want to allow users to do so.

1. Enter service mode.

2. Set "On" for the following service mode:

- SERVICE MODE > FUNCTION GR. > MEAP > CDS-MEAP

When this setting is enabled, [Delivered Installation] is displayed on the [Register/Update Software] screen of the [Settings/Registration] menu.

Enabling [Manual Update] Button of [Settings / Registration] Menu

Set to display the [Update Firmware] menu on the [Register/Update Software] menu of the Remote UI.

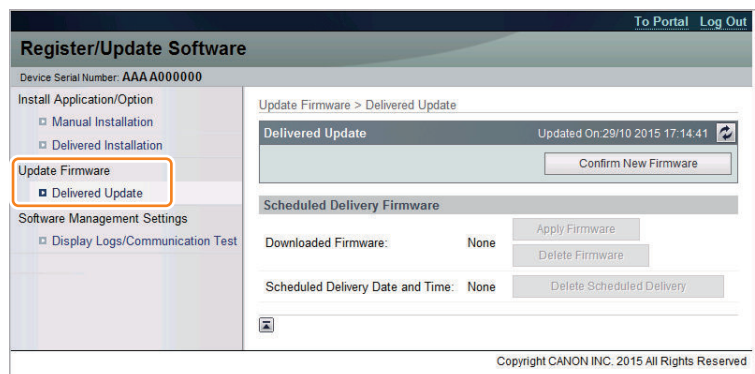

Specify this setting to allow users to upgrade the firmware using the Updater function. This operation is not necessary if you do not want to allow users to do so.

1. Enter service mode.

2. Set "On" for the following service mode:

- SERVICE MODE > FUNCTION GR. > MEAP > CDS-FIRM

When this setting is enabled, the [Update Firmware] menu is displayed on the [Register/Update Software] screen of the [Settings/Registration] menu.

■ Firmware Update Procedure

● UGW-linked Download and Update (Full-remote Update)

The procedure for updating the firmware using "UGW-linked Download and Update" is described below.

1. The firmware distribution schedule to the certain device should be set on UGW.

CAUTION:

See "UGW-linked Download and Update" in Operation Manual of Content Delivery System for Firmware Distribution for details.

The device checks the schedule concerned every 12 hours on UGW. This allows the device to register the firmware distribution setting, enabling automatic firmware download and update.

CAUTION:

[Device without the function to wait for job completion]

- Explain to the user in advance that a job cannot be accepted during firmware update. Also, it is recommended to execute the operation during the period of time when no print job is accepted.

[Device with the function to wait for job completion]

- When the following jobs exist at the time of firmware update, firmware update processing is not executed until job completion. (When the firmware update processing is not executed more than 10 minutes, it will be timeout error.)
 - Printing
 - I-FAX

NOTE:

To contacts registered for E-mail notification on UGW, the E-mail is sent from UGW upon completing firmware update.

● UGW-linked Download (Remote Distribution Update)

The procedure for updating the firmware using "UGW-linked download" is described below.

1. The firmware distribution schedule to the certain device should be set on UGW.

NOTE:

See "UGW-linked Download" in Operation Manual of Content Delivery System (for Firmware Distribution) for details.

2. When using the Control Panel, execute the following service mode to update the firmware downloaded to the device using the Updater function.

- SERVICE MODE > F/W UPDATE GR. > CDS

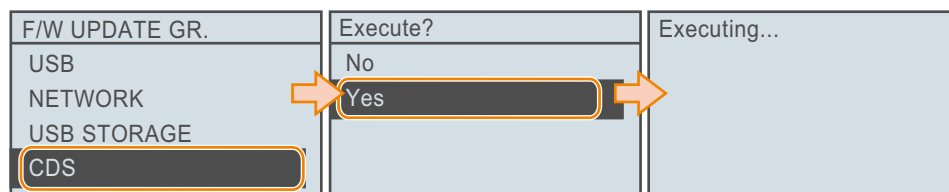

CAUTION:

When using the [Register/Update Software] screen of the Remote UI, click [Apply Firmware] in [Delivered Update].

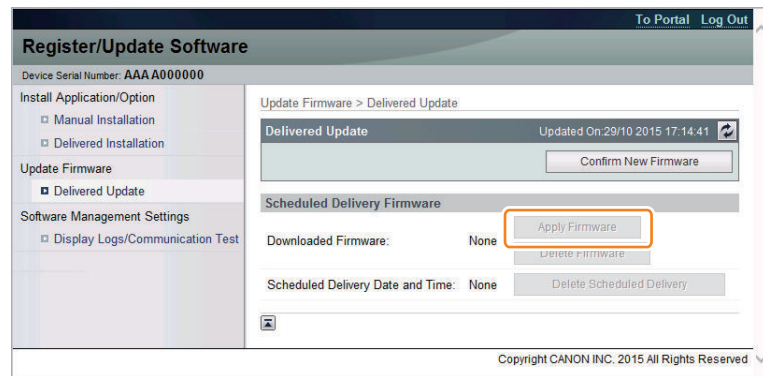

Example of Using the Remote UI

This machine is automatically restarted when the update processing is complete.

■ Updater Function Maintenance

● Checking Logs

If an error occurs when upgrading the firmware using the Updater, a log can be checked on the [Register/Update Software] screen of the Remote UI.

There are two types of logs; update logs and system logs.

Update log

A log regarding installation of system options/MEAP applications and firmware updates.

System log

The system log of this machine. Records all operations.

The procedure for checking a log is described below.

1. Access the following URL from the browser on a PC connected to the same network as this machine, and log in to the management screen.
 - <https://<device address>:8443/svm/>
 Confirm the password to the Support Dept. of the sales company.
2. Select [Display Logs/Communication Test], select [Update Logs] or [System Logs] in the Log View, and click [Switch].

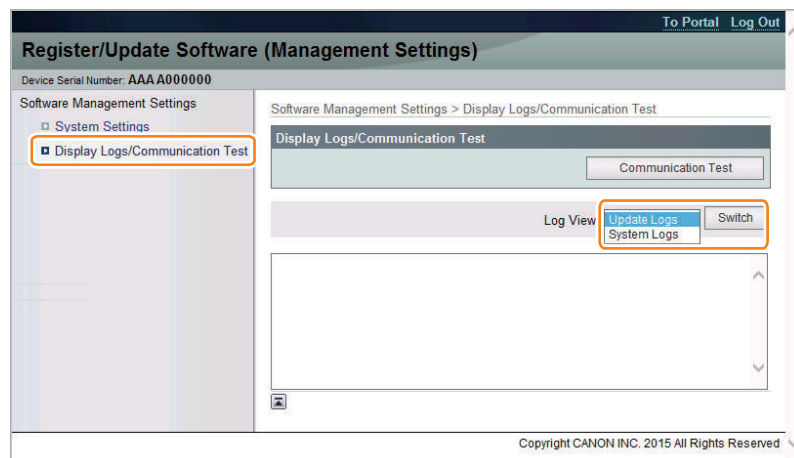

3. Check the log displayed in the log display area.

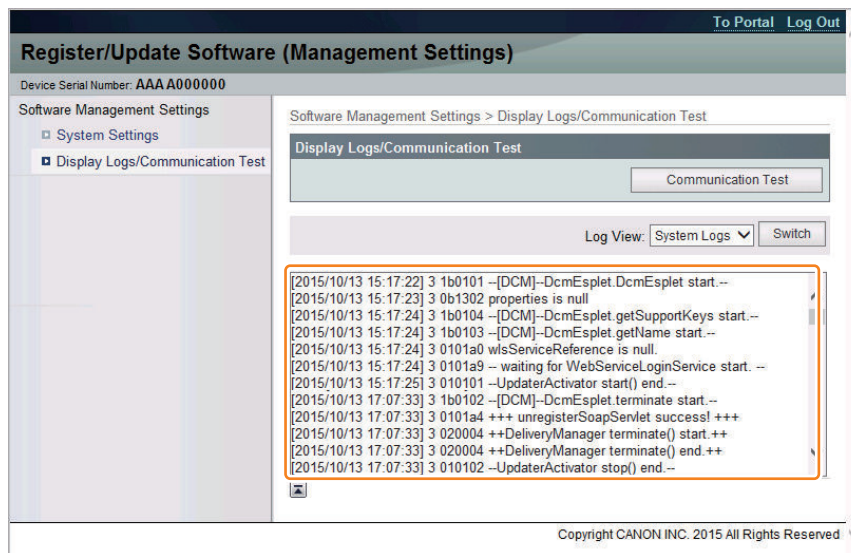

CAUTION:

To escalate the content of the log, copy the full text of the log and paste it in a text editor such as Notepad, then save it.

• Management of [Register/Update Software]

The [Register/Update Software] menu enables you to apply and delete firmware downloaded to this machine. When distribution is scheduled by linking with UGW, those schedules can also be deleted.

Applying Downloaded Firmware

This section describes the procedure for applying firmware downloaded to this machine.

When there is downloaded firmware in this machine, the [Update Firmware] button in the [Delivered Update] menu is activated.

1. Access [Register/Update Software] in the Remote UI, and select [Delivered Update].
2. Press the [Apply Firmware] button.
3. Check the downloaded firmware, and press the [Yes] button.

The processing for applying the firmware starts, and the device is automatically restarted when the processing is complete.

4. Output [Status Print] to check whether the firmware was upgraded correctly.

1. Press the [Utility Menu] key on the Control Panel.
2. Select [Status Print].
3. Select [Yes] when the message confirming whether you want to execute the operation is displayed.

Applying Downloaded Firmware

This section describes the procedure for deleting firmware downloaded to this machine.

When there is downloaded firmware in this machine, the [Delete Firmware] button in the [Delivered Update] menu is activated.

1. Access [Register/Update Software] in the Remote UI, and select [Delivered Update].
2. Press the [Delete Firmware] button.
3. Check the downloaded firmware, and press the [Yes] button.

The processing for deleting the firmware starts.

4. Confirm that the [Delete Firmware] button is grayed out and deactivated.

Deleting a Scheduled Distribution Date/Time

This section describes the procedure for deleting a scheduled distribution date/time set in this machine.

The [Scheduled Delivery Date and Time:] button in the [Delivered Update] menu is activated when a scheduled firmware distribution date/time is set in this machine by linking with a UGW server.

1. Access [Register/Update Software] in the Remote UI, and select [Delivered Update].

2. Press the [Delete Scheduled Delivery] button.
3. Check the scheduled distribution date/time, and press the [Yes] button.
The processing for deleting the scheduled distribution date/time starts.
4. Confirm that the [Delete Scheduled Delivery] button is grayed out and deactivated.

● Other Maintenance

Migrating Setting Information

In the following cases, the settings of the Updater function must be configured again because they cannot be migrated. For the detailed procedure, refer to "Preparation" on page 67.

- When replacing the Main Controller PCB including the SRAM
- When replacing this machine due to failure or when a lease is up

Upgrading the Updater

The Updater function is a part of the machine firmware. Therefore, the Updater function is also upgraded when the firmware of the machine is upgraded. When the machine firmware is upgraded, the setting information and logs (update logs and system logs) of the Updater function are migrated.

■ Error Messages of Updater Function

This section describes the error codes and error messages output by the Updater function.

● Updater Error Messages

Error messages displayed in Remote UI are shown below. As to error codes, see the next list.

No.	Messages	Timing of display	Cause	Remedy
1	An error occurred with the delivery server. Contact your sales representative. Error Code: [xxx]	In communicating with the delivery server.	System error occurred in server.	Obtain the log etc. (Refer to "System Management Operations" under "Version Upgrade" of "Updater" in "Troubleshooting" of this manual.) and contact Support Div. of the sales company.
2	Delivery server is stopped. Wait a while and then try to perform the operation again. Check the following URL for details. <Stopped Delivery Server URL>	In communicating with the delivery server.	Delivery server stopped.	Check the delivery server stop information. After the delivery server starts, perform the operation from this application. When the delivery server stop information is not available, contact the sales company's Support Department.
3	Failed to connect to delivery server. Check the delivery server and network.	In communicating with the delivery server.	Communication error due to incorrect settings of CDS URL.	Set correct CDS URL in the Updater settings.
			Excluding delivery server stop, communication error to the delivery server occurred.	Check if the network environment is correct to solve the cause of the error occurrence. If the network environment of the device is correct, obtain the log etc. (Refer to "System Management Operations" under "Version Upgrade" of "Updater" in "Troubleshooting" of this manual.) and contact Support Div. of the sales company.
4	Download was stopped because an error occurred with the file server. Check the network.	At the time of file download	Communication error to the delivery server occurred.	Check if the network environment is correct to solve the cause of the error occurrence. If the network environment of the device is correct, obtain the log etc. (Refer to "System Management Operations" under "Version Upgrade" of "Updater" in "Troubleshooting" of this manual.) and contact Support Div. of the sales company.

No.	Messages	Timing of display	Cause	Remedy
5	Downloaded files are invalid. Check the network.	At the time of file download	The received file is broken.	After checking the network environment of the device, re-execute the job. If it recurs, obtain the log etc. (Refer to "System Management Operations" under "Version Upgrade" of "Updater" in "Troubleshooting" of this manual.) and contact Support Div. of the sales company.
6	Failed to retrieve information of special firmware. Check the retrieval ID and password.	Acquisition of applicable firmware information	No information exists about firmware for special firmware retrieval ID or Password is invalid.	Enter the correct firmware ID or Password applicable to the firmware information. If it recurs, obtain the log etc. (Refer to "System Management Operations" under "Version Upgrade" of "Updater" in "Troubleshooting" of this manual.) and contact Support Div. of the sales company.
7	Scheduled delivery information of firmware does not exist. Check it because it may already have been deleted.	Acquisition of applicable firmware information	Delivery information with specified delivery ID does not exist.	Register the delivery schedule again. If this occurs at the time of canceling file download, deleting downloaded firmware or deleting scheduled delivery, no remedy is required.
8	Failed to apply firmware.	Firmware application error	Error due to the application (NLM)	Obtain the log etc. (Refer to "System Management Operations" under "Version Upgrade" of "Updater" in "Troubleshooting" of this manual.) and contact Support Div. of the sales company.
9	Delivery Server : Connect Failed File Server : Retrieve Failed Error Code: [xxxx]	Communication test, etc. (communication test result dialogue)	In the communication test, failed to connect to the delivery server. In SOAP communication, failed to success after 1 min retry.	Check the network environment of the device, and re-execute the job. If it recurs, obtain the log etc. (Refer to "System Management Operations" under "Version Upgrade" of "Updater" in "Troubleshooting" of this manual.) and contact Support Div. of the sales company.
			ID and Password required for proxy to connect to the internet are not configured in device.	Set proxy and restart the communication test. If it recurs, obtain the log etc. (Refer to "System Management Operations" under "Version Upgrade" of "Updater" in "Troubleshooting" of this manual.) and contact Support Div. of the sales company.
			The access to the network is limited.	Set the user environment to make the access to the following domain available. https://device.cdsknn.net/ http://cdsknn.net.edgesuite.net/ If it recurs, obtain the log etc. (Refer to "System Management Operations" under "Version Upgrade" of "Updater" in "Troubleshooting" of this manual.) and contact Support Div. of the sales company.
			Delivery server stopped.	Contact Field Support Group in the sale company. After confirmation that the delivery server has been restored, restart the communication test. If it recurs, obtain the log etc. (Refer to "System Management Operations" under "Version Upgrade" of "Updater" in "Troubleshooting" of this manual.) and contact Support Div. of the sales company again.
10	Delivery Server : Connect OK File Server : Retrieve Failed Error Code: [xxxx]	Delivery Server : Connect OK File Server : Retrieve Failed Error Code: [XXXX]	Due to no return of data for the communication test, time-out (in HTTP communication, no response for 1min) occurred. After that, retried but failed to connect to server.	Check the network environment of the device and re-execute the job. If it recurs, obtain the log etc. (Refer to "System Management Operations" under "Version Upgrade" of "Updater" in "Troubleshooting" of this manual.) and contact Support Div. of the sales company.
			The network cable was disconnected during data download in the communication test.	Reconnect the network cable and then restart the communication test. If it recurs, obtain the log etc. (Refer to "System Management Operations" under "Version Upgrade" of "Updater" in "Troubleshooting" of this manual.) and contact Support Div. of the sales company.

No.	Messages	Timing of display	Cause	Remedy	
10	Delivery Server : Connect OK File Server : Retrieve Failed Error Code: [xxxx]	Delivery Server : Connect OK File Server : Retrieve Failed Error Code: [XXXX]	The file server stopped during data download in the communication test.	Contact the sales company's Support Department. After confirmation that the delivery server has been restored, restart the communication test. If it recurs, obtain the log etc. (Refer to "System Management Operations" under "Version Upgrade" of "Updater" in "Troubleshooting" of this manual.) and contact Support Div. of the sales company again.	
			Hash value in the communication test file is incorrect.	Check the network environment and re-execute the job. If it recurs, obtain the log etc. (Refer to "System Management Operations" under "Version Upgrade" of "Updater" in "Troubleshooting" of this manual.) and contact Support Div. of the sales company.	
11	An error occurred. Error Code: [xxx]	communication test, etc. (main screen)	The max value (space/file) was exceeded and new log was not accepted. Normally an old log file is deleted before the max value (space/file) is exceeded, but error may occur due to other element (e.g. I/O error).	Check if the log file exceeded the max value. <Update log> Max space: 128KB/file Max file number: 4 <System log> Max space: 512KB/file Max file number: 4 If it recurs, obtain the log etc. (Refer to "System Management Operations" under "Version Upgrade" of "Updater" in "Troubleshooting" of this manual.) and contact Support Div. of the sales company.	
			Notice of version information (main screen)	Failed to acquire version information of device due to no CDS registration of firmware version of device.	Re-execute the job. If it recurs, obtain the log etc. (Refer to "System Management Operations" under "Version Upgrade" of "Updater" in "Troubleshooting" of this manual.) and contact Support Div. of the sales company.
			At the time of notifying version information, failed to connect to the delivery server.	No return of notifying version information	Check if the network environment is correct to solve the cause of the error occurrence. If the network environment of the device is correct, obtain the log etc. (Refer to "System Management Operations" under "Version Upgrade" of "Updater" in "Troubleshooting" of this manual.) and contact Support Div. of the sales company.
			Network cable was disconnected during notice of version information.		Re-connect the network cable and re-execute the job. If it recurs, obtain the log etc. (Refer to "System Management Operations" under "Version Upgrade" of "Updater" in "Troubleshooting" of this manual.) and contact Support Div. of the sales company.
			Failed to send notice of version information since the main power was turned OFF and then ON during the sending.	Re-execute the job. If it recurs, obtain the log etc. (Refer to "System Management Operations" under "Version Upgrade" of "Updater" in "Troubleshooting" of this manual.) and contact Support Div. of the sales company.	
			Server stopped at the time of sending notice of version information.	Check the network environment of the device and re-execute the job. If it recurs, obtain the log etc. (Refer to "System Management Operations" under "Version Upgrade" of "Updater" in "Troubleshooting" of this manual.) and contact Support Div. of the sales company.	
			An internal error occurred at the time of sending notice of version information.	Obtain the log etc. (Refer to "System Management Operations" under "Version Upgrade" of "Updater" in "Troubleshooting" of this manual.) and contact Support Div. of the sales company.	
			UGW linkage (main screen)	UGW linkage was turned ON when eRDS was OFF.	For a device using eRDS, turn ON the eRDS. For a device not using eRDS, turn OFF the UGW linkage. If it recurs, obtain the log etc. (Refer to "System Management Operations" under "Version Upgrade" of "Updater" in "Troubleshooting" of this manual.) and contact Support Div. of the sales company.
11	An error occurred. Error Code: [xxx]	UGW linkage (main screen)	UGW linkage was turned ON when eRDS was OFF.	For a device using eRDS, turn ON the eRDS. For a device not using eRDS, turn OFF the UGW linkage. If it recurs, obtain the log etc. (Refer to "System Management Operations" under "Version Upgrade" of "Updater" in "Troubleshooting" of this manual.) and contact Support Div. of the sales company.	

No.	Messages	Timing of display	Cause	Remedy
11	An error occurred. Error Code: [xxx]	UGW linkage (main screen)	An internal error occurred at the time of acquiring delivery information.	Re-execute the job. If it recurs, obtain the log etc. (Refer to "System Management Operations" under "Version Upgrade" of "Updater" in "Troubleshooting" of this manual.) and contact Support Div. of the sales company.
		On-site (error dialogue)	An internal error occurred at the time of acquiring applicable firmware information.	Re-execute the job. If it recurs, obtain the log etc. (Refer to "System Management Operations" under "Version Upgrade" of "Updater" in "Troubleshooting" of this manual.) and contact Support Div. of the sales company.
			An internal error occurred at the time of sending approval information.	Re-execute the job. If it recurs, obtain the log etc. (Refer to "System Management Operations" under "Version Upgrade" of "Updater" in "Troubleshooting" of this manual.) and contact Support Div. of the sales company.
			An internal error occurred at the time of delivery order	Re-execute the job. If it recurs, obtain the log etc. (Refer to "System Management Operations" under "Version Upgrade" of "Updater" in "Troubleshooting" of this manual.) and contact Support Div. of the sales company.
		Immediate download (error dialogue)	An internal error occurred at the time of requesting firmware delivery information.	Re-execute the job. If it recurs, obtain the log etc. (Refer to "System Management Operations" under "Version Upgrade" of "Updater" in "Troubleshooting" of this manual.) and contact Support Div. of the sales company.
			During the download, all space in the storage disk was occupied. (DiskFull)	After adding vacant space of the storage disk, re-execute the job. If it recurs, obtain the log etc. (Refer to "System Management Operations" under "Version Upgrade" of "Updater" in "Troubleshooting" of this manual.) and contact Support Div. of the sales company.
			At the end of receipt, an internal error occurred.	Re-execute the job. If it recurs, obtain the log etc. (Refer to "System Management Operations" under "Version Upgrade" of "Updater" in "Troubleshooting" of this manual.) and contact Support Div. of the sales company.
		Manual update (error dialogue)	At the update start, an internal error occurred.	Re-execute the job. If it recurs, obtain the log etc. (Refer to "System Management Operations" under "Version Upgrade" of "Updater" in "Troubleshooting" of this manual.) and contact Support Div. of the sales company
		Automatic update (error dialogue)	At the update start, an internal error occurred.	Re-execute the job. If it recurs, obtain the log etc. (Refer to "System Management Operations" under "Version Upgrade" of "Updater" in "Troubleshooting" of this manual.) and contact Support Div. of the sales company.
		Deletion of downloaded firmware	At the time of notifying cancellation, an internal error occurred.	Re-execute the job. If it recurs, obtain the log etc. (Refer to "System Management Operations" under "Version Upgrade" of "Updater" in "Troubleshooting" of this manual.) and contact Support Div. of the sales company.
12	An error occurred. Check the Update Firmware screen.	UGW linkage (main screen)	eRDS sent an order but Updater failed to connect to server.	Conduct a communication test to analyze the cause of the error. After solving the cause, resend the order from the eRDS. If it recurs, obtain the log etc. (Refer to "System Management Operations" under "Version Upgrade" of "Updater" in "Troubleshooting" of this manual.) and contact Support Div. of the sales company.

No.	Messages	Timing of display	Cause	Remedy
12	An error occurred. Check the Update Firmware screen.	UGW linkage (main screen)	Delivery server stopped.	Contact the sales company's Support Department. After confirming restoration of the delivery server, re-execute the job. If it recurs, obtain the log etc. (Refer to "System Management Operations" under "Version Upgrade" of "Updater" in "Troubleshooting" of this manual.) and contact Support Div. of the sales company.
			Scheduled date and time acquired from the delivery server was before current time (15 or more min had passed.)	Do the delivery setting from UGW again. If it recurs, obtain the log etc. (Refer to "System Management Operations" under "Version Upgrade" of "Updater" in "Troubleshooting" of this manual.) and contact Support Div. of the sales company.
			Scheduled data and time acquired from the delivery server did not exist.	Do the delivery setting from UGW again. If it recurs, obtain the log etc. (Refer to "System Management Operations" under "Version Upgrade" of "Updater" in "Troubleshooting" of this manual.) and contact Support Div. of the sales company.
		Immediate download (main screen)	At the time of immediate download, turned OFF and then ON the power of device main body.	Re-execute the job. If it recurs, obtain the log etc. (Refer to "System Management Operations" under "Version Upgrade" of "Updater" in "Troubleshooting" of this manual.) and contact Support Div. of the sales company.
		Manual update (main screen) Automatic update (main screen)	Updated version was different from the ordered version.	Re-execute the job. If it recurs, obtain the log etc. (Refer to "System Management Operations" under "Version Upgrade" of "Updater" in "Troubleshooting" of this manual.) and contact Support Div. of the sales company.
			After the update, failed to connect to the delivery server.	Check the network environment and re-execute the job. If it recurs, obtain the log etc. (Refer to "System Management Operations" under "Version Upgrade" of "Updater" in "Troubleshooting" of this manual.) and contact Support Div. of the sales company.
			After the update, delivery server stopped.	Contact the sales company's Support Department. After confirming restoration of the delivery server, re-execute the job. If it recurs, obtain the log etc. (Refer to "System Management Operations" under "Version Upgrade" of "Updater" in "Troubleshooting" of this manual.) and contact Support Div. of the sales company.
			After the update, the network cable was disconnected.	Re-connect the network cable and re-execute the job. If it recurs, obtain the log etc. (Refer to "System Management Operations" under "Version Upgrade" of "Updater" in "Troubleshooting" of this manual.) and contact Support Div. of the sales company.
			After the update, server returned an error.	Obtain the log etc. (Refer to "System Management Operations" under "Version Upgrade" of "Updater" in "Troubleshooting" of this manual.) and contact Support Div. of the sales company.
			After the update, an internal error occurred.	If it recurs, obtain the log etc. (Refer to "System Management Operations" under "Version Upgrade" of "Updater" in "Troubleshooting" of this manual.) and contact Support Div. of the sales company.
13	Delivery Error Error Code: [xxx]	UGW linkage (Update Firmware screen)	eRDS sent an order but Updater failed to connect to the server.	Conduct a communication test to analyze the cause of the error. After solving the cause, resend the order from the eRDS. If it recurs, obtain the log etc. (Refer to "System Management Operations" under "Version Upgrade" of "Updater" in "Troubleshooting" of this manual.) and contact Support Div. of the sales company.

No.	Messages	Timing of display	Cause	Remedy
13	Delivery Error Error Code: [xxx]	UGW linkage (Update Firmware screen)	The delivery server stopped.	Contact the sales company's Support Department. After confirming restoration of the delivery server, re-execute the job. If it recurs, obtain the log etc. (Refer to "System Management Operations" under "Version Upgrade" of "Updater" in "Troubleshooting" of this manual.) and contact Support Div. of the sales company.
			The scheduled data and time acquired from delivery server does not exist.	Do the delivery setting from UGW again. If it recurs, obtain the log etc. (Refer to "System Management Operations" under "Version Upgrade" of "Updater" in "Troubleshooting" of this manual.) and contact Support Div. of the sales company.
14	Delivery Error Delivery Time Delivery Firmware Label Delivery Firmware version Error Code: [xxx]	UGW linkage (Update Firmware screen) Immediate download (Update Firmware screen)	The scheduled date and time acquired from delivery server was before current time (15 or more min had passed).	Do the delivery setting from UGW again. If it recurs, obtain the log etc. (Refer to "System Management Operations" under "Version Upgrade" of "Updater" in "Troubleshooting" of this manual.) and contact Support Div. of the sales company.
			At the time of immediate download, turned OFF and then ON the power of device main body.	Re-execute the job. If it recurs, obtain the log etc. (Refer to "System Management Operations" under "Version Upgrade" of "Updater" in "Troubleshooting" of this manual.) and contact Support Div. of the sales company.
15	Applicable firmware is not registered.	On-site (error dialogue)	At the user site, no latest firmware exists.	This means the current firmware is the latest, so this error has no impact. But when the latest firmware to be retrieved must exist e.g. released new firmware information has been notified, contact Field Support Group in the sales company.
			No applicable firmware exists on CDS, so the service person can't select any applicable firmware.	Contact the sales company's Support Department.
16	Restart failed. Turn the main power OFF and ON.	Manual update (error dialogue)	An error occurred at the time of the device restart.	After turning OFF and then ON the main power of the device, re-execute the job. If it recurs, obtain the log etc. (Refer to "System Management Operations" under "Version Upgrade" of "Updater" in "Troubleshooting" of this manual.) and contact Support Div. of the sales company.
		Automatic update (error dialogue)	An error occurred at the time of the device restart.	After turning OFF and then ON the main power of the device, re-execute the job. If it recurs, obtain the log etc. (Refer to "System Management Operations" under "Version Upgrade" of "Updater" in "Troubleshooting" of this manual.) and contact Support Div. of the sales company.
17	Specify [E-Mail Address] with up to 64 characters.	At the time of periodical update setting	The specified E-mail address exceeded 64 characters.	Specify E-mail address within 64 characters.
18	The following characters cannot be used for the [E-Mail Address]: , ; " () [] < > \	At the time of periodical update setting	The E-mail address was including the characters which could not be used.	Do not specify E-mail address with characters which cannot be used.
19	Specify [Comments] with up to 128 characters.	At the time of periodical update setting	Comments exceeded 128 characters.	Specify comments within 128 characters.
20	The [Delivery Server URL] is incorrect.	In setting with the deliver server URL.	The specified deliver server URL is wrong.	Enter the right URL(https://device.c-cdsknn.net/cds_soap/updaterif)

Backup/Restoration

Depending on the works to be done such as replacing parts, this data needs to be backed up and restored.

There are some ways to back up and restore data, and the appropriate one should be used depending on the purpose and storage destination.

This section describes the procedure for backing up and restoring service mode setting values.

For the procedure for backing up and restoring other information, refer to “[Backup Data List](#)” on page 257 in the Appendix.

Backup/Restoration Using the DCM Function

Use the DCM (Device Configuration Manager) function equipped in the machine to back up/restore the various data.

This operation can be performed from the [Settings/Registration] menu or from service mode.

The backup file can be saved in a USB flash drive or the local disk of a PC accessed via the Remote UI.

Backup/Restoration Using PCB

An Expansion ROM for servicing and the Sublog Board can be used to back up setting data from a PCB that has failed, to migrate the setting information to an unused Main Controller.

Backup/Restoration Using the DCM Function

■ Function Overview

This machine has a setting information export/import function (hereinafter referred to as DCM (Device Configuration Management function) which exports/imports the machine's setting value information as a file. The file exported/imported using the DCM function is called a DCM file, and the target setting information is as follows:

- Setting information of [Settings/ Registration]
- Setting information of service mode

The DCM file is exported to a USB flash drive or PC local disk from the Control Panel or remote UI.

The exported DCM file can be returned to the original device or imported to a different device.

When the file is returned to the original device, this can be used as a setting backup function, and when the file is imported to a different device, this can be used as a setting information migration function.

Data can also be imported to or exported from an iR-ADV machine by using iW EMC/MC DCM Plug-in.

In the case of the setting value backup function before DCM, an exported file could be imported to the same device, but the DCM function enables import of an exported file to a different device.

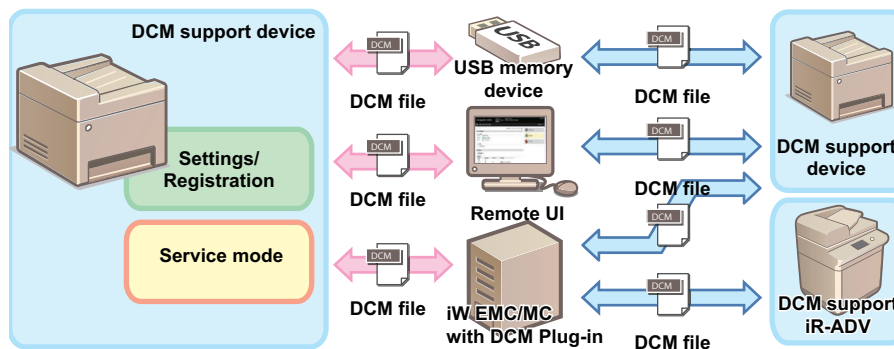

Image

NOTE:

In order to export or import setting information using DCM, it is necessary that the device supports DCM.

● Backup/Restoration for Service Technicians

Backup and Restoration from the [Settings/Registration] Menu

Setting information can be backed up and restored from the Control Panel of the device or from the [Settings/Registration] menu of remote UI.

Although the [Settings/Registration] menu is for users, the service mode settings information can be backed up and restored from the Import/Export function by changing the service mode setting.

In order to back up and restore the service mode setting information from the [Settings/Registration] menu, it is necessary to access from remote UI.

Backup/Restoration Using Service Mode

Some of the functions in service mode can be used to backup and restore data.

The setting value information and service counter values of each controller can be backed up and restored.

• Combination of Information Exported/Imported by DCM, Means, and Storage Locations

A DCM file is exported and imported using the Control Panel, remote UI, or the iW EMC server, depending on the situation of the site.

The information exported/imported differs depending on the means.

Combinations of them are shown in the following table.

Menu used	Menu used Operation	Information exported		Save destination
		Setting values of menu options	Service mode setting values	
[Settings/Registration] menu	Control panel	Yes (fixed)**1	No	USB flash drive
	Remote UI	Yes	With conditions**2	PC local disk
Service mode	Control panel	No	Yes	USB flash drive
	Remote UI	No	Yes	PC local disk

• Compatibility of Data

The following table shows compatibility of data in the case where the device from which the data is exported and the device to which the data is imported differ in model and/or serial number.

For items that are imported in Cases A, B, and C, refer to “List of Items Which Can Be Imported” on page 89.

Model	Serial number	Import process
Same	Same	Items corresponding to Case A are imported.*3
Same	Different	Items corresponding to Case B are imported.*4
Different	Different	Items corresponding to Case C are imported.*4
Different	Same	The file is judged to be invalid, and the process ends with an error.

• Limitations

Disk Size Constraints

There is no problem when exporting/importing setting information between devices of the same model, but when exchanging information between devices of a different model, it is possible for the disk capacity to be insufficient. In particular, the disk capacity may be insufficient when importing the export file from an advanced model with many setting values registered to a model with fewer functions, because the data size that can be handled by the device is exceeded. The following behavior occurs this case:

- If the disk capacity is insufficient when receiving a file to import, an error occurs before starting the import processing, and the information is not imported.
- The import processing performed until the disk capacity became insufficient remain reflected and a rollback does not occur.
- If the file to import remains in the temporary area of the controller, it is deleted.
- If the file to export remains in the temporary area of the controller, it is deleted.

*1. When the [Settings/Registration] menu is used from the Control Panel, both the setting menu information and the address book are imported/exported. It is not possible to export/import only either of them.
Information which is not included in the data to be imported is not imported.

*2. Service mode is added to the data to be exported only when service mode level 1 > COPIER > OPTION > USER > SMD-EXPT is set.

For information on items that are imported, refer to “Service Mode” on page 89.

*3. If the firmware version at the time of import differs from that at the time of export, predetermined corrective processing may be performed.

*4. Predetermined corrective processing may be performed.

■ Import/Export Procedure from [Settings/Registration] of Remote UI

This section describes the procedure for backing up and restoring service mode setting information by using the [Import/Export] function in the [Settings/Registration] menu of Remote UI.

CAUTION:

- The service mode setting information can be backed up and restored only from the [Settings/Registration] menu on Remote UI, and the operation cannot be performed from the [Settings/Registration] menu on the Control Panel.
- In the case of backing up and restoring only the setting information of the [Settings/Registration] menu or the address book, refer to the procedure described in the e-Manual (e-Manual Top page > [Managing the Printer] > [Importing and Exporting Settings]).

● Limitations

The following limitations exist when backing up and restoring the service mode settings information from the [Settings/Registrations] menu of remote UI.

A job must not be accepted during an import/export processing.

Except for the calibration requested by the engine, a job is not allowed to be accepted during a processing. In addition, import/export must not be performed during execution of a job.

Firmware must not be updated during an import/export processing.

Fax cannot be received while firmware is updated during a processing. In addition, import/export must not be performed also during firmware update.

Power must not be turned off during an import/export processing.

If power discontinuity occurs during an import processing, a rollback processing is not performed, therefore the settings imported up to that point are reflected while the rest of the settings remain as-is.

When power discontinuity occurs during an export processing, export is not executed.

● Procedure for Export Using Remote UI ([System Management Settings] Menu)

Service mode setting information can be exported from the [System Management Settings] menu by setting the following service mode setting value to "1".

1. Enter service mode, and set the following item to "1".

- SERVICE MODE > FUNCTION GR. > SMD-EXPT

The image shows two screenshots illustrating the configuration of the SMD-EXPT setting. On the left, a table shows the navigation path:

FUNCTION GR.	SMD-EXPT
ECONF	Off
Import/Export Set.	On
SMD-EXPT	
USB-H	

An arrow points from the SMD-EXPT row in the first table to the SMD-EXPT row in the second table. On the right, a screenshot of the Remote UI interface shows the 'SERVICE MODE' menu with 'FUNCTION GR.' selected. The 'FUNCTION GR. EDIT' dialog box is open, showing 'SMD-EXPT' checked and 'USB-H' unchecked. The 'MEAP' field is set to '8000' and the 'MEAP-PN' field is set to '(1-65535)'. The interface also shows a 'REBOOT' button and a 'Copyright CANON INC. 2015' notice.

NOTE:

[SMD-EXPT] setting can be specified either from the Control Panel or from the remote UI.

2. Exit service mode, start remote UI, log in as a system administrator, and then select the following item:

- [Settigs/Registration] > [Import/Export] > [Import]

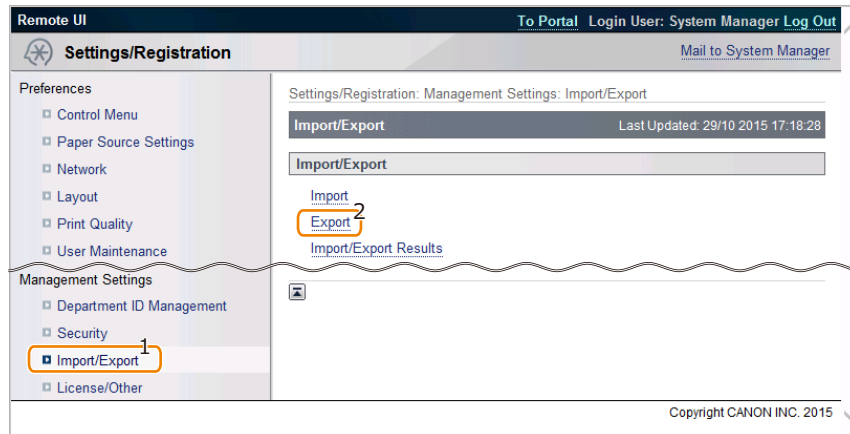

3. After confirming that [Service Mode] is displayed/selected in [Select Item to Export], enter the password and click [Start Exporting].

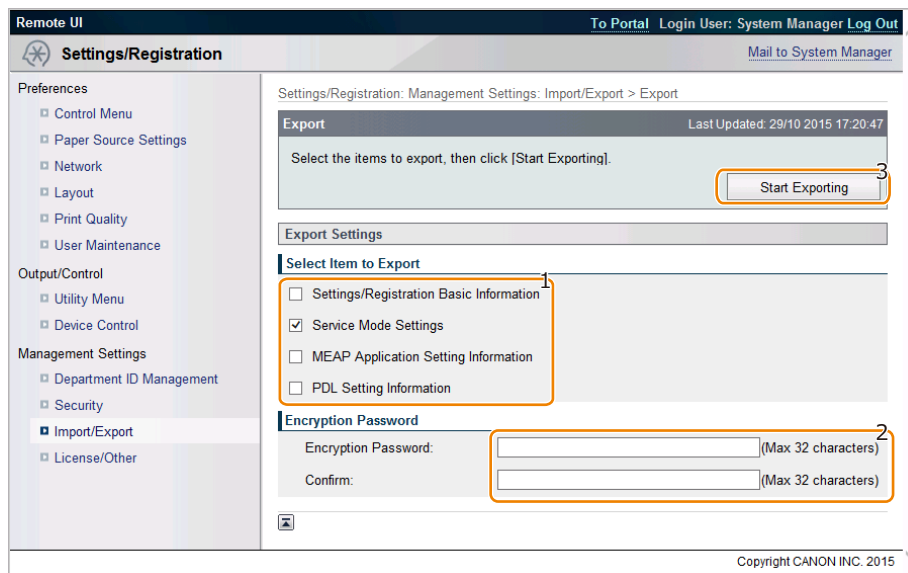

Settings/Registration Basic Information

Select this check box to export basic setting data of menu options.

Service Mode Settings

Select this check box to export various setting data of service mode.

MEAP Application Setting Information

Select this check box to export the setting information of MEAP applications.

PDL Setting Information

Select this check box to export the setting information of page description languages.

Encryption Password

Enter 32 or less numeric characters set when the file was exported.

4. The File Download dialog box will appear. Save the file to any location.

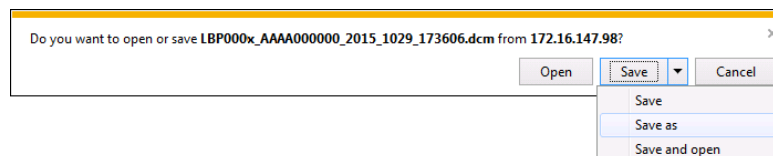

5. Enter service mode, and set the following item to "0".

- SERVICE MODE > FUNCTION GR. > SMD-EXPT

CAUTION:

Since the screen of export function can also be accessed by the user, be sure to disable the [SMD-EXPT] setting (setting value: 0).

• Procedure for Import Using Remote UI ([System Management Settings] Menu)

Import the service mode setting information file that was exported in the previous procedure.

1. Enter service mode, and set the following item to "1".

- SERVICE MODE > FUNCTION GR. > SMD-EXPT

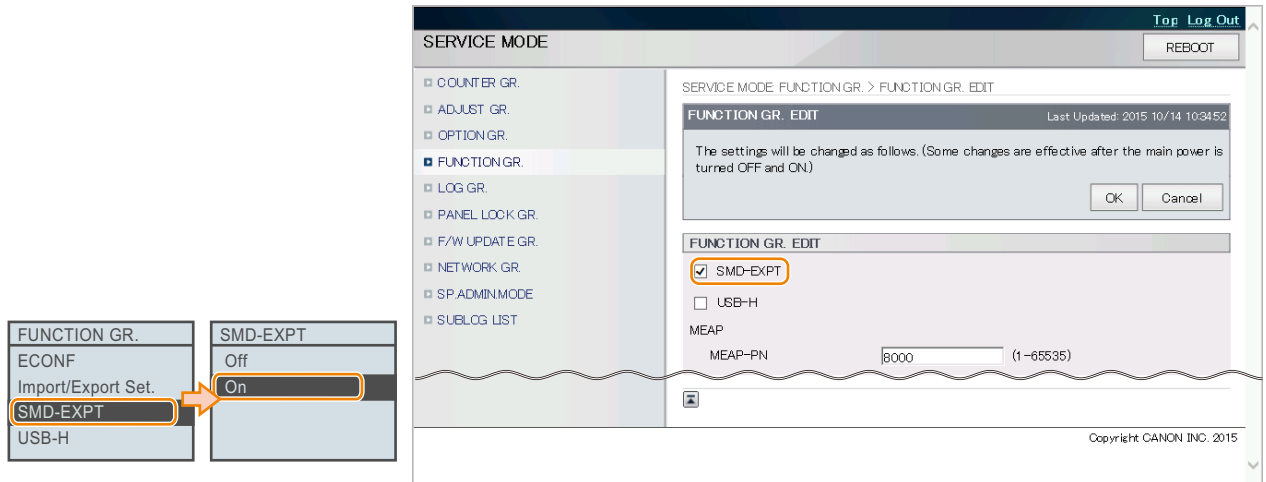

NOTE:

The [SMD-EXPT] setting can be specified either from the Control Panel or from the remote UI.

2. Exit service mode, start remote UI, log in as a system administrator, and then select the following item:

- [Settings/Registration] > [Import/Export] > [Import]

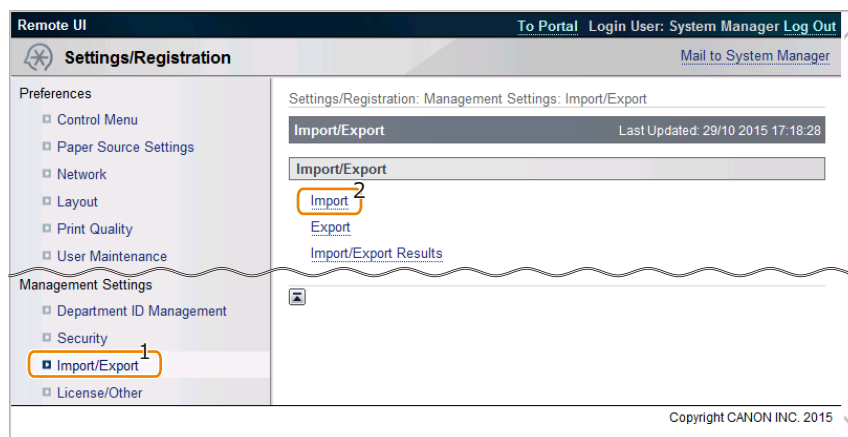

3. Configure the import setting, and click [Start Importing].

Entering the encryption password and clicking [Start Importing] imports the menu option data.

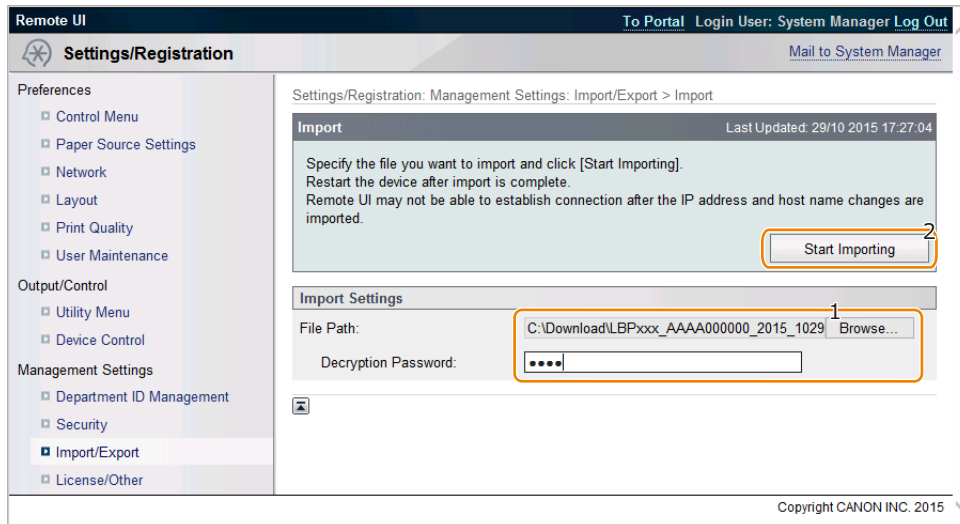

[Browse..]button

Click to select the file to import.

Decryption Password

Enter up to 32 alphanumeric characters for the password that was set when the file was exported.

4. A dialog box asking whether the user wants to execute import will appear. Click [OK].

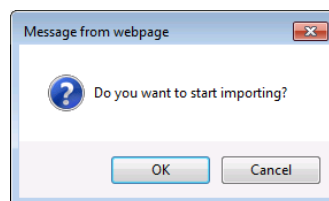

5. A message will appear to indicate that the process has been completed. Click the [OK] button.

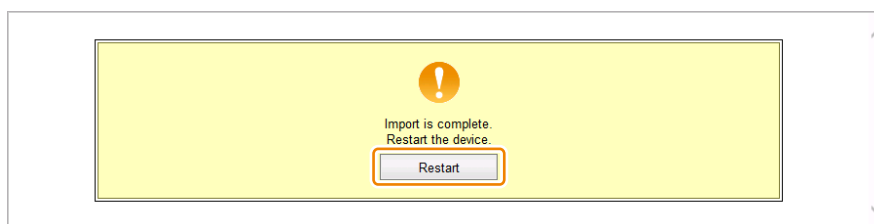

6. Restart the host machine, enter service mode, and then check that the setting information is reflected. This completes the procedure for importing a setting information file.

7. Enter service mode, and set the following item to "0".

- SERVICE MODE > FUNCTION GR. > SMD-EXPT

CAUTION:

The [SMD-EXPT] setting can be specified either from the Control Panel or from the remote UI.

■ Backup/Restoration Procedure Using Service Mode

Service mode setting information can be backed up and restored by using the [Import/Export] function in service mode.

● Procedure for Exporting to a USB Flash Drive

Use the service mode function to save the service mode setting information to a USB flash drive.

With this model, service mode can be used from the Remote UI.

The following USB flash drives can be used for export/import.

- USB flash drive in FAT 16 format (storage capacity: 2 GB)
- USB flash drive in FAT 32 format (storage capacity: 32 GB)

Note that the descriptions in parenthesis in the procedure are the descriptions in the case of remote UI.

1. Connect a USB memory device to the USB memory port.

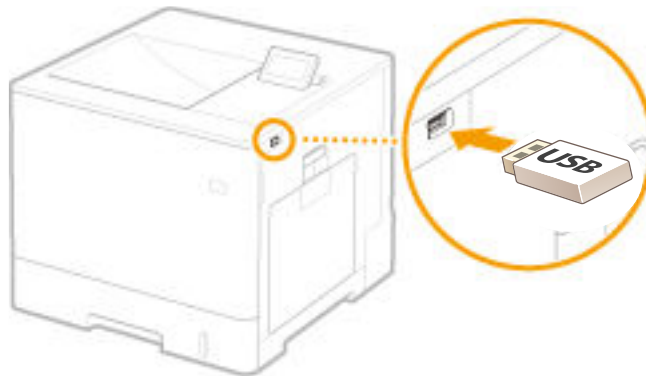

2. Enter service mode, select the following service mode, and enter the password.

- SERVICE MODE > FUNCTION GR. > Import/Export Set. > EXPORT > Password

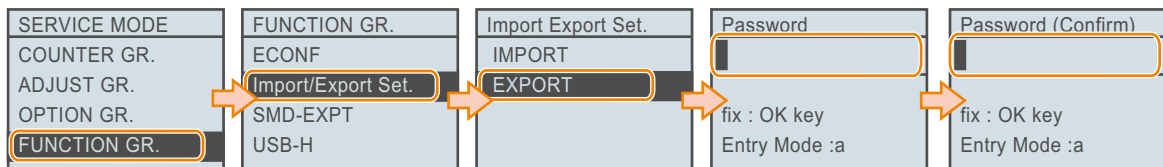

3. When the [Import Export Set.] screen is displayed after the processing is complete, press the [Application] button on the Control Panel, select [<Remove USB Memory>], and remove the USB flash drive.

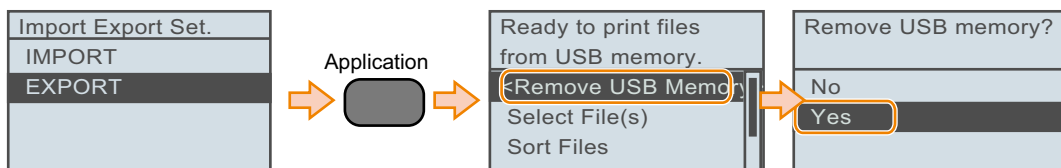

4. Check that a setting information file (".dcm" file) exists in the directory directly under the root of the USB flash drive.
This completes the procedure for exporting a setting information file.

• Procedure for Import from USB Flash Drive

Use the service mode function to import the service mode setting information.

1. Prepare a USB flash drive containing the setting information file (".dcm" file) to import.
2. Connect a USB memory device to the USB memory port.

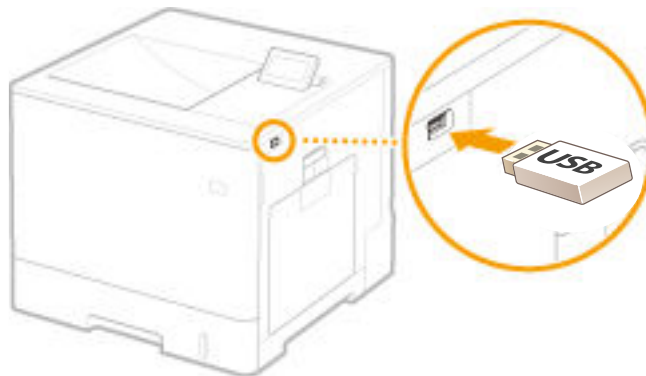

3. Access the following service mode from the Control Panel, specify the file to import, enter the encryption password, and press the [OK] key.

- SERVICE MODE > FUNCTION GR. > Import/Export Set. >IMPORT

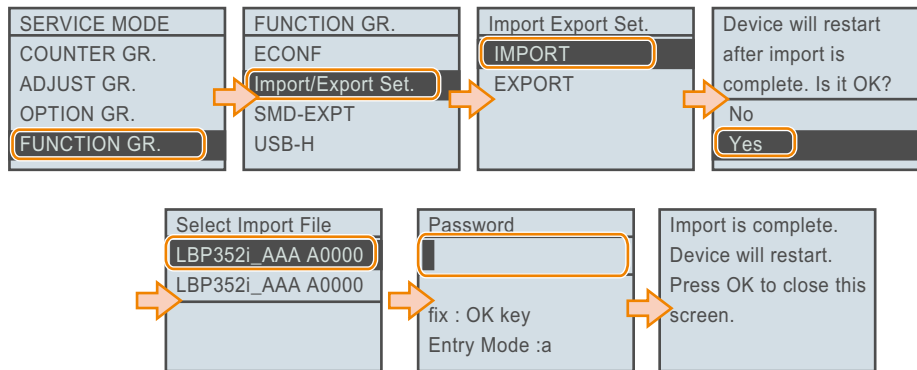

The message "Import is complete. Device will restart. Press OK to close this screen." is displayed when the processing is complete. Press the [OK] key.

4. When the machine has restarted, press the [Application] key on the Control Panel, select [<Remove USB Memory>], and remove the USB flash drive.

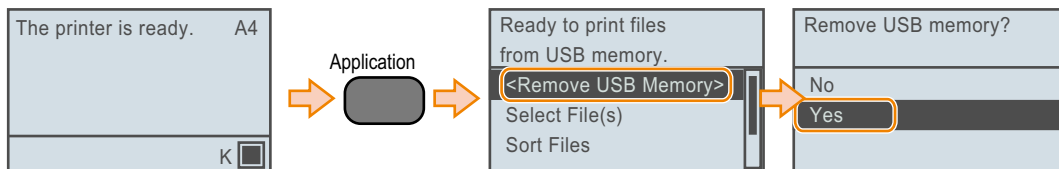

5. Restart this machine, enter service mode, and confirm that the setting information is reflected.

This completes the procedure for importing a setting information file.

• Exporting to a PC

You can export the service mode setting information by accessing from the Remote UI to use the service mode function.

1. Select the following service mode from the Remote UI service mode, enter the password, and click [Start Exporting].

- SERVICE MODE > FUNCTION GR. > Import/Export Set. > EXPORT

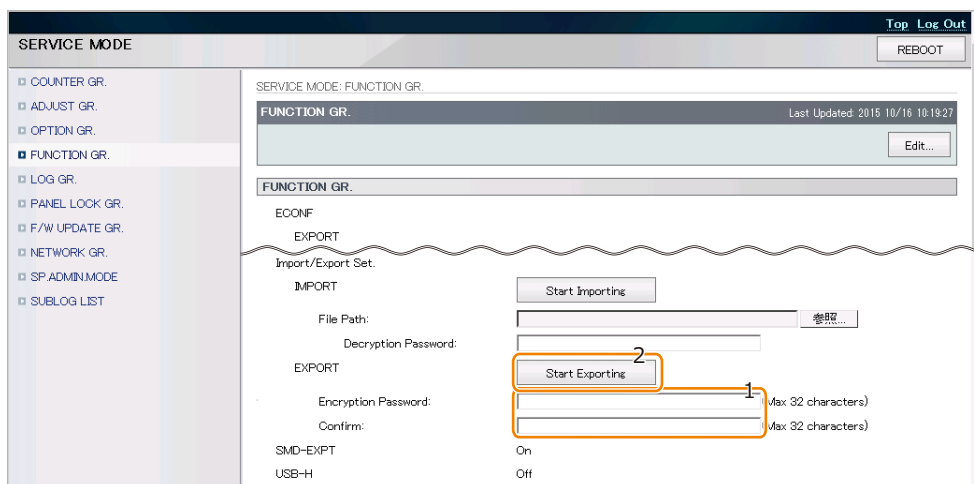

2. A dialog box for saving the file is displayed after the completion of the export processing. Select the location to save the file.

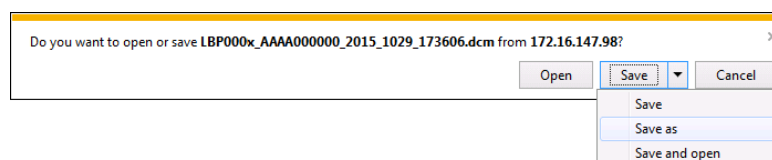

This completes the procedure for importing a setting information file.

● Procedure for Importing from a PC

1. Prepare the setting information file (".dcm" file) to import.
2. Access the following service mode in the Remote UI from a PC browser, specify the file to import, enter the encryption password, and click [Start Importing].
 - SERVICE MODE > FUNCTION GR. > Inport/Export Set. > IMPORT

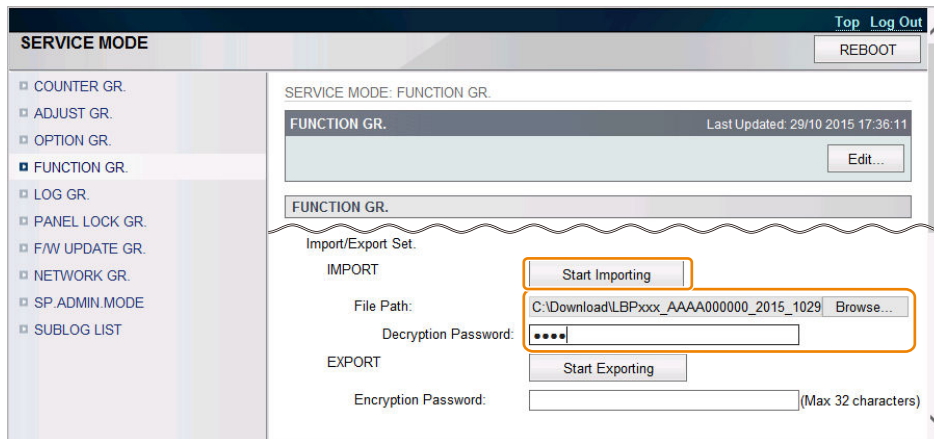

3. When the following message is displayed after the processing is complete, click [Restart].

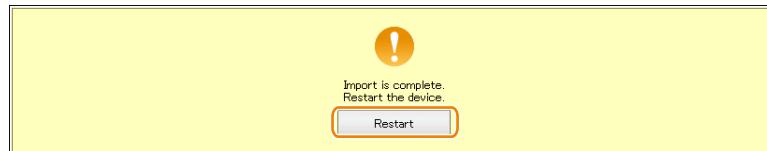

4. Restart this machine, enter service mode, and confirm that the setting information is reflected. This completes the procedure for importing a setting information file.

■ List of Items Which Can Be Imported

The following shows the items to be imported for this model.

Note that the setting values are not imported in cases such as below:

- Items which are originally not included in a DCM file (e.g.: "Settings/Registration Basic Information" of a DCM file exported using service mode)
- Not included in the import coverage (Cases A to C)
- There are no options and functions related to setting values

The import coverage shown in the table below is as shown below. Those that are not described here cannot be imported.

Import coverage	Description
Case A: The same machine	Import to the same machine (for backup and restoration, etc.)
Case B: The same model	Import to a different machine of the same model (the same series)
Case C: Different model	Import to a different machine of a different model (a different series)

● Service Mode

The service mode items that can be imported using the DCM function are described below.

Initial screen	Large	Small	Case A	Case B	Case C
ADJUST GR.					
	SPECIAL DENSITY ADJ.		Yes	-	-
	SUBTLE DENSITY CORR.		Yes	Yes	-
	LINE DENSITY ADJ.		Yes	Yes	-
	LINE DENS. EMP TURN		Yes	Yes	-
	Special Grad.Process		Yes	Yes	-
OPTION GR.					
	B4-L-CNT		Yes	Yes	-

Initial screen	Large	Small	Case A	Case B	Case C
	CRG LIFE STEP		Yes	Yes	-
	CRG LIFE STOP		Yes	Yes	-
	CHANGE CRG WARN LV		Yes	Yes	-
	SLEEP SETTINGS		Yes	Yes	-
	RMT-SW		Yes	Yes	-
	Reduce Black Spots		Yes	Yes	-
FUNCTION GR.					
	SMD-EXPT		-	-	-
	USB-H		Yes	Yes	-
	MEAP				
		MEAP FUNCTION	Yes	Yes	-
	DDNSINTY		Yes	Yes	Yes
	IPMTU		Yes	Yes	Yes
	PDL Z Logic		Yes	Yes	-
LOG GR.					
	SYSTEM LOG		Yes	Yes	-
	LOGGING UTILITY		Yes	Yes	-
	DEBUGLOG-SW		Yes	Yes	-
	DEBUGLOG-MODE		Yes	Yes	-
PANEL LOCK GR.					
	PANEL LOCK		Yes	Yes	-
NETWORK GR.					
	DNSTRANS		Yes	Yes	Yes
	JOB SERIALIZE		Yes	Yes	Yes
	BUFFER LIMIT		Yes	Yes	
	E-RDS				
		E-RDS SWITCH	Yes	Yes	Yes
		RGW-ADDRESS	Yes	Yes	Yes
		RGW-PORT	Yes	Yes	Yes
	WOLtrans		Yes	Yes	Yes
	PROXYRES		Yes	Yes	Yes
	IPSEC SETTING				
		IKERETRY	Yes	Yes	Yes
		IKEINTVL	Yes	Yes	Yes
		SPDALDEL	Yes	Yes	Yes
		IPSDEBLY	Yes	Yes	Yes
	PFW SETTING				
		ILOGKEEP	Yes	Yes	Yes
		ILOGMODE	Yes	Yes	Yes
		IPTBROAD	Yes	Yes	Yes
	EAPOL_WT		Yes	Yes	Yes
GCP-URLC		Yes	Yes	Yes	

Backup/Restoration Using a Function Other Than the DCM Function

This machine is equipped with functions other than the DCM function for migrating data to an unused Main Controller PCB when the Main Controller PCB has failed.

Backup Method

This machine is equipped with the following backup methods other than the DCM function.

Backup Method	Items which can be backed up
USB	Setting Value(USER MODE, SERVICE MODE, etc)

Backup Method	Items which can be backed up
Expansion ROM for servicing/Sublog Board	Setting Value(USER MODE, SERVICE MODE, etc) Management Data (Page Counter, Main Controller service counter, Serial No.)

■ Backup to/Restoration from a USB Flash Drive Using Service Mode

You can use service mode to back up settings information to a USB flash drive and restore data backed up to a USB flash drive, without using the DCM function.

Target Data for Backup

- [Settings/Registration] menu setting values
- Service mode setting values

● Backing Up to a USB Flash Drive

This section describes the procedure for backing up to a USB flash drive.

1. Connect the USB flash drive to the USB Memory Port of this machine.

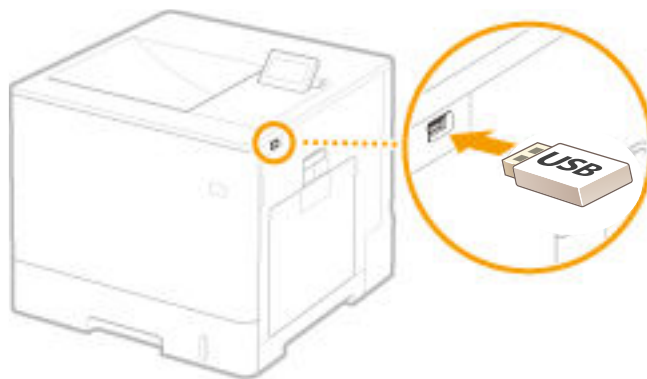

2. Execute the following service mode to export the setting values in the machine to the USB flash drive.

- SERVICE MODE > FUNCTION GR. > ECONF > EXPORT > ALL > Yes



3. Remove the USB flash drive when the previous screen is displayed again after the export processing is complete.

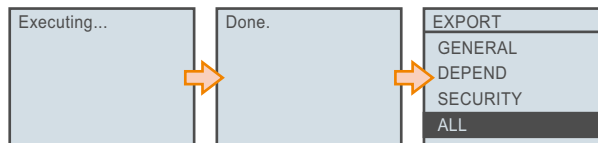

4. Check the content of the USB flash drive to confirm that the setting information file has been saved (backed up).

- <Root directory>\SETTING\CGJLALL.BIN

● Restoration from a USB Flash Drive

You can import (restore) a setting information file exported (backed up) to a USB flash drive to the host machine.

1. Connect the USB flash drive to the Memory Port.

2. Execute the following service mode to import the setting values saved in the USB flash drive to the host machine.

- SERVICE MODE > FUNCTION GR. > ECONF > IMPORT > Yes

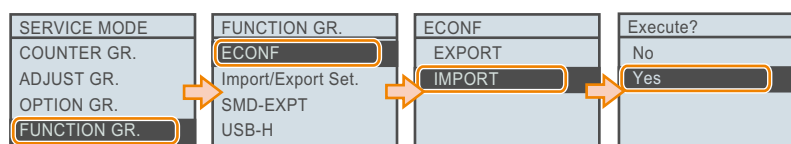

3. Remove the USB flash drive when the previous screen is displayed again after the export processing is complete.

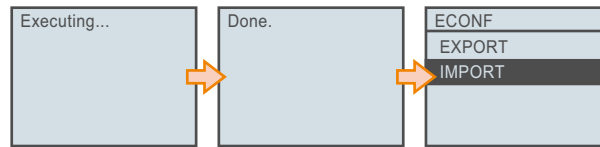

4. Access service mode and confirm that the settings are reflected.

5. Remove the USB flash drive.

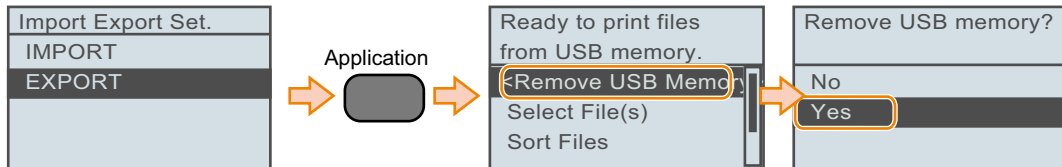

■ Backup/restoration using the Expansion ROM for servicing and the Sublog Board

Use the Expansion ROM for servicing and the Sublog Board to migrate the setting information in a failed Main Controller PCB to an unused Main Controller.

Target data for backup

Target data for backup is as follows: (For details, see [Appendix] > [Backup List] in this manual.)

- User mode setting values
- Service mode setting values

• Backup and Restoration (Export and Import) Procedure

Flow Chart

The flow of backup/restoration using the Expansion ROM for servicing and the Sublog Board is described below.

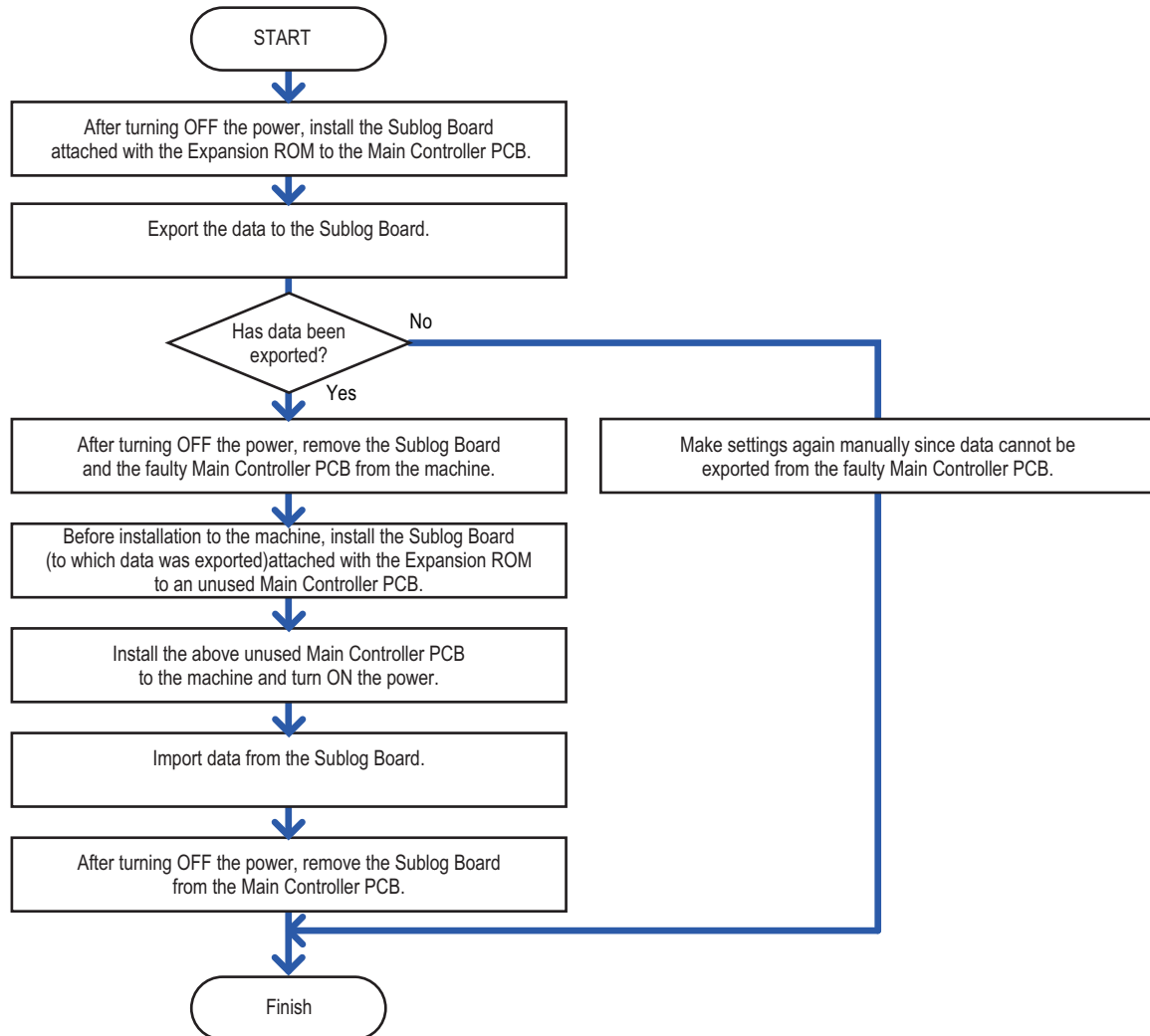

Changing the Height of the Sublog Board

NOTE:

When installing the Sublog Board, it needs to be installed parallel to the Main Controller PCB in order to prevent connection error of the connector connecting the Main Controller PCB and the Sublog Board.

This machine utilizes the height of the spacer (short), and how to replace the spacers with each other is shown below.

1. Disassemble the Sublog Board [1], and replace the spacer (short) [1] and the spacer (long) [3] with each other.

- 1 screw [4]

CAUTION:

Because the screw [4] is a molded part, do not tighten it too much. Otherwise, it may be damaged.

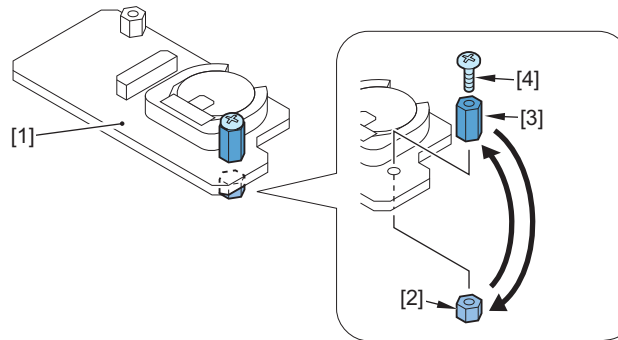

Installing the Expansion ROM for servicing and Sublog Board

1. Push SW1 on the board and confirm that LED1 turns on.

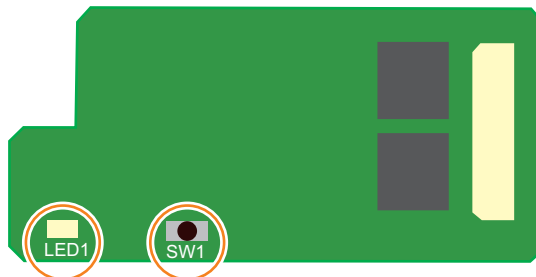

If LED1 does not turn on, You need change the battery on Sublog Board is located at BATS1 (CR2032).

CAUTION:

There is danger of explosion if the battery is replaced with an incorrect type. Replace it only with the same type of battery. Dispose of used batteries according to the manufacturer's instructions.

2. Install the Expansion ROM for servicing to the Sublog Board.

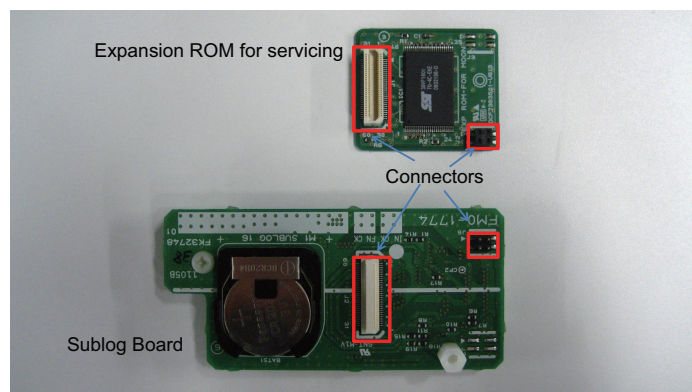

3. Install the above Sublog Board to the machine.

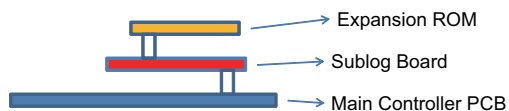
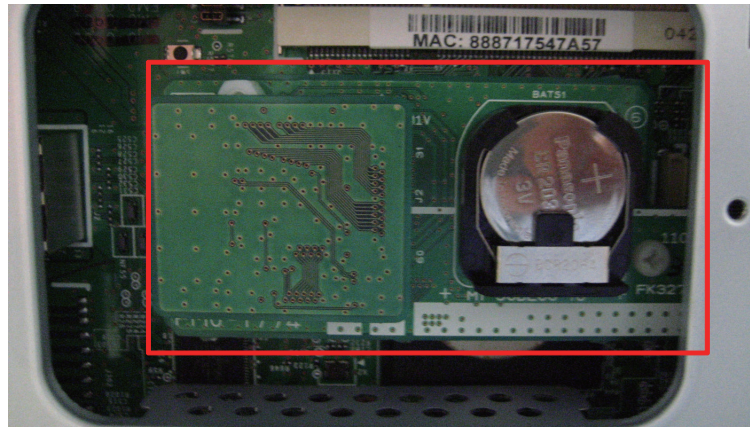

CAUTION:

Connect a PCB (Expansion ROM for servicing and Sublog Board) which has the setting information backed up, to an unused Main Controller PCB.

Be sure to connect a PCB in which the setting information is backed up (Expansion ROM for servicing and Sublog Board) when connecting to an unused Main Controller PCB.

Backup data cannot be imported to a once-used PCB. Therefore, if a PCB from which the setting information is not exported (backed up) is connected to an unused Main Controller PCB, backup data cannot be imported.

Backup Procedure (Export)

1. The menu is displayed when turning ON the power while the Sublog Board attached with the Expansion ROM for servicing is installed.



2. Press the down arrow key on the Control Panel.

This operation causes the information stored in the machine to be exported to the Sublog Board.

3. The following message is displayed when backup is completed successfully.

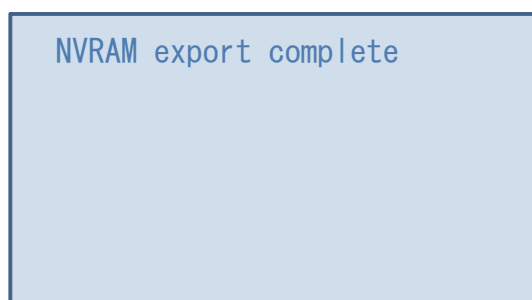

4. Turn OFF the power, and remove the faulty Main Controller PCB and the Sublog Board to which data was exported.

CAUTION:

Since data cannot be migrated to a Main Controller PCB that has been used before, connect an unused Main Controller PCB to the Sublog Board and Expansion ROM PCB where the data has been backed up (exported to) before installing it to the machine.

A Main Controller PCB that has been connected to a machine and powered ON even once becomes a used PCB.

Restoration Procedure (Import)

1. Connect the Sublog Board with the Expansion ROM for servicing which has data exported, to an unused Main Controller PCB.
2. Install the unused Main Controller PCB to the machine, and turn ON the power.
3. Perform the following operation to write the information saved in the Sublog Board back to the machine.

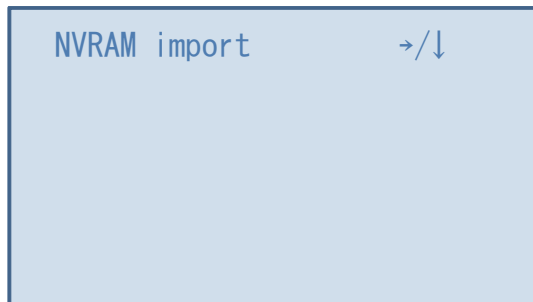

1. Press the right arrow key on the Control Panel.
2. Select [NVRAM import].
3. Press the down arrow key.

4. If the import processing completes without a problem, the data saved on the Sublog Board is deleted and the following message is displayed.

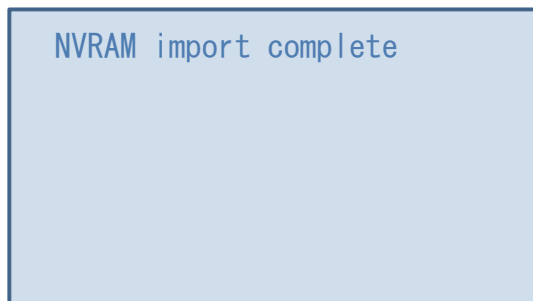
**CAUTION:**

If the Main Controller PCB has not been replaced with an unused Main Controller PCB, the following message is displayed and the operation stops. In this case, turn OFF the power, and replace the Main Controller PCB with an unused Main Controller PCB.

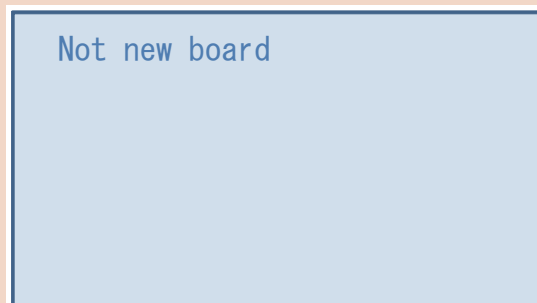

5. Turn OFF the power and remove the Sublog Board.

Deletion of unnecessary data

In case data is exported but not imported, it is strongly recommended to delete the data to prevent information leakage. The procedure to delete unnecessary data is described below.

1. Install the Sublog PCB with the Extended ROM already installed (where data to be deleted is stored) on the Main Controller PCB, and turn ON the power.
2. Select [NVRAM erase] with the right arrow key (->) on the Control Panel, and delete the information stored in the Sublog PCB.

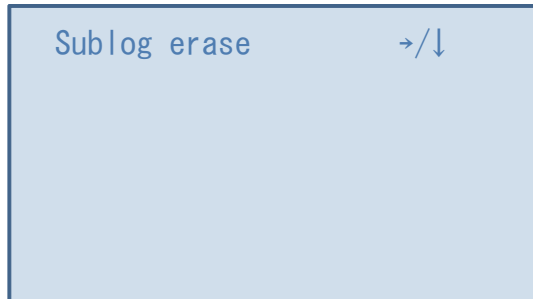

3. The following message is displayed when it is completed normally.

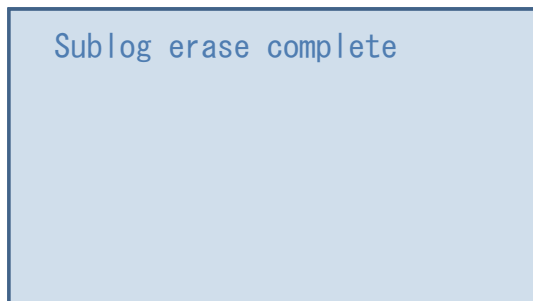

4. Turn OFF the power and remove the Sublog PCB.

Error message list

The following messages are displayed when there are some failures during operation.

Message List	Details
Sublog board not found	The Sublog PCB is not installed.
NVRAM read error	Since the faulty Main Controller PCB is damaged to the extent that information cannot be read, export is not possible.
Sublog R/W error	In case there is a fault in the Sublog PCB and the same data cannot be read three times consecutively, error is displayed and operation stops.
NVRAM write error	In case information cannot be written to the Main Controller PCB that is not used for some reasons, error is displayed and operation stops.
Sublog data not found	In case exported data is not saved to the Sublog PCB (including checksum check error), import process and erase process cannot be executed.
Not new board	Import cannot be executed since the Main Controller PCB is not an unused one or the serial number has not been written on it.
Different product	Data was attempted to be imported to a different model other than the exported model.

Monitoring Function (imageWARE Remote)

Overview of System

Function Overview

Embedded RDS (hereinafter referred to as E-RDS) is a monitoring program that runs on the host machine. When the monitoring option is enabled by making the setting on this machine, information such as the status change of the machine, counter information, and failure information are collected. The collected device information is sent to a remote maintenance server called UGW (Universal Gateway Server) via Internet, thus allowing for imageWARE Remote (Remote Diagnosis System).

The following device information/ status can be monitored:

- Billing counts
- Parts counter
- Firmware info
- Service call error log
- Jam log
- Alarm log
- Status changes (Toner low/ out, etc.)

Since high confidentiality is required for the information shown above, it performs communication between this machine and the UGW using HTTPS/ SOAP protocol.

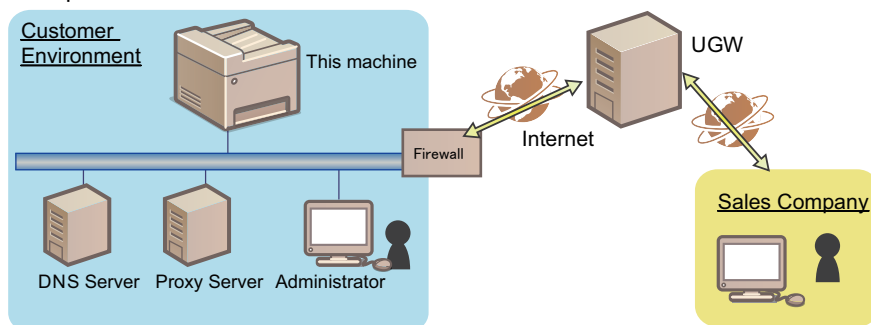

The imageWARE Remote system configuration

Features

E-RDS is embedded in the network module of the device, and the front-end module of the imageWARE Remote system is realized without requiring hardware besides the device.

Main Functions

Functional category	Sub category	Description
Communication test	COM-TEST	Execute service mode to communicate with the server, retrieve schedule information, and establish communication.
Transmission of counters	Billing / all resources / parts / mode-by-mode counters	Periodically send billing/all resources/parts/mode-by-mode counters to the server.
Transmission of event logs	Alerts	Each time the status of the device is changed, the status information is sent to the server.
	Service call/alarm/jam log *1	Each time a service call, alarm, or jam log occurs, the error log is sent to the server.
Data transmission:	ROM version	Periodically send firmware information of the device.
	Schedule	Periodically send schedule information of the device.
	Debug log	Send debug information of E-RDS which exceeds a specific size to the server.
	Environment log*1	Periodically send environment information (such as the temperature inside the machine).
	Service call button	Send error information (image failure, jams, etc.) with a user command.

*1. Only some models

Functional category	Sub category	Description
Data transmission:	Sublog	Send data such as device Sublogs and DCON logs to the server.
Operation instruction	Operation check	Contact the server to check if there is processing to be executed, and receive the following instructions if any. <ul style="list-style-type: none"> • Change the schedule • Change the alarm level • Change the alert filter

Cautions when Using E-RDS

- The following settings in service mode must not be change unless there are specific instructions to do so. Changing these values will cause error in communication with UGW.
 - Port number of UGW
SERVICE MODE > NETWORK GR. > E-RDS > RGW-PORT
Default :
- If the imageWARE Remote contract of the device is invalid, be sure to turn OFF the E-RDS setting (E-RDS: 0).
- The following restrictions apply when enabling IPv6 in the network settings.
 - If the router advertisement expires while the machine is in the sleep mode when only a stateless address is enabled, transmission will fail immediately after the machine returns from the sleep mode.
 - When only a manual address is enabled, it is necessary to set a default router address.
 - When only DHCPv6 is enabled, transmission fails because the router address is unknown.

Setting Procedure

■ Preparation

Since this function communicates with the UGW server, it is necessary to connect to the external network. Check the following items, and make the settings if not yet set.

- IP address settings
- DNS server settings
- Proxy server settings^{*1}
- Installation of CA certificate (arbitrary ^{*2})

CAUTION:

- Obtain the information on the network environment from the system administrator of the user.
- When having changed the network settings, turn OF and then ON the main power of the machine.

^{*1}. If authentication is necessary, make the settings of the authentication information as well.

^{*2}. When using a certificate other than those pre-installed in the device

■ Setting Items

Configure E-RDS in service mode. The setting items are described below.

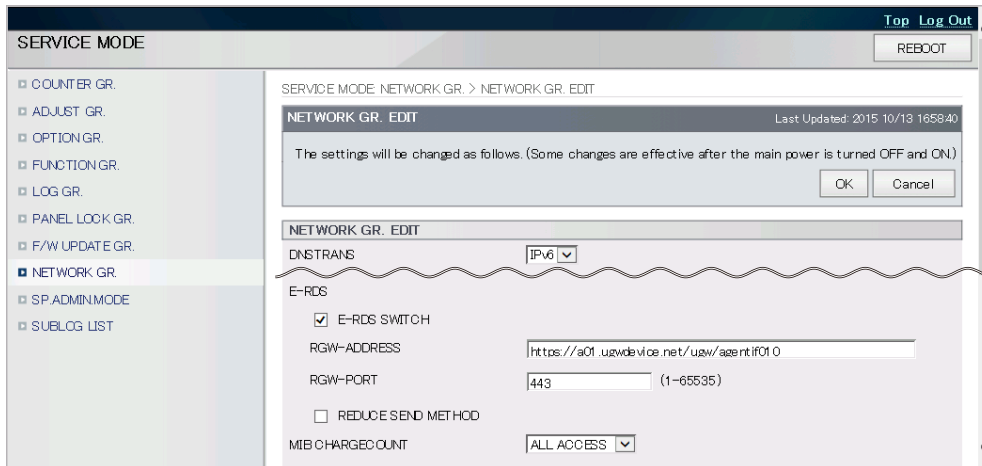

Example of the Remote UI Screen

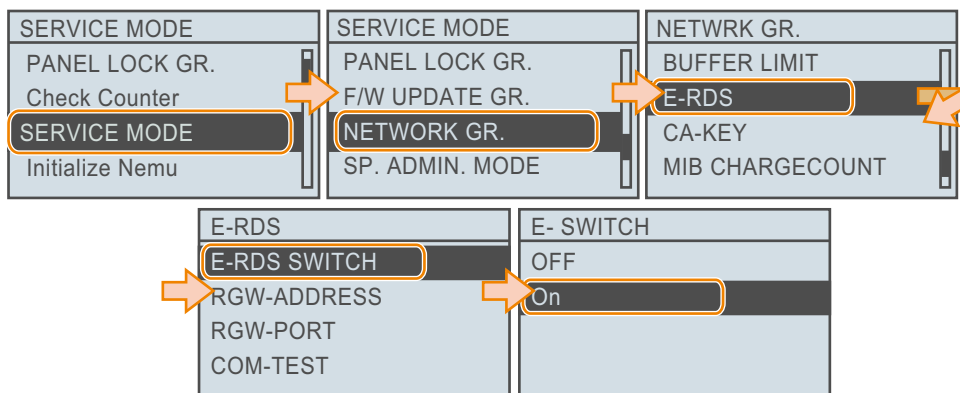

Example of the Control Panel Screen

Service mode	Description	Setting value
E-RDS SWITCH	The switch for enabling Embedded-RDS. Enables this function.	ON: Use Embedded-RDS OFF: Do not use Embedded-RDS (default value)
RGW-ADDRESS	The destination URL for the UGW server. Use the "up, down, left and right keys, Job Status/Cancel key and Feeder selection key" to enter URL, and "OK key" to determine it. "↓" is displayed at the end of the character string. The number of characters which can be entered is 128. The default value is the server URL. Characters which can be set are as follows. 0123456789ABCDEFGHIJKLMNOPQRSTUVWXYZabcdefghijklmnopqrstuvwxyz!#\$%&'()*+,-./:;<=>@[¥]_`{ }~ If "ugwdevice.net/" is not included in the character string when entering the URL, it is judged as an authentication error and an error message is displayed.	https://a01.ugwdevice.net/ugw/agentif010
RGW-PORT	The port number used when communicating with the UGW server.	443
COM-TEST	Executes a communication test with the UGW server and displays the result.	-
COM-LOG	Displays details of the communication test result. Attempts to communicate with the UGW server, and the time, error codes and error information of errors up to the present date are displayed. Maximum of 5 logs are saved, and the latest log is displayed. Error information is 130 byte maximum.	-
CLEAR	Initializes the setting values related to E-RDS. Clears the schedule information, alarm errors, and filtering information.	-

■ Procedure for Setting E-RDS

Refer to the above service mode setting items to specify the initial settings of E-RDS.

1. Open the following service mode, and confirm that the URL for accessing UGW is set correctly. If the correct URL is not set, set it.

- SERVICE MODE > NETWORK GR.> E-RDS > RGW-ADDRESS

E-RDS	RGW-ADDRESS
E-RDS SWITCH	https://a01.ugwdevice.net/u
RGW-ADDRESS	
RGW-PORT	fix : OK key
COM-TEST	Entry Mode: a

2. Open the following service mode, and confirm the port number used when communicating with the UGW server. If the correct number is not set, set it.

- SERVICE MODE > NETWORK GR.> E-RDS > RGW-PORT

E-RDS	RGW-PORT
E-RDS SWITCH	
RGW-ADDRESS	
RGW-PORT	443
COM-TEST	(1~65535)

3. Open the following service mode, and set whether to reduce transmission costs for E-RDS data when the power is turned ON.

- SERVICE MODE > NETWORK GR.> E-RDS > REDUCE SEND METHOD

4. Execute the following service mode to perform a communication test with the UGW server.

- SERVICE MODE > NETWORK GR.> E-RDS > COM-TEST

E-RDS	Execute?
E-RDS SWITCH	No
RGW-ADDRESS	Yes
EGW-PORT	
COM-TEST	

Maintenance

■ Initializing E-RDS settings

It is possible to clear the FLASH data of E-RDS and change the E-RDS setting back to the default value.

● Initialization procedure

1. Press [OK] to execute the following service mode to initialize the E-RDS settings.

- NETWORK GR. > E-RDS > CLEAR

E-RDS	Execute?
RGW-PORT	No
COM-TEST	Yes
COM-LOG	
CLEAR	

● Setting values and data to be initialized

The following E-RDS settings, internal data, and Alarm filtering information are initialized.

- SERVICE MODE > NETWORK GR. > E-RDS > E-RDS SWITCH
- SERVICE MODE > NETWORK GR. > E-RDS > RGW-PORT
- SERVICE MODE > NETWORK GR. > E-RDS > RGW-ADR
- SERVICE MODE > NETWORK GR. > E-RDS > COM-LOG

■ Communication Test

When the E-RDS function is enabled, a communication test can be conducted from the [Setup] menu of the machine's Control Panel.

1. From the [Setup] menu on the Control Panel, select the following item to conduct a communication test.

- [Setup] > [Network] > [Monitoring Service] > [Comm. Test] > [Yes]

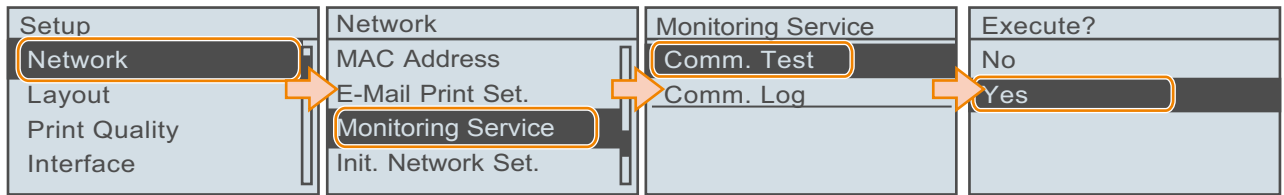

If the communication results in failure, an error code (hexadecimal number, 8 digit) is displayed on the Control Panel.

CAUTION:

- During a communication test, do not take any actions such as pressing a key. Actions are not accepted until the communication test is completed (actions are ignored).
- When a communication test is being conducted from service mode or from the [Setup] menu, do not conduct a communication test from the other. This operation is not guaranteed.

■ Checking Communication Logs

Display the details of the communication test (COM-TEST).

1. Enter service mode, and select the following item.

- NETWORK GR. > E-RDS > COM-LOG

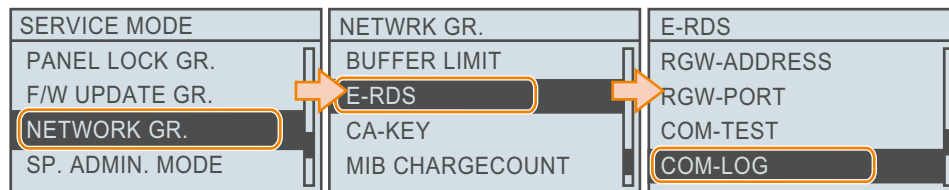

2. Select the log you want to check by pressing the up/down arrow key on the Control Panel.

COM-LOG
1 CODE: 05000003
2 CODE: 05000003
3 CODE: 05000003
4 CODE: 00000000

3. Press the left/right arrow key, and check the details of the log.

COM-LOG	COM-LOG	COM-LOG
2015 1022 15:24	SUSPEND: Communication	test is not performed.

After checking the details, exit the service mode.

● List of Detailed Information on Logs

List of detailed information displayed in COM-LOG is shown below.

Character strings	Description
Success	COM-TEST has succeeded.

Character strings	Description
URL Scheme error (not https)	URL schema specification error
Server connection error	Server connection error
URL server specified is illegal	Server-specified URL error
Proxy connection error	Proxy connection error
Proxy authentication error	Proxy authentication error
Proxy address resolution error	Proxy address resolution error
Server certificate error	Server certificate error
Server certificate verify error	Server certificate verification (URL check) error
Server certificate expired	The server certificate has expired.
Unknown error	Other communication errors
SOAP Fault	SOAP error (SOAP Fault)
Server response error (NULL)	Server reply error (when processing of the server error code failed)
Server response error ([Hex number]) [Server side detail error]	Server reply error
Device internal error	Device internal error
Server schedule is invalid	The schedule specified from the server is invalid.
Schedule is invalid	The schedule specified from the UI is invalid.
Server response time out	Server reply time-out
Service not found	The service is not found (invalid path).
E-RDS switch is setted OFF	E-RDS is not enabled.
Server schedule does not exist	The schedule does not exist.
Network is not ready, try later	The network function is not ready.
URL error	URL setting error
Server address resolution error	Server address resolution error
Operation is not supported	Unsupported operation
Communication test is not performed	Communication test has not been completed.
Server specified list is too big	The number of elements UGW server instructed to send for the alert code filter function exceeds the upper limit.
Server specified list is wrong	The information the UGW server instructed to send for the alert code/alarm code filter function is invalid.
WebDAV Server authentication error	Authentication error (Sublog transmission)
WebDAV Server connection error	Connection failed (Sublog transmission)
WebDAV Server Proxy connection error	Proxy connection error (Sublog transmission)
WebDAV Server Proxy address resolution error	Proxy address resolution error (Sublog transmission)
Data Receive error (from WebDAV Server)	Data receiving error (Sublog transmission)
WebDAV Server address resolution error	Proxy address resolution error (Sublog transmission)
Data Send error (to WebDAV Server)	Data transmission error (Sublog transmission)
WebDAV Server certificate error	Server certificate verification error (Sublog transmission)
WebDAV Server certificate expired	The server certificate has expired. (Sublog transmission)
Device internal error	Server certificate verification function error (Sublog transmission)
WebDAV Server certificate CommonName error	Server certificate CommonName verification function error (Sublog transmission)
Requested Resource in WebDAV Server is forbidden	Resource access error (Sublog transmission)
Requested Resource is not found in WebDAV Server	The requested resource has not been detected. (Sublog transmission)
WebDAV Server is short of Storage	Sufficient resource does not exist. (Sublog transmission)
WebDAV Server internal error	Server internal processing error (Sublog transmission)
Requested Resource in WebDAV Server is moved temporary	The location of the resource has been temporarily moved. (Sublog transmission)
Requested Resource in WebDAV Server is locked	The resource has been locked and cannot be operated. (Sublog transmission)
Requested Resource WebDAV Server is already exist in WebDAV Server	The requested resource already exists. (Sublog transmission)
Unknown error	Other errors (Sublog transmission)
WebDAV Server URL Scheme error (not https)	WebDAV server schema error (Sublog transmission)
WebDAV Server URL error	WebDAV server URL error (Sublog transmission)

Character strings	Description
Device internal error	Internal error (Sublog transmission)
Ethernet speed is too slow (10BASE-T)	The ethernet link speed is too slow. (Sublog transmission)
Resource error, try later	Resource error
server operation error	Server side error

MEAP Application Management

About MEAP

MEAP (Multifunctional Embedded Application Platform) is an application platform (execution platform) that allows the user to execute an application written in the Java language on a Java virtual machine installed on the device.

In this chapter, a device with MEAP is called a device supporting MEAP, and an application which runs on MEAP is called a MEAP application.

MEAP applications are installed on a MEAP device to provide various functions to the device.

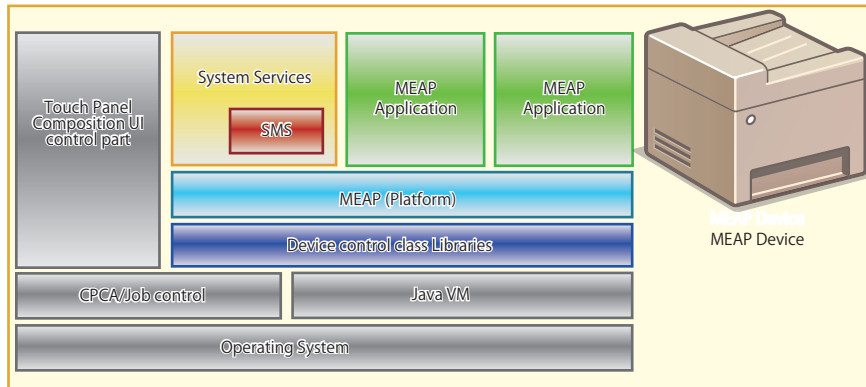

NOTE:

For basic information on MEAP, see "Function Guide for MEAP Application Management".

About SMS

MEAP has SMS (Service Management Service) as a service for managing login services and MEAP applications. SMS is a servlet-type service which is used via a PC's browser.

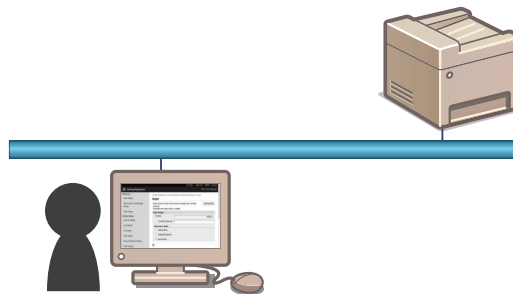

Example of the SMS screen

■ Preparation of PC for Accessing SMS

● Checking of operation environment

The PC and browser used to access SMS require the following system environment.

Combination of the Browser and the OS

OS	Supported browser
Windows XP Professional SP3	Internet Explorer 7 Internet Explorer 8
Windows Vista SP2	Internet Explorer 7 Internet Explorer 8 Internet Explorer 9
Windows 7 SP1	Internet Explorer 8 Internet Explorer 9
Windows 8	Internet Explorer 10
Mac OS X v10.5	Safari 4.0.5 Safari 5.0.5
Mac OS X v10.6	Safari 4.0.5 Safari 5.0.5 Safari 5.1
Mac OS X Lion	Safari 5.1
Mac OS X Mountain Lion	Safari 6.0

● PC and browser settings

The PC and browser used to access SMS must meet the following conditions.

- The supported browser language should be the same with the language of the OS.
- Session cookie should be enabled.
- The supported screen size should be 800 x 600 or larger (recommended size: 1024 x 768).
- Java Script should be enabled.

■ Initial Display Languages of SMS

SMS supports English and Japanese. Display language can be changed with selecting by the drop down list on a login page. The initial display language at the time of accessing SMS depends on the setting.

1. The language priority set in the browser (the settings in the Accept-Language header sent by the browser)
2. The order of the display language settings in the [Settings/Registration] menu
3. English is used if a language other than English or Japanese is set

■ Resources availability (remaining amount)

The necessary resources (free storage space and free memory available) must be secured for an MEAP application to run; otherwise, you cannot install the MEAP application.

To check the resource information, see [Resource Information] .

The screenshot displays the 'Service Management Service' interface. The left sidebar contains a navigation menu with 'MEAP Application Management' selected. The main content area shows 'MEAP Application Management' with a table of installed applications and a 'Resource Information' section. The 'Resource Information' table is highlighted with an orange border.

Application Name	Installed on	Status	License
Sample Application A	4.4.0 09/26/2012	Installed	Installed
Sample Application B	4.4.0 09/25/2012	Installed	Installed
Sample Application C	4.4.0 09/25/2012	Installed	Installed

Resource Name	Amount Used	Remaining	Percent Used
Storage	2877 KB	160963 KB	2%
Memory	200 KB	32568 KB	1%
Threads	4	144	3%
Sockets	0	128	0%
File Descriptors	1	127	1%

■ Reusable license

When reinstalling, Disable License file should be downloaded or a license for reinstallation should be obtained from LMS, before reinstallation.

This specification aims to prevent misuse of applications.

To increase convenience of users, only application with unlimited validity date and application counter (e.g. Portal Service, SDL, SSO) has been made to be able to install as many times as needed by the same license file. This kind of license is called 'Reusable license'.

Reinstallation of MEAP applications is necessary after replacing the Main PCB. In this case, it is necessary to perform installation using a reusable license.

For other MEAP applications that do not have a reusable license, use a special license for reinstallation, as when the storage drive fails.

For information on obtaining a special license for reinstallation, see ["Special license for reinstallation"](#) on page 116.

■ MEAP Application Setting Information Management and Log Management

The MEAP Application Setting Information Management page and the MEAP Application Log Management page provide menu related to "MEAP Application Configuration Service" for managing MEAP application setting information and menu related to "MEAP Application Log Service" for managing log information respectively

The screenshot displays the 'Service Management Service' interface. The left sidebar contains a navigation menu with 'MEAP Application Management' selected. The main content area shows 'MEAP Application Management' with a table of installed applications and a 'Resource Information' section. The 'MEAP Application Setting Information Management' menu item in the sidebar is highlighted with an orange border.

Application Name	Installed on	Status	License
Sample Application A	4.4.0 09/26/2012	Installed	Installed
Sample Application B	4.4.0 09/25/2012	Installed	Installed
Sample Application C	4.4.0 09/25/2012	Installed	Installed

Resource Name	Amount Used	Remaining	Percent Used
Storage	3865 KB	415975 KB	1%
Memory	200 KB	32568 KB	1%
Threads	4	144	3%
Sockets	0	128	0%
File Descriptors	1	127	1%

MEAP Application Configuration Service

This service is used to manage the MEAP application setting information. It has functions such as saving setting information to the MEAP area. Ver 57 of MEAP Specifications supports this service.

MEAP Application Log Service

This service is used to collect MEAP application logs (debug logs and authentication logs).

Ver 58 of MEAP Specifications supports this service.

The collected logs can be downloaded or deleted in user mode.

The settings such as the log level to be saved cannot be made from SMS.

These settings depend on the MEAP application. For detailed information, refer to the manual for the application.

• Advantages Obtained When Using the Services

By using MEAP Application Setting Information Management and MEAP Application Log Service, as long as the MEAP application supports these services, you can collectively perform data management tasks.

Devices and MEAP applications which do not support new functions

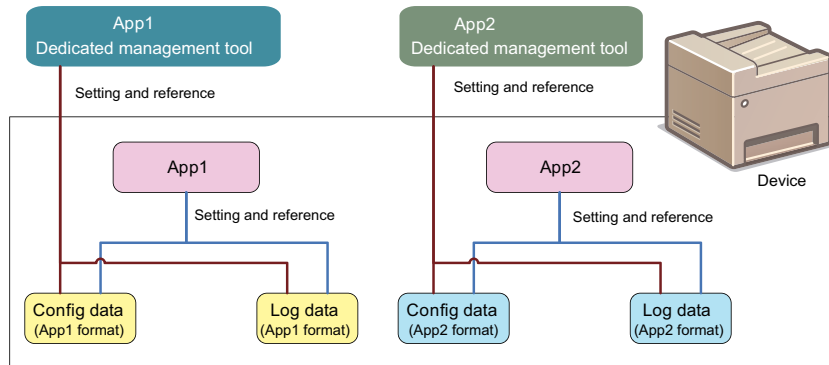

As for devices and MEAP applications that do not support the service, the setting information and log data are managed on an application-by-application basis.

Devices and MEAP applications which support new functions

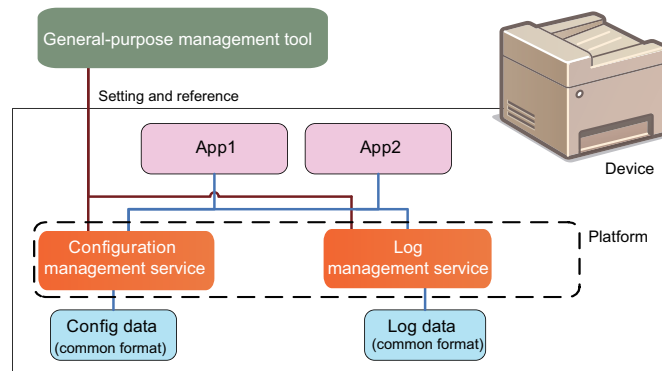

As for devices and MEAP applications that support the service, information can be collectively managed.

Setting Procedure

■ Preparation

The following settings are required on the machine to provide a MEAP device with support via a network such as SMS.

Network Settings (HTTP)

Select [Setup] > [Network] > [TCP/IP Settings] > [HTTP] from the setup menu to activate the network. ([ON] is specified at the time of shipment.) For details on the work procedure, refer to e-Manual [Top page] > [Setting Menu List] > [Setup Menu] > [Network].

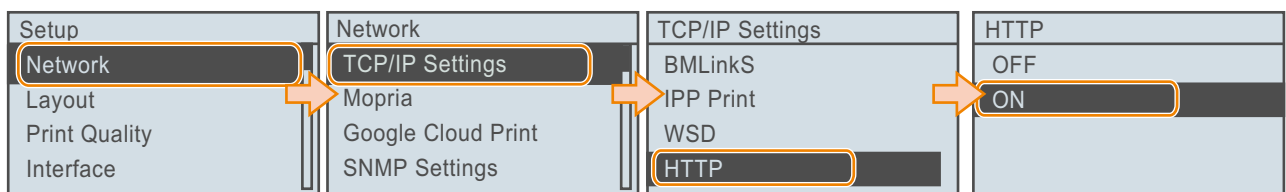

Network Settings (Remote UI)

Select [Setup] > [Network] > [Remote UI Settings] from the setup menu to activate the Remote UI function. ([ON] is specified at the time of shipment.) For details on the work procedure, refer to e-Manual [Top page] > [Setting Menu List] > [Setup Menu] > [Network].

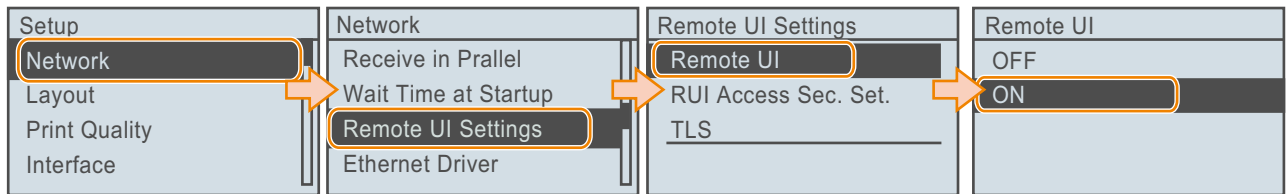

Setting the Key Pair and Server Certificate Used When Communicating with TLS Encryption

To use SMS via TLS connection, it is required to specify a key pair and server certificate as the key to be used.

Since a key (default key) that can be used for encrypted TLS communication is installed as standard on this device, advance setting of the key pair and server certificate is not required.

To use an encryption key other than the default key, refer to the e-Manual [Top page] > [Security] > [Implementing Robust Security Features] > [Using TLS for Encrypted Communications] to set the key pair and server certificate required to perform encrypted TLS communication.

NOTE:

As for SMS, by setting a Default Key, encrypted SSL communication is always executed regardless of the following setting: [Setup] > [Network] > [Remote UI Settings] > [TLS]: ON/OFF.

Setting the Network Port

The default port of the HTTP server used for MEAP and MEAP applications to provide the servlet function is 8000, and the HTTPS server's default port is 8443. In the case that these ports have already used by the customer who is to introduce this application, the MEAP application cannot use the HTTP (or HTTPS) server(s).

By changing the following ports to use, however, the MEAP application can be used as well as the existing system.

For details on the work procedure, refer to .

NOTE:

A port number can be any integer from 0 to 65535. To avoid port numbers that are frequently used, do not use any integer from 0 to 1023.

Server	Setting value	Default value / Value after RAM clear
HTTP Server	1024 to 65535	8000
HTTPS Server	1024 to 65535	8443

NOTE:

- If Print Server is connected, do not specify port 8080.
If port 8080 is specified, it is not possible to access the remote UI of the device where the MEAP authentication application is running. (Port 8080 is reserved to allow the PS Print Server Unit to redirect to the device.)
- As for port on HTTPS server, it only applies to the device that supports SSL function.

■ MEAP Application Managemet

Log in to SMS to manage MEAP applications.

Installing MEAP Applications

Install the MEAP application on this machine.

Specify an application file (.jar) and license file (.lic) on the [Install MEAP Application] page of SMS. For details on the procedure, see [Top Page] > [MEAP Application Settings] > [Installing MEAP Applications] in "Function Guide for MEAP Application Management".

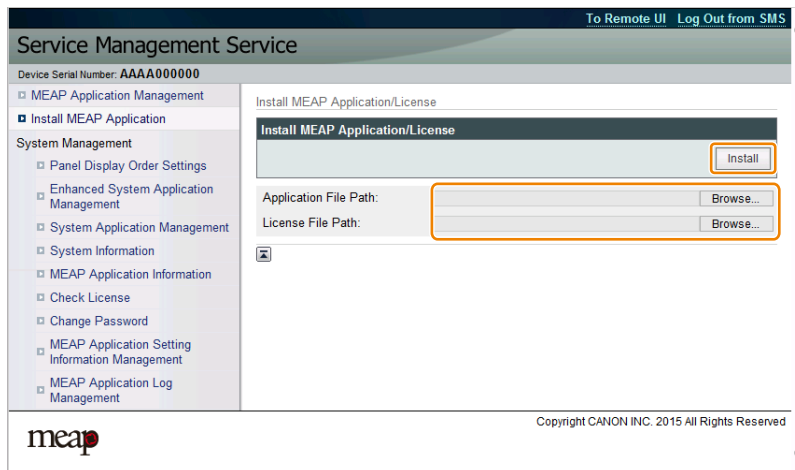

Uninstalling MEAP Applications

Uninstall MEAP applications by clicking [Uninstall] for the target application on the [MEAP Application Management] page (the SMS top page).

It is necessary to disable/delete the license to uninstall a MEAP application. For details on the procedure, see [Top Page] > [MEAP Application Settings] > [Uninstalling MEAP Applications] in "Function Guide for MEAP Application Management".

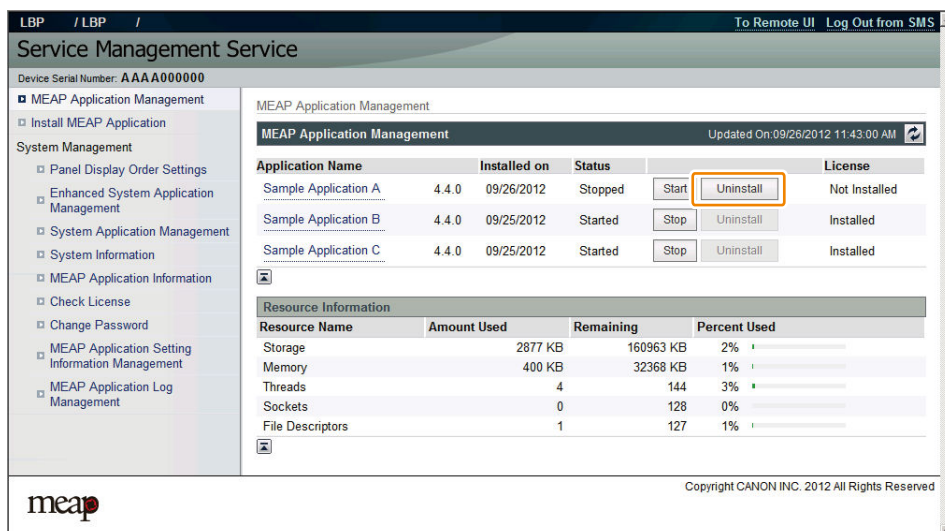

Starting/Stopping MEAP Applications

Start and stop MEAP applications by clicking [Start] and [Stop] for the target application from the [MEAP Application Management] page (the SMS top page).

For details on the procedure, see [Top Page] > [MEAP Application Settings] > [Starting/Stopping MEAP Applications] in "Function Guide for MEAP Application Management".

The screenshot displays the 'Service Management Service' interface. At the top, it shows 'LBP / LBP /' and 'To Remote UI Log Out from SMS'. The main title is 'Service Management Service'. Below this, the device serial number is 'AAAA000000'. The left sidebar contains a tree view with 'MEAP Application Management' selected, and sub-items like 'Install MEAP Application', 'System Management', 'Panel Display Order Settings', etc. The main content area is titled 'MEAP Application Management' and shows a table of installed applications. The table has columns for 'Application Name', 'Installed on', 'Status', and 'License'. Three applications are listed: 'Sample Application A', 'Sample Application B', and 'Sample Application C', all with version 4.4.0 and installed on 09/25/2012. Each application has a 'Start' button, which is highlighted with a red box. Below the table is a 'Resource Information' section with a table showing 'Resource Name', 'Amount Used', 'Remaining', and 'Percent Used'. The resources listed are Storage, Memory, Threads, Sockets, and File Descriptors. The footer of the interface shows the 'meap' logo and 'Copyright CANON INC. 2012 All Rights Reserved'.

MEAP Application Authentication Information Settings

When executing jobs from an application that does not require a printer operation, it is necessary to set authentication information in advance. For details on the procedure, see [Top Page] > [MEAP Application Settings] > [Setting Authentication Information for MEAP Applications] in "Function Guide for MEAP Application Management".

License Management

The following cases exist for the license management of MEAP applications. Since license management is generally performed by the user, see "Function Guide for MEAP Application Management" for the basic operations.

Adding License Files

Add a license when you want to continue using an application after a license has expired. For details on the procedure, see [MEAP Application License Settings] in "Function Guide for MEAP Application Management".

Disabling/Deleting License Files

It is necessary to disable and delete the license to uninstall a MEAP application. For details on the procedure, see [MEAP Application License Settings] in "Function Guide for MEAP Application Management".

Downloading License Files

When uninstalling and reinstalling a MEAP application in cases such as initializing the storage, download the license before deleting the disabled license. The downloaded license can be used as the license for reinstalling to the same device. For details on the procedure, see [MEAP Application License Settings] in "Function Guide for MEAP Application Management".

Downloading a License for Forwarding

The license downloaded in "Downloading License Files" can be used when reinstalling to the same device (a machine with the same serial number), but cannot be installed to a different machine. When migrating a MEAP application to another machine, it is necessary to download a "License for Forwarding". For details on the procedure, see the following.

● Procedure for Downloading a License for Forwarding

1. Log in to SMS, stop the application to be forwarded.

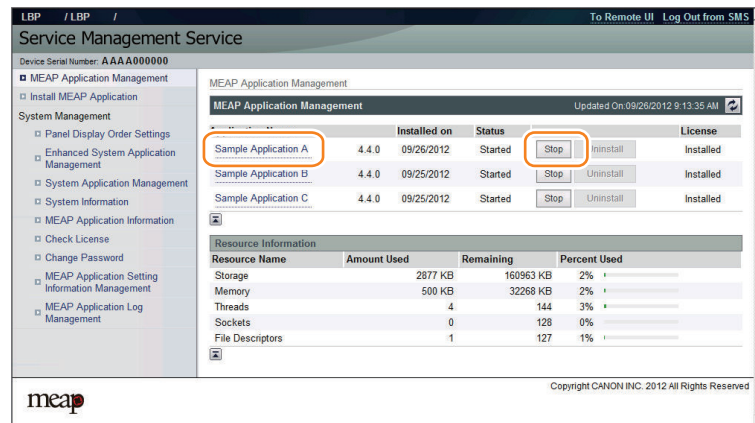

2. Move to the download page of license forwarded for the device as sender ([https:// <IP address of device>:8443/sms/ForwardLicense](https://<IP address of device>:8443/sms/ForwardLicense)).

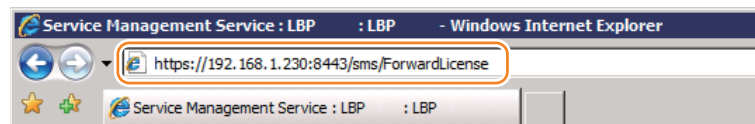

3. Specify the application to be forwarded.

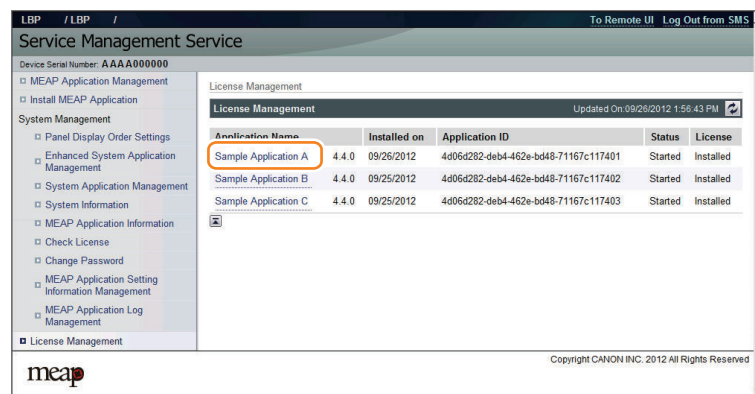

4. Click [Disable] on the [Disable License File].

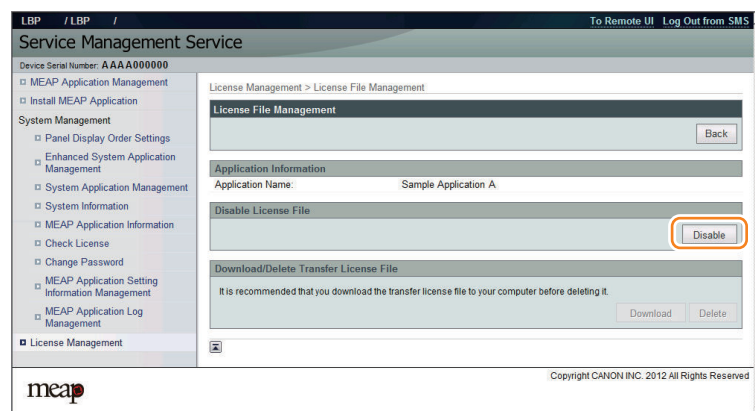

5. The window to confirm whether to create a transfer licence will be displayed. Click [Yes].

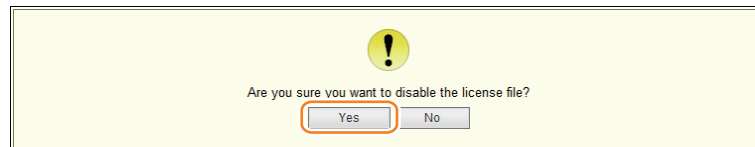

6. When [Download] on the [Download / Delete Transfer License File] becomes effective, click [Download].

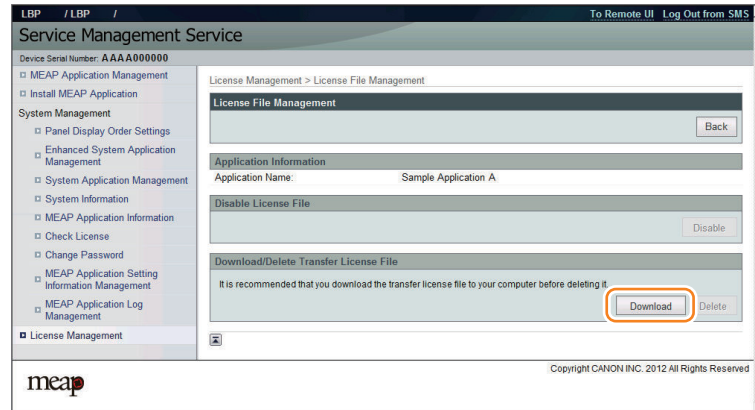

7. Specify the preservation place of the file according to the instruction of the screen.
8. After downloading the license file for forwarding, click [Delete] to display the confirmation screen and click [Yes] to delete the file (in consideration of breakage of license for forwarding, deleting disabled license can be executed after all steps have been completed).

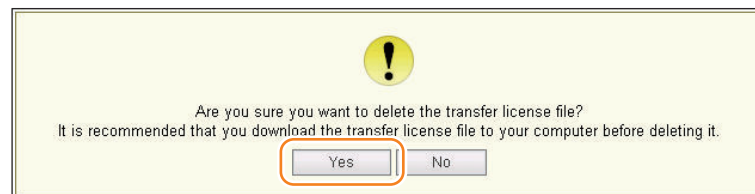

9. Log out of SMS.
10. Since this downloaded transfer license is the file only to prove the license invalidation, it cannot be used for installation to the other device as it is. Send the transfer license to the service support contact of your nearest sales company to request issuance of the new license for installation in the new device.

NOTE:

When requesting issuance of license for forwarding, inform the sales company of the name of product name and serial No. of the device as sender, and of the name of product name and serial No. of the forwarding destination.

11. Install application using the license for forwarding issued by the sales company.

■ Authentication Settings Management (Enhanced System Application Management)

The authentication function (login application) used when logging in to the machine is configured on the [Enhanced System Application Management] screen of SMS.

Change Login Application Procedure

If multiple login applications are installed*¹, you can activate the login application that you wish to use by accessing the [Enhanced System Application Management] screen of SMS, clicking the [SWITCH] button of the login application, and restarting this machine. For details on the procedure, see [Top Page] > [System Settings] > [Setting Enhanced System Applications] > [Starting/Stopping Enhanced System Applications] in "Function Guide for MEAP Application Management".

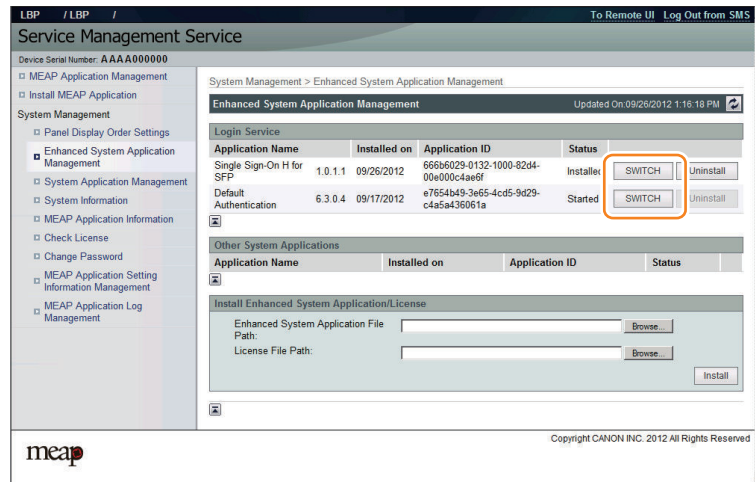

Login Service Installation Procedure

To install a login application to this machine, access the [Enhanced System Application Management] screen of SMS, specify the program file (.jar) and license file (.lic) of the login application that you wish to use, and click the [Install] button. For details on the procedure, see [Top Page] > [System Settings] > [Setting Enhanced System Applications] > [Installing Enhanced System Applications] in "Function Guide for MEAP Application Management".

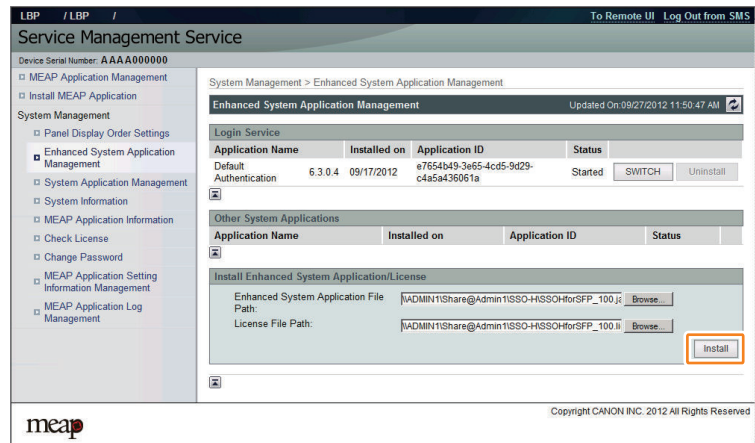

*1. When a 3rd party login application is installed, etc.

Login Service Uninstallation Procedure

To uninstall a login application, access the [Enhanced System Application Management] screen of SMS, stop the corresponding login application (change its status to "Installed"), and click the [Uninstall] button. For details on the procedure, see [Top Page] > [System Settings] > [Setting Enhanced System Applications] > [Uninstalling Enhanced System Applications] in "Function Guide for MEAP Application Management".

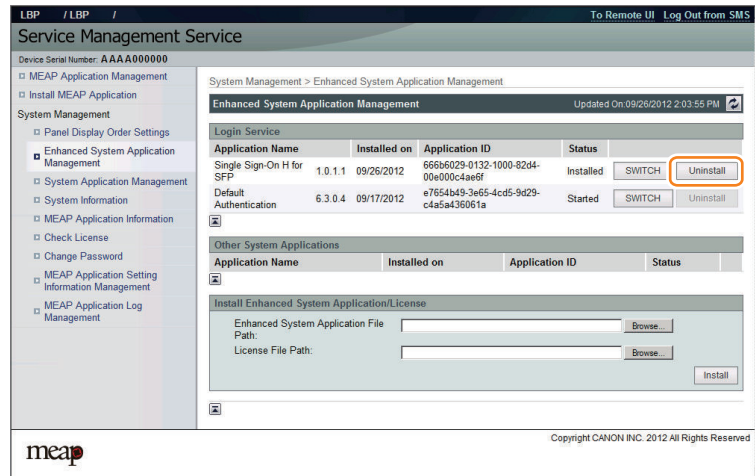

■ Changing the SMS Password

The password used to log in to SMS can be changed by accessing the [Change Password] screen and entering the old password and new password. It is recommended that the SMS password is changed to prevent security threats. For details on the procedure, see [Top Page] > [System Settings] > [Changing the SMS Password] in "Function Guide for MEAP Application Management".

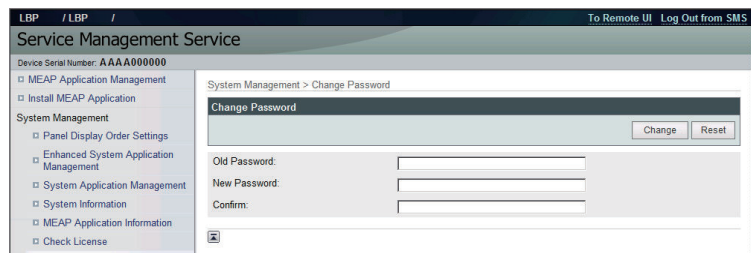

■ Checking Various Information

SMS has a screen for checking the information of this machine.

System Information

You can access the [System Information] screen of SMS to check the system information relating to the MEAP of this machine. The following information can be checked on this screen.

- Platform Information
- System Application Information

CAUTION:

The detailed information for system applications can be checked by clicking the [Display Details] button.

MEAP Application Information

You can access the [MEAP Application Information] screen of SMS to check the information relating to the MEAP applications installed in this machine.

License File

You can access the [Check License] screen of SMS, specify a license, and click [Check] to check information such as the expiration date of the license.

Maintenance

■ When Replacing the PCB

● Special license for reinstallation

When replacing the PCB, a special license file is required to reinstall the application with the expiration date of the current counter value migrated as it is. This special license file is handled as a service tool and cannot be obtained by end users.

In order to obtain a special license file, the service technician needs to contact the person in charge of support at the sales company.

The service technician needs to give the device serial number and the names of the MEAP applications that had been installed. Since the support department of the sales company manages all the issued application license files by device serial number, it is basically possible for them to successively issue license files once the device serial number is confirmed.

NOTE:

The application that is installed with a reusable license can be reinstalled by using the same license.

● Procedure for reinstalling MEAP applications after replacing the PCB

The following shows the procedure when replacing the PCB.

1. Preparation before replacement

The following work needs to be done before replacing the PCB.

- Some MEAP applications have a function to back up or export the data to be used. If such a MEAP application is installed, back up or export the data in advance.
- In order to reinstall the applications, copy the licenses (special licenses, reusable licenses, etc.) of all the MEAP applications to the laptop PC.

2. Replacing the drive

Prepare the necessary service parts, and replace the drive.

3. Reinstalling the MEAP application

When the device has started normally, obtain the jar files of the MEAP applications from the user, and install them using the license files for reinstallation.

Installation method is the same as normal installation.

4. Importing user information

As necessary, make login service selections and import user information.

NOTE:

When you replace the PCB without uninstalling MEAP applications, make sure to reinstall the previously installed applications. Unless reinstalling them, MEAP counter will not be released and the message “The number of applications that can be installed has exceeded the limit. Try to install this application after uninstalling other applications.” is displayed so that the installation of new applications may not be accepted. If you want to install new applications in this case, once reinstall the applications in-stalled before formatting and uninstall unnecessary applications.

CAUTION:

Do not install a Main PCB of another device and conduct operation check in order to check whether an error has occurred in the Main PCB. If the PCB is replaced and the system is started, the data on the installed PCB will be initialized.

■ Actions to be taken when E616 is displayed

When E602 is displayed and then the device is restarted as a remedy, E616 may be displayed in some cases.

This is a symptom that occurs when the power is cut off without shutdown (such as disconnecting the plug of the device). The error code is displayed when the file system of the MEAP storage area is in an abnormal status.

When the device is started, it checks the file system. If the device detects an error, it displays the error code E602, disables the MEAP function, and then starts.

When the device is restarted according to the remedy for E602, the file system is recovered automatically in the system. If the recovery procedure succeeds, the device starts normally with the MEAP function enabled.

However, if the file system could not be recovered by auto recovery, E616 is displayed.

Since the system is automatically formatted when E616 is displayed, the installed MEAP applications will disappear and the device's MEAP function itself will also be disabled.

For this reason, it is necessary to enable the MEAP function and then reinstall the MEAP applications.

• Work procedure

Perform the following procedure when E616 is displayed.

1. Start the device in service mode.
2. Select [Setup] > [SERVICE MODE] > [FUNCTION GR.] > [MEAP FUNCTION] > On to enable the MEAP function.
3. Restart the device to start the MEAP function.
4. Access SMS, and then use a reusable license or special license for reinstallation to install the MEAP application.

NOTE:

As for MEAP applications that were installed using reusable licenses, the reusable licenses can be used to reinstall the applications. For other MEAP applications without reusable licenses, use special license files to reinstall them, in the same as way as handling a storage drive failure.

For information on how to obtain a special license for reinstallation, see "Special license for reinstallation" on page 116 in this chapter. Then contact the support department of the sales company to have the license issued before starting the work.

5. Start the MEAP application.

■ MEAP Safe Mode

Use safe mode if you need to start up the system without worrying about extra applications. It will start up only those system software files (including SMS) that normally start up as default files while preventing MEAP applications and the like from starting up.

When you have made changes and restart the device, the control panel will indicate 'MPSF' in its lower right corner. The MEAP applications that may have been active before you shut down the equipment will not start up on their own. Make use of safe mode when restoring the system software as when MEAP applications or services cause a fault as the result of a conflict or wrong sequence of registration/use. You can access to SMS in this condition so that you can take necessary measures, for example, you can stop application that may cause the trouble.

If default authentication has been selected, the mode of authentication remains valid; otherwise, the message "The login service must be set again with SMS" appears. Change the login service as necessary.

• Starting in Safe Mode

To start the device in the MEAP SAFE mode, turn ON the power with the [Application] key and the [ID] key pressed.

• How to cancel MEAP SAFE mode

If you want to cancel MEAP SAFE mode, just restart the device as usual. It will start in normal mode.

NOTE:

If accessed to SMS in MEAP SAFE mode, the device started mode is shown on the title bar of the browser

When normally started:

Service Management Service : <Device Name>: <Product Name>

When starting in MEAP SAFE mode:

Service Management Service : <Device Name>:<Product Name>: Safe Mode

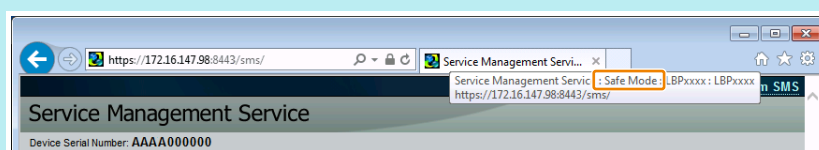

CAUTION:

If the device has been started in the MEAP SAFE mode, all MEAP applications stop and the status becomes "Installed". This status remains unchanged even if the MEAP SAFE mode is cancelled and the device is started again in normal mode. It is therefore necessary to access SMS after normal startup, and start the MEAP application.

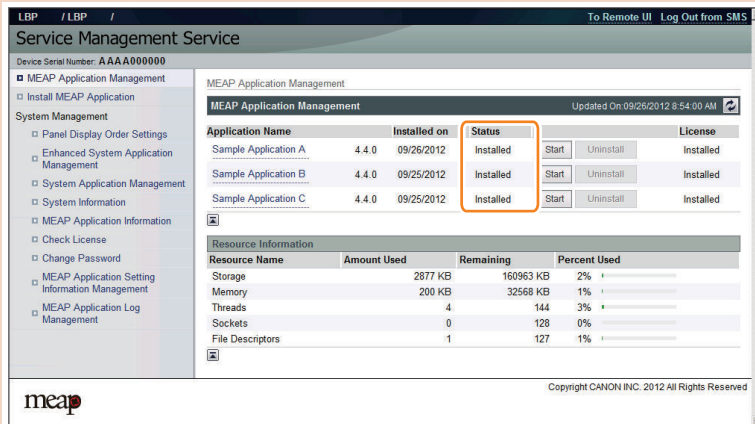

■ Using USB Devices

● Two types of USB drivers

While the USB driver that can be used in iR series is only the USB driver designed exclusively for MEAP application (hereinafter referred to as "MEAP driver"), not only MEAP driver but also USB system driver (hereinafter referred to as "system driver") can be used in this device.

System driver and MEAP driver cannot be used together. When either of them is used, the other driver cannot be used. In this model, the USB system driver supports only Mass Storage; HID is not supported. In other words, storage devices such as USB Flash memory can be used via system driver, but interface devices such as USB keyboard cannot be used via system driver.

● USB driver setting

System driver is active by default in this device. The driver can be changed in setup menu. Usually, It is not necessary to change the setting because it is specified in the MEAP application side. Only in the case of a special MEAP application, it is necessary to change the USB driver setting. For details, refer to specifications of MEAP application side.

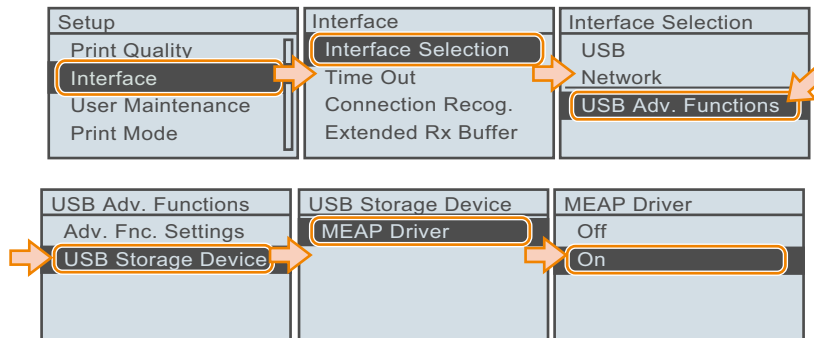

USB Storage Device : [MEAP Driver]	Application that supports mass storage device	MEAP application that supports system driver
ON MEAP driver (compatibility mode)	Can use USB mass storage device. Can work only on the applications that support the MEAP application driver.	Cannot use USB mass storage device.
OFF (default) Native driver	Cannot use USB mass storage device. (Device cannot be detected.)	Can use USB mass storage device.

NOTE:

When any settings changes are made, the device must be restarted.



Periodical Service

Periodically Replaced Parts.....	120
Consumable parts.....	121
Periodical Service.....	122

Periodically Replaced Parts

Periodically Replaced Parts

- Periodic replacement parts are not required in this machine.

Consumable parts

No.	Type	Name	Parts number *1	Q'ty	Estimated life *2	Service Task	Remarks
1	Main Body	Waste Toner Container	FM1-M435	1	54,000 image	Replace	

*1 : The parts numbers may change according to engineering change.

*2 : The values included in this section are all estimated life values in the case of A4-size paper. The estimated life is a reference value in the case of usage in a typical office. The actual value varies depending on the customer environment, field operation status, etc.

Periodical Service

Periodical Service

- No periodic services are required to this machine.



Disassembly/ Assembly

List of Parts.....	124
Removing from the connection equipment.....	129
External Cover System.....	130
Laser Exposure System.....	142
Image Formation System.....	147
Fixing System.....	158
Pickup Feed Delivery System.....	162
Controller System.....	182

List of Parts

Main Unit

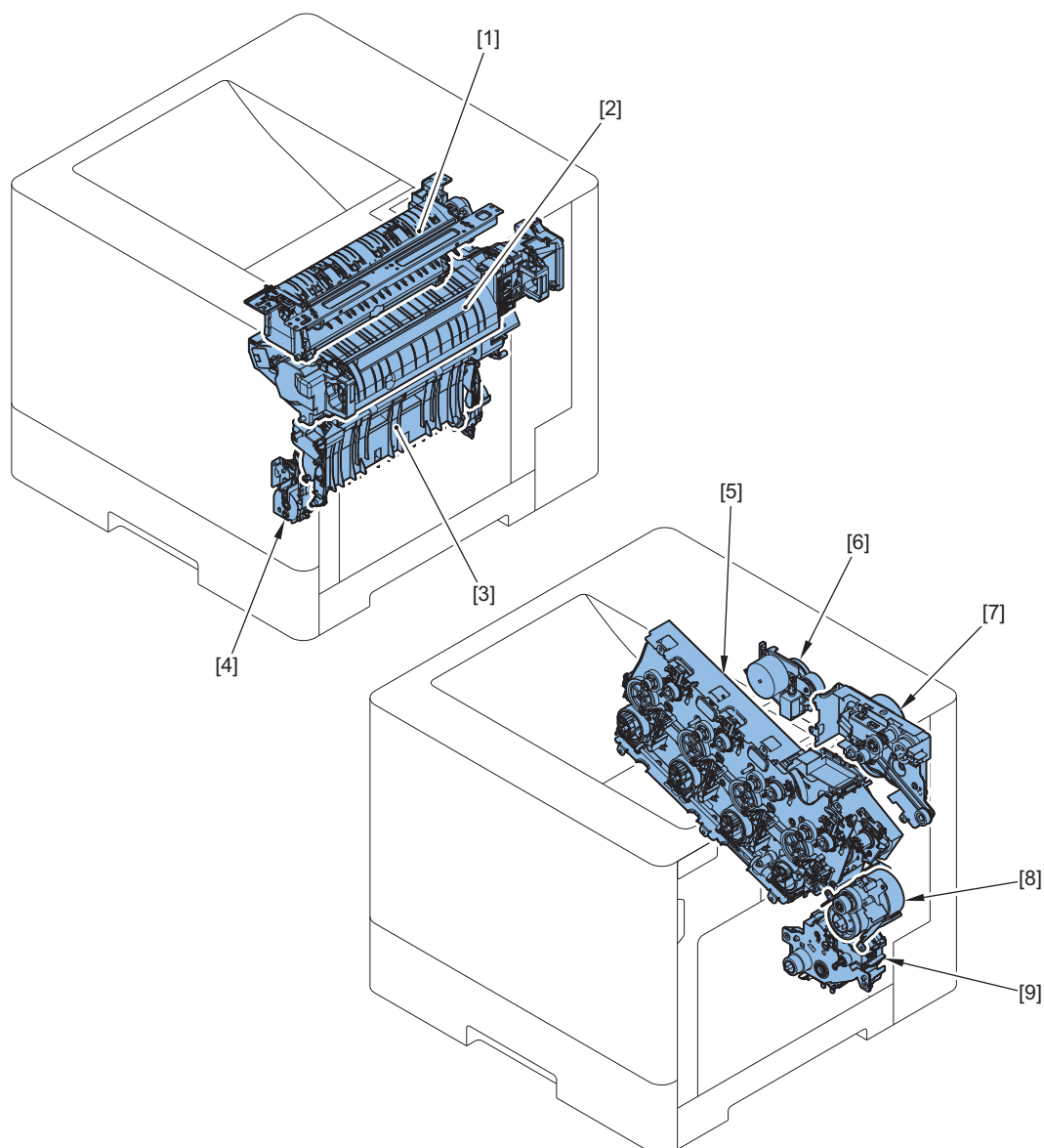

No.	Name	Reference
[1]	Delivery Unit	"Removing the Delivery Unit" on page 162
[2]	Fixing Assembly	"Removing the Fixing Assembly" on page 158
[3]	Secondary Transfer Unit	"Removing the Secondary Transfer Unit" on page 147
[4]	Registration Unit	"Removing the Registration Unit" on page 166
[5]	Main Drive Unit	"Removing the Main Drive Unit" on page 193
[6]	Duplex Switchback Drive Unit	"Removing the Duplex Reverse Drive Unit" on page 179
[7]	Fixing Drive Unit	"Removing the Fixing Drive Unit" on page 158
[8]	Pickup Drive Unit	"Removing the Pickup Drive Unit" on page 165
[9]	Lifter Drive Unit	"Removing the Lifter Drive Unit" on page 163

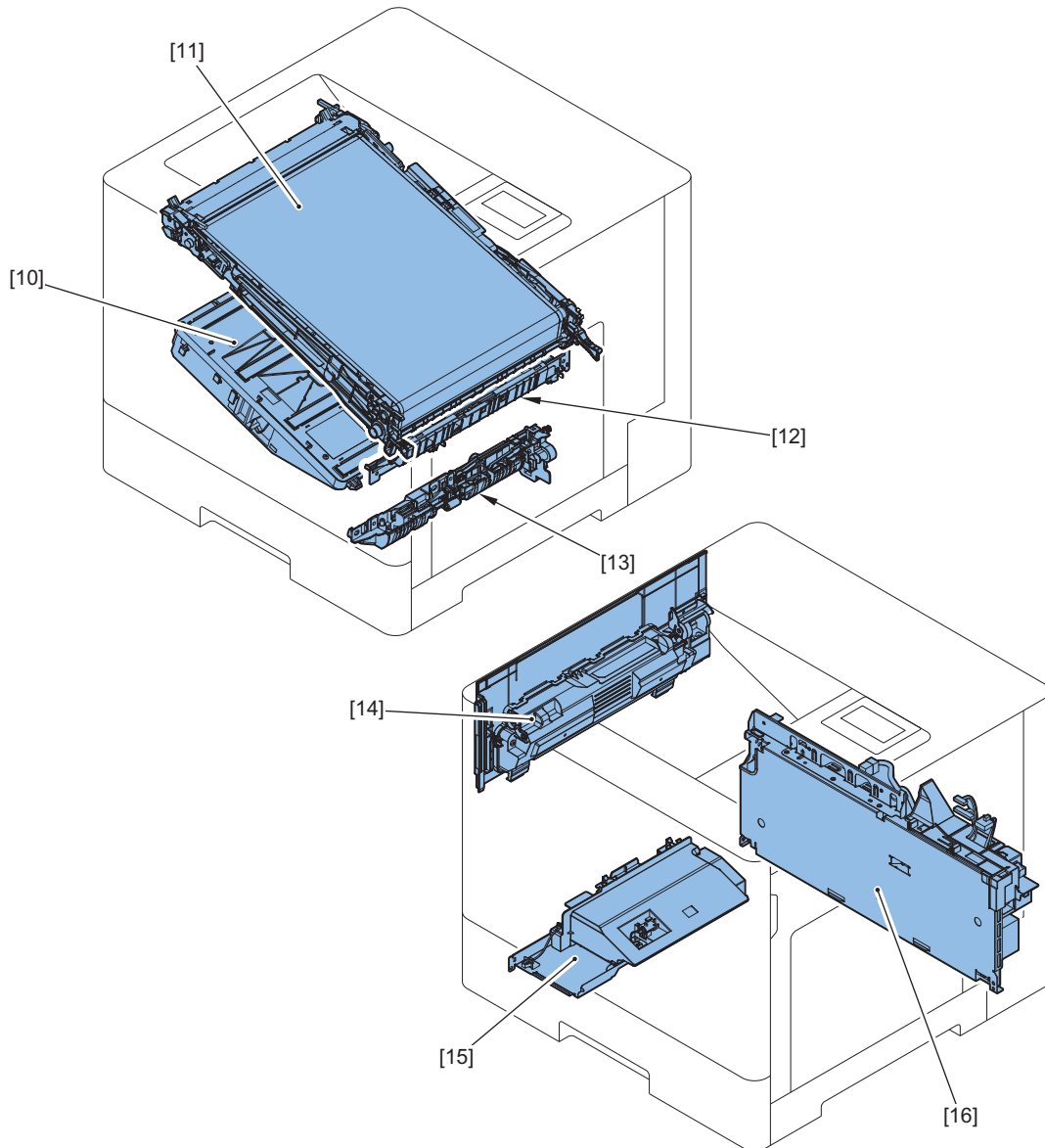

No.	Name	Reference
[10]	Laser Scanner Unit	"Removing the Laser Scanner Unit" on page 142
[11]	ITB Unit	"Removing the ITB Unit" on page 150
[12]	Color Displacement Density Sensor Unit	"Removing the Color Displacement Density Sensor Unit" on page 155
[13]	Cassette Pickup Unit	"Removing the Cassette Pickup Unit" on page 170
[14]	Waste Toner Container	"Removing the Waste Toner Container Cover Unit" on page 130
[15]	Fixing Power Supply Unit	"Removing the Fixing Power Supply Unit" on page 185
[16]	Low Voltage Power Supply Unit	"Removing the Low Voltage Power Supply Unit" on page 189

Electrical Components List

■ Motor/Fan

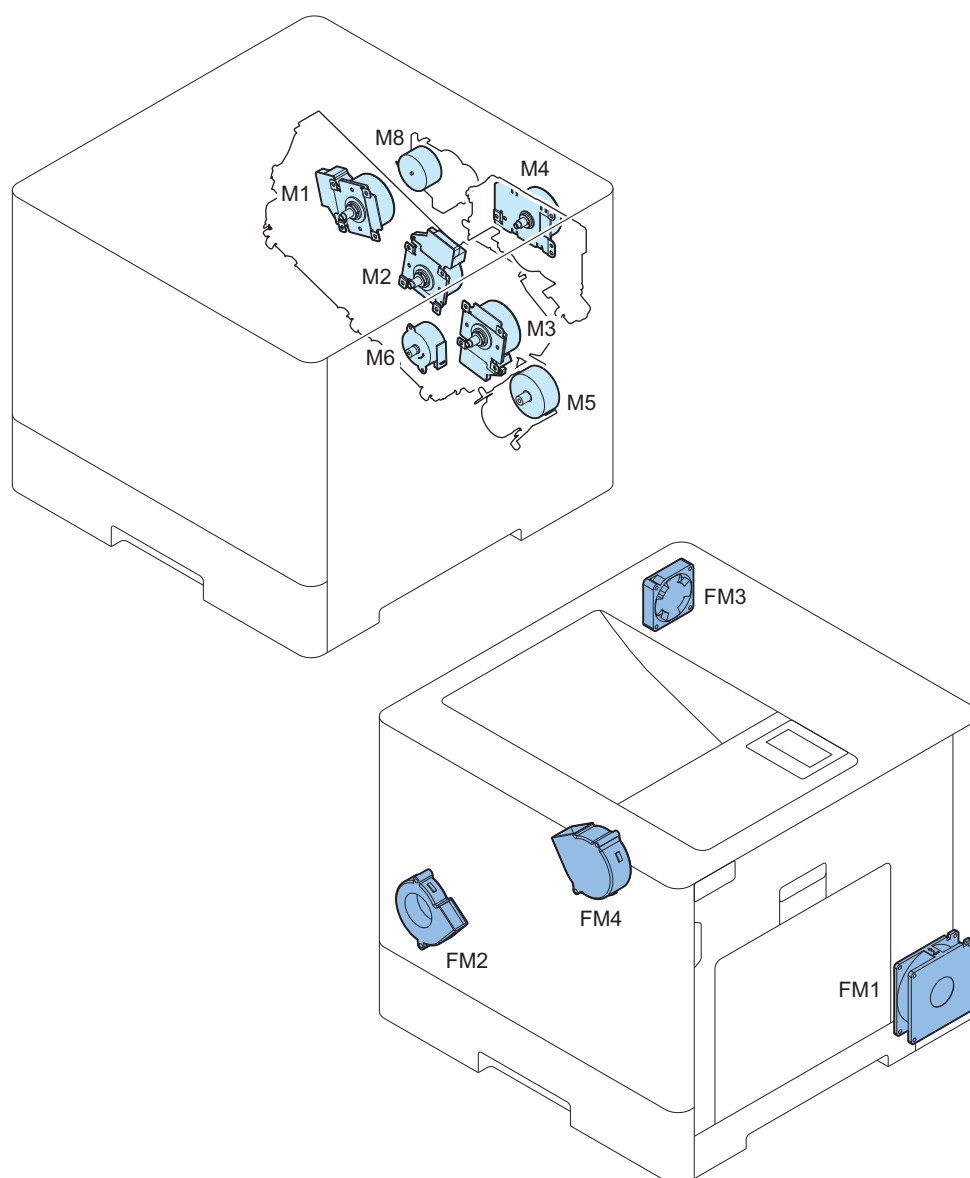

No.	Name	Reference
M1	Drum Motor 1	"Removing the Drum Motor (Y)" on page 153
M2	Drum Motor 2	"Removing the Drum Motor (M)" on page 154
M3	Drum Motor 3	"Removing the Drum Motor (C)" on page 154
M4	Fixing Motor	"Removing the Fixing Motor" on page 160
M5	Pickup Motor	-
M6	Developing disengagement Motor	"Removing the Developing Disengagement Motor" on page 152
M8	Duplex Switchback Motor	-
FM1	Power Fan	"Removing the Power Fan" on page 201
FM2	Cartridge Fan	"Removing the Cartridge Fan" on page 202
FM3	Exhaust Fan	"Removing the Exhaust Fan" on page 203
FM4	Fixing Fan	"Removing the Fixing Fan" on page 205

■ Heater

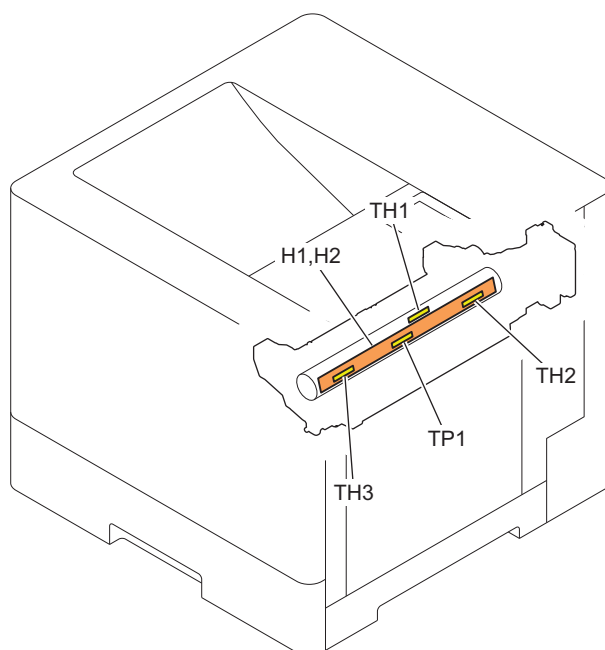

No.	Name	Reference
H1	Fixing Main Heater	-
H2	Fixing Sub Heater	-
TH1	Main Thermistor	-
TH2	Sub Thermistor 1	-
TH3	Sub Thermistor 2	-
TP1	Thermoswitch	-

■ Switch

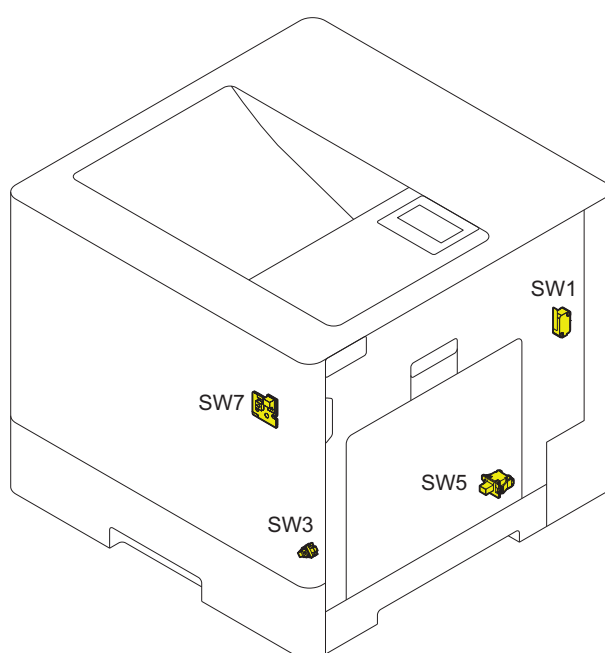

No.	Name	Reference
SW1	24V Interlock Switch	-
SW3	Right Door Switch	-
SW5	Cassette Detection Switch	-

No.	Name	Reference
SW7	Main Switch	-

■ PCB

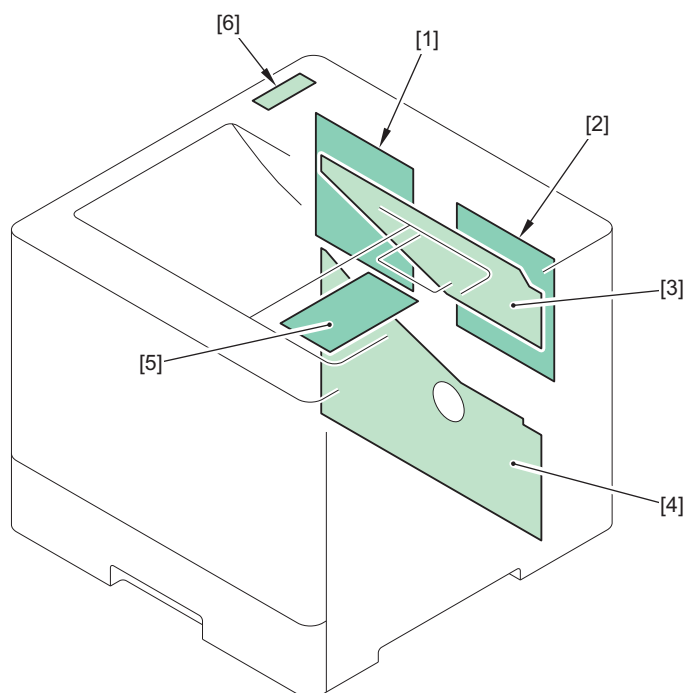

No.	Name	Reference
[1]	Main Controller PCB	"Removing the Main Controller PCB" on page 182
[2]	DC Controller PCB	"Removing the DC Controller PCB" on page 184
[3]	Upper High Voltage Power Supply PCB	"Removing the Upper High Voltage Power Supply PCB" on page 192
[4]	Lower High Voltage Power Supply PCB	"Removing the Lower High Voltage Power Supply PCB" on page 191
[5]	Control Panel Key PCB	"Removing the Control Panel Unit Key PCB" on page 199
[6]	Relay PCB	-

Removing from the connection equipment

Disengaging the Paper Feeder

Preparation

1. Remove the Cassette.

Procedure

NOTE:

Disengage the Paper Feeder from the host machine as needed when disassembling/assembling this equipment.

1. Release the 2 locks [2] engaging the host machine and the Paper Feeder [1].

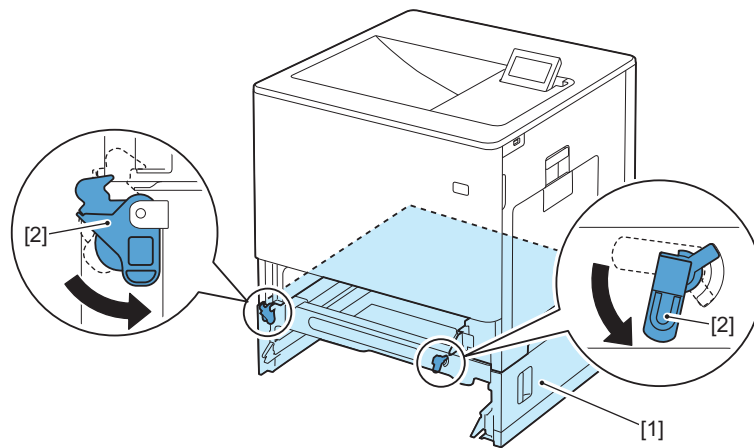

2. Hold the 2 grips [1], lift the host machine [2] and place it at a location where it is moved to.

CAUTION:

Because the weight of the host machine is 20 kg or more, be sure to move it with 2 or more people.

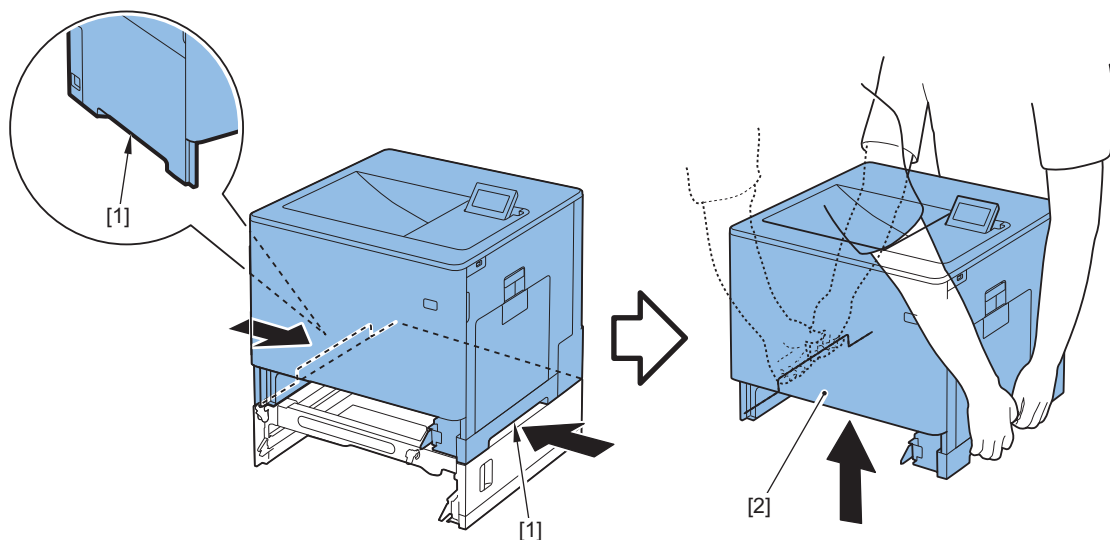

External Cover System

● Removing the Waste Toner Container Cover Unit

■ Procedure

1. Open the Front Cover [1].



2. Open and remove the Waste Toner Container Cover Unit [1].

- 2 Hooks [2]

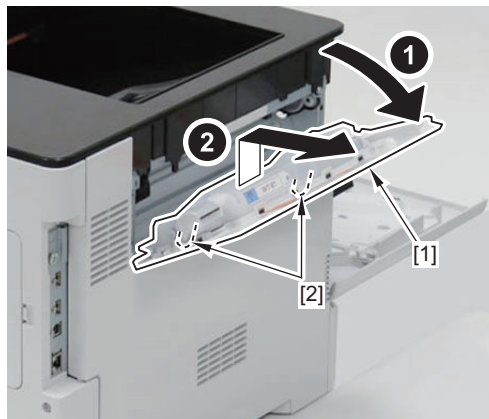

Removing the Rear Cover

Procedure

1. Remove the Rear Cover [1].

- 4 Screws [2]
- 7 Hooks [3]

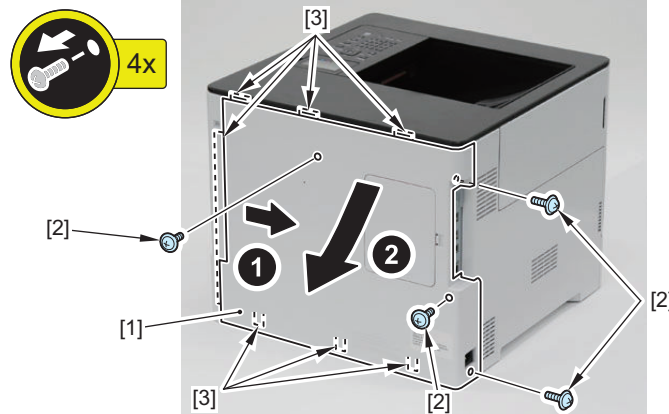

Installing the Back Cover

1. Insert the 3 hooks [2] of the Back Cover [1] into the inner side [A] of the Upper Cover [3].

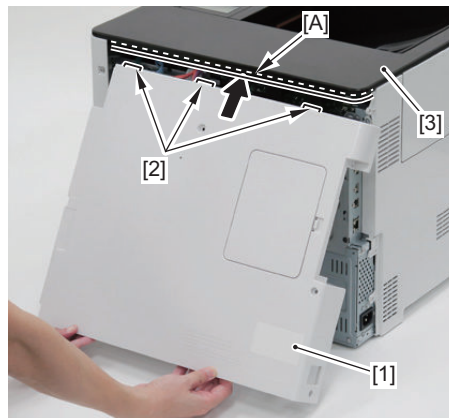

2. Align the marks [B] of the hooks [2] of the Back Cover [1] with the end face [C] of the Right Rear Cover [3], and push while sliding the bottom [D] of the Back Cover [1] to install it.

- 3 Hooks [4]

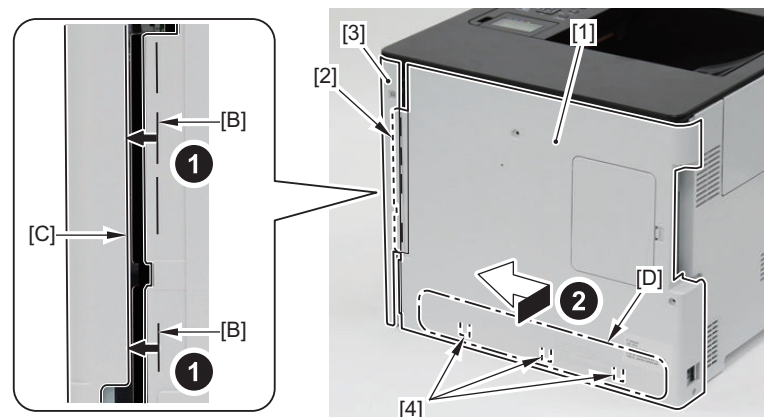

3. Install the 4 removed screws.

● Removing the Left Cover

■ Preparation

1. “Removing the Waste Toner Container Cover Unit” on page 130
2. “Removing the Rear Cover” on page 131

■ Procedure

1. Pull out the Cassette [1] roughly 10 cm, and remove the SD Card Slot Cover [2].
 - 1 Coin Screw [3]
 - 2 Hooks [4]

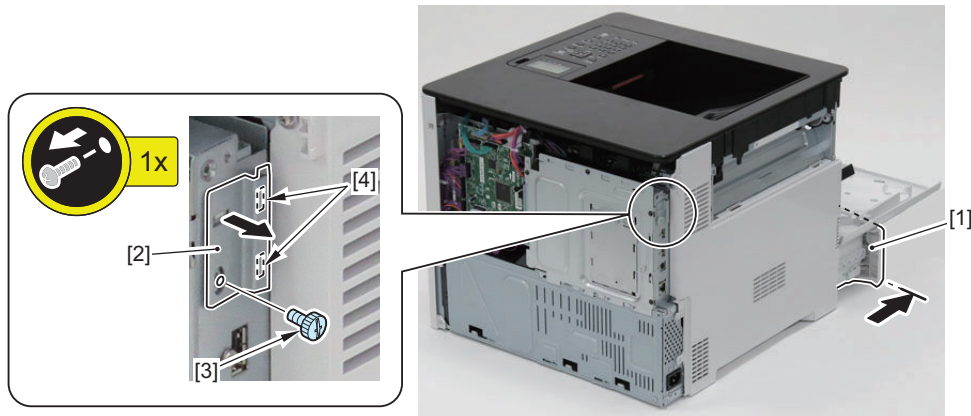

2. Remove the SD Card [1] (if using an SD Card).

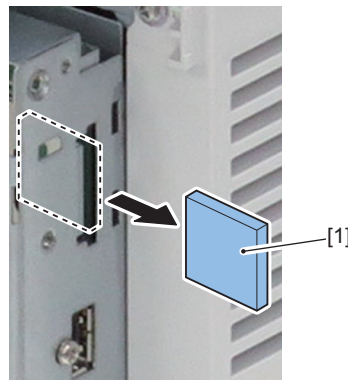

3. Remove the screw [1].

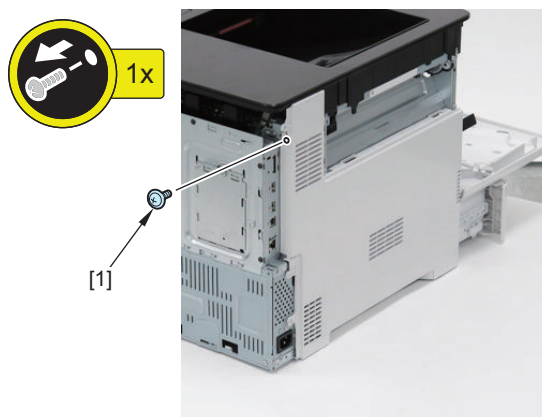

4. Remove the Left Cover [1] by slightly lifting up the boss [2] and the right end [A] of the cover and sliding it to the left.

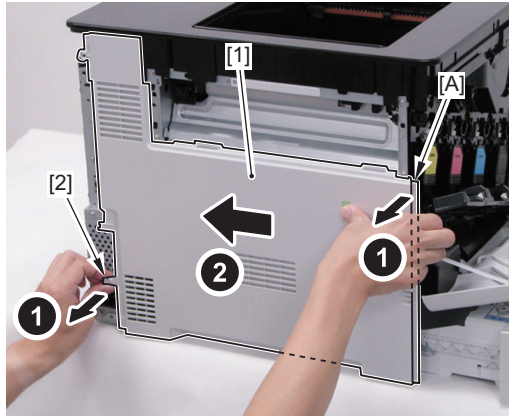

Procedure for Installing the Left Cover

1. Fit the 3 hooks [1] of the Left Cover in the 3 holes [A] on the host machine side, and align the end [B] of the Left Cover with the end [C] of the Upper Cover.

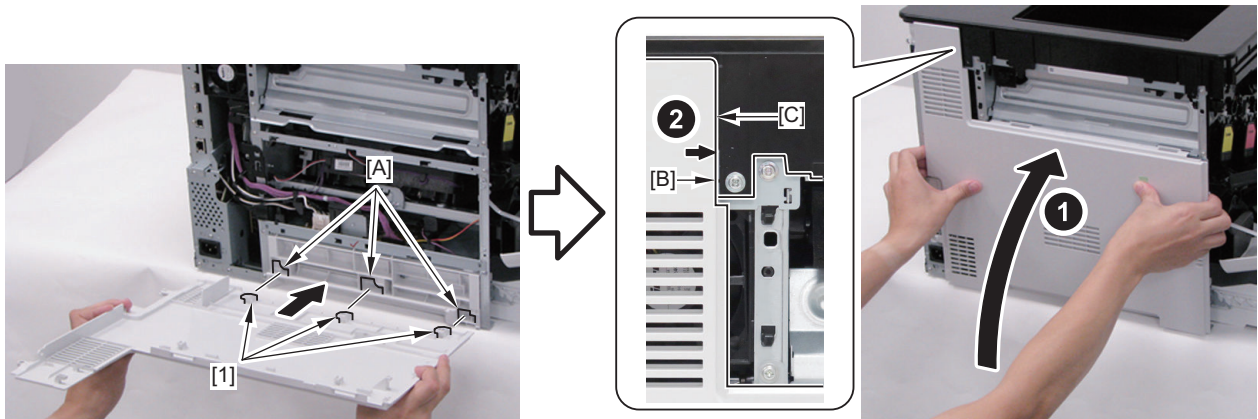

2. Place your fingers over the right end [A] and left end [B] of the Left Cover [1] and slide the cover to the right while pressing it with your thumbs to install it.

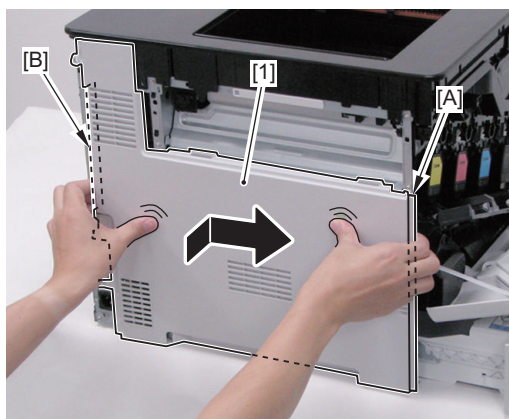

3. Install the removed screw.

Removing the Right Rear Cover

Preparation

1. "Removing the Rear Cover" on page 131

■ Procedure

1. Open the Right Cover Unit [1], and remove the Right Rear Cover [2].

- 2 Screws [3]
- 3 Bosses [4]
- 6 Hooks [5]

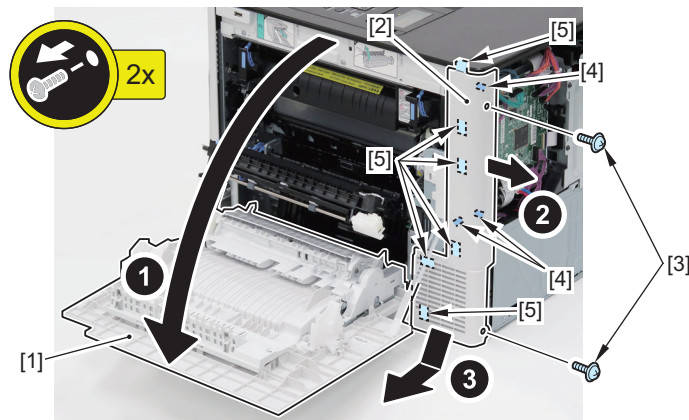

● Removing the Right Cover Unit

■ Procedure

1. Open the Right Cover Unit [1], and close the Secondary Transfer Unit [2].

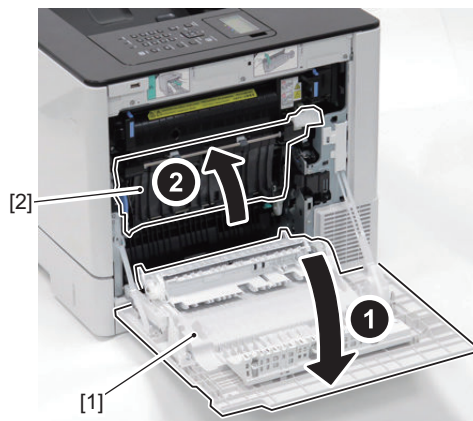

2. Release the left hinge [1] and the right hinge [2].

- 2 Hooks [3]

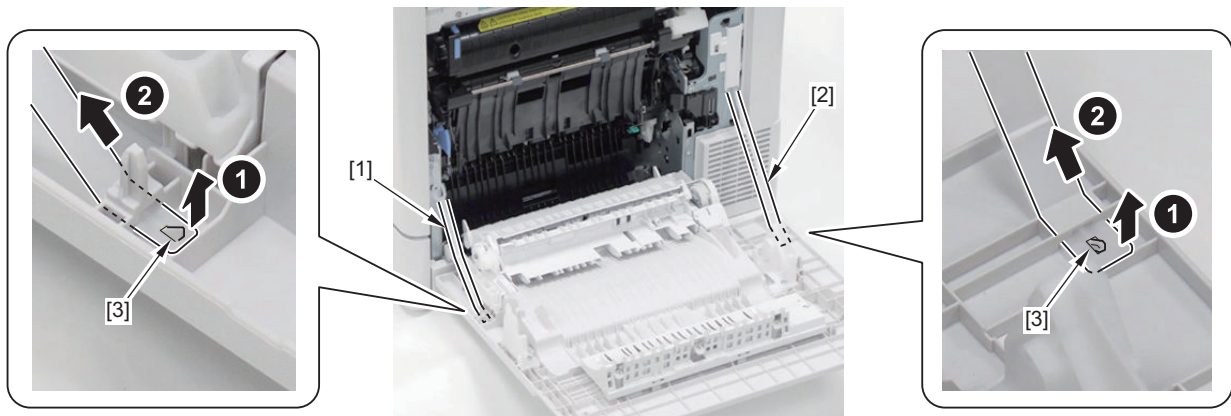

3. Remove the Connector Cover [1].

- 2 Claws [2]
- 1 Hook [3]

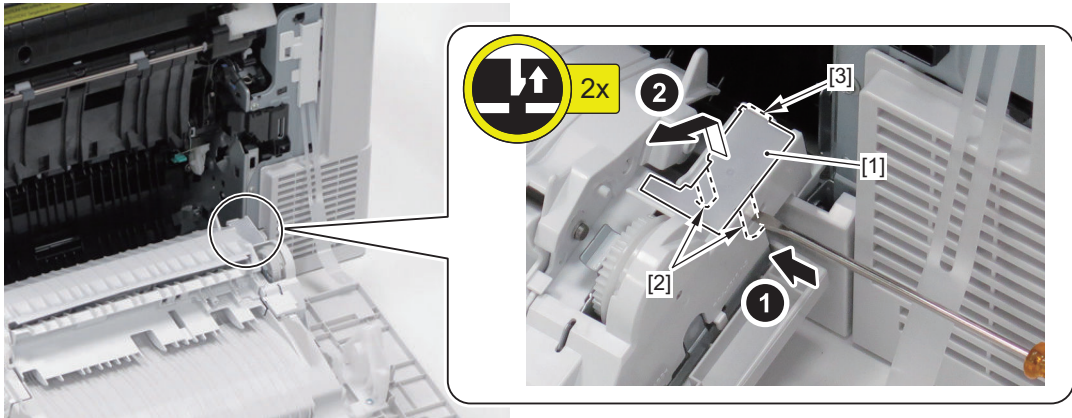

4. Disconnect the 2 connectors [1], and remove the harness [2] and Harness Band [3].

- Guide [A]

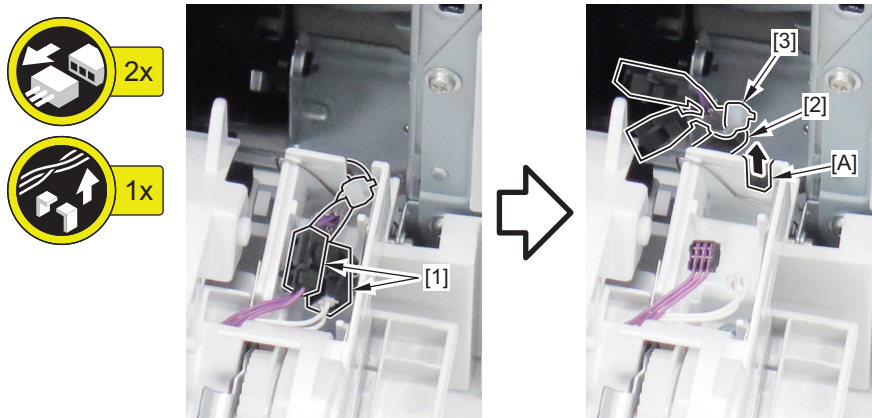

5. Remove the Left Open/Close Shaft [1].

- 2 Screws [2]

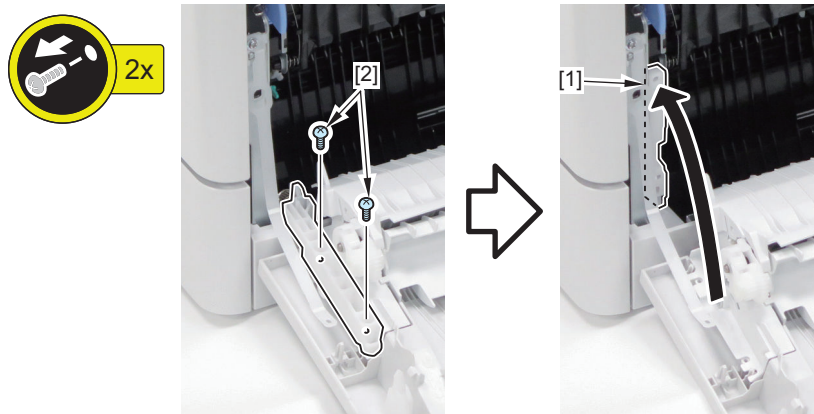

6. Remove the Right Cover Unit [1].

- 1 Shaft [2]

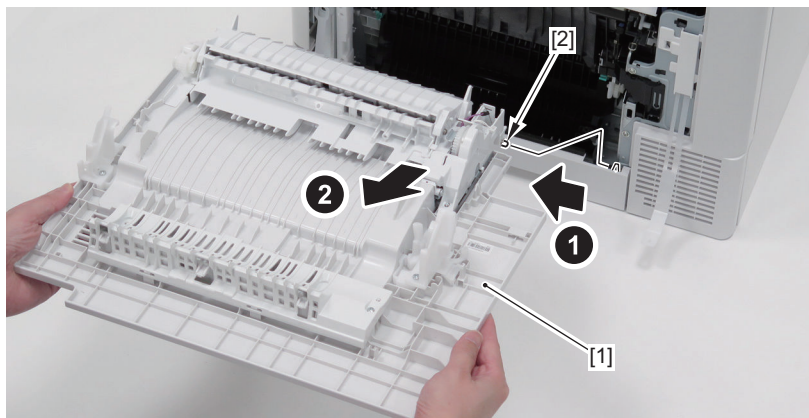

Removing the Right Lower Cover

■ Preparation

1. Remove the Cassette.
2. "Removing the Rear Cover" on page 131
3. "Removing the Right Rear Cover" on page 133
4. "Removing the Right Cover Unit" on page 134

■ Procedure

1. Place this equipment [1] so that the right end [A] of this equipment [1] and the end [B] of the table [2] are parallel, then shift it 10 cm forward from the end [B] of the table [2].

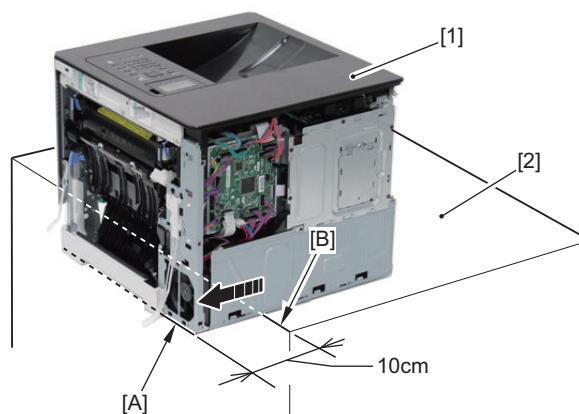

2. Remove the Right Lower Cover [1].

- 7 Hooks [2]

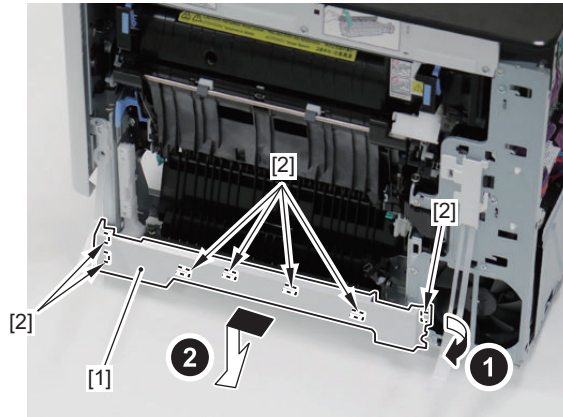

Removing the Upper Cover Unit

■ Preparation

1. “Removing the Waste Toner Container Cover Unit” on page 130
2. “Removing the Rear Cover” on page 131
3. “Removing the Left Cover” on page 132
4. “Removing the Right Rear Cover” on page 133

■ Procedure

1. Remove the Right Upper Inner Cover [1].

- 3 Screws [2]
- 1 Hook [3]

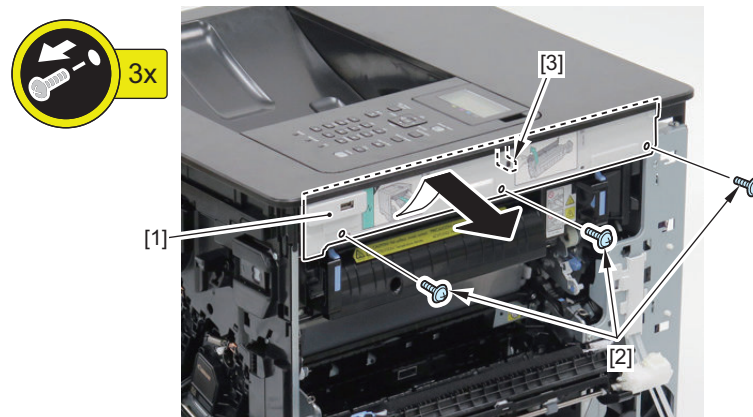

2. Disconnect the harness [1] and the Grounding Wire (with Ferrite Core) [2].

- 1 Connector [3]
- 1 Screw [4]

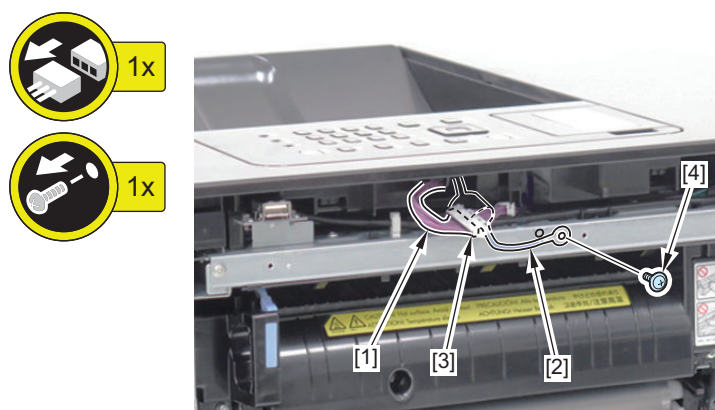
**3. Remove the Upper Cover Unit [1].**

- 2 Screws [2] (TP)
- 1 Screw (Binding) [3]
- 5 Claws [4]

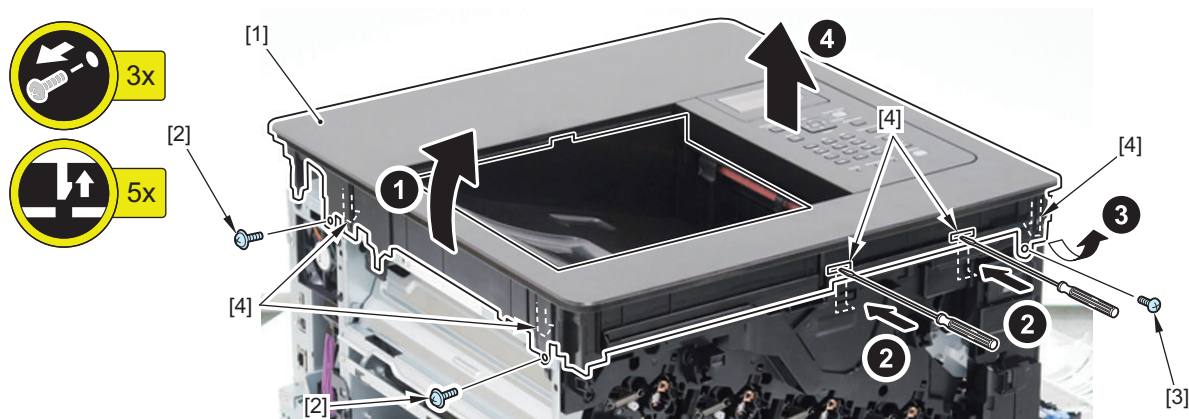

Removing the Output Tray Unit

■ Preparation

1. "Removing the Waste Toner Container Cover Unit" on page 130
2. "Removing the Rear Cover" on page 131
3. "Removing the Left Cover" on page 132
4. "Removing the Right Rear Cover" on page 133
5. "Removing the Upper Cover Unit" on page 137

■ Procedure

CAUTION:

- When disengaging, be sure not to damage the ITB [2] and Flat Cable [3] connecting the Output Tray Unit [1].

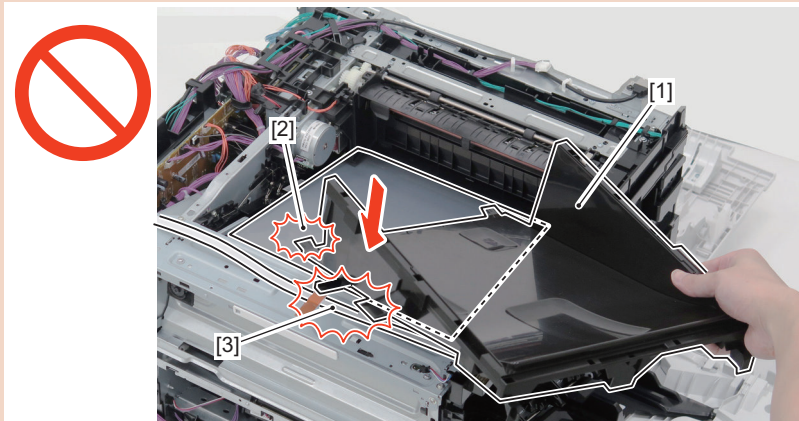

- When disengaging, be sure to pass the duct part [A] of the Output Tray Unit [1] under [B] the motor [2].

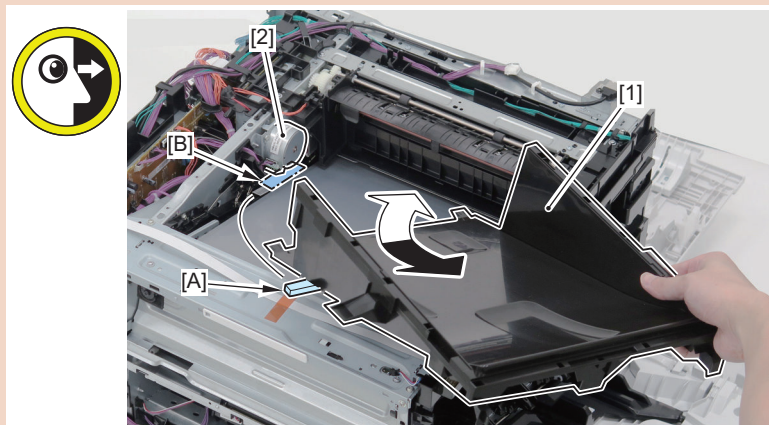

1. Remove the Output Tray Unit [1].

- 4 Hooks [2]

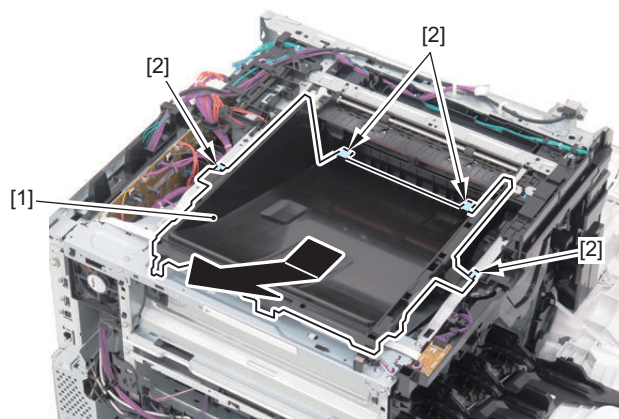

CAUTION:

When installing to the machine, be sure to check that the 5 claws of the duct [2] of the Output Tray Unit [1] are not disengaged, and engage the claws if they are disengaged.

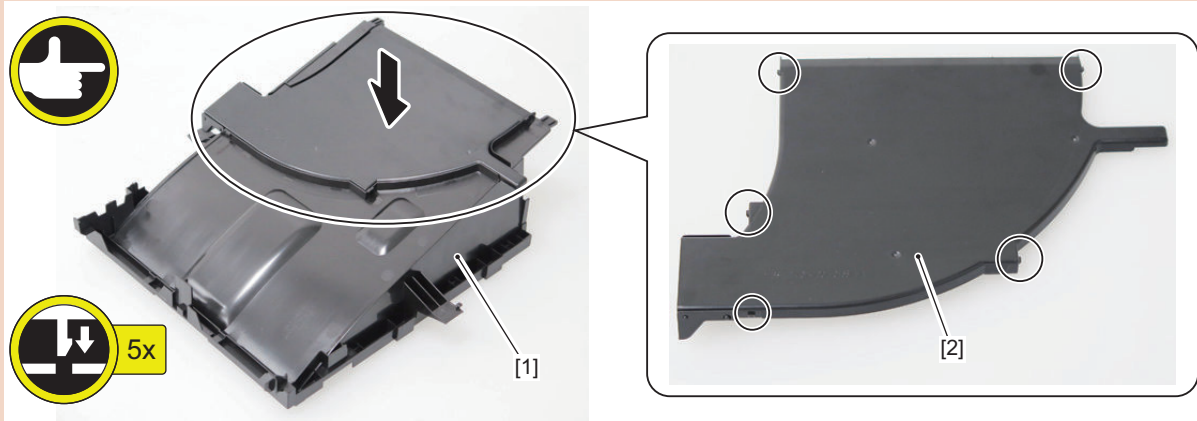

● Removing the Front Cover Unit

■ Preparation

1. Remove the Cassette.

■ Procedure

1. Open the Front Cover Unit [1], and remove the left hinge [2] and right hinge [3].
 - 2 Claws [4]

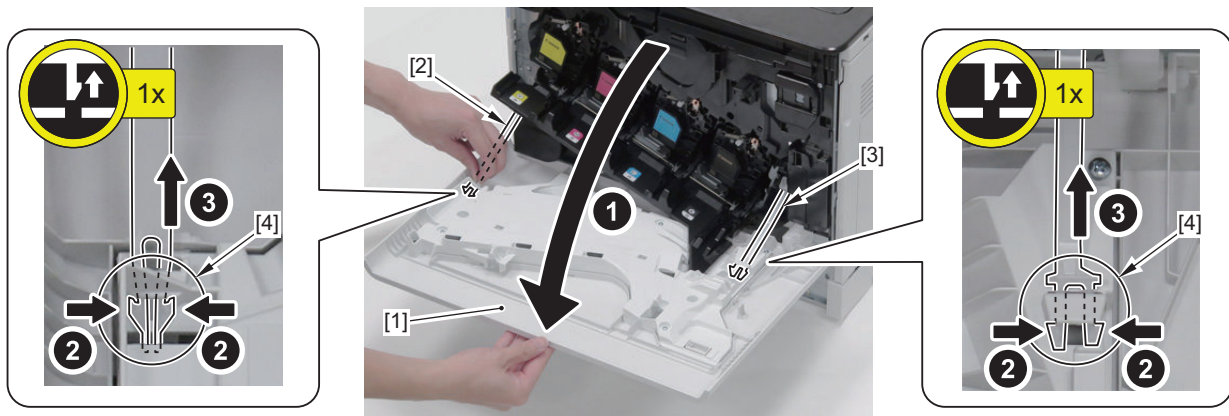

2. Open the Front Cover Unit [1], and align the guide [A] of the shaft [2] and the cut-off hole [B] of the Front Cover Unit [1].

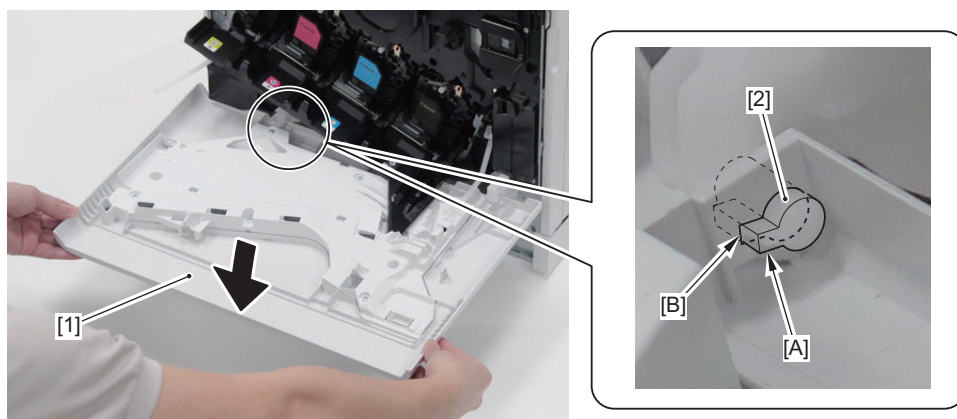

3. Remove the Front Cover Unit [1].

- Cartridge Cover Guide [A]
- 2 Shafts [2]

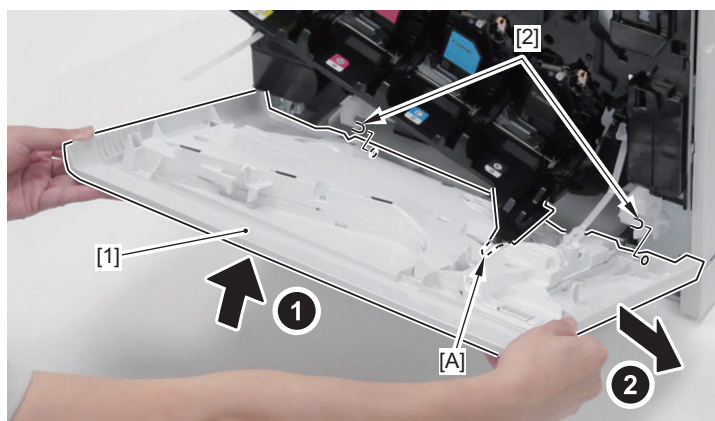

Laser Exposure System

Removing the Laser Scanner Unit

Preparation

1. "Removing the Waste Toner Container Cover Unit" on page 130
2. "Removing the Rear Cover" on page 131
3. "Removing the Left Cover" on page 132
4. "Removing the Controller Cover" on page 182
5. "Removing the Controller Box" on page 187
6. "Removing the Lower High Voltage Power Supply PCB" on page 191

Procedure

1. Free the harness [1] from the guide [A], and remove the Flat Cable Guide Sub Cover [2].

- 2 Bosses [3]
- 3 Hooks [4]

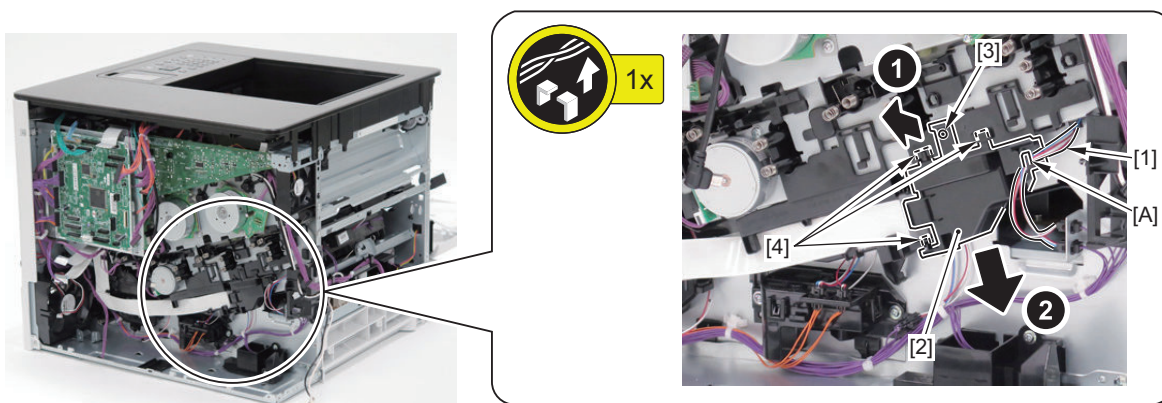

2. Disconnect the Flat Cable [1] and remove the Flat Cable Guide [2].

- 2 Bosses [3]
- 3 Hooks [4]
- 1 Guide [A]

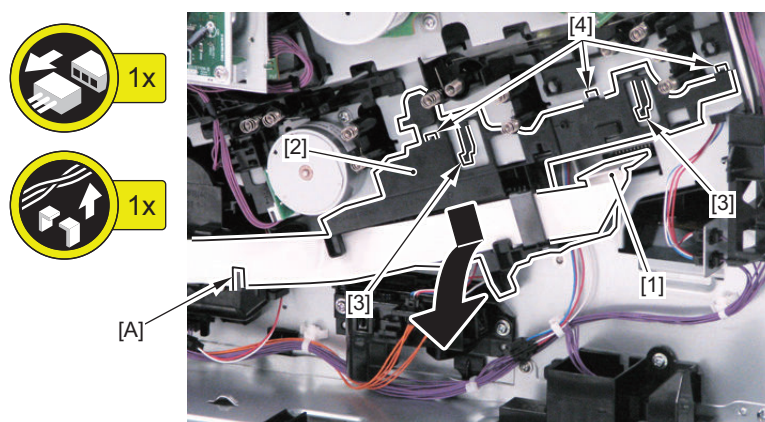

3. Disconnect the Flat Cable [1].

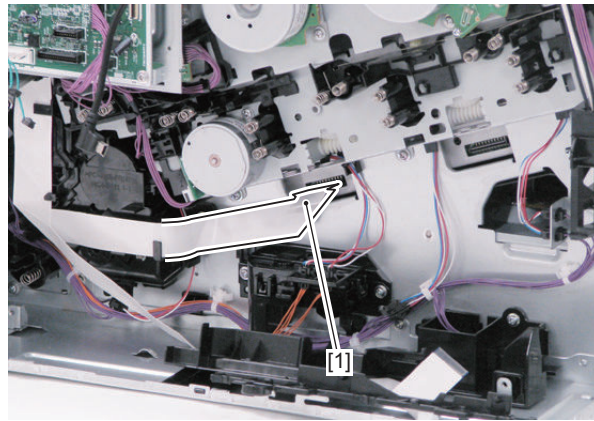

4. Free the 2 harnesses [1].

- 2 Connectors [2]
- Guides [A] and [B]

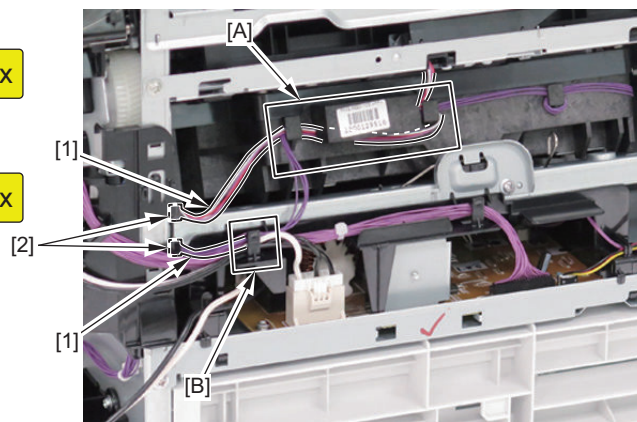

5. Remove the Laser Scanner Unit Fixation Plate [1].

- 1 Screw [2]
- 1 Hook [3]

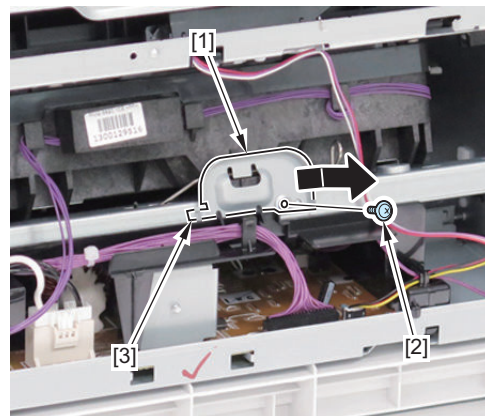

6. Remove the Laser Scanner Unit Fixation Spring [1].

- 2 Hooks [2]

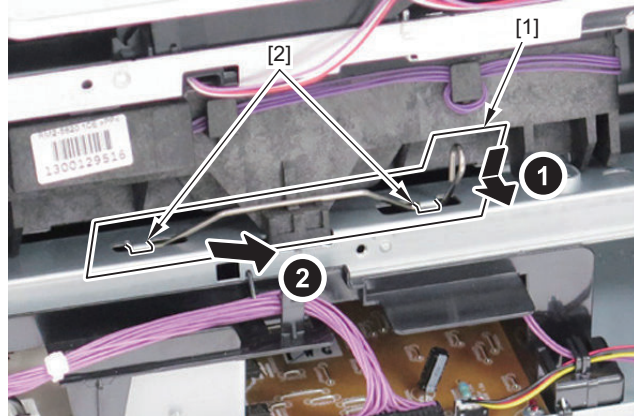

CAUTION:

- Be sure not to touch the 4 surfaces of the Dustproof Glass [A] of the Laser Scanner Unit [1].

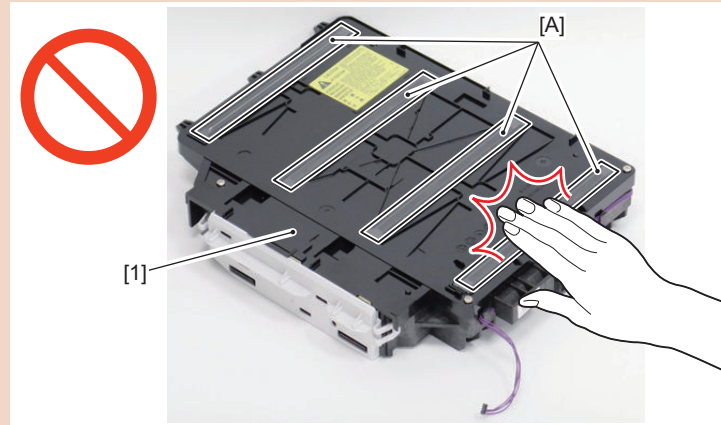

- When disengaging the Laser Scanner Unit [1], be sure to close the Front Cover [2]. This disengages the 4 sections of the Dustproof Glass Cleaning Tool [3] from the Laser Scanner Unit [1].

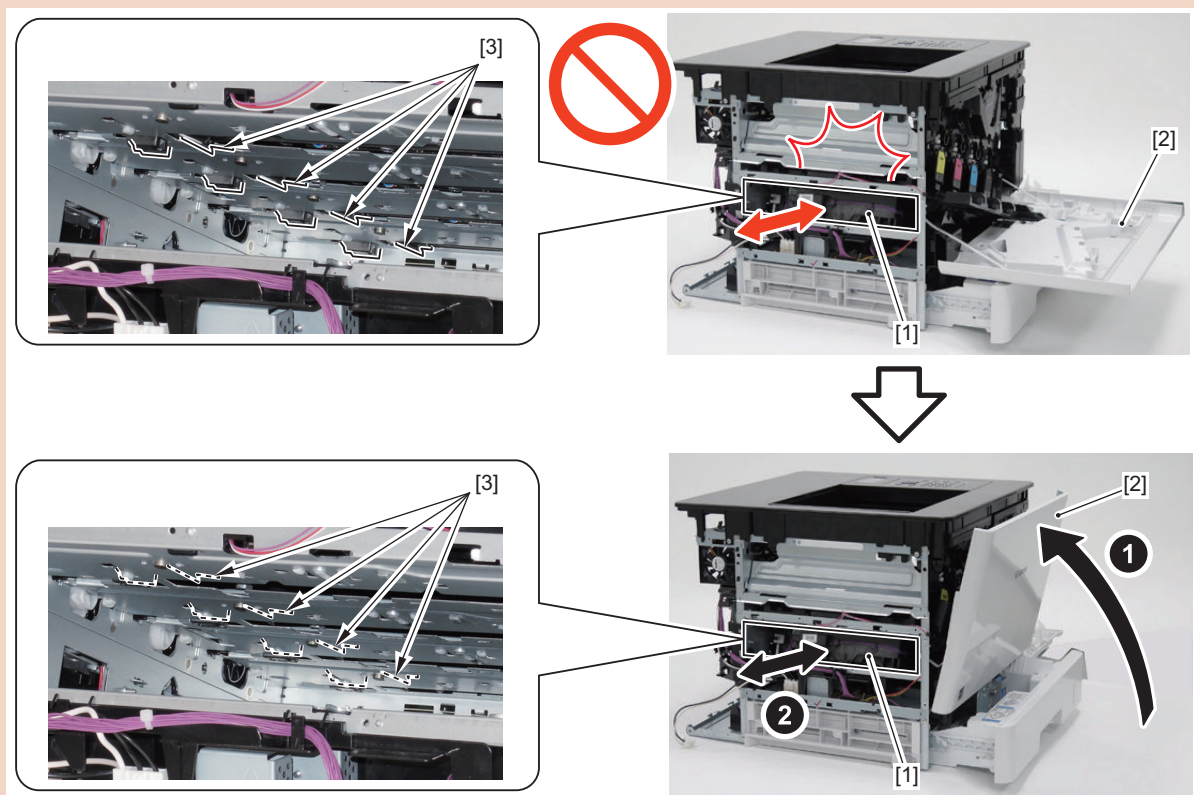

7. Close the Front Cover [1], and remove the Laser Scanner Unit [2].

- 1 Hook [3]

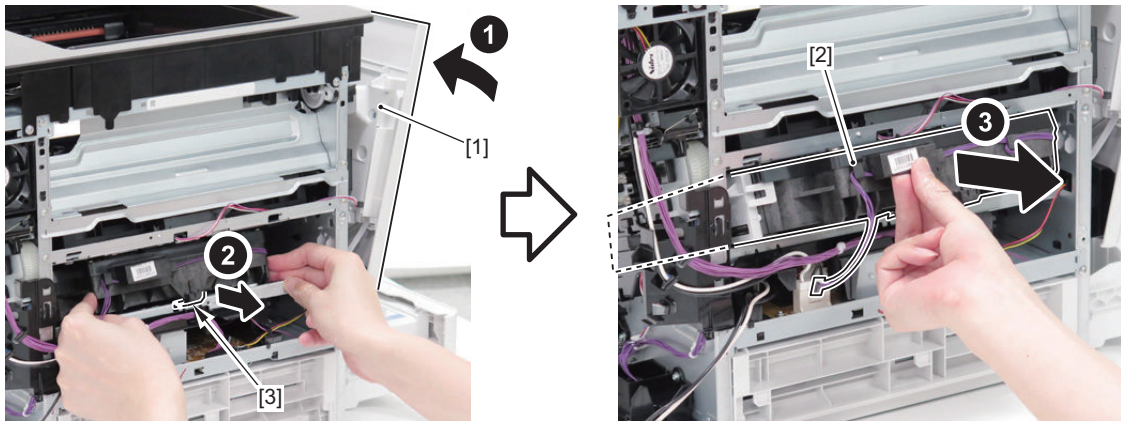

Image Formation System

● Removing the Secondary Transfer Unit

■ Procedure

CAUTION:

Be sure not to touch the 3 rollers [1] or the drive gear section [A].

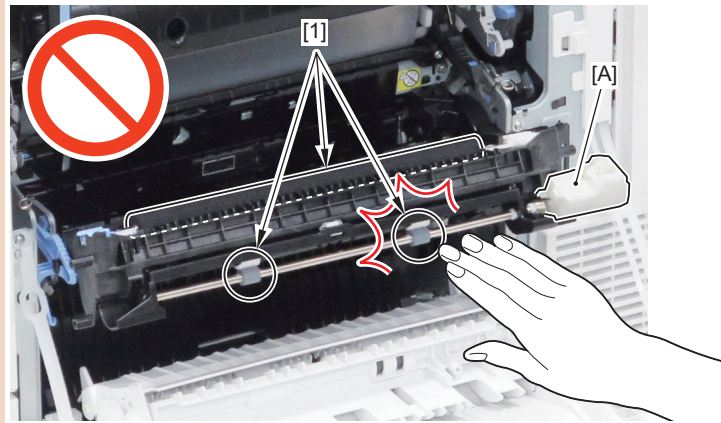

1. Open the Right Cover Unit [1].

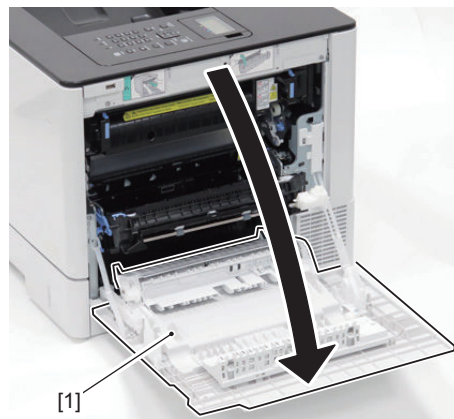

2. Remove the arm [2] from the Secondary Transfer Unit shaft [1].

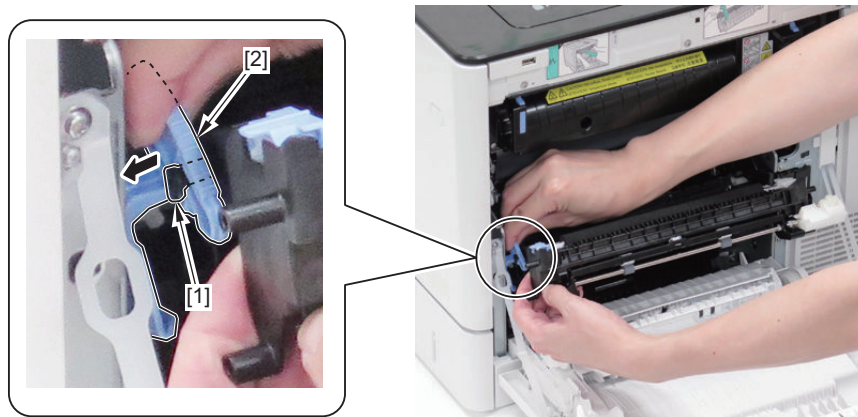

3. Remove the Secondary Transfer Unit [2] while closing the Transport Guide [1].

- 2 Shafts [3]

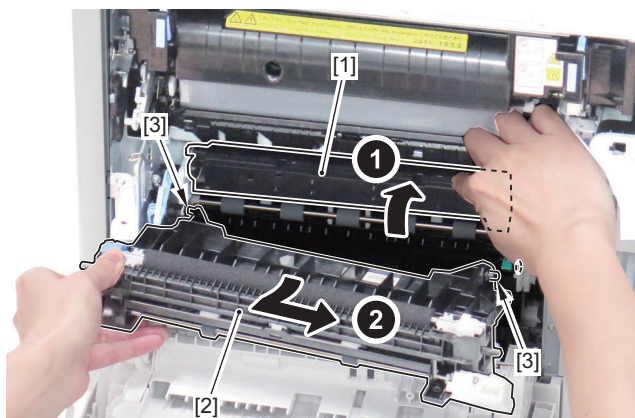

● Removing the Secondary Transfer Roller Unit

■ Procedure

1. Open the Right Cover Unit [1].

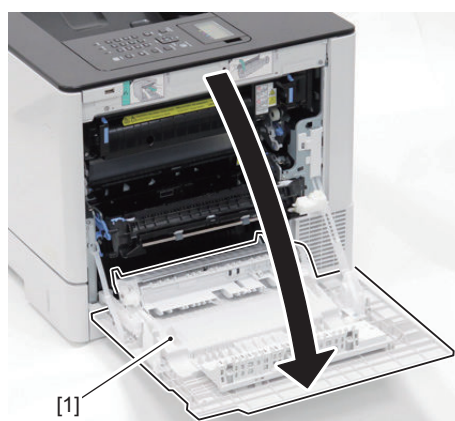

2. Press the [A] part of the arm [1], and further open the Secondary Transfer Unit [2].

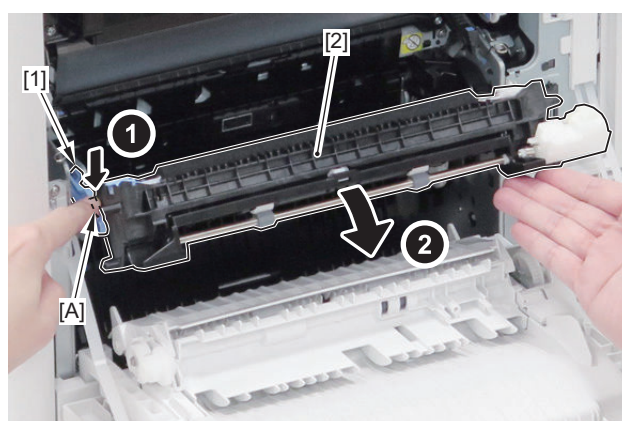

3. Lift up the Shaft Support [1] on the left side, and remove the Secondary Transfer Roller Unit [2].

- 1 Claw [3]
- 1 Shaft [4]

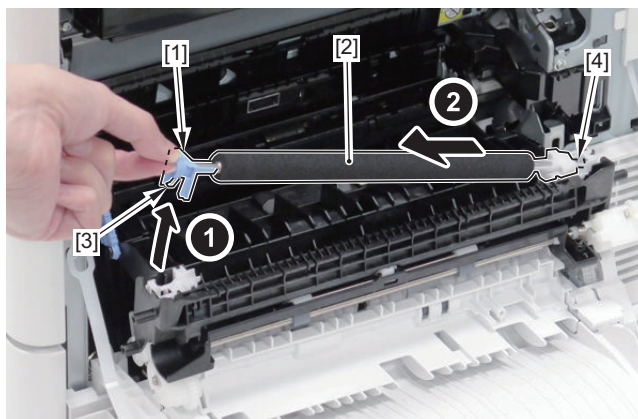

Removing the ITB Unit

■ Procedure

CAUTION:

- Be sure to place the ITB Unit [1] on a sheet of paper [2].

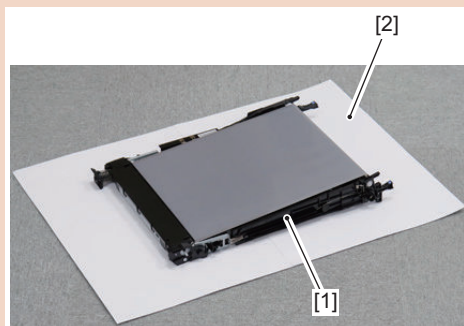

- Be sure not to touch or damage the ITB [1].

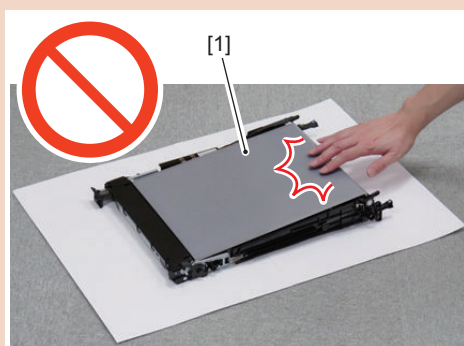

1. Open the Right Cover Unit [1].

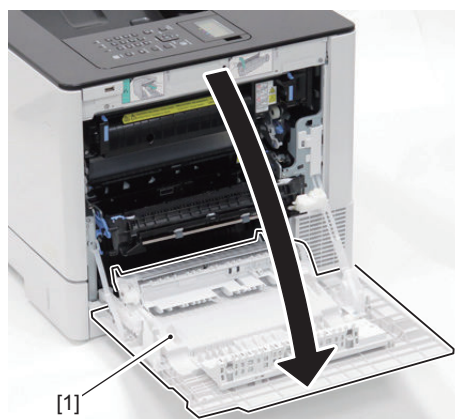

2. Press the [A] part of the arm [1], and further open the Secondary Transfer Unit [2].

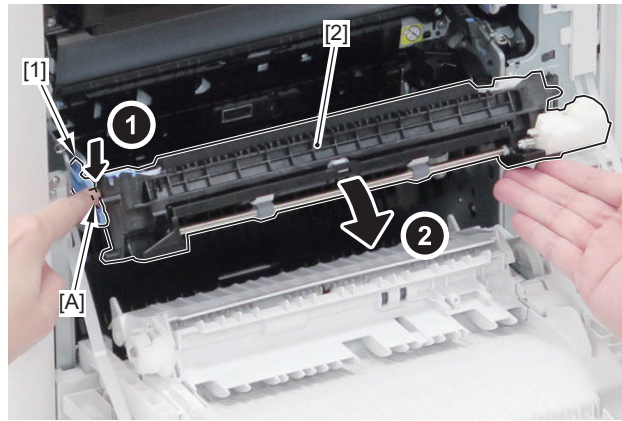

3. Pull out the ITB Lock Lever [1] until it stops.

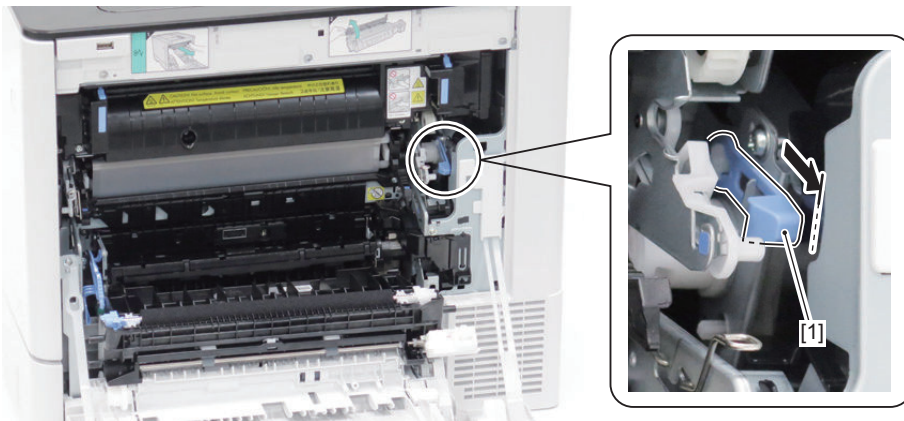

4. Move the left side spring [1] from the ITB lock position hook [2] to the ITB lock release position hook [3].

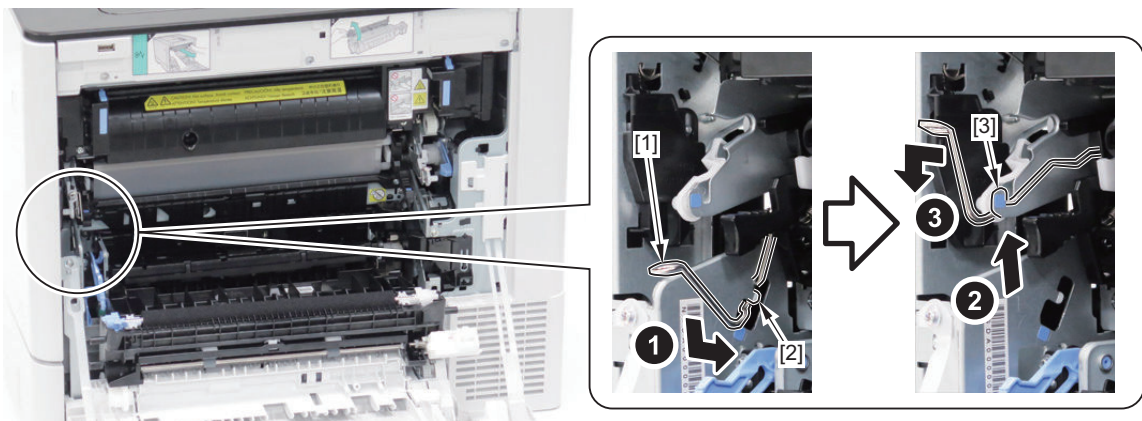

5. Move the right side spring [1] from the ITB lock position hook [2] to the ITB lock release position hook [3].

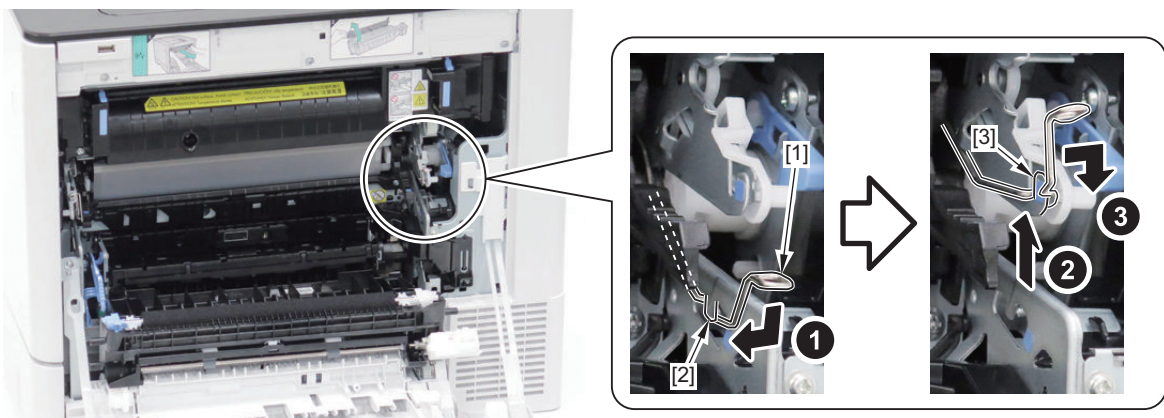

6. Grip the handles [1] on the right and left side, and pull the ITB Unit [2] out 15 cm.

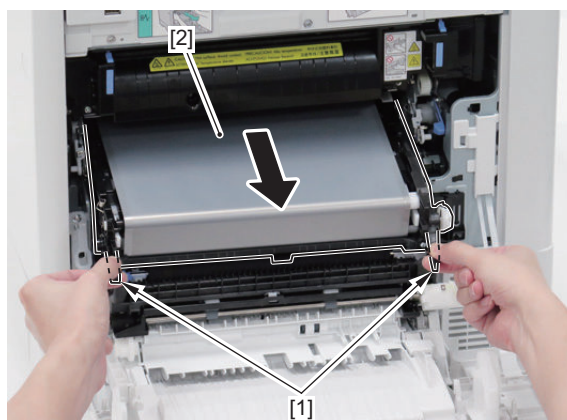

7. Switch your grip to the Left Guide section [A] and Right Guide section [B], and remove the ITB Unit [1].

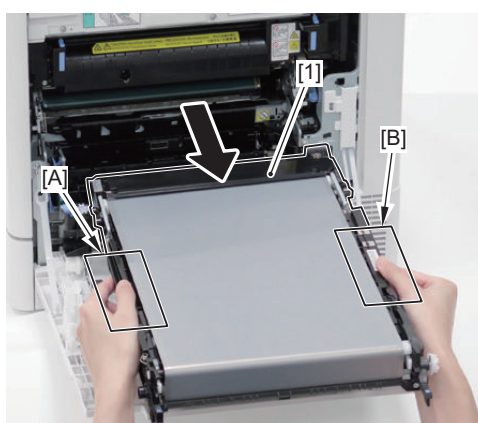

CAUTION:

When installing the ITB Unit [1], be sure to check that the spring on the right side [2] and the spring on the left side [3] are hooked to the hooks [4] at the ITB lock release position.

If you insert the ITB Unit [1] while the spring on the right side [2] and the spring on the left side [3] are not hooked to the hooks [4], the ITB may be damaged or the springs may be deformed.

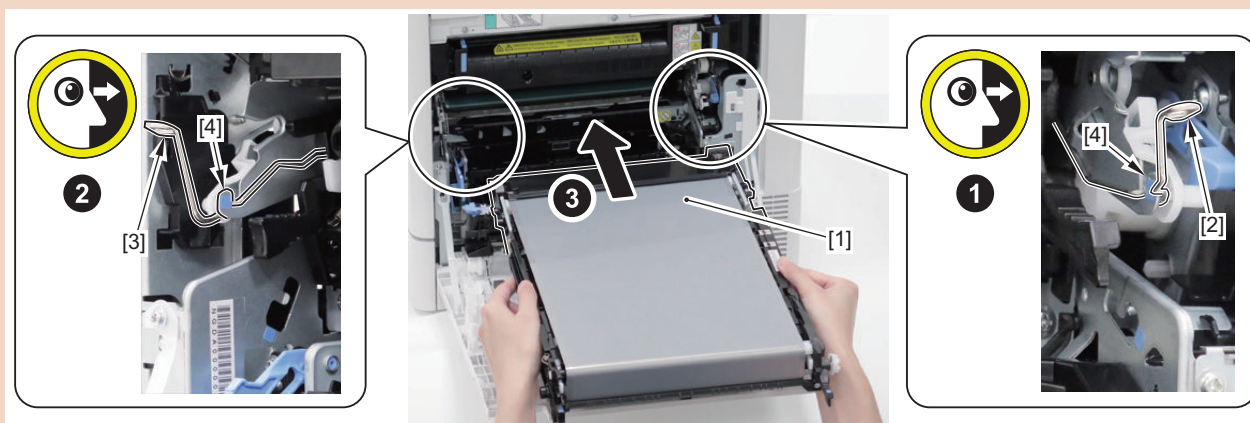

● Removing the Developing Disengagement Motor

■ Preparation

1. "Removing the Waste Toner Container Cover Unit" on page 130
2. "Removing the Rear Cover" on page 131

3. "Removing the Left Cover" on page 132
4. "Removing the Controller Cover" on page 182
5. "Removing the Controller Box" on page 187
6. "Removing the Lower High Voltage Power Supply PCB" on page 191

■ Procedure

1. Remove the Developing Disengagement Motor [1].

- 1 Connector [2]
- 2 Screws [3]

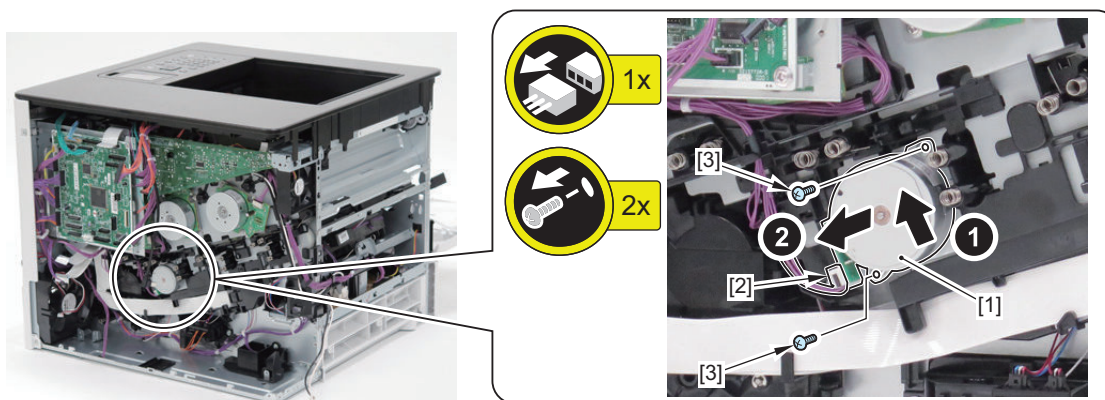

● Removing the Drum Motor (Y)

■ Preparation

1. "Removing the Waste Toner Container Cover Unit" on page 130
2. "Removing the Rear Cover" on page 131
3. "Removing the Left Cover" on page 132
4. "Removing the Controller Cover" on page 182
5. "Removing the Controller Box" on page 187

■ Procedure

1. Remove the Drum Motor (Y) [1].

- 1 Connector [2]
- 4 Screws [3]

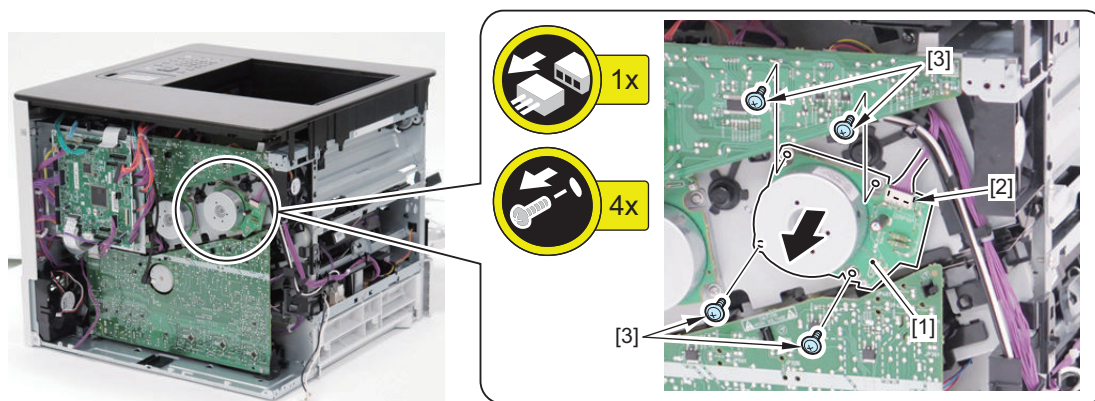

● Removing the Drum Motor (M)

■ Preparation

1. "Removing the Waste Toner Container Cover Unit" on page 130
2. "Removing the Rear Cover" on page 131
3. "Removing the Left Cover" on page 132
4. "Removing the Controller Cover" on page 182
5. "Removing the Controller Box" on page 187
6. "Removing the Right Rear Cover" on page 133
7. "Removing the DC Controller Support Plate" on page 190
8. "Removing the Upper Cover Unit" on page 137
9. "Removing the Upper High Voltage Power Supply PCB" on page 192

■ Procedure

1. Remove the Drum Motor (M) [1].

- 1 Connector [2]
- 4 Screws [3]

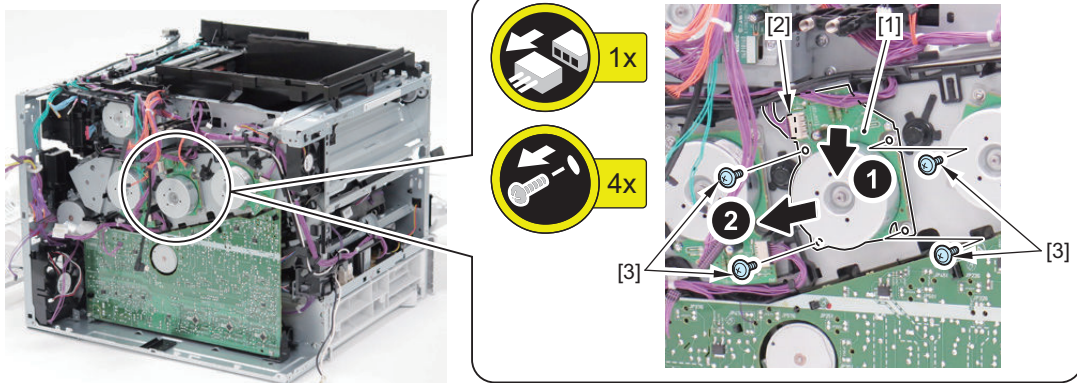

● Removing the Drum Motor (C)

■ Preparation

1. "Removing the Waste Toner Container Cover Unit" on page 130
2. "Removing the Rear Cover" on page 131
3. "Removing the Left Cover" on page 132
4. "Removing the Controller Cover" on page 182
5. "Removing the Controller Box" on page 187
6. "Removing the Right Rear Cover" on page 133
7. "Removing the DC Controller Support Plate" on page 190

■ Procedure

1. Remove the Drum Motor (C) [1].

- 1 Connector [2]
- 4 Screws [3]

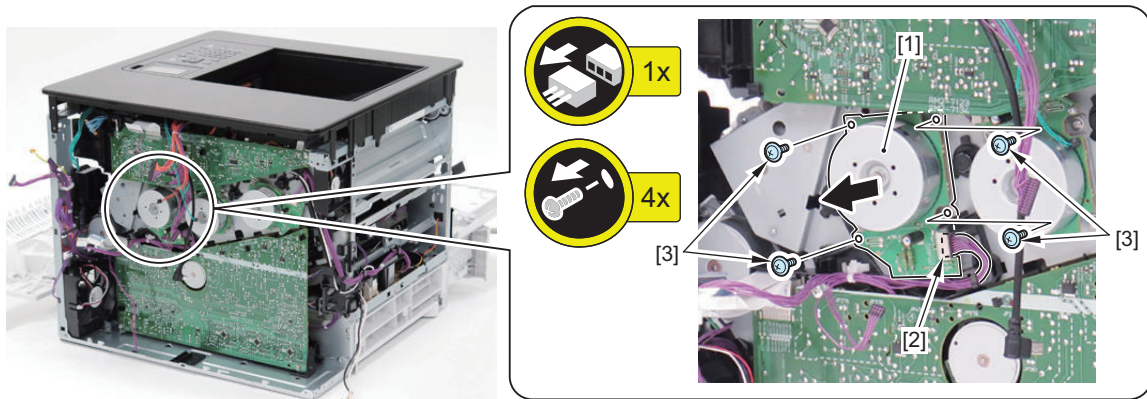

● Removing the Color Displacement Density Sensor Unit

■ Preparation

1. Remove the Toner Cartridge (Bk).
2. “Removing the Waste Toner Container Cover Unit” on page 130
3. “Removing the Rear Cover” on page 131
4. “Removing the Left Cover” on page 132
5. “Removing the Controller Cover” on page 182
6. “Removing the Controller Box” on page 187
7. “Removing the Right Rear Cover” on page 133
8. “Removing the DC Controller Support Plate” on page 190
9. “Removing the Secondary Transfer Unit” on page 147
10. “Removing the ITB Unit” on page 150
11. “Removing the Registration Unit” on page 166

■ Procedure

CAUTION:

Be sure not to touch the 2 sensor surfaces [A] of the Color Displacement Density Sensor Unit [1].

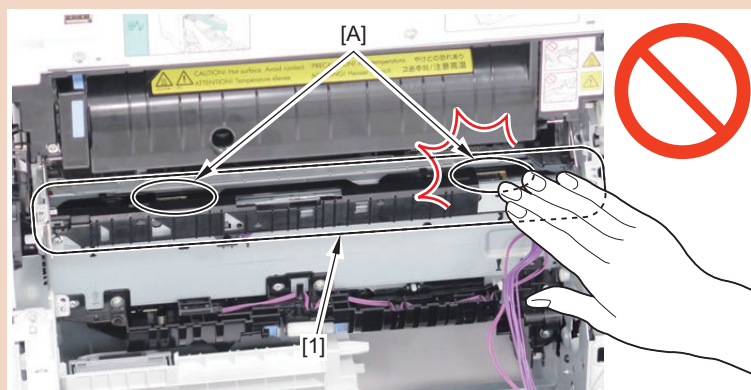

1. Shift the right hinge of the Base Cover [1].

- 1 Screw [2]
- 2 Bosses [3]
- 1 Hook [4]

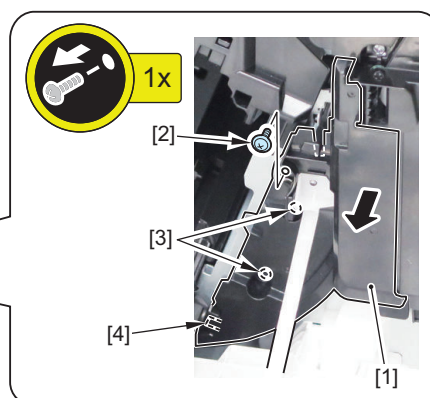
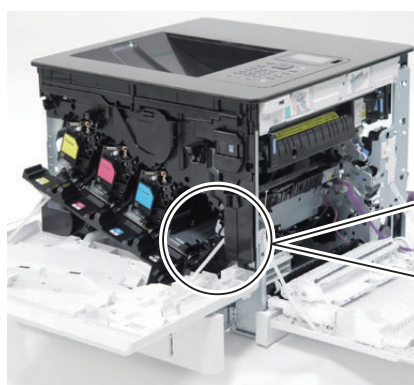

2. Place the Color Displacement Density Sensor Unit [1] down temporarily.

- 2 Screws [2]
- 1 Hook [3]

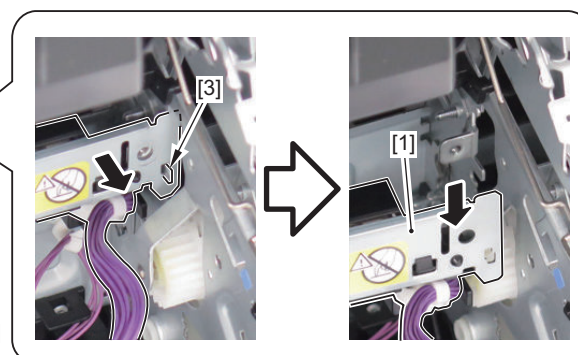
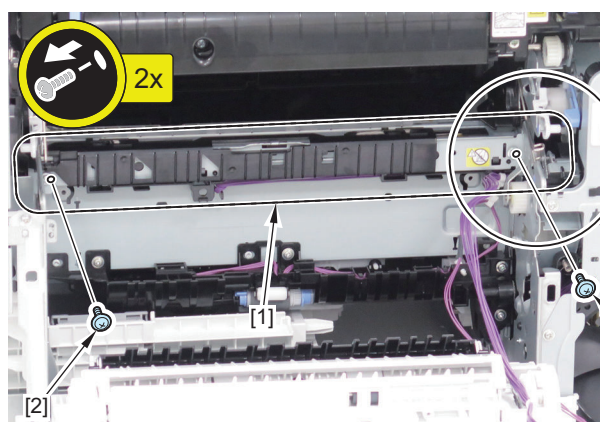

3. Pull out and remove the Color Displacement Density Sensor Unit [1] from the hole [A].

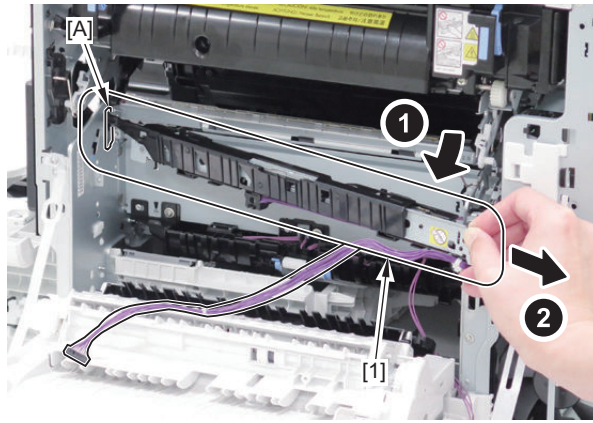

Fixing System

Removing the Fixing Assembly

Procedure

CAUTION:

Since the Fixing Assembly is hot immediately after the power is turned OFF, give it time to cool down before removing it.

1. Open the Right Cover Unit [1], and remove the Fixing Assembly [3] while pulling the right and left Lock Levers [2].

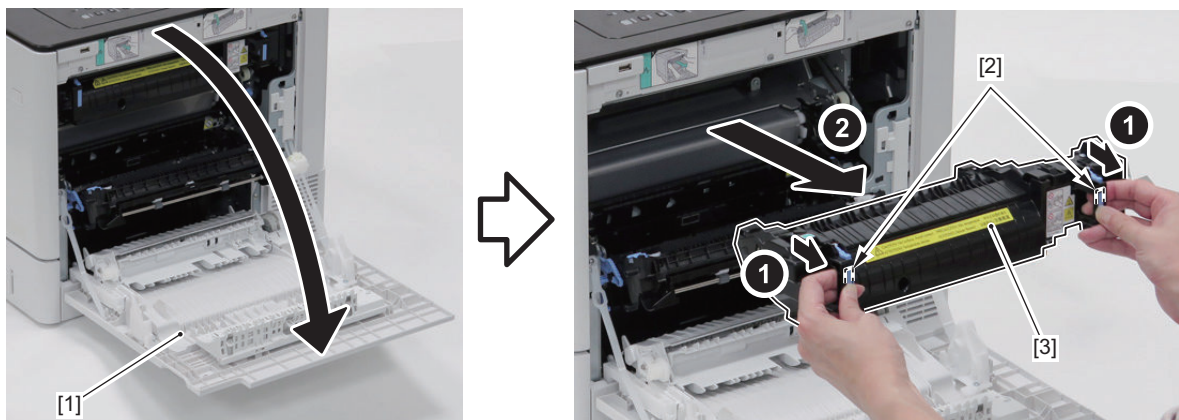

Removing the Fixing Drive Unit

Preparation

1. "Removing the Waste Toner Container Cover Unit" on page 130
2. "Removing the Rear Cover" on page 131
3. "Removing the Left Cover" on page 132
4. "Removing the Controller Cover" on page 182
5. "Removing the Controller Box" on page 187
6. "Removing the Right Rear Cover" on page 133
7. "Removing the DC Controller Support Plate" on page 190
8. "Removing the Upper Cover Unit" on page 137
9. "Removing the Upper High Voltage Power Supply PCB" on page 192
10. "Removing the Fixing Assembly" on page 158

■ Procedure

1. Free the 5 harnesses [1] from the 5 guides [A].

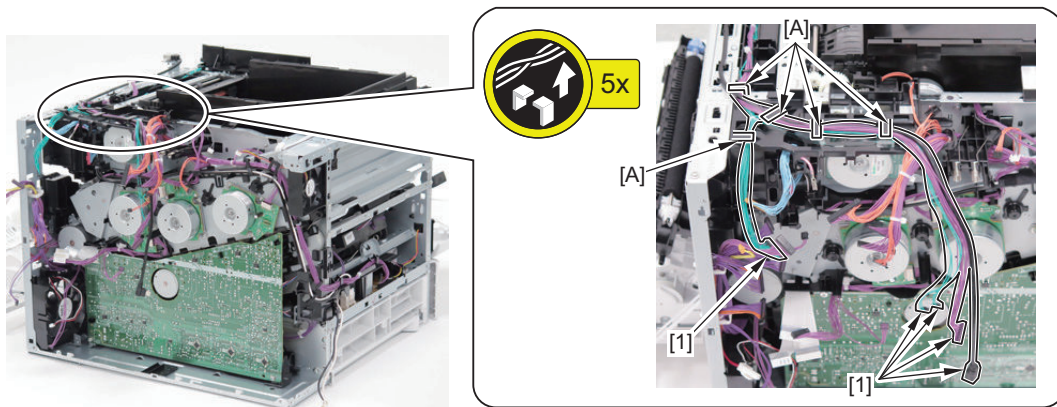

2. Free the 3 harnesses [1] from the 3 guides [B], and remove the Harness Guide [2].

- 1 Boss [3]
- 4 Hooks [4]

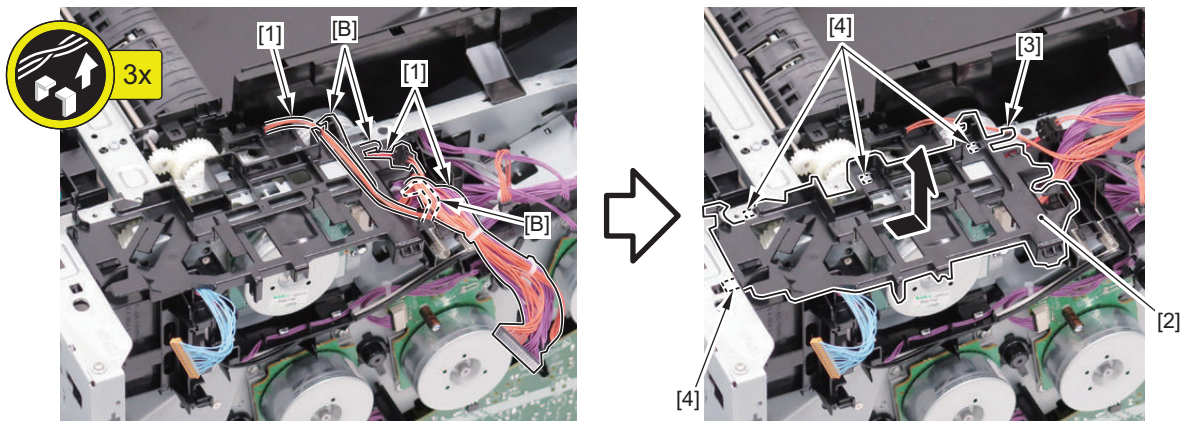

3. Disconnect the Fixing Drawer Connector [1].

- 1 Screw [2]
- 1 Claw [3]
- 1 Boss [4]
- 1 Hook [5]

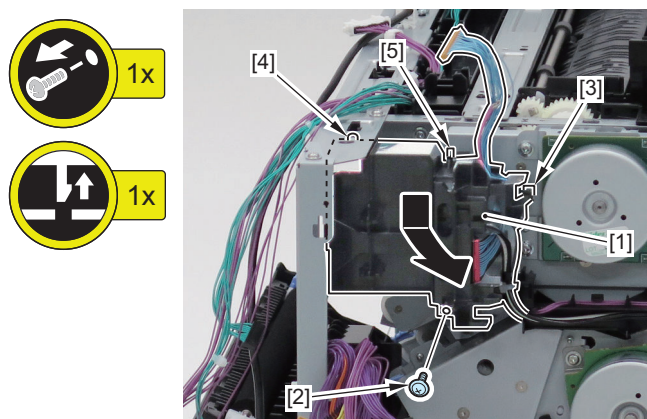

4. Remove the Fixing Drive Unit [1].

CAUTION:

Be sure to carefully remove/install the Fixing Drive Unit [1] so that the 2 gears [5] do not come off.

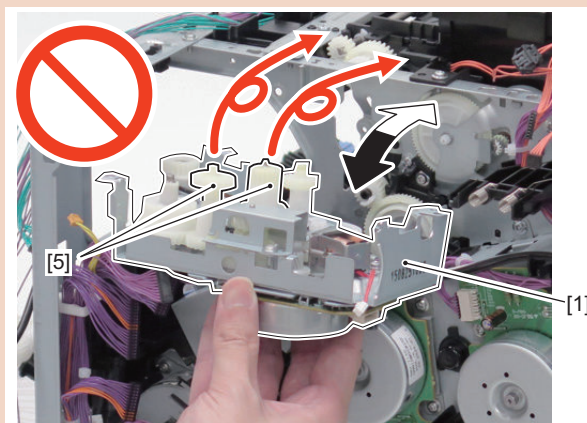

- 2 Connectors [2]
- 3 Screws [3]
- 1 Hook [4]

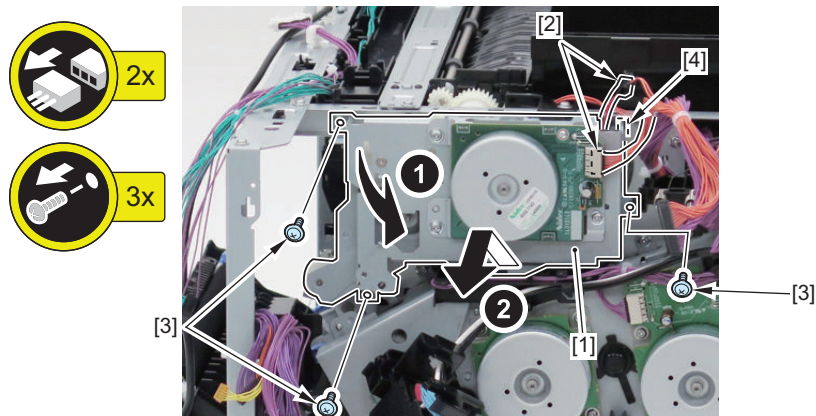

● Removing the Fixing Motor

■ Preparation

1. "Removing the Waste Toner Container Cover Unit" on page 130
2. "Removing the Rear Cover" on page 131
3. "Removing the Left Cover" on page 132
4. "Removing the Controller Cover" on page 182
5. "Removing the Controller Box" on page 187
6. "Removing the Right Rear Cover" on page 133
7. "Removing the DC Controller Support Plate" on page 190
8. "Removing the Upper Cover Unit" on page 137
9. "Removing the Upper High Voltage Power Supply PCB" on page 192

■ Procedure

1. Remove the Fixing Motor [1].

- 1 Connector [2]
- 3 Screws [3]
- 1 Boss [4]

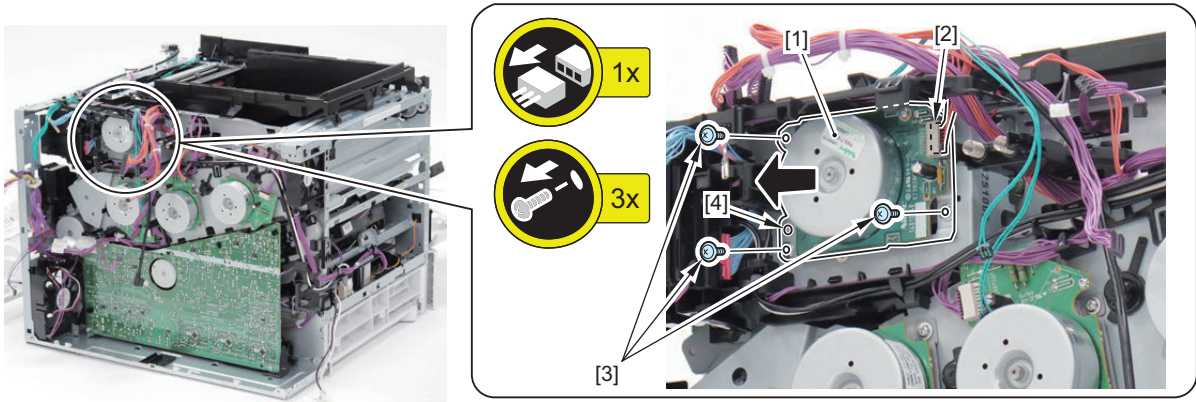

Pickup Feed Delivery System

● Removing the Delivery Unit

■ Preparation

1. Remove the Toner Cartridge (Y/M/C/Bk).
2. "Removing the Waste Toner Container Cover Unit" on page 130
3. "Removing the Rear Cover" on page 131
4. "Removing the Left Cover" on page 132
5. "Removing the Right Rear Cover" on page 133
6. "Removing the Upper Cover Unit" on page 137
7. "Removing the Output Tray Unit" on page 138
8. "Removing the Fixing Assembly" on page 158
9. "Removing the ITB Unit" on page 150

■ Procedure

1. Remove the Upper Cover Guide [1].

- 1 Screw [2]
- 2 Hooks [3]

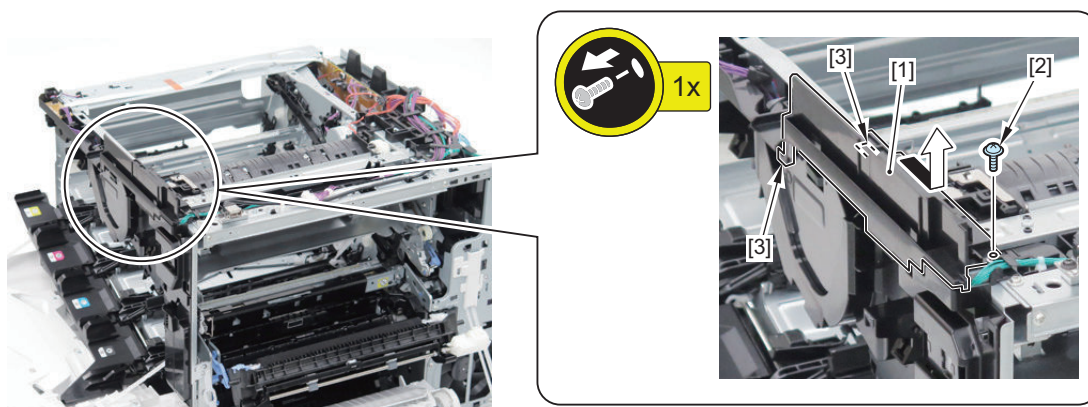

2. Remove the Delivery Unit [1].

- 1 Connector [2]
- 2 Screws [3] (Binding)
- 4 Screws [4] (TP)

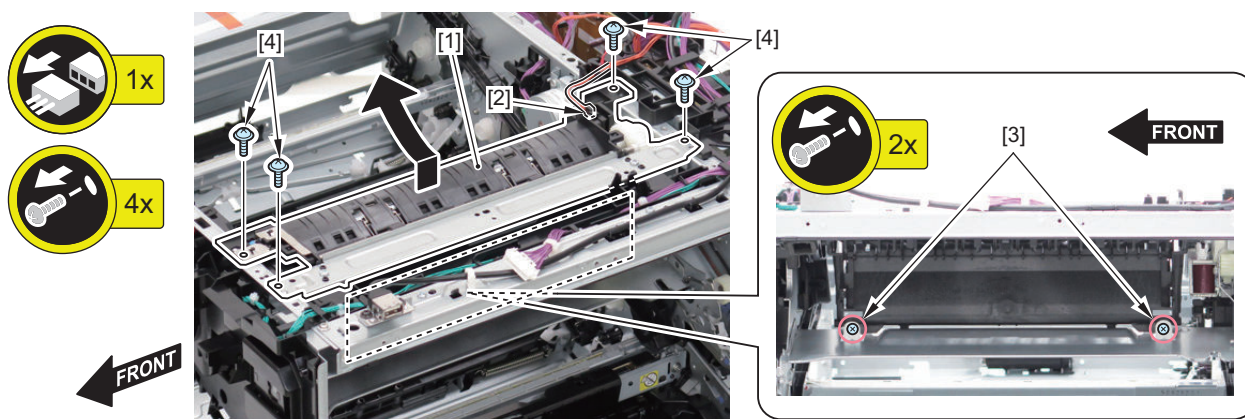

3. Remove the Solenoid Arm [2] and Solenoid Pin [3] from the Delivery Unit [1].

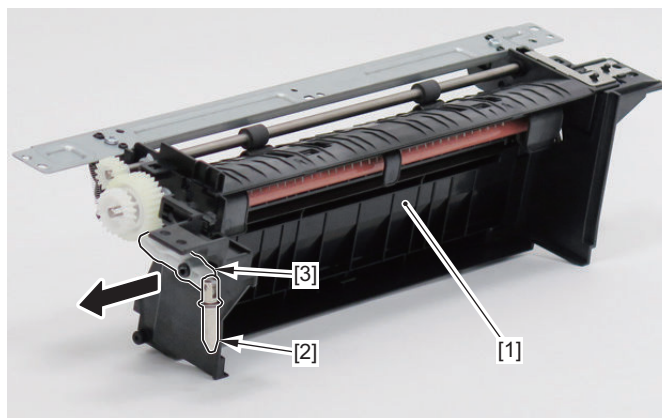

CAUTION:

- When installing, insert the flapper [2] of the Delivery Unit [1] under the guide [3] on the host machine side.

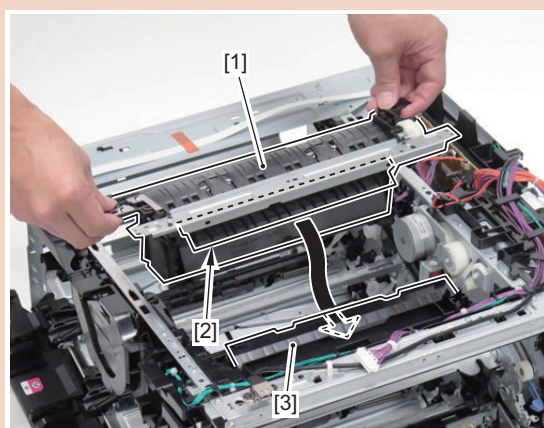

- When installing, insert the Solenoid Pin [2] of the Delivery Unit [1] into the hole [A] of the solenoid on the host machine side [3].

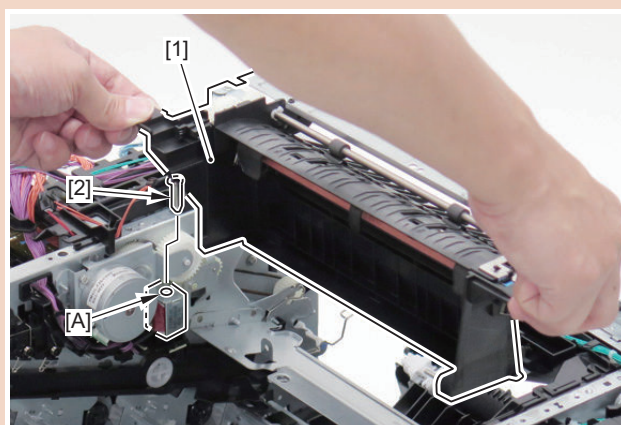

● Removing the Lifter Drive Unit

■ Preparation

- “Removing the Waste Toner Container Cover Unit” on page 130
- “Removing the Rear Cover” on page 131
- “Removing the Left Cover” on page 132
- “Removing the Controller Cover” on page 182

5. "Removing the Controller Box" on page 187

6. "Removing the Lower High Voltage Power Supply PCB" on page 191

■ Procedure

1. Disconnect the 2 Flat Cables [1].

- 2 Connectors [2]
- 1 Guide [A]
- 3 Guides [B]

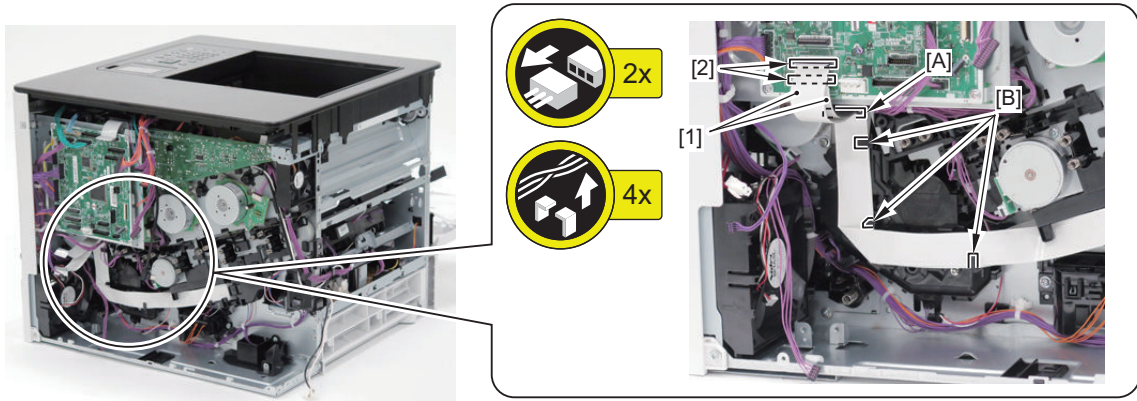

2. Free the 2 harnesses [1].

- 2 Connectors [2]
- 1 Guide [C]
- 2 Guides [D]

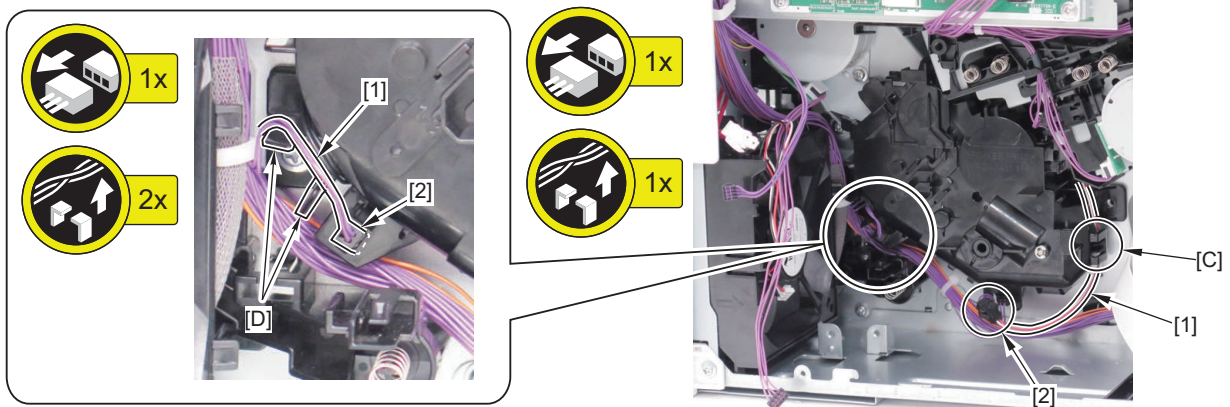

3. Remove the Lifter Drive Unit [1].

- 2 Screws [2]
- 3 Claws [3]

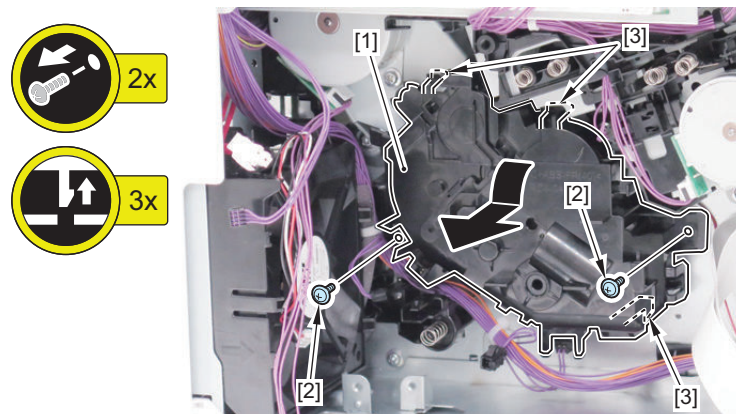

● Removing the Pickup Drive Unit

■ Preparation

1. “Removing the Waste Toner Container Cover Unit” on page 130
2. “Removing the Rear Cover” on page 131
3. “Removing the Left Cover” on page 132
4. “Removing the Controller Cover” on page 182
5. “Removing the Controller Box” on page 187
6. “Removing the Lower High Voltage Power Supply PCB” on page 191
7. “Removing the Lifter Drive Unit” on page 163
8. “Removing the Right Rear Cover” on page 133
9. “Removing the DC Controller Support Plate” on page 190

■ Procedure

1. Free the harness [1] from the guide [A], and remove the Power Fan Unit [2].

- 1 Screw [3]
- 3 Hooks [4]

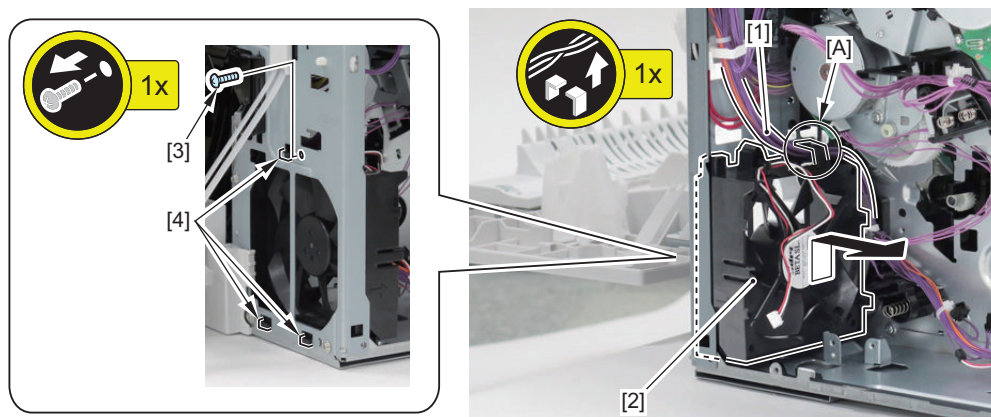

2. Remove the Pickup Drive Unit [1].

- 1 Connector [2]
- 3 Screws [3]
- 1 Hook [4]

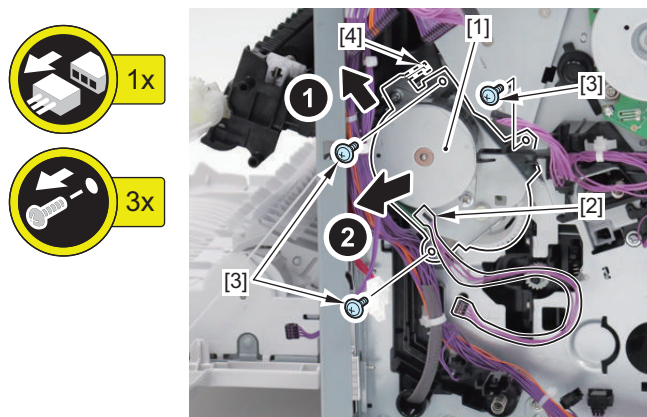

CAUTION:

When installing, be sure to check that the teeth of the contact parts [A] of gear [1] and gear [2] are engaged. If there is a gap between the contact parts [A], be sure to move gear [1] approximately 2 mm so that the gears are engaged (due to gear [1] being placed on the rib [B] of gear [2]).

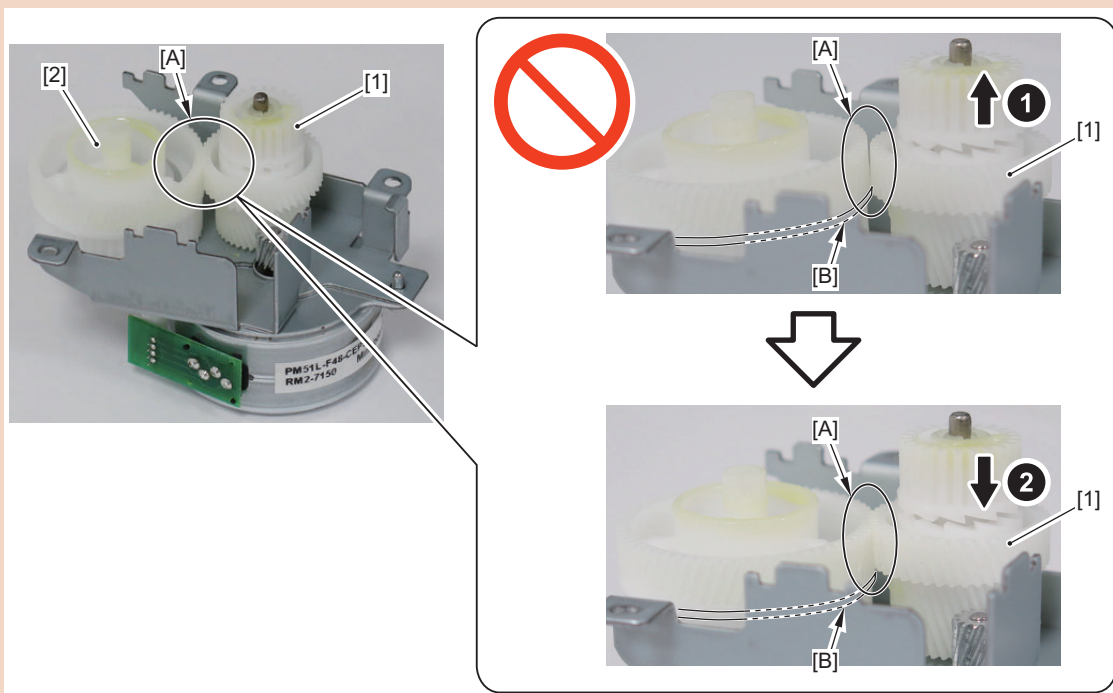

● Removing the Registration Unit

■ Preparation

1. Remove the Toner Cartridge (Bk).
2. “Removing the Waste Toner Container Cover Unit” on page 130
3. “Removing the Rear Cover” on page 131
4. “Removing the Left Cover” on page 132
5. “Removing the Controller Cover” on page 182
6. “Removing the Controller Box” on page 187
7. “Removing the Right Rear Cover” on page 133
8. “Removing the DC Controller Support Plate” on page 190
9. “Removing the Secondary Transfer Unit” on page 147
10. “Removing the ITB Unit” on page 150

■ Procedure

CAUTION:

Do not touch the Gear Unit [2] of the Registration Unit [1].

Grease is applied on the Gear Unit [2]. If you have accidentally touched grease, wipe with lint-free paper so as not to smear other parts with your greasy hand.

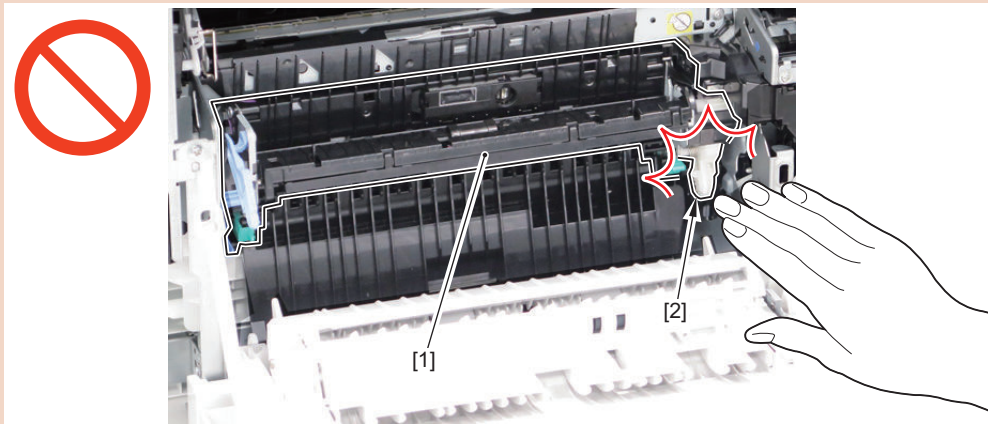

1. Remove the Harness Guide Cover [1].

- 1 Claw [2]
- 2 Hooks [3]

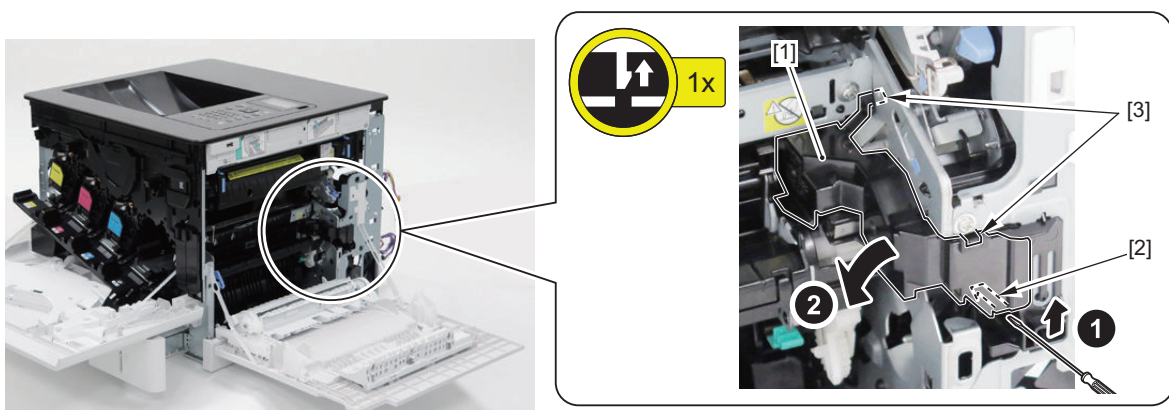

2. Remove the 4 harnesses [1].

- 2 Wire Saddles [2]

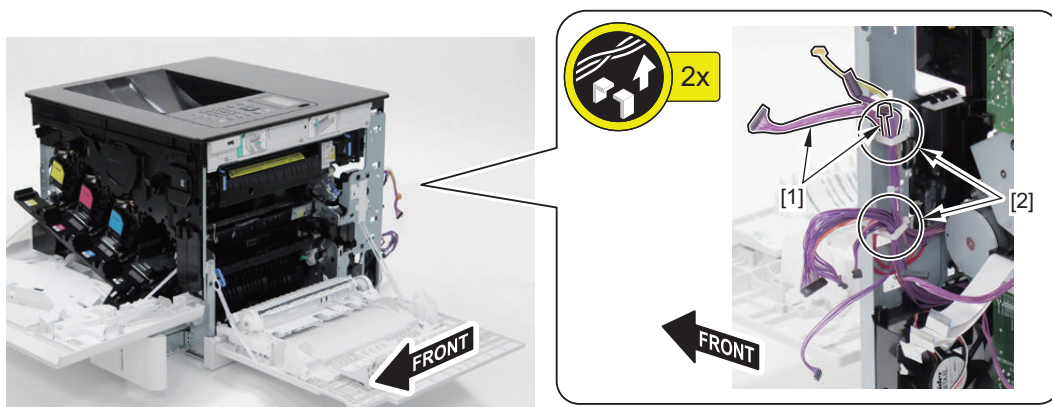

3. Pull out the harness [1] and free it from the Harness Guide [A].

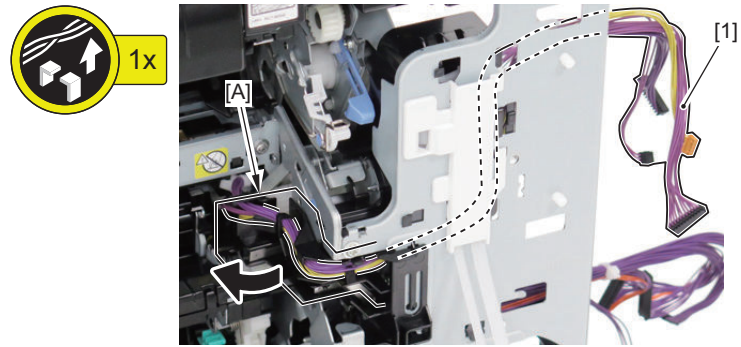

4. Remove the Harness Guide [1].

- 1 Boss [2]
- 2 Hooks [3]

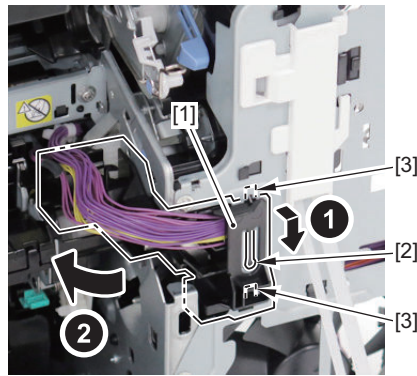

5. Remove the 4 connectors [1] from the hole of the plate [A] and the Harness Guide [2].

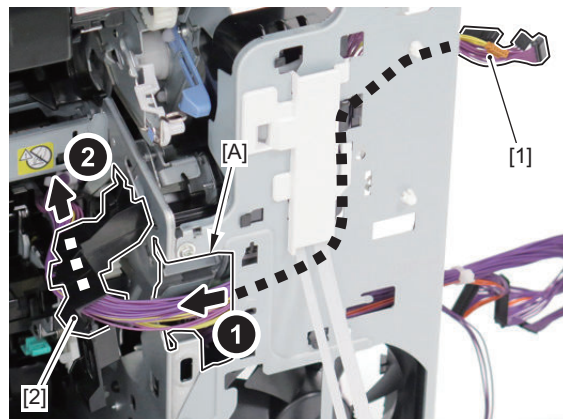

6. Lower the 2 levers [1], and open the guide [2].

- 2 Shafts [3]

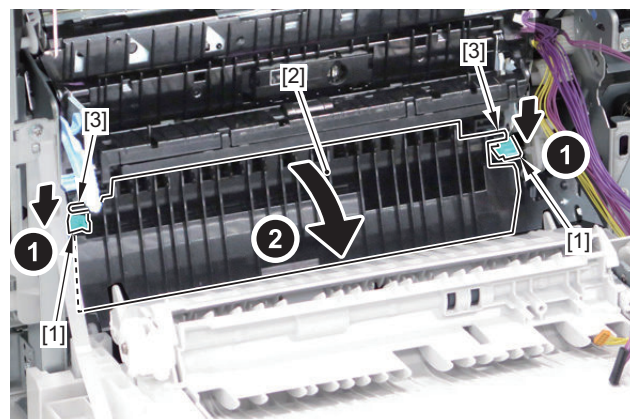

7. Free the harness [1] from the Harness Guide [A].

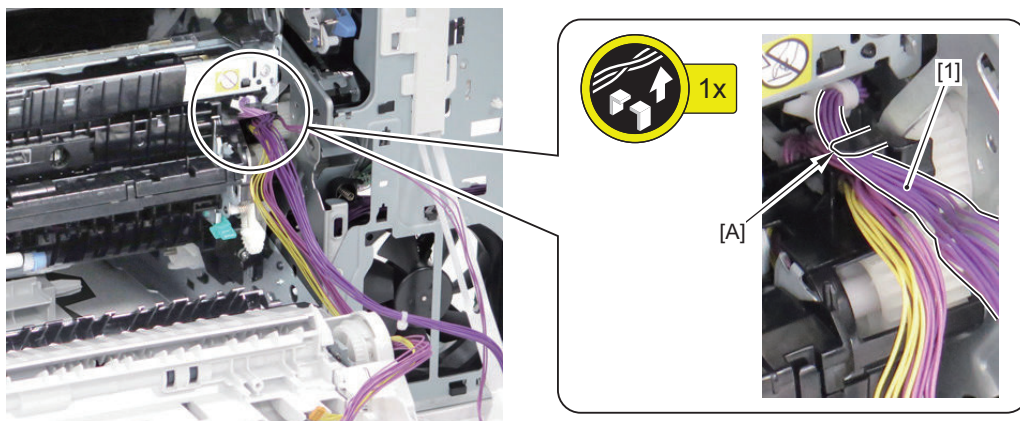

8. Remove the Registration Unit [1].

- 3 Screws [2]
- 1 Shaft [3]

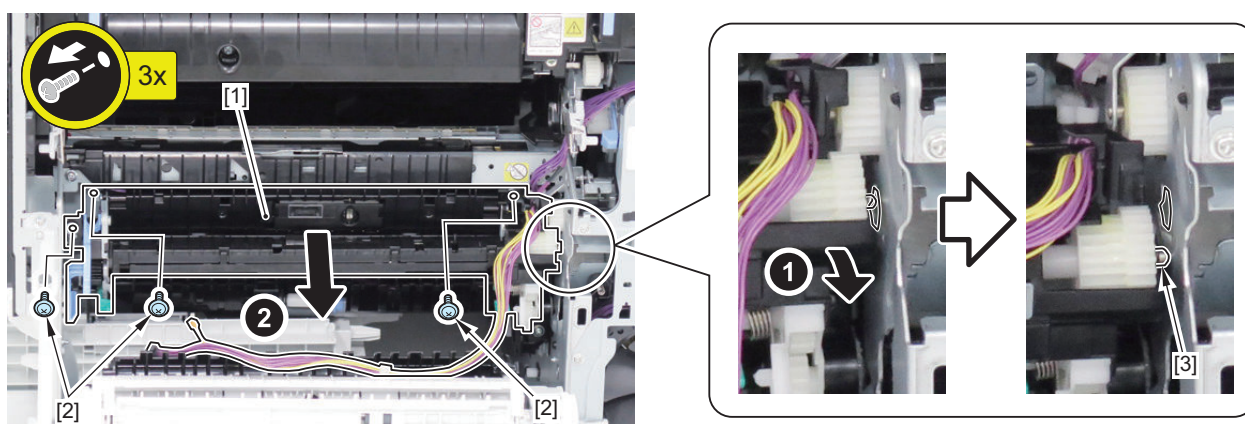

Procedure for Installing the Registration Unit

1. Insert the 2 hooks [1] approximately halfway into the holes of the machine [A].

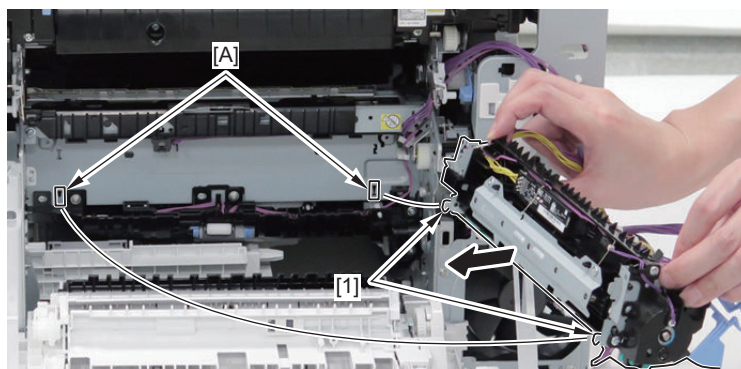

2. Insert the shaft [1] into the guide hole of the machine [B].

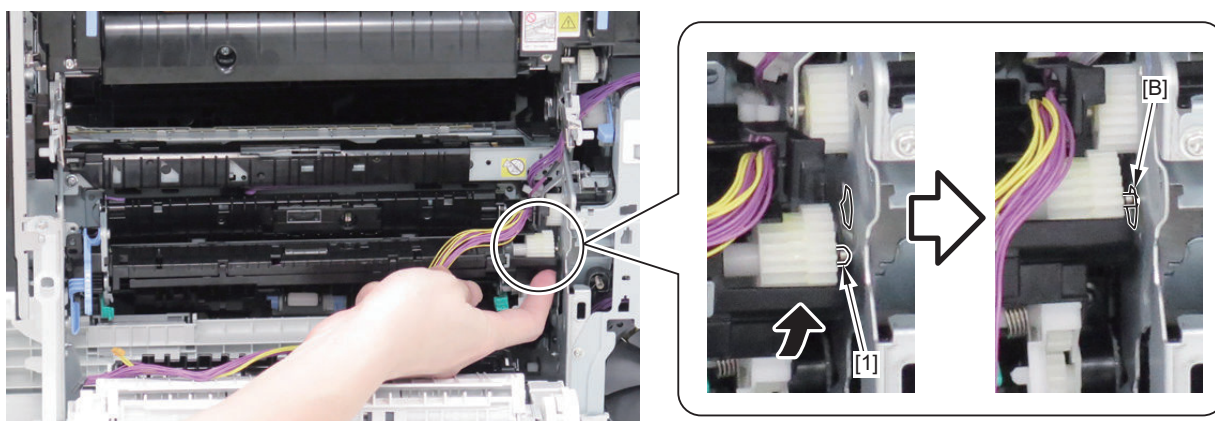

3. Push the 2 [C] parts of the Registration Unit, and peep through the receptacle hole [D] of the Toner Cartridge (Bk) to check that the 2 hooks [1] and 2 positioning plates [2] are inserted.

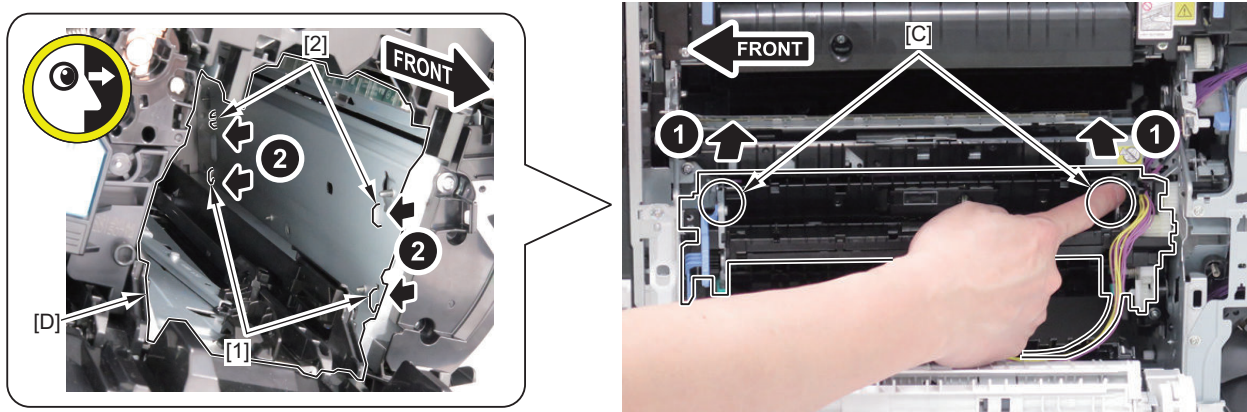

4. Secure the Registration Unit with the 3 removed screws.

Removing the Cassette Pickup Unit

Preparation

1. Remove the Toner Cartridge (Bk).
2. Remove the Cassette.
3. [“Removing the Waste Toner Container Cover Unit” on page 130](#)
4. [“Removing the Rear Cover” on page 131](#)
5. [“Removing the Left Cover” on page 132](#)

6. "Removing the Controller Cover" on page 182
7. "Removing the Controller Box" on page 187
8. "Removing the Lower High Voltage Power Supply PCB" on page 191
9. "Removing the Lifter Drive Unit" on page 163
10. "Removing the Right Rear Cover" on page 133
11. "Removing the DC Controller Support Plate" on page 190
12. "Removing the Secondary Transfer Unit" on page 147
13. "Removing the ITB Unit" on page 150
14. "Removing the Registration Unit" on page 166

■ Procedure

CAUTION:

Do not touch the 3 rollers [2] of the Cassette Pickup Unit [1].

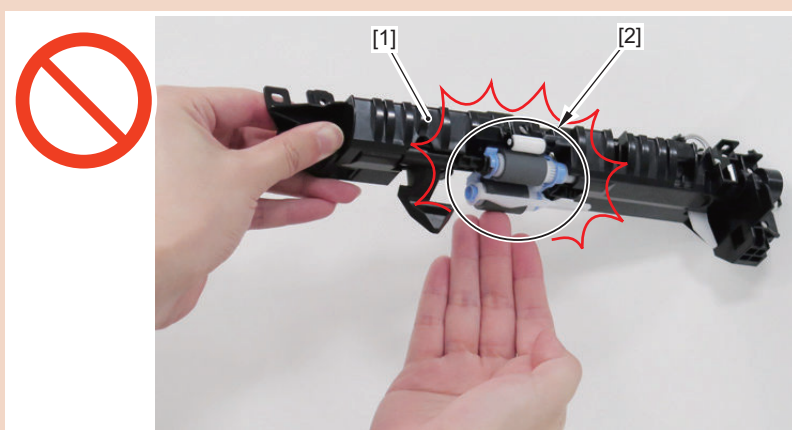

1. Remove the Right Hinge [1].

- 1 Hook [2]

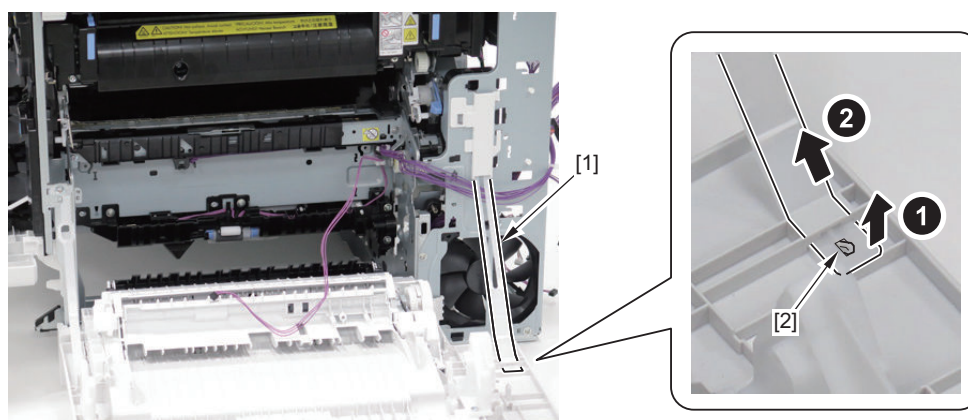

2. Remove the Cassette Pickup Unit [1].

- 1 Wire Saddle [2]
- 4 Screws [3]

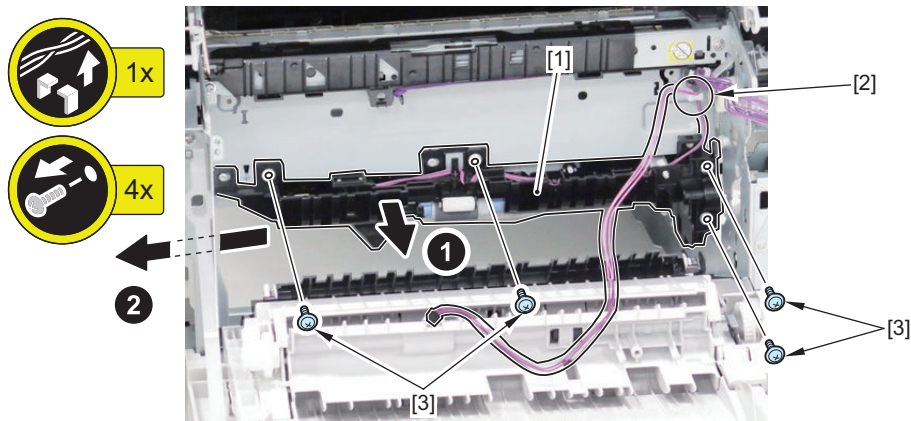

Removing the Cassette Pickup Roller Unit

■ Preparation

1. Remove the Cassette.

■ Procedure

CAUTION:

Do not touch the 2 rollers [1] of the Cassette Pickup Roller Unit.

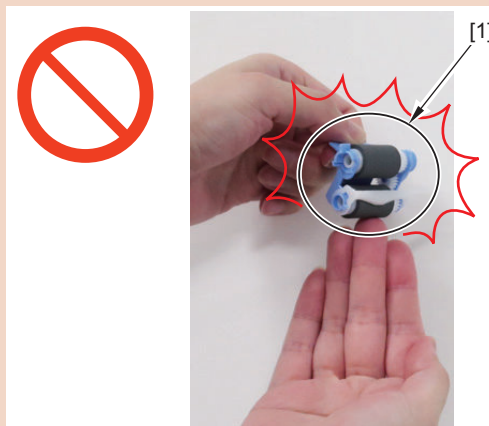

1. Open the Right Cover Unit [1], and close the Secondary Transfer Unit [2].

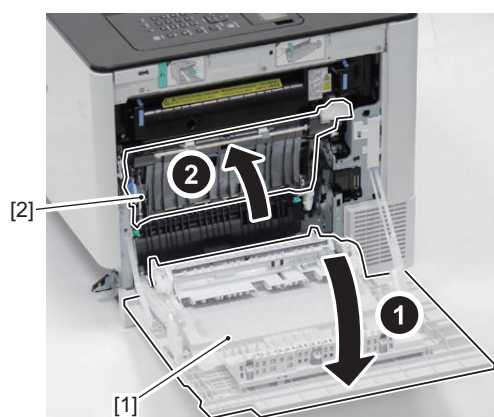

2. Lower the 2 levers [1], and open the guide [2].

- 2 Shafts [3]

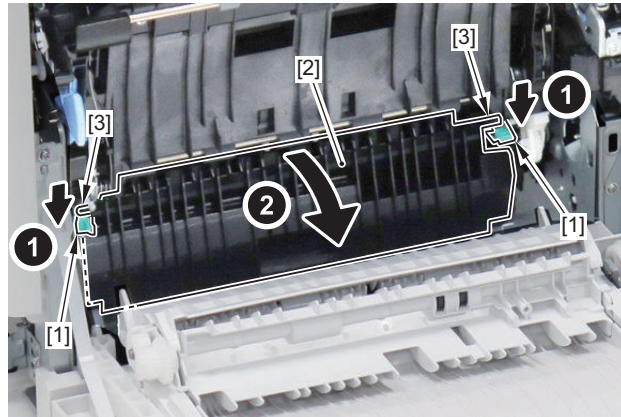

3. Push the left shaft [1] in until it stops, and remove the Cassette Pickup Roller Unit [3] from the right shaft [2].

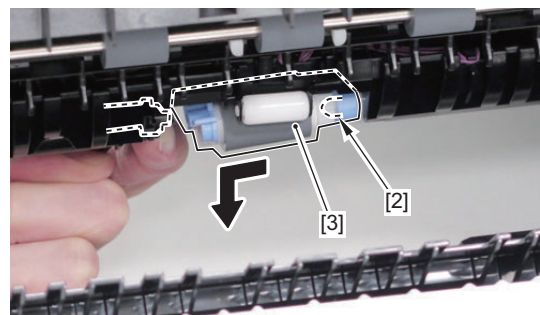
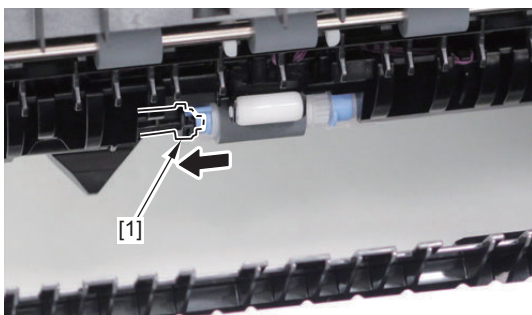

Procedure for Installing the Cassette Pickup Roller Unit

1. When installing, align the left shaft [1] with the hole [A] of the Cassette Pickup Roller Unit [2], and push it in until it stops.

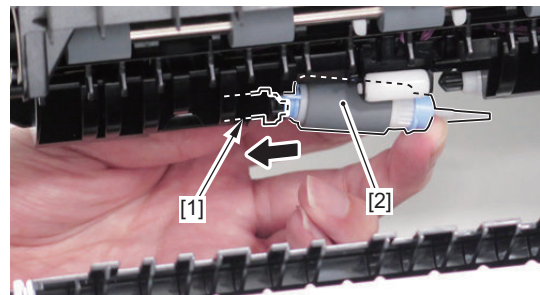
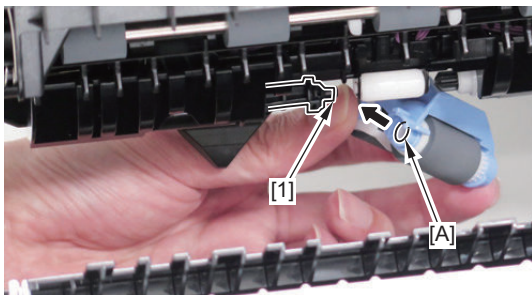

2. Install the Cassette Pickup Roller Unit [3] while returning the left shaft [2] so that the right shaft [1] aligns with the hole [B] of the Cassette Pickup Roller Unit.

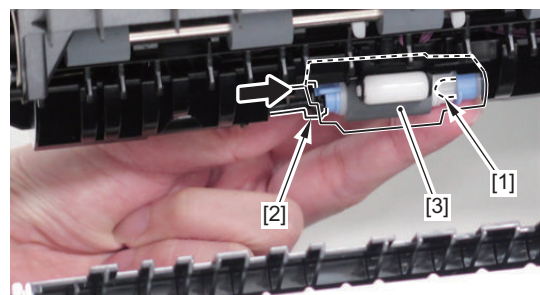
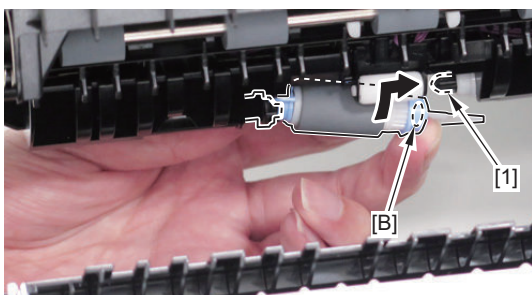

CAUTION:

After installing, push the lever of the machine [1] from the Cassette Receptacle hole, and check that the link of the machine [2] is fit in the hook of the Cassette Pickup Roller Unit [3]. If it is not fit, be sure to install the Cassette Pickup Roller Unit again.

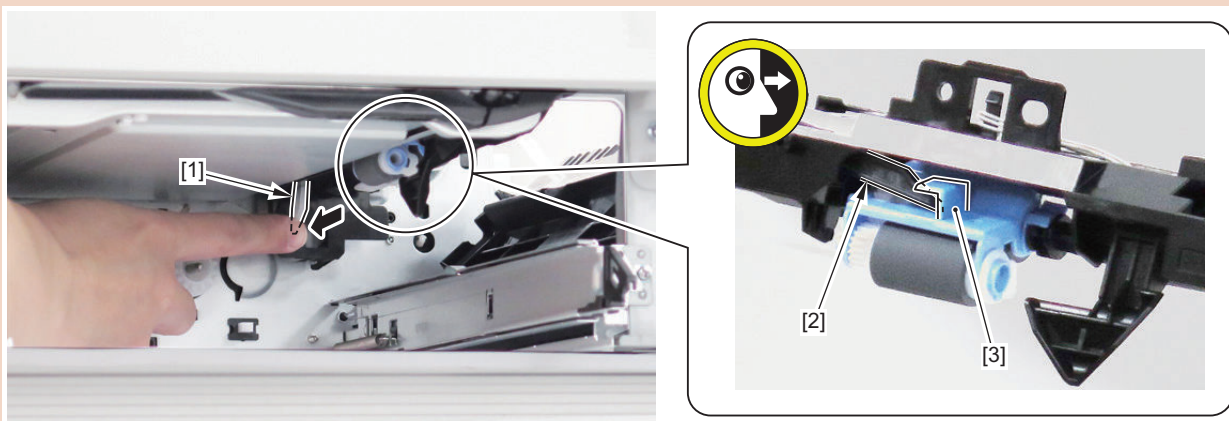

● Removing the Cassette Separation Roller Unit

■ Preparation

1. Remove the Cassette.

■ Procedure

CAUTION:

Do not touch the Cassette Separation Roller [1].

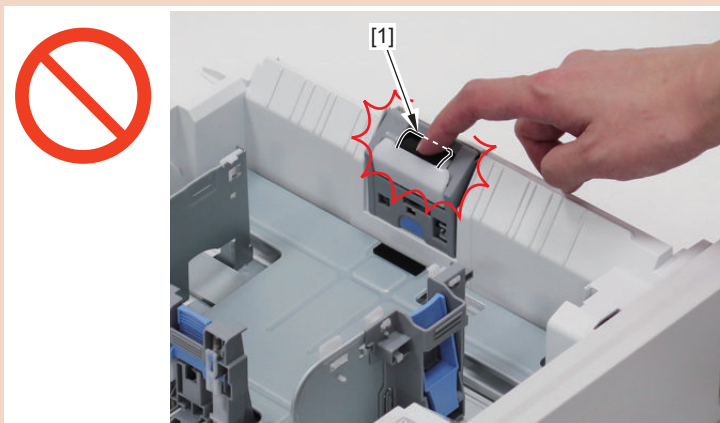

1. Remove the Cassette Separation Roller Unit [1].

- 1 Claw [2]

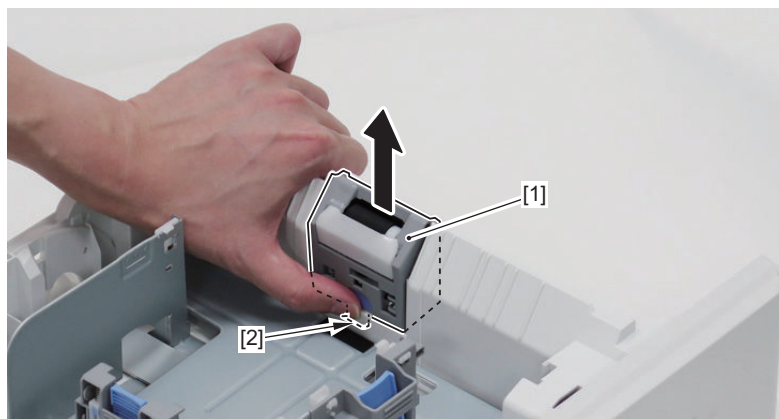

● Removing the Multi-purpose Tray Pickup Roller

■ Procedure

CAUTION:

Do not touch the Multi-purpose Tray Pickup Roller [1].

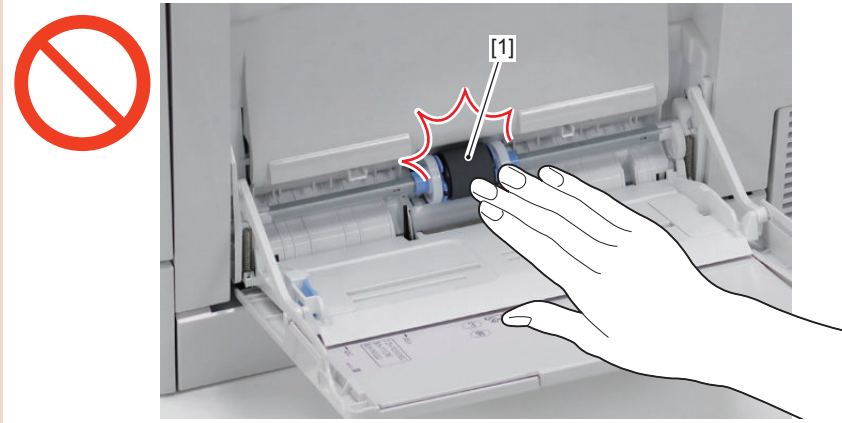

1. Open the Multi-purpose Tray Unit Cover [1].

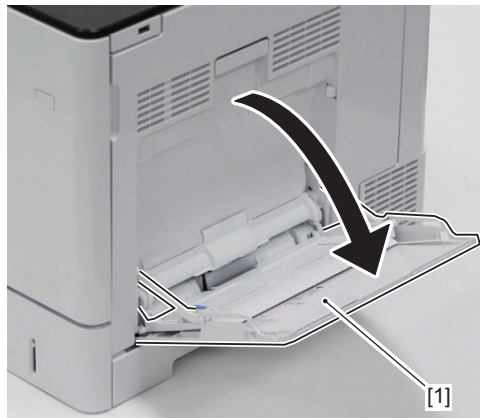

2. Remove the Roller Cover [1].

- 2 Claws [2]
- 2 Bosses [3]
- 2 Shaft Supports [4]

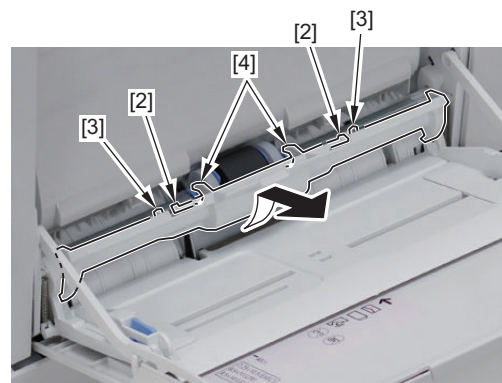
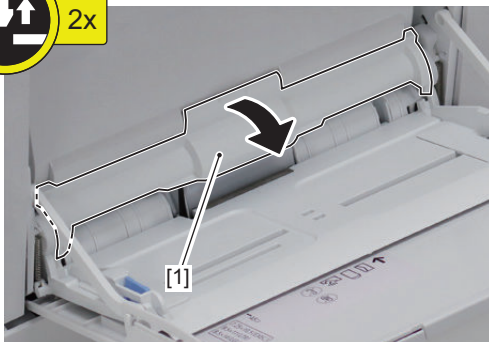

3. Insert a flat-blade screwdriver, etc. into the 2 grooves [A], and remove the Multi-purpose Tray Pickup Roller [1].

- 2 Claws [2]
- 2 Hooks [3]

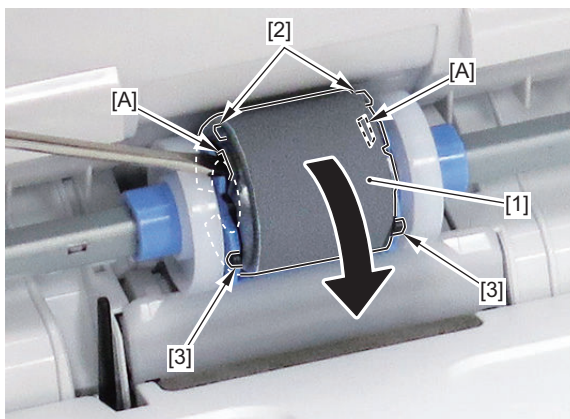

● Removing the Multi-purpose Tray Separation Roller

■ Preparation

1. "Removing the Right Cover Unit" on page 134

■ Procedure

CAUTION:

Do not touch the Multi-purpose Tray Separation Roller [1].

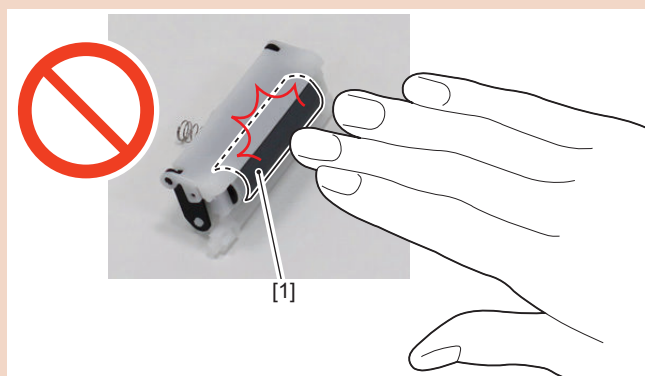

1. Remove the Feed Guide [1].

- 2 Bosses [2]
- 2 Shafts [3]

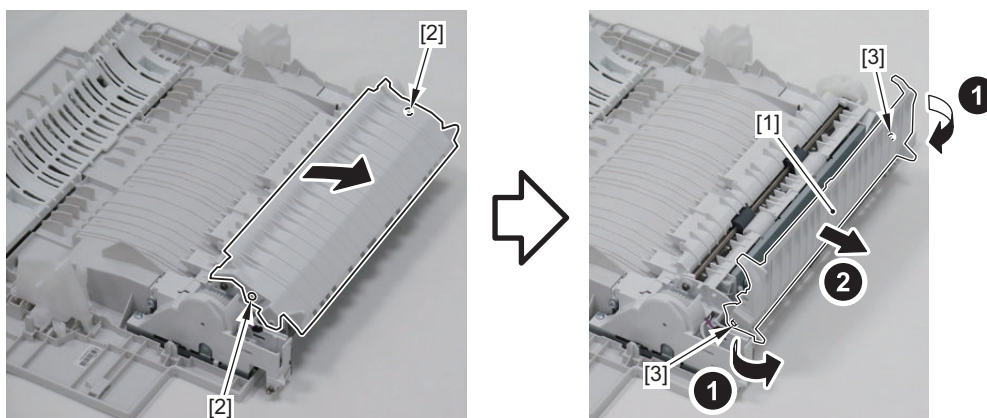

2. Remove the Multi-purpose Tray Unit Base Plate [1].

- 3 Screws [2]
- 4 Claws [3]
- 4 Bosses [4]

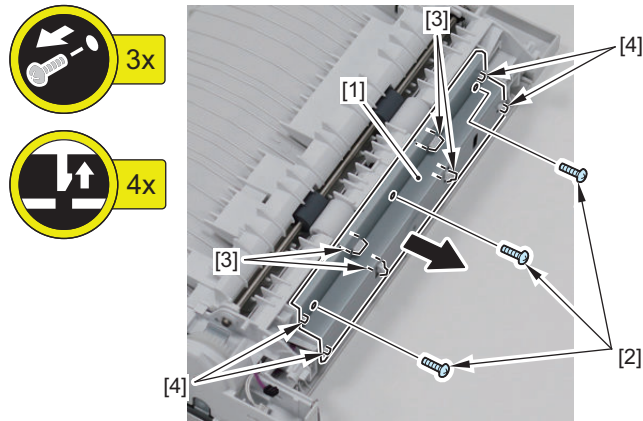

CAUTION:

When installing, be sure to align the hole of the spring [1] with the boss [3] of the Multi-purpose Tray Unit Base Plate [2].

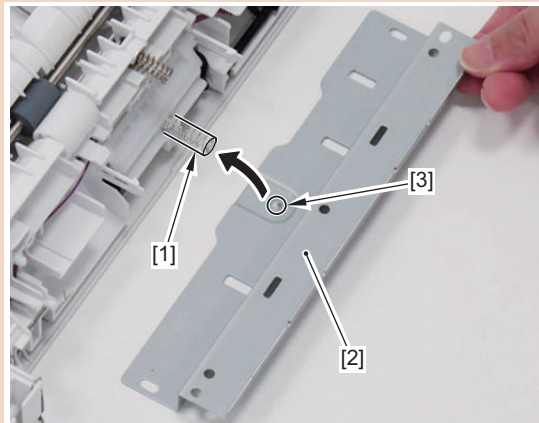

3. Remove the Multi-purpose Tray Separation Guide Unit [1].

- 2 Hooks [2]

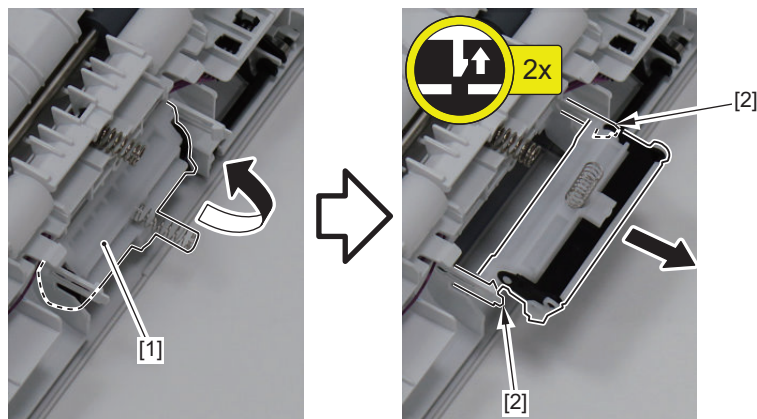

4. Remove the Roller Cover [1].

- 4 Bosses [2]

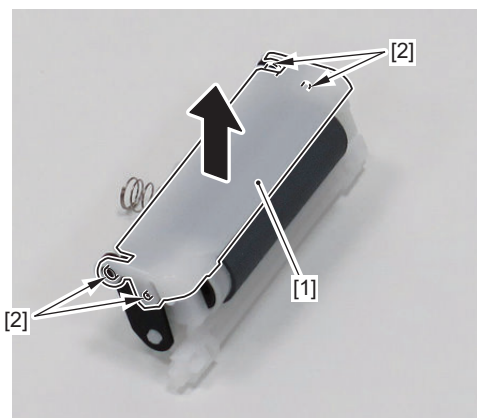
**5. Remove the Multi-purpose Tray Separation Roller [1].**

- 1 Claw [2]

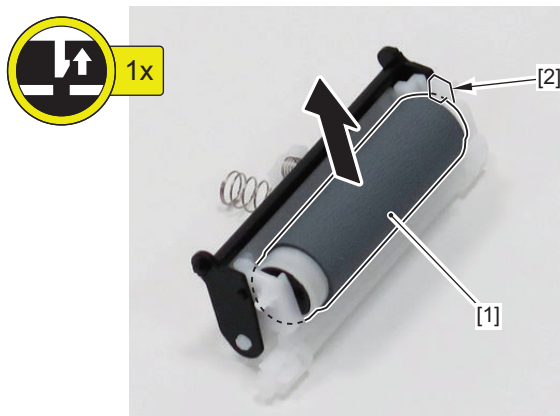
**NOTE:**

When installing, be sure that the shaft [A] of the Multi-purpose Tray Separation Roller [1] and the D-cut of the Roller Holder groove [B] are oriented in the same direction.

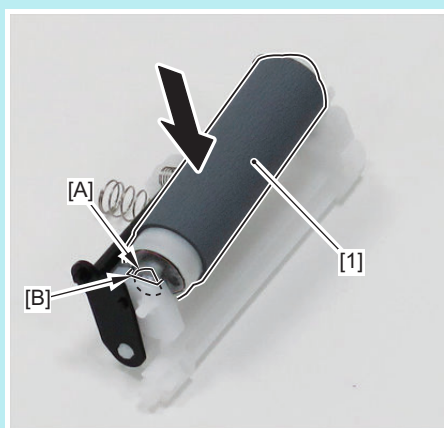

Removing the Duplex Reverse Drive Unit

■ Preparation

1. Remove the Toner Cartridge (Y/M/C/Bk).
2. [“Removing the Waste Toner Container Cover Unit” on page 130](#)

3. "Removing the Rear Cover" on page 131
4. "Removing the Left Cover" on page 132
5. "Removing the Controller Cover" on page 182
6. "Removing the Controller Box" on page 187
7. "Removing the Right Rear Cover" on page 133
8. "Removing the DC Controller Support Plate" on page 190
9. "Removing the Upper Cover Unit" on page 137
10. "Removing the Upper High Voltage Power Supply PCB" on page 192
11. "Removing the Fixing Assembly" on page 158
12. "Removing the Fixing Drive Unit" on page 158
13. "Removing the Output Tray Unit" on page 138
14. "Removing the ITB Unit" on page 150
15. "Removing the Delivery Unit" on page 162

■ Procedure

1. Free the Motor Harness [1] and Solenoid Harness [2] from the guide [A].

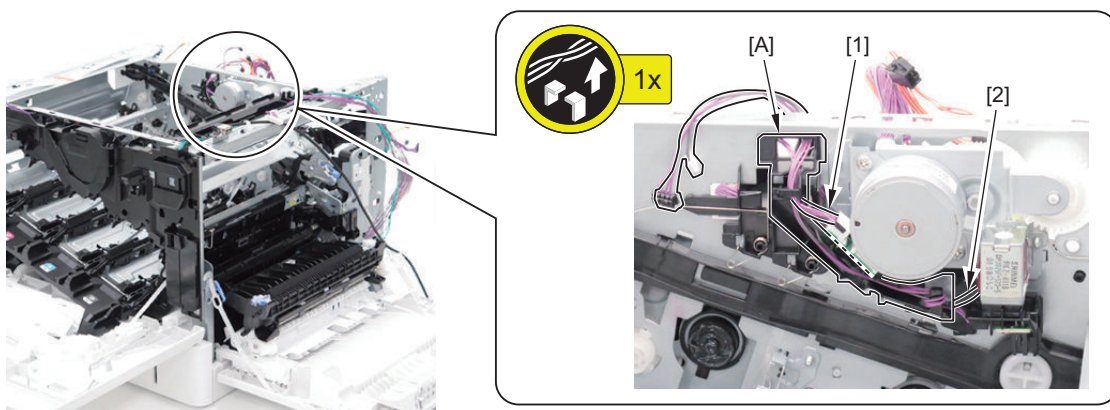

2. Free the Motor Harness [1].

- 1 Connector [2]

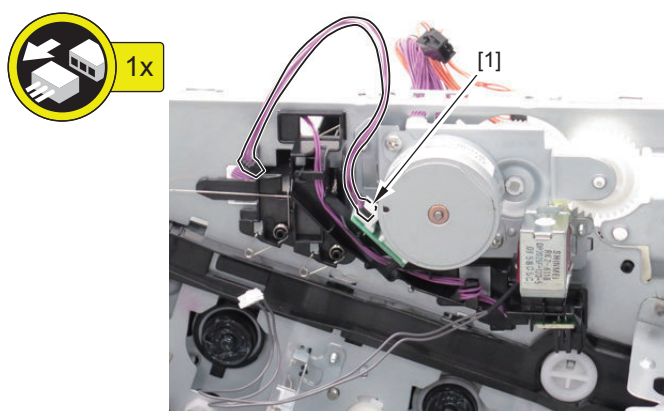

3. Remove the Duplex Reverse Drive Unit [1].

- 2 Screws [2]
- 2 Hooks [3]

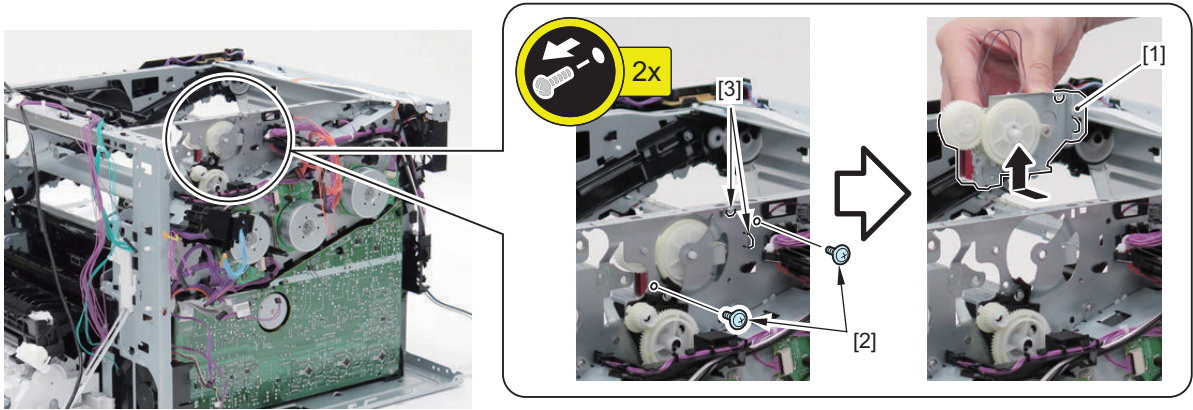

Controller System

Removing the Controller Cover

Preparation

1. [“Removing the Rear Cover” on page 131](#)

Procedure

1. **Remove the Controller Cover [1].**

- 5 Screws [2]
- 5 Hooks [3]

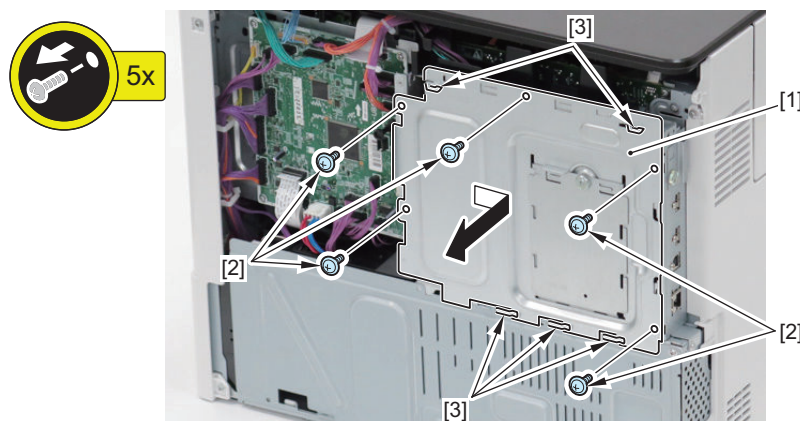

Removing the Main Controller PCB

Before Replacing the Main Controller PCB

The following setting values are recorded in the Main Controller PCB. When the Main Controller PCB is replaced, these setting values are all returned to the default unless they are restored.

- User mode setting values
- Service mode setting values

These setting values can be restored by performing backup by either of the following methods:

Refer to the Backup List for the details of items that are backed up. [“Backup Data” on page 257](#)

- Backup/restoration using the Expansion ROM for servicing and the Sublog Board (Recommended) [“Backup/restoration using the Expansion ROM for servicing and the Sublog Board” on page 92](#)
- SERVICE MODE > FUNCTION GR. > ECONF > EXPORT
- SERVICE MODE > FUNCTION GR. > Import/Export Set. > EXPORT
- Setup > User Maintenance > Import/Export Set. > Export
- RUI > Settings/Registration > Management Settings > Import/Export > Export.

CAUTION:

Perform backup immediately before replacing the Main Controller.

Preparation

1. [“Removing the Rear Cover” on page 131](#)
2. [“Removing the Controller Cover” on page 182](#)

■ Procedure

1. Remove the SD Card Slot Cover [1].

- 1 Coin Screw [2]
- 2 Hooks [3]

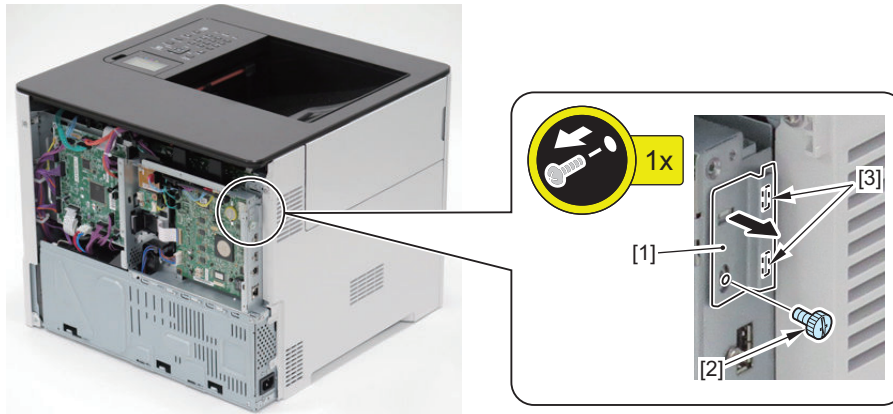

2. Remove the SD Card [1]. (If using an SD Card)

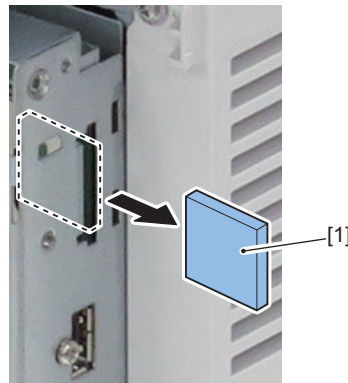

3. Disconnect the Flat Cable [1], USB Cable [2], and 6 connectors [3], and free the harness from the guide [A].

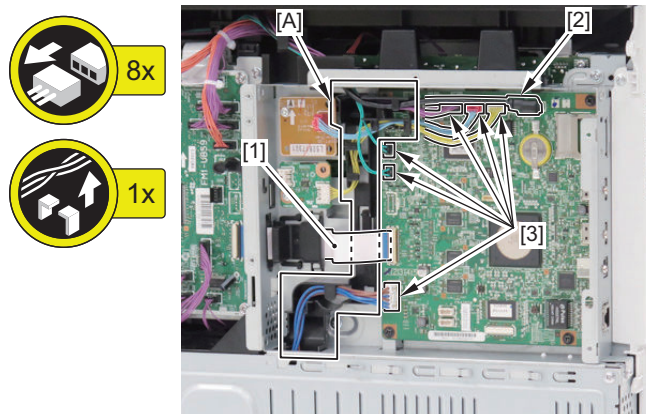

4. Shift the Harness Guide [1].

- 1 Boss [2]
- 2 Hooks [3]

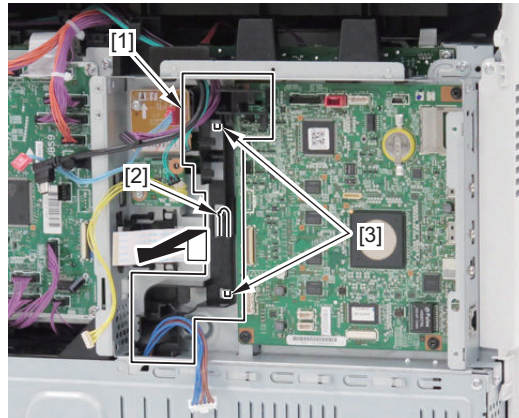
**5. Remove the Main Controller PCB [1].**

- 3 Screws [2] (Binding)
- 4 Screws [3] (TP)
- 1 Hook [4]

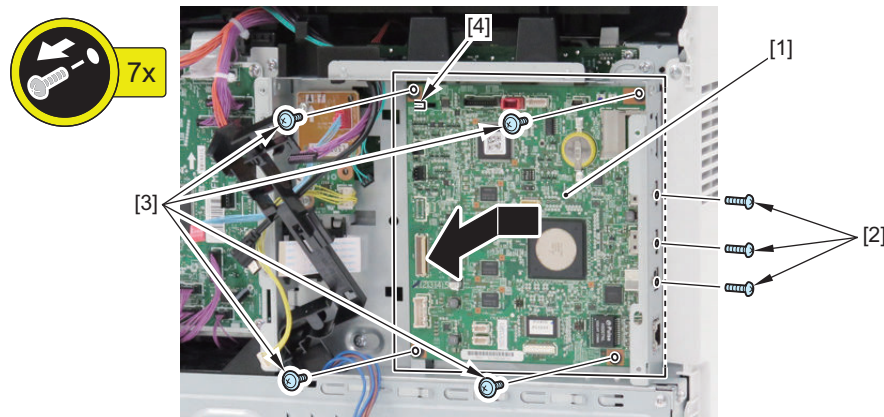
**■ After Replacing the Main Controller PCB**

Restore the data in the same way as that of backup. Refer to the Backup List for the setting values that are restored.
Update firmware as necessary.

● Removing the DC Controller PCB**■ Before Replacing the DC Controller PCB**

The setting values stored in the DC Controller PCB NVRAM can be backed up to the Main Controller PCB NVRAM.
The setting values can be backed up by performing the following method.

- SERVICE MODE > FUNCTION GR. > CLEAR DCON

Turn OFF and then ON the power of the host machine.

CAUTION:

Perform backup immediately before replacing the DC Controller.

■ Preparation

1. "Removing the Rear Cover" on page 131

■ Procedure

1. Remove the DC Controller PCB [2] while avoiding the Switch Guide [1].

- 5 Flat Cables [3]
- 18 Connectors [4]
- 4 Screws [5]
- 2 Hooks [6]

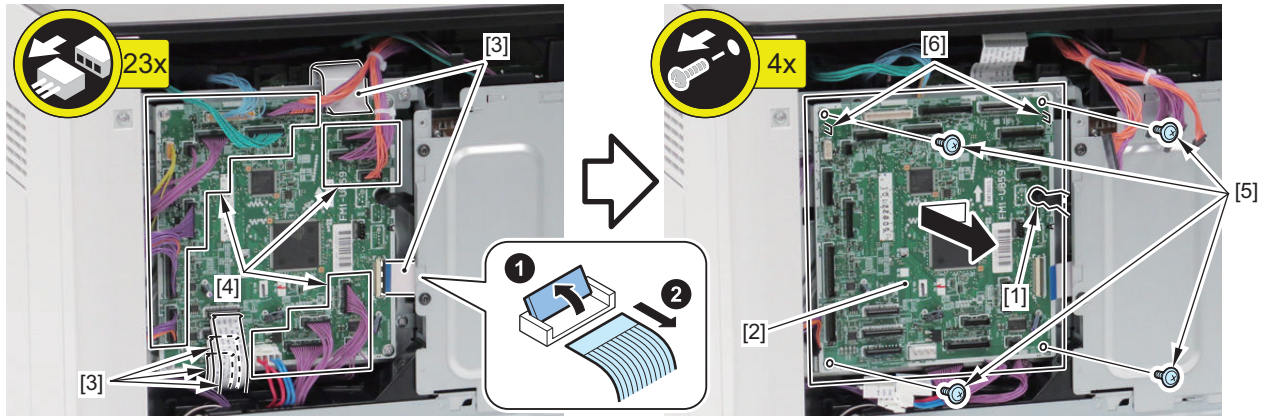

■ After Replacing the DC Controller PCB

The setting values of the NVRAM on the DC Controller PCB are stored in the NVRAM on the Main Controller PCB as a backup. The setting values can be restored by performing the following method.

- SERVICE MODE > FUNCTION GR. > RESTORE DCON

Turn OFF and then ON the power of the host machine.

● Removing the Fixing Power Supply Unit

■ Preparation

1. “Removing the Waste Toner Container Cover Unit” on page 130
2. “Removing the Rear Cover” on page 131
3. “Removing the Left Cover” on page 132
4. “Removing the Controller Cover” on page 182

■ Procedure

1. Remove the Low Voltage Power Supply Unit Cover [1].

- 2 Screws [2]
- 7 Hooks [3]

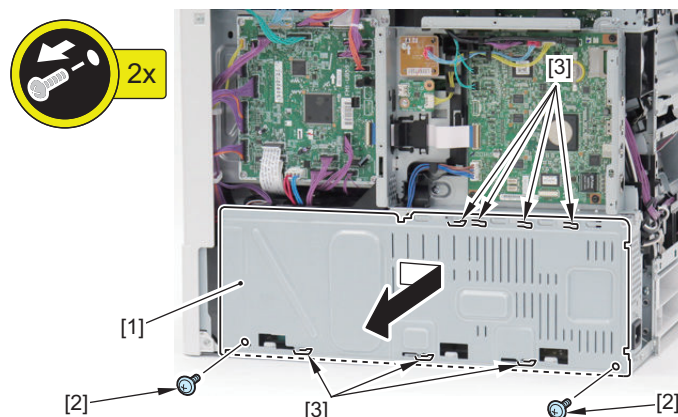

2. Remove the Power Supply Harness [1].

- 1 Connector [2]
- 2 Wire Saddles [3]
- 1 Hole [A]

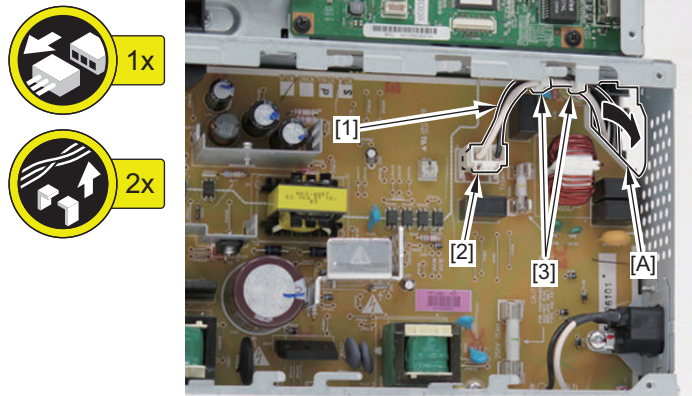

3. Remove the Power Supply Harness [1].

- 2 Guides [A]

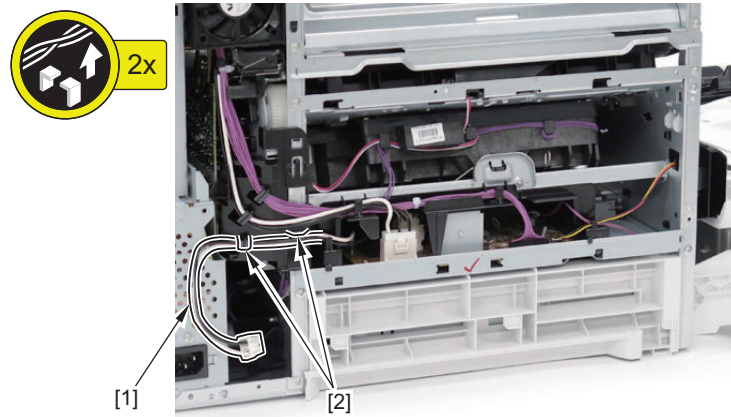

4. Remove the 4 harnesses [1].

- 3 Connectors [2]
- Harness Guides [A], [B], [C], and [D]

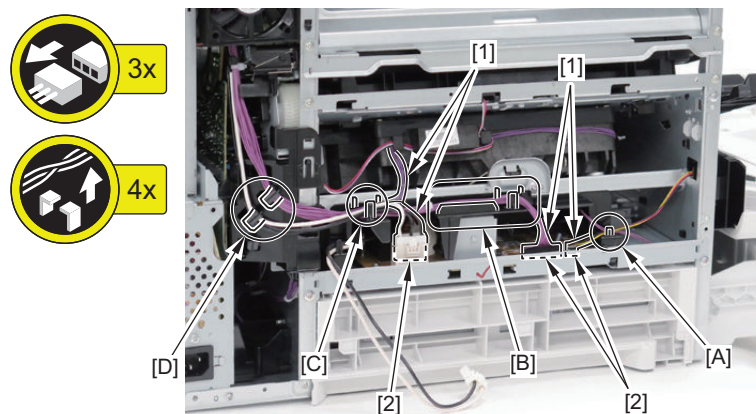

5. Remove the Fixing Power Supply Unit [1].

- 2 Screws [2]
- 2 Hooks [3]

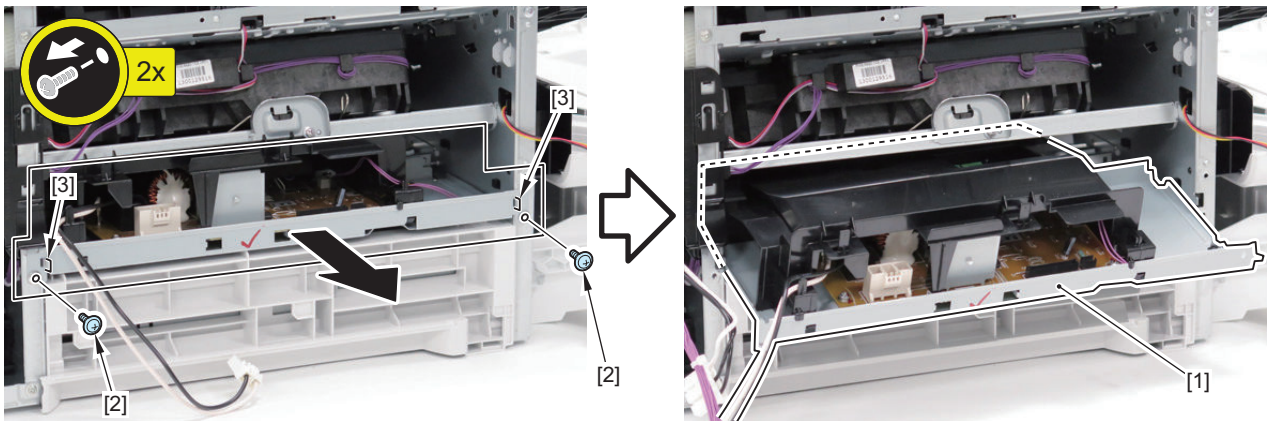

Removing the Controller Box

■ Preparation

1. “Removing the Waste Toner Container Cover Unit” on page 130
2. “Removing the Rear Cover” on page 131
3. “Removing the Left Cover” on page 132
4. “Removing the Controller Cover” on page 182

■ Procedure

1. Remove the Low Voltage Power Supply Unit Cover [1].

- 2 Screws [2]
- 7 Hooks [3]

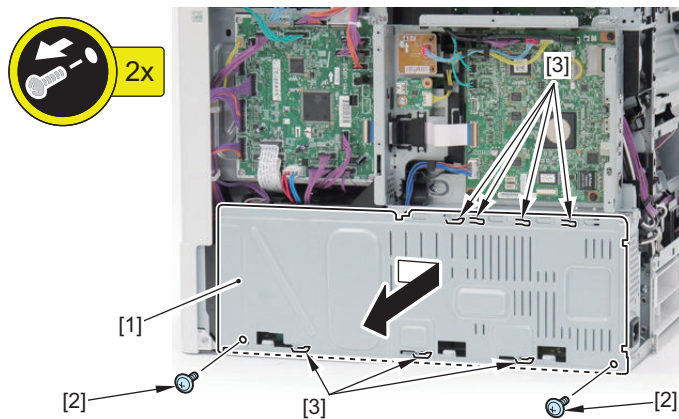

2. Disconnect the 3 connectors [1] of the DC Controller PCB, and remove the Flat Cable [2].

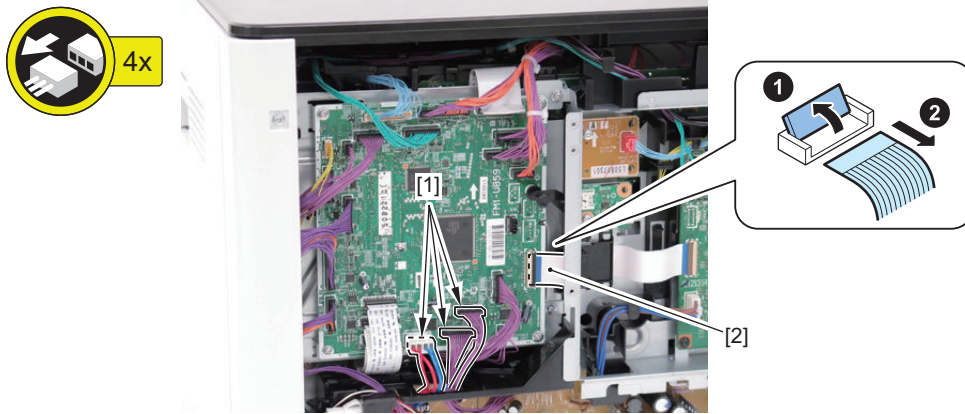

3. Remove the Power Supply Harness [1].

- 1 Connector [2]
- 2 Wire Saddles [3]
- 1 Hole [A]

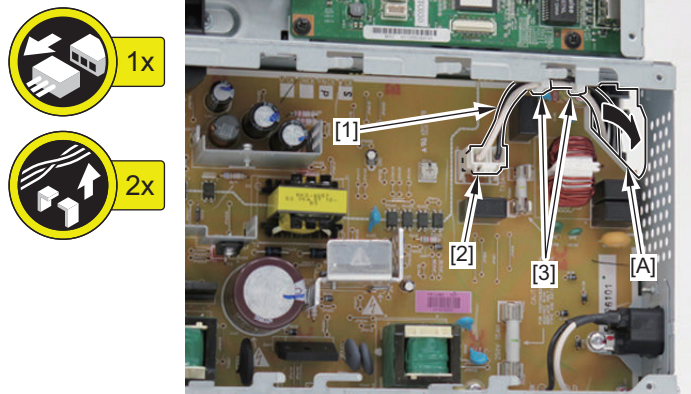

4. Disconnect the 4 connectors, and free the harness from the Harness Guide [A].

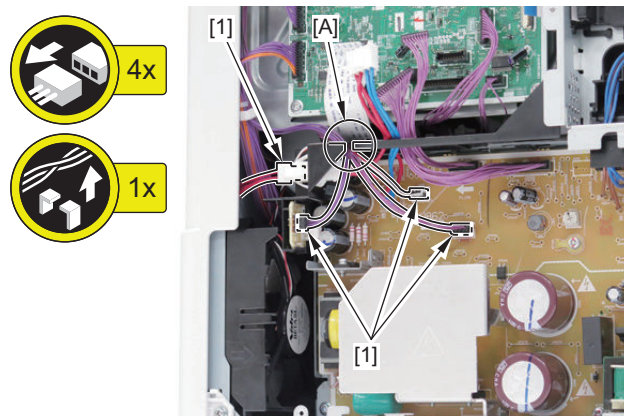

5. Disconnect the USB Cable [1] and 3 connectors [2], and free the harness from the guide [A].

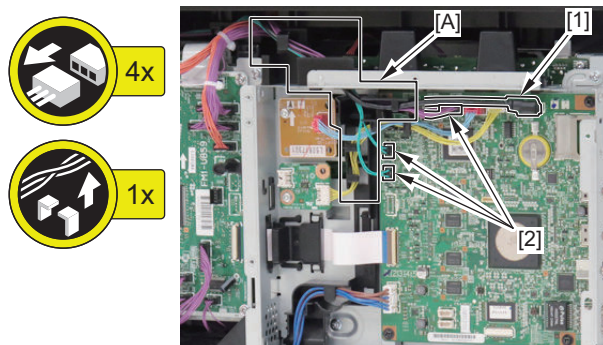

6. Remove the Controller Box [1].

- 6 Screws [2]

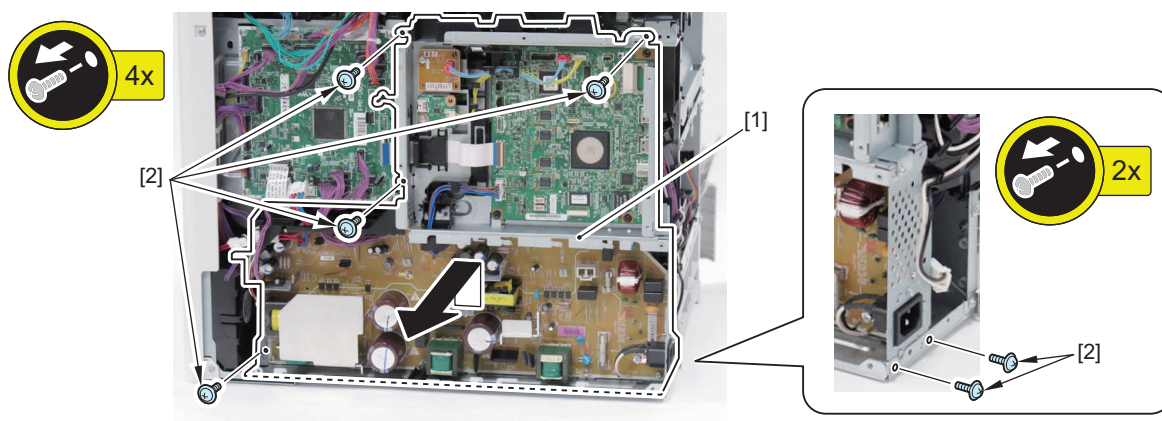

● Removing the Low Voltage Power Supply Unit

■ Preparation

1. "Removing the Waste Toner Container Cover Unit" on page 130
2. "Removing the Rear Cover" on page 131
3. "Removing the Left Cover" on page 132
4. "Removing the Controller Cover" on page 182
5. "Removing the Controller Box" on page 187
6. "Removing the Main Controller PCB" on page 182

■ Procedure

1. Free the harness [1] from the guide [2] and the hole [A] in the plate.

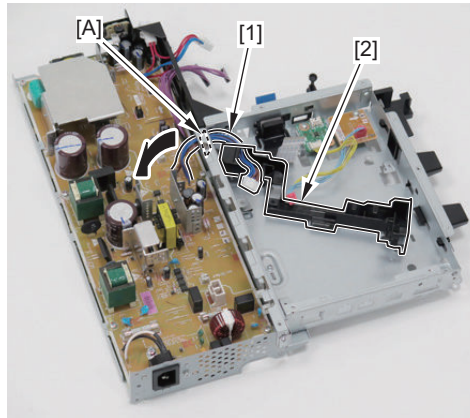

2. Remove the Low Voltage Power Supply Unit [2] from the Controller Box [1].
 - 3 Screws [3]
 - 1 Boss [4]
 - 2 Hooks [5]

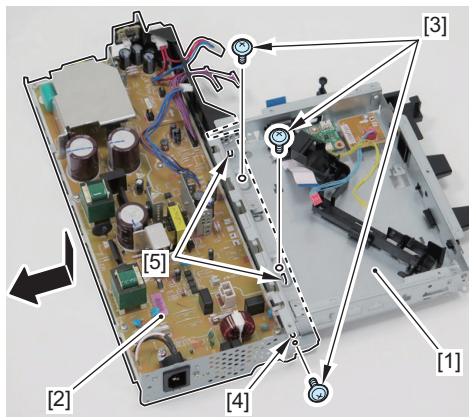

● Removing the DC Controller Support Plate

■ Preparation

1. “Removing the Waste Toner Container Cover Unit” on page 130
2. “Removing the Rear Cover” on page 131
3. “Removing the Left Cover” on page 132
4. “Removing the Controller Cover” on page 182
5. “Removing the Controller Box” on page 187
6. “Removing the Right Rear Cover” on page 133

■ Procedure

1. Disconnect the 15 connectors [1] and the 4 Flat Cables [2] from the DC Controller PCB.

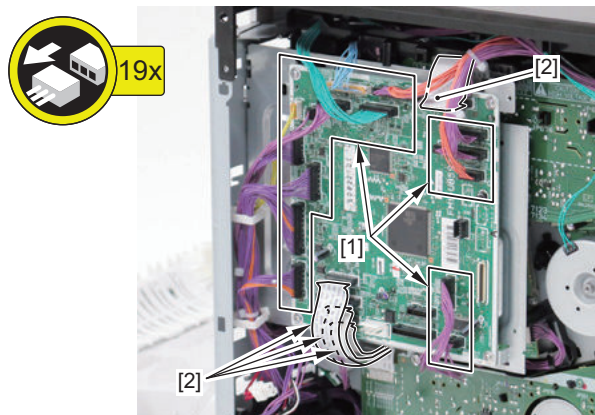

2. Remove the DC Controller Support Plate [1].

- 2 Screws [2]
- Guide [A]
- 1 Boss [3]
- 2 Hooks [4]

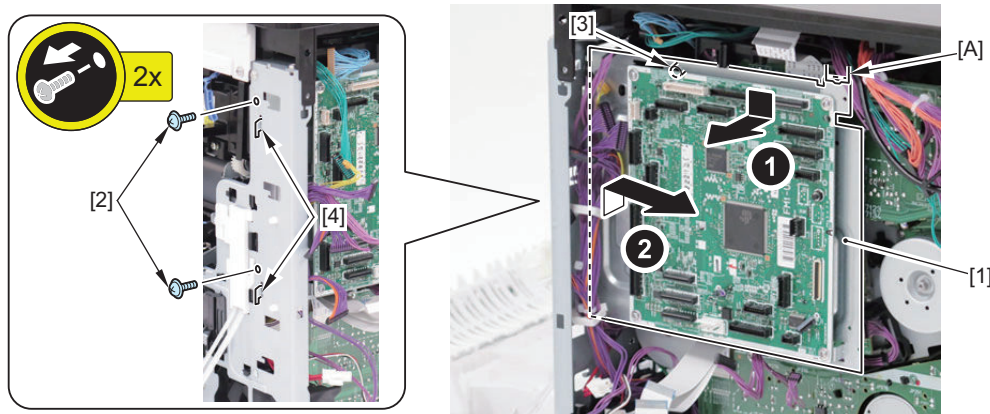

● Removing the Lower High Voltage Power Supply PCB

■ Preparation

1. "Removing the Waste Toner Container Cover Unit" on page 130
2. "Removing the Rear Cover" on page 131
3. "Removing the Left Cover" on page 132
4. "Removing the Controller Cover" on page 182
5. "Removing the Controller Box" on page 187

■ Procedure

1. Remove the Lower High Voltage Power Supply PCB [1].

- 1 Flat Cable [2]
- 1 Screw [3] (Binding)
- 2 Screws [3] (W Sems)
- 3 Claws [5] (Large)
- 2 Claws [6] (Small)
- 1 Hook [7]

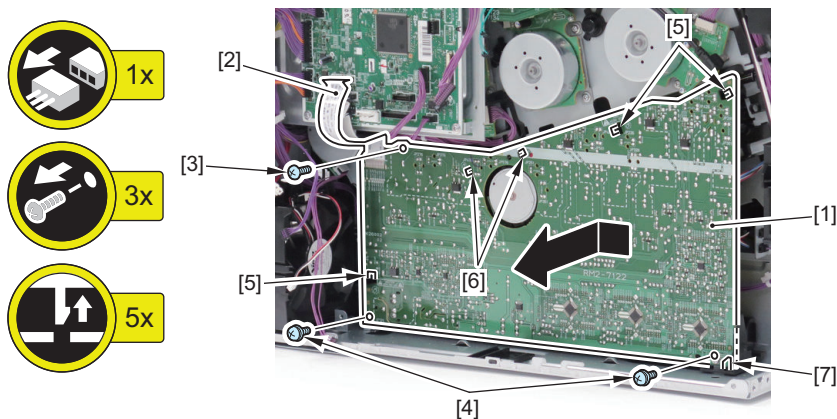

CAUTION:

When installing, be sure that the Contact Springs [3] are in contact from the 25 holes [2] of the Lower High Voltage Power Supply PCB [1].

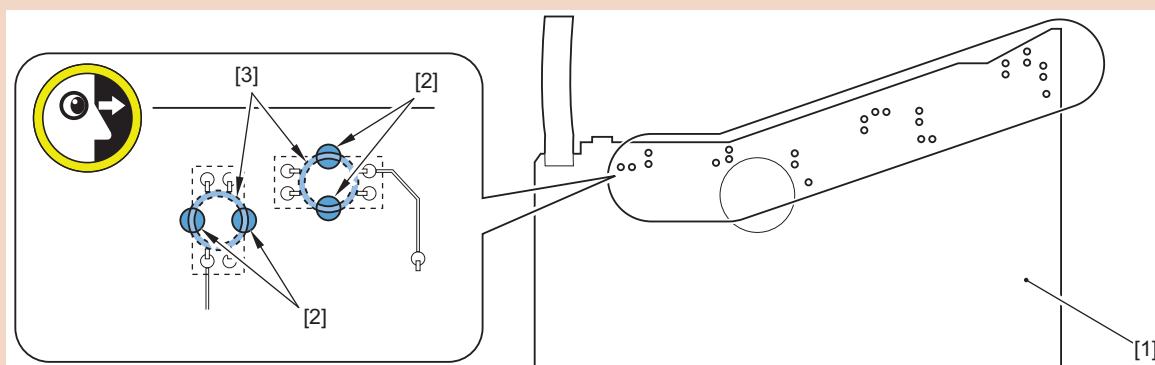

● Removing the Upper High Voltage Power Supply PCB

■ Preparation

1. "Removing the Waste Toner Container Cover Unit" on page 130
2. "Removing the Rear Cover" on page 131
3. "Removing the Left Cover" on page 132
4. "Removing the Controller Cover" on page 182
5. "Removing the Controller Box" on page 187
6. "Removing the Right Rear Cover" on page 133
7. "Removing the DC Controller Support Plate" on page 190
8. "Removing the Upper Cover Unit" on page 137

■ Procedure

1. Remove the Upper High Voltage Power Supply PCB [1].

- 1 Flat Cable [2]
- 5 Connectors [3]
- 1 Screw [4]
- 2 Claws [5]
- 2 Hooks [6]
- 1 Fasten Terminal [7]

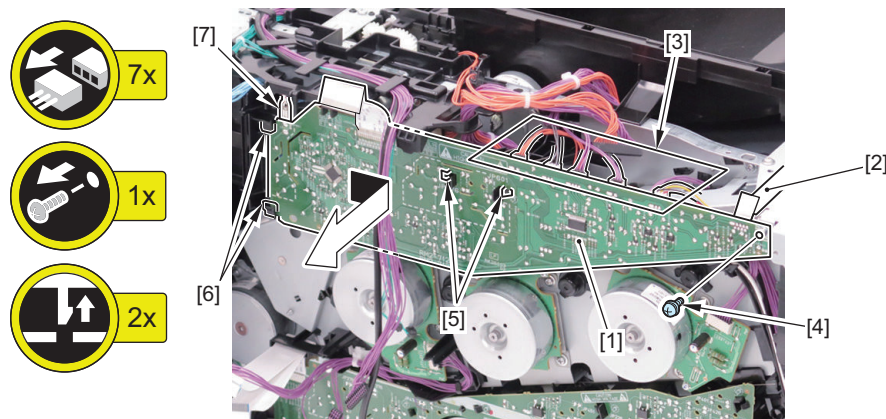

CAUTION:

When installing, be sure that the Contact Springs [3] are in contact from the 2 holes [2] of the Upper High Voltage Power Supply PCB [1].

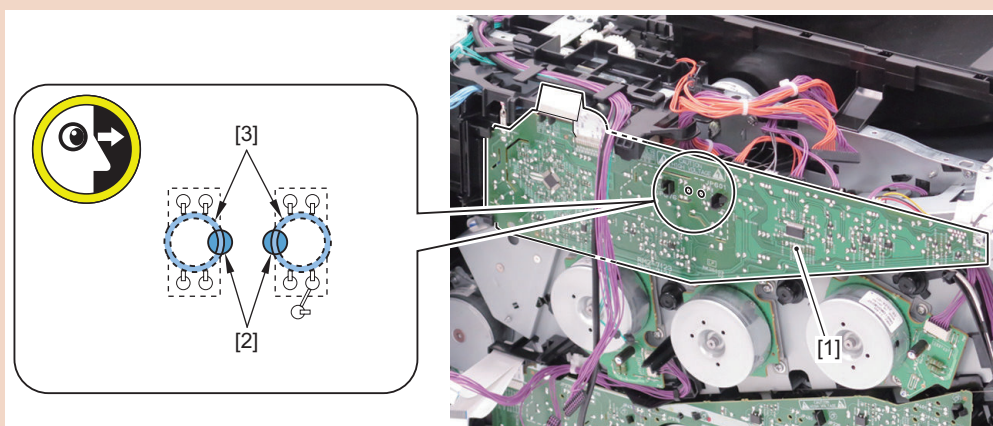

● Removing the Main Drive Unit

■ Preparation

1. Remove the Toner Cartridge (Y/M/C/Bk).
2. [“Removing the Waste Toner Container Cover Unit” on page 130](#)
3. [“Removing the Rear Cover” on page 131](#)
4. [“Removing the Left Cover” on page 132](#)
5. [“Removing the Controller Cover” on page 182](#)
6. [“Removing the Controller Box” on page 187](#)
7. [“Removing the Right Rear Cover” on page 133](#)
8. [“Removing the DC Controller Support Plate” on page 190](#)

9. "Removing the Upper Cover Unit" on page 137
10. "Removing the Upper High Voltage Power Supply PCB" on page 192
11. "Removing the Fixing Assembly" on page 158
12. "Removing the Fixing Drive Unit" on page 158
13. "Removing the ITB Unit" on page 150
14. "Removing the Lower High Voltage Power Supply PCB" on page 191
15. "Removing the Lifter Drive Unit" on page 163

■ Procedure

1. Remove the 3 harnesses [1].

- 2 Connectors [2]
- Guides [A], [B], and [C]

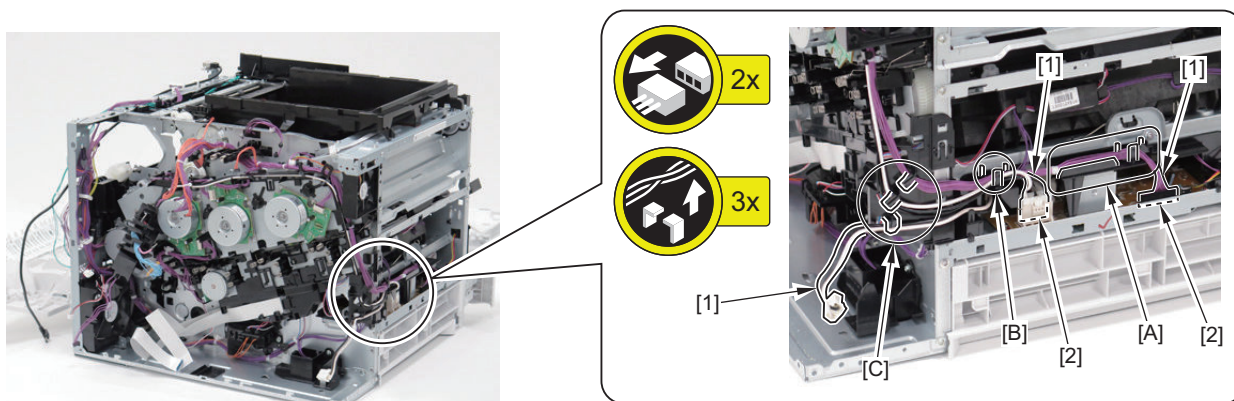

2. Remove the Harness Guide [1].

- 1 Boss [2]
- 2 Hooks [3]

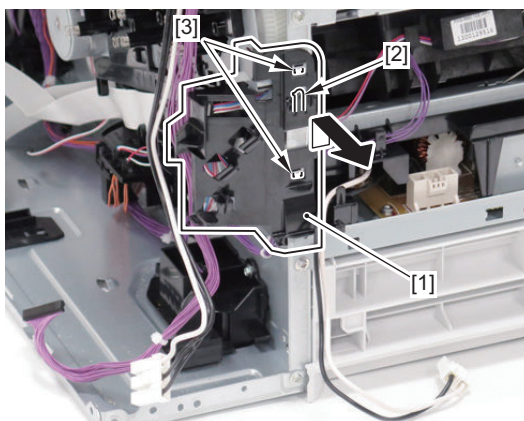

3. Remove the Fixing Power Supply Harness [1] and the Fan Harness [2].

- Guides [A] and [B]

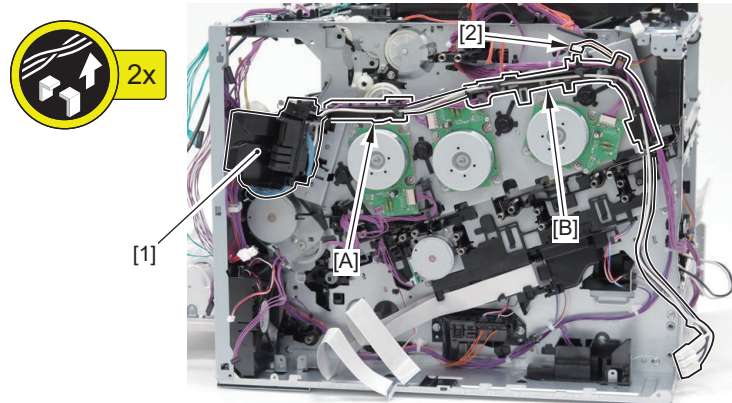

CAUTION:

When installing the Fixing Power Supply Harness [1], be sure to place the Harness Band [2] inside the guide [C].

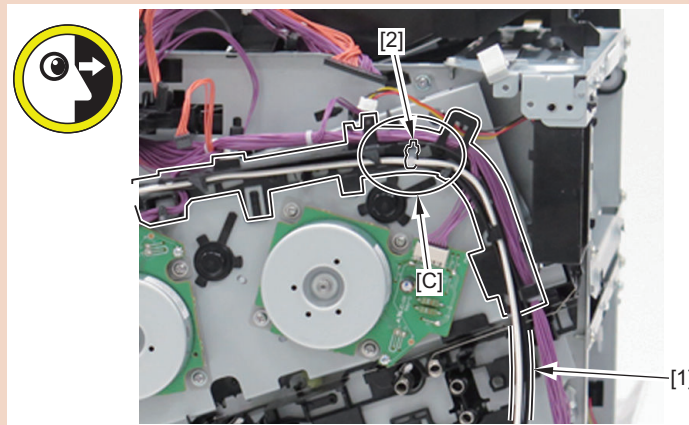

4. Free the harness [1] from the guide [A], and remove the Flat Cable Guide Sub Cover [2].

- 1 Bosses [3]
- 3 Hooks [4]

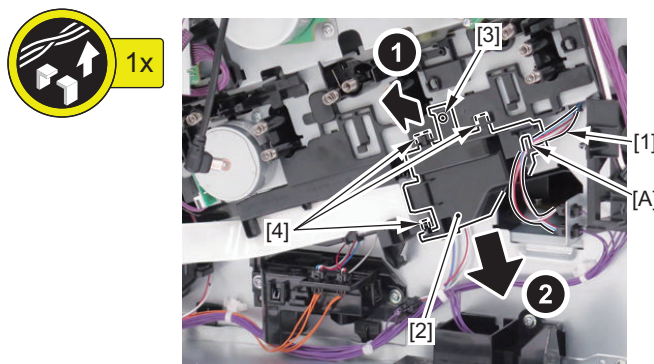

5. Disconnect the Flat Cable [1] and remove the Flat Cable Guide [2].

- 2 Bosses [3]
- 3 Hooks [4]
- 1 Guide [A]

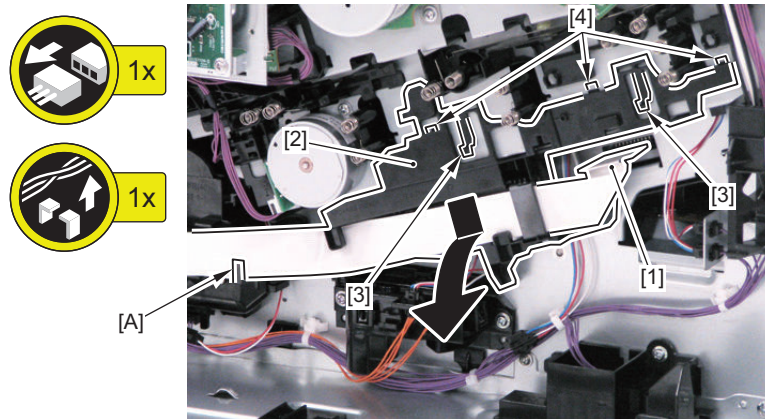

6. Free the harness [1].

- 1 Connector [2]
- Guide [A]

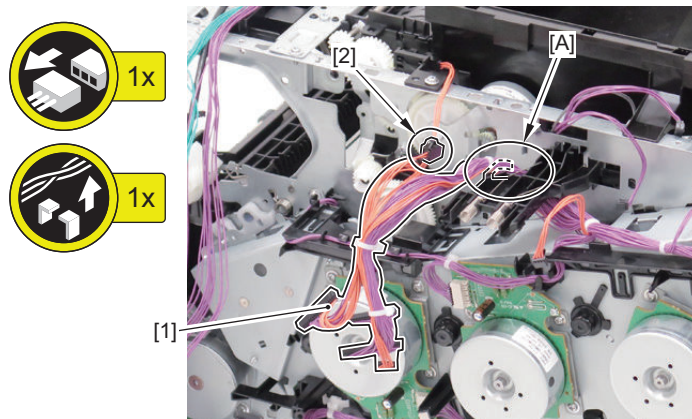

7. Close the Front Cover [1].

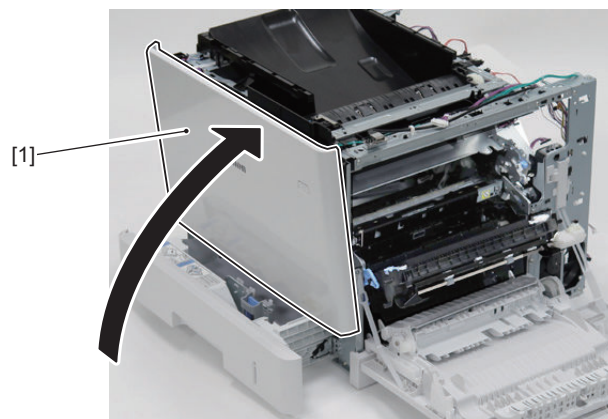

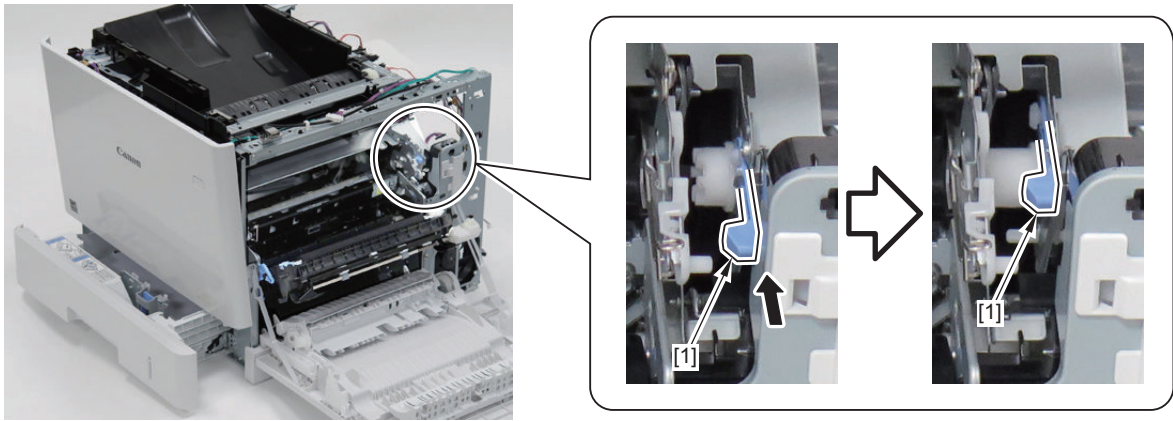
8. Return the ITB Release Lever [1] to the original position.**9. Remove the Main Drive Unit [1].**

- 7 Screws [2]
- 2 Hooks [3]
- 2 Guides [4]

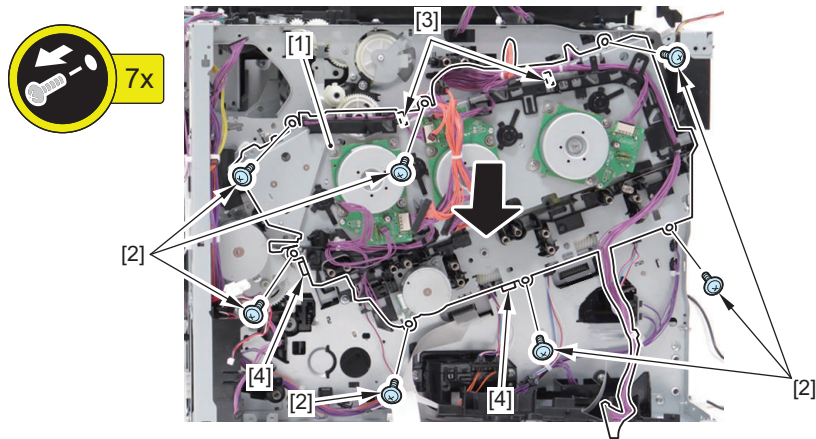

CAUTION:

Points to Note when Assembling and Disassembling the Main Drive Unit

The position of the cams and gears of the Main Drive Unit cannot be adjusted when it is removed from the machine. Therefore, when removing the Main Drive Unit from the machine, be sure to install the Main Drive Unit service parts. Each of the hole positions [A] of the 4 cams [1] for the Main Drive Unit service parts are adjusted (the 4 Main Drive Unit Frame holes [B] overlap with the 4 cam [1] holes [A]) to the correct position for installing to the machine.

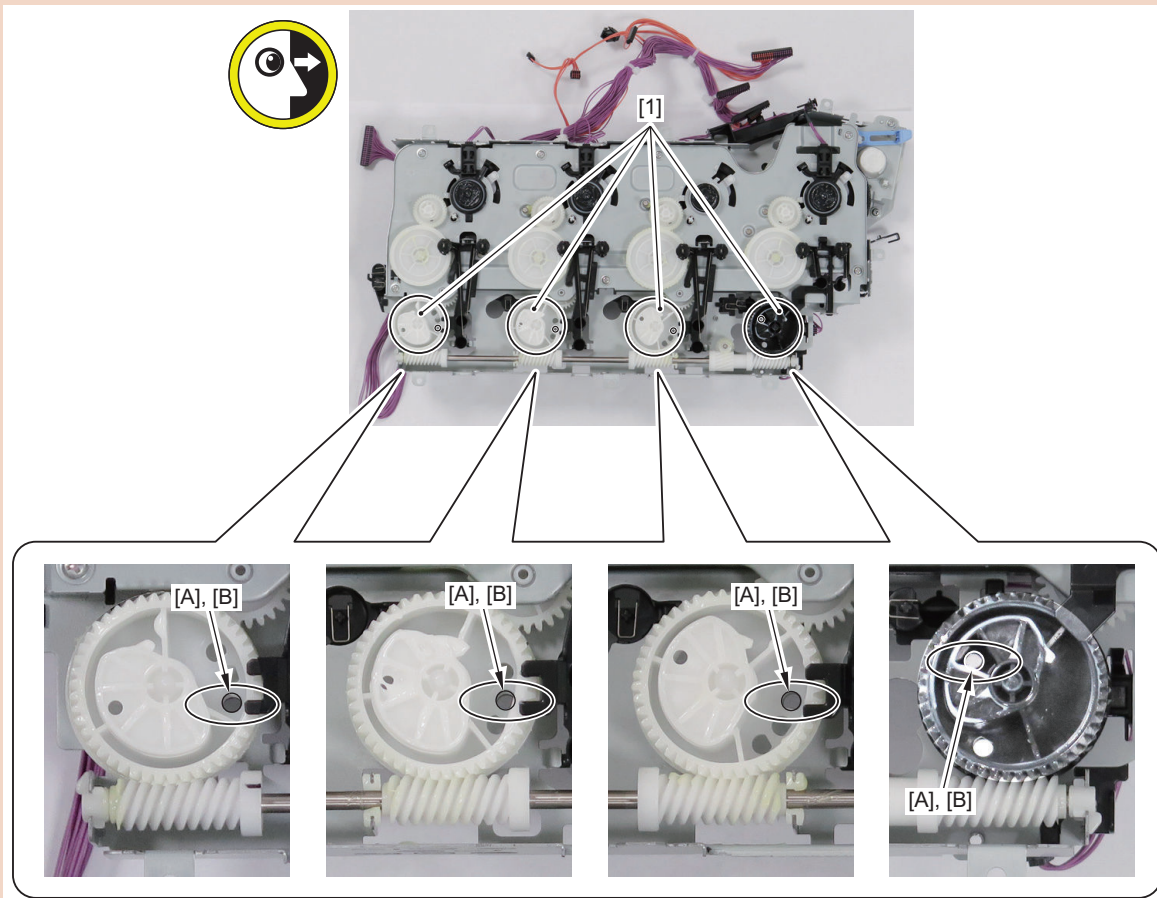

● Removing the Control Panel Unit

■ Procedure

1. Open the Right Cover Unit [1].

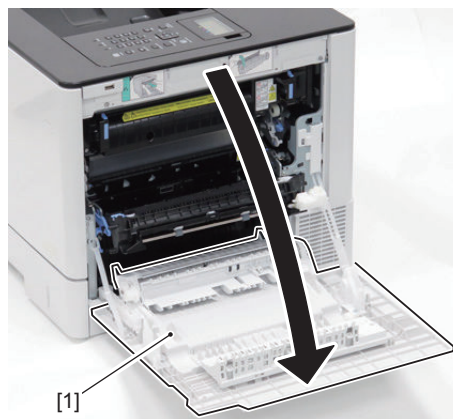

2. Remove the Right Upper Inner Cover [1].

- 3 Screws [2]
- 1 Hook [3]

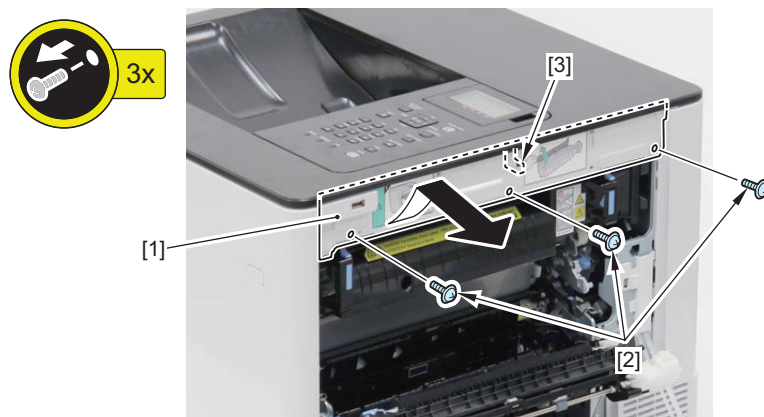
**3. Disconnect the harness [1] and the Grounding Wire (with Ferrite Core) [2].**

- 1 Connector [3]
- 1 Screw [4]

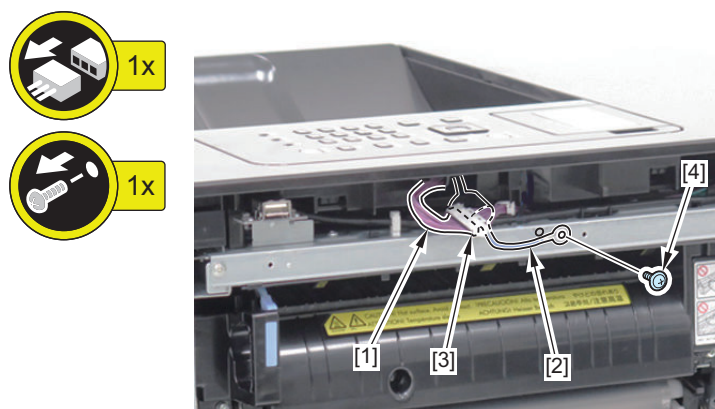
**4. Put the harness [1] and Grounding Wire [2] through the hole [A] in the Upper Cover, and then remove the Control Panel Unit [3].**

- 2 Claws [4]
- 3 Hooks [5]

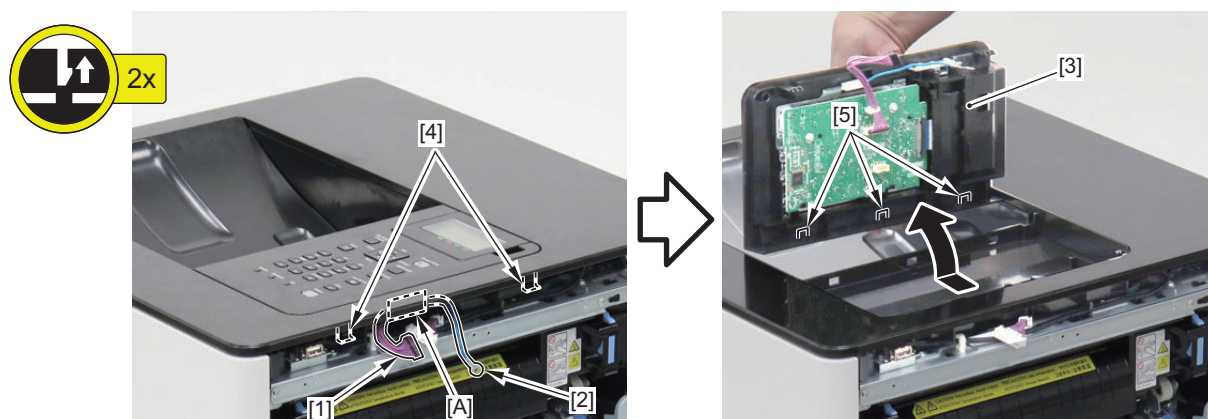

● Removing the Control Panel Unit Key PCB

■ Preparation

1. "Removing the Control Panel Unit" on page 198

■ Procedure

1. Place the Control Panel Unit [1] on a base [2] with a height of approximately 5 cm, and tilt the indicator [3].

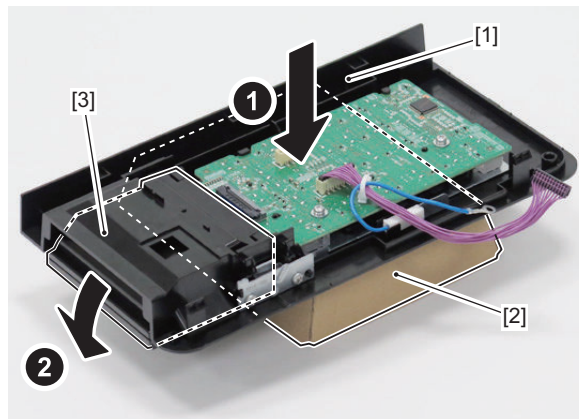

2. Remove the Control Panel Unit Key PCB [1].

- 1 Flat Cable [2]
- 1 Wire Saddle [3]
- 1 Connector [4]
- 2 Screws [5]
- 2 Hooks [6]

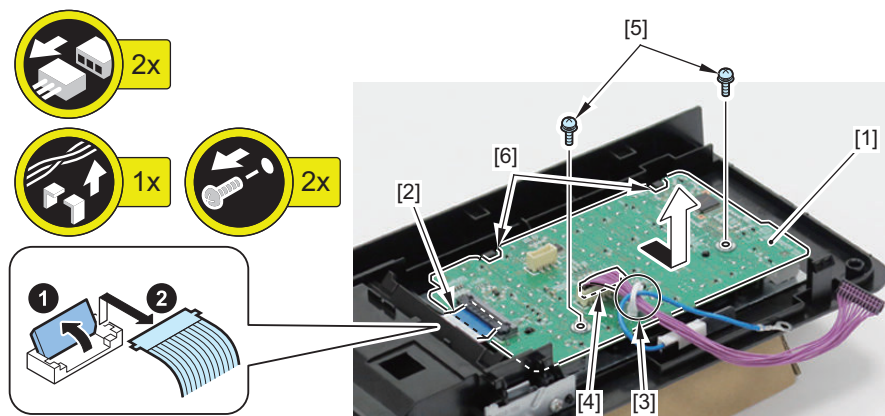

CAUTION:

When assembling, be sure to pass the Grounding Wire [1] through the Wire Saddle [2] from the same direction [A] as that of the harness [3]. If you pass the Grounding Wire [1] through the Wire Saddle [2] from the direction opposite to the direction of the harness [3] and roll it up in a bundle, the Grounding Wire [1] may be placed on the rib [C] so it may cause it being trapped.

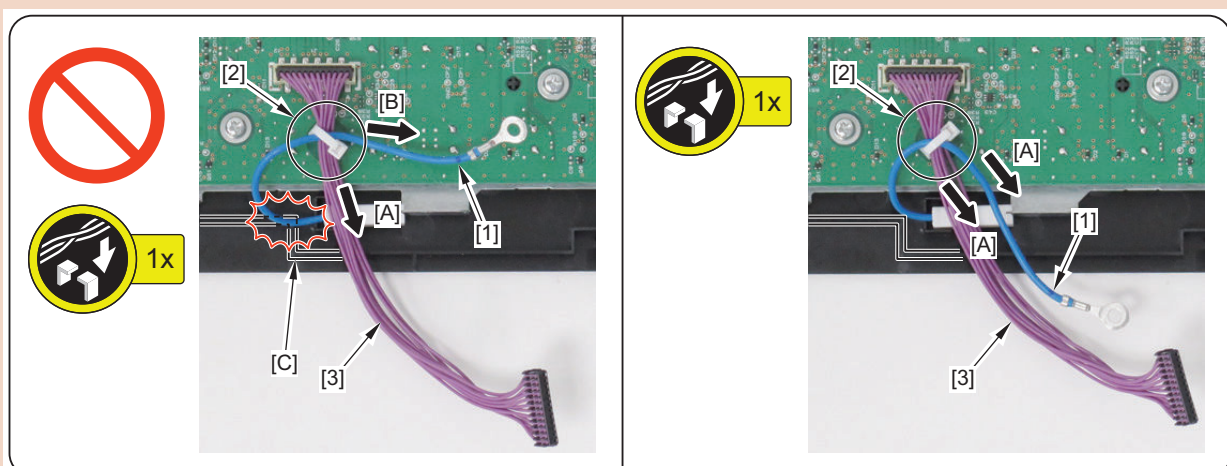

3. Remove the Wire Saddle [2] from the Control Panel Unit Key PCB [1].

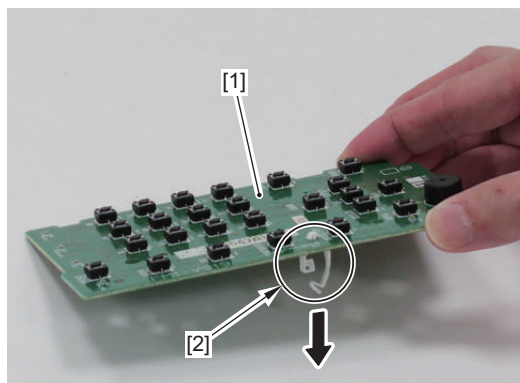

● Removing the Power Fan

■ Preparation

1. “Removing the Waste Toner Container Cover Unit” on page 130
2. “Removing the Rear Cover” on page 131
3. “Removing the Left Cover” on page 132
4. “Removing the Controller Cover” on page 182
5. “Removing the Controller Box” on page 187
6. “Removing the Right Rear Cover” on page 133

■ Procedure

1. Free the harness [1] from the guide [A], and remove the Power Fan Unit [2].

- 1 Screw [3]
- 3 Hooks [4]

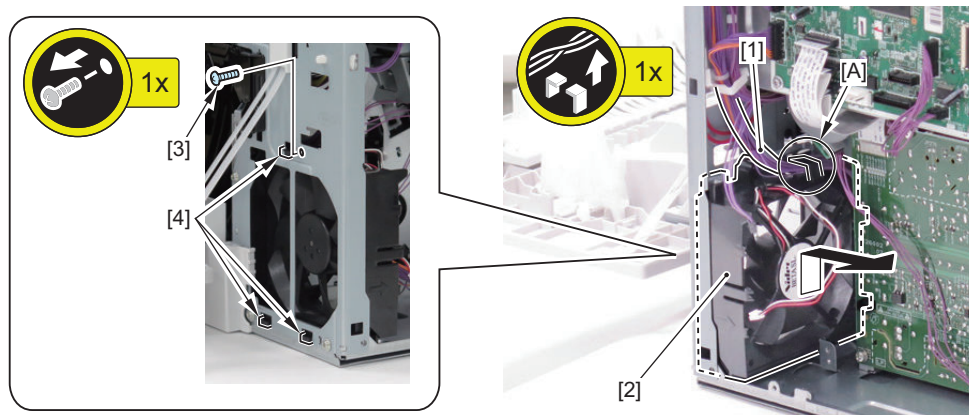

2. Remove the Power Fan [1].

- 1 Guide [A]
- 5 Claws [2]

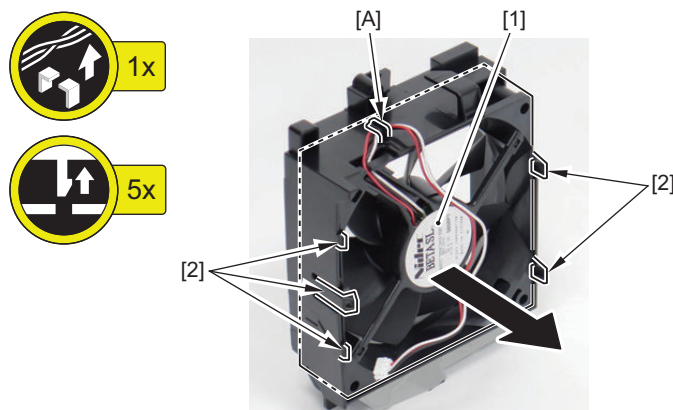
**CAUTION:**

When installing, be sure that the arrow mark of the Fan Holder [1] and the arrow mark of the Power Fan [2] are facing the same direction.

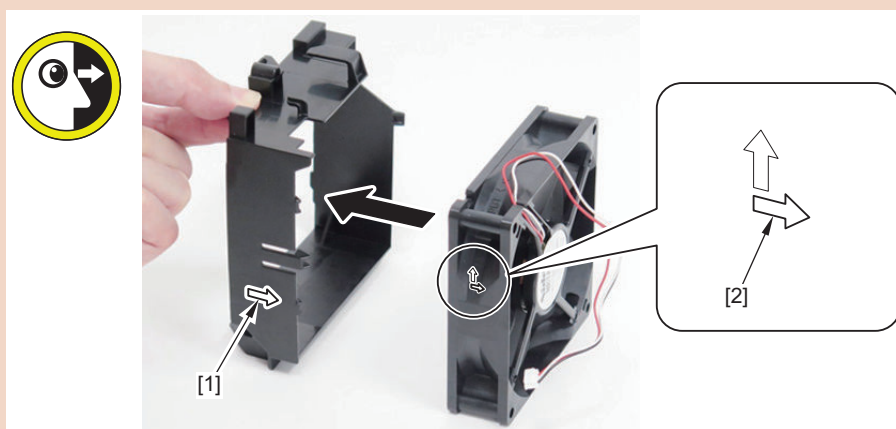

● Removing the Cartridge Fan

■ Preparation

1. Remove the Cassette.
2. “Removing the Waste Toner Container Cover Unit” on page 130
3. “Removing the Rear Cover” on page 131
4. “Removing the Left Cover” on page 132
5. “Removing the Front Cover Unit” on page 140

■ Procedure

1. Free the harness [1] from the guide [A].

- 1 Connector [2]

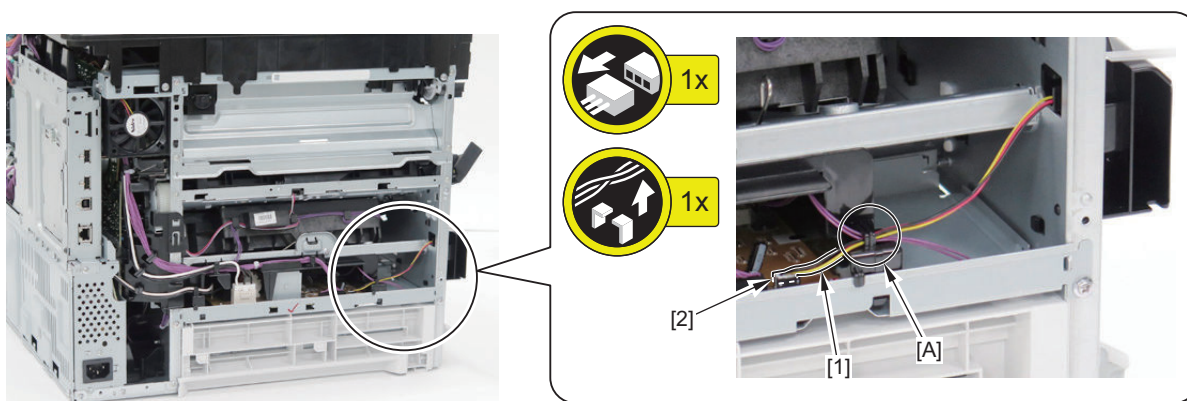

2. Remove the Cartridge Fan Unit [1] and pull out the harness [2] through the hole [A].

- 1 Boss [3]
- 3 Hooks [4]

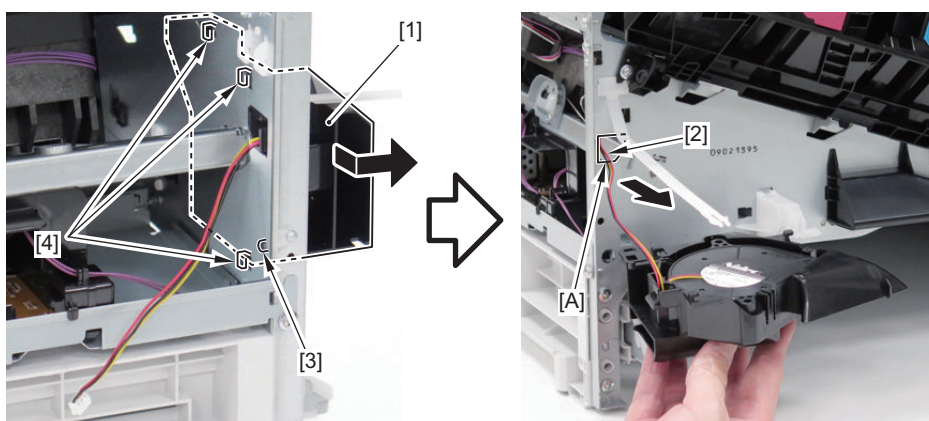

3. Free the harness [1] from the guide [A], and insert a finger through the hole of the Fan Duct [B] to lift up the Cartridge Fan [2] and remove it.

- 2 Claws [3]
- 1 Hook [4]

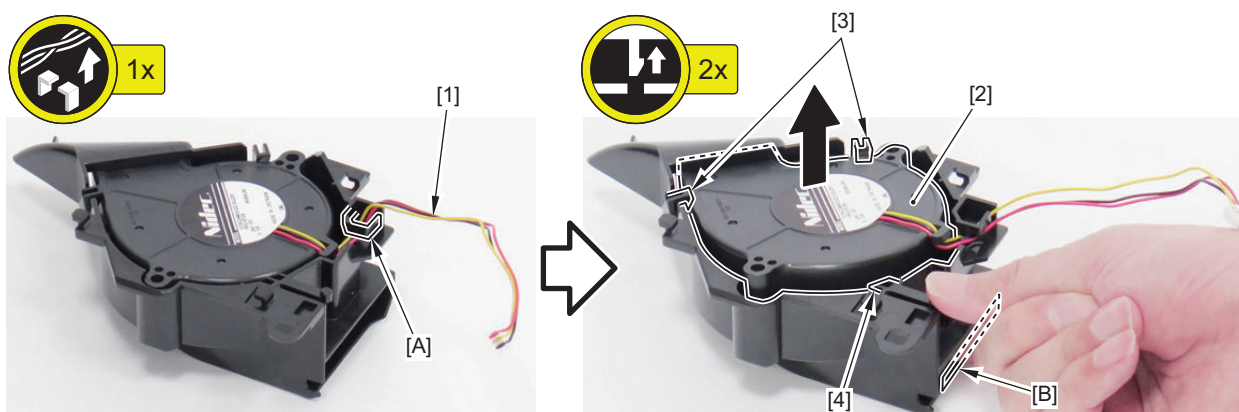

● Removing the Exhaust Fan

■ Preparation

1. "Removing the Waste Toner Container Cover Unit" on page 130

2. "Removing the Rear Cover" on page 131
3. "Removing the Left Cover" on page 132
4. "Removing the Controller Cover" on page 182
5. "Removing the Controller Box" on page 187
6. "Removing the Right Rear Cover" on page 133
7. "Removing the DC Controller Support Plate" on page 190
8. "Removing the Upper Cover Unit" on page 137
9. "Removing the Upper High Voltage Power Supply PCB" on page 192

■ Procedure

1. Free the harness [1] from the guide [A], and remove the Exhaust Fan Unit [2].
 - 1 Claw [3]
 - 1 Boss [4]
 - 2 Hooks [5]

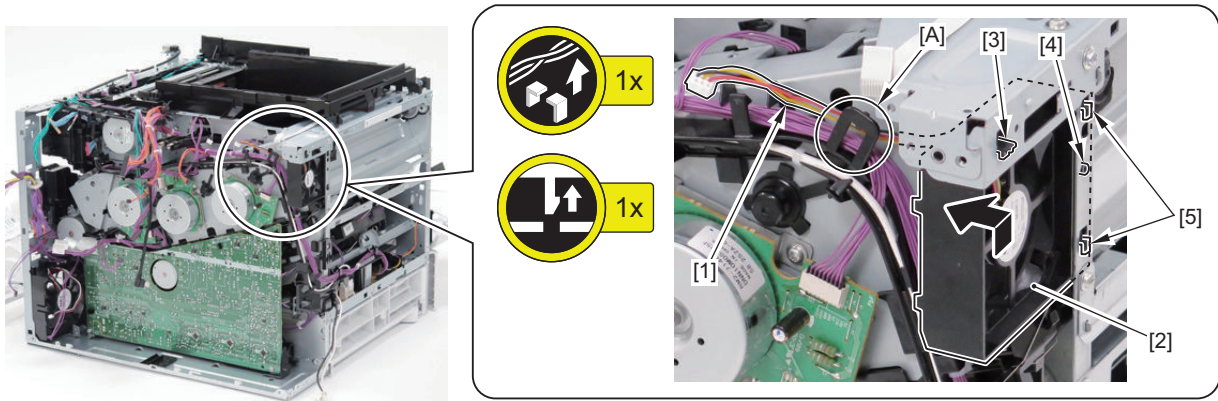

2. Remove the Exhaust Fan [1].

- 1 Guide [A]
- 4 Claws [2]

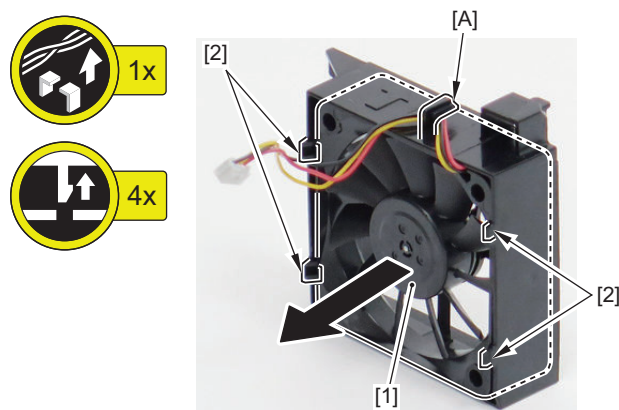
**CAUTION:**

When installing, be sure that the arrow mark of the Fan Duct [1] and the arrow mark of the Exhaust Fan [2] are facing the same direction.

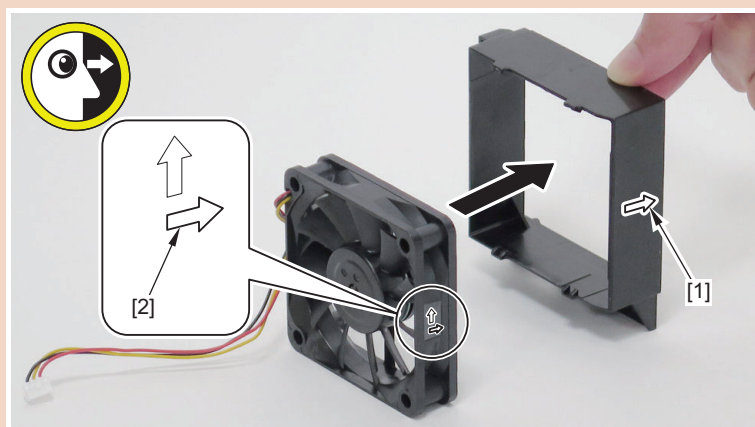

Removing the Fixing Fan

■ Preparation

1. "Removing the Waste Toner Container Cover Unit" on page 130
2. "Removing the Rear Cover" on page 131
3. "Removing the Left Cover" on page 132
4. "Removing the Right Rear Cover" on page 133
5. "Removing the Upper Cover Unit" on page 137

■ Procedure

1. Remove the Upper Cover Guide [1].

- 1 Screw [2]
- 2 Hooks [3]

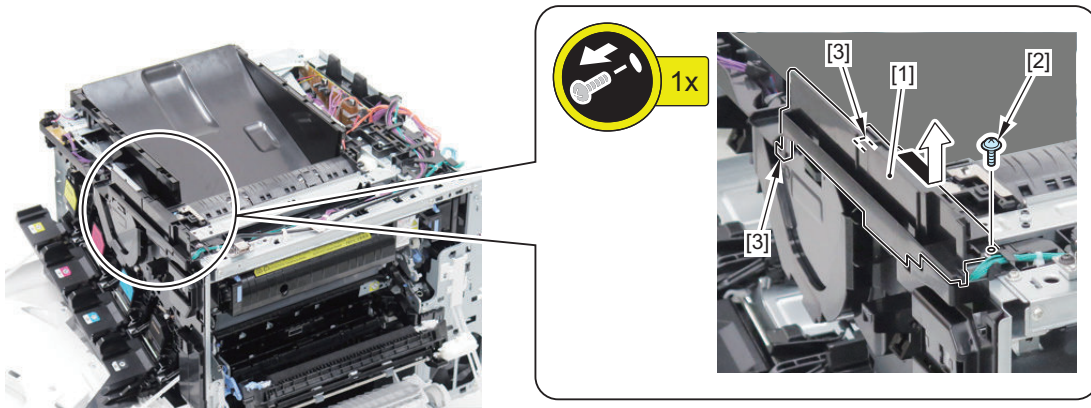

2. Remove the Switch Cover [1].

- 1 Screw [2]
- 2 Claws [3]
- 2 Hooks [4]

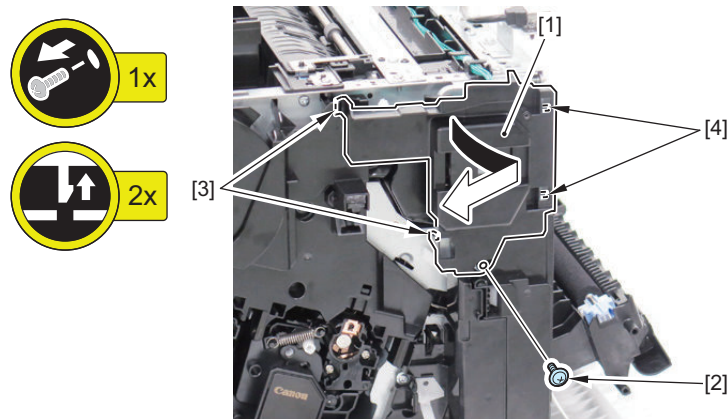

3. Remove the Right Hinge Base Cover [1].

- 1 Screw [2]
- 2 Bosses [3]
- 1 Hook [4]

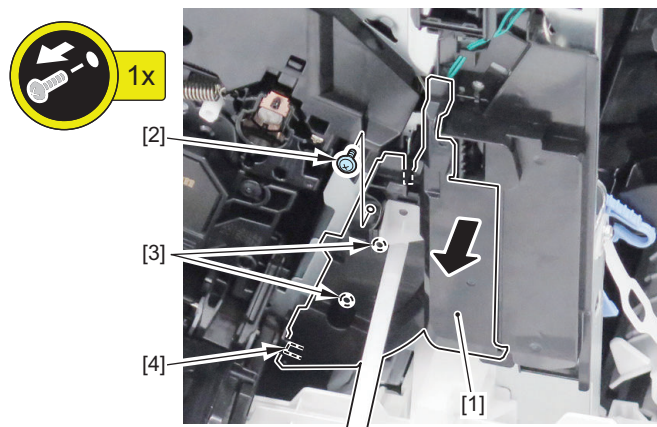

4. Shift the Relay PCB [1].

- Harness Guides [A] and [B]
- 1 Claw [2]
- 1 Hook [3]

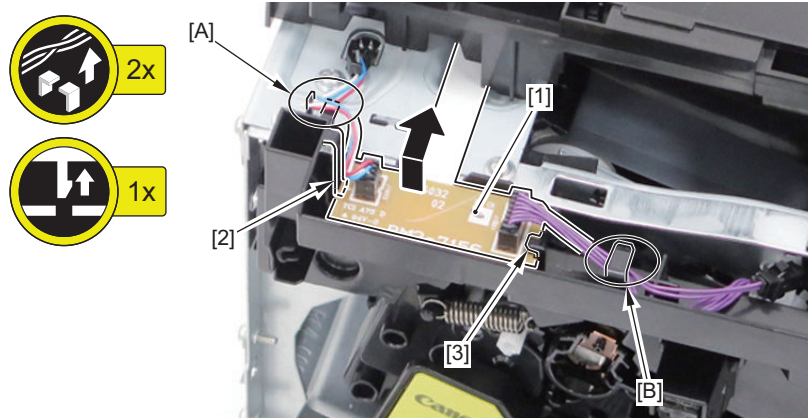

CAUTION:

Before removing the Front Inner Upper Cover Unit in the following procedure, if the ITB Unit has been removed, be sure to return the spring [1] on the left side from the ITB lock release position hook [2] to the ITB lock position hook [3].

Otherwise, the spring [1] will come off.

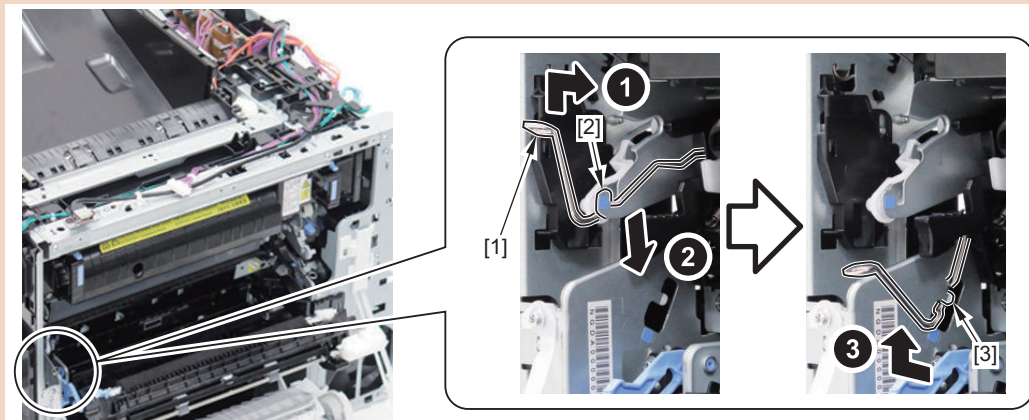

5. Remove the Front Inner Upper Cover Unit [1].

- 2 Screws [2]
- 2 Claws [3]

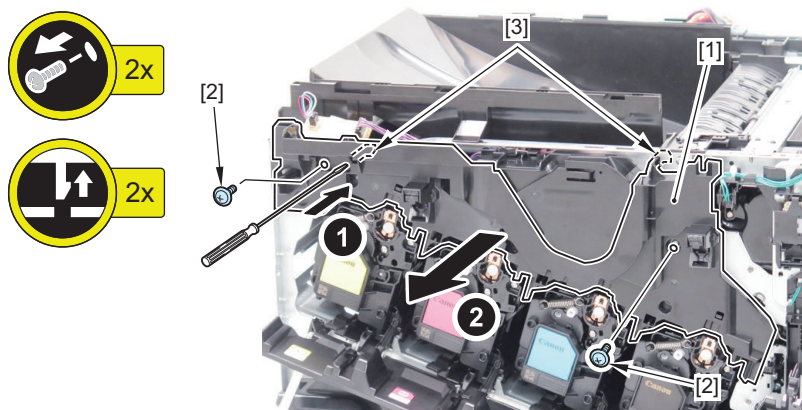
**CAUTION:**

When installing, be sure to attach the Front Cover Open/Close Flag [2] to the Front Inner Upper Cover Unit [1] in advance (as it may have come free from the unit).

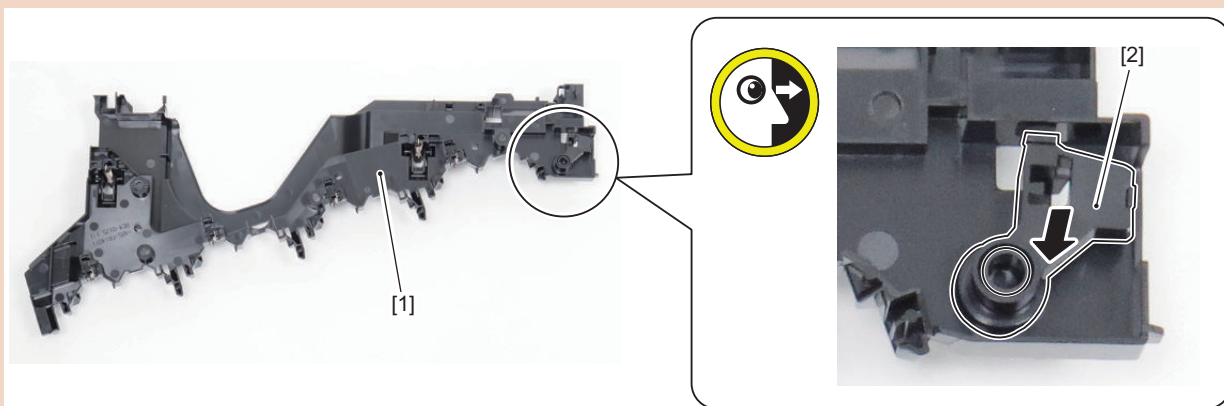

6. Free the 4 harnesses [1] from the 4 guides [A], and disconnect the Relay Connector [2].

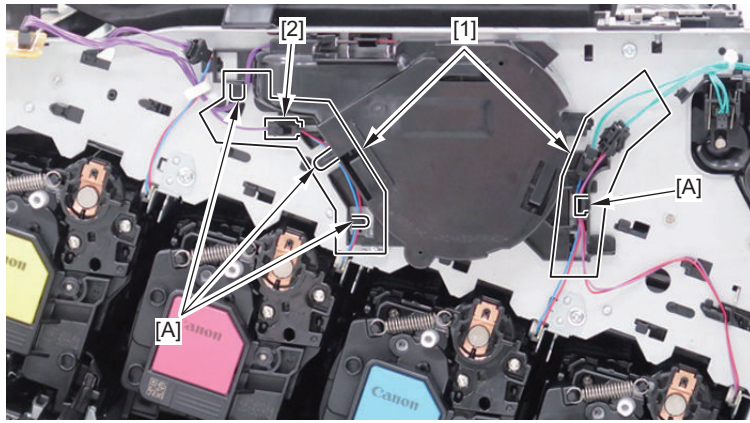
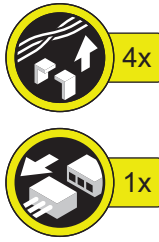

7. Remove the Fixing Fan Unit [1], and free the harness [2] from the guide [A].

- 1 Boss [3]
- 3 Hooks [4]
- 1 Connector [5]

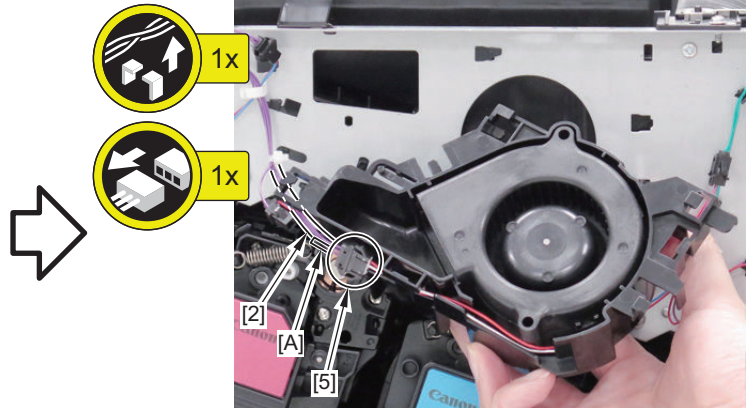
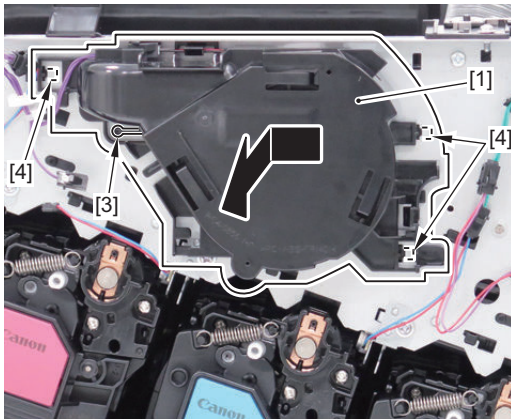

8. Remove the Fixing Fan [1].

- 2 Guides [A]

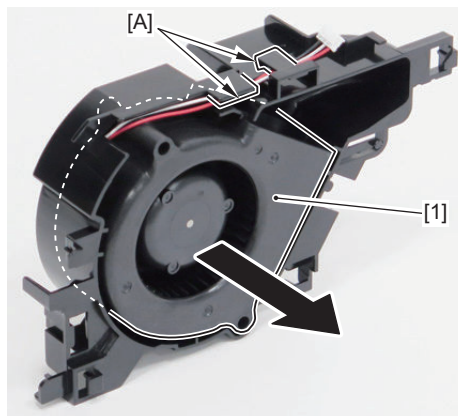



Adjustment

Actions after Replacement.....211

Actions after Replacement

Before Replacing the Main Controller PCB

The following setting values are recorded in the Main Controller PCB. When the Main Controller PCB is replaced, these setting values are all returned to the default unless they are restored.

- User mode setting values
- Service mode setting values

These setting values can be restored by performing backup by either of the following methods:

Refer to the Backup List for the details of items that are backed up. [“Backup Data” on page 257](#)

- Backup/restoration using the Expansion ROM for servicing and the Sublog Board (Recommended) [“Backup/restoration using the Expansion ROM for servicing and the Sublog Board” on page 92](#)
- SERVICE MODE > FUNCTION GR. > ECONF > EXPORT
- SERVICE MODE > FUNCTION GR. > Import/Export Set. > EXPORT
- Setup > User Maintenance > Import/Export Set. > Export
- RUI > Settings/Registration > Management Settings > Import/Export > Export.

CAUTION:

Perform backup immediately before replacing the Main Controller.

After Replacing the Main Controller PCB

Restore the data in the same way as that of backup. Refer to the Backup List for the setting values that are restored.

Update firmware as necessary.

Before Replacing the DC Controller PCB

The setting values stored in the DC Controller PCB NVRAM can be backed up to the Main Controller PCB NVRAM.

The setting values can be backed up by performing the following method.

- SERVICE MODE > FUNCTION GR. > CLEAR DCON

Turn OFF and then ON the power of the host machine.

CAUTION:

Perform backup immediately before replacing the DC Controller.

After Replacing the DC Controller PCB

The setting values of the NVRAM on the DC Controller PCB are stored in the NVRAM on the Main Controller PCB as a backup.

The setting values can be restored by performing the following method.

- SERVICE MODE > FUNCTION GR. > RESTORE DCON

Turn OFF and then ON the power of the host machine.



Troubleshooting

Test Print.....	213
Troubleshooting.....	220
Obtaining Debug Log.....	225

Test Print

Overview

Printing test pages helps determine if the printer is functioning.

CAUTION:

There are two types of test pages: engine-test page and Main Controller-test page. Print a test page to make sure the printer engine and the Main Controller are functioning.

■ Engine Test Print

Press the test print switch on the PCB using a thin screwdriver through the hole on the rear of the host machine to print a test pattern as shown below.

The image of the engine test print is recorded in the DC Controller. Because of this, it can be output even if the Main Controller is faulty.

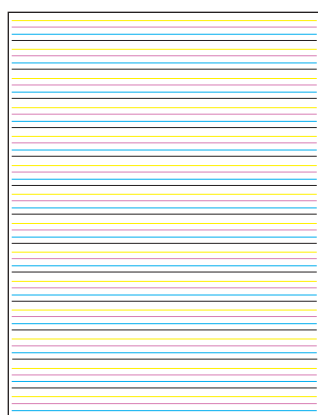

■ Controller Test Print

Data of the controller test print is created inside the Main Controller. When no image failure is found in the test print in normal output mode, it is assumed that the failure is caused by the PDL input.

NOTE:

Method to display the test print: It appears in the menu by pressing [Job Status/Cancel] key and [Utility] key simultaneously.

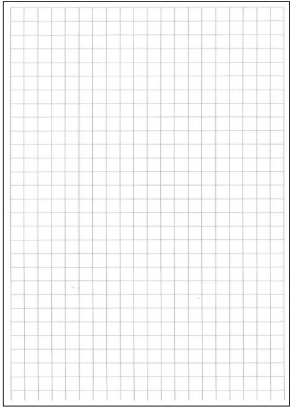
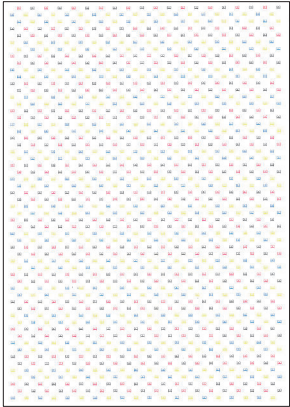
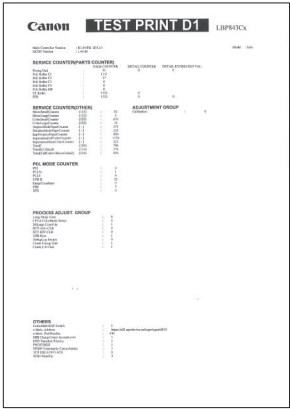
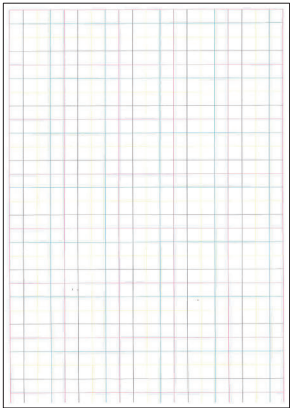
Test Print	Pattern	Purpose of use	Image
B	Grid *1	To check the right angle accuracy and straight line accuracy.	
D	Print letters "E" all over the page *1	To check for any distorted letters	
D1	--	To check the counter values and information on devices for service. <ul style="list-style-type: none"> • Firmware version • Service counter • PDL mode counter • Service mode setting values 	
E	Color grid *1	To check the right angle accuracy and straight line accuracy.	

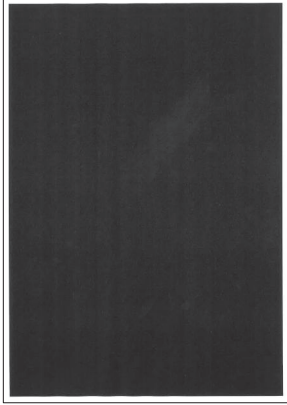
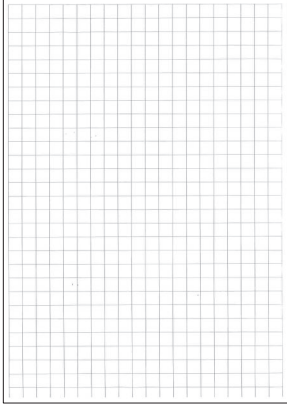
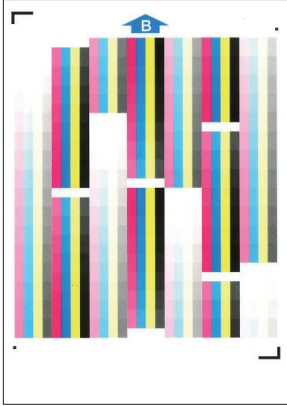
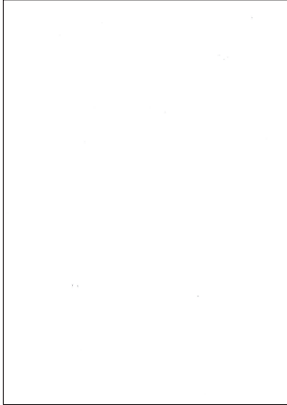
Test Print	Pattern	Purpose of use	Image
I	Solid black	To check transfer failure, white line, and margin	
L	Grid	To check the right angle accuracy and straight line accuracy.	
N	Patch pattern	For calibration of the scanner	
Z	Blank (not printed)	To check fogging	

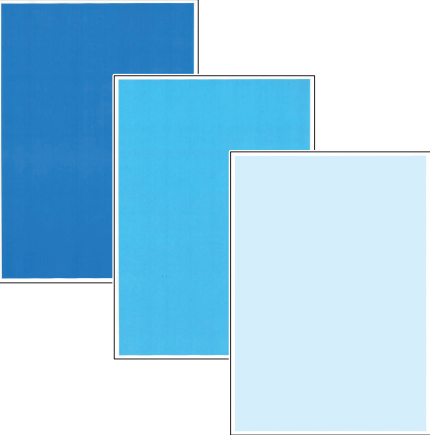
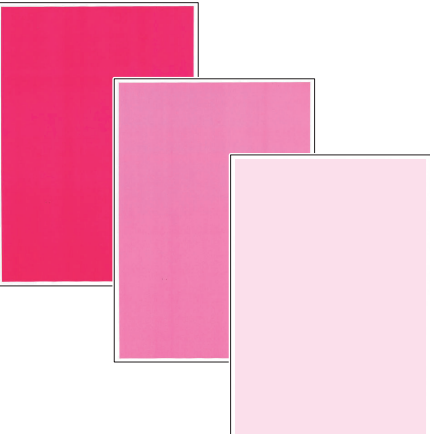
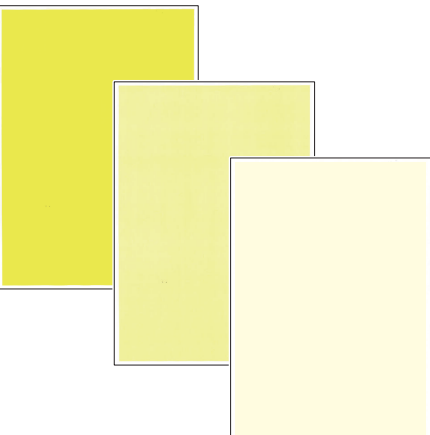
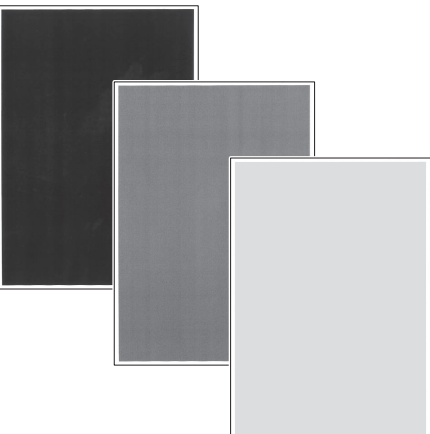
Test Print	Pattern	Purpose of use	Image
AL	Cyan, 3 sheets (differ in density)	To check the symptom of various image failures such as lines, uneven density, and scratches.	
AM	Magenta, 3 sheets (differ in density)	To check the symptom of various image failures such as lines, uneven density, and scratches.	
AN	Yellow, 3 sheets (differ in density)	To check the symptom of various image failures such as lines, uneven density, and scratches.	
AO	Black, 3 sheets (differ in density)	To check the symptom of various image failures such as lines, uneven density, and scratches.	

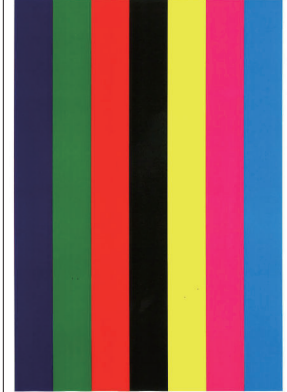
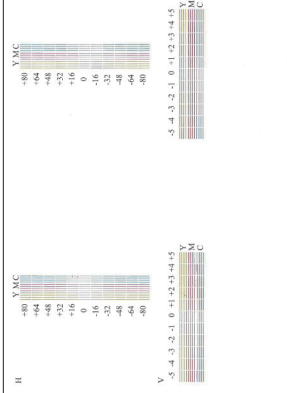
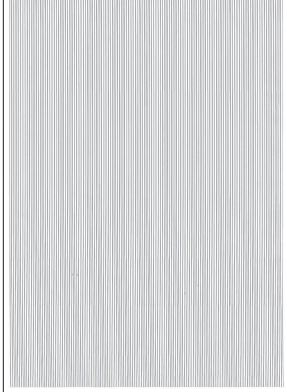
Test Print	Pattern	Purpose of use	Image
AP	Four-color chart, 6 sheets (differ in Dhalf/dither settings)	To check gradation performance and registration displacement	
AQ	Stripes of C, M, Y, K, R, G, and B	To check transferability.	
AR	Y, M, C thin lines	To check color displacement	
AS	Vertical lines with respect to the paper feed direction	To check smeared image	

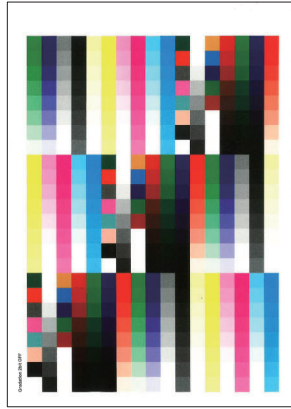
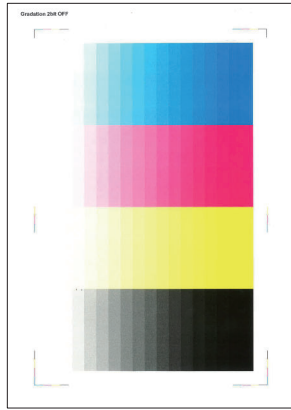
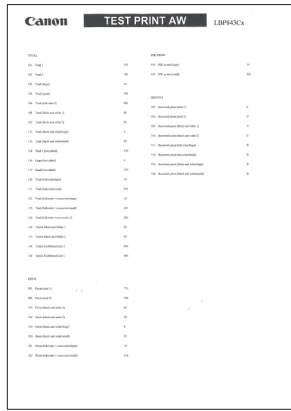
Test Print	Pattern	Purpose of use	Image
AT	6 sheets with different resolutions	To check gradation performance and color displacement of the engine alone	
AU	8 sheets with different resolutions	To check image characteristics of the engine alone	
AW	Software counter list	To check the software counter (billing counter)	
AY/AZ/BA/BB/B C/BD/BE/BF/BI/ BK	-	For factory test	-

*1: Since this is a continuous test print with no designated number of pages, the following operation needs to be done to stop the printing.

1. Press the [Online] key and then the [Job Status/Cancel] key.
[1: --- ReportPri] appears on the display.
2. Press the [OK] key. The screen to choose whether to stop appears.
3. Select "Yes", and press the [OK] key.

Device Log List

Print jam, error and alarm logs.

NOTE:

Method to display the test print

It appears in the menu by pressing [Job Status/Cancel] + [Utility] simultaneously.

Log	Purpose of use
Log1	Jam log list Print 50 logs at a maximum.
Log2	Jam log list stored in the controller Print 50 logs at a maximum.
Log3	Error log list Print 50 logs at a maximum.
Log4	Alarm log list Print 50 logs at a maximum.

Canon **Device Log List** LBP8730

Page 1

Number	Date	Time	Code	Total Printed Pages
01	10/21/2012	01:28:46	0001	00001110
02	10/21/2012	01:28:56	0000	00001114
03	10/21/2012	01:29:06	0001	00001114
04	10/21/2012	01:29:16	0001	00000000
05	10/21/2012	01:29:26	0001	00000000

Page 2

Number	Date	Time	Code	Total Printed Pages	Size	Type
06	10/21/2012	01:29:36	0000	00001114		
07	10/21/2012	01:29:46	0000	00001114		
08	10/21/2012	01:29:56	0000	00001114		
09	10/21/2012	01:30:06	0000	00000000		
10	10/21/2012	01:30:16	0000	00000000		

Page 3

Number	Date	Time	Code	Total Printed Pages
11	10/21/2012	01:30:26	0000	00001114
12	10/21/2012	01:30:36	0000	00001114
13	10/21/2012	01:30:46	0000	00001114
14	10/21/2012	01:30:56	0000	00000000
15	10/21/2012	01:31:06	0000	00000000

Page 4

Number	Date	Time	Code	Total Printed Pages
16	10/21/2012	01:31:16	0000	00000000

Troubleshooting

Remedy for Image Failure

When an image failure occurs, perform the remedy by referring to the following material.

- Top > Troubleshooting > When You Cannot Print Properly

Intervals of Soiling, White Spots, Etc. That Occur on Images

Cause of failure		Intervals (mm)	Symptom			
			Soiling	White spots	Soiled back	Fixing failure
Registration Roller		Approx. 42	Yes	-	Yes	-
Cartridge	Primary Charging Roller	Approx. 27	-	Yes	-	-
	Photosensitive Drum	Approx. 75	Yes	Yes	-	-
	Developing Roller	Approx. 32	-	Yes	-	-
Secondary Transfer Roller		Approx. 50	-	Yes	Yes	-
Fixing Assembly	Fixing Film	Approx. 58	Yes	Yes	-	Yes
	Pressure Roller	Approx. 69	Yes	-	Yes	Yes

Checking the Amount of Fixing Nip

Although the nip width of the Fixing Assembly cannot be adjusted with this machine, it can be checked.

By checking the nip width when fixing failure occurs, it is possible to judge whether there is a problem with the Fixing Assembly. Check the nip width of the Fixing Assembly by the following procedure.

NOTE:

Method to display the test print: It appears in the menu by pressing [Job Status/Cancel] key and [Utility] key simultaneously.

1. Output Test Print I (solid black).
2. Load the solid black printed paper with its printing side facing down in a cassette of the machine.
3. Output Test Print Z to feed paper in the cassette.
4. When the leading edge of the paper comes out to the Delivery Outlet, open the Front Cover to cause a jam.
5. About 10 seconds afterwards, remove the jammed paper.
6. Measure the widths of the glossy part of the toner shown in the figure below on the printed paper, and check the following.

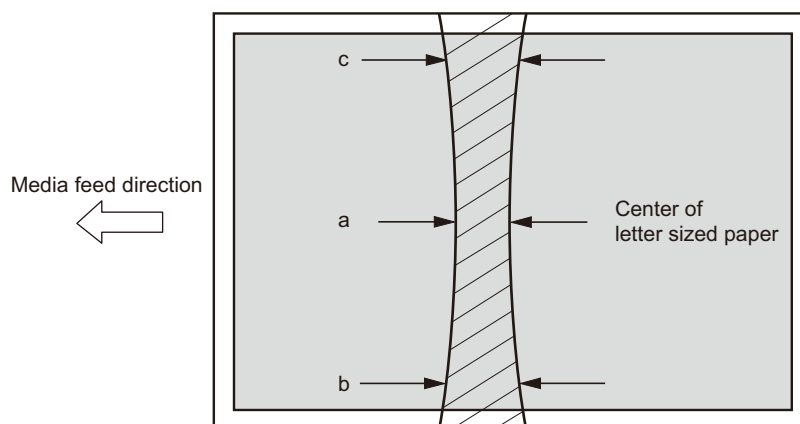

1. The center value (a), front value (b), and rear value (c) should be within 7.7 +/- 0.7 mm. If the foregoing values are outside the range, fixing failure may occur.

● Installing the Laser Scanner Dustproof Glass Cleaning Tools When They Have Come Off

CAUTION:

When removing/installing the Laser Scanner Unit [1], the Front Cover [2] needs to be closed and the 4 Dustproof Glass Cleaning Tools [3] need to be disengaged from the Laser Scanner Unit [1] without fail.

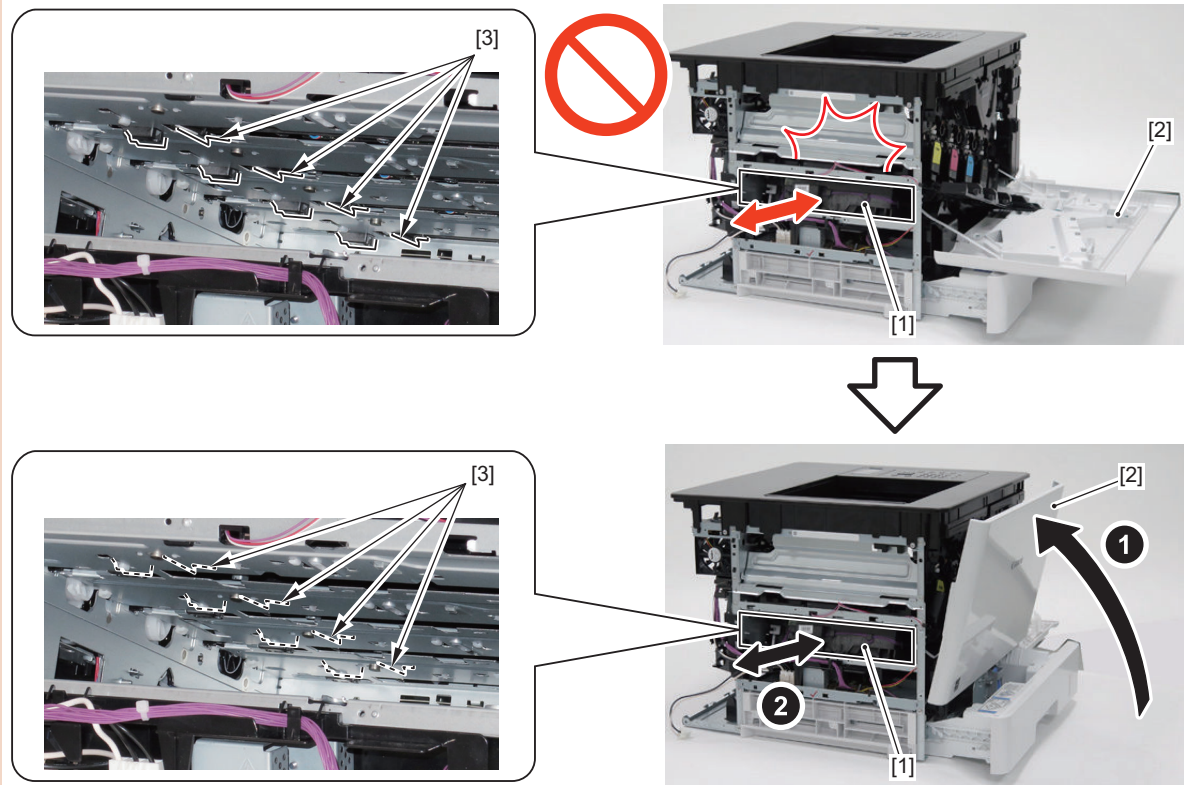

If the Laser Scanner Unit is removed/installed without closing the Front Cover and the Dustproof Glass Cleaning Tools come off, perform this procedure to install them again.

CAUTION:

Be sure not to touch the Cleaning Pads and Sheets [A] of the 4 Dustproof Glass Cleaning Tools [1].

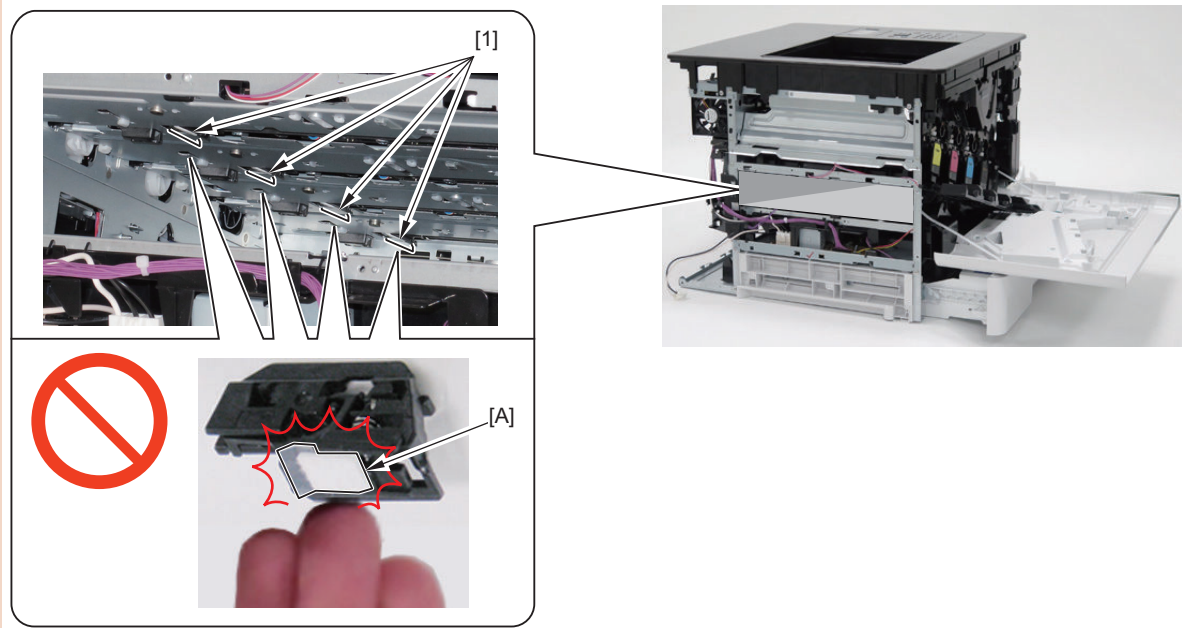

1. Open the Front Cover [1], and remove the Toner Cartridges (Y/M/C/Bk) [2].

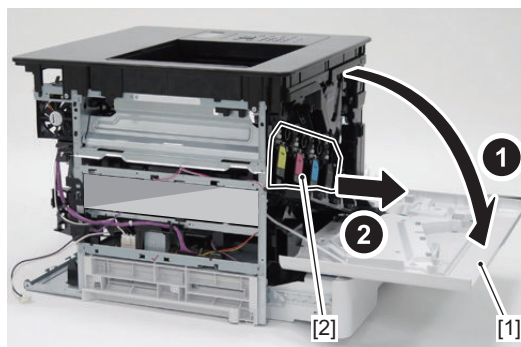

2. If the spring [1] and the Cleaning Pad Base [2] of the Dustproof Glass Cleaning Tool have come off but the holder [3] has not come free from the rail [4] of the host machine, perform step 3 to remove the rail [3].

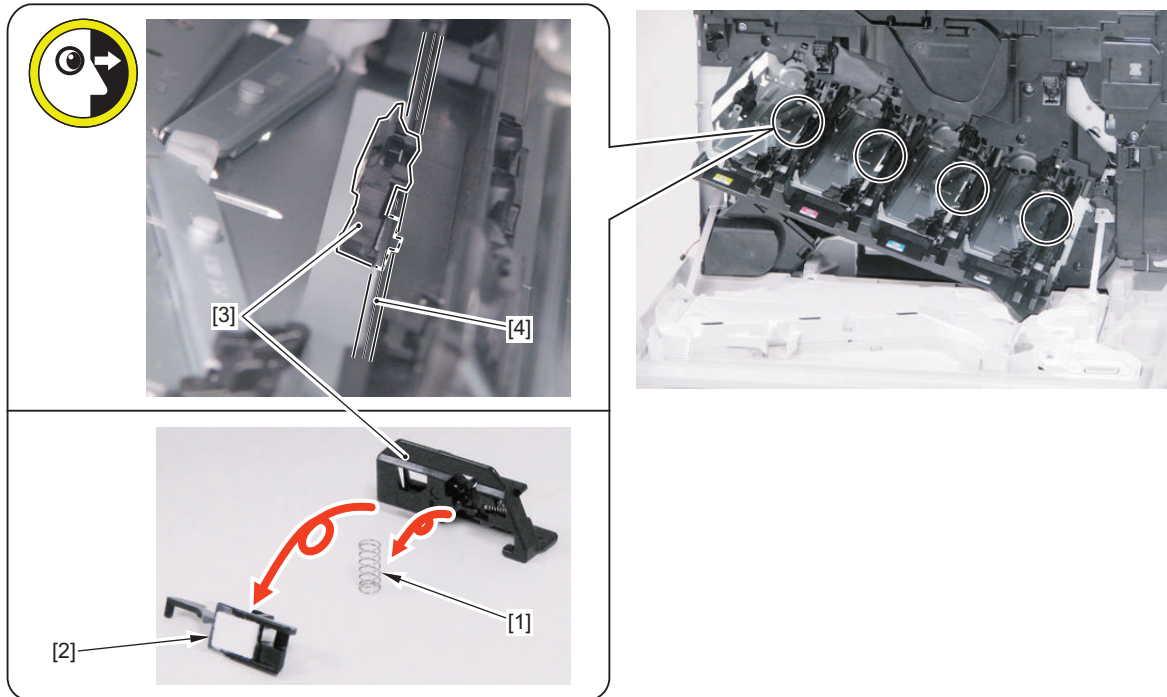

3. Free the Lower Claw [A] using a flat-blade screwdriver, and remove the holder [1] from the rail [2].
- 2 Upper Claws [B]

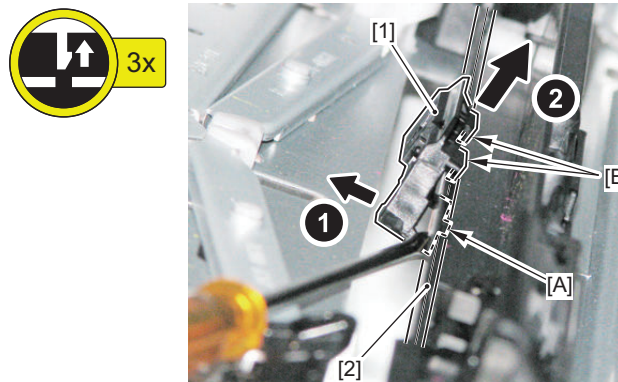

4. If the Dustproof Glass Cleaning Tool has been disassembled into 3 pieces, the holder [1], spring [2], and Cleaning Pad Base [3], perform steps 5 to 7 to assemble them.

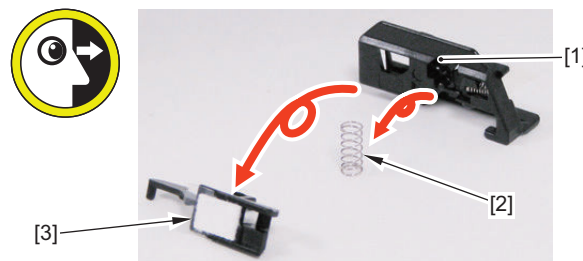

5. Assemble the holder [1] and the spring [2] by aligning the spring with the boss [A].

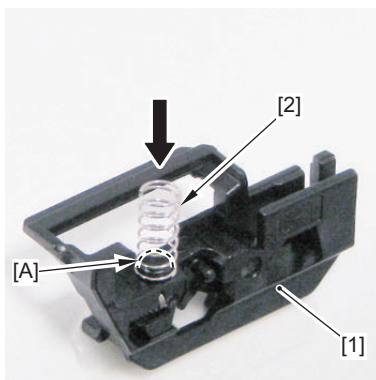

6. Align the boss [B] of the Cleaning Pad Base [3] with the spring [2], and hook the [C] part of the Cleaning Pad Base on the hook [D] of the holder.

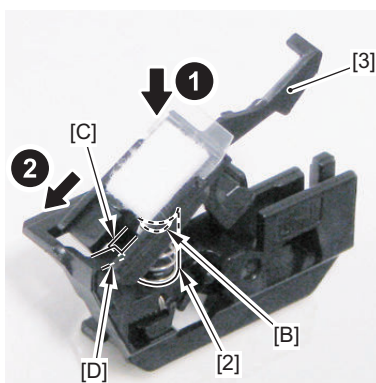

7. While inserting the end [E] of the Cleaning Pad Base into the groove [F] of the holder, hook the hook [G] on the shaft [H] of the holder.

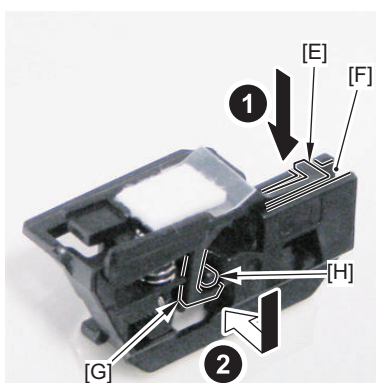

8. After hooking the 2 Upper Claws [A] on the rail [1], push the Dustproof Glass Cleaning Tool [2] to attach it to the rail [1] (you will hear a click sound when the Lower Claw [B] is fitted).

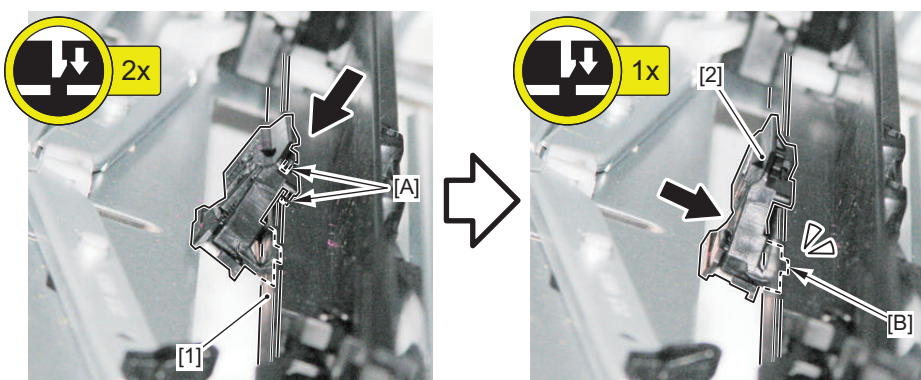

Obtaining Debug Log

Function Overview

Debug logs (hereinafter "Sublogs") are logs that record the internal operations of the Main Controller, and are used to analyze program operations and used by developers to identify problems.

When a problem that is difficult to reproduce occurs, collecting a Sublog immediately after the problem has occurred on site can increase the efficiency of analyzing the problem and reduce the time it takes to deal with the problem.

Be sure to collect the debug log when the Support Dept. of sales company so instructs.

Note that there is no need for service technicians to check the content of collected debug log.

Sublog

It is available only when the Sublog Board is installed on the Main Controller PCB.

When the Sublog Board is not installed, log is not saved anywhere.

It is stored in the Sublog Board and its content is stored even when the power is turned OFF to be displayable when the power is turned ON again.

The Sublog Board has a limited capacity and when the log exceeding this storage number is attempted to be stored, the log is deleted in the order of length of time stored.

How the log is written

The RAM of the Sublog Board is directly overwritten by a processing of the Main Controller. The logs are not erased when the power of this machine is turned OFF, because a button battery is included.

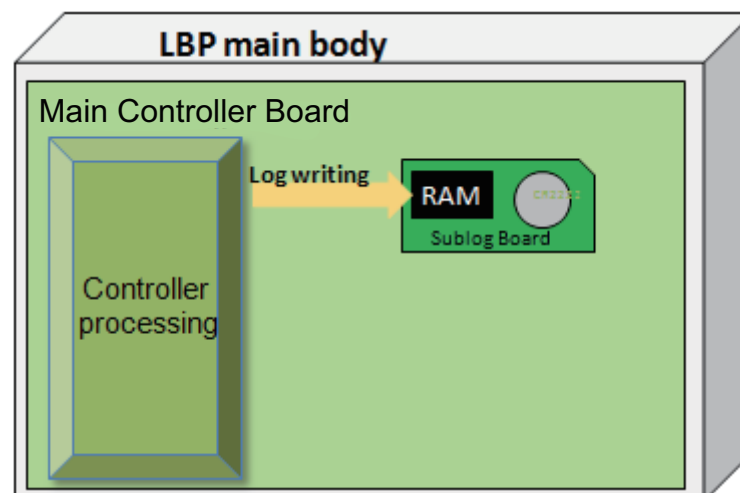

Conditions for collecting logs

Conditions where log collection is valid

Collection of debug log is effective in the following cases:

- Neither the Support Dept. of sales company nor CINC can reproduce the trouble that occurred at the customer site.
- When the error frequency is low
- When a failure of firmware, etc. is suspected, rather than a mechanical failure or electrical failure

CAUTION:

If the procedure for reproducing the failure is clear and the Support Dept. of sales company and CINC can reproduce it, collection of debug log is not necessary.

Conditions where logs cannot be collected

Logs cannot be collected under the following conditions:

- Service mode screen cannot be accessed
- The machine cannot recognize a USB flash drive.
- The machine does not have a USB port.

Sublog Collection Procedure

1. Push SW1 on the board and confirm that LED1 turns on.

If LED1 does not turn on, You need change the battery on Sublog board is located at BATS1 (CR2032) .

CAUTION:

There is danger of explosion if the battery is replaced with an incorrect type.

Replace it only with the same type of battery.

Dispose of used batteries according to the manufacturer's instructions.

2. Check that the power supply of the host machine is OFF. Remove the ROM Outer Cover on the right side of the host machine.
3. Remove the screw of the ROM Inner Cover, and then remove the cover.



4. Install the Sublog Expansion Board into the slot over the Controller.



5. Turn ON the power of the machine, and reproduce the problem that is occurring.
The log is automatically written to the ROM of the Sublog Board.
6. Turn OFF the power of the host machine.

7. Insert the USB flash drive into the host machine.

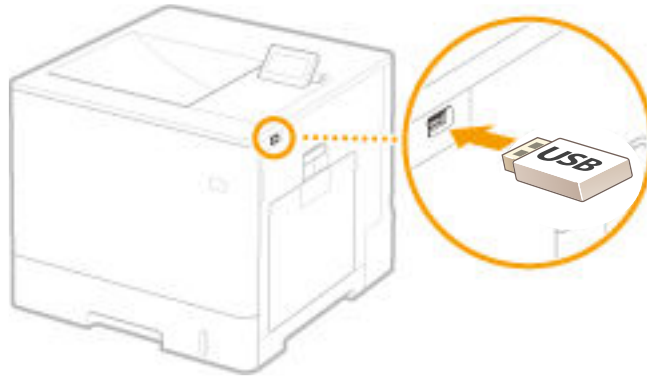

8. Turn ON the power while pressing down the "<-", "OK" and "Online" simultaneously.



9. Press the left arrow key or the right arrow key on the Control Panel until the "LOG TO USBMEM" menu is displayed.

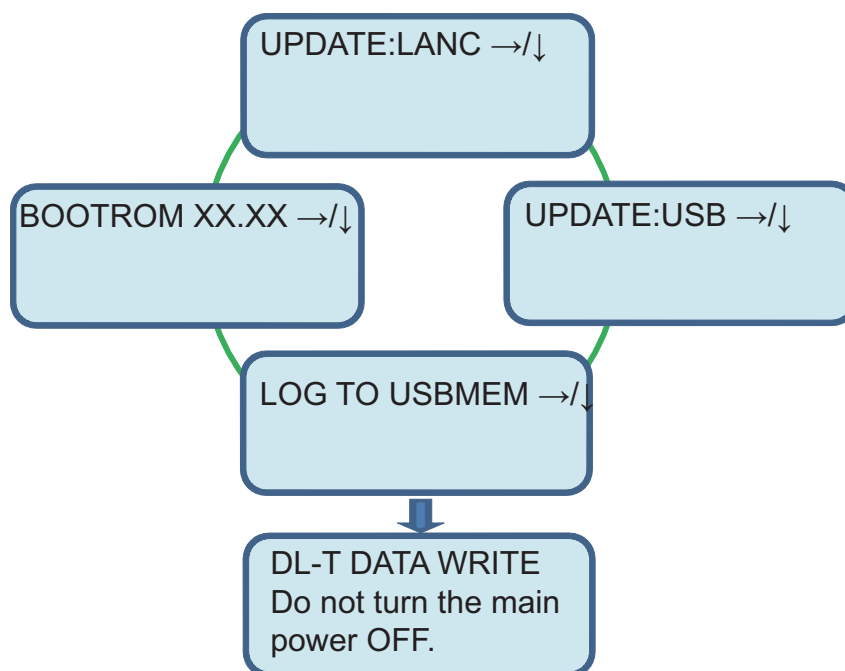

10. Press the down arrow key on the Control Panel, and check that "DL-T DATA WRITE Do not turn the main power OFF." is displayed.

CAUTION:

The log is written when the machine is restarted the next time after the Sublog Board is attached. Therefore, make sure to quickly turn OFF the power after the problem has occurred and write to the USB flash drive to collect the log for the problem. If you do not perform this operation quickly, the target operation log may be overwritten by the logs that are written periodically, etc.

The message "UPDATE:LANC→/↓" is displayed when the log has been written.

11. Turn OFF the power of the machine, and remove the USB flash drive.
12. Connect the USB flash drive to the PC, and check that the Sublog has been saved to the following path:
- /LOG_TMP/SUBLOG.bin

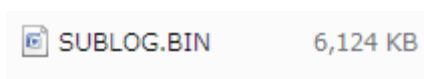

13. Send the file saved to the USB flash drive to the Support Dept. of the sales company.



Error/Jam/Alarm

Overview.....	230
Error Code Details.....	231
Jam Code.....	238
Alarm Code.....	240

Overview

This section describes the error codes that are displayed when failure has occurred. The codes are divided into three categories. The codes can be checked by printing the device log list.

Code types	Description
Error codes	This code is displayed when a failure which impacts printing has occurred.
Jam code	This code is displayed when a jam occurs inside the machine.
Alarm code	This code is displayed when some functions are disabled.

NOTE:

Device Log List Print Method

"Job Status/Stop Key" + "Utility Menu" > [Device Log List]

If a code which is not mentioned in the Service Manual occurs, obtain the following information as much as possible.

- Logs (jam/error log report, etc.)
- Version information, machine configuration
- Debug log
- Occurrence status

Obtaining the foregoing information allows for smooth response when the case is escalated to the department in charge of quality management.

Error Code Details

Error Code	Title	Detection description	Remedy
A4-nn-Error	System error	System error	- Turn OFF and then ON the main power. If the error persists, obtain the following information and contact the department in charge of quality management. - Output STATUS PRINT/P-PRINT. - Collect Sublog - Collect information on conditions to reproduce the error - Obtain user's print data (binary data)
A5-nn-Error	System error	System error	- Turn OFF and then ON the main power. If the error persists, obtain the following information and contact the department in charge of quality management. - Output STATUS PRINT/P-PRINT. - Collect Sublog - Collect information on conditions to reproduce the error - Obtain user's print data (binary data)
A7-nn-Error	System error	System error	- Turn OFF and then ON the main power. If the error persists, obtain the following information and contact the department in charge of quality management. - Output STATUS PRINT/P-PRINT. - Collect Sublog - Collect information on conditions to reproduce the error - Obtain user's print data (binary data)
D0-nn-Error	System error	System error	- Turn OFF and then ON the main power. If the error persists, obtain the following information and contact the department in charge of quality management. - Output STATUS PRINT/P-PRINT. - Collect Sublog - Collect information on conditions to reproduce the error - Obtain user's print data (binary data)
D7-nn-Error	System error	System error	- Turn OFF and then ON the main power. If the error persists, obtain the following information and contact the department in charge of quality management. - Output STATUS PRINT/P-PRINT. - Collect Sublog - Collect information on conditions to reproduce the error - Obtain user's print data (binary data)
D8-nn-Error	System error	System error	- Turn OFF and then ON the main power. If the error persists, obtain the following information and contact the department in charge of quality management. - Output STATUS PRINT/P-PRINT. - Collect Sublog - Collect information on conditions to reproduce the error - Obtain user's print data (binary data)
D9-nn-Error	System error	System error	- Turn OFF and then ON the main power. If the error persists, obtain the following information and contact the department in charge of quality management. - Output STATUS PRINT/P-PRINT. - Collect Sublog - Collect information on conditions to reproduce the error - Obtain user's print data (binary data)
F9-nn-Error	System error	Communication error between the Main Controller and the Control Panel	- Check for any poor contact/open circuit of the connector between the Main Controller and the Control Panel. If there is no problem with the connector but the error persists, obtain the following information and contact the department in charge of quality management. - Output STATUS PRINT/P-PRINT. - Collect Sublog - Collect information on conditions to reproduce the error
E000-0000	Fixing temperature rising error	Temperature of the Main Thermistor did not become the specified temperature although the specified time had passed.	<ol style="list-style-type: none"> 1. Check the drawer connector between the Fixing Assembly and the Fixing Power Supply Unit. 2. Replace the Fixing Assembly. 3. Replace the Fixing Power Supply Unit.
E001-0000	Abnormally high fixing temperature 1	The Main Thermistor detected a temperature higher than the specified temperature.	<ol style="list-style-type: none"> 1. Check the drawer connector between the Fixing Assembly and the Fixing Power Supply Unit. 2. Replace the Fixing Assembly. 3. Replace the Fixing Power Supply Unit.
E001-0001	Abnormally high fixing temperature 2	The Sub Thermistor 1 detected a temperature higher than the specified temperature.	<ol style="list-style-type: none"> 1. Check the drawer connector between the Fixing Assembly and the Fixing Power Supply Unit. 2. Replace the Fixing Assembly. 3. Replace the Fixing Power Supply Unit.
E001 - 0004	Abnormally high fixing temperature 3	The Sub Thermistor 2 detected a temperature higher than the specified temperature.	<ol style="list-style-type: none"> 1. Check the drawer connector between the Fixing Assembly and the Fixing Power Supply Unit. 2. Replace the Fixing Assembly. 3. Replace the Fixing Power Supply Unit.

Error Code	Title	Detection description	Remedy
E003-0000	Abnormally low fixing temperature detection 1	Temperature of the Main Thermistor was lower than the specified temperature when the heater was ON.	<ol style="list-style-type: none"> 1. Check the drawer connector between the Fixing Assembly and the Fixing Power Supply Unit. 2. Replace the Fixing Assembly. 3. Replace the Fixing Power Supply Unit.
E003-0001	Abnormally low fixing temperature detection 2	Temperature of the Sub Thermistor 1 was lower than the specified temperature when the heater was ON.	<ol style="list-style-type: none"> 1. Check the drawer connector between the Fixing Assembly and the Fixing Power Supply Unit. 2. Replace the Fixing Assembly. 3. Replace the Fixing Power Supply Unit.
E003 - 0004	Abnormally low fixing temperature detection 3	Temperature of the Sub Thermistor 2 was lower than the specified temperature when the heater was ON.	<ol style="list-style-type: none"> 1. Check the drawer connector between the Fixing Assembly and the Fixing Power Supply Unit. 2. Replace the Fixing Assembly. 3. Replace the Fixing Power Supply Unit.
E004-0000	Fixing Drive Assembly circuit error	Error in either the Fixing Heater or the Fixing Motor	<ol style="list-style-type: none"> 1. Check the drawer connector between the Fixing Assembly and the Fixing Power Supply Unit. 2. Check the connection of the Fixing Motor. 3. Replace the Fixing Assembly. 4. Replace the Fixing Motor. 5. Replace the Fixing Power Supply Unit.
E004-0004	Mismatch of Fixing Assembly type	A fixing assembly of another product was installed.	<ol style="list-style-type: none"> 1. Replace the fixing assembly with that of this product.
E012-0000	Pickup Motor error	Pickup Motor error (startup error)	<ol style="list-style-type: none"> 1. Check the connector between the Pickup Motor and the DC Controller PCB. 2. Replace the Pickup Motor. 3. Replace the DC Controller PCB 4. Replace the Pickup Drive Unit.
E012-0001	Pickup Motor error	Pickup Motor error (rotation error)	<ol style="list-style-type: none"> 1. Check the connector between the Pickup Motor and the DC Controller PCB. 2. Replace the Pickup Motor. 3. Replace the DC Controller PCB 4. Replace the Pickup Drive Unit.
E012 - 0002	Yellow Drum Motor error	Drum Motor error (startup error)	<ol style="list-style-type: none"> 1. Check the connector between the Drum Motor and the DC Controller PCB. 2. Replace the Drum Motor. 3. Replace the DC Controller PCB 4. Replace the Main Drive Unit.
E012 - 0003	Yellow Drum Motor error	Drum Motor error (rotation error)	<ol style="list-style-type: none"> 1. Check the connector between the Drum Motor and the DC Controller PCB. 2. Replace the Drum Motor. 3. Replace the DC Controller PCB 4. Replace the Main Drive Unit.
E012 - 0004	Magenta Drum Motor error	Drum Motor error (startup error)	<ol style="list-style-type: none"> 1. Check the connector between the Drum Motor and the DC Controller PCB. 2. Replace the Drum Motor. 3. Replace the DC Controller PCB 4. Replace the Main Drive Unit.
E012 - 0005	Magenta Drum Motor error	Drum Motor error (rotation error)	<ol style="list-style-type: none"> 1. Check the connector between the Drum Motor and the DC Controller PCB. 2. Replace the Drum Motor. 3. Replace the DC Controller PCB 4. Replace the Main Drive Unit.
E012 - 0006	Cyan Drum Motor error	Drum Motor error (startup error)	<ol style="list-style-type: none"> 1. Check the connector between the Drum Motor and the DC Controller PCB. 2. Replace the Drum Motor. 3. Replace the DC Controller PCB 4. Replace the Main Drive Unit.
E012 - 0007	Cyan Drum Motor error	Drum Motor error (rotation error)	<ol style="list-style-type: none"> 1. Check the connector between the Drum Motor and the DC Controller PCB. 2. Replace the Drum Motor. 3. Replace the DC Controller PCB 4. Replace the Main Drive Unit.

Error Code	Title	Detection description	Remedy
E012 - 0008	Black Drum Motor error	Drum Motor error (startup error)	<ol style="list-style-type: none"> 1. Check the connector between the Drum Motor and the DC Controller PCB. 2. Replace the Drum Motor. 3. Replace the DC Controller PCB 4. Replace the Main Drive Unit.
E012 - 0009	Black Drum Motor error	Drum Motor error (rotation error)	<ol style="list-style-type: none"> 1. Check the connector between the Drum Motor and the DC Controller PCB. 2. Replace the Drum Motor. 3. Replace the DC Controller PCB 4. Replace the Main Drive Unit.
E014-0000	Fixing Motor error	Error in startup of the Fixing Motor	<ol style="list-style-type: none"> 1. Check the connection of the Fixing Motor. 2. Replace the Fixing Motor. 3. Replace the DC Controller PCB
E014-0001	Fixing Motor error	Error in rotation of the Fixing Motor	<ol style="list-style-type: none"> 1. Check the connection of the Fixing Motor. 2. Replace the Fixing Motor. 3. Replace the DC Controller PCB
E015 - 0000	Developing disengagement Motor error	Error in rotation of the Developing disengagement Motor	<ol style="list-style-type: none"> 1. Check the connection of the Developing disengagement Motor. 2. Replace the Developing disengagement Motor. 3. Replace the DC Controller PCB
E020 - 0000	Color Displacement Density Sensor error	Error in the Color Displacement Density Sensor	<ol style="list-style-type: none"> 1. Check the connection of the Color Displacement Density Sensor. 2. Replace the Color Displacement Density Sensor. 3. Replace the DC Controller PCB
E066 - 0000	Environment Sensor error	Failure of the Environment Sensor was detected.	<ol style="list-style-type: none"> 1. Check the connection of the Environment Sensor. 2. Replace the Environment Sensor. 3. Replace the DC Controller PCB
E06F - 0068	EEPROM access error	A failure of the EEPROM is detected.	<ol style="list-style-type: none"> 1. Turn OFF and then ON the power. 2. Replace the Main Controller PCB.
E078 - 0001	Primary transfer disengagement mechanism error	Failure of the primary transfer disengagement mechanism	<ol style="list-style-type: none"> 1. Check that the ITB Unit is installed properly. 2. Check the connector between the Fixing Motor and the DC Controller PCB. 3. Replace the Fixing Motor. 4. Replace the DC Controller PCB
E100 - 0000	Yellow Laser Scanner error	Failure of the Laser Assembly in the Laser Scanner Unit (Yellow)	<ol style="list-style-type: none"> 1. Check the connector of the Laser Scanner Unit. 2. Replace the Laser Scanner Unit. 3. Replace the DC Controller PCB
E100 - 0001	Magenta Laser Scanner error	Failure of the Laser Assembly in the Laser Scanner Unit (Magenta)	<ol style="list-style-type: none"> 1. Check the connector of the Laser Scanner Unit. 2. Replace the Laser Scanner Unit. 3. Replace the DC Controller PCB
E100 - 0002	Cyan Laser Scanner error	Failure of the Laser Assembly in the Laser Scanner Unit (Cyan)	<ol style="list-style-type: none"> 1. Check the connector of the Laser Scanner Unit. 2. Replace the Laser Scanner Unit. 3. Replace the DC Controller PCB
E100 - 0003	Black Laser Scanner error	Failure of the Laser Assembly in the Laser Scanner Unit (Black)	<ol style="list-style-type: none"> 1. Check the connector of the Laser Scanner Unit. 2. Replace the Laser Scanner Unit. 3. Replace the DC Controller PCB
E100 - 0005	Yellow scanner area memory error warning	A memory error of the Laser Scanner Unit is detected.	<ol style="list-style-type: none"> 1. Turn OFF and then ON the power. 2. Replace the Laser Scanner Unit.
E100 - 0006	Magenta scanner area memory error warning	A memory error of the Laser Scanner Unit is detected.	<ol style="list-style-type: none"> 1. Turn OFF and then ON the power. 2. Replace the Laser Scanner Unit.
E100 - 0007	Cyan scanner area memory error warning	A memory error of the Laser Scanner Unit is detected.	<ol style="list-style-type: none"> 1. Turn OFF and then ON the power. 2. Replace the Laser Scanner Unit.
E100 - 0008	Black scanner area memory error warning	A memory error of the Laser Scanner Unit is detected.	<ol style="list-style-type: none"> 1. Turn OFF and then ON the power. 2. Replace the Laser Scanner Unit.
E110 - 0000	Scanner Motor error	Error in the initial operation of the Scanner Motor	<ol style="list-style-type: none"> 1. Check the connector of the Laser Scanner Unit. 2. Replace the Laser Scanner Unit. 3. Replace the DC Controller PCB

Error Code	Title	Detection description	Remedy
E196 - 0000	Firmware error (the host machine or the option cassette)	Engine firmware error	1. Turn OFF and then ON the power. 2. Update firmware. 3. Replace the DC Controller PCB
E196 - 0001	Firmware error (the option cassette)	Engine firmware error	1. Turn OFF and then ON the power. 2. Update firmware. 3. Replace the DC Controller PCB
E196 - 0002	DC Controller internal error	The memory area in the DC Controller cannot be accessed.	1. Turn OFF and then ON the power. 2. Update firmware. 3. Replace the DC Controller PCB
E197 - 0002	Firmware error	Engine firmware error	1. Turn OFF and then ON the power. 2. Update firmware. 3. Replace the DC Controller PCB
E198 - 0000	DC Controller memory failure	A failure of the DC Controller memory is detected.	1. Turn OFF and then ON the power. 2. Replace the DC Controller PCB
E245 - 1011	System error	System error	Contact the sales company.
E245 - 1012	System error	System error	Contact the sales company.
E245 - 1013	System error	System error	Contact the sales company.
E245 - 1021	System error	System error	Contact the sales company.
E245 - 1022	System error	System error	Contact the sales company.
E245 - 1023	System error	System error	Contact the sales company.
E245 - 2012	System error	System error	Contact the sales company.
E245 - 2022	System error	System error	Contact the sales company.
E246 - 0001	System error	System error	Contact the sales company.
E246 - 0002	System error	System error	Contact the sales company.
E246 - 0003	System error	System error	Contact the sales company.
E246 - 0004	System error	System error	Contact the sales company.
E246 - 0005	System error	System error	Contact the sales company.
E247 - 0001	System error	System error	Contact the sales company.
E247 - 0002	System error	System error	Contact the sales company.
E247 - 0003	System error	System error	Contact the sales company.
E247 - 0004	System error	System error	Contact the sales company.
E350 - 1001	System error	System error	Contact the sales company.
E350 - 1002	System error	System error	Contact the sales company.
E350 - 1003	System error	System error	Contact the sales company.
E350 - 3000	System error	System error	Contact the sales company.
E354 - 0001	System error	System error	Contact the sales company.
E354 - 0002	System error	System error	Contact the sales company.
E355 - 0001	System error	System error	Contact the sales company.
E355 - 0003	System error	System error	Contact the sales company.
E602 - 0001	Insufficient SD Card capacity	Capacity of the installed SD Card is smaller than the size of the area used for the system.	1. Check the capacity of the SD Card. 2. Replace the SD Card with another one with 2 GB or more capacity.
E602 - 0002	Firmware error	Loading of Bootable ends in failure.	1. Reinstall the firmware. 2. Replace the Main Controller PCB.
E602 - 0003	SD Card access error	Error caused by hardware (such as damage on the sector, etc.) occurred when accessing to the SD Card during execution of Boot ROM	1. Turn OFF and then ON the power. 2. Back up data, and format the SD Card. 3. Replace the SD Card. 4. Replace the Main Controller PCB.
E602 - 0006	Firmware error	Loading of Subbootable ends in failure.	1. Reinstall the firmware. 2. Replace the Main Controller PCB.
E602 - 0007	Firmware error	Damage on the internal file	1. Reinstall the firmware. 2. Replace the Main Controller PCB.
E602 - 0008	The memory area in the Main Controller is depleted.	Remaining memory area in the Main Controller is small.	* Turning OFF and then ON the main power stops the error code to be displayed, but the continuous use causes the memory area in the Main Controller PCB to be completely used up or causes symptoms such as machine freeze. 1. Replace the Main Controller PCB.

Error Code	Title	Detection description	Remedy
E602 - 0009	MEAP cannot be started.	MEAP cannot be started due to an error caused by invalid power down.	1. Select Function.gr > MEAP > MEAP FUNCTION = ON, and turn OFF and then ON the main power. * Since the installed MEAP application and its management information are all cleared after reboot, MEAP needs to be reinstalled.
E602 - 1102	File system could not be initialized normally (MEAP-related).	File system could not be initialized normally (MEAP-related).	1. Turning OFF and then ON the main power executes auto recovery. Since E616-0001 may be displayed in some cases, execute the remedy for E616-0001. * When this error occurs, the firmware downloaded by the CDS Updater will be lost.
E602 - 1112	Device access error (MEAP-related)	Device access error (MEAP-related)	1. Turning OFF and then ON the main power executes auto recovery. Since E616-0001 may be displayed in some cases, execute the remedy for E616-0001. * When this error occurs, the firmware downloaded by the CDS Updater will be lost.
E602 - 1113	Device access error (MEAP-related)	Device access error (MEAP-related)	1. Turning OFF and then ON the main power executes auto recovery. Since E616-0001 may be displayed in some cases, execute the remedy for E616-0001. * When this error occurs, the firmware downloaded by the CDS Updater will be lost.
E602 - 1302	File system could not be initialized normally.	File system could not be initialized normally.	1. Turning OFF and then ON the main power executes auto recovery. * When this error occurs, the firmware downloaded by the CDS Updater will be lost.
E602 - 1312	Device access error	Device access error	1. Turning OFF and then ON the main power executes auto recovery. * When this error occurs, the firmware downloaded by the CDS Updater will be lost.
E602 - 1313	Device access error	Device access error	1. Turning OFF and then ON the main power executes auto recovery. * When this error occurs, the firmware downloaded by the CDS Updater will be lost.
E602 - 1602	File system could not be initialized normally (CDS-related).	File system could not be initialized normally (CDS-related).	1. Turning OFF and then ON the main power executes auto recovery. * When this error occurs, the firmware downloaded by the CDS Updater will be lost.
E602 - 1612	Device access error (CDS-related)	Device access error (CDS-related)	1. Turning OFF and then ON the main power executes auto recovery. * When this error occurs, the firmware downloaded by the CDS Updater will be lost.
E602 - 1613	Device access error (CDS-related)	Device access error (CDS-related)	1. Turning OFF and then ON the main power executes auto recovery. * When this error occurs, the firmware downloaded by the CDS Updater will be lost.
E604 - 0000	Insufficient memory capacity	Insufficient memory capacity	1. Check the memory capacity of ROM mounted on the Main Controller. 2. Replace the Main Controller PCB.
E604 - 0001	Memory error	Memory required to start PDL cannot be allocated.	Check the installed memory, remove and then install the memory, and replace the memory.
E616 - 0001	MEAP application is lost.	MEAP application is lost.	1. Select Function.gr > MEAP > MEAP FUNCTION = ON, and turn OFF and then ON the main power. * The setting is switched to the following after reboot. <ul style="list-style-type: none"> • Initial screen setting: Native • MEAP authentication: Off • USB-Host setting: Native • CDS-related: Off
E616 - 0002	System error	System error	1. Execute Setup > Initialize Menu to initialize NVRAM.
E730 - 100A	System error	System error	1. Turn OFF and then ON the power. 2. Replace the Main Controller PCB.
E730 - C000	An error, such as failure in memory retrieval at initialization, occurred.	An error, such as failure in memory retrieval at initialization, occurred.	1. Turning OFF and then ON the main power executes auto recovery.

Error Code	Title	Detection description	Remedy
E730 - C001	An error occurred when accessing the controller.	An error occurred when accessing the controller.	1. Turning OFF and then ON the main power executes auto recovery.
E730 - D000	An error, such as failure in memory retrieval at initialization, occurred.	An error, such as failure in memory retrieval at initialization, occurred.	1. Turn OFF and then ON the power. 2. Replace the Main Controller PCB.
E730 - D001	System error	System error	1. Turn OFF and then ON the power. 2. Replace the Main Controller PCB.
E733 - 0001	Printer communication error	Communication error occurred after normal startup.	1. Turn OFF and then ON the power. 2. Replace the Main Controller PCB.
E733 - 0004	Printer communication error	Command error	1. Turn OFF and then ON the power. 2. Replace the Main Controller PCB.
E733 - 0006	Printer communication error	Unknown communication error	1. Turn OFF and then ON the power. 2. Replace the Main Controller PCB.
E740 - 0002	An invalid MAC address has been detected.	An invalid MAC address has been detected.	1. Check the Mac address. 2. Replace the Main Controller PCB.
E740 - 0004	Network Chip error detection	Controller Chip access error	1. Turn OFF and then ON the power. 2. Replace the Main Controller PCB.
E744 - 0800	System error	System error	Contact the sales company.
E744 - 0900	Detection of invalid Bootable	Bootable of another model was detected.	1. Turn OFF and then ON the power. 2. Reinstall the firmware. 3. Replace the Main Controller PCB.
E744 - 1000	Firmware error	Mismatch of the model for which the firmware was downloaded is detected.	1. Install the firmware according to the model.
E744 - 1100	System error	System error	1. Turn OFF and then ON the power. 2. Replace the Main Controller PCB.
E748 - 2012	System error	System error	Contact the sales company.
E760 - 0000	Firmware error	An error in connection occurred due to controller software.	Due to firmware error, the possibility of solving the error by replacing the Main Controller PCB is low. 1. Check the downloaded firmware again.
E805 - 0000	Fixing Fan failure	Fixing Fan failure	1. Check the connection of the Fixing Fan. 2. Replace the Fixing Fan. 3. Replace the DC Controller PCB
E805 - 0018	Exhaust Fan failure	Exhaust Fan failure	1. Check the connection of the Exhaust Fan. 2. Replace the Exhaust Fan. 3. Replace the DC Controller PCB.
E805 - 0019	Cartridge Fan failure	Cartridge Fan failure	1. Check the connection of the Cartridge Fan. 2. Replace the Cartridge Fan. 3. Replace the DC Controller PCB.
E805 - 0020	Power Fan failure	Power Fan failure	1. Check the connection of the Power Fan. 2. Replace the Power Fan. 3. Replace the DC Controller PCB.
E808 - 0001	Low-voltage power supply failure	Low-voltage power supply failure was detected.	1. Check the connection of the Low Voltage Power Supply Unit or the connector. 2. Check the connection of the AC Relay PCB or the connector. 3. Replace the Low Voltage Power Supply Unit. 4. Replace the AC Relay PCB.
E825 - 0000	Yellow Drum Home Position Sensor error warning	An error of the Drum Home Position Sensor is detected.	1. Check the connector of the Drum Home Position Sensor. 2. Replace the Drum Home Position Sensor. 3. Replace the DC Controller PCB.
E825 - 0001	Magenta Drum Home Position Sensor error warning	An error of the Drum Home Position Sensor is detected.	1. Check the connector of the Drum Home Position Sensor. 2. Replace the Drum Home Position Sensor. 3. Replace the DC Controller PCB.

Error Code	Title	Detection description	Remedy
E825 - 0002	Cyan Drum Home Position Sensor error warning	An error of the Drum Home Position Sensor is detected.	<ol style="list-style-type: none"> 1. Check the connector of the Drum Home Position Sensor. 2. Replace the Drum Home Position Sensor. 3. Replace the DC Controller PCB.
E825 - 0003	Black Drum Home Position Sensor error warning	An error of the Drum Home Position Sensor is detected.	<ol style="list-style-type: none"> 1. Check the connector of the Drum Home Position Sensor. 2. Replace the Drum Home Position Sensor. 3. Replace the DC Controller PCB.
E840 - 0000	Fixing disengagement error	Fixing pressure release mechanism error	<ol style="list-style-type: none"> 1. Check the drawer connector between the Fixing Assembly and the Fixing Power Supply Unit. 2. Replace the Fixing Assembly. 3. Replace the Fixing Power Supply Unit.

* XX-nn-Error:nn: 2-digit alphanumeric

Jam Code

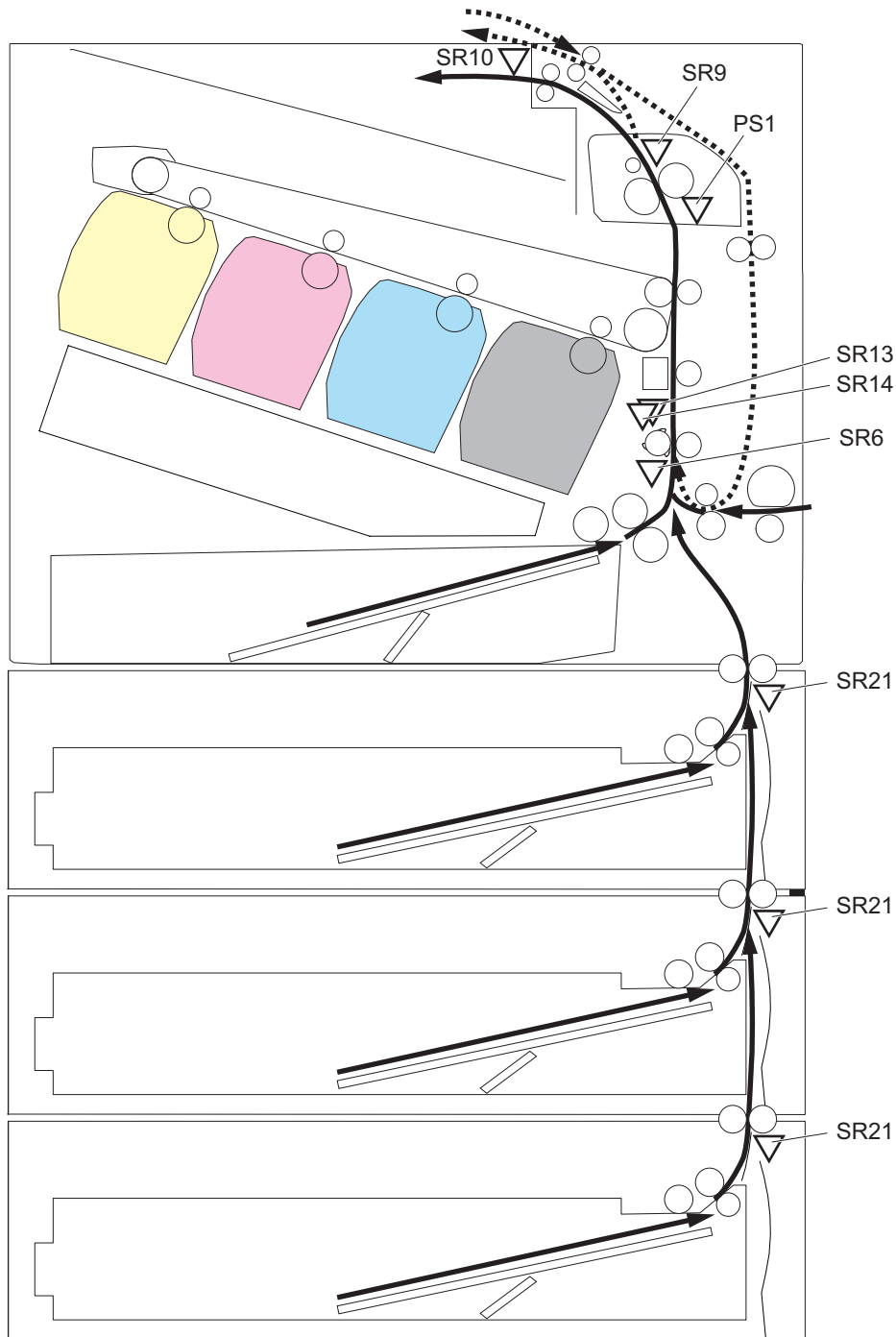

High Order	Low Order	Sensor ID	Sensor Name	Type	Area
84	01	SR6	TOP Sensor	Pickup Delay Jam 1	Multi-purpose Tray
84	02	SR6	TOP Sensor	Pickup Delay Jam 1	Cassette 1
85	03	SR21	PF Paper Path Sensor	Pickup Delay Jam 2	Cassette 2
85	04	SR21	PF Paper Path Sensor	Pickup Delay Jam 2	Cassette 3
85	05	SR21	PF Paper Path Sensor	Pickup Delay Jam 2	Cassette 4
86	03	SR21	PF Paper Path Sensor	Pickup Delay Jam 3	Cassette 2
86	04	SR21	PF Paper Path Sensor	Pickup Delay Jam 3	Cassette 3
88	07	SR6	TOP Sensor	Pickup Stationary Jam 1	Registration Area to Cartridge
88	0C	SR6	TOP Sensor	Pickup Stationary Jam 1	Duplex Reverse Area

High Order	Low Order	Sensor ID	Sensor Name	Type	Area
8C	08	SR9	Fixing Delivery Sensor	Fixing Delivery Delay Jam	Cartridge to Fixing Roller Area
8C	0C	SR9	Fixing Delivery Sensor	Fixing Delivery Delay Jam	Duplex Reverse Area
90	09	SR9	Fixing Delivery Sensor	Fixing Delivery Stationary Jam 1	Fixing Roller to Delivery Area
90	0C	SR9	Fixing Delivery Sensor	Fixing Delivery Stationary Jam 1	Duplex Reverse Area
91	09	SR10	Delivery Tray Full Level Sensor	Fixing Delivery Stationary Jam 2	Fixing Roller to Delivery Area
94	02	SR21	PF Paper Path Sensor	Power ON Jam 1 (*2)	Cassette 2
94	03	SR21	PF Paper Path Sensor	Power ON Jam 1 (*2)	Cassette 3
94	04	SR21	PF Paper Path Sensor	Power ON Jam 1 (*2)	Cassette 4
94	07	SR6/SR13/SR14	TOP Sensor/Paper Width Sensor Front/Paper Width Sensor Rear	Power ON Jam 1 (*2)	Registration Area to Cartridge
94	08	PS1	Loop Sensor	Power ON Jam 1 (*2)	Cartridge to Fixing Roller Area
94	09	SR9	Fixing Delivery Sensor	Power ON Jam 1 (*2)	Fixing Roller to Delivery Area
98	02	SR21	PF Paper Path Sensor	Door Open Jam (*1)	Cassette 2
98	03	SR21	PF Paper Path Sensor	Door Open Jam (*1)	Cassette 3
98	04	SR21	PF Paper Path Sensor	Door Open Jam (*1)	Cassette 4
98	07	SR6/SR13/SR14	TOP Sensor/Paper Width Sensor Front/Paper Width Sensor Rear	Door Open Jam (*1)	Registration Area to Cartridge
98	08	PS1	Loop Sensor	Door Open Jam (*1)	Cartridge to Fixing Roller Area
98	09	SR9	Fixing Delivery Sensor	Door Open Jam (*1)	Fixing Roller to Delivery Area
98	0C	SR6	TOP Sensor	Door Open Jam (*1)	Duplex Reverse Area
98	0E	SR6	TOP Sensor	Door Open Jam (*1)	Duplex Re-pickup Assembly
9C	09	SR9	Fixing Delivery Sensor	Wrap Jam	Fixing Roller to Delivery Area
9C	0C	SR9	Fixing Delivery Sensor	Wrap Jam	Duplex Reverse Area
A4	0C	SR6	TOP Sensor	Duplex Re-pickup Assembly Jam	Duplex Reverse Area
A4	0E	SR6	TOP Sensor	Duplex Re-pickup Assembly Jam	Duplex Re-pickup Assembly

*1 : It is a jam that appears when door open is detected during printing.

When the power is turned OFF and then ON while the door open jam is detected, it is displayed as an internal stationary jam instead of a door open jam.

*2 : It is a jam that appears when residual paper is detected in the machine at power-on.

When the power is turned OFF and then ON while the door open jam is detected, it is displayed as an internal stationary jam instead of a door open jam.

Alarm Code

Alarm Code	Area	Details	Cause	Remarks
05 - 0001	ITB Unit	ITB Unit Alarm	ITB Unit Life	
06 - 0002	Fixing Assembly, This machine	Fixing Assembly Alarm	Fixing Assembly Life	
11 - 0001	Waste Toner Container	Waste Toner Container Alarm	Waste Toner Container Full	



Service Mode

Overview.....	242
Service Mode.....	246

Overview

Entering Service Mode

For information on how to enter service mode, contact the Support Dept. of the sales company.

Remote UI Service Mode

Function Overview

It is possible to display, configure, and execute various service mode modes as well as restart the host machine by using remote UI.

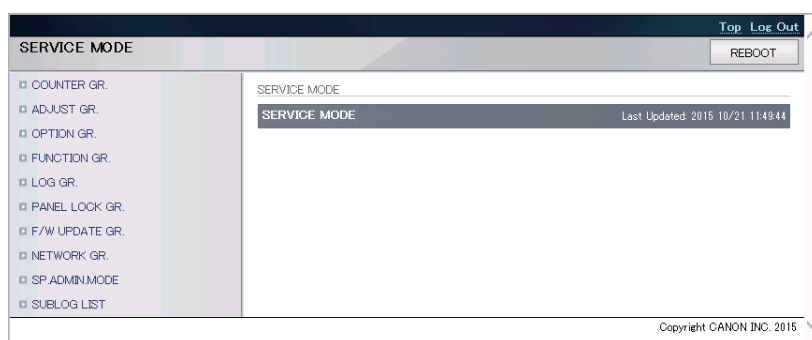

Operating conditions

In order to operate service mode using Remote UI, the following conditions must be met.

- The Remote UI is enabled in the settings on the Control Panel
[Setup] > [Network] > [Remote UI Settings] > [Remote UI] > [ON]
- The RMT-SW (Remote UI service mode function) setting is enabled (set to 1) in service mode
Set RMT-SW by performing one of the following operations. Both operations have the same effect.
 - SERVICE MODE > OPTION GR. > RMT-SW
 - [Setup] > [Control Menu] > [RMT-SW]
0: Off, 1: On (default)

How to Use

1. Activate the Web browser, and access the following URL:

<http://<Host machine's IP address or host name>/servicemode.html>

2. Enter the password, and click [LOGIN].

Password required for authentication differs depending on the following service mode setting:

SERVICE MODE > OPTION GR. > PSWD-SW

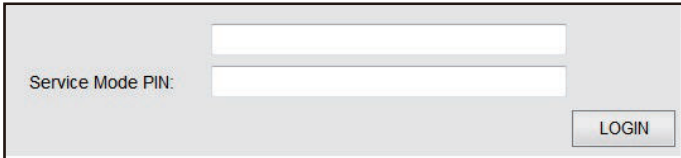
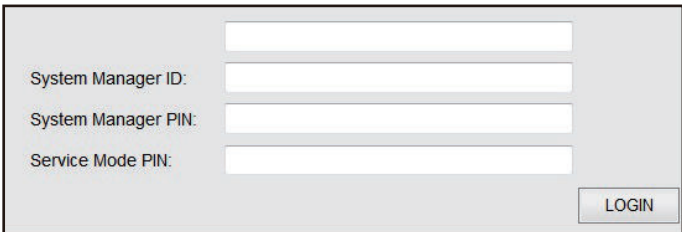
PSWD-SW setting value	Password required for authentication	Authentication screen
0	<ul style="list-style-type: none"> Password of RUI service mode 	
1	<ul style="list-style-type: none"> Password of RUI service mode Service mode password 	
2	<ul style="list-style-type: none"> Password of RUI service mode User's system administrator ID Password of system administrator Service mode password 	

3. When finishing the operation, click [Log Out].

NOTE:

If you logged in and then closed the browser without "logging out", you are recognized as "logged in". Therefore, when logging in service mode again, wait for a fixed time (3 minutes) from the last access to let the session time out, or turn OFF and then ON the power.

Service Report

■ Output of Service Report Data

This machine has a function for outputting service reports such as P-PRINT.

Service Print and Data File Name Supported for File Output

Report	Description
P-PRINT	Output of service mode setting values

CAUTION:

When P-PRINT is printed and output, items set to a value other than the default value are marked.

Canon		Configuration Page		LBPxxx					
Main Controller Version : RxxxxPH Bxxxx			RAM Size : xxxMB						
DCON Version : xxxxx			Model : xxxxx						
Option Drawer Version : OPTxxxx									
Font Version : 00000000									
<hr/>									
<table border="0"> <tr> <td style="vertical-align: top;"> <ul style="list-style-type: none"> Toner Cart. Warning Auto Skip Error Language * Alarm Show Warnings Toner Cart. Warning Mnt. Kit Warning Drawer Empty E-Mail Trans. Error Date/Time Settings Date Time (24 hour) Main Pwr Quick Start * USB-Connected PC OS PDL Selection (PnP) Mng. Settings Settings Key Lock RMT-SW Adjust Screen Contrast Backlight Brightness Animated Instruction </td> <td style="vertical-align: top;"> <ul style="list-style-type: none"> Continue Printing Off English Off On On On On 2015 10/29 14:32:30 Off Windows LIPSLX Off Off 0 Level 3 On </td> <td style="vertical-align: top;"> <ul style="list-style-type: none"> Interface Interface Selection USB Network USB Adv. Functions Adv. Func. Settings USB Storage Device MEAP Driver Timeout Timeout Timeout Time Connection Recog. Extended RX Buffer User Maintenance Adj. Print Position 0 fset Y (MP Tray) 0 fset X (MP Tray) 0 fset Y (Drawer 1) 0 fset X (Drawer 1) 0 fset Y (Drawer 2) 0 fset X (Drawer 2) </td> <td style="vertical-align: top;"> <ul style="list-style-type: none"> On On Meap Priority Off On 15 sec On On 0.0 mm 0.0 mm 0.0 mm 0.0 mm 0.0 mm </td> </tr> </table>						<ul style="list-style-type: none"> Toner Cart. Warning Auto Skip Error Language * Alarm Show Warnings Toner Cart. Warning Mnt. Kit Warning Drawer Empty E-Mail Trans. Error Date/Time Settings Date Time (24 hour) Main Pwr Quick Start * USB-Connected PC OS PDL Selection (PnP) Mng. Settings Settings Key Lock RMT-SW Adjust Screen Contrast Backlight Brightness Animated Instruction 	<ul style="list-style-type: none"> Continue Printing Off English Off On On On On 2015 10/29 14:32:30 Off Windows LIPSLX Off Off 0 Level 3 On 	<ul style="list-style-type: none"> Interface Interface Selection USB Network USB Adv. Functions Adv. Func. Settings USB Storage Device MEAP Driver Timeout Timeout Timeout Time Connection Recog. Extended RX Buffer User Maintenance Adj. Print Position 0 fset Y (MP Tray) 0 fset X (MP Tray) 0 fset Y (Drawer 1) 0 fset X (Drawer 1) 0 fset Y (Drawer 2) 0 fset X (Drawer 2) 	<ul style="list-style-type: none"> On On Meap Priority Off On 15 sec On On 0.0 mm 0.0 mm 0.0 mm 0.0 mm 0.0 mm
<ul style="list-style-type: none"> Toner Cart. Warning Auto Skip Error Language * Alarm Show Warnings Toner Cart. Warning Mnt. Kit Warning Drawer Empty E-Mail Trans. Error Date/Time Settings Date Time (24 hour) Main Pwr Quick Start * USB-Connected PC OS PDL Selection (PnP) Mng. Settings Settings Key Lock RMT-SW Adjust Screen Contrast Backlight Brightness Animated Instruction 	<ul style="list-style-type: none"> Continue Printing Off English Off On On On On 2015 10/29 14:32:30 Off Windows LIPSLX Off Off 0 Level 3 On 	<ul style="list-style-type: none"> Interface Interface Selection USB Network USB Adv. Functions Adv. Func. Settings USB Storage Device MEAP Driver Timeout Timeout Timeout Time Connection Recog. Extended RX Buffer User Maintenance Adj. Print Position 0 fset Y (MP Tray) 0 fset X (MP Tray) 0 fset Y (Drawer 1) 0 fset X (Drawer 1) 0 fset Y (Drawer 2) 0 fset X (Drawer 2) 	<ul style="list-style-type: none"> On On Meap Priority Off On 15 sec On On 0.0 mm 0.0 mm 0.0 mm 0.0 mm 0.0 mm 						

■ Output Procedure (from the Control Panel to a USB Flash Drive)

1. Connect the USB flash drive to the USB Memory Port of this machine.

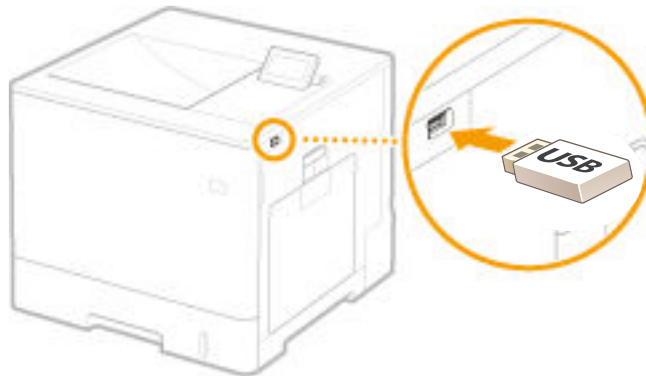

2. Enter service mode, and execute the following service mode.

- SERVICE MODE > FUNCTION GR. > MISC-P > RPT2USB > Yes

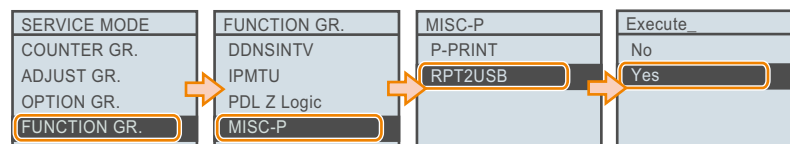

The service report (P-PRINT) is saved to the USB flash drive as a text file.

■ Output Procedure (from the Remote UI Service Mode to a PC)

1. Select the following service mode from the Remote UI service mode, enter the password, and click [Start Exporting].
 - SERVICE MODE > FUNCTION GR. > MISC-P > RPT2USB

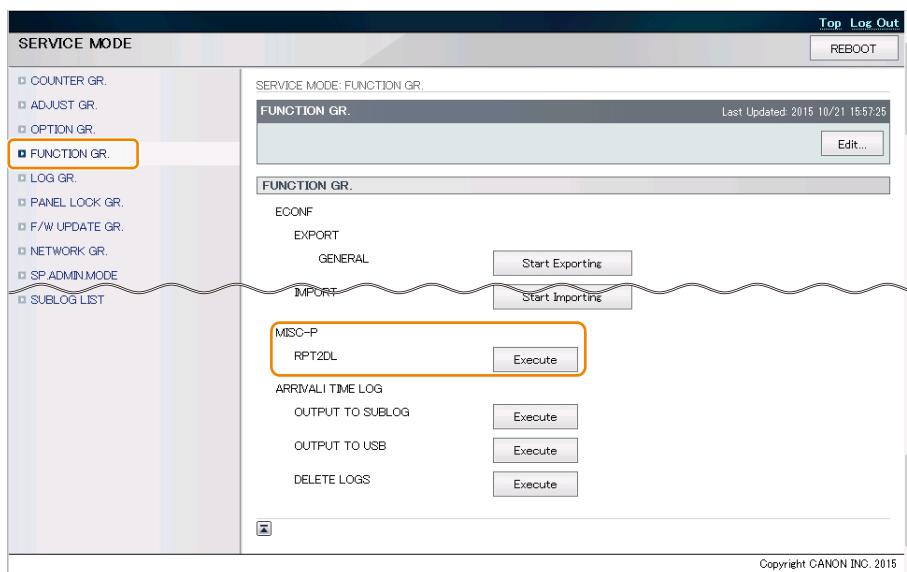

2. When a dialog box for saving the file is displayed, select the location to save the file.

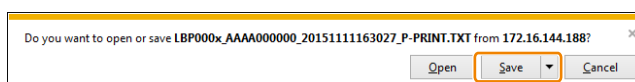

This completes the procedure for exporting a setting information file.

Service Mode

COUNTER GR.

* : Default Value

Item	Description
INIT.FIX. COUNT	Initialize the counter value of the fixing assembly.
INT.ITB UNIT	Initialize the counter value of the ITB unit.
INT.REG-ROLL	Initialize the counter value of the registration roller.

ADJUST GR.

* : Default Value

Item	Description	Setting range
CALIBRATION	Execute calibration.	• OFF , ON*
CHARGE BIAS Y	Change the primary charging bias value for yellow.	• -5 to 5 (0*)
CHARGE BIAS M	Change the primary charging bias value for magenta.	• -5 to 5 (0*)
CHARGE BIAS C	Change the primary charging bias value for cyan.	• -5 to 5 (0*)
CHARGE BIAS K	Change the primary charging bias value for black.	• -5 to 5 (0*)
DEV BIAS K	Change the developing bias value for black.	• -5 to 5 (0*)
DEV BIAS YMC	To change the yellow, magenta, and cyan developing bias values.	• -5 to 5 (0*)
FRT FUSE TENP	Change the fixing temperature on the front side.	• -4 to 4 (0*)
BCK FUSE TENP	Change the fixing temperature on the backside at duplex printing.	• -4 to 4 (0*)
T1 ATVC BIAS K	Change the primary transfer ATVC value for black.	• -5 to 5 (0*)
T2 ATVC BIAS F	Change the secondary transfer ATVC value on the front side.	• -5 to 5 (0*)
T2 ATVC BIAS B	Change the secondary transfer ATVC value on the backside at duplex printing.	• -5 to 5 (0*)
REG INFO CLEAR	Clear the color registration information.	-
ADJ.BK TEXT DENSITY	Execute density correction.	• OFF , ON*
BLADE BIAS Y	To change the yellow blade bias value.	• 0 to 5 (0*)
BLADE BIAS M	To change the magenta blade bias value.	• 0 to 5 (0*)
BLADE BIAS C	To change the cyan blade bias value.	• 0 to 5 (0*)
BLADE BIAS K	To change the black blade bias value.	• 0 to 5 (0*)
RS BIAS Y	To change the yellow RS bias value.	• -5 to 5 (0*)
RS BIAS M	To change the magenta RS bias value.	• -5 to 5 (0*)
RS BIAS C	To change the cyan RS bias value.	• -5 to 5 (0*)
RS BIAS K	To change the black RS bias value.	• -5 to 5 (0*)
IPSP Pattern	To change the density of paper interval patch.	• Standard* , Oversupply of Toner , Undersupply of Toner
LASER BRIGHT Y	To change the light emission value of the yellow Laser Scanner.	• -4 to 4 (0*)
LASER BRIGHT M	To change the light emission value of the magenta Laser Scanner.	• -4 to 4 (0*)
LASER BRIGHT C	To change the light emission value of the cyan Laser Scanner.	• -4 to 4 (0*)
LASER BRIGHT K	To change the light emission value of the black Laser Scanner.	• -4 to 4 (0*)



* : Default Value

*1: Supporting the North America models with the charge counter only

Item	Description	Setting range
B4-L-CNT	Set to determine B4 size to be large size or small size. ON : B4 size is to be large size. OFF : B4 size is to be small size.	• OFF *, ON
COUNTER-SW *1	Set the counter switch. • MODEL1 : Setting value 1 • MODEL2 : Setting value 2	• MODEL1, MODEL2
CALIB IN JOB	Settings for calibration execution during job	• OFF *, ON
Fixing Unit Warning	Fixing Unit Warning	• OFF *, ON
ITB Unit Warn- ing	ITB Unit Warning	• OFF *, ON
LIMIT AUTO CALIBRATE	To control whether to execute or restrain calibration when calibration of color displacement correction and density correction are requested by the engine.	• OFF *, ON
CRG LIFE STEP	To set the operation performed when a cartridge reaches the end of life. It is a menu to set 3 kinds of operation (printing is not stopped/temporarily stopped/completely stopped) when a cartridge has reached the end of life.	• CONT. PRINTING *: Printing is not stopped. • TEMP. STOP PRINT: Printing is temporarily stopped. • STOP PRINTING: Printing is completely stopped.
CRG LIFE STOP	To be able to change the end of cartridge life. Change the setting value when using a cartridge for a period longer than its life. Note that an image failure may occur.	• 100 to 200 %(100*)
CHANGE CRG WARN LV	To switch display/hide of the menu for setting the toner check timing (Setup > User Maintenance > Toner Check Timing).	• OFF, ON *
PSWD-SW	Setting of the password type used to log in to remote UI service mode	• 0: Password for service technician * • 1: Password for service technician + system administrator
SLEEP SET- TINGS	To change the display items of the sleep mode setting menu (Setup > Control Menu > Sleep Mode).	• Mode 1 (* except for EUR) • Mode 2 (*EUR only)
RMT-SW	ON/OFF of remote UI service mode function	• OFF *, ON
Red Image Corr.	This setting is used when calcium carbonate paper is fed.	• OFF *, ON
Adj.Scndry Transfer	To disable the Secondary Transfer Unit ATVC (Secondary Transfer Unit bias auto adjustment function).	• OFF *, ON
Wrinkle Correc- tion	This setting is used when wrinkles occur on envelopes.	• OFF *, ON
Wrinkle Correc- tion 2	This setting is used when wrinkles occur on paper whose edges have absorbed moisture.	• OFF *, ON
Afterimage Corr.	This setting is used when hot offset has occurred.	• OFF *, ON
Curl Correction 2	This setting is used when curl has occurred. (This setting is stronger than Setup > User Maintenance > Special Print Mode > Curl Correction.)	• OFF *, ON
Color Mismatch Corr.	This setting is used when color displacement occurs.	• OFF *, ON
Drum Line Corr.	This setting is used when horizontal lines appear at intervals of drum circumference.	• OFF *, ON
Paper Delivery Adj.	This setting is used when there is a problem with the pickup performance of the Multi-purpose Tray.	• OFF *, ON
Blue Image Corr.	This setting is used when low density or uneven image density has occurred due to retransferring.	• OFF *, ON

Item	Description	Setting range
Clean 2nd Trans Roll	This setting is used to ensure that cleaning of the Secondary Transfer Unit is executed at the end of every print job where free size is selected as the paper size.	• OFF *, ON
Smooth Plain Paper	This setting is used when printing on smooth plain paper.	• OFF *, ON
Sp.Transfer Mode 2	This setting is used when toner scatters on images.	• OFF *, ON
Smooth Heavy Paper	This setting is used when printing on smooth Heavy 3 paper.	• OFF *, ON
Tracking Off Mode	This setting is used to disable the tracking control (control for restraining hue variation of halftone images by changing the scanner laser intensity according to changes in the environment).	• OFF *, ON
Uneven Color Corr.	This setting is used when uneven image density occurs.	• OFF *, ON
Improve Toner Fixing	This setting is used when water drops on the Fixing Unit Guide attach to paper being fed and cause transfer failure at secondary transfer of the 2nd side.	• OFF *, ON

FUNCTION GR.

* : Default Value

Item	Description
ECONF	
EXPORT	To export the binary file of setting data. To export the setting data to a USB flash drive. <ul style="list-style-type: none"> • GENERAL Whether to set items whose device settings do not depend on the PCB, but can be performed commonly within the same device as the target. • DEPEND Whether to set items whose device settings change depending on the PCB as the target. • SECURITY Whether to set items related to security as the target. • ALL Whether to set all items exported in GENERAL/DEPEND/SECURITY as the target.
IMPORT	To import the setting data to a USB flash drive.
Import/Export Set.	
IMPORT	To import service mode setting values. This function supports the following import methods. <ul style="list-style-type: none"> • USB flash drive • PC (using remote UI service mode)
EXPORT	To export service mode setting values. This function supports the following export methods. <ul style="list-style-type: none"> • USB flash drive • PC (using remote UI service mode)
SMD-EXPT	To set whether to export "service mode data" from remote UI. When 1 is set, "service mode data" is displayed as the target data of export on remote UI. When installing more than 1 machine at the same time, the same service mode data can be registered. Remote UI > Settings/Registration: Management Settings: Import/Export > Export
USB-H	To set to enable/disable the USB host function. By turning ON the host function, USB flash drive can be used. <div style="border: 1px solid black; background-color: #f9cb9c; padding: 10px; margin-top: 10px;"> <p>CAUTION: Points to note when pulling out the USB flash drive</p> <ul style="list-style-type: none"> • Be sure to pull out the USB flash drive after turning USB-H to OFF because the USB flash drive is in the connected state when USB-H is ON. • Pulling out the USB flash drive while it is being accessed causes an error. <ul style="list-style-type: none"> ON: Use the USB host function. OFF: Do not use the USB host function. (* default) </div>

Item	Description
SUBLOG TO USB	To output sublog to the USB flash drive. It can be used regardless of the USB-H setting. CAUTION: It cannot be executed more than 2 times consecutively. Since automatic recording of sublog can no longer be performed when executed once, be sure to turn OFF and then ON the main power after execution.
RESTORE DCON	To restore the backup data of the DC Controller stored in the Main Controller NVRAM to the DC Controller EEPROM.
CLEAR DCON	To initialize backup data of DC Controller EEPROM.
COLOR MODE SLCT	To set whether decision of color/B&W print is made at the printer side. • OFF *, ON
SHIPLOCK	This setting is used to lock and prevent the actuators from operating. • MODE 1: Lock and prevent the actuators from operating. • MODE 2*: Unlocked next time the power is turned ON.
MEAP	
MEAP-PN	To specify the port number of MEAP HTTP. • 1 to 65535 (8000 *default)
MEAP-SSL	To specify the port number of MEAP HTTPS. • 1 to 65535 (8443 *default)
CDS-MEAP	To set whether to permit the user administrator to install MEAP application. • On*/Off
CDS-FIRM	To set whether to permit the user administrator to update firmware. • On/Off*
CDS-UGW	To set whether to permit firmware update from UGW. • On/Off*
CDS-LVUP	To set whether to permit service technician or user administrator to use the periodical update function of CDS. • On/Off*
CDS-CTL	It is a menu to switch countries for obtaining firmware via CDS. Use this item to switch countries when obtaining firmware from another country due to the distance to the location server.
MEAP FUNCTION	Use this item when "E602-0009" occurs. It is a menu to clear the error code and recover MEAP. • ON: Recover MEAP. (default) • OFF: Do not recover MEAP.
LCDSFLG	To set whether to allow the user administrator to use the CDS in local environment (L-CDS). • On/Off*
CLEAR MEAP	To delete the following data retained by MEAP application at the next startup. • MEAP application • Data retained by MEAP application • Data retained by the service-purposed area in the MEAP platform
CLEAR CDS	To delete the CDS-related settings at the next startup.
DDNSINTY	To change DDNS periodical update interval • 0: Do not perform periodical update. • 1 to 48: 1 to 48 hours (default value: 24) NOTE: [Description of terminology] DDNS (Dynamic Domain Name System): A system to dynamically register and manage the IP addresses which are dynamically allocated and their host names

Item	Description
IPMTU	To change MTU size of network packet. Use this item when performing communications between locations (such as SEND) connected with Ethernet in a field environment where MTU black hole problem occurs (NTT/FLET'S). • 1 to 10 NOTE: [Description of terminology] • MTU: A unit of transmission showing the maximum value of data which can be sent per 1 transfer (1 frame) in a network. • MTU black hole: A problem which occurs when ICMP packet is being filtered by fire-wall, etc. (Since the message does not reach the sender, the sender is not aware of the packet being lost, which then results in time-out.)
PDL Z Logic	Not use
FILE BOX FUNC.	To switch to enable/disable the stored job print function. * Displayed only when Set up > Control Menu > SD Card > ON is set. The SD card needs to be formatted in advance.
MISC-P	
P-PRINT	To print P-PRINT. * This cannot be used in remote UI service mode.
RPT2USB	To output P-PRINT to the connected USB flash drive in .TXT format. * This cannot be used in remote UI service mode.
RPT2DL	To output P-PRINT to the PC in .TXT format using remote UI service mode. * This can be used only in remote UI service mode.
ARRIVAL TIME LOG	
OUTPUT TO SUBLOG	For R&D
OUTPUT TO USB	For R&D
DELETE LOGS	For R&D



* : Default Value

Item	Description
SYSTEM LOG	To set whether to use the system log function. • ON: Use the system log function. (* default) • OFF: Do not use the system log function.
SUBLOG FTP GET	To obtain sublog without using the serial console. For details on how to obtain sublog, refer to Chapter 5 "Debug Log". * This item can only be executed when no job is in progress.
LOGGING UTILITY	To set whether to use the "Logging Utility" function in the utility menu. • ON: Use the logging utility function. • OFF: Do not use the logging utility function. (* default)
DEBUGLOG-SW	To set whether to perform sublog auto output when error code/exception/service call occurs. • ON: Output automatically. • OFF: Do not output automatically. (* default) - Basic procedure: [A] In the case of manual setting by service technicians (LUI) 1. Insert the USB flash drive. 2. Set the service switch [USB-H] to ON. 3. Set the service switch [DEBUGLOG-SW] to ON. 4. After an error occurs, record the debug log from the menu (LUI) to the USB flash drive. 5. Perform shutdown operation and turn OFF and then ON the power of the device. [B] In the case of remote setting from RDS 1. Insert the USB flash drive. 2. Set the service switch [DEBUGLOG-SW] to ON from RDS. 3. After an error occurs, record the debug log to the USB flash drive. 4. Turn OFF and then ON the power.

Item	Description
DEBUGLOG-MODE	<ul style="list-style-type: none"> • Mode 1 The file name of the debug log is fixed. When the number of debug logs exceeds the maximum number of logs that can be saved at saving of debug logs, the latest debug log file is deleted to save the new file. • Mode 2 (* default) The file name of the debug log is one with a device serial number and time stamp. When the number of debug logs exceeds the maximum number of logs that can be saved at saving of debug logs, the oldest debug log file is deleted to save the new file.

PANEL.GR

* : Default Value

Item	Description
PANEL LOCK	To perform access restriction for each key on the Control Panel. <ul style="list-style-type: none"> • ON: Enable the panel lock function. • OFF: Disable the panel lock function. (* default)

F/W UPDATE GR

* : Default Value

Item	Description
USB	Not used
NETWORK	Not used
USB STRAGE	Not used
CDS	Firmware auto/manual update function by MEAP application (updater). <ul style="list-style-type: none"> • ON: Update automatically/manually. • OFF: Do not update automatically/manually. Update procedure is as follows. <ol style="list-style-type: none"> 1. Start MEAP (Updater). 2. The Updater downloads the firmware via network. 3. The Updater calls the program, and interrupts job input or user operation. 4. The Updater decompress the firmware. 5. The Updater calls the program and instructs to reboot. 6. The machine reboots, and the new firmware starts operation. Before executing this menu, service technicians should perform up to step 2.

NETWORK GR.

* : Default Value

Item	Description
DNSTRANS	To determine priority order of the protocol (IPv4/IPv6) to be used for DNS query. <ul style="list-style-type: none"> • IPV4 • IPV 6*
FTP SYSLOG	To set the function to obtain various system log files. <ul style="list-style-type: none"> • ON: Obtain the function. (*default) • OFF: Do not obtain the function.
JOB SERIALIZE	To set connection serialize function. <ul style="list-style-type: none"> • ON: Use the function. • OFF: Do not use. the function. (*default)
BUFFER LIMIT	To clear the buffer acquisition limit of PSS. <ul style="list-style-type: none"> • ON: Clear the buffer acquisition limit. • OFF: Limit the buffer acquisition. (*default)
E-RDS	

Item	Description
E-RDS SWITCH	Set use/no use of Embedded-RDS function <ul style="list-style-type: none"> • ON: Use Embedded-RDS. • OFF: Do not use Embedded-RDS.
RGW-ADDRESS	To check and set the server URL. Use the "up, down, left and right keys, Job Status/Cancel key and Feeder selection key" to enter URL, and "OK key" to determine it. "↓" is displayed at the end of the character string. The number of characters which can be entered is 128. The default value is the server URL. Characters which can be set are as follows. 01233456789ABCDEFGHIJKLMNQRSTUvwxyz!"#\$%&'()*+,-./:;<=>? @[¥]^_`{ }~ <div style="background-color: #fce4d6; padding: 10px; margin-top: 10px;"> <p>CAUTION: If "ugwdevice.net/" is not included in the character string when entering an URL, it is judged as an authentication error and an error message is displayed.</p> </div>
RGW-PORT	To set the port number of the server. <ul style="list-style-type: none"> • 443*
COM-TEST	To execute a communication test, and display the result.
COM-LOG	To display the detail of the communication test result. Communication with the server is attempted, and the time, error codes and error information at error occurrence up to the present date are displayed. Maximum of 5 logs are saved, and the latest log is displayed. Error information is 130 byte maximum.
CLEAR	To clear the schedule information, alarm error and filtering information besides the eRDS setting value in service mode by executing this item.
CA-KEY	
CLEAR	To change CA certificate to the default by executing this item and turning ON and then OFF the power.
MIB CHARGECOUNT	To set the range of counter information that can be obtained as MIB (Management Information Base). <ul style="list-style-type: none"> • ALL ACCESS: All charge counters are obtained (*default) • DISP ACCESS: Only displayed counter is obtained • NON ACCESS: All charge counters are not obtained
TCP DELAYED ACK	<ul style="list-style-type: none"> • ON: Enable ACK delay function of TCP. (*default) • OFF: Disable ACK delay function of TCP. <div style="background-color: #e0f2f1; padding: 10px; margin-top: 10px;"> <p>NOTE: [Remarks] ACK: Text sent by the reception side to the sending side to notify that reception was performed correctly.</p> </div>
WOLtrans	To set recovery from sleep mode. <ul style="list-style-type: none"> • 1: Recover from sleep by WSD, and do not recover from sleep by the old utility using the broadcast packet. (*default) • 2: Recover from sleep by WSD, and do not have the function to recover from sleep by the old utility using the SNMP search broadcast packet. • 3. Enable recovery from sleep by the old utility, and do not recover from sleep by WSD. <div style="background-color: #fce4d6; padding: 10px; margin-top: 10px;"> <p>CAUTION: [Description of terminology] WSD (Web services on devices): A protocol to easily set up connection and use of various devices connected to the network</p> </div>
SLEEP ADVERTISE	
SWITCH	To set whether to use the sleep notification. <ul style="list-style-type: none"> • ON: Notify sleep. (*default) • OFF: Do not notify sleep.
PORT	To set the port number as the destination of sleep notification. <ul style="list-style-type: none"> • Setting value: 1 to 65535 (*Default value: 11427)
TTL	To set the number of routers which can send sleep notification messages. <ul style="list-style-type: none"> • Setting value: 0 to 254 (*Default value: 3)
INTERVAL	To set the notification interval (seconds) of sleep notification. <ul style="list-style-type: none"> • Setting value: 60 to 65535 (*Default value: 600)

Item	Description
PROXYRES	To set whether the proxy server (instead of internal network) returns proxy response to the external network. <ul style="list-style-type: none"> • ON: Perform proxy response. (*Default) • OFF: Do not perform a proxy response.
IPSEC SETTING	
IKERETRY	To set the IKE retry times. <ul style="list-style-type: none"> • 0 to 3 (* Default value: 1)
IKEINTVL	To set the IKE retry interval (seconds). <ul style="list-style-type: none"> • 1 to 30 (* Default value: 5)
SPDALDEL	To set whether to initialize the device at next startup. Be sure to return this value to "0" after initialization is completed. <ul style="list-style-type: none"> • 0: Initialize the device. (*default) • 1: Do not initialize the device.
IPSDEBLY	Since IPsec operates by a different process from the main program, log information is not kept in the Sublog Board. Therefore, change the value when obtaining the IPsec log. The setting is enabled after restart, and this value becomes "0" internally after restart. When this log is enabled, a file named "/APL_LOG/ipsec/ipseclog.txt" is generated, in which the log information is stored. However, this file is cleared when turning ON and then OFF the power. <ul style="list-style-type: none"> • 0: Do not keep logs. (*default) • 1 to 3: Log level 1 to 3, fatal error information • 4 to 6: Log level 4 to 6, warning information • 7: Log level 7, important log information • 8 to 10: Log level 8, all logs
PFW SETTING	
ILOGKEEP	The time is saved when an address is blocked by packet filtering. The log is not notified to UI when an access is made from the same address within the specified period of time. The specified period of time mentioned above can be set. <ul style="list-style-type: none"> • 0: 1 minute • 1: 1 hour • 2: 2 hours • 3: 3 hours • ... • 47: 47 hours • 48: 48 hours Restart is necessary to reflect the setting.
ILOGMODE	Since packet filtering becomes enabled for all protocols, it blocks packets not related to this machine, for which logs can be kept. Therefore, logs of devices which are not malicious are kept as well, causing the log volume to become large. Use this item for users who want to keep logs precisely. <ul style="list-style-type: none"> • 0: Keep unicast to the own machine only. (*default) • 1: Keep all filter logs.
IPTBROAD	Transmission to IPv4 multicast address, broadcast address and subnet broadcast address is allowed even if the default policy is set to "Reject" in the IPv4 transmission setting. In addition, IPv6 multicast address transmission is allowed even if the default policy is set to "Reject" in the IPv6 transmission setting. When setting to reject multicast transmission also, the setting can be changed by switching the service mode value. <ul style="list-style-type: none"> • 0: Allow multicast transmission. (*default) • 1: Reject multicast address transmission when the transmission default policy is set to "Reject". • 2 to 10: Not used
EAPOL_WT	Time to wait for a response (or the next request) to EAPOL packet sent by the device. <ul style="list-style-type: none"> • 10 to 120 (* Default value: 30)
GCP-URLC	To enable changing of the connection destination URL for cloud print from remote UI. Remote UI> Settings/Registration: Preferences: Network > Google Cloud Print Settings > Edit Basic Settings > Connection Destination <ul style="list-style-type: none"> • ON: Can be changed (display) * default • OFF: Cannot be changed (hide)

SP.ADMIN.MODE

Item	Description
MANTENANCE C.	Not used

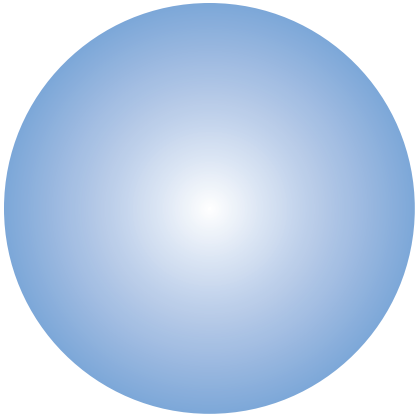

APPENDICES

Service Tools.....	255
General Circuit Diagram.....	256
Backup Data List.....	257
Soft counter specifications.....	258

Service Tools

Solvents and Oil List

No.	Type	Purpose	Remark
1	Ethyl alcohol	<ul style="list-style-type: none">• Cleaning: metal part, oil stains, toner stains	<ul style="list-style-type: none">• Purchase locally• Keep away from flame

General Circuit Diagram

General Circuit Diagram

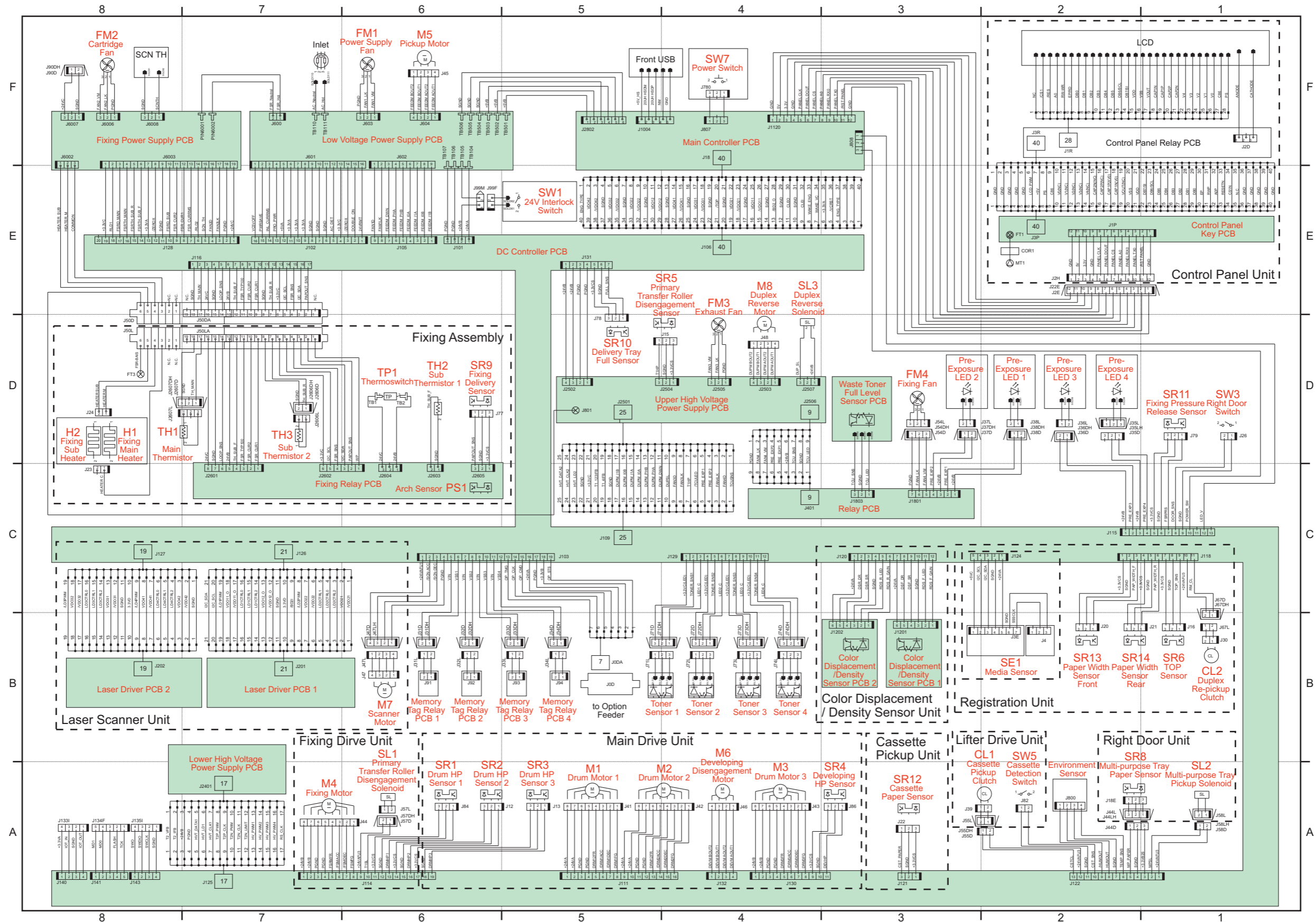

Backup Data List

Backup Data

Data	Location	Replacement		Delete Method				Backup by User			Backup by Service		
				Setup			Service Function	Yes/No	Method	Location	Yes/No	Method	Location
		DC Control- ler PCB	Main Control- ler PCB	Initialize Menu	Network > Init. Network Set.	User Mainte- nance > Initialize Counter	Service Mode						
Panel Settings (excluding Network Settings)	Main Controller PCB	-	Clear	Clear	-	-	-	Yes	LUI *5, RUI *6	PC, USB flash drive	Yes	Service Mode *7, *8 RUI Service Mode *7 Expansion ROM for servicing + Sublog Board *10	PC, USB flash drive, Sublog Board
Panel Settings (Network Settings)		-	Clear	-	Clear	-	-						
MEAP (Application/Setting Data)		-	Clear	-	-	-	Clear *1						
eRDS Settings		-	Clear	-	-	-	Clear *2	No	-	-			
Key and Certificate		-	Clear	-	-	-	Clear *3	No	-	-	No	-	-
Logs		-	Clear	-	-	-	-	No	-	-	No	-	-
Parts Counter		-	Clear	-	-	-	Clear *4	Yes *9	LUI *5, RUI *6	PC, USB flash drive	Yes	Service Mode *7, *8 RUI Service Mode *7 Expansion ROM for servicing + Sublog Board *10	PC, USB flash drive, Sublog Board
Service Mode Setting Values		-	Clear	Clear	-	-	-						

*1: Execute SERVICE MODE > FUNCTION GR. > MEAP > CLEAR MEAP to initialize data/settings.

*2: Execute SERVICE MODE > NETWORK GR. > E-RDS > CLEAR to initialize settings.

*3: Execute SERVICE MODE > NETWORK GR. > CA-KEY to initialize data.

*4: Items in SERVICE MODE > COUNTER GR. are the target.

*5: Perform backup in Setup > User Maintenance > Import/Export Set. > Export.

*6: Perform backup in RUI > Settings/Registration > Management Settings > Import/Export > Export.

*7: Perform backup in SERVICE MODE > FUNCTION GR. > Import/Export Set. > EXPORT.

*8: Perform backup in SERVICE MODE > FUNCTION GR. > ECONF > EXPORT.

*9: It is enabled only in the case of SERVICE MODE > FUNCTION GR. > SMD-EXPT = 1.

*10: Refer to [Backup/Restoration by Expansion ROM for servicing and Sublog Board].

Soft counter specifications

The numbers entered for software counters are classified as follows:

No.	Counter Details
100 to 119	Total
300 to 399	Print
700 to 799	Reception print

- Meanings of symbols in tables -

- L: Large size (larger than B4 size)
- S: Small size (smaller than B4 size)

Counter No.	Counter Description		
	Job	Counter Type	
101	Total	Total 1	
102		Total 2	
104		Total (small)	
106		Total (Full Color 2)	
108		Total (black and white 1)	
109		Total (black and white 2)	
113		Total (black and white/small)	
114		Total 1(double sided)	
117		small (double sided)	
121		Total (Full Color/Small)	
123		Total (Full Color + Single Color/Small)	
124		Total (Full Color + Single Color 2)	
132		Total A black and white 1	
133		Total A black and white 2	
148		Total A (Full Color + Single Color 2)	
149		Total A (Full Color + Single Color 1)	
301		Print	Print (Total 1)
302			Print (Total 2)
313			Print (black and white1)
314	Print (black and white2)		
320	Print (black and white/small)		
322	Print (Full Color + Single Color/Small)		
334	PDL Print		PDLPrint (small)
701	Reception print	Reception print (Total 1)	
702		Reception print (Total 2)	
709		Reception print (black and white1)	
710		Reception print (black and white2)	
712		Reception Print (Full Color/Small)	
716		Reception print (black and white/small)	