

**Canon**

**Revision 1.0**

**LBP253 SM**

# Introduction

## Important Notices

### Application

This manual has been issued by Canon Inc. for qualified persons to learn technical theory, installation, maintenance, and repair of products.

This manual covers all localities where the products are sold. For this reason, there may be information in this manual that does not apply to your locality.

### Corrections

This manual may contain technical inaccuracies or typographical errors due to improvements or changes in products. When changes occur in applicable products or in the contents of this manual, Canon will release technical information as the need arises. In the event of major changes in the contents of this manual over a long or short period, Canon will issue a new edition of this manual.

The following paragraph does not apply to any countries where such provisions are inconsistent with local law.

### Trademarks

The product names and company names used in this manual are the registered trademarks of the individual companies.

### Copyright

This manual is copyrighted with all rights reserved. Under the copyright laws, this manual may not be copied, reproduced or translated into another language, in whole or in part, without the consent of Canon Inc.







© CANON INC. 2015















### Caution

Use of this manual should be strictly supervised to avoid disclosure of confidential information.



### Explanation of Symbols

The following symbols are used throughout this Service Manual.

Symbols	Explanation	Symbols	Explanation
	Check.		Remove the claw.
	Check visually.		Insert the claw.
	Check a sound.		Push the part.

Symbols	Explanation	Symbols	Explanation
	Disconnect the connector.		Connect the power cable.
	Connect the connector.		Disconnect the power cable.
	Remove the cable/wire from the cable guide or wire saddle.		Turn on the power.
	Install the cable/wire to the cable guide or wire saddle.		Turn off the power.
	Remove the screw.		Loosen the screw.
	Install the screw.		Tighten the screw.
	Cleaning is needed.		Measurement is needed.

The following rules apply throughout this Service Manual:

- Each chapter contains sections explaining the purpose of specific functions and the relationship between electrical and mechanical systems with reference to the timing of operation.  
In the diagrams,  represents the path of mechanical drive; where a signal name accompanies the symbol, the arrow  indicates the direction of the electric signal.  
The expression "turn on the power" means flipping on the power switch, closing the front door, and closing the delivery unit door, which results in supplying the machine with power.
- In the digital circuits, '1' is used to indicate that the voltage level of a given signal is "High", while '0' is used to indicate "Low". (The voltage value, however, differs from circuit to circuit.) In addition, the asterisk (\*) as in "DRMD\*" indicates that the DRMD signal goes on when '0'.  
In practically all cases, the internal mechanisms of a microprocessor cannot be checked in the field. Therefore, the operations of the microprocessors used in the machines are not discussed: they are explained in terms of from sensors to the input of the DC controller PCB and from the output of the DC controller PCB to the loads.

The descriptions in this Service Manual are subject to change without notice for product improvement or other purposes, and major changes will be communicated in the form of Service Information bulletins.

All service persons are expected to have a good understanding of the contents of this Service Manual and all relevant Service Information bulletins and be able to identify and isolate faults in the machine.

# Contents

<b>Safety Precautions.....</b>	<b>1</b>
Laser Safety.....	2
How to Handle the Laser Scanner Unit.....	2
Toner Safety.....	2
About Toner.....	2
Handling Adhered Toner.....	2
Notes When Handling a Lithium Battery.....	3
Notes on Assembly/Disassembly.....	3
<b>1. Product Overview.....</b>	<b>4</b>
Product Lineups.....	5
Main unit.....	5
Options.....	5
Features.....	6
Features.....	6
Product Specifications.....	7
List of Parts.....	10
External View.....	10
Cross Sectional View.....	11
Operation.....	12
Operation Panel.....	12
<b>2. Technology.....</b>	<b>13</b>
Basic Operation.....	14
Function Structure.....	14
Sequence of Operation.....	15
Outline.....	15
Laser Exposure System.....	16
Outline.....	16
Optical Unit Failure Detection.....	16
Image Formation System.....	17
Outline.....	17
Image Formation Process.....	17
High-voltage Power Supply.....	20
Fixing System.....	22
Outline.....	22
Fixing control circuit.....	22
Pickup Feeding System.....	26
Outline.....	26
Jam Detection.....	27
Controller System.....	29
Outline.....	29
DC Controller.....	29
Low-voltage Power Supply.....	32

Energy Saving Function.....	33
Embedded RDS.....	34
Product Overview.....	34
Service cautions.....	34
E-RDS Setup.....	35
FAQ.....	37
Troubleshooting.....	39
Error code and strings.....	40
Setting Information Export/Import Function (DCM).....	44
Function Overview.....	44
Specifications.....	46
Limitations.....	47
Procedure for Exporting/Importing Service Mode Setting Information.....	49
List of Items Which Can Be Imported.....	56

### **3. Periodical Service..... 62**

Periodically Replaced Parts.....	63
Consumable Parts.....	64
Periodical Service.....	65
Cleaning.....	66

### **4. Disassembly/Assembly..... 67**

Outline.....	68
List of Parts.....	69
External View.....	69
List of Main Unit.....	70
Motor / Fan.....	72
Solenoid.....	72
Heater / Thermo Switch / Thermistor / Switch.....	73
Sensor.....	74
PCB.....	75
Connector Layout Drawing.....	76
Connector List.....	76
External Cover, Internal Cover.....	80
Removing the Left Cover.....	80
Removing the Right Cover.....	80
Removing the Rear Cover Unit / Duplex Feed Unit.....	81
Removing the Upper Cover Unit.....	82
Removing the Cartridge Cover Unit.....	82
Controller System.....	84
Removing the Main Controller Board.....	84
Remove the Sleep Interface PCB.....	85
Remove the Duplex Reverse Sensor Unit.....	86
Remove the All-Night Power Supply PCB.....	86
Remove the Power Supply PCB.....	87
Removing the Engine Controller Board.....	87
Removing the Control Panel Unit.....	90
Removing the Main Motor.....	91
Removing the Main Fan.....	91

Removing the Main Drive Unit.....	91
Removing the Duplex Drive Unit.....	93
Removing the Cassette Pickup Solenoid.....	93
Removing the Multi-purpose Solenoid.....	94
Removing the Duplex Reversal Solenoid.....	94
Removing the Wireless LAN PCB.....	95
Laser Exposure System.....	96
Removing the Laser Scanner Unit.....	96
Image Forming System.....	97
Removing the Transfer Roller.....	97
Removing the Registration Unit.....	97
Fixing System.....	98
Removing the Fixing Unit.....	98
Paper Pickup/Transport/Output System.....	100
Removing the Cassette Pickup Roller.....	100
Removing the Cassette Separation Pad.....	100
Removing the Multi-purpose Pickup Roller.....	101
Removing the Multi-purpose Separation Pad.....	101
<b>5. Troubleshooting.....</b>	<b>103</b>
Trouble Shooting.....	104
Test Pages.....	104
Confirming nip width.....	106
Version Upgrade.....	108
Overview.....	108
Version Upgrade Using UST.....	108
Upgrading via Internet.....	112
Corrective Actions.....	114
Image Defects.....	114
Debug Log .....	120
Function Overview.....	120
Conditions for collecting logs.....	120
Collection procedure.....	120
<b>6. Error/Jam/Alarm.....</b>	<b>122</b>
Error Codes.....	123
Overview.....	123
Error Codes.....	123
JamCode.....	126
Alarm Code.....	126
<b>7. Service Mode.....</b>	<b>128</b>
Service Mode.....	129
Overview.....	129
COPIER.....	133
TESTMODE.....	151
SERVICE REPORT.....	153

**APPENDICES..... 154**

- Service Tools..... 155
  - Special Tools..... 155
  - Solvents and Oil List..... 155
- General Circuit Diagram..... 156
- Print Sequence..... 157
- Backup Data..... 158
- Soft Counter Specifications..... 160

# Safety Precautions

Laser Safety.....	2
Toner Safety.....	2
Notes When Handling a Lithium Battery.....	3
Notes on Assembly/Disassembly.....	3



## Laser Safety

Since radiation emitted inside the machine is completely confined within protective housings and external covers, the laser beam cannot escape from the machine during any phase of user operation.

Therefore this machine is classified in Class 1 laser products that are regarded as safe during normal use according to International Standard IEC60825-1.

### How to Handle the Laser Scanner Unit

This machine is classified in Class 1 laser products.

However, inside the scanner unit, there is source of Class 3B laser beam and the laser beam is hazardous when entered into an eye. So, be sure not to disassemble the laser scanner unit. No adjustment can be made to the laser scanner unit in this machine in the field.

The label shown in the following figure is attached on the laser scanner unit.

The following warnings are given to comply with Safety Principles (EN60950-1).

Diese Maschine ist der Klasse 1 der Laserprodukte zugeordnet.

Innerhalb der Scannereinheit befindet sich jedoch die Laserstrahlquelle der Klasse 3B und es ist gefährlich, wenn dieser Strahl in die Augen gerät. Die Laserscannereinheit darf unter keinen Umständen entfernt werden.

Es dürfen in diesem Umfeld der Maschine keine Justagen an der Laserscannereinheit vorgenommen werden. Das Etikett in folgendem Bild ist auf der Laserscannereinheit angebracht.



## Toner Safety

### About Toner

Toner is a nontoxic matter composed of plastic, iron and a trace of pigments.

#### **CAUTION:**

Never throw toner in flames to avoid explosion.

### Handling Adhered Toner

- Use dry tissue paper to wipe off toner adhered to skin or clothes and wash in water.
- Never use warm water for cleaning up toner to prevent toner particles from being gelated to soak into fibers permanently.
- Toner particles are reactive with vinyl polymers. Avoid contacting these materials.

## Notes When Handling a Lithium Battery

**⚠ CAUTION:**

RISK OF EXPLOSION IF BATTERY IS REPLACED BY AN INCORRECT TYPE.  
DISPOSE OF USED BATTERIES ACCORDING TO THE INSTRUCTIONS.

The following warnings are given to comply with Safety Principles (EN60950-1).

**⚠ CAUTION:**

Wenn mit dem falschen Typ ausgewechselt, besteht Explosionsgefahr.  
Gebrauchte Batterien gemäß der Anleitung beseitigen.

**警告**

如果更換不正確之電池型式會有爆炸的風險  
請依製造商說明書處理用過之電池

## Notes on Assembly/Disassembly

Follow the items below to assemble/disassemble the device.

1. Disconnect the power plug to avoid any potential dangers during assembling/disassembling works.
2. If not specially instructed, reverse the order of disassembly to reinstall.
3. Ensure to use the right screw type (length, diameter, etc.) at the right position when assembling.
4. To keep electric conduction, binding screws with washers are used to attach the grounding wire and the varistor. Ensure to use the right screw type when assembling.
5. Unless it is specially needed, do not operate the device with some parts removed.
6. Never remove the paint-locked screws when disassembling.



# Product Overview

Product Lineups.....	5
Features.....	6
Product Specifications.....	7
List of Parts.....	10
Operation.....	12

## Product Lineups

### Main unit

Function	LBP253
Appearance	
Copy	No
Print	Yes
FAX	No
Remote UI	Yes
Automatic 2-sided Print (60 to 120g / m2 paper )	Yes
MEAP	No
Network	Yes
WLAN	Yes

### Options

No.	Name	Description	Remarks
[1]	Paper FeederUnit PF-44	Approx. 500 Sheets (Plain paper 80g/ m <sup>2</sup> )	-

# Features

## Features

1. Small and high-speed printer  
The printer is compact size that realizes print speed of approximately 33 pages per minute.
2. Automatic duplex print  
Automatic two-sided printing is available with standard equipped duplex unit.
3. High-volume continuous printing  
In addition to the standard equipped universal cassette (holds up to 250 sheets of 80g/m<sup>2</sup> paper) and Multi-purpose tray (holds up to 50 sheets of 80g/m<sup>2</sup> paper), the printer supports optional paper feeder (holds up to 500 sheets of 80g/m<sup>2</sup> paper) for a total capacity of 800 sheets. Thus high-volume continuous printing is available.
4. LUI(display)
  - LUI(display )touch-panel display
  - The display is a touch panel, allowing you to operate directly on the screen.

## Product Specifications

Item	Specification/function
Installation Format	Desktop type page printer
Photosensitive Element	OPC drum
Exposure Principle	Laser beam method
Development Principle	Jumping development
Transfer Principle	Roller transfer
Separation Principle	Self stripping
Cassette Feed Principle	Separate design
Multi Purpose Tray Principle	Pad separation
Drum Cleaning Principle	Rubber blade cleaning
Fixing Method	On-demand
Paper Output Principle	Face-down/Face-up
Toner Supply Principle	Toner cartridgesNumber
Warm-up Time	From power ON: max. 16 seconds
Recovery Time	Approx. 9 seconds or less
Print Area	Top 5.0 mm, Bottom 5.0 mm, Left/Right 5.0 mm (Envelope: Top/Bottom/Right/Left 10.0 mm)
Printing Resolution	600dpi
First Print Output Time (1-sided printing on A4 size paper, with the output tray used)	Approx. 6 seconds or less
Printing Speed (Plain paper (60 to 89 g/m <sup>2</sup> ), A4 continuous printing)	1-sided printing: 33 pages/minute 2-sided printing: 16.8 pages/minute (8.4 sheets/minute)
Cassette Paper Size	Standard sizes: A4, B5, A5, A6, Legal, Letter, Executive Custom size range (user-specified): (Width 105.0 to 215.9 mm, Length 148.0 to 355.6 mm)
Multi Purpose Paper Size	Standard sizes: A4, B5, A5, A6, Legal, Letter, Executive, Postcard, Reply-paid Postcard, Four-side Postcard, Japanese Western-style Envelope Size No. 3, Envelope Size No. 3 Custom size range (user-specified): (Width 76.2 to 215.9 mm, Length 127.0 to 355.6 mm)
Cassette Paper Type	Plain paper (60 to 89 g/m <sup>2</sup> ), Heavy paper (90 to 120 g/m <sup>2</sup> )
Multi Purpose Paper Type	Plain paper (60 to 89 g/m <sup>2</sup> ), Heavy paper (90 to 163 g/m <sup>2</sup> ), OHP film, label paper, postcard, envelope
Cassette Paper Capacity	Approx. 250 sheets (Plain paper 80 g/m <sup>2</sup> )
Multi Purpose Paper Capacity	Approx. 50 sheets (Plain paper 80 g/m <sup>2</sup> )
Output Tray Paper Capacity	Face-down output: approx. 150 sheets (80 g/m <sup>2</sup> ), face-up output: 1 sheet
Duplex Printing Principle	Auto Duplex
Interfaces	USB: HI-Speed USB/USB2.0 Network: 10 Base-T/100BASE-T/1000Base-T common (RJ-45) Full duplex/half duplex
Memory Capacity	1GB
Hard Disk Capacity	Standard: None, Option: None
Ambient Temperature Range for Use	Temperature: 10 to 30 °C
Ambient Humidity Range for Use	Humidity: 20 to 80% RH (no condensation)

Item	Specification/function
Noise (measured in accordance with ISO 7779, declared noise emission in accordance with ISO 9296)	LwAd (declared A-weighted sound power level (1 B = 10 dB)) During standby: Inaudible * During printing: 6.8 B or less LpAm (declared A-weighted sound pressure level (bystander position)) During standby: Inaudible * During printing: 54 dB *:Indicates that the sound pressure level of each bystander position is below the ISO 7779 absolute criteria for the background noise level.
Power Supply	120 to 127 V, 60 Hz 220 to 240 V (± 10 %), 50/60 Hz (± 2 Hz)
Power Consumption*(at 68 °F (20 °C)) *:Even if the machine is turned OFF, a slight amount of power is still consumed while the power plug is plugged into the AC power outlet. To stop power consumption completely, unplug the power plug from the AC power outlet.	220 to 240 V, 50/60 Hz <ul style="list-style-type: none"> <li>Maximum: 1,150 W or less</li> <li>During operation: Approx. 550 W</li> <li>During standby: Approx. 12.1 W</li> <li>During sleep mode: <ul style="list-style-type: none"> <li>Approx. 0.9 W (USB connection)</li> <li>Approx. 1.0 W (wired LAN connection)</li> <li>Approx. 1.5 W (wireless LAN connection)</li> </ul> </li> <li>When the power switch is turned OFF: 0.1 W or less</li> </ul> 120 to 127 V, 60 Hz <ul style="list-style-type: none"> <li>Maximum: 990 W or less</li> <li>During operation: Approx. 570 W</li> <li>During standby: Approx. 11.7 W</li> <li>During sleep mode: <ul style="list-style-type: none"> <li>Approx. 0.8 W (USB connection)</li> <li>Approx. 1.0 W (wired LAN connection)</li> <li>Approx. 1.6 W (wireless LAN connection)</li> </ul> </li> <li>When the power switch is turned OFF: 0.1 W or less</li> </ul>
Dimensions	403(W)×376(D)×320(H)mm
Weight	Printer main unit: approx. 11.5 kg (excl. toner cartridges)
Option	Paper Feeder

## Wireless LAN

Item	Specification/function
Standard	IEEE 802.11g, IEEE 802.11b, IEEE 802.11n
Transmission Scheme	DS-SS System, OFDM System
Frequency Range	2,412 to 2,472 MHz
Communication Mode	Infrastructure Mode
Security	WEP, WPA-PSK (TKIP/AES-CCMP), WPA2-PSK (TKIP/AES-CCMP)
Connection Method	WPS (Wi-Fi Protected Setup), Manual setup

## Supported Paper Sizes

Paper sizes that can be loaded in the paper drawer, the multi-purpose tray, and optional paper feeders are listed below.

Yes : Available - : Unavailable

Paper Size	Paper Drawer	Multi-Purpose Tray	Automatic 2-Sided Printing *1
A4 (210.0 × 297.0 mm)	Yes	Yes	Yes
B5 (182.0 × 257.0 mm)	Yes	Yes	-
A5 (148.0 × 210.0 mm)	Yes	Yes	-
A6 (105.0 × 148.0 mm)	Yes	Yes	-
Legal (LGL) (215.9 × 355.6 mm)	Yes	Yes	Yes
Letter (LTR) (215.9 × 279.4 mm)	Yes	Yes	Yes
Statement (STMT) (139.7 × 215.9 mm)	Yes	Yes	-
Executive (EXEC) (184.1 × 266.7 mm)	Yes	Yes	-
Oficio (215.9 × 317.5 mm)	Yes	Yes	Yes *2
Oficio (Brazil) (215.9 × 355.0 mm)	Yes	Yes	Yes *2

Paper Size	Paper Drawer	Multi-Purpose Tray	Automatic 2-Sided Printing *1
Oficio (Mexico) (215.9 × 341.0 mm)	Yes	Yes	Yes *2
Letter (Government) (203.2 × 266.7 mm)	Yes	Yes	-
Legal (Government) (203.2 × 330.2 mm)	Yes	Yes	-
Foolscap (215.9 × 330.2 mm)	Yes	Yes	Yes *2
Foolscap (Australia) (206.0 × 337.0 mm)	Yes	Yes	-
Legal (India) (215.0 × 345.0 mm)	Yes	Yes	*2
Envelope No.10 (COM10) (104.7 x 241.3 mm)	-	Yes	-
Envelope Monarch (98.4 x 190.5 mm)	-	Yes	-
C5 (162.0 x 229.0 mm)	-	Yes	-
Envelope DL (110.0 x 220.0 mm)	-	Yes	-
3x5inch (76.2 x 127.0 mm)	-	Yes	-
Custom	Yes *3	Yes *4	-

\*1 Automatic 2-sided printing is available without necessity of paper reloading.

\*2 Set the paper size switch lever in the same position as that for Letter/Legal size.

\*3 Custom size paper with width 105.0 to 216.0 mm and length 148.0 to 356.0 mm can be loaded.

\*4 Custom size paper with width 76.2 to 216.0 mm and length 127.0 to 356.0 mm can be loaded.

### Paper Type and Paper Source Capacity

Chlorine-free paper can be used with this machine.

Paper Type		Paper Capacity for Paper Drawer	Paper Capacity for Multi-Purpose Tray
Plain paper *	60 to 89 g/m <sup>2</sup>	250 sheets	50 sheets
Heavy paper	90 to 120 g/m <sup>2</sup> *	200 sheets	40 sheets
	121 to 163 g/m <sup>2</sup>	-	25 sheets
Recycled paper *	60 to 89 g/m <sup>2</sup>	250 sheets	50 sheets
Color paper *	60 to 89 g/m <sup>2</sup>	250 sheets	50 sheets
Label		-	20 sheets
Envelope		-	5 sheets

\* Automatic 2-sided printing is available without replacing paper.



## List of Parts

### External View

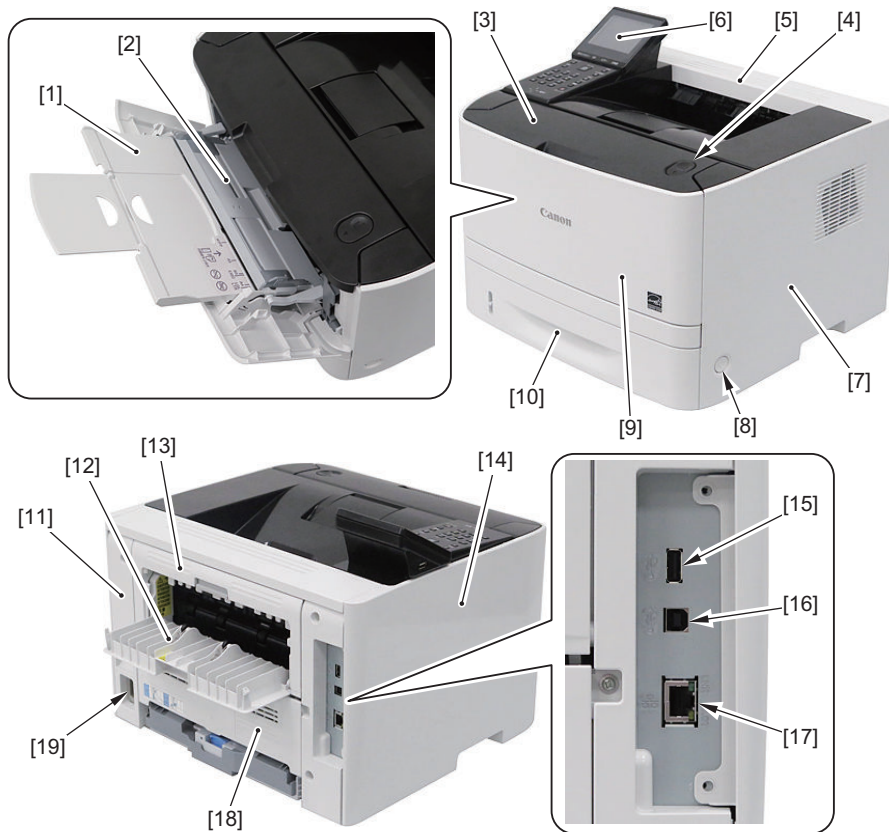

No.	Name	No.	Name
[1]	Auxiliary Tray	[11]	Rear Cover
[2]	Multi-purpose Tray	[12]	Face-up Output Tray
[3]	Front Cover	[13]	Pressure Release Cover
[4]	Open Button	[14]	Left Cover
[5]	Upper Cover	[15]	USB Host
[6]	Control Panel	[16]	USB Device
[7]	Right Cover	[17]	LAN Connector
[8]	Power Switch	[18]	Duplex Unit Cover
[9]	Face-down Output Tray Cover	[19]	Power Socket
[10]	Paper Cassette		

## Cross Sectional View

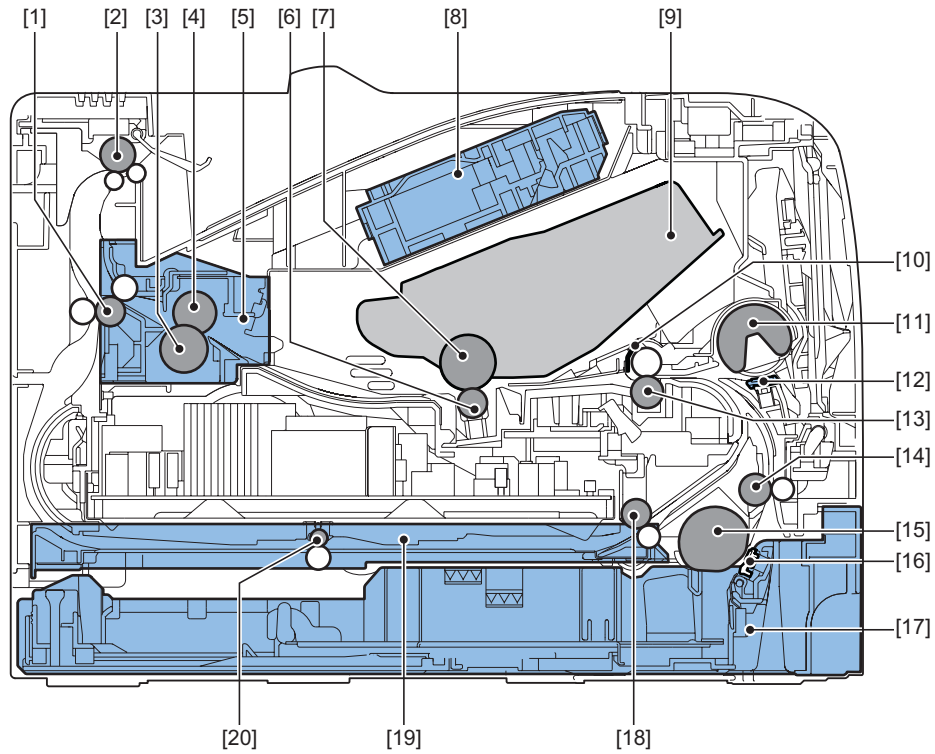

No.	Name	No.	Name
[1]	Fixing Delivery Roller	[11]	Multi-purpose Tray Pickup Roller
[2]	Face-down Delivery Roller	[12]	Multi-purpose Tray Separation Pad
[3]	Pressure Roller	[13]	Registration Roller
[4]	Fixing Film Unit	[14]	Feed Roller
[5]	Fixing Unit	[15]	Cassette Pickup Roller
[6]	Transfer Roller	[16]	Cassette Separation Pad
[7]	Photosensitive Drum	[17]	Cassette
[8]	Laser Scanner Unit	[18]	Duplex Re-pickup Roller
[9]	Cartridge	[19]	Duplex Feed Unit
[10]	Registration Shutter	[20]	Duplex Feed Roller

# Operation

## Operation Panel

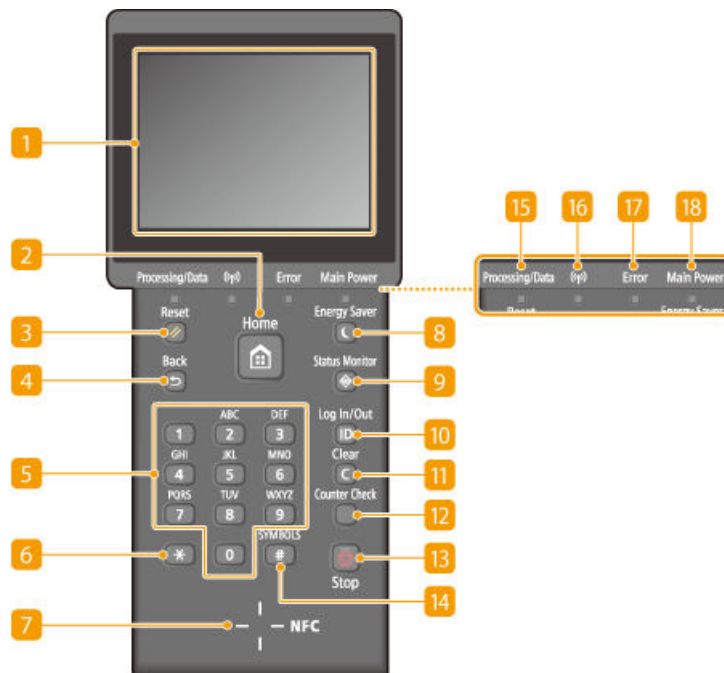

No.	Name	No.	Name
1	Display	10	[ID] key
2	[Home] key	11	[Clear] key
3	[Reset] key	12	[Counter Check] key
4	[Back] key	13	[Stop] key
5	Numeric keys ([0]-[9] keys)	14	[#] key
6	[*] key	15	[Processing/Data] indicator
7	NFC (Near Field Communication) mark	16	Wi-Fi indicator
8	[Energy Saver] key	17	[Error] indicator
9	[Status Monitor] key	18	[Main Power] indicator



# Technology

Basic Operation.....	14
Sequence of Operation.....	15
Laser Exposure System.....	16
Image Formation System.....	17
Fixing System.....	22
Pickup Feeding System.....	26
Controller System.....	29
Embedded RDS.....	34
Setting Information Export/Import Function (DCM).....	44

## Basic Operation

### Function Structure

The function structure of the printer contains the following five systems:

- Engine control system
- Laser scanner system
- Image-formation system
- Media feed system
- Option

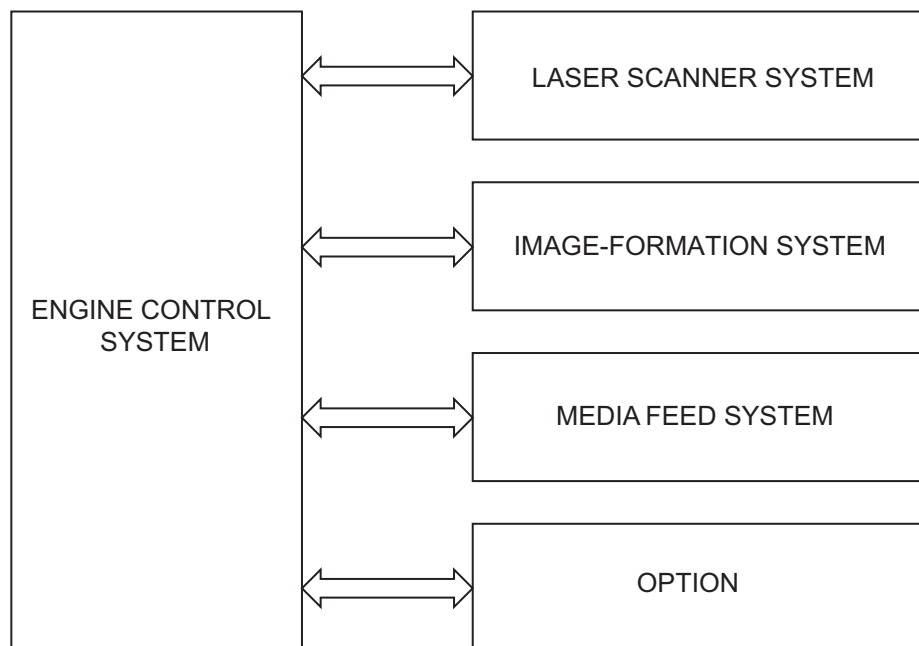

## Sequence of Operation

### Outline

The operation sequence is controlled by the DC Controller in the engine control system.

Operations for each period of a print operation from the machine is turned on until the motor stops rotating are described below.

Period	Duration	Operation
WAIT	From the time power switch is turned on or the door is closed until the printer gets ready for a print operation.	Brings the printer to printable condition. The printer performs the following during this period:-Detects cartridge presence.
STBY (Standby)	From the end of WAIT or LSTR period until either the print command is received the main controller or the power switch is turned off.	Maintains the printer in printable condition.
INTR (Initial rotation)	From the time print command is received from the main controller until the temperature of the fixing unit reaches its targeted temperature.	Starts up each high-voltage biases, laser scanner and fixing unit in preparing for print operation.
PRINT	From the end of INTR period until the last media completes the fixing operation.	Forms the image on the photosensitive drum based on the VIDEO signals from the main controller. Transfers and fuses the toner image to the print media.
LSTR (Last rotation)	From the end of PRINT period until the motor stops rotating.	Moves the last printed sheet out of the printer. Stops laser scanner operation and high-voltage biases output. The printer enters INTR period as the LSTR period is completed if the main controller sends another print command.

# Laser Exposure System

## Outline

The laser exposure system forms a latent image on the photosensitive drum according to the VIDEO signal sent from the Main Controller.

The main components of the laser scanner are the laser unit and the scanner motor unit, which are controlled by the signals sent from the DC controller.

Diagram of the Laser Scanner Unit is shown below.

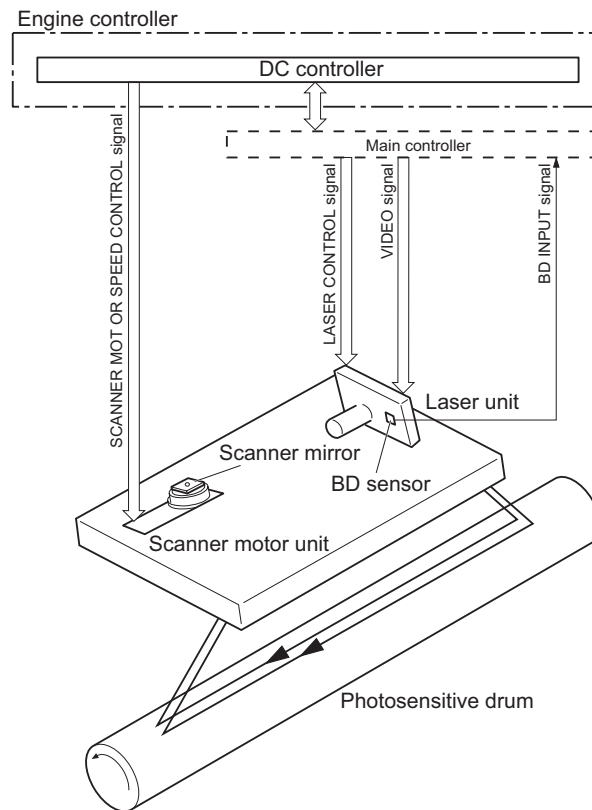

## Optical Unit Failure Detection

The optical unit failure detection manages the laser scanner failure detection functions.

The DC controller determines an optical unit failure and notifies E100 to the Main controller if the laser scanner encounters the following conditions:

- If the scanner motor does not reach a specified rotation within a specified period of start-up.
- If the rotation of the scanner motor is out of specified range for a specified period during drive.
- If an out of specified BD interval is detected during a print operation.

## Image Formation System

### Outline

The image formation system forms a toner image on print media.

The following are the main components of the image formation system:

- Cartridge
- Transfer roller
- Fixing unit
- Laser scanner

The DC controller controls the laser scanner and high-voltage power supply to form the toner image on the photosensitive drum. The image is transferred to the print media and fixed.

Diagram of the image formation system is shown below.

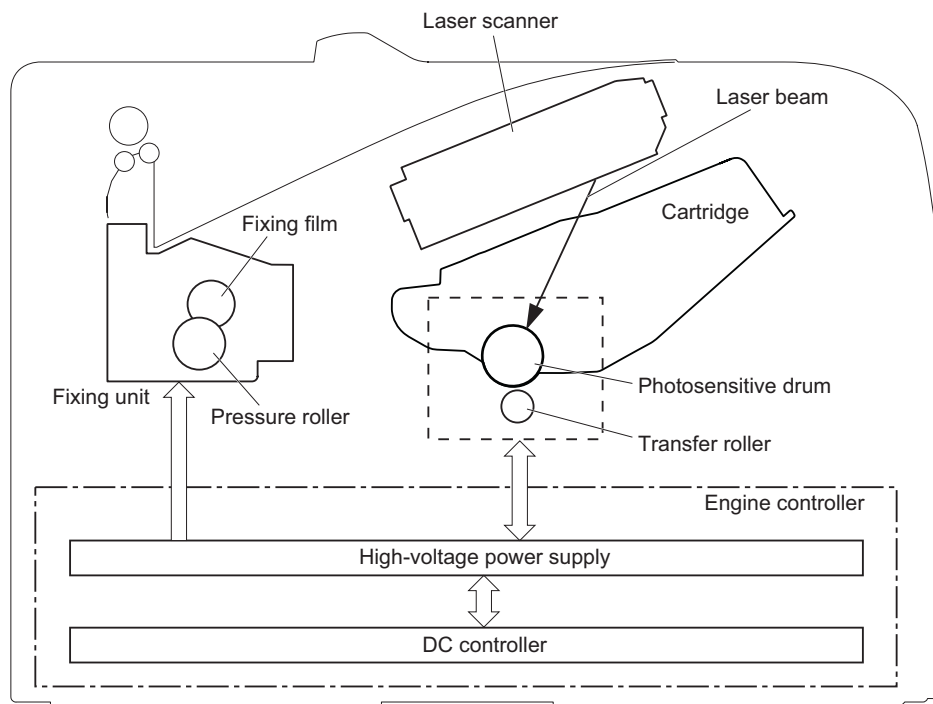

### Image Formation Process

#### Outline

The image formation process consists of the following seven steps divided among five functional blocks:

Latent image formation block

Step 1: Primary charging

Step 2: Laser-beam exposure

Developing block

Step 3: Developing

Transfer block

Step 4: Transfer

Step 5: Separation

Fixing block

Step 6: Fixing

Drum cleaning block

Step 7: Drum cleaning



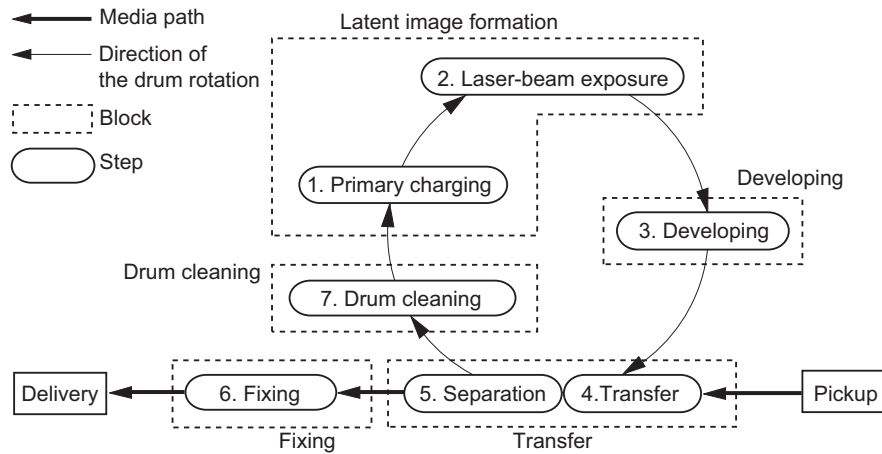

## ■ Latent image formation block

During the two steps that comprise this block, an invisible latent image is formed on the photosensitive drum.

### Step 1: Primary charging

To prepare for latent image formation, the surface of the photosensitive drum is charged with a uniform negative potential. The primary charging bias is applied to the primary charging roller and the roller charges the drum directly.

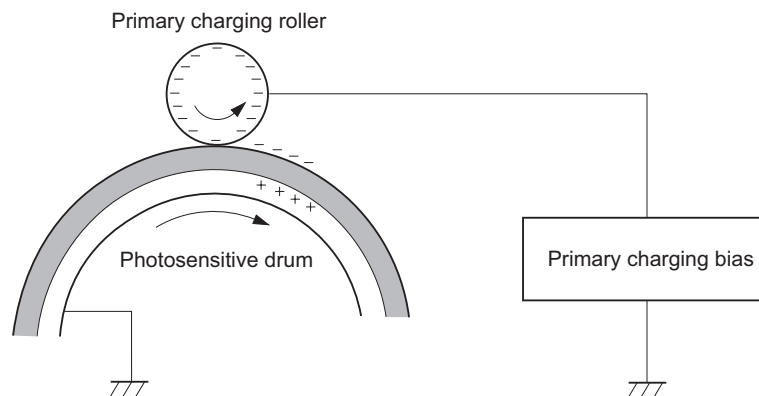

### Step 2: Laser-beam exposure

The laser beam scans the photosensitive drum to neutralize the negative charge on portions of the drum surface. An electrostatic latent image forms where the negative charge was neutralized.

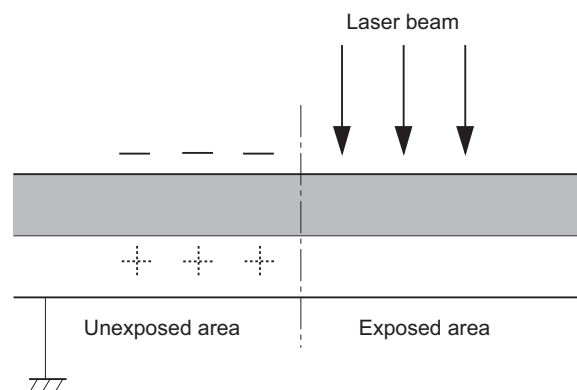

## ■ Developing block

Toner adheres to the electrostatic latent image on the photosensitive drum, which becomes visible.

### Step 3: Developing

Toner acquires a negative charge from the friction that occurs when the developing roller rotates against the developing blade. The negatively charged toner is attracted to the latent image on the photosensitive drum surface because the drum surface has a higher potential. The developing bias is applied to the developing roller.

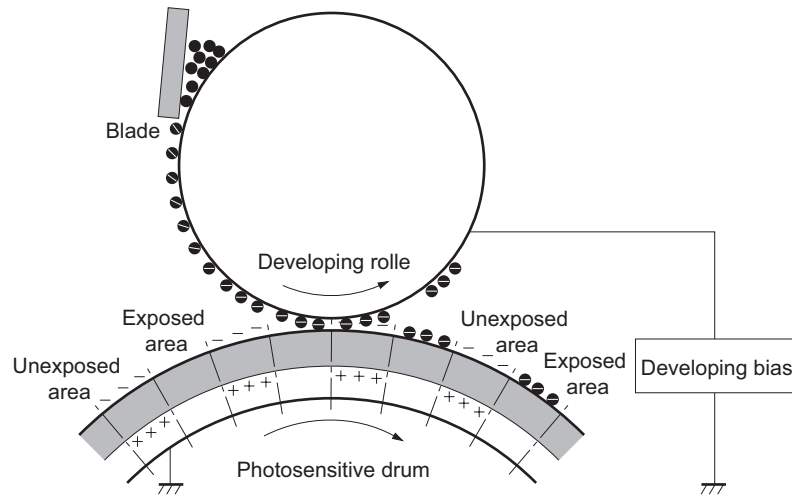

## ■ Transfer block

During the two steps that comprise this block, a toner image on the photosensitive drum is transferred to the print media.

### Step 4: Transfer

The transfer bias is applied to the transfer roller to charge the print media positive. The positively charged media attracts the negatively charged toner from the photosensitive drum surface.

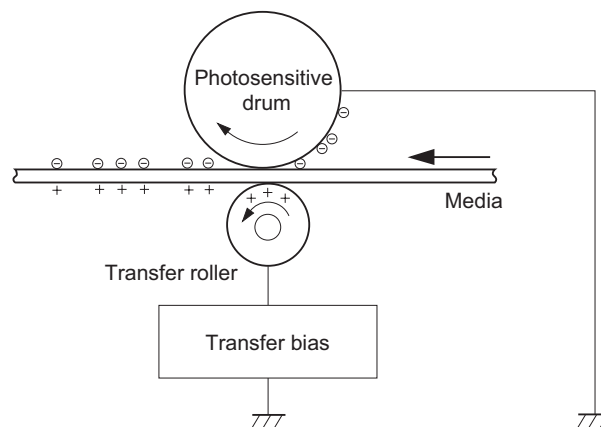

### Step 5: Separation

The elasticity of the print media and the curvature of the photosensitive drum cause the media to separate from the drum surface. The static charge eliminator reduces back side static discharge of the media for stable media feed and image quality.

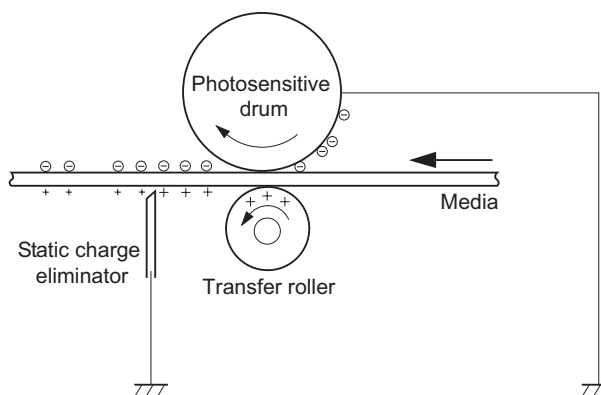

## ■ Fixing block

The toner image is fixed onto the print media.

### Step 6: Fixing

The printer uses an on-demand fixing method. The toner image is permanently affixed to the print media by heat and pressure. The fixing bias is applied to the fixing film to improve image quality.

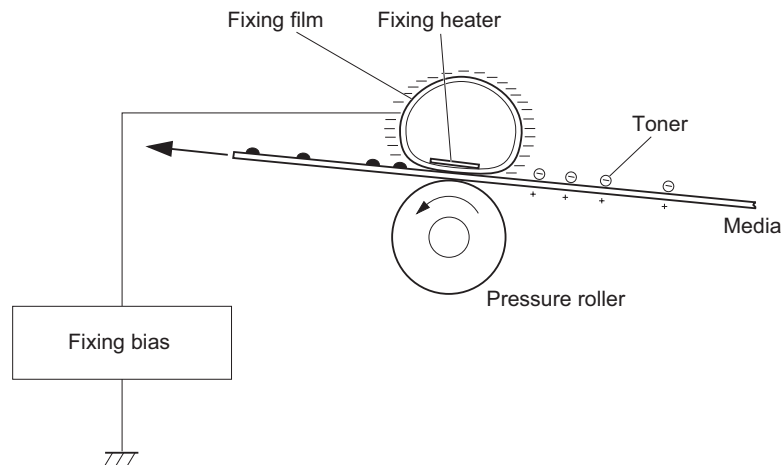

### ■ Drum cleaning block

The residual toner is cleared from the photosensitive drum surface.

### Step 7: Drum cleaning

The cleaning blade scrapes the residual toner off the surface of the photosensitive drum. The residual toner is deposited in the toner collection box.

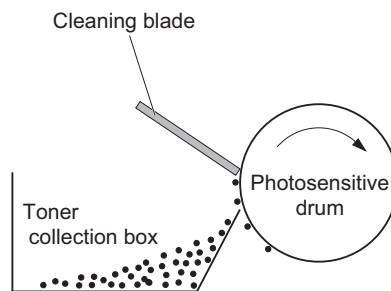

## ● High-voltage Power Supply

### ■ Outline

The high-voltage power supply applies biases to the following components:

- Primary charging roller
- Developing roller
- Transfer roller
- Fixing film

The DC controller controls the high-voltage power supply to generate biases. See "IV. IMAGE-FORMATION SYSTEM" ("[Outline on page 17](#)") for detailed information.

The Figure below shows the configuration of the High-voltage Power Supply.

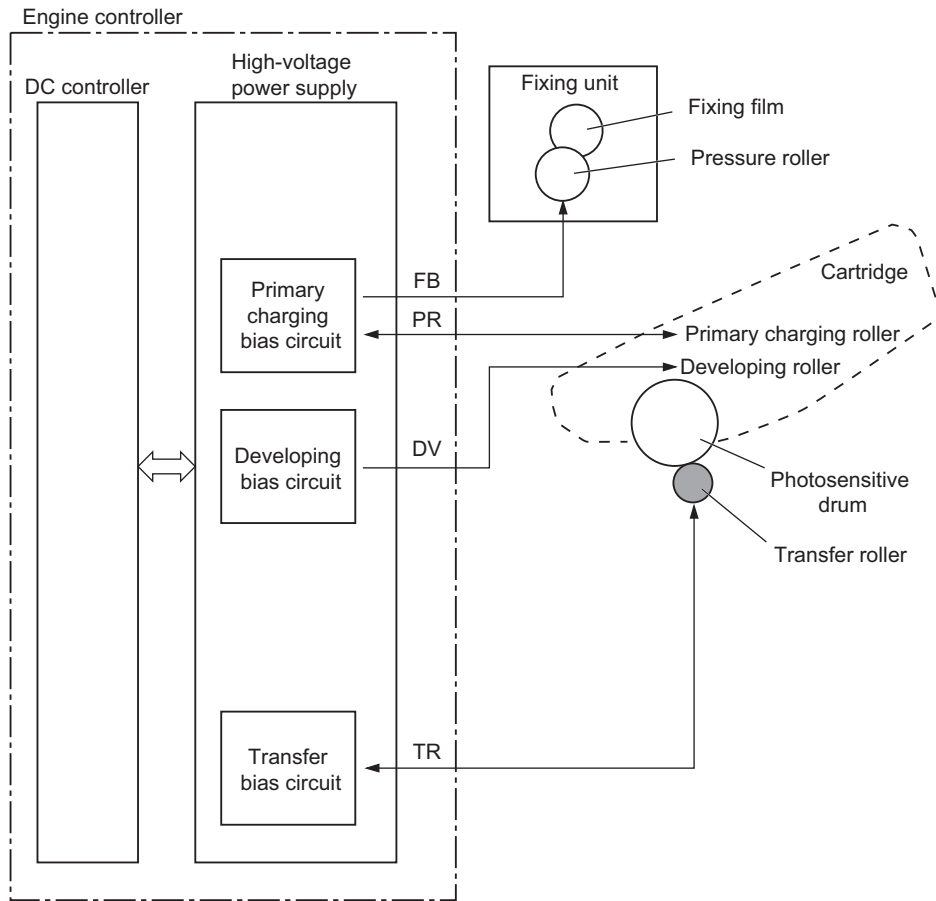

## Fixing System

### Outline

The fixing/delivery unit fixes the toner onto a print paper and delivers it to the delivery tray.

The operation of the fixing/delivery unit is explained in the following.

1. The print paper fed from the pick-up/feed unit is fused the toner by the fixing film and the pressure roller.
2. The print paper delivered from the fixing unit is delivered to the face-down delivery tray or the face-up delivery slot. When the engine controller detects that the heater temperature reaches 50 deg C after the last rotation is completed, it drives the main motor for 50 msec. and dislocates the nip part. This prevents the toner adhering to the pressure roller.

The fixing unit of this printer utilizes the on-demand fixing method. It is structured as shown below.

- Heater:  
This fixing unit incorporates one heater.  
Fixing heater (H1): To heat the fixing film (ceramic heater)
- Thermistor:  
This fixing unit incorporates one thermistor.  
Thermistor (TH1): Sit almost at the center of the fixing film. (contact type)  
To control the temperature of the fixing film
- Thermal switch:  
Thermoswitch (TP1): Sit almost at the center of the fixing film (contact type)  
If the temperature of the heater rises abnormally high, the contact gets broken and cuts off the AC voltage supply to the fixing heater to interrupt the power supply to the heater.

The temperature control of the fixing unit incorporated as above is operated by the fixing temperature control circuit according to the command from the CPU (IC201) on the DC controller.

The followings describe the each circuit and function of the temperature control of the fixing unit.

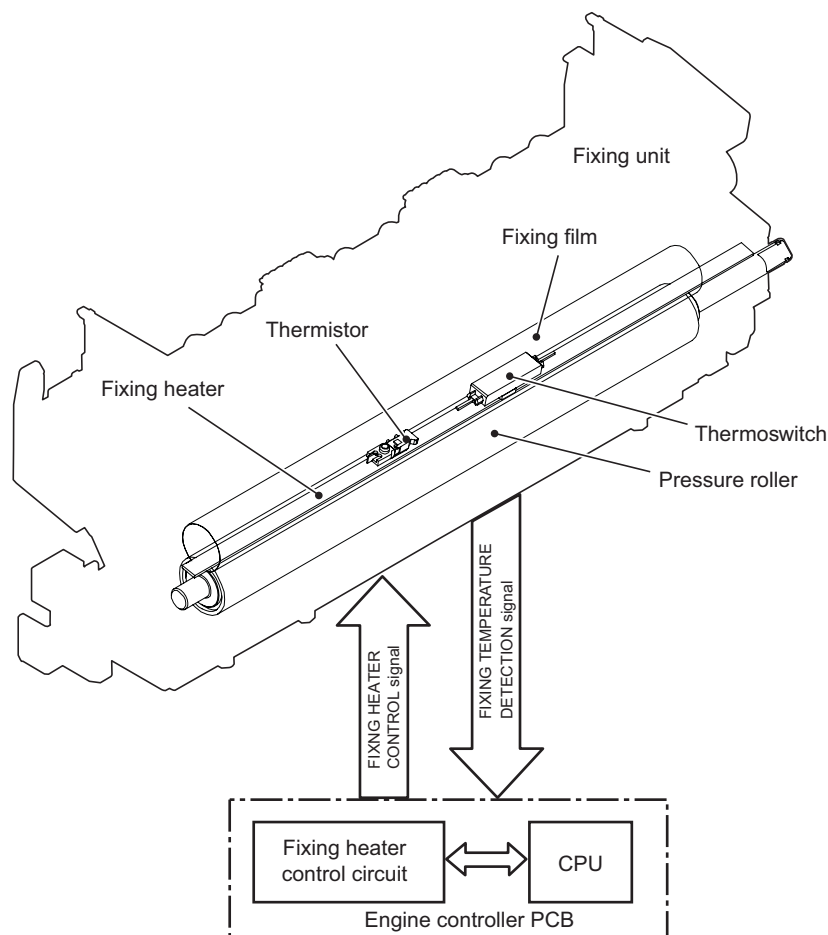

### Fixing control circuit

The fixing control circuit controls the temperature in the fixing unit. The printer uses an on-demand fixing method.

The Figure below shows the configuration of the fixing control circuit.

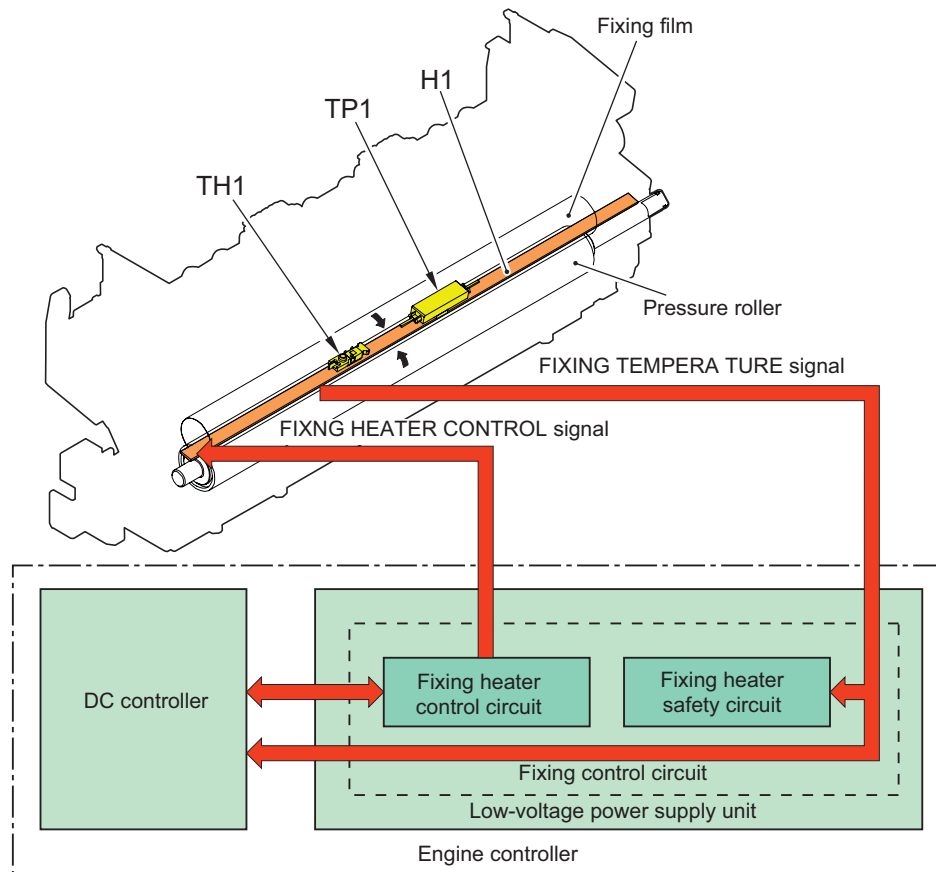

- Fixing heater (H1): Heats the fixing film
- Thermistor (TH1): Detects fixing temperature (Contact type)
- Thermoswitch (TP1): Prevents an abnormal temperature rise of the fixing heater (Contact type)

These temperature controls in the fixing unit are performed by the fixing heater control circuit and the fixing heater safety circuit according to the commands from the DC controller.

## ■ Fixing temperature control

The fixing temperature control maintains the temperature of the fixing heater at its targeted temperature. Block diagram of this control is shown below.

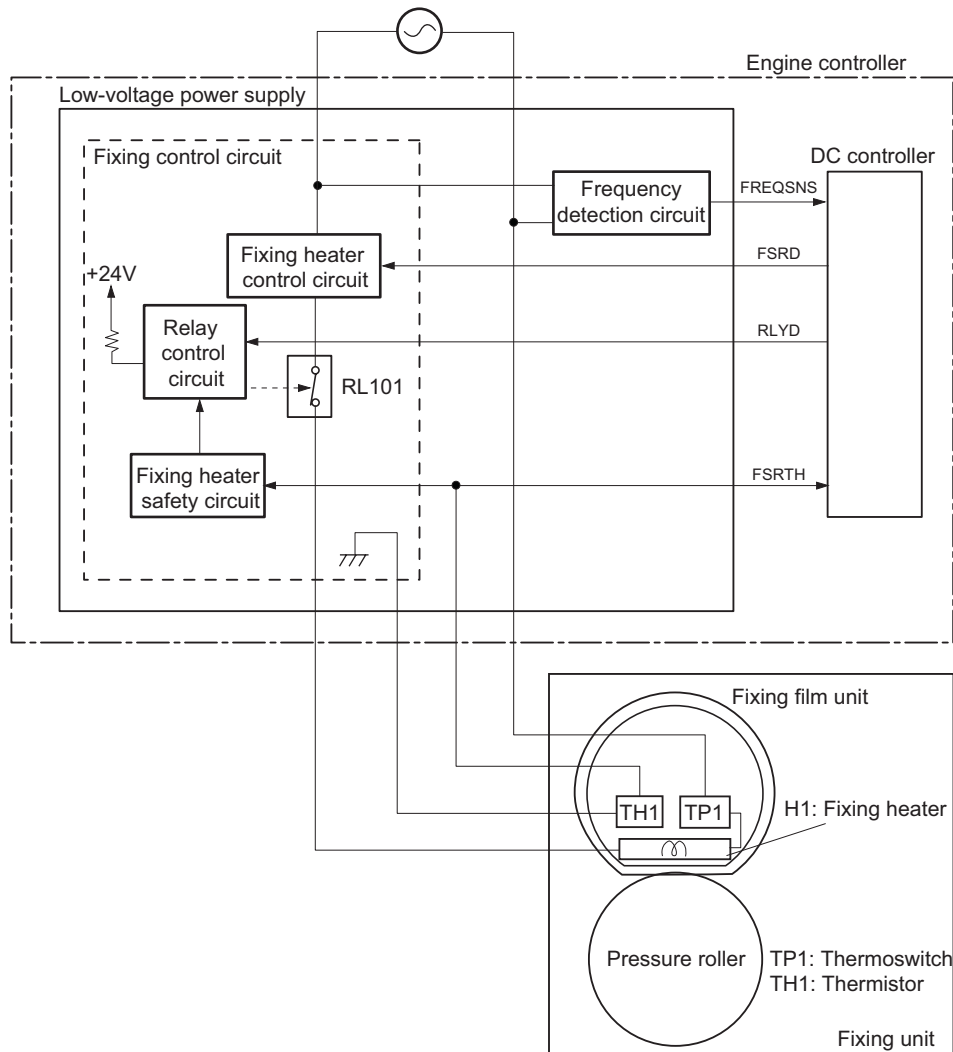

The DC controller monitors the FIXING TEMPERATURE (FSRTH) signal and sends the FIXING HEATER CONTROL (FSRD) signal according to the detected temperature. The fixing heater control circuit controls the fixing heater depending on the signal so that the heater remains at the targeted temperature.

## ■ Protective function

The protective function detects an abnormal temperature rise in the fixing unit and interrupts power supply to the fixing heater. The following three protective components prevent an abnormal temperature rise of the fixing heater:

- DC controller
- Fixing heater safety circuit
- Thermoswitch

### 1. Thermoswitch

The contact of the thermoswitch is broken to interrupt power supply to the fixing heater under the following condition:

- Temperature fuse: 228°C (442.4°F) or higher

### 2. DC controller

The DC controller monitors the detected temperature of the thermistor. The DC controller makes the FIXING HEATER CONTROL signal inactive and releases the relay to interrupt power supply to the fixing heater under the following condition:

- Thermistor: 240°C (464°F) or higher

### 3. Fixing heater safety circuit

The fixing heater safety circuit monitors the detected temperature of the thermistor.

The fixing heater safety circuit releases the relay control circuit to interrupt power supply to the fixing heater under the following condition:

- Thermistor: 270°C (518°F) or higher

## ■ Failure detection

The DC controller determines a fixing unit failure, makes the FIXING HEATER CONTROL signal inactive, releases the relay to interrupt power supply to the fixing heater and notifies the Main Controller of a failure state when it encounters the following conditions:

1. Start-up failure (E000)
  - If the detected temperature of the thermistor is kept a specified degrees or higher for a specified period of heater start-up during the wait period.
  - If the detected temperature of the thermistor is kept a specified degrees or lower for a specified period under the heater temperature control during the initial rotation period.
  - If the detected temperature of the thermistor is kept a specified degrees or lower for a specified period under the heater temperature control during the print period.
  - If the detected temperature of the thermistor does not reach its targeted temperature within a specified period under the heater temperature control during the initial rotation period.
2. Abnormal high temperature (E001)
  - If the detected temperature of the main thermistor is kept a specified degrees or higher for a specified period.
3. Abnormal low temperature (E003)
  - If the detected temperature of the thermistor is kept a specified degrees or lower for a specified period under the heater temperature control.
4. Drive circuit failure (E004)
  - If a specified frequency of the FREQUENCY signal is not detected within a specified period after the printer is turned on.
  - If an out of specified frequency of the FREQUENCY signal is detected after the printer is turned on and the signal is once detected.



# Pickup Feeding System

## Outline

The pickup feeding system picks up, feeds and delivers the print media. It consists of several types of rollers. The duplex feed unit in the duplex model reverses and refeeds the print media to print on both sides of media. The media path is shown below.

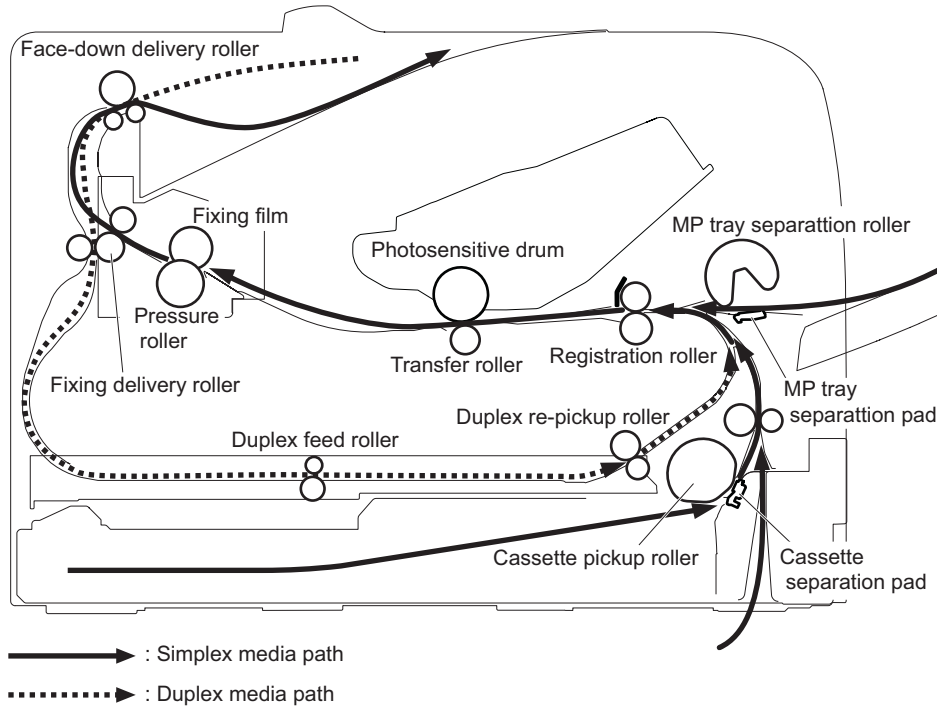
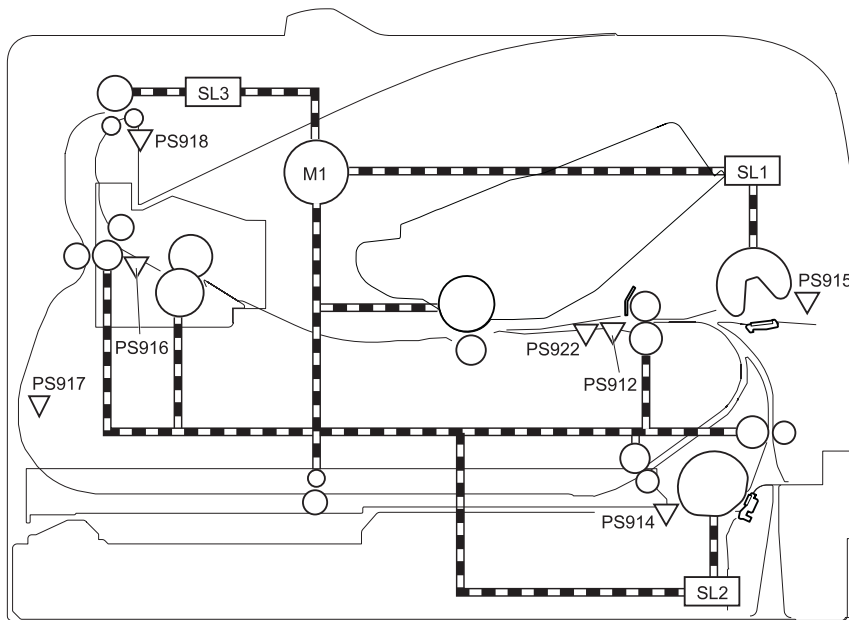

Diagram and table of the electrical components are shown below.



Electrical component		Signal
Main Motor	M1	Main Motor Control Signal
Cassette Pickup Solenoid	SL1	Cassette Pickup Solenoid Control Signal
Multi-purpose Tray Pickup Solenoid	SL2	Multi-purpose Tray Pickup Solenoid Control Signal
Duplex Reverse Solenoid	SL3	Duplex Reverse Solenoid Control Signal

Electrical component		Signal
TOP Sensor	PS912	TOP Signal
Cassette Media Presence Sensor	PS914	Cassette Media Presence Signal
Multi-purpose Tray Presence Sensor	PS915	Multi-purpose Tray Media Presence Signal
Fixing Delivery Sensor	PS916	Fixing Delivery Signal
Duplex Reverse Sensor	PS917	Duplex Reverse Signal
FD Tray Media Full Sensor	PS918	FD Tray Media Full Signal
Media Width Sensor	PS922	Media Width Signal

## Jam Detection

### ■ Outline

The printer uses the following sensors to check whether media is being fed correctly or has jammed:

- TOP sensor (PS912)
- Fixing delivery sensor (PS916)
- Duplex reverse sensor (PS917)
- Media width sensor (PS922)

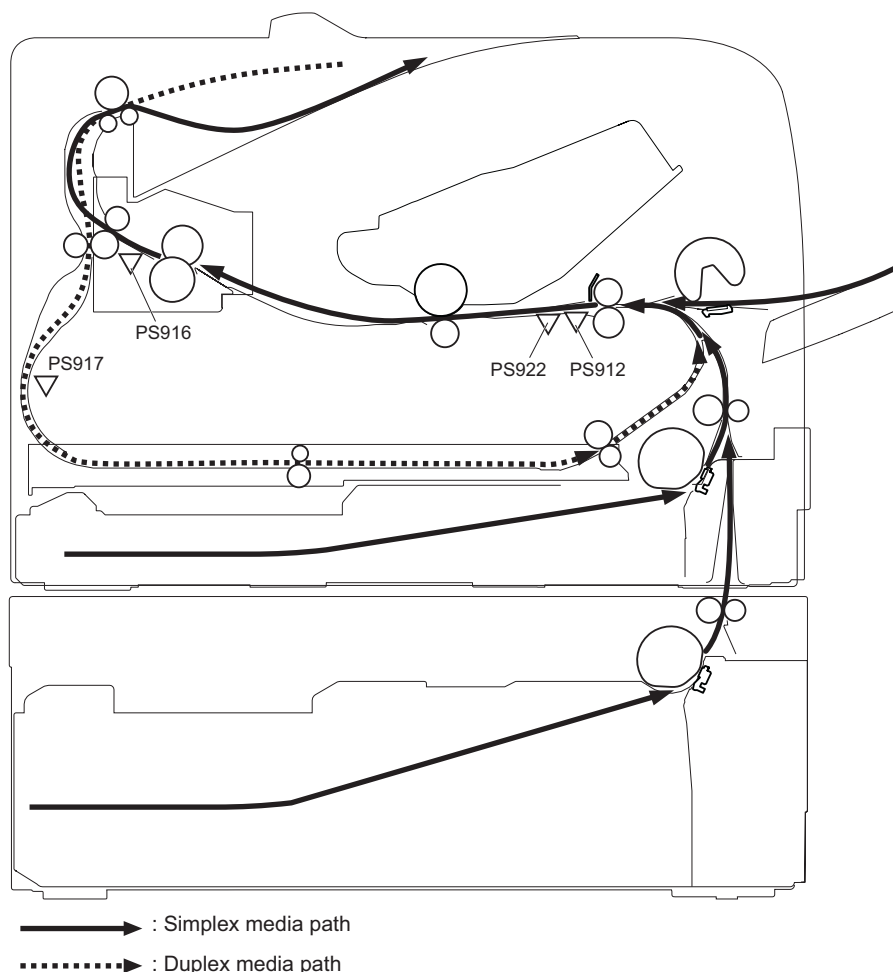

### ■ Pickup Delay Jam

When the TOP Sensor (PS912) cannot detect the leading edge of paper within the specified time after starting pickup from a cassette, pickup retry is executed twice. After that, the sensor still cannot detect the leading edge of paper within the specified time, it is judged as a pickup jam.

### ■ Pickup Stationary Jam

When the TOP Sensor (PS912) cannot detect the trailing edge of paper after the specified time has passed since it detected the leading edge of paper, it is judged as a pickup stationary jam.

## ■ Delivery Delay Jam

When the Fixing Delivery Sensor (PS916) cannot detect the leading edge of paper after the specified time has passed since the TOP Sensor (PS912) detected the leading edge of paper, it is judged as a delivery delay jam.

## ■ Fixing Paper Wrap Jam

After judging that it is not a delivery delay jam, execute the detection of fixing paper wrap jam.

It is judged as a fixing paper wrap jam when all of the following conditions are met: after the specified time had passed since the Fixing Delivery Sensor (PS916) detected the leading edge of paper, after the specified time had passed since the TOP Sensor (PS912) detected the leading edge of paper, and the Fixing Delivery Sensor (PS916) detects no paper.

## ■ Delivery Stationary Jam

After judging that it is not a fixing paper wrap, execute the detection of delivery stationary jam.

When the Fixing Delivery Sensor (PS916) does not detect no paper within the specified time since the TOP Sensor (PS912) detected the trailing edge of paper, it is judged as a delivery stationary jam.

## ■ Reverse Delay Jam

After judging that it is not a delivery stationary jam, execute the detection of reverse stationary jam.

When the Duplex Reverse Sensor (PS917) does not detect paper after the specified time has passed since the Fixing Delivery Sensor (PS916) detected the trailing edge of paper, it is judged as a reverse delay jam.

## ■ Reverse Stationary Jam

When the Duplex Reverse Sensor (PS917) cannot detect the trailing edge of paper after the specified time has passed since the sensor detected the leading edge of paper, it is judged as a reverse stationary jam.

## ■ Internal Residual Jam

When a paper is detected by the TOP Sensor (PS912), Fixing Delivery Sensor (PS916), Paper Width Sensor (PS922), or Duplex Reverse Sensor (PS917) at the time of starting initial rotation, it is judged as an internal residual jam.

## ■ Door Open Jam

When a door-open is detected while feeding papers, it is judged as a door open jam.

# Controller System

## Outline

The controller system controls all the other systems according to commands from the Main Controller.

The controller system contains the following components:

- DC controller
- Low-voltage power supply
- High-voltage power supply

Block diagram of the controller system is shown below.

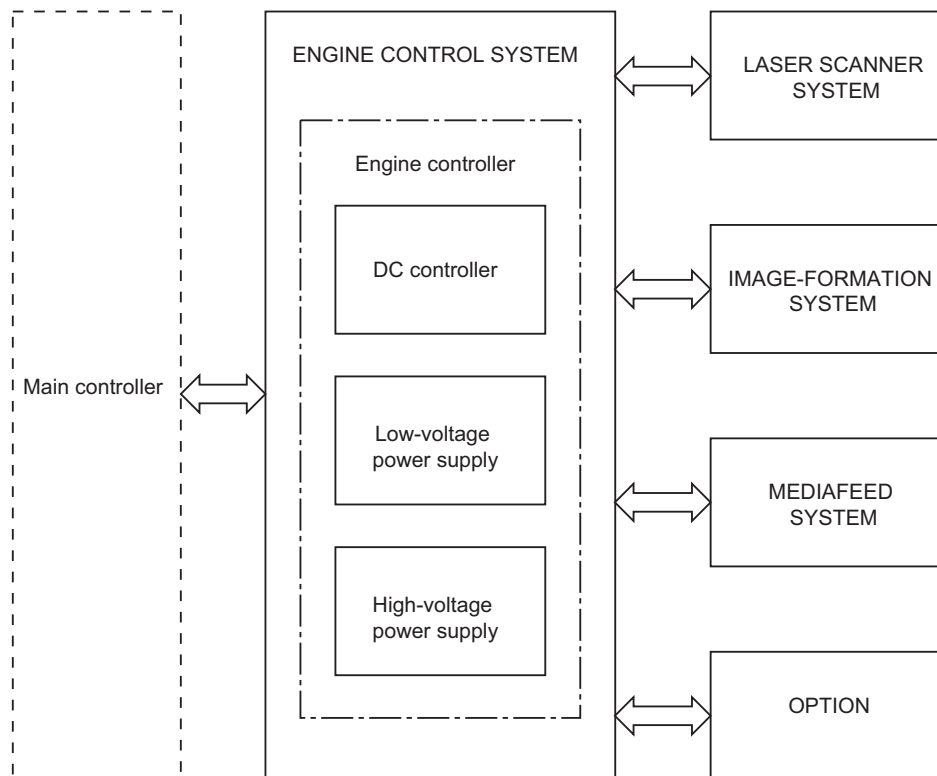

## DC Controller

### Outline

The DC controller controls the operational sequence of the printer.

Block diagram of the DC Controller and table of the electrical components are shown below.

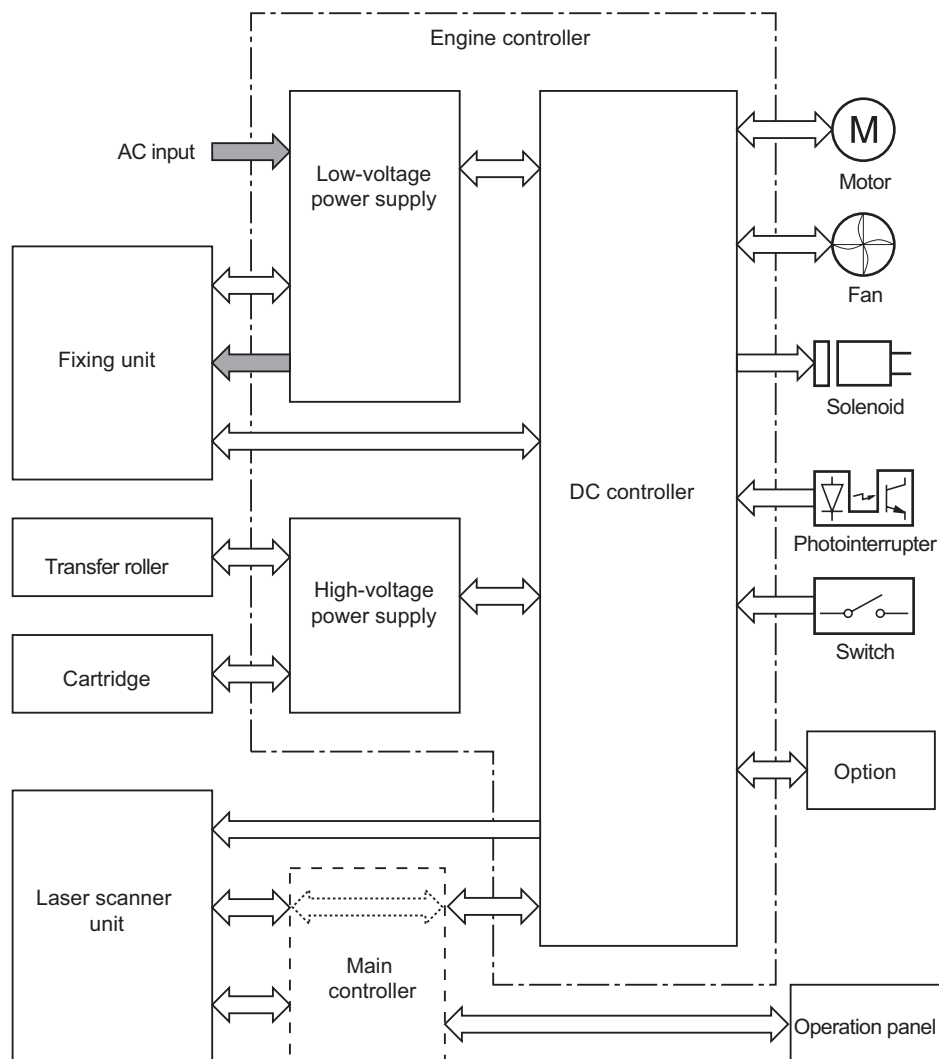

Symbol for component		Component
Fan	FM1	Main Fan
Motor	M1	Main Motor
Solenoid	SL1	Multi-purpose Tray Pickup Solenoid
	SL2	Cassette Pickup Solenoid
	SL3	Duplex Reverse Solenoid (NOTE)
Switch	SW1001	Power Switch
	SW301	Door Switch
Photointerrupter	PS912	TOP Sensor
	PS914	Cassette Media Presence Sensor
	PS915	Multi-purpose Tray Media Presence Sensor
	PS916	Fixing Delivery Sensor
	PS917	Duplex Reverse Sensor (NOTE)
	PS918	FD Tray Media Full Sensor (NOTE)
	PS922	Media Width Sensor

## ■ Motor control

The printer has one motor for media feed and image formation. Arrangement of motor and the specifications are shown below.

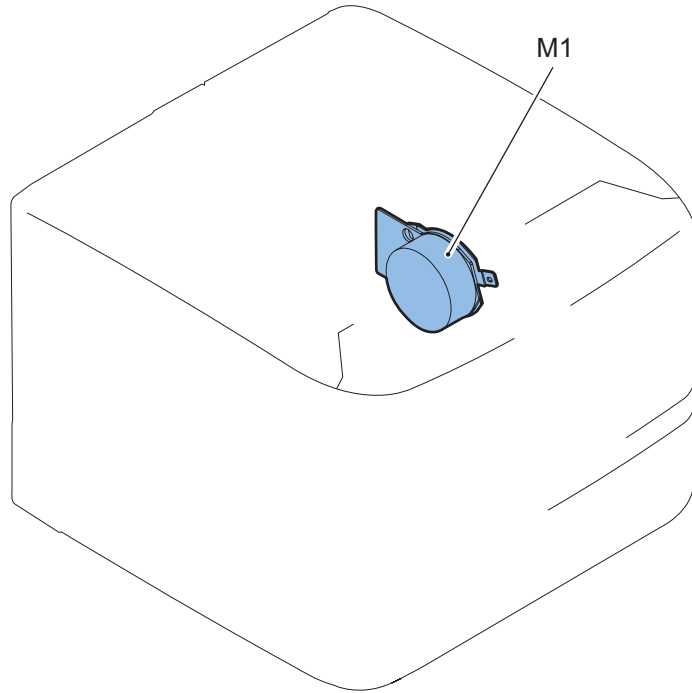

Description		Driving part	Failure detection
M1	Main Motor	Roller in the printer and rollers in the paper feeder	Yes

### ■ Fan control

The printer has one fan for preventing a temperature rising inside the printer. Arrangement of fan motor and the specifications are shown below.

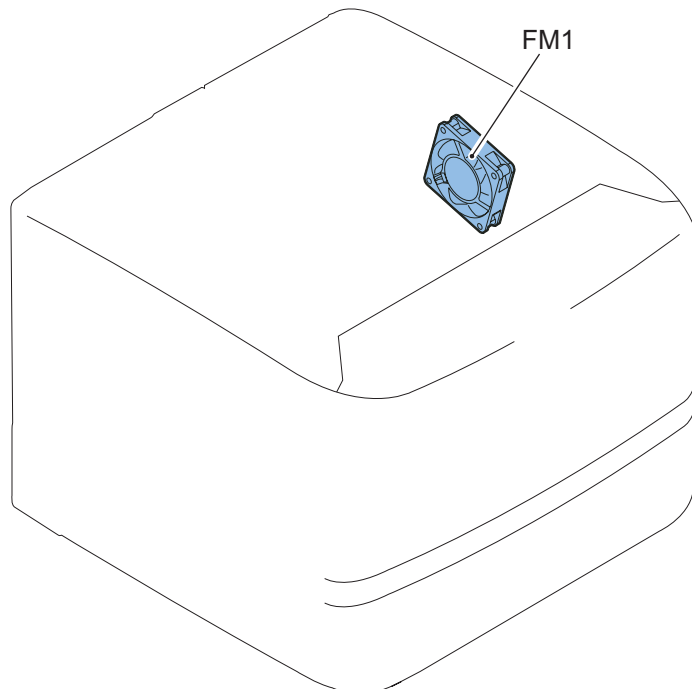

Description	Cooling area	Type	Speed
Main Fan	inside the printer	intake	Full

## ■ Failure Detection

Failure Point	Error Code	Cause of Failure
Main Motor	E014	In the case that the speed of motor does not reach the specified speed after the specified time has passed since the startup of the Main Motor.
Main Fan	E805	In the case that the fan has been locked continuously for the specified period of time since the startup of the Main Fan Motor.

## ● Low-voltage Power Supply

### ■ Outline

The low-voltage power supply converts AC power from the power receptacle into DC power to cover the DC loads. Block diagram of the Low Voltage Power Supply is shown below.

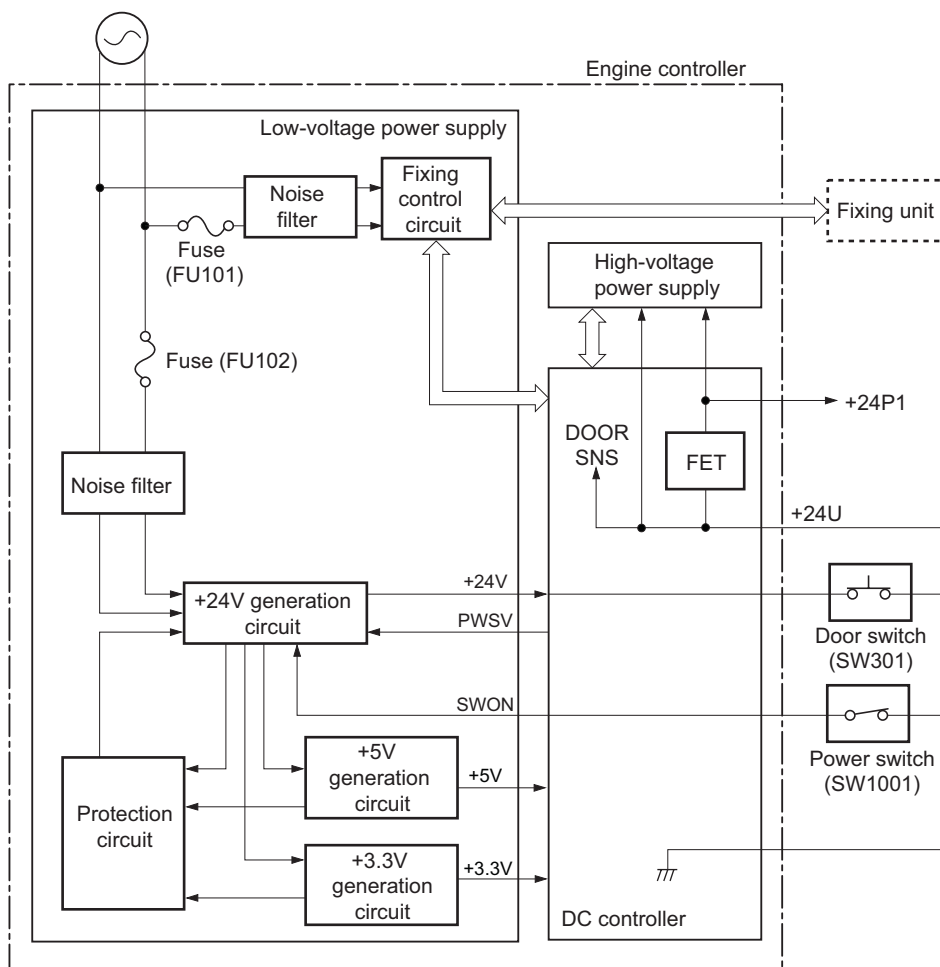

### ■ Protective function

The low-voltage power supply has a protective function against overcurrent and overvoltage to prevent failures in the power supply circuit. If there flows an overcurrent or an overvoltage, the system automatically cuts off the output voltage. If the DC power is not being supplied from the low-voltage power supply, the protective function may be running. In such case, turn off the power switch and unplug the power cord. Do not plug in the power cord or turn the power switch on again until the root cause is found.

In addition, two fuses in the low-voltage power supply protect against overcurrent. If overcurrent flows into the AC line, the fuse blows and cuts off the power distribution.

## ■ Safety

For user and service technician's safety, the printer has a function to interrupt 24V power supply to the fixing unit and the high-voltage power supply unit.

The door switch is turned off and 24V stops under the following condition:

- If the cartridge door is opened (SW301 is turned off)

The printer has the power switch on the DC line so the AC power flows even the power switch is turned off. Be sure to unplug the power cord before disassembling the printer.

## ■ Low-voltage power supply unit failure detection

The DC controller determines a low-voltage power supply unit failure, stops +24V1 output and notifies E808 to the Main controller when it encounters the following condition:

- +24V is higher than a specified voltage

## Energy Saving Function

This machine is equipped with energy saving function.

The following shows energy saving status and condition of transition.

Condition	Description	Condition of Transition
Panel off	Turn OFF the panel.	Press [Power key].
Deep sleep	Turn OFF the panel, engine and controller. (Only the power lamp lights up.)	Transition time to sleep mode has elapsed. (Default setting: 5 minutes) * When USB is connected, the machine does not enter deep sleep.

## ■ Conditions for Not Entering Deep Sleep

Situations in which the machine does not enter sleep mode
<ul style="list-style-type: none"> <li>• When the machine is in operation</li> <li>• When the [Processing/Data] indicator is lit up or blinking</li> <li>• When the machine is performing an operation such as adjustment or cleaning</li> <li>• When a paper jam occurs</li> <li>• When the menu screen is displayed</li> <li>• When an error message is displayed on the screen (There are some exceptions. The machine sometimes enters sleep mode when error messages are displayed.)</li> <li>• When the SSID/network key screen for Direct Connection is displayed.</li> <li>• When settings data is being imported/exported</li> </ul>



# Embedded RDS

## Product Overview

### Overview

Embedded RDS (hereinafter referred to as E-RDS) is a monitoring program that runs on the host machine. When the monitoring option is enabled by making the setting on this machine, information such as the status change of the machine, counter information, and failure information are collected. The collected device information is sent to a remote maintenance server called UGW (Universal Gateway Server) via Internet, thus allowing for e-Maintenance/ imageWARE Remote (Remote Diagnosis System).

The following device information/ status can be monitored.

- Billing counts
- Parts counter
- Firmware info
- Service call error log
- Jam log
- Alarm log
- Status changes (Toner low/ out, etc.)

Since high confidentiality is required for the information shown above, it performs communication between this machine and the UGW using HTTPS/ SOAP protocol.

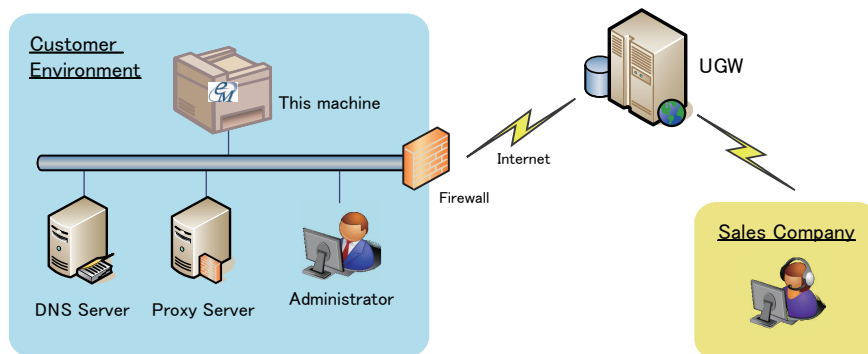

The e-Maintenance/ imageWARE Remote system configuration

### Features and benefits

E-RDS embedded with a network module in advance can realize a front-end processing of e-Maintenance/ imageWARE Remote system without attaching any extra hardware equipment.

## Service cautions

1. After clearing the Main Controller PCB, initialization of the E-RDS setting (ERDS-DAT) and a communication test (COM-TEST) need to be performed. Failure to do so will result that the counter transmitting value to the UGW may become unusual. Also, after replacing the main controller board, all settings must be reprogrammed.
2. The following settings in service mode must not be change unless there are specific instructions to do so. Changing these values will cause error in communication with UGW.
  - Set port number of UGW  
[COPIER] > [FUCTION] > [INSTALL] > [RGW-PORT]  
Default : 443
3. If the e-Maintenance/ imageWARE Remote contract of the device is invalid, be sure to turn OFF the E-RDS setting (E-RDS : 0).

## E-RDS Setup

### ■ Confirmation and preparation in advance

To monitor this machine with e-Maintenance/ imageWARE Remote, the following settings are required.

#### ● Advance preparations

The following network-related information needs to be obtained from the user's system administrator in advance.

##### Information item 1

IP address settings

- Automatic setting : DHCP
- Manual setting : IP address, subnet mask and gateway address to be set

##### Information item 2

Is there a DNS server in use?

If there is a DNS server in use, find out the following.

- Primary DNS server address
- Secondary DNS server address

##### Information item 3

Is there a proxy server?

If there is a proxy server in use, find out the following.

- Proxy server address
- Port No. for proxy server

##### Information item 4

Is proxy server authentication required?

If proxy server authentication is required, find out the following.

- User name and password required for proxy authentication

#### ● Network settings

Based on the results of the information obtained in "Advance preparations", make this machine network related settings. See Users' Guide for detailed procedures.

#### CAUTION:

When changes are made to the above-mentioned network settings, be sure to turn OFF and then ON the main power of this machine.

### ■ Steps to E-RDS settings

1. Start [SERVICE MODE].
2. Select [COPIER] > [FUNCTION] > [CLEAR] > [ERDS-DAT] and touch the [Yes].

#### NOTE:

This operation initializes the E-RDS settings to factory setting values. For the setting values to be initialized, see the section of "Initialization procedure" on page 36.

3. Select [COPIER] > [FUNCTION] > [INSTALL] > [ERDS].

4. Press the numeric key [1] on the control panel (the setting value is changed to 1) and touch the [Apply].

**CAUTION:**

The following settings i.e. RGW-PORT in Service mode must not be change unless there are specific instructions to do so. Changing these values will cause error in communication with UGW.

**NOTE:**

This initiates the communication test between the device and the UGW.

5. Select [COM-TEST] and then touch [Yes].

The communication test with UGW will be executed.

6. Select [COM-RSLT] .

If the communication is successful, "OK" is displayed. If "NG" (failed) appears, refer to the ""Troubleshooting"" on page 39 and repeat until "OK" is displayed.

**NOTE:**

The communication results with UGW can be distinguished by referring to the COM-LOG. By performing the communication test with UGW, E-RDS acquires schedule information and starts monitoring and meter reads operation.

## ■ Initializing E-RDS settings

It is possible to clear the FLASH data of E-RDS and change the E-RDS setting back to the default value.

### ● Initialization procedure

1. Start [SERVICE MODE].
2. Select [COPIER] > [FUNCTION] > [CLEAR] > [ERDS-DAT] and touch the [Yes].

### ● Setting values and data to be initialized

The following E-RDS settings, internal data, and Alarm filtering information are initialized.

- [COPIER] > [FUNCTION] > [INSTALL] > [ERDS]
- [COPIER] > [FUNCTION] > [INSTALL] > [RGW-PORT]
- [COPIER] > [FUNCTION] > [INSTALL] > [COM-LOG]

## ■ COM-LOG Report

A report of communication error log information on five affairs can be output.

### ● Report output procedure

1. Start [SERVICE MODE] .

**2. Select [COPIER] > [FUNCTION] > [MISC-P] > [ERDS-LOG] and touch the [Yes].**

Output sample

```

12/03 2015 10:14AM
*****
*** E-RDS-COM-LOG ***
*****

No.01  DATE 12/03 2015  TIME 03:21 AM  CODE 05000003
      Information  SUSPEND: Communication test is not performed.

No.02  DATE 12/03 2015  TIME 03:21 AM  CODE 00000000
      Information  SUSPEND: mode changed.

No.03  DATE 12/03 2015  TIME 03:18 AM  CODE 05000003
      Information  SUSPEND: Communication test is not performed.

No.04  DATE 12/03 2015  TIME 03:18 AM  CODE 00000000
      Information  SUSPEND: mode changed.

No.05  DATE 12/03 2015  TIME 01:56 AM  CODE 05000003
      Information  SUSPEND: Communication test is not performed.

```

 **FAQ**
**Q: In what case does a communication test with UGW fail?****Ans.**

The following cases can be considered in the becoming "NG" case.

- Name resolution was failed due to an incorrect host name or DNS server has been halted.
- Network cable is blocked off.
- Proxy server settings is not correct.

**Q: When does E-RDS send counter information to UGW? How many data is sent?****Ans.**

The schedule of data transmitting, the start time are determined by settings in the UGW side. The send time cannot be specified on the E-RDS side. Data is sent once every 16 hours.

The data size of counter information is approx. 285 KB.

**Q: Will data which failed to be sent due to an error in communication with UGW be resent?****Ans.**

Data shown below will be resent.

- Jam log
- Service call log
- Alarm log
- Browser information

It is resent only when the web browser option is enabled.

Data is resent endlessly (after 5, 10, 15, 20, 25, and 30 minutes since the occurrence of communication error; once 30 minutes have passed, it is resent at 30-minute intervals) until it is sent successfully. Resend continues even if the power is turned OFF and then ON.

**Q: What is the upper limit of the number of COM-LOGs? What is the upper limit of the number of characters of error information displayed in a COM-LOG?****Ans.**

Up to 5 log data can be saved.

**Q: Although Microsoft ISA as a proxy server is introduced, the authentication check is failed. Can E-RDS adopt with Microsoft ISA?**

**Ans.**

E-RDS must comply with "Basic" while "Integrated" authentication is used for Microsoft ISA (as default); therefore, authentication with E-RDS is available if you change the setting to "Basic" authentication on the server.

**Q: Can I turn this machine power off during the e-Maintenance/ imageWARE Remote system operation?**

**Ans.**

While operating the e-Maintenance/ imageWARE Remote system, the power of the device must be ON. If power OFF is needed, do not leave the device power OFF for long time.

It will become "Device is busy, try later" errors if the power supply of network equipment such as HUB is made prolonged OFF.

**Q: Although a Service call error may not be notified to UGW, the reason is what?**

**Ans.**

If a service technician in charge turns off the power supply of this machine immediately after error occurred once, It may be unable to notify to UGW because data processing does not take a time from the controller of this machine to NIC though, the data will be saved on the RAM.

If the power supply is blocked off while starting up, the data will be inevitably deleted.

**Q: How does E-RDS operate while this machine is placed in the sleep mode?**

**Ans.**

While being in Real Deep Sleep, and if data to be sent is in E-RDS, the system wakes up asleep, then starts to send the data to the UGW. The system also waits for completion of data transmission and let the device to shift to asleep status again. However, transition time to the Real Deep Sleep depends on the device, and the transition to sleep won't be done if the next data transmission will be done within 10 minutes.

**Q: Is E-RDS compatible with Department counter?**

**Ans.**

No, E-RDS does not support Department counter.

**Q: Counter information could not be sent at the scheduled send time due to the power of this machine being turned OFF. Will the counter information be sent later when the power of this machine is turned ON?**

**Ans.**

Yes. When a scheduled send such as that for counter could not be executed due to the power of this machine being turned OFF, etc., and the scheduled send time has already passed at power-on, the send is executed immediately.

The following shows data send according to the status of this machine.

Send types	Status of this machine		
	Power ON	Power OFF	Sleep
Scheduled send	Sent	Not sent *1	Sent *2
Immediate send (Service call log / Alarm log / Jam log)	Sent	-	Sent *2

\*1: Immediately sent if the send time has already passed at power-on.

\*2: Sent after recovery from sleep mode.

**Q: What is the number of the network port used by E-RDS?**

**Ans.**

The port number used by E-RDS for communication with UGW is "443".

If this setting is changed, an error occurs during communication with UGW. Therefore this setting should not be changed unless otherwise instructed.

**Q: After the setting for E-RDS was made, the IP address of the host machine was changed. In that case, is it necessary to execute COM-TEST again?**

**Ans.**

It is not necessary to execute COM-TEST again because the IP address used by E-RDS is automatically changed. However, it is necessary to turn OFF and then ON the main power of this machine to reflect the change in the setting of the IP address.

## Troubleshooting

**Symptom: A communication test (COM-TEST) results NG.**

**Cause:**

Initial settings or network conditions is incomplete.

**Remedy 1:**

Check and take actions mentioned below.

1. Check network connections  
Is the status indicator LED for the HUB port to which this machine is connected ON?  
YES: Proceed to Step 2.  
NO: Check that the network cable is properly connected.
2. Confirm loop back address (\* In case of IPv4 )  
Select [Settings/Registration] > [Preferences] > [Network] > [TCP/IP Settings] > [IPv4 Settings] > [PING Command], enter "127.0.0.1", and touch the [Start] button.  
Does the screen display "Response from the host."?  
YES: Proceed to Step 3.  
NO: There is a possibility that this machine's network settings are wrong. Check the details of the IPv4 settings once more.
3. Confirmation from another PC connected to same network.  
Request the user to ping this machine from a PC connected to same network. Does this machine respond?  
YES: Proceed to Step 4.  
NO: Confirm the details of this machine's IP address and subnet mask settings.
4. Confirm DNS connection  
(a) Select [Settings/Registration] > [Preferences] > [Network] > [TCP/IP Settings] > [DNS Settings] > [DNS Server Address Settings], write down the primary and secondary addresses of the DNS server, and touch the [Cancel] button.  
(b) Touch the [Up] button.  
(c) [Select IPv4 Settings] > [PING Command], enter the primary DNS server noted down in step (a) as the IP address, and touch the [Start] button.  
Does the screen display "Response from the host."?  
YES: Proceed to Remedy 2.  
NO: Proceed to step (d).  
(d) Enter the secondary DNS server noted down in step (a) as the IP address, and then touch the [Start] button.  
Does the screen display "Response from the host."?  
YES: Proceed to Remedy 2.  
NO: There is a possibility that the DNS server address is wrong. Reconfirm the address with the user's system administrator.

**Remedy 2:**

Troubleshooting using communication error log (COM-LOG)

1. Start [SERVICE MODE].
2. Select [COPIER] > [FUNCTION] > [MISC-P] > [ERDS-LOG], and press [Yes] to execute report output of the communication error log information.
3. When a message is displayed, take an appropriate action referring to ["Error code and strings" on page 40](#).

**Symptom: A communication test results NG even if network setting is set properly.**

**Cause:**

The network environment is inappropriate, or RGW-ADR or RGW-PORT settings for E-RDS have been changed.

**Remedy:**

The following points should be checked.

1. Check network conditions such as proxy server settings and so on.

2. Check the E-RDS setting values.
  - Check the communication error log from COM-LOG.
  - Check whether RGW-ADR or RGW-PORT settings has changed. If RGW-ADR or RGW-PORT settings has changed, restore initial values. For initial values, see ["Service cautions" on page 34](#).

**Symptom: Registration information of the E-RDS machine was deleted from the device information on Web Portal, and then registered again. After that, if a communication test is left unperformed, the device setting in the UGW becomes invalid.**

**Cause:**

When the registration information of the E-RDS machine is deleted, information related to E-RDS is also deleted. Therefore, when 7 days have passed without performing a communication test after registering the E-RDS machine again, the device setting becomes invalid.

**Remedy:**

Perform a communication test before the device setting becomes invalid.

**Symptom: There was a log, indicating "Network is not ready, try later" in error details of COM-LOG list.**

**Cause:**

A certain problem occurred in networking.

**Remedy:**

Check and take actions mentioned below.

1. Check networking conditions and connections.
2. Turn on the power supply of this machine and perform a communication test about 60 seconds later.

**Symptom: "Unknown error" is displayed though a communication test (COM-TEST) has done successfully.**

**Cause:**

It could be a problem at the UGW side or the network load is temporarily faulty.

**Remedy:**

Try again after a period of time. If the same error persists, check the UGW status with a network and UGW administrator.

**Symptom: When a communication test (COM-TEST) is repeatedly executed, an error occurs.**

**Cause:**

During communication conducted after execution of a COM-TEST, another COM-TEST was executed again.

**Remedy:**

When repeatedly executing COM-TEST, execute COM-TEST at intervals of 5 minutes or more.

## Error code and strings

The following error information is displayed on the communication error log details screen.

(Here, "server" means UGW.)

- The error information are displayed in the following form.  
[\*] [Character strings] [Functional classification (Method name)] [Error details provided by UGW]

**NOTE:**

"\*" is added to the top of the error text in the case of an error in communication test (method name: getConfiguration or communicationTest) only.

No.	Code	Character strings	Cause	Remedy
1	0000 0000	SUSPEND: mode changed.	Unmatched Operation Mode	Initialize the E-RDS setting (ERDS-DAT).
2	0500 0003	SUSPEND: Communication test is not performed.	Turning OFF and then ON the main power of this machine while the communication test had not been performed although E-RDS is enabled.	Perform a communication test (COM-TEST).

No.	Code	Character strings	Cause	Remedy
3	0xxx 0003	Server schedule is not exist	Blank schedule data have been received from UGW.	Perform and complete a communication test (COM-TEST).
4	0xxx 0003	Communication test is not performed	Communication test has not completed.	Perform and complete a communication test (COM-TEST).
5	84xx 0003	E-RDS switch is setted OFF	A communication test has been attempted with the E-RDS switch being OFF.	Set E-RDS switch (E-RDS) to 1, and then perform a communication test (COM-TEST).
6	8600 0002 8600 0003 8600 0101 8600 0201 8600 0305 8600 0306 8600 0401 8600 0403 8600 0414 8600 0415	Event Registration is Failed	Processing (event processing) within the device has failed.	Turn the device OFF/ ON. If the error persists, replace the device system software. (Upgrade)
7	8700 0306	SRAM version unmatched!	Improper value is written in at the head of the NVMEM domain (nonvolatile memory domain) of E-RDS.	Turn the device OFF/ ON.
8	8700 0306	SRAM AeRDS version unmatched!	Improper value is written in at the head of the NVMEM domain (nonvolatile memory domain) of Ae-RDS.	Turn the device OFF/ ON.
9	8xxx 0004	Operation is not supported	Method which E-RDS is not supporting attempted.	Contact help desk.
10	8xxx 0101	Server response error (NULL)	Communication with UGW has been successful, but an error of some sort has prevented UGW from responding. When (Null) is displayed at the end of the message, this indicates that there has been an error in the HTTPS communication method.	Perform and complete a communication test (COM-TEST).
11	8xxx 0201 8xxx 0202 8xxx 0203 8xxx 0204 8xxx 0206	Server schedule is invalid	During the communication test, there has been some kind of error in the schedule values passed from UGW.	When the error occurs, report the details to the support section. After the UGW side has responded, try the communication test again.
12	8xxx 0207 8xxx 0208	Internal Schedule is broken	The schedule data in the inside of E-RDS is not right.	Perform a communication test (COM-TEST).
13	8xxx 0221	Server specified list is too big	Alarm/Alert filtering error: The number of elements of the list specified by the server is over restriction value.	Alert filtering is not supported by UGW.
14	8xxx 0222	Server specified list is wrong	Alarm filtering error: Unjust value is included in the element of the list specified by the server.	Alert filtering is not supported by UGW.
15	8xxx 0304	Device is busy, try later	The semaphore consumption error at the time of a communication test.	Try again a communication test after a period of time.
16	8xxx 0709	Tracking ID is notmatch	When upgrading firmware, the TrackingID notified by Updater differs from the thing of UGW designates.	Obtain the sublog, and contact the support department of the sales company.
17	8xxx 2000	Unknown error	Some other kind of communication error has occurred.	Perform and complete a communication test (COM-TEST).
18	8xxx 2001	URL Scheme error(not https)	The header of the URL of the registered UGW is not in https format.	Check that the value of URL of UGW (RGW-ADR) is https://a01.ugwdevice.net/ugw/agentif010.



No.	Code	Character strings	Cause	Remedy
19	8xxx 2002	URL server specified is illegal	A URL different to that specified by the UGW has been set.	Check that the value of URL of UGW (RGW-ADR) is https://a01.ugwdevice.net/ugw/agentif010.
20	8xxx 2003	Network is not ready, try later	Communication attempted without confirming network connection, just after turning OFF and then ON the main power of this machine in which the network preparations are not ready.	Check the network connection, as per the initial procedures described in the troubleshooting. Perform a communication test (COM-TEST) about 60 seconds later, after turn on the device.
21	8xxx 2004	Server response error ([Hexadecimal]) [Error detailed in UGW]*1	Communication with UGW has been successful, but an error of some sort has prevented UGW from responding.	Try again after a period of time. Check detailed error code (Hexadecimal) and [Error details in UGW] from UGW displayed after the message.
22	8xxx 200A	Server connection error	<ul style="list-style-type: none"> <li>TCP/IP communication fault</li> <li>The IP address of device is not set.</li> </ul>	<ul style="list-style-type: none"> <li>Check the network connection, as per the initial procedures described in the troubleshooting.</li> <li>When proxy is used, make the settings for proxy, and check the status of the proxy server.</li> </ul>
23	8xxx 200B	Server address resolution error	Server address name resolution has failed.	<ul style="list-style-type: none"> <li>Check that the value of URL of UGW (RGW-ADR) is https://a01.ugwdevice.net/ugw/agentif010.</li> <li>Check that Internet connection is available in the environment.</li> </ul>
24	8xxx 2014	Proxy connection error	Could not connect to proxy server due to improper address.	Check proxy server address / port and re-enter as needed.
25	8xxx 2015	Proxy address resolution error	Could not connect to proxy server due to name resolution error of proxy address.	<ul style="list-style-type: none"> <li>Check that the proxy server name is correct. If the proxy server name is correct, check the DNS connection, as per the initial procedures described in the troubleshooting.</li> <li>Specify the IP address as the proxy server name.</li> </ul>
26	8xxx 201E	Proxy authentication error	Proxy authentication is failed.	Check the user name and password required in order to login to the proxy, and re-enter as needed.
27	8xxx 2028	Server certificate error	<ul style="list-style-type: none"> <li>No route certificate installed in device.</li> <li>Certificate other than that initially registered in the user's operating environment is being used, but has not been registered with the device.</li> <li>The date and time of the device is not correct.</li> </ul>	<ul style="list-style-type: none"> <li>Install the latest device system software. (Upgrade)</li> <li>Correctly set the date and time of the device.</li> <li>Execute CLEAR &gt; CA-KEY, and turn OFF and then ON the device. (The CA certificate at the time of shipment is automatically installed.)</li> </ul>
28	8xxx 2029	Server certificate verify error	The server certificate verification error occurred.	Check that the value of URL of UGW (RGW-ADR) is https://a01.ugwdevice.net/ugw/agentif010.
29	8xxx 2046	Server certificate expired	<ul style="list-style-type: none"> <li>The route certificate registered with the device has expired.</li> <li>Certificate other than that initially registered in the user's operating environment is being used, but has not been registered with the device.</li> <li>The device time and date is outside of the certificated period.</li> </ul>	Check that the device time and date are correctly set. If the device time and date are correct, upgrade to the latest system software.

No.	Code	Character strings	Cause	Remedy
30	8xxx 2047	Server response time out	Due to network congestion, etc., the response from UGW does not come within the specified time. (HTTPS level time out)	If this error occurs when the communication test is being run or Service Browser is being set, try again after a period of time.
31	8xxx 2048	Service not found	There is a mistake in the UGW URL, and UGW cannot be accessed. (Path is wrong)	Check that the value of URL of UGW (RGW-ADR) is https://a01.ugwdevice.net/ugw/agentif010.
32	8xxx 2052	URL error	The data which is not URL is inputted into URL field.	Check that the value of URL of UGW (RGW-ADR) is https://a01.ugwdevice.net/ugw/agentif010.
33	8xxx 2058	Unknown error	SOAP Client fails to obtain SOAP Response. Possibility of a problem in UGW or of a temporary problem in the network load.	Perform and complete a communication test (COM-TEST).
34	8xxx 2063	SOAP Fault	SOAP communication error has occurred.	Check that the value of port number of UGW (RGW-PORT) is 443.
35	xxxx xxxx	Device internal error	An internal error, such as memory unavailable, etc., has occurred during a device internal error phase.	Turn the device OFF/ ON. Or replace the device system software. (Upgrade)
36	xxxx xxxx	SUSPEND: Initialize Failure!	Internal error occurred at the initiating E-RDS.	Turn the device OFF/ ON.

\*1: [Hexadecimal]: indicates an error code returned from UGW.

[Error details in UGW]: indicates error details returned from UGW.

# Setting Information Export/Import Function (DCM)

## Function Overview

This function (DCM: Device Configuration Management) is used to export/import setting value information in the host machine as a file (DCM file).

The following setting information is exported/imported.

- Setting information of [Settings/ Registration]
- Setting information of service mode
- Address Book

The DCM file is exported to a USB flash drive or PC local disk from the Control Panel or remote UI.

The exported DCM file can be returned to the original device or imported to a different device.

When the file is returned to the original device, this can be used as a setting backup function, and when the file is imported to a different device, this can be used as a setting information migration function.

Data can also be imported to or exported from an iR-ADV machine by using iW EMC/MC DCM Plug-in.

In the case of the setting value backup function before DCM, an exported file could be imported to the same device, but the DCM function enables import of an exported file to a different device.

Image

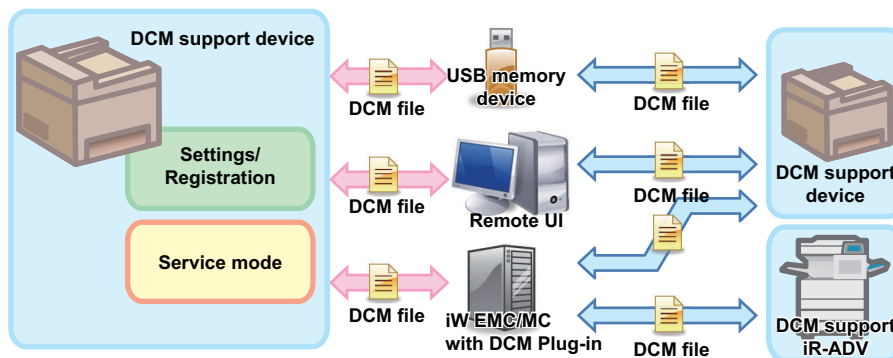

### NOTE:

In order to export or import setting information using DCM, it is necessary that the device supports DCM.

## Purpose for Using the Function

The purpose of using the DCM function is described below using three use cases.

Case	Export/ Import	Use Case
A	Export from and import to the same device	<ul style="list-style-type: none"> <li>• Used as backup in preparation for a device failure</li> <li>• Used as backup before changing settings</li> </ul>
B	Export from and import to a different device of the same model	<ul style="list-style-type: none"> <li>• Collectively migrate data when replacing the host machine</li> <li>• Copy the settings to multiple devices (during kitting)</li> </ul>
C	Export from and import to a different model	<ul style="list-style-type: none"> <li>• Migrate the settings from the old model to the new model when replacing the host machine</li> <li>• Migrate the settings of the base machine to a different model for a large-scale user</li> </ul>

### Export from and Import to the Same Device (Case A)

In this use case, setting information is exported as backup in preparation for a device failure or backup before changing settings. Information of various settings is backed up just in case.

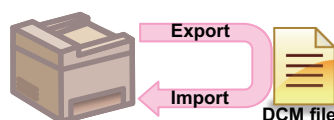

## ● Export from and Import to a Different Device of the Same Model (Case B)

In this use case, the exported setting information is copied to a different device of the same model.

This enables efficient installation in the case of installing multiple devices of the same model at a time (for example, kitting).

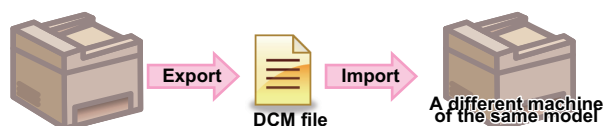

## ● Export from and Import to a Different Model (Case C)

In this use case, the exported setting information is copied to a device of a different model.

Not that all the information that can be exported using DCM can be imported, but this is effective in the case of replacing an old device or copying the settings of the base machine in an environment where various models exist.

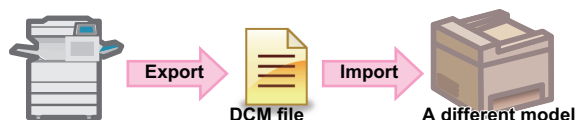

## ■ Combination of Information Exported/Imported by DCM, Means, and Storage Locations

### ● Information Exported/Imported as a DCM File

A DCM file is exported and imported using the Control Panel, remote UI, or the iW EMC server, depending on the situation of the site.

The information exported/imported differs depending on the means.

Combinations of them are shown in the following table.

Menu used	Operation	Information exported		
		Setting values of menu options	Address book <sup>*1</sup>	Service mode setting values
[Settings/Registration] menu	Control panel	Yes (fixed) <sup>*2</sup>	Yes (fixed) <sup>*2</sup>	No
	Remote UI	Yes	Yes	With conditions <sup>*3</sup>
Service mode	Control panel	No	No	Yes
	Remote UI	No	No	Yes
iW EMC/ MC DCM Plug-in	iW EMC/ MC DCM Plug-in	Yes	Yes	With conditions <sup>*4</sup>

\*1: Models without address books are excluded. In the case of a fax option model without SEND function, address books are exported only if a fax option is connected with the device.

\*2: When the [Settings/ Registration] menu is used from the Control Panel, both the setting menu information and the address book are imported/exported. It is not possible to export/import only either of them.

Information which is not included in the data to be imported is not imported.

\*3: Service mode is added to the data to be exported only when service mode level 1 > COPIER > OPTION > USER > SMD-EXPT is set.

For items to be imported, refer to "List of Items Which Can Be Imported".

\*4: It is included only in the data to be imported. If service mode data is not included in the data to be imported, the data is not imported.

### ● DCM File Storage Location

DCM files are saved in the following locations.

Operation	Menu used	Storage destination
Operation Panel	[Settings/ Registration] menu	USB flash drive
	Service mode	
Remote UI	[Settings/ Registration] menu	PC local disk
	Service mode	
DCM Pug-in	DCM Pug-in	Local disk of the iW EMC/MC server

## ■ Compatibility

### ● Compatibility of DCM Files

Compatibility of DCM files differs depending on the export/import method as shown below.

Exported from	Imported to				
	iR series not supporting DCM	iR series supporting DCM		iR-ADV series	
		Remote UI	Via DCM Plug-in	Remote UI/USB	DCM Plug-in
iR series not supporting DCM	Yes	No	With conditions *1	No	No
iR series supporting DCM	No	Yes	Yes	With conditions *2	No
iR-ADV series	No	With conditions *2	No	Yes	Yes

Yes: Compatible

With conditions \*1: Address books can be imported. Other information cannot be imported.

With conditions \*2: A part of address book can be imported using ABM Plug-in. Other information cannot be imported.

Compatibility of the DCM file imported via DCM Plug-in depends on the specification of DCM Plug-in.

No: Incompatible

### ● Compatibility of Data

The following table shows compatibility of data in the case where the device from which the data is exported and the device to which the data is imported differ in model and/or serial number.

For items that are imported in Cases A, B, and C, refer to "List of Items Which Can Be Imported".

Model	Serial number	Import Process
Same	Same	Items corresponding to Case A are imported. *1
Same	Different *3	Items corresponding to Case B are imported. *1
Different	Different *3	Items corresponding to Case C are imported. *2
Different	Same	The file is judged to be invalid, and the process ends with an error.

\*1: If the firmware version at the time of import differs from that at the time of export, predetermined corrective processing may be performed.

\*2: Predetermined corrective processing may be performed.

\*3: If a serial number is missing, the serial numbers are judged to be mismatched.

## ● Specifications

### ■ Specifications Related to DCM Files

#### ● Overall Specifications Related to DCM Files

- The DCM file to be exported is created directly under the root of the USB flash drive.
- The file name is not case sensitive.
- The DCM file exported/imported from the Control Panel or service mode is named as shown below:
  - Control Panel: compact.dcm
  - Service mode: service.dcm
- When the file is exported, if a file of the same name exists in the export destination, the behavior will be as shown below.
  - When the file is exported from the Control Panel: A message asking whether the user wants to overwrite appears.
  - When the file is exported from service mode: The file is always overwritten.

#### ● Import of an Invalid File

- When an invalid file is imported, the process ends with an error.
- When a file which does not contain any data to be imported is imported, the process ends with an error.
- When there is an error in the imported file, the import process ends with an error in some cases.
- When there is an error in the imported data, the data is skipped and the import process continues.
- When the imported file fails to be read in the middle of the reading process or when the format is invalid, the import process is stopped. In that case, the machine is not rebooted. The data is not rolled back to the state it was before import.

## ● Encryption Password

- It is necessary to set a password during the export process because data such as the password of the address book set by the user are encrypted when the DCM file is exported/imported.
- The password must consist of 32 or less ASCII characters. A password exceeding 32 characters cannot be entered.
- If a wrong password is entered at import, the encrypted setting values cannot be decoded, and the import of the setting values end with an error.
- It is necessary to specify a password even when the data to be exported does not contain any data to be encrypted. However, in the case of export from service mode, it is not necessary to enter the password, and the password (28282828) is entered automatically.

## ■ Specifications Related to Department ID Management

- Department ID information is exported only when the Department ID management setting is enabled. Regardless of the state of the department ID management setting, the state of department ID management (enabled/disabled) and the system administrator information are exported. The department ID counter is not exported.
- When importing department ID information, the import process differs depending on the combination of the department ID set in the host machine and the department ID set in the data to be imported.

	"ID_1" has not been set in the host machine.	"ID_1" has been set in the host machine.
"ID_1" has been set in the data to be imported.	Information of "ID_1" is imported. The department ID counter is "0".	Information excluding the department ID counter information of "ID_1" in the host machine is imported.
"ID_1" has not been set in the data to be imported.	Not overwritten	Information of "ID_1" is deleted.
Department ID information has not been set in the data to be imported.	Not overwritten	Not overwritten

\* ID\_1 indicates a department ID.

## ■ Specifications during Execution of a Process

## ● Limitations

### ■ Job Control

Do not execute the following processes during import or export.

- Reception of a new job (Execution of calibration requested by the engine is allowed.)
- Firmware update (during which faxes cannot be received due to busy line.)

If any of the following conditions is met, import/export is not executed.

- A job exists. (If calibration is requested by the engine, import/export is executed, ignoring the calibration job.)
- A firmware update is being performed.
- Another import or export is being executed.

#### CAUTION:

During import, print/fax jobs from the PC are not received and are stuck in the spooler on the PC. Those jobs stuck in the spooler may not be printed properly after reboot of the host machine. In that case, those jobs have not been received and are not even recorded in history.

## ■ Control Characters

If the character string to be exported (e.g. a destination name in the address book) includes an ASCII control character (0x01-0x08, 0xb, 0xc, 0xe-0x19, or 0x7f), the character string excluding the control character is exported.

## ■ Corrective Processing

When data is imported, corrective processing of setting values (changing a process to another process that can be performed) may be performed. Corrective processing is performed to process data so that it can be used by the import destination device.

Even when a setting value has been changed by corrective processing, the import process is treated as successful. Examples are shown below. Please note that the following cases are just examples, and how each item is processed by corrective processing varies depending on the initial settings and the service mode settings.

- When the length of the character string exceeds the limit  
If a character string exceeding the length permitted by the import destination device is registered as, for example, a device name, only the length of the character string that can be registered on the import destination device is registered. The excess characters of the character string are deleted.
- When an out-of-range value is imported  
Since the value is not comprehensible to the import destination device, the out-of-range value is not imported. In that case, the default value is not set but the originally registered value remains effective.
- When a necessary license or software option does not exist  
In that case, the specification differs depending on the setting value.  
Depending on the type of the license or software option, import is executed without the license or software option in some cases. Therefore the following behaviors may occur.

### Assumption

There is "Setting 1" (default value: 0) which is required only when "License 1" has been activated.

Device A: "License 1" activated, "Setting 1" set to "1"

Device B: "License 1" not activated, "Setting 1" set to "0"

Device C: "License 1" activated, "Setting 1" set to "2"

### Operation

Export the settings of Device A and import them to Device B.

Export the settings of Device B and import them to Device C.

### Result

"Setting 1" of Device C is set to "1".

The foregoing behavior may occur because the setting value related to the license is not always the default value in Device B where the license has not been activated.

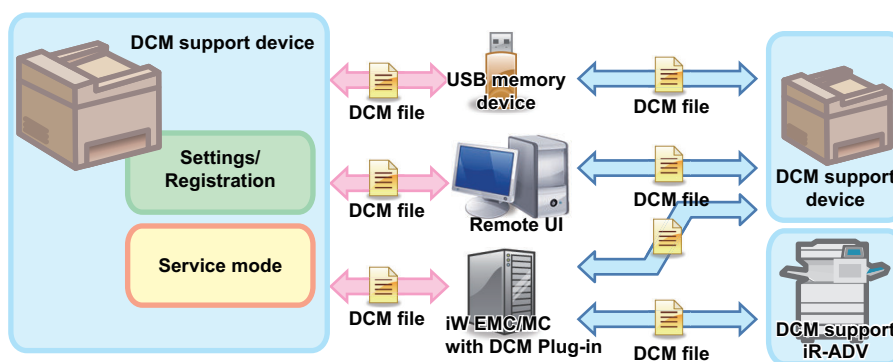

Image of DCM file import

- When a necessary hardware option does not exist  
The corrective processing performed is the same as that performed when an option has been changed during power discontinuity.

### Example

Corrective processing performed when "Paper Source = Optional Deck" has been set as a favorite setting. Examples are shown below:

- When this connection is released due to a failure of the optional deck, etc.
- When a setting file exported from a device with an optional deck is imported to a device without an optional deck. Please note that this rule does not always apply to all the setting values.

Please note that this rule does not always apply to all the setting values.

## ■ Power Supply Control

When power discontinuity occurs during export or import, the following behavior occurs.

- The import process that had been performed before the power discontinuity remains reflected, and the data is not rolled back.
- When power discontinuity occurs during an export process, export is not executed. Moreover, since the import/export history is not retained in the host machine, no records remain.

## ■ Sleep Operation during a Process

The device does not enter deep sleep mode during import or export.

Although this is not disclosed to users, sleep mode internally changes according to the usage conditions of the host machine. Sleep mode ranges from energy saver mode where indicators such as LEDs are turned OFF to deep sleep mode where even the CPU stops.

Even if the conditions for entering deep sleep mode are met, the device does not enter deep sleep mode during export or import. If a process is started from remote UI or iW EMC/ MC, the host machine recovers to energy saver mode and performs the process. However, if service mode data is not included in the process, the process is started without waiting for recovery of the engine.

## ● Procedure for Exporting/Importing Service Mode Setting Information

This chapter describes the procedure for exporting/importing the service mode setting information using DCM.

For the procedure for exporting/importing [Settings/Registration] or address book data that can be performed by users, refer to the User's Guide (e-Manual).

### ■ Procedure for Export/Import Using the Control Panel (Service Mode)

By operating from the Control Panel (service mode), it is possible to export/import a file (service.dcm) containing service mode setting information from/to a USB flash drive connected to the host machine.

The following USB flash drives can be used as the export destination.

- USB flash drive in FAT 16 format (storage capacity: 2 GB)
- USB flash drive in FAT 32 format (storage capacity: 32 GB)

### ● Procedure for Export Using Service Mode

1. **Connect a USB memory device to the USB memory port.**

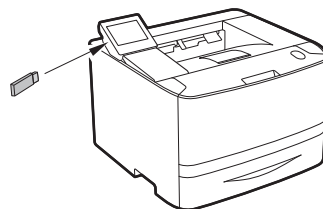

xxxxxx

2. **Enter service mode, and execute the following service mode.**

- COPIER > FUNCTION > SYSTEM > EXPORT

3. **The message shown below which is displayed during the process will disappear. When the display has returned to the original state, remove the USB flash drive.**



The procedure for removing the USB flash drive is shown below.



1. Press the [Reset] (🔧)key.
2. Press the [Status Monitor] (📄)key.
3. Tap "Device Status".
4. Tap "Remove Memory Media".  
Wait until the message "The memory media can be safely removed." is displayed.
5. Remove the USB flash drive.

**CAUTION:**

When exporting setting information using the [Settings/Registration] menu, if a USB flash drive is not connected, a message prompting the user to connect a USB flash drive will appear and the process cannot be executed. On the other hand, when this function is used, export can be executed without connecting a USB flash drive, therefore be sure to connect a USB flash drive before executing export.

4. Check that a setting information file (service.dcm) exists in the directory directly under the root of the USB flash drive.

This completes the procedure for exporting a setting information file.

### ● Procedure for Import Using Service Mode

1. To the directory directly under the root of the USB flash drive, save a setting information file (service.dcm) to be imported.
2. Connect a USB memory device to the USB memory port.

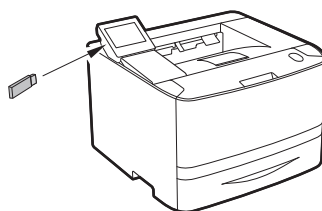

3. Enter service mode, and execute the following service mode.

- COPIER > FUNCTION > SYSTEM > IMPORT

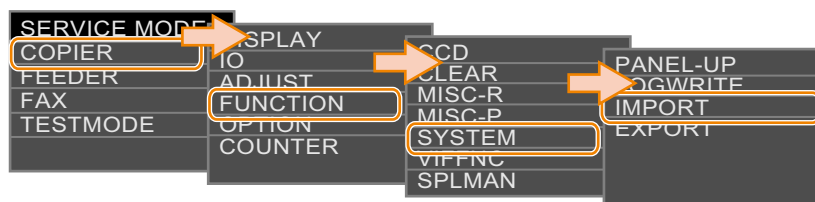

4. The message shown below which is displayed during the process will disappear. When the display has returned to the original state, remove the USB flash drive.

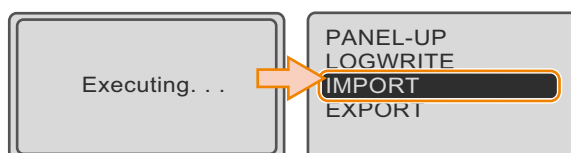

5. Enter service mode, and check that the setting information is reflected.

This completes the procedure for importing a setting information file.

### ■ Procedure for Export/Import Using Remote UI (Service Mode)

By operating from the remote UI, it is possible to export/import a file containing service mode setting information from/to a USB flash drive connected to the host machine or the local disk on the PC.

### ● Procedure for Export Using Service Mode (Remote UI)

With this model, service mode can be used from the Remote UI.

Setting information can be exported by remote control by following the procedure shown below.

Since the information can be output only to a USB flash drive connected to the host machine, this is not strictly remote operation.

The following USB flash drives can be used for export/import.

- USB flash drive in FAT 16 format (storage capacity: 2 GB)
- USB flash drive in FAT 32 format (storage capacity: 32 GB)

1. Connect a USB memory device to the USB memory port.

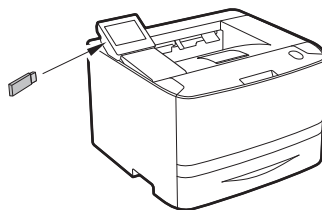

Connect the USB memory of Operation Panel. The USB port on the rear side of the host machine cannot be used.

2. Enter service mode, and execute the following service mode.

Access service mode (Remote UI), select COPIER > FUNCTION > SYSTEM > EXPORT, and click [EXEC].

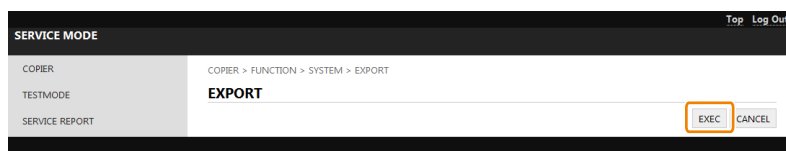

#### CAUTION:

When it is executed without connecting USB flash drive, the error message is not displayed.

Processing doesn't export anywhere of any though it seems to have completed it correctly.

Confirm USB memory device has been connected before it executes it from the above-mentioned reason without fail.

3. The message shown below which is displayed during the process will disappear. When the display has returned to the original state, remove the USB flash drive.

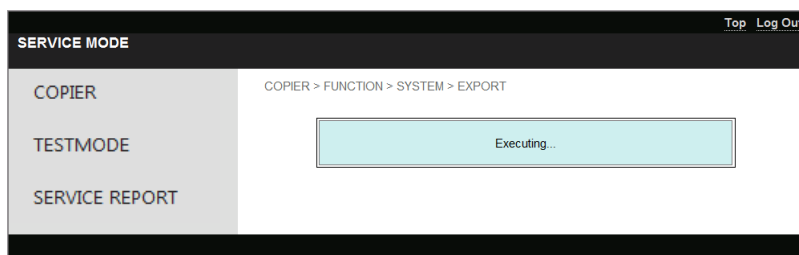

4. Check that a setting information file (service.dcm) exists in the directory directly under the root of the USB flash drive.

This completes the procedure for exporting a setting information file.

## ● Procedure for Import Using Service Mode

1. To the directory directly under the root of the USB flash drive, save a setting information file (service.dcm) to be imported.
2. Connect a USB memory device to the USB memory port.

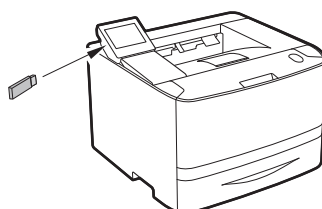

### 3. Enter service mode, and execute the following service mode.

- COPIER > FUNCTION > SYSTEM > IMPORT

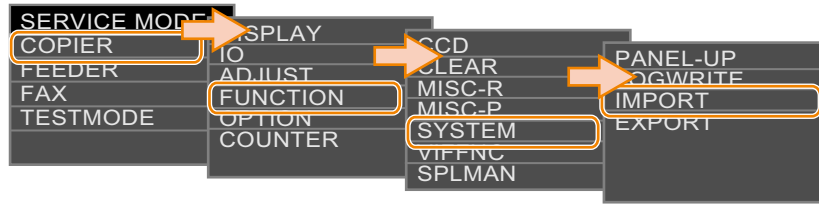

### 4. The message shown below which is displayed during the process will disappear. When the display has returned to the original state, remove the USB flash drive.



### 5. Enter service mode, and check that the setting information is reflected.

This completes the procedure for importing a setting information file.

## ■ Procedure for Export/Import Using Remote UI ([System Management Settings] Menu)

### ● Procedure for Import Using Remote UI ([System Management Settings] Menu)

Import the service mode setting information file that was exported in the previous procedure.

#### 1. Enter service mode, and set the following item to "1".

- COPIER > OPRION > USER > SMD-EXPT

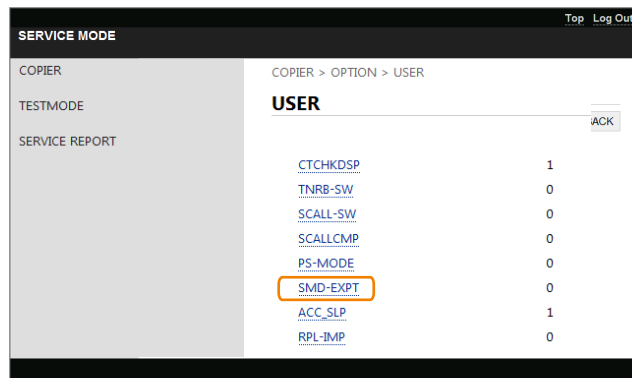

#### NOTE:

The [SMD-EXPT] setting can be specified either from the Control Panel or from the remote UI.

#### 2. Exit service mode, and start the remote UI and log on in System Manager Mode.

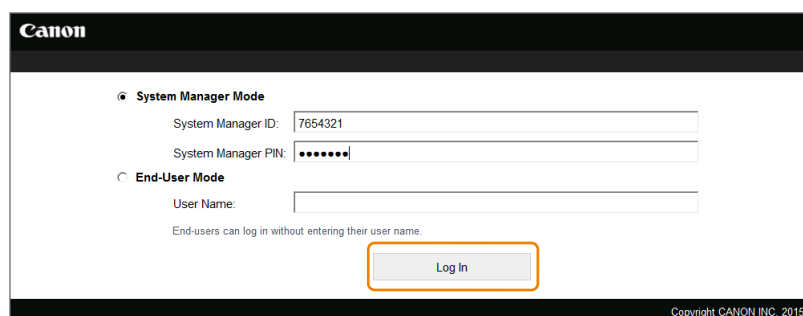

### 3. Click [Settings/Registration].

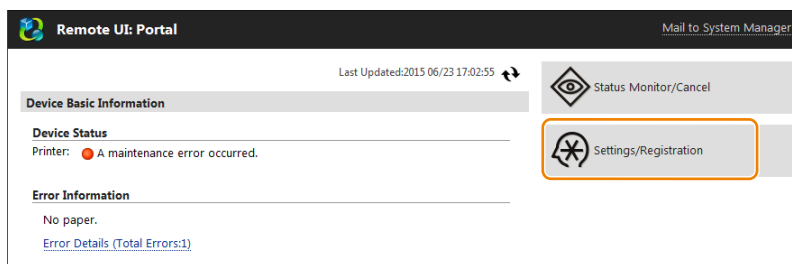

### 4. Click [Import/Export] > [Import].

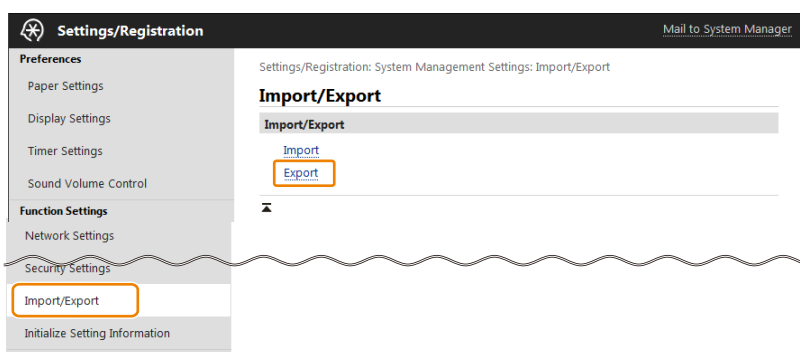

### 5. Specify the settings for Importing, and click [Start Import].

Enter the encryption password and click [Start Import]. The menu options data will be Imported.

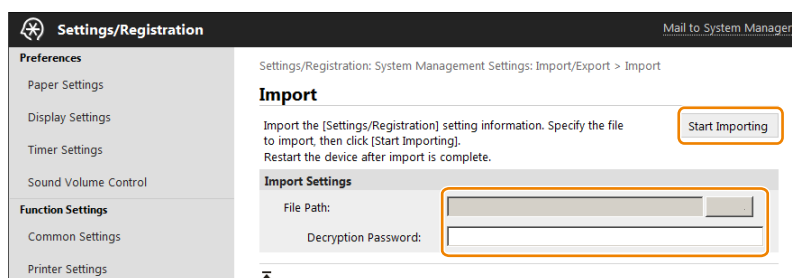

#### [Browse..]button

Click to select the file to import.

#### Decryption Password

Enter up to 32 alphanumeric characters for the password that was set when the file was exported.

#### Address Book

Select the check box to import the Address Book data.

#### Address Book PIN

If the Address Book PIN is set, enter the PIN in the [Address Book PIN:] text box. Setting a PIN for Address Book.

#### Settings/Registration

Select the check box to import the setting data of the menu options.

### 6. A dialog box asking whether the user wants to execute import will appear. Click [OK].

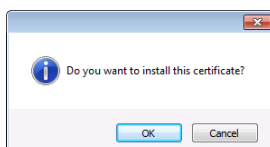

### 7. A message will appear to indicate that the process has been completed. Click the [OK] button.

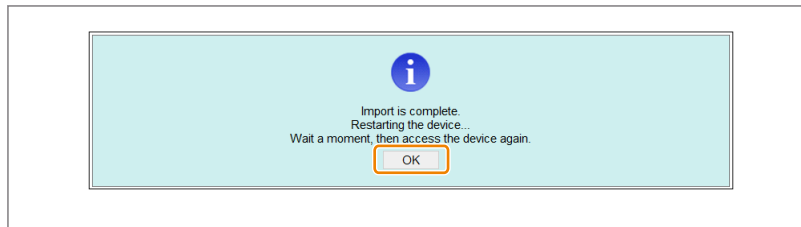

8. Restart the host machine, enter service mode, and then check that the setting information is reflected.
9. Enter service mode, and set the following item to "0".
  - COPIER > OPRION > USER > SMD-EXPT

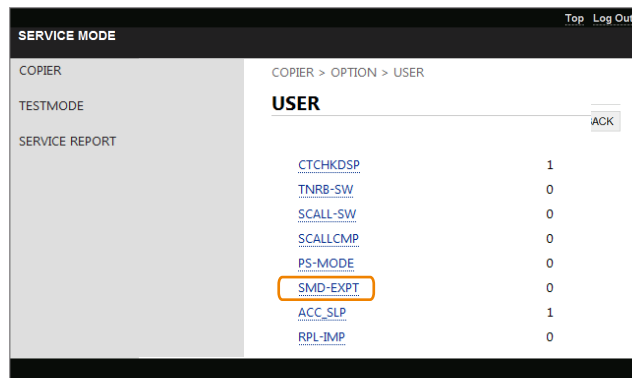
**NOTE:**

The [SMD-EXPT] setting can be specified either from the Control Panel or from the remote UI.

### • Procedure for Export Using Remote UI ([System Management Settings] Menu)

Service mode setting information can be exported from the [System Management Settings] menu by setting the following service mode setting value to "1".

1. Enter service mode, and set the following item to "1".
  - COPIER > OPRION > USER > SMD-EXPT

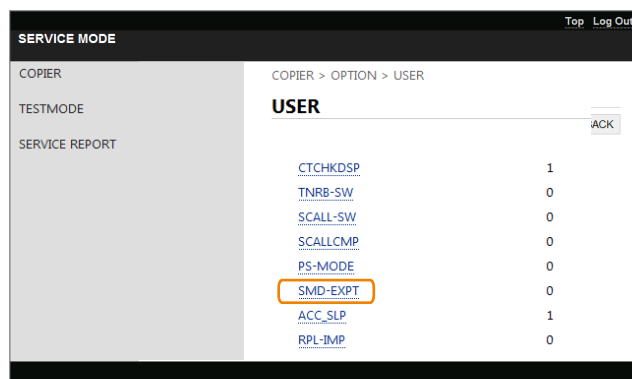
**NOTE:**

The [SMD-EXPT] setting can be specified either from the Control Panel or from the remote UI.

2. Exit service mode, and start the remote UI and log on in System Manager Mode.

### 3. Click [Settings/ Registration].

### 4. Click [Import/Export] > [Export].

### 5. Specify the settings for exporting, and click [Start Exporting].

Enter the encryption password and click [Start Exporting]. The menu options data will be exported.

#### Address Book

Select the check box to export the Address Book data.

#### Settings/ Registration

Select the check box to export the setting data of the menu options.

#### Service Mode

Selected and grayed out. If this item does not exist, perform step 1 again

#### Encryption Password

Enter up to 32 alphanumeric characters for the encryption password. For confirmation, enter the same password in the [Confirm:] text box. This password will be required when you import the data to the machine.

### 6. Follow the on-screen instructions to specify the location where the exported data is saved.

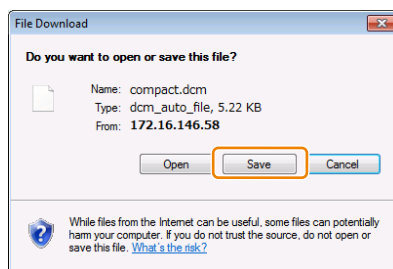

## 7. Enter service mode, and set the following item to "0".

- COPIER > OPRION > USER > SMD-EXPT

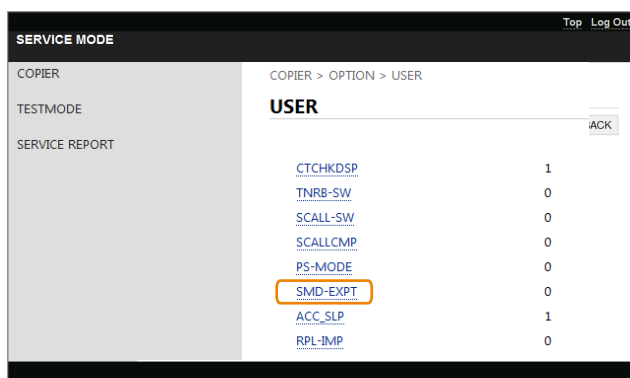

### NOTE:

The [SMD-EXPT] setting can be specified either from the Control Panel or from the remote UI.

## List of Items Which Can Be Imported

The following shows the items to be imported for this model.

Note that the setting values are not imported in cases such as below:

- Items which are originally not included in a DCM file (e.g.: "Settings/Registration Basic Information" of a DCM file exported using service mode)
- Not included in the import coverage (Cases A to C)
- There are no options and functions related to setting values

The import coverage shown in the table below is as shown below. Those that are not described here cannot be imported.

Import coverage	Description
Case A: The same machine	Import to the same machine (for backup and restoration, etc.)
Case B: The same model	Import to a different machine of the same model (the same series)
Case C: Different model	Import to a different machine of a different model (a different series)

## Settings/Registration Basic Information

### System Management Settings

Layer1	Layer2	Layer3	Layer4	Layer5	Case1	Case2	Case3
System Manager Information Settings	System Manager ID				Yes	Yes	Yes
	System Manager PIN				Yes	Yes	Yes
	System Manager Name				Yes	Yes	Yes
Device Information Settings	Device Name				Yes	No	No
	Location				Yes	No	No

Layer1	Layer2	Layer3	Layer4	Layer5	Case1	Case2	Case3	
Department ID Management	Department ID Management				Yes	Yes	Yes	
	Registering/Editing Department ID and PIN				Yes	Yes	Yes	
	Blocking Jobs When Department ID Is Unknown				Yes	Yes	Yes	
Network Settings	TCP/IP Settings	IPv4 Settings	IP Address Settings		Yes	Yes	Yes	
			Auto Acquire	AutoIP	Yes	Yes	Yes	
			IP Address		Yes	No	No	
			Subnet Mask		Yes	Yes	Yes	
			DNS Settings	Primary DNS Server	Yes	Yes	Yes	
				Secondary DNS Server	Yes	Yes	Yes	
				DNS Host Name/Domain Name Settings	Yes	No	No	
				Host Name	Yes	No	No	
				Domain Name	Yes	No	No	
				DNS Dynamic Update Settings	Yes	Yes	Yes	
				DNS Dynamic Update	Yes	Yes	Yes	
				DNS Dynamic Update Interval	Yes	Yes	Yes	
			mDNS Settings		Yes	No	No	
			DHCP Option Settings	Acquire Host Name (option12)	Yes	Yes	Yes	
				DNS Dynamic Update (option81)	Yes	Yes	Yes	
		Acquire DNS Server Address (option6)		Yes	Yes	Yes		
		Acquire Domain Name (option15)		Yes	Yes	Yes		
		Acquire WINS Server Address (option44)		Yes	Yes	Yes		
		IPv6 Settings	Use IPv6			Yes	Yes	Yes
			Stateless Address Settings	Enable or disable stateless addresses		Yes	Yes	Yes
				Prefix Length		Yes	No	No
				DNS Settings	DNS Server Settings	Yes	Yes	Yes
			Primary DNS Server Address		Yes	Yes	Yes	
			Secondary DNS Server Address		Yes	Yes	Yes	
			DNS Host Name Domain Name		Yes	No	No	
			Use IPv4 Host/Domain		Yes	No	No	
			Host Name		Yes	No	No	



Layer1	Layer2	Layer3	Layer4	Layer5	Case1	Case2	Case3	
Network Settings	TCP/IP Settings	IPv6 Settings	DNS Settings	Domain Name	Yes	No	No	
				DNS Dynamic Update Interval	Yes	Yes	Yes	
			mDNS Settings	Use Same mDNS Name as IPv4	Yes	No	No	
				mDNS Name	Yes	No	No	
			DHCP Option Settings	Acquire DNS Server Address (option23)	Yes	Yes	Yes	
		Acquire Domain Name (option24)		Yes	Yes	Yes		
		WINS Settings	WINS Resolution		Yes	Yes	Yes	
			WINS Server Address		Yes	Yes	Yes	
		LPD Settings	LPD Print Settings		Yes	Yes	Yes	
			RX Timeout		Yes	Yes	Yes	
		RAW Settings	RAW Print Settings		Yes	Yes	Yes	
			RX Timeout		Yes	Yes	Yes	
		WSD Settings	WSD Print Settings	Use WSD Print	Yes	Yes	Yes	
				Use WSD Browsing	Yes	Yes	Yes	
			Use Multicast Discovery		Yes	Yes	Yes	
		Use HTTP			Yes	Yes	Yes	
		Port Number Settings	LPD		Yes	Yes	Yes	
			RAW		Yes	Yes	Yes	
			HTTP		Yes	Yes	Yes	
			SNMP		Yes	Yes	Yes	
	WSD Multicast Discovery			Yes	Yes	Yes		
	Multicast Discovery			Yes	Yes	Yes		
	MTU Size			Yes	Yes	Yes		
	IPP Print Settings	Use IPP Printing		Yes	Yes	Yes		
		Use SSLPrinting		Yes	Yes	Yes		
	Google Cloud Print Settings	Enable Google Cloud Print			Yes	Yes	Yes	
	SNMP Settings	SNMPv1 Settings	Enable SNMPv1		Yes	Yes	Yes	
		SNMPv3 Settings	Enable SNMPv3		Yes	Yes	Yes	
		Acquire Printer Management Information from Host			Yes	Yes	Yes	
	Ethernet Driver Settings	Auto Detect			Yes	Yes	Yes	
		Ethernet Type			Yes	Yes	Yes	
	Security Settings	IPv4 Address Filter	Outbound Filter	ON/OFF		Yes	Yes	Yes

Layer1	Layer2	Layer3	Layer4	Layer5	Case1	Case2	Case3
Security Settings	IPv4 Address Filter	Inbound Filter	ON/OFF		Yes	Yes	Yes
	IPv6 Address Filter	Outbound Filter	ON/OFF		Yes	Yes	Yes
		Inbound Filter	ON/OFF		Yes	Yes	Yes
	MAC Address Filter	Outbound Filter	ON/OFF		Yes	Yes	Yes
		Inbound Filter	ON/OFF		Yes	Yes	Yes
Display Job Log	ON/OFF				Yes	Yes	Yes
Use as USB Device	ON/OFF				Yes	Yes	Yes
Enable Product Extended Survey Program	ON/OFF				Yes	Yes	Yes
Google Cloud Print Settings	ON/OFF				Yes	Yes	Yes
Notify to Check Paper Settings	ON/OFF				Yes	Yes	Yes
Secure Print Settings	ON/OFF				Yes	Yes	Yes
	Secure Print Deletion Time				Yes	Yes	Yes
PDL Selection (Plug and Play)	USB				Yes	Yes	No
Enable NFC	Enable NFC				Yes	Yes	Yes

### • Besides system management

Layer1	Layer2	Layer3	Case1	Case2	Case3
Preferences	Volume Settings	Entry Tone	Yes	Yes	Yes
		Invalid Entry Tone	Yes	Yes	Yes
		Restock Supplies Tone	Yes	Yes	Yes
		Job Done Tone	Yes	Yes	Yes
		Energy Saver Alert	Yes	Yes	Yes
	Display Settings	Default Screen after Startup/Restoration	Yes	Yes	Yes
		Language	Yes	Yes	Yes
		Remote UI Language	Yes	Yes	Yes
		Brightness	Yes	Yes	Yes
		Invert Screen Colors	Yes	Yes	Yes
		Millimeter/Inch Entry Switch	Yes	Yes	Yes
		Gram/Pound Switch	Yes	Yes	Yes
		Message Display Time	Yes	Yes	Yes
	English Keyboard Layout	USA Layout, UK Layout	Yes	Yes	Yes
Timer Settings	Date/Time Settings	Date Format	Yes	Yes	Yes
		Time Format	Yes	Yes	Yes
		Time Zone	Yes	Yes	
		Daylight Saving Time Settings	Yes	Yes	Yes
	Auto Reset Time		Yes	Yes	Yes
	Function After Auto Reset		Yes	Yes	Yes
Auto Sleep Time		Yes	Yes	Yes	
Common Settings	Switch Paper Feed Method	Multi-Purpose Tray	Yes	Yes	
		Drawer 1	Yes	Yes	
		Drawer 2	Yes	Yes	

Layer1	Layer2	Layer3	Case1	Case2	Case3
Memory Media Print Settings	Change Default Settings		Yes	Yes	Yes
	File Sort Default Settings		Yes	Yes	Yes
	File Name Display Format		Yes	Yes	Yes
	Default Display Settings		Yes	Yes	Yes
Printer Settings	Printer Settings	Action When Free Paper Size Mismatch	Yes	Yes	Yes
		Copies	Yes	Yes	No
		2-Sided Printing	Yes	Yes	Yes
		Paper Size Override	Yes	Yes	Yes
		Print Quality	Yes	Yes	Yes
		Layout	Yes	Yes	Yes
		Auto Error Skip	Yes	Yes	Yes
		Timeout	Yes	Yes	Yes
		Personality	Yes	Yes	Yes
	UFR II	Halftones	Yes	Yes	Yes
	PDF	Enlarge/Reduce to Fit Paper Size	Yes	Yes	Yes
		Enlarge Print Area	Yes	Yes	Yes
		N on 1	Yes	Yes	Yes
		Print Comments	Yes	Yes	Yes
		Halftones	Yes	Yes	Yes
		Grayscale Conversion	Yes	Yes	Yes
	XPS	Halftones	Yes	Yes	Yes
		Grayscale Conversion	Yes	Yes	Yes
		Compressed Image Output	Yes	Yes	Yes
Adjustment/Maintenance	Printer Density		Yes	Yes	
	Toner Save		Yes	Yes	
	Adjust Print Position	Multi-Purpose Tray	Yes		
		Drawer 1	Yes		
		Drawer 2	Yes		
	Special Processing	Special Printing Mode A	Yes	Yes	
		Special Printing Mode U	Yes	Yes	
		Special Printing Mode V	Yes	Yes	
		Special Printing Mode B	Yes	Yes	
		Special Printing Mode D	Yes	Yes	

### • Service Mode

Layer1	Layer2	Layer3	Layer4	Case A	Case B	Case C
COPIER	ADJUST	CST-ADJ	ADJ-MFY	Yes	No	No
COPIER	ADJUST	CST-ADJ	ADJ-MFX	Yes	No	No
COPIER	ADJUST	CST-ADJ	ADJ-MFYR	Yes	No	No
COPIER	ADJUST	CST-ADJ	ADJ-MFXR	Yes	No	No
COPIER	ADJUST	CST-ADJ	ADJ-C1Y	Yes	No	No
COPIER	ADJUST	CST-ADJ	ADJ-C1X	Yes	No	No
COPIER	ADJUST	CST-ADJ	ADJ-C1YR	Yes	No	No
COPIER	ADJUST	CST-ADJ	ADJ-C1XR	Yes	No	No
COPIER	ADJUST	CST-ADJ	ADJ-C2Y	Yes	No	No
COPIER	ADJUST	CST-ADJ	ADJ-C2X	Yes	No	No
COPIER	ADJUST	CST-ADJ	ADJ-C2YR	Yes	No	No
COPIER	ADJUST	CST-ADJ	ADJ-C2XR	Yes	No	No
COPIER	FUNCTION	SPLMAN	SPL14159	Yes	Yes	Yes
COPIER	FUNCTION	SPLMAN	SPL65677	Yes	No	No

Layer1	Layer2	Layer3	Layer4	Case A	Case B	Case C
COPIER	FUNCTION	SPLMAN	SPL68676	Yes	No	No
COPIER	FUNCTION	SPLMAN	SPL68677	Yes	No	No
COPIER	FUNCTION	SPLMAN	SPL25607	Yes	No	No
COPIER	FUNCTION	SPLMAN	SPL93822	Yes	Yes	Yes
COPIER	FUNCTION	SPLMAN	SPL78788	Yes	Yes	Yes
COPIER	FUNCTION	SPLMAN	SPL00171	Yes	Yes	Yes
COPIER	FUNCTION	SPLMAN	SPL84194	Yes	Yes	Yes
COPIER	FUNCTION	INSTALL	ERDS	Yes	Yes	Yes
COPIER	FUNCTION	INSTALL	RGW-PORT	Yes	Yes	Yes
COPIER	FUNCTION	BODY	MIBCOUNT	Yes	Yes	Yes
COPIER	FUNCTION	BODY	NS-CMD5	Yes	No	No
COPIER	FUNCTION	BODY	NS-PLN	Yes	No	No
COPIER	FUNCTION	BODY	NS-LGN	Yes	No	No
COPIER	FUNCTION	BODY	SLPMODE	Yes	Yes	Yes
COPIER	FUNCTION	BODY	SDTM-DSP	Yes	Yes	Yes
COPIER	FUNCTION	FNC-SW	IMGCNTPR	Yes	Yes	Yes
COPIER	FUNCTION	FNC-SW	LCDSFLG	Yes	Yes	Yes
COPIER	FUNCTION	FNC-SW	CRG-PROC	Yes	Yes	No
COPIER	FUNCTION	FNC-SW	CRGLF-K	Yes	Yes	No
COPIER	FUNCTION	DSPLY-SW	CRGLW-LV	Yes	Yes	Yes
COPIER	FUNCTION	IMG-MCON	"REGM-SEL"	Yes	No	No
COPIER	FUNCTION	USER	CTCHKDSP	Yes	No	No
COPIER	FUNCTION	USER	TNRB-SW	Yes	No	No
COPIER	FUNCTION	USER	SCALL-SW	Yes	Yes	Yes
COPIER	FUNCTION	USER	SMD-EXPT	Yes	No	No
COPIER	FUNCTION	USER	ACC-SLP	Yes	Yes	Yes



# Periodical Service

Periodically Replaced Parts.....	63
Consumable Parts.....	64
Periodical Service.....	65
Cleaning.....	66

## Periodically Replaced Parts

### Periodically Replaced Parts

- Periodic replacement parts are not required in this printer.

## Consumable Parts

Durables Replaced by the Service Person

- Consumable parts are not required in this printer.

## Periodical Service

### Periodical Service

- No periodic services are required to this printer.



## Cleaning

### Cleaning at Service Visit

Follow the procedure below when cleaning the printer during service visit.

Component	Cleaning Method
Pickup Roller / Sepalation Pad	Wipe With A Lint-free Cloth.
Registration Roller / Registration Arm Unit	Wipe With A Lint-Free Cloth.
Transfer Guide Unit	Wipe With A Soft and Dry Flannel Cloth.
Media Feed Belt / Media Feed Guide Unit	Wipe With A Lint-Free Cloth.
Fixing Inlet Guide	Wipe With Alcohol Dampened Flannel Cloth.

Do not clean the following components:

- Photosensitive drum
- Transfer roller

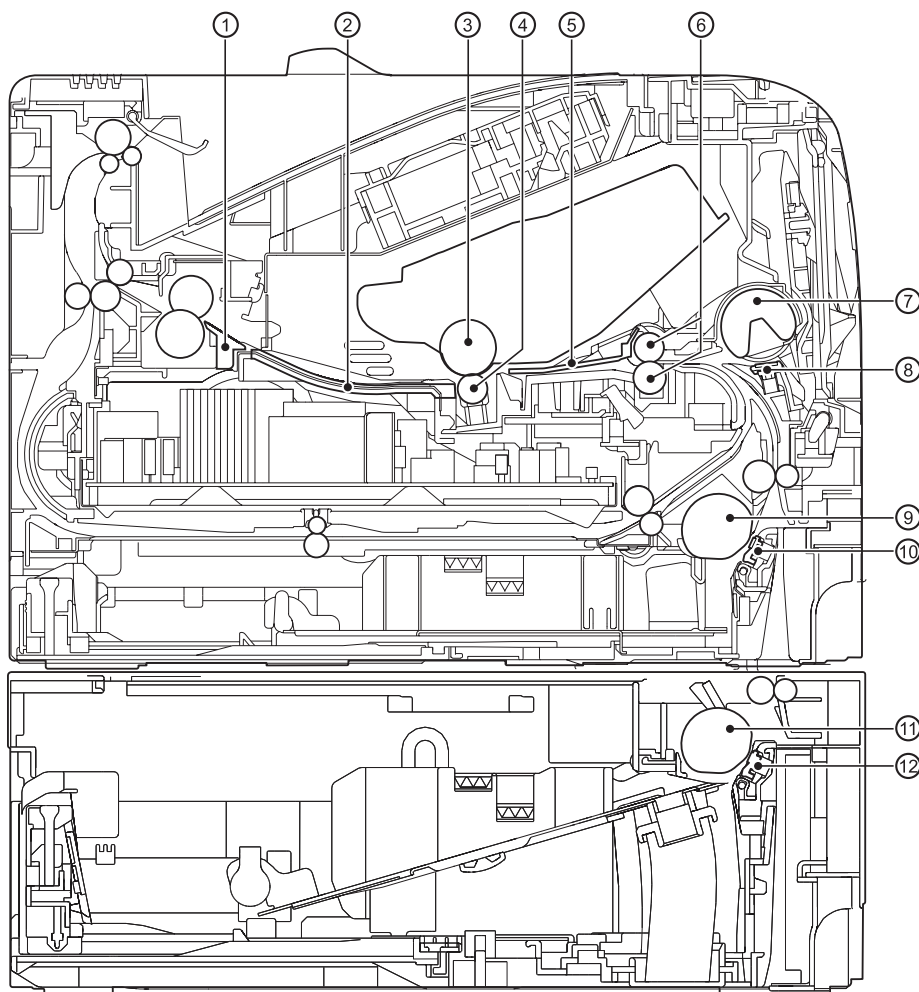

No.	Name	No.	Name
[1]	Fixing Inlet Guide	[7]	Multi-purpose Tray Pickup Roller
[2]	Media Feed Guide	[8]	Multi-purpose Tray Separation Pad
[3]	Photosensitive Drum	[9]	Cassette Pickup Roller
[4]	Transfer Roller	[10]	Cassette Separation Pad
[5]	Transfer Guide Unit	[11]	PF Pickup Roller
[6]	Registration Roller Unit	[12]	PF Separation Pad



# 4

## Disassembly/ Assembly

Outline.....	68
List of Parts.....	69
Connector Layout Drawing.....	76
External Cover, Internal Cover.....	80
Controller System.....	84
Laser Exposure System.....	96
Image Forming System.....	97
Fixing System.....	98
Paper Pickup/Transport/Output System.....	100

## Outline

This chapter describes disassembly and reassembly procedures of the printer.

Note the following precautions when working on the printer.

1. CAUTION: Before disassembling or reassembling the printer, be sure to disconnect its power cord from the electrical outlet.
2. During disassembly, reassembly or transportation of the printer, remove the cartridge if required. When the cartridge is out of the printer, put it in a protective bag even in a short period of time to prevent the adverse effect of light.
3. Reassembling procedures are followed by the reverse of disassembly unless otherwise specified.
4. Note the length, diameters, and locations of screws as you remove them. When reassembling the printer, be sure to use them in their original locations.
5. Do not run the printer with any parts removed as a general rule.
6. Ground yourself by touching the metal part of the printer before handling the PCB to reduce the possibility of damage caused by static electricity.
7. When you replace the part that the rating plate or the product code label is attached, be sure to remove the rating plate or the product code label and put it to the new part.

## List of Parts

### External View

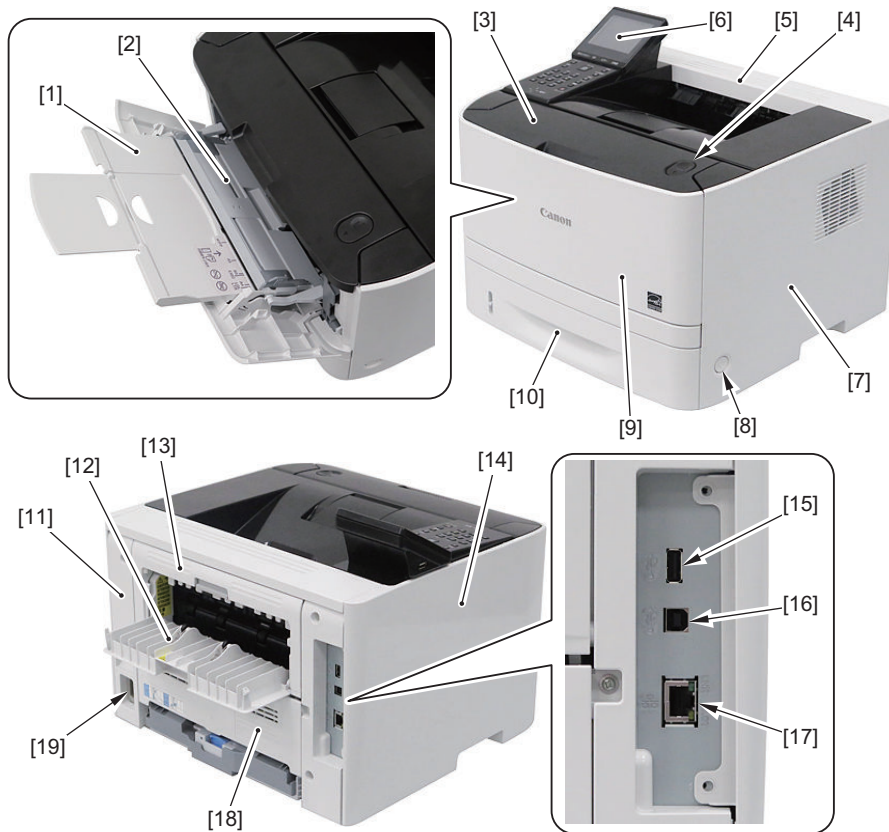

No.	Name	No.	Name
[1]	Auxiliary Tray	[11]	Rear Cover
[2]	Multi-purpose Tray	[12]	Face-up Output Tray
[3]	Front Cover	[13]	Pressure Release Cover
[4]	Open Button	[14]	Left Cover
[5]	Upper Cover	[15]	USB Host
[6]	Control Panel	[16]	USB Device
[7]	Right Cover	[17]	LAN Connector
[8]	Power Switch	[18]	Duplex Unit Cover
[9]	Face-down Output Tray Cover	[19]	Power Socket
[10]	Paper Cassette		

**List of Main Unit**

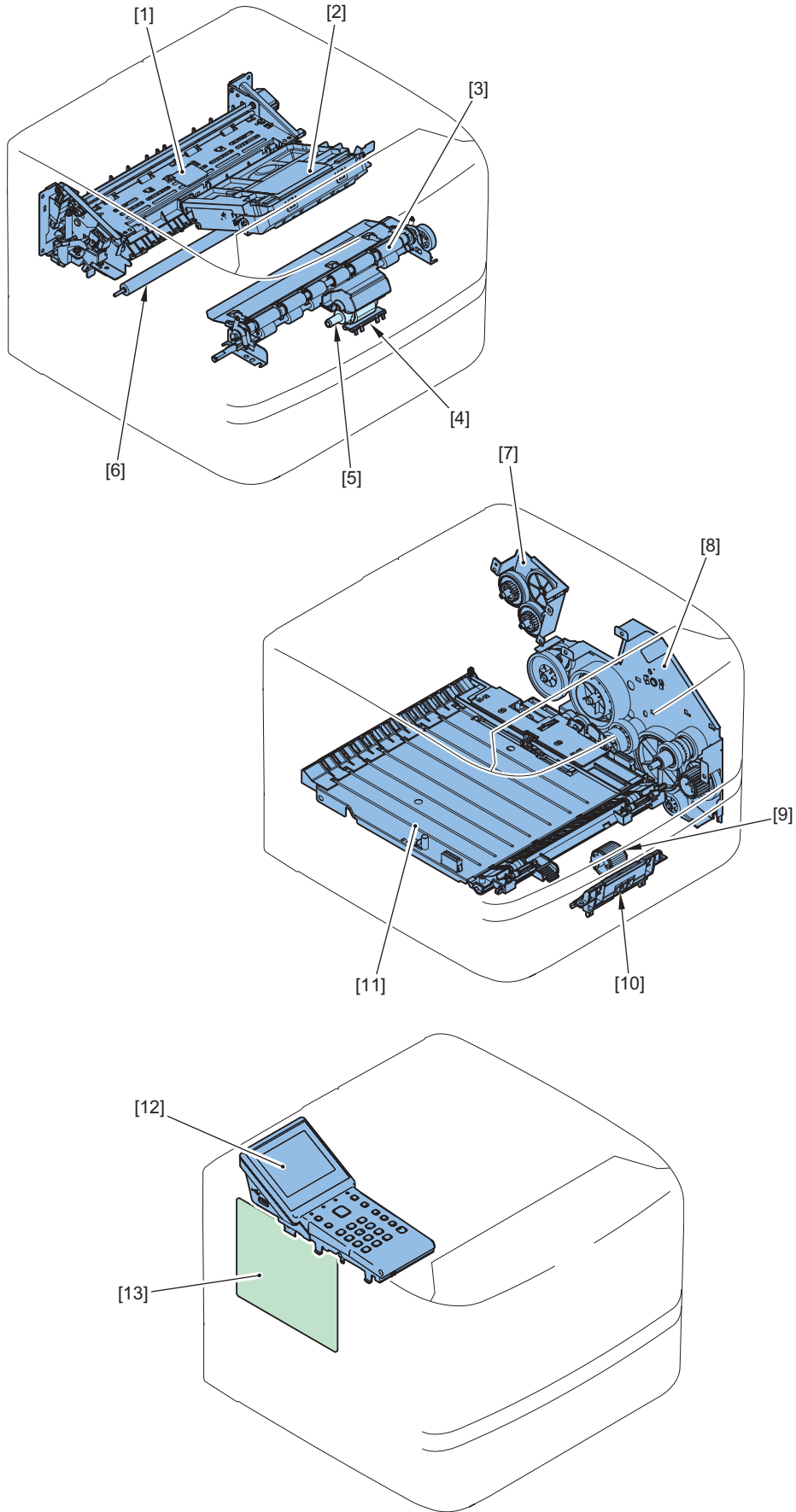

No.	Name	Reference
[1]	Fixing Unit	"Removing the Fixing Unit" on page 98

No.	Name	Reference
[2]	Laser Scanner Unit	"Removing the Laser Scanner Unit" on page 96
[3]	Registration Unit	"Removing the Registration Unit" on page 97
[4]	Multi-purpose Separation Pad	"Removing the Multi-purpose Separation Pad" on page 101
[5]	Multi-purpose Pickup Roller	"Removing the Multi-purpose Pickup Roller" on page 101
[6]	Transfer Roller	"Removing the Transfer Roller" on page 97
[7]	Duplex Drive Unit	"Removing the Duplex Drive Unit" on page 93
[8]	Main Drive Unit	"Removing the Main Drive Unit" on page 91
[9]	Cassette Pickup Roller	"Removing the Cassette Pickup Roller" on page 100
[10]	Cassette Separation Pad	"Removing the Cassette Separation Pad" on page 100
[11]	Duplex Feed Unit	"Removing the Rear Cover Unit / Duplex Feed Unit" on page 81
[12]	Control Panel	"Removing the Control Panel Unit" on page 90
[13]	Main Controller Board	"Removing the Main Controller Board" on page 84

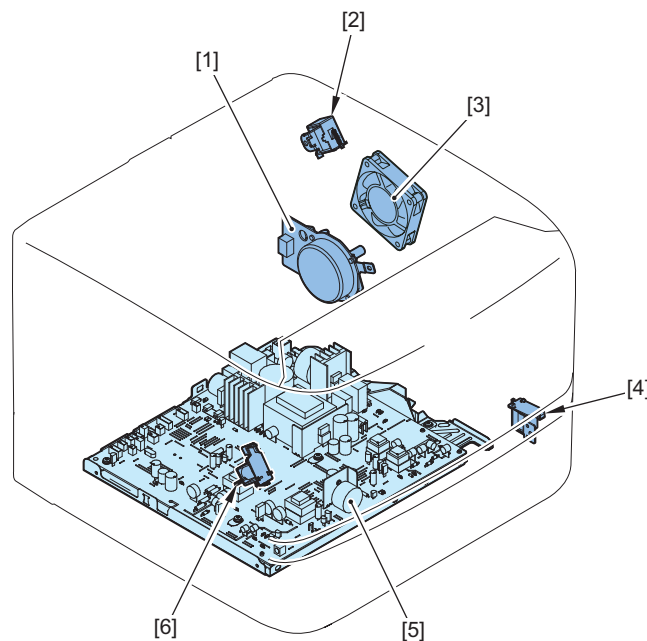

No.	Name	Reference
[1]	Main Motor	"Removing the Main Motor" on page 91
[2]	Duplex Reversal Solenoid	"Removing the Duplex Reversal Solenoid" on page 94
[3]	Main Fan	"Removing the Main Fan" on page 91
[4]	Cassette Pickup Solenoid	"Removing the Cassette Pickup Solenoid" on page 93
[5]	Engine Controller Board	"Removing the Engine Controller Board" on page 87
[6]	Multi-purpose Solenoid	"Removing the Multi-purpose Solenoid" on page 94

## Motor / Fan

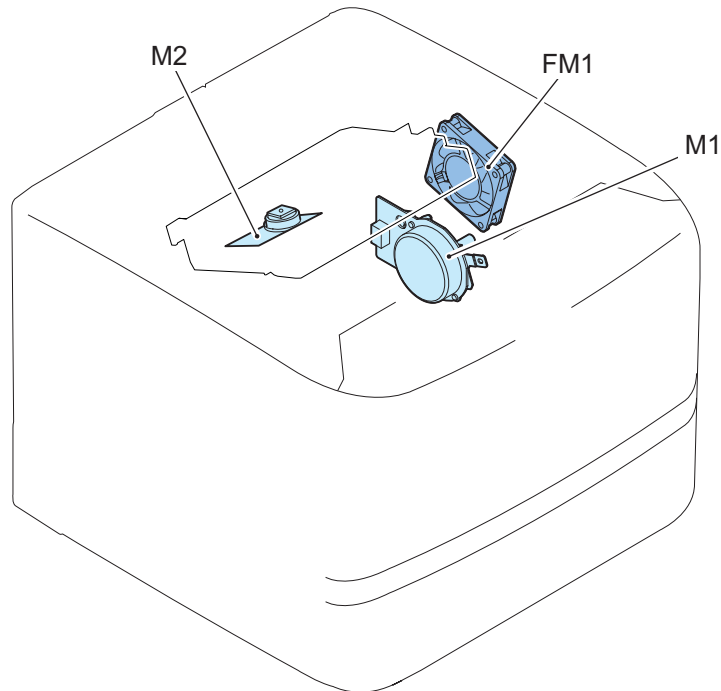

No.	Name	Main Units	Reference
M1	Main Motor	-	"Removing the Main Motor" on page 91
M2	Scanner Motor	Laser Scanner Unit	"Removing the Laser Scanner Unit" on page 96
FM1	Main Fan	-	"Removing the Main Fan" on page 91

## Solenoid

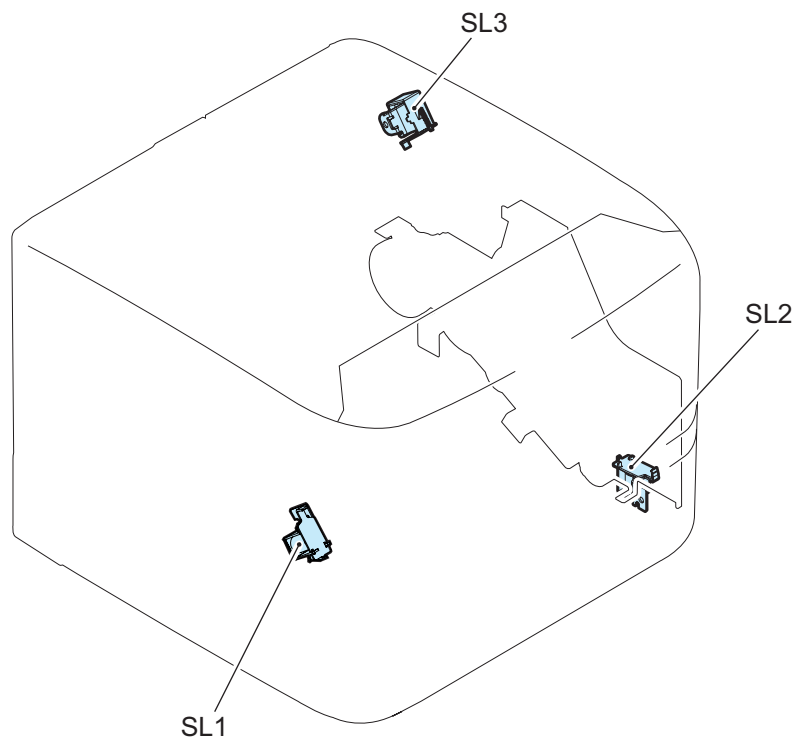

No.	Name	Main Units	Reference
SL1	Multi-purpose Solenoid	-	"Removing the Multi-purpose Solenoid" on page 94

No.	Name	Main Units	Reference
SL2	Cassette Pickup Solenoid	Main Drive Unit	"Removing the Cassette Pickup Solenoid" on page 93
SL3	Duplex Reversal Solenoid	-	"Removing the Duplex Reversal Solenoid" on page 94

## ● Heater / Thermo Switch / Thermistor / Switch

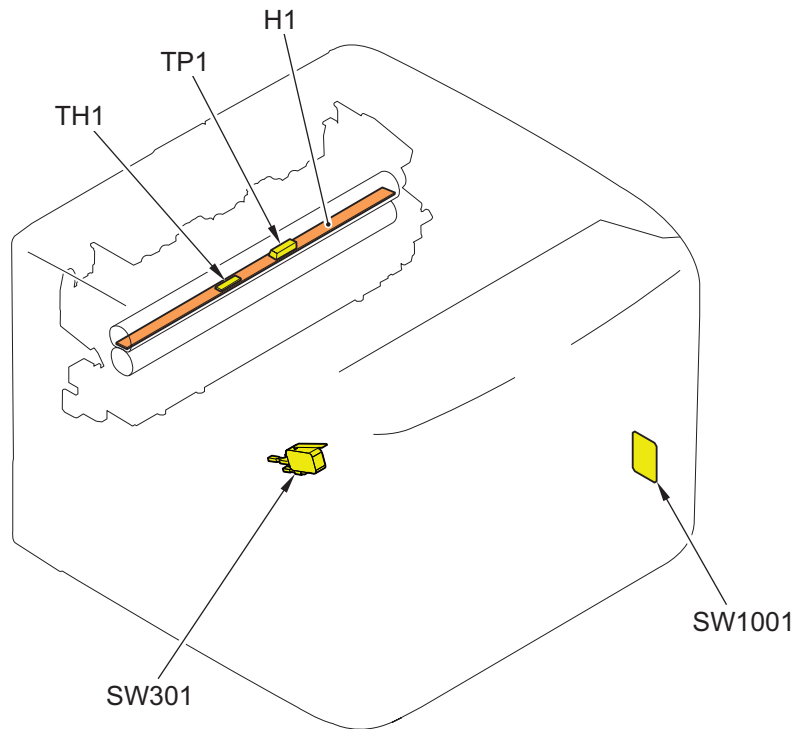

No.	Name	Main Units	Reference
H1	Fixing Heater	Fixing Unit	-
TP1	Fixing Thermo Switch	Fixing Unit	-
TH1	Fixing Thermistor	Fixing Unit	-
SW1001	Power Switch	-	-
SW301	Door Switch	-	-



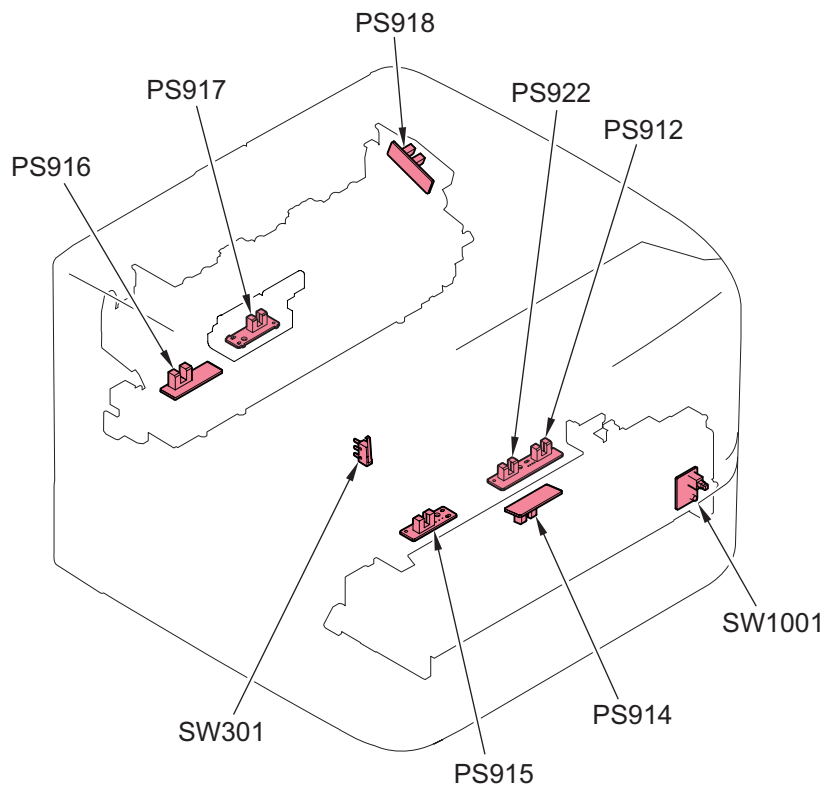

No.	Name	Main Units	Reference
PS912	Top Sensor	-	-
PS914	Cassette Paper Sensor	-	-
PS915	Manual Tray Detection Sensor	-	-
PS916	Fixing Paper Output Sensor	-	-
PS917	Duplex Reverse Sensor	-	-
PS918	Output Tray Full Sensor	-	-
PS922	Paper Width Sensor	-	-
SW1001	Power Switch	-	-
SW301	Door Switch	-	-

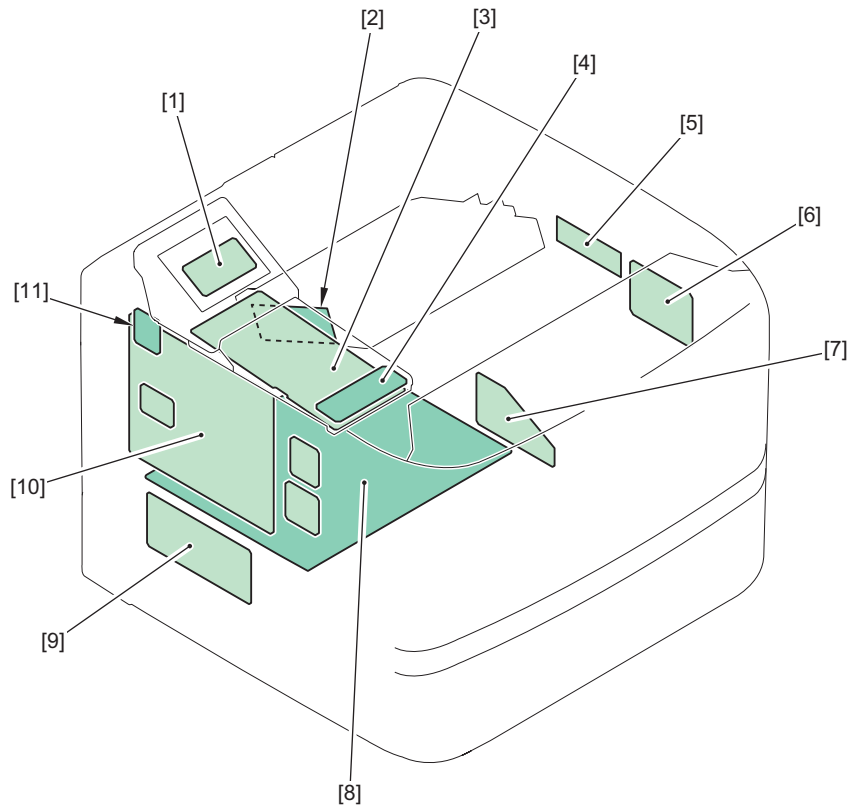

No.	Name	Main Units	Reference
[1]	Control Panel Relay PCB	Control Panel	
[2]	Laser Driver PCB	Laser Scanner Unit	
[3]	Control Panel PCB	Control Panel	
[4]	NFC PCB	Control Panel	
[5]	Connecting PCB	-	
[6]	All-night power PCB	-	
[7]	Power Supply PCB	-	
[8]	Engine Controller PCB	-	
[9]	Sleep Interface PCB	-	
[10]	Main Controller PCB	-	
[11]	Wireless LNA PCB	-	

# Connector Layout Drawing

## Connector List

### ■ Main Controller PCB

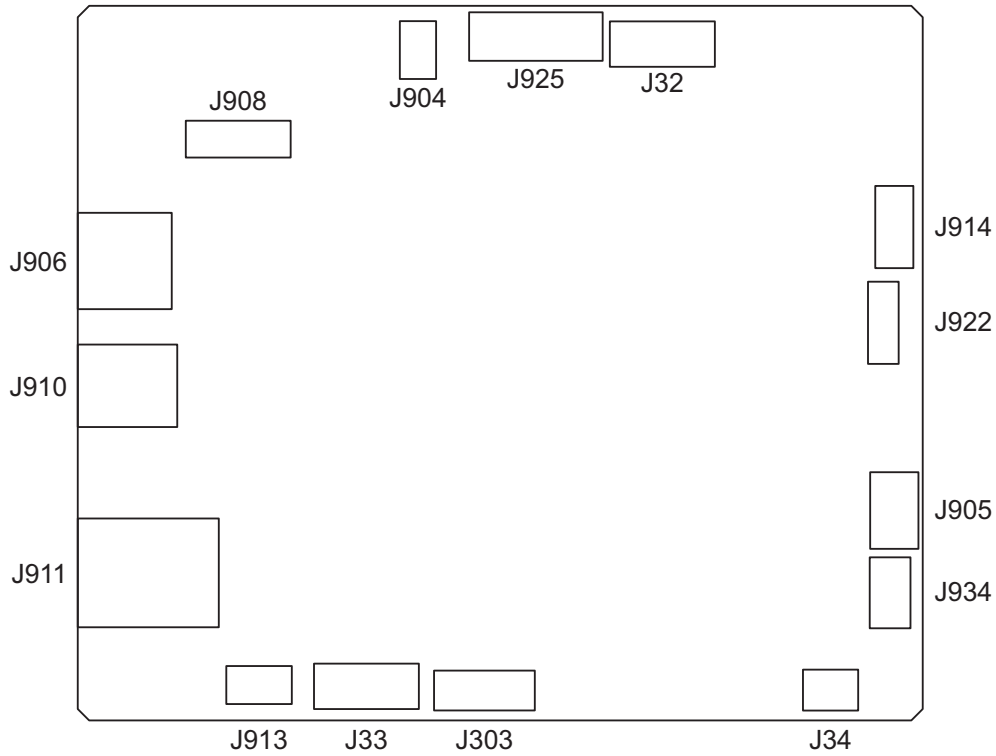

### ■ Engin Controller PCB

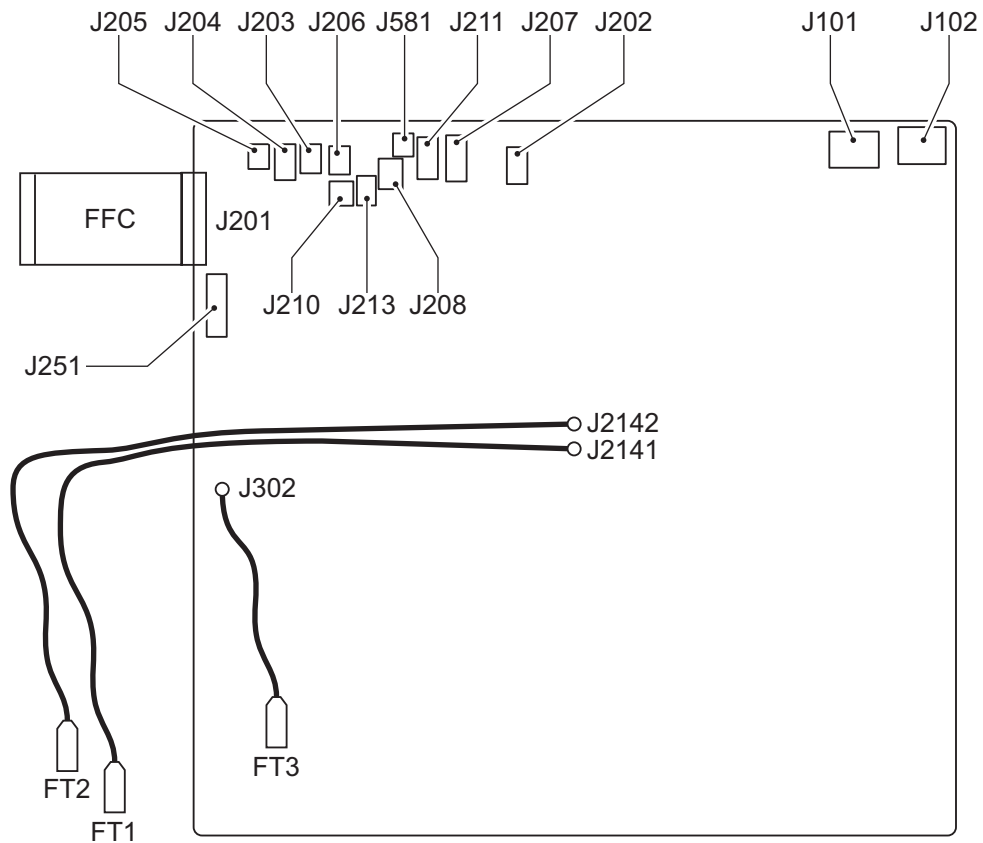

## Internal

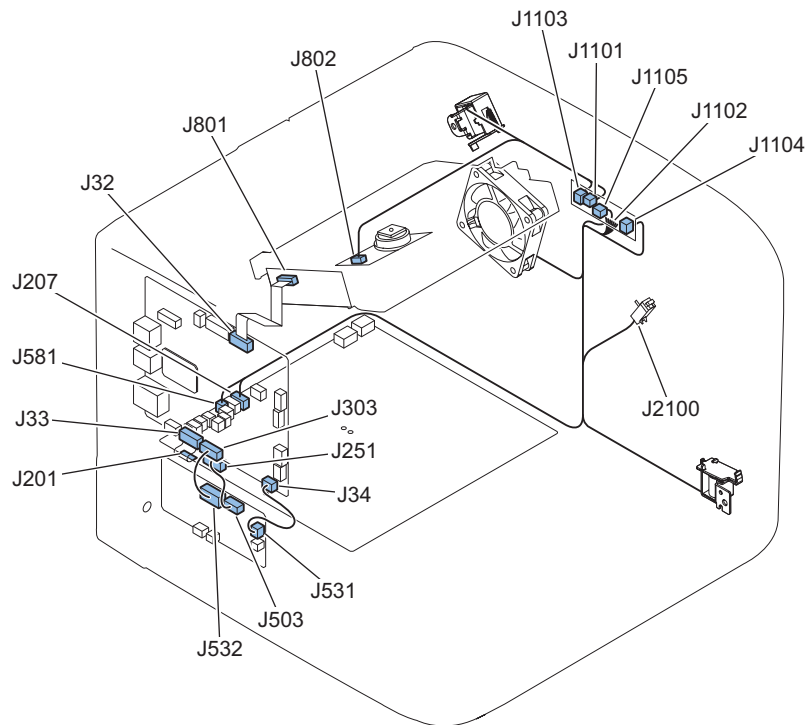

J No.	Sym- bol	Name	Relay con- nector	J No.	Sym- bol	Name
J201	-	Engin Controller PCB		J33	-	Main Controller PCB
J251	-	Engin Controller PCB		J503	-	Sleep Interface PCB
J581	-	Engin Controller PCB		J2100	-	TAG
J207	-	Engin Controller PCB		J1102	-	Power Supply PCB
J1101	-	Power Supply PCB		J1101	SL3	Duplex Reversal Solenoid
J1104	-	Power Supply PCB		J1104	SL2	Cassette Pickup Solenoid
J1105	-	Power Supply PCB		J1105	FM1	Main Fan
J1103	-	Power Supply PCB		J802	M2	Scanner Motor
J32	-	Main Controller PCB		J801	-	Laser Driver PCB
J34	-	Main Controller PCB		J531	-	Sleep Interface PCB
J303	-	Main Controller PCB		J532	-	Sleep Interface PCB

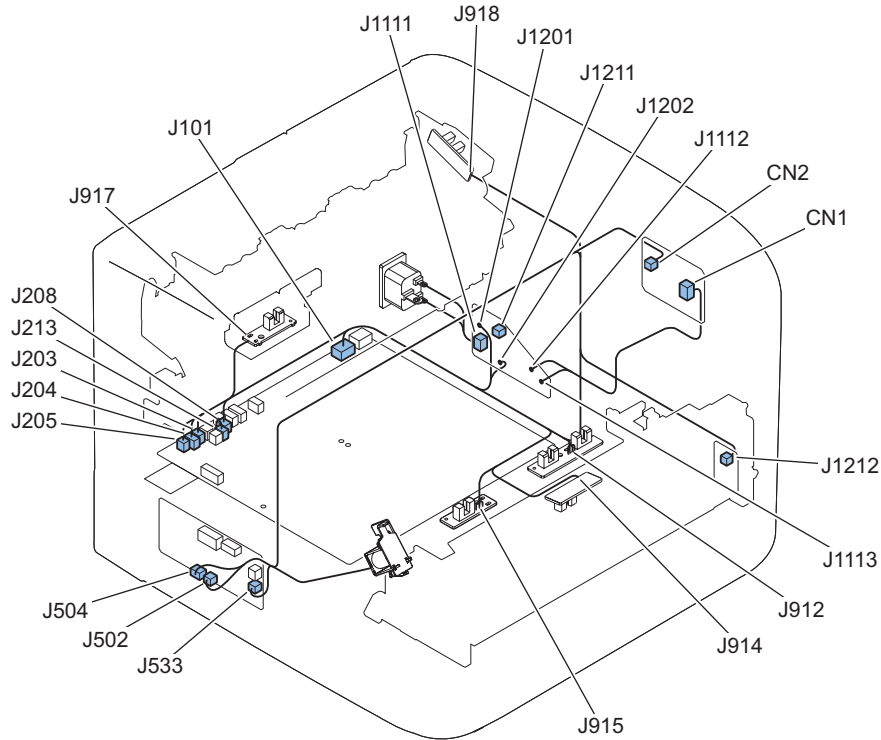

J No.	Sym- bol	Name	Relay con- nector	J No.	Symbol	Name
J203	-	Engin Controller PCB		J912	-	Top Sensor
J204	-	Engin Controller PCB		J914	PS914	Cassette Paper Sensor
J205	-	Engin Controller PCB		J915	PS915	Manual Tray Detection Sensor
J208	-	Engin Controller PCB		J917	PS917	Duplex Reverse Sensor
J213	-	Engin Controller PCB		J918	PS918	Output Tray Full Sensor
J101	-	Engin Controller PCB		J1201	-	Connecting PCB
J101	-	Engin Controller PCB		J1202	-	Connecting PCB
J1111	-	Connecting PCB		-	-	INL101
J1112	-	Connecting PCB		CN1	-	All-night Power PCB
J1113	-	Connecting PCB		CN1	-	All-night Power PCB
J502	-	Sleep Interface PCB		CN2	-	All-night Power PCB
J504	-	Sleep Interface PCB	J5001	J1212	SW1001	Power Switch
J504	-	Sleep Interface PCB	J5001	J1211	-	Connecting PCB
J533	-	Sleep Interface PCB		J533	SL1	Multi-purpose Solenoid

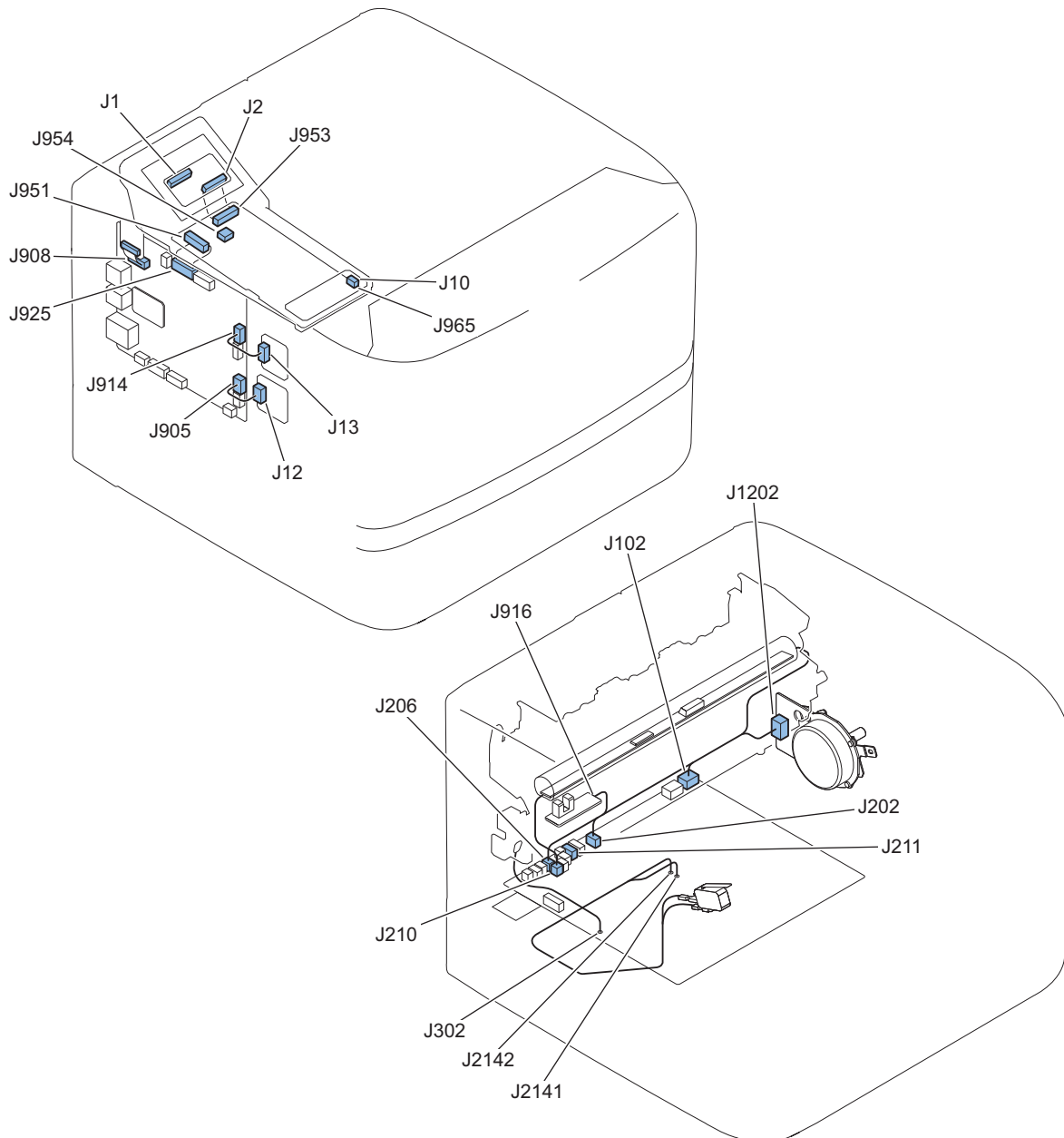

J No.	Symbol	Name	Relay connector	J No.	Symbol	Name
J102	-	Engin Controller PCB		J102	-	Fixing Heater
J210	-	Engin Controller PCB		J210	-	Fixing Thermistor
J202	-	Engin Controller PCB		J1202	M1	Main Motor
J206	-	Engin Controller PCB		J916	PS916	Fixing Paper Output Sensor
J211	-	Engin Controller PCB	J1205	-	-	-
J302	-	Engin Controller PCB		-	-	-
J2141	-	Engin Controller PCB		-	SW301	Door Switch
J2142	-	Engin Controller PCB		-	SW301	Door Switch
J908	-	Main Controller PCB		-	-	Wireless LNA PCB
J905	-	Main Controller PCB		J12	-	SOFT-ID PCB
J914	-	Main Controller PCB		J13	-	COUNTER PCB
J925	-	Main Controller PCB		J951	-	Control Panel PCB
J965	-	Control Panel PCB		J10	-	NFC PCB
J953	-	Control Panel PCB		J2	-	Control Panel Relay PCB
J1	-	Control Panel Relay PCB		-	-	LCD
J954	-	Control Panel PCB		-	-	Touch Panel

## External Cover, Internal Cover

### Removing the Left Cover

1. Remove Cassette [1].
2. Press Release Button [2] and open Cartridge Door Unit [3].

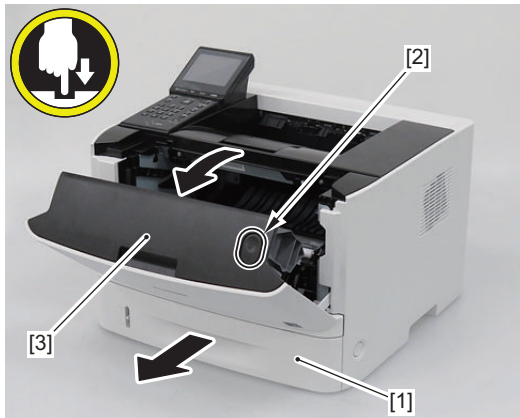

3. Remove 2 screw [2] and 3 disengage tab [3] in direction.
4. Remove Left Cover [1] in direction.



2. Press Release Button [2] and open Cartridge Door Unit [3].

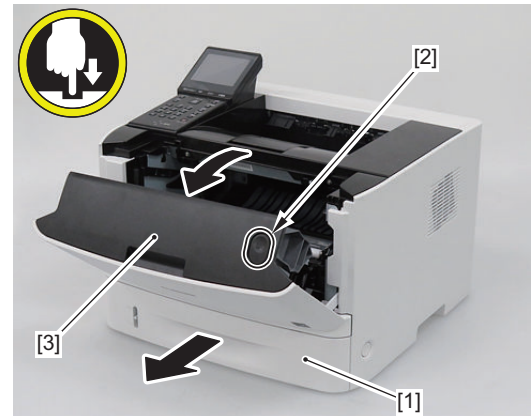

3. Release the 6 claws [1] and remove the Right Cover [2] while opening it in the direction of the arrow.

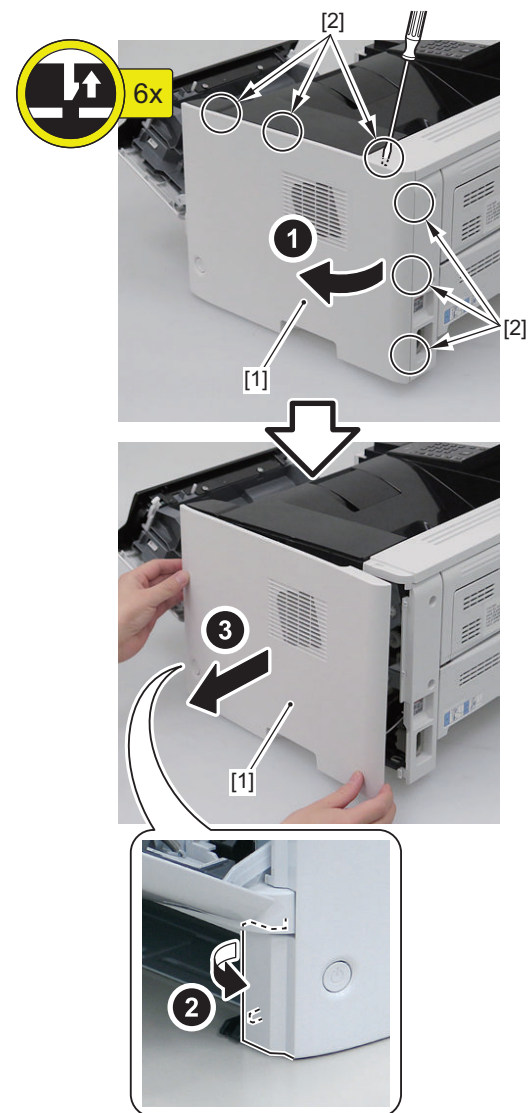

### Removing the Right Cover

1. Remove Cassette [1].

## Removing the Rear Cover Unit / Duplex Feed Unit

### Preparations

1. Remove Cassette.
2. Remove Right Cover. "Removing the Right Cover" on page 80
3. Remove Left Cover. "Removing the Left Cover" on page 80

### Procedure

1. Lift Lever [1] and move Duplex Feed Unit [2] downwards.

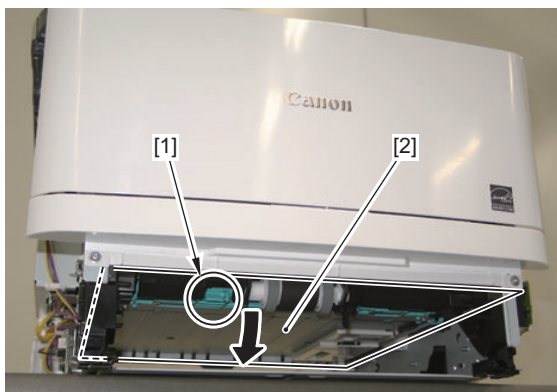

#### CAUTION:

During reassembly, 2 raise Lever of Duplex Feed Unit and attach Duplex Feed Unit to Main Unit by using 2 magnet on each side.

2. Open Rear Cover [1].
3. Remove Rear Cover Unit [2] together with Duplex Feed Unit.
  - 5 Screw [3]

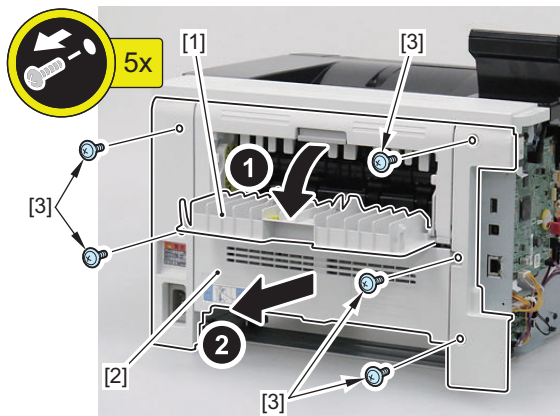

4. Remove Rear Cover Unit [1] together with Duplex Feed Unit [2].

- 2 Boss [3]

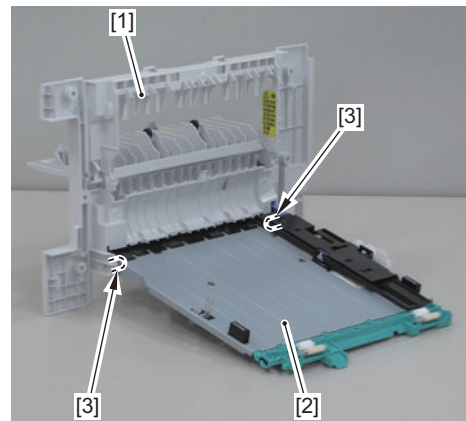

#### CAUTION:

1. Fit the 2 Upper Claw [2] of the Rear Cover Unit [1] With the Upper Cover.
2. Open the Rear Upper Cover [3] and While Pushing the Duplex Reverse Sensor Flag [4] Downward, Install the Rear Cover Unit.

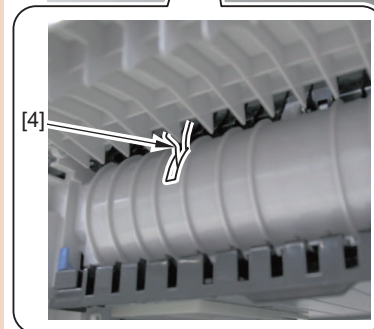
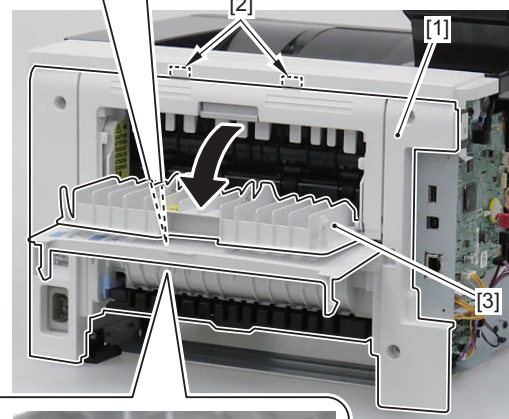
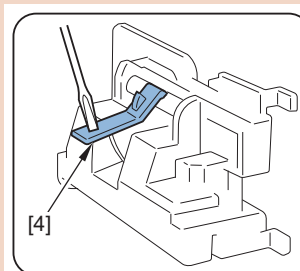



## Removing the Upper Cover Unit

### Preparations

1. Remove Right Cover. "Removing the Right Cover" on page 80
2. Remove Left Cover. "Removing the Left Cover" on page 80
3. Remove Rear Cover Unit. "Removing the Rear Cover Unit / Duplex Feed Unit" on page 81

### Procedure

#### 1. Remove Upper Cover Unit [1].

- 7 Connector [2]
- 3 Wire Saddles [3]
- Edge Sddles [4]
- 3 Screws [5]
- 1 Screw (bind) [6]

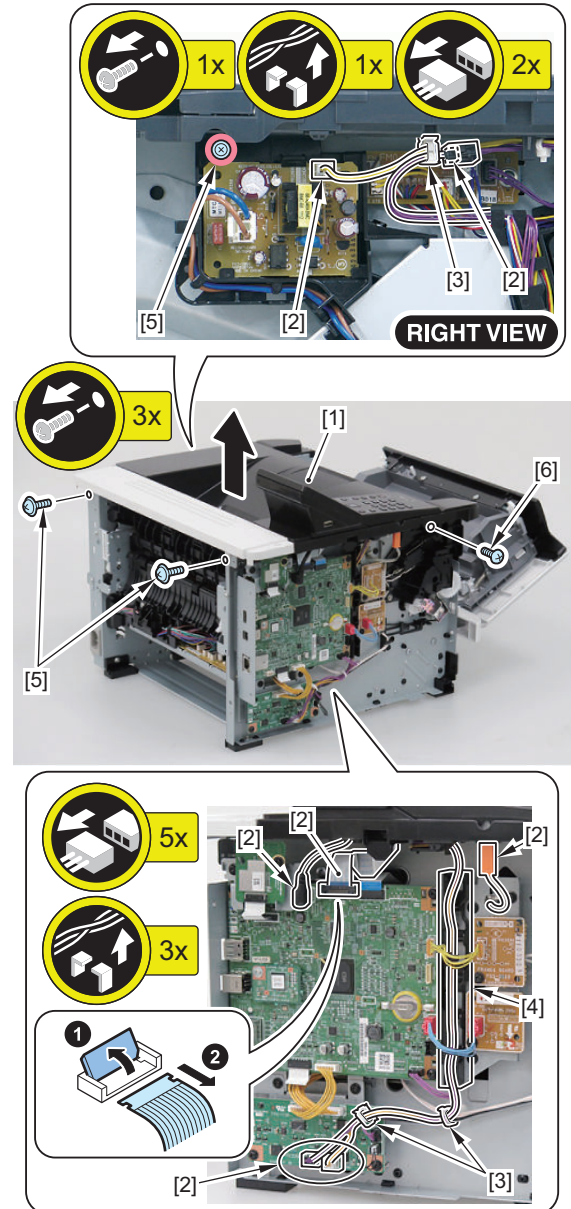

## Removing the Cartridge Cover Unit

### Preparations

1. Remove Right Cover. "Removing the Right Cover" on page 80
2. Remove Left Cover. "Removing the Left Cover" on page 80

## ■ Procedure

### 1. Close Front Cover [1] and remove Link arm [2].

- 2 Tab [3]

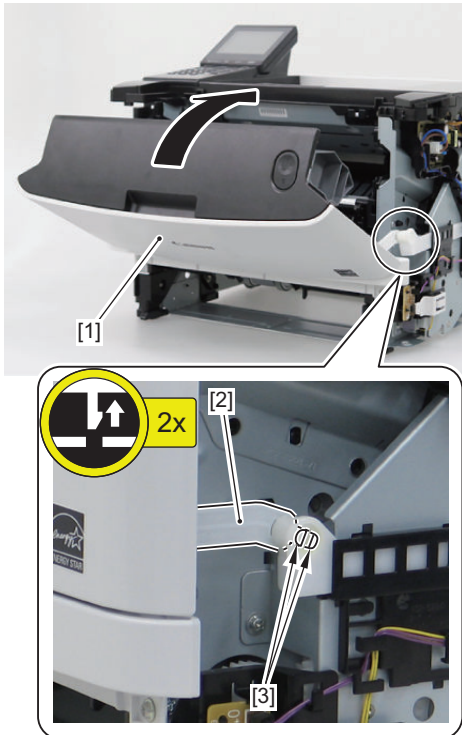

### 2. Remove Cartridge Cover Unit [1].

- 2 Screw [2]

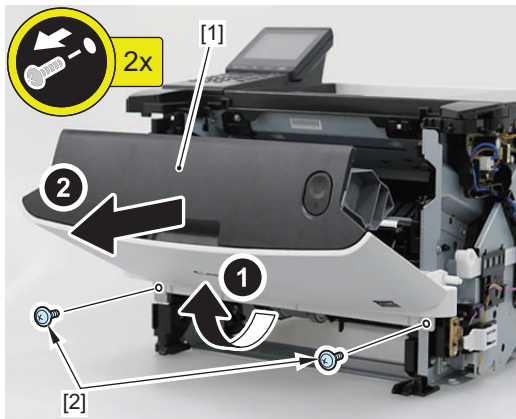

## Controller System

### Removing the Main Controller Board

#### Actions before Replacement

##### CAUTION:

Actions before Replacement

- Back up user data (settings, registered data, etc.) and service mode data for setting and registration after PCB replacement. Take notes if data is unable to back up.

#### Actions before Replacement

Perform backup of user data (such as Settings/Registration data) and service mode data in preparation to set/register them again after replacing the PCB. Write down the data which cannot be backed up.

1. Write down the data of Settings/Registration > System Settings > Device Information > Location.
2. Export user data using remote UI.
3. Insert the USB memory into the host machine, and execute COPIER > FUNCTION > SYSTEM > EXPORT to write the setting values of the service mode to the USB memory.
4. Write down the each factory adjustment value written on the service label. (Enter them after replacement.)

##### CAUTION:

Reference: The data recorded on the Main Controller can be backed up and restored by the following procedure.

Storage destination	Backup target	Backup procedure
USB flash drive	Settings of [Settings/Registration]	Connect the USB flash drive . (The USB port on the rear side of the host machine cannot be used.) Home key > System Management Settings > Import/Export of Settings > Export Remove the USB flash drive. [Status Monitor] key > Device Status > Remove Memory Media
USB flash drive	Service mode setting values	Connect the USB flash drive . (The USB port on the rear side of the host machine cannot be used.) COPIER > FUNCTION > SYSTEM > EXPORT [Status Monitor] key > Device Status > Remove Memory Media

Storage destination	Backup target	Backup procedure
PC	Settings of [Settings/Registration] Service mode setting values	COPIER > OPTION > USER > SMD-EXPT > 1 Remote UI: Settings/Registration > Import/Export > Export > Start Exporting Save the backup file to any location.

### Removing the Main Controller Board

#### Preparations

1. Remove Left Cover. "Removing the Left Cover" on page 80
2. Remove Wireless LAN PCB. "Removing the Wireless LAN PCB" on page 95

#### Procedure

1. Remove the Support Plate [1] of the Wireless LAN PCB.
  - 1 Screw [2]
  - 2 Hooks [3]

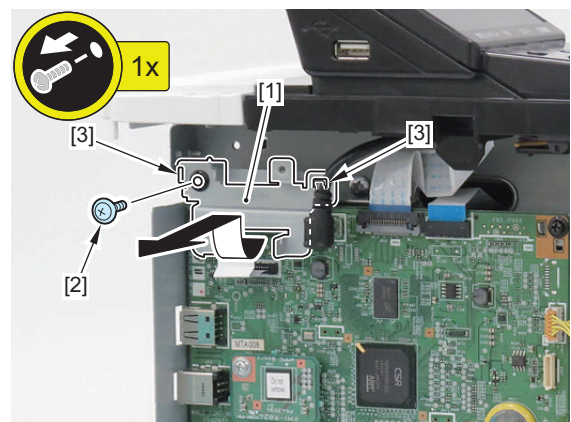

2. Remove Main Controller Board Connector [1].

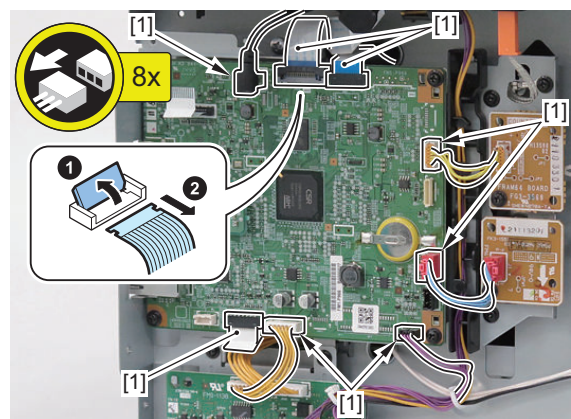

### 3. Remove Main Controller Board [1].

- 4 Screws [2]
- 1 Edge Sddles [3]

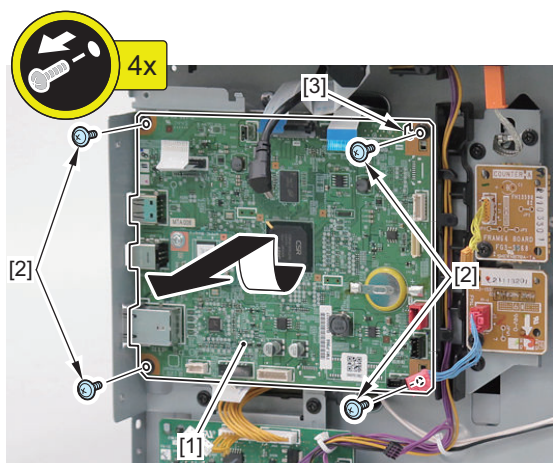

#### CAUTION:

Do not remove the eMMC PCB.

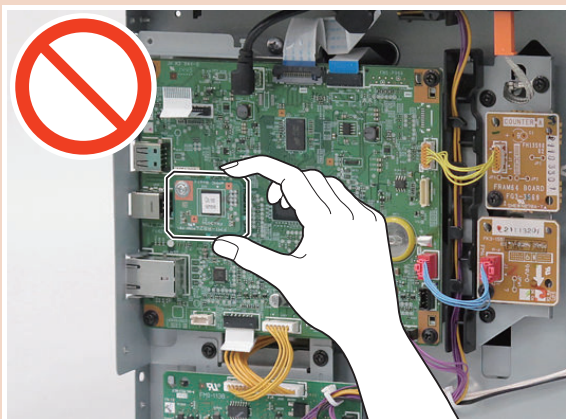

## ■ After replacing main controller PCB

### 1. Setting of destination/paper size group

COPIER > OPTION > BODY > LOCALE (to set destination groups)

- [Settings]
  - 1: Japan, 2: North America, 3: Korea, 4: China, 5: Taiwan, 6: Europe, 7: Asia, 8: Oceania

COPIER > OPTION > BODY > SIZE-LC (to set paper size groups)

- [Settings]
  - 1: AB series, 2: Inch series, 3: A series, 4: AB/Inch series

### 2. Clearing Setting/Registration data

COPIER > FUNCTION > CLEAR > ALL (to clear all data)

Once executed, the following data are cleared according to the values of LOCALE and SIZE-LC set in step 1

Executing initial settings.

Perform the following procedure to change the settings back to the initial settings.

- Job IDs
- Log data
- Dates

#### CAUTION:

Note that the following data is not cleared.

- Service counter

### 3. Turn OFF and then ON the main power.

### 4. Operate according to the instruction on the screen since the initial installation mode is activated. (Setting the date/time, executing the auto gradation adjustment)

### 5. Execute COPIER > FUNCTION > MISC-P > SPEC to output the spec report to check the serial number (Body.No.).

### 6. Enter the data backed up earlier in Settings/Registration > System Settings > Device Information > Location.

### 7. Import the service mode data backed up before replacement.

Insert the USB flash drive into the host machine, and execute COPIER > FUNCTION > SYSTEM > IMPORT.

### 8. Import user data using remote UI.

### 9. Uninstall the drivers on the user's PC.

Printer driver

\*For the procedure, refer to the Printer Driver User Guide.

### 10. Reinstall the drivers which were uninstalled.

\* For the procedure, refer to the Printer Driver User Guide.

In case of network connection:"Connecting to a Network"

### 11. Execute COPIER > FUNCTION > CLEAR > COUNTER to clear the service counter.

### 12. Correction of coordinate position of Touch Panel in the following service mode.

COPIER > ADJUST > PANEL > TOUCHCHK

## ● Remove the Sleep Interface PCB

### ■ Preparations

#### 1. Remove Left Cover. "Removing the Left Cover" on page 80

## ■ Procedure

### 1. Remove Power Supply PCB [1].

- 6 Connectors [2]
- 1 Wire Saddle [3]
- 2 Screw [4]
- 1 Tab [5]

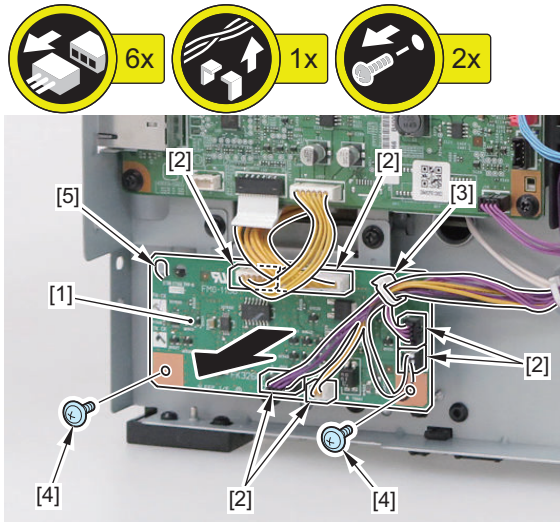

## ● Remove the Duplex Reverse Sensor Unit

### ■ Preparations

1. Remove Left Cover. "Removing the Left Cover" on page 80
2. Remove Right Cover. "Removing the Right Cover" on page 80
3. Remove Rear Cover Unit. "Removing the Rear Cover Unit / Duplex Feed Unit" on page 81

## ■ Procedure

### 1. Remove Duplex Reverse Sensor Unit [1].

- 1 Screw [2]
- 1 Connector [3]

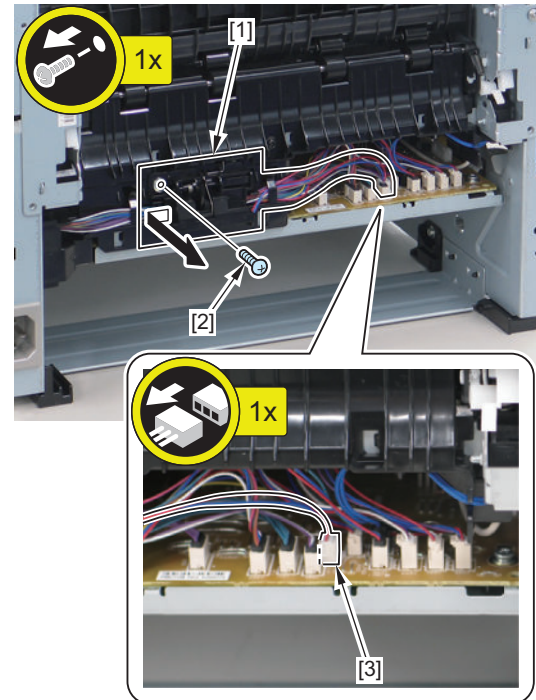

## ● Remove the All-Night Power Supply PCB

### ■ Preparations

1. Remove Right Cover. "Removing the Right Cover" on page 80

### ■ Procedure

### 1. Remove All-Night Power Supply PCB [1].

- 2 Connector [2]
- 1 Screw [3]

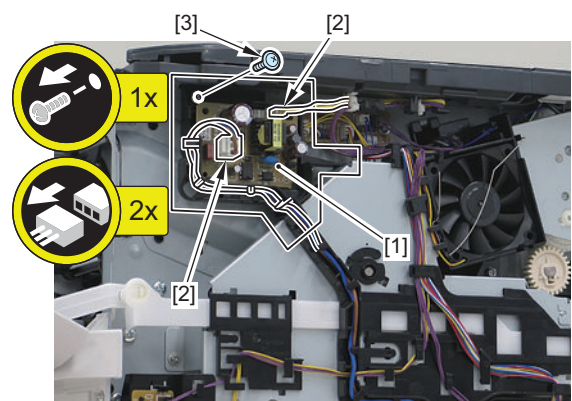

## Remove the Power Supply PCB

### ■ Preparations

1. Remove Left Cover. "Removing the Left Cover" on page 80
2. Remove Right Cover. "Removing the Right Cover" on page 80
3. Remove Rear Cover Unit. "Removing the Rear Cover Unit / Duplex Feed Unit" on page 81
4. Remove Main Controller Board. "Removing the Main Controller Board" on page 84
5. Remove Duplex Reverse Sensor Unit. "Remove the Duplex Reverse Sensor Unit" on page 86
6. Remove Engine Controller Board. "Removing the Engine Controller Board" on page 87

### ■ Procedure

#### 1. Remove Power Supply PCB [1].

- 3 Connectors [2]
- 1 Screw [3]
- 1 Ring Core [4]

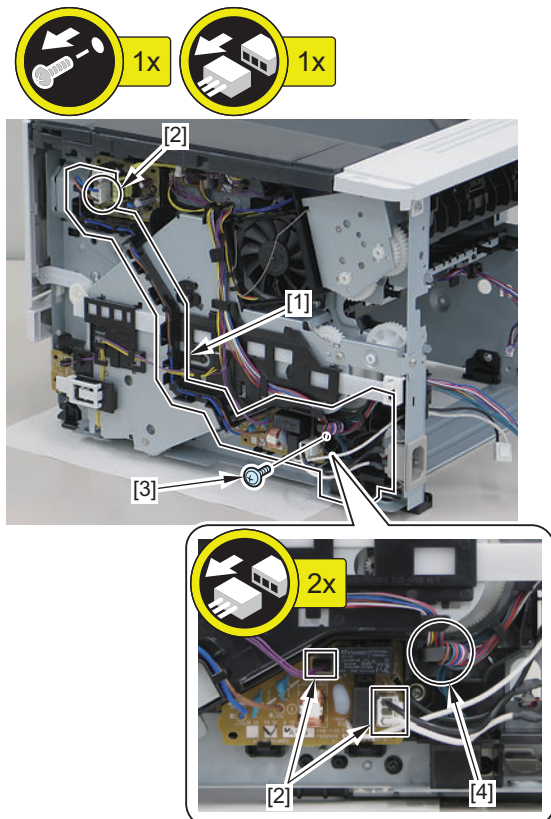

## Removing the Engine Controller Board

### ■ Preparations

1. Remove Left Cover. "Removing the Left Cover" on page 80
2. Remove Right Cover. "Removing the Right Cover" on page 80
3. Remove Main Controller Board. "Removing the Main Controller Board" on page 84
4. Remove Rear Cover Unit. "Removing the Rear Cover Unit / Duplex Feed Unit" on page 81
5. Remove Duplex Reverse Sensor Unit. "Remove the Duplex Reverse Sensor Unit" on page 86

### ■ Procedure

#### 1. Remove harness guide [1].

- 2 Harness guide [1]
- 5 Connectors [3]

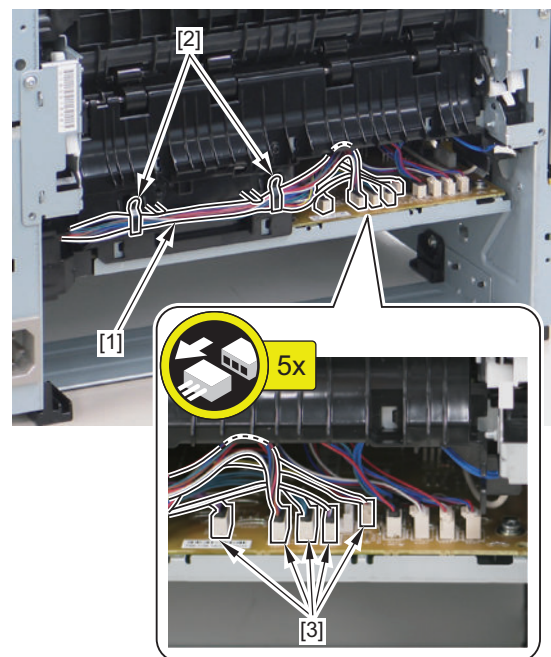

**2. Remove Feed guide [1].**

- 1 Screw [2]

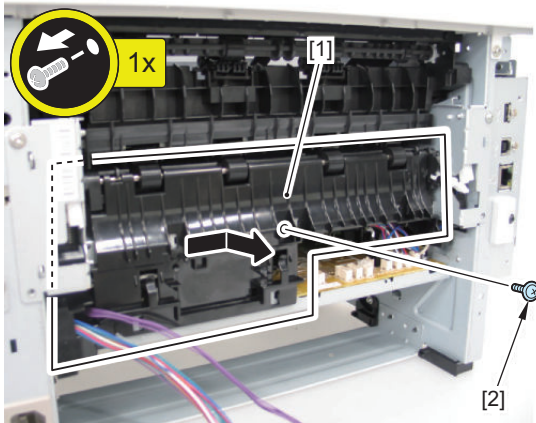

**3. Remove connectors**

- 7 connectors [1]
- 1 Terminal [2]

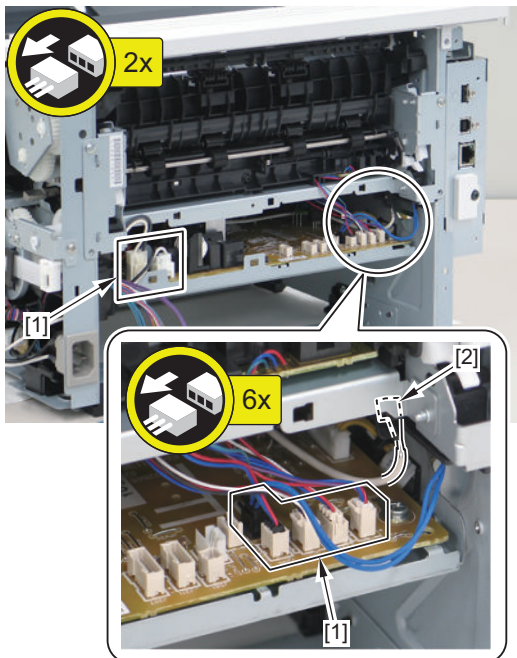

**4. Remove 1 screw [1].**

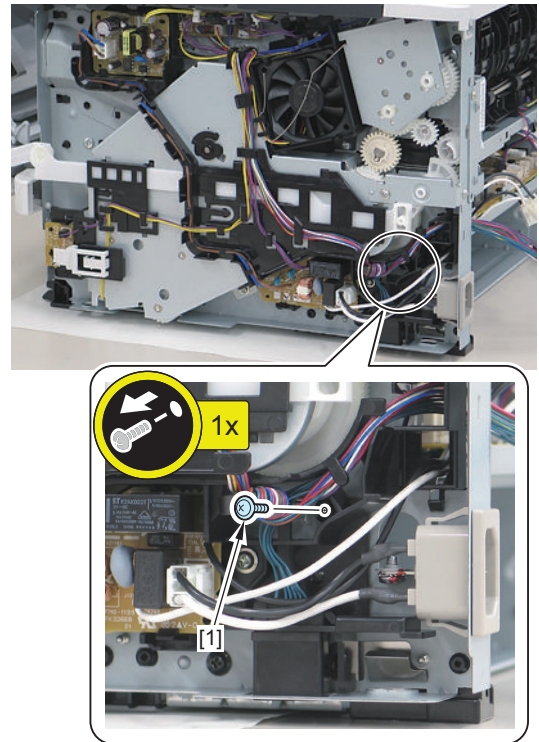

**5. Remove Controller Box[1]**

- 5 connectors [2]
- 2 Wire Saddle [3]
- Harness guide [4]
- 5 Screw [5]

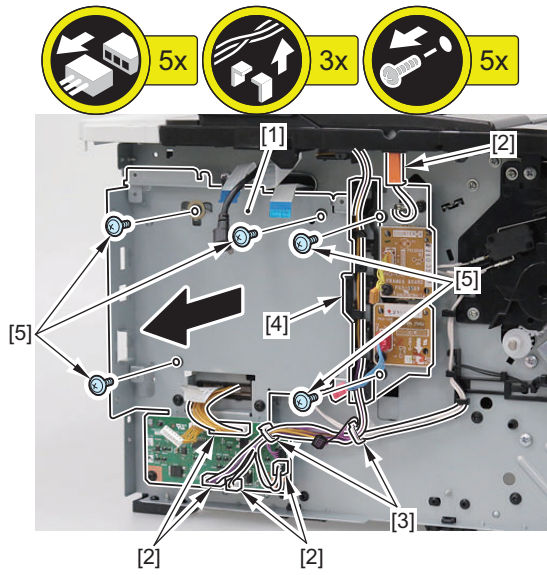

**CAUTION:**

Points to Note when Removing the Controller Box:  
A washer is attached to the screw, so be careful not to lose it when removing.

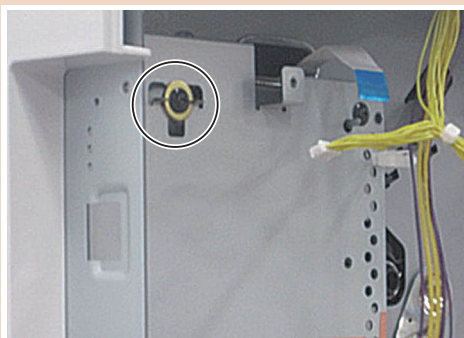

**6. Remove 2 screw [1].**

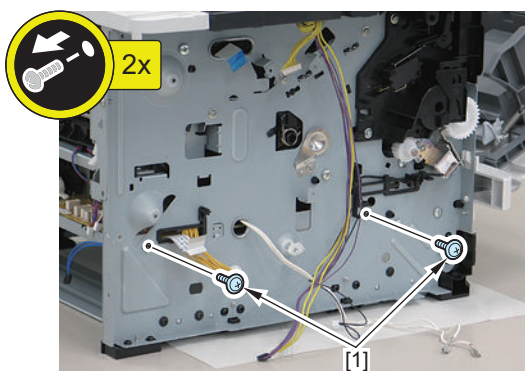

**7. Disengage 2 latch [1] on left and right side of frame, and move Engine Controller Board [2] downwards.**

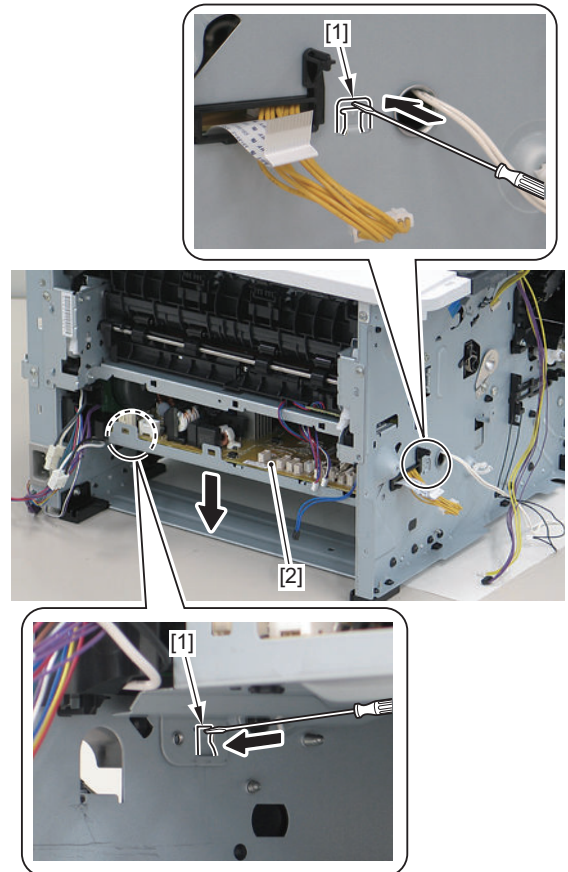

**8. Remove the Engine Controller PCB [1] while paying attention not to get the harness [2] and the Flat Cable [3] caught.**

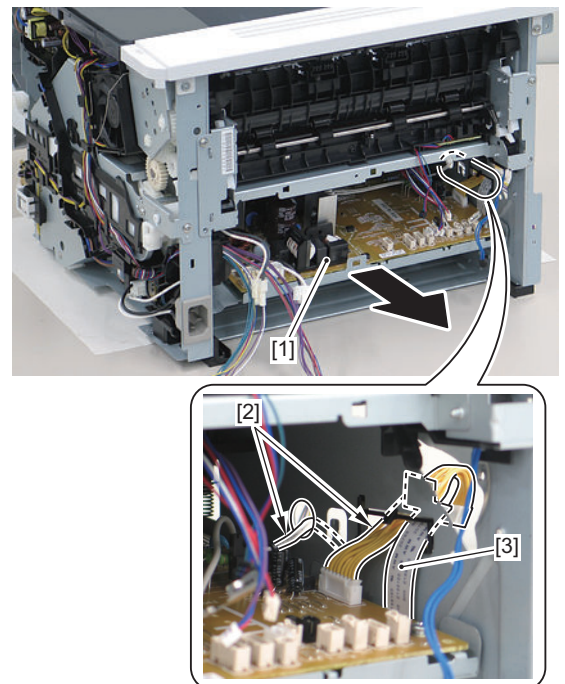



## Removing the Control Panel Unit

### ■ Preparations

1. Remove Right Cover. "Removing the Right Cover" on page 80
2. Remove Left Cover. "Removing the Left Cover" on page 80
3. Remove Rear Cover Unit. "Removing the Rear Cover Unit / Duplex Feed Unit" on page 81
4. Remove Upper Cover Unit. "Removing the Upper Cover Unit" on page 82

### ■ Procedure

1. Remove the Control Panel Unit [1] from the Upper Cover Unit.
  - 4 Screw [2]

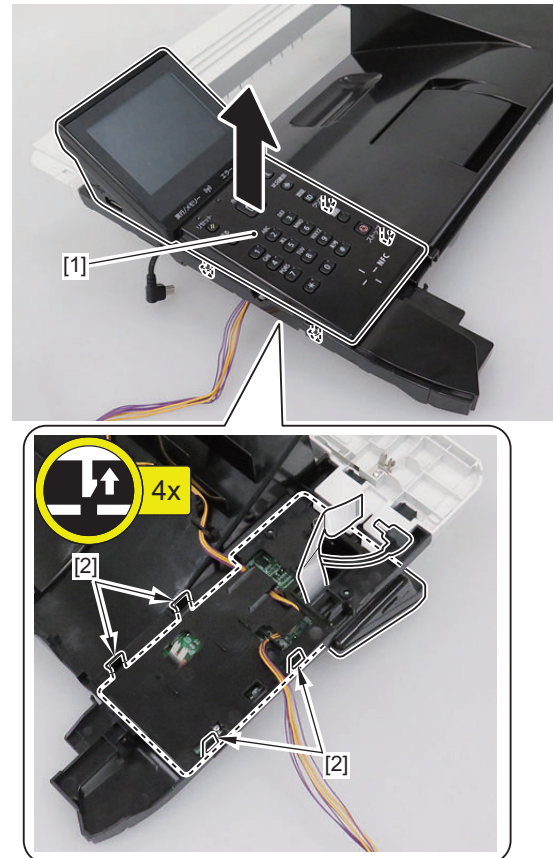

#### Adjustment of Control Panel Unit

To adjust the coordinate on the Touch Panel.  
Execute COPIER > ADJUST > PANEL > TOUCHCHK and touch the center (intersection point) of "+" (plus) mark displayed on the Touch Panel with something with a sharp tip such as a pen. After touching it, another "+" (plus) mark is displayed, therefore touch it with a tip of a pen, etc. in the same manner.

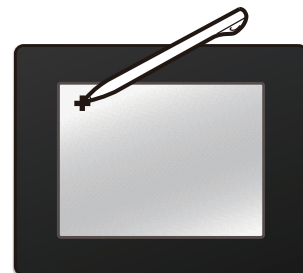

Confirm that TOUCHCHK-R became 1.  
After completing the above, check that the value of COPIER > ADJUST > PANEL > TOUCHCHK-R reads "1" (adjustment successful). If "0" (adjustment failed) is displayed, correct the coordinates on the Touch Panel again.

## Removing the Main Motor

### Preparations

1. Remove Left Cover. "Removing the Left Cover" on page 80
2. Remove Right Cover. "Removing the Right Cover" on page 80
3. Remove Rear Cover Unit. "Removing the Rear Cover Unit / Duplex Feed Unit" on page 81
4. Remove Engine Controller Board. "Removing the Engine Controller Board" on page 87
5. Remove Fixing Unit. "Removing the Fixing Unit" on page 98

### Procedure

1. Remove Harness guide [1] and Main Motor [2]
  - 2 Hook [3]
  - 3 Screw [4]

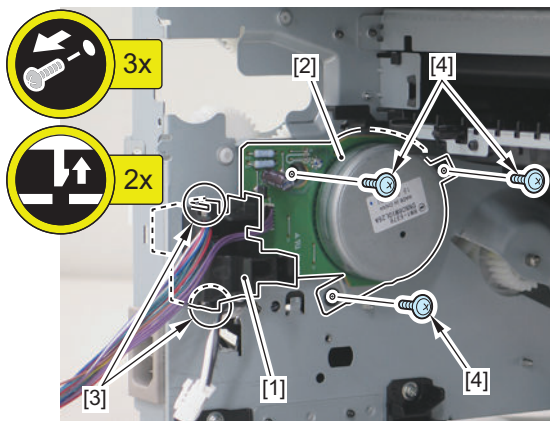

2. Remove Main Fan [2].

- 1 Connector [3]
- 2 screws [4]

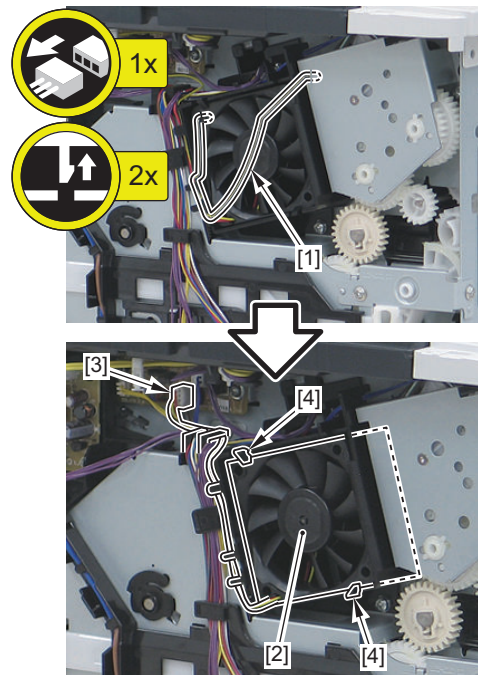

## Removing the Main Drive Unit

### Preparations

1. Remove Left Cover. "Removing the Left Cover" on page 80
2. Remove Right Cover. "Removing the Right Cover" on page 80
3. Remove Rear Cover Unit. "Removing the Rear Cover Unit / Duplex Feed Unit" on page 81
4. Remove All-Night Power Supply PCB. "Remove the All-Night Power Supply PCB" on page 86
5. Remove Main Fan. "Removing the Main Fan" on page 91
6. Remove Duplex Reverse Sensor Unit. "Remove the Duplex Reverse Sensor Unit" on page 86

## Removing the Main Fan

### Preparations

1. Remove Left Cover. "Removing the Left Cover" on page 80
2. Remove Right Cover. "Removing the Right Cover" on page 80
3. Remove Rear Cover Unit. "Removing the Rear Cover Unit / Duplex Feed Unit" on page 81
4. Remove Upper Cover Unit. "Removing the Upper Cover Unit" on page 82

### Procedure

1. Remove grounding spring [1].

## ■ Procedure

### 1. Remove the Harnesses [1].

- 2 harness guide [2]
- 5 Connectors [3]

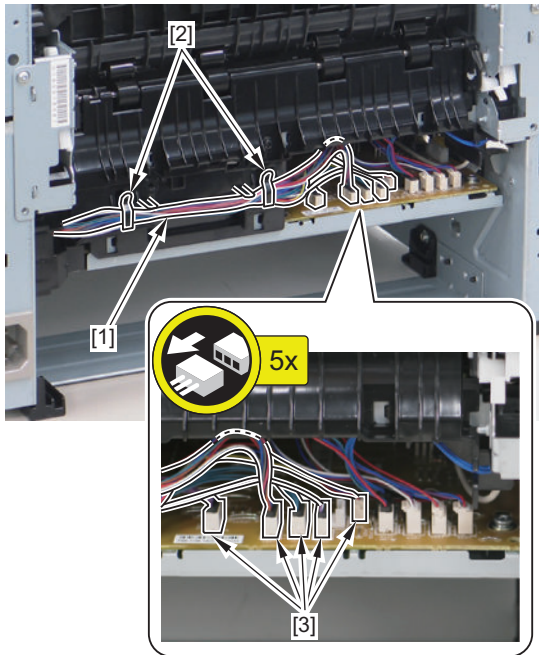

### 2. Remove Gear [1]

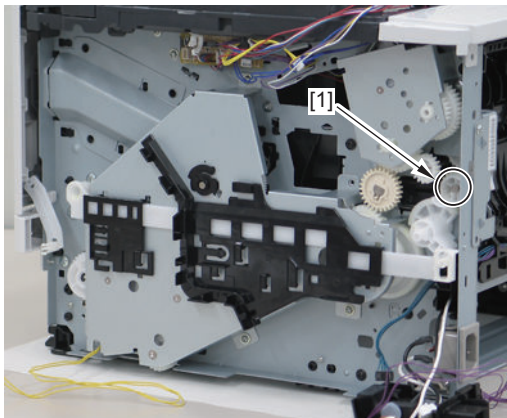

### 3. Remove harnesses from the guide [3].

- 3 Connectors [1]
- 1 Wire Saddle [2]

### 4. Remove main switch unit [4].

- 1 Screw [5]

### 5. Remove Link Arm [6].

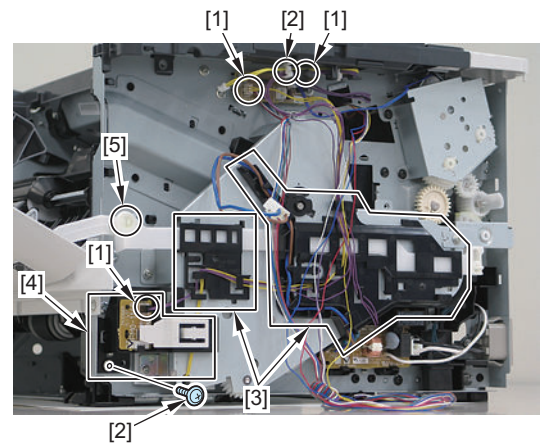

### 6. Remove Power Supply PCB Unit

- 2 Connector [1]
- 1 Wire Saddle [2]

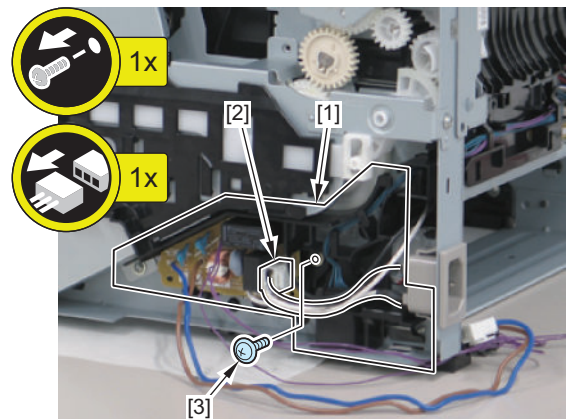

### 7. Remove Plate [2]

- 2 Screw [1]

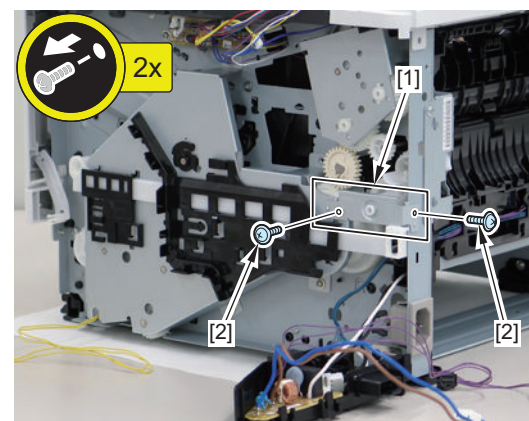

### 8. Remove Link guide [3] and remove Link Arm [4].

## 9. Remove Main Drive Unit [1].

- 4 Screw [2]

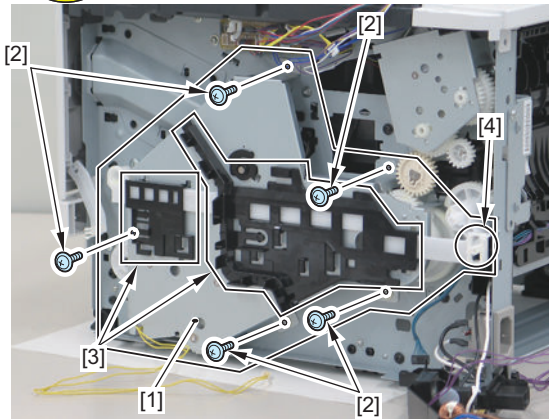

### CAUTION:

The main drive gears are not fastened to the metal plate. Take care that the gears do not come apart.

## Removing the Duplex Drive Unit

### Preparations

1. Remove Right Cover. "Removing the Right Cover" on page 80
2. Remove Main Fan. "Removing the Main Fan" on page 91

## Procedure

### 1. Remove Duplex Drive Unit [1].

- 3 Screw [2]

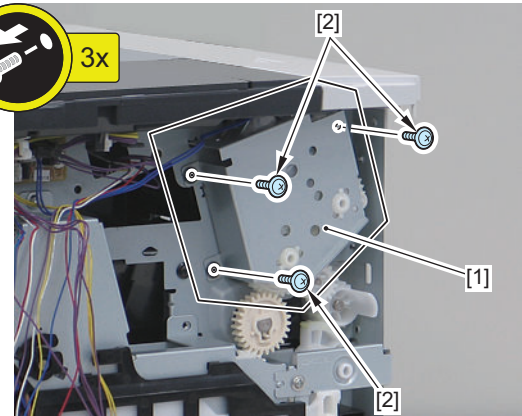

### CAUTION:

Be sure to install the black gear [2] to the side where a left-direction arrow [1] is marked.

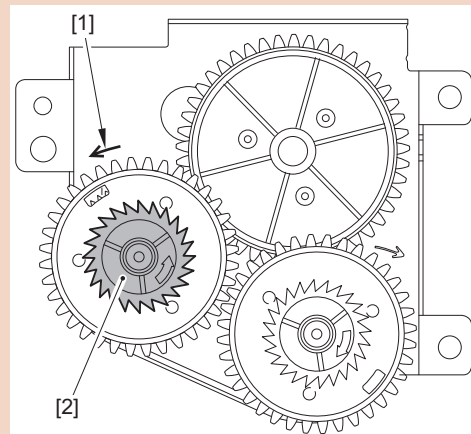

## Removing the Cassette Pickup Solenoid

### Preparations

1. Remove Right Cover. "Removing the Right Cover" on page 80

## ■ Procedure

### 1. Remove main switch unit [1].

- 1 Screw [2]
- 1 Connector [3]

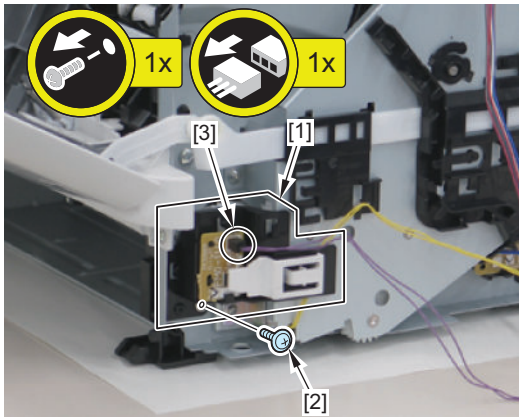

### 2. Remove Cassette Pickup Solenoid [1].

- 1 Screw [2]
- 1 Connector [3]

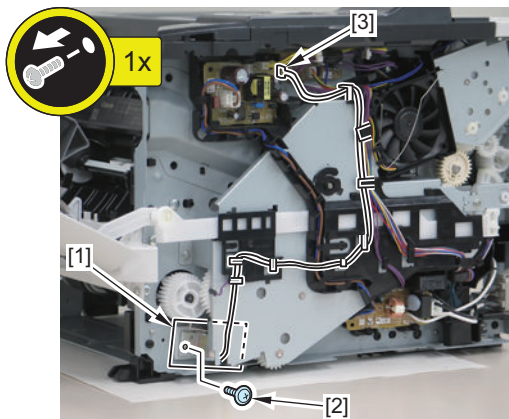

## ● Removing the Multi-purpose Solenoid

### ■ Preparations

1. Remove Left Cover. [“Removing the Left Cover” on page 80](#)

## ■ Procedure

### 1. Remove Multi-purpose Solenoid [1].

- 1 screws [2]
- 1 Connector [3]
- 2 Wire Saddle [4]

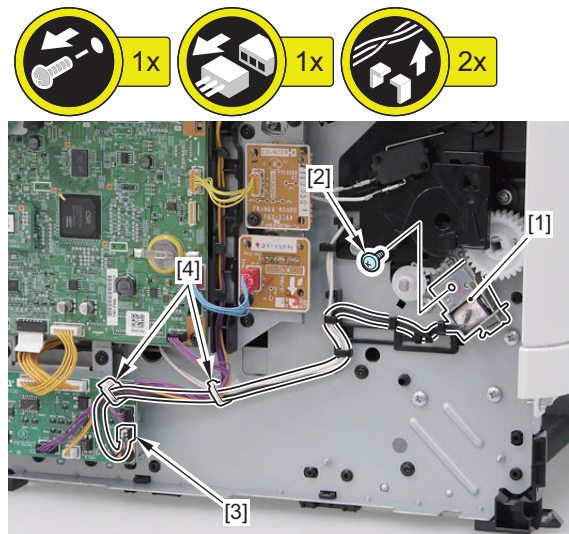

## ● Removing the Duplex Reversal Solenoid

### ■ Preparations

1. Remove Right Cover. [“Removing the Right Cover” on page 80](#)
2. Remove Main Fan. [“Removing the Main Fan” on page 91](#)
3. Remove Duplex Drive Unit. [“Removing the Duplex Drive Unit” on page 93](#)

### ■ Procedure

#### 1. Remove Duplex Reversal Solenoid [1].

- 1 Connector [2]
- 1 Screw [3]

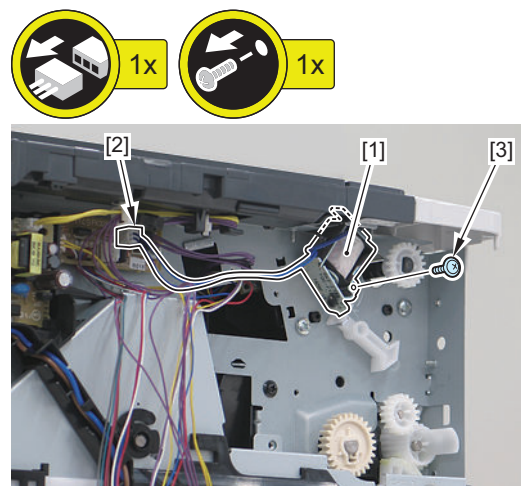

## Removing the Wireless LAN PCB

### ■ Preparations

1. Remove Left Cover. “Removing the Left Cover” on page 80

### ■ Procedures

1. Remove the Wireless LAN PCB [1].

- 1 Connector [2]
- 1 Screws [3]
- 1 Edge Sddles [4]

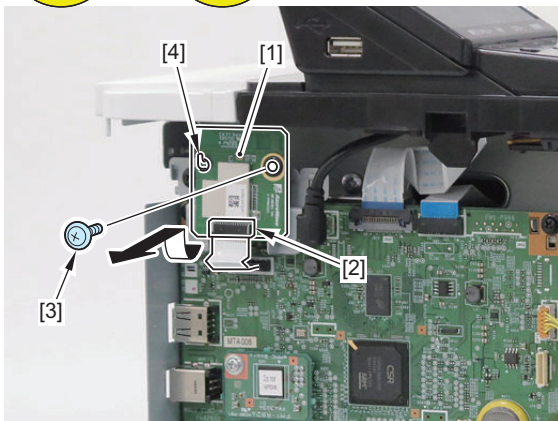

## Laser Exposure System

### Removing the Laser Scanner Unit

#### ■ Preparations

1. Remove Right Cover. "Removing the Right Cover" on page 80
2. Remove Left Cover. "Removing the Left Cover" on page 80
3. Remove Rear Cover Unit. "Removing the Rear Cover Unit / Duplex Feed Unit" on page 81
4. Remove Upper Cover Unit. "Removing the Upper Cover Unit" on page 82

#### ■ Procedure

##### 1. Remove Laser Scanner Unit [1].

- 1 Sponge [2]
- 1 Connector [3]
- 1 Flat cable [4]
- 4 Screw [5]

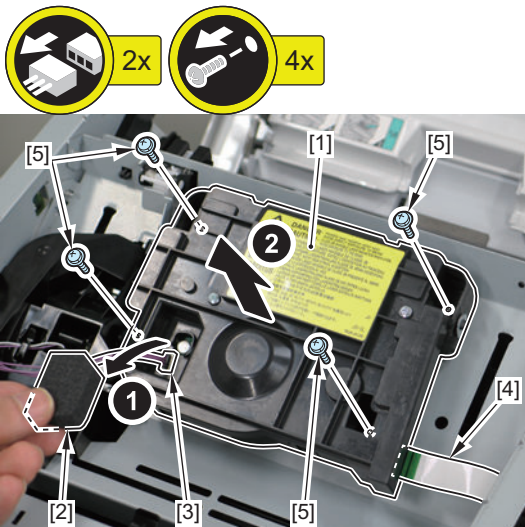

#### CAUTION:

Do not disassemble the laser scanner unit at a field. It may cause a malfunction.



## Image Forming System

### Removing the Transfer Roller

#### Procedure

##### CAUTION:

When assembling / disassembling the transfer charging roller, hold the shaft or bushing of the transfer charging roller and do not touch the sponge parts.

1. Press Release Button [1] and open Front Cover Unit [2].
2. Pinch the Holder [1] and Remove It In the Direction Of the Arrow.
3. Remove the Transfer Roller [2] In the Direction Of the Arrow.

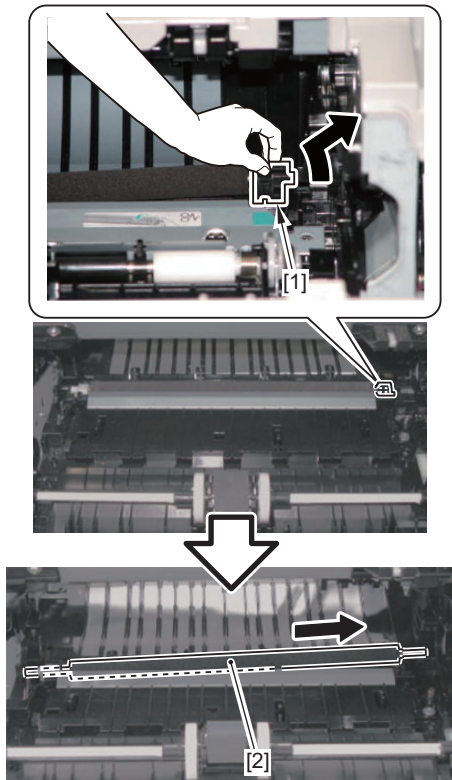

### Removing the Registration Unit

#### Preparations

1. Remove Left Cover. "Removing the Left Cover" on page 80
2. Remove Right Cover. "Removing the Right Cover" on page 80

3. Remove Rear Cover Unit. "Removing the Rear Cover Unit / Duplex Feed Unit" on page 81
4. Remove Upper Cover Unit. "Removing the Upper Cover Unit" on page 82

#### Procedure

1. Remove tab [1] and gear [2].

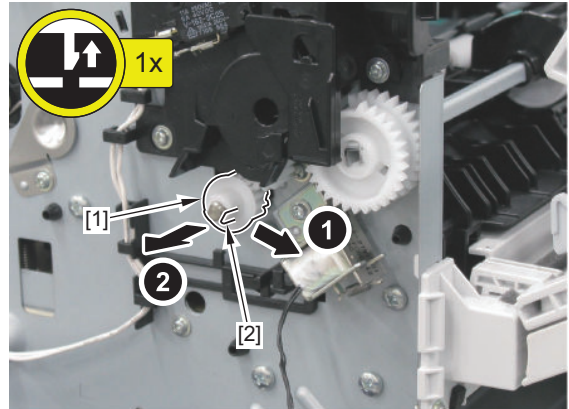

2. Lift guide [1] up to remove.
  - 2 Hook [2]

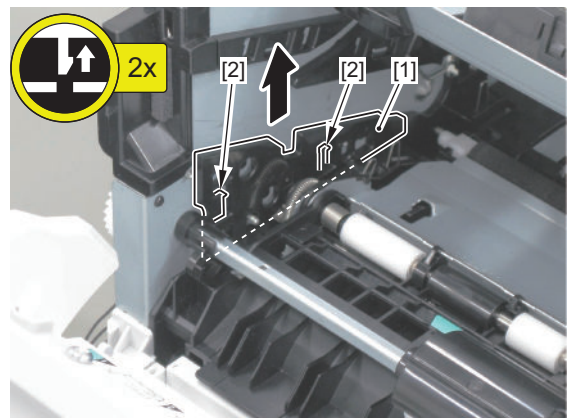

3. Remove gear cover [3] and Registration Unit [1].
  - 5 Screw [2]

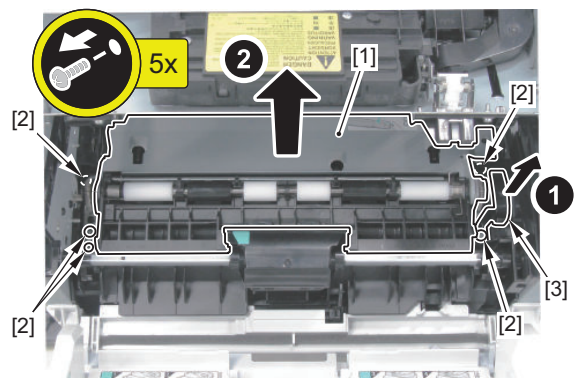



## Fixing System

### Removing the Fixing Unit

#### Preparations

1. Remove Left Cover. "Removing the Left Cover" on page 80
2. Remove Right Cover. "Removing the Right Cover" on page 80
3. Remove Rear Cover Unit. "Removing the Rear Cover Unit / Duplex Feed Unit" on page 81

#### Procedure

##### CAUTION:

When removing the fixing assembly, perform the operation after the fixing assembly is surely cooled. The fixing assembly just after printing may cause burn injury.

1. Close Front Cover. Turn a gear to the position that can take off the fixing assembly.

2. Remove 3 gears.

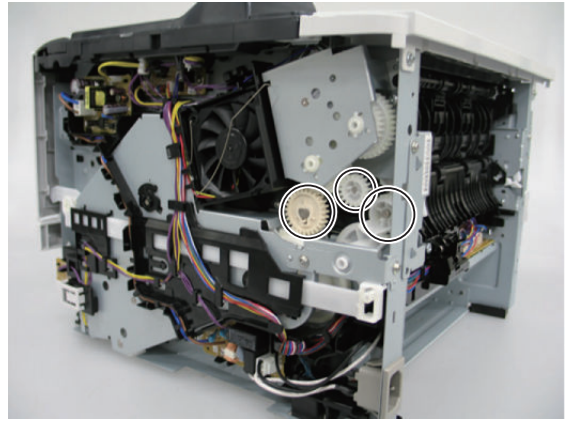

##### CAUTION:

Points to Note at Installation:

- Close Front Cover.
- Fit the Protrusion [2] of the Gear [1] With the Cut-off of the Gear [3] and Install it.
- Fit the Cut-off [4] of the Gear [1] With the Teeth of the Fan Gear [5] and Install it.

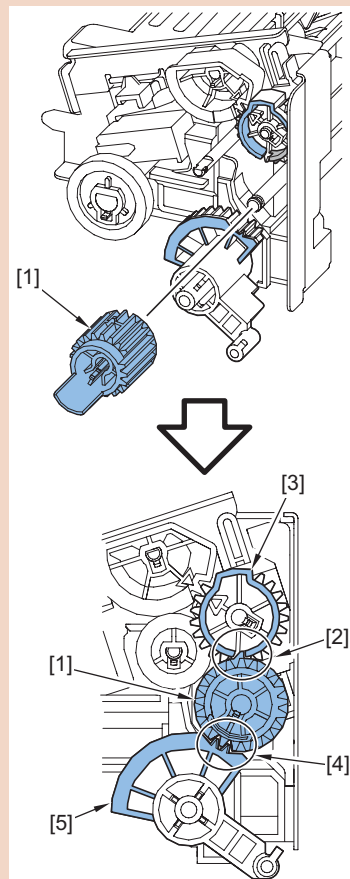

**3. Remove Duplex Reverse Sensor Unit [1].**

- 1 Screws [2]
- 1 Connector [3]

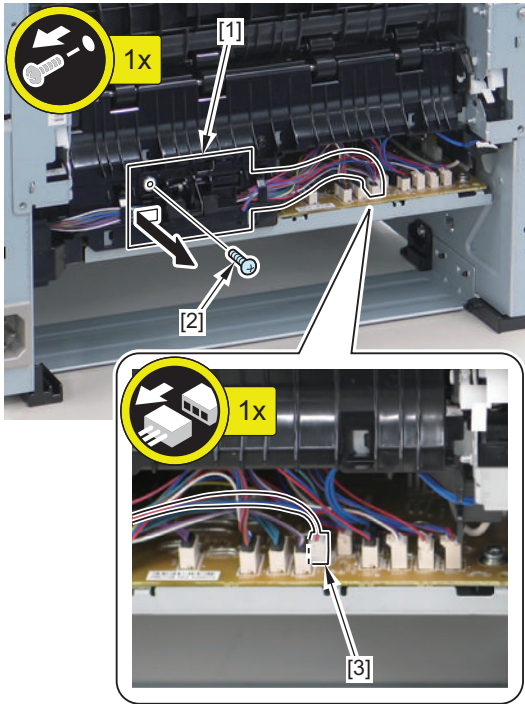

**5. Remove Feed guide [1].**

- 1 Screw

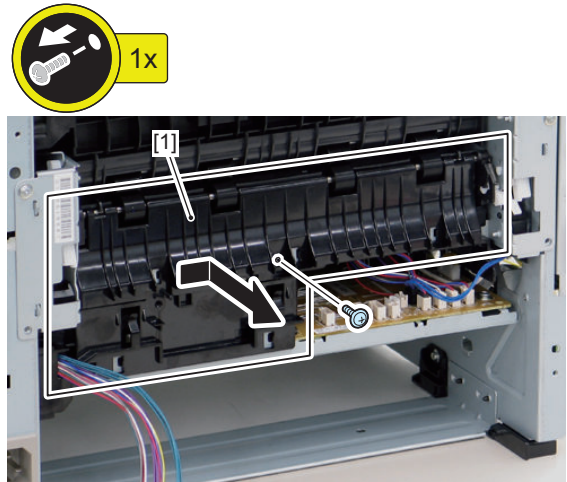

**4. Remove harness [1].**

- 2 harness guide [2]
- 5 Connector [3]

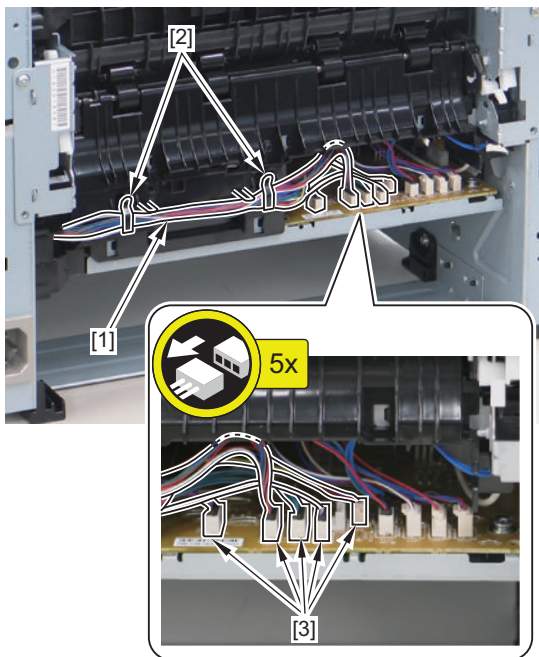

**6. Remove Fixing Unit [1].**

- 3 Connectors [2]
- 1 Terminal [3]
- 2 Screws [4]

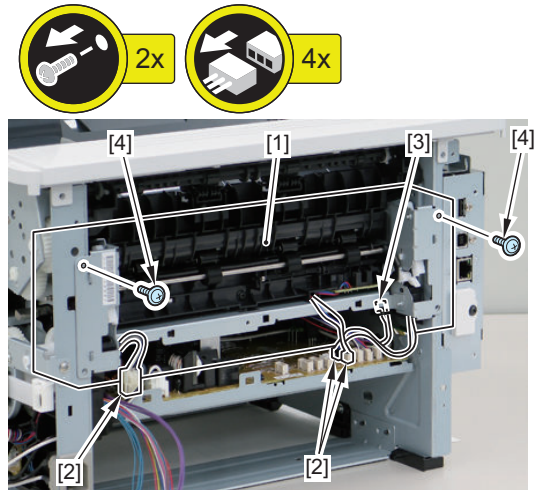

**CAUTION:**

Do not disassemble the Fixing Unit at a field. It may cause a malfunction.

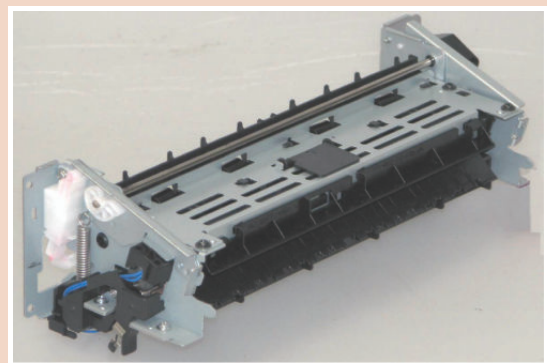

## Paper Pickup/Transport/Output System

### Removing the Cassette Pickup Roller

**CAUTION:**

Do not touch the surface of the Cassette Pickup Roller when removing or mounting it.

1. Remove Cassette.
2. Lift Lever [1] and move Duplex Feed Unit [2] downwards.

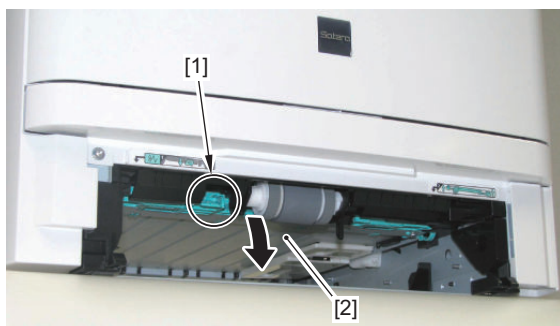

**CAUTION:**

During reassembly, 2 raise Lever [1] of Duplex Feed Unit and attach Duplex Feed Unit [3] to Main Unit by using 2 magnet [2] on each side.

3. Rotate left-side bushing [1] in arrow direction.
  - 1 Tab [2]

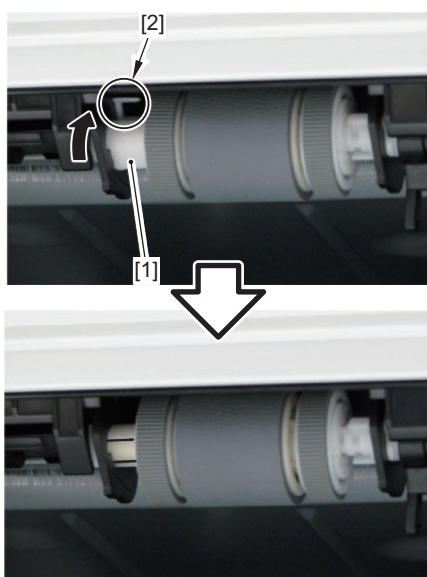

4. Remove Cassette Pickup Roller [1] in arrow direction.

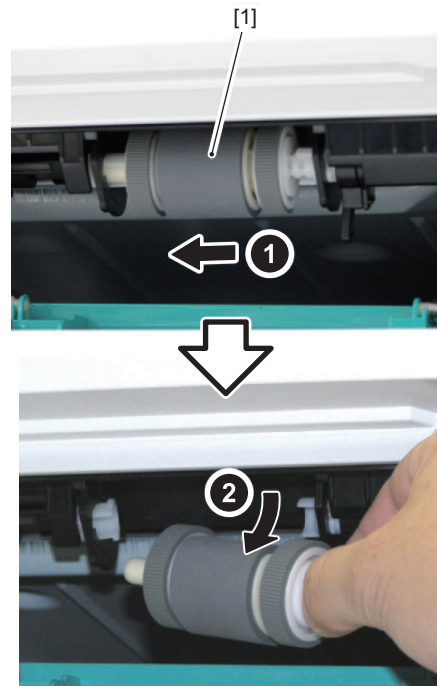

5. Remove 2 Pickup Toller [2] from Cassette Pickup Roller [1].

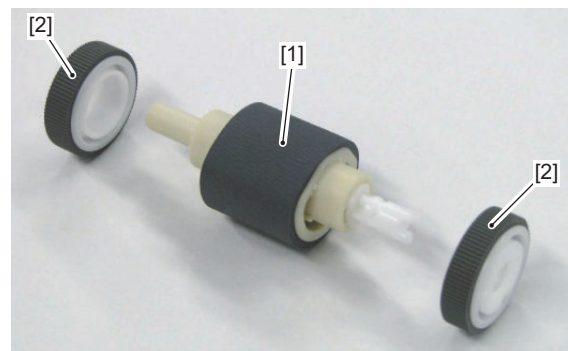

### Removing the Cassette Separation Pad

**CAUTION:**

Do not touch the surface of the Cassette Separation Pad when removing or mounting it.

1. Remove Cassette.

## 2. Remove Cassette Separation Pad [1].

- 2 Screw [2]

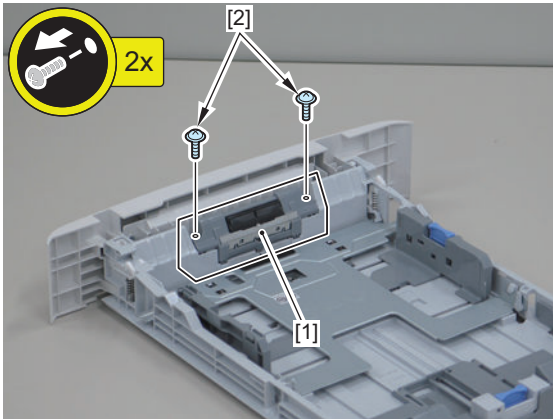

## Removing the Multi-purpose Pickup Roller

### CAUTION:

Do not touch the surface of the Multi-purpose Pickup Roller when removing or mounting it.

1. Press Release Button [1] and open Front Cover Unit [2].

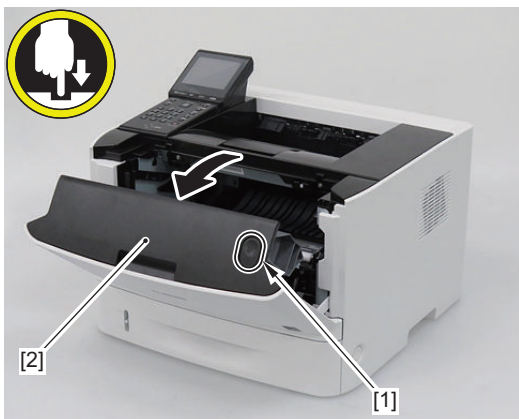

2. Open pickup roller cover [1].

3. Open pickup roller holder [2] and remove Multi-purpose Pickup Roller [3].

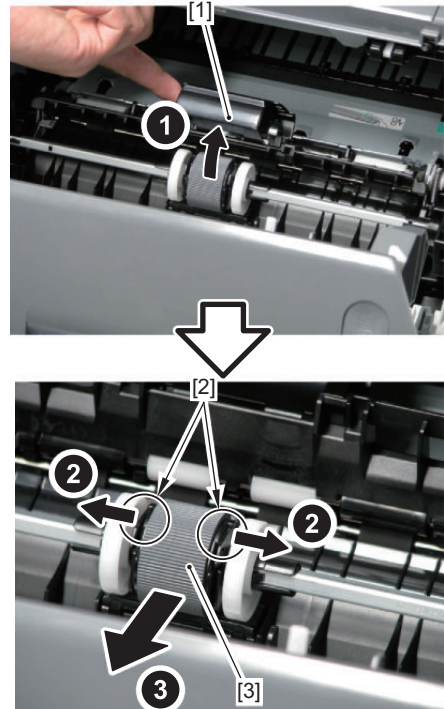

## Removing the Multi-purpose Separation Pad

### ■ Preparations

1. Remove Multi-purpose Pickup Roller. "Removing the Multi-purpose Pickup Roller" on page 101

### ■ Procedure

### CAUTION:

Do not touch the surface of the Multi-purpose Separation Pad when removing or mounting it.

1. Open Front Cover [1].
2. While pushing down the manual tray [1], insert a flatblade screwdriver into the Multi-purpose Separation Pad [2] clearance and prize it open.

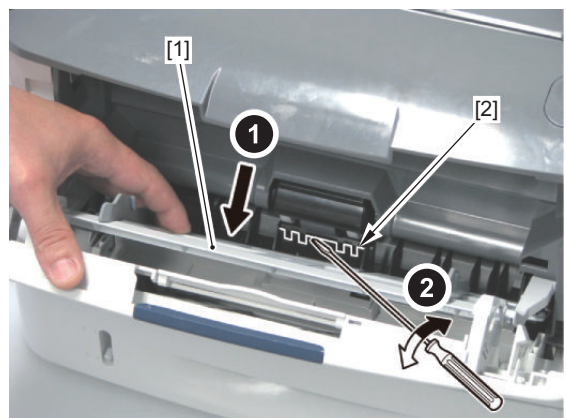

**3. Press Release Button and open Front Cover Unit [1].**

- Remove Multi-purpose Separation Pad [2].

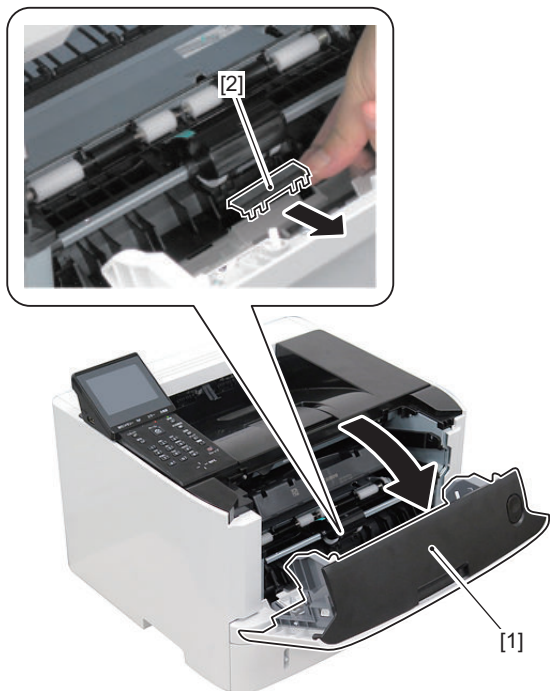



# Troubleshooting

Trouble Shooting.....	104
Version Upgrade.....	108
Corrective Actions.....	114
Debug Log .....	120

## Trouble Shooting

### Test Pages

Printing test pages helps determine if the printer is functioning.

#### CAUTION:

There are two types of test pages: engine-test page and Main Controller-test page. Print a test page to make sure the printer engine and the Main Controller are functioning.

#### ■ Engine-test page

There are two types of engine-test pages simplex print and duplex print.

##### a. Simplex print

Open and close the cartridge door three times continuously within 2 seconds during the standby period. The engine-test page should have a test print pattern on one side of media as shown below.

##### b. Duplex print

Open and close the cartridge door five times continuously within 2 seconds during the standby period. The engine-test page should have a test print pattern on both sides of media as shown below.

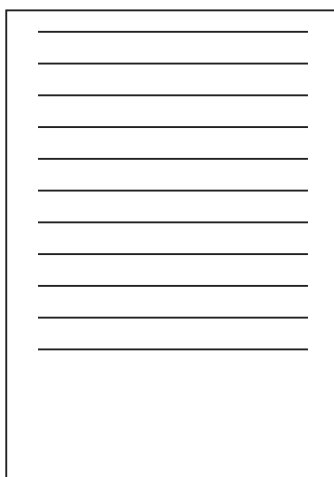



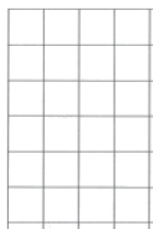

#### ■ Overview

This product provides the following 7 test chart types to determine causes of faulty images.

The data for test charts are created in the main controller. If no problem is found on the output test charts, the cause may lie in the PDL input or the reader.

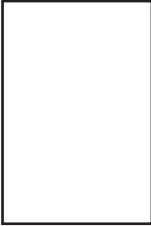
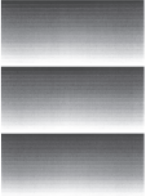
TYPE No.	Test chart type	image check item
0	Grid Bk	Right angle accuracy Straight line accuracy 

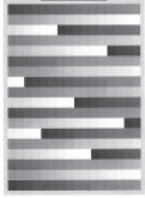
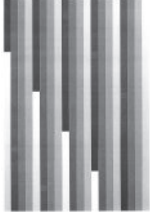
TYPE No.	Test chart type	image check item
1	Halftone	Transfer failure, Black line, White line, Margin 
2	Solid black	Transfer failure, White line, Margin 
3	Solid white	Fogging 
4	17 gradations	Tone confirmation 
5	Thin horizontal line	Feed confirmation 
6	Pascal correction	Tone confirmation 
7	Chart128	Tone confirmation 

## ■ Selecting test chart

### 1. Select the following item in service mode.

- TESTMODE > PRINT > PG-TYPE

### 2. Enter the TYPE NO



3. The settings for test print can be changed in the following service mode. If the settings are not changed, a test print will be executed with the default values of service mode settings.

Item	Description	Default value
TESTMODE > PRINT > COUNT	Enter the number of sheets to output. Settings: 1 to 99	1
TESTMODE > PRINT > PHASE	Setting of PG 2-sided mode Even if 2-sided print is set for a machine that only supports 1-sided print, the setting is disabled. Settings: 0 : 1-sided 1 : 2-sided	0
TESTMODE > PRINT > MODE	To set the image formation method for the test print. If PG-TYPE is 0/1, this setting is disabled because a specific image formation method is applied. Settings: 0: TBIC 1: Resolution dithering 2: Gradation dithering 3: Color tone dithering 4: High-resolution dithering	0
TESTMODE > PRINT > THRU	Setting of image correction table at test print Settings: 0 : Normal gamma LUT 1 : Through (linear) gamma LUT	0
TESTMODE > PRINT > DENS	This setting is used to adjust the F value of the engine of test print. The density increases as the value increases. Settings: -4 to 4	0
TESTMODE > PRINT > MABK	This setting is used to perform thinning to reduce toner scattering during test print. The thinning amount of toner increases in accordance with Mode 1 to Mode 4. Settings: 0: OFF 1: Mode1 2: Mode2 3: Mode3 4: Mode4	0
TESTMODE > PRINT > FEED	This setting is used to specify the paper source used when outputting FEED test print. In order to specify the Multi-purpose Tray, paper needs to be set and the paper size and paper type need to be specified (just like other paper sources). If the Cassette 2 is specified when the Cassette 2 does not exist, paper will be fed from the Cassette 1. Settings: 0:MPTray 1:Cassette1 2:Cassette2 3:Cassette3 4:Cassette4	1

4. Select the following item in service mode.

- TESTMODE > PRINT > PG-TYPE > START

## Confirming nip width

This product does not provide the function to adjust nip width. Improper nip width, however, may cause faulty fixing. To avoid potential faults, confirm the nip width of the fixing assembly in the following steps.

1. Set Test print Type No.2 and print solid black.
2. Set the solid black sheet face-down to the cassette of this product.
3. Set Test print Type No.3 and print a solid white image on the sheet.

**4. When the tip of the paper comes out to Output tray, Open a Front cover and make the door opening jam.**

Close Front cover immediately. (To make it a pressurization state)

Wait for about 20 seconds.

Open Front cover and take out jam paper.

**5. Measure the glossy part on the printed sheet as shown in the figure below to confirm if the width is in the tolerable ranges.**

- Center (a): 6 to 9 mm
- Sides(b): 6 to 9 mm
- Sides(c): 6 to 9 mm

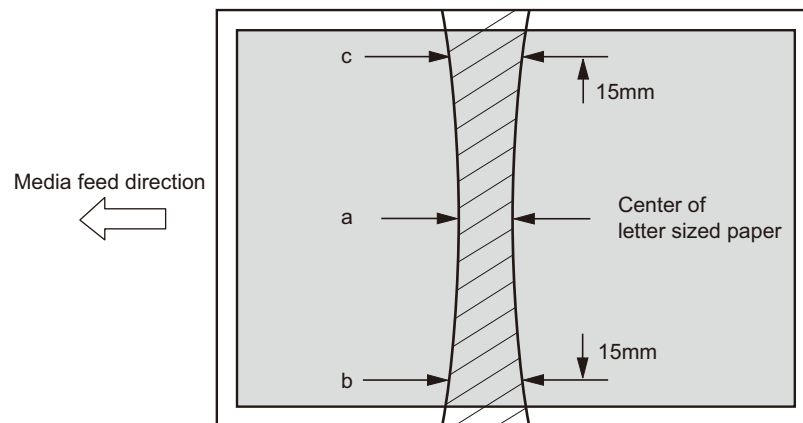

## Version Upgrade

### Overview

This machine supports the following two methods for upgrading the firmware.

1. User Support Tool (UST)
2. Via Internet

### ■ Checking the Version

In order to check the model name and the version, it is necessary to following procedure.

1. Home key > System Management Settings > Update Firmware > Version Information
2. You can upgrade the machine when the downloaded UST is later than the machine's version.

### Version Upgrade Using UST

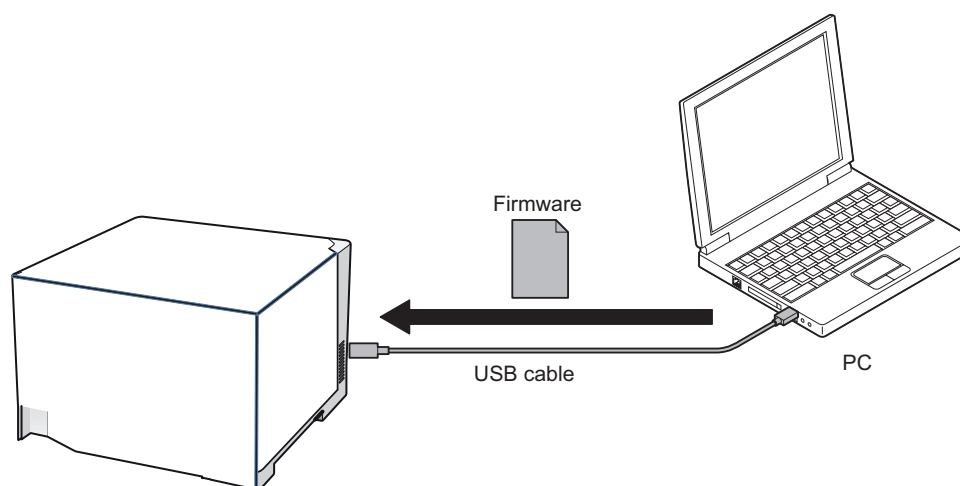

Firmware Configuration

Firmware	Function	Storage area
BOOTROM	Startup of the main controller	Main Controller PCB
BOOTABLE	Overall control	Main Controller PCB
LANGUAGE	Manage languages used in panel / Remote UI and font data.	Main Controller PCB

A number of firmware may be less than the above depending on the UST version.

### ■ Preparation

#### ● System Requirements

- OS (one of the following)
  - Microsoft Windows Server 2003
  - Microsoft Windows Vista
  - Microsoft Windows Server 2008
  - Microsoft Windows 7
  - Microsoft Windows Server 2012
  - Microsoft Windows 8

- PC
  - Compatible to the selected
  - OSMemory (RAM): 128MB or more free space
  - Hard Disk: 100MB or more free space
  - Display: 640x480 pixels or more in resolution, 256 tones or more
  - With USB ports
- UST file for this product\*
  - \*: Download the corresponding file from the service site (ask the service technician in charge for details)
- USB cable (USB1.1/2.0)

## • Before Downloading the System Software

1. Start up the PC.
2. Connect the host machine and the PC with a USB cable.
3. Turn on the host machine, and place it in the standby status.

## • Downloading System Software

1. Home key or Menu key > System Management Settings > Update Firmware > Via PC
2. Open UST.

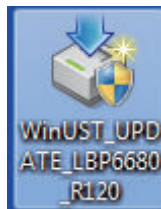

3. Take a note of the firmware version to upgrade and click [Next] button.

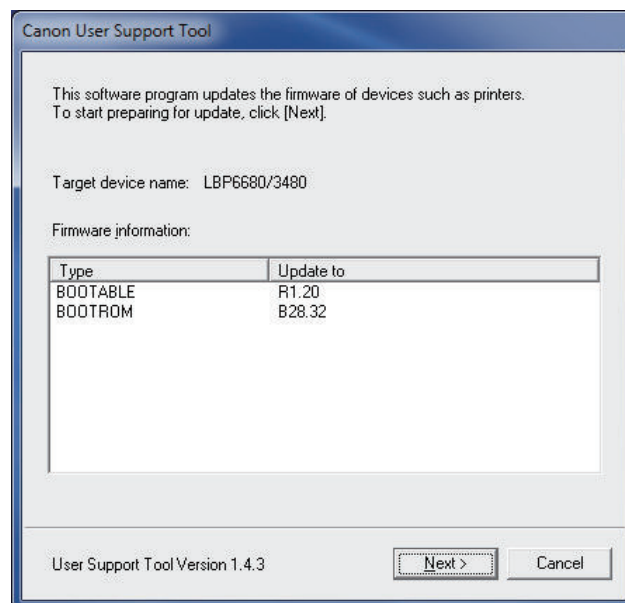

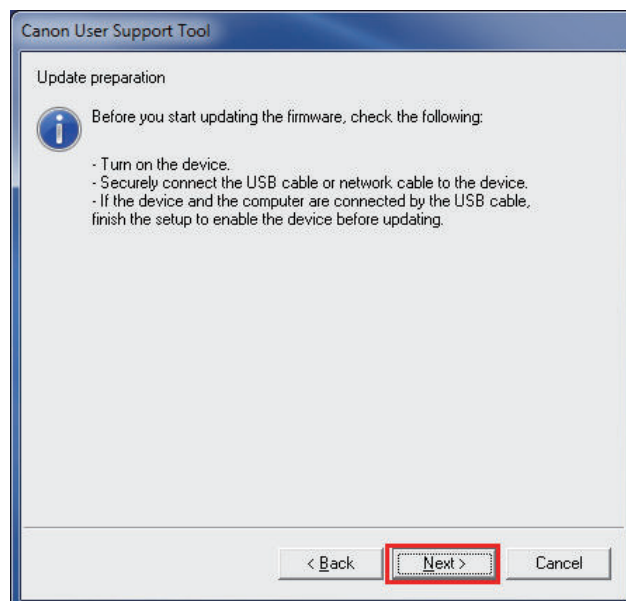
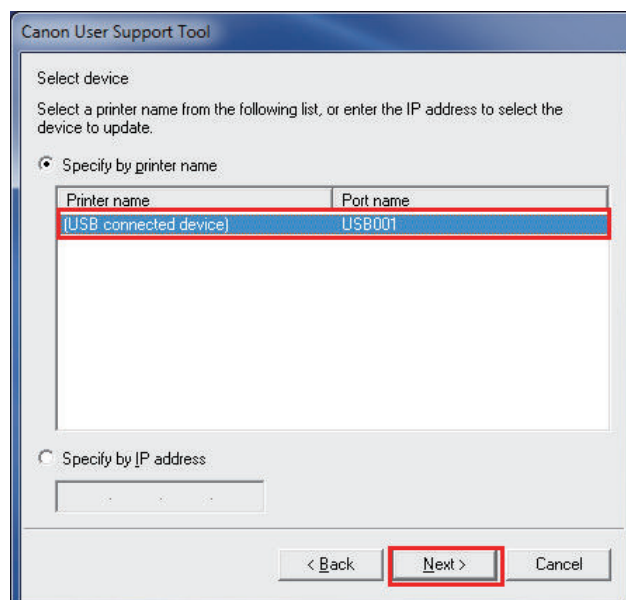
**4. Click [Next] button.****5. Select [USB Device] and click [Next] button.**

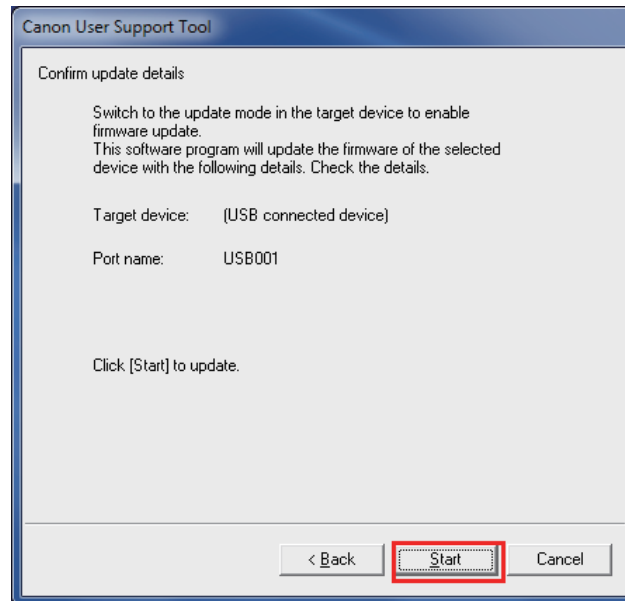
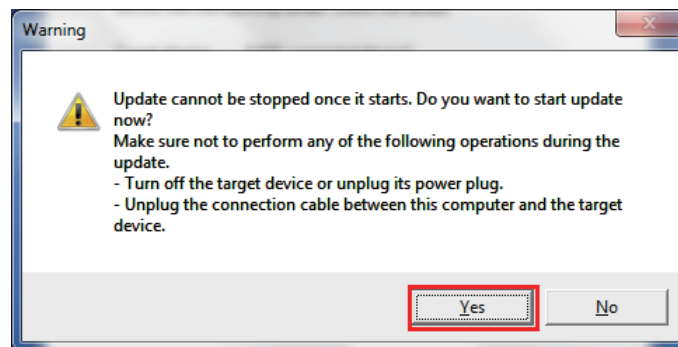
**6. Click [Start] button.****7. Click [Yes] button for the warning message to start download.**

Start download

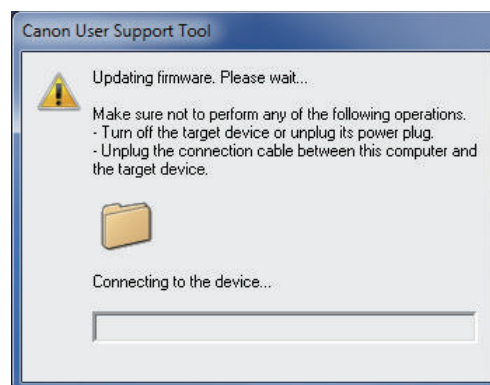

8. Click [OK] button when download is completed. Reboot a device.

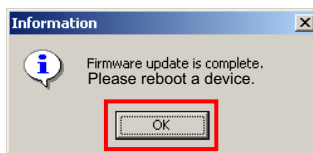

**CAUTION:**

When the Control Panel still shows the download screen even after the host machine is restarted, the internal firmware update has not been completed. Leave it as is for 10 minutes or more and press the Stop button.

9. Perform Version Information, and make sure that the firmware version matches the Version Information.

## Upgrading via Internet

### Overview

Select to automatically install the firmware update without using a computer.

### Preparation

1. Check that there are no other jobs being executed.
2. In an environment where access is obtained via a proxy server, the proxy setting is made from the remote UI.  
Settings/Registration > Network Settings > TCP/IP Settings > Proxy Settings > Edit... > Use Proxy(select)Select the [Use Proxy] check box and specify the required settings.

### Procedure

1. Press the [Menu] key, and update the firmware via the Internet in user mode.  
System Management Settings > Update Firmware > Via Internet

**NOTE:**

- Refer to the User's Manual of the device for how to connect the device to the external network.
- This is applicable either in a wired LAN environment or a wireless LAN environment.

### Messages

The message displayed on the device operation panel is as follows.

No.	Error message	The timing of occurrence	Remedy
1	Job in progress... Wait a moment, then try again.	If there is a job being executed:	1. Wait until the job is completed. 2. Cancel the job.
2	Cannot check the firmware version. (Server communication error.)	Network error	1. Check whether the device can be connected to the external network. 2. Check whether the proxy setting has been made (in case of access via a proxy server).
3	Cannot download the firmware. (Error during download.)		1. Check whether the device can be connected to the external network. 2. Check whether the proxy setting has been made (in case of access via a proxy server). 3. Check that the serial number of the host machine is shown on the Main Controller PCB.
4	***DOWNLOAD MODE*** NETWORK AVAILABLE IP ADDRESS IP address of the machine PRESS STOP KEY TO EXIT	If update (writing) of the firmware has ended in failure:	1. Update the firmware again using UST.

No.	Error message	The timing of occurrence	Remedy
5	***DOWNLOAD MODE*** FAILED TO UPDATE	If update (writing) of the firmware has ended in failure:	1. Update the firmware again using UST.
6	***DOWNLOAD MODE*** UPDATE IS COMPLETE	If the update of the firmware is successful	-



## Corrective Actions

### Image Defects

#### Light print



Image is light in entire page

Cause	Solution
1) Print density is not adjusted properly	Adjust the print density.
Open the Cartridge Cover Unit during a print operation and remove the cartridge. Open the Photosensitive Drum shield of the cartridge to check the toner image on the drum surface. If the toner image is not fully transferred to the media, go to step 2. If the toner on the Photosensitive Drum is faint, go to step 5. Do not open the drum shield for longer than 10 seconds.	
2) The Transfer Roller is deformed or has deteriorated	Replace the Transfer Roller.
3) Poor contact exists between the Transfer Roller and its shaft	Clean the contact if dirty.
4) The High-Voltage Power Supply is defective	Replace the Engine Controller.
5) The Laser Scanner Unit is defective	Replace the Laser Scanner Unit.
6) The CRG is defective	Replace the CRG.

#### Dark print



Image is obviously dark

Cause	Solution
1) Print density is not adjusted properly	Adjust the print density.
2) The Transfer Roller is deformed or has deteriorated	Replace the Transfer Roller.
3) Poor contact exists between the Transfer Roller and its shaft	Clean the contact if dirty.
4) The High-Voltage Power Supply is defective	Replace the Engine Controller.
5) The Laser Scanner Unit is defective	Replace the Laser Scanner Unit.

## ■ Completely blank

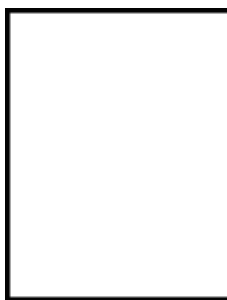

No image prints

Cause	Solution
1) The Laser Shutter open/close projection part of the cartridge is damaged	Replace the cartridge.
2) The Laser Shutter Arm and Laser Shutter are malfunctioning or damaged	If the Laser Shutter Arm or Laser Shutter does not move smoothly or if the part is damaged, replace any defective parts.
3) Poor developing bias contact with the cartridge	Clean the contact if dirty.
4) The High-Voltage Power Supply is defective	Replace the Engine Controller.

## ■ All black

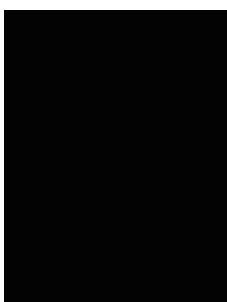
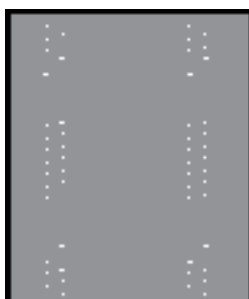

Image is all black

Cause	Solution
1) Poor primary charging bias contact with the cartridge	Clean the contact if dirty.
2) The Primary Charging Roller is defective	Replace the cartridge.
3) The High-Voltage Power Supply is defective	Replace Engine Controller.

## ■ White spots



White spots appear in image

Cause	Solution
1) Poor contact exists to the static charge eliminator	Clean the contact if dirty.
2) The Transfer Roller is deformed or has deteriorated	Replace the Transfer Roller.
3) Poor contact exists between the Transfer Roller and its shaft	Clean the contact if dirty.

Cause	Solution
4) The High-Voltage Power Supply is defective	Replace the Engine Controller.

## ■ Dirt on back



The back of page is dirty

Cause	Solution
1) The print media is dirty	Replace the print media to new one. Advise the customer on how to store the print media.
2) Dirt on leading edge of image (Cassette Pickup Roller)	Clean the Cassette Pickup Roller. If the dirt does not come off, replace the roller.
3) Repetitive dirt (Registration Slave Roller, Transfer Roller or Pressure Roller)	See "Repetitive image defects ruler" to identify the dirty roller. Clean the dirty roller. If the dirt does not come off, replace the roller.
4) The Feed Guide Unit or Fixing Inlet Guide is dirty	Clean the dirty parts.

## ■ Vertical lines



Vertical line appears in image

Cause	Solution
1) Scratches on the circumference of the Photosensitive Drum	Replace the cartridge.
2) The Fixing Inlet Guide is dirty	Clean the Fixing Inlet Guide.
3) Scratches on the Fixing Film Unit	Replace the Fixing Assembly.

## ■ Horizontal lines



Horizontal line appears in image

Cause	Solution
1) Horizontal scratches on the Photosensitive Drum	Replace the cartridge.
2) The Fixing Film Unit is dirty, deformed or worn	Replace the Fixing Assembly.

## ■ Dirt on front



The front of page is dirty.

Cause	Solution
1) The print media is dirty	Replace the print media to new one. Advise the customer on how to store the print media.
2) Dirt on leading edge of image (Multi-purpose Tray Pickup Roller)	Clean the Multi-purpose Tray Pickup Roller. If the dirt does not come off, replace the roller.
3) Repetitive dirt (Registration Slave Roller, Fixing Film Unit unit or cartridge)	See "Repetitive image defects ruler" to identify the dirty roller. Clean the dirty part. If the dirt does not come off, replace the part.
4) The Delivery Roller is dirty	Clean the Delivery Roller.

## ■ Dropouts



Dropout appears in image

Cause	Solution
1) The Transfer Roller is dirty or deformed	Replace the Transfer Roller.
2) Contact failure between the contact point of the machine and the cartridge	Clean the contact if dirty.
3) The Photosensitive Drum, Primary Charging Roller or Developing Roller is defective	Replace the cartridge.
4) Scratches or foreign substance on the Fixing Film Unit	Replace the Fixing Assembly.
5) The High-Voltage Power Supply is defective	Replace the Engine Controller.

## ■ Vertical white lines

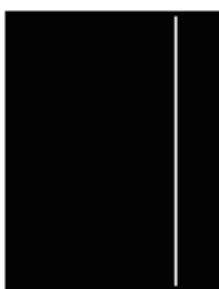

Vertical white line appears in image

Cause	Solution
1) Scratches on the circumference of the Photosensitive Drum	Replace the cartridge.
2) The Developing Roller is defective	Replace the cartridge.
3) Foreign substance adheres to the Laser Beam Window of the printer or cartridge	Remove foreign substance from the Laser Beam Window.
4) Foreign substance adheres to the Fixing Inlet Guide or the guide is dirty	Clean the Fixing Inlet Guide.
5) Scratches or foreign substance on the Fixing Film Unit	Replace the Fixing Assembly.
6) The mirror in the Laser Scanner Unit is dirty	Replace the Laser Scanner Unit.

## ■ Horizontal white lines



Horizontal white line appears in image

Cause	Solution
1) Horizontal scratches on the Photosensitive Drum	Replace the cartridge.
2) The Fixing Film Unit is defective	Replace the Fixing Assembly.

## ■ Loose toner



Toner image is not fully fixed on the media

Cause	Solution
1) The Pressure Roller is not within nip-width specifications	Check the nip-width specifications. If the Pressure Roller is not within the specifications, replace the Fixing Assembly.
2) The Pressure Roller is dirty	Replace the Fixing Assembly.
3) The Pressure Roller is scarred or dent	Replace the Fixing Assembly.
4) Scratches or foreign substance on the Fixing Film Unit	Replace the Fixing Assembly.
5) The Thermistor has deteriorated	Replace the Fixing Assembly.

## ■ Misformed image



Image is misformed

Cause	Solution
1) Poor contact exists to the connectors on the Laser Scanner Unit	Reconnect the connectors: J801, J802.
2) Poor contact exists to the connectors on the DC Controller	Reconnect the connectors: J3, J7.
3) The Laser Scanner Unit is defective	Replace the Laser Scanner Unit.
4) The High-Voltage Power Supply is defective	Replace the Engine Controller.

## ■ Repetitive image defects ruler

Component	Distance between defects (mm)	Image defects			
		Dirt	Dropouts	Dirt on back	Loose toner
Registration Slave Roller	About43	Yes		Yes	
Primary Charging Roller	About38	Yes	Yes		
Photosensitive Drum	About75	Yes	Yes		
Developing Roller	About42	Yes	Yes		
Transfer Roller	About39		Yes	Yes	
Fixing Film Unit unit	About57	Yes	Yes		Yes
Pressure Roller	About63			Yes	Yes

## Debug Log

### Function Overview

The debug log is a log that analyzes the program behavior of the machine to enable developers to identify problems. This machine is embedded with a function that compiles the log of the behavior of each software module as debug log and outputs it as integrated log for analyzing problems.

Be sure to collect the debug log when the Support Dept. of sales company so instructs.

Note that there is no need for service technicians to check the content of collected debug log.

#### ■ Cases in which collection of debug log is effective

Collection of debug log is effective in the following cases:

- Neither the Support Dept. of sales company nor CINC can reproduce the trouble that occurred at the customer site
- When the error frequency is low
- When the failure is suspected to be due to firmware rather than a mechanical/electrical failure.

#### NOTE:

If the procedure for reproducing the failure is clear and the Support Dept. of sales company and CINC can reproduce it, collection of debug log is not necessary.

### Conditions for collecting logs

#### ■ Conditions for not being able to collect logs

In the following cases, the procedure for obtaining logs is not required because logs cannot be obtained.

- Service mode screen cannot be accessed
- The machine cannot recognize a USB flash drive
- No USB port is installed in the machine (when the model has only a copy function)

#### ■ What is necessary to collect logs

A USB flash drive that satisfies the following conditions is required to obtain the debug logs of the machine:

- Formatted in FAT 16/FAT32
- With sufficient free space (of several MB)
- Can be recognized by the machine

### Collection procedure

The following shows the procedure for collecting the debug log from the Control Panel.

1. **Connect the USB memory to the machine. In the case of a model having a USB connector on a side of the Control Panel, be sure to connect the USB memory to the Control Panel. In the case of a model having a USB connector only on the rear side, connect the USB memory to the USB connector on the rear side.**

#### CAUTION:

In the case of a model having a USB connector on the Control Panel, if the USB memory is connected to the USB connector on the rear side, debug logs are not transferred to the USB memory.

2. **Execute the following service mode from the Control Panel or Remote UI.**

- COPIER > FUNCTION > SYSTEM > LOGWRITE

"Executing..." is displayed while log collection is executed. When it is completed, the screen shows the service mode screen again.

**3. Execute the following service mode from the Control Panel or Remote UI.**

- COPIER > FUNCTION > SYSTEM > LOG2USB

"Executing..." is displayed while log collection is executed. When it is completed, the screen shows the service mode screen again.

**4. Remove the USB flash drive by the correct procedure.**

Connect the USB flash memory to the PC, and check that the log file (SUBLOG.TXT) has been saved.

**CAUTION:**

The debug log file (SUBLOG.TXT) that can be collected from the machine is saved in clear text data that is not encrypted. As this data may contain information attributed to the user, it is necessary to gain approval from the user before collecting it.

Also, the collected file needs to be handled in the same manner as that for user data necessary for reproduction.

**NOTE:**

The following information is not included in the debug log of the machine:

- Job list (job name, user name, address)
- Communications log (address, user name)
- Job log (user name, job name)





# Error/Jam/Alarm

Error Codes.....123

## Error Codes

### Overview

This section describes codes shown in case any problem is occurred.

Code type	Description	Reference
Error code	Shown for any problem occurred in the device.	List of error codes
Jam code	This code is displayed when a jam occurs inside the machine.	List of jam codes
Alarm code	This code is displayed when the machine's function has been partially lost.	List of jam codes

### Error Codes

E Code	Detail Code	Item	Description
E000	0000	Title	Error in temperature rising of Fixing Assembly
		Detection description	Temperature of the Fixing Assembly did not reach a certain temperature within the specified period of time.
		Remedy	<ol style="list-style-type: none"> <li>1. Check the connection of connectors between the Fixing Assembly and the Engine Controller PCB.</li> <li>2. If the connector at the Fixing Assembly side does not have induction while the assembly is removed, replace the assembly.</li> <li>3. Replace the Engine Controller PCB.</li> </ol>
E001	0000	Title	Abnormal high temperature of Fixing Assembly
		Detection description	It was detected that the temperature of the Fixing Assembly was abnormally high.
		Remedy	<ol style="list-style-type: none"> <li>1. Check the connection of connectors between the Fixing Assembly and the Engine Controller PCB.</li> <li>2. If the connector at the Fixing Assembly side does not have induction while the assembly is removed, replace the assembly.</li> <li>3. Replace the Engine Controller PCB.</li> </ol>
E003	0000	Title	Abnormal low temperature of Fixing Assembly
		Detection description	After Heater turns on, Main Thermistor detected a temperature of 120 deg C or lower for more than 20 seconds.
		Remedy	<ol style="list-style-type: none"> <li>1. Check the connection of connectors between the Fixing Assembly and the Engine Controller PCB.</li> <li>2. If the connector at the Fixing Assembly side does not have induction while the assembly is removed, replace the assembly.</li> <li>3. Replace the Engine Controller PCB.</li> </ol>
E004	0000	Title	Error in fixing power supply drive circuit
		Detection description	Error in either the Fixing Heater or the Main Motor
		Remedy	<ol style="list-style-type: none"> <li>1. Check the connection of connectors between the Fixing Assembly and the Engine Controller PCB.</li> <li>2. If the connector at the Fixing Assembly side does not have induction while the assembly is removed, replace the assembly.</li> <li>3. Reconnect the connector on the Main Motor.</li> <li>4. Replace the Main Motor.</li> <li>5. Replace the Engine Controller PCB.</li> </ol>
E100	0000	Title	Laser Scanner error
		Detection description	Error is detected in the Laser Scanner or the Scanner Motor.
		Remedy	<ol style="list-style-type: none"> <li>1. Reconnect the connector on Laser Scanner Unit.</li> <li>2. Replace the Laser Scanner Unit.</li> </ol>
E110	0000	Title	Laser Scanner error

E Code	Detail Code	Item	Description
E110	0000	Detection description	The Laser Scanner did not become ready although a specified period of time had passed.
		Remedy	1. Replace the Laser Scanner Unit. 2. Replace the Engine Controller PCB.
E196	1000	Title	ROM writing/reading error
		Detection description	An error occurred when writing/reading data to/from the ROM.
		Remedy	Replace the Main Controller PCB.
E196	2000	Title	ROM writing/reading error
		Detection description	An error occurred when writing/reading data to/from the ROM.
		Remedy	Replace the Main Controller PCB.
E196	3000	Title	ROM writing/reading error (eMMC)
		Detection description	An error occurred when writing/reading data to/from the ROM.
		Remedy	Replace the Main Controller PCB.
E196	3001	Title	ROM-ID mismatch (eMMC)
		Detection description	An error occurred when writing/reading data to/from the ROM.
		Remedy	Replace the Main Controller PCB.
E246	0000	Title	System error
		Detection description	System error
		Remedy	Contact the service company office
E247	0000	Title	System error
		Detection description	System error
		Remedy	Contact the service company office
E350	0000	Title	System error
		Detection description	System error
		Remedy	Contact the service company office
E351	0000	Title	System error
		Detection description	System error
		Remedy	Contact the service company office
E354	0000	Title	System error
		Detection description	System error
		Remedy	Contact the service company office
E355	0000	Title	System error
		Detection description	System error
		Remedy	Contact the service company office
E355	0004	Title	System error
		Detection description	System error
		Remedy	Contact the service company office
E355	0005	Title	System error
		Detection description	System error
		Remedy	Contact the service company office
E733	0000	Title	Printer communication error
		Detection description	Communication error occurred after normal startup.

E Code	Detail Code	Item	Description
E733	0000	Remedy	1. Turn OFF and then ON the main power.
			2. Replace the Main Controller PCB.
E744	0001	Title	Invalid combination of language file versions
		Detection description	Mismatch of the model for which the firmware was downloaded is detected.
		Remedy	Install the firmware according to the model
E744	0002	Title	Language file error
		Detection description	Mismatch of the model for which the firmware was downloaded is detected.
		Remedy	Install the firmware according to the model
E744	1001	Title	Version mismatch
		Detection description	Mismatch of the model for which the firmware was downloaded is detected.
		Remedy	Install the firmware according to the model
E744	4000	Title	Detection of firmware of another model
		Detection description	Mismatch of the model for which the firmware was downloaded is detected.
		Remedy	Install the firmware according to the model
E744	5000	Title	Panel microcomputer error
		Detection description	Mismatch of the model for which the firmware was downloaded is detected.
		Remedy	Install the firmware according to the model
E744	6000	Title	Error in communication with the Wireless LAN Board
		Detection description	Mismatch of the model for which the firmware was downloaded is detected.
		Remedy	1. Check the connection of the Wireless LAN Board.
			2. Install the firmware according to the model
3. Replace the Main Controller PCB.			
E744	7000	Title	Backup microcomputer error
		Detection description	Mismatch of the model for which the firmware was downloaded is detected.
		Remedy	1. Install the firmware according to the model
2. Replace the Main Controller PCB.			
E746	0000	Title	Main Controller PCB error
		Detection description	Microcomputer error
		Remedy	Install the firmware according to the model
			Replace the Main Controller PCB.
E748	2012	Title	System error
		Detection description	System error
		Remedy	Contact the service company office
E760	0000	Title	Firmware error
		Detection description	An error due to the controller software occurred so that print could not be proceeded.
		Remedy	Due to firmware error, the possibility of solving the error by replacing the Main Controller PCB is low.
			Check the downloaded firmware again.
E805	0000	Title	Main Fan error
		Detection description	Main Fan failure is detected.
		Remedy	1. Check the Main Fan or the connector.
			2. Replace the Main Fan
3. Replace the Main Controller PCB.			
E808	0001	Title	Failure detection of Low Voltage Power Supply PCB

E Code	Detail Code	Item	Description
E808	0001	Detection de- scription	Failure detection of Low Voltage Power Supply PCB
		Remedy	1. Check the connection of the Engine Controller or the connector. 2. Replace the Engine Controller PCB.

## JamCode

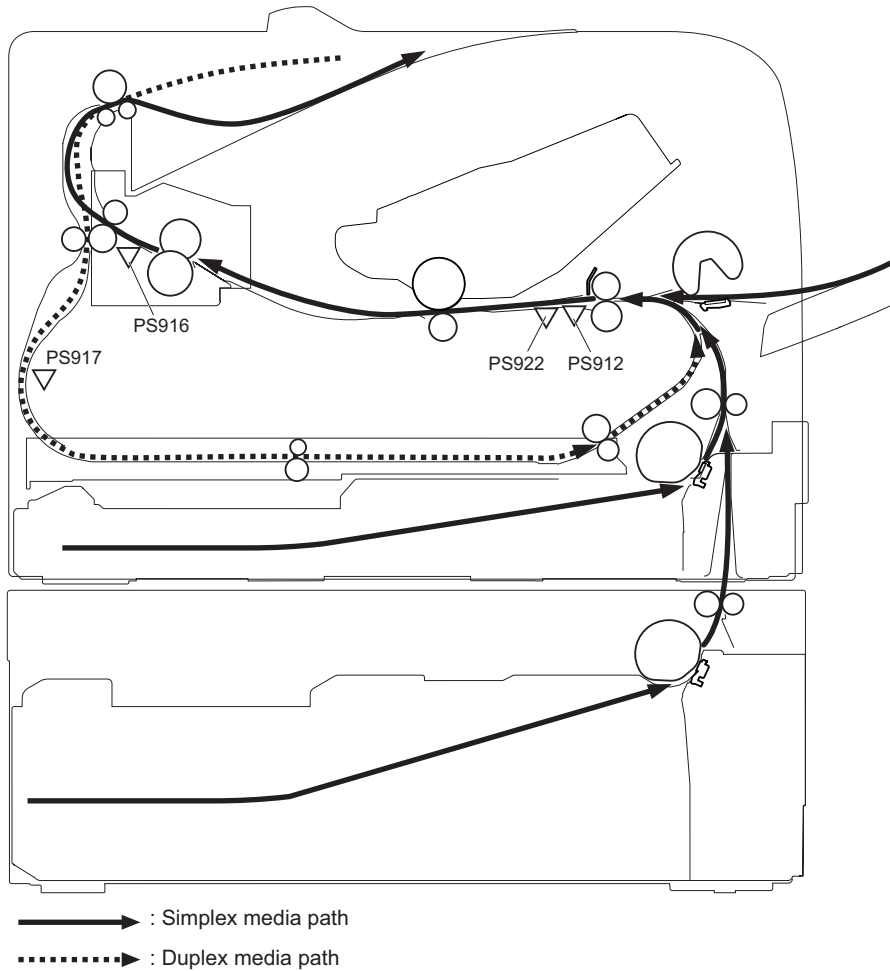

JamCode	Type	Sensor Name	Sensor ID
0104	Pickup Delay Jam 1	TOP Sensor	PS912
0208	Pickup Stationary Jam 1	TOP Sensor	PS912
010C	Delivery Delay Jam 1	Fixing delivery sensor	PS916
0210	Fixing Delivery Stationary Jam 1	Fixing delivery sensor	PS916
1014	Stationary Jam 1	TOP Sensor	PS912
1118	Door Open Jam 1	TOP Sensor	PS912
021C	Fixing Paper Wrap Jam 1	Fixing delivery sensor	PS916
0220	Reverse Jam	Duplex reverse sensor	PS917
0221	Reverse Jam 2	Duplex reverse sensor	PS917

## Alarm Code

Alarm Code	Title	A. Operation / B. Cause / C. Action
85-0001	System error	Contact the sales company.
85-0002	System error	Contact the sales company.

<b>Alarm Code</b>	<b>Title</b>	<b>A. Operation / B. Cause / C. Action</b>
85-0003	System error	Contact the sales company.
85-0004	System error	Auto recovery due to replacement with a new Main Controller PCB, which is a service part.
85-0005	System error	Auto recovery due to replacement with a used Main Controller PCB.



# Service Mode

Service Mode..... 129

# Service Mode

## Overview

### Service Mode Menu

COPIER	DISPLAY	VERSION	MAIN BOOT LANG DEMADATA ECONT PANEL	
		ERR		
		JAM		
	ADJUST	FEED-ADJ	USER	SPDTYPE
			ADJ-MFY	
			ADJ-MFX	
			ADJ-MFYR	
			ADJ-MFXR	
			ADJ-C1Y	
			ADJ-C1X	
			ADJ-C1YR	
			ADJ-C1XR	
			ADJ-C2Y	
			ADJ-C2X	
	P A N E L	TOUCHCHK		
		TOUCHCHK-R		
	FUNCTION	CLEAR	SRVC-DAT	
			COUNTER	
			HIST	
			ALL	
		MISC-P	ERDS-DAT	
			CNTR	
			ERR-LOG	
SPEC				
SYSTEM		ERDS-LOG		
		PANEL-UP		
		LOGWRITE		
		IMPORT		
		EXPORT		
		SAVE-SM		
SPLMAN		RSTR-SM		
		LOG2USB		
		LOG-DEL		
	SPL14159			
	SPL65677			
	SPL68676			
	SPL68677			
	SPL25607			
	SPL93822			
	SPL78788			
SPL00171				
INSTALL	SPL27354			
	SPL84194			
	SPL32620			
	SPL60061			
	SPL71700			
ERDS				
RGW-PORT				
COM-TEST				
COM-RSLT				
COM-LOG				



COPIER	OPTION	BODY	LOCALE
			SIZE-LC
			MIBCOUNT
			NS-CMD5
			NS-PLN
			NS-LGN
			SLPMODE
			SDTM-DSP
			RMT-SW
			PSWD-SW
		SM-PSWD	
		FNC-SW	IMGCNTPR
			LCDSFLG
			CRG-PROC
			CRGLF-K
		DSPLY-SW	CRGLW-LV
		IMG-MCON	REGM-SEL
		USER	SCALL-SW
			SCALLCMP
			PS-MODE
			SMD-EXPT
			ACC_SLP
			RPL-IMP
		ACC	WLAN
			WLANMODE
			UNIF-OF
		COUNTER	TOTAL
SERVICE2			
TTL			
COPY			
PICK-UP	PDL-PRT	RPT-PRT	
		MD-PRT	
		2-SIDE	
		C1	
JAM	TOTAL	2-DIDE	
		MF	
		C1	
		C2	
TESTMODE	PRINT	START	
		PG-TYPE	
		COUNT	
		PHASE	
		MODE	
		THRU	
		DENS	
		MABK	
FEED			
SERVICE REPORT	CNTR	COUNTER REPORT etc.	
	ERR-LOG	JAM	
		ERROR	
		ALARM2	
SPEC	ALARM3		
	SPEC REPORT etc.		
	ERDS-LOG		

## ■ Backing up Service Mode

Each device is tuned at the time of shipment and the tuned values are written on the service label.

Because setting values and management data of the host machine are stored in the eMMC of the Main Controller PCB, they need to be backed up before replacing the Main Controller PCB. (Do not remove the eMMC PCB from Main Controller PCB.)

Also, restoration of the backup data is necessary after replacing the Main Controller PCB.

Backup: Connect a USB memory device to the USB memory port.

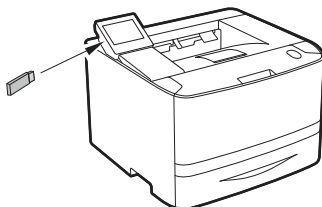

FUNCTION > SYSTEM > IMPORT / FUNCTION > SYSTEM > EXPORT

Restore: Restore backup data of the USB memory

FUNCTION > SYSTEM > IMPORT / FUNCTION > SYSTEM > IMPORT

Reference:

- Saving Registered Data: Remote UI > Settings/Registration > Import/Export > Export
- Loading Registered Data: Remote UI > Settings/Registration > Import/Export > Import

## ■ Screen flow of Service mode

- Initial screen
- Scroll the screen. : Flick with the finger on the display.
- Go to Category/Sub category selection screen : Tap with the finger on the display.
- Go to Up category screen : [Back] key

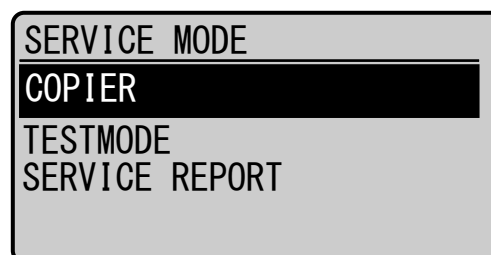

- Category/Sub category selection screen
- Scroll the screen. : Flick with the finger on the display.
- Go to Category/Sub category selection screen : Tap with the finger on the display.
- Go to Up category screen : [Back] key



- Item selection screen
- Select the item : Flick with the finger on the display.
- Go to Category/Sub category selection screen : Tap with the finger on the display.
- Go to Up category screen : [Back] key

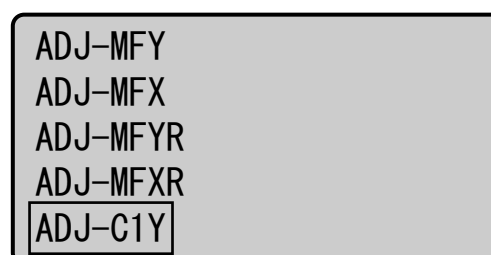

- Numeric value entry screen
- Enter the setting value. : Numeric keys ([0]-[9] keys)
- Switch the sign (+/-) of the value : [\*] key
- Increment the setting value one by one : [▲] (Tap with the finger on the display. )
- Decrease the setting value one by one : [▼] (Tap with the finger on the display. )
- Change the setting : [Apply] key (Tap with the finger on the display. )
- Change no settings : [Back] key

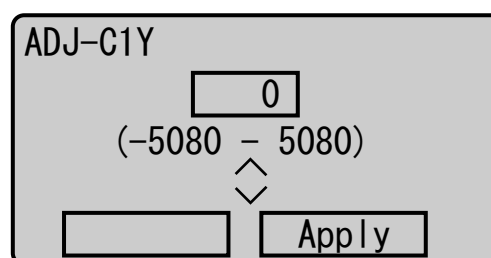

- Method to display the setting value of switch
  - On decimal display format, display is left aligned. (Comma is put every 3 digits.)
  - On binary display format, the most significant bit is placed at the leftmost position and the least significant bit is placed at the rightmost position.

## ■ Remote UI service mode

### ■ Function Overview

Remote UI can be used to display, set and implement various service mode in addition to rebooting the machine. In this case, machine's UI displays "Remote service mode".

### ■ Operating condition

Operation of service mode using remote UI becomes possible in the following cases:

- Service mode is not used on LUI.
- There is no user who has been logged in to the remote UI service mode (this function).
- Remote UI is enabled in the setting of LUI.  
Setting Menu > System Management Settings > Remote UI On/Off
- "RMT-SW" is enabled in service mode (Enabled when the setting value is "1".)  
COPIER > OPTION > BODY > RMT-SW (Remote UI service mode function)  
0: OFF (default), 1: ON  
Memo: After using service mode of remote UI, be sure to change the setting back to "OFF".

### ■ Usage method

#### 1. Activate the Web browser.

#### 2. Enter the following URL in the address input field.

http://<IP address of the machine or host name>/servicemode.html

#### 3. Enter the password and click "Log In".

\* Password required for authentication differs depending on the service mode setting.

COPIER > OPTION > BODY > PSWD-SW

PSWD-SW	Password required for authentication
0	1. Password of RUI service mode
1	1. Password of RUI service mode 2. Password of service mode
2	1. Password of RUI service mode 2. User's system administrator ID 3. Password of system administrator 4. Password of service mode

\* Password of service mode can be changed in COPIER > OPTION > BODY > SM-PSWD.

### ■ Authentication screen

#### 1. PSWD-SW: 0



#### 2. PSWD-SW: 1

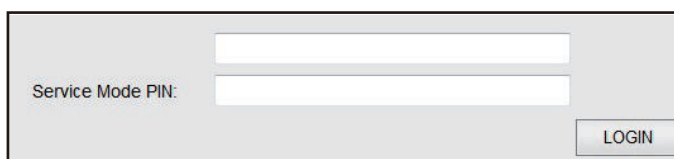

## 3. PSWD-SW: 2

System Manager ID:	<input type="text"/>
System Manager PIN:	<input type="text"/>
Service Mode PIN:	<input type="text"/>
<input type="button" value="LOGIN"/>	

4. Click “Logout” to end the operation.

**NOTE:**

After login, if you close the browser without “logout”, it is recognized that you have been “logged in”. Therefore, in order to log in to service mode again, you must wait for a certain period of time (3 minutes) from the last access to make the system timeout or turn OFF/ON the power.



## ■ VERSION

COPIER > DISPLAY > VERSION	
Item	Description
VERSION	
Title	Version
Details	MAIN: Bootable version BOOT: BootROM version LANG: Language pack version DEMODATA: Demo print data version ECONT: Printer ROM version PANEL: Panel microcomputer firmware version
Adj/set/operate method	None (display only)
Display/adj/set range	00.00 to 99.99
Default value	0
ERR	
Title	Error code display
Details	Error code display screen To display the error code and detail code of the system error.
Adj/set/operate method	None (display only)
JAM	
Title	Jam log
Details	To display the jam history.
Adj/set/operate method	None (display only)
USER	
Title	SPDTYPE: To display the engine speed type (ppm) of Controller Board.
Details	To display the engine speed type (ppm) of Controller Board.
Use case	When checking the engine speed type
Adj/set/operate method	None (display only)
Display/adj/set range	00 to 99

## ■ ADJUST

COPIER > ADJUST > FEED-ADJ	
Item	Description
ADJ-MFY	
Title	Adjustment of the write start position in the vertical scanning direction when picking up paper from the Multi-purpose Tray

COPIER > ADJUST > FEED-ADJ	
Item	Description
Details	To adjust the write start position in the vertical scanning direction when picking up paper from the Multi-purpose Tray. As the value is changed by 1, the leading edge margin is increased by approx. 0.001 mm. +: Leading edge margin becomes larger. (An image moves to the trailing edge.) -: Leading edge margin becomes smaller. (An image moves to the leading edge.) When replacing the Engine Controller PCB/clearing RAM data, enter the value of service label.
Use case	When replacing the Engine Controller PCB/clearing RAM data
Adj/set/operate method	1) Enter the setting value (switch negative/positive by -/+ key) and press Yes key. 2) Turn OFF/ON the main power switch.
Display/adj/set range	-5080 to 5080(-0.2inch to +0.2inch)
Unit	0.001mm
Default value	±0
ADJ-MFX	
Title	Adjustment of the write start position in the horizontal scanning direction when picking up paper from the Multi-purpose Tray
Details	To adjust the write start position in the horizontal scanning direction when picking up paper from the Multi-purpose Tray. As the value is changed by 1, the margin on the left edge of paper is increased by approx. 0.001 mm. +: Left margin becomes larger. (An image moves to the right.) -: Left margin becomes smaller. (An image moves to the left.) When replacing the Engine Controller PCB/clearing RAM data, enter the value of service label.
Use case	When replacing the Engine Controller PCB/clearing RAM data
Adj/set/operate method	1) Enter the setting value (switch negative/positive by -/+ key) and press Yes key. 2) Turn OFF/ON the main power switch.
Display/adj/set range	-3048 to 3048(-0.12inch to +0.12inch)
Unit	0.001mm
Default value	±0
ADJ-MFYR	
Title	Adjustment of the write start position in the vertical scanning direction at 2-sided pickup from the Multi-purpose Tray
Details	To adjust the write start position in the vertical scanning direction at 2-sided pickup from the Multi-purpose Tray. As the value is changed by 1, the margin on the left edge of paper is increased by approx. 0.001 mm. +: Leading edge margin becomes larger. (An image moves to the trailing edge.) -: Leading edge margin becomes smaller. (An image moves to the leading edge.) When replacing the Engine Controller PCB/clearing RAM data, enter the value of service label.
Use case	When replacing the Engine Controller PCB/clearing RAM data
Adj/set/operate method	1) Enter the setting value (switch negative/positive by -/+ key) and press Yes key. 2) Turn OFF/ON the main power switch.
Display/adj/set range	-5080 to 5080(-0.2inch to +0.2inch)
Unit	0.001mm
Default value	±0
ADJ-MFXR	
Title	Adjustment of the write start position in the horizontal scanning direction at 2-sided pickup from the Multi-purpose Tray
Details	To adjust the write start position in the horizontal scanning direction at 2-sided pickup from the Multi-purpose Tray. As the value is changed by 1, the margin on the left edge of paper is increased by approx. 0.001 mm. +: Left margin becomes larger. (An image moves to the right.) -: Left margin becomes smaller. (An image moves to the left.) When replacing the Engine Controller PCB/clearing RAM data, enter the value of service label.
Use case	When replacing the Engine Controller PCB/clearing RAM data
Adj/set/operate method	1) Enter the setting value (switch negative/positive by -/+ key) and press Yes key. 2) Turn OFF/ON the main power switch.
Display/adj/set range	-3048 to 3048(-0.12inch to +0.12inch)
Unit	0.001mm

COPIER > ADJUST > FEED-ADJ	
Item	Description
Default value	±0
ADJ-C1Y	
Title	Adjustment of the write start position in the vertical scanning direction at pickup from the Cassette 1
Details	To adjust the write start position in the vertical scanning direction at pickup from the Cassette 1. As the value is changed by 1, the leading edge margin is increased by approx. 0.001 mm. +: Leading edge margin becomes larger. (An image moves to the trailing edge.) -: Leading edge margin becomes smaller. (An image moves to the trailing edge.) When replacing the Engine Controller PCB/clearing RAM data, enter the value of service label.
Use case	When replacing the Engine Controller PCB/clearing RAM data
Adj/set/operate method	1) Enter the setting value (switch negative/positive by -/+ key) and press Yes key. 2) Turn OFF/ON the main power switch.
Display/adj/set range	-5080 to 5080(-0.2inch to +0.2inch)
Unit	0.001mm
Default value	±0
ADJ-C1X	
Title	Adjustment of the write start position in the horizontal scanning direction for the Cassette 1
Details	To adjust the write start position in the horizontal scanning direction for the Cassette 1. As the value is changed by 1, the margin on the left edge of paper is increased by approx. 0.001 mm. +: Left margin becomes larger. (An image moves to the right.) -: Left margin becomes smaller. (An image moves to the left.) When replacing the Engine Controller PCB/clearing RAM data, enter the value of service label.
Use case	When replacing the Engine Controller PCB/clearing RAM data
Adj/set/operate method	1) Enter the setting value (switch negative/positive by -/+ key) and press Yes key. 2) Turn OFF/ON the main power switch.
Display/adj/set range	-3048 to 3048(-0.12inch to +0.12inch)
Unit	0.001mm
Default value	±0
ADJ-C1YR	
Title	Adjustment of the write start position in the vertical scanning direction at 2-sided printing for the Cassette 1
Details	To adjust the write start position in the vertical scanning direction at 2-sided printing for the Cassette 1. As the value is changed by 1, the leading edge margin is increased by approx. 0.001 mm. +: Leading edge margin becomes larger. (An image moves to the trailing edge.) -: Leading edge margin becomes smaller. (An image moves to the trailing edge.) When replacing the Engine Controller PCB/clearing RAM data, enter the value of service label.
Use case	When replacing the Engine Controller PCB/clearing RAM data
Adj/set/operate method	1) Enter the setting value (switch negative/positive by -/+ key) and press Yes key. 2) Turn OFF/ON the main power switch.
Display/adj/set range	-5080 to 5080(-0.2inch to +0.2inch)
Unit	0.001mm
Default value	±0
ADJ-C1XR	
Title	Adjustment of the write start position in the horizontal scanning direction at 2-sided printing for the Cassette 1
Details	To adjust the write start position in the horizontal scanning direction at 2-sided printing for the Cassette 1. As the value is changed by 1, the margin on the left edge of paper is increased by approx. 0.001 mm. +: Left margin becomes larger. (An image moves to the right.) -: Left margin becomes smaller. (An image moves to the left.) When replacing the Engine Controller PCB/clearing RAM data, enter the value of service label.
Use case	When replacing the Engine Controller PCB/clearing RAM data
Adj/set/operate method	1) Enter the setting value (switch negative/positive by -/+ key) and press Yes key. 2) Turn OFF/ON the main power switch.
Display/adj/set range	-3048 to 3048(-0.12inch to +0.12inch)
Unit	0.001mm

COPIER > ADJUST > FEED-ADJ	
Item	Description
Default value	±0
ADJ-C2Y	
Title	Adjustment of the write start position in the vertical scanning direction at pickup from the Cassette 2
Details	To adjust the write start position in the vertical scanning direction at pickup from the Cassette 2. As the value is changed by 1, the leading edge margin is increased by approx. 0.001 mm. +: Leading edge margin becomes larger. (An image moves to the trailing edge.) -: Leading edge margin becomes smaller. (An image moves to the trailing edge.) When replacing the Engine Controller PCB/clearing RAM data, enter the value of service label.
Use case	When replacing the Engine Controller PCB/clearing RAM data
Adj/set/operate method	1) Enter the setting value (switch negative/positive by +/- key) and press Yes key. 2) Turn OFF/ON the main power switch.
Display/adj/set range	-5080 to 5080(-0.2inch to +0.2inch)
Unit	0.001mm
Default value	±0
ADJ-C2X	
Title	Adjustment of the write start position in the horizontal scanning direction at pickup from the Cassette 2
Details	To adjust the write start position in the horizontal scanning direction at pickup from the Cassette 2. As the value is changed by 1, the margin on the left edge of paper is increased by approx. 0.001 mm. +: Left margin becomes larger. (An image moves to the right.) -: Left margin becomes smaller. (An image moves to the left.) When replacing the Engine Controller PCB/clearing RAM data, enter the value of service label.
Use case	When replacing the Engine Controller PCB/clearing RAM data
Adj/set/operate method	1) Enter the setting value (switch negative/positive by +/- key) and press Yes key. 2) Turn OFF/ON the main power switch.
Display/adj/set range	-3048 to 3048(-0.12inch to +0.12inch)
Unit	0.001mm
Default value	±0
ADJ-C2YR	
Title	Adjustment of the write start position in the vertical scanning direction at 2-sided pickup from the Cassette 2
Details	To adjust the write start position in the vertical scanning direction at 2-sided pickup from the Cassette 2. As the value is changed by 1, the leading edge margin is increased by approx. 0.001 mm. +: Leading edge margin becomes larger. (An image moves to the trailing edge.) -: Leading edge margin becomes smaller. (An image moves to the trailing edge.) When replacing the Engine Controller PCB/clearing RAM data, enter the value of service label.
Use case	When replacing the Engine Controller PCB/clearing RAM data
Adj/set/operate method	1) Enter the setting value (switch negative/positive by +/- key) and press Yes key. 2) Turn OFF/ON the main power switch.
Display/adj/set range	-5080 to 5080(-0.2inch to +0.2inch)
Unit	0.001mm
Default value	±0
ADJ-C2XR	
Title	Adjustment of the write start position in the horizontal scanning direction at 2-sided pickup from the Cassette 2
Details	To adjust the write start position in the horizontal scanning direction at 2-sided pickup from the Cassette 2. As the value is changed by 1, the margin on the left edge of paper is increased by approx. 0.001 mm. +: Left margin becomes larger. (An image moves to the right.) -: Left margin becomes smaller. (An image moves to the left.) When replacing the Engine Controller PCB/clearing RAM data, enter the value of service label.
Use case	When replacing the Engine Controller PCB/clearing RAM data
Adj/set/operate method	1) Enter the setting value (switch negative/positive by +/- key) and press Yes key. 2) Turn OFF/ON the main power switch.

COPIER > ADJUST > FEED-ADJ	
Item	Description
Display/adj/set range	-3048 to 3048(-0.12inch to +0.12inch)
Unit	0.001mm
Default value	±0

COPIER > ADJUST > PANEL	
Item	Description
TOUCHCHK	
Title	Correction of coordinate position of Touch Panel
Details	To correct the coordinate on the Touch Panel.
Use case	When a problem occurs to the coordinate position in such a way that a position different from the one that was touched reacts.
Adj/set/operate method	Touch the "+" (plus)" mark displayed on the Touch Panel with something with a sharp tip such as a pen.
Display/adj/set range	
Unit	
Default value	
TOUCHCHK-R	
Title	Flag to check whether the correction of coordinates on the Touch Panel was properly executed.
Details	To check whether the correction of coordinates on the Touch Panel was properly executed. 1 is displayed when the correction of coordinates is properly executed. 0 is displayed when it fails.
Use case	When executing the correction of coordinates after replacing the Touch Panel with a new one.
Adj/set/operate method	0 to 1
Display/adj/set range	0: Not executed 1: Executed
Unit	
Default value	1

## ■ CLEAR

COPIER> FUNCTION> CLEAR	
Item	Description
SRVC-DAT	
Title	Clearing of service mode setting values
Details	To clear the service mode setting values. The user mode setting values are not cleared.
Adj/set/operate method	1. Press Yes key. 2. Turn OFF / ON the main power switch.
COUNTER	
Title	Clearing of service counter
Details	To clear the counter by maintenance / part/mode. The numerator printed on a system dump list becomes 0.
Adj/set/operate method	1. Press Yes key. 2. Turn OFF / ON the main power switch.
HIST	
Title	Clear of logs
Details	To clear the communication management / print / jam / error log.
Use case	When clearing logs
Adj/set/operate method	1. Press Yes key. 2. Turn OFF / ON the main power switch.
ALL	
Title	Clearing of setting information



COPIER> FUNCTION> CLEAR	
Item	Description
Details	Clear/initialize the following setting information according to the location set in COPIER > OPTION > BODY > LOCALE, SIZE-LC: <ul style="list-style-type: none"> <li>• User mode setting values</li> <li>• Service mode setting values (excluding service counter)</li> <li>• ID and password of the system administrator</li> <li>• Communication management / printing / jam / error history</li> <li>• E719-CLR (counter meter-installed models only) The following is not initialized: <ul style="list-style-type: none"> <li>• Service counter</li> <li>• Factory adjustment values of the Reader / ADF</li> </ul> </li> </ul>
Use case	At installation
Adj/set/operate method	1. Press Yes key. 2. Turn OFF / ON the main power switch.
Related service mode	COPIER > OPTION > BODY > LOCALE, SIZE-LC
ERDS-DAT	
Title	Initialization of Embedded-RDS setting value
Details	To initialize the Embedded-RDS setting values. ON / OFF of Embedded-RDS, UGW (remote monitoring service system) port number, and communication error log set in service mode are initialized.
Use case	When upgrading the version of Bootable in the Embedded-RDS environment
Adj/set/operate method	Press Yes key.
Caution	Use of the SRAM in Embedded-RDS differs depending on the Bootable version. Therefore, unless initialization is executed at the time of version upgrade, data inconsistency occurs.
Related service mode	COPIER > FUNCTION > INSTALL > E-RDS, RGW-PORT, COM-LOG
Supplement/memo	Embedded-RDS: Function to send device information such as the device counter, failure, and consumables to UGW via SOAP protocol UGW (Universal Gate Way): Remote monitoring service system

## ■ MISC-P

COPIER> FUNCTION> MISC-P	
Item	Description
CNTR	
Title	Output of counter report
Details	To output the counter report. The usage of functions (reading, recording, communication and copy) is output.
Adj/set/operate method	Select the item, and then press Yes key.
ERR-LOG	
Title	Output of error log report
Details	To output the error log report.
Adj/set/operate method	Select the item, and then press Yes key.
SPEC	
Title	Output of spec report
Details	To output the spec report. The current device specifications such as the location, model information, and ROM version are output.
Adj/set/operate method	Select the item, and then press Yes key.
ERDS-LOG	
Title	Output of Embedded-RDS log
Details	To execute report output of the log relating to Embedded-RDS. The date, time, code, and details (up to 130 characters) of each error that occurred are output.
Use case	When using Embedded-RDS
Adj/set/operate method	Select the item, and then press Yes key.
Related service mode	COPIER> FUNCTION> INSTALL> COM-LOG
Supplement/memo	Embedded-RDS: Function to send device information such as the device counter, failure, and consumables to UGW via SOAP protocol UGW (Universal Gate Way): Remote monitoring service system

## ■ SYSTEM

COPIER> FUNCTION> SYSTEM	
Item	Description
PANEL-UP	
Title	Download from USB memory (PANEL)
Details	To perform downloading when PANEL exists in the root directory of the USB memory.
Use case	At upgrade
Adj/set/operate method	<ol style="list-style-type: none"> <li>1. Install the USB memory.</li> <li>2. Select the item, and then select Yes.</li> <li>3. Turn OFF and the ON the main power.</li> </ol>
Caution	Do not turn OFF / ON the power before "Executing..." disappears.
Display/adj/set range	Yes / No
Related service mode	COPIER > FUNCTION > SYSTEM > DOWNLOAD, BKUP-UP
LOGWRITE	
Title	Writing sublog to USB memory
Details	To write sublog that includes the following information to the USB memory. <ul style="list-style-type: none"> <li>• Job list (job name, user name, address book)</li> <li>• Communications log (address book, user name)</li> <li>• Job log (user name, job name)</li> </ul>
Use case	When analyzing the cause of a problem
Adj/set/operate method	<ol style="list-style-type: none"> <li>1. Install the USB memory.</li> <li>2. Select the item, and then select Yes.</li> <li>3. Turn OFF and the ON the main power.</li> </ol>
Caution	Do not turn OFF / ON the power before "Executing..." disappears.
Display/adj/set range	Yes / No
EXPORT	
Title	Writing of service mode setting value to USB memory
Details	To write the service mode setting values to the USB memory.
Use case	When replacing the Main Controller PCB as a measure against failures
Adj/set/operate method	<ol style="list-style-type: none"> <li>1. Install the USB memory.</li> <li>2. Select the item, and then press Yes.</li> </ol>
Caution	"Executing..." disappears when writing is completed.
SAVE-SM	
Title	Backup of service mode
Details	To record the backup of service mode in the device using DCM.
Use case	When saving the state of the device before changing the service mode setting values.
RSTR-SM	
Title	Restoration of service mode
Details	To restore the backup data in the device.
Use case	When returning the state of the device to a previous one after having changed the service mode setting values
LOG2USB	
Title	Output of log saved in eMMC to a USB
Details	Output of log saved in eMMC to a USB
Use case	When collecting debug log.
Adj/set/operate method	<ol style="list-style-type: none"> <li>1. Install the USB memory.</li> <li>2. Select the item, and then select Yes.</li> </ol>
LOG-DEL	
Title	Deletion of log saved in eMMC
Details	Deletion of log saved in eMMC
Use case	When deleting log that has become unnecessary

## ■ SPLMAN

COPIER> FUNCTION> SPLMAN	
Item	Description
SPL14159	
Title	Fixing of USB device ID
Details	To fix the USB device ID to "000000000000". Driver for each machine is installed to a PC. However, by fixing the serial number, the PC considers that any connected machine to be the same machine; thus, there will be no need to install the drivers many times.
Adj/set/operate method	1. Enter the value, and then press Apply key. 2. Turn OFF / ON the main power switch.
Display/adj/set range	0 to 1 0 : OFF 1 : ON
Default value	0
SPL65677	
Title	Increase of paper leading edge margin
Details	To increase the margin on the leading edge of paper. As the value is incremented by 1, the margin is increased by 0.1 mm. The value obtained by adding this value and SPL68676 (decrease of the margin) is applied.
Adj/set/operate method	1. Enter the setting value, and then press Apply key. 2. Turn OFF/ON the main power switch.
Display/adj/set range	0 to 20
Unit	0.1 mm
Default value	0
Related service mode	COPIER > FUNCTION > SPLMAN > SPL68676
SPL68676	
Title	Decrease of paper leading edge margin
Details	To decrease the margin on the leading edge of paper. As the value is incremented by 1, the margin is decreased by 0.1 mm. The value obtained by adding this value and SPL65677 (increase of the margin) is applied.
Adj/set/operate method	1. Enter the setting value, and then press Apply key. 2. Turn OFF/ON the main power switch.
Display/adj/set range	0 to 20
Unit	0.1 mm
Default value	0
Related service mode	COPIER > FUNCTION > SPLMAN > SPL65677
SPL68677	
Title	Increase of paper right and left margins
Details	To increase the margin on the right and left of paper. As the value is incremented by 1, the margin is increased by 0.1 mm. The value obtained by adding this value and SPL25607 (decrease of the margin) is applied.
Adj/set/operate method	1. Enter the setting value, and then press Apply key. 2. Turn OFF/ON the main power switch.
Display/adj/set range	0 to 20
Unit	0.1 mm
Default value	0
Related service mode	COPIER > FUNCTION > SPLMAN > SPL25607
SPL25607	
Title	Decrease of paper right and left margins
Details	To decrease the margin on the right and left of paper. As the value is incremented by 1, the margin is decreased by 0.1 mm. The value obtained by adding this value and SPL68677 (increase of the margin) is applied.
Adj/set/operate method	1. Enter the setting value, and then press Apply key. 2. Turn OFF/ON the main power switch.
Display/adj/set range	0 to 20
Unit	0.1 mm

COPIER> FUNCTION> SPLMAN	
Item	Description
Default value	0
Related service mode	COPIER > FUNCTION > SPLMAN > SPL68677
SPL93822	
Title	Setting of department ID count all clear
Details	To set whether to disable clearing of all department ID counts.
Adj/set/operate method	1. Enter the setting value, and then press Apply key. 2. Turn OFF/ON the main power switch.
Caution	Be sure to perform this mode after consulting with the system administrator at user's site.
Display/adj/set range	0 to 1 0: Disabled 1: Enabled
Default value	0
Related service mode	
SPL78788	
Title	Setting of department ID count clear
Details	To set whether to disable clearing of department ID count.
Adj/set/operate method	1. Enter the setting value, and then press Apply key. 2. Turn OFF/ON the main power switch.
Caution	Be sure to perform this mode after consulting with the system administrator at user's site.
Display/adj/set range	0 to 1 0: Disabled 1: Enabled
Default value	
Related service mode	COPIER > FUNCTION > SPLMAN > SPL93822
SPL00171	
Title	To change the maximum auto sleep shift time.
Details	To change the maximum value of auto sleep shift time in Settings/Registration > Timer Settings > Auto Sleep Time.
Use case	When changing the setting time to shift to auto sleep mode
Adj/set/operate method	
Display/adj/set range	From 0 (Default for Europe) to 60 min From 1 (Default for locations other than Europe) to Maximum value for each model
Default value	1
SPL27354	
Title	PC-less update, RMDS environment setting
Adj/set/operate method	1. Enter the setting value, and then press Apply key. 2. Turn OFF/ON the main power switch.
Display/adj/set range	
Default value	0
Default value	0
SPL84194	
Title	ON / OFF of E-RDS function
Adj/set/operate method	1. Enter the setting value, and then press Apply key. 2. Turn OFF/ON the main power switch.
Display/adj/set range	
Default value	0
SPL32620	
Title	Switching to enable / disable PC-less update
Details	To switch whether to enable the PC-less update function.
Adj/set/operate method	1. Enter the setting value, and then press Apply key. 2. Turn OFF/ON the main power switch.
Display/adj/set range	
Default value	1
SPL60061	
Title	Switching to display the connection destination URL setting of GoogleCloudPrint on the remote UI

COPIER> FUNCTION> SPLMAN	
Item	Description
Details	To display the connection destination URL setting of GoogleCloudPrint on the remote UI.
Adj/set/operate method	1. Enter the setting value, and then press Apply key. 2. Turn OFF/ON the main power switch.
Display/adj/set range	
Default value	0
SPL71700	
Title	Saving of Sublog stored in eMMC to a USB memory
Details	To save Sublog stored in eMMC to a USB memory.
Adj/set/operate method	
Display/adj/set range	
Default value	0
SPL01734	
Title	ON/OFF of RUI service mode function
Details	To turn ON/OFF the RUI service mode function. (linked with OPTION->BODY->RMT-SW) 0: OFF* 1: ON This should be supported together with OPTION->BODY->RMT-SW as a set.
Adj/set/operate method	
Display/adj/set range	0 to 1
Default value	0

## ■ INSTALL

COPIER> FUNCTION> INSTALL	
Item	Description
E-RDS	
Title	ON / OFF of Embedded-RDS
Details	To set ON / OFF of Embedded-RDS function.
Use case	When using Embedded-RDS
Adj/set/operate method	1. Select the item, and then press Yes key. 2. Turn OFF / ON the main power switch.
Caution	Be sure to use ERDS, RGW-PORT, COM-TEST, COM-RSLT, and COM-LOG as a set.
Display/adj/set range	0 to 1 0 : OFF 1 : ON
Default value	0
Related service mode	COPIER > FUNCTION > INSTALL > COPIER > FUNCTION > INSTALL > RGW-PORT COPIER > FUNCTION > INSTALL > COM-TEST COPIER > FUNCTION > INSTALL > COM-RSLT COPIER > FUNCTION > INSTALL > COM-LOG
Supplement/memo	Embedded-RDS: Function to send device information such as the device counter, failure, and consumables to UGW via SOAP protocol UGW (Universal Gate Way): Remote monitoring service system
RGW-PORT	
Title	Setting of UGW port number when using Embedded-RDS
Details	To set the port number of UGW to be used for Embedded-RDS.
Use case	When using Embedded-RDS
Adj/set/operate method	1. Select the item, and then press Yes key. 2. Turn OFF / ON the main power switch.
Caution	Be sure to use ERDS, RGW-PORT, COM-TEST, COM-RSLT, and COM-LOG as a set.
Display/adj/set range	1 to 65535
Default value	443
Related service mode	COPIER > FUNCTION > INSTALL > ERDS COPIER > FUNCTION > INSTALL > COM-TEST COPIER > FUNCTION > INSTALL > COM-RSLT COPIER > FUNCTION > INSTALL > COM-LOG

COPIER> FUNCTION> INSTALL	
Item	Description
Supplement/memo	Embedded-RDS: Function to send device information such as the device counter, failure, and consumables to UGW via SOAP protocol UGW (Universal Gate Way): Remote monitoring service system
COM-TEST	
Title	Execution of Embedded-RDS communication test
Details	To execute Embedded-RDS communication test. If the connection fails, the information is added to the communication error log.
Use case	When using E-RDS
Adj/set/operate method	Select the item, and then press Yes key.
Caution	Be sure to use ERDS, RGW-PORT, COM-TEST, COM-RSLT, and COM-LOG as a set.
Display/adj/set range	0 to 1
Default value	0
Related service mode	COPIER > FUNCTION > INSTALL > ERDS COPIER > FUNCTION > INSTALL > RGW-PORT COPIER > FUNCTION > INSTALL > COM-RSLT COPIER > FUNCTION > INSTALL > COM-LOG
Supplement/memo	Embedded-RDS: Function to send device information such as the device counter, failure, and consumables to UGW via SOAP protocol UGW (Universal Gate Way): Remote monitoring service system
COM-RSLT	
Title	Embedded-RDS communication test result
Details	To display the Embedded-RDS communication test result.
Use case	When using E-RDS
Adj/set/operate method	N/A (Display only)
Caution	Be sure to use ERDS, RGW-PORT, COM-TEST, COM-RSLT, and COM-LOG as a set.
Display/adj/set range	When not in execution : Unknown, When connection is completed : OK, When connection is failed : NG
Default value	Unknown
Related service mode	COPIER > FUNCTION > INSTALL > ERDS COPIER > FUNCTION > INSTALL > RGW-PORT COPIER > FUNCTION > INSTALL > COM-TEST COPIER > FUNCTION > INSTALL > COM-LOG
Supplement/memo	Embedded-RDS: Function to send device information such as the device counter, failure, and consumables to UGW via SOAP protocol UGW (Universal Gate Way): Remote monitoring service system
COM-LOG	
Title	Embedded-RDS communication error log
Details	To display the Embedded-RDS communication error log. The dates, times, and error codes of the latest 5 errors that occurred are displayed. As for the error detail information, the report can be output by executing COPIER > FUNCTION > MISC-P > ERDS-LOG.
Use case	When using Embedded-RDS
Caution	Be sure to use ERDS, RGW-PORT, COM-TEST, COM-RSLT, and COM-LOG as a set.
Display/adj/set range	Date : 6 digits Time : 4 digits Error code : 8 digits
Related service mode	COPIER > FUNCTION > INSTALL > ERDS COPIER > FUNCTION > INSTALL > RGW-PORT COPIER > FUNCTION > INSTALL > COM-TEST COPIER > FUNCTION > INSTALL > COM-RSLT COPIER > FUNCTION > MISC-P > ERDS-LOG
Supplement/memo	Embedded-RDS: Function to send device information such as the device counter, failure, and consumables to UGW via SOAP protocol UGW (Universal Gate Way): Remote monitoring service system

## ■ BODY

COPIER > OPTION > BODY	
Item	Description
LOCALE	
Title	Setting of location

COPIER > OPTION > BODY	
Item	Description
Details	To set the location. At installation in areas other than Japan, perform the following procedure to match the setting information with that of the location.
Use case	<ul style="list-style-type: none"> <li>At installation</li> <li>When changing the location information</li> </ul>
Adj/set/operate method	<ol style="list-style-type: none"> <li>Enter the setting value under LOCALE, and then press Apply key.</li> <li>Set the paper size configuration under SIZE-LC.</li> <li>Execute COPIER &gt; FUNCTION &gt; CLEAR &gt; ALL.</li> <li>Turn OFF/ON the main power switch.</li> </ol>
Caution	Since COPIER> FUNCTION> CLEAR> ALL is executed when changing the location, the setting information of user mode, service mode, etc. is initialized. The setting information of this item is not initialized.
Display/adj/set range	1 to 8 1 : Japan 2 : North America 3 : Korea 4 : China 5 : Taiwan 6 : Europe 7 : Asia 8 : Oceania
Default value	1
Related service mode	COPIER> FUNCTION> CLEAR> ALL COPIER> OPTION> BODY> SIZE-LC
SIZE-LC	
Title	Setting of paper size configuration
Details	To set the paper size configuration. At installation in areas other than Japan, perform the following procedure to match the setting information with that of the location.
Use case	<ul style="list-style-type: none"> <li>At installation</li> <li>Upon user's request</li> </ul>
Adj/set/operate method	<ol style="list-style-type: none"> <li>Set the location under LOCALE.</li> <li>Set the paper size configuration under SIZE-LC, and then press Apply key.</li> <li>Execute COPIER &gt; FUNCTION &gt; CLEAR &gt; ALL.</li> <li>Turn OFF / ON the main power switch.</li> </ol>
Caution	Since COPIER > FUNCTION > CLEAR > ALL is executed when changing the location, the setting information of user mode, service mode, etc. is initialized. The setting information of this item is not initialized.
Display/adj/set range	1 to 4 1 : AB configuration 2 : Inch configuration 3 : A configuration 4 : AB / Inch configuration
Related service mode	COPIER > FUNCTION > CLEAR > ALL COPIER > OPTION > BODY > LOCALE
MIBCOUNT	
Title	Setting of MIB collection charge counter
Details	To set the range of charge counter information that can obtain MIB (Management Information Base).
Use case	When preventing the Charge Counter MIB from being used by a third party
Adj/set/operate method	<ol style="list-style-type: none"> <li>Enter the setting value, and then press Apply key.</li> <li>Turn OFF / ON the main power switch.</li> </ol>
Display/adj/set range	0 to 2 0: All charge counters are obtained 1: Only the displayed counter* is obtained 2: All charge counters are not obtained *: Counter specified by the following: COPIER > OPTION > USER > COUNTER 1 to 6
Default value	0
Related service mode	COPIER > OPTION > USER > COUNTER1 to 6
NS-CMD5	
Title	Setting of CRAM-MD5 authentication method at SMTP authentication
Details	Restriction of the use of CRAM-MD5 authentication method at SMTP authentication When 1 is set, CRAM-MD5 authentication method is not used.

COPIER > OPTION > BODY	
Item	Description
Use case	Upon user's request
Adj/set/operate method	1. Enter the setting value, and then press Apply key. 2. Turn OFF / ON the main power switch.
Display/adj/set range	0 to 1 0 : Used (SMTP server-dependent), 1 : Not used
Default value	0
Supplement/memo	SMTP authentication: Protocol in which user authentication function is added to SMTP, which is the protocol to be used for e-mail transmission. At the time of e-mail transmission, this protocol executes authentication of the user account and the password between the SMTP server and the user to approve e-mail transmission only when it's authenticated.
NS-PLN	
Title	Setting of plaintext authentication at SMTP authentication
Details	To restrict use of PLAIN / LOGIN authentication, which is plaintext authentication, at the time of SMTP authentication under the environment where the communication packet is not encrypted. When 1 is set, plaintext authentication is not used.
Use case	Upon user's request
Adj/set/operate method	1. Enter the setting value, and then press Apply key. 2. Turn OFF / ON the main power switch.
Display/adj/set range	0 to 1 0 : Used (SMTP server-dependent), 1 : Not used
Default value	0
Supplement/memo	SMTP authentication: Protocol in which user authentication function is added to SMTP, which is the protocol to be used for e-mail transmission. At the time of e-mail transmission, this protocol executes authentication of the user account and the password between the SMTP server and the user to approve e-mail transmission only when it's authenticated.
NS-LGN	
Title	Setting of LOGIN authentication at SMTP authentication
Details	Restriction of the use of LOGIN authentication method at SMTP authentication When 1 is set, LOGIN authentication method is not used.
Use case	Upon user's request
Adj/set/operate method	1. Enter the setting value, and then press Apply key. 2. Turn OFF / ON the main power switch.
Display/adj/set range	0 to 1 0 : Used (SMTP server-dependent), 1 : Not used
Default value	0
Supplement/memo	SMTP authentication: Protocol in which user authentication function is added to SMTP, which is the protocol to be used for e-mail transmission. At the time of e-mail transmission, this protocol executes authentication of the user account and the password between the SMTP server and the user to approve e-mail transmission only when it's authenticated.
SLPMODE	
Title	Setting of shift to sleep mode
Details	To restrict shift to sleep mode 1/sleep mode 3. When 1 is set, the machine does not shift to sleep mode.
Use case	When sleep failure occurs
Adj/set/operate method	1. Enter the setting value, and then press Apply key. 2. Turn OFF / ON the main power switch.
Display/adj/set range	0 to 1 0 : Shift is available. 1 : Shift is not available.
Default value	0
SDTM-DSP	
Title	Setting of automatic shutdown menu display



COPIER > OPTION > BODY	
Item	Description
Details	It is a new function added to support LOT6.To display the auto shutdown menu in the machine supporting LOT6.
Adj/set/operate method	1. Enter the setting value, and then press Apply key. 2. Turn OFF / ON the main power switch.
Caution	Even the models not supporting auto shutdown function display the service mode item (In such case, the menu will not be displayed even 1 is set).
Display/adj/set range	0 to 1 0 : Hide the menu 1 : Display the menu
Default value	0
RMT-SW	
Title	ON/OFF of RUI service mode function
Details	To set whether to enable the service mode function that can be used on remote UI.
Adj/set/operate method	1. Enter the setting value, and then press Apply key. 2. Turn OFF / ON the main power switch.
Display/adj/set range	0 to 1 0 : OFF * 1 : ON
Default value	0
PSWD-SW	
Title	Service mode password level
Details	To change the service mode password level.
Adj/set/operate method	1. Enter the setting value, and then press Apply key. 2. Turn OFF / ON the main power switch.
Display/adj/set range	0 to 2 0: Password is not required 1: Password for service engineer is required 2: Passwords for service engineer and system administrator at user's site are required
Default value	0
SM-PSWD	
Title	Password for service engineer
Details	To set the password for service technician in 8-digit decimal number.
Adj/set/operate method	1. Enter the setting value, and then press Apply key. 2. Turn OFF / ON the main power switch.
Display/adj/set range	1 to 99999999
Default value	11111111

## ■ FNC-SW

COPIER > OPTION > FNC-SW	
Item	Description
IMGCNTPR	
Title	Switching of PS / PDF image quality mode
Details	To switch the image quality mode of PS/PDF. The UI value (default) of PS / PDF is changed according to the value (mode) of IMGCNTPR.
Adj/set/operate method	Enter the setting value, and then press Apply key.
Display/adj/set range	0 to 1 In the case of 0 Output profile => PS Photo RGB pure black process => No CMYK pure black process => No In the case of 1 Output profile =>PS TR Photo RGB pure black process => Yes CMYK pure black process => Yes
Default value	1
CRG-PROC	
Title	Setting of the operation at the end of CRG life

COPIER > OPTION > FNC-SW	
Item	Description
Details	To set the following 3 kinds of operations at the end of CRG life: Not stopped / Stopped once/ Completely stopped.
Adj/set/operate method	Enter the setting value, and then press Apply key.
Display/adj/set range	0 to 2 0 : Not stopped (default of B&W machine) 1 : Stopped once (default for color machine) 2 : Completely stopped
Default value	1
CRGLF-K	
Title	Reference value of components other than toner included in the CRG life (for K)
Details	Reference value of the life of the components other than toner (Drum / Developing Assembly / waste toner) included in the life of CRG (for K)
Adj/set/operate method	Enter the setting value, and then press Apply key.
Display/adj/set range	100 to 200
Default value	100
Measure	1%
Default value	100

## ■ DSPL-SW

COPIER > OPTION > USER	
Item	Description
CRGLW-LV	
Title	SW to display / hide the setting menu (user mode) of toner low threshold value
Details	To switch whether to display the menu to set the threshold value in user mode which generates toner low.
Adj/set/operate method	Enter the setting value, and then press Yes key.
Display/adj/set range	0 to 1
Default value	1

## ■ IMG-MCON

COPIER > OPTION > USER	
Item	Description
REGM-SEL	
Title	Adjustment of fine density correction
Details	To adjust fine density correction.
Use case	When the density of fine line or text is dark of light at 1200 dpi printing.
Adj/set/operate method	Set +1 to make the density of fine line or text darker, and -1 to make it lighter at 1200 dpi printing.
Display/adj/set range	-1, 0, +1
Default value	0

## ■ USER

COPIER > OPTION > USER	
Item	Description
CTCHKDSP	
Title	ON/OFF of charge counter print
Details	To set whether to print the charge counter on the Counter Check screen in the System Manager Data List. When 1 is set, the charge counter is printed.
Use case	Upon user's request
Adj/set/operate method	Enter the setting value, and then press Apply key.

COPIER > OPTION > USER	
Item	Description
DisCTCHKDSP play/adj/set range	0 to 1 0 : OFF 1 : ON
Default value	1
TNRB-SW	
Title	ON/OFF of toner replacement counter display
Details	To set whether to display the toner replacement counter on the Counter Check screen. When 1 is set, the user can check the toner replacement counter.
Use case	Upon user's request
Adj/set/operate method	1. Enter the setting value, and then press Apply key. 2. Turn OFF/ON the main power switch.
Display/adj/set range	0 to 3 <Cartridge model> 0 : Hide the Toner Cartridge replacement counter 1 : Display the Toner Cartridge replacement counter (No. 19x) 2 : Not used (same as the setting value of 0) 3 : Not used (same as the setting value of 0)  <Toner supply model> 0 : Hide the Toner Bottle / Unidentified Toner Bottle replacement counter 1 : Display the Toner Bottle replacement counter (No. 07x) 2 : Not used (same as the setting value of 1) 3 : Display the Toner Bottle / Unidentified Toner Bottle replacement counter (No. 017x/No. 18x) * TNRB-SW setting is not used with the machines for China. It is to always display the Toner Bottle / Unidentified Toner Bottle replacement counter (No. 017x/No. 18x) (cannot be hidden)
Default value	0
SCALL-SW	
Title	ON/OFF of Service Call button display
Details	To set whether to display or hide the Service Call button on the Panel. When 1 is set, the button is displayed.
Use case	When the sales company supports service initiated by the Service Call button
Adj/set/operate method	Enter the setting value, and then press Apply key.
Display/adj/set range	0 to 1 0 : OFF 1 : ON
Default value	0
SCALLCMP	
Title	Setting of Service Call complete notice
Details	To set whether to notify the completion of Service Call. With this setting enabled, a notification of repair completion is sent to UGW to clear the Service Call status that is retained internally.
Use case	When service technician uses this mode after completing repair
Adj/set/operate method	Enter the setting value, and then press Apply key.
Caution	After executing "1: Notified", the setting value becomes 0 immediately.
Display/adj/set range	0 to 1 0 : Not notified 1 : Notified
Default value	0
PS-MODE	
Title	Setting of compatible mode at PS usage
Details	To set for compatibility with existing machine regarding image process or print specification with PS print. Setting of a value other than the setting values means that multiple settings are combined. (Example: 7=1+2+4)
Use case	At replacement
Adj/set/operate method	1. Enter the setting value, and then press Apply key. 2. Turn OFF/ON the main power switch.

COPIER > OPTION > USER	
Item	Description
Display/adj/set range	0 to 63 1 : ( not used) 2 : ( not used) 4 : Compatible with EFI at PS 2-sided delivery 8 : Change of default value of StrokeAdjust 16 : Change of default value of DeferredMediaSelection 32 : Change of printing accuracy of SmallText horizontal line
Default value	0
SMD-EXPT	
Title	Enabling of the export of service mode setting values from RUI
Details	To enable the export of service mode setting values from RUI.
Adj/set/operate method	1. Enter the setting value, and then press Apply key. 2. Turn OFF/ON the main power switch.
Display/adj/set range	0 to 1 0: Disabled 1: Enabled
Default value	0
ACC-SLP	
Title	Switching of the restriction to shift to sleep mode 3 when the card is connected
Details	To switch whether to restrict the shift to sleep 3 when the card is connected.
Adj/set/operate method	Enter the setting value, and then press Apply key.
Display/adj/set range	0 to 1 0 : The machine does not shift to sleep mode 3. 1 : The machine shifts to sleep mode 3.
Default value	1
RPL-IMP	
Title	Turning ON/OFF at replacement mode
Details	To be able to import the settings values (which are exported by DCM and can only be imported to host machine) unique to the model such as IPv4 addresses to a different machine by turning ON the replacement mode.
Use case	When migrating the settings at replacement of a host machine with a different one of the same model.
Display/adj/set range	0,1 Default 0
Default value	0

## ■ ACC

COPIER > OPTION > ACC	
Item	Description
WLAN	
Title	Presence/absence of the wireless LAN function
Details	To set whether to enable the wireless LAN function.
Use case	Upon user's request
Adj/set/operate method	1. Enter the setting value, and then press Apply key. 2. Turn OFF/ON the main power switch.
Display/adj/set range	0 to 1 0: Disabled 1: Enabled
Default value	0 (Model where wireless LAN is provided as an option) 1 (Wireless LAN model)
WLANMODE	
Title	Setting of IEEE802.11n
Details	To set whether to enable IEEE802.11n which is the wireless LAN standard.
Use case	Upon user's request
Adj/set/operate method	1. Enter the setting value, and then press Apply key. 2. Turn OFF/ON the main power switch.

COPIER > OPTION > ACC	
Item	Description
Display/adj/set range	0 to 1 0: Disabled 1: Enabled
Default value	1 (All models)
UNIF-OF	
Title	Forcible deactivation of the uniFLOW function
Details	If this switch is set to 1 and the device power is turned OFF and then ON while the uniFLOW function is in active state, the uniFLOW function is forcibly deactivated. In addition, when this switch is set to 1, Activate/Deactivate request from the server is ignored.
Use case	Avoidance operation performed by a service engineer in the event of a uniFLOW failure. Used when, for example, connection to the uniFLOW server fails due to an error in the device.
Adj/set/operate method	1. Enter the setting value, and then press Apply key. 2. Turn OFF/ON the main power switch.
Caution	Use only when necessary. After the work is completed, set the value back to 0.
Display/adj/set range	0 to 1 0: Disabled 1: Enabled

## ■ TOTAL

COPIER > COUNTER >	
Item	Description
TOTAL	
Title	Service-purposed total counter
Details	SERVICE1:To advance the counter when a paper is delivered outside the printer. SERVICE2:o advance the counter when a paper is delivered outside the printer. TTL:To display the total of counters of COPY, PDL-PRT, RPT-PRT, and MD-PRT. COPY:To advance the counter when a paper is delivered outside the printer. PDL-PRT:To count up when the PDL print is delivered outside the machine/2-sided printout is stacked. RPT-PRT:To count up when the report print is delivered outside the machine/2-sided printout is stacked. MD-PRT:To count up when the media print is delivered outside the machine. 2-SIDE:To count up the number of 2-sided copies/prints when the copy/printout is delivered outside the machine/2-sided copy/printout is stacked.
Display/adj/set range	0 to 99999999
Measure	Number of sheets
Default value	0
PICK-UP	
Title	Pickup total counter
Details	To count up the number of sheets picked up from the Cassette 1 (standard Pickup Cassette). To count up the number of sheets picked up from the Cassette 2 (option Pickup Cassette). To count up the number of sheets picked up from the Multi-purpose Tray Pickup Unit. To count up the number of sheets picked up in duplex mode. The counter is advanced regardless of the original size. The counter is advanced by printout in service mode.
Display/adj/set range	0 to 99999999
Measure	Number of sheets
Default value	0
JAM	
Title	Total jam counter
Details	To count up the number of jam occurrences in the entire machine. To count up the number of jam occurrences in the Duplex Unit. To count up the number of jam occurrences in the Multi-purpose Tray Pickup Unit. To count up the number of jam occurrences in the Cassette 1 (standard Pickup Cassette). To count up the number of jam occurrences in the Cassette 2 (option Pickup Cassette). The counter is advanced by paper size mismatch or misprint.
Display/adj/set range	0 to 99999999
Measure	frame

COPIER > COUNTER >	
Item	Description
Default value	0

## TESTMODE

### ■ PRINT

TESTMODE> PRINT	
Item	Description
START	
Title	Output of test print
Details	To output a test print with the PG pattern set in PG-TYPE, MODE, etc.
Use case	At trouble analysis
Adj/set/operate method	Enter the setting value, and then press Apply key.
PG-TYPE	
Title	Setting of PG number
Details	To set the PG number of the test print.
Use case	At trouble analysis
Adj/set/operate method	Enter the setting value, and then press Apply key.
Display/adj/set range	0: Grid Bk 1: HT 2: Solid black 3: Solid white 4: 17 gradations 5: Thin horizontal line 6: Pascal correction chart 7: Chart128
Default value	0
COUNT	
Title	Setting of PG output quantity
Details	To set the number of sheets for PG output.
Use case	At trouble analysis
Adj/set/operate method	Enter the setting value, and then press Apply key.
Display/adj/set range	1 to 99
Measure	1 sheet
Default value	1
PHASE	
Title	Setting of PG 2-sided mode
Details	To set 1-sided/2-sided print for PG output. Even if 2-sided print is set for a machine that only supports 1-sided print, the setting is disabled.
Use case	At trouble analysis
Adj/set/operate method	Enter the setting value, and then press Apply key.
Display/adj/set range	0 to 1 0 : 1-sided 1 : 2-sided
Default value	0
MODE	
Title	Setting of test print image formation method
Details	To set the image formation method for the test print. If PG-TYPE is 0/1, this setting is disabled because a specific image formation method is applied.
Use case	At trouble analysis
Adj/set/operate method	Enter the setting value, and then press Apply key.

TESTMODE> PRINT	
Item	Description
Display/adj/set range	0 to 4 (Default 0) 0: TBIC 1: Resolution dithering 2: Gradation dithering 3: Color tone dithering 4: High-resolution dithering
Default value	0
THRU	
Title	Setting of image correction table at test print
Details	It is possible to check the density characteristics due to the density correction process when normal gamma LUT is used, and the density characteristics of the engine when the linear gamma LUT is used.
Use case	At trouble analysis
Adj/set/operate method	Enter the setting value, and then press Apply key.
Display/adj/set range	0 to 1 0 : Normal gamma LUT 1 : Through (linear) gamma LUT
Default value	0
Supplement/memo	Gamma LUT: Density gradation characteristic table
DENS	
Title	Adjustment of test print engine F value
Details	This setting is used to adjust the F value of the engine of test print. The density increases as the value increases.
Use case	At trouble analysis
Adj/set/operate method	Enter the setting value (switch negative/positive by -/+ key) and press Apply key.
Default value	0
MABK	
Title	Set toner thinning process at test print
Details	To execute the thinning process to alleviate the toner scattering at test print. The thinning amount of toner increases in accordance with Mode 1 to Mode 4.
Use case	Print Test print
Adj/set/operate method	Enter the setting value, and then press Apply key.
Display/adj/set range	"0: OFF1: Mode12: Mode23: Mode34: Mode4"
Default value	0
FEED	
Title	Setting of paper source at test print
Details	To set the paper source at the time of test print output. If this mode is set when there is no Cassette 2 (option Pickup Cassette), the output is made from Cassette 1 (standard Pickup Cassette).
Use case	Print Test print
Adj/set/operate method	Enter the setting value, and then press Apply key.
Display/adj/set range	0 to 4 0:MPTray, 1:Cassette1 2:Cassette2 3:Cassette3 4:Cassette4 Default 1(d)
Default value	1

**SERVICE REPORT**
**■ MISC-P**

<b>COPIER&gt; FUNCTION&gt; MISC-P</b>	
<b>Item</b>	<b>Description</b>
CNTR	
Title	Output of counter report
Details	To output the counter report. The usage of functions (reading, recording, communication and copy) is output.
Adj/set/operate method	Select the item, and then press Yes key.
ERR-LOG	
Title	Output of error log report
Details	To output the error log report.
Adj/set/operate method	Select the item, and then press Yes key.
SPEC	
Title	Output of spec report
Details	To output the spec report. The current device specifications such as the location, model information, and ROM version are output.
Adj/set/operate method	Select the item, and then press Yes key.
ERDS-LOG	
Title	Output of Embedded-RDS log
Details	To execute report output of the log relating to Embedded-RDS. The date, time, code, and details (up to 130 characters) of each error that occurred are output.
Use case	When using Embedded-RDS
Adj/set/operate method	Select the item, and then press Yes key.
Related service mode	COPIER> FUNCTION> INSTALL> COM-LOG
Supplement/memo	Embedded-RDS: Function to send device information such as the device counter, failure, and consumables to UGW via SOAP protocol UGW (Universal Gate Way): Remote monitoring service system



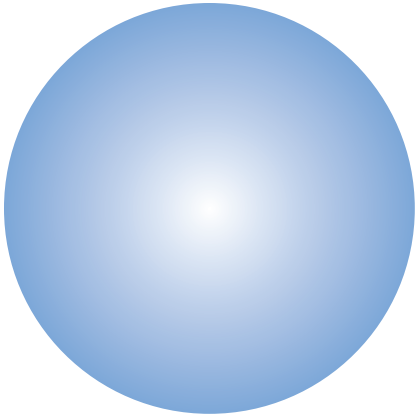

# APPENDICES

Service Tools.....	155
General Circuit Diagram.....	156
Print Sequence.....	157
Backup Data.....	158
Soft Counter Specifications.....	160

## Service Tools

### Special Tools

No special tools are required for servicing this printer other than the standard tools.

### Solvents and Oil List

No.	Type	Purpose	Remark
1	Lubricant	Apply to gear	<ul style="list-style-type: none"><li>• MOLYKOTE® EM-50L (Dow Corning Corporation)</li><li>• Tool No. HY9-0007</li></ul>



# Print Sequence

Timing chart two consecutive prints

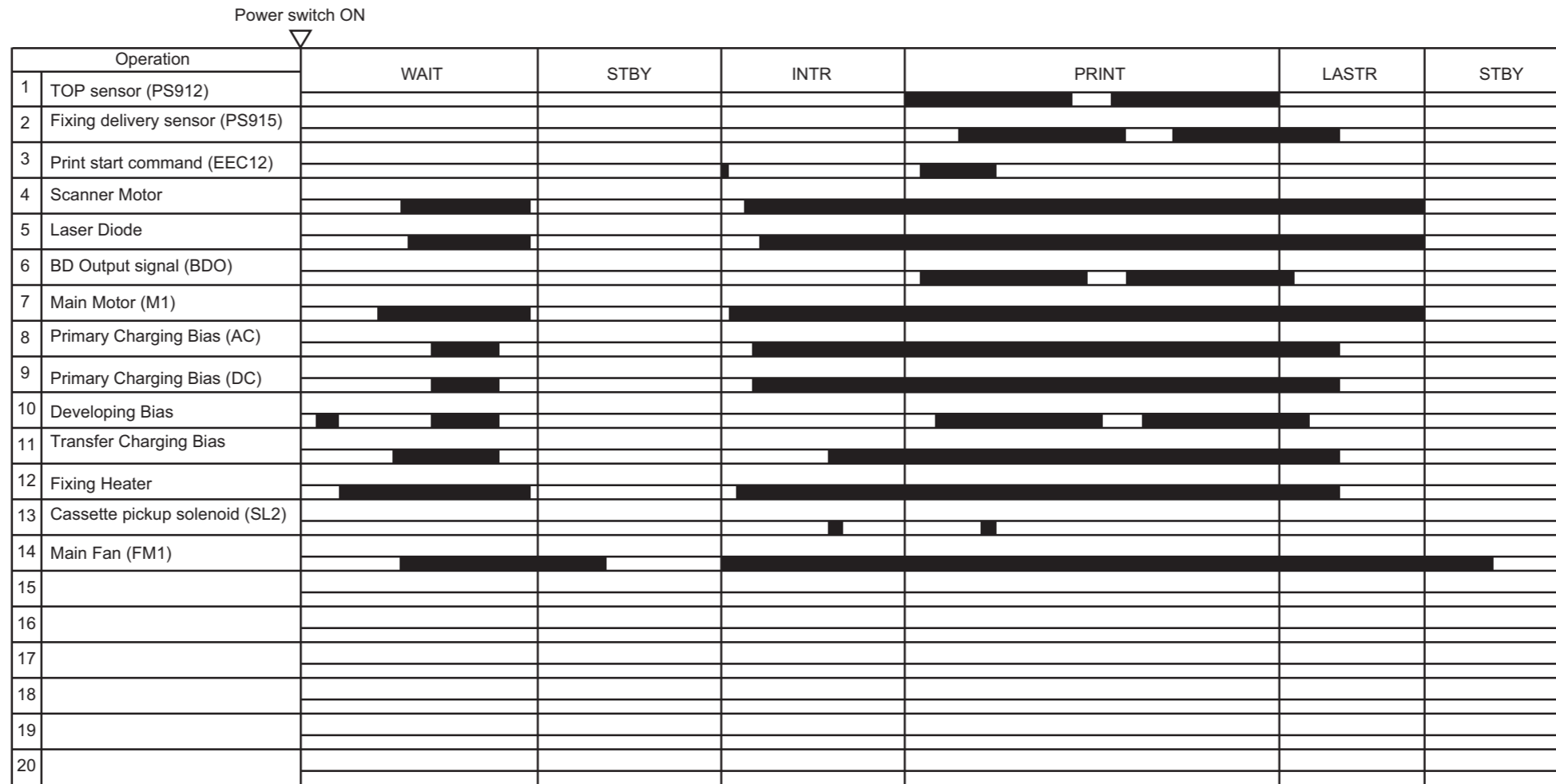

## Backup Data

Data		Location	Replace			Delete									Backup by User			Backup by Service		
						Menu > System Management Settings				COPIER > FUNCTION > CLEAR										
			Engine Controller PCB	Main Controller PCB	eMMC *1	Initialize All Data/ Settings	Initializing Key and Certificate	Initializing Menu > Initialize All	System Management Settings	SRVC-DAT *2	COUNTER	HIST *3	ALL *4	ERDS-DAT	Yes/No	Method	Location	Yes/No	Method	Location
Menu u	Paper Settings	eMMC	-	-	Clear	Clear	-	Clear	-	-	-	Clear	-	Yes	Remote UI *8 LUI *9	PC, USB memory	No	-	-	
	Network Settings	eMMC	-	-	Clear	Clear	-	Clear	-	-	-	Clear	-	Yes	Remote UI *8 LUI *9	PC, USB memory	No	-	-	
	Preferences	eMMC	-	-	Clear	Clear	-	Clear	-	-	-	Clear	-	Yes	Remote UI *8 LUI *9	PC, USB memory	No	-	-	
	Timer Settings	eMMC	-	-	Clear	Clear	-	Clear	-	-	-	Clear	-	Yes	Remote UI *8 LUI *9	PC, USB memory	No	-	-	
	Common Settings	eMMC	-	-	Clear	Clear	-	Clear	-	-	-	Clear	-	Yes	Remote UI *8 LUI *9	PC, USB memory	No	-	-	
	Memory Media Print Settings	eMMC	-	-	Clear	Clear	-	Clear	-	-	-	Clear	-	Yes	Remote UI *8 LUI *9	PC, USB memory	No	-	-	
	Printer Settings	eMMC	-	-	Clear	Clear	-	Clear	-	-	-	Clear	-	Yes	Remote UI *8 LUI *9	PC, USB memory	No	-	-	
	Adjustment/ Maintenance	eMMC	-	-	Clear	Clear	-	Clear	-	-	-	Clear	-	Yes	Remote UI *8 LUI *9	PC, USB memory	No	-	-	
	System Management Settings	eMMC	-	-	Clear	Clear	-	Clear	Clear	-	-	Clear *6	-	Yes	Remote UI *8 LUI *9	PC, USB memory	No	-	-	
Key and Certificate	eMMC	-	-	Clear	Clear	Clear *5	-	-	-	-	Clear	-	No	-	-	No	-	-		
eRDS	eMMC	-	-	Clear	Clear	-	-	-	-	-	Clear	Clear	No	-	-	No	-	-		
Serial Number	EE-PROM(SOFT-ID PCB) / OnBoard-Fram / Fram(COUNTER PCB)	-	-	-	-	-	-	-	-	-	-	-	-	No	-	-	No	-	-	
Job History	eMMC	-	-	Clear	Clear	-	-	-	-	-	Clear	Clear	-	No	-	-	No	-	-	
Page counter	eMMC / OnBoard-Fram / Fram(COUNTER PCB)	-	-	Clear	-	-	-	-	-	-	Clear	-	-	No	-	-	No	-	-	
Part counter	None	-	-	Clear	-	-	-	-	-	-	Clear	-	-	No	-	-	No	-	-	
Service Mode	Service Mode setting (Main Controller)	eMMC	-	-	Clear	Clear	-	-	-	Clear	-	Clear	-	No	Remote UI *8	PC, USB memory	Yes	Service mode *7	PC, USB memory	
Service Mode	Service Mode setting (Engine Controller)	eMMC	-	-	Clear	Clear	-	-	-	Clear	-	Clear	-	No	Remote UI *8	PC, USB memory	Yes	Service mode *7	PC, USB memory	

\*1 Log data such as Mac address, USB serial number, printer-related setting values, user data, and logs are initialized.

\*2 Service data is cleared. User data is not cleared.

\*3 The logs (communication management, print, jam, error, and alarm) are cleared.

\*4 The user data, service data, logs, and system administrator are initialized. (The system manager ID and password are changed back to the default values.)

\*5. When the key and certificate are initialized, TLS authentication of IEEE802.1X and the SSL setting are changed to "OFF".

- \*6. The system administrator ID and the password are changed back to the default values. ID: 7654321 / PWD: 7654321.
- \*7. FUNCTION > SYSTEM > IMPORT / FUNCTION > SYSTEM > EXPORT
- \*8. Settings/Registration > Import/Export
- \*9. Setting Menu List > System Management Settings > Import/Export of Settings

## Soft Counter Specifications

The numbers entered for software counters are classified as follows:

No.	Counter Details	Counter Name
101	Total1	Total 1
102	Total2	Total 2
113	Total (Black / Small)	Total (Black / Small)
114	Total1 (2-Sided)	Total 1 (2-Sided)
194	Toner replacement /Black *1	Toner replacement /Black

\*1: The counter can be displayed in COPIER > OPTION > USER > TNRB-SW.