

imageCLASS LBP162dw

SERVICE MANUAL



Canon

November 22, 2017
Rev. 1

Introduction

Important Notices

Application

This manual has been issued by Canon Inc. for qualified persons to learn technical theory, installation, maintenance, and repair of products.

This manual covers all localities where the products are sold. For this reason, there may be information in this manual that does not apply to your locality.

Corrections

This manual may contain technical inaccuracies or typographical errors due to improvements or changes in products. When changes occur in applicable products or in the contents of this manual, Canon will release technical information as the need arises. In the event of major changes in the contents of this manual over a long or short period, Canon will issue a new edition of this manual.

The following paragraph does not apply to any countries where such provisions are inconsistent with local law.

Trademarks

The product names and company names used in this manual are the registered trademarks of the individual companies.

Copyright

The copyright of this document belongs to Canon Inc. This document may not be copied, reproduced or translated into another language, in whole or in part, without the prior consent of Canon Inc.







Copyright CANON INC. 2017















Caution

Use of this manual should be strictly supervised to avoid disclosure of confidential information.



Explanation of Symbols

The following symbols are used throughout this Service Manual.

Symbols	Explanation	Symbols	Explanation
	Check.		Remove the claw.
	Check visually.		Insert the claw.
	Check a sound.		Push the part.

Symbols	Explanation	Symbols	Explanation
	Disconnect the connector.		Connect the power cable.
	Connect the connector.		Disconnect the power cable.
	Remove the cable/wire from the cable guide or wire saddle.		Turn on the power.
	Install the cable/wire to the cable guide or wire saddle.		Turn off the power.
	Remove the screw.		Loosen the screw.
	Install the screw.		Tighten the screw.
	Cleaning is needed.		Measurement is needed.

The following rules apply throughout this Service Manual:

- Each chapter contains sections explaining the purpose of specific functions and the relationship between electrical and mechanical systems with reference to the timing of operation.
In the diagrams,  represents the path of mechanical drive; where a signal name accompanies the symbol, the arrow  indicates the direction of the electric signal.
The expression "turn on the power" means flipping on the power switch, closing the front door, and closing the delivery unit door, which results in supplying the machine with power.
- In the digital circuits, '1' is used to indicate that the voltage level of a given signal is "High", while '0' is used to indicate "Low". (The voltage value, however, differs from circuit to circuit.) In addition, the asterisk (*) as in "DRMD*" indicates that the DRMD signal goes on when '0'.
In practically all cases, the internal mechanisms of a microprocessor cannot be checked in the field. Therefore, the operations of the microprocessors used in the machines are not discussed: they are explained in terms of from sensors to the input of the DC controller PCB and from the output of the DC controller PCB to the loads.

The descriptions in this Service Manual are subject to change without notice for product improvement or other purposes, and major changes will be communicated in the form of Service Information bulletins.

All service persons are expected to have a good understanding of the contents of this Service Manual and all relevant Service Information bulletins and be able to identify and isolate faults in the machine.

Contents

Safety Precautions.....	1
Laser Safety.....	2
How to Handle the Laser Scanner Unit.....	2
Power Supply.....	2
Toner Safety.....	2
About Toner.....	2
Handling Adhered Toner.....	3
Notes When Handling a Lithium Battery.....	3
Notes Before it Works Serving.....	3
Points to Note at Cleaning.....	3
Notes on Assembly/Disassembly.....	4
1. Product Overview.....	5
Product Overview.....	6
Product Lineup.....	6
Specifications.....	7
Parts Name.....	9
2. Technology.....	12
Basic Configuration.....	13
Functional Configuration.....	13
Controller System.....	14
Configuration/Function.....	14
Main Controller PCB.....	14
Engine Controller PCB.....	15
Motor Control.....	17
Door Open Detection.....	17
Power Supply Control Overview.....	17
Protection Function.....	18
Power-saving Mode.....	19
Laser Exposure System.....	20
Functional Configuration.....	20
Failure Detection.....	20
Image Formation System.....	22
Functional Configuration.....	22
Image Formation Process.....	22
High Voltage Power Supply Control.....	23
Cartridge.....	23
Fixing System.....	27
Functional Configuration.....	27
Fixing Temperature Control.....	27
Fixing Assembly Failure Detection.....	28
Fixing Assembly Failure Detection.....	29
Pickup Feed System.....	30

Functional Configuration.....	30
Parts Configuration.....	31
Paper Detection.....	32
Pickup Control.....	32
Paper Width Detection.....	33
Paper Length Detection.....	33
Jam Detection.....	34
3. Periodical Service.....	35
Periodical Service.....	36
Periodically Replaced Parts.....	36
Consumable Parts.....	36
Periodical Service.....	36
Cleaning Parts.....	36
4. Parts Replacement and Cleaning.....	37
List of Parts.....	38
External Cover.....	38
Main Unit.....	39
Electrical Components List.....	40
External Cover System.....	43
Removing the Cartridge.....	43
Removing the Right Cover.....	44
Removing the Left Cover.....	45
Removing the Cartridge Door Unit.....	47
Removing the Rear Upper Cover.....	49
Removing the Duplexing Door.....	50
Removing the Upper Front Cover.....	51
Removing the Front Cover.....	53
Removing the Multi-purpose Tray.....	56
Controller System.....	58
Removing the Wireless Lan PCB.....	58
Removing the Main Controller PCB.....	58
Removing the Low Voltage Power Supply Unit.....	59
Removing the Engine Controller PCB.....	60
Removing the Motor PCB.....	64
Removing the Environment Sensor PCB.....	65
Removing the Main Fan.....	66
Laser Exposure System.....	69
Removing the Laser Scanner Cover.....	69
Removing the Laser Scanner Unit.....	70
Image Formation System.....	72
Removing the Transfer Roller.....	72
Removing the Transfer Unit.....	73
Removing the Developing Disengagement Solenoid.....	76
Fixing System.....	79
Removing the Fixing Assembly.....	79
Removing the Fixing Film Unit.....	82
Pickup Feed Delivery System.....	86

Removing the Pickup Roller.....	86
Removing the Separation Pad Assembly.....	86
Removing the Duplexing Frame Unit.....	87
Removing the Duplexing Reverse Unit.....	91
Removing the Pickup Sensor PCB.....	92
Removing the Delivery Sensor PCB.....	93
5. Adjustment.....	94
Adjustment at Parts Replacement.....	95
Main Controller PCB.....	95
6. Troubleshooting.....	96
Test Print.....	97
Engine Test Print.....	97
Report Print List.....	97
Cartridge Log Report.....	97
Troubleshooting Items.....	101
Recurring faulty image.....	101
Confirming nip width.....	101
Remedy for Image Failure.....	102
Light print.....	102
Dark print.....	103
Completely blank.....	103
All black.....	103
White spots.....	104
Dirt on back.....	104
Vertical lines.....	105
Vertical white lines.....	105
Horizontal lines.....	105
Horizontal white lines.....	106
Dropouts.....	106
Loose toner.....	106
Misformed image/misplaced image.....	107
Wrinkles or creases.....	107
Dirt on front.....	107
Vertical density variation.....	108
Repetitive image defects.....	108
Debug Log.....	110
Function Overview.....	110
Firmware Log Collection Using Log Collection Tool.....	110
Version Upgrade.....	113
Function Overview.....	113
Version Upgrade Using UST.....	113
Version Upgrade via Internet.....	113
7. Error/Jam/Alarm.....	116
Overview.....	117
About Code.....	117
Error/Jam Log Indication.....	117

Error Code.....	120
Error Code Details.....	120
Jam Code.....	123
Host machine.....	123
Alarm Code.....	124
8. Service Mode.....	125
Overview.....	126
Entering Service Mode.....	126
COPIER (Service mode for printer).....	127
DISPLAY (State display mode).....	127
FUNCTION (Operation / inspection mode).....	128
OPTION (Specification setting mode).....	133
COUNTER (Counter mode).....	136
TESTMODE (Service mode for test print, operation check, etc.).....	139
SYSTEM (SYSTEM Test Mode).....	139
SCAN (SCAN Test Mode).....	139
PANEL (PANEL Test Mode).....	139
APPENDICES.....	140
Service Tools.....	141
Special Tools.....	141
Solvents and Oil List.....	141
General Circuit Diagram.....	142
Backup Data.....	144
BackupData.....	144

Safety Precautions

Laser Safety.....	2
How to Handle the Laser Scanner Unit	2
Power Supply.....	2
Toner Safety.....	2
Notes When Handling a Lithium Battery.....	3
Notes Before it Works Serving.....	3
Points to Note at Cleaning.....	3
Notes on Assembly/Disassembly.....	4

⚠ CAUTION:

Never throw toner in flames to avoid explosion.

Handling Adhered Toner

- Use dry tissue paper to wipe off toner adhered to skin or clothes and wash in water.
- Never use warm water for cleaning up toner to prevent toner particles from being gelled to soak into fibers permanently.
- Toner particles are reactive with vinyl polymers. Avoid contacting these materials.

Notes When Handling a Lithium Battery

Dispose of used batteries according to the instructions.

⚠ CAUTION:

Risk of explosion if battery is replaced by an incorrect type.

The following warnings are given to comply with Safety Principles (EN60950-1).

⚠ CAUTION:

Wenn mit dem falschen Typ ausgewechselt, besteht Explosionsgefahr.
Gebrauchte Batterien gemäß der Anleitung beseitigen.

警告

如果更換不正確之電池型式會有爆炸的風險
請依製造商說明書處理用過之電池

Notes Before it Works Serving

- At servicing, be sure to turn OFF the power source according to the specified steps and disconnect the power plug.
- Be sure to disconnect the power plug on a regular basis and remove dust and dirt accumulated around the outlet with dry cloth.

⚠ CAUTION:

Leaving the power plug connected for a long time in an environment having a lot of dust, moisture, or oily smoke will cause a fire. (Because dust accumulated in the surrounding area will absorb moisture and cause an insulation failure)

Points to Note at Cleaning

When performing cleaning using organic solvent such as alcohol, be sure to check that the component of solvent is vaporized completely before assembling.

Notes on Assembly/Disassembly

Follow the items below to assemble/disassemble the device.

1. Disconnect the power plug to avoid any potential dangers during assembling/disassembling works.
2. If not specially instructed, reverse the order of disassembly to reinstall.
3. Ensure to use the right screw type (length, diameter, etc.) at the right position when assembling.
4. To keep electric conduction, binding screws with washers are used to attach the grounding wire and the varistor. Ensure to use the right screw type when assembling.
5. Unless it is specially needed, do not operate the device with some parts removed.
6. Never remove the paint-locked screws when disassembling.



Product Overview

Product Overview.....6

Product Overview

Product Lineup

Host Machine



Function

Function	LBP162dw	LBP161dn
COPY	-	-
PRINT	Yes	Yes
FAX	-	-
Remote UI	Yes	Yes
2-sided printing	Yes	Yes
Control Panel	LCD(5-line)	LCD(5-line)
MEAP	-	-
Network	Yes	Yes
WiFi	Yes	-

NOTE:

Model name : d = 2-sided printing, w = WiFi + LAN or WiFi, n = LAN

PDL

Name of PDL	LBP162dw	LBP161dn
UFRII LT	Yes	Yes
PCL	Yes	No

Features

This machine is a low-speed class A4 B&W SFP.

Improved productivity

Print speed of 28 ppm (A4)/30 ppm (LTR) in 1-sided printing has been achieved.

PCL supported (LBP162dw only)

PCL5e/PCL6 supported (Driver is provided only to PCL6)

Compact machine that can be placed on a desk

Width and height have been significantly reduced as compared with the current models.

Control Panel with a screen excellent in visibility and operability

The 5-line Control Panel has been added to the SFP.

Specifications

■ Specifications of Host Machine

Item	Specification / Function
Device Installation	Desktop
Photoreceptor	OPC drum (φ 20)
Light exposure method	Laser beam exposure
Charging method	Roller charging
Developing method	Contact development
Transfer method	Roller transfer
Separation method	Curvature separation
Cassette paper feed	Pad separation method
Drum cleaning method	-
Transfer cleaning method	-
Fixing method	On-demand fixing
Paper delivery method	Face-down
Toner level sensor	-
Toner type	Non-magnetic one-component toner
Toner supply method	<ul style="list-style-type: none"> • Toner cartridge (Developing Assembly / Toner) • Drum cartridge (Drum Unit)
Toner save mode	Mounted
Warm-up time *1	15 sec or less
Printing resolution	600 x 600 dpi
First print time	Approx. 5.2 seconds(A4), Approx. 5.1 seconds(LTR)
Print speed *2	Approx. 28 sheets/min. (A4R) , Approx. 30 sheets/min. (LTR)
Paper Drawer Paper type	Plain paper, Recycled paper, Heavy paper, Bond paper, Label sheet, Envelope
Paper Drawer paper size	A4R, B5R, A5, A5R, A6R, LGLR, LTRR, STMTR, EXECR, OFICIOR, B-OFICIOR, M-OFICIOR, G-LTRR, G-LGLR, AFLS-R, FLS-R, 16KR, IndianLGLR, F4AR, Index Card(3x5inch), Envelope:COM10, Monarch C5, Monarch DL, Custom (Min. 76.2 x 127.0 mm to Max. 215.9 x 355.6 mm)
Paper Drawer Tray capacity	Plain paper (60~80 g/m ²): 250 sheet Plain paper (81~90 g/m ²): 170 sheet Heavy paper (91~105 g/m ²): 170 sheet Heavy paper (106~163 g/m ²): 100 sheet Bond paper: 100 sheet Recycled paper: 100 sheet Label sheet: 100 sheet Envelope: 10 sheet Index Card: 50 sheet
Output tray stack *2	50 Sheets (60~80 g/m ²)
Memory capacity	256MB
Sleep mode	Available
Allowable environmental temperature	10 to 30 °C
Allowable humidity	20 to 80 % in relative humidity (no condensation)
Power rating	120 - 127V : 60Hz : 4.0A (US, Mexico) 110 - 120V : 60Hz : 4.0A (TW) 220 - 240V : 50/60Hz : 2.2A (EU, ASIA, IND, KOR, AUS) 220V : 50Hz : 2.2A (CN)
Maximum power consumption	120V : 1060W or less 230V : 1120W or less
Average power at operation	120V : 290W 230V : 280W
Average power at standby	120V : 3.1W 230V : 3.4W

Item	Specification / Function
Average power at sleep mode	120V : (USB) Approx. 0.6W (Wired) Approx. 0.6W (WiFi) Approx. 0.5W 230V : (USB) Approx. 0.6W (Wired) Approx. 0.7W (WiFi) Approx. 0.5W
Power consumption at Main Power Switch OFF	0.1W or less
Dimensions (W x D x H)	371 × 404 × 225 mm
Weight (Excluding cartridges)	Approx. 7.0 kg

*1: The time from when the power is turned ON to when the basic screen appears. This may vary depending on the usage conditions and environment of this machine.

*2: The actual stack capacity varies depending on the site environment and the type of paper used.

■ Paper size

Paper size	
A4R	297.0 mm x 210.0 mm
B5R	257.0 mm x 182.0 mm
A5R	210.0 mm x 148.0 mm
A5	148.0 mm x 210.0 mm
LGL	355.6 mm x 215.9 mm
LTRR	279.4 mm x 215.9 mm
STMTR	215.9 mm x 139.7 mm
EXECR	266.7 mm x 184.1 mm
OFFICIO	317.5 mm x 215.9 mm
B-OFFICIO	355.0 mm x 215.9 mm
M-OFFICIO	341.0 mm x 215.9 mm
G-LTR	266.7 mm x 203.2 mm
G-LGL	330.2 mm x 203.2 mm
FLSC	330.2 mm x 215.9 mm
AFLS	338.0 mm x 206.0 mm
Indian LGL	345.0 mm x 215.0 mm
16KR	270.0 mm x 195.0 mm
F4A	343.0 mm x 215.9mm
A6	148.0 mm x 105.0mm
Envelope No.10 (COM10)	241.3 mm x 104.7 mm
Envelope Monarch	190.5 mm x 98.4 mm
Envelope C5	229.0 mm x 162.0 mm
Envelope DL	220.0 mm x 110.0 mm
Index Card(3x5inch)	127.0mm x 76.2mm
Custom	Min.76.2 x 127mm to Max. 215.9 x 355.6mm

■ Paper type

Paper type	Basis weight	Paper settings in this machine
Plain paper	71~89 g/m ²	Plain
	61~70 g/m ²	Plain L
	60 g/m ²	Plain L2
Recycled	71~89 g/m ²	Recycled
Heavy paper	90~105 g/m ²	Heavy 1
	106~120 g/m ²	Heavy 2

Paper type		Basis weight	Paper settings in this machine
Heavy paper		121~163 g/m ²	Heavy 3
		121~163 g/m ²	Heavy 4 *1
Bond paper		60~104 g/m ²	Bond 1
		105~163 g/m ²	Bond 2
Label paper		-	Labels
Envelope	COM10, Monarch, C5, DL	-	Envelope
	COM10, Monarch, C5, DL	-	Envelope H *2

*1: Use this type when fixing performance is poor with heavy paper 3 or when using linen paper.

*2: Use this type when fixing performance is poor with envelope or when using linen envelope.

Parts Name

External view

Front side of the machine

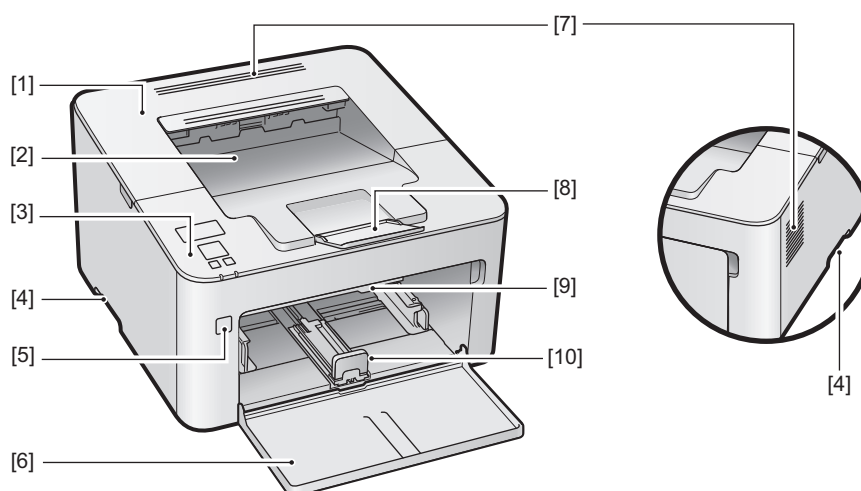

No.	Name	
1	Door Cartridge	Toner cover
2		Output tray
3	Operation panel	
4	Lift handles	
5	Power switch	
6	Front cover	
7	Ventilation slots	
8	Output tray	
9	Multi-purpose tray	
10	Paper Drawer	

• Rear side of the machine

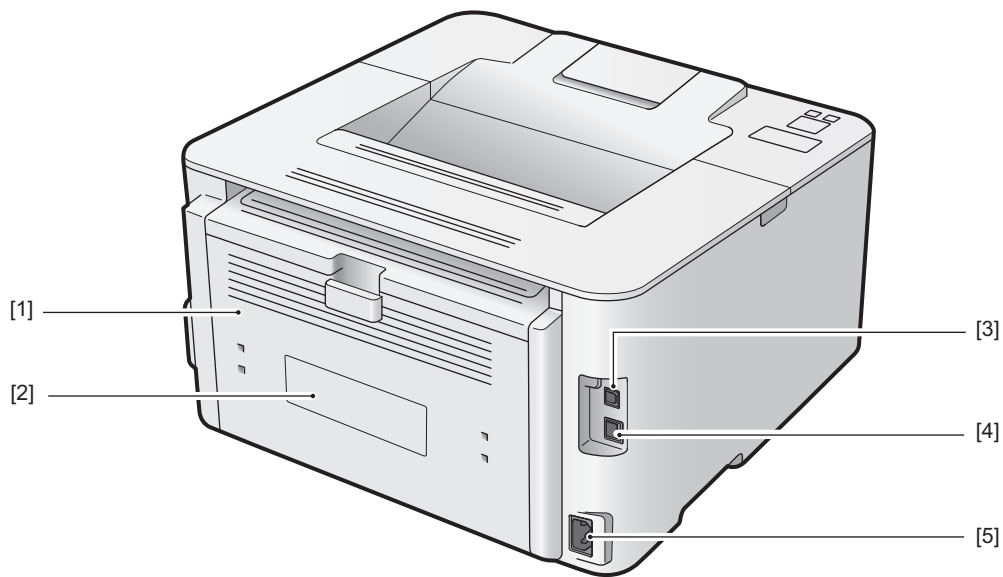

No.	Name
1	Door Duplex
2	Rating label
3	USB port
4	LAN port
5	Power socket

■ Cross Section View

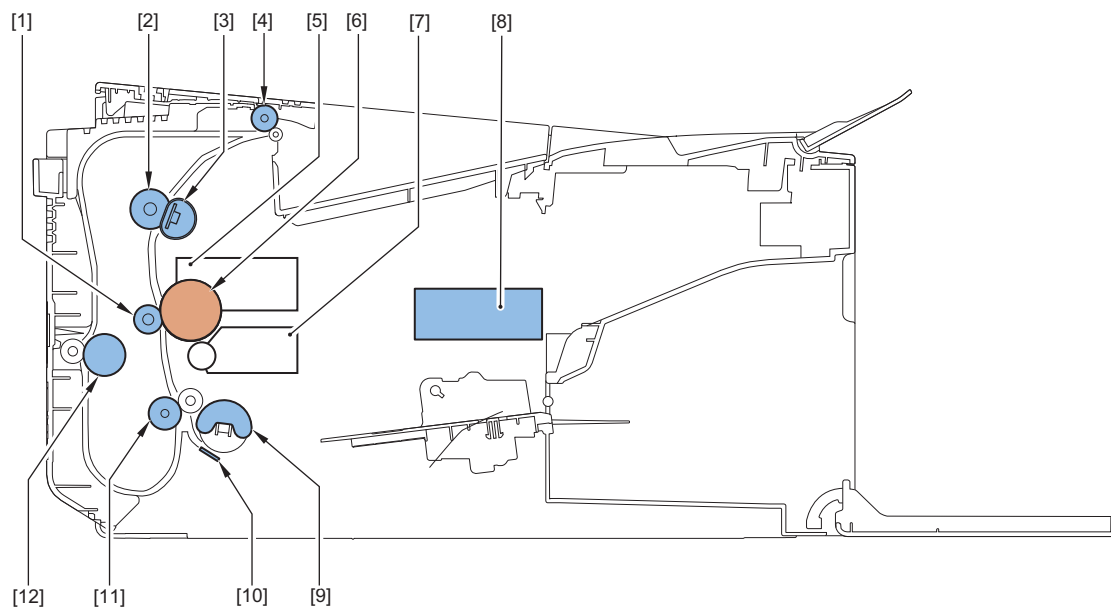

No.	Name
1	Transfer Roller
2	Pressure Roller
3	Fixing Film Unit
4	Delivery Roller
5	Dram Cartridge
6	Photosensitive Drum
7	Toner Cartridge
8	Laser Scanner Unit
9	Pickup Roller

No.	Name
10	Separation Pad
11	Feed Roller
12	Duplexing Roller

■ Control Panel

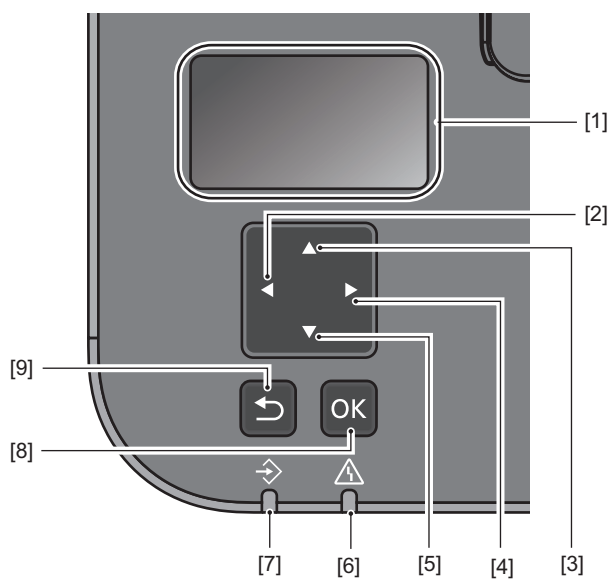

No.	Name
1	Display (screen)
2	Left Key
3	Up Key
4	Right Key
5	Down Key
6	Alarm indicator
7	Job indicator
8	OK key
9	Back key



Technology

Basic Configuration.....	13
Controller System.....	14
Laser Exposure System.....	20
Image Formation System.....	22
Fixing System.....	27
Pickup Feed System.....	30

Basic Configuration

Functional Configuration

Description

This machine is roughly composed of the following five blocks.

- Laser Exposure System
- Controller System
- Image Formation System
- Pickup/ Feed System
- Fixing System

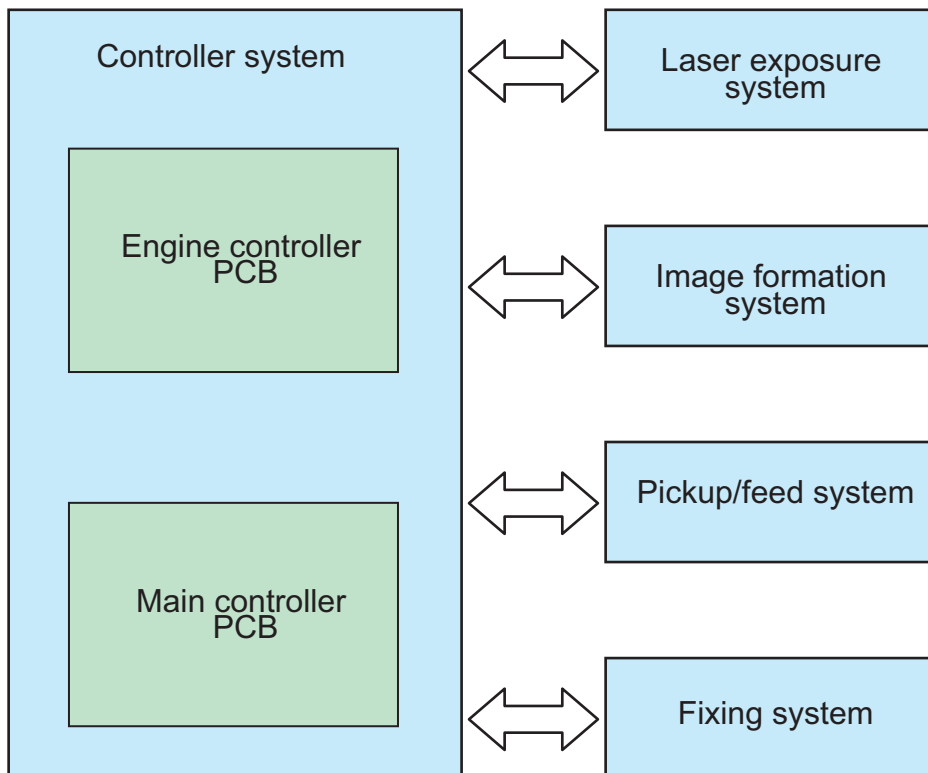

Controller System

Configuration/Function

Description

This product is mainly controlled by the main and Engine controllers.

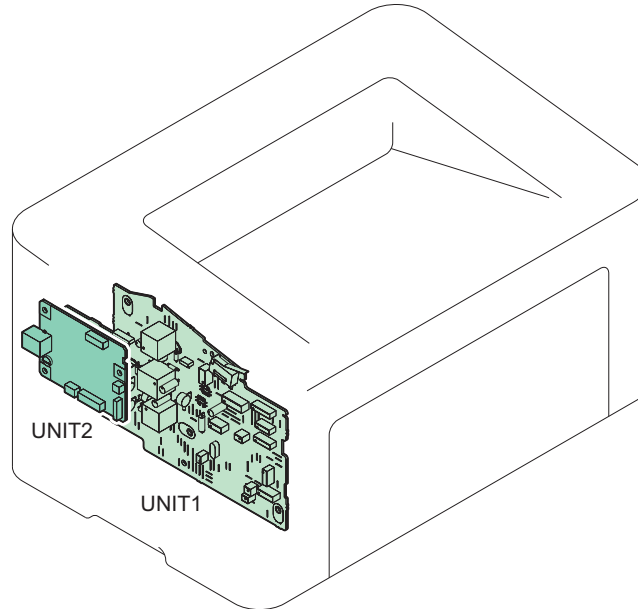

No.	Parts nam	Role
UNIT 1	Engine Controller PCB *1	Provides controls on printer, laser, high-voltage PCBs, I/O, etc. and maintain setting values.
UNIT 2	Main Controller PCB	Provides controls on the system, image processing, network and maintain various setting values.

*1: The engine controller PCB consists of it by a high voltage power supply circuit and a DC controller circuit.

Main Controller PCB

Overview

Main controller receives the print information from the external devices (computer etc.) through the interface cable.

Print information is divided into 2 types such as command data to handle the printer status or specific data and the dot data to printout.

After the main controller receives the dot data, it creates the video data and send it to the engine controller.

The command data is the data to monitor the printer status from the external device using interface.

When this data arrives, the main controller communicates with the engine controller and sends the printer status to the external devices.

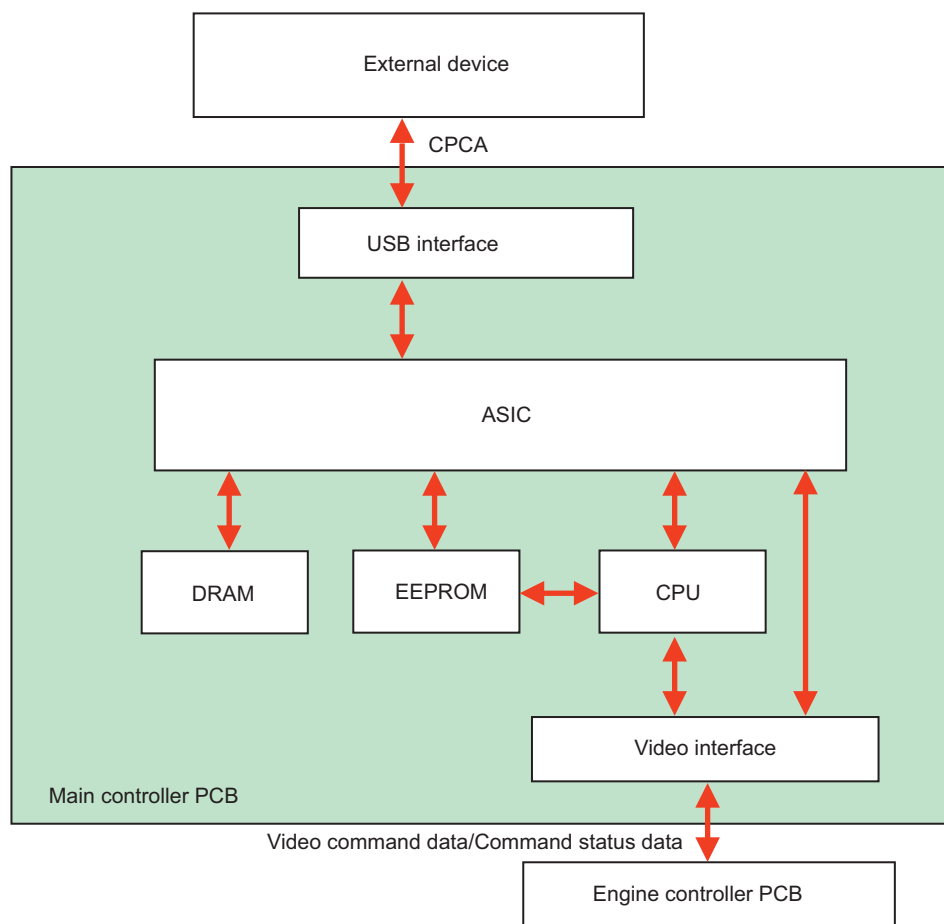

Description

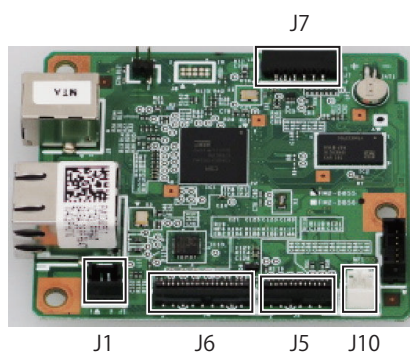

Jack	Function	Jack	Function
J1	Multi-purpose Sensor	J7	Wireless LAN PCB I/F
J5	Engine Controller PCB I/F	J10	Power Supply I/F
J6	Control Panel PCB I/F (LCD)		

Engine Controller PCB

Overview

Engine controller is the circuit to control the operation sequence of the host machine and it is controlled by the CPU inside the engine controller.

When the DC power is supplied via the low voltage power supply, the CPU starts to control the printer operation.

Then, CPU drives the loads such as laser diode, motors and solenoids etc. according to the image data that is input by the main controller when status becomes stand-by mode.

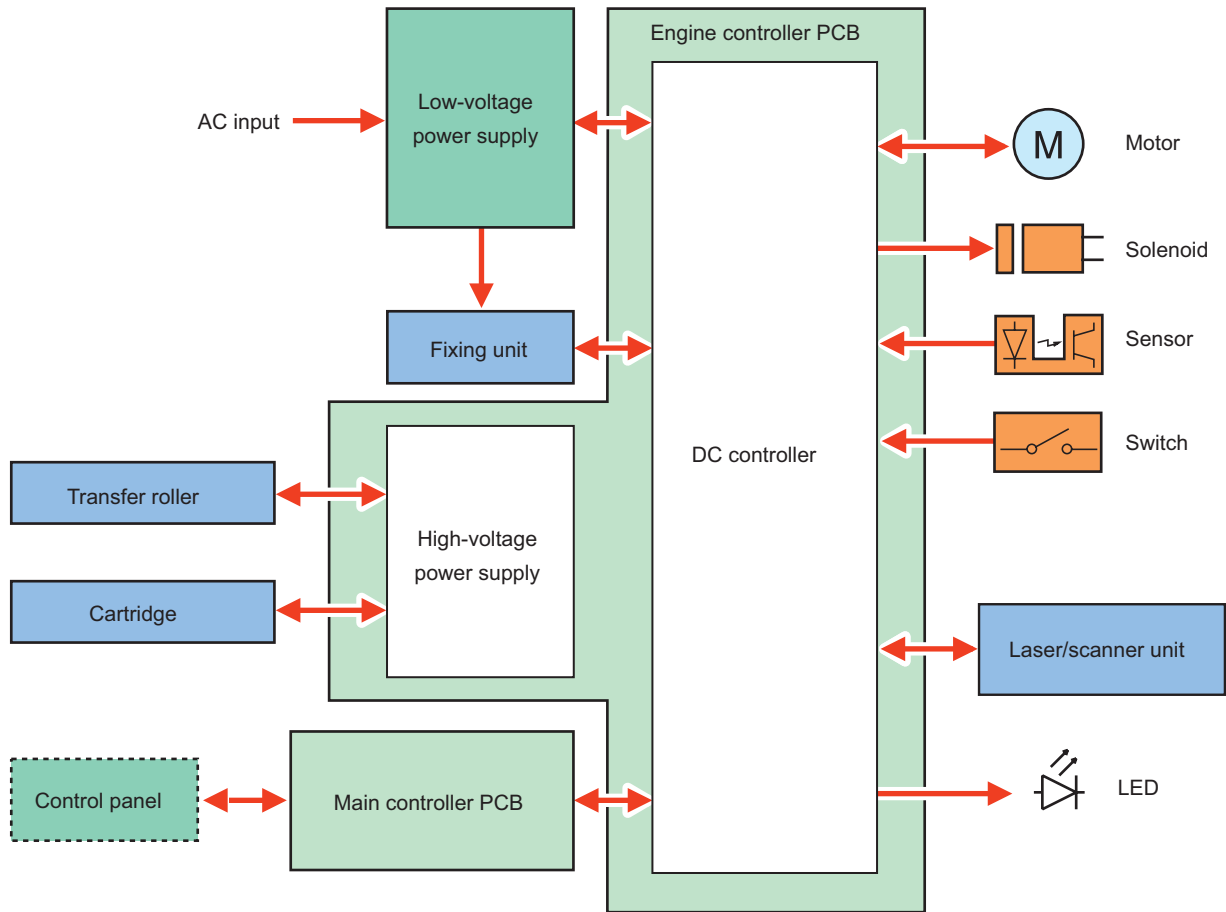

Description

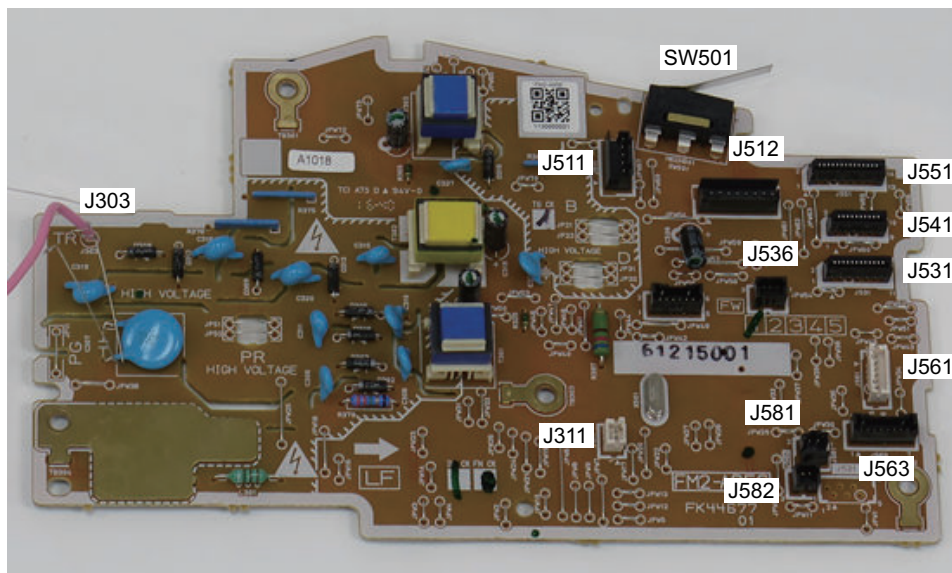

Jack	Function	Jack	Function
J303	Transfer/High Voltage I/F	J541	Laser Scanner Unit I/F
J311	Pre-Exposure LED I/F	J551	Motor PCB I/F
J511	Low-voltage Power Supply PCB I/F	J561	TOP Sensor PCB I/F
J512	Low-voltage Power Supply PCB I/F	J563	Environment Sensor I/F
J531	Main Controller PCB I/F	J581	Drum Cartridge Memory I/F
J536	Power Supply LED I/F	J582	Toner Cartridge Memory I/F
		SW501	Interlock Switch I/F

Motor Control

Overview

This machine uses motors for paper feed and image formation.

Description

Name	Symbol	Drive parts	Failure Detection
Main Motor	M2	Pickup Roller, Photosensitive Drum, Feed Roller, Pressure Roller, Output Roller	None
Scanner Motor	M1	Scanner Mirror	Yes

Door Open Detection

Overview

This machine uses the Interlock Switch (SW501) of the Engine Controller PCB (UNIT1) to detect whether the door is opened or closed.

Description

When door open is detected by this switch (SW501), the Engine Controller PCB (UNIT1) stops drive of the motors and the solenoids.

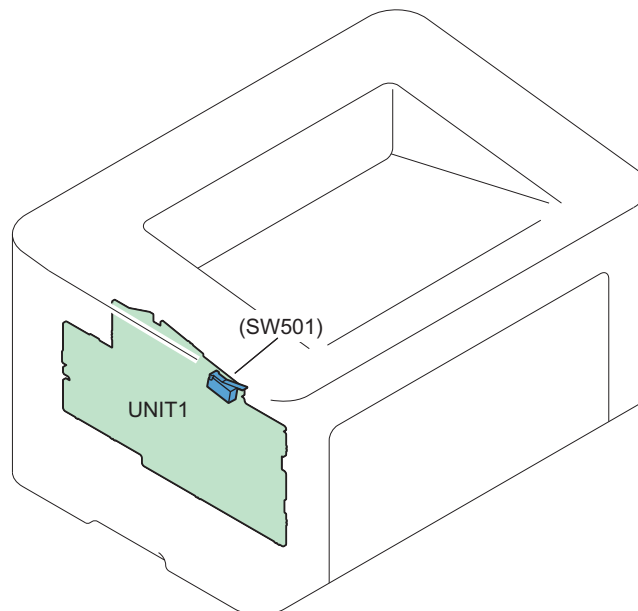

Power Supply Control Overview

Overview

This circuit converts the AC voltage to DC power supply and provides it to each load.

Description

The following shows a block diagram of the low voltage power supply and fixing power supply .

Low voltage power supply: Generates the DC power supply needed inside the printer.

Fixing power supply: Fixing power supply: Controls the temperature of the Fixing Heater of the Fixing Assembly.

The low voltage power supply starts to operate when the AC power supply is connected to the inlet. The AC power supply is converted to +24 V, which is the DC power supply required by the printer, and +3.3 V.

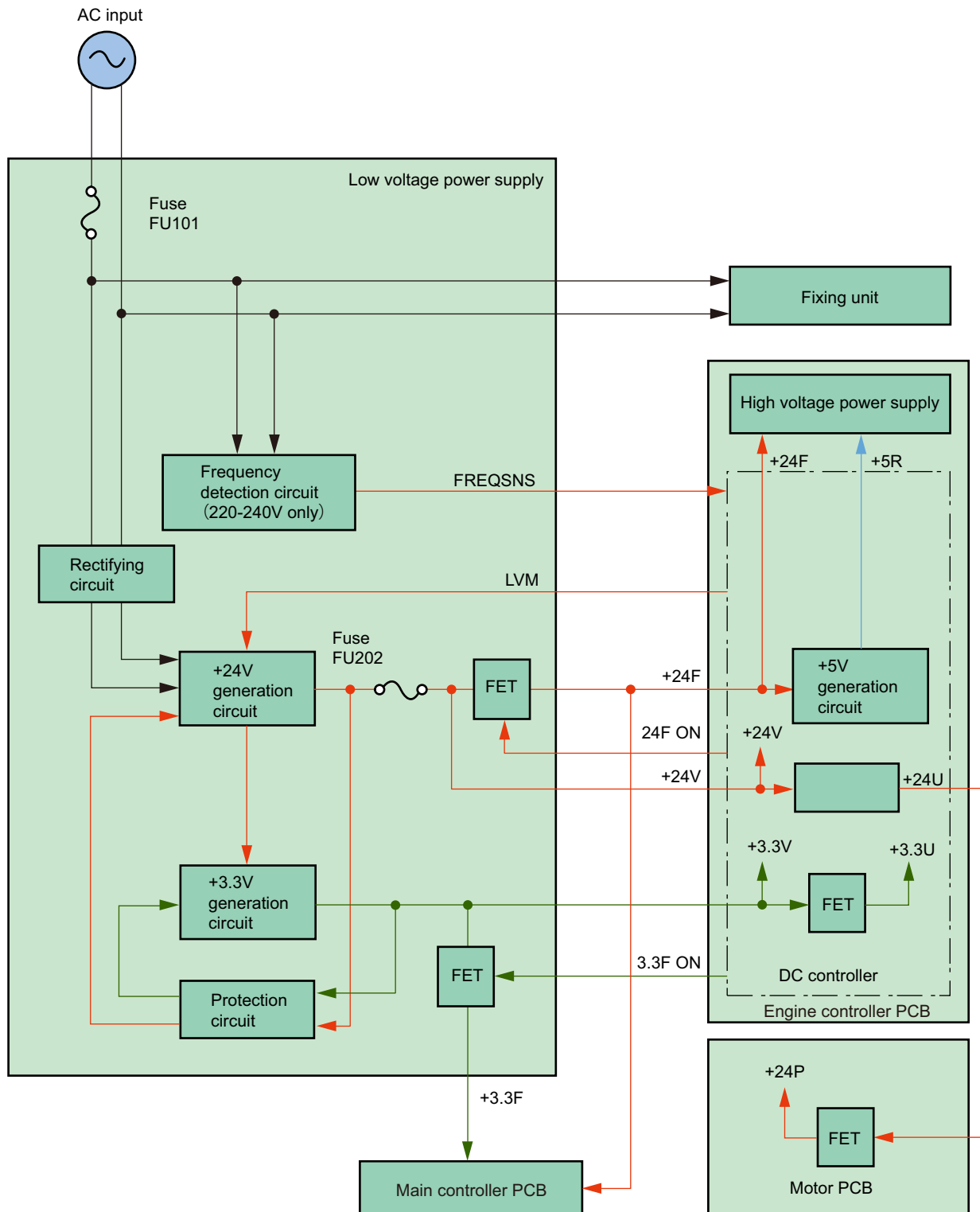

Protection Function

Overview

This machine has a protection function against overcurrent and overvoltage.

Description

Low voltage power circuit carries the overcurrent preventive function against and overvoltage preventive function that block the voltage output automatically to prevent the power circuit brokerage when the overcurrent or overvoltage occur due to load errors such as short circuit etc.

Also the circuit carries the 2 fuses (FU101, FU202) as a preventive function. FU101 is the fuse against overcurrent in the AC line. FU202 is the fuse against overcurrent in the +24 V line.

If overcurrent occurs, the power supply fuse blows and cuts off the power supply.

CAUTION:

When restoring the low voltage power after protective function is activated, leave it for 2 minutes or more from turning off the switch or plugging out before turning ON.

The host machine equips the function of stopping 24V of fixing assembly and the high voltage power unit to avoid users and engineers from getting burned or electric shock.

When the cartridge door is opened, the interlock switch (SW501) is turned off and 24V supplied to fixing assembly and the high voltage power unit is shut.

Engine controller CPU determines the door open when each interlock switch is turned OFF.

WARNING:

As the power of this machine is turned ON/OFF by the remote switch control circuit, power is supplied to the AC line even when the Power Switch is turned OFF. Do not perform disassembly work while the Power Supply Cord is connected to the inlet.

Power-saving Mode

Overview

Power-saving mode is a function that reduces the printer power consumption.

Description

The following shows energy saving status and electricity mode.

Electricity mode		Condition
Standby		Power-on
Sleep mode	Sleep mode 1	Power-off The main controller turns on electricity.
	Sleep mode 2	Power-off The main controller is a sleep mode.

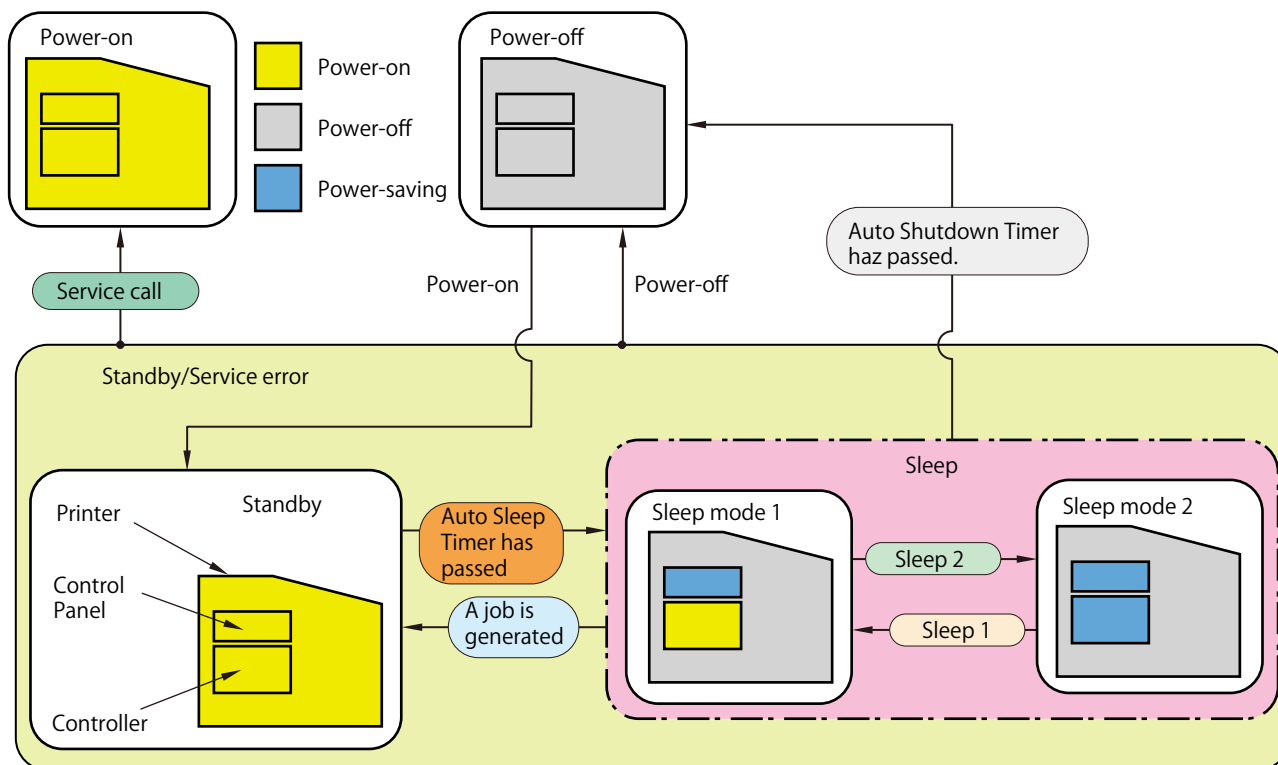

The low voltage power supply stops supplying power from the +24V generation circuit when it receives a power-saving transition mode signal (LVM) from the DC Controller.

Laser Exposure System

Functional Configuration

Overview

The laser exposure system forms a static latent image on the Photosensitive Drum by laser exposure.

Description

The Laser Scanner Unit consists of the Laser Unit and the Scanner Motor Unit, and is controlled by the signal input from the DC Controller.

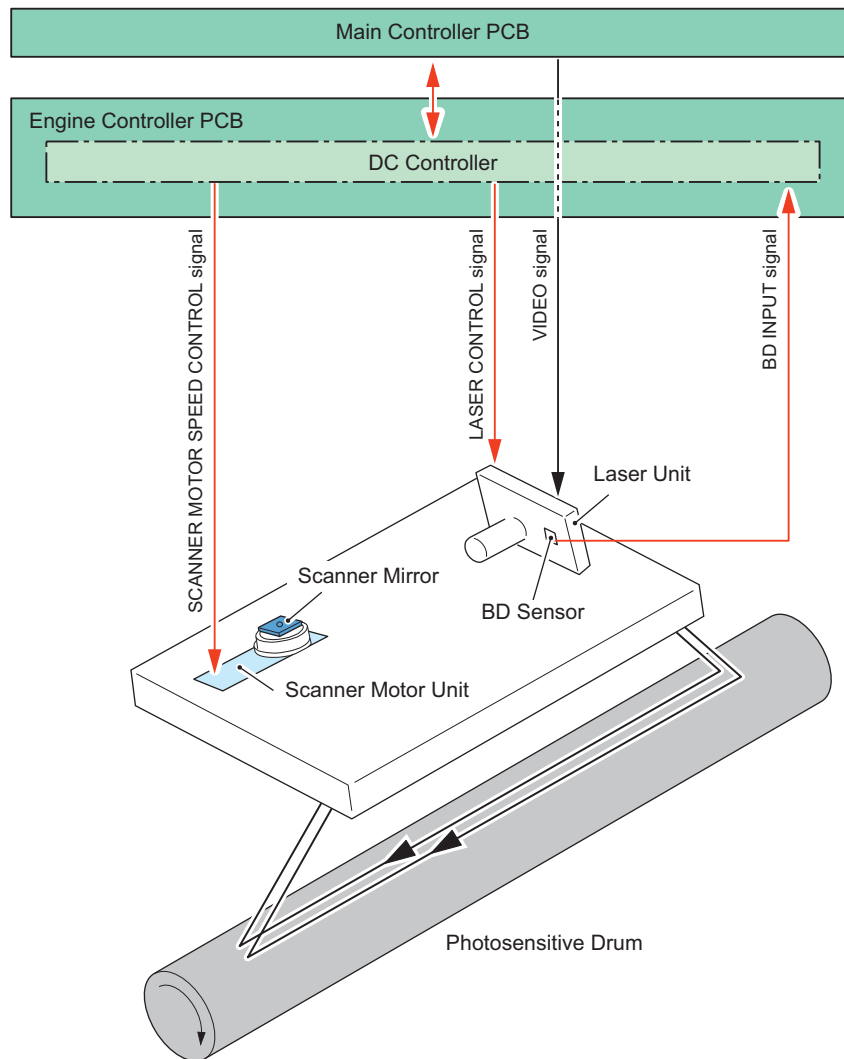

Shutter Control

The Laser Scanner Unit of this machine has the laser shutter mechanism.

The Laser Shutter blocks laser path of the Laser Scanner Unit when the Cartridge Door is opened for the safety of users and service technicians.

Failure Detection

Overview

The DC Controller detects the following failures in the Laser Scanner Unit.

- Scanner area failure
- Scanner Motor failure

Description

Scanner area failure detection

If an error in any of the Scanner Motor, Laser Driver, or BD detection in the scanner area is detected, an error code is notified.

Scanner Motor failure detection

- When the BD cycle is out of the specified range, an error code is notified.
- If a motor error is detected while the Scanner Motor is being driven, an error code is notified.

Error Code

E100: Scanner area failure

- E100-0001 : BD correction error

E110 : Scanner Motor failure

- E110-0000 : Scanner Motor start-up error
- E110-0001 : Scanner Motor rotation error

Image Formation System

Functional Configuration

Overview

The image formation system forms a toner image on the paper.

Description

The DC Controller controls the Laser Scanner Unit and High Voltage Power Supply to form the toner image on the Photosensitive Drum, and transfers and fixes this to the paper.

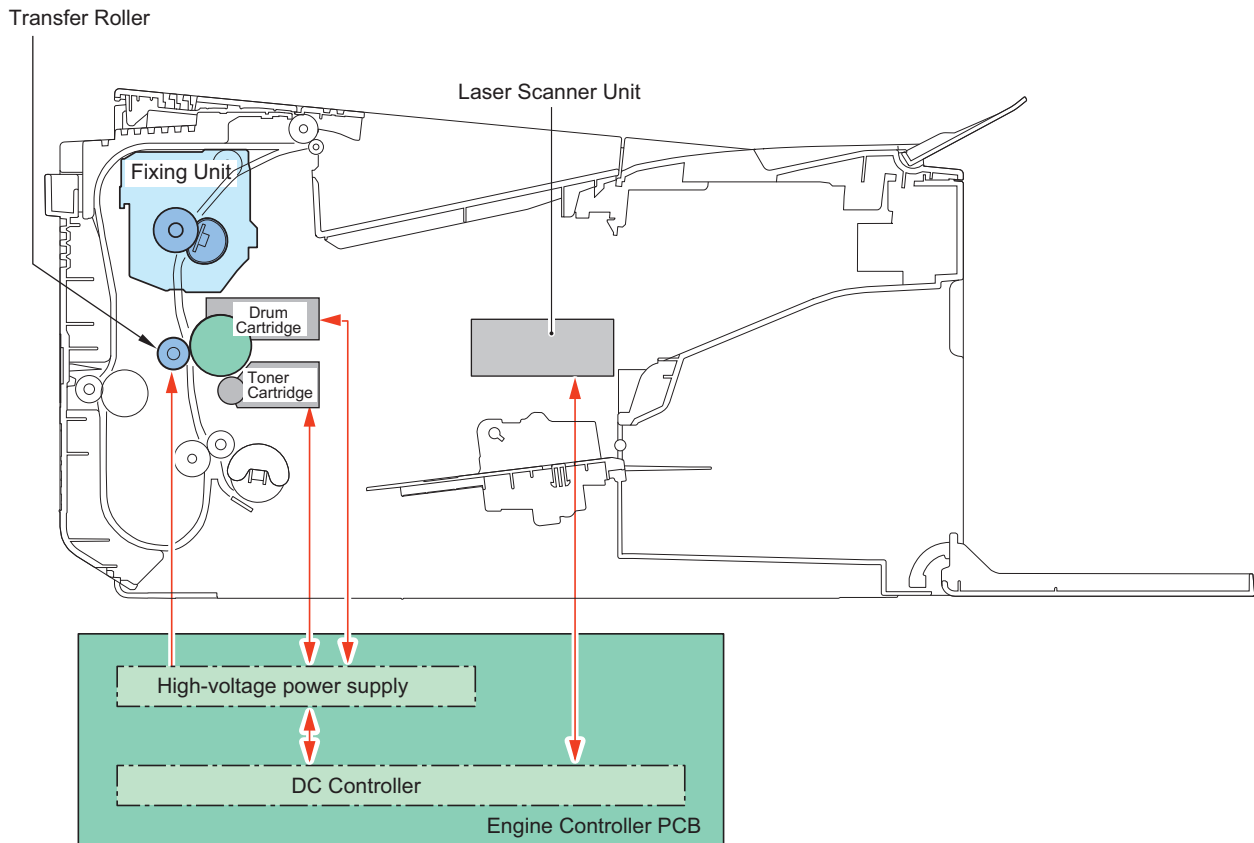
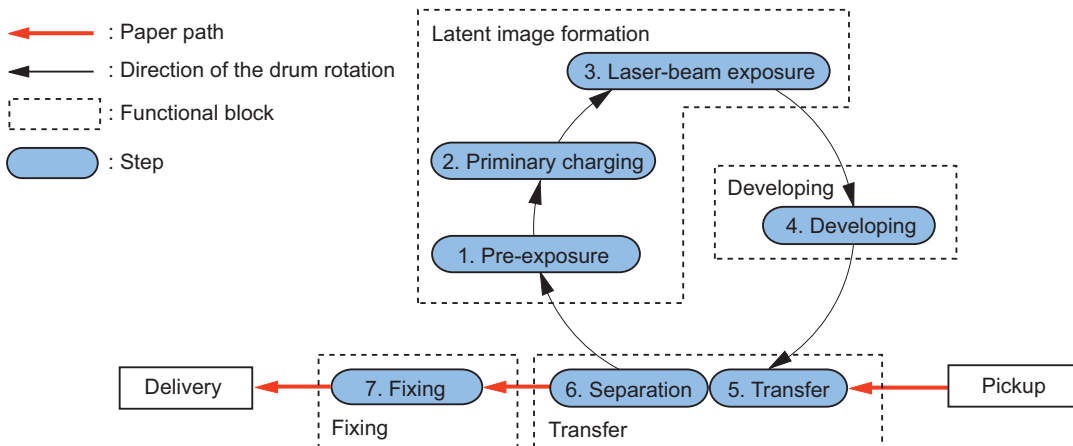

Image Formation Process

Description



High Voltage Power Supply Control

Description

The High Voltage Power Supply applies high voltage biases to the following:

- Primary Charging Roller (inside the cartridge)
- Developing Roller (inside the cartridge)
- Developing Blade (inside the cartridge)
- Transfer Front Guide
- Transfer Roller

The high voltage biases are generated by the DC Controller controlling the High Voltage Power Supply.

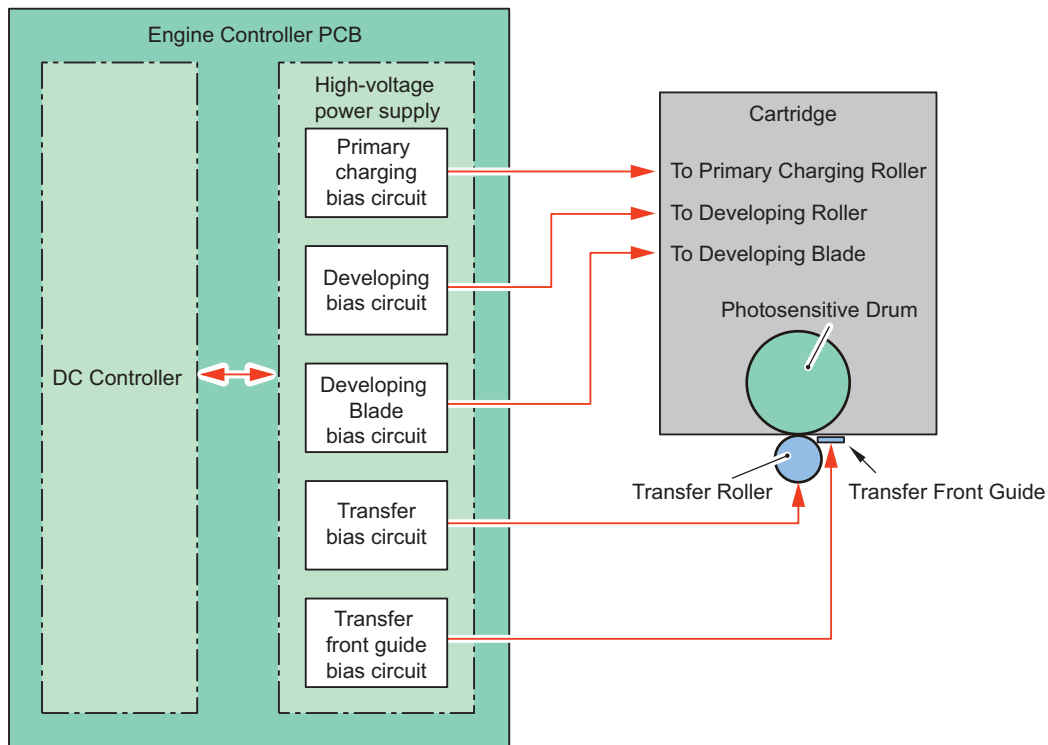

Cartridge

Overview

Overview

The cartridge has the function to form a visible image on the Photosensitive Drum with toner.

Description

The cartridge consists of the Photosensitive Drum, Developing Unit, Primary Charging Roller, Memory, etc.

The DC Controller drives the Main Motor, and rotates the Photosensitive Drum and Developing Roller. The Primary Charging Roller rotates by engaging with the Photosensitive Drum.

The cartridge of this machine is the separated type cartridge.

The Toner Cartridge and Drum Cartridge are combined into one cartridge to operate.

Drum separated type

- Toner Cartridge : Developing Unit/Toner
- Drum Cartridge : Drum

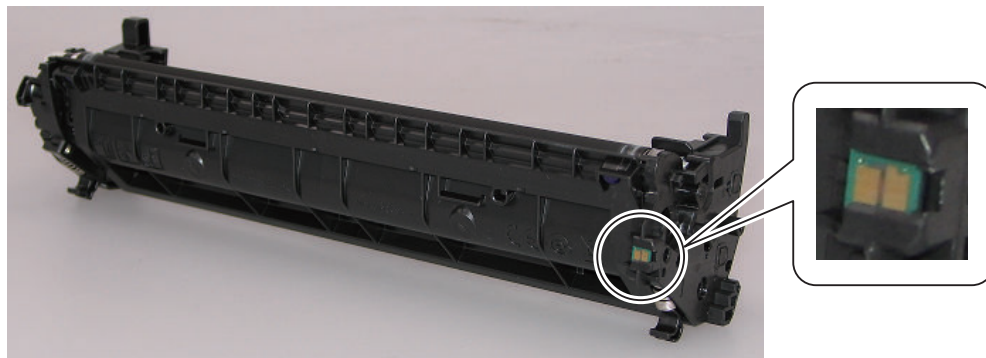
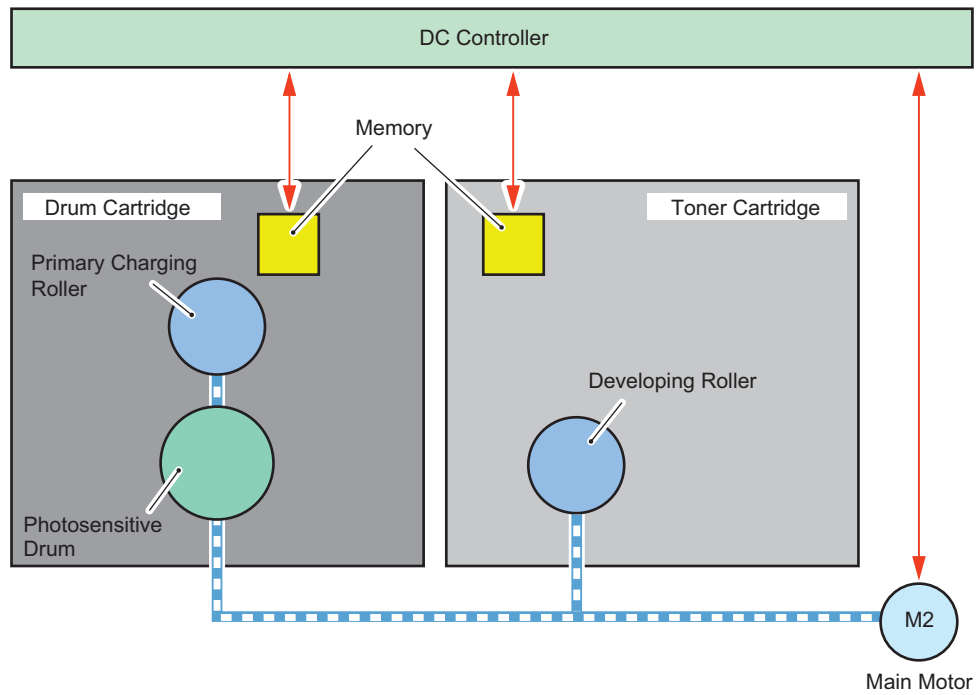

Location of memory (Toner Cartridge)

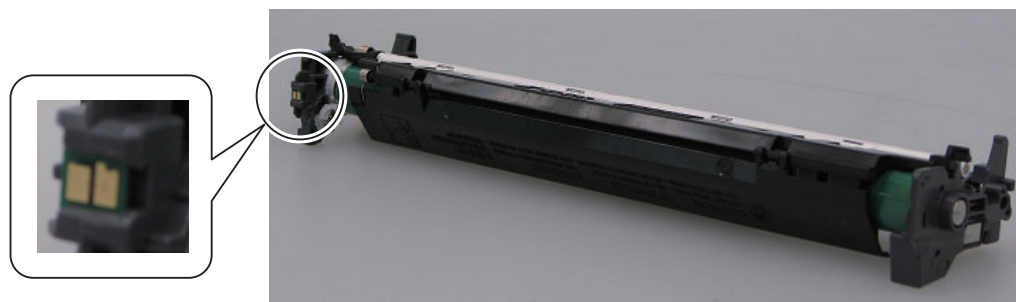

Location of memory (Drum Cartridge)

■ Cartridge State Detection

Execution Condition/Timing

- At power-on
- When the Cartridge Door is closed

Description

DC Controller detects/records the cartridge usage status, etc. by reading/writing data stored in the memory. When the memory cannot be detected or a non-genuine part is detected, it notifies the Main Controller and displays a warning message on the Control Panel.

Message displayed when a memory error is detected

Cartridge type	Display
Toner Cartridge	Cartridge communication error. A counterfeit or non-Canon toner cartridge may be in use.
Drum Cartridge	Cartridge communication error. A counterfeit or non-Canon drum cartridge may be in use.

Message displayed when a non-genuine part is detected

Cartridge type	Display
Toner Cartridge	A counterfeit or non-Canon toner cartridge may be in use.
Drum Cartridge	A counterfeit or non-Canon drum cartridge may be in use.

■ Cartridge Detection

Execution Condition/Timing

- At power-on
- When the Cartridge Door is closed

Description

The DC Controller detects whether a cartridge is installed according to the memory.

When the DC Controller judges that there is no cartridge, it notifies the Main Controller and displays a warning message on the Control Panel

Message displayed when cartridge is not installed

Cartridge type	Display
Toner Cartridge	Insert the toner cartridge.
Drum Cartridge	Insert the drum cartridge.
Toner Cartridge /Drum Cartridge	

■ Cartridge Life Detection

Execution Condition/Timing

Toner Cartridge /Drum Cartridge :

- At power-on
- When the engine operation is completed after the Cartridge Door is closed
- At completion of printing
- When the reference value of cartridge life is changed

Description

The DC Controller notifies the Main Controller of the absence of a cartridge if it judges there is no cartridge.

Upon receipt of the notification, the Main Controller displays a warning or a message that the cartridge has reached the end of its life.

	Warning display	End of life display*3
Toner/Drum level*1	Differs depending on the setting*2	Toner Cartridge/Drum Cartridge : 0%
Detected to (location)	Toner Cartridge/Drum Cartridge : Memory	Toner Cartridge/Drum Cartridge : Memory

*1: Remaining toner/drum level can be checked on the Status Monitor

Refer to "Checking remaining toner/drum level" in "Settings/Registration Mode/Menu" shown below.

*2: The threshold value to display a warning can be specified in the menu.

Menu > Adjustment/Maintenance > Displ. Timing for Cartridge Prep. Notif.

*3: The operation when the cartridge has reached the end of life can be specified in service mode.

Refer to "Setting of the behavior when the cartridge reaches the end of life" in "Service Mode" shown below.

Messages indicating the cartridge warning

Cartridge type	Display
Toner Cartridge	Preparing a toner cart. is recommended.
Drum Cartridge	Preparing a drum cart. is recommended.

Messages indicating the cartridge life

Cartridge type	Display
Toner Cartridge	Toner cart. life end. Replace the toner cartridge.
Drum Cartridge	Drum cart. life end. Replace the Drum cartridge.

Service Mode

- Setting of the behavior when the cartridge reaches the end of life:
 - COPIER > OPTION > FNC-SW > CRG-PROC
 - COPIER > OPTION > FNC-SW > DRUM-PROC

Additional Functions Mode/Menu

- Checking remaining toner/drum level:
 - Status Monitor > Device Information > Cartridge Level
- Setting of the threshold value to display a warning
 - Adjustment/Maintenance > Displ. Timing for Cartridge Prep. Notif. > Display Timing

■ Developing Roller Engagement/Disengagement Control

Overview

The DC Controller controls engages/disengages the Developing Roller in the Toner Cartridge with/from the Photosensitive Drum.

Execution Condition/Timing

The Developing Roller is engaged or disengaged depending on the state of this machine.

State of this machine	Developing Roller
Power Supply Off/Standby	Disengagement
Print	Engagement

Description

The Developing Roller is engaged with the Photosensitive Drum only at printing.

The Developing Rollers are engaged only when needed, and this prevents deterioration of the Photosensitive Drum and ensures the maximum life.

For engagement/disengagement of the Developing Rollers, the DC Controller drives the Developing Disengagement Solenoid (SL2) while the Main Motor (M2) is driving to change the orientation of the Engagement/Disengagement Cam.

The DC Controller detects the current state using the Developer Alienation Switch (SW1), and determines the state (engaged or disengaged) of the Developing Rollers on the basis of the amount of rotation of the Main Motor after the Developing Disengagement Solenoid starts to be driven.

Error Code

- E015-0001: Error in Developing Disengagement Motor

Fixing System

Functional Configuration

Overview

The fixing system fixes the toner on the paper using pressure and heat.

Description

The fuser heater control circuit and the fuser safety circuit control the fuser temperature according to the commands from the DC controller.

The printer uses an on-demand fusing method.

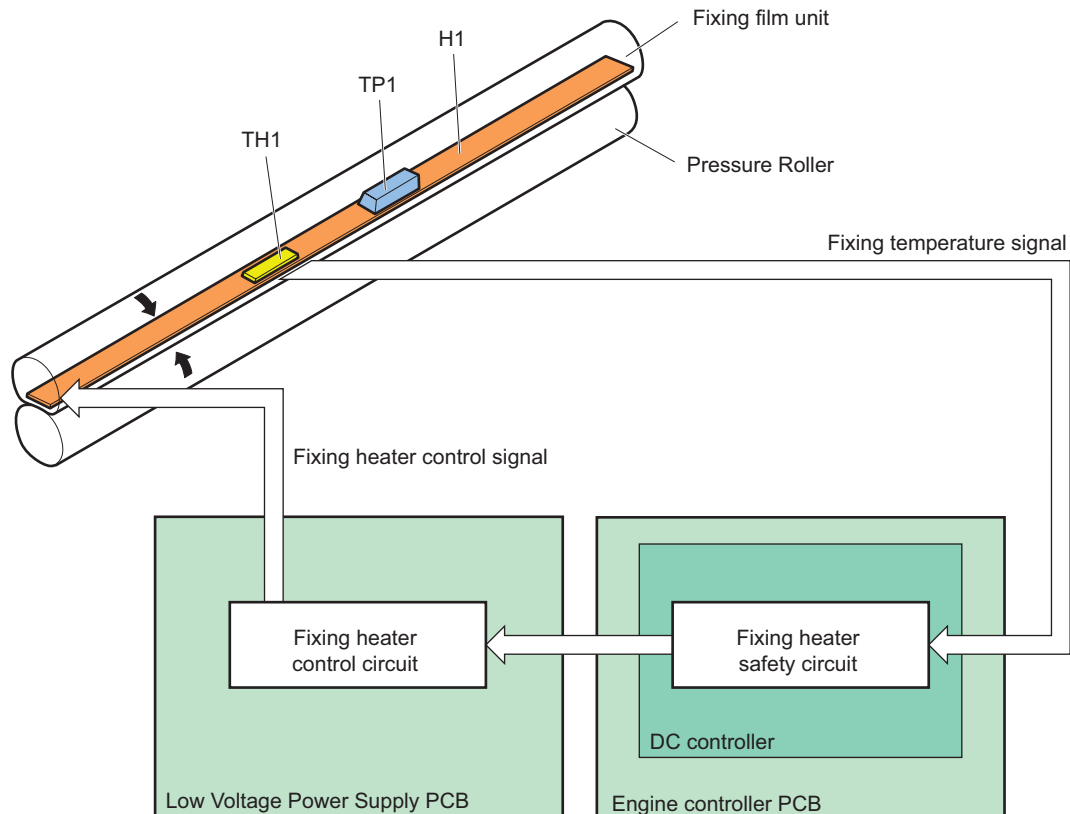

Symbol	Component name	Function
H1	Fixing Heater	Heats the fuser film ass'y.
TH1	Thermistor	Detects the temperature of the fuser heater
TP1	Thermal Fuse	Prevents an abnormal temperature rise of fuser heater

Temperature control of the Fixing Assembly which consists of these parts is performed by the Fixing Heater control circuit and Fixing Heater safety circuit according to the command of the DC Controller.

Fixing Temperature Control

Overview

This control circuit controls the temperature such that the Fixing Heater reaches the target temperature.

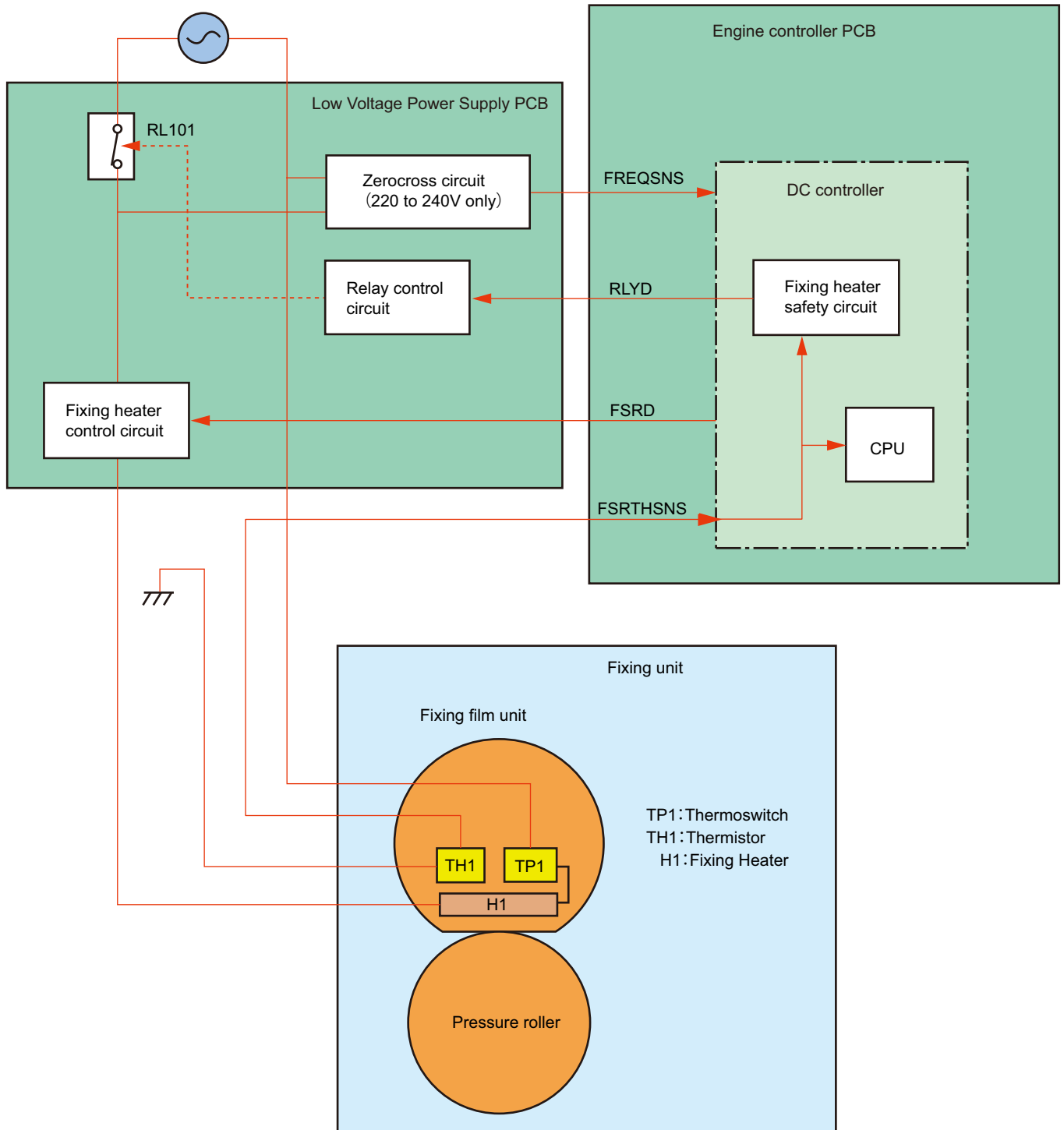

Description

The DC Controller monitors the fixing temperature detection signal and outputs a fixing control signal according to the detected temperature. The fixing control circuit controls the Fixing Heater on the basis of this signal, and controls the temperature of the Fixing Heater to the target value.

Fixing Assembly Failure Detection

Overview

The fuser heater protective function detects an excessive temperature rise of the fuser and interrupts power supply to the fuser heater.

Description

The following four protective components prevent the fuser heater from excessive rising temperature.

- DC controller

- Fuser heater safety circuit
- Thermoswitch
- Down Sequence control

DC controller

The DC controller constantly monitors the temperature of the thermistor. The DC controller deactivates the FUSER HEATER CONTROL signal and turns off the relays (RL101) to interrupt power supply to the fuser heater when it detects an excessive temperature.

Fuser heater safety circuit

The fuser heater safety circuit constantly monitors the temperature of the thermistor. The fuser heater safety circuit turns off the relays (RL101) to interrupt power supply to the fuser heater when it detects an excessive temperature.

Thermoswitch

Contact of the thermoswitch opens and it interrupts power supply to the fuser heater when the temperature of the fuser heater is abnormally high.

Down Sequence control

When the temperature rising counter value exceeds the threshold, the machine delivers paper being printed, and then it drives the fan and repeats the stopped state (approx. 30 seconds) and 50% reduced productivity state to decrease the temperature.

Fixing Assembly Failure Detection

Overview

When the machine is under the following conditions, the DC Controller shuts down the power supply to the Fixing Assembly and notifies an error.

- Startup failure
- Abnormal high temperature failure
- Abnormal low temperature failure

Description

Fixing Assembly startup failure

An error code is notified if the Fixing Assembly does not reach a certain temperature within a specified period of time.

Abnormal high temperature failure

An error code is notified if an abnormally high temperature is detected in the Fixing Assembly.

Abnormal low temperature failure

An error code is notified if an abnormally low temperature is detected in the Fixing Assembly.

Error Code

E000: Startup failure

- E000-0000: Fixing Assembly startup failure

E001: Abnormal high temperature failure

- E001-0000: Abnormal high temperature of Fixing Assembly

E003: Abnormal low temperature failure

- E003-0000: Abnormal low temperature of Fixing Assembly

Pickup Feed System

Functional Configuration

Overview

The pickup, feed, and delivery systems are controlled by the DC Controller.

The DC Controller controls the blocks in the pickup, feed, and delivery systems to pickup, feed, and deliver paper inside the machine.

Description

The pickup, feed, and delivery systems consist of the following two blocks.

- Pickup/Feed: From pickup slot to the inlet of the Fixing Assembly
- Fixing/Delivery: From the Fixing Assembly to the delivery outlet
- Delivery/Duplex block: From the delivery outlet to the TOP Sensor

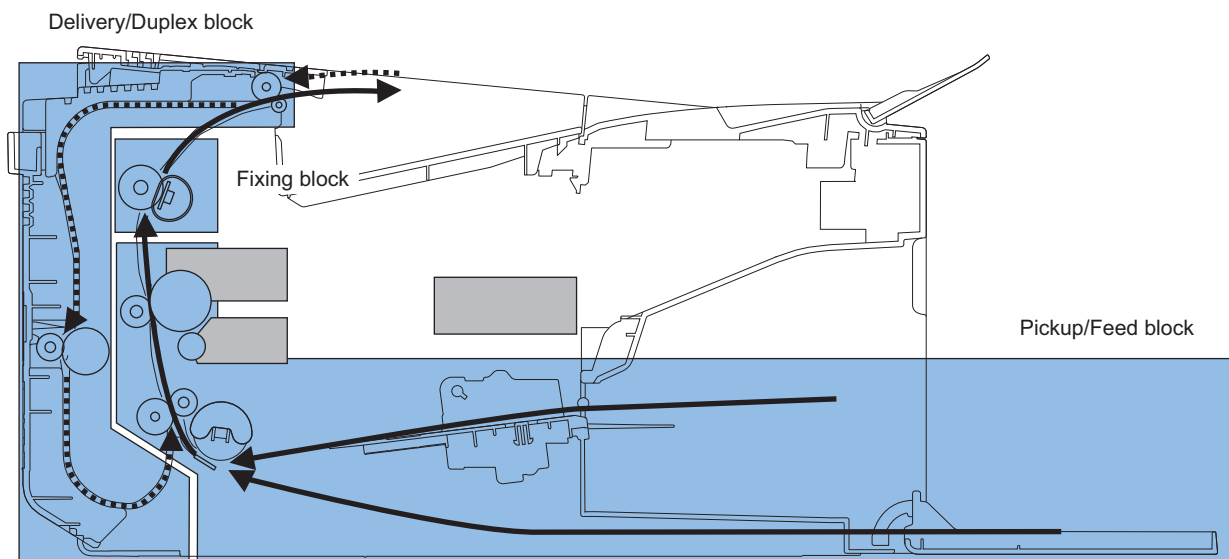

Parts Configuration

Layout Drawing of Rollers

Description

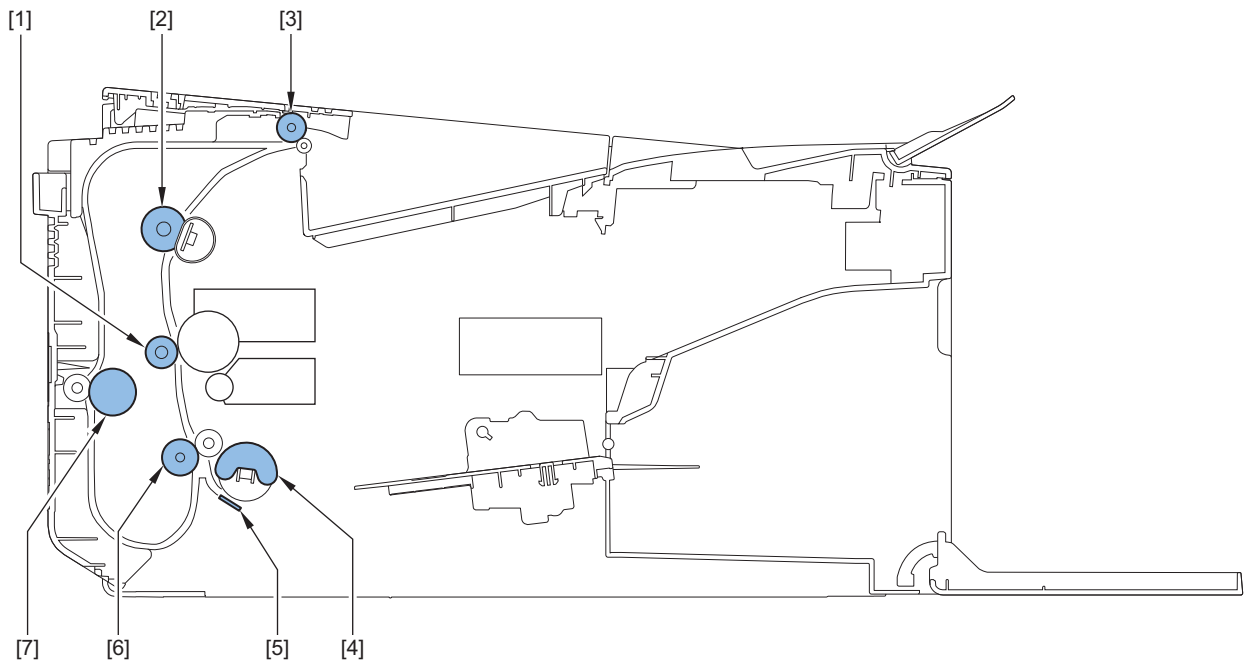

No.	Name	No.	Name
[1]	Transfer Roller	[5]	Separation Pad
[2]	Pressure Roller	[6]	Feed Roller
[3]	Output Roller	[7]	Duplexing Roller
[4]	Pickup Roller		

Layout Drawing of Sensors

Description

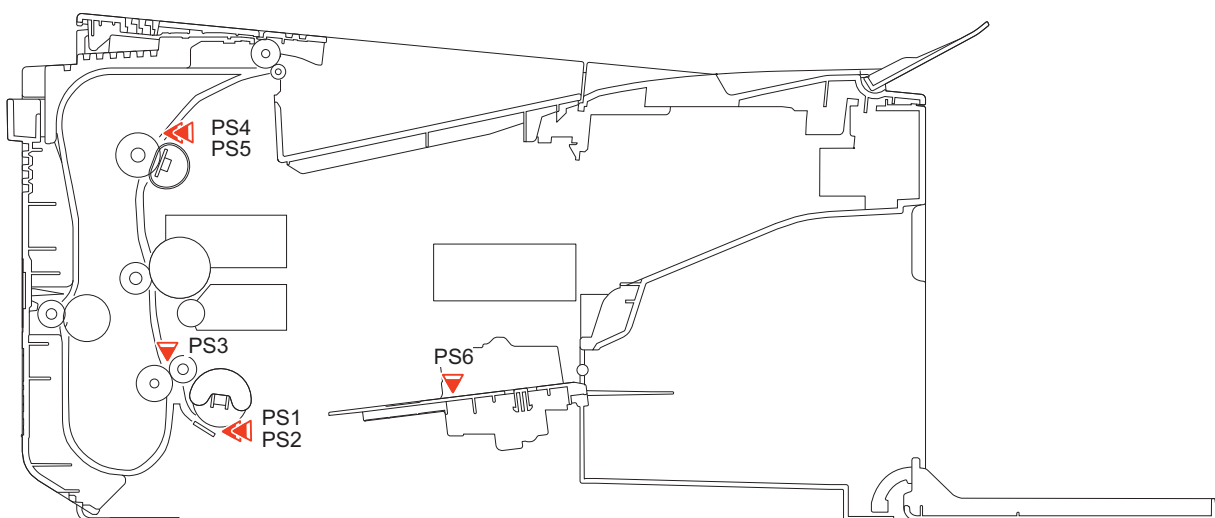

Symbol	Name	Symbol	Name
PS1	Paper Sensor	PS4	Fixing Output Sensor
PS2	Pickup Media Width Sensor	PS5	Fixing Media Width Sensor
PS3	TOP Sensor	PS6	Multi-purpose Sensor

■ Diagram of load drives

Description

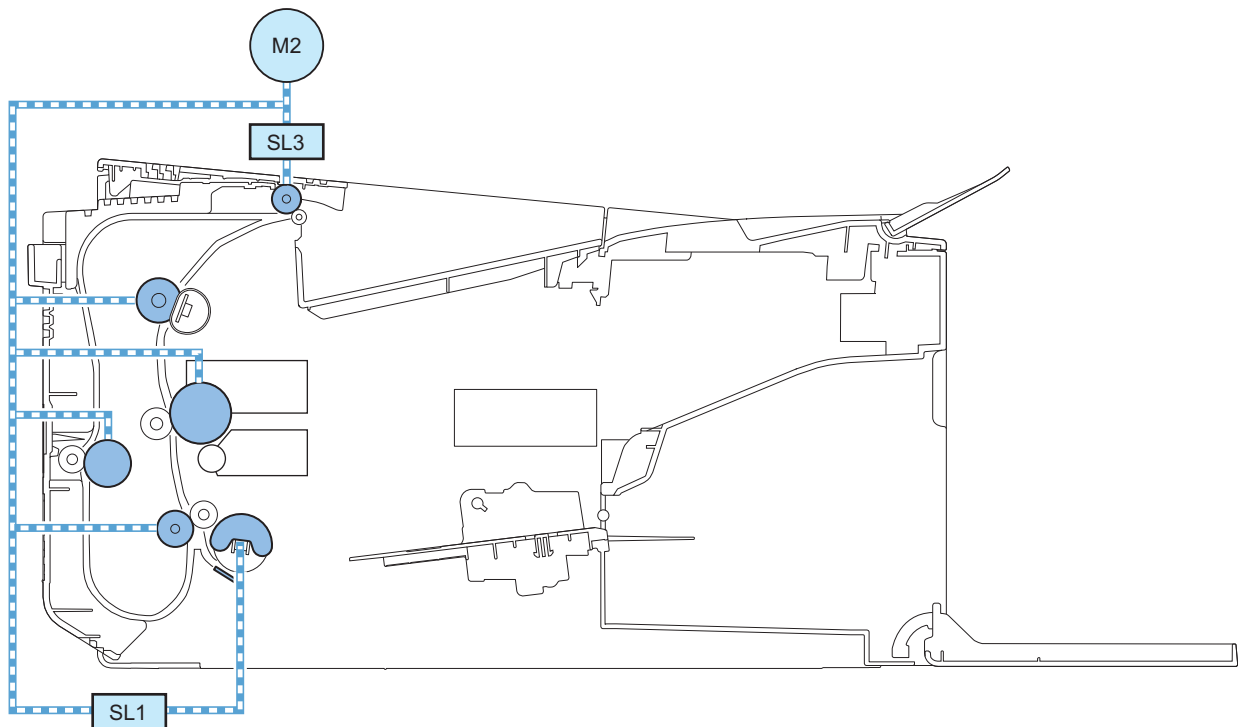

Symbol	Name	Symbol	Name
SL1	Pickup Solenoid	M2	Main Motor
SL3	Duplex Reverse Solenoid		

● Paper Detection

Description

The DC Controller uses the Paper Sensor (PS1) to detect whether there is paper on the Paper Drawer. The Main Controller uses the Multi-purpose Sensor (PS6) to detect whether there is paper on the Multi-purpose Tray.

Pickup is started even if paper is not detected by the Paper Sensor (PS1) or the Multi-purpose Sensor (PS6). If the Top Sensor still fails to detect the leading edge of paper after two pickup retries, the Engine Controller judges that a misprint due to no paper has occurred, and notifies it to the Main Controller.

● Pickup Control

Description

In this machine performs the following control for feed one sheet of paper at a time into the machine.

1. The DC Controller rotates the Main Motor (M2) when it receives a print command from the Main Controller.
2. The Feed Roller rotates.
3. The Pickup Solenoid (SL1) is driven at a specified timing.
4. The Pickup Roller rotates and picks up the top paper.
5. The Separation Pad removes any multiple-fed sheets.
6. One sheet of paper is fed into the printer.

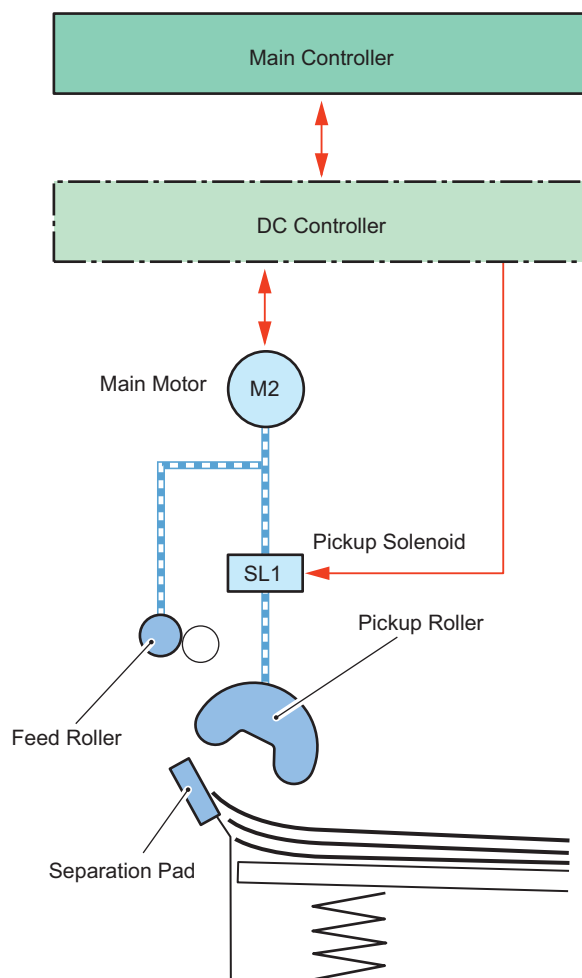

Paper Width Detection

Paper Size Mismatch

If the paper width detected by the Pickup Paper Width Sensor (PS2) does not match the specified paper size, it is judged as a paper width mismatch. However, the paper width mismatch is not detected if "Universal" has been selected in the Main Controller setting or if it is the second side of 2-sided print.

Fixing Paper Width Detection

When paper is fed for the specified distance after the Fixing Delivery Sensor (PS4) detects the leading edge of paper, the status of the Fixing Paper Width Sensor (PS5) is checked.

- When the Fixing Paper Width Sensor (PS5) detects presence of paper
Paper width is judged as "large".
- When the Fixing Paper Width Sensor (PS5) detects that there is no paper
Paper width is judged as "small".

When the paper width is "small", the fixing temperature is reduced and the productivity is reduced to prevent temperature rising at the edge of the Fixing Heater.

When the following paper sizes differ, the DC Controller judges paper size mismatch and notifies the Main Controller.

- Paper size being detected
- Paper size being specified by a job

Paper Length Detection

Description

Paper length is detected by measuring the time from when the TOP Sensor (PS3) detects the leading edge of paper until when the trailing edge of paper passes through.

When the following paper sizes differ, the DC Controller judges paper size mismatch and notifies the Main Controller.

- Paper size being detected
- Paper size being specified by a job

Jam Detection

Description

The sensors are provided at the locations shown below to detect the presence of print paper and whether the print paper is being fed correctly.

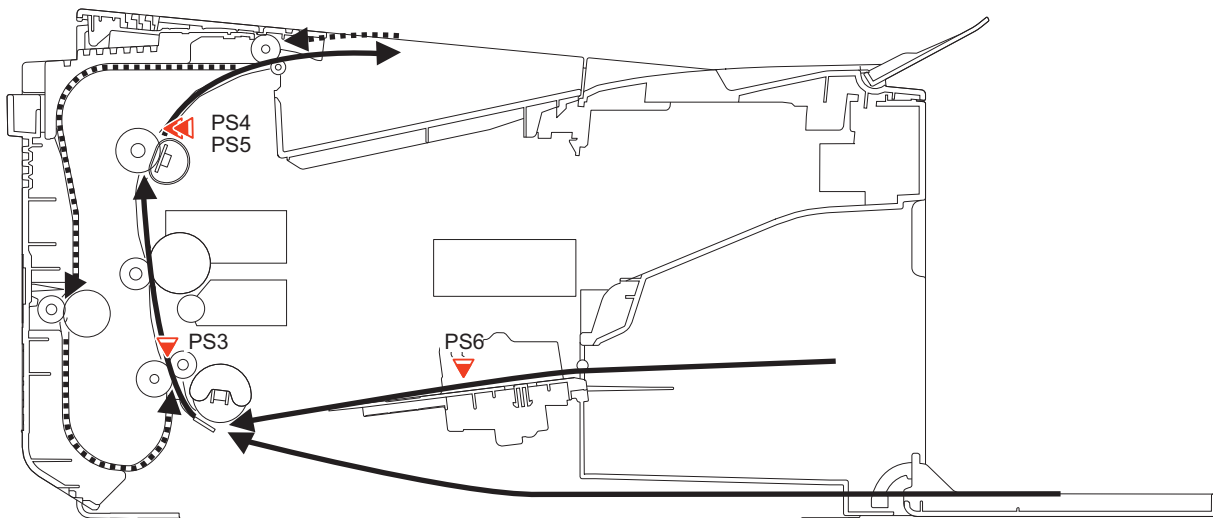

Symbol	Name	Symbol	Name
PS3	Top Sensor	PS5	Fixing Media Width Sensor
PS4	Fixing Output Sensor	PS6	Multi-purpose Sensor

Occurrence of a jam is judged by whether paper is in the sensor area at the timings stored in the DC Controller. When the DC Controller judges that a jam has occurred, the printing operation is stopped and the jam is notified to the Main Controller at the same time.

Jam Details

Jam name	Details
Pickup Stationary Jam	When the Top Sensor (PS3) fails to detect the trailing edge of paper within a specified period of time after the start of re-pickup
Fixing delivery delay jam	When the Fixing Output Sensor (PS4) fails to detect the leading edge of paper within a specified period of time after the Top Sensor (PS3) to detect the trailing edge of paper
Fixing delivery stationary jam	When the Fixing Output Sensor (PS4) fails to detect the trailing edge of paper within a specified period of time after the Top Sensor (PS3) detects the trailing edge of paper
Internal stationary jam	When one of the following sensors detects presence of paper at power-on, door close, or before/after print operation <ul style="list-style-type: none"> • Top Sensor (PS3) • Fixing Output Sensor (PS4) • Fixing Media Width Sensor (PS5)
Door Open Jam	When one of the sensors detects presence of paper when door open is detected during printing
Wrapping jam	The time from when the Fixing Output Sensor (PS4) detected the paper leading edge until the OFF status of the sensor was detected was shorter than the predetermined time.
Reverse Assembly jam	When the Fixing Delivery Sensor (PS4) fails to detect the leading edge of paper within a specified period of time after the paper is reversed at 2-sided print
Duplex Re-pickup Assembly jam	When the TOP Sensor (PS3) fails to detect the leading edge of paper within a specified period of time after the Fixing Delivery Sensor (PS4) detects the leading edge of paper



Periodical Service

Periodical Service..... 36

Periodical Service

Periodically Replaced Parts

Periodic replacement parts are not required in this machine.

Consumable Parts

Consumable parts are not required in this machine.

Periodical Service

No periodic services are required to this machine.

Cleaning Parts

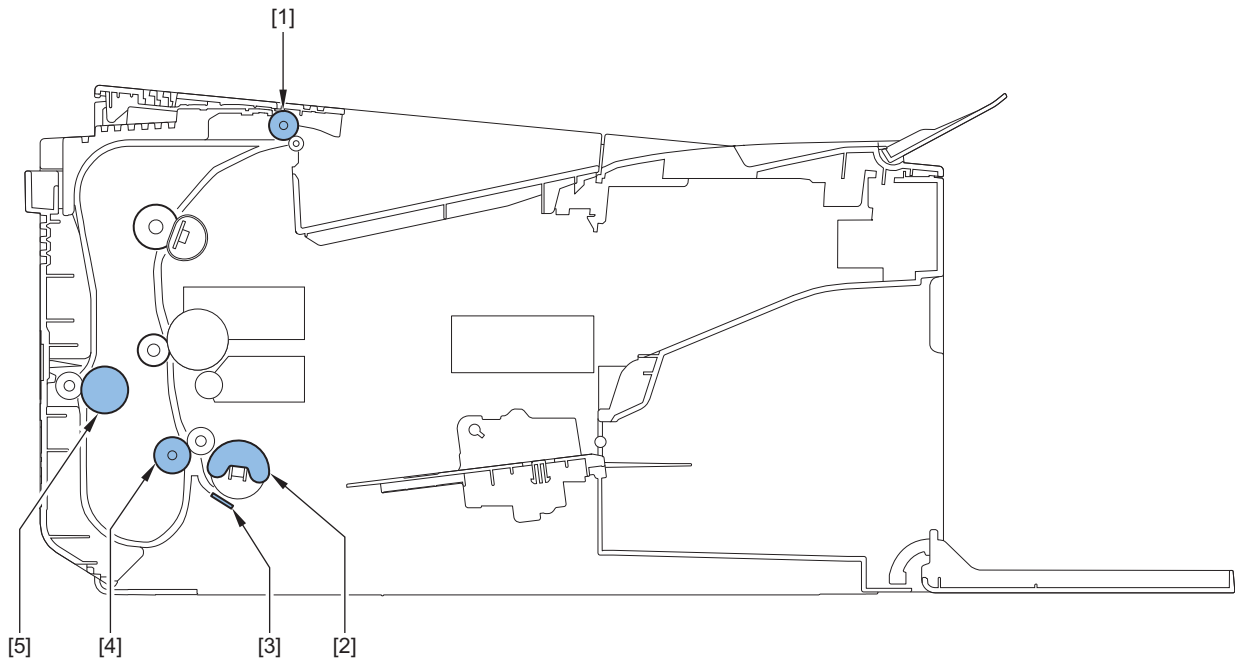

No.	Name	Work description
[1]	Delivery Roller	When there is soiling or foreign matter, clean with lint-free paper moistened with alcohol.
[2]	Pickup Roller	
[3]	Separation Pad	
[4]	Feed Roller	
[5]	Duplex Roller	



4

Parts Replacement and Cleaning

List of Parts.....	38
External Cover System.....	43
Controller System.....	58
Laser Exposure System.....	69
Image Formation System.....	72
Fixing System.....	79
Pickup Feed Delivery System.....	86

List of Parts

External Cover

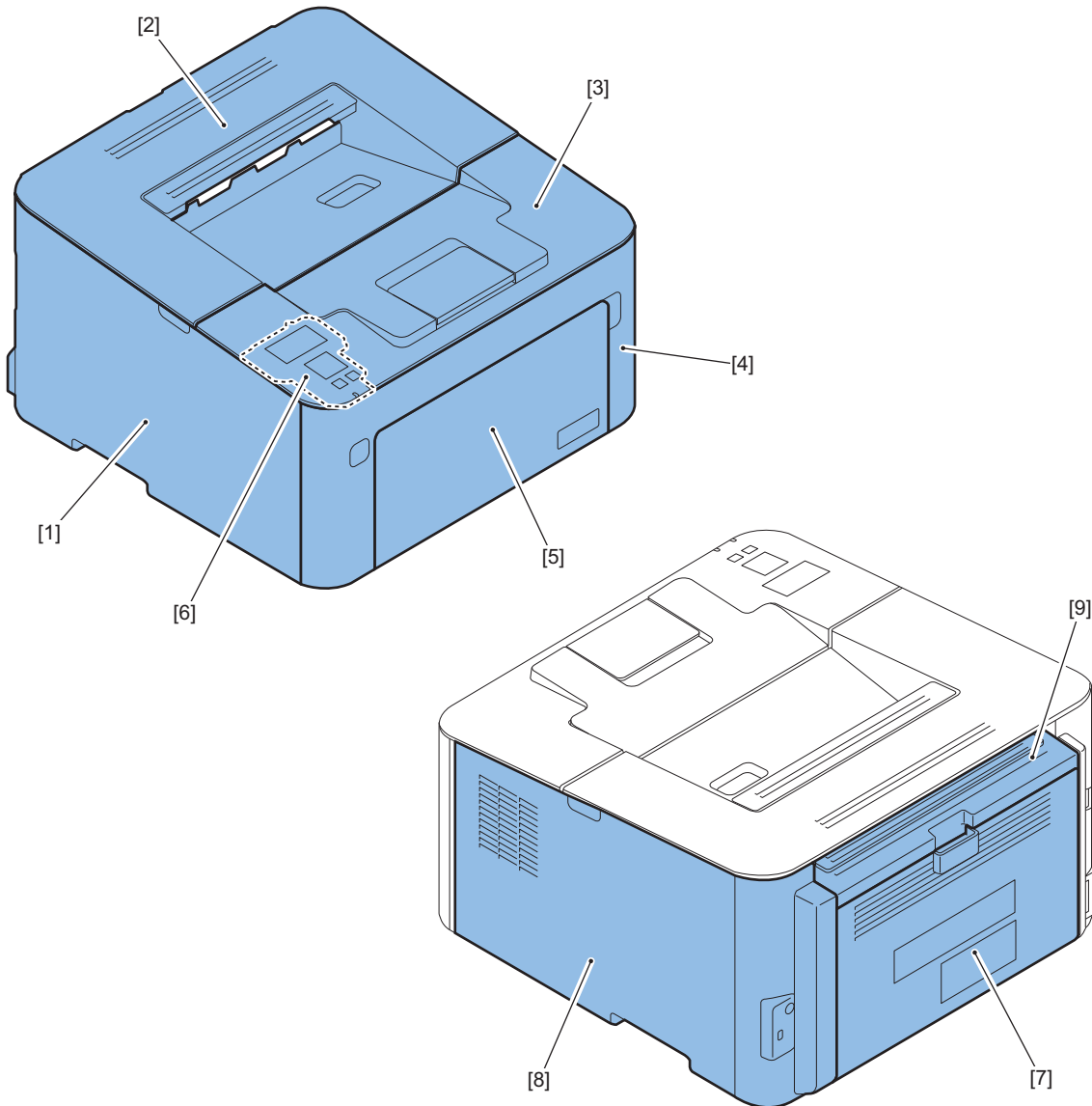

No.	Name
[1]	Left Cover
[2]	Cartridge Door Unit
[3]	Upper Front Cover (I include an operation panel unit)
[4]	Front Cover
[5]	Multi-purpose Tray
[6]	Operation Panel Unit
[7]	Duplexing Door
[8]	Right Cover
[9]	Rear Upper Cover

Main Unit

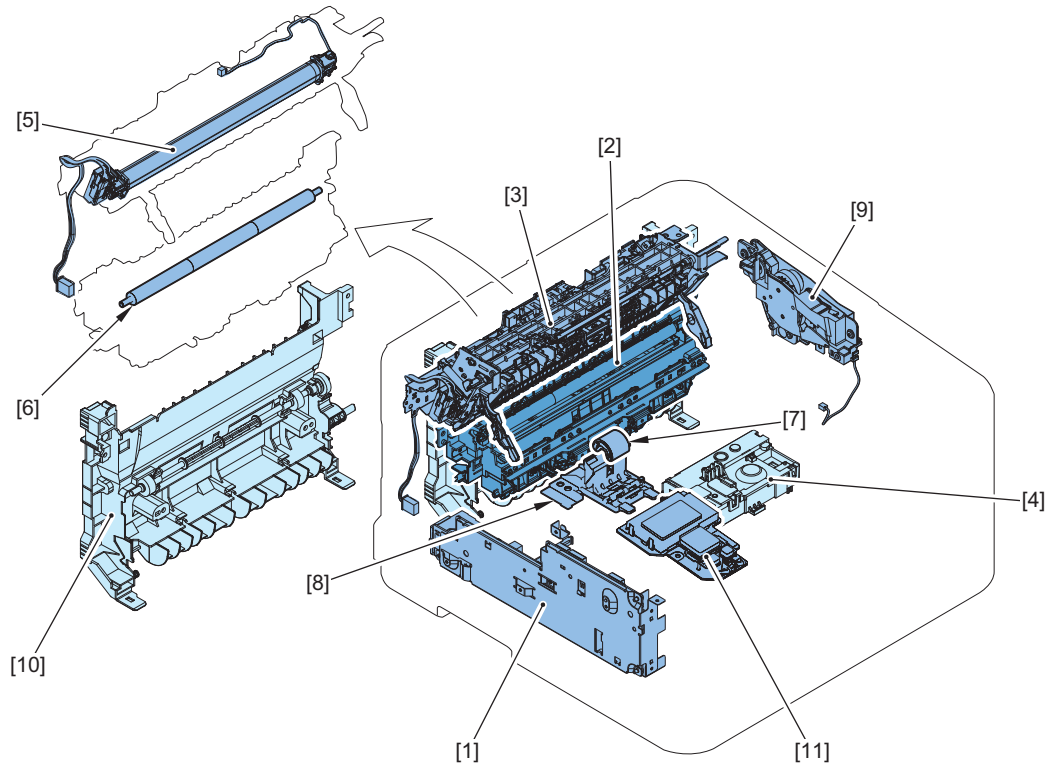

No.	Name
[1]	Low-Voltage Power Supply Unit
[2]	Transfer Unit
[3]	Fixing Unit
[4]	Laser Scanner Unit
[5]	Fixing Film
[6]	Transfer Roller
[7]	Pickup Roller
[8]	Separation Pad Unit
[9]	Duplexing Reverse Unit
[10]	Duplexing Frame Unit
[11]	Control Panel Unit

Electrical Components List

Motor/Fan/Solenoid

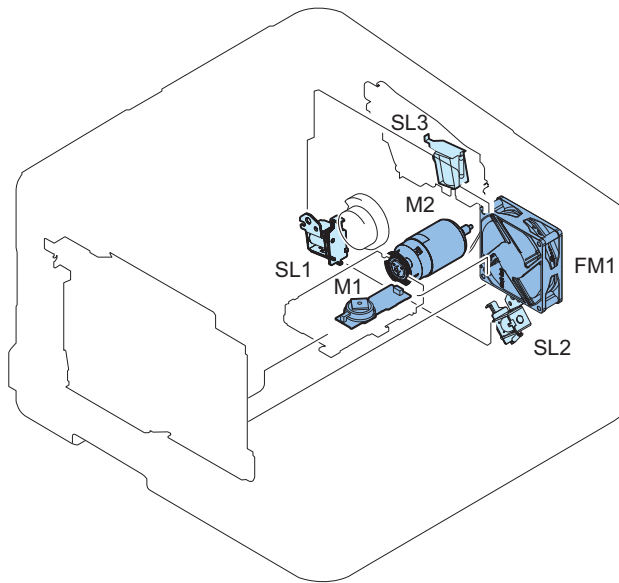

No.	Name
M1	Scanner Motor
M2	Main Motor
FM1	Main Fan
SL1	Pickup Solenoid
SL2	Developing Disengagement Solenoid
SL3	Duplexing Reverse Solenoid

Heater

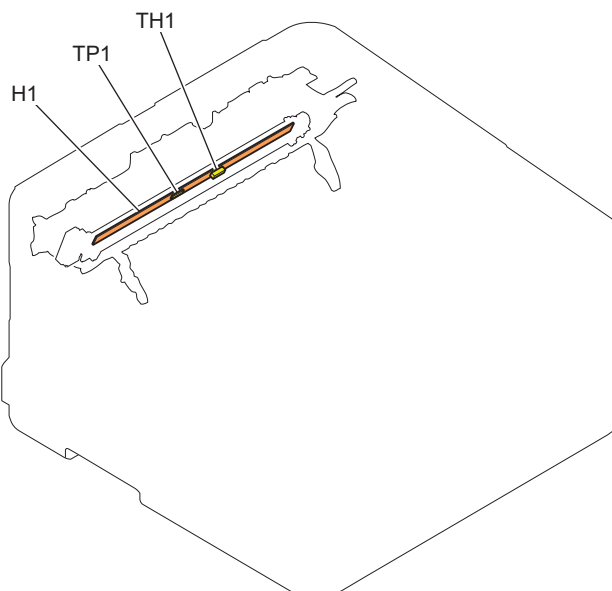

No.	Name
H1	Fixing Heater
TH1	Thermistor
TP1	Thermostwitch

■ Switch

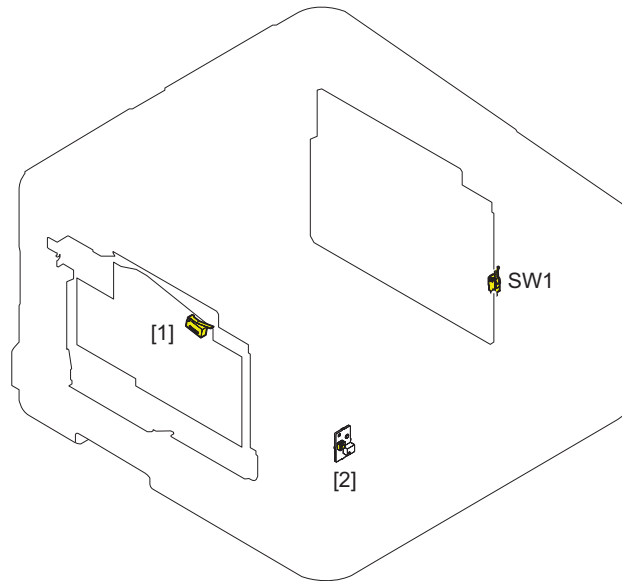

No.	Name
SW1	Developer Alienation Switch
[1]	Cartridge Door Switch
[2]	Power Switch

■ Sensor

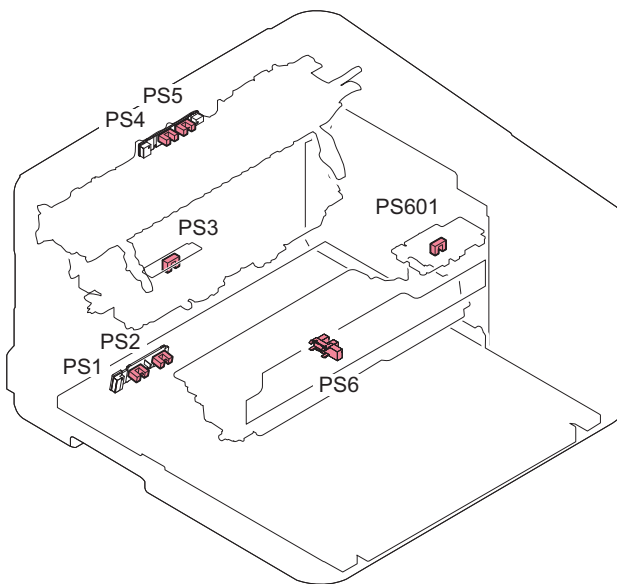

No.	Name
PS1	Media Out Sensor
PS2	Pickup Media Width Sensor
PS3	Top Sensor
PS4	Fixing Output Sensor
PS5	Fixing Media Width Sensor
PS6	Multi-purpose Sensor
P601	Main Motor Rotation Number Sensor

■ PCB

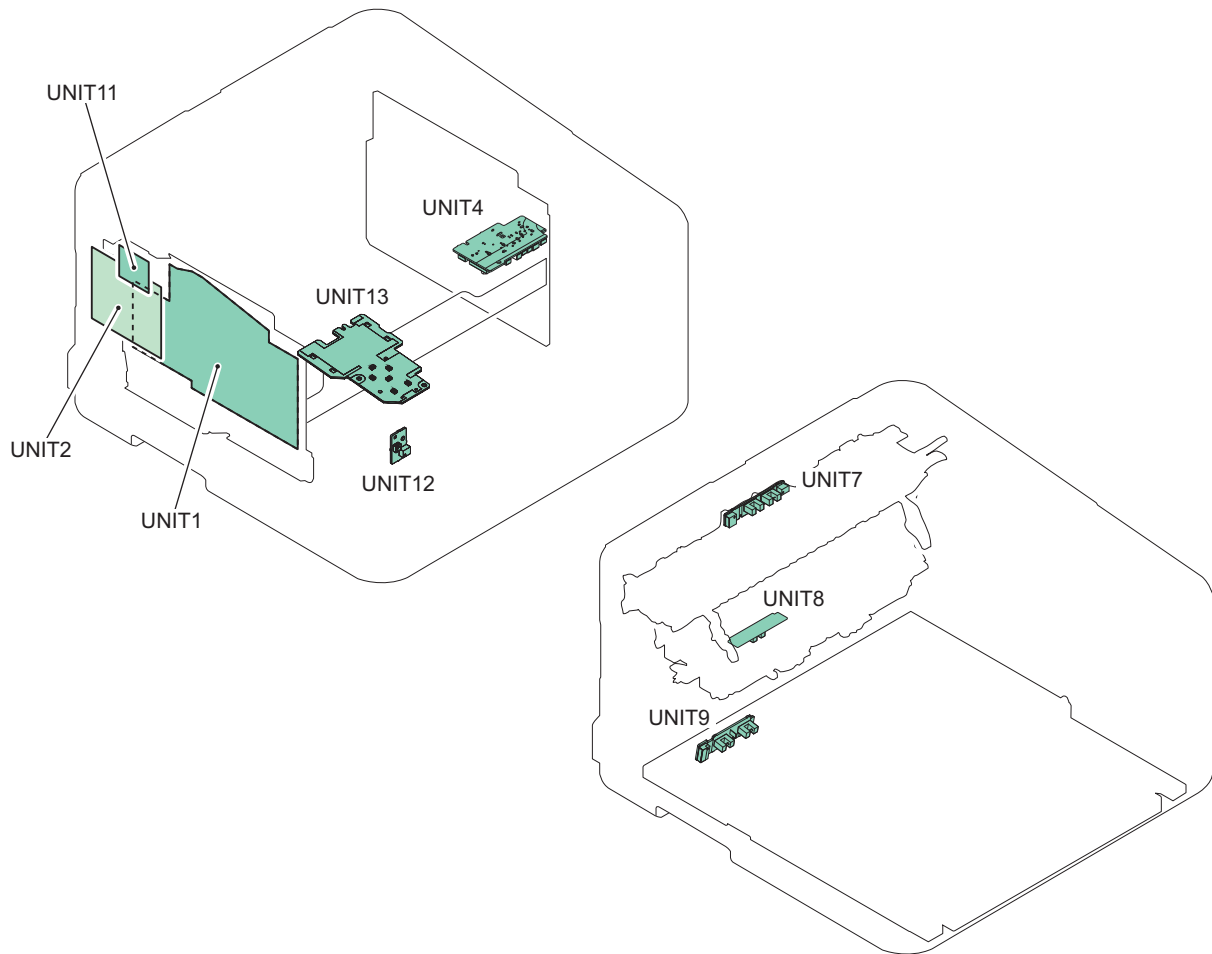

No.	Name
UNIT1	Engine Controller PCB
UNIT2	Main Controller PCB
UNIT4	Motor PCB
UNIT7	Delivery Sensor PCB
UNIT8	Pickup Sensor PCB
UNIT9	Environment Sensor
UNIT11	Wireless Lan PCB
UNIT12	Power Switch PCB
UNIT13	Control Panel PCB

External Cover System

● Removing the Cartridge

■ Procedure

CAUTION:

When handling the cartridge, be sure to follow the CAUTION shown below.

1. When removing the cartridge, be sure to block light to the Photosensitive Drum. Cover the removed drum with 5 or more sheets of paper to block light.
2. Do not place the cartridge in a location where it is exposed to direct rays of the sun (e.g. near the window).

1.

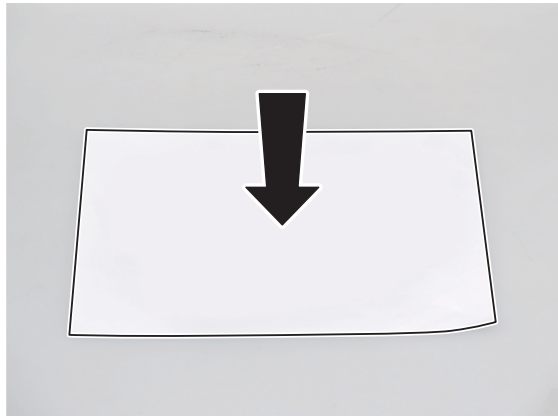

2.

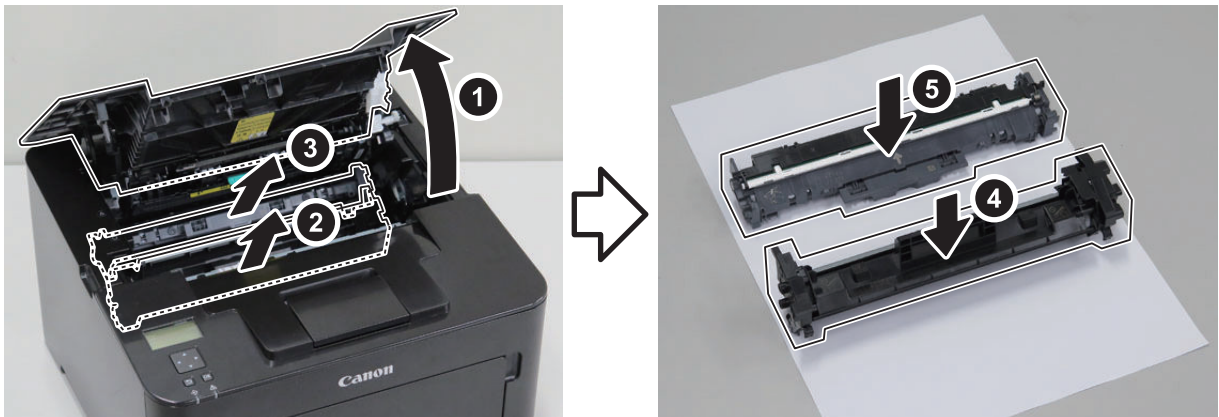

3.

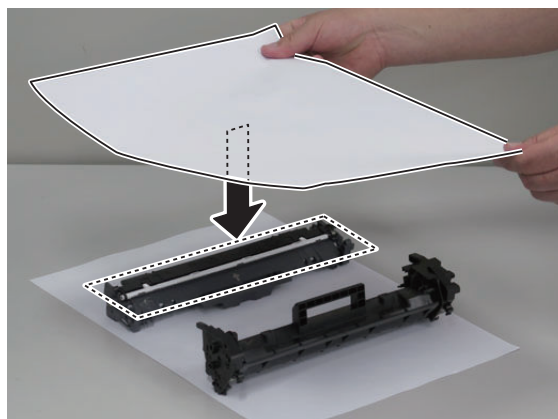

4.

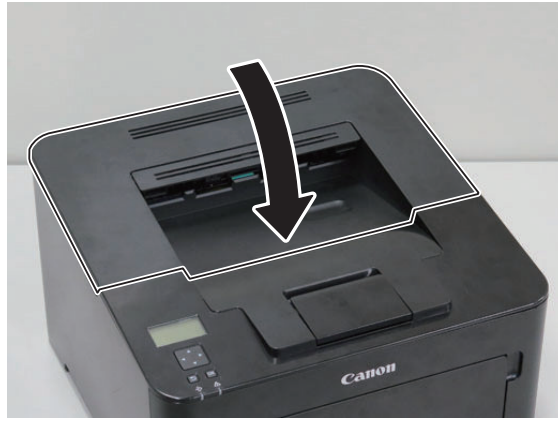

● Removing the Right Cover

■ Preparation

1. "Removing the Cartridge" on page 43

■ Procedure

1.

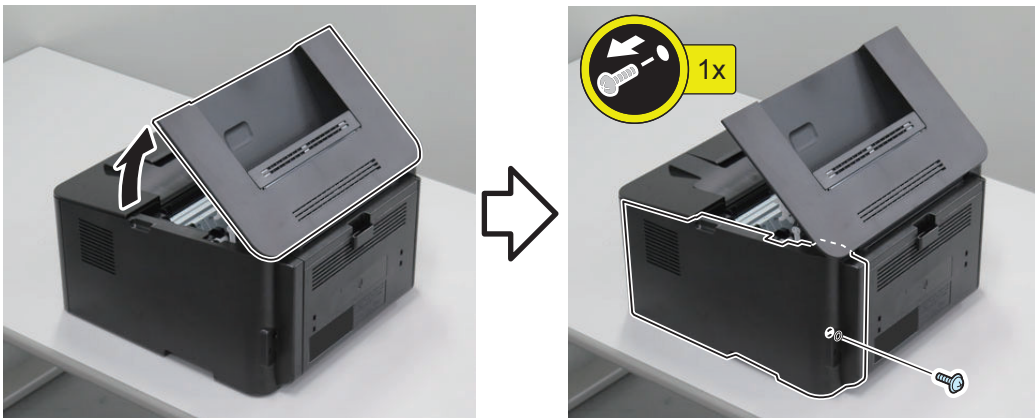

2.

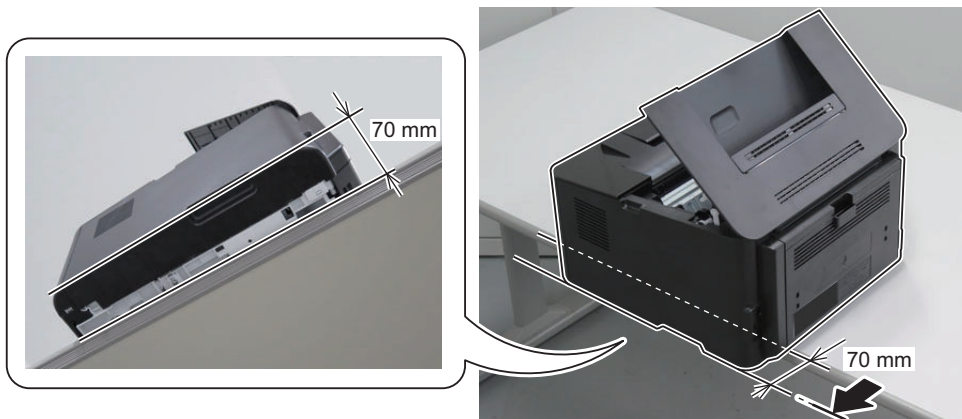

3.

NOTE:

The following shows the locations of the 4 claws [1] and the rib [2] of the Right Cover.

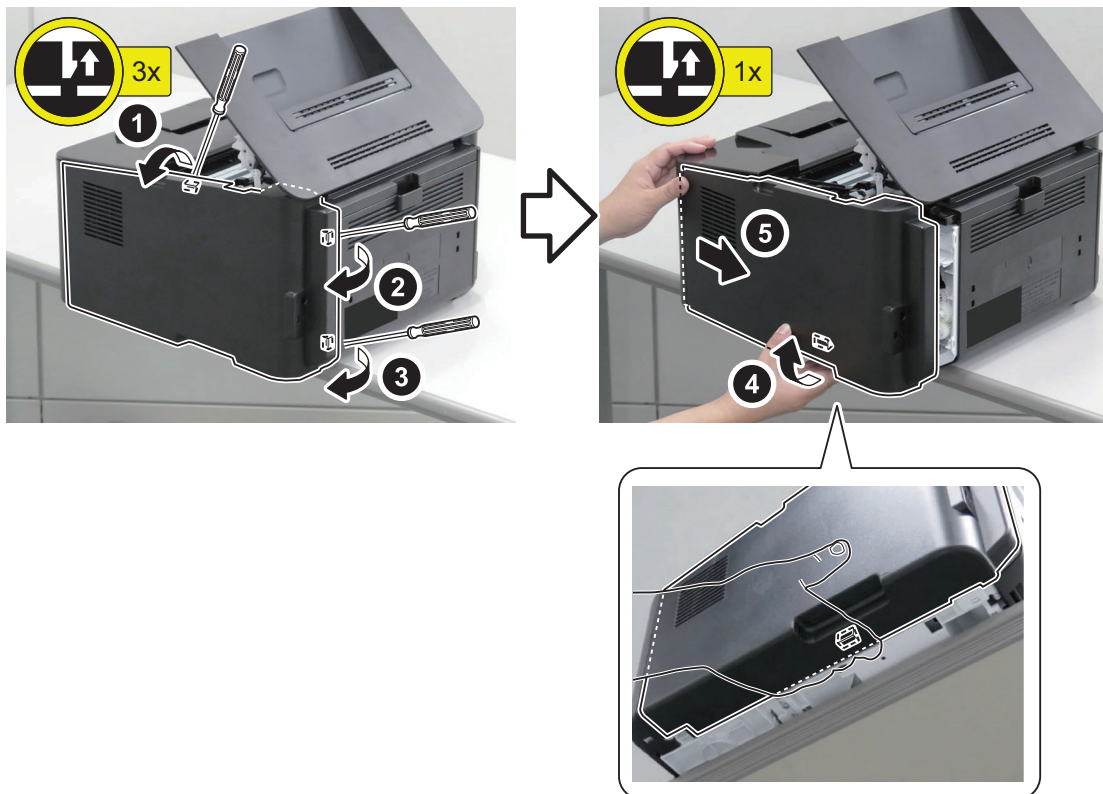
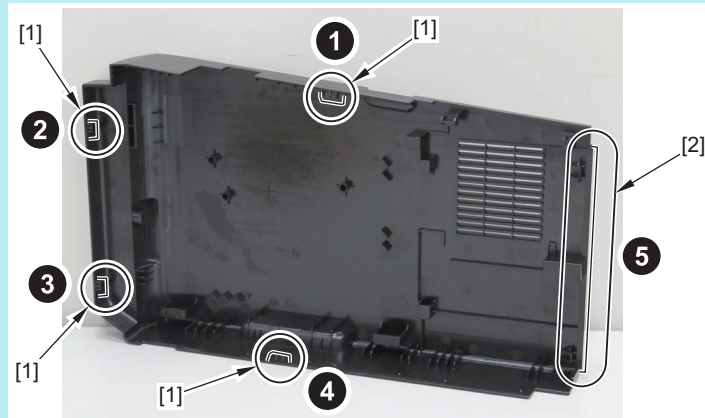
**CAUTION:**

Shift the host machine back to the center of the working table to prevent it from falling down.

● Removing the Left Cover

■ Preparation

1. "Removing the Cartridge" on page 43

■ Procedure

1.

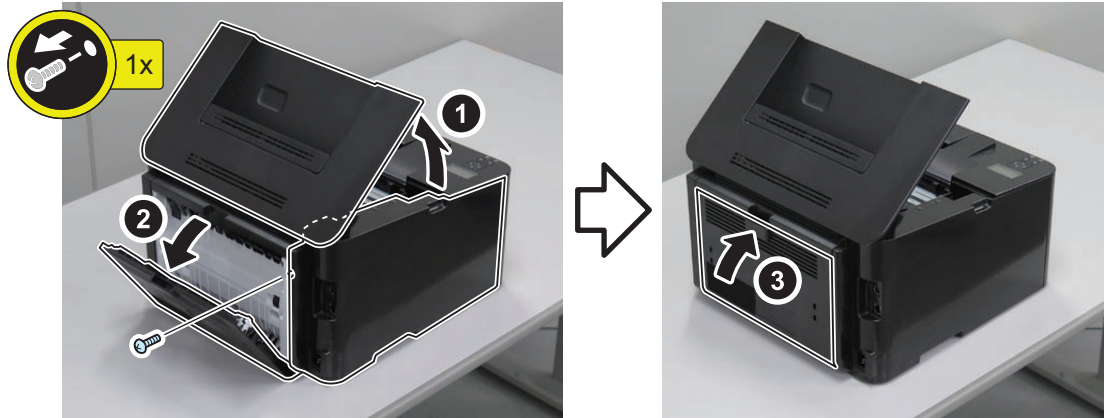

2.

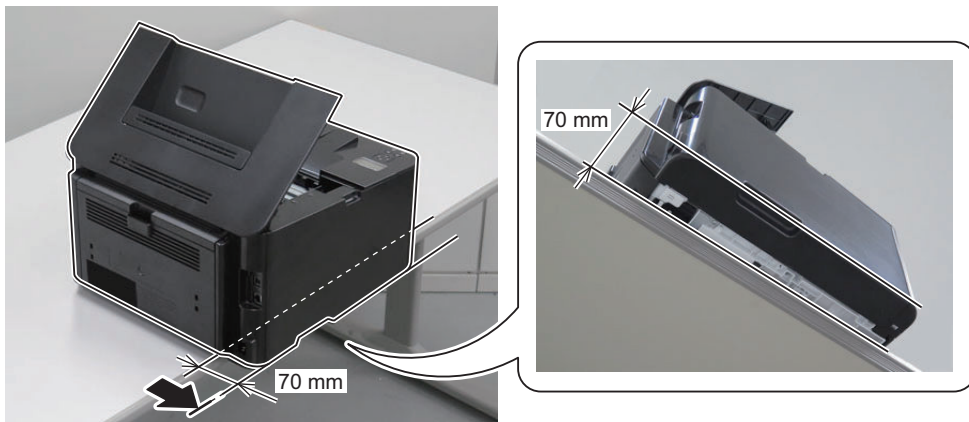

3.

NOTE:

The following shows the locations of the 4 claws [1] and the rib [2] of the Left Cover.

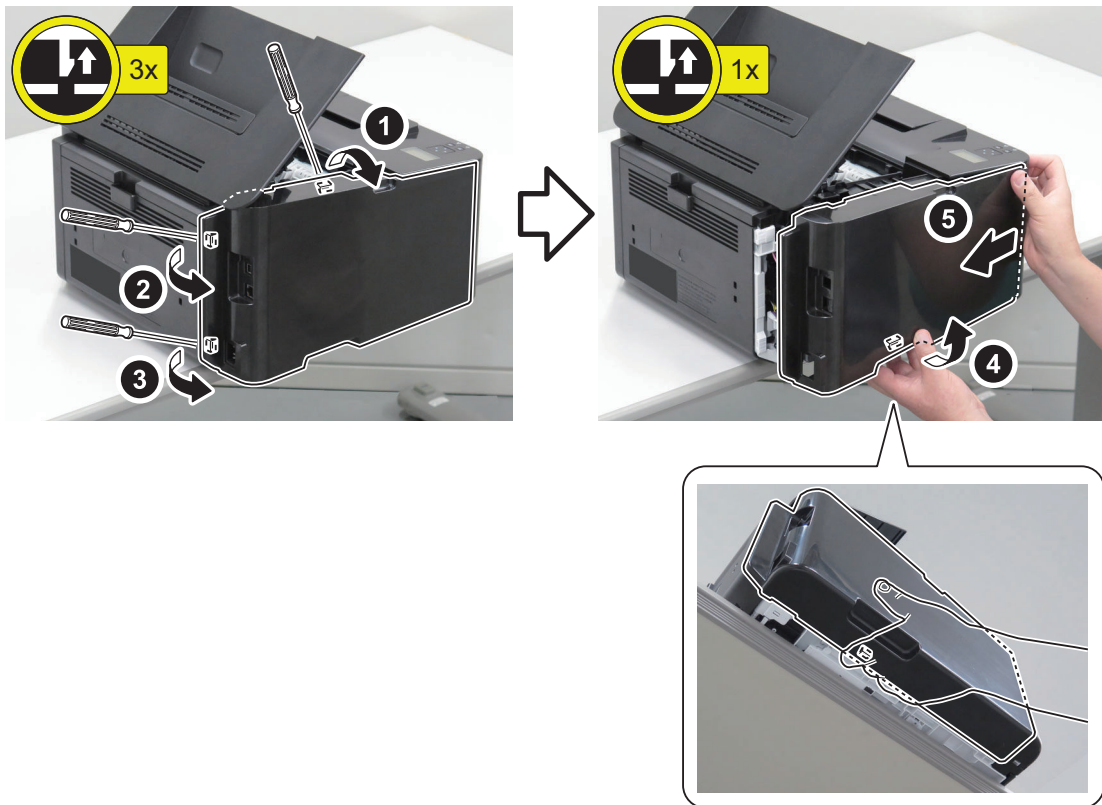
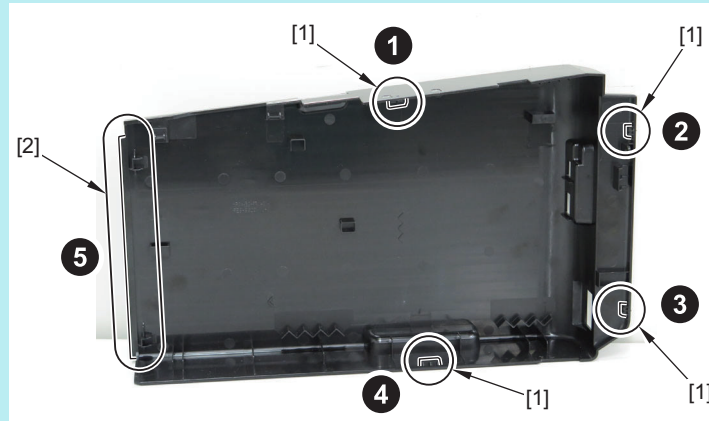
**CAUTION:**

Shift the host machine back to the center of the working table to prevent it from falling down.

● Removing the Cartridge Door Unit

■ Preparation

1. "Removing the Cartridge" on page 43
2. "Removing the Right Cover" on page 44

■ Procedure

1.

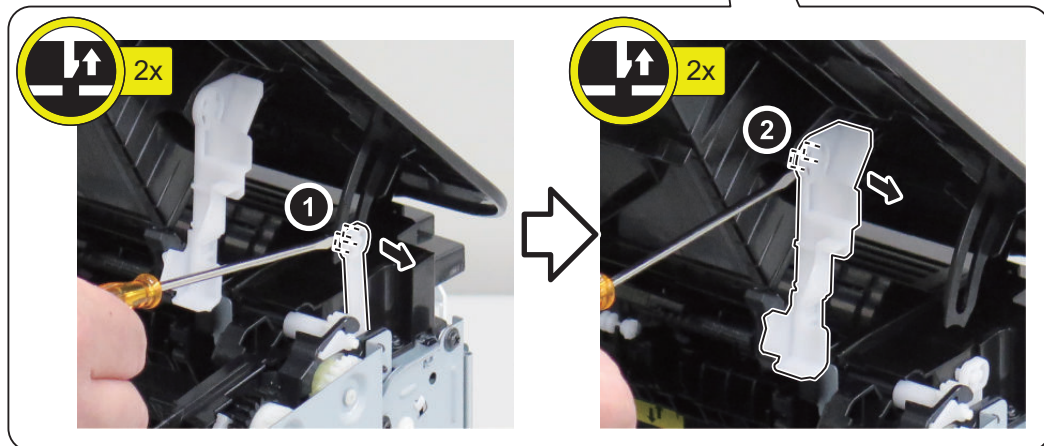
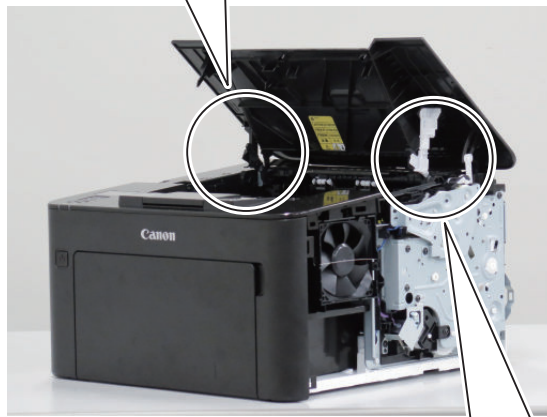
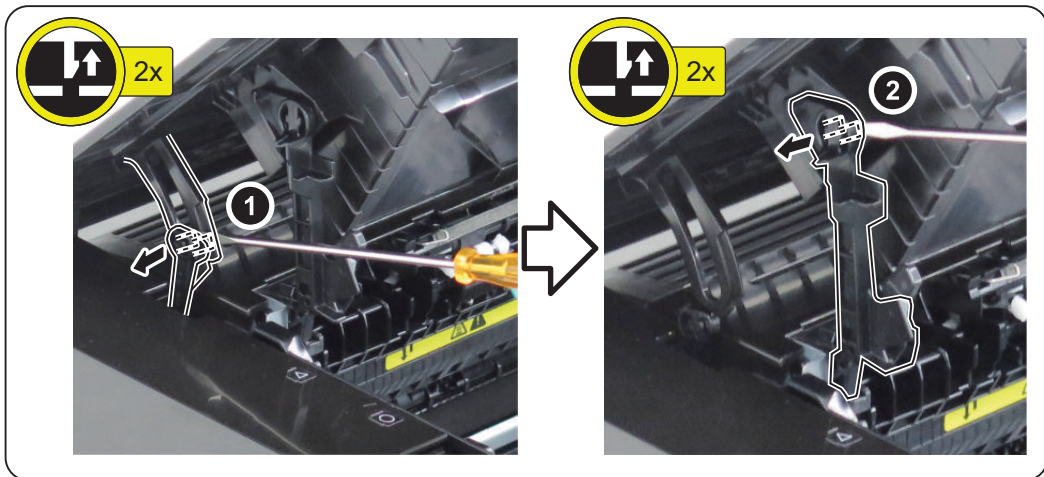

2.

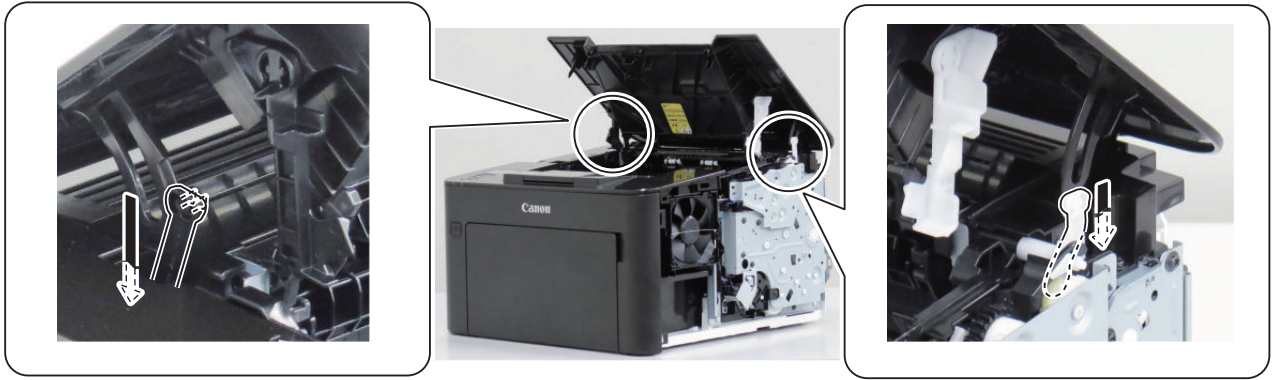

3.

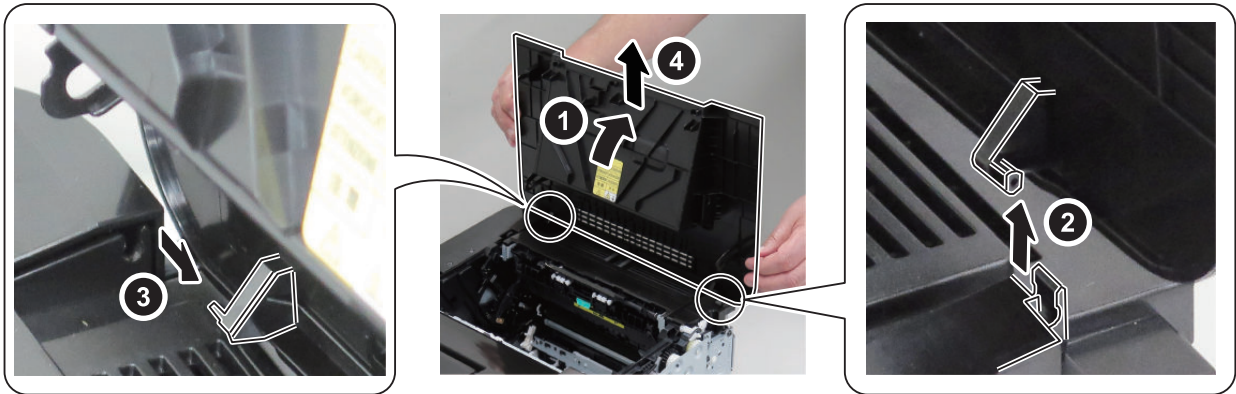

● Removing the Rear Upper Cover

■ Preparation

1. "Removing the Cartridge" on page 43
2. "Removing the Right Cover" on page 44
3. "Removing the Left Cover" on page 45
4. "Removing the Cartridge Door Unit" on page 47

■ Procedure

1.

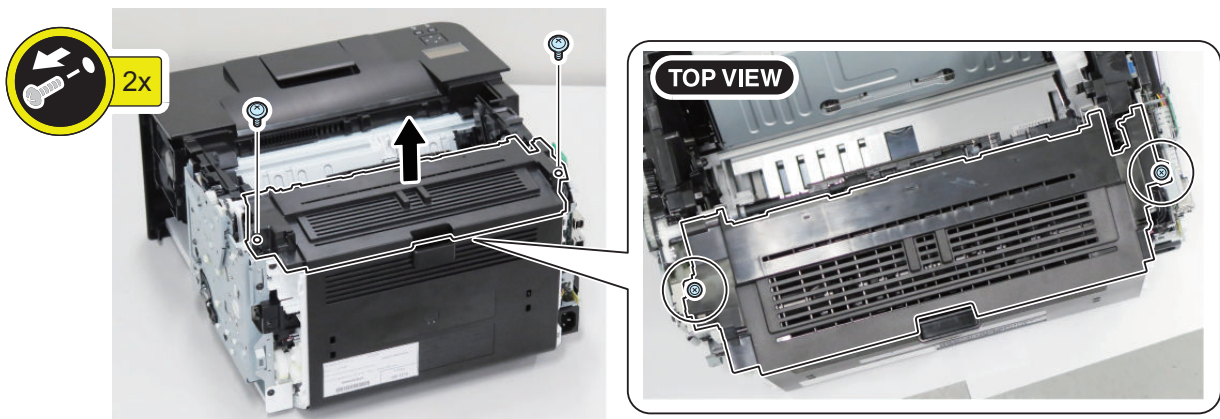

● Removing the Duplexing Door

■ Preparation

1. “Removing the Cartridge” on page 43
2. “Removing the Right Cover” on page 44
3. “Removing the Left Cover” on page 45
4. “Removing the Cartridge Door Unit” on page 47
5. “Removing the Rear Upper Cover” on page 49

■ Procedure

1.

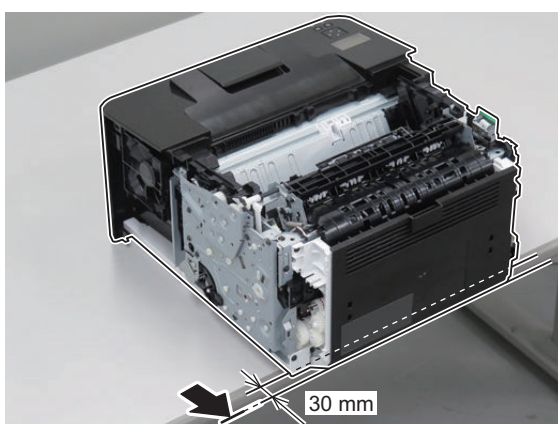

2.

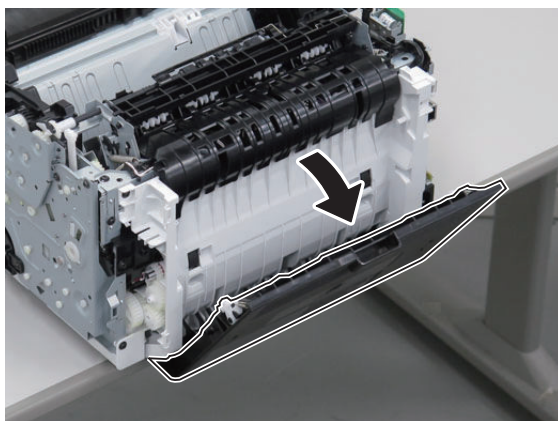

3.

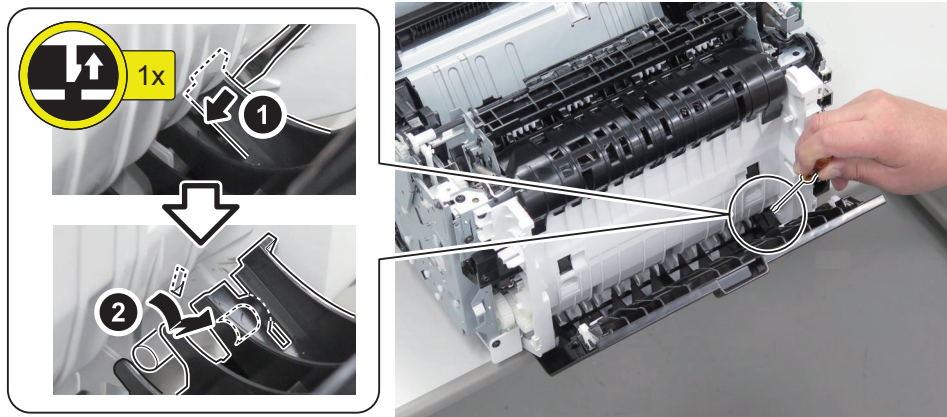

4.

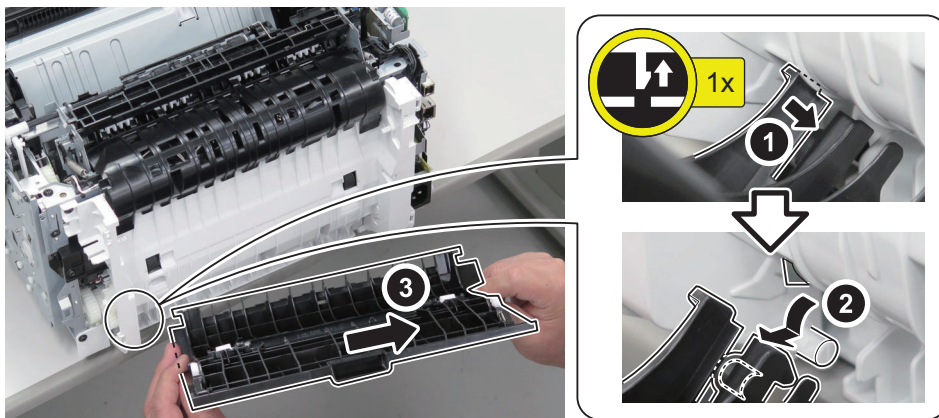
**⚠ CAUTION:**

Shift the host machine back to the center of the working table to prevent it from falling down.

● Removing the Upper Front Cover

■ Preparation

1. "Removing the Cartridge" on page 43
2. "Removing the Right Cover" on page 44
3. "Removing the Left Cover" on page 45
4. "Removing the Cartridge Door Unit" on page 47

■ Procedure

1.

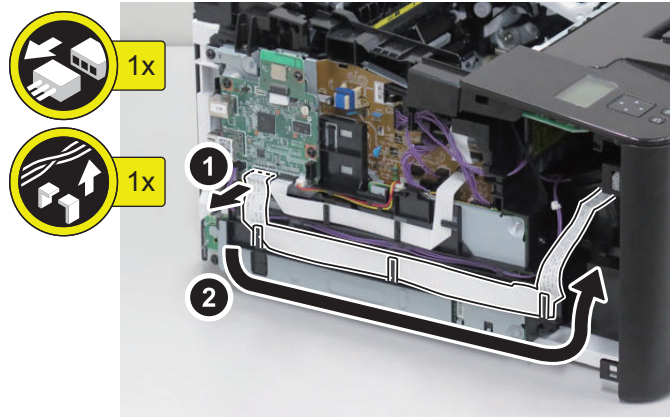

2.

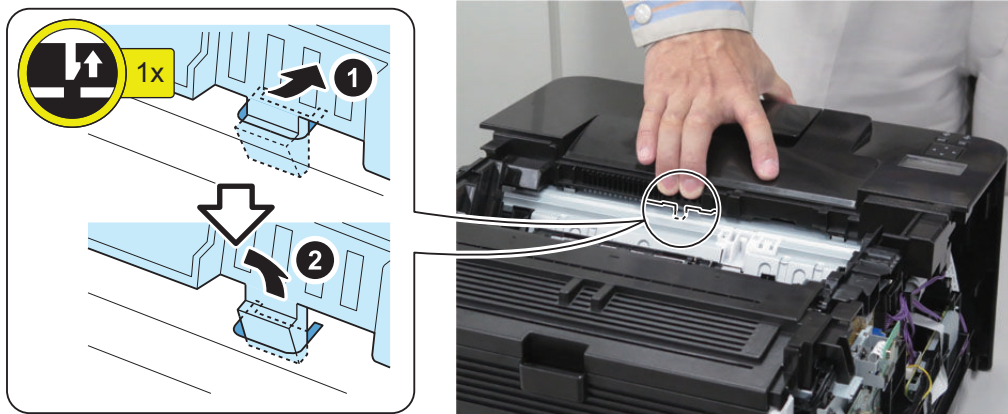

NOTE:

- Be sure to fit the claw into the hole by holding the both sides of the claw with your hands.

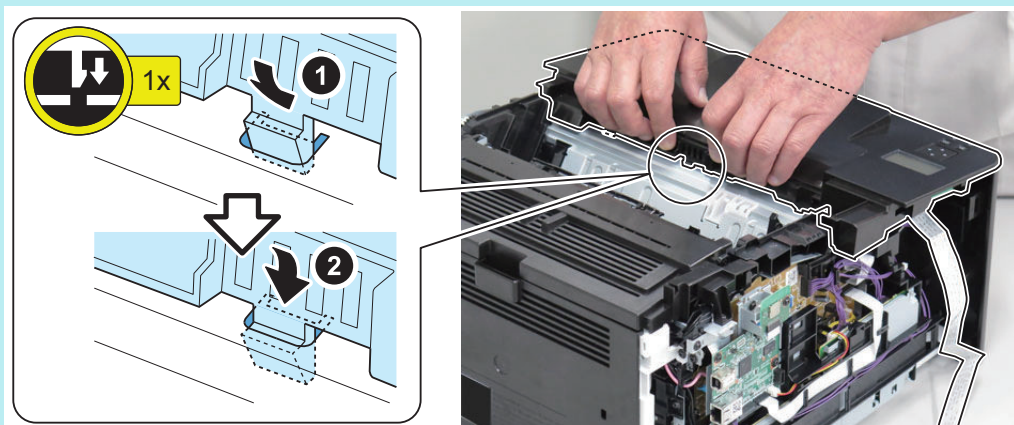

3.

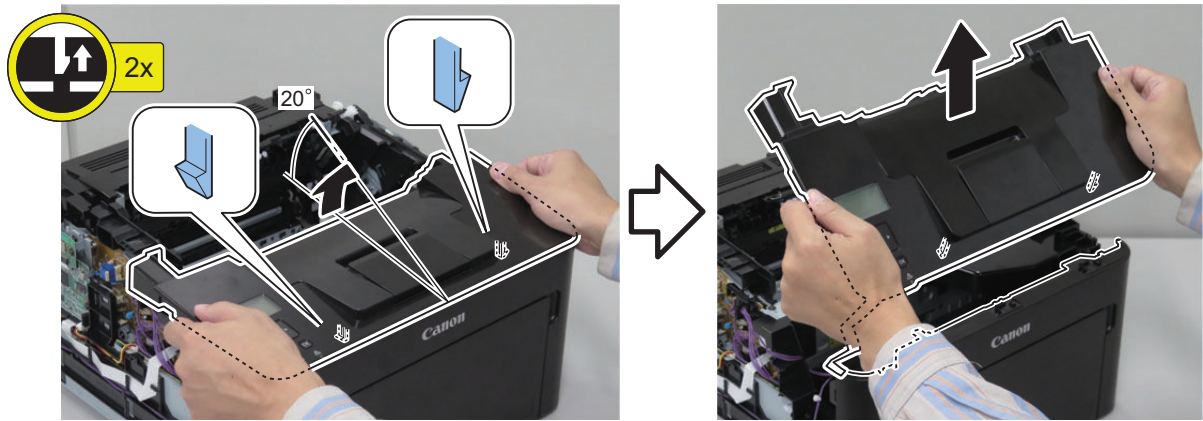

4.

NOTE:

When replacing the Upper Front Cover, be sure to disconnect the Flat Cable.

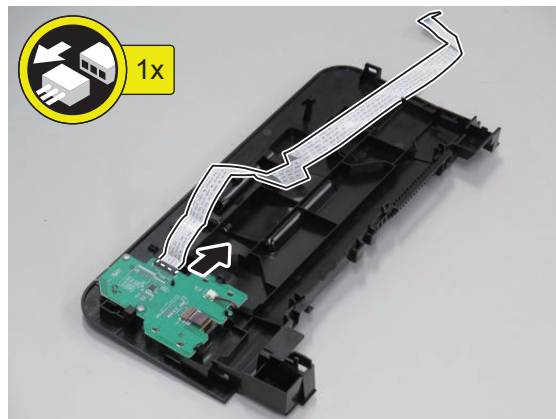
**CAUTION:**

Points to Note When Installing the Upper Front Cover

- Be sure that the PCB does not interfere with the Front Cover because it may damage the PCB.

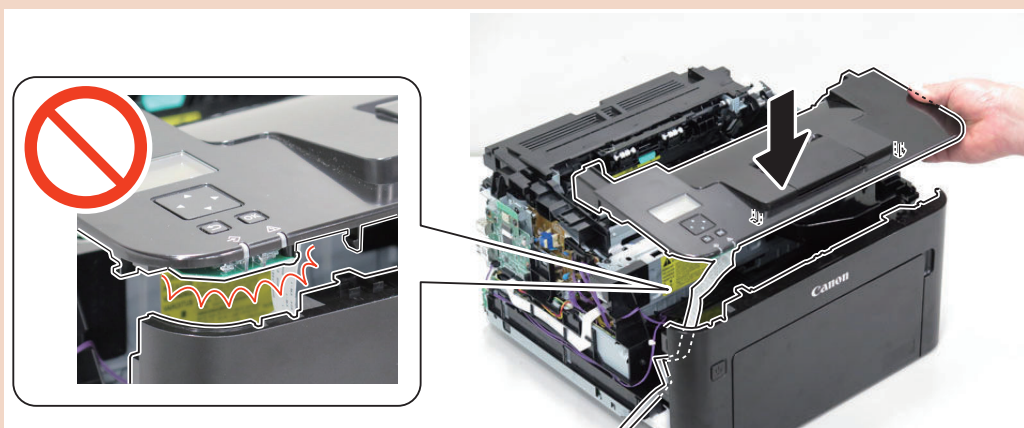

● Removing the Front Cover

■ Preparation

1. "Removing the Cartridge" on page 43

2. "Removing the Right Cover" on page 44
3. "Removing the Left Cover" on page 45
4. "Removing the Cartridge Door Unit" on page 47
5. "Removing the Upper Front Cover" on page 51

■ Procedure

1.

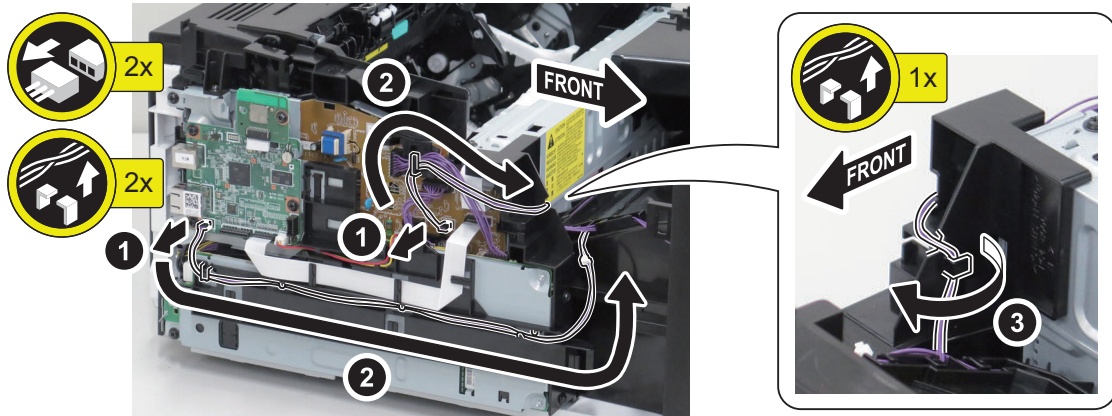

2.

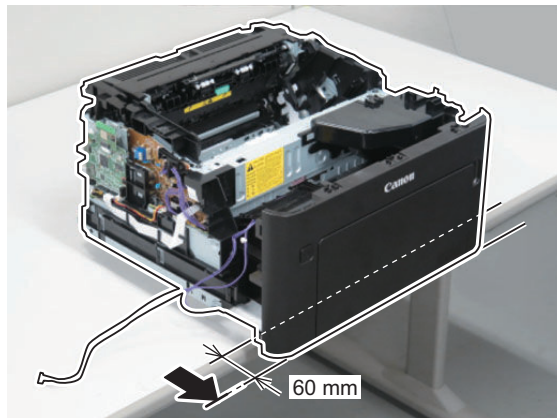

3.

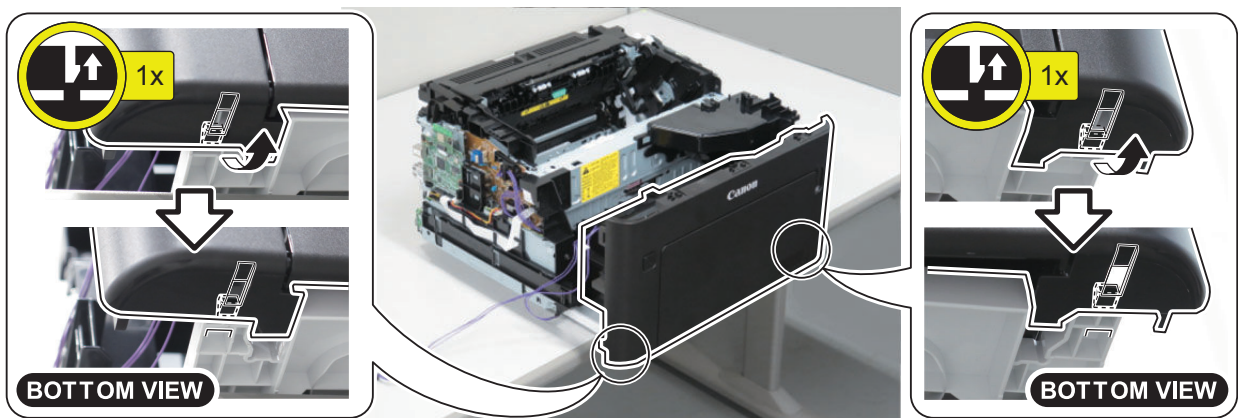

4.

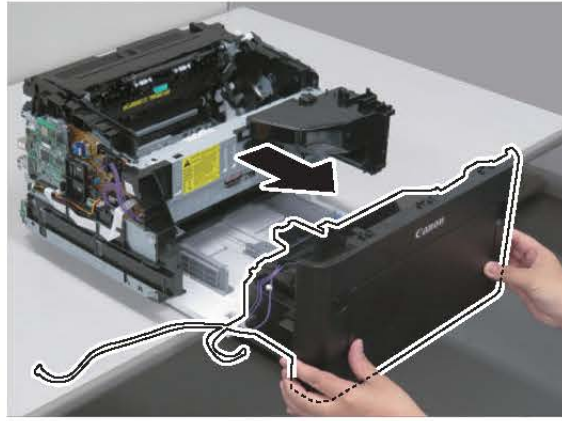

CAUTION:

Points to Note When Installing the Front Cover

Be careful not to damage or drop the Multi-purpose Tray Paper Detection Actuator by interfering with the Pickup Guide.

1. Lift the Multi-purpose Tray Paper Detection Actuator using a screwdriver and insert the Front Cover.

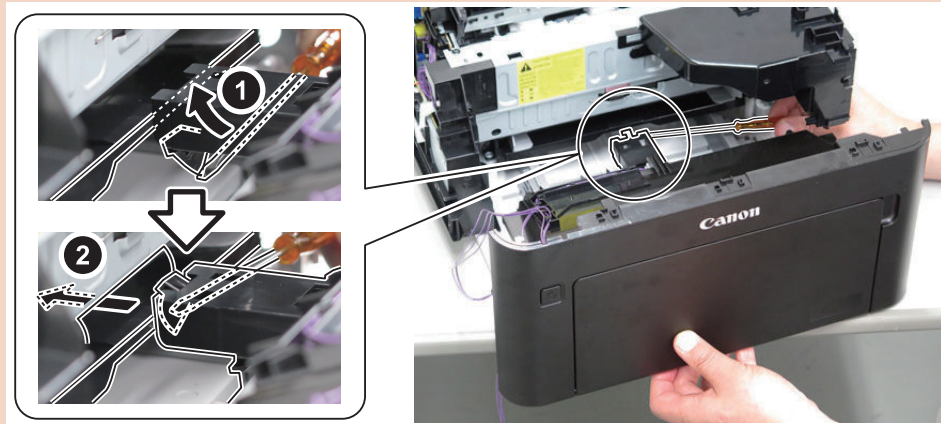

2. Insert the Front Cover in parallel by aligning with the positions of boss holes on the right and left sides.

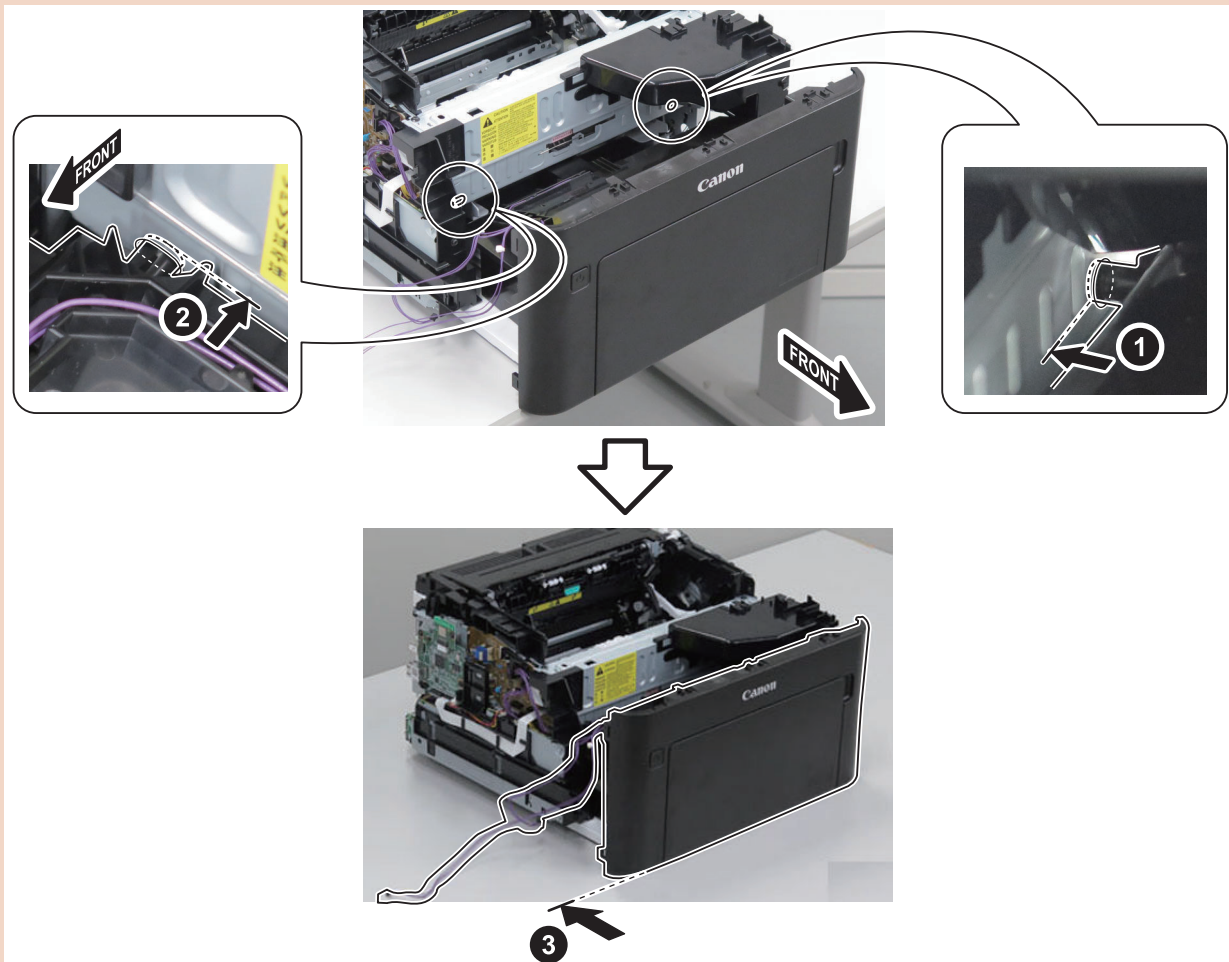

● Removing the Multi-purpose Tray

■ Preparation

1. "Removing the Cartridge" on page 43
2. "Removing the Right Cover" on page 44

3. "Removing the Left Cover" on page 45
4. "Removing the Cartridge Door Unit" on page 47
5. "Removing the Upper Front Cover" on page 51
6. "Removing the Front Cover" on page 53

■ Procedure

1.

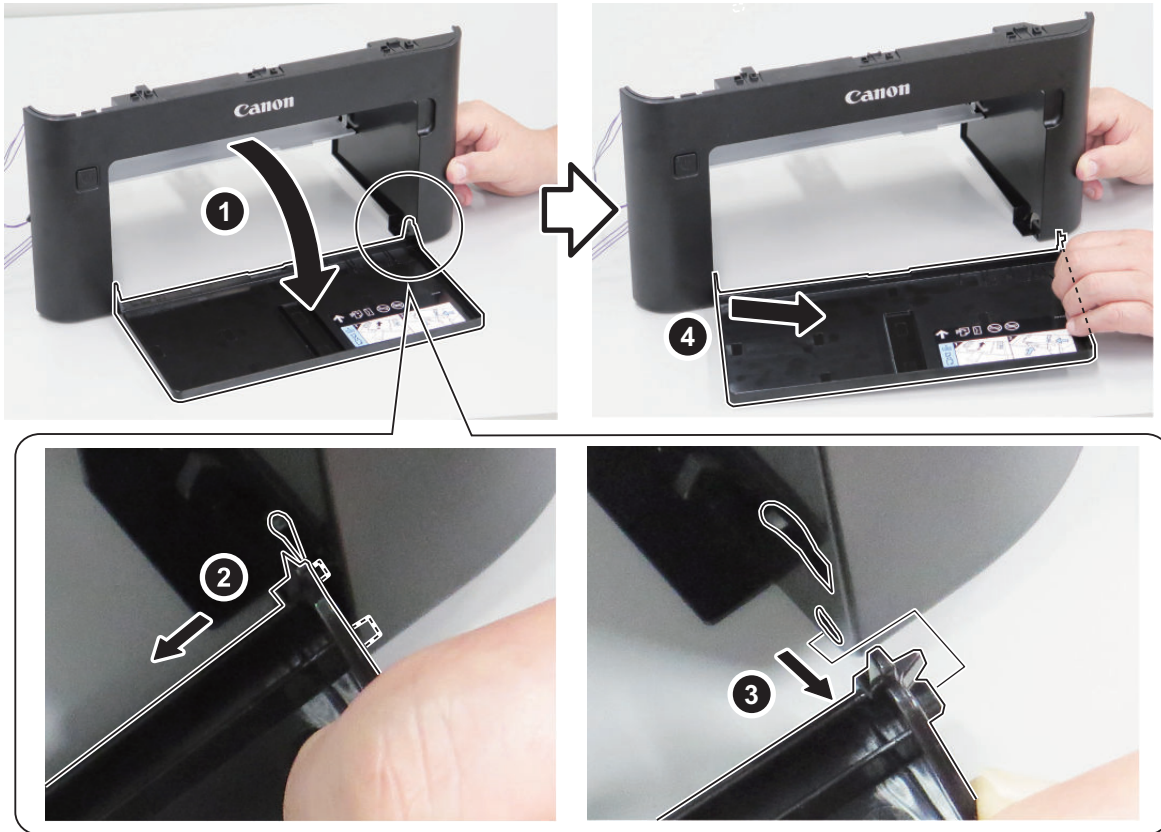

Controller System

● Removing the Wireless Lan PCB

■ Preparation

1. "Removing the Cartridge" on page 43
2. "Removing the Left Cover" on page 45

■ Procedure

1.

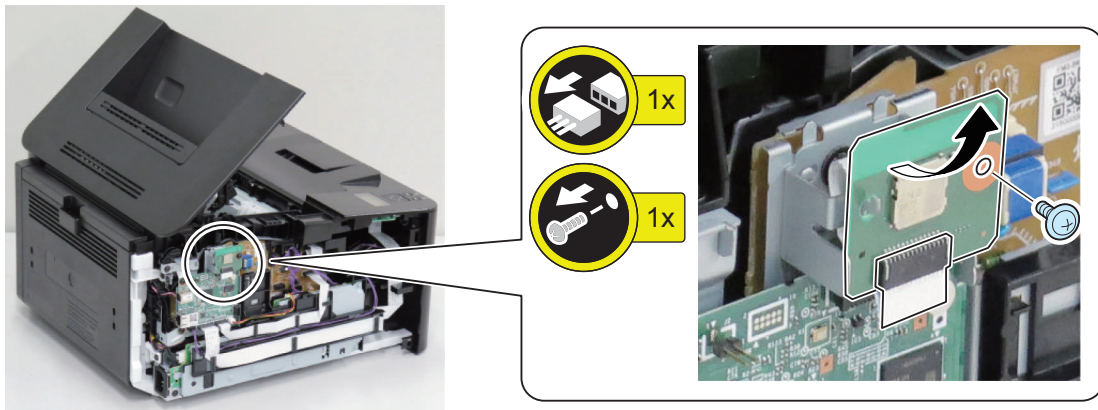

● Removing the Main Controller PCB

■ Preparation

1. Actions before Parts Replacement "Main Controller PCB" on page 95
2. "Removing the Cartridge" on page 43
3. "Removing the Left Cover" on page 45
4. "Removing the Wireless Lan PCB" on page 58

■ Procedure

1.

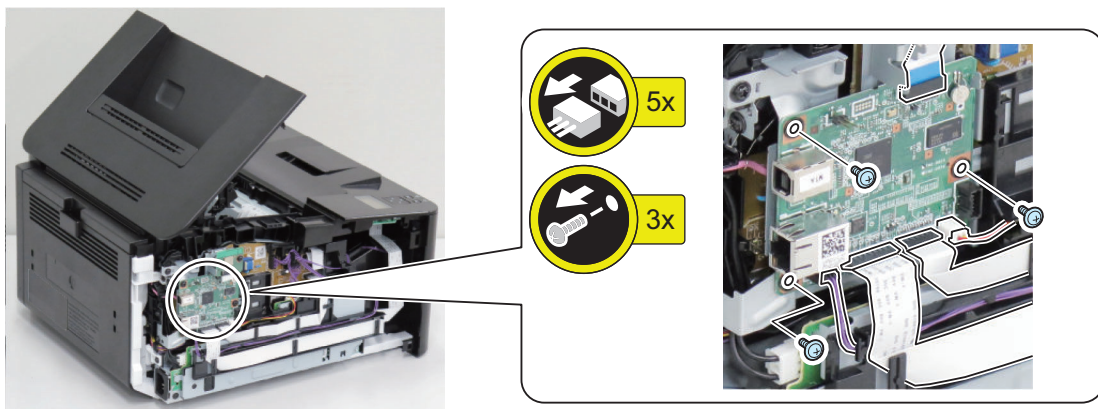

2.

Actions after Parts Replacement
 “Main Controller PCB” on page 95

● Removing the Low Voltage Power Supply Unit

■ Preparation

1. “Removing the Cartridge” on page 43
2. “Removing the Right Cover” on page 44
3. “Removing the Left Cover” on page 45
4. “Removing the Cartridge Door Unit” on page 47
5. “Removing the Rear Upper Cover” on page 49
6. “Removing the Duplexing Door” on page 50
7. “Removing the Duplexing Frame Unit” on page 87
8. “Removing the Upper Front Cover” on page 51
9. “Removing the Front Cover” on page 53

■ Procedure

1.

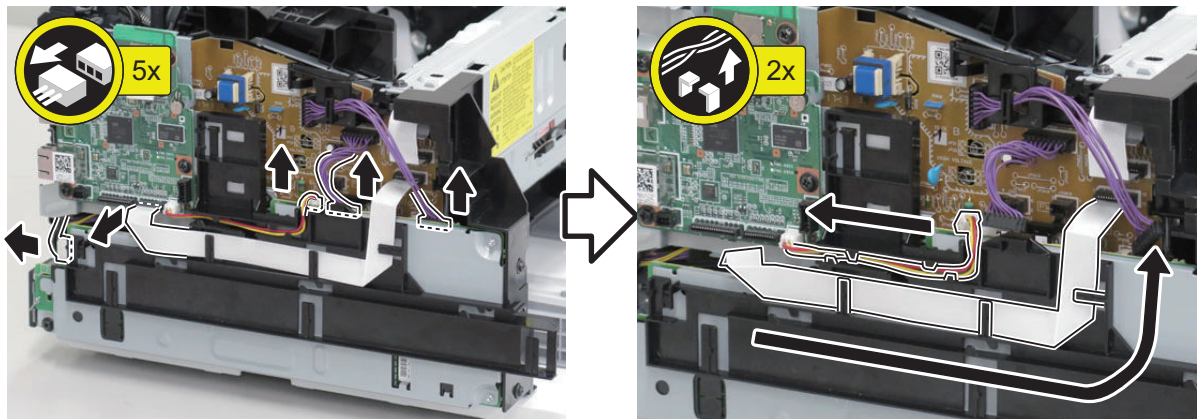

2.

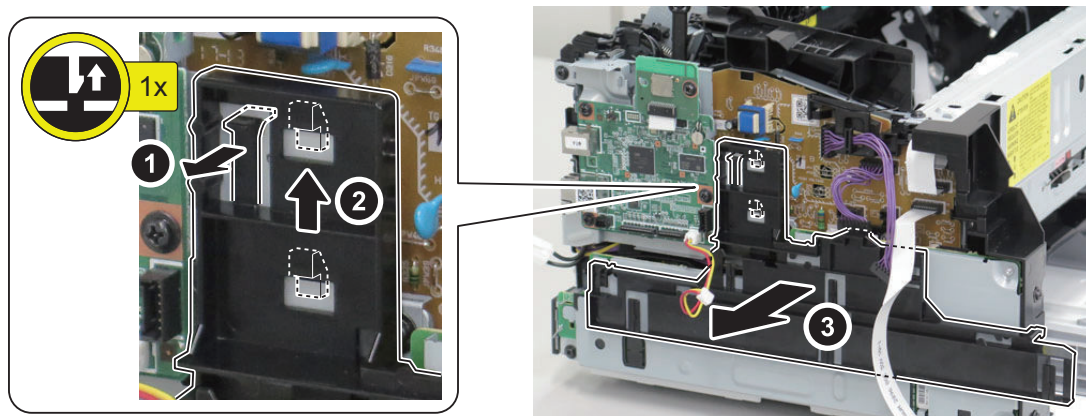

3.

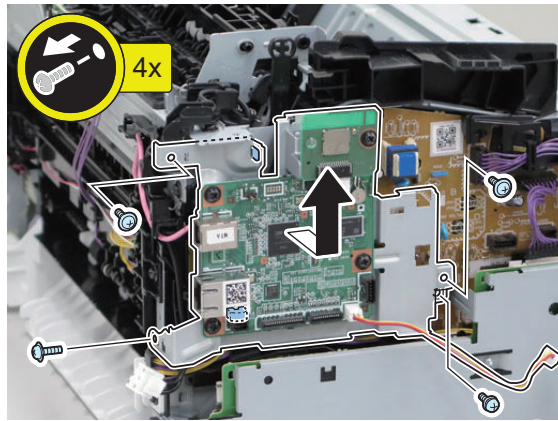

4.

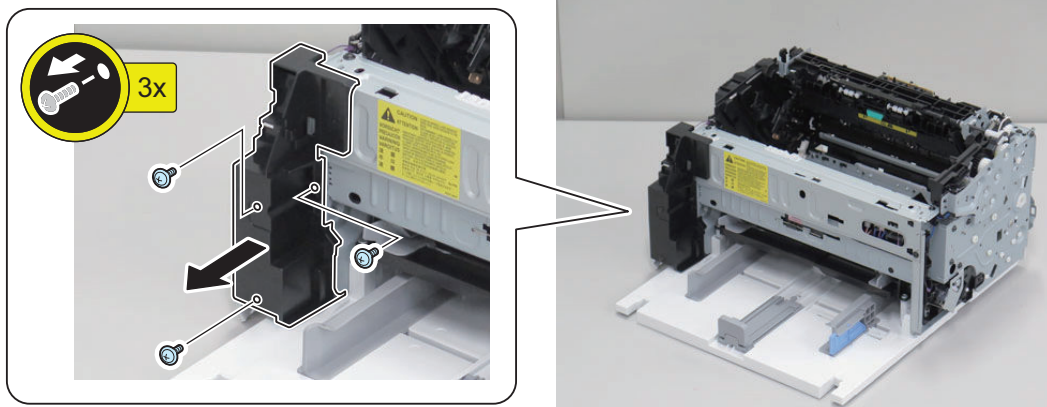

5.

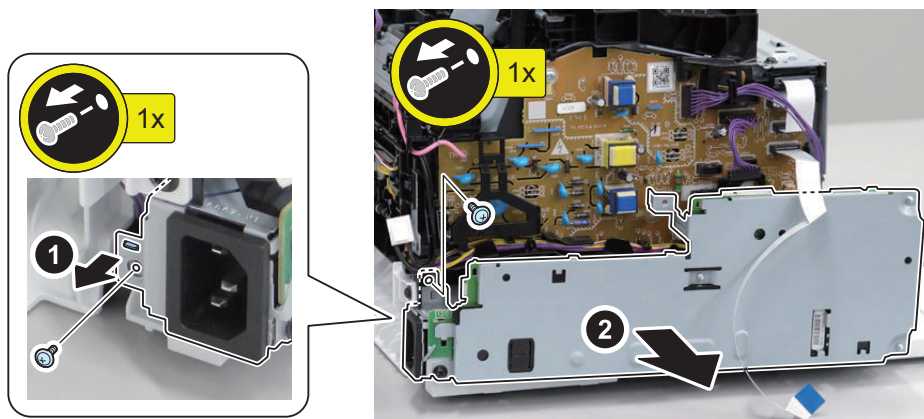

● Removing the Engine Controller PCB

■ Preparation

1. "Removing the Cartridge" on page 43
2. "Removing the Right Cover" on page 44
3. "Removing the Left Cover" on page 45
4. "Removing the Cartridge Door Unit" on page 47
5. "Removing the Rear Upper Cover" on page 49
6. "Removing the Duplexing Door" on page 50

7. "Removing the Duplexing Frame Unit" on page 87
8. "Removing the Upper Front Cover" on page 51
9. "Removing the Front Cover" on page 53
10. "Removing the Low Voltage Power Supply Unit" on page 59

■ Procedure

1.

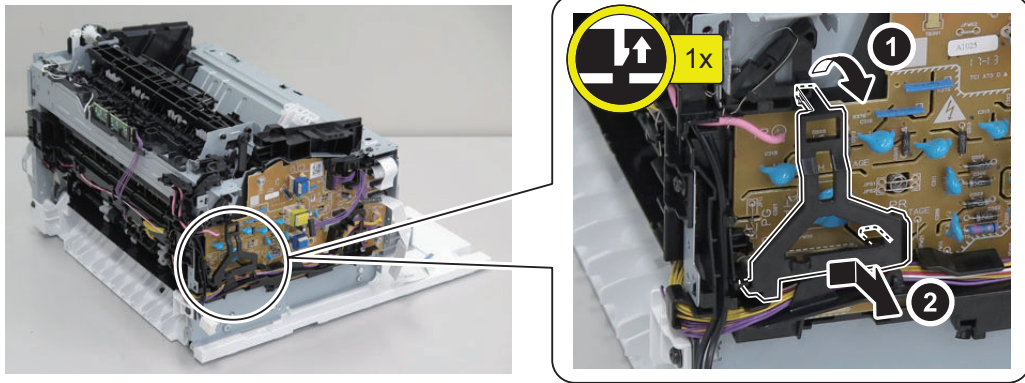

2.

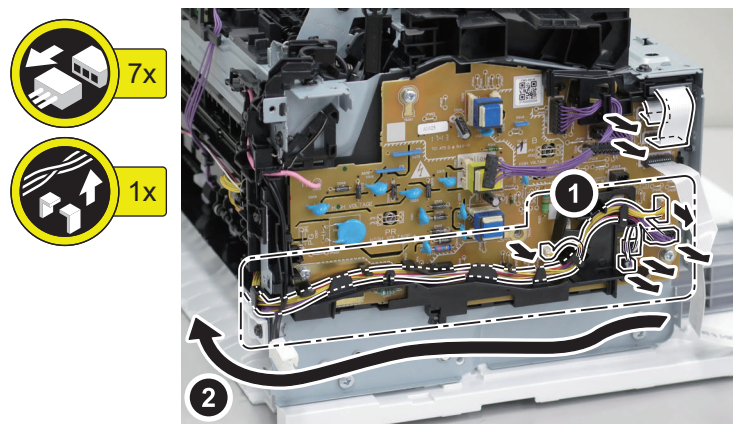

3.

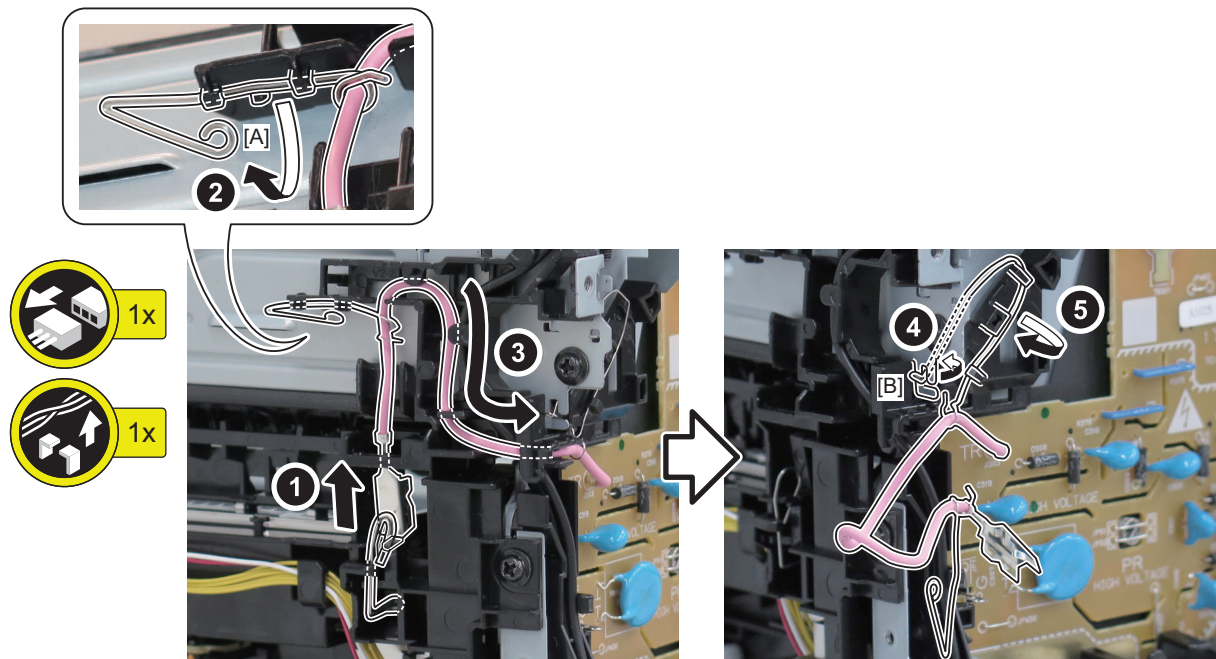

CAUTION:

Points to Note when Installing the Engine Controller PCB

- Be sure that the Grounding Contact Spring [A] is in contact with the frame.
- Be sure that the Grounding Contact Spring [B] is fitted in the groove on the plate.

4.

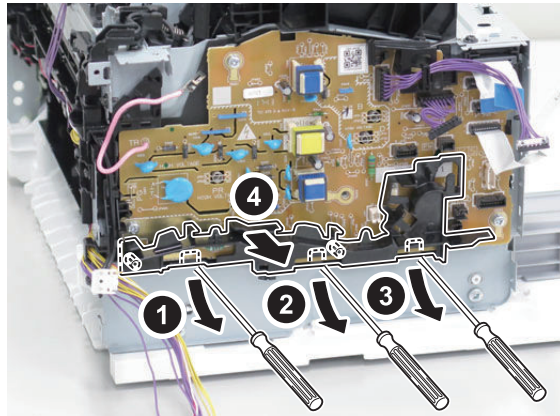

5.

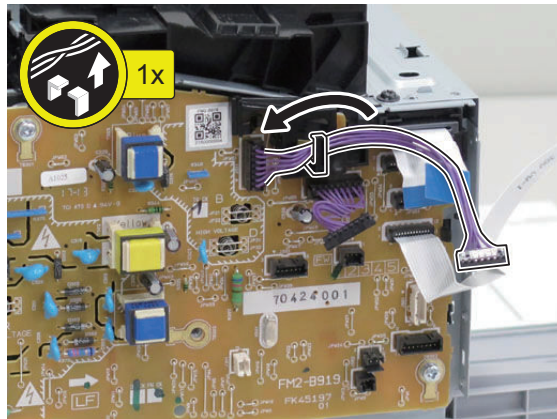

6.

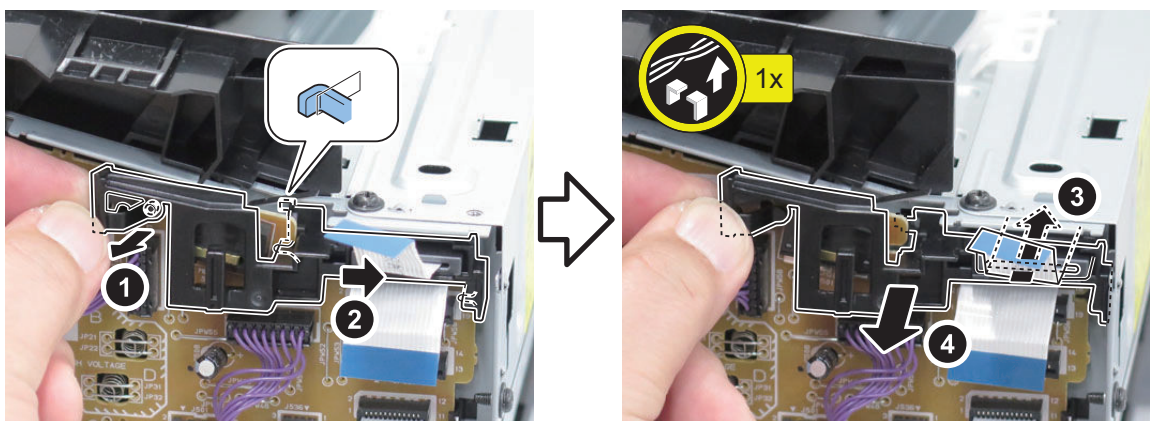

7.

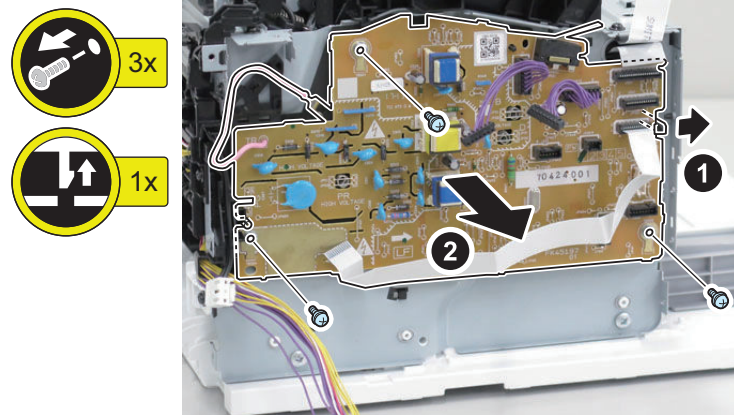

8.

NOTE:

When replacing the Engine Controller PCB, be sure to disconnect the harnesses.

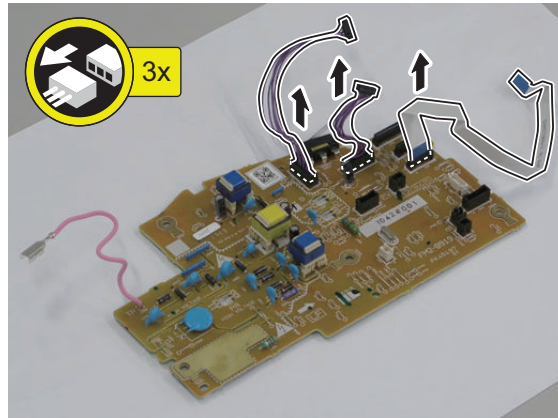

CAUTION:

Points to Note when Installing the Engine Controller PCB

- Be sure that the 3 Contact Springs are in the correct position.

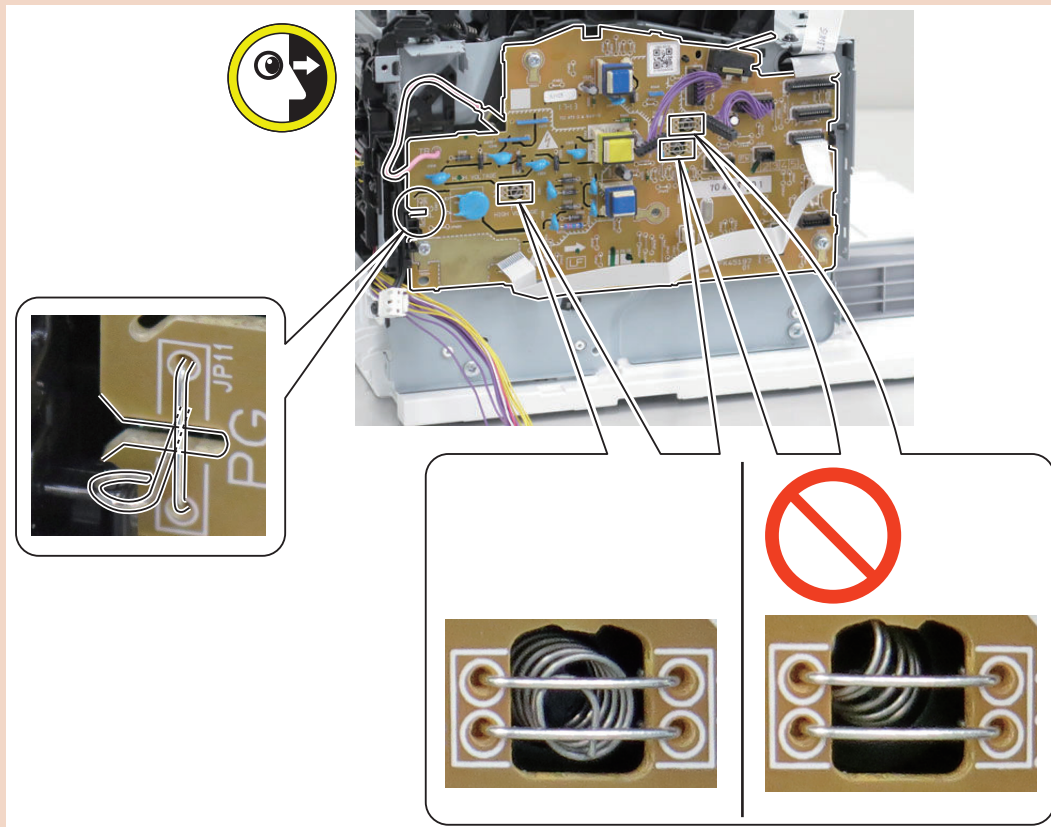

● Removing the Motor PCB

■ Preparation

1. "Removing the Cartridge" on page 43
2. "Removing the Right Cover" on page 44
3. "Removing the Left Cover" on page 45
4. "Removing the Cartridge Door Unit" on page 47
5. "Removing the Upper Front Cover" on page 51
6. "Removing the Front Cover" on page 53
7. "Removing the Main Fan" on page 66
8. "Removing the Laser Scanner Cover" on page 69

■ Procedure

1.

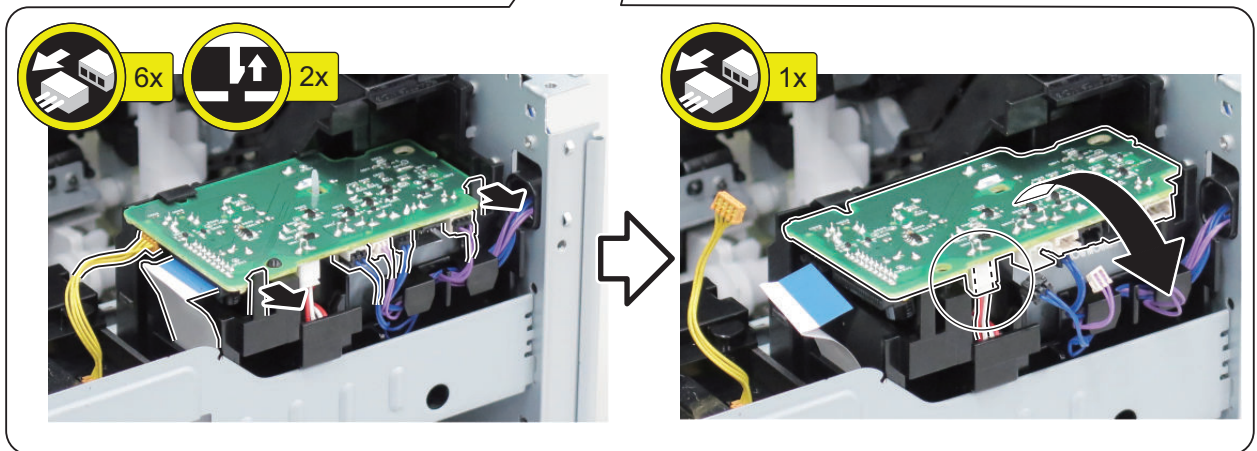
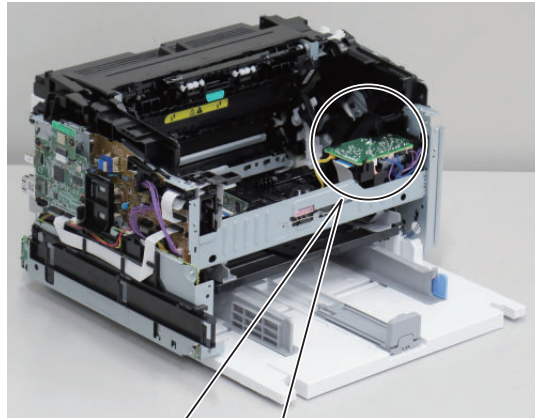

● Removing the Environment Sensor PCB

■ Preparation

1. "Removing the Cartridge" on page 43
2. "Removing the Separation Pad Assembly" on page 86
3. "Removing the Right Cover" on page 44
4. "Removing the Left Cover" on page 45
5. "Removing the Cartridge Door Unit" on page 47
6. "Removing the Rear Upper Cover" on page 49
7. "Removing the Duplexing Door" on page 50
8. "Removing the Duplexing Frame Unit" on page 87

■ Procedure

1.

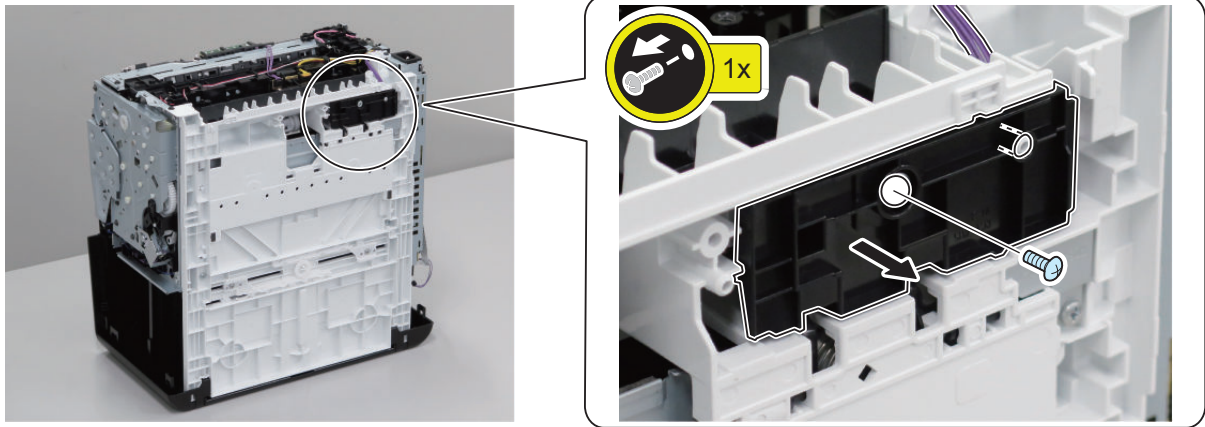

2.

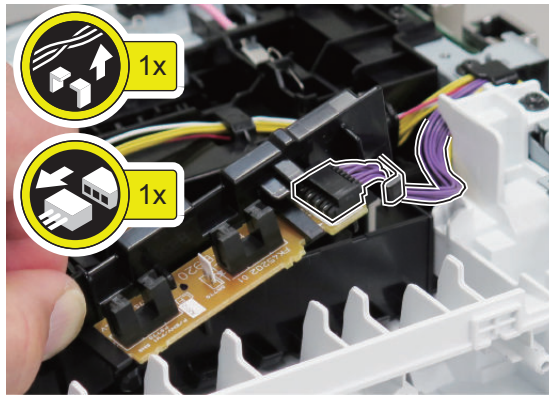

3.

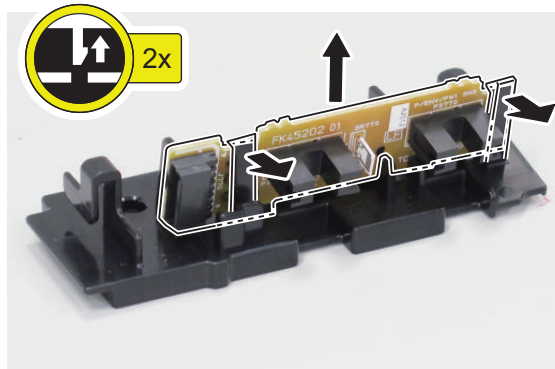

● Removing the Main Fan

■ Preparation

1. "Removing the Cartridge" on page 43
2. "Removing the Right Cover" on page 44
3. "Removing the Left Cover" on page 45
4. "Removing the Cartridge Door Unit" on page 47
5. "Removing the Upper Front Cover" on page 51
6. "Removing the Front Cover" on page 53

■ Procedure

1.

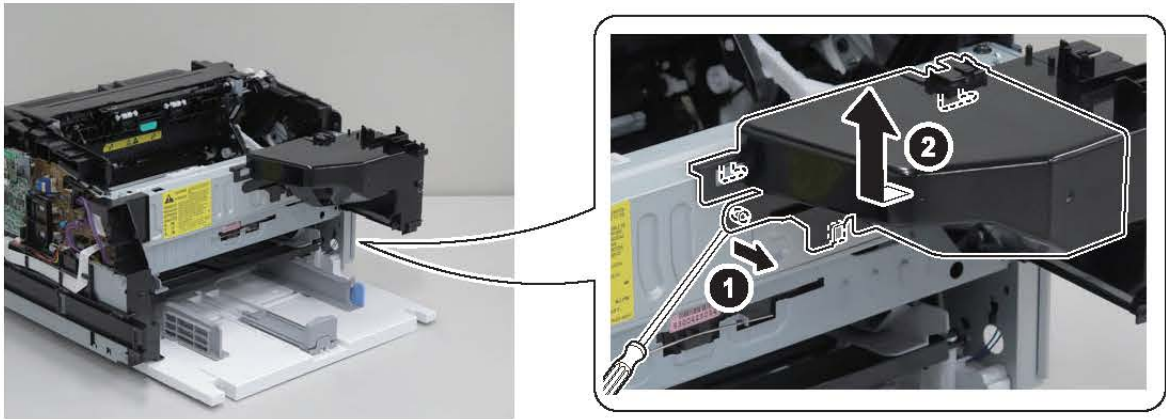

2.

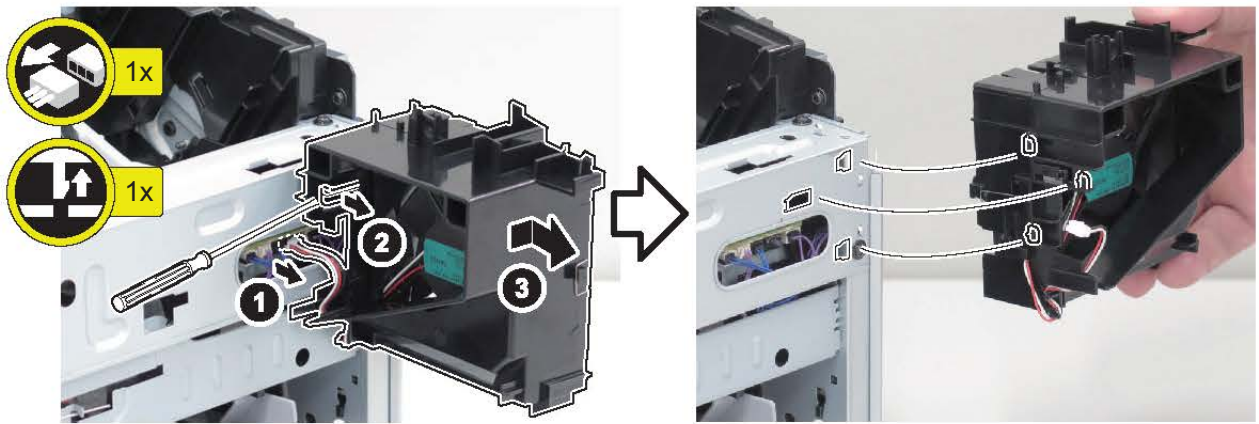

3.

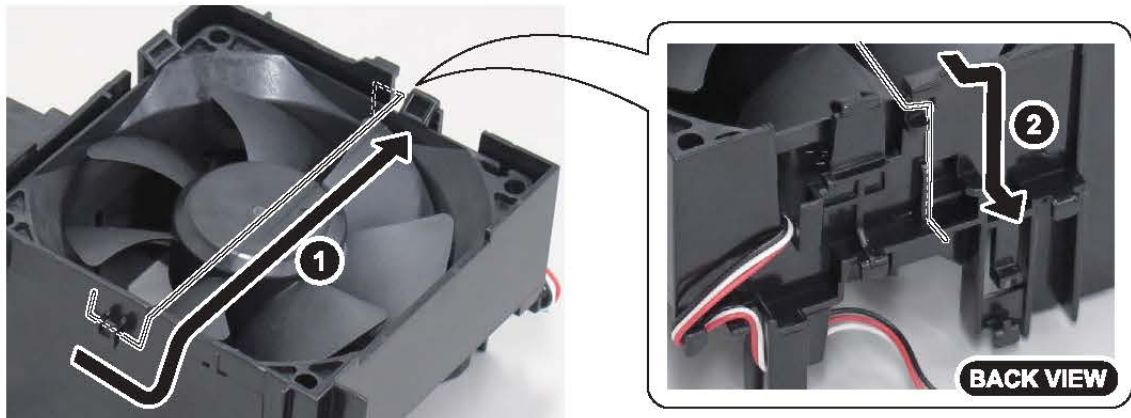

4.

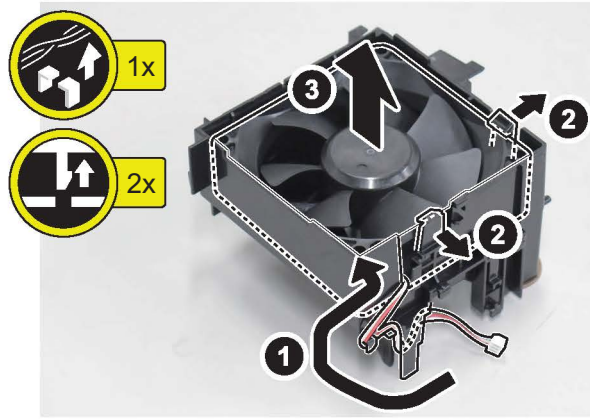

Laser Exposure System

● Removing the Laser Scanner Cover

■ Preparation

1. "Removing the Cartridge" on page 43
2. "Removing the Right Cover" on page 44
3. "Removing the Left Cover" on page 45
4. "Removing the Cartridge Door Unit" on page 47
5. "Removing the Upper Front Cover" on page 51
6. "Removing the Front Cover" on page 53
7. "Removing the Main Fan" on page 66

■ Procedure

1.

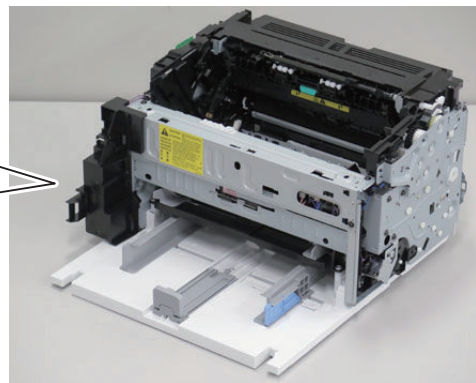
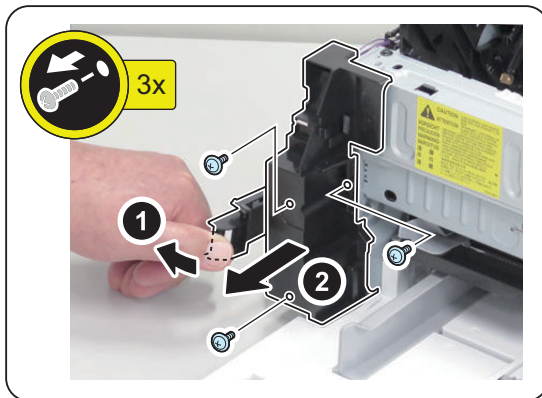

2.

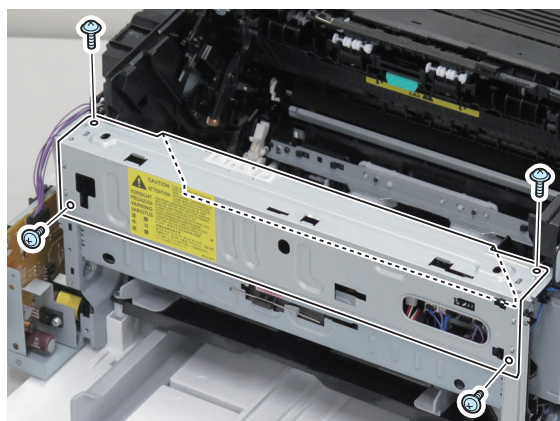

3.

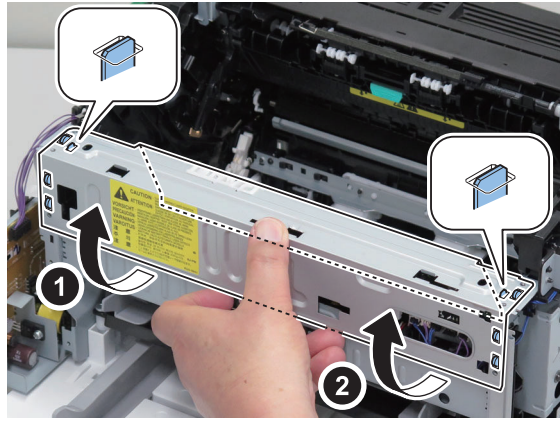

4.

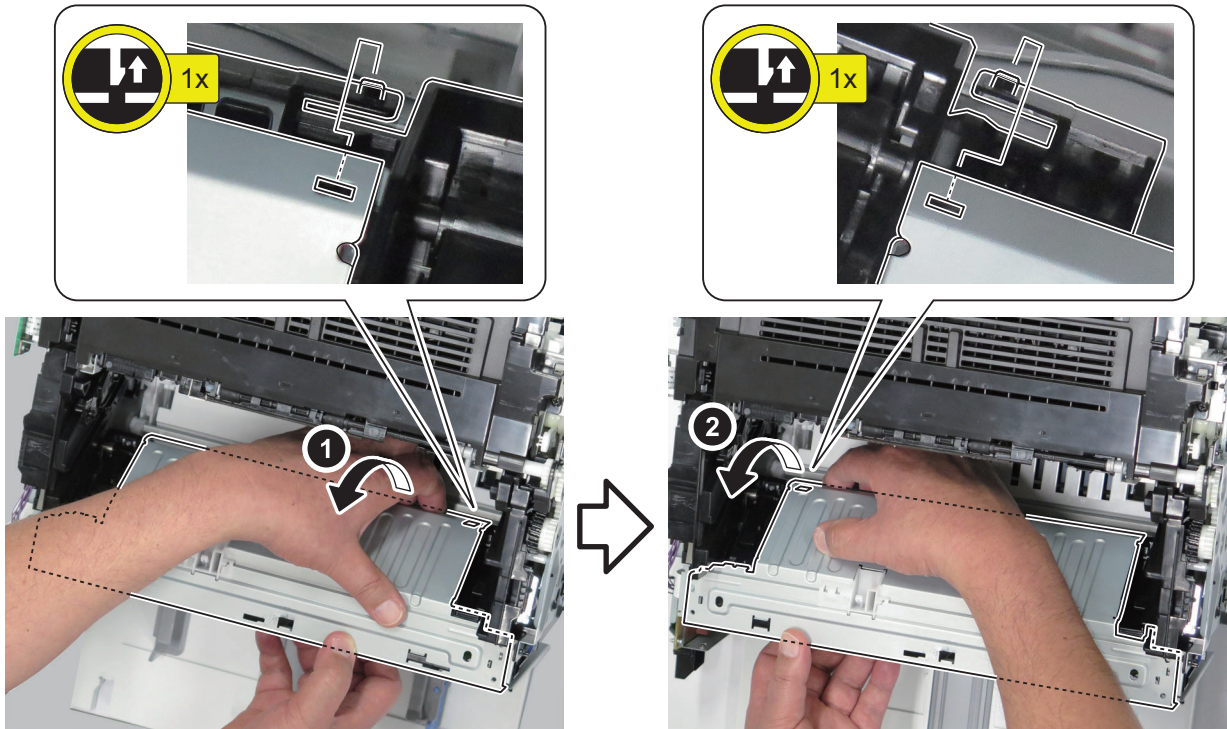

5.

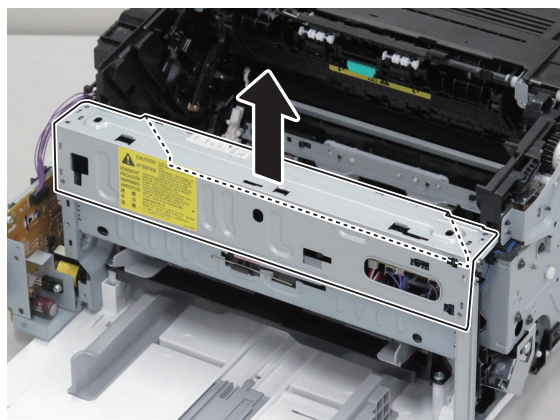

● Removing the Laser Scanner Unit

■ Preparation

1. "Removing the Cartridge" on page 43
2. "Removing the Right Cover" on page 44
3. "Removing the Left Cover" on page 45
4. "Removing the Cartridge Door Unit" on page 47
5. "Removing the Upper Front Cover" on page 51
6. "Removing the Front Cover" on page 53
7. "Removing the Main Fan" on page 66
8. "Removing the Laser Scanner Cover" on page 69

■ Procedure

CAUTION:

Do not disassemble the Laser Scanner Unit because it requires adjustment.

1.

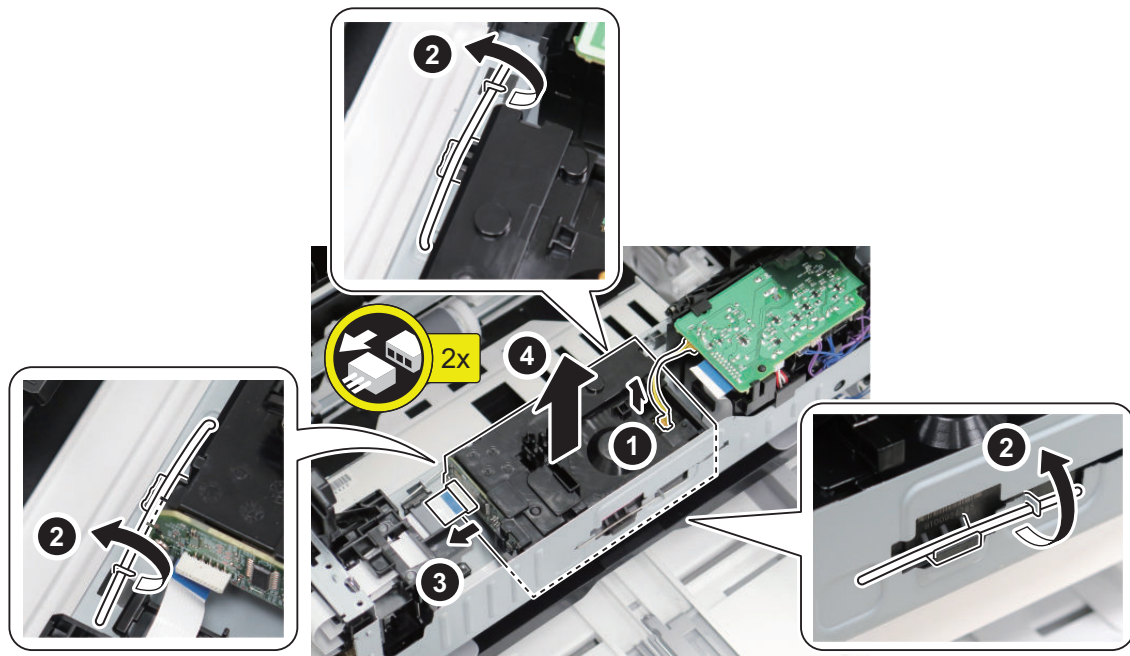

Image Formation System

● Removing the Transfer Roller

■ Preparation

1. "Removing the Cartridge" on page 43

■ Procedure

1.



2.

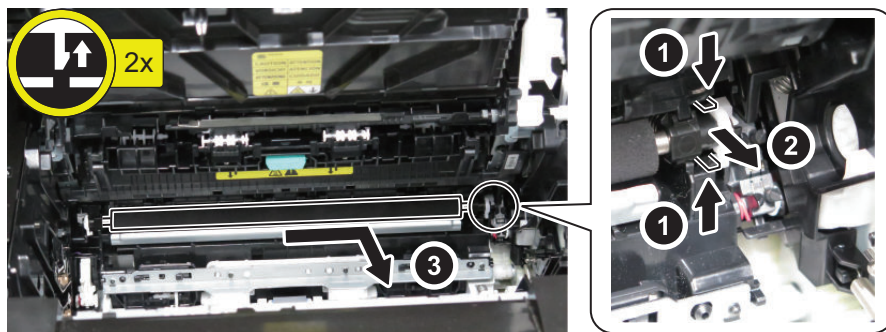

NOTE:

When assembling, be sure to install the bushing as shown in the figure.

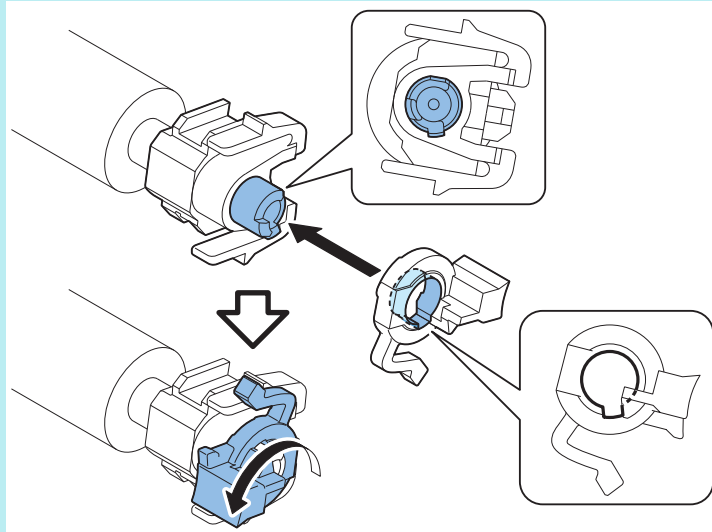
**NOTE:**

When installing it, be sure to fit the boss to the spring.

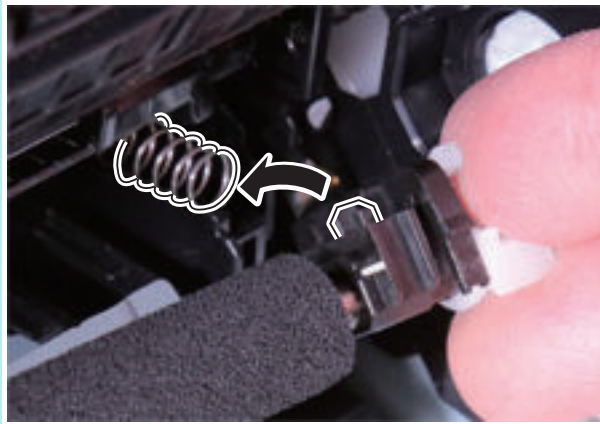

● Removing the Transfer Unit

■ Preparation

1. "Removing the Cartridge" on page 43
2. "Removing the Right Cover" on page 44
3. "Removing the Left Cover" on page 45
4. "Removing the Cartridge Door Unit" on page 47
5. "Removing the Rear Upper Cover" on page 49
6. "Removing the Duplexing Door" on page 50
7. "Removing the Duplexing Frame Unit" on page 87
8. "Removing the Upper Front Cover" on page 51
9. "Removing the Front Cover" on page 53
10. "Removing the Low Voltage Power Supply Unit" on page 59

■ Procedure

1.

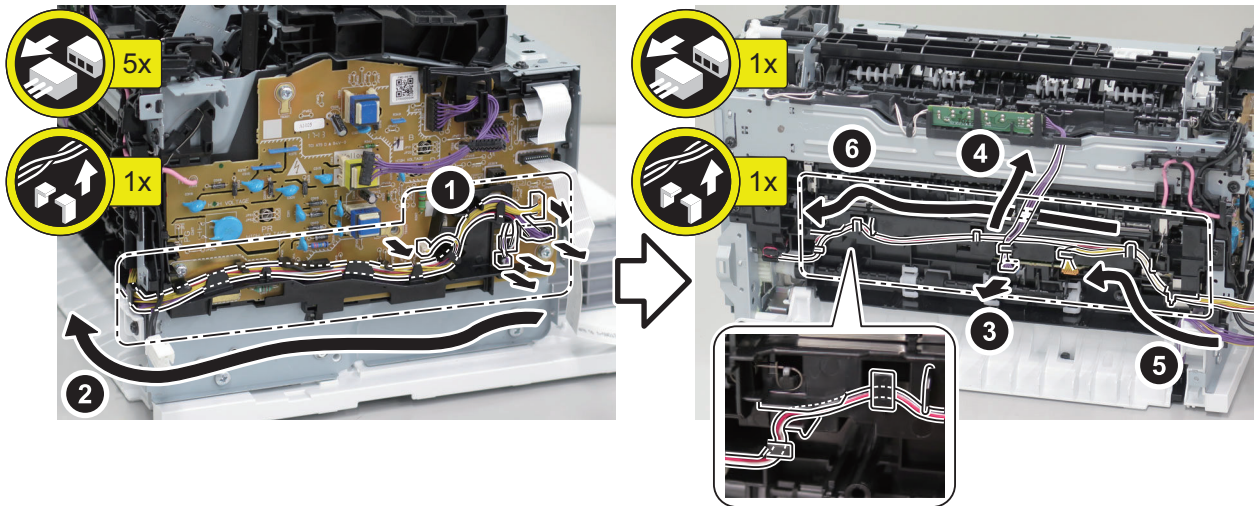

2.

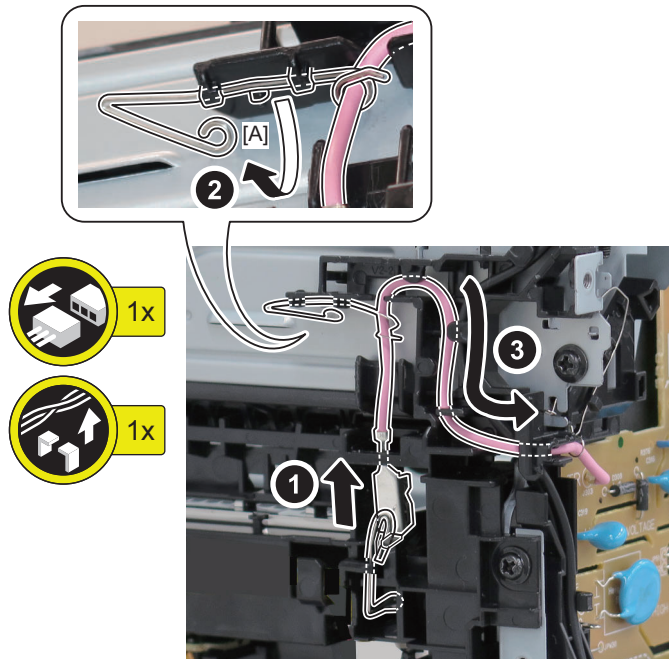

CAUTION:

Points to Note when Installing the Transfer Unit

- Be sure that the Grounding Contact Spring [A] is in contact with the frame.

3.

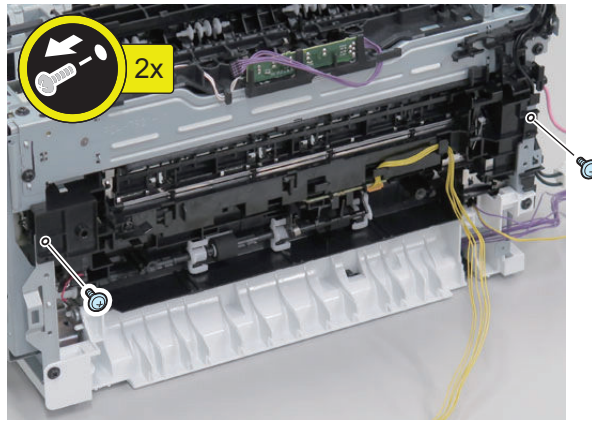

4.

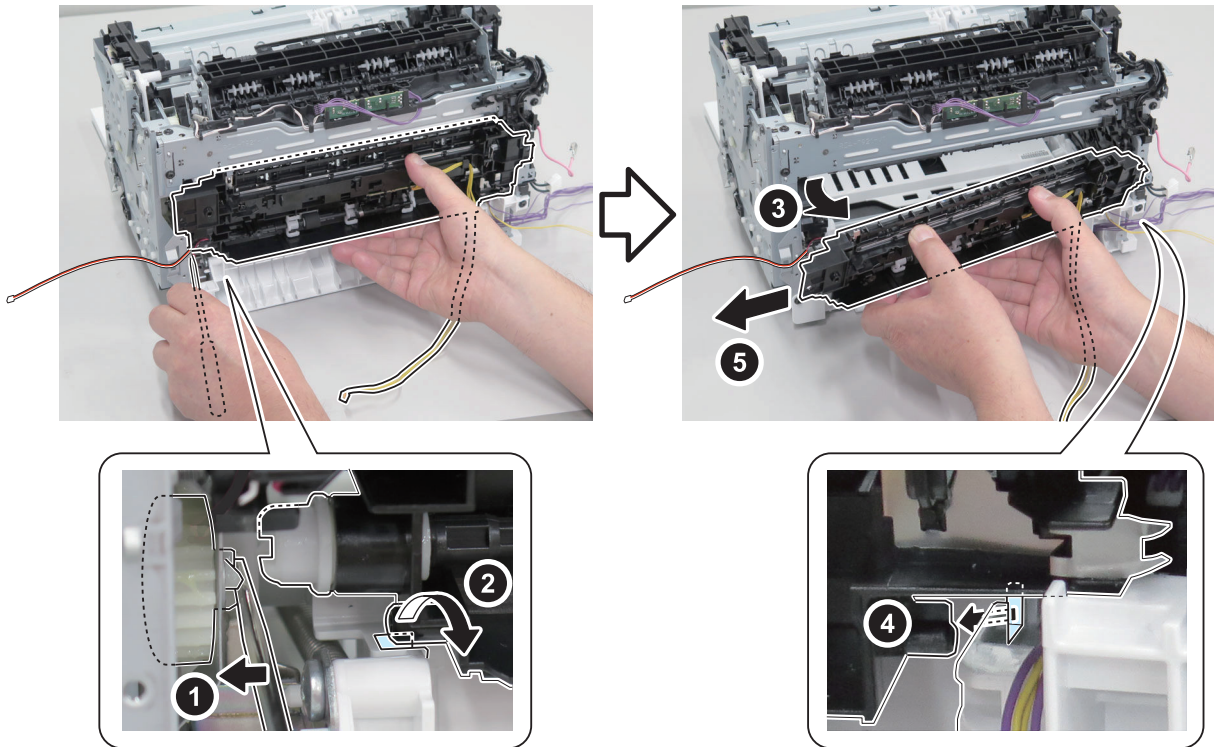

5.

NOTE:
When replacing the Transfer Unit, be sure to remove the Pickup Sensor PCB.

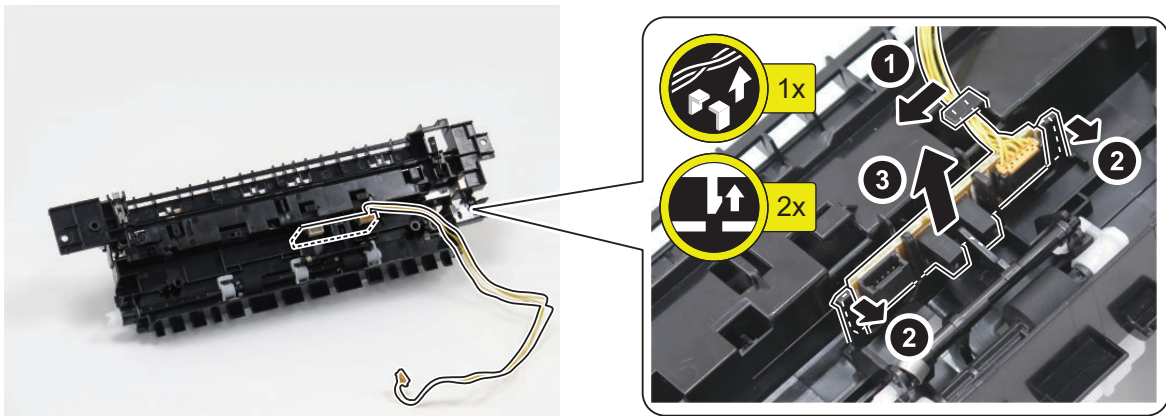

CAUTION:

Points to Note When Installing the Transfer Unit

- Insert the shaft into the Shaft Support by aligning the Contact Spring with the Grounding Plate.

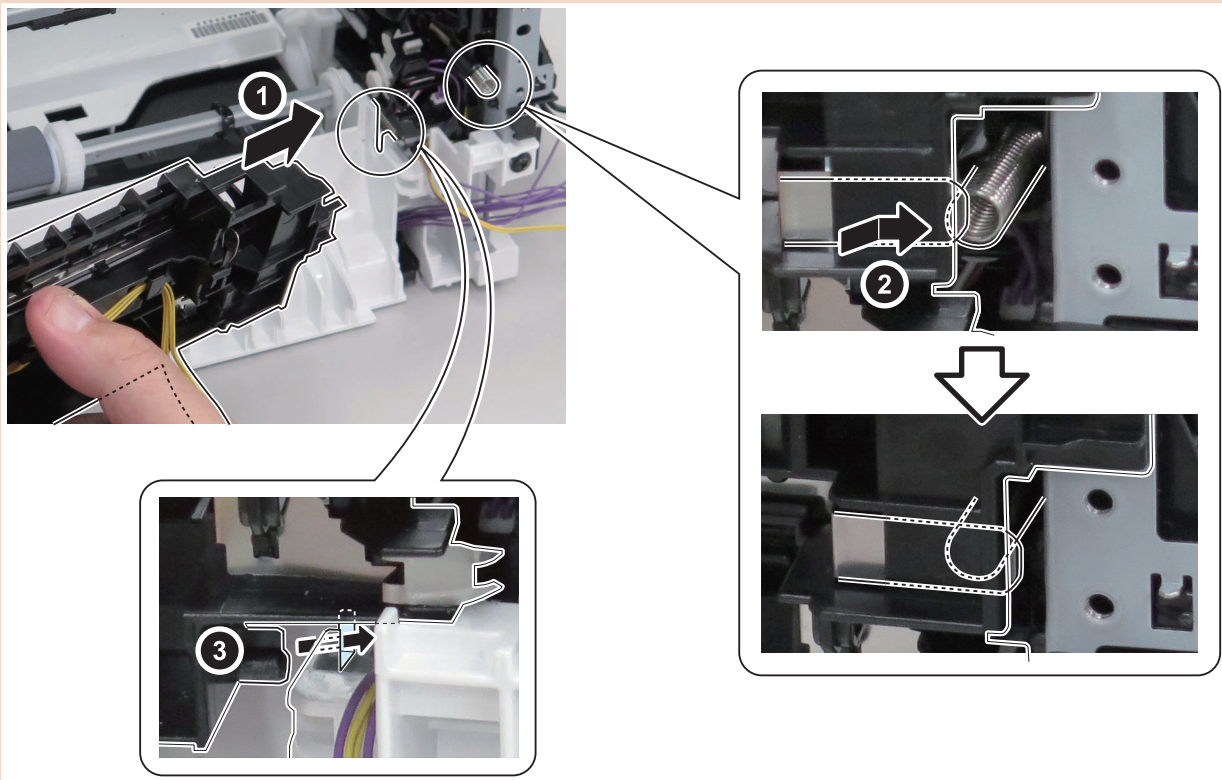

- Be careful not to let the Contact Spring come off from the Grounding Plate.

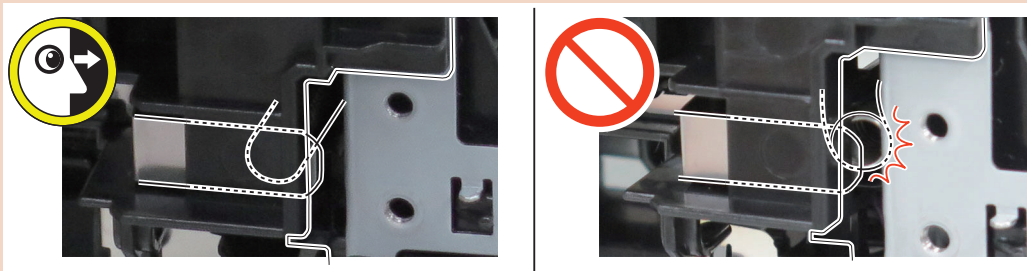

- The following shows the correct procedure for routing the TAG harness.

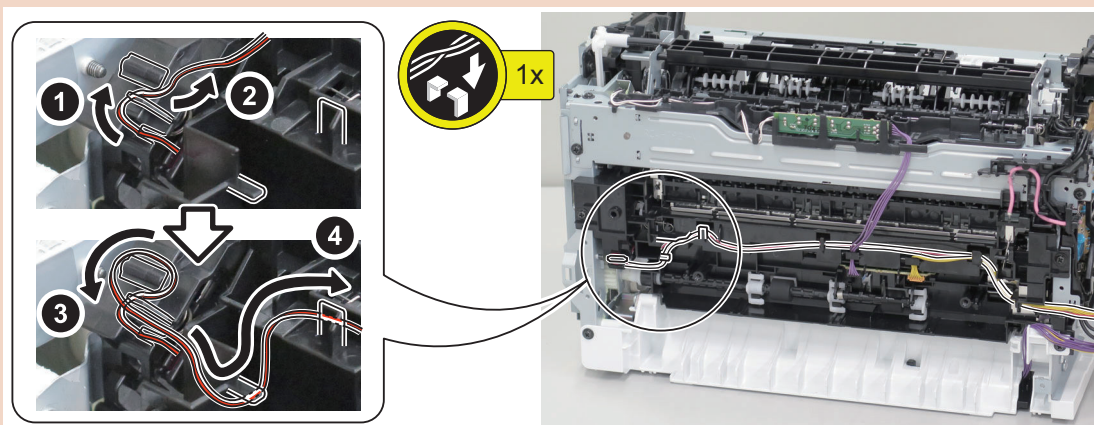

● Removing the Developing Disengagement Solenoid

■ Preparation

1. "Removing the Cartridge" on page 43
2. "Removing the Right Cover" on page 44
3. "Removing the Left Cover" on page 45
4. "Removing the Cartridge Door Unit" on page 47
5. "Removing the Upper Front Cover" on page 51
6. "Removing the Front Cover" on page 53
7. "Removing the Main Fan" on page 66
8. "Removing the Laser Scanner Cover" on page 69

■ Procedure

1.

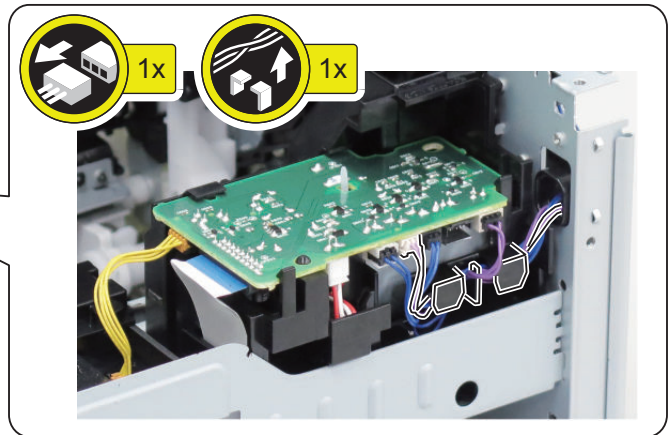
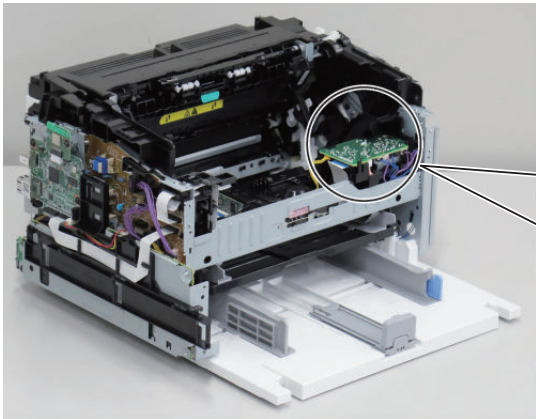

2.

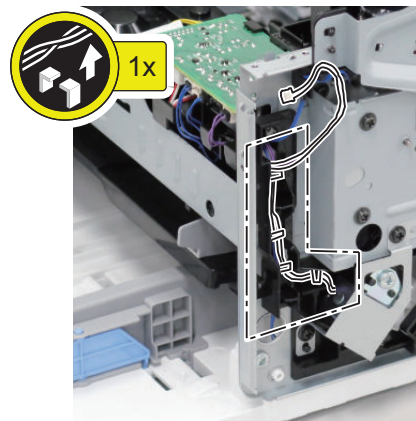
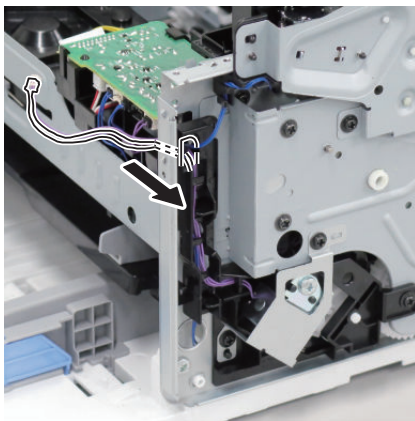

3.

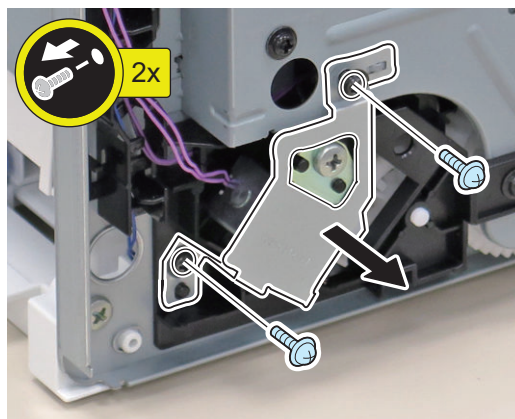

4.

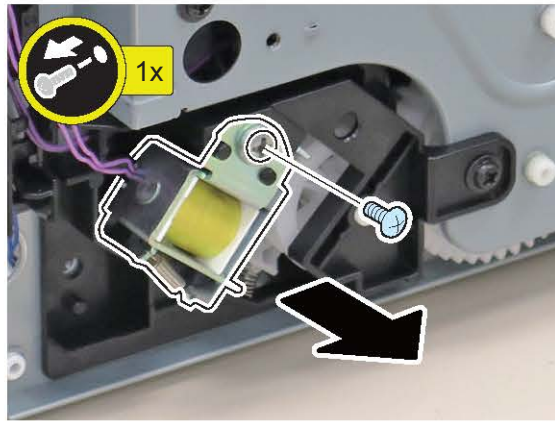

Fixing System

● Removing the Fixing Assembly

■ Preparation

1. "Removing the Cartridge" on page 43
2. "Removing the Right Cover" on page 44
3. "Removing the Left Cover" on page 45
4. "Removing the Cartridge Door Unit" on page 47
5. "Removing the Rear Upper Cover" on page 49
6. "Removing the Duplexing Door" on page 50
7. "Removing the Duplexing Frame Unit" on page 87
8. "Removing the Upper Front Cover" on page 51
9. "Removing the Front Cover" on page 53
10. "Removing the Low Voltage Power Supply Unit" on page 59
11. "Removing the Transfer Unit" on page 73

■ Procedure

1.

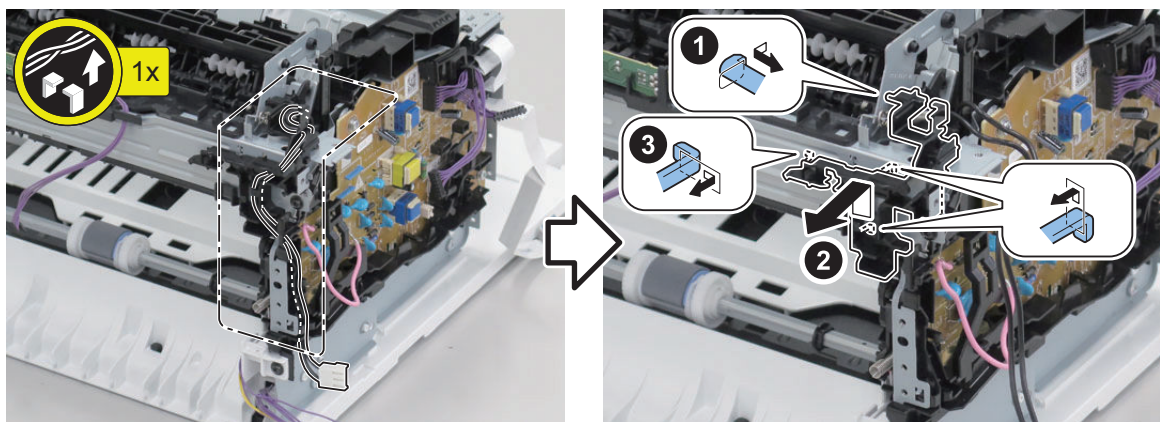

2.

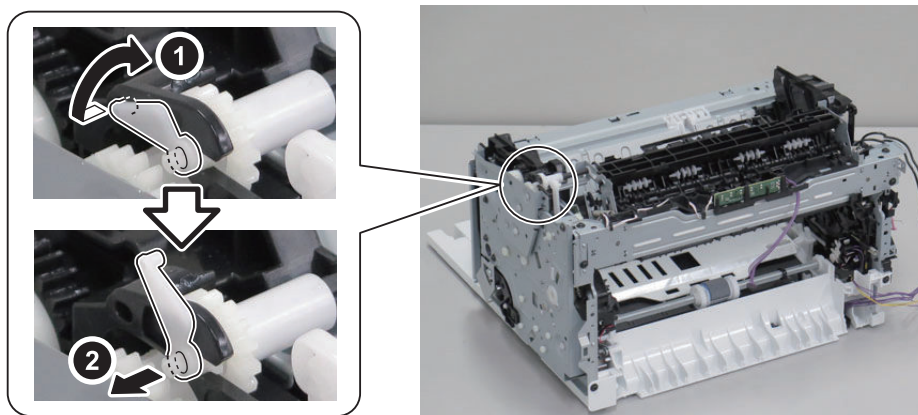

3.

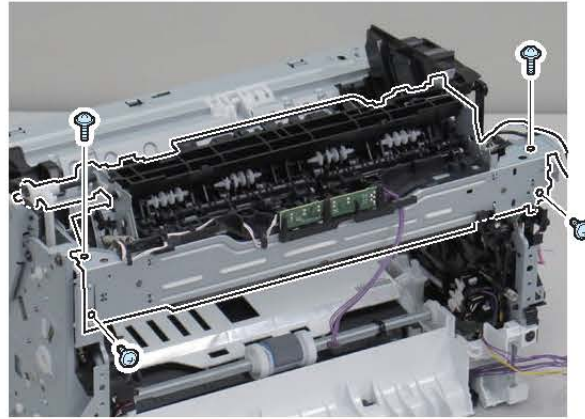

4.



5.

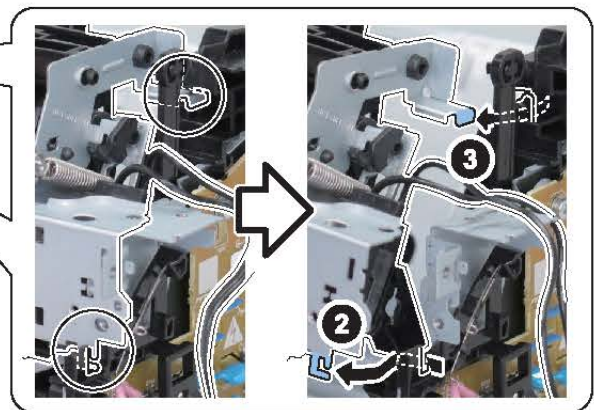
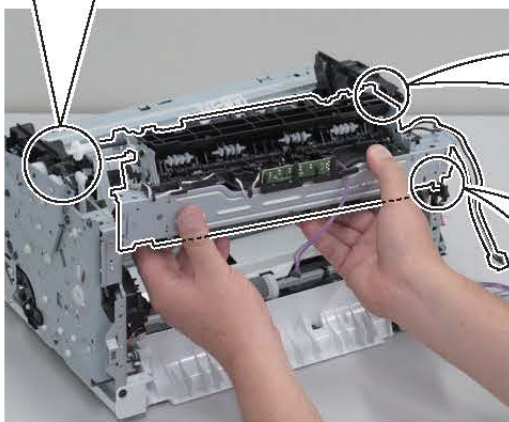
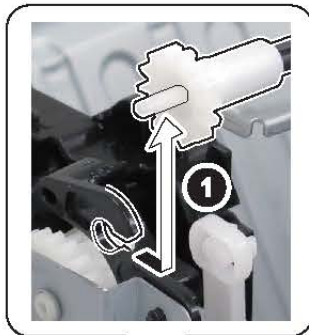

6.

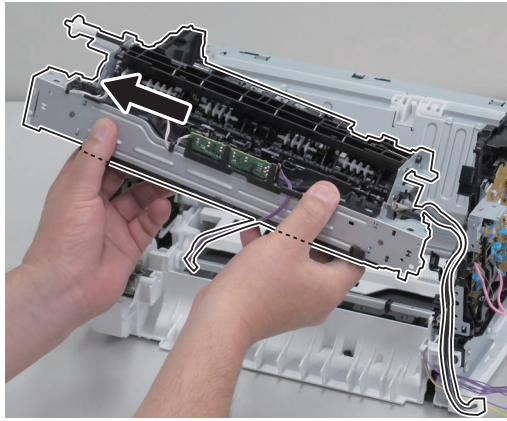

7.

NOTE:

When replacing the Fixing Assembly, be sure to remove the Delivery Sensor PCB.

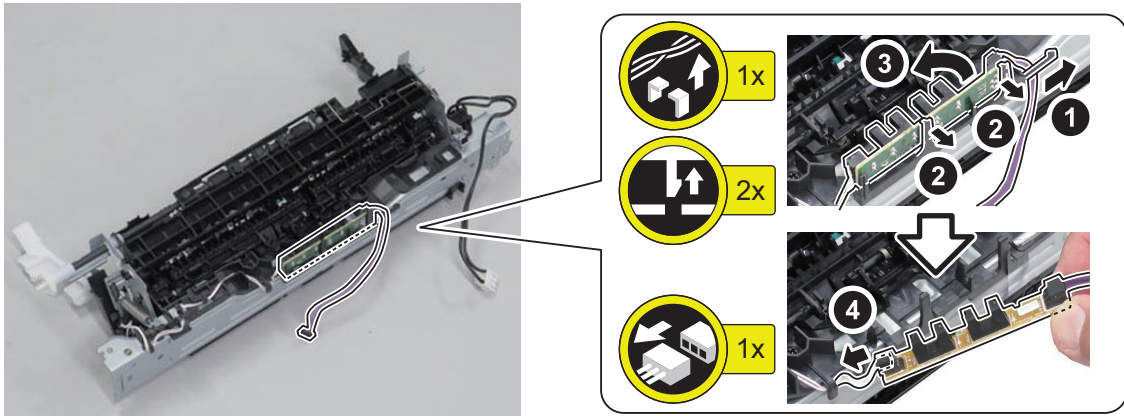

CAUTION:

Points to Note When Removing the Fixing Assembly

Be sure to handle the gear with care because it is not secured to the shaft.

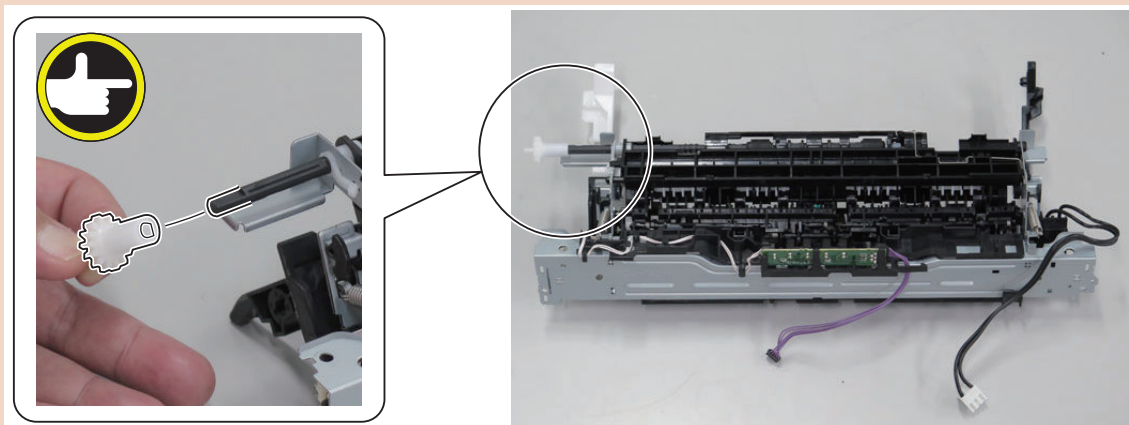

CAUTION:

Points to Note when Installing the Fixing Assembly

- Be sure to check the orientation of Fixing Shutter Link.

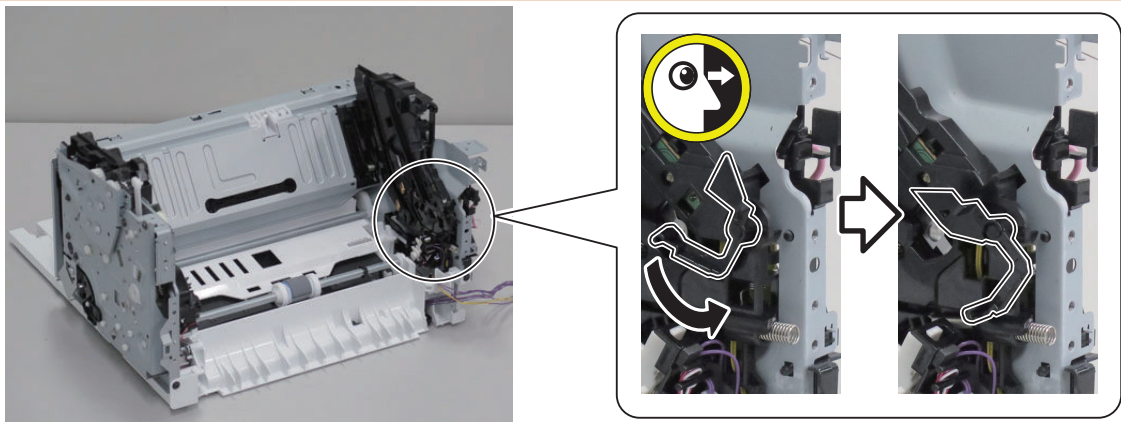

- Be sure that the Fixing Shutter Link is positioned as shown in the figure.

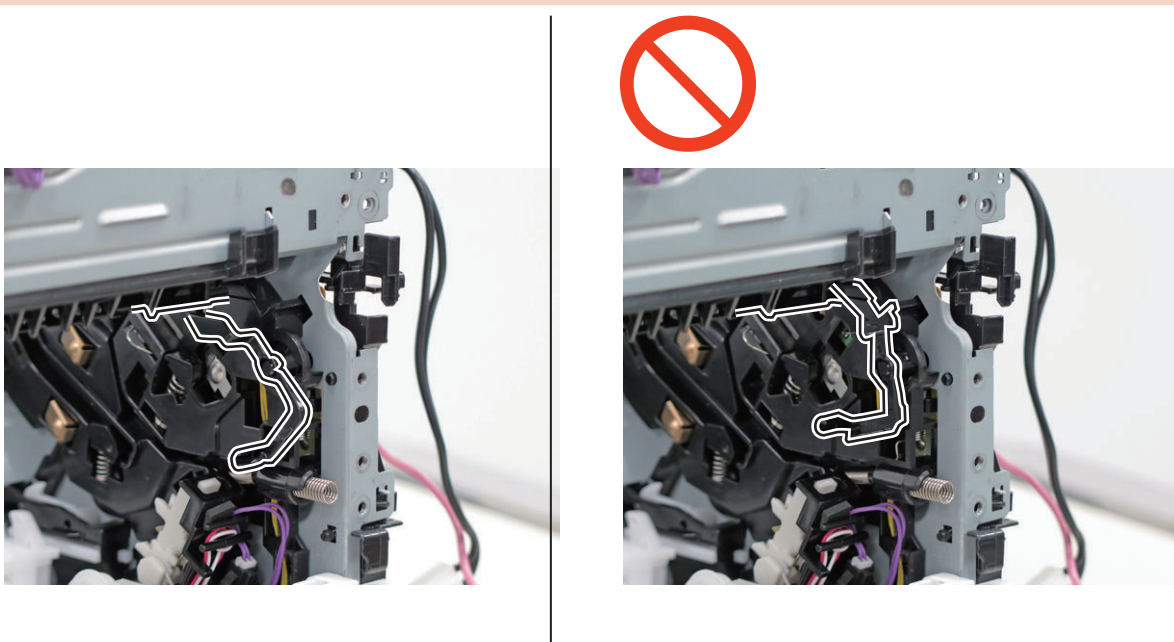

Removing the Fixing Film Unit

■ Preparation

1. “Removing the Cartridge” on page 43
2. “Removing the Right Cover” on page 44
3. “Removing the Left Cover” on page 45
4. “Removing the Cartridge Door Unit” on page 47
5. “Removing the Rear Upper Cover” on page 49
6. “Removing the Duplexing Door” on page 50
7. “Removing the Duplexing Frame Unit” on page 87
8. “Removing the Upper Front Cover” on page 51
9. “Removing the Front Cover” on page 53

- 10. "Removing the Low Voltage Power Supply Unit" on page 59
- 11. "Removing the Transfer Unit" on page 73
- 12. "Removing the Fixing Assembly" on page 79

■ Procedure

1.

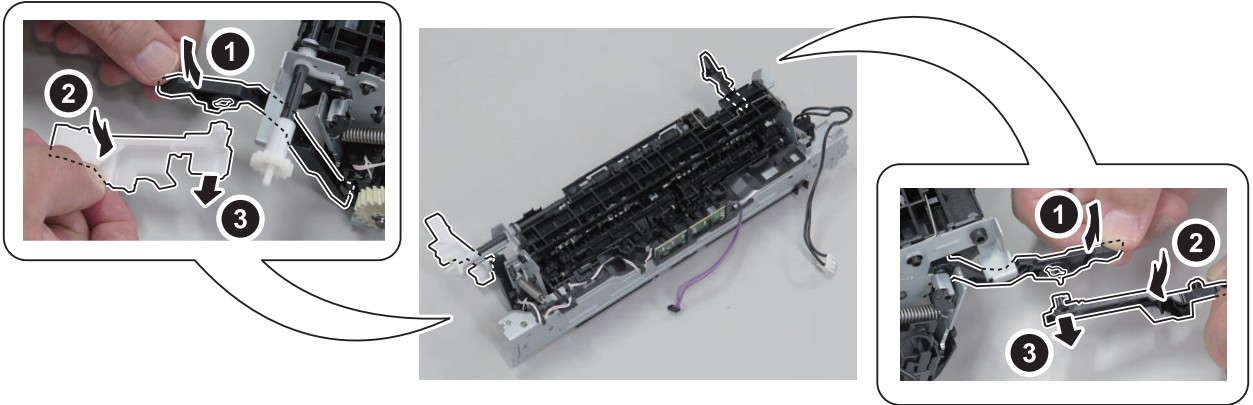

2.

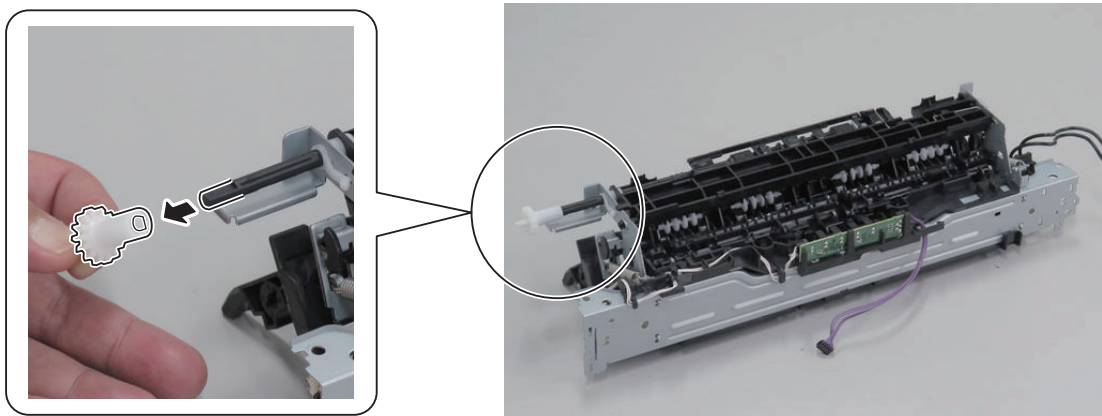

3.

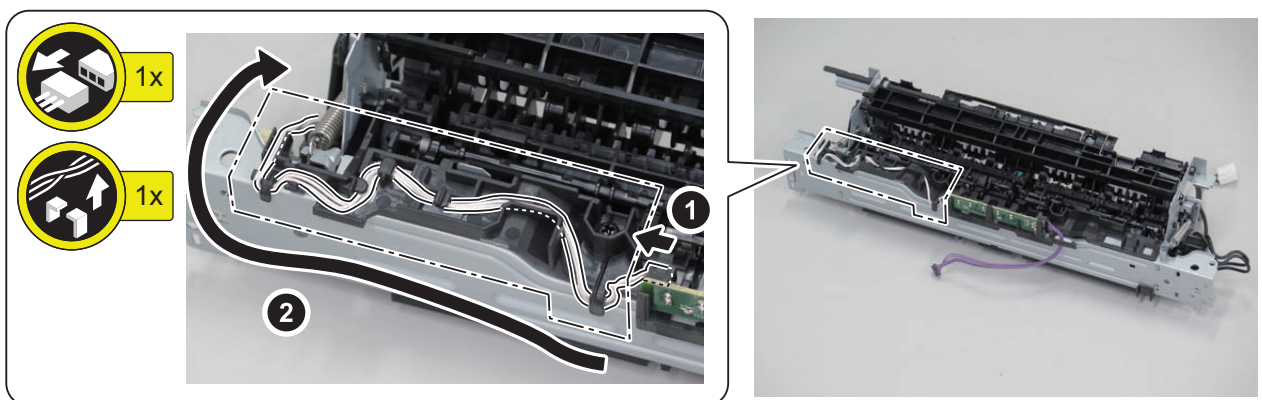

4.

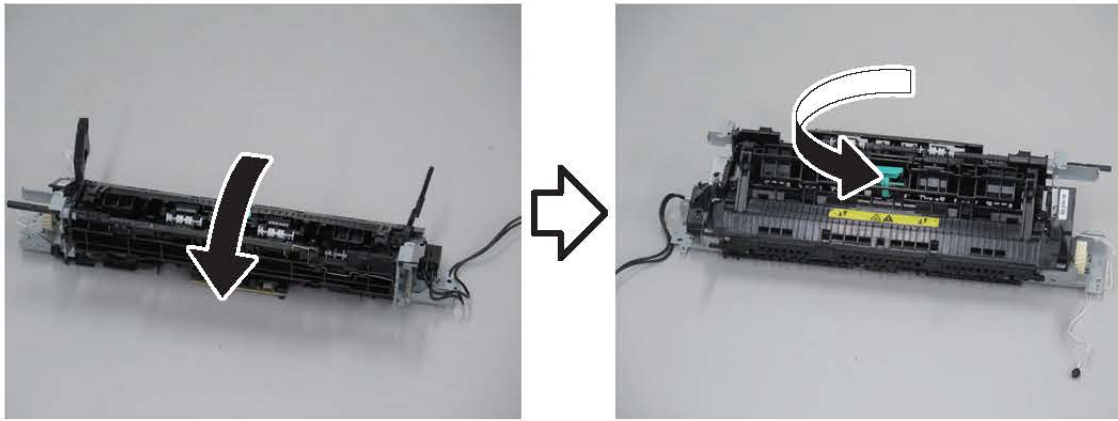

5.

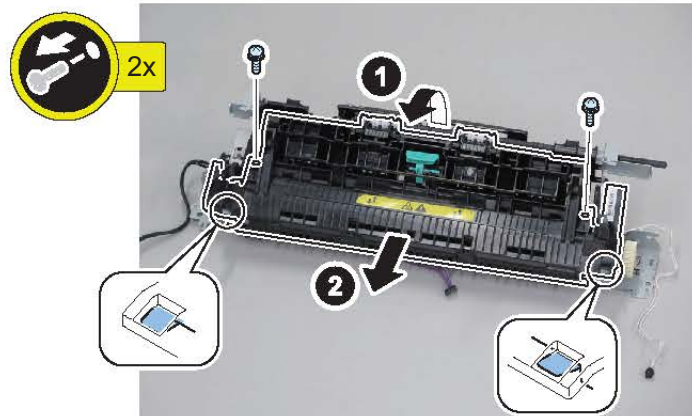

6.

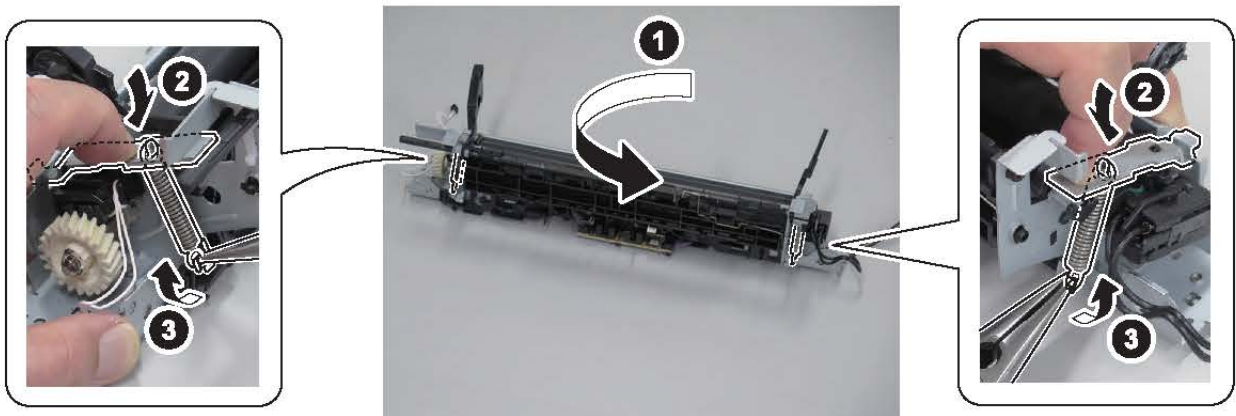

7.

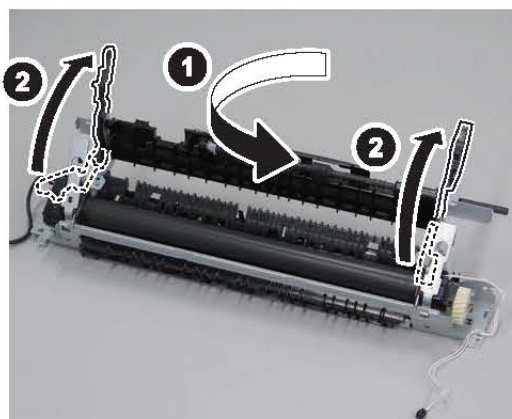

8.

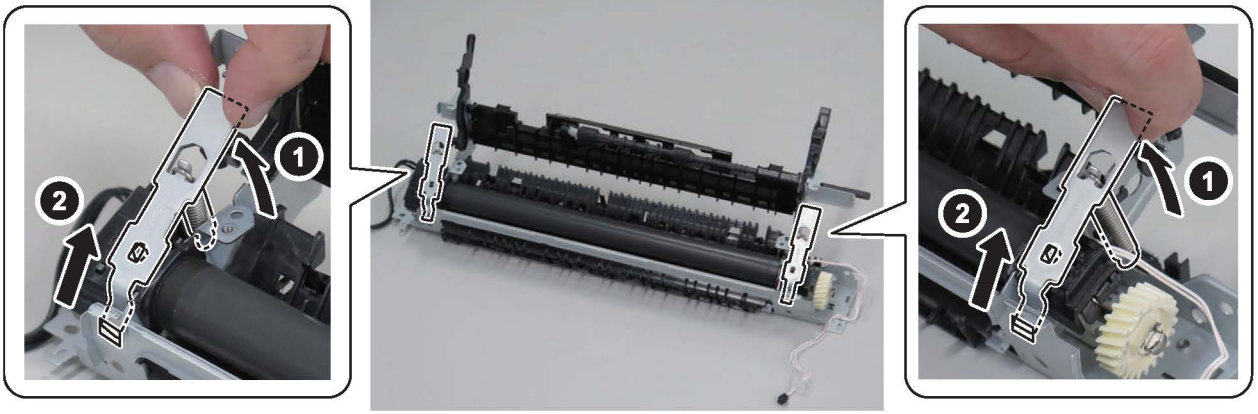

9.

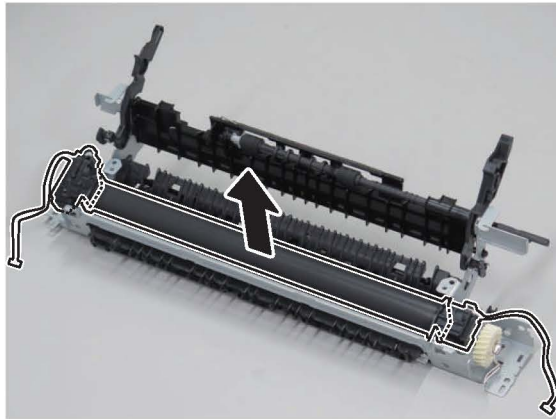

Pickup Feed Delivery System

● Removing the Pickup Roller

■ Preparation

1. “Removing the Cartridge” on page 43

■ Procedure

CAUTION:

Do not touch the surface of the roller with bare hands, as doing so will attach skin oil on it and decrease feedability.

1.



2.

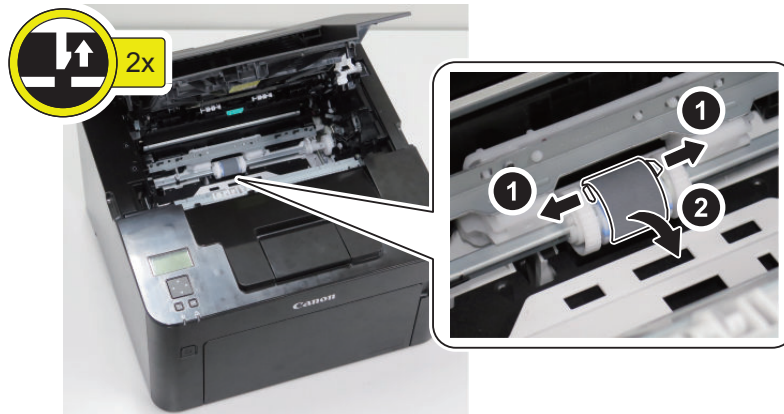

● Removing the Separation Pad Assembly

■ Preparation

1. “Removing the Cartridge” on page 43

■ Procedure

1.

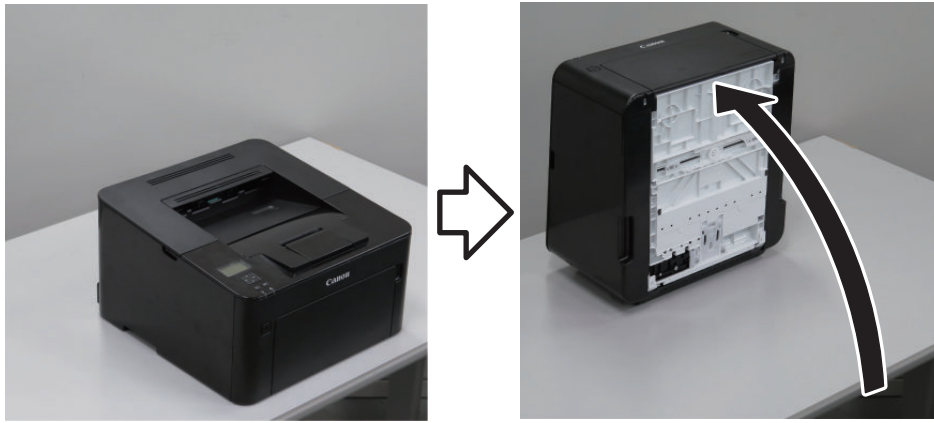

2.

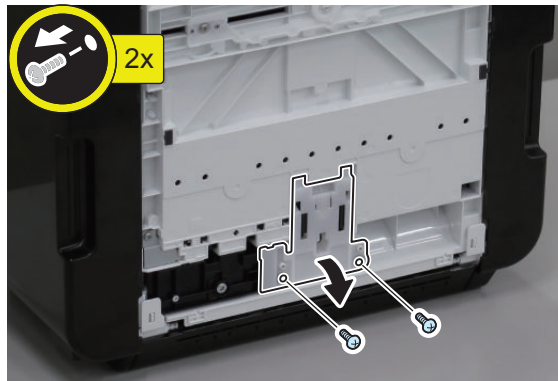

● Removing the Duplexing Frame Unit

■ Preparation

1. "Removing the Cartridge" on page 43
2. "Removing the Right Cover" on page 44
3. "Removing the Left Cover" on page 45
4. "Removing the Cartridge Door Unit" on page 47
5. "Removing the Rear Upper Cover" on page 49
6. "Removing the Duplexing Door" on page 50

■ Procedure

1.

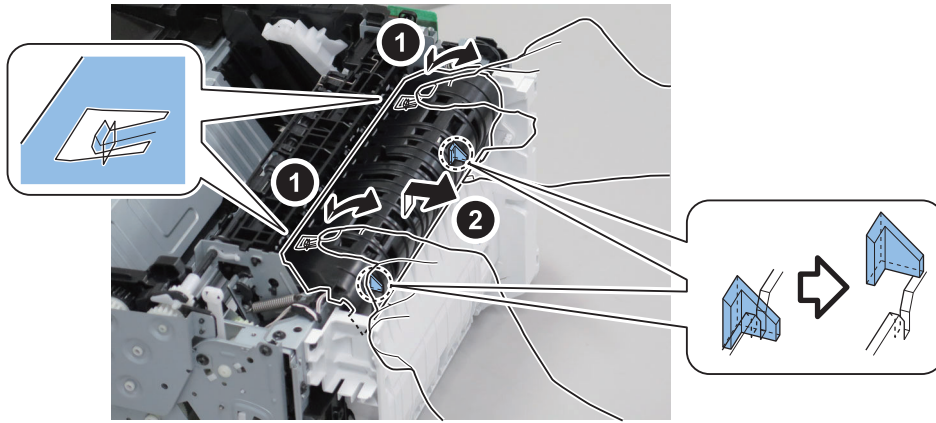

CAUTION:

Points to Note When Installing the Duplexing Reverse Guide

- Be sure that the 2 hooks are fitted in the grooves of the Duplexing Frame Unit.

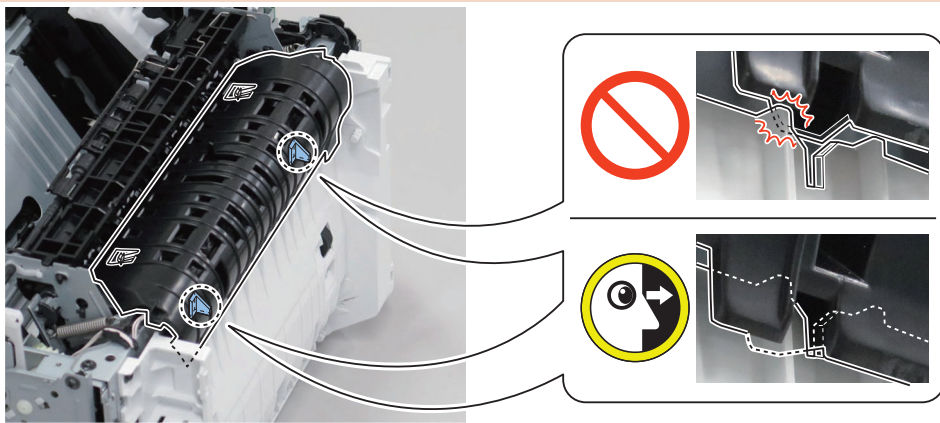

2.

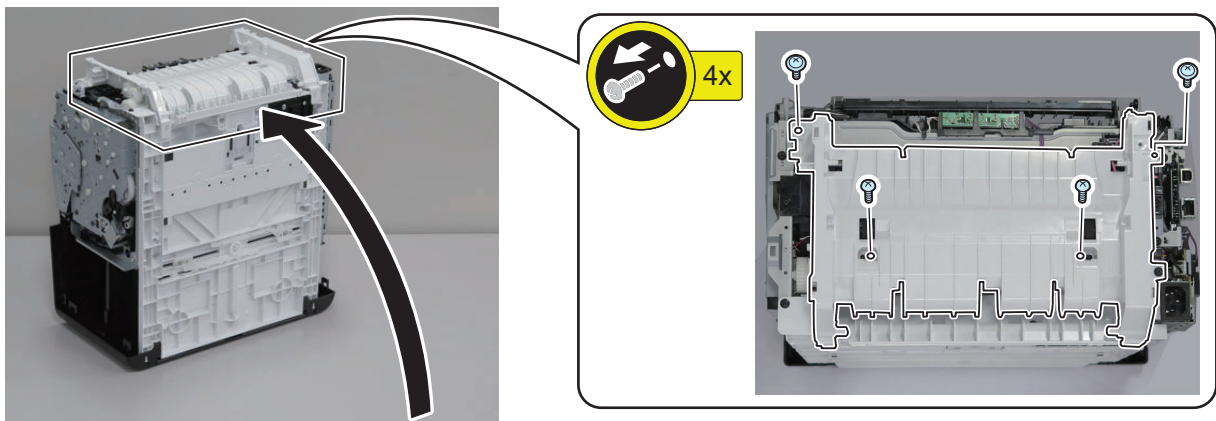

3.

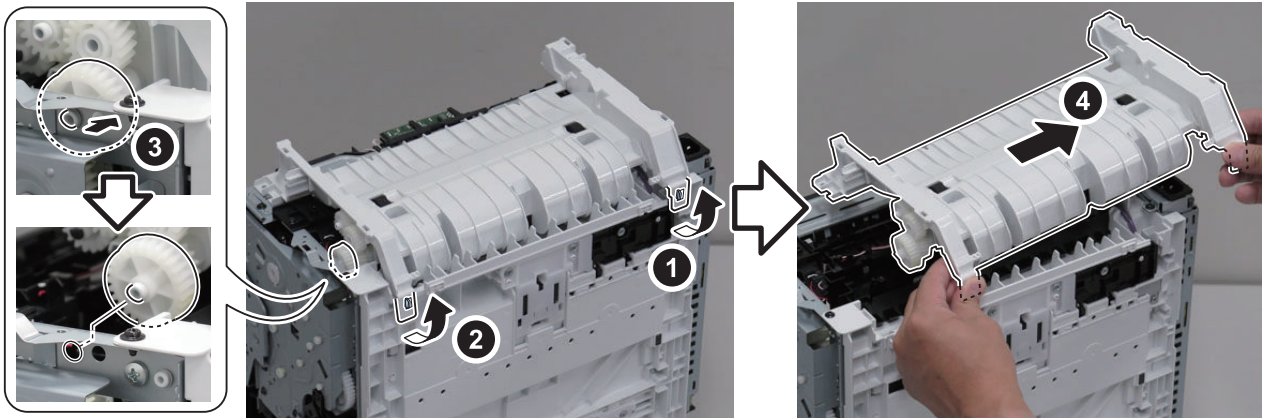
**NOTE:**

Return the host machine to its original position.

CAUTION:

Points to Note when Installing/Removing the Duplexing Frame Unit

- Be careful not to touch the grease on the gear.
- Be sure to handle the gear with care because it is not secured to the shaft.

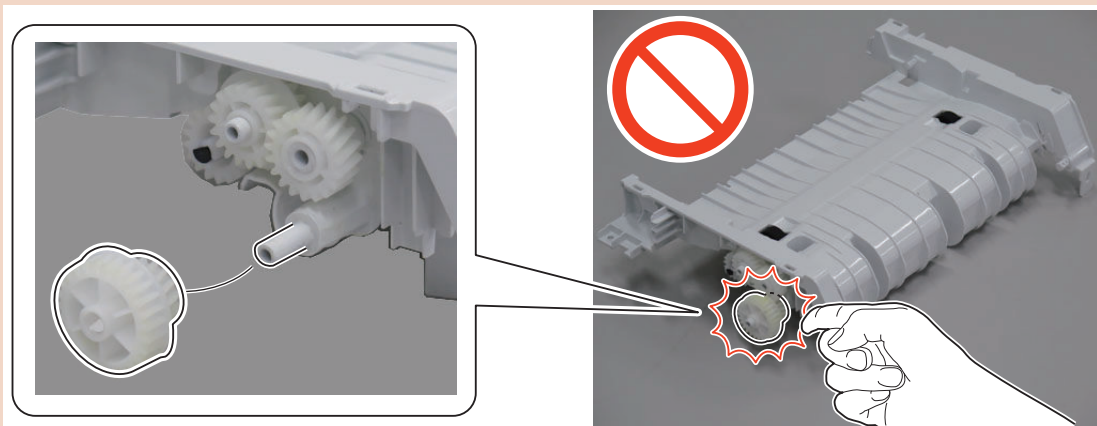

CAUTION:

Points to Note When Installing the Duplexing Frame Unit

- The following shows the correct procedure for routing the TAG harness.

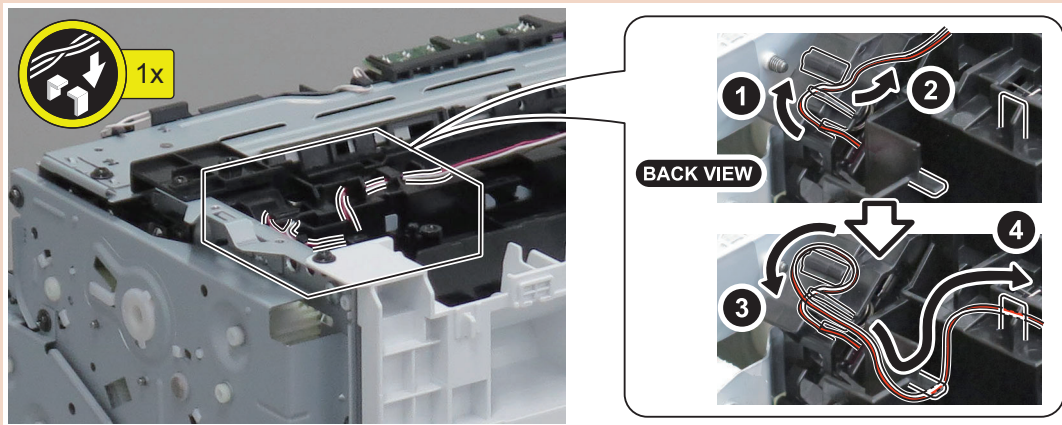

- Pass the harness through the guide to prevent the harness from interfering with the gear.

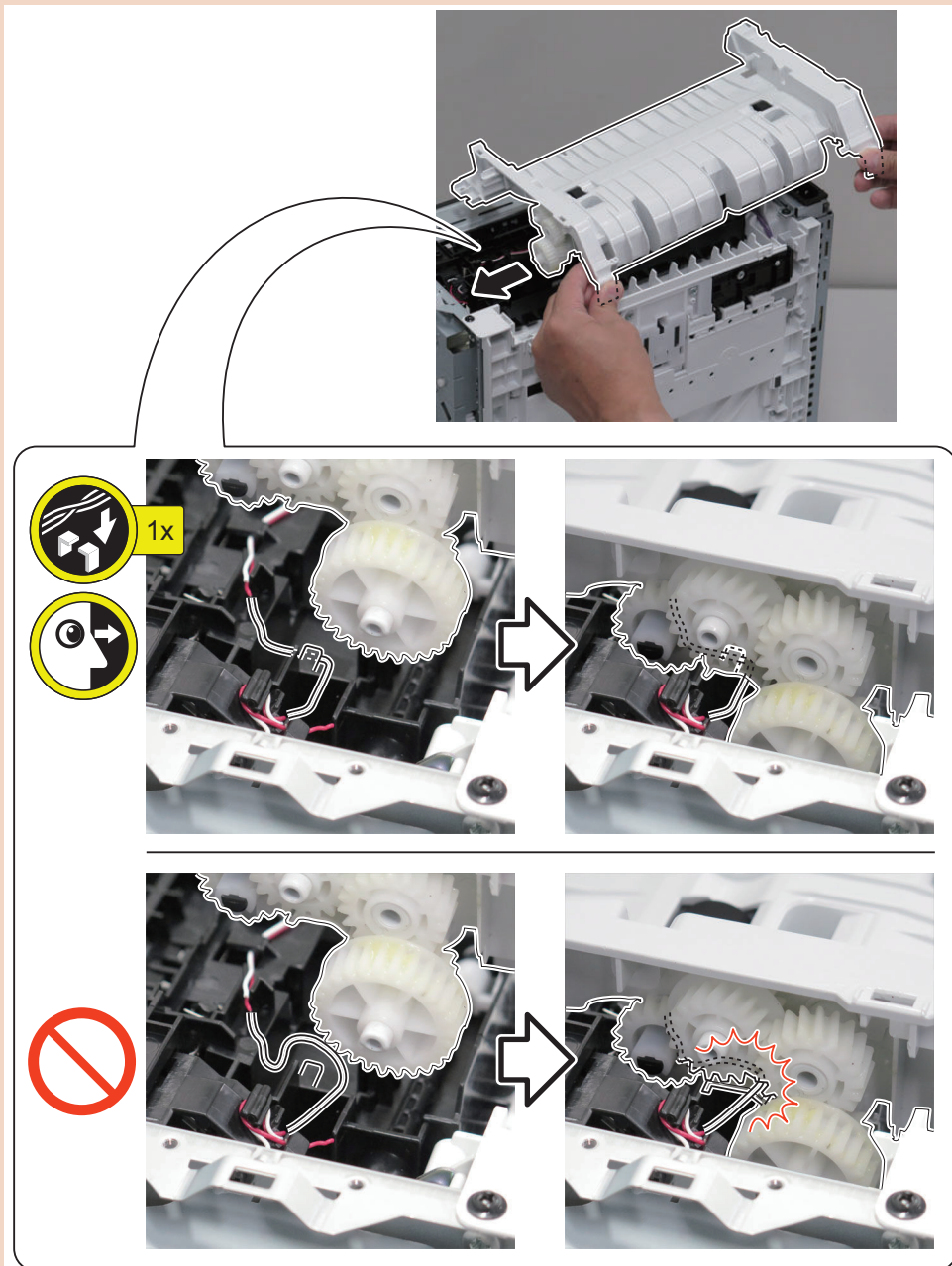

● Removing the Duplexing Reverse Unit

■ Preparation

1. “Removing the Cartridge” on page 43
2. “Removing the Right Cover” on page 44
3. “Removing the Left Cover” on page 45
4. “Removing the Cartridge Door Unit” on page 47
5. “Removing the Upper Front Cover” on page 51
6. “Removing the Front Cover” on page 53
7. “Removing the Main Fan” on page 66
8. “Removing the Laser Scanner Cover” on page 69

■ Procedure

1.

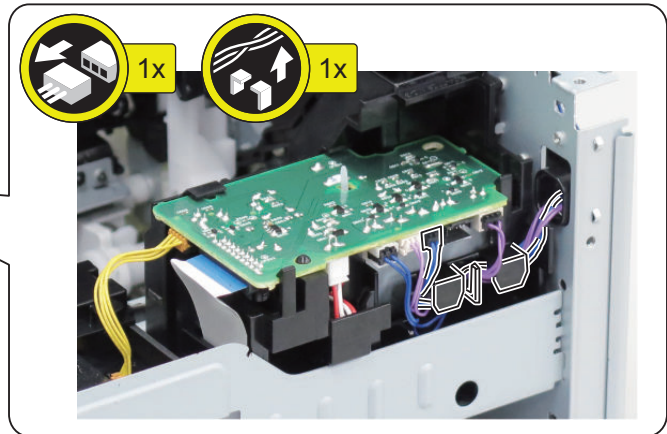
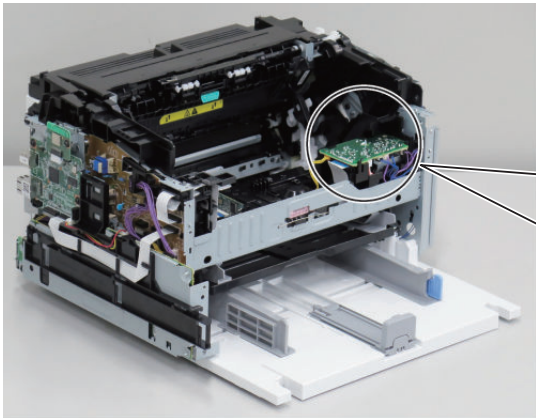

2.

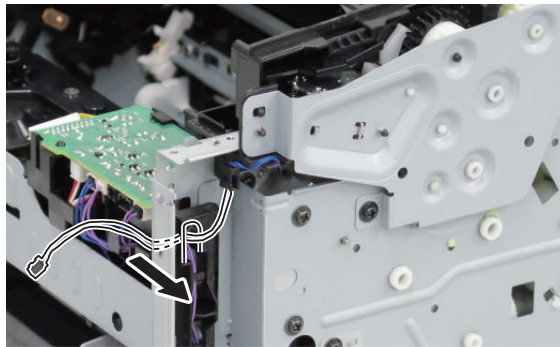

3.

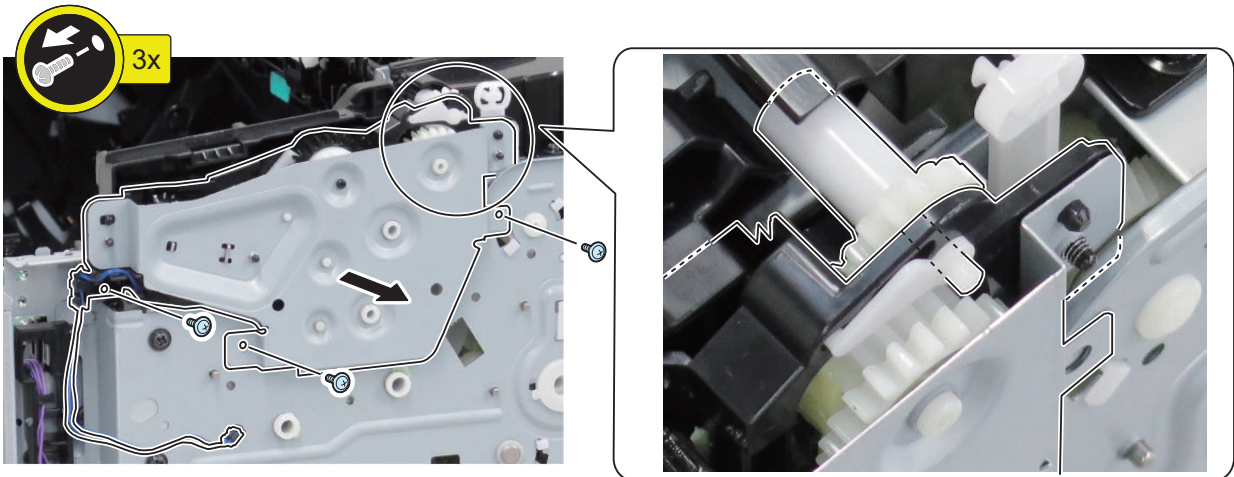
**CAUTION:**

Points to Note when Installing/Removing the Duplexing Reverse Unit

- Be sure to handle the gear with care because it is not secured to the shaft.

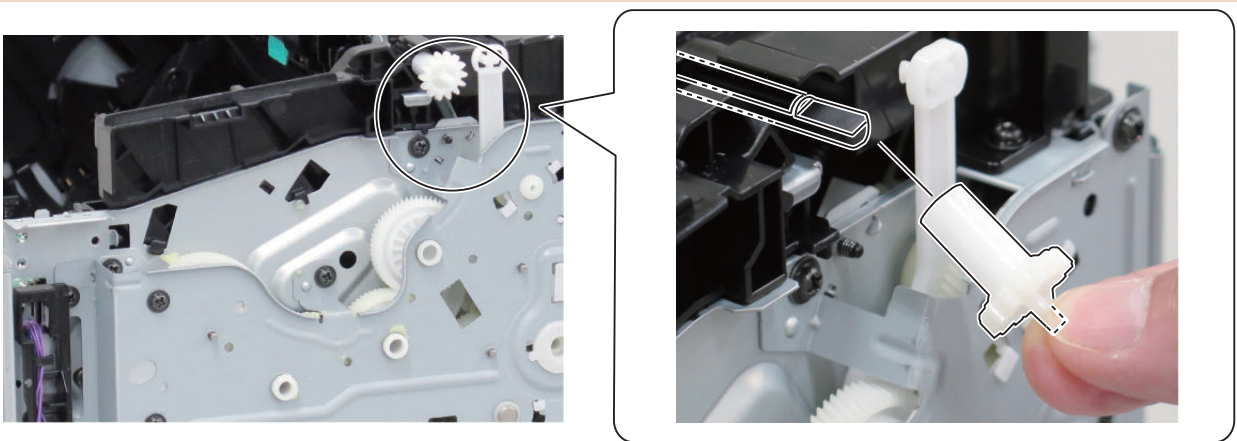

● Removing the Pickup Sensor PCB

■ Preparation

1. "Removing the Cartridge" on page 43
2. "Removing the Right Cover" on page 44
3. "Removing the Left Cover" on page 45
4. "Removing the Cartridge Door Unit" on page 47
5. "Removing the Rear Upper Cover" on page 49
6. "Removing the Duplexing Door" on page 50
7. "Removing the Duplexing Frame Unit" on page 87

■ Procedure

1.

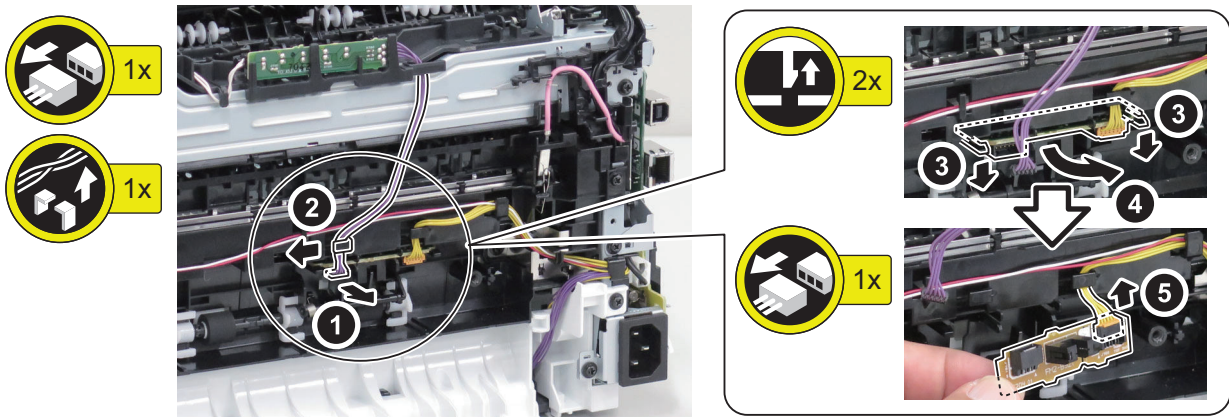

● Removing the Delivery Sensor PCB

■ Preparation

1. "Removing the Cartridge" on page 43
2. "Removing the Right Cover" on page 44
3. "Removing the Left Cover" on page 45
4. "Removing the Cartridge Door Unit" on page 47
5. "Removing the Rear Upper Cover" on page 49
6. "Removing the Duplexing Door" on page 50
7. "Removing the Duplexing Frame Unit" on page 87

■ Procedure

1.

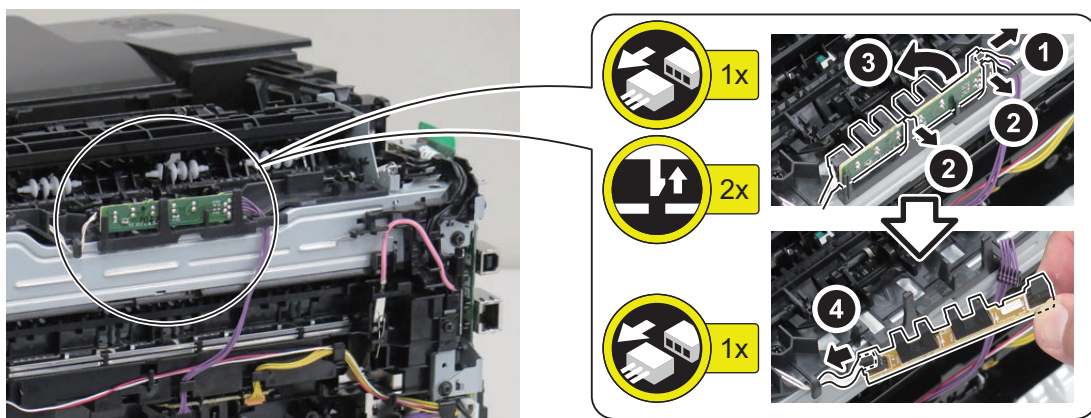



Adjustment

Adjustment at Parts Replacement..... 95

Adjustment at Parts Replacement

Main Controller PCB

Actions before Parts Replacement

1. Output the spec report from the service mode shown below and the user data list from the LUI, and write down the serial number information.
 - COPIER > FUNCTION > MISC-P > OUTPUT > SPEC
 - [Menu] > [Output Reports] > [User Data List]
2. Write down the character string shown in the following item on the Control Panel.
 - [System Management Settings] > [Device Information Settings] > [Location]

Actions after Parts Replacement

1. On the LUI, enter the serial number you wrote down before replacement of the part in the item shown below (10 alphanumeric characters).
 - [System Management Settings] > [Device Information Settings] > [Location]
2. Execute the service mode shown below to write the serial number to the controller.
 - COPIER > OPTION > SERIAL > SN-MAIN
3. Turn OFF and then ON the main power of the host machine.
4. - Set the location in the following service mode.
Location information setting
[Setting value]
1: Japan, 2: North America, 3: Korea, 4: China, 5: Taiwan, 6: Europe, 7: Asia
 - COPIER > OPTION > BODY > LOCALE
5. In the following service mode, select "ALL" to clear the data.
 - COPIER > FUNCTION > CLEAR > ALL
6. Turn OFF and then ON the main power of the host machine.
7. Execute the following service mode to output the spec report, and check the serial number and the location.
 - COPIER > FUNCTION > MISC-P > OUTPUT > SPEC
8. In the following menu, enter the character string of [Location] you wrote down before replacing the PCB.
 - [System Management Settings] > [Device Information Settings] > [Location]



Troubleshooting

Test Print.....	97
Troubleshooting Items.....	101
Debug Log.....	110
Version Upgrade.....	113

Test Print

Engine Test Print

This machine has an engine test print function to check whether the printer engine is operating normally.

NOTE:

In the case of engine test print, a test print can be performed by using only the Engine Controller.

CAUTION:

When performing an engine test print, use A4/LTR size paper.

1. Load A4/LTR paper in the paper drawer.
2. Open/close the cartridge door four times within 5 seconds and the one simplex page is printed. Open/close the cartridge door five times or more within 5 seconds and the one duplex page is printed.
3. An engine test print is executed, and the test pattern as shown below is printed.

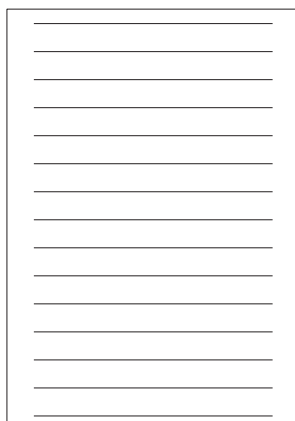

Report Print List

Item	Place	Remarks
COUNTER REPORT	COPIER > FUNCTION > MISC-P > OUTPUT > CNTR	POutput the PRINT and JAM counters.
JAM/ERR HISTORY RE-PORT	COPIER > FUNCTION > MISC-P > OUTPUT > ERR-LOG	Output the jam log, error (error code) log, and alarm log.
SPEC REPORT	COPIER > FUNCTION > MISC-P > OUTPUT > SPEC	Output the current machine specifications (country, model information, ROM version, etc.).
Cartridge Log Report	COPIER > FUNCTION > MISC-P > OUTPUT > CRG-LOG	Output the toner/drum cartridge log information (serial number, remaining level, installed hours, etc.) stored in an equipment that outputs the detailed toner/drum cartridge log print.

Cartridge Log Report

Paper size that can output the Cartridge Lot Report is A4 or LTR

Serial Number : NMHA000020

Cartridge : Toner Cartridge or Drum Cartridge

(1)Serial No. (2)Type (3)Cpcty. (4)First Used
(6)Last Used

(a)Pg.Count (5)Left (b)Toner (c)Drum (d)Parts
(e)Pg.Count (7)Left (f)Toner (g)Drum (h)Parts

```

*****
*** Cartridge Log Report ***
*****
Cartridge : Toner Cartridge
Serial Number : NMHA000020
(1)Serial No. (2)Type (3)Cpcty. (4)First Used (a)Pg.Count (5)Left (b)Toner (c)Drum (d)Parts
(6)Last Used (e)Pg.Count (7)Left (f)Toner (g)Drum (h)Parts
1703100000 C5 Unknown 2017 07/13 11:44 0000004 -% -% -% -%
00000000 C1 Unknown 2009 01/01 00:00 0000007 -% -% -% -%
1703100001 C1 Unknown 2017 08/21 10:40 0000000 100% 100% -% -100%
2552310020 2017 08/29 12:18 0000114 90% 84% -% 90%

Use of counterfeit/non-Canon cartridges
is not covered by the warranty.
C4:0000 0000000000 C5:0004 0000000004
C8:0000 0000000000
  
```

Replacement logs

Cartridge type: Number of defections of non-genuine cartridge
Page count of non-genuine cartridge

```

C4:0000 0000000000 C5:0004 0000000004
C8:0000 0000000000
  
```

Output method

CAUTION:

Points to note when using service mode CRG-LOG:

- Cartridge Log Report (for service)
SERVICE MODE > COPIER > FUNCTION > MISC-P > CRG-LOG

NOTE:

- Paper size that can output the Cartridge Lot Report is A4 or LTR.

⚠ CAUTION:

Points to note when using service mode CRG-LOG: CRG-LOG has two types of functions. Note that the function differs depending on the service mode layer in which CRG-LOG is displayed.

- COPIER > FUNCTION > CLEAR > CRG-LOG (Clear the cartridge log)
- COPIER > FUNCTION > MISC-P > CRG-LOG (Output the toner/drum cartridge log information (serial number, remaining level, installed hours, etc.) stored in an equipment that outputs the detailed toner/drum cartridge log print.)

Do not provide users with the cartridge log print for service technicians because it contains detailed information that are not disclosed to end users.

Cartridge Log Report

CAUTION:

The record of replacement and usage of cartridges will be printed. Just after the cartridge has been replaced with a genuine cartridge or when a non-genuine cartridge is used, accurate information cannot be obtained and a random or approximate value may be printed. The remaining lives of some of the parts are not supported depending on the model.

No.	Description	Remarks	
(1)	Serial number of the cartridge		
(2)	Type	Menu > Output Reports > Cartridge Log Report <ul style="list-style-type: none"> • C1 : genuine • C3 : OEM • C2 : Communication error • C2 : Authentication failed 	COPIER > FUNCTION > MISC-P > OUTPUT > CRGLOG <ul style="list-style-type: none"> • C1 : genuine • C5 : OEM • C4 : Communication error • C8 : Authentication failed
(3)	Cartridge capacity	Indication depending on toner filling capacity	
(4)	Date and time first used	Date and time first used	
(a)	Page count at the time of the setting	0000000~9999999	
(5)	The remaining life of the cartridge when it was installed	0~100% (New:100%)	
(b)	The remaining life of the toner when it was installed	0~100% (New:100%,No value:-%)	
(c)	The remaining life of the drum when it was installed	-127~100% (New:100%,No value:-%)	
(d)	The remaining life of the Developing Assembly when it was installed	-127~100% (New:100%,No value:-%)	
(6)	Date and time last used		
(e)	Page count at last usage	0000000~9999999	
(7)	The remaining life of the cartridge when it was last used	0~100% (New:100%)	
(f)	The remaining life of the toner when it was last used	-127~100% (New:100%,No value:-%)	
(g)	The remaining life of the drum when it was last used	-127~100% (New:100%,No value:-%)	
(h)	The remaining life of the Developing Assembly when it was last used	-127~100% (New:100%,No value:-%)	

Cartridge Type

When a cartridge cannot be recognized as a genuine one, it is classified as a cartridge type C2 to C8, and the number of detections of each type and the number of pages printed with the cartridge installed are recorded.

Judgment classification	Cartridge Type		Description
	Report for the user	Report for the Service	
OEM	C3	C5	The number of detections of an OEM cartridge, and the number of pages printed
Communication error	C2	C4	The number of detections of a cartridge without memory and the number of pages printed
Authentication failed	C2	C8	The number of detections of a cartridge that cannot be authenticated, and the number of pages printed

NOTE:

The number of detections of non-genuine cartridge and the page count of non-genuine cartridge can be reset.

- SERVICE MODE > COPIER > FUNCTION > CLEAR > CRG-LOG

⚠ CAUTION:

Points to note when using service mode CRG-LOG: CRG-LOG has two types of functions. Note that the function differs depending on the service mode layer in which CRG-LOG is displayed.

- COPIER > FUNCTION > CLEAR > CRG-LOG (Clear the cartridge log)
- COPIER > FUNCTION > MISC-P > CRG-LOG (Output the toner/drum cartridge log information (serial number, remaining level, installed hours, etc.) stored in an equipment that outputs the detailed toner/drum cartridge log print.)

NOTE:

In addition to output as a log print, the cartridge log can be displayed on the remote UI screen.

- To display cartridge logs (for users)
Status Monitor/Cancel: Cartridge Log

Troubleshooting Items

Recurring faulty image

Overview

Foreign matters or lines on rollers along the paper feed path may cause faulty images in the vertical scanning direction.

Field Remedy

See the roller pitches listed in the tables below to clean and/or replace the corresponding parts.

CAUTION:

Since the Primary Charging Roller, Photosensitive Drum, and Developing Roller are located inside the cartridge and they cannot be cleaned on a single part basis, replace the cartridge itself.

Roller pitch	Parts	Symptom			
		Soiling	White spots	Soiled back	Fixing failure
Approx. 39 mm	Transfer Roller	-	Occurs	Occurs	-
Approx. 28 mm	Primary Charging Roller	Occurs	Occurs	-	-
Approx. 63 mm	Photosensitive Drum	Occurs	Occurs	-	-
Approx. 26 mm	Developing Roller	Occurs	Occurs	-	-
Approx. 57 mm	Fixing Film	Occurs	Occurs	-	Occurs
Approx. 45 mm	Pressure Roller	Occurs	-	Occurs	Occurs

Confirming nip width

Overview

Although the nip width of the Fixing Assembly cannot be adjusted with this machine, it can be checked.

By checking the nip width when fixing failure occurs, it is possible to judge whether there is a problem with the Fixing Assembly.

Field Remedy

Check the nip width of the Fixing Assembly by the following procedure.

1. **Print a solid black image on a A4/LTR size paper using the cartridge same as that used with this machine and bring it to the customer site.**
2. **Load the solid black printed paper with its printed side facing down on the Multi-purpose Tray of the machine.**
3. **Execute the engine test print.(Refer to“[Engine Test Print](#)” on page 97)**
4. **When the leading edge of the printed paper comes out from the face-down delivery outlet, turn OFF the power.**
5. **Open the Cartridge Door approx. 60 seconds after the power is turned OFF, and pull out the printed paper from the machine.**

6. Measure the widths of the glossy part of the toner on the printed paper, and check that they are within the range as follows.

- Center (a): 5.8 ± 0.8 mm
- Edge (b) and (c): 5.8 ± 0.8 mm each

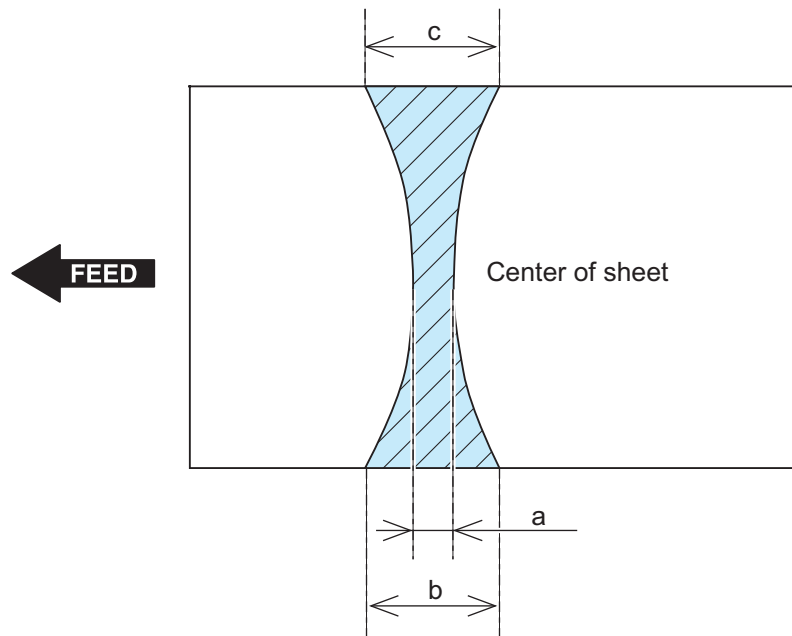

Remedy for Image Failure

When an image failure occurs, perform the remedy by referring to the following material.

- User's Guide > Top > Troubleshooting > When You Cannot Print Properly

NOTE:

URL of User's Guide -> <http://canon.com/oip-manual>

Light print



Print is light on entire page.

Cause	Solution
1) Poor contact exists between the transfer rollercontact and the transfer roller shaft.	Clean the contacts. If the problem remains after cleaning, check the contacts for deformation or damage. Replace any defective parts.

Dark print



Image is too dark.

Cause	Solution
1) Poor contact exists between the drum grounding contact and the cartridge.	Clean the grounding contacts. If the problem remains after cleaning, check the contacts for deformation or damage. Replace any defective parts.
2) Poor contact exists between the primary charging bias contact and the cartridge.	Clean the contacts. If the problem remains after cleaning, check the contacts for deformation or damage. Replace any defective parts.

Completely blank

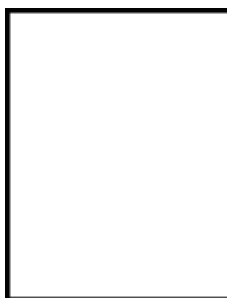

Page is blank.

Cause	Solution
1) Poor contact exists between the developing bias contact and the cartridge.	Clean the grounding contacts. If the problem remains after cleaning, check the contacts for deformation or damage. Replace any defective parts.
2) The high-voltage power supply is defective (no developing bias output).	Replace the engine controller PCA.

All black

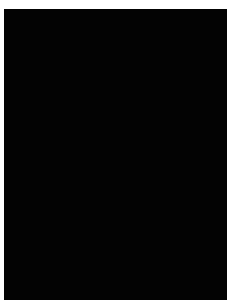

The page is all black

Cause	Solution
1) Poor contact exists between the primary charging bias contact and the cartridge.	Clean the contacts. If the problem remains after cleaning, check the contacts for deformation or damage. Replace any defective parts.
2) The primary charging roller is defective.	Replace the Drum cartridge.

White spots

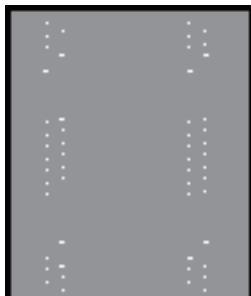

White spots appear on the page.

Cause	Solution
1) The static charge eliminator is dirty.	Clean the static charge eliminator.
2) The static charge eliminator is deformed.	Replace the transfer ass'y.
3) Poor contact exists the static charge eliminator.	Clean the contact. If the problem remains after cleaning, check the contact for deformation or damage. Replace any defective parts.
4) The transfer roller is deformed or has deteriorated.	Replace the transfer roller.
5) Poor contact exists between the transfer roller contact and the transfer roller shaft.	Clean the contacts. If the problem remains after cleaning, check the contacts for deformation or damage. Replace any defective parts.

Dirt on back



The back of the page is dirty.

Cause	Solution
1) The transfer roller is dirty.	Replace the transfer roller.
2) The transfer front guide is dirty.	Clean the dirty parts. If the dirt does not come off, replace the transfer ass'y.
3) The fuser inlet guide or separation guide is dirty.	Clean the dirty parts. If the dirt does not come off, replace the fuser.
4) The pressure roller is dirty.	Execute a "fuser roller cleaning designation" of the multi-purpose mode. If the dirt does not come off, replace the fuser.

Vertical lines



Vertical streaks or bands appear on the page.

Cause	Solution
1) Scratches are present on the circumference of the photosensitive drum.	Replace the Drum cartridge.
2) Scratches are present on the circumference of the fuser film.	Replace the fuser.

Vertical white lines

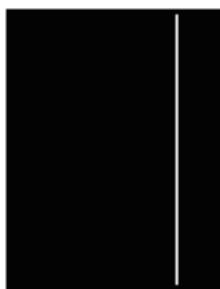

Vertical white lines appear in a particular color.

Cause	Solution
1) Scratches are present on the circumference of the photosensitive drum.	Replace the Drum cartridge.
2) Scratches are present on the circumference of the developer roller.	Replace the Toner cartridge.
3) The laser scanner mirror is dirty.	Replace the laser scanner ass'y.

Horizontal lines



Horizontal lines appear on the page.

Cause	Solution
1) Repetitive horizontal lines appear.	Identify the dirty roller which causes the repetitive image defects. Clean the roller. If the dirt does not come off, replace the corresponding ass'y including affected rollers.
2) Horizontal scratches are present on the photosensitive drum.	Replace the Drum cartridge.

Cause	Solution
3) Horizontal scratches are present on the fuser film.	Replace the fuser.

Horizontal white lines



Horizontal white lines appear on the page.

Cause	Solution
1) Repetitive horizontal white lines appear.	Identify the dirty roller which causes the repetitive imagedefects based on the pitch between the white lines andclean the roller. If the dirt does not come off, replace thecorresponding assembly including affected rollers.
2) Horizontal scratches are present on thephotosensitive drum.	Replace the Drum cartridge.

Dropouts

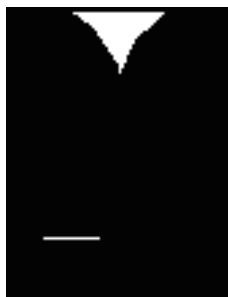

Dropouts appear.

Cause	Solution
1) The transfer roller is deformed or has deteriorated.	Replace the transfer roller.
2) The primary charging roller or photosensitive drumis deformed or has deteriorated.	Replace the Drum cartridge.
3) The developer roller is deformed or hasdeteriorated.	Replace the Toner cartridge.
4) The fuser film is deformed or has deteriorated.	Replace the fuser.
5) The high-voltage power supply is defective (nottransfer bias output).	Replace the engine controller PCA.

Loose toner



The toner is not fully fused to the media.

Cause	Solution
1) The fuser film or pressure roller is scarred or deformed.	Replace the fuser.
2) The thermistor is defective.	Replace the fuser.
3) The fuser heater is defective.	Replace the fuser.
4) The fuser control circuit is defective.	Replace the low-voltage power supply ass'y.

Misformed image/misplaced image



Print is misformed or incorrectly placed.

Cause	Solution
1) The laser scanner ass'y is defective.	Replace the laser scanner ass'y.

Wrinkles or creases

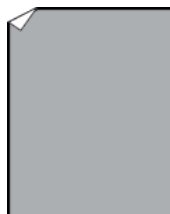

The printed page contains wrinkles or creases.

Cause	Solution
1) The feed roller or paper feed guide is dirty.	Clean any dirty parts.
2) The feed roller is deformed or worn.	Replace the feed roller which is deformed or worn.
3) The paper feed guide is damaged.	Replace the paper feed guide.
4) The fuser inlet guide is dirty.	Clean the fuser inlet guide. If the dirt does not come off, replace the fuser.

Dirt on front



The front of the page is dirty.

Cause	Solution
1) The photosensitive drum is dirty.	Replace the Drum cartridge.
2) The developer roller is dirty.	Replace the Toner cartridge.
3) The fuser film or pressure roller is dirty.	Execute a "fuser roller cleaning designation" of the multi-purpose mode. If the dirt does not come off, replace the fuser.

Vertical density variation



Vertical density variation appears on the page.

Cause	Solution
1) The photosensitive drum surface has deteriorated.	Replace the Drum cartridge.
2) The developer blade is defective.	Replace the Toner cartridge.
3) The laser scanner ass'y is defective.	Replace the laser scanner ass'y.

Repetitive image defects

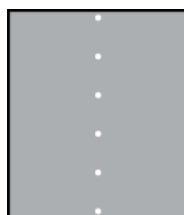

Repetitive white spots appear in an image.

Cause	Solution
1) Repetitive white spots appear.	Identify the dirty roller which causes the repetitive image defects. Clean the roller. If the dirt does not come off, replace the corresponding ass'y.
2) The transfer roller is deformed or has deteriorated.	Replace the transfer roller.
3) Foreign substance adheres to the primary charging roller or photosensitive drum.	Replace the Drum cartridge.

Repetitive image defects ruler

Distance between defects (mm) approx.	Component	Image defects			
		Dirt	Dropouts	Dirt on back	Loose toner
39 mm	Transfer roller		Yes	Yes	
28 mm	Primary charging roller (Note)	Yes	Yes		
63 mm	Photosensitive drum (Note)	Yes	Yes		
26 mm	Developer roller (Note)	Yes	Yes		
57 mm	Fuser film	Yes	Yes		Yes
45 mm	Pressure roller	Yes		Yes	Yes

CAUTION:

The primary charging roller, photosensitive drum and developer roller cannot be cleaned as these rollers are located inside the cartridge. If any of these rollers are indicated, replace the cartridge.

Debug Log

Function Overview

The debug log is a log that analyzes the program behavior of the machine to enable developers to identify problems. When a problem that is difficult to reproduce occurs, collecting a Sublog immediately after the problem has occurred on site can increase the efficiency of analyzing the problem and reduce the time it takes to deal with the problem.

Be sure to collect the debug log when the Support Dept. of sales company so instructs.

Note that there is no need for service technicians to check the content of collected debug log.

The types of debug log that can be collected from the machine are partially different between the model with the Control Panel Unit and the model without the Control Panel Unit.

Types of log that can be collected	Model with Control Panel Unit	Model without Control Panel Unit	Remarks
Firmware log	Yes	Yes	Use the log collection tool
Printer status window log	-	Yes	-

Cases in which collection of debug log is effective

- Neither the Support Dept. of sales company nor CINC can reproduce the trouble that occurred at the customer site
- When the error frequency is low
- When the failure is suspected to be due to firmware rather than a mechanical/electrical failure

NOTE:

If the procedure for reproducing the failure is clear and the Support Dept. of sales company and CINC can reproduce it, collection of debug log is not necessary.

Firmware Log Collection Using Log Collection Tool

Overview

The log collection tool (LogCollector) is used to collect the firmware log of the machine.

This tool runs on a PC connected to the machine with a USB Cable and collects operational status log in the machine.

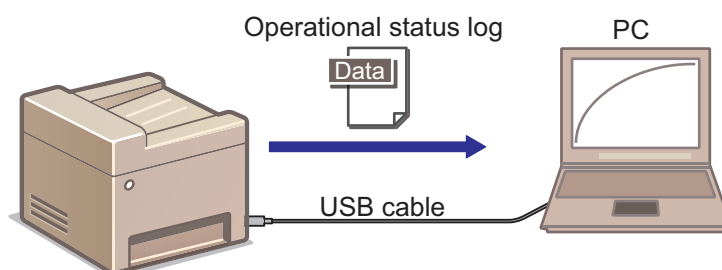

CAUTION:

This tool does not recognize multiple machines at a time. Therefore, if multiple machines are connected to a PC with multiple USB ports, the tool does not work.

Only one machine should be connected to a PC with a USB Cable to use the tool.

Log File

The specifications of the log file are shown below.

- Log file name: It is recorded as "usb_yyyymmdd_hhmmss.log". (yyyymmdd_hhmmss indicates year, month, date, and time (hour, minute, second) when the log is collected.)
- A log file is generated in the folder where the execution file (CanonLogCollector.exe) exists.

Supported Languages

Languages supported by this tool are shown below.

- English
- Korean
- Japanese

What to Prepare

- Machine where the problem has occurred
- USB Cable (Connector shape: A-B)
- PC that meets the following conditions:
 - USB port is usable
 - One of the following OS should be running.
 - Windows Vista
 - Windows 7
 - Windows 8
 - Windows 8.1
 - Windows 10
- Tool (CanonLogCollector.zip) ^{*1}

■ Log Collection Procedure

1. Connect the machine and the PC using the USB Cable while both of them are in operation.
2. Decompress the tool (CanonLogCollector.zip) on a directory with write permission on the PC. CanonLogCollector.exe is extracted in the decompressed folder.

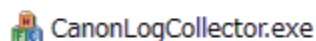

3. Double-click to start CanonLogCollector.exe.

NOTE:

It is not necessary to install this tool and it can be executed in any location.

The CanonLogCollector screen appears and "There is one connected device." is displayed.

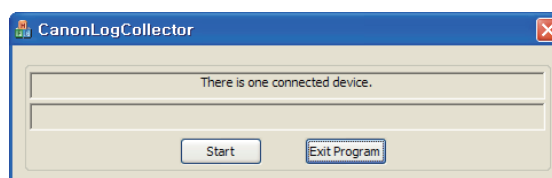

4. Press the [Start] button.

"Receiving log is successfully finished." is displayed.

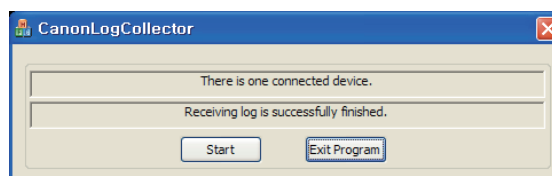

CAUTION:

If the machine is in sleep mode, time-out may occur when collecting logs. If time-out occurs, press the [Start] button again to collect logs.

5. Press the [Exit Program] button to quit the tool.

*1. Follow the instruction of the Support Dept. of the sales company to obtain the tool.

6. Send the collected log file to the Support Dept. of the sales company.

NOTE:

The collected log file is saved in the folder where CanonLogCollector.exe exists.

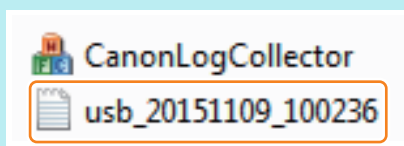

CAUTION:

While the machine is in operation, log information is continually added. However, capacity of the machine's log storage area is not large, log information may be overwritten when a long time has passed. Therefore, be sure to collect the log as soon as possible.

• Troubleshooting

The [Start] button is not activated

Remedy differs according to the displayed contents on the status line.

- "There is no connected device." is displayed.
Check the following possible causes and take necessary steps.
 - The connected machine has not been started
 - The USB Cable is not connected properly
 - The setting of USB connection is not correct
- "There are more than one connected device." is displayed.
More than one machines are connected to the PC with the USB cable. Disconnect the machines other than the target machine.

"Receiving log is finished. (Receive timeout.)" is displayed

If this message is displayed after pressing the [Start] button, the log data has not been properly sent from the machine to the PC.

NOTE:

The file size of the log data is approx. 1 KB when the data has not been properly sent.

Check the following possible causes and take necessary steps.

- The machine is in sleep mode.
- The USB Cable is not connected properly
- The setting of USB connection is not correct

After performing the remedy work, collect the log by pressing the [Start] button again.

Version Upgrade

Function Overview

The following firmware upgrade methods are available with this device.

Version Upgrade Using UST (“Version Upgrade Using UST” on page 113)

Upgrade the firmware of the device using UST.

Open the file for UST version upgrade on a PC connected with the device and upgrade the firmware.

Since the work is performed by connecting the host machine and the PC using a USB Cable, version upgrade can be performed also in an environment where network is not available.

Version Upgrade via Internet (“Version Upgrade via Internet” on page 113)

Access the dedicated server, and download and update the firmware.

Provided that Internet connection is available, the system automatically configures the connection destination setting and executes processing such as download and version upgrade.

Version upgrade by replacing the PCB

Version upgrade by replacing the existing PCB with a PCB where the latest firmware is installed

Version Upgrade Using UST

UST is included in the firmware for the machine that can be downloaded from the website of CINC. Firmware is downloaded as a zip file and a folder containing UST is extracted by decompressing the file.

When executing UST on the PC connected to the machine with a USB Cable, the firmware can be upgraded by downloading it from the PC to the machine. For the detailed procedure, refer to "User Support Tool Operation Guide" stored in the decompressed folder. "User Support Tool Operation Guide" is also available on the website of CINC.

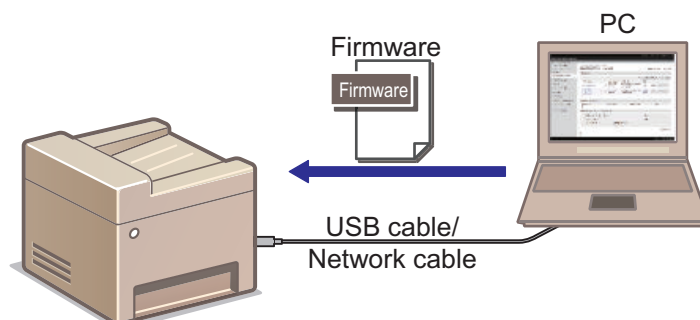

Version Upgrade via Internet

Connect to the Internet using the network function of the device, and download and upgrade the latest firmware from the server. If the device is in an environment where Internet connection is available, firmware versions can be upgraded only by operation from the menu without using PC.

■ Prerequisite

In order to perform version upgrade of the device via Internet, the following conditions must be met.

There should be no other jobs being executed.

Firmware cannot be upgraded while there is a job being executed. If there is a job being executed, wait for completion of the job and then perform the work.

The device should be able to be connected to the external network.

If connection is not available because, for example, there is a proxy server, follow the e-Manual to configure the proxy server settings and enable connection to the external network.

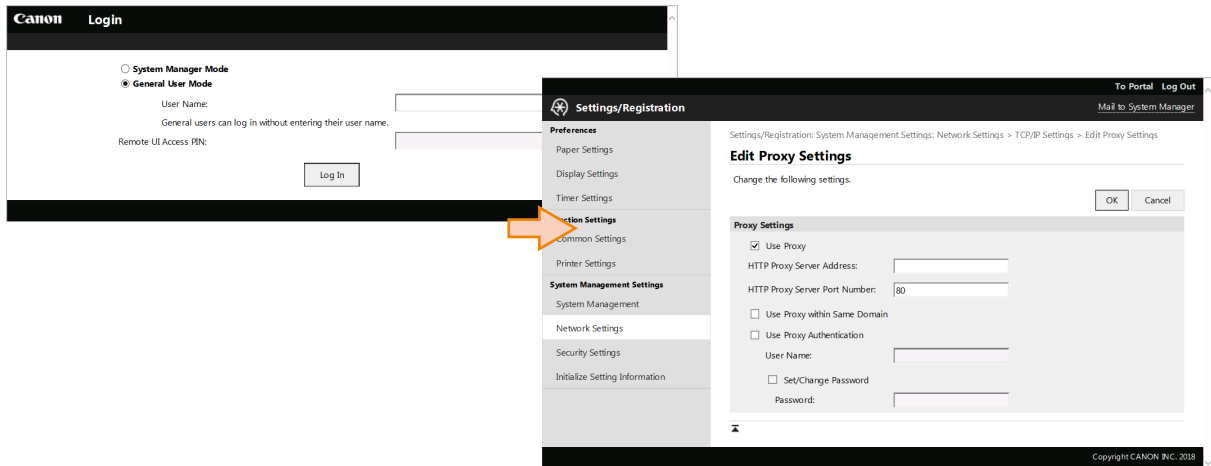

The serial number of the host machine should be shown on the Main Controller PCB.

Whether or not the serial number of the host machine is shown on the Main Controller PCB can be checked from the Control Panel or SPEC REPORT.

The procedure for checking the serial number using SPEC REPORT is shown below as reference information.

Procedure to check from SPEC REPORT

- Execute the following service mode to print SPEC REPORT.
 - COPIER > FUNCTION > MISC-P > OUTPUT > SPEC
- Check if the serial number (4 alphabetical characters + 6-digit number) is shown in [MACHINE SERIAL NUMBER] of the printed SPEC REPORT.

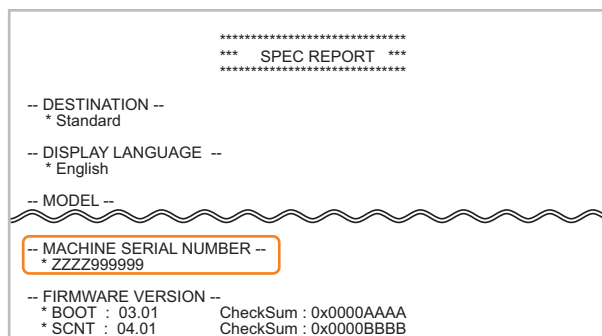

■ Procedure for Upgrading the Firmware via Internet

1. Select the following menu to upgrade the firmware via Internet:

- [Menu] > [System Management Settings] > [Update Firmware] > [Via Internet]

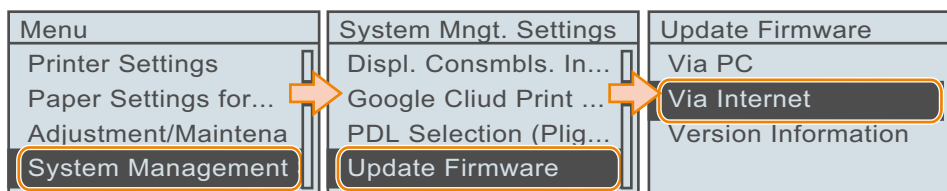

When the upgrading of firmware is completed, the machine automatically restarts.

2. Select the following menu, and check that the firmware has been correctly upgraded:

- [Menu] > [System Management Settings] > [Update Firmware] > [Version Information]

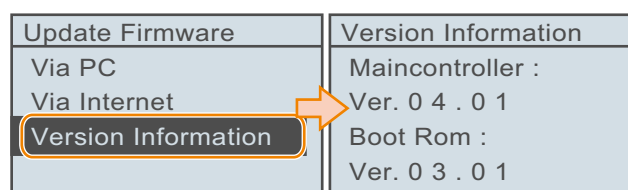

CAUTION:

This function does not support the operations from remote UI. ([Update Firmware] does not exist in the [System Management Settings] menu of the remote UI.)



Error/Jam/Alarm

Overview.....	117
Error Code.....	120
Jam Code.....	123
Alarm Code.....	124

Overview

About Code

This section describes codes shown in case any problem is occurred.

Code type	Description
Error code	This code is displayed when a failure which impacts printing has occurred.
Jam code	This code is displayed when a jam has occurred in this machine.
Alarm code	None

It can be checked by outputting the jam/error history report. It is not displayed on the Control Panel.

If a code which is not mentioned in the Service Manual occurs, obtain the following information as much as possible. Obtaining the foregoing information allows for smooth response when the case is escalated to the department in charge of quality management.

- Logs (jam/error log report, etc.)
- Version information
- Debug log
- Occurrence status

Error/Jam Log Indication

Error log

Service Mode > COPIER > DISPLAY > ERR

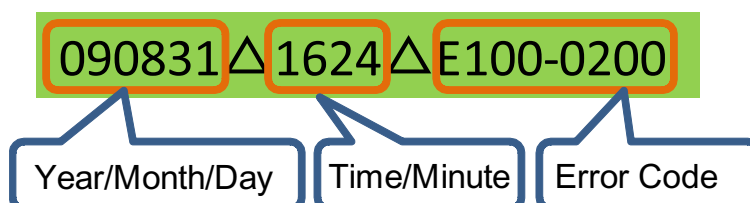

Jam log

Service Mode > COPIER > DISPLAY > JAM

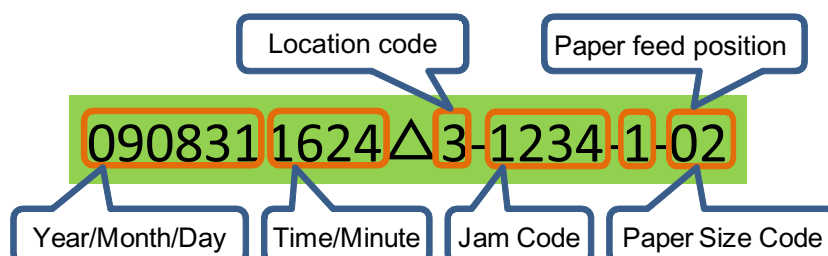

Location Code

The jam codes of this machine contain information on the location.

The location information is displayed in a single digit and has the meaning shown below:

Device	Location code
Host machine	3

■ Pickup Position Code

When a jam occurs, the pickup location is indicated with the following pickup position code.

Pickup position	Pickup position code
Paper Drawer	1

■ JAM/ERR HISTORY REPORT

Logs of jam (jam code) and error (error code) histories are output as a report.

```

*****
***      JAM/ERR HISTORY REPORT      ***
*****

JAM
Number  Date       Time    Time    Source  Size  Code  Total Printed Pages
1       2000/02/24  18:27  18:28  01      02   0003  25
2       2000/02/24  18:26  18:27  01      02   0001  25
3       2000/02/24  18:21  18:21  01      00   000E  25
4       2000/02/24  18:20  18:21  01      02   000F  25
5       2000/02/24  18:18  18:20  01      02   000F  25

ERROR
Number  Date       Time    Code  Total Printed Pages
1       2000/01/13  22:21  0000  5
2       2000/01/13  22:21  0000  5
3       2000/01/01  00:13  0110  0
4       2000/01/01  00:10  0110  0
5       2000/01/01  00:05  0110  0
6       2000/01/01  00:03  0110  0
7       2000/01/01  00:40  0110  0
8       2000/01/01  00:37  0110  0

```

Output method

Output the jam/error history report by executing the following service mode.

- Output of a jam/error history report:
COPIER > FUNCTION > MISC-P > OUTPUT > ERRLOG

History log

Up to 20 jam and error (error code) logs each are printed.

Item	Description	Remarks
JAM		
Number	Reference number	
Date	Date of jam occurrence	YYYY/MM/DD
Time	Time of jam occurrence	HH:MM (24-hour notation)
Time	Time of jam recovery	HH:MM (24-hour notation)
Source	Pickup position of paper when a jam occurs	01:Paper Drawer
Size	Paper size code when a jam occurs	00: Unknown, 02: A4R, 07: B5R, 03: A5R, 0C: LGL, 0D: LTRR, 3C: STMTR, 0A: EXEGR, 3E: OFFICIO, CC: B-OFFICIO, D2: M-OFFICIO, D0: GLTR-R, D1: GLGL, D7: Indian LGL, CA: AFLS, 3D: FLS, D4: 16KR, D6: FA4, 04: A6, 13: Custom paper, 4E: Universal, 40: 3x5 inch, 16: COM10, 17: Monarch, 15: ISO-C5, 18: DL
Code	Jam code	
Total Printed Pages	The number of total printed pages when a jam occurs	
ERROR		
Number	Reference number	
Date	Date of error occurrence	YYYY/MM/DD
Time	Time of error occurrence	HH:MM (24-hour notation)

Item	Description	Remarks
Code	Error code	(Example) Notation when Eaaa-bbbb occurs: "0aaa"
Total Printed Pages	The number of total printed pages when an error occurs	

Error Code

Error Code Details

E000-0000---	Fixing temperature control startup failure
Detection Description	Temperature of the Fixing Assembly did not reach the specified temperature within the specified period of time.
Remedy	<ol style="list-style-type: none"> 1. Check the harness/connector of the Fixing Assembly. 2. Replace the Fixing Film Unit. 3. Replace the Fixing Assembly. 4. Replace the Engine Controller PCB.
E001-0000---	Abnormal high temperature of Fixing Assembly
Detection Description	It was detected that the temperature of the Fixing Assembly was abnormally high.
Remedy	<ol style="list-style-type: none"> 1. Check the harness/connector of the Fixing Assembly. 2. Replace the Fixing Film Unit. 3. Replace the Fixing Assembly. 4. Replace the Engine Controller PCB.
E003-0000---	Abnormal low temperature of Fixing Assembly
Detection Description	It was detected that the temperature of the Fixing Assembly was abnormally low.
Remedy	<ol style="list-style-type: none"> 1. Check the harness/connector of the Fixing Assembly. 2. Replace the Fixing Film Unit. 3. Replace the Fixing Assembly. 4. Replace the Engine Controller PCB.
E004-0000---	Fixing Heater drive circuit error
Detection Description	A frequency failure was detected in the Fixing Assembly.
Remedy	<ol style="list-style-type: none"> 1. Check the harness/connector of the Fixing Assembly. 2. Replace the Fixing Film Unit. 3. Replace the Fixing Assembly. 4. Replace the Engine Controller PCB.
E015-0001---	Developing Disengagement Motor error
Detection Description	A developing disengagement error was detected.
Remedy	<ol style="list-style-type: none"> 1. Check the harness/connector between the Developing Disengagement Solenoid and the Engine Controller PCB. 2. Replace the Developing Disengagement Solenoid. 3. Replace the Motor PCB. 4. Replace the Engine Controller PCB.
E066-0000---	Environment Sensor error
Detection Description	An error in the Environment Sensor was detected.
Remedy	<ol style="list-style-type: none"> 1. Check the harness/connector between the Environment Sensor PCB and the Engine Controller PCB. 2. Replace the Environment Sensor PCB. 3. Replace the Engine Controller PCB.
E100-0001---	BD error
Detection Description	BD error was detected.
Remedy	<ol style="list-style-type: none"> 1. Check the harness/connector between the Laser Scanner Unit and the Engine Controller PCB. 2. Replace the Laser Scanner Unit. 3. Replace the Engine Controller PCB.

E110-0000---	Error in startup of the Scanner Motor
Detection Description	An error in any of the Scanner Motor, Laser Unit, or BD detection was detected at startup of the Scanner Motor.
Remedy	<ol style="list-style-type: none"> 1. Check the harness/connector between the Laser Scanner Unit and the Engine Controller PCB. 2. Replace the Laser Scanner Unit. 3. Replace the Engine Controller PCB.
E110-0001---	Scanner Motor rotation error
Detection Description	An error in any of the Scanner motor, Laser Unit, or BD detection was detected during steady rotation of the Scanner Motor.
Remedy	<ol style="list-style-type: none"> 1. Check the harness/connector between the Laser Scanner Unit and the Engine Controller PCB. 2. Replace the Laser Scanner Unit. 3. Replace the Engine Controller PCB.
E196-0001---	Error in accessing the NVRAM
Detection Description	NVRAM cannot be accessed.
Remedy	Replace the Engine Controller PCB.
E196-2000---	Controller communication error
Detection Description	The Flash ROM in the Main Controller cannot be accessed.
Remedy	<ol style="list-style-type: none"> 1. Update the set of the controller firmware. 2. Replace the Main Controller PCB.
E733-0000---	Controller communication error
Detection Description	Communication error between the Main Controller PCB and the Engine Controller PCB
Remedy	<ol style="list-style-type: none"> 1. Update the set of the controller firmware. 2. Replace the Main Controller PCB. 3. Replace the Engine Controller PCB.
E740-0002---	Network error
Detection Description	A Network Board error or an error in the Mac address was detected.
Remedy	<ol style="list-style-type: none"> 1. Check the Network cable between the Host machine and the LAN socket. 2. Replace the Main Controller PCB.
E744-0002---	Language file error
Detection Description	The size of the language file exceeded the upper limit.
Remedy	Update the set of the controller firmware.
E744-4000---	Engine ID error
Detection Description	Invalid engine connection was detected.
Remedy	<ol style="list-style-type: none"> 1. Check the D-CON. 2. Update the D-CON. 3. Update the set of the controller firmware. 4. Check the model code (because this error occurs even when the model code and the engine code are mismatched).
E744-6000---	Wireless LAN communication error
Detection Description	Communication error between the Main Controller PCB and the Wireless LAN PCB
Remedy	<ol style="list-style-type: none"> 1. Check the connection of the wireless LAN PCB. 2. Update the set of the controller firmware. 3. Replace the Main Controller PCB.
E760-0001---	Main Controller PCB error
Detection Description	An error occurred with the firmware of the Main Controller.
Remedy	<ol style="list-style-type: none"> 1. Update the set of the controller firmware. 2. Replace the Main Controller PCB.

E806-0000---	Main Fan failure
Detection Description	The Main Fan Motor fails to rotate at the specified rotation speed.
Remedy	<ol style="list-style-type: none">1. Check the harness/connector of the Main Fan.2. Replace the Main Fan.3. Replace the Engine Controller PCB.
E808-0000---	Low-voltage power supply failure detection
Detection Description	Printer detected low-voltage power supply failure.
Remedy	<ol style="list-style-type: none">1. Check the harness/connector of the Low Voltage Power Supply PCB.2. Replace the Low Voltage Power Supply PCB.3. Replace the Engine Controller PCB.

Jam Code

Host machine

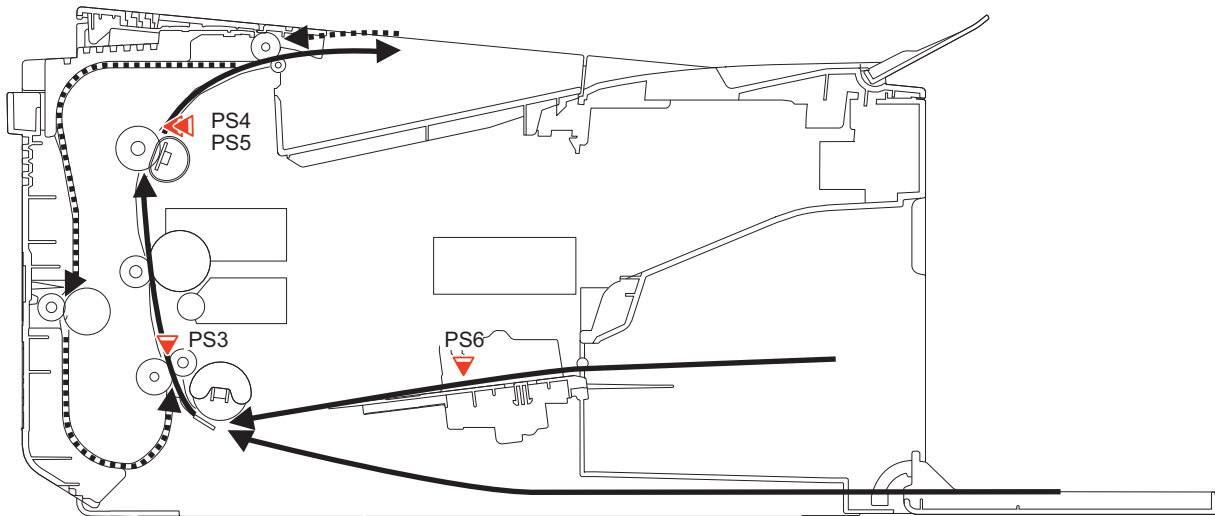

Location code	Jam Code	Type	Sensor Name	Sensor ID
3	0002	Pickup Stationary Jam	Top Sensor	PS3
3	0003	Fixing delivery delay jam	Fixing Output Sensor	PS4
3	0004	Fixing delivery stationary jam	Fixing Output Sensor	PS4
3	0007	Reverse delay jam	Fixing Output Sensor	PS4
3	000B	Duplex re-pickup delay jam	Top Sensor	PS3
3	000C	Wrapping jam	Fixing Output Sensor	PS4
3	000E	Internal stationary jam	Top Sensor/Fixing Output Sensor/Fixing Media Width Sensor	PS3/PS4/PS5
3	000F	Door Open Jam	Top Sensor/Fixing Output Sensor/Fixing Media Width Sensor	PS3/PS4/PS5

Alarm Code

This machine does not require any Alarm Code.



Service Mode

Overview.....	126
COPIER (Service mode for printer)...	127
TESTMODE (Service mode for test print, operation check, etc.).....	139

Overview

Entering Service Mode

For information on how to enter service mode, contact the Support Dept. of the sales company.

COPIER (Service mode for printer)

DISPLAY (State display mode)

COPIER (Service mode for printer) > DISPLAY (State display mode)

■ VERSION

COPIER (Service mode for printer) > DISPLAY (State display mode) > VERSION

MAIN	Display of MAIN (main program) version
Detail	To display the firmware version of controller PCB.
Use Case	When upgrading the firmware
Adj/Set/Operate Method	N/A (Display only)
Display/Adj/Set Range	00.00 to 99.99
Default Value	0
BOOT	Boot ROM version
Detail	To display the version of boot ROM.
Use Case	When upgrading the firmware
Display/Adj/Set Range	N/A (Display only)
Default Value	0
LANG	Language pack version
Detail	To display the version of language pack.
Use Case	When upgrading the firmware
Adj/Set/Operate Method	N/A (Display only)
Display/Adj/Set Range	00.00 to 99.99
Default Value	0
ECONT	Engine ROM version
Detail	To display the version of engine ROM.
Use Case	When upgrading the firmware
Adj/Set/Operate Method	N/A (Display only)
Display/Adj/Set Range	00.00 to 99.99
Default Value	0
ERR	
Detail	To display the error code and detail code of the system error.
Adj/Set/Operate Method	N/A (Display only)
JAM	
Detail	To display the jam logs of the printer.
Display/Adj/Set Range	N/A (Display only)

FUNCTION (Operation / inspection mode)

■ CLEAR

COPIER (Service mode for printer) > FUNCTION (Operation / inspection mode) > CLEAR

SRVC-DAT	Clearing of service data
Detail	To clear service data.
Use Case	When it is necessary to clear a service mode set up value.
Adj/Set/Operate Method	1) Select the item, and then press OK key. 2) Turn OFF/ON the main power switch.
Caution	Cannot clear user data with this mode.
PWDCLEAR	Clear of system administrator password
Detail	To clear the password of the system administrator set in Settings/Registration menu.
Use Case	When clearing the password of the system administrator
Adj/Set/Operate Method	Select the item, and then press OK key.
CRG-LOG	Clearing of cartridge log
Detail	To clear cartridge log.
Use Case	When it is necessary to clear a cartridge log value.
Adj/Set/Operate Method	1) Select the item, and then press OK key. 2) Turn OFF/ON the main power switch.
ALL	Clearing setting information
Detail	The following items are cleared. - User data - Service data - JOB ID - Log - Clear data - KEY Log data - CRG log
Use Case	When replacing the controller PCB
Adj/Set/Operate Method	1) Select the item, and then press OK key. 2) Turn OFF/ON the main power switch.
Caution	In addition, USER DATA/SERVICE DATA is initialized to the forwarding setting of the default.

● HIST

COPIER (Service mode for printer) > FUNCTION (Operation / inspection mode) > CLEAR > HIST

ACC-HIST	Clear of print log
Detail	To clear the print log.
Use Case	When clearing print log
Adj/Set/Operate Method	1) Select the item, and then press OK key. 2) Turn OFF/ON the main power switch.
JAM-HIST	Clear of jam log
Detail	To clear the jam log
Use Case	When clearing jam logs
Adj/Set/Operate Method	1) Select the item, and then press OK key. 2) Turn OFF/ON the main power switch.
ERR-HIST	Clear of error code
Detail	To clear the error code.
Use Case	When clearing error code
Adj/Set/Operate Method	1) Select the item, and then press OK key. 2) Turn OFF/ON the main power switch.

■ MISC-P

● OUTPUT

COPIER (Service mode for printer) > FUNCTION (Operation / inspection mode) > MISC-P > OUTPUT

CNTR	To output the counter report.
Detail	Counter values of use trend for reading, storage, communications, and copy are displayed.
Use Case	When the counter report is output
Adj/Set/Operate Method	Select the item, and then press OK key.
ERR-LOG	Output of error log report
Detail	To output the error log report.
Use Case	When the error log report is output
Adj/Set/Operate Method	Select the item, and then press OK key.
SPEC	Output of spec report
Detail	The current device specifications such as the location, model information, and ROM version are output.
Use Case	When the spec report is output
Adj/Set/Operate Method	Select the item, and then press OK key.
CRG-LOG	Output of Toner cartridge, Drum cartridge detailed report
Detail	Output the toner/drum cartridge log information (serial number, remaining level, installed hours, etc.) stored in an equipment that outputs the detailed toner/drum cartridge log print.
Use Case	When the Toner cartridge, Drum cartridge detailed report is output
Adj/Set/Operate Method	Select the item, and then press OK key.

■ SYSTEM

COPIER (Service mode for printer) > FUNCTION (Operation / inspection mode) > SYSTEM

DOWNLOAD	Shift to download mode
Detail	To switch to the download mode.
Use Case	At upgrade
Adj/Set/Operate Method	1) Select the item, and then press OK key. 2) Perform downloading by UST.
Additional Functions Mode	Settings/Registration> System Management Settings> Update Firmware

■ SPLMAN

COPIER (Service mode for printer) > FUNCTION (Operation / inspection mode) > SPLMAN

TOP-MPT	Adjustment of leading edge margin when feeding from Multi-Purpose Tray.
Detail	As the value is incremented by 1, the margin on the top edge of paper is increased by 0.1 mm. +: Top margin becomes larger (An image moves to the back-end.) -: Top margin becomes smaller (An image moves to the leading edge.)
Use Case	When adjust the leading edge margin at the time of the Multi-Purpose Tray paper feed.
Adj/Set/Operate Method	Select the item, and then press OK key.
Display/Adj/Set Range	50 to 150
Unit	0.1mm
Default Value	100

COPIER (Service mode for printer) > FUNCTION (Operation / inspection mode) > SPLMAN

TOP-DUP-MPT	Adjustment of leading edge margin(The back side of 2-Sided Printing) when feeding from Multi-Purpose Tray.
Detail	As the value is incremented by 1, the left margin of paper is increased by 0.1 mm. +: Left margin becomes larger (An image moves to the right.) -: Left margin becomes smaller (An image moves to the left.)
Use Case	When adjust the leading edge margin(The back side of 2-Sided Printing) at the time of the Multi-Purpose Tray paper feed.
Adj/Set/Operate Method	Select the item, and then press OK key.
Display/Adj/Set Range	50 to 150
Unit	0.1mm
Default Value	100
LEFT-MPT	Adjustment of Left edge margin when feeding from Multi-Purpose Tray.
Detail	As the value is incremented by 1, the left margin of paper is increased by 0.1 mm. +: Left margin becomes larger (An image moves to the right.) -: Left margin becomes smaller (An image moves to the left.)
Use Case	When adjust the Left edge margin at the time of the Multi-Purpose Tray paper feed.
Adj/Set/Operate Method	Select the item, and then press OK key.
Display/Adj/Set Range	50 to 150
Unit	0.1mm
Default Value	91
LEFT-DUP-MPT	Adjustment of Left edge margin(The back side of 2-Sided Printing) when feeding from Multi-Purpose Tray.
Detail	As the value is incremented by 1, the left margin of paper is increased by 0.1 mm. +: Left margin becomes larger (An image moves to the right.) -: Left margin becomes smaller (An image moves to the left.)
Use Case	When adjust the Left edge margin(The back side of 2-Sided Printing) at the time of the Multi-Purpose Tray paper feed.
Adj/Set/Operate Method	Select the item, and then press OK key.
Display/Adj/Set Range	50 to 150
Unit	0.1mm
Default Value	92
TOP-CST	Adjustment of leading edge margin when feeding from Paper Drawer.
Detail	As the value is incremented by 1, the margin on the top edge of paper is increased by 0.1 mm. +: Top margin becomes larger (An image moves to the back-end .) -: Top margin becomes smaller (An image moves to the leading edge.)
Use Case	When adjust the leading edge margin at the time of the Drawer paper feed.
Adj/Set/Operate Method	Select the item, and then press OK key.
Display/Adj/Set Range	50 to 150
Unit	0.1mm
Default Value	100

COPIER (Service mode for printer) > FUNCTION (Operation / inspection mode) > SPLMAN

TOP-DUP-CST	Adjustment of leading edge margin(The back side of 2-Sided Printing) when feeding from Paper Drawer.
Detail	As the value is incremented by 1, the margin on the top edge of paper is increased by 0.1 mm. +: Leading margin becomes larger (An image moves to the back-end.) -: Leading margin becomes smaller (An image moves to the leading edge.)
Use Case	When adjust the Leading edge margin(The back side of 2-Sided Printing) at the time of the Paper Drawer paper feed.
Adj/Set/Operate Method	Select the item, and then press OK key.
Display/Adj/Set Range	50 to 150
Unit	0.1mm
Default Value	100
LEFT-CST	Adjustment of left margin when feeding from Paper Drawer
Detail	As the value is incremented by 1, the left margin of paper is increased by 0.1 mm. +: Left margin becomes larger (An image moves to the right.) -: Left margin becomes smaller (An image moves to the left.)
Use Case	When adjust the left margin at the time of the Paper Drawer paper feed
Adj/Set/Operate Method	Select the item, and then press OK key.
Display/Adj/Set Range	50 to 150
Unit	0.1mm
Default Value	91
LEFT-DUP-CST	Adjustment of Left edge margin(The back side of 2-Sided Printing) when feeding from Paper Drawer.
Detail	As the value is incremented by 1, the left margin of paper is increased by 0.1 mm. +: Left margin becomes larger (An image moves to the right.) -: Left margin becomes smaller (An image moves to the left.)
Use Case	When adjust the Left edge margin(The back side of 2-Sided Printing) at the time of the Paper Drawer paper feed.
Adj/Set/Operate Method	Select the item, and then press OK key.
Display/Adj/Set Range	50 to 150
Unit	0.1mm
Default Value	92
SPL14159	ON/OFF of USB device ID fixing
Detail	To set whether to fix the USB device ID to "000000000000". A PC attempts to install the driver every time it is connected to a machine. However, by fixing the USB device ID, it recognizes that the same machine is connected so that it does not attempt to install the driver again.
Use Case	When saving the trouble of selecting a device used for printing from the candidate devices because the driver is installed every time a USB is connected
Adj/Set/Operate Method	Select the item, and then press OK key.
Display/Adj/Set Range	0 to 1 0: Disabled 1: Enabled
Default Value	0

COPIER (Service mode for printer) > FUNCTION (Operation / inspection mode) > SPLMAN

SPL27354	PC-less update, RMDS environment setting
Detail	PC-less update, RMDS environment setting
Adj/Set/Operate Method	Select the item, and then press OK key.
Display/Adj/Set Range	0 to 5 0: Production environment/Release environment 1: Production environment/Staging environment 2: Maintenance environment 1/Release environment 3: Maintenance environment 1/Staging environment 4: Maintenance environment 2/Release environment 5: Maintenance environment 2/Staging environment
Default Value	0
SPL32620	Setting of PC-less update
Detail	Switching to enable/disable PC-less update.
Use Case	When changing the setting of PC-less update.
Adj/Set/Operate Method	Select the item, and then press OK key.
Display/Adj/Set Range	0 to 1 0: Invalidity 1: Enable
Default Value	1
SPL10249	Setting at Toner Cartridge error
Detail	To set whether to display the error screen when a non-genuine toner cartridge or a toner cartridge which memory cannot be read is installed.
Adj/Set/Operate Method	Select the item, and then press OK key.
Caution	When "1" is set, the error screen is displayed and printing is paused.
Display/Adj/Set Range	0 to 1 0: Non-indication 1: Indication
Default Value	1
SPL10250	Setting at Drum Cartridge error
Detail	To set whether to display the error screen when a non-genuine drum cartridge or a drum cartridge which memory cannot be read is installed.
Adj/Set/Operate Method	Select the item, and then press OK key.
Caution	When "1" is set, the error screen is displayed and printing is paused.
Display/Adj/Set Range	0 to 1 0: Non-indic 1: Indication
Default Value	1
SPL12612	Setting of auto sleep setting display
Detail	To set whether to display the auto sleep time screen.
Adj/Set/Operate Method	Select the item, and then press OK key.
Caution	When 0 is set, auto sleep time cannot be set and auto sleep is disabled (OFF).
Display/Adj/Set Range	0 to 1 0: Non-indic 1: Indication
Default Value	1

COPIER (Service mode for printer) > FUNCTION (Operation / inspection mode) > SPLMAN

SPL78148		Mode to execute new B&W processing of PCL
Detail	Compatible Mode for Unification of Black and White Gradation	
Use Case	To make the density gradation characteristics of halftone the same as those of conventional machines. Resolution: Further increase the density in high-density areas. Gradation: Uniformly change the gradation from a low-density area to a high-density area. Color Tone: Further reduce the density in low-density areas. Use case: When setting the density gradation characteristics in line with those of conventional machines	
Adj/Set/Operate Method	Select the item, and then press OK key.	
Display/Adj/Set Range	0 to 1 0: Enable 1: Invalidity	
Default Value	1	
Supplement/Memo	PCL only	

OPTION (Specification setting mode)

■ BODY

COPIER (Service mode for printer) > OPTION (Specification setting mode) > BODY

LOCALE		Setting of location
Detail	To set the location.	
Use Case	When changing the location information. Ex: At the time of main controller PCB exchange.	
Adj/Set/Operate Method	1) Enter the setting value under LOCALE, and then press OK key. 2) Execute COPIER> FUNCTION> CLEAR> ALL. 3) Turn OFF/ON the main power switch.	
Caution	Since COPIER> FUNCTION> CLEAR> ALL is executed when changing the location, the setting information of user mode, service mode, etc. is initialized.	
Display/Adj/Set Range	1 to 7 1: Japan, 2: North America, 3: Korea, 4: China, 5: Taiwan, 6: Europe, 7: Asia	
Related Service Mode	COPIER>FUNCTION>CLEAR>ALL	
ASLPMAX		Setting of the automatic sleep shift time
Detail	Change of the maximum value of auto sleep shift time	
Use Case	When changing the setting time to shift to auto sleep mode	
Adj/Set/Operate Method	1) Select the item, and then press OK key. 2) Turn OFF/ON the main power switch.	
Display/Adj/Set Range	0 to 1 0: 30min 1: 240min	
Default Value	0	
SDTM-DSP		ON/OFF of auto shutdown shift time dsp
Detail	To set whether to display [Auto Shutdown Time] in [Menu]. The setting is enabled only for the model with automatic shutdown function.	
Use Case	When switching to display or hide the items related to auto shutdown	
Display/Adj/Set Range	0 to 1 0: OFF 1: ON	
Default Value	Europe : 1 Other : 0	

COPIER (Service mode for printer) > OPTION (Specification setting mode) > BODY

SSLSTRNG		Allow weak encryption algorithm for SSL
Detail		To set whether to allow using weak encryption algorithm for SSL. When 1 is set, weak encryption algorithm cannot be used.
Use Case		When prohibiting weak encryption algorithm because of security concern
Adj/Set/Operate Method		1) Enter the setting value, and then press OK key. 2) Turn OFF/ON the main power switch.
Display/Adj/Set Range		0 to 1 0: Normal mode 1: Secured mode(RC4 encryption is not used.)
Default Value		1
CLP-DSP		Setting of cartridge log report print menu display
Use Case		To set whether to display or hide the cartridge log report menu on the report output screen.
Display/Adj/Set Range		0: Non-indic *1: Indication
Default Value		1

■ ACC

COPIER (Service mode for printer) > OPTION (Specification setting mode) > ACC

WLAN		Setting of wireless LAN function
Detail		To set whether to enable the wireless LAN function.
Use Case		Upon user's request
Adj/Set/Operate Method		1) Enter the setting value, and then press OK key. 2) Turn OFF/ON the main power switch.
Display/Adj/Set Range		0 to 1 0: Disabled 1: Enabled
Default Value		1
Supplement/Memo		In the case of models without Wi-Fi, none of the behaviors are linked with the settings.

■ SERIAL

COPIER (Service mode for printer) > OPTION (Specification setting mode) > SERIAL

SN-MAIN	Input of the serial number
Detail	To write the serial number of this machine in the Main Controller PCB. When this item is executed, the 1-byte alphanumeric characters entered in [Location] in [Settings/Registration] are written in the Main Controller PCB. When replacing the Main Controller PCB, be sure to write the serial number in the new PCB to prepare for trouble since the serial number of the device is not succeeded.
Use Case	-At the time of setting -At the time of main controller PCB exchange
Adj/Set/Operate Method	1) Write down the current data in [Location]. 2) Turn OFF the main power switch. 3) Replace the Main Controller PCB. 4) Turn ON the main power switch. 5) Enter the serial number of the machine in [Location]. 6) Execute this item. 7) Turn OFF/ON the main power switch. After the serial number of this machine is written in the Main Controller PCB, data in [Location] is deleted. 8) Output the spec report by SPEC, and check that the entered serial number is registered. 9) Enter the data backed up in step 1 in [Location].
Caution	Since the above "Location" is only temporarily used to store data, back up the data before input and enter it again after writing is completed.
Related Service Mode	COPIER> FUNCTION> MISC-P> SPEC
Additional Functions Mode	RUI : Settings/Registration: System Management Settings: System Management > Edit System Management > Device Information > Location: LUI : Menu > System Management Settings > Device Management > Device Information Settings > Location

■ FNC-SW

COPIER (Service mode for printer) > OPTION (Specification setting mode) > FNC-SW

CRG-PROC	Set oprtn at cartridge estd life reach
Detail	To set the operation of the machine when the parts counter of the cartridge reaches the estimated life value.
Adj/Set/Operate Method	Enter the setting value, and then press OK key.
Display/Adj/Set Range	0 to 2 0: Not stopped 1: Stopped once 2: Completely stopped
Default Value	0
DRUM-PROC	Set oprtn at cartridge estd life reach
Detail	To set the operation of the machine when the parts counter of the cartridge reaches the estimated life value.
Adj/Set/Operate Method	Enter the setting value, and then press OK key.
Display/Adj/Set Range	0 to 2 0: Not stopped 1: Stopped once 2: Completely stopped
Default Value	0 (The default value of the Drum Cartridge is 1.)

COUNTER (Counter mode)

■ TOTAL

COPIER (Service mode for printer) > COUNTER (Counter mode) > TOTAL

SERVICE1	Service-purposed total counter 1
Detail	To count up when the paper is delivered outside the machine.
Adj/Set/Operate Method	N/A (Display only)
Display/Adj/Set Range	0 to 999999
Unit	sheet
Default Value	0
SERVICE2	Service-purposed total counter 2
Detail	To count up when the paper is delivered outside the machine.
Adj/Set/Operate Method	N/A (Display only)
Display/Adj/Set Range	0 to 999999
Unit	sheet
Default Value	0
TTL	Total counter
Detail	To count up the total number of output sheets.
Adj/Set/Operate Method	N/A (Display only)
Display/Adj/Set Range	0 to 999999
Unit	N/A (Display only)
Appropriate Target Value	sheet
Default Value	0
PDL-PRT	PDL print counter
Detail	To count up when the paper is delivered outside the machine according to the charge counter at PDL print.
Adj/Set/Operate Method	N/A (Display only)
Display/Adj/Set Range	0 to 999999
Unit	sheet
Default Value	0
RPT-PRT	Report print counter
Detail	To count up when the report print is delivered outside the machine.
Adj/Set/Operate Method	N/A (Display only)
Display/Adj/Set Range	0 to 999999
Unit	sheet
Default Value	0
2-SIDE	2-Sided Printing jam counter
Detail	To count up the number of 2-sided prints when the printout is delivered outside the machine/2-sided printout is stacked. A blank sheet is counted.
Adj/Set/Operate Method	N/A (Display only)
Display/Adj/Set Range	0 to 999999
Unit	sheet
Default Value	0

■ PICK-UP

COPIER (Service mode for printer) > COUNTER (Counter mode) > PICK-UP

C1	Total pickup counter of the Papaer Drawer
Detail	To count up the number of sheets picked up from the Papaer Drawer.
Adj/Set/Operate Method	N/A (Display only)
Display/Adj/Set Range	0 to 999999
Unit	sheet
Default Value	0
MF	Multi-purpose Tray pickup total counter
Detail	To count up the number of sheets picked up from the Multi-purpose Tray Pickup Unit.
Adj/Set/Operate Method	N/A (Display only)
Display/Adj/Set Range	0 to 999999
Unit	sheet
Default Value	0
2-SIDE	2-sided pickup total counter
Detail	To count up the number of sheets picked up in duplex mode.
Adj/Set/Operate Method	N/A (Display only)
Display/Adj/Set Range	0 to 999999
Unit	sheet
Default Value	0

■ JAM

COPIER (Service mode for printer) > COUNTER (Counter mode) > JAM

TOTAL	Total jam counter
Detail	To count up the number of jam occurrences in the entire machine.
Adj/Set/Operate Method	N/A (Display only)
Display/Adj/Set Range	0 to 999999
Unit	times
Default Value	0
2-SIDE	2-Sided Printing jam counter
Detail	To count up the number of 2-Sided Printing jam occurrences.
Adj/Set/Operate Method	N/A (Display only)
Display/Adj/Set Range	0 to 999999
Unit	times
Default Value	0
MF	Multi-Purpose Tray jam counter
Detail	To count up the number of Multi-Purpose Tray jam occurrences.
Adj/Set/Operate Method	N/A (Display only)
Display/Adj/Set Range	0 to 999999
Unit	times
Default Value	0

COPIER (Service mode for printer) > COUNTER (Counter mode) > JAM

C1	Paper Drawer jam counter
Detail	To count up the number of jams occurred in the Paper Drawer. The counter is advanced even in the case of paper size mismatch and misprint.
Adj/Set/Operate Method	N/A (Display only)
Display/Adj/Set Range	0 to 999999
Unit	times
Default Value	0

TESTMODE (Service mode for test print, operation check, etc.)

SYSTEM (SYSTEM Test Mode)

TESTMODE (Service mode for test print, operation check, etc.) > SYSTEM (SYSTEM Test Mode)

TEST1	Checking of data migration
Detail	To check data reading/writing of DRAM area (excluding system work area).
Adj/Set/Operate Method	Press OK key.
Caution	In some cases, the test may take longer time. After performing this test, turn OFF and then ON the power.
Display/Adj/Set Range	A result of a check is displayed.

SCAN (SCAN Test Mode)

■ SCAN (SCAN > SENSOR Test Mode)

TESTMODE (Service mode for test print, operation check, etc.) > SCAN (SCAN Test Mode) > SCAN (SCAN > SENSOR Test Mode)

ESS DOOR SENS	Cartridge door switch CHECK
Detail	To check for any failure of the Cartridge Door Switch.
Adj/Set/Operate Method	Opening the Cartridge Door changes the displayed value from "1" to "0".
Display/Adj/Set Range	0 to 1 1 : ON (CLOSE) 0 : OFF (OPEN)

PANEL (PANEL Test Mode)

TESTMODE (Service mode for test print, operation check, etc.) > PANEL (PANEL Test Mode)

KEY CHECK START	KEY CHECK
Details	To check for any failure of the keys.
Adj/set/operate method	By pressing a key, the corresponding character is hidden in response to the key operation.
Caution	Only the keys controlled by SCNT are checked. The power key is not checked.
Display/adj/set range	The character corresponding to the key is displayed.
LED CHECK START	LED CHECK
Details	To check for any failure of the LEDs.
Adj/set/operate method	All LED turns on.
Caution	Only the LEDs controlled by SCNT are checked. The Power Supply LED is not checked.
Display/adj/set range	LED turns on.
LCD CHECK START	LCD CHECK
Details	To check for any failure of the LCD.
Adj/set/operate method	When this item is executed, characters are displayed on the whole LCD. The whole LCD display is inverted by pressing OK key. Check whether the display is proper.
Display/adj/set range	Characters are displayed on the whole area. By pressing OK key, the whole LCD lights up.

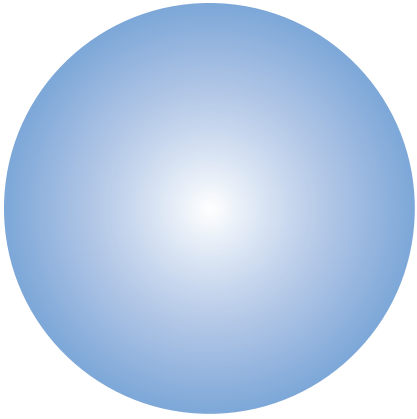

APPENDICES

Service Tools.....	141
General Circuit Diagram.....	142
Backup Data.....	144

Service Tools

Special Tools

In addition to the standard tools set, the following special tools are required when servicing the machine:

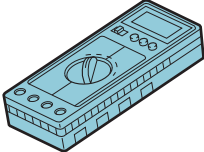
Name of Tool	Parts.No	Use
Digital Multimeter	FY9-2002	Used as a probe extension when making electrical checks. 

Solvents and Oil List

No.	Type	Purpose	Remark
1	Ethyl alcohol	Cleaning	<ul style="list-style-type: none"> • Purchase locally • Keep away from flame
2	Lubricant	Apply to gears	<ul style="list-style-type: none"> • Super lube grease:FY9-6005

General Circuit Diagram

General Circuit Diagram (1/2)

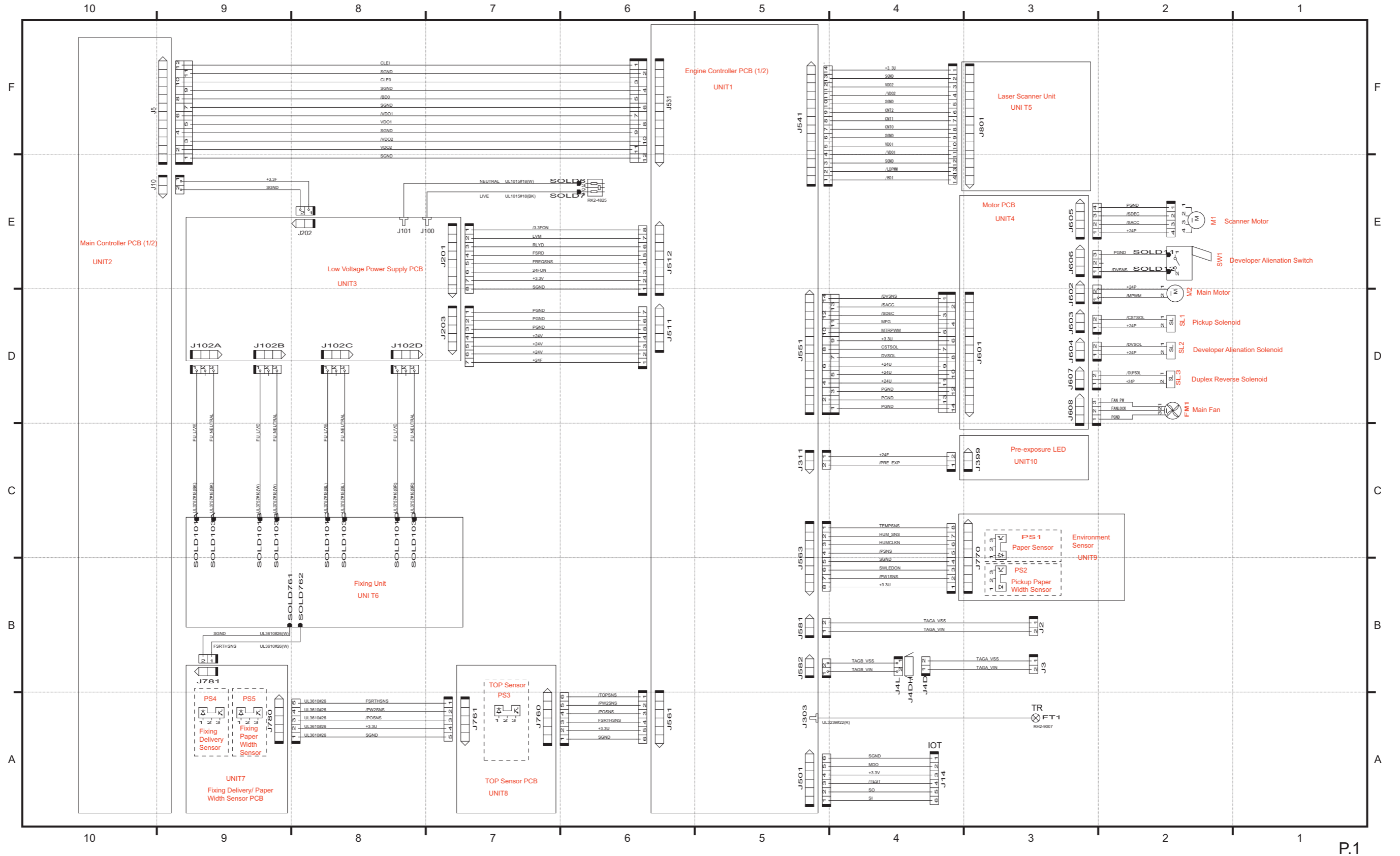

General Circuit Diagram (2/2)

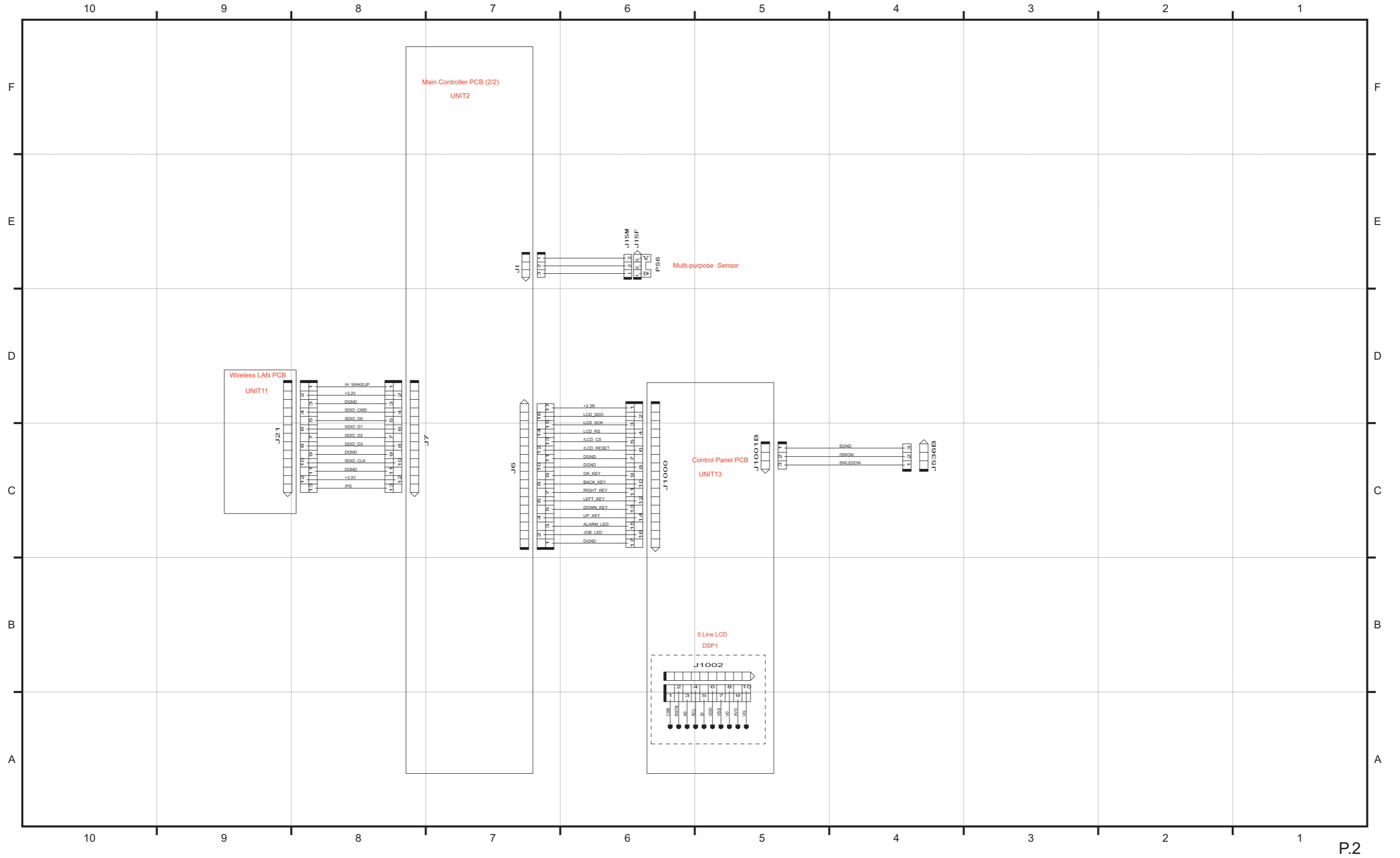

Backup Data



Data			Replacement		DeleteMethod						Backup by User			Backup by Service		
			Main Controller PCB*1	Engine Controller PCB	Setup by User		ServiceMode COPIER > FUNCTION > CLEAR				Yes/No	Method	Location	Yes/No	Method	Location
					Settings/Registration: System Management Settings: Initialize Setting Information		ALL	SRVC-DAT	CRG-LOG	HIST > ACC-HIST,JAM-HIST,ERR-HIST						
					Initialize Menu	Initialize Key and Certify										
Remote UI	Preferences	Paper Settings	Clear	-	Clear	-	Clear	-	-	-	No	-	-	No	-	-
		Display Settings	Clear	-	Clear	-	Clear	-	-	-	No	-	-	No	-	-
		Timer Settings	Clear *1	-	Clear	-	Clear	-	-	-	No	-	-	No	-	-
	Function Settings	Common Settings	Clear	-	Clear	-	Clear	-	-	-	No	-	-	No	-	-
		Printer Settings	Clear	-	Clear	-	Clear	-	-	-	No	-	-	No	-	-
	System Management Settings	System Management	Clear *1	-	Clear	-	Clear	-	-	-	No	-	-	No	-	-
		Network Settings	Clear	-	Clear	-	Clear	-	-	-	No	-	-	No	-	-
		SecuritySettingsInitializeKey and Certificate are excluded.	Clear	-	-	Clear	Clear	-	-	-	No	-	-	No	-	-
	Security Settings (Initialize Key and Certificate)	Clear	-	-	Clear	Clear	-	-	-	No	-	-	No	-	-	
Service Mode	Service data(Set value)		Clear	-	-	-	Clear	Clear	-	-	No	-	-	No	-	-
	COUNTER	Service counter	Clear	-	-	-	Clear	-	-	-	No	-	-	No	-	-
		JOB ID	Clear	-	-	-	Clear	-	-	-	No	-	-	No	-	-
		Log(Print Log, Jam log, Error log)	Clear	-	-	-	Clear	-	-	Clear	No	-	-	No	-	-
		CRG log	Clear	-	-	-	Clear	-	Clear	-	No	-	-	No	-	-

*1. When the system has been updated, the items shown below need to be reset.

- Current Date / Time Settings
- Consumables Supplier Information