

**LASER CLASS<sup>®</sup> 5000**  
**PLAIN PAPER FACSIMILE**  
**LASER CLASS<sup>®</sup> 5500**  
**PLAIN PAPER FACSIMILE**

**SERVICE**  
**MANUAL**

REVISION 0

LASER CLASS 5000	H11-2922	120V
LASER CLASS 5500	H12-0042	120V
FXL-FEEDER1	H12-3012	120V
HANDSET KIT 2	H12-3042	120V

**Canon**

MAR. 1994

**HY8-19A0-000**

034 SC 1.30-0

***LASER CLASS<sup>®</sup> 5000***

***PLAIN PAPER FACSIMILE***

***LASER CLASS<sup>®</sup> 5500***

***PLAIN PAPER FACSIMILE***

**SERVICE  
MANUAL**

**Canon**

## **Application**

This manual has been issued by Canon Inc. for qualified persons to learn technical theory, installation, maintenance, and repair of products. This manual covers all localities where the products are sold. For this reason, there may be information in this manual that does not apply to your locality.

## **Corrections**

This manual may contain technical inaccuracies or typographical errors due to improvements or changes in products. When changes occur in applicable products or in the content of this manual, Canon will release technical information as the need arises. In the event of major changes in the contents of this manual over a long or short period, Canon will issue a new editions of this manual.

**The following paragraph does not apply to any countries where such provisions are inconsistent with local law.**

## **Trademarks**

The product names and company names described in this manual are the registered trademarks of the individual companies.

## **Copyright**

This manual is copyrighted with all rights reserved. Under the copyright laws, this manual may not be copied, reproduced or translated into another language, in whole or in part, without the written consent of Canon Inc.,

**Copyright © 1994 by Canon Inc.**

**CANON INC.**

**Office Imaging Products Technical Support**

**30-2 Shimomaruko 3-Chome, Ohta-ku, Tokyo 146, Japan**

## **DTP System**






This manual was produced on an Apple Macintosh™ personal computer, and Canon Postscript™ Intelligent Processing Unit; final pages were printed on Afga ProSet 9800 with 9000 PS MAX PLUS/J.

All graphics were produced with Aldus FreeHand™.

All documents and all page layouts were created with QuarkXPress™.

# I. MEANINGS OF MARKS

The marks used in this manual have the following meanings.

Mark	Meaning
	States a precaution to be taken to prevent danger to personnel.
	States a precaution to be taken to avoid damage to the product.
	States a precaution to be taken to prevent damage to electronic components by electrostatic discharge.
	Gives useful information to understand descriptions.
	Indicates sections to be read to obtain more detailed information.

## II. ABOUT THIS MANUAL

This manual is divided into five parts, and contains information required for servicing the product.

### **Chapter 1: Safety and Precautions**

This part explains how to service the unit safely. It is very important, so please read it.

### **Chapter 2: Operating Instructions**

This part explains how to operate the unit properly. Information required about installation, service operations and service switches.

### **Chapter 3: Technical Reference**

This part explains the product specifications and the technical theory of the product.

### **Chapter 4: Maintenance and Service**

This part explains how to maintain the products for adjustment and troubleshooting.

### **Chapter 5: Appendices**

This part explains the informations of the optional products.



---

For more details of user operations, see the separate volume of Instruction Book.  
Procedures for assembly/disassembly are not given in this manual. See the illustrations in the separate volume of Parts Catalog.

---

# III. TABLE OF CONTENTS

	<b>Chapter 1: Safety and Precautions</b>
Page	
1-1	1. DANGER TO PERSONNEL
1-1	1.1 Electrical Shock
1-1	1.1.1 Power supply primary side
1-2	1.1.2 Telephone line primary side
1-3	1.1.3 Printer high voltage terminal
1-4	1.2 High-Temperature Sections
1-6	1.3 Moving and Rotating Parts
1-8	1.4 Laser/Scanner Unit
1-9	2. DANGER TO EQUIPMENT
1-9	2.1 Precaution in the Instruction Book
1-12	2.2 Storage and Handling of Toner Cartridge
1-12	2.2.1 Storing a sealed FX 2 cartridge package
1-13	2.2.2 Storing a unsealed FX 2 cartridge package
1-14	2.2.3 Notes on handling
1-18	2.2.4 Recycling
1-22	2.3 Precautions when Servicing
1-22	2.3.1 Parts replacement
1-24	2.3.2 Precautions for Danger by Static Charge
1-24	2.3.3 Handling the contact sensor
1-25	2.3.4 ADF section roller handling
1-25	2.3.5 Installation
1-26	2.3.6 Printer section handling
1-28	2.3.7 Recording paper jam handling
1-38	2.3.8 Precautions for replacing the SCNT board
1-40	2.3.9 Precautions for replacing the lithium battery
1-41	2.3.10 Precautions for handling the NCU board
1-42	2.4 Precautions for Carrying, Moving, and Transporting
1-43	3. DATA PRECAUTIONS
1-43	3.1 Data Cleared When the Power Goes Off
1-43	3.2 Data Initialization
1-44	3.3 Master Password
1-45	3.4 Precautions for Setting the Polling Password
1-46	3.5 Precautions for Using the FAX/TEL Switching Function
1-47	4. PROTECTIVE FUNCTIONS
1-47	4.1 Data Backed Up by Lithium Battery
1-48	4.2 Image Data Transfer
1-49	4.3 Printer Protective Functions
	<b>Chapter 2: Operating Instructions</b>
2-1	1. NAMES OF PARTS AND THEIR FUNCTIONS
2-1	1.1 Main Unit External View
2-4	1.2 Operation Switches
2-4	1.2.1 Control panel section
2-7	1.2.2 Left side section
2-7	1.2.3 Handset (LASER CLASS 5500 only)

2-8	2. SIMPLE OPERATIONS
2-8	2.1 COPYING
2-10	2.2 Telephone
2-11	2.3 Transmission
2-11	2.3.1 Memory transmission
2-11	2.3.2 Direct transmission
2-11	2.3.3 Manual transmission
2-12	2.4 Reception
2-12	2.4.1 Automatic reception
2-12	2.4.2 FAX/TEL switching (automatic reception)
2-12	2.4.3 Manual reception
2-13	2.5 Registering information for your fax
2-16	3. SERVICE OPERATION FUNCTION
2-16	3.1 Error Display Function
2-16	3.1.1 Error displays
2-17	3.1.2 Errors displayed in error report
2-18	3.2 Report Output Function
2-18	3.2.1 User report output functions
2-38	3.2.2 Service report output functions
2-49	3.3 User Data
2-49	3.3.1 Overview of user data
2-51	3.3.2 User data menu
2-58	3.3.3 The basic data settings
2-60	3.3.4 The reports setting
2-62	3.3.5 The send settings
2-64	3.3.6 The receive settings
2-68	3.3.7 The printer settings
2-70	3.3.8 The file settings
2-72	3.3.9 The system settings
2-74	3.4 Service Data Registration/Setting
2-74	3.4.1 Overview of service data
2-75	3.4.2 Service data registration/setting method
2-76	3.4.3 Service data menu
2-82	3.4.4 Explanation of service data
2-117	3.5 Test Functions
2-117	3.5.1 Test mode overview
2-118	3.5.2 Test mode flowcharts
2-124	3.5.3 D-RAM tests
2-125	3.5.4 CS test
2-125	3.5.5 Print test
2-130	3.5.6 Modem and NCU tests
2-133	3.5.7 Aging test
2-133	3.5.8 Faculty tests
2-141	4. SUPPLEMENTARY ITEMS FOR INSTRUCTION BOOK
2-141	4.1 Automatic Redial Interval
2-141	4.2 Superfine Communications
2-141	4.3 Transaction Number
2-141	4.4 Side Cassette Recording Paper Size Setting
2-142	4.5 Quick Memory Transmission/Memory Reception Page Count



### **Chapter 3: Technical Reference**

3-1	1. SPECIFICATIONS
3-1	1.1 Device Overview
3-3	1.2 Configuration and Structure
3-3	1.2.1 Product name
3-3	1.2.2 External View
3-5	1.2.3 Mechanical configuration
3-6	1.3 Specifications and Functions
3-6	1.3.1 Basic specifications
3-7	1.3.2 Communications Specifications
3-9	1.3.3 Document Scanner Specifications
3-12	1.3.4 Printer section specifications
3-15	1.3.5 Communications functions
3-20	2. OPERATIONS
3-20	2.1 Product Overview
3-20	2.1.1 Fax main unit overview
3-20	2.1.2 Option overview (Only for LASER CLASS 5000)
3-20	2.1.3 Consumables
3-22	2.2 Structural Section Overview
3-22	2.2.1 Unit layout diagram
3-22	2.2.2 Document and recording paper flow
3-24	2.2.3 Drive system layout
3-26	2.2.4 Electrical system layout
3-28	2.2.5 Arrangement of sensors
3-30	2.3 Scanner Section
3-30	2.3.1 Document feed section
3-34	2.3.2 Optical section
3-36	2.4 Pickup Section
3-36	2.4.1 Recording paper pickup section
3-44	2.5 Printer Section
3-48	2.5.1 Recording paper feed/eject section
3-54	2.5.2 Laser/scanner
3-60	2.5.3 Toner cartridge
3-68	2.5.4 Toner transfer section
3-70	2.5.5 Fixing unit
3-74	2.6 Circuit Overview
3-74	2.6.1 Function block diagram
3-75	2.6.2 SCNT board functions
3-81	2.6.3 Component block diagram
3-85	2.6.4 Components block diagram
3-90	2.6.5 Image signal flow
3-93	3. COMMUNICATION SYSTEM OPERATIONS
3-93	3.1 FAX/TEL Switching
3-93	3.1.1 Operation specifications
3-94	3.1.2 Operation settings
3-94	3.1.3 List of related parameters
3-96	3.1.4 Operation procedure summary (The values are all default settings.)
3-98	3.2 Answering Machine Connection

3-98	3.2.1 Operating specifications
3-99	3.2.2 Operation setting
3-99	3.2.3 List of related parameters
3-100	3.2.4 Operations procedure summary
3-103	3.3 Remote Reception
3-103	3.3.1 Operation specifications
3-104	3.3.2 Operation settings
3-104	3.3.3 List of related parameters
3-105	3.3.4 Operation procedure summary
3-107	4. NEW FUNCTIONS
3-107	4.1 Quick-on-line TX
3-107	4.2 Superfine Communications with Other Companies' Fax Machines
3-108	4.3 Canon Express Protocol 2
3-108	4.3.1 Operations Summary
3-108	4.3.2 Operations conditions
3-109	4.3.3 Standard protocol
3-110	4.3.4 Transmission side operations
3-110	4.3.5 Reception side operations
3-111	4.4 Processing When Memory Scanning Is Full
3-111	4.4.1 Specifications
3-111	4.5 Forced Reduction
3-111	4.5.1 Setting method
3-112	4.6 Selected Transmission Result Report Output
3-112	4.6.1 Output method
3-112	4.7 Memory Transmission Check Start
3-112	4.7.1 Setting method
3-113	4.8 DRPD (Distinctive Ringing Pattern Detection) function
3-113	4.8.1 Setting method
3-114	4.8.2 DRPD ring patterns (Ringing voltage patterns)

#### **Chapter 4: Maintenance & Service**

4- 1	1. MAINTENANCE
4- 1	1.1 Maintenance Items
4- 1	1.1.1 Consumables
4- 2	1.1.2 Cleaning
4- 3	1.1.3 Periodic inspections
4- 3	1.1.4 Periodic replacement parts
4- 4	1.2 Tools
4- 4	1.2.1 General tools
4- 4	1.2.2 Special tools
4- 5	2. CLEANING
4- 5	2.1 Separation Roller
4- 5	2.2 Loading Roller
4- 5	2.3 Separation Guide
4- 5	2.4 Scanning Glass (Contact Sensor)
4- 5	2.5 Document Feed Roller/Eject Roller
4- 6	2.6 Mirror
4- 6	2.6.1 Using blower brush

4-6	2.6.2 Using Inst-free paper
4-10	2.7 Transfer Charging Roller/Static Charge Eliminator
4-10	2.7.1 Preparations for cleaning
4-12	2.7.2 Cleaning
4-14	2.8 Fixing Film/Fixing Entrance Guide
4-14	2.8.1 Preparations for cleaning
4-15	2.8.2 Cleaning
4-16	2.9 Fixing Pressure Roller
4-16	2.9.1 Preparations for cleaning
4-18	2.9.2 Cleaning
4-19	2.10 Fixing Eject Roller
4-19	2.10.2 Cleaning
4-20	2.11 Fixing Eject Guide
4-20	2.11.1 Preparations for cleaning
4-22	2.11.2 Cleaning
4-23	2.12 Paper feed guide
4-23	2.12.1 Preparations for cleaning
4-27	2.12.2 Cleaning
4-28	2.14 High voltage Terminal
4-30	3. PARTS REPLACEMENT AND ADJUSTMENT
4-30	3.1 Parts Replacement
4-30	3.2 Greasing Locations
4-30	3.2.1 Non-electroconductive grease
4-31	3.2.2 Electroconductive grease
4-32	3.3 Adjustment
4-32	3.3.1 Adjustment items
4-32	3.3.2 Transmission level adjustment
4-32	3.3.3 NL equalizer adjustment
4-34	3.3.4 Mirror position adjustment
4-40	3.3.5 Leading edge margin adjustment
4-44	3.3.6 LED light emission level adjustment
4-48	4. TROUBLESHOOTING
4-48	4.1 Troubleshooting
4-48	4.1.1 Environment
4-48	4.1.2 Precautions for troubleshooting
4-49	4.2 Errors
4-49	4.2.1 Error shown on the display
4-54	4.2.2 Error codes
4-82	4.3 Breakdowns and Recovery
4-100	5. WIRING DIAGRAM
4-100	5.1 Wiring Diagram
4-101	5.2 Connector Location and Signals
4-101	5.2.1 SCNT board
4-107	5.2.2 NCU board
4-109	5.2.3 OPCNT board
4-113	5.2.4 PSU board
4-115	5.2.5 PCNT board
4-122	5.2.6 Paper Sensor board

4-125	5.2.7 Laser/Scanner unit
4-127	5.2.8 CS unit
4-129	5.2.9 Fixing unit
4-130	5.2.10 VR board
4-131	5.2.11 LED board
4-131	5.2.12 Toner sensor board
4-133	5.2.13 Document sensor (DS)
4-133	5.2.14 Document edge sensor (DES)
4-134	5.2.15 Exit paper cover sensor
4-135	5.2.16 Recording paper feed solenoid
4-135	5.2.17 Recording paper pickup sensor
4-136	5.2.18 Document feed motor
4-137	5.2.19 Main motor
4-137	5.2.20 Fan motor
4-138	5.2.21 Speaker

### **Chapter 5: Appendices**

5- 1	1. INSTALLATION
5- 2	1.1 Important precautions
5- 5	1.2 Have you got everything ?
5- 7	1.3 Assembling the fax
5- 8	1.4 Installing the toner cartridge
5-11	1.5 Loading recording paper
5-15	1.6 Making connections
5-17	1.7 Getting ready to use the fax
5-20	1.8 Checking Operations
5-21	1.9 Adjustments
5-23	2. OPTION
5-23	2.1 G3 FAX OPTION MEMORY II (0.5M-BYTE)
5-23	2.1.1 Safety and precautions
5-23	2.1.2 Service operations
5-27	2.1.3 Technical information
5-29	2.1.4 Maintenance and service
5-30	2.2 HANDSET KIT 2
5-30	2.2.1 Service operations
5-31	2.2.2 Technical information
5-32	2.2.3 Operations
5-33	2.2.4 Maintenance and service
5-35	2.3 FXL-CASSETTE 1 LTR/500
5-35	2.3.1 Service operations
5-37	2.3.2 Technical information
5-39	2.4 FXL-FEEDER 1
5-39	2.4.1 Safety and precautions
5-40	2.4.2 Service operations
5-49	2.4.3 Technical information
5-51	2.4.4 Operations
5-57	2.4.5 Maintenance and service
5-65	2.4.6 Recording Paper Size Priority

5-73	<b>3. SERVICE TOOLS</b>
5-73	3.1 Printer Driver Tester
5-73	3.1.1 Outline
5-74	3.1.2 Explanation of LEDs and Switches
5-74	3.1.3 Connector signal list
5-75	3.1.4 Laser malfunction diagnosis flowchart

## IV. ILLUSTRATION INDEX

Page	<i>Chapter 1: Safety and Precautions</i>	
1- 1	Figure 1-1	Power Supply Primary Side
1- 2	Figure 1-2	Telephone Line Primary Side
1- 3	Figure 1-3	Printer High Voltage Terminal
1- 5	Figure 1-4	Fixing Unit
1- 5	Figure 1-5	Paper eject guide (lower)
1- 6	Figure 1-6	Right Cover Sensor Arm
1- 7	Figure 1-7	Moving and Rotating Parts
1- 8	Figure 1-8	Laser Shutter
1- 9	Figure 1-9	Instruction Book Page 3
1-10	Figure 1-10	Instruction Book Page 4
1-11	Figure 1-11	Instruction Book Page 5
1-14	Figure 1-12	Handling Toner Cartridge
1-14	Figure 1-13	Shaking Toner Cartridge
1-15	Figure 1-14	Incorrect Handling
1-15	Figure 1-15	External View (FX 2 Cartridge)
1-18	Figure 1-16	Cartridge Recycling (U.S.A) 1/2
1-19	Figure 1-17	Cartridge Recycling (U.S.A) 2/2
1-20	Figure 1-18	Cartridge Recycling (Canada) 1/2
1-21	Figure 1-19	Cartridge Recycling (Canada) 2/2
1-22	Figure 1-20	Lifting Arm Initial Position
1-23	Figure 1-21	Pickup Roller Initial Position
1-24	Figure 1-22	Drive Gear Ass'y
1-27	Figure 1-23	Printer Section
1-28	Figure 1-24	Paper Jam in the Paper Feed Section (1/2)
1-29	Figure 1-25	Paper Jam Recover. 1
1-29	Figure 1-26	Paper Jam Recover. 2
1-30	Figure 1-27	Paper Jam Recover. 3
1-30	Figure 1-28	Paper Jam in the Paper Feed Section (2/2)
1-31	Figure 1-29	Paper Jam Recover. 4
1-32	Figure 1-30	Paper Jam in the Paper Pickup Section
1-32	Figure 1-31	Paper Jam Recover. 5
1-33	Figure 1-32	Paper Jam Recover. 6
1-34	Figure 1-33	Paper Jam in the Paper Eject Section
1-34	Figure 1-34	Paper Jam Recover. 7
1-35	Figure 1-35	Paper Jam Recover. 8
1-36	Figure 1-36	Paper Jam in the Fixing Ass'y
1-37	Figure 1-37	Disassembly Procedure (Fixing Ass'y)
1-39	Figure 1-38	Inputting the Print Page Count and Scan Page Count
1-41	Figure 1-39	Control on NCU Board
1-42	Figure 1-40	Precaution for Carrying and Moving
1-45	Figure 1-41	Password Comparison Table
1-46	Figure 1-42	FAX/TEL Switching Function
1-48	Figure 1-43	Image Data Transfer Operations Method
1-12	Table 1-1	Temperature and Humidity/Storage Conditions

## **Chapter 2: Operating Instructions**

2- 1	Figure 2-1	Main Unit External View (1)
2- 2	Figure 2-2	Main Unit External View (2)
2- 4	Figure 2-3	Control Panel Section (Left)
2- 5	Figure 2-4	Control Panel Section (Right)
2- 6	Figure 2-5	Function Keys
2- 7	Figure 2-6	Left Side Section
2- 7	Figure 2-7	Handset
2- 8	Figure 2-8	Document Loading Display
2- 9	Figure 2-9	Paper Guide Adjustment
2- 9	Figure 2-10	Setting A Document
2- 9	Figure 2-11	Adding Pages to A Document
2-19	Figure 2-12	One-Touch Speed Dial List 1
2-20	Figure 2-13	Coded Speed Dial List 1
2-21	Figure 2-14	Group Dial List
2-22	Figure 2-15	One-Touch Speed Dial List 2
2-23	Figure 2-16	Coded Speed Dial List 2
2-24	Figure 2-17	User's Data List (1/2)
2-25	Figure 2-18	User's Data List (2/2)
2-26	Figure 2-19	Confidential Mail box Report
2-26	Figure 2-20	Transmission Reserve List
2-27	Figure 2-21	Document Memory List
2-28	Figure 2-22	Transmission Report
2-29	Figure 2-23	Error Transmission Report
2-30	Figure 2-24	Reception Report
2-31	Figure 2-25	Confidential Reception Report
2-32	Figure 2-26	Multi-Transaction Report
2-33	Figure 2-27	Activity Report
2-34	Figure 2-28	Activity Report (When Restricting Sending/ Printing Operating, Separate Transmission/ Reception Report)
2-35	Figure 2-29	Activity Report (Separate Transmission/ Reception Reports)
2-36	Figure 2-30	Activity Report (When Restricting Sending/Printing Operating, Separate Transmission/Reception Report)
2-37	Figure 2-31	Memory Clear Report
2-39	Figure 2-32	System Data List (1/5)
2-40	Figure 2-33	System Data List (2/5)
2-41	Figure 2-34	System Data List (3/5)
2-42	Figure 2-35	System Data List (4/5)
2-43	Figure 2-36	System Data List (5/5)
2-44	Figure 2-37	System Dump List (top of 1st page)
2-45	Figure 2-38	System Dump List (Data on most recent three errors)
2-46	Figure 2-39	Service Error Transmission Report
2-47	Figure 2-40	Service (Error) Reception Report
2-51	Figure 2-41	User Data (1/7)
2-52	Figure 2-42	User Data (2/7)
2-53	Figure 2-43	User Data (3/7)

2-54	Figure 2-44	User Data (4/7)
2-55	Figure 2-45	User Data (5/7)
2-56	Figure 2-46	User Data (6/7)
2-57	Figure 2-47	User Data (7/7)
2-75	Figure 2-48	Service Data Registration/Setting
2-76	Figure 2-49	Service Data (1/6)
2-77	Figure 2-50	Service Data (2/6)
2-78	Figure 2-51	Service Data (3/6)
2-79	Figure 2-52	Service Data (4/6)
2-80	Figure 2-53	Service Data (5/6)
2-81	Figure 2-54	Service Data (6/6)
2-82	Figure 2-55	Bit Switch Display
2-76	Figure 2-56	Reading Bit Switch Tables
2-87	Figure 2-57	Setting the Long Distance Mode with the Service Soft Switch
2-97	Figure 2-58	Page Timer Settings
2-102	Figure 2-59	Reading Tables
2-113	Figure 2-60	Print Density Settings
2-116	Figure 2-61	How to Read ROM Management Data
2-118	Figure 2-62	Test Mode (1/6)
2-119	Figure 2-63	Test Mode (2/6)
2-120	Figure 2-64	Test Mode (3/6)
2-121	Figure 2-65	Test Mode (4/6)
2-122	Figure 2-66	Test Mode (5/6)
2-123	Figure 2-67	Test Mode (6/6)
2-124	Figure 2-68	D-RAM Test
2-125	Figure 2-69	Print Pattern Check
2-126	Figure 2-70	Print Sample 1
2-128	Figure 2-71	Test Print Switch
2-129	Figure 2-72	Print Sample 2
2-130	Figure 2-73	Relay Test
2-132	Figure 2-74	Tonal and DTMF Signal Reception Tests
2-135	Figure 2-75	Sensor Tests 1
2-136	Figure 2-76	Sensor Tests 2
2-137	Figure 2-77	ADF Test
2-137	Figure 2-78	Speaker Test
2-139	Figure 2-79	Control Panel

### **Chapter 3: Technical Reference**

3- 1	Figure 3-1	Instruction Book vi
3- 2	Figure 3-2	Instruction Book vii
3- 3	Figure 3-3	External View (LASER CLASS 5000)
3- 4	Figure 3-4	External View (LASER CLASS 5500)
3-11	Figure 3-5	Scanning Range
3-14	Figure 3-6	Printing Range
3-21	Figure 3-7	Overview
3-23	Figure 3-8	Cross-Section
3-24	Figure 3-9	Driver Layout (Front View)
3-25	Figure 3-10	Drive Layout (Top View)



3-27	Figure 3-11	Electrical System Layout
3-29	Figure 3-12	Arrangement of Sensors
3-31	Figure 3-13	Document Feed Structure (Front View)
3-35	Figure 3-14	Contact Sensor (Cross-Section)
3-37	Figure 3-15	Pickup Configuration
3-39	Figure 3-16	Recording Paper Pickup Detection Configuration
3-41	Figure 3-17	Recording Paper Pickup Jam
3-43	Figure 3-18	Recording Paper Size Detection Configuration
3-47	Figure 3-20	Printer Section Configuration
3-49	Figure 3-21	Recording Paper Feed/Eject Configuration
3-51	Figure 3-22	Recording Paper Feed Jam
3-51	Figure 3-23	Fixing Unit Wrap-Around Jam
3-51	Figure 3-24	Recording Paper Eject Jam
3-52	Figure 3-25	Power Up Recording Paper Jam 1
3-53	Figure 3-26	Power Up Recording Paper Jam 2
3-55	Figure 3-27	Laser/Scanner Unit
3-57	Figure 3-28	Photosensitive Drum Exposure Configuration
3-58	Figure 3-29	Unblinking Signal
3-59	Figure 3-30	Horizontal Scan Reference Position Detection Configuration
3-61	Figure 3-31	Toner Cartridge
3-62	Figure 3-32	High Voltage Terminals
3-63	Figure 3-33	Primary Charging Configuration
3-63	Figure 3-34	Exposure Configuration
3-64	Figure 3-35	Developing Configuration
3-65	Figure 3-36	Toner Projection Phenomenon
3-67	Figure 3-37	Cleaning Configuration
3-67	Figure 3-38	No-toner Detection Configuration
3-69	Figure 3-39	Transfer Configuration
3-71	Figure 3-40	Fixing Unit
3-71	Figure 3-41	Fixing Film Unit (Internal View)
3-74	Figure 3-42	Function Block Diagram
3-81	Figure 3-43	Components Block Diagram
3-83	Figure 3-44	Components Block Diagram (PCNT board)
3-90	Figure 3-45	Transmission Image Signal Flow
3-91	Figure 3-46	G3 Receive Image Signal Flow
3-95	Figure 3-47	Pseudo-Ringback Tone/Pseudo-ring Signal Pattern 1
3-95	Figure 3-48	Pseudo-Ringback Tone/Pseudo-ring Signal Pattern 2
3-97	Figure 3-49	FAX/TEL Switching
3-98	Figure 3-50	CNG Pattern
3-100	Figure 3-51	Answering Machine Connection 1
3-101	Figure 3-52	Answering Machine Connection 2
3-102	Figure 3-53	Answering Machine Connection 3
3-103	Figure 3-54	CNG Pattern
3-105	Figure 3-55	Remote Reception (ID CALL #)
3-106	Figure 3-56	Remote Reception (Hook)
3-109	Figure 3-57	Canon Express Protocol 2
3-114	Figure 3-58	DRPD Ring Pattern (Ringing Voltage Patterns)

## **Chapter 4: Maintenance and Service**

4- 5	Figure 4-1	Cleaning Locations 1
4- 6	Figure 4-2	Cleaning Locations 2
4- 7	Figure 4-3	Disassembly Procedure (Covers)
4- 8	Figure 4-4	Cleaning Locations 3
4-11	Figure 4-5	Disassembly Procedure (Transfer Charging Roller)
4-12	Figure 4-6	Cleaning Locations 4
4-12	Figure 4-7	Cleaning Locations 5
4-14	Figure 4-8	Disassembly Procedure (Fixing ass'y)
4-15	Figure 4-9	Cleaning Locations 6
4-16	Figure 4-10	Disassembly Procedure (Fixing ass'y)
4-17	Figure 4-11	Disassembly Procedure (Fixing Upper Cover)
4-17	Figure 4-12	Disassembly Procedure (Fixing Film Unit)
4-18	Figure 4-13	Caution for Cable Connecting
4-18	Figure 4-14	Cleaning Locations 7
4-19	Figure 4-15	Disassembly Procedure (Paper Exit Roller Ass'y)
4-19	Figure 4-16	Cleaning Locations 8
4-20	Figure 4-17	Disassembly Procedure (Fixing ass'y)
4-21	Figure 4-18	Disassembly Procedure (Fixing Upper Cover)
4-21	Figure 4-19	Disassembly Procedure (Fixing Upper Guide)
4-22	Figure 4-20	Cleaning Locations 9
4-23	Figure 4-21	Disassembly Procedure (Fixing ass'y)
4-24	Figure 4-22	Disassembly Procedure (Covers)
4-25	Figure 4-23	Disassembly Procedure (Mirror)
4-26	Figure 4-24	Disassembly Procedure (Transfer Charging Roller)
4-27	Figure 4-25	Cleaning Locations 10
4-27	Figure 4-26	Cleaning Locations 11
4-28	Figure 4-27	Cleaning Locations 12
4-30	Figure 4-28	Grease Application Locations 1
4-31	Figure 4-29	Grease Application Locations 2
4-35	Figure 4-30	Disassembly Procedure (Covers)
4-36	Figure 4-31	Mirror Position Adjustment 1
4-37	Figure 4-32	Test Print Switch
4-38	Figure 4-33	Mirror Position Adjustment 2
4-39	Figure 4-34	Mirror Position Adjustment 3
4-41	Figure 4-35	Disassembly Procedure (Covers)
4-43	Figure 4-36	Leading Edge Margin Adjustment
4-44	Figure 4-37	Disassembly Procedure (Front Cover)
4-45	Figure 4-38	Cartridge Cover Position Correction
4-46	Figure 4-39	Flowchart of LED Light Emission Level Adjustment Mode
4-47	Figure 4-40	VR Board
4-54	Figure 4-41	Service Error Code Display
4-84	Figure 4-42	Faulty Print Samples
4-93	Figure 4-43	Nip Width
4-100	Figure 4-44	Wiring Diagram
4-101	Figure 4-45	SCNT Board
4-107	Figure 4-46	NCU Board
4-109	Figure 4-47	OPCNT Board

4-113	Figure 4-48	PSU Board
4-115	Figure 4-49	PCNT Board
4-122	Figure 4-50	Paper Sensor Board
4-125	Figure 4-51	Laser/Scanner Unit
4-127	Figure 4-52	CS Unit
4-129	Figure 4-53	Fixing Unit
4-130	Figure 4-54	VR Board
4-131	Figure 4-55	LED Board
4-132	Figure 4-56	Toner Sensor Board
4-133	Figure 4-57	Document Sensor (DS)
4-133	Figure 4-58	Document Edge Sensor (DES)
4-134	Figure 4-59	Exit Paper Cover Sensor
4-135	Figure 4-60	Recording Paper Feed Solenoid
4-135	Figure 4-61	Recording Paper Pickup Solenoid
4-136	Figure 4-62	Document Feed Motor
4-137	Figure 4-63	Main Motor
4-137	Figure 4-64	Fan Motor
4-138	Figure 4-65	Speaker

### **Chapter 5: Appendices**

5-18	Figure 5-1	Initializing the RAM
5-20	Figure 5-2	Copy Operation Flow Chart
5-21	Figure 5-3	Transmission Level Adjustment Flow Chart
5-21	Figure 5-4	NL Equalizer Adjustment Flow Chart
5-23	Figure 5-5	External View
5-24	Figure 5-6	Preparation for Installation
5-25	Figure 5-7	Installation
5-26	Figure 5-8	Check After Memory IC Installation
5-27	Figure 5-9	Memory External View
5-30	Figure 5-10	External View
5-30	Figure 5-11	Attachment to the main unit
5-31	Figure 5-12	External View
5-32	Figure 5-13	Electric Circuit Section
5-35	Figure 5-14	External View
5-36	Figure 5-15	Loading Recording Paper
5-37	Figure 5-16	External View
5-39	Figure 5-17	Moving Sections
5-40	Figure 5-18	External Views
5-41	Figure 5-19	Attachment to the Main Unit 1
5-42	Figure 5-20	Attachment to the Main Unit 2
5-43	Figure 5-21	Attachment to the Main Unit 3
5-44	Figure 5-22	Attachment to the Main Unit 4
5-45	Figure 5-23	Attachment to the Main Unit 5
5-46	Figure 5-24	Pickup Roller Initial Position
5-47	Figure 5-25	Loading Recording Paper
5-49	Figure 5-26	External View
5-53	Figure 5-27	Cross-Sectional Diagram
5-54	Figure 5-28	Arrangement of Sensors

5-56	Figure 5-29	Electrical Circuit Section
5-58	Figure 5-30	Driver Board
5-62	Figure 5-31	Front Cassette No-Paper LED
5-62	Figure 5-32	Front Cassette Recording Paper Sensor
5-63	Figure 5-33	Feeder Section Pickup Solenoid
5-63	Figure 5-34	Feeder Right Cover Sensor
5-65	Figure 5-35	Summary of Reception Image Printing
5-67	Figure 5-36	Summary of Automatic Reduction
5-70	Figure 5-37	Reading the Recording Paper Size Table
5-73	Figure 5-38	Printer Driver Tester
5-74	Figure 5-39	LEDs and Switches
5-74	Figure 5-40	Signal List
5-76	Figure 5-41	Connect Printer Driver Tester
5-77	Figure 5-42	Dust cover on the Laser/Scanner Unit
5-78	Figure 5-43	Diagnosis Flowchart
5-79	Figure 5-44	Testpoint Locations
5-79	Figure 5-45	Cartridge Cover Sensor Lever

# ***Chapter 1***

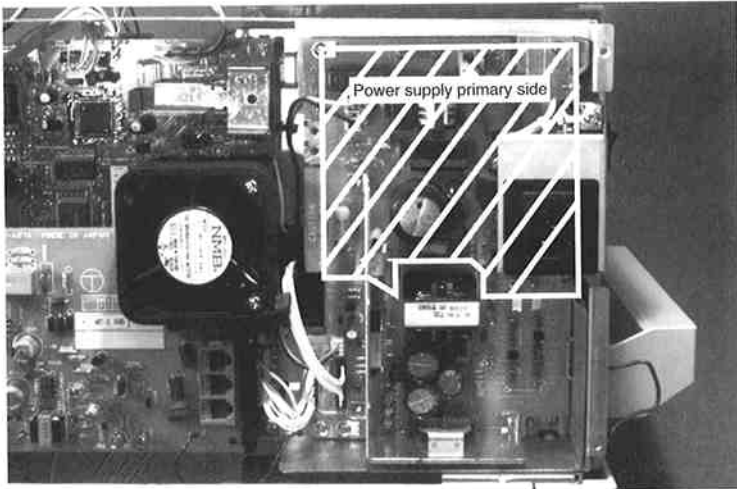
## ***Safety and Precautions***

## 1. DANGER TO PERSONNEL

### 1.1 Electrical Shock

#### 1.1.1 Power supply primary side

When the power switch is on, primary side AC power is supplied as is to the primary side of the power supply unit. Therefore, always unplug the power cord from the outlet before starting any servicing.



**Figure 1-1 Power Supply Primary Side**

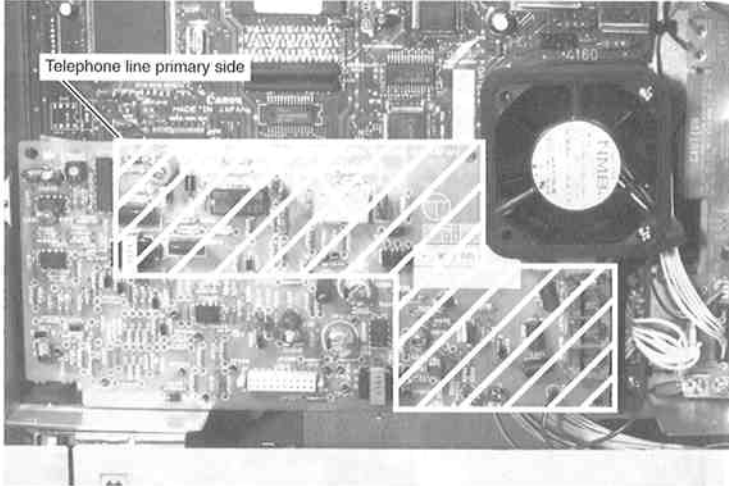


**WARNING**

Make sure that you are **not** grounded when you are working on plugged in equipment.

**1.1.2 Telephone line primary side**

The line voltage of approx. 48 VDC is supplied as is to the telephone line primary side. When the ringing voltage arrives, a voltage of approx. 210 Vrms maximum is supplied. Always remove the modular line cord from the modular jack before starting service.



**Figure 1-2 Telephone Line Primary Side**

### 1.1.3 Printer high voltage terminal

When the cartridge cover sensor lever and the cartridge sensor lever are pressed with the right cover and exit paper cover closed, voltage of approx. 3000 VDC maximum is supplied to the printer high voltage terminal. When you press the cartridge cover sensor lever and the cartridge sensor lever, be careful not to touch the high voltage terminal.

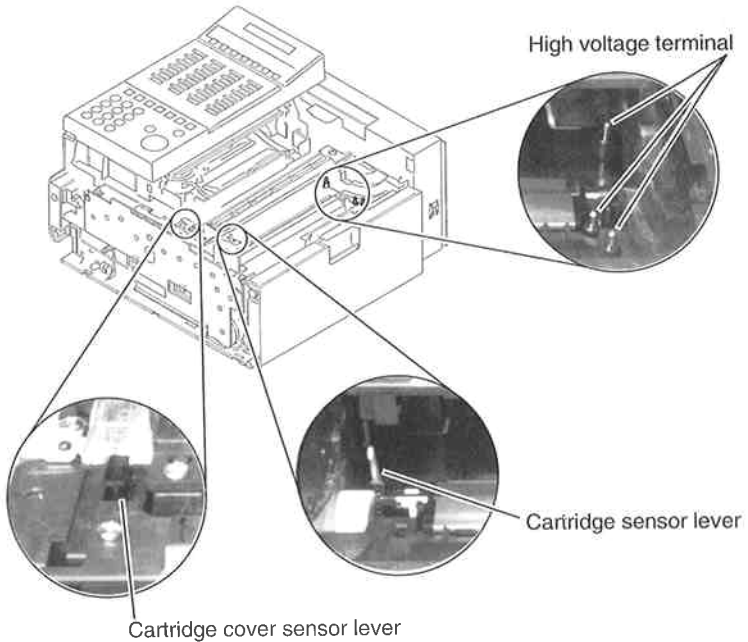


Figure 1-3 Printer High Voltage Terminal



**WARNING**

Make sure that you are **not** grounded when you are working on plugged in equipment.



## **1.2 High-Temperature Sections**

This fax has parts that become hot during use. Be careful not to burn yourself on any of these parts during servicing. Burns are caused by heat of approx. 50°C or more.



---

### **Danger!**

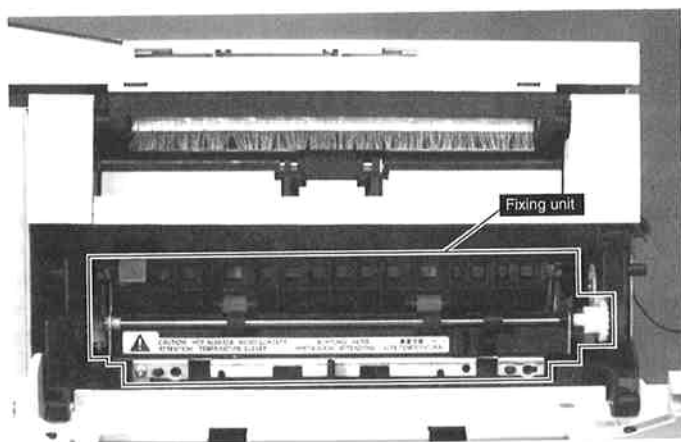
During printing, the temperature of the fixing unit rises to approx. 176°F (80°C) maximum, the temperature of the fixing heater of the fixing unit rises to approx. 374°F (190°C) maximum, the temperature of the paper eject guide (lower) rises to approx. 138°F (59°C) maximum, and the temperature of the main motor that drives the printer section rises to approx. 158°F (70°C) maximum.

When the main motor is operating, the temperature of its driver IC (IC601) on the PCNT board rises to approx. 163°F (73°C) maximum.

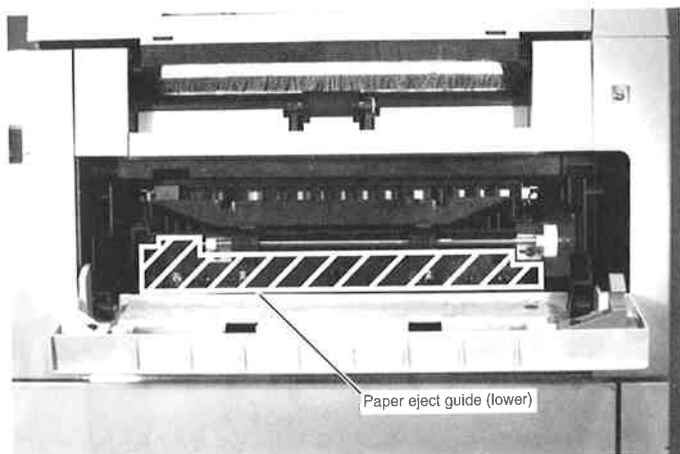
When the document feed motor that drives the scanner section is operating, the temperature of its driver IC (IC11) on the SCNT board rises to approx. 130°F (54°C) maximum.

The temperatures of the power supply unit heatsink rise to approx. 131°F (55°C) maximum during operation.

---



**Figure 1-4 Fixing Unit**



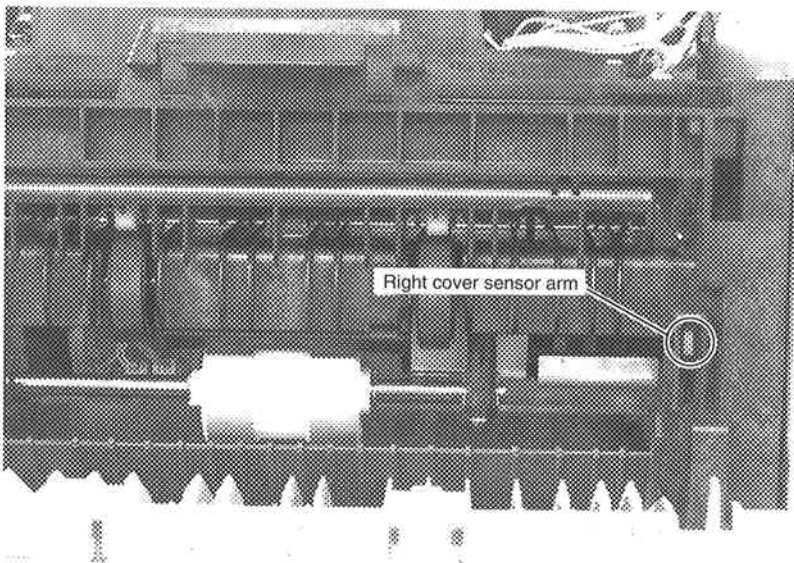
**Figure 1-5 Paper eject guide (lower)**

### **1.3 Moving and Rotating Parts**

Be careful to keep hair, clothes, accessories, etc. from becoming wrapped up in moving and rotating parts.

These parts include the document pickup roller, loading roller, separation roller, and document eject roller, which are rotated by the document feed motor, the paper pickup roller and paper feed roller, which are rotated by the main motor, the pickup solenoid, which controls the paper pickup roller, and the feed solenoid, which controls the paper feed roller.

When the right cover sensor arm is lifted up, the main motor turns the moving and rotating parts. Also, since this fax does not have a sensor to detect when the front cover is removed, even if you remove the front cover while this fax is operating, the gears and rollers continue to move. During servicing, if you have to operate the sensor arm and remove the front cover, be careful to keep hair, clothes, accessories, etc. from becoming wrapped up in moving and rotating parts.



**Figure 1-6 Right Cover Sensor Arm**

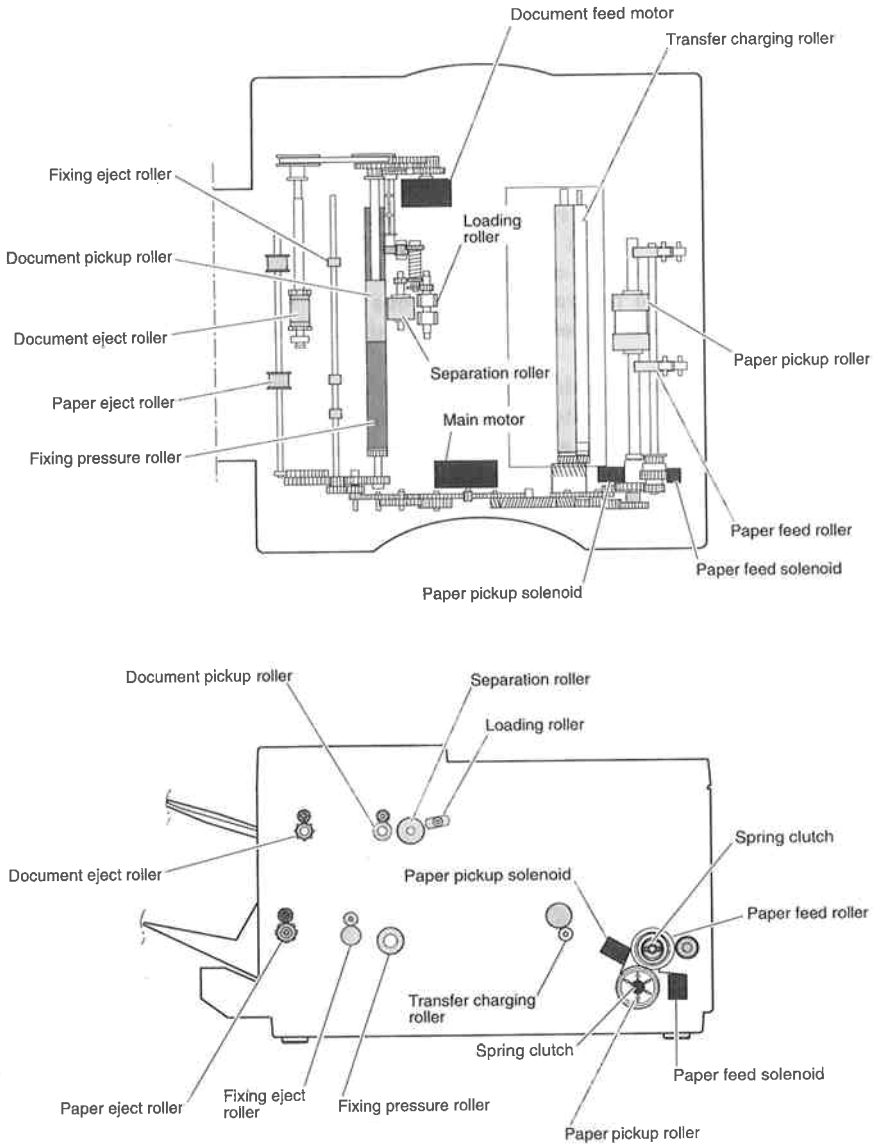


Figure 1-7 Moving and Rotating Parts

### 1.4 Laser/Scanner Unit



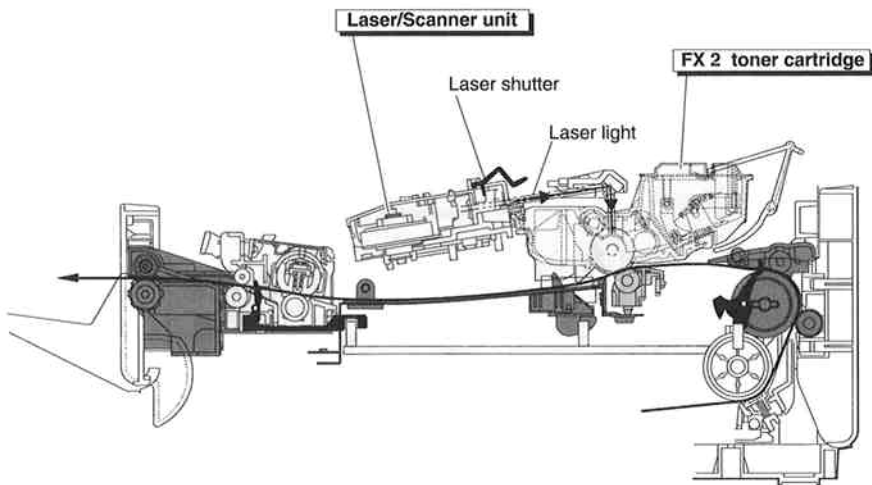
**Danger!**

Never disassemble, modify, or adjust the laser/scanner unit. There are no service operations involving disassembly/ adjustment of the laser/scanner unit.

This fax is a Class 1 Laser Product under the Laser Performance Standards of the United States Department of Health, Education, and Welfare and is a product falling under Subchapter J of DHHS Rules 21 CFR. This means that this product uses lasers that do not radiate dangerous laser beam and conforms to the regulations because the laser beam does not affect the user during operations.

If the 780-nm wavelength light produced by the Class 1 laser used in the laser/scanner unit gets into the eyes, it harms the retina. Always follow the service operation methods given in this manual and do not carry out any service operations not contained in this manual. Within the range of service operations covered in this manual, you will not be subject to laser beam.

This fax is designed with a structure such that the laser shutter only opens when the toner cartridge has been inserted into this fax. This keeps the laser from operating other than during normal operations.



**Figure 1-8 Laser Shutter**

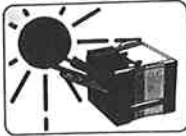
## 2. DANGER TO EQUIPMENT

### 2.1 Precautions in the Instruction Book

Pay attention to the following precautions before you set up your fax and use it.

#### Where to set up the fax

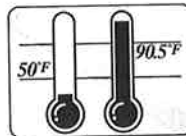
Use the following check list to choose a location to install and use your fax.



- Avoid direct sunlight. If you have to locate the fax near a window, install heavy curtains or blinds to protect the fax from direct sunlight.



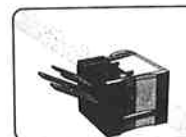
- Choose a flat, stable surface for the fax that is free of vibration



- Avoid a location subject to extreme temperature fluctuation. Use in a room that is within a temperature range of 50°F (10°C) and 90.5°F (32.5°C).



- Do not locate the fax near a television, radio, or heavy equipment that can generate strong electromagnetic fields. Large equipment can generate electronic noise that can interfere with the operation of the fax.

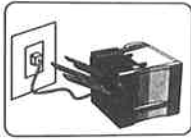


- Choose a location that is clean and free from dust.



- Do not use or store the facsimile unit outdoors.

Figure 1-9 Instruction Book Page 3



- ❑ Place the fax near a telephone line. You must have an RJ11-C wall jack installed. If you need assistance, contact your local Canon authorized dealer sales or service representative, or your local telephone company. For more information, refer to the important notices and instructions inside the front cover of this instruction book.

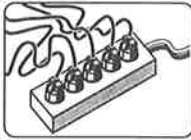


### Power requirements

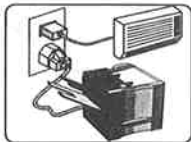
Observe the following precautions about the fax power supply.



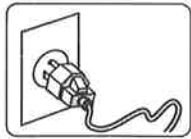
- ❑ Place the fax near a standard 120 V AC power outlet. This fax unit is intended for domestic use. Do not attempt to use it outside the country where you purchased it.



- ❑ Don't plug the power cord into an extension cord connector or outlet shared with other plugs.



- ❑ Don't plug the fax into a power outlet shared with an air conditioner, personal computer, electric typewriter, copier, or other equipment that generates electrical noise.



- ❑ Check the plug frequently to be sure that it is firmly plugged into the socket.



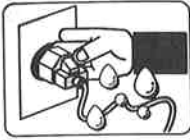
### General precautions



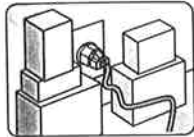
- ❑ After you turn the fax off, always wait at least 5 seconds before you turn it on again. Always turn the power off before you move the fax.



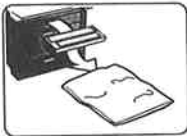
- ❑ During electrical storms, turn the fax off and disconnect the plug from the power outlet.



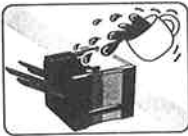
- ❑ When you attach or remove the plug from the power outlet, be sure your hands are dry.



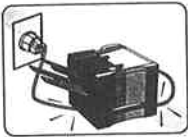
- ❑ Do not stack boxes or furniture around the power outlet. Keep the area open so you can reach the outlet quickly. If you notice anything unusual (smoke, strange odor, noise) around the fax, turn the fax off and unplug it.



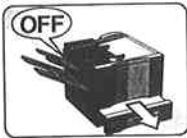
- ❑ Before you transport the fax unit, remove the cartridge. To protect the cartridge from bright light, cover it with a bag or cloth.



- ❑ Keep liquids, cleaners, and other solvents away from the fax unit. Keep metal pins, paper clips, staples and other objects away from the fax. If something falls inside the fax, turn the fax off, remove the plug from the power outlet.



- ❑ Do not set the main unit or other equipment or furniture on the power cord. Never knot the cord or wrap it around another object.



- ❑ Never turn off the power switch and remove the paper cassette during printing. Removing the cassette during printing can cause the fax unit to jam.



- ❑ When you lift up the fax, hold it by the front and back side. Never lift it by the side cassette.



## 2.2 Storage and Handling of Toner Cartridge

The FX 2 cartridge is constantly affected by the environment as sealed in the package or installed on fax. It changes with time regardless of the number of sheets printed. Since the progress of aging depends on the installation and storage environments, no general rule is available. The FX 2 cartridge should be carefully stored and handled.

### 2.2.1 Storing a sealed FX 2 cartridge package

When storing an FX 2 cartridge in a warehouse or workshop, use the range shown in the table. Also note the following:

- a) Avoid any areas exposed to direct sunlight.
- b) Do not place the package in any location which are subject to severe vibration.
- c) Do not bump or drop the package.
- d) Avoid any environments which are subject to high-temperature. Keep the package below 95°F (35°C).

**Table 1-1 Temperature and Humidity / Storage Conditions**

Temperature	Normal (total storage time × 9/10)		32 to 95°F (0 to 35°C)
	Severe (total storage time × 1/10)	High	95 to 104°F (35 to 40°C)
		Low	-36 to 32°F (-20 to 0°C)
Temperature change (within 3 minutes or so)			104°F → 59°F (40°C → 15°C) -36°F → 77°F (-20°C → 25°C)
Relative humidity	Normal (total storage time × 9/10)		35 to 85% RH
	Severe (total storage time × 1/10)	High	85 to 95% RH
		Low	10 to 35% RH
Air pressure			460 to 760 mmHg (0.6 to 1 atm)

### **2.2.2 Storing a unsealed FX 2 cartridge package**

The organic photoconductor (OPC) is used in the photosensitive drum. Intensive light damages the photosensitive drum. And the toner is also contained in the FX 2 cartridge. It is very important to fully explain the various points regarding storing and handling an opened package to customers.

- a) Avoid any areas which are exposed to direct sunlight and any bright areas such as a window side. Avoid leaving the package in a car for an extended period of time since the temperature inside a car may become very hot. Even when the package is kept in a storage box, it is still important to avoid any areas which are directly exposed to sunlight or leaving the package in a car for an extended period of time.
- b) Avoid environments subject to high-temperature and high-humidity, or low-temperature and low-humidity. Also avoid any areas which are subject to abrupt changes in the temperature or humidity such as near an airconditioner.
- c) Avoid any dusty areas or any locations which are subject to ammonia gas or organic solvent gas.
- d) Keep the FX 2 cartridge below 95°F (35°C).
- e) Avoid placing the package near a CRT, disk drive unit, or floppy disk.

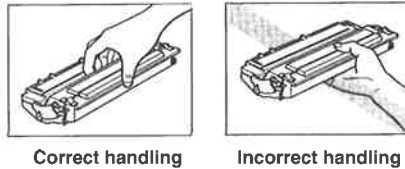
### 2.2.3 Notes on handling



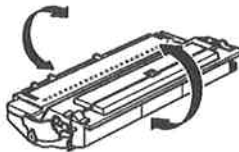
Do not place the cartridge in fire. Toner powder is flammable.

- a) Before installing a new FX 2 cartridge in the fax, hold the FX 2 cartridge horizontally as shown below, and slowly shake it approx. 5 times at a 45 degree angle in both directions to even the toner. Do not shake the FX 2 cartridge in any other manner, since the toner may leak from the developing and cleaner unit.

To be sure that an output image is not soiled by a toner leak, print 3 to 5 sheets of test patterns after setting the FX 2 cartridge in the fax.



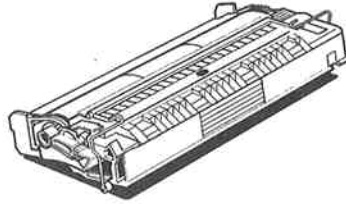
**Figure 1-12 Handling Toner Cartridge**



**Figure 1-13 Shaking Toner Cartridge**

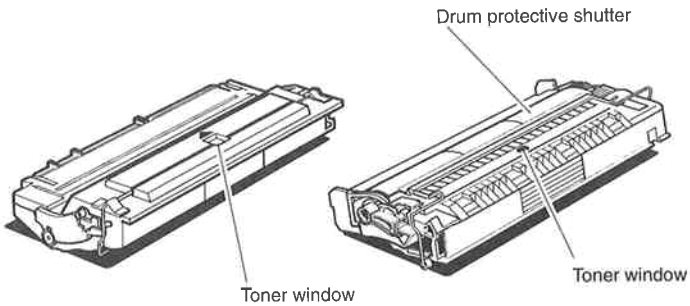
- b) If blank spots do occur in some areas of the output image during printing due to an uneven distribution of toner in the cartridge, shake the FX 2 cartridge as indicated in 1) above to evenly distribute the toner.

- c) Do not place the FX 2 cartridge in an upright position or turn it upside down as shown below. Do not swing the cartridge.



**Figure 1-14 Incorrect Handling**

- d) Do not open the protective shutter of the photosensitive drum. And never touch the drum surface. If the drum surface is dirty, replace the FX 2 cartridge.



**Figure 1-15 External View (FX 2 Cartridge)**

- e) Never disassemble the FX 2 cartridge.
- f) Do not subject the FX 2 cartridge to vibration or shock.
- g) Never touch the toner window on the top and bottom of the cartridge.

h) The photosensitive drum can be easily damaged by intensive light. If it is exposed to strong light, blank spots or black stripes may appear on the print image.

Faulty print images such as blank spots or black stripes can be corrected by stopping the print operation. However, if the drum is exposed to light for an extended period time, the blank spots and black stripes may remain even after stopping the print operation.

To prevent this, be sure to always place the FX 2 cartridge into a storage box or keep it covered. Do not leave unprotected the FX 2 cartridge removed from the fax.



---

If the FX 2 cartridge is irradiated by ordinary light for five minutes and then left in a dark area for five minutes, it will be possible to correct the print quality to virtually allowable level. However, do not expose the FX 2 cartridge to direct sunlight.

---

i) Save the protective bag. You may need to repack and transport the FX 2 cartridge at a later date.

**This page intentionally left blank**

## 2.2.4 Recycling

# The Clean Earth Campaign

## (U.S.A. Campaign)



Canon has made a commitment to harmonizing technology with the environment on a global basis with an eye toward the 21st century by establishing the "E" Project ("E" for environment, ecology, energy). This cartridge collection program, The Clean Earth Campaign, is an outgrowth of this concern.

The overabundance of waste in our environment is a matter of serious concern to us all. And with your help, Canon U.S.A. is working to contribute to the solution through nationwide collection of used cartridges from Canon PC copiers, laser beam printers (LBPs), laser facsimile machines and micro-graphics printers.

The Clean Earth Campaign will serve many beneficial and useful purposes.

First, it will help to keep the environment clean because cartridges are returned for recycling instead of being thrown in the trash.

Second, it will conserve precious industrial resources by utilizing portions of the returned cartridge to create new ones.

And, it will help protect wildlife as well as the environment. The National Wildlife Federation and The Nature Conservancy will equally share a \$1-per-cartridge contribution from Canon U.S.A., Inc. The more cartridges we receive, the more generous our contribution.

Becoming a part of this worthwhile program is easy, too. When your cartridge is of no further use, simply follow the instructions.

We appreciate your cooperation in helping us do our part. Together we can make a significant contribution to a cleaner planet.

Thank you.

- **The cartridges are not collected for refilling.**
- **You are not entitled to a tax deduction for the return of used cartridges.**
- **Defective cartridges under warranty should be returned to an authorized dealer or service facility as provided in the warranty. Do not send them by UPS authorized return label.**
- **This campaign is subject to change or discontinuance without notice.**

**Figure 1-16 Cartridge Recycling (U.S.A.) 1/2**

**PACKAGING PROCEDURE**



**Step 1:**

Slip your used cartridge into the bag the cartridge came in. Seal the bag, then place it into the cartridge box with the protectors.



**Step 2a: Single used cartridge returns.**

Carefully seal the box with tape and apply the supplied \*UPS authorized return label. Please cross out all old labels and be sure to enter your ZIP Code in the space provided.

**Step 2b: Volume used cartridge returns.**

(We encourage you to use this option as a more efficient way to ship cartridges. Please use this method when returning four or more cartridges.) Carefully seal the box with tape. Bundle multiple cartridge boxes together securely with tape

or  
place them into a large carton.

**Please be careful that the shipment does not exceed**

**these UPS specifications:**

**Maximum girth (length + 2 x width + 2 x height) = 130 in.**

**Maximum length = 108 in.**

**Maximum weight = 70 lbs.**

Apply the supplied \*UPS authorized return label. Please cross out all old labels and be sure to enter your ZIP Code in the space provided.

**Residents of Alaska and Hawaii:**

\*Do not use UPS authorized return label for cartridge returns from Alaska and Hawaii. For Alaska and Hawaii Canon set up alternative mail service with the U.S. Postal Service. Please call the appropriate number listed below to receive a U.S. Postal Service merchandise return label to forward your cartridge(s) by mail at no charge to you.

**In Alaska:**  
**907-243-7891**

**In Hawaii:**  
**808-521-0361**

**SHIPPING METHOD**



**Option 1: MBE**

Take the shipment to your nearest MBE (Mail Boxes Etc.) Center.

For the location of your nearest MBE Center, please call **1-800-949-6660**.

OR



**Option 2: UPS Driver**

Give the shipment to your UPS driver when you receive your next regular delivery

or

Take the shipment to your local UPS receiving point.

By using either of the above methods of shipment, your used cartridge(s) will be forwarded to the Canon Cartridge Collection Center at no charge to you.

For further information about The Clean Earth Campaign in the United States, please call:

**1-800-962-2708**



National Wildlife Federation  
1400 16th Street, N.W.  
Washington, D.C. 20036

**Canon**

Canon U.S.A., Inc.

One Canon Plaza

Lake Success, NY 11042



The Nature Conservancy  
1815 N. Lynn Street  
Arlington, VA 22209

**Figure 1-17 Cartridge Recycling (U.S.A.) 2/2**



# The Clean Earth Campaign (Canada Campaign)



Canon has made a commitment to harmonizing technology with the environment on a global basis with an eye toward the 21st century by establishing the "E" Project ("E" for environment, ecology and energy). This cartridge collection program, The Clean Earth Campaign, is an outgrowth of this concern.

The overabundance of waste in our environment is a matter of serious concern to us all. And with your help, Canon Canada is working to contribute to the solution through nationwide collection of used cartridges from Canon PC copiers, laser beam printers (LBPs), laser facsimile machines and micrographic printers.

The Clean Earth Campaign will serve many beneficial and useful purposes.

First, it will help to keep the environment clean because cartridges are returned for recycling instead of being thrown in Canadian landfill sites.

Second, it will conserve precious industrial resources by utilizing portions of the old cartridge to create new ones.

And, it will help protect wildlife as well as the environment. World Wildlife Fund (Canada) and The Nature Conservancy of Canada will equally share a \$1-per-cartridge contribution from Canon Canada Inc. The more cartridges we receive, the more we can contribute.

Becoming a part of this worthwhile program is easy, too. When your cartridge is of no further use, simply follow the instructions.

We appreciate your cooperation in helping us do our part. Together we can make a significant contribution to a cleaner planet. Thank you.



**Step 1:**  
Open new carton and install new cartridge. Retain box, protectors and wrapper.



**Step 2:**  
Place used cartridge in old wrapper and box using protectors. Please ensure that the boxes are properly sealed for shipment.



**Step 3:**  
For those with one to seven used cartridges, please return them to your dealer, who will ensure that they are delivered to the Canon Clean Earth Centre for recycling.

NOTE: DO NOT USE UPS AUTHORIZED RETURN LABEL FOR CANADA CAMPAIGN.

For users with a minimum of eight (8) and a maximum of 40 used toner cartridges, you may return them to your dealer. Or, you can order a collection kit from a participating dealer. The kit contains bills of lading (with pre-printed consignee address) and shipping labels. Our participating carrier will then pick up your cartridges and deliver them to the Canon Clean Earth Centre at no charge to you.

- The cartridges are not collected for refilling.
- You are not entitled to a tax deduction for the return of used cartridges.
- Defective cartridges under warranty should be returned to an authorized dealer as provided in the warranty.

For further information on The Clean Earth Campaign please contact your local Canon dealer

or call: **1-800-667-2666**  
or write: Canon Cartridge Recycling Department  
Canon Canada Inc.,  
6390 Dixie Road  
Mississauga, Ontario L5T 1P7



**WWF** World Wildlife Fund

\* FMI at WWF - World Wide Fund for Nature - Switzerland

**Canon**  
Canon Canada Inc.



LA SOCIÉTÉ CANADIENNE  
POUR LA  
CONSERVATION  
DE LA NATURE

**Figure 1-18 Cartridge Recycling (Canada) 1/2**

# La campagne pour une planète propre (Campagne Canadienne)



Canon s'est engagée à harmoniser la technologie et l'environnement sur une base globale en vue du 21e siècle en établissant le Projet "E" ("E" pour environnement, écologique et énergie). Ce programme de ramassage des cartouches, la Campagne pour une planète propre, est une conséquence naturelle de cette préoccupation.

La surabondance des déchets dans notre environnement est une question dont nous devons tous nous préoccuper sérieusement. Et avec votre aide, Canon Canada s'efforce de contribuer à la solution par le biais d'un ramassage national des cartouches épuisées utilisées dans les copieurs Canon PC, les imprimantes et les télécopieurs à laser et les imprimantes micrographiques.

La campagne pour une planète propre servira à de nombreuses fins bénéfiques et utiles.

En premier lieu, elle contribuera à garder l'environnement propre puisque les cartouches sont retournées pour recyclage plutôt que d'être envoyées dans les décharges canadiennes.

En deuxième lieu, le programme permettra de conserver des ressources industrielles précieuses en utilisant des parties de la vieille cartouches pour en créer de nouvelles.

Et, elle contribuera à protéger la faune ainsi que l'environnement. World Wildlife Fund (Canada) et la Société canadienne pour la conservation de la nature partageront également la contribution de 1 \$ par cartouche que versera Canon Canada Inc. Plus nous recevrons de cartouches, plus nous contribuerons.

Il est également facile de participer à ce programme valable. Une fois que votre cartouche est épuisée, vous n'avez qu'à suivre les instructions.

Nous apprécions que vous aidiez à faire notre part. Ensemble, nous pouvons faire une contribution importante en vue d'une planète plus propre.  
Merci.



**Étape 1:**  
Ouvrez la boîte et installez la nouvelle cartouche. Conservez la boîte, les protecteurs et l'emballage.



**Étape 2:**  
Enveloppez la cartouche épuisée dans le viell emballage et placez-la dans la boîte avec les protecteurs. Assurez-vous que les boîtes sont bien scellées pour l'expédition.



**Étape 3:**  
Si vous avez une à sept cartouches épuisées, veuillez les retourner à votre concessionnaire qui verra à ce qu'elles soient livrées au Centre Canon pour une planète propre, pour recyclage.

REMARQUE: NE PAS UTILISER L'ÉTIQUETTE DE RETOUR AUTORISÉ UPS POUR LA CAMPAGNE CANADIENNE.

Si vous avez huit (8) à 40 cartouches de toner épuisées, vous pouvez les retourner à votre concessionnaire, ou commander un nécessaire de ramassage d'un concessionnaire participant. Le nécessaire contient des connaissances (portant déjà d'adresse du consignataire) et des étiquettes d'expédition. Le service des messageries que nous utilisons passera les prendre et les livrera au Centre Canon pour une planète propre, sans frais pour vous.

- Les cartouches ne sont pas recueillies pour être rechargées.
- Le retour des cartouches épuisées ne vous donne pas droit à une déduction de taxe
- Les cartouches défectueuses et encore sous garantie devraient être retournées à un dépositaire agréé conformément à la garantie.

Pour une plus amples renseignements sur la Campagne pour une planète propre, veuillez communiquer avec votre concessionnaire Canon local.

composer le: **1-800-667-2666**  
ou écrire à: Service de recyclage des cartouches Canon  
Canon Canada Inc.  
6390 Dixie Road  
Mississauga, Ontario L5T 1P7



\*MD du Fonds Mondial pour la Nature, Suisse



Canon Canada Inc.



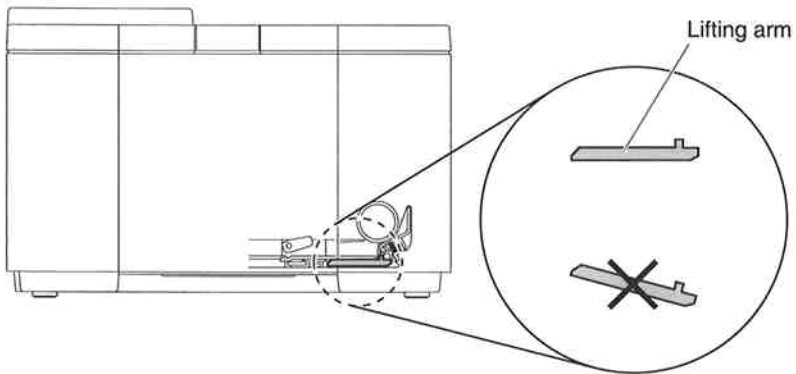
LA SOCIÉTÉ CANADIENNE  
POUR LA  
CONSERVATION  
DE LA NATURE

Figure 1-19 Cartridge Recycling (Canada) 2/2

## 2.3 Precautions when Servicing

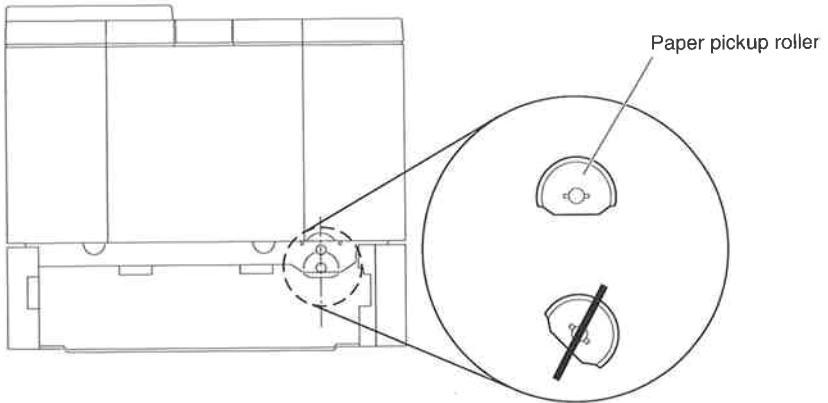
### 2.3.1 Parts replacement

- a) Before replacing a unit or disconnecting any connectors, always switch off the power and disconnect the telephone line.
- b) Do not touch the metal parts of connectors with your hands. If you do touch them, this can cause poor contact.
- c) When plugging in connectors, be sure to plug each connector to the correct connector and facing in the correct direction.
- d) Be careful of static electricity when touching a printed circuit board with your hands.
- e) Exposure to outside light can cause deterioration of contact sensor, so as much as possible avoid subjecting them to outside light.
- f) After having assembled the separation ass'y, before setting the side cassette, install the toner cartridge, close the cartridge cover, switch the power on, and the lifting arm moves automatically to its initial position.



**Figure 1-20 Lifting Arm Initial Position**

- g) After having assembled the paper pickup roller ass'y, before setting the front cassette, install the toner cartridge, close the cartridge cover, switch the power on, and the pickup roller moves automatically to its initial position. (LASER CLASS 5500 only)



**Figure 1-21 Pickup Roller Initial Position**

- h) This fax has functions to count the number of pages printed and the number of pages scanned. When replacing parts, output a system dump list or select service data "**COUNTER**" and verify the number of pages printed and the number of pages scanned.



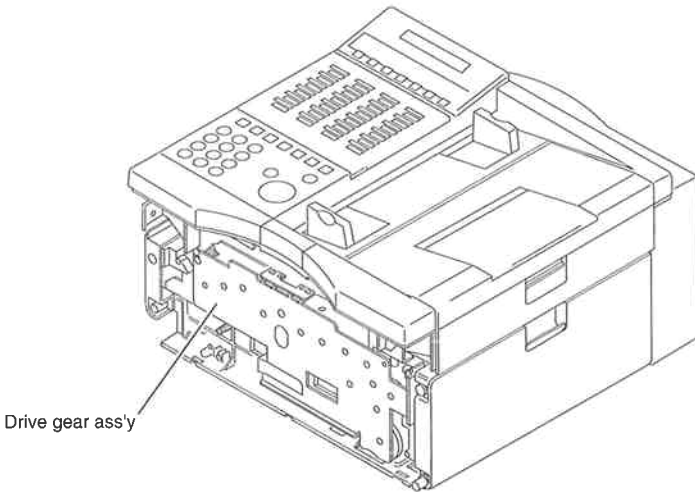
For details on the count functions, see *Chapter 2: 3.2.2 Service report output functions and 3.4.4 Explanation of service data.*

### 2.3.2 Precautions for Danger by Static Charge

Static charge can change the electrical characteristics of electrical parts in the contact sensor unit or on the SCNT or other boards or damage them. Do not handle electrical parts under circumstances where static charge might occur easily.



When repairing or replacing electrical parts, first touch the metal part of the drive gear ass'y to prevent damage from static charge.



**Figure 1-22 Drive Gear Ass'y**

### 2.3.3 Handling the contact sensor

Handle the contact sensor carefully to avoid scratching or dirtying its scanning surface. Scratches or dirtying of the scanning surface can cause vertical stripes or other defects in the scanned image.

Also, if the contact sensor scanning section is exposed to outside light for prolonged periods, its characteristics may deteriorate, resulting in blackish scanned images. During servicing, do not expose the contact sensor scanning section to outside light for a prolonged period.



### 2.3.6 Printer section handling

#### a) Transfer charging roller

Do not touch the sponge section of the transfer charging roller. Doing so can cause marks on back of paper or blank spots in copied or received images.

#### b) Fixing film

Do not touch the fixing film. Doing so can cause marks or fixing defects in copied or received images.

#### c) Mirror

Do not touch the mirror. Doing so can cause can cause vertical stripes in copied or received images.



---

If you touch the sponge section of the transfer charging roller, the fixing film, or the mirror, clean it as explained in *Chapter 4: 2. CLEANING*.

---

#### d) Paper feed guide

Do not peel the paint off the paper feed guide. Doing so can cause disruption of the print image.



---

To prevent loss of the charge on the paper, the paper feed guide is coated with semiconductive paint.

---

#### e) Others

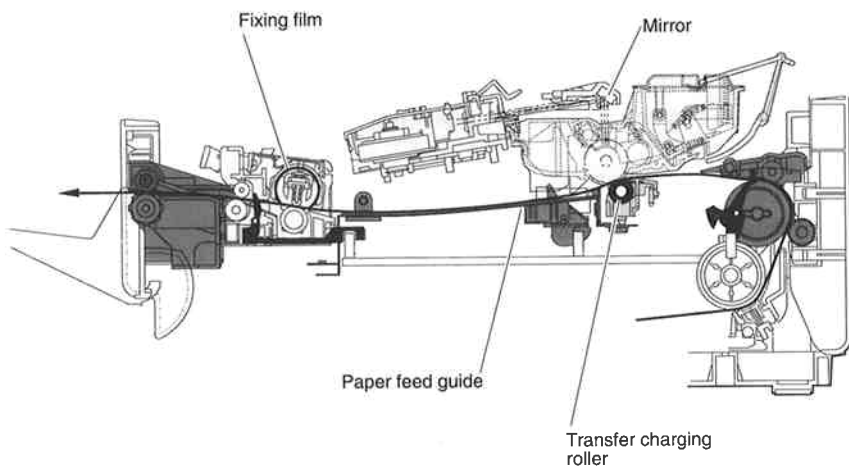
Do not switch off the power when replacing the toner cartridge or when removing jammed paper. Doing so will clear image data accumulated in memory with memory reception, confidential reception, delayed transmission, etc.



---

If you must switch off the power when image data has been accumulated in memory, transfer the accumulated image data to another fax machine before switching off the power. For details, see *4.2 Image Data Transfer*.

---



**Figure 1-23 Printer Section**

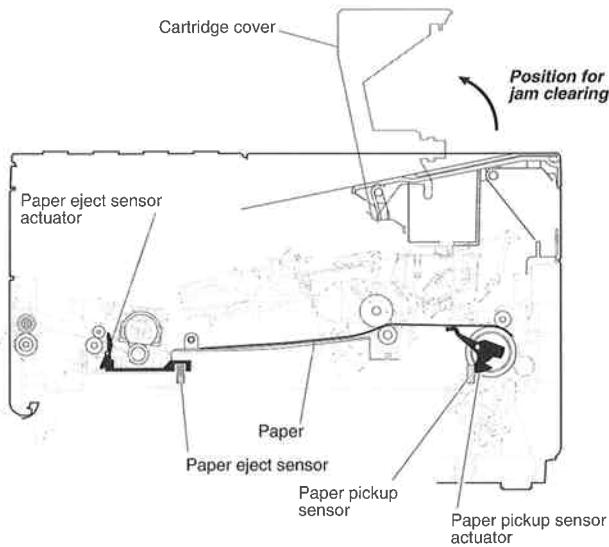


### 2.3.7 Recording paper jam handling



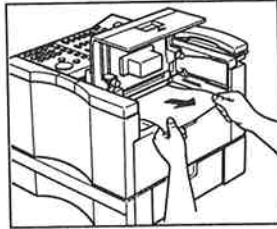
While removing the jammed paper, some toner may stain the inside of the fax and make the first few printouts dirty when printing resumes. Make a few copies beforehand.

#### a) Paper jam in the paper feed section



**Figure 1-24 Paper Jam in the Paper Feed Section (1/2)**

When a paper jam occurs shown in the figure, open the cartridge cover, remove the toner cartridge, and pull the jammed paper forward carefully to remove it. Keep the edge of the paper down.



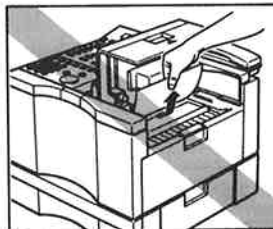
**Figure 1-25 Paper Jam Recover 1**



Do not touch the inside of the fax to avoid getting toner on your hands or clothes.

If this happens, wash it off immediately with water.

When you removed the jammed paper, do not lift it as shown in the figure. This prevents scattering loose toner which can cause reduction in print quality.



**Figure 1-26 Paper Jam Recover 2**

---



Never touch the mirror shown in the figure.

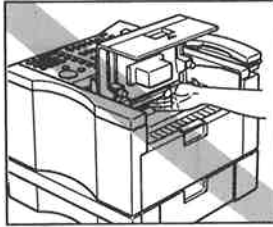


Figure 1-27 Paper Jam Recover 3

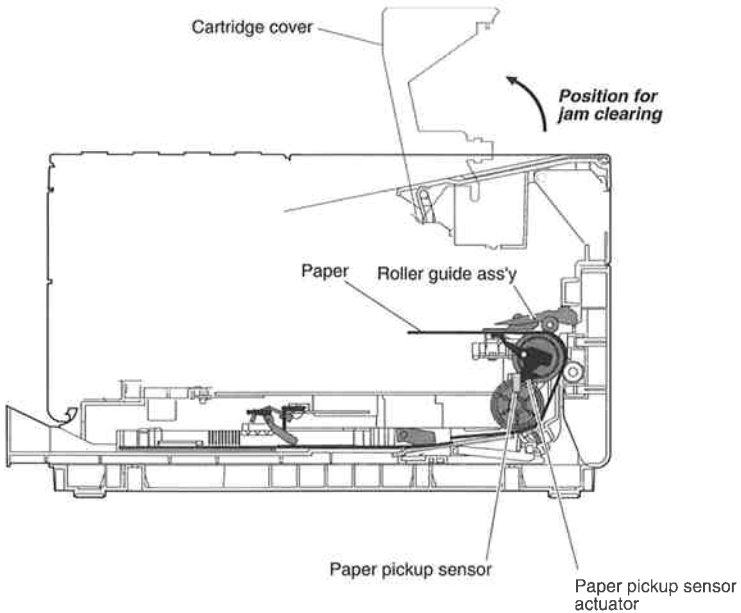
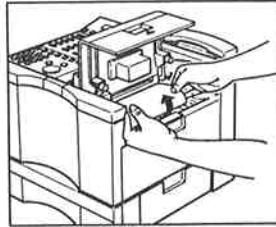


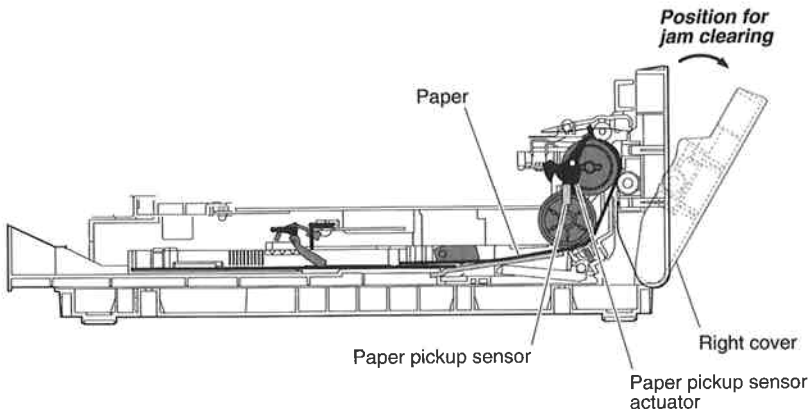
Figure 1-28 Paper Jam in the Paper Feed Section (2/2)

If the trailing edge of the jammed paper is under the roller guide ass'y, use both hands to pull the paper forward as shown in the figure. After the trailing edge is free, pull the jammed paper forward carefully to remove it.



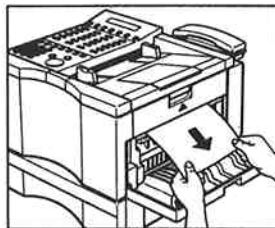
**Figure 1-29 Paper Jam Recover 4**

b) Paper jam in the paper pickup section



**Figure 1-30 Paper Jam in the Paper Pickup Section**

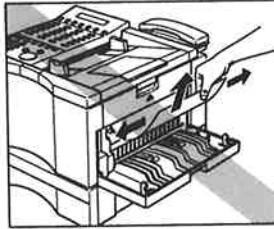
When a paper jam occurs shown in the figure, open the right cover, and pull the jammed paper straight down to remove it.



**Figure 1-31 Paper Jam Recover 5**



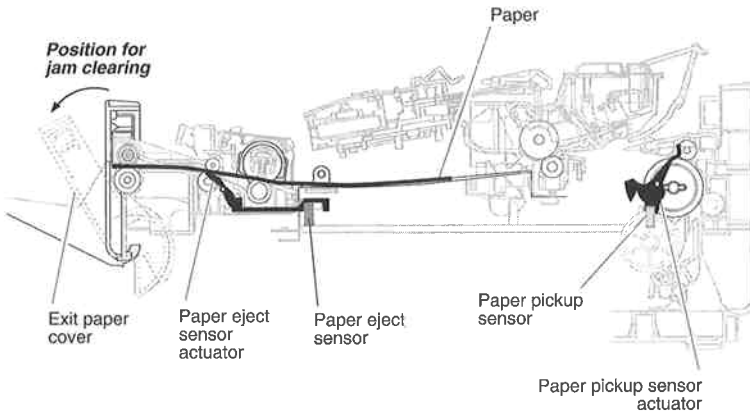
Never pull the jammed paper in the up or side direction.



**Figure 1-32 Paper Jam Recover 6**

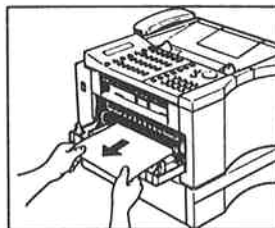
---

c) Paper jam in the paper eject section



**Figure 1-33 Paper Jam in the Paper Eject Section**

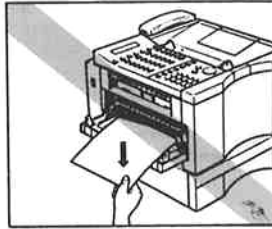
When a paper jam occurs shown in the figure, open the exit paper cover, and pull the jammed paper straight out to avoid tearing.



**Figure 1-34 Paper Jam Recover 7**



Never pull the jammed paper out at an angle. Always pull it straight out.

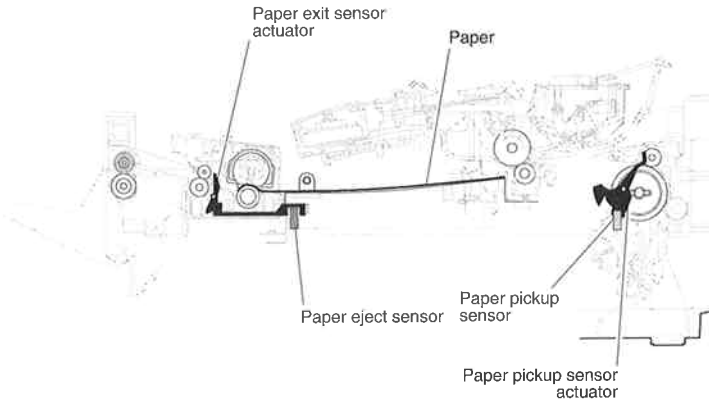


**Figure 1-35 Paper Jam Recover 8**

---



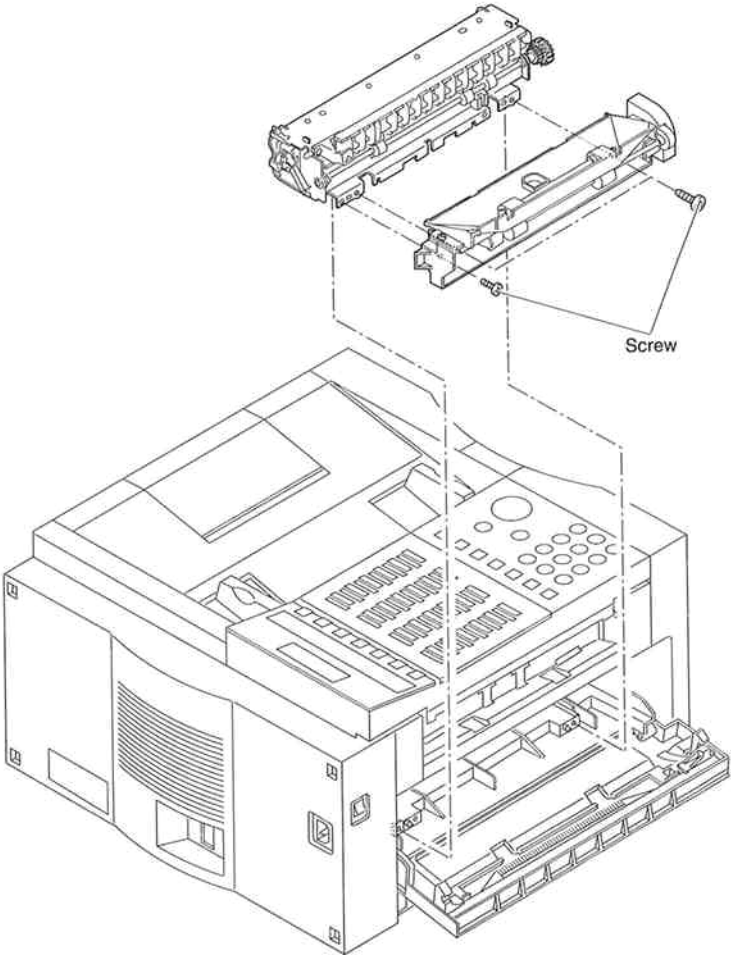
d) Paper jam in the fixing ass'y



**Figure 1-36 Paper Jam in the Fixing Ass'y**

When a paper jam occurs shown in the figure, go on to the following procedure.

- a) Remove the side cassette, open the exit paper cover.
- b) Remove the three screws, and remove the paper exit roller ass'y and the fixing ass'y shown in the next page.
- c) Remove the jammed paper in the fixing unit.



**Figure 1-37 Disassembly Procedure (Fixing Ass'y)**

### 2.3.8 Precautions for replacing the SCNT board

The SCNT board has a lithium battery to backup various data. When replacing it, observe the following precautions.



---

For details on the data backed up with the lithium battery, see *4.1 Data Backed Up by Lithium Battery*.

---

#### a) Installing a new SCNT board

- a-1) Before replacing the SCNT board, output a system dump list or select service data "**COUNTER**", and verify the number of pages printed and the number of pages scanned.



---

For details on the count functions, see *Chapter 2: 3.2.2 Service report output functions and 3.4.4 Explanation of service data*.

---

- a-2) Remove the short plug from the jumper switch (J111) on the old SCNT board and install it on the jumper switch (J111) on the new SCNT board.



---

The jumper switch (J111) switches the lithium battery memory backup function on/off.

---



---

In order to prevent wear on the lithium battery, SCNT boards stored as service parts do not have the short plug installed, so be careful not to lose the short plug from the old SCNT board when replacing an SCNT board.

---

- a-3) After replacing the SCNT board, switch on the power. "**DATA ERROR PRESS SET KEY**" is displayed on the display. Press the Set key to initialize the lost data.

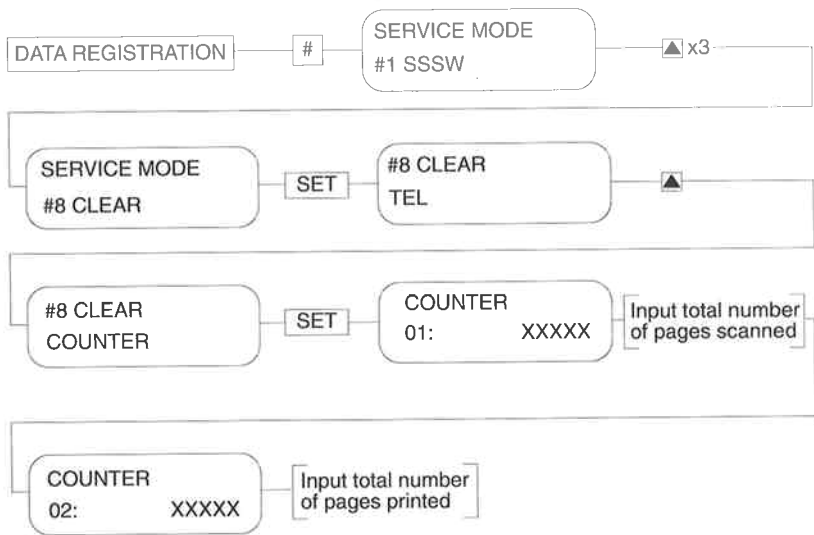


---

The "**DATA ERROR PRESS SET KEY**" display means that a checksum error occurred and that the SRAM data backed up by the lithium battery has been lost.

---

- a-4) Use the operations method below to input the number of pages printed and the number of pages scanned output after the SCNT board replacement.



**Figure 1-38 Inputting the Print Page Count and Scan Page Count**



The input data is not initialized even when the service data **"#8 CLEAR"** is selected.

**b) Precautions for disposing the SCNT board**

When disposing the SCNT board, observe the applicable local laws and ordinances.



The lithium battery on the SCNT board contains lithium, organic solvents, and other flammable materials. If you throw it into a fire, it can burst open and burn furiously. When disposing the lithium battery, observe the applicable local laws and ordinances.

### 2.3.9 Precautions for replacing the lithium battery

#### a) Replacing the lithium battery

The dial data, user data, service data, and other data is backed up by the lithium battery. Replacing the lithium battery erases this data.



---

For details on the data backed up with the lithium battery, see 4.1 *Data Backed Up by Lithium Battery*.

---

Before replacing the lithium battery, output the following list, then after installing the new battery, register the erased data again.

- . User data list
- . Coded speed dialing telephone number list
- . One-touch speed dialing telephone number list
- . Group dialing telephone number list
- . System data list

After replacing the lithium battery, switch on the power. **"DATA ERROR PRESS SET KEY"** is displayed on the display. Press the Set key to initialize the lost data.



---

The **"DATA ERROR PRESS SET KEY"** display means that a checksum error occurred and that the SRAM data backed up by the lithium battery has been lost.

---

#### b) Precautions for disposing the lithium battery

When disposing the lithium battery, observe the applicable local laws and ordinances.



---

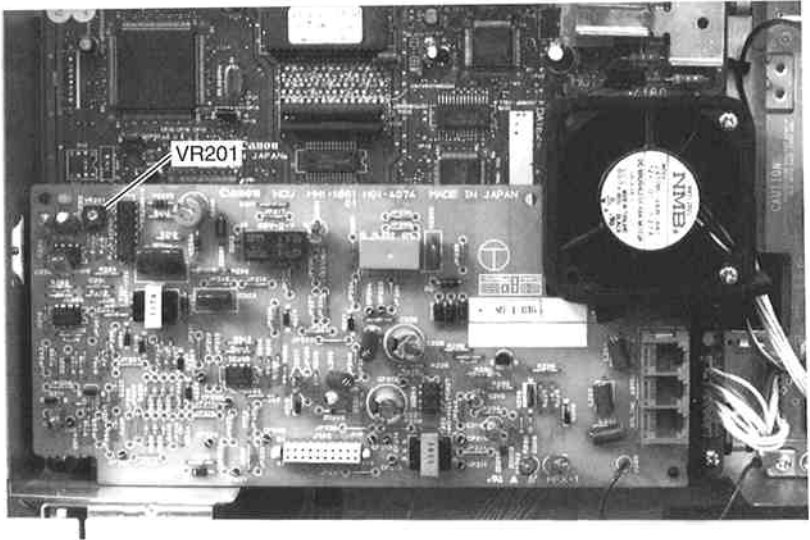
The lithium battery contains lithium, organic solvents, and other flammable materials. If you throw it into a fire, it can burst open and burn furiously.

When disposing the lithium battery, observe the applicable local laws and ordinances.

---

### 2.3.10 Precautions for handling the NCU board

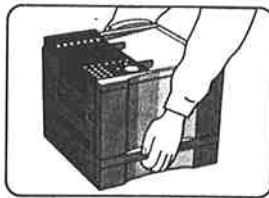
The control (VR201) on the NCU board is for factory adjustments. Since adjustment requires special tools, it can not be done in the field. Do not touch this control.



**Figure 1-39 Control on NCU Board**

### **2.4 Precautions for Carrying, Moving, and Transporting**

- a) When shipping this fax, pack it up in its packing materials to protect it from shock, vibration, dust, etc.
- b) When carrying this fax, do not hold it by the right cover and by the side cassette, because holding it this way could break the side cassette.
- c) When moving this fax, always remove the toner cartridge to prevent any toner leaks.
- d) Leaving this fax anywhere subject to direct sunlight for a prolonged period of time can deform plastic parts.



**Figure 1-40 Precaution for Carrying and Moving**

## 3. DATA PRECAUTIONS

### 3.1 Data Cleared When the Power Goes Off

When the power is switched off, the image data in this fax is cleared. Be careful when it is necessary to switch off the power for servicing.

#### Data cleared

<b>Transmission image</b>	Memory transmission images Delayed (broadcast) transmission images Confidential transmission images
<b>Reception image</b>	Memory polling images Memory reception images Confidential reception images



Management data for the image data cleared when the power is switched off is printed in the memory clear list and the management data from before the power was switched off is cleared.

### 3.2 Data Initialization

This fax can initialize individual data items with Service Data #8 Clear. Below are the data items which can be initialized.

Item on display	Data item initialized
TEL	Dialing data and "FILE SETTINGS" in user data
USSW SW	User data* and Service data #1~#3
SERVICE SW	User data* and Service Data #1, #3, #6, #7
NCU	Service Data #4
SERVICE DATA	Data on system dump list
REPORT	Data on activity report
ALL	All settings/registered data, image data

\*Except "FILE SETTINGS" in user data



When an individual data item is initialized, it is set to its factory setting.



### **3.3 Master Password**

Normally, the confidential box and polling box passwords are four digits and set by the user, but this fax has a master password in case the user forgets a password.

The master password, which is seven digits, permits output of images already received in all the confidential boxes and revision or cancellation of user-set passwords, so this master password permits the user to change or cancel the password for polling boxes.

Below is the master password.

**Master Password: 4559769**



---

The master password is only for emergency use and is only to be used by service personnel. Do not tell it to the user. The master password is not covered in the Instruction Book.

---

### 3.4 Precautions for Setting the Polling Password

On this fax, the polling password is set to a 3-digit number from 000 to 255. If the other fax machine uses an 8-digit binary, set the password according to the table below.



Among the passwords, the following two have special meanings.

[000]: Regardless of the other fax's password, the document is sent.

[255]: Regardless of the other fax's password, the document is not sent.

Your ID	Other party's ID	Your ID	Other party's ID	Your ID	Other party's ID	Your ID	Other party's ID
000	—	064	01000000	128	10000000	192	11000000
001	00000001	065	01000001	129	10000001	193	11000001
002	00000010	066	01000010	130	10000010	194	11000010
003	00000011	067	01000011	131	10000011	195	11000011
004	00000100	068	01000100	132	10000100	196	11000100
005	00000101	069	01000101	133	10000101	197	11000101
006	00000110	070	01000110	134	10000110	198	11000110
007	00000111	071	01000111	135	10000111	199	11000111
008	00001000	072	01001000	136	10001000	200	11001000
009	00001001	073	01001001	137	10001001	201	11001001
010	00001010	074	01001010	138	10001010	202	11001010
011	00001011	075	01001011	139	10001011	203	11001011
012	00001100	076	01001100	140	10001100	204	11001100
013	00001101	077	01001101	141	10001101	205	11001101
014	00001110	078	01001110	142	10001110	206	11001110
015	00001111	079	01001111	143	10001111	207	11001111
016	00010000	080	01010000	144	10010000	208	11010000
017	00010001	081	01010001	145	10010001	209	11010001
018	00010010	082	01010010	146	10010010	210	11010010
019	00010011	083	01010011	147	10010011	211	11010011
020	00010100	084	01010100	148	10010100	212	11010100
021	00010101	085	01010101	149	10010101	213	11010101
022	00010110	086	01010110	150	10010110	214	11010110
023	00010111	087	01010111	151	10010111	215	11010111
024	00011000	088	01011000	152	10011000	216	11011000
025	00011001	089	01011001	153	10011001	217	11011001
026	00011010	090	01011010	154	10011010	218	11011010
027	00011011	091	01011011	155	10011011	219	11011011
028	00011100	092	01011100	156	10011100	220	11011100
029	00011101	093	01011101	157	10011101	221	11011101
030	00011110	094	01011110	158	10011110	222	11011110
031	00011111	095	01011111	159	10011111	223	11011111
032	00100000	096	01100000	160	10100000	224	11100000
033	00100001	097	01100001	161	10100001	225	11100001
034	00100010	098	01100010	162	10100010	226	11100010
035	00100011	099	01100011	163	10100011	227	11100011
036	00100100	100	01100100	164	10100100	228	11100100
037	00100101	101	01100101	165	10100101	229	11100101
038	00100110	102	01100110	166	10100110	230	11100110
039	00100111	103	01100111	167	10100111	231	11100111
040	00101000	104	01101000	168	10101000	232	11101000
041	00101001	105	01101001	169	10101001	233	11101001
042	00101010	106	01101010	170	10101010	234	11101010
043	00101011	107	01101011	171	10101011	235	11101011
044	00101100	108	01101100	172	10101100	236	11101100
045	00101101	109	01101101	173	10101101	237	11101101
046	00101110	110	01101110	174	10101110	238	11101110
047	00101111	111	01101111	175	10101111	239	11101111
048	00110000	112	01110000	176	10110000	240	11110000
049	00110001	113	01110001	177	10110001	241	11110001
050	00110010	114	01110010	178	10110010	242	11110010
051	00110011	115	01110011	179	10110011	243	11110011
052	00110100	116	01110100	180	10110100	244	11110100
053	00110101	117	01110101	181	10110101	245	11110101
054	00110110	118	01110110	182	10110110	246	11110110
055	00110111	119	01110111	183	10110111	247	11110111
056	00111000	120	01111000	184	10111000	248	11111000
057	00111001	121	01111001	185	10111001	249	11111001
058	00111010	122	01111010	186	10111010	250	11111010
059	00111011	123	01111011	187	10111011	251	11111011
060	00111100	124	01111100	188	10111100	252	11111100
061	00111101	125	01111101	189	10111101	253	11111101
062	00111110	126	01111110	190	10111110	254	11111110
063	00111111	127	01111111	191	10111111	255	—

Figure 1-41 Password Comparison Table

### 3.5 Precautions for Using the FAX/TEL Switching Function

The FAX/TEL switching function automatically switches to facsimile reception when there is a fax at the other end, and to telephone if a person is calling. However, since it takes some time to determine whether the caller is a fax or a person after the fax answers the call, the caller is charged for this time. The fax returns pseudo-ringback tone to the caller while it is determining whether the caller is a fax or a person.

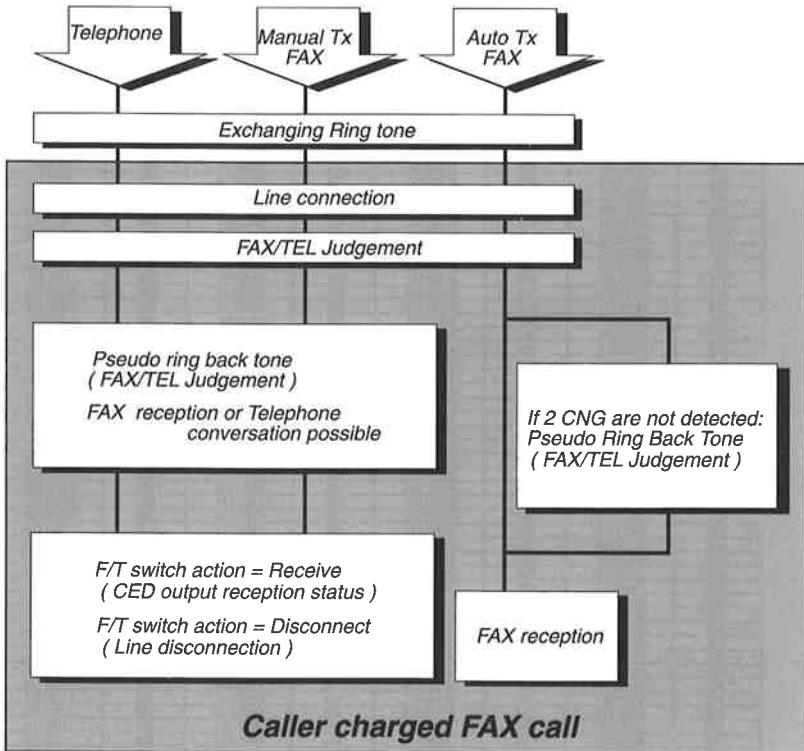


Figure 1-42 FAX/TEL Switching Function

## 4. PROTECTIVE FUNCTIONS

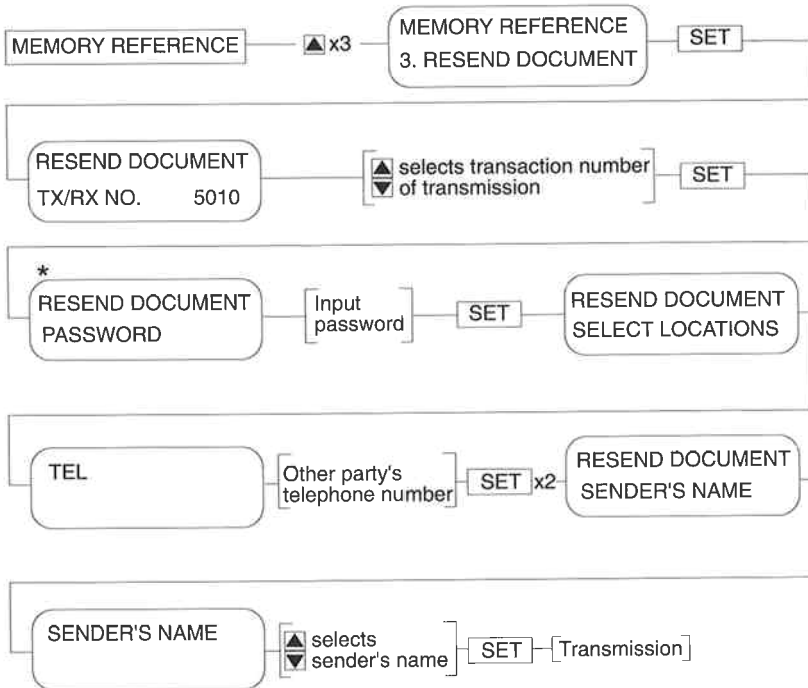
### 4.1 Data Backed Up by Lithium Battery

This fax backs up the following data with the lithium battery on the SCNT board even when the power is off.

<b>Backed up data</b>	<b>Item</b>
Dial data	One-touch speed dialing data Coded speed dialing
User data	User data
Service data	Service data
System management data	Timer registration data Memory management data Redialing data

## 4.2 Image Data Transfer

When the power is switched off, the image data accumulated in memory with memory reception, confidential reception, delayed transmission, etc. is erased. If you must switch off the power while there is image data in memory, transfer the accumulated image data to another fax before switching off the power. The operations method is given below.



\* If you are transferring memory reception image data, you need not enter a password. You will need the password only when transferring confidential image data.

**Figure 1-43 Image Data Transfer Operations Method**



The transaction numbers effective in reception mode are in the 5000's. When transferring received images, select a number in the 5000's.

### 4.3 Printer Protective Functions

#### a) Cleaning the transfer charging roller

To keep toner from adhering to the transfer charging roller, this fax has a cleaning function that returns the toner on the transfer charging roller to the cartridge's photosensitive drum.



---

This fax returns the toner on the negatively charged transfer charging roller to the photosensitive drum charged to 0 V by applying negative voltage to the transfer charging roller.

The cleaning function works automatically during power on initialization and during the rotation before and after printing.

---

#### b) Fixing unit protective functions

When the fixing heater temperature reaches approx. 410°F (210°C) to 455°F (235°C), this fax switches off the relay on the PCNT board and automatically stops the power to the fixing heater. If the fixing heater temperature climbs over 464°F (240°C), the thermal fuse in the fixing unit automatically stops the power to the fixing heater.



---

The temperature of the fixing heater is constantly detected by a thermistor within the fixing heater.

When the protective function is triggered, this fax displays "**CHECK PRINTER**" on the display.

In order to prevent dangerously high temperature in the fixing heater, after the protective function is triggered, after the power is switched off, for 10 minutes power is not fed to the fixing heater even if the power is switched back on.

---

**This page intentionally left blank**

# ***Chapter 2***

## ***Operating Instructions***



# 1. NAMES OF PARTS AND THEIR FUNCTIONS

## 1.1 Main Unit External View

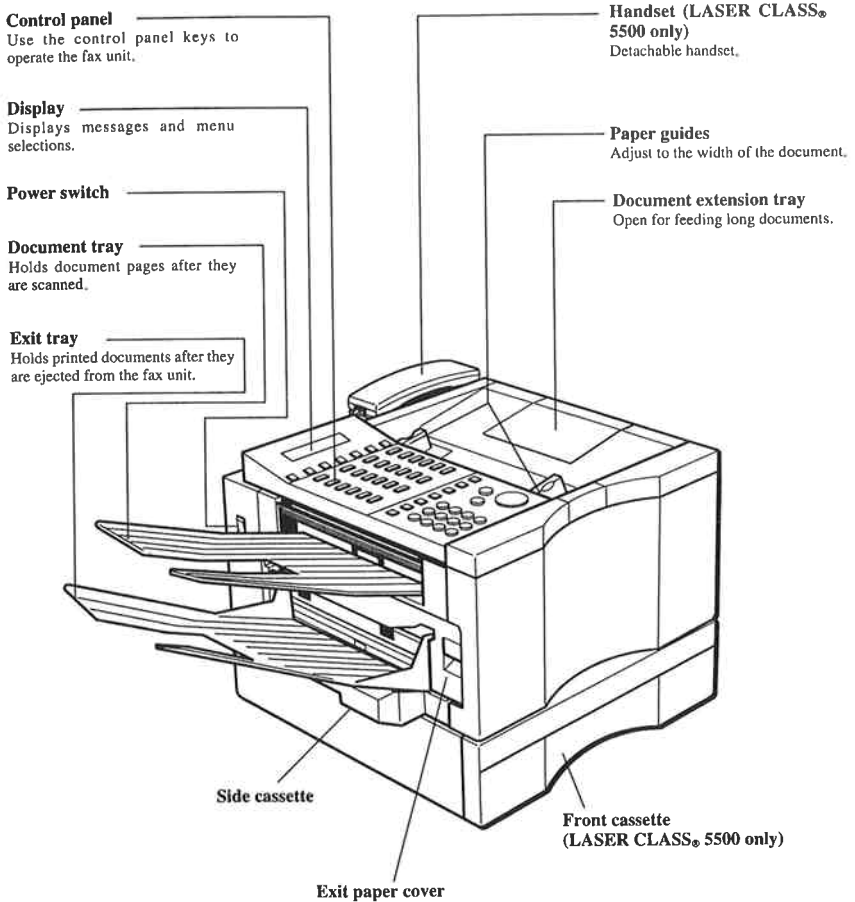
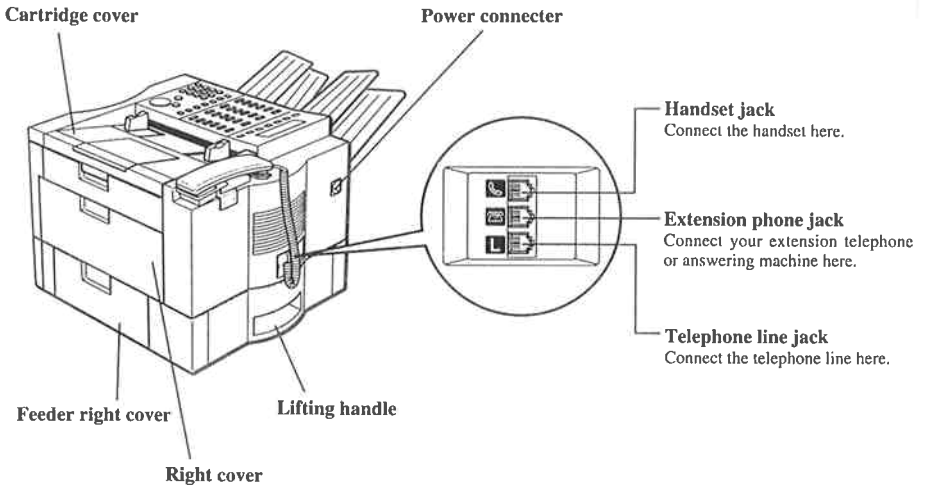


Figure 2-1 Main Unit External View (1)



**Figure 2-2 Main Unit External View (2)**

**This page intentionally left blank**

## 1.2 Operation Switches

### 1.2.1 Control panel section

**Display**

Displays messages and prompts during operation. Displays functions for selection, text, and names when registering information.

**DARKER-STANDARD-LIGHTER**

Use to adjust the lightness/darkness of the documents you send or copy.

**SUPER FINE-FINE-STANDARD**

Use to set resolution for the type of document you want to send or copy.

**TYPE OF DOC.-AA**

Press and light TYPE OF DOC. for document with photographs or graphics. Press and light AA for a document with both text and photographs.

**ANS HOOK UP-MANUAL**

When both lamps are off, the fax is set for automatic receiving. Press and light ANS HOOKUP when an answering machine is connected. Press and light MANUAL for manual document receiving.

**DIRECT TX**

Press for direct sending urgent documents ahead of other documents waiting to be sent from the memory. Direct sending scans the document and sends it immediately without storing the document in the memory.

**TTI SELECTOR**

Press this key to select a registered sender name before sending a facsimile. The name you select is printed at the top of the document you send.

**One-touch Speed Dialing keys**

Press to dial numbers registered for One-touch Speed Dialing.

**One-touch Speed Dialing panel**

Open this panel when you need to use the keys to register information.

**Numeric keys**

Use the numeric keys to enter phone numbers when dialing. These keys also enter text, numbers, and symbols when registering names.

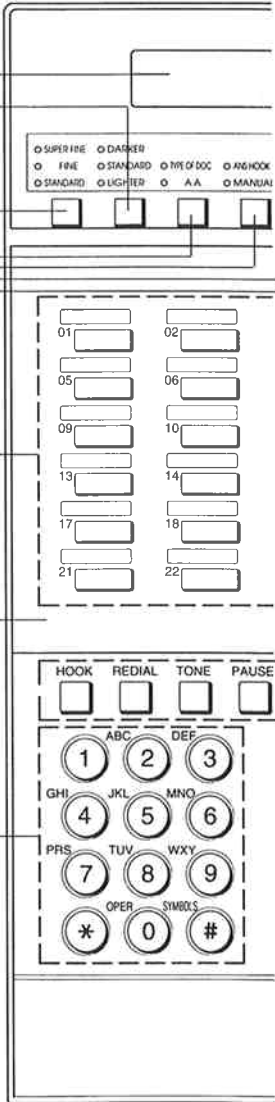


Figure 2-3 Control Panel Section (Left)

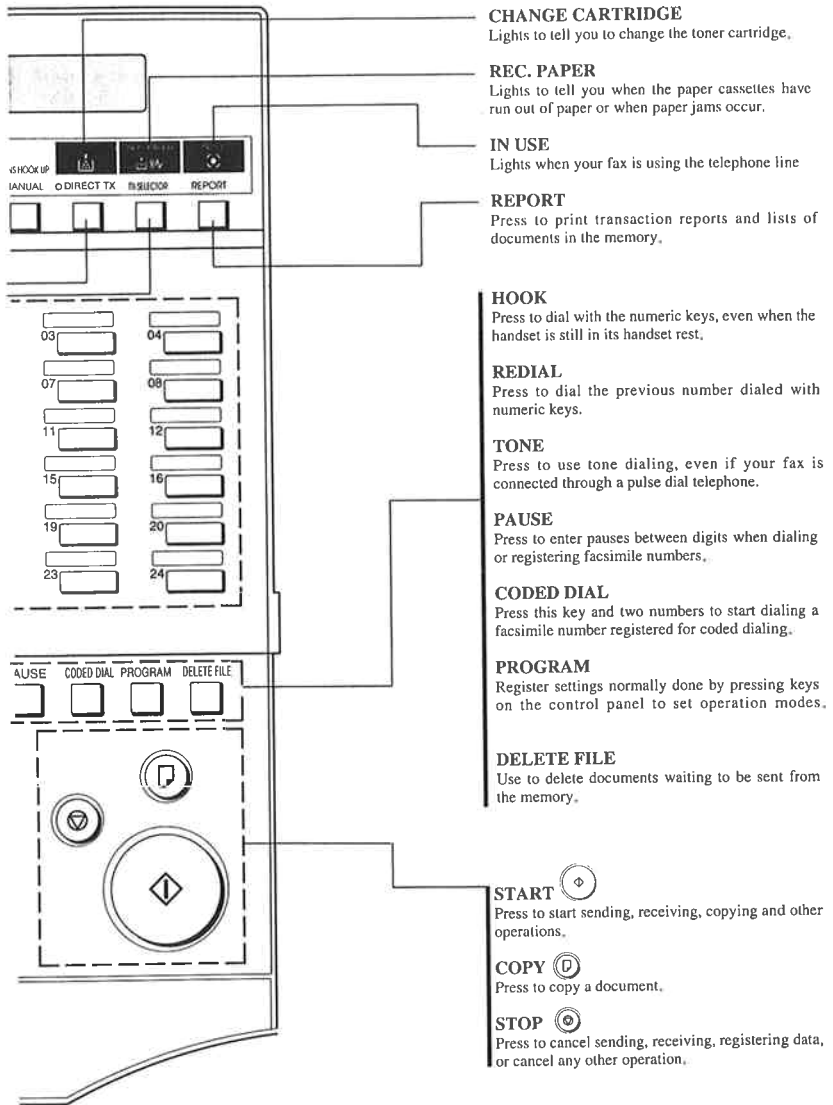
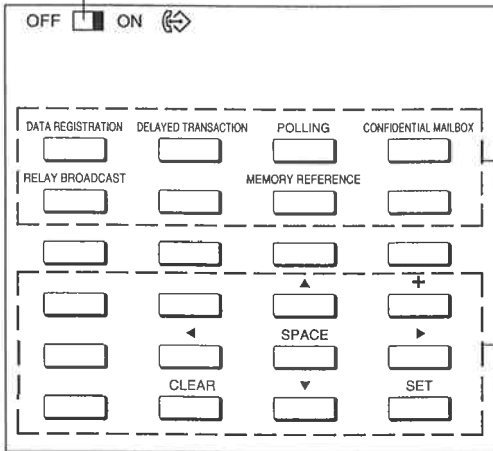


Figure 2-4 Control Panel Section (Right)



Do not touch this switch.



**DATA REGISTRATION**

Press to start data registration for facsimile numbers, names, box numbers, and other important settings for sending and receiving.

**DELAYED TRANSACTION**

Press to start registering a time for delayed sending.

**POLLING**

Use for polling sending and receiving.

**CONFIDENTIAL MAILBOX**

Use for sending and receiving confidential documents.

**RELAY BROADCAST**

Use for setting up relay sending.

**MEMORY REFERENCE**

Use to check the content of memory, delete documents from the memory, and other useful functions.

**Search keys (▲ ▼)**

Use to scroll the display when you need to make a selection during registration.

**Cursor keys (◀ ▶)**

Use to change the display for certain operations or to move the cursor.

**+**  
Press to enter a + in your facsimile number.

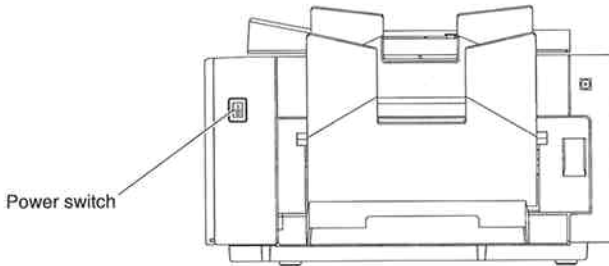
**SPACE**  
Press to enter a space between numbers or letters when you register facsimile numbers and names.

**CLEAR**  
Press during data registration to clear a number or name quickly so you can start again.

**SET**  
Press to select an item from the menus during registration.

**Figure 2-5 Function Keys**

### 1.2.2 Left side section



**Figure 2-6 Left Side Section**

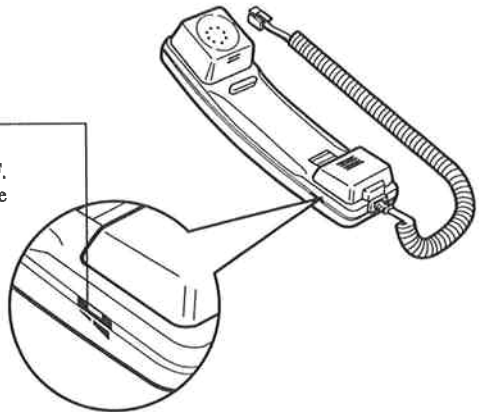
#### **Power switch**

This is the power switch for this fax. Up is on; down is off.

### 1.2.3 Handset (LASER CLASS 5500 only)

#### **Ringer volume switch**

Adjusts the volume of the ringer. There are three settings: HIGH LOW and OFF. Use a pen or other pointed object to adjust the switch.



**Figure 2-7 Handset**

## 2. SIMPLE OPERATIONS

### 2.1 COPYING

#### (1) Load recording paper



For details on how to load the recording paper, see *Chapter 5: 1. INSTALLATION.*

#### (2) Place the document on the document tray with the front facing down.

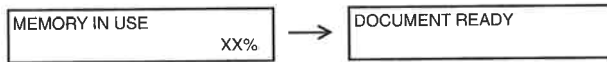
Adjust the sliders to match the width of the document. When the document is long, use the document extension tray.

#### (3) Insert the document.

Insert until you hear a beep. The document will be pulled in the rest of the way automatically.



When the document is pulled in, the following message is displayed.



**Figure 2-8 Document Loading Display**

#### (4) Press the Copy key.

#### (5) Specify the number of copies (up to 99) with the numeric keys. (LASER CLASS 5500 only)



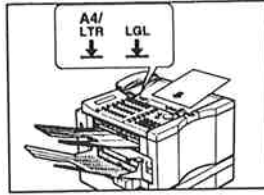
When adding a document, when the trailing edge of the document reaches a position about 3/4" (2 cm) from the edge of the control panel, place the leading edge of the additional document on top of the previous document and insert it.



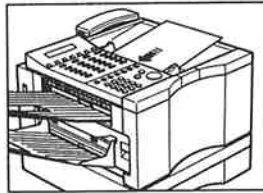
If the 0.5 M-Byte optional memory is added to a LASER CLASS 5000, the number of copies (up to 99) can be specified.

#### (6) Press the START key.

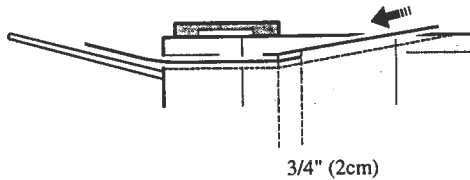




**Figure 2-9 Paper Guide Adjustment**



**Figure 2-10 Setting A Document**



**Figure 2-11 Adding Pages to A Document**

## **2.2 Telephone**

**(1) Press the Hook key.**

You may also just pick up the handset without pressing the Hook key.

**(2) Dial the telephone number for the other party.**

You can use the numeric keys, one-touch speed dialing, or coded speed dialing.

**(3) When you hear the other party's voice, pick up the handset and start your conversation.**

If the other party does not answer, press the Hook key to hang up.

## 2.3 Transmission

There are three ways to transmit a document: memory transmission, direct transmission, and manual transmission.

### 2.3.1 Memory transmission

The entire document is read into memory before it is transmitted.

#### Setting method

Press the DIRECT TX key to put out the DIRECT TX lamp.



---

The number of pages that can be read into memory at one time is 12 pages of the CCITT No.1 chart. Extra pages are read as memory becomes free.

LASER CLASS 5500: 44 pages

---

### 2.3.2 Direct transmission

Direct transmission transmits the document without reading it into memory.

#### Setting method

Press the DIRECT TX key to light up the DIRECT TX lamp.



---

Direct transmission takes priority even when there are multiple documents in memory with transmission reserved.

---

### 2.3.3 Manual transmission

With this method, you can transmit the document after talking with the other party over the telephone. You can even set a document and transmit it when a call comes from the other party's facsimile.



---

For details on the various transmission methods, refer to the *INSTRUCTION BOOK*.

---

## 2.4 Reception

There are three methods of reception: automatic reception, FAX/TEL switching reception (automatic reception), and manual reception.

### 2.4.1 Automatic reception

This mode is set when using this machine only as a facsimile machine.

#### Setting method

- (1) Use the ANS HOOK UP-MANUAL key to turn off the MANUAL lamp and the ANS HOOK UP lamp.
- (2) Use the DATA REGISTRATION key to select "RX SETTINGS", use the ▲ ▼ key to display "RX MODE" as the reception mode, then finalize this selection with the SET key.



---

This fax is shipped from the factory set to automatic reception.

---

### 2.4.2 FAX/TEL switching (automatic reception)

This machine can be used as a facsimile and telephone on a single line. If the other party is a facsimile, the facsimile is automatically received, and if the other party is a telephone, the bell is rung to notify the user.

#### Setting method

- (1) Use the ANS HOOK UP-MANUAL key to put out the MANUAL lamp and the ANS HOOK UP lamp.
- (2) Use the DATA REGISTRATION key to select "RX SETTINGS", use the ▲ ▼ key to display "RX MODE" as the reception mode, then finalize this selection with the SET key.

### 2.4.3 Manual reception

In this mode, the fax rings its bell when a call arrives, whether that call is from a telephone or from a facsimile. When the other party is a facsimile, you can receive the fax by pressing the START key. You can also receive by remote control, using an extension telephone.

#### Setting method

- (1) Use the ANS HOOK UP-MANUAL key to light the MANUAL lamp.



---

For further details on the reception modes, refer to the *Instruction Book*.

---

2.5

**Registering information for your fax**

In accordance with recent amendments to the FCC rules governing the use of facsimile equipment, you are now required to include your fax number, your name or company name, the date and time of the fax that you are sending each and every time that you send a fax. Please follow the instructions in this manual in order to set these features. This section shows you how to do the following operations:

- Set the date and time.
- Enter your own telephone number to be displayed at the top of documents you send.
- Enter your name to be displayed along with your telephone number at the top of documents you send.

Do these procedures and keep in mind that you will use the same basic procedures to enter letters, names, and numbers for other settings throughout this instruction book.



**1 Open the One-touch Speed Dialing panel. Then press DATA REGISTRATION.**



**2 Press SET.**



**3 Press SET.**



If you do not want to set the date and time, press ▼ and go on to step 7.

**4 If you want to set the date and time, press SET.**



**5 Use the numeric keys to enter the month, day, and year.**



**6 Use the numeric keys to enter the correct time.**

- When you register a time, be sure to use the 24-hour system. For example, 1:00 p.m. is 13:00.
- If you see a number already displayed, just enter the new number over the old one.



**7 Press SET.**



Getting started



8 Press SET.



9 Use these keys to enter your own facsimile number.

- 0-9 Press to enter a number.
- SPACE Press to enter a space. Spaces are optional.
- + Press to enter a +
- CLEAR Press to erase the entire entry if you want to start again.

You can register a number of up to 20 digits.



10 Press SET. Then press SET again.



11 Enter your name.

You can register a name of up to 24 characters.

Changing the entry mode

In the upper right corner of the display, you will see the letter A. This means you are in the letter entry mode.



In the letter mode, press a numeric key to enter a letter on the display. Press \*. In the upper right corner you will see the number 1.



This means you are in the number entry mode. In the number entry mode, press a numeric key to enter a number.

Press \* to switch quickly between the letter and number entry modes.

Entering a name



Look at the numeric keys. Above each key you will see a group of letters. These are the letters you can enter if you press the key below.

Select the group that contains the letter you want to enter, then press the key. Keep pressing the key until the letter you want appears. If you go past the letter you want, keep pressing the key until it appears again. Each key contains the upper and lower case letters for its group of letters. (For example: ABCabc)

Press another key to enter the displayed key and to move the cursor one space to the right.



You can also press ► to move the cursor to the right.

To enter a double letter or another letter of the same group, you will have to use the right cursor key. For example, to enter AAA, press 1 to enter the first A. Press ► to move the cursor 1 space to the right. Press 1 again to enter the second A. Repeat the procedure to enter the third A.



Press SPACE to enter a space. Pressing SPACE will also delete the character at the cursor position.



### Deleting a name

If you make a mistake and want to start again, press CLEAR to erase the entire entry.

### Entering symbols

If you want to enter symbols, first be sure you are in the letter entry mode. The letter A should be displayed in the upper right corner of the display. If it is not displayed, press \* to display A.

To enter a symbol, press # until you see the symbol you want, then press ► to move the cursor 1 space to the right or press another key. These are the symbols you can enter:

- \_ \* # ! " , ; : ^ ` \_ = / ! ' ? \$ @ % & + ( ) { } [ ] < >



### Making a correction

If you want to correct a single character, press the cursor keys (◀ ►) to move the cursor under the letter you want to change, then enter another letter. You can also use the SPACE key to delete letters.

#### Correction Keys

0-9	Press the numeric key with the group that contains the letter you want. Keep pressing the key until the letter you want appears.
*	Press to switch between the letter and number entry modes.
#	Press and keep pressing to select a symbol for text entry. You can enter symbols only in the letter entry mode.
►	Press to move to the next position.
◀	Press to move to the previous position.
SPACE	Press to enter a space. Press to erase a letter at the cursor position.
CLEAR	Press to erase the entire entry to start again.



### 12 Press SET.



You have registered your facsimile number and company name. This number and name will appear at the top of documents you send to other fax units.



### 13 Press STOP to return to standby.



## 3. SERVICE OPERATION FUNCTIONS

### 3.1 Error Display Function

#### 3.1.1 Error displays

This fax uses its error lamp, the error beep, and the display to indicate the type of error.

When service data is set On, if there is a communications error, the service error code is displayed on the display.

Display	Error	Error beep
REPLACE CARTRIDGE	No toner	-
CHECK PRINTER DOOR	No cartridge	-
	Cartridge cover, right cover, exit paper cover, or feeder right cover (LASER CLASS 5500 only) is not completely closed.	
REC. PAPER JAM	Recording paper jam	-
NOT AVAILABLE NOW	Confidential and relay double registration	-
NOT FOUND, TRY AGAIN	Box not registered	-
HANG UP PHONE	Handset still offhook after end of communication	Alarm
# ALREADY IN USE	Box in use	-
NO TEL#	One-touch/coded speed dialing number not registered	-
CHECK PRINTER	Printer error not recoverable by user	Beep
NO RX PAPER	Other party out of paper	Beep
NO ANSWER	No response from other party/other fax not G3	Beep
SUPPLY REC. PAPER	No recording paper/no cassette	Beep
DOCUMENT TOO LONG	One page transmission time over 32 minutes (16 minutes when TYPE OF DOC/AA lamp On) or length over 1 meter	Beep
CHECK DOCUMENT	Document jam	Beep
NO CONFID. TX	Confidential transmission error	Beep
NO ORIGINAL RELAY TX	Relay sending error	Beep
POLLING ID ERROR	Polling password not matching	Beep
BUSY/NO SIGNAL	No response after redialing	Beep
MEMORY FULL	Memory full error	Beep
START AGAIN	Poor line/system operation error	Beep
DATA ERROR	Checksum error	-
PRESS SET KEY		



When the no toner error occurs, the CHANGE CARTRIDGE lamp blinks.

When the no recording paper or no cassette error occurs, the REC. PAPER lamp blinks.

The error beep only beeps for direct transmission and manual reception. However, in the case of a compulsory stop of communications with the Stop key, the error beep will beep.



### 3.1.2 Errors displayed in error report

If an error occurs during facsimile communications, a report is output to inform the error.

#### a) Error transmission report/reception result report

An error transmission report or a reception result report is output if an error occurs during transmission or reception. However, the service data must be set for output.



---

#### Output setting

The user data registration report settings select whether transmission result reports and reception result reports are always output or are only output for errors.

The service error code and error dump list can be attached with a service data setting.

---



---

For a sample error transmission report and reception result report (for when an error occurs), see *3.2 Report Output Function* on this chapter.

---

### 3.2 Report Output Function

#### 3.2.1 User report output functions

This fax outputs user reports when the user outputs them manually and when automatic output has been set with the user data.

##### a) Manual output of reports by user operation

On this fax, the following reports can be output from the control panel.

Report Type	Operations
One-touch speed dial list 1	After pressing the DATA REGISTRATION key, display " <b>2. TEL REGISTRATION</b> ", press the SET key and the REPORT key.
Coded speed dial list 1 Group dial list	All three reports are output at the same time.
One-touch speed dial list 2 Coded speed dial list 2	Output when the Report key is pressed during the respective registration.
User's data list	After pressing the DATA REGISTRATION key and the SET key, press the Report key.
Confidential mail box report	After pressing the CONFIDENTIAL MAILBOX key, display " <b>2. CONFIDENTIAL RX</b> " and press the SET key and the REPORT key.
Transmission reserve list	Press the DELAYED TRANSACTION key, then press the Report key.
Document memory list	After pressing the MEMORY REFERENCE key, press the SET key.



**a-1) One-touch speed dial list 1**

This list shows registered one-touch speed dialing telephone numbers.



01/31/94 MON 14:02 FAX 123 456 7890 Canon TOKYO 001

```

*****
*** 1-TOUCH SPD DIAL LIST 1 ***
*****
    
```

NO.	CONNECTION TEL	CONNECTION ID	MODE		
[ 01]	111 111 1111	Canon 1	MEMORY TX		
[ 02]	222 222 2222	Canon 2	CONFID. TX	00	10:00
[ 03]	333 333 3333	Canon 3	ORG RELAY TX	00	
[ 04]	444 444 4444	Canon 4	MEMORY TX		
[ 05]	555 555 5555	Canon 5	MEMORY TX		
[ 06]	888 888 8888	Canon 6	MEMORY TX		08:00
[ 07]	777 777 7777	Canon 7	CONFID. TX	01	
[ 08]	888 888 8888	Canon 8	MEMORY TX		
[ 09]	999 999 9999	Canon 9	ORG RELAY TX	00	
[ 15]	GROUP DIAL	GROUP 1	MEMORY TX		
[ 16]	GROUP DIAL	GROUP 2	MEMORY TX		
[ 17]	GROUP DIAL	GROUP 3	MEMORY TX		

**Figure 2-12 One-Touch Speed Dial List 1**

- NO.** : One-touch speed dialing number 01-24
- CONNECTION TEL** : Maximum display 40 digits (from 41st digit on, omitted)
- CONNECTION ID** : Maximum display 16 characters
- MODE** : Memory transmission, confidential transmission, relay control transmission
-  : Confidential box numbers 00-99, relay group numbers 00-99
-  : Delayed transmission start time, 24-hour display (When more than one delayed transmission start time is specified, only the initial time is displayed here.)

a-2) Coded speed dial list 1

This list shows registered coded speed dialing telephone numbers.

01/31/94 MON 14:02 FAX 123 458 7890 Canon TOKYO 001

```

*****
*** CODED SPEED DIAL LIST 1 ***
*****
    
```





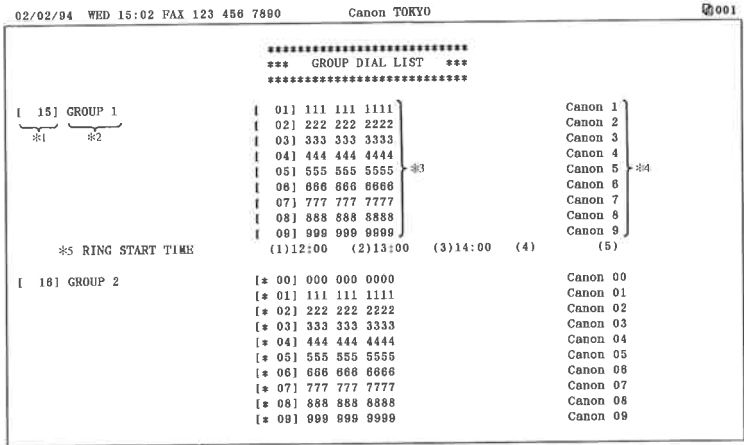
NO.	CONNECTION TEL	CONNECTION ID	MODE		
[* 00]	000 000 0000	Canon 00	MEMORY TX		
[* 01]	111 111 1111	Canon 01	MEMORY TX		
[* 02]	222 222 2222	Canon 02	CONFID. TX	00	09:00
[* 03]	333 333 3333	Canon 03	ORG RELAY TX	00	
[* 04]	444 444 4444	Canon 04	MEMORY TX		
[* 05]	555 555 5555	Canon 05	MEMORY TX		
[* 06]	666 666 6666	Canon 06	CONFID. TX	00	
[* 07]	777 777 7777	Canon 07	ORG RELAY TX	00	
[* 08]	888 888 8888	Canon 08	MEMORY TX		
[* 09]	999 999 9999	Canon 09	MEMORY TX		

Figure 2-13 Coded Speed Dial List 1

- NO.** : Coded speed dialing number \*00-\*99
- CONNECTION TEL** : Maximum display 40 digits (from 41st digit on, omitted)
- CONNECTION ID** : Maximum display 16 characters
- MODE** : Memory transmission, confidential transmission, relay originating transmission
-  : Confidential box numbers 00-99, relay group numbers 00-99
-  : Delayed transmission start time, 24-hour display (When more than one delayed transmission start time is specified, only the initial time is displayed here.)

**a-3) Group dial list**

This list shows registered group dialing telephone numbers.



**Figure 2-14 Group Dial List**

- \*1: One-touch speed dialing telephone numbers 01-24 registered for group dialing
- \*2: Group dialing ID Maximum display 16 characters
- \*3: One-touch speed dialing telephone numbers, coded speed dialing telephone numbers, and telephone numbers registered as a group Up to 123 destinations
- \*4: One-touch speed dialing and coded speed dialing group dialing IDs registered as a group Maximum display 16 characters
- \*5: Ring start time Five delayed transmission times specified by a 24-hour clock are displayed.

a-4) One-touch speed dial list 2

This list shows registered one-touch speed dialing telephone numbers in more detail than List 1.

01/31/94 MON 14:08 FAX 123 456 7890		Canon TOKYU		001	
***** *** 1-TOUCH SPD DIAL LIST 2 *** *****					
[ 01]	CONNECTION TEL	111 111 1111			
	CONNECTION ID	Canon 1			
	TX SPEED	9600bps(0)			
[ 02]	CONNECTION TEL	222 222 2222			
	CONNECTION ID	Canon 2			
	RING START TIME	(1)10:00 (2)11:00 (3)12:00 (4) (5)			
	TX SPEED	4800bps(1)			
	MODE	CONFID. TX #00			
[ 03]	CONNECTION TEL	333 333 3333			
	CONNECTION ID	Canon 3			
	TX SPEED	9600bps(2)			
	MODE	ORG RELAY TX #00			
[ 04]	CONNECTION TEL	444 444 4444			
	CONNECTION ID	Canon 4			
	TX SPEED	9600bps(3)			
[ 05]	CONNECTION TEL	555 555 5555			
	CONNECTION ID	Canon 5			
	TX SPEED	4800bps(0)			
[ 06]	CONNECTION TEL	666 666 6666			
	CONNECTION ID	Canon 6			
	RING START TIME	(1)09:00 (2)10:00 (3)11:00 (4)12:00 (5)13:00			
	TX SPEED	4800bps(1)			
[ 07]	CONNECTION TEL	777 777 7777			
	CONNECTION ID	Canon 7			
	TX SPEED	4800bps(0)			
	MODE	CONFID. TX #01			
[ 08]	CONNECTION TEL	888 888 8888			
	CONNECTION ID	Canon 8			
	TX SPEED	9600bps(3)			
[ 09]	CONNECTION TEL	999 999 9999			
	CONNECTION ID	Canon 9			
	TX SPEED	4800bps(2)			
	MODE	ORG RELAY TX #00			
[ 15]	CONNECTION TEL	GROUP DIAL			
	CONNECTION ID	GROUP 1			

Figure 2-15 One-Touch Speed Dial List 2

- [01]-[24] : One touch speed dialing number
- CONNECTION TEL : Maximum display 120 digits
- CONNECTION ID : Maximum display 16 digits
- RING START TIME : Delayed transmission times; displays the five timer transmission times set with the 24-hour clock.
- TX SPEED : High speed, medium-high speed, medium speed, low speed 0 in parentheses: domestic transmission; 1, 2, 3: international transmission
- MODE : Confidential transmission, relay originating transmission #00: confidential box number; 00-99: relay group number

**a-5) Coded speed dial list 2**

This list shows registered coded speed dialing telephone numbers more detailed than List 1.

01/31/94 MON 14:09 FAX 123 456 7890 Canon TOKYO 001

```

*****
*** CODED SPEED DIAL LIST 2 ***
*****

[* 00] CONNECTION TEL      000 000 0000
      CONNECTION ID      Canon 00
      TX SPEED           8800bps(0)

[* 01] CONNECTION TEL      111 111 1111
      CONNECTION ID      Canon 01
      TX SPEED           4800bps(1)

[* 02] CONNECTION TEL      222 222 2222
      CONNECTION ID      Canon 02
      RING START TIME     (1)09:00 (2)10:00 (3)11:00 (4)12:00 (5)13:00
      TX SPEED           9800bps(0)
      MODE                CONFID. TX #00

[* 03] CONNECTION TEL      333 333 3333
      CONNECTION ID      Canon 03
      TX SPEED           9800bps(0)
      MODE                ORG RELAY TX #00

[* 04] CONNECTION TEL      444 444 4444
      CONNECTION ID      Canon 04
      TX SPEED           8800bps(2)

[* 05] CONNECTION TEL      555 555 5555
      CONNECTION ID      Canon 05
      TX SPEED           9800bps(3)

[* 06] CONNECTION TEL      666 666 6666
      CONNECTION ID      Canon 06
      TX SPEED           4800bps(0)
      MODE                CONFID. TX #00

[* 07] CONNECTION TEL      777 777 7777
      CONNECTION ID      Canon 07
      TX SPEED           8800bps(0)
      MODE                ORG RELAY TX #00

[* 08] CONNECTION TEL      888 888 8888
      CONNECTION ID      Canon 08
      TX SPEED           4800bps(3)

[* 09] CONNECTION TEL      999 999 9999
      CONNECTION ID      Canon 09
      TX SPEED           4800bps(3)
    
```

**Figure 2-16 Coded Speed Dial List 2**

- [\*00]-[\*99]** : Coded speed dialing numbers 00-99
- CONNECTION TEL** : Maximum display 120 digits
- CONNECTION ID** : Maximum display 16 digits
- RING START TIME** : Delayed transmission start times; displays the five timer transmission times set with the 24-hour clock.
- TX SPEED** : High speed, medium-high speed, medium speed, low speed 0 in parentheses: domestic transmission; 1, 2, 3: international transmission
- MODE** : Confidential transmission, relay originating transmission
  - #00 : confidential box number; 00-99
  - : relay group number

a-6) User's data list

This list shows user data setting statuses.

```

02/02/94 WED 11:49 FAX 123 458 7890 Canon TOKYO @001

*****
*** USER'S DATA LIST ***
*****

1.USER SETTINGS
UNIT TELEPHONE # 123 458 7890
UNIT NAME Canon TOKYO
SENDER NAME 01: Canon A
02: Canon B
03: Canon C
04: Canon D
05: Canon E
08: Canon F
07: Canon G
08: Canon H
09: Canon I

TX TERMINAL ID ON
TTI POSITION OUTSIDE IMAGE
TELEPHONE # MARK FAX
TYPE OF DOCUMENT HALFTONE
DENSITY CONTROL
LIGHTER 5
STANDARD 4
DARKER 2
PROGRAM KEY
OFFHOOK ALARM ON
VOLUME CONTROL
CALLING VOLUME 4
KEYPAD VOLUME 4
ALARM VOLUME 4
LINE MONITOR VOL. 4
RX CALL LEVEL STANDARD
OMIT DIALING TONE OFF
TEL LINE TYPE TOUCH TONE

2.REPORT SETTINGS
TX REPORT OUTPUT YES
TX CONFIRMATION REP. OFF
RX REPORT OUTPUT YES
CONFID. RX REPORT OUTPUT YES
ACTIVITY REPORT
AUTO PRINT ON
DAILY REPORT TIME OFF
TX/RX SEPARATE OFF
PRINT REPORT WHERE OFF

3.TX SETTINGS
ECM TX ON
MID PAUSE 2SEC
AUTO REDIAL ON
REDIAL TIMES 2TIMES
REDIAL INTERVAL 2MIN.
TX ERROR RESEND ON
RESEND TX FROM ERROR & 1ST PG
BATCH TX ON
QUICK ON-LINE TX ON
ERASE FAILED TX OFF
TIME OUT ON
    
```

Figure 2-17 User's Data List (1/2)



```

02/02/94 WED 11:49 FAX 123 456 7890          Canon TOKYO          002
4.RX SETTINGS
ECM RX                      ON
RX MODE                     AUTO RX
INCOMING RING               OFF
ANS/FAX SWITCH             ON
ANS/FAX SW TIME            6SEC
MAN/AUTO SWITCH            OFF
REMOTE RX                  ID CALL #
    REMOTE RX ID          25
MEMORY RX                  ON
    MEMORY RX ALARM      OFF
RX PAGE FOOTER            OFF

5.PRINTER SETTINGS
SELECT CASSETTE
    CASSETTE SW A          ON
    CASSETTE SW B          ON
RX REDUCTION
    RX REDUCTION          ON
    AUTO SELECTION
PRINT IN ORDER             OFF
SELECT DENSITY             STANDARD
TONER SUPPLY LOW          RX TO MEMORY

6.FILE SETTINGS
1.CONFID. MAILBOX
    #00 FILE NAME

2.PRESET POLLING
    FILE NAME              A
    CONNECTION TEL/ID
    START TIME

3.POLLING BOX
    FILE NAME              B
    ERASE AFTER TX        ON

7.SYSTEM SETTINGS
RESTRICTIVE CODES
TX SETTINGS                ON
DEPT. ACCESS CODE          ON
    1:1111
    2:2222
    3:3333
    4:4444
    5:5555
    6:6666
    7:7777
    8:8888
    9:9999
    0:0000
PRINTER SETTINGS          ON
RX RESTRICTION            OFF
POLLING ID                000
DATE SETUP                MM/DD/YY
DISPLAY LANGUAGE          ENGLISH
TX START SPEED            9800bps
RX START SPEED            8800bps

DIAL DIGITS REMAIN          99%
    
```

Figure 2-18 User's Data List (2/2)

**a-7) Confidential mail box report**

This list shows the faxes received with confidential reception and still in a confidential box.

02/01/94 TUE 20:43 FAX 123 456 7890 Canon TOKYO 001

```

*****
*** CONFID. MAIL BOX REPORT ***
*****

CONFID. MBOX #          CONFID. MBOX NAME          PGS.
-----
00                      Canon                      1
    
```

**Figure 2-19 Confidential Mail Box Report**

- MAIL BOX #** : 00 - 99
- FILE NAME** : Maximum display 24digits
- PGS.** : Number of pages received (Maximum display 3 digits)

**a-8) Transmission reserve list**

This list shows transmission reservations have been made.

02/02/94 WED 13:26 FAX 123 456 7890 Canon TOKYO 001

```

*****
*** TX RESERVE LIST ***
*****

```

TX/RX NO	MODE	CONNECTION TEL/ID	PGS.	SET TIME	ST. TIME	SENDER NAME
0008	DELAYED TX	{* 011Canon 01	1	02/02 13:27	15:00	Canon TOKYO 1111
0009	DELAYED TX	{ 011Canon 1	1	02/02 13:27	15:10	Canon TOKYO 1111

**Figure 2-20 Transmission Reserve List**

- TX/RX NO.** : 4-digit display
- MODE** : Delayed transmission, confidential transmission, relay originating transmission, broadcast transmission, delayed broadcast transmission, delayed polling transmission, polling transmission.
- CONNECTION** : One-touch speed dialing, coded speed dialing, group dialing number + ID
- TEL/ID** (16 digits), numeric key dialing 22 digits
- PGS.** : Number of pages transmitted
- SET TIME** : Reservation reception time, displayed in 24-hour time
- ST. TIME** : Transmission start time, displayed in 24-hour time
- SENDER NAME** : Sender name (24 digits) appended to transmission
- DEPT. ACCESS** : When the restricting sending function is on, this shows the registered department access code (4 digits).
- CODE**

**a-9) Document memory list**

This list shows data concerning the documents in the memory.

02/02/84 WED 11:12 FAX 123 456 7890 Canon TOKYO 001

```

*****
*** DOC. MEMORY LIST ***
*****

```

TX/RX NO	MODE	CONNECTION TEL/ID	PGS.	SET TIME	ST. TIME	SENDER NAME
0004	DELAYED TX	[* 01]Canon 01	1	02/02 11:09	12:00	Canon TOKYO 1111
0005	DELAYED TX	[* 01]Canon 01	1	02/02 11:10	12:30	Canon TOKYO 2222
0006	DELAYED TX	[ 01]Canon 1	1	02/02 11:10	12:40	Canon TOKYO 3333
5004	POLLING TX		1	02/02 11:11		Canon TOKYO 1111
5005	POLLING TX		1	02/02 11:12		Canon TOKYO 4444

**Figure 2-21 Document Memorys List**

- TX/RX NO.** : 4-digit display
- MODE** : Delayed transmission, confidential transmission, relay originating transmission, broadcast transmission, polling transmission, transmission, delayed broadcast transmission, delayed polling transmission, confidential reception, memory reception
- CONNECTION TEL/ID** : One-touch speed dialing, coded speed dialing number + ID (16 digits), numeric key dialing 22 digits
- PGS.** : Number of pages transmitted
- SET TIME** : Reservation reception time, displayed in 24-hour time
- ST. TIME** : Transmission start time, displayed in 24-hour time
- SENDER NAME** : Sender name of up to 24 digits appended to transmission
- DEPT. ACCESS CODE:** When the restricting sending function is on, this shows the registered department access code (4 digits).

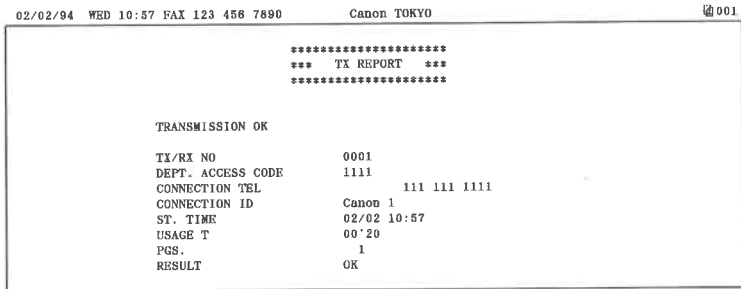
**b) Reports output automatically with soft switch settings**

This fax outputs the reports below according to user data settings.

Report Type	Settings
Transmission report	Output of all the reports on the left is set with the data registration report setting menu.
Error transmission result report	
Reception report	
Confidential reception report	
Multi-transaction report	
Activity report	

**b-1) Transmission report**

This report is output automatically after completion of transmission.



**Figure 2-22 Transmission Report**

- TX/RX NO.** : 4-digit display
- CONNECTION TEL** : Displays up to 20 digits for the telephone number sent from the other party or the number dialed.
- CONNECTION ID** : Displays the ID sent from the other party, if it is a Canon machine.
- ST. TIME** : Date and time (24-hour display)
- USAGE T** : Transmission time (in minutes and seconds)
- PGS.** : Number of pages transmitted
- RESULT** : OK display
- DEPT. ACCESS CODE** : When the restricting sending function is on, this shows the registered department access code (4 digits).

**b-2) Error transmission report**

This report is output automatically each time transmission ends in an error.

```

02/02/94 WED 11:05 FAX 123 456 7890          Canon TOKYO          001
*****
***  ERROR TX REPORT  ***
*****

TX FUNCTION WAS NOT COMPLETED

TX/RX NO          0002
DEPT. ACCESS CODE 1111
CONNECTION TEL    111 111 1111
CONNECTION ID    Canon 01
ST. TIME         02/02 11:04
USAGE T         00'37
PGS.            1
RESULT          NG
1
    
```

**Figure 2-23 Error Transmission Report**

- TX/RX NO** : 4-digit display
- CONNECTION TEL** : Displays up to 20 digits for the telephone number sent from the other party or the number dialed.
- CONNECTION ID** : Displays the ID sent from the other party, if it is a Canon machine.
- ST. TIME** : Date and time (24-hour display)
- USAGE T** : Transmission time (in minutes and seconds)
- PGS.** : Number of pages for which transmission completed
- RESULT** : NG display, display of number of pages for which transmission interrupted, user error code
- DEPT. ACCESS CODE** : When the restricting sending function is on, this shows the registered department access code (4 digits).

**b-3) Reception report**

This report is output automatically after completion of reception (even in an error).

```
02/02/94 WED 11:03 FAX 123 456 7890 Canon TOKYO 001
*****
*** RX REPORT ***
*****

RECEPTION OK

TX/RX NO          5002
DEPT. ACCESS CODE
CONNECTION TEL    123 456 7890
CONNECTION ID     Canon
ST. TIME         02/02 11:02
USAGE T          00'32
PGS.             1
RESULT           OK
```

**Figure 2-24 Reception Report**

- TX/RX NO** : 4-digit display
- CONNECTION TEL** : Displays up to 20 digits for the telephone number sent from the other party or the number dialed.
- CONNECTION ID** : Displays the ID sent from the other party, if it is a Canon machine.
- ST. TIME** : Date and time (24-hour display)
- USAGE T** : Reception time (in minutes and seconds)
- PGS.** : Number of pages for which reception completed
- RESULT** : OK, NG display  
For NG, display of page number whose reception was interrupted and user error code
- DEPT. ACCESS CODE** : When the restricting sending function is on, this shows the registered department access code (4 digits).

**b-4) Confidential reception report**

Output automatically after confidential reception.

```

02/02/94 WED 11:22 FAX 123 456 7890          Canon TOKYO          001
-----
*****
*** CONFID. RX REPORT ***
*****

CONFID. MBOX #          #00
TX/RX NO                5007
DEPT. ACCESS CODE
CONNECTION TEL          Canon      123 456 7890
CONNECTION ID
ST. TIME                02/02 11:21
USAGE T                 00'33
PGS.                    1
RESULT                  OK
    
```

**Figure 2-25 Confidential Reception Report**

- CONFID MBOX #** : 00-99
- TX/RX NO** : 4-digit display
- CONNECTION TEL** : Displays the telephone number sent from the other party.
- CONNECTION ID** : Displays the ID sent from the other party.
- ST. TIME** : Date and time (24-hour display)
- USAGE** : Reception time (in minutes and seconds)
- PGS.** : Number of pages received
- RESULT** : OK, NG display  
For NG, display of page number whose reception was interrupted and user error code
- DEPT. ACCESS CODE** : When the restricting sending function is on, this shows the registered department access code (4 digits).

**b-5) Multi-transaction report**

Output automatically after the completion of sequential broadcasting.

```
02/02/94 WED 11:55 FAX 123 458 7890 Canon TOKYO 001
*****
*** MULTI TN REPORT ***
*****
TX/RX NO          0007
DEPT. ACCESS CODE 1111
INCOMPLETE TX/RX
TRANSACTION OK    { * 011111 111 1111          Canon 01
                  { 011111 111 1111          Canon 1
ERROR
```

**Figure 2-26 Multi-Transaction Report**

- TX/RX NO** : 4-digit display
- INCOMPLETE TX/RX** : Displays the telephone numbers and IDs for which communications are not complete.
- TRANSACTION OK** : Displays the telephone numbers and IDs for which communications are complete.
- ERROR** : Displays the telephone numbers and IDs for which communications ended in an error.
- DEPT. ACCESS CODE** : When the restricting sending function is on, this shows the registered department access code (4 digits).



**b-6) Activity report**

Automatically output after the completion of every 40th communication. User data settings can output this report at specified times and can output transmission and reception reports separately.

02/02/94 WED 11:43 FAX 123 456 7890 Canon TOKYO 001

***** *** ACTIVITY REPORT *** *****							
ST. TIME	CONNECTION TEL/ID	SENDER NAME	NO.	MODE	PGS.	RESULT	
*02/02 10:57	Canon 1 111 111 1111	Canon TOKYO	0001	TRANSMIT ECM	1	OK	00'20
*02/02 11:02	Canon 123 456 7890	Canon TOKYO	5002	AUTO RX ECM	1	OK	00'32
*02/02 11:04	Canon 01 111 111 1111	Canon TOKYO	0002	TRANSMIT ECM	1	OK	00'37
*02/02 11:08	Canon 01 111 111 1111	Canon TOKYO	0002	TRANSMIT ECM	1	NG	00'40
*02/02 11:09	Canon 01 111 111 1111	Canon TOKYO	0003	TRANSMIT ECM	1	OK	00'35
*02/02 11:10	Canon 01 111 111 1111	Canon TOKYO	0002	TRANSMIT ECM	1	OK	00'19
*02/02 11:13	Canon 123 456 7890	Canon TOKYO	5008	AUTO RX ECM	1	NG	00'30
*02/02 11:21	Canon 123 456 7890	Canon TOKYO	5007	CONFID. RX ECM	1	OK	00'33
*02/02 11:23	Canon 123 456 7890	Canon TOKYO	5008	CONFID. RX ECM	1	OK	00'32
*02/02 11:24	Canon 123 456 7890	Canon TOKYO	5009	CONFID. RX ECM	1	OK	00'32

**Figure 2-27 Activity Report**

- ST. TIME** : Date and time (24-hour display)  
\* indicates communications for which a report has already been output.
- CONNECTION TEL/ID** : The telephone number sent from the other party or the telephone number dialed and the ID sent from the other party or the ID registered for one-touch speed dialing or coded speed dialing
- SENDER NAME** : 20-digit display
- NO.** : Communications transaction number (transmission: 0001-4999 ; reception: 5001-9999)
- MODE** : Displays manual reception, manual transmission, automatic reception, transmission, polling reception, polling transmission, relay originating transmission, delayed transmission, delayed broadcast transmission, memory polling, broadcast transmission, confidential reception, confidential transmission, or memory reception.  
+G3 or ECM displayed
- PGS.** : Number of pages transmitted and received
- RESULT** : OK, NG  
For NG, the error code is displayed too.

02/02/94 WED 11:35 FAX 123 456 7890 Canon TOKYO 001

\*\*\*\*\*  
 \*\*\* ACTIVITY REPORT \*\*\*  
 \*\*\*\*\*

DEPT. ACCESS CODE:1111

ST. TIME	CONNECTION TEL/ID	SENDER NAME	NO.	MODE	PGS.	RESULT
02/02 10:57	Canon 1 111 111 1111	Canon TOKYO 1111	0001	TRANSMIT ECM	1	OK 00'20
02/02 11:04	Canon 01 111 111 1111	Canon TOKYO 1111	0002	TRANSMIT ECM	1	NG 00'37 1
02/02 11:08	Canon 01 111 111 1111	Canon TOKYO 1111	0002	TRANSMIT ECM	1	NG 00'40 1
02/02 11:09	Canon 01 111 111 1111	Canon TOKYO 1111	0003	TRANSMIT ECM	1	OK 00'35
02/02 11:10	Canon 01 111 111 1111	Canon TOKYO 1111	0002	TRANSMIT ECM	1	OK 00'19

DEPT. ACCESS CODE:

ST. TIME	CONNECTION TEL/ID	SENDER NAME	NO.	MODE	PGS.	RESULT
02/02 11:02	Canon 123 456 7890	Canon TOKYO	5002	AUTO RX ECM	1	OK 00'32
02/02 11:13	Canon 123 456 7890	Canon TOKYO	5006	AUTO RX ECM	1	NG 00'30 1
02/02 11:21	Canon 123 456 7890	Canon TOKYO	5007	CONFID. RX ECM	1	OK 00'33
02/02 11:23	Canon 123 456 7890	Canon TOKYO	5008	CONFID. RX ECM	1	OK 00'32
02/02 11:24	Canon 123 456 7890	Canon TOKYO	5009	CONFID. RX ECM	1	OK 00'32

**Figure 2-28 Activity Report  
 (When restricting Sending/Printing  
 Operating, Separate Transmission/  
 Reception Report)**

- ST. TIME** : Date and time (24-hour display)  
 \* indicates communications for which a report has already been output.
- CONNECTION TEL/ID** : The telephone number sent from the other party or the telephone number dialed and the ID sent from the other party or the ID registered for one-touch speed dialing or coded speed dialing
- SENDER NAME** : 20-digit display
- NO.** : Communications transaction number (transmission: 0001-4999; reception: 5001-9999)
- MODE** : Displays manual reception, manual transmission, automatic reception, transmission, polling reception, polling transmission, relay originating transmission, delayed transmission, delayed broadcast transmission, memory polling, broadcast transmission, confidential reception, confidential transmission, or memory reception.  
 +G3 or ECM displayed
- PGS.** : Number of pages transmitted and received
- RESULT** : OK, NG  
 For NG, the error code is displayed too.
- DEPT. ACCESS CODE** : When the restricting sending function is on, this shows the registered department access code (4 digits).

02/02/04 WED 11:44 FAX 123 456 7890 Canon TOKYO 001

\*\*\*\*\*  
 \*\*\* ACTIVITY MANAGEMENT REPORT TX \*\*\*  
 \*\*\*\*\*

ST. TIME	CONNECTION TEL/ID	SENDER NAME	NO.	MODE	PGS.	RESULT
*02/02 10:57	Canon I 111 111 1111	Canon TOKYO	0001	TRANSMIT ECM	1	OK 00'20
*02/02 11:04	Canon 01 111 111 1111	Canon TOKYO	0002	TRANSMIT ECM	1	NG 00'37 1
*02/02 11:08	Canon 01 111 111 1111	Canon TOKYO	0002	TRANSMIT ECM	1	NG 00'40 1
*02/02 11:09	Canon 01 111 111 1111	Canon TOKYO	0003	TRANSMIT ECM	1	OK 00'35
*02/02 11:10	Canon 01 111 111 1111	Canon TOKYO	0002	TRANSMIT ECM	1	OK 00'19

\*\*\*\*\*  
 \*\*\* ACTIVITY MANAGEMENT REPORT RX \*\*\*  
 \*\*\*\*\*

ST. TIME	CONNECTION TEL/ID	RX NAME	NO.	MODE	PGS.	RESULT
*02/02 11:02	Canon 123 456 7890	Canon TOKYO	5002	AUTO RX ECM	1	OK 00'32
*02/02 11:13	Canon 123 456 7890	Canon TOKYO	5006	AUTO RX ECM	1	NG 00'30 1
*02/02 11:21	Canon 123 456 7890	Canon TOKYO	5007	CONFID. RX ECM	1	OK 00'33
*02/02 11:23	Canon 123 456 7890	Canon TOKYO	5008	CONFID. RX ECM	1	OK 00'32
*02/02 11:24	Canon 123 456 7890	Canon TOKYO	5009	CONFID. RX ECM	1	OK 00'32

**Figure 2-29 Activity Report  
 (Separate Transmission/Reception Reports)**

02/02/94 WED 11:46 FAX 123 456 7890		Canon TOKYO		001		
***** *** ACTIVITY MANAGEMENT REPORT TX *** *****						
DEPT. ACCESS CODE:1111						
ST. TIME	CONNECTION TEL/ID	SENDER NAME	NO.	MODE	PGS.	RESULT
*02/02 10:57	Canon 1 111 111 1111	Canon TOKYO 1111	0001	TRANSMIT ECM	1	OK 00'20
*02/02 11:04	Canon 01 111 111 1111	Canon TOKYO 1111	0002	TRANSMIT ECM	1	NG 00'37 1
*02/02 11:08	Canon 01 111 111 1111	Canon TOKYO 1111	0002	TRANSMIT ECM	1	NG 00'40 1
*02/02 11:09	Canon 01 111 111 1111	Canon TOKYO 1111	0003	TRANSMIT ECM	1	OK 00'35
*02/02 11:10	Canon 01 111 111 1111	Canon TOKYO 1111	0002	TRANSMIT ECM	1	OK 00'19
DEPT. ACCESS CODE:						
ST. TIME	CONNECTION TEL/ID	SENDER NAME	NO.	MODE	PGS.	RESULT
***** *** ACTIVITY MANAGEMENT REPORT RX *** *****						
DEPT. ACCESS CODE:1111						
ST. TIME	CONNECTION TEL/ID	RX NAME	NO.	MODE	PGS.	RESULT
DEPT. ACCESS CODE:						
ST. TIME	CONNECTION TEL/ID	RX NAME	NO.	MODE	PGS.	RESULT
*02/02 11:02	Canon 123 456 7890	Canon TOKYO	5002	AUTO RX ECM	1	OK 00'32
*02/02 11:13	Canon 123 456 7890	Canon TOKYO	5006	AUTO RX ECM	1	NG 00'30 1
*02/02 11:21	Canon 123 456 7890	Canon TOKYO	5007	CONFID. RX ECM	1	OK 00'33
*02/02 11:23	Canon 123 456 7890	Canon TOKYO	5008	CONFID. RX ECM	1	OK 00'32
*02/02 11:24	Canon 123 456 7890	Canon TOKYO	5009	CONFID. RX ECM	1	OK 00'32

**Figure 2-30 Activity Report  
(When Restricting Sending/Printing Operating, Separate  
Transmission/Reception Reports)**

**c) Reports output automatically**

This fax automatically outputs a memory clear list when the images in memory have been erased by the power being switched off, then on again.

**c-1) Memory clear report**

02/02/94 WED 12:08 FAX 123 456 7880		Canon TOKYO		001		
***** *** MEMORY CLEAR REPORT *** *****						
MEMORY FILES DELETED						
TX/RX NO	MODE	CONNECTION TEL/ID	PGS.	SET TIME	ST. TIME	SENDER NAME
0005	DELAYED TX	[* 01]Canon 01	1	02/02 11:10	12:30	Canon TOKYO 2222
0006	DELAYED TX	[ 01]Canon 1	1	02/02 11:10	12:40	Canon TOKYO 3333
5004	POLLING TX		1	02/02 11:11		Canon TOKYO 1111
5005	POLLING TX		1	02/02 11:12		Canon TOKYO 4444
5007	CONFID. RX		1	02/02 11:21		
5008	CONFID. RX		1	02/02 11:23		
5009	CONFID. RX		1	02/02 11:24		

**Figure 2-31 Memory Clear Report**

- TX/RX NO** : 4-digit display
- MODE** : Displays transmission, polling transmission, delayed transmission, relay originating transmission, confidential transmission, confidential reception, or memory reception, broadcast transmission, delayed polling transmission, transmission, manual transmission, manual reception.
- CONNECTION TEL/ID** : The one-touch speed dialing, coded speed dialing, group dialing number and ID (16 digits)
- PGS.** : Number of pages communicated
- SET TIME** : Displays date and time in 24-hour time.
- ST. TIME** : Communications start time (24-hour display)
- SENDER NAME** : Sender name appended to transmission (up to 24 characters)
- DEPT. ACCESS CODE** : When the restricting sending function is on, this shows the registered department access code (4 digits).

### 3.2.2 Service report output functions

This fax outputs service data setting status and past communications history reports and detailed error data reports for use in service.

#### a) List of service reports

This fax outputs the following service reports.

<b>Report Type</b>	<b>Operations</b>
System data list System dump list	In service mode, press the Report key. The two reports are output at the same time. (However, when service data #1 SSSW SW01 Bit 1 is on, a system dump list is output.)
Error transmission report (with error code and dump list)	Output set with data registration report setting menu (Whether or not error codes and dump lists are attached can be selected by switching service data #1 SSSW SW01 Bit 0 and 1 on/off.)
(Error) Reception report (with error code and dump list)	Output set with data registration report setting menu (Whether or not error codes and dump lists are attached can be selected by switching service data #1 SSSW SW01 Bit 0 and 1 on/off.)

a-1) System data list

This list shows service data setting statuses.

01/31/94	MON 16:14 FAX 123 456 7890	Canon TOKYO	001
***** *** SYSTEM DATA LIST *** *****			
#1 SSSW			
SW01	----	00000000	
SW02	----	10000000	
SW03	----	00000000	
SW04	----	10000000	
SW05	----	00000000	
SW06	----	00010000	
SW07	----	00000000	
SW08	----	00000000	
SW09	----	00000000	
SW10	----	00000000	
SW11	----	00000000	
SW12	----	00000110	
SW13	----	00000000	
SW14	----	00000000	
SW15	----	00000000	
SW16	----	00000000	
SW17	----	00000000	
SW18	----	00000000	
SW19	----	00000000	
SW20	----	00000000	
SW21	----	00000000	
SW22	----	00000000	
SW23	----	00000000	
SW24	----	00000000	
SW25	----	00000000	
SW26	----	00000000	
SW27	----	00000000	
SW28	----	00000000	
SW29	----	00000000	
SW30	----	00000000	
#2 MENU			
05:	----	OFF	
06:	----	DIAL	
07:	----	10	
10:	----	25Hz	
#3 NUMERIC Param.			
02:	----	10	
03:	----	15	
04:	----	12	
10:	----	3500	
15:	----	120	
16:	----	4	
17:	----	100	
18:	----	0	
19:	----	200	
20:	----	100	
21:	----	0	
22:	----	200	
23:	----	4	
24:	----	20	
25:	----	60	
26:	----	4	
30:	----	20	

Figure 2-32 System Data List (1/5)

01/31/94 MON 15:15 FAX 123 456 7890		Canon TOKYO	002
#4 NCU			
1.TONE / PULSE			
1.TONE			
01 :	----	90	
02 :	----	180	
2.PULSE			
01 :	----	100	DP(N)
02 :	----	200	
03 :	----	40	
04 :	----	780	
2.DIAL TONE			
00000000			
01 :	----	350	
02 :	----	90	
03 :	----	10	
04 :	----	0	
05 :	----	0	
06 :	----	300	
07 :	----	500	
08 :	----	5	
09 :	----	0	
3.2nd DIAL TONE			
10000000			
01 :	----	4000	
02 :	----	3	
03 :	----	25	
04 :	----	5	
05 :	----	25	
06 :	----	300	
07 :	----	500	
08 :	----	5	
09 :	----	5	
4.BUSY TONE 0			
00000000			
01 :	----	1000	
02 :	----	40	
03 :	----	80	
04 :	----	40	
05 :	----	80	
06 :	----	350	
07 :	----	450	
08 :	----	5	
09 :	----	3	
5.BUSY TONE 1			
00000000			
01 :	----	500	
02 :	----	40	
03 :	----	80	
04 :	----	40	
05 :	----	60	
06 :	----	350	
07 :	----	450	
08 :	----	5	
09 :	----	3	

Figure 2-33 System Data List (2/5)



01/31/94 MON 16:16 FAX 123 456 7890		Canon TOKYO	003
6. REORDER TONE			
01 :	----	10000000	0
02 :	----		15
03 :	----		32
04 :	----		18
05 :	----		32
06 :	----		400
07 :	----		800
08 :	----		5
09 :	----		3
7. MULTI			
01 :	----		8
02 :	----		10
03 :	----		300
04 :	----		0
8. AUTO RX			
01 :	----		15
02 :	----		60
03 :	----		10
04 :	----		120
05 :	----		1100
06 :	----		0
07 :	----		2
08 :	----		10
09 :	----		20
9. CNG DETECT			
01 :	----		40
02 :	----		80
03 :	----		0
04 :	----		0
05 :	----		0
06 :	----		85
07 :	----		40
08 :	----		60
09 :	----		8
10 :	----		0
11 :	----		2
12 :	----		70
10. SPECIAL			
SW01	----	00000000	
SW02	----	00000000	
SW03	----	00000000	
SW04	----	00000000	
SW05	----	00000000	
SW06	----	00000000	
SW07	----	00000000	
SW08	----	00000000	
SW09	----	00000000	
SW10	----	00000000	
SW11	----	00000000	
SW12	----	00000000	
SW13	----	00000000	
SW14	----	00000000	
SW15	----	00000000	
SW16	----	00000000	
SW17	----	00000000	
SW18	----	00000000	
SW19	----	00000000	
SW20	----	00000000	

Figure 2-34 System Data List (3/5)

01/31/84 MON 15:17 FAX 123 456 7890		Canon TOKYO	004
01 :	----	5	
02 :	----	30	
03 :	----	30	
04 :	----	4	
05 :	----	150	
06 :	----	100	
07 :	----	8	
08 :	----	0	
09 :	----	0	
10 :	----	0	
11 :	----	0	
12 :	----	3	
13 :	----	5	
14 :	----	60	
15 :	----	1000	
16 :	----	6	
17 :	----	6	
18 :	----	8	
19 :	----	0	
20 :	----	0	
11. RKEY			
01 :	----	0	
02 :	----	0	
03 :	----	0	
12. PBX DIAL TONE			
01 :	----	350	00000000
02 :	----	80	
03 :	----	10	
04 :	----	0	
05 :	----	0	
06 :	----	300	
07 :	----	500	
08 :	----	5	
09 :	----	0	
13. PBX BUSY TONE			
01 :	----	1000	00000000
02 :	----	40	
03 :	----	80	
04 :	----	40	
05 :	----	80	
06 :	----	350	
07 :	----	450	
08 :	----	5	
09 :	----	3	
#5 TYPE			
TYPE	----		STANDARD
#7 PRINTER			
SW01	----	00000000	
SW02	----	00000000	
SW03	----	00000000	
SW04	----	00000000	
SW05	----	00000000	
SW06	----	00000010	
SW07	----	00000000	
SW08	----	00000000	
SW09	----	00000000	
SW10	----	00000000	

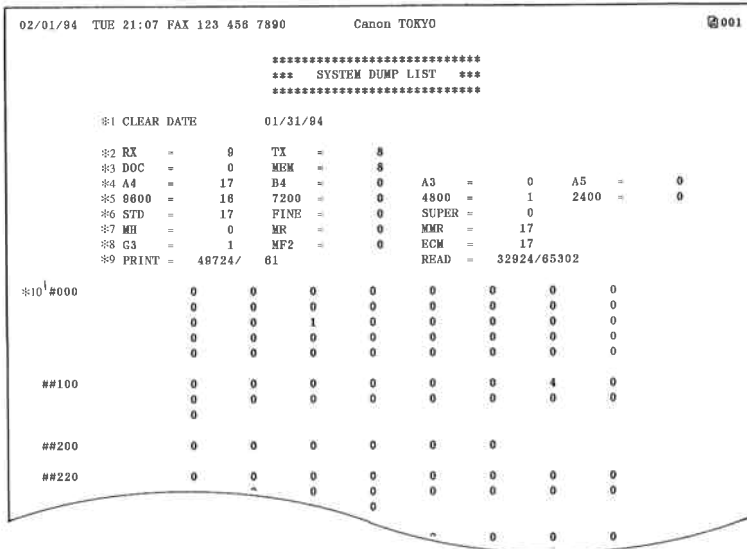
Figure 2-35 System Data List (4/5)

01/31/04	MON 15:17 FAX 123 456 7890	Canon TOKYO	005
	SW11	-----	00000000
	SW12	-----	00000000
	SW13	-----	00000000
	SW14	-----	00000000
	SW15	-----	00000000
	SW16	-----	00000000
	SW17	-----	00000000
	SW18	-----	00000000
	SW19	-----	00000000
	SW20	-----	00000000
	01 :	-----	12
	02 :	-----	0
	03 :	-----	0
	04 :	-----	3
	05 :	-----	4
	06 :	-----	0
	07 :	-----	0
	08 :	-----	0
	09 :	-----	0
	10 :	-----	0
	11 :	-----	0
	12 :	-----	0
	13 :	-----	0
	14 :	-----	0
	15 :	-----	0
	16 :	-----	0
	17 :	-----	0
	18 :	-----	0
	19 :	-----	0
	20 :	-----	0
	21 :	-----	0
	22 :	-----	0
	23 :	-----	0
	24 :	-----	0
	25 :	-----	0
	26 :	-----	0
	27 :	-----	0
	28 :	-----	0
	29 :	-----	0
	30 :	-----	0
#9 ROM	VERSION		ZLL-USA-05-02
START DATE	DATE	-----	22/00/20

Figure 2-36 System Data List (5/5)

**a-2) System dump list**

Outputs the past communications statuses and error communications history.



**Figure 2-37 System Dump List (top of 1st page)**

- \*1: Date on which data initialized
- \*2: RX: number of receptions; TX: number of transmissions
- \*3: DOC: direct transmission page count; MEM: memory transmission page count
- \*4: Pages by document size
- \*5: Transmission/reception page count by modem speed
- \*6: Transmission/reception page count by mode (standard/fine/superfine)
- \*7: Transmission/reception page count by encoding type
- \*8: Transmission/reception count by mode (MF2 indicates Japanese domestic network.)
- \*9: PRINT: Total number of pages printed; READ: total number of pages scanned

[Display example]

PRINT = 30\*/100\*\* READ = 30\*/100\*\*

\* Indicates the value input with Service Data #8 CLEAR, COUNTER.

\*\* Indicates the value counted since shipment from the factory.

- \*10: Number of occurrences for each error code

[Display example]

```

##280      1          7          3          0          0
##280 errors  ##281 errors  ##282 errors
  
```

#1 LATEST	*1		##106
	*2	START TIME	02/01 20:59
	*3	OTHER PARTY	123 456 7890
	*4	MAKER CODE	10001000
	*5	MACHINE CODE	11000010 00000000
	*6	(bit 1)	00000000 01100000 00011111 00100010 00000000 00000000 (bit48)
	*7	(bit 1)	00000000 01110011 00010101 00100011 00000000 00000000 (bit48)
*8		Rx :	NSS TSI DCS PIX
		Tx :	NSF CSI DIS CFR
		02/01/94 TUE 21:08 FAX 123 456 7890	Canon TOKYO
#2			##106
		START TIME	02/01 20:57
		OTHER PARTY	123 456 7890
		MAKER CODE	10001000
		MACHINE CODE	11000010 00000000
		(bit 1)	00000000 01100000 00011111 00100010 00000000 00000000 (bit48)
		(bit 1)	00000000 01110011 00010101 00100011 00000000 00000000 (bit48)
		Rx :	NSS TSI DCS PIX
		Tx :	NSF CSI DIS CFR
#3 OLDEST			##106
		START TIME	02/01 20:54
		OTHER PARTY	123 456 7890
		MAKER CODE	10001000
		MACHINE CODE	11000010 00000000
		(bit 1)	00000000 01100000 00011111 00100010 00000000 00000000 (bit48)
		(bit 1)	00000000 01110011 00010101 00100011 00000000 00000000 (bit48)
		Rx :	NSS PIX NSS TSI DCS
		Tx :	NSF CSI DIS

**Figure 2-38 System Dump List  
(Data on most recent three errors)**

- \*1: Service error code
- \*2: START TIME: Date and time (on 24-hour clock)
- \*3: OTHER PARTY: Telephone number sent from other party
- \*4: MAKER CODE: Maker code (Indicates a Canon fax.)
- \*5: MACHINE CODE: For future use
- \*6: Received DIS, DCS, or DTS Bits 1-48
- \*7: Transmitted DIS, DCS, or DTS Bits 1-48
- \*8: RX = received procedure signal  
TX = transmitted procedure signal

**a-3) Service error transmission report**

The service error transmission report attaches service error codes and error dump lists to the error transmission report.

```

02/02/84  WED 11:08 FAX 123 456 7890          Canon TOKYO          001
*****
***  ERROR TX RREPORT  ***
*****

TX FUNCTION WAS NOT COMPLETED

TX/RX NO           0002
DEPT. ACCESS CODE  1111
CONNECTION TEL           111 111 1111
CONNECTION ID        Canon 01
ST. TIME            02/02 11:08
USAGR T            00'40
PGS.                1
RESULT              NG
                   1      #760

START TIME          02/02 11:08
OTHER PARTY         111 111 1111
MAKER CODE          10001000
MACHINE CODE        11000010 00000000

(bit 1) 00000000 01110011 10010101 00100011 00000001 00000011 (bit48)
(bit 1) 00000000 01100000 00011111 00100010 00000000 00000000 (bit48)

Rx : NSF CSI DIS          CFR
Tx :      NSS TSI DCS     PIX PPS-EOM PPS-EOM PPS-EOM DCN
    
```

**Figure 2-39 Service Error Transmission Report**

**a-4) Service reception report**

The service reception result report attaches service error codes and error dump lists to the reception result report.

```

02/02/94 WED 11:14 FAX 123 456 7890          Canon TOKYO          001
*****
***  RX REPORT  ***
*****

INCOMPLETE RECEPTION

TX/RX NO                5008
DEPT. ACCESS CODE
CONNECTION TEL          123 456 7890
CONNECTION ID           Canon
ST. TIME                02/02 11:13
USAGE T                 00'30
PGS.                    1
RESULT                   NG
                        1  ##108

START TIME              02/02 11:13
OTHER PARTY             123 456 7890
MAKER CODE              10001000
MACHINE CODE           11000010 00000000

(bit 1) 00000000 01100000 00011111 00100010 00000000 00000000 (bit48)
(bit 1) 00000000 11110011 00010101 00100011 00000000 00000000 (bit48)

Rx :      NSS TSI DCS      PIX
Tx : NSF CSI DIS          CFR
    
```

**Figure 2-40 Service (Error) Reception Report**

**This page intentionally left blank**



## 3.3 User Data

### 3.3.1 Overview of user data

The settings that determine how the fax operates are collectively called user data. These settings can be switched on and off to change how the fax works for you.

#### Displaying the user data settings



- 1 **Open the One-touch Speed Dialing panel. Then press DATA REGISTRATION.**

REGISTRATION  
1. DATA REGISTRATION



- 2 **Press SET.**  
The next menu is displayed.

DATA REGISTRATION  
1. USER SETTINGS



- 3 **Use the search keys to display the item you want to set or change.**

DATA REGISTRATION  
1. USER SETTINGS

DATA REGISTRATION  
7. SYSTEM SETTINGS

After you display the item you want to set or change, press SET. For details, refer to the following section.



## **Summary of user data features**

The user data menu selections are displayed in the display one line at a time. You can use the search keys to display these settings so you can check the settings or change them.

Here's a summary of the user data menu.

### **1. USER SETTINGS**

Contains 13 settings that set up the operating environment of the fax. Use **USER SETTINGS** to register the data that prints on documents you send, to set alarms and scanning density, and so on. Do these settings as soon as you set up your fax. After they are set, you should not need to change them very often.

### **2. REPORT SETTINGS**

Allows you to set the fax to print a report every time you send or receive a document, and to set up printing a summary report for all your sending and receiving transactions. Use these features if you want to keep track of your fax transmissions.

### **3. TX SETTINGS**

Lets you customize how the fax sends documents. With these settings you can turn ECM on and off, set mid-pause time, set up redialing and other features.

### **4. RX SETTINGS**

Lets you customize how the fax receives documents. These settings are important because they determine how the fax operates when it receives a document.

### **5. PRINTER SETTINGS**

Allows you to set the fax not to print on certain types of recording paper.

### **6. FILE SETTINGS**

Allows you to set up, change, or delete confidential, timed polling and polling sending/receiving.

### **7. SYSTEM SETTINGS**

Contains a collection of miscellaneous settings that let you change how the fax operates.

### 3.3.2 User data menu

(\* Indicates the default setting.)

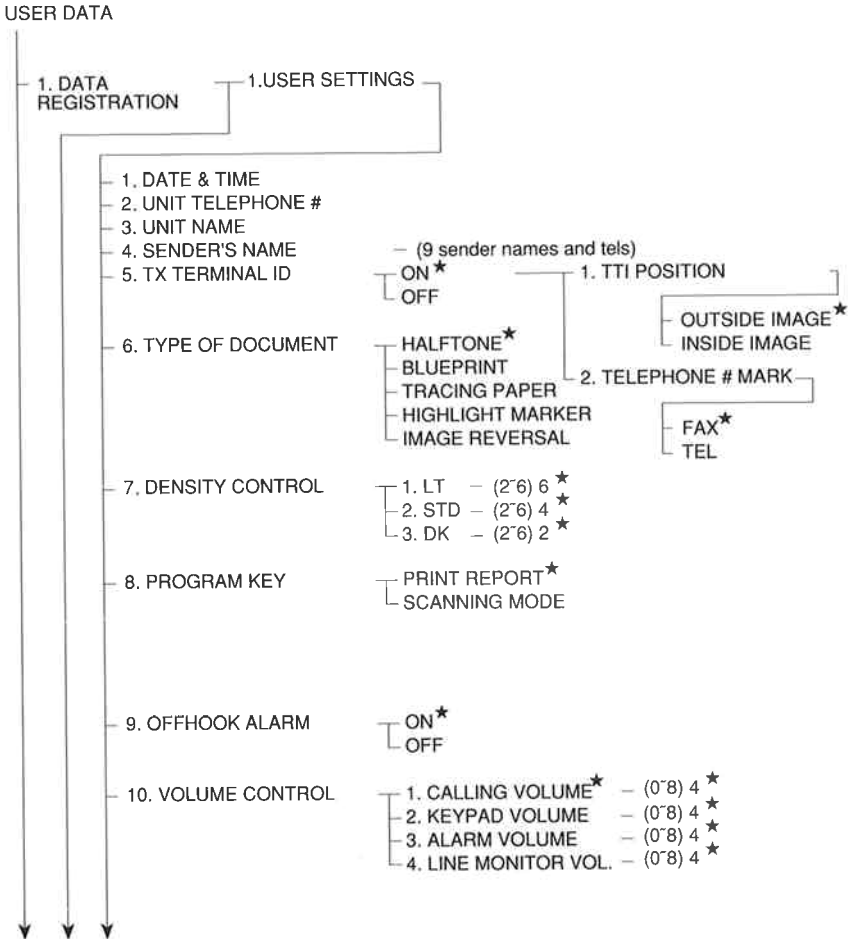


Figure 2-41 User Data (1/7)

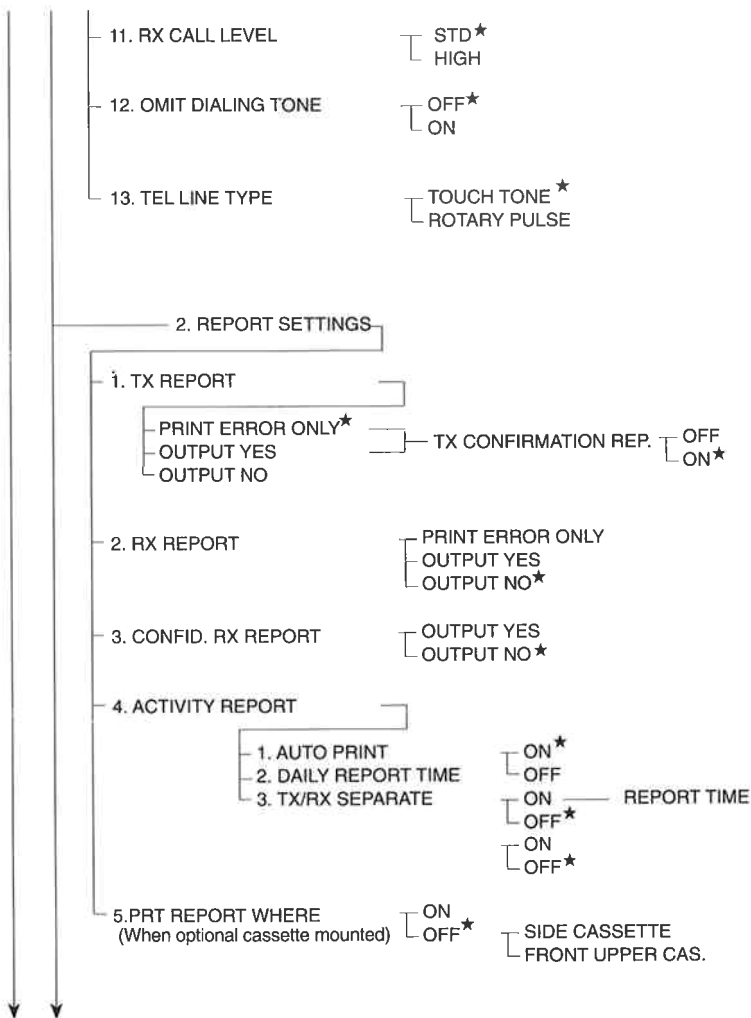


Figure 2-42 User Data (2/7)

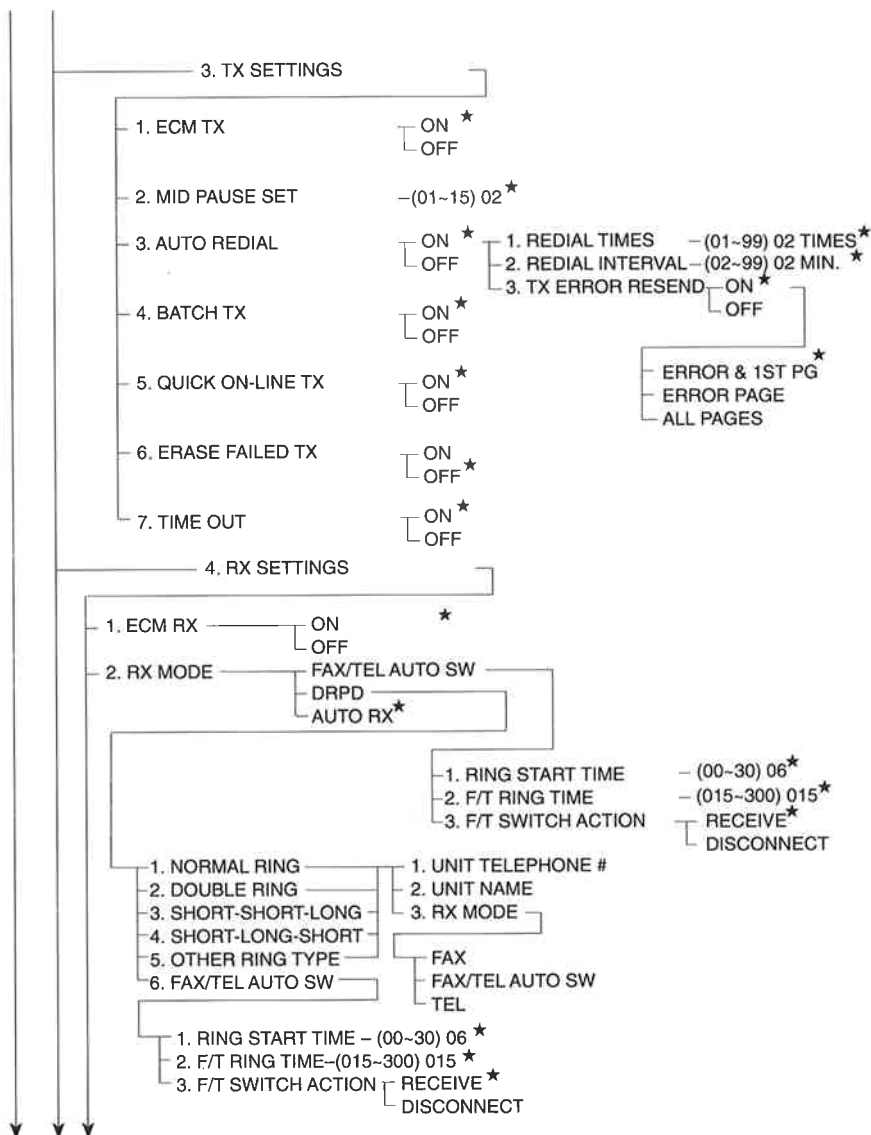


Figure 2-43 User Data (3/7)

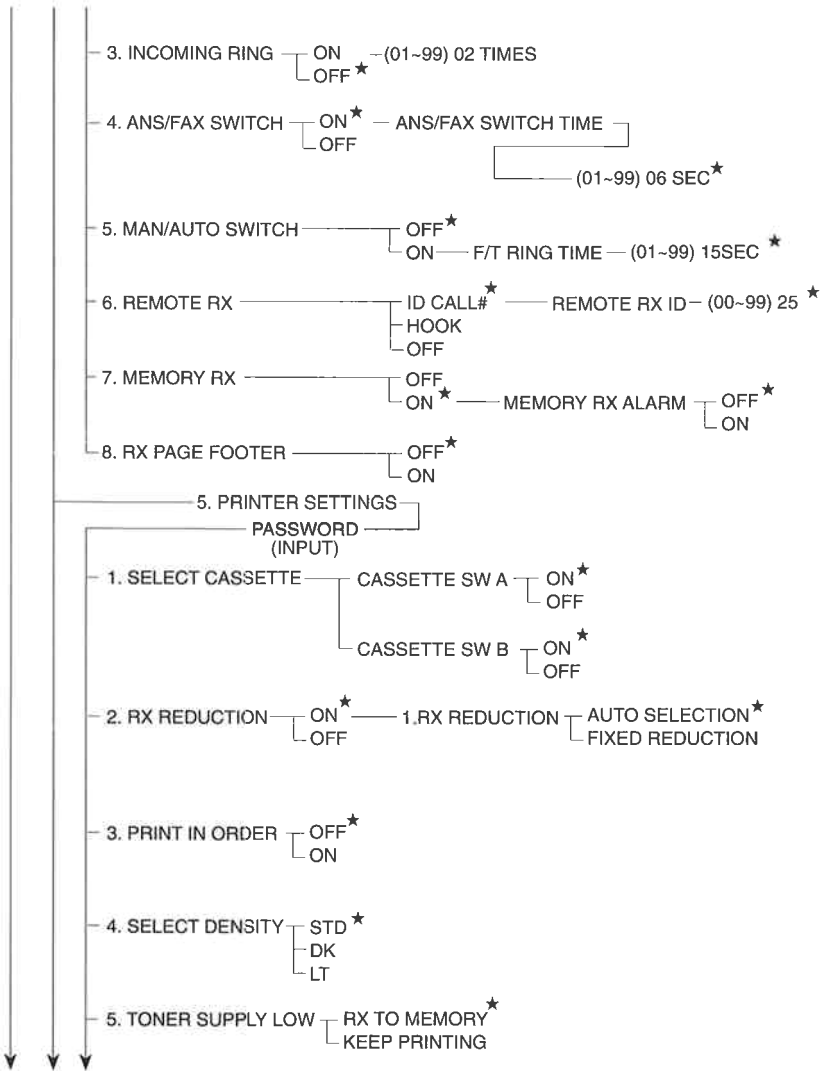


Figure 2-44 User Data (4/7)



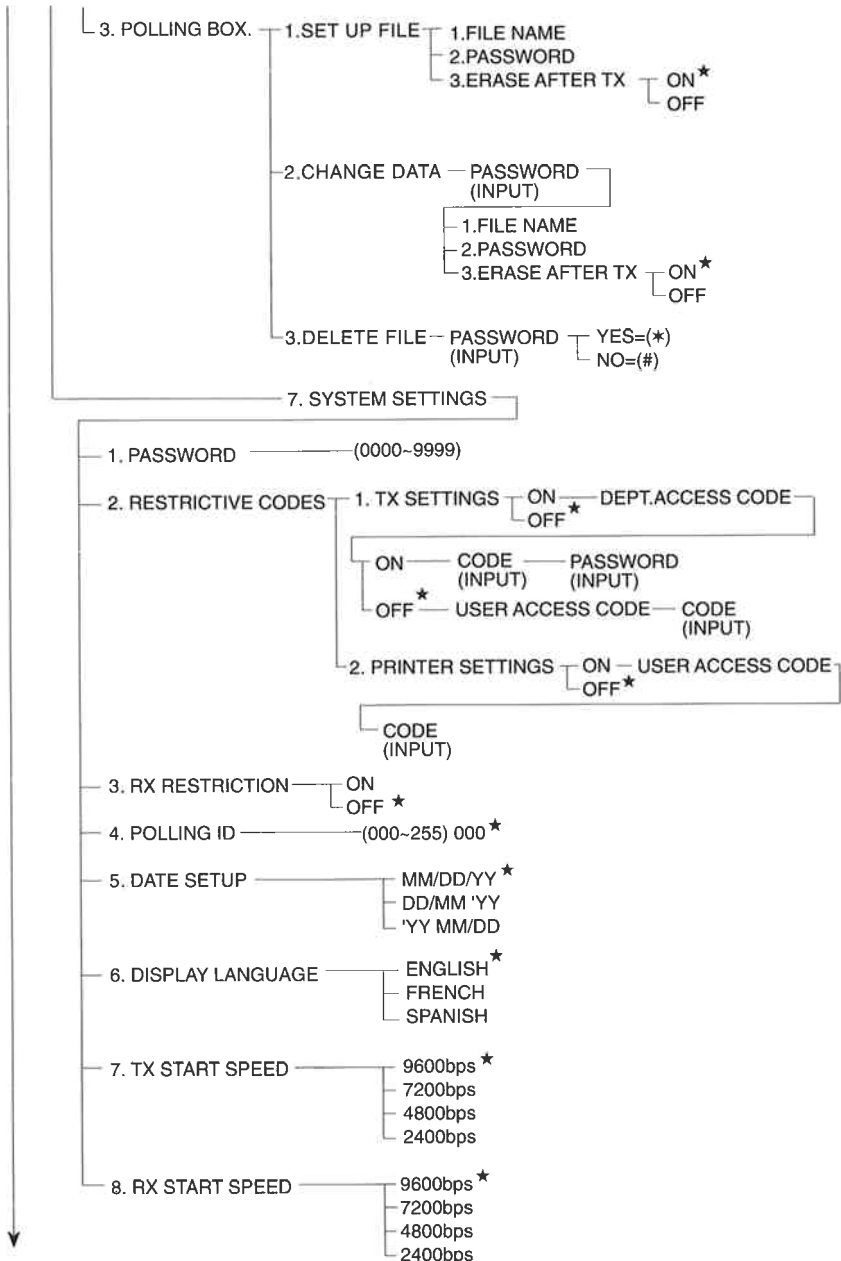


Figure 2-46 User Data (6/7)



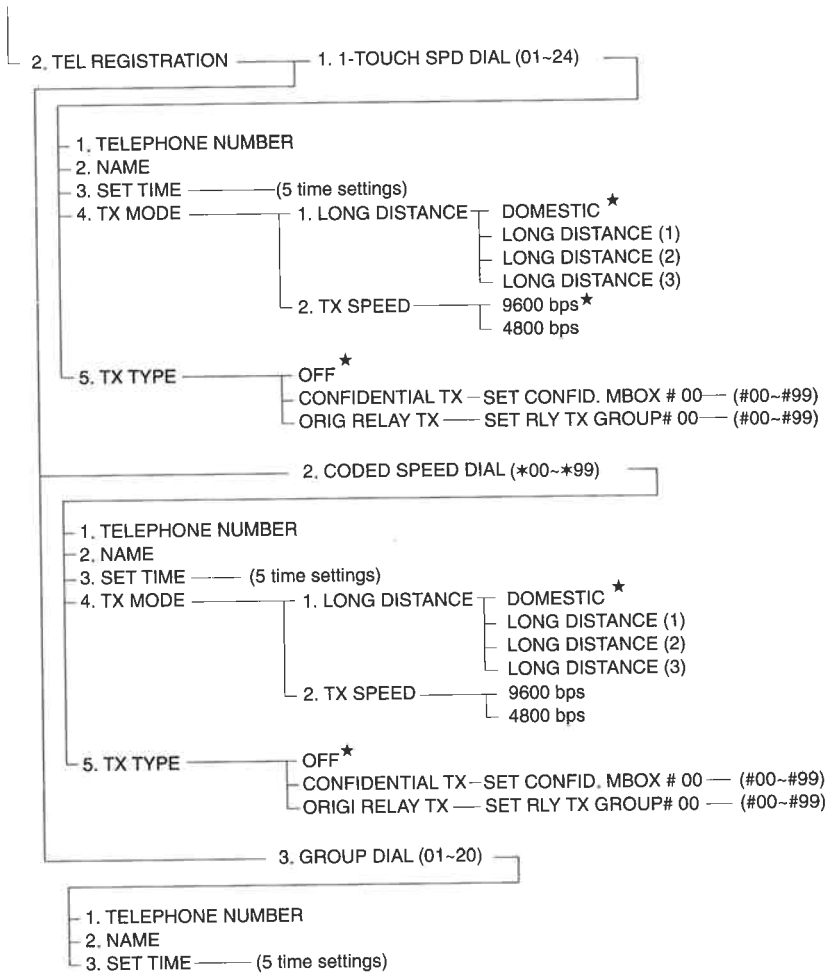


Figure 2-47 User Data (7/7)

3.3.3

The basic data settings



1 Open the One-touch Speed Dialing panel. Then press DATA REGISTRATION.



2 Press SET twice.



3 Use the search keys to display the item you want to set or change.



4 Press SET.

User Settings				
The Default settings remain in effect unless you change them.				
Setting	Description	Default	Other	Comments
1 DATE & TIME	Sets the current date and time shown in your facsimile display and printed on documents that you send.	---	---	Enter the numbers with the number keys. Use the 24-hour system. For example, 1:00 p.m. is 13:00.
2 UNIT TELEPHONE #	This is your facsimile number that prints at the top of documents that you send.	---	---	Enter a number up to 20 digits long.
3 UNIT NAME	The user name you enter here (your company or section name, for example) is printed on documents that you send.	---	---	Enter a name up to 24 characters long.
4 SENDER'S NAME	You can register up to 9 sender names. Before you send a document, you can select a sender name with the TTI SELECTOR key. If you select a sender name, it replaces the user name you registered for item 3 above.	---	---	You can enter 9 user names up to 24 characters long (including spaces and symbols).
5 TX TERMINAL ID	Turns on and off all your terminal identification information printed at the top of documents you send.	ON	OFF	If you turn the terminal ID feature ON, you can also set where you want the information to print on the documents you send: INSIDE IMAGE or OUTSIDE IMAGE. You can also select the mark to prefix the telephone number: FAX or TEL

User Settings				
The Default settings remain in effect unless you change them.				
Setting	Description	Default	Other	Comments
6 TYPE OF DOCUMENT	Sets the default document setting for scanning: photographs, blueprints, tracings, text marked with a felt tip pen, and reverse black and white images,	HALFTONE	BLUEPRINT TRACING PAPER HIGHLIGHT MARKER IMAGE REVERSAL	Choose the setting for the type of document you send most frequently. Press the document setting key to light TYPE OF DOC before you scan the document into the memory.
7 DENSITY CONTROL	Sets the degree of the scan density selected when you press the density key on the control panel of the facsimile to select a setting.	1. LT 6 2. STD 4 3. DK 2	3-7 2-6 1-5	Each setting can be changed.
8 PROGRAM KEY	Sets the feature you want to assign to the program key.	—	PRINT REPORT SCANNING MODE	PRINT REPORT prints an activity report for the document you are about to send. SCANNING MODE lets you set up the control panel at the touch of one key.
9 OFFHOOK ALARM	Allows you to turn the offhook alarm on and off. The offhook alarm goes off during sending or receiving if the handset is not completely on its handset rest.	ON	OFF	You may want to turn this setting OFF to preserve a quiet office environment.
10 VOLUME CONTROL	Allows you to set the sound levels for the fax ring, key touch, and alarms.	1. CALLING VOLUME 4 2. KEYPAD VOLUME 4 3. ALARM VOLUME 4 4. LINE MONITOR VOL. 4	0-8 0-8 0-8 0-8	Settings can be changed in the range 0 to 8. 0 turns the sound off, 8 is the loudest setting. Adjust the settings to suit your office environment.
11 RX CALL LEVEL	Sets the ring tone higher.	STD	HIGH	You can set the ring tone higher.
12 OMIT DIALING TONE	Turns the dial tone off and on for dialing.	OFF	ON	If you don't want to hear your facsimile dialing telephone numbers.
13 TEL LINE TYPE	Sets the fax for operation on the type of line you have.	TOUCH TONE	ROTARY PULSE	Select TOUCH TONE if your line is for a touch tone telephone. Select ROTARY PULSE if your line is for a rotary dial telephone.

3.3.4

**The reports setting**

There are five selections on the report menu.



**1 Open the One-touch Speed Dialing panel. Then press DATA REGISTRATION.**



**2 Press SET.**



**3 Use the search keys to display REPORT SETTINGS.**



**4 Press SET.**



**5 Use the search keys to display the item that you want to set or change.**



**6 Press SET.**

Report Settings				
The Default settings remain in effect unless you change them.				
Setting	Description	Default	Other	Comments
1 TX REPORT	Sets when the fax prints an activity report for transmitting.	PRINT ERROR ONLY	OUTPUT YES OUTPUT NO	PRINT ERROR ONLY prints only when an error occurs during sending. OUTPUT YES sets the fax to print an activity report every time you send a document. OUTPUT NO sets the fax to print no report for sending.
TX CONFIRMATION REP.	If you set OUTPUT YES to print a report every time you send a document, you can specify if you want the first page of the document to print to use as a reminder of what the document contains.	ON	OFF	Use the printed page for filing and later reference.

Report Settings				
The Default settings remain in effect unless you change them.				
Setting	Description	Default	Other	Comments
2 RX REPORT	Sets how the fax prints an activity report for receiving.	OUTPUT NO	PRINT ERROR ONLY  OUTPUT YES	OUTPUT NO sets the fax to print no report for receiving. PRINT ERROR ONLY prints only when an error occurs during receiving. OUTPUT YES sets the fax to print an activity report every time you receive a document.
3 CONFID. RX REPORT	Sets a report to print every time you receive a confidential document in your confidential mailbox.	OUTPUT NO	OUTPUT YES	When you receive a confidential report in your mailbox, the fax displays a message: RECEIVED IN MAILBOX. In addition to this message, you can set the fax to print a confidential message notice every time you receive a document in your confidential mailbox.
4 ACTIVITY REPORT	Unless you change the setting, your fax is set to print an activity management report for every 40 transactions (sending or receiving). You can turn this feature off.			
1. AUTO PRINT	Print a report for every 40 transactions.	ON	OFF	
2. DAILY REPORT TIME	You can also set the time you want the report to print every day.	OFF	ON	Set the print time using the 24-hour system (1:00 p.m. is 13:00 for example)
3. TX/RX SEPARATE	You can also set how the report will be printed.	OFF	ON	You can print sending and receiving transactions all in the same report, or print them in separate reports, one for sending and one for receiving transactions.
5 PRT REPORT WHERE	Sets which paper cassette is used.	OFF	ON	If you select ON, you can select the SIDE or FRONT CASSETTE.
SIDE CASSETTE	Feeds paper from the side cassette			
FRONT CASSETTE*	Feeds paper from the front cassette			

\* You can set this item for the LASER CLASS<sub>®</sub> 5500 or for the LASER CLASS<sub>®</sub> 5000 with the optional front cassette.

### 3.3.5

## The send settings

This is a summary of the document send settings.



- 1 **Open the One-touch Speed Dialing panel. Then press DATA REGISTRATION.**



- 2 **Press SET.**



- 3 **Use the search keys to display TX SETTINGS.**



- 4 **Press SET.**



- 5 **Use the search keys to display the item you want to set or change.**



- 6 **Press SET.**

Send Features				
The Default settings remain in effect unless you change them.				
Setting	Description	Default	Other	Comments
1. ECM TX	Turns the ECM feature on or off.	ON	OFF	ON: Transmitting is done in the error correction mode, OFF: Transmitting is done without error correction. This mode may be slightly faster. If the telephone lines are in good condition, you may want to use this setting.
2. MID PAUSE SET	Sets the length of a pause entered in a number by pressing the PAUSE key.	02 SEC	1-15	Set the pause within a range of 1 to 15 seconds.
3. AUTO REDIAL	Sets if your facsimile automatically redials the other party when their line is busy.	ON	OFF	ON: You can make additional settings for REDIAL TIMES, REDIAL INTERVAL, and TX ERROR RESEND.
1. REDIAL TIMES	Sets the number of retries.	02 TIMES	01-99	Set the number of retries from 01 to 99.
2. REDIAL INTERVAL	The period of time between redialings.	02 MIN	02-99	Set the time between dialing attempts from 02 to 99 minutes.
3. TX ERROR RESEND	Redialing after a send error.	ERROR & 1ST PG	ERROR PAGE ALL PAGES	ERROR & 1ST PG re-sends the first page of the document and error page, ERROR PAGE re-sends only the error page, ALL PAGE re-sends all the document pages.
4. BATCH TX	Sends documents going to the same destination by dialing the number only once.	ON	OFF	When you are sending several documents, if more than 1 document is going to the same destination, the fax dials the number only once and sends the documents.
5. QUICK ON-LINE TX	Turns quick memory sending off and on.	ON	OFF	When ON, the fax starts sending the document while it is being scanned.
6. ERASE FAILED TX	Determines what happens to the document in the memory if an error occurs during transmission.	OFF	ON	ON: Fax automatically clears the document in the memory if an error occurs during sending. OFF: The document will remain in the memory even if an error occurs during sending.
7. TIME OUT	Sets the time interval between dialing when sending to more than one destination.	ON	OFF	ON :5 sec. interval between dialing. OFF: 60 sec. interval between dialing.

### 3.3.6

## The receive settings

This is a summary of the document receive settings.



- 1 **Open the One-touch Speed Dialing panel. Then press DATA REGISTRATION.**



- 2 **Press SET.**



- 3 **Use the search keys to display RX SETTINGS.**



- 4 **Press SET.**



- 5 **Use the search keys to display the item you want to set or change.**



- 6 **Press SET.**



Receive Features				
The Default settings remain in effect unless you change them.				
Setting	Description	Default	Other	Comments
1. ECM RX	Turns ECM receiving off and on.	ON	OFF	ON: Receiving is done in the error correction mode. OFF: Receiving is done without error correction. This mode may be slightly faster. If the telephone lines are in good condition, you may want to use this setting.
2. RX MODE	Sets how the fax unit handles incoming calls.	AUTO RX	FAX/TEL AUTO SW  DRPD	AUTO RX treats all incoming calls as fax transmissions. FAX/TEL AUTO SW switches between facsimile/telephone receiving based on the presence or absence of a CNG signal. DRPD allows the fax to respond to ringing patterns.



<b>Receive Features</b>				
The Default settings remain in effect unless you change them.				
<b>Setting</b>	<b>Description</b>	<b>Default</b>	<b>Other</b>	<b>Comments</b>
1. RING START TIME	Sets the time elapsed before the fax does FAX/TEL switching.	06SEC	00-30	Set a time from 00 to 30 seconds.
2. F/T RING TIME	Sets the length of time the fax rings for FAX/TEL switching.	015SEC	15-300	Set a time from 15 to 300 seconds.
3. F/T SWITCH ACTION	Sets the operation for when after the specified amount of time no one lifts the handset.	RECEIVE	DISCONNECT	RECEIVE: Fax switches to the receive mode. DISCONNECT: Fax hangs up and disconnects the call.
3. INCOMING RING	When the fax is set for automatic receiving (AUTO RX), sets the fax to ring when it receives a document.	OFF	ON	If you select ON, you can set the number of times you want the fax to ring.
RING COUNT	Sets the number of times you want the fax to ring.	02 TIMES	01-99	Set the number of rings from 01 to 99.
4. ANS/FAX SWITCH	Sets whether the fax will switch to automatic receive when an answering machine is connected through the fax and turned on when you are out of the office.	ON	OFF	If you select ON, you can set the amount of time before the fax switches to automatic receiving.
ANS/FAX SWITCH TIME	Sets the amount of time for the fax to wait before switching to automatic receiving when the caller does not talk.	06SEC	01-99	Set a time from 01 to 99 seconds.
5. MAN/AUTO SWITCH	Determines if the fax switches to document receive mode after the fax rings for a specified time when the fax is in the manual receive mode.	OFF <sup>2</sup>	ON	If you select ON, you can set the amount of time the fax will ring before switching to document receiving.
F/T RING TIME	Sets the amount of time the fax will ring before switching to document receiving.	15SEC	01-99	Set a time from 01 to 99 seconds.
6. REMOTE RX	Lets you change the remote receiving ID (ID CALL #), or you can set far hook receiving (HOOK). With ID CALL # remote receiving, you can dial a number code on the remote extension to start receiving a document. With HOOK remote receiving, you can just hang up the handset to start receiving.	ID CALL #	OFF HOOK	If you select ID CALL #, you can also change the remote receiving ID.

Receive Features				
The Default settings remain in effect unless you change them.				
Setting	Description	Default	Other	Comments
REMOTE RX ID	If ID CALL.# is selected, you can change the remote receiving ID.	25	00-99	Enter a new ID from 00 to 99.
7. MEMORY RX	Turns off and on memory receiving of a document when the fax runs out of paper. When off and the recording paper runs out, the remainder of the document is not stored in the memory. When on and the recording paper runs out, the remainder of the document is stored in the memory so you can print it as soon as you refill the paper cassette.	ON	OFF	With ON, you can also turn the alarm on and off.
MEMORY RX ALARM	Turns the memory receive alarm on and off.	OFF	ON	ON: Alarm sounds when a document is received in the memory. OFF: No alarm sounds when a document is received in the memory.
8. RX PAGE FOOTER	Sets the fax to print the time a document is received, the transaction number, page numbers, and other useful information.	OFF	ON	OFF: Prints no footer information. ON: Prints footer information.

**This page intentionally left blank**

3.3.7

**The printer settings**

This is a summary of the print settings.



- 1 **Open the One-touch Speed Dialing panel. Then press DATA REGISTRATION.**



- 2 **Press SET.**



- 3 **Use the search keys to display PRINTER SETTINGS.**



- 4 **Press SET.**



- 5 **Use the search keys to display the item you want to set or change.**



- 6 **Press SET.**

<b>Printer Settings</b>				
The Default settings remain in effect unless you change them.				
Setting	Description	Default	Other	Comments
1. SELECT CASSETTE	Determines how the fax receives documents according to their size.			
CASSETTE SW A	Sets how the fax receives a document when the document size is larger than the paper in the cassette.	ON	OFF	ON: Divides a legal-size document into two pages. OFF: A legal-size document is received in the memory.
CASSETTE SW B	Sets how the fax receives a document when the incoming document size is smaller than the paper in the cassette	ON	OFF	ON: Prints a letter-size document on legal-size paper with white space. OFF: Receives a letter-size document in the memory.

<b>Printer Settings</b>				
The Default settings remain in effect unless you change them.				
<b>Setting</b>	<b>Description</b>	<b>Default</b>	<b>Other</b>	<b>Comments</b>
2. RX REDUCTION  AUTO SELECTION  FIXED REDUCTION	Reduces received documents to ensure they fit on the recording paper.  When ON is selected, you can set automatic or fixed reduction.	ON  AUTO SELECTION	OFF  FIXED REDUCTION	ON: Reduces the received document. OFF: Received document is not reduced.  AUTO SELECTION: The fax decides to reduce the document to 90% based on the size of the other party's document. FIXED REDUCTION: The fax always reduces the document to 90% the original size.
3. PRINT IN ORDER*	Determines the order of printing.	OFF	ON	ON: Prints documents in the order they are sent. OFF: Prints documents in the reverse order that they were sent.
4. SELECT DENSITY	Allows you to fine adjust the print density of documents you receive.	STD	DK LT	STD: Standard DK: Dark LT: Light
5. TONER SUPPLY LOW	Determines if printing continues when toner level drops in the cartridge.	RX TO MEMORY	KEEP PRINTING	RX TO MEMORY: Receives the document in the memory as soon as toner in the cartridge becomes low, and the fax unit receives the document in memory. KEEP PRINTING: Continues printing even after the toner supply becomes low in the cartridge.
* You can set this item for the LASER CLASS <sub>5</sub> 5500 or for the LASER CLASS <sub>5</sub> 5000 with the optional memory kit.				

3.3.8

**The file settings**

This is a summary of the memory management features.



- 1 **Open the One-touch Speed Dialing panel. Then press DATA REGISTRATION.**



- 2 **Press SET.**



- 3 **Use the search keys to display FILE SETTINGS.**



- 4 **Press SET.**



- 5 **Use the search keys to display the item you want to set or change.**



- 6 **Press SET.**

The File Settings				
The Default settings remain in effect unless you change them.				
Setting	Description	Default	Other	Comments
1. CONFID. MAILBOX	Creates, changes, and deletes a confidential mailbox and password. You must create a mailbox before you can use confidential receiving.	—	—	Refer to the Instruction Book on page 105.
2. PRESET POLLING	Sets the fax to poll other facsimile units at specified times.	—	—	Refer to the Instruction Book on page 114.
3. POLLING BOX	Creates, changes, deletes your fax polling and password for when you set up your fax to send a document in response to polling from another fax unit.	—	—	Refer to the Instruction Book on page 122.

**This page intentionally left blank**

3.3.9

**The system settings**

This is a summary of the system setup features.



**1 Open the One-touch Speed Dialing panel. Then press DATA REGISTRATION.**



**2 Press SET.**



**3 Press ▲ to display SYSTEM SETTINGS.**



**4 Press SET.**



**5 Use the search keys to display the item.**



**6 Press SET**

System Setup Features				
The Default settings remain in effect unless you change them.				
Setting	Description	Default	Other	Comments
1. PASSWORD	Protects the system settings menu.	—	0000 to 9999	After the password is set, you have to enter it before you can open the system settings menu.
2. RESTRICTIVE CODES	Restricts sending and printing with a department code and user access code.	OFF	ON	See 4 NEW FUNCTION on Chapter 3.
TX SETTINGS	Lets you restrict sending with department access code and user access code.	OFF	ON	See 4 NEW FUNCTION on Chapter 3.
PRINTER SETTINGS	Lets you restrict printing with user access code.	OFF	ON	See 4 NEW FUNCTION, on Chapter 3.
3. RX RESTRICTION	Prevents unwanted junk mail from wasting your fax operation time and recording paper.	OFF	ON	OFF: Anyone can dial your fax and send a document. ON: A party can dial your fax and send a document only if their number is registered on your fax for speed dialing.



System Setup Features				
The Default settings remain in effect unless you change them.				
Setting	Description	Default	Other	Comments
4. POLLING ID	Sets the polling ID.	—	—	Enter a decimal number as the polling ID from 0-255.
5. DATE SETUP	Sets the date format. Three formats are possible.	MM/DD/YY	DD/MM' YY 'YY MM/DD	Sets the format for the date displayed in the LCD on your fax and printed on documents you send.
6. DISPLAY LANGUAGE	Sets the language for the messages displayed during operation of the fax.	ENGLISH	FRENCH SPANISH	Choice of 3 languages
7. TX START SPEED	Sets the transmission speed for documents you send.	9600 bps	7200 bps 4800 bps 2400 bps	Four settings are possible: 9600, 4800, 2400. The higher the setting, the faster the transmission. If you experience problems when sending documents, try a lower setting.
8. RX START SPEED	Sets the speed for documents you receive.	9600 bps	7200 bps 4800 bps 2400 bps	Three settings are possible: 9600, 4800, 2400. The higher the setting, the faster the document is received.

## 3.4 Service Data Registration/Setting

### 3.4.1 Overview of service data

Service data can be checked and changed with items on display menus. The service data menu items are divided into the following nine blocks.

#### #1 SSSW; service soft switch settings

These ten registration/setting items are for basic fax service functions such as error management, echo countermeasures, and communication troubles countermeasures.

#### #2 MENU; menu switch settings

These three registration/setting items are for functions required during installation, such as NL equalizer and transmission levels.

#### #3 NUMERIC Param.; numeric parameter settings

These seventeen registration/setting items are for inputting numeric parameters such as the various conditions for the FAX/TEL switching function.

#### #4 NCU; NCU settings

These thirteen registration/setting items are for telephone network control functions such as the selection signal transmission conditions and the detection conditions for the control signals sent from the exchange.

#### #5 TYPE; type setting

The type setting makes the service data conform to a specific nation's communications standards. There is only one registration/setting item in this block.

#### #6 UHQ; UHQ function setting

These three registration/setting items are for scanned image processing such as edge emphasis and error dispersion processing.

#### #7 PRINTER; printer function settings

These six registration/setting items are for basic printer service functions such as the reception picture reduction conditions.

There is an item for resetting the printer section without switching the power switch off-on.

#### #8 CLEAR; data initialization mode and page counter settings

Various data are initialized by selecting one of these seven registration/setting items.

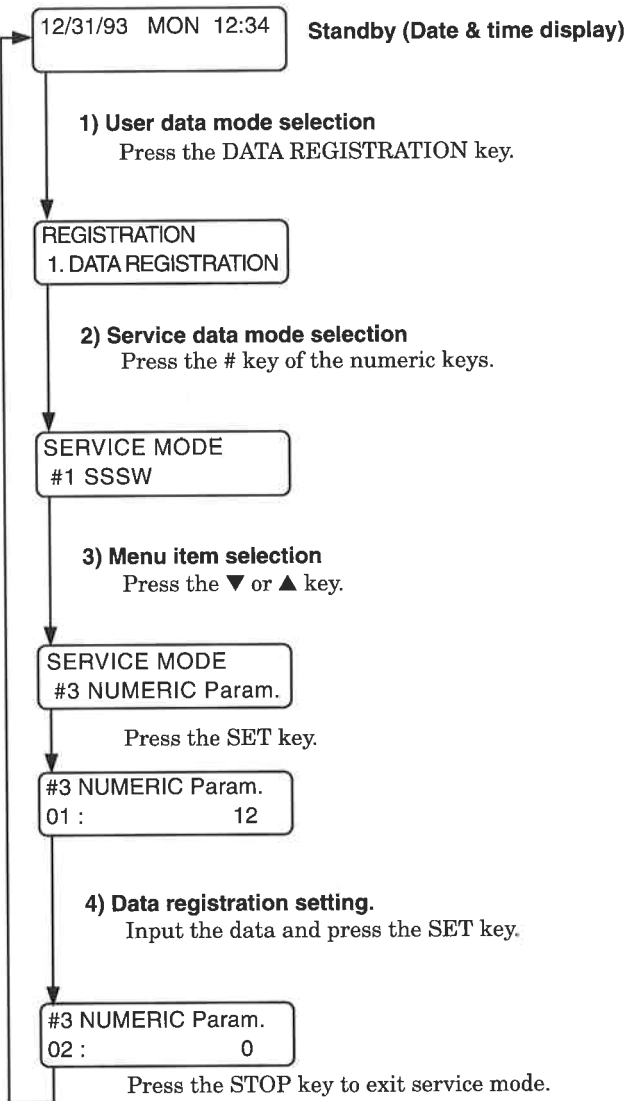
There is a registration/setting item for checking/inputting the total number of pages printed and total number of pages scanned by this fax.

#### #9 ROM; ROM management

ROM data such as the version number and the checksum are displayed on the display.

### 3.4.2 Service data registration/setting method

Service data can be registered/set with the following operations



**Figure 2-48 Service Data Registration/Setting**

### 3.4.3 Service data menu

\* Indicates the default setting.

#### SERVICE DATA

#1 SSSW (Service soft switch setting)	SW01	00000000	Error management
	SW02	10000000	Not used
	SW03	00000000	Echo countermeasure settings
	SW04	10000000	Communication trouble countermeasure settings
	SW05	00000000	Standard function <DIS signal> settings
	SW06	00010000	Scan condition settings
	SW07	00000000	Closed network function settings
	SW08	00000000	Closed network ID settings
	SW09	00000000	Not used
	SW10	00000000	Not used
	SW11	00000000	Not used
	SW12	00000110	1 page timer settings
	SW13	00000000	Not used
	SW14	00000000	Not used
	SW15	00000000	Not used
	SW16	00000000	Not used
	SW17	00000000	Not used
	SW18	00000000	Not used
	SW19	00000000	Not used
	SW20	00000000	Not used
	SW21	00000000	Not used
	SW22	00000000	Not used
	SW23	00000000	Not used
	SW24	00000000	Not used
	SW25	00000000	Report display function settings
	SW26	00000000	Transmission function settings
	SW27	00000000	Not used
	SW28	00000000	Not used
	SW29	00000000	Not used
	SW30	00000000	Not used

Figure 2-49 Service Data (1/6)



Switches 02, 9-11, 13-24, and 27-30 are not used. Do not change their settings.

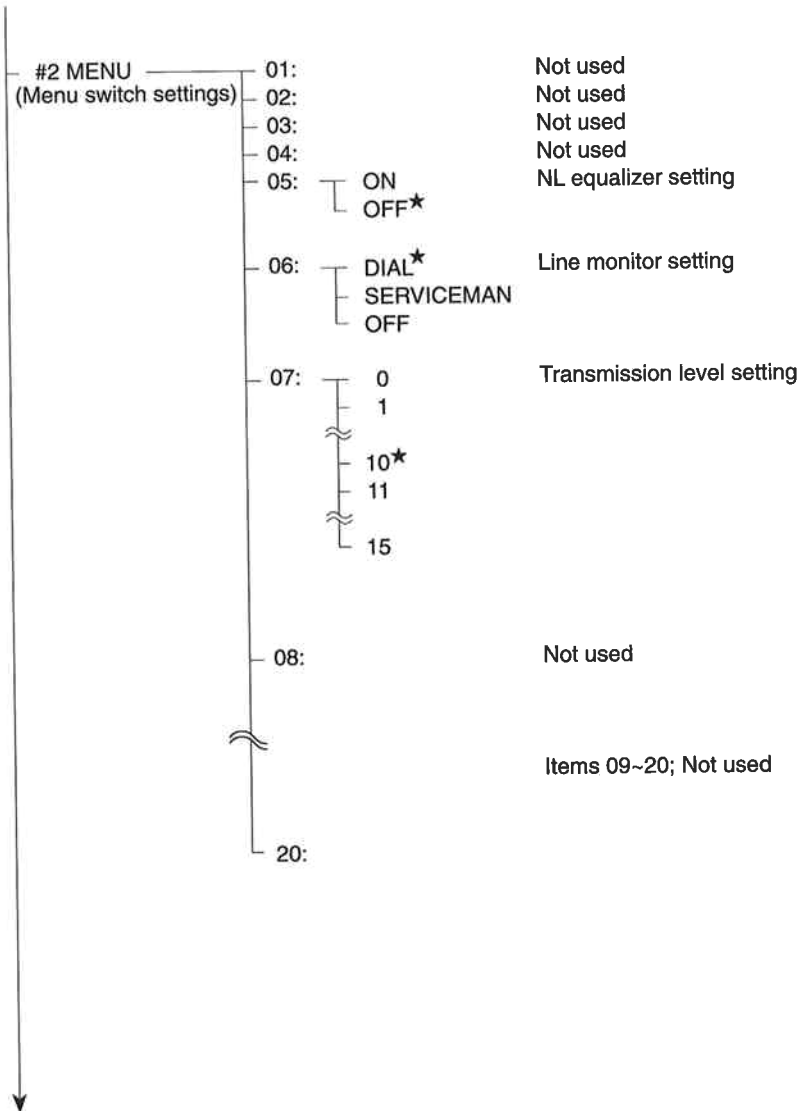


Figure 2-50 Service Data (2/6)



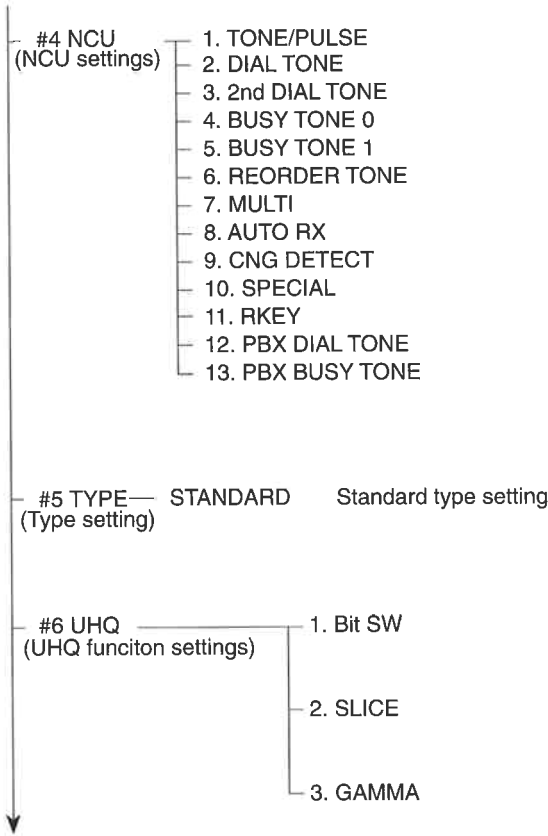
No. 01-04, 08-09, and 11-20 are not used. Do not change their settings.

#3 NUMERIC Param. (Numeric parameter settings)	01:	Not used
	02: — 10	RTN signal transmission condition (x)
	03: — 15	RTN signal transmission condition (n)
	04: — 12	RTN signal transmission condition (m)
	05:	Not used
	06:	Not used
	07:	Not used
	08:	Not used
	09: — 6	Stopping unwanted direct mail function Number of digits in telephone number compared against TSI signal.
	10: — 3500	T1 timer (Line connection identification time)
	11:	Not used
	12:	Not used
	13:	Not used
	14:	Not used
	15: — 120	Hooking detection time
	16: — 4	FAX/TEL switching function : signal detection time
	17: — 100	Psuedo-RBT signal pattern On time
	18: — 0	Psuedo-RBT signal pattern Off time (short)
	19: — 200	Psuedo-RBT signal pattern Off time (long)
	20: — 100	Psuedo-ring signal pattern On time
	21: — 0	Psuedo-ring signal pattern Off time (short)
	22: — 200	Psuedo-ring signal pattern Off time (long)
	23: — 4	FAX/TEL switching function : signal detection level
	24: — 20	Psuedo-RBT signal transmission level
	25: — 60	Answering machine connection function : signal detection time
	26: — 4	Answering machine connection function : no sound detection level
	27:	Not used
	28:	Not used
	29:	Not used
	30:	Not used

**Figure 2-51 Service Data (3/6)**



No. 01, 05-08, 11-14, and 27-30 are not used. Do not change their settings.



**Figure 2-52 Service Data (4/6)**



**#4 NCU (NCU settings)**

The values of these items are all set to match a specific nation's communications standards by the #5 TYPE setting. Do not change these settings.

**#6 UHQ (UHQ function settings)**

This setting may the scanned image quality. Do not change this settings.

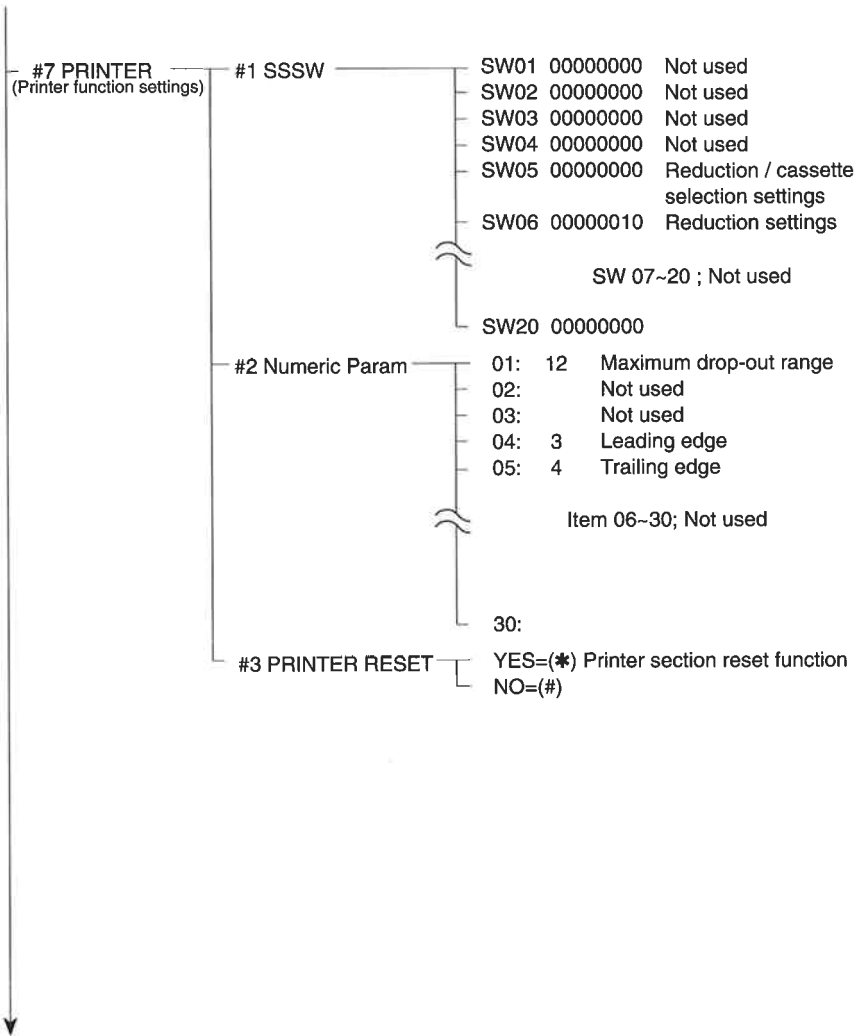
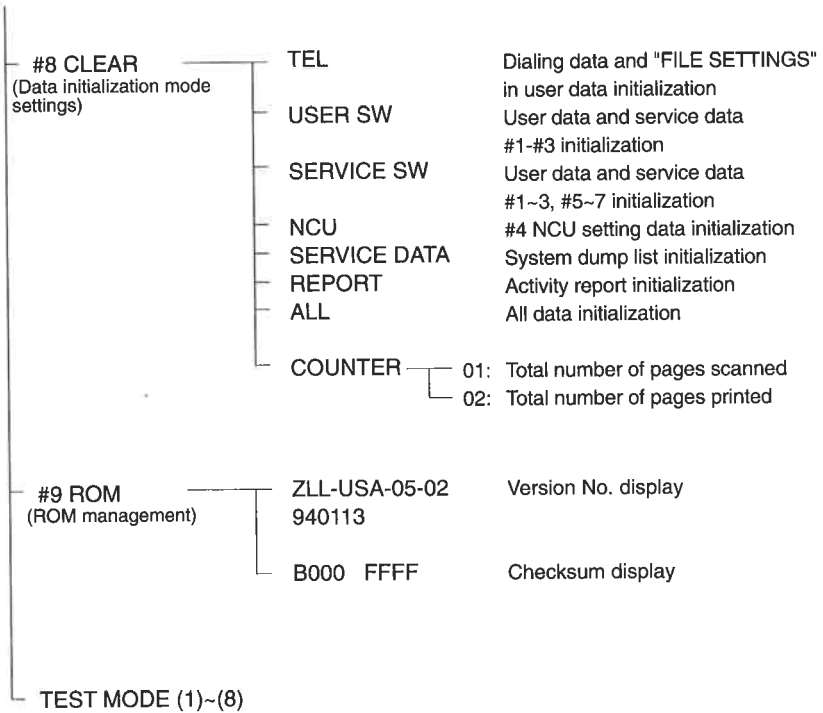


Figure 2-53 Service Data (5/6)



Switches 01-04, 06-20, and No. 2 04-30 are not used. Do not change their settings.





**Figure 2-54 Service Data (6/6)**

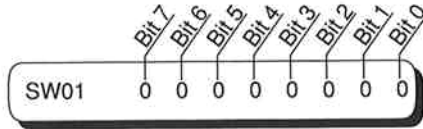


For details on test mode, see *Chapter 2: 3.5 Test Functions*.

### 3.4.4 Explanation of service data

#### a) #1 SSSW (service soft switch setting)

The items registered and set by each of these switches are comprised of 8 bit switches. The figure below shows which numbers are assigned to which bits. Each bit has a value of either 0 or 1.



**Figure 2-55 Bit Switch Display**

Below are examples showing how to read the bit switch tables.

Bit	Function	1	0
0	Service error code	Output	Not output*
1	Error dump list	Output	Not output*
2	Not used		
3	Not used		
4	Not used		
5	Not used		
6	Not used		
7	Not used		

\* Indicates that the setting is "1".  
 \* Indicates that the setting is "0".  
 \* Indicates that this is the default setting.

**Figure 2-56 Reading Bit Switch Tables**

---

**This page intentionally left blank**

#1 SSSW

SW01 (service soft switch 01; error management)

Bit	Function	1	0
0	Service error code	Output	Not output *
1	Error dump list	Output	Not output *
2	Enter password at confidential Rx image data transfer	No	Yes *
3	Copy function	No	Yes *
4	Not used		
5	Not used		
6	Not used		
7	Not used		

[Bit 0]

Selects whether or not service error codes are output.

When "Output" is selected, service error codes are displayed on the display and in reports.



For details on the service error whose code is shown on the display or in a report, see *Chapter 2: 3.1.1 Error displays, 3.2.2 Service report output functions.*

For a list of service error codes and recovery methods, see *Chapter 4: MAINTENANCE AND SERVICE.*

[Bit 1]

Selects whether or not error dump lists are output.

[Bit 2]

Allows selection of whether to enter password at confidential Rx image data transfer.



For Image Data Transfer, see *Chapter 1: 4.2 Image Data Transfer.*



For details on error dump lists, see *Chapter 2: 3.2.2 Service report output functions.*

[Bit 3]

Selects whether or not there is a copy function.

When "No" is selected, the copy function does not work even if the COPY key is pressed.

**This page intentionally left blank**

#1 SSSW

SW03 (service soft switch 03; echo countermeasure setting)

Bit	Function	1	0
0	Not used		
1	Echo protect tone for high-speed transmission	Transmitted	Not transmitted *
2	Not used		
3	Not used		
4	Transmission mode; long distance (1)	Yes	No *
5	Transmission mode; long distance (2) or long distance (3)	Yes	No *
6	Transmission mode	Long distance (3)	Long distance (2)*
7	Tonal signal before CED signal transmission	Transmitted	Not transmitted *

[Bit 1]

Selects whether or not the echo protect tone is transmitted for high-speed transmission (9600 or 7200 bps).

If errors due to line conditions occur frequently during fax transmission, select "Transmitted".



**Codes for errors that can occur during transmission because of line conditions:**

##100, ##104, ##281, ##282, ##283, ##750, ##755, ##760, ##765

When "Transmitted" is selected, a non-modulated carrier is transmitted as a synchronization signal before the image transmission.

[Bit 7]

Selects whether or not a 1080-Hz tone signal is transmitted before the CED signal is transmitted. If errors due to echoes occur frequently during reception, select "Transmitted" to transmit the tonal signal before transmitting the CED signal.



**Codes for errors that can occur during reception because of echo**

##005, ##101, ##106, ##107, ##114, ##200, ##201, ##790

**[Bit 4, 5, 6]**

Select the transmission mode, long distance (1), long distance (2), or long distance (3). If errors due to echo occur frequently in transmission to overseas, set the transmission mode with the dial registration or service soft switch.




---

**Codes for errors that can occur during transmission because of echo**

##005, ##100, ##101, ##102, ##104, ##201, ##280, ##281, ##283, ##284, ##750, ##760, ##765, ##774, #779, #784, ##794

**Setting in the dial registration (user level)**

Set "**Long distance (1)**" when registering the one-touch speed dialing and coded speed dialing transmission mode. If errors do not disappear, try "**Long distance (2)**" and "**Long distance (3)**".

The transmission mode set in one-touch speed dialing and coded speed dialing registration takes priority over the one set with the service soft switch.

---

When the transmission mode is selected with this switch, the long distance mode can be set even for transmission dialed with the numeric keys. Look at the following table and set "Long distance (1)". If errors persist, try "Long distance (2)" or "Long distance (3)".

TX mode \ Bit	7	6	5	4	3	2	1	0
Long distance (1)	*	0	0	1	0	0	*	0
Long distance (2)	*	0	1	0	0	0	*	0
Long distance (3)	*	1	1	0	0	0	*	0

\*0 or 1 (depending on the respective setting)

**Figure 2-57 Setting the Long Distance Mode with the Service Soft Switch**




---

Long distance (1) ignores the first DIS signal sent by the other fax. Long distance (2) sends an 1850-Hz tonal signal when the DIS signal is transmitted. Long distance (3) sends a 1650-Hz tonal signal when the DIS signal is transmitted.

---

#1 SSSW

**SW04 (service soft switch 04; communication trouble countermeasures settings)**

Bit	Function	1	0
0	Not used		
1	Not used		
2	The number of the final flag sequence for procedure signals	2	1 *
3	Reception mode after CFR signal transmission	High speed	High speed/ Low speed *
4	Not used		
5	Not used		
6	CNG signal for manual transmission	Not transmitted	Transmitted *
7	CED signal for manual reception	No transmitted*	Transmitted

**[Bit 2]**

Selects the number of the final flag sequence for procedure signals (300 bps transmission speed). When the other fax does not correctly receive the procedure sent signals by this fax, select "2" for the number of the final flag sequences.

**[Bit 3]**

Selects the reception mode after CFR signal transmission. When errors due to line conditions occur frequently in reception, select "High speed" for this reception mode.



**Codes for errors that can occur during reception because of line conditions**

**##106, ##107, ##114, ##201**

When "High speed" is selected, this fax only receives high-speed (image) signals after transmitting the CFR signal.

---



**[Bit 6]**

Selects whether or not to transmit CNG signal during manual transmission. In manual transmitting to a fax with the FAX/TEL switching mode, if there are frequent errors due to failure to switch to fax mode, select "Transmitted" for the CNG signal.

**[Bit 7]**

Selects whether or not to transmit CED signals during manual reception. If the other fax does not transmit even when you start manual reception, select "Transmitted" for the CED signal.

#1 SSSW

SW05 (service soft switch 05; standard function <DIS signal> setting)

Bit	Function	1	0
0	Not used		
1	Not used		
2	Not used		
3	Not used		
4	Recording paper length availability declared in DIS signal	A4 size	Arbitrary size *
5	Not used		
6	Not used		
7	Not used		

[Bit 4]

Selects whether or not the recording paper length declared in the DIS signal is A4 size. When receiving documents made up of long pages, to have the document divided into two pages at the transmitting fax, select "A4".



---

When "A4" is selected, this fax uses the DIS signal to tell the transmitting fax that it is equipped with A4 size recording paper. The transmitting fax that receives this DIS signal divides long pages into A4 size pages before transmitting it to the receiving fax. Some fax models do not so divide long documents.

---

**This page intentionally left blank**

**#1 SSSW**

**SW06 (service soft switch 06; scan condition settings)**

Bit	Function	1	0
0	Document feed after DES On	No feed	feed *
1	Prescan for document scanning	No prescan	Prescan *
2	Document length restriction	Not restricted	14" (355.9mm) max. *
3	Not used		
4	Document scan width	LETTER *	A4
5	Recording paper output for long image copy	First page only	Divided onto multiple pages
6	Copy function resolution	Variable	Always fine mode *
7	Superfine mode setting when TYPE OF DOC./A4 key selected	Set	Not set *

**[Bit 0]**

Selects whether to feed the document after the document edge sensor (DES) comes on.




---

When "No feed" is selected, the document scan start is delayed by the distance the document is not fed, so a blank is created at the leading edge of the transmitted image.

---

**[Bit 1]**

Selects whether or not prescanning is used when the first page of a document is scanned.




---

When "No prescan" is selected, this fax only prescans when the power is switched on.  
 When "Prescan" is selected, this fax prescans when the power is switched on and when the first page of a document is scanned.

---

If the document is skew, the skewed document edge color may be read in and cause a prescan defect. If prescan defects occur even when you correct the skewing of the document, set Bit 0 and Bit 1 for "No feed" and "No prescan", respectively.

**[Bit 2]**

Selects document length restriction. To copy or transmit pages more than 14" (355.9mm) long, select "Not restricted".

**[Bit 4]**

Selects the document scanning width, either Letter or A4.

**[Bit 5]**

Selects whether or not just the first page of the recording paper is output when long images are copied.



---

With this bit set to its initial value, if an image is copied that is longer than the effective recording length, this machine prints that copied image divided over 2 pages.

---



---

For details on the effective recording length, see *Chapter 3: 1.3.4 Printer section specifications*.

---

**[Bit 6]**

Selects whether or not the copy function resolution can be changed using the control panel key. To decide the copy resolution using the control panel key, select "Variable".

**[Bit 7]**

Selects whether or not superfine mode is set when the TYPE OF DOC./A4 key is selected. To set superfine mode for when the TYPE OF DOC./A4 key is selected, select "Set".

**#1 SSSW**

**SW07 (service soft switch 07; closed network function settings)**

Bit	Function	1	0
0	Not used		
1	Not used		
2	Not used		
3	Not used		
4	Not used		
5	Not used		
6	Closed network reception function	Yes	No *
7	Closed network transmission function	Yes	No *

The closed network functions are for communicating only with specific faxes. This function can only be used when the other fax is also a Canon fax with the closed network functions.

**[Bit 6]**

Selects whether or not the closed network reception function is used. To receive only from specific faxes, select "Yes" and set the same ID as the other fax.



---

The ID is comprised of the 8 bits specified by SW08.

---

**[Bit 7]**

Selects whether or not the closed network transmission function is used. To send only to specific faxes, select "Yes" and set the same ID as the other fax.



---

The ID is comprised of the 8 bits specified by SW08.  
If the ID of this fax and the ID of the other fax do not match, this fax displays error code #039.

---

**#1 SSSW**

**SW08 (service soft switch 08; closed network ID setting)**

Bit	Function	1	0
0	Closed network ID Bit 0		
1	Closed network ID Bit 1		
2	Closed network ID Bit 2		
3	Closed network ID Bit 3		
4	Closed network ID Bit 4		
5	Closed network ID Bit 5		
6	Closed network ID Bit 6		
7	Closed network ID Bit 7		

When using the closed network functions, use this switch to set the same ID as the other fax.

#1 SSSW

SW12 (service soft switch 12; page timer settings)

Bit	Function	1	0
0	Transmission page timer (TYPE OF DOC./AA lamp off)		
1	Transmission page timer (TYPE OF DOC./AA lamp off)		
2	Transmission page timer (TYPE OF DOC./AA lamp on)		
3	Transmission page timer (TYPE OF DOC./AA lamp on)		
4	Reception page timer		
5	Reception page timer		
6	Not used		
7	Separate transmission and reception page timers	Yes	No *

This switch sets the page timers.

This fax stops transmission if it takes longer than 32 minutes and stops reception if it takes longer than 32 minutes. To communicate for longer than this, check the table on the next page and set the desired time.



**Transmission/reception time-out time**

Time-out time \ Bit	7	6	5	4	3	2	1	0
8 min.	0	*	*	*	*	*	0	0
16 min.	0	*	*	*	*	*	0	1
32 min.	0	*	*	*	*	*	1	0
64 min.	0	*	*	*	*	*	1	1

**Transmission time-out time  
(TYPE OF DOC./AA lamp; OFF)**

Time-out time \ Bit	7	6	5	4	3	2	1	0
8 min.	1	*	*	*	*	*	0	0
16 min.	1	*	*	*	*	*	0	1
32 min.	1	*	*	*	*	*	1	0
64 min.	1	*	*	*	*	*	1	1

**Transmission time-out time  
(TYPE OF DOC./AA lamp; ON)**

Time-out time \ Bit	7	6	5	4	3	2	1	0
8 min.	1	*	*	*	0	0	*	*
16 min.	1	*	*	*	0	1	*	*
32 min.	1	*	*	*	1	0	*	*
64 min.	1	*	*	*	1	1	*	*

**Reception time-out time**

Time-out time \ Bit	7	6	5	4	3	2	1	0
8 min.	1	*	0	0	*	*	*	*
16 min.	1	*	0	1	*	*	*	*
32 min.	1	*	1	0	*	*	*	*
64 min.	1	*	1	1	*	*	*	*

\*0 or 1 (according to the setting)

**Figure 2-58 Page Timer Settings**

**#1 SSSW**

**SW25 (service soft switch 25; report display function settings)**

Bit	Function	1	0
0	Transmission telephone numbers displayed on reports	Other fax number from CSI	Called number *
1	Other party ID displayed on reports	Other fax ID from NSF	Registered ID *
2	Not used		
3	Not used		
4	Not used		
5	Not used		
6	Not used		
7	Not used		

**[Bit 0]**

Selects the transmission telephone number displayed on reports after the completion of transmission.

When "Called number" is selected, the telephone number this fax called is displayed on reports.

When "Other fax number" is selected, the telephone number sent from the other fax (the CSI signal data) is displayed on reports.

**[Bit 1]**

Selects the other party ID displayed on reports after the completion of transmission.

When "Registered ID" is selected, the other party ID registered for this fax's one-touch speed dialing or coded speed dialing is displayed on reports.

When "Other fax ID" is selected, the ID sent from the other fax (the NSF signal data) is displayed on reports.

## #1 SSSW

## SW26 (service soft switch 26; transmission function settings)

Bit	Function	1	0
0	Compulsory direct transmission function	Set	Not set *
1	Not used		
2	Not used		
3	Not used		
4	Not used		
5	Not used		
6	When STOP key is pressed during a sequential broad casting	Only cancel communication in progress	Cancel all *
7	Error report when transmission is stopped	Not output	Output *

**[Bit 0]**

Selects whether or not to set the compulsory direct transmission function. When "Set" is selected, all transmission other than sequential broadcasting is direct transmission.

**[Bit 6]**

Selects whether or not sequential broadcasting to all other parties is stopped when sequential broadcasting is stopped.

**[Bit 7]**

Selects whether or not an error report is output when transmission is stopped.

**b) #2 MENU (menu switch settings)**

No.	Function	Selection range	Default setting
05	NL equalizer	On/Off	Off
06	Telephone line monitor	Dial/Serviceman/Off	Dial
07	Transmission level (ATT)	0-15	10 (-10 dBm)

**[No. 05]**

Selects whether the NL equalizer is on or off.

If frequent errors occur during transmission and reception because of line conditions, select the NL equalizer "On".



---

Here is the relationship between the settings and the NL equalizer levels.

OFF: 0dB, ON: 10 dB

---



---

**Codes for errors that may occur during transmission because of line conditions**

**##100, ##101, ##102, ##104, ##201, ##281, ##282, ##283, ##750, ##755, ##760, ##765, ##774, ##779, ##784, ##789**

**Codes for errors that may occur during reception because of line conditions**

**##103, ##107, ##114, ##201, ##790, ##793**

---

**[No. 06]**

Sets the telephone line monitor function.

To use the telephone line monitor sound to check the state of communications for this fax, select "Serviceman".

When you select "Dial", the fax emits a telephone line monitor sound from the speaker from the start of communications until the DIS signal is transmitted.

When you select "Serviceman", the fax emits a telephone line monitor sound from the speaker from the start of communications until the end.

When you select "Off", the fax does not emit any telephone line monitor sound from the speaker.

**[No. 07]**

Sets the transmission level (ATT).

If frequent errors occur during transmission and reception because of line conditions, raise the transmission level.



---

**Codes for errors that may occur during transmission because of line conditions**

**##100, ##101, ##102, ##104, ##201, ##281, ##282, ##283, ##284, ##750, ##752, ##754, ##755, ##757, ##759, ##760, ##762, ##764, ##765, ##767, ##769, ##770, ##772, ##774, ##775, ##777, ##779, ##780, ##782, ##784, ##785, ##787, ##789**

**Codes for errors that may occur during reception because of line conditions**

**##103, ##106, ##107, ##201, ##793**

---

**c) #3 NUMERIC PARAM. (numeric parameter settings)**

Below are examples showing how to read the numeric parameter setting data tables.

No.	Function	Selection range	Default setting
02	RTN signal transmission condition	1~99	10 (10%)
23	FAX/TEL switching function signal detection level	0~7	4 (-38dbm)

**Figure 2-59 Reading Tables**

**This page intentionally left blank**

No.	Function	Selection range	Default setting
02	RTN signal transmission condition (x)	1-99	10 (10%)
03	RTN signal transmission condition (n)	2-99	15 (15 lines)
04	RTN signal transmission condition (m)	1-99	12 (12 times)
09	Stopping unwanted direct mail function Number of digits in telephone number compared against TSI signal	0-20	6 (6 digits)
10	Line connection identification time	0-9999	3500 (35 seconds)
15	Hooking detection time	0-999	120 (1200 ms)
16	FAX/TEL switching function Time from line seized to pseudo-RBT signal transmission	0-9	4 (4 seconds)
17	Pseudo-RBT signal pattern On time	0-999	100 (1000 ms)
18	Pseudo-RBT signal pattern Off time (short)	0-999	0 (0 ms)
19	Pseudo-RBT signal pattern Off time (long)	0-999	200 (2000 ms)
20	Pseudo-ring signal pattern On time	0-999	100 (1000 ms)
21	Pseudo-ring signal pattern Off time (short)	0-999	0 (0 ms)
22	Pseudo-ring signal pattern Off time (long)	0-999	200 (2000 ms)
23	FAX/TEL switching function signal detection level	0-7	4 (-38 dBm)
24	Pseudo-RBT signal transmission level	0-20	20 (-21 dBm)
25	Answering machine connection function signal detection time	0-999	60 (60 ms)
26	Answering telephone connection no-sound detection level	0-7	4 (-38 dBm)



**[No. 02, 03, 04]**

Set the RTN transmission conditions.

During reception if frequent errors occur because of RTN signal transmission, raise these parameters to loosen the RTN signal transmission conditions.



---

**Codes for errors that may occur during transmission because of RTN signal transmission conditions**

**##104, ##107, ##114, ##201**

RTN signal transmission condition (x) is the ratio of the number of error lines to the total number of lines per page of the received image.

RTN signal transmission condition (n) is the reference value \*\* for burst errors \*.

RTN signal transmission condition (m) is the number of errors not fulfilling the burst error reference value.

\* Consecutive multi-line transmission error

\*\* When "15" is set, this fax identifies a 15 consecutive line transmission error as a burst error.

If this fax detects any one of these conditions during image signal reception after it receives the transmitting fax's protocol signals, it sends the RTN signal. Raising these parameters makes it less likely that the RTN signal will be sent.

---

**[No. 09]**

Sets the number of digits of the telephone number that this fax compares against the transmitting fax's TSI signal when the stopping unwanted direct mail function is operating.



---

When the stopping unwanted direct mail function is operating, the comparison between the telephone numbers registered for one-touch speed dialing and coded speed dialing and the TSI signal data that the transmitting fax sends is carried out from the bottom digit.

---

**[No. 10]**

Sets the T1 timer (line connection identification time).

If frequent errors occur during transmission and reception because of line connection conditions, raise the value of this parameter.



---

**Codes for errors that may occur because of line connection conditions**

**##005, ##018**

On the transmission side, the line connection ID time is the time from after dial signal transmission until the line connection is cut; on the reception side, it is the time from after DIS signal transmission until the line connection is cut.

---

**[No. 15]**

Sets the hooking detection time.

When changing the hooking timing, adjust this parameter.



---

When "50" is set, this fax identifies hooking of 50 ms or longer as on-hook.

---

**[No. 16]**

Sets the time from line seized to the start of pseudo-RBT signal transmission for FAX/TEL switching function operation. When the FAX/TEL switching function is operating, if the function does not operate normally because this fax does not detect signals sent from the line, raise this parameter to increase the signal detection time.

**[No. 17, 18, 19]**

Set the pattern for the pseudo-RBT signal this fax sends when the FAX/TEL switching function operates.

**[No. 21, 22, 23]**

Set the pattern for the pseudo-ring signal this fax sends when the FAX/TEL switching function operates.

**[No. 23]**

Sets the signal detection level for FAX/TEL switching function operation. When the FAX/TEL switching function is operating, if the function does not operate normally because this fax does not detect CNG or ROT\* signals sent from other fax, lower this parameter to increase the signal detection possibility.

\*ROT: ReOrder Tone



---

Here is the relationship between the settings and the detection levels.

0: -25 dBm, 1: -30 dBm, 2: -32 dBm, 3: -35 dBm  
4: -38 dBm, 5: -40 dBm, 6: -44 dBm, 7: -49 dBm

---

**[No. 24]**

Sets the signal transmission level for the pseudo-RBT signal for when the FAX/TEL switching function operates.



---

Items **No. 16 to 24** are for the FAX/TEL switching function. For details on the FAX/TEL switching function, see *Chapter 3: 3.1 FAX/TEL Switching*.

---

**[No. 25]**

Sets the signal detection time for the answering machine connection function operation. When the answering machine connection function is operating, if the function does not operate normally because the fax does not detect CNG or 2nd NSS signal sent from the line, raise this parameter to increase the signal detection time.

**[No. 26]**

Sets the no-sound detection level for the answering machine connection function operation. When the answering machine connection function is operating, if the fax does not detect no-sound because it detects noise from the line, raise this parameter to lower the detection possibility.



---

Here is the relationship between the settings and the detection levels.

0: -25 dBm, 1: -30 dBm, 2: -32 dBm, 3: -35 dBm  
4: -38 dBm, 5: -40 dBm, 6: -44 dBm, 7: -49 dBm

---

**d) #4 NCU (NCU settings)**



---

Item #5 (type setting) sets all the values for the NCU settings to match national telecommunications standards. Do not change these settings.

---

**e) #5 TYPE (type setting)**

If STANDARD is set, all the #4 NCU data is set to match national telecommunications standards.

**f) #6 UHQ (UHQ function setting)**



---

The settings for this item may reduce the scan image quality. Do not change these settings.

---

**This page intentionally left blank**

**g) #7 PRINTER (printer function settings)**

**g-1) Service soft switch settings**

**SW05 (switch 05; reduction/cassette selection settings)**

Bit	Function	1	0
0	Printing to letter recording paper as priority	Print	Do not print*
1	Printing to legal recording paper as priority	Print	Do not print*
2	Report output when recording paper runs out from selected cassette	Not output	Output using other cassette *
3	Reduction printing for copying	Reduction	No reduction *
4	Reduction printing to A4 recording paper	Do not print	Print *
5	Reduction printing to letter recording paper	Do not print	Print *
6	Not used		
7	Vertical scanning priority recording	Set	Not set *

**[Bit 0]**

Selects whether or not to give priority to letter recording paper for printing. Select "print" to print on letter recording paper when a received image can be recorded on both A4 and letter recording paper.

**[Bit 1]**

Selects whether or not to give priority to legal recording paper for printing. Select "print" to print on legal recording paper when a received image can be recorded on both A4 and legal recording paper.

**[Bit 2]**

Selects whether reports are output using recording paper from another cassette when the recording paper cassette for reports is specified in the user data and that cassette runs out of recording paper.

**[Bit 3]**

Selects whether or not reduction printing is used for copying.

**[Bit 4]**

Selects whether or not reduction printing to A4 recording paper is used. To print received images on other recording paper without reducing the printing to A4 recording paper, select "Do not print".

**[Bit 5]**

Selects whether or not reduction printing to letter recording paper is used. To print received images on other recording paper without reducing the printing to letter recording paper, select "Do not print".

**[Bit 7]**

Selects whether or not Vertical scanning priority recording is set or not. When legal recording paper and letter recording paper is set and an letter long length image\* is received, to print on legal recording paper, select "Set".

\* An image shorter than legal length, but which not be reduced and printed on letter recording paper



---

For details on recording paper selection for reception, see *Chapter 5: 2.4.6 Recording Paper Size Priority*.

---

**SW06 (switch 06; reduction settings)**

Bit	Function	1	0
0	Reduction during divided printing	No reduction	Reduction*
1	Drop outs for printed image when long image received	Drop out*	Do not drop out
2	Not used		
3	Not used		
4	Not used		
5	Not used		
6	Not used		
7	Not used		

**[Bit 0]**

Selects whether or not to use reduction when printing received images divided over two pages.

**[Bit 1]**

Selects whether or not to drop out the trailing edge when printing received long images. If you do not want to drop out the trailing edge of received images that are longer than the effective recording length, select "Do not drop out."



When you select "Do not drop out", this machine does not use automatic reduction.

---



---

For details on the effective recording length, see *Chapter 3: 1.3.4 Printer Section Specifications*.  
For details on reduction during printing, see *Chapter 5: b)Reduction*.

---



**SW16 (switch 16; print density settings)**

Bit	Function	1	0
0	Print density		
1	Print density		
2	Print density		
3	Print density		
4	Print density		
5	Print density		
6	Print density		
7	Print density		

This switch sets the print density. To further increase the print density, check the following table and set the optimum value.

Density \ Bit	7	6	5	4	3	2	1	0
Lighter	0	1	0	1	0	0	0	0
	0	1	1	0	0	0	0	0
	0	1	1	1	0	0	0	0
Darker	0	1	1	1	1	1	1	0

**Figure 2-60 Print Density Settings**



The print density set with this switch takes priority over the user data "SELECT DENSITY" setting.

**g-2) Numeric parameter settings**

No.	Function	Selection range	Default setting
01	Maximum drop out range for reception image printing	0-9999	12 (12 mm)
04	Leading edge margin	0-9999	3 (3 mm)
05	Trailing edge margin	0-9999	4 (4 mm)

**[No. 01]**

Sets the image range for drop outs for printing received long images. To avoid dropping out the trailing edge of the received image even when an image exceeding the effective recording length is received, lower this parameter to reduce the drop out range.



When this fax receives an image longer than the effective recording length, this fax prints it reduces to a maximum of 90% \*. At this time, if the length of the reduced reception image is within 0.47" (12 mm) \*\* of the effective recording length, it drops out that range and prints the reception image reduced. If the length of the reduced reception image is more than 0.47" (12 mm) beyond the effective recording length, this fax prints the reduced reception image divided over two pages.

\* When user data automatic reduction is "On"

\*\* Default setting



For details on the effective recording length, see *Chapter 3: 1.3.4 Printer section specifications.*

For details on reduction during reception, see *Chapter 5: b) Reduction.*

**[No. 04]**

Sets the print image leading edge margin.



Adjust the leading edge margin with VR301 on the PCNT board before setting this switch.

For details on the leading edge margin adjustment, see *Chapter 4: 3.3.5 Leading edge margin adjustment.*

**[No. 05]**

Sets the print image trailing edge margin.

**g-3) Printer reset function**

By selecting this item, you can reset the printer section without switching the power switch on/off.



Selecting this item does not initialize the setting/registration data or the image data.

**h) #8 CLEAR (data initialization mode setting)**

The items below can be initialized by selecting them.

Item on display	Data initialized
TEL	Dialing data and "FILE SETTINGS" in user data
USSW SW	User data* and Service data #1-#3
SERVICE SW	User data* and Service Data #1, #3, #6, #7
NCU	Service Data #4
SERVICE DATA	Data on system dump list
REPORT	Data on activity report
ALL	All settings/registered data, image data

\* Except "FILE SETTINGS" in user data

When "COUNTER" is selected, the page counter can be set separately for each of the following items.

No.	Item	Selection range
01	Total number of pages scanned	0-65535
02	Total number of pages printed	0-65535



After replacing the SCNT board, set the total number of pages scanned and the total number of pages printed to the values they had before board replacement.

The set data is not initialized even when the above data initialization mode is selected.

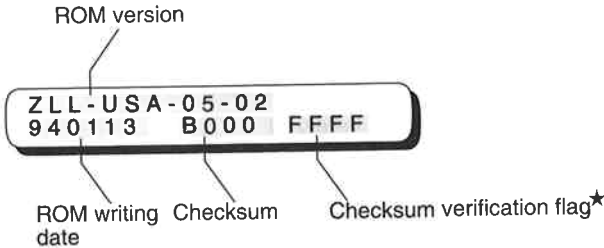


The total number of pages scanned and the total number of pages printed before board replacement can also be checked with the system dump list.

For details on the system dump list, see *Chapter 2: 3.2.2 Service report output functions.*

**i) #9 ROM (ROM management)**

When this item is set, the ROM management data (version No., checksum) is displayed on the display.



★ If the checksum is normal, "FFFF" is displayed.

**Figure 2-61 How to Read ROM Management Data**

### 3.5 Test Functions

This fax has functions for testing individual operations, such as scanning, printing, communications, document feed, and recording paper feed.

#### 3.5.1 Test mode overview

Test mode can be executed by following the menu items from the display. The test mode menu items are divided into eight blocks.

**a) D-RAM test**

Writes data to all D-RAM areas and reads that data to check operations.

**b) CS test**

Lights up the contact sensor unit LED array.

**c) Print test**

Prints ten different patterns in fine mode within the print area in fine mode.

**d) Modem, NCU tests**

The relay operation test and the modem DTMF and tonal signal transmission and reception tests

**e) Aging test**

Lights up the contact sensor unit LED array and drives the document feed motor in fine mode. The printer prints the slant band pattern in fine mode and the print darkness pattern in normal mode.

**f) Faculty tests**

Test the operation of microswitch, sensor, and speaker functions, telephone line signal and telephone off-hook detection, and the ADF.

**g) Data set**

This mode is only for use at the factory.



Never operate data set mode! If you do, the registered user data will be automatically changed.

---

### 3.5.2 Test mode flowcharts

To operate test mode, select service mode by pressing the DATA REGISTRATION key then pressing the # key, select test mode with the Search key, then press the Set key. To end test mode, press the Clear key.

TEST MODE [1] - [8]  
CF-ZLL :ZLL-USA-05

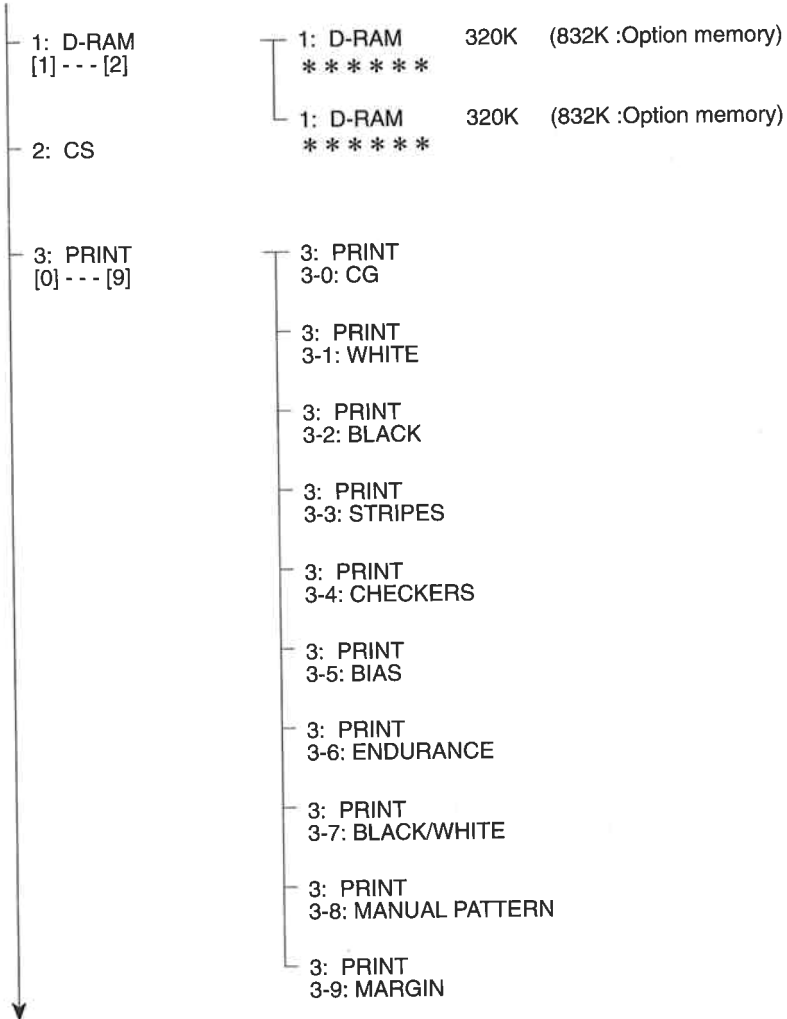


Figure 2-62 Test Mode (1/6)

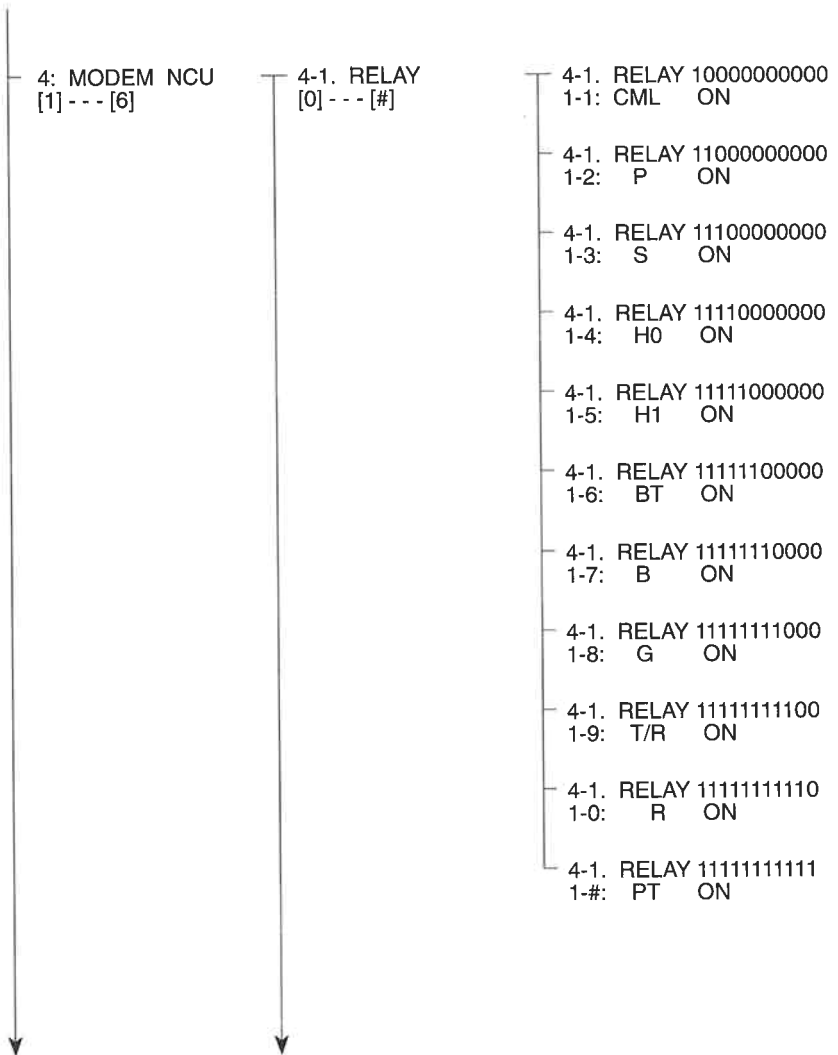


Figure 2-63 Test Mode (2/6)

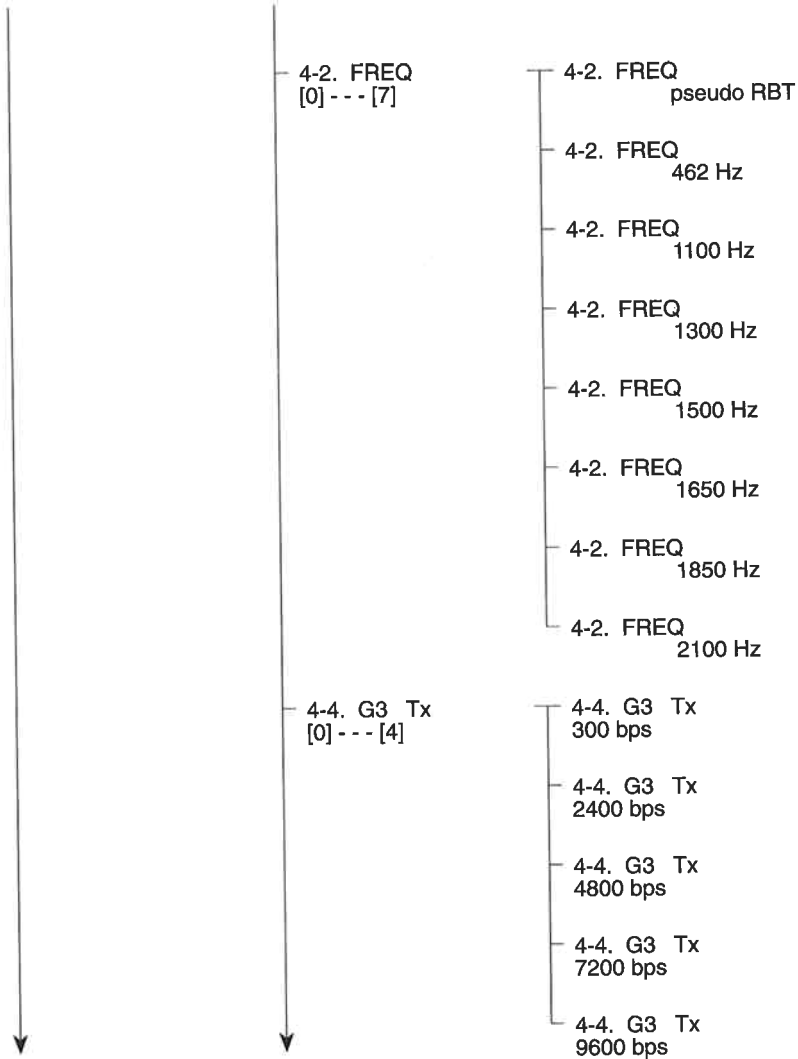


Figure 2-64 Test Mode (3/6)



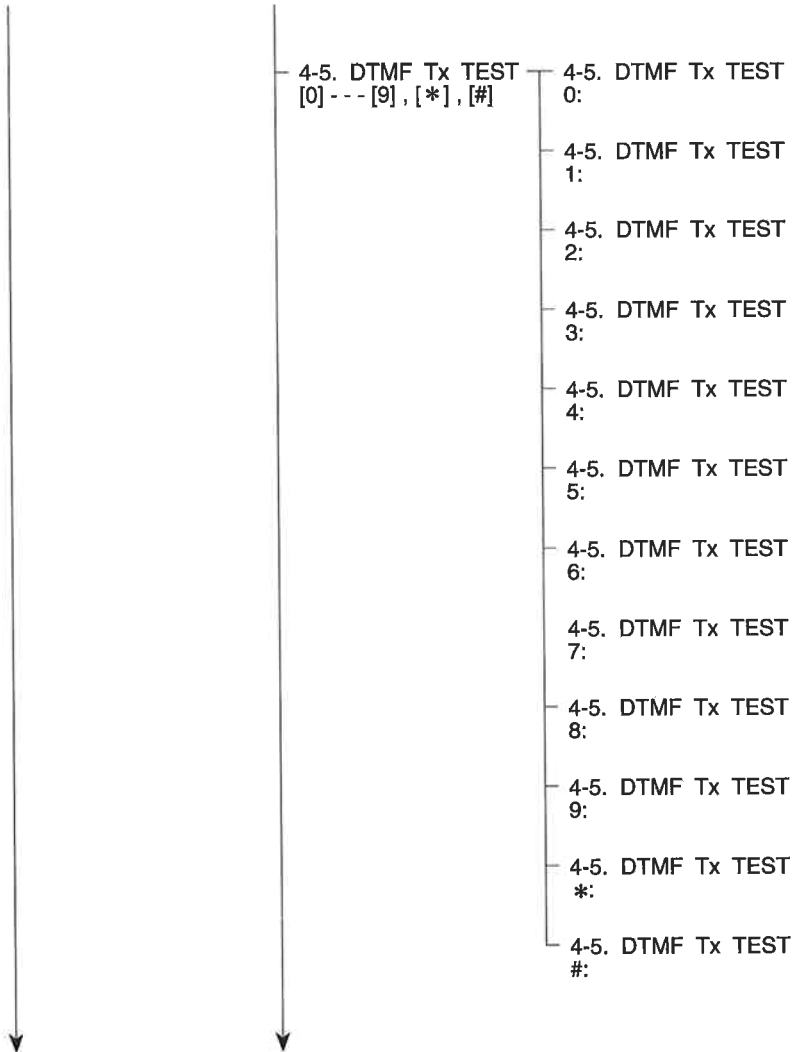


Figure 2-65 Test Mode (4/6)

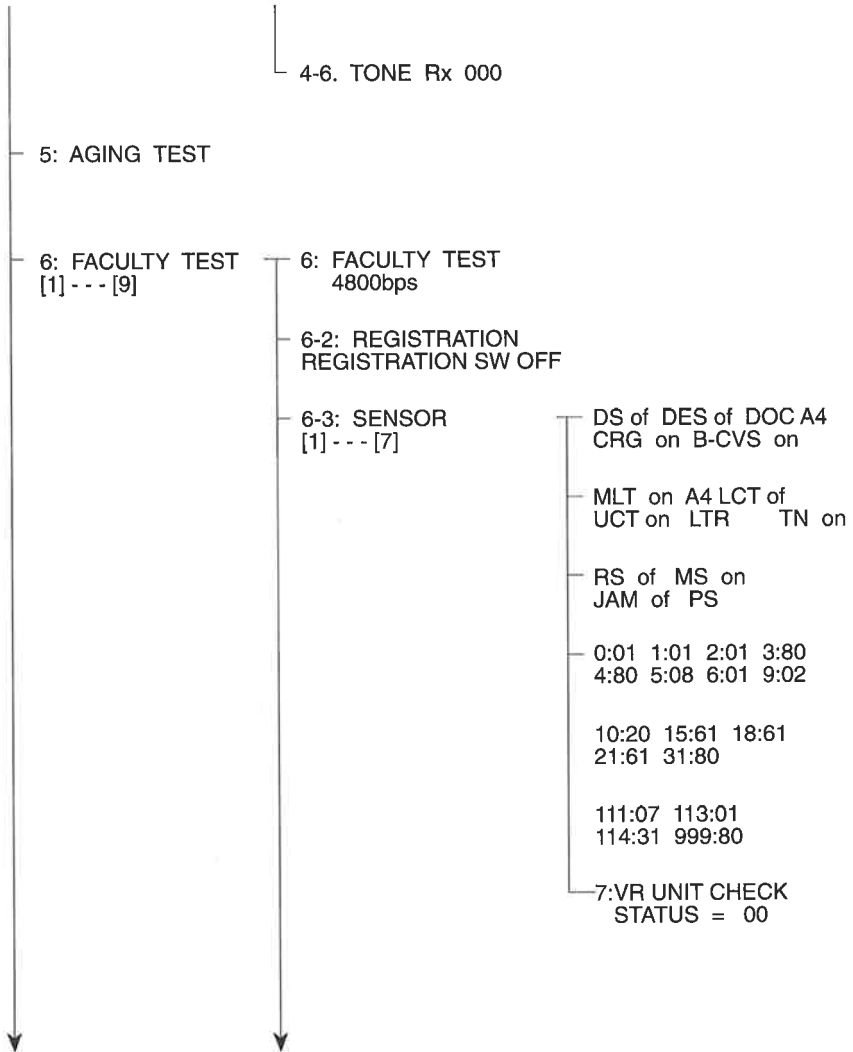


Figure 2-66 Test Mode (5/6)

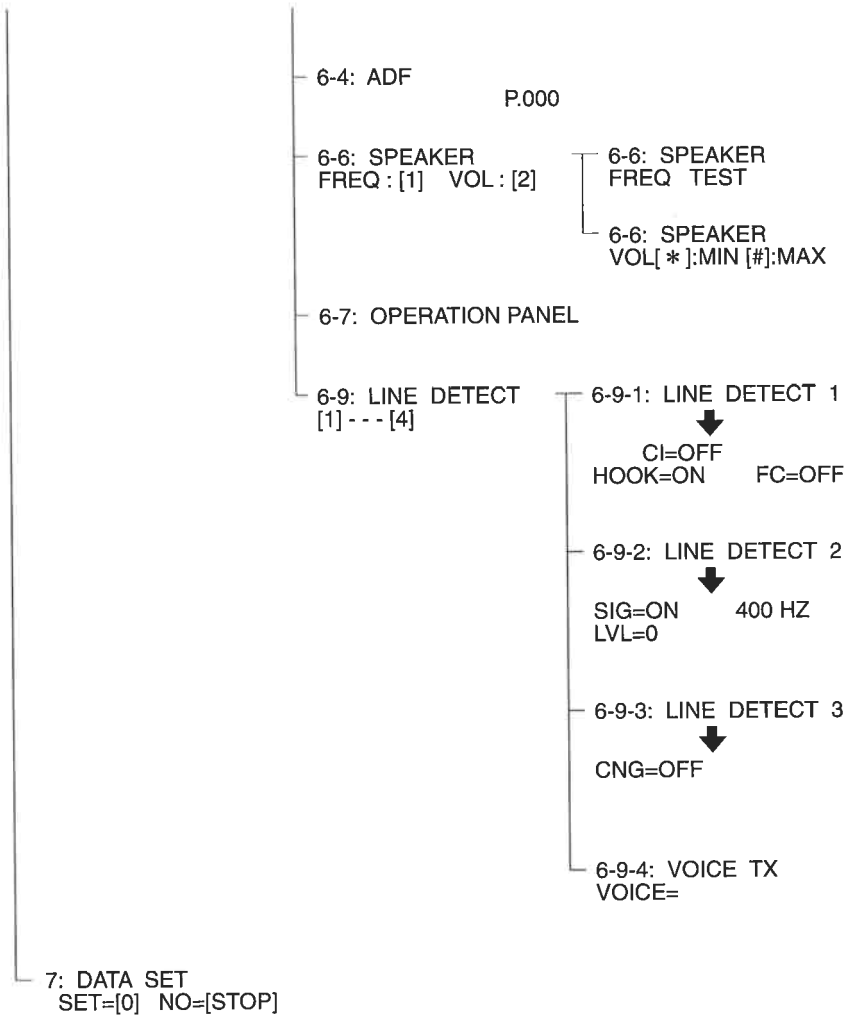


Figure 2-67 Test Mode (6/6)

### 3.5.3 D-RAM tests

Pressing the 1 key from the test mode menu selects the D-RAM tests. D-RAM Test 1 writes data to the entire D-RAM region and reads it out to check that operations are correct. D-RAM Test 2 just reads data at high speed. This test can be used to check operations when optional memory has been added.

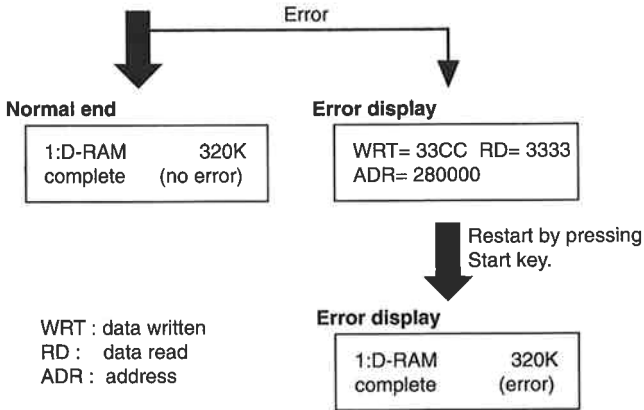
#### Operating

```

1:D-RAM      320K
* . . . . * * * * *
    
```

320K: D-RAM total memory capacity (Kbytes)  
 (Option memory added 832 Kbytes)

\*: Indicates an address for which write testing is complete.  
 .: Indicates an address for which read testing is complete.



**Figure 2-68 D-RAM Test**

### 3.5.4 CS test

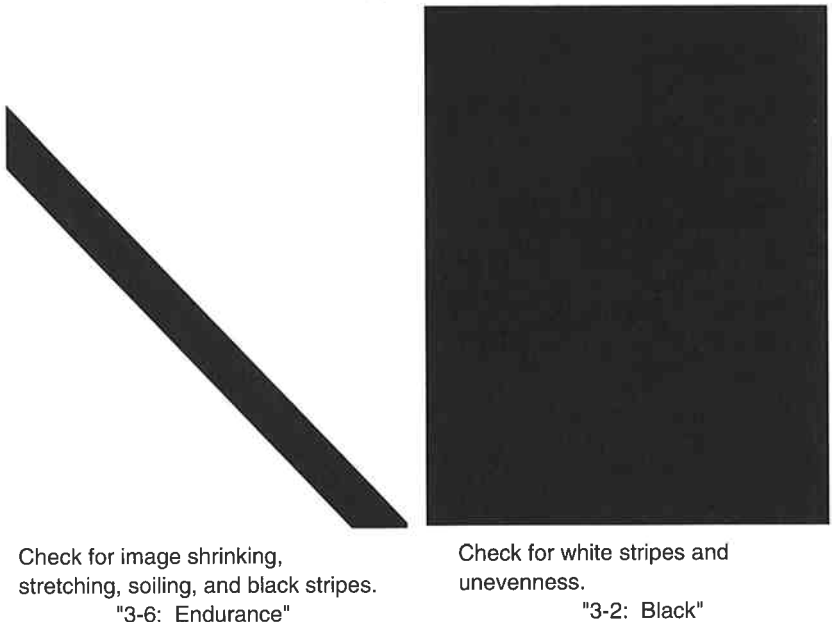
The CS test is selected by pressing the 2 key from the test mode menu. In this test, the contact sensor unit LED array is operated. Verify that the LED array lights up. End the test by pressing the Stop key.

### 3.5.5 Print test

#### a) Test mode print test

The Print Test menu is selected by pressing the 3 key from the test mode menu. In this test, various print patterns are output from the printer. As service print patterns, press the 2 key from the Print Test menu to select "**3-2: Black**" or press the 6 key to select "**3-6: Endurance**". Do not use the other patterns. They are for development and factory use.

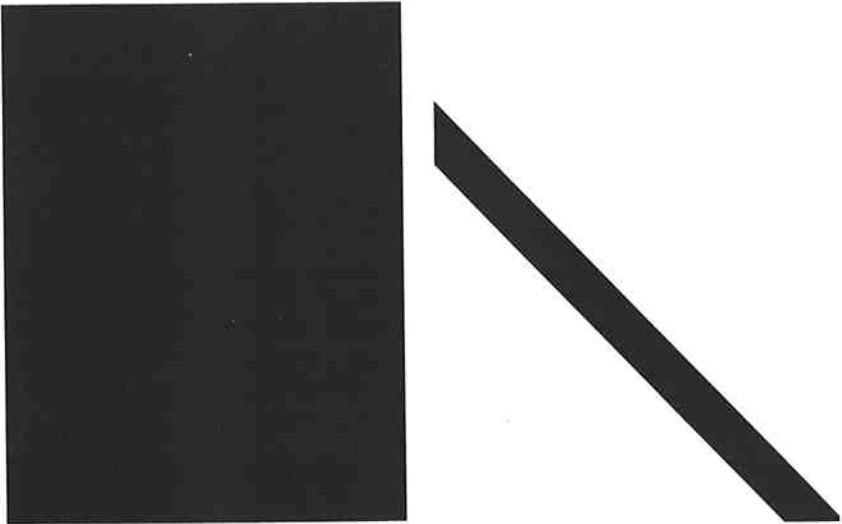
Check the following for the print pattern.



**Figure 2-68 Print Pattern Check**



After completion of the print test, if the printing was normal, copy a document. If there is any defect in the copied image, there is a defect in the scan section.

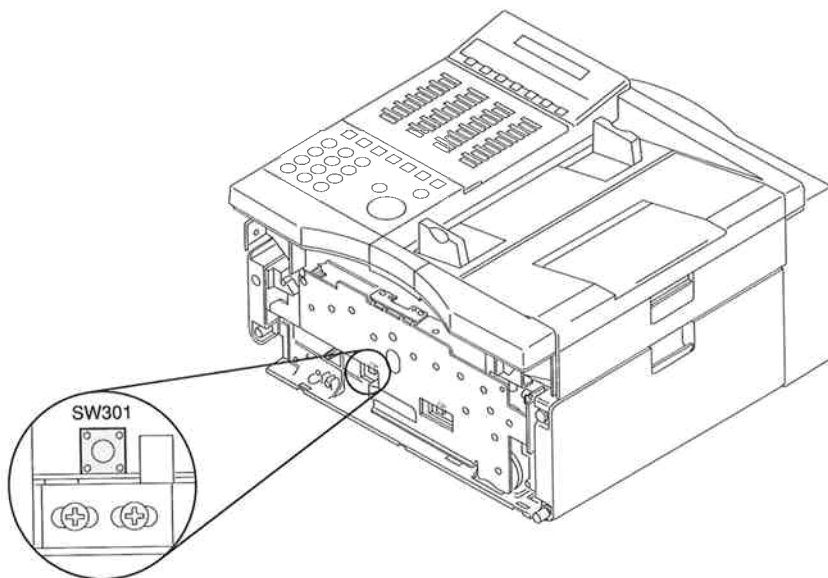


**Figure 2-69 Print Sample 1**

**This page intentionally left blank**

**b) Hard switch print test**

Pressing the test print switch (SW301) on the PCNT board outputs the following print pattern. This test checks the orthogonality and leading edge margin for the print image. Check the print image to verify that it is perpendicular and that the leading edge margin is 0.08" (2 mm).



**Figure 2-71 Test Print Switch**

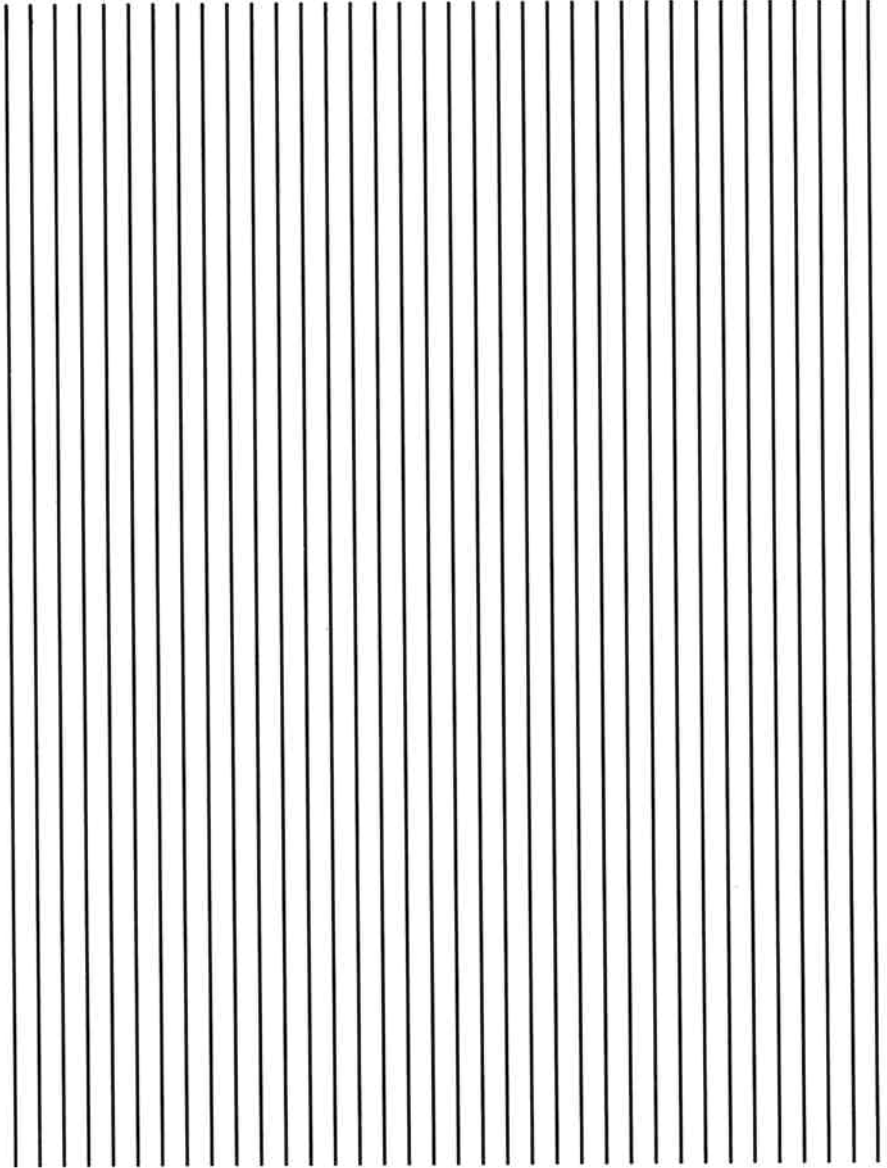


---

For details on the adjustment methods, see *Chapter 4: 3.3 Adjustment*.

---





**Figure 2-72 Print Sample 2**

### 3.5.6 Modem and NCU tests

These tests test modem and NCU transmission and reception. The modem tests check whether signals are sent correctly from the modem by comparing the sound of the signals from the speaker with the sounds from a normal modem. Also, you check on the display whether or not the modem correctly detected received tone signals and DTMF signals. End this test by pressing the Stop key.

Modem test type	Overview
Relay test	Switches the selected relay on/off with numeric keys.
Frequency test	The modem sends tone signals from the modular jack and the speaker.
G3 signal transmission test	The modem sends G3 signals from the modular jack and the speaker.
DTMF transmission test	The modem sends DTMF signals from the modular jack and the speaker.
Tonal signal reception tests	The modem detects specific frequencies and DTMF signals received from the modular jack.

#### a) Relay test

The Relay test menu is selected by pressing the 1 key from the MODEM NCU test menu. This test operates the relays mounted on the NCU board with numeric keys.



The On/Off displayed indicate the transmission of the relay operation signals when numeric keys are pressed. Therefore, breakdown of a relay alone can not be checked with the display. In this fax, the H1, BT, B, G, R, and PT relays are not mounted.

4-1 : RELAY	0100000000	1 : Relay on
1-2 : P	ON	2 : Relay off
	0 1 0 0 0 0 0 0 0 0 0 0	
Relay	CML P S H0 H1 BT B G CNG R PT	
Numeric key	0 1 2 3 4 5 6 7 8 9 #	

Figure 2-73 Relay Test

**b) Frequency test**

The frequency test menu is selected by pressing the 2 key from the MODEM NCU test menu. Signals of the frequencies below are sent from the modem using the modular jack and the speaker. The frequency can be changed with the numeric keys.

<b>Numeric key</b>	<b>Frequency</b>
0	Pseudo-RBT
1	462 Hz
2	1100 Hz
3	1300 Hz
4	1500 Hz
5	1650 Hz
6	1850 Hz
7	2100 Hz



---

The pseudo-ringback tone transmission pattern and frequency and the output levels for each frequency follow the service data transmission level settings.

---

**c) G3 signal transmission test**

The G3 signal transmission test menu is selected by pressing the 4 key from the MODEM NCU test menu. The G3 signals below are sent from the modem using the modular jack and the speaker. The frequency can be changed with the numeric keys.

<b>Numeric key</b>	<b>Frequency</b>
0	300 bps
1	2400 bps
2	4800 bps
3	7200 bps
4	9600 bps



---

The transmission level for each frequency follows the service data.

---

**d) DTMF signal transmission test**

The DTMF signal transmission test is selected by pressing the 5 key from the MODEM NCU test menu. In this test mode, the DTMF signals are sent from the modem using the modular jack and the speaker.

The DTMF signal sent is that for the pressed numeric key.



The transmission level for each signal follows the service data settings.

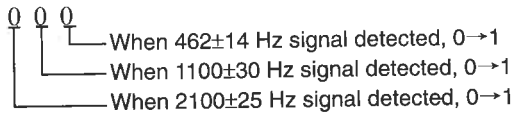
**e) Tonal and DTMF signal reception tests**

The tonal and DTMF signal reception test is selected by pressing the 6 key from the MODEM NCU test menu. In these tests, you can check whether the tonal signals and DTMF signals received from the modular jack are detected by the modem.

The  $462 \pm 14$  Hz test is included because the modem has a  $462 \pm 14$  Hz detection function.

**Tonal signal reception test**

4-6 : TONE Rx	0 0 0
---------------	-------



**DTMF signal reception test**

4-6 : TONE Rx	0 0 0
	1 2 3 4 5 6 7 8 9 0

The received DTMF signals are displayed in order from the right on the second line of the display.

**Figure 2-74 Tonal and DTMF Signal Reception Tests**



The 462-Hz tonal signal detected in the tonal signal reception test is the G2 standard PIS signal. This fax's modem has a function for detecting that signal.

### 3.5.7 Aging test

The aging test is selected by pressing the 5 key from the test mode. In this test mode, the contact sensor unit LED array is lit up and the document feed motor is driven in fine mode. Also, a skew band pattern is printed in fine mode.

The aging test is ended by pressing the Stop key after the printer completes printing of one page of recording paper.

### 3.5.8 Faculty tests

The faculty tests are selected by pressing the 6 key from the test mode menu. These tests test the following faculties of this fax.

<b>Test type</b>	<b>Overview</b>
G3 signal transmission test	Transmits 4800-bps G3 signals to the telephone line and the speaker.
Slide switch test	Tests whether the slide switch on the control panel is operating correctly.
Sensor tests	Test whether the sensors are operating correctly.
ADF test	Tests whether the ADF function is operating correctly.
Speaker test	Tests whether signals are sent from the speaker.
Operation panel test	Tests whether the key switches on the control panel are operating correctly.
Line signal reception test	Tests whether the NCU board signal sensor and frequency counter are operating correctly.

**a) G3 signal transmission test**

The G3 signal transmission test is selected by pressing the 1 key from the faculty test menu. In this test, 4800-bps G3 signals are sent to the telephone line and the speaker.

**b) Slide switch test**

The slide switch test is selected by pressing the 1 key from the faculty test menu. This test tests whether the slide switch on the top left of the control panel is operating correctly. Switching the slide switch on/off should display ON/OFF on the display.



---

The display says REGISTRATION SW, but this slide switch is not a registration switch.

---

**c) Sensor tests**

The sensor test is selected by pressing the 1 key from the faculty test menu. In this test, you can check the status of each sensor of this fax in items 1-3 on the display.

You can also check if sensors that use actuators and microswitches are operating correctly by moving the actuator or microswitch. 4-6 are for a special mode.

With item 7, you can use the display to check the adjustment of sensor output error due to installation position error for the LED board, toner sensor board, and VR board, and variations in LED and toner sensor performance.



---

For details on LED light reception level adjustment, see *Chapter 4: 3.3.6 LED light emission level adjustment.*

---

6-3 : SENSOR  
[1] --- [6]

Pressing the 1 key.

DS of DES of DOC A4  
CRG on B-CVS on

DS: Document sensor    DES: Document edge sensor  
on/of: document/no document  
DOC: Document width sensor    A4  
CRG: Cartridge cover sensor  
B-CVS: Right cover sensor, Exit paper cover sensor  
Feeder right cover sensor

Pressing the 2 key.

MLT on A4 LCT of  
UCT on LTR TN on

MLT on A4 LCT of  
UCT on LTR TN on

Front cassette recording paper sensor: on/of recording paper/no recording paper  
Front cassette  
Side cassette recording paper size sensor: A4/LTR/LGL  
Side cassette recording paper sensor: on/of recording paper/no record paper  
Side cassette

UCT on LTR TN on  
Toner sensor: on/of toner/no toner  
Toner sensor  
Front cassette recording paper size sensor: LTR  
Front cassette recording paper sensor: on/of recording paper/no recording  
Front cassette

Pressing the 3 key.

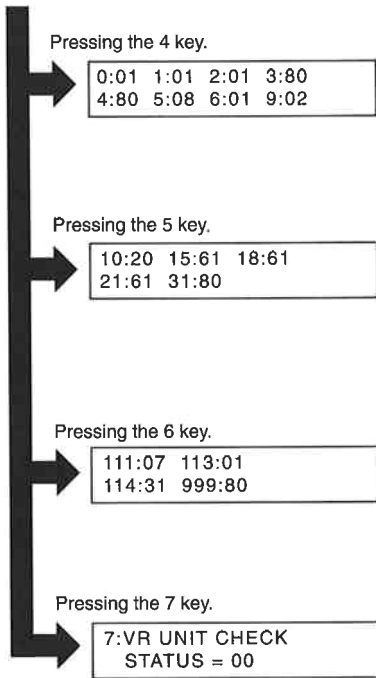
RS of MS on  
JAM of PS

RS: Recording paper detection  
on/of: no recording paper/recording paper  
MS: paper jam sensor  
JAM: paper pick up sensor  
paper eject sensor  
paper jam sensor  
PS: paper eject sensor

Figure 2-75 Sensor Tests 1



Since the paper eject sensor only operates during printing, "on" or "off" is displayed on the display. Since the paper jam sensor only operates after the main motor is driven when the power is switched on, during standby "on" is always displayed on the display. During printing, neither "on" nor "off" is displayed on the display.



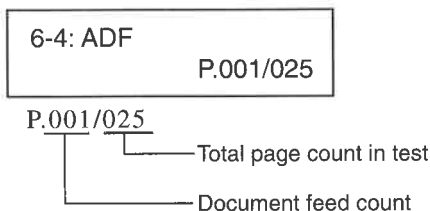
**Figure 2-76 Sensor Tests 2**



**d) ADF test**

The ADF test is selected by pressing the 4 key from the faculty test menu. In this test, check if the document scanner section ADF function operates correctly.

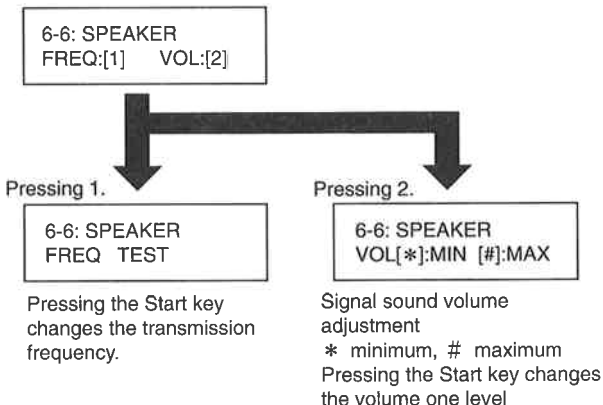
When a document is set in the document intake, the document is fed at the speed corresponding to the Superfine-Fine-Standard key. Each time one page is scanned, the counter on the display is increased as well. This fax can set up to 30 pages of A4 or letter size or 5 pages of legal size.



**Figure 2-77 ADF Test**

**e) Speaker test**

The speaker test is selected by pressing the 6 key from the faculty test menu. In this test, tonal signals every 100 Hz from 200 Hz to 5 kHz are output and the volume is switched. Verify that the signals are output from the speaker.



When this test starts, this machine outputs an audible signal from the speaker with the volume set with the user data "ALARM VOLUME".

**Figure 2-78 Speaker Test**

**f) Control panel tests**

The control panel test is selected by pressing the 7 key from the faculty test menu. In this test, check that the display, LED lamps, and keys on the control panel are operating correctly.

**f-1) Display test**

Pressing the Start key from the control panel menu, "H" is displayed 20 characters by 2 lines on the display. The next time the Start key is pressed, all the LCD dots on the display are displayed. Check for any LCD dots in the display that are not displayed.

**f-2) LED lamp test**

The LED lamp test is selected by pressing the Start key after the display test.

When the Start key is pressed, all the lamps on the control panel light. The blinking lamps are the change cartridge lamp, the rec. paper lamp, and the in use lamp. Check for any LED that does not blink during the test.

**f-3) Operation key test**

The Operation key test is selected by pressing the Start key after the LED lamp test.

In this test, you press the key corresponding to the displayed character to put it out. The table giving the correspondence between the characters and the keys is below. When the LEDs for the character for the SUPER FINE-FINE-STANDARD key, the DARKER-STANDARD-LIGHTER key, the TYPE OF DOC.-AA key, or the Reception Mode key are all lit up, the display goes out.

Character	Operation key	Character	Operation key
1-#	Numeric keys	M	Delete file key
P	Pause key	/	Program key
T	Tone key	\$	Super Fine-Fine-Standard key
R	Redial key	U	Darker-Standard-Lighter key
C	Copy key	A	Type of doc.-AA key
O	Hook key	&	Ans hook up-Manual key
D	Coded dial key	%	Tx key
?	TTI selector key	p	Report key

When all the characters displayed have gone out, the system next starts the one-touch speed dialing key test. The letters a-x are displayed on the display, corresponding to one-touch speed dialing keys 01-24. Each letter displayed on the display goes out when its corresponding one-touch speed dialing key is pressed.

In this test, check for operation keys whose corresponding character or letter does not go out when the key is pressed.



**g) Line signal reception test**

The line detect test menu is selected by pressing the 9 key from the faculty test menu. This test checks the operation of the NCU signal sensor and frequency counter. In Menu 1, the CI, FC, and extension telephone hook status can be detected and in Menu 2 the frequency can be detected at changing detection levels. In this way, you can check if the NCU board is correctly detecting signals.

**g-1) Test Menu 1**

Test Menu 1 is selected by pressing the 1 key from the Line Detect menu. When CI, FC, or the extension telephone off-hook is detected from the modular jack, the display changes from OFF to ON.

**g-2) Test Menu 2**

Test Menu 2 is selected by pressing the 2 key from the Line Detect menu. When a tonal frequency is detected from the modular jack, the display changes from OFF to ON and the received frequency is displayed. The frequency detection level can be set with the numeric keys.

<b>Numeric key</b>	<b>Detection level (dBm)</b>
0	-25.96~-3
1	-30.66~-3
2	-32.96~-3
3	-35.96~-3
4	-38.46~-3
5	-40.96~-3
6	-44.70~-3
7	-49.71~-3

**g-3) Test Menu 3**

Test Menu 3 is selected by pressing the 3 key from the Line Detect menu. When CNG is detected from the modular jack, the display changes from OFF to ON.

**g-4) Test Menu 4**

This item is not used. Do not select it.

## 4. SUPPLEMENTARY ITEMS FOR INSTRUCTION BOOK

### 4.1 Automatic Redial Interval

The automatic redial interval for this machine can be set from 2 to 99 minutes with the user data, but since this interval is counted the next time the clock display (in minutes) changes after the redial time arrives, there is an error of 0-59 seconds in the interval duration.

**Example:** At 18:50:02, it is time for automatic redialing and the automatic redial interval is 2 minutes. The redial interval is:

$$\begin{aligned} 18:51:00 - 18:50:02 &= 58 \text{ seconds} \\ 58 \text{ seconds} + 2 \text{ minutes} &= 2:58 \end{aligned}$$

Therefore, the redial interval is 2 minutes 58 seconds.

### 4.2 Superfine Communications

This machine has a superfine mode transmission function, but no reception function. Therefore, it can not receive from another one of these machines or from any other model with superfine mode.

### 4.3 Transaction Number

The transaction numbers for this machine start from 0001 for transmission and for 5001 for reception.

### 4.4 Side Cassette Recording Paper Size Setting

With this fax, letter recording paper can be loaded with the side cassette paper guides set to legal. Reception in this state is memory reception.

#### 4.5 Quick-on-line TX/Memory Reception Page Count

The capacity of the image memory and the number of pages that can be stored before memory expansion are as shown below.

	No. of pages (CCITT No. 1 chart)	Image memory capacity	Memory capacity for other than images (work area + reserved area)
Quick-on-line Tx	approx. 16 pages	192 kbytes	192 kbytes + 128 kbytes
Memory reception when the paper runs out during reception	approx. 18 pages	288 kbytes	192 kbytes + 32 kbytes

Expanding item memory adds 512 kbytes to the capacity, and increases the communications capacity as follows.

	No. of pages (CCITT No. 1 chart)	Image memory capacity	Memory capacity for other than images (work area + reserved area)
Quick-on-line Tx	approx. 22 pages	704 kbytes	192 kbytes + 128 kbytes
Memory reception when the paper runs out during reception	approx. 50 pages	800 kbytes	192 kbytes + 32 kbytes



This machine uses 192 kbytes as a work area (for image processing, communications related tasks, etc.) It also has another 128-kbyte reserved area.

The purpose of the reserved area is to enable memory reception even when all the image memory is used.

# ***Chapter 3***

## ***Technical Reference***

# 1. SPECIFICATIONS

## 1.1 Device Overview

This machine is a G3 facsimile transceiver conforming to the ITU-T (formally CCITT) international standards.

### Main features



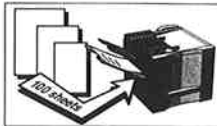
#### Ultra High Quality (UHQ) image

Canon's ultra-high quality image processing produces excellent reproductions in documents you send and copy.



#### Laser beam printer

Quiet, clean laser technology guarantees quality reproduction.



#### Universal cassette & 500-sheet front cassette\*

The side cassette can be adjusted to fit a variety of paper sizes, Easy access to the cassette for refilling with paper.  
The front cassette\* can be installed with up to 500 sheets letter-size paper.

\* Optional for LASER CLASS<sub>0</sub> 5000



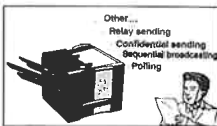
#### Automatic dialing

Includes One-touch and Coded Speed Dialing, as well as group dialing which allows you to send the same document to several destinations at the touch of a key.



#### FAX/TEL auto switch over

Switches automatically between document receiving and telephone ringing. The fax can receive documents automatically without ringing, or ring to alert you to pick up the handset when the call is a telephone call.



#### Variety of send and receive features

Includes multiple broadcasting, polling, relay sending and receiving, and confidential mailbox sending and receiving. These features can now be registered with the speed dialing features.

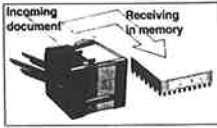


#### ECM send and receive

ECM (error correction mode) reduces errors during sending and receiving on noisy or poor quality telephone lines.

Figure 3-1 Instruction Book Page vi





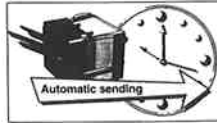
**Memory receiving when you run out of paper**

If you run out of paper while you are receiving a document, the fax continues to receive by putting the remainder of the document in the fax memory so you can print it out after you refill the paper cassette.



**Answering machine connection**

You can connect an answering machine to your fax to take voice messages and receive documents. A handy feature if you have only one telephone line coming into your office.



**Delayed sending**

Scans a document into the memory and set it to be sent at a later time so you can take advantage of holiday or late night telephone rates.



**Dual access**

Even while you are sending or receiving a document, you can continue to use the fax to register information with the fax or record documents into the memory.



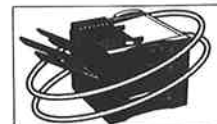
**Quick-on-line TX**

Scans the document quickly into the memory and starts sending the document before scanning is finished. You can walk away from the fax with your original document without waiting for the fax to scan and send every page.



**Easy to use**

A larger display and control panel with larger keys makes the fax easier to use.



**Economical and quiet**

Canon's RAPID Fusing System™, realizes quiet operation while you save money. The fan remains shut down until you start to use the facsimile unit. When operation is completed, the fan and head element shut down again. You can also use recycled paper in this fax.

Figure 3-2 Instruction Book Page vii

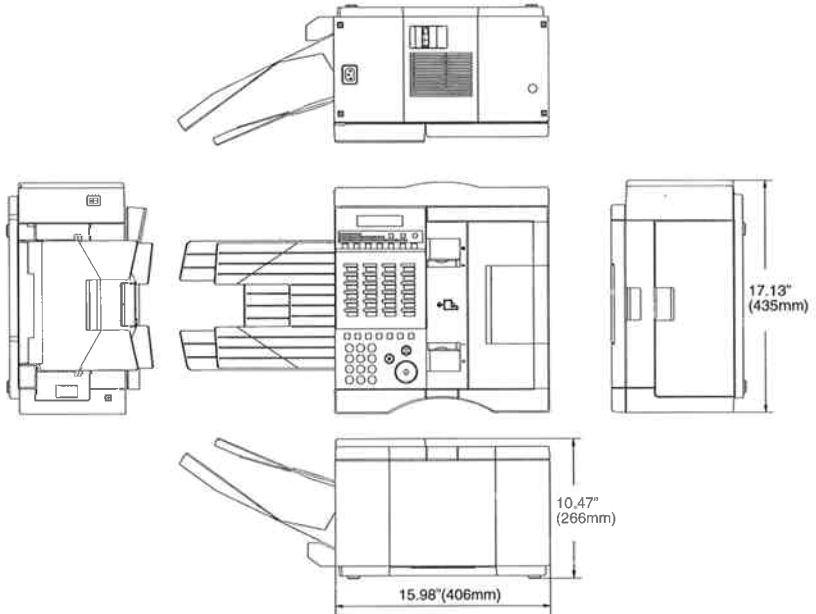
## 1.2 Configuration and Structure

### 1.2.1 Product name

LASER CLASS 5000/5500 laser beam printer recording G3 LTR facsimile

### 1.2.2 External View

#### a) LASER CLASS 5000



**Figure 3-3 External View (LASER CLASS 5000)**

b) LASER CLASS 5500

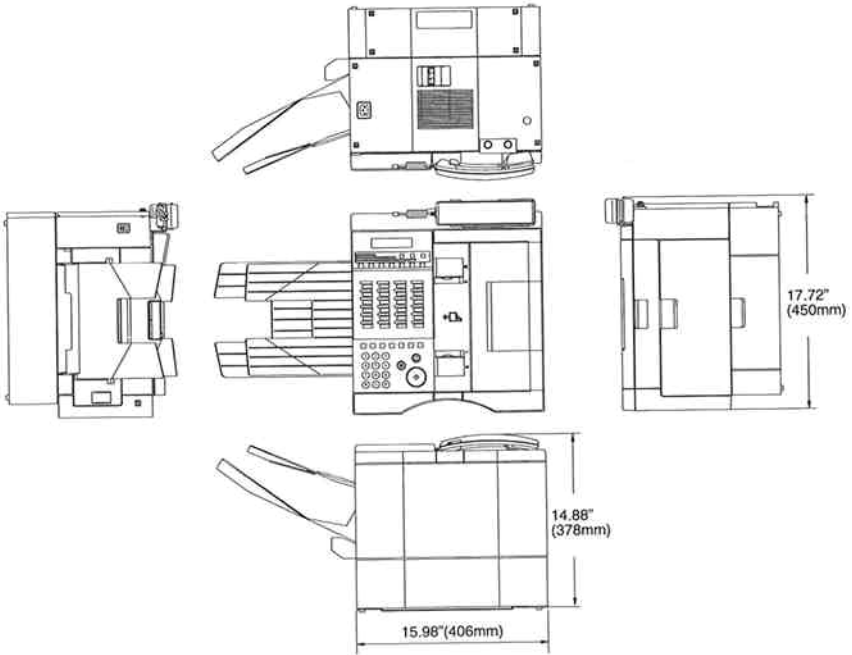


Figure 3-4 External View (LASER CLASS 5500)

### 1.2.3 Mechanical configuration

#### a) Main unit

- Structural sections: frame, motors, rollers, covers, others (sensors etc.)
- Control section: SCNT board
- Scanner section: CS unit
- Printing section: Laser beam printer unit
- Operation section: OPCNT board
- Power supply section: Power supply unit
- Line interface section: NCU board

#### b) Accessories

- Exit tray
- Document tray
- Modular jack cord
- Side cassette
- Power cord
- Destination labels
- Instruction book
- Warranty registration card
- Limited warranty note
- Installation completion report
- Front cassette (LTR) \*1
- Front cassette feeder 1 \*1
- Handset (CT-15) \*1
- Handset rest \*1
- Handset rest screws \*1

\*1 LASER CLASS 5500

#### c) Option: FXL-CASSETTE 1 LTR/500\*

Structural section: Covers

Accessories: Front cassette (LTR)

#### d) Option: FXL-FEEDER 1\*

Structural section: frame, motors, rollers, covers, others (sensors etc.)

Accessories: Front cassette feeder 1, screws, installation manual

#### e) Option: HANDSET Kit 2\*

Accessories: Handset (CT-15), handset rest, screws

#### f) Option: G3 FAX OPTION MEMORY II (0.5M-BYTE)\*

Accessories: 0.5M-Byte DRAM 1

\*Only for LASER CLASS 5000

## 1.3 Specifications and Functions

### 1.3.1 Basic specifications

#### Model

Desktop facsimile transceiver

#### Body color

Art-gray

#### Product life

50,000 sheets reception/transmission copy, or 5 years

#### Applicable Power Source

Allowable voltage 85-135 Vac

Allowable frequency 48-62 Hz

#### Power consumption

Standby Approx. 13 W

Operating Approx. 480 W (100% darkness document copying)

#### Operating environment

Temperature 50 °F - 90.5 °F (10 °C - 32.5 °C)

Humidity 20% - 80% relative humidity

Atmospheric pressure 532 - 760 mmHg

Horizontality  $\pm 5^\circ$

#### Noise levels

Measured accordance with ISO guidelines

Standby 35 dB(A) max.

Transmission 53 dB(A) max.

Direct transmission 50 dB(A) max.

Reception 50 dB(A) max.

Copy 50 dB(A) max.

#### External dimensions

15.98" (W)  $\times$  17.12" (D)  $\times$  10.47" (H) (406  $\times$  435  $\times$  266 mm)

Including protrusions from control panel, no handset

15.98" (W)  $\times$  17.72" (D)  $\times$  14.88" (H) (406  $\times$  450  $\times$  378 mm)

(LASER CLASS 5500)

#### Weight

30.64 lbs \*1 (13.9 kg)

Including document tray or exit tray, but without cartridge or recording paper

\*1 45.19 lbs (20.5 kg) (LASER CLASS 5500)

## 1.3.2 Communications Specifications

### Applicable lines

Analog line (1 line)

- . Public switched telephone network line (PSTN)
- . PBX

### Handset

Handset with no numeric keys (CT-15)

### Transmission method

Half-duplex

### Transmission control procedure

ITU-T (formely CCITT) T30 binary protocol/ECM

Canon Express Protocol (CEP)

### Modulation method

G3 image signals

ITU-T (formely CCITT) V27ter (2400 bps, 4800 bps)

ITU-T (formely CCITT) V29 (7200 bps, 9600 bps)

G3 procedure signals

ITU-T (formely CCITT) V21 (No. 21) 300 bps

### Transmission speeds

9600 bps, 7200 bps, 4800 bps, 2400 bps

With automatic fallback function

### Encoding

MH, MR, ECM-MMR

### Error correction

ITU-T (formely CCITT) ECM

**Time required for document transmission time**

Time required to transmit a CCITT No. 1 chart (excluding time for transmission protocol)

<b>Format</b>	<b>Standard</b>	<b>Fine</b>	<b>Superfine</b>
ECM-MMR	Approx. 9 s	Approx. 15 s	Approx. 28 s
G3-MR	Approx. 12 s	Approx. 24 s	Approx. 40 s
G3-MH	Approx. 15 s	Approx. 29 s	Approx. 60 s

**Time required for transmission protocol**

<b>Mode</b>	<b>Post-message protocol*1</b>	<b>Post-message protocol*2 (between pages)</b>	<b>Post-message protocol*3 (after last pages)</b>
Standard/fine	Approx. 12 s	Approx. 4 s	Approx. 3.5 s
New Canon Express Protocol	Approx. 2 s	Approx. 1 s	Approx. 1 s
Old Canon Express Protocol	Approx. 9 s	Approx. 1 s	Approx. 1 s

\*1 Pre-message: The time from when the other fax is connected to the line until the shift to image transmission

\*2 Post-message (between pages): Multiple pages are being transmitted, the protocol between each page of image transmission.

\*3 Post-message (after last pages): Image transmission has been completed, to disconnection.

**Minimum transmission time**

<b>Mode</b>	<b>Tx</b>	<b>Rx</b>
Standard	10 ms	10 ms
Fine	5 ms	5 ms
ECM	0 ms	0 ms

**Transmission output level**

0 to -15 dBm

**Reception input level**

-3 dBm to -43 dBm

**Modem IC**

Rockwell R96DFXL

### 1.3.3 Document Scanner Specifications

#### Document type

Sheet

#### Document dimensions

Maximum document	Width 8.5" × length 14" (Width 215.9 mm × length 355.9mm)
Minimum document	Width 5.83" × length 4.13" (Width 148 mm × length 105 mm)
Thickness	0.00236" - 0.00512" (0.06 - 0.13 mm)

#### ADF document loading

A4/letter-size documents	30 pages max. (depending upon paper quality)
Legal-size documents	5 pages max. (depending upon paper quality)

#### Document eject stacking

A4/letter-size documents	30 pages max. (depending upon paper quality)
Legal-size documents	5 pages max. (depending upon paper quality)

#### Effective reading

A4 document	8.19" (208 mm)
Letter-size document	8.42" (214 mm)
Legal-size document	8.42" (214 mm)

#### Scanning method

Contact scanning method (using letter-width contact sensor unit)

#### Scanning resolution

**Horizontal:** 8 pels/mm (203.2 dpi)

**Vertical:**

Standard	(97.79 dpi) 3.85 line/mm
Fine	(195.58 dpi) 7.7 line/mm
Superfine	(391.16 dpi) 15.4 line/mm

#### Scanning speed

5 ms/line

CCITT No. 1 Chart scanning

Standard	6 seconds/page
Fine	12 seconds/page
Superfine	24 seconds/page



**Memory scanning**

Scanning CCITT No. 1 Chart in standard resolution

Standard max. 12 pages approx. (LASER CLASS 5500: 44)

Memory expanded max. 44 pages approx.

**Copy resolution**

Fine mode (can be changed with service data)

**Scanning magnification**

Horizontal 100%

Vertical 100%

**Copy magnification ratio (on recording paper)**

Horizontal 100%

Vertical 90, 100% (100% for direct copy)

**Scanning density adjustment**

3 gradations (Light, regular, dark; each density level can be selected by the user from 7 gradations)

**Picture modes**

Binary Black-and-white text

AA Mixed photographs and text

Document Select from one of the following five

. Half-tone: photographs

. Blueprint: blueprints

. Trace: tracing paper documents

. Line marker: shows blue or green line markers as gray

. Inverse: Inverts the black and white portions of the document

**Intermediate tone method**

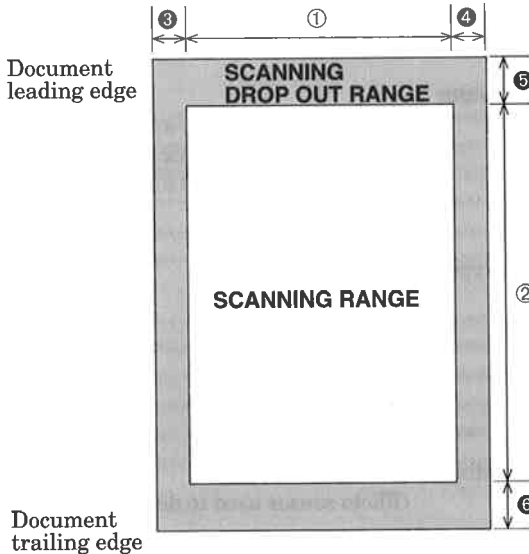
64-gradation error diffusion method (UHQ IV)

**Scanning range**

Including readable area + document feed precision, excluding skew.

Item	A4 document	Letter-size document	Legal-size document
① Effective scanning width	8.09" (205.5 mm)	8.32" (211.4 mm)	8.32" (211.4 mm)
② Effective scanning length	11.54" ±0.16" (293 ±4 mm)	10.84" ±0.16" (275.4 ±4 mm)	13.84" ±0.16" (351.6 ±4 mm)
③ Left margin	0.04" ±0.12" (1 ±3 mm)	0.04" ±0.12" (1 ±3 mm)	0.04" ±0.12" (1 ±3 mm)
④ Right margin	0.04" ±0.14" (1 ±3.5 mm)	0.04" ±0.14" (1 ±3.5 mm)	0.04" ±0.14" (1 ±3.5 mm)
⑤ Leading edge margin	0.08" ±0.08" (2 ±2 mm)	0.08" ±0.08" (2 ±2 mm)	0.08" ±0.08" (2 ±2 mm)
⑥ Trailing edge margin	0.08" ±0.08" (2 ±2 mm)	0.08" ±0.08" (2 ±2 mm)	0.08" ±0.08" (2 ±2 mm)

Units are inches with mm shown in brackets.



**Figure 3-5 Scanning Range**

### **1.3.4 Printer section specifications**

#### **Recording format**

Fixed size plain paper

Fixed size recycled paper

#### **Recording paper dimensions**

A4	8.27" × 11.69" (210 (W) × 297 (L) mm)
Letter	8.50" × 10.98" (216 (W) × 279 (L) mm)
Legal	8.50" × 10.07" (216 (W) × 256 (L) mm)
Weight	64-90 g/m <sup>2</sup>

#### **Recording paper cassette capacity**

Side cassette

A4/letter/legal Max. 100 sheets, or stacked to a height of 10 mm max.

Front cassette

Letter Max. 500 sheets, or stacked to a height of 50 mm max.

#### **Recording paper ejection capacity**

A4/letter	Approx. 250 sheets
Legal	Approx. 100 sheets
Letter/legal mixed	Approx. 100 sheets

#### **Effective recording width**

A4	8.01" × 11.42" (203.5 (W) × 290 (L) mm)
Letter	8.24" × 10.72" (209.4 (W) × 272.4 (L) mm)
Legal	8.24" × 13.72" (209.4 (W) × 348.6 (L) mm)

#### **Printing method**

Laser beam printer type

#### **Recording cartridge**

Product code	H11-6321
Product name	Canon FX 2 Cartridge

#### **No toner detection**

Reception/copy recording Toner out detected.  
(Photo sensor used to detect toner in cartridge)

**Recording speed**

Recording speed Pickup from side cassette: Approx. 3.8 sheets/min.  
(Copying CCITT No. 1 Chart)  
Pickup from front cassette: Approx. 4 sheets/min.  
(Copying CCITT No. 1 chart)

**Recording density**

Horizontal density	203.2 dpi (8 pels/mm)	Fine/standard
Vertical density	195.58 dpi * <sup>1</sup> (7.7 line/mm)	Fine
	97.79 dpi * <sup>1</sup> (3.85 line/mm)	Standard

\*<sup>1</sup> Can be changed to 391.16 dpi (15.4 line/mm) with smoothing feature.

**Printing magnification**

Horizontal direction	100%
Vertical direction	90, 100%

**Smoothing**

Vertical density of documents received in standard or fine resolution is changed to 391.16 dpi (15.4 line/mm).

**Recommended recording paper**

Canon Np Copier Paper Dry Toner A4

Weight	80 g/m <sup>2</sup>
Paper size	A4
Manufacturer	Kangas

Canon Copy Paper for Dry Toner Copies

Weight	80 g/m <sup>2</sup>
Paper size	A4
Manufacturer	Neusiedler

Copier LTR Premium Paper

Weight	75 g/m <sup>2</sup>
Paper size	LETTER
Manufacturer	Boise Cascade

Copier LGL Premium Paper

Weight	75 g/m <sup>2</sup>
Paper size	Legal
Manufacturer	Boise Cascade

**Recording range**

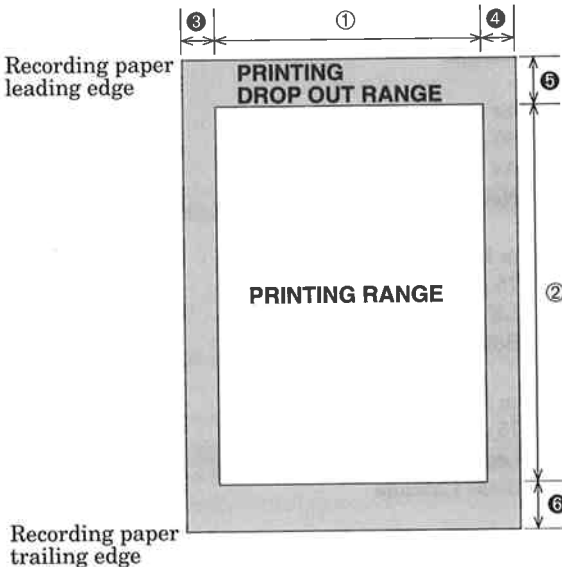
Including printable area + document feed precision, including skew

Item paper	A4 recording paper	Letter recording paper	Legal recording paper
① Effective recording width	8.01" (203.5 mm)	8.24" (209.4 mm)	8.24" (209.4 mm)
② Effective recording length	11.42" ±0.12" (290 ±3 mm)	10.72" ±0.12" (272.4 ±3 mm)	13.72" ±0.12" (348.6 ±3 mm)
③ Left margin	0.08" ±0.10" (2 ±2.5 mm)	0.08" ±0.10" (2 ±2.5 mm)	0.08" ±0.10" (2 ±2.5 mm)
④ Right margin	0.08" ±0.18" (2 ±4.5 mm)	0.08" ±0.18" (2 ±4.5 mm)	0.08" ±0.18" (2 ±4.5 mm)
⑤ Leading edge margin	0.12" ±0.12" (3 ±3 mm)	0.12" ±0.12" (3 ±3 mm)	0.12" ±0.12" (3 ±3 mm)
⑥ Trailing edge margin	0.16" +0.20/-0.16" (4 +5/-4 mm)	0.16" +0.20/-0.16" (4 +5/-4 mm)	0.16" +0.20/-0.16" (4 +5/-4 mm)

Units are inches with mm shown in brackets.



The header and footer are printed in the recording range.



**Figure 3-6 Printing Range**

### 1.3.5 Communication functions

#### Auto dial function

One-touch destinations	max. 24
Coded speed dialing destinations	max. 100

#### Delayed transmission

Transmits to a designated address at a designated time.

One touch locations	Max. 24
Coded speed dial locations	Max. 100
Numeric key desitinations	Max. 5
Reservations 8 (LASER CLASS 5500: 30)	
With expanded memory	30

#### Polling

##### Polling reception

Receives from a fax in automatic transmission mode

Polling ID	3-digit decimal with password
000: disabled	
255: No ID match required	
One touch locations	Max. 24
Coded speed dial locations	Max. 100
Numeric key desitinations	Max. 5

##### Polling transmission

The document is accumulated into memory ahead of time, then transmitted when there is a polling request from the other party.

##### Broadcast transmission function

Locations	One touch: Max. 24; Coded: Max. 100; Ten key: Max. 5
Group key locations	One touch: Max. 23; Coded: Max. 100

##### Confidential function

###### Confidential transmission

Sends transmission images to receiving fax machines with the confidential reception function for memory reception.

Box No. 00-99	
Destinations	Max. 129 (normal)
	Max. 123 (group key registered)
Confidential box master password	4559769

###### Confidential reception

Memory reception of images from a transmitting fax that has the confidential transmission function.

Boxes	Max. 30
Operation password	4 digits

**Relay broadcasting originating**

Box No.	00-99
Locations	Max. 129 (normal)
	Max. 123 (group key registered)

**Auto dialing**

Redial interval	2 - 99 min. (variable)
Redial count	1 - 99 times (variable)

**Memory reception**

When receiving CCITT No. 1 Chart	
Receive	Max. 12 pages (LASER CLASS 5500: 44)
Memory expanded	Max. 44 pages

**Dual access**

On-line operations and off-line operations can be accessed simultaneously.

**Remote reception**

You can receive by inputting the ID from the extension telephone and putting the extension telephone on-hook.

ID No.	25
ID length	2 digits

**Program key**

The document mode for scanning or a transmission result report can be registered with the program key.

Count 1

**Memory reception alert**

The fax error alarm sounds continuously to alert the operator that a document has been received in memory.

**Reception picture reduction**

All received images can be reduced by setting 90% reduction in USER DATA.

**Reception footer**

The date, time, Rx transaction No., Page No. are printed at the bottom of each received image.

**Time-sharing dial**

If one transmission is to be redialed, when the time is reached for the next reserved transmission, that reserved transmission is started.

### Restricting document sending and printing

Communications and copying are enabled by inputting a password.

### Stopping unwanted direct mail

A fax is only received if the telephone number specified by the TSI signal of the transmitting fax is registered for one-touch or coded speed dialing.

### Print in <sup>reverse</sup> order (only for LASER CLASS 5500 with expanded memory)

The received images can be output from the last page.

### Quick on-line Tx

Transmission can be started while the document is being scanned and the time until transmission can be shortened.

### Activity management

Activity report (After every 40 transactions can be divided according to Tx/Rx, or by sender.)

Tx/Rx report (After every transaction)

Error transmission report

Confidential reception report

Confidential memory report

One-touch speed dial list 1

One-touch speed dial list 2

Coded speed dial list 1

Coded speed dial list 2

Group dial list

User's data list

Multi transaction report

Transmission reserve list

Error Tx Report

Document memory list

Memory clear report

System data list

System dump list

### Sender identification

Records:	Time, tel number (20 digits), Tx page count (3 digit), destination, sender's name
Addresses:	Input with one-touch keys (24 up to 16 characters long)
Sender's name	9 to 24 characters long. Selected by the operator.

### Automatic transmission function

Signal types:	Pulse dial or tone dialing
Signal speed:	Pulse dial



Dialing memory: Max. 120 digits  
Address destination : One-touch key: Max. 24  
Coded dial: Max. 100

**Manual transmission**

Numeric key dialing

**Redial**

Pressing Redial key redials the last number dialled by numeric keys.

**FAX/TEL switching**

System Automatic CNG detection  
Message None  
Pseudo-CI None  
Pseudo bell Yes  
Remark 400-Hz pseudo-ringback tone transmitted to line.

**DRPD (Distinguish Ringing Pattern Detection)**

DRPD allows the unit to recognize five incoming ringing signal pattern and respond according to the user settings.

For example, the machine may be set for fax reception when the standard ringing signal is detected, and set for regular telephone reception when the double ringing signal is detected.

A user's telephone number and user's ID can be registered for each ringing pattern.

**Data backup**

Contents Dialing registration, user data, service data,  
clock, communications management report  
IC 256-kbit SRAM  
Battery Lithium battery 3.0 VDC/560 mAh  
Battery life Approx. 5 years

**Image memory**

Standard 0.5 M-Byte DRAM (LASER CLASS 5500: 1.0 M-Byte)  
Expanded 1.0 M-Byte (standard 0.5 M-Byte + optional 0.5 M-Byte)  
DRAM

**Clock**

Data Year/month/day/day of week/hour/minute  
(24-hour display)  
Accuracy ± 30 seconds/month

**Display**

LCD 20 digits/characters × 2 rows

**This page intentionally left blank**

## 2. OPERATIONS

### 2.1 Product Overview

#### 2.1.1 Fax main unit overview

This fax operates on ordinary 120 VAC household current and has fax, telephone, and copy functions.

The communication functions include 9600-bps G3 transmission with ECM, contact sensor scanning with an ADF that can consecutively transmit multi-page documents, and a laser beam printer that can print on plain paper.

The telephone has an accessory handset\*<sup>1</sup> and a modular jack for connecting an extension telephone set.

The copy function is multi-copy\*<sup>1</sup>, and can make up to 99 copies of scanned documents.

\*<sup>1</sup> Only for LASER CLASS 5500

#### 2.1.2 Option overview (Only for LASER CLASS 5000)

##### a) Front cassette feeder

##### b) Front cassette

With the front cassette feeder installed in the bottom of the main unit and a front cassette installed in the pickup cassette feeder, this fax operates as a two-cassette machine.

A cassette can hold up to 500\*<sup>2</sup> pages of letter-size recording paper at a time. For example, if letter-size recording paper is loaded in the front cassette and legal-size recording paper is loaded in the side cassette, the paper appropriate to the document received can be fed.

Also, if the same size paper is loaded into both cassettes, up to 600 pages can be printed on one loading.

\*<sup>2</sup> Loaded paper height of 1.97" (50mm) max.

##### c) 0.5MB memory kit

When one 512-KB DRAM is installed, the total of memory scan pages + memory reception pages is from 12 pages to a maximum of 44 pages\*<sup>3</sup>.

\*<sup>3</sup> Measured with CCITT No.1 Chart

##### d) Handset kit

Installing the handset enables the telephone functions to be used.

#### 2.1.3 Consumables

##### a) Toner cartridge

FX 2

**Main unit**

LASER CLASS 5000

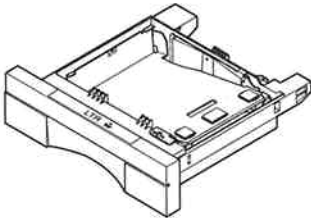


LASER CLASS 5500

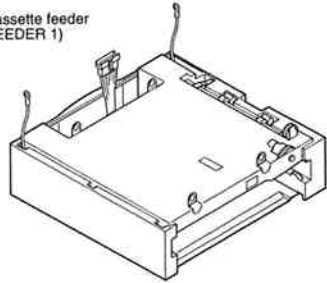


**Option (LASER CLASS 5000 only)**

Front cassette  
(FXL-CASSETTE 1 LTR/500)



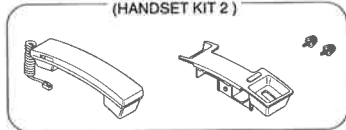
Front cassette feeder  
(FXL-FEEDER 1)



0.5MB memory kit  
(G3 FAX OPTION MEMORY II)

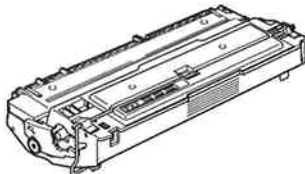


Handset kit  
(HANDSET KIT 2)



**Consumables**

Toner cartridge  
(FX 2)



**Figure 3-7 Overview**

## **2.2 Structural Section Overview**

### **2.2.1 Unit layout diagram**

The structural sections of this fax are the scanner section, the pickup section, and the printer section.

#### **a) Scanner section**

The scanner section has an ADF (auto document feeder) function and can automatically feed 30 pages of a letter-size document (5 for legal size). The scanning is done by contact sensor (CS) and can scan 6 seconds/page (standard). Approx. 12 pages of the CCITT No. 1 Chart can be stored in the memory of this fax.

#### **b) Pickup section**

The pickup section feeds recording paper from a cassette to the printer section. The universal cassette type side cassette can hold up to 100 pages at a time, or paper to a maximum height of 0.39" (10 mm), whichever is the lesser, and the guide positions can be adjusted for letter, A4, and legal paper sizes. The recording paper is fed into the printer unit one page at a time, powered by the main motor.

#### **c) Printer section**

The printer section uses a new laser beam printer engine, originally designed for computer peripheral equipment.

### **2.2.2 Document and recording paper flow**

#### **a) Document flow**

When the document is inserted into the document insertion slot at the right of the main unit, it is fed by the loading roller to the separation roller and the separation guide, and one page at a time is separated. Then, the document is fed onto the contact sensor unit by the pickup roller, and ejected by the eject roller to the document delivery tray from the document outlet at the left of the main unit.

#### **b) Recording paper flow**

After one page of the recording paper is separated and fed by the pickup roller from the recording paper cassette, it is inverted by the feed roller and at the same time fed from the pickup section to the printer section. Then, after the recording paper is printed by the printer section toner cartridge and fixing section, the paper is ejected by the eject roller at the recording paper outlet on the left side of the main unit.

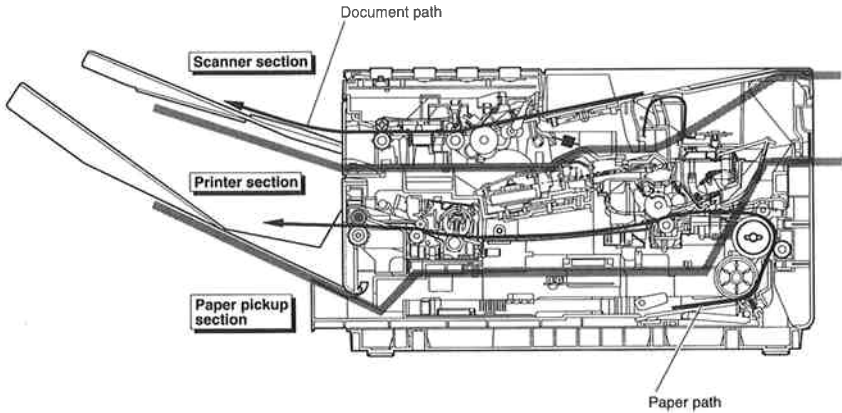


Figure 3-8 Cross-Section

### 2.2.3 Drive system layout

#### a) Scanner section

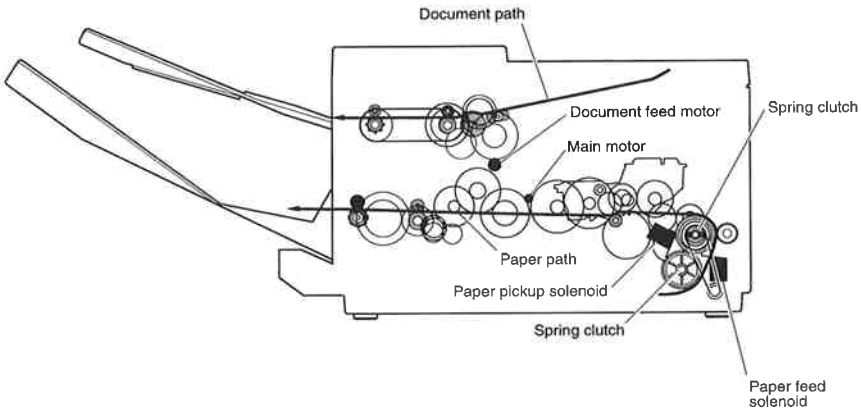
The power of the document drive motor is transmitted by gears to drive the pickup, separation, feed, and eject rollers.

#### b) Pickup section

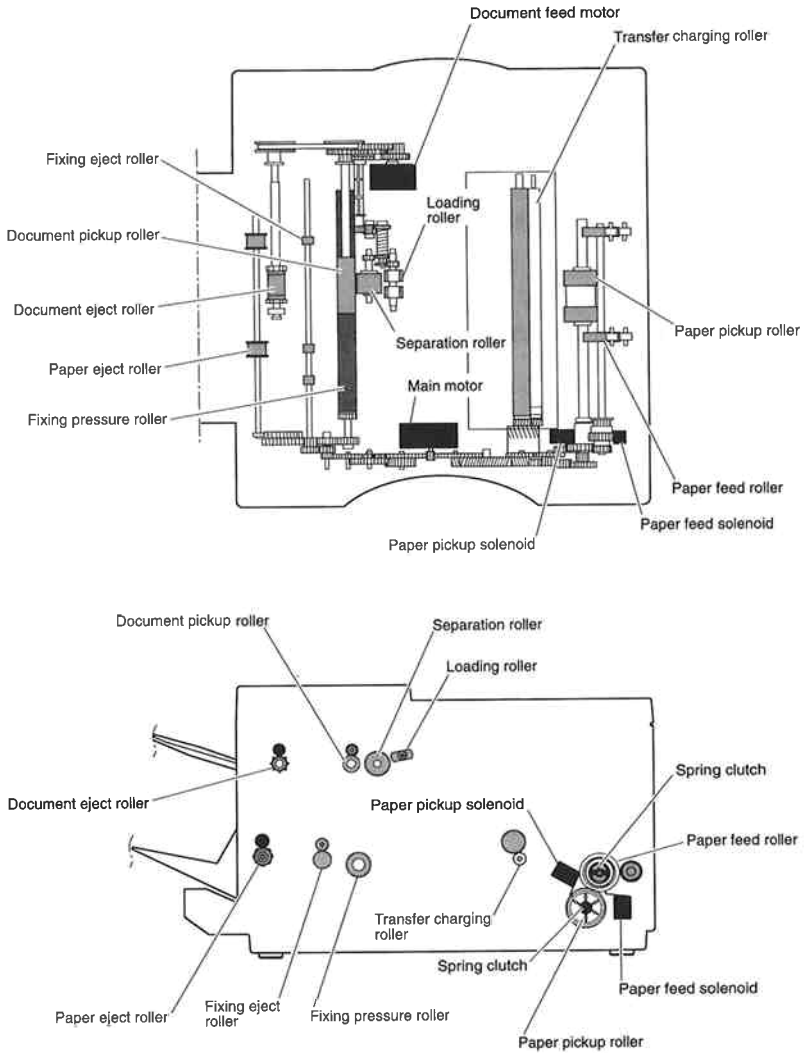
The power of the main motor is transmitted by gears to drive the recording paper pickup and feed rollers. The rotation of each roller, the pickup roller and the feed roller, is controlled by a solenoid and spring clutch.

#### c) Printer section

The power of the main motor is transmitted by gears to drive the transfer charging roller, the toner cartridge photo-sensitive drum, primary charging roller, and developing cylinder, and the fixing unit pressure roller and eject roller. The recording paper eject roller is driven by power transmitted by gear from the fixing unit eject roller.



**Figure 3-9 Drive Layout (Front View)**



**Figure 3-10 Drive Layout (Top View)**



## **2.2.4 Electrical system layout**

### **a) SCNT board**

The SCNT, which controls the fax machine as a whole is installed at the rear of the main unit.

### **b) NCU board**

The NCU board, which controls the telephone line is installed at the rear of the SCNT board at the rear of the main unit.

### **c) PCNT board**

The PCNT board, which drives the motors, solenoids, toner cartridge, and fixing unit used in the printer section, is installed at the bottom of the main unit.

### **d) OPCNT board**

The OPCNT board, which controls the control panel, is installed within the operation panel.

### **e) Power supply unit**

The power supply unit is installed in the left side of the SCNT board at the rear of the main unit.

### **f) LED board**

The LED board containing the toner detection LED is installed in the cartridge cover ass'y.

### **g) VR board**

The VR board that adjusts the toner detection LED light emitting current is installed in the front side of the fax.

### **h) Toner sensor board**

The toner sensor board, which detects when the toner runs out, is installed at the pickup section under the toner cartridge.



---

The LASER CLASS 5500 front feeder and handset have a drive board and TELCNT board. For details on these boards, see *Chapter 5: 2. OPTION*.

---

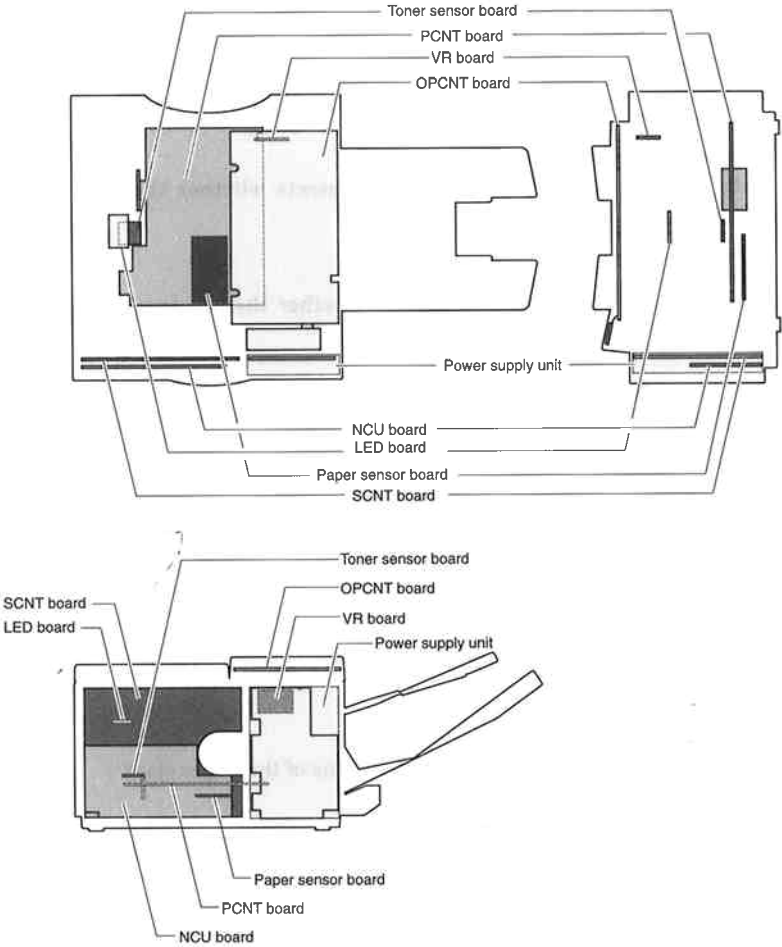


Figure 3-11 Electrical System Layout

## **2.2.5 Arrangement of sensors**

### **a) Document sensor**

Located on the ADF ass'y (upper) and detects whether there is document or not.

### **b) Document edge sensor**

Located on the ADF ass'y (upper) and detects whether there is document leading edge or not.

### **c) Panel sensor**

Located on the OPCNT board, detects whether the one-touch speed dialing panel is open or closed.

### **d) Recording paper sensor**

Located on the paper sensor board, detects whether there is recording paper or not in the side cassette.

### **e) Recording paper size sensor (A) / Recording paper size sensor (B)**

Located on the paper sensor board and detects that the side cassette is installed and the size of the recording paper in it.

### **f) Recording paper pickup sensor**

Located on the PCNT board, detects the status of the paper pickup and paper feed.

### **g) Recording paper eject sensor**

Located on the PCNT board, detects the status of the paper eject.

### **h) Recording paper jam sensor**

Located on the PCNT board, detects whether there is recording paper or not during power up.

### **i) Right cover sensor**

Located on the PCNT board, detects whether the right cover is open or closed.

### **j) Cartridge cover sensor**

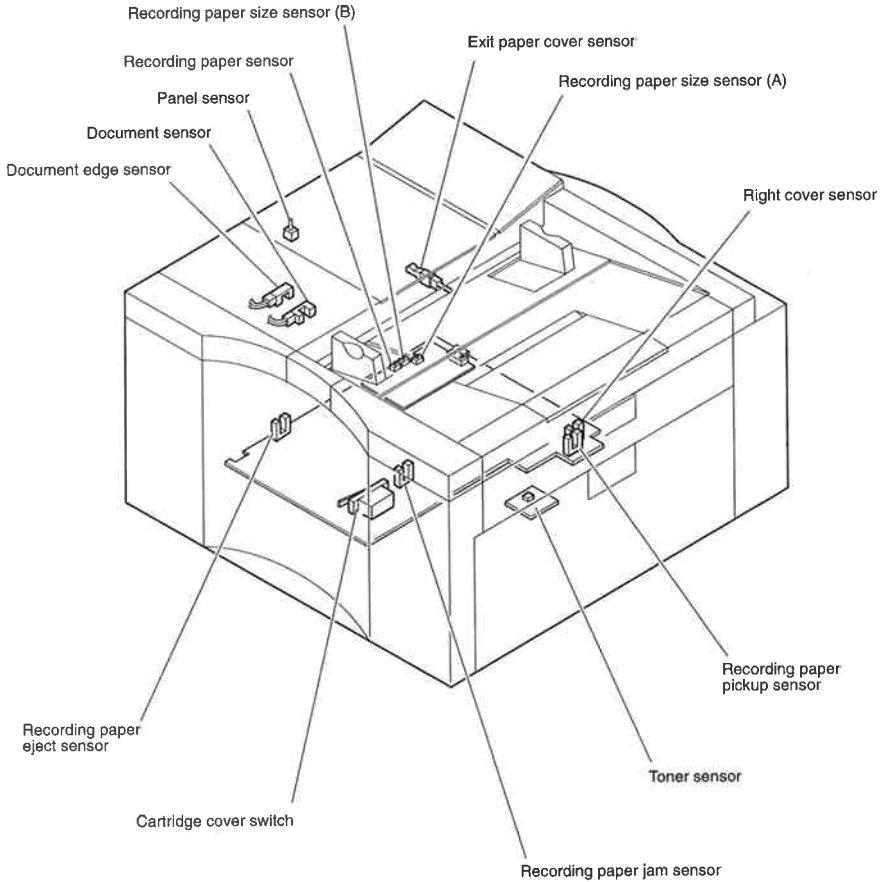
Located on the PCNT board, detects that the cartridge cover is closed and toner cartridge is installed.

### **k) Exit paper cover sensor**

Located on the printer frame, detects whether the exit paper cover is open or closed.

**l) Toner sensor**

Located in the paper feed section, detects whether there is toner in the toner cartridge or not.



**Figure 3-12 Arrangement of Sensors**

## 2.3 Scanner Section

The scanner section comprises the document feed section and the optical section.

### 2.3.1 Document feed section

#### a) Document feed function

##### a-1) ADF (auto document feed) function

The ADF feeds up to 30 pages\*1 of documents placed on the document table, separates each page with the separation roller and separation guide, passes the page over the contact sensor unit, then ejects the paper to the document exit tray.

\*1: Letter size: up to 30 pages, Legal size: up to 5 pages

##### a-2) Document jam detection function

The document jam detection function senses to detect eject paper jams and over-length documents with.

\*2: DES

#### b) Document feed section structure

##### b-1) ADF structure

In the ADF structure, the rollers needed for document pickup, document separation, document feed, and document ejection are driven via gears with the power for the stepping pulse type document feed motor. To prevent jams after the document is separated into single pages, the document pickup and document separation rollers switch the feed speed with a spring clutch.

The ADF is controlled by the SCNT board's main CPU counting the document feed motor step pulses, and the photo-interruptor type document edge sensor and document sensor\*3 equipped with actuator arms detecting the document feed status.

\*3: DS

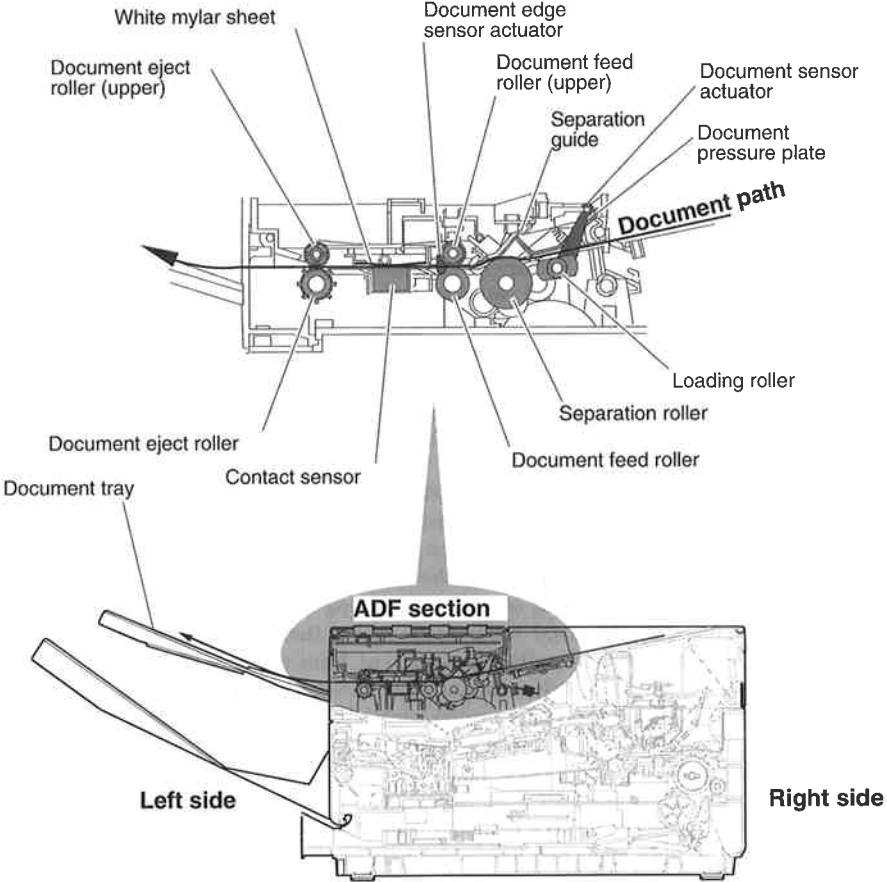


Figure 3-13 Document Feed Structure (Front View)



**ADF movement**

**(1) Document pickup operation**

When a document is inserted into the ADF section and pushes up the actuator of the document sensor, the loading roller feeds the document approx. 0.98" (25 mm), as far as the separation roller and the separation guide.

**(2) Document separation operation**

After the document is picked up, when the Start key is pressed, the separation roller and the separation guide separate one page of the document at a time from the bottom. The following relationships are employed in separation.

- Coefficient of friction between document and separation roller >
- Coefficient of friction between separation pad and document >
- Coefficient of friction between pages of the document

**(3) Document feed operation**

The separated document is fed to the optical section, where the contact sensor is, by the feed roller. When the leading edge of the document pushes up the actuator of the document edge sensor in the feed roller section, monitoring of the document length starts. Also the feed roller feeds faster than the document separation roller and pulls the document from the separation roller, so the spring clutch within the separation roller turns the separation roller and pickup roller together to equalize the feed speed of all the document feed section rollers.

**(4) Document scan operation**

The document is held down by the white mylar sheet from above, and stops just before the contact sensor scan position.

After the contact sensor detects the white level from the white mylar sheet\*<sup>1</sup>, the document passes over the contact sensor and is scanned.

\*<sup>1</sup> The white level is only detected for the first page of the document.

**(5) Document eject operation**

When the trailing edge of the document passes the feed roller, the actuator of the document sensor comes down and the document length monitoring ends. When the trailing edge of the document finishes passing the separation roller, the spring clutch lowers the feed speed of the separation roller and the pickup roller.

Then, the document is ejected into the document tray by the eject roller.

**b-2) Document jam detection structure**

The document edge sensor detects such document jams as pickup jams and no-paper jams/over-length documents.

A "pickup jam" means the document edge sensor can not detect the leading edge of the document, even after document separation operations start and the paper is fed for more than 15 seconds.

A "no-paper jam/over-length document" means the document edge sensor detects the leading edge of the document during document feeding and ejection, but cannot detect the trailing edge of the document even after more than 14" (355.9 mm) of paper has been.



---

**Document jam processing**

When a document jam occurs, the fax stops the document feed motor and stops ADF operations, displays the error on the display.

For a pickup jam, "**CHECK DOCUMENT**" is displayed on the display; for a no-paper jam/over-length document, "**DOCUMENT TOO LONG**" is displayed on the display.

When a document jam occurs, if the document is being copied, the image data read in and stored in memory are erased for all pages and print operations are stopped. If the document is being transmitted, the data remaining in memory at the point when the jam is detected are erased.

For memory transmission, if the transmission time for one page exceeds 32 minutes, "**DOCUMENT TOO LONG**" is displayed.

---



## **2.3.2 Optical section**

### **a) Optical section functions**

#### **a-1) Document scanning function**

The contact sensor (CS) scans in documents up to the width of letter-size paper (214 mm) with a horizontal scanning resolution of 8 pels/mm. The resolution of the vertical scanning, changes according to the document feed speed, selected with the Resolution button on the operation panel. The resolution is 3.85 pels/mm for standard mode, 7.7 pels/mm for fine mode, and 15.4 pels/mm for superfine mode. The image processing IC processes the scanned data in AA mode, line marker mode, trace mode (for tracing paper), blueprint document mode, negative-positive inverse mode, or half-tone mode.

#### **a-2) Prescan function**

The variation of the contact sensor output during document scanning is corrected by the prescan function.

#### **a-3) Automatic slice level setting function**

The image processing IC on the SCNT board contains an Automatic Background Control (ABC) circuit. Since the slice level is set for each line in the scanned image data to 60% of the maximum value for that line, documents are scanned with sharp contrast regardless of the document background.

### **b) Optical section configuration**

#### **b-1) CS (contact sensor)**

The contact sensors have a dust-proof structure to keep dust and dirt off the surface of the sensor and out of the sensor.

The contact sensor comprises the LED that emits the scanning light, the contact glass that refracts the scanning light and shines it on the document, the rodless array that collects the light reflected from the document, the photo transistor array that receives the reflected light, and the guide mylar that keeps the document from being caught on anything.

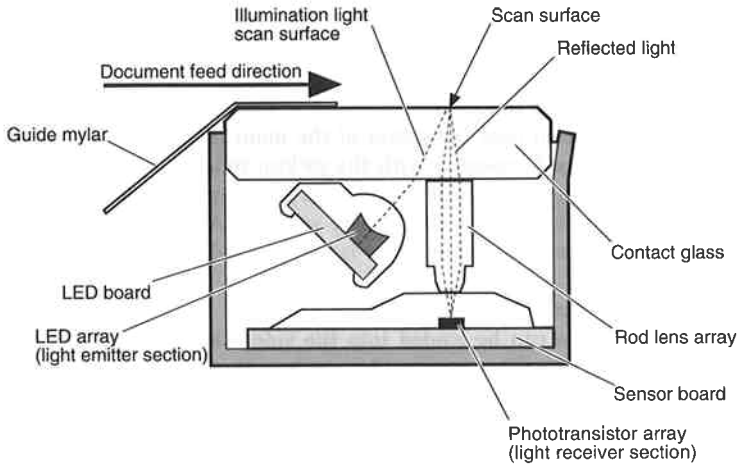
The LED array comprises 30 LEDs and is controlled by the SCNT board. The photo transistor array comprises 1738 photo transistors\*1 and contains 11 driver circuits that amplify the received light output for 158 LEDs each.

The output from these 11 driver circuits is converted into serial data and conveyed to the SCNT board.

\*1 Data beyond the scanning width detected by the document guides are not used.

#### **b-2) Prescan**

At the start of each communication, the prescan function reads in one line of the white mylar sheet pasted to the document feed section at the top of the contact sensor, stores the contact sensor output variation correction value into memory, and corrects contact sensor output for the image then read in.



**Figure 3-14 Contact Sensor (Cross-Section)**

## 2.4 Pickup Section

### 2.4.1 Recording paper pickup section

#### a) Pickup section functions

##### a-1) Cassette pickup function

The pickup section uses the power of the main motor to separate recording paper from the side cassette with the pickup roller and the separation pad, then feed it with the feed rollers through the U-turn paper path at the right of the main unit and into the printer section. After the optional feeder is added, the power of the main motor is transmitted to it by gears.

##### a-2) Universal recording paper cassette function

Up to 100 pages can be loaded into the side cassette at one time and the position of the movable paper guides can be adjusted for letter, A4, and legal size paper. The recording paper is picked up at the left position of the printer section print section.

##### a-3) Recording paper pickup jam detection function

When there is a recording paper pickup jam, this is detected by the recording paper pickup sensor\*1.

\*1 RPPS: Recording Paper Pickup Sensor

##### a-4) No recording paper detection function

When there is no recording paper in the side cassette, this is detected by the recording paper sensor\*2.

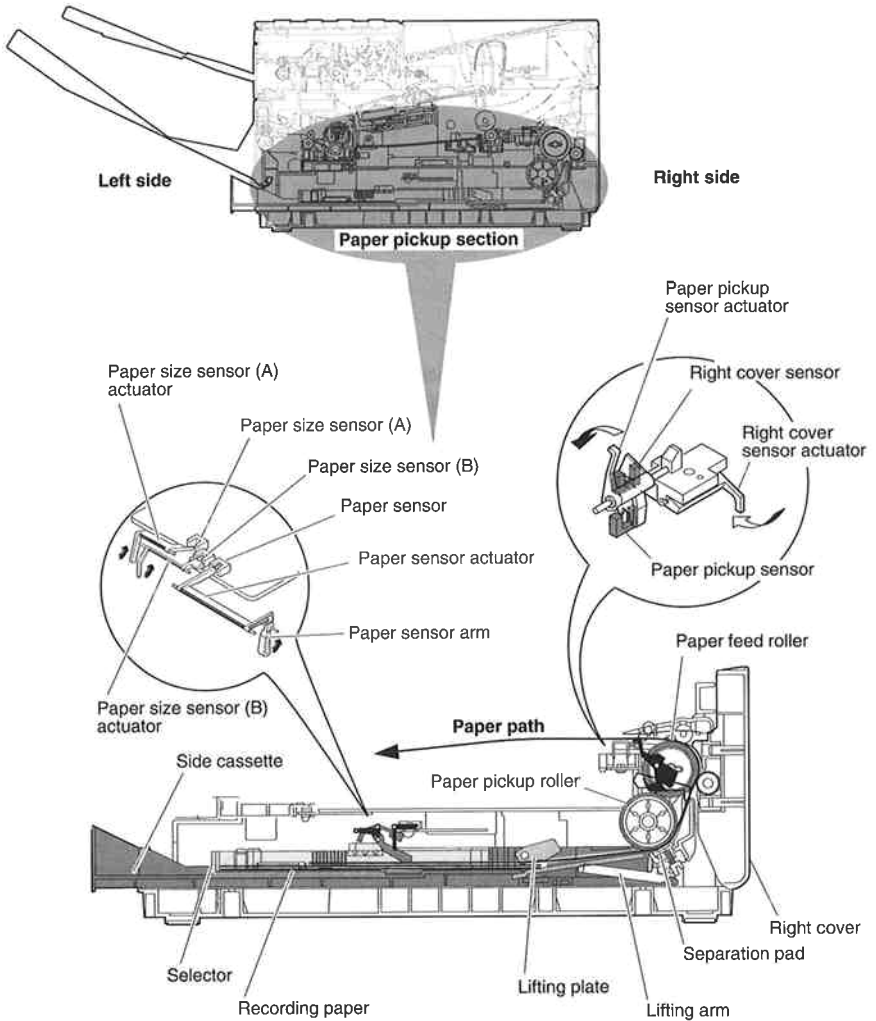
\*2 RPS: Recording Paper Sensor

##### a-5) Recording paper size and no cassette detection function

The size of the paper in the side cassette and the absence of the side cassette are detected by the recording paper size sensor (A)\*3 and the recording paper size sensor (B)\*4.

\*3 RPSS (A): Recording paper size sensor (A)

\*4 RPSS (B): Recording paper size sensor (B)



**Figure 3-15 Pickup Configuration**

## b) Pickup configuration

### b-1) Cassette pickup configuration

In the cassette pickup configuration, the recording paper pickup roller and the recording paper feed roller are driven with power transmitted by gears from the main motor, which is a stepping pulse type motor. The cassette pickup configuration is controlled by the PCNT board CPU counting the step pulses and the photo-interrupter type recording paper sensor equipped with an actuator arm monitoring the recording paper pickup status.



---

### Pickup operations

#### 1. Start of pickup

After the main motor rotation rate has reached a stipulated value, when the pickup solenoid spring clutch is released, the recording paper pickup roller turns  $7/8$  rotations, the lifting arm lifts up the lifting plate and the one page of recording paper held by the separation pad is picked up.

#### 2. Feed standby

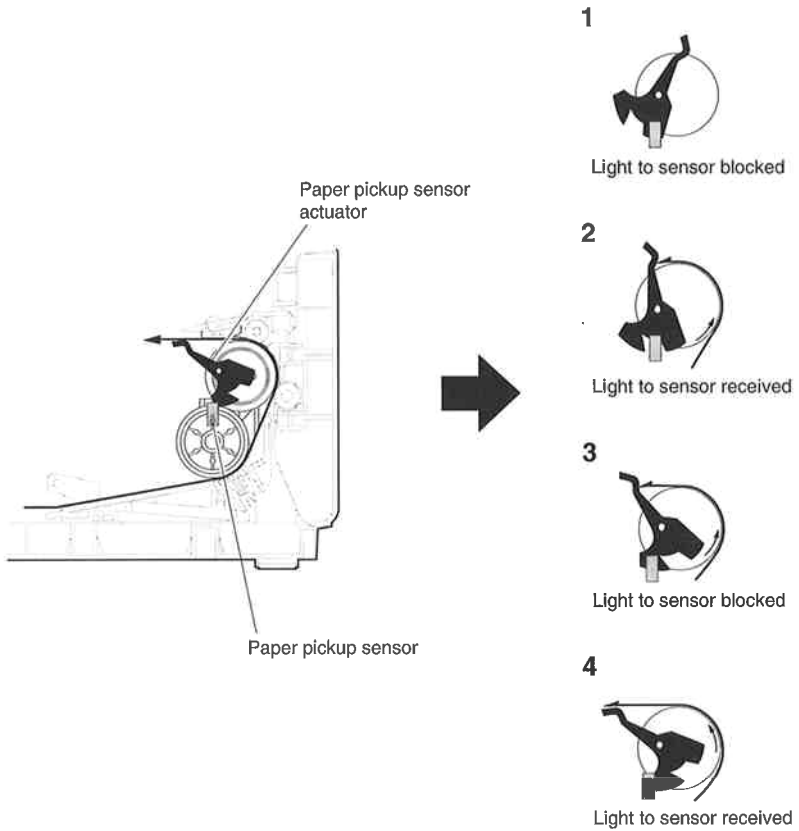
The recording paper is fed by the recording paper feed roller into the printer section and when the printer section recording paper pickup sensor detects the recording paper feed standby position (Point 3 in the figure on the next page), the feed solenoid stops and the feed stops. If the PCNT board CPU detects the Initial Rotation Ready state<sup>\*1</sup>, the feed solenoid doesn't stop and the feed continues.

<sup>\*1</sup> State where the scanner motor rotation rate and the fixing heater temperature have reached a stipulated value.

When copying, from the second page on, while the previous page is fed, the SCNT board printer interface IC sends the PRFD<sup>\*2</sup> signal (prefeed signal) to the PCNT board CPU to start paper pickup.

<sup>\*2</sup> PRFD: PRe-FeeD.

---



**Figure 3-16 Recording Paper Pickup Detection Configuration**

### b-2) Recording paper pickup jam detection configuration

Recording paper pickup jams are detected by the photo-interrupter type recording paper pickup sensor equipped with an actuator arm.

There are the following two types of recording paper pickup jams.

#### Recording paper pickup jam 1

A "recording paper pickup jam 1" means that the recording paper pickup sensor can not detect the leading edge of the recording paper within 9.8\*1 seconds of the pickup solenoid coming on.

\*1 When recording paper pickup from the feeder section: 11.9 seconds

#### Recording paper pickup jam 2

A "recording paper pickup jam 2" means that the recording paper pickup sensor cannot detect the trailing edge of the recording paper within 17.7 seconds of detecting the leading edge of the recording paper at Point 4 in the figure on the before page.



---

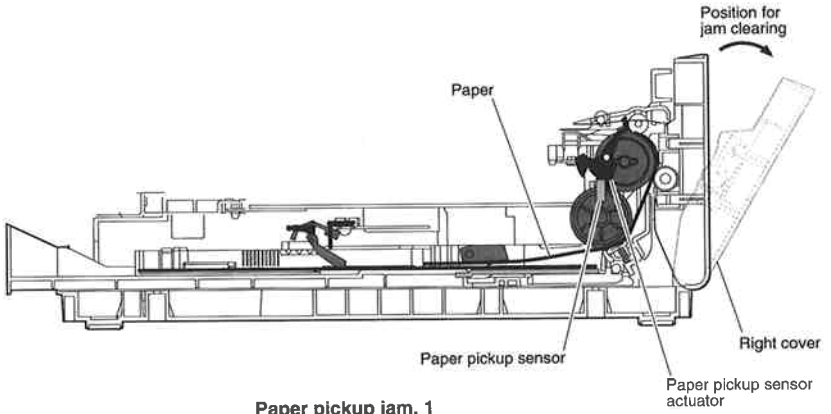
#### Recording paper pickup jam processing

When a recording paper pickup jam occurs, the main motor drive is stopped, print operations are stopped, the error is displayed on the display, and the REC. PAPER lamp blinks red.

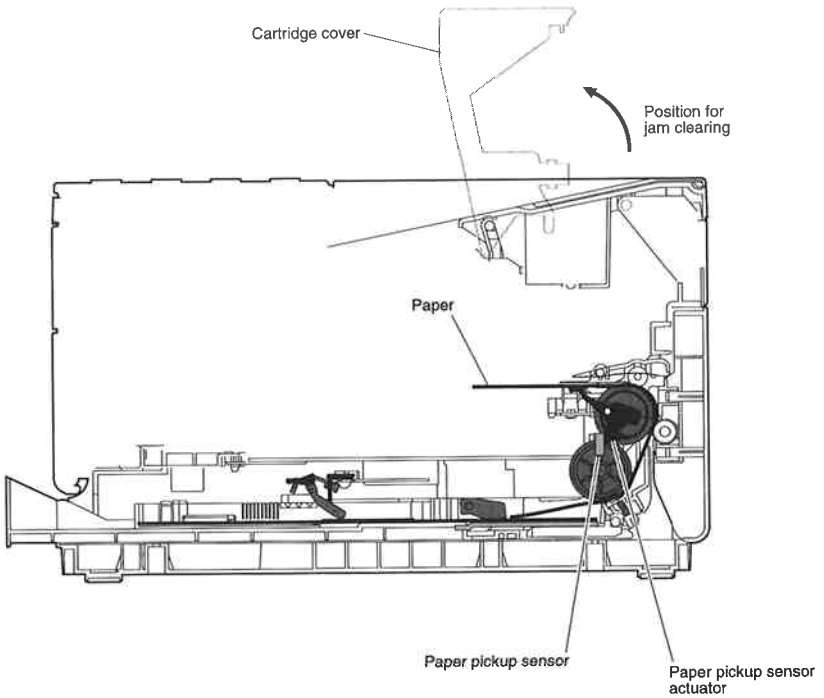
For recording paper jams, "REC. PAPER JAM" is displayed on the display. If the error occurs during reception, the reception images are received into memory starting from the page during which the error occurred, but if the error occurs during copying, the copy image is erased.

If the cartridge cover, the right cover, or the eject cover is opened during recording paper feed, this causes a recording paper jam.

---



Paper pickup jam. 1



Paper pickup jam. 2

Figure 3-17 Recording Paper Pickup Jam



**b-3) No recording paper detection configuration**

A "no recording paper error" means that the photo-interrupter type recording paper sensor equipped with an actuator arm detects that the side cassette has no recording paper.



---

**No recording paper processing**

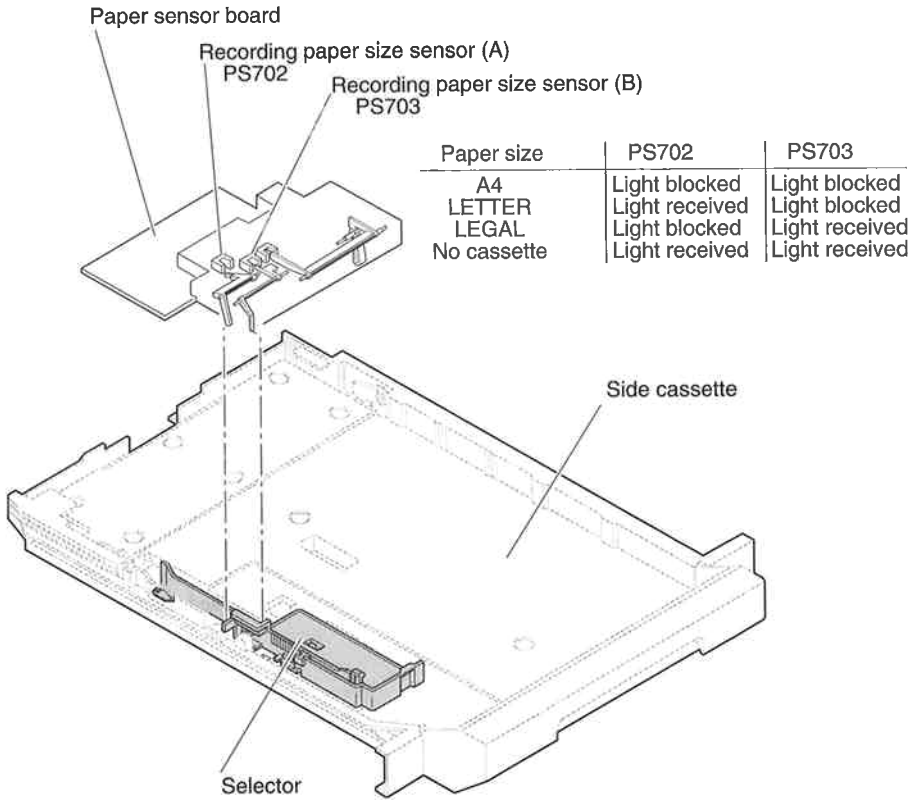
When a no recording paper error occurs, the main motor drive is stopped, print operations are stopped, the error is displayed on the display, and the REC. PAPER lamp blinks red.

"**SUPPLY REC. PAPER**" is displayed on the display. If the error occurs during reception, the reception images are received into memory reception starting from the page during which the error occurred, but if the error occurs during copying, the copy image is erased.

---

**b-4) Recording paper size and no cassette detection configuration**

The recording paper size sensor (A) and the recording paper size sensor (B), which are photo-interrupter type sensors equipped with actuator arms, detect the recording paper size and no cassette from the positions of the side cassette selector.



**Figure 3-18 Recording Paper Size Detection Configuration**

## **2.5 Printer section**

The print process outline of the laser beam printer engine section is as follows.

### **1. Primary charge**

The primary charging roller to which the AC bias and DC bias are applied is rotated, and charges the surface of the photosensitive drum to approx. -670 V or more.

### **2. Image exposure**

As the laser beam travels across the photosensitive drum, it is turned on and off by digital image data. Where the laser beam strikes the surface of the photosensitive drum, the exposed areas goes to approx. -100 V. It should be clear then that as the photosensitive drum turns, this process effectively builds up an invisible image on the photosensitive drum.

### **3. Developing**

The developing cylinder to which the AC bias and DC bias are applied is rotated, and the toner which is magnetically attracted to the developing cylinder is charged to negative electropotential by friction with the rotating cylinder. The electropotential difference between the toner and the photosensitive drum makes the toner adhere to the exposed sections of the drum charged to approx. -100 V.

### **4. Toner transfer**

The transfer charging roller applies positively voltage to the paper, and it will attract the negatively charged toner. As the photosensitive drum turns, the toner migrates from the photosensitive drum's surface and onto the paper. The residual charge on the paper is removed with an electrically conductive static charge eliminator.

### **5. Cleaning**

As the photosensitive drum rotates, the cleaning blade wipes off the residual toner into waste toner room to clean the photosensitive drum surface after toner transfer.

### **6. Fixing**

The heat of the fixing film directly heated by the fixing heater and pressure of the fixing pressure roller to thermally fix onto the paper the toner image.

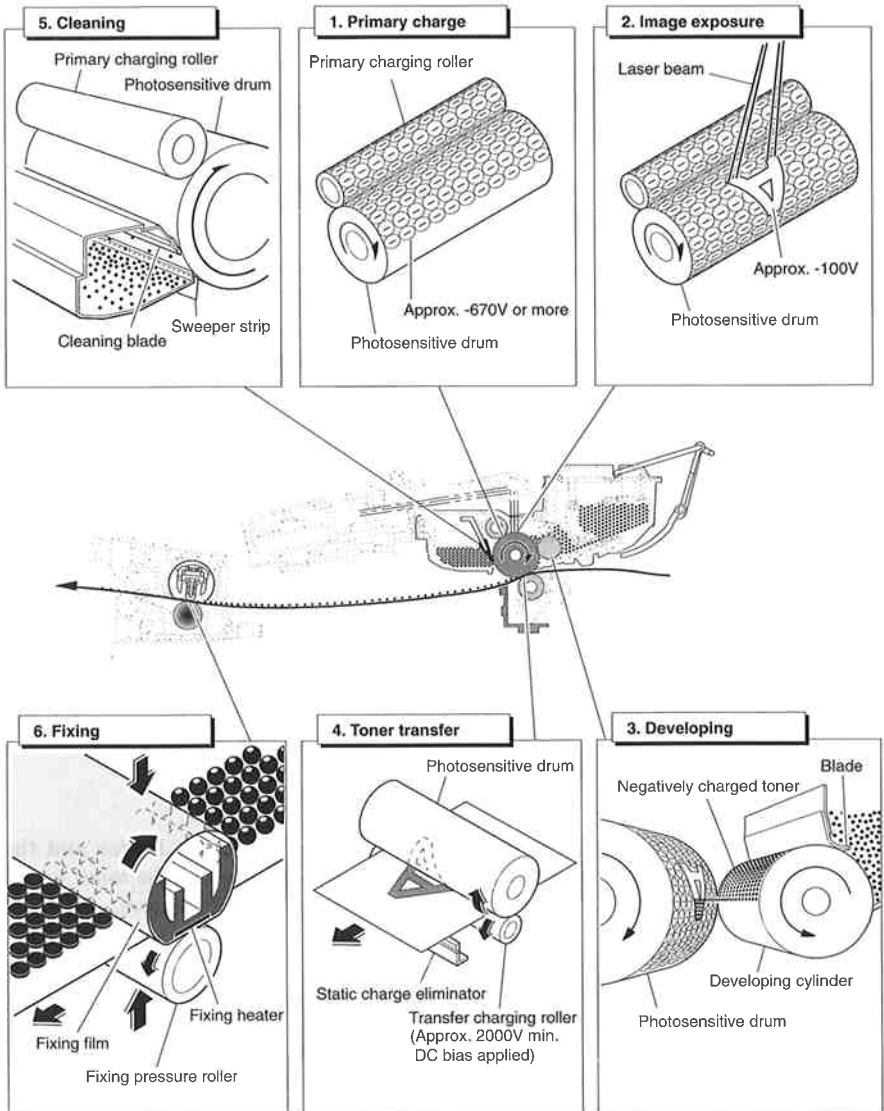


Figure 3-19 Print Process Outline

The laser beam printer engine section comprises the following.

**a) Recording paper feed/eject section**

The recording paper feed section feeds the paper sent in from the pickup section with the power of the main motor to the toner transfer section and fixing unit.

The eject section ejects the paper from the recording paper eject outlet with the power of the main motor.

**b) Laser/scanner unit**

The laser/scanner unit reflects a laser beam based on the laser drive signal on the mirror to expose the toner cartridge photosensitive drum. The laser drive signal is made by the PCNT board from the print signal sent to the PCNT board from the SCNT board and is sent to the laser/scanner unit.

**c) Toner cartridge**

The toner cartridge, which includes the photosensitive drum, the primary charging roller, and the developing cylinder, uses power from the main motor and high-voltage output from the PCNT board to make toner adhere to the section of the surface of the photosensitive drum exposed to the laser beam.

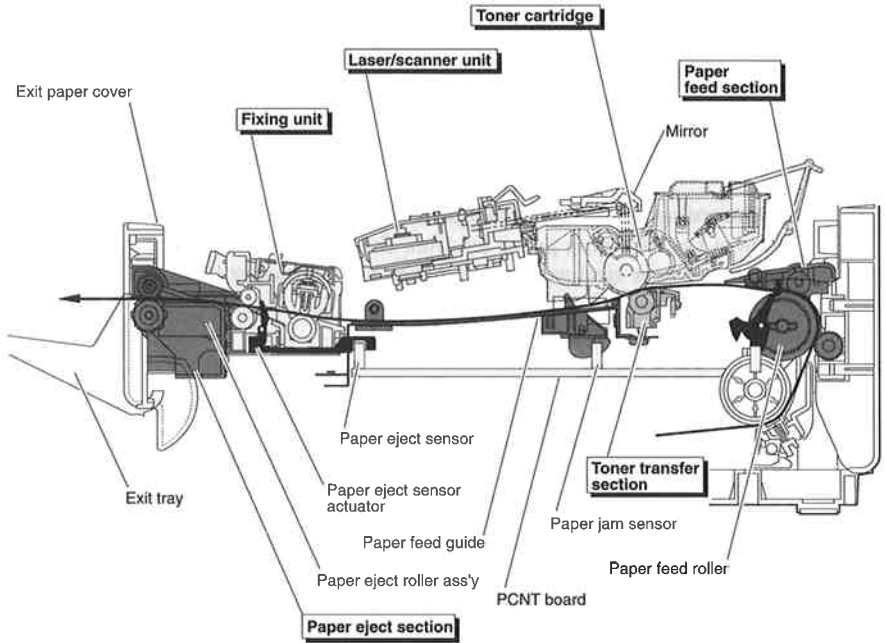
The toner sensor at the bottom of the pickup section detects the toner after printing.

**d) Toner transfer section**

The toner transfer section uses the transfer charging roller under the photosensitive drum to transfer the toner image formed on the photosensitive drum onto the recording paper.

**e) Fixing unit**

The on-demand type fixing unit uses the heat of the fixing heater and the pressure of the pressure roller to fix onto the recording paper the toner image that was formed on the recording paper in the toner transfer section.



**Figure 3-20 Printer Section Configuration**

## 2.5.1 Recording paper feed/eject section

### a) Recording paper feed/eject section functions

#### a-1) Recording paper feed function

The feed section feeds the recording paper fed from the pickup section to the toner transfer section and fixing unit. The eject section ejects the paper from the recording paper eject outlet at the left of the main unit after printing.

#### a-2) Recording paper jam detection function

Jams of the recording paper fed from the pickup section are detected by the recording paper eject sensor\*1 and the recording paper jam sensor\*2.

\*1 RPES: Recording Paper Eject Sensor

\*2 RPJS: Recording Paper Jam Sensor

### b) Recording paper feed/eject section configuration

#### b-1) Recording paper feed configuration

The recording paper is fed to the toner transfer section by the recording paper feed roller which is driven by gears with power from the stepping pulse main motor.

The recording paper feed is controlled by the PCNT board CPU counting the step pulses of the main motor and the photo-interruptor type recording paper pickup sensor and recording paper eject sensor, which are equipped with actuator arms detecting the recording paper feed status.

After fixing, the recording paper is ejected by the spur and the eject roller driven by gears with power from the main motor through the recording paper eject outlet at the left of the main unit and accumulated in the order printed.

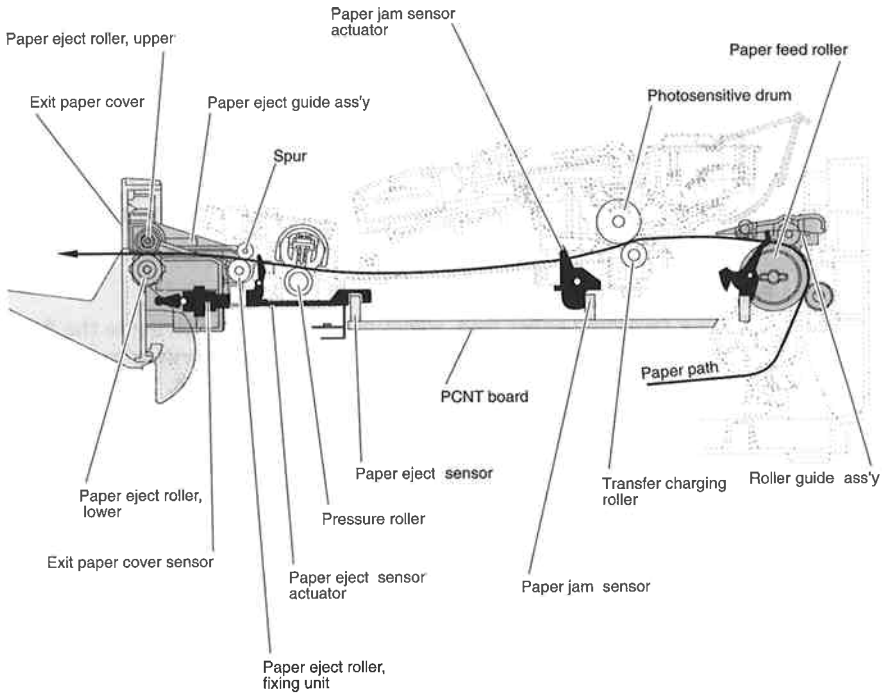


#### Start of printing

When the -PRNT\*1 signal (print signal) from the printer interface IC on the SCNT board is received, the feed solenoid comes on and the recording paper that has been brought to the feed standby position (Point 3 in the figure 3-16) by the pickup section is fed by the recording paper feed roller. 0.9 to 1.2 seconds after the recording paper pickup sensor detects the leading edge of the recording paper at Point 4 in the figure 3-16 on the next page, the PCNT board CPU outputs the -TOP\*2 signal (vertical sync signal) to the SCNT board. The SCNT board sends one page of print signals to the PCNT board synchronized with the -TOP signal.

\*1 PRNT: PRiNT \*2 TOP: Top Of Page

The time from the detection of the leading edge of the recording paper until the output of the -TOP signal can be adjusted with VR301 on the PCNT board.



**Figure 3-21 Recording Paper Feed/Eject Configuration**



### **b-2) Recording paper jam detection configuration**

Recording paper jams in the paper feed/eject section are detected by the photo-interrupter type recording paper eject sensor, which is equipped with an actuator arm.

#### **Recording paper feed jam**

A "recording paper feed jam" means that the recording paper eject sensor can not detect the leading edge even 10.91 seconds after the PCNT board CPU has sent the -TOP signal\*<sup>1</sup>.

#### **Fixing unit wrap-around jam**

During recording paper feed, sometimes the toner adhering to the fixing unit pressure roller and fixing film makes the recording paper wrap around the pressure roller without separating from it. A "fixing unit wrap-around jam" means that the recording paper feed jam discussed above was not detected, but the recording paper eject sensor cannot detect the leading edge of the recording paper during the 1.3 seconds from after the 0.5-second recording paper feed jam detection time.

#### **Recording paper eject jam**

A "recording paper eject jam" means that the recording paper eject sensor cannot detect the trailing edge even 26.36\*<sup>2</sup> seconds after the PCNT board CPU has sent the -TOP signal\*<sup>1</sup>.

\*<sup>1</sup> TOP: Top Of Page

\*<sup>2</sup> Legal: 26.38 seconds; Letter-size: 23.19 seconds; A4: 23.93 seconds



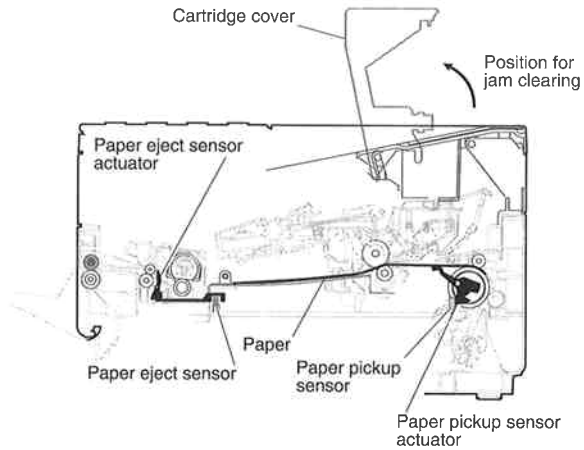
#### **Recording paper jam detection processing**

When a recording paper jam occurs, the main motor drive is stopped, print operations are stopped, the error is displayed on the display, and the REC. PAPER lamp blinks red. Also, if the cartridge cover, right cover, or exit paper cover is opened during recording paper feed, this is treated as a recording paper jam.

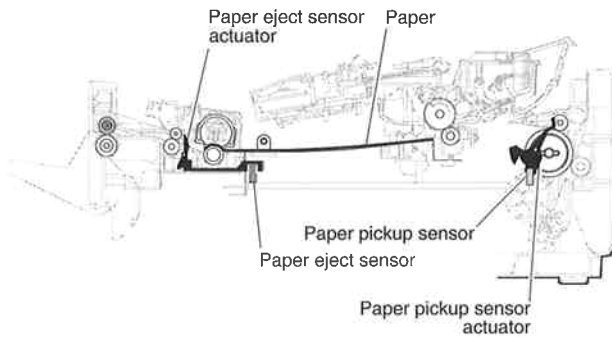
"REC. PAPER JAM" is displayed on the display.

If the jam occurs during reception, the reception images are received into memory reception starting from the page during which the recording paper jam occurred, but if the jam occurs during copying, the copy image data are erased.

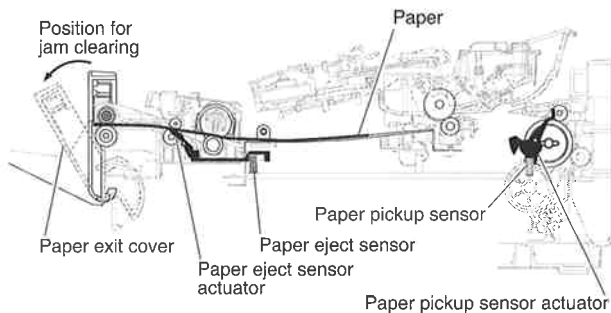
---



**Figure 3-22 Recording Paper Feed Jam**



**Figure 3-23 Fixing Unit Wrap-Around Jam**



**Figure 3-24 Recording Paper Eject Jam**



This machine also detects recording paper jams during power up. The recording paper jams during power up are the following two types.

**Power up recording paper jam 1**

"Power up recording paper jam 1" means that 0.7-1.2 seconds after the power comes on, the recording paper jam sensor detects recording paper.

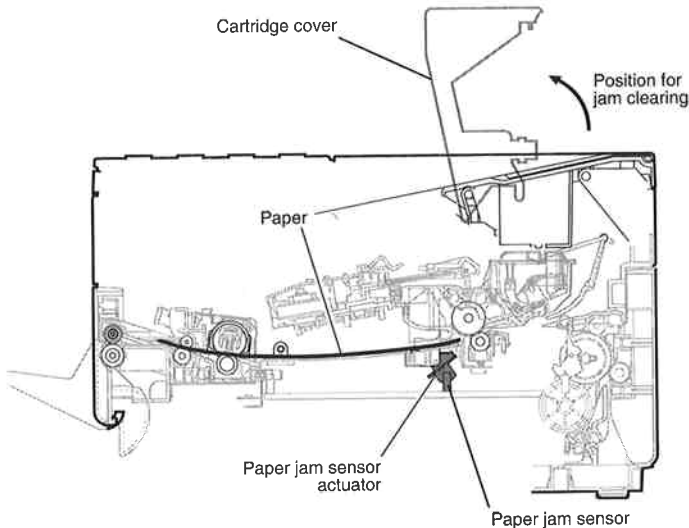
**Power up recording paper jam 2**

"Power up recording paper jam 2" means that 0.9-1.4 seconds after the power comes on, the recording paper pickup sensor or the recording paper eject sensor detects recording paper.

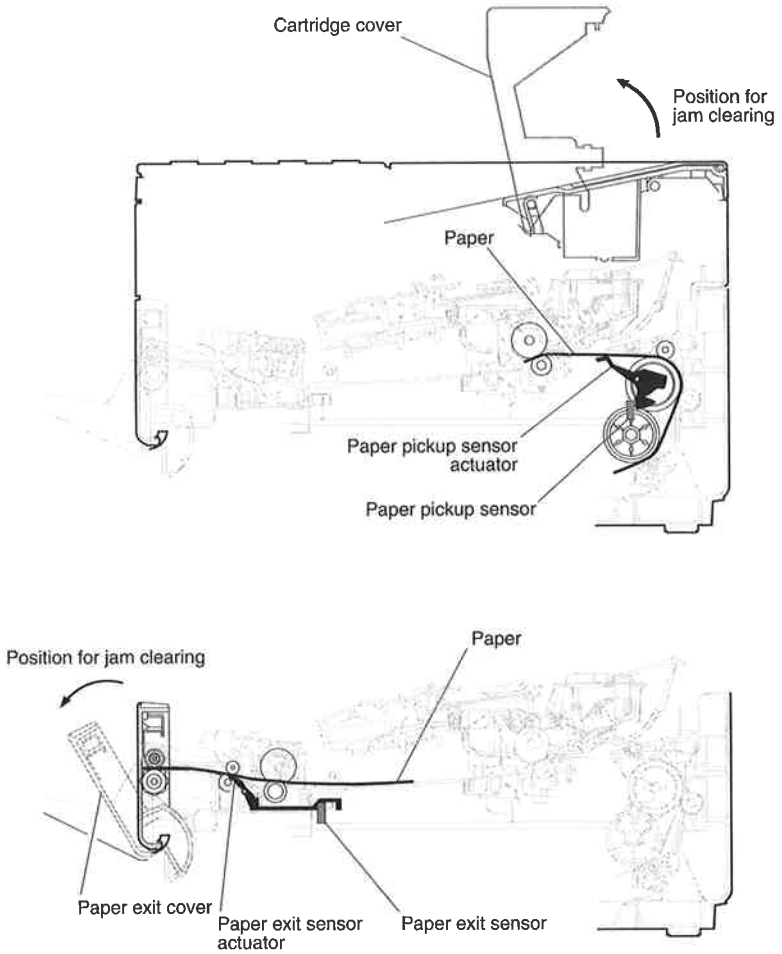
**Automatic paper eject**

During power on, if there are none of the above recording paper jams, the pickup section, feed section, and eject section are driven by the main motor. If the recording paper pickup sensor detects recording paper at this driving, the printer section automatically ejects the recording paper.

During automatic ejection, the recording paper eject sensor monitors the recording paper feed status to detect jams.



**Figure 3-25 Power Up Recording Paper Jam 1**



**Figure 3-26 Power Up Recording Paper Jam 2**

## 2.5.2 Laser/scanner unit

### a) Laser/scanner unit functions

#### a-1) Laser beam unit function

The laser beam generation function generates the laser beam by lighting up the laser diode in the laser unit with the laser drive signals sent from the PCNT board. The laser beam shone from the laser diode is corrected to parallel light by the collimeter lens and then is focused on the scanner mirror surface by the cylindrical lens, and shone on the scanner mirror.

#### a-2) Photosensitive drum exposure function

The photosensitive drum exposure function reflects the laser beam with the two-surface scanner mirror rotating at a fixed speed to expose the surface of the photosensitive drum in the horizontal direction.

#### a-3) Horizontal scan reference position detection function

The horizontal scan reference position detection function detects the laser beam horizontal scan start reference position for each scan by shining the laser beam reflected by the BD mirror onto the photo-receiver elements in the BD sensor. The laser beam shone onto the BD sensor is sent through the connector to the PCNT board CPU and the PCNT board CPU makes the -BD signal \*1 (horizontal sync signal) and sends it to the SCNT board.

\*1 BD: Beam Detection

### b) Laser/scanner unit configuration

#### b-1) Laser beam generation function

The laser/scanner driver IC lights the laser diode with the laser drive signals sent from the PCNT board CPU to generate a 5-mW, 780-nm wavelength laser beam.

The laser drive signals (-VDOUT \*2) are made by the PCNT board CPU and are based on the print signals (-VDO \*3) from the SCNT board.

\*2 VDOUT: ViDeo OUTput \*3 VDO: ViDeO



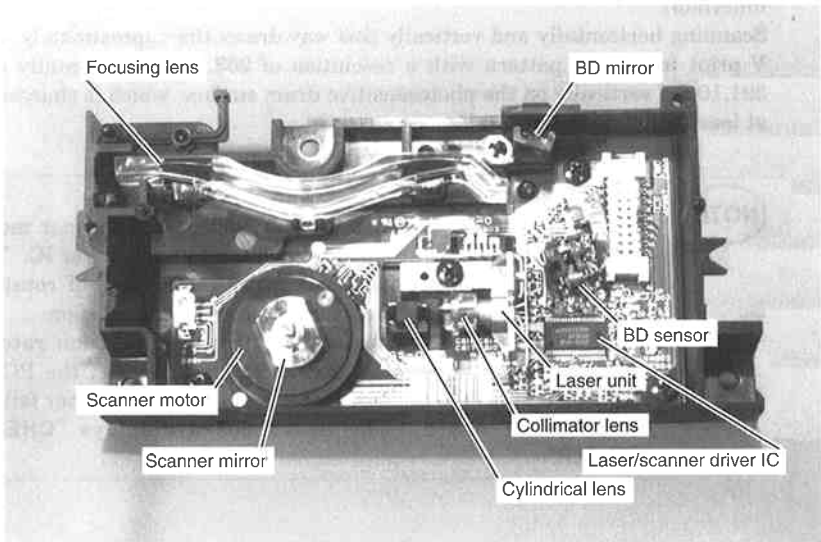
The laser drive signal (-VDOUT) combines the print signal (-VDO) and the unblanking signal (-UNBL). For details on the unblanking signal, see *b-3) Horizontal scanning reference position detection configuration*.

---



**Laser diode automatic light emission control (APC: Auto Power Control)**

In order to stabilize the amount of laser light, after the emitted laser beam is received by the photo-diode next to the laser diode, the resulting signal is sent to the laser/scanner driver IC and the amount of laser light is controlled to match the target laser light amount within the laser/scanner driver IC.



**Figure 3-27 Laser/Scanner Unit**

### b-2) Photosensitive drum exposure configuration

The laser beam reflected from the scanner mirror rotating at a fixed speed is focused on the photosensitive drum by the focusing lens placed before the scanner mirror and the mirror on top of the toner cartridge, and scans the photosensitive drum horizontally.

While the rotation of the scanner mirror makes the laser beam scan the photosensitive drum horizontally with a resolution of 203.2 dpi (8 pels), the photosensitive drum rotates at a fixed speed, so the laser beam scans the photosensitive drum vertically with a resolution of 391.16 dpi (15.4 lines/mm).

Scanning horizontally and vertically this way draws the approximately -100 V print image dot pattern with a resolution of 203.2 dpi horizontally and 391.16 dpi vertically on the photosensitive drum surface, which is charged to at least approximately -670 V.



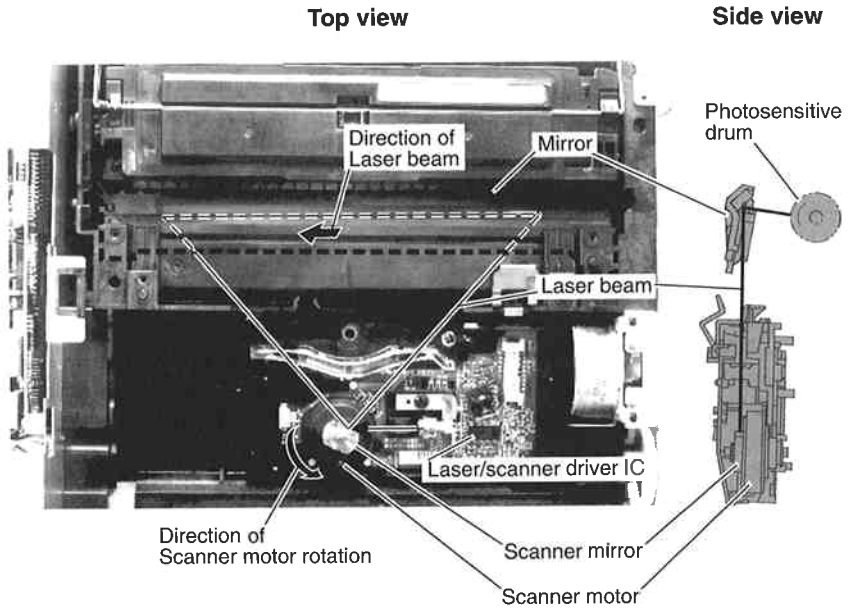
---

#### Scanner mirror control

The scanner motor is driven by the 3-phase DC scanner motor and the rotation is controlled by the laser/scanner driver IC. The PCNT board CPU counts the scanner motor rate of rotation signal pulses to monitor the scanner motor rate of rotation.

If the scanner motor does not attain the regulation rate of rotation within 30 seconds after it starts to rotate, the PCNT board CPU stops the scanner motor and reports a scanner failure to the SCNT board. The SCNT board displays "**CHECK PRINTER**".

---



**Figure 3-28 Photosensitive Drum Exposure Configuration**



**b-3) Horizontal scanning reference position detection configuration**

The laser beam that has reached the horizontal scan start position is reflected by the BD mirror and is detected as the horizontal sync signal that becomes the print start reference position by the photo-receiver elements in the BD sensor. The BD signal is sent to the PCNT board CPU through the connector as the -BDI\*1 signal.

\*1 BDI: Beam Detection Input

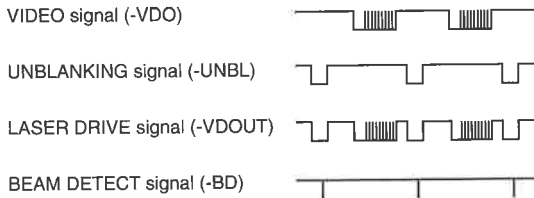


The horizontal scan reference position uses for reference the BD signal that detects the physical position before the laser beam strikes the toner cartridge photosensitive drum. The print data is output from the SCNT board a fixed time after the BD signal is detected. As a result, horizontal scanning starts from the fixed position on the drum.

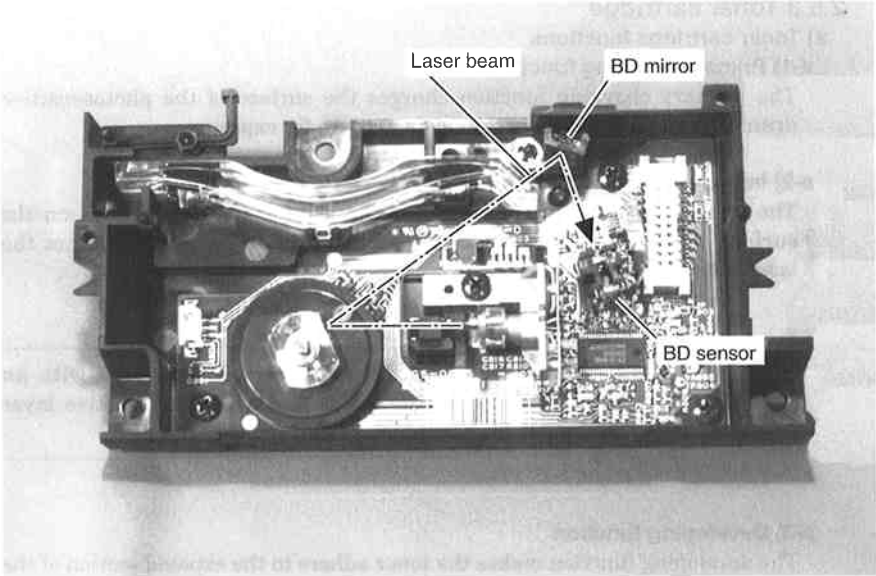
In order to make the BD signal, at the BD mirror position, the laser beam is shone by the -UNBL\*2 signal inside the CPU even if there are no print signals.

\*2 UNBL: UNBLanking

The CPU combines the -UNBL signal and the print signal (-VDO) from the SCNT board to the laser drive signal (-VDOUT).



**Figure 3-29 Unblanking Signal**



**Figure 3-30 Horizontal Scan Reference Position Detection Configuration**

## 2.5.3 Toner cartridge

### a) Toner cartridge functions

#### a-1) Primary charging function

The primary charging function charges the surface of the photosensitive drum to a uniform negative voltage to prepare for exposure.

#### a-2) Image exposure function

The image exposure function exposes the print image dot pattern on the surface of the photosensitive drum with the laser beam shone from the laser/scanner unit via the mirror.



---

The photosensitive drum has a 2-layer configuration with an aluminum substrate on the inside and a photoconductive layer using an organic photoconductor (OPC) on the outside.

---

#### a-3) Developing function

The developing function makes the toner adhere to the exposed section of the photosensitive drum.

#### a-4) Cleaning functions

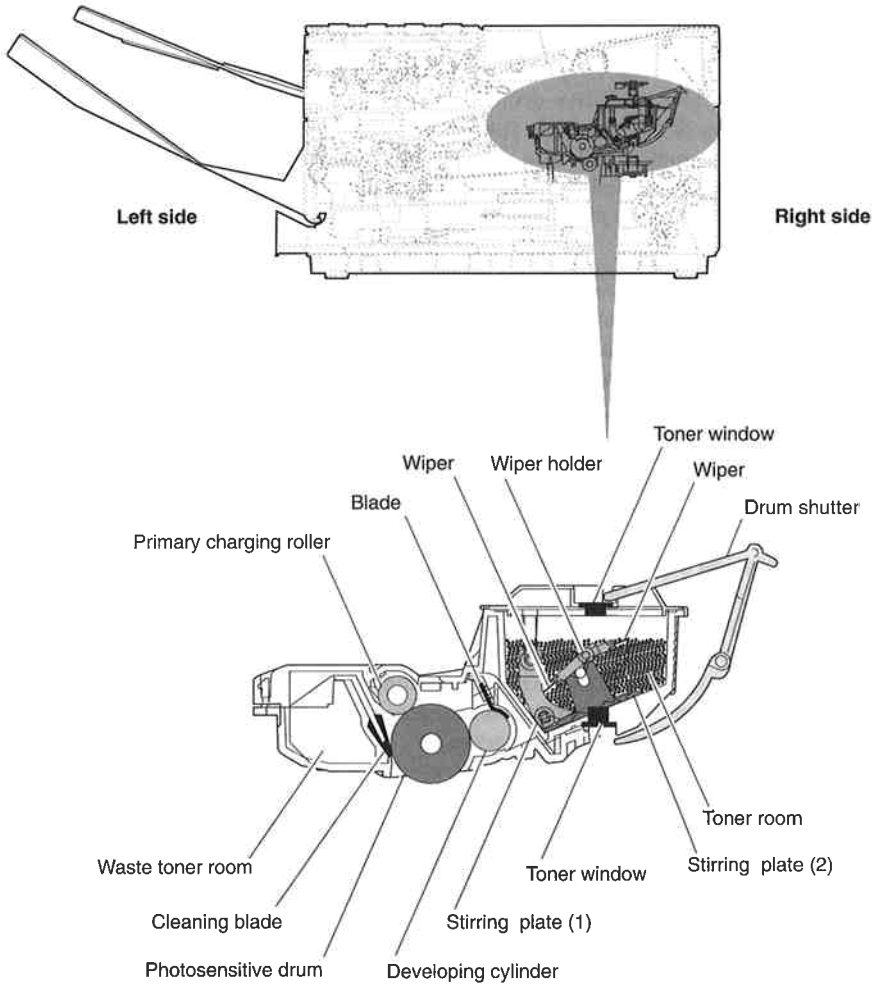
There are the following two cleaning functions.

##### **Cleaning using the blade**

In order to maintain the printer section's high quality printing, after printing, the toner left on the surface of the photosensitive drum is cleaned off with a blade.

##### **Cleaning using the wiper**

In order to maintain the accuracy of the no-toner detection, the toner on the toner window is cleaned off with a wiper.



**Figure 3-31 Toner Cartridge**

**b) Toner cartridge configuration**

**b-1) Primary charging configuration**

The primary charging configuration comprises the primary charging roller and the photosensitive drum. When the print start signal (-PRNT) is sent from the SCNT board to the PCNT board, the primary charging roller, to which is applied AC bias and DC bias from the PCNT board high-voltage terminal, is rotated by being driven by the photosensitive drum and charges the surface of the photosensitive drum to approx. -670 V or more.

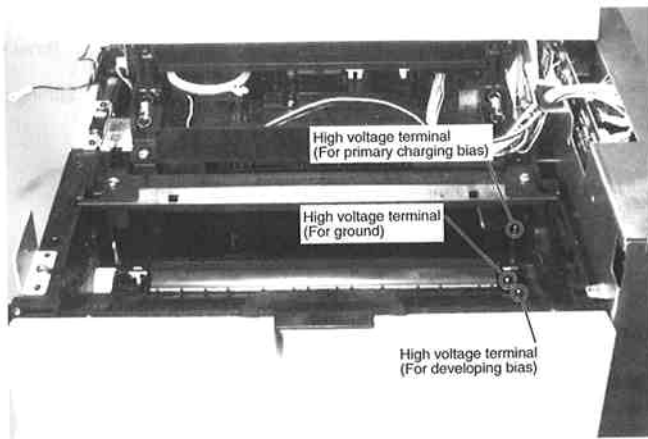


In order to maintain an even electropotential on the surface of the photosensitive drum, the PCNT board applies DC bias of at least -550 V and AC bias of at least 1000 V to the primary charging roller, which is made of conductive rubber.

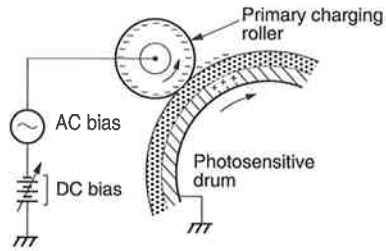
The DC bias of at least -550 V varies with "SELECT DENSITY" set in the user data.

**b-2) Image exposure configuration**

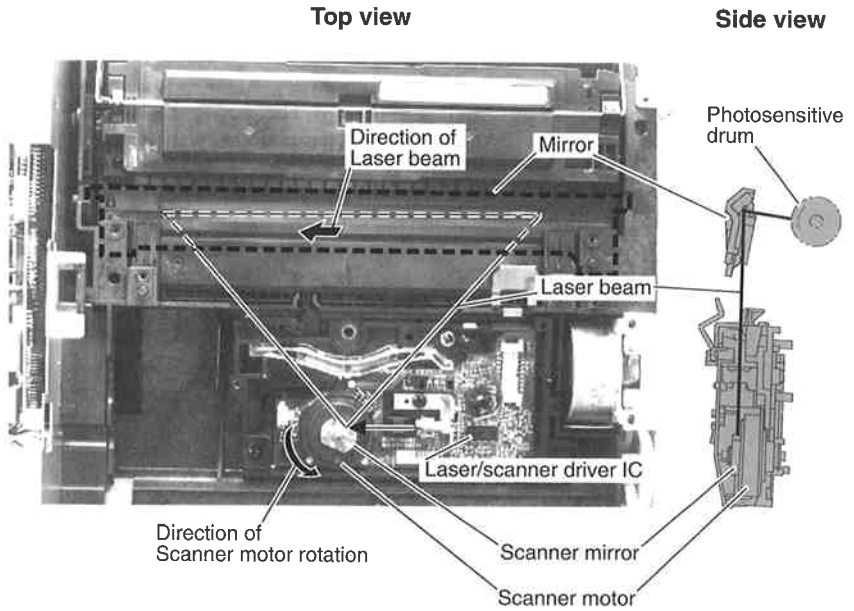
The surface of the photosensitive drum that has been charged to at least approx. -670 V is rotated at a fixed speed by power transferred by gear from the main motor and the laser beam is shone from the laser/scanner unit. The section where the laser beam shines goes to approx. -100 V and draws the print image dot pattern on the drum surface with a density of 203.2 dpi horizontally and 391.6 dpi vertically.



**Figure 3-32 High Voltage Terminals**



**Figure 3-33 Primary Charging Configuration**



**Figure 3-34 Image Exposure Configuration**

**b-3) Developing configuration**

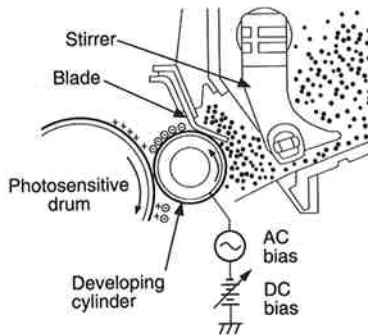
The developing configuration comprises the developing cylinder, two toner stirring plates, and the blade. The toner is insulating and comprises magnetic elements and plastic resin and is magnetically attracted to the developing cylinder.

The developing cylinder to which the AC bias and DC bias are applied from the PCNT board high-voltage terminals is rotated by power transmitted by gear from the main motor and the toner on the cylinder is charged to negative electropotential by friction with the rotating cylinder.

When the toner layer that has been spread evenly over the cylinder surface by the blade contacts the exposed section of the photosensitive drum, the electropotential difference between the toner and the photosensitive drum makes the toner adhere to the exposed sections of the drum charged to approx. -100 V. (Toner projection phenomenon)



In order to make it easier for the toner to adhere to the photosensitive drum surface and raise the print image contrast, the PCNT board applies a 1200 Vp-p AC bias to the developer cylinder, which has a fixed magnet inside. The center voltage of the 1200 Vp-p voltage varies with the -320 to -480 V DC bias. This varies the electropotential difference between the cylinder and the photosensitive drum to vary the print darkness. The -320 to -480 V DC bias varies with "SELECT DENSITY" set in the user data.



**Figure 3-35 Developing Configuration**



**Toner projection phenomenon**

Details on the toner projection phenomenon are given below. Both the light and dark sections of the photosensitive drum have negative electropotential, but in order to make this explanation easier to understand, when the electropotential of the surface of the photosensitive drum is higher than that of the developing cylinder, it will be called "+" and when it is lower, "-".

Latent image	Developing bias	Toner movement	Description
Bright area	Negative		By the force of the electric field produced by the potential difference between the drum surface and the developing cylinder, the toner on the developing cylinder jumps over to the drum in pulling itself free from the magnet attraction. The amount of jumping toner depends on the DC bias voltage at the developing cylinder.
	Positive		As the potential difference between the drum surface and the developing cylinder becomes small, both the force of the weak electric field by the potential difference and the magnet attraction operate to attract the toner toward the developing cylinder. Consequently, the toner attached to the drum is returned to the developing cylinder. This removes excess toner collected on the drum and improves the contrast.
Dark area	Negative		As the potential difference between the drum surface and the developing cylinder becomes small, the magnet attraction becomes greater than the force of the electric field produced by the potential difference. Therefore little toner on the developing cylinder jumps over to the drum.
	Positive		Both the force of the electric field produced by the potential difference between the drum surface and the developing cylinder and the magnet attraction operate to attract the toner toward the developing cylinder. Consequently excess toner collected on the dark area of the drum surface is pulled back to the developing cylinder, which prevents fogging.

**Figure 3-36 Toner Projection Phenomenon**



### b-3) Cleaning configurations

#### Cleaning using the blade

As the photosensitive drum rotates, the cleaning blade wipes off the residual toner into the waste toner room to clean the photosensitive drum surface after printing.

#### Cleaning using the wiper

The wiper rotates with power transmitted by the toner stirring plates, the toner stirring arm, and the stirring gear from the photosensitive drum. The rotating wiper cleans off the toner window by wiping off any toner adhering to the toner window.

### b-4) No-toner detection function

When the toner in the toner cartridge runs out, this is detected by the photosensor-type toner sensor on the toner sensor board. "No-toner" means that the light shone from the LED board onto the toner cartridge toner window is detected by the toner sensor.

No-toner detection is carried out during printing of each page.

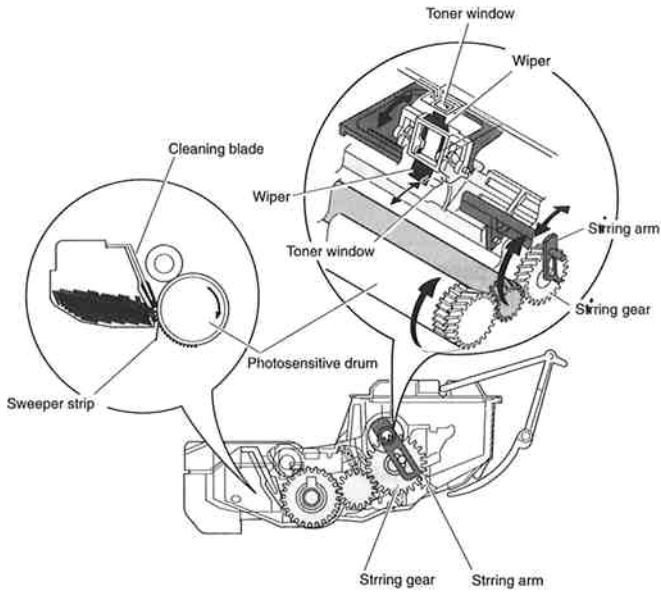


#### No-toner processing

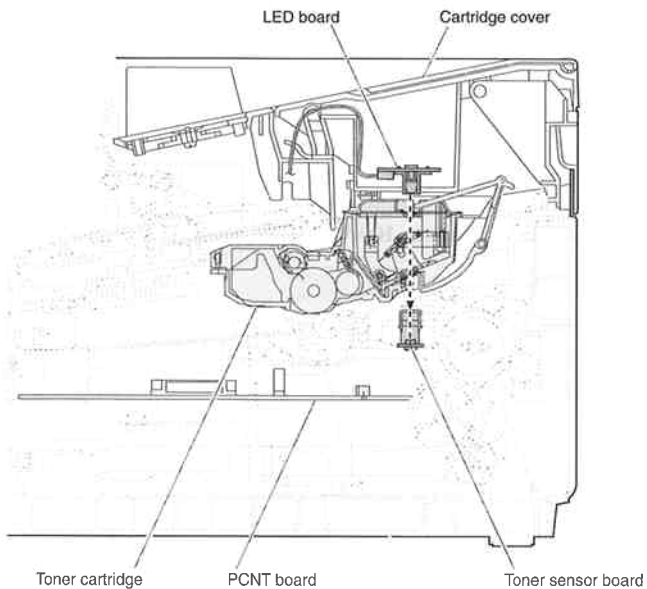
When the toner runs out, after the page being printed when the toner ran out is ejected, subsequent printing is stopped, the error is displayed on the display, and the CHANGE CARTRIDGE lamp blinks red. "**REPLACE CARTRIDGE**" is displayed on the display.

If this error occurs during reception, the reception images are received with memory reception starting from the page during which the error occurred, but if the error occurs during copying, the copy image is erased.

---



**Figure 3-37 Cleaning Configuration**



**Figure 3-38 No-toner Detection Configuration**

## 2.5.4 Toner transfer section

### a) Toner transfer section functions

The toner transfer function uses the transfer charging roller to apply positive voltage to the rear side of the recording paper fed by the recording paper feed roller and thus to make the negatively charged toner on the surface of the photosensitive drum adhere to the surface of the recording paper.



---

#### Recording paper curvature separation

Since the photosensitive drum has a small external radius, after the transfer the recording paper is automatically separated from the photosensitive drum without wrapping around it.

---



---

#### Static charge eliminator

Residual charge on the rear side of the recording paper can make the recording paper adhere to the photosensitive drum or in low-temperature low-humidity environments can make the toner on the recording paper fly off. To prevent these phenomena, after transfer the residual charge on the rear side of recording paper is removed with an electrically conductive static charge eliminator on the left side of the transfer charging roller.

---

### b) Toner transfer section configuration

The transfer charging roller is rotated by power transmitted by gear from the main motor, the approx. 2000 V min. DC bias (print bias) from the PCNT board is applied to this roller, and the toner on the exposed sections of the drum, charged to approx. -100 V, is transferred to the recording paper.

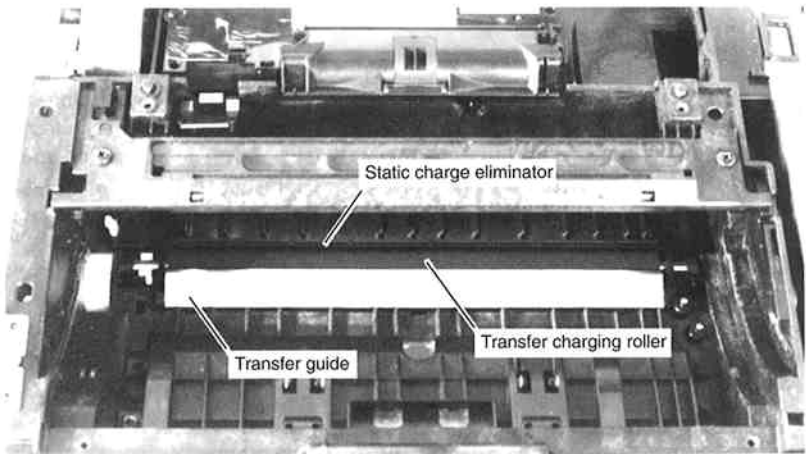


**Negative bias**

In order to clean the transfer charging roller, from when the power is switched on until the end of main motor initial drive, at the start and after end of printing, the PCNT board applies at least -1000 VDC to the transfer charging roller in order to move the toner adhering to the transfer charging roller to the photo-sensitive drum, which is charged to 0 V.

**Bias between pages**

When printing multiple pages, in order to prevent electrical damage to the photo-sensitive drum, after the completion of printing of each page, the PCNT applies a DC voltage lower than the print bias to the transfer charging roller.



**Figure 3-39 Transfer Configuration**

## 2.5.5 Fixing unit

### a) Fixing unit function

The fixing function uses the heat of the film directly heated by the fixing heater and the pressure of the pressure roller to thermally fix onto the recording paper the toner image that was transferred onto the recording paper in the toner transfer section. After thermal fixing, the recording paper is fed to the eject section by the fixing eject roller, which is driven by the main motor.

### b) Fixing unit configuration

#### b-1) Fixing configuration

When the PCNT board receives the print start signal (-PRINT) from the SCNT board, the PCNT board applies 85-132 VAC voltage to the fixing heater touching the fixing film to directly heat the fixing film.



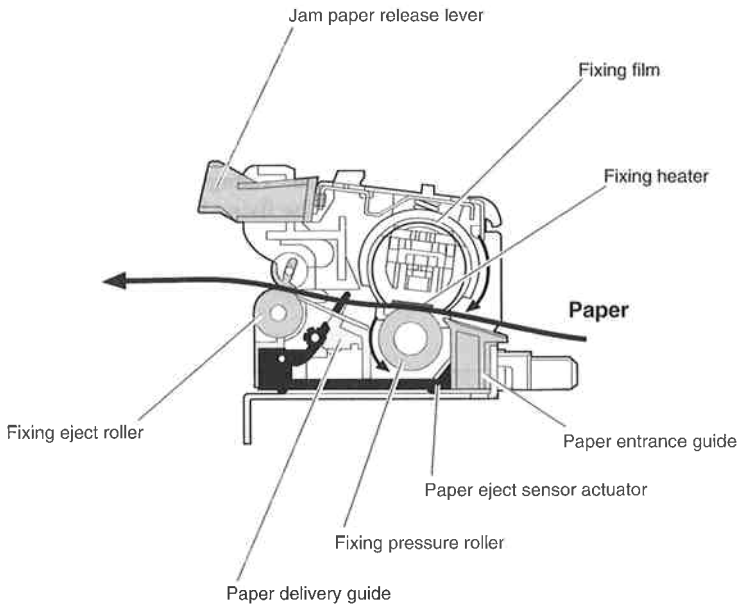
---

#### Fixing film

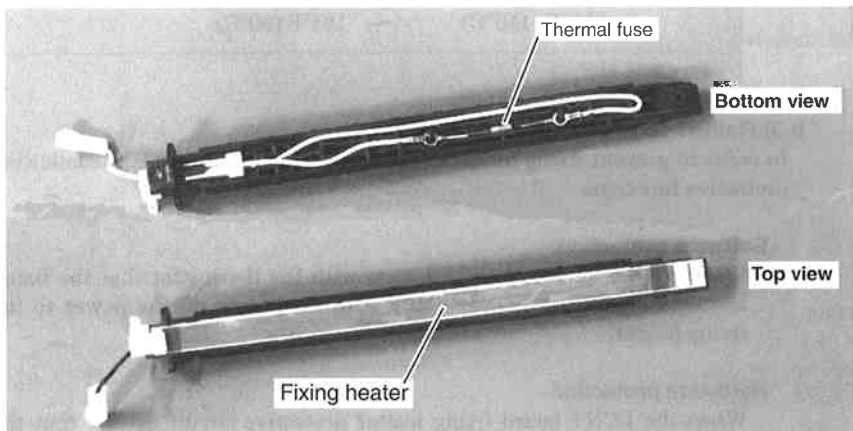
The heat capacity of the fixing film, which is approx. 61- $\mu$ m thick polyimide, is about 1/100th that for previous roller fixing. Since the fixing film directly heated by the fixing heater reaches fixing temperature instantaneously, the fixing heater only operates during printing.

Moreover, the surface of the fixing film is fluorine coated to prevent offset printing.

---



**Figure 3-40 Fixing Unit**



**Figure 3-41 Fixing Film Unit (Internal View)**

**b-2) Fixing heater temperature control configuration**

The PCNT board CPU detects the status of the thermistor on the fixing heater and controls the fixing heater's temperature to be optimum for fixing. This optimum temperature for fixing is determined by the temperature of the fixing heater, which is detected at the start of printing and between pages for multi-page printing, and DC voltage, which is supplied to the PCNT board, in response to the input AC voltage. The PCNT board CPU sets the fixing temperature high when the fixing heater temperature is low and low when the fixing heater temperature is high. The fixing temperature has five settings: 374 (190), 356 (180), 338 (170), 325.4 (163), and 311°F (155°C).



**Temperature between pages**

To keep the inside of the machine from heating up, this machine lowers the fixing heater temperature between pages when it is printing multiple pages. Here is the relationship between the fixing temperature and the temperature between pages.

---

<u>Fixing temperature</u>	<u>Temperature between pages</u>
374°F (190°C)	325.4°F (163°C)
356°F (180°C)	325.4°F (163°C)
338°F (170°C)	307.4°F (153°C)
325.4°F (163°C)	307.4°F (153°C)
311°F (155°C)	194°F (90°C)

---

**b-3) Fixing heater protective configuration**

In order to prevent fixing heater overheating, this machine has the following protective functions

**Software protection**

When the PCNT board CPU detects with the thermistor that the fixing heater temperature is over 419°F (215°C), it cuts off the power to the fixing heater.

**Hardware protection**

When the PCNT board fixing heater protective circuit detects that the fixing heater temperature is 428-455°F (220-235°C), it cuts off the power to the fixing heater regardless of the PCNT board CPU output.

### Temperature fuse protection

When the fixing heater temperature is over 464°F (240°C), the temperature fuse in the fixing film unit blows, cutting off power to the fixing heater.



### Software detection of fixing heater breakdown

When the PCNT board CPU detects any of the following states with the thermistor, it judges that the fixing heater has broken down.

1. The detected temperature does not reach the fixing temperature within 35 seconds after the start of temperature control.
2. The detected temperature is over 419°F (215°C).
3. At the start of fixing heater drive, the detected temperature is under 20°C. (This means that the line to the thermistor is cut.)
4. The detected temperature falls below 32°F (0°C) after a cut thermistor line is detected.
5. The detected temperature falls below 194°F (90°C) during temperature control.
6. When a fixing heater breakdown is detected, the power is switched off, then switched on again within 10 minutes.

### Fixing heater break down processing

If a fixing heater breakdown occurs, the power to the fixing heater is cut off and main motor drive is stopped, print operations are stopped, and the error is displayed on the display.

"**CHECK PRINTER**" is displayed on the display.

If a fixing heater breakdown occurs during reception, the reception images are received into memory starting from the page during which the breakdown occurred, but if the breakdown occurs during copying, the copy image is erased.

In order to prevent fixing heater overheating, during the first ten minutes after this machine is switched off after a fixing heater breakdown, even if the power is switched on this machine does not supply power to the fixing heater.

---



2.6 Circuit Overview  
2.6.1 Function block diagram

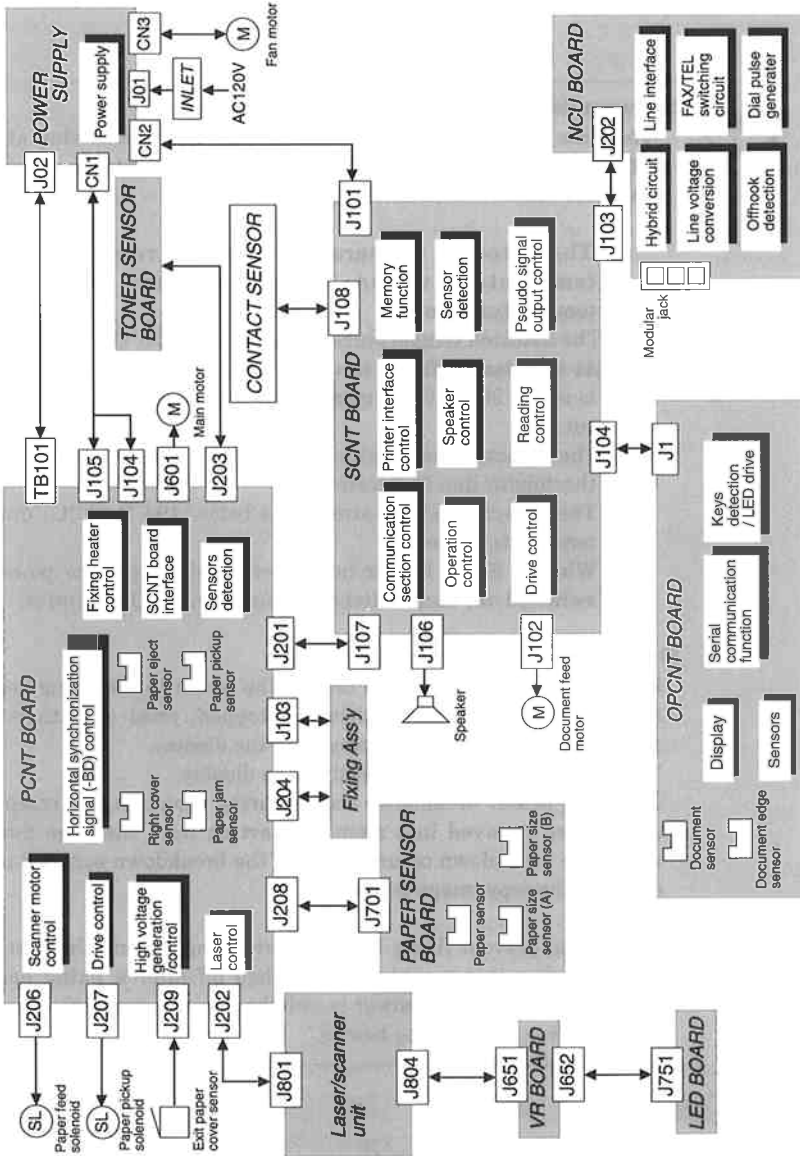


Figure 3-42 Function Block Diagram

## 2.6.2 Functions

### a) SCNT board functions

#### a-1) Drive control

The drive control section controls the document feed motor in the document read section.

#### a-2) Operation control

The operation control section serially transfers data to or from the control IC on the OPCNT board, detects the operation keys status, and sends the LED and display signals to the control IC on the OPCNT board.

#### a-3) Reading control

The imaging processing IC in the reading control section processes image data read from the contact sensor and sends them to the DRAM via the system control gate array and CPU.

#### a-4) Printer interface control

The printer interface control section converts image data with a vertical resolution of 3.85 line/mm or 7.7 line /mm to the 391.16 dpi (15.4 line /mm) print data. It also serially transmits command signals to the PCNT board, receives status signals from the PCNT board, and detects the printer section status.

#### a-5) Communication section control

The SCNT board detects line signals, such as CNG , DTMF and ROT. The modem, with a transmission rate of 9600 bps, modulates and demodulates transmission/reception data and sends DTMF signals.

#### a-6) Pseudo signal output control

During fax communication, and if the remote telephone is off-hooked while the handset is being used for telephone conversation (or the handset is off-hooked while the remote telephone is being used for telephone conversation), a pseudo busy tone is sent to the remote telephone (or handset).

#### a-7) Sensor detection

The SCNT board detects the statuses of the sensors in the document read section, operation control section, and covers to monitor the drive section.

#### a-8) Speaker control

The SCNT board controls the alarm, key operation, and line monitor tones. It also controls the volumes of the alarm and key operation tones.

**a-9) Memory function**

The 192-kbyte DRAM for image data storage can contain approximately 12 pages of CCITT No.1 chart. With an option memory extension, approx. 44pages can be stored.

The 256-kbit SRAM stores registration data, including user data and service data. These data are backed up by a lithium battery.

**b) NCU board functions**

**b-1) Hybrid circuit**

The hybrid circuit prevents the signals transmitted from the SCNT board from entering the reception circuit on the NCU board.

**b-2) FAX/TEL switching circuit**

If a telephone calls arrives in FAX TEL switching mode or FAX/ANSWERING switching mode, the FAX/TEL switching circuit switches the line signal to the handset or extension telephone. If a facsimile call arrives, this circuit switches the line signal to the SCNT board by switching the relay in the circuit.

**b-3) Dial pulse generator**

The dial pulse generator generates a dial pulse to send a dial signal from the fax through the dial line by turning the relay on and off using the control signal from the SCNT board.

**b-4) Offhook detection**

Offhook is detected by detecting the DC current that flows when the handset or extension telephone is offhook.

**b-5) Line voltage conversion**

The line primary on the NCU board is controlled by a +48VDC line voltage, therefore, the line voltage conversion transformer converts the voltage of the control TTL for the line secondary.

**b-6) Line interface**

The NCU board has modular jacks for the line, handset, and extension telephone. The line interface section transfers signals from the line to the SCNT board, and sends signals from the fax to the telephone line.

**c) OPCNT board functions**

**c-1) Keys detection and LED drive function**

The control IC on the OPCNT board detects the operation keys status, and drives the LED.

**c-2) Display**

The control IC in the LCD module controls the 20-column × 2-line LCD according to the display signals from the SCNT board.

**c-3) Serial communication function**

The control IC on the OPCNT board serially transfers data, such as the operation keys status data, LED drive data and display signals, to or from the SCNT board.

**c-4) Sensors**

The signals detected by the document sensor, document edge sensor and one-touch dial cover sensor are sent to the SCNT board via the control IC on the OPCNT board.

**d) PCNT board functions**

**d-1) Fixing heater control**

The fixing heater control section monitors the DC voltage (ACVIN) supplied from the power supply in response to the 85~132 VAC voltage, and the fixing heater thermistor, and drives the heater so that the temperature reaches the specified level. If the heater temperature is judged to be abnormal, the power supply to the heater is shut off.

**d-2) High voltage generation/control**

The high voltage control section is to control the high voltage applied to the toner cartridge primary charge roller and developing cylinder, and the transfer charging roller of the toner transfer section.

**d-3) Drive control**

The drive control section controls the main motor, paper pickup solenoid, paper feed solenoid and fan. Also, the FANTAC signal from the fan via the power supply unit is detected, and the fan rotation monitored.

**d-4) Sensors detection**

The PCNT board monitors the drive section by detecting the statuses of the sensors in the printer section and paper pickup section.

**d-5) SCNT board interface**

The SCNT board interface section serially transmits the horizontal synchronization signal (-BD) and the vertical synchronization signal (-TOP) to the SCNT board, and, in turn, receives serially transmitted command signals from the SCNT board, and returns status signals, in order to inform the SCNT board of the printer section status.

**d-6) Laser control**

The laser control section controls the drive of the laser diode in the laser/scanner unit, in response to print data from the SCNT board. It also the laser diode auto power check, performed on each line of print data.

**d-7) Horizontal synchronization signal control**

When the laser beam reaches the horizontal printing start position, the horizontal position detection signal (-BDI) from the laser laser/scanner unit is detected, and the horizontal synchronization signal (-BD) sent to the SCNT board. Also, the output frequency status of the horizontal synchronization signal (-BD) is monitored.

**d-8) Scanner motor control**

The scanner motor drive is controlled so that the print image horizontal resolution reaches 391.6 dpi. Also, the SCANTAC signal from the laser/scanner unit is detected, and the scanner motor rotation status monitored.

**e) Power supply functions**

DC voltage sources of +13.9 V, +12 V, +5.1 V and AC voltage sources of 85 ~ 132 V are generated from the 120 VAC power supply and supplied to the units of the fax. Also, DC voltage is supplied to the PCNT board, in response to the input AC voltage, as shown below.

<u>Input AC voltage</u>	<u>ACVIN</u>
85 VAC	2.16 VDC
110 VAC	2.77 VDC
132 VAC	3.31 VDC

**f) Paper sensor board functions**

The paper size sensor (A), paper size sensor (B), and paper sensor are attached to the paper sensor board. The signals detected by these sensors are sent to the PCNT board.

**g) LED board functions**

A toner detection LED is attached to the LED board. The LED is powered by drive current from the VR board, according to the control signals from the PCNT board.

**h) VR board functions**

The VR board receives 12 VDC voltage from the power supply unit, via the laser/scanner unit, and supplies drive current to the LED board to drive the LED.

**i) Toner sensor board functions**

A toner detection sensor is attached to the toner sensor board. The detected status is relayed to the PCNT board.

**This page intentionally left blank**

2.6.3 Component block diagram

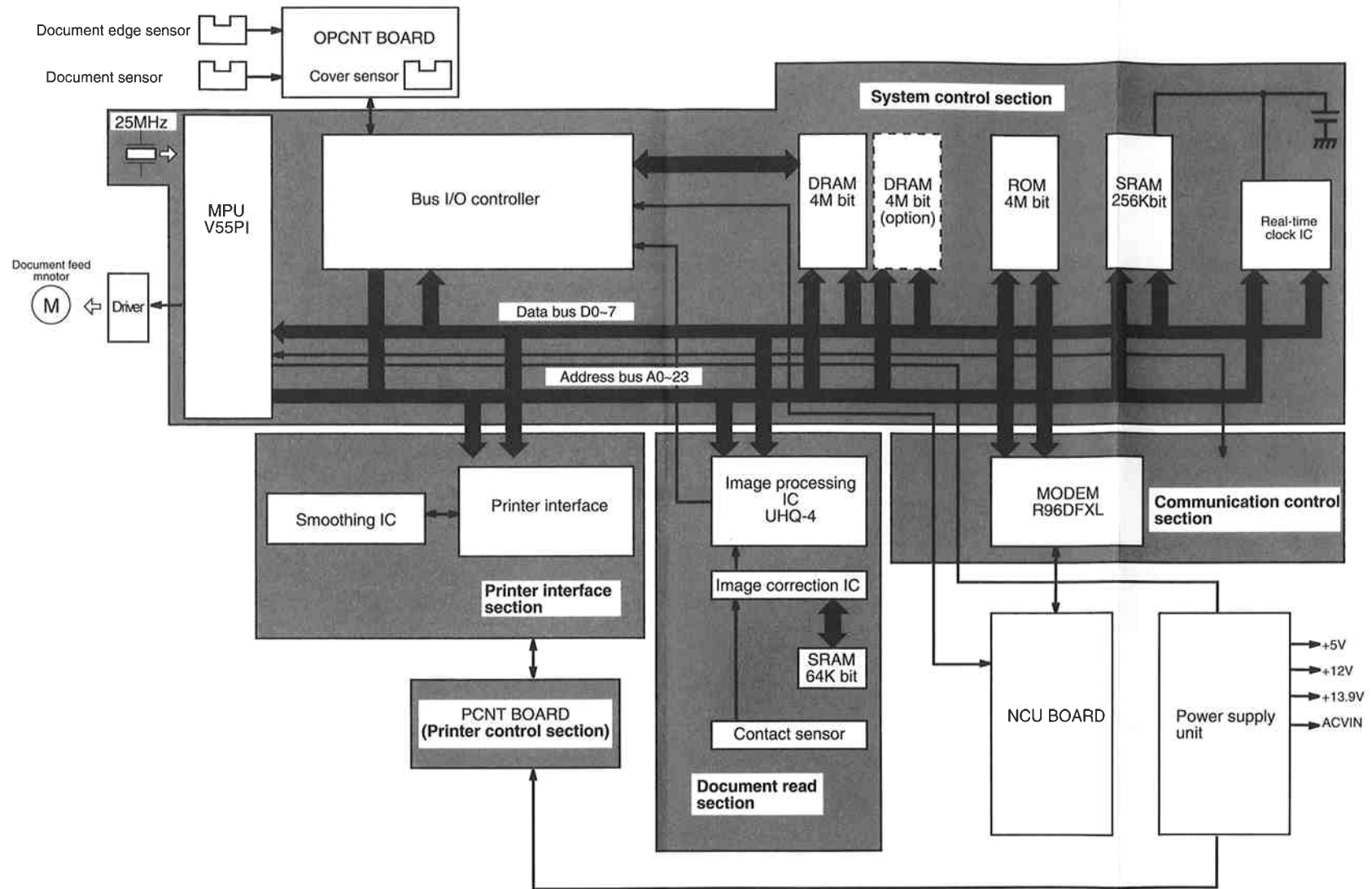


Figure 3-43 Components Block Diagram



**This page intentionally left blank**

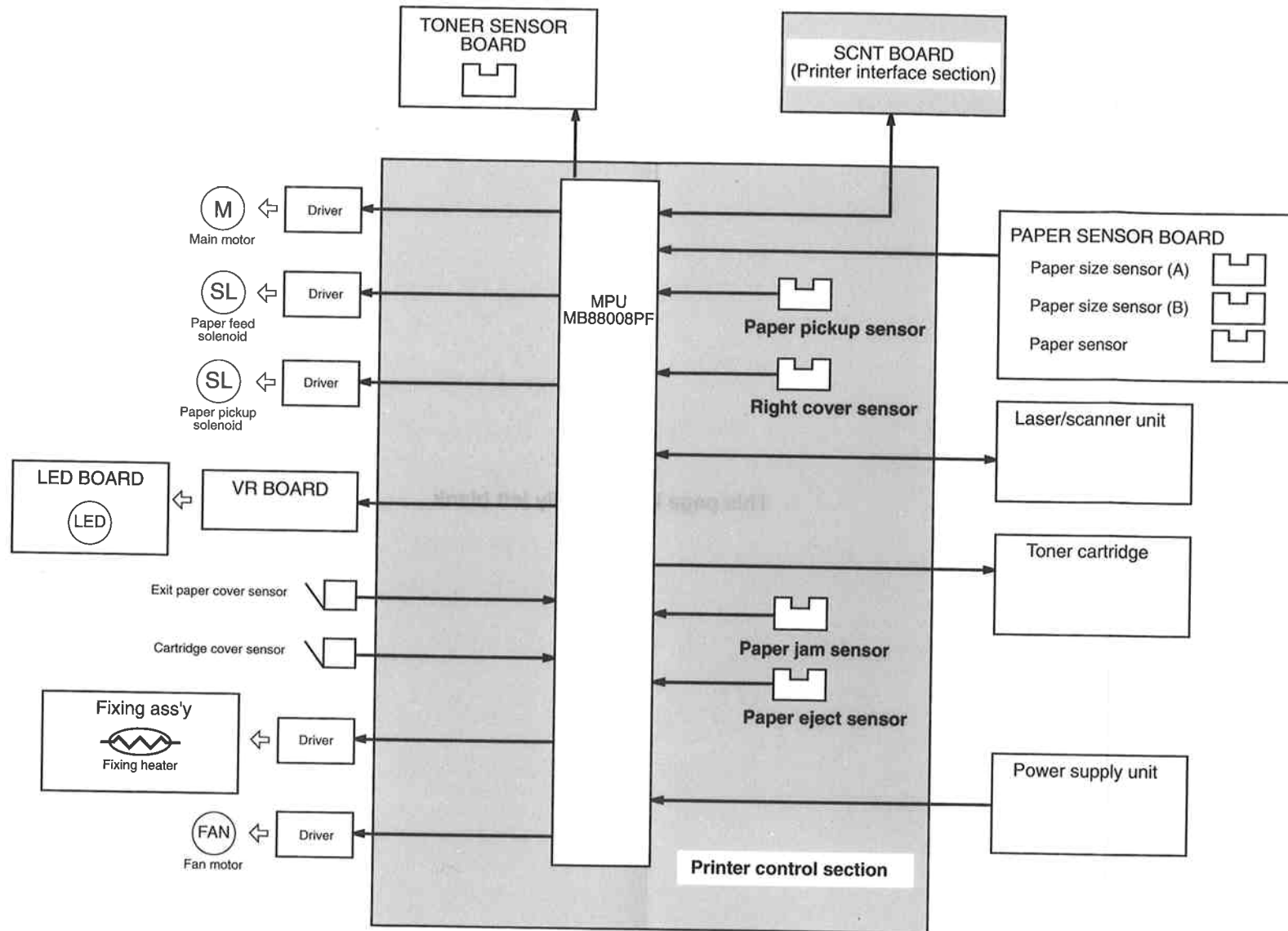


Figure 3-44 Components Block Diagram (PCNT board)

**This page intentionally left blank**

## 2.6.4 Components block diagram

### a) System control section

The system control section consists of the following components and controls the entire facsimile system.

#### a-1) MPU (IC1)

The MPU, on NEC  $\mu$  PD70433GD-5BB (V55PI), has the following main functions.

- 8-bit CPU
- 24-bit address bus
- 8-bit data bus
- Document feed motor control

#### a-2) Bus and I/O controller (IC3)

The Bus and I/O controller, on NEC  $\mu$  PD65641GM-029-3ED, has the following main functions.

- DRAM control
- OPCNT board interface
- DMA transfer to read image data DRAM
- NCU board control
- Document sensor and document edge sensor detection
- Imaging correction IC control

#### a-3) EP-ROM (IC12)

The 4-Mbit EP-ROM contains the control program for the operation section, read section, and communication control section of the fax.

#### a-4) DRAM (IC13)

A 512-kbit DRAM is used to store image data for delayed transmission, memory reception, and confidential reception, and as a work area.

#### a-5) SRAM (IC14)

The 256-kbit SRAM backed up with a lithium battery contains user data, service data, and image data management data.

#### a-6) Real-time clock IC (IC10)

A Epson RTC-4553A real-time clock IC, with a lithium battery, counts the time and date.

**b) Document read section**

The document read section consists of the following components and processes read image data.

**b-1) Image correction IC (IC5)**

The Canon LS500NA image correction IC, has the following main functions.

- Digitization of image data read with contact sensor
- Image processing, such as automatic slice level setting (Auto Background Control), and shading control
- Contact sensor interface
- SRAM interface

**b-2) Image processing IC (UHQ-4) (IC4)**

The Canon HG51b144FB image processing IC (UHQ-4), processes the image data digitized by the image correction IC as follows.

- Read density - document density conversion
- Edge emphasis processing
- Notch processing
- Error diffusion processing

**b-3) SRAM (IC16)**

A 64-kbit SRAM stores shading correction data from the image correction IC.

**c) Communication control section**

The communication control section consists of the following components and controls facsimile communication.

The modem IC (IC6) uses a Rockwell R96DFXL G3, and modulates the transmission data received from the CPU according to the ITU-T V.27ter., V.29. The modem G3-demodulates the incoming signals from the telephone line according to ITU-T V.27ter., V.29.

**d) Printer interface section**

The printer interface section consists of the following components and controls the printer section by conversion data from the system control section into print data and printer control commands.

**d-1) Printer interface IC (IC2)**

The Fujitsu MBCG24942 printer interface IC, has the following main functions.

- Printer interface
- Vertical scanning direction reduction processing (90/100%)
- APS: Auto laser Pulse Saving
- Smoothing IC control
- SRAM interface

**d-2) Smoothing IC (IC28)**

The smoothing IC, on Oki MSM91V067GS-V1K, converts of standard or fine data (horizontal resolution: 3.85 or 7.7 lines/mm) to superfine data (horizontal resolution: 15.4 lines/mm).

**d-3) SRAM (IC15)**

A 64-kbit SRAM stores print data from the printer interface IC.

**e) Printer control section**

The Printer control section consists of the following components and controls the LBP printer.

**e-1) MPU (IC301)**

The MPU (Fujitsu MB88008PF) has the following main functions.

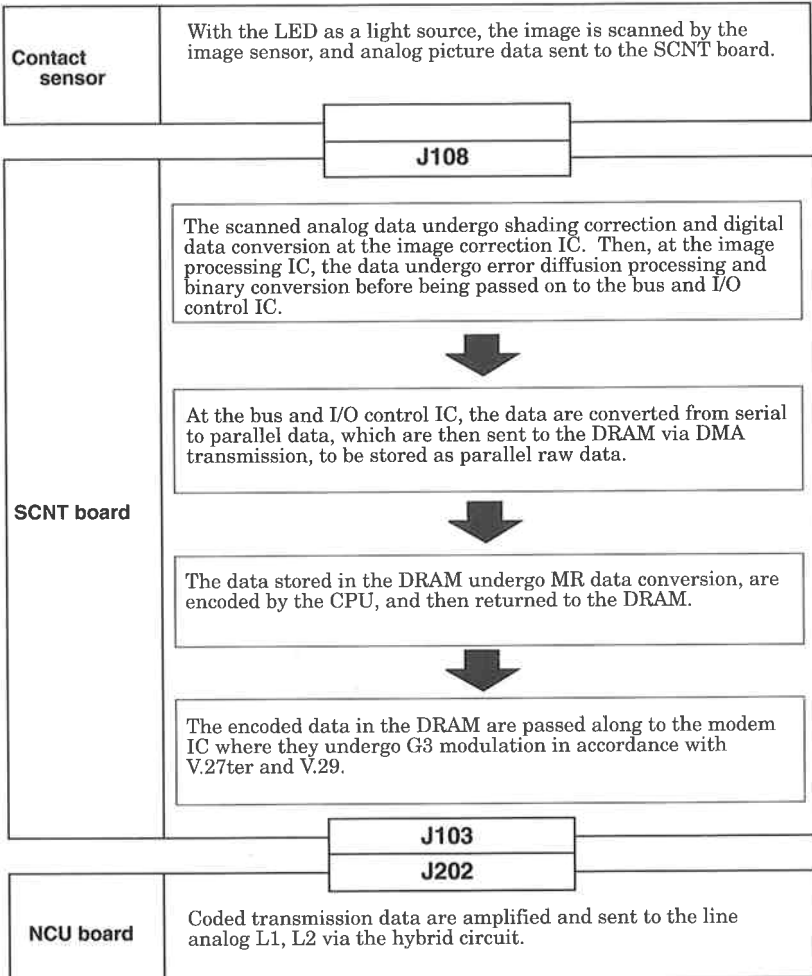
- 4-bit CPU
- Fixing heater control
- Thermistor detection
- Paper eject sensor, paper jam sensor, paper pickup sensor, cartridge cover sensor, exit paper cover sensor, toner sensor, right cover sensor, paper sensor, paper size sensor (A), and paper size sensor (B) detection
- Main motor control
- Toner cartridge, transfer charging roller high voltage control
- Fan control
- Paper pickup solenoid, and paper feed solenoid control
- SCNT board interface
- Scanner motor control
- Beam detection signal (-BD) detection
- Laser diode control
- LED board control
- Paper sensor, paper size sensor, and right cover sensor detection in the feeder section
- paper pickup solenoid, and paper LED control in the feeder section

**This page intentionally left blank**



## 2.6.5 Image signal flow

### a) G3 transmission



**Figure 3-45 G3 Transmission Image Signal Flow**

b) G3 reception

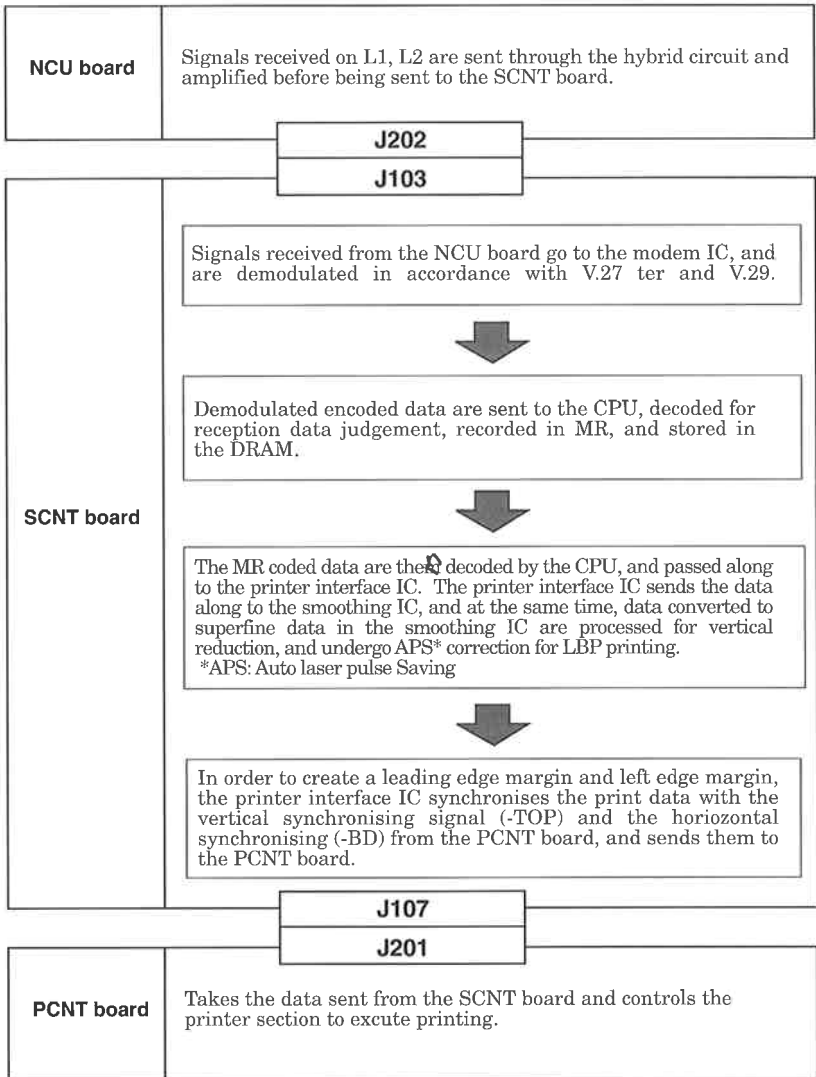


Figure 3-46 G3 Receive Image Signal Flow

**This page intentionally left blank**

## 3. COMMUNICATION SYSTEM OPERATIONS

### 3.1 FAX/TEL Switching

This fax is set for automatically switching between fax and telephone use on the same telephone line. If the other party is a fax, the fax is received automatically, and if the other party is a telephone, the pseudo-ring is rung to alert the user. At this time, a pseudo-ringback tone signal is sent to the other fax.

#### 3.1.1 Operation specifications

- a) **FAX/TEL switching method:** CNG, 2nd NSS, re-order tone (ROT) detection technique
- b) **Pseudo-CI:** None
- c) **Voice response (OGM):** None



#### Signal detection timing

CNG, 2nd NSS, and re-order tone (ROT) are detected while the pseudo-ringback tone signal is off.

#### CNG detection

The CNG signal is detected by the modem. The second time it is detected, reception starts.

#### Re-order tone

This is a signal transmitted from the exchange when the other party disconnects the line after the line has been connected. However, some exchanges do not send the re-order tone.

#### Off-hook detection

If the handset or extension telephone is picked up while the pseudo-ring is ringing, the off-hook state is detected and the telephone call starts.



For details on the 2nd NSS, refer to 4.3 *Canon Express Protocol 2*.

### 3.1.2 Operation settings

- 1) Set "RX MODE" in user data to "FAX/TEL AUTO SW".
- 2) Press the ANS HOOK UP/MANUAL key to extinguish the ANS HOOK UP/MANUAL lamp.
- 3) User data "F/T SWITCH ACTION" sets the operation after the completion of pseudo-RBT transmission to either "RECEIVE" or "DISCONNECT".

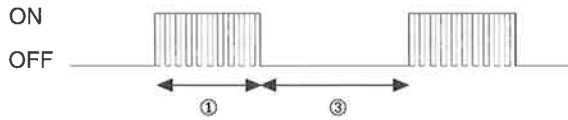
### 3.1.3 List of related parameters

Item	Default setting	Setting switch	Selection range
Pseudo-RBT transmission from CML on Time until start	4 s	Service data	0-9 s.
User call start time	6 s	User data	0-30 s.
User call time	15 s	User data	15-300 s.
Operation after user call	RECEIVE	User data	RECEIVE/DISCONNECT
Pseudo-RBT frequency	400 Hz	None	None (fixed)
Pseudo-RBT pattern On time	1000 ms	Service data	0-9990 ms
Pseudo-RBT pattern Off time (short)	0 ms	Service data	0-9990 ms
Pseudo-RBT pattern Off time (long)	2000 ms	Service data	0-9990 ms
Pseudo-RBT transmission level	-21 dBm	Service data	-1, -21 dBm
Pseudo-ring frequency	25 Hz	None	None
Pseudo-ring sound pattern On time	1000 ms	Service data	0-9990 ms
Pseudo-ring sound pattern Off time (short)	0 ms	Service data	0-9990 ms
Pseudo-ring sound pattern Off time (long)	2000 ms	Service data	0-9990 ms
CNG, ROT detection level	-38 dBm	Service data	-25 to -49 dBm



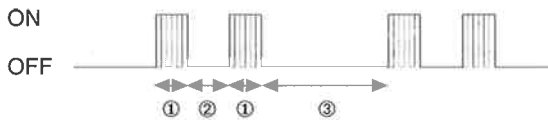
For service data parameter numbers, see *Chapter 2: 3.4.4 Explanation of service data.*

When the pattern OFF time (short) is 0 ms



**Figure 3-47 Pseudo-Ringback Tone/Pseudo-ring Signal Pattern 1**

When the pattern OFF time (short) is not 0 ms



**Figure 3-48 Pseudo-Ringback Tone/Pseudo-ring Signal Pattern 2**

- ①: **Pattern On time**
- ②: **Pattern Off time (short)**
- ③: **Pattern Off time (long)**



When the pseudo-ringback tone is on, the 400Hz signal is switched on/off every 30 ms. While the DRPD function is working, the above pseudo-ring signal pattern is ignored and the pseudo-ring signal pattern set with user data "DRPD" is set.



For details on the DRPD function, see 4.8 *DRPD Function* in this chapter.

### 3.1.4 Operation procedure summary

(The values are all default settings.)

- 1) After the CML relay comes on, there are for another 4 seconds of no-sound and CNG, 2nd NSS, and the re-order tone are monitored.
  
- 2) During this time, if CNG or the 2nd NSS is detected, reception is started immediately. If the re-order tone is detected, the line is released and this fax goes back on standby. If none of these signals can be detected, this fax transmits the pseudo-ringback tone to the line and at the same time rings the pseudo-ring tone to alert the user.  
Even while the user is being called, during the period in which the pseudo-ringback tone pattern is off (② in the figure on the next page), the fax continues to monitor CNG, 2nd NSS, and the re-order tone continues.
  
- 3) If the above signals can not be detected during the user call period (⑦ in the figure on the next page), the fax moves into reception. However, if user data "F/T SWITCH ACTION" is set to "DISCONNECT", the line is disconnected.



Communications with Canon Express Protocol 2 are possible even with the FAX/TEL switch and ANS HOOK UP mode.  
Canon Express Protocol 2 only works between faxes equipped with that function. Communications with faxes equipped only with Canon Express Protocol 1 must use Canon Express Protocol 1.

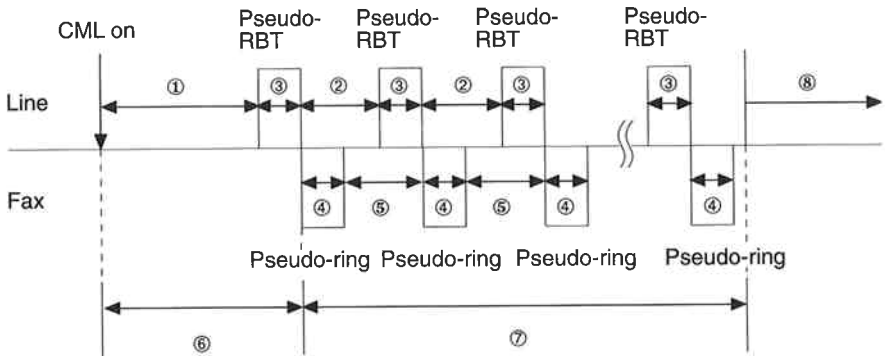
---



For details on the 2nd NSS and Canon Express Protocol 2, see 4.3 *Canon Express Protocol 2*.

---

### Operation Flow Example (when other party is telephone or manually transmitting fax)



**Figure 3-49 FAX/TEL Switching**

- ①: **Time from when CML comes on until pseudo-RBT transmission starts**  
Default value 4 seconds; can be set to from 0 to 9 seconds with Service Data #3 Parameter 16
- ②: **Pseudo-RBT pattern Off time (long)**  
Default value 2 seconds; can be set to from 0 to 9.99 seconds with Service Data #3 Parameter 19
- ③: **Pseudo-RBT pattern On time**  
Default value 1 second; can be set to from 0 to 9.99 seconds with Service Data #3 Parameter 17
- ④: **Pseudo-ring pattern On time**  
Default value 1 second; can be set to from 0 to 9.99 seconds with Service Data #3 Parameter 20
- ⑤: **Pseudo-ring pattern Off time (long)**  
Default value 2 seconds; can be set to from 0 to 9.99 seconds with Service Data #3 Parameter 22
- ⑥: **Ringing start time**  
Default value 6 seconds; can be set to from 0 to 30 seconds with user data
- ⑦: **Ringing time**  
Default value 15 seconds; can be set to from 15 to 300 seconds with user data
- ⑧: **Operation after reception**  
Default value "RECEIVE"; can be changed to "DISCONNECT" with user data.



If CNG or the 2nd NSS is detected between ① and ②, the fax moves into automatic reception. If the re-order tone is detected, the fax release, the line and returns to standby.



### 3.2 Answering Machine Connection

This is for effective use of an answering machine connected to the extension phone jack. If the other party is a telephone, the answering telephone records the message and if the other party is a fax, the fax receives automatically.

#### 3.2.1 Operating specifications

(The values are all default settings)

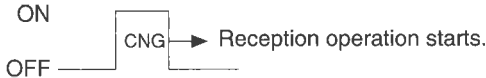
- a) **ANS/FAX switching method** CNG, 2nd NSS, no-sound detection (The values are all default settings.)



---

#### CNG detection

Reception takes place when CNG has been detected. The On detection duration is 400-600 ms; Off is not detected.



**Figure 3-50 CNG Pattern**

#### No-sound detection

No-sound detection is used for faxes that do not transmit CNG. If 6 consecutive seconds of no sound are detected within 60 seconds of the answering machine detecting the ringing signal, the fax shifts into reception operations.

If the user data "ANS/FAX SWITCH" setting is "OFF", no-sound detection is not carried out.

#### DTMF detection

If two digits of 0-9, #, or \* signals are detected, CNG detection is stopped and after that, reception does not start. However, if the detected DTMF signals match the 2-digit ID number set for remote reception, reception starts.

---

### 3.2.2 Operation setting

- 1) Connect the answering machine to the extension phone jack and set the answering machine to "**Answer**".
- 2) Press this fax's ANS HOOK UP/MANUAL key. The ANS HOOK UP lamp lights up.
- 3) When putting the fax into reception mode by detecting no-sound on the line, set the user data "**ANS/FAX SWITCH**" to "**ON**", then set the no-sound time with the user data "**ANS/FAX SWITCH TIME**".

### 3.2.3 List of related parameters

Item	Default setting	Setting switch	Selection range
ANS/FAX SWITCH	ON	User Data	ON/OFF
ANS/FAX SWITCH TIME	6 seconds	User data	1-99 seconds
No-sound detection level	-38 dBm	Service data	-25 to -49 dBm
Signal detection time	60 seconds	Service data	0-999 seconds



For service data parameter numbers, see *Chapter 2: 3.4.4 Explanation of service data.*

### 3.2.4 Operations procedure summary

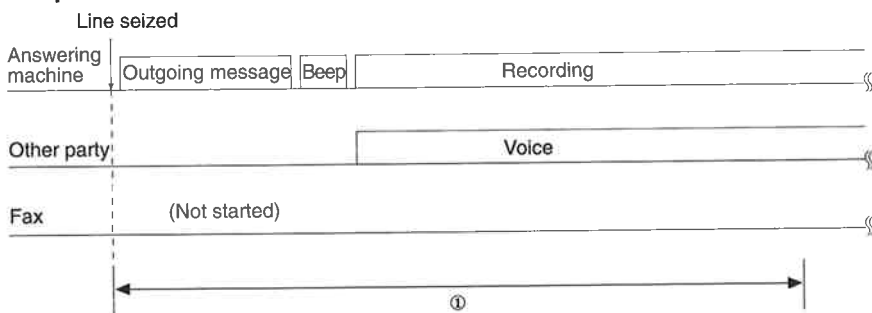
#### a) When the other party is a person

- a-1) When the line is seized, the answering machine operates.
- a-2) From the point in time at which the answering machine seize the line, this fax monitors CNG, 2nd NSS, and no-sound for up to 60 seconds. During this time, if the fax detects that the answering machine is on-hook, it disconnects and goes on standby.



When the user data "ANS/FAX SWITCH" is set to "ON", no-sound is detected for 6 seconds (default setting) and reception starts.

#### Operation flow



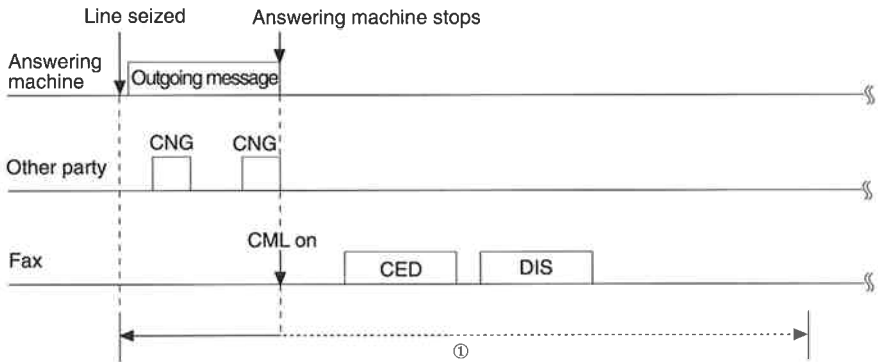
**Figure 3-51 Answering Machine Connection 1**

- ①: CNG, 2nd NSS, no-sound detection time  
60 seconds maximum

**b) When the other party is a fax that transmits CNG**

- b-1)** When the line is seized, the answering machine operates.
- b-2)** From the point in time at which the answering machine seized, this fax monitors CNG, 2nd NSS, and no-sound for up to 60 seconds. During this time, if the fax detects that the answering machine is on-hook, it disconnects and goes on standby.
- b-3)** If CNG is detected twice during this time, reception starts.

**Operation flow**



**Figure 3-52 Answering Machine Connection 2**

①: CNG, 2nd NSS, no-sound detection time  
60 seconds maximum

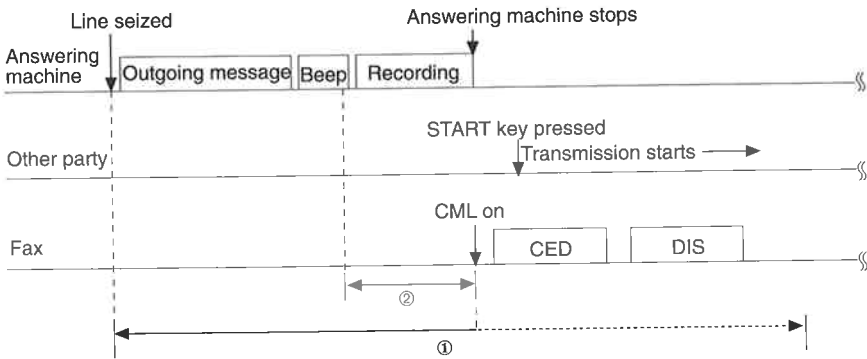


Sometimes the outgoing message sent by the answering machine and CNG are sent at the same time and CNG can not be detected. After CML comes on, direct current feed to the answering machine is stopped to stop the answering machine.

**c) When the other party is a fax that does not transmit CNG or a fax transmitting manually**

- c-1)** When the line is seized, the answering machine operates.
- c-2)** From the point in time at which the answering machine seizes the line, this fax monitors CNG, 2nd NSS, and no-sound for up to 60 seconds. During this time, if the fax detects that the answering machine is on-hook, it disconnects and goes on standby.
- c-3)** When the answering machine starts recording operations, if 6 seconds (default setting) of no sound are detected, the fax moves to reception.

**Operation flow (when other party is transmitting manually)**



**Figure 3-53 Answering Machine Connection 3**

- ①: **CNG, 2nd NSS, no-sound detection time**  
60 seconds maximum
- ②: **No-sound time**  
Default setting 6 seconds; can be set to from 1 to 99 seconds with user data

### 3.3 Remote Reception

You can receive by dialing the remote reception ID from the extension telephone and putting the extension telephone on-hook.

#### 3.3.1 Operation specifications

##### Remote switching type: ID Call #

Remote reception ID number dialed on extension telephone (tone/pulse)

##### Remote switching method: Hook

After extension telephone goes off-hook, then on-hook, CNG and 2nd NSS are detected.



The condition for operations is that off-hook be detected after the ring signal is detected one or more times. Also, if the fax is set for tones, remote reception with pulse dialing is not possible.



##### CNG detection

Reception takes place when CNG has been detected.



**Figure 3-54 CNG Pattern**

On detection time: 400-600 ms

##### DTMF detection

The DTMF signals input as the remote reception ID are detected with the modem.

### 3.3.2 Operation settings

User data "REMOTE RX" is set to "ID CALL #" or "HOOK".



---

**The type of remote switching depends on the reception mode.**

Manual reception setting: ID CALL # or HOOK possible  
FAX/TEL switching setting: Only ID CALL # possible  
Answering machine mode setting: Only ID CALL # possible

---

### 3.3.3 List of related parameters

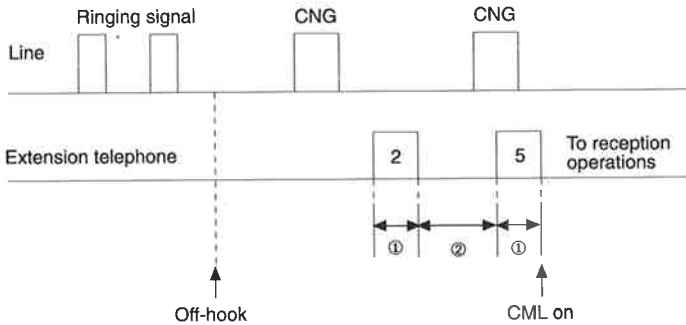
Item	Default setting	Setting switch	Selection range
REMOTE RX	ID CALL #	User data	ID CALL #/HOOK/NO
REMOTE RX ID	25		User data 00-99

### 3.3.4 Operation procedure summary

#### a) ID CALL # (ID input) method

- a-1) When the line is seized, after the extension telephone goes off-hook, then dial the remote reception ID. (The default setting is 25.)
- a-2) The line is switched to FAX, CED and DIS are transmitted, and the fax moves into reception operations.

#### Operation timing example (tone setting)



**Figure 3-55 Remote Reception (ID CALL #)**

- ①: **DTMF on time**  
100 ms min. (fixed)
- ②: **DTMF off time**  
100 ms min. (fixed)



For the ID CALL # (ID input) method, CNG is not detected.



## 4. NEW FUNCTIONS

### 4.1 Quick-on-line TX

For memory transmission, if no other communications are being carried out while the first page is being accumulated into memory, dialing starts and transmission starts. Unlike previous machine, the time until the start of dialing can be greatly reduced.

This function is valid when the user data **TX SETTING** item "**QUICK-ON-LINE TX**" is "**ON**".

#### Operation Specifications

- a) At the start of scanning of the first page, if the amount of used image memory is 92% or more (96% or more with optional memory mounted), direct transmission is used.
- b) The documents are transmitted in the order in which they are accumulated into memory.
- c) This function only works for memory transmission to one destination. (It does not work for broadcast transmission.)



If a jam or other document feed error occurs during transmission, the line is released the moment the error occurs and the transmission ends in an error. For all-white and other documents for which the transmission time is short compared to the scanning time, communications take longer than when the entire image is scanned before transmission.

When accumulation in memory can not keep up with scanning and for G3 transmission, when the image data for one line is less than the minimum transmission time, fill is inserted, and for ECM transmission the frame length is adjusted by continuing to emit 0s (flags) until the next frame comes.

### 4.2 Superfine Communications with Other Companies' Fax Machines

Since this fax supports the high resolution recommended by the ITU-T (formerly CCITT), it can communicate in superfine mode (8 pels x 15.4 lines) with other companies' fax machines equipped with the same function.

For transmission, if the user specifies superfine resolution, if the receiving machine DIS Bit 41 is 1, this fax sets its DCS Bit 41 to 1 and sends it. This makes enables superfine communications with other companies' fax machines.



Since this fax does not have superfine recording capacity, superfine mode does not work for reception.

If the other fax machine is a Canon fax that has both Canon superfine mode and the ITU-T (formerly CCITT) recommended superfine mode, the ITU-T (formerly CCITT) recommended superfine mode takes precedence.

### 4.3 Canon Express Protocol 2

In order to reduce transmission time, this protocol changes the pre-protocol portion of the previous Express Protocol (C. E. P 1). The high-speed signal portion and post-protocol portion of C.E.P 2 are the same as for C.E.P 1.

C.E.P 2 only works with another Canon fax machine with this function. Communications with Canon fax machines equipped only with C.E.P 1 switch automatically to C.E.P 1.

#### 4.3.1 Operations Summary

For automatic transmission, in order to give the C.E.P 2 start instruction before the receiving fax machine sends CED, this fax sends the 2nd NSS with one-second intervals immediately after the end of dialing. (It does not send CNG.)

When the receiving fax machine receives the 2nd NSS after CML comes on and before it sends CED, it sends CFR and waits for the high-speed/low-speed signal. When the transmitting fax machine receives CFR, it starts sending high-speed signals. The rest of the procedure is the same as for C.E.P 1.

#### 4.3.2 Operation conditions

**a) All of the conditions for C.E.P 1 must be observed.**

- Express protocol must not be inhibited (on the transmission or the reception fax machine).
- ECM must not be inhibited (on the transmission or the reception fax machine).
- The transmission speed must not be restricted to 7200 bps or lower (on the transmission or the reception fax machine).
- Long Distance must not be set in one-touch speed dialing or coded speed dialing registration (transmission fax machine).
- Confidential transmission, relay control, and closed network transmission must not be set (transmission fax machine).
- Direct mail prevention or closed network reception must not be set (reception fax machine).
- The other fax machine must be registered for one-touch speed dialing or coded speed dialing (transmission fax machine).
- The following errors must not have occurred within the last 5 communications (transmission fax machine).
  - Communications ended in an error.
  - PFR, FIT, or RTN was received.
  - After high-speed signal transmission, DIS was received.
  - In express protocol, a low-speed Q signal was transmitted.

- b) This fax machine must have already transmitted to the other fax machine using protocol recommended by ITU-T (formerly CCITT), or with C.E.P 1, and have stored the other fax machine's data (DIS, NSF) into memory (transmission fax machine).

By storing the capacity of the receiving fax machine into memory before hand, this fax machine makes reception of the reception fax machine's NSF, CSI, and DIS unnecessary.

- c) The call must not be manual or an automatic redial (transmission fax machine).

Redialing does not use C.E.P 2, even if the other conditions are fulfilled.

### 4.3.3 Standard protocol

Since the transmission fax machine cannot identify when the reception fax machine seizes the line, from immediately after the completion of dialing, it sends the 2nd NSS consecutively, and after it receives CFR, it starts the high-speed signals.

When the reception fax machine receives the 2nd NSS immediately after CML comes on, it starts transmission of high-speed signals 1.2 seconds after the start of reception of the 2nd NSS.

At the head of the high-speed signals are added training signals + flags + high-speed NSS, TSI, and DCS, so the pre-protocol takes at least 2 seconds.

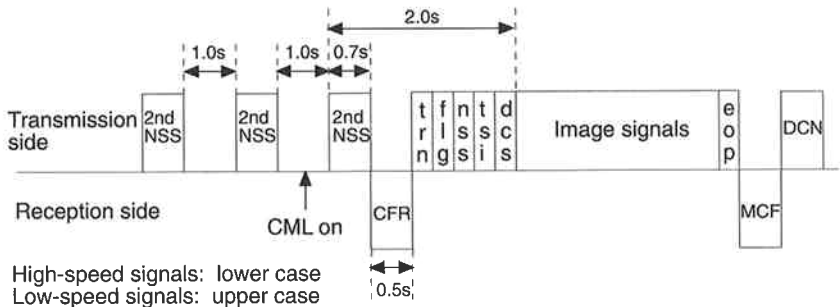


Figure 3-57 Canon Express Protocol 2

**Communication time when the 2nd NSS is detected immediately after CML comes on (9600 bps, CCITT No. 1 chart)**

C.E.P 2: Pre-protocol 2 s + Image transmission 9 s + post-protocol 1 s

(C.E.P 1: Pre-protocol 10 s + Image transmission 9 s + post-protocol 1 s)



The 2nd NSS is a low-speed (300 bps) signal including the ITU-T (formerly CCITT) member's code, maker code, C.E.P 1. 2 identification, data signal speed, and image frame size data. Since the reception fax machine detects the 2nd NSS immediately after CML comes on, it uses C.E.P 2 even when it is in FAX/TEL switching mode or ANS/FAX switching mode.

---

#### 4.3.4 Transmission side operations

- 1) For transmission, the transmission fax machine checks whether C.E.P 2 can be used, based on the above operation conditions. If C.E.P 2 cannot be used, the transmission fax machine starts the communications procedure recommended by the ITU-T (formerly CCITT) protocol or C.E.P 1.
- 2) If C.E.P 2 can be used, the transmission fax machine sends the 2nd NSS with one-second intervals.
- 3) When it receives CFR in response to the 2nd NSS, it sends NSS (TSI) DCS at high speed. From here on, the procedure is the same as C.E.P 1.
- 4) When it receives a signal other than CFR (CED, DIS, etc.) in response to the 2nd NSS, the transmission fax machine starts the communications procedure recommended by the ITU-T (formerly CCITT) protocol.
- 5) If the T1 time (35 s) passes without the transmission fax machine being able to receive a meaningful signal, it releases the line.



Since the other fax machine's data is not backed up, if the one-touch speed dialing or coded speed dialing is reregistered or the power is switched off, then on again, the data for the other fax machine are erased and communications start with the communication procedure recommended by the ITU-T (formerly CCITT) protocol.

---

#### 4.3.5 Reception side operations

- 1) After the call arrives, the reception fax machine checks if C.E.P 2 can be used, based on the above operation conditions. If C.E.P 2 can not be used, the reception fax machine carries out the communications procedure recommended by the ITU-T (formerly CCITT) protocol or C.E.P 1.
- 2) If C.E.P 2 can be used, after the line is connected, the reception fax machine monitors for the 2nd NSS from when CML comes on until the transmission of CED.
- 3) If the 2nd NSS could not be detected within this time, the reception fax machine starts the communications procedure recommended by the ITU-T (formerly CCITT) protocol or C.E.P 1 and sends CED.

- 4) When the reception fax machine receives the 2nd NSS, if the contents (data communications speed) are valid, it sends CFR and waits for high-speed signals. If the contents are not valid, it starts the communications procedure recommended by the ITU-T (formerly CCITT) protocol or C.E.P 1 and sends CED.
- 5) When the reception fax machine receives the high-speed signals, it checks the contents of NSS (TSI) DCS at the head of those signals and if those contents match its own capacity, it continues reception. From here on the procedure is the same as C.E.P 1.



---

If the contents of NSS (TSI) DCS do not match the reception fax machine's capacity, after completion of high-speed signal reception, it returns NSF (CSI) DIS and the transmission fax machine resends the image with the communications procedure recommended by the ITU-T (formerly CCITT) protocol or C.E.P 1.

---

#### 4.4 Processing When Memory Scanning Is Full

If image storage memory become full, document scanning is paused, but transmission continues as is. When the Q signal for the page before memory full is sent, scanning resumes. In this way, a memory full transmission error is prevented.

##### 4.4.1 Specifications

- a) When memory full is detected during image storage, if other communications operations are being carried out, the call is placed when the line is free.
- b) When memory full is detected during image storage, document scanning is stopped and "**MEMORY FULL PLEASE WAIT**" is displayed on the display, but transmission continues as is.

#### 4.5 Forced Reduction

When received images are recorded, the document is forcibly reduced to the specified reduction ratio in the vertical scanning direction to prevent image loss. The image is centered in the middle of the recording paper.

When the reduction ratio is fixed with the user data setting, the image reduction ratio is 90%.

##### 4.5.1 Setting method

Switch the user data "**PRINTER SETTINGS**" item "**RX REDUCTION**" "**ON**" and set "**FIXED REDUCTION**".

## 4.6 Selected Transmission Result Report Output

The user data has a setting that allows you to select just before each transmission whether or not the fax will print a report for that transmission.

### 4.6.1 Output method

- 1) Set the user data "USER SETTINGS" item "PROGRAM KEY" to "PRINT REPORT".
- 2) Set the document and press the program key.
- 3) The fax asks whether or not to print a transmission report by displaying "(YES=\*) (NO=#)" on the display, so press the \* key.
- 4) Dial the other fax's telephone number.



---

To automatically output the transmission result report each time, set the user data "REPORT SETTINGS" item to "TX REPORT".  
When the fax machine is set to output transmission result reports, the transmission image is attached to the report.

---

## 4.7 Memory Transmission Check Start

The user data can set two methods for checking destinations for memory transmission.

- a) After one destination is specified, if the next destination is not specified within 5 seconds, the fax machine judges that there is only one destination and makes the call. If another destination is specified within 5 seconds, the fax machine judges this to be broadcast transmission. From then on, if the next destination is not specified within 10 seconds, the fax machine judges that all the destinations have been specified and starts the calls.
- b) For both broadcast and one-destination transmission, memory scanning starts when the Start key is pressed. If the Start key is not pressed for one minute, the fax machine goes on standby.

### 4.7.1 Setting method

- a) To set the method described in a) above, set the user data "TX SETTINGS" item "TIME OUT" to "ON".
- b) To set the method described in b) above, set the user data "TX SETTINGS" item "TIME OUT" to "OFF".

## 4.8 DRPD (Distinctive Ringing Pattern Detection) function

This function enables the fax to recognize and answer certain special ringing patterns generated from the telephone exchange. This allows the user to set up the facsimile to receive telephone and facsimile transmissions with different numbers on the same line. The user can also receive telephone and facsimile transmissions to the same number on one line.

This feature works together with optional services provided by some local phone companies. Using a single telephone line, separate numbers are given to fax calls and telephone calls based on a designated ring pattern which, when dialled, will ring at the same telephone line with its own distinctive ring. Therefore, each call is answered properly as a fax or telephone call.

There are five ring patterns that the user can set for a telephone number, a facsimile number, or a number that is to be used for both the fax and telephone. Each pattern can be selected for one of three modes:

- **FAX mode:**

The setting for the phone number that is to be used for the facsimile.

- **TEL mode:**

The setting for the phone number that is to be used for the telephone.

- **FAX/TEL SWITCH mode:**

The setting for the phone number that can be used for automatic switching between telephone and facsimile operation.

A user's telephone number and user's ID can be registered for each ringing pattern.

When registering the sender's ID, the sender's telephone number can also be registered.

### 4.8.1 Setting method

Set "DRPD" within "RX MODE" in the "RX SETTINGS" data registration item, select the selective ring patterns, and register the user name, user number (TTI), and rx mode.



---

When DRPD is set, if automatic FAX/TEL switching is set in RX mode, the **RING START TIME**, **F/T RING TIME**, and **F/T ACTION** can be changed as follows.

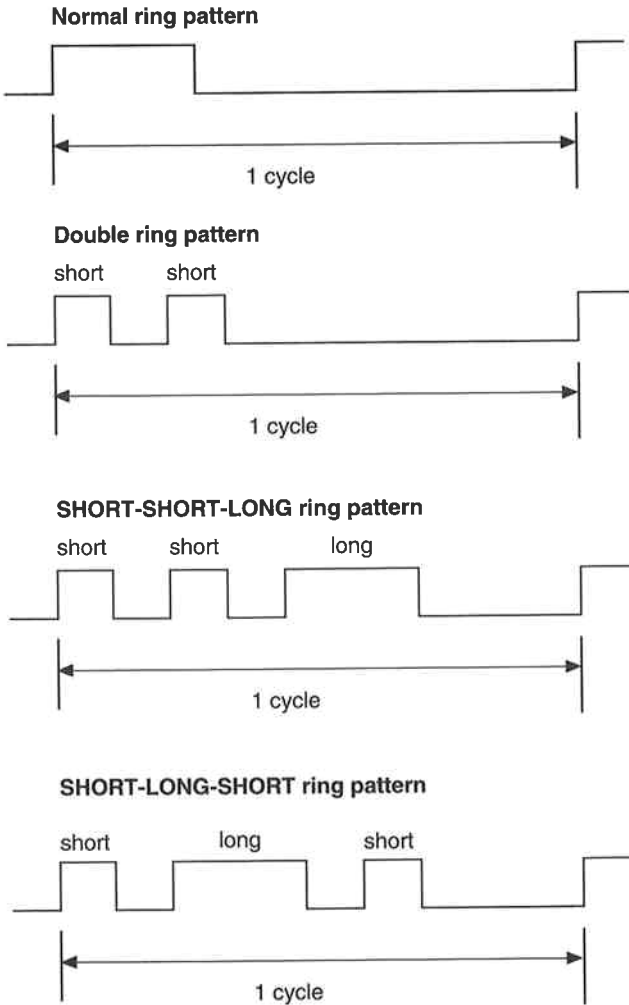
**RING START TIME:** 00 - 30 seconds (default setting: 6 seconds)

**F/T RING TIME:** 15 - 300 seconds (default setting: 15 seconds)

**F/T SWITCH ACTION:** Can be changed to **RECEIVE** or **DISCONNECT**. (default setting: **RECEIVE**)

---

### 4.8.2 DRPD ring patterns (Ringing voltage patterns)



**OTHER ring pattern**

ALL ring patterns other than the above.

**Figure 3-58 DRPD Ring Pattern (Ringing Voltage Patterns)**



# ***Chapter 4***

## ***Maintenance and Service***

# 1. MAINTENANCE

## 1.1 Maintenance Items

### 1.1.1 Consumables

<b>Responsibility of</b>	<b>Consumable</b>	
User	Toner cartridge	Canon FX 2 Cartridge
	Recording paper	Canon NP Copier Paper Dry Toner A4 Canon Copy Paper for Dry Toner Copies Copier LTR Premium Paper Copier LGL Premium Paper
Service technician	None	

### 1.1.2 Cleaning

<b>Responsibility of</b>	<b>Section to clean</b>	<b>When to clean</b>
User	Main unit outer cover	When dirty
	Separation roller	When the document separation performance fails.
	Loading roller	When the document feed performance fails.
	Separation guide	When the document feed performance fails.
	Scanning glass	When black vertical stripes appear in copied or transmitted images.
	Document pickup/eject rollers	When the document feed performance fails.
Service technician	Mirror	When black or white vertical stripes in copied or received images.
	Transfer charging roller	When marks on back of paper or blank spots at intervals of 1.73" (44 mm) in copied or received images.
	Fixing film	When marks at intervals of 2.95" (75 mm) or poor fixing in copied or received images.
	Fixing entrance guide	When marks , marks on back of paper, irregular/smudged black vertical line, paper jam, or wrinkles in copied or received images.
	Fixing pressure roller	When marks on back of paper at intervals of 1.97" (50 mm), poor fixing, paper jam, or wrinkles in copied or received images.
	Fixing eject roller	When paper jam in copied or received images.
	Fixing eject guide	When paper jam in copied or received images.
	Paper feed guide	When marks, or marks on back of paper in copied or received images.
	Static charge eliminator	When polka dots in copied or received images.
	High voltage terminal	When copied or received images are light, dark, or completely blank.

### 1.1.3 Periodic inspections

Responsibility of	Inspection section	When to inspect
User	None	_____
Service technician	None	_____

### 1.1.4 Periodic replacement parts

Responsibility of	Periodic replacement parts	When to replace
User	None	
Service technician	Separation roller/ Loading roller	When scanned document count exceeds approx. 50,000 pages.
	Separation guide	When scanned document count exceeds approx. 30,000 pages.
	Pickup roller/ Separation pad	When printed document count exceeds approx. 50,000 pages.

## 1.2 Tools

### 1.2.1 General tools

<b>Tool</b>	<b>Use</b>
Phillips screwdriver	Removing/driving screws
Flat blated screwdriver	Removing/driving screws
Precision Phillips screwdriver	Adjust VR
Precision flat blated screwdriver	Removing plastic tabs
Hex wrench	Removing hex socket setscrew
Tweezers	Removing coil springs
Pliers	NCU board removal
Digital volt meter	Check Laser light volume
Blower brush	Clean mirror
Lint-free paper	Clean transfer charging roller, mirror, fixing film
Isopropyl alcohol	Clean mirror, fixing film, fixing entrance guide, fixing pressure roller, fixing eject roller, fixing eject guide, static charge eliminator
Setsquare	Check alignment of print image
Ruler	Measure leading edge margin of print image

### 1.2.2 Special tools

<b>Tool</b>	<b>Use</b>	<b>Part Number</b>
Grease (FLOIL GE676)	Applied to specified locations	CK-0544
Grease (Permalub G-2)	Applied to specified locations	CK-0551
Printer driver checker	Check laser light volume	RY9-0093
External cable	Connect printer driver checker to the main unit	HY9-0005

## 2. CLEANING

### 2.1 Separation Roller

Open the control panel and wipe any dirt off the separation roller with a soft, dry cloth.

### 2.2 Loading Roller

Open the control panel and wipe any dirt off the loading roller with a soft, dry cloth.

### 2.3 Separation Guide

Open the control panel and wipe any dirt off the separation guide with a soft, dry cloth.

### 2.4 Scanning Glass (Contact Sensor)

Open the control panel and wipe any dirt off the scanning glass with a soft, dry cloth.

### 2.5 Document Feed Roller/Eject Roller

Open the control panel and wipe any dirt off the pickup roller/eject roller with a soft, dry cloth.

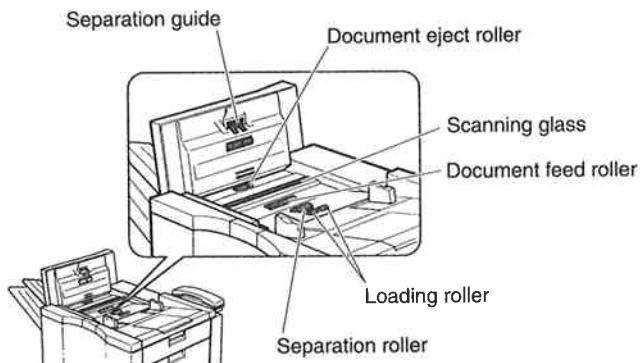


Figure 4-1 Cleaning Locations 1



Do not use tissues. Dust from them can cause static charge.

## 2.6 Mirror

### 2.6.1 Using blower brush

#### a) Preparations for cleaning

Open the cartridge cover and remove the toner cartridge.

#### b) Cleaning

Clean with the blower brush.

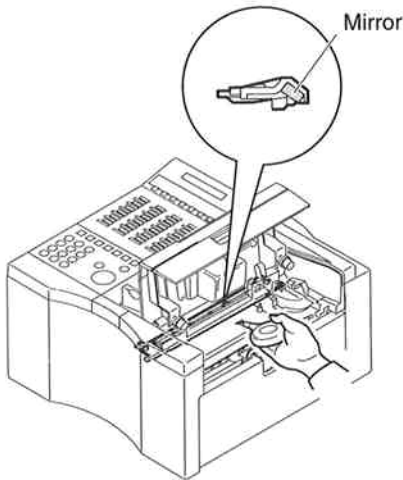


Figure 4-2 Cleaning Locations 2

### 2.6.2 Using lint-free paper

If the blower brush can not remove all the dirt, clean with lint-free paper.

#### a) Preparations for cleaning

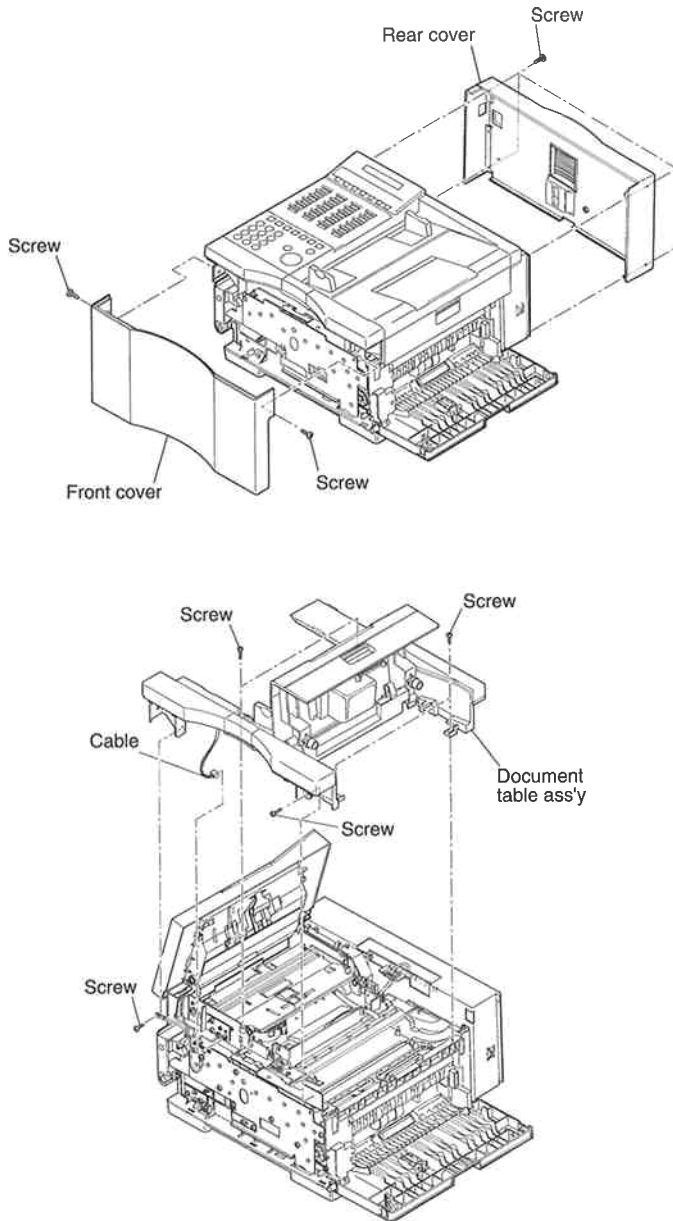
- (1) Open the cartridge cover and remove the toner cartridge.
- (2) Remove the six screws and remove the rear cover and the front cover. (Figure 4-3)
- (3) Remove the six screws, disconnect the cable, and remove the document table ass'y. (Figure 4-3)
- (4) Remove the two screws and remove the mirror. (Figure 4-4)
- (5) Remove the rod from the mirror. (Figure 4-4)

#### b) Cleaning

Using lint-free paper dipped in alcohol, wipe carefully in one direction only to remove any dirt. (Figure 4-4)

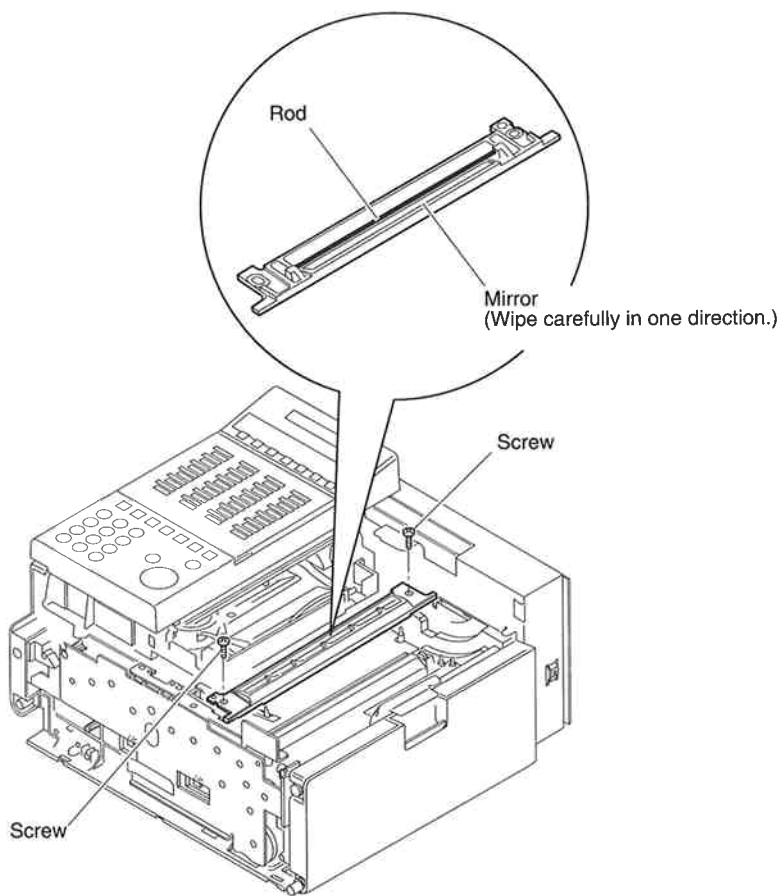


When re-installing the mirror, always adjust its position, as explained in 3. PARTS REPLACEMENT AND ADJUSTMENT.



**Figure 4-3 Disassembly Procedure (Covers)**





**Figure 4-4 Cleaning Locations 3**

**This page intentionally left blank**

## 2.7 Transfer Charging Roller / Static Charge Eliminator

### 2.7.1 Preparations for cleaning

- (1) Open the cartridge cover and remove the toner cartridge.
- (2) Remove the transfer guide tabs at three points.
- (3) Raise the left-most end of the transfer charging roller shaft clear of the transfer roller mount (left). (See ❶)
- (4) Slide the transfer charging roller and transfer guide to the left and remove the transfer roller shaft from the transfer roller mount (right). (See ❷ & ❸)
- (5) Remove the transfer charging roller from the transfer guide.



---

When removing the transfer charging roller, hold it by the transfer charging roller shaft. Do not hold it by the sponge section.

---

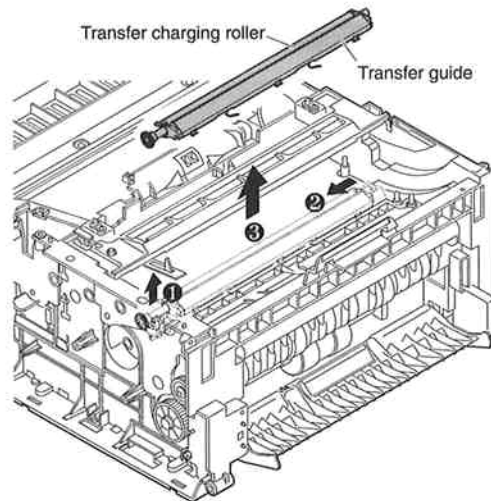
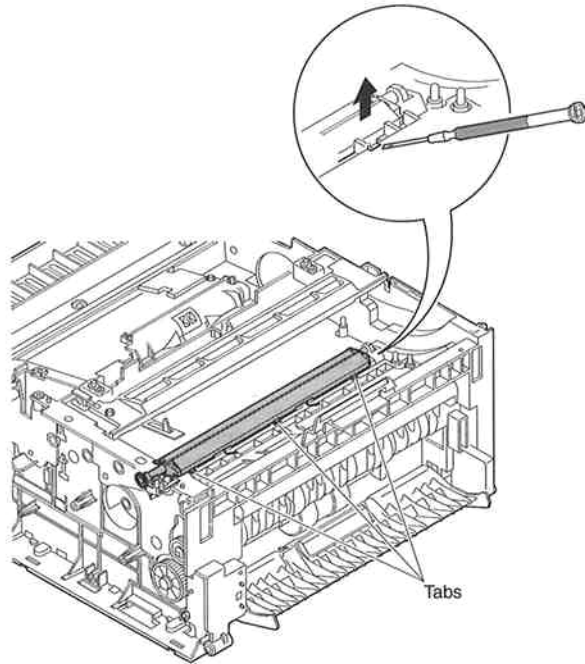
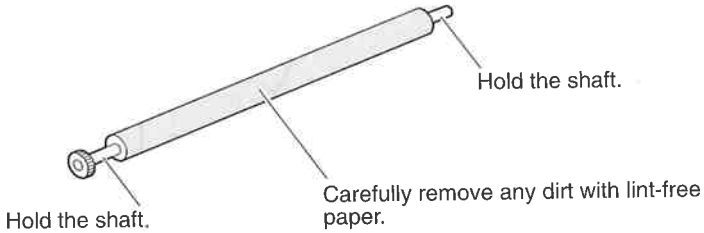


Figure 4-5 Disassembly Procedure (Transfer Charging Roller)

### 2.7.2 Cleaning

Use lint-free paper and remove any dirt, such as paper fragments and toner.



**Figure 4-6 Cleaning Locations 4**

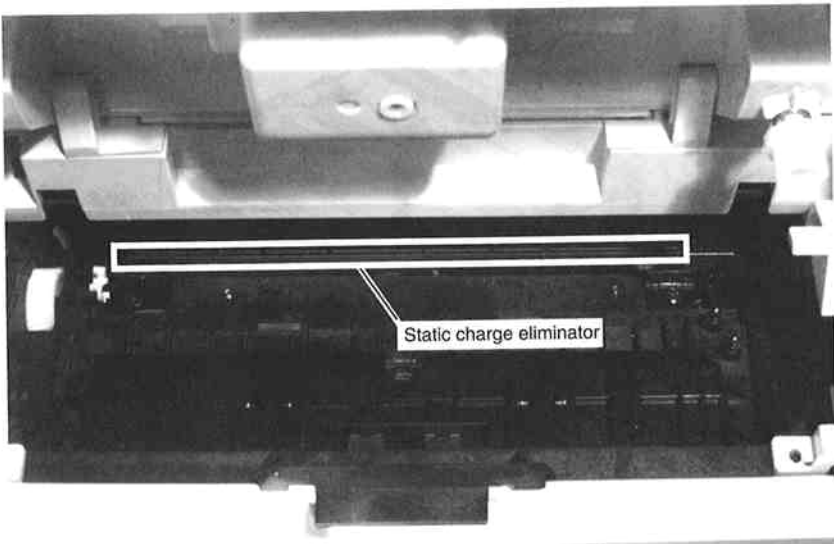


Do not touch or hold the sponge section of the transfer charging roller. Doing so can cause marks on back of paper or blank spots in copied or received images.

Never clean with solvents!

If lint-free paper can not fully clean the transfer charging roller or if the roller is deformed, replace it.

Open the cartridge cover, and use lint-free paper and remove any dirt, such as paper fragments and toner.



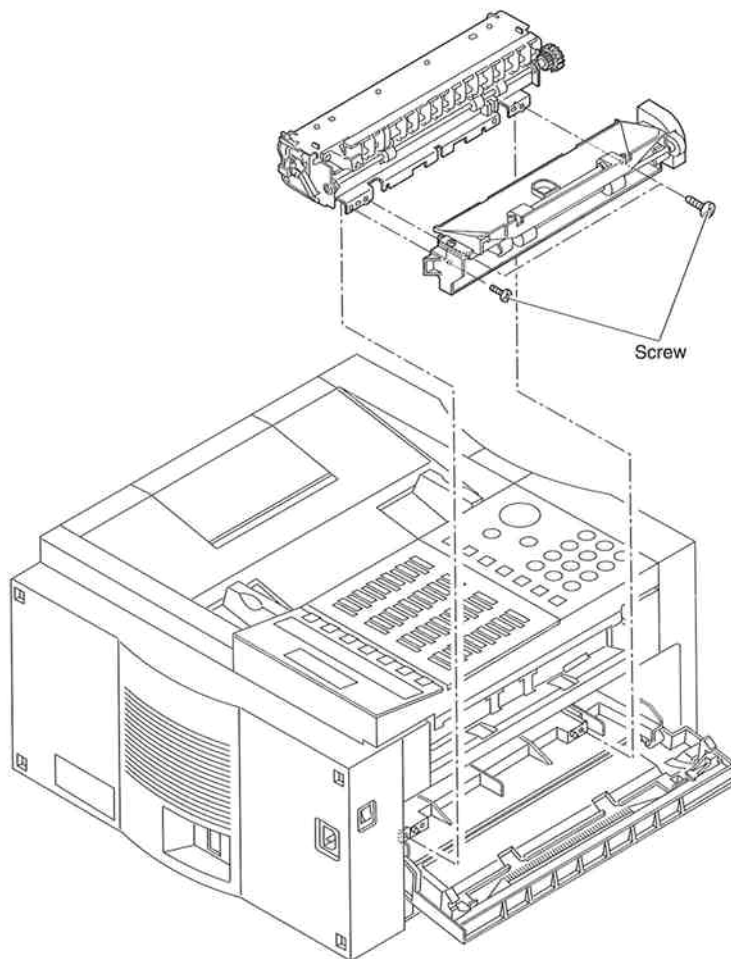
**Figure 4-7 Cleaning Locations 5**

**This page intentionally left blank**

## 2.8 Fixing Film / Fixing Entrance Guide

### 2.8.1 Preparations for cleaning

- (1) Remove the side cassette and open the exit paper cover .
- (2) Remove the three screws, and remove the paper exit roller ass'y and the fixing ass'y.



**Figure 4-8 Disassembly Procedure (Fixing ass'y)**

### 2.8.2 Cleaning

Using lint-free paper dipped in alcohol, wipe any dirt off the fixing entrance guide, and the fixing film with rotating the gear.

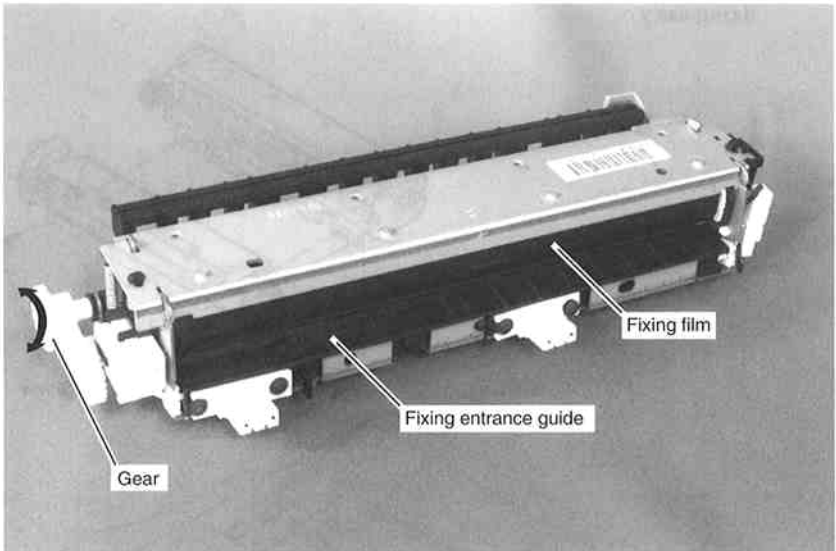


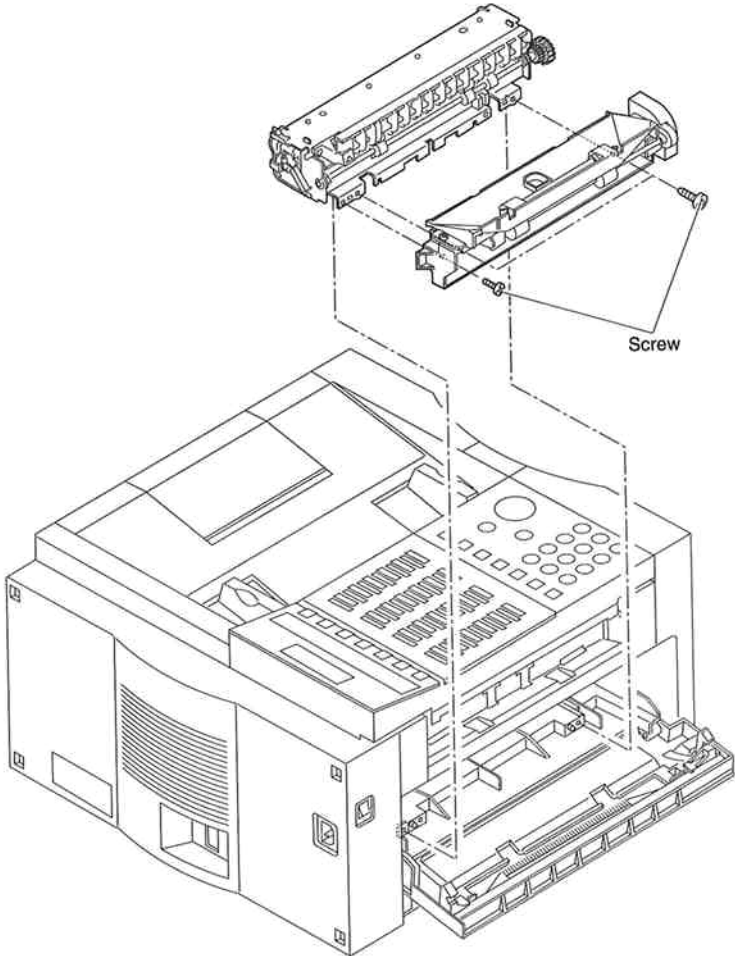
Figure 4-9 Cleaning Locations 6



## 2.9 Fixing Pressure Roller

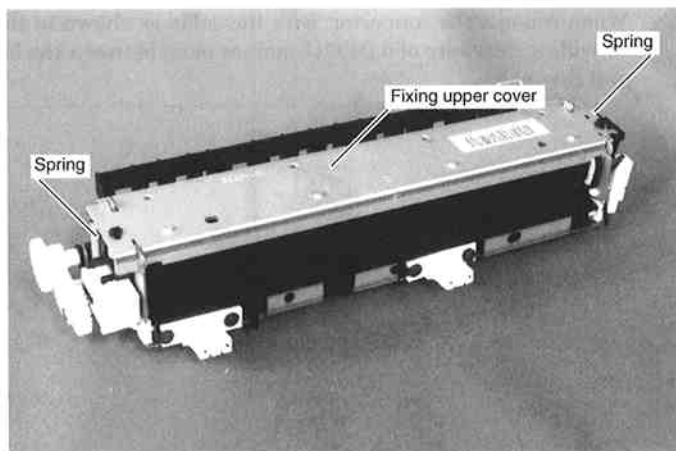
### 2.9.1 Preparations for cleaning

- (1) Remove the side cassette and open the exit paper cover .
- (2) Remove the three screws, and remove the paper exit roller ass'y and the fixing ass'y.



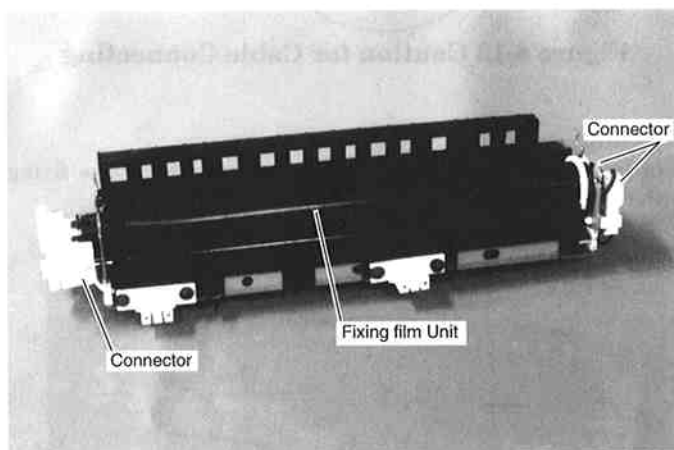
**Figure 4-10 Disassembly Procedure (Fixing ass'y)**

- (3) Remove the two springs and remove the fixing upper cover.



**Figure 4-11 Disassembly Procedure (Fixing Upper Cover)**

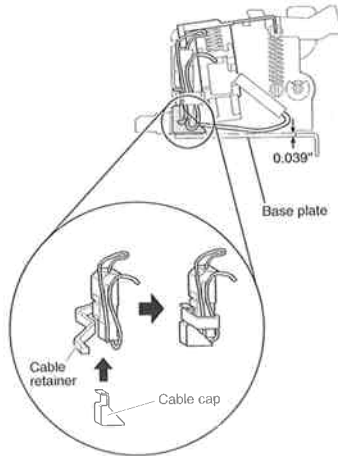
- (4) Disconnect the three connectors and remove the fixing film unit.



**Figure 4-12 Disassembly Procedure (Fixing Film Unit)**



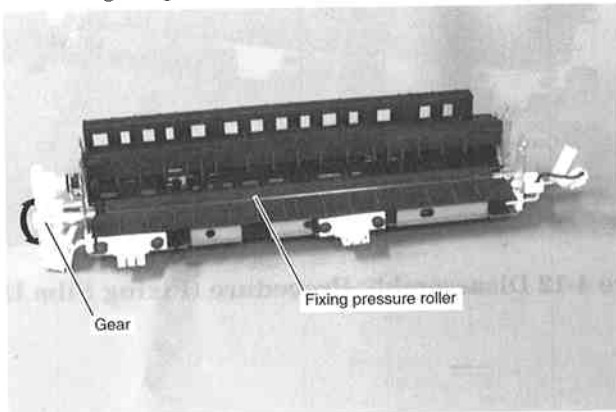
When disconnect the connector, be careful not to damage the cable.  
When connect the connector, wire the cable as shown in the figure.  
Provide a clearance of 0.039" (1 mm) or more between the base plate and the cable.



**Figure 4-13 Caution for Cable Connecting**

### 2.9.2 Cleaning

Using lint-free paper dipped in alcohol, wipe any dirt off the fixing pressure roller with rotating the gear.



**Figure 4-14 Cleaning Locations 7**

## 2.10 Fixing Eject Roller

### 2.10.1 Preparations for cleaning

- (1) Remove the side cassette and open the exit paper cover .
- (2) Remove the two screws, and remove the paper exit roller ass'y.

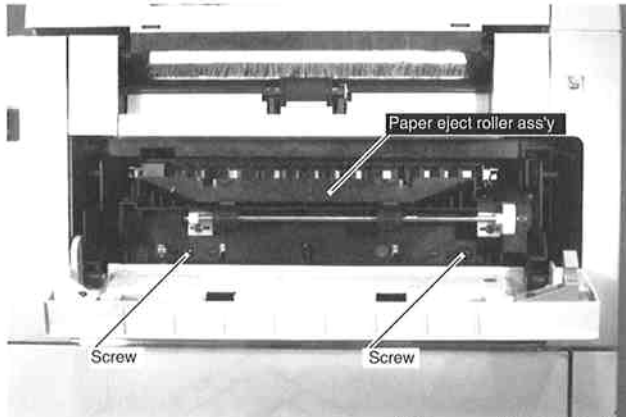


Figure 4-15 Disassembly Procedure (Paper Exit Roller Ass'y)

### 2.10.2 Cleaning

Using lint-free paper dipped in alcohol, wipe any dirt off the fixing eject roller and fixing eject guide.

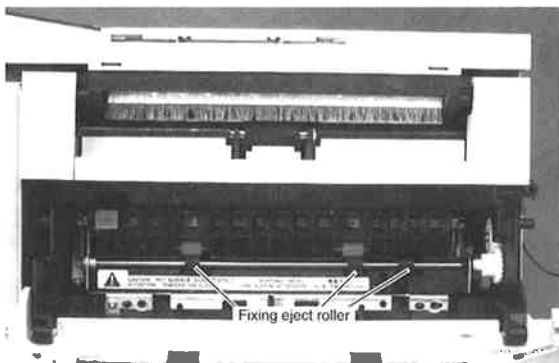
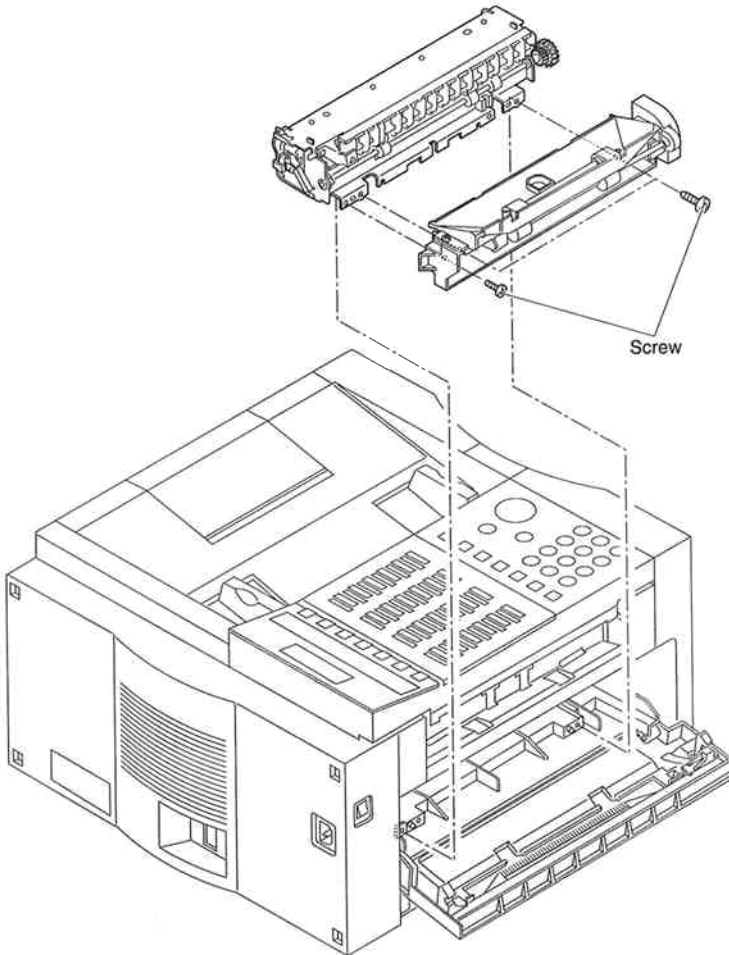


Figure 4-16 Cleaning Locations 8

## 2.11 Fixing Eject Guide

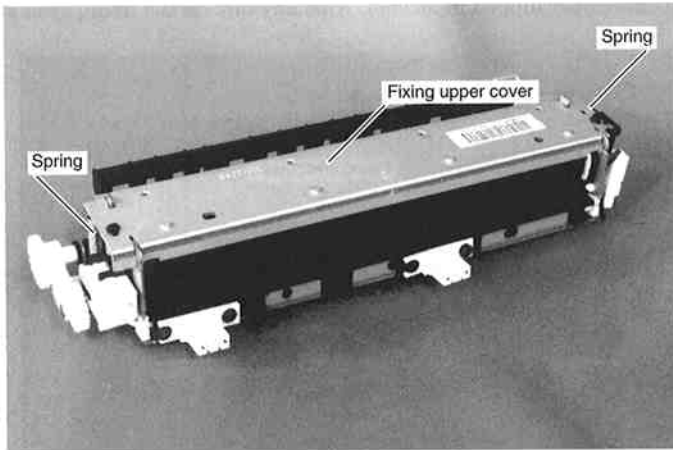
### 2.11.1 Preparations for cleaning

- (1) Remove the side cassette and open the exit paper cover .
- (2) Remove the three screws, and remove the paper exit roller ass'y and the fixing ass'y.



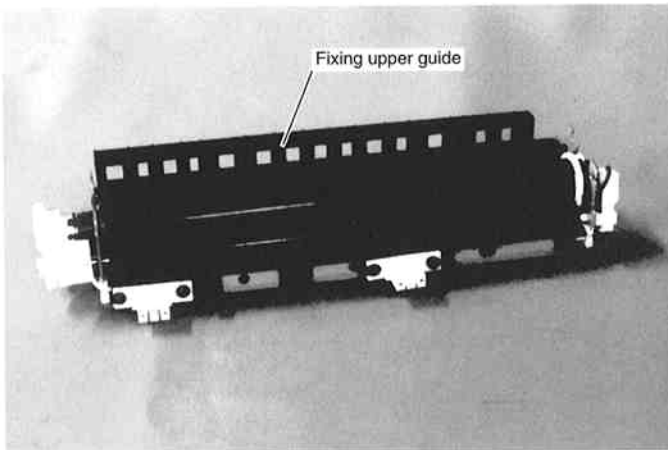
**Figure 4-17 Disassembly Procedure (Fixing ass'y)**

- (3) Remove the two springs and remove the fixing upper cover.



**Figure 4-18 Disassembly Procedure (Fixing Upper Cover)**

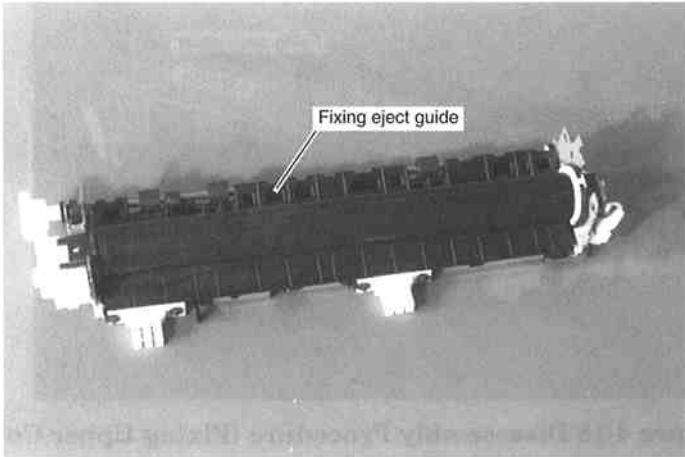
- (4) Remove the fixing upper guide.



**Figure 4-19 Disassembly Procedure (Fixing Upper Guide)**

### **2.11.2 Cleaning**

Using lint-free paper dipped in alcohol, wipe any dirt off the fixing eject guide.

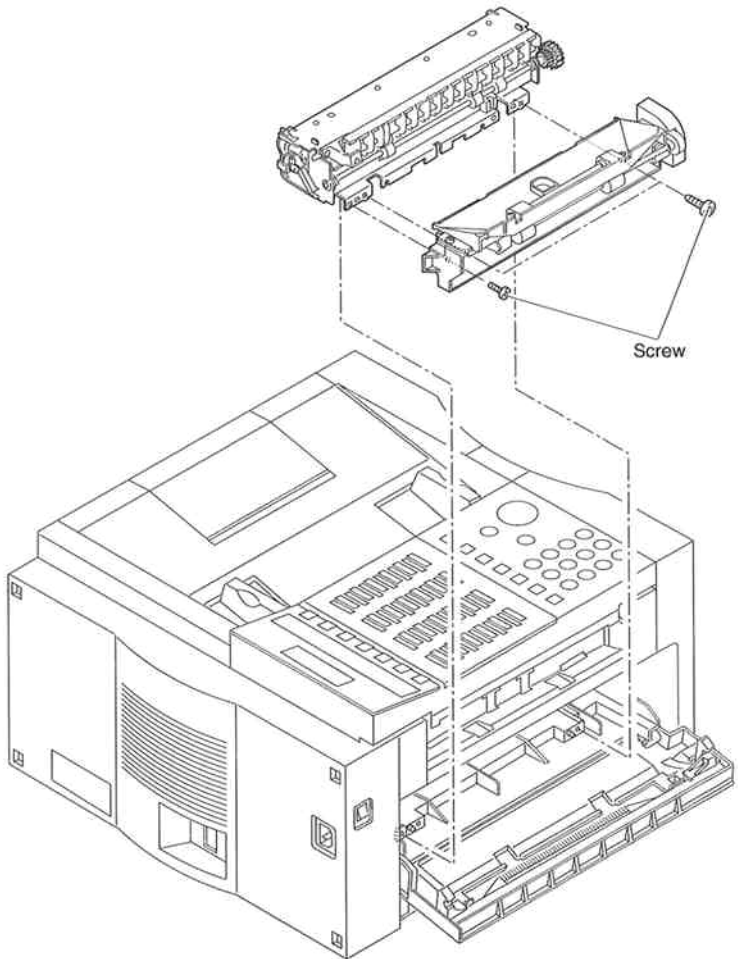


**Figure 4-20 Cleaning Locations 9**

## 2.12 Paper feed guide

### 2.12.1 Preparations for cleaning

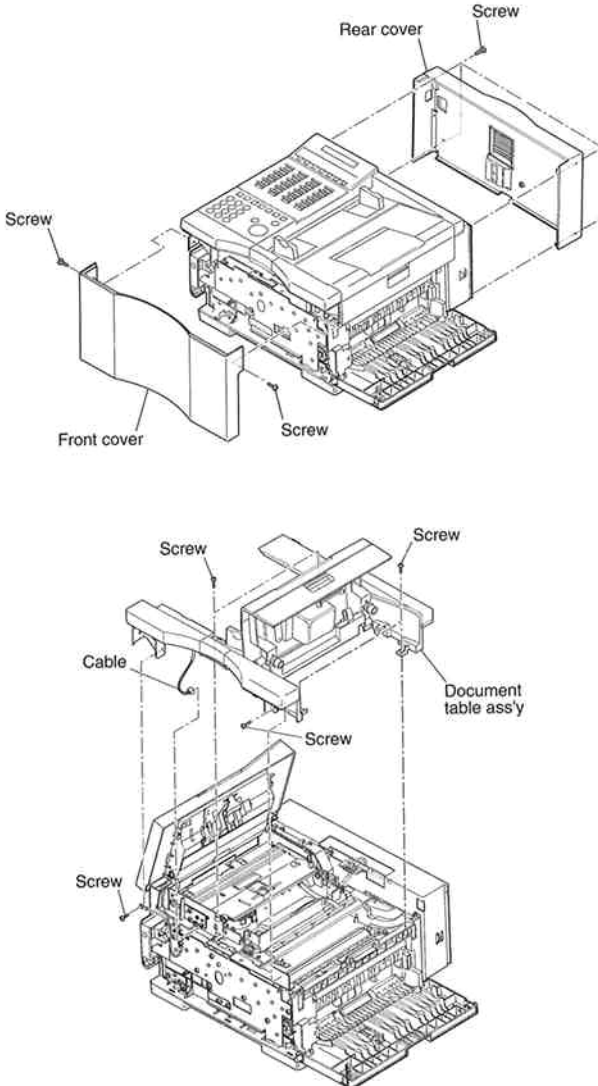
- (1) Remove the side cassette and open the exit paper cover .
- (2) Remove the three screws, and remove the paper exit roller ass'y and the fixing ass'y.



**Figure 4-21 Disassembly Procedure (Fixing ass'y)**

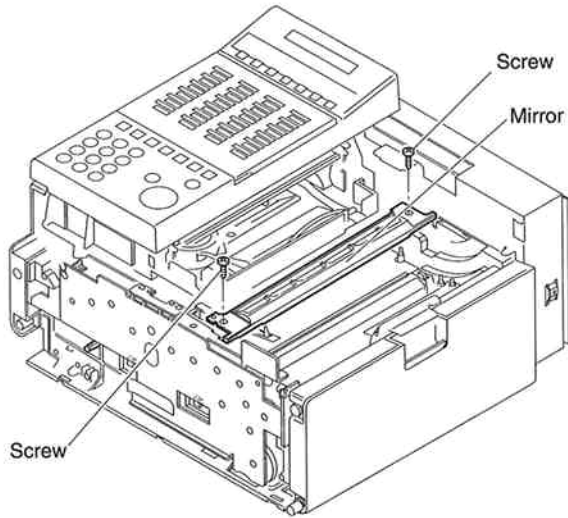


- (3) Open the cartridge cover and remove the toner cartridge.
- (4) Remove the six screws and remove the rear cover and the front cover.
- (5) Remove the six screws, disconnect the cable, and remove the document table ass'y.



**Figure 4-22 Disassembly Procedure (Covers)**

(6) Remove the two screws and remove the mirror.



**Figure 4-23 Disassembly Procedure (Mirror)**

- (7) Remove the transfer guide tabs at three points.
- (8) Raise the left-most end of the transfer charging roller shaft clear of the transfer roller mount (left). (See ❶)
- (9) Slide the transfer charging roller and transfer guide to the left and remove the transfer roller shaft from the transfer roller mount (right). (See ❷ & ❸)

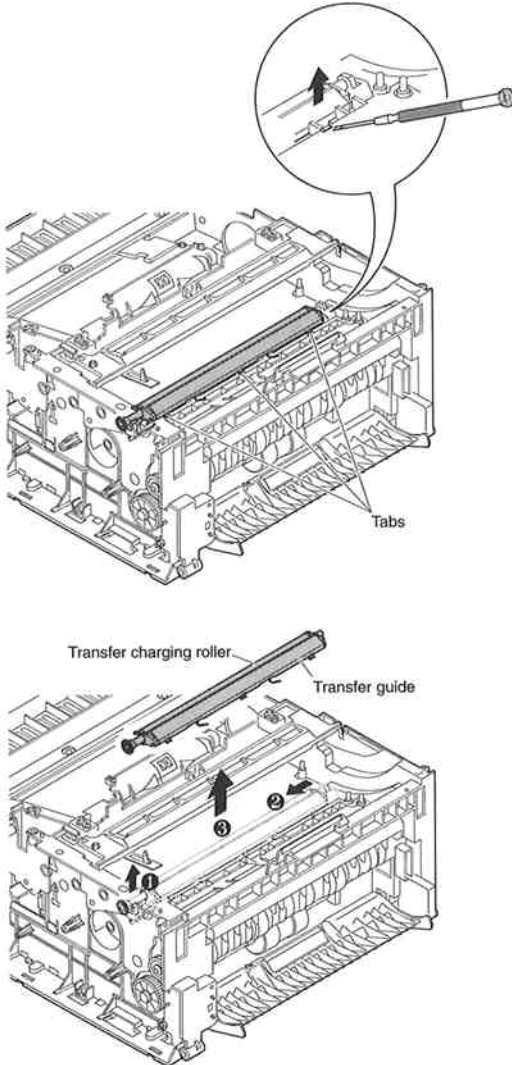
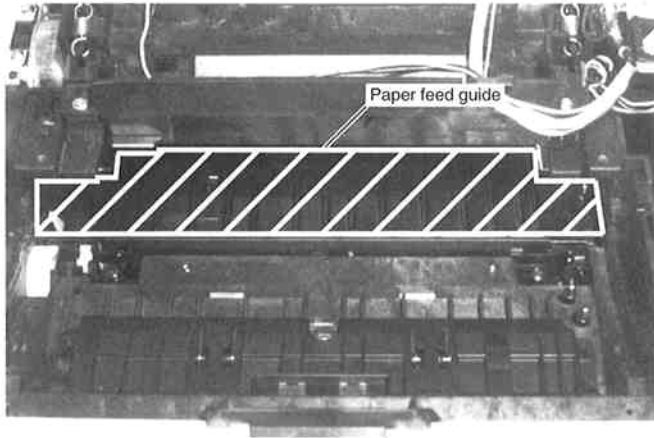


Figure 4-24 Disassembly Procedure (Transfer Charging Roller)

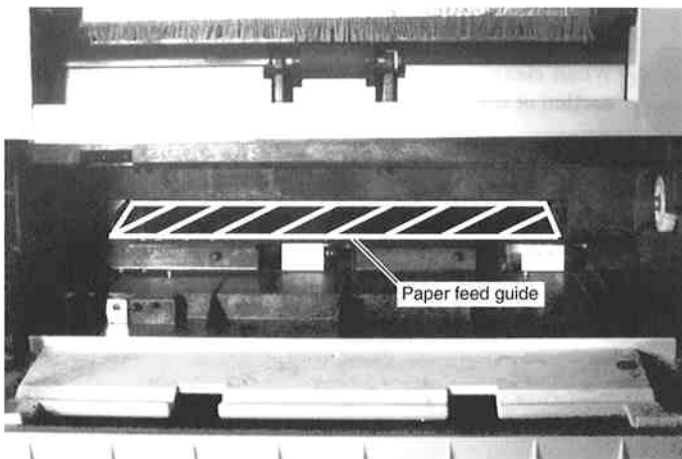
### 2.12.2 Cleaning

- (1) Open the cartridge cover and wipe any dirt off the paper feed guide with lint-free paper.



**Figure 4-25 Cleaning Locations 10**

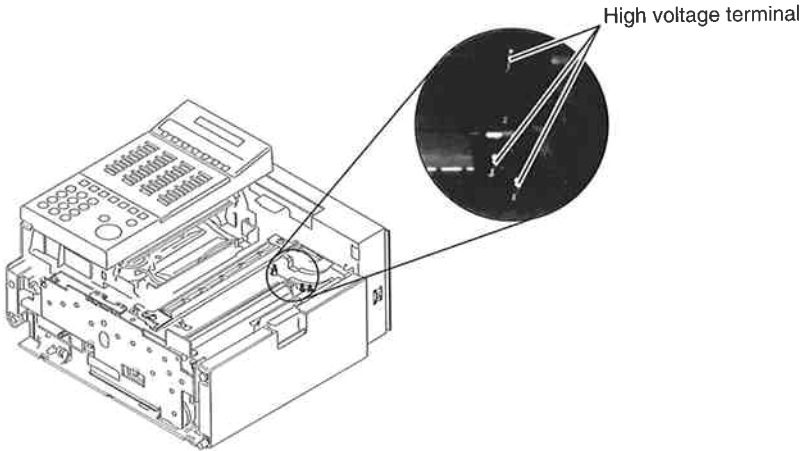
- (2) Open the exit paper cover and wipe any dirt off the paper feed guide with lint-free paper.



**Figure 4-26 Cleaning Locations 11**

### 2.14 High Voltage Terminal

- (1) Open the cartridge cover and remove the toner cartridge.
- (2) Using lint-free paper, wipe any dirt off the high-voltage terminal.



**Figure 4-27 Cleaning Locations 12**



When cleaning the high voltage terminal, do not touch the sponge section of the transfer charging roller.

---

**This page intentionally left blank**

## 3. PARTS REPLACEMENT AND ADJUSTMENT

### 3.1 Parts Replacement

For disassembly/assembly procedures when replacing parts, refer to the separate Parts Catalog. The Parts Catalog has illustrations that follow the order of disassembly. There are also exploded diagrams and supplementary illustrations for those parts requiring care during disassembly and assembly. Precautions on the illustrations indicate items requiring particular care.

### 3.2 Greasing Locations

Some parts have grease applied to them to enable them to move smoothly and to increase conductivity. Apply grease after a part containing a greased section is replaced or after the grease has wiped off, been.

#### 3.2.1 Non-electroconductive grease

G-2 Permalub grease is used.

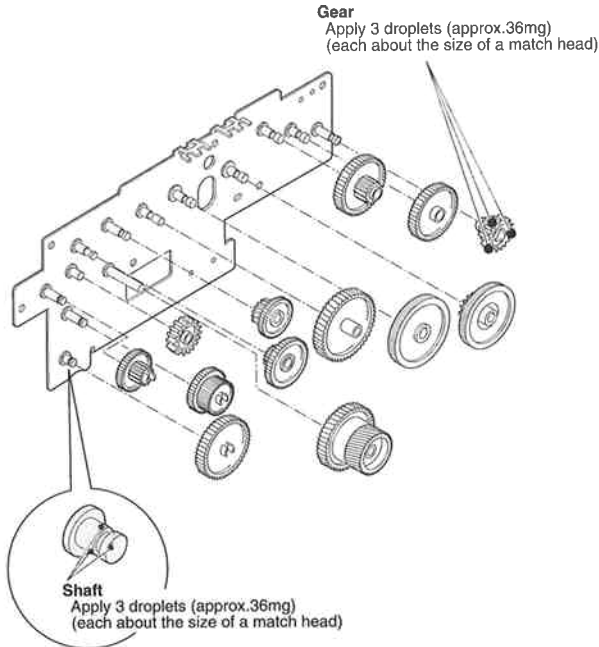
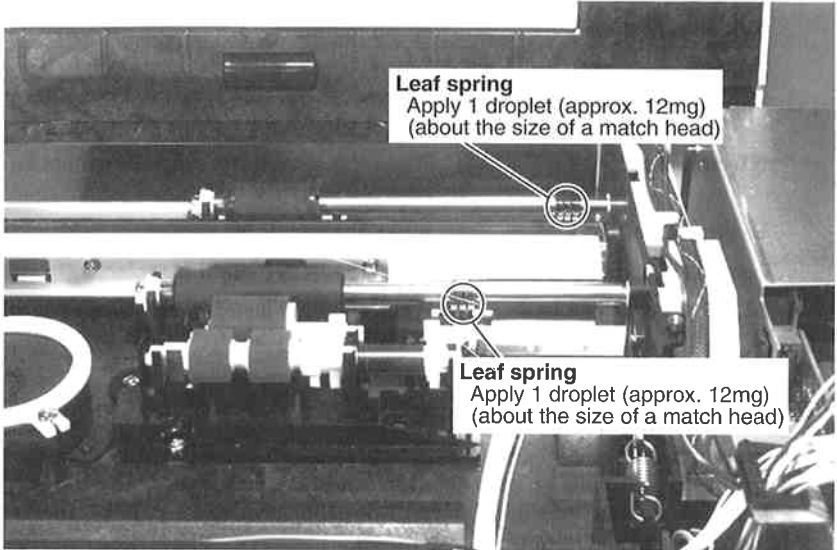


Figure 4-28 Grease Application Locations 1

### 3.2.2 Electroconductive grease

FLOIL GE676 is used.



**Figure 4-29 Grease Application Locations 2**



### 3.3 Adjustment

#### 3.3.1 Adjustment items

On this fax, the following items require adjustment.

<b>Adjustment item</b>	<b>When required</b>
Transmission level	When there is serve deterioration in the transmission signal level, and the other party cannot receive the signals correctly.
NL equalizer	When the other party's signals cannot be received properly.
Position of mirror	When the mirror is removed.
Leading edge margin	When the PCNT board is replaced.
LED light emission level	When the LED board, toner sensor board, or VR board is replaced.

#### 3.3.2 Transmission level adjustment

When the other party cannot receive because the signal level of this fax has dropped, for example because the line conditions are poor or the transmission signal level has deteriorated, if you raise this transmission level, the level of signals transmitted from this fax is raised.

#### 3.3.3 NL equalizer adjustment

This is adjusted when the signals from the other party cannot be received correctly.



---

For details on the transmission level and NL equalizer adjustment methods, see *Chapter 5: 1.7 Adjustments*.

---

**This page intentionally left blank**

### 3.3.4 Mirror position adjustment

#### a) When required

When the mirror has been removed, adjust its position after re-installing it. This adjustment assures the alignment of printed images.

#### b) Tools required

<b>Tool</b>	<b>Use</b>
Phillips screwdriver	Removing/driving screws
Set square	Measuring alignment of print image

#### c) Adjustment method

##### c-1) Preparations for adjustment

- (1) Open the cartridge cover and remove the toner cartridge.
- (2) Remove the six screws and remove the rear cover and the front cover.
- (3) Remove the six screws, disconnect the cable, and remove the document table ass'y.
- (4) Set letter or A4 size recording paper in the side cassette.

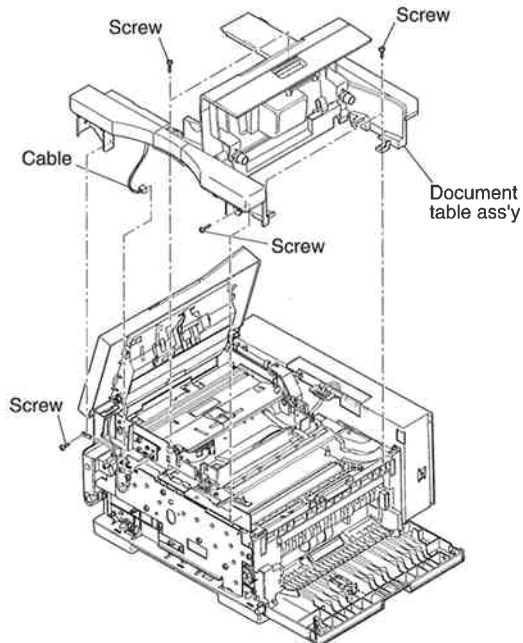
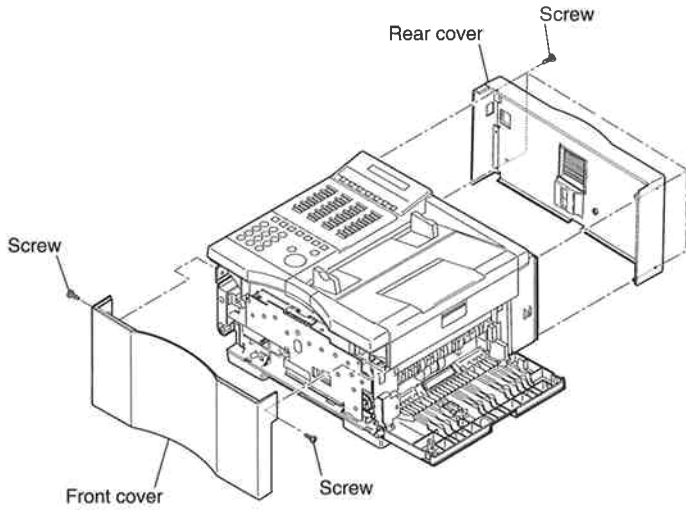
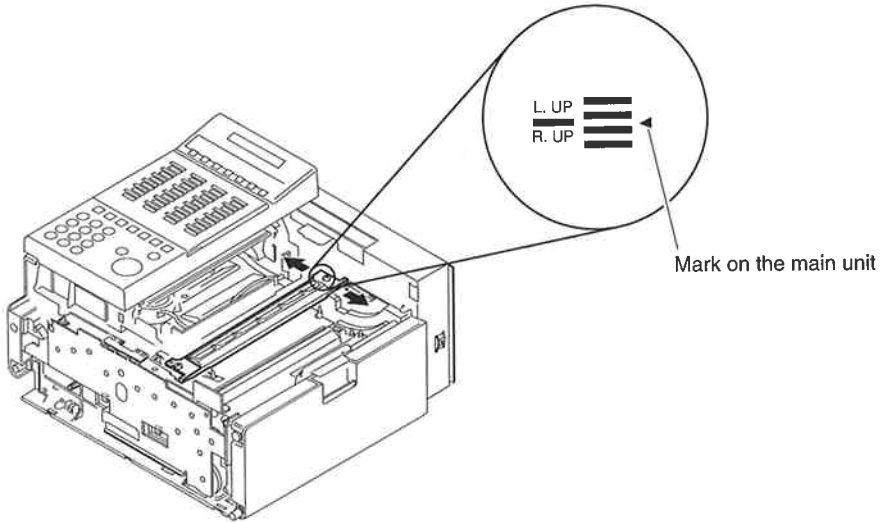


Figure 4-30 Disassembly Procedure (Covers)

- (5) Move the mirror so that the center line of the adjustment scale on its right edge lines up with the mark on the main unit.

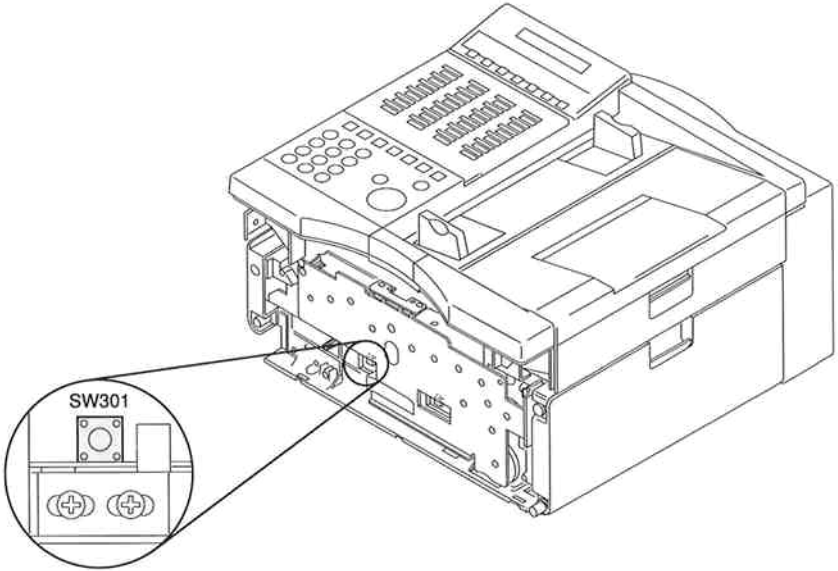


**Figure 4-31 Mirror Position Adjustment 1**

- (6) Open the control panel and install the document table ass'y with the six screws.
- (7) Open the cartridge cover and set the toner cartridge.

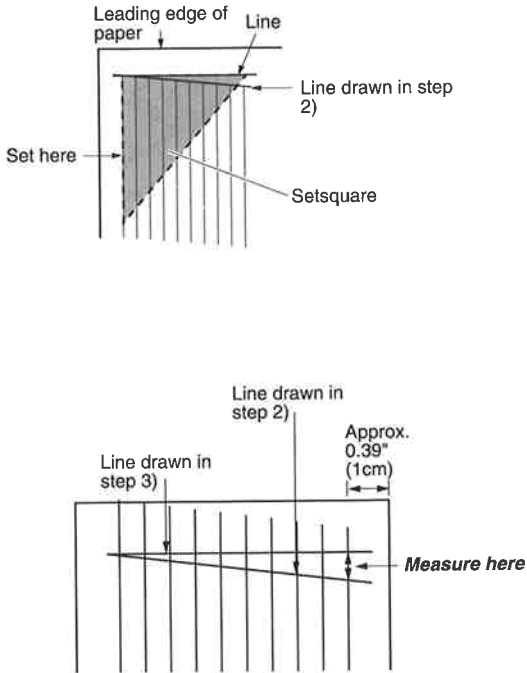
**c-2) Adjustment**

- (1) Switch ON the power and press the test print switch (SW 301) on the PCNT board to start a test print.



**Figure 4-32 Test Print Switch**

- (2) Draw a line connecting the top ends of the vertical lines on the test print image.
- (3) Draw a line by aligning the vertical lines of the test print image and one side of the setsquare.
- (4) The displacement between the line drawn in (2), and that drawn in (3) is measured at the far right of the test print image.

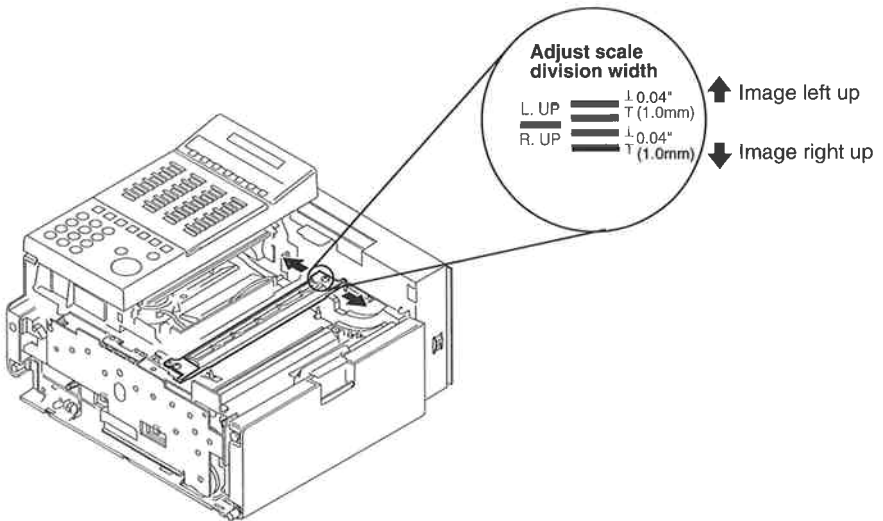


**Figure 4-33 Mirror Position Adjustment 2**

- (5) After removing the toner cartridge and the document table ass'y, adjust the alignment by moving the right edge of the mirror so that the gap in 4) is no greater than 0.06" (1.5 mm).

The adjustment scale has the intervals shown in the figure below. Moving the mirror one gradation moves the image approx. 0.04" (1 mm).

- (6) After making this correction and installing the document table ass'y, test print another page to verify that the gap is no greater than 0.06" (1.5 mm).



**Figure 4-34 Mirror Position Adjustment 3**



### 3.3.5 Leading edge margin adjustment

#### a) When adjustment

Carry out this adjustment after replacing the PCNT board. Making this adjustment assures the print image leading edge margin.

#### b) Tools required

<b>Tool</b>	<b>Use</b>
Phillips screwdriver	Removing/driving screws
Precision phillips screwdriver	Adjusting controls
Ruler	Measuring leading edge margin of printed image

#### c) Adjustment method

##### c-1) Preparations for adjustment

- (1) Open the cartridge cover and remove the toner cartridge.
- (2) Remove the six screws and remove the rear cover and the front cover.
- (3) Remove the six screws, disconnect the cable, and remove the document table ass'y.
- (4) Set letter or A4 size recording paper in the side cassette.
- (5) Open the cartridge cover and set the toner cartridge.

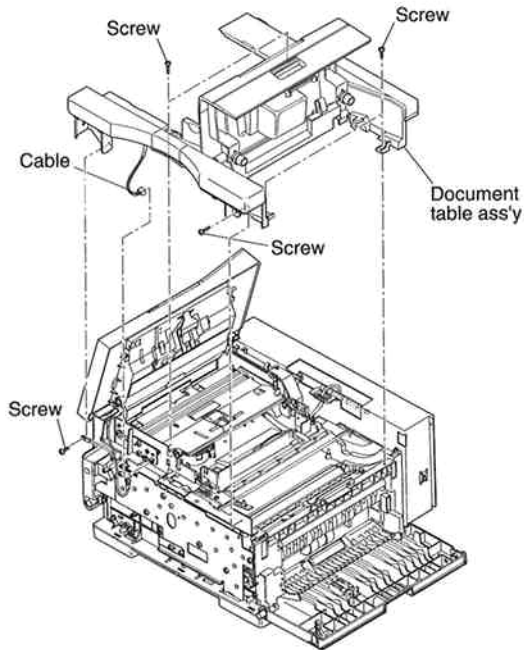
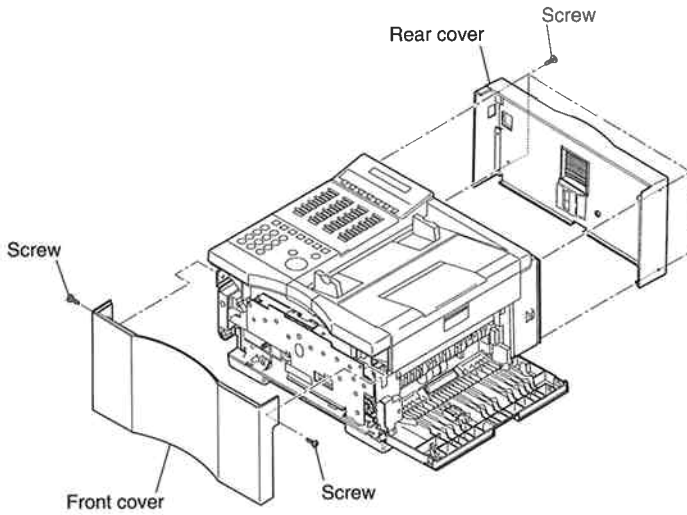
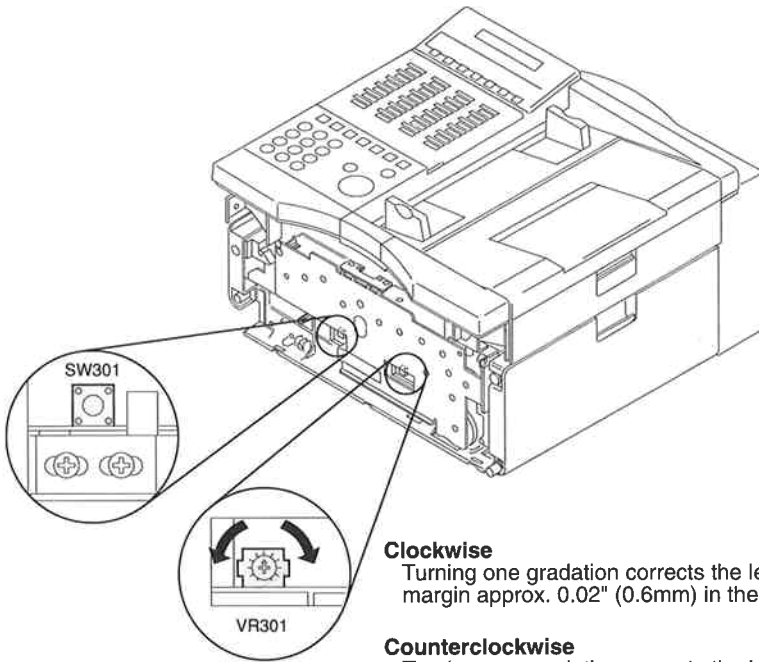


Figure 4-35 Disassembly Procedure (Covers)

**c-2) Adjustment**

- (1) Set VR301 on the PCNT board to the center position ( $\pm 0$ ).
- (2) Switch ON the power and press the test print switch (SW 301) on the PCNT board to start a test print.
- (3) Measure the length from the leading edge of the recording paper to the test print image (the leading edge margin).
- (4) Make a number of test printings and find the average of the leading edge margin.
- (5) Adjust VR301 so that the leading edge margin found in 4) is 0.08" (2.0 mm). Turning VR301 one gradation clockwise corrects the leading edge margin approx. 0.02" (0.6 mm) in the + direction in the next page; turning VR301 one gradation counter-clockwise corrects the leading edge margin approx. 0.02" (0.6 mm) in the - direction in the next page.

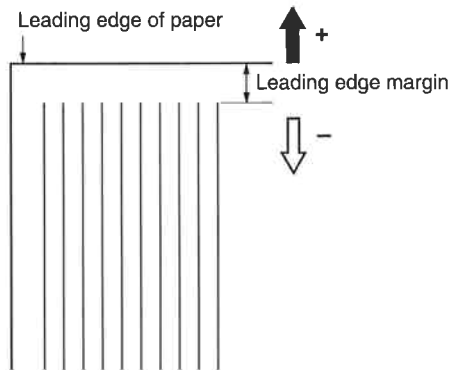


**Clockwise**

Turning one gradation corrects the leading edge margin approx. 0.02" (0.6mm) in the - direction.

**Counterclockwise**

Turning one gradation corrects the leading edge margin approx 0.02" (0.6mm) in the + direction.



**Figure 4-36 Leading Edge Margin Adjustment**

### 3.3.6 LED light emission level adjustment

#### a) When adjustment

Carry out this adjustment after replacing the LED board, toner sensor board, or VR board. The controls on the VR board are adjusted to obtain the optimum levels and correct for variation in the LED and toner sensor (photo-diode) performance and sensor output error due to error in the LED and toner sensor installation position.

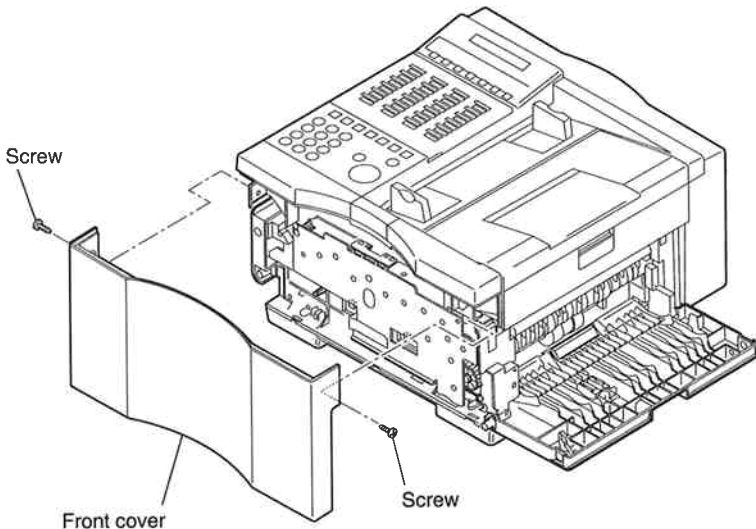
#### b) Tools required

Tool	Use
Phillips screwdriver	Removing/driving screws
Precision regular screwdriver	Adjusting VRs
Paper (letter or A4 size)	Cartridge cover position correction

#### c) Adjustment method

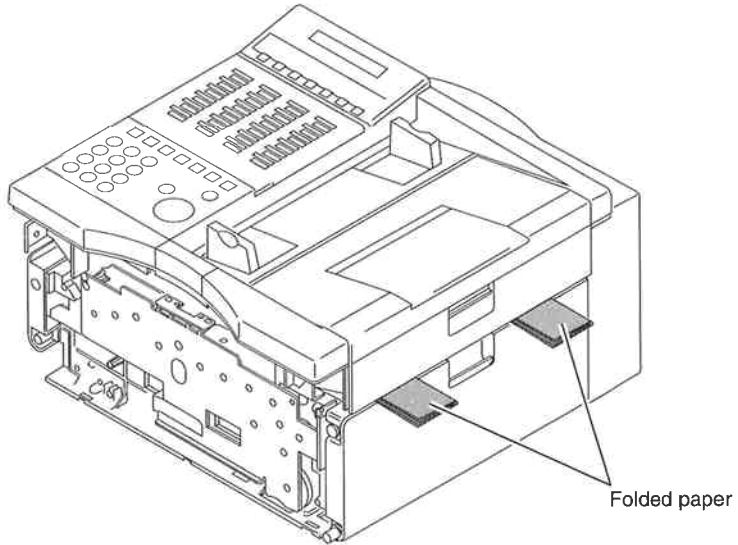
##### c-1) Preparations for adjustment

- (1) Open the cartridge cover and remove the toner cartridge.
- (2) Remove the two screws and remove the front cover.



**Figure 4-37 Disassembly Procedure (Front Cover)**

- (3) Fold two sheets of paper in half four times.
- (4) Sandwich the paper folded in (3) between the cartridge cover and right cover as in the figure below (with the covers unlocked).
- (5) Close the cartridge cover.



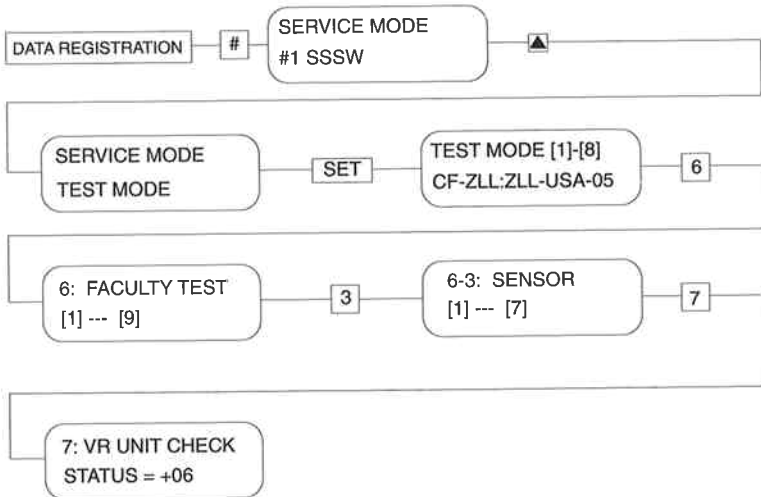
**Figure 4-38 Cartridge Cover Position Correction**

**c-2) Adjustment**

- (1) Switch on the power.
- (2) In test mode menu, select [6] to enter faculty test mode.
- (3) In faculty test mode, select [3] to enter sensor test mode.
- (4) In sensor test mode, select [7] to enter LED light emission level adjustment mode.



When this fax goes into toner sensor adjustment test mode, the LED on the LED board lights up and the toner sensor (photo-diode) on the toner sensor board receives that light. The value displayed on the display is the toner sensor (photo-diode) light reception level.

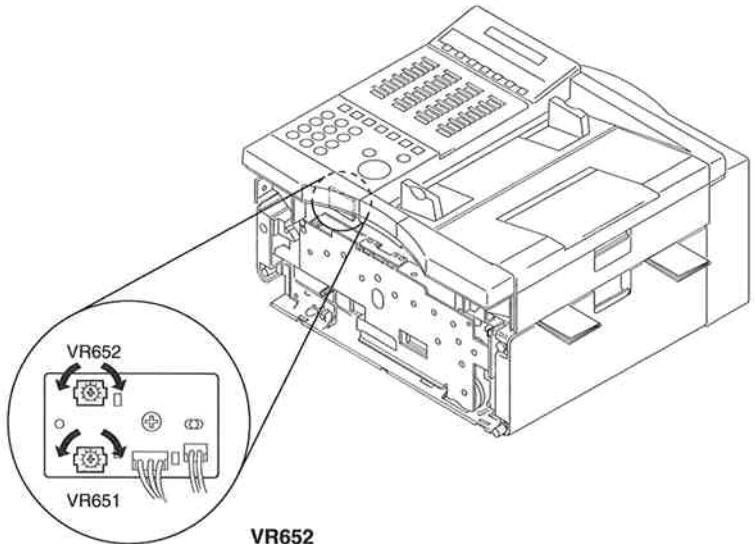


**Figure 4-39 Flowchart of LED Light Emission Level Adjustment Mode**

- (5) Adjust the VRs on the VR board so that the light reception level is [+00].  
Turning VR 652 one gradation clockwise increases the LED light reception level 02; turning VR 652 one gradation clockwise decreases the LED light reception level 02.  
Turning VR651 one gradation clockwise increases the LED light reception level 15; turning VR651 one gradation counter-clockwise decreases the LED light reception level 15.



If the light reception level becomes [+00], the buzzer buzzes.  
If this test mode is carried out when the toner cartridge is set, "CHECK DOOR" is displayed on the display.



**VR652**

**Clockwise**

Turning one gradation increases the LED light reception level approx. 02.

**Counterclockwise**

Turning one gradation decreases the LED light reception level approx. 02.

**VR651**

**Clockwise**

Turning one gradation increases the LED light reception level approx. 15.

**Counterclockwise**

Turning one gradation decreases the LED light reception level approx. 15.

**Figure 4-40 VR Board**



## 4. TROUBLESHOOTING

### 4.1 Troubleshooting

#### 4.1.1 Environment

##### a) Checking the installation environment

Check if the installation environment meets the following usage environment standards.

- (1) Use the fax on a level surface.
- (2) Use the fax in temperatures 50°F (10°C) to 90.5°F (32.5°C) with relative humidity of 10% to 90% RH.
- (3) Avoid locations with ammonia gas, locations with high temperature and humidity (such as near water faucets, hot water heaters, humidifiers, etc.), locations near fire sources, and dusty locations.
- (4) Avoid locations subject to direct sunlight. If such a location must be used, instruct the user to install a curtain or the like.
- (5) Use a well-ventilated location.

##### b) Recording paper check

- (1) Use the paper recommended for this fax.
- (2) Take care with the storage of the paper. Store paper in an environment similar to the fax's usage environment.

#### 4.1.2 Precautions for troubleshooting

- (1) Before starting any other troubleshooting, make sure that the connectors are all connected properly.
- (2) When repairs require you to plug in the power cord for this fax with a cover removed, take care to avoid electrical shocks from the power supply section and to avoid shorting any boards.
- (3) After completing troubleshooting, check that you reconnected any connectors you disconnected and that you tightened any screws you loosened.
- (4) After completing troubleshooting, carry out a communications test to make sure that the fax operates normally.

## 4.2 Errors

### 4.2.1 Error shown on the display

Error shown on the display may be recovered as follows.

#### "REPLACE CARTRIDGE"

**Causes:** (1) The toner in the toner cartridge has run out. This is displayed when the toner sensor can not detect any toner.

(2) Toner detection structure defect

**Solutions:** (1) Replace the toner cartridge.

(2) Check the LED board and VR board connector connections.

(3) Check the VR board and laser/scanner unit connector connections.

(4) Check the toner sensor board and PCNT board J203 connector connections.

(5) Check the LED light emission level, as explained in 3.3.6 *LED light emission level adjustment*.

(6) Replace the LED board.

(7) Replace the toner sensor board.

(8) Replace the VR board.

(9) Replace the PCNT board.

(10) Replace the SCNT board.

#### "CHECK PRINTER DOOR"

**Cause:** (1) Displayed when the cartridge cover sensor, right cover sensor, exit paper cover sensor, or feeder right cover sensor (LASER CLASS 5500 only) detects an open cover.

(2) Displayed when the toner cartridge is not installed.

**Solutions:** (1) Close the open cover.

(2) Install a toner cartridge.

#### "REC. PAPER JAM" (#009)

**Cause:** Recording paper jam

This is displayed when the recording paper pickup sensor, recording paper exit sensor, or the recording paper jam sensor detects a paper jam.

**Solutions:** Recover paper jam, as explained in *Chapter 1: 2.3.7 Recording paper jam handling*.

#### "NO RX PAPER" (#012)

**Cause:** Declares that the other fax has no recording paper for DIS.

**Solutions:** Contact the other party and have them load paper into their fax.

**"BUSY/NO SIGNAL" (#005, #018)**

**Cause:** There was no response from the other fax within 35 seconds. (T1 timer over)

**Solutions:** Transmit again. Since there is a possibility that the other fax is not a G3 fax, check the other fax's communications mode.

**"SUPPLY REC. PAPER" (#009)**

**Cause:** Either the recording paper ran out or there was no recording paper cassette loaded. This is displayed when the recording paper sensor detects no paper.

**Solutions:** Refill the recording paper cassette or install the cassette correctly.

**"DOCUMENT TOO LONG" (#003)**

**Cause:** Displayed when one page of the document was longer than 1 meter or transmission/copying took longer than the regulated time (32 minutes).

**Solutions:** Use a copy machine to copy the document onto several shorter pages, then transmit again.

**"CHECK DOCUMENT" (#001, #011)**

**Cause:** Document jam. This is displayed when the document sensor detects paper, but the document edge sensor cannot detect the leading edge of the document with 15 seconds from the start of the feed operation.

**Solutions:** Open the operating panel and remove the document.

**"NO CONFID. TX" (#033, #034)**

**Causes:** (1) The other fax machine may not have the confidential function. Confidential transmission is only possible if the other fax is a Canon fax with the confidential function.  
(2) There is an error in the designated confidential box.  
(3) It is possible that the other fax has no free memory.

**Solutions:** Check the above items for the other fax.

**"NO ORIGINAL RELAY TX" (#035, #036)**

**Causes:** (1) It is possible that the other fax has no relay function. Relay control transmission is only possible if the other fax is a Canon fax with the relay function.  
(2) It is possible that the relay fax is set not to accept reception.  
(3) It is possible that there is an error in the relay control transmission group number.  
(4) It is possible that the other fax has no free memory.

**Solutions:** Check the above items for the other fax.

**"POLLING ID ERROR" (#008, #021)**

---

**Cause:** Polling was impossible because the polling password did not match.

**Solutions:** Check the polling password with the other party and try polling again.

**"NO TEL#" (#022)**

---

**Cause:** No one-touch speed dialing, coded speed dialing, or group dialing telephone number is registered.

**Solutions:** Register the one-touch speed dialing, coded speed dialing, or group dialing telephone number.

**"NO ANSWER"**

---

**Cause:** The number was redialed, but there was no answer.

**Solutions:** Transmit again.

**"MEMORY FULL" (#037)**

---

**Cause:** The image data storage memory area is full.

**Solutions:** Output the image data stored in memory.

**"START AGAIN" (#995)**

---

**Cause:** An error due to system malfunction or line breakdown.

**Solutions:** Carry out the same operation again.

**"CHECK PRINTER"**

---

**Cause:** Status signal abnormality (**##321**)

**Solutions:** (1) Check the SCNT board and PCNT board (J201) connector connections.

(2) Replace the PCNT board.

**Cause:** Fixing heater temperature abnormality (**##322**)

**Solutions:** (1) Check the PCNT board and fixing unit (J103 and J204) connector connections.

(2) Remove the fixing unit and check the resistance between fixing unit J204-1 and J204-2, which should be 440 k $\Omega$  (at room temperature of 20°C).

(3) Remove the fixing unit and check the conductance between fixing unit J103-1 and J103-2.

(4) Replace the fixing film unit.

(5) Replace the PCNT board.

**Cause:** Laser/scanner unit -BD signal output function abnormality (**##323**)

**Solutions:** (1) Check the laser/scanner unit and PCNT board (J202) connector connections.

(2) Check the amount of laser light, as explained in *Chapter 5: 3. SERVICE TOOLS*.

(3) Replace the laser/scanner unit.

(4) Replace the PCNT board.

**Cause:** Scanner motor rotation rate abnormality (##324)

**Solutions:** (1) Check the laser/scanner unit and PCNT board (J202) connector connections.

(2) Replace the laser/scanner unit.

(3) Replace the PCNT board.

**Cause:** Fan motor rotation rate abnormality (##325)

**Solutions:** (1) Check the fan motor and power supply unit (J4) connector connections.

(2) Check if the voltage between power supply unit J4-1 and J4-3 goes from 0 to 12 VDC immediately after the power is switched on. If not so, replace the fan motor.

(3) Replace the power supply unit.

**Cause:** Power unit ACVIN signal abnormality (##330)

**Solutions:** (1) Check the PCNT board and the power supply unit (CN1) connector connections.

(2) Check if the voltage between the power supply unit CN1-6 and CN1-3, which should be 1 VDC or more. If not so, replace the power supply unit.

(3) Replace the PCNT board.

---

#### "DATA ERROR PRESS SET KEY"

**Cause:** Check sum error. This is displayed when the SCNT board is replaced, when the SRAM is defective, or when the backup battery is replaced.

**Solutions:** Press the Set key.

---

#### "NOT AVAILABLE NOW"

**Cause:** Confidential transmission and relay control transmission were specified at the same time.

**Solutions:** Check the contents of the one-touch dialing registration, then try again.

---

#### "NOT FOUND, TRY AGAIN"

**Cause:** An attempt was made to change the specification of a non-registered box for confidential or polling communications.

**Solutions:** Check again if the box is registered.

**"HANG UP PHONE"**

**Cause:** The handset was left off the hook after the completion of transmission or reception.

**Solutions:** Put the handset back on the hook.

**"# ALREADY IN USE"**

**Cause:** The box specified with confidential or polling communications is already in use.

**Solutions:** Change the setting or select another box.

## 4.2.2 Error codes

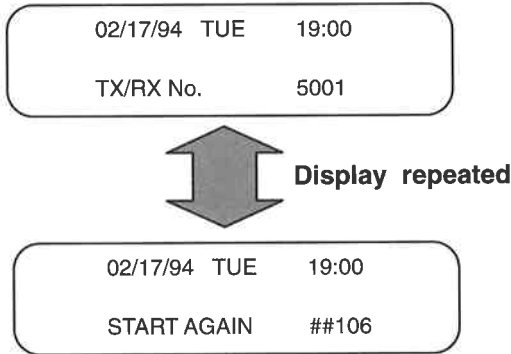
### a) Service error code output

If Service Data #1 SSSW Bit 0 is set to "1", then service error codes are printed on the activity management reports, reception result reports, error transmission reports, and system dump lists when communication ends in an error. Also, the following is displayed on the display when an error occurs.



For samples of reports with the service codes displayed, see *Chapter 2: 3.2.2 Service report output functions.*

---



**Figure 4-41 Service Error Code Display**

**b) Error codes and recovery methods**

**b-1) User error codes**

**#001 [TX] Document jam**

---

- Causes:**
- (1) The document jammed in the fax machine.
  - (2) The document width size or thickness does not meet the standards.
  - (3) Internal structure defect

- Solutions:**
- (1) Remove the document and transmit again.
  - (2) Use a copy machine to copy the document to A4 or other standard size paper, then transmit that copy.
  - (3) Check the document sensor (DS), document edge sensor (DES), and OPCNT board (J5, J6) connections.
  - (4) Check if the document sensor (DS) and document edge sensor (DES) are operating correctly using the methods given in *Chapter 2: 3.5.8 Faculty tests*, Test Mode [6] Faculty Test, [3] Sensor Tests.
  - (5) Replace the document sensor (DS) or document edge sensor (DES).
  - (6) Replace the OPCNT board.
  - (7) Check the document feed motor and SCNT board (J102) connections.
  - (8) Use the *Chapter 2: 3.5.7 Aging Test*, Test Mode [5] Aging Test to check if the document feed motor is operating correctly.  
Motor check: 4  $\Omega$  per stepping coil phase
  - (9) Replace the SCNT board.

**#003 [TX/RX] One-page copy/transmission-reception time over**

---

- Causes:**
- (1) One page of the document was longer than 1 meter or transmission/copying took longer than the regulated time (32 minutes).
  - (2) Reception took longer than the regulated time (32 minutes).
  - (3) Internal structure defect

- Solutions:**
- (1) Use a copy machine to copy the document onto several shorter page, then transmit/copy.
  - (2) Raise the page timer value with Service Data #1 SSSW SW12.
  - (3) Have the other party split the document over multiple pages and receive it that way.
  - (4) Contact the other party and check the cause.
  - (5) Check the document edge sensor (DES) and OPCNT board (J6) connections.



- (6) Check if the document edge sensor (DES) is operating correctly using the methods given in *Chapter 2: 3.5.8 Faculty tests*, Test Mode [6] Faculty Test, [3] Sensor Tests.
- (7) Replace the document edge sensor.
- (8) Replace the OPCNT board.
- (9) Check the document feed motor and SCNT board (J102) connections.
- (10) Use the *Chapter 2: 3.5.7 Aging Test*, Test Mode [5] Aging Test to check if the document feed motor is operating correctly.  
Motor check: 4  $\Omega$  per stepping coil phase
- (11) Replace the SCNT board.

---

**#005 [TX/RX] Initial identification time (T1) over**

- Causes:**
- (1) Tone/pulse parameter set incorrectly.
  - (2) The time until connection with the other fax is too long.
  - (3) The other fax does not answer.
  - (4) The communications mode (G2, G3, etc.) of the other fax does not match that of this fax.
  - (5) The other fax malfunctioned during transmission due to echoes.
  - (6) Malfunction due to echoes during reception
- Solutions:**
- (1) Set the tone/pulse parameter correctly.
  - (2) When registering for auto dialing, add a long pause to delay the start of the timer.
  - (3) Lengthen the T1 timer with Service Data #3 Numeric PARAM 10 so that the timer does not time out.
  - (4) Contact the other party and have them check for the cause.
  - (5) The communications mode is a part of specification for the fax, so there is no countermeasure.
  - (6) Implement echo countermeasures, given in this manual in *Chapter 2: 3.4.4 Explanation of service data, #1 SSSW SW03*.

---

**#008 [TX] During polling transmission, the password did not match.**

- Cause:** The password on this fax and on the other fax did not match.
- Solutions:**
- (1) If the other fax is a Canon fax, contact the other party and agree on identical passwords.
  - (2) If the other fax is not a Canon fax, set the password to "255".
  - (3) Record the sounds of the communications procedure onto DAT and ask the local Canon office and/or Technical Center for analysis.

**#009 [RX] Recording paper jam/no recording paper**

---

- Causes:** (1) The recording paper jammed.  
(2) There is no recording paper.  
(3) Internal structure defect

- Solutions:** (1) Clear the recording paper jam.  
(2) Load recording paper.  
(3) Check if the paper sensor, paper pickup sensor, paper eject sensor, and paper jam sensor are operating correctly using the methods given in *Chapter 2: 3.5.8 Faculty tests, Test Mode* [6] Faculty Test, [3] Sensor Tests.  
(4) Replace the paper sensor board. (paper sensor defect)  
(5) Replace the PCNT board. (paper pickup sensor, paper exit sensor, or paper jam sensor defect)  
(6) Check the main motor and PCNT board connector J601 connections.  
Motor check:  $3\Omega$  per stepping coil phase  
(7) Check the PCNT board (J208) and paper sensor board (J701) connections.  
(8) Check the PCNT board (J706) and driver board (J901) connections.  
(LASER CLASS 5500)  
(9) Check the driver board (J908) and feeder board recording paper sensor connections. (LASER CLASS 5500)  
(10) Replace the feeder section recording paper sensor.  
(11) Replace the driver board. (LASER CLASS 5500)

**#011 [RX] Polling reception error**

---

- Causes:** (1) The document is not set in the other fax.  
(2) Transmission was intended, but since the document was not set correctly, polling reception was carried out instead.

- Solutions:** (1) Have the other party set the document in their fax.  
(2) Set the document correctly, then transmit.

**#012 [RX] No recording paper in other fax**

---

**Cause:** The other fax has no recording paper.

**Solutions:** Have the other party set recording paper in their fax.

**#018 [TX/RX] Auto call error**

---

- Causes:** (1) Tone/pulse parameter set incorrectly.  
(2) The line connection time is too long.  
(3) The timer ran out because the other fax is busy.  
(4) The timer ran out because the other fax is not connected or is not switched on.  
(5) The timer ran out because the other fax has no recording paper.

- Solutions:** (1) Set the tone/pulse parameter correctly.  
(2) When registering for auto dialing, add a long pause to delay the start of the timer.  
(3) Lengthen the T1 timer with Service Data #3 Numeric PARAM 10 so that the timer does not run out.  
(4) Call again.  
(5) Contact the operator for the other party and have them check for the cause.  
(6) Have the other party load recording paper in their fax.

**#021 [RX] DCN received during polling reception**

---

**Cause:** The password in this fax and in the other fax did not match.

**Solutions:** Contact the other party and agree on identical passwords.

**#022 [TX] Can not call**

---

**Cause:** During broadcast transmission or broadcast polling reception, the other fax's telephone number was not registered for auto dialing.

**Solutions:** Register the other fax's telephone number for auto dialing.

**#025 [TX/RX] Auto dialing setting error**

---

**Cause:** An attempt was made to auto dial with confidential and relay set in auto dialing.

**Solutions:** Set confidential and relay correctly for auto dialing.

**#033 [TX] Confidential transmission not possible**

---

**Cause:** The other fax does not have the confidential function.

**Solutions:** Since confidential transmission is not possible, use ordinary transmission.

**#034 [TX] Can not transmit to other fax's confidential box**

---

**Causes:** (1) The other fax does not have the specified confidential box.  
(2) The other fax's memory is full.

**Solutions:** (1) Check the other fax's confidential box number, then execute confidential transmission.  
(2) Have the other party clear any unnecessary image data from their fax.

**#035 [TX] Relay control transmission not possible**

---

**Cause:** The other fax does not have the relay function.

**Solutions:** Since relay control transmission is not possible, use broadcast transmission.

**#036 [TX] Relay control transmission not possible**

- Causes:**
- (1) The relay control station user telephone is not registered for auto dialing in the relay fax.
  - (2) The relay control station user telephone is incorrectly registered for auto dialing in the relay fax.
  - (3) The relay switch in the relay fax is off.
  - (4) The relay fax's memory is full.

- Solutions:**
- (1) Have the relay control station user telephone registered for auto dialing in the relay fax.
  - (2) Have the relay control station user telephone correctly registered for auto dialing in the relay fax.
  - (3) Have the relay station relay switch switched on.
  - (4) Contact the relay station and have them clear any unnecessary image data from their fax.

**#037 [RX] Image memory overflow during reception**

**Cause:** Too many documents received

**Solutions:** Clear any unnecessary image data, then have the other party transmit again.

**#039 [TX] Closed network transmission not possible**

- Causes:**
- (1) The closed network transmission switch is switched off.
  - (2) The other fax's closed network transmission switch is switched off.
  - (3) The closed network ID does not match the other fax's.

- Solutions:**
- (1) Set Service Data #1 SSSW SW07 bit 7 to "1" to switch on closed network transmission.
  - (2) Have the other party switch on the closed network reception switch on their fax.
  - (3) Use Service Data #1 SSSW SW08 to set the same closed network ID for your fax and for the other fax.

**#995 [TX] Memory transmission reservation cancellation**

**Cause:** The user accidentally canceled the memory transmission reservation.

**Solutions:** Transmit again.

**b-2) Service error codes**

• **G3 mode error codes**

**##100 [TX] During transmission, the procedure signals were retransmitted the maximum allowed number of times.**

---

**Cause (If after Q signal transmission after image signals):**

The line conditions were poor and the other fax could not receive the image signals or the Q signals correctly.

**Solutions (If after Q signal transmission after image signals):**

- (1) Use Service Data #2 Menu Parameter 07 to raise the modem transmission level so that the other fax can receive the image signals and Q signals correctly.
- (2) Set user data "**SYSTEM SETTINGS**", "**TX START SPEED**" to "**7200 bps**", "**4800 bps**" or "**2400 bps**".
- (3) Use Service Data #2 Menu Parameter 05 to adjust the NL equalizer so that the other fax can receive the image signals and Q signals correctly.
- (4) Use Service Data #1 SSSW SW03, Bit 1 to attach the echo protect tones to the V29 modem signals.

**Causes (If after TCF transmission before image signals):**

- (1) The transmission level is too low for the other fax to receive the signals correctly.
- (2) The other fax malfunctioned due to echoes.

**Solutions (If after TCF transmission before image signals):**

- (1) Use Service Data #2 Menu Parameter 07 to set the modem transmission level so that the other fax can receive the signals correctly.
- (2) Implement echo countermeasures, given in this manual in *Chapter 2: 3.4.4 Service data, #1 SSSW SW03*.
- (3) When registering for auto dialing, add a long pause after the telephone number to prevent response to the first DIS from the other party.
- (4) For manual calls, wait for the first DIS from the other fax before pressing the START key.

**##101 [TX/RX] Different modem speed from other fax**

---

**Causes (Transmission):**

- (1) The fax's modem speed does not match that of the other fax.
- (2) When the fax falls back to a lower speed, it does not match that of the other fax.

**Solutions (Transmission):** (1) The modem speed is a part of specification for the fax, so there is no countermeasure.

- (2) Use Service Data #2 Menu Parameter 07 to raise the modem transmission level so that the other fax can correctly receive TCF correctly.
- (3) Use Service Data #2 Menu Parameter 05 to adjust the NL equalizer so that the other fax can receive TCF correctly.
- (4) When registering for auto dialing, add a long pause after the telephone number to prevent response to the first DIS from the other party.
- (5) For manual calls, wait for the first DIS from the other fax before pressing the START key.

**Cause (Reception):** The fax's modem speed does not match that of the other fax.

**Countermeasure (Reception):** The modem speed is part of the specification for the fax, so there is no countermeasure.

#### **##102 [TX] Fall back impossible for transmission**

**Causes:** (1) The line conditions were too poor for correct TCF transmission.

(2) The other fax malfunctioned due to echoes.

**Solutions:** (1) Use Service Data #2 Menu Parameter 07 to raise the modem transmission level so that the other fax can correctly receive TCF.

(2) Use Service Data #2 Menu Parameter 05 to adjust the NL equalizer so that the other fax can receive TCF correctly.

(3) Implement echo countermeasures, given in this manual in *Chapter 2: 3.4.4 Explanation of service data, #1 SSSW SW03*.

(4) When registering auto dialing, add a long pause after the telephone number to prevent response to the first DIS from the other party.

(5) For manual calls, wait for the first DIS from the other fax before pressing the START key.

(6) Have the other party lower the transmission level of their fax so that it does not receive echoes.

#### **##103 [RX] For reception, EOL could not be detected for 5 seconds (for CBT, 15 seconds).**

**Causes:** (1) The line conditions were poor and the fax could not receive the image signals correctly.

(2) Malfunction due to CFR echoes

**Solutions:** (1) Have the transmission start speed for the other fax lowered to 4800 bps.

(2) Use Service Data #2 Menu Parameter 05 to adjust the NL equalizer so that the fax can receive the image data correctly.

- (3) Implement echo countermeasures, given in this manual in *Chapter 2: 3.4.4 Explanation of service data, #1 SSSW SW03*.
- (4) Use Service Data #2 Menu Parameter 07 to lower the modem transmission level so that the fax does not receive echoes from transmitted CFR.

**##104 [TX] RTN or PIN received during transmission**

---

**Causes:** (1) The line conditions were poor and the other fax could not receive the image signals correctly.

(2) The other fax malfunctioned due to echoes.

**Solutions:** (1) Use Service Data #2 Menu Parameter 07 to raise the modem transmission level so that the other fax can correctly receive the image data.

(2) Lower the user data "**SYSTEM SETTINGS**", "**TX START SPEED**" to "**7200 bps**", "**4800 bps**" or "**2400 bps**".

(3) Use Service Data #1 SSSW SW03, Bit 1 to attach the echo protect tones to the V29 modem signals.

(4) Have the other fax's RTN transmission conditions relaxed so that the other fax does not transmit RTN.

(5) Use Service Data #2 Menu Parameter 05 to adjust the NL equalizer so that the other fax can receive the image data correctly.

(6) Implement echo countermeasures, given in this manual in *Chapter 2: 3.4.4 Explanation of service data, #1 SSSW SW03*.

(7) When registering for auto dialing, add a long pause after the telephone number to prevent response to the first DIS from the other party.

(8) For manual calls, wait for the first DIS from the other fax before pressing the START button.

(9) Have the other fax's transmission level lowered so that it does not receive echoes.

**##106 [RX] When waiting for protocol signals during reception, protocol signals could not be received for 6 seconds.**

---

**Causes (line conditions were poor):**

(1) The line conditions were poor and the fax could not receive the protocol signals from the other fax.

(2) The line conditions were poor and the other fax could not receive the image signals correctly.

**Solutions:** (1) Have the other fax's transmission level raised so that the protocol signals can be received correctly.

(2) Use Service Data #2 Menu Parameter 07 to raise this fax's modem transmission level so that the other fax can correctly receive the image data.

**Causes (Malfunction due to echoes):** Malfunction due to echoes

- (1) Implement echo countermeasures, given in this manual in *Chapter 2: 3.4.4 Explanation of service data, #1 SSSW SW03.*
- (2) Use Service Data #2 Menu Parameter 07 to lower this fax's modem transmission level so that this fax does not receive echoes from transmitted CFR.

**##107 [RX] During reception, the transmitting fax could not fall back.**

**Causes (Line conditions were poor):**

- (1) Line conditions were poor and after going to 2400-bps reception, the signals from the other fax could not be received correctly.

**Solutions:** (1) Have the other fax's transmission level raised so that this fax can receive the other fax's signals correctly.

- (2) Use Service Data #2 Menu Parameter 05 to adjust the NL equalizer so that the other fax can receive TCF correctly.
- (3) Use Service Data #3 Numeric Parameters 02-04 to relax the RTN transmission conditions so that RTN is not transmitted.

**Solutions (Malfunction due to echoes):**

- (1) Implement echo countermeasures, given in this manual in *Chapter 2: 3.4.4 Explanation of service data, #1 SSSW SW03.*
- (2) Use Service Data #2 Menu Parameter 07 to lower the modem transmission level so that the fax does not receive echoes from transmitted signals.

**##109 [TX] During transmission, after DCS was transmitted, a signal other than DIS, DTC, FTT, CFR, or CRP was received, and the protocol signals were retransmitted the maximum allowed number of times.**

**Cause:** Protocol signal abnormality

**Solutions:** Record the communications protocol onto DAT and ask the local Canon office and/or Technical Center.

**##111 [TX/RX] Memory error**

**Causes:** (1) Noise caused a data error during print output of data stored in image memory.

- (2) Noise caused a dialing error. (The print/display telephone number pointer and the call pointer did not match.)

**Solutions:** (1) Output all the data, clear all the data, then register the data.

- (2) Replace the SCNT board.



**###114 [RX] RTN transmitted during reception**

- Causes:** (1) The line conditions were poor and the fax could not receive the image signals from the other fax correctly.  
(2) CFR echoes
- Solutions:** (1) Have the other fax's transmission level raised so that this fax can receive the other fax's signals correctly.  
(2) Have the other fax's transmission start speed lowered to 4800 bps.  
(3) Use Service Data #2 Menu Parameter 05 to adjust the NL equalizer so that the fax can receive the image signals correctly.  
(4) Use Service Data #3 Numeric Parameters 02-04 to relax the RTN transmission conditions so that RTN is not transmitted.  
(5) Implement echo countermeasures, given in this manual in *Chapter 2: 3.4.4 Explanation of service data, #1 SSSW SW03*.  
(6) Use Service Data #2 Menu Parameter 07 to lower the modem transmission level so that the fax does not receive echoes from the transmitted CFR.

**###200 [RX] During reception, no carrier could be detected for 5 seconds during image reception.**

- Causes:** (1) The line conditions were poor and the fax could not receive the image signals correctly.  
(2) Time over because training signals could not be received due to CFR echoes
- Solutions:** (1) Have the other fax's transmission level raised so that this fax can receive the other fax's signals correctly.  
(2) Have the other fax's transmission start speed lowered to 4800 bps.  
(3) Implement echo countermeasures, given in this manual in *Chapter 2: 3.4.4 Explanation of service data, #1 SSSW SW03*.  
(4) Use Service Data #2 Menu Parameter 07 to lower the modem transmission level so that the fax does not receive echoes from the transmitted CFR.

**###201 [TX/RX] DCN received other than with normal binary procedure**

- Causes:** (1) The other fax is not online. (No recording paper)  
(2) The user telephone is not registered. (If the other fax is a Ricoh 3000L)  
(3) In polling reception, the passwords did not match.  
(4) In polling transmission, no document was set.  
(5) Transmission was reserved from the other fax, but there was no recording paper.

- (6) The line conditions were poor and the fax could not receive the image signals correctly.
- (7) Malfunction due to echoes
- (8) The image signals or the Q signals could not be received and the other (transmitting) fax retransmitted the protocol signals the maximum allowed number of times.
- (9) The line conditions were poor and the other (transmitting) fax could not fall back.

**Solutions:** (1) Have the other fax put online. (Set recording paper.)

- (2) Register the user telephone.
- (3) If the other fax is a Canon, contact the other party and agree on identical passwords. If the other fax is from any other company, contact the other party and set the passwords on both faxes to "255".
- (4) Set the document and have the other fax call again.
- (5) Load recording paper.
- (6) Use Service Data #2 Menu Parameter 07 to raise the modem transmission level so that the other fax can correctly receive the protocol signals.
- (7) Implement echo countermeasures, given in this manual in *Chapter 2: 3.4.4 Explanation of service data, #1 SSSW SW03*.
- (8) Use Service Data #2 Menu Parameter 07 to lower the modem transmission level so that the fax does not receive echoes.
- (9) Have the other fax's transmission level raised so that signals can be received correctly.
- (10) Use Service Data #2 Menu Parameter 05 to adjust the NL equalizer so that signals can be received correctly.
- (11) Have the other fax's transmission start speed lowered to 4800 bps.
- (12) Use Service Data #3 Numeric Parameters 02-04 to loosen the RTN transmission conditions so that RTN is not transmitted.

**##220 [TX/RX] System error (main program locked up)**

---

**Cause:** The CPU malfunctioned due to noise.

**Solutions:** Switch the power off/on.

**##224 [TX/RX] Abnormality in protocol signals for G3 communications**

---

**Cause:** Protocol signal abnormality

**Solutions:** Record the communications protocol onto DAT and ask the local Canon office and/or Technical Center.

**##226 [TX/RX] Stack pointer out of RAM area**

**Cause:** The CPU malfunctioned due to noise.

**Solutions:** Switch the power off/on.

**##229 [RX] The recording system was locked for one minute.**

**Cause:** Not known

**Solutions:** Press the START key and print the image.

**##232 [TX] The encode control unit malfunctioned.**

**Cause:** The operation of the encode control UPI did not end normally.

**Solutions:** Replace the encode control unit (SCNT board).

**##237 [RX] The decode UPI malfunctioned.**

**Cause:** The operation of the decode control UPI did not end normally.

**Solutions:** Replace the decode control unit (SCNT board).

**##238 [RX] The print control unit malfunctioned.**

**Cause:** The operation of the print control UPI did not end normally.

**Solutions:** Replace the print control unit (PCNT board).

**##280 [TX] In transmission, the protocol signals were retransmitted the maximum allowed number of times.**

**Causes:** (1) The transmission level was low and after TCF was sent, the other fax could not receive the appropriate signals correctly.  
(2) The other fax malfunctioned due to echoes.

**Solutions:** (1) Use Service Data #2 Menu Parameter 07 to raise the modem transmission level so that the other fax can correctly receive the appropriate signals.  
(2) Implement echo countermeasures, given in this manual in *Chapter 2: 3.4.4 Explanation of service data, #1 SSSW SW03*.  
(3) When registering auto dialing, add a long pause after the telephone number to prevent response to the first DIS from the other party.  
(4) For manual calls, wait for the first DIS from the other fax before pressing the START key.  
(5) Have the other fax's transmission level lowered so that it does not receive echoes.

**##281 [TX] In transmission, the protocol signals were retransmitted the maximum allowed number of times.**

**Cause:** The line conditions were poor and since the image signals or EOP was not transmitted correctly, after EOP transmission, the appropriate signals could not be received.

- Solutions:**
- (1) Use Service Data #2 Menu Parameter 07 to raise the modem transmission level so that the other fax can correctly receive the image signals and EOP.
  - (2) Set user data "TX START SPEED" in "SYSTEM SETTINGS" to "7200 bps", "4800 bps" or "2400 bps".
  - (3) Use Service Data #2 Menu Parameter 05 to adjust the NL equalizer so that the other fax can receive the image signals and EOP correctly.
  - (4) Use Service Data #1 SSSW SW03, Bit 1 to attach the echo protect tones to the V29 modem signals.

**##282 [TX] During transmission, the protocol signals were retransmitted the maximum allowed number of times.**

---

**Cause:** The line conditions were poor and since the image signals or EOM was not transmitted correctly, after EOM transmission, the appropriate signals could not be received.

- Solutions:**
- (1) Use Service Data #2 Menu Parameter 07 to raise the modem transmission level so that the other fax can correctly receive the image signals and EOM.
  - (2) Set user data "TX START SPEED" in "SYSTEM SETTINGS" to "7200 bps", "4800 bps" or "2400 bps".
  - (3) Use Service Data #2 Menu Parameter 05 to adjust the NL equalizer so that the other fax can receive the image signals and EOM correctly.
  - (4) Use Service Data #1 SSSW SW03, Bit 1 to attach the echo protect tones to the V29 modem signals.

**##283 [TX] During transmission, the protocol signals were retransmitted the maximum allowed number of times.**

---

**Cause:** The line conditions were poor and since the image signals or MPS was not transmitted correctly, after MPS transmission, the appropriate signals could not be received.

- Solutions:**
- (1) Use Service Data #2 Menu Parameter 07 to raise the modem transmission level so that the other fax can correctly receive the image signals and MPS.
  - (2) Set user data "TX START SPEED" in "SYSTEM SETTINGS" to "7200 bps", "4800 bps" or "2400 bps".
  - (3) Use Service Data #2 Menu Parameter 05 to adjust the NL equalizer so that the other fax can receive the image signals and MPS correctly.
  - (4) Use Service Data #1 SSSW SW03, Bit 1 to attach the echo protect tones to the V29 modem signals.

**##284 [TX] During transmission, after TCF transmission, DCN received**

---

- Causes:**
- (1) The other fax is not online. (No recording paper)
  - (2) The user telephone is not registered. (If the other fax is a Ricoh 3000L)
  - (3) The other fax can not receive.
  - (4) The other fax malfunctioned due to echoes.
  - (5) Relay instructions were given to the other fax, but the other fax was relay broadcasting.

- Solutions:**
- (1) Have the other fax put online (recording paper loaded.)
  - (2) Register the user telephone.
  - (3) Use Service Data #2 Menu Parameter 07 to raise the modem transmission level so that the other fax can correctly receive.
  - (4) Implement echo countermeasures, given in this manual in *Chapter 2: 3.4.4 Explanation of service data, #1 SSSW SW03*.
  - (5) When registering auto dialing, add a long pause after the telephone number to prevent response to the first DIS from the other party.
  - (6) When dialing with the numeric keys, for manual calls, wait for the first DIS from the other fax before pressing the START key.
  - (7) Have the other fax's transmission level lowered so that it does not receive echoes.
  - (8) Wait a while, then transmit again.

**##285 [TX] During transmission, after EOP transmission, DCN was received.**

---

**Cause:** The Stop key was pressed during communication.

**Solutions:** Transmit again.

**##286 [TX] During transmission, after EOM transmission, DCN was received.**

---

**Cause:** The Stop key was pressed during communication.

**Solutions:** Transmit again.

**##287 [TX] During transmission, after MPS transmission, DCN was received.**

---

**Cause:** The Stop key was pressed during communication.

**Solutions:** Transmit again.

**##288 [TX] During transmission, after EOP transmission, a signal other than PIN, PIP, MCF, RTP, or RTN was received.**

---

**Cause:** Protocol signal abnormality

**Solutions:** Record the sounds of the communications protocol onto DAT and ask the local Canon office and/or Technical Center.

**##289 [TX] During transmission, after EOM transmission, a signal other than PIN, PIP, MCF, RTP, or RTN was received.**

**Cause:** Protocol signal abnormality

**Solutions:** Record the sounds of the communications protocol onto DAT and ask the local Canon office and/or Technical Center.

**##290 [TX] During transmission, after MPS transmission, a signal other than PIN, PIP, MCF, RTP, or RTN was received.**

**Cause:** Protocol signal abnormality

**Solutions:** Record the sounds of the communications protocol onto DAT and ask the local Canon office and/or Technical Center.

- Printer error codes

**##321 [RX] Printer section status error**

**Cause:** Internal unit defect (returned status signal abnormal)

**Solutions:** Check the SCNT board and PCNT board (J201) connector connections. Replace the PCNT board.

**##322 [RX] Fixing heater temperature abnormality**

**Cause:** Internal unit defect

**Solutions:** (1) Check the PCNT board and fixing heater (J103 and J204) connector connections.  
(2) Remove the fixing unit, and check the resistance between fixing unit J204-1 and J204-2, which should be 440 KW (at room temperature of 20°C).  
(3) Remove the fixing unit and check the conductance between fixing unit J103-1 and J103-2.  
(4) Replace the fixing film unit.  
(5) Replace the PCNT board.

**##323 [RX] Laser/scanner unit BD signal output function abnormality**

**Cause:** Internal unit defect

**Solutions:** (1) Check the laser/scanner unit and PCNT board (J202) connector connections.  
(2) Check the amount of laser light, as explained in *Chapter 5: 3. SERVICE TOOLS*.  
(3) Replace the laser/scanner unit.  
(4) Replace the PCNT board.

**##324 [RX] Printer section scanner motor rotation rate abnormality**

**Cause:** Internal unit defect

**Solutions:** (1) Check the laser/scanner unit and PCNT board (J202) connector connections.  
(2) Replace the laser/scanner unit  
(3) Replace the PCNT board.

**##325 [RX] Fan motor rotation rate abnormality**

---

**Cause:** Internal unit defect

- Solutions:** (1) Check the fan motor and power supply unit (J4) connector connections.
- (2) Check if the voltage between power supply unit J4-1 and J4-3 goes from 0 to 12 VDC immediately after the power is switched on. If not so, replace the fan motor.
- (3) Replace the power supply unit.

**##330 [RX] Power supply unit ACVIN signal abnormality**

---

**Cause:** Internal unit defect

- Solutions:** (1) Check the PCNT board and the power supply unit (CN1) connector connections.
- (2) Check if the voltage between the power supply unit CN1-6 and CN1-3, which should be 1 VDC or more. If not so, replace the power supply unit.
- (3) Replace the PCNT board.

• **ECM mode error codes**

**##750 [TX] After PPS-NUL transmission, no significant signals could be received and the protocol signals were retransmitted the maximum allowed number of times.**

---

- Causes:** (1) Line conditions were poor and PPS-NUL was not correctly transmitted.
- (2) Line conditions were poor and signals could not be correctly received.

- Solutions:** (1) Use Service Data #2 Menu Parameter 07 to raise the modem transmission level so that the other fax can correctly receive PPS-NUL.
- (2) Use Service Data #2 Menu Parameter 05 to adjust the NL equalizer so that the other fax can receive PPS-NUL.
- (3) Use Service Data #1 SSSW SW03, Bit 1 to attach the echo protect tones to the V29 modem signals.
- (4) Have the other fax's transmission level raised so that signals can be received correctly.

**##752 [TX] During transmission, after PPS-NUL transmission, DCN was received.**

---

- Causes:** (1) Line conditions were poor and the other fax could not correctly receive PPS-NUL.
- (2) The Stop key was pressed during communication.

- Solutions:** (1) Use Service Data #2 Menu Parameter 07 to raise the modem transmission level so that the other fax can correctly receive PPS-NUL.

(2) Transmit again.

**##753 [TX] After PPS-NULL transmission, the protocol signals were retransmitted the maximum allowed number of times or the T5 timer (60 seconds) ran out.**

**Cause:** The other fax's page buffer is full or is being used, so PPS-NULL was transmitted, then RNR was received and after RR transmission, no significant signals could be received.

**Solutions:** (1) In the user data "TX SETTINGS", set "ECM TX" to "OFF".  
(2) Set user data "TX START SPEED" in "SYSTEM SETTINGS" to "7200 bps", "4800 bps" or "2400 bps".

**##754 [TX] After PPS-NULL transmission, the protocol signals were retransmitted the maximum allowed number of times.**

**Causes:** (1) Line conditions were poor and after PPS-NULL transmission, PPR was received four times and CTC transmitted, but the other fax could not receive it correctly.  
(2) Line conditions were poor and after PPS-NULL transmission, PPR was received four times and CTC transmitted, but then significant signals could not be received correctly.

**Solutions:** (1) Use Service Data #2 Menu Parameter 07 to raise the modem transmission level so that the other fax can correctly receive CTC.  
(2) Have the other fax's transmission level raised so that signals can be received correctly.

**##755 [TX] After PPS-MPS transmission, significant signals could not be received and the protocol signals were retransmitted the maximum allowed number of times.**

**Causes:** (1) Line conditions were poor and PPS-MPS was not transmitted correctly.  
(2) Line conditions were poor and signals could not be received correctly.

**Solutions:** (1) Use Service Data #2 Menu Parameter 07 to raise the modem transmission level so that the other fax can correctly receive PPS-MPS.  
(2) Use Service Data #2 Menu Parameter 05 to adjust the NL equalizer so that the other fax can correctly receive PPS-MPS.  
(3) Use Service Data #1 SSSW SW03, Bit 1 to attach the echo protect tones to the V29 modem signals.  
(4) Have the other fax's transmission level raised so that signals can be received correctly.



**##757 [TX] After PPS-MPS transmission, DCN was received.**

**Causes:** (1) Line conditions were poor and the other fax could not correctly receive PPS-MPS.

(2) The Stop KEY was pressed during communication.

**Solutions:** (1) Use Service Data #2 Menu Parameter 07 to raise the modem transmission level so that the other fax can correctly receive PPS-MPS.

(2) Transmit again.

**##758 [TX] After PPS-MPS transmission, the protocol signals were retransmitted the maximum allowed number of times or the T5 timer (60 seconds) ran out.**

**Cause:** The other fax's page buffer is full or is being used, so PPS-MPS was transmitted, then RNR was received and after RR transmission, no significant signals could be received.

**Solutions:** (1) In the user data "TX SETTINGS", set "ECM TX" to "OFF".

(2) Set user data "TX START SPEED" in "SYSTEM SETTINGS" to "7200 bps", "4800 bps" or "2400 bps".

**##759 [TX] After PPS-MPS transmission, the protocol signals were retransmitted the maximum allowed number of times.**

**Causes:** (1) Line conditions were poor and after PPS-MPS transmission, PPR was received four times and CTC transmitted, but the other fax could not receive it correctly.

(2) Line conditions were poor and after PPS-MPS transmission, PPR was received four times and CTC transmitted, but then significant signals could not be received correctly.

**Solutions:** (1) Use Service Data #2 Menu Parameter 07 to raise the modem transmission level so that the other fax can correctly receive CTC.

(2) Have the other fax's transmission level raised so that signals can be received correctly.

**##760 [TX] After PPS-EOM transmission, significant signals could not be received and the protocol signals were retransmitted the maximum allowed number of times.**

**Causes:** (1) Line conditions were poor and the other fax could not receive PPS-EOM.

(2) Line conditions were poor and signals could not be received correctly.

**Solutions:** (1) Use Service Data #2 Menu Parameter 07 to raise the modem transmission level so that the other fax can correctly receive PPS-EOM.

- (2) Use Service Data #2 Menu Parameter 05 to adjust the NL equalizer so that the other fax can correctly receive PPS-EOM.
- (3) Use Service Data #1 SSSW SW03, Bit 1 to attach the echo protect tones to the V29 modem signals.
- (4) Have the other fax's transmission level raised so that signals can be received correctly.

**##762 [TX] After PPS-EOM transmission, DCN was received.**

---

- Causes:** (1) Line conditions were poor and the other fax could not correctly receive PPS-EOM.  
(2) The Stop key was pressed during communication.
- Solutions:** (1) Use Service Data #2 Menu Parameter 07 to raise the modem transmission level so that the other fax can correctly receive PPS-EOM.  
(2) Transmit again.

**##763 [TX] After PPS-EOM transmission, the protocol signals were retransmitted the maximum allowed number of times or the T5 timer (60 seconds) ran out.**

---

- Cause:** The other fax's page buffer is full or is being used, so PPS-EOM was transmitted, then RNR was received and after RR transmission, no significant signals could be received.
- Solutions:** (1) In the user data "TX SETTINGS", set "ECM TX" to "OFF".  
(2) Set user data "TX START SPEED" in "SYSTEM SETTINGS" to "7200 bps", "4800 bps" or "2400 bps".

**##764 [TX] After PPS-EOM transmission, the protocol signals were retransmitted the maximum allowed number of times.**

---

- Causes:** (1) Line conditions were poor and after PPS-EOM transmission, PPR was received four times and CTC transmitted, but the other fax could not receive it correctly.  
(2) Line conditions were poor and after PPS-EOM transmission, PPR was received four times and CTC transmitted, but then significant signals could not be received correctly.
- Solutions:** (1) Use Service Data #2 Menu Parameter 07 to raise the modem transmission level so that the other fax can correctly receive CTC.  
(2) Have the other fax's transmission level raised so that signals can be received correctly.

**##765 [TX] After PPS-EOP transmission, significant signals could not be received and the protocol signals were retransmitted the maximum allowed number of times.**

---

- Causes:** (1) Line conditions were poor and the other fax could not receive PPS-EOP.  
(2) Line conditions were poor and signals could not be received correctly.
- Solutions:** (1) Use Service Data #2 Menu Parameter 07 to raise the modem transmission level so that the other fax can correctly receive PPS-EOP.  
(2) Use Service Data #2 Menu Parameter 05 to adjust the NL equalizer so that the other fax can correctly receive PPS-EOP.  
(3) Use Service Data #1 SSSW SW03, Bit 1 to attach the echo protect tones to the V29 modem signals.  
(4) Have the other fax's transmission level raised so that signals can be received correctly.

**##767 [TX] After PPS-EOP transmission, DCN was received.**

---

- Causes:** (1) Line conditions were poor and the other fax could not correctly receive PPS-EOP.  
(2) The Stop key was pressed during communication.
- Solutions:** (1) Use Service Data #2 Menu Parameter 07 to raise the modem transmission level so that the other fax can correctly receive PPS-EOP.  
(2) Transmit again.

**##768 [TX] After PPS-EOP transmission, the protocol signals were retransmitted the maximum allowed number of times or the T5 timer (60 seconds) timed out.**

---

- Cause:** The other fax's page buffer is full or is being used, so PPS-EOP was transmitted, then RNR was received and after RR transmission, no significant signals could be received.
- Solutions:** (1) In the user data "TX SETTINGS", set "ECM TX" to "OFF".  
(2) Set user data "TX START SPEED" in "SYSTEM SETTINGS" to "7200 bps", "4800 bps" or "2400 bps".

**##769 [TX] After PPS-EOP transmission, the protocol signals were retransmitted the maximum allowed number of times.**

---

- Causes:** (1) Line conditions were poor and after PPS-EOP transmission, PPR was received four times and CTC transmitted, but the other fax could not receive it correctly.  
(2) Line conditions were poor and after PPS-EOP transmission, PPR was received four times and CTC transmitted, but then significant signals could not be received correctly.

- Solutions:** (1) Use Service Data #2 Menu Parameter 07 to raise the modem transmission level so that the other fax can correctly receive CTC.  
(2) Have the other fax's transmission level raised so that signals can be received correctly.

**##770 [TX] After EOR-NULL transmission, no significant signals could be received and the protocol signals were retransmitted the maximum allowed number of times.**

- Causes:** (1) Line conditions were poor and the other fax could not receive EOR-NULL correctly.  
(2) Line conditions were poor and signals could not be correctly received.

- Solutions:** (1) Use Service Data #2 Menu Parameter 07 to raise the modem transmission level so that the other fax can correctly receive EOR-NULL.  
(2) Have the other fax's transmission level raised so that signals can be received correctly.

**##772 [TX] After EOR-NULL transmission, DCN was received.**

- Causes:** (1) Line conditions were poor and the other fax could not correctly receive EOR-NULL.  
(2) The Stop key was pressed during communication.

- Solutions:** (1) Use Service Data #2 Menu Parameter 07 to raise the modem transmission level so that the other fax can correctly receive EOR-NULL.  
(2) Transmit again.

**##773 [TX] After EOR-NULL transmission, the protocol signals were retransmitted the maximum allowed number of times or the T5 timer (60 seconds) timed out.**

- Cause:** The other fax's page buffer is full or is being used, so EOR-NULL was transmitted, then RNR was received and after RR transmission, no significant signals could be received.

- Solutions:** (1) In the user data "TX SETTINGS", set "ECM TX" to "OFF".  
(2) Set user data "TX START SPEED" in "SYSTEM SETTINGS" to "7200 bps", "4800 bps" or "2400 bps".

**##774 [TX] After EOR-NULL transmission, ERR was received.**

- Causes:** (1) Line conditions are poor and other faxes frequently can not receive image data correctly.  
(2) Malfunction due to echoes

- Solutions:** (1) Use Service Data #2 Menu Parameter 07 to raise the modem transmission level so that the other fax can correctly receive image signals.
- (2) Use Service Data #2 Menu Parameter 05 to adjust the NL equalizer so that the other fax can correctly receive image signals.
- (3) Implement echo countermeasures, given in this manual in *Chapter 2: 3.4.4 Explanation of service data, #1 SSSW SW03.*

**##775 [TX] After EOR-MPS transmission, no significant signals could be received and the protocol signals were retransmitted the maximum allowed number of times.**

---

- Causes:** (1) Line conditions were poor and the other fax could not receive EOR-MPS correctly.
- (2) Line conditions were poor and signals could not be correctly received.

- Solutions:** (1) Use Service Data #2 Menu Parameter 07 to raise the modem transmission level so that the other fax can correctly receive EOR-MPS.
- (2) Have the other fax's transmission level raised so that signals can be received correctly.

**##777 [TX] After EOR-MPS transmission, DCN was received.**

---

- Causes:** (1) Line conditions were poor and the other fax could not correctly receive EOR-MPS.
- (2) The Stop key was pressed during communication.

- Solutions:** (1) Use Service Data #2 Menu Parameter 07 to raise the modem transmission level so that the other fax can correctly receive EOR-MPS.
- (2) Transmit again.

**##778 [TX] After PPS-MPS transmission, the protocol signals were retransmitted the maximum allowed number of times or the T5 timer (60 seconds) timed out.**

---

- Cause:** The other fax's page buffer is full or is being used, so PPS-MPS was transmitted, then RNR was received and after RR transmission, no significant signals could be received.

- Solutions:** (1) In the user data "TX SETTINGS", set "ECM TX" to "OFF".
- (2) Set user data "TX START SPEED" in "SYSTEM SETTINGS" to "7200 bps", "4800 bps" or "2400 bps".

**##779 [TX] After EOR-MPS transmission, ERR was received.**

---

- Causes:** (1) Line conditions are poor and other faxes frequently can not receive image data correctly.
- (2) The other fax malfunctioned due to echoes.

- Solutions:**
- (1) Use Service Data #2 Menu Parameter 07 to raise the modem transmission level so that the other fax can correctly receive image signals.
  - (2) Use Service Data #2 Menu Parameter 05 to adjust the NL equalizer so that the other fax can correctly receive image signals.
  - (3) Implement echo countermeasures, given in this manual in *Chapter 2: 3.4.4 Explanation of service data, #1 SSSW SW03*.
  - (4) When registering for auto dialing, add a long pause after the telephone number to prevent response to the first DIS from the other party.
  - (5) For manual calls, wait for the first DIS from the other fax before pressing the START key.
  - (6) Have the other fax's transmission level lowered so that it does not receive echoes.

**##780 [TX] After EOR-EOM transmission, no significant signals could be received and the protocol signals were retransmitted the maximum allowed number of times.**

---

- Causes:**
- (1) Line conditions were poor and the other fax could not receive EOR-EOM correctly.
  - (2) Line conditions were poor and signals could not be correctly received.

- Solutions:**
- (1) Use Service Data #2 Menu Parameter 07 to raise the modem transmission level so that the other fax can correctly receive EOR-EOM.
  - (2) Have the other fax's transmission level raised so that signals can be received correctly.

**##782 [TX] After EOR-EOM transmission, DCN was received.**

---

- Causes:**
- (1) Line conditions were poor and the other fax could not correctly receive EOR-EOM.
  - (2) The Stop key was pressed during communication.

- Solutions:**
- (1) Use Service Data #2 Menu Parameter 07 to raise the modem transmission level so that the other fax can correctly receive EOR-EOM.
  - (2) Transmit again.

**##783 [TX] After PPS-EOM transmission, the protocol signals were retransmitted the maximum allowed number of times or the T5 timer (60 seconds) timed out.**

---

- Cause:** The other fax's page buffer is full or is being used, so PPS-EOM was transmitted, then RNR was received and after RR transmission, no significant signals could be received.

- Solutions:** (1) In the user data "TX SETTINGS", set "ECM TX" to "OFF".  
(2) Set user data "TX START SPEED" in "SYSTEM SETTINGS" to "7200 bps", "4800 bps" or "2400 bps".

**##784 [TX] After EOR-EOM transmission, ERR was received.**

- Causes:** (1) Line conditions are poor and other faxes frequently can not receive image data correctly.  
(2) The other fax malfunctioned due to echoes.

- Solutions:** (1) Use Service Data #2 Menu Parameter 07 to raise the modem transmission level so that the other fax can correctly receive image signals.  
(2) Use Service Data #2 Menu Parameter 05 to adjust the NL equalizer so that the other fax can correctly receive image signals.  
(3) Implement echo countermeasures, given in this manual in *Chapter 2: 3.4.4 Explanation of service data, #1 SSSW SW03*.  
(4) When registering for auto dialing, add a long pause after the telephone number to prevent response to the first DIS from the other party.  
(5) For manual calls, wait for the first DIS from the other fax before pressing the START key.  
(6) Have the other fax's transmission level lowered so that it does not receive echoes.

**##785 [TX] After EOR-EOP transmission, no significant signals could be received and the protocol signals were retransmitted the maximum allowed number of times.**

- Causes:** (1) Line conditions were poor and the other fax could not receive EOR-EOP correctly.  
(2) Line conditions were poor and signals could not be correctly received.

- Solutions:** (1) Use Service Data #2 Menu Parameter 07 to raise the modem transmission level so that the other fax can correctly receive EOR-EOP.  
(2) Have the other fax's transmission level raised so that signals can be received correctly.

**#787 [TX] After EOR-EOP transmission, DCN was received.**

- Causes:** (1) Line conditions were poor and the other fax could not correctly receive EOR-EOP.  
(2) The Stop key was pressed during communication.

- Solutions:** (1) Use Service Data #2 Menu Parameter 07 to raise the modem transmission level so that the other fax can correctly receive EOR-EOP.  
(2) Transmit again.

**##788 [TX] After EOR-EOP transmission, the protocol signals were retransmitted the maximum allowed number of times or the T5 timer (60 seconds) timed out.**

**Cause:** The other fax's page buffer is full or is being used, so EOR-EOP was transmitted, then RNR was received and after RR transmission, no significant signals could be received.

**Solutions:** (1) In the user data "TX SETTINGS", set "ECM TX" to "OFF".  
(2) Set user data "TX START SPEED" in "SYSTEM SETTINGS" to "7200 bps", "4800 bps" or "2400 bps".

**##789 [TX] After EOR-EOP transmission, ERR was received.**

**Causes:** (1) Line conditions are poor and other faxes frequently can not receive image data correctly.

(2) The other fax malfunctioned due to echoes.

**Solutions:** (1) Use Service Data #2 Menu Parameter 07 to raise the modem transmission level so that the other fax can correctly receive image signals.

(2) Use Service Data #2 Menu Parameter 05 to adjust the NL equalizer so that the other fax can correctly receive image signals.

(3) Implement echo countermeasures, given in this manual in *Chapter 2: 3.4.4 Explanation of service data, #1 SSSW SW03*.

(4) When registering auto dialing, add a long pause after the telephone number to prevent response to the first DIS from the other party.

(5) For manual calls, wait for the first DIS from the other fax before pressing the START key.

(6) Have the other fax's transmission level lowered so that it does not receive echoes.

**##790 [RX] After EOR-Q transmission, ERR was received.**

**Causes:** (1) Line conditions are poor and other faxes frequently can not receive image data correctly.

(2) The other fax malfunctioned due to echoes.

**Solutions:** (1) Have the other fax's transmission level raised so that image signals can be received correctly.

(2) Use Service Data #2 Menu Parameter 05 to adjust the NL equalizer so that the image signals are correctly received.

(3) Implement echo countermeasures, given in this manual in *Chapter 2: 3.4.4 Explanation of service data, #1 SSSW SW03*.

**##791 [TX/RX] Something other than significant signals was received in the protocol in ECM mode.**

**Cause:** Protocol signal abnormality



**Solutions:** Record the communications protocol onto DAT and ask the local Canon office and/or Technical Center.

**##792 [RX] PPS-NULL between partial pages could not be detected**

---

**Causes:** Line conditions were poor and signals could not be received.

**Solutions:** Have the other fax's transmission level raised so that the signals can be received correctly.

**##793 [RX] During reception of high-speed signals, the maximum allowable time ran out without this fax being able to detect a valid frame**

---

**Causes:** (1) Line conditions were poor and the other fax could not receive signals correctly.

(2) Line conditions were poor and signals could not be correctly received.

(3) Training signals could not be received due to CFR echoes

**Solutions:** (1) Use Service Data #2 Menu Parameter 07 to raise the modem transmission level so that the other fax can correctly receive signals.

(2) Use Service Data #2 Menu Parameter 05 to adjust the NL equalizer so that the other fax can correctly receive signals.

(3) Have the other fax's transmission start speed lowered to 4800 bps.

(4) Have the other fax's transmission level raised so that signals can be received correctly.

(5) Implement echo countermeasures, given in this manual in *Chapter 2: 3.4.4 Explanation of service data, #1 SSSW SW 03.*

**##794 [TX] All-0 PPR was received.**

---

**Cause:** Protocol signal abnormality

**Solutions:** Record the communications protocol onto DAT and ask the local Canon office and/or Technical Center.

**##795 [TX/RX] Trouble in the decoding processing during communication**

---

**Cause:** The communications coding was busy.

**Solutions:** (1) Switch the power off/on.

(2) Replace the SCNT board.

**##799 [TX] System error**

---

**Cause:** An attempt was made to transmit EOR during the Canon express protocol.

**Solutions:** (1) Switch the power off/on.

(2) Replace the SCNT board.

**This page intentionally left blank**

### 4.3 Breakdowns and Recovery

#### a) The power does not come on.

- Solutions:** (1) Plug the power cord into a socket and switch on the Power switch.
- (2) Check the fuse in the power supply unit. If the fuse (F001) blows, check the fixing unit cables.
- (3) Check the power supply and board connector connections.
- (4) Replace the power supply unit.

#### b) No display on display

- Solutions:** (1) Check the SCNT board (J104) and OPCNT board (J1) connector connections.
- (2) Replace the OPCNT board.
- (3) Replace the SCNT board.

#### c) Keys do not function.

- Solutions:** (1) Check the SCNT board (J104) and OPCNT board (J1) connector connections.
- (2) Replace the OPCNT board (defective key switches).
- (3) Replace the OPCNT board (defective OPCNT control IC).
- (4) Replace the SCNT board.

#### d) Document feed is defective.

##### The document is not fed.

- Solutions:** (1) Check the J5 connector connections to the document sensor OPCNT board.
- (2) Use the *Chapter 2: 3.5.8 Faculty Test*, Test Mode [6] Faculty Test [3] Sensor Test to check whether the document feed motor is working normally.
- (3) Replace the document sensor.
- (4) Check the SCNT board (J104) and OPCNT board (J1) connector connections.
- (5) Replace the OPCNT board.
- (6) Replace the SCNT board.

**The document feed motor does not move or is out of adjustment.**

- Solutions:** (1) Check the SCNT board (J102) and document feed motor connector connections.  
(2) Use the *Chapter 2: 3.5.7 Aging Test*, Test Mode [5] Aging Test to check if the document feed motor is operating correctly.  
(3) Motor check: 4  $\Omega$  per stepping coil phase  
(4) Replace the document feed motor.  
(5) Replace the SCNT board.

**e) Scanning is defective.**

First carry out a test print as described in *Chapter 2: 3.5.5 Print test* to check if there is any print defect.

**No printing for copying either**

- Solutions:** (1) Check the contact sensor and SCNT board (J108) connections.  
(2) Replace the contact sensor.  
(3) Replace the SCNT board.

**Vertical stripes in images**

- Solutions:** (1) Clean the white mylar sheet.  
(2) Clean the contact sensor glass.  
(3) Check the contact sensor and SCNT board (J108) connections.  
(4) Replace the contact sensor.

**Thick vertical stripes in images**

- Solutions:** (1) Clean the white mylar sheet.  
(2) Clean the contact sensor glass.  
(3) Set SSSW #1 SW06 Bits 0 and 1 to "1", as explained in *Chapter 2: 3.4.4 Explanation of service data*.  
(4) Check the contact sensor and SCNT board (J108) connections.  
(5) Replace the contact sensor.

**f) No sound from the speaker**

- Solutions:** (1) Check the speaker and SCNT board (J106) connection.  
(2) Replace the speaker.  
(3) Replace the SCNT board.

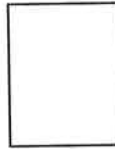
**g) Print defects**



Light



Dark



Completely blank



All black



Dots



Marks on back of paper



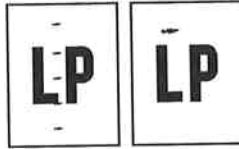
Black vertical lines



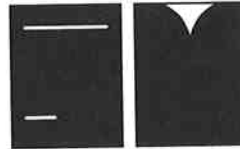
Irregular and smudged black vertical lines



Irregular and smudged black horizontal lines



Marks



Blank spots



White vertical lines



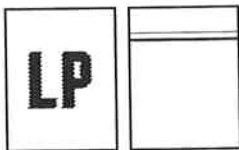
White horizontal lines



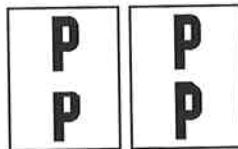
Faulty registration



Poor fixing



Distortion  
-BD failure



Partially compressed/stretched image

**Figure 4-42 Faulty Print Samples**

Light



- Solutions:**
- (1) In user data, set "**SELECT DENSITY**" to "**DK**".
  - (2) Replace the toner cartridge.
  - (3) During printing, open the cartridge cover, open the toner cartridge drum shutter by hand, and check that the toner image on the photosensitive drum is transferred to the recording paper. If it is transferred and the toner image on the drum surface is light, proceed to 6); if not, proceed to the next step.
  - (4) Replace the transfer charging roller.
  - (5) Clean the transfer bias contact and the transfer charging roller shaft contact.
  - (6) Check that the laser shutter opens when you press the laser shutter lever.
  - (7) Replace the laser shutter lever or the laser shutter.
  - (8) Clean the developing bias contact and the toner cartridge contact.
  - (9) Check the amount of laser light, as explained in *Chapter 5: 3 SERVICE TOOLS*.
  - (10) Replace the PCNT board.
  - (11) Replace the laser/scanner unit.

**Dark**



- 
- Solutions:**
- (1) In user data, set "**SELECT DENSITY**" to "**LT**".
  - (2) Clean the drum ground contact and the toner cartridge contact.
  - (3) Clean the primary charging contact and the toner cartridge contact.
  - (4) Check the amount of laser light, as explained in *Chapter 5: 3 SERVICE TOOLS*.
  - (5) Replace the PCNT board.
  - (6) Replace the laser/scanner unit.

**Completely blank**



- 
- Solutions:**
- (1) Clean the developing bias contact and the toner cartridge contact.
  - (2) Check if the laser shutter opens when you press the laser shutter lever.
  - (3) Replace the laser shutter lever or the laser shutter.
  - (4) Check the amount of laser light, as explained in *Chapter 5: 3 SERVICE TOOLS*.
  - (5) Replace the PCNT board.
  - (6) Replace the laser/scanner unit.

**All black**



- 
- Solutions:** (1) Replace the toner cartridge.  
(2) Check the amount of laser light, as explained in *Chapter 5: 3. SERVICE TOOLS*.  
(3) Replace the PCNT board.  
(4) Replace the laser/scanner unit.

**Dots**



- 
- Solutions:** (1) Clean the static charge eliminator in the toner transfer section.  
(2) Check the static charge eliminator contact.  
(3) Clean the transfer charging roller.  
(4) Replace the transfer charging roller.



### Marks on back of papers



- Solutions:**
- (1) If the marks are at intervals of approx. 1.73"(44 mm), clean the transfer charging roller, but if they are at intervals of approx. 1.97" (50 mm), clean the fixing pressure roller.
  - (2) Replace the transfer charging roller.
  - (3) Replace the fixing pressure roller.
  - (4) Clean the paper feed guide.
  - (5) Clean entrance guide in the fixing unit.

### Black vertical lines



- Solutions:**
- (1) Clean the mirror.
  - (2) During printing, open the cartridge cover, open the toner cartridge drum shutter by hand, and check if there are vertical black lines on the photosensitive drum.
  - (3) If there are vertical black lines on the photosensitive drum, replace the toner cartridge.
  - (4) If there are not vertical black lines on the photosensitive drum, replace the fixing unit.

**Irregular and smudged black vertical lines**



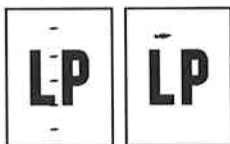
- 
- Solutions:** (1) Clean the entrance guide in the fixing unit.  
(2) Replace the toner cartridge.

**Irregular and smudged black horizontal lines**



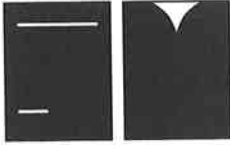
- 
- Solutions:** If the irregular smudged black lines occur cyclically, replace the toner cartridge. If they are non-cyclically, replace the fixing film unit.

**Marks**



- 
- Solutions:** (1) If the marks are at intervals of approx. 1.73" (44 mm), clean the transfer charging roller; if they are at intervals of approx. 2.95" (75 mm), clean the fixing film unit; and if they are at intervals of approx. 2.95" (75 mm), 0.95" (25 mm), or 1.5" (38 mm), replace the toner cartridge.  
(2) Clean the paper feed guide.  
(3) Clean the the entrance guide in the fixing unit.

### Blank spots



- 
- Solutions:**
- (1) Clean the transfer charging roller.
  - (2) Replace the transfer charging roller.
  - (3) Replace the toner cartridge.
  - (4) Check for foreign matter between the transfer charging roller gear and the drive gear.
  - (5) Clean the developing bias contact and the toner cartridge contact.
  - (6) Replace the PCNT board.

### White vertical lines



- 
- Solutions:**
- (1) Shake the toner cartridge.
  - (2) Open the toner cartridge drum shutter and if there are vertical white lines on the photosensitive drum, replace the toner cartridge.
  - (3) Clean the mirror.
  - (4) Check for foreign matter stuck in the laser output hole on the laser/scanner unit or the laser input hole on the toner cartridge.
  - (5) Replace the laser/scanner unit.

### White horizontal lines



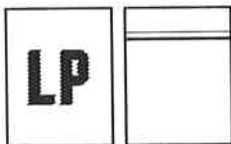
- 
- Solutions:** (1) Replace the toner cartridge.  
(2) Replace the fixing film unit.

### Faulty registration



- 
- Solutions:** (1) Check if more than the regulation amount of recording paper is loaded in the cassette.  
(2) Adjust the leading edge margin as explained in 3.3.5 *Leading edge margin adjustment*.  
(3) Replace the pickup roller.  
(4) Replace the feed roller.  
(5) Replace the pickup sensor actuator.  
(6) Replace the feed solenoid.  
(7) Replace the PCNT board.

**Distortion / -BD signal failure**



- Solutions:**
- (1) Check the laser/scanner unit and PCNT board (J202) connector connections.
  - (2) Check the amount of laser light, as explained in *Chapter 5: 3. SERVICE TOOLS*.
  - (3) Replace the PCNT board.
  - (4) Replace the laser/scanner unit.

**Poor fixing**



- Solutions:**
- (1) If the dirt is at intervals of approx. 2.95" (75 mm), clean the fixing film unit; if they are at intervals of approx. 1.97" (50 mm), clean the fixing pressure roller.
  - (2) Replace the fixing film unit.
  - (3) Replace the fixing pressure roller.
  - (4) Check the nip width of the fixing ass'y. If it is not as specified, replace the fixing unit.

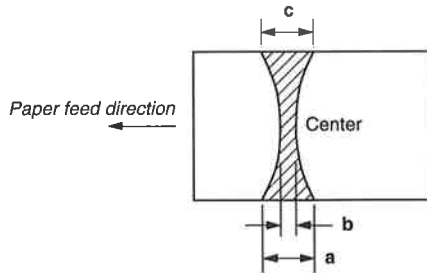


**Checking the nip width**

Improperly set nip may cause a fixing unit problem. The fixing unit is not designed to allow adjustment of the nip.

Check the fixing unit nip by using the following procedure.

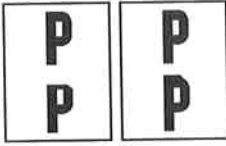
- (1) Either take along one or two all-black copies of A4 or letter size made with a copier, or make it using a copier at the customer site.
- (2) Set the black copy in the side cassette with the black side facing down.
- (3) Press the test print switch (SW 301) on the PCNT board.
- (4) Turn the power OFF when the beginning of the paper appears on the paper exit slot. Next, open the exit paper cover and remove the jam paper from the machine.
- (5) Measure the widths of an area on the paper where toner luster is visible and check whether they fall within the range shown in below table.



	Dimension
b	0.1" to 0.16" (2.5 to 4 mm)
a - c	0.02" (0.5 mm) or less
a - b	0.06" (1.5 mm) or less
b - c	0.06" (1.5 mm) or less

**Figure 4-43 Nip Width**

**Partially compressed/stretched image**



- 
- Solutions:** (1) Check for foreign matter between the toner cartridge gear and the drive gear.  
(2) Check if the toner cartridge gear is broken.  
(3) Replace the toner cartridge.

**h) Recording paper pickup is defective.**

**The recording paper is not picked up from the side cassette.**

- Solutions:**
- (1) Check that the side cassette is installed correctly.
  - (2) Check if more than the regulation amount of recording paper is loaded in the side cassette.
  - (3) Check that the recording paper is set correctly on the cassette retaining tabs.
  - (4) Check that the lifting arm is at its initial position. If it is not, after switch the power on, insert the side cassette into the main unit.
  - (5) Replace the separation pad.
  - (6) Replace the separation ass'y.
  - (7) Check the pickup solenoid and PCNT board (J206) connections.
  - (8) Replace the pickup solenoid.
  - (9) Replace the pickup roller.
  - (10) Replace the PCNT board.

**Recording paper is not picked up from the front cassette**

**(LASER CLASS 5500 only)**

- Solutions:**
- (1) Check that the front cassette is installed correctly.
  - (2) Check if more than the regulation amount of recording paper is loaded in the front cassette.
  - (3) Check that the recording paper is set correctly on the cassette retaining clips.
  - (4) Check that the feeder pickup roller is at its initial position. If it is not, after switch the power on, insert the front cassette into the main unit.
  - (5) Check the feeder pickup solenoid and driver board (J903) connections.
  - (6) Replace the feeder pickup solenoid.
  - (7) Replace the feeder pickup roller.
  - (8) Check the PCNT board (J706) and driver board (J901) connections.
  - (9) Replace the driver board.
  - (10) Replace the PCNT board.



i) Printer operation is defective.



---

For fixing heater temperature abnormality (##321), laser/scanner unit signal -BD signal output function abnormality, (##323), Scanner motor rotation abnormality (##324), or fan motor rotation abnormality (##325), see 4.2.1 Error shown on the display, "CHECK PRINTER".

---

**"REC. PAPER JAM" is displayed on the display even though a paper jam has not occurred**

- Solutions:**
- (1) Check that the cartridge cover, right cover, exit paper cover, or feeder right cover (LASER CLASS 5500 only) is closed correctly.
  - (2) Check that the toner cartridge is installed correctly.
  - (3) Check that the paper eject roller ass'y is attached correctly.
  - (4) Check if the paper pickup sensor, paper eject sensor, and paper jam sensor are operating correctly using methods given in *Chapter 2: OPERATION 3.5.8 Faculty tests*, Test Mode [6] Faculty Test, [3] Sensor tests.
  - (5) Check that the paper pickup sensor actuator is damaged.
  - (6) Replace the paper pickup sensor actuator.
  - (7) Check that the paper eject sensor actuator in the fixing ass'y is damaged.
  - (8) Replace the paper eject sensor actuator.
  - (9) Check that the paper jam sensor actuator in the fixing ass'y is damaged.
  - (10) Replace the paper jam sensor actuator.
  - (11) Replace the PCNT board.

**"SUPPLY REC. PAPER" is displayed on the display even though a paper is loaded in the side cassette**

- Solutions:**
- (1) Re-install the side cassette correctly.
  - (2) Check if the paper sensor is operating correctly using methods given in *Chapter 2: OPERATION 3.5.8 Faculty tests*, Test Mode [6] Faculty Test, [3] Sensor tests.
  - (3) Check the paper sensor board and PCNT board (J208) connections.
  - (4) Check that the paper sensor actuator is damaged.
  - (5) Replace the paper sensor actuator.
  - (6) Replace the paper sensor board.
  - (7) Replace the PCNT board.

**Front cassette No-paper LED is on even though a paper is loaded in the front cassette (LASER CLASS 5500 only)**

---

- Solutions:**
- (1) Re-install the front cassette correctly.
  - (2) Check if the paper sensor is operating correctly using methods given in Chapter 2: OPERATION 3.5.8 Faculty tests, Test Mode [6] Faculty Test, [3] Sensor tests.
  - (3) Check the feeder paper sensor and driver board (J906) connections.
  - (4) Check that the feeder paper sensor actuator is damaged.
  - (5) Replace the feeder paper sensor actuator.
  - (6) Replace the feeder paper sensor.
  - (7) Replace the driver board.

**Main motor does not rotate**

---

- Solutions:**
- (1) Check the main motor and PCNT board (J601) connections.
  - (2) Check that the voltage between the power supply unit CN1-3 and CN1-5 is 13 VDC. If it is not, replace the power supply unit.
  - (3) Replace the main motor.

## j) Recording paper jam

### Recording paper jam in the paper pickup section

---

- Solutions:**
- (1) Check that the side cassette is installed correctly.
  - (2) Check if more than the regulation amount of recording paper is loaded in the side cassette.
  - (3) Check that the recording paper is set correctly on the cassette retaining tabs.
  - (4) Check that the lifting arm is at its initial position. If it is not, after switch the power on, insert the side cassette into the main unit.
  - (5) Replace the separation pad.
  - (6) Replace the separation ass'y.
  - (7) Check the pickup solenoid and PCNT board (J206) connections.
  - (8) Replace the pickup solenoid.
  - (9) Replace the pickup roller.
  - (10) Replace the PCNT board.

### Recording paper jam in the feeder section

#### (LASER CLASS 5500 only)

---

- Solutions:**
- (1) Check that the front cassette is installed correctly.
  - (2) Check if more than the regulation amount of recording paper is loaded in the front cassette.
  - (3) Check that the recording paper is set correctly on the cassette retaining clips.
  - (4) Check that the feeder pickup roller is at its initial position. If it is not, after switch the power on, insert the front cassette into the main unit.
  - (5) Check the feeder pickup solenoid and driver board (J903) connections.
  - (6) Replace the feeder pickup solenoid.
  - (7) Replace the feeder pickup roller.
  - (8) Check the PCNT board (J706) and driver board (J901) connections.
  - (9) Replace the driver board.
  - (10) Replace the PCNT board.

**Recording paper jam in the fixing unit**

---

- Solutions:** (1) Clean the fixing entrance guide.  
(2) Clean the fixing film unit.  
(3) Clean the fixing eject roller.  
(4) Clean the fixing pressure roller.  
(5) Clean the fixing eject guide.  
(6) Replace the fixing film unit.  
(7) Replace the fixing eject roller.  
(8) Replace the fixing pressure roller.  
(9) Replace the fixing ass'y.

**Recording paper jam in the paper eject section**

---

- Solutions:** (1) Check that the paper eject roller ass'y is attached correctly.  
(2) Replace the paper eject roller.  
(3) Replace the paper eject roller ass'y.

**k) Recording paper feed is defective.**

**Multiple feed / Skew feed / Bend of paper leading edge**

---

- Solutions:** (1) Check that the cassette is installed correctly.  
(2) Check if more than the regulation amount of recording paper is loaded in the cassette.  
(3) Check that the recording paper is set correctly on the cassette retaining tabs.  
(4) Replace the separation pad.

**Wrinkles**

---

- Solutions:** (1) During printing, open the cartridge cover before the paper enters the fixing ass'y, and check that wrinkles is on the paper. If it is, check paper pickup section using methods given in *h) Recording paper pickup is defective*.  
(2) Clean the fixing entrance guide.  
(3) Clean the fixing pressure roller.  
(4) Replace the fixing ass'y.

## 5. WIRING DIAGRAM

### 5.1 Wiring Diagram

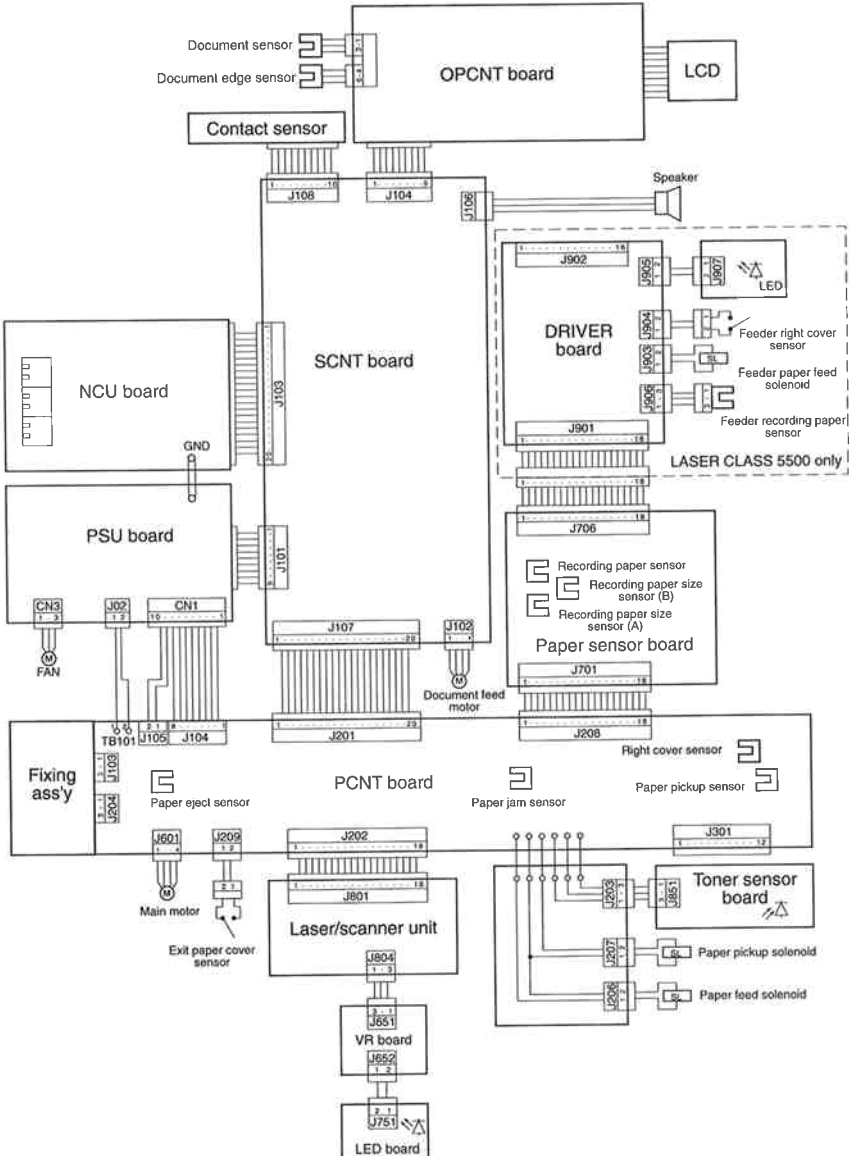


Figure 4-44 Wiring Diagram

## 5.2 Connector Location and Signals

### 5.2.1 SCNT board

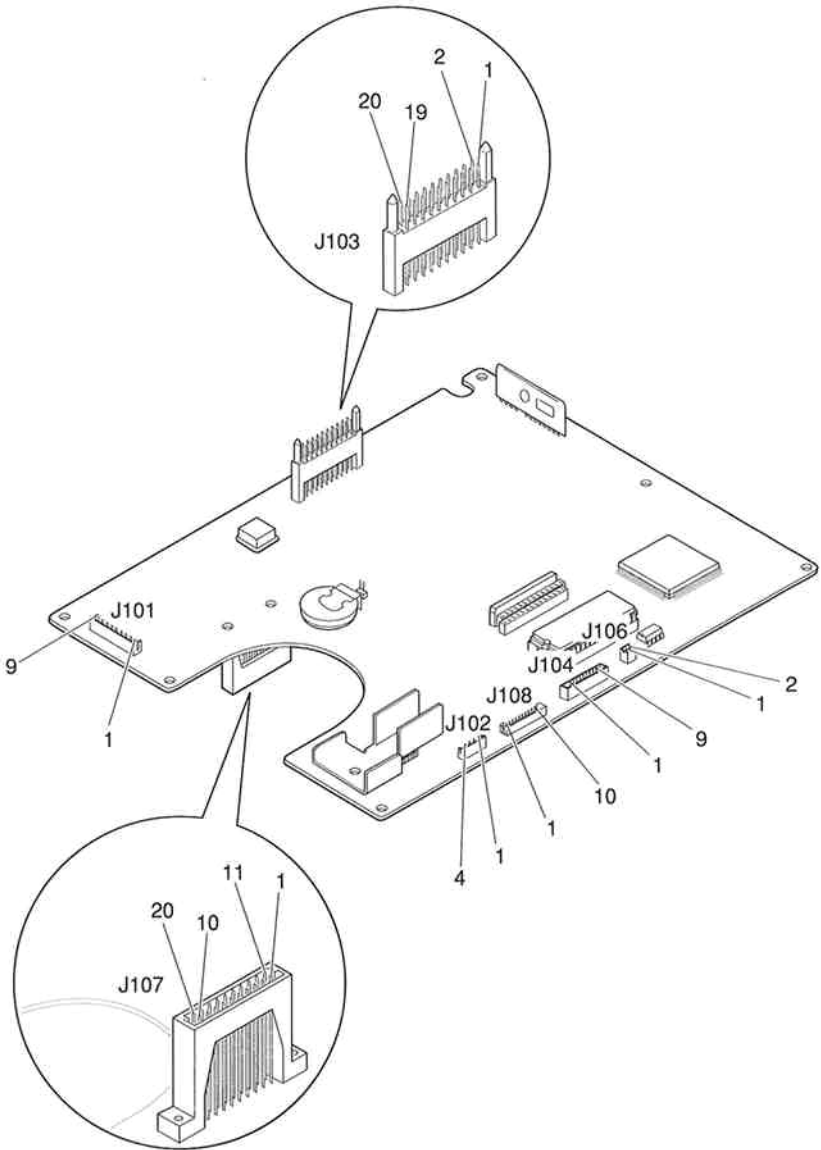


Figure 4-45 SCNT Board

**J101 (PSU board connector)**

<b>Pin No.</b>	<b>Signal</b>	<b>In/Out</b>	<b>Output from</b>	<b>Details</b>
1	+13 V	In	Power supply	Main motor supplementary power
2	+12 V	In	Power supply	Logic drive voltage
3	+12 V	In	Power supply	Logic drive voltage
4	AGND	—	—	Ground
5	AGND	—	—	Ground
6	+5 V	In	Power supply	Logic drive voltage
7	+5 V	In	Power supply	Logic drive voltage
8	DGND	—	—	Ground
9	DGND	—	—	Ground

**J102 (Document feed motor connector)**

<b>Pin No.</b>	<b>Signal</b>	<b>In/Out</b>	<b>Output from</b>	<b>Details</b>
1	-RMB	Out	Driver IC (IC11) A phase	
2	RMB	Out	Driver IC (IC11) -A phase	
3	-RMA	Out	Driver IC (IC11) B phase	
4	RMA	Out	Driver IC (IC11) -B phase	

**J103 (NCU board connector)**

Pin No.	Signal	In/Out	Output from	Details
1	-CI	In	Telephone line	CI signal from telephone line
2	CIFRQ	In	Telephone line	CI signal frequency
3	-ONHOOK	In	Handset	Handset onhook detect signal
4	LPL0	—	—————	Not used
5	LPL1	—	—————	Not used
6	-GRD	—	—————	Not used
7	-CNG	In	Telephone line	CNG signal from telephone line
8	-PRD	Out	Gate array (IC3)	P relay control signal
9	-SRD	Out	Gate array (IC3)	S relay control signal
10	-HRD	Out	Gate array (IC3)	H relay control signal
11	-CMLD	Out	Gate array (IC3)	CML relay control signal
12	-RRD	—	—————	Not used
13	-WRD	—	—————	Not used
14	+5 V	Out	Power supply	Logic drive signal
15	DGND	—	—————	Digital ground
16	+12 V	Out	Power supply	Logic drive signal
17	TELMONIT	In	Telephone line	Answering machine telephone connection line monitor signal
18	LININ	In	Telephone line	Signal received from telephone line
19	AGND	—	—————	Analog ground
20	LINOUT	Out	Modem IC (IC6)	Signal transmitted from telephone line



**J104 (OPCNT board connector)**

Pin No.	Signal	In/Out	Output from	Details
1	GND	—	—	Ground
2	GND	—	—	Ground
3	+5 V	Out	Power supply	Logic drive voltage
4	+5 V	Out	Power supply	Logic drive voltage
5	PROT	In	OPCNT control IC (IC1)	Memory protect signal
6	-RESET	Out	Gate array (IC3)	Reset signal
7	TXD	Out	Gate array (IC3)	Data signal for LEDs, display, buttons, and sensors
8	RXD	In	OPCNT control IC (IC1)	Data signal from LEDs, display, buttons, and sensors
9	DCLK	Out	Gate array (IC3)	Clock signal

**J106 (speaker connector)**

Pin No.	Signal	In/Out	Output from	Details
1	SPKOH	Out	IC 27	Speaker drive signal
2	SPKOL	Out	IC 27	Speaker drive signal

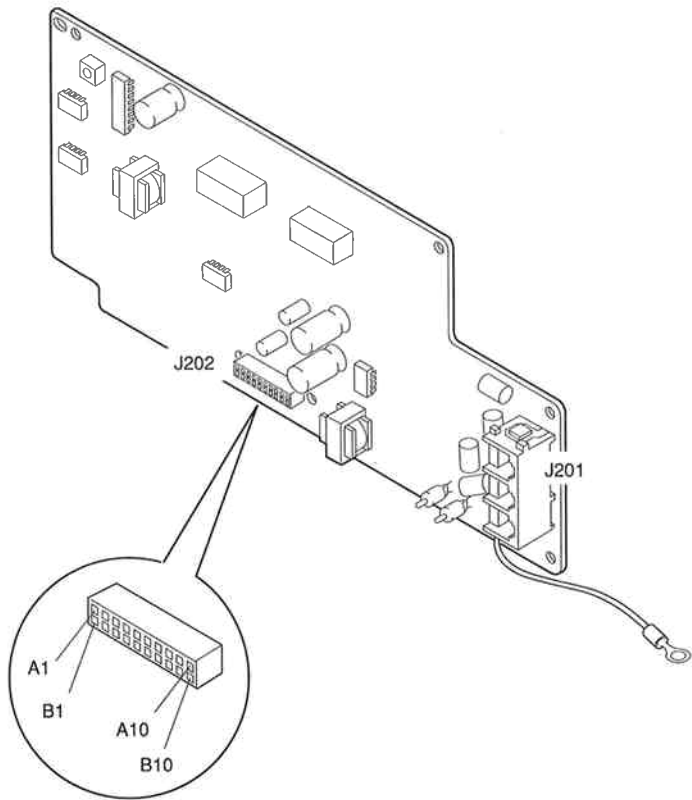
**J107 (PCNT board connector)**

Pin No.	Signal	In/Out	Output from	Details
1	GND	—	—	Ground
2	-PPRDV	—	—	Not used
3	-TOP	In	PCNT CPU (IC301)	Vertical sync signal
4	-STS	In	PCNT CPU (IC301)	Status signal
5	-CBSY	Out	Gate array (IC2)	Command busy signal
6	-TRGON	Out	Gate array (IC2)	Scanner motor driving signal
7	-VDO	Out	Gate array (IC2)	Video signal
8	-CCLK	Out	Gate array (IC2)	Controller clock signal
9	-PRFD	Out	Gate array (IC2)	Prefeed signal
10	GND	—	—	Ground
11	-BD	In	PCNT CPU (IC301)	Horizontal sync signal
12	-RDY	In	PCNT CPU (IC301)	Ready signal
13	-SBSY	In	PCNT CPU (IC301)	Status busy signal
14	NC	—	—	Not connected
15	-PRINT	Out	Gate array (IC2)	Print signal
16	-CPRDY	Out	Gate array (IC2)	Controller power ready signal
17	-CMD	Out	Gate array (IC2)	Command signal
18	NC	—	—	Not connected
19	+5 V	Out	Power supply	Logic drive voltage
20	+5 V	Out	Power supply	Logic drive voltage

**J108 (CS connector)**

<b>Pin No.</b>	<b>Signal</b>	<b>In/Out</b>	<b>Output from</b>	<b>Details</b>
1	VOUT	In	Contact sensor	Image signal
2	GND	—	—	Ground
3	+5 V	Out	Power supply	Logic drive signal
4	GND	—	—	Ground
5	GND	—	—	Ground
6	SP	Out	Gate array (IC5)	Image read start signal
7	GND	—	—	Ground
8	MALCK	Out	Gate array (IC5)	Contact sensor drive clock
9	-LEDON	Out	Gate array (IC5)	LED drive signal
10	+12R	Out	Power supply	LED drive voltage

### 5.2.2 NCU board



**Figure 4-46 NCU Board**

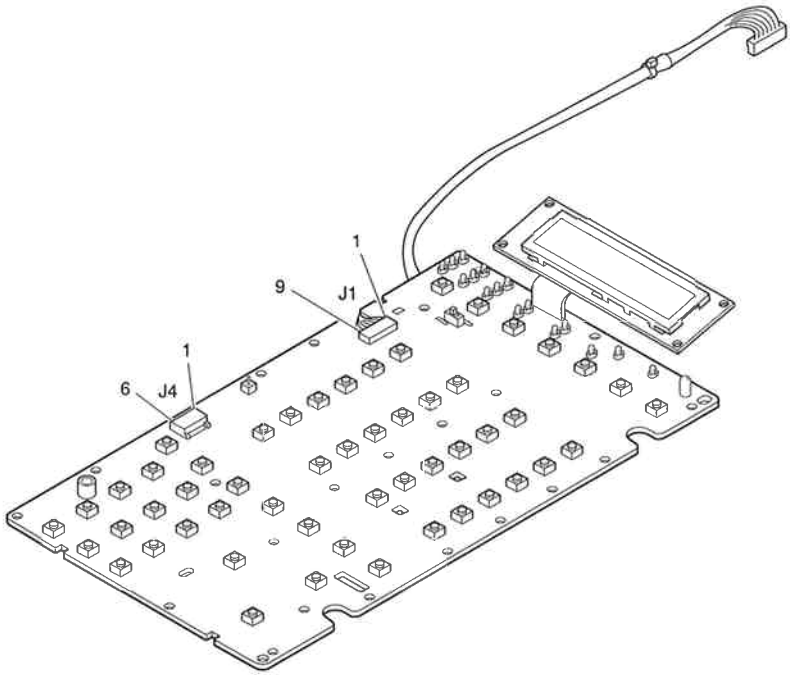
**J201 (Modular jack connector)**

Pin No.	Signal	In/Out	Output from	Details
1	T1			Extension telephone line
2	T2			Extension telephone line
3	T1			Handset telephone line
4	T2			Handset telephone line
5	L1			Telephone line
6	L2			Telephone line

**J202 (SCNT board connector)**

Pin No.	Signal	In/Out	Output from	Details
A1	-CI	Out	Telephone line	CI signal from telephone line
A2	ONHOOK	Out	Handset	Handset onhook detect signal
A3	LPL1	—	—	Not used
A4	CNG	Out	Telephone line	CNG signal from the telephone line
A5	-SRD	In	Gate array (IC3)	S relay control signal
A6	-CMLD	In	Gate array (IC3)	CML relay control signal
A7	-WRD	—	—	Not used
A8	DGND	—	—	Digital ground
A9	MONIT	Out	Telephone line	Answering machine telephone connection line monitor signal
A10	AGND	—	—	Analog ground
B1	CIFRQ	Out	Telephone line	CI signal frequency
B2	LPL0	—	—	Not used
B3	-GRD	—	—	Not used
B4	-PRD	In	Gate array (IC3)	P relay control signal
B5	-HRD1	In	Gate array (IC3)	H relay control signal
B6	-RRD	—	—	Not used
B7	+5 V	In	Power supply	Logic drive signal
B8	+12 V	In	Power supply	Logic drive signal
B9	LININ	In	Telephone line	Signal received from telephone line
B10	LINOUT	Out	Modem IC (IC6)	Signal received from telephone line

### 5.2.3 OPCNT board



**Figure 4-47 OPCNT Board**

**J1 (SCNT board connector)**

<b>Pin No.</b>	<b>Signal</b>	<b>In/Out</b>	<b>Output from</b>	<b>Details</b>
1	CK	In	Gate array (IC3)	Clock signal
2	TXD	In	Gate array (IC3)	Data signal from LEDs, display, keys, and sensors
3	RXD	Out	OPCNT control IC (IC1)	Data signal to LEDs, display, buttons, and sensors
4	-RST	In	Gate array (IC3)	Reset signal
5	PROT	Out	OPCNT control IC (IC1)	Memory protect signal
6	+5 V	In	Power supply	Logic drive voltage
7	+5 V	In	Power supply	Logic drive voltage
8	GND	—	—————	Ground
9	GND	—	—————	Ground
10	DS	—	—————	Not used
11	DES	—	—————	Not used

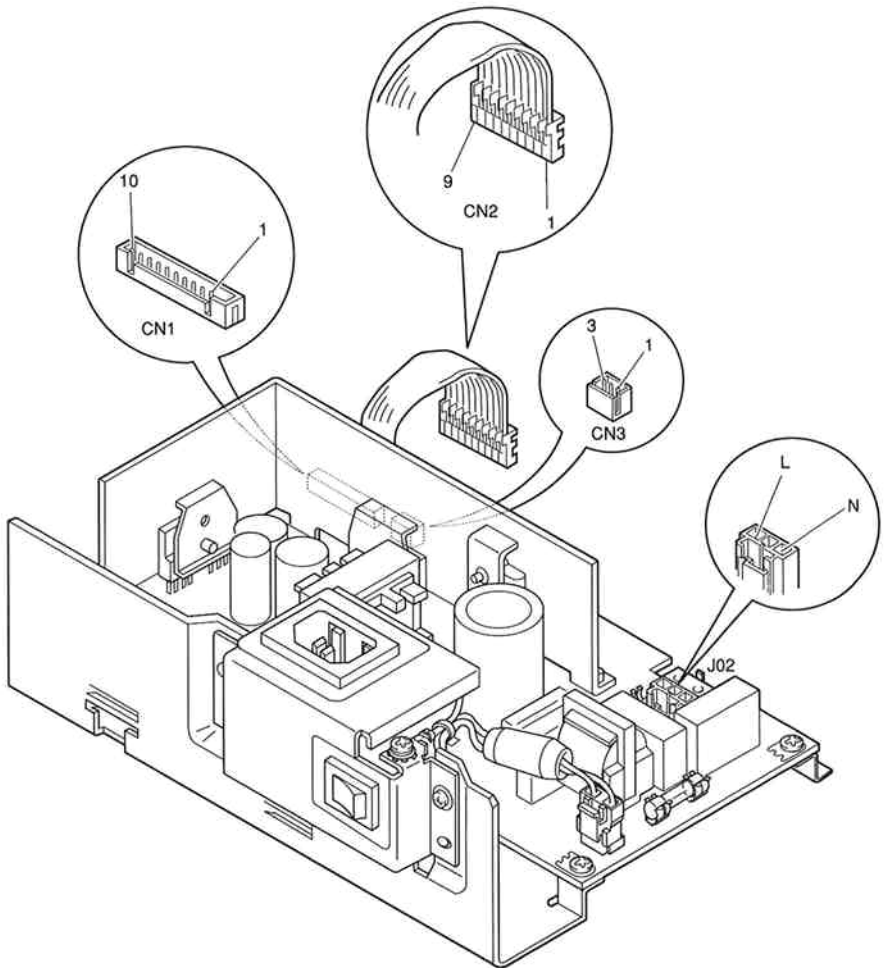
**J4 (DS/DES)**

<b>Pin No.</b>	<b>Signal</b>	<b>In/Out</b>	<b>Output from</b>	<b>Details</b>
1	+5 V	Out	Power supply	Document sensor drive signal
2	GND	—	—	Ground
3	DS	In	Document sensor	Document detect signal (H: yes; L: no)
4	+5 V	Out	Power supply	Document edge sensor drive signal
5	GND	—	—	Ground
6	DES	In	Document edge sensor	Document edge detect signal (H: yes; L: no)



**This page intentionally left blank**

### 5.2.4 PSU board



**Figure 4-48 PSU Board**

**CN1 (PCNT board connector)**

Pin No.	Signal	In/Out	Output from	Details
1	+12 V	Out	Power supply	Fan, solenoid, scanner motor power supply
2	+12 V	Out	Power supply	Fan, solenoid, scanner motor power supply
3	AGND	—	—	Analog ground
4	AGND	—	—	Analog ground
5	VBOOT	Out	Power supply	Main motor supplementary power supply (13 V)
6	ACVIN	Out	Power supply	Input voltage monitor power supply
7	FANON	In	PCNT CPU (IC301)	Fan drive signal
8	FANTAC	Out	Fan motor	Fan motor clock detect signal
9	+5 V	Out	Power supply	Logic drive signal
10	DGND	—	—	Digital ground

**CN2 (SCNT board connector)**

Pin No.	Signal	In/Out	Output from	Details
1	VBOOT	Out	Power supply	Main motor supplementary power supply
2	+12 V	Out	Power supply	Logic drive signal
3	+12 V	Out	Power supply	Logic drive signal
4	AGND	—	—	Analog ground
5	AGND	—	—	Analog ground
6	+5 V	Out	Power supply	Logic drive signal
7	+5 V	Out	Power supply	Logic drive signal
8	DGND	—	—	Digital ground
9	DGND	—	—	Digital ground

**CN3 (Fan connector)**

Pin No.	Signal	In/Out	Output from	Details
1	FAND	Out	Power supply	Fan drive signal
2	FANTAC	In	Fan motor	Fan motor clock detect signal
3	AGND	—	—	Analog ground

**JO2 (PCNT board connector)**

Pin No.	Signal	In/Out	Output from	Details
N	ACN	Out	Power supply	Fixing unit drive signal
L	ACL	Out	Power supply	Fixing unit drive signal

5.2.5 PCNT board

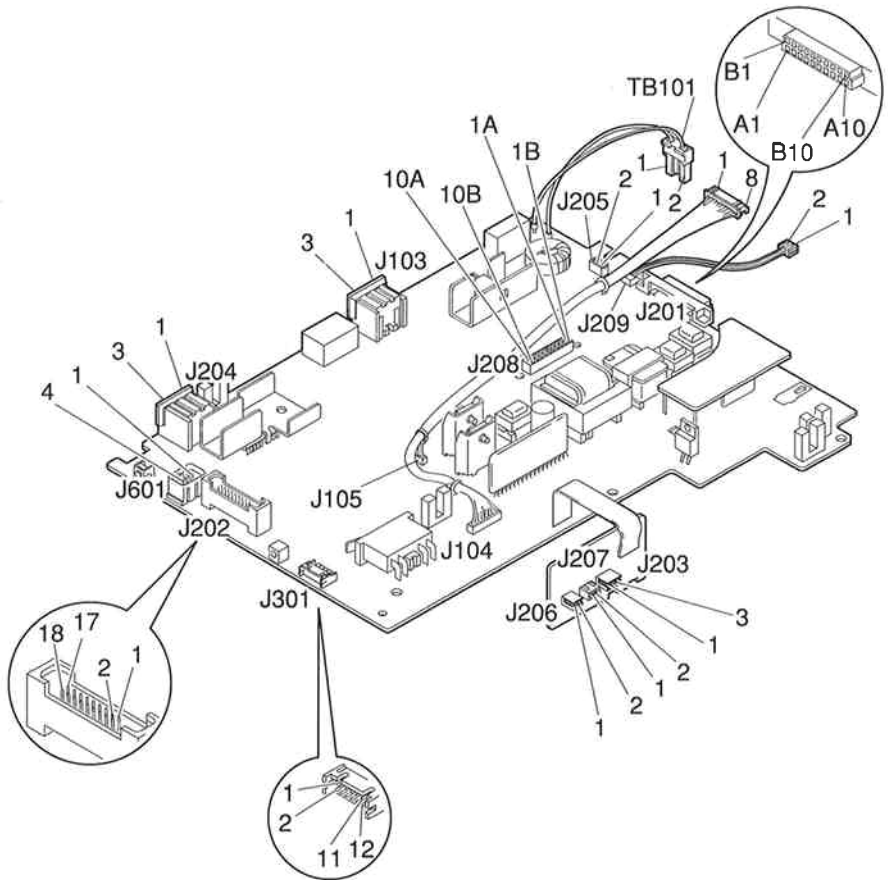


Figure 4-49 PCNT Board

**J103 (Fixing unit)**

Pin No.	Signal	In/Out	Output from	Details
1	AC N	In	Power supply	Fixing unit drive signal
2	—	—	—	—
3	AC L	In	Power supply	Fixing unit drive signal

**J104 (PSU board connector)**

Pin No.	Signal	In/Out	Output from	Details
1	+12 V	In	Power supply	Fan, solenoid, and scanner motor power supply
2	+12 V	In	Power supply	Fan, solenoid, and scanner motor power supply
3	GND	—	—	Ground
4	GND	—	—	Ground
5	VBOOT	In	Power supply	Main motor supplementary power supply (13 V)
6	ACVIN	In	Power supply	Input voltage monitor power supply
7	FANON	Out	PCNT CPU (IC301)	Fan drive signal
8	FANTAC	In	Fan motor	Fan motor clock detect signal

**J105 (PSU board connector)**

Pin No.	Signal	In/Out	Output from	Details
1	+5 V	In	Power supply	Logic drive signal
2	GND	—	—	Ground

**TB101 (PCU board connector)**

Pin No.	Signal	In/Out	Output from	Details
1	ACL	In	Power supply	Fixing unit drive signal
2	ACN	In	Power supply	Fixing unit drive signal

**J201 (SCNT board connector)**

Pin No.	Signal	In/Out	Output from	Details
A1	GND	—	—————	Ground
A2	GND	—	—————	Ground
A3	-TOP	Out	PCNT CPU (IC301)	Vertical sync signal
A4	-STS	Out	PCNT CPU (IC301)	Status signal
A5	-CBSY	In	Gate array (IC2)	Command busy signal
A6	-TRGON	In	Gate array (IC2)	Scanner motor driving signal
A7	-VDO	In	Gate array (IC2)	Video signal
A8	-CCLK	In	Gate array (IC2)	Controller clock signal
A9	-PRFD	In	Gate array (IC2)	Prefeed signal
A10	GND	—	—————	Ground
B1	-BD	Out	PCNT CPU (IC301)	Horizontal sync signal
B2	-RDY	Out	PCNT CPU (IC301)	Ready signal
B3	-SBSY	Out	PCNT CPU (IC301)	Status busy signal
B4	-PCLK	—	—————	Not used
B5	-PRINT	In	Gate array (IC2)	Print signal
B6	-CPRDY	In	Gate array (IC2)	Controller power ready signal
B7	-CMD	In	Gate array (IC2)	Command signal
B8	—	—	—————	Not connected
B9	+5 V	In	Power supply	Logic drive voltage
B10	+5 V	In	Power supply	Logic drive voltage

**J202 (Laser/scanner unit connector)**

Pin No.	Signal	In/Out	Output from	Details
1	GND	—	—	Ground
2	GND	—	—	Ground
3	+12VBS	Out	Power supply	Scanner motor power supply
4	+12VBS	Out	Power supply	Toner sensor LED power supply
5	+12VBS	Out	Power supply	Scanner motor power supply
6	LEDON1	Out	PCNT CPU (IC301)	Toner sensor LED drive signal
7	SCNTAC	In	Laser/scanner unit	Scanner rotation rate monitor signal
8	+5 V	Out	Power supply	Logic drive signal
9	GND	—	—	Ground
10	-BDI	In	Laser/scanner unit	Horizontal sync signal
11	LPCHG	Out	PCNT CPU (IC301)	Laser drive switch signal
12	GND	—	—	Ground
13	SCNCLK	Out	PCNT CPU (IC301)	Scanner reference clock signal
14	SCNON*	Out	PCNT CPU (IC301)	Scanner motor drive signal
15	GND	—	—	Ground
16	-VDOUT	Out	PCNT CPU (IC301)	Laser drive control signal
17	+5 V	Out	Power supply	Logic drive signal
18	APCSH	Out	PCNT CPU (IC301)	APC sample hold signal

**J203 (Toner sensor board connector)**

Pin No.	Signal	In/Out	Output from	Details
1	GND	—	—	Ground
2	TNSNS	In	Toner sensor board	Toner detect signal
3	+5 V	Out	Power supply	Toner sensor drive signal

**J204 (Fixing unit connector)**

Pin No.	Signal	In/Out	Output from	Details
1	FSRTHR	In	PCNT CPU (IC301)	Fixing motor monitor detect signal
2	—	—	—	—
3	GND	—	—	Ground

**J205 (Not used)**

Pin No.	Signal	In/Out	Output from	Details
1	STMPD	---	-----	Not used
2	+12VBS	---	-----	Not used

**J206 (Pickup solenoid)**

Pin No.	Signal	In/Out	Output from	Details
1	MCPUD	Out	PCNT CPU (IC301)	Pickup solenoid control signal
2	+12VBS	Out	Power supply	Pickup solenoid drive voltage

**J207 (Feed solenoid)**

Pin No.	Signal	In/Out	Output from	Details
1	+12VBS	Out	Power supply	Feed solenoid drive voltage
2	PAUSD	Out	PCNT CPU (IC301)	Feed solenoid control signal



**J208 (Paper sensor board connector)**

Pin No.	Signal	In/Out	Output from	Details
A1	GND	—	—	Ground
A2	+5 V	Out	Power supply	Logic drive signal
A3	VBOOT	—	—	Not used
A4	USIZE	In	Front cassette paper size sensor	Front cassette paper size sensor detect signal
A5	MSIZ0	In	Side cassette paper size sensor (A)	Side cassette paper size sensor (A) detect signal (H: A4/legal; L: letter/no cassette)
A6	0LPSNS	—	—	Not used
A7	UCVSNS	In	Feeder section right cover sensor	Feeder section right cover sensor detect signal (H: yes; L: no)
A8	UCPUD	Out	PCNT CPU (IC301)	Feeder section pickup solenoid control signal
A9	OMTRST	—	—	Not used
A10	LCPUD	—	—	Not used
B1	GND	—	—	Ground
B2	LSIZE	—	—	Not used
B3	+12VAS	Out	Power supply	LED and solenoid control signal
B4	-MPSNS	In	Side cassette recording paper sensor	Side cassette recording paper sensor detect signal (H: yes; L: no)
B5	MSIZ1	In	Side cassette paper size sensor (B)	Side cassette paper size sensor (B) detect signal (H: A4/legal; L: letter/no cassette)
B6	-UPSNS	In	Front cassette recording paper sensor	Front cassette recording paper sensor detect signal (H: yes; L: no)
B7	LCVSNS	—	—	Not used
B8	UPLED	Out	PCNT CPU (IC301)	Front cassette no-paper LED drive signal
B9	PH4	—	—	Not used
B10	STMPD	—	—	Not used

**J209 (Exit paper cover sensor)**

Pin No.	Signal	In/Out	Output from	Details
1	FCVSNS	In	PCNT CPU (IC301)	Exit paper cover sensor detect signal (H: open; L: closed)
2	GND	—	—————	Ground

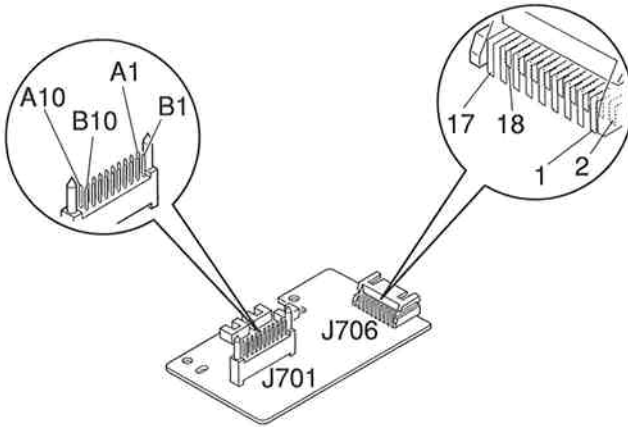
**J301 (Printer driver checker connector)**

Pin No.	Signal	In/Out	Output from	Details
1	FMODE1	In	PCNT CPU (IC301)	Factory check signal
2	+5 V	Out	Power supply	Logic drive signal
3	FMODE0	In	PCNT CPU (IC301)	Factory check signal
4	TOPVR	Out	PCNT CPU (IC301)	Leading edge margin control voltage
5	-PISNS	In	Pickup sensor	Pickup sensor detect signal
6	THR	Out	PCNT CPU (IC301)	Fixing unit
7	+12VAS	Out	PCNT	Monitor signal after cartridge cover sensor On
8	PAUSD	Out	PCNT CPU (IC301)	Feed solenoid drive signal
9	DGND	—	—————	Digital ground
10	AGND	—	—————	Analog ground
11	TNSNS	Out	Toner sensor board	Toner detect signal
12	MCPUD	Out	PCNT CPU (IC301)	Pickup solenoid drive signal

**J601 (Main motor)**

Pin No.	Signal	In/Out	Output from	Details
1	A	Out	Driver IC (IC601)	A phase
2	-A	Out	Driver IC (IC601)	-A phase
3	B	Out	Driver IC (IC601)	B phase
4	-B	Out	Driver IC (IC601)	-B phase

### 5.2.6 Paper sensor board



**Figure 4-50 Paper Sensor Board**

## J701 (PCNT board)

Pin No.	Signal	In/Out	Output from	Details
A1	GND	—	—————	Ground
A2	+5 V	In	Power supply	Logic drive signal
A3	VBOOT	—	—————	Not used
A4	USIZE	Out	Front cassette paper size sensor	Front cassette paper size sensor detect signal
A5	MSIZ0	Out	Side cassette size sensor (A)	Side cassette paper size sensor (A) detect signal (H: A4/legal; L: letter/no cassette)
A6	-LPSNS	—	—————	Not used
A7	UCVSNS	Out	Feeder right cover sensor	Feeder right cover sensor detect signal (H: yes; L: no)
A8	UCPUD	In	PCNT CPU (IC301)	Feeder pickup solenoid control signal
A9	OMTRST	—	—————	Not used
A10	LCPUD	—	—————	Not used
B1	GND	—	—————	Ground
B2	LSIZE	—	—————	Not used
B3	+12VAS	In	Power supply	LED and solenoid control signal
B4	-MPSNS	Out	Side cassette recording paper sensor	Side cassette recording paper sensor detect signal (H: yes; L: no)
B5	MSIZ1	Out	Side cassette paper size sensor (B)	Side cassette paper size sensor (B) detect signal (H: A4/letter; L: legal/no cassette)
B6	-UPSNS	Out	Front cassette recording paper sensor	Front cassette recording paper sensor detect signal (H: yes; L: no)
B7	LCVSNS	—	—————	Not used
B8	UPLED	In	PCNT CPU (IC301)	Front cassette no-paper LED control signal
B9	PH4	—	—————	Not used
B10	STMPD	—	—————	Not used

**J706 (Driver board connector)**

<b>Pin No.</b>	<b>Signal</b>	<b>In/Out</b>	<b>Output from</b>	<b>Details</b>
1	-UPSNS	In	Front cassette recording paper sensor	Front cassette recording paper sensor detect signal (H: yes; L: no)
2	UCVSNS	In	Feeder right cover sensor	Feeder right cover sensor detect signal (H: yes; L: no)
3	UCPUD	Out	PCNT CPU	Feeder section pickup solenoid control signal
4	-LPSNS	—	—————	Not used
5	LCVSNS	—	—————	Not used
6	+5 V	Out	Power supply	Solenoid drive signal
7	GND	—	—————	Ground
8	+12VAS	Out	Power supply	LED and solenoid drive signal
9	GND	—	—————	Ground
10	GND	—	—————	Ground
11	UPLED	Out	PCNT CPU (IC301)	Front cassette no-paper LED control signal
12	VBOOT	—	—————	Not used
13	PH3	—	—————	Not used
14	PH4	—	—————	Not used
15	OMTRST	—	—————	Not used
16	LCPUD	—	—————	Not used
17	LSIZE	—	—————	Not used
18	USIZE	In	Front cassette recording paper size sensor	Front cassette recording paper size sensor detect signal

5.2.7 Laser/scanner unit

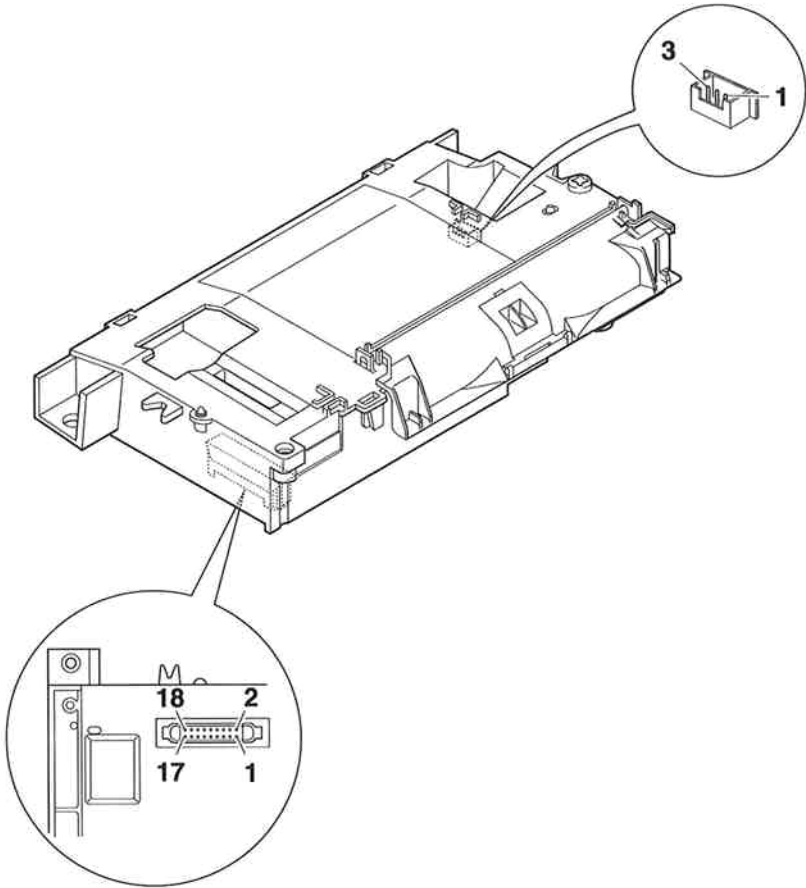


Figure 4-51 Laser/scanner Unit

**J801 (PCNT board connector)**

Pin No.	Signal	In/Out	Output from	Details
1	GND	—	—————	Ground
2	GND	—	—————	Ground
3	+12VBS	In	Power supply	Toner sensor LED drive signal
4	+12VBS	In	Power supply	Toner sensor LED drive signal
5	+12VBS	In	Power supply	Toner sensor LED drive signal
6	LEDON	In	PCNT CPU (IC301)	Toner sensor LED control signal
7	SCNTAC	Out	Laser/scanner unit	Scanner rotation rate monitor signal
8	+5V	In	Power supply	Logic drive signal
9	GND	—	—————	Ground
10	-BDI	Out	Laser/scanner unit	Horizontal sync signal
11	LPCHG	In	PCNT CPU (IC301)	Lazer drive switch signal
12	GND	—	—————	Ground
13	SCNCLK	In	PCNT CPU (IC301)	Scanner reference clock signal
14	-SCNON	In	PCNT CPU (IC301)	Scanner motor drive signal
15	GND	—	—————	Ground
16	-VDOUT	In	PCNT CPU (IC301)	Laser drive control signal
17	+5V	In	Power supply	Logic drive signal
18	APCSH	In	PCNT CPU (IC301)	APC sample hold signal

**J804 (VR board connector)**

Pin No.	Signal	In/Out	Output from	Details
1	GND	—	—————	Ground
2	LEDON	Out	PCNT CPU (IC301)	Toner sensor LED control signal
3	+12VBS	Out	Power supply	Toner sensor LED drive signal

5.2.8 CS unit

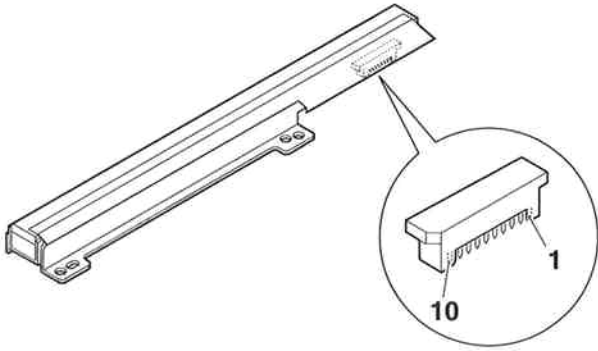


Figure 4-52 CS Unit



**J108 (SCNT board connector)**

<b>Pin No.</b>	<b>Signal</b>	<b>In/Out</b>	<b>Output from</b>	<b>Details</b>
1	VOUT	Out	Contact sensor	Image signal
2	GND	—	—	Ground
3	+5V	In	Power supply	Logic drive signal
4	GND	—	—	Ground
5	GND	—	—	Ground
6	SP	In	Gate array (IC5)	Image read start signal
7	GND	—	—	Ground
8	MALCK	In	Gate array (IC5)	Contact sensor drive clock
9	-LEDON	In	Gate array (IC5)	LED drive signal
10	+12R	In	Power supply	LED drive voltage

### 5.2.9 Fixing unit

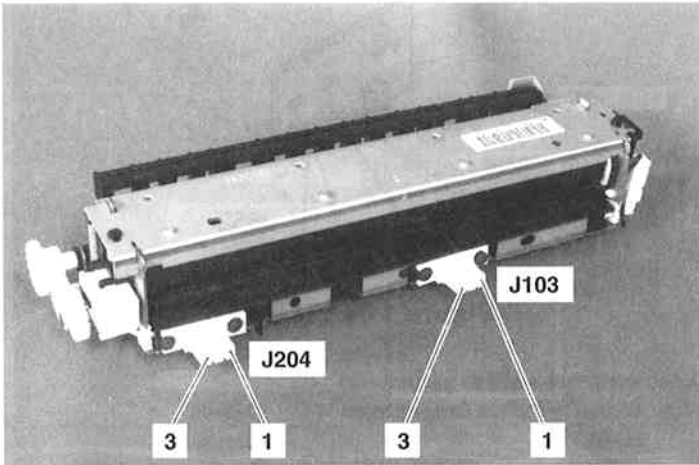


Figure 4-53 Fixing Unit

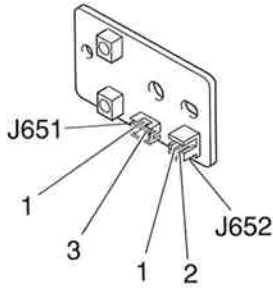
#### J103 (PCNT board)

Pin No.	Signal	In/Out	Output from	Details
1	ACN	Out	Power supply	Fixing unit drive signal
2	—	—	—	—
3	ACN	Out	Power supply	Fixing unit drive signal

#### J204 (PCNT board)

Pin No.	Signal	In/Out	Output from	Details
1	FSRTHR	Out	PCNT CPU (IC301)	Fixing motor monitor detect signal
2	—	—	—	—
3	GND	—	—	Ground

### 5.2.10 VR board



**Figure 4-54 VR Board**

**J651 (Laser/scanner section connector)**

Pin No.	Signal	In/Out	Output from	Details
1	GND	—	—	Ground
2	LEDON	In	PCNT CPU (IC301)	Toner sensor LED control signal
3	+12VBS	In	Power supply	Toner sensor LED control signal

**J652 (LED board connector)**

Pin No.	Signal	In/Out	Output from	Details
1	LEDON 1	Out	LED board	Toner sensor LED drive signal 1
2	RCS	Out	LED board	Toner sensor LED rated current feed signal

## 5.2.11 LED board

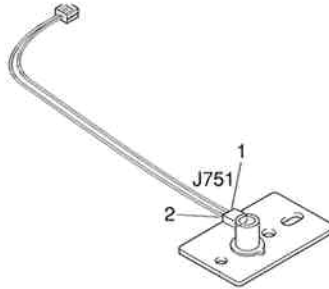


Figure 4-55 LED Board

## J751 (VR board connector)

Pin No.	Signal	In/Out	Output from	Details
1	LEDON1	In	VR board	Toner sensor LED drive signal 2
2	RC	In	VR board	Toner sensor LED rated current feed signal

## 5.2.12 Toner sensor board

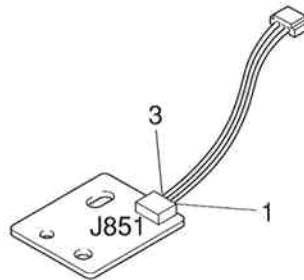


Figure 4-56 Toner Sensor Board

## J851 (PCNT Board Connector)

Pin No.	Signal	In/Out	Output from	Details
1	+5 V	In	Power supply	Toner sensor drive signal
2	TNSNS	Out	Toner sensor	Toner sensor detect signal
3	GND	—	—	Ground

**This page intentionally left blank**

### 5.2.13 Document sensor (DS)

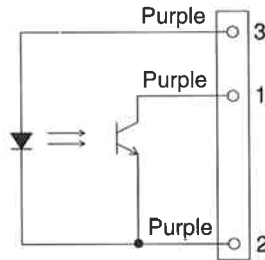


Figure 4-57 Document Sensor (DS)

#### J5 (OPCNT board)

Pin No.	Signal	In/Out	Output from	Details
1	DS	Out	Document sensor	Document detect signal (H: yes; L: no)
2	GND	—	—	Ground
3	+5 V	In	Power supply	Document sensor drive signal

### 5.2.14 Document edge sensor (DES)

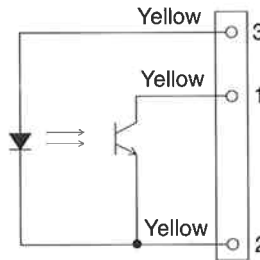


Figure 4-58 Document Edge Sensor (DES)

#### J6 (OPCNT board)

Pin No.	Signal	In/Out	Output from	Details
1	DES	Out	Document edge sensor	Document edge detect signal (H: yes; L: no)
2	GND	—	—	Ground
3	+5 V	In	Power supply	Document edge sensor drive signal

5.2.15 Exit paper cover sensor

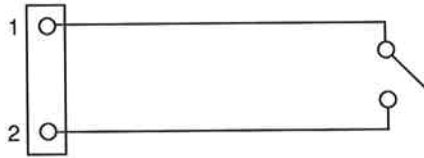


Figure 4-59 Exit Paper Cover Sensor

J209 (PCNT board)

Pin No.	Signal	In/Out	Output from	Details
1	GND	—	—	Ground
2	FCVSNS	Out	Exit paper cover sensor	Exit paper cover sensor detect signal (H: open; L: closed)

## 5.2.16 Recording paper feed solenoid

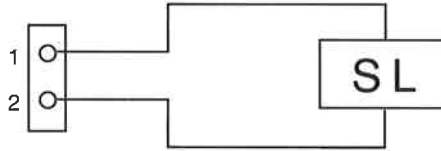


Figure 4-60 Recording Paper Feed Solenoid

J207 (PCNT board)

Pin No.	Signal	In/Out	Output from	Details
1	+12VBS	In	Power supply	Feed solenoid drive signal
2	PAUSD	In	PCNT CPU (IC301)	Feed solenoid control signal

## 5.2.17 Recording paper pickup sensor

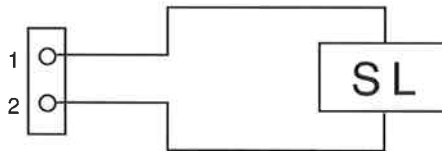


Figure 4-61 Recording Paper Pickup Solenoid

J206 (PCNT board)

Pin No.	Signal	In/Out	Output from	Details
1	MCPUD	In	PCNT CPU (IC301)	Pickup solenoid control signal
2	+12VBS	In	Power supply	Pickup solenoid drive voltage



5.2.18 Document feed motor

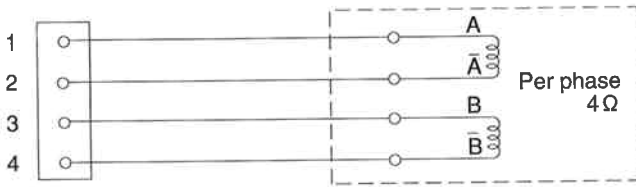


Figure 4-62 Document Feed Motor

J102 (SCNT board)

Pin No.	Signal	In/Out	Output from	Details
1	-RMB	In	Driver IC (IC11)	A phase
2	RMB	In	Driver IC (IC11)	-A phase
3	-RMA	In	Driver IC (IC11)	B phase
4	RMA	In	Driver IC (IC11)	-B phase

5.2.19 Main motor

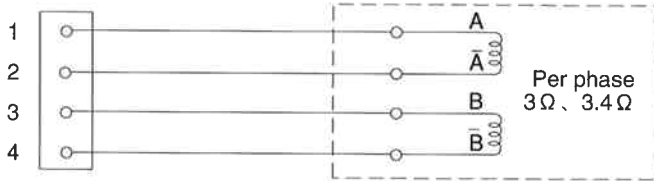


Figure 4-63 Main Motor

J601 (PCNT board)

Pin No.	Signal	In/Out	Output from	Details
1	A	In	Driver IC (IC601)	A phase
2	-A	In	Driver IC (IC601)	-A phase
3	B	In	Driver IC (IC601)	B phase
4	-B	In	Driver IC (IC601)	-B phase

5.2.20 Fan motor

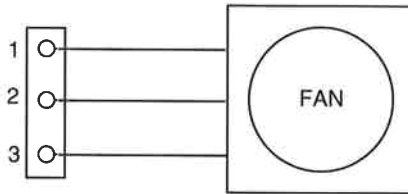


Figure 4-64 Fan Motor

J4 (PSU board)

Pin No.	Signal	In/Out	Output from	Details
1	FAND	In	Power supply	Fan drive signal
2	FANTAC	Out	Fan motor	Fan motor clock detect signal
3	AGND	—	—	Analog ground

5.2.21 Speaker

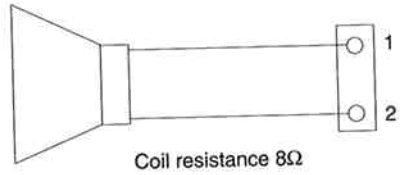


Figure 4-65 Speaker

J106 (SCNT board connector)

Pin No.	Signal	In/Out	Output from	Details
1	SPKOH	In	IC27	Speaker drive signal
2	SPKOL	In	IC27	Speaker drive signal



For Feeder Right Cover Sensor, Feeder Section Recording Paper Sensor, Feeder Section Recording Paper Pickup Solenoid, and driver board see *Chapter 5: 2.4. FXL-FEEDER 1.*

# ***Chapter 5***

## ***Appendices***

# 1. INSTALLATION

Here is the procedure for installing this fax.

## Contents

---

### 1.1 Important precautions

- . Where to set up the fax
- . Power requirements
- . General precautions

### 1.2 Do you have everything?

### 1.3 Assembling the fax

### 1.4 Installing the toner cartridge

- . Handling and storing toner cartridges

### 1.5 Loading recording paper

- . Loading the side cassette
- . Loading paper in the front cassette

### 1.6 Making connections

- . Connecting the telephone line
- . Connecting the handset (LASER CLASS 5500 only)
- . Connecting an extension phone or answering machine

### 1.7 Getting ready to use the fax

- . Turning on the power switch
- . Checking the type of telephone line you have
- . Initializing RAM
- . Setting the type of phone line

### 1.8 Checking operations

- . Copy operation
- . Communication test

### 1.9 Adjustments

- . Adjusting the transmission level
- . Adjusting the NL equalizer



---

This installation section is the same as in the instruction book, so its layout differs from other pages.

---

# 1.1

## Important precautions

Pay attention to the following precautions before you set up your fax and use it.



### Where to set up the fax

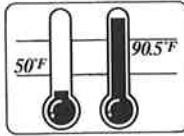
Use the following check list to choose a location to install and use your fax.



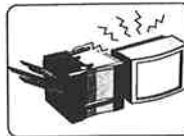
- Avoid direct sunlight. If you have to locate the fax near a window, install heavy curtains or blinds to protect the fax from direct sunlight.



- Choose a flat, stable surface for the fax that is free of vibration



- Avoid a location subject to extreme temperature fluctuation. Use in a room that is within a temperature range of 50°F (10°C) and 90.5°F (32.5°C).



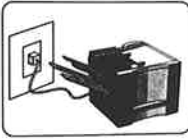
- Do not locate the fax near a television, radio, or heavy equipment that can generate strong electromagnetic fields. Large equipment can generate electronic noise that can interfere with the operation of the fax.



- Choose a location that is clean and free from dust.



- Do not use or store the facsimile unit outdoors.



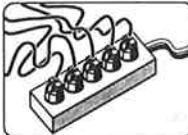
- ❑ Place the fax near a telephone line. You must have an RJ11-C wall jack installed. If you need assistance, contact your local Canon authorized dealer sales or service representative, or your local telephone company. For more information, refer to the important notices and instructions inside the front cover of this instruction book.

## Power requirements

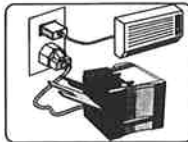
Observe the following precautions about the fax power supply.



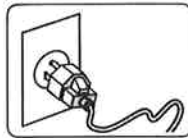
- ❑ Place the fax near a standard 120 V AC power outlet. This fax unit is intended for domestic use. Do not attempt to use it outside the country where you purchased it.



- ❑ Don't plug the power cord into an extension cord connector or outlet shared with other plugs.



- ❑ Don't plug the fax into a power outlet shared with an air conditioner, personal computer, electric typewriter, copier, or other equipment that generates electrical noise.



- ❑ Check the plug frequently to be sure that it is firmly plugged into the socket.

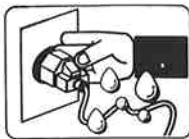
## General precautions



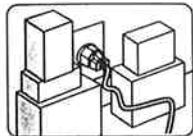
- ❑ After you turn the fax off, always wait at least 5 seconds before you turn it on again. Always turn the power off before you move the fax.



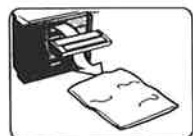
- ❑ During electrical storms, turn the fax off and disconnect the plug from the power outlet.



- ❑ When you attach or remove the plug from the power outlet, be sure your hands are dry.



- ❑ Do not stack boxes or furniture around the power outlet. Keep the area open so you can reach the outlet quickly. If you notice anything unusual (smoke, strange odor, noise) around the fax, turn the fax off and unplug it. Call for service.



- ❑ Before you transport the fax unit, remove the cartridge. To protect the cartridge from bright light, cover it with a bag or cloth.



- ❑ Keep liquids, cleaners, and other solvents away from the fax unit. Keep metal pins, paper clips, staples and other objects away from the fax. If something falls inside the fax, turn the fax off, remove the plug from the power outlet, and call for service.



- ❑ Do not set the main unit or other equipment or furniture on the power cord. Never knot the cord or wrap it around another object.



- ❑ Never turn off the power switch and remove the paper cassette during printing. Removing the cassette during printing can cause the fax unit to jam.



- ❑ When you lift up the fax, hold it by the front and back side. Never lift it by the side cassette.



## 1.2

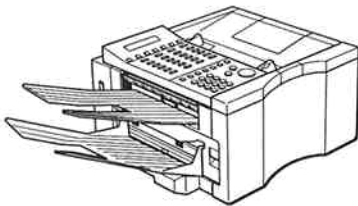
### Have you got everything?

#### LASER CLASS® 5000/5500

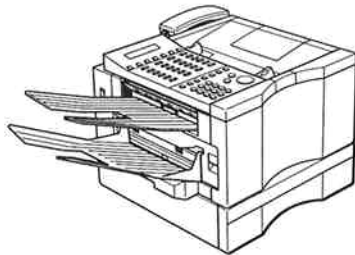
- 1 Main unit
- 1 Document tray
- 1 Exit tray
- 1 Side cassette (multi-size, 100-sheet capacity)
- 1 Power cord
- 1 Modular line cord
- 2 Sheets of destination labels
- 1 Instruction book
- 1 Warranty registration card
- 1 Limited warranty note
- 1 Installation completion report

#### LASER CLASS® 5500 (Option for LASER CLASS® 5000)

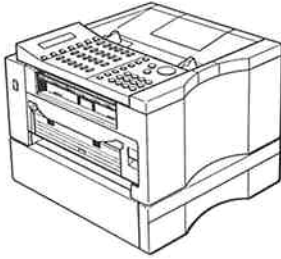
- 1 Front cassette (Letter, 500-sheet capacity)
- 1 Front cassette feeder
- 1 Handset
- 1 Handset rest
- 2 Screws



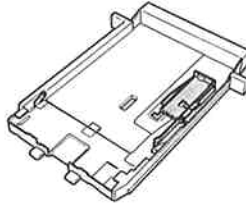
LASER CLASS® 5000



LASER CLASS® 5500



**Main unit**



**Side cassette**



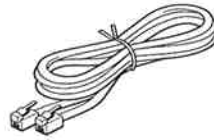
**Document tray**



**Exit tray**



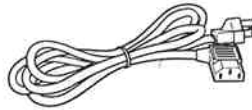
**Instruction book**



**Modular line cord**



**Destination labels**

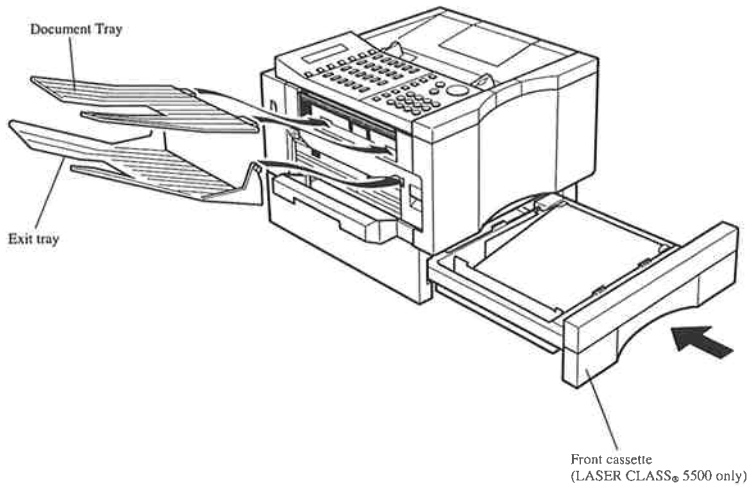


**Power cord**

## 1.3

# Assembling the fax

Attach the trays and insert the paper cassette as shown below.



## 1.4

# Installing the toner cartridge

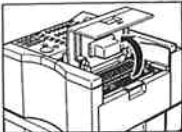
The fax uses a Canon FX2 toner cartridge.



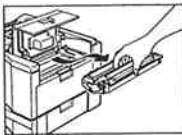
■ *If you try to install other cartridges, you may damage the fax.*

Change the toner cartridge when you see the lamp light and see this message:

REPLACE CARTRIDGE

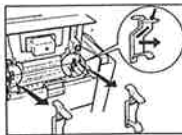


**1** To open the cartridge cover, pull up the lever above the ▲ mark.



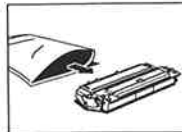
**2** Remove the old cartridge.

-or-



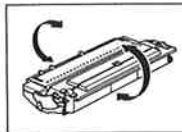
**When you set up the fax, remove the shipping materials.**

Press on the arrows then remove them.



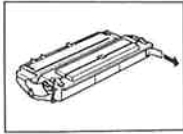
**3** Remove a new toner cartridge from the protective bag.

- Hold the cartridge by the ends. Avoid touching the toner windows on the top and bottom of the cartridge. (→ 5-10)
- Save the protective bag. You may need it to repack and transport the cartridge at a later date.



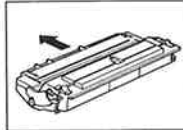
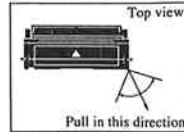
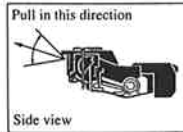
**4** Rock the new cartridge five or six times to distribute the toner evenly inside the cartridge.

**5** Place the cartridge on a flat, clean surface.

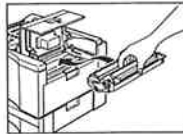


**6 Steady the cartridge with one hand, and remove the seal by gently pulling on the plastic tab with your other hand.**

- Use a firm, even pull to remove the plastic seal. To avoid breaking the seal, do not jerk on it unevenly.

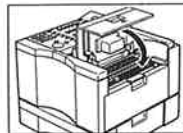


**7 Load the cartridge in the direction indicated by the arrow.**



**8 Gently slide the cartridge into the printer until it is down inside the main unit and level.**

- Avoid touching the toner windows on the top and bottom of the cartridge. (→ 5-10)



**9 Close the cartridge cover.**

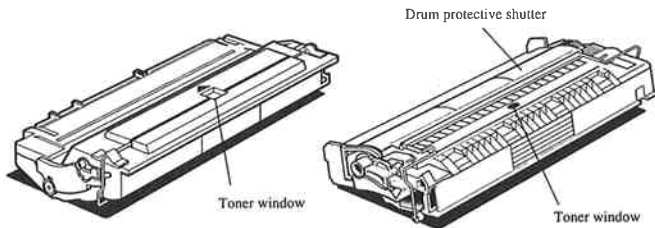
- Never leave the cartridge cover open. Exposure to light can damage the drum surface.

## Handling and storing cartridges

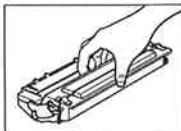
Follow these recommendations when you store and handle cartridges for the fax.

- Leave a cartridge sealed in its bag until you are ready to use it.
- Never expose a cartridge to bright light for longer than 5 minutes.
- Never touch the toner windows on the top and bottom of the cartridge.
- Keep the cartridge away from computer screens, disk drives, and floppy disks. The magnet inside the cartridge may harm these items.
- Store the cartridge between 32°F and 95°F (0°C-35°C), and avoid locations subject to high temperature, high humidity, or rapid temperature changes.
- Do not open the drum protective shutter on the cartridge. If the drum surface is exposed to light and damaged, print quality may deteriorate.
- Do not stand the cartridge on end, and do not turn it upside down. If the toner becomes caked in the cartridge, it may prove impossible to free it even by shaking the cartridge.
- Save the protective bag. You may need to repack and transport the cartridge at a later date.
- Do not store the cartridge in salty air or where there are corrosive gases such as from aerosol sprays.

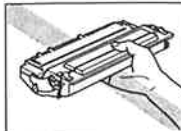
**CAUTION**  
**DO NOT PLACE THE CARTRIDGE IN FIRE. TONER POWDER IS FLAMMABLE.**



- Never touch the drum protective shutter. Avoid holding the cartridge so that your hand is touching the drum protective shutter.



Correct handling



Incorrect handling

## 1.5

### Loading recording paper

Use this procedure to load paper in the side and front cassettes of the fax unit.  
Pay attention to the following points about loading recording paper in the fax unit:

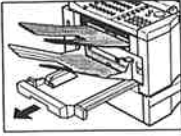
- The side cassette can be adjusted to accept letter, legal, or A4 size paper.
- Use Canon standard 17~241b (64-90 g/m<sup>2</sup>) weight paper.
- To avoid paper jams, do not load wrinkled or curled paper in the paper cassette.
- To avoid paper curling, do not open paper packs until you are ready to load the paper in the fax unit. Store unused paper from opened packs in a cool, dry location in the original packing.
- Let the paper run out before you refill the cassette. To prevent paper jams, avoid mixing new paper with paper remaining in the paper cassette.
- Load paper in the cassette when the lamp on the control panel lights and you see this message:



SUPPLY REC. PAPER

## Loading the side cassette

The side cassette holds approximately 100 sheets of letter, legal or A4 size paper.

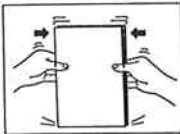
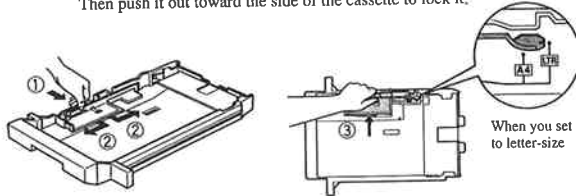


**1 Pull out the side cassette.**

**2 Check the selector and be sure it is set for the size of the paper you want to load.**

**3 To set the paper cassette for a different paper size, slide the selector to the correct position.**

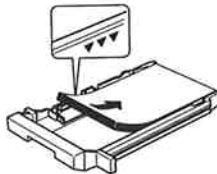
- To release the guide, push it in gently toward the center of the cassette. Gently push it up or back until the tip is just below the line of the setting you want. Then push it out toward the side of the cassette to lock it.



**4 Before you load paper in the side cassette, stack it so the leading edge and sides of the paper are even.**

**5 Load the paper into the cassette.**

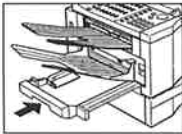
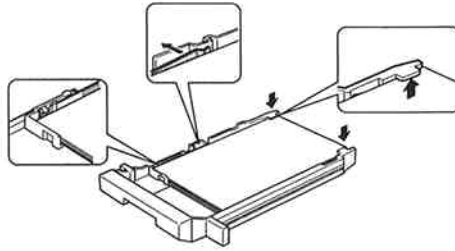
- Make sure the stack of paper is not higher than the limit mark (▼▼▼) on the side of the cassette.
- Check all the corners and edges of the paper stack to be sure they are flat and even.
- The cassette can hold about 100 sheets of paper.



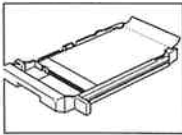


**6 Gently press the paper down at each corner of the stack.**

- Make sure that the stack is below the retaining tabs at the back of the cassette and at the left front corner.
- Make sure the paper does not go beyond the left front corner. If necessary, move it outside a little as shown in the illustration.



**7 Insert the cassette into the fax.**

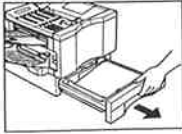


If you pull out the side cassette with paper remaining in the cassette:

- Make sure paper is not out of the cassette.
- Before you insert the cassette again, make sure there is no loose paper in the fax unit.

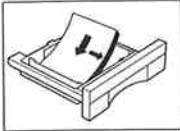
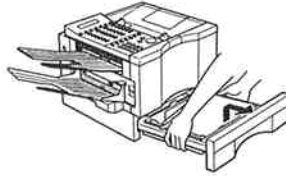
## Loading paper in the front cassette

Follow this procedure to load the front paper cassette if you have a front cassette on your fax unit.



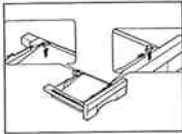
### 1 Pull out the front cassette.

- Lift it up at a slight angle, then pull it up and out.



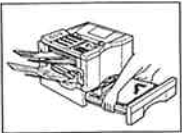
### 2 Load the paper into the front cassette.

- Before you load paper in the front cassette, stack it so the leading edge and sides of the paper are even.

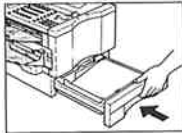


### 3 Be sure the paper is below the retaining clips at the back and front of the cassette.

- The front cassette can hold about 500 sheets.
- Before loading 500 sheets, divide the stack into approximately equal thirds about half an inch thick. Then load each stack separately.
- Be sure the level of the paper in the cassette is not higher than the level limit mark (▼) on the cassette.



### 4 Push the front cassette into the main unit gently until it clicks.



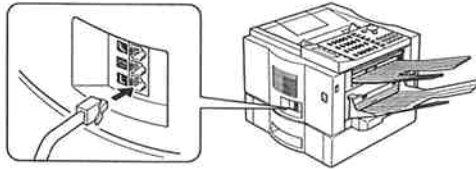
## 1.6

## Making connections

Follow these procedures to set up your fax unit and get it ready to use. Before you do this, be sure you have prepared a place to put the fax.

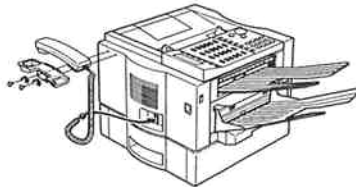
### Connecting the telephone line

- 1 Check and be sure you have an RJ11-C wall jack. If you need assistance, contact your dealer or telephone company.
- 2 Connect the telephone line to the fax jack marked L.

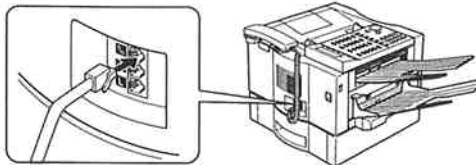


### Connecting the handset (LASER CLASS® 5500 only)

- 1 Fit the handset rest over the holes.
- 2 Fasten the handset rest with the screws provided.

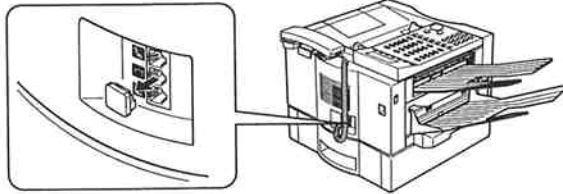


- 3 Connect the end of the modular handset cord to the jack marked .

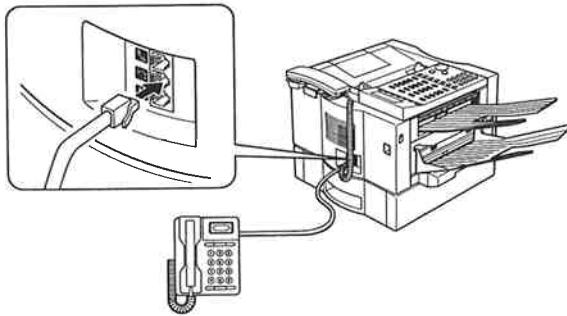


### Connecting an extension phone or answering machine

- 1 To connect an extension phone to the fax, remove the cover of the jack marked .



- 2 Connect the extension phone cord to the jack marked .



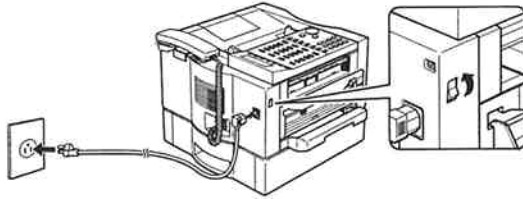
## 1.7

## Getting ready to use the fax

Be sure you have completed all the procedures in this section before you try to use the fax unit.

### Turning on the power switch

- 1 Plug the fax power cord into a power outlet.
- 2 The power switch is on the left, rear corner of the unit. Press the power switch to turn the power on.



- 3 It will take about 30 seconds for the unit to warm up.

PLEASE WAIT

The unit is warmed up and ready to use when you see the date and time displayed.

12/31/93 FRI 12:20

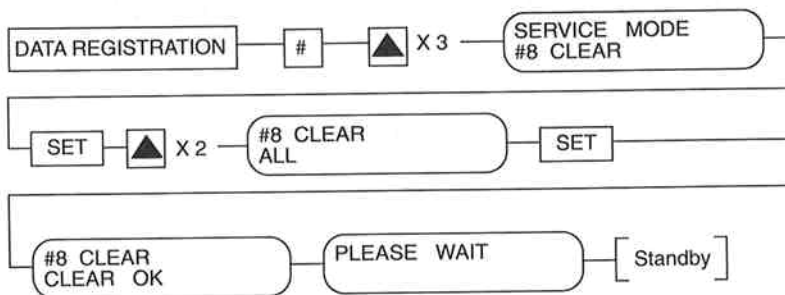
When the date is displayed, the fax is in the standby mode and ready for normal operation.

### Checking the type of telephone line you have

If you are not sure what type of telephone line you have, check with your local telephone company. To operate the fax you must know if the fax is connected through a tone or pulse line. The fax can be set to operate with either type of telephone line. The fax unit is set to operate through a tone line without making adjustments.

### Initializing the RAM

Initialize the RAM before setting the type of phone line.



**Figure 5-1 Initializing the RAM**



---

When the RAM is initialised, all setting/registration data and image data will be initialized.

---

## Setting the type of phone line

Use this procedure to switch the fax setup between tone and pulse dialing.



- 1 Open the One-touch Speed Dialing panel. Then press **DATA REGISTRATION**.

REGISTRATION  
1. DATA REGISTRATION



- 2 Press **SET**.

DATA REGISTRATION  
1. USER SETTINGS



- 3 Press **SET**.

USER SETTINGS  
1. DATE & TIME



- 4 Use the search keys to display **TEL LINE TYPE**.

USER SETTINGS  
13. TEL LINE TYPE



- 5 Press **SET**.

TEL LINE TYPE  
TOUCH TONE



- 6 Use the search keys to alternate the settings.

TEL LINE TYPE  
TOUCH TONE

TEL LINE TYPE  
ROTARY PULSE



- 7 Display the setting you want, then press **SET**.

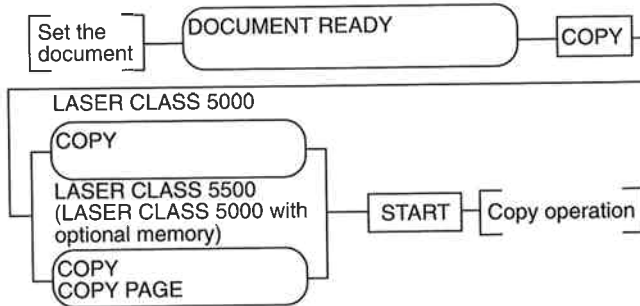


- 8 Press **STOP** to return to standby.

## 1.8 Checking Operations

### Copy operation

Check that normal images are printed.



**Figure 5-2 Copy Operation Flow Chart**

### Communication Test

Transmit to, and receive from other faxes, and check that images are sent normally for transmission, and are printed normally for reception.

Here is a procedure for a general communication test.

- (1) Switch on the power.
- (2) Pickup the handset and check that you can hear the dial tone. If you cannot, check the line connections.
- (3) Dial the other fax and check that the line is connected. If you cannot connect with the other fax, check the line settings (tone/pulse).
- (4) Transmit and receive a document and check the operation and the image.





**This page intentionally left blank**

## 2. OPTION

### 2.1 G3 FAX OPTION MEMORY II (0.5M-BYTE)

#### 2.1.1 Safety and precautions

##### Install direction

Be careful to plug the memory IC into the sockets facing the correct direction. Installing a memory IC backwards could destroy it.

##### Danger by Static Charge

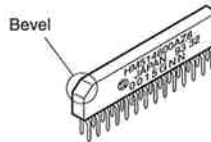
Static charge can change the electrical characteristics of the memory IC or damage it. Do not handle the memory IC under circumstances where static charge might occur easily.



When repairing or replacing the memory IC, first touch the grounded metal part to prevent damage from static charge.

#### 2.1.2 Service operations

##### a) External view



**Figure 5-5 External View**

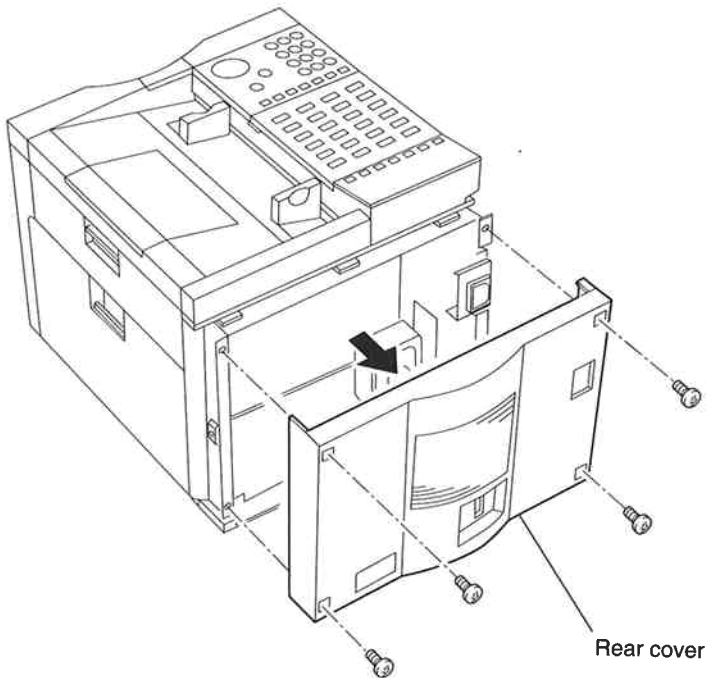
**b) Installation**

**b-1) Unpacking**

Check that the package contains one D-RAM chip.

**b-2) Disassembling the main unit**

- (1) Switch off the power.
- (2) Remove the rear cover of the unit.



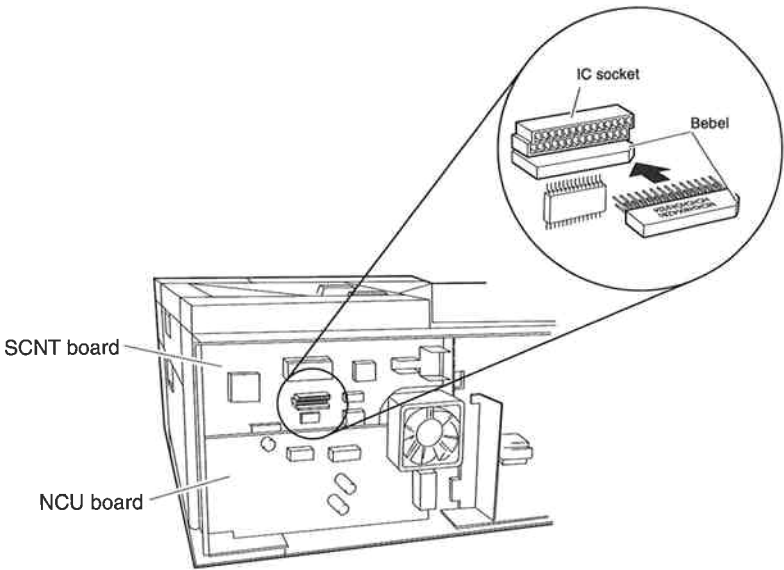
**Figure 5-6 Preparations for Installation**

**b-3) Memory IC installation**

- (1) As shown in Figure 5-7, align the bevel section of the memory IC in the same direction as the memory IC already soldered onto the board, and be careful not to bend the pins on the IC socket. You install the memory IC in its socket.
- (2) After installation is complete, switch on the power.



Installing an IC backwards will destroy it! Make absolutely sure to install the IC facing the correct direction.

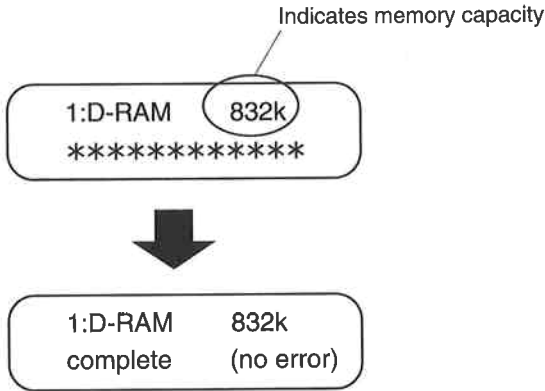


**Figure 5-7 Installation**

**b-4) Check after memory IC installation**

After installing the memory IC, carry out the following procedure to ensure that the memory IC is properly identified by the fax.

- (1) See to *Chapter 2: 3.5.3 D-RAM Tests* of this manual, then enter Test Mode D-RAM test 1.
- (2) When you enter Test Mode D-RAM test 1, D-RAM writing and reading checks are carried out. Check that the following is displayed on the display.



**Figure 5-8 Check After Memory IC Installation**

- (3) If this test does not end normally, check that the memory IC is plugged securely into the memory IC socket, then check the memory with the D-RAM test again.

## 2.1.3 Technical information

### a) Configuration and construction

Product name           **G3 FAX OPTION MEMORY II (0.5M Byte)**

External structure



**Figure 5-9 Memory External View**

### b) Specifications

Memory type	D-RAM
Capacity	0.5 Mbytes
Package	ZIP 28-pin
Access time	80 ms
Manufacturer model name	HITACHI HM514800AZ-8

**c) Operations**

The amount of memory and the number of pages that can be stored before memory expansion is as follows

	<b>Number of sheet (CCITT No.1 chart)</b>	<b>image data</b>	<b>other (work area + reserve area)</b>
In memory Tx:	approx. 12 sheets	192kbyte	192kbyte + 128kbyte
In quick memory Tx:	approx.6sheets	192kbyte	192kbyte + 128kbyte
Memory reception with no recording paper set at outset.	approx.12sheets	192kbyte	192kbyte + 128kbyte
Memory reception when recording paper runs out in mid operation:	approx.18sheets	288kbyte	192kbyte + 32kbyte

Memory expansion increases the capacity to 512 kbytes, as shown below.

	<b>Number of sheet (CCITT No.1 chart)</b>	<b>image data</b>	<b>other (work area + reserve area)</b>
In memory Tx:	approx.44sheets	704kbyte	192kbyte + 128kbyte
In quick memory Tx:	approx.22sheets	704kbyte	192kbyte + 128kbyte
Memory reception with no recording paper set at outset.	approx.44sheets	704kbyte	192kbyte + 128kbyte
Memory reception when recording paper runs out in mid operation:	approx.50sheet	800kbyte	192kbyte + 32kbyte



This machine uses 192 kbytes as a work area (for image data processing, communications, etc). In addition, 128 k bytes are used as a reserve area. Its purpose is to ensure that, even when the memoryfor memory transmission (memory reception) and image data storage is full, the memory reception (memory transmission) function can still work. Memory expansion allows greater use of the multi copy function.

---



## **2.1.4 Maintenance and service**

### **a) Troubleshooting**

**The fax does not recognize the memory IC even when the test mode D-RAM test is executed.**

- 
- Solutions:** (1) Check that the memory IC is securely connected.  
(2) Replace the memory IC.  
(3) Replace the SCNT board.

## 2.2 HANDSET KIT 2

### 2.2.1 Service operations

#### a) External view

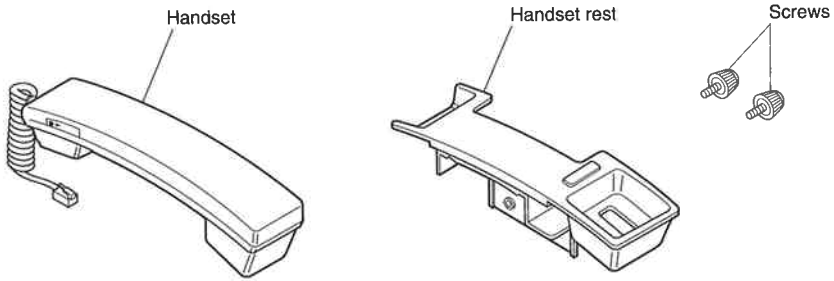


Figure 5-10 External View

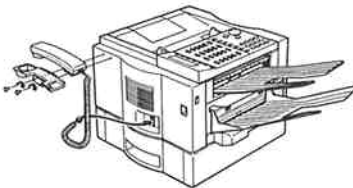
#### b) Installation

##### b-1) Unpacking

Check that the box contains the handset itself, the handset rest, and two screws.

##### b-2) Attachment to the main unit

- 1 Fit the handset rest over the holes.
- 2 Fasten the handset rest with the screws provided.



- 3 Connect the end of the modular handset cord to the jack marked .

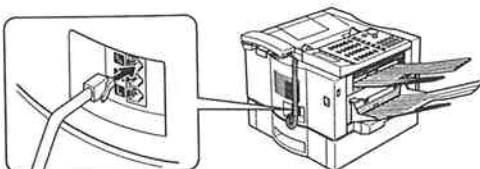


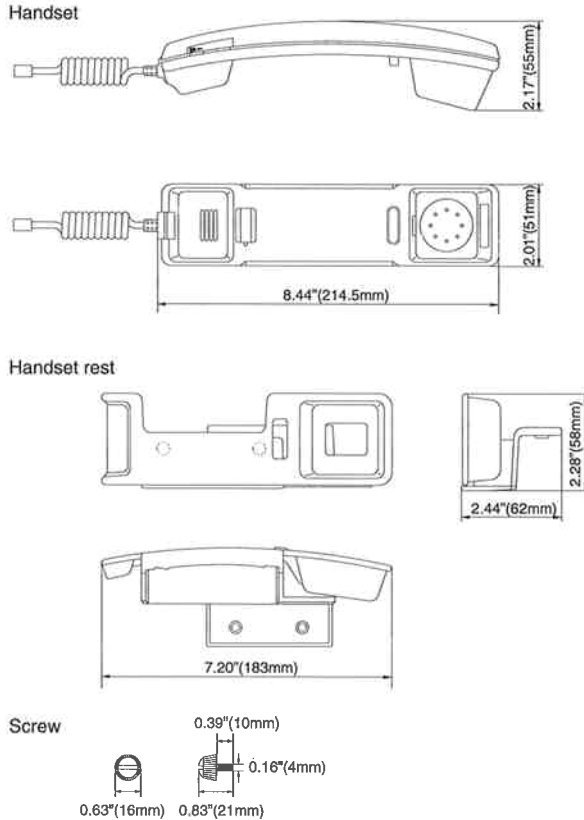
Figure 5-11 Attachment to the main unit

## 2.2.2 Technical information

### a) Configuration and construction

Product name **HANDSET KIT 2**

#### External structure



**Figure 5-12 External View**

### b) Specifications

Applicable line	PSTN
Ring volume	Selectable from 3 levels
External dimensions	2.01" (W) × 8.44" (D) × 2.17" (H) (51 × 214.5 × 55 mm)
Weight	approx. 0.42 lbs (0.19 kg)

### 2.2.3 Operations

#### a) Functions

##### a-1) Telephone call function

The handset is connected to the main unit's handset jack. When the other party is a telephone, you can talk on the handset just as on an ordinary telephone. You can also place a call using the main unit's calling function.

##### a-2) Ring back tone function

Receives the ringing signal from the exchange and sounds the ring back tone from the handset speaker.

##### a-3) Fax switch function

When you lift the handset up from the handset rest, the off-hook state is detected and the DC loop with the line is completed.

##### a-4) Ring back tone volume adjustment function

The ring back tone volume adjustment switch on the side of the handset can adjust the ring back tone volume among three levels, high, low, and off.

#### b) Electric circuit section

The handset electric circuit section comprises the speaker, the microphone, and the TELCNT board.

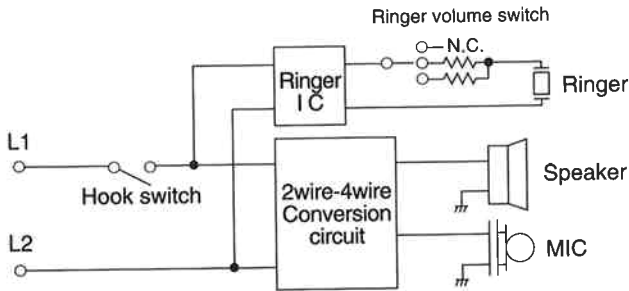


Figure 5-13 Electric Circuit Section

## 2.2.4 Maintenance and service

### a) Troubleshooting

#### **Even when a call is received, the bell does not ring.**

- Solutions:**
- (1) Check that the handset modular jack connector is properly connected to the handset jack on the main unit of the fax.
  - (2) Check that the ring back tone volume adjustment switch is set to Off.
  - (3) Check that the user data "INCOMING RING" switch is set to OFF.
  - (4) Replace the handset.
  - (5) Replace the NCU board.

#### **You can not hear the dialing sounds from the handset.**

- Solutions:**
- (1) Check that the handset modular jack connector is properly connected to the handset jack on the main unit of the fax.
  - (2) Check that the modular cord from the telephone line is properly connected to the telephone line jack on the main unit of the fax.
  - (3) Check that documents can be transmitted and received normally.
  - (4) Replace the handset.
  - (5) Replace the NCU board.

#### **There is no response when you dial.**

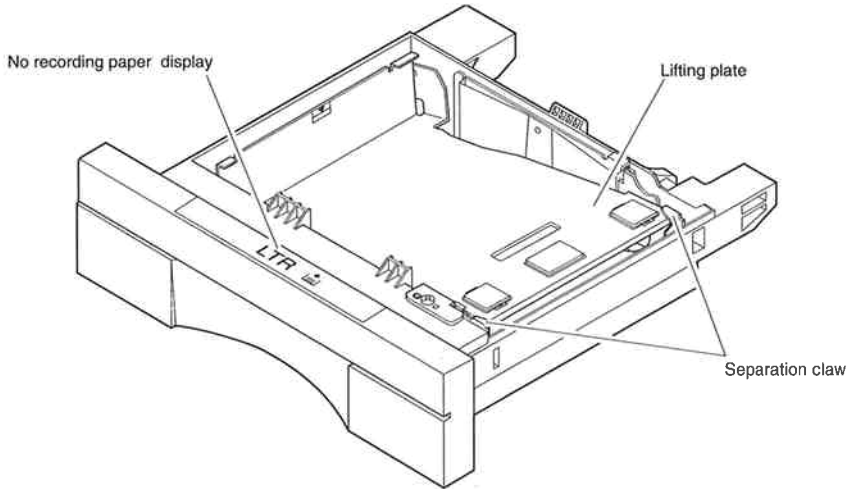
- Solutions:**
- (1) Check that user data "TEL LINE TYPE" (TONE/PULSE) is set to the same type as the telephone line you are using.
  - (2) Check that the modular cord from the telephone line is properly connected to the telephone line jack on the main unit of the fax.
  - (3) Replace the NCU board.

**This page intentionally left blank**

## 2.3 FXL-CASSETTE 1 LTR/500

### 2.3.1 Service operations

#### a) External view



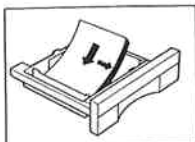
**Figure 5-14 External View**

**b) Installation**

**b-1) Unpacking**

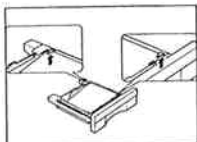
Check that the box contains one front cassette.

**b-2) Loading the recording paper in the front cassette**



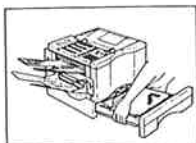
**1) Load the paper into the front cassette.**

- Before you load paper in the front cassette, stack it so the leading edge and sides of the paper are even.

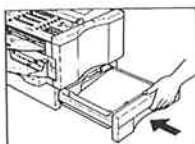


**2) Be sure the paper is below the retaining clips at the back and front of the cassette.**

- The front cassette can hold about 500 sheets.
- Before loading 500 sheets, divide the stack into approximately equal thirds about half an inch thick. Then load each stack separately.
- Be sure the level of the paper in the cassette is not higher than the level limit mark (▼) on the cassette.



**3) Push the front cassette into the main unit gently until it clicks.**



**Figure 5-15 Loading Recording Paper**



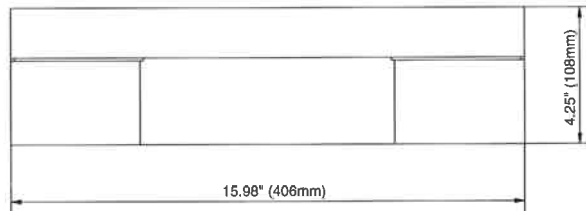
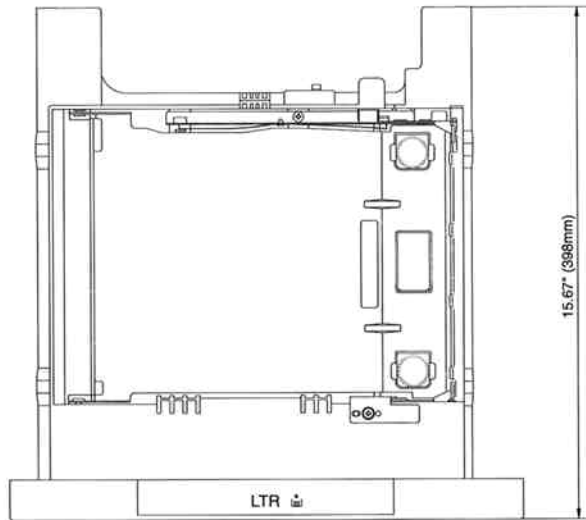
**2.3.2 Technical information**

**a) Configuration and construction**

Product name **FXL-CASSETTE 1 LTR/500**

External structure

Item	Dimensions and weight	Remarks
External dimensions	15.98" (W) × 15.67" (D) × 4.25" (H) (406 × 398 × 108mm)	
Weight	approx. 4.19 lbs (1.9 kg)	



**Figure 5-16 External View**

**b) Specifications**

**Recording format**

Fixed size plain paper

Fixed size recycled paper

**Recording paper dimensions**

Letter      8.50" (W) × 10.98" (L) (216 × 279 mm)

**Recording paper cassette capacity**

Max. 500 sheets, or stacked to a height of 50 mm max.

**Recommended recording paper**

Canon NP Copier Paper Dry Toner A4

Weight              80 g/m<sup>2</sup>

Paper size          A4

Manufacturer      Kangas

Canon Copy Paper for Dry Toner Copies

Weight              80 g/m<sup>2</sup>

Paper size          A4

Manufacturer      Neusiedler

Boise Cascade

Weight              75 g/m<sup>2</sup>

Paper size          LETTER

Manufacturer      Boise Cascade

Copier LGL Premium Paper

Weight              75 g/m<sup>2</sup>

Paper size          LEGAL

Manufacturer      Boise Cascade

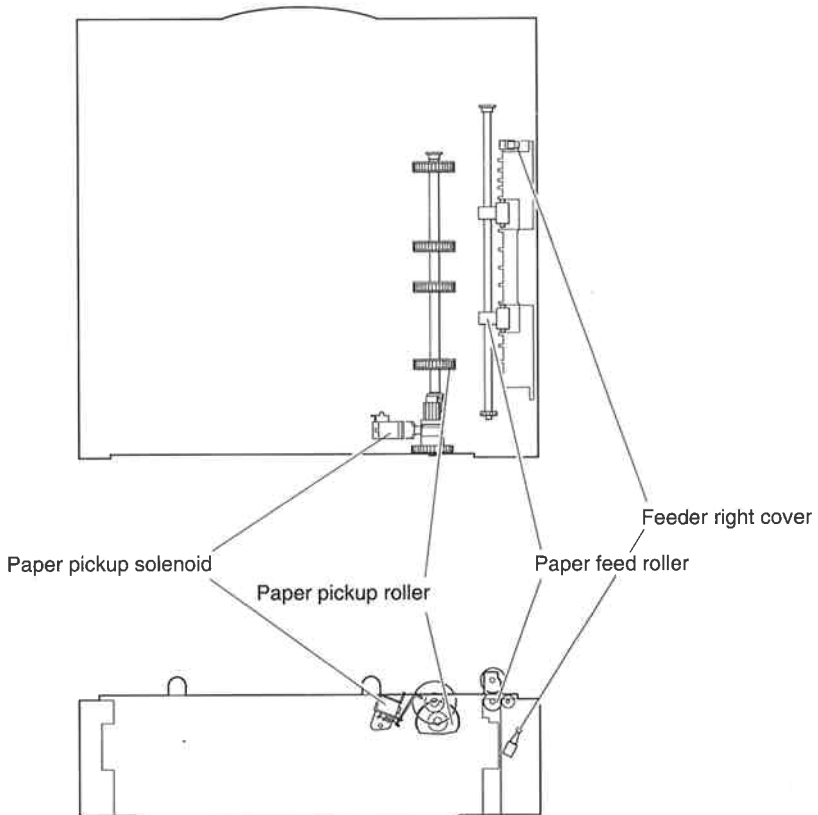
## 2.4 FXL-FEEDER 1

### 2.4.1 Safety and precautions

#### a) Personal precautions

Be careful not to let hair, clothing, personal accessories, etc. become caught in moving sections. Moving parts of this fax include the pickup roller and paper feed roller, which are rotated by the main motor, and the pickup solenoid, which controls the pickup roller.

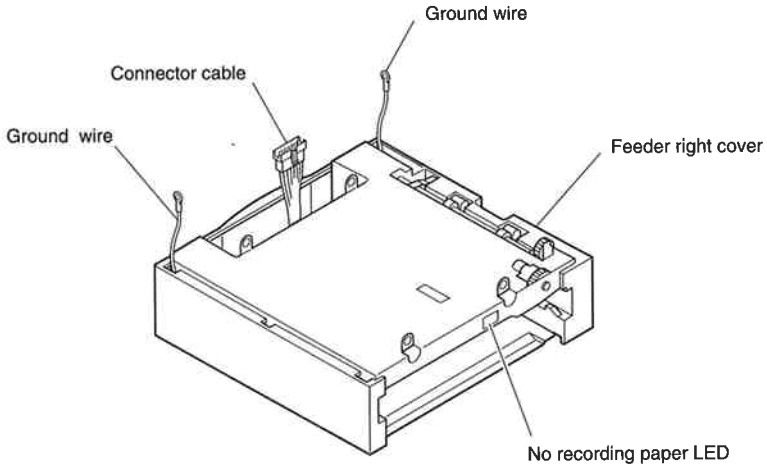
If you raise the right cover sensor arm, the moving sections are rotated by the main motor. During service operations, if you must operate this sensor arm, be careful not to let hair, clothing, personal accessories, etc. become caught on moving sections.



**Figure 5-17 Moving Sections**

## 2.4.2 Service operations

### a) External Views



**Figure 5-18 External Views**

**b) Installation**

**b-1) Unpacking**

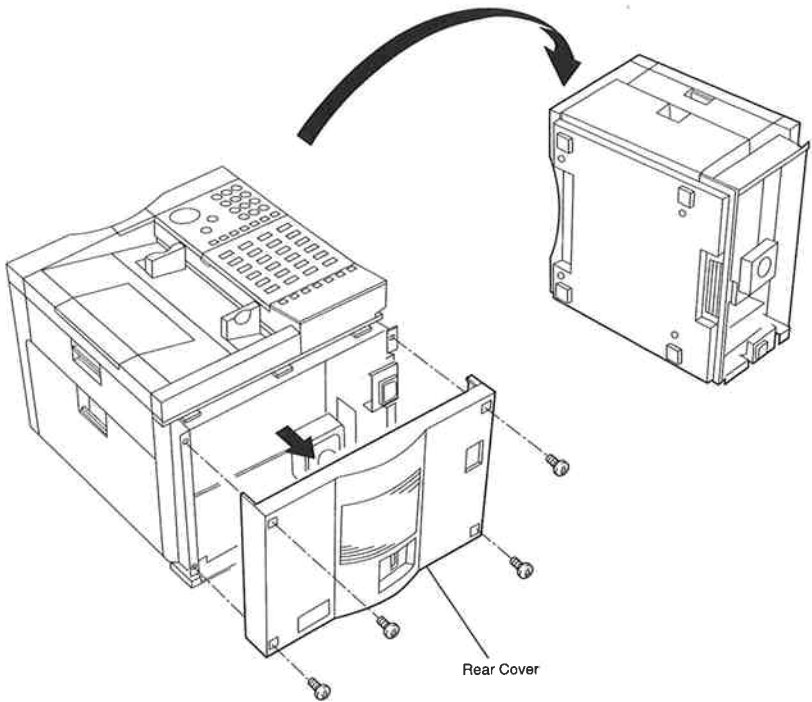
Check that the box contains the feeder main unit and two screws.

**b-2) Preparations for installation**

A magnetic Philips screwdriver with a long shaft (7.87"/200mm) will be required for the installation of the feeder. Otherwise, it may prove impossible to attach the feeder to the fax, and there is a possibility that screws may fall out inside the feeder unit.

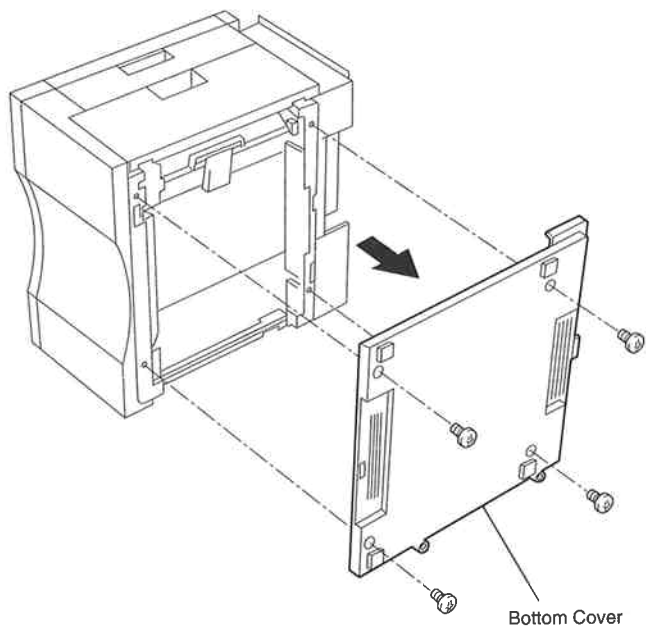
**b-3) Attachment to the main unit**

- (1) Switch off the power and unplug the power cord from the socket.
- (2) Remove the side cassette, document tray, exit tray, and toner cartridge.
- (3) Remove the four screws and remove the rear cover.



**Figure 5-19 Attachment to the Main Unit 1**

- (4) Place the main unit on its side so that the left side faces down.
- (5) Remove the four screws and remove the bottom cover.  
These screws are used for attaching the feeder, so do not lose them.

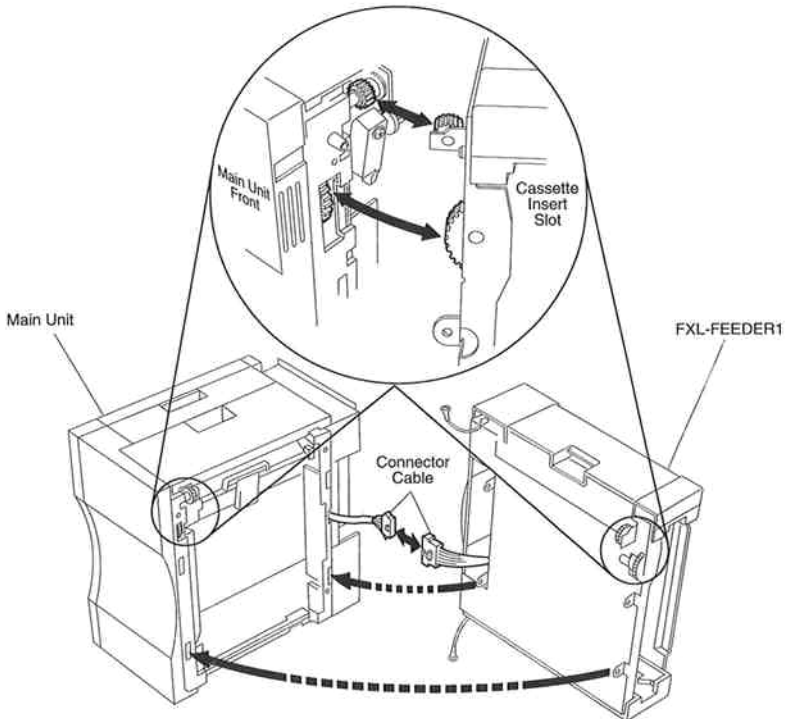


**Figure 5-20 Attachment to the Main Unit 2**

- (6) Similarly, place the feeder on its side next to the main unit, and connect the connector cable from the main unit to the feeder connector cable.

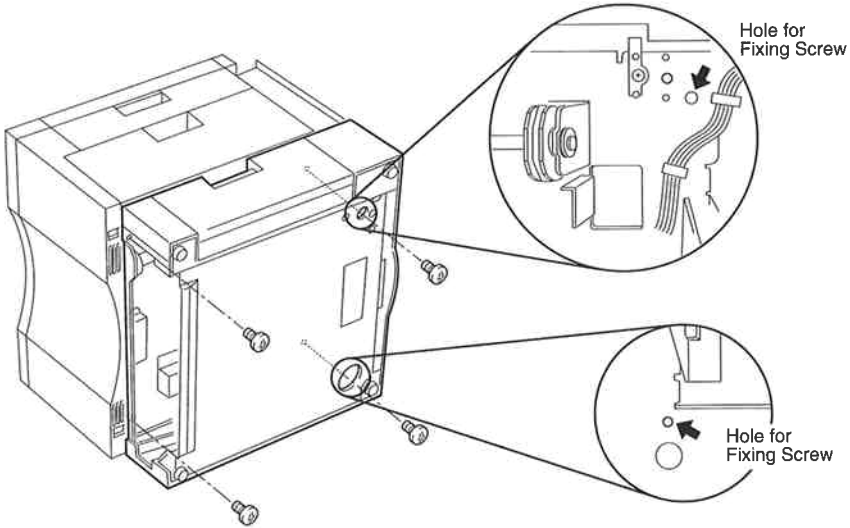


When attaching the feeder, check that the feeder gears and the main unit drive gear shown in Figure 5-21 mesh properly.



**Figure 5-21 Attachment to the Main Unit 3**

- (7) Attach the feeder to the main unit and secure from the rear with the four screws that held the bottom cover of the main unit.



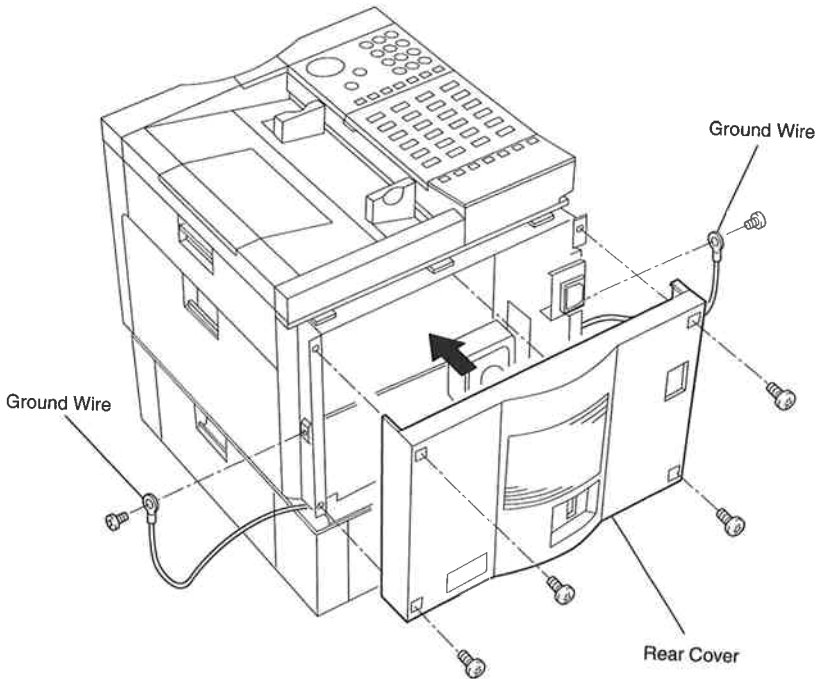
**Figure 5-22 Attachment to the Main Unit 4**



When attaching the feeder, be careful not to sandwich the cable between the feeder and the main unit. Doing so could cut or damage the cable or ground wire.



- (8) Lift up the main unit with the feeder attached and secure the two ground wires onto the main unit with the two screws that were packed together with the feeder.
- (9) Attach the side cassette and toner cartridge.
- (10) Attach the rear cover with four screws and install the document tray and exit tray.



**Figure 5-23 Attachment to the Main Unit 5**

**b-3) FXL-CASSETTE 1 LTR/500 installation**

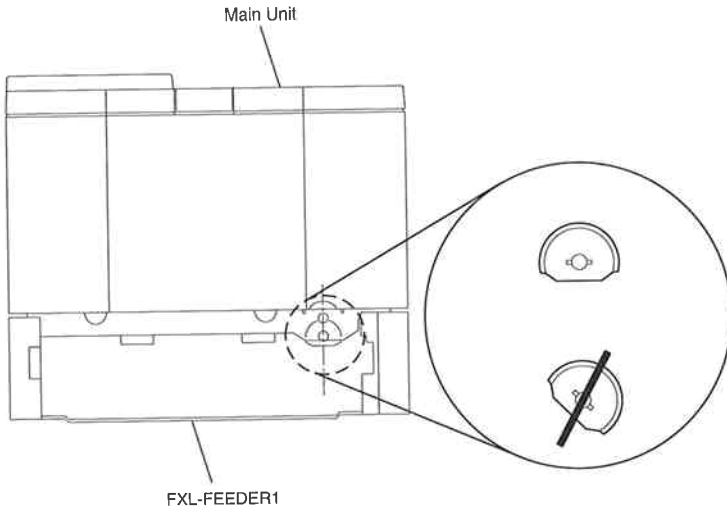
- (1) When you plug the power cord into a socket and switch on the power, "SUPPLY REC.PAPER" is displayed on the display, the REC.PAPER lamp blinks, and the LED on the front of the feeder that indicates that there is no recording paper lights up.
- (2) Check that the feeder's recording paper pickup roller is at its initial position.



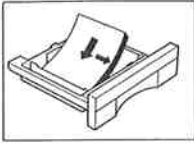
After connecting the feeder and install the toner cartridge, when you switch on the power, the main unit automatically detects that the feeder is connected and the feeder's recording paper pickup roller is set to its initial position. This initial position is as shown in Figure 5-24.



After connecting the feeder, if you load the front cassette when the recording paper pickup roller is not in its initial position, then the cassette will strike the roller and may break it. Always check that the roller is in its initial position before loading the cassette.

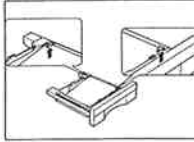


**Figure 5-24 Pickup Roller Initial Position**



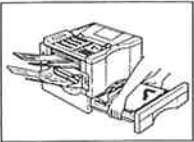
**3) Load the paper into the front cassette.**

- Before you load paper in the front cassette, stack it so the leading edge and sides of the paper are even.

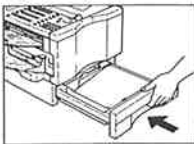


**4) Be sure the paper is below the retaining clips at the back and front of the cassette.**

- The front cassette can hold about 500 sheets.
- Before loading 500 sheets, divide the stack into approximately equal thirds about half an inch thick. Then load each stack separately.
- Be sure the level of the paper in the cassette is not higher than the level limit mark (▼) on the cassette.



**5) Push the front cassette into the main unit gently until it clicks.**



**Figure 5-25 Loading Recording Paper**

**b-4) Operation Check**

When you load the front cassette, the error display goes out and the fax goes on standby. Make a copy and check that the recording paper is picked up correctly.

**b-5) Removing the feeder from the main unit**

- (1) Switch off the power, and unplug the power cord from the socket.
- (2) Remove the feeder by reversing the attachment procedure.

**This page intentionally left blank.**

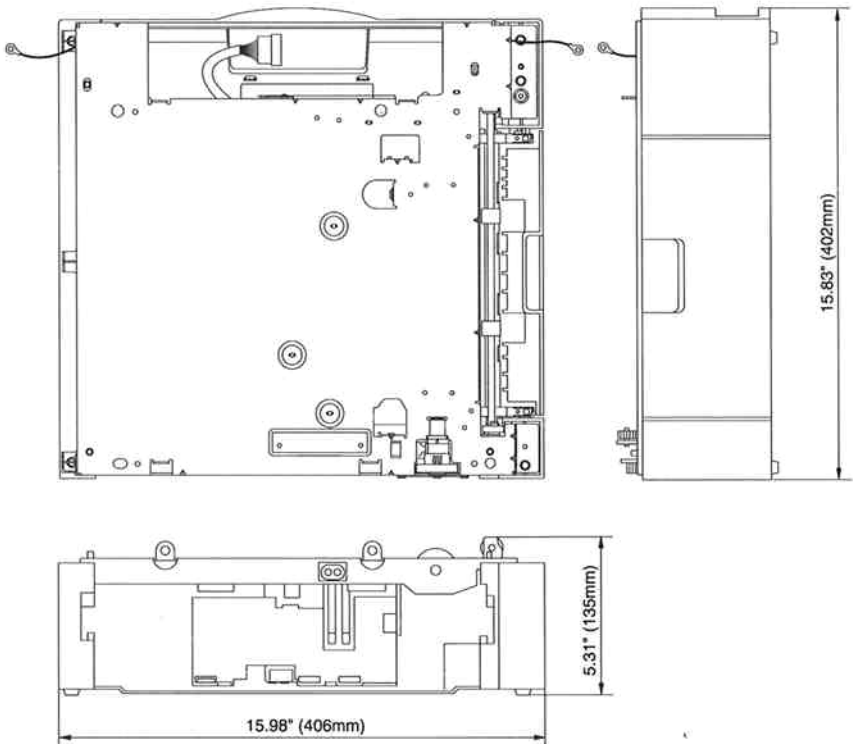
### 2.4.3 Technical information

#### a) Configuration and construction

Product name **FXL-FEEDER 1**

External structure

Item	Dimensions and weight	Remarks
Dimensions	15.98" (W) × 15.83" (D) × 5.31" (H) (406 × 402 × 135 mm)	
	15.98" (W) × 17.09" (D) × 5.31" (H) (406 × 434 × 135 mm)	With cassette
Weight	approx. 9.26 lbs (4.2 kg)	



**Figure 5-26 External View**

**b) Specifications**

**Recording format**

Fixed size plain paper  
Fixed size recycled paper

**Recording paper dimensions**

Letter 8.50" (W) × 10.98" (L) (216 × 279 mm)

**Recording paper cassette capacity**

Max. 500 sheets, or stacked to a height of 50 mm max.

**Recommended recording paper**

Canon NP Copier Paper Dry Toner A4

Weight 80 g/m<sup>2</sup>  
Paper size A4  
Manufacturer Kangas

Canon Copy Paper for Dry Toner Copies

Weight 80 g/m<sup>2</sup>  
Paper size A4  
Manufacturer Neusiedler

Boise Cascade

Weight 75 g/m<sup>2</sup>  
Paper size LETTER  
Manufacturer Boise Cascade

Copier LGL Premium Paper

Weight 75 g/m<sup>2</sup>  
Paper size LEGAL  
Manufacturer Boise Cascade

## 2.4.4 Operations

### a) Functions

#### a-1) Recording paper pickup function

After a page of recording paper is separated from the front cassette by claws on both sides driven by the fax main unit's main motor, it is sent through the paper path at the back of the fax main unit by the recording paper feed roller to the printer section.

#### a-2) No recording paper detection function

The recording paper sensor\* in the feeder detects whether or not there is recording paper in the front cassette.

\*: RPS

#### a-3) Cassette size detection function

Protrusions on the rear of the cassettes switch the two push switches on the driver board via size detection springs. In this way, this function detects letter-size cassette, A4-size cassette, or no cassette.

Letter-size cassette : SW901 on, SW902 off

A4-size cassette : SW901 off, SW902 on

No cassette : SW901 off, SW902 off

#### a-4) Feeder right cover open/close detection function

The right cover sensor detects whether the Feeder right cover is open or closed.

#### a-5) Front cassette no-paper LED light up function

If there is no recording paper, this function lights up the LED on the front of the feeder.

## b) Configuration

### b-1) Recording paper pickup configuration

In the recording paper pickup configuration, the recording paper pickup roller and the recording paper feed roller are driven with power transmitted by gears from the main motor in the fax main unit. Operation of the recording paper pickup roller is controlled by a solenoid and spring clutch. The pickup mechanism is controlled by the PCNT board CPU counting the step pulses, and a photo-interrupter type recording paper pickup sensor in the printer section equipped with an actuator arm monitoring the recording paper pickup status.



---

#### Pickup operation

After the main motor starts rotating, when the feeder pickup solenoid spring clutch is released, the crescent shaped recording paper pickup roller rotates once, and one page of recording paper held by the separation claws at the front edge of the cassette is picked up. The recording paper is fed to the printer section by the feeder's recording paper feed roller.

From the second page on, while the previous page is fed, the SCNT board printer interface IC sends the PRFD\* signal (prefeed signal) to the PCNT board CPU to start paper pickup.

\*PRFD: Pre-Feed.

---



---

#### Feeder section jam detection

Paper jam in the feeder section is detected by the recording paper pickup sensor in the main unit.

For details of the paper jam detection configuration see to *Chapter 3 : 2.4.1. Recording paper pickup section.*

---

### b-2) No recording paper detection configuration

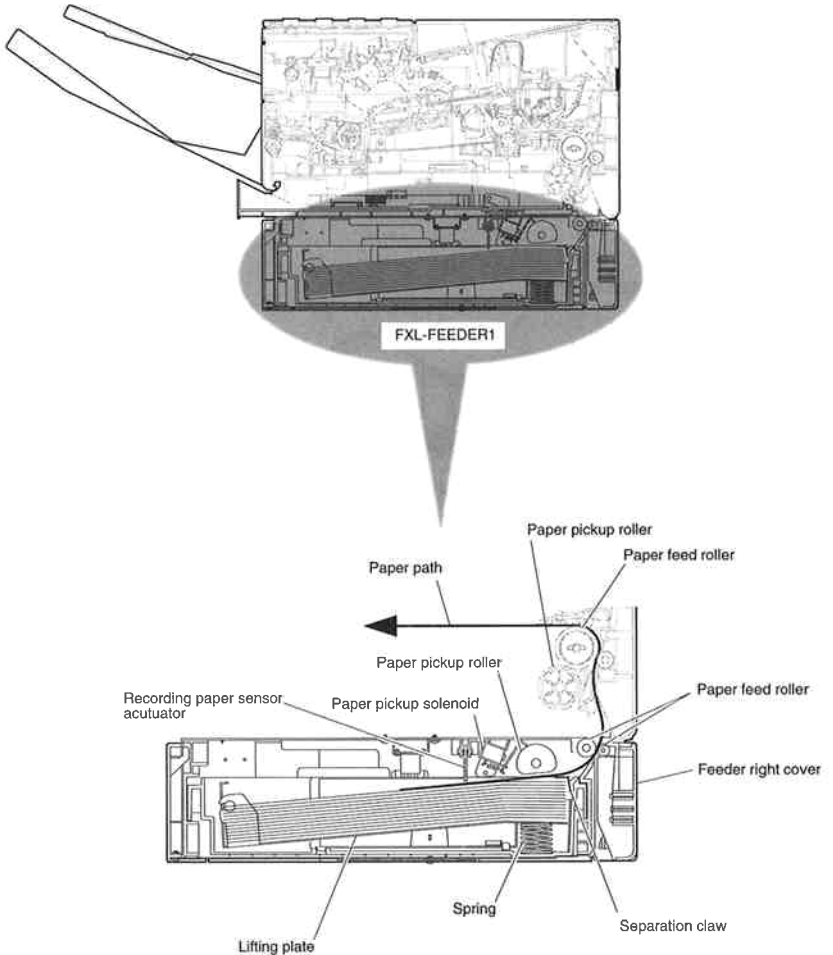
A no recording paper error is detected by the photo-interrupter type recording paper sensor equipped with an actuator arm.

The "no recording paper error" means that the recording paper sensor detects that there is no recording paper in the recording paper cassette.



**NOTE****No recording paper processing**

"SUPPLY REC.PAPER" is displayed on the display. Reception images are received with memory reception starting from the page during which the recording paper ran out, but the copy data are erased.



**Figure 5-27 Cross-Sectional Diagram**

**c) Arrangement of sensors.**

**c-1) Recording paper sensor (RPS)**

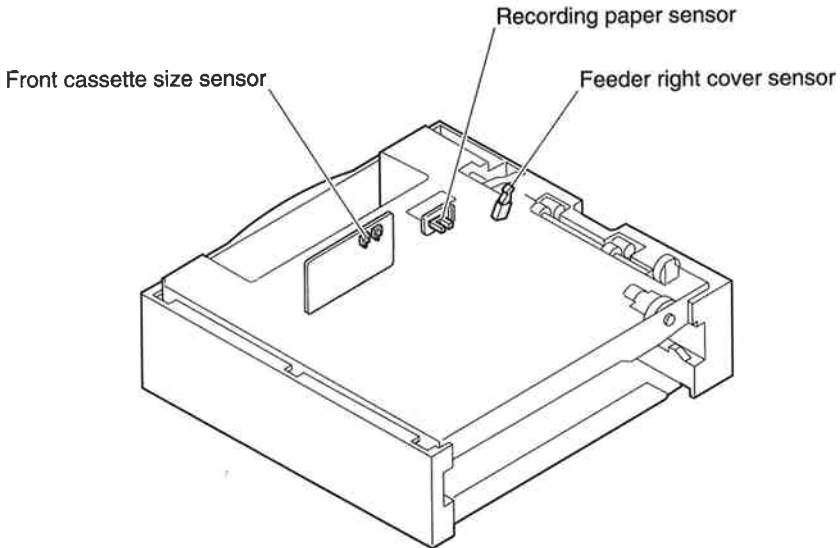
Located on the upper portion of the frame at the rear of the cassette opening and detects whether there is recording paper or not.

**c-2) Feeder right cover sensor**

Located on the right as the feeder right cover is opened and detects whether the feeder cover is open or closed.

**c-3) Front cassette size sensor**

Located on the driver board at the rear of the feeder and detects that the front cassette is loaded and the size of the recording paper in it.

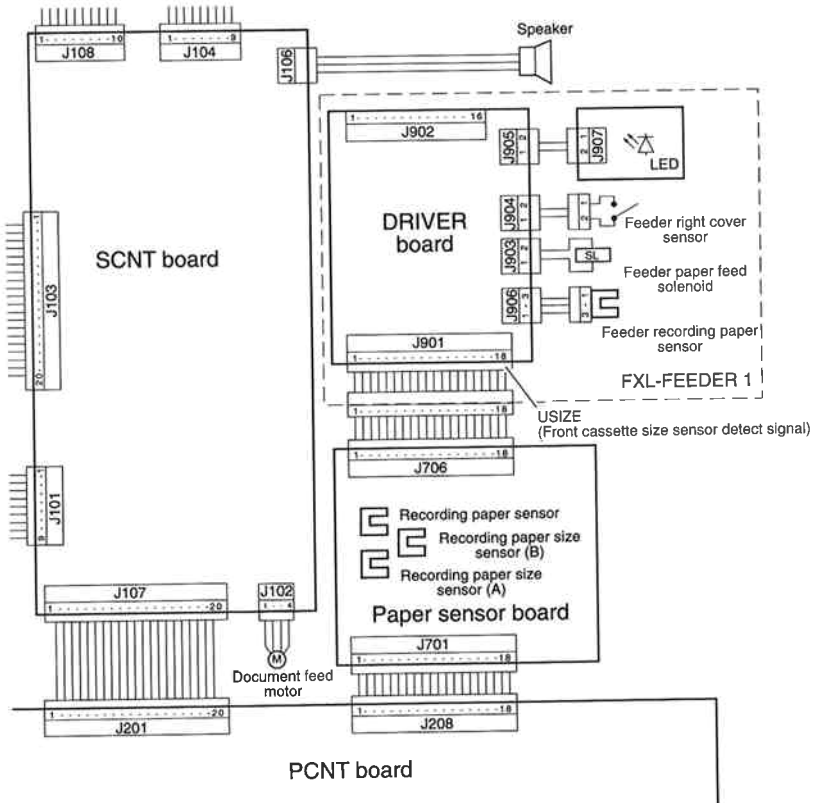


**Figure 5-28 Arrangement of Sensors**

**This page intentionally left blank**

**d) Electrical circuit section**

The FXL-FEEDER 1 has a driver board that relays control signals to the pickup solenoid and from the recording paper sensor in the main unit. When you connect the connector cable from connector J706 on the paper sensor board side of the main unit and the connector cable from connector J901 of the driver board, the voltage at Pin 18 of connector J901 changes. The PCNT board CPU detects this, and detects that the feeder is mounted, and the cassette type.



**Figure 5-29 Electrical Circuit Section**

## 2.4.5 Maintenance and service

### a) Troubleshooting

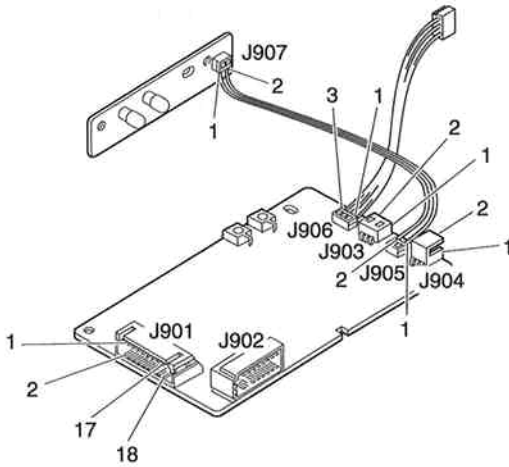
#### **The fax main unit does not detect that the FXL-FEEDER 1 is mounted.**

- Solutions:**
- (1) Check the connection between the main unit and feed connector cables.
  - (2) Check connector J901 on the driver board in the feeder.
  - (3) Check connectors J701 and J706 on the sensor board.
  - (4) Check connectors J208 on the main unit PCNT board.
  - (5) Replace the driver board in the feeder.
  - (6) Replace the main unit sensor board.
  - (7) Replace the main unit PCNT board.

#### **Recording paper is not picked up.**

- Solutions:**
- (1) Check connector J903 on the driver board in the feeder, and the pickup solenoid in the feeder.
  - (2) Replace the pickup solenoid.
  - (3) Replace the driver board in the feeder.
  - (4) Replace the main unit sensor board.
  - (5) Replace the main unit PCNT board.

**b) Connector locations and signals**  
**b-1) Driver board**



**Figure 5-30 Driver Board**

**J901 (Paper sensor board connector)**

Pin No.	Signal	In/Out	Output from	Details
1	-UPSNS	Out	Front cassette recording paper sensor	Front cassette recording paper sensor detect signal (H: yes; L: no)
2	UCVSNS	Out	Feeder right cover sensor	Feeder right cover sensor detect signal (H: yes; L: no)
3	UCPUD	In	PCNT CPU (IC301)	Feeder section pickup solenoid control signal
4	-LPSNS	—	—	Not used
5	LCVSNS	—	—	Not used
6	+5 V	In	Power supply	Sensor drive voltage
7	GND	—	—	Ground
8	+12VAS	In	Power supply	LED/Solenoid drive voltage
9	GND	—	—	Ground
10	GND	—	—	Ground
11	UPLD	In	PCNT CPU (IC301)	Front cassette no-paper LED control signal
12	VBOOT	—	—	Not used
13	PH3	—	—	Not used
14	PH4	—	—	Not used
15	OMTRST	—	—	Not used
16	LCPUD	—	—	Not used
17	LSIZE	—	—	Not used
18	USIZE	In	Front cassette recording paper size sensor	Front cassette recording paper size sensor detect signal

**J902 (For future expansion)**

<b>Pin No.</b>	<b>Signal</b>	<b>In/Out</b>	<b>Output from</b>	<b>Details</b>
A1	Not connected	—	—	Not used
A2	LCPUD	—	—	Not used
A3	PH4	—	—	Not used
A4	VBOOT	—	—	Not used
A5	GND	—	—	Not used
A6	+12VAS	—	—	Not used
A7	+5VAS	—	—	Not used
A8	-LPSNS	—	—	Not used
B1	LCVSNS	—	—	Not used
B2	GND	—	—	Not used
B3	+12VAS	—	—	Not used
B4	GND	—	—	Not used
B5	PH3	—	—	Not used
B6	OMTRST	—	—	Not used
B7	LSIZE	—	—	Not used
B8	Not connected	—	—	Not used



**J903 (Feeder section pickup solenoid)**

Pin No.	Signal	In/Out	Output from	Details
1	+12VAS	Out	Power supply	Pickup solenoid drive voltage
2	UCPUD	Out	PCNT CPU (IC301)	Pickup solenoid control signal

**J904 (Feeder right cover sensor)**

Pin No.	Signal	In/Out	Output from	Details
1	UCVSNS	In	Feeder right cover sensor	Feeder right cover sensor detect signal
2	GND	—	—	Ground

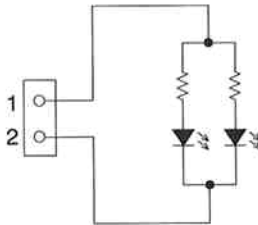
**J905/J907 (Front cassette no-paper LED)**

Pin No.	Signal	In/Out	Output from	Details
1	+12VAS	Out	Power supply	LED drive voltage
2	UCLED	Out	PCNT CPU (IC301)	LED control signal

**J906 (Front cassette recording paper sensor)**

Pin No.	Signal	In/Out	Output from	Details
1	+5V	Out	Power supply	Front cassette recording paper sensor drive voltage
2	GND	—	—	Ground
3	-UPSNS	In	Front cassette recording paper sensor	Front cassette recording paper sensor detect signal

**b-2) Front cassette no-paper LED**

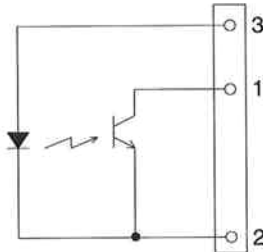


**Figure 5-31 Front Cassette No-Paper LED**

**J907**

Pin No.	Signal	In/Out	Output from	Details
1	+12 VAS	In	Power supply	LED drive voltage
2	UPLD	In	PCNT CPU (IC 301)	LED control signal

**b-3) Front cassette recording paper sensor**



**Figure 5-32 Front Cassette Recording Paper Sensor**

**J906**

Pin No.	Signal	In/Out	Output from	Details
1	-UPSNS	Out	Front cassette recording paper sensor	Front cassette recording paper sensor detect signal (H: Yes; L: No)
2	GND	—	—	Ground
3	+5V	In	Power supply	Sensor drive voltage

## b-4) Feeder section pickup solenoid

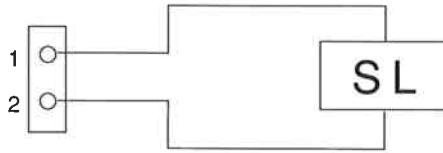


Figure 5-33 Feeder Section Pickup Solenoid

## J903

Pin No.	Signal	In/Out	Output from	Details
1	+12VAS	In	Power supply	Pickup solenoid drive voltage
2	UCPUD	In	PCNT CPU (IC 301)	Pickup solenoid control signal

## b-5) Feeder right cover sensor

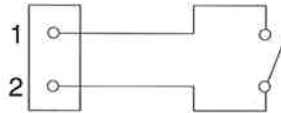


Figure 5-34 Feeder Right Cover Sensor

## J904

Pin No.	Signal	In/Out	Output from	Details
1	UCVSNS	Out	Feeder right cover sensor	Feeder right cover sensor detect signal (H: Yes, L: No)
2	GND	—	—	Ground

**This page intentionally left blank**

## 2.4.6 Recording Paper Size Priority

### a) Summary

This fax machine has the following reduction and recording paper selection functions so that when it receives an image longer than the effective recording paper length, it can print the received image on one page of recording paper.

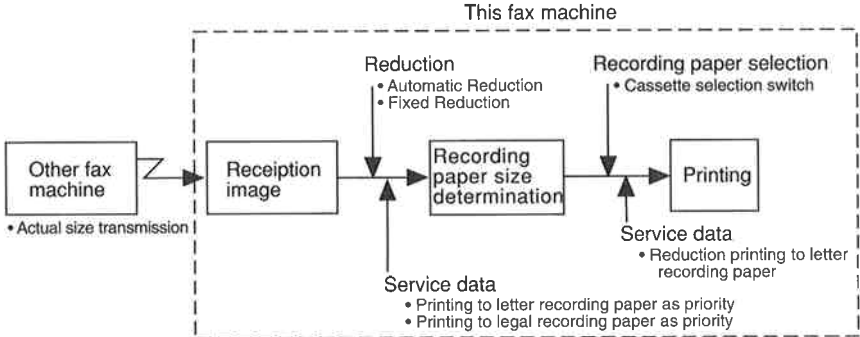


Figure 5-35 Summary of Reception Image Printing

### a-1) Reduction

With user data setting, either of the following reduction processing is carried out to determine the recording paper size.

#### Automatic reduction

The optimum reduction ratio (90 or 100%) is obtained from the length of the recorded image and the reception image is reduced to that reduction ratio.

#### Fixed reduction

The reception image is reduced to the reduction ratio set in the user data (90%).

### a-2) Recording paper selection

The reduced image is printed on recording paper from the cassette set in the user data "PRINTER SETTINGS" item "SELECT SETTINGS".

### a-3) Service data

#### Reduction printing to letter recording paper

When both A4 and letter cassettes are installed and the received image can be printed on either A4 or letter paper, this function reduces the image and prints it on letter-size paper. The default value for "print".

**Printing to letter recording paper as priority**

When both A4 and letter cassettes are installed and the received image can be printed on either A4 or letter paper, this function prints the image on letter-size paper. The default value for "**Do not print**".

**Printing to legal recording paper as priority**

When both A4 and legal cassettes are installed and the received image can be printed on either A4 or legal paper, this function prints the image on legal-size paper. The default value for "**Do not print**".



---

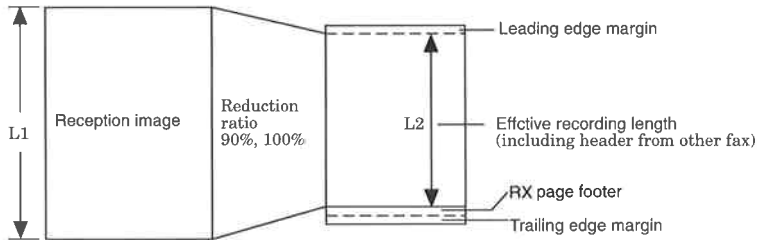
When the front cassette is not in the front cassette feeder, the recording paper cassette size data from when the front cassette was loaded are retained.

The cassette selection switch is only valid when the optional front cassette feeder is installed. If only the side cassette is installed or if the front cassette and the side cassette have the same size recording paper, this switch does not work.

---

**b) Reduction****b-1) Automatic reduction**

To avoid dividing one page of reception image into two pages of paper, when reception of one page of image data is completed, the length of the received image and the length of the recording paper in the cassette are compared and a reduction ratio of either 90% or 100% selected.

**L1: Reception image length**

Depends on the other fax

**L2: Effective recording length**

A4: 11.69" (297mm) (leading edge margin + trailing edge margin + RX page footer)

Letter: 10.98" (279mm) (leading edge margin + trailing edge margin + RX page footer)

Legal: 14.02" (356mm) (leading edge margin + trailing edge margin + RX page footer)

**Reduction ratio:**

If the received image can not be printed at the same size (100%), it is automatically reduced to 90%. If a reduction ratio of less than 90% would be required to fit the received image onto one page of paper, it is reduced, and printed, divided over two pages of paper.

**Figure 5-36 Summary of Automatic Reduction****b-2) Fixed reduction**

All received images are processed to reduce them to the reduction ratio set with the user data (90%).

**c) Reduction ratio table**

<b>Effective recording length</b>	<b>Recording paper size</b>	<b>Reduction ratio</b>
Under 285 mm	A4	100%
285-316.6 mm	A4	90%
Under 267 mm	Letter	100%
267-296.6 mm	Letter	90%
267-344 mm	Legal	100%
267-382.2 mm	Legal	90%



**d) Cassette selection switches**

Here are the two cassette selection switch items.

**Switch A: same system paper divided recording**

Enables/disables recording of received images onto same-system recording paper with a secondary scanning length shorter than the received secondary scanning length.

**Switch B: same system paper margin recording**

Enables/disables recording with margins of received images onto same-system recording paper with a secondary scanning length longer than the received secondary scanning length.



When the print image can be printed on multiple recording paper sizes, the smallest recording cassette takes priority.

When printing divided across multiple pages, the recording paper size is selected giving priority to the size that will require the fewest pages.

The second and subsequent pages for divided printing use the same size recording paper as the first page. If enough recording paper of that size is not available, memory reception is used.

The cassette selection switch is only valid when the optional front cassette feeder is installed.

Recording paper is selected for received images with the following procedure.

- 1) The minimum size that can print the image without image data loss at the same size or with reduction to a reduction ratio as low as 90%
- 2) The size that requires the fewest pages to print the image without image data loss at the same size or with reduction to a reduction ratio as low as 90%.



For details on the print image data loss range, see *Chapter 2: 3.4 Service Data Registration/Setting, #7 Printer (Printer function settings)*.

---

**e) Reading the recording paper size table**

When the recording paper size is determined with reduction, the combination of user data cassette selection switches A and B determine the priority order for the recording paper actually printed and the contents of printing. Below are examples of how to read the recording paper size table that shows this data.

**A4-size recording paper**

Cassette switches		Recording paper printed	
A	B	A4/Letter	Letter/Legal
OFF	OFF	1) Automatic reduction (Letter) 2) <u>Memory reception</u> (A4)	1) Automatic reduction (Letter) 2) Memory reception (Legal)

①
②

**Figure 5-37 Reading the Recording Paper Size Table**

**① Priority order**

The printed recording paper priority is determined by the contents of user data and service data settings.

**② Contents of printing**

- Memory reception: Compulsory memory reception
- With margins: Margins attached where image leaves extra space
- Division (2): Recording divided onto multiple pages; the number in parentheses indicates the page count.
- Automatic reduction: The optimum reduction ratio (90 or 100%) is obtained from the length of the received image and the received image is reduced to that reduction ratio.
- Actual size: Printed out in actual size.

## f) Printed recording paper table

## f-1) A4-size recording paper

Cassette switches		Recording paper printed	
A	B	A4/Letter	Letter/Legal
OFF	OFF	1) Automatic reduction (Letter) 2) Memory reception (A4)	1) Automatic reduction (Letter) 2) Memory reception (Legal)
OFF	ON	1) Automatic reduction (Letter) 2) Actual size (A4)	1) Automatic reduction (Letter) 2) Actual size (Legal)
ON	OFF	1) Automatic reduction (Letter) 2) Memory reduction (A4)	1) Automatic reduction (Letter) 2) Memory reception (Legal)
ON	ON	1) Automatic reduction (Letter) 2) Actual size (A4)	1) Automatic reduction (Letter) 2) Actual size (Legal)

## f-2) Letter-size recording paper

Cassette switches		Recording paper printed	
A	B	A4/Letter	Letter/Legal
OFF	OFF	1) Actual size (Letter) 2) Memory reception (A4)	1) Actual size (Letter) 2) Memory reception (Legal)
OFF	ON	1) Actual size (Letter) 2) Actual size (A4)	1) Actual size (Letter) 2) Actual size (Legal)
ON	OFF	1) Actual size (Letter) 2) Memory reception (A4)	1) Actual size (Letter) 2) Memory reception (Legal)
ON	ON	1) Actual size (Letter) 2) Actual size (A4)	1) Actual size (Letter) 2) Actual size (Legal)

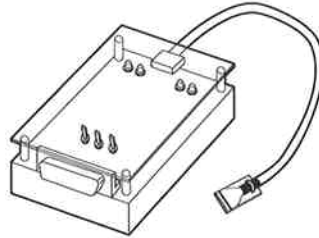
f-3) Letter-size recording paper

Cassette switches		Recording paper printed	
A	B	A4/Letter	Letter/Legal
OFF	OFF	1) Divided (2) (Letter) 2) Divided (2) (A4)	1) Actual size (Legal) 2) Memory reception (Letter)
OFF	ON	1) Divided (2) (Letter) 2) Divided (2) (A4)	1) Actual size (Legal) 2) Memory reception (Letter)
ON	OFF	1) Divided (2) (Letter) 2) Divided (2) (A4)	1) Actual size (Legal) 2) Divided (2) (Letter)
ON	ON	1) Divided (2) (Letter) 2) Divided (2) (A4)	1) Actual size (Legal) 2) Divided (2) (Letter)

## 3. SERVICE TOOLS

### 3.1 Printer Driver Tester

#### 3.1.1 Outline



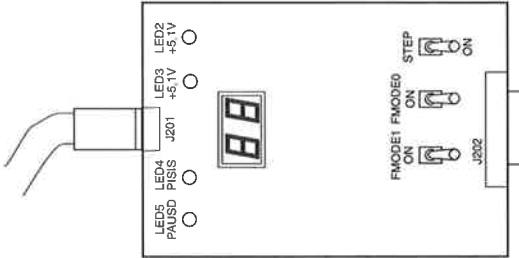
**Figure 5-38 Printer Driver Tester**

The printer driver tester allows this machine to operate without an external device to determine whether the printer is operating normally.

The tester has the following two functions:

- a) It permits the printer section to output an image with vertical lines to determine the quality of the printed image. This also allows the serviceman to determine whether a problem is caused by the printer section or by the SCNT board.
- b) It causes the printer section to emit the laser beam. The serviceman measures the output voltage which is proportional to the laser beam intensity with a digital multimeter and determine whether the laser beam intensity is within the specified range.

### 3.1.2 Explanation of LEDs and Switches



**Figure 5-39 LEDs and Switches**

- LED2: Monitors the 5V power supply.
- LED3: Monitors the 12V power supply.
- LED4: Monitors the PISIS signal output from J301-5.
- LED5: Monitors the PAUSD signal output from J301-8.
- FMODE0 switch, FMODE1 switch: Selects the function of the tester.
- STEP switch: Not used for servicing

### 3.1.3 Connector signal list

Conneceor contact No.	Signal name	Function
J301-1	FMODE1	FMODE1
J301-2	+5V	+5V
J301-3	FMODE0	FMODE0
J301-4	TOPVR	Output voltage of VR301
J301-5	-PISIS	Paper Pickup sensor signal
J301-6	FSRTHR	Output voltage of the thermister
J301-7	+12VAS	+12VAS
J301-8	PAUSD	Feed solenoid drive
J301-9	GND	GND
J301-10	GND	GND
J301-11	TNSNS	Toner detect signal
J301-12	MCPUD	Pickup solenoid drive signal

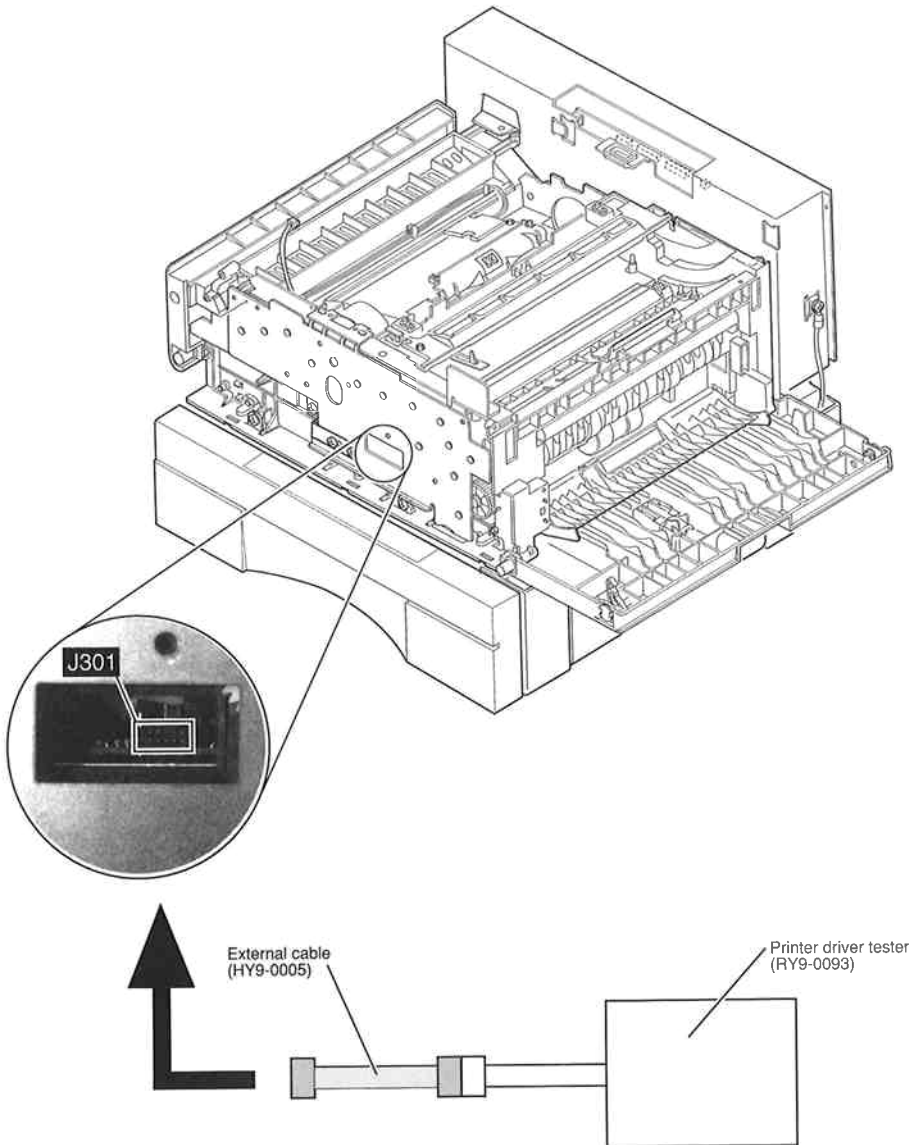
**Figure 5-40 Signal List**

### **3.1.4 Laser malfunction diagnosis flowchart**

This machine is designed to use the laser beam which is invisible. When a problem in the laser output occurs, use the laser diagnosis flowchart to determine whether the malfunction was caused by the laser/scanner unit or the PCNT board.

#### **a) Notes for the flowchart**

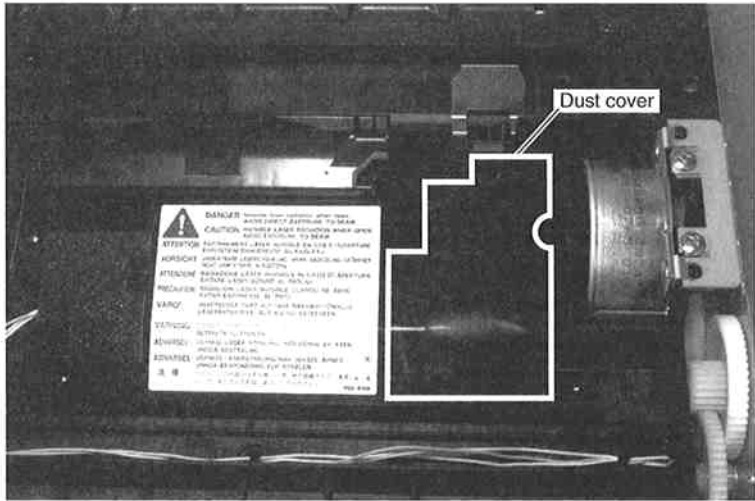
- The following abbreviations are used in the flowchart.
  - a. Printer driver tester; Driver tester
  - b. Digital multimeter; Meter
  - c. FX 2 cartridge; Cartridge
  
- The voltage must be measured three times, and the average taken.



**Figure 5-41 Connector Printer Driver Tester**



(4) Peel the dust cover on the laser/scanner unit.



**Figure 5-42 Dust cover on the Laser/Scanner Unit**

(5) Set the driver tester switches as follows:

FMODE0: OFF

FMODE1: ON

(6) Check by using the flowchart shown in the next page.

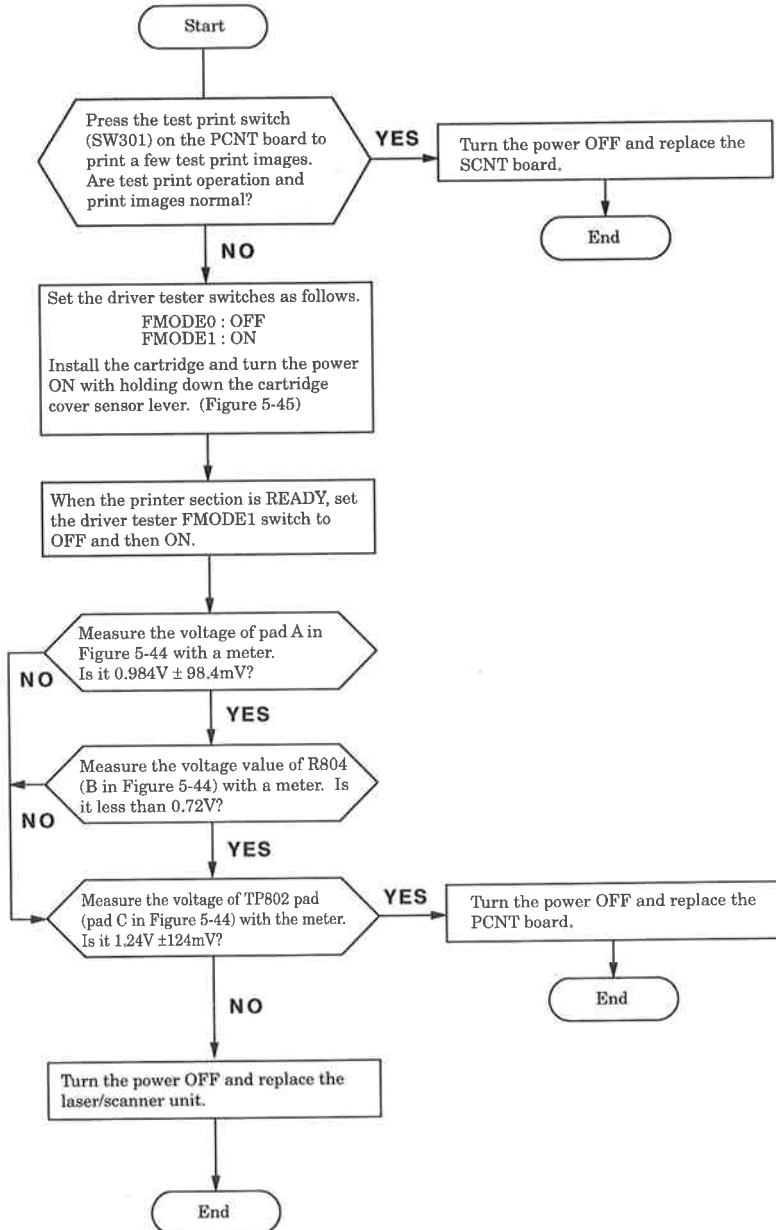
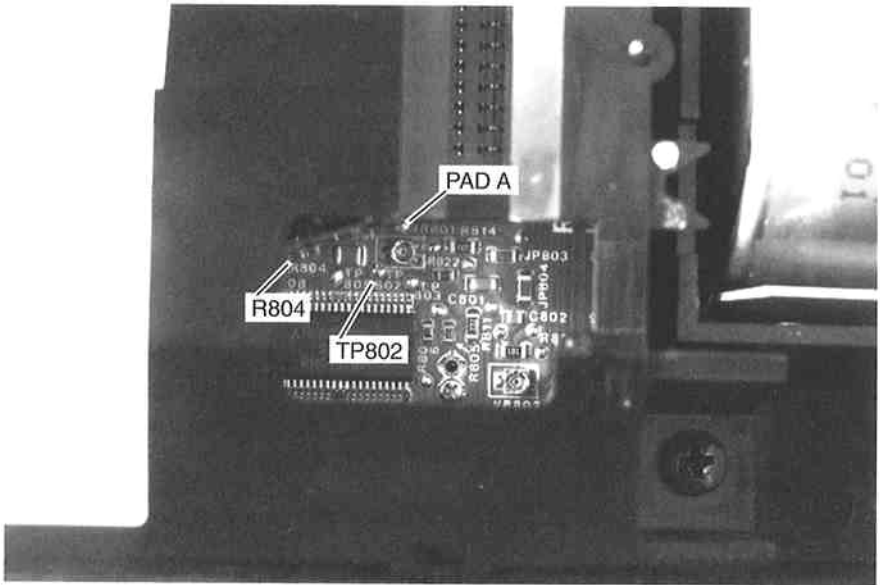
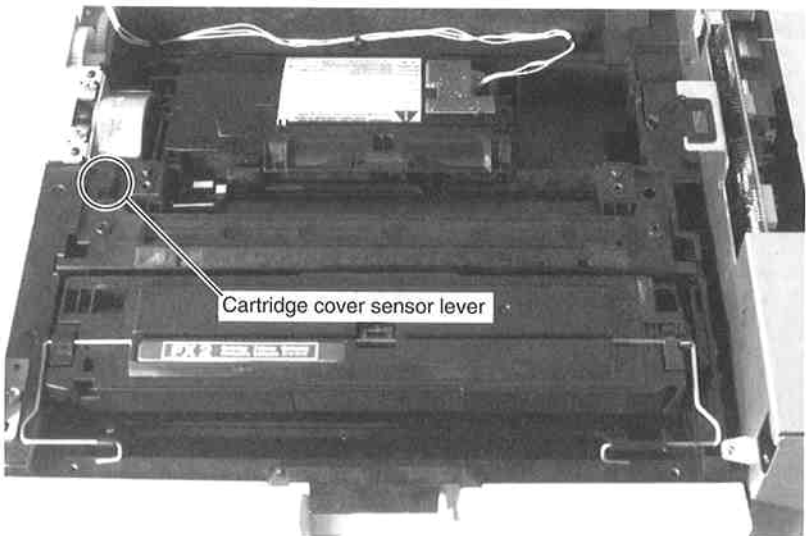


Figure 5-43 Diagnosis Flowchart



**Figure 5-44 Testpoint Locations**



**Figure 5-45 Cartridge Cover Sensor Lever**

**This page intentionally left blank**





Printed on paper that  
contains 50% reused paper.

**Canon**