



**FACSIMILE EQUIPMENT
SERVICE MANUAL**

**MODEL: FAX4750/5750
MFC8300/8600/8700
FAX8350P/8750P
MFC9650**

© Copyright Brother 2000

All rights reserved.

No part of this publication may be reproduced in any form or by any means without permission in writing from the publisher.

Specifications are subject to change without notice.

All products and company names mentioned in this manual are trademarks or registered trademarks of their respective holders.

PREFACE

This publication is a Service Manual covering the specifications, construction, theory of operation, and maintenance of the Brother facsimile equipment. It includes information required for field troubleshooting and repair--disassembly, reassembly, and lubrication--so that service personnel will be able to understand equipment function, to rapidly repair the equipment and order any necessary spare parts.

To perform appropriate maintenance so that the facsimile equipment is always in best condition for the customer, the service personnel must adequately understand and apply this manual.

This manual is made up of six chapters and appendices.

| | |
|---------------------|---|
| CHAPTER I. | GENERAL DESCRIPTION |
| CHAPTER II. | INSTALLATION |
| CHAPTER III. | THEORY OF OPERATION |
| CHAPTER IV. | DISASSEMBLY/REASSEMBLY AND LUBRICATION |
| CHAPTER V. | MAINTENANCE MODE |
| CHAPTER VI. | ERROR INDICATION AND TROUBLESHOOTING |
| Appendix 1. | EEPROM Customizing Codes |
| Appendix 2. | Circuit Diagrams |

This manual describes the models and their versions to be destined for major countries. The specifications and functions are subject to change depending upon each destination.

SAFETY INFORMATION

Laser Safety (110-120V Model only)

This printer is certified as a Class 1 laser product under the US Department of Health and Human Services (DHHS) Radiation Performance Standard according to the Radiation Control for Health and Safety Act of 1968. This means that the printer does not produce hazardous laser radiation.

Since radiation emitted inside the printer is completely confined within the protective housings and external covers, the laser beam cannot escape from the machine during any phase of user operation.

CDRH Regulations (110-120V Model only)

The Center for Device and Radiological Health (CDRH) of the US Food and Drug Administration implemented regulations for laser products on August 2, 1976. These regulations apply to laser products manufactured from August 1, 1976. Compliance is mandatory for products marketed in the United States. The label shown below indicates compliance with the CDRH regulations and must be attached to laser products marketed in the United States.

The label for Chinese products

| |
|--|
| MANUFACTURED: JULY 1999 C |
| BROTHER CORP. (ASIA) LTD. |
| BROTHER BUJI NAN LING FACTORY |
| Gold Garden Industry, Nan Ling Village, Buji, |
| Rong Gang, Shenzhen, China. |
| This product complies with FDA radiation |
| performance standards, 21 CFR Subchapter J. |

CHAPTER I.

GENERAL DESCRIPTION

CHAPTER I. GENERAL DESCRIPTION

CONTENTS

| | |
|--|------------|
| 1. EQUIPMENT OUTLINE..... | I-1 |
| 1.1 External Appearance and Weight | I-1 |
| 1.2 Components | I-1 |
| 2. SPECIFICATIONS..... | I-2 |

1. EQUIPMENT OUTLINE

1.1 External Appearance and Weight

The figure below shows the equipment appearance and approximate dimensions.

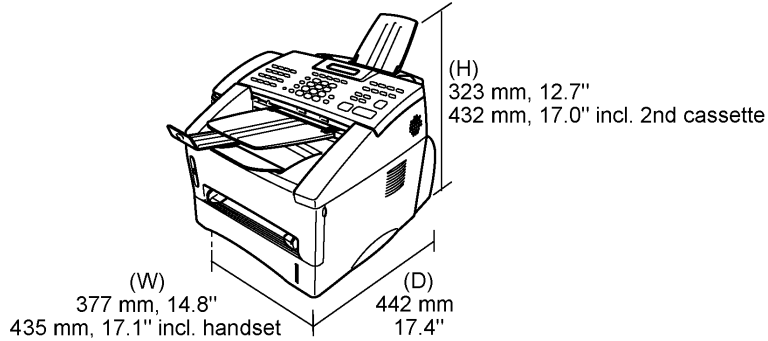

| Weight: | Machine proper | w/o 2nd cassette | w/ 2nd cassette |
|---------|---|------------------|-----------------|
| | Machine (incl. drum unit & toner cartridge) | 10.5 kg | 14.0 kg |
| | In package | 12.0 kg | 15.5 kg |
| | | 16.5 kg | 22.0 kg |

1.2 Components

The equipment consists of the following major components:

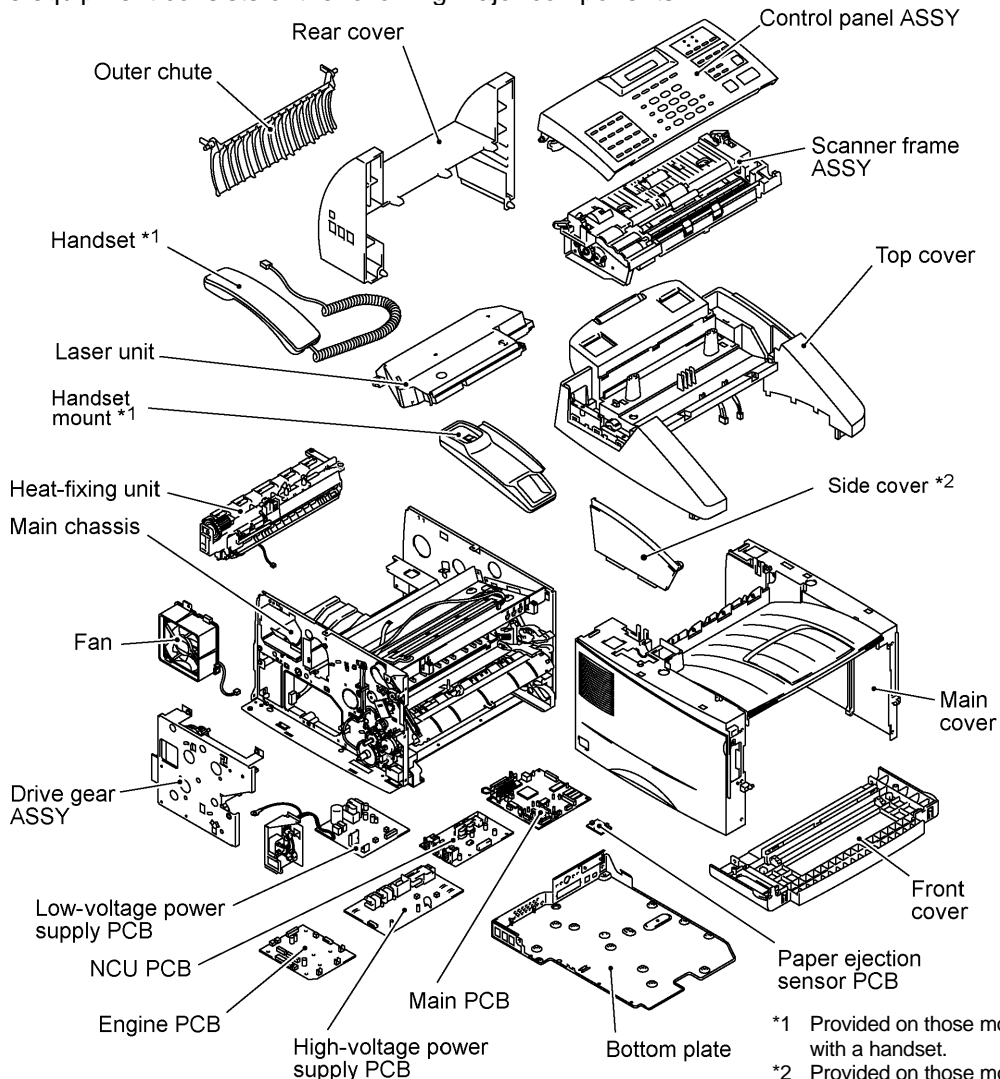

2. SPECIFICATIONS

(1/4)

| Model | FAX4750 | MFC8300 |
|--|---|---|
| GENERAL | | |
| Print Engine | Laser (ZL) | Laser (ZL) |
| Modem Speed (bps) | 14,400 (Fax) | 14,400 (Fax) |
| Transmission Speed (sec.) | 6 | 6 |
| ITU-T Group | G3 | G3 |
| Coding Method | MH/MR/MMR | MH/MR/MMR |
| Input/Output Width | 5.8" to 8.5" x 2.75" to 8.5" | 5.8" to 8.5" x 2.75" to 8.5" |
| ADF (pages) | 30 (50 * ¹) | 30 |
| LCD Size | 16 chars x 2 lines | 16 chars x 2 lines |
| On-Screen Programming | Yes | Yes |
| Backup Clock | Yes (1 hour) | Yes (1 hour) |
| Memory Capacity (MB) | 4 | 2 |
| Backup Memory | No | No |
| Optional Memory | Yes (8 & 16 MB) | Yes (8 & 16 MB) |
| Color | Gray 1495 | Gray 1495 |
| Standby Mode | Yes | Yes |
| PC-Fax Protocol Compliance | Class 2 | Class 2 |
| Simultaneous Operation | Yes | Yes |
| Data Modem | No | No |
| Energy Star Compliance (for U.S.A.) | Yes | Yes |
| LCD Backlight | No | No |
| Operating Environment Temperature Humidity | 10 to 32.5 °C 20 to 80% (without condensation) | 10 to 32.5 °C 20 to 80% (without condensation) |
| Power Source | 120 VAC, 50/60Hz | 120 VAC, 50/60Hz |
| Power Consumption (Sleep/Peak) | Less than 9W/60W/850W | Less than 9W/60W/850W |
| TELEPHONE | | |
| Automatic Redial | Yes | Yes |
| Handset | Yes | Yes |
| One-Touch Dial | 32 (16 x 2) | 32 (16 x 2) |
| Speed Dial | 100 | 100 |
| Telephone Index | Yes | Yes |
| Speaker Phone | No | No |
| Chain Dialing | Yes | Yes |
| Caller ID | Yes | Yes |
| Call Waiting Caller ID | Yes | Yes |
| Distinctive Ringing | Yes | Yes |
| Hold/Mute Key | Yes | Yes |
| Power Failure Dialing | No | No |
| Speaker Volume | Yes (3 levels + OFF) | Yes (3 levels + OFF) |
| Ringer Volume | Yes (3 levels + OFF) | Yes (3 levels + OFF) |
| Receiver Volume | Yes (2 levels + Hearing amplify level) | Yes (2 levels + Hearing amplify level) |
| PBX Feature | No | No |
| Transfer Method | Flash | Flash |
| Digits of One-Touch & Speed Dial | 20 digits | 20 digits |
| Registrable Number of Characters | 15 chars | 15 chars |

*¹ Xerox 4200 (20 lb/LTR) in normal business environments

| Model | MFC8600 | MFC8700 |
|-------------------------------------|---|---|
| GENERAL | | |
| Print Engine | Laser (ZL) | Laser (ZL) |
| Modem Speed (bps) | 14,400 (Fax) | 14,400 (Fax) |
| Transmission Speed (sec.) | 6 | Approx. 5 |
| ITU-T Group | G3 | G3 |
| Coding Method | MH/MR/MMR | MH/MR/MMR/JBIG |
| Input/Output Width | 5.8" to 8.5" x 2.75" to 8.5" | 5.8" to 8.5" x 2.75" to 8.5" |
| ADF (pages) | 30 | 30 (50 Conditional *1) |
| LCD Size | 16 chars x 2 lines | 16 chars x 2 lines |
| On-Screen Programming | Yes | Yes |
| Backup Clock | Yes (1 hour) | Yes (1 hour) |
| Memory Capacity (MB) | 4 | 4 |
| Backup Memory | No | No |
| Optional Memory | Yes (8 & 16 MB) | Yes (8 & 16 MB) |
| Color | Gray 1495 | Gray 1495 |
| Standby Mode | Yes | Yes |
| PC-Fax Protocol Compliance | Class 2 | Class 1 & 2 |
| Simultaneous Operation | Yes | Yes |
| Data Modem | No | No |
| Energy Star Compliance (for U.S.A.) | Yes | Yes |
| LCD Backlight | No | No |
| Operating Environment | Temperature Humidity | Temperature Humidity |
| | 10 to 32.5 °C 20 to 80% (without condensation) | 10 to 32.5 °C 20 to 80% (without condensation) |
| Power Source | 120 VAC, 50/60Hz | 120 VAC, 50/60Hz |
| Power Consumption (Sleep/Peak) | Less than 9W/60W/850W | Less than 9W/60W/850W |
| TELEPHONE | | |
| Automatic Redial | Yes | Yes |
| Handset | Yes | Yes |
| One-Touch Dial | 32 (16 x 2) | 32 (16 x 2) |
| Speed Dial | 100 | 100 |
| Telephone Index | Yes | Yes |
| Speaker Phone | No | No |
| Chain Dialing | Yes | Yes |
| Caller ID | Yes | Yes |
| Call Waiting Caller ID | Yes | Yes |
| Distinctive Ringing | Yes | Yes |
| Hold/Mute Key | Yes | Yes |
| Power Failure Dialing | No | No |
| Speaker Volume | Yes (3 levels + OFF) | Yes (3 levels + OFF) |
| Ringer Volume | Yes (3 levels + OFF) | Yes (3 levels + OFF) |
| Receiver Volume | Yes (2 levels + Hearing amplify level) | Yes (2 levels + Hearing amplify level) |
| PBX Feature | No | No |
| Transfer Method | Flash | Flash |
| Digits of One-Touch & Speed Dial | 20 digits | 20 digits |
| Registrable Number Of Characters | 15 chars | 15 chars |

*1 Xerox 4200 (20 lb/LTR) in normal business environments

| Model | FAX5750 | FAX8350P |
|-------------------------------------|---|---|
| GENERAL | | |
| Print Engine | Laser (ZL) | Laser (ZL) |
| Modem Speed (bps) | 33,600 (Fax) | 14,400 (Fax) |
| Transmission Speed (sec.) | Approx. 2 | 6 |
| ITU-T Group | Super G3 | G3 |
| Coding Method | MH/MR/MMR/JBIG | MH/MR/MMR |
| Input/Output Width | 5.8" to 8.5" x 2.75" to 8.5" | 5.8" to 8.5" x 2.75" to 8.5" |
| ADF (pages) | 30 (50 * ¹) | 30 (50 * ¹) |
| LCD Size | 16 chars x 2 lines | 16 chars x 2 lines |
| On-Screen Programming | Yes | Yes |
| Backup Clock | Yes (1 hour) | Yes (9 hours) |
| Memory Capacity (MB) | 4 | 4 (RAM) + 2 (flash ROM) |
| Backup Memory | No | Yes |
| Optional Memory | Yes (8 & 16 MB) | Yes (2 or 4 MB: flash) |
| Color | Gray 1495 | Gray 1495 |
| Standby Mode | Yes | Yes |
| PC-Fax Protocol Compliance | Class 2 | Class 2 |
| Simultaneous Operation | Yes | Yes |
| Data Modem | No | No |
| Energy Star Compliance (for U.S.A.) | Yes | No |
| LCD Backlight | No | No |
| Operating Environment | Temperature Humidity | Temperature Humidity |
| | 10 to 32.5 °C 20 to 80% (without condensation) | 10 to 32.5 °C 20 to 80% (without condensation) |
| Power Source | 120 VAC, 50/60Hz | 220-240 VAC, 50/60Hz |
| Power Consumption (Sleep/Peak) | Less than 9W/60W/850W | Less than 7W/9W/60W/850W |
| TELEPHONE | | |
| Automatic Redial | Yes | Yes |
| Handset | Yes | No |
| One-Touch Dial | 32 (16 x 2) | 32 (16 x 2) |
| Speed Dial | 100 | 100 |
| Telephone Index | Yes | Yes |
| Speaker Phone | No | No |
| Chain Dialing | Yes | Yes |
| Caller ID | Yes | No |
| Call Waiting Caller ID | No | No |
| Distinctive Ringing | Yes | Yes |
| Hold/Mute Key | Yes | No |
| Power Failure Dialing | No | No |
| Speaker Volume | Yes (3 levels + OFF) | Yes (3 levels + OFF) |
| Ringer Volume | Yes (3 levels + OFF) | Yes (3 levels + OFF) |
| Receiver Volume | Yes (2 levels + Hearing amplify level) | N/A |
| PBX Feature | No | Yes |
| Transfer Method | Flash | Flash/Earth |
| Digits of One-Touch & Speed Dial | 20 digits | 20 digits |
| Registrable Number Of Characters | 15 chars | 15 chars |

*¹ Xerox 4200 (20 lb/LTR) in normal business environments

| Model | MFC9650 | FAX8750P |
|-------------------------------------|----------------------------------|----------------------------------|
| GENERAL | | |
| Print Engine | Laser (ZL) | Laser (ZL) |
| Modem Speed (bps) | 14,400 (Fax) | 33,600 (Fax) |
| Transmission Speed (sec.) | 6 | Approx. 2 |
| ITU-T Group | G3 | Super G3 |
| Coding Method | MH/MR/MMR | MH/MR/MMR/JBIG |
| Input/Output Width | 5.8" to 8.5" x 2.75" to 8.5" | 5.8" to 8.5" x 2.75" to 8.5" |
| ADF (pages) | 30 (50 * ¹) | 30 (50 * ¹) |
| LCD Size | 16 chars x 2 lines | 16 chars x 2 lines |
| On-Screen Programming | Yes | Yes |
| Backup Clock | Yes (9 hours) | Yes (9 hours) |
| Memory Capacity (MB) | 4 (RAM) + 2 (flash ROM) | 4 (RAM) + 8 (flash ROM) |
| Backup Memory | Yes | Yes |
| Optional Memory | Yes (2 or 4 MB: flash) | N/A |
| Color | Gray 1495 | Gray 1495 |
| Standby Mode | Yes | Yes |
| PC-Fax Protocol Compliance | Class 1 & 2 | Class 1 & 2 |
| Simultaneous Operation | Yes | Yes |
| Data Modem | No | No |
| Energy Star Compliance (for U.S.A.) | | |
| LCD Backlight | No | No |
| Operating Environment | 10 to 32.5 °C | 10 to 32.5 °C |
| Temperature | 20 to 80% (without condensation) | 20 to 80% (without condensation) |
| Humidity | | |
| Power Source | 220-240 VAC, 50/60Hz | 220-240 VAC, 50/60Hz |
| Power Consumption (Sleep/Peak) | Less than 7W/9W/60W/850W | Less than 7W/9W/60W/850W |
| TELEPHONE | | |
| Automatic Redial | Yes | Yes |
| Handset | No | No |
| One-Touch Dial | 32 (16 x 2) | 32 (16 x 2) |
| Speed Dial | 100 | 100 |
| Telephone Index | Yes | Yes |
| Speaker Phone | No | No |
| Chain Dialing | Yes | Yes |
| Caller ID | No | No |
| Call Waiting Caller ID | No | No |
| Distinctive Ringing | Yes | Yes |
| Hold/Mute Key | No | No |
| Power Failure Dialing | No | No |
| Speaker Volume | Yes (3 levels + OFF) | Yes (3 levels + OFF) |
| Ringer Volume | Yes (3 levels + OFF) | Yes (3 levels + OFF) |
| Receiver Volume | N/A | N/A |
| PBX Feature | Yes | Yes |
| Transfer Method | Flash/Earth | Flash/Earth |
| Digits of One-Touch & Speed Dial | 20 digits | 20 digits |
| Registrable Number Of Characters | 15 chars | 15 chars |

*¹ Xerox 4200 (20 lb/LTR) in normal business environments

| Model | FAX4750 | MFC8300 |
|---|--|--|
| FAX | | |
| Internet FAX | N/A | N/A |
| Easy Receive/Fax Detect | Yes | Yes |
| Fax/Tel Switch | Yes | Yes |
| Super Fine | Yes (TX & RX) | Yes (TX & RX) |
| 300 dpi Transmission | No | No |
| Gray Scale | 64 | 64 |
| Contrast | Yes (Auto/S.Light/S.Dark) | Yes (Auto/S.Light/S.Dark) |
| Smoothing | Yes | Yes |
| Call Reservation Over Auto TX | Yes | Yes |
| Password Check | No | No |
| Enhanced Remote Activation | Yes | Yes |
| Multi-Resolution Transmission | Yes | Yes |
| Multi Transmission | No | No |
| Next-Fax Reservation | Yes (Dual access) | Yes (Dual access) |
| Delayed Timer | Yes (Up to 50 timers or 50 jobs) | Yes (Up to 50 timers or 50 jobs) |
| Polling | Yes (Std/Seq) | Yes (Std/Seq) |
| Quick Scan (Memory Transmission) | Approx. 2 sec/page (A4, std. resolution) | Approx. 2 sec/page (A4, std. resolution) |
| Broadcasting | Yes (182 locations) | Yes (182 locations) |
| Batch Transmission | Yes | Yes |
| Auto Reduction | Yes | Yes |
| Out-of-Paper Reception (Brother #1 Chart) | Up to 270 pages | Up to 90 pages |
| Dual Access | Yes | Yes |
| ECM (Error Correction Mode) | Yes | Yes |
| ITU SUB Addressing | No | No |
| Group Dial | Yes (6) | Yes (6) |
| Re-send After Receive Error Signal | No | No |
| Confidential | No | No |
| Station ID | 1 (20 digits/20 characters) | 1 (20 digits/20 characters) |
| Off-Hook Alarm | No | No |
| Remote Maintenance | Yes | Yes |
| Call Reservation Over Manual TX | Yes | Yes |
| RX Mode Indication | LED | LED |
| Resolution Indication | LED | LED |
| LIST REPORT | | |
| Activity Report/Journal Report | Yes (up to 50) | Yes (up to 50) |
| Transmission Verification Report | Yes | Yes |
| Coverpage | Yes (Super) | Yes (Super) |
| Help List | Yes | Yes |
| Callback Message | Yes | Yes |
| Caller ID List | Yes | Yes |
| INTERFACE | | |
| External TAD Interface | Yes | Yes |
| Missing Link/PC Interface | No | No |
| Host Interface | Yes (Parallel) | Yes (Auto switching : Parallel/USB ^{*2}) |
| LAN Interface | No | No |

*2 USB for Windows98 only

| Model | MFC8600 | MFC8700 |
|---|--|--|
| FAX | | |
| Internet FAX | N/A | Available with optional LAN board |
| Easy Receive/Fax Detect | Yes | Yes |
| Fax/Tel Switch | Yes | Yes |
| Super Fine | Yes (TX & RX) | Yes (TX & RX) |
| 300 dpi Transmission | No | No |
| Gray Scale | 64 | 64 |
| Contrast | Yes (Auto/S.Light/S.Dark) | Yes (Auto/S.Light/S.Dark) |
| Smoothing | Yes | Yes |
| Call Reservation Over Auto TX | Yes | Yes |
| Password Check | No | No |
| Enhanced Remote Activation | Yes | Yes |
| Multi-Resolution Transmission | Yes | Yes |
| Multi Transmission | No | No |
| Next-Fax Reservation | Yes (Dual access) | Yes (Dual access) |
| Delayed Timer | Yes (Up to 50 timers or 50 jobs) | Yes (Up to 50 timers or 50 jobs) |
| Polling | Yes (Std/Seq) | Yes (Std/Seq) |
| Quick Scan (Memory Transmission) | Approx. 2 sec/page (A4, std. resolution) | Approx. 2 sec/page (A4, std. resolution) |
| Broadcasting | Yes (182 locations) | Yes (182 locations) |
| Batch Transmission | Yes | Yes |
| Auto Reduction | Yes | Yes |
| Out-of-Paper Reception (Brother #1 Chart) | Up to 270 pages | Up to 310 pages |
| Dual Access | Yes | Yes |
| ECM (Error Correction Mode) | Yes | Yes |
| ITU SUB Addressing | No | No |
| Group Dial | Yes (6) | Yes (6) |
| Re-send After Receive Error Signal | No | No |
| Confidential | No | No |
| Station ID | 1 (20 digits/20 characters) | 1 (20 digits/20 characters) |
| Off-Hook Alarm | No | No |
| Remote Maintenance | Yes | Yes |
| Call Reservation Over Manual TX | Yes | Yes |
| RX Mode Indication | LED | LED |
| Resolution Indication | LED | LED |
| LIST REPORT | | |
| Activity Report/Journal Report | Yes (up to 50) | Yes (up to 50) |
| Transmission Verification Report | Yes | Yes |
| Coverpage | Yes (Super) | Yes (Super) |
| Help List | Yes | Yes |
| Call Back Message | Yes | Yes |
| Caller ID List | Yes | Yes |
| INTERFACE | | |
| External TAD Interface | Yes | Yes |
| Missing Link/PC Interface | No | No |
| Host Interface | Yes (Auto switching : Parallel/USB* ²) | Yes (Auto switching : Parallel/USB* ²) |
| LAN Interface | No | Available with optional LAN board (10-BaseT) |

*² USB for Windows98 only

| Model | FAX5750 | FAX8350P |
|--|--|--|
| FAX | | |
| Internet FAX | Available with optional LAN board | N/A |
| Easy Receive/Fax Detect | Yes | Yes |
| Fax/Tel Switch | Yes | Yes |
| Super Fine | Yes (TX & RX) | Yes |
| 300 dpi Transmission | No | No |
| Gray Scale | 64 | 64 |
| Contrast | Yes (Auto/S.Light/S.Dark) | Yes (Auto/Light/Dark) |
| Smoothing | Yes | Yes |
| Call Reservation Over Auto TX | Yes | Yes |
| Password Check | No | No |
| Enhanced Remote Activation | Yes | Yes |
| Multi-Resolution Transmission | Yes | Yes |
| Multi Transmission | No | No |
| Next-Fax Reservation | Yes (Dual access) | Yes (Dual access) |
| Delayed Timer | Yes (Up to 50 timers or 50 jobs) | Yes (Up to 50 timers or 50 jobs) |
| Polling | Yes (Std/Seq) | Yes (Std(+Seq)/Sec/Dil) |
| Quick Scan (Memory Transmission) | Approx. 2 sec/page (A4, std. resolution) | Approx. 2 sec/page (A4, std. resolution) |
| Broadcasting | Yes (182 locations) | Yes (182 locations) |
| Batch Transmission | Yes | Yes |
| Auto Reduction | Yes | Yes |
| Out-of-Paper Reception (Brother #1 Chart) (ITU-T Chart) | Up to 310 pages - | - Up to 130 pages |
| Dual Access | Yes | Yes |
| ECM (Error Correction Mode) | Yes | Yes |
| ITU SUB Addressing | No | No |
| Group Dial | Yes (6) | Yes (6) |
| Re-send After Receive Error Signal | No | No |
| Confidential | No | No |
| Station ID | 1 (20 digits/15 characters) | 1 (20 digits/20 characters) |
| Off-Hook Alarm | No | No |
| Remote Maintenance | Yes | Yes |
| Call Reservation Over Manual TX | Yes | Yes |
| RX Mode Indication | LED | LED |
| Resolution Indication | LED | LED |
| LIST REPORT | | |
| Activity Report/Journal Report | Yes (up to 50) | Yes (up to 50) |
| Transmission Verification Report | Yes | Yes |
| Coverpage | Yes (Super) | Yes (Super) |
| Help List | Yes | Yes |
| Call Back Message | Yes | Yes |
| Caller ID List | Yes | No |
| INTERFACE | | |
| External TAD Interface | Yes | Yes |
| Missing Link/PC Interface | No | No |
| Host Interface | Yes (Parallel) | No ^{*3} |
| LAN Interface | Available with optional LAN board (10-BaseT) | No |

*3 There is a parallel I/F behind the cover.

| Model | MFC9650 | FAX8750P |
|--------------------------------------|--|--|
| FAX | | |
| Internet FAX | Available with optional LAN board | Available with optional LAN board |
| Easy Receive/Fax Detect | Yes | Yes |
| Fax/Tel Switch | Yes | Yes |
| Super Fine | Yes | Yes |
| 300 dpi Transmission | No | No |
| Gray Scale | 64 | 64 |
| Contrast | Yes (Auto/Light/Dark) | Yes (Auto/Light/Dark) |
| Smoothing | Yes | Yes |
| Call Reservation Over Auto TX | Yes | Yes |
| Password Check | No | No |
| Enhanced Remote Activation | Yes | Yes |
| Multi-Resolution Transmission | Yes | Yes |
| Multi Transmission | No | No |
| Next-Fax Reservation | Yes (Dual access) | Yes (Dual access) |
| Delayed Timer | Yes (Up to 50 timers or 50 jobs) | Yes (Up to 50 timers or 50 jobs) |
| Polling | Yes (Std(+Seq)/Sec/Dil) | Yes (Std(+Seq)/Sec/Dil) |
| Quick Scan (Memory Transmission) | Approx. 2 sec/page (A4, std. resolution) | Approx. 2 sec/page (A4, std. resolution) |
| Broadcasting | Yes (182 locations) | Yes (182 locations) |
| Batch Transmission | Yes | Yes |
| Auto Reduction | Yes | Yes |
| Out-of-Paper Reception (ITU-T Chart) | Up to 130 pages | Up to 460 pages |
| Dual Access | Yes | Yes |
| ECM (Error Correction Mode) | Yes | Yes |
| ITU SUB Addressing | Yes (Wordcraft: MFL Pro:Class1 only) | No |
| Group Dial | Yes (6) | Yes (6) |
| Re-send After Receive Error Signal | No | No |
| Confidential | No | No |
| Station ID | 1 (20 digits/20 characters) | 1 (20 digits/20 characters) |
| Off-Hook Alarm | No | No |
| Remote Maintenance | Yes | Yes |
| Call Reservation Over Manual TX | Yes | Yes |
| RX Mode Indication | LED | LED |
| Resolution Indication | LED | LED |
| LIST REPORT | | |
| Activity Report/Journal Report | Yes (up to 50) | Yes (up to 50) |
| Transmission Verification Report | Yes | Yes |
| Coverpage | Yes (Super) | Yes (Super) |
| Help List | Yes | Yes |
| Call Back Message | Yes | Yes |
| Caller ID List | No | No |
| INTERFACE | | |
| External TAD Interface | Yes | Yes |
| Missing Link/PC Interface | No | No |
| Host Interface | Yes (Auto switching : Parallel/USB* ²) | Yes (Auto switching : Parallel/USB* ²) |
| LAN Interface | Available with option (LAN Board) | Available with option (LAN Board) |

*² USB for Windows98 only

| Model | FAX4750 | MFC8300 |
|---|--|--|
| PRINTER | Available with option or download from Web Site | Yes |
| Color/Mono | Mono | Mono |
| Engine Type | Laser (ZL) | Laser (ZL) |
| Resolution (dpi) | 600 x 600 | 600 x 600 |
| Speed (ppm) | 12 | 12 |
| Paper Capacity (sheets) | 250 | 250 |
| Additional Paper Capacity (sheets) | 250 (User option) | N/A |
| Output Paper Capacity (sheets) | 150 | 150 |
| Standard Print Language | Windows GDI (600 x 600) | Windows GDI (600 x 600) |
| Emulation | No | PCL4 |
| Resident Fonts | No | 24 bitmap (PCL4 Comp.) |
| Fonts Disk Based | No | Yes (35 True type) |
| Paper Handling Size | LTR, LGL, A4, B5, A5, EXE | LTR, LGL, A4, B5, A5, EXE |
| Manual Feed Slot | Custom size (2.75 x 5 to 8.5 x 14) Envelop (DL/C5/CM10/Mona) | Custom size (2.75 x 5 to 8.5 x 14) Envelop (DL/C5/CM10/Mona) |
| Other Paper Type | OHP, envelopes, labels, organizer | OHP, envelopes, labels, organizer |
| Sheet Weight (Paper Cassette) (Manual Slot) | 64 to 105 g/m ² (17 to 28 lb) 64 to 157 g/m ² (17 to 43 lb) | 64 to 105 g/m ² (17 to 28 lb) 64 to 157 g/m ² (17 to 43 lb) |
| Printer Driver | Windows3.1x, 95/98 and NT4.0 Driver with Auto Installer Program | Windows3.1x, 95/98 and NT4.0 Driver with Auto Installer Program |
| Utility Software | No | Yes (Remote printer console for PCL4) |
| Toner Life (High Yield : TN-430) (Standard Yield : TN-460) | 6,000 pages (A4, @5%) 3,000 pages (A4, @5%) | 6,000 pages (A4, @5%) 3,000 pages (A4, @5%) |
| Drum Life (DR400) | Up to 20,000 pages | Up to 20,000 pages |
| Interface Type | Parallel | Parallel & USB*2 |
| Bundled Cable | No | Yes (Parallel) |
| COPY | | |
| Color | No | No |
| Speed (ppm) | Up to 12 | Up to 12 |
| Multi Copy (Stack) | Up to 99 | Up to 99 |
| Multi Copy (Sort) | Yes | Yes |
| Reduction/Enlargement | 50 to 200% in 1% increments | 50 to 200% in 1% increments |
| Resolution (dpi) | 300 x 600 | 300 x 600 |
| SCANNER | Available with Option | Available with Option |
| Color/Mono | Mono | Mono |
| Resolution (dpi) | 1,200 x 1,200 (Int.), 300 x 600 (Opt.) | 1,200 x 1,200 (Int.), 300 x 600 (Opt.) |
| Gray Scale | 256 | 256 |
| TWAIN Compliant | Yes | Yes |
| Formats (Import) | TIFF/BMP/PCX/DCX/BTF/BTX/MAX/PDF | TIFF/BMP/PCX/DCX/BTF/BTX/MAX/PDF |
| Formats (Export) | TIFF/BMP/MAX/PDF | TIFF/BMP/MAX/PDF |
| OCR | Yes (ScanSoft TextBridge) | Yes (ScanSoft TextBridge) |
| MESSAGE CENTER/MESSAGE MANAGER | No | No |
| ICM Recording Time | N/A | N/A |
| Page Memory | N/A | N/A |
| OGM (MC/MC Pro/Paging) | N/A | N/A |
| TAD Type | N/A | N/A |
| Memo/Recording Conversation | N/A | N/A |
| Toll Saver | N/A | N/A |

*2 USB for Windows98 only

| Model | MFC8600 | MFC8700 |
|---|--|--|
| PRINTER | Yes | Yes |
| Color/Mono | Mono | Mono |
| Engine Type | Laser (ZL) | Laser (ZL) |
| Resolution (dpi) | 600 x 600 | 600 x 600 |
| Speed (ppm) | 12 | 12 |
| Paper Capacity (sheets) | 250 | 500 (250 + 250) |
| Additional Paper Capacity (sheets) | 250 (User option) | N/A |
| Output Paper Capacity (sheets) | 150 | 150 |
| Standard Print Language | Windows GDI (600 x 600) | Windows GDI (600 x 600) |
| Emulation | PCL4 | PCL4 |
| Resident Fonts | 24 bitmap (PCL4 Comp.) | 24 bitmap (PCL4 Comp.) |
| Fonts Disk Based | Yes (35 TrueType) | Yes (35 TrueType) |
| Paper Handling Size | LTR, LGL, A4, B5, A5, EXE | LTR, LGL, A4, B5, A5, EXE |
| Manual Feed Slot | Custom Size (2.75x5 to 8.5x14) Envelop (DL/C5/CM10/Mona) | Custom Size (2.75x5 to 8.5x14) Envelop (DL/C5/CM10/Mona) |
| Other Paper Type | OHP, envelopes, labels, organizer | OHP, envelopes, labels, organizer |
| Sheet Weight (Paper Cassette) (Manual Slot) | 64 to 105 g/m2 (17 to 28 lb) 64 to 157 g/m2 (17 to 43 lb) | 64 to 105 g/m2 (17 to 28 lb) 64 to 157 g/m2 (17 to 43 lb) |
| Printer Driver | Windows3.1x, 95/98 and NT4.0 Driver with Auto Installer Program | Windows3.1x, 95/98 and NT4.0 Driver with Auto Installer Program |
| Utility Software | Yes (Remote printer console for PCL4) | Yes (Remote printer console for PCL4) |
| Toner Life (High Yield : TN-430) (Standard Yield : TN-460) | 6,000 pages (A4, @5%) 3,000 pages (A4, @5%) | 6,000 pages (A4, @5%) 3,000 pages (A4, @5%) |
| Drum Life (DR400) | Up to 20,000 pages | Up to 20,000 pages |
| Interface Type | Parallel & USB*2 | Parallel & USB*2 |
| Bundled Cable | Yes (Parallel) | Yes (Parallel) |
| COPY | | |
| Color | No | No |
| Speed (ppm) | Up to 12 | Up to 12 |
| Multi Copy (Stack) | Up to 99 | Up to 99 |
| Multi Copy (Sort) | Yes | Yes |
| Reduction/Enlargement | 50 to 200% in 1% increments | 50 to 200% in 1% increments |
| Resolution (dpi) | 300 x 600 | 300 x 600 |
| SCANNER | Yes | Yes |
| Color/Mono | Mono | Mono |
| Resolution (dpi) | 1,200 x 1,200 (Int.)/300 x 600 (Opt.) | 1,200 x 1,200 (Int.)/300 x 600 (Opt.) |
| Gray Scale | 256 | 256 |
| TWAIN Compliant | Yes | Yes |
| Formats (Import) | TIFF/BMP/PCX/DCX/BTF/BTX/MAX/PDF | TIFF/BMP/PCX/DCX/BTF/BTX/MAX/PDF |
| Formats (Export) | TIFF/BMP/MAX/PDF | TIFF/BMP/MAX/PDF |
| OCR | Yes (ScanSoft TextBridge) | Yes (ScanSoft TextBridge) |
| MESSAGE CENTER/MESSAGE MANAGER | No | No |
| ICM Recording Time | N/A | N/A |
| Page Memory | N/A | N/A |
| OGM (MC/MC Pro/Paging) | N/A | N/A |
| TAD Type | N/A | N/A |
| Memo/Recording Conversation | N/A | N/A |
| Toll Saver | N/A | N/A |

*2 USB for Windows98 only

| Model | FAX5750 | FAX8350P |
|---|--|--|
| PRINTER | Available with option or download from Web Site | N/A |
| Color/Mono | Mono | Mono |
| Engine Type | Laser (ZL) | Laser (ZL) |
| Resolution (dpi) | 600 x 600 | 600 x 600 |
| Speed (ppm) | 12 | 12 |
| Paper Capacity (sheets) | 500 (250+250) | 250 |
| Additional Paper Capacity (sheets) | N/A | 250 (User option) |
| Output Paper Capacity (sheets) | 150 | 150 |
| Standard Print Language | Windows GDI (600 x 600) | Windows GDI (600 x 600) |
| Emulation | No | No |
| Resident Fonts | No | No |
| Fonts Disk Based | No | No |
| Paper Handling Size | LTR, LGL, A4, B5, A5, EXE | LTR, A4, B5, A5, EXE |
| Manual Feed Slot | Custom Size (2.75x5 to 8.5x14) Envelop (DL/C5/CM10/Mona) | Custom Size (2.75x5 to 8.5x14) Envelop (DL/C5/CM10/Mona) |
| Other Paper Type | OHP, envelopes, labels, organizer | OHP, envelopes, labels, organizer |
| Sheet Weight (Paper Cassette) (Manual Slot) | 64 to 105 g/m2 (17 to 28 lb) 64 to 157 g/m2 (17 to 43 lb) | 64 to 105 g/m2 (17 to 28 lb) 64 to 157 g/m2 (17 to 43 lb) |
| Printer Driver | Windows 3.1x, 95/98 and NT4.0 Driver with Auto Installer Program | N/A |
| Utility Software | No | No |
| Toner Life (High Yield : TN-430) (Standard Yield : TN-460) | 6,000 pages (A4, @5%) 3,000 pages (A4, @5%) | 6,000 pages (A4, @5%) 3,000 pages (A4, @5%) |
| Drum Life (DR400) | Up to 20,000 pages | Up to 20,000 pages |
| Interface Type | Parallel | ---*3 |
| Bundled Cable | No | No |
| COPY | | |
| Color | No | No |
| Speed (ppm) | Up to 12 | Up to 12 |
| Multi Copy (Stack) | Up to 99 | Up to 99 |
| Multi Copy (Sort) | Yes | Yes |
| Reduction/Enlargement | 50 to 200% in 1% increments | 50 to 200% in 1% increments |
| Resolution (dpi) | 300 x 600 | 300 x 600 |
| SCANNER | Available with option | N/A |
| Color/Mono | Mono | --- |
| Resolution (dpi) | 1,200 x 1,200 (Int.)/300 x 600 (Opt.) | --- |
| Gray Scale | 256 | --- |
| TWAIN Compliant | Yes | --- |
| Formats (Import) | TIFF/BMP/PCX/DCX/BTF/BTX/MAX/PDF | --- |
| Formats (Export) | TIFF/BMP/MAX/PDF | --- |
| OCR | Yes (ScanSoft TextBridge) | --- |
| MESSAGE CENTER/MESSAGE MANAGER | No | N/A |
| ICM Recording Time | N/A | N/A |
| Page Memory | N/A | N/A |
| OGM (MC/MC Pro/Paging) | N/A | N/A |
| TAD Type | N/A | N/A |
| Memo/Recording Conversation | N/A | N/A |
| Toll Saver | N/A | N/A |

*3 There is a parallel I/F behind the cover.

| Model | MFC9650 | FAX8750P |
|---|--|--|
| PRINTER | Yes | Yes |
| Color/Mono | Mono | Mono |
| Engine Type | Laser (ZL) | Laser (ZL) |
| Resolution (dpi) | 600 x 600 | 600 x 600 |
| Speed (ppm) | 12 | 12 |
| Paper Capacity (sheets) | 250 | 250 |
| Additional Paper Capacity (sheets) | 250 (User option) | 250 (User option) |
| Output Paper Capacity (sheets) | 150 | 150 |
| Standard Print Language | Windows GDI (600 x 600) | Windows GDI (600 x 600) |
| Emulation | PCL4 | PCL4 |
| Resident Fonts | 24 bitmap (PCL4 Comp.) | 24 bitmap (PCL4 Comp.) |
| Fonts Disk Based | Yes (35 True type) | Yes (35 True type) |
| Paper Handling Size | LTR, A4, B5, A5, EXE | LTR, A4, B5, A5, EXE |
| Manual Feed Slot | Custom Size (2.75x5 to 8.5x14) Envelop (DL/C5/CM10/Mona) | Custom Size (2.75x5 to 8.5x14) Envelop (DL/C5/CM10/Mona) |
| Other Paper Type | OHP, envelopes, labels, organizer | OHP, envelopes, labels, organizer |
| Sheet Weight (Paper Cassette) (Manual Slot) | 64 to 105 g/m2 (17 to 28 lb) 64 to 157 g/m2 (17 to 43 lb) | 64 to 105 g/m2 (17 to 28 lb) 64 to 157 g/m2 (17 to 43 lb) |
| Printer Driver | Windows3.1x, 95/98 and NT4.0 Driver with Auto Installer Program | Windows3.1x, 95/98 and NT4.0 Driver with Auto Installer Program |
| Utility Software | Yes (Remote printer console for PCL4) | No |
| Toner Life (High Yield : TN-430) (Standard Yield : TN-460) | 6,000 pages (A4, @5%) 3,000 pages (A4, @5%) | 6,000 pages (A4, @5%) 3,000 pages (A4, @5%) |
| Drum Life (DR400) | Up to 20,000 pages | Up to 20,000 pages |
| Interface Type | Parallel & USB*2 | Parallel & USB*2 |
| Bundled Cable | No (up to country) | No |
| COPY | | |
| Color | No | No |
| Speed (ppm) | Up to 12 | Up to 12 |
| Multi Copy (Stack) | Up to 99 | Up to 99 |
| Multi Copy (Sort) | Yes | Yes |
| Reduction/Enlargement | 50 to 200% in 1% increments | 50 to 200% in 1% increments |
| Resolution (dpi) | 300 x 600 | 300 x 600 |
| SCANNER | Yes | Available with option |
| Color/Mono | Mono | Mono |
| Resolution (dpi) | 1,200 x 1,200 (Int.)/300 x 600 (Opt.) | 1,200 x 1,200 (Int.)/300 x 600 (Opt.) |
| Gray Scale | 256 | 256 |
| TWAIN Compliant | Yes | Yes |
| Formats (Import) | TIFF/BMP/PCX/DCX/BTF/BTX/MAX/PDF | TIFF/BMP/PCX/DCX/BTF/BTX/MAX/PDF |
| Formats (Export) | TIFF/BMP/MAX/PDF | TIFF/BMP/MAX/PDF |
| OCR | Yes (ScanSoft TextBridge) | Yes (ScanSoft TextBridge) |
| MESSAGE CENTER/MESSAGE MANAGER | N/A | N/A |
| ICM Recording Time | N/A | N/A |
| Page Memory | N/A | N/A |
| OGM (MC/MC Pro/Paging) | N/A | N/A |
| TAD Type | N/A | N/A |
| Memo/Recording Conversation | N/A | N/A |
| Toll Saver | N/A | N/A |

*2 USB for Windows98 only

| Model | FAX4750 | MFC8300 |
|---|-----------------------|-----------------------|
| Fax Forwarding | Yes | Yes |
| Fax Retrieval | Yes | Yes |
| Paging | Yes | Yes |
| Remote Access | Yes | Yes |
| MESSAGE CENTER Pro/MESSAGE MANAGER Pro | No | No |
| Fax & Voice Mail Box | N/A | N/A |
| Fax- & Voice-on-Demand | N/A | N/A |
| MESSAGE CENTER (PC MC) | No | No |
| Fax Forwarding | N/A | N/A |
| Paging | N/A | N/A |
| ICM Recording Time | N/A | N/A |
| OGM MC/MC Pro/Paging | N/A | N/A |
| Fax & Voice Mail Box | N/A | N/A |
| Fax- & Voice-on-Demand | N/A | N/A |
| VIDEO CAPTURE | No | No |
| Video Capture | N/A | N/A |
| Video Print | N/A | N/A |
| Video Format | N/A | N/A |
| BUNDLED SOFTWARE | | |
| For Windows | | |
| Printer Driver (Brother) | Available with option | Yes |
| Viewer (ScanSoft) | Available with option | Available with option |
| TWAIN (Brother) | Available with option | Available with option |
| PC Fax (SMSI) ^{*3} | Available with option | Available with option |
| | | |
| For iMAC | | |
| Printer Driver (Brother) | N/A | Yes |
| Viewer (InfoWAVE) | N/A | N/A |
| TWAIN (TII) | N/A | N/A |
| PC Fax (SMSI or InfoWAVE) | N/A | N/A |

*3 The parallel interface only works.

| Model | MFC8600 | MFC8700 |
|---|----------------|----------------|
| Fax Forwarding | Yes | Yes |
| Fax Retrieval | Yes | Yes |
| Paging | Yes | Yes |
| Remote Access | Yes | Yes |
| MESSAGE CENTER Pro/MESSAGE MANAGER Pro | No | No |
| Fax & Voice Mail Box | N/A | N/A |
| Fax- & Voice-on-Demand | N/A | N/A |
| MESSAGE CENTER (PC MC) | No | No |
| Fax Forwarding | N/A | N/A |
| Paging | N/A | N/A |
| ICM Recording Time | N/A | N/A |
| OGM MC/MC Pro/Paging | N/A | N/A |
| Fax & Voice Mail Box | N/A | N/A |
| Fax- & Voice-on-Demand | N/A | N/A |
| VIDEO CAPTURE | Yes | Yes |
| Video Capture | Yes (Color) | Yes (Color) |
| Video Print | Yes (Mono) | Yes (Mono) |
| Video Format | NTSC | NTSC |
| BUNDLED SOFTWARE | | |
| For Windows | | |
| Printer Driver (Brother) | Yes | Yes |
| Viewer (ScanSoft) | Yes | Yes |
| TWAIN (Brother) | Yes | Yes |
| PC Fax (SMSI) ^{*3} | Yes | Yes |
| | | |
| For iMAC | | |
| Printer Driver (Brother) | Yes | Yes |
| Viewer (InfoWAVE) | N/A | N/A |
| TWAIN (TII) | Yes | Yes |
| PC Fax (SMSI or InfoWAVE) | N/A | N/A |

*3 The parallel interface only works.

| Model | FAX5750 | FAX8350P |
|---|-----------------------|-----------------|
| Fax Forwarding | Yes | Yes |
| Fax Retrieval | Yes | Yes |
| Paging | Yes | N/A |
| Remote Access | Yes | N/A |
| MESSAGE CENTER Pro/MESSAGE MANAGER Pro | No | N/A |
| Fax & Voice Mail Box | N/A | N/A |
| Fax- & Voice-on-Demand | N/A | N/A |
| MESSAGE CENTER (PC MC) | No | N/A |
| Fax Forwarding | N/A | N/A |
| Paging | N/A | N/A |
| ICM Recording Time | N/A | N/A |
| OGM MC/MC Pro/Paging | N/A | N/A |
| Fax & Voice Mail Box | N/A | N/A |
| Fax- & Voice-on-Demand | N/A | N/A |
| VIDEO CAPTURE | No | N/A |
| Video Capture | N/A | N/A |
| Video Print | N/A | N/A |
| Video Format | N/A | N/A |
| BUNDLED SOFTWARE | | |
| For Windows | | |
| Printer Driver (Brother) | Available with option | N/A |
| Viewer (ScanSoft) | Available with option | N/A |
| TWAIN (Brother) | Available with option | N/A |
| PC Fax (SMSI) ^{*3} | Available with option | N/A |
| | | |
| For iMAC | | |
| Printer Driver (Brother) | Available with option | N/A |
| Viewer (InfoWAVE) | N/A | N/A |
| TWAIN (TII) | Available with option | N/A |
| PC Fax (SMSI or InfoWAVE) | N/A | N/A |

*3 The parallel interface only works.

| Model | MFC9650 | FAX8750P |
|---|-----------------|-----------------------|
| Fax Forwarding | Yes | Yes |
| Fax Retrieval | Yes | Yes |
| Paging | N/A | N/A |
| Remote Access | N/A | N/A |
| MESSAGE CENTER Pro/MESSAGE MANAGER Pro | N/A | N/A |
| Fax & Voice Mail Box | N/A | N/A |
| Fax- & Voice-on-Demand | N/A | N/A |
| MESSAGE CENTER (PC MC) | N/A | N/A |
| Fax Forwarding | N/A | N/A |
| Paging | N/A | N/A |
| ICM Recording Time | N/A | N/A |
| OGM MC/MC Pro/Paging | N/A | N/A |
| Fax & Voice Mail Box | N/A | N/A |
| Fax- & Voice-on-Demand | N/A | N/A |
| VIDEO CAPTURE | N/A | N/A |
| Video Capture | N/A | N/A |
| Video Print | N/A | N/A |
| Video Format | N/A | N/A |
| BUNDLED SOFTWARE | | |
| For Windows | | |
| Printer Driver (Brother) | Yes (Wordcraft) | Available with option |
| Viewer (ScanSoft) | Yes (Wordcraft) | Available with option |
| TWAIN (Brother) | Yes (Brother) | Yes (Brother) |
| PC Fax (SMSI) ^{*3} | Yes (Brother) | Available with option |
| | | |
| For iMAC | | |
| Printer Driver (Brother) | N/A | N/A |
| Viewer (InfoWAVE) | N/A | N/A |
| TWAIN (TII) | N/A | N/A |
| PC Fax (SMSI or InfoWAVE) | N/A | N/A |

*3 The parallel interface only works.

CHAPTER II.

INSTALLATION

CHAPTER II. INSTALLATION

CONTENTS

- 1. INSTALLING THE UPDATE DATA TO THE FACSIMILE EQUIPMENT II-1**

1. INSTALLING THE UPDATE DATA TO THE FACSIMILE EQUIPMENT

If the program version is updated or the main PCB is replaced, install the update program onto the flash ROM of the main PCB.

The program installation requires a PC/AT-compatible computer (which is capable of running MS-DOS or its compatible OS).

Connecting the facsimile equipment to your computer

- (1) Make sure that the equipment's power cord is unplugged from a wall socket.
- (2) Make sure that your computer is powered off.
- (3) Connect the interface cable to the parallel interface port on the back of the equipment and secure it with the lock wires.
- (4) Connect the other end of the interface cable to the printer port of your computer and secure it with the two screws.
- (5) Power on your computer.
- (6) Plug the equipment's power cord into a wall socket.

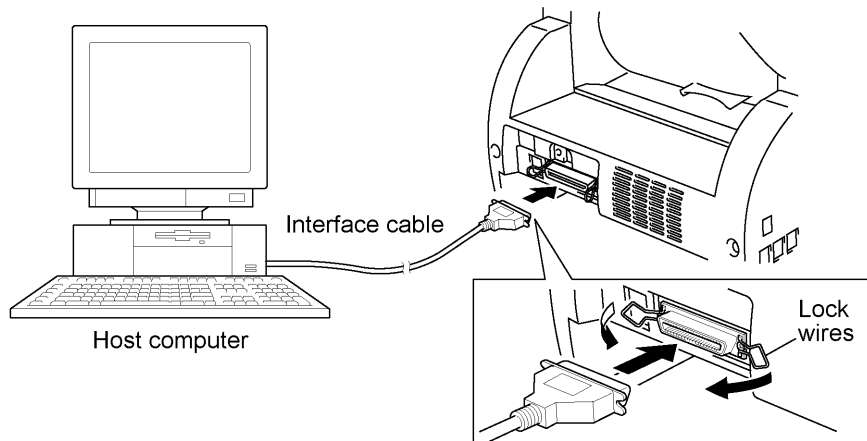

Installing the update data onto the flash ROM of the facsimile equipment

NOTE: The following is an installation procedure example on a PC that is running Windows 95/98.

- (1) Copy the update data and transfer utility onto the desired directory of the hard disk.
e.g., C:\UPDATE
- (2) Click the Start button, point to Programs, and then click MS-DOS Prompt to open an MS-DOS window.
- (3) Type the drive letter where the update data and transfer utility are located. In the above example, type C:\ from the command line and press the **ENTER** key.

Then type CD UPDATE and press the **ENTER** key.

- (4) Check that your computer is connected with the facsimile equipment correctly.
- (5) To start the transfer utility transmitting the update data to the flash ROM of the facsimile equipment, type the following:

```
ICEN filename /b
```

Then press the **ENTER** key.

During downloading, the equipment beeps *intermittently*.

Upon completion of the downloading, the equipment beeps *continuously*.

NOTE: If the facsimile equipment cannot return to the standby state after completion of downloading, turn the power off and on.

CHAPTER III.
THEORY OF OPERATION

CHAPTER III. THEORY OF OPERATION

CONTENTS

| | |
|---|---------------|
| 1. OVERVIEW..... | III-1 |
| 2. MECHANISMS..... | III-2 |
| 2.1 Scanner Mechanism..... | III-3 |
| 2.1.1 Document feeding and ejecting mechanism | III-3 |
| 2.1.2 Scanner | III-3 |
| 2.2 Laser Printing Mechanism | III-4 |
| 2.2.1 Paper pick-up and registration mechanism..... | III-4 |
| 2.2.2 Print process mechanism | III-5 |
| (1) Charging process..... | III-6 |
| (2) Exposing process | III-6 |
| (3) Developing process | III-7 |
| (4) Transferring process..... | III-7 |
| 2.2.3 Heat-fixing mechanism | III-8 |
| 2.2.4 Paper ejecting mechanism | III-9 |
| 2.3 Sensors and Actuators..... | III-10 |
| 3. CONTROL ELECTRONICS..... | III-12 |
| 3.1 Configuration..... | III-12 |
| 3.2 Main PCB..... | III-13 |
| 3.3 Engine PCB..... | III-15 |
| 3.4 NCU PCB..... | III-16 |
| 3.5 Control Panel PCB | III-19 |
| 3.6 Power Supply PCB..... | III-20 |
| [1] Low-voltage power supply PCB..... | III-20 |
| [2] High-voltage power supply PCB..... | III-21 |

1. OVERVIEW

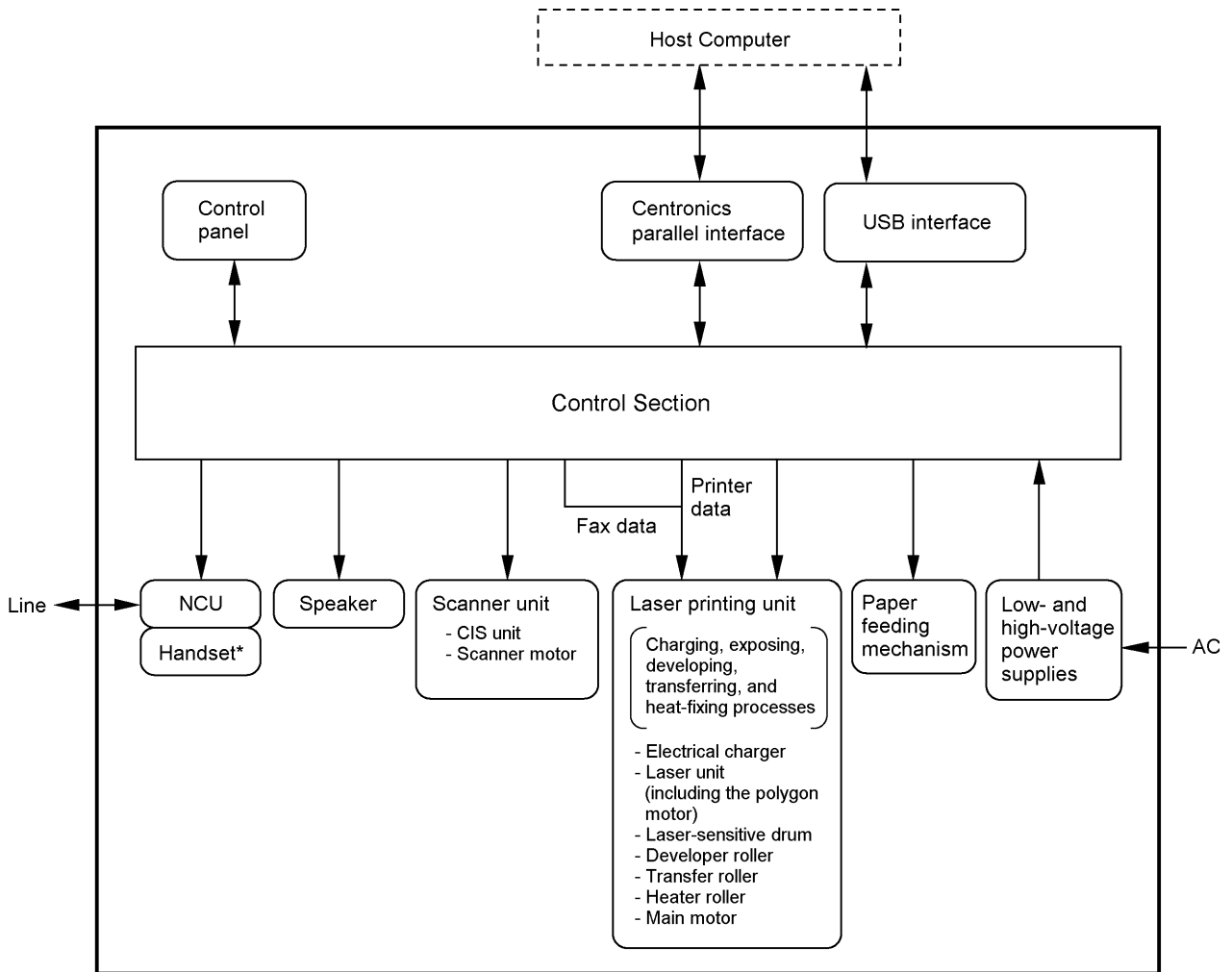

*Not provided on those models without handset.

2. MECHANISMS

The facsimile equipment is classified into the following mechanisms:

SCANNER MECHANISM

- Document feeding and ejecting mechanism
- Document scanning mechanism

LASER PRINTING MECHANISM

- Paper pick-up and registration mechanism
- Print process mechanism (consisting of charging, exposing, developing, and transferring processes) with paper feeding mechanism
- Heat-fixing mechanism with paper feeding mechanism
- Paper ejecting mechanism

SENSORS AND ACTUATORS

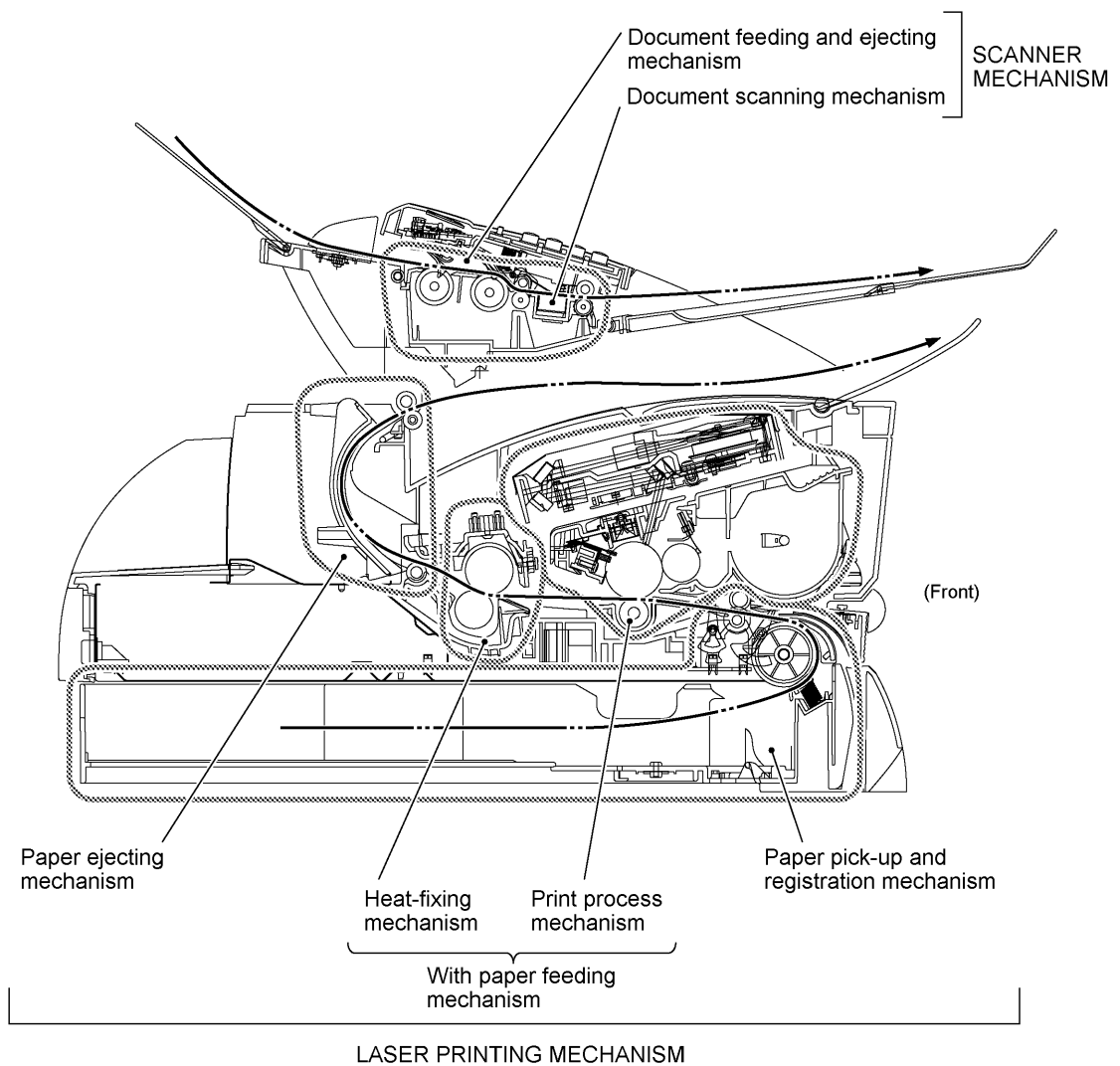

2.1 Scanner Mechanism

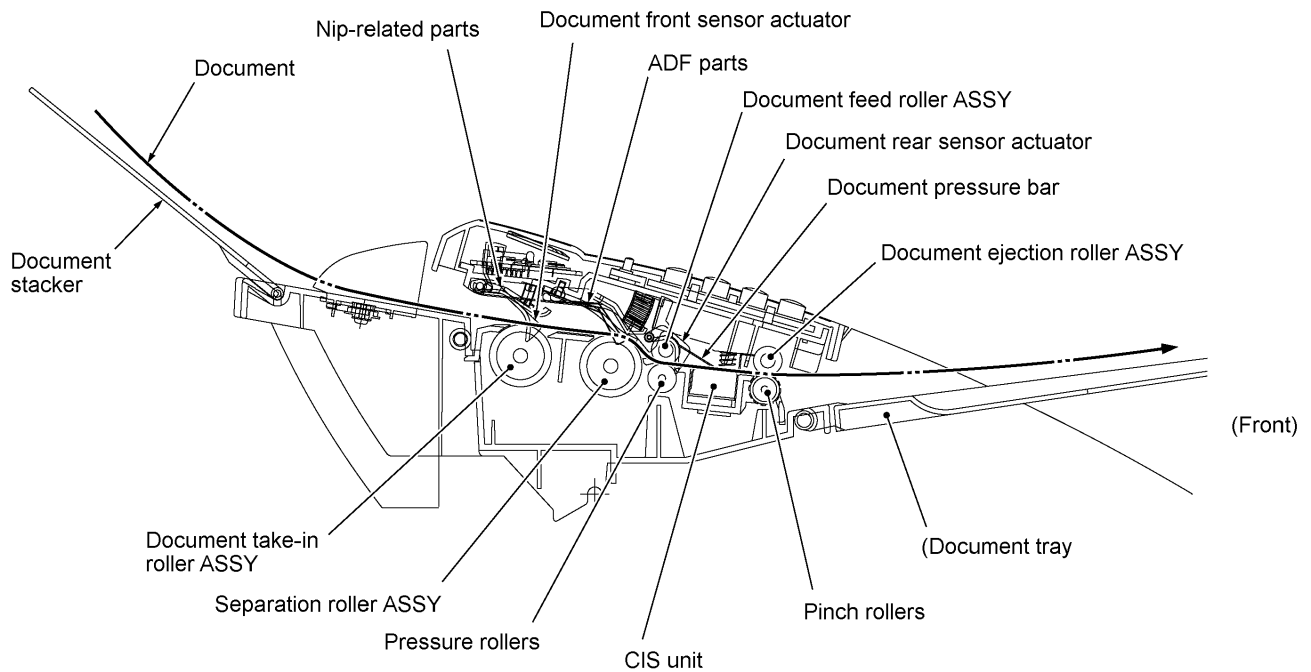

2.1.1 Document feeding and ejecting mechanism

This mechanism consists of the document stacker, automatic document feeder (ADF), document ejection roller ASSY, and document sensors. (For details about the sensors, refer to Section 2.3.)

If the operator sets documents on the document stacker and starts the scanning operation, the scanner motor rotates so that the ADF (which consists of the document take-in roller ASSY, nip-related parts, separation roller ASSY, and ADF parts) feeds those documents into the equipment, starting from the bottom sheet to the top, page by page. Each document advances with the document feed roller ASSY to the scanner, and then it is fed out of the equipment with the document ejection roller ASSY.

2.1.2 Scanner

The scanner uses a contact image sensor (CIS) unit which consists of an LED array illuminating documents, a self-focus lens array collecting the reflected light, a CIS PCB carrying out photoelectric conversion to output picture element data, and a cover glass on which a document advances. When the document passes between the document pressure bar and the cover glass, it is scanned.

2.2 Laser Printing Mechanism

2.2.1 Paper pick-up and registration mechanism

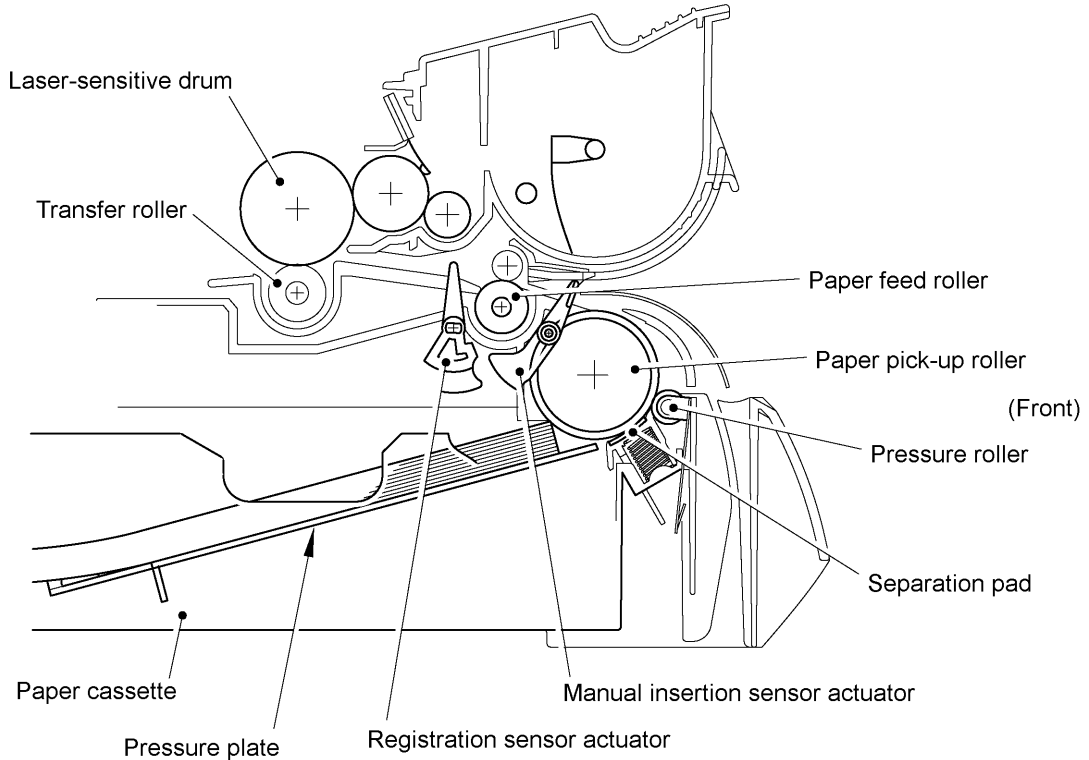

At the 1st stage, the controller drives the main motor without energizing the solenoid so that the paper feed roller simply idles.

At the 2nd stage, the controller energizes the solenoid so that the paper feed roller no longer rotates and the paper pick-up roller starts rotating to pick up paper into the equipment, a sheet at a time. After the leading edge of the pulled-in paper passes through the manual insertion sensor actuator, the paper is further fed for the specified time length. Accordingly, the leading edge will reach the paper feed roller where the paper skew will be eliminated.

At the 3rd stage, the controller deenergizes the solenoid to rotate the paper feed roller for feeding paper to the transfer block in the drum unit.

When the leading and trailing edges of the paper pass through the registration sensor actuator, the sensor signals them to the controller. According to those signals, the controller may determine the first print position on the paper.

2.2.2 Print process mechanism

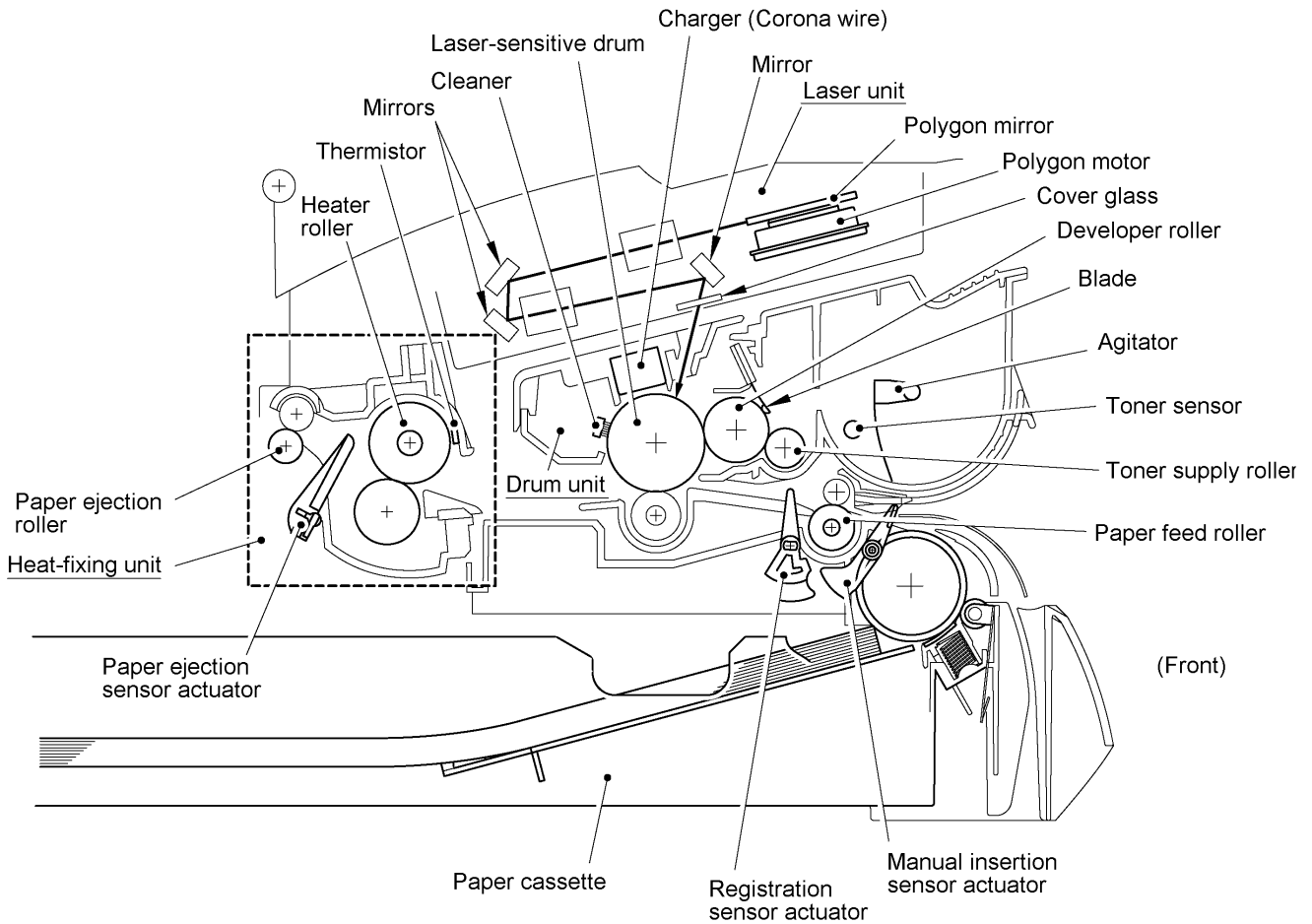

The print process unit works with laser beam, electrical charges, and toner. The graph below shows the transition of electrical charge on the surface of the laser-sensitive drum through the four processes: charging, exposing, and transferring processes.

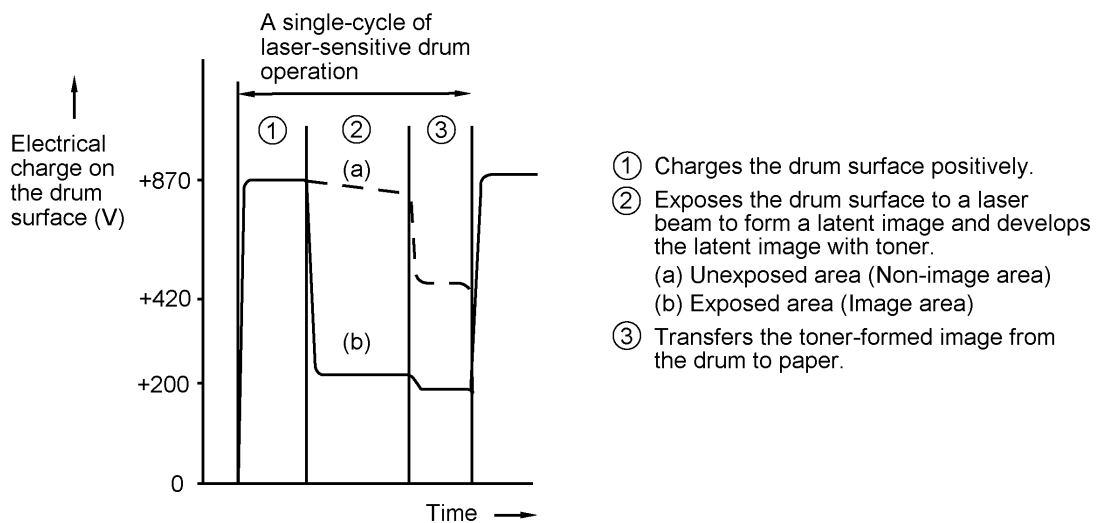

(1) Charging process

The high-voltage power supply applies DC bias to the corona wire to generate ion on the grid. The ion uniformly charges the surface of the laser-sensitive drum to approx. 870V which is kept by the voltage regulator grounding the grid to the frame.

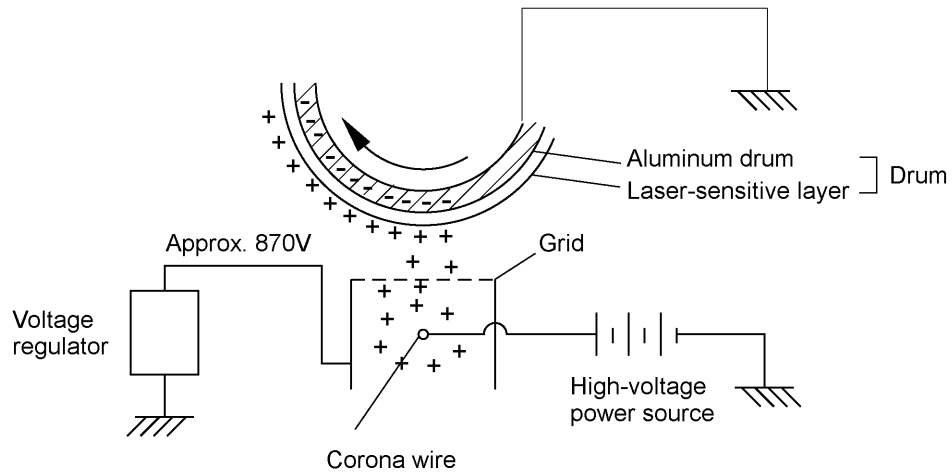

(2) Exposing process

When the laser-sensitive drum holds a positive electrical charge, the laser beam issued from the laser unit scans the drum according to the print image to expose the drum surface for neutralizing the spots where black should be, forming an electrostatic latent image.

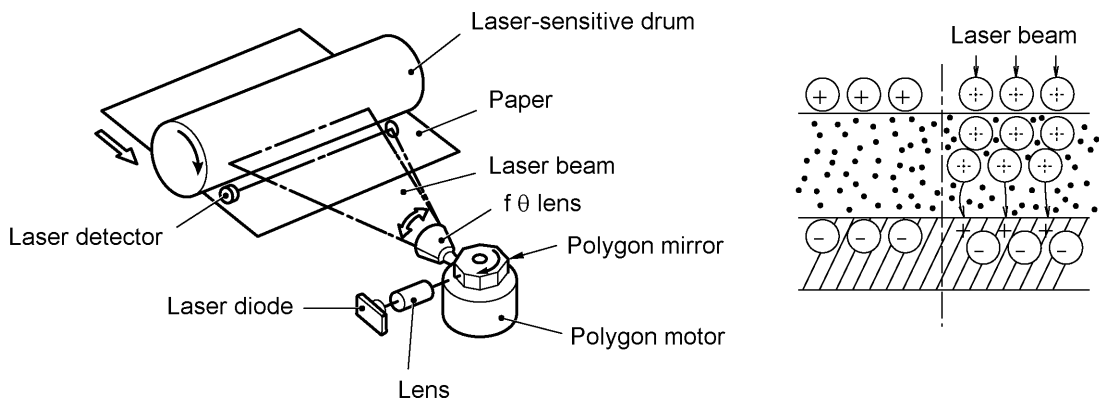

(3) Developing process

The developing process develops an electrostatic latent image formed on the drum in the exposing process, into a toner image.

The developer roller attracts the toner particles fed from the toner cartridge by the toner supply roller, and then conveys them to the contact section with the laser-sensitive drum

On the contact section between the developer roller and drum, the positive toner particles stick to the neutralized spots on the drum according to the principles of attraction and repulsion, transforming a latent image into a toner image.

The agitator (which agitate toner particles in the chamber) and the blade allow toner particles to be fed onto the developer roller at an even thickness.

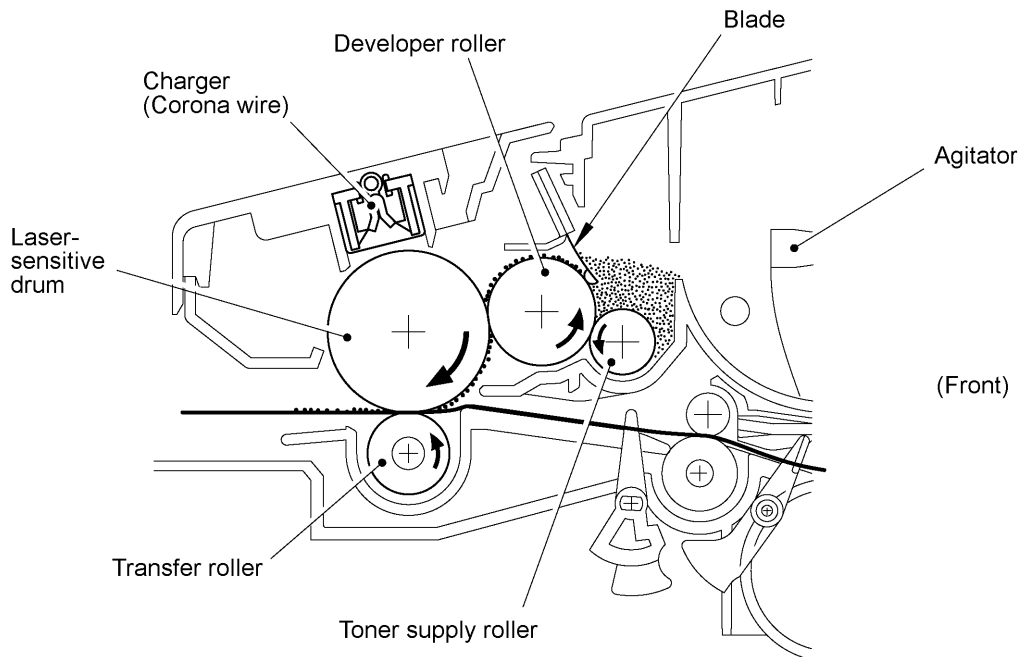

(4) Transferring process

When a paper passes between the drum and the transfer roller, the controller negatively charges the transfer roller. The toner is positive, so the toner image formed on the drum will be transferred onto the paper according to the same principle as for the developing process.

Cleaning the transfer roller

In the transferring process, the transfer roller may be contaminated with toner since not all the toner particles on the drum are transferred onto the paper but some toner particles will remain on the drum and will be transferred from the drum to the transfer roller. If paper jam or other errors occur, the toner image fails to stick to the paper and will stick to the transfer roller.

To repulse this toner, the controller positively charges the transfer roller. The toner returns from the transfer roller to the drum. During non-printing rotation of the drum, the toner particles on the drum will be returned to the chamber through the developer roller.

2.2.3 Heat-fixing mechanism

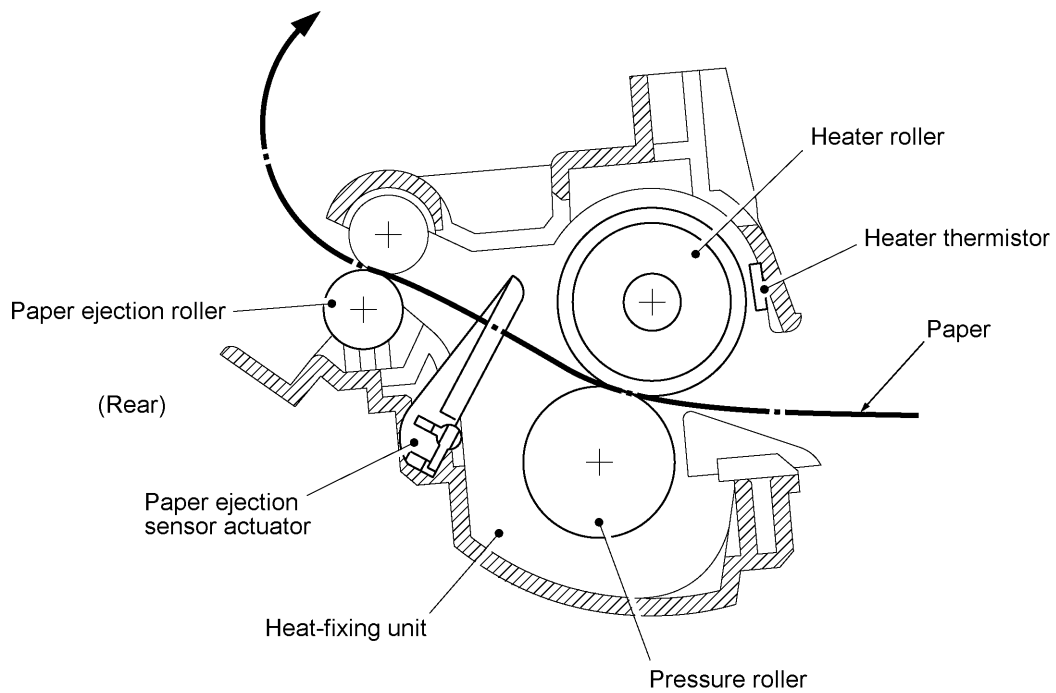

As the paper passes between the heater roller and the pressure roller in the heat-fixing unit, the heater roller fuses the toner on the paper.

The controller monitors the internal resistance of the heater thermistor to keep the surface temperature of the heater roller constant by turning the halogen heater lamp on and off.

2.2.4 Paper ejecting mechanism

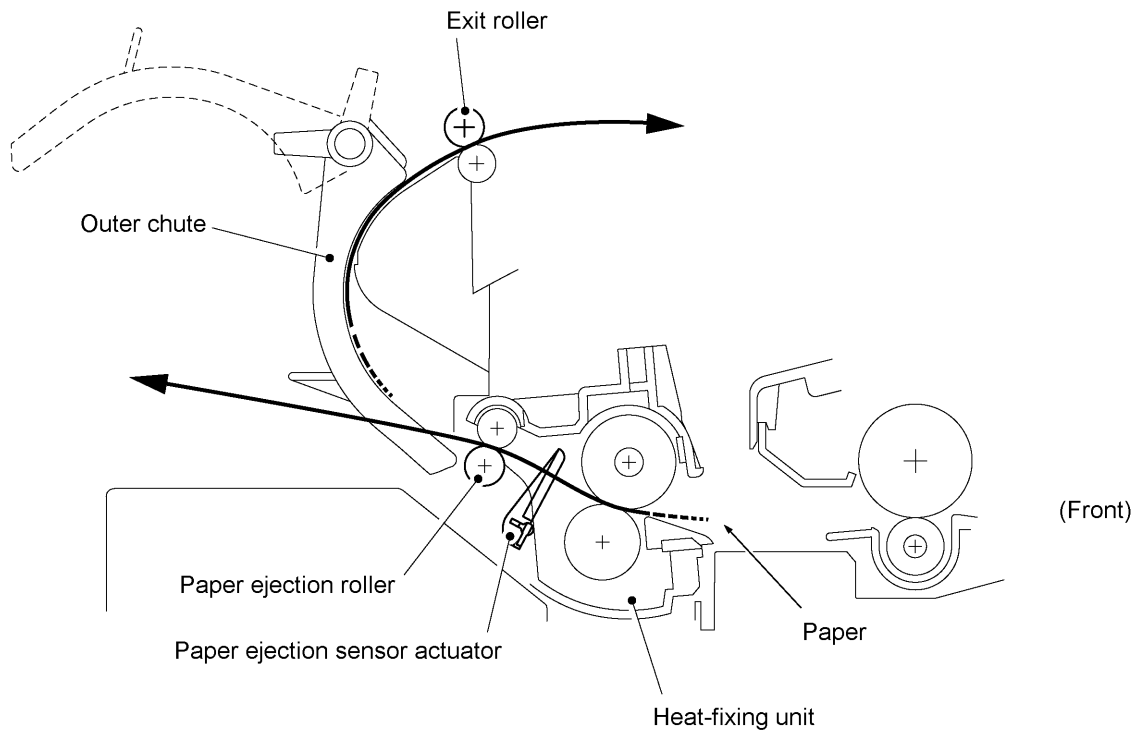

After the paper passes through the heat-fixing process, it will be ejected from the heat-fixing unit by the paper ejection roller.

If the leading edge of the paper pushes up the actuator of the paper ejection sensor, the sensor signals the start of paper ejection. If the trailing edge has passed through the sensor actuator, the sensor signals the completion of paper ejection.

The paper will be turned over along the outer chute and ejected onto the main cover by the exit roller.

2.3 Sensors and Actuators

This equipment has eleven sensors: eight photosensors, two thermistors and a mechanical switch as described below.

| Sensor name | Type | Located on |
|------------------------------|-------------------|--|
| Document front sensor | Photosensor | Control panel PCB |
| Document rear sensor | Photosensor | Document sensor PCB |
| Manual insertion sensor | Photosensor | Engine PCB |
| Registration sensor | Photosensor | Engine PCB |
| Cassette sensor | Photosensor | Engine PCB |
| Paper ejection sensor | Photosensor | Paper ejection sensor PCB |
| Toner sensor | Photosensor | Toner sensor (LED) PCB and toner sensor (light-receiver) PCB |
| Cover sensor | Photosensor | Toner sensor (LED) PCB |
| Heater thermistor | Thermistor | Heat-fixing unit |
| In-casing temperature sensor | Thermistor | Left-hand plate of the main chassis |
| Hook switch* | Mechanical switch | Hook switch PCB* |

*For models equipped with a handset

- Document front sensor which detects the presence of documents.
- Document rear sensor which detects the leading and trailing edges of pages to tell the control circuitry when the leading edge of a new page has reached the starting position and when the scan for that page is over.
- Manual insertion sensor which detects whether paper is inserted manually through the paper slot or whether paper fed through the paper cassette has jammed.
- Registration sensor which detects the leading and trailing edges of recording paper, which allows the controller to determine the registration timing and check paper jam.
- Cassette sensor which detects whether the paper cassette is loaded.
- Paper ejection sensor which detects whether the recording paper goes out of the equipment.
- Toner sensor which detects whether there is toner or a toner cartridge is loaded.
- Cover sensor which detects whether the front cover is closed.
- Heater thermistor which allows the controller to monitor the temperature of the heater roller of the fixing unit.
- In-casing temperature sensor which allows the controller to monitor the temperature inside the equipment.
- Hook switch* which detects whether the handset is placed on the handset mount*.

The above photosensors are a photo-interrupter consisting of a light-emitting diode and a light-sensitive transistor. Each of them has an actuator separately arranged as shown on the next page.

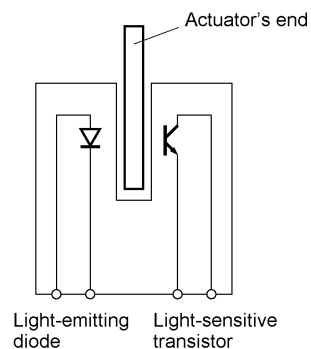

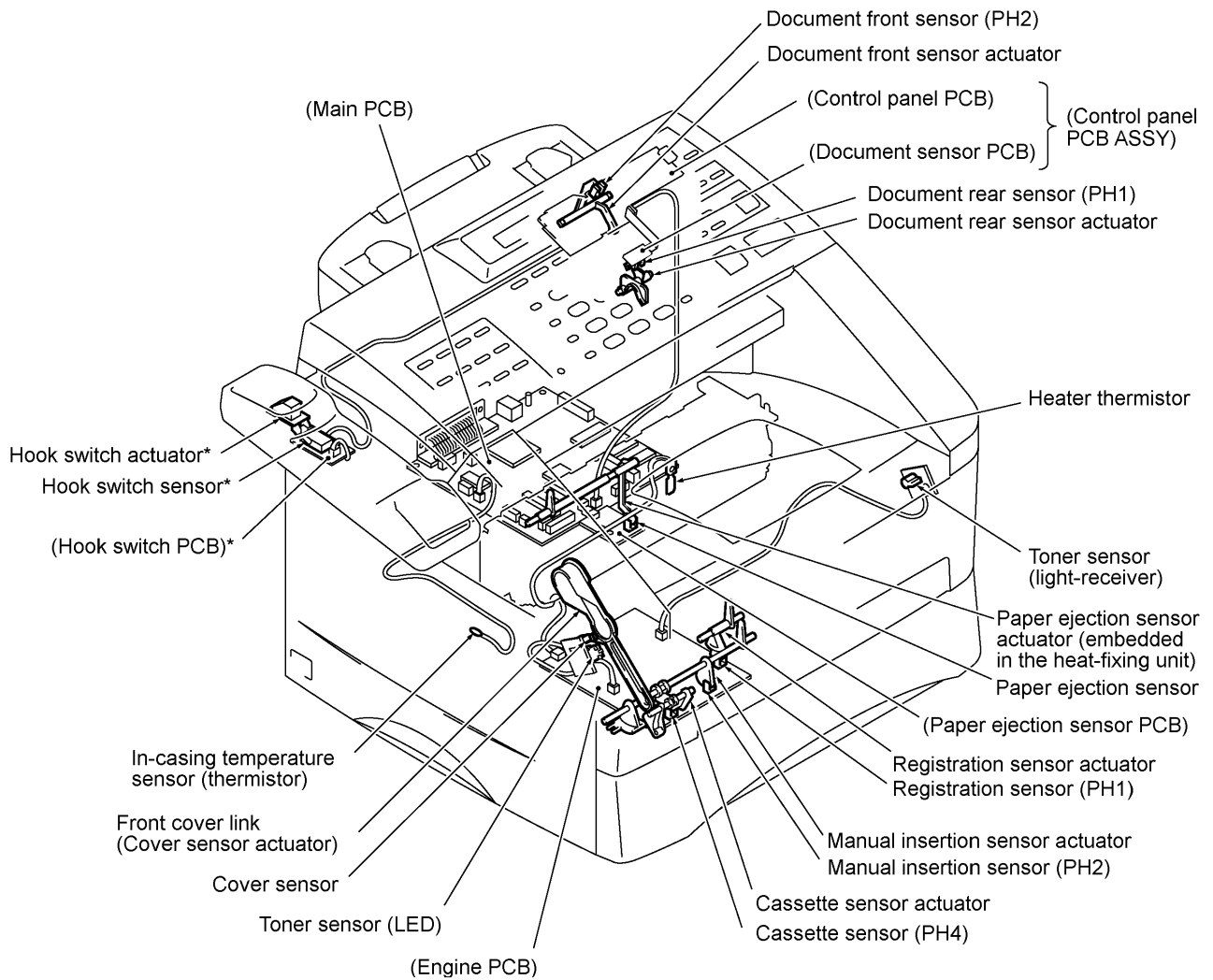

* Provided on models equipped with a handset.

Location of Sensors and Actuators

3. CONTROL ELECTRONICS

3.1 Configuration

The hardware configuration of the facsimile equipment is shown below.

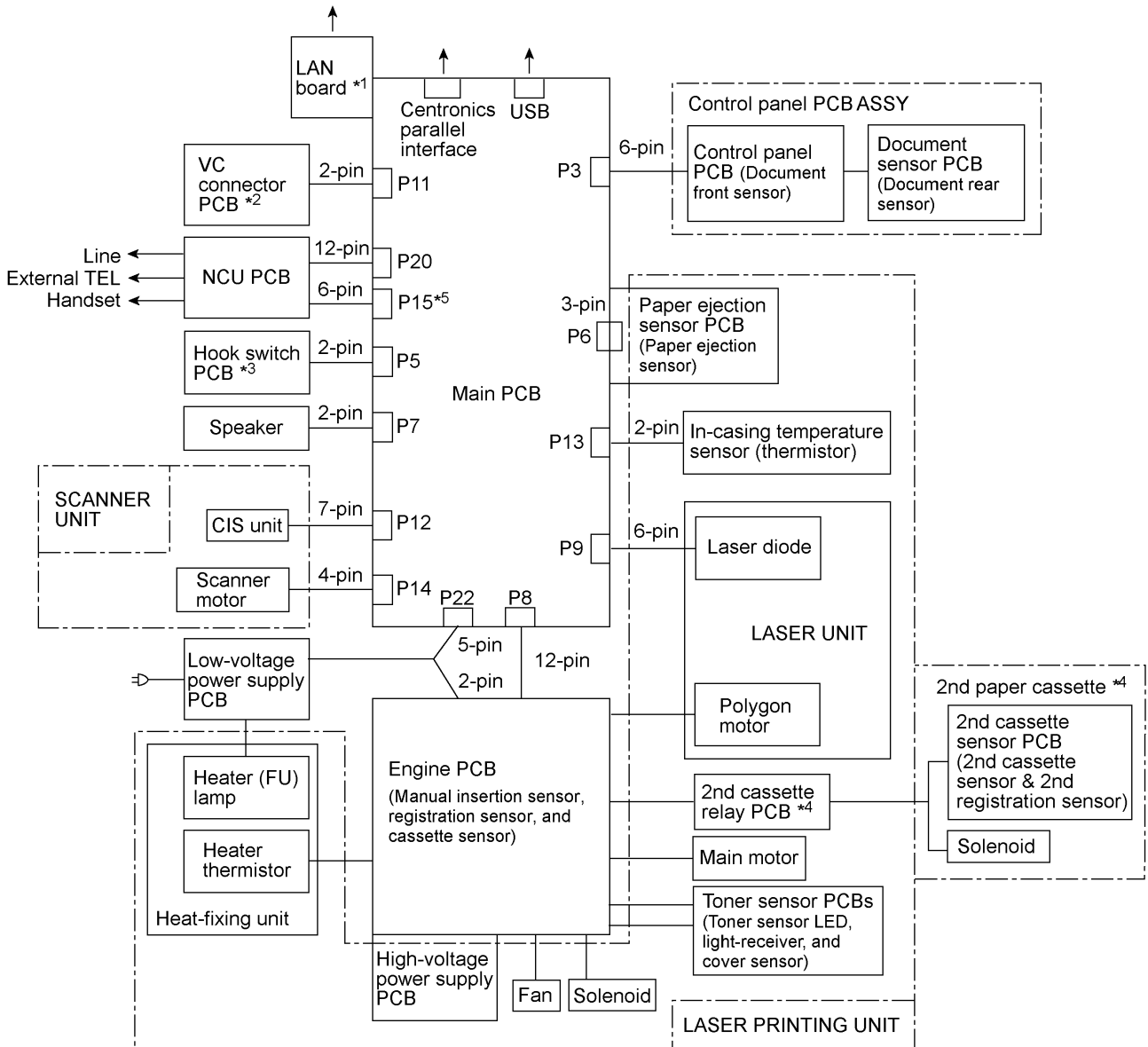

- *1 Provided on models supporting LAN interface.
- *2 Provided on models supporting video capture.
- *3 Provided on models equipped with a handset.
- *4 Provided on models available with a 2nd paper cassette (as an option or standard).
- *5 Provided on European models.

Configuration of Facsimile Equipment

3.2 Main PCB

The main PCB, which is the nucleus controlling the entire operation of the equipment, consists of a FAX engine (ASIC), memories, MODEM, motor drive circuitry, sensor detection circuitry, and analog circuits for scanning, printing, and power transmission shifting.

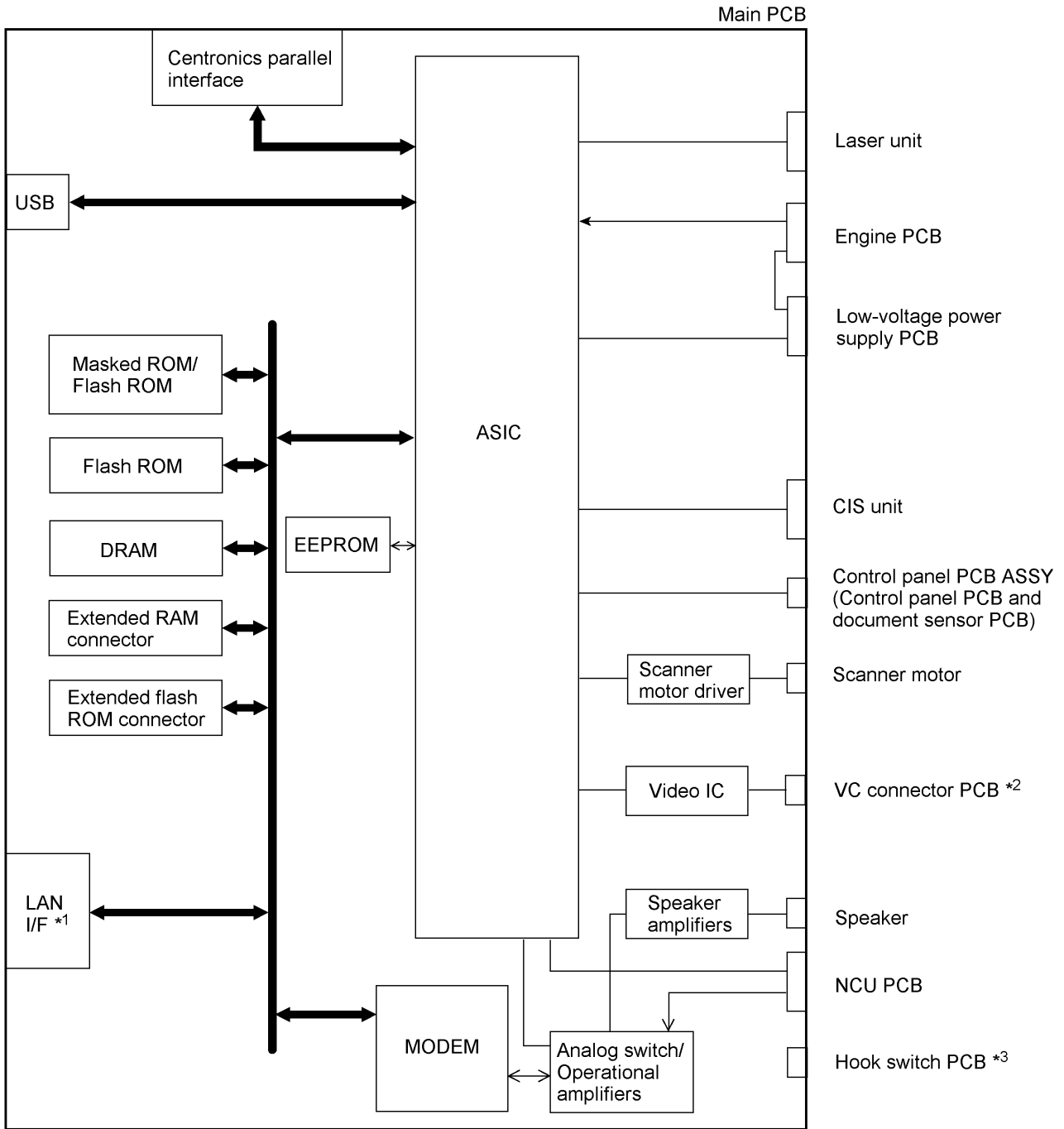

EEPROM: Electrically Erasable Programmable Read-only Memory
 DRAM: Dynamic Random Access Memory

- *1 Provided on models supporting LAN interface.
- *2 Provided on models supporting video capture.
- *3 Provided on models equipped with a handset.

Block Diagram of Main PCB

Main PCB

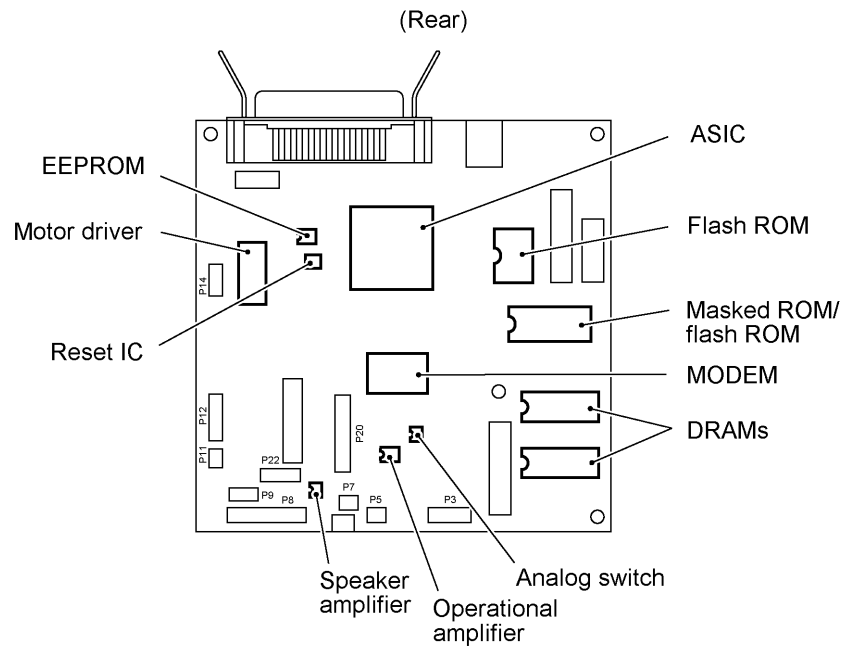

3.3 Engine PCB

On the engine PCB is a gate array which converts serial signals sent from the main PCB into parallel signals. According to those signals, the engine PCB controls the following:

- Motors--main motor, fan motor, and polygon motor
- High-voltage power supply
- Solenoid(s)
- Heater
- Heater thermistor
- Sensors--cover sensor, toner sensor, manual insertion sensor, registration sensor(s), and cassette sensor(s)

3.4 NCU PCB

The NCU PCB switches the communications line to telephone or built-in MODEM, under the control of the main PCB.

US versions

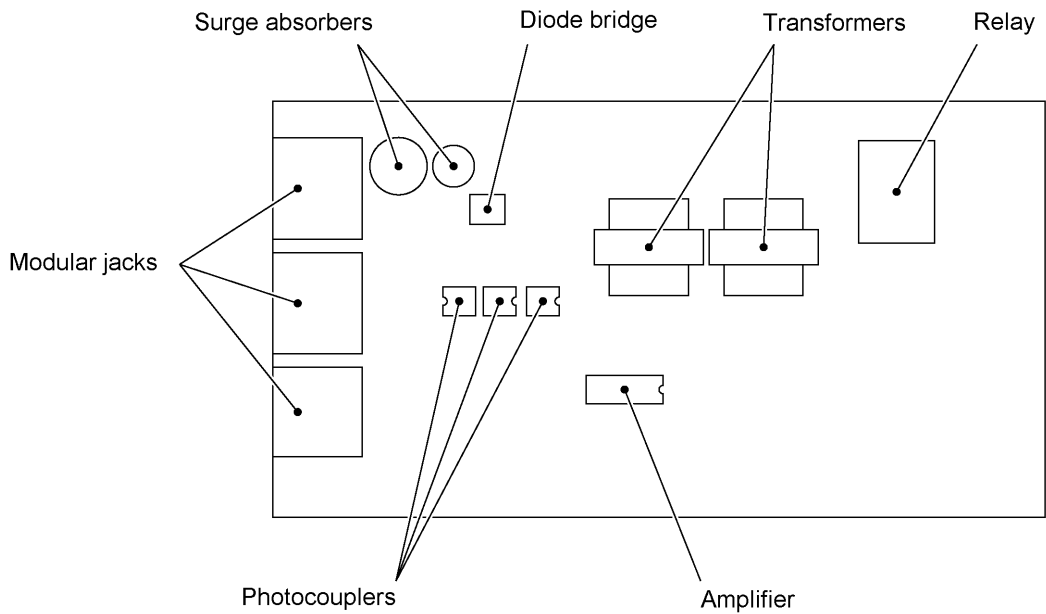
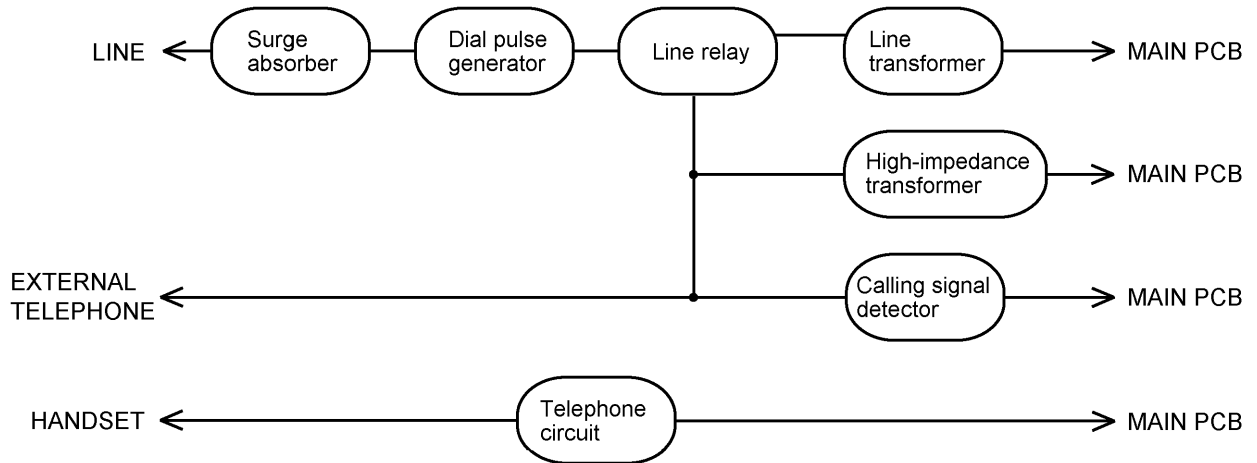

European versions

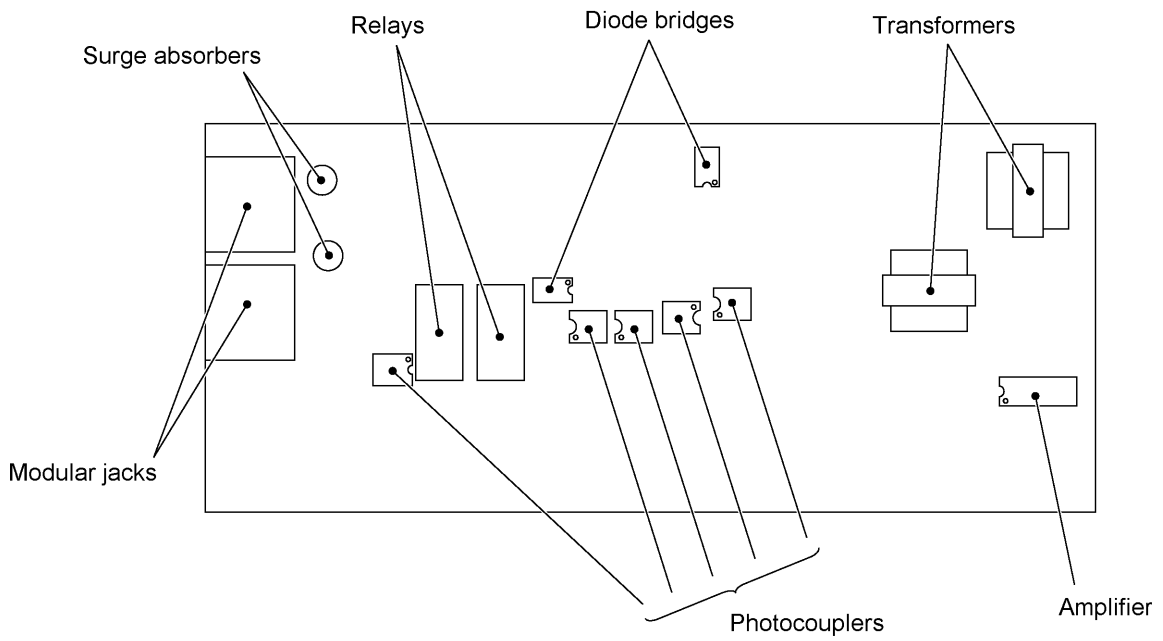
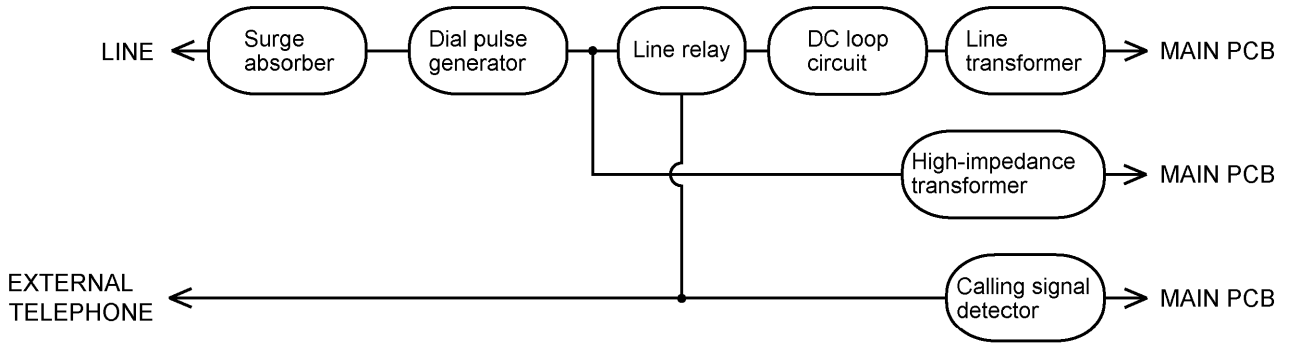

Asian/Oceanian versions

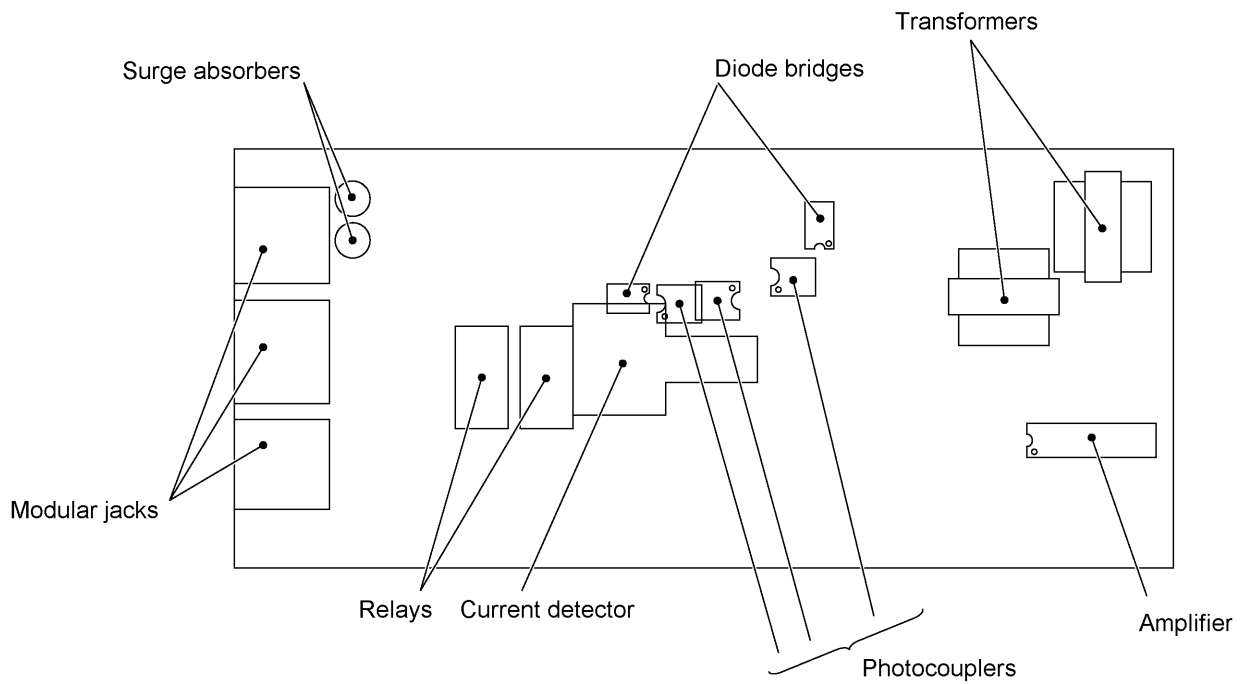
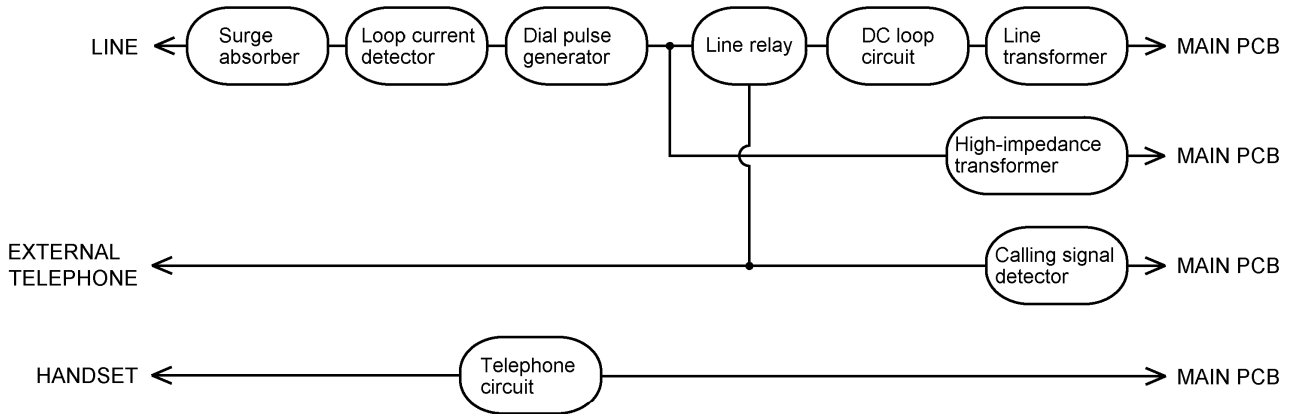

3.5 Control Panel PCB

The control panel PCB and the main PCB communicate with each other by serially transmitting commands and data.

The control panel unit consists of a gate array, an LCD and LEDs, which are controlled by the gate array according to commands issued from the FAX engine on the main PCB.

The panel FPC is a flexible keyboard PCB which integrates the key matrix having rubber keytops.

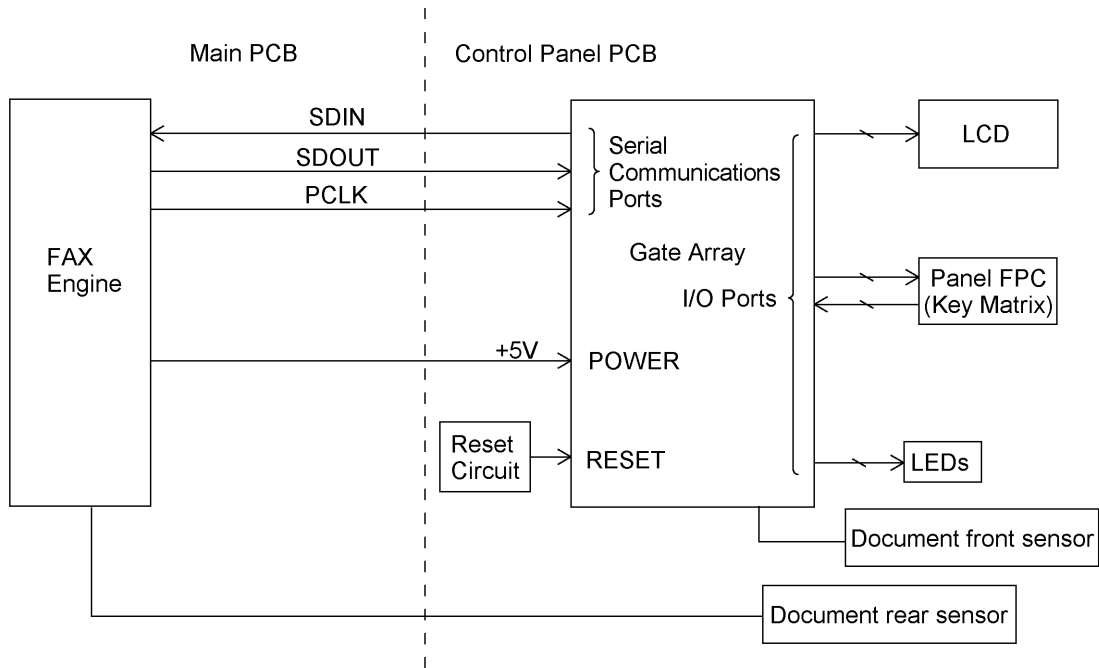

Control Panel PCB and its Related Circuit

3.6 Power Supply PCB

[1] Low-voltage power supply PCB

The low-voltage power supply uses the switching regulation system to generate DC power (+5V and +24V) from a commercial AC power supply for the driver circuits. The +5V source is fed to the logic, control panel, sensors, CIS unit, etc. The 24V source is fed to the motors, solenoid, fan, and high-voltage power supply PCB.

The low-voltage power supply also feeds AC power to the heater of the heat-fixing unit.

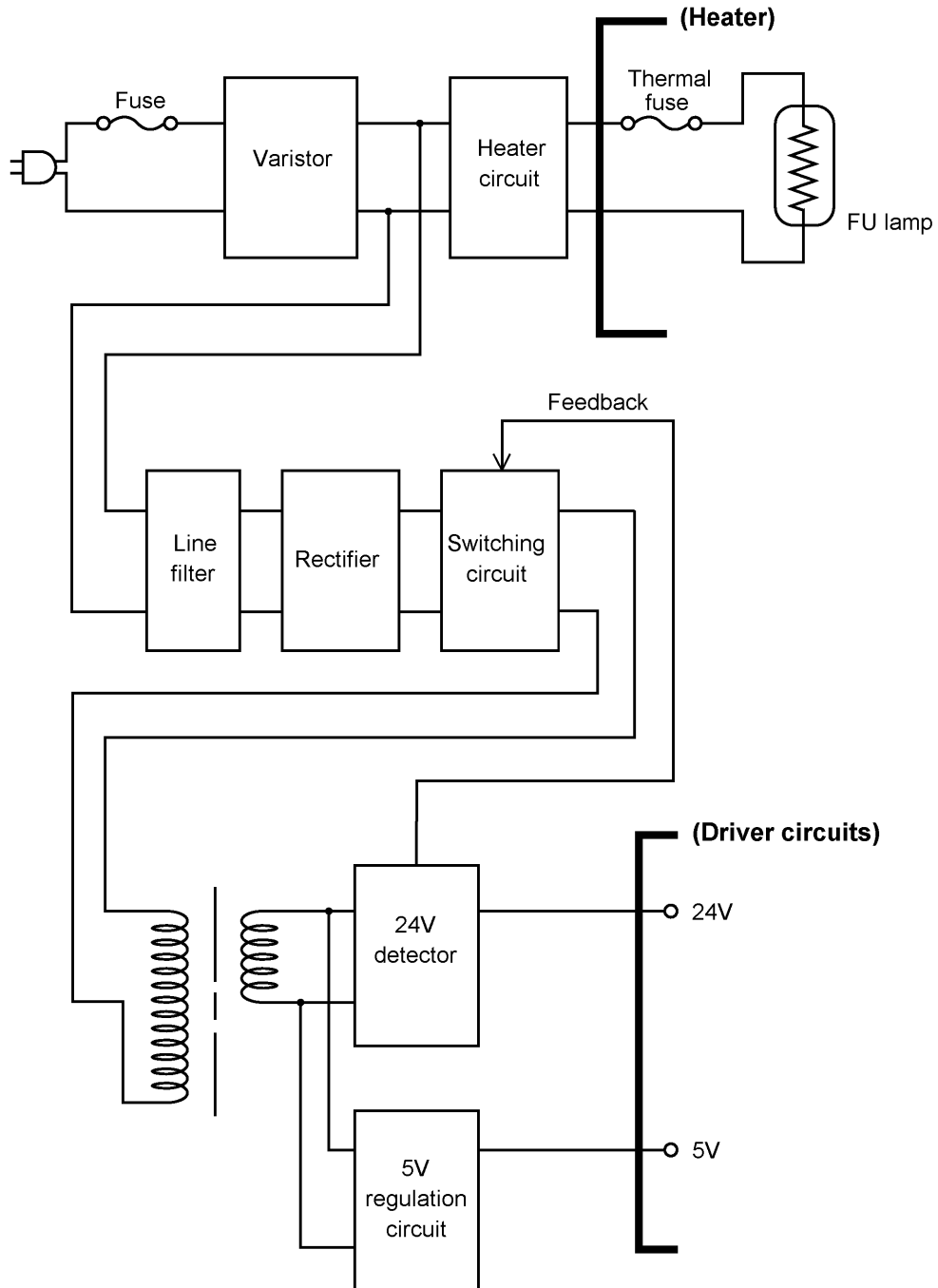

Low-voltage Power Supply Circuit

[2] High-voltage power supply PCB

This power supply generates high-voltage power sources from the 24V source fed from the low-voltage power supply for charging, developing, and transferring in the laser printing process.

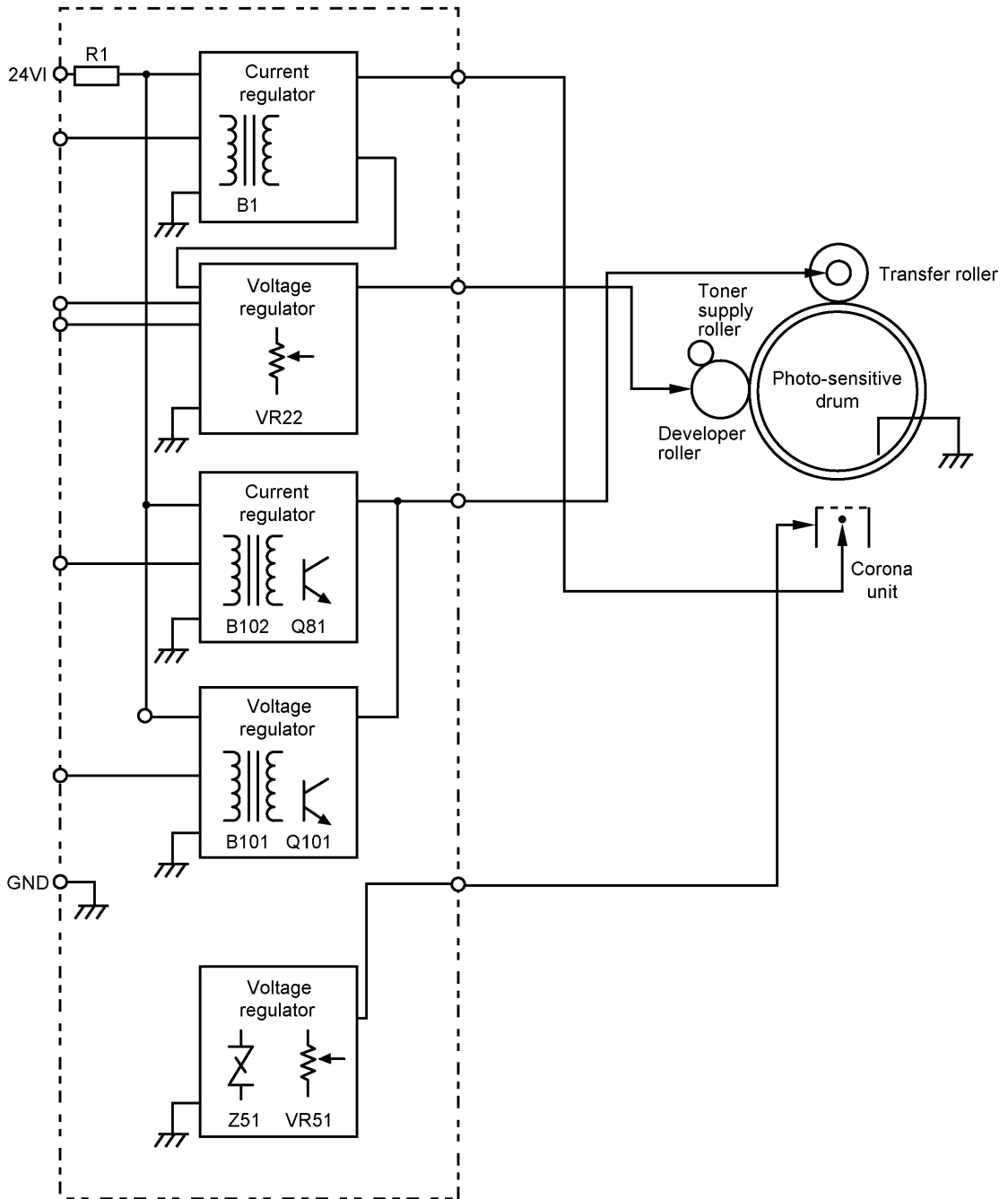

High-voltage Power Supply Circuit

CHAPTER IV.
DISASSEMBLY/REASSEMBLY AND
LUBRICATION

CHAPTER IV. DISASSEMBLY/REASSEMBLY AND LUBRICATION

CONTENTS

| | |
|---|-------------|
| 1. DISASSEMBLY/REASSEMBLY | IV-1 |
| Safety Precautions..... | IV-1 |
| Preparation..... | IV-2 |
| How to Access the Object Component | IV-2 |
| Disassembly Order Flow | IV-3 |
| 1.1 Rear Cover..... | IV-4 |
| 1.2 Access Plates R and F | IV-4 |
| 1.3 Control Panel ASSY | IV-5 |
| 1.4 Panel Rear Cover and Control Panel..... | IV-6 |
| 1.5 Document Feed Roller ASSY, Document Ejection Roller ASSY, and Pinch Rollers | IV-9 |
| 1.6 CIS Unit | IV-10 |
| 1.7 Scanner Frame ASSY (Scanner Motor, Scanner Drive Unit, Document Take-in Roller, Separation Roller, Pressure Rollers, and Control Panel Locks) | IV-11 |
| 1.8 Top Cover (Exit Roller, Speaker, and Document Guides)..... | IV-15 |
| 1.9 Handset Mount and Hook Switch PCB (for models equipped with a handset) Side Cover (for models without handset)..... | IV-21 |
| 1.10 Paper Sub Tray | IV-23 |
| 1.11 VC Cover, VC Bracket, and VC Connector PCB (for models supporting video capture)..... | IV-24 |
| 1.12 Front Cover Front Sub Cover (for models not supporting video capture)..... | IV-25 |
| 1.13 Outer Chute and Paper Pinch Rollers..... | IV-26 |
| 1.14 Main Cover..... | IV-27 |
| 1.15 Switch Cover..... | IV-28 |
| 1.16 Laser Unit..... | IV-29 |
| 1.17 Heat-fixing Unit and FU Lamp | IV-30 |
| 1.18 Fan..... | IV-34 |
| 1.19 Drive Gear ASSY and Main Motor ASSY..... | IV-36 |
| 1.20 NCU Shield and NCU PCB..... | IV-38 |
| 1.21 Bottom Plate, Main PCB and Bottom Insulation Film | IV-40 |
| 1.22 Low-voltage Power Supply PCB and Power Inlet..... | IV-44 |
| 1.23 Inner Insulation Film, High-voltage Power Supply PCB, Engine PCB, and 2nd Cassette Relay PCB* | IV-46 |

| | | |
|-----------|--|--------------|
| 1.24 | Toner Sensor (light-receiver) PCB and Toner Sensor (LED) PCB..... | IV-48 |
| 1.25 | Gears and Paper Pick-up Roller | IV-49 |
| 1.26 | Paper Feed Roller ASSY | IV-50 |
| 1.27 | Clutch Levers, Cassette Guide L, and Solenoid | IV-51 |
| 1.28 | Paper Cassette..... | IV-52 |
| 1.29 | Cleaning of High-voltage Contacts and Grounding Contacts..... | IV-53 |
| 2. | LUBRICATION | IV-55 |
| [1] | Document feed roller ASSY and document ejection roller ASSY..... | IV-55 |
| [2] | Control panel locks | IV-56 |
| [3] | Scanner frame ASSY, document take-in roller and its shaft, and separation roller and its shaft..... | IV-56 |
| [4] | Top cover | IV-57 |
| [5] | Drive gear ASSY | IV-58 |
| [6] | Paper cassette..... | IV-59 |

1. DISASSEMBLY/REASSEMBLY

Safety Precautions

To prevent the creation of secondary problems by mishandling, observe the following precautions during maintenance work.

- (1) Unplug the power cord from the power outlet before accessing parts or units inside the machine. When having access to the power supply, be sure to unplug the power cord from the power outlet.
- (2) When servicing the optical system of the laser printing unit, be careful not to place screwdrivers or other reflective objects in the path of the laser beam. Be sure to take off any personal accessories such as wrist watches and rings before working on the printer. A reflected beam, though invisible, can permanently damage your eyes.
- (3) If the equipment has been printing, allow the heat-fixing unit (inside this unit is a red-colored heater roller) sufficient time to cool down before starting maintenance jobs. It is HOT!
- (4) Be careful not to lose screws, washers, or other parts removed for parts replacement.
- (5) Do not remove gears from the document feed roller ASSY or document ejection roller ASSY if at all possible. Once removed, they will become unusable and new gears will have to be put back in.
- (6) When using soldering irons and other heat-generating tools, take care not to damage the resin parts such as wires, PCBs, and covers.
- (7) Before handling the PCBs, touch a metal portion of the equipment to discharge static electricity; otherwise, the electronic parts may be damaged due to the electricity charged in your body.
- (8) When transporting PCBs, be sure to wrap them in conductive sheets such as aluminum foil.
- (9) Be sure to reinsert self-tapping screws correctly, if removed. Unless otherwise specified, tighten screws to the following torque values:

| | |
|---------------------------|-------------|
| Taptite, bind B and cup B | M3: 0.7 N•m |
| | M4: 0.8 N•m |
| Taptite, cup S | M3: 0.8 N•m |
| Other screws | M3: 0.7 N•m |
| | M4: 0.8 N•m |

- (10) When connecting or disconnecting cable connectors, hold the connector bodies not the cables. If the connector has a lock, always slide the connector lock to unlock it.
- (11) Before reassembly, apply the specified lubricant to the specified points. (Refer to Section 2 in this chapter.)
- (12) After repairs, check not only the repaired portion but also that the connectors and other related portions function properly before operation checks.

Preparation

Prior to proceeding to the disassembly procedure,

(1) Unplug

- the power cord,
- the modular jack of the telephone line,
- the modular jack of the curled cord (and remove the handset)*,
- the PC interface cable, and
- the modular jack of an external telephone set if connected. (Not shown below.)

(2) Remove

- the document support,
- the document tray,
- the paper cassette, and
- the drum unit (with toner cartridge loaded)

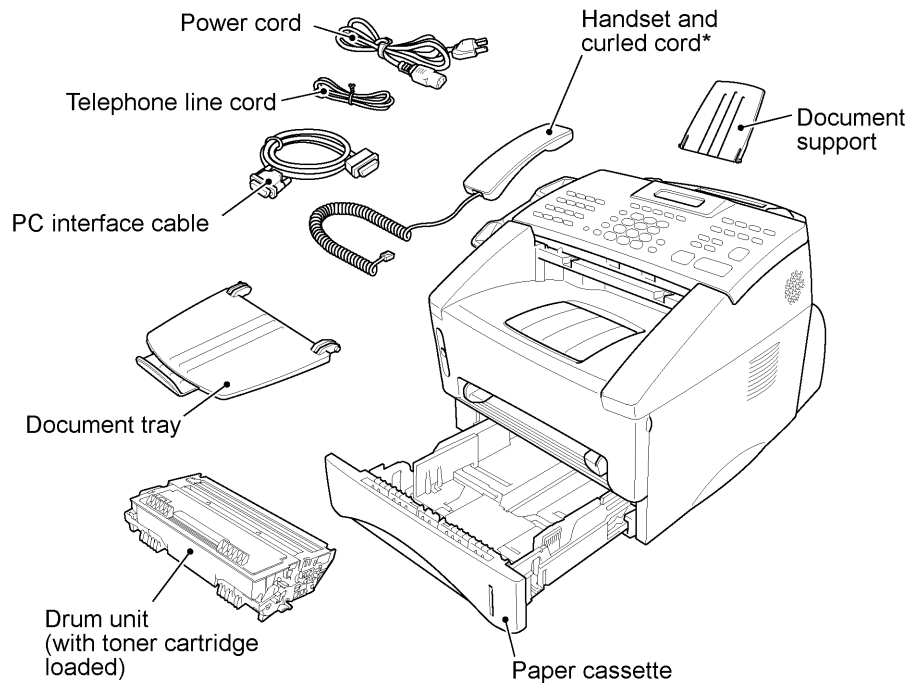

(*For those models equipped with handset.)

How to Access the Object Component

- On the next page is a disassembly order flow which helps you access the object components. To remove the heat-fixing unit, for example, first find it on the flow and learn its number (1.17 in this case). You need to remove parts numbered (1.3), (1.7), (1.8), (1.11), (1.12), and (1.14) so as to access the heat-fixing unit.
- Unless otherwise specified, the disassembled parts or components should be reassembled in the reverse order of removal.

Disassembly Order Flow

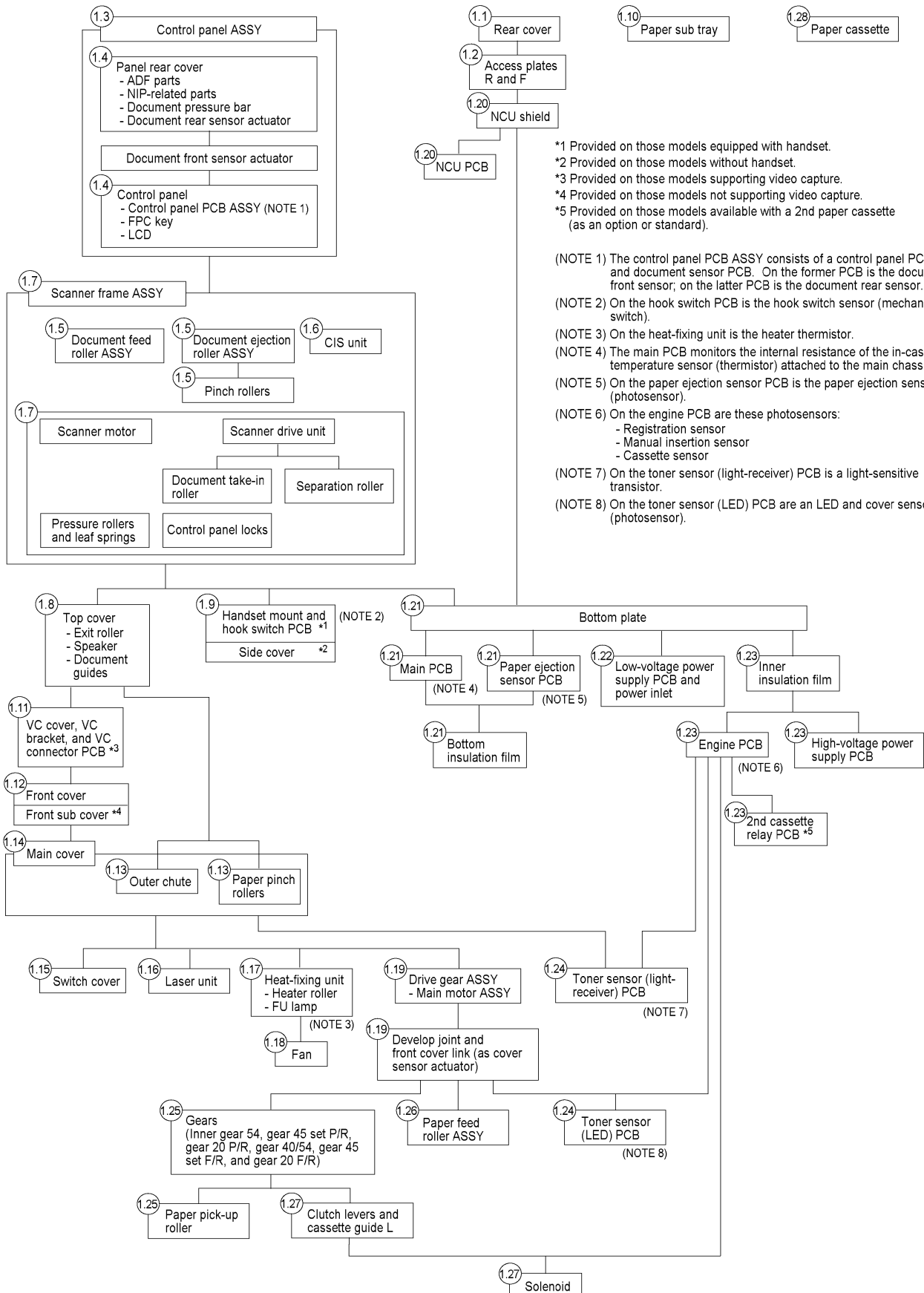

- *1 Provided on those models equipped with handset.
- *2 Provided on those models without handset.
- *3 Provided on those models supporting video capture.
- *4 Provided on those models not supporting video capture.
- *5 Provided on those models available with a 2nd paper cassette (as an option or standard).

- (NOTE 1) The control panel PCB ASSY consists of a control panel PCB and document sensor PCB. On the former PCB is the document front sensor; on the latter PCB is the document rear sensor.
- (NOTE 2) On the hook switch PCB is the hook switch sensor (mechanical switch).
- (NOTE 3) On the heat-fixing unit is the heater thermistor.
- (NOTE 4) The main PCB monitors the internal resistance of the in-casing temperature sensor (thermistor) attached to the main chassis.
- (NOTE 5) On the paper ejection sensor PCB is the paper ejection sensor (photosensor).
- (NOTE 6) On the engine PCB are these photosensors:
 - Registration sensor
 - Manual insertion sensor
 - Cassette sensor
- (NOTE 7) On the toner sensor (light-receiver) PCB is a light-sensitive transistor.
- (NOTE 8) On the toner sensor (LED) PCB are an LED and cover sensor (photosensor).

1.1 Rear Cover

- (1) FAX8350P and FAX8750P: Remove the sub rear cover.
- (2) Remove the three screws (two "a" and one "b") from the rear cover. Screw "b" is provided on those models available with a 2nd paper cassette (as an option or standard).
- (3) Lightly pressing sections "X," pull out the rear cover.

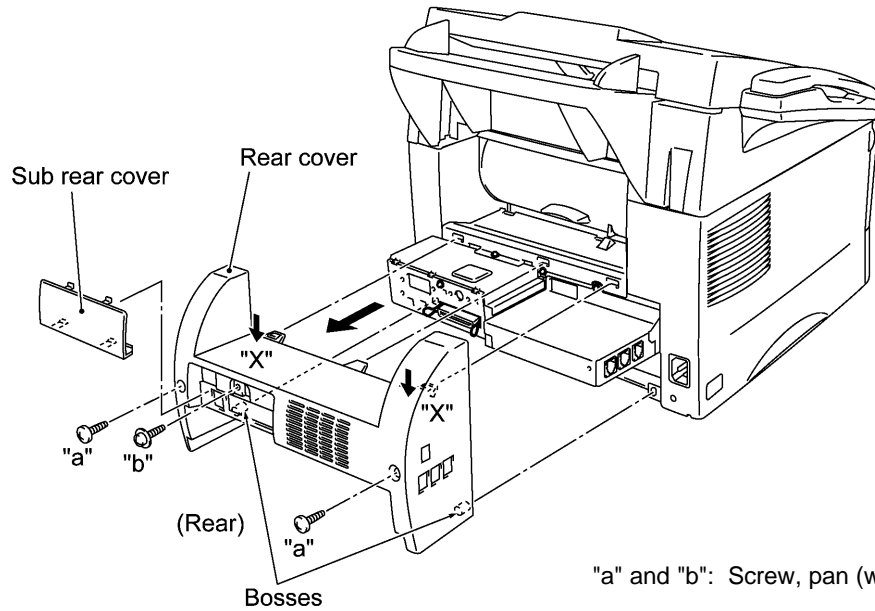

1.2 Access Plates R and F

- (1) Remove screw "c" that secures access plates R and F together to the main chassis.
- (2) Remove screws "d" and "e" from access plate R.
- (3) Take out access plates R and F together.
- (4) Remove screw "f" to separate those access plates.

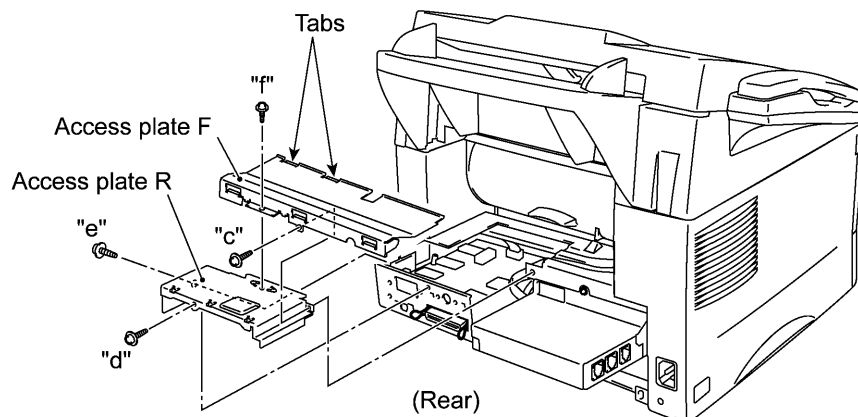

Reassembling Notes

- When reinstalling access plate F, fit the two tabs provided on the front end underneath the center edge of the main chassis.

1.3 Control Panel ASSY

- (1) Slightly open the control panel ASSY.
- (2) Push the right and left arms of the control panel ASSY outwards (in the direction of arrow) with your thumbs, then open the control panel ASSY further (arrow to unhook those arms from bosses "x" provided on the scanner frame ASSY) while sliding the control panel ASSY to the front (arrow to release its bosses "y" from the grooves of the scanner frame ASSY).
- (3) Slightly lift up the control panel ASSY and disconnect the panel-main harness from the control panel PCB.

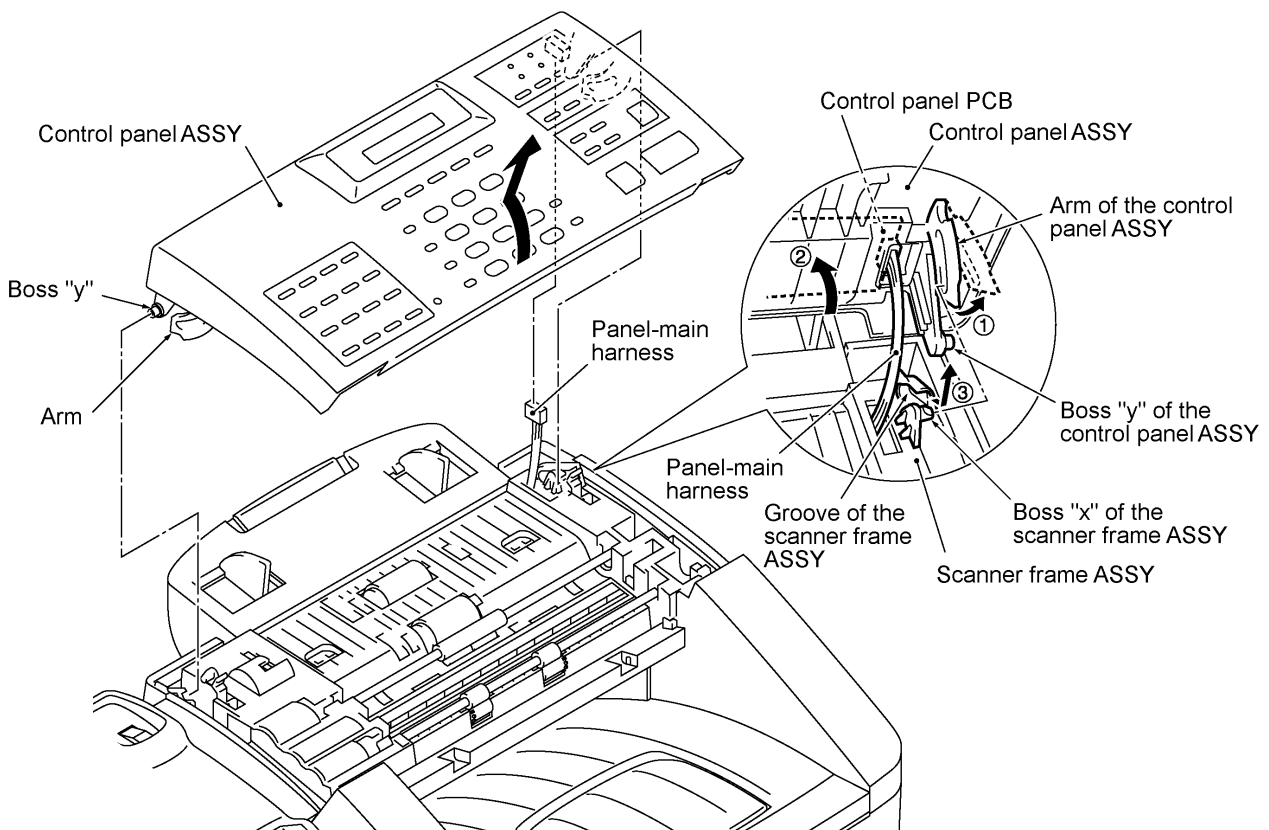

1.4 Panel Rear Cover and Control Panel

- (1) Place the control panel ASSY upside down.

If you do not need to remove the ADF parts, nip-related parts, document pressure bar, or document rear sensor actuator, or anti-static brush, skip to step (7).

- (2) To remove the ADF parts (spring plates, separation rubber and spring), remove the screw.
- (3) To remove the nip-related parts (nip piece and spring), push down the nip piece (arrow ①) and then press either side of the piece inwards (arrow ②).

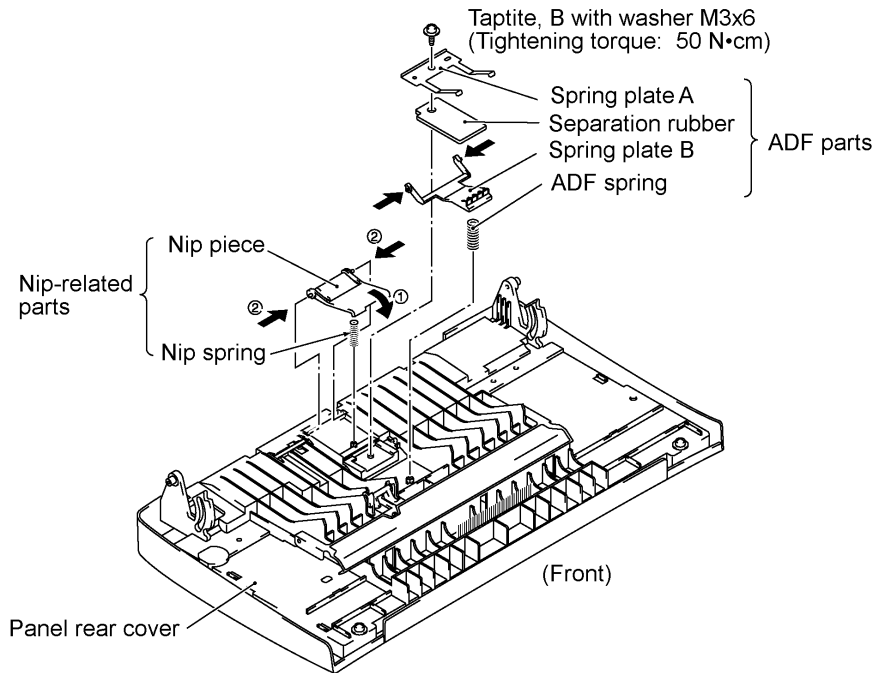

- (4) To remove the document pressure bar, press either of supports "a" provided on the panel rear cover inwards and then lift the pressure bar up and towards the rear to release the three tabs from the cutouts provided in the panel rear cover. The spring also comes off.
- (5) To remove the document rear sensor actuator, pull support "b" on the panel rear cover outwards.
- (6) To replace the anti-static brush, peel it off.

NOTE: Once removed, it will become unusable and a new part will have to be put back in.

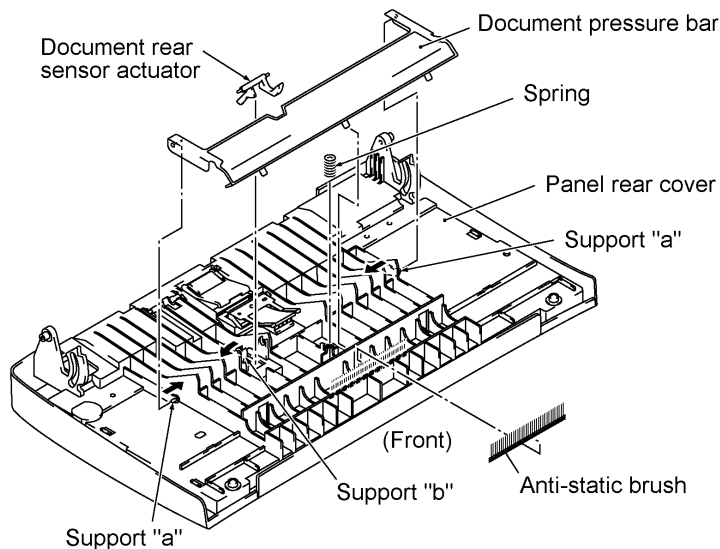

- (7) Remove the two screws from the panel rear cover.
- (8) Unhook the panel rear cover from eight "X" latches provided on the control panel and lift up the panel rear cover.
- (9) Fully turn the document front sensor actuator to the rear and take it out.
- (10) Unhook the document sensor PCB from two "Y" latches.
- (11) Unhook the control panel PCB from three "Z" latches.
- (12) Slightly lift up the control panel PCB, then unlock the LCD cable connector and disconnect the LCD flat cable. Next, unlock the FPC key connector and disconnect the FPC key.

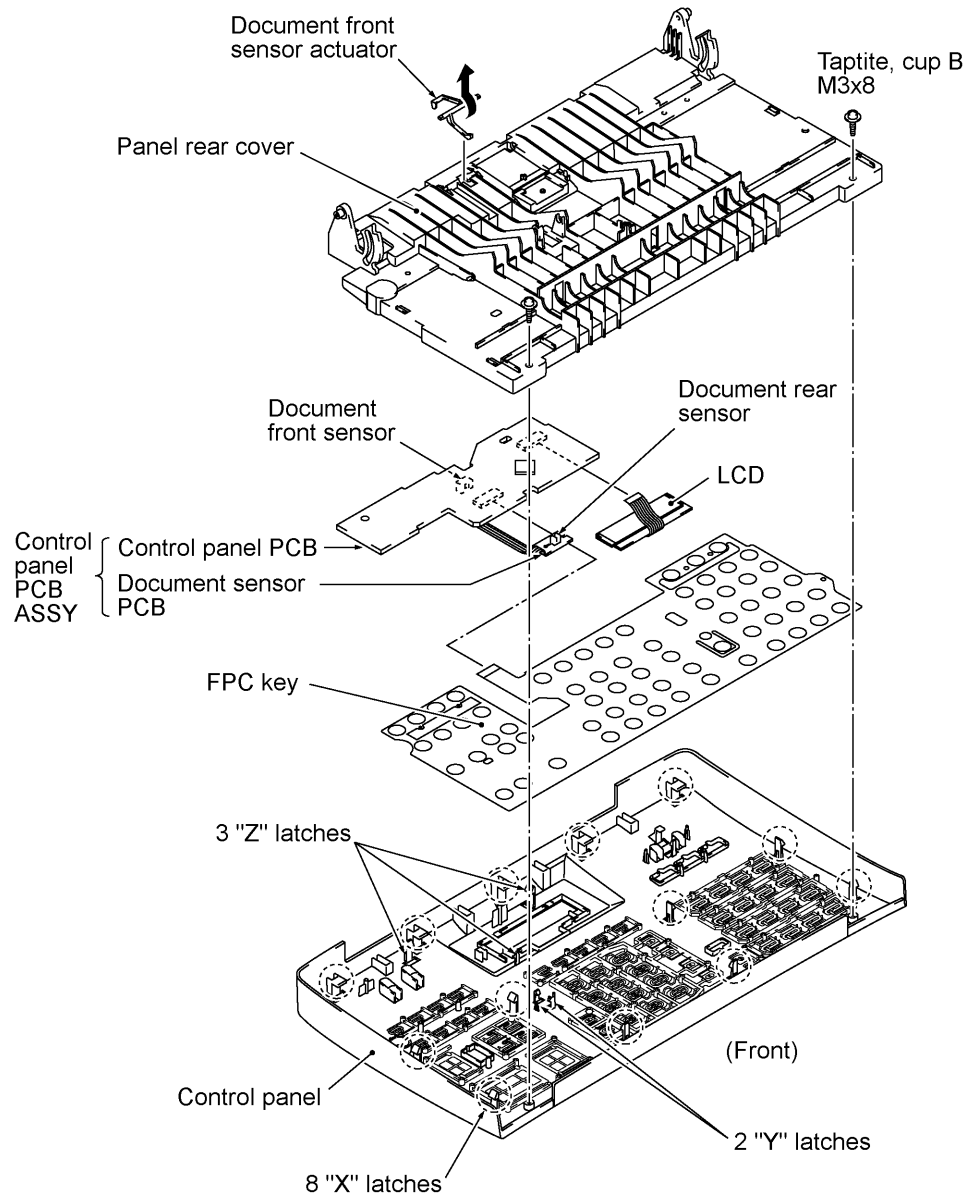

(13) As shown below, slightly pull the clamps to the front and take out the LCD while pulling the LCD flat cable gently.

NOTE: Do not take out the LCD except when the LCD is defective and requires replacement.

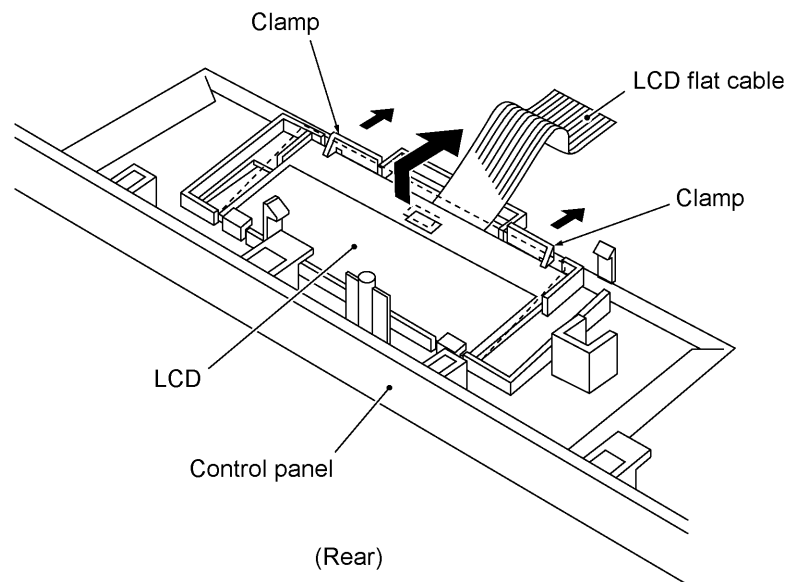

Reassembling Notes

- Before reinstalling the LCD to the control panel, wipe fingerprints or dust off the LCD surface and control panel window with a soft cloth.
- A new LCD is covered with a protection sheet. Before installing it, remove the protection sheet.

1.5 Document Feed Roller ASSY, Document Ejection Roller ASSY, and Pinch Rollers

- (1) Lightly push arm rib "a" to the rear, then pull the document feed roller ASSY to the left and upwards.
- (2) Lightly push arm rib "b" to the rear, then pull the document ejection roller ASSY to the left and upwards.

NOTE: Take care not to break the arm ribs. They may easily break.

- (3) Pull up the pinch rollers and their shafts (springs).

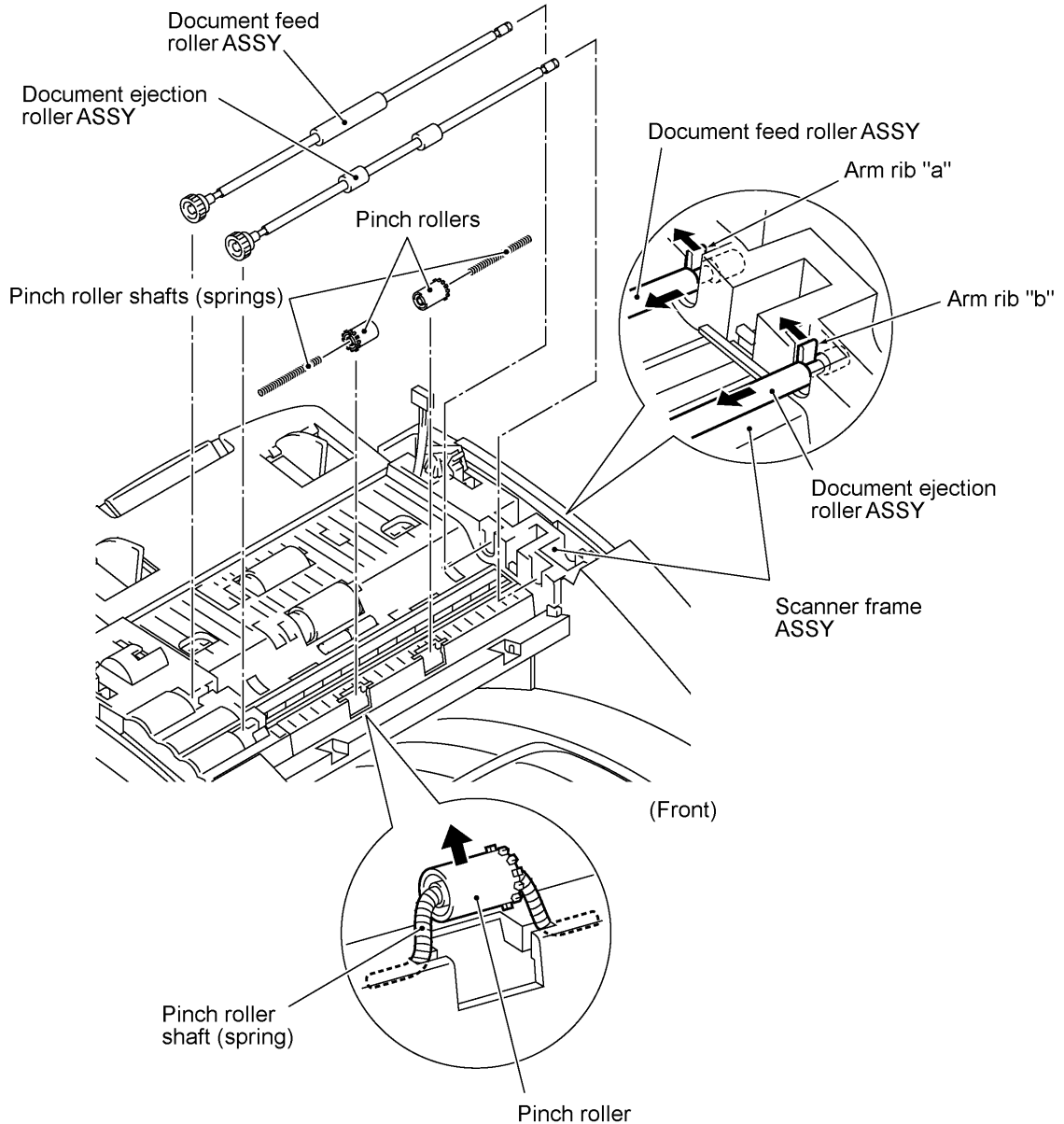

1.6 CIS Unit

- (1) Lightly pull up the arm, move the CIS unit to the right, and lift up the left edge of the CIS unit gently.

NOTE: Do not lift up the left edge exceeding 30 mm to prevent the CIS harness connector on the CIS unit from getting broken.

- (2) While holding up the CIS unit, disconnect the CIS harness. The CIS springs also come off.

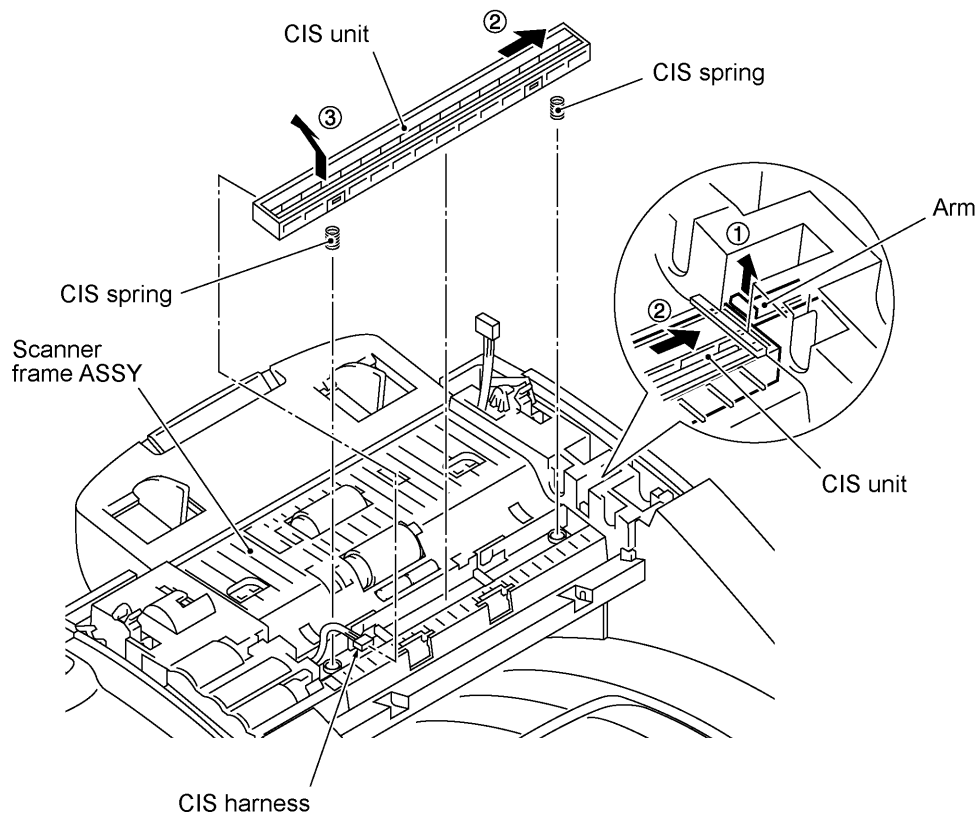

Reassembling Notes

- When reinstalling the CIS unit, first connect the CIS harness, insert the right end under the arm of the scanner frame, put the CIS unit into the scanner frame, and then move it to left.

1.7 Scanner Frame ASSY (Scanner Motor, Scanner Drive Unit, Document Take-in Roller, Separation Roller, Pressure Rollers, and Control Panel Locks)

- (1) Remove the two screws from the scanner frame ASSY.
- (2) Lift up the front edge of the scanner frame ASSY and pull the ASSY towards you to release the three tabs provided on the rear end from the top cover.

NOTE: If the CIS unit is mounted, do not lift up the scanner frame ASSY exceeding 30 mm to prevent the CIS harness connector on the CIS unit from getting broken.

- (3) Hold up the ASSY and disconnect the scanner motor harness (and the CIS harness if the CIS is mounted).

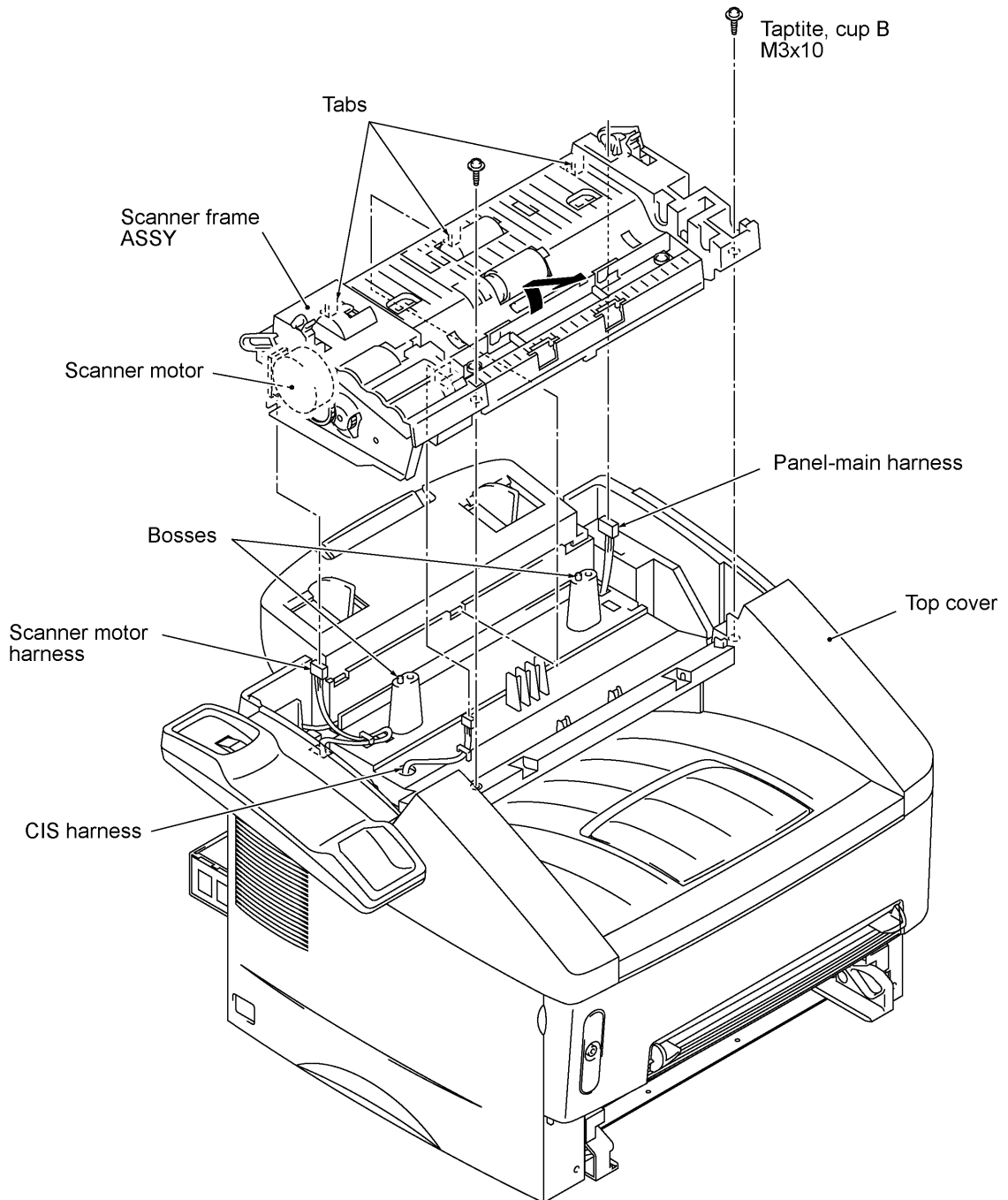

- (4) Turn the scanner frame ASSY upside down.
- (5) Remove the screw from the scanner motor and turn the motor (as shown below) to release it from the latch.

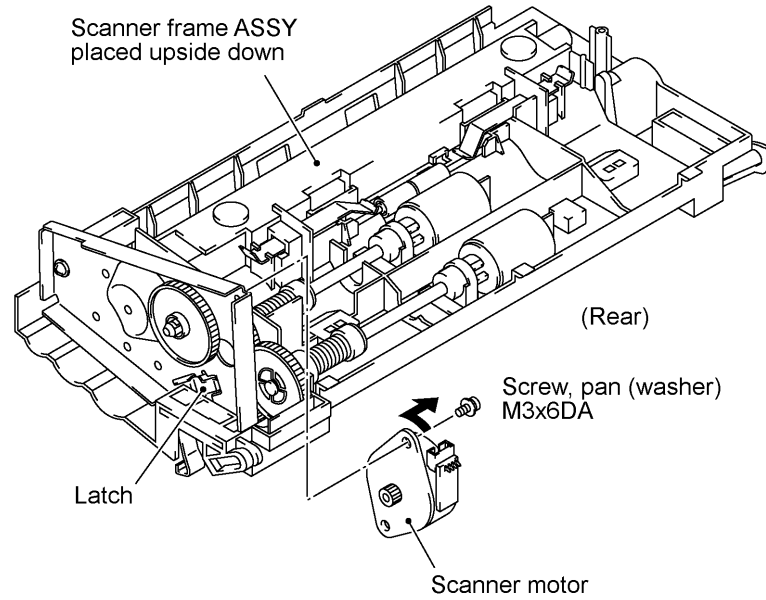

- (6) Remove the two screws and take off the scanner drive unit.

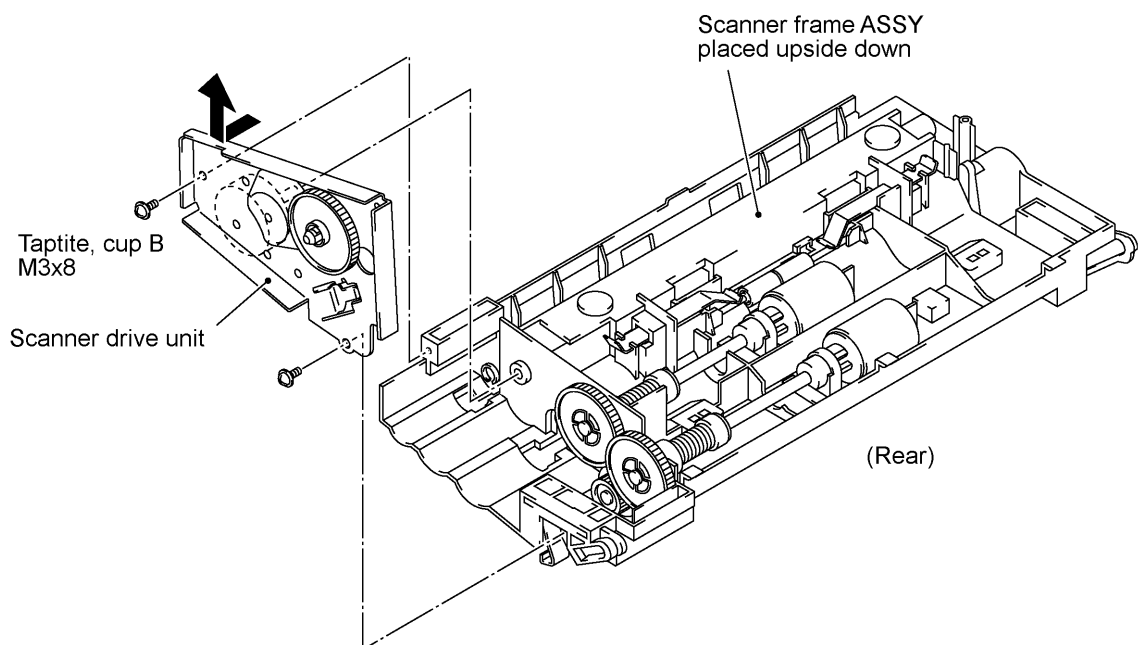

- (7) Remove the document take-in roller gear (in the direction of arrow) by pulling its pawls outwards. Slightly push down the arm (arrow) and shift the document take-in roller shaft to the left (arrow) and take it up.
Then shift the document take-in roller to the left and take it up.
- (8) Remove the separation roller gear (in the direction of arrow) by pulling its pawls outwards. Slightly push down the arm (arrow) and shift the separation roller shaft to the left (arrow) and take it up.
Then shift the separation roller to the left and take it up.

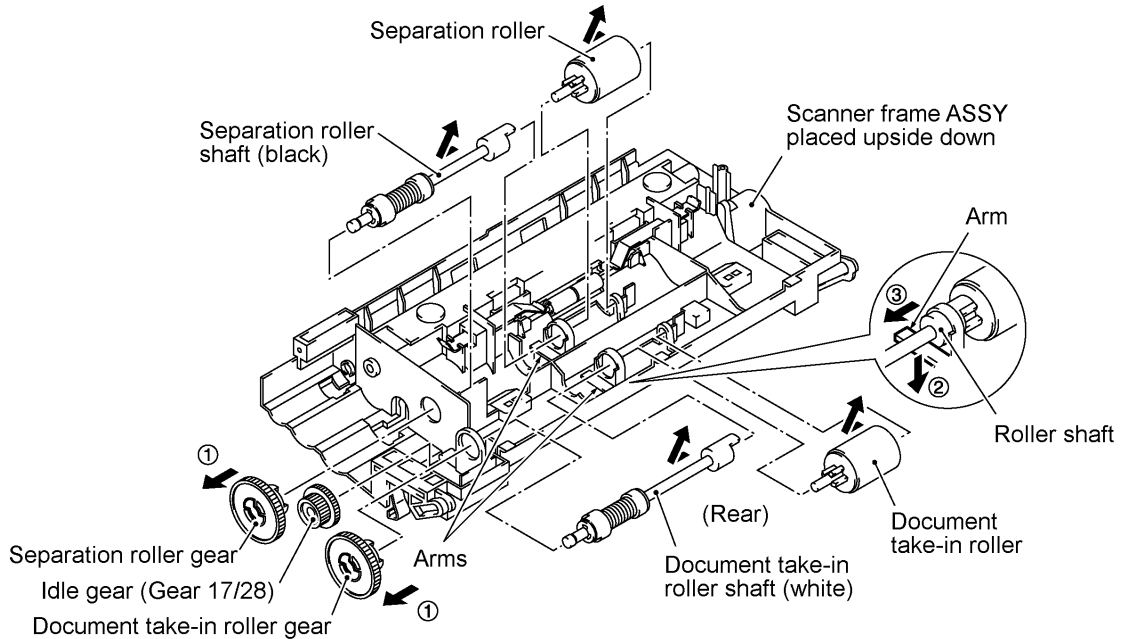

- (9) Remove the two pressure roller leaf springs by pulling them in the direction of arrows and in this order as shown below. Then remove the pressure rollers and shaft.
- (10) Remove the two control panel locks (leaf springs) with a flat screwdriver in the direction shown below.

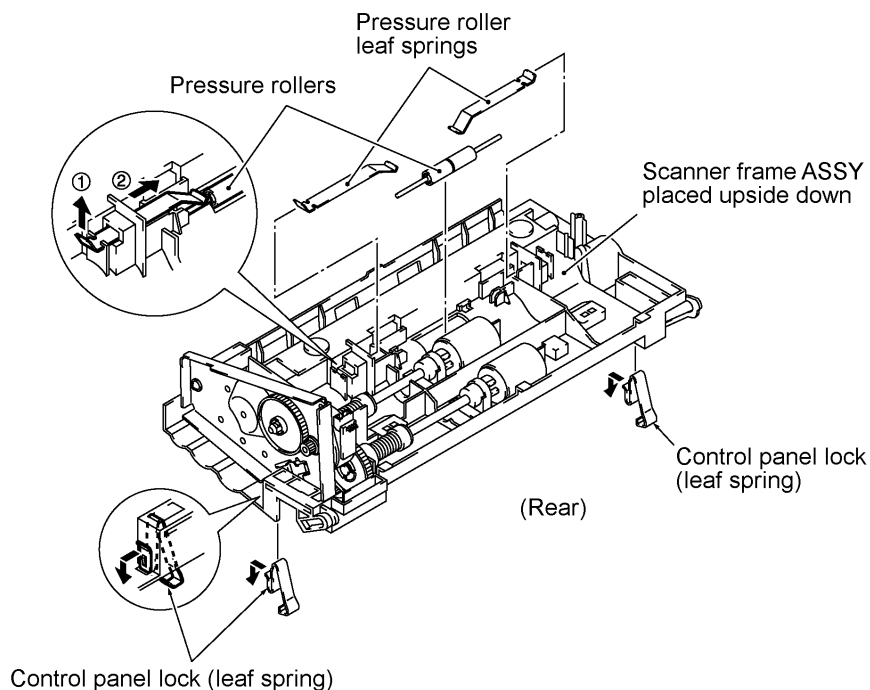

Reassembling Notes

- The document take-in roller and separation roller are compatible with each other. Their gears are also compatible with each other. However, their shafts are not compatible. The document take-in roller shaft should be a white one; the separation roller shaft should be a black one.

When setting these shaft to their rollers, fit the groove provided in each shaft over the longer boss provided on each roller.

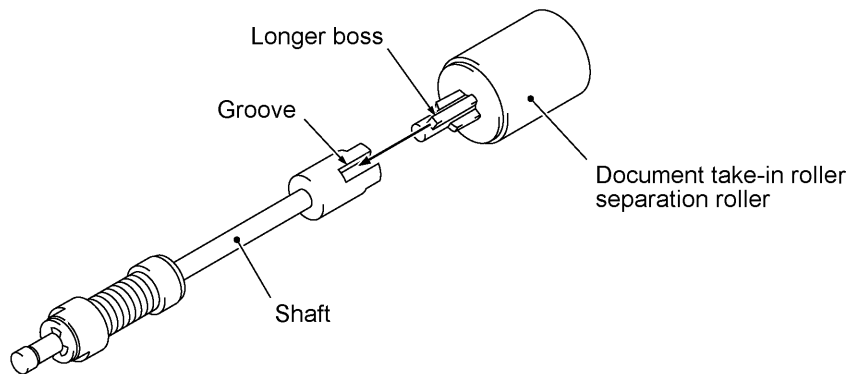

- When reinstalling the scanner motor, fit it in the latch provided on the scanner frame with the connector facing up and then secure it with the screw. (See page IV-12.)
- When setting the scanner frame ASSY back into place, be sure to
 - route the scanner motor harness through the hook on the top cover as shown on page IV-11 and connect it to the scanner motor,
 - route the CIS harness through the hook on the top cover as shown on page IV-11 and connect it to the CIS unit (if the CIS unit is not mounted, route the CIS harness through the left-hand cutout provided in the scanner frame ASSY), and
 - route the panel-main harness through the right-hand cutout provided in the scanner frame ASSY.

1.8 Top Cover (Exit Roller, Speaker, and Document Guides)

- (1) Disconnect the hook switch harness* and speaker harness from the main PCB.

*For models equipped with a handset

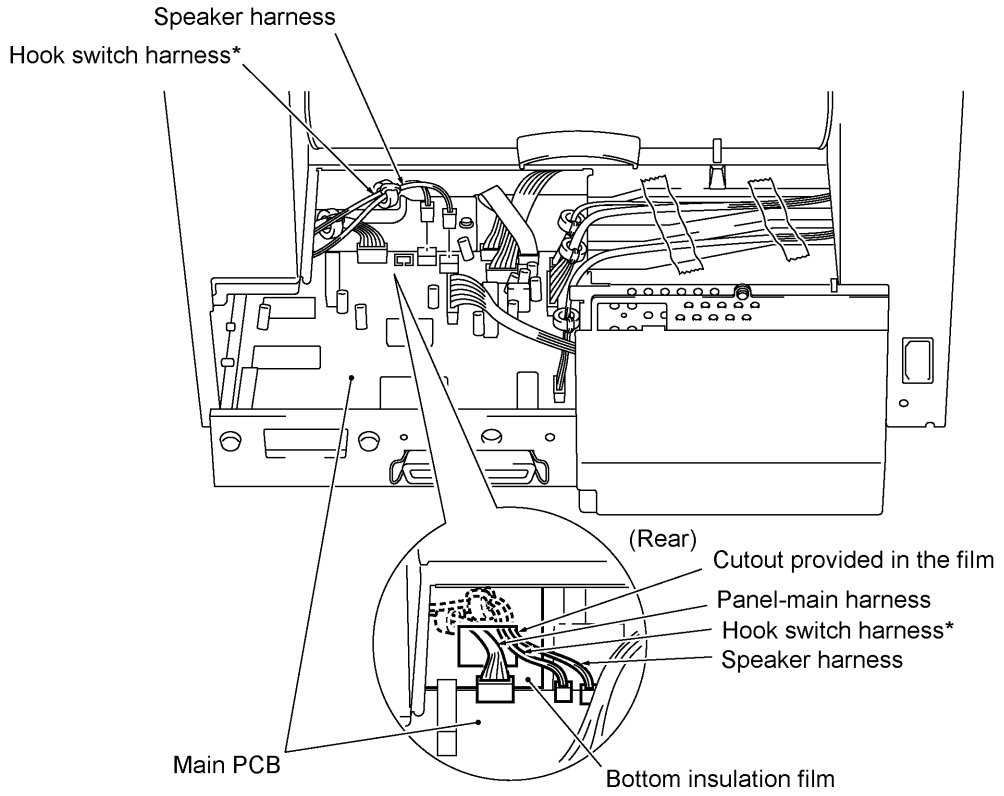

Routing the panel-main harness,
hook switch harness* and speaker harness

- (2) Remove the harness support rubbers to release the hook switch harness*.
- (3) Release the scanner motor harness and CIS harness from the hooks provided on the top cover.

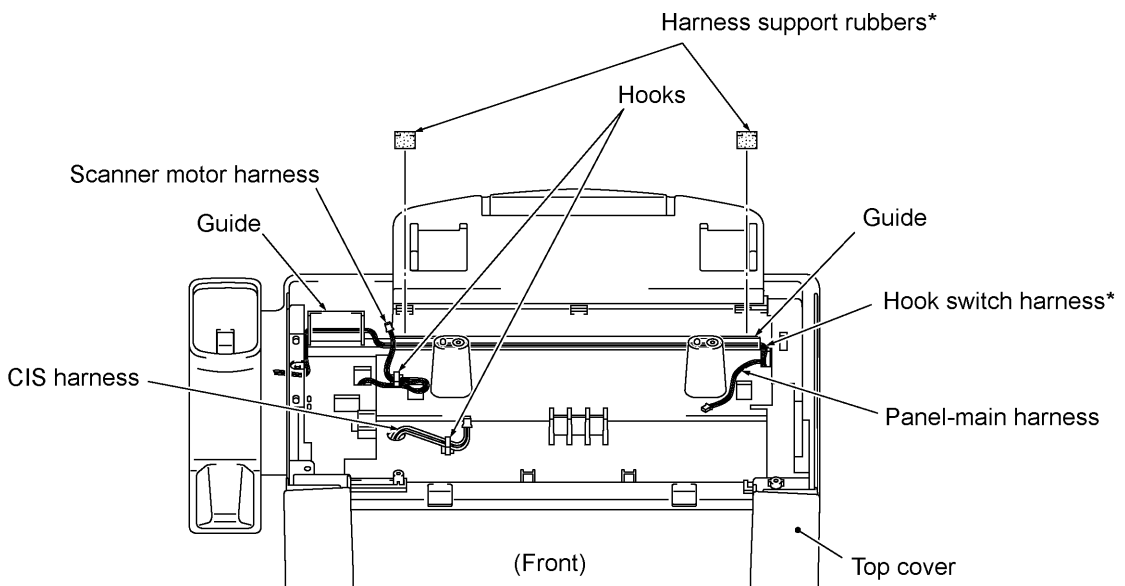

- (4) Remove two screws "a."
- (5) Open the front cover and remove two screws "b."
- (6) Pull the tabs of the top cover to the front and upwards (in the direction of arrows) to release them from the bosses provided on the main cover.
- (7) Insert the tip of a flat screwdriver and unhook the latches of the top cover (in the direction of arrows), then lift up the top cover (arrow).

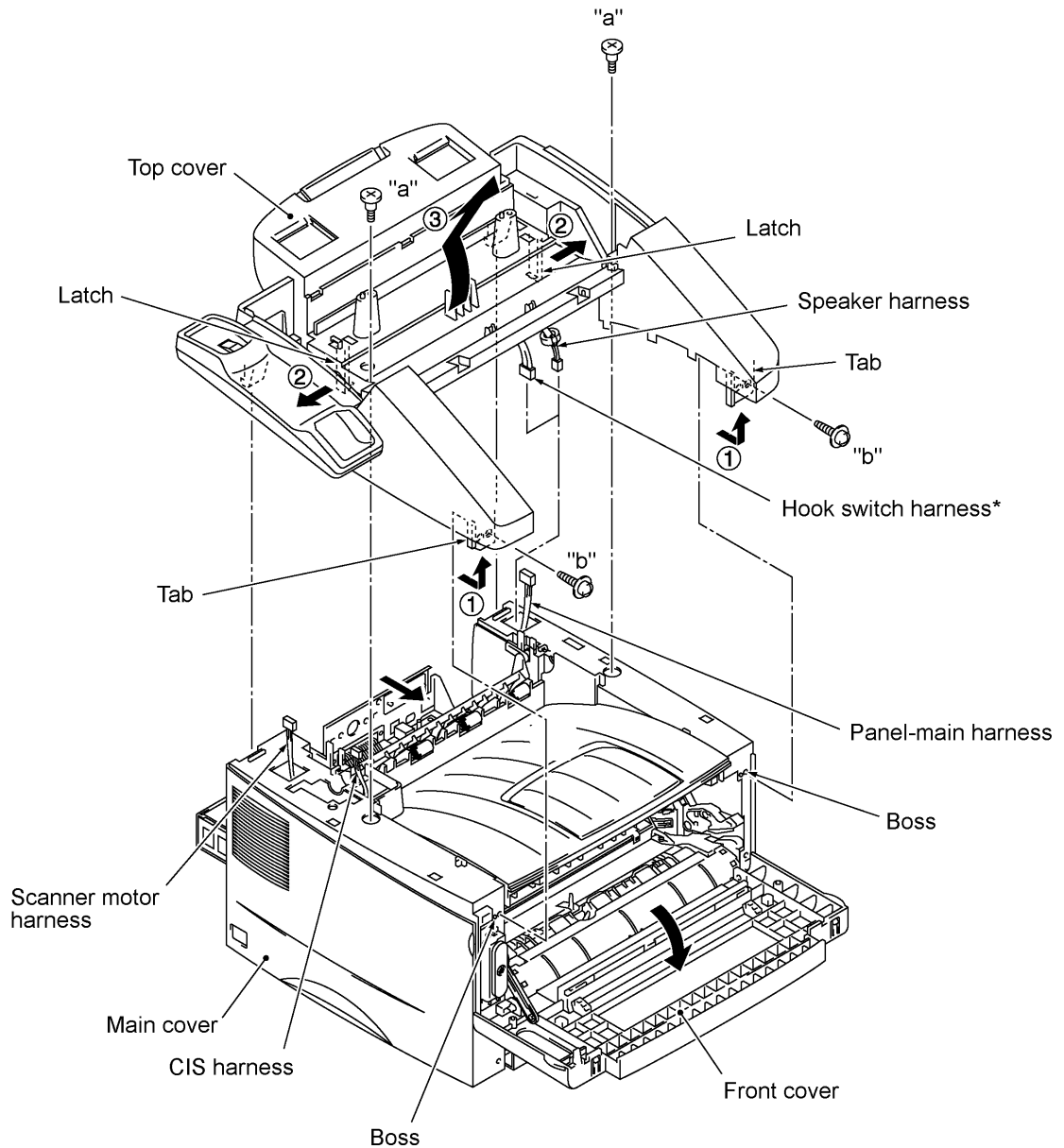

"a": Stepped screw
 "b": Taptite, cup S M3x10

*For models equipped with a handset

- (8) Turn the top cover upside down.
- (9) Peel off anti-static brushes.

NOTE: Once removed, they will become unusable and new parts will have to be put back in.
- (10) As shown below, warp the gear-equipped end of the exit roller and remove it.

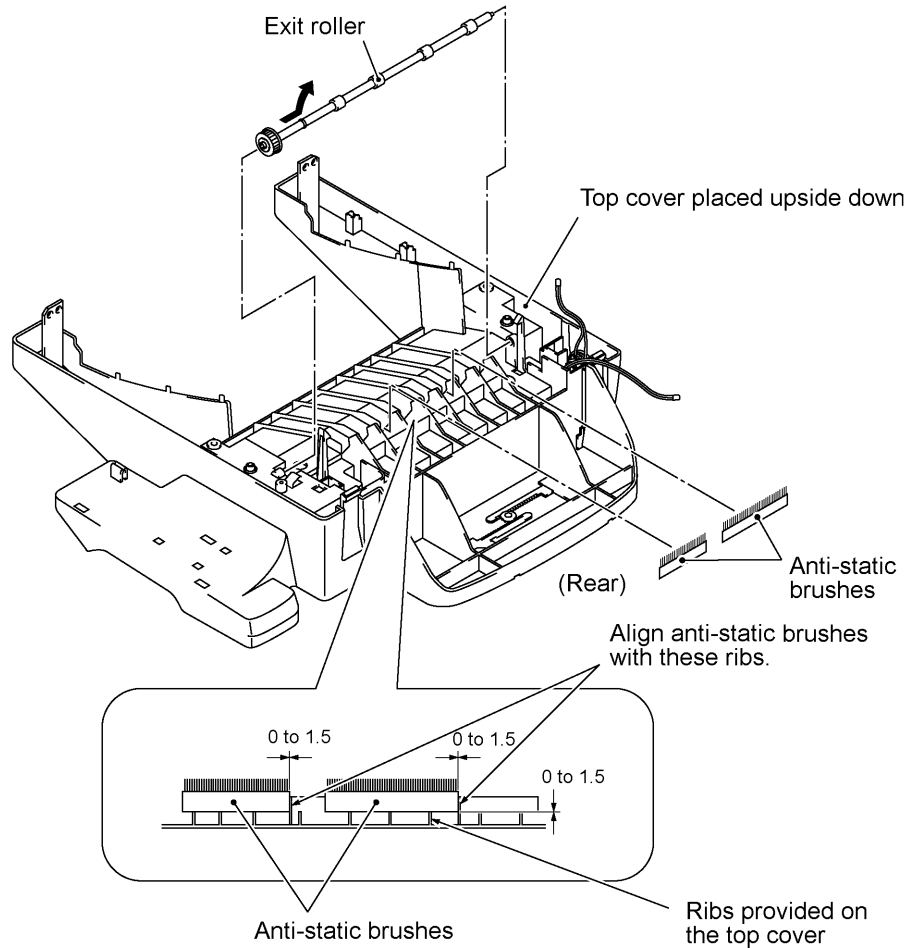

- (11) Unhook the latch from the speaker spring and pull it up. (To make this easier, insert the tip of a flat screwdriver from the bottom of the top cover placed upside down.) Lift up the speaker.

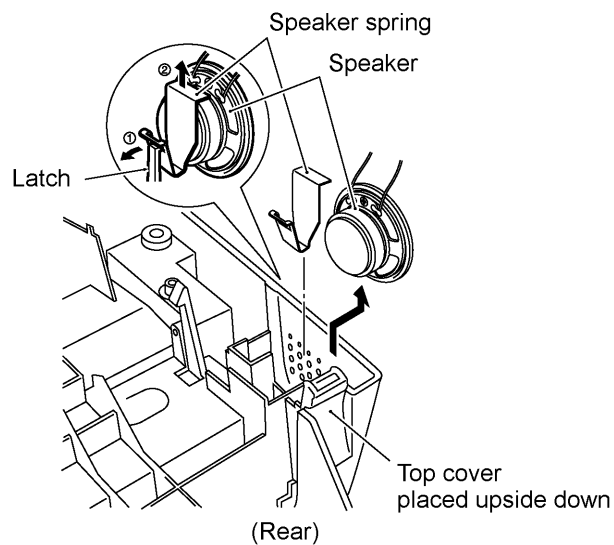

(12) Remove the screw from the inside of the top cover, then remove the document guides L and R as shown below.

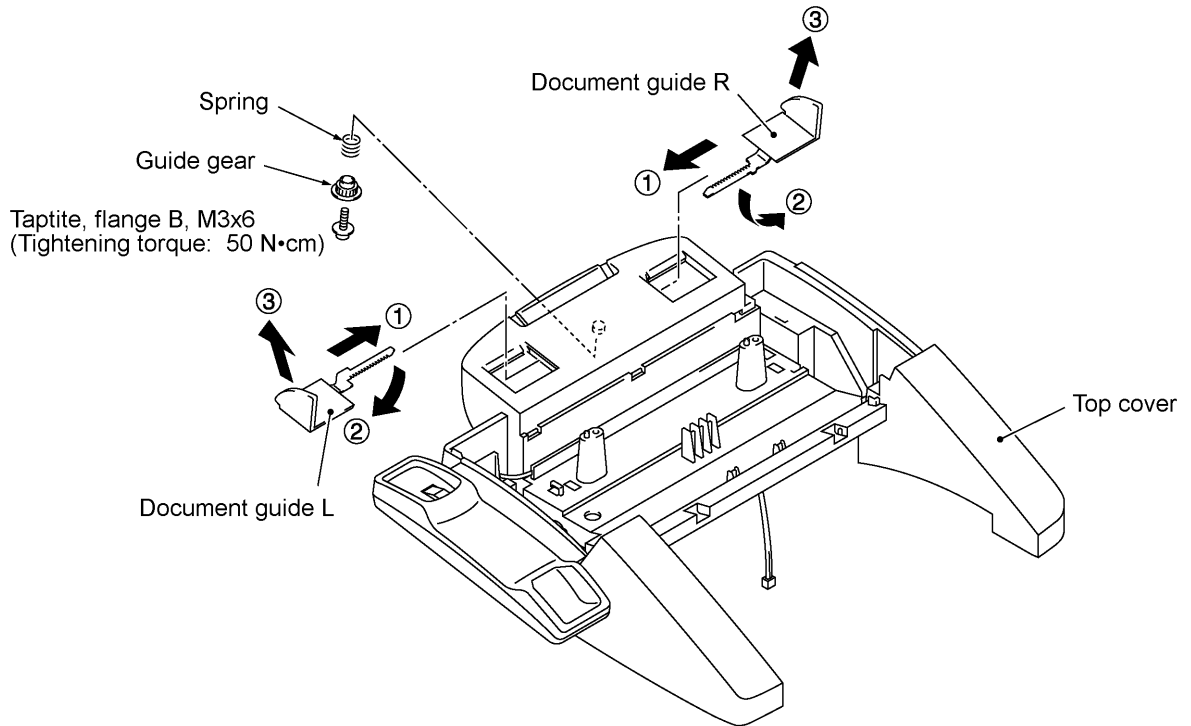

Reassembling Notes

- When reinstalling the paper guides, set them into place, pull them outwards (in the direction of arrows 1), and then secure them with the spring, guide gear, and screw (arrow 2).

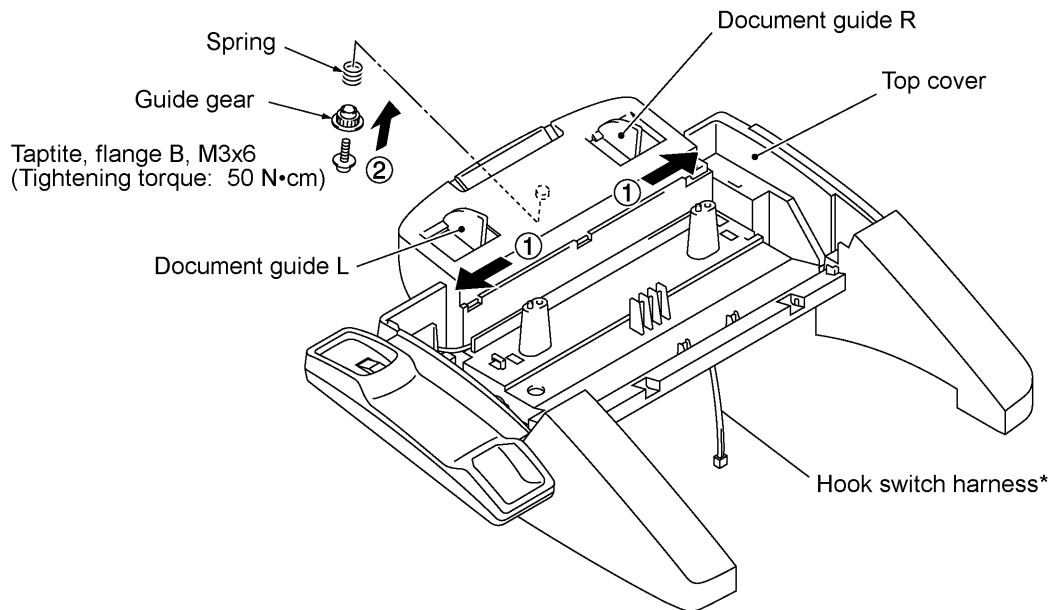

*For models equipped with a handset

- When setting the top cover back into place:
 - at the right-hand side, put the speaker harness and hook switch harness* into square cutout "X" provided in the right rear corner of the main cover. Raise the panel-main harness coming through the main cover up and through cutout "x" provided in the top cover (through which the hook switch harness* passes).
 - If the panel-main harness has been taken out from the machine, first put it into square cutout "X" with the core-equipped end down and then raise its upper end up and through cutout "x" provided in the top cover.
 - at the left-hand side, pull up the scanner motor harness and CIS harness and raise them up and through square and round cutouts ("y" and "z") provided in the top cover, respectively.
 - If the scanner motor harness or CIS harness has been taken out from the machine, first put it into the respective cutout ("Y" or "Z") provided in the left rear corner of the main cover with the core-equipped end down and then raise its upper end up and through the respective cutout "y" or "z."

*For models equipped with a handset

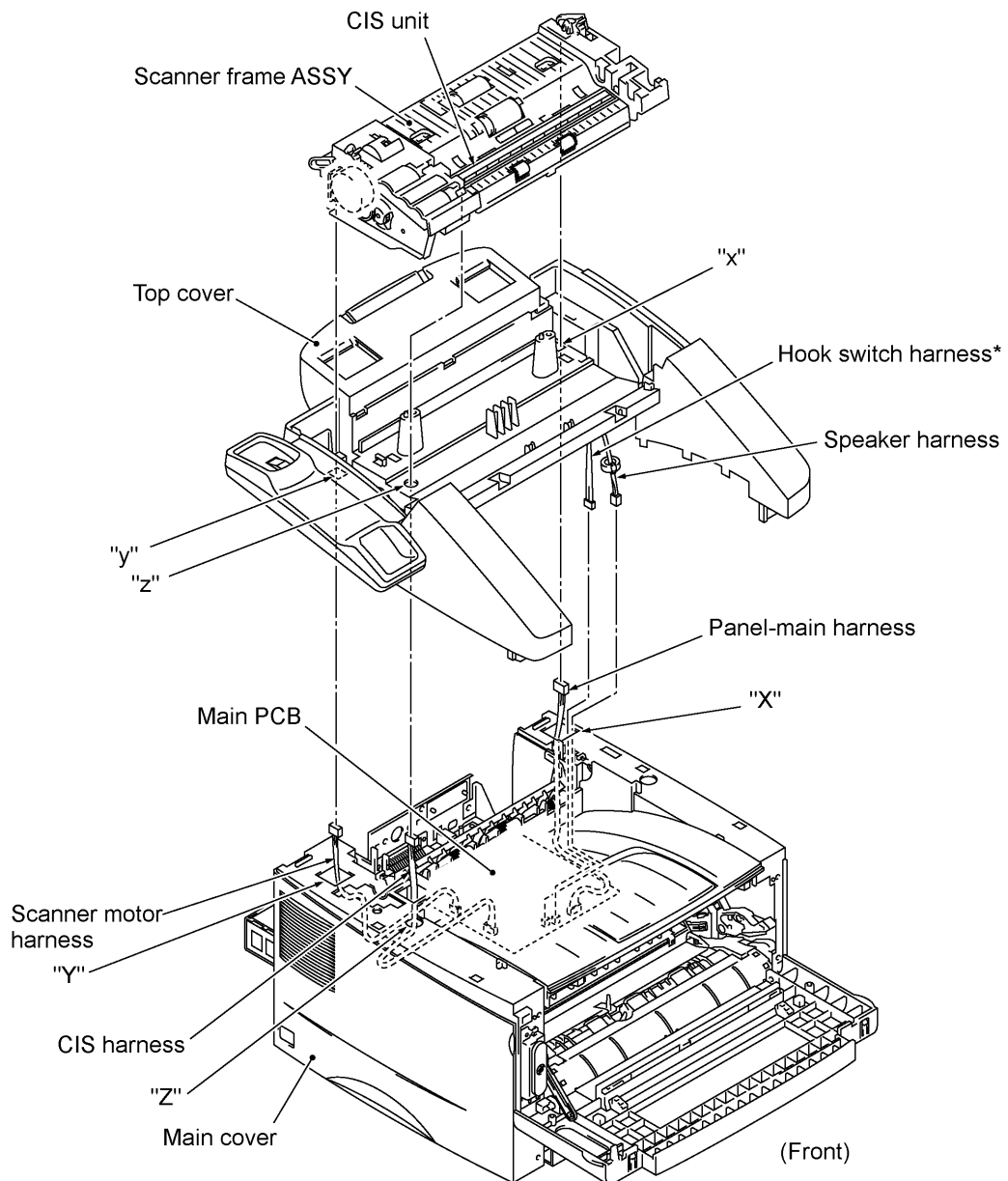

- When connecting the speaker harness and hook switch harness* to the main PCB:
 - route the hook switch harness* through the ferrite core of the speaker harness,
 - make sure that the panel-main harness, speaker harness, and hook switch harness* are routed through the cutout provided in the bottom insulation film, and
 - make sure that the ferrite cores of the pane-main harness and speaker harness lie inside the bottom insulation film.

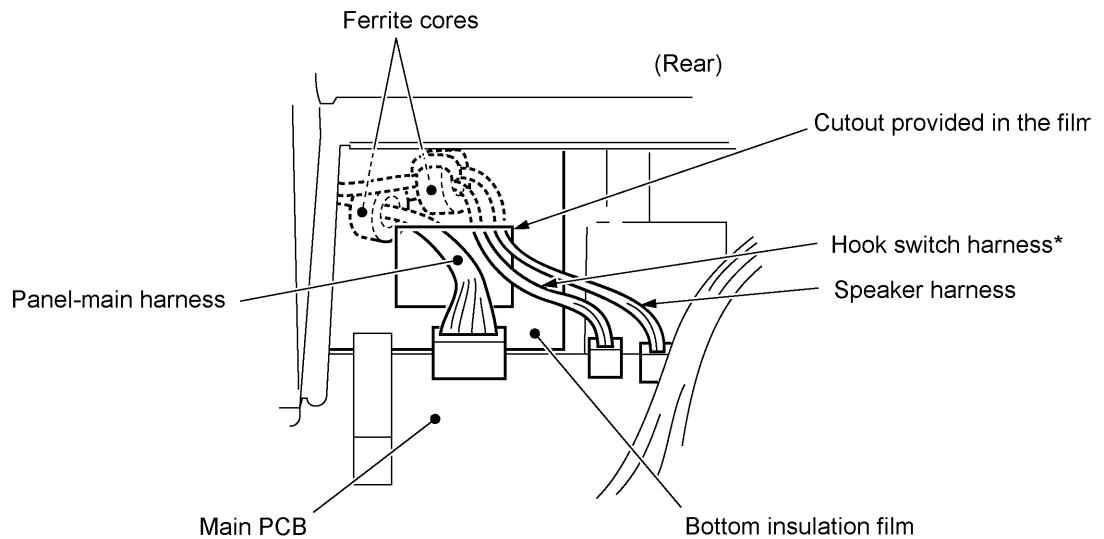

**1.9 Handset Mount and Hook Switch PCB (for models equipped with a handset)
Side Cover (for models without handset)**

- (1) Remove the two screws from the handset mount* or side cover**.
- (2) Twist the handset mount* or side cover** so that it tilts over to the left and its upper end works out of the bosses provided on the top cover.

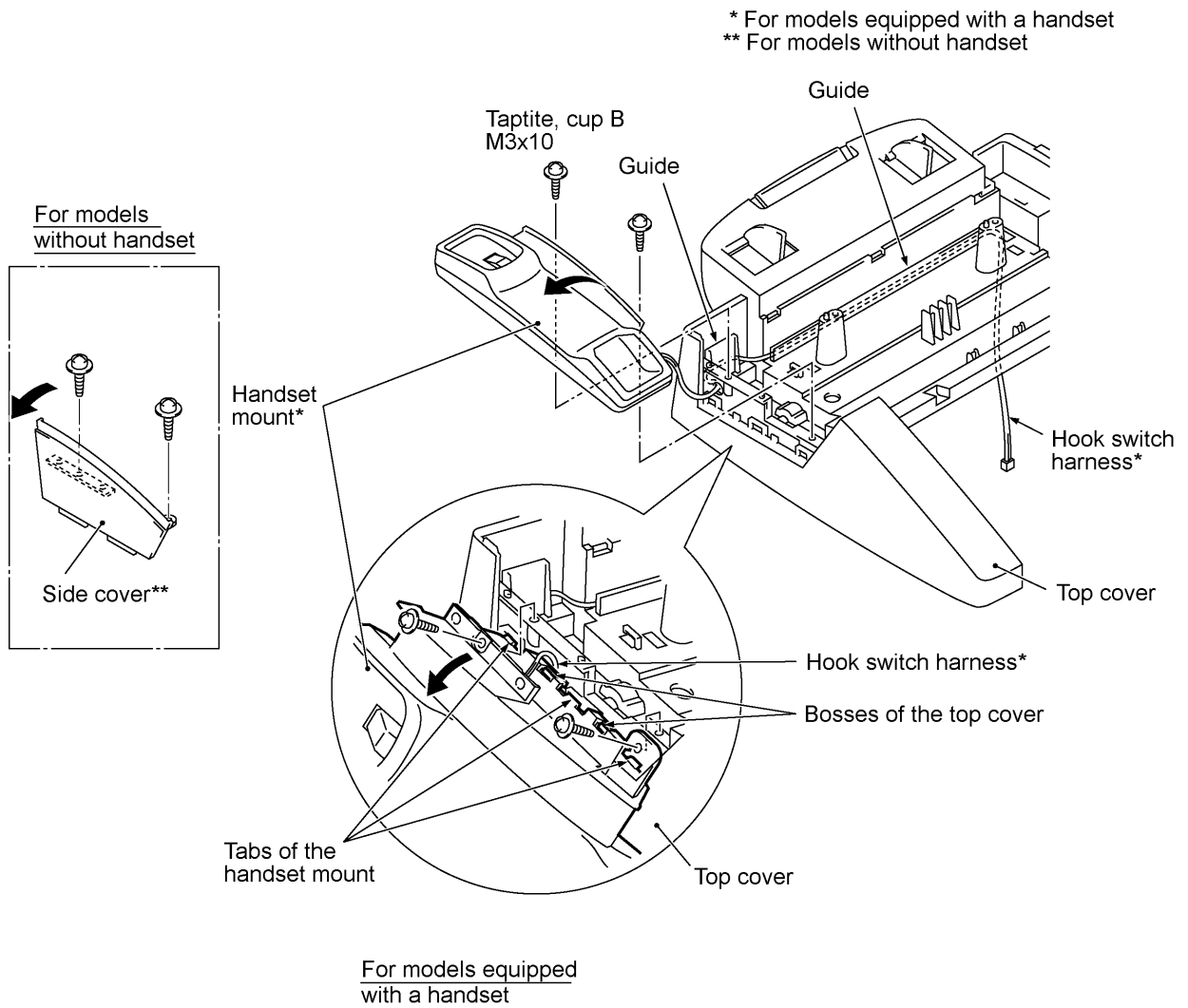

The following steps should apply to those models equipped with a handset:

- (3) Disassemble the handset mount by unhooking two latches "a" of the upper handset mount with a flat screwdriver.
- (4) Remove the hook switch PCB ASSY by unhooking latch "b."
- (5) Disconnect the hook switch harness from the hook switch PCB.

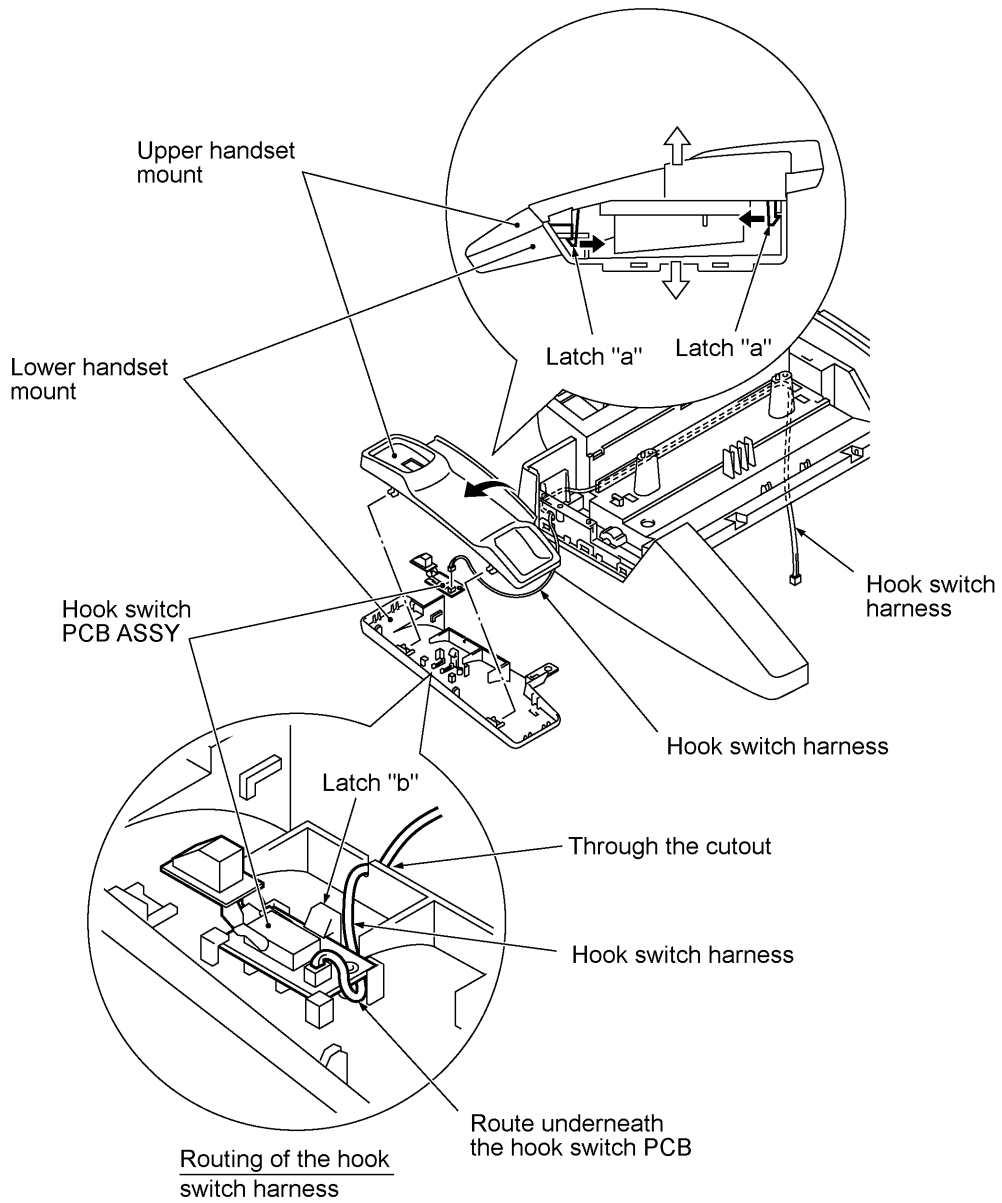

Reassembling Notes

- When assembling the upper and lower handset mounts, route the hook switch harness underneath the hook switch PCB and through the cutout as shown above. Take care not to pinch the harness between the upper and lower mounts.
- Make sure that the hook switch harness is routed along the guides on the top cover.

1.10 Paper Sub Tray

- (1) Turn the paper sub tray up (in the direction of arrow).
- (2) Warp the sub tray and lift it up (arrows and).

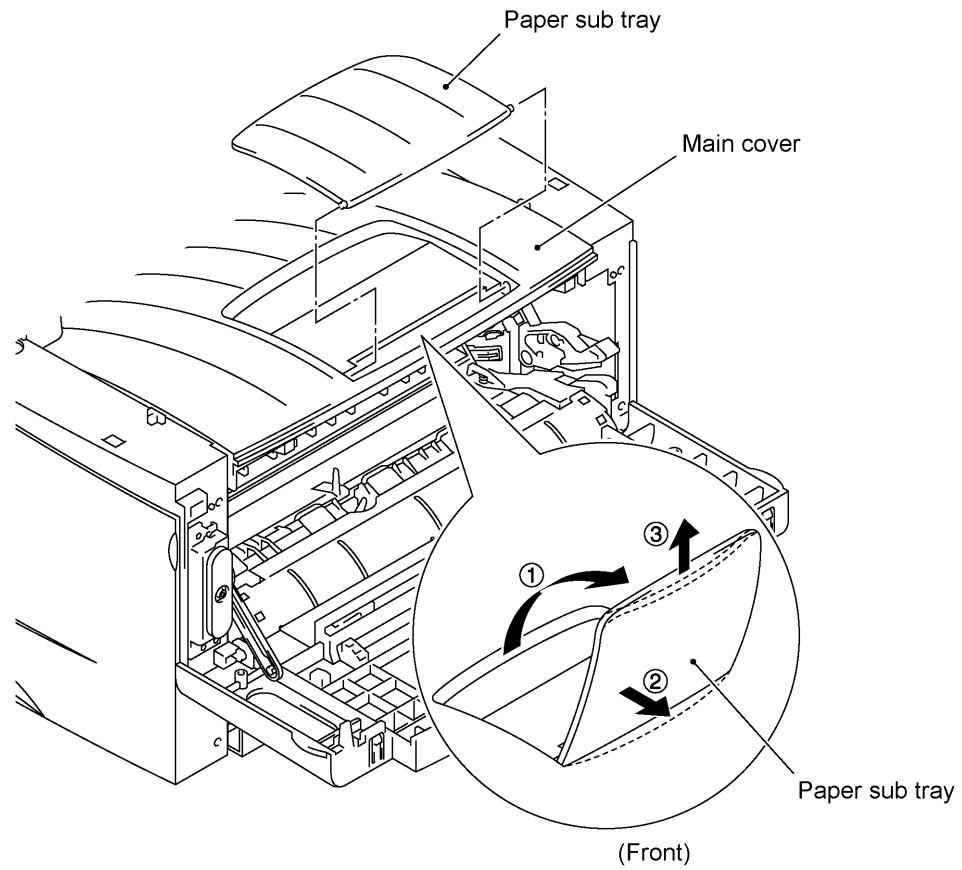

1.11 VC Cover, VC Bracket, and VC Connector PCB (for models supporting video capture)

- (1) Remove two screws ("a" and "b"), then take off the VC cover.
- (2) Remove screw "c," take out the VC bracket together with the VC connector PCB, and disconnect the VC harness.
- (3) Remove two screws "d," then take off the VC connector PCB.

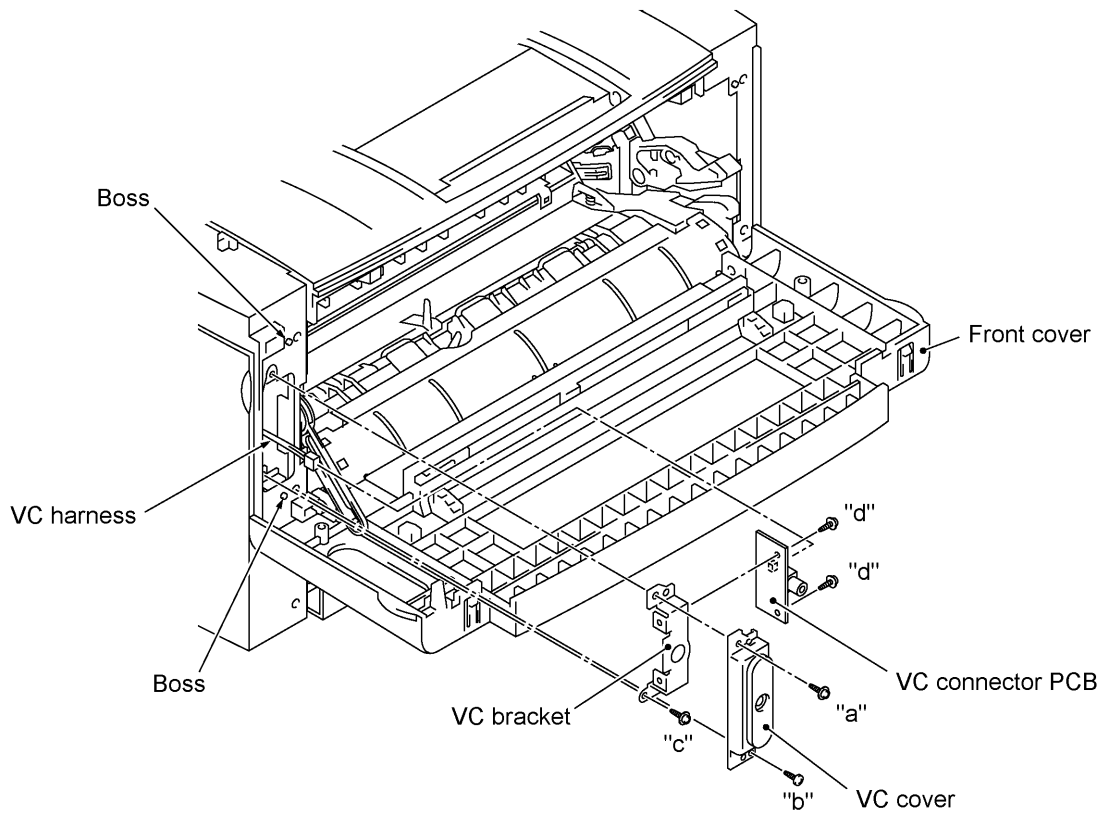

"a": Taptite, cup S M3x10
"b": Taptite, bind S M3x8
"c" and "d": Taptite, cup S M3x6

Reassembling Notes

- The routing of the VC harness is shown on page IV-27.

1.12 Front Cover
Front Sub Cover (for models not supporting video capture)

- (1) For models not supporting video capture:
 Remove the screw and take off the front sub cover from the front cover.

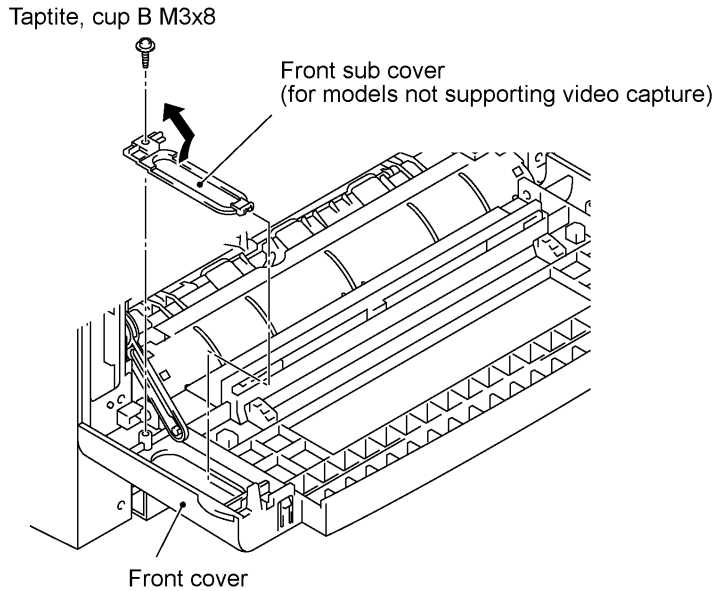

- (2) Remove the screw from the left bottom of the front side of the main cover.
- (3) Hold the front cover at an angle of 45° and pull the front cover link to the left to release it from the front cover.
- (4) Pull the bottom left front corner of the main cover to the left (in the direction of arrow) and release the front cover from the boss provided on the main cover (arrow).

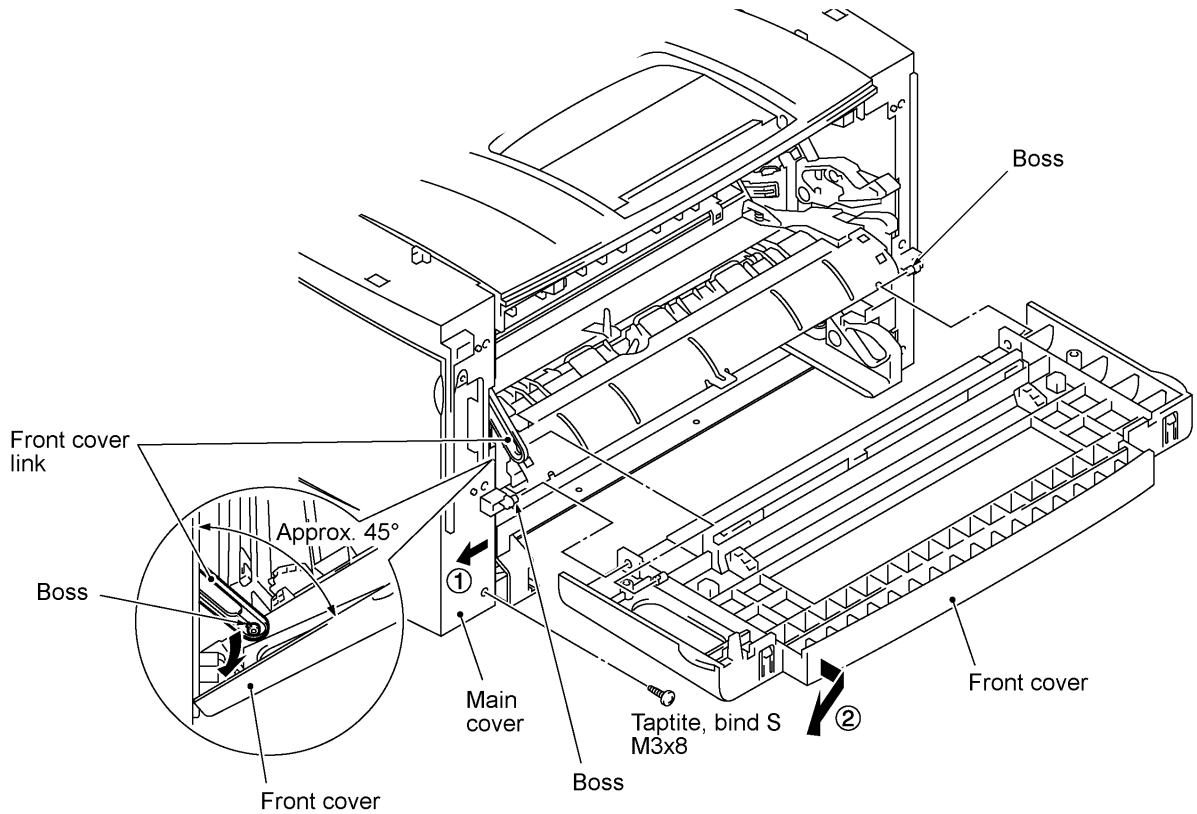

1.13 Outer Chute and Paper Pinch Rollers

- (1) Pull up the outer chute and open it (in the direction of arrow).
- (2) Remove the chute springs from the hooks provided on the main cover (arrow), then lift up the outer chute (arrow).

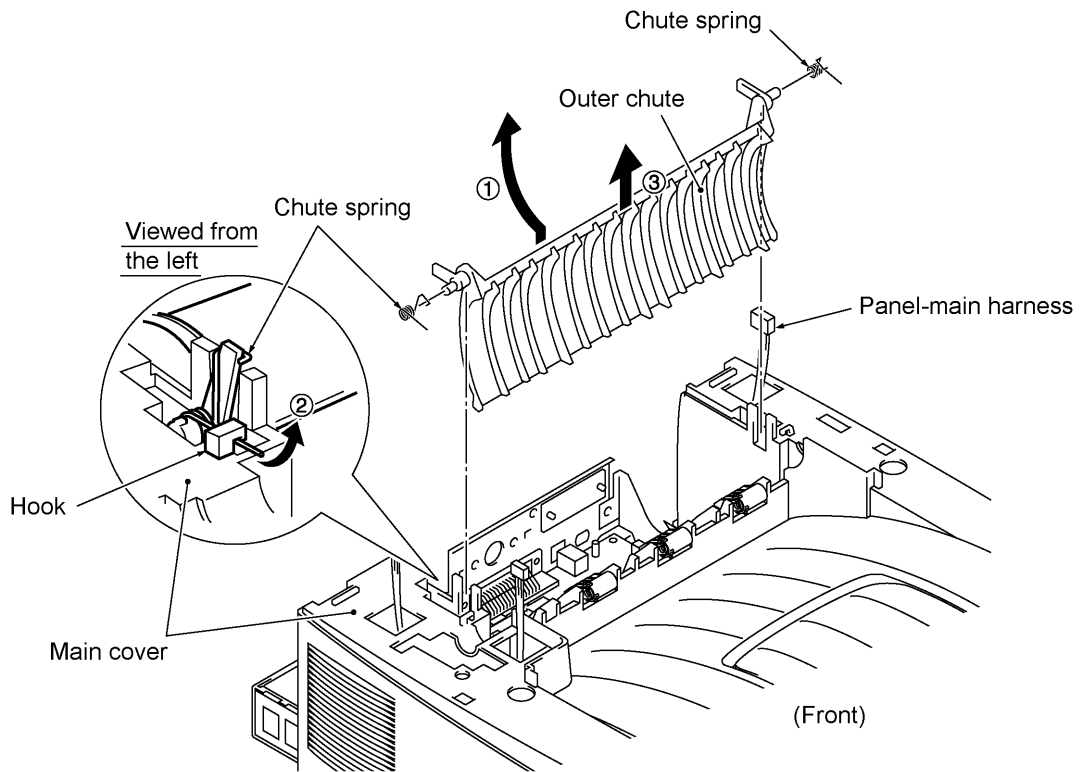

- (3) Remove the paper pinch rollers, their supports, and their springs.

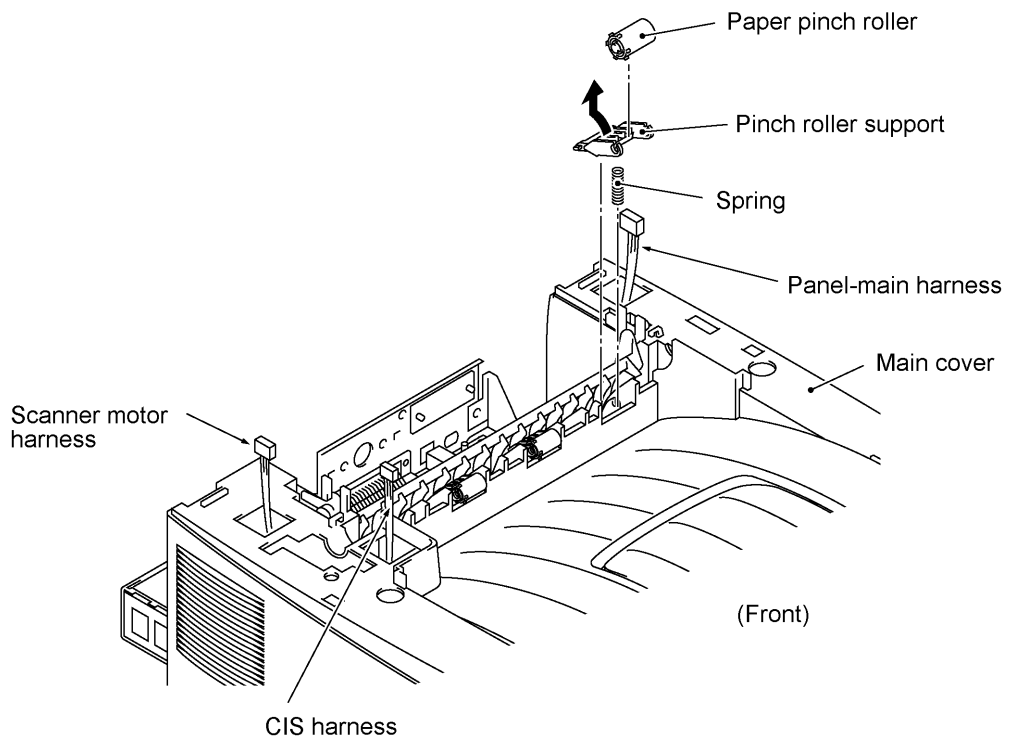

1.14 Main Cover

- (1) Remove two screws "a" from the front side of the main cover.
- (2) Remove two screws "b" from the rear side of the main cover, and then pull corner edges "X" outwards to dislocate the main cover from the main chassis. Make sure that the cutout provided in the main cover is dislocated from the power inlet.
- (3) Unhook the two latches with the tip of a flat screwdriver, then lift up the main cover.

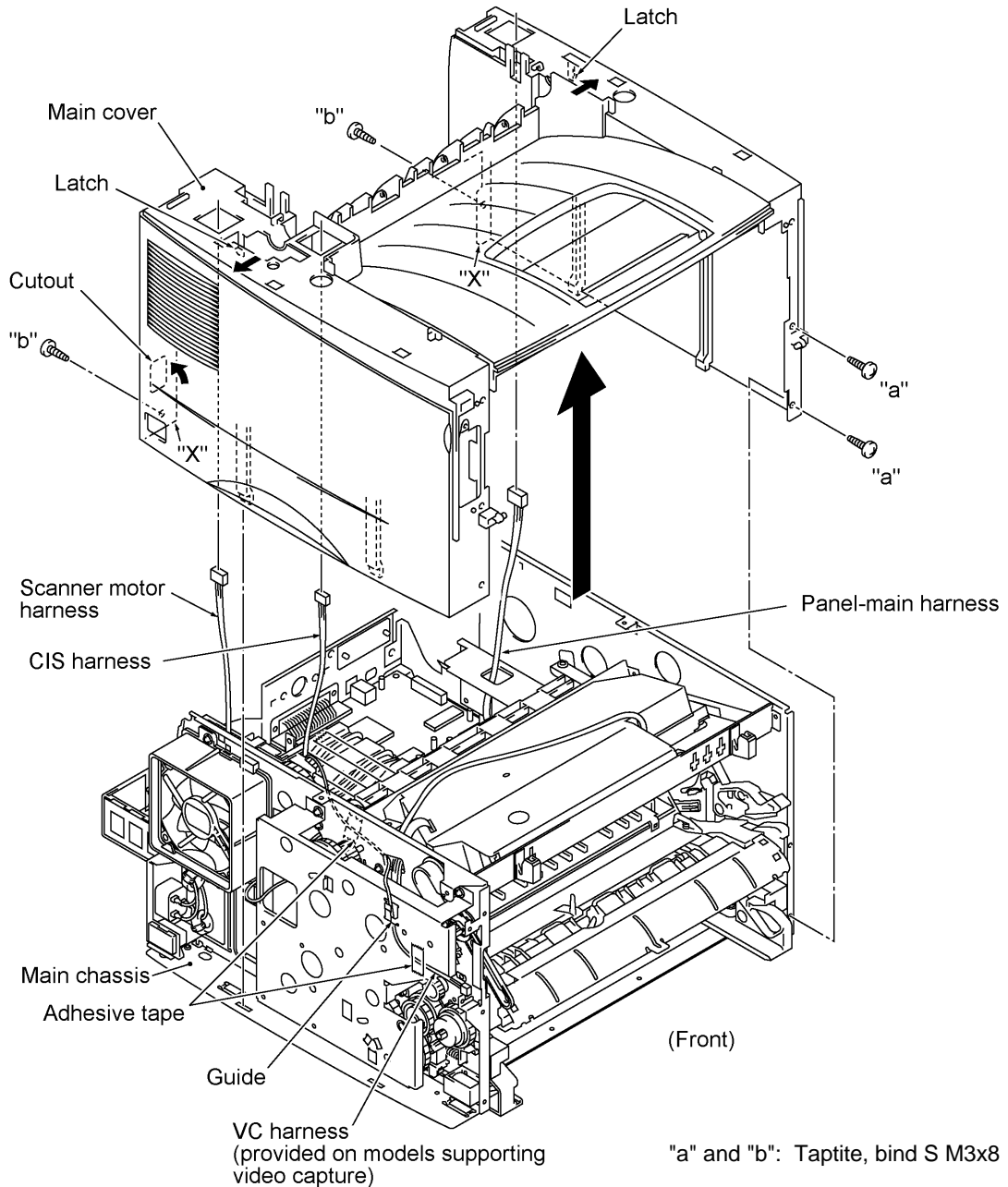

Reassembling Notes

- When reinstalling the main cover, route the panel-main harness, CIS harness, and scanner motor harness through the respective cutouts provided in the main cover, as illustrated above.

1.15 Switch Cover

- (1) Push the locks of the switch cover as shown below and remove it.

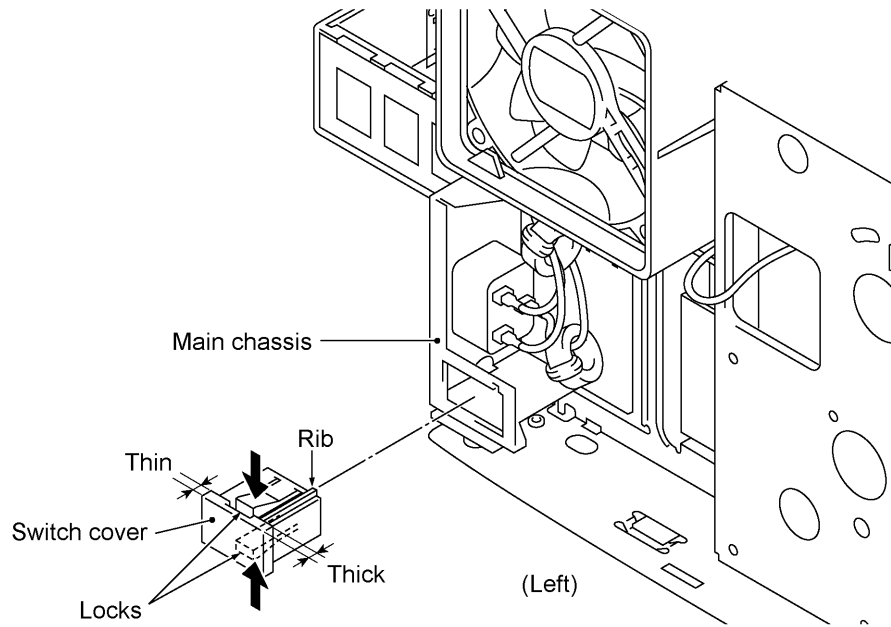

1.16 Laser Unit

- (1) Remove screw "a" and take off the harness cover.
- (2) Remove two screws "b."
- (3) Disconnect the polygon motor harness and laser flat cable from the laser unit.
- (4) Lift up the laser unit.

NOTE: When handling the laser unit, take care not to touch the inside of the unit, glass, or mirror.

NOTE: On the small PCB in the laser unit is a 2-pin connector which is for the adjustment in the factory. Do not disturb it.

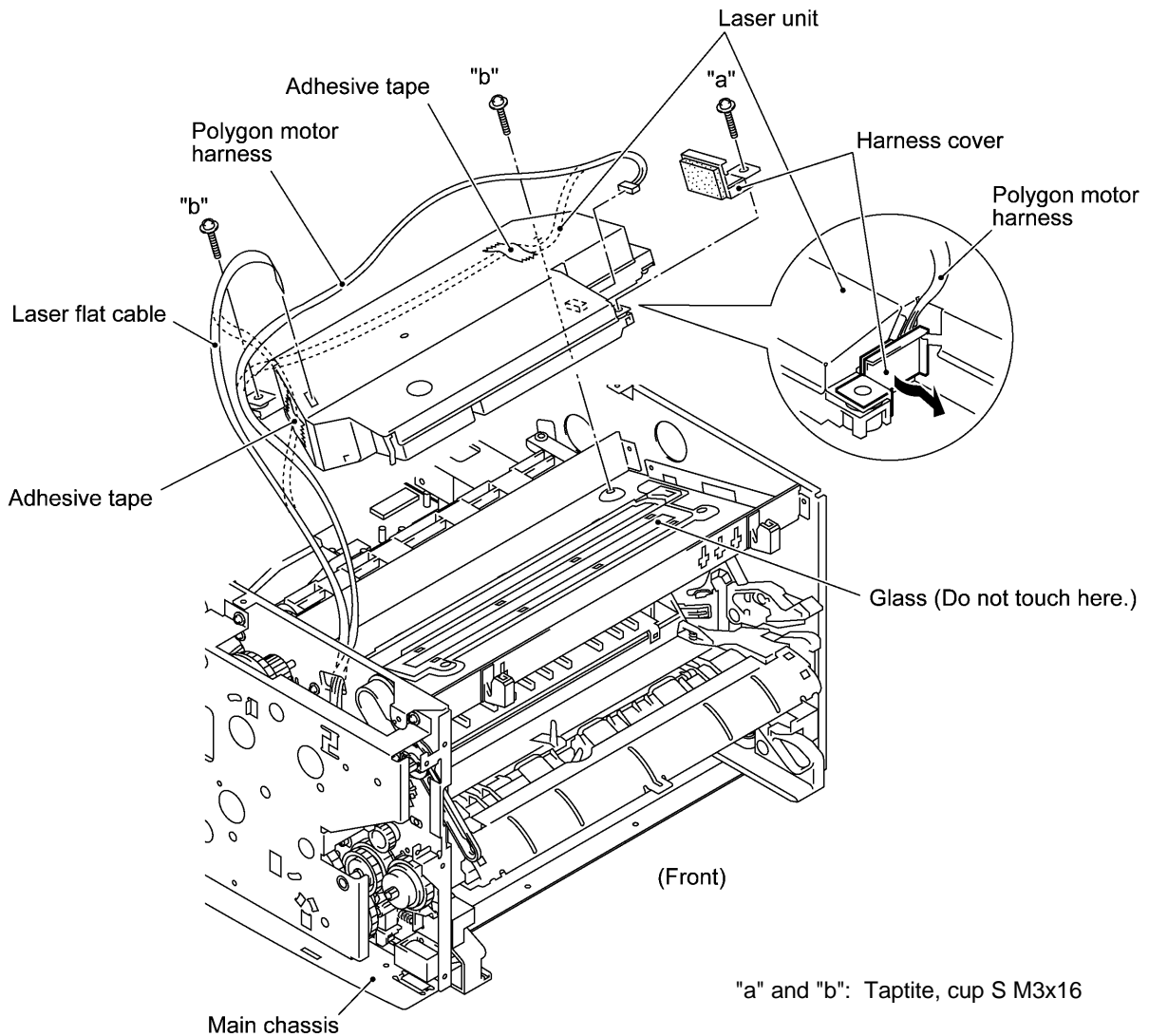

Reassembling Notes

- Before putting the laser unit back into place, check for any toner particles, paper dust or dirt, and clean them out.
- After routing the polygon motor harness and laser flat cable, tape them onto the laser unit as shown above.

1.17 Heat-fixing Unit and FU Lamp

- (1) Remove the screw from the harness duct.
- (2) Peel off tape and take off the scanner motor harness, CIS harness, and VC harness* from the harness duct.
- (3) Unhook the harness duct from the main chassis in the directions of arrows and .

*Provided on models supporting video capture

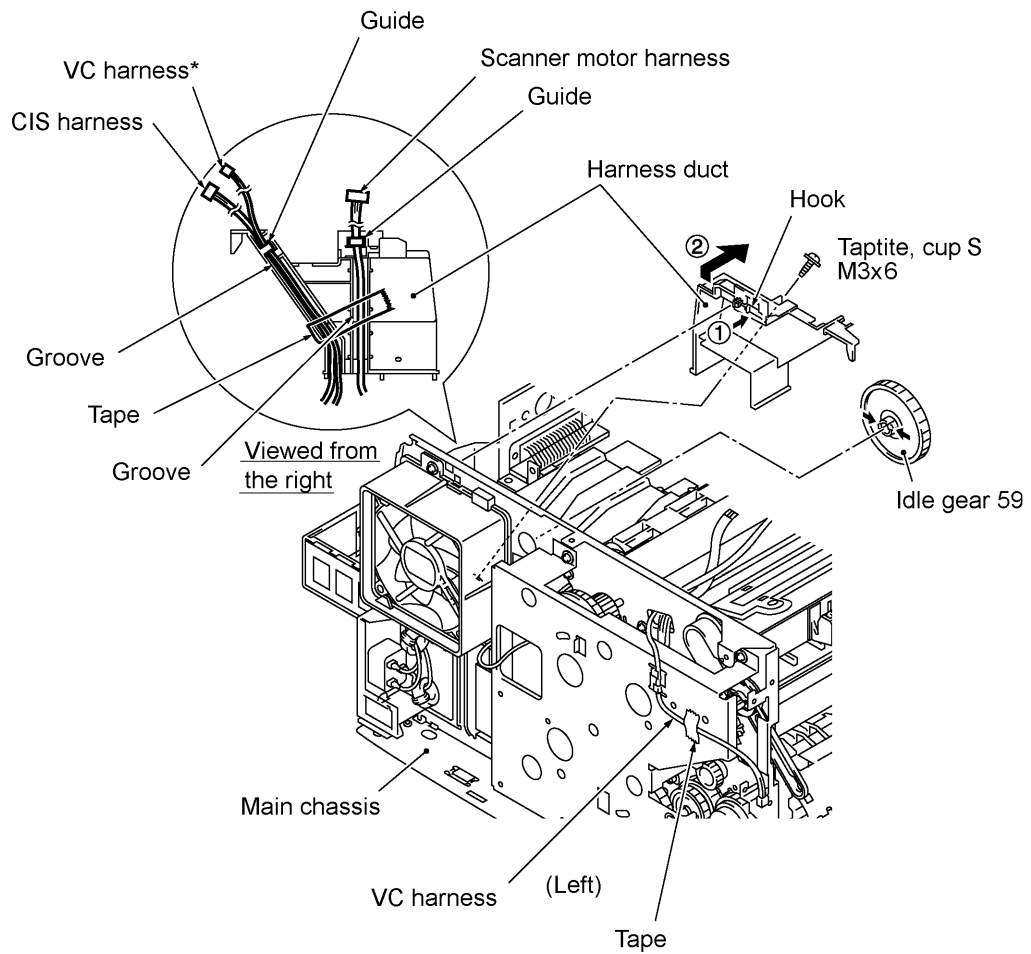

- (4) Remove three screws (two "a" and one "b").
- (5) Disconnect the long heater wire (of the heater harness) from the upper center of the heat-fixing unit.
- (6) Disconnect the short heater wire (of the heater harness) from the left end of the heat-fixing unit.
- (7) Lift up the heat-fixing unit and disconnect the heater thermistor harness from the engine PCB.

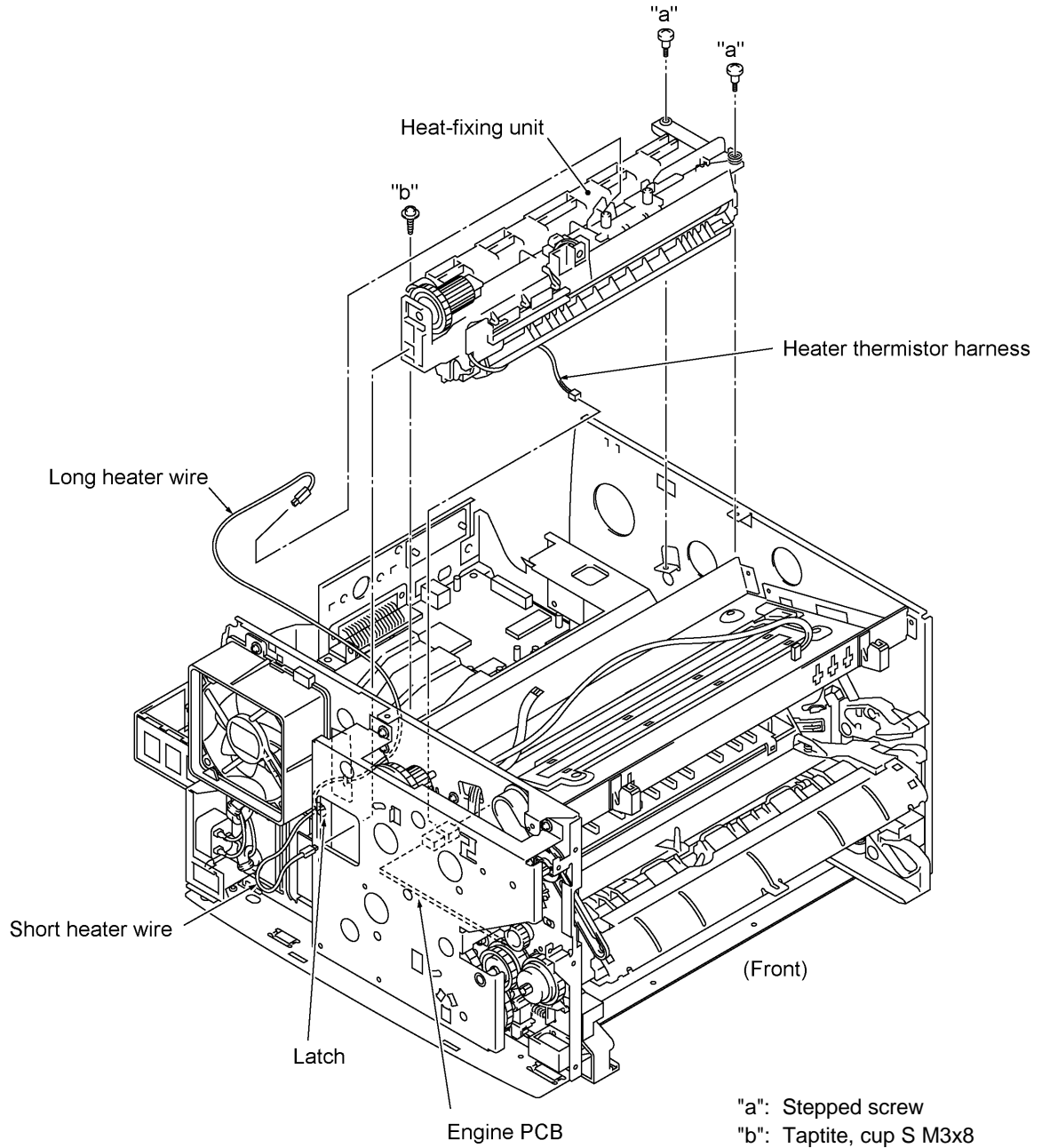

- (8) To take out the FU lamp from the heat-fixing unit, remove two screws "c."
- (9) Unhook the two latches outwards (in the direction of arrows) with the tip of a flat screwdriver and open the upper cover (arrow). The upper and lower covers will become separated from each other.
- (10) Loosen screw "d" (arrow).
- (11) Remove screw "e," slightly lift up the heater roller gear (arrow), hold the lock plate L of the FU lamp between your fingers, and pull out the FU lamp from the heater roller (arrow).

CAUTION: Do not touch the FU lamp. If you have touched it, clean it thoroughly with alcohol.

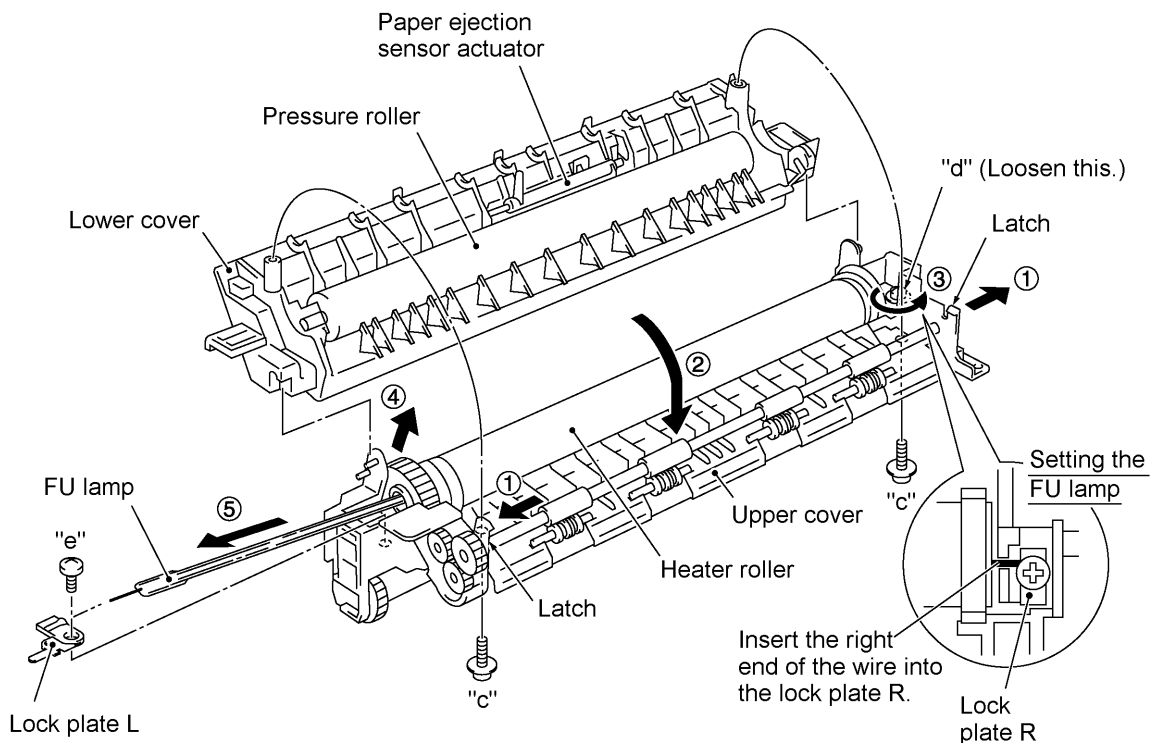

"c": Taptite, cup B M3x20
 "d": Pan cup M3x6
 "e": Taptite, pan M3x10DB

Reassembling Notes

- When setting the FU lamp into the heat-fixing unit, be sure to insert the right end of the wire into the lock plate R as illustrated above.

- When securing the lock plate R with screw "d," be sure to use the plastic jig as shown below to avoid damaging the edge of the FU lamp with a screwdriver.

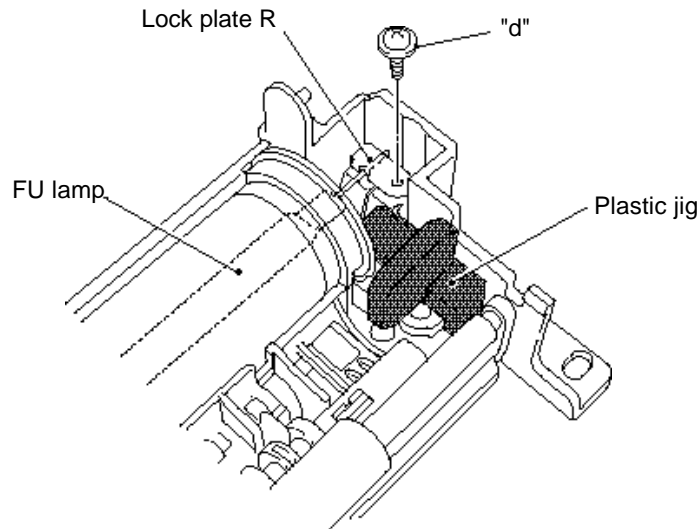

- A new heat-fixing unit will be provided with the heater thermistor harness being taped to the unit. Before installing the unit, remove the tape.
- When setting the heat-fixing unit back into place, make sure that the heater wires are routed through the latch of the fan duct (see the illustration given on page IV-34) and then route the long heater wire as shown below.

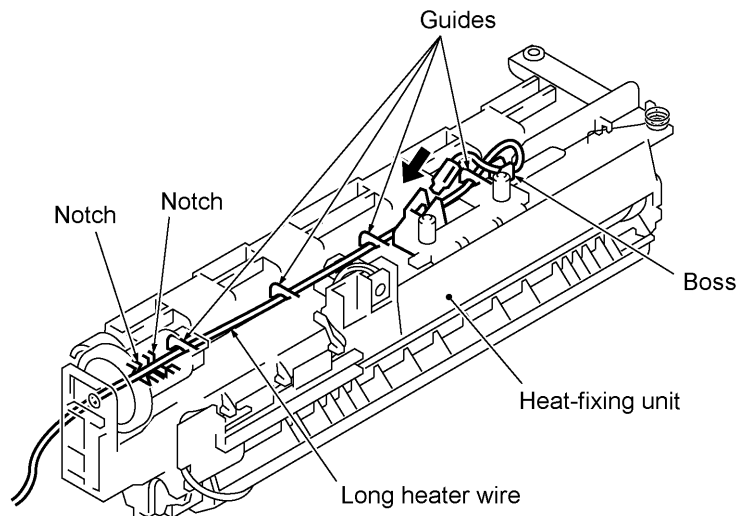

- If you remove and reinstall the heat-fixing unit because of any failure, make the equipment enter the maintenance mode (by pressing the **Function/Menu**, * **2**, **8**, **6**, and **4** keys) after completion of reassembly and then make it exit from the mode (by pressing the **9** key twice). Otherwise, the heat-fixing unit may not become energized because of the following reason:

If the failure of the heat-fixing unit is caused by an opening of the thermistor circuit (that senses the temperature of the heat-fixing unit), the system misinterprets the hot heater as being cold. As a result, the temperature of the heat-fixing unit may become excessively high. To prevent the system from heating the hot heater further at the next powering-on, it is designed so that the heater will not be energized. To cancel this setting, you need to carry out the above maintenance-mode procedure.

1.18 Fan

- (1) Disconnect the fan harness from the engine PCB.
- (2) Remove two screws, take out the heater wires from the latch of the fan duct, and take off the fan duct together with the fan.

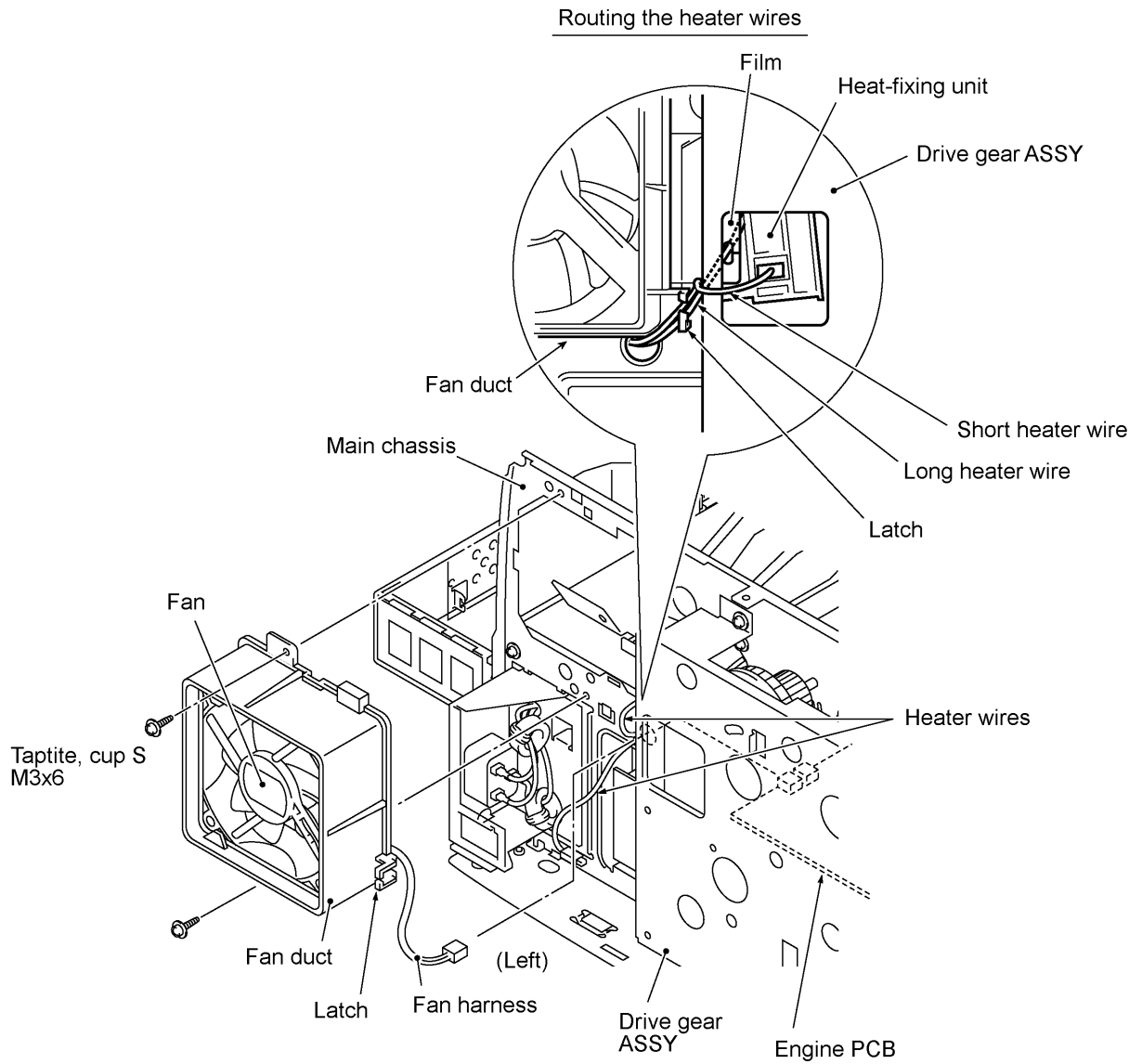

(3) As shown below, pull the fan duct outwards and take out the fan.

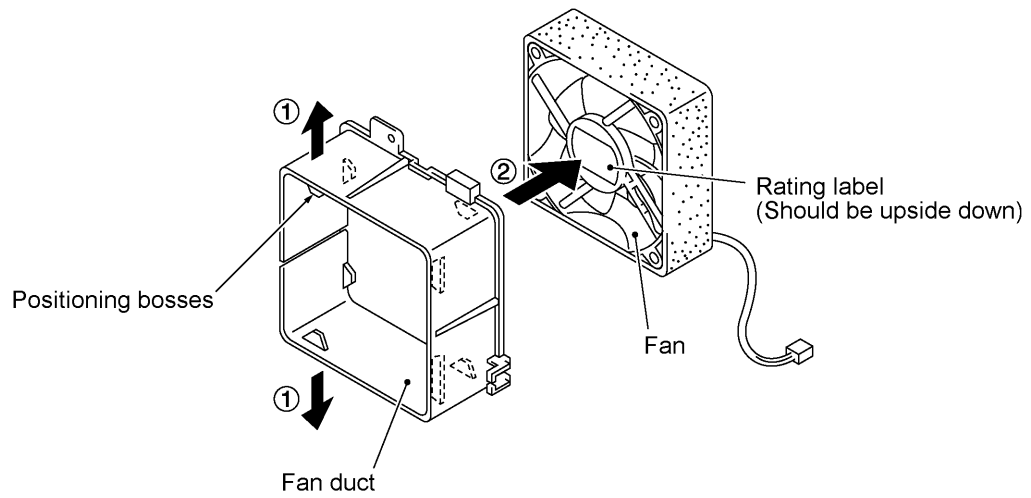

Reassembling Notes

- Put the fan back into place so that the rating label faces outwards and upside down.
- Route the heater wires through the latch of the fan duct as shown on the previous page.

1.19 Drive Gear ASSY and Main Motor ASSY

- (1) Remove five screws from the drive gear ASSY.
- (2) Tilt the drive gear ASSY towards you while taking care not to drop the develop joint and spring, and then disconnect the main motor harness.
- (3) Remove the front cover link and idle gear 56 from the main chassis.

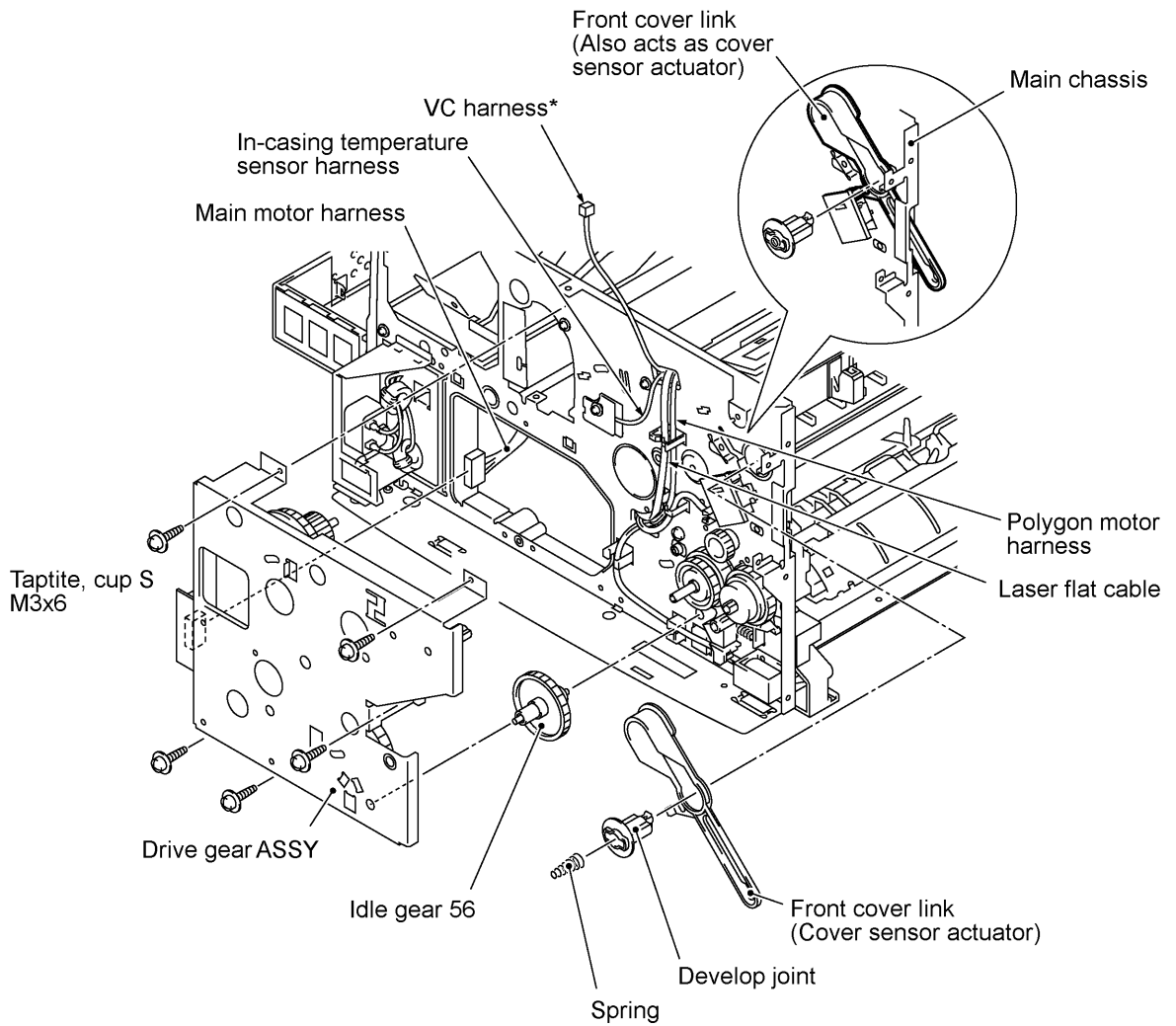

*Provided on models supporting video capture

- (4) Remove four screws and take off the main motor ASSY from the drive gear ASSY.

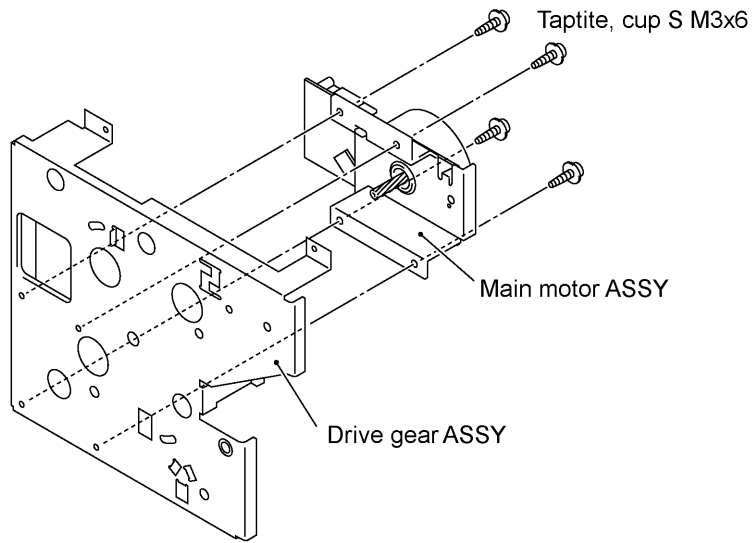

Reassembling Notes

- If you have removed the gear 39/98 from the drive gear ASSY, hook the spring as shown below.

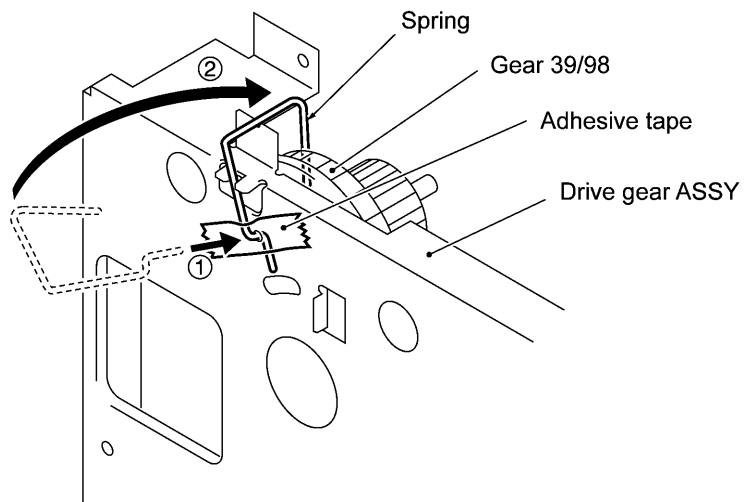

1.20 NCU Shield and NCU PCB

- (1) Remove three screws from the NCU shield, then take off the NCU shield.

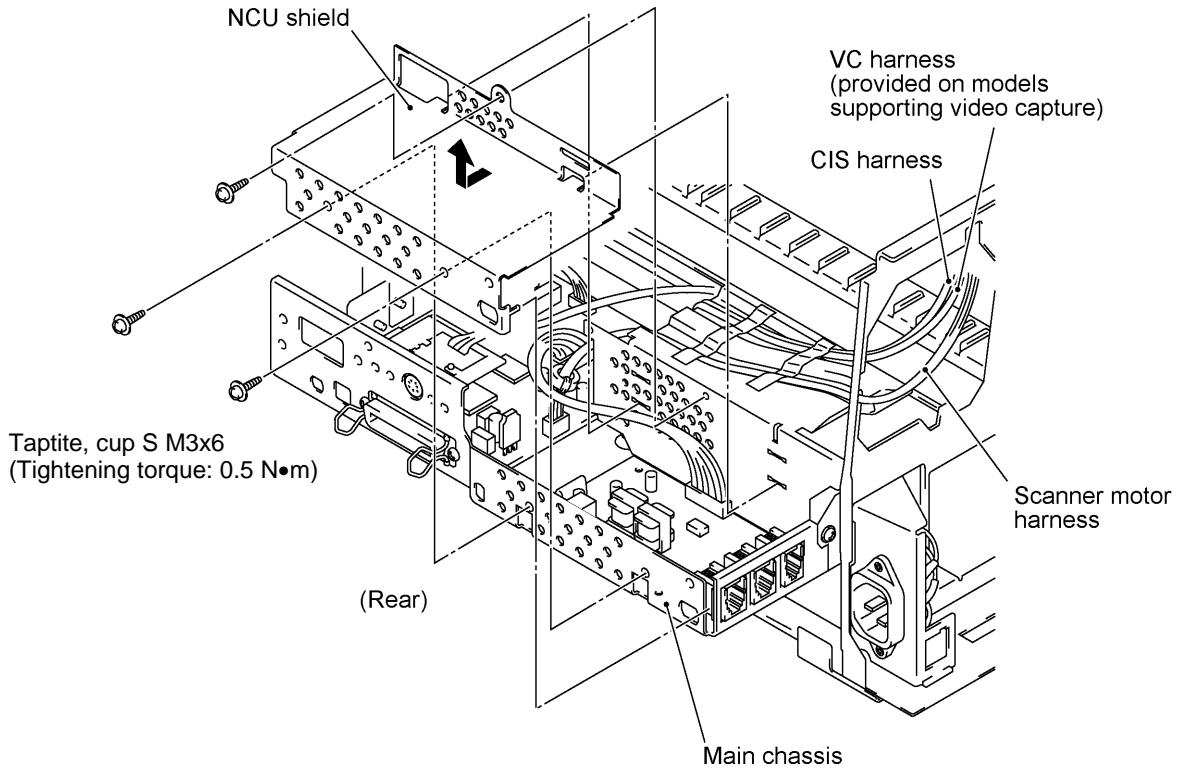

- (2) USA version: Disconnect the main-NCU harness from the main PCB.
European version: Disconnect the main-NCU harness and main-NCU harness 2 from the main PCB. See the illustration given on the next page.
- (3) Remove the screw from the NCU PCB and take out the PCB.

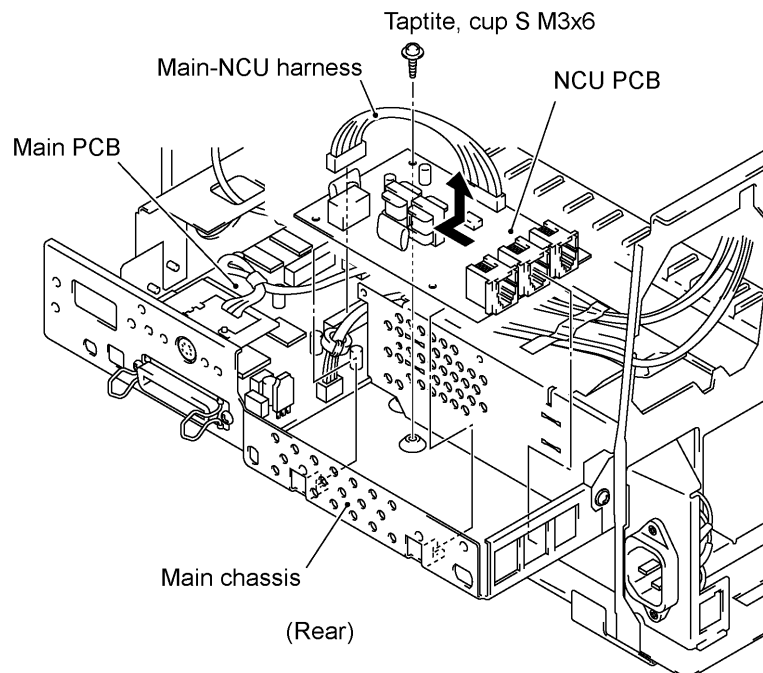

Reassembling Notes

[USA version]

- Route the main-NCU harness above the scanner motor harness as illustrated below.

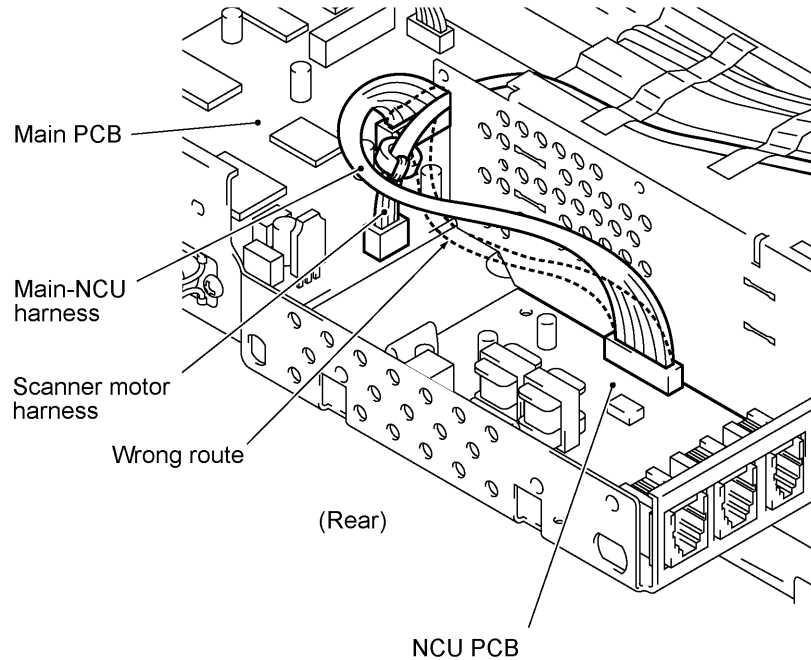

[European version]

- As illustrated below, route the main-NCU harness and main-NCU harness 2 between the NCU PCB and the power supply bracket to prevent them from interfering with the primary circuitry on the NCU PCB. Then install the NCU shield.

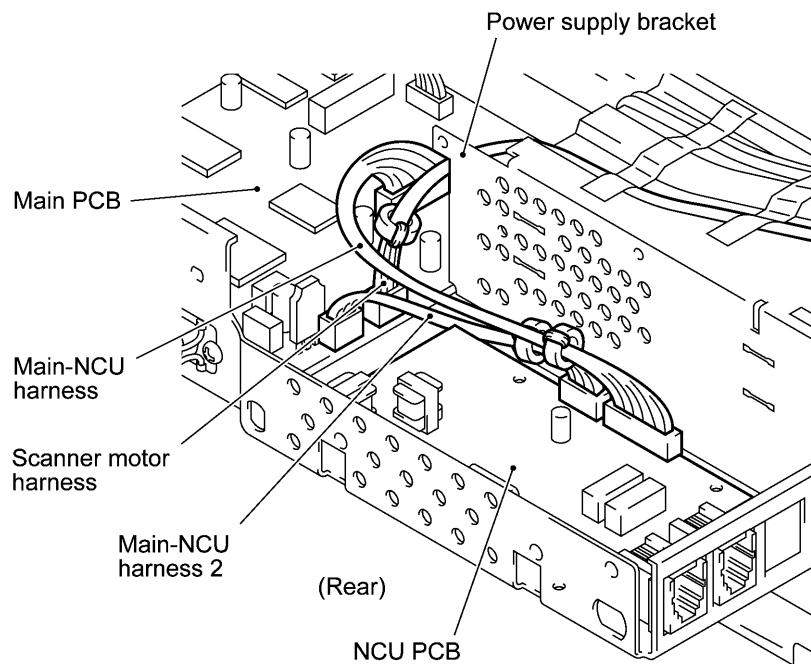

1.21 Bottom Plate, Main PCB, and Bottom Insulation Film

(1) Disconnect the following harnesses and flat cable from the main PCB:

- Panel-main harness (6-pin, P3)
- Main-LV-engine harness (6-pin, P22)
- Laser flat cable (P9)
- Engine-main harness (12-pin, P8)
- VC harness*¹ (2-pin, P11)
- CIS harness (7-pin, P12)
- In-casing temperature sensor harness (2-pin, P13)
- Scanner motor harness (4-pin, P14)

*¹ Provided on models supporting video capture

*² Provided on models equipped with a handset

*³ Provided on the European version

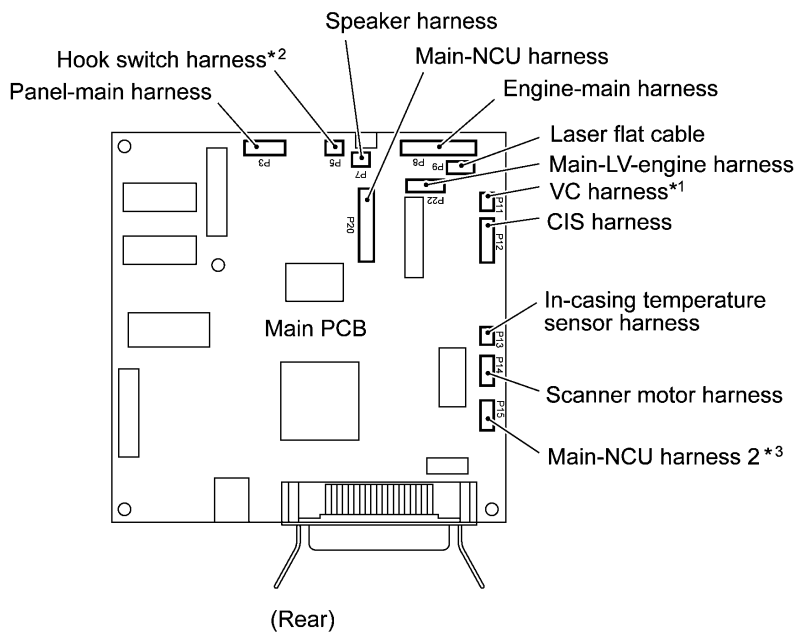
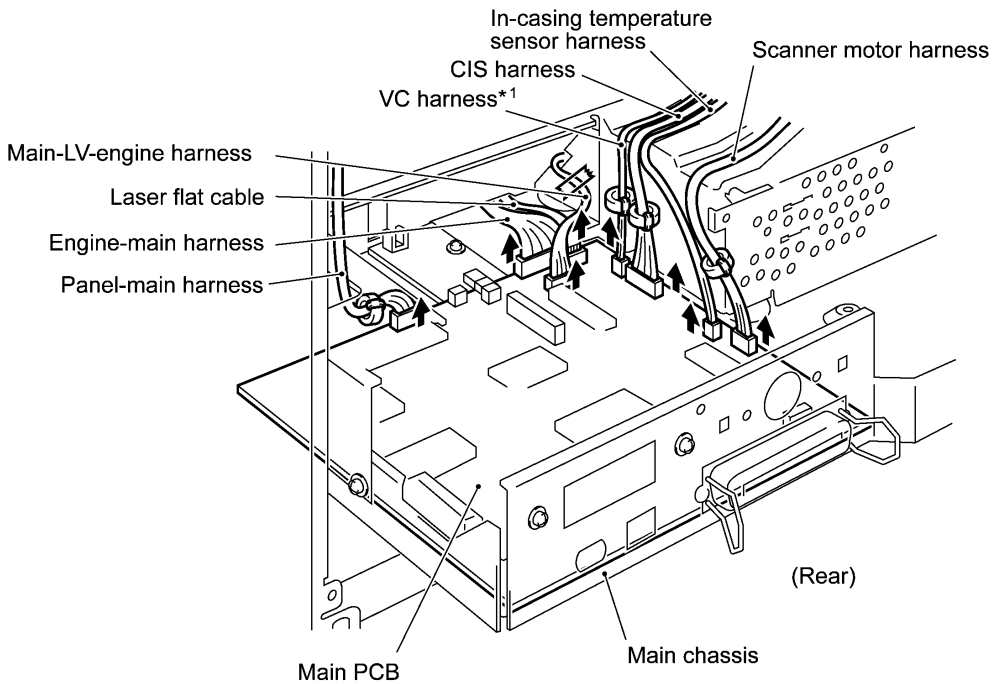

- (2) Turn the main chassis upside down.
- (3) Remove 14 screws (nine "a" and five "b").
- (4) Slightly lift up the bottom plate and pull it to the rear until you can remove screw "c."
- (5) Remove screw "c" to release the grounding wire.
- (6) For models available with a 2nd paper cassette: Unhook the 2nd cassette relay PCB bracket from the bottom plate.
- (7) Pull the bottom plate to the rear and out of the main chassis.

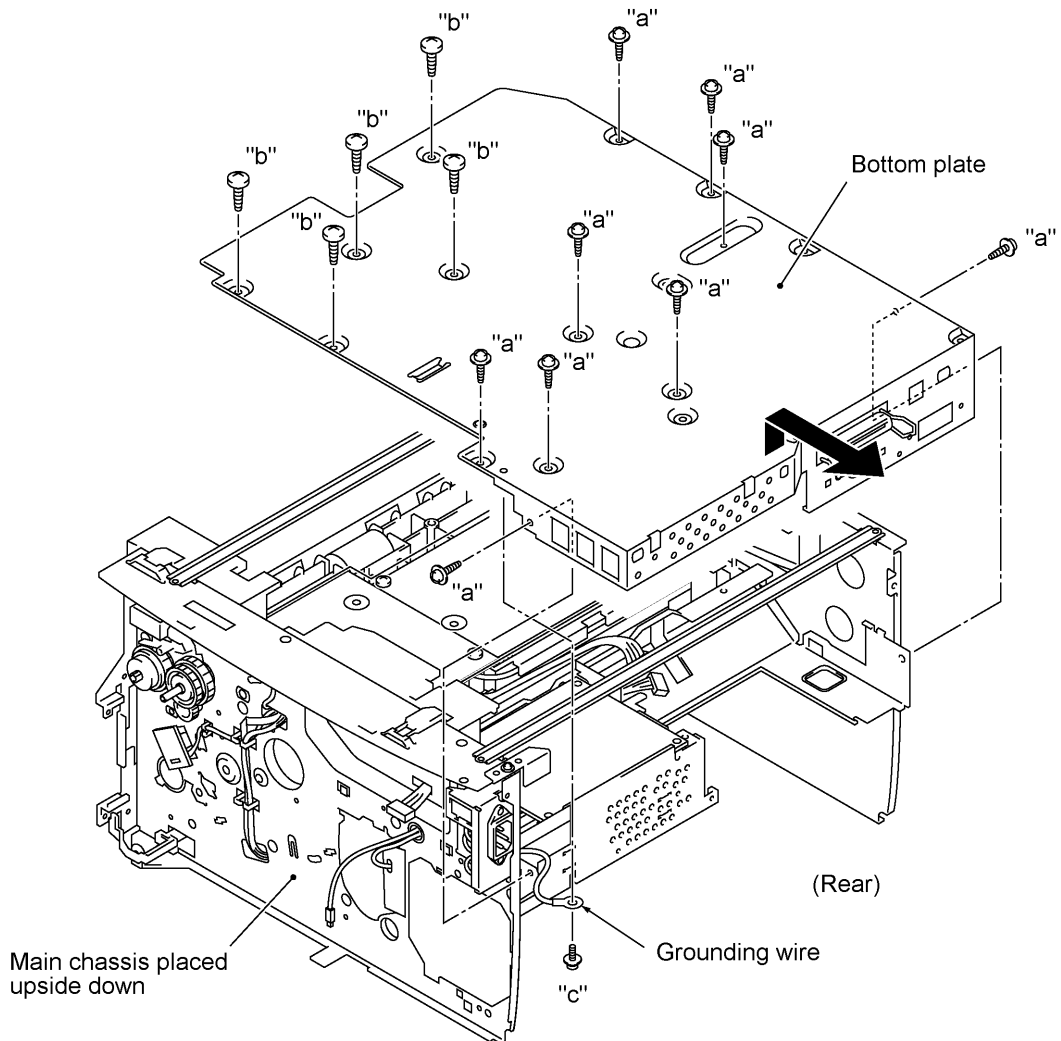

- "a": Taptite cup S M3x6
- "b": Taptite, blind B M4x12
- "c": Screw, pan (washer) M3.5x6

- (8) Remove screw "d" and disconnect the paper ejection sensor PCB from the main PCB.
- (9) Remove five screws (three "e" and two "f"), then take off the main PCB from the bottom plate.
- (10) Remove the bottom insulation film.

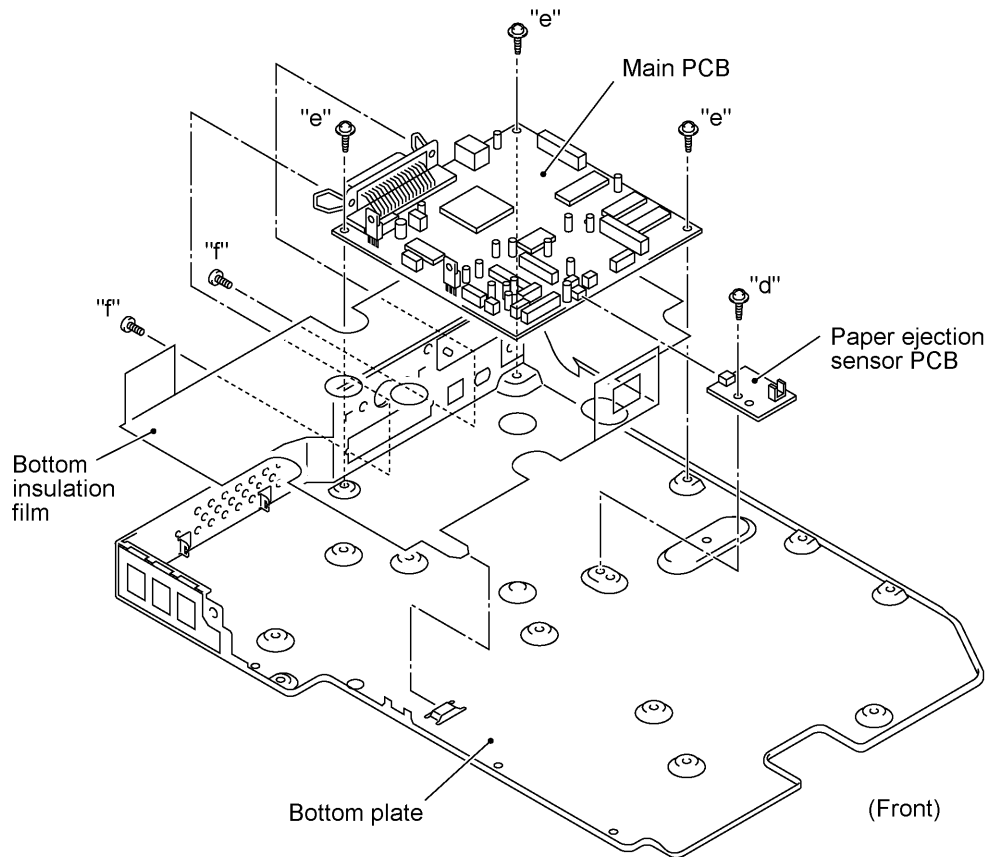

"d" and "e": Taptite, cup S M3x6
 "f": Machine screw, pan M3x6

Reassembling Notes

- When putting the bottom plate back into place, make sure that the grounding wire is looped and routed through the support film (as illustrated on page IV-44) and then secure the grounding wire to the bottom plate with screw "c" (shown on the previous page).
- When connecting the engine-main harness, laser flat cable, and main-LV-engine harness to the main PCB, prevent them from interfering with each other in the vicinity of the connectors.
- After you replace the main PCB, be sure to follow the flowchart given on the next page.

Setting up the main PCB after replacement

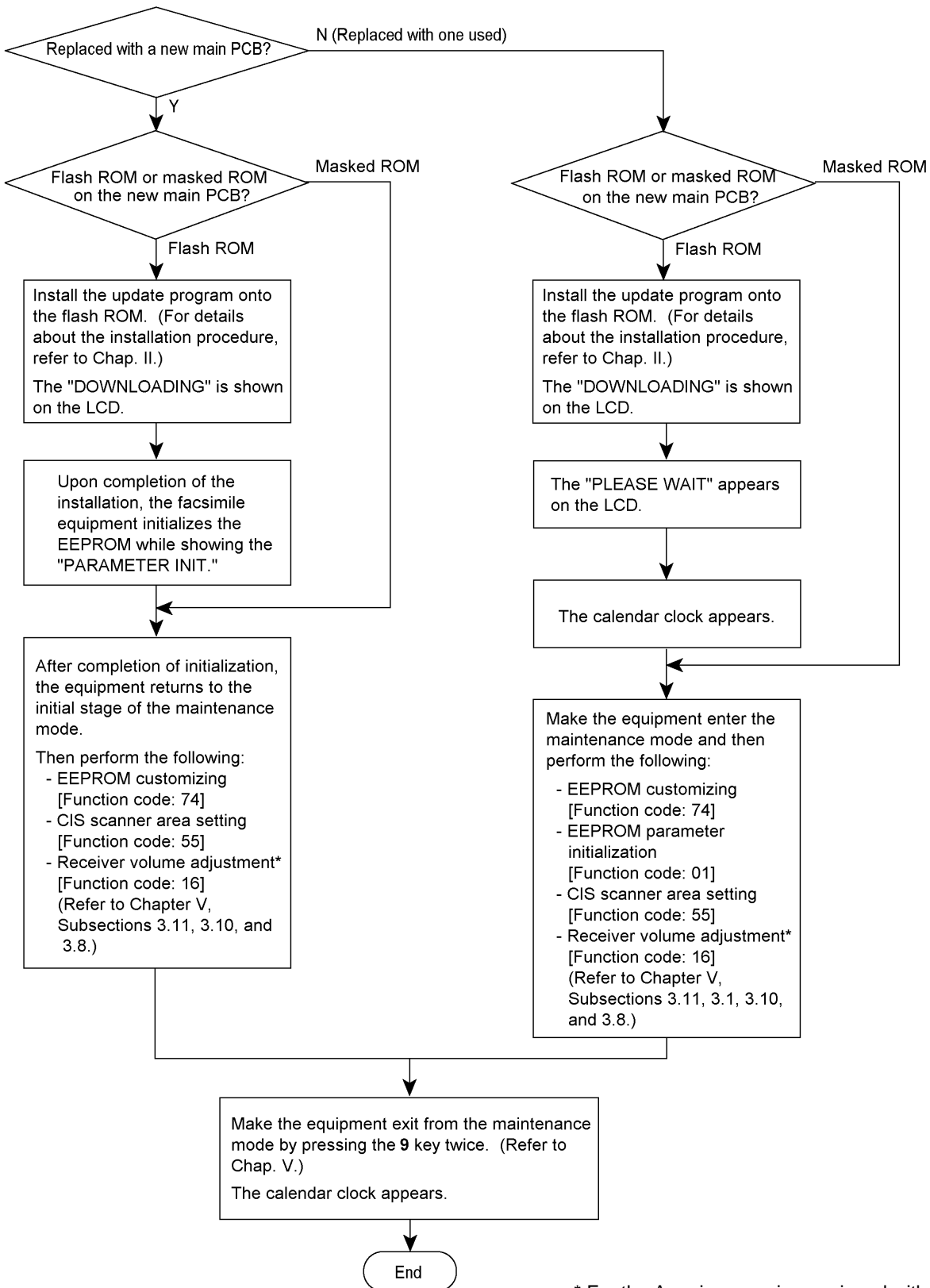

* For the American version equipped with a handset.

1.22 Low-voltage Power Supply PCB and Power Inlet

- (1) Remove two screws "g" and take off the rear underbar.
- (2) Remove screw "h."
- (3) Slightly lift up the low-voltage power supply PCB and disconnect the heater harness and main-LV-engine harness. The low-voltage power supply PCB is connected to the power inlet with soldered lead wires.
- (4) Remove screw "i."
- (5) While holding up the low-voltage power supply PCB, take out the power inlet from the main chassis to the inside in the direction of the arrow shown below.
- (6) To separate the power inlet from the low-voltage power supply PCB, unsolder the two lead wires from the PCB.

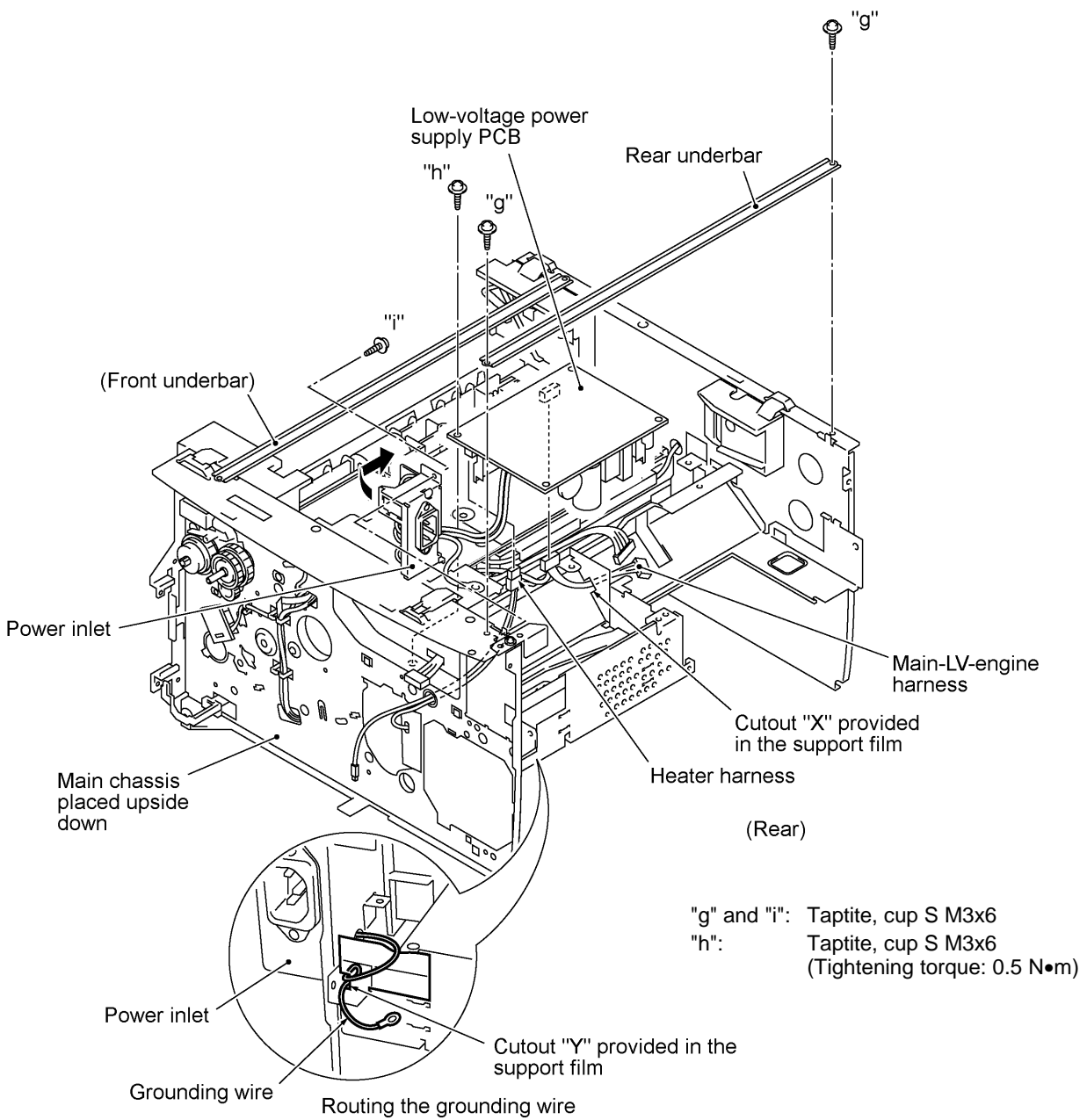

Reassembling Notes

- When connecting the power inlet to the low-voltage power supply PCB, insert the brown and blue lead wires into eyelets L and N in the PCB, respectively, and then solder those wires on the solder side of the PCB.

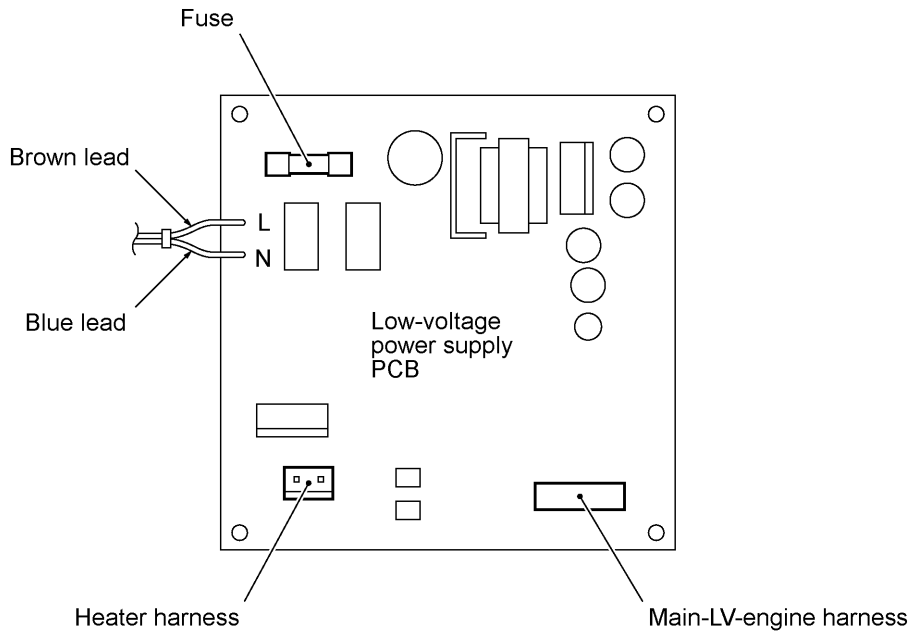

- After setting the power inlet back into place, fold the grounding wire into two and route the fold through cutout "Y" provided in the support film as shown on the previous page.
- When reinstalling the low-voltage power supply PCB, route the main-LV-engine harness through cutout "X" provided in the support film as shown on the previous page.

1.23 Inner Insulation Film, High-voltage Power Supply PCB, Engine PCB, and 2nd Cassette Relay PCB*

(*Provided on models available with a 2nd paper cassette)

- (1) Remove screw "a" and take off the inner insulation film.
- (2) Remove three screws (two "b" and one "c") from the high-voltage power supply PCB and engine PCB.
- (3) Slightly lift up the high-voltage power supply PCB and disconnect it from the engine PCB.
- (4) Pull the spring up and out.
- (5) Slightly hold up the engine PCB and disconnect the following harnesses:
 - Toner sensor (light-receiver) harness (3-pin, P1)
 - Main-LV-engine harness (2-pin, P15)
 - 2nd cassette relay harness* (8-pin, P8)
 - Heater thermistor harness (2-pin, P6), if the heat-fixing unit has not been removed
 - Fan harness (2-pin, P7), if the fan has not been removed
 - Toner sensor (LED) harness (4-pin, P10)
 - Main motor harness (6-pin, P9)
 - Polygon motor harness (5-pin, P12)
 - Solenoid harness (2-pin, P13)

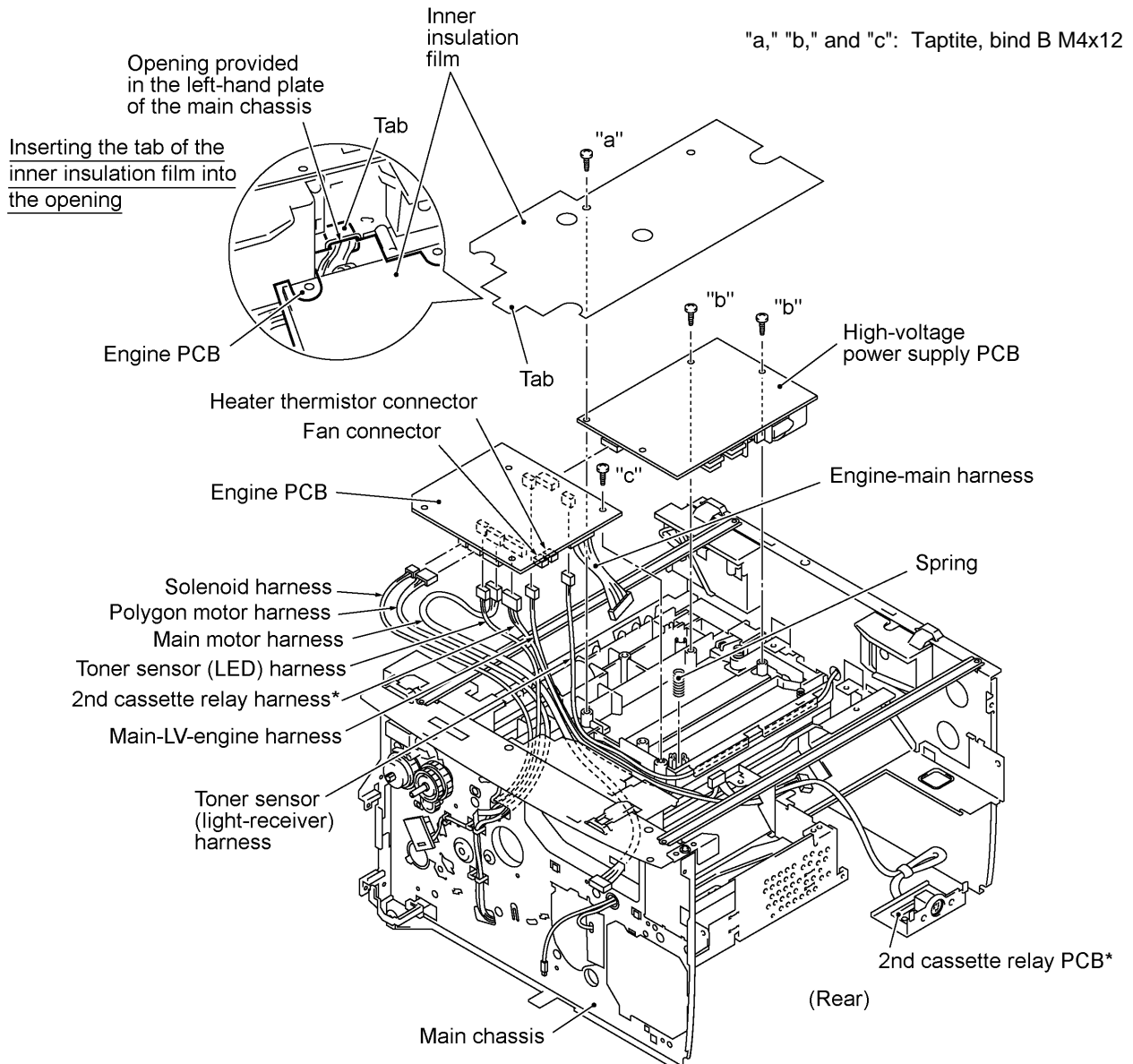

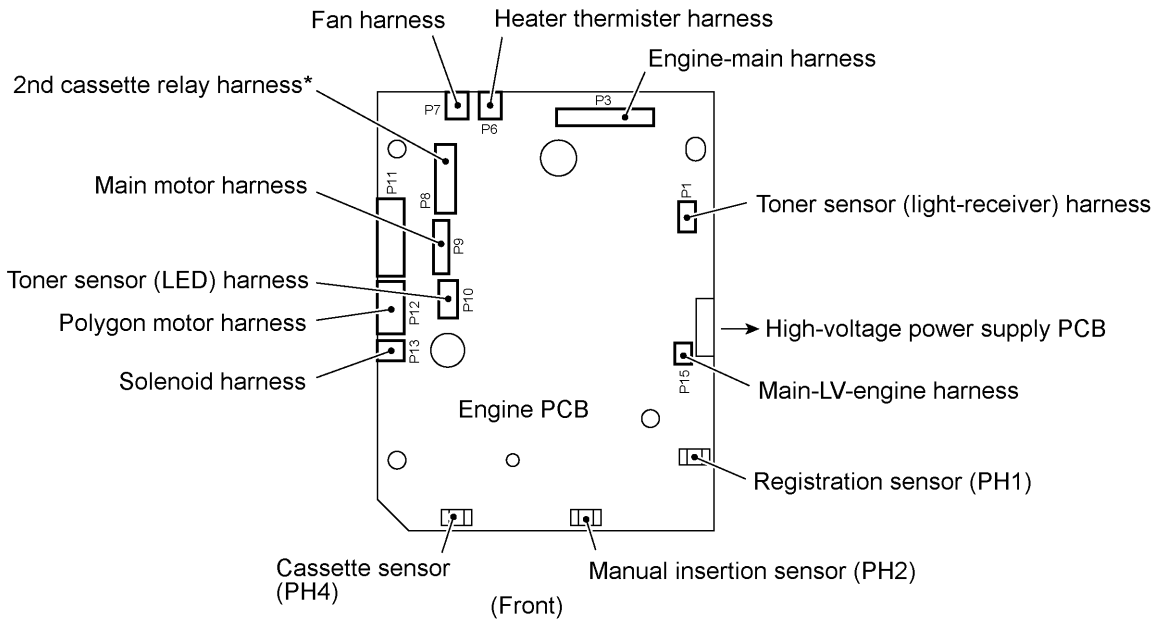

- (6) For models available with a 2nd paper cassette: Pull the 2nd cassette relay PCB bracket to take out its harness. Remove the screw and take off the 2nd cassette relay PCB from its bracket.

Reassembling Notes

- Before reinstalling the high-voltage power supply PCB, push in the spring with a flat screwdriver until it snaps into place as shown below.

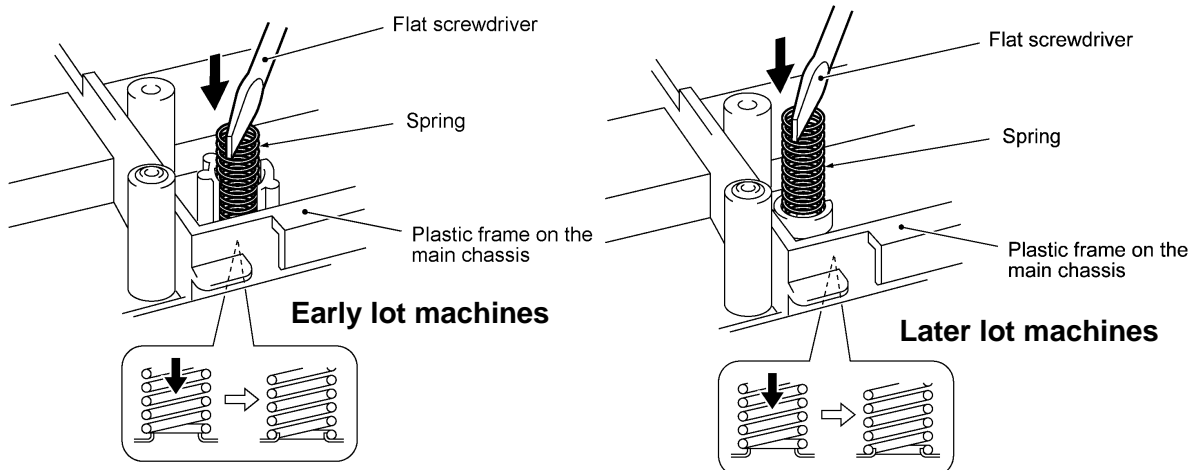

- Before reinstalling the high-voltage power supply PCB, check the high-voltage contacts for any toner particles, paper dust or dirt, and clean them out.

1.24 Toner Sensor (light-receiver) PCB and Toner Sensor (LED) PCB

- (1) At the right-hand plate of the main chassis, remove the screw from the toner sensor (light-receiver) PCB, release its harness from the two harness latches, and then pull it out.
- (2) At the left-hand plate of the main chassis, press the both sides of the lens support on the toner sensor (LED) PCB with your fingers to release them from the main chassis, release its harness from the two latches, and then pull it out.

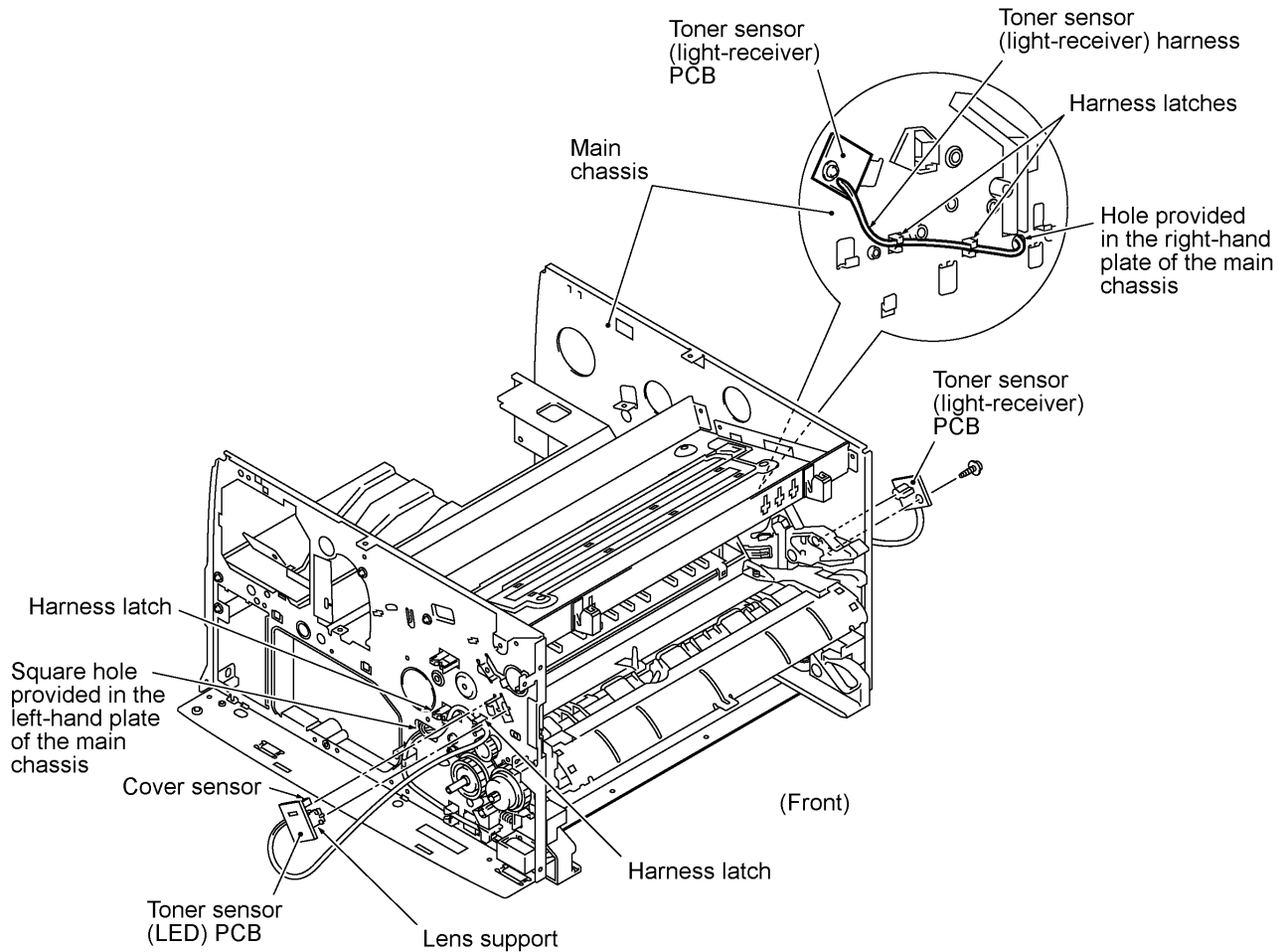

Reassembling Notes

- Route the toner sensor (LED) harness on the left-hand side of the main chassis as shown above. Also refer to the illustration given on page IV-46.
- Route the toner sensor (light-receiver) harness on the right-hand side of the main chassis as shown above and on the top of the plastic frame as shown on page IV-46.

1.25 Gears and Paper Pick-up Roller

- (1) Place the main chassis upside down.
- (2) Remove the inner gear 54 (by pulling its pawl outwards), gear 45 set P/R, gear 20 P/R, and the bushing from the end of the paper pick-up roller shaft.
- (3) Remove the pawled bushing by pulling its pawl outwards, then remove the paper pick-up roller and its shaft.
- (4) Remove the gear 40/54, gear 45 set F/R, and gear 20 F/R.
- (5) If the engine PCB has been removed, take out the cassette sensor actuator. (This prevents the actuator from dropping during the following disassembly jobs.)

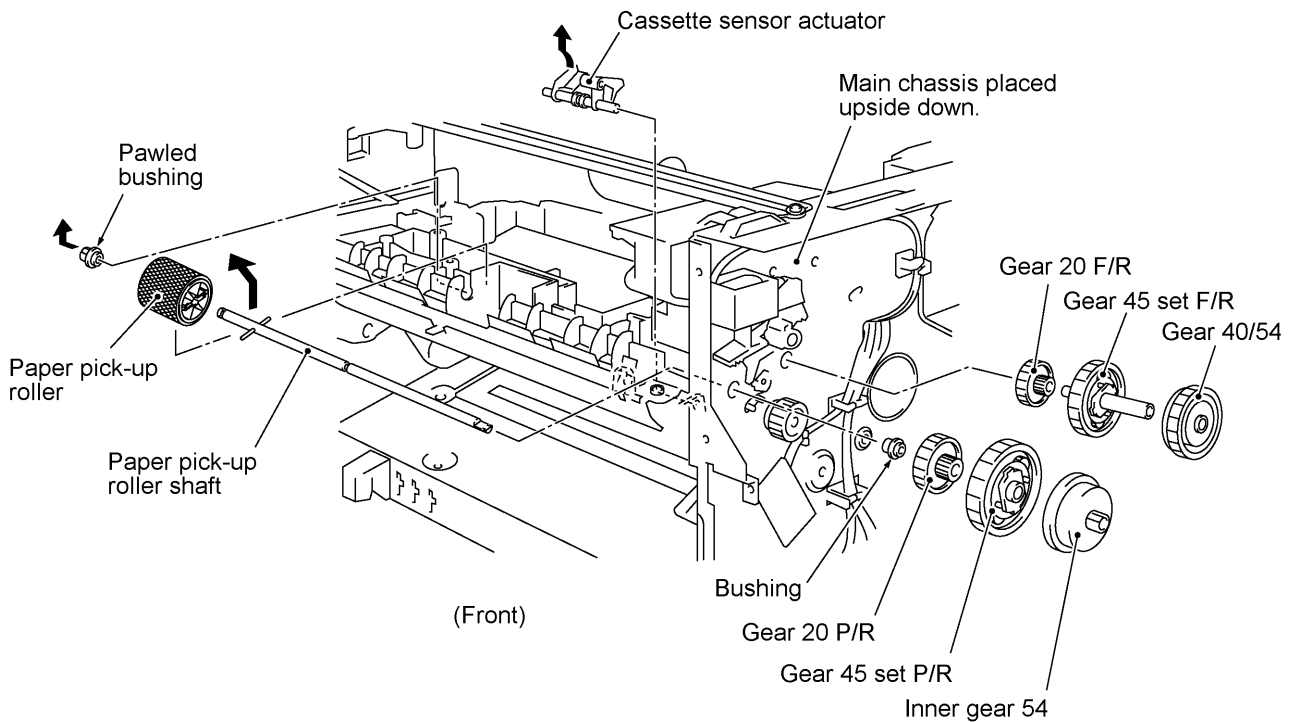

1.26 Paper Feed Roller ASSY

- (1) Unhook the latch (arrow) provided on the underside of the plastic frame by using a small flat screwdriver and pull out the gear 21 (arrow).
- (2) Place the main chassis rightside up.
- (3) At the right end of the paper feed roller shaft, pull up the pawl of the bushing (arrow) with the tip of a flat screwdriver and move the paper feed roller ASSY to the left (arrow). Then take out the bushing and paper feed roller ASSY.
- (4) Remove the joint (arrow).

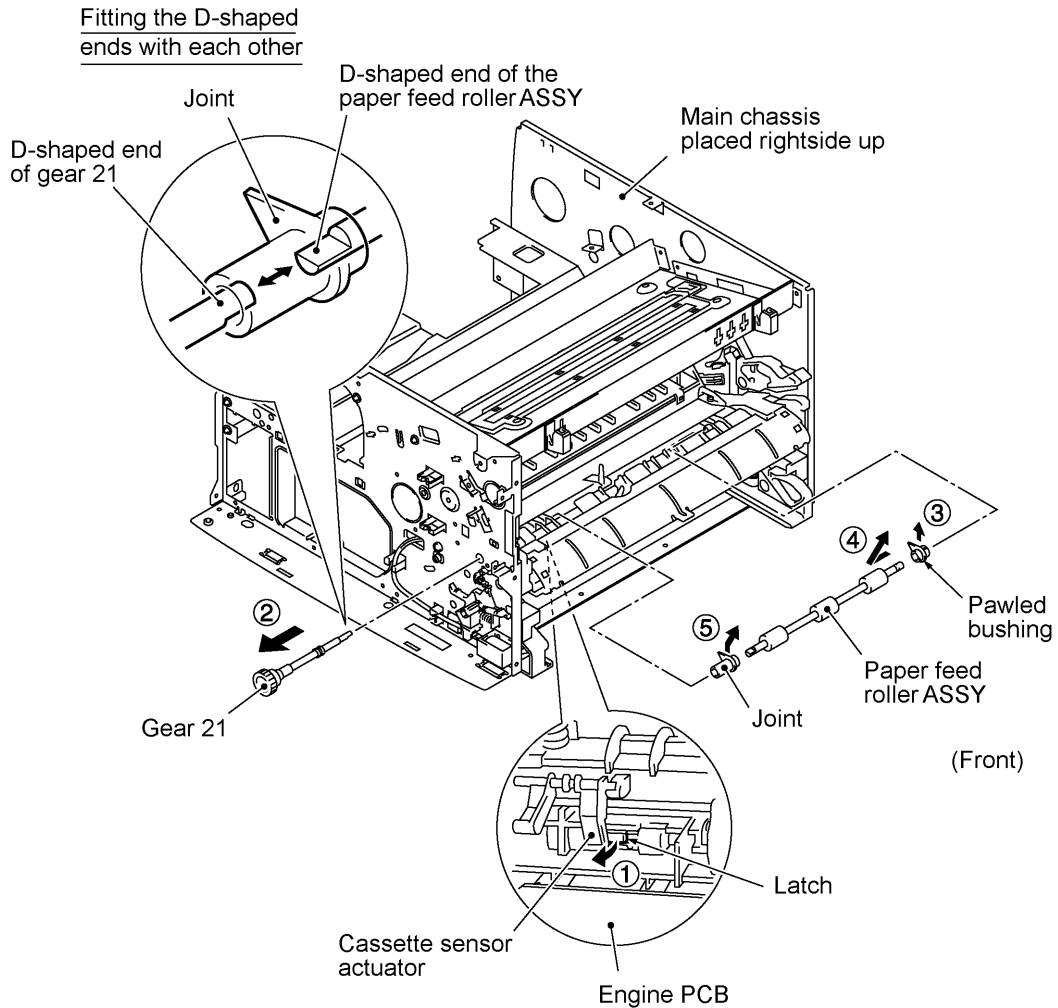

Reassembling Notes

- When setting the gear 21 back into place, insert it and turn it so that its D-shaped end becomes fitted with the D-shaped end of the paper feed roller ASSY.

1.27 Clutch Levers, Cassette Guide L, and Solenoid

- (1) Turn the main chassis upside down.
- (2) Remove the two screws and take off the front underbar (which is shown on page IV-44).
- (3) Place the main chassis rightside up.
- (4) Remove the clutch lever F/R by pulling its pawl outwards.
- (5) Remove the clutch lever spring and clutch lever P/R.
- (6) Remove the plunger and solenoid release spring.
- (7) Remove two screws "a" and take off the cassette guide L.
- (8) Remove screw "b" and take off the solenoid.

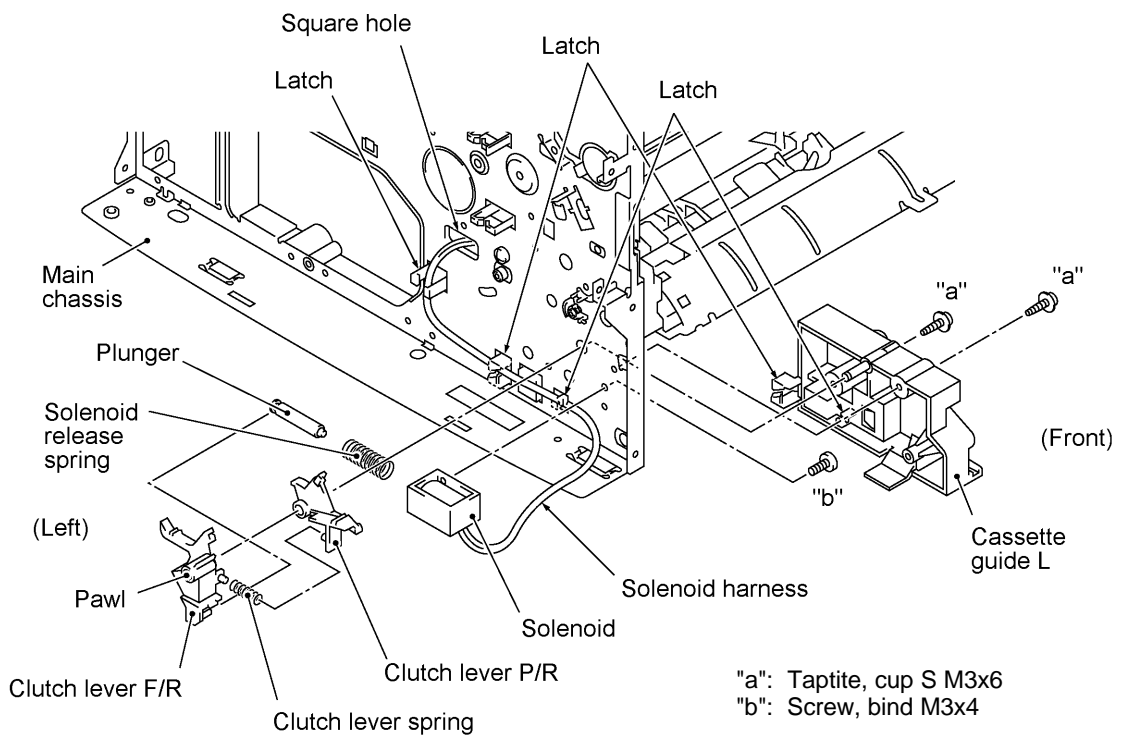

Reassembling Notes

- Route the solenoid harness through three latches and pass it through the square hole provided in the left-hand plate of the main chassis.

1.28 Paper Cassette

- (1) Pull the pressure plate release lever to the front to release the pressure plate.
- (2) Fully slide the side guide (R or L) inwards (in the direction of arrow) and remove the screw. Then release the latches (arrow) and pull up the side guide (arrow).
- (3) Release the pressure plate from the bosses (arrow) and remove it (arrow).
- (4) Fully slide the paper rear guide to the front and lift it up (arrow).

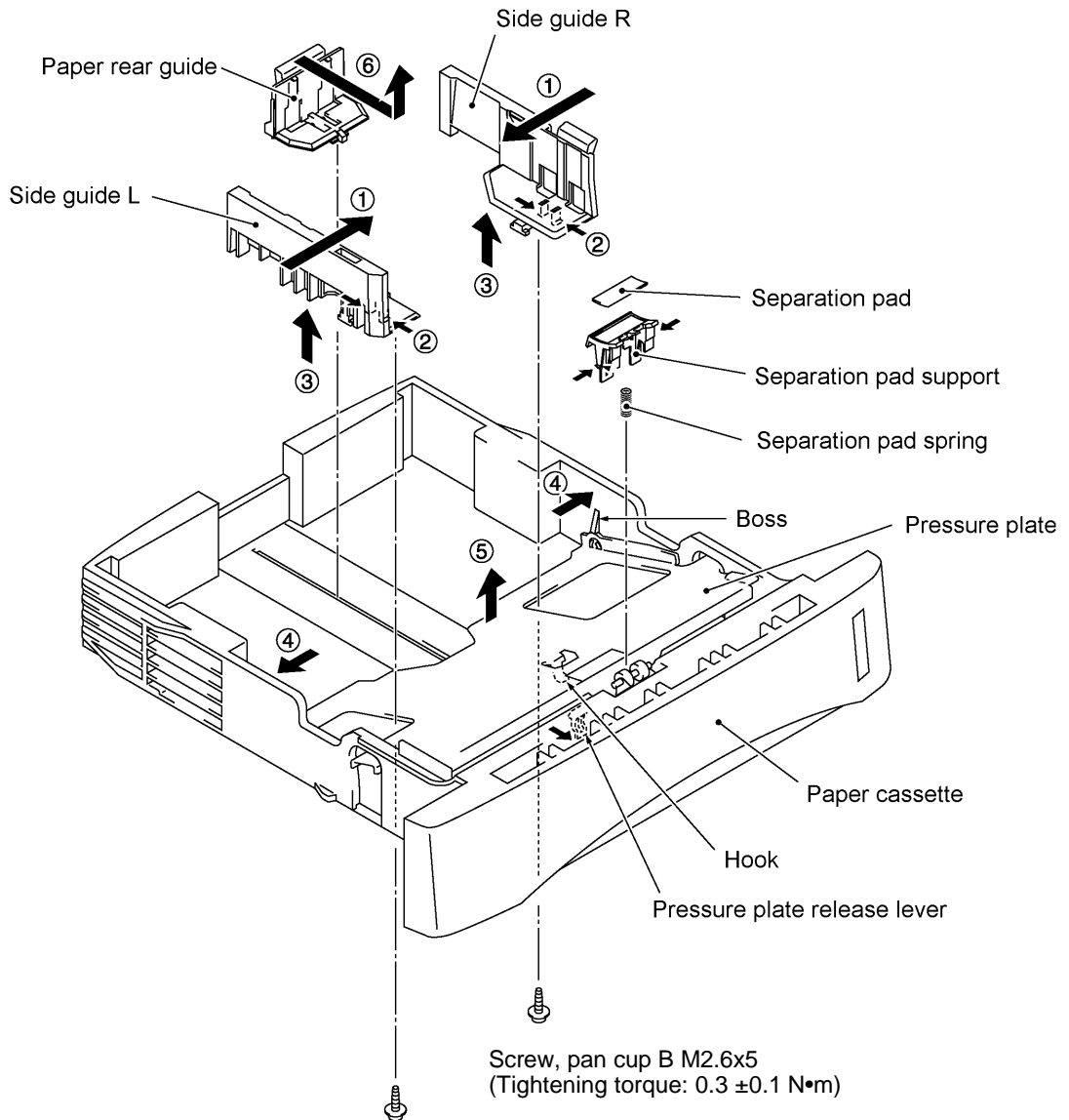

1.29 Cleaning of High-voltage Contacts and Grounding Contacts

If any toner particles, paper dust or dirt are on the contacts, clean them out. This will ensure that power flows correctly to enable printing.

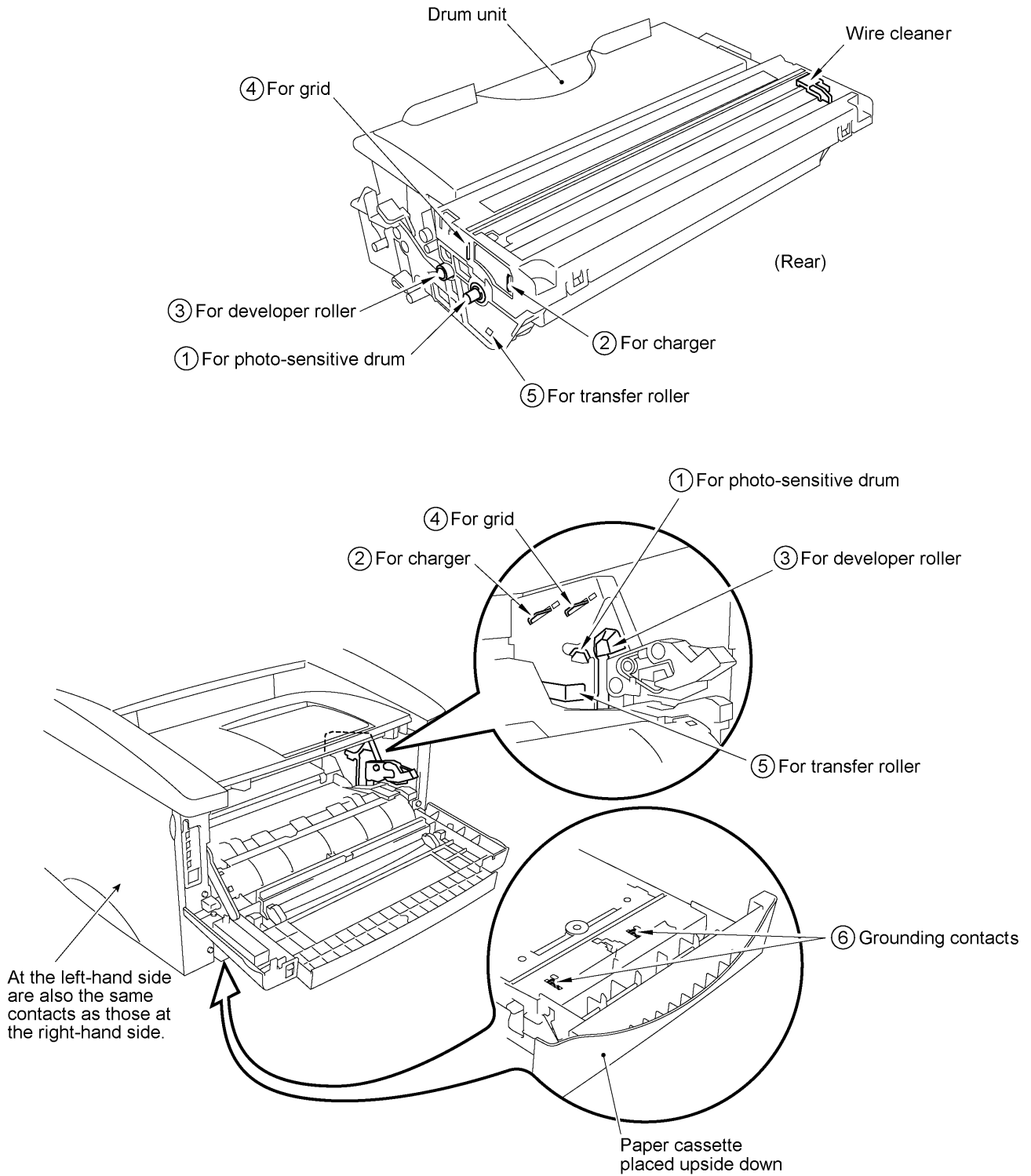

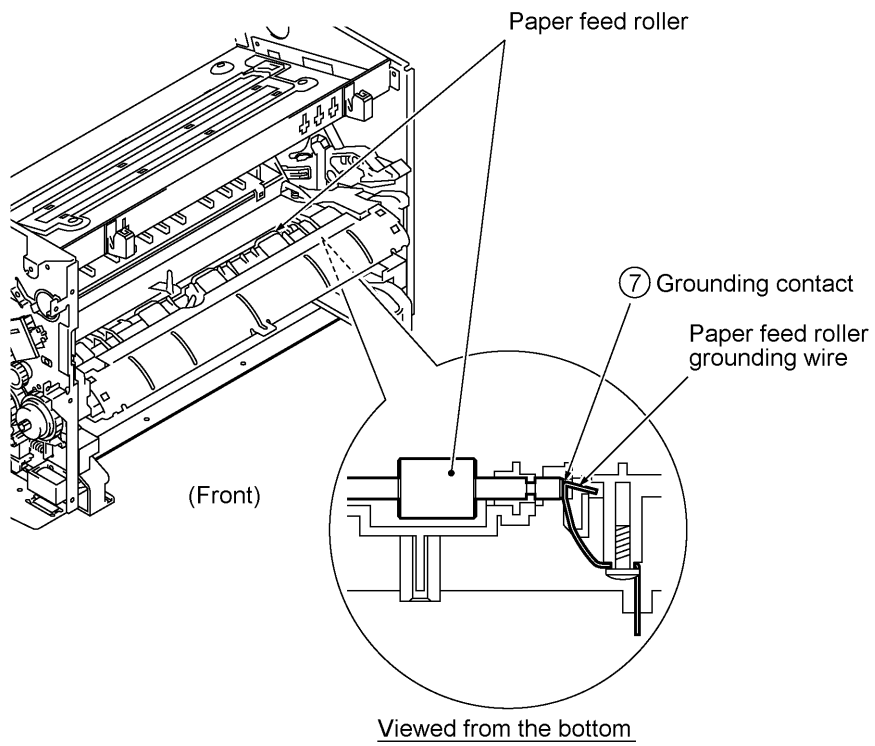

2. LUBRICATION

Apply the specified lubricants to the lubrication points as shown below.

| Lubricant type (Manufacturer) | Lubricant amount | | | |
|--|---|--|---|--|
| | Half of a rice-sized pinch of grease (3 mm ³) | Rice-sized pinch of grease (6 mm ³) | Two rice-sized pinches of grease (12 mm ³) | Five rice-sized pinches of grease (30 mm ³) |
| Molykote grease EM-30L (Dow Corning) | EM0.5 | EM1 | EM2 | EM5 |
| Molykote grease EMD-110 (Dow Corning.) | _____ | EMD1 | _____ | _____ |
| Molykote grease PG662 (Dow Corning) | _____ | PG1 | _____ | _____ |

[1] Document feed roller ASSY and document ejection roller ASSY

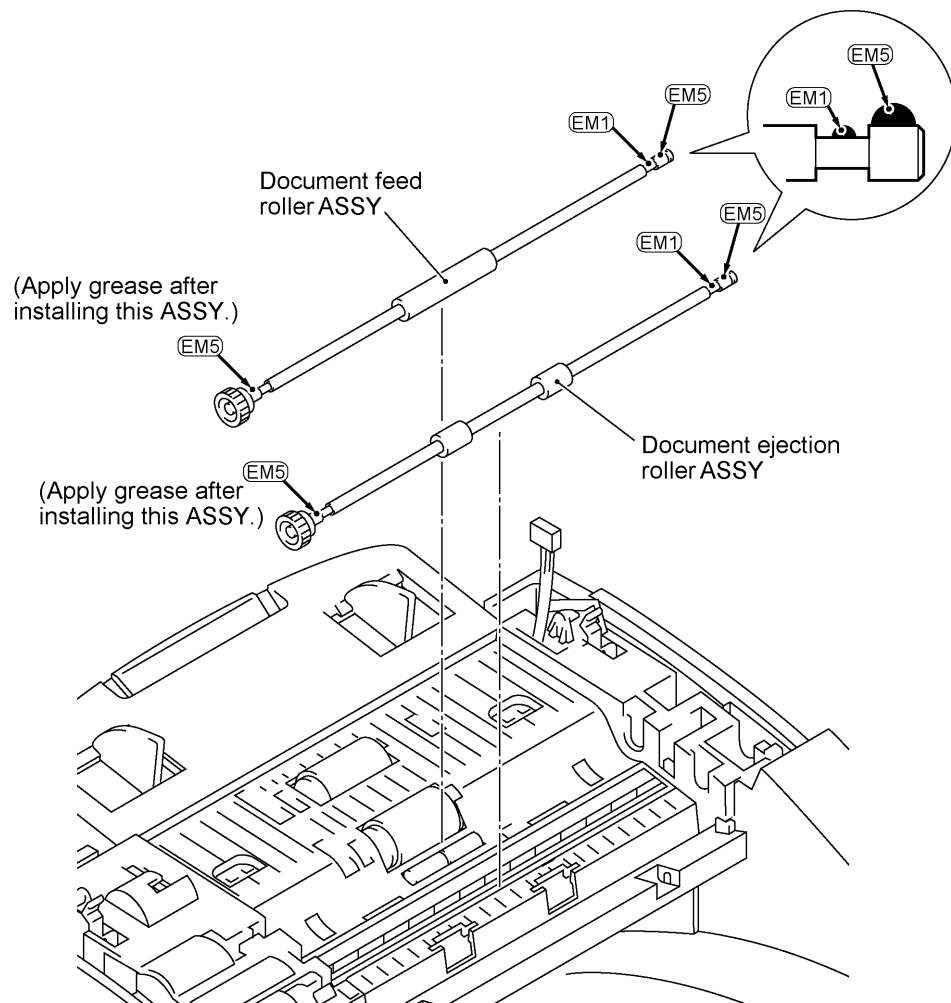

[2] Control panel locks

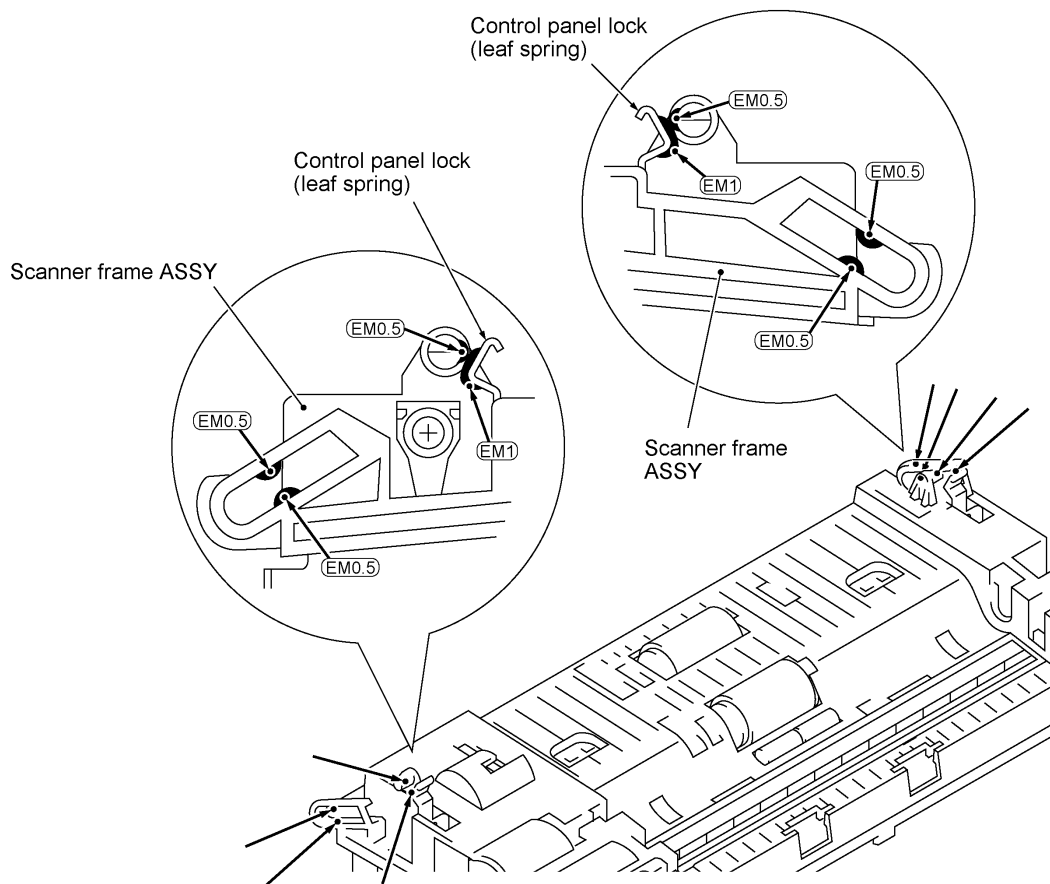

[3] Scanner frame ASSY, document take-in roller and its shaft, and separation roller and its shaft

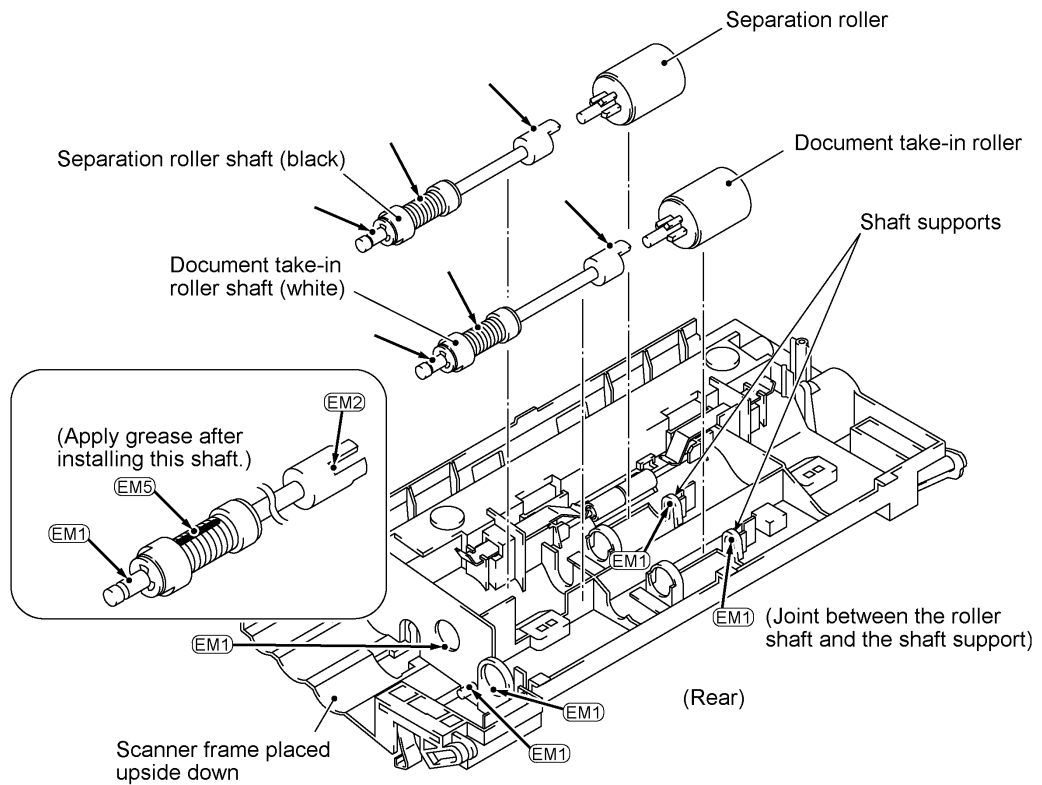

[4] Top cover

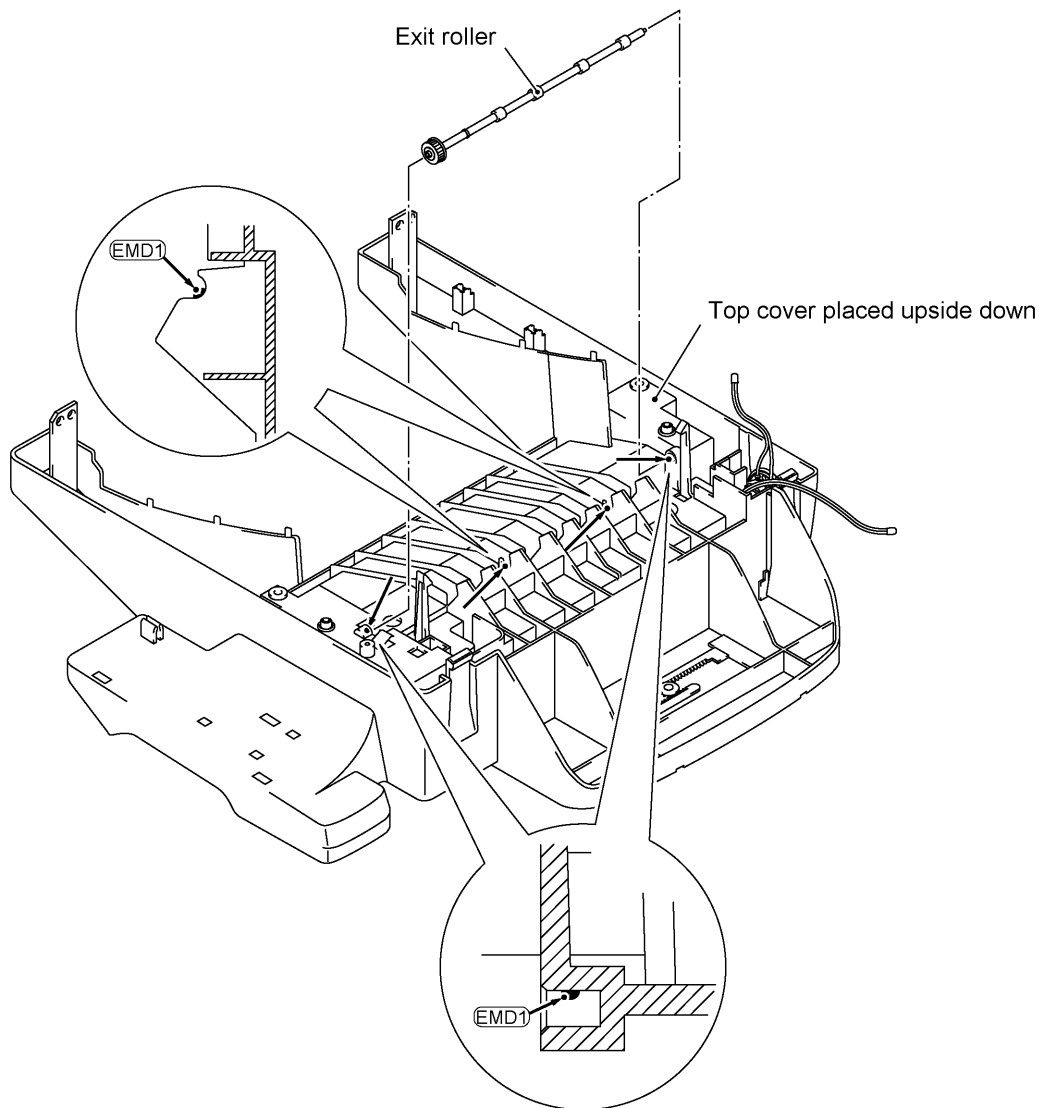

[5] Drive gear ASSY

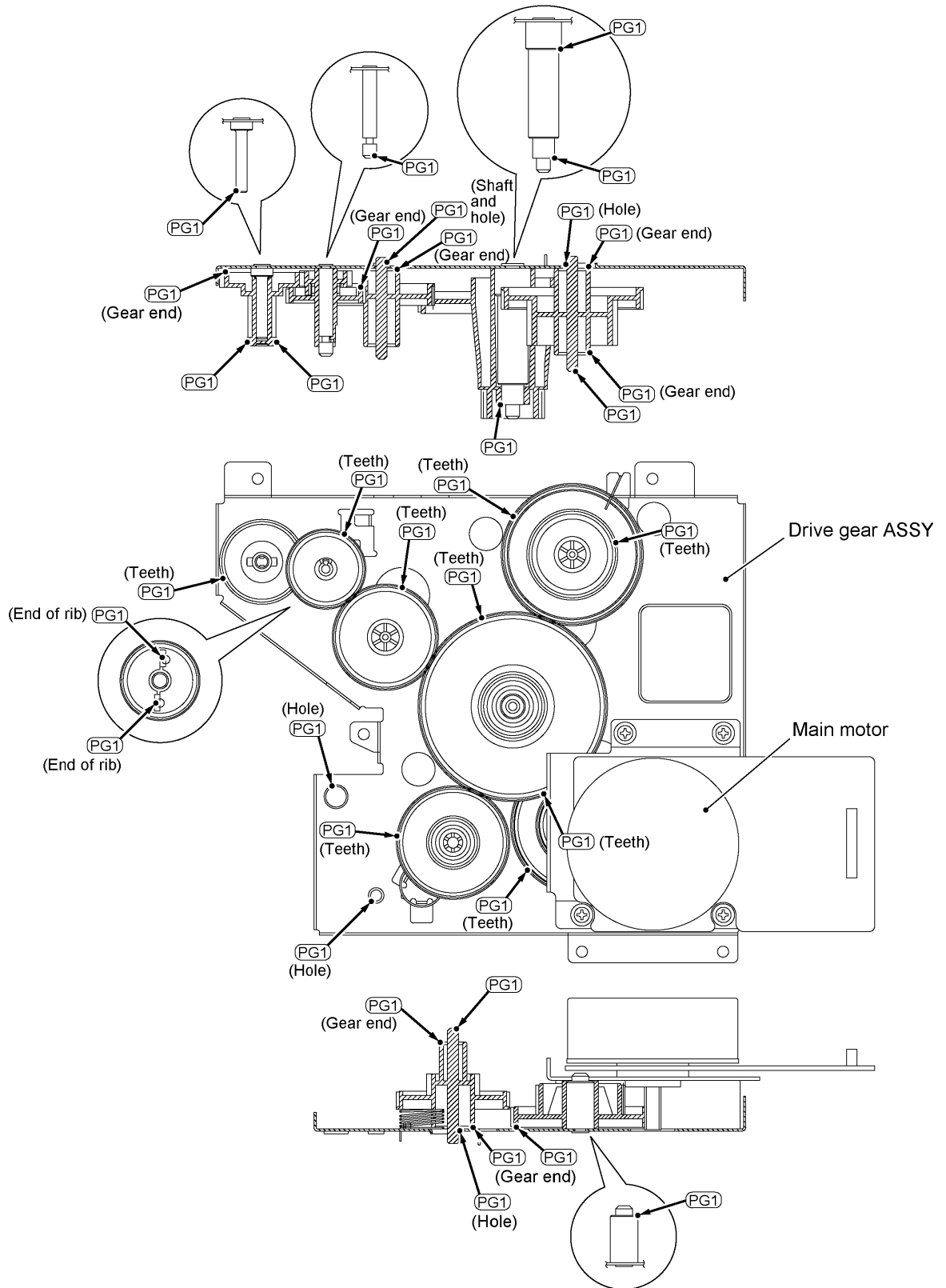

[6] Paper cassette

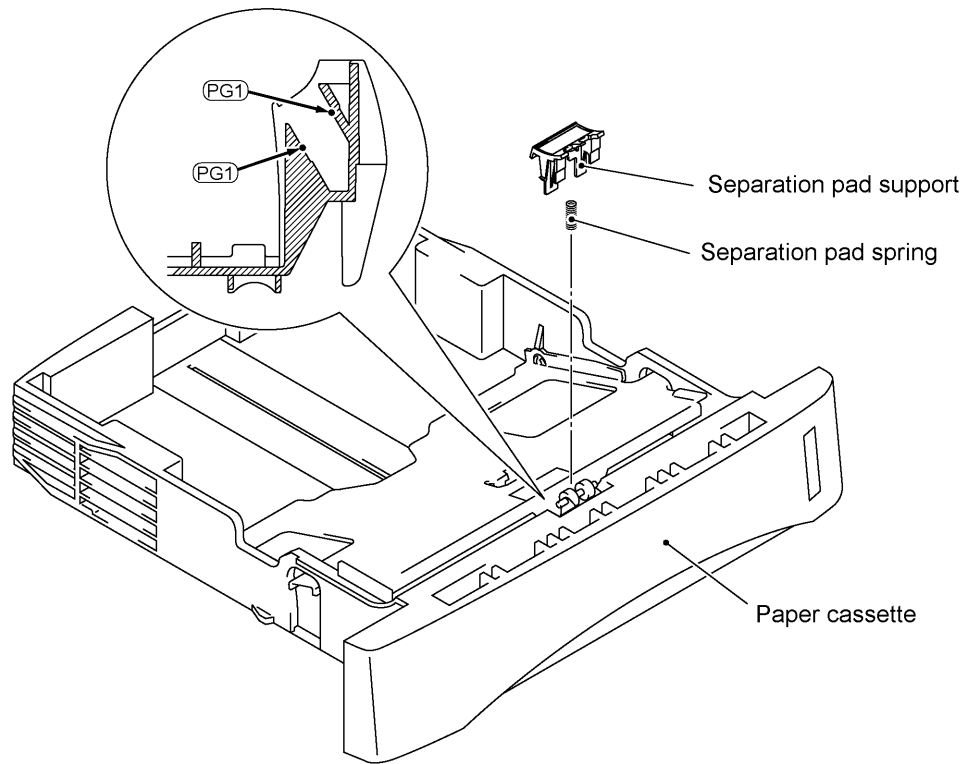

CHAPTER V.

MAINTENANCE MODE

CHAPTER V. MAINTENANCE MODE

CONTENTS

| | | |
|-----------|--|------------|
| 1. | ENTRY INTO THE MAINTENANCE MODE..... | V-1 |
| 2. | LIST OF MAINTENANCE-MODE FUNCTIONS..... | V-2 |
| 3. | DETAILED DESCRIPTION OF MAINTENANCE-MODE FUNCTIONS | V-4 |
| 3.1 | EEPROM Parameter Initialization..... | V-4 |
| 3.2 | Printout of Scanning Compensation Data | V-5 |
| 3.3 | ADF Performance Test..... | V-7 |
| 3.4 | Test Pattern 1..... | V-8 |
| 3.5 | Firmware Switch Setting and Printout..... | V-9 |
| 3.6 | Operational Check of LCD..... | V-55 |
| 3.7 | Operational Check of Control Panel PCB | V-55 |
| 3.8 | Receiver Volume Adjustment (applicable to the American version only)..... | V-57 |
| 3.9 | Sensor Operational Check..... | V-58 |
| 3.10 | CIS Scanner Area Setting..... | V-59 |
| 3.11 | EEPROM Customizing | V-59 |
| 3.12 | Erasure of Received FAX Messages Temporarily Stored in the Flash Memory | V-60 |
| 3.13 | Equipment Error Code Indication..... | V-60 |
| 3.14 | Output of Transmission Log to the Telephone Line..... | V-61 |
| 3.15 | Cancellation of the Memory Security Mode (applicable to the European version only)..... | V-61 |

1. ENTRY INTO THE MAINTENANCE MODE

American models: To make the equipment enter the maintenance mode, press the **Function**, *, **2**, **8**, **6**, and **4** keys in this order.

|← Within 2 seconds →|

European models: To make the equipment enter the maintenance mode, press the **Menu**, *, **2**, **8**, **6**, and **4** keys in this order.

|← Within 2 seconds →|

The equipment beeps for approx. one second and displays " ■■ MAINTENANCE ■■■ " on the LCD, indicating that it is placed in the initial stage of the maintenance mode, a mode in which the equipment is ready to accept entry from the keys.

To select one of the maintenance-mode functions listed in Section 2, enter the corresponding 2-digit function code with the numerical keys on the control panel. (The details of each maintenance-mode function are described in Section 3.)

- NOTES:**
- Pressing the **9** key twice in the initial stage of the maintenance mode makes the equipment exit from the maintenance mode, restoring it to the standby state.
 - Pressing the **Stop** key after entering only one digit restores the equipment to the initial stage of the maintenance mode.
 - If an invalid function code is entered, the equipment resumes the initial stage of the maintenance mode.

2. LIST OF MAINTENANCE-MODE FUNCTIONS

Maintenance-mode Functions

| Function Code | Function | Reference Subsection (Page) |
|---------------|--|-----------------------------|
| 01 | EEPROM Parameter Initialization | 3.1 (V-4) |
| 02 | _____ | _____ |
| 03 | _____ | _____ |
| 04 | _____ | _____ |
| 05 | Printout of Scanning Compensation Data | 3.2 (V-5) |
| 06 | _____ | _____ |
| 07 | _____ | _____ |
| 08 | ADF* Performance Test | 3.3 (V-7) |
| 09 | Test Pattern 1 | 3.4 (V-8) |
| 10 | Firmware Switch Setting | 3.5 (V-9) |
| 11 | Printout of Firmware Switch Data | 3.5 (V-54) |
| 12 | Operational Check of LCD | 3.6 (V-55) |
| 13 | Operational Check of Control Panel PCB (Check of Keys and Buttons) | 3.7 (V-55) |
| 14 | _____ | _____ |
| 15 | _____ | _____ |
| 16 | Receiver Volume Adjustment (applicable to the American version only) | 3.8 (V-57) |
| 32 | Sensor Operational Check | 3.9 (V-58) |
| 55 | CIS Scanner Area Setting | 3.10 (V-59) |
| 74 | EEPROM Customizing | 3.11 (V-59) |
| 79 | Erasure of Received FAX Messages Temporarily Stored in the Flash Memory (not applicable to the American version) | 3.12 (V-60) |
| 82 | Equipment Error Code Indication | 3.13 (V-60) |
| 87 | Output of Transmission Log to the Telephone Line | 3.14 (V-61) |
| 91 | EEPROM Parameter Initialization (except the telephone number storage area) | 3.1 (V-4) |
| 99 | Exit from the Maintenance Mode | ---- (V-1) |

* ADF: Automatic document feeder

----- **IMPORTANT** -----

Basically, the maintenance-mode functions listed on the previous page should be accessed by service personnel only. However, you may allow end users to access some of these under the guidance of service personnel (e.g., by telephone).

The user-accessible functions (codes 10, 11, 12, 82, 87 and 91) are shaded in the table given on the previous page. Function code 10 accesses the firmware switches WSW01 to WSW43, each of which has eight selectors. You should not allow end users to access all of those selectors, but you may allow them to access user-accessible selectors which are shaded in the firmware switch tables in Subsection 3.5.

The service personnel should instruct end users to follow the procedure given below.

- (1) American models: Press the **Function** and **Mode** keys in this order.
 European models: Press the **Menu** and **Mode** keys in this order.
 The LCD clears the current display.
NOTE: The **Mode** key is inoperable during standby for redialing and timer.
- (2) Press the **0** key.
- (3) Enter the desired function code (10, 11, 12, 82, 87, or 91) with the numerical keys.
 For function code 10, access the desired firmware switch according to the operating procedure described in Subsection 3.5.
- (4) To make the equipment return to the standby state, press the **Stop** key.

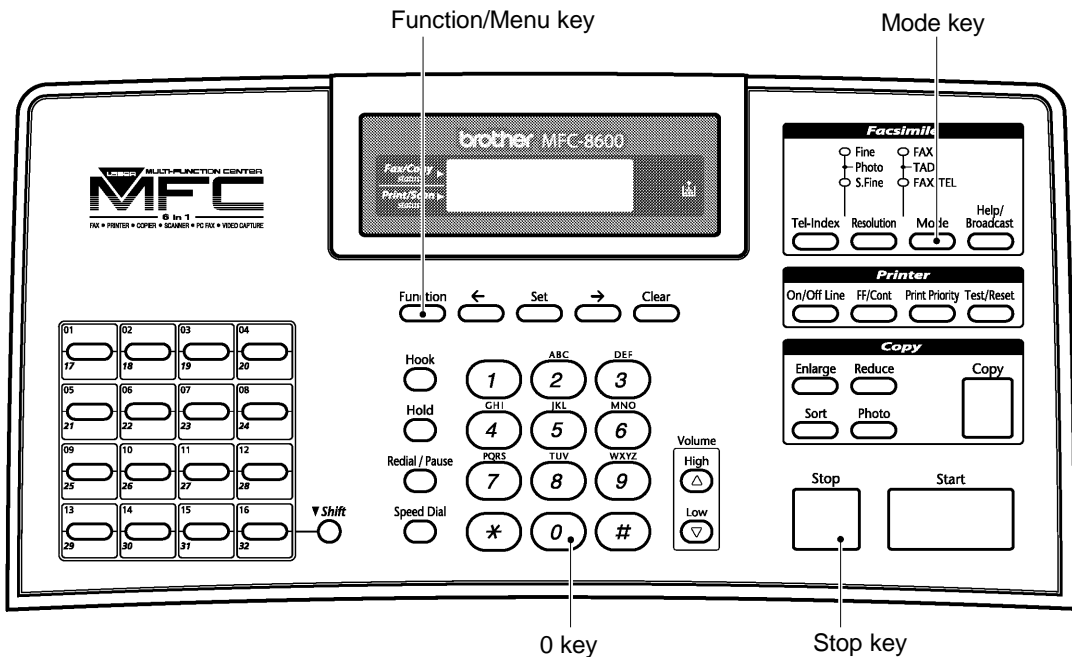

3. DETAILED DESCRIPTION OF MAINTENANCE-MODE FUNCTIONS

3.1 EEPROM Parameter Initialization

Function

The equipment initializes the parameters, user switches, and firmware switches registered in the EEPROM, to the initial values. Entering the function code 01 initializes all of the EEPROM areas, but entering 91 does not initialize some areas, as listed below.

| Function code Data item | 01 | 91 |
|--|--|--------------------------------------|
| Maintenance-mode functions User switches Firmware switches Remote activation code Activity report | All of these will be initialized | These will be initialized |
| Station ID data Outside line number Telephone function registration One-touch dialing Speed dialing Group dialing | | These will <u>not</u> be initialized |
| Received FAX messages temporarily stored in the flash memory (Not applicable to the American version) EEPROM customizing code (4-digit) | These will <u>not</u> be initialized. (Note that the first digit of the 4-digit customizing code will be initialized to "0." If the code is <u>1</u> 001, for example, it will be initialized to <u>0</u> 001.) | |

NOTE: If you replace the main PCB with one used for other facsimile equipment, carry out this procedure and then customize the EEPROM (maintenance-mode function code 74 in Subsection 3.11).

Operating Procedure

- (1) Press the **0** and **1** keys (or the **9** and **1** keys according to your need) in this order in the initial stage of the maintenance mode.
The "PARAMETER INIT" will appear on the LCD.
- (2) Upon completion of parameter initialization, the equipment returns to the initial stage of the maintenance mode.

3.2 Printout of Scanning Compensation Data

Function

The equipment prints out the white and black level data for scanning compensation.

Operating Procedure

Do not start this function merely after powering on the equipment but start it after carrying out a sequence of scanning operation. Unless the equipment has carried out any scanning operation, this function cannot print out correct scanning compensation data. This is because at the start of scanning operation, the equipment initializes white and black level data and takes in the scanning compensation reference data.

- (1) Press the **0** and **5** keys in this order in the initial stage of the maintenance mode.
The "WHITE LEVEL 1" will appear on the LCD.
- (2) The equipment prints out the scanning compensation data list containing the following:
 - a) 2-value quantization white level data (2496 bytes)
 - b) 2-value quantization black level data (1 byte)
 - c) LED light intensity value, 2-value quantization LED light intensity value, and photo mode LED light intensity value (3 bytes)
 - d) 2-value quantization A/D-high and photo-mode A/D-high values (2 bytes)
 - e) A/D-low value (1 byte)
 - f) Compensation data for background color (1 byte)
- (3) Upon completion of recording of the compensation data list, the equipment returns to the initial stage of the maintenance mode.

NOTE: When the equipment prints monochrome images after monochrome scanning, only the green data is valid.

NOTE: If any data is abnormal, its code will be printed in inline style, as shown on the next page.

```

9A90 : 77 73 73 70 6D 70 77 77 73 70 73 6C 72 70 73 77
9AA0 : 70 77 68 09 70 6A 72 6A 66 67 68 64 64 64 64 64 64
9AB0 : 67 67 64 64 64 64 64 64 64 64 64 64 64 64 64 64 64
9AC0 : 67 67 64 64 64 64 64 64 64 64 64 64 64 64 64 64 64
9AD0 : 69 6D 61 62 6D 64 64 64 64 64 64 64 64 64 64 64 64
9AE0 : 61 62 62 67 67 67 67 67 67 67 67 67 67 67 67 67 67
9AF0 : 65 65 6A 6A 6A 6A 6A 6A 6A 6A 6A 6A 6A 6A 6A 6A 6A
9B00 : 65 6A 65 6D 70 6A 6A 6A 6C 73 73 70 6D 6D 6C 6C
9B10 : 6C 70 6F 70 65 6C 6A 6A 6A 6D 6A 6D 6A 65 68 67
9B20 : 65 67 6F 62 61 61 65 62 65 64 64 64 65 67 67 65
9B30 : 64 6D 6F 6F 6F 6F 6F 6F 6F 6F 6F 6F 6F 6F 6F 6F 6F
9B40 : 67 65 62 68 6D 67 64 64 65 6C 65 6A 6A 6A 6A 6A 6A
9B50 : 62 61 6D 6D 61 67 67 67 67 67 67 67 67 67 67 67 67
9B60 : 67 67 61 68 68 72 6C 67 67 68 66 66 67 67 67 67 67
9B70 : 67 64 67 67 64 67 6A 67 68 67 68 67 6D 6A 6C 67 68
9B80 : 65 67 68 70 73 64 6D 6D 68 6A 6D 6D 70 70 70 70 70
9B90 : 6A 6D 6C 6D 65 6A 6A 65 65 65 65 65 65 65 65 65 65 65
9BA0 : 6A 6C 6F 6F 6C 6C 6A 6A 65 65 65 65 65 65 65 65 65 65
9BB0 : 49 4C 46 44 43 41 41 41 41 41 41 41 41 41 41 41 41 41
9BC0 : 3E 3E 43 43 43 46 46 43 43 43 43 43 43 43 43 43 43 43
9BD0 : 1B 1B 15 15 15 15 15 15 15 15 15 15 15 15 15 15 15 15
9BE0 : 25 25 25 25 25 25 25 25 25 25 25 25 25 25 25 25 25 25
9BF0 : 1B 1B 15 15 15 15 15 15 15 15 15 15 15 15 15 15 15 15
9C00 : 15 12 16 1B 1B 1B 1B 1B 1B 1B 1B 1B 1B 1B 1B 1B 1B
9C10 : 18 18 15 15 15 15 15 15 15 15 15 15 15 15 15 15 15 15
9C20 : 16 16 15 15 15 15 15 15 15 15 15 15 15 15 15 15 15 15
9C30 : 15 16 15 15 15 15 15 15 15 15 15 15 15 15 15 15 15 15
9C40 : 0E 10 18 FF 08 FF FF FF FF FF FF FF FF FF FF FF FF
9C50 : FF 07 08 08 08 08 08 08 08 08 08 08 08 08 08 08 08 08
9C60 : 10 0E 12 10 15 0D 0E 0E 10 13 13 13 12 12 12 12 12 12
9C70 : 10 0E 0E 0E 0E 0E 0E 0E 0E 0E 0E 0E 0E 0E 0E 0E 0E 0E
9C80 : 0E 0B 0E 18 18 18 18 18 18 18 18 18 18 18 18 18 18 18
9C90 : 13 15 15 13 0E 15 15 15 15 15 15 15 15 15 15 15 15 15
9CA0 : 15 16 16 16 16 16 16 16 16 16 16 16 16 16 16 16 16 16
9CB0 : 12 12 10 0E 07 0D 0B 0B 0A 0A 0A 07 0A 08 08 08 08 08
9CC0 : 08 0A 10 0A 0B 07 07 08 07 FF FF FF FF FF FF FF FF FF
9CD0 : FF 0A 0E 0D FF 0E 0B 0E 0B 0E 0E 0E 0E 0E 0E 0E 0E 0E 0E
9CE0 : 13 12 13 15 15 15 15 15 15 15 15 15 15 15 15 15 15 15
9CF0 : 15 16 15 0E 15 15 15 15 15 15 15 15 15 15 15 15 15 15
9D00 : 18 18 18 18 18 26 1B 1B 20 19 19 1B 1B 1B 1B 1B 1B 1B
9D10 : 1E 1B 18 19 15 18 18 18 18 18 18 18 18 18 18 18 18 18
9D20 : 1D 1B 1D 1B 1E 16 1B 1B 18 1B 1B 1B 1B 1B 1B 1B 1B 1B
9D30 : 16 16 18 18 18 18 18 18 18 18 18 18 18 18 18 18 18 18
9D40 : 10 13 1B 15 15 1B 15 15 15 15 15 15 15 15 15 15 15 15
9D50 : 12 13 13 13 10 10 18 18 15 15 15 15 15 15 15 15 15 15
9D60 : 19 1B 18 1B 1E 18 18 18 1E 1E 1E 1E 1E 1E 1E 1E 1E 1E
9D70 : 1B 1B 1D 1D 15 1D 1D 1D 1E 1D 1D 1E 21 21 21 21 21 21
9D80 : 21 20 28 28 28 28 28 28 28 28 28 28 28 28 28 28 28 28
9D90 : 2C 2C 2B 2B 2B 2B 2B 2B 2B 2B 2B 2B 2B 2B 2B 2B 2B 2B
9DA0 : 3F 37 34 2B 28 18 37 3F 62 62 67 67 6A 6C 70 70 70 70
9DB0 : 6C 6A 6A 68 62 67 67 6A 6C 70 70 6D 6D 6D 6D 6D 6D 6D
9DC0 : 6D 73 7A 6A 65 62 62 67 68 6D 6D 6D 6D 6D 6D 6D 6D 6D
9DD0 : 6A 6D 6D 6C 67 70 6F 73 70 6F 70 6C 6F 70 70 73 73
9DE0 : 73 73 73 70 73 73 73 73 77 77 75 78 7B 80 7D 7B 7B 7B
9DF0 : 7B 7D 77 78 78 82 82 83 7D 7D 80 82 80 82 86 80 80 80
9EA0 : 85 85 83 90 93 96 93 92 93 93 92 92 96 99 95 96 95 96
9E10 : 98 93 95 96 96 9B 96 96 96 93 93 93 96 98 99 95 98 98
9E20 : 96 93 98 96 A0 93 98 93 93 92 93 9D 96 93 93 96 96 96
9E30 : 90 93 96 93 90 92 90 8D 8E 8E 90 93 90 8E 8D 86 86 86
9E40 : 86 8B 93 80 80 82 7D 78 7D 75 7A 7B 77 7D 7A 7A 7A 7A
9E50 : 7F 82 83 83 82 83 83 86 86 8B 8A 86 86 83 83 88 88 88
9E60 : 83 8B 86 88 8E 85 86 88 85 8B 8D 8A 8E 8B 8D 8B 8B 8B
9E70 : 92 95 8A 8E 86 90 90 90 93 92 90 92 92 92 92 96 95 95
9E80 : 96 99 95 A0 99 9E 9E A1 A9 9D A3 A0 A0 A6 A9 AB AB AC
9E90 : A8 A6 A6 A3 A0 A6 A4 A9 A6 A3 A8 A1 A9 A8 AB AC CA CC
9EA0 : A9 AC A9 A8 AC A9 AC AB A6 A3 A3 A6 A5 A8 AC A6 C6 C2
9EB0 : A9 A0 A1 A3 A0 A6 A0 9D A0 9D 9B 9D A0 A1 A6 9D C1 C4
9EC0 : A1 9E A4 9E 9E 9D 98 9D 93 92 92 90 96 98 98 95 AC B3
9ED0 : 95 98 A0 A0 9D 9D A3 9D 9E 9D A0 A3 A4 9B A3 A0 C2 BF
9EE0 : A1 A3 A6 A9 AB 9D A3 A0 A4 A9 A8 B0 A8 A8 A3 A1 C2 C4
9EF0 : A4 A8 A4 A9 9E A8 A1 A6 A3 A3 A6 A3 A0 A3 9B A1 BE BB
9F00 : A8 A0 A6 A9 A9 A3 A3 A9 A6 AB A9 A3 A5 A0 A6 A9 BF C2
9F10 : A6 AB A6 A3 9E 9E A1 9E A6 A9 A1 A3 A0 9D A0 A3 BB BC
9F20 : A4 A6 9E 9E A1 A3 A3 A1 A3 A0 A0 A6 9D A3 A0 A6 B4 AE
9F30 : A8 A3 A4 A3 9E A3 A3 A3 A5 A1 A0 9D 9B A1 9D A1 AE AC
9F40 : A0 9D A6 80 8A 86 8E 92 8A 80 80 83 86 82 85 8B A6 A9
9F50 : 86 86 83 88 83 90 90 8E 8A 8A 8D 8A 90 95 93 93 B9 C2
9F60 : 98 8E 8B 96 99 9D 99 92 95 92 96 9D 98 A0 99 9B C4 C7
9F70 : 99 96 95 93 93 9E 96 96 92 95 96 98 9D 99 9B 98 CC C9
9F80 : 99 99 99 A6 A4 9E 9D 9D 9E A0 A3 A8 A4 A0 A1 99 C2 B9

```

```

99 98
99 9D
96 99
90 8D
9D A0
AB B3
B0 AC
B6 B3
AB A8
A1 9D
93 8E
8E 95
9E A6
B4 B4
B4 B7
BF BF
B7 BC
B3 A9
A0 A0
95 95
A6 A4
AE AE
A9 AE
AE B7
B4 B6
B4 B6
AC B0
A3 9E
B3 B1
BC B7
B9 B4
BF C1
C4 C6
C2 CA
C6 C9
CE C1
DE DA
E7 E5
E2 DF
EC E5
E5 E5
DC DA
CC C4
B9 BB
C4 CA
C9 D1
D1 D4
DC E5
F5 F3
F3 F8
FB F5
DD DC
E5 DC
D9 D9
C6 CA
C9 CA
CA CC
C6 C2
C1 C4
AC B3
C2 BF
C2 C4
BE BB
BF C2
BB BC
B4 AE
AE AC
A6 A9
B9 C2
C4 C7
CC C9
C2 B9
A9 A6
8B 86
68 68
65 65

```

```

A420 : A3 A3 9E A3 AB A1 9D 92 99 93 93 98 99 93
A430 : 86 80 86 85 83 83 77 7B 7A 73 72 77 75 6D
A440 : 65 6A 70 FF FF FF FF FF FF FF FF FF FF FF

```

```

9A90 : 1F
9A90 : 00

```

Scanning Compensation Data List

3.3 ADF Performance Test

Function

The equipment counts the documents fed by the automatic document feeder (ADF) and displays the count on the LCD for checking the ADF performance.

Operating Procedure

- (1) Set documents. (Allowable up to the ADF capacity.)

The "DOC. READY" will appear on the LCD.

- (2) Press the **0** and **8** keys in this order.

While counting the documents, the equipment feeds them in and out, displaying the current count on the LCD as shown below.

ADF CHECK P.01

↑ Current count (1st page in this example)

- (3) After showing the final count, the equipment beeps for one second. To return the equipment to the initial stage of the maintenance mode, press the **Stop** key.

3.4 Test Pattern 1

Function

This function, much like the copying function, prints out test pattern 1 to allow the service personnel to check for record data missing or print quality.

Operating Procedure

Press the **0** and **9** keys in this order in the initial stage of the maintenance mode.

The figure below shows test pattern 1.

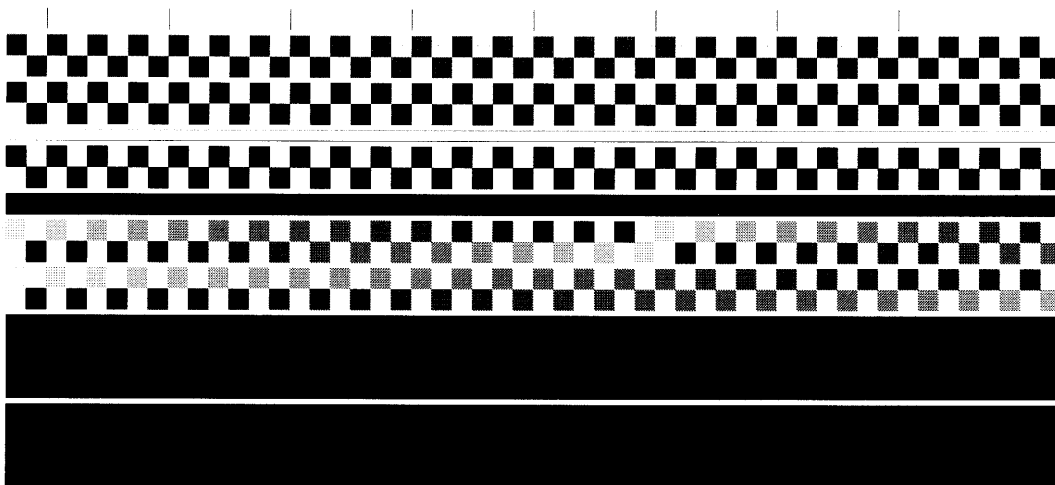

Test Pattern 1

3.5 Firmware Switch Setting and Printout

[A] Firmware switch setting

Function

The facsimile equipment incorporates the following firmware switch functions (WSW01 through WSW43) which may be activated with the procedures using the control panel keys and buttons. The firmware switches have been set at the factory in conformity to the communications standards and codes of each country. Do not disturb them unless necessary. Some firmware switches may not be applicable in some versions. The firmware switch data list indicates "Not used." for those inapplicable switches.

Firmware Switches (WSW01 through WSW43)

| WSW No. | Function | Reference Page |
|---------|--|----------------|
| WSW01 | Dial pulse setting | V-11 |
| WSW02 | Tone signal setting | V-12 |
| WSW03 | PABX mode setting | V-13 |
| WSW04 | TRANSFER facility setting | V-15 |
| WSW05 | 1st dial tone and busy tone detection | V-16 |
| WSW06 | Pause key setting and 2nd dial tone detection | V-18 |
| WSW07 | Dial tone setting 1 | V-20 |
| WSW08 | Dial tone setting 2 | V-21 |
| WSW09 | Protocol definition 1 | V-22 |
| WSW10 | Protocol definition 2 | V-23 |
| WSW11 | Busy tone setting | V-24 |
| WSW12 | Signal detection condition setting | V-25 |
| WSW13 | Modem setting | V-26 |
| WSW14 | AUTO ANS facility setting | V-27 |
| WSW15 | REDIAL facility setting | V-28 |
| WSW16 | Function setting 1 | V-29 |
| WSW17 | Function setting 2 | V-30 |
| WSW18 | Function setting 3 | V-31 |
| WSW19 | Transmission speed setting | V-32 |
| WSW20 | Overseas communications mode setting | V-33 |
| WSW21 | TAD setting 1 | V-34 |
| WSW22 | ECM setting | V-34 |
| WSW23 | Communications setting | V-35 |
| WSW24 | TAD setting 2 | V-36 |
| WSW25 | TAD setting 3 | V-37 |
| WSW26 | Function setting 4 | V-38 |
| WSW27 | Function setting 5 | V-39 |
| WSW28 | Function setting 6 | V-40 |
| WSW29 | Function setting 7 | V-41 |
| WSW30 | Function setting 8 | V-41 |
| WSW31 | Function setting 9 | V-42 |
| WSW32 | Function setting 10 | V-43 |
| WSW33 | Function setting 11 | V-44 |
| WSW34 | Function setting 12 | V-45 |
| WSW35 | Function setting 13 | V-45 |
| WSW36 | Function setting 14 | V-46 |

Firmware Switches (WSW01 through WSW43) Continued

| WSW No. | Function | Reference Page |
|---------|---------------------|----------------|
| WSW37 | Function setting 15 | V-47 |
| WSW38 | Function setting 16 | V-48 |
| WSW39 | Function setting 17 | V-49 |
| WSW40 | Function setting 18 | V-50 |
| WSW41 | Function setting 19 | V-51 |
| WSW42 | Function setting 20 | V-52 |
| WSW43 | Function setting 21 | V-53 |

Operating Procedure

- (1) Press the **1** and **0** keys in this order in the initial stage of the maintenance mode.
The equipment displays the "WSW00" on the LCD and becomes ready to accept a firmware switch number.
- (2) Enter the desired number from the firmware switch numbers (01 through 43).
The following appears on the LCD:
WSWXX = 0 0 0 0 0 0 0
- (3) Use the ◀ and ▶ keys to move the cursor to the selector position to be modified.
- (4) Enter the desired number using the **0** and **1** keys.
- (5) Press the **Set** key. This operation saves the newly entered selector values onto the EEPROM and readies the equipment for accepting a firmware switch number.
- (6) Repeat steps (2) through (5) until the modification for the desired firmware switches is completed.
- (7) Press the **Set** or **Stop** key to return the equipment to the initial stage of the maintenance mode.

- NOTES:**
- To cancel this operation and return the equipment to the initial stage of the maintenance mode during the above procedure, press the **Stop** key.
 - If there is a pause of more than one minute after a single-digit number is entered for double-digit firmware switch numbers, the equipment will automatically return to the initial stage of the maintenance mode.

Note

The user-accessible selectors of the firmware switches are shaded in the tables given on the following pages.

Detailed Description for the Firmware Switches

WSW01 (Dial pulse setting)

| Selector No. | Function | Setting and Specifications |
|--------------|--|--|
| 1 2 | Dial pulse generation mode | No. 1 2 0 0 : N 0 1 : N+1 1 0 : 10-N 1 1 : N |
| 3 4 | Break time length in pulse dialing | No. 3 4 0 0 : 60 ms 0 1 : 67 ms 1 0 : 40 ms (for 16 PPS) 1 1 : 64 ms (at 106-ms intervals) |
| 5 6 | Inter-digit pause | No. 5 6 0 0 : 800 ms 0 1 : 850 ms 1 0 : 950 ms 1 1 : 600 ms |
| 7 | Switching between pulse (DP) and tone (PB) dialing, by the function switch | 0: Yes 1: No |
| 8 | Default dialing mode, pulse (DP) or tone (PB) dialing | 0: PB 1: DP |

- Selectors 1 and 2: Dial pulse generation mode**

These selectors set the number of pulses to be generated in pulse dialing.

N: Dialing "N" generates "N" pulses. (Dialing "0" generates 10 pulses.)

N + 1: Dialing "N" generates "N + 1" pulses.

10 - N: Dialing "N" generates "10 - N" pulses.

- Selectors 3 and 4: Break time length in pulse dialing**

These selectors set the break time length in pulse dialing.

(Example: If "1," "2," and "3" are dialed when N is set by selectors 1 and 2.)

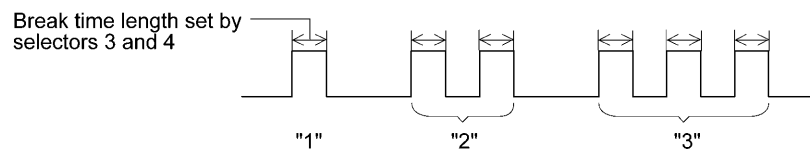

- Selectors 5 and 6: Inter-digit pause**

These selectors set the inter-digit pause in pulse dialing.

(Example: If "1," "2," and "3" are dialed when N is set by selectors 1 and 2.)

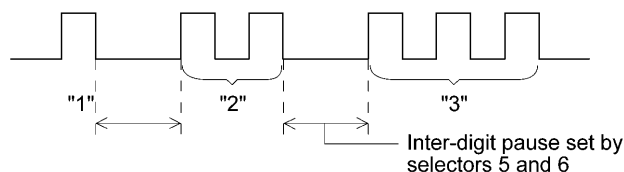

- **Selector 7: Switching between pulse (DP) and tone (PB) dialing, by the function switch**

This selector determines whether or not the dialing mode may be switched between the pulse (DP) and tone (PB) dialing by using the function switch.

- **Selector 8: Default dialing mode, pulse (DP) or tone (PB) dialing**

This selector sets the default dialing mode (pulse dialing or tone dialing) which may be changed by the function switch. If the user switches it with the function switch when selector 7 is set to "0," the setting specified by this selector will also be switched automatically.

WSW02 (Tone signal setting)

| Selector No. | Function | Setting and Specifications |
|--------------|--|--|
| 1 2 | Tone signal transmission time length | No. 1 2 0 0 : 70 ms 0 1 : 80 ms 1 0 : 90 ms 1 1 : 100 ms |
| 3 4 | Min. pause in tone dialing | No. 3 4 0 0 : 70 ms 0 1 : 80 ms 1 0 : 90 ms 1 1 : 140 ms |
| 5 8 | Attenuator for pseudo ring backtone to the line (selectable in the range of 0-15 dB) | 0: 0 dB 1: 8 dB 0: 0 dB 1: 4 dB 0: 0 dB 1: 2 dB 0: 0 dB 1: 1 dB |

- **Selectors 1 through 4: Tone signal transmission time length and Min. pause in tone dialing**

These selectors set the tone signal transmission time length and minimum pause in tone dialing.

(Example: If "1," "2," "3," "4," and "5" are dialed.)

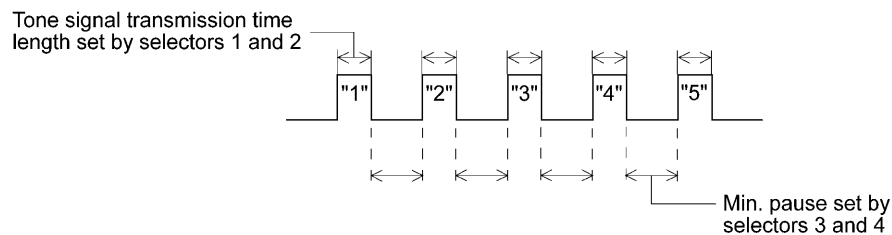

- **Selectors 5 through 8: Attenuator for pseudo ring backtone to the line**

These selectors are used to adjust the sound level of beep generated as a ring backtone in the F/T mode or as a signal during remote control operation or at the start of ICM recording.

Setting two or more selectors to "1" produces addition of attenuation assigned to each selector.

WSW03 (PABX* mode setting)

| Selector No. | Function | Setting and Specifications |
|--------------|--|---|
| 1 | CNG detection when sharing a modular wall socket with a telephone | 0: A 1: B |
| 2 4 | Min. detection time length of PABX* dial tone, required for starting dialing | No. 2 3 4 0 0 0 : 50 ms 0 0 1 : 210 ms 0 1 0 : 500 ms 0 1 1 : 800 ms 1 0 0 : 900 ms 1 0 1 : 1.5 sec. 1 1 0 : 2.0 sec. 1 1 1 : 2.5 sec. |
| 5 | CNG detection when sharing a modular wall socket with a telephone | 0: A 1: B |
| 6 7 | Dial tone detection in PABX* | No. 6 7 0 0 : No detection (3.5 sec. WAIT) 0 1 : No detection (5 sec. WAIT) 1 0 : No detection (7 sec. WAIT) 1 1 : Detection (Frequency only) |
| 8 | Not used. | |

* PABX: Private automatic branch exchange

NOTE: Selectors 2 through 4, 6 and 7 are not applicable where no PABX is installed.

● **Selectors 1 and 5: CNG detection when sharing a modular wall socket with a telephone**

These selectors determine whether or not the equipment detects a CNG signal when a line is connected to a telephone sharing a modular wall socket with the equipment. Upon detection of CNG signals by the number of cycles specified by these selectors, the equipment interprets CNG as an effective signal and then starts FAX reception.

| Selector | | Cycle |
|----------|-------|------------|
| No. 1 | No. 5 | |
| 0 (A) | 0 (A) | 0.5 cycle |
| 0 (A) | 1 (B) | 1.0 cycle |
| 1 (B) | 0 (A) | 1.5 cycles |
| 1 (B) | 1 (B) | 2.0 cycles |

● **Selectors 2 through 4: Min. detection time length of PABX dial tone, required for starting dialing**

Upon detection of the PABX dial tone for the time length set by these selectors, the equipment starts dialing.

These selectors are effective only when both selectors 6 and 7 are set to "1" (Detection).

- **Selectors 6 and 7: Dial tone detection in PABX**

These selectors activate or deactivate the dial tone detection function which detects a dial tone when a line is connected to the PABX.

Setting both of these selectors to "1" activates the dial tone detection function so that the equipment starts dialing upon detection of a dial tone when a line is connected.

Other setting combinations deactivate the dial tone detection function so that the equipment starts dialing after the specified WAIT (3.5, 5.0, or 7.0 sec.) without detection of a dial tone when a line is connected.

WSW04 (TRANSFER facility setting)

| Selector No. | Function | Setting and Specifications |
|--------------|--------------------------------------|---|
| 1 4 | Not used. | |
| 5 6 | Earth time length for earth function | No. 5 6 0 0 : 200 ms 0 1 : 300 ms 1 0 : 500 ms 1 1 : 700 ms |
| 7 8 | Break time length for flash function | No. 7 8 0 0 : 80 ms 0 1 : 110 ms 1 0 : 250 ms 1 1 : 500 ms |

NOTE: Selectors 5 through 8 are not applicable in those countries where no transfer facility is supported.

- **Selectors 5 and 6: Earth time length for earth function**

These selectors set the short-circuiting time length of the telephone line (La or Lb) to ground.

This setting is effective only when the earth function is selected for the R key by using the function switch.

- **Selectors 7 and 8: Break time length for flash function**

These selectors set the break time length.

This setting is effective only when the flash function is selected for the R key by using the function switch.

WSW05 (1st dial tone and busy tone detection)

| Selector No. | Function | Setting and Specifications |
|--------------|--|---|
| 1 3 | 1st dial tone detection | No. 1 2 3 0 0 0 : 3.5 sec. WAIT 0 0 1 : 7.0 sec. WAIT 0 1 0 : 10.5 sec. WAIT 0 1 1 : 14.0 sec. WAIT 1 0 0 : 17.5 sec. WAIT 1 0 1 : 21.0 sec. WAIT 1 1 0 : 24.5 sec. WAIT 1 1 1 : Detection (Without WAIT) |
| 4 | Max. pause time allowable for remote ID code detection | 0 : 2 seconds 1: 1 second |
| 5 6 | Busy tone detection in automatic sending mode | No. 5 6 0 0 : No detection 0 1 : Detection only after dialing 1 0 : No detection 1 1 : Detection before and after dialing |
| 7 | Busy tone detection in automatic receiving mode | 0: Yes 1: No |
| 8 | Not used. | |

NOTE: Selectors 5 through 7 are not applicable in those countries where no busy tone detection is supported.

- **Selectors 1 through 3: 1st dial tone detection**

These selectors activate or deactivate the 1st dial tone detection function which detects the 1st dial tone issued from the PSTN when a line is connected to the PSTN.

Setting all of these selectors to "1" activates the dial tone detection function so that the equipment starts dialing upon detection of a dial tone when a line is connected. For the detecting conditions of the 1st dial tone, refer to WSW07 and WSW08.

Other setting combinations deactivate the dial tone detection function so that the equipment starts dialing after the specified WAIT (3.5, 7.0, 10.5, 14.0, 17.5, 21.0, or 24.5 seconds) without detection of a dial tone when a line is connected to the PSTN.

- **Selector 4: Max. pause time allowable for remote ID code detection**

This selector sets the maximum pause time allowable for detecting the second digit of a remote ID code after detection of the first digit in remote reception.

If selector 4 is set to "0" (2 seconds), for instance, only a remote ID code whose second digit is detected within 2 seconds after detection of the first digit will become effective so as to activate the remote function.

- **Selectors 5 and 6: Busy tone detection in automatic sending mode**

These selectors determine whether or not the equipment automatically disconnects a line upon detection of a busy tone in automatic sending mode.

Setting selector 6 to "0" ignores a busy tone so that the equipment does not disconnect the line.

Setting selectors 5 and 6 to "0" and "1," respectively, makes the equipment detect a busy tone only after dialing and disconnect the line.

Setting both of selectors 5 and 6 to "1" makes the equipment detect a busy tone before and after dialing and then disconnect the line.

- **Selector 7: Busy tone detection in automatic receiving mode**

This selector determines whether or not the equipment automatically disconnects a line upon detection of a busy tone in automatic receiving mode.

WSW06 (Pause key setting and 2nd dial tone detection)

| Selector No. | Function | Setting and Specifications |
|--------------|--|--|
| 1 3 | Pause key setting and 2nd dial tone detection | No.1 2 3 0 0 0 : No pause 0 0 1 : 3.5 sec. WAIT 0 1 0 : 7 sec. WAIT 0 1 1 : 10.5 sec. WAIT 1 0 0 : 14 sec. WAIT 1 1 0 : 2nd dial tone detection only in pulse dialing (DP) system 1 0 1 : } 2nd dial tone detection 1 1 1 : } both in DP and push-button (PB) dialing system |
| 4 6 | Detection of 2nd dial tone | No.4 5 6 0 0 0 : 50 ms 0 0 1 : 210 ms 0 1 0 : 500 ms 0 1 1 : 800 ms 1 0 0 : 900 ms 1 0 1 : 1.5 sec. 1 1 0 : 2.0 sec. 1 1 1 : 2.5 sec. |
| 7 | No. of 2nd dial tone detection times | 0: Once 1: Twice |
| 8 | 2nd dial tone interrupt detecting time | 0: 30 ms 1: 50 ms |

- **Selectors 1 through 3: Pause key setting and 2nd dial tone detection**

| Selectors | | | |
|-----------|---|---|--|
| 1 | 2 | 3 | |
| 0 | 0 | 0 | No WAIT is inserted even if the Pause key is pressed. |
| 0 | 0 | 1 | If you press the Pause key during dialing, the facsimile equipment will insert WAIT as defined in the above table. If the Pause key is pressed repeatedly, the equipment inserts the specified WAIT multiplied by the number of depressions. It applies also in hook-up dialing. |
| 0 | 1 | 0 | |
| 0 | 1 | 1 | |
| 1 | 0 | 0 | |
| 1 | 0 | 1 | When these selectors are set to "1, 0, 1": If you press the Pause key during dialing, the equipment will wait for the 2nd dial tone to be sent via the communications line. When these selectors are set to "1, 1, 0" or "1, 1, 1": If you press the Pause key during dialing, the equipment will first wait for the 2nd dial tone to be sent via the communications line. After that, the equipment will insert a WAIT of 3.5 seconds. If no 2nd dial tone is received within the specified time length (set by WSW08), the equipment will disconnect the line if in automatic dialing, or it will start transmitting the dial signal if given after depression of the Pause key in hook-up dialing. |
| 1 | 1 | 0 | |
| 1 | 1 | 1 | |
| | | | |

- **Selectors 4 through 6: Detection of 2nd dial tone**

Upon detection of the 2nd dial tone for the time length specified by these selectors, the equipment starts dialing.

This setting is effective only when the 2nd dial tone detection function is activated by selectors 1 through 3 (Setting 101, 110, or 111).

This function does not apply in those countries where no dial tone detection function is supported.

- **Selector 7: No. of 2nd dial tone detection times**

This selector sets the number of dial tone detection times required for starting dialing.

- **Selector 8: 2nd dial tone interrupt detecting time**

This selector sets the allowable time length of an interrupt which should not be interpreted as an interrupt in the 2nd tone dialing.

WSW07 (Dial tone setting 1)

| Selector No. | Function | Setting and Specifications |
|--------------|--|---|
| 1 2 | Frequency band range | No. 1 2 0 0 : Narrows by 10 Hz 0 1 : Initial value 1 X : Widens by 10 Hz |
| 3 | Line current detection | 0: No 1: Yes |
| 4 6 | 2nd dial tone detection level (Z = 600 Ω) | No. 4 5 6 0 0 0 : -21 dBm 0 0 1 : -24 dBm 0 1 0 : -27 dBm 0 1 1 : -30 dBm 1 0 0 : -33 dBm 1 0 1 : -36 dBm 1 1 0 : -39 dBm 1 1 1 : -42 dBm |
| 7 | 1st dial tone interrupt detecting time | 0: 30 ms 1: 50 ms |
| 8 | Not used. | |

NOTE: Selectors 1 through 7 are not applicable in those countries where no dial tone or line current detection is supported, e.g., U.S.A.

- **Selectors 1 and 2: Frequency band range**

These selectors set the frequency band for the 1st dial tone and the busy tone (before dialing) to be detected.

This setting is effective only when selectors 1 through 3 of WSW05 are set to "1,1,1."

- **Selector 3: Line current detection**

This selector determines whether or not the equipment should detect a line current before starting dialing.

- **Selectors 4 through 6: 2nd dial tone detection level**

These selectors set the detection level of the 2nd dial tone.

- **Selector 7: 1st dial tone interrupt detecting time**

This selector sets the allowable time length of an interrupt which should not be interpreted as an interrupt in the 1st dial tone dialing.

WSW08 (Dial tone setting 2)

| Selector No. | Function | Setting and Specifications |
|--------------|---|---|
| 1 3 | 1st dial tone detection time length | No. 1 2 3 0 0 0 : 50 ms 0 0 1 : 210 ms 0 1 0 : 500 ms 0 1 1 : 800 ms 1 0 0 : 900 ms 1 0 1 : 1.5 sec. 1 1 0 : 2.0 sec. 1 1 1 : 2.5 sec. |
| 4 5 | Time-out length for 1st and 2nd dial tone detection | No. 4 5 0 0 : 10 sec. 0 1 : 20 sec. 1 0 : 15 sec. 1 1 : 30 sec. |
| 6 8 | Detection level of 1st dial tone and busy tone before dialing | No. 6 7 8 0 0 0 : -21 dBm 0 0 1 : -24 dBm 0 1 0 : -27 dBm 0 1 1 : -30 dBm 1 0 0 : -33 dBm 1 0 1 : -36 dBm 1 1 0 : -39 dBm 1 1 1 : -42 dBm |

NOTE: The WSW08 is not applicable in those countries where no dial tone detection is supported, e.g., U.S.A.

- **Selectors 1 through 3: 1st dial tone detection time length**

Upon detection of the 1st dial tone for the time length set by these selectors, the equipment starts dialing.

This setting is effective only when selectors 1 through 3 of WSW05 are set to "1,1,1."

- **Selectors 4 and 5: Time-out length for 1st and 2nd dial tone detection**

These selectors set the time-out length for the 1st and 2nd dial tone detection so that the equipment waits dial tone input for the specified time length and disconnects itself from the line when no dial tone is inputted.

WSW09 (Protocol definition 1)

| Selector No. | Function | Setting and Specifications |
|--------------|---|---|
| 1 | Frame length selection | 0: 256 octets 1: 64 octets |
| 2 | Use of non-standard commands | 0: Allowed 1: Prohibited |
| 3 4 | No. of retries | No. 3 4 |
| | | 0 0 : 4 times |
| | | 0 1 : 3 times |
| | | 1 0 : 2 times |
| | | 1 1 : 1 time |
| 5 | T5 timer | 0: 300 sec. 1: 60 sec. |
| 6 | T1 timer | 0: 35 sec. 1: 40 sec. |
| 7 8 | Elapsed time for time-out control for no response from the called station in automatic sending mode | No. 7 8 |
| | | 0 0 : 60 sec. (55 sec. for US and Canada) |
| | | 0 1 : 140 sec. |
| | | 1 0 : 90 sec. |
| | | 1 1 : 35 sec. |

NOTE: Selectors 1 through 6 are not applicable in those models which do not support ECM.

- **Selector 1: Frame length selection**

Usually a single frame consists of 256 octets (1 octet = 8 bits). For communications lines with higher bit error rate, however, set selector 1 to "1" so that the facsimile equipment can divide a message into 64-octet frames.

Remarks: The error correction mode (ECM) is a facsimile transmission manner in which the equipment divides a message into frames for transmission so that if any data error occurs on the transmission line, the equipment retransmits only those frames containing the error data.

- **Selector 2: Use of non-standard commands**

If this selector is set to "0," the equipment may use non-standard commands (the machine's native-mode commands, e.g., NSF, NSC, and NSS) for communications. If it is set to "1," the equipment will use standard commands only.

- **Selectors 3 and 4: No. of retries**

These selectors set the number of retries in each specified modem transmission speed.

- **Selector 5: T5 timer**

This selector sets the time length for the T5 timer.

- **Selector 6: T1 timer**

This selector sets the time length for the T1 timer.

- **Selectors 7 and 8: Elapsed time for time-out control**

If the equipment receives no response (no G3 command) from the called terminal in automatic sending during the time set by these selectors, it disconnects the line.

WSW10 (Protocol definition 2)

| Selector No. | Function | Setting and Specifications |
|--------------|---|--|
| 1 | Not used. | |
| 2 | Time length from transmission of the last dial digit to CML ON | 0: 100 ms 1: 50 ms |
| 3 | Time length from CML ON to CNG transmission | 0: 2 sec. 1: 4 sec. |
| 4 | Time length from CML ON to CED transmission (except for facsimile-to-telephone switching) | 0: 0.5 sec. 1: 2 sec. |
| 5 6 | No. of training retries | No. 5 6 0 0 : 1 time 0 1 : 2 times 1 0 : 3 times 1 1 : 4 times |
| 7 | Encoding system (Compression) | MR 0: Allowed 1: Not allowed |
| 8 | | MMR 0: Allowed 1: Not allowed |

- **Selector 2: Time length from transmission of the last dial digit to CML ON**

This selector sets the time length from when the equipment transmits the last dial digit until the CML relay comes on.
- **Selector 3: Time length from CML ON to CNG transmission**

This selector sets the time length until the equipment transmits a CNG after it turns on the CML relay.
- **Selector 4: Time length from CML ON to CED transmission**

This selector sets the time length until the equipment transmits a CED after it turns on the CML relay. This setting does not apply to switching between facsimile and telephone.
- **Selectors 5 and 6: No. of training retries**

These selectors set the number of training retries to be repeated before automatic fallback.
- **Selectors 7 and 8: Encoding system (Compression)**

This selector determines whether or not use of the MR/MMR coding system will be allowed.

WSW11 (Busy tone setting)

| Selector No. | Function | Setting and Specifications |
|--------------|--|---|
| 1 2 | Frequency band range | No. 1 2 0 0 : Narrows by 10 Hz 0 1 : Initial value 1 x : Widens by 10 Hz |
| 3 | Not used. | |
| 4 | ON/OFF time length ranges (More than one setting allowed) | 1: 400-600/400-600 ms |
| 5 | | 1: 175-440/175-440 ms |
| 6 | | 1: 700-800/700-800 ms |
| 7 | | 1: 110-410/320-550 ms |
| 8 | | 1: 100-660/100-660 ms |

NOTE: WSW11 is not applicable in those countries where no busy tone detection is supported.

NOTE: The setting of WSW11 is effective only when selectors 5 and 6 of WSW05 are set to "0, 1" or "1, 1" (Busy tone detection).

- **Selectors 1 and 2: Frequency band range**

These selectors set the frequency band for busy tone to be detected.

- **Selectors 4 through 8: ON/OFF time length ranges**

These selectors set the ON and OFF time length ranges for busy tone to be detected. If more than one selector is set to "1," the ranges become wider. For example, if selectors 4 and 5 are set to "1," the ON and OFF time length ranges are from 175 to 600 ms.

WSW12 (Signal detection condition setting)

| Selector No. | Function | Setting and Specifications |
|--------------|---|--|
| 1 2 | Min. OFF time length of calling signal (Ci) | No. 1 2 0 0 : 1500 ms 0 1 : 500 ms 1 0 : 700 ms 1 1 : 900 ms |
| 3 4 | Max. OFF time length of calling signal (Ci) | No. 3 4 0 0 : 6 sec. 0 1 : 7 sec. 1 0 : 9 sec. 1 1 : 11 sec. |
| 5 6 | Detecting time setting | No. 5 6 0 0 : 800 ms 0 1 : 200 ms 1 0 : 250 ms 1 1 : 150 ms |
| 7 8 | Not used. | |

- **Selectors 1 through 4: Min. and max. OFF time length of calling signal (Ci)**

If the equipment detects the OFF state of calling signal (Ci) for a time length which is greater than the value set by selectors 1 and 2 and less than the value set by selectors 3 and 4, it interprets the Ci signal as OFF.

- **Selectors 5 and 6: Detecting time setting**

These selectors set the time length required to make the equipment acknowledge itself to be called. That is, if the equipment continuously detects calling signals with the frequency set by selectors 1 through 4 of WSW14 during the time length set by these selectors 5 and 6, it acknowledges the call.

WSW13 (Modem setting)

| Selector No. | Function | Setting and Specifications |
|--------------|------------------|--|
| 1 2 | Cable equalizer | No. 1 2 0 0 : 0 km 0 1 : 1.8 km 1 0 : 3.6 km 1 1 : 5.6 km |
| 3 4 | Reception level | No. 3 4 0 0 : -43 dBm 0 1 : -47 dBm 1 0 : -49 dBm 1 1 : -51 dBm |
| 5 8 | Modem attenuator | 0: 0 dB 1: 8 dB 0: 0 dB 1: 4 dB 0: 0 dB 1: 2 dB 0: 0 dB 1: 1 dB |

The modem should be adjusted according to the user's line conditions.

- **Selectors 1 and 2: Cable equalizer**

These selectors are used to improve the pass-band characteristics of analogue signals on a line. (Attenuation in the high-band frequency is greater than in the low-band frequency.)

Set these selectors according to the distance from the telephone switchboard to the facsimile equipment.

- **Selectors 3 and 4: Reception level**

These selectors set the optimum receive signal level.

- **Selectors 5 through 8: Modem attenuator**

These selectors are used to adjust the transmitting level of the modem when the reception level at the remote station is improper due to line loss. This function applies to G3 protocol signals.

Setting two or more selectors to "1" produces addition of attenuation assigned to each selector.

This setting will be limited if selector 8 of WSW23 is set to "0."

WSW14 (AUTO ANS facility setting)

| Selector No. | Function | Setting and Specifications |
|--------------|---|---|
| 1 2 | Frequency band selection (Lower limit) | No. 1 2 0 0 : 13 Hz 0 1 : 15 Hz 1 0 : 23 Hz 1 1 : 20 Hz |
| 3 4 | Frequency band selection (Upper limit) | No. 3 4 0 0 : 30 Hz 0 1 : 55 Hz 1 X : 70 Hz |
| 5 8 | No. of rings in AUTO ANS mode | No. 5 6 7 8 0 0 0 0 : Fixed to once 0 0 0 1 : Fixed to 2 times 0 0 1 0 : Fixed to 3 times 0 0 1 1 : Fixed to 4 times 0 1 0 0 : 1 to 2 times 0 1 0 1 : 1 to 3 times 0 1 1 0 : 1 to 4 times 0 1 1 1 : 1 to 5 times 1 0 0 0 : 2 to 3 times 1 0 0 1 : 2 to 4 times 1 0 1 0 : 2 to 5 times 1 0 1 1 : 2 to 6 times 1 1 0 0 : 1 to 10 times 1 1 0 1 : 2 to 10 times 1 1 1 0 : 3 to 5 times 1 1 1 1 : 4 to 10 times |

- **Selectors 1 through 4: Frequency band selection**

These selectors are used to select the frequency band of calling signals for activating the AUTO ANS facility.

In the French versions, if the user sets the PBX to OFF from the control panel, the setting made by selectors 1 and 2 will take no effect and the frequency's lower limit will be fixed to 32 Hz. (Even if the setting made by these selectors does not apply, it will be printed on the configuration list.)

- **Selectors 5 through 8: No. of rings in AUTO ANS mode**

These selectors set the number of rings to initiate the AUTO ANS facility.

WSW15 (REDIAL facility setting)

| Selector No. | Function | Setting and Specifications |
|--------------|---|---|
| 1 2 | Selection of redial interval | No. 1 2 0 0 : 5 minutes 0 1 : 1 minute 1 0 : 2 minutes 1 1 : 3 minutes |
| 3 6 | No. of redialings | No. 3 4 5 6 0 0 0 0 : 16 times 0 0 0 1 : 1 times 0 0 1 0 : 2 times 0 0 1 1 : 3 times 1 1 1 1 : 15 times |
| 7 | Redialing for no response sent from the called terminal | 0: Redialing 1: No redialing |
| 8 | Not used. | |

NOTE: Selector 7 is not applicable in those countries where no busy tone detection is supported.

- **Selectors 1 through 6: Selection of redial interval and No. of redialings**

The equipment redials by the number of times set by selectors 3 through 6 at intervals set by selectors 1 and 2.

This setting is effective only when selector 7 is set to "0."

- **Selectors 7: Redialing for no response sent from the called terminal**

This selector determines whether or not the equipment redials if no G3 command response comes from the called station after dialing within the time length set by selectors 7 and 8 of WSW09.

WSW16 (Function setting 1)

| Selector No. | Function | Setting and Specifications |
|--------------|--|--|
| 1 | Not used. | |
| 2 | CCITT superfine recommendation | 0: OFF 1: ON |
| 3 6 | Not used. | |
| 7 | Max. document length limitation | 0: 400 cm 1: 90 cm |
| 8 | Stop key pressed during reception | 0: Not functional 1: Functional |

- **Selector 2: CCITT superfine recommendation**

If this selector is set to "1," the equipment communicates in CCITT recommended superfine mode (15.4 lines/mm). If it is set to "0," it communicates in native superfine mode.

- **Selector 7: Max. document length limitation**

This selector is used to select the maximum length of a document to be sent.

- **Selector 8: Stop key pressed during reception**

If this selector is set to "1," pressing the **Stop** key can stop the current receiving operation. The received data will be lost.

WSW17 (Function setting 2)

| Selector No. | Function | Setting and Specifications |
|--------------|---------------------|--|
| 1 2 | Off-hook alarm | No. 1 2 0 0 : No alarm 0 1 : Always valid 1 X : Valid except when 'call reservation' is selected. |
| 3 4 | Not used. | |
| 5 | Calendar clock type | 0: U.S.A. type 1: European type |
| 6 | Not used. | |
| 7 | Non-ring reception | 0: OFF 1: ON |
| 8 | Not used. | |

- **Selectors 1 and 2: Off-hook alarm**

These selectors activate or deactivate the alarm function which sounds an alarm when the communication is completed with the handset being off the hook.

- **Selector 5: Calendar clock type**

If this selector is set to "0" (USA), the MM/DD/YY hh:mm format applies; if it is set to "1" (Europe), the DD/MM/YY hh:mm format applies: DD is the day, MM is the month, YY is the last two digits of the year, hh is the hour, and mm is the minute.

- **Selector 7: Non-ring reception**

Setting this selector to "1" makes the equipment receive calls without ringer sound if the ring delay is set to 0.

WSW18 (Function setting 3)

| Selector No. | Function | Setting and Specifications |
|--------------|--|--|
| 1 | Not used. | |
| 2 3 | Detection enabled time for CNG and no tone | No. 2 3 0 0 : 40 sec. 0 1 : 0 sec. (No detection) 1 0 : 5 sec. 1 1 : 80 sec. |
| 4 5 | Not used. | |
| 6 | Registration of station ID | 0: Permitted 1: Prohibited |
| 7 8 | Tone sound monitoring | No. 7 8 0 X : No monitoring 1 0 : Up to phase B at the calling station only 1 1 : All transmission phases both at the calling and called stations |

- **Selectors 2 and 3: Detection enabled time for CNG and no tone**

After the line is connected via the external telephone or by picking up the handset of the facsimile equipment, the equipment can detect a CNG signal or no tone for the time length specified by these selectors. The setting specified by these selectors becomes effective only when selector 8 of WSW20 is set to "1."

- **Selectors 7 and 8: Tone sound monitoring**

These selectors set monitoring specifications of the tone sound inputted from the line.

WSW19 (Transmission speed setting)

| Selector No. | Function | Setting and Specifications |
|--------------|--|--|
| 1 3 | First transmission speed choice for fallback | No. 1 2 3 No. 4 5 6 0 0 0 : 2,400 bps 0 0 1 : 4,800 bps 0 1 0 : 7,200 bps 0 1 1 : 9,600 bps 1 0 0 : 12,000 bps 1 0 1 : } 1 1 0 : } 14,400 bps 1 1 1 : } |
| 4 6 | Last transmission speed choice for fallback | |
| 7 | V. 34 mode | 0: Permitted 1: Prohibited |
| 8 | V. 17 mode | 0: Permitted 1: Prohibited |

- **Selectors 1 through 6: First and last choices of transmission speed for fallback**

These selectors are used to set the modem speed range. With the first transmission speed choice specified by selectors 1 through 3, the equipment attempts to establish the transmission link via the modem. If the establishment fails, the equipment automatically steps down to the next highest speed and attempts to establish the transmission link again. The equipment repeats this sequence while stepping down the transmission speed to the last choice specified by selectors 4 through 6.

If the modem always falls back to a low transmission speed (e.g., 4,800 bps), set the first transmission speed choice to the lower one (e.g., modify it from 12,000 bps to 7,200 bps) in order to deactivate the high-speed modem function and reduce the training time for shorter transmission time.

Generally, to save the transmission time, set the last transmission speed choice to a higher one.

- **Selector 7: V. 34 mode**

This selector determines whether or not the equipment communicates with the remote station in the V. 34 mode when that station supports the V. 34 mode.

WSW20 (Overseas communications mode setting)

| Selector No. | Function | Setting and Specifications |
|--------------|--|---|
| 1 | EP* tone prefix | 0: OFF 1: ON |
| 2 | Overseas communications mode (Reception) | 0: 2100 Hz 1: 1100 Hz |
| 3 | Overseas communications mode (Transmission) | 0: OFF 1: Ignores DIS once. |
| 4 5 | Min. time length from reception of CFR to start of transmission of video signals | No. 4 5 0 0 : 100 ms 0 1 : 200 ms 1 0 : 300 ms 1 1 : 400 ms |
| 6 7 | Chattering noise elimination at detection of CNG | No. 6 7 0 0 : Yes (When CNG goes either ON or OFF) 0 1 : Yes (Only when CNG goes OFF) 1 0 : No 1 1 : No |
| 8 | CNG detection on/off | 0: OFF 1: ON |

* EP: Echo protection

- **Selector 1: EP tone prefix**

Setting this selector to "1" makes the equipment transmit a 1700 Hz echo protection (EP) tone immediately preceding training in V.29 modulation system to prevent omission of training signals.

Prefixing an EP tone is effective when the equipment fails to transmit at the V.29 modem speed and always has to fall back to 4800 bps transmission.

- **Selectors 2 and 3: Overseas communications mode**

These selectors should be used if the facsimile equipment malfunctions in overseas communications. According to the communications error state, select the signal specifications.

Setting selector 2 to "1" allows the equipment to use 1100 Hz CED signal instead of 2100 Hz in receiving operation. This prevents malfunctions resulting from echoes, since the 1100 Hz signal does not disable the echo suppressor (ES) while the 2100 Hz signal does.

Setting selector 3 to "1" allows the equipment to ignore a DIS signal sent from the called station once in sending operation. This operation suppresses echoes since the first DIS signal immediately follows a 2100 Hz CED (which disables the ES) so that it is likely to be affected by echoes in the disabled ES state. However, such a disabled ES state will be removed soon so that the second and the following DIS signals are not susceptible to data distortion due to echoes. Note that some models when called may cause error by receiving a self-outputted DIS.

- **Selectors 8: CNG detection on/off**

If this selector is set to "1," the equipment detects a CNG signal according to the condition preset by selectors 2 and 3 of WSW18 after a line is connected. If it is set to "0," the equipment detects a CNG signal as long as the line is connected.

WSW21 (TAD setting 1)

| Selector No. | Function | Setting and Specifications |
|--------------|--|----------------------------|
| 1 7 | Not used. | |
| 8 | Erasure of message stored in the memory after the message transfer | 0: Yes 1: No |

- **Selector 8: Erasure of message**

Setting this selector to "0" will erase the message recorded in the memory after the document retrieval feature transfers the message.

WSW22 (ECM setting)

| Selector No. | Function | Setting and Specifications |
|--------------|---|--|
| 1 | ECM* in sending | 0: ON 1: OFF |
| 2 | ECM* in receiving | 0: ON 1: OFF |
| 3 | Call Waiting Caller ID | 0: ON 1: OFF |
| 4 | Not used. | |
| 5 8 | Acceptable TCF bit error rate (%) (Only at 4800 bps) | 0: 0% 1: 8% 0: 0% 1: 4% 0: 0% 1: 2% 0: 0% 1: 1% |

* ECM: Error correction mode

NOTE: Selector 3 is applicable to the American version only, but not applicable to those models equipped with high-speed modem.

NOTE: Selectors 5 through 8 are applicable to the Asian version only.

- **Selector 3: Call Waiting Caller ID**

Setting this selector to "0" allows the user to decide whether or not to interrupt the current call when a new call comes in. If Call Waiting Caller ID service is available in the area and the user subscribes to it, he/she can see information about his/her incoming call.

- **Selectors 5 through 8: Acceptable TCF bit error rate (%)**

Setting two or more selectors to "1" produces addition of percent assigned to each selector. If you set selectors 7 and 8 to "1," the acceptable TCF bit error rate will be 3%.

WSW23 (Communications setting)

| Selector No. | Function | Setting and Specifications |
|--------------|--|--|
| 1 | Starting point of training check (TCF) | 0: From the head of a series of zeros 1: From any arbitrary point |
| 2 3 | Allowable training error rate | No. 2 3 0 0 : 0% 0 1 : 0.5% 1 0 : 1% 1 1 : 2% |
| 4 5 | | No. 4 5 0 0 : 16% 0 1 : 14% 1 0 : 10% 1 1 : 8% |
| 6 7 | Not used. | |
| 8 | Limitation of attenuation level | 0: Yes 1: No |

NOTE: Selector 8 is not applicable to the French versions.

- **Selector 1: Starting point of training check (TCF)**

At the training phase of receiving operation, the called station detects for 1.0 second a training check (TCF) command, a series of zeros which is sent from the calling station for 1.5 seconds to verify training and give the first indication of the acceptability of the line.

This selector sets the starting point from which the called station should start counting those zeros. If this selector is set to "0," the called station starts counting zeros 100 ms after the head of a series of zeros is detected.

If it is set to "1," the called station starts counting zeros upon detection of 10-ms successive zeros 50 ms after the head of a series of zeros is detected. In this case, if the detection of 10-ms successive zeros is too late, the data counting period will become less than 1.0 second, making the called station judge the line condition unacceptable.

- **Selectors 2 and 3: Allowable training error rate**

The called station checks a series of zeros gathered in training (as described in Selector 1) according to the allowable training error rate set by these selectors. If the called station judges the line condition to be accepted, it responds with CFR; if not, it responds with FTT.

- **Selectors 4 and 5: Decoding error rate for transmission of RTN**

The facsimile equipment checks the actual decoding errors and then transmits an RTN according to the decoding error rate (Number of lines containing an error per page ÷ Total number of lines per page) set by these selectors.

- **Selector 8: Limitation of attenuation level**

Setting this selector to "0" limits the transmitting level of the modem to 10 dB.

This setting has priority over the settings selected by WSW02 (selectors 5 through 8) and WSW13 (selectors 5 through 8).

WSW24 (TAD setting 2)

| Selector No. | Function | Setting and Specifications | | | | | | | | | | | | | | | | | | | | |
|--------------|---|--|----------|------|----|------|----|------|----|----------|----|------|----|----------|----|------|----|----------|--|---|---|----------|
| 1 2 | Not used. | | | | | | | | | | | | | | | | | | | | | |
| 3 4 | Time length from CML ON to start of pseudo ring backtone transmission | <table> <tr> <td>No.</td> <td>3</td> <td>4</td> <td></td> </tr> <tr> <td></td> <td>0</td> <td>0</td> <td>: 4 sec.</td> </tr> <tr> <td></td> <td>0</td> <td>1</td> <td>: 3 sec.</td> </tr> <tr> <td></td> <td>1</td> <td>0</td> <td>: 2 sec.</td> </tr> <tr> <td></td> <td>1</td> <td>1</td> <td>: 1 sec.</td> </tr> </table> | No. | 3 | 4 | | | 0 | 0 | : 4 sec. | | 0 | 1 | : 3 sec. | | 1 | 0 | : 2 sec. | | 1 | 1 | : 1 sec. |
| No. | 3 | 4 | | | | | | | | | | | | | | | | | | | | |
| | 0 | 0 | : 4 sec. | | | | | | | | | | | | | | | | | | | |
| | 0 | 1 | : 3 sec. | | | | | | | | | | | | | | | | | | | |
| | 1 | 0 | : 2 sec. | | | | | | | | | | | | | | | | | | | |
| | 1 | 1 | : 1 sec. | | | | | | | | | | | | | | | | | | | |
| 5 8 | Attenuator for playback of ICM/OGM to the line (Selectable from the range of 0-15 dB) | <table> <tr> <td>0:</td> <td>0 dB</td> <td>1:</td> <td>8 dB</td> </tr> <tr> <td>0:</td> <td>0 dB</td> <td>1:</td> <td>4 dB</td> </tr> <tr> <td>0:</td> <td>0 dB</td> <td>1:</td> <td>2 dB</td> </tr> <tr> <td>0:</td> <td>0 dB</td> <td>1:</td> <td>1 dB</td> </tr> </table> | 0: | 0 dB | 1: | 8 dB | 0: | 0 dB | 1: | 4 dB | 0: | 0 dB | 1: | 2 dB | 0: | 0 dB | 1: | 1 dB | | | | |
| 0: | 0 dB | 1: | 8 dB | | | | | | | | | | | | | | | | | | | |
| 0: | 0 dB | 1: | 4 dB | | | | | | | | | | | | | | | | | | | |
| 0: | 0 dB | 1: | 2 dB | | | | | | | | | | | | | | | | | | | |
| 0: | 0 dB | 1: | 1 dB | | | | | | | | | | | | | | | | | | | |

- **Selectors 3 and 4: Time length from CML ON to start of pseudo ring backtone transmission**

These selectors set the length of time from CML-ON up to the start of pseudo ring backtone transmission.

In those versions which have an OGM facility, the settings made by these selectors also apply to the length of time from CML-ON up to the start of OGM transmission.

- **Selectors 5 through 8: Attenuator for playback of ICM/OGM to the line**

Setting two or more selectors to "1" produces addition of attenuation assigned to each selector.

This setting will not be limited by selector 8 of WSW23.

WSW25 (TAD setting 3)

| Selector No. | Function | Setting and Specifications |
|--------------|-------------------------------------|---|
| 1 4 | Not used. | |
| 5 7 | Pause between paging number and PIN | No. 5 6 7 0 0 0 : 2 sec. 0 0 1 : 4 sec. 0 1 0 : 6 sec. 0 1 1 : 8 sec. 1 0 0 : 10 sec. 1 0 1 : 12 sec. 1 1 0 : 14 sec. 1 1 1 : 16 sec. |
| 8 | Not used. | |

- **Selectors 5 through 7: Pause between paging number and PIN**

These selectors set the pause time between a telephone number being paged and PIN (private identification number) for the paging feature.

WSW26 (Function setting 4)

| Selector No. | Function | Setting and Specifications |
|--------------|--|---|
| 1 2 | Not used. | |
| 3 | Dialing during document reading into the temporary memory in in-memory message transmission | 0: Disabled 1: Enabled |
| 4 5 | No. of CNG cycles to be detected (when the line is connected via the external telephone except in the external TAD mode) | No. 4 5 0 0 : 0.5 (A) 0 1 : 1 (B) 1 0 : 1.5 (C) 1 1 : 2 (D) |
| 6 7 | No. of CNG cycles to be detected (when the line is connected via the facsimile equipment in the F/T mode or via the external telephone in the external TAD mode) | No. 4 5 0 0 : 0.5 (A) 0 1 : 1 (B) 1 0 : 1.5 (C) 1 1 : 2 (D) |
| 8 | Not used. | |

NOTE: Selectors 6 and 7 take effect only in the V.34 mode.

- **Selector 3: Dialing during document reading into the temporary memory in in-memory message transmission**

If this selector is set to "0," the equipment waits for document reading into the memory to complete and then starts dialing. This enables the equipment to list the total number of pages in the header of the facsimile message.

- **Selectors 4 and 5: No. of CNG cycles to be detected (when the line is connected via the external telephone except in the external TAD mode)**

The equipment interprets a CNG as an effective signal if it detects a CNG signal by the number of cycles specified by these selectors when the line is connected via the external telephone except in the external TAD mode.

- **Selectors 6 and 7: No. of CNG cycles to be detected (when the line is connected via the facsimile equipment in the F/T mode or via the external telephone in the external TAD mode)**

The equipment interprets a CNG as an effective signal if it detects a CNG signal by the number of cycles specified by these selectors when the line is connected via the external telephone except in the external TAD mode.

WSW27 (Function setting 5)

| Selector No. | Function | Setting and Specifications |
|--------------|--|----------------------------|
| 1 | Not used. | |
| 2 | Ringer OFF setting | 0: Yes 1: No |
| 3 | Not used. | |
| 4 | Detection of distinctive ringing pattern | 0: No 1: Yes |
| 5 7 | Not used. | |
| 8 | Toner save mode | 0: Yes 1: No |

NOTE: Selector 4 is applicable only to the U.S.A. versions.

- **Selector 2: Ringer OFF setting**

This selector determines whether or not the ringer can be set to OFF.

WSW28 (Function setting 6)

| Selector No. | Function | Setting and Specifications |
|--------------|---|---|
| 1 3 | Transmission level of DTMF high-band frequency signal | No. 1 2 3 0 0 0 : 0 dB 0 0 1 : +1 dB 0 1 0 : +2 dB 0 1 1 : +3 dB 1 0 0 : 0 dB 1 0 1 : -1 dB 1 1 0 : -2 dB 1 1 1 : -3 dB |
| 4 6 | Transmission level of DTMF low-band frequency signal | No. 4 5 6 0 0 0 : 0 dB 0 0 1 : +1 dB 0 1 0 : +2 dB 0 1 1 : +3 dB 1 0 0 : 0 dB 1 0 1 : -1 dB 1 1 0 : -2 dB 1 1 1 : -3 dB |
| 7 8 | Not used. | |

• **Selectors 1 through 6: Transmission level of DTMF high-/low-band frequency signal**

These selectors are intended for the manufacturer who tests the equipment for the Standard. Never access them.

WSW29 (Function setting 7)

| Selector No. | Function | Setting and Specifications |
|--------------|--|----------------------------|
| 1 6 | Not used. | |
| 7 | Impedance switching control in pulse dialing | 0: OFF 1: ON |
| 8 | Beep when the memory area for the activity report becomes full | 0: No 1: Yes |

NOTE: Selectors 7 and 8 are applicable to the European version only.

- **Selector 8: Beep when the memory area for the activity report becomes full**

If this selector is set to "1," the equipment will beep when the memory area for the activity report becomes full (as well as displaying a message on the LCD, prompting the output of the activity report).

WSW30 (Function setting 8)

| Selector No. | Function | Setting and Specifications |
|--------------|---|----------------------------|
| 1 3 | Not used. | |
| 4 | Duty cycle control of pulsed current for the heat-fixing unit | 0: OFF 1: ON |
| 5 | Drum cleaning prompt settings | 0: ON 1: OFF |
| 6 8 | Not used. | |

NOTE: Selector 4 is applicable to the European version only.

- **Selector 4: Duty cycle control of pulsed current for the heat-fixing unit**

Setting this selector to "1" activates the duty cycle control that suppresses the rush current. The duty cycle is 10-ms ON and 20-ms OFF.

However, the duty cycle control may emit switching noise to the AC line. Depending upon the codes and regulations in the country, this selector should be set to "0."

- **Selector 5: Drum cleaning prompt settings**

Setting this selector to "1" (OFF) deactivates all of the drum cleaning prompt settings enabled by selectors 5 to 7 of WSW42.

WSW31 (Function setting 9)

| Selector No. | Function | Setting and Specifications |
|--------------|--|---|
| 1 | Not used. | |
| 2 | Default reduction rate for failure of automatic reduction during recording | 0: 100% 1: 75% (Letter) 87% (A4) 95% (Legal) |
| 3 4 | Not used. | |
| 5 | Minimum short-OFF duration in distinctive ringing | 0: 130 ms 1: 90 ms |
| 6 7 | Not used. | |
| 8 | "CHANGE DRUM SOON" message | 0: Yes 1: No |

- **Selector 2: Default reduction rate for failure of automatic reduction during recording**

This selector sets the default reduction rate to be applied if the automatic reduction function fails to record one-page data sent from the calling station in a single page of the current recording paper.

If it is set to "0," the equipment records one-page data at full size (100%) without reduction; if it is set to "1," the equipment records it at the size* specified according to the current paper size.

(*American versions allow the user to select the desired paper size from the control panel. According to the paper size setting, the equipment determines the reduction rate. Other versions can handle only A4-size paper, so the reduction rate is always 87%.)

- **Selector 5: Minimum short-OFF duration in distinctive ringing**

The ringer pattern consists of short and long rings, e.g., short-short-long rings. This selector sets the minimum OFF duration following a short ring in order to avoid missing ringer tones in distinctive ringing.

If this selector is set to "1," when the short-OFF duration is a minimum of 90 ms long, then the equipment will interpret the short-OFF as OFF.

- **Selector 8: "CHANGE DRUM SOON" message**

This selector determines whether or not the "CHANGE DRUM SOON" message should appear on the LCD when the service life of the laser-sensitive drum in the laser unit will expire soon.

WSW32 (Function setting 10)

| Selector No. | Function | Setting and Specifications |
|--------------|--------------------|--|
| 1 4 | Not used. | |
| 5 6 | Default resolution | No. 5 6 0 0 : Standard 0 1 : Fine 1 0 : Super fine 1 1 : Photo |
| 7 8 | Default contrast | No. 7 8 0 X : Automatic 1 0 : Super light 1 1 : Super dark |

- **Selectors 5 and 6: Default resolution**

These selectors set the default resolution which applies when the equipment is powered up or completes a transaction.

- **Selectors 7 and 8: Default contrast**

These selectors set the default contrast which applies when the equipment is powered up or completes a transaction.

WSW33 (Function setting 11)

| Selector No. | Function | Setting and Specifications |
|--------------|---|----------------------------|
| 1 5 | Not used. | |
| 6 | Report output of polled transmission requests | 0: Yes 1: No |
| 7 8 | Not used. | |

NOTE: Selector 6 is not applicable to American versions.

WSW34 (Function setting 12)

| Selector No. | Function | Setting and Specifications |
|--------------|---|---|
| 1 3 | Not used. | |
| 4 5 | No. of CNG cycles to be detected (when the line is connected via the facsimile equipment or external telephone except in the external TAD mode) | No. 6 7 0 0 : 0.5 (A) 0 1 : 1 (B) 1 0 : 1.5 (C) 1 1 : 2 (D) |
| 6 7 | Number of DTMF tone signals for inhibiting the detection of CNG during external TAD operation | No. 6 7 0 0 : 3 0 1 : 2 1 0 : 1 1 1 : OFF |
| 8 | CNG detection when the external telephone is connected with a line in TAD mode | 0: Only when the equipment detects itself being called 1: Always |

NOTE: Selectors 4 and 5 are not applicable to the American version.

- **Selectors 4 and 5: No. of CNG cycles to be detected**

The equipment interprets a CNG as an effective signal if it detects a CNG signal by the number of cycles specified by these selectors when the line is connected via the facsimile equipment or external telephone except in the external TAD mode.

- **Selectors 6 and 7: Number of DTMF tone signals for inhibiting the detection of CNG during external TAD operation**

If the equipment receives this specified number of DTMF tone signals during external TAD operation, it will not detect CNG afterwards.

If these selectors are set to "1, 1," the CNG detection will not be inhibited.

- **Selector 8: CNG detection when the external telephone is connected with a line in TAD mode**

If this selector is set to "0," the equipment will detect a CNG signal only when it detects itself being called. If the external telephone is connected with a line before the equipment detects itself being called, the equipment will no longer detect a CNG signal.

If this selector is set to "1," the equipment will detect a CNG signal every time the external telephone is connected with a line, even without detecting itself being called.

WSW35 (Function setting 13)

| Selector No. | Function | Setting and Specifications |
|--------------|-----------|----------------------------|
| 1 8 | Not used. | |

WSW36 (Function setting 14)

| Selector No. | Function | Setting and Specifications |
|--------------|--|--|
| 1 | ECP* mode | 0: ON 1: OFF |
| 2 | Recovery from inactive PC interface | 0: Disabled 1: Enabled |
| 3 | PC power-off recognition time | 0: Normal 1: Long |
| 4 | Not used. | |
| 5 | Escape from phase C | 0: Yes 1: No |
| 6 8 | Lower limit of frequency to be ignored after detection of calling signals (Ci) | No. 6 7 8 0 0 0 : 0 (Not ignored) 0 0 1 : 4 (448 Hz) 0 1 0 : 8 (244 Hz) 0 1 1 : 12 (162 Hz) 1 0 0 : 16 (122 Hz) 1 0 1 : 20 (97 Hz) 1 1 0 : 24 (81 Hz) 1 1 1 : 28 (69 Hz) |

*ECP (Enhanced Capabilities Port)

- **Selector 1: ECP mode**

The ECP mode enhances the normal bidirectional communications between the facsimile equipment and the connected PC for higher transmission speed.

- **Selector 2: Recovery from inactive PC interface**

If the facsimile equipment recognizes via the STB signal line that the connected PC is powered off, it will turn the PC interface outputs Low to protect the PC from hazards that could be caused by weak electric current accidentally flown from the equipment.

This selector determines whether the equipment should recover from the inactive PC interface to normal interfacing state upon receipt of data from the PC.

- **Selector 3: PC power-off recognition time**

This selector sets the time length from when the equipment detects the PC powered off until it recognizes the detected state as power-off.

If selector 2 is set to "0," it is recommended that selector 3 be set to "1": otherwise, the equipment may mistakenly detect PC powered off.

- **Selector 5: Escape from phase C**

This selector determines whether or not the equipment will escape from phase C when it detects an RTC (Return to Control) in non-ECM mode or an RCP (Return to Control Partial page) in ECM mode.

- **Selectors 6 through 8: Lower limit of frequency to be ignored after detection of calling signals (Ci)**

At the start of reception, if the equipment detects the frequency of calling signals (Ci) specified by selectors 1 through 4 of WSW14, it will start the ringer sounding. When doing so, the equipment may fail to detect the calling signals normally due to noises superimposed at the time of reception. To prevent it, use selectors 6 through 8 of WSW36.

If the equipment detects higher frequencies than the lower limit specified by these selectors, it will regard them as noise and interpret that detecting state as being normal, allowing the ringer to keep sounding (until the equipment starts automatic reception of FAX data if in the FAX mode or enters the TAD mode if set in the TEL mode, according to the preset number of ringers).

WSW37 (Function setting 15)

| Selector No. | Function | Setting and Specifications |
|--------------|---|----------------------------|
| 1 | Printout of the stored image data of an unsent document onto the error report | 0: No 1: Yes |
| 2 | Erasure of the stored image data of an unsent document at the time of the subsequent in-memory message transmission | 0: No 1: Yes |
| 3 8 | Not used. | |

- **Selector 1: Printout of the stored image data of an unsent document onto an error report**

This selector determines whether or not the 1st-page image data of a document will be printed out onto the error report if the document image data stored in the temporary memory cannot be transmitted normally.

- **Selector 2: Erasure of the stored image data of an unsent document at the time of the subsequent in-memory message transmission**

If in-memory message transmission fails repeatedly when selector 1 is set to "1," the temporary memory will be occupied with image data. Setting selector 2 to "1" will automatically erase the stored 1st-page image data of an unsent document at the time of the subsequent in-memory message transmission only when recording paper or toner runs out.

WSW38 (Function setting 16)

| Selector No. | Function | Setting and Specifications |
|--------------|--|--|
| 1 2 | Setting of the equalizer | No. 1 2 0 X Automatic 1 0 : Fixed to 4 points 1 1 : Fixed to 16 points |
| 3 | Sending level of guard tone at phase 2 | 0: Normal - 7 db 1: Normal |
| 4 | Stepping down the transmission speed at fallback each | 0: 2400 bps 1: 4800 bps |
| 5 6 | Automatic control of modem's EQM gain for proper transmission speed choice | No. 5 6 0 0 For higher transmission speed than the current setting 0 1 : No change from the current setting 1 0 : For lower transmission speed than the current setting 1 1 : For further lower transmission than the setting made by 1, 0 |
| 7 | Redialing when a communications error occurs | 0: ON 1: OFF |
| 8 | Not used. | |

NOTE: WSW38 takes effect only in the V. 34 mode.

- **Selectors 1 and 2: Setting of the equalizer**

These selectors set the equalizer's training level to be applied if the facsimile equipment fails to send training due to weak line connection. If these selectors are set to "0, X," the modem will automatically set the appropriate training level.

- **Selector 3: Sending level of guard tone at phase 2**

This selector sets the sending level of guard tone for 1800 Hz to be sent at Phase 2 in the V. 34 mode.

- **Selector 4: Stepping down the transmission speed at fallback each**

This selector determines how much the modem steps down the transmission speed at fallback when called by the remote station. If this selector is set to "1," the modem may step down the transmission speed from 33600 bps to 28800 bps by one-time fallback.

- **Selectors 5 and 6: Automatic control of modem's EQM gain for proper transmission speed choice**

These selectors determine how the modem controls the EQM (Eye Quality Monitor) gain for proper choice of the transmission speed, which applies if the modem selects higher transmission speed than the possible speed so that it always repeats falling back.

WSW39 (Function setting 17)

| Selector No. | Function | Setting and Specifications |
|--------------|--|--|
| 1 4 | First transmission speed choice for fallback | No. 1 2 3 4 No. 5 6 7 8 0 0 0 0 : 2400 bps 0 0 0 1 : 4800 bps 0 0 1 0 : 7200 bps 0 0 1 1 : 9600 bps 0 1 0 0 : 12000 bps 0 1 0 1 : 14400 bps 0 1 1 0 : 16800 bps 0 1 1 1 : 19200 bps |
| 5 8 | Last transmission speed choice for fallback | 1 0 0 0 : 21600 bps 1 0 0 1 : 24000 bps 1 0 1 0 : 26400 bps 1 0 1 1 : 28800 bps 1 1 0 0 : 31200 bps 1 1 0 1 : 33600 bps 1 1 1 0 : 33600 bps 1 1 1 1 : 33600 bps |

NOTE: WSW39 takes effect only in the V. 34 mode.

• **Selectors 1 through 8: First and last choices of transmission speed for fallback**

These selectors are used to set the modem speed range. With the first transmission speed choice specified by selectors 1 through 4, the equipment attempts to establish the transmission link via the modem. If the establishment fails, the equipment automatically steps down to the next highest speed and attempts to establish the transmission link again. The equipment repeats this sequence while stepping down the transmission speed to the last choice specified by selectors 5 through 8.

If the modem always falls back to a low transmission speed (e.g., 24,000 bps), set the first transmission speed choice to the lower one (e.g., modify it from 31,200 bps to 26,400 bps) in order to deactivate the high-speed modem function and reduce the training time for shorter transmission time.

WSW39 will be limited by selectors 3 through 8 of WSW40.

WSW40 (Function setting 18)

| Selector No. | Function | Setting and Specifications | | | |
|--------------|---------------------------|----------------------------|---------|---|------------------|
| 1 2 | Not used. | | | | |
| 3 8 | Masking of symbol rate(s) | Not masking | Masking | | |
| | | No. 3 | 0 | 1 | 3429 symbols/sec |
| | | No. 4 | 0 | 1 | 3200 symbols/sec |
| | | No. 5 | 0 | 1 | 3000 symbols/sec |
| | | No. 6 | 0 | 1 | 2800 symbols/sec |
| | | No. 7 | - | - | Not used. |
| | | No. 8 | 0 | 1 | 2400 symbols/sec |

NOTE: WSW40 takes effect only in the V. 34 mode.

- **Selectors 3 and 8: Masking of symbol rate(s)**

These selectors allow you to limit the transmission speed range in the V. 34 mode by masking the desired symbol rate(s). Transmission speeds assigned to the symbol rates are listed below. The setting made by these selectors will limit the setting made by selectors 1 through 4 of WSW39.

If selector 3 is set to "1" to mask the 3429 symbols/second when the first transmission speed choice is 33600 bps (specified by selectors 1 through 4 of WSW39), for example, the allowable maximum transmission speed will be limited to 31200 bps. If selector 8 is set to "1" to mask the 2400 symbols/second when the first transmission speed choice is 33600 bps, then the allowable maximum transmission speed remains 33600 bps.

If selector 8 is set to "1" to mask the 2400 symbols/second when the first transmission speed choice is 21600 bps (specified by selectors 1 through 4 of WSW39), the allowable maximum transmission speed remains 21600 bps but the minimum transmission speed will be limited to 4800 bps.

| Symbol rate | Transmission speed (bps) | Symbol rate | Transmission speed (bps) | Symbol rate | Transmission speed (bps) |
|-------------|--------------------------|-------------|--------------------------|-------------|--------------------------|
| 2400 | 2400 | 3000 | 4800 | 3429 | 4800 |
| | 4800 | | 7200 | | 7200 |
| | 7200 | | 9600 | | 9600 |
| | 9600 | | 12000 | | 12000 |
| | 12000 | | 14400 | | 14400 |
| | 14400 | | 16800 | | 16800 |
| | 16800 | | 19200 | | 19200 |
| | 19200 | | 21600 | | 21600 |
| | 21600 | | 24000 | | 24000 |
| | 2400 | | 4800 | | 3200 |
| 7200 | 28800 | 31200 | | | |
| 9600 | 4800 | 33600 | | | |
| 12000 | 7200 | | | | |
| 14400 | 9600 | | | | |
| 16800 | 12000 | | | | |
| 19200 | 14400 | | | | |
| 21600 | 16800 | | | | |
| 24000 | 19200 | | | | |
| 26400 | 21600 | | | | |
| | 24000 | | | | |
| | 26400 | | | | |
| | 28800 | | | | |
| | 31200 | | | | |

WSW41 (Function setting 19)

| Selector No. | Function | Setting and Specifications | | | | | | | | | | | | | | | | | | | | | | | | | | | | | | | | | | | | | | | | | | | | | | | | | | | | | | | | |
|--------------|------------------|--|-----|---|---|---------|---|---|--|--|---|---|---|---|---|---------|--|---|---|---|---|---|---------|--|---|---|---|---|---|---------|--|---|---|---|---|---|---------|--|---|---|---|---|---|---------|--|--|--|--|--|---|--|--|---|---|---|---|---|---------|
| 1 4 | Not used. | | | | | | | | | | | | | | | | | | | | | | | | | | | | | | | | | | | | | | | | | | | | | | | | | | | | | | | | | |
| 5 8 | Modem attenuator | <table border="0"> <tr> <td>No.</td> <td>5</td> <td>6</td> <td>7</td> <td>8</td> <td>:</td> <td></td> </tr> <tr> <td></td> <td>0</td> <td>0</td> <td>0</td> <td>0</td> <td>:</td> <td>-10 dBm</td> </tr> <tr> <td></td> <td>0</td> <td>0</td> <td>0</td> <td>1</td> <td>:</td> <td>-11 dBm</td> </tr> <tr> <td></td> <td>0</td> <td>0</td> <td>1</td> <td>0</td> <td>:</td> <td>-12 dBm</td> </tr> <tr> <td></td> <td>0</td> <td>0</td> <td>1</td> <td>1</td> <td>:</td> <td>-13 dBm</td> </tr> <tr> <td></td> <td>0</td> <td>1</td> <td>0</td> <td>0</td> <td>:</td> <td>-14 dBm</td> </tr> <tr> <td></td> <td></td> <td></td> <td> </td> <td></td> <td>:</td> <td> </td> </tr> <tr> <td></td> <td>1</td> <td>1</td> <td>1</td> <td>1</td> <td>:</td> <td>-25 dBm</td> </tr> </table> | No. | 5 | 6 | 7 | 8 | : | | | 0 | 0 | 0 | 0 | : | -10 dBm | | 0 | 0 | 0 | 1 | : | -11 dBm | | 0 | 0 | 1 | 0 | : | -12 dBm | | 0 | 0 | 1 | 1 | : | -13 dBm | | 0 | 1 | 0 | 0 | : | -14 dBm | | | | | | : | | | 1 | 1 | 1 | 1 | : | -25 dBm |
| No. | 5 | 6 | 7 | 8 | : | | | | | | | | | | | | | | | | | | | | | | | | | | | | | | | | | | | | | | | | | | | | | | | | | | | | | |
| | 0 | 0 | 0 | 0 | : | -10 dBm | | | | | | | | | | | | | | | | | | | | | | | | | | | | | | | | | | | | | | | | | | | | | | | | | | | | |
| | 0 | 0 | 0 | 1 | : | -11 dBm | | | | | | | | | | | | | | | | | | | | | | | | | | | | | | | | | | | | | | | | | | | | | | | | | | | | |
| | 0 | 0 | 1 | 0 | : | -12 dBm | | | | | | | | | | | | | | | | | | | | | | | | | | | | | | | | | | | | | | | | | | | | | | | | | | | | |
| | 0 | 0 | 1 | 1 | : | -13 dBm | | | | | | | | | | | | | | | | | | | | | | | | | | | | | | | | | | | | | | | | | | | | | | | | | | | | |
| | 0 | 1 | 0 | 0 | : | -14 dBm | | | | | | | | | | | | | | | | | | | | | | | | | | | | | | | | | | | | | | | | | | | | | | | | | | | | |
| | | | | | : | | | | | | | | | | | | | | | | | | | | | | | | | | | | | | | | | | | | | | | | | | | | | | | | | | | | | |
| | 1 | 1 | 1 | 1 | : | -25 dBm | | | | | | | | | | | | | | | | | | | | | | | | | | | | | | | | | | | | | | | | | | | | | | | | | | | | |

NOTE: WSW41 takes effect only in the V. 34 mode.

- **Selectors 5 through 8: Modem attenuator**

These selectors are used to adjust the transmitting level of the modem when the reception level at the remote station is improper due to line loss. This function applies to super G3 protocol signals.

WSW42 (Function setting 20)

| Selector No. | Function | Setting and Specifications | |
|--------------|--|----------------------------|-------------|
| 1 | Incoming mail server POP* ¹ | 0: OFF | 1: ON |
| 2 | Incoming mail server SMTP* ² | 0: OFF | 1: ON |
| 3 | Internet-FAX forward function | 0: OFF | 1: ON |
| 4 | JBIG* ³ coding system | 0: Disabled | 1: Enabled |
| 5 | Alarm message when the corona wire abnormally emits ions | 0: Enabled | 1: Disabled |
| 6 | Issue of a drum cleaning prompting sheet when the corona wire abnormally emits ions | 0: Enabled | 1: Disabled |
| 7 | Issue of a drum cleaning prompting sheet when the specified number of pages has been printed | 0: Enabled | 1: Disabled |
| 8 | Not used. | | |

*¹ POP: Post Office Protocol
 *² SMTP: Simple Mail Transfer Protocol
 *³ JBIG: Joint Bi-level Image Group

NOTE: Selectors 1 through 3 are applicable to those models equipped with LAN interface.

NOTE: Selectors 5 through 7 take effect only when selector 5 of WSW30 is set to "ON" (0).

- **Selector 3: Internet-FAX forward function**

If this selector is set to "ON," the machine may forward a FAX message received through Internet to other remote G3 facsimile equipment.

- **Selector 5: Alarm message when the corona wire abnormally emits ions**

This selector determines whether or not the alarm message "PLS CLEAN DRUM" will appear on the LCD when the corona wire abnormally emits ions.

- **Selector 6: Issue of drum cleaning prompting sheet when the corona wire abnormally emits ions**

This selector determines whether or not a drum cleaning prompting sheet will be printed out when the corona wire abnormally emits ions. The sheet prompts the user to clean the corona wire of the laser-sensitive drum.

- **Selector 7: Issue of a drum cleaning prompting sheet when the specified number of pages has been printed**

This selector determines whether or not a drum cleaning prompting sheet will be printed out when the specified number of pages has been printed (that is, when it is assumed that the corona wire becomes dirty). The sheet prompts the user to clean the corona wire of the laser-sensitive drum.

WSW43 (Function setting 21)

| Selector No. | Function | Setting and Specifications |
|--------------|---|---|
| 1 | Addition of a header (station ID) to FAX images to be sent to PCs having e-mail addresses | 0: Yes 1: No |
| 2 3 | Wait time for PCFax reception (Class 2) and FPTS command transmission | No. 2 3 0 0 : 50 ms 0 1 : 100 ms 1 0 : 150 ms 1 1 : 0 ms |
| 4 5 | Detection time of 2100 Hz CED or ANSam | No. 4 5 0 0 : 200 ms 0 1 : 300 ms 1 0 : 400 ms 1 1 : 500 ms |
| 6 8 | Not used. | |

NOTE: Selector 1 is applicable to those models equipped with LAN interface.

[B] Printout of firmware switch data

Function

The equipment prints out the setting items and contents specified by the firmware switches.

Operating Procedure

- (1) Press the 1 key twice in the initial stage of the maintenance mode.
The "PRINTING" will appear on the LCD.
- (2) The equipment prints out the configuration list as shown in the figure below.
- (3) Upon completion of printing, the equipment returns to the initial stage of the maintenance mode.

CONFIGURATION LIST

MODEL: 8X5-401
 TIME : 06/28/1999 05:54
 REV. : U9906251842VER.0
 PCI : 5.00
 SUM : 0029

54
.0

| | |
|--|------------------|
| <pre> WSW01 = 00000000 1-2. DIAL FORMAT : NORMAL 3-4. BREAK TIME : 60 MS 5-6. INTERDIGIT PAUSE : 800 MS 7. DP/PB CHANGE IN USER SW : Yes 8. DP/PB FIXING SELECTION : PB WSW02 = 11111010 1-2. ON TIME : 100 MS 3-4. ON TIME : 140 MS 5-8. LINE BEEP ATTENUATOR : 10 dB WSW03 = 10000000 1. PARA. ONG DETECTION2 : B 2-4. NOT USED 5. PARA. ONG DETECTION1 : A 6-8. NOT USED WSW04 = 00010111 1. EARTH IN TRANSFER : ON 2-4. NOT USED 5-6. EARTHING TIME : 300 MS 7-8. FLASHING TIME : 500 MS WSW05 = 00000110 1-3. DIAL TONE DETECTION : 3.5 SEC WAITING 4. REMOTE ID DETECTION TIMEOUT : 2 SEC 5-6. BUSY TONE DETECTION (CALLING) : AFTER DIALING 7. BUSY TONE DETECTION (CALLED) : OFF 8. DTMF DETECTION : 4 WSW06 = 00101100 1-3. PAUSE KEY : 3.5 SEC WAITING 4-8. NOT USED WSW07 = 01001100 1-2. FREQUENCY RANGE : INITIAL DATA 3. CURRENT LOOP DETECTION : OFF 4-8. NOT USED WSW08 = 01100100 1-8. NOT USED WSW09 = 00000000 1. ECM FRAME : 256 OCTET 2. NON STANDARD FACILITIES : ON 3-4. TIMES OF FALL BACK : 4 5. T5 TIMER : 300 SEC 6. T1 TIMER : 35 SEC 7-8. CALLING TIMEOUT : 60 SEC WSW10 = 00010100 1. DPS LINK WITH CML : Yes 2. TIMING OF LAST DIGIT-MODEM CHANGE : 100 MS 3. TIMING OF CML ON ONG TRANSMISSION : 2 SEC 4. TIMING OF CML ON CED TRANSMISSION : 2 SEC 5-6. TRAINING RETRIES : 2 7. CODING METHOD MR : ON 8. CODING METHOD MMR : ON WSW11 = 01011000 1-2. FREQUENCY RANGE : INITIAL DATA 3. NOT USED 4-8. ON/OFF TIME : 175 - 600 / 175 - 600 ms WSW12 = 10011011 1-2. OFF DETECTION TIME : 700 MS 3-4. AUTO ANS OFF DETECTION TIME : 7 SEC 5-6. ON DETECTION TIME : 250 MS 7. DELAY : OFF 8. NOT USED WSW13 = 00011010 1-2. CABLE EQUALIZER : 0 km 3-4. RECEIVING LEVEL : -47 dBm 5-8. ATTENUATOR : 10 dB WSW14 = 01110110 1-2. CALLING SIGNAL RANGE (LOW) : 14 Hz 3-4. CALLING SIGNAL RANGE (HIGH) : 70 Hz 5-8. DELAY TIMES : 1 - 4 WSW15 = 00001110 1-2. INTERVAL TIME : 5 min 3-6. RETRIES : 3 7. REDIAL IN CASE OF NO FAX RESPONSE : No </pre> | <p>54 .0</p> |
| <pre> 6-7. NOT USED 8. TONER SAVE IF EMPTY : No </pre> | |
| <pre> 3. INTERNET FAX : ON 4-8. NOT USED </pre> | |

Configuration List

3.6 Operational Check of LCD

Function

This function allows you to check whether the LCD on the control panel works normally.

Operating Procedure

- (1) Press the **1** and **2** keys in this order in the initial stage of the maintenance mode.

The LCD shows

- (2) Press the **Start** key. Each time you press the **Start** key, the LCD cycles through the displays shown at right.

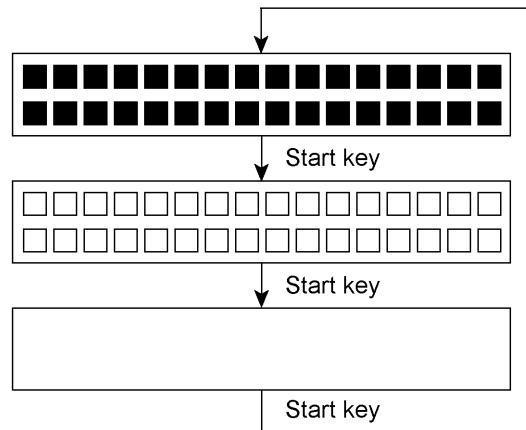

- (3) Press the **Stop** key in any process of the above display cycle. The equipment beeps for one second and returns to the initial stage of the maintenance mode.

3.7 Operational Check of Control Panel PCB

Function

This function allows you to check the control panel PCB for normal operation.

Operating Procedure

- (1) Press the **1** and **3** keys in this order in the initial stage of the maintenance mode.

The "00 " will appear on the LCD.

- (2) Press the keys and buttons in the order designated in the illustration shown below.

The LCD shows the corresponding number in decimal notation each time a key or button is pressed. Check that the displayed number is correct by referring to the illustration below.

If a key or button is pressed out of order, the equipment beeps and displays the "INVALID OPERATE" on the LCD. To return to the status ready to accept key & button entry for operational check, press the **Stop** key.

- (3) After the last number key or button is pressed, the equipment beeps and returns to the initial stage of the maintenance mode.

To terminate this operation, press the **Stop** key. The equipment returns to the initial stage of the maintenance mode.

FAX4750/FAX5750/FAX8350P

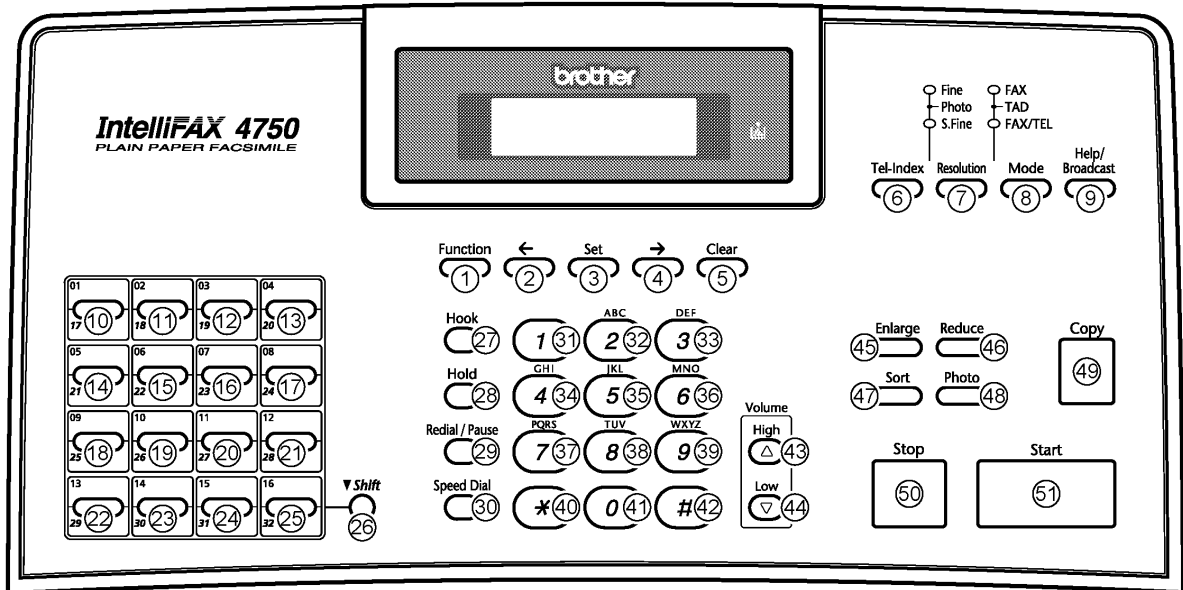

MFC8300/MFC8600/MFC8700/MFC9650/FAX8750P

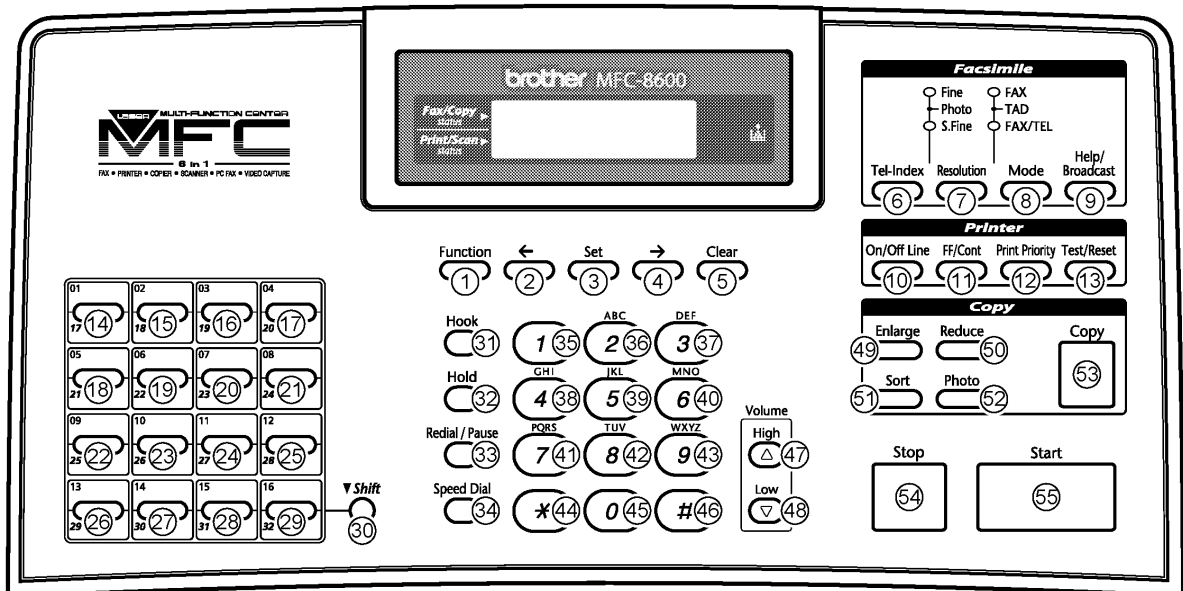

Key & Button Entry Order

3.8 Receiver Volume Adjustment (applicable to the American version only)

Function

The HIGH level of the handset receiver's volume will be influenced by the characteristics of the FET on the main PCB, so it requires fine adjustment according to the procedure given below.

Operating Procedure

- (1) Connect the telephone line cord to the modular jack of the facsimile equipment and the telephone wall socket.
- (2) Pick up the handset and listen to the dial tone. If the receiver volume is not appropriate, proceed to the following steps:
- (3) Press the **1** and **6** keys in this order in the initial stage of the maintenance mode.
The LCD shows the current receiver volume (default: HIGH).
- (4) If the current receiver volume is not HIGH, use the right or left arrow key to choose HIGH.
- (5) Press the **Start** key.
The equipment enters the receiver volume adjustment mode and shows the PWM duty ratio at the right end of the LCD.
- (6) Adjust the receiver volume by using the **1**, **3**, **4**, or **6** key.
1 key: Decrease 10H
3 key: Increase 10 H
4 key: Decrease 1H
6 key: Increase 1H
- (7) To escape from the receiver volume adjustment mode, press the **Set** key.
The LCD shows the "PWM SETTING." One second later, the LCD returns to the screen shown in step (3).
- (8) To return the equipment to the initial stage of the maintenance mode, press the **Stop** key.

3.9 Sensor Operational Check

Function

This function allows you to check whether the nine sensors (eight sensors on European models)-- document front sensor, document rear sensor, cover sensor, registration sensor, toner sensor, paper ejection sensor, hook switch sensor*, manual insertion sensor, and cassette sensor--operate correctly.

(*European models have no hook switch sensor.)

Operating Procedure

- Press the **3** and **2** keys in this order in the initial stage of the maintenance mode. The equipment beeps 1100 Hz and 400 Hz tones cyclically through the following volumes for testing the speaker.

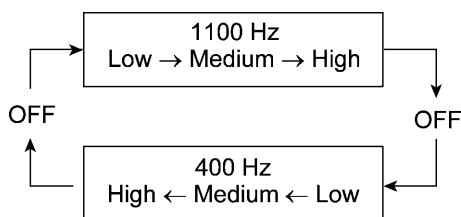

NOTE: To stop beeping, press the **Function** key (American models) or **Menu** key (European models).

If the sensing status are as listed below, the LCD will show the following:

"DFDRCVRSTNPOHKR2" and "MNCSC2" (which can be switched by pressing the **Start** key) on American models

"DFDRCVRSTNPO R2" and "MNCSC2" (which can be switched by pressing the **Start** key) on European models

Given below is the relationship between the LCD indication, sensor names and sensor status.

| LCD | Sensors | Sensing status |
|-----|---------------------------|---------------------------|
| DF | Document front sensor | No document detected. |
| DR | Document rear sensor | No document detected. |
| CV | Cover sensor | Front cover closed. |
| RS | Registration sensor | No paper detected. |
| TN | Toner sensor | No toner detected. |
| PO | Paper ejection sensor | No paper jam. |
| HK | Hook switch sensor* | On-hook state. |
| R2 | 2nd registration sensor** | No paper detected. |
| MN | Manual insertion sensor | No paper detected. |
| CS | Cassette sensor | No paper cassette loaded. |
| C2 | 2nd cassette sensor** | No paper cassette loaded. |

(**These error indications will always be displayed in models not equipped with a 2nd paper cassette.)

- Change the detecting conditions (e.g., insert paper through the document sensors or the registration sensor(s), open the front cover, remove the toner cartridge, jam paper at the paper outlet, lift up the handset*, insert paper manually through the paper slot, and load the paper cassette(s)), and then check that the indication on the LCD changes according to the sensor states.
- To stop this operation and return the equipment to the initial stage of the maintenance mode, press the **Stop** key.

NOTE: If you have opened and closed the front cover during the above procedure, you need to open and close the front cover again upon completion of the procedure.

3.10 CIS Scanner Area Setting

Function

The equipment sets the CIS scanner area and stores it into the EEPROM.

Operating Procedure

- (1) Press the **5** key twice in the initial stage of the maintenance mode.
The "SCANNER AREA SET" will appear on the LCD.
The equipment checks and sets the area to be scanned.
If no error is noted, the equipment returns to the initial stage of the maintenance mode.
If any error is noted, the "SCANNER ERROR" will appear on the LCD. To return the equipment to the initial stage of the maintenance mode, press the **Stop** key.

3.11 EEPROM Customizing

Function

This function allows you to customize the EEPROM according to language, function settings, and firmware switch settings. The customizing codes list is given in Appendix 1.

NOTE: If you replace the main PCB, be sure to carry out this procedure.

Operating Procedure

- (1) Press the **7** and **4** keys in this order in the initial stage of the maintenance mode.
The current customizing code (e.g., 1101 in the case of MFC8300 USA version) appears.
- (2) Enter the desired customizing code (e.g., 0202 in the case of MFC8600 Canadian version).
The newly entered code appears.
NOTE: *If a wrong 4-digit code is entered, the equipment will malfunction.*
- (3) Press the **Start** key.
The equipment saves the setting and returns to the initial stage of the maintenance mode.
If you press the **Stop** key or no keys are pressed for one minute in the above procedure, the equipment stops the procedure and returns to the initial stage of the maintenance mode.

3.12 Erasure of Received FAX Messages Temporarily Stored in the Flash Memory (not applicable to the American version)

Function

This function erases received FAX messages which are temporarily stored in the flash memory so that they will not be lost by powering off the equipment. This function also erases activity report data stored in the flash memory.

Operating Procedure

- (1) Press the **7** and **9** keys in this order in the initial stage of the maintenance mode.

The equipment shows the "BACKUP CLEAR" on the LCD and erases received FAX messages temporarily stored in the flash memory.

Upon completion of erasure, the equipment will automatically return to the initial stage of the maintenance mode.

3.13 Equipment Error Code Indication

Function

This function displays an error code of the last error on the LCD.

Operating Procedure

- (1) Press the **8** and **2** keys in this order in the initial stage of the maintenance mode.

The LCD shows the "MACHINE ERROR X X."

- (2) To stop this operation and return the equipment to the initial stage of the maintenance mode, press the **Stop** key.

3.14 Output of Transmission Log to the Telephone Line

Function

This function outputs the transmission log (that the equipment has stored about the latest transmission) to the telephone line. It allows the service personnel to receive the transmission log of the user's equipment at a remote location and use it for analyzing problems arising in the user's equipment.

Operating Procedure

- (1) If the user's equipment has a transmission-related problem, call the user's equipment at a remote location from your equipment.
- (2) If the line is connected, have the user perform the following:
 - 1) American models: Press the **Function**, **Mode**, and **0** keys in this order.
European models: Press the **Menu**, **Mode**, and **0** keys in this order.
 - 2) Press the **8** and **7** keys.The above operation makes the user's equipment send CNG to your equipment for sending the transmission log.
- (3) If you hear the CNG sent from the user's equipment, press the **Start** key of your equipment. Your equipment will start to receive the transmission log from the user's equipment.

3.15 Cancellation of the Memory Security Mode (applicable to the European version only)

Function

This procedure can cancel the memory security mode. Use this procedure if the user forgets his/her password entered when setting the memory security mode so as not to exit from the memory security mode.

NOTE: Carrying out this procedure will lose passwords previously entered but retain FAX messages received in the memory security mode.

Operating Procedure

- (1) When the SECURE MODE is displayed on the LCD, hold down the **Menu** key and press the **#** key. Within two seconds, start to press the **2**, **7**, **9**, **0**, and **0** keys.
The memory security mode will be canceled and the equipment returns to the calendar clock screen.

CHAPTER VI.
ERROR INDICATION AND
TROUBLESHOOTING

CHAPTER VI. ERROR INDICATION AND TROUBLESHOOTING

CONTENTS

| | |
|---|--------------|
| 1. ERROR INDICATION | VI-1 |
| 1.1 Equipment Errors..... | VI-1 |
| [1] Error messages on the LCD | VI-1 |
| [2] Error codes shown in the "MACHINE ERROR <u>X</u> <u>X</u> " message..... | VI-4 |
| 1.2 Communications Errors | VI-6 |
| | |
| 2. TROUBLESHOOTING..... | VI-16 |
| 2.1 Introduction..... | VI-16 |
| 2.2 Precautions..... | VI-16 |
| 2.3 Checking prior to Troubleshooting..... | VI-16 |
| 2.4 Troubleshooting Procedures | VI-18 |
| [1] Control panel related..... | VI-18 |
| [2] Telephone related | VI-18 |
| [3] Communications related..... | VI-19 |
| [4] Paper/document feeding related..... | VI-19 |
| [5] Print-image related..... | VI-20 |
| Location of High-voltage Contacts and Grounding Contacts..... | VI-27 |

1. ERROR INDICATION

To help the user or the service personnel promptly locate the cause of a problem (if any), the facsimile equipment incorporates the self-diagnostic functions which display error messages for equipment errors and communications errors.

For the communications errors, the equipment also prints out the transmission verification report and the communications list.

1.1 Equipment Errors

If an equipment error occurs, the facsimile equipment emits an audible alarm (continuous beeping) for approximately 4 seconds and shows the error message on the LCD. For the error messages, see [1] below.

To display detailed error information, use the maintenance-mode function code 82 described in Chapter V, Section 3.13 (that is, make the equipment enter the maintenance mode and then press the **8** and **2** keys). Following the MACHINE ERROR, one of the error codes listed in [2] will appear on the LCD.

[1] Error messages on the LCD

| Messages on the LCD | Probable Cause |
|--|---|
| CHECK PAPER CHECK PAPER#1 CHECK PAPER#2 | Even after paper pick-up operation, the manual insertion sensor does not detect paper. (For those models available with a 2nd paper cassette, the "CHECK PAPER#1" or "CHECK PAPER#2" will appear if the manual insertion sensor or 2nd registration sensor does not detect paper, respectively. If both sensors detect no paper, the "CHECK PAPER" will appear.) |
| CHECK CASSETTE CHECK CASSETTE#1 CHECK CASSETTE#2 | The cassette sensor detects that no paper cassette is loaded. (For those models available with a 2nd paper cassette, the "CHECK CASSETTE#1" or "CHECK CASSETTE#2" will appear if the cassette sensor or the 2nd cassette sensor does not detect paper cassette, respectively. If both sensors detect no cassette, the "CHECK CASSETTE" will appear.) |
| COVER OPEN | The cover sensor detects that the front cover is not closed. |
| PRINTER JAM | (1) The paper ejection sensor stays OFF even after the registration sensor has gone OFF and the paper has been fed by the specified amount. (2) The paper ejection sensor stays ON even after it has come ON and the paper has been fed by the specified amount. |

| Messages on the LCD | Probable Cause |
|---------------------|--|
| DOCUMENT JAM | <p>Document jam</p> <p>(1) The document length exceeds the limitation (400 or 90 cm) registered by firmware switch WSW16. (Refer to Chapter V, Section 3.5.)</p> <p>(Both the document front and rear sensors stay ON after the document has been fed by the registered length.)</p> <p>(2) The document rear sensor detects no trailing edge of a document after the document has been fed by 400 cm.</p> <p>(The document rear sensor stays ON even after the document has been fed when the document front and rear sensors were OFF and ON, respectively.)</p> |
| | <p>Document loading error</p> <p>(1) The document rear sensor detects no leading edge of a document within 10 seconds from the start of document loading operation.</p> <p>(The document rear sensor stays OFF even after the document has been fed when the document front sensor was ON.)</p> <p>(2) The loaded document is too short.</p> <p>(Since the document is shorter than the distance between the document front and rear sensors, the document front sensor is turned OFF before the document rear sensor is turned ON.)</p> |
| CLEAN UP SCANNER | <p>In the scanning compensation data list printed by the maintenance-mode function code 05, less than fifty percent of the white level data is faulty.</p> <p>(This message may appear only in the maintenance mode.)</p> |
| SCANNER ERROR | <p>In the scanning compensation data list printed by the maintenance-mode function code 05, fifty percent or more of the white level data is faulty.</p> <p>(This message may appear only in the maintenance mode.)</p> |
| TONER LOW | <p>The toner sensor has detected that there is not enough toner.</p> |
| TONER EMPTY | <p>The toner sensor has detected that there is no toner in the cartridge or that no toner cartridge is loaded. If this message appears, recording is no longer possible.</p> |
| COOLING DOWN | <p>The controller, which monitors the internal resistance of the in-casing temperature sensor (thermistor) and heater thermistor, has detected that the temperature inside the equipment or the heater temperature exceeded the specified level. If either temperature exceeds the preset level, recording is no longer possible.</p> |

| Messages on the LCD | Probable Cause |
|---------------------|---|
| MACHINE ERROR XX | "XX" indicates an error code. Refer to [2] on pages VI-4 and VI-5. |
| CHANGE DRUM SOON | <p>The service life of the drum unit will expire soon. This message appears for one minute.</p> <p>(You can turn this message indication on or off by the maintenance-mode function code 10, WSW31, selector 8. Refer to Chapter V, Section 3.5.)</p> |
| PLS OPEN COVER | <p>To display the relating detailed error code, use maintenance-mode function code 82. (Refer to Chapter V, Section 3.13.)</p> <p>If this message appears, open and close the front cover. The message may disappear if opening/closing the front cover removes the error. If the error persists, the "MACHINE ERROR XX" will appear.</p> |

If only an alarm beep is heard without any message on the LCD when the equipment is powered up, the ROM or RAM will be defective.

[2] Error codes shown in the "MACHINE ERROR X X " message

| Error Code <u>X X</u> (Hex.) | Error factor |
|------------------------------------|--|
| (71 | Polygon motor does not synchronize with the reference clock.) |
| (72 | Cannot detect Beam Detect signal.) |
| (73 | No toner cartridge loaded.) |
| (74 | Toner empty.) |
| (75 | In-casing temperature error.) |
| (76 | Heater harness disconnected or broken.) |
| (77 | Heater thermistor short circuit.) |
| (78 | Heater thermistor harness disconnected or broken.) |
| (79 | In-casing temperature sensor harness disconnected or broken.) |
| (7A | Main motor does not synchronize with the reference clock.) |
| (7B | ASIC error on the main PCB.) |
| (7C | Engine PCB error.) |
| (80 | Paper size setting error.) |
| (82 | Paper feeding error.) |
| (83 | Paper jam. The registration sensor, 2nd registration sensor, and/or manual insertion sensor remains ON.) |
| (84 | Paper jam. The paper ejection sensor remains ON.) |
| (85 | No paper cassette loaded.) |
| (86 | No 2nd paper cassette loaded.) |
| (88 | Paper jam. Even after the registration sensor has gone OFF, the paper ejection sensor still stays OFF.) |
| (A1 | Front cover opened.) |
| (A2 | Document too long to scan.) |
| (A3 | Document not detected by the document rear sensor.) |
| (A4 | 50% or more faulty of white level data.) |
| (A7 | One-line feeding timeout error.) |
| (A8 | One-line scanning timeout error.) |
| (A9 | Abnormal scanning reference voltage.) |
| (AC | Less than 50% faulty of white level data.) |

Error codes in parentheses do not appear in the "MACHINE ERROR X X", since those errors are displayed as messages described in "[1] Error messages on the LCD." In the maintenance mode (Function code 82), those error codes may be displayed.

| Error Code X X (Hex.) | Error factor |
|-----------------------------|--|
| (B7 | A/D converter reference voltage error (at High level).) |
| (B8 | A/D converter reference voltage error (at Low level).) |
| (B9 | Light emission intensity error of the LED array.) |
| (BA | Magnification error for substantial white level data.) |
| (BB | Substantial white level data error in black & white mode.) |
| (BC | Substantial white level data error in photo mode.) |
| (BD | Black level data error.) |
| (D5 | The MODEM fails to complete the command transmission sequence.) |
| (E4 | Out of recording paper.) |
| E6 | Write error in EEPROM. |
| (E8 | Data scanning error during transmission.) |
| (EA | Document removed in phase B.) |
| (F5 | EOL not found in page memory transmission mode.) |
| (F6 | PC interface error.) |

Error codes in parentheses do not appear in the "MACHINE ERROR X X", since those errors are displayed as messages described in "[1] Error messages on the LCD." In the maintenance mode (Function code 82), those error codes may be displayed.

1.2 Communications Errors

If a communications error occurs, the facsimile equipment

- ① emits an audible alarm (intermittent beeping) for approximately 4 seconds,
- ② displays the corresponding error message, and
- ③ prints out the transmission verification report if the equipment is in sending operation.

Definition of Error Codes on the Communications List

(1) Calling

| Code 1 | Code 2 | Causes |
|--------|--------|--|
| 10 | 08 | Wrong number called. |
| 10 | 20 | Retrieval file error. |
| 10 | 21 | Image data entry error. |
| 11 | 01 | No dial tone detected before start of dialing. |
| 11 | 02 | Busy tone detected before dialing. |
| 11 | 03 | 2nd dial tone not detected. |
| 11 | 05 | No loop current detected.* |
| 11 | 06 | Busy tone detected after dialing or called. |
| 11 | 07 | No response from the remote station in sending. |
| 11 | 10 | No tone detected after dialing. |
| | | |
| 17 | 07 | No response from the calling station in receiving. |
| 1A | 01 | Calling impossible due to memory full. |

*Available in German versions only.

(2) Command reception

| Code 1 | Code 2 | Causes |
|--------|--------|---|
| 20 | 01 | Unable to detect a flag field. |
| 20 | 02 | Carrier was OFF for 200 ms or longer. |
| 20 | 03 | Abort detected ("1" in succession for 7 bits or more). |
| 20 | 04 | Overrun detected. |
| 20 | 05 | A frame for 3 seconds or more received. |
| 20 | 06 | CRC error in answerback. |
| 20 | 07 | Undefined command received. |
| 20 | 08 | Invalid command received. |
| 20 | 09 | Command ignored once for document setting or for dumping-out at turn-around transmission. |
| 20 | 0A | T5 timeout error |
| 20 | 0B | CRP received. |

| Code 1 | Code 2 | Causes |
|--------|--------|--|
| 20 | 0C | EOR and NULL received. |
| 20 | 0D | Effective command not received. |
| 20 | 10 | Unable to reserve a command receiver memory. |
| 20 | 11 | Image data file error. |

(3) Compatibility [checking the NSF and DIS]

| Code 1 | Code 2 | Causes |
|--------|--------|---|
| 32 | 01 | Remote terminal only with V.29 capability in 2400 or 4800 bps transmission. |
| 32 | 02 | Remote terminal not ready for polling. |
| | | |
| | | |
| 32 | 10 | Remote terminal not equipped with password function or its password switch OFF. |
| 32 | 11 | Remote terminal not equipped with or not ready for confidential mail box function. |
| 32 | 12 | Remote terminal not equipped with or not ready for relay broadcasting function. |
| 32 | 13 | No confidential mail in the remote terminal. |
| 32 | 14 | The available memory space of the remote terminal is less than that required for reception of the confidential or relay broadcasting instruction. |
| | | |
| | | |
| | | |

(4) Instructions received from the remote terminal [checking the NSC, DTC, NSS, and DCS]

| Code 1 | Code 2 | Causes |
|--------|--------|---|
| 40 | 02 | Illegal coding system requested. |
| 40 | 03 | Illegal recording width requested. |
| | | |
| 40 | 05 | ECM requested although not allowed. |
| 40 | 06 | Polled while not ready. |
| 40 | 07 | No document to send when polled. |
| | | |
| | | |
| 40 | 10 | Nation code or manufacturer code not coincident. |
| 40 | 11 | Unregistered group code entered for relay broadcasting function, or the specified number of broadcasting subscribers exceeding the limit. |
| 40 | 12 | Retrieval attempted when not ready for retrieval. |
| 40 | 13 | Polled by any other manufacturers' terminal while waiting for secure polling. |
| 40 | 17 | Invalid resolution selected. |
| | | |
| | | |

(5) Command reception [checking the NSF and DIS after transmission of NSS and DCS]

| Code 1 | Code 2 | Causes |
|--------|--------|--|
| 50 | 01 | Vertical resolution capability changed after compensation of background color. |
| | | |
| | | |
| | | |

(6) ID checking

| Code 1 | Code 2 | Causes |
|--------|--------|---|
| 63 | 01 | Password plus "lower 4 digits of telephone number" not coincident. |
| 63 | 02 | Password not coincident. |
| 63 | 03 | Polling ID not coincident. |
| 63 | 04 | Entered confidential mail box ID uncoincident with the mail box ID. |
| 63 | 05 | Relay broadcasting ID not coincident. |
| 63 | 06 | Entered retrieval ID uncoincident with that of the mail box ID. |
| | | |
| | | |
| | | |

(7) DCN reception

| Code 1 | Code 2 | Causes |
|--------|--------|---------------|
| 74 | | DCN received. |
| | | |
| | | |
| | | |

(8) TCF transmission/reception

| Code 1 | Code 2 | Causes |
|--------|--------|----------------------|
| 80 | 01 | Fallback impossible. |
| | | |
| | | |
| | | |
| | | |
| | | |

(9) Signal isolation

| Code 1 | Code 2 | Causes |
|--------|--------|--|
| 90 | 01 | Unable to detect video signals and commands within 6 seconds after CFR is transmitted. |
| 90 | 02 | Received PPS containing invalid page count or block count. |
| | | |
| | | |

(10) Video signal reception

| Code 1 | Code 2 | Causes |
|--------|--------|---|
| A0 | 03 | Error correction sequence not terminated even at the final transmission speed for fallback. |
| A0 | 11 | Receive buffer empty. (5-second time-out) |
| A0 | 12 | Receive buffer full during operation except receiving into memory. |
| A0 | 13 | Decoding error continued on 500 lines. |
| A0 | 14 | Decoding error continued for 10 seconds. |
| A0 | 15 | Timeout: Five seconds or more for one-line transmission. |
| A0 | 16 | RTC not found and carrier OFF signal detected for 6 seconds. |
| A0 | 17 | RTC found but no command detected for 60 seconds. |
| A0 | 18 | Receive buffer full during receiving into memory. |
| A0 | 19 | Unable to obtain compressed image data to be sent in phase C. |
| A8 | 01 | RTN, PIN, or ERR received at the calling terminal.* |
| A9 | 01 | RTN, PIN, or ERR received at the called terminal.* |

* Available in German versions only

(11) General communications-related

| Code 1 | Code 2 | Causes |
|--------|--------|--|
| B0 | 02 | Unable to receive the next-page data. |
| B0 | 03 | Unable to receive polling even during turn-around transmission due to call reservation. |
| B0 | 04 | PC interface error. |
| BF | 01 | Transmission canceled by pressing the Stop key (before completion of the G3 FAX negotiation). |
| BF | 02 | Transmission canceled by pressing the Stop key (after completion of the G3 FAX negotiation). |
| BF | 03 | Transmission canceled due to a scanning error. |

(12) Transmission in V. 34 mode

| Code 1 | Code 2 | Causes |
|--------|--------|---|
| C0 | 01 | No common modulation mode or failed to poll. |
| C0 | 02 | Unable to detect JM. |
| C0 | 03 | Unable to detect CM. |
| C0 | 04 | Unable to detect CJ. |
| | | |
| C0 | 10 | Cannot finish V. 34 negotiation or training. |
| C0 | 11 | Modem error detected during V. 34 negotiation or training. (For modem error details, refer to the table below.) |
| | | |
| C0 | 20 | Modem error detected during sending of commands. (For modem error details, refer to the table below.) |
| C0 | 21 | Modem error detected during receiving of commands. (For modem error details, refer to the table below.) |
| C0 | 22 | Control channel connection time-out. |
| | | |
| C0 | 30 | Modem error detected during sending of video signals. (For modem error details, refer to the table below.) |
| C0 | 31 | Modem error detected during receiving of video signals. (For modem error details, refer to the table below.) |
| | | |

Modem error details (Code 3)

| Code 3 | Causes |
|--------|--|
| 21 | Timeout waiting for INFO0. |
| 22 | Checksum error in INFO0. |
| 23 | Timeout waiting for tone A or B. |
| 24 | Timeout waiting for first phase reverse. |
| 25 | Timeout waiting for probing cut-off tone. |
| 26 | Timeout waiting for second phase reverse. |
| 27 | Timeout waiting for end of probing. |
| 28 | Timeout waiting for third phase reverse. |
| 29 | Timeout waiting for INFO1. |
| 2A | Checksum error in INFO1. |
| 2B | Tone detected preceding INFO0. |
| 2C | Unexpected INFO0 detected. |
| 31 | Timeout waiting for turning off the receive control channel. |
| 91 | Error occurred in the first CC train. |
| 92 | Timeout waiting for PPh. |
| 93 | Tone A/B detected in the CC retrain. |
| 94 | Timeout waiting for ALT. |
| 95 | ACh found. |
| 96 | FED turned off during reception of CC data. |
| 97 | Timeout waiting for turning off the CC. |
| A1 | Retraining forced for problems not fixed in phase 2. |
| B0 | Problem with S-sequence of HDX-resync. |
| B1 | FED turned off in the S-sequence of HDX-resync. |
| B2 | S-sequence finished before prediction in HDX-resync. |
| B3 | Timeout waiting for S-Sbar in HDX-resync. |
| B4 | Timeout waiting for S-Sbar in HDX-resync. |
| B5 | Timeout waiting for S in HDX-resync. |
| B6 | Timeout waiting for synchronization with PP. |
| C0 | Problem with S-sequence in phase 3. |
| C1 | FED turned off in the S-sequence in phase 3. |

| Code 3 | Causes |
|--------|--|
| C2 | S-sequence finished before prediction in phase 3. |
| C3 | Timeout waiting for S-Sbar in phase 3. |
| C4 | Timeout waiting for S-Sbar in phase 3. |
| C5 | Timeout waiting for S in phase 3. |
| C7 | Training after TRN failure. |
| D0 | Problem with S-sequence in phase 4. |
| D1 | FED turned off in S-sequence in phase 4. |
| D2 | S-sequence finished before prediction in phase 4. |
| D3 | Timeout waiting for S-Sbar in phase 4. |
| D4 | Timeout waiting for S-Sbar in phase 4. |
| D5 | Timeout waiting for S in phase 4. |
| D6 | Timeout waiting for MP. |
| D8 | Timeout waiting for E. |
| DA | Timed out in re-negotiation of the transmitter rate. |
| DB | Timed out in the transmitter MPh. |
| E2 | Retraining detected in phase 2. |
| E3 | Retraining detected in phase 3. |
| E4 | Retraining detected in phase 4. |
| FE | DTR turned off during retraining. |
| FF | Tx set-abort flag. |
| 71 | Did not write onto the first mapping frame. |

(13) Maintenance mode

| Code 1 | Code 2 | Causes |
|--------|--------|--|
| E0 | 01 | Failed to detect 1300 Hz signal in burn-in operation. |
| E0 | 02 | Failed to detect PB signals in burn-in operation. |
| E0 | 03 | Failed to detect commands from the RS-232C in burn-in operation. |

(14) Equipment error

| Code 1 | Code 2 | Causes |
|--------|--------|---|
| FF | 00 | Burn-in operation canceled by pressing the Stop key. |
| FF | FF | Unrecoverable MODEM error. |
| | | |
| | | |

2. TROUBLESHOOTING

2.1 Introduction

This section gives the service personnel some of the troubleshooting procedures to be followed if an error or malfunction occurs with the facsimile equipment. It is impossible to anticipate all of the possible problems which may occur in future and determine the troubleshooting procedures, so this section covers some sample problems. However, those samples will help service personnel pinpoint and repair other defective elements if he/she analyzes and examines them well.

2.2 Precautions

Be sure to observe the following to prevent the secondary troubles from happening:

- (1) Always unplug the AC power cord from the outlet when removing the covers and PCBs, adjusting the mechanisms, or conducting continuity testing with a circuit tester.
- (2) When disconnecting the connectors, do not pull the lead wires but hold the connector housings.
- (3)
 - Before handling the PCBs, touch a metal portion of the machine to discharge static electricity charged in your body.
 - When repairing the PCBs, handle them with extra care.

After repairing the defective section, be sure to check again if the repaired section works correctly. Also record the troubleshooting procedure so that it would be of use for future trouble occurrence.

2.3 Checking prior to Troubleshooting

Prior to proceeding to the troubleshooting procedures given in Subsection 2.4, make the following initial checks:

Environmental conditions

Check that:

- (1) The machine is placed on a flat, firm surface.
- (2) The machine is used in a clean environment at or near normal room temperature (10°C to 32.5°C) with normal relative humidity (20 to 80%).
- (3) The machine is not subjected to rapid change of the ambient temperature. (Moving the machine from a cold place to warm place will cause condensation inside the machine. If it takes place, leave the machine in the warm place for approx. two hours before turning on the power.) Powering on the machine with dew condensation will result in damaged electronic devices.
- (4) The machine is not exposed to direct sunlight or harmful gases.

Power requirements

Check that:

- (1) The power supply specified on the rating plate located on the bottom of the machine is used. The supply voltage stays within the rating $\pm 10\%$.
- (2) Each voltage level on AC input lines and DC lines is correct.

- (3) All cables and harnesses are firmly connected.
- (4) None of the fuses are blown.

Recording paper

Check that:

- (1) A recommended type of recording paper is used.
- (2) The recording paper is not dampened.

2.4 Troubleshooting Procedures

[1] Control panel related

| Trouble | Check: |
|--------------------------------|---|
| (1) LCD shows nothing. | <ul style="list-style-type: none"> • Panel-main harness between the main PCB and the control panel PCB • Control panel PCB • Low-voltage power supply PCB • Main PCB • LCD |
| (2) Control panel inoperative. | <ul style="list-style-type: none"> • Panel-main harness between the main PCB and the control panel PCB • Control panel PCB • FPC key • Main PCB |

[2] Telephone related

| Trouble | Check: |
|---|---|
| (1) No phone call can be made. | <ul style="list-style-type: none"> • FPC key • Control panel PCB • NCU PCB • Main PCB |
| (2) Speed dialing or one-touch dialing will not work. | <ul style="list-style-type: none"> • Ordinary dialing function (other than the speed and one-touch dialing) <p>If it works normally, check the main PCB; if not, refer to item (1) above.</p> |
| (3) Speaker silent during on-hook dialing. | <ul style="list-style-type: none"> • Ordinary dialing function (other than the on-hook dialing with the hook key) <p>If it works normally, proceed to the following checks; if not, refer to item (1) above.</p> |
| (4) Dial does not switch between tone and pulse. | <ul style="list-style-type: none"> • Main PCB |
| (5) Telephone does not ring. | <ul style="list-style-type: none"> • Speaker • NCU PCB • Main PCB |

[3] Communications related

| Trouble | Check: |
|-----------------------------|---|
| (1) No tone is transmitted. | <ul style="list-style-type: none"> • Main PCB • NCU PCB |



[4] Paper/document feeding related

| Trouble | Check: |
|---|---|
| (1) Neither "COPY: PRESS COPY" nor "FAX: NO. & START" message appears although documents are set. | <ul style="list-style-type: none"> • Sensors by using the maintenance-mode function code 32. (Refer to Chapter V, Subsection 3.9.) • Document front sensor actuator and document rear sensor actuator • Main PCB |
| (2) Document not fed. | <ul style="list-style-type: none"> • ADF and its related sections • Scanner motor and its harness • Document feed roller and its related gears • Main PCB |
| (3) Document double feeding | <ul style="list-style-type: none"> • ADF parts • Nip-related parts |
| (4) Recording paper not fed. | <ul style="list-style-type: none"> • Paper loaded in the paper cassette(s) • Paper cassette(s) • Drum unit • Heat-fixing unit • Drive gear ASSY • Engine PCB • Main PCB |
| (5) Recording paper double feeding | <ul style="list-style-type: none"> • Separation pad on the paper cassette(s) |

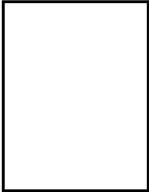

[5] Print-image related

If the received or sent image has any problem, first make a copy with the facsimile equipment.

If the copied image is normal, the problem may be due to the remote terminal; if it is abnormal, proceed to the following checks:

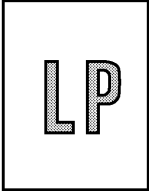
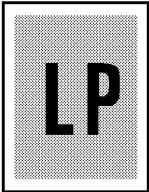
| Trouble | Action to be taken |
|---|---|
| <p>(1) Completely blank</p>  | <p><u>At the scanner</u></p> <p>Check the following components:</p> <ul style="list-style-type: none"> - CIS harness - Main PCB - CIS unit <p><u>At the printer side</u></p> <ul style="list-style-type: none"> ● Clean the high-voltage contacts for the developer roller on the drum unit, main cover, and high-voltage power supply PCB. (Contacts in the illustration given on page VI-27) ● Clean the grounding contacts on the drum unit, main cover, and high-voltage power supply PCB. (Contacts in the illustration given on page VI-27) ● Replace the toner cartridge. ● Replace the drum unit. ● Check the connection of the laser flat cable on the main PCB. ● Replace the main PCB. ● Replace the laser unit. ● Replace the high-voltage power supply PCB. |
| <p>(2) All black</p>  | <p><u>At the scanner</u></p> <p>Check the following components:</p> <ul style="list-style-type: none"> - CIS harness - CIS unit - Main PCB <p><u>At the printer side</u></p> <ul style="list-style-type: none"> ● Clean the high-voltage contacts for the grid and charger on the drum unit, main cover, and high-voltage power supply PCB. (Contacts and in the illustration given on page VI-27) ● Clean the charger (corona wires) itself. ● Check the connection of the laser flat cable on the main PCB. ● Replace the drum unit. ● Replace the high-voltage power supply PCB. ● Replace the main PCB. |

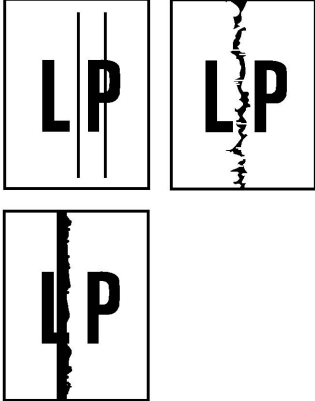
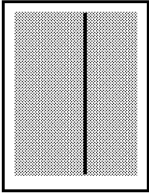

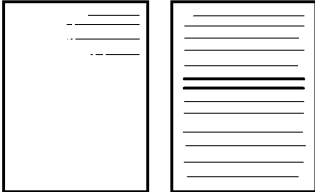
| Trouble | Action to be taken |
|---|--|
| <p>(3) Light</p>  | <p><u>At the scanner</u></p> <p>Check the following components:</p> <ul style="list-style-type: none"> - CIS unit - Main PCB <p><u>At the printer side</u></p> <ul style="list-style-type: none"> • Replace the toner cartridge with a new one and print 4 to 5 pages. If the problem persists, proceed to the next step. • Remove the toner cartridge and start printing. If printing takes place, clean the toner sensors (LED and light-receiver), check the sensor harnesses, and then replace the toner sensor PCBs. • Clean the high-voltage contacts for the transfer roller on the drum unit, main cover, and high-voltage power supply PCB. (Contacts in the illustration given on page VI-27) • Clean the high-voltage contacts for the developer roller on the drum unit, main cover, and high-voltage power supply PCB. (Contacts in the illustration given on page VI-27) • Clean the grounding contacts on the drum unit and main cover. (Contacts in the illustration given on page VI-27) • Check the connection of the main PCB and high-voltage power supply PCB. • Replace the drum unit. • Replace the high-voltage power supply PCB. • Replace the engine PCB. • Replace the main PCB. • Replace the laser unit. |
| <p>(4) Dark</p>  | <p><u>At the scanner</u></p> <p>Check the following components:</p> <ul style="list-style-type: none"> - CIS unit - Main PCB <p><u>At the printer side</u></p> <ul style="list-style-type: none"> • Slide the wire cleaner to clean the corona wire inside the drum unit. • Clean the high-voltage contacts for the grid and charger on the drum unit, main cover, and high-voltage power supply PCB. (Contacts and in the illustration given on page VI-27) • Replace the toner cartridge. • Replace the drum unit. • Replace the high-voltage power supply PCB. • Replace the main PCB. • Replace the engine PCB. |

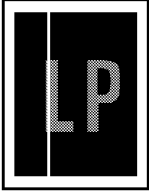
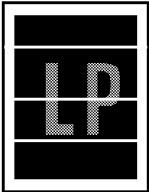
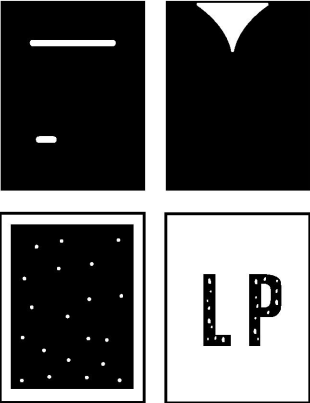
| Trouble | Action to be taken |
|---|---|
| <p>(5) Black and blurred vertical stripes or band</p>  | <p><u>At the scanner</u> Check the following components:</p> <ul style="list-style-type: none"> - CIS unit <p><u>At the printer side</u></p> <ul style="list-style-type: none"> • Clean the paper path which may be contaminated with toner. • Slide the wire cleaner to clean the corona wire inside the drum unit. • Make sure that the wire cleaner is returned to its home position. • Replace the toner cartridge. • Replace the drum unit. • Replace the heat-fixing unit. |
| <p>(6) Black vertical streaks on gray background</p>  | <p><u>At the printer side</u></p> <ul style="list-style-type: none"> • Clean the laser beam window (glass) on the laser unit. • Replace the laser unit. |
| <p>(7) Black and blurred horizontal stripes</p>  | <p><u>At the printer side</u></p> <ul style="list-style-type: none"> • Slide the wire cleaner to clean the corona wire inside the drum unit. • If the horizontal stripes appear at 39-mm intervals, replace the toner cartridge. • If they appear at 94-mm intervals, replace the drum unit. • If they appear at 79-mm intervals, replace the heat-fixing unit. • Clean the grounding contacts. (Contacts in the illustration given on page VI-27.) • Replace the high-voltage power supply PCB. |
| <p>(8) Horizontal lines</p>  | <p><u>At the printer side</u></p> <ul style="list-style-type: none"> • Check the connection between the right end of the paper feed roller and the grounding wire. (Contact in the illustration given on page VI-28.) |

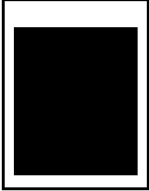
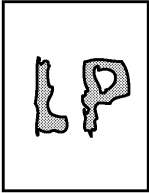
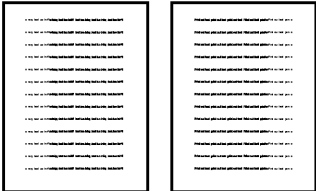
| Trouble | Action to be taken |
|---|--|
| <p>(9) White vertical streaks</p>  | <p><u>At the scanner</u> Check the following components:</p> <ul style="list-style-type: none"> - CIS unit <p><u>At the printer side</u></p> <ul style="list-style-type: none"> • Clean the laser beam window on the laser unit. • Replace the toner cartridge. • Replace the drum unit. |
| <p>(10) White horizontal stripes</p>  | <p><u>At the printer side</u></p> <ul style="list-style-type: none"> • Replace the drum unit. |
| <p>(11) Dropout, white spots, or hollow print</p>  | <p><u>At the printer side</u></p> <ul style="list-style-type: none"> • Check the connection of the main PCB and high-voltage power supply PCB. • Replace the toner cartridge. • Gently wipe off the surface of the photo-sensitive drum with a cotton swab. • Replace the drum unit. • Replace the high-voltage power supply PCB. |

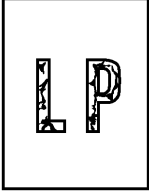
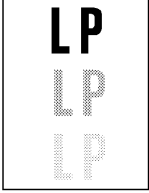
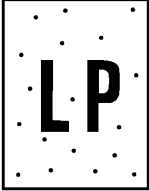
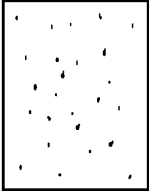
| Trouble | Action to be taken |
|--|---|
| <p>(12) Faulty image registration (Leading edge of image starts too late on paper)</p>  | <p><u>At the printer side</u></p> <ul style="list-style-type: none"> ● Instruct the user not to load paper exceeding the limit on the paper cassette(s). ● Instruct the user to use the recommended types of paper. ● Replace the paper cassette(s). ● Check the position of the registration sensor. ● Replace the drive gear ASSY. |
| <p>(13) Image distortion or improper image alignment</p>  | <p><u>In communications</u></p> <p>Check the following components:</p> <ul style="list-style-type: none"> - Error code displayed. (Refer to Section 1, "ERROR INDICATION" in this chapter.) - NCU PCB - Main PCB <p><u>At the scanner</u></p> <p>Check the following components:</p> <ul style="list-style-type: none"> - Document take-in roller, separation roller, and their related sections - Document feed roller and its related gears - Scanner motor and its harness - Main PCB <p><u>At the printer side</u></p> <ul style="list-style-type: none"> ● Check that the laser unit is secured with the screws without looseness. ● Check the connection of the polygon motor harness on the engine PCB. ● Check the connection of the laser flat cable on the main PCB. ● Replace the laser unit. |
| <p>(14) Blurred at either side</p>  | <p><u>At the printer side</u></p> <ul style="list-style-type: none"> ● Check that the equipment is placed on a flat surface. ● Shake the toner cartridge horizontally. If the problem persists, replace it. ● Clean the laser beam window (glass) on the laser unit. ● Replace the laser unit. |

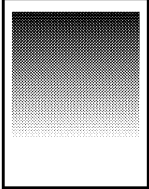
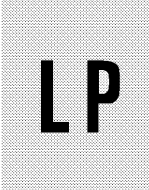
| Trouble | Action to be taken |
|--|---|
| <p>(15) Dirt back of paper</p>  | <p><u>At the printer side</u></p> <ul style="list-style-type: none"> • Clean the pressure roller in the heat-fixing unit. Replace the heat-fixing unit. • Replace the drum unit. • Replace the high-voltage power supply PCB. |
| <p>(16) Poor fixing</p>  | <p><u>At the printer side</u></p> <ul style="list-style-type: none"> • Instruct the user to use paper of the recommended weight (less than 36 lb./m²). • Clean the toner sensors (LED and light-receiver). • Replace the toner cartridge. • Replace the drum unit. • Check the fitting of the heater thermistor. Replace the heat-fixing unit. • Replace the low-voltage power supply PCB. |
| <p>(17) Ghost</p>  | <p><u>At the printer side</u></p> <ul style="list-style-type: none"> • Instruct the user to use paper of the recommended weight (less than 36 lb./m²). • Replace the drum unit. • Replace the high-voltage power supply PCB. |
| <p>(18) Black spots</p>  | <p><u>At the printer side</u></p> <ul style="list-style-type: none"> • Gently wipe off the surface of the photo-sensitive drum with a cotton swab. • Replace the drum unit. • Replace the heat-fixing unit. • Replace the high-voltage power supply PCB. |
| <p>(19) Light rain</p>  | <p><u>At the printer side</u></p> <ul style="list-style-type: none"> • Replace the drum unit. • Replace the high-voltage power supply PCB. |

| Trouble | Action to be taken |
|---|--|
| <p>(20) Fading (black to white)</p>  | <p><u>At the printer side</u></p> <ul style="list-style-type: none"> • Replace the toner cartridge. • Replace the high-voltage power supply PCB. |
| <p>(21) Gray background</p>  | <p><u>At the printer side</u></p> <ul style="list-style-type: none"> • Instruct the user to use paper of the recommended weight (less than 36 lb./m²). • Clean the toner sensors (LED and light-receiver). • Check the toner sensor harnesses. • Replace the toner cartridge. • Replace the drum unit. • Replace the high-voltage power supply PCB. |
| <p>(22) Toner specks</p>  | <p><u>At the printer side</u></p> <ul style="list-style-type: none"> • Instruct the user to use paper of the recommended weight (less than 36 lb./m²). • Replace the toner cartridge. • Replace the drum unit.. |

Location of High-voltage Contacts and Grounding Contacts

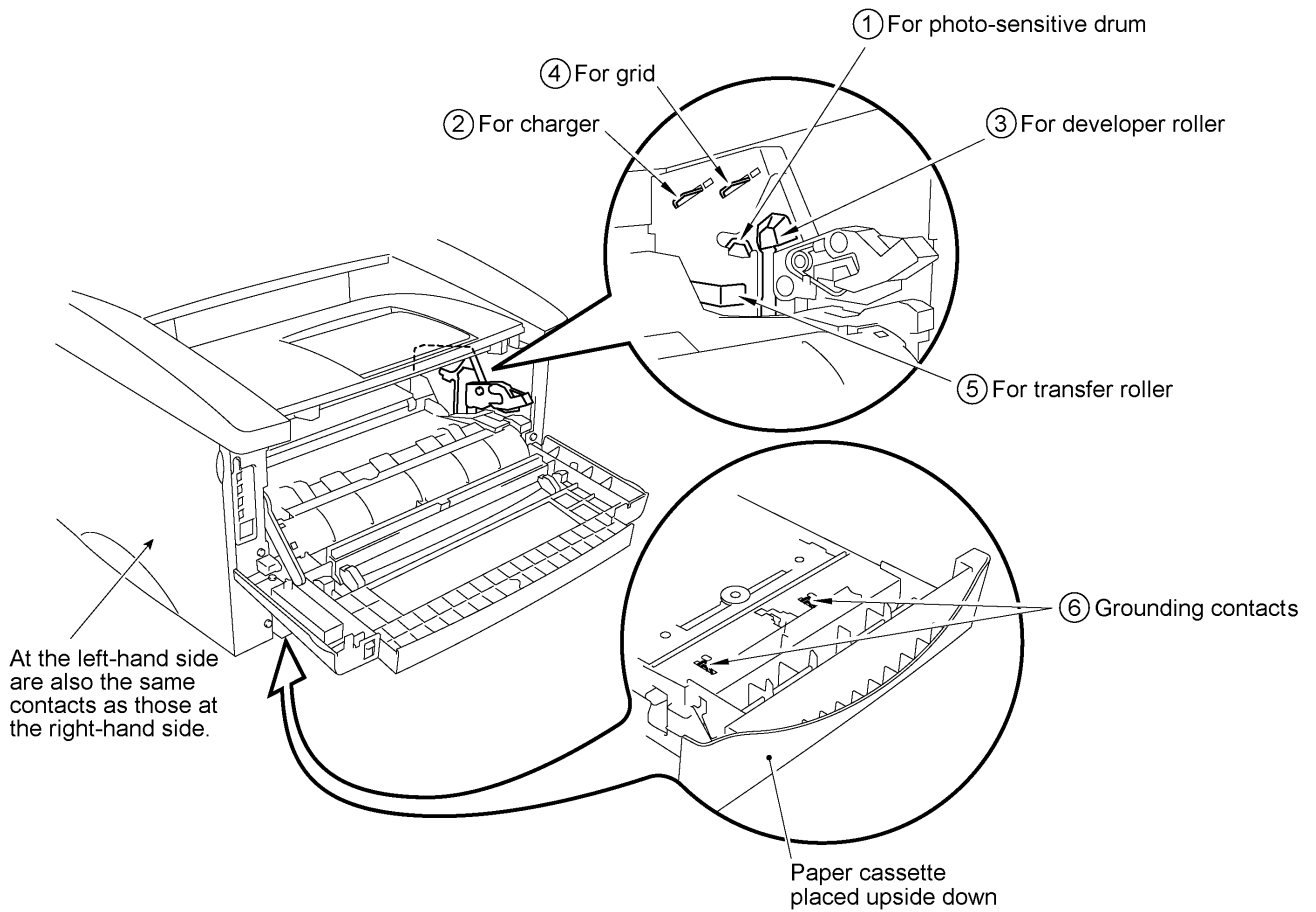
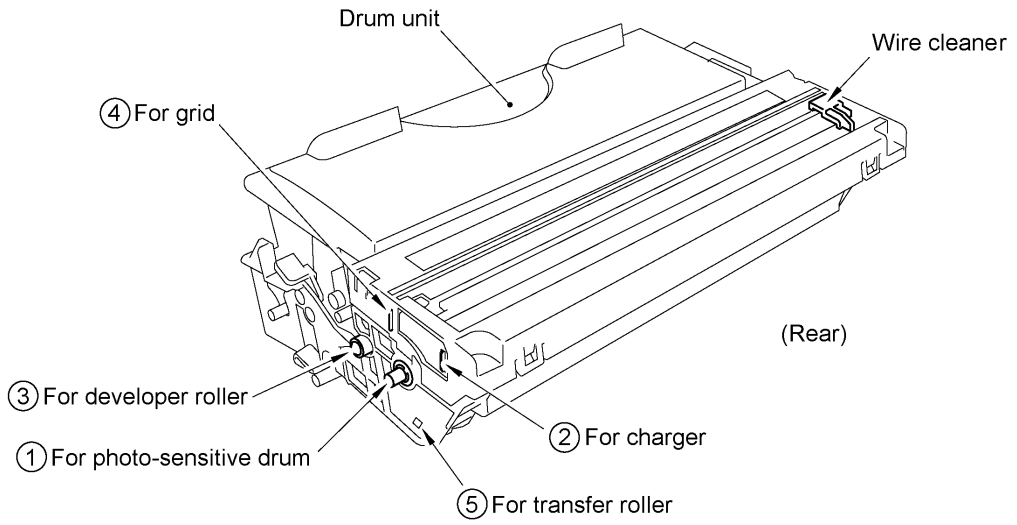

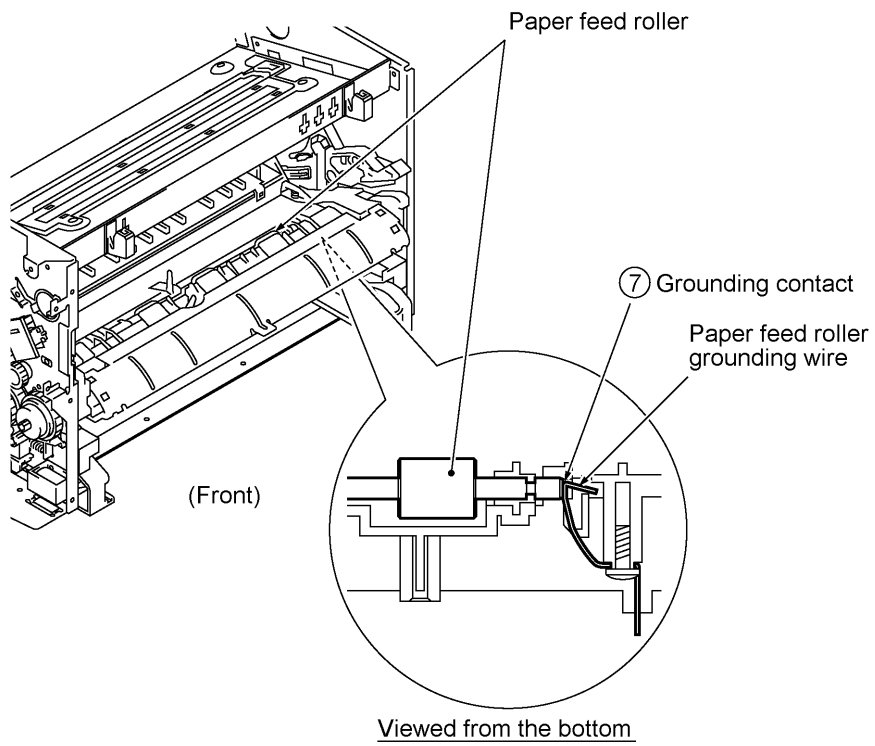

FAX4750/5750
MFC8300/8600/8700
FAX8350P/8750P
MFC9650

Appendix 1. EEPROM Customizing Codes

EEPROM Customizing Codes

This function allows you to customize the EEPROM according to language, function settings, and firmware switch settings.

Operating Procedure

- (1) American models: To make the equipment enter the maintenance mode, press the **Function**, *, **2**, **8**, **6**, and **4** keys in this order.

← Within 2 seconds →

European models: To make the equipment enter the maintenance mode, press the **Menu**, *, **2**, **8**, **6**, and **4** keys in this order.

← Within 2 seconds →

The equipment beeps for approx. one second and displays “■■ MAINTENANCE ■■” on the LCD.

- (2) Press the **7** and **4** keys in this order in the initial stage of the maintenance mode.

The current customizing code (e.g., 1001 in the case of FAX4750 USA version) appears.

- (3) Enter the desired customizing code (e.g., 0002 in the case of FAX4750 Canadian version).

The newly entered code appears.

NOTE: *If a wrong 4-digit code is entered, the equipment will malfunction.*

- (4) Press the **Start** key.

The equipment saves the setting and returns to the initial stage of the maintenance mode.

If you press the **Stop** key or no keys are pressed for one minute in the above procedure, the equipment stops the procedure and returns to the initial stage of the maintenance mode.

EEPROM Customizing Codes List

| Versions | Model | | | | |
|---------------|---------|---------|---------|---------|---------|
| | FAX4750 | MFC8300 | MFC8600 | MFC8700 | FAX5750 |
| U.S.A. | 1001 | 1101 | 1201 | 1001 | 1001 |
| CANADA | 0002 | 0102 | 0202 | 0002 | 0002 |
| AUSTRALIA | 0006 | - | 0006 | - | 0006 |
| NEW ZEALAND | 0027 | - | 0027 | - | - |
| CHINA | - | - | - | - | - |
| TAIWAN | - | - | - | - | - |
| HONG KONG | - | - | - | - | - |
| ARGENTINA | - | - | - | - | - |
| THAILAND | - | - | - | - | - |
| CHILLE | - | - | - | - | - |
| SOUTH AMERICA | - | - | - | - | - |
| ASIA | 0040 | - | 0040 | - | - |
| GULF | - | - | - | - | - |
| BRAZIL | - | - | - | - | - |
| INDONESIA | - | - | - | - | - |
| INDIA | - | - | - | - | - |
| MEXICO | - | - | - | - | - |
| RUSSIA | - | - | - | - | - |

| Versions | Model | | |
|-------------|----------|---------|----------|
| | FAX8350P | MFC9650 | FAX8750P |
| GERMANY | 0003 | 0003 | 0003 |
| U.K. | 0004 | 0004 | 0004 |
| FRANCE | 0005 | - | 0005 |
| NORWAY | 0007 | 0007 | 0007 |
| BELGIUM | 0008 | 0008 | 0008 |
| NETHERLANDS | 0009 | 0009 | 0009 |
| SWITZERLAND | 0010 | 0010 | 0010 |
| IRELAND | 0011 | - | - |
| FINLAND | - | 0012 | - |
| DENMARK | 0013 | 0013 | - |
| AUSTRIA | 0014 | - | - |
| SPAIN | - | 0015 | - |
| ITALY | - | 0016 | 0016 |
| ISRAEL | - | - | - |
| POTUGAL | - | - | - |
| SWEDEN | 0026 | 0026 | 0026 |

FAX4750/5750
MFC8300/8600/8700
FAX8350P/8750P
MFC9650

Appendix 2. Circuit Diagrams

- A. Main PCB
- B. Modem PCB
- C. Engine PCB
- D. Network Control Unit (NCU) PCB
- E. Control Panel PCB
- F. Power Supply PCBs

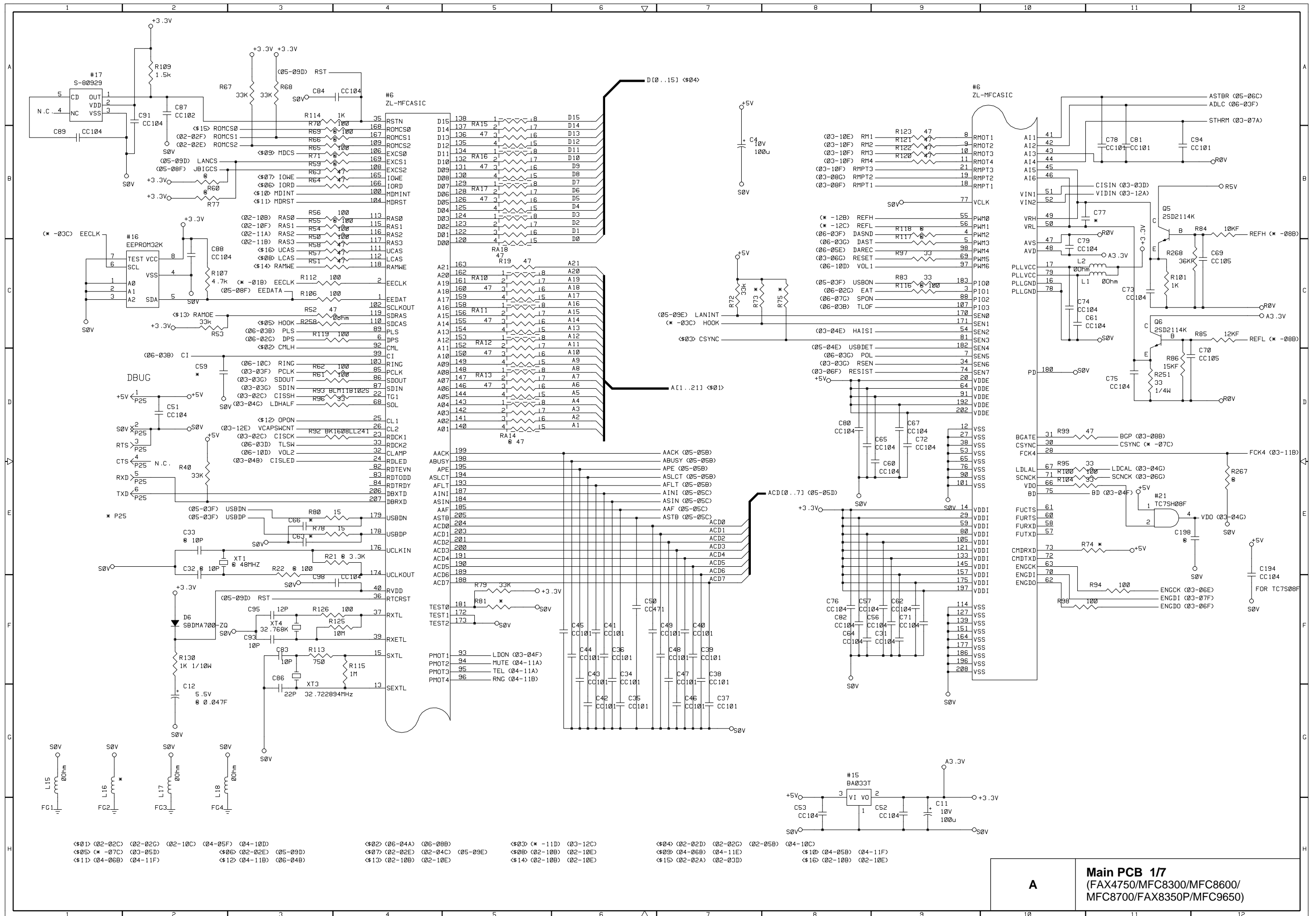

A Main PCB 1/7
 (FAX4750/MFC8300/MFC8600/
 MFC8700/FAX8350P/MFC9650)

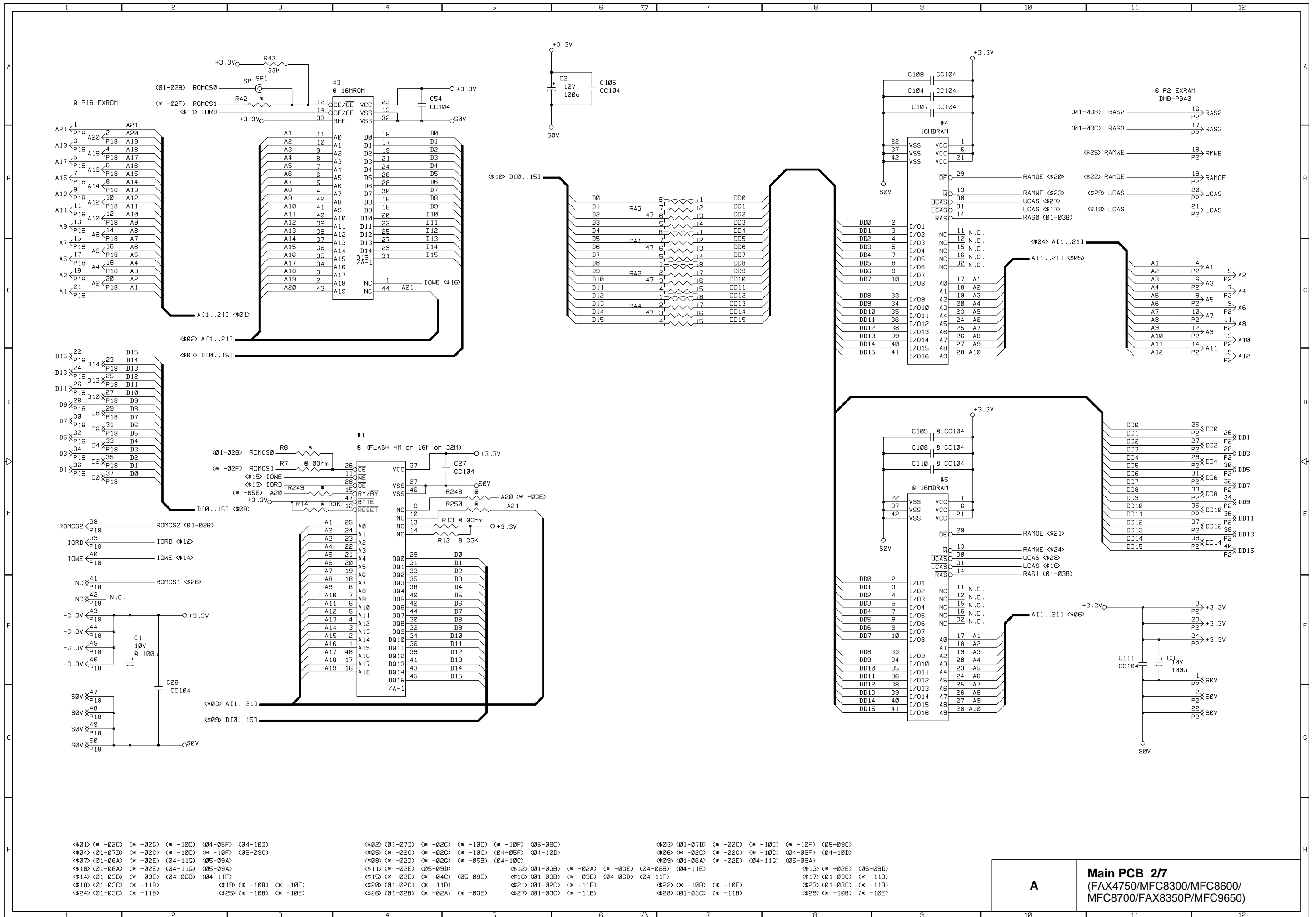

A

Main PCB 2/7
 (FAX4750/MFC8300/MFC8600/
 MFC8700/FAX8350P/MFC9650)

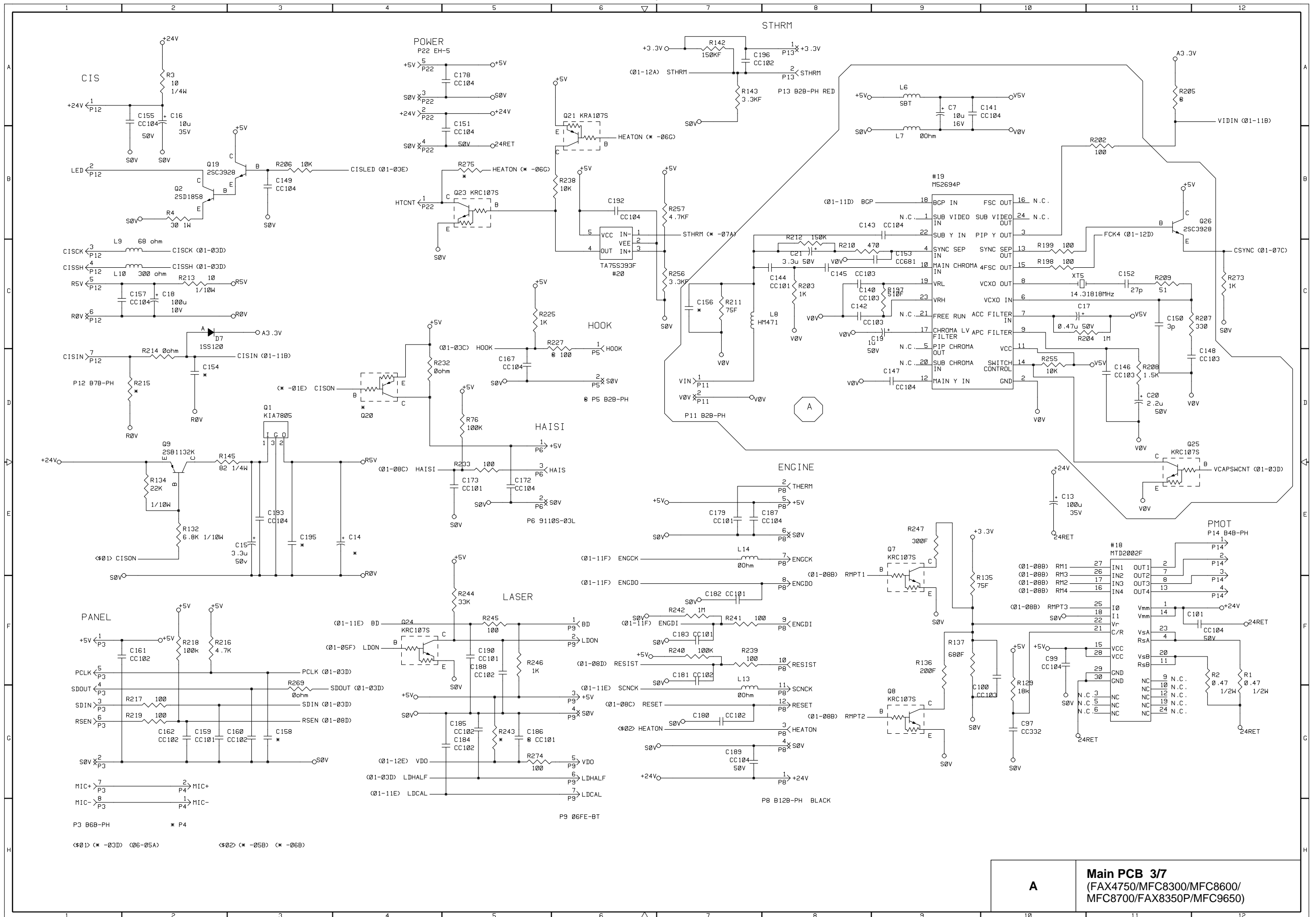

A
Main PCB 3/7
(FAX4750/MFC8300/MFC8600/
MFC8700/FAX8350P/MFC9650)

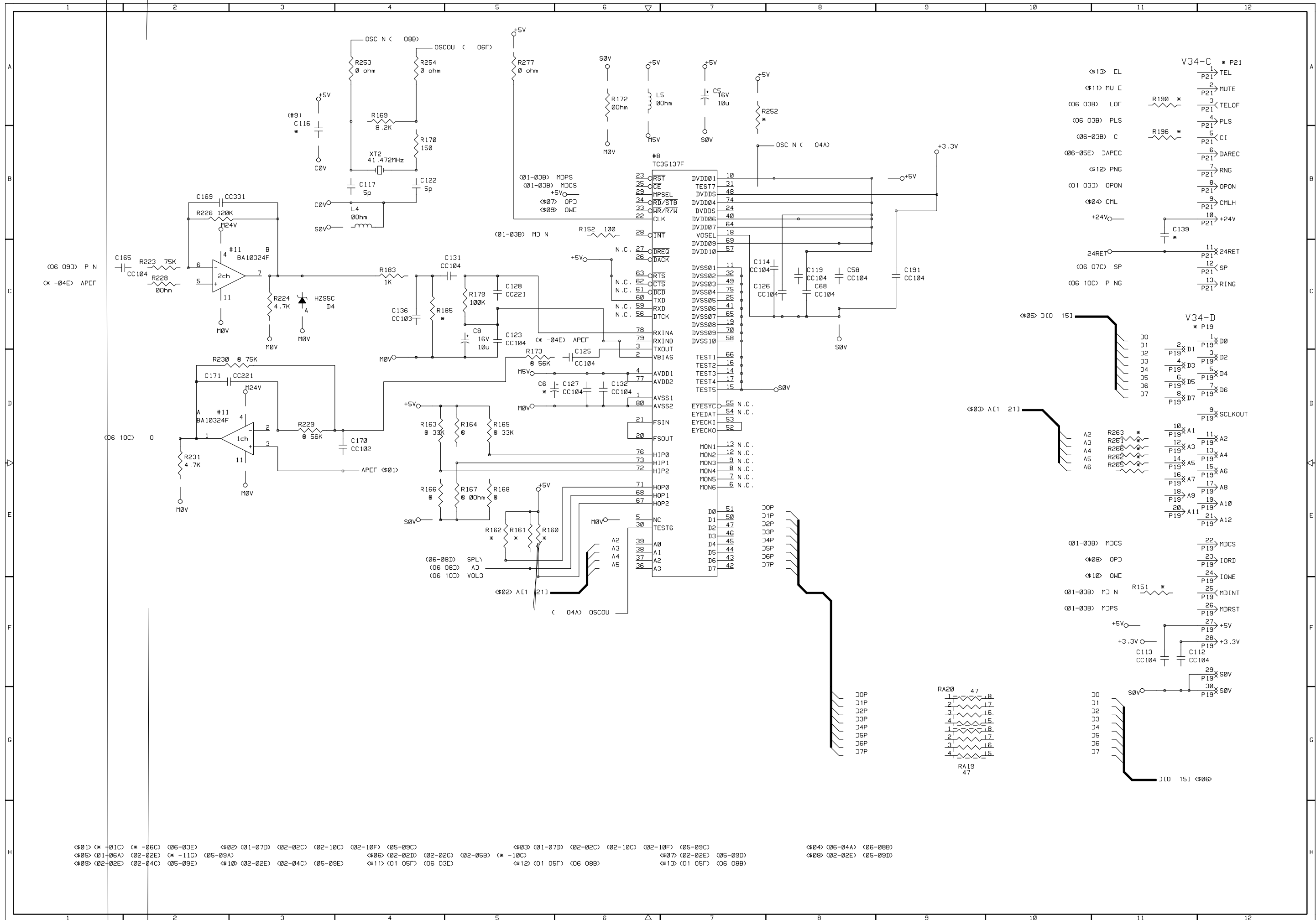

(06 09C) P N
 (* -04E) APCΓ

(06 10C) 0

<#01> (* -01C) (* -06C) (06-03E) <#02> (01-07D) (02-02C) (02-10C) (02-10F) (05-09C) <#03> (01-07D) (02-02C) (02-10C) (02-10F) (05-09C) <#04> (06-04A) (06-08B)
 <#05> (01-06A) (02-02E) (* -11C) (05-09A) <#06> (02-02D) (02-02G) (02-05B) (* -10C) <#07> (02-02E) (05-09D) <#08> (02-02E) (05-09D)
 <#09> (02-02E) (02-04C) (05-09E) <#10> (02-02E) (02-04C) (05-09E) <#11> (01 05Γ) (06 03C) <#12> (01 05Γ) (06 08B) <#13> (01 05Γ) (06 08B)

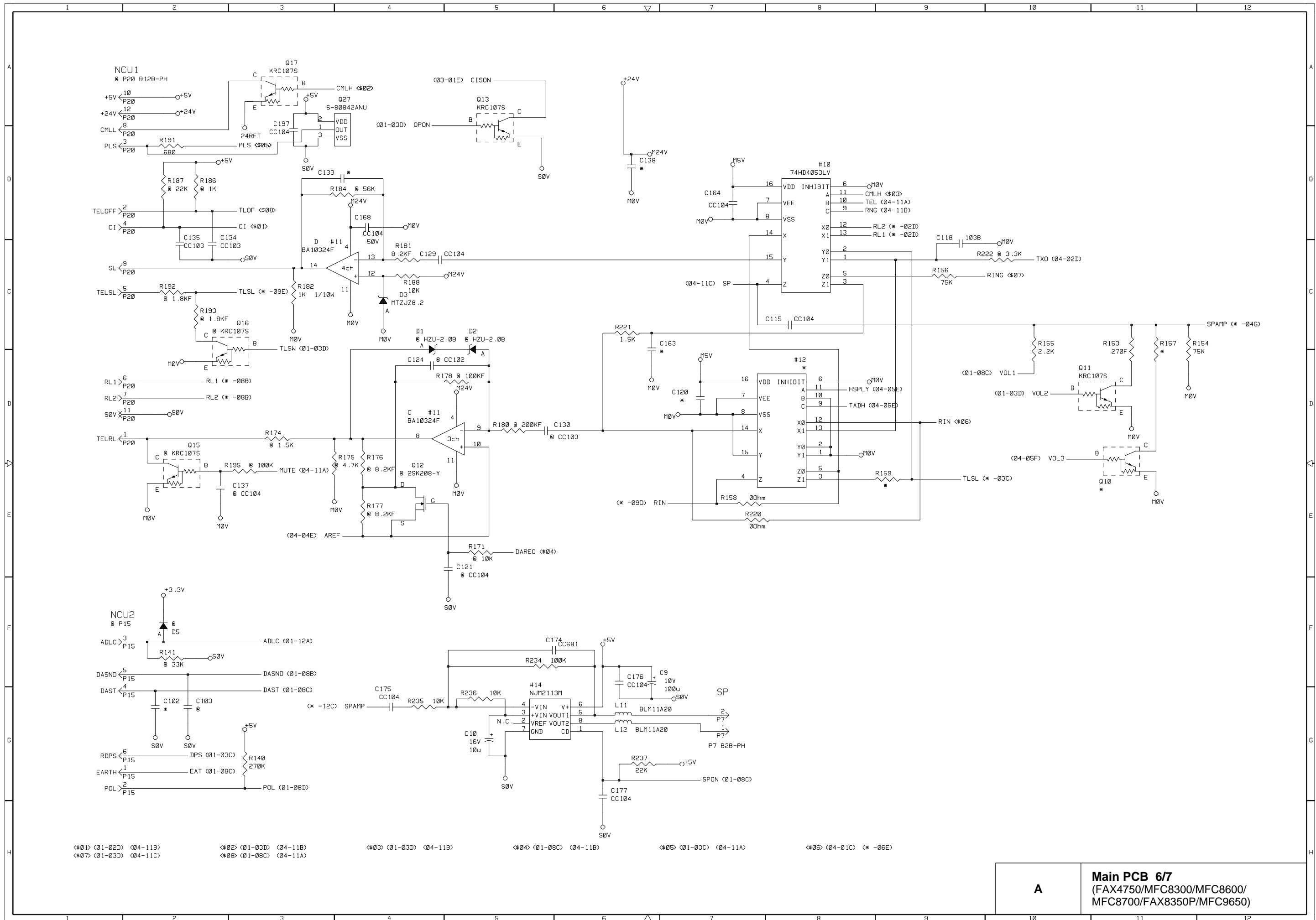

$\langle\#01\rangle$ (01-02D) (04-11B) $\langle\#02\rangle$ (01-03D) (04-11B) $\langle\#03\rangle$ (01-03D) (04-11B) $\langle\#04\rangle$ (01-08C) (04-11B) $\langle\#05\rangle$ (01-03C) (04-11A) $\langle\#06\rangle$ (04-01C) (\ast-06E)
 $\langle\#07\rangle$ (01-03D) (04-11C) $\langle\#08\rangle$ (01-08C) (04-11A)

A **Main PCB 6/7**
 (FAX4750/MFC8300/MFC8600/
 MFC8700/FAX8350P/MFC9650)

| | No. | US | | | | EUR | | ASA/OCE | |
|----------------------|------|---------------------------|---------------------------|---------------------------|---------------------------|-----------------------------|----------------------------|----------------------------|----------------------------|
| | | FAX4750 ASSY. 1 UG6224001 | MFC8300 ASSY. 2 UG6225001 | MFC8600 ASSY. 3 UG6226001 | MFC8700 ASSY. 4 LG2192001 | FAX8350P ASSY. 21 LG2082001 | MFC9650 ASSY. 31 LG2252001 | FAX4750 ASSY. 22 LG2250001 | MFC8600 ASSY. 32 LG2251001 |
| USB | XT1 | NOT ASSY | XTAL48.00MHZ | XTAL48.00MHZ | XTAL48.00MHZ | NOT ASSY | XTAL48.00MHZ | NOT ASSY | XTAL48.00MHZ |
| | C32 | NOT ASSY | Cera C 50C100CH | Cera C 50C100CH | Cera C 50C100CH | NOT ASSY | Cera C 50C100CH | NOT ASSY | Cera C 50C100CH |
| | C33 | 0 Ω | Cera C 50C100CH | Cera C 50C100CH | Cera C 50C100CH | 0 Ω | Cera C 50C100CH | 0 Ω | Cera C 50C100CH |
| | R21 | NOT ASSY | 3.3K Ω | 3.3KΩ | 3.3KΩ | NOT ASSY | 3.3KΩ | NOT ASSY | 3.3KΩ |
| | R22 | NOT ASSY | 100Ω | 100Ω | 100Ω | NOT ASSY | 100Ω | NOT ASSY | 100Ω |
| LAN | R59 | NOT ASSY | NOT ASSY | NOT ASSY | 100Ω | NOT ASSY | 100Ω | NOT ASSY | 100Ω |
| | R71 | NOT ASSY | NOT ASSY | NOT ASSY | 100Ω | NOT ASSY | 100Ω | NOT ASSY | 100Ω |
| ROMCS1 | R69 | NOT ASSY | 100Ω | 100Ω | 100Ω | 100Ω | 100Ω | 100Ω | 100Ω |
| ROMCS2 | R66 | NOT ASSY | NOT ASSY | NOT ASSY | NOT ASSY | 100Ω | 100Ω | 100Ω | 100Ω |
| RAS1 | R55 | 100Ω | NOT ASSY | 100Ω | 100Ω | 100Ω | 100Ω | 100Ω | 100Ω |
| ADRESS | RA14 | 47Ω | 47Ω | 47Ω | 47Ω | 47Ω | 47Ω | 47Ω | 47Ω |
| DAST | R117 | NOT ASSY | NOT ASSY | NOT ASSY | NOT ASSY | BLM11B102S | BLM11B102S | BLM11B102S | BLM11B102S |
| DASND | R118 | NOT ASSY | NOT ASSY | NOT ASSY | NOT ASSY | NOT ASSY | NOT ASSY | 10KΩ | 10KΩ |
| EAT | R116 | 100Ω | 100Ω | 100Ω | 100Ω | BLM11B102S | BLM11B102S | BLM11B102S | BLM11B102S |
| FCK4 | R267 | 0 Ω | 0 Ω | NOT ASSY | NOT ASSY | 0 Ω | 0 Ω | 0 Ω | 0 Ω |
| VDO(#21) | C198 | NOT ASSY | NOT ASSY | NOT ASSY | NOT ASSY | NOT ASSY | NOT ASSY | NOT ASSY | NOT ASSY |
| LANCS P.U. | R60 | NOT ASSY | NOT ASSY | NOT ASSY | 33KΩ | NOT ASSY | 33KΩ | NOT ASSY | 33KΩ |
| EEPROM (LAN)CLK P.U. | R77 | NOT ASSY | NOT ASSY | NOT ASSY | 33KΩ | NOT ASSY | 33KΩ | NOT ASSY | 33KΩ |
| SUPER CAP. | C12 | 5.5V/0.047F | 5.5V/0.047F | 5.5V/0.047F | 5.5V/0.047F | 5.5V/0.22F | 5.5V/0.22F | 5.5V/0.22F | 5.5V/0.22F |
| ROM | #3 | 16MbitFLASH | 16MbitFLASH | 16MbitFLASH | 16MbitFLASH | 16MbitFLASH | 16MbitFLASH | 16MbitFLASH | 16MbitFLASH |
| FLASH | #1 | NOT ASSY | 4MbitFLASH | 4MbitFLASH | 16MbitFLASH | 16MbitFLASH | 32MbitFLASH | 16MbitFLASH | 32MbitFLASH |
| | R7 | NOT ASSY | 0Ω | 0Ω | 0Ω | 0Ω | 0Ω | 0Ω | 0Ω |
| | R12 | NOT ASSY | 33KΩ | 33KΩ | NOT ASSY | NOT ASSY | 3.3KΩ | NOT ASSY | 3.3KΩ |
| | R13 | NOT ASSY | 0 Ω | 0 Ω | NOT ASSY | NOT ASSY | NOT ASSY | NOT ASSY | NOT ASSY |
| | R14 | NOT ASSY | 33KΩ | 33KΩ | 33KΩ | 33KΩ | 33KΩ | 33KΩ | 33KΩ |
| | R248 | NOT ASSY | NOT ASSY | NOT ASSY | 0 Ω | 0 Ω | 0 Ω | 0 Ω | 0 Ω |
| | R250 | NOT ASSY | NOT ASSY | NOT ASSY | NOT ASSY | NOT ASSY | 0 Ω | NOT ASSY | 0 Ω |
| EXROM | P18 | NOT ASSY | NOT ASSY | NOT ASSY | NOT ASSY | 52340-0501 | 52340-0501 | 52340-0501 | 52340-0501 |
| | C1 | 10V/100 μ | 10V/100μ | 10V/100μ | 10V/100μ | 10V/100μ (7mm height) | 10V/100μ (7mm height) | 10V/100μ (7mm height) | 10V/100μ (7mm height) |
| DRAM | #5 | EDODRAM: 16Mbit | NOT ASSY | EDODRAM: 16Mbit | EDODRAM: 16Mbit | EDODRAM: 16Mbit | EDODRAM: 16Mbit | EDODRAM: 16Mbit | EDODRAM: 16Mbit |
| | C105 | CC25C104 | NOT ASSY | CC25C104 | CC25C104 | CC25C104 | CC25C104 | CC25C104 | CC25C104 |
| | C108 | CC25C104 | NOT ASSY | CC25C104 | CC25C104 | CC25C104 | CC25C104 | CC25C104 | CC25C104 |
| | C110 | CC25C104 | NOT ASSY | CC25C104 | CC25C104 | CC25C104 | CC25C104 | CC25C104 | CC25C104 |
| EXRAM | P2 | DHB-PB40 | DHB-PB40 | DHB-PB40 | DHB-PB40 | NOT ASSY | NOT ASSY | NOT ASSY | NOT ASSY |
| VIDEO CAPTURE BLOCK | A | NOT ASSY | NOT ASSY | ASSY | ASSY | NOT ASSY | NOT ASSY | NOT ASSY | NOT ASSY |
| | R205 | 1KΩ | 1KΩ | NOT ASSY | NOT ASSY | 1KΩ | 1KΩ | 1KΩ | 1KΩ |
| VDO(P9) | C186 | Cera C 50C101CH | Cera C 50C101CH | Cera C 50C101CH | Cera C 50C101CH | Cera C 50C101CH | Cera C 50C101CH | Cera C 50C101CH | Cera C 50C101CH |
| HOOK | P5 | B2B-PH | B2B-PH | B2B-PH | B2B-PH | NOT ASSY | NOT ASSY | B2B-PH | B2B-PH |
| | R227 | 100Ω | 100Ω | 100Ω | 100Ω | NOT ASSY | NOT ASSY | 100Ω | 100Ω |

| | No. | US | | | | EUR | | ASA/OCE | |
|-----------------|----------|---------------------------|---------------------------|---------------------------|---------------------------|-----------------------------|----------------------------|----------------------------|----------------------------|
| | | FAX4750 ASSY. 1 UG6224001 | MFC8300 ASSY. 2 UG6225001 | MFC8600 ASSY. 3 UG6226001 | MFC8700 ASSY. 4 LG2192001 | FAX8350P ASSY. 21 LG2082001 | MFC9650 ASSY. 31 LG2252001 | FAX4750 ASSY. 22 LG2250001 | MFC8600 ASSY. 32 LG2251001 |
| MODEL DETECTION | R165 | NOT ASSY | NOT ASSY | 33KΩ | NOT ASSY | NOT ASSY | NOT ASSY | NOT ASSY | NOT ASSY |
| | R168 | 0 Ω | 0 Ω | NOT ASSY | 0 Ω | 0 Ω | 0 Ω | 0 Ω | 0 Ω |
| | R164 | NOT ASSY | NOT ASSY | NOT ASSY | 33KΩ | NOT ASSY | NOT ASSY | 33KΩ | 33KΩ |
| | R167 | 0 Ω | 0 Ω | 0 Ω | NOT ASSY | 0 Ω | 0 Ω | NOT ASSY | NOT ASSY |
| | R163 | NOT ASSY | 33KΩ | 33KΩ | 33KΩ | NOT ASSY | 33KΩ | NOT ASSY | 33KΩ |
| | R166 | 0 Ω | NOT ASSY | NOT ASSY | NOT ASSY | 0 Ω | NOT ASSY | 0 Ω | NOT ASSY |
| TX. AMP | R173 | 56KΩ | 56KΩ | 56KΩ | 56KΩ | 56KΩ (F) | 56KΩ (F) | 56KΩ (F) | 56KΩ (F) |
| | R229 | 56KΩ | 56KΩ | 56KΩ | 56KΩ | 56KΩ (F) | 56KΩ (F) | 56KΩ (F) | 56KΩ (F) |
| | R230 | 75KΩ | 75KΩ | 75KΩ | 75KΩ | 75KΩ (F) | 75KΩ (F) | 75KΩ (F) | 75KΩ (F) |
| USB | P17 | NOT ASSY | USB-212-T | USB-212-T | USB-212-T | NOT ASSY | USB-212-T | NOT ASSY | USB-212-T |
| | Q3 | NOT ASSY | KRA107S | KRA107S | KRA107S | NOT ASSY | KRA107S | NOT ASSY | KRA107S |
| | Q4 | NOT ASSY | KRC107S | KRC107S | KRC107S | NOT ASSY | KRC107S | NOT ASSY | KRC107S |
| | R6 | NOT ASSY | 3.3K Ω | 3.3KΩ | 3.3KΩ | NOT ASSY | 3.3KΩ | NOT ASSY | 3.3KΩ |
| | R10 | NOT ASSY | 1.5K Ω | 1.5KΩ | 1.5KΩ | NOT ASSY | 1.5KΩ | NOT ASSY | 1.5KΩ |
| | R11 | NOT ASSY | 1.5K Ω | 1.5KΩ | 1.5KΩ | NOT ASSY | 1.5KΩ | NOT ASSY | 1.5KΩ |
| | R16 | NOT ASSY | 1.5K Ω | 1.5KΩ | 1.5KΩ | NOT ASSY | 1.5KΩ | NOT ASSY | 1.5KΩ |
| | R17 | NOT ASSY | 10KΩ | 10KΩ | 10KΩ | NOT ASSY | 10KΩ | NOT ASSY | 10KΩ |
| | R18 | NOT ASSY | 1MΩ | 1MΩ | 1MΩ | NOT ASSY | 1MΩ | NOT ASSY | 1MΩ |
| | C29 | 0 Ω | CC25C104 | CC25C104 | CC25C104 | 0 Ω | CC25C104 | 0 Ω | CC25C104 |
| LAN | P1 | NOT ASSY | NOT ASSY | NOT ASSY | DHB-PB34 | DHB-PB34 | DHB-PB34 | NOT ASSY | DHB-PB34 |
| | R5 | NOT ASSY | NOT ASSY | NOT ASSY | 100Ω | 100Ω | 100Ω | NOT ASSY | 100Ω |
| NCU1 | P20 | B12B-PH | B12B-PH | B12B-PH | B12B-PH | B11B-PH | B11B-PH | B12B-PH | B12B-PH |
| NCU2 | P15 | NOT ASSY | NOT ASSY | NOT ASSY | NOT ASSY | B6B-PH | B6B-PH | B6B-PH | B6B-PH |
| TLOF | R186 | 1KΩ | 1KΩ | 1KΩ | 1KΩ | 1KΩ | 1KΩ | 22KΩ | 22KΩ |
| CI | R187 | 22KΩ | 22KΩ | 22KΩ | 22KΩ | 120KΩ | 120KΩ | 120KΩ | 120KΩ |
| DASND | C103 | NOT ASSY | NOT ASSY | NOT ASSY | NOT ASSY | NOT ASSY | NOT ASSY | CC25C104 | CC25C104 |
| ADLC | D5 | NOT ASSY | NOT ASSY | NOT ASSY | NOT ASSY | NOT ASSY | NOT ASSY | SID1SS120 | SID1SS120 |
| | R141 | 33KΩ | 33KΩ | 33KΩ | 33KΩ | 33KΩ | 33KΩ | NOT ASSY | NOT ASSY |
| TXO | R222 | 3.3KΩ | 3.3KΩ | 3.3KΩ | 3.3KΩ | 3.3KΩ (F) | 3.3KΩ (F) | 3.3KΩ (F) | 3.3KΩ (F) |
| TX. AMP | R184 | 56KΩ | 56KΩ | 56KΩ | 56KΩ | 56KΩ (F) | 56KΩ (F) | 56KΩ (F) | 56KΩ (F) |
| TSL | R192 | 1.8K Ω (F) | 1.8KΩ (F) | 1.8KΩ (F) | 1.8KΩ (F) | NOT ASSY | NOT ASSY | 0 Ω | 0 Ω |
| | R193 | 1.8K Ω (F) | 1.8KΩ (F) | 1.8KΩ (F) | 1.8KΩ (F) | NOT ASSY | NOT ASSY | NOT ASSY | NOT ASSY |
| | Q16 | KRC107S | KRC107S | KRC107S | KRC107S | NOT ASSY | NOT ASSY | NOT ASSY | NOT ASSY |
| RX. AMP | D1 | ZDHZU-2.0B | ZDHZU-2.0B | ZDHZU-2.0B | ZDHZU-2.0B | NOT ASSY | NOT ASSY | ZDHZU-2.0B | ZDHZU-2.0B |
| | D2 | ZDHZU-2.0B | ZDHZU-2.0B | ZDHZU-2.0B | ZDHZU-2.0B | NOT ASSY | NOT ASSY | ZDHZU-2.0B | ZDHZU-2.0B |
| | C124 | CC50C102B | CC50C102B | CC50C102B | CC50C102B | NOT ASSY | NOT ASSY | NOT ASSY | NOT ASSY |
| | R178 | 100KΩ (F) | 100KΩ (F) | 100KΩ (F) | 100KΩ (F) | 0 Ω | 0 Ω | 39KΩ (F) | 39KΩ (F) |
| | C130 | CC50C103B | CC50C103B | CC50C103B | CC50C103B | NOT ASSY | NOT ASSY | CC25C104 | CC25C104 |
| | R180 | 200KΩ (F) | 200KΩ (F) | 200KΩ (F) | 200KΩ (F) | NOT ASSY | NOT ASSY | 130KΩ (F) | 130KΩ (F) |
| | R174 | 1.5K Ω | 1.5KΩ | 1.5KΩ | 1.5KΩ | NOT ASSY | NOT ASSY | 1.5KΩ (F) | 1.5KΩ (F) |
| | R175 | 4.7K Ω | 4.7KΩ | 4.7KΩ | 4.7KΩ | NOT ASSY | NOT ASSY | 4.7KΩ (F) | 4.7KΩ (F) |
| | R176 | 8.2K Ω (F) | 8.2KΩ (F) | 8.2KΩ (F) | 8.2KΩ (F) | 0 Ω | 0 Ω | 1KΩ (F) | 1KΩ (F) |
| | R177 | 8.2K Ω (F) | 8.2KΩ (F) | 8.2KΩ (F) | 8.2KΩ (F) | NOT ASSY | NOT ASSY | 680Ω (F) | 680Ω (F) |
| | Q12 | 2SK208-Y | 2SK208-Y | 2SK208-Y | 2SK208-Y | NOT ASSY | NOT ASSY | 2SK208 | 2SK208 |
| | R171 | 10KΩ | 10KΩ | 10KΩ | 10KΩ | NOT ASSY | NOT ASSY | 10KΩ | 10KΩ |
| | C121 | CC25C104 | CC25C104 | CC25C104 | CC25C104 | NOT ASSY | NOT ASSY | CC25C104 | CC25C104 |
| Q15 | KRC107S | KRC107S | KRC107S | KRC107S | NOT ASSY | NOT ASSY | KRC107S | KRC107S | |
| R195 | 100KΩ | 100KΩ | 100KΩ | 100KΩ | NOT ASSY | NOT ASSY | 100KΩ | 100KΩ | |
| C137 | CC25C104 | CC25C104 | CC25C104 | CC25C104 | NOT ASSY | NOT ASSY | CC25C104 | CC25C104 | |

A

Main PCB 7/7
(FAX4750/MFC8300/MFC8600/
MFC8700/FAX8350P/MFC9650)

| | | | |
|-----|--------|-------|-----|
| 35 | PS N | D15 | 138 |
| 168 | POMCS0 | D14 | 137 |
| 167 | POMCS1 | D13 | 136 |
| 109 | POMCS2 | D12 | 135 |
| 106 | C CS0 | D11 | 134 |
| 169 | C CS1 | D10 | 132 |
| 108 | C CS2 | D09 | 131 |
| 165 | OWC | D08 | 130 |
| 166 | OPD | D07 | 129 |
| 100 | MCM N | D06 | 128 |
| 104 | MJPS | D05 | 126 |
| | | D04 | 125 |
| 113 | PAS0 | D03 | 124 |
| 115 | PAS1 | D02 | 123 |
| 116 | PAS2 | D01 | 122 |
| 117 | PAS3 | D00 | 120 |
| 111 | UCAS | | |
| 112 | LCAS | | |
| 118 | PAMMC | A21 | 163 |
| | | A20 | 162 |
| 2 | CCCL | A19 | 161 |
| | | A18 | 160 |
| 1 | CCJA | A17 | 159 |
| 102 | SCL OU | A16 | 158 |
| 119 | SCPAS | A15 | 156 |
| 110 | SCCAS | A14 | 155 |
| 89 | PLS | A13 | 154 |
| 6 | DPS | A12 | 153 |
| 92 | CML | A11 | 152 |
| 99 | C | A10 | 150 |
| 103 | P NG | A09 | 149 |
| 85 | PCL | A08 | 148 |
| 86 | SDOU | A07 | 147 |
| 87 | SD N | A06 | 146 |
| 22 | G1 | A05 | 144 |
| 68 | SOL | A04 | 143 |
| | | A03 | 142 |
| 25 | CL1 | A02 | 141 |
| 26 | CL2 | A01 | 140 |
| 23 | PJC 1 | | |
| 33 | PJC 2 | | |
| 32 | CLAMP | AAC | 199 |
| 24 | PJLCJ | ABUS1 | 198 |
| 82 | PJ CVN | APC | 194 |
| 83 | PJ OJJ | ASLC | 193 |
| 84 | PJ PJ1 | AGL | 187 |
| 206 | DB J | A N | 184 |
| 207 | DBP J | AS N | 185 |
| | | AAJ | 205 |
| 179 | USBJN | AS B | 204 |
| | | ACJ0 | 203 |
| 178 | USBJP | ACJ1 | 201 |
| | | ACJ2 | 200 |
| 176 | UCL N | ACJ3 | 191 |
| | | ACJ4 | 190 |
| 174 | UCL OU | ACJ5 | 189 |
| | | ACJ6 | 188 |
| | | ACJ7 | 188 |
| 40 | PVJJ | | |
| 36 | P CPS | | |
| | | CS 0 | 1 |
| 37 | P L | CS 1 | |
| | | CS 2 | |
| 39 | P C L | | |
| 15 | S L | PMO 1 | |
| | | PMO 2 | |
| | | PMO 3 | |
| | | PMO 4 | |
| 13 | SE L | | |

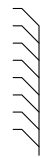

6
ZL MFCAS C

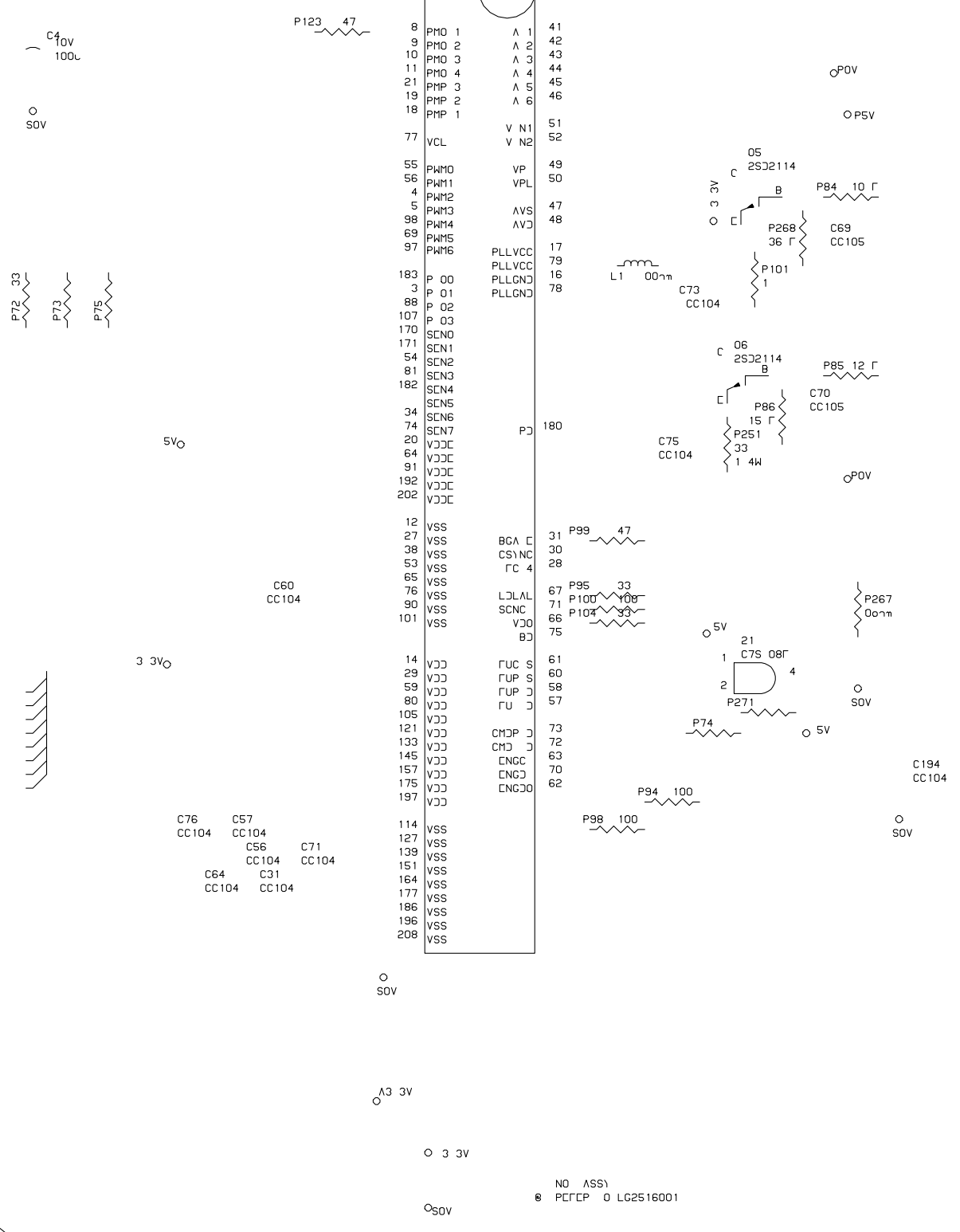

NO ASSY
 8 PFCFP 0 LG2516001

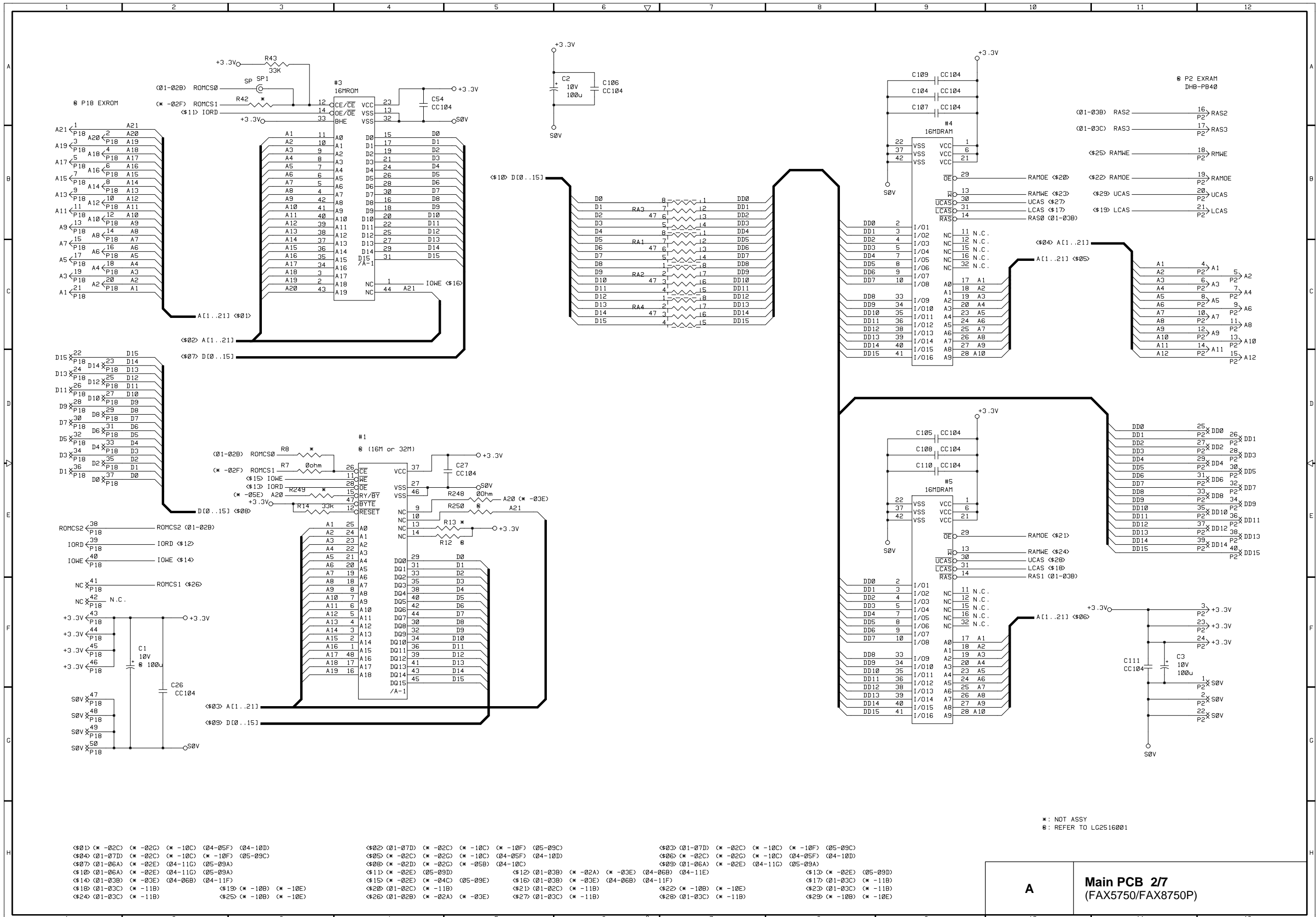

*: NOT ASSY
 @: REFER TO LG2516001

| | | | | | | | | | | | | | | |
|-----------------|---------|----------|----------|----------|-----------------|----------|----------|-----------------|----------|-----------------|----------|----------|-----------------|----------|
| (\$01) (*-02C) | (*-02G) | (*-10C) | (04-05F) | (04-10D) | (\$02) (01-07D) | (*-02C) | (*-10C) | (*-10F) | (05-09C) | (\$03) (01-07D) | (*-02C) | (*-10C) | (*-10F) | (05-09C) |
| (\$04) (01-07D) | (*-02C) | (*-10C) | (*-10F) | (05-09C) | (\$05) (*-02C) | (*-02C) | (*-10C) | (04-05F) | (04-10D) | (\$06) (*-02C) | (*-02C) | (*-10C) | (04-05F) | (04-10D) |
| (\$07) (01-06A) | (*-02E) | (04-11G) | (05-09A) | | (\$08) (*-02D) | (*-02C) | (*-05B) | (04-10C) | | (\$09) (01-06A) | (*-02E) | (04-11G) | (05-09A) | |
| (\$10) (01-06A) | (*-02E) | (04-11G) | (05-09A) | | (\$11) (*-02E) | (05-09D) | | | | (\$12) (01-03B) | (*-02A) | (*-03E) | (04-06B) | (04-11E) |
| (\$14) (01-03B) | (*-03E) | (04-06B) | (04-11F) | | (\$15) (*-02E) | (*-04C) | (05-09E) | (\$16) (01-03B) | (*-03E) | (04-06B) | (04-11F) | | | |
| (\$18) (01-03C) | (*-11B) | | | | (\$20) (01-02C) | (*-11B) | | (\$21) (01-02C) | (*-11B) | (\$22) (*-10B) | (*-10E) | | (\$23) (01-03C) | (*-11B) |
| (\$24) (01-03C) | (*-11B) | | | | (\$25) (*-10B) | (*-10E) | | (\$27) (01-03C) | (*-11B) | (\$28) (01-03C) | (*-11B) | | (\$29) (*-10B) | (*-10E) |

A

Main PCB 2/7
 (FAX5750/FAX8750P)

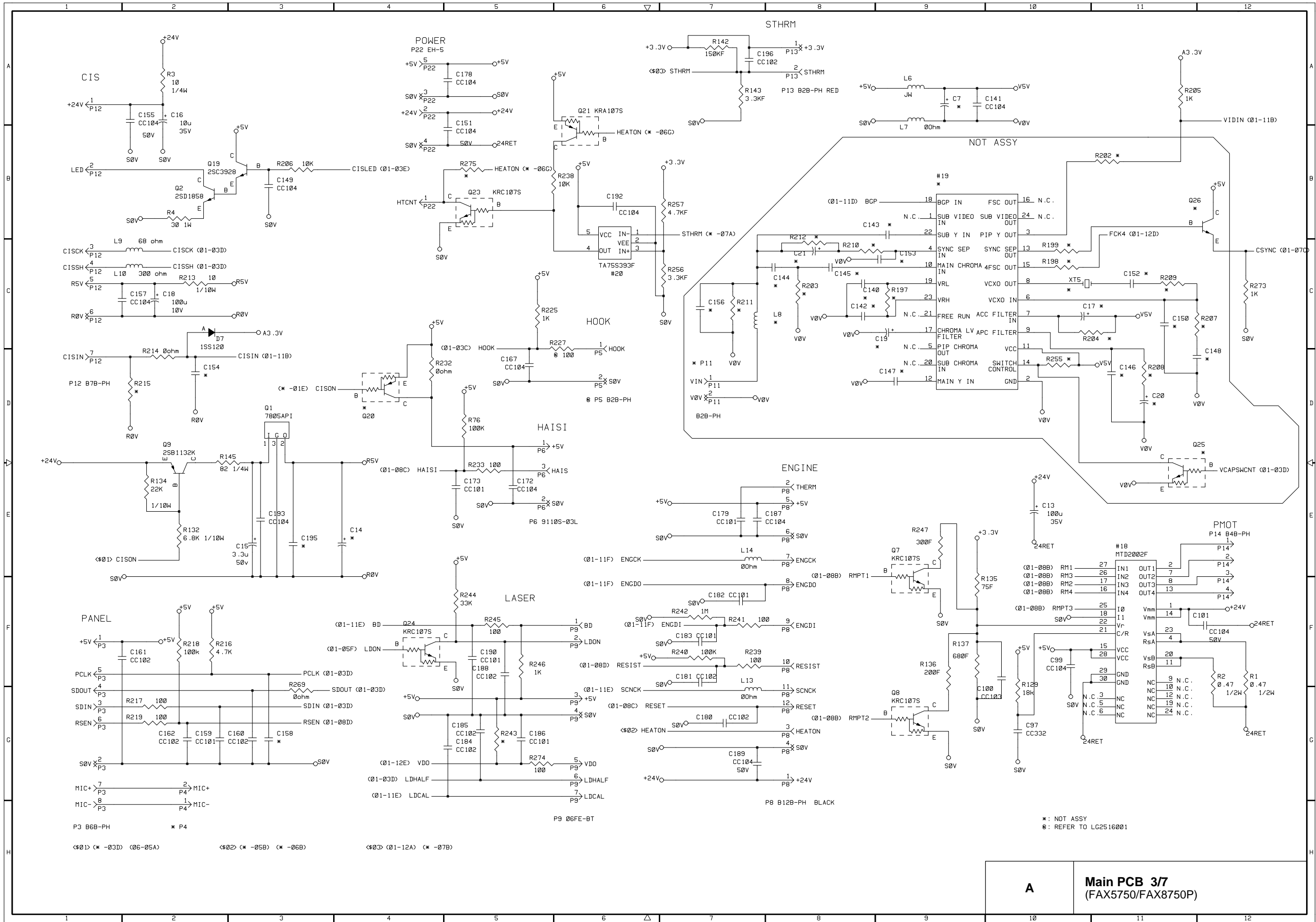

A **Main PCB 3/7**
(FAX5750/FAX8750P)

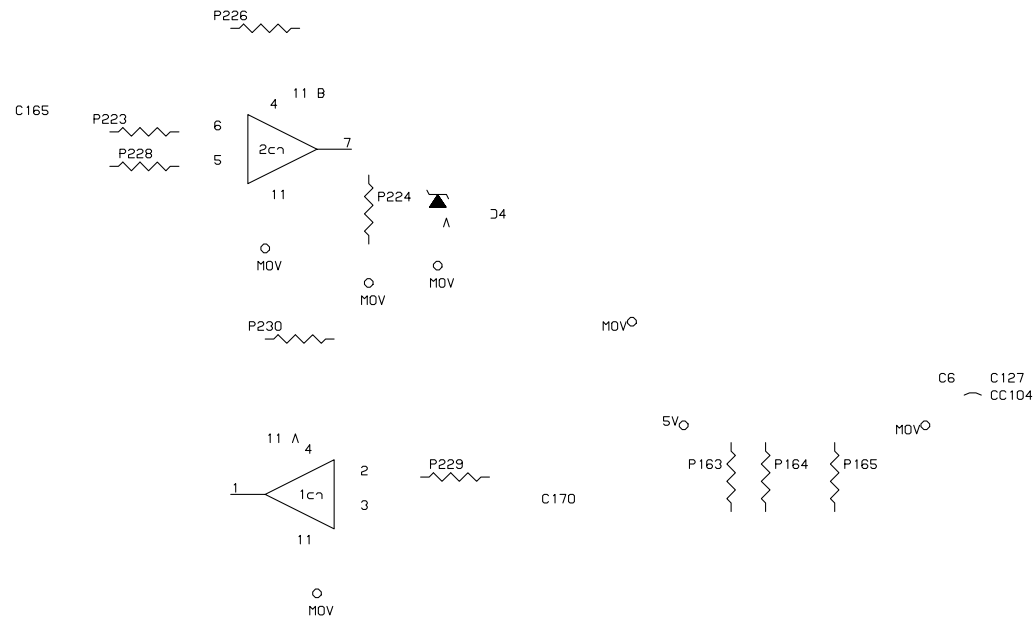

| | | | |
|----|---------|---------|----|
| 23 | OPS | JVJ001 | 10 |
| 35 | OCC | CS 7 | 31 |
| 29 | MPSEL | JVJ005 | 48 |
| 34 | OPJ S B | JVJ004 | 74 |
| 33 | OWP P W | JVJ005 | 24 |
| 22 | CL | JVJ006 | 40 |
| | | JVJ007 | 64 |
| 28 | O N | VOSEL | 18 |
| | | JVJ009 | 69 |
| 27 | OJPCO | JVJ010 | 57 |
| 26 | OJAC | | |
| | | JVSS01 | 11 |
| 63 | OP S | JVSS02 | 32 |
| 62 | OC S | JVSS03 | 49 |
| 61 | OJCC | JVSS04 | 75 |
| 60 | J | JVSS05 | 25 |
| 59 | P J | JVSS06 | 41 |
| 56 | J C | JVSS07 | 65 |
| | | JVSS08 | 19 |
| 78 | P NA | JVSS09 | 70 |
| 79 | P NB | JVSS10 | 58 |
| 3 | OU | | |
| 2 | VB AS | CS 1 | 66 |
| | | CS 2 | 16 |
| 4 | AVJ01 | CS 3 | 14 |
| 7 | AVJ02 | CS 4 | 17 |
| | | CS 5 | 15 |
| 1 | AVSS1 | CVES1 C | 55 |
| 80 | AVSS2 | CVES2 A | 54 |
| | | CVES3 C | 53 |
| 21 | FS N | CVES4 0 | 52 |
| 20 | FSOU | | |
| | | MON1 | 13 |
| 76 | P0 | MON2 | 12 |
| 73 | P1 | MON3 | 9 |
| 72 | P2 | MON4 | 8 |
| | | MON5 | 7 |
| | | MON6 | 6 |
| 71 | OP0 | | |
| 68 | OP1 | | |
| 67 | OP2 | | |
| | | | 51 |
| 5 | NC | | 50 |
| 30 | CS 6 | | 47 |
| | | | 46 |
| | | | 33 |
| 39 | A0 | | 45 |
| 38 | A1 | | 44 |
| 37 | A2 | | 43 |
| 36 | A3 | | 37 |
| | | | 42 |

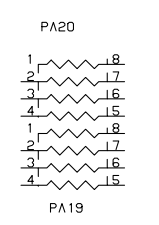
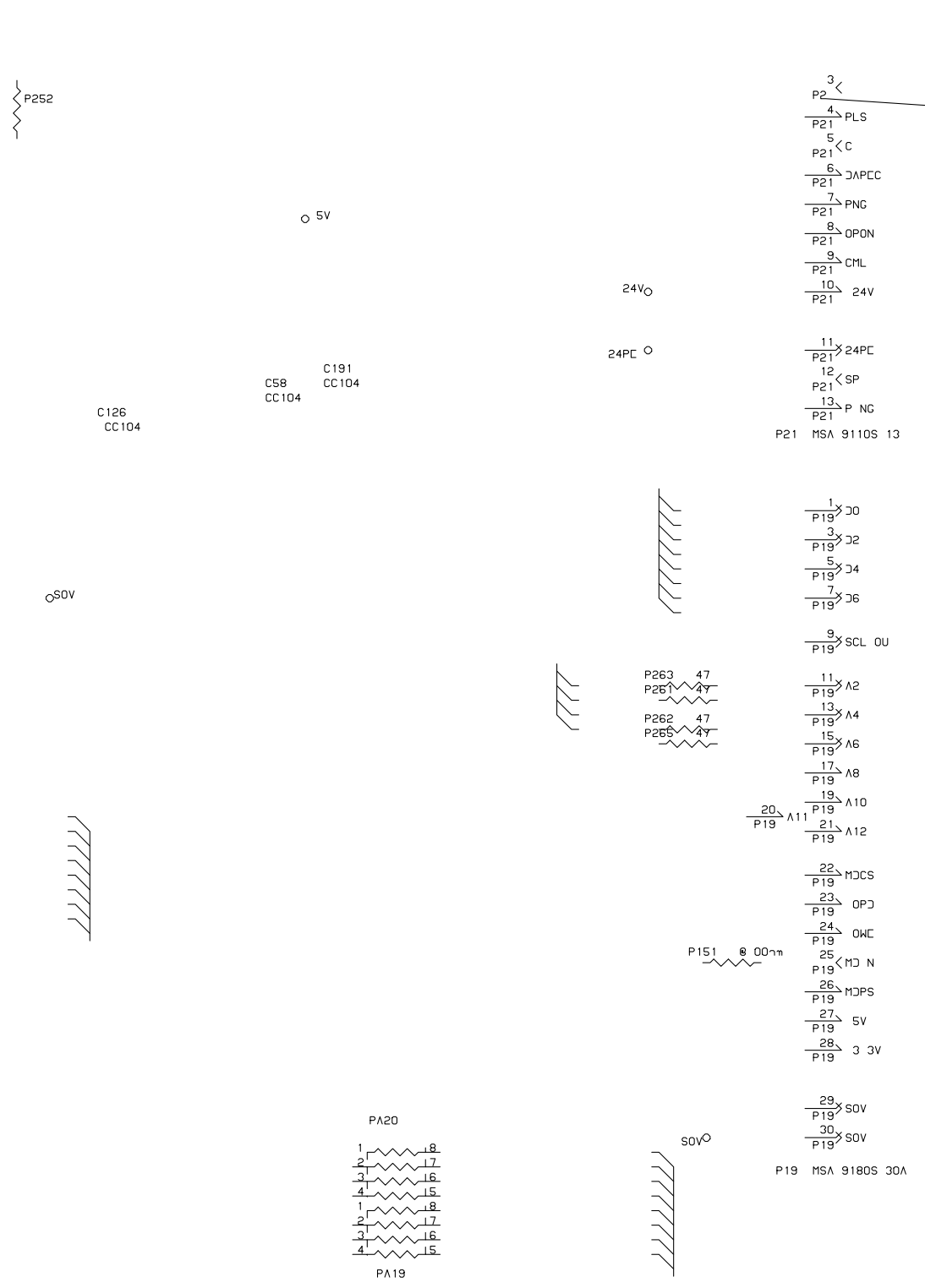

NO ASSY
 PECEP O LG2516001

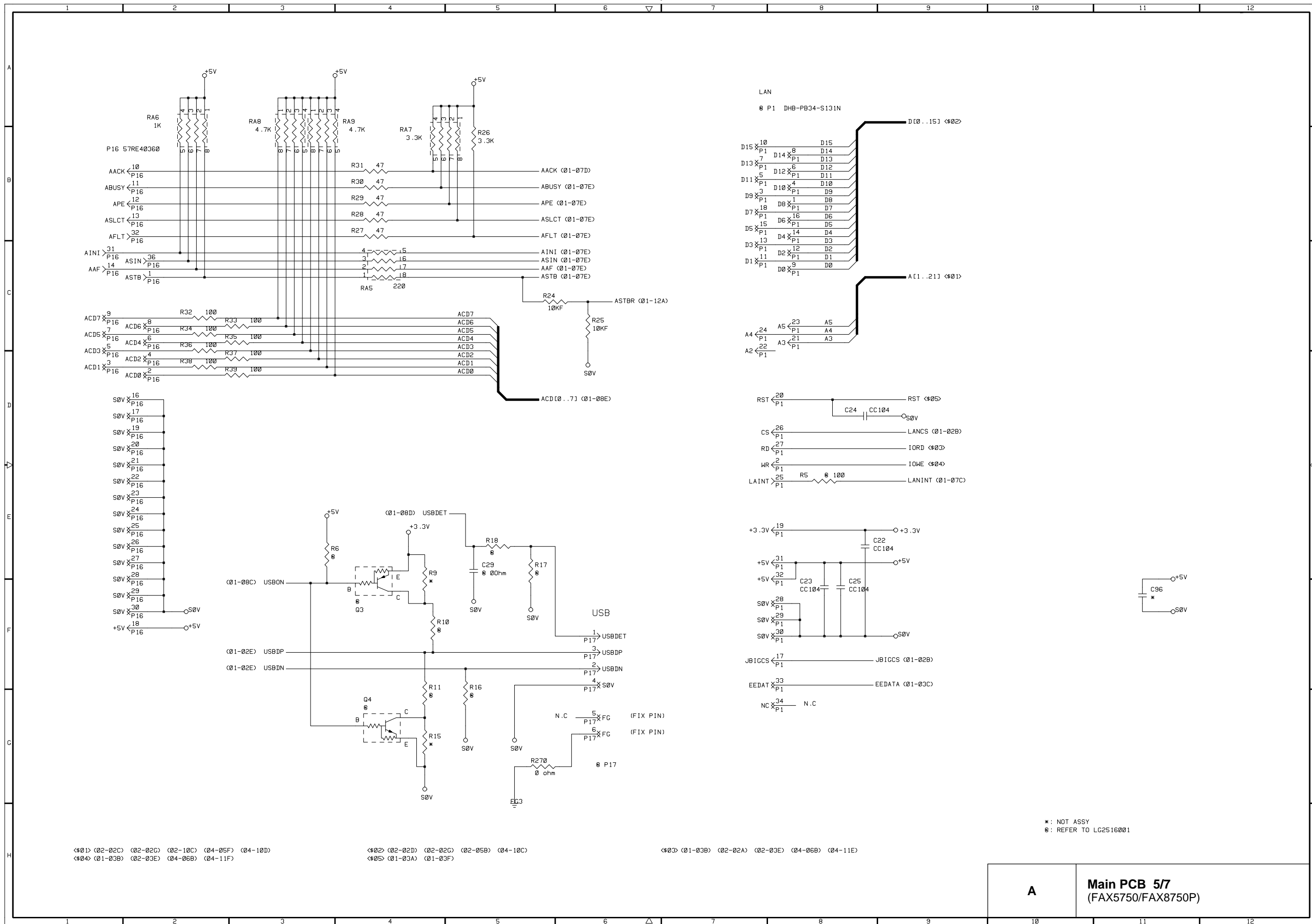

<#01> (02-02C) (02-02G) (02-10C) (04-05F) (04-10D)
 <#04> (01-03B) (02-03E) (04-06B) (04-11F)

<#02> (02-02D) (02-02G) (02-05B) (04-10C)
 <#05> (01-03A) (01-03F)

<#03> (01-03B) (02-02A) (02-03E) (04-06B) (04-11E)

*: NOT ASSY
 #: REFER TO LG2516001

A Main PCB 5/7
 (FAX5750/FAX8750P)

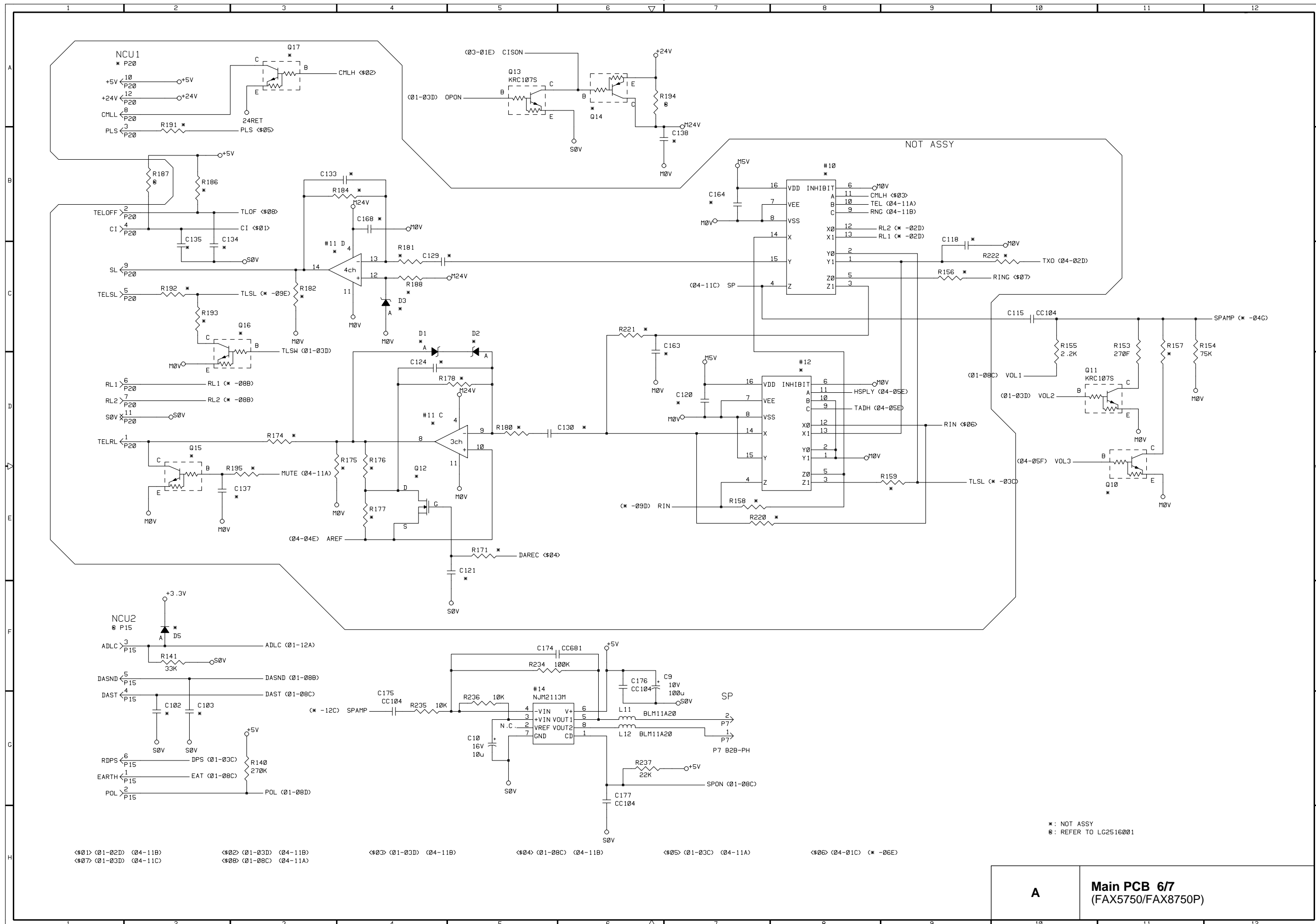

A Main PCB 6/7 (FAX5750/FAX8750P)

| | No. | US | EUR |
|---------------------|------|---------------------------------|-----------------------------------|
| | | FAX5750 ASSY. 5 LG2332001 | FAX8750P ASSY. 25 LG2365001 |
| USB | XT1 | NOT ASSY | XTAL48.00MHZ |
| | C32 | NOT ASSY | Cera C50 C100CH |
| | C33 | 0 Ω | Cera C50C 100CH |
| | R21 | NOT ASSY | 3.3KΩ |
| | R22 | NOT ASSY | 100Ω |
| LAN | R59 | 100Ω | 100Ω |
| | R71 | 100Ω | 100Ω |
| ROMCS2 | R66 | NOT ASSY | 100Ω |
| DAST | R117 | NOT ASSY | BLM11B102S |
| EAT | R116 | 100Ω | BLM11B102S |
| LANCS P.U. | R60 | 33KΩ | 33KΩ |
| EEPROM(LAN)CLK P.U. | R77 | 33KΩ | 33KΩ |
| SUPER CAP. | C12 | 5.5V/0.047F | 5.5V/0.22F |
| FLASH | #1 | 16MbitFLASH | 32MbitFLASH |
| | R12 | NOT ASSY | 3.3KΩ |
| | R250 | NOT ASSY | 0 Ω |
| EXROM | P18 | NOT ASSY | 52340-0501 |
| | C1 | 10V/100μ | 10V/100μ (7mm height) |
| EXRAM | P2 | DHB-PB40 | NOT ASSY |
| HOOK | P5 | B2B-PH | NOT ASSY |
| | R227 | 100Ω | NOT ASSY |
| | R151 | 0 Ω | 100Ω |
| USB | P17 | NOT ASSY | USB-212-T |
| | Q3 | NOT ASSY | KRA107S |
| | Q4 | NOT ASSY | KRC107S |
| | R6 | NOT ASSY | 3.3KΩ |
| | R10 | NOT ASSY | 1.5KΩ |
| | R11 | NOT ASSY | 1.5KΩ |
| | R16 | NOT ASSY | 1.5KΩ |
| | R17 | NOT ASSY | 10KΩ |
| | R18 | NOT ASSY | 1MΩ |
| | C29 | 0 Ω | CC25C104 |
| LAN | P1 | DHB-PB34 | DHB-PB34 |
| | R5 | 100Ω | 100Ω |
| NCU2 | P15 | NOT ASSY | B6B-PH |
| CI | R187 | NOT ASSY | 120KΩ |
| | R194 | NOT ASSY | 0 Ω |

A

Main PCB 7/7
(FAX5750/FAX8750P)

*: NOT ASSY
 @: REFER TO LG2516001

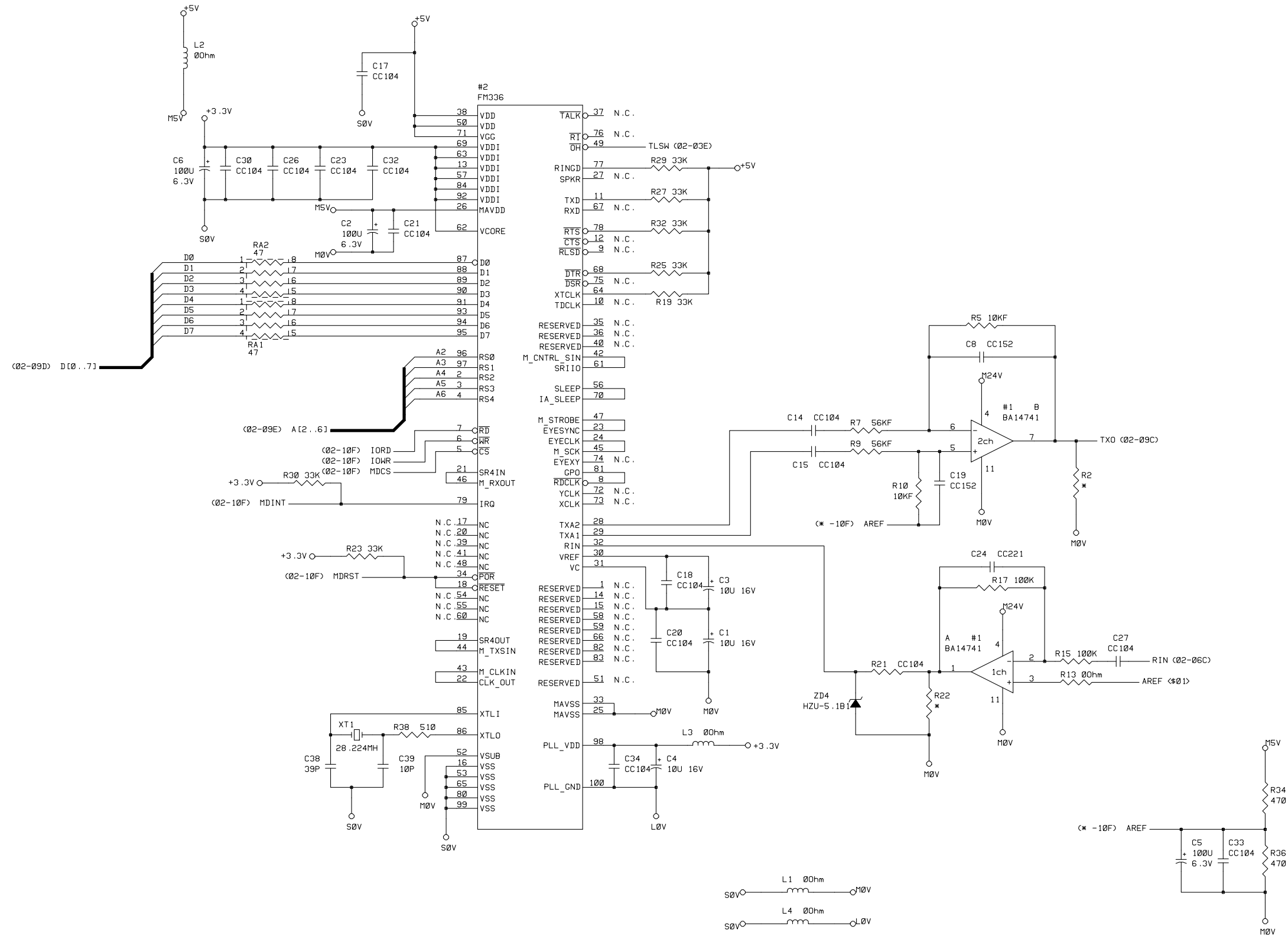

<#01> (* -08E) (* -10C) (02-03F)

*: NOT ASSY
 @: REFER TO LG2516001

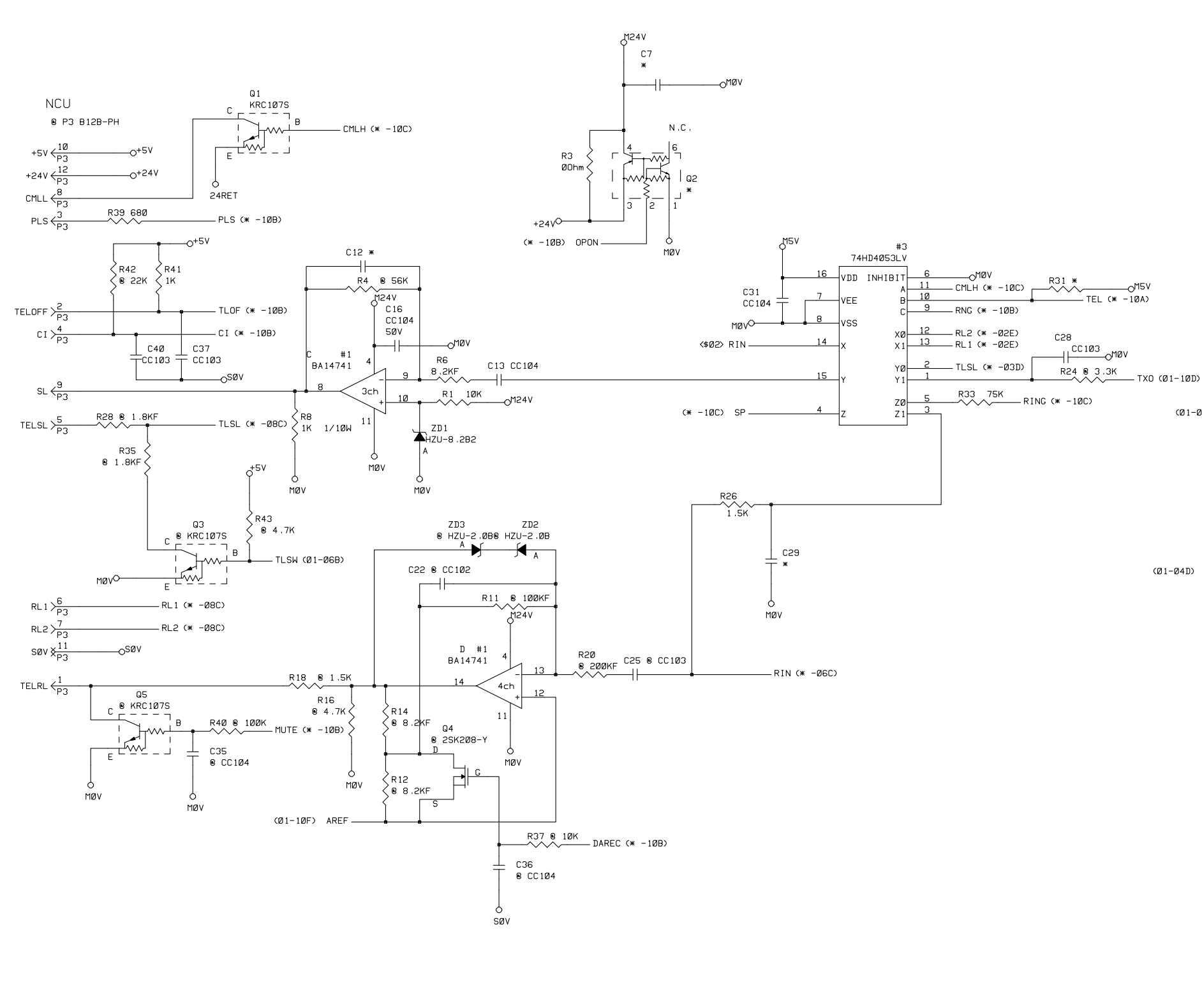

V34-C
 P1 IMSA-9210B-13Z

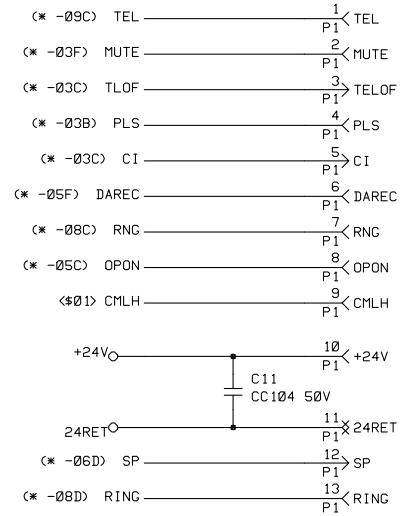

V34-D

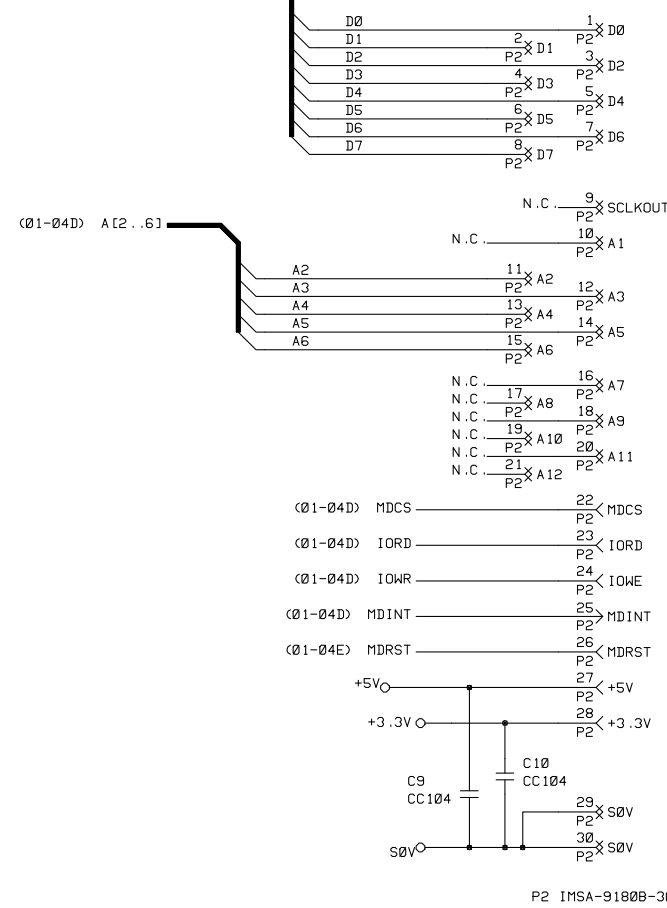

<S01> (* -04B) (* -08C) <S02> (01-10E) (* -06E)

B **Modem PCB 2/3**
 (FAX5750/FAX8750P)

| | | US | EUR |
|---------|----------|---------------------------------|-----------------------------------|
| | No. | FAX5750 ASSY. 1 LG2334001 | FAX8750P ASSY. 21 LG2366001 |
| NCU1 | P3 | B12B-PH | B11B-PH |
| CI | R42 | 22 K Ω | NOT ASSY |
| TXO | R24 | 3.3K Ω | 3.3K Ω (F) |
| TXAMP | R4 | 56 K Ω | 56K Ω (F) |
| TSL | R28 | 1.8K Ω (F) | NOT ASSY |
| | R35 | 1.8K Ω (F) | NOT ASSY |
| | R43 | 4.7 K Ω | NOT ASSY |
| | Q3 | KRC107S | NOT ASSY |
| RX. AMP | ZD2 | ZDHZU-2.0B | NOT ASSY |
| | ZD3 | ZDHZU-2.0B | NOT ASSY |
| | C22 | CC50C102B | NOT ASSY |
| | R11 | 100K Ω (F) | 0 Ω |
| | C25 | CC50C103B | NOT ASSY |
| | R20 | 200K Ω (F) | NOT ASSY |
| | R18 | 1.5 K Ω | NOT ASSY |
| | R16 | 4.7 K Ω | NOT ASSY |
| | R14 | 8.2K Ω (F) | 0 Ω |
| | R12 | 8.2K Ω (F) | NOT ASSY |
| | Q4 | 2SK208-Y | NOT ASSY |
| | R37 | 10 K Ω | NOT ASSY |
| | C36 | CC25C104 | NOT ASSY |
| | Q5 | KRC107S | NOT ASSY |
| | R40 | 100 K Ω | NOT ASSY |
| C35 | CC25C104 | NOT ASSY | |

B

Modem PCB 3/3
(FAX5750/FAX8750P)

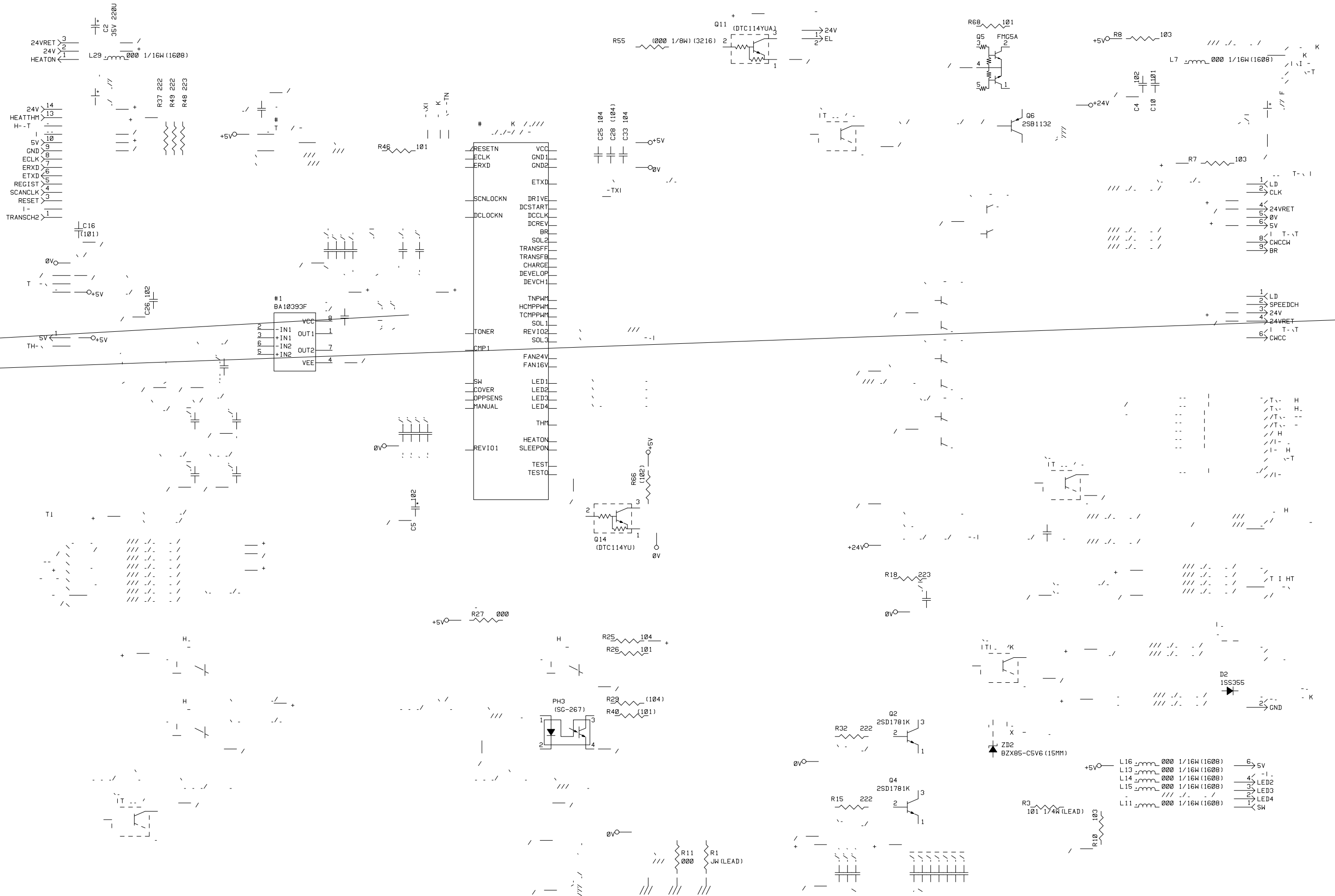

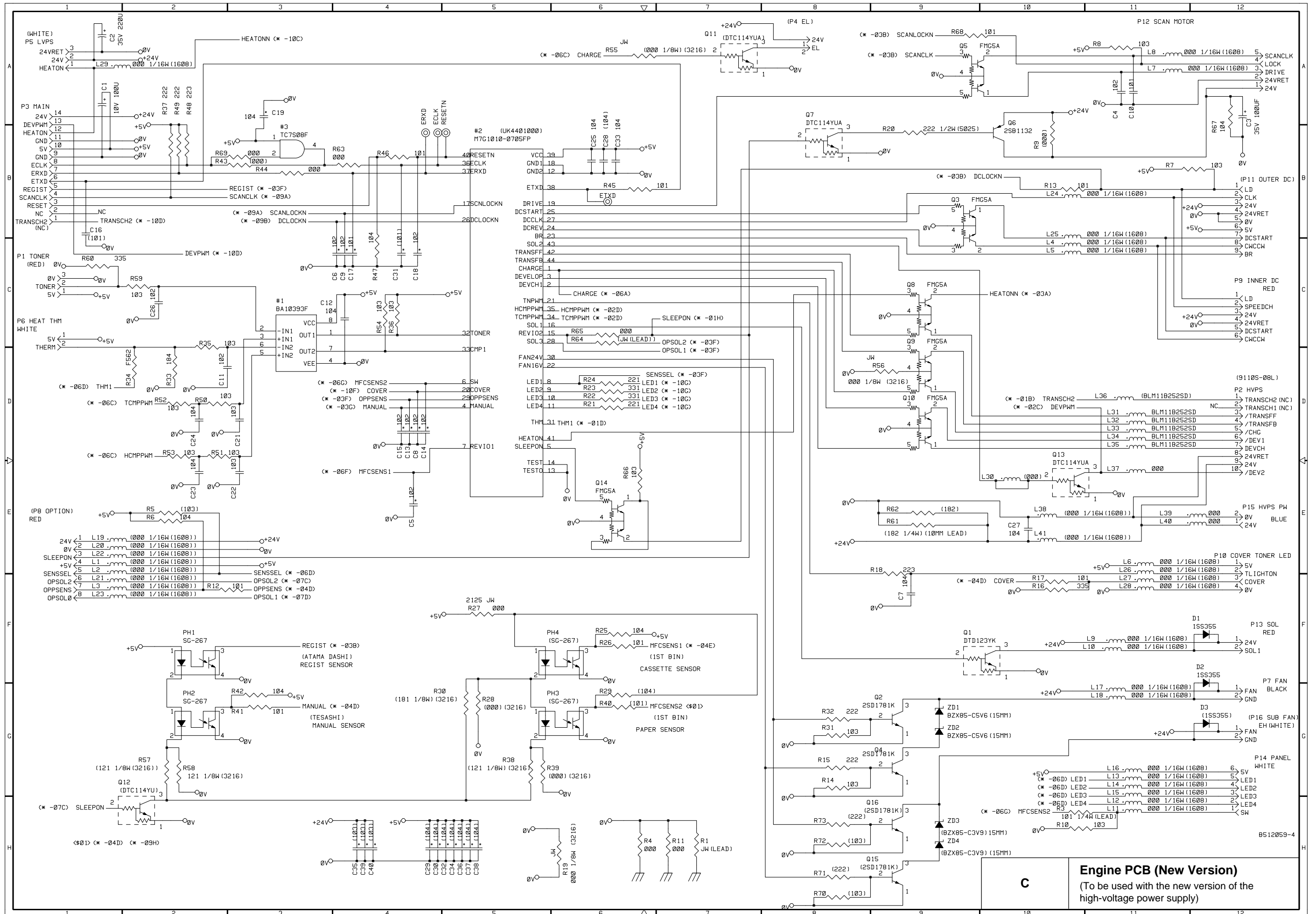

C
Engine PCB (New Version)
 (To be used with the new version of the high-voltage power supply)

1. 指示ナキ抵抗ノ消費電力ハ1/4Wトスル。
 1. UNLESS OTHERWISE SPECIFIED, POWER CONSUMPTION OF RESISTORS IS 1/4W.
 2. 指示ナキコンデンサノ耐圧ハ25V又ハ50Vトスル。
 2. UNLESS OTHERWISE SPECIFIED, THE VOLTAGE RESISTANCE OF CAPACITORS IS 25V OR 50V.
 3. ()内ノ部品ハ未実装トスル。
 3. COMPONENTS IN PARENTHESES NOT TO BE MOUNTED.

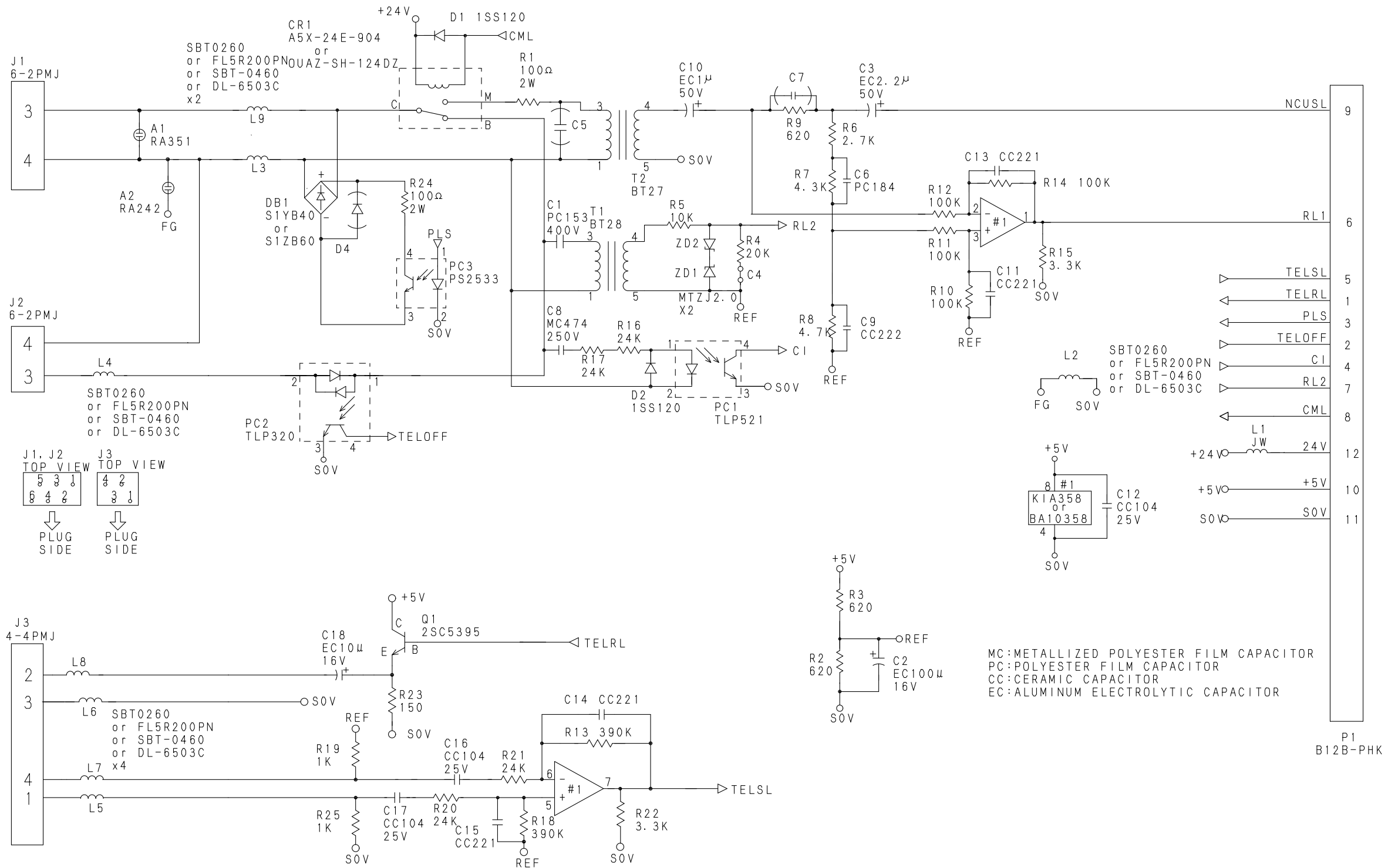

D **NCU PCB**
 (FAX4750/MFC8300/8600/8700,
 U.S.A./Canada)

1. 指示ナキ抵抗ノ消費電力ハ1/4Wトスル。
 1. UNLESS OTHERWISE SPECIFIED, POWER CONSUMPTION OF RESISTORS IS 1/4W.
2. 指示ナキコンテナノ耐圧ハ25V又ハ50Vトスル。
 2. UNLESS OTHERWISE SPECIFIED, THE VOLTAGE RESISTANCE OF CAPACITORS IS 25V OR 50V.
3. () 内ノ部品ハ未実装トスル。
 3. COMPONENTS IN PARENTHESIS NOT TO BE MOUNTED.

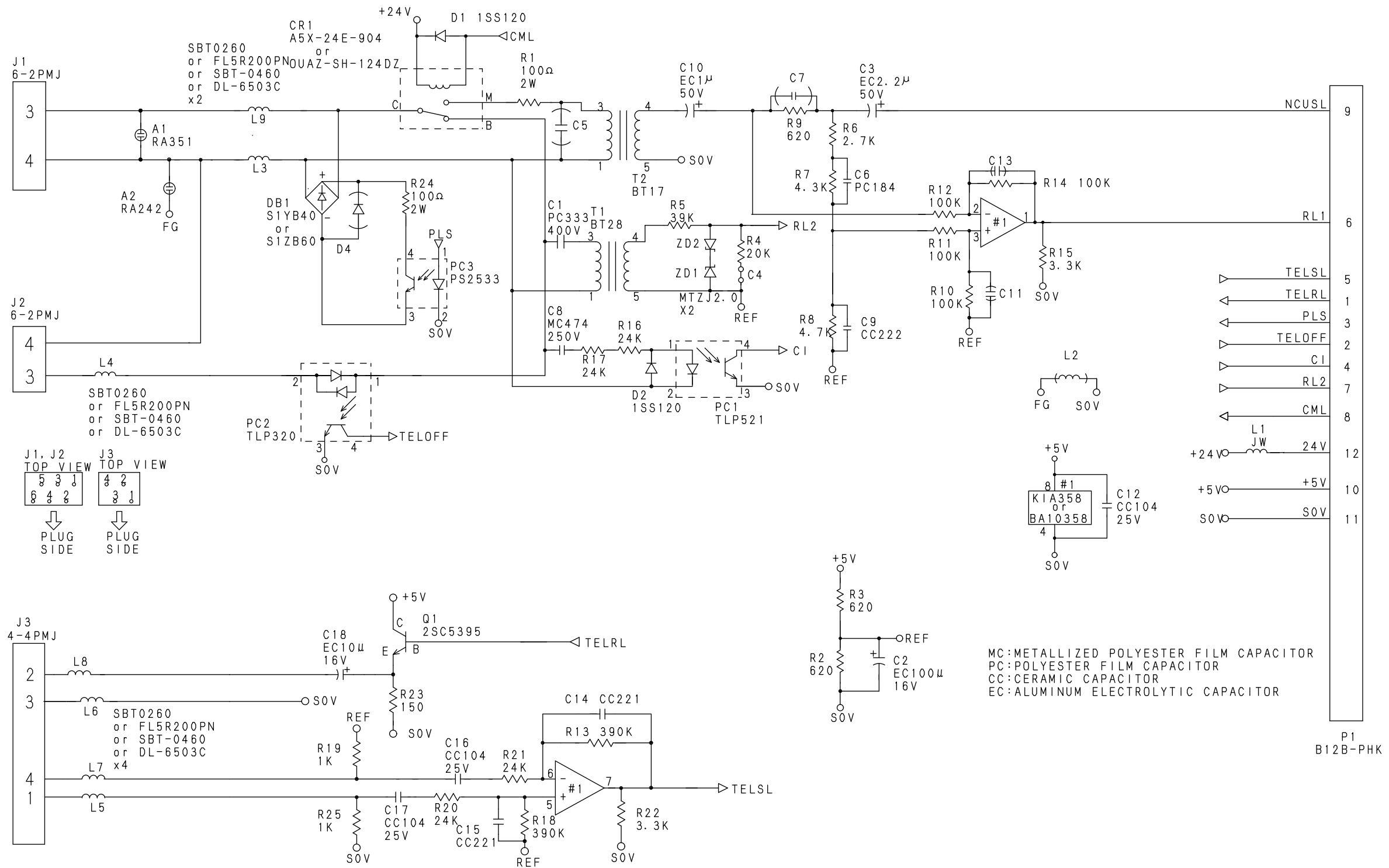

MC: METALLIZED POLYESTER FILM CAPACITOR
 PC: POLYESTER FILM CAPACITOR
 CC: CERAMIC CAPACITOR
 EC: ALUMINUM ELECTROLYTIC CAPACITOR

D

NCU PCB
 (FAX5750, U.S.A./Canada)

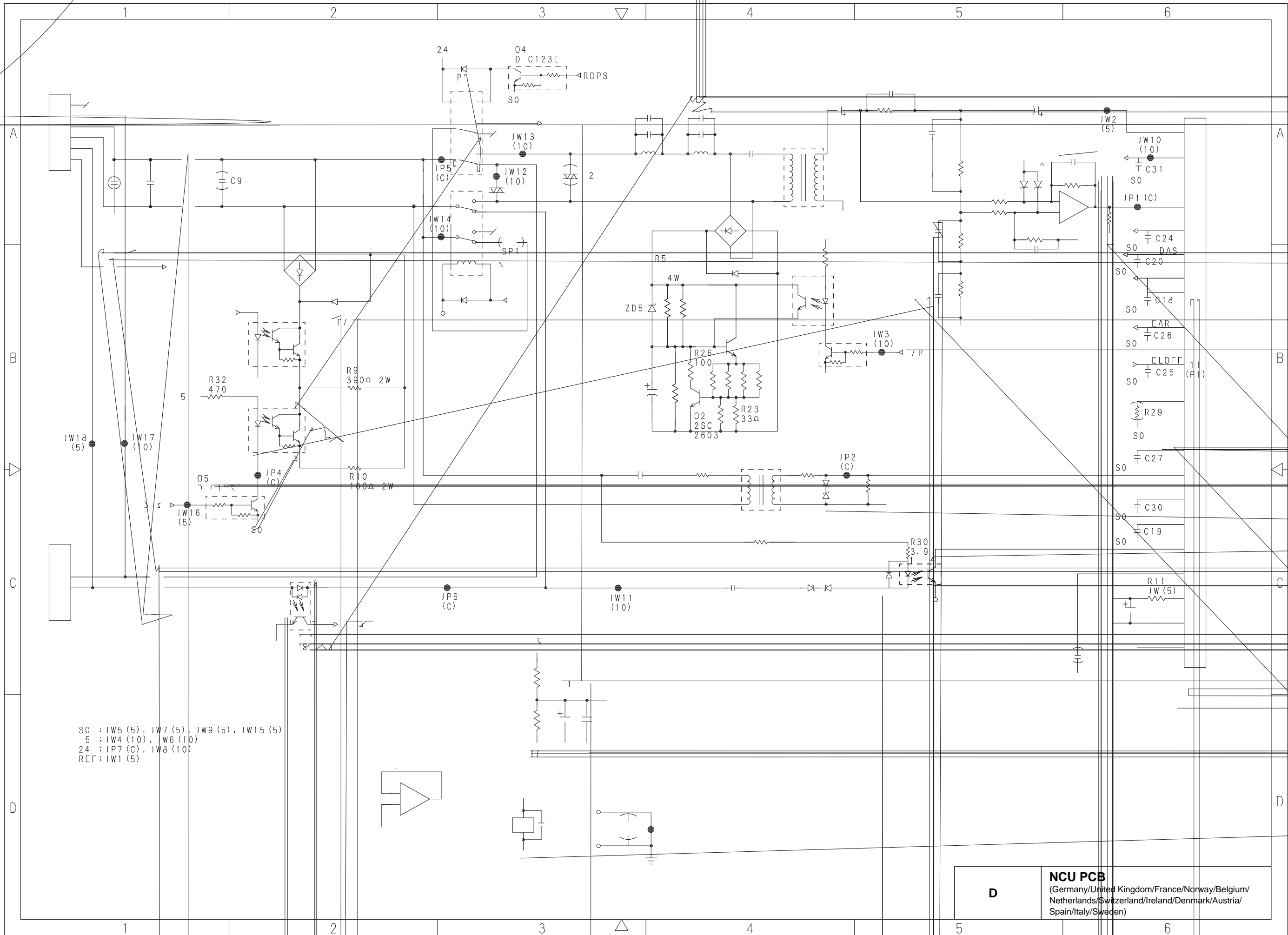

S0 : JW5 (5), JW7 (5), JW9 (5), JW15 (5)
 5 : JW4 (10), JW6 (10)
 24 : JP7 (C), JW8 (10)
 REF : JW1 (5)

D **NCU PCB**
 (Germany/United Kingdom/France/Norway/Belgium/
 Netherlands/Switzerland/Ireland/Denmark/Austria/
 Spain/Italy/Sweden)

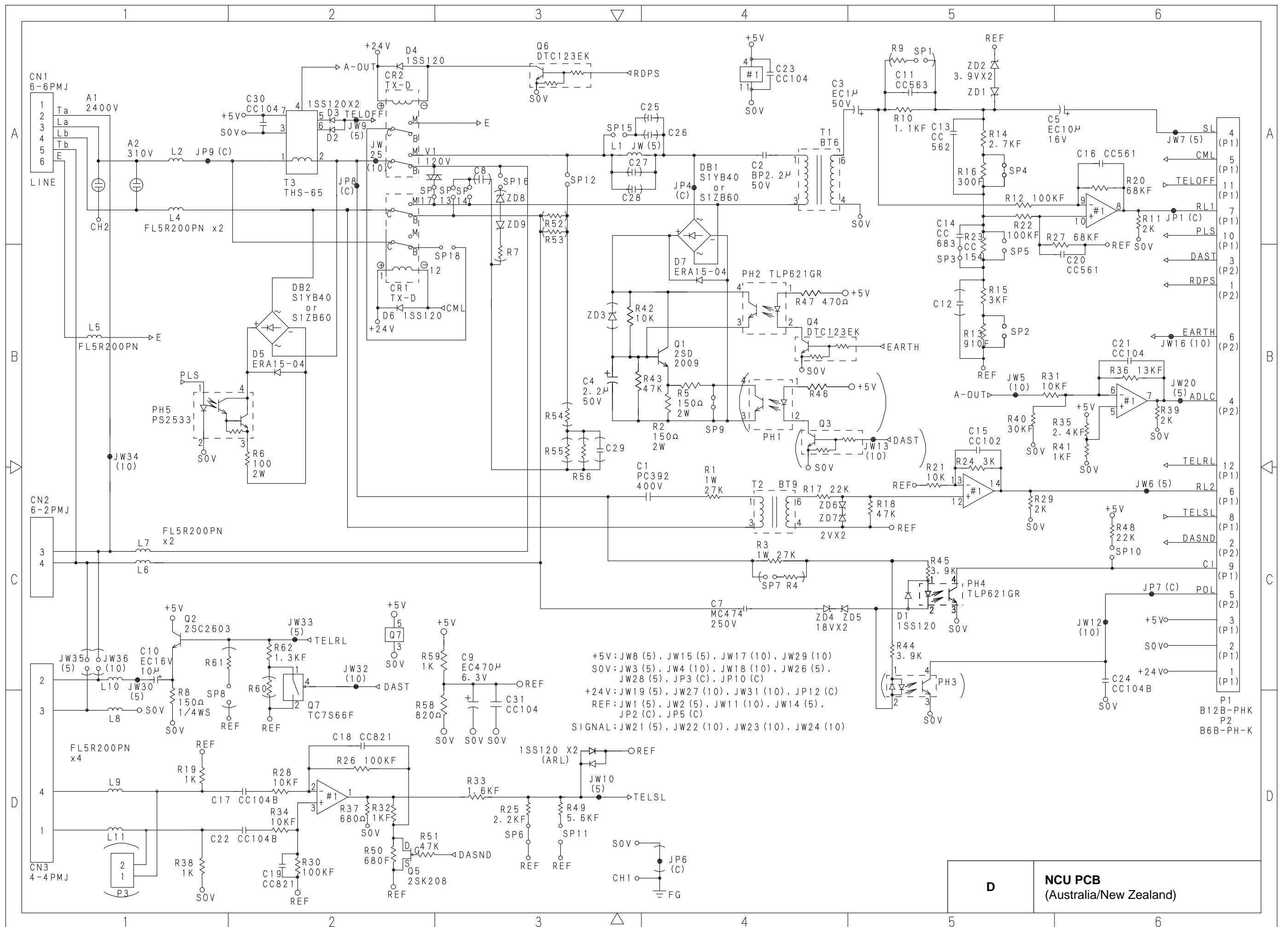

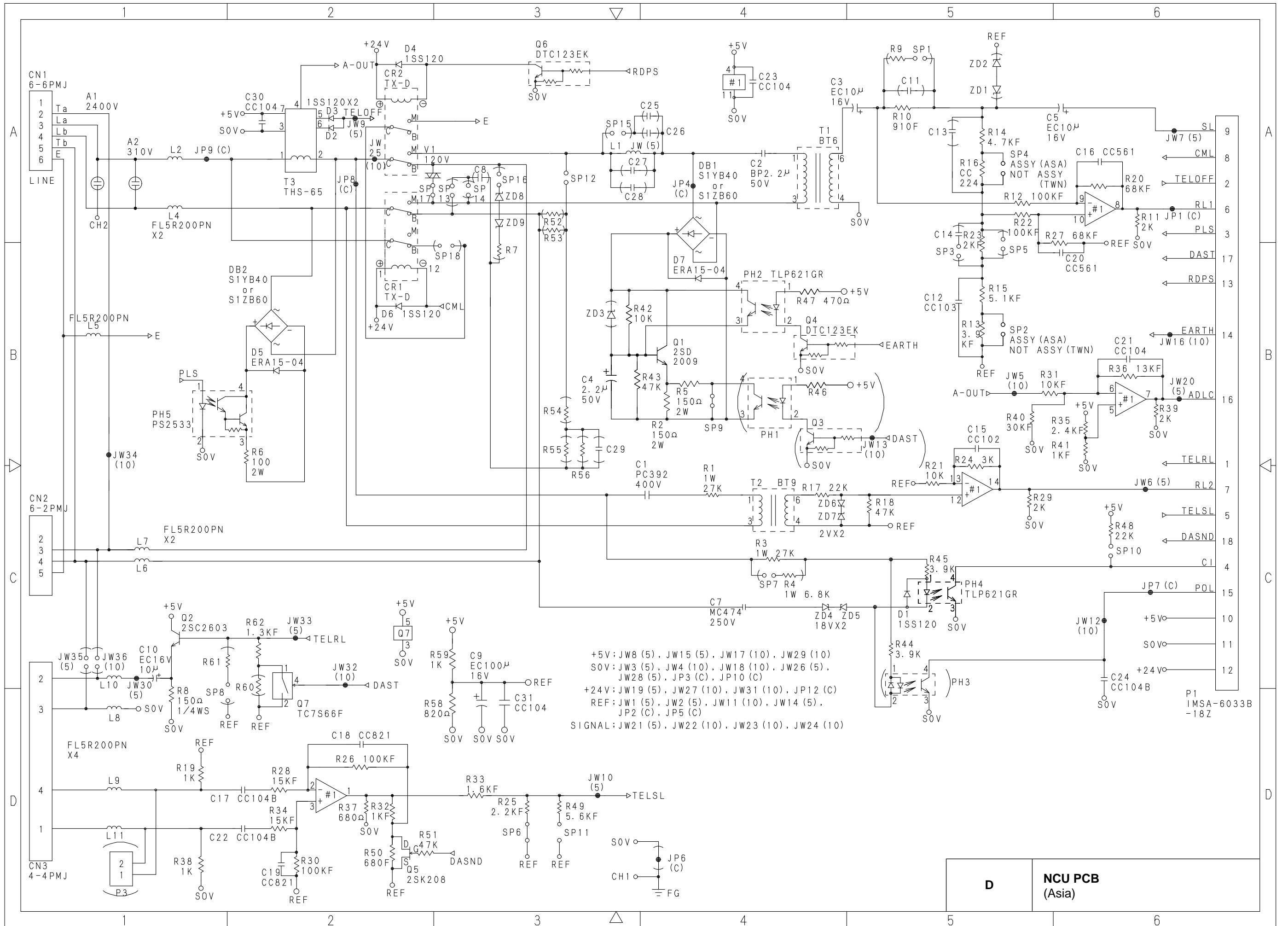

1. () 内ノ部品ハ未実装トスル。
 1. COMPONENTS IN PARENTHESIS NOT TO BE MOUNTED.

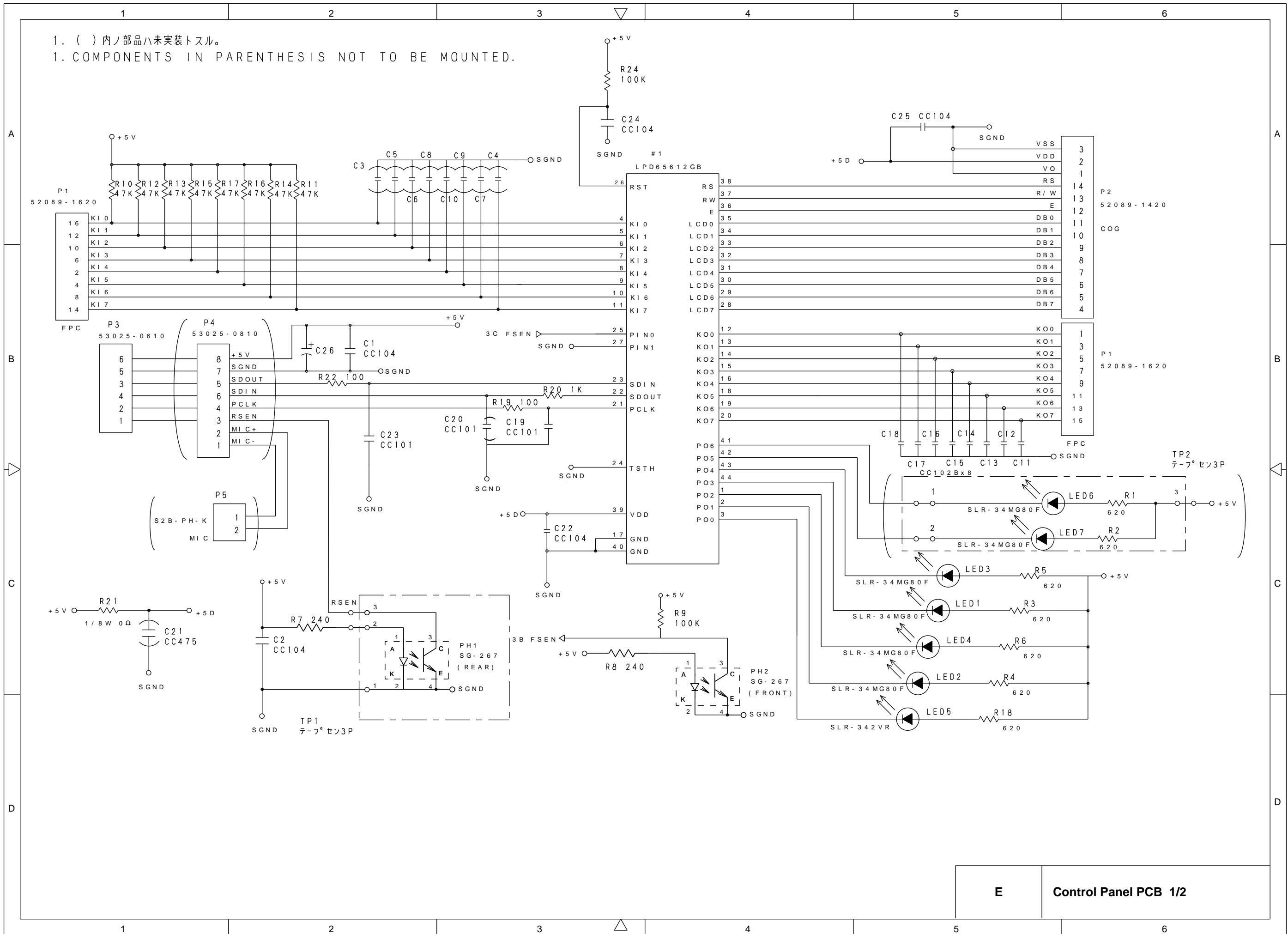

ZL PANEL KEY MATRIX REFERENCE TABLE 1

| KEY NO. | KEY NAME | KEY CODE |
|---------|--------------|----------|
| 1 / 63 | | 25 |
| 2 / 62 | | 2D |
| 3 / 64 | | 2E |
| 4 | | 2C |
| 5 | 1TOUCH-01/17 | 0D |
| 6 | 1TOUCH-02/18 | 05 |
| 7 | 1TOUCH-03/19 | 26 |
| 8 | 1TOUCH-04/20 | 24 |
| 9 | 1TOUCH-05/21 | 35 |
| 10 | 1TOUCH-06/22 | 0E |
| 11 | 1TOUCH-07/23 | 06 |
| 12 | 1TOUCH-08/24 | 04 |
| 13 | 1TOUCH-09/25 | 15 |
| 14 | 1TOUCH-10/26 | 36 |
| 15 | 1TOUCH-11/27 | 16 |
| 16 | 1TOUCH-12/28 | 34 |
| 17 | | 0C |
| 18 | 1TOUCH-13/29 | 1D |
| 19 | 1TOUCH-14/30 | 1E |
| 20 | 1TOUCH-15/31 | 1C |
| 21 | 1TOUCH-16/32 | 14 |
| 22 | Shift | 3C |
| 23 | Function | 2F |
| 24 | ← | 27 |
| 25 | SET | 22 |
| 26 | → | 23 |
| 27 | Clear | 2B |
| 28 | Hook | 07 |
| 29 | 10KEY-1 | 37 |
| 30 | 10KEY-2 | 2A |
| 31 | 10KEY-3 | 33 |
| 32 | Hold | 0F |
| 33 | 10KEY-4 | 02 |
| 34 | 10KEY-5 | 32 |
| 35 | 10KEY-6 | 03 |
| 36 | Redial/Pause | 17 |

| KEY NO. | KEY NAME | KEY CODE |
|---------|----------------|----------|
| 37 | 10KEY-7 | 0A |
| 38 | 10KEY-8 | 12 |
| 39 | 10KEY-9 | 13 |
| 40 | Volume High | 0B |
| 41 | Speed Dial | 1F |
| 42 | 10KEY-* | 1A |
| 43 | 10KEY-0 | 3A |
| 44 | 10KEY-# | 1B |
| 45 | Volume Low | 3B |
| 46 | Tel-index | 29 |
| 47 | Resolution | 21 |
| 48 | Mode | 28 |
| 49 | Help/Broadcast | 30 |
| 50 | On/Off Line | 19 |
| 51 | FF/Cont | 11 |
| 52 | Print Priority | 18 |
| 53 | Test/Reset | 20 |
| 54 | Enlarge | 01 |
| 55 | Reduce | 31 |
| 56 | Copy | 38 |
| 57 | Sort | 39 |
| 58 | Photo | 09 |
| 59 | Stop | 10 |
| 60 | Start | 08 |
| 61 | | 3D |

ZL PANEL KEY MATRIX REFERENCE TABLE 2

| | KO0 P1-1P | KO1 P1-3P | KO2 P1-5P | KO3 P1-7P | KO4 P1-9P | KO5 P1-11P | KO6 P1-13P | KO7 P1-15P |
|---------------|--------------|--------------|--------------|--------------|--------------|---------------|---------------|---------------|
| KI0 P1-16P | 54 | 58 | 51 | 50 | 47 | 46 | 55 | 57 |
| KI1 P1-12P | 33 | 37 | 38 | 42 | 25 | 30 | 34 | 43 |
| KI2 P1-10P | 35 | 40 | 39 | 44 | 26 | 27 | 31 | 45 |
| KI3 P1-6P | 12 | 17 | 21 | 20 | 8 | 4 | 16 | 22 |
| KI4 P1-2P | 6 | 5 | 13 | 18 | 1 / 63 | 2 / 62 | 9 | 61 |
| KI5 P1-4P | 11 | 10 | 15 | 19 | 7 | 3 / 64 | 14 | |
| KI6 P1-8P | 28 | 32 | 36 | 41 | 24 | 23 | 29 | |
| KI7 P1-14P | 60 | 59 | 52 | 53 | 48 | 49 | 56 | |

E

Control Panel PCB 2/2

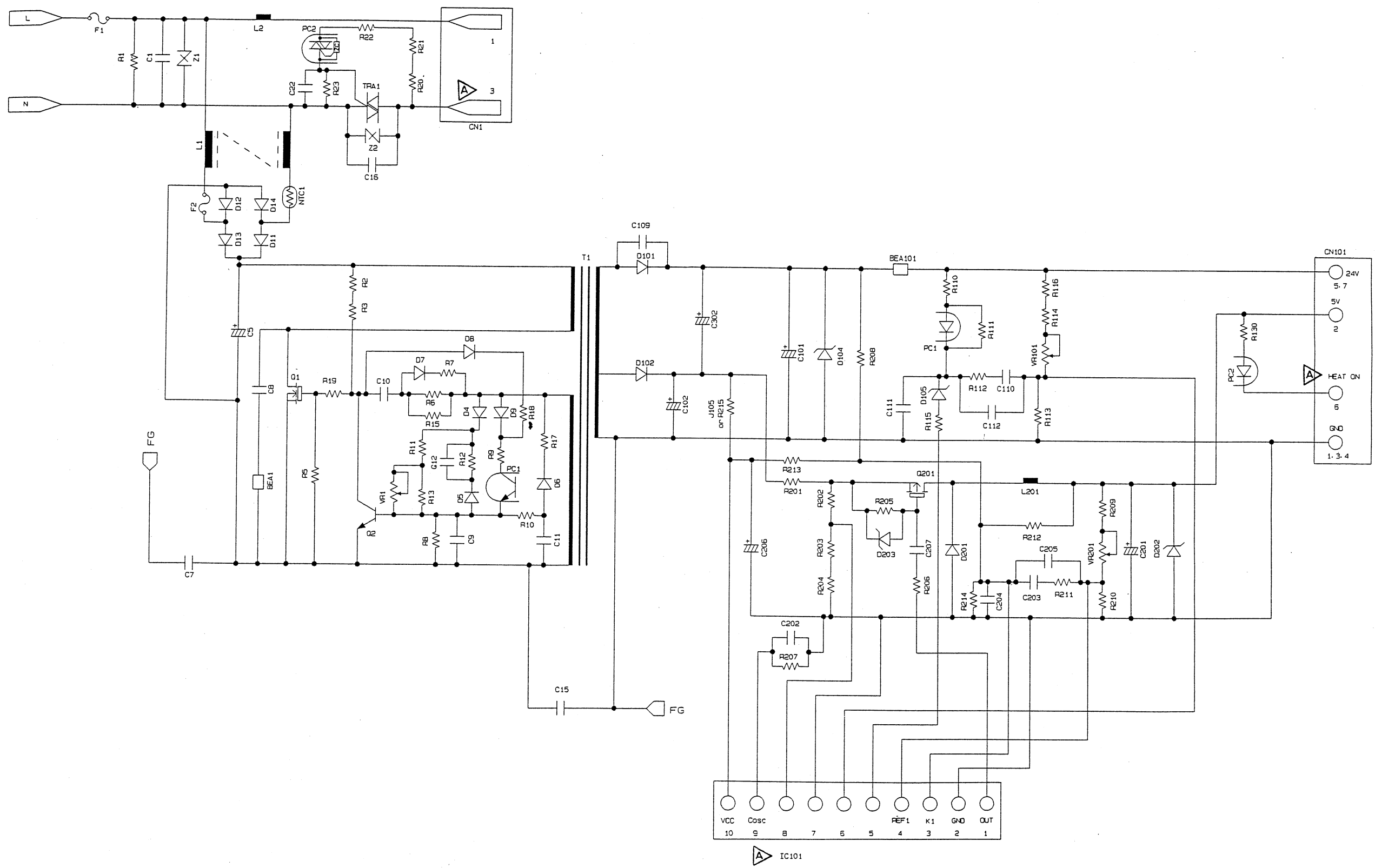

F Power Supply PCB (100-120V)
Low-voltage power supply

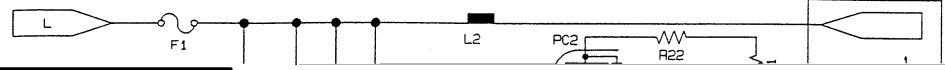

F

Power Supply PCB (200-240V)
Low-voltage power supply

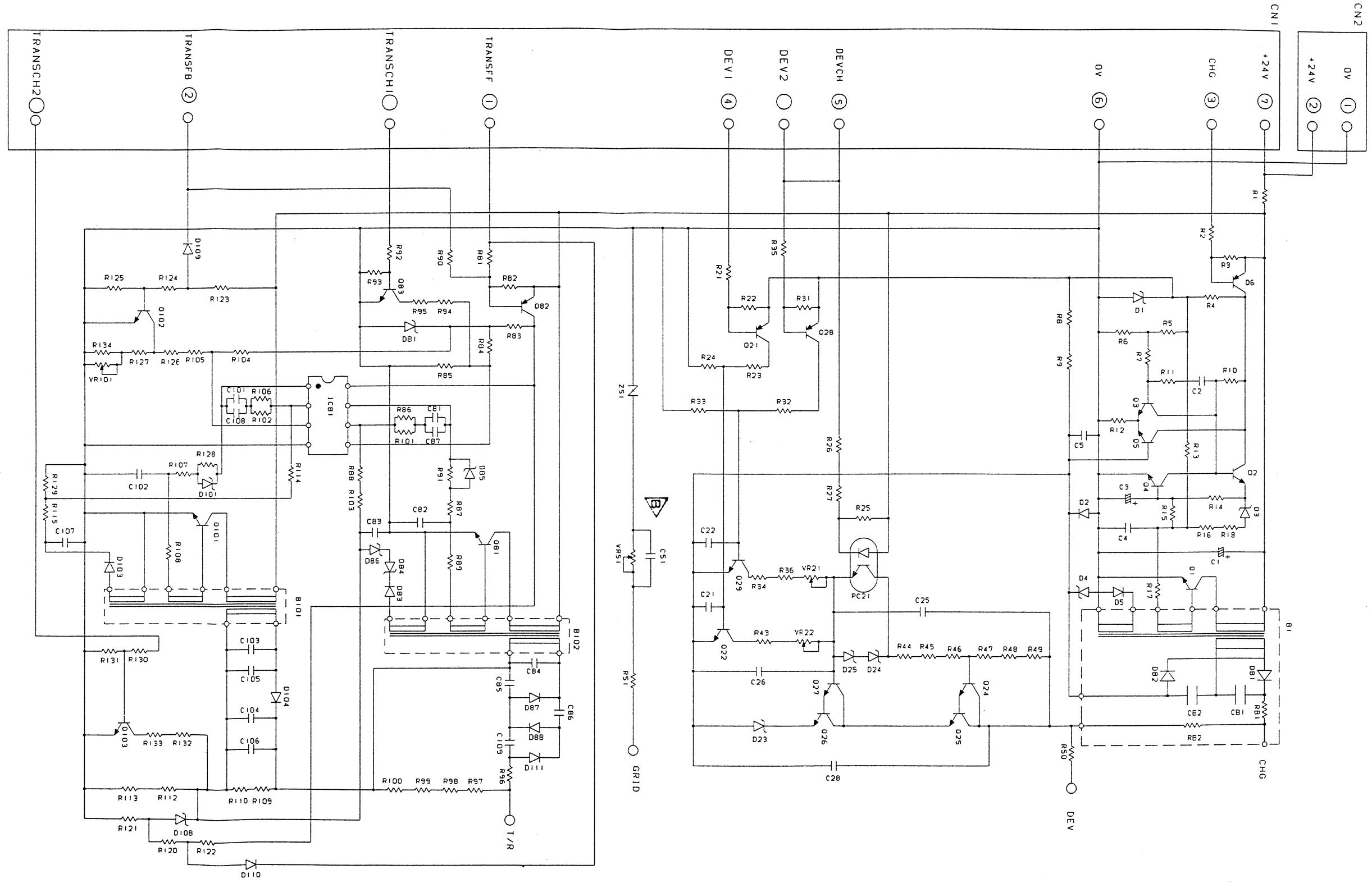

| | |
|---|---|
| F | Power Supply PCB High-voltage power supply (Old Version) |
|---|---|

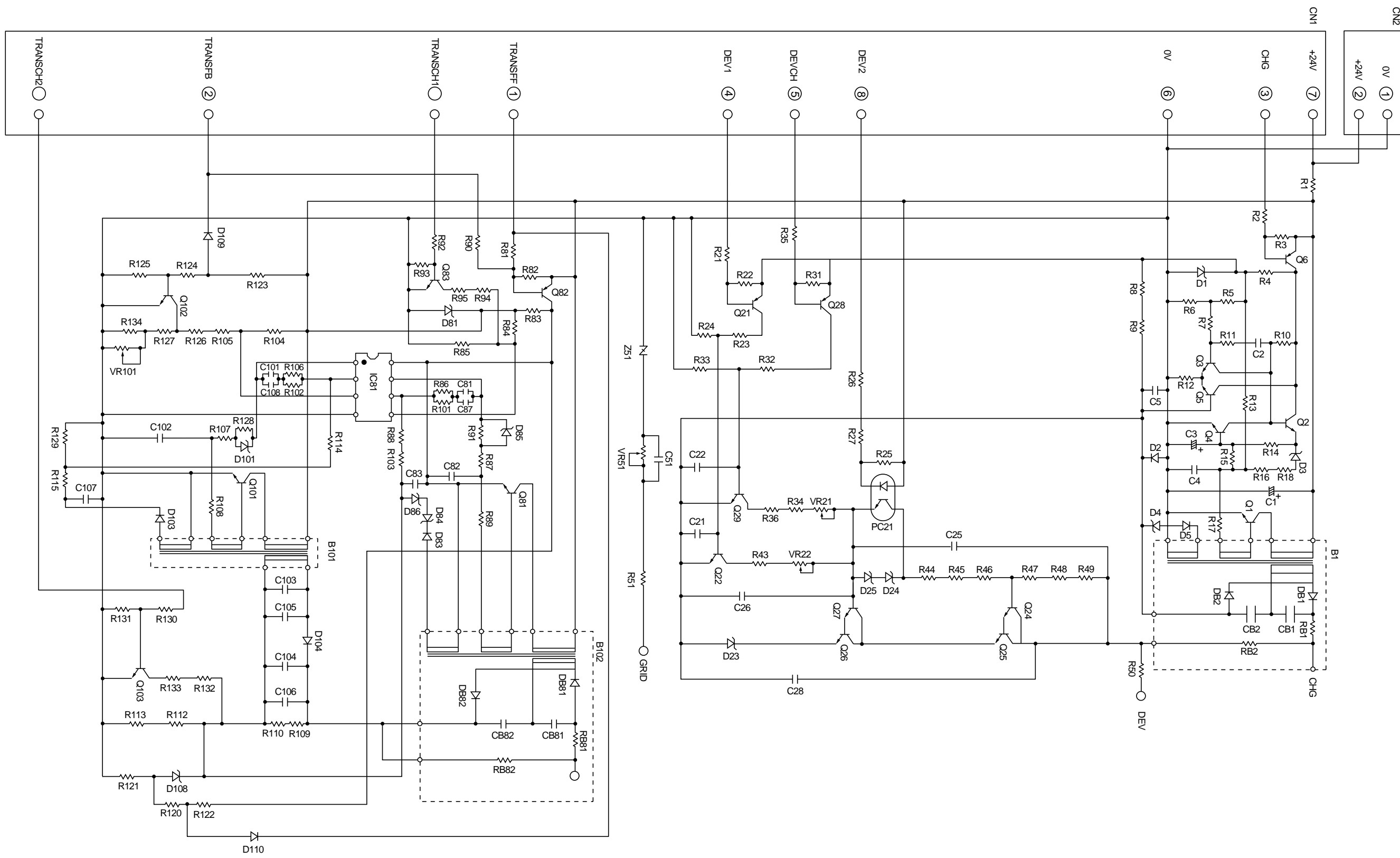

| | |
|---|---|
| F | Power Supply PCB High-voltage power supply (New Version) |
|---|---|

brother®

Jan. '00
SM8X5401
Printed in Japan